

APPENDIX E – GEOTECHNICAL REPORT





WILDFLOWER DEVELOPMENT SERVICES

4215 Tierra Rejada Rd., Ste. 192
Moorpark, California 93021

April 29, 2021

Project No.: 1-0379

Attention: Ms. Nancy Johns

Subject: **UPDATED GEOTECHNICAL REPORT**
The Beltramo Ranch Project
City of Moorpark, California

References: See Appendix A

Dear Ms. Johns:

Presented herein is Alta California Geotechnical, Inc.'s (Alta) geotechnical updated report for the Beltramo Ranch project, in the City of Moorpark, California. This report is based on a recent subsurface investigation conducted by Alta, review of the Conceptual Site Plan 3, and a review of the referenced reports.

Alta's review of the data indicates that the proposed development is feasible from a geotechnical standpoint, provided that the recommendations presented in this report are incorporated into the improvement plans and implemented during site development. Included in this report are:

- Discussion of the site geotechnical and geologic conditions.
- Recommendations for remedial and site grading, including unsuitable soil removals/reconditioning.
- Geotechnical site construction recommendations.
- Foundation design parameters.

If you have any questions or should you require any additional information, please contact the undersigned at (951) 509-7090. Alta appreciates the opportunity to provide geotechnical consulting services for your project.

Sincerely,
Alta California Geotechnical, Inc.

Reviewed By:



FERNANDO RUIZ
Civil Engineering Associate

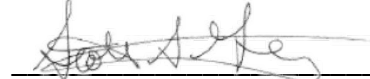

SCOTT A. GRAY/RGE 2857
Reg. Exp.: 12-31-22
Registered Geotechnical Engineer
President



JAMES B. COYNE
Engineering Geology Associate



THOMAS J. MCCARTHY/CEG 2080
Reg. Exp.: 9-30-22
Certified Engineering Geologist
Vice President



Distribution: (1) Addressee

FR: JCB: SAG: TJM:-1-0379, April 29, 2021 (Updated Geotechnical Report, Beltramo Ranch, Moorpark)

1.0	INTRODUCTION.....	4
1.1	Purpose	4
1.2	Scope of Work	4
1.3	Report Limitations	5
2.0	PROJECT DESCRIPTION.....	5
2.1	Site Location and Existing Conditions	5
2.2	Proposed Development.....	6
3.0	SITE INVESTIGATION	6
3.1	Current Subsurface Investigation	6
3.2	Previous Subsurface Investigation.....	6
3.3	Infiltration Testing	7
4.0	GEOLOGIC CONDITIONS.....	7
4.1	Geologic and Geomorphic Setting	7
4.2	Stratigraphy.....	8
	4.2.1 Artificial Fill - Undocumented (map symbol afu).....	8
	4.2.2 Alluvium (map symbol Qa)	8
4.3	Geologic Structure.....	8
	4.3.1 Tectonic Framework	8
	4.3.2 Regionally Mapped Active Faults	9
	4.3.3 Geologic Structure	9
4.4	Groundwater	9
4.5	Earthquake Hazards.....	10
	4.5.1 Local and Regional Faulting.....	10
	4.5.2 Surface Rupture	10
	4.5.3 Seismicity	10
	4.5.4 Liquefaction	11
	4.5.5 Dry Sand Settlement	13
5.0	ENGINEERING PROPERTIES AND ANALYSIS	13
5.1	Materials Properties	13
	5.1.1 Excavation Characteristics.....	13
	5.1.2 Compressibility.....	13
	5.1.3 Moisture	14
	5.1.4 Hydro-Consolidation	14
	5.1.5 Expansion Potential.....	14
	5.1.6 Earthwork Adjustments	15
	5.1.7 Chemical Analyses.....	15
5.2	Engineering Analysis	15
	5.2.1 Bearing Capacity and Lateral Earth Pressures	16
6.0	CONCLUSIONS AND RECOMMENDATIONS.....	16

6.1	Remedial Grading Recommendations	16
6.1.1	Site Preparation	16
6.1.2	Unsuitable Soil Removals	17
6.2	General Earthwork Recommendations.....	18
6.2.1	Compaction Standards	18
6.2.2	Groundwater/Seepage.....	19
6.2.3	Documentation of Removals.....	19
6.2.4	Treatment of Removal Bottoms.....	19
6.2.5	Fill Placement.....	19
6.2.6	Moisture Content.....	20
6.2.7	Mixing	20
6.2.8	Import Soils	20
6.2.9	Utility Trenches	20
6.2.10	Backcut Stability.....	22
6.3	Liquefaction.....	23
6.4	Storm Water Infiltration Systems	23
6.5	Boundary Conditions	24
7.0	DESIGN CONSIDERATIONS	25
7.1	Structural Design	25
7.1.1	Foundation Design	25
7.1.2	Post-Tensioned Slabs/Foundation Design Recommendations	26
7.2	Moisture Barrier	26
7.3	Seismic Design	27
7.4	Fence and Garden Walls.....	28
7.5	Footing Excavations.....	29
7.6	Retaining Walls.....	29
7.7	Exterior Slabs and Walkways.....	31
7.7.1	Subgrade Compaction.....	31
7.7.2	Subgrade Moisture.....	31
7.7.3	Concrete Slab Thickness.....	31
7.7.4	Concrete Slab Reinforcement	31
7.7.5	Control Joints	32
7.8	Concrete Design	32
7.9	Corrosion.....	32
7.10	Pavement Design.....	33
7.11	Site Drainage	34
8.0	LOT MAINTENANCE.....	34
8.1	Lot Drainage	34
8.2	Burrowing Animals	35
9.0	FUTURE PLAN REVIEWS	35

10.0 CLOSURE.....35
 10.1 Geotechnical Review 35
 10.2 Limitations..... 36

APPENDIX A: REFERENCES
APPENDIX B: SUBSURFACE INVESTIGATION
APPENDIX B-1 PREVIOUS SUBSURFACE INVESTIGATION (Krazan, 2019)
APPENDIX C: LABORATORY TESTING
APPENDIX C-1: PREVIOUS LABORATORY TESTING AND INFILTRATION RESULTS (Krazan, 2019)
APPENDIX D: LIQUEFACTION ANALYSIS
APPENDIX E: MAINTENANCE CONSIDERATIONS
APPENDIX F: EARTHWORK SPECIFICATIONS
APPENDIX G: GRADING DETAILS

1.0 INTRODUCTION

The following report presents Alta's findings, conclusions, and geotechnical recommendations for Beltramo Ranch Project located at 11930-11934 West Los Angeles Avenue, in the City of Moorpark, County of Ventura, California.

1.1 Purpose

The purpose of this report is to examine the existing onsite geotechnical conditions and assess the impacts that the geotechnical conditions may have on the proposed development as depicted on the attached Conceptual Site Plan 3 (Plate 1). This report is suitable for use in developing grading plans and engineer's cost estimates.

1.2 Scope of Work

Alta's *Scope of Work* for this geotechnical investigation included the following:

- Reviewing the referenced reports and air photos (Appendix A).
- Site geologic mapping.
- Excavating, logging, and sampling six (6) backhoe test pits to a maximum depth of 13.5-feet below the existing surface (Appendix B).
- Conducting four (4) CPT soundings to a maximum depth of 50-feet (Appendix B).
- Conducting laboratory testing on samples obtained during our investigation (Appendix C).
- Compiling previous subsurface and laboratory data from the referenced report (Appendices B-1 and C-1)
- Performing an infiltration study on (1) boring to provide an assessment of the infiltration characteristics of the onsite soil and their impact on storm water disposal.
- Conducting a liquefaction analysis.

- Evaluating engineering geologic and geotechnical engineering data, including laboratory data, to develop recommendations for site remedial grading including specialized grading techniques for unsuitable soil removals along the property boundary, import soil, foundations and utilities.
- Preparing this report and accompanying exhibits.

1.3 Report Limitations

The conclusions and recommendations presented in this report are based on the field and laboratory information generated during this investigation, and a review of the referenced reports. The information contained in this report is intended to be used for the development of grading plans and preliminary construction cost estimates.

2.0 PROJECT DESCRIPTION

2.1 Site Location and Existing Conditions

The approximate 7.4-acre project is located at 11930-11934 West Los Angeles Avenue, in the City of Moorpark. The site consists of a church with several related structures and two private residential properties. The site is relatively flat and is bounded by West Los Angeles Avenue to the north and residential developments to the west, east and south. An unimproved dirt road (Beltramo Ranch Road) is present along the western portion of the site.

Historic aerial photographs indicate that the site was previously utilized for agricultural purposes. By 1967, the site was vacant with the adjacent residential development completed. The church and two private properties were completed by 1980 with the site remaining largely unchanged since that time.

2.2 Proposed Development

Based on our review of the Conceptual Site Plan 3, the existing structures and parking areas will be demolished, and the site will be redeveloped to support forty-seven (47) two-story single-family homes, two open spaces and associated streets. Alta anticipates that remedial grading will be required to develop the site to support the proposed structures with shallow foundations and reinforced concrete slabs-on-grade. Significant height slopes are not anticipated for the project.

3.0 SITE INVESTIGATION

3.1 Current Subsurface Investigation

Alta conducted a subsurface investigation on March 31, 2021 and April 9, 2021 consisting of the excavation, logging and select sampling of six (6) rubber tire backhoe test pits up to a maximum depth of 13.5 feet and four (4) cone penetrometer tests to a maximum depth of 50 feet below the existing ground surface, respectively. The locations of the exploratory excavations are shown on Plate 1 and the test pit logs are presented in Appendix B.

Laboratory testing was performed on bulk samples obtained during the field investigation. A brief description of the laboratory test procedures and the test results are presented in Appendix C.

3.2 Previous Subsurface Investigation

Krazan and Associates, Inc. (Krazan) prepared a geotechnical investigation in 2019 for the subject site. Their subsurface investigation included excavating logging and sampling twelve (12) hollow-stem auger borings up to 50 feet in depth and an additional four (4) borings were excavated for infiltration testing. The approximate locations of the borings are shown on the attached Plate 1 and the logs of the borings are presented in Appendix B-1. The lab data and infiltration results are presented in Appendix C-1.

3.3 Infiltration Testing

It is Alta’s understanding that the project may utilize infiltration systems for storm water disposal. Details of the system are not known at this time.

Infiltration testing was undertaken using one (1) five-foot-deep boring excavated with a handheld power auger. The testing was performed in general accordance with the County of Ventura WQMP standards. The test well was presoaked at least 24 hours prior to testing. During testing, the water level readings were recorded every 30 minutes until the readings stabilized.

The data was then adjusted to provide an infiltration rate utilizing the Porchet Method. The resulting infiltration rates are presented in Table 3-1. The results do not include a factor of safety. Recommendations for infiltration BMP design are presented in Section 6.4.

Table 3-1-Summary of Infiltration Testing (No Factor of Safety)	
Test Designation	P-1
Approximate Depth of Test	5 ft
Time Interval	30 minutes
Radius of Test Hole	4 inches
Tested Infiltration Rate	0.6 (in/hr)

4.0 GEOLOGIC CONDITIONS

4.1 Geologic and Geomorphic Setting

Regionally, the subject site is located on the Santa Ynez sub-block of the Traverse Ranges geomorphic province. The Santa Ynez sub-block is bounded on the south by the San Monica and Raymond fault zones, on the north by the Big Pine fault zone, and on the east by the San Gabriel fault zone. This province is characterized by predominantly east-west trending, left lateral and/or reverse faults.

4.2 Stratigraphy

Based on or review of geologic literature and our subsurface investigation, the project site is underlain by alluvium with a section of undocumented artificial fill located in the southern section of the site. The geologic units are briefly described below.

4.2.1 Artificial Fill - Undocumented (map symbol afu)

The undocumented artificial fill encompasses most of the site and consists of tan to brown sand in a dry and medium dense condition. The unit was logged to a depth of 3 feet below the ground surface and is underlain by alluvium.

4.2.2 Alluvium (map symbol Qa)

The alluvium observed at the site consists of tan to brown, silty sand and sand, in a dry to slightly moist, loose to medium dense condition. The unit was logged to a depth of 13.5 feet below the ground surface.

4.3 Geologic Structure

4.3.1 Tectonic Framework

Jennings (1985) defined eight structural provinces within California that have been classified by predominant regional fault trends and similar fold structure. These provinces are in turn divided into blocks and sub-blocks that are defined by "major Quaternary faults." These blocks and sub-blocks exhibit similar structural features. Within this framework, the subject site is located within Structural Province II, the Transverse Range Block, which is controlled by the dominant east-west trend of faulting. The Transverse Range Block is characterized by a series of sub-parallel, east-west trending faults that exhibit left lateral and/or reverse movement. This block is bounded by the Mojave and Coast Range blocks to the north and by the Peninsular Range block to the south. Various

northwest and east-west trending faults divide the Transverse Range block into five sub-blocks. The site is located on the Santa Ynez sub-block, one of the five sub-blocks, and it is bounded on the south by the San Monica and Raymond fault zones, on the north by the Big Pine fault zone, and on the east by the San Gabriel fault zone.

4.3.2 Regionally Mapped Active Faults

Several large, active fault systems, including the Simi-Santa Rosa, the San Cayetano, and the San Gabriel, occur in the region surrounding the site. These fault systems have been studied extensively and, in some part, control the geologic structure of southern California.

4.3.3 Geologic Structure

Based upon our site investigation and literature review, the onsite sediments are of Quaternary-age, and are not fractured, folded, or faulted.

4.4 Groundwater

Groundwater was encountered during the previous investigation at a depth of approximately 20 feet below the ground surface. Based on state-provided information, the historic-high groundwater is approximately 15 feet below the ground surface (CDMG, 2000). A water well, located within approximately half a mile to the west at an elevation of 459.81-ft, indicates that the groundwater was 48 feet below the ground surface in March of 1980 (State Well No. 02N19W07A003S). More recent data from State Well No. 02N19W07G001S, at elevation 453.0-ft, showed a depth to groundwater of 16.9-ft in October of 2020.

4.5 Earthquake Hazards

The subject site is located in southern California, which is a tectonically active area. The type and magnitude of seismic hazards affecting a site are dependent on the distance to the causative fault and the intensity and magnitude of the seismic event. The seismic hazard may be primary, such as surface rupture and/or ground shaking, or secondary, such as liquefaction and/or ground lurching.

4.5.1 Local and Regional Faulting

The site is located on the southern central portion of the Santa Ynez sub-block, approximately 1.7, 6.7, 8.8, 9.4, 13.9, 14.3, 14.7, 14.8, 15.9, 20.3, and 20.4 miles away from the Simi-Santa Rosa, Oakridge, San Cayetano, Santa Susana, Holser, Northridge, Pitas Point, Ventura-Pitas, Malibu, Mission Ridge, and Santa Ynez fault zones respectively.

4.5.2 Surface Rupture

Active faults are not known to exist within the project and a review of Special Publication 42 indicates the site is not within a California State designated earthquake fault zone. Accordingly, the potential for fault surface rupture on the subject site is very low.

4.5.3 Seismicity

Ground shaking hazards caused by earthquakes along other active regional faults do exist. The 2019 California Building Code requires use-modified spectral accelerations and velocities for most structural designs. Seismic design parameters using soil profile types identified in the 2019 California Building Code are presented in Section 7.3.

4.5.4 Liquefaction

Seismic agitation of relatively loose saturated sands, silty sands, and some silts can result in a buildup of pore pressure. If the pore pressure exceeds the overburden stresses, a temporary quick condition known as liquefaction can occur. Liquefaction effects can manifest in several ways including: 1) loss of bearing; 2) lateral spread; 3) dynamic settlement; and 4) flow failure. Lateral spreading has typically been the most damaging mode of failure.

In general, the more recent that a sediment has been deposited, the more likely it will be susceptible to liquefaction. Other factors that must be considered are groundwater, confining stresses, relative density, and the intensity and duration of seismically-induced ground shaking.

Groundwater was encountered during the previous subsurface investigation at a depth approximately 20 feet below the ground surface in boring B-1. The regional groundwater map indicates that the historic-high groundwater level is approximately 15 feet below the ground surface (CDMG, 2000).

Alta performed a liquefaction analysis utilizing data from the CPT soundings to analyze the liquefaction potential of the alluvium. A description of Alta's analysis and calculations are presented in Appendix D of this report. A groundwater level of 15 feet below existing ground surface was assumed. The results of our findings are discussed below under the headings of the specific types of liquefaction which can be manifested during seismic shaking. Conclusions regarding liquefaction are presented in Section 6.3.

➤ **Loss of Bearing:**

Liquefaction can potentially cause foundation bearing failure due to ground softening. Based on the removal recommendations presented in this report, Alta anticipates that the potential for loss of bearing will be minimal

➤ **Lateral Spreading:**

The lateral displacement of surficial blocks of sediment can occur as a result of liquefaction in a subsurface layer. The most pervasive forms of lateral spreading typically involve sites located near a "free-face" (large slopes, channels, etc.), however, it has been noted that lateral spreading can occur on sites with gently sloping (1% or more) ground, such as the subject site.

Determination of the potential for lateral spread is based on the presence of continuous potentially liquefiable soil layers underneath the structures, the presence of lateral confinement, and various analyses such as empirical modeling. Bartlett, Hansen and Youd (2002) states that surface manifestation of lateral spread is typically limited to sites with liquefiable soils within 10 meters (32 feet) of grade, and that sites underlain by soils with $(N1)_{60}$ values 15 and greater do not experience significant displacements from earthquakes with magnitudes less than 8.

Given the flat nature of the site, the limited liquefiable layers with $(N1)_{60}$ values less than 15, our recommended unsuitable soil removals (Section 6.1.2) and our foundation design recommendations (Section 7.1), it is our opinion that the potential for lateral spread to occur onsite is considered minimal and within design tolerances of the proposed foundation systems, upon the completion of remedial grading.

➤ **Settlement:**

Settlement due to seismic shaking can occur as a result of both liquefaction of saturated sediments or rearrangement of dry sand particles. Our liquefaction analysis was performed utilizing CPT data and laboratory test results to analyze the potential amount of settlement. A description of Alta's analysis and calculations are presented in Appendix D of this report. A discussion of settlement analysis results is presented in Section 6.3. Dynamic settlement design recommendations are presented in Section 7.1.

➤ **Flow Failure:**

Due to the relatively flat nature of the site, and the relatively horizontal deposition of the underlying deposits, the potential for flow failure onsite is considered minimal.

4.5.5 Dry Sand Settlement

Dry sand settlement is the process of non-uniform settlement of the ground surface during a seismic event. Based on our subsurface investigation, the previous investigation and our removal/recompaction recommendations, the potential for dry sand settlement is anticipated to be low and within foundation design tolerances. Design dynamic settlement parameters are presented in Table 7-1.

5.0 ENGINEERING PROPERTIES AND ANALYSIS

5.1 Materials Properties

Presented herein is a general discussion of the engineering properties of the onsite materials that will be encountered during construction of the proposed project. Descriptions of the soil (Unified Soil Classification System) are presented on the boring logs in Appendix B.

5.1.1 Excavation Characteristics

Based on the data provided from the subsurface investigations, it is our opinion that the majority of the onsite materials possess favorable excavation characteristics such that conventional earth moving equipment can be utilized.

5.1.2 Compressibility

The artificial fill and upper portions of the alluvium onsite are considered compressible and unsuitable to support the proposed improvements. Recommended removal depths are presented in Section 6.1.2.

5.1.3 Moisture

The moisture content of the upper portions of alluvium that will require removal and recompaction as discussed in Section 6.1.2 varies and may require moisture conditioning for compaction.

5.1.4 Hydro-Consolidation

Hydro-consolidation is the effect of introducing water into soil that is prone to collapse. Upon loading and initial wetting, the soil structure and apparent strength are altered resulting in almost immediate settlement. That settlement can have adverse impacts on engineered structures, particularly in areas where it is manifested differentially. Differential settlements are typically associated with differential wetting, irregularities in the subsurface soil conditions, or irregular loading patterns.

Based on previous laboratory testing (Appendix C-1), there is potential for hydro-collapse in the alluvium onsite. As such, it is recommended to utilize the unsuitable soil removal recommendations presented in Section 6.1.2 of this report to mitigate the hydro-collapse potential.

5.1.5 Expansion Potential

Expansion index testing was performed on samples taken during our subsurface investigation (Appendix C). Based on the results, it is anticipated that the majority of materials onsite are “very low” to “low” in expansion potential ($0 \leq EI \leq 50$, Appendix C) when tested per ASTM D: 4829.

5.1.6 Earthwork Adjustments

The values presented in Table 5-1 are deemed appropriate for estimating purposes and may be used in an effort to balance earthwork quantities. As is the case with every project, contingencies should be made to adjust the earthwork balance when grading is in-progress and actual conditions are better defined.

TABLE 5-1 Earthwork Adjustment Factors		
Geologic Unit	Adjustment Factor Range	Average
Artificial Fill- Undocumented/Alluvium	Shrink 4% to 8%	6%

5.1.7 Chemical Analyses

Chemical testing was performed on samples of material underlying the proposed site during our investigation and the previous investigation. Soluble sulfate test results indicate that the soluble sulfate concentrations of the soils tested are classified as negligible (Category S0) per ACI 318-14.

Negligible chloride levels were detected in the onsite soils. Resistivity testing conducted as part of this investigation, indicates that the soils are moderately corrosive to corrosive to buried metals (per Romanoff, 1989). Additional discussions on corrosion are presented in Section 7.9.

Corrosion tests results are presented in Appendix C.

5.2 Engineering Analysis

Presented below is a general discussion of the engineering analysis methods that were utilized to develop the conclusions and recommendations presented in this report.

5.2.1 Bearing Capacity and Lateral Earth Pressures

Ultimate bearing capacity values were obtained using the graphs and formula presented in NAVFAC DM-7.1. Allowable bearing was determined by applying a factor of safety of at least 3 to the ultimate bearing capacity. Static lateral earth pressures were calculated using Rankine methods for active and passive cases. If it is desired to use Coulomb forces, a separate analysis specific to the application can be conducted.

6.0 CONCLUSIONS AND RECOMMENDATIONS

Based on Alta's findings during our subsurface investigation, the laboratory test results, and our staff's previous experience in the area, it is Alta's opinion that the development of the site is feasible from a geotechnical perspective. Presented below are recommendations that should be incorporated into site development and construction plans.

6.1 Remedial Grading Recommendations

All grading shall be accomplished under the observation and testing of the project geotechnical consultant in accordance with the recommendations contained herein and the City of Moorpark criteria.

6.1.1 Site Preparation

Vegetation, construction debris, and other deleterious materials are unsuitable as structural fill material and should be disposed of off-site prior to commencing grading/construction. Any septic tanks, seepage pits or wells should be abandoned as per the County of Ventura Department of Health Services.

Existing concrete should be removed prior to the placement of engineered fill. The demolished concrete may be incorporated into compacted, engineered fills after it is crushed to a maximum size of six (6) inches. Prior to placement as engineered fill any protruding steel rebar should be cut from the concrete pieces and disposed of offsite.

Existing asphaltic concrete should be removed prior to the placement of engineered fill. From a geotechnical perspective, this material may be incorporated into compacted, engineered fills after it is crushed to a maximum size of six (6) inches. The crushed asphalt should not be placed under residential structures, but rather, it can be placed in approved non-residential areas, such as streets, parking areas or open space. These recommendations should be verified by the environmental consultant.

6.1.2 Unsuitable Soil Removals

The artificial fill and the upper portions of the alluvium near the surface are compressible and as such, are not suitable to support the proposed structures. As such, it is anticipated that, on average, the upper five (5) feet of existing soils will require removal and recompaction, extending a minimum of five (5) feet horizontally outside the structures. This recommended removal combined with the foundation recommendations presented in Section 7.1 should provide suitable support for the proposed structures.

Footings for structures should be underlain by a minimum of two (2) feet of compacted fill. As such, for building pads where unsuitable soil removals do not provide the minimum depth of compacted fill, or where design grades and/or remedial grading activities create cut/fill transitions, the cut and shallow fill portions of the building pads should be over-excavated during grading and replaced with compacted fill.

The Project Geotechnical Consultant should observe the removal bottom prior to placing fill. If unsuitable soils such as undocumented artificial fill is exposed upon the completion of the removals recommended above, additional removals may be required.

For fill areas in streets, in general, a minimum removal and recompaction of the upper two (2) feet is recommended, however all undocumented artificial fill shall be removed and recompacted. For cuts greater than two (2) feet in street areas, removals are not required. For cuts less than two (2) feet, the two (2) foot removal and recompaction applies.

Material removed as part of the unsuitable soil removals can be used as artificial fill, provided it is free of deleterious materials.

6.2 General Earthwork Recommendations

6.2.1 Compaction Standards

All fill and processed natural ground shall be compacted to a minimum relative compaction of 90 percent, as determined by ASTM Test Method: D-1557. Fill material should be moisture conditioned to optimum moisture or above, and as generally discussed in Alta's Earthwork Specification Section presented in Appendix F. Compaction shall be achieved with the use of sheepfoot rollers or similar kneading type

equipment. Mixing and moisture conditioning will be required in order to achieve the recommended moisture conditions.

6.2.2 Groundwater/Seepage

It is anticipated that groundwater will not be encountered during construction. It is possible that perched water conditions could be encountered depending on the time of year construction occurs.

6.2.3 Documentation of Removals

All removal/over-excavation bottoms should be observed and approved by the project Geotechnical Consultant prior to fill placement. Consideration should be given to surveying the removal bottoms and undercuts after approval by the geotechnical consultant and prior to the placement of fill. Staking should be provided in order to verify undercut locations and depths.

6.2.4 Treatment of Removal Bottoms

At the completion of removals/over-excavation, the exposed removal bottom should be ripped to a minimum depth of eight (8) inches, moisture-conditioned to above optimum moisture content and compacted in-place to the project standards.

6.2.5 Fill Placement

After removals, scarification, and compaction of in-place materials are completed, additional fill may be placed. Fill should be placed in eight-inch bulk maximum lifts, moisture conditioned to optimum moisture content or above, compacted and tested as grading/construction progresses until final grades are attained.

6.2.6 Moisture Content

The moisture content of the upper in-situ soils varies, as shown on the boring logs in Appendix B. Moisture conditioning will be required during grading to achieve optimum or above conditions. Most soils will require the addition of water and mixing prior to placement as compacted fill.

6.2.7 Mixing

Mixing of materials may be necessary to prevent layering of different soil types and/or different moisture contents. The mixing should be accomplished prior to and as part of compaction of each fill lift.

6.2.8 Import Soils

Import soils, if necessary, should consist of clean, structural quality, compactable materials similar to the on-site soils and should be free of trash, debris, or other objectionable materials. The project Geotechnical Consultant should be notified not less than 72 hours in advance of the locations of any soils proposed for import. Import sources should be sampled, tested, and approved by the project Geotechnical Consultant at the source prior to the importation of the soils to the site. The project Civil Engineer should include these requirements on plans and specifications for the project.

6.2.9 Utility Trenches

6.2.9.1 Excavation

Utility trenches should be supported, either by laying back excavations or shoring, in accordance with applicable OSHA standards. In general, existing site soils are classified as Soil Type "B" and "C" per OSHA standards. Upon completion of the recommended removals and recompaction, the artificial fill will be classified as Soil Type "B". The Project

Geotechnical Consulting should be consulted if geologic conditions vary from what is presented in this report.

6.2.9.2 Backfill

Trench backfill should be compacted to at least 90 percent of maximum dry density as determined by ASTM D-1557.

Onsite soils will not be suitable for use as bedding material but will be suitable for use in backfill provided oversized materials are removed. No surcharge loads should be imposed above excavations. This includes spoil piles, lumber, concrete trucks, or other construction materials and equipment. Drainage above excavations should be directed away from the banks. Care should be taken to avoid saturation of the soils. Compaction should be accomplished by mechanical means. Jetting of native soils will not be acceptable.

Under-slab trenches should also be compacted to project specifications. If select granular backfill ($SE > 30$) is used, compaction by flooding will be acceptable.

6.2.10 Backcut Stability

Temporary backcuts, if required during unsuitable soil removals, should be made no steeper than 1:1 without review and approval of the geotechnical consultant. Flatter backcuts may be necessary where geologic conditions dictate and where minimum width dimensions are to be maintained.

Care should be taken during remedial grading operations in order to minimize risk of failure. Should failure occur, complete removal of the disturbed material will be required.

In consideration of the inherent instability created by temporary construction backcuts for removals, it is imperative that grading schedules are coordinated to minimize the unsupported exposure time of these excavations. Once started, these excavations and subsequent fill operations should be maintained to completion without intervening delays imposed by avoidable circumstances. In cases where five-day workweeks comprise a normal schedule, grading should be planned to avoid exposing at-grade or near-grade excavations through a non-work weekend. Where improvements may be affected by temporary instability, either on or offsite, further restrictions such as slot cutting, extending workdays, implementing weekend schedules, and/or other requirements considered critical to serving specific circumstances may be imposed.

6.3 Liquefaction

As discussed in Section 4.5.4 of this report, there is a potential for liquefaction to occur at the site during seismic shaking. More specifically, liquefaction could cause differential settlement. Typically, half to two thirds of that settlement should be considered differential (California Division of Mines and Geology, 2008, Special Publication 117a). If the analysis is based on multiple borings, seismic induced differential settlement may be determined as one-half the total settlement (City of Los Angeles, 2020). For lightly loaded, well-constructed structures underlain by a non-liquefiable layer over the liquefiable layers, such as will be developed at the site, the ultimate differential settlement across the structure may be more limited (Idriss and Boulinger, 2008). The differential settlement shown between the CPT's was as much as approximately 1.7-inches. In consideration of the proposed removal and recompaction of the soils below the proposed structures, the differential settlement shown in the liquefaction calculations, and the relatively uniform thickness of the liquefiable layers under the site, it is Alta's opinion that a dynamic differential settlement of 2.0-inches in 40 feet can be utilized in the design of the proposed structures onsite. It is recommended that the structures onsite be supported on a post-tensioned slab/foundation or mat slab system.

6.4 Storm Water Infiltration Systems

From a geotechnical perspective, allowing storm water to infiltrate the onsite soil in concentrated areas increases the potential for settlement, liquefaction, and water-related damage to structures/improvements, such as wet slabs or pumping subgrade, and should be avoided where possible. If infiltration systems are required on this site, care should be taken in designing systems that control the storm water as much as possible.

Preliminary infiltration testing was conducted at the site as part of this investigation, and the methodology is discussed in 3.2. The resulting infiltration rates for P-1 was calculated to be 0.6-inches per hour, respectively. The results do not include a factor of safety. Test P-1 was conducted in sand lenses of the alluvium onsite at approximately 5-feet below the ground surface.

Groundwater was encountered during the previous investigation at a depth of approximately 20 feet below the ground surface. The historic high ground water is approximately 15 feet below the ground surface (CDMG, 2000).

Based on our infiltration rates and the previous infiltration rates of the underlying soil, infiltration-type WQMP's are likely feasible for project within the depths tested, although historic high groundwater may be a limiting factor. The Project Geotechnical Consultant should review the final WQMP design prior to construction.

6.5 Boundary Conditions

The site is bounded by West Los Angeles Avenue to the north and residential developments to the west, east and south. Construction of retaining/screen walls along these boundaries may require additional geotechnical recommendations concerning unsuitable soil removals and foundation design parameters. The enclosed site plan indicates structures may be located within 5-feet of the northern boundary. As such, slot cutting may be required to achieve the recommended unsuitable soil removal/recompaction presented in Section 6.1.2. Boundary conditions for the project should be reviewed by the Project Geotechnical Consultant as the design progresses.

7.0 DESIGN CONSIDERATIONS

7.1 Structural Design

It is anticipated that multi-story wood-framed residential structures with slab on-grade and shallow foundations will be constructed. Upon the completion of rough grading, finish grade samples should be collected and tested in order to provide specific recommendations as they relate to the individual building pads. These test results and corresponding design recommendations should be presented in a final rough grading report. Final slab and foundation design recommendations should be made based upon specific structure sitings, loading conditions, and as-graded soil conditions.

It is anticipated that the majority of onsite soils will possess “very low” to “low” expansion potential when tested in general accordance with ASTM Test Method D: 4829. For budgeting purposes, the following foundation design requirements for a range of potential expansion characteristics are presented. Due to the anticipated potential for dynamic settlement onsite, it is recommended to utilize post-tensioned or mat slabs for this project.

7.1.1 Foundation Design

Foundations may be preliminary designed based on the values presented in Table 7-1 below.

Table 7-1 Foundation Design Parameters*	
Allowable Bearing	2000 lbs/ft ² (assuming a minimum embedment depth and width of 12 inches)
Lateral Bearing	250 lbs/ft ² at a depth of 12 inches plus 250 lbs/ft ² for each additional 12 inches of embedment to a maximum of 2000 lbs/ft ² .
Sliding Coefficient	0.30
Settlement	Static Settlement – 0.5 inch in 40 feet Dynamic Settlement – 2.0 inches in 40 feet

*These values may be increased as allowed by Code to resist transient loads such as wind or seismic. Building code and structural design considerations may govern depth and reinforcement requirements and should be evaluated.

7.1.2 Post-Tensioned Slabs/Foundation Design Recommendations

Post-tensioned slabs for the project may be designed utilizing the parameters presented in Tables 7-1 and 7-2. The parameters presented herein are based on methodology provided in the Design of Post-Tensioned Slabs-On-Ground, Third Edition, by the Post-Tensioning Institute, in accordance with the 2019 CBC.

TABLE 7-2 POST-TENSION SLAB DESIGN PARAMETERS						
Category	Expansion Potential	Minimum Embedment*	Edge Lift		Center Lift	
			Em (ft)	Ym (inch)	Em (ft)	Ym (inch)
I	Very low to Low	12 inches	5.4	0.61	9.0	0.26
Slab Subgrade Moisture						
Category I	Minimum 110% of optimum moisture to a depth of 12 inches prior to pouring concrete					
Embedment*						
The minimum footing embedments presented herein are based on expansion indexes. The structural engineer should determine minimum embedments based on the number of floors supported by the footings, the structural loading, and the requirements of the latest California Building Code. If mat slabs are utilized, alternate embedment depths can be provided.						
Moisture Barrier						
A moisture barrier should be provided in accordance with the recommendations presented in Section 7.2						
<i>The parameters presented herein are based on procedures presented in the <u>Design of Post-Tensioned Slabs-On-Ground, Third Edition</u>. No corrections for vertical barriers at the edge of the slab, or for adjacent vegetation have been assumed. The design parameters are based on a Constant Suction Value of 3.9 pF.</i>						

7.2 Moisture Barrier

A moisture and vapor retarding system should be placed below the slabs-on-grade in portions of the structure considered to be moisture sensitive and should be capable of effectively preventing the migration of water and reducing the transmission of water vapor to acceptable levels. Historically, a 10-mil plastic membrane, such as Visqueen, placed between two to four inches of clean sand, has been used for this purpose. The use of this system or other systems can be considered, at the discretion of the designer, provided the system reduces the vapor transmission rates to acceptable levels.

7.3 Seismic Design

In accordance with the requirements in Section 11.4.8 of ASCE 7-16 for sites with Site Class F, Alta has performed a site-specific ground motion analysis for the subject project. The analysis was performed in accordance with Chapter 21 of ASCE 7-16, the 2019 CBC, and the 2014 USGS Ground Acceleration Maps. The USGS Unified Hazard Tool

(<https://earthquake.usgs.gov/hazards/interactive/index.php>) and the USGS National Seismic Hazard Map source model was utilized to perform the analysis.

The site class was determined based on the referenced reports and published geologic maps in the area in general conformance with Chapter 20 of ASCE 7-16. There is a potential for liquefaction onsite which would result in a Site Class of F. However, it is assumed that the proposed structures onsite will have a fundamental period of vibration equal to or less than 0.5s. As such, per Section 20.3.1 of ASCE 7-16, a Site Class of D may be utilized for the onsite soils. The structural engineer shall verify the fundamental period of vibration of the proposed structures.

Probabilistic (MCER) ground motions were determined in accordance with Method 2 of Section 21.2.1 of ACE 7-16. The site specific MCER was taken as the lesser of the probabilistic and deterministic ground motions.

The design response spectrum was determined per Section 21.3 of ASCE 7-16. Design acceleration parameters were determined per Section 21.4 of ASCE 7-16 and the results are presented in Table 7-3. These parameters should be verified by the structural engineer. Additional parameters should be determined by the structural engineer based on the Occupancy Category of the proposed structures.

TABLE 7-3 Seismic Ground Motion Values 2019 CBC and ASCE 7-16	
<i>Parameter</i>	<i>Value</i>
Site Class	D (assuming structures fundamental period of vibration is equal to or less than 0.5s)
Site Latitude	34.2777
Site Longitude	-118.8972
Spectral Response Acceleration Parameter, S_S	1.851
Spectral Response Acceleration Parameter, S_1	0.684
Site Coefficient, F_a	1.0
Site Coefficient, F_v (Per Table 11.4-2 of ASCE 7-16. Site Specific Parameters Govern)	1.7
<i>Site Specific Parameters Per Chapter 21 of ASCE 7-16</i>	
MCE Spectral Response Acceleration Parameter, S_{M5}	1.851
MCE Spectral Response Acceleration Parameter, S_{M1}	1.16
Design Spectral Response Acceleration Parameter, S_{D5}	1.234
Design Spectral Response Acceleration Parameter, S_{D1}	0.775
Peak Ground Acceleration, PGA_M	0.84

7.4 Fence and Garden Walls

Block walls, if used, should be embedded a minimum of 2 feet below the lowest adjacent grade. Construction joints (not more than 20 feet apart) should be included in the block wall construction. Side yard walls should be structurally separated from the rear yard wall.

7.5 Footing Excavations

Soils from the footing excavations should not be placed in slab-on-grade areas unless properly compacted and tested. The excavations should be cleaned of all loose/sloughed materials and be neatly trimmed at the time of concrete placement. The Project Geotechnical Consultant should observe the footing excavations prior to the placement of concrete to determine that the excavations are founded in suitably compacted material.

7.6 Retaining Walls

Retaining walls should be founded on engineered fill and should be backfilled with granular soils that allow for drainage behind the wall. Foundations may be designed in accordance with the recommendations presented in Table 7-1, above. Unrestrained walls, free to horizontally move $0.0005H$ (for dense cohesionless backfill), may be designed to resist lateral pressures imposed by a fluid with a unit weight determined in accordance with the Table 7-4 below. The table also presents design parameters for restrained (at-rest) retaining walls. These parameters may be used to design retaining walls that may be considered as restrained due to the method of construction or location (corner sections of unrestrained retaining walls).

Backfill	Active Pressure (psf/ft)	At-Rest Pressure (psf/ft)
Level	35	55

Per the requirements of the 2019 CBC, the seismic force acting on the retaining walls with backfill exceeding 6-feet in height may be resolved utilizing the formula $17H^2$ lb/lineal ft (H =height of the wall). This force acts at approximately $0.6H$ above the base of the wall. The seismic value can be converted as required by the retaining wall engineer. Retaining walls should be designed in general accordance with Section 1807A.2 of the 2019 CBC.

- Restrained retaining walls should be designed for “at-rest” conditions.
- The design loads presented in the above table are to be applied on the retaining wall in a horizontal fashion and as such friction between wall and retained soils should not be allowed in the retaining wall analyses.
- Additional allowances should be made in the retaining wall design to account for the influence of construction loads, temporary loads, and possible nearby structural footing loads.
- Select backfill should be granular, structural quality backfill with a Sand Equivalent of 20 or better and an ASCE Expansion Index of 20 or less. The backfill must encompass the full active wedge area. The upper one foot of backfill should be comprised of native on-site soils (see Plate A).
- The wall design should include waterproofing (where appropriate) and backdrains or weep holes for relieving possible hydrostatic pressures. The backdrain should be comprised of a 4-inch perforated PVC pipe in a 1 ft. by 1 ft., $\frac{3}{4}$ -inch gravel matrix, wrapped with a geofabric. The backdrain should be installed with a minimum gradient of 2 percent and should be outletted to an appropriate location. For subterranean walls this may include drainage by sump pumps.
- No backfill should be placed against concrete until minimum design strengths are achieved.

RETAINING WALL BACKFILL DETAIL

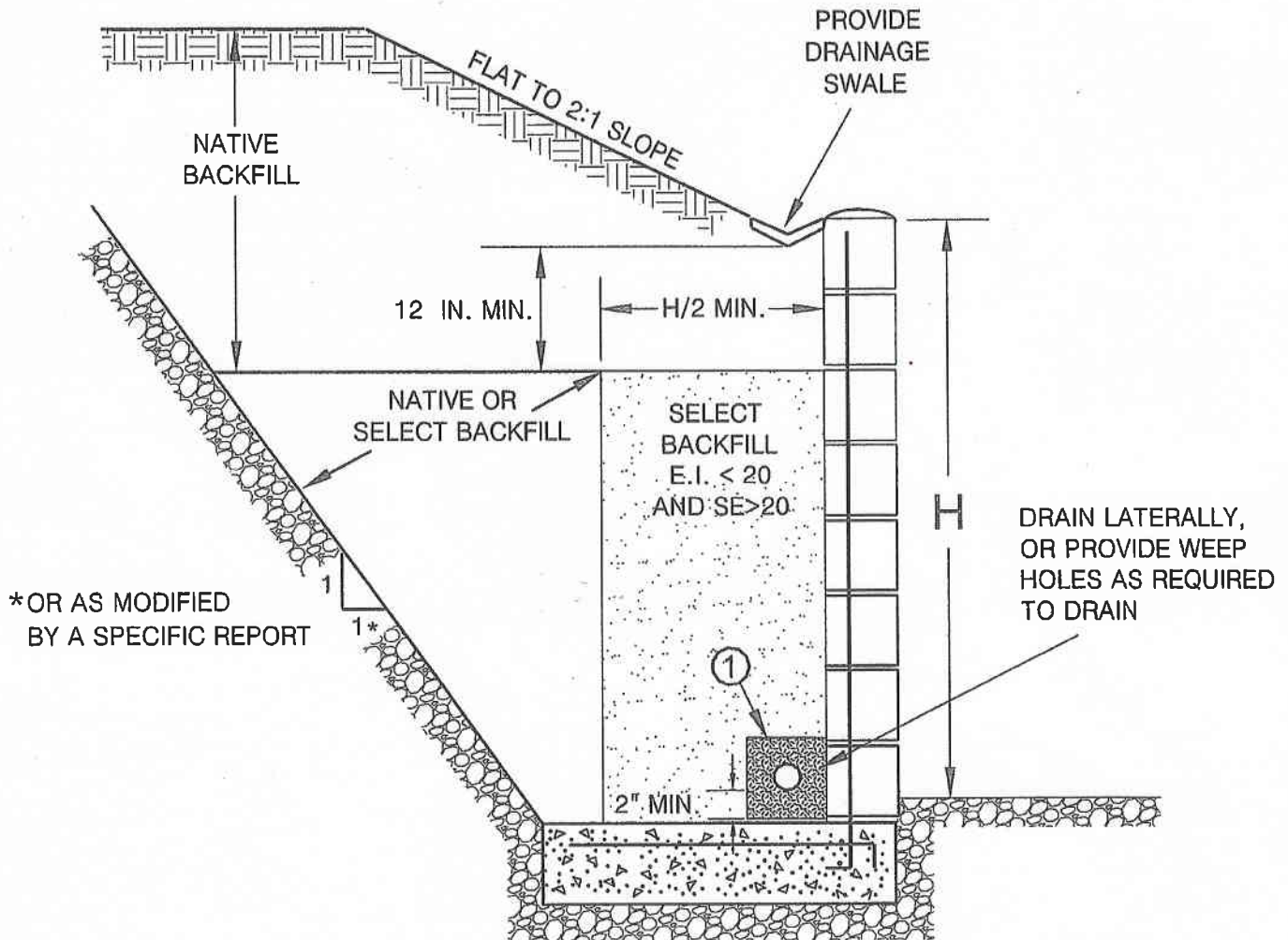

①

PIPE: 4-INCH PERFORATED PVC, SCHEDULE 40, SDR35 OR APPROVED ALTERNATE
 MINIMUM 8 PERFORATIONS (1/4-IN. DIA.) PER LINEAL FT. IN BOTTOM HALF OF PIPE

ROCK: MINIMUM VOLUME OF 1 CU. FT. OF 3/4-IN. MAX. ROCK PER. LINEAL FOOT OF PIPE, OR APPROVED ALTERNATE

FILTER FABRIC: MIRAFI 140 FILTER FABRIC OR APPROVED EQUIVALENT



ALTA CALIFORNIA GEOTECHNICAL, INC.
 VER. 1/10

PLATE A

It should be noted that the allowable bearing and lateral bearing values presented in Table 7-1 are based on level conditions at the toe. Modified design parameters can be presented for retaining walls with sloping condition at the toe. Other conditions should be evaluated on a case-by-case basis.

7.7 Exterior Slabs and Walkways

Exterior concrete slabs and walkways should be designed and constructed in consideration of the following recommendations.

7.7.1 Subgrade Compaction

The subgrade below exterior concrete slabs should be compacted to a minimum of 90 percent relative compaction as determined by ASTM Test Method: D 1557.

7.7.2 Subgrade Moisture

The subgrade below concrete slabs should be moisture conditioned to a minimum of 110 percent of optimum moisture prior to concrete placement.

7.7.3 Concrete Slab Thickness

Concrete flatwork and driveways should be designed utilizing four-inch minimum thickness.

7.7.4 Concrete Slab Reinforcement

Utilization of reinforcement for flatwork and driveways is subject to a cost/benefit analysis. Reinforcement will decrease the amount of cracking that may occur in flatwork, however, planning for occasional repairs may be more cost effective. Utilizing closely spaced control joints is likely more cost-effective than utilizing reinforcement. The majority of the soils onsite are classified as very low to low in expansion potential. Consideration should be given to reinforcing flatwork with irregular (non-square/rectangular) shapes.

7.7.5 Control Joints

Weakened plane joints should be installed on walkways at intervals of approximately eight feet (maximum) or less. Exterior slabs should be designed to withstand shrinkage of the concrete.

7.8 Concrete Design

As stated in Section 5.1.7, negligible concentrations of sulfates were detected in the onsite soils (Class S0). Therefore, the use of sulfate resistant concrete is not required per ACI 318-14 at this time. Post-grading conditions should be evaluated, and final recommendations made at that time.

7.9 Corrosion

Based on preliminary testing from our investigation and the previous investigation, the onsite soils are moderately corrosive to corrosive to buried metal objects. Buried ferrous metals should be protected against the effects of corrosive soils in accordance with the manufacturer's recommendations. Typical measures may include using non-corrosive backfill, protective coatings, wrapping, plastic pipes, or a combination of these methods. A corrosion engineer should be consulted if specific design recommendations are required by the improvement designer.

Per ACI 318-14, an exposure class of C1 would be applicable to metals encased in concrete (rebar in footings) due to being exposed to moisture from surrounding soils. Per Table 19.3.2.1 of ACI 318-14, the requirements for concrete with an exposure class of C1 are a minimum compressive strength of 2500 psi and a maximum water-soluble chloride ion content in concrete of 0.30 (percent by weight of cement).

7.10 Pavement Design

Pavement sections for the proposed streets shall be designed based on laboratory testing conducted on samples taken from the soil subgrade. Preliminarily, based on an assumed R-Value of 30, the pavement may be designed utilizing the sections presented in Table 7-5. These sections should be verified upon the completion of grading, based on R-Value testing. The ultimate pavement section design for public streets is under the City of Moorpark’s purview.

Table 7-6 Preliminary Pavement Sections		
Traffic Index	Pavement Section Options OR	
5.0	3-inch AC on 6-inch AB	4-inch AC on 4-inch AB
5.5	3-inch AC on 7-inch AB	4-inch AC on 5-inch AB
6.0	3.5-inch AC on 7.5-inch AB	4-inch AC on 6.5-inch AB
AC-Asphalt Concrete		
AB-Caltrans Class II Base		

Construction of the streets should be accomplished in accordance with the current criteria of the City of Moorpark. Prior to the placement of base material, the subgrade should be suitably moisture conditioned, processed and compacted to a minimum 95 percent of the laboratory maximum density (ASTM: D 1557) to at least twelve (12) inches below subgrade. After subgrade compaction, the exposed grade should then be "proof"-rolled with heavy equipment to ensure the grade does not "pump" and is verified as non-yielding. Aggregate base material should be placed on the compacted subgrade and compacted in-place to a minimum 95 percent of the laboratory standard obtained per ASTM: D 1557.

7.11 Site Drainage

Positive drainage away from the proposed structures should be provided and maintained. Roof, pad, and lot drainage should be collected and directed away from the structures toward approved disposal areas through drainage terraces, gutters, down drains, and other devices. Design fine grade elevations should be maintained through the life of the structure or if design fine grade elevations are altered, adequate area drains should be installed in order to provide rapid discharge of water, away from structures.

8.0 LOT MAINTENANCE

Ongoing maintenance of the improvements is essential to the long-term performance of structures. As such, the owners must implement certain maintenance procedures. The attached "Maintenance and Improvement Considerations" presented in the Appendix D may be included as part of the sales packet to educate the owners in issues related to drainage, maintenance, improvements, etc. The following recommendations should also be implemented.

8.1 Lot Drainage

Roof, pad, and lot drainage should be collected and directed away from structures and slopes and toward approved disposal areas. Design fine grade elevations should be maintained through the life of the structure or if design fine grade elevations are altered, adequate area drains should be installed in order to provide rapid discharge of water, away from structures and slopes. Residents should be made aware that they are responsible for maintenance and cleaning of all drainage terraces, down drains, and other devices that have been installed to promote structure and slope stability.

8.2 Burrowing Animals

Owners should undertake a program for the elimination of burrowing animals.

9.0 FUTURE PLAN REVIEWS

This report represents a geotechnical review of the site. As the project design for the project progresses, site specific geologic and geotechnical issues should be considered in the design and construction of the project. Consequently, future plan reviews may be necessary. These reviews may include reviews of:

- Grading Plans
- Foundation Plans
- Utility Plans

These plans should be forwarded to the project Geotechnical Consultant for review.

10.0 CLOSURE

10.1 Geotechnical Review

For the purposes of this report, multiple working hypotheses were established for the project, utilizing the available data and the most probable model is used for the analysis. Future information collected during the proposed grading operations is intended to evaluate the hypothesis and as such, some of the assumptions summarized in this report may need to be changed. Some modifications of the grading recommendations may become necessary, should the conditions encountered in the field differ from the conditions hypothesized in this report.

Plans and sections of the project specifications should be reviewed by Alta to evaluate conformance with the intent of the recommendations contained in this report. If the project description or final design varies from that described in herein, Alta must be consulted regarding the applicability of the recommendations contained herein and whether any changes are required. Alta

accepts no liability for any use of its recommendations if the project description or final design varies and Alta is not consulted regarding the alterations.

10.2 Limitations

This report is based on the following: 1) the project as presented on the attached plan; 2) the information obtained from Alta's laboratory testing included herein; and 3) from the information presented in the referenced reports. The findings and recommendations are based on the results of the subsurface investigation, laboratory testing, and office analysis combined with an interpolation and extrapolation of conditions between and beyond the subsurface excavation locations. However, the materials adjacent to or beneath those observed may have different characteristics than those observed, and no precise representations are made as to the quality or extent of the materials not observed. The results reflect an interpretation of the direct evidence obtained. Work performed by Alta has been conducted in a manner consistent with the level of care and skill ordinarily exercised by members of the geotechnical profession currently practicing in the same locality under similar conditions. No other representation, either expressed or implied, and no warranty or guarantee is included or intended.

The recommendations presented in this report are based on the assumption that an appropriate level of field review will be provided by a geotechnical consultant who is familiar with the design and site geologic conditions. That field review shall be sufficient to confirm that geotechnical and geologic conditions exposed during grading are consistent with the geologic representations and corresponding recommendations presented in this report.

The conclusions and recommendations included in this report are applicable to the specific design of this project as discussed in this report. They have no applicability to any other project or to any other location and any and all subsequent users accept any and all liability resulting from any use or reuse of the data, opinions, and recommendations without the prior written consent of Alta.

Alta has no responsibility for construction means, methods, techniques, sequences, procedures, safety precautions, programs in connection with the construction, acts or omissions of the CONTRACTOR or any other person performing any of the construction, or for the failure of any of them to carry out the construction in accordance with the final design drawings and specifications.

APPENDIX A

REFERENCES

APPENDIX A

Selected References

1. California Code of Regulations, 2019, California Building Code, Title 24, Part 2, Volume 2, Based on the 2018 International Building Code, Effective Date January 1, 2020.
2. California Department of Conservation, Division of Mines and Geology, 2000, Seismic Hazard Zone Report for the Moorpark 7.5-Minute Quadrangles, Ventura County, California, Seismic Hazard Zone Report 041.
3. California Geological Survey, 2018, Earthquake Fault Zones, A guide for Government Agencies, Property Owners/Developers, and Geoscience Practitioners for Assessing Fault Rupture Hazards in California, Special Publication 42, revised 2018, 83 pages.
4. City of Los Angeles, Department of Building and Safety, 2020, Liquefaction Analysis Guidelines, Document No.: P/BC 2020-151, dated January 1, 2020.
5. Dibblee, T.W., and Ehrenspeck, H.E., ed, 1992, Geologic map of the Moorpark quadrangle, Ventura County, California, Dibblee Foundation Map DF-40, scale 1:24,000.
6. Historic Aerials, 2021, www.historicaerials.com, by NETROnline, Copyright 1999-2021, accessed May 2020, online review of vintage air photos from 1947, 1967, 1969, 1978, 1980, 1994, 2002, 2005, 2009, 2010, 2012, 2014, and 2016.
7. Idriss, I.M. and Boulanger, R.W., 2008, Soil Liquefaction during Earthquakes, Oakland, California: Earthquake Engineering Research Institute.
8. Ishihara, K., and Yoshimine, M., 1992, Evaluation of settlements in sand deposits following liquefaction during earthquakes: Soil and Foundations, Japanese Society of Soil Mechanics and Foundation Engineering, v. 32, n. 1, p. 173-188.
9. Jennings, C.W., and Bryant, W.A., 2010, Fault Activity Map of California: California Geological Survey Geologic Data Map No. 6, map scale 1:750,000.
10. Jennings, C. W., and Bryant, W.A., 2010, An explanatory text to accompany the 1:750,000 scale fault and geologic map of California: California Division of Mines and Geology, special publication 42, revised 1985, 24 p.
11. Jennings, C. W., 1985, An explanatory text to accompany the 1:750,000 scale fault and geologic maps of California: California Division of Mines and Geology, Bulletin 201, 197 p.
12. Romanoff, Melvin, 1989, Underground Corrosion, NBS Circular 579, Reprinted by NACE, Houston, TX, 1989
13. U.S. Geological Survey, 2008, National Seismic Hazards Maps – Source Parameters, http://geohazards.usgs.gov/cfusion/hazfaults_2008_search/query_main.cfm.

APPENDIX B

Subsurface Investigation

APPENDIX B
Subsurface Investigation

Alta's subsurface investigation consisted of excavating, logging, and sampling six (6) backhoe test pits and commissioning four (4) CPT soundings. Details of the subsurface investigation are presented in Table B. The approximate location of the exploratory excavation is shown on the accompanying Plate 1 and the Geotechnical Logs are attached.

TABLE B			
<i>SURFACE INVESTIGATION DETAILS</i>			
Equipment	Range of Depths	Sampling Methods	Sample Locations
Backhoe	Up to 13.5 feet	1. Bulk	1. Bulk-Select Depths

UNIFIED SOIL CLASSIFICATION SYSTEM

Major Divisions		grf	ltr	Description	Major Divisions	grf	ltr	Description
Coarse Grained Soils	Gravel and Gravelly Soils	More than 50% of coarse fraction retained on No. 4 sieve	GW	Well-graded gravels or gravel sand mixtures, little or no fines	Fine Grained Soils	Silts And Clays LL, <50	ML	Inorganic silts and very fine sands, rock flour, silty or clayey fine sands or clayey silts with slight plasticity
			GP	Poorly-graded gravels or gravel sand mixture, little or no fines			CL	Inorganic clays of low to medium plasticity, gravelly clays, sandy clays, silty clays, lean clays
			GM	Silty gravels, gravel-sand-silt mixtures			OL	Organic silts and organic silt-clays of low plasticity
			GC	Clayey gravels, gravel-sand-clay mixtures			MH	Inorganic silts, micaceous or diatomaceous fine or silty soils, elastic silts
	Sand and Sandy Soils	More than 50% of coarse fraction passes on No. 4 sieve	SW	Well-graded sands or gravelly sands, little or no fines		VH	Inorganic clays of high plasticity, fat clays	
			SP	Poorly-graded sands or gravelly sands, little or no fines		OH	Organic clays of medium to high plasticity	
			SM	Silty sands, sand-silt mixtures		Highly Organic Soils	PT	Peat and other highly organic soils
			SC	Clayey sands, and-clay mixtures				

BOUNDARY CLASSIFICATION: Soils possessing characteristics of two groups are designated by combinations of group symbols.

PARTICLE SIZE LIMITS

U.S. STANDARD SERIES SIEVE				CLEAR SQUARE SIEVE OPENINGS			
200	40	10	4	3/4"	3"	12"	
Silts and Clays	Sand			Gravel		Cobbles	Boulders
	Fine	Medium	Coarse	Fine	Coarse		

RELATIVE DENSITY

Sands and Gravels	Blows/Foot (SPT)
Very Loose	<4
Loose	4-10
Medium Dense	11-30
Dense	31-50
Very Dense	>50

CONSISTENCY CLASSIFICATION

Silts and Clays	Criteria
Very Soft	Thumb penetrates soil >1 in.
Soft	Thumb penetrates soil 1 in.
Firm	Thumb penetrates soil 1/4 in.
Stiff	Readily indented with thumbnail
Very Stiff	Thumbnail will not indent soil

HARDNESS

Bedrock
Soft
Moderately Hard
Hard
Very Hard

LABORATORY TESTS

Symbol	Test
DS	Direct Shear
DSR	Direct Shear (Remolded)
CON	Sieve Analysis
SA	Maximum Density
MAX	Resistance (R) Value
RV	Expansion Index
EI	Sand Equivalent
SE	Atterberg Limits
AL	Chemical Analysis
CHEM	Hydrometer Analysis
HY	

SOIL MOISTURE

Increasing Visual Moisture Content
↓
Dry - Dry to touch
Moist - Damp, but no visible free water
wet - Visible free water

SIZE PROPORTIONS

Trace - <5%
Few - 5 to 10%
Some - 15 to 25%



Project No.	1-0379
Date Excavated	March 31, 2020
Logged by	JC
Equipment	JD 310

TABLE I

LOG OF TEST PITS

Test Pit No.	Depth (ft.)	USCS	Description
T-1	0.0-10.0	SP	ALLUVIUM (Qa): SAND, very fine to fine grained, tan, dry, loose, with roots.
		SM	@3.0ft. Silty Sand, very fine to fine grained, tan, dry, loose. @6.0ft. few cobbles <12" @7.5ft. GRAVELLY SAND, fine grained, tan, dry, loose, fine gravel <3/4".
			TOTAL DEPTH 10.0 FEET NO GROUNDWATER ENCOUNTERED CAVING OBSERVED BELOW 6.5 FEET

Test Pit No.	Depth (ft.)	USCS	Description
T-2	0.0-11.0	SP	ALLUVIUM (Qa): SAND, very fine to fine grained, tan, dry, loose, with roots. @0.9ft. slightly moist @4.0ft. medium dense
			TOTAL DEPTH 11.0 FEET NO GROUNDWATER ENCOUNTERED NO CAVING OBSERVED

Test Pit No.	Depth (ft.)	USCS	Description
T-3	0.0-13.0	SP	<p><u>ALLUVIUM</u> (Qa): SAND, fine grained, tannish brown, dry, loose to medium dense, some silt, some fine to coarse gravel <3", with roots. @1.0ft. trace pores. @3.0ft. SILTY SAND, fine grained, tannish brown, dry, loose to medium dense @5.0ft. medium dense. @6.5ft. trace fine gravel <3/4".</p> <p>TOTAL DEPTH 13.0 FEET NO GROUNDWATER ENCOUNTERED NO CAVING OBSERVED</p>

Test Pit No.	Depth (ft.)	USCS	Description
T-4	0.0-13.5	SP	<p><u>ALLUVIUM</u> (Qa): SAND, fine grained, tannish brown, dry, medium dense, some silt, some fine to coarse gravel <3", with roots. @1.3ft. slightly moist. @6.0ft. fine to medium grained, dry @8.0ft. slightly moist</p> <p>TOTAL DEPTH 13.5 FEET NO GROUNDWATER ENCOUNTERED NO CAVING OBSERVED</p>

Test Pit No.	Depth (ft.)	USCS	Description
T-5	0.0-3.0	SP	<p><u>ARTIFICIAL FILL-UNDOCUMENTED</u> (afu): SAND, fine grained, slightly tannish brown, dry, medium dense, trace pores. @0.5ft. dense.</p>
	3.0-10.0		<p><u>ALLUVIUM</u> (Qa): SAND, very fine to fine grained, tannish brown, dry, medium dense, some silt, some fine to coarse gravel <3", with roots. @4.3ft. fine to medium grained. @7.0ft. very fine to fine grained, slightly moist.</p> <p>TOTAL DEPTH 13.5 FEET NO GROUNDWATER ENCOUNTERED NO CAVING OBSERVED</p>

Test Pit No.	Depth (ft.)	USCS	Description
T-6	0.0-10.0	SP	<u>ALLUVIUM</u> (Qa): SAND, very fine to fine grained, tan, dry, loose, with roots. @0.8ft. trace pores. @4.0ft. few cobbles <12" @9.3ft. GRAVELLY SAND, fine grained, tan, dry, loose, fine gravel <3/4". TOTAL DEPTH 12.0 FEET NO GROUNDWATER ENCOUNTERED CAVING OBSERVED BELOW 6.5 FEET

GEOTECHNICAL BORING LOG

PROJECT NO. 1-0379
 DATE STARTED 3/31/21
 DATE FINISHED 3/31/21
 DRILLER Alta
 TYPE OF DRILL RIG Power Auger

PROJECT NAME Beltramo Ranch Project
 GROUND ELEV. _____
 GW DEPTH (FT) _____
 DRIVE WT. _____
 DROP _____

BORING DESIG. P-1
 LOGGED BY JC
 NOTE _____

DEPTH (Feet)	ELEV	SAMPLE TYPE	BLOWS	LITHOLOGY	GROUP SYMBOL	GEOTECHNICAL DESCRIPTION	MOISTURE CONT (%)	DRY (pcf) DENSITY	SAT-URATION (%)	OTHER TESTS
5				SAND	SP	<p>Alluvium (Qa): SAND, very fine to fine grained, tannish brown, dry, loose to medium dense, few fine gravel <3/4", with roots.</p> <p>@2.0ft. slightly moist.</p>				
TOTAL DEPTH 5.0 FEET NO GROUNDWATER ENCOUNTERED NO CAVING OBSERVED										

SAMPLE TYPES:
 RING (DRIVE) SAMPLE
 SPT (SPLIT SPOON) SAMPLE
 BULK SAMPLE TUBE SAMPLE

GROUNDWATER
 SEEPAGE
 J: JOINTING C: CONTACT
 B: BEDDING F: FAULT
 S: SHEAR RS: RUPTURE SURFACE

Alta California Geotechnical, Inc.
 P.N. 1-0379 PLATE P-1

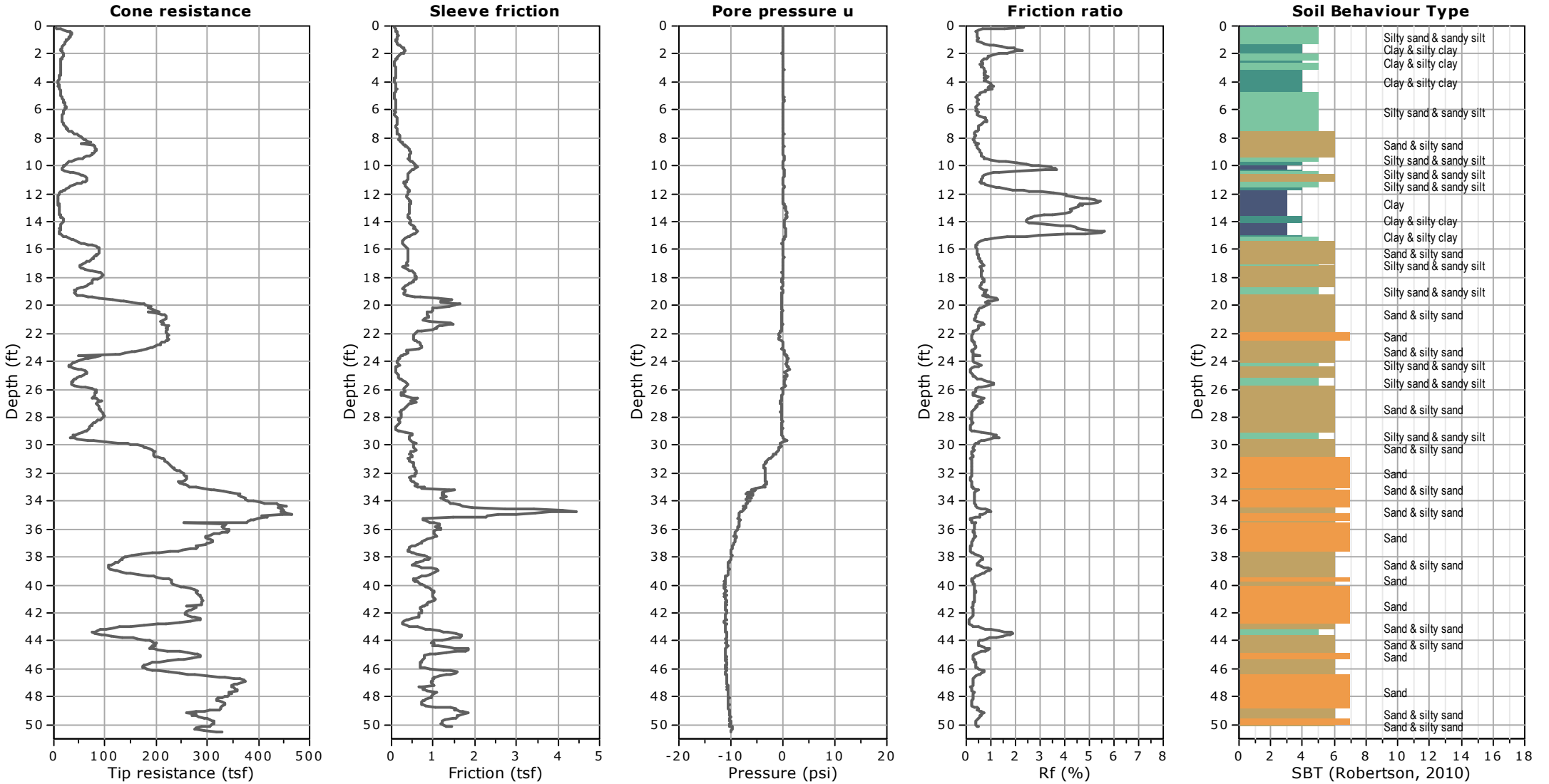

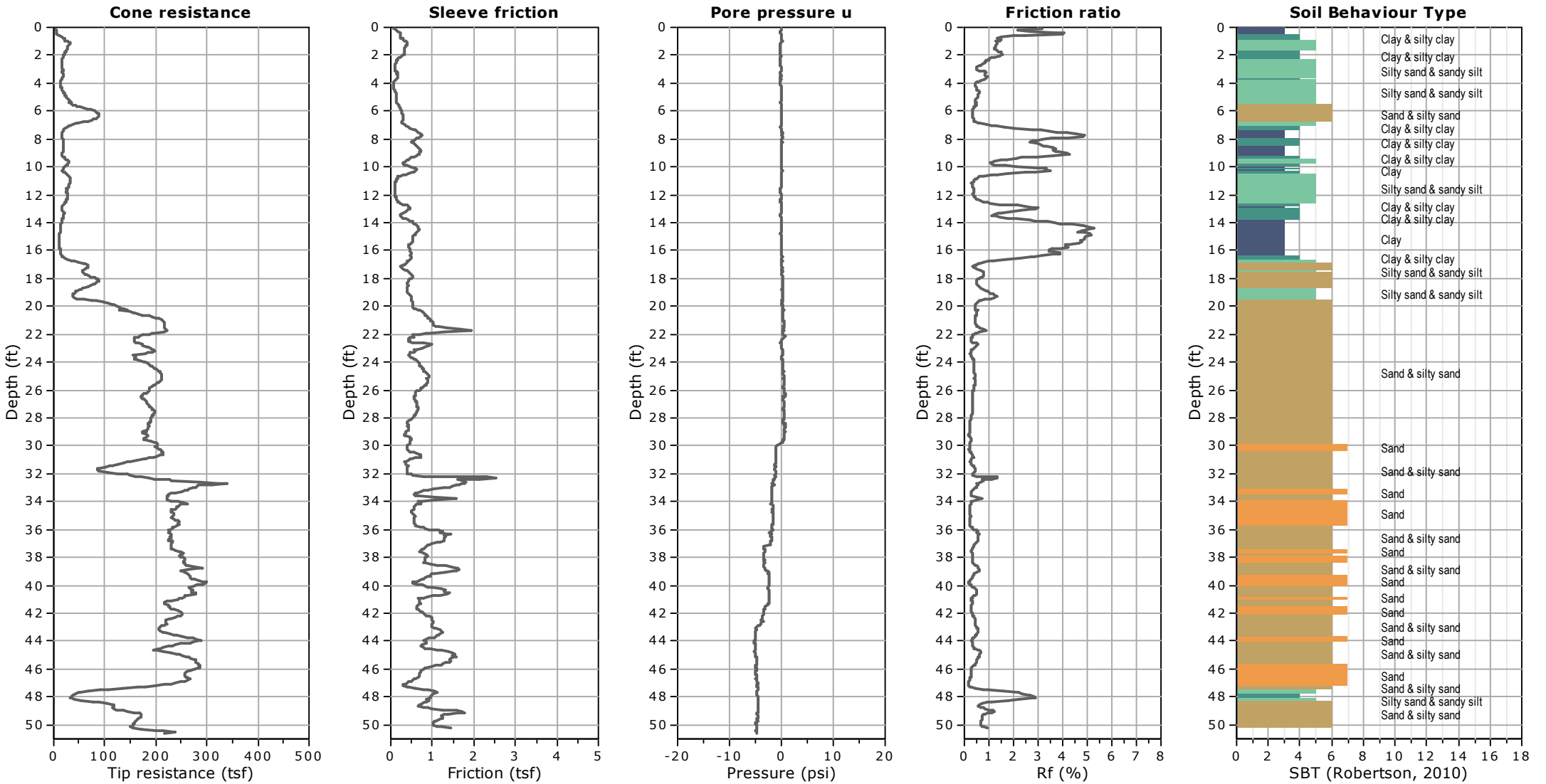

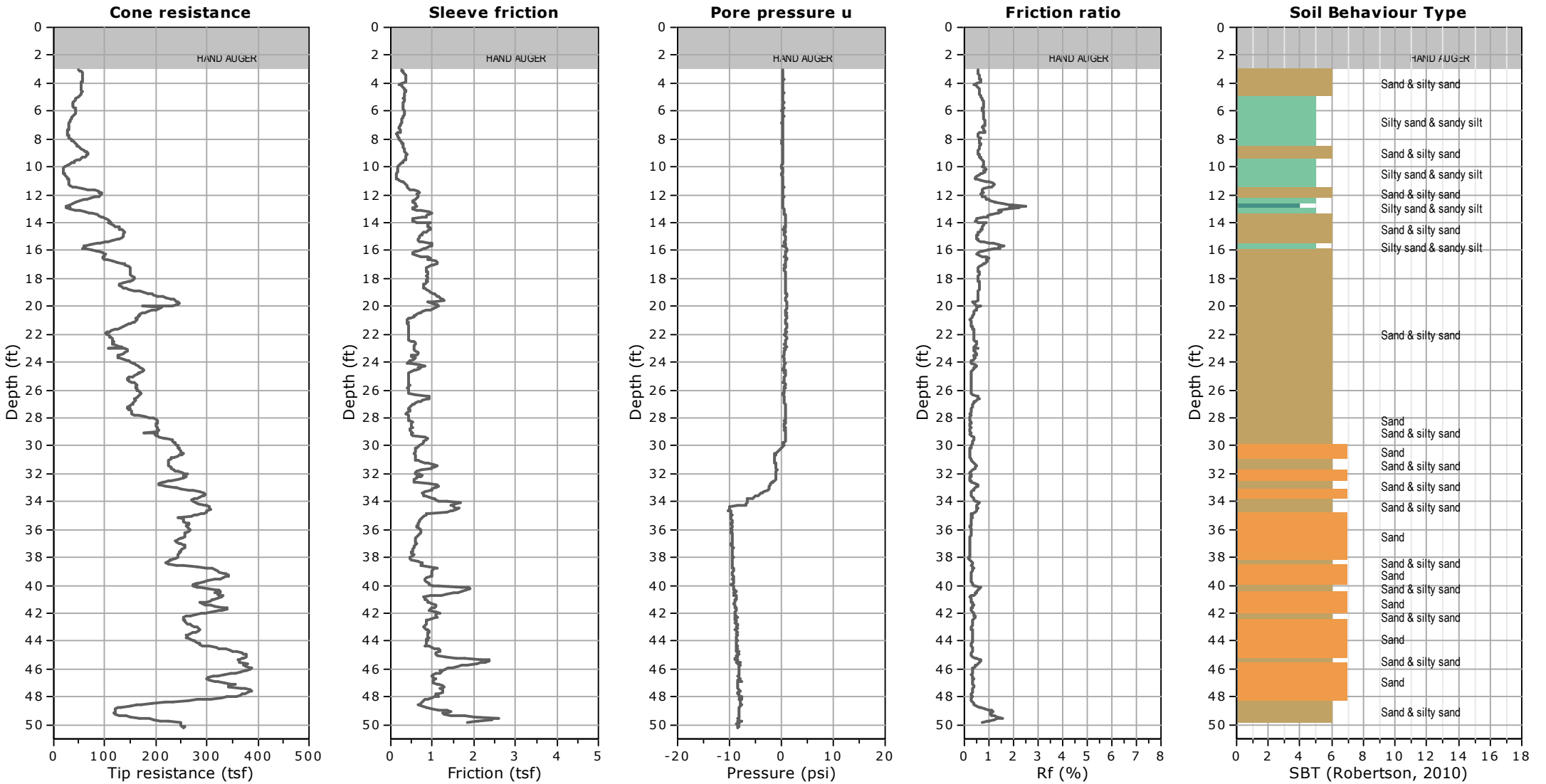

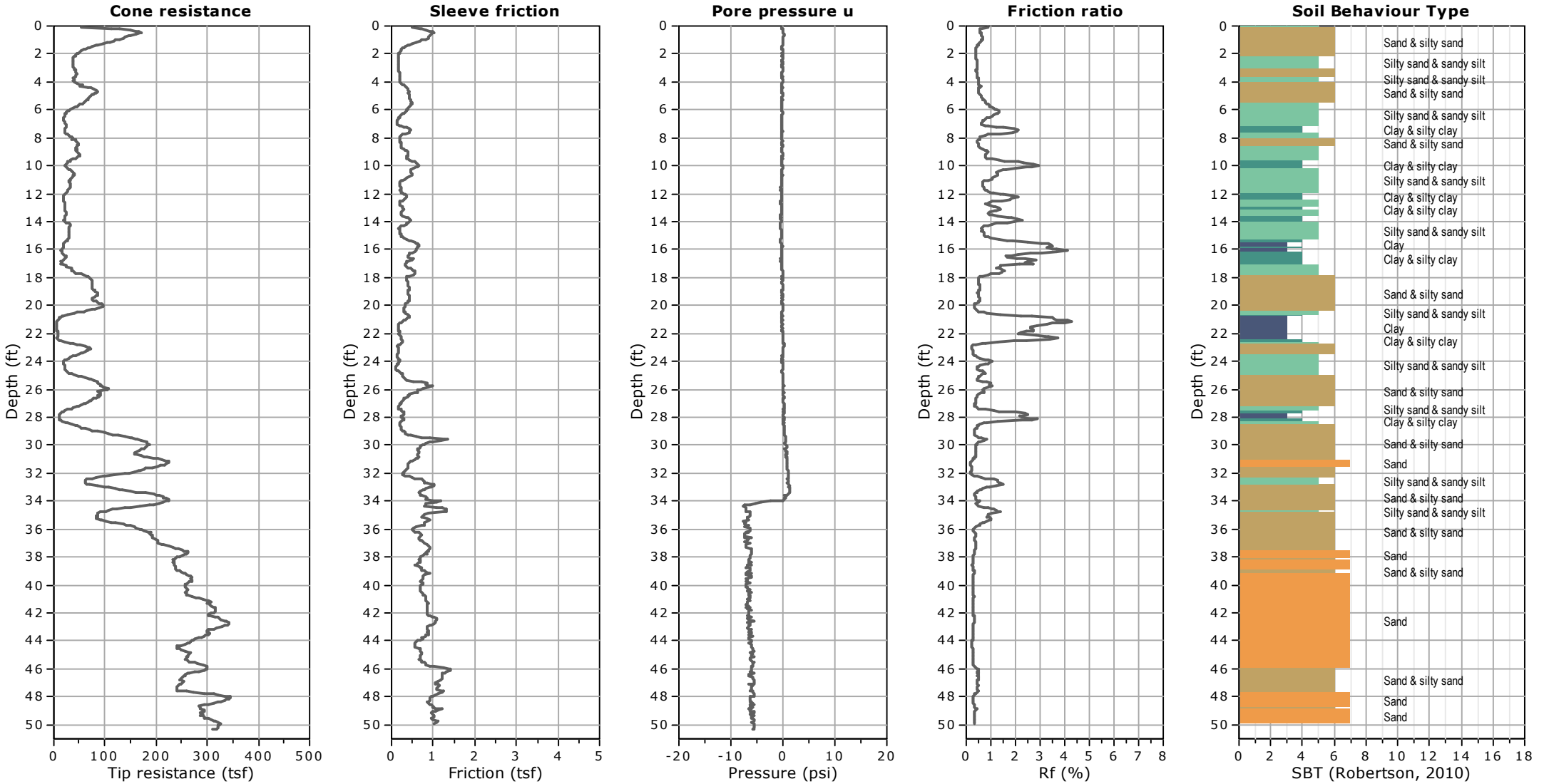

APPENDIX B-1

**Previous Subsurface Investigation
(Krazan, 2019)**

UNIFIED SOIL CLASSIFICATION SYSTEM

UNIFIED SOIL CLASSIFICATION AND SYMBOL CHART		
COARSE-GRAINED SOILS (more than 50% of material is larger than No. 200 sieve size.)		
GRAVELS More than 50% of coarse fraction larger than No. 4 sieve size	Clean Gravels (Less than 5% fines)	
	GW	Well-graded gravels, gravel-sand mixtures, little or no fines
	GP	Poorly-graded gravels, gravel-sand mixtures, little or no fines
	Gravels with fines (More than 12% fines)	
	GM	Silty gravels, gravel-sand-silt mixtures
	GC	Clayey gravels, gravel-sand-clay mixtures
SANDS 50% or more of coarse fraction smaller than No. 4 sieve size	Clean Sands (Less than 5% fines)	
	SW	Well-graded sands, gravelly sands, little or no fines
	SP	Poorly graded sands, gravelly sands, little or no fines
	Sands with fines (More than 12% fines)	
	SM	Silty sands, sand-silt mixtures
	SC	Clayey sands, sand-clay mixtures
FINE-GRAINED SOILS (50% or more of material is smaller than No. 200 sieve size.)		
SILTS AND CLAYS Liquid limit less than 50%	ML	Inorganic silts and very fine sands, rock flour, silty of clayey fine sands or clayey silts with slight plasticity
	CL	Inorganic clays of low to medium plasticity, gravelly clays, sandy clays, silty clays, lean clays
	OL	Organic silts and organic silty clays of low plasticity
	SILTS AND CLAYS Liquid limit 50% or greater	MH
CH		Inorganic clays of high plasticity, fat clays
OH		Organic clays of medium to high plasticity, organic silts
PT		Peat and other highly organic soils
HIGHLY ORGANIC SOILS		

CONSISTENCY CLASSIFICATION	
Description	Blows per Foot
<i>Granular Soils</i>	
Very Loose	< 5
Loose	5 - 15
Medium Dense	16 - 40
Dense	41 - 65
Very Dense	> 65
<i>Cohesive Soils</i>	
Very Soft	< 3
Soft	3 - 5
Firm	6 - 10
Stiff	11 - 20
Very Stiff	21 - 40
Hard	> 40

GRAIN SIZE CLASSIFICATION		
Grain Type	Standard Sieve Size	Grain Size in Millimeters
Boulders	Above 12 inches	Above 305
Cobbles	12 to 13 inches	305 to 76.2
Gravel	3 inches to No. 4	76.2 to 4.76
Coarse-grained	3 to ¾ inches	76.2 to 19.1
Fine-grained	¾ inches to No. 4	19.1 to 4.76
Sand	No. 4 to No. 200	4.76 to 0.074
Coarse-grained	No. 4 to No. 10	4.76 to 2.00
Medium-grained	No. 10 to No. 40	2.00 to 0.042
Fine-grained	No. 40 to No. 200	0.042 to 0.074
Silt and Clay	Below No. 200	Below 0.074

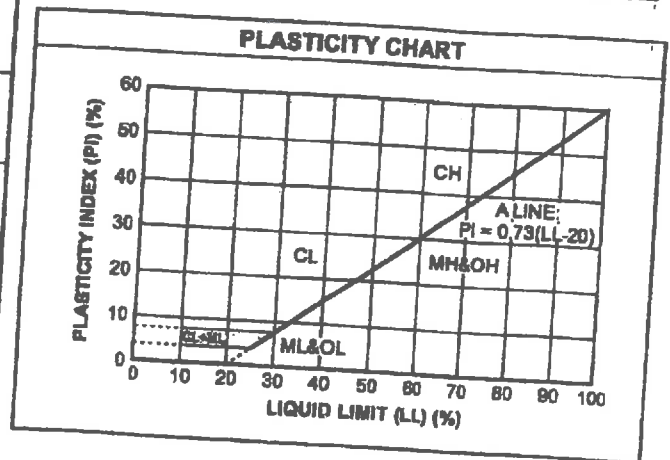

Log of Boring B1

Project: Moorpark Apartments

Project No.: 112-19014

Client: USA Multifamily Development

Figure No.: A-1

Location: 119360 W. Los Angeles Avenue, Moorpark, California

Logged By: Matt Vo

Depth to Water > 20 Feet

Initial: 20 Feet

At Completion: 50 Feet

SUBSURFACE PROFILE			SAMPLE				Penetration Test blows/ft			Water Content (%)			
Depth (ft)	Symbol	Description	Dry Density (pcf)	Moisture (%)	Type	Blows/ft.	Penetration Test			Water Content (%)			
							20	40	60	10	20	30	40
0		Ground Surface											
0 - 6		SILTY SAND (SM) Medium dense, medium- to fine-grained; brown, moist	102.1	10.6		15							
6 - 10		SANDY SILT (ML) Stiff, fine-grained; dark brown, moist											
10 - 16		SILTY SAND (SM) Medium dense, medium- to fine-grained; dark brown, moist	111.2	14.2		22							
16 - 20				15.5		16							
20		▽											

Drill Method: Hollow Stem

Drill Date: 2-20-19

Drill Rig: CME 75

Krazan and Associates

Hole Size: 5½ Inches

Driller: Baja Exploration

Elevation: 50 Feet

Sheet: 1 of 3

Log of Boring B1

Project: Moorpark Apartments

Project No: 112-19014

Client: USA Multifamily Development

Figure No.: A-1

Location: 119360 W. Los Angeles Avenue, Moorpark, California

Logged By: Matt Vo

Depth to Water > 20 Feet

Initial: 20 Feet

At Completion: 50 Feet

SUBSURFACE PROFILE			SAMPLE				Penetration Test blows/ft	Water Content (%)
Depth (ft)	Symbol	Description	Dry Density (pcf)	Moisture (%)	Type	Blows/ft.		
22	SP	POORLY GRADED SAND (SP) Medium dense to dense, medium- to fine-grained; light brown, moist to very moist		14.7		27		
24								
26			19.4		31			
28								
30			16.2		35			
32								
34								
36			14.1		38			
38								
40								

Drill Method: Hollow Stem

Drill Date: 2-20-19

Drill Rig: CME 75

Krazan and Associates

Hole Size: 5½ Inches

Driller: Baja Exploration

Elevation: 50 Feet

Sheet: 2 of 3

Log of Boring B1

Project: Moorpark Apartments

Project No: 112-19014

Client: USA Multifamily Development

Figure No.: A-1

Location: 119360 W. Los Angeles Avenue, Moorpark, California

Logged By: Matt Vo

Depth to Water > 20 Feet

Initial: 20 Feet

At Completion: 50 Feet

SUBSURFACE PROFILE			SAMPLE				Penetration Test blows/ft	Water Content (%)
Depth (ft)	Symbol	Description	Dry Density (pcf)	Moisture (%)	Type	Blows/ft.		
42	SP	POORLY GRADED SAND (SP) Medium dense to dense, medium- to fine-grained; light brown, moist to very moist		21.0		45		
44								
46				18.5		43		
48								
50		End of Borehole		14.8		47		
52								
54								
56		Water encountered at 20 feet Boring backfilled with soil cuttings						
58								
60								

Drill Method: Hollow Stem

Drill Date: 2-20-19

Drill Rig: CME 75

Krazan and Associates

Hole Size: 5½ Inches

Driller: Baja Exploration

Elevation: 50 Feet

Sheet: 3 of 3

Log of Boring B2

Project: Moorpark Apartments

Project No: 112-19014

Client: USA Multifamily Development

Figure No.: A-2

Location: 119360 W. Los Angeles Avenue, Moorpark, California

Logged By: Matt Vo

Depth to Water: Not Encountered

Initial: N/A

At Completion: N/A

SUBSURFACE PROFILE			SAMPLE				Penetration Test blows/ft	Water Content (%)
Depth (ft)	Symbol	Description	Dry Density (pcf)	Moisture (%)	Type	Blows/ft.		
0		Ground Surface						
0 - 6		SILTY SAND (SM) Medium dense, medium- to fine-grained; brown, moist	101.3	9.2		17		
6 - 14		SANDY SILT (ML) Stiff, fine-grained; dark brown, moist	118.9	7.3		22		
14 - 18		SILTY SAND (SM) Dense, medium- to fine-grained; dark brown, moist		10.3		31		
18 - 20		Water not encountered Boring backfilled with soil cuttings POORLY GRADED SAND (SP) Dense, medium- to fine-grained; light brown, moist		9.4		35		



Drill Method: Hollow Stem

Drill Date: 2-20-19

Drill Rig: CME 75

Krazan and Associates

Hole Size: 5½ Inches

Driller: Baja Exploration

Elevation: 20 Feet

Sheet: 1 of 1

Log of Boring B3

Project: Moorpark Apartments

Project No: 112-19014

Client: USA Multifamily Development

Figure No.: A-3

Location: 119360 W. Los Angeles Avenue, Moorpark, California

Logged By: Matt Vo

Depth to Water > Not Encountered

Initial: N/A

At Completion: N/A

SUBSURFACE PROFILE			SAMPLE				Penetration Test blows/ft	Water Content (%)					
Depth (ft)	Symbol	Description	Dry Density (pcf)	Moisture (%)	Type	Blows/ft.		20	40	60	10	20	30
0		Ground Surface											
0 - 5.5		SILTY SAND (SM) Medium dense, medium- to fine-grained; brown, moist											
5.5 - 7.5			108.8	3.0		20							
7.5 - 14		SANDY SILT (ML) Stiff, fine-grained; dark brown, moist											
14 - 15.5			111.5	18.5		15							
15.5 - 18		SILTY SAND (SM) Medium dense, medium- to fine-grained; dark brown, moist											
18 - 18.5		Water not encountered Boring backfilled with soil cuttings											
18.5 - 20		POORLY GRADED SAND (SP) Medium dense, medium- to fine-grained; light brown, moist											
20			13.1			23							

Drill Method: Hollow Stem

Drill Date: 2-20-19

Drill Rig: CME 75

Krazan and Associates

Hole Size: 5½ Inches

Driller: Baja Exploration

Elevation: 20 Feet

Sheet: 1 of 1

Log of Boring B4

Project: Moorpark Apartments

Project No: 112-19014

Client: USA Multifamily Development

Figure No.: A-4

Location: 119360 W. Los Angeles Avenue, Moorpark, California

Logged By: Matt Vo

Depth to Water: Not Encountered

Initial: N/A

At Completion: N/A

SUBSURFACE PROFILE			SAMPLE				Penetration Test blows/ft	Water Content (%)						
Depth (ft)	Symbol	Description	Dry Density (pcf)	Moisture (%)	Type	Blows/ft.		20	40	60	10	20	30	40
0		Ground Surface												
0 - 5.5		SILTY SAND (SM) Medium dense, medium- to fine-grained; brown, moist												
5.5 - 6.5			101.5	12.9		16								
6.5 - 10		SANDY SILT (ML) Medium stiff, fine-grained; dark brown, moist												
10 - 11			119.6	7.1		10								
11 - 14		SILTY SAND (SM) Medium dense, medium- to fine-grained; dark brown, moist												
14 - 16				9.8		16								
16 - 18		Water not encountered Boring backfilled with soil cuttings												
18 - 20		POORLY GRADED SAND (SP) Medium dense, medium- to fine-grained; light brown, moist												
20				15.6		32								

Drill Method: Hollow Stem

Drill Date: 2-20-19

Drill Rig: CME 75

Krazan and Associates

Hole Size: 5½ Inches

Driller: Baja Exploration

Elevation: 20 Feet

Sheet: 1 of 1

Log of Boring B5

Project: Moorpark Apartments

Project No: 112-19014

Client: USA Multifamily Development

Figure No.: A-5







Location: 119360 W. Los Angeles Avenue, Moorpark, California

Logged By: Matt Vo

Depth to Water: Not Encountered

Initial: N/A

At Completion: N/A

SUBSURFACE PROFILE			SAMPLE				Penetration Test blows/ft	Water Content (%)
Depth (ft)	Symbol	Description	Dry Density (pcf)	Moisture (%)	Type	Blows/ft.		
0		Ground Surface						
0 - 6		SILTY SAND (SM) Medium dense, medium- to fine-grained; brown, moist						
6			100.4	9.2		16		
6 - 8		SANDY SILT (ML) Stiff, fine-grained; dark brown, moist						
8								
8			108.6	15.7		18		
10		End of Borehole						
10 - 20		Water not encountered Boring backfilled with soil cuttings						

Drill Method: Hollow Stem

Drill Date: 2-20-19

Drill Rig: CME 75

Krazan and Associates

Hole Size: 5½ Inches

Driller: Baja Exploration

Elevation: 10 Feet

Sheet: 1 of 1

Log of Boring B6

Project: Moorpark Apartments

Project No: 112-19014

Client: USA Multifamily Development

Figure No.: A-6







Location: 119360 W. Los Angeles Avenue, Moorpark, California

Logged By: Matt Vo

Depth to Water: Not Encountered

Initial: N/A

At Completion: N/A

SUBSURFACE PROFILE			SAMPLE				Penetration Test blows/ft	Water Content (%)
Depth (ft)	Symbol	Description	Dry Density (pcf)	Moisture (%)	Type	Blows/ft.		
0		Ground Surface						
0 - 7.5		SILTY SAND (SM) Medium dense, medium- to fine-grained; brown, moist						
6			115.9	11.3		15		
7.5 - 10		SANDY SILT (ML) Stiff, fine-grained; dark brown, moist						
10			112.7	11.1		18		
10 - 20		End of Borehole						
16 - 20		Water not encountered Boring backfilled with soil cuttings						

Drill Method: Hollow Stem

Drill Date: 2-20-19

Drill Rig: CME 75

Krazan and Associates

Hole Size: 5½ Inches

Driller: Baja Exploration

Elevation: 10 Feet

Sheet: 1 of 1

Log of Boring B7

Project: Moorpark Apartments

Project No: 112-19014

Client: USA Multifamily Development

Figure No.: A-7

Location: 119360 W. Los Angeles Avenue, Moorpark, California

Logged By: Matt Vo

Depth to Water: Not Encountered

Initial: N/A

At Completion: N/A

SUBSURFACE PROFILE			SAMPLE				Penetration Test blows/ft	Water Content (%)
Depth (ft)	Symbol	Description	Dry Density (pcf)	Moisture (%)	Type	Blows/ft.		
0		Ground Surface						
0 - 6		SILTY SAND (SM) Medium dense, medium- to fine-grained; brown, moist	109.0	15.2		19		
6 - 14		SANDY SILT (ML) Stiff, fine-grained; dark brown, moist	117.0	10.9		18		
14 - 18		SILTY SAND (SM) Medium dense, medium- to fine-grained; dark brown, moist		21.7		13		
18 - 20		Water not encountered Boring backfilled with soil cuttings POORLY GRADED SAND (SP) Dense, medium- to fine-grained; light brown, moist		19.5		32		

Drill Method: Hollow Stem

Drill Date: 2-20-19

Drill Rig: CME 75

Krazan and Associates

Hole Size: 5½ Inches

Driller: Baja Exploration

Elevation: 20 Feet

Sheet: 1 of 1

Log of Boring B8

Project: Moorpark Apartments

Project No: 112-19014

Client: USA Multifamily Development

Figure No.: A-8





Location: 119360 W. Los Angeles Avenue, Moorpark, California

Logged By: Matt Vo

Depth to Water: Not Encountered

Initial: N/A

At Completion: N/A

SUBSURFACE PROFILE			SAMPLE				Penetration Test blows/ft	Water Content (%)
Depth (ft)	Symbol	Description	Dry Density (pcf)	Moisture (%)	Type	Blows/ft.		
0		Ground Surface						
0 - 7.5		SILTY SAND (SM) Medium dense, medium- to fine-grained; brown, moist	104.7	22.0		17	■	
7.5 - 10		SANDY SILT (ML) Medium stiff, fine-grained; dark brown, moist	123.3	7.9		9	■	
10 - 20		End of Borehole Water not encountered Boring backfilled with soil cuttings						

Drill Method: Hollow Stem

Drill Date: 2-20-19

Drill Rig: CME 75

Krazan and Associates

Hole Size: 5½ Inches

Driller: Baja Exploration

Elevation: 10 Feet

Sheet: 1 of 1

Log of Boring B9

Project: Moorpark Apartments

Project No: 112-19014

Client: USA Multifamily Development

Figure No.: A-9

Location: 119360 W. Los Angeles Avenue, Moorpark, California

Logged By: Matt Vo

Depth to Water: Not Encountered

Initial: N/A

At Completion: N/A

SUBSURFACE PROFILE			SAMPLE				Penetration Test blows/ft	Water Content (%)
Depth (ft)	Symbol	Description	Dry Density (pcf)	Moisture (%)	Type	Blows/ft.		
0		Ground Surface						
0 - 2		ASPHALT PAVING = 2 inches AGGREGATE BASE = 4 inches						
2 - 6		SILTY SAND (SM) Medium dense, medium- to fine-grained; brown, moist	109.1	14.7		18		
6 - 10		SANDY SILT (ML) Stiff, fine-grained; dark brown, moist						
10 - 14		SILTY SAND (SM) Medium dense, medium- to fine-grained; dark brown, moist	118.5	8.6		13		
14 - 16		Water not encountered Boring backfilled with soil cuttings						
16 - 18				15.9		17		
18 - 20		POORLY GRADED SAND (SP) Medium dense, medium- to fine-grained; light brown, moist	20.0			17		

Drill Method: Hollow Stem

Drill Date: 2-20-19

Drill Rig: CME 75

Krazan and Associates

Hole Size: 5½ Inches

Driller: Baja Exploration

Elevation: 20 Feet

Sheet: 1 of 1

Log of Boring B10

Project: Moorpark Apartments

Project No.: 112-19014

Client: USA Multifamily Development

Figure No.: A-10

Location: 119360 W. Los Angeles Avenue, Moorpark, California

Logged By: Matt Vo

Depth to Water: Not Encountered

Initial: N/A

At Completion: N/A

SUBSURFACE PROFILE			SAMPLE				Penetration Test blows/ft	Water Content (%)
Depth (ft)	Symbol	Description	Dry Density (pcf)	Moisture (%)	Type	Blows/ft.		
0		Ground Surface						
0		ASPHALT PAVING = 2 inches						
0		AGGREGATE BASE = 4 inches						
0		SILTY SAND (SM)						
0		Medium dense, medium- to fine-grained;						
0		brown, moist						
2								
4								
6			114.8	12.4		16		
8								
8		SANDY SILT (ML)						
8		Stiff, fine-grained; dark brown, moist						
10								
10			112.0	15.9		15		
12								
14								
14		SILTY SAND (SM)						
14		Dense, medium- to fine-grained; dark						
14		brown, moist						
16								
16		Water not encountered						
16		Boring backfilled with soil cuttings						
18								
18		POORLY GRADED SAND (SP)						
18		Medium dense, medium- to fine-grained;						
18		light brown, moist						
20								
20			15.2			19		

Drill Method: Hollow Stem

Drill Date: 2-20-19

Drill Rig: CME 75

Krazan and Associates

Hole Size: 5½ Inches

Driller: Baja Exploration

Elevation: 20 Feet

Sheet: 1 of 1

Log of Boring B11

Project: Moorpark Apartments

Project No: 112-19014

Client: USA Multifamily Development

Figure No.: A-11

Location: 119360 W. Los Angeles Avenue, Moorpark, California

Logged By: Matt Vo

Depth to Water: Not Encountered

Initial: N/A

At Completion: N/A

SUBSURFACE PROFILE			SAMPLE				Penetration Test blows/ft	Water Content (%)					
Depth (ft)	Symbol	Description	Dry Density (pcf)	Moisture (%)	Type	Blows/ft.		20	40	60	10	20	30
0		Ground Surface											
		ASPHALT PAVING = 2 inches AGGREGATE BASE = 4 inches											
2		SILTY SAND (SM) Medium dense, medium- to fine-grained; brown, moist											
6			112.3	12.9		16							
8		SANDY SILT (ML) Stiff, fine-grained; dark brown, moist											
10			118.6	11.0		19							
14		SILTY SAND (SM) Medium dense, medium- to fine-grained; dark brown, moist											
16				18.3		16							
16		Water not encountered Boring backfilled with soil cuttings											
18		POORLY GRADED SAND (SP) Medium dense, medium- to fine-grained; light brown, moist											
20				9.4		13							

Drill Method: Hollow Stem

Drill Date: 2-20-19

Drill Rig: CME 75

Krazan and Associates

Hole Size: 5½ Inches

Driller: Baja Exploration

Elevation: 20 Feet

Sheet: 1 of 1

Log of Boring B12

Project: Moorpark Apartments

Project No: 112-19014

Client: USA Multifamily Development

Figure No.: A-12

Location: 119360 W. Los Angeles Avenue, Moorpark, California

Logged By: Matt Vo

Depth to Water> Not Encountered

Initial: N/A

At Completion: N/A

SUBSURFACE PROFILE			SAMPLE				Penetration Test blows/ft	Water Content (%)			
Depth (ft)	Symbol	Description	Dry Density (pcf)	Moisture (%)	Type	Blows/ft.		10	20	30	40
0		Ground Surface									
		ASPHALT PAVING = 2 inches AGGREGATE BASE = 4 inches									
2		SILTY SAND (SM) Medium dense, medium- to fine-grained; brown, moist									
6			113.1	15.0		17					
8		SANDY SILT (ML) Medium stiff, fine-grained; dark brown, moist									
10			112.8	19.1		8					
14		SILTY SAND (SM) Medium dense, medium- to fine-grained; dark brown, moist									
16		Water not encountered Boring backfilled with soil cuttings		6.9		13					
18											
20		POORLY GRADED SAND (SP) Dense, medium- to fine-grained; light brown, moist		16.5		35					

Drill Method: Hollow Stem

Drill Date: 2-20-19

Drill Rig: CME 75

Krazan and Associates

Hole Size: 5½ Inches

Driller: Baja Exploration

Elevation: 20 Feet

Sheet: 1 of 1

APPENDIX C

Laboratory Testing

LABORATORY TESTING

The following laboratory tests were performed on a representative sample in accordance with the applicable latest standards or methods from the ASTM, California Building Code (CBC) and California Department of Transportation.

Classification

Soils were classified with respect to the Unified Soil Classification System (USCS) in accordance with ASTM D-2487 and D-2488.

Particle Size Analysis

Modified hydrometer testing was conducted to aid in classification of the soil. The results of the particle size analysis are presented in Table C.

Maximum Density/Optimum Moisture

The maximum dry density and optimum moisture content of two representative bulk samples were evaluated in accordance with ASTM D-1557. The results are summarized in Table C.

Expansion Index Tests

Two (2) expansion index tests were performed to evaluate the expansion potential of typical on-site soil. Testing was carried out in general conformance with ASTM Test Method D-4829. The results are presented in Table C.

Chemical Analyses

Chemical testing was performed on two select samples by Alta. The results of these tests (sulfate content, resistivity, chloride content and pH) are presented on Table C.

TABLE C
SUMMARY OF LABORATORY TEST DATA
P.N. 1-0379

Boring/Pit No.	Depth (Feet)	Soil Description	Group Symbol - Unified Soil Classification System	Maximum Dry Density		Direct Shear	Grain Size Analysis				Expansion Index	Sulfate Content (%)	Consolidation	Other Tests Remarks
				Maximum Density (pcf)	Optimum Moisture (%)		Gravel (% + No. 4 Screen)	% Sand	% Silt (0.074 to 0.005mm)	% Clay (<0.005 mm)				
T-1	3	Silty Sand (Qa)	SM	114.1	10.7	-	0	83	12	5	0	ND	-	Min. Resistivity: 12,000 OHM-CM Chloride: 0ppm PH: 8.47
T-3	3	Silty Sand (Qa)	SM	121.4	10.3	-	2	64	20	14	7	ND	-	Min. Resistivity: 3,800 OHM-CM Chloride: 5ppm PH: 8.03

Alta California Geotechnical, Inc.

APPENDIX C-1

**Previous Laboratory Testing and Infiltration Results
(Krazan, 2019)**

Sieve Analysis

Project Number : 11219014
 Project Name : Moorpark Apartments
 Date : 2/20/2019
 Sample Location : B-1 @ 5'
 Soil Classification : SM

Wet Weight	:	461.90
Dry Weight	:	461.90
Moisture Content	:	0%

Sieves Size/Number	Sieve Size, mm	Retained Weight	Retained, %	Cum % Retained	Cum. % Passing.
1-1/2"	37.50				100.0
1"	25.00				100.0
3/4"	19.00				100.0
1/2"	12.50				100.0
3/8"	9.50				100.0
#4	4.75	0.9	0.2	0.2	99.8
#8	2.36	2.5	0.5	0.7	99.3
#16	1.18	6.7	1.5	2.2	97.8
#30	0.60	27.1	5.9	8.1	91.9
#50	0.30	50.3	10.9	18.9	81.1
#100	0.15	54.0	11.7	30.6	69.4
#200	0.08	94.6	20.5	51.1	48.9

Grain Size Analysis

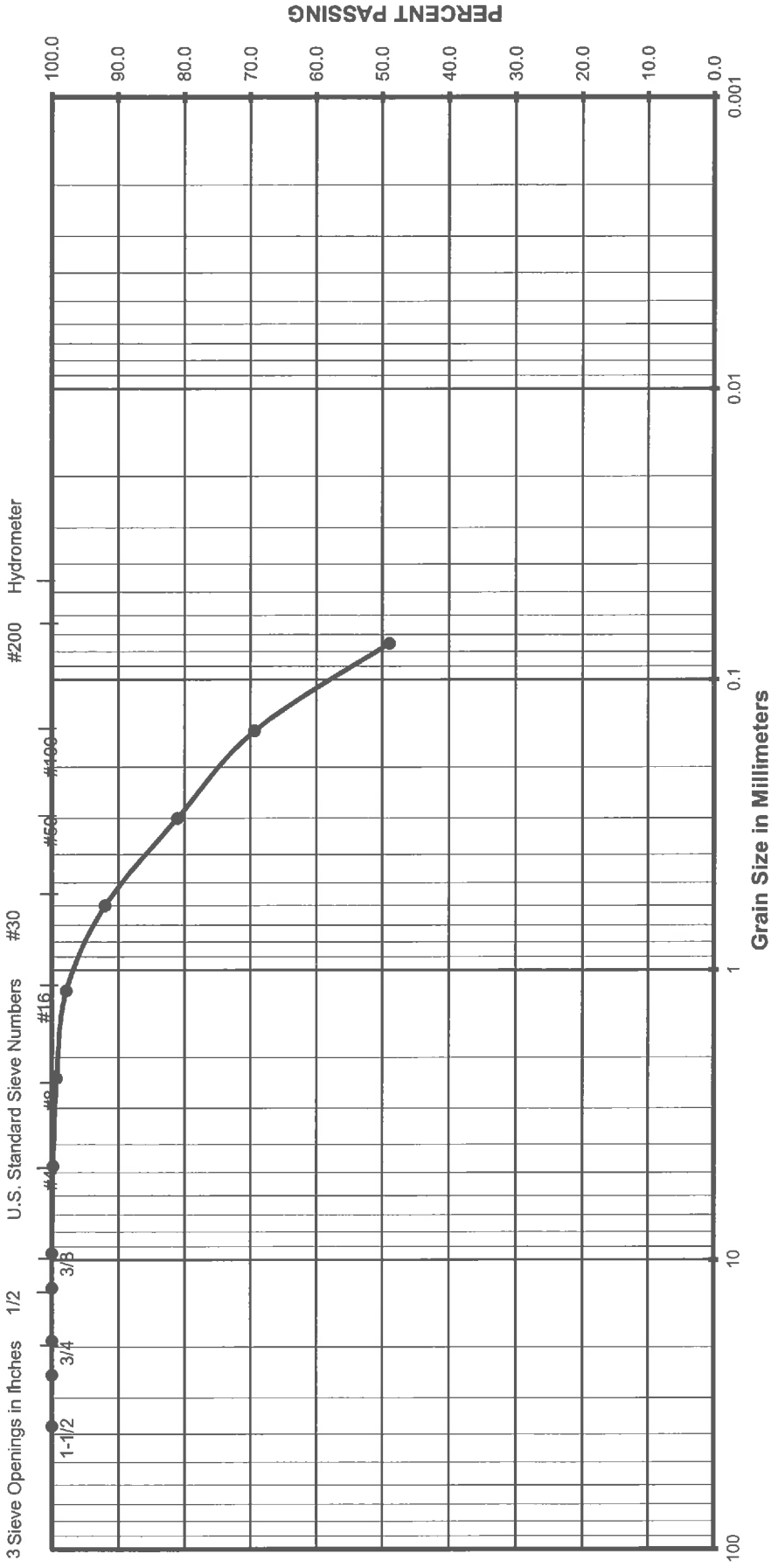

Gravel		Sand		Silt or Clay	
Coarse	Fine	Coarse	Medium	Fine	Fine

(Unified Soils Classification)

Project Name: Moorpark Apartments
 Project Number: 11219014
 Soil Classification: SM
 Sample Number: B-1 @ 5'

Sieve Analysis

Project Number : 11219014
 Project Name : Moorpark Apartments
 Date : 2/20/2019
 Sample Location : B-1 @ 10'
 Soil Classification : ML

Wet Weight	: 444.80
Dry Weight	: 444.80
Moisture Content	: 0%

Sieves Size/Number	Sieve Size, mm	Retained Weight	Retained. %	Cum % Retained	Cum. % Passing.
1-1/2"	37.50				100.0
1"	25.00				100.0
3/4"	19.00				100.0
1/2"	12.50				100.0
3/8"	9.50				100.0
#4	4.75	0.2	0.0	0.0	100.0
#8	2.36	0.1	0.0	0.1	99.9
#16	1.18	0.4	0.1	0.2	99.8
#30	0.60	1.1	0.2	0.4	99.6
#50	0.30	11.5	2.6	3.0	97.0
#100	0.15	21.5	4.8	7.8	92.2
#200	0.08	24.0	5.4	13.2	86.8

Grain Size Analysis

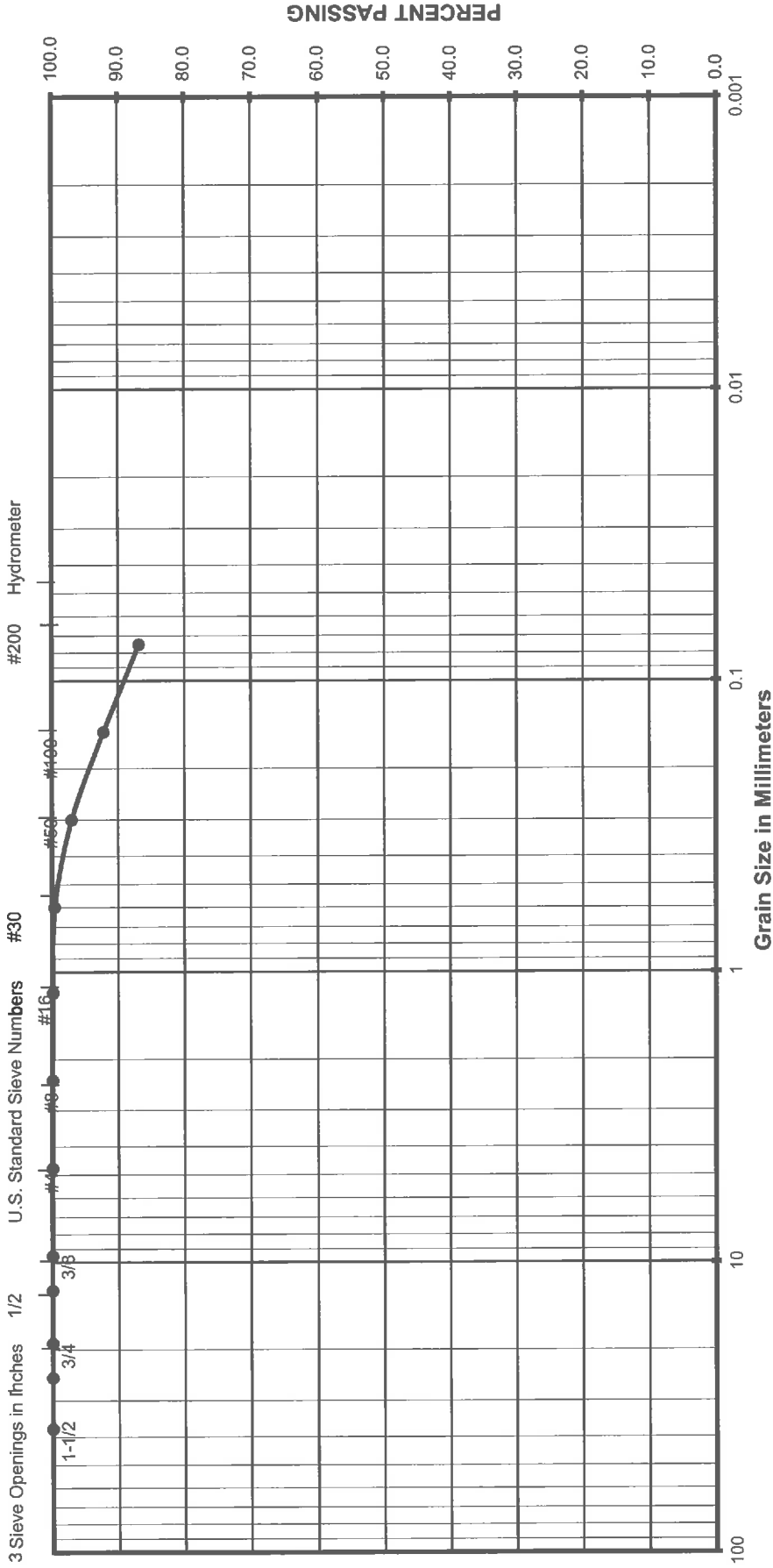

Gravel		Sand			Silt or Clay
		Fine	Coarse	Fine	

(Unified Soils Classification)

Project Name: Moorpark Apartments
 Project Number: 11219014
 Soil Classification: ML
 Sample Number: B-1 @ 10'

Sieve Analysis

Project Number : 11219014
 Project Name : Moorpark Apartments
 Date : 2/20/2019
 Sample Location : B-1 @ 15'
 Soil Classification : SM

Wet Weight	:	442.80
Dry Weight	:	442.80
Moisture Content	:	0%

Sieves Size/Number	Sieve Size, mm	Retained Weight	Retained. %	Cum % Retained	Cum. % Passing.
1-1/2"	37.50				100.0
1"	25.00				100.0
3/4"	19.00				100.0
1/2"	12.50				100.0
3/8"	9.50				100.0
#4	4.75				100.0
#8	2.36	1.0	0.2	0.2	99.8
#16	1.18	3.2	0.7	0.9	99.1
#30	0.60	17.7	4.0	4.9	95.1
#50	0.30	72.3	16.3	21.3	78.7
#100	0.15	73.0	16.5	37.8	62.2
#200	0.08	97.4	22.0	59.8	40.2

Grain Size Analysis

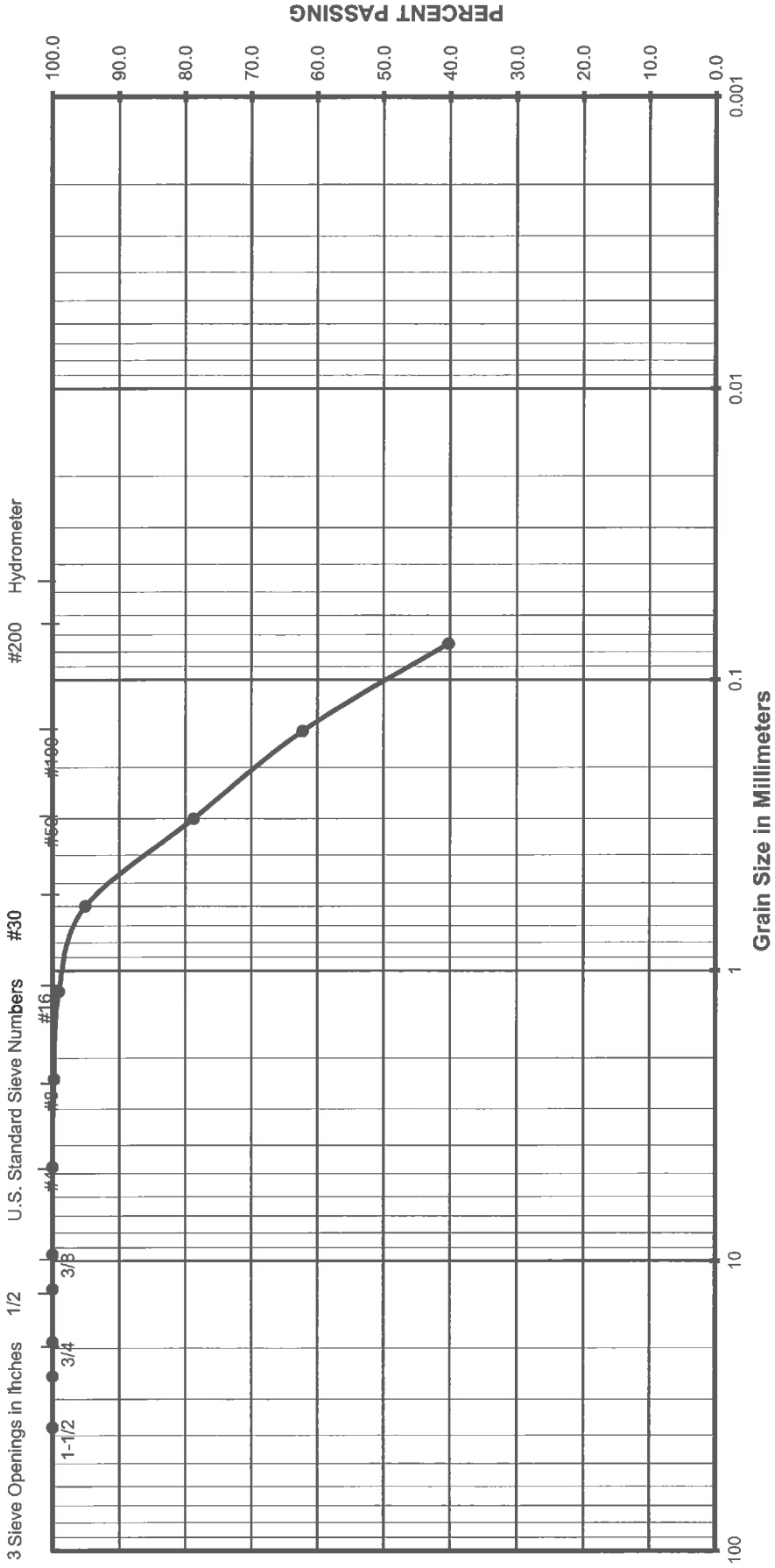

Gravel		Sand			Silt or Clay
		Fine	Coarse	Medium	

(Unified Soils Classification)

Project Name: Moorpark Apartments
 Project Number: 11219014
 Soil Classification: SM
 Sample Number: B-1 @ 15'

Sieve Analysis

Project Number : 11219014
 Project Name : Moorpark Apartments
 Date : 2/20/2019
 Sample Location : B-1 @ 20'
 Soil Classification : SP

Wet Weight	:	461.50
Dry Weight	:	461.50
Moisture Content	:	0%

Sieves Size/Number	Sieve Size, mm	Retained Weight	Retained. %	Cum % Retained	Cum. % Passing.
1-1/2"	37.50				100.0
1"	25.00				100.0
3/4"	19.00				100.0
1/2"	12.50				100.0
3/8"	9.50	1.6	0.3	0.3	99.7
#4	4.75	15.7	3.4	3.7	96.3
#8	2.36	21.3	4.6	8.4	91.6
#16	1.18	38.0	8.2	16.6	83.4
#30	0.60	96.2	20.8	37.4	62.6
#50	0.30	197.0	42.7	80.1	19.9
#100	0.15	48.2	10.4	90.6	9.4
#200	0.08	24.4	5.3	95.9	4.1

Grain Size Analysis

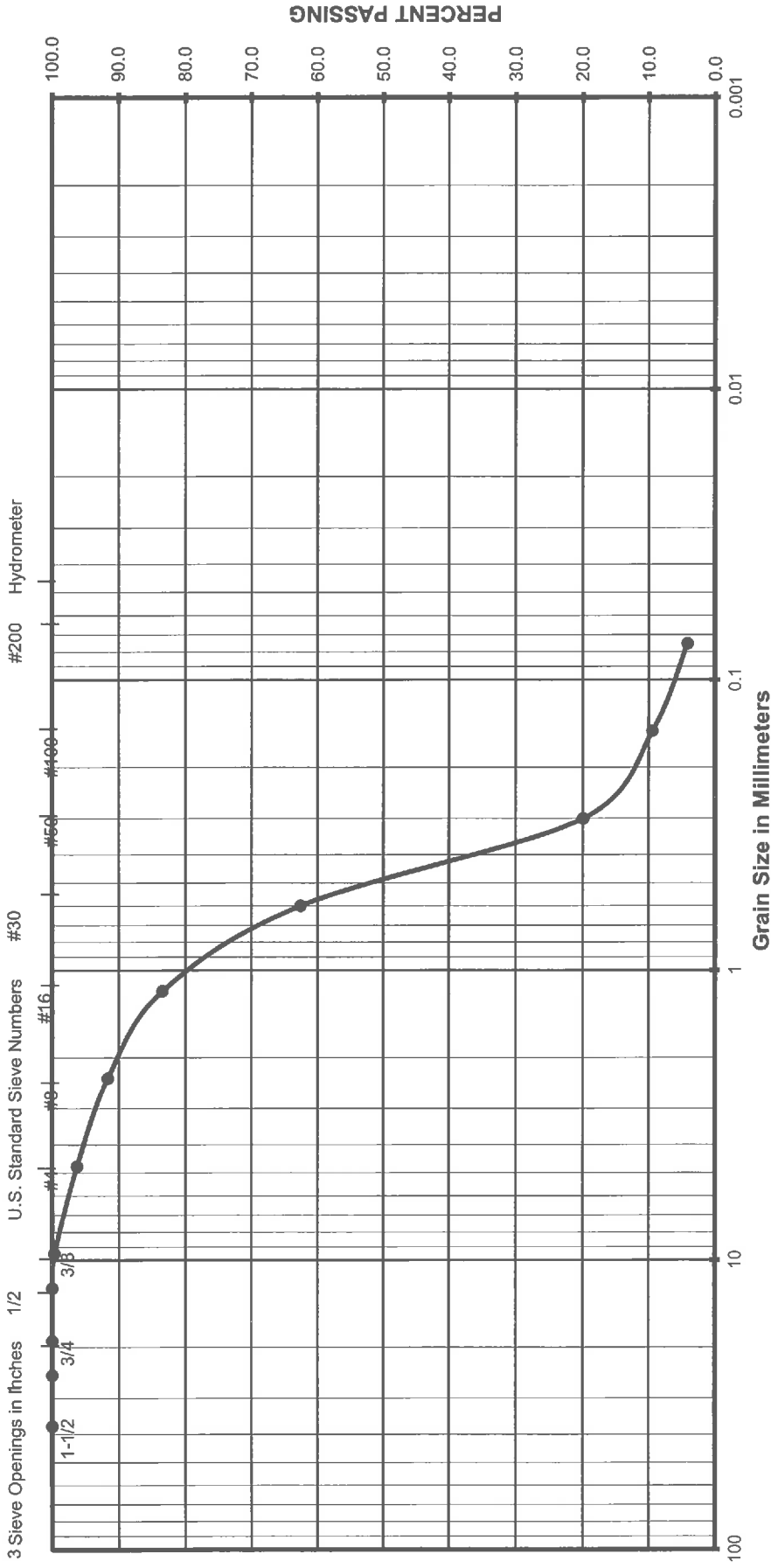

Gravel		Sand		Silt or Clay
		Fine	Coarse	
Coarse	Fine	Medium	Fine	

(Unified Soils Classification)

Project Name: Moorpark Apartments
 Project Number: 11219014
 Soil Classification: SP
 Sample Number: B-1 @ 20'

Sieve Analysis

Project Number : 11219014
 Project Name : Moorpark Apartments
 Date : 2/20/2019
 Sample Location : B-1 @ 25'
 Soil Classification : SP

Wet Weight	:	469.10
Dry Weight	:	469.10
Moisture Content	:	0%

Sieves Size/Number	Sieve Size, mm	Retained Weight	Retained. %	Cum % Retained	Cum. % Passing.
1-1/2"	37.50				100.0
1"	25.00				100.0
3/4"	19.00				100.0
1/2"	12.50				100.0
3/8"	9.50	2.1	0.4	0.4	99.6
#4	4.75	1.3	0.3	0.7	99.3
#8	2.36	4.7	1.0	1.7	98.3
#16	1.18	14.7	3.1	4.9	95.1
#30	0.60	62.3	13.3	18.1	81.9
#50	0.30	193.6	41.3	59.4	40.6
#100	0.15	80.1	17.1	76.5	23.5
#200	0.08	64.0	13.6	90.1	9.9

Grain Size Analysis

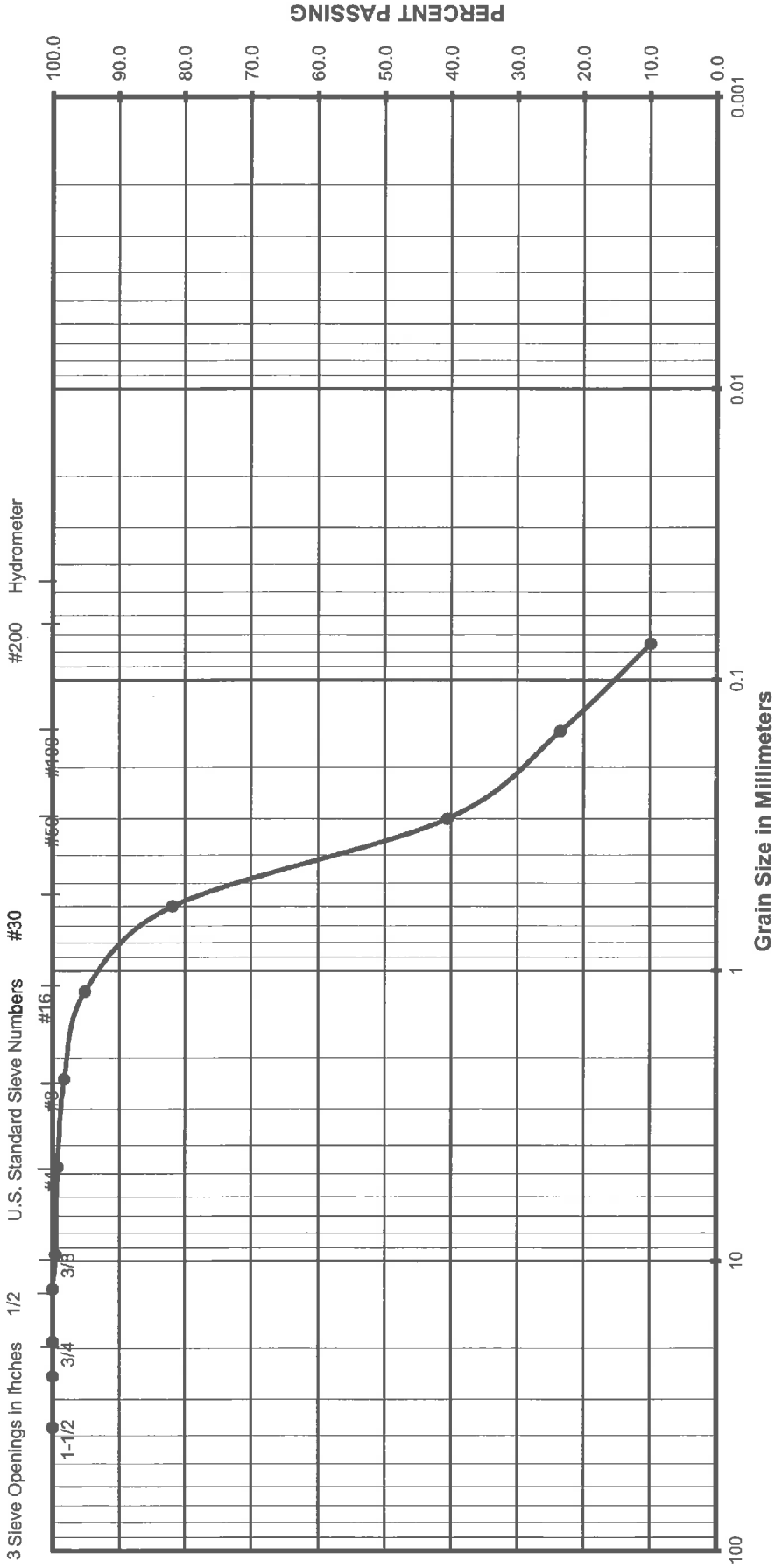

Gravel	Sand	Silt or Clay
Coarse	Fine Medium Coarse	Fine

(Unified Soils Classification)

Project Name: Moorpark Apartments
 Project Number: 11219014
 Soil Classification: SP
 Sample Number: B-1 @ 25'

Sieve Analysis

Project Number : 11219014
 Project Name : Moorpark Apartments
 Date : 2/20/2019
 Sample Location : B-1 @ 30'
 Soil Classification : SP

Wet Weight	:	440.50
Dry Weight	:	440.50
Moisture Content	:	0%

Sieves Size/Number	Sieve Size, mm	Retained Weight	Retained. %	Cum % Retained	Cum. % Passing.
1-1/2"	37.50				100.0
1"	25.00				100.0
3/4"	19.00				100.0
1/2"	12.50				100.0
3/8"	9.50	3.7	0.8	0.8	99.2
#4	4.75	5.3	1.2	2.0	98.0
#8	2.36	15.3	3.5	5.5	94.5
#16	1.18	38.1	8.6	14.2	85.8
#30	0.60	104.2	23.7	37.8	62.2
#50	0.30	131.5	29.9	67.7	32.3
#100	0.15	66.1	15.0	82.7	17.3
#200	0.08	54.9	12.5	95.1	4.9

Grain Size Analysis

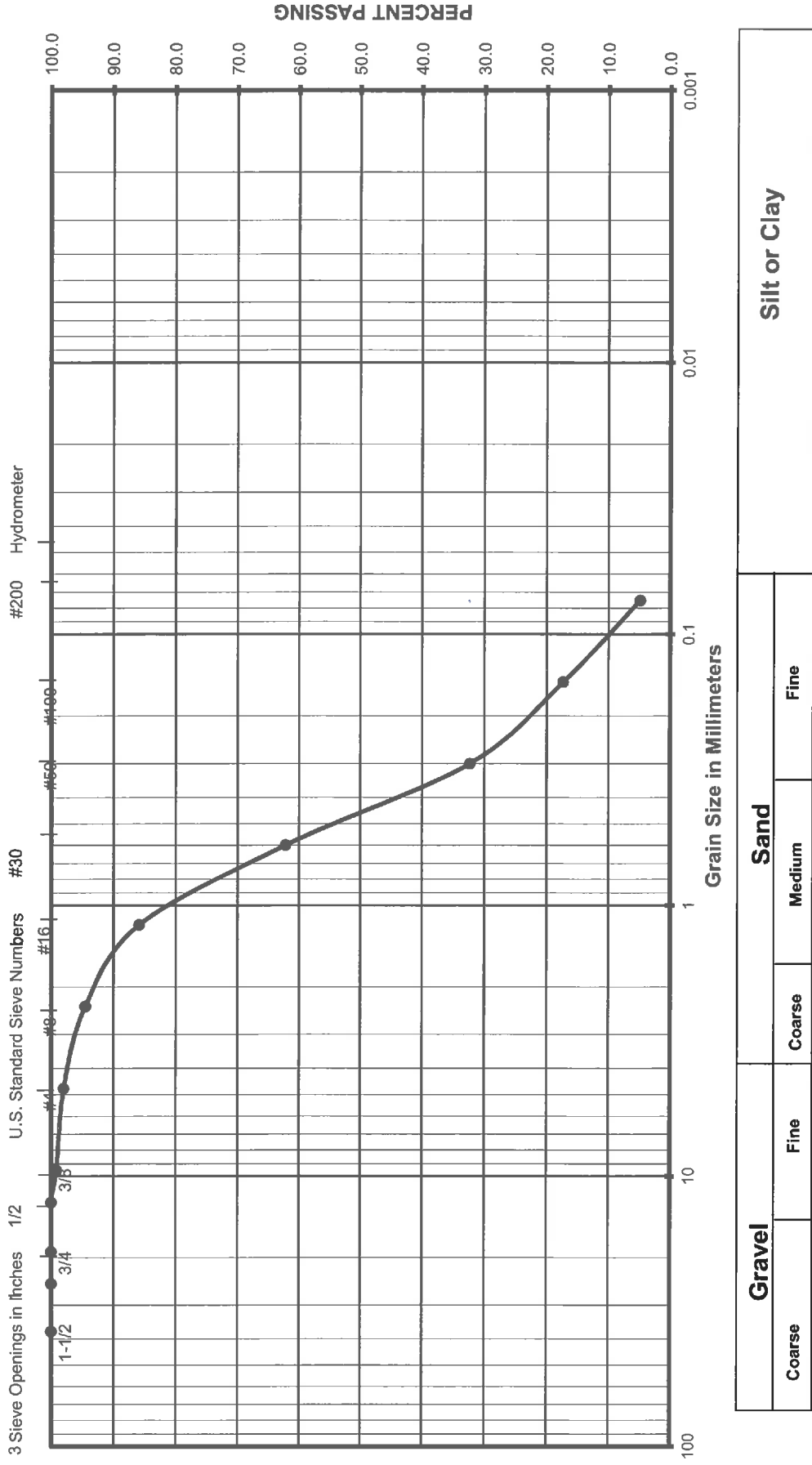

Gravel		Sand		Silt or Clay	
Coarse	Fine	Coarse	Medium	Fine	Fine

(Unified Soils Classification)

Project Name: Moorpark Apartments
 Project Number: 11219014
 Soil Classification: SP
 Sample Number: B-1 @ 30'

Sieve Analysis

Project Number : 11219014
 Project Name : Moorpark Apartments
 Date : 2/20/2019
 Sample Location : B-1 @ 35'
 Soil Classification : SP

Wet Weight	:	477.90
Dry Weight	:	477.90
Moisture Content	:	0%

Sieves Size/Number	Sieve Size, mm	Retained Weight	Retained. %	Cum % Retained	Cum. % Passing.
1-1/2"	37.50				100.0
1"	25.00				100.0
3/4"	19.00				100.0
1/2"	12.50				100.0
3/8"	9.50	26.7	5.6	5.6	94.4
#4	4.75	34.9	7.3	12.9	87.1
#8	2.36	42.1	8.8	21.7	78.3
#16	1.18	62.8	13.1	34.8	65.2
#30	0.60	103.9	21.7	56.6	43.4
#50	0.30	103.3	21.6	78.2	21.8
#100	0.15	35.0	7.3	85.5	14.5
#200	0.08	33.4	7.0	92.5	7.5

Grain Size Analysis

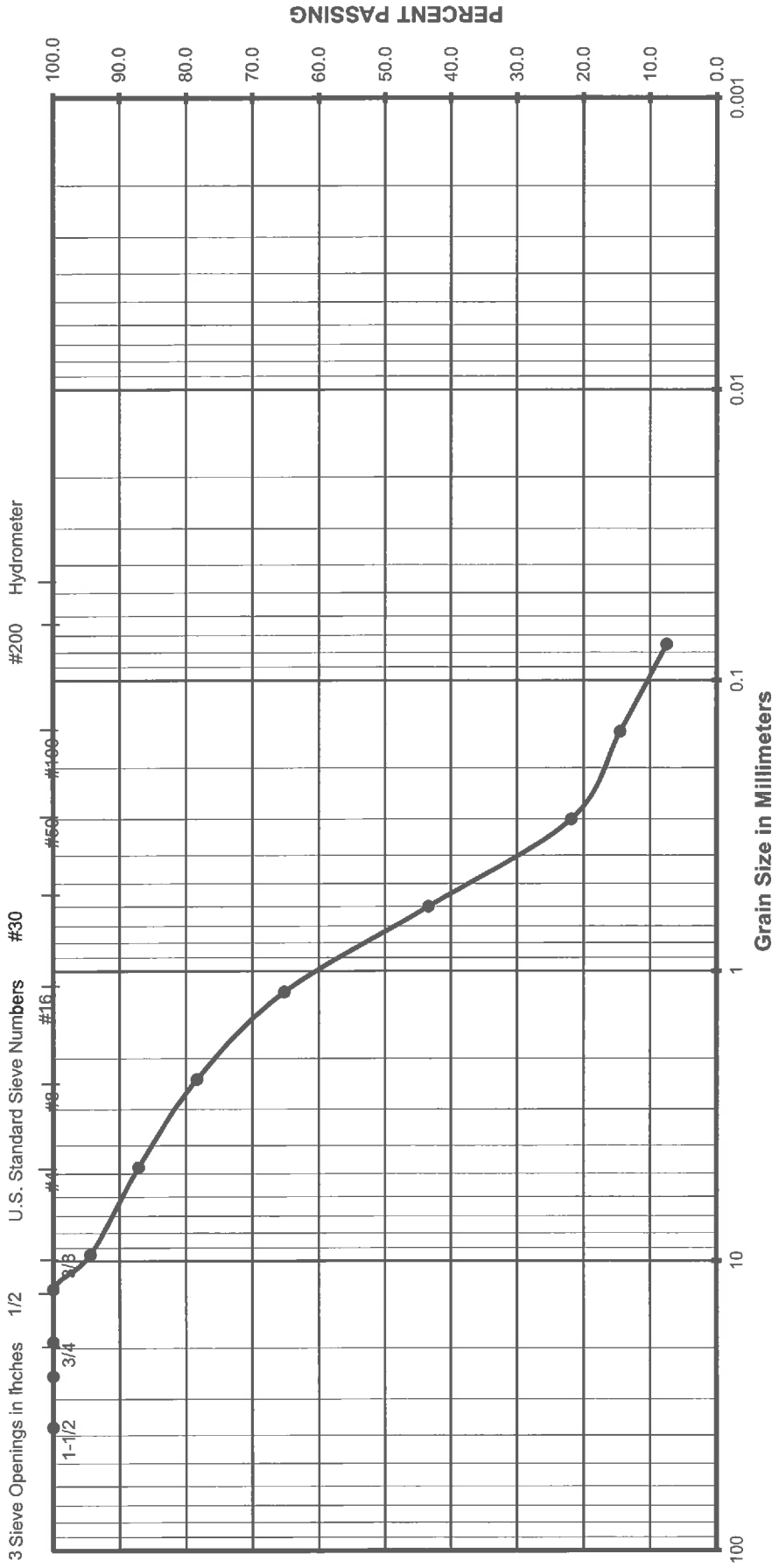

Gravel		Sand			Silt or Clay
		Fine	Coarse	Medium	

(Unified Soils Classification)

Project Name: Moorpark Apartments
 Project Number: 11219014
 Soil Classification: SP
 Sample Number: B-1 @ 35'

Sieve Analysis

Project Number : 11219014
 Project Name : Moorpark Apartments
 Date : 2/20/2019
 Sample Location : B-1 @ 40'
 Soil Classification : SP

Wet Weight	:	432.40
Dry Weight	:	432.40
Moisture Content	:	0%

Sieves Size/Number	Sieve Size, mm	Retained Weight	Retained. %	Cum % Retained	Cum. % Passing.
1-1/2"	37.50				100.0
1"	25.00				100.0
3/4"	19.00				100.0
1/2"	12.50				100.0
3/8"	9.50	3.0	0.7	0.7	99.3
#4	4.75	18.6	4.3	5.0	95.0
#8	2.36	29.7	6.9	11.9	88.1
#16	1.18	41.4	9.6	21.4	78.6
#30	0.60	78.6	18.2	39.6	60.4
#50	0.30	153.0	35.4	75.0	25.0
#100	0.15	54.3	12.6	87.6	12.4
#200	0.08	29.0	6.7	94.3	5.7

Grain Size Analysis

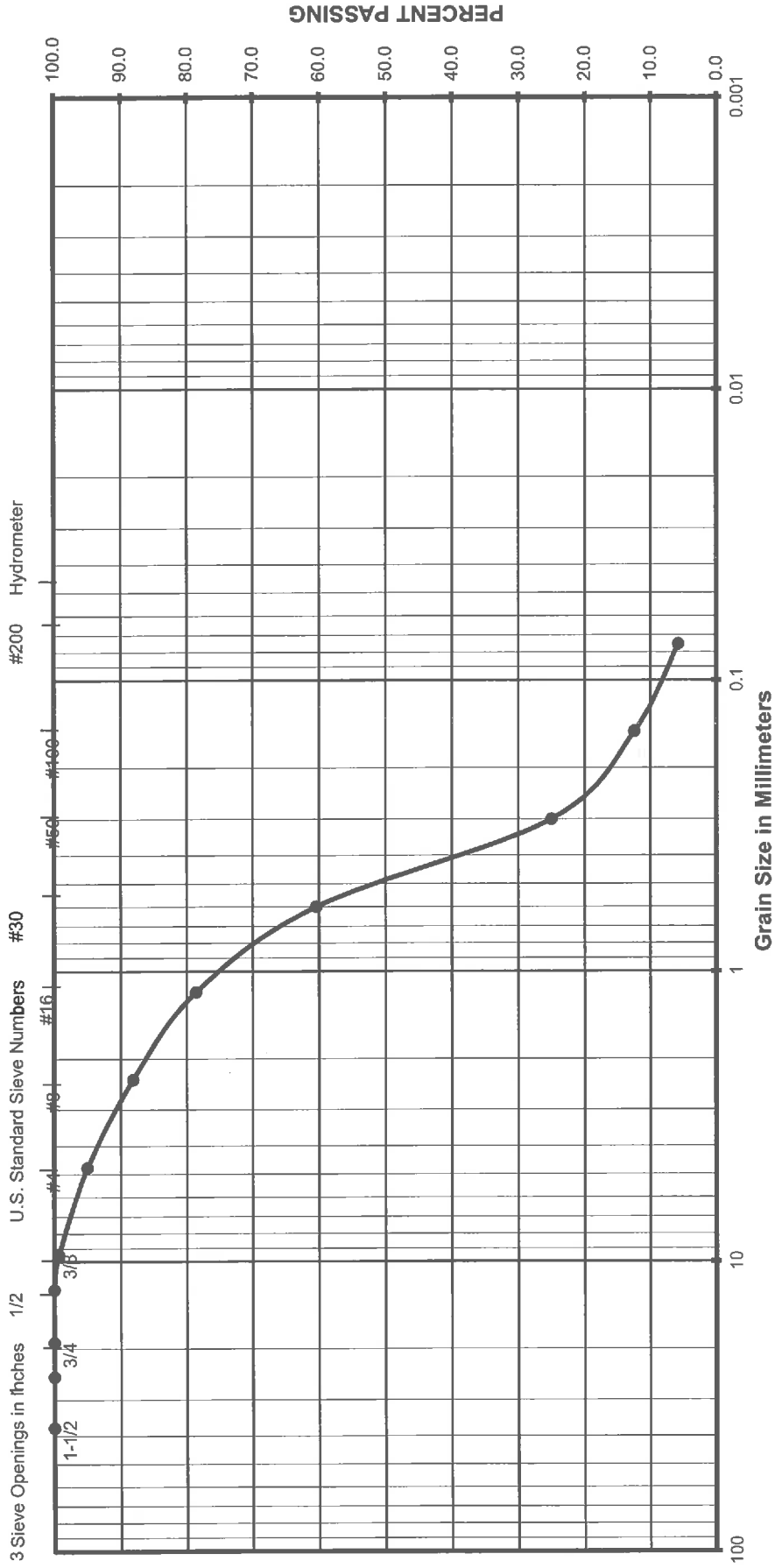

Gravel		Sand			Silt or Clay
		Fine	Coarse	Fine	

(Unified Soils Classification)

Project Name: Moorpark Apartments
 Project Number: 11219014
 Soil Classification: SP
 Sample Number: B-1 @ 40'

Sieve Analysis

Project Number : 11219014
 Project Name : Moorpark Apartments
 Date : 2/20/2019
 Sample Location : B-1 @ 45'
 Soil Classification : SP

Wet Weight	:	436.60
Dry Weight	:	436.60
Moisture Content	:	0%

Sieves Size/Number	Sieve Size, mm	Retained Weight	Retained. %	Cum % Retained	Cum. % Passing.
1-1/2"	37.50				100.0
1"	25.00				100.0
3/4"	19.00				100.0
1/2"	12.50				100.0
3/8"	9.50				100.0
#4	4.75	5.1	1.2	1.2	98.8
#8	2.36	7.1	1.6	2.8	97.2
#16	1.18	29.8	6.8	9.6	90.4
#30	0.60	105.7	24.2	33.8	66.2
#50	0.30	196.8	45.1	78.9	21.1
#100	0.15	44.1	10.1	89.0	11.0
#200	0.08	28.0	6.4	95.4	4.6

Grain Size Analysis

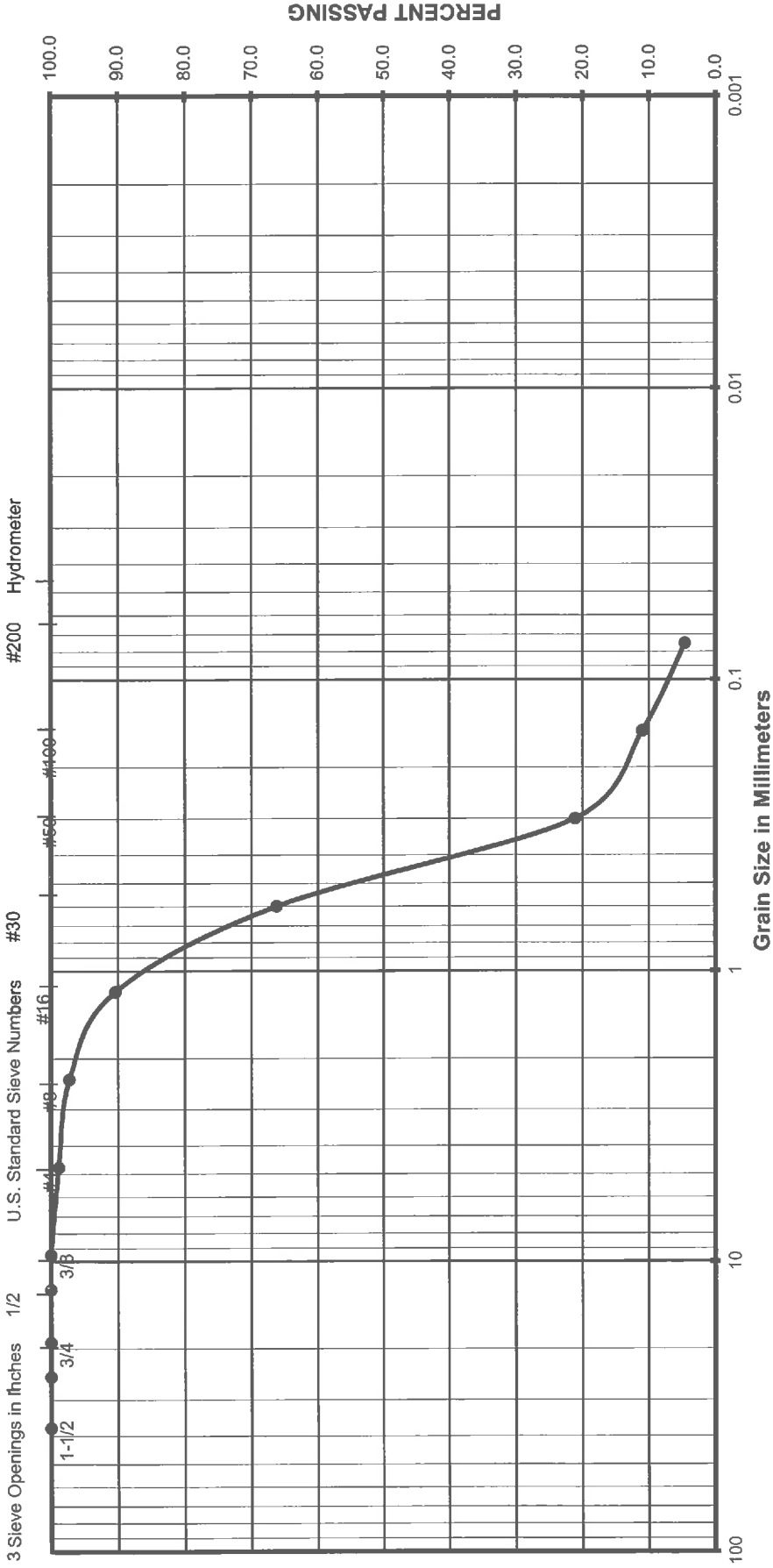

Gravel		Sand			Silt or Clay
		Fine	Coarse	Medium	
Coarse	Fine	Coarse	Medium	Fine	

(Unified Soils Classification)

Project Name: Moorpark Apartments
 Project Number: 11219014
 Soil Classification: SP
 Sample Number: B-1 @ 45'

Sieve Analysis

Project Number : 11219014
 Project Name : Moorpark Apartments
 Date : 2/20/2019
 Sample Location : B-1 @ 50'
 Soil Classification : SP

Wet Weight	: 453.80
Dry Weight	: 453.80
Moisture Content	: 0%

Sieves Size/Number	Sieve Size, mm	Retained Weight	Retained. %	Cum % Retained	Cum. % Passing.
1-1/2"	37.50				100.0
1"	25.00				100.0
3/4"	19.00				100.0
1/2"	12.50				100.0
3/8"	9.50	3.2	0.7	0.7	99.3
#4	4.75	11.4	2.5	3.2	96.8
#8	2.36	26.1	5.8	9.0	91.0
#16	1.18	72.9	16.1	25.0	75.0
#30	0.60	160.0	35.3	60.3	39.7
#50	0.30	116.4	25.7	85.9	14.1
#100	0.15	25.0	5.5	91.4	8.6
#200	0.08	19.7	4.3	95.8	4.2

Grain Size Analysis

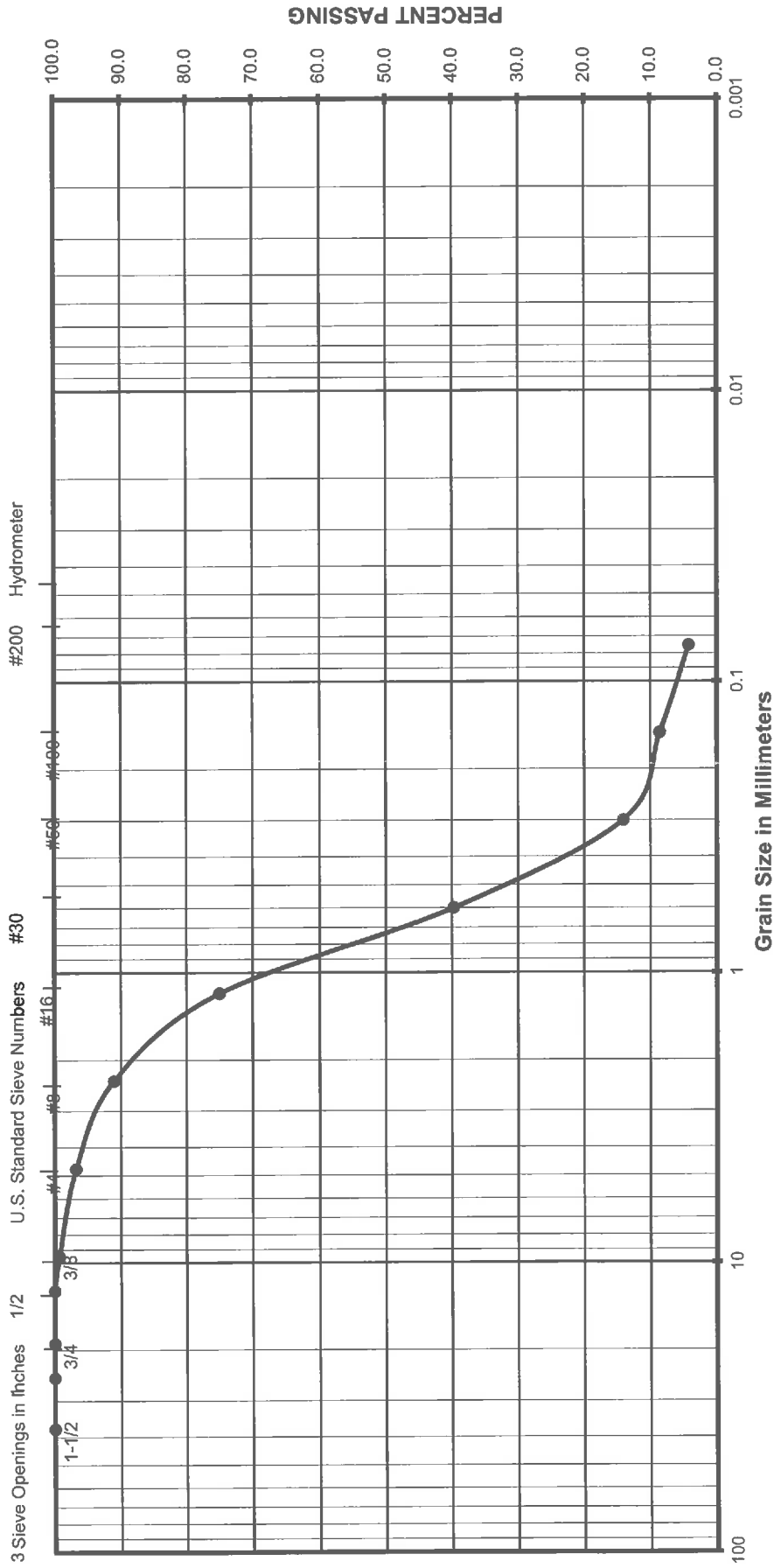

Gravel		Sand		Silt or Clay
Coarse	Fine	Coarse	Fine	

(Unified Soils Classification)

Project Name Moorpark Apartments
 Project Number 11219014
 Soil Classification SP
 Sample Number B-1 @ 50'

Shear Strength Diagram (Direct Shear)
ASTM D - 3080 / AASHTO T - 236

Project Number	Boring No. & Depth	Soil Type	Date
11219014	B-6 @ 5'	SM	3/11/2019

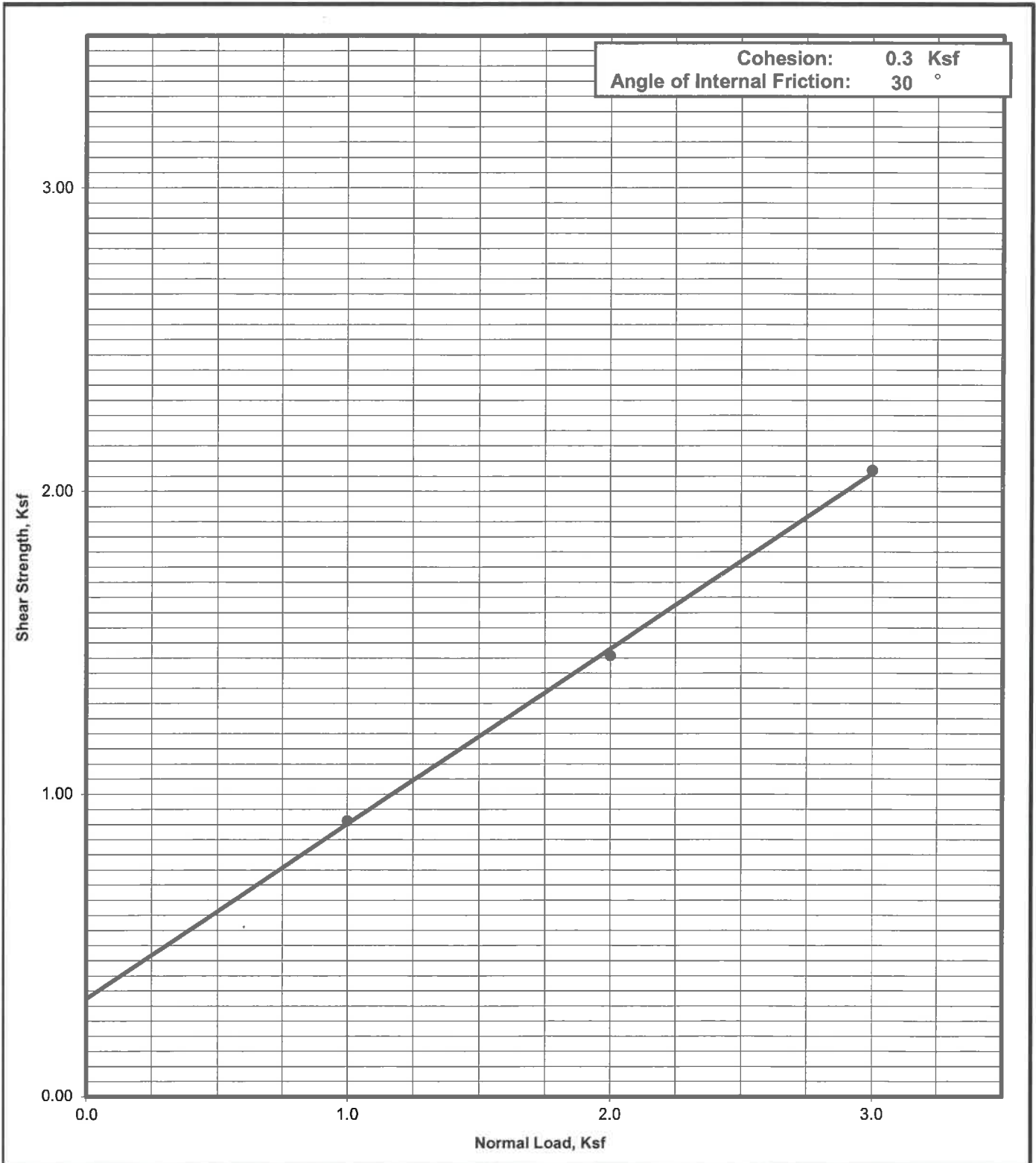

Shear Strength Diagram (Direct Shear)
ASTM D - 3080 / AASHTO T - 236

Project Number	Boring No. & Depth	Soil Type	Date
11219014	B-10 @ 5'	SM	3/11/2019

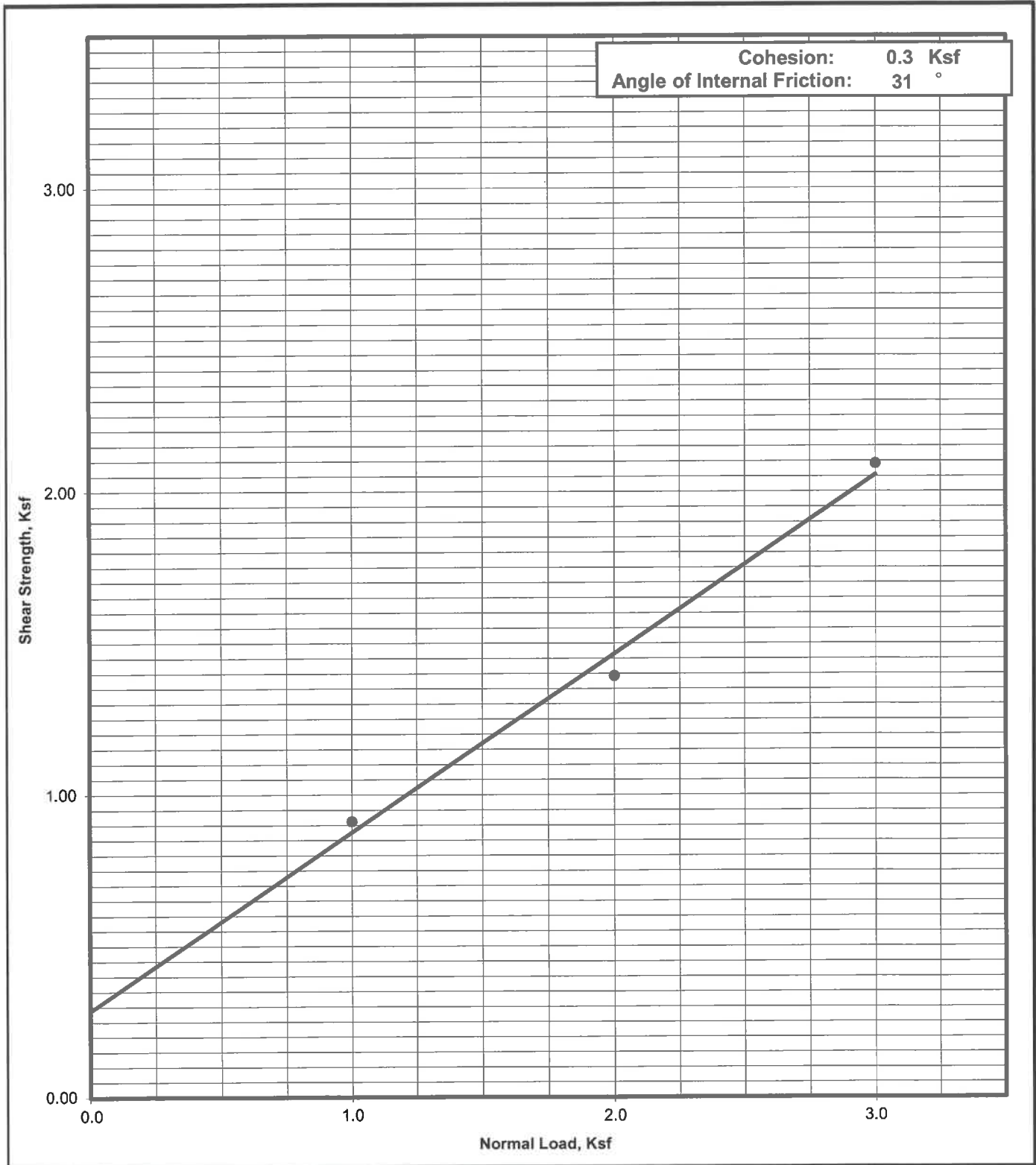

Consolidation Test

Project No	Boring No. & Depth	Date	Soil Classification
11219014	B-2 @ 5'	3/11/2019	SM

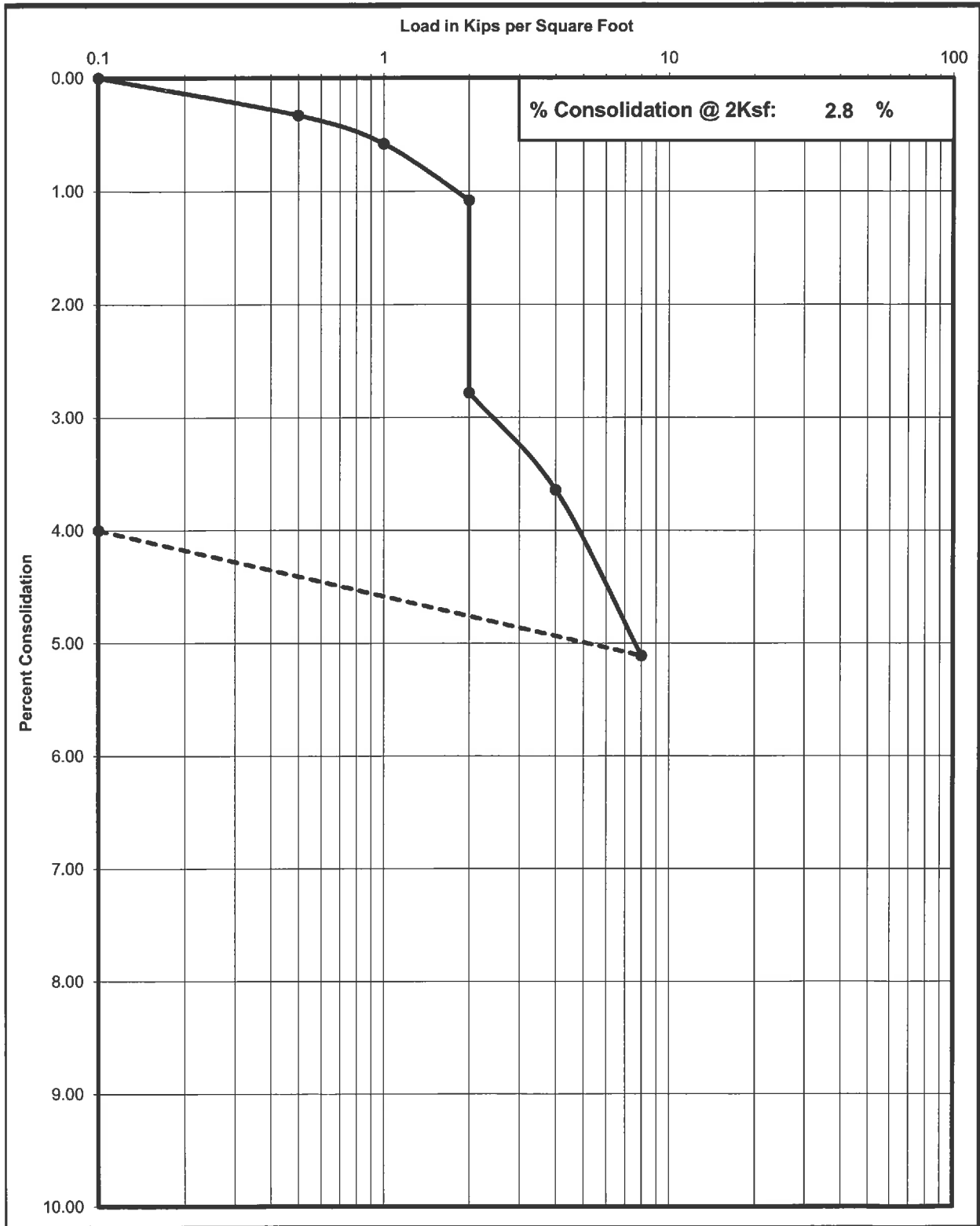

Consolidation Test

Project No	Boring No. & Depth	Date	Soil Classification
11219014	B-2 @ 10'	3/11/2019	ML

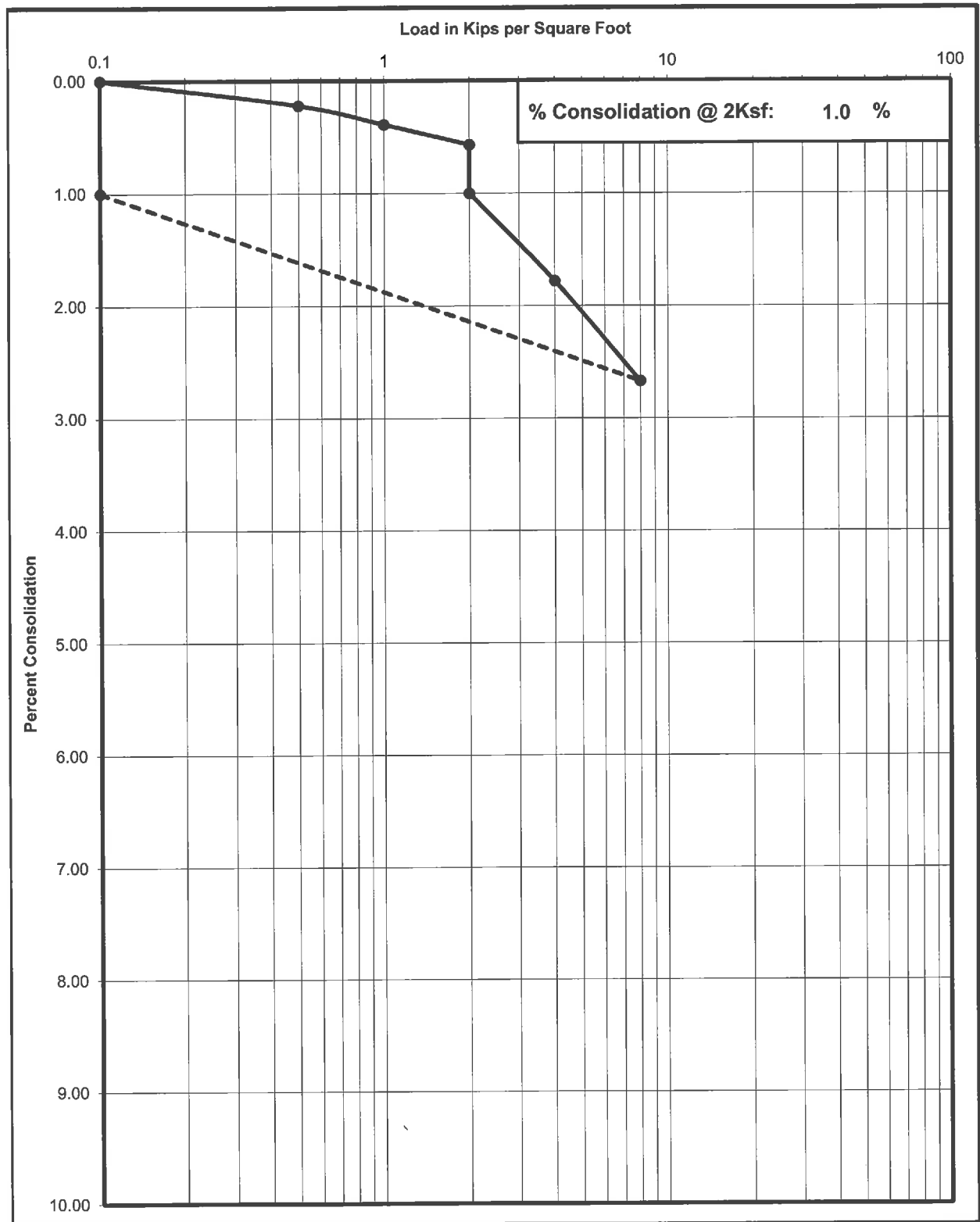

Consolidation Test

Project No	Boring No. & Depth	Date	Soil Classification
11219014	B-8 @ 5'	3/11/2019	SM

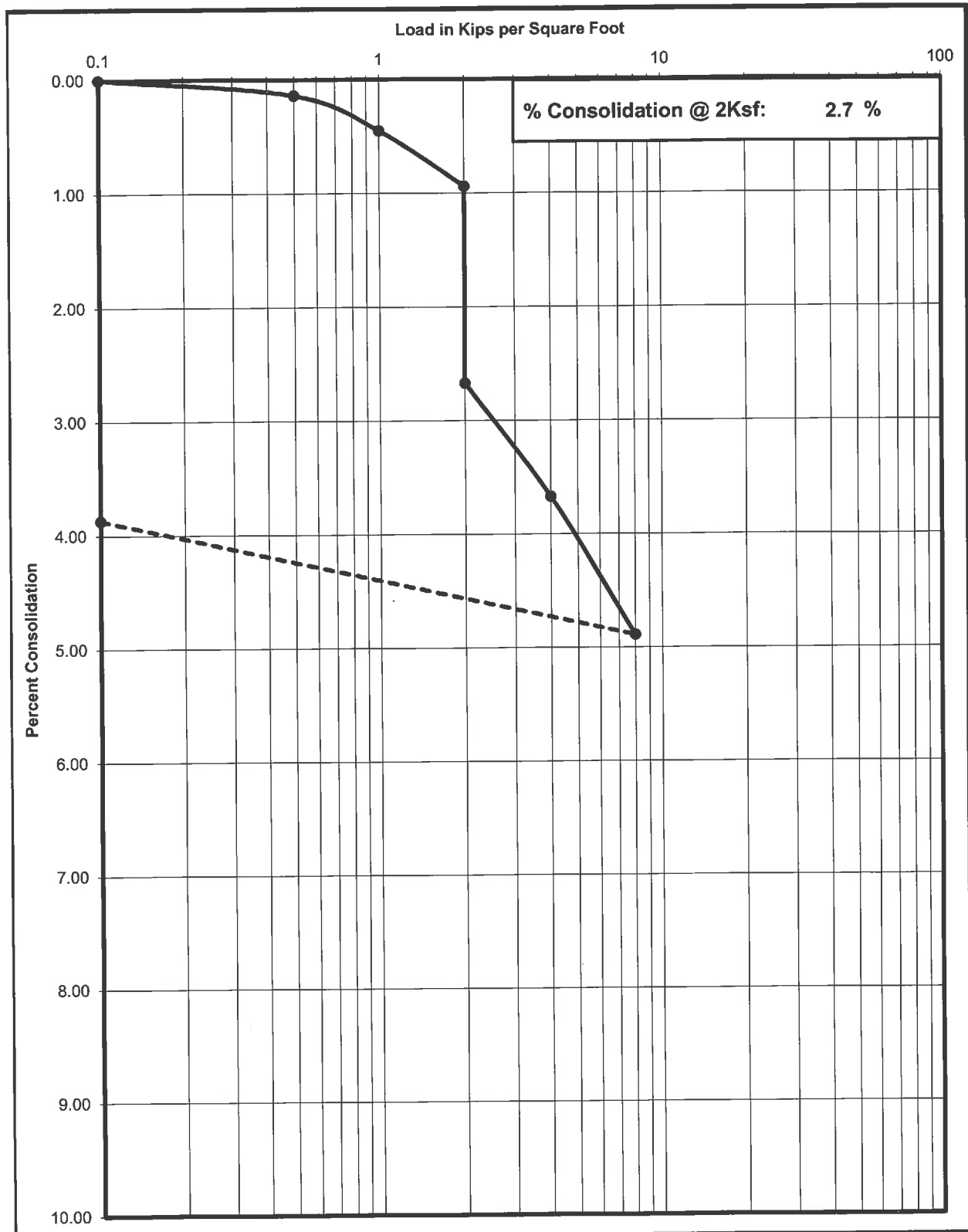

Consolidation Test

Project No	Boring No. & Depth	Date	Soil Classification
11219014	B-8 @ 10'	3/11/2019	ML

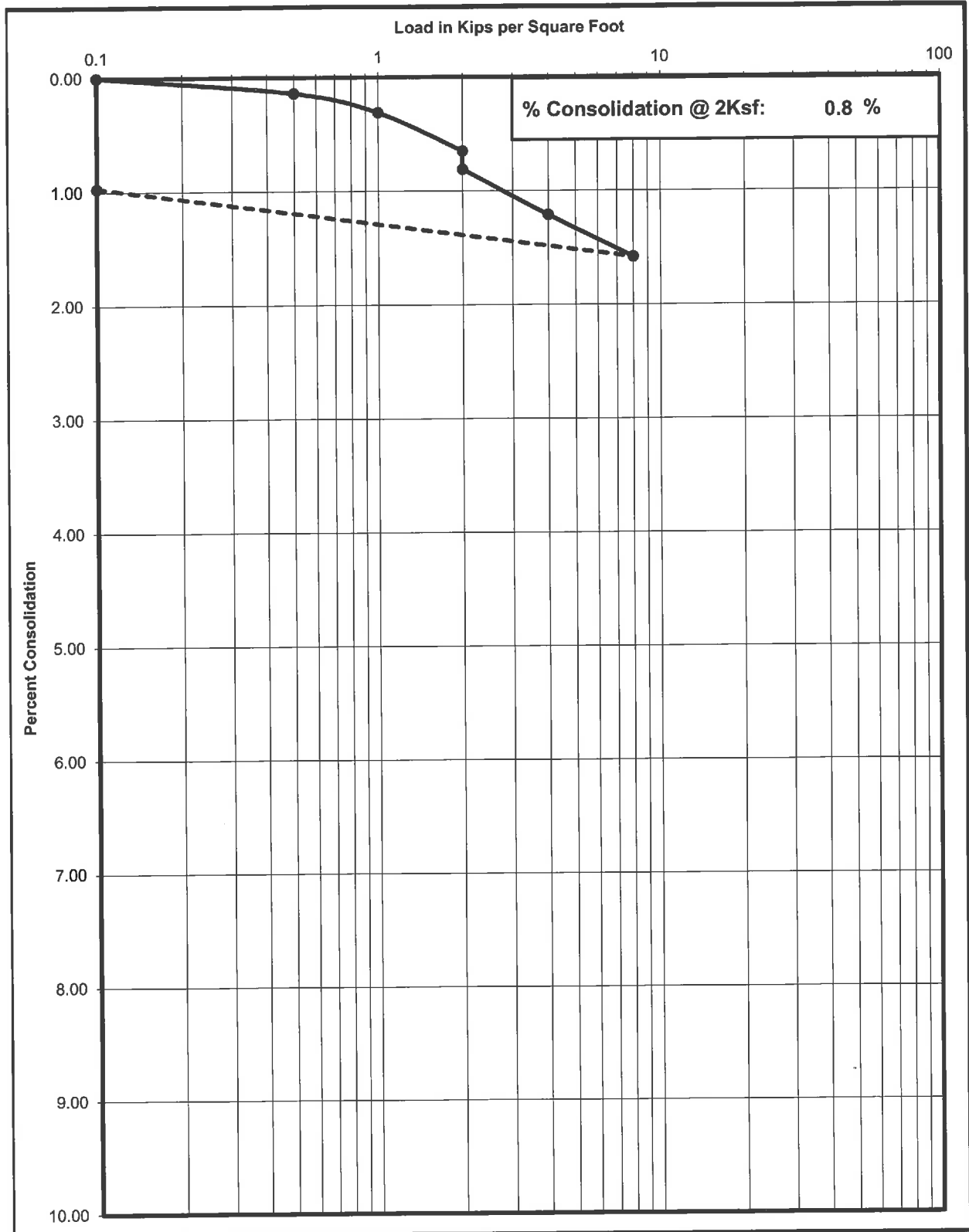

RESULTS OF INFILTRATION TESTS - REVERSE BOREHOLE

Project #	11219014	Date	3/6/2019
Project Name	Moorpark Apartments		
Project Address	Moorpark, CA		

Test No:	IT-1	Total Depth (in.)	60	Test Size (in)	8
Depth To Water	20'	Soil Classification	SM		

Reading	Elapsed Time(min.)	Incremental Time (min.)	Initial Depth To Water(in.)	Final Depth To Water(in.)	Incremental Fall of Water(in.)	Incremental Infiltration Rate (in/hr)
Start	0	0.00		6.0	--	--
1	20.00	20.00	6.0	9.0	3.00	0.35
2	40.00	20.00	9.0	12.0	3.00	0.37
3	60.00	20.00	12.0	14.5	2.50	0.32
4	80.00	20.00	14.5	17.0	2.50	0.34
5	100.00	20.00	17.0	19.5	2.50	0.36
6	120.00	20.00	19.5	22.0	2.50	0.39
7	140.00	20.00	22.0	24.3	2.25	0.37
8	160.00	20.00	24.3	26.5	2.20	0.38
9	180.00	20.00	26.5	28.3	1.80	0.33
10	200.00	20.00	28.3	30.2	1.90	0.37
11	220.00	20.00	30.2	32.0	1.80	0.37
12	240.00	20.00	32.0	33.6	1.60	0.35
Infiltration Rate in Inches per Hour						0.32

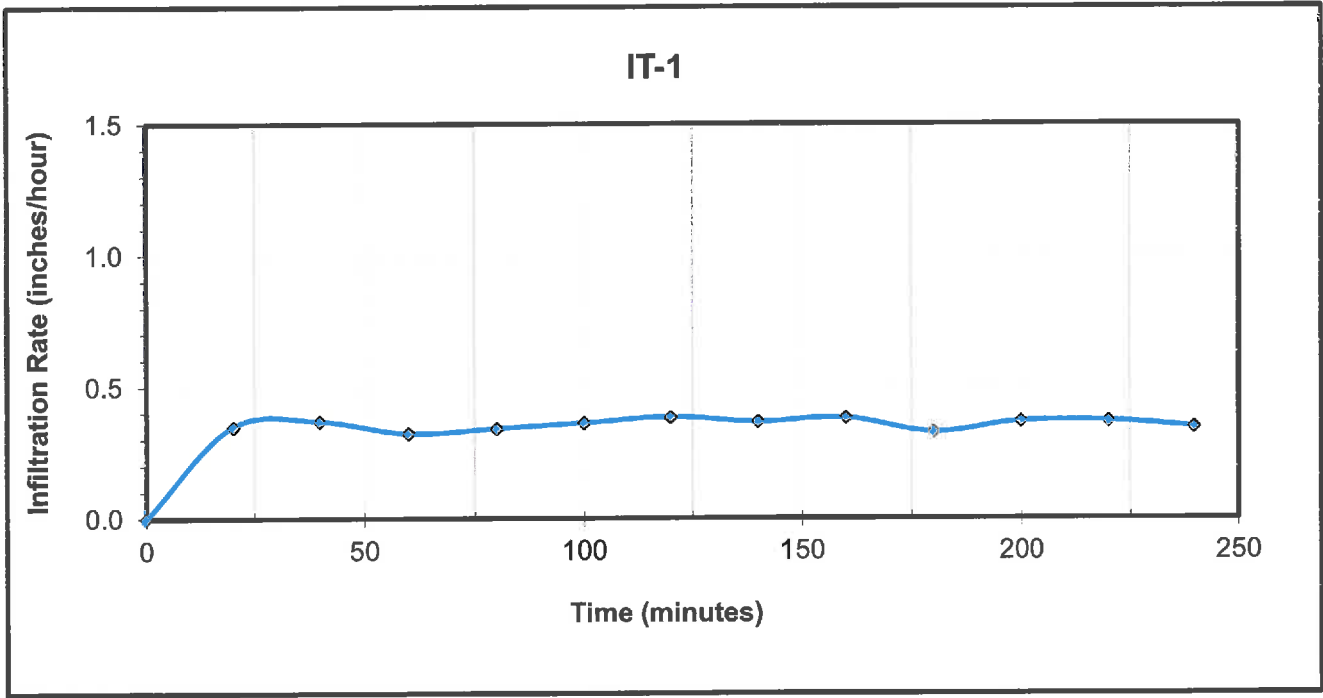

RESULTS OF INFILTRATION TESTS - REVERSE BOREHOLE

Project #	11219014	Date	3/6/2019
Project Name	Moorpark Apartments		
Project Address	Moorpark, CA		

Test No:	IT-2	Total Depth (in.)	96	Test Size (in)	8
Depth To Water	20'	Soil Classification	SM		

Reading	Elapsed Time(min.)	Incremental Time (min.)	Initial Depth To Water(in.)	Final Depth To Water(in.)	Incremental Fall of Water(in.)	Incremental Infiltration Rate (in/hr)
Start	0	0.00		4.0	--	--
1	20.00	20.00	4.0	10.0	6.00	0.42
2	40.00	20.00	10.0	16.0	6.00	0.46
3	60.00	20.00	16.0	22.0	6.00	0.49
4	80.00	20.00	22.0	27.0	5.00	0.44
5	100.00	20.00	27.0	32.0	5.00	0.47
6	120.00	20.00	32.0	36.2	4.20	0.42
7	140.00	20.00	36.2	40.0	3.80	0.41
8	160.00	20.00	40.0	43.7	3.70	0.42
9	180.00	20.00	43.7	47.3	3.60	0.44
10	200.00	20.00	47.3	50.5	3.20	0.42
11	220.00	20.00	50.5	53.5	3.00	0.42
12	240.00	20.00	53.5	56.5	3.00	0.45
Infiltration Rate in Inches per Hour						0.41

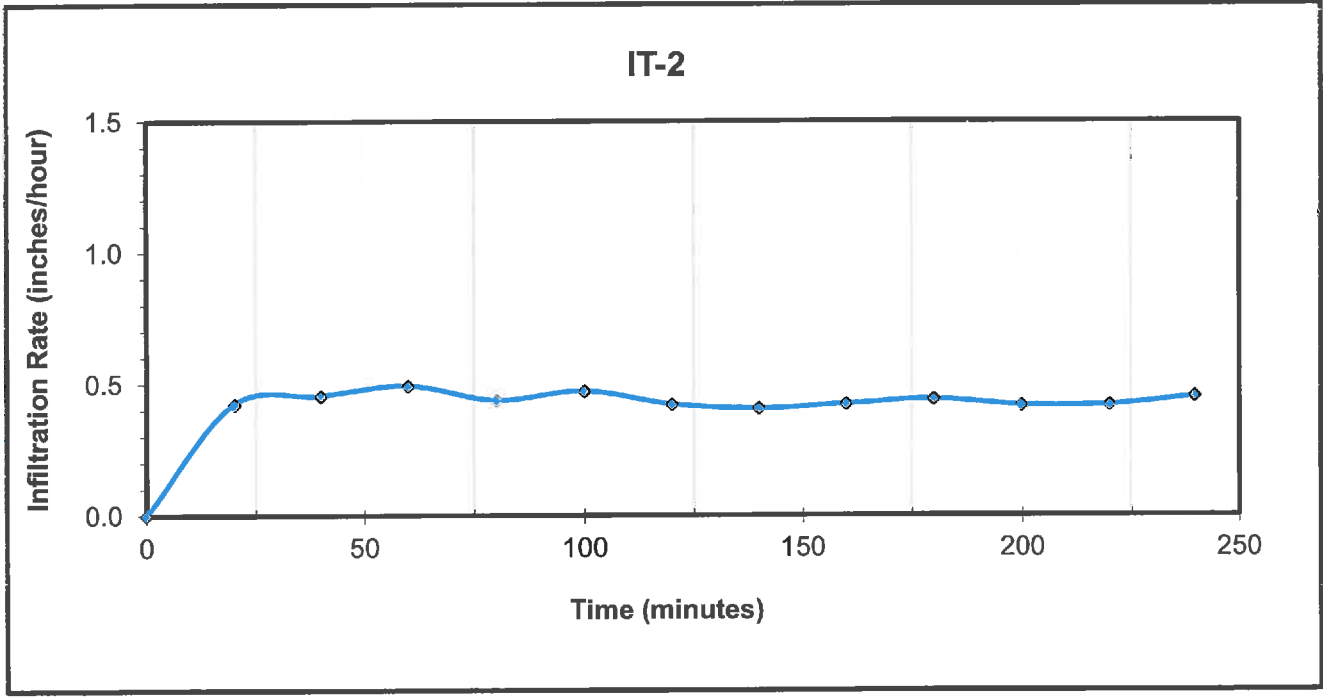

RESULTS OF INFILTRATION TESTS - REVERSE BOREHOLE

Project #	11219014	Date	3/6/2019
Project Name	Moorpark Apartments		
Project Address	Moorpark, CA		

Test No:	IT-3	Total Depth (in.)	96	Test Size (in)	8
Depth To Water	20'	Soil Classification	SM		

Reading	Elapsed Time(min.)	Incremental Time (min.)	Initial Depth To Water(in.)	Final Depth To Water(in.)	Incremental Fall of Water(in.)	Incremental Infiltration Rate (in/hr)
Start	0	0.00		4.0	--	--
1	20.00	20.00	4.0	9.0	5.00	0.35
2	40.00	20.00	9.0	14.2	5.20	0.38
3	60.00	20.00	14.2	19.0	4.80	0.38
4	80.00	20.00	19.0	23.0	4.00	0.33
5	100.00	20.00	23.0	27.0	4.00	0.35
6	120.00	20.00	27.0	30.5	3.50	0.32
7	140.00	20.00	30.5	34.3	3.80	0.37
8	160.00	20.00	34.3	37.5	3.20	0.33
9	180.00	20.00	37.5	41.0	3.50	0.38
10	200.00	20.00	41.0	44.0	3.00	0.34
11	220.00	20.00	44.0	47.0	3.00	0.36
12	240.00	20.00	47.0	49.8	2.80	0.36
Infiltration Rate in Inches per Hour						0.32

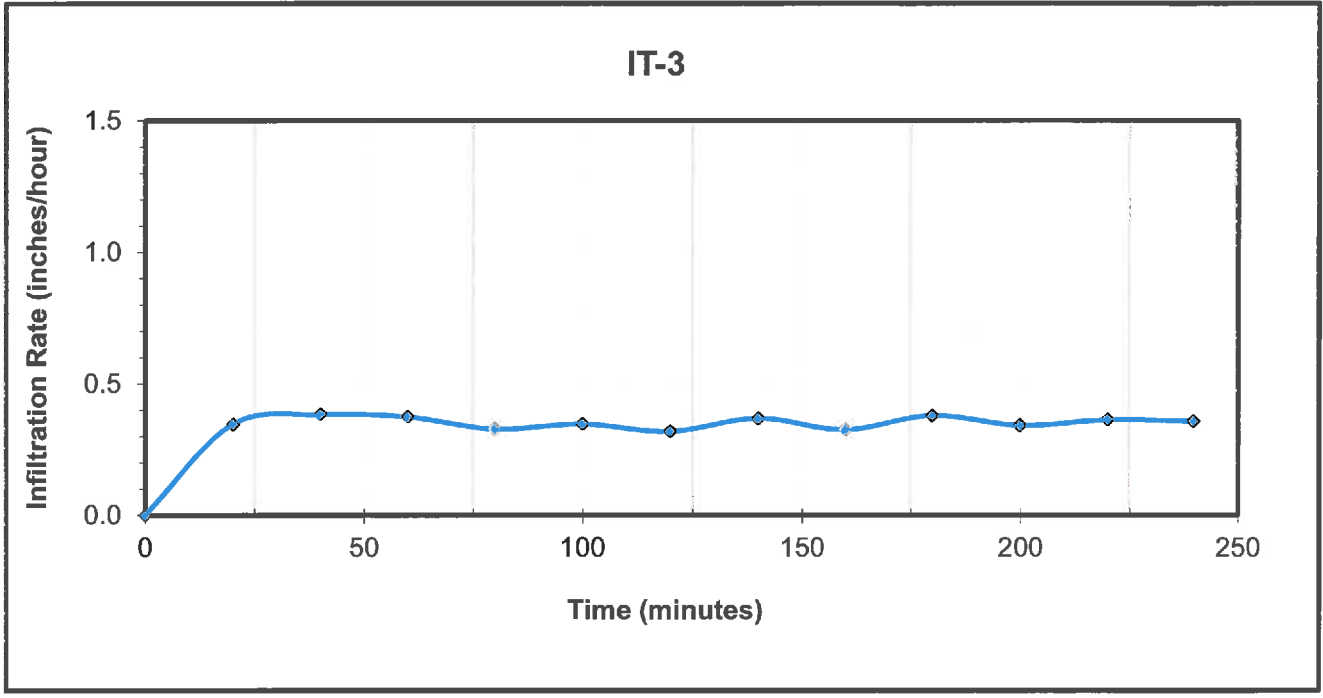

RESULTS OF INFILTRATION TESTS - REVERSE BOREHOLE

Project #	11219014	Date	3/6/2019
Project Name	Moorpark Apartments		
Project Address	Moorpark, CA		

Test No:	IT-4	Total Depth (in.)	60	Test Size (in)	8
Depth To Water	20'	Soil Classification	SM		

Reading	Elapsed Time(min.)	Incremental Time (min.)	Initial Depth To Water(in.)	Final Depth To Water(in.)	Incremental Fall of Water(in.)	Incremental Infiltration Rate (in/hr)
Start	0	0.00		6.0	--	--
1	20.00	20.00	6.0	9.0	3.00	0.35
2	40.00	20.00	9.0	12.0	3.00	0.37
3	60.00	20.00	12.0	14.5	2.50	0.32
4	80.00	20.00	14.5	17.0	2.50	0.34
5	100.00	20.00	17.0	19.5	2.50	0.36
6	120.00	20.00	19.5	22.0	2.50	0.39
7	140.00	20.00	22.0	24.3	2.25	0.37
8	160.00	20.00	24.3	26.5	2.20	0.38
9	180.00	20.00	26.5	28.3	1.80	0.33
10	200.00	20.00	28.3	30.2	1.90	0.37
11	220.00	20.00	30.2	32.0	1.80	0.37
12	240.00	20.00	32.0	33.6	1.60	0.35
Infiltration Rate in Inches per Hour						0.32

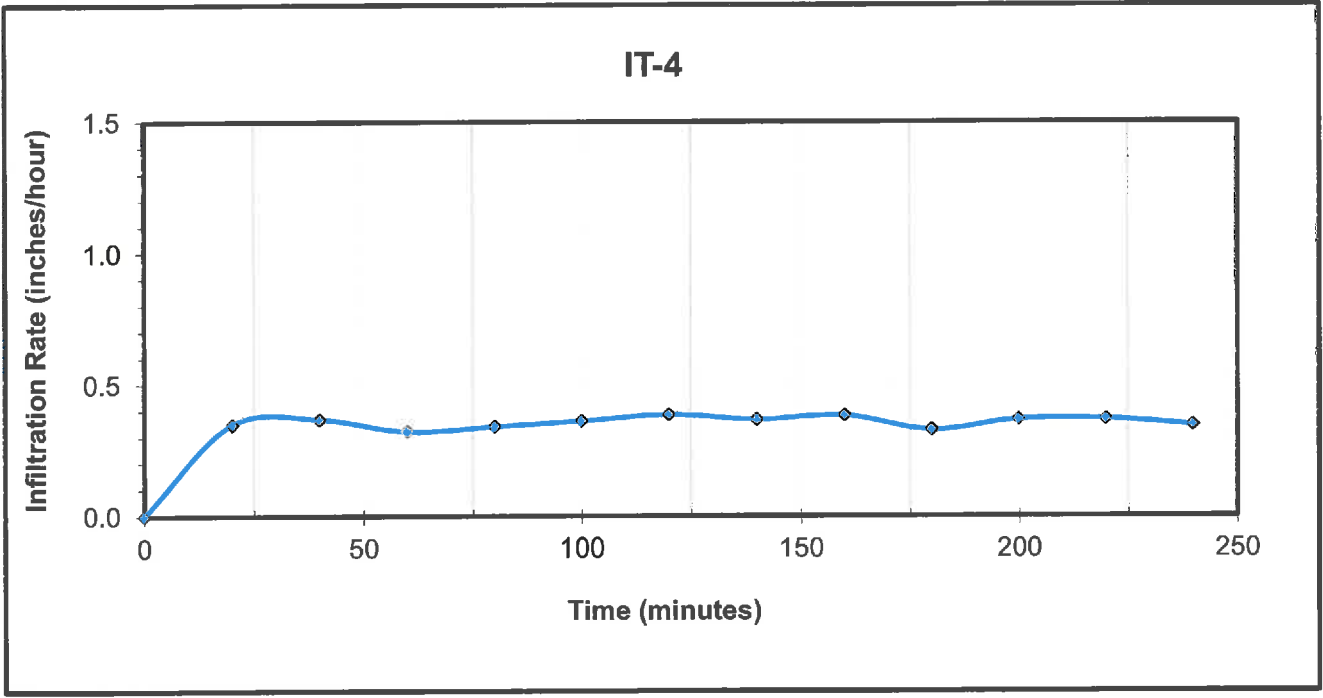

ANAHEIM TEST LAB, INC

3008 ORANGE AVENUE
SANTA ANA, CALIFORNIA 92707
PHONE (714) 549-7267

Krazan & Associates, Inc
1100 Olympic Drive, Ste. 103
Corona, CA 92881

DATE: 03/05/2019

P.O. NO: Verbal

LAB NO: C-1232

SPECIFICATION: 417/422/643

MATERIAL: Soil

Project No: 11219014
Moorpark Apartments
B-3 @ 0-5'

ANALYTICAL REPORT

CORROSION SERIES SUMMARY OF DATA

pH	SOLUBLE SULFATES per CA. 417 ppm	SOLUBLE CHLORIDES per CA. 422 ppm	MIN. RESISTIVITY per CA. 643 ohm-cm
7.5	199	25	2,750

RESPECTFULLY SUBMITTED



WES BRIDGER CHEMIST

APPENDIX D

Liquefaction Analysis

APPENDIX D

LIQUEFACTION ANALYSIS

A liquefaction analysis was performed for the site based on CPT data presented on the enclosed logs by Kehoe Testing & Engineering. Our analysis was based on City of Los Angeles guidelines (City of Los Angeles, 2020) and utilized two methods. Method 1 utilized $2/3$ of the PGA_M , the predominant earthquake magnitude assuming a 10% probability of exceedance in 50 years, and a factor of safety of 1.1. Method 2 utilized the PGA_M , the predominant earthquake magnitude assuming a 2% probability of exceedance in 50 years, and a factor of safety of 1.0. The results for Method 1 are presented on Plates D-1, D-3 and D-5, and the results for Method 2 are presented on Plates D-2, D-4 and D-6.

LIQUEFACTION ANALYSIS

1-0379

Hole No.=CPT-1 Water Depth=15 ft

Magnitude=6.83
Acceleration=0.65g

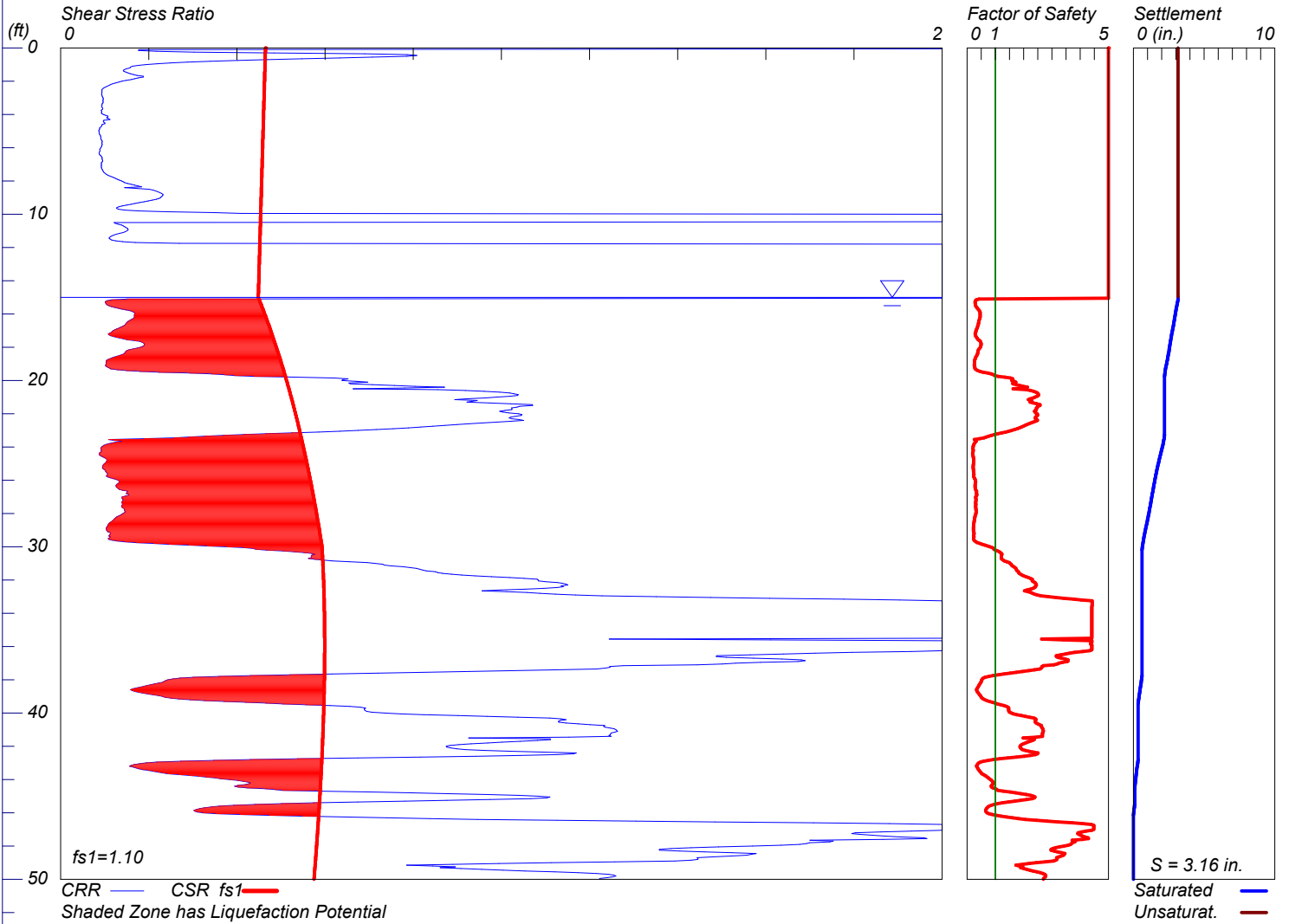

LiquefyPro CivilTech Software USA www.civitech.com

LIQUEFACTION ANALYSIS

1-0379

Hole No.=CPT-1 Water Depth=15 ft

Magnitude=6.97
Acceleration=0.97g

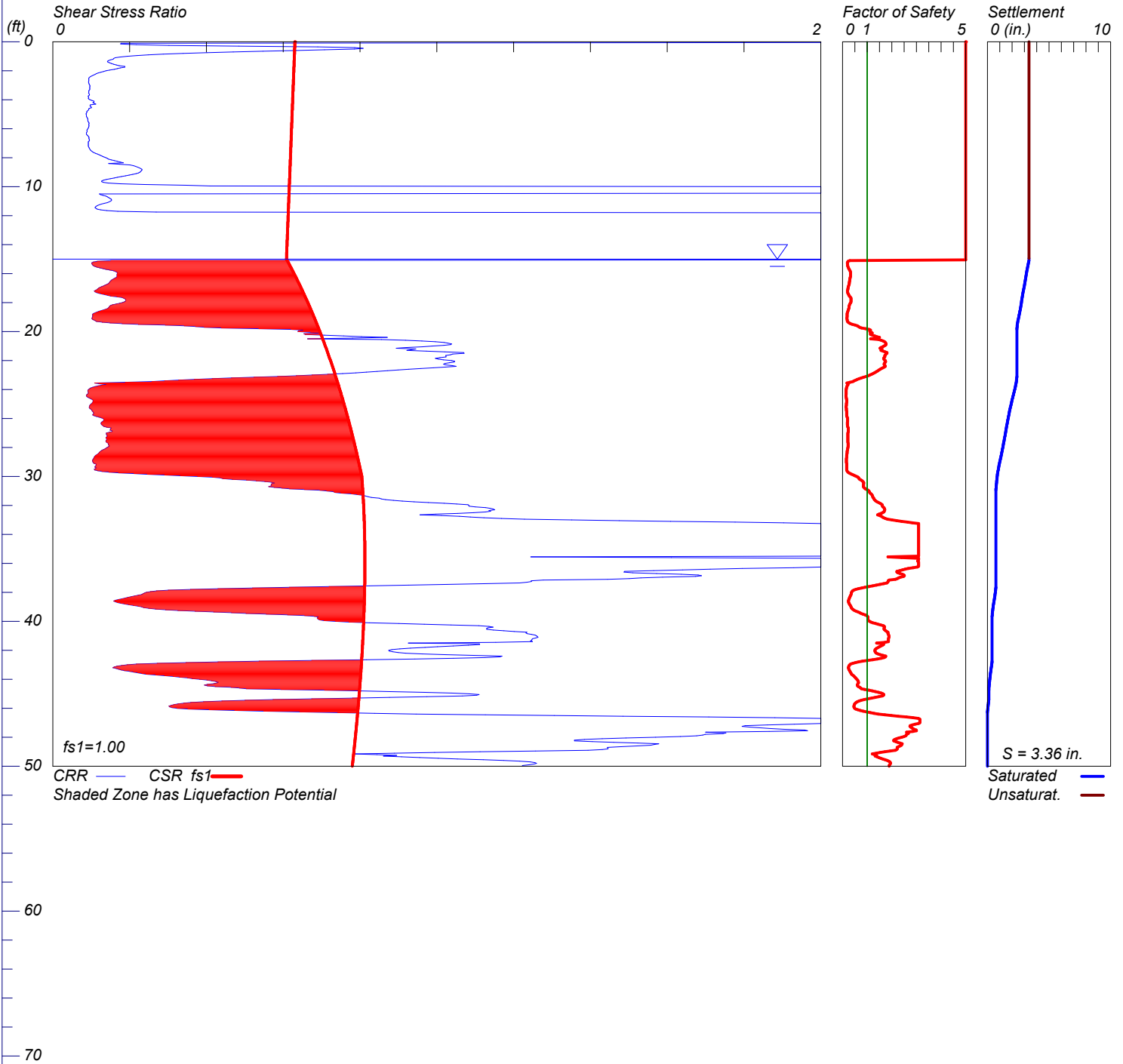

LiquefyPro CivilTech Software USA www.civitech.com

LIQUEFACTION ANALYSIS

1-0379

Hole No.=CPT-2 Water Depth=15 ft

Magnitude=6.83
Acceleration=0.65g

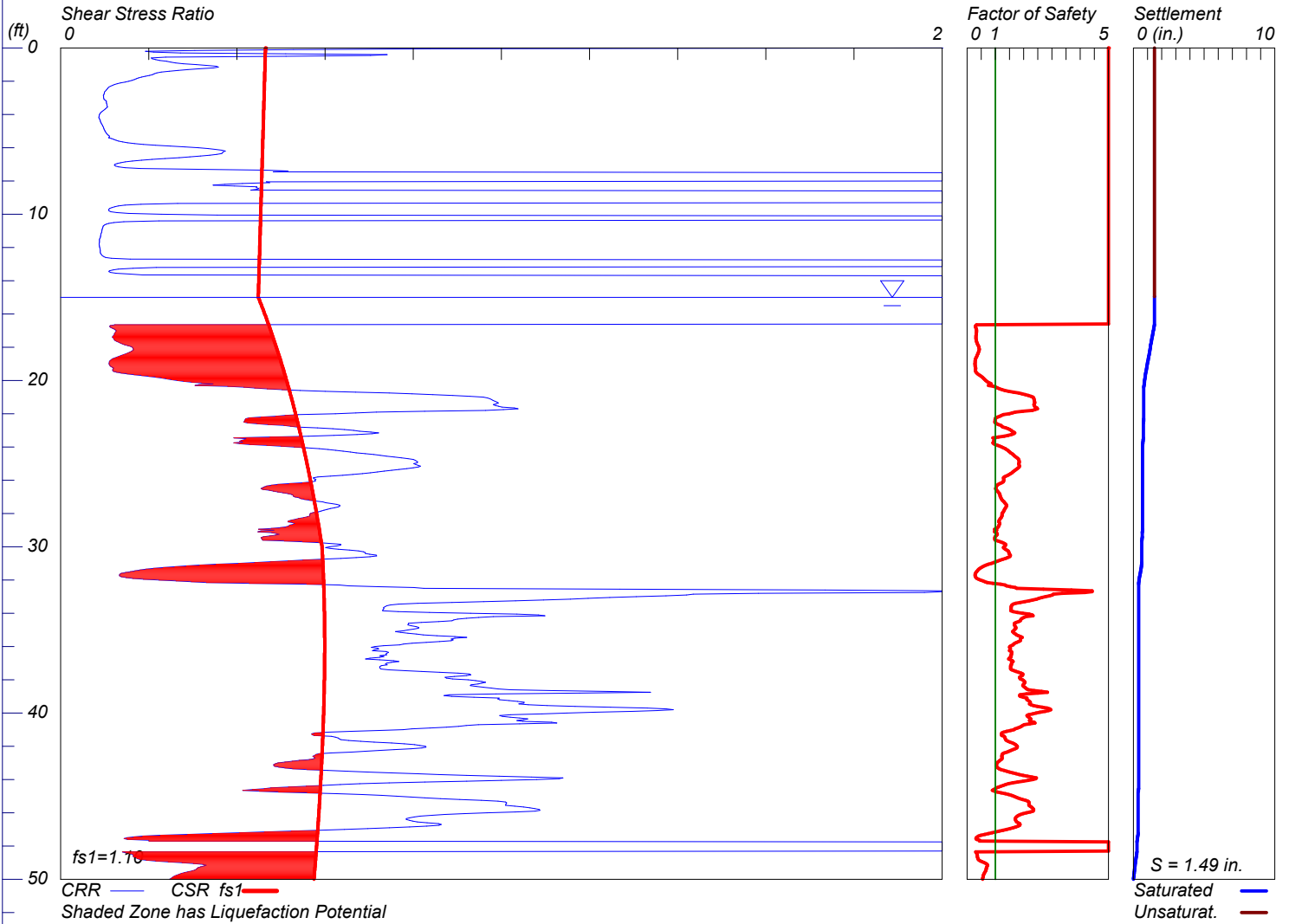

LiquefyPro CivilTech Software USA www.civitech.com

LIQUEFACTION ANALYSIS

1-0379

Hole No.=CPT-2 Water Depth=15 ft

Magnitude=6.97
Acceleration=0.97g

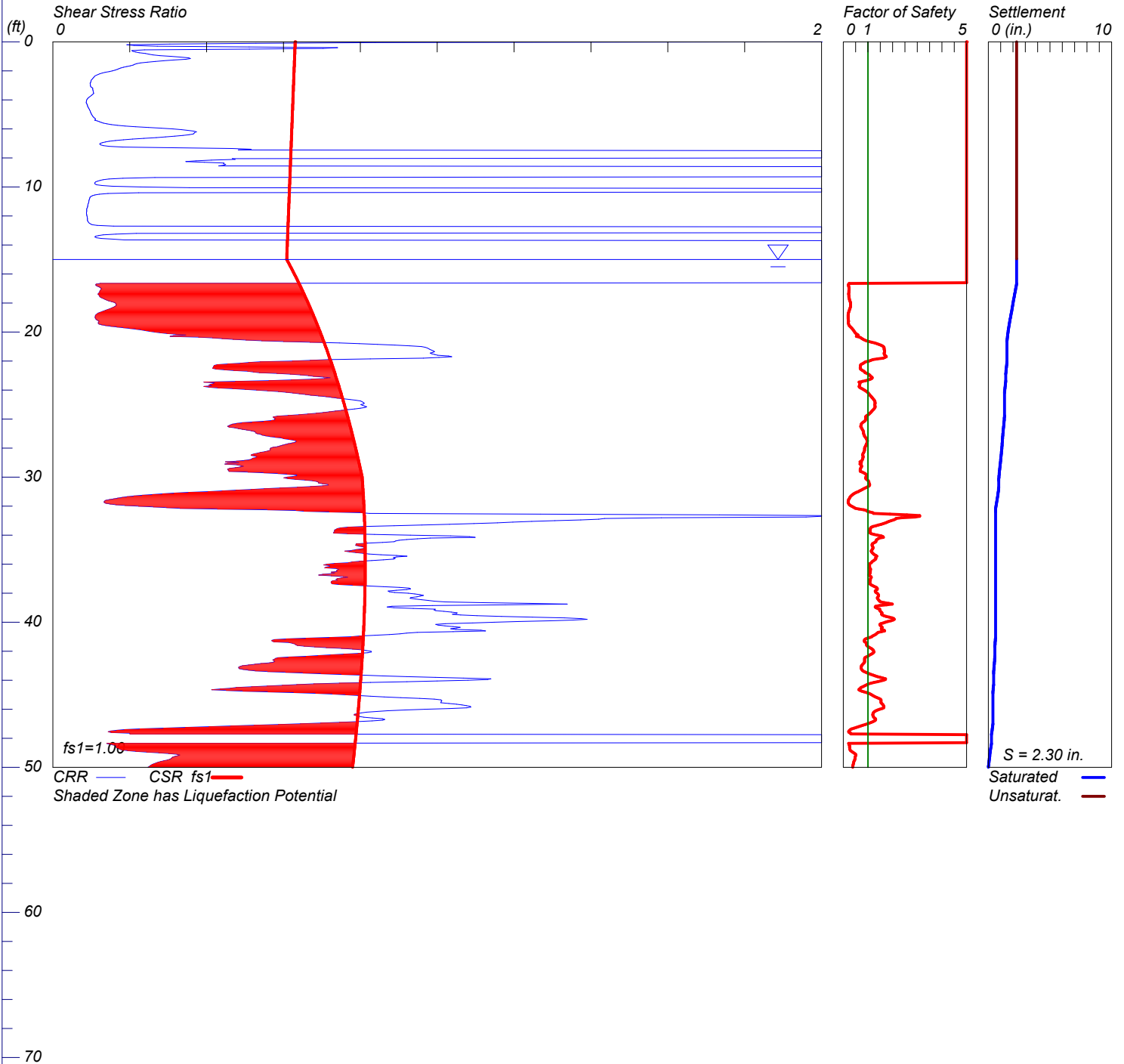

LiquefyPro CivilTech Software USA www.civiltch.com

LIQUEFACTION ANALYSIS

1-0379

Hole No.=CPT-3 Water Depth=15 ft

Magnitude=6.83
Acceleration=0.65g

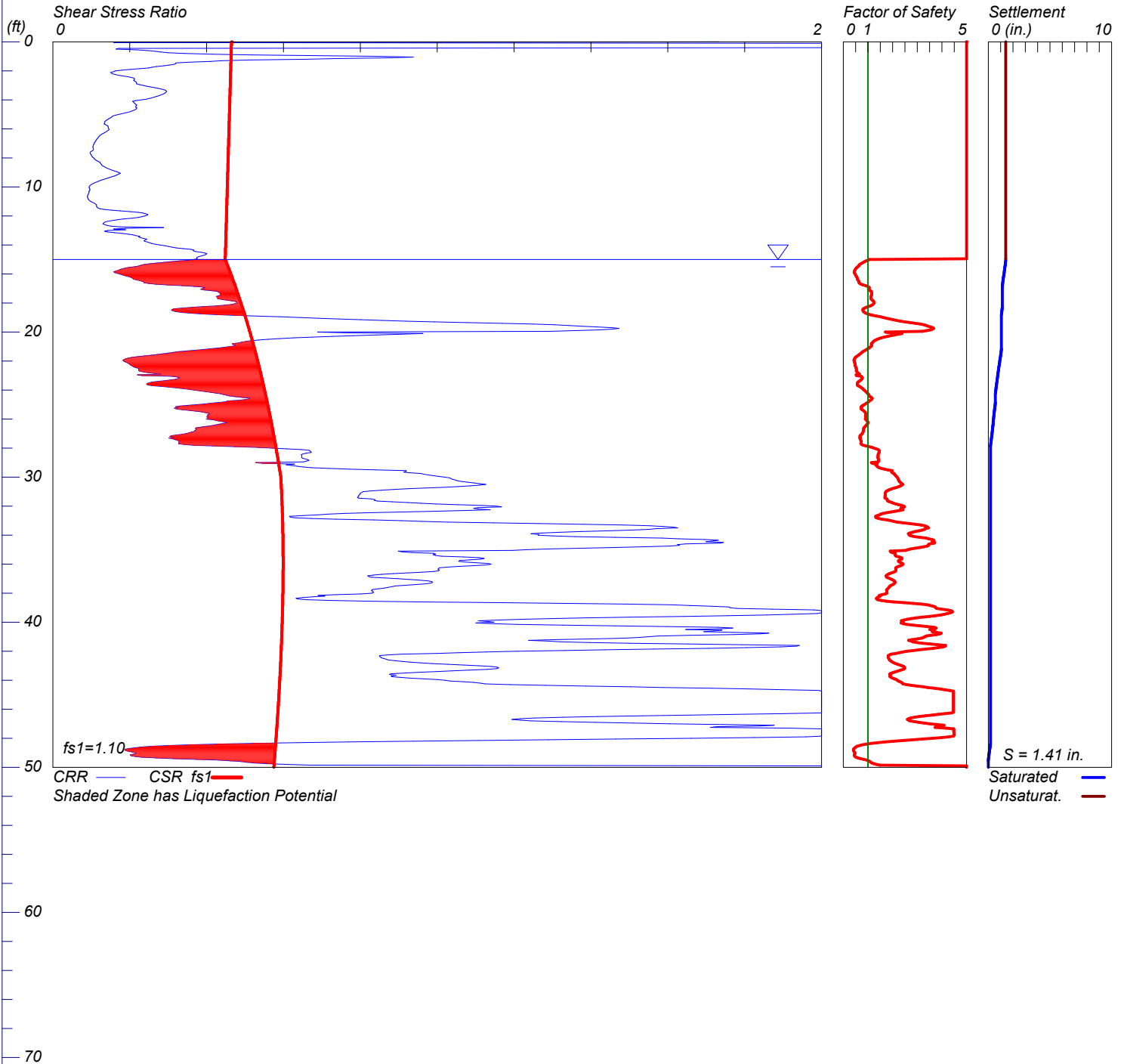

LiquefyPro CivilTech Software USA www.civiltch.com

LIQUEFACTION ANALYSIS

1-0379

Hole No.=CPT-3 Water Depth=15 ft

Magnitude=6.97
Acceleration=0.97g

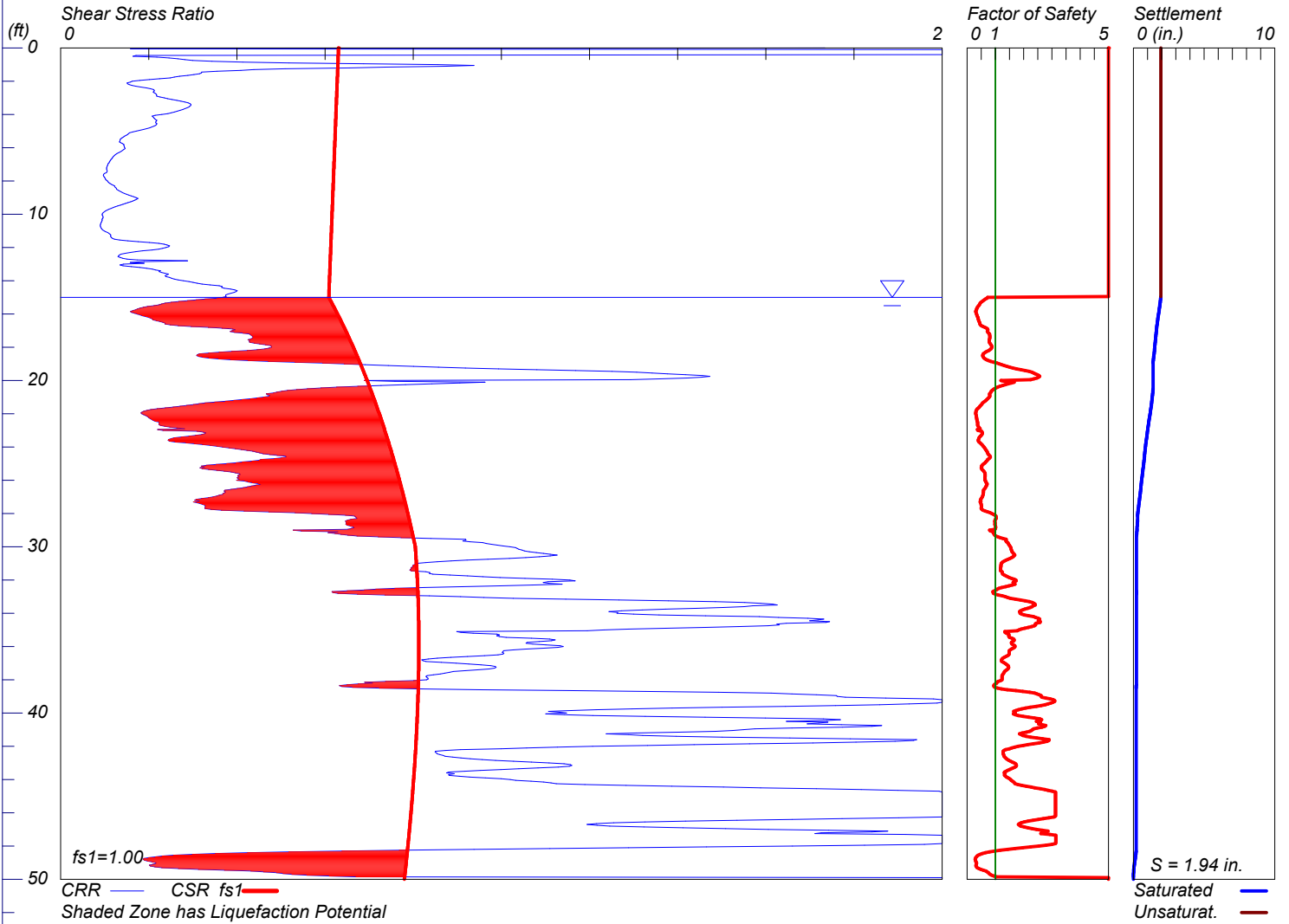

LiquefyPro CivilTech Software USA www.civiltch.com

LIQUEFACTION ANALYSIS

1-0379

Hole No.=CPT-4 Water Depth=15 ft

Magnitude=6.83
Acceleration=0.65g

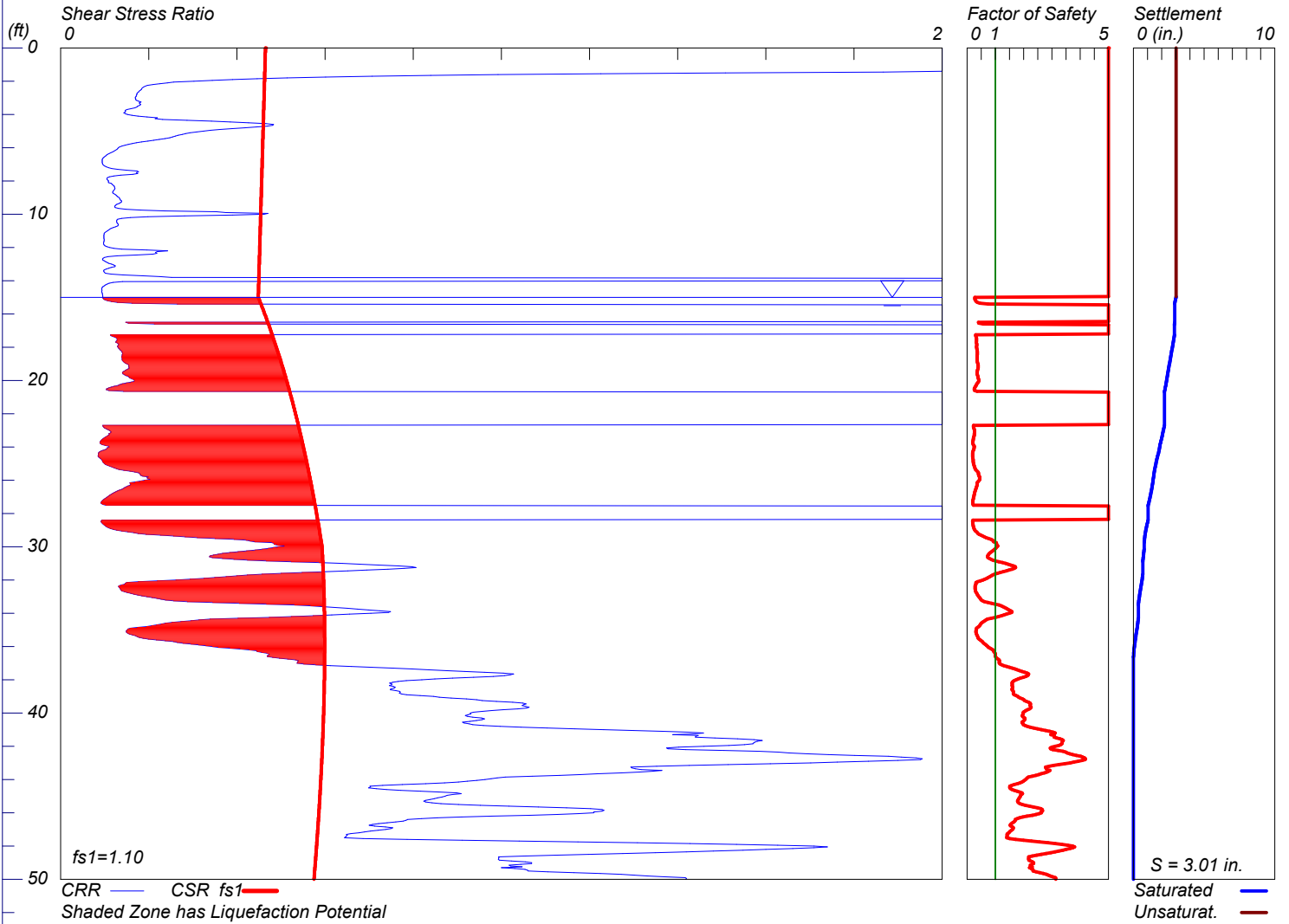

LiquefyPro CivilTech Software USA www.civitech.com

LIQUEFACTION ANALYSIS

1-0379

Hole No.=CPT-4 Water Depth=15 ft

Magnitude=6.97
Acceleration=0.97g

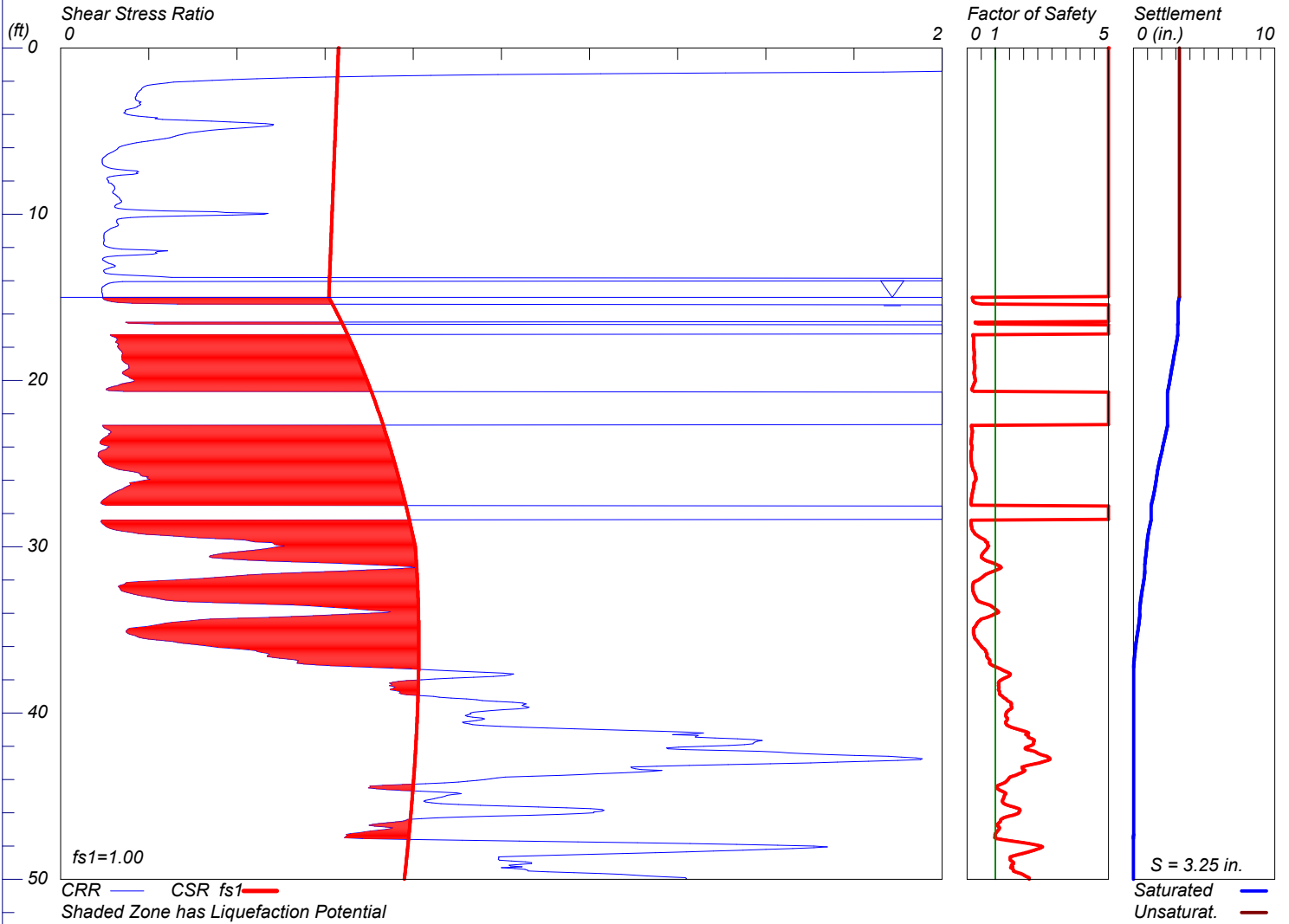

LiquefyPro CivilTech Software USA www.civiltch.com

APPENDIX E

Maintenance and Improvement Considerations

MAINTENANCE AND IMPROVEMENT CONSIDERATIONS

General

Owners purchasing property must assume a certain degree of responsibility for improvements and for maintaining conditions around their home. Of primary importance from a geotechnical standpoint are maintaining drainage patterns and minimizing the soil moisture variation below all improvements. Such design, construction and owner maintenance provisions may include:

- Employing contractors for improvements who design and build in recognition of local building codes and specific site soils conditions.
- Establishing and maintaining positive drainage away from all foundations, walkways, driveways, patios, and other improvements.
- Avoiding the construction of planters adjacent to structural improvements. Alternatively, planter sides/bottoms can be sealed with an impermeable membrane and drained away from the improvements via subdrains into approved disposal areas.
- Sealing and maintaining construction/control joints within concrete slabs and walkways to reduce the potential for moisture infiltration into the subgrade soils.
- Utilizing landscaping schemes with vegetation that requires minimal watering. Watering should be done in a uniform manner, as equally as possible on all sides of the foundation, keeping the soil "moist" but not allowing the soil to become saturated.
- Maintaining positive drainage away from structures and providing roof gutters on all structures with downspouts that are designed to carry roof runoff directly into area drains or discharged well away from the foundation areas.
- Avoiding the placement of trees closer to the proposed structures than a distance of one-half the mature height of the tree.
- Observation of the soil conditions around the perimeter of the structure during extremely hot/dry or unusually wet weather conditions so that modifications can be made in irrigation programs to maintain relatively uniform moisture conditions.

Sulfates

Owners should be cautioned against the import and use of certain inorganic fertilizers, soil amendments, and/or other soils from offsite sources in the absence of specific information relating to their chemical composition. Some fertilizers have been known to leach sulfate compounds into soils and increase the sulfate concentrations to potentially detrimental levels.

Site Drainage

- The owners should be made aware of the potential problems that may develop when drainage is altered through construction of hardscape improvements. Pondered water, drainage over the slope face, leaking irrigation systems, overwatering, or other conditions which could lead to ground saturation must be avoided.
- No water should be allowed to flow over the slopes. No alteration of pad gradients should be allowed that would prevent pad and roof runoff from being directed to approved disposal areas.
- Drainage patterns have been established at the time of the fine grading should be maintained throughout the life of the structure. No alterations to these drainage patterns should be made unless designed by qualified professionals in compliance with local code requirements and site-specific soils conditions.

Slope Drainage

- Residents should be made aware of the importance of maintaining and cleaning all interceptor ditches, drainage terraces, down drains, and any other drainage devices, which have been installed to promote slope stability.
- Subsurface drainage pipe outlets may protrude through slope surfaces and/or wall faces. These pipes, in conjunction with the graded features, are essential to slope and wall stability and must be protected in-place. They should not be altered or damaged in any way.

Planting and Irrigation of Slopes

- Seeding and planting of the slopes should be planned to achieve, as rapidly as possible, a well-established and deep-rooted vegetal cover requiring minimal watering.
- It is the responsibility of the landscape architect to provide such plants initially and of the residents to maintain such planting. Alteration of such a planting scheme is at the resident's risk.
- The resident is responsible for proper irrigation and for maintenance and repair of properly installed irrigation systems. Leaks should be fixed immediately.
- Sprinklers should be adjusted to provide maximum uniform coverage with a minimum of water usage and overlap. Overwatering with consequent wasteful runoff and serious ground saturation must be avoided.
- If automatic sprinkler systems are installed, their use must be adjusted to account for seasonal and natural rainfall conditions.

Burrowing Animals

- Residents must undertake a program to eliminate burrowing animals. This must be an ongoing program in order to promote slope stability.

Owner Improvement

Owner improvements (pools, spas, patio slabs, retaining walls, planters, etc.) should be designed to account for the terrain of the project, as well as expansive soil conditions and chemical characteristics. Design considerations on any given lot may need to include provisions for differential bearing materials, ascending/descending slope conditions, bedrock structure, perched (irrigation) water, special geologic surcharge loading conditions, expansive soil stresses, and long-term creep/settlement.

All owner improvements should be designed and constructed by qualified professionals utilizing appropriate design methodologies, which account for the on-site soils and geologic conditions. Each lot and proposed improvement should be evaluated on an individual basis.

Setback Zones

Manufactured slopes maybe subject to long-term settlement and creep that can manifest itself in the form of both horizontal and vertical movement. These movements typically are produced as a result of weathering, erosion, gravity forces, and other natural phenomenon. A setback adjacent to slopes is required by most building codes, including the California Building Code. This zone is intended to locate and support the residential structures away from these slopes and onto soils that are not subject to the potential adverse effects of these natural phenomena.

The owner may wish to construct patios, walls, walkways, planters, swimming pools, spas, etc. within this zone. Such facilities may be sensitive to settlement and creep and should not be constructed within the setback zone unless properly engineered. It is suggested that plans for such improvements be designed by a professional engineer who is familiar with grading ordinances and design and construction requirements. In addition, we recommend that the designer and contractor familiarize themselves with the site specific geologic and geotechnical conditions on the specific lot.

APPENDIX F

Earthwork Specifications

**ALTA CALIFORNIA GEOTECHNICAL, INC.
EARTHWORK SPECIFICATIONS**

These specifications present the generally accepted standards and minimum earthwork requirements for the development of the project. These specifications shall be the project guidelines for earthwork except where specifically superseded in preliminary geology and soils reports, grading plan review reports or by the prevailing grading codes or ordinances of the controlling agency.

A. GENERAL

1. The Contractor shall be responsible for the satisfactory completion of all earthwork in accordance with the project plans and specifications.
2. The project Geotechnical Engineer and Engineering Geologist, or their representatives, shall provide observation and testing services, and Geotechnical consultation for the duration of the project.
3. All clearing, grubbing, stripping and site preparation for the project shall be accomplished by the Contractor to the satisfaction of the Geotechnical Engineer/Engineering Geologist.
4. It is the Contractor's responsibility to prepare the ground surface to receive fill to the satisfaction of the Geotechnical Engineer and to place, spread, mix, moisture condition, and compact the fill in accordance with the job specifications and as required by the Geotechnical Engineer. The Contractor shall also remove all material considered by the Geotechnical Engineer to be unsuitable for use in the construction of engineered fills.
5. The Contractor shall have suitable and sufficient equipment in operation to handle the amount of fill being placed. When necessary, equipment will be shut down temporarily in order to permit the proper preparation of fills.

B. PREPARATION OF FILL AREAS

1. Excessive vegetation and all deleterious material should be disposed of offsite as required by the Geotechnical Engineer.

Existing fill, soil, alluvium or rock materials determined by the Geotechnical Engineer as being unsuitable for placement in compacted fills shall be removed and hauled from the site. Where applicable, the Contractor may obtain the

approval of the Soils Engineer and the controlling authorities for the project to dispose of the above described materials, or a portion thereof, in designated areas onsite.

After removal of the deleterious materials have been accomplished, earth materials deemed unsuitable in their natural, in-place condition, shall be removed as recommended by the Geotechnical Engineer/Engineering Geologist.

2. Upon achieving a suitable bottom for fill placement, the exposed removal bottom shall be disced or bladed by the Contractor to the satisfaction of the Geotechnical Engineer. The prepared ground surfaces shall then be brought to the specified moisture content mixed as required, and compacted and tested as specified. In localities where it is necessary to obtain the approval of the controlling agency prior to placing fill, it will be the Contractor's responsibility to contact the proper authorities to visit the site.
3. Any underground structure such as cesspools, cisterns, mining shafts, tunnels, septic tanks, wells, pipelines or other structures not located prior to grading are to be removed or treated in a manner prescribed by the Geotechnical Engineer and/or the controlling agency for the project.

C. ENGINEERED FILLS

1. Any material imported or excavated on the property may be utilized as fill, provided the material has been determined to be suitable by the Geotechnical Engineer. Deleterious materials shall be removed from the fill as directed by the Geotechnical Engineer.
2. Rock or rock fragments less than twelve inches in the largest dimension may be utilized in the fill, provided they are not placed in concentrated pockets and the distribution of the rocks is approved by the Geotechnical Engineer.
3. Rocks greater than twelve inches in the largest dimension shall be taken offsite, or placed in accordance with the recommendations of the Geotechnical Engineer in areas designated as suitable for rock disposal.
4. All materials to be used as fill, shall be tested in the laboratory by the Geotechnical Engineer. Proposed import materials shall be approved by the Geotechnical Engineer 48 hours prior to importation.
5. The fill materials shall be placed by the Contractor in lifts, that when compacted, shall not exceed six inches. Each lift shall be spread evenly and shall be

thoroughly mixed to achieve a near uniform moisture condition and a uniform blend of materials.

All compaction shall be achieved at or above the optimum moisture content, as determined by the applicable laboratory standard. The Contractor will be notified if the fill materials are too wet or too dry to achieve the required compaction standard.

6. When the moisture content of the fill material is below the limit specified by the Geotechnical Engineer, water shall be added and the materials shall be blended until a uniform moisture content, within specified limits, is achieved. When the moisture content of the fill material is above the limits specified by the Geotechnical Engineer, the fill materials shall be aerated by discing, blading, mixed with dryer fill materials, or other satisfactory methods until the moisture content is within the specified limits.
7. Each fill lift shall be compacted to the minimum project standards, in compliance with the testing methods specified by the controlling governmental agency, and in accordance with recommendations of the Geotechnical Engineer.

In the absence of specific recommendations by the Geotechnical Engineer to the contrary, the compaction standard shall be the most recent version of ASTM:D 1557.

8. Where a slope receiving fill exceeds a ratio of five-horizontal to one-vertical, the fill shall be keyed and benched through all unsuitable materials into sound bedrock or firm material, in accordance with the recommendations and approval of the Geotechnical Engineer.
9. Side hill fills shall have a minimum key width of 15 feet into bedrock or firm materials, unless otherwise specified in the soil report and approved by the Geotechnical Engineer in the field.
10. Drainage terraces and subdrainage devices shall be constructed in compliance with the ordinances of the controlling governmental agency and/or with the recommendations of the Geotechnical Engineer and Engineering Geologist.
11. The Contractor shall be required to maintain the specified minimum relative compaction out to the finish slope face of fill slopes, buttresses, and stabilization fills as directed by the Geotechnical Engineer and/or the governing agency for the project. This may be achieved by either overbuilding the slope and cutting

back to the compacted core; by direct compaction of the slope face with suitable equipment; or by any other procedure which produces the required result.

12. The fill portion of fill-over-cut slopes shall be properly keyed into rock or firm material; and the fill area shall be stripped of all soil or unsuitable materials prior to placing fill.

The design cut portion of the slope should be made first and evaluated for suitability by the Engineering Geologist prior to placement of fill in the keyway above the cut slope.

13. Pad areas in cut or natural ground shall be approved by the Geotechnical Engineer. Finished surfaces of these pads may require scarification and recompaction, or over excavation as determined by the Geotechnical Engineer.

D. CUT SLOPES

1. The Engineering Geologist shall observe all cut slopes and shall be notified by the Contractor when cut slopes are to be started.
2. If, during the course of grading, unforeseen adverse or potentially adverse geologic conditions are encountered, the Engineering Geologist and Soil Engineer shall investigate, analyze and make recommendations to remediate these problems.
3. Non-erodible interceptor swales shall be placed at the top of cut slopes that face the same direction as the superjacent, prevailing drainage.
4. Unless otherwise specified in specific geotechnical reports, no cut slopes shall be excavated higher or steeper than that allowed by the ordinances of controlling governmental agencies.
5. Drainage terraces shall be constructed in compliance with the ordinances of the controlling governmental agencies, and/or in accordance with the recommendations of the Geotechnical Engineer or Engineering Geologist.

E. GRADING CONTROL

1. Fill placement shall be observed and tested by the Geotechnical Engineer and/or his representative during grading.

Field density tests shall be made by the Geotechnical Engineer and/or his representative to evaluate the compaction and moisture compliance of each fill lift. Density tests shall be conducted at intervals not to exceed two feet of fill

height. Where sheepsfoot rollers are used, the fill may be disturbed to a depth of several inches. Density determinations shall be taken in the compacted material below the disturbed surface at a depth determined by the Geotechnical Engineer or his representative.

2. Where tests indicate that the density of any layer of fill, or portion thereof, is below the required relative compaction, or improper moisture content is in evidence, that particular layer or portion thereof shall be reworked until the required density and/or moisture content has been attained. Additional fills shall not be placed over an area until the previous lift of fill has been tested and found to meet the density and moisture requirements for the project and the previous lift is approved by the Geotechnical Engineer.
3. When grading activities are interrupted by heavy rains, fill operations shall not be resumed until field observations and tests by the Geotechnical Engineer indicate the moisture content and density of the fill are within the specified limits.
4. During construction, the Contractor shall properly grade all surfaces to maintain good drainage and prevent the ponding of water. The Contractor shall take remedial action to control surface water and to prevent erosion of graded areas until such time as a permanent drainage and erosion devices have been installed.
5. Observation and testing by the Geotechnical Engineer and/or his representative shall be conducted during filling and compacting operations in order that he will be able to state in his opinion that all cut and filled areas are graded in accordance with the approved specifications.
6. Upon the completion of grading activities and after the Geotechnical Engineer and Engineering Geologist have finished their observations of the work, final reports shall be submitted. No further excavation or fill placement shall be undertaken without prior notification of the Geotechnical Engineer and/or Engineering Geologist.

F. FINISHED SLOPES

All finished cut and fill slopes shall be planted and irrigated and/or protected from erosion in accordance with the project specifications, governing agencies, and/or as recommended by a landscape architect.

APPENDIX G

Grading Details

DETAIL FOR FILL SLOPE TOEING OUT ON FLAT ALLUVIATED CANYON

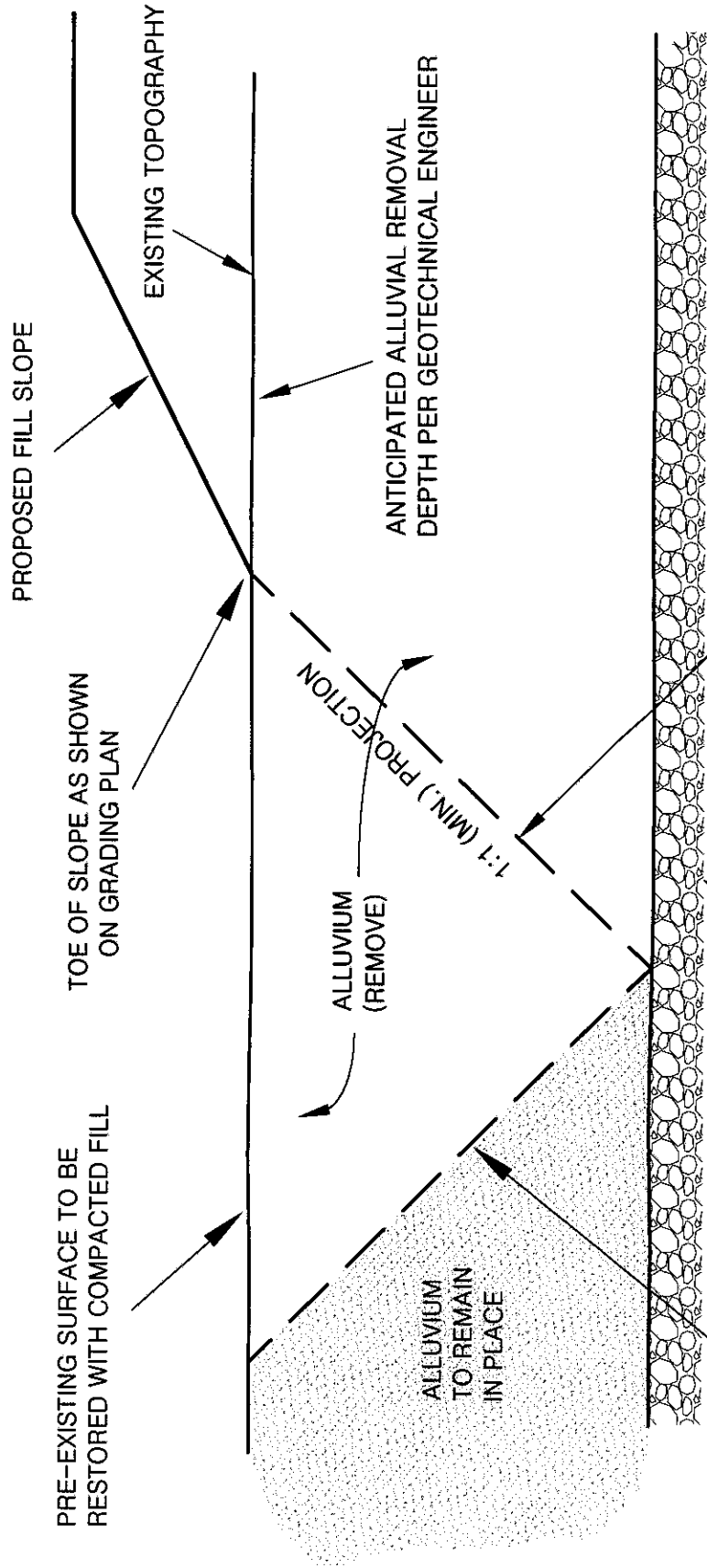

PRE-EXISTING SURFACE TO BE RESTORED WITH COMPACTED FILL

PROPOSED FILL SLOPE

TOE OF SLOPE AS SHOWN ON GRADING PLAN

EXISTING TOPOGRAPHY

ALLUVIUM (REMOVE)

ALLUVIUM TO REMAIN IN PLACE

1:1 (MIN.) PROJECTION

ANTICIPATED ALLUVIAL REMOVAL DEPTH PER GEOTECHNICAL ENGINEER

FORECUT VARIES; FOR DEEP REMOVALS, FORECUT SHOULD BE MADE NO STEEPER THAN 1:1, OR AS REQUIRED FOR SAFETY CONSIDERATIONS

APPROVED COMPETENT MATERIAL

PROVIDE A 1:1 MIN. PROJECTION FROM TOE OF SLOPE AS SHOWN ON GRADING PLAN TO THE RECOMMENDED REMOVAL BOTTOM. SLOPE HEIGHT, SITE CONDITIONS, AND/OR LOCAL CONDITIONS COULD DICTATE FLATTER PROJECTIONS



ALTA CALIFORNIA GEOTECHNICAL, INC.

VER. 3/12

PLATE G-1

REMOVAL ADJACENT TO EXISTING FILL

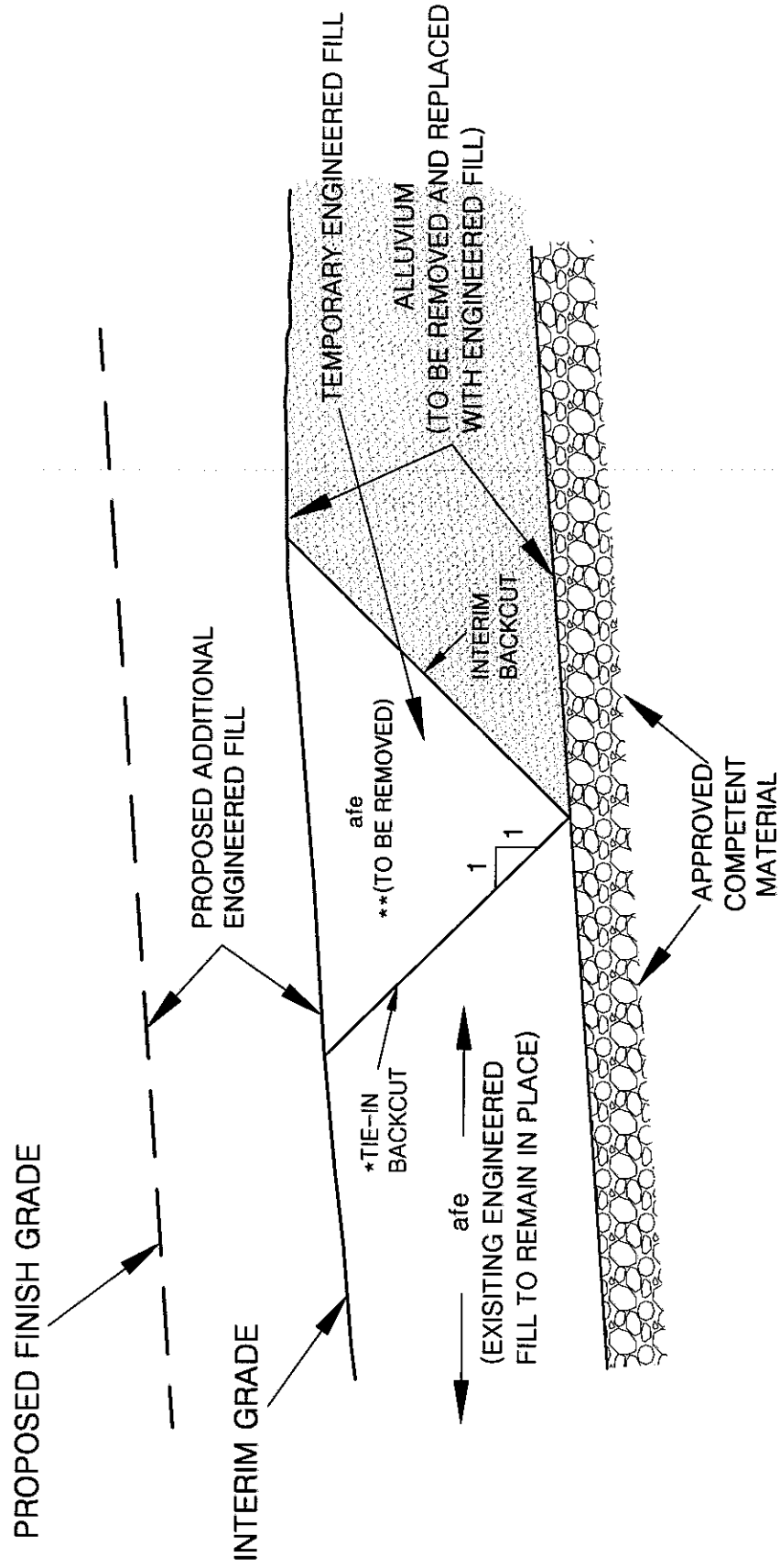

*INITIATE 1:1 TIE-IN BACKCUT TO INTERCEPT TOE OF INTERIM BACKCUT

** AS PART OF TIE-IN FOR ADDITIONAL ENGINEERED FILL

CANYON SUBDRAIN

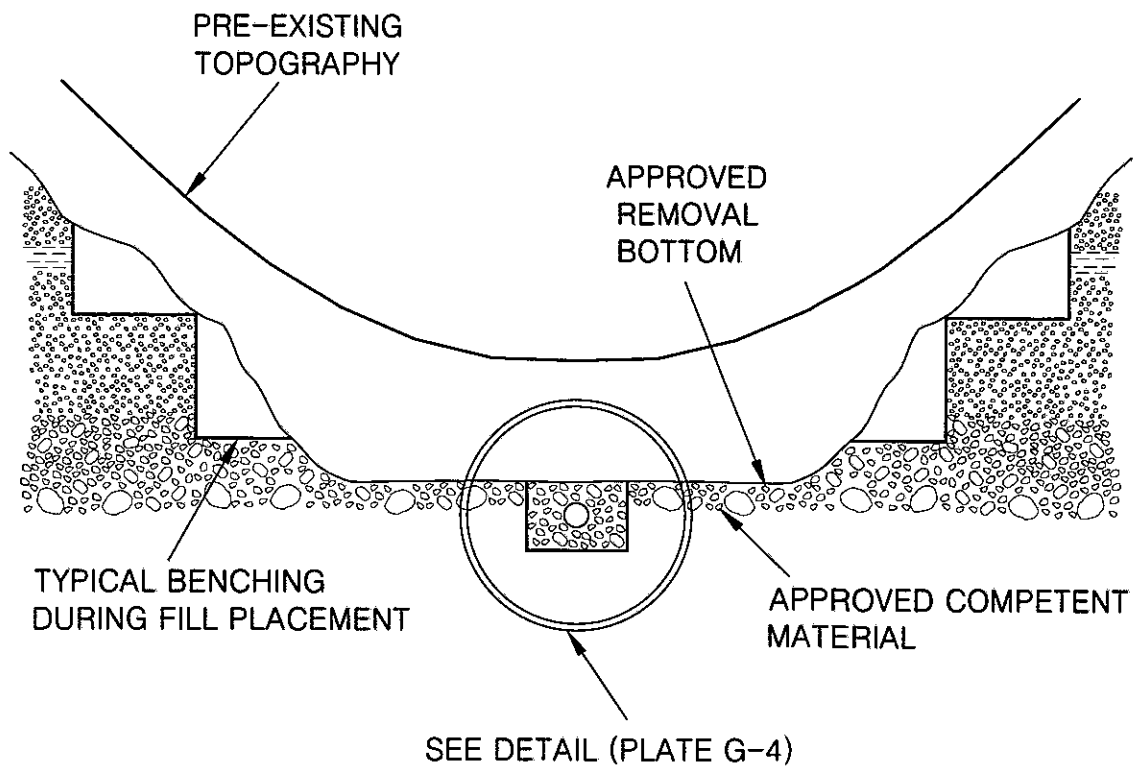

CANYON SUBDRAIN DETAIL

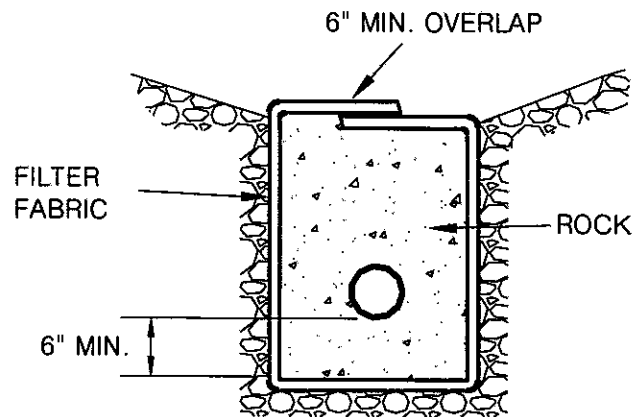

PERFORATED PIPE SURROUNDED WITH ROCK AND FILTER FABRIC

ROCK: MIN. VOLUME OF 9 CU.FT. PER LINEAL FT. OF 3/4 IN. MAX. ROCK

PIPE: 6 IN. ABS OR PVC PIPE WITH A MINIMUM OF 8 PERFORATIONS

(1/4-IN. DIA.) PER LINEAL FT. IN BOTTOM HALF OF PIPE

ASTM D2751, SDR 35, OR ASTM D3034 OR ASTM D1527,

SCHD. 40 ASTM D1785, SCHD. 40

FILTER FABRIC: MIRAFI 140 FILTER FABRIC OR APPROVED EQUIVALENT

NOTES:

1. FOR CONTINUOUS RUN IN EXCESS OF 500. FT USE 8 IN. DIA. PIPE
2. ENGINEERED FILL PLACED BELOW DRAINS SHALL BE COMPACTED TO 93% OF THE LABORATORY MAXIMUM DRY DENSITY (ASTM:D1557)



ALTA CALIFORNIA GEOTECHNICAL, INC.
VER. 3/12

PLATE G-4

OVEREXCAVATION CUT LOT

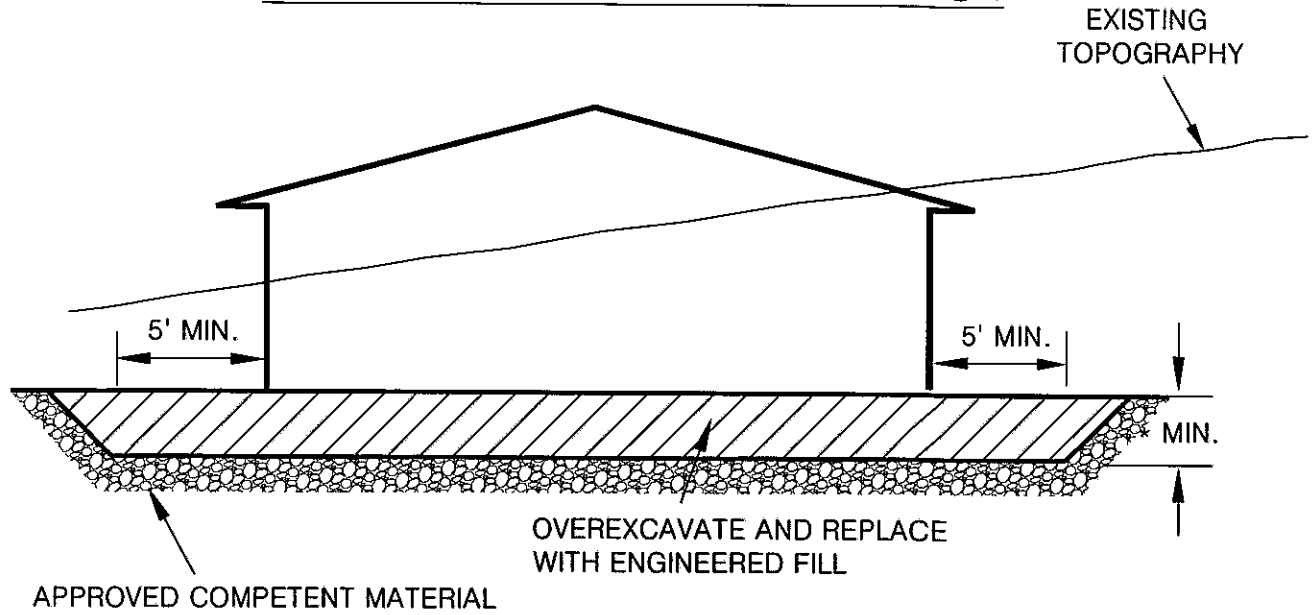

CUT-FILL LOT (TRANSITION)

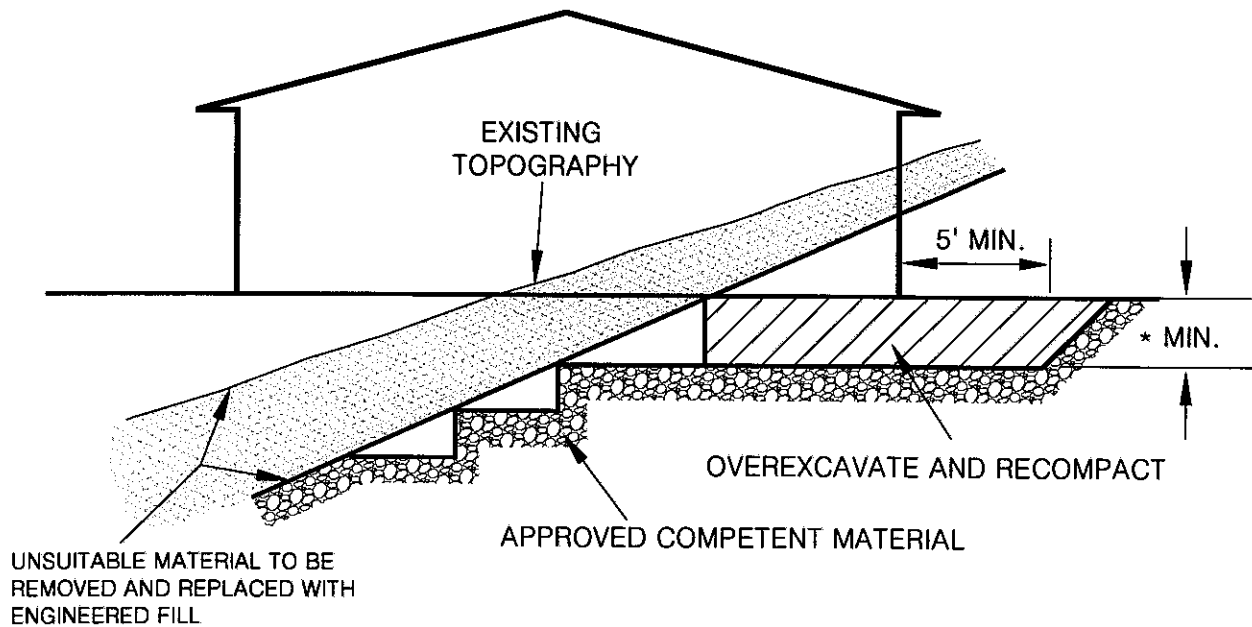

***NOTE** ALL BUILDING PADS SHALL BE OVER EXCAVATED TO A MINIMUM OF $\frac{1}{3}$ OF THE MAXIMUM DEPTH OF FILL BELOW THE BUILDING PAD TO A MAXIMUM OF 17 FEET (SEE PLATE G-16)



ALTA CALIFORNIA GEOTECHNICAL, INC.
VER. 3/12

PLATE G-5

SIDE HILL SLOPE FILL DETAIL

(NATURAL SLOPES 5:1 OR STEEPER)

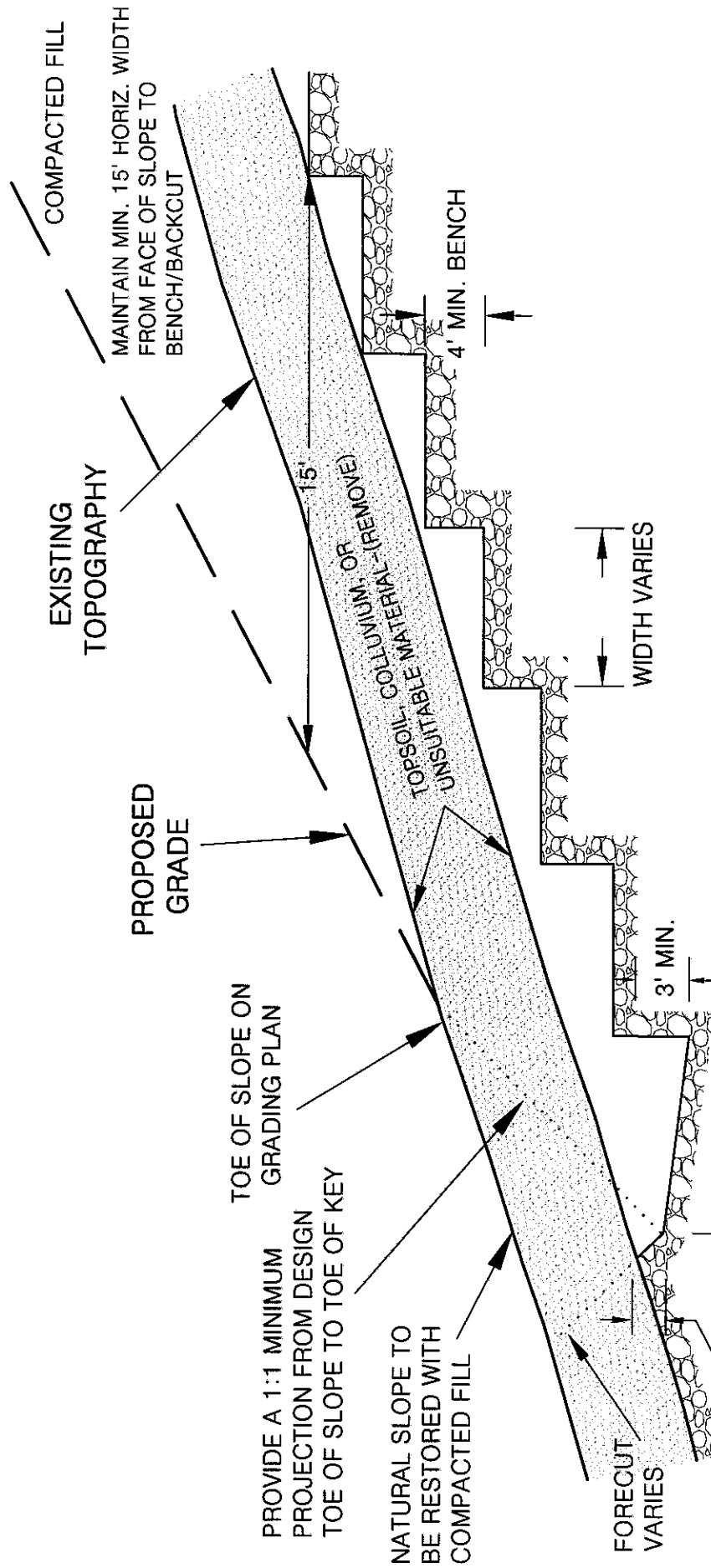

- NOTES:
1. WHERE NATURAL SLOPE GRADIENT IS 5:1 OR LESS, SEE PLATE G-1. WHERE THE NATURAL SLOPE APPROACHES OR EXCEEDS THE DESIGN SLOPE RATIO, SPECIAL RECOMMENDATIONS WILL BE PROVIDED BY THE GEOTECHNICAL ENGINEER.
 2. THE NEED FOR AND PLACEMENT OF DRAINS WILL BE DETERMINED BY THE GEOTECHNICAL ENGINEER OR GEOLOGIST BASED UPON EXPOSED FIELD CONDITIONS.

FILL OVER CUT SLOPE DETAIL

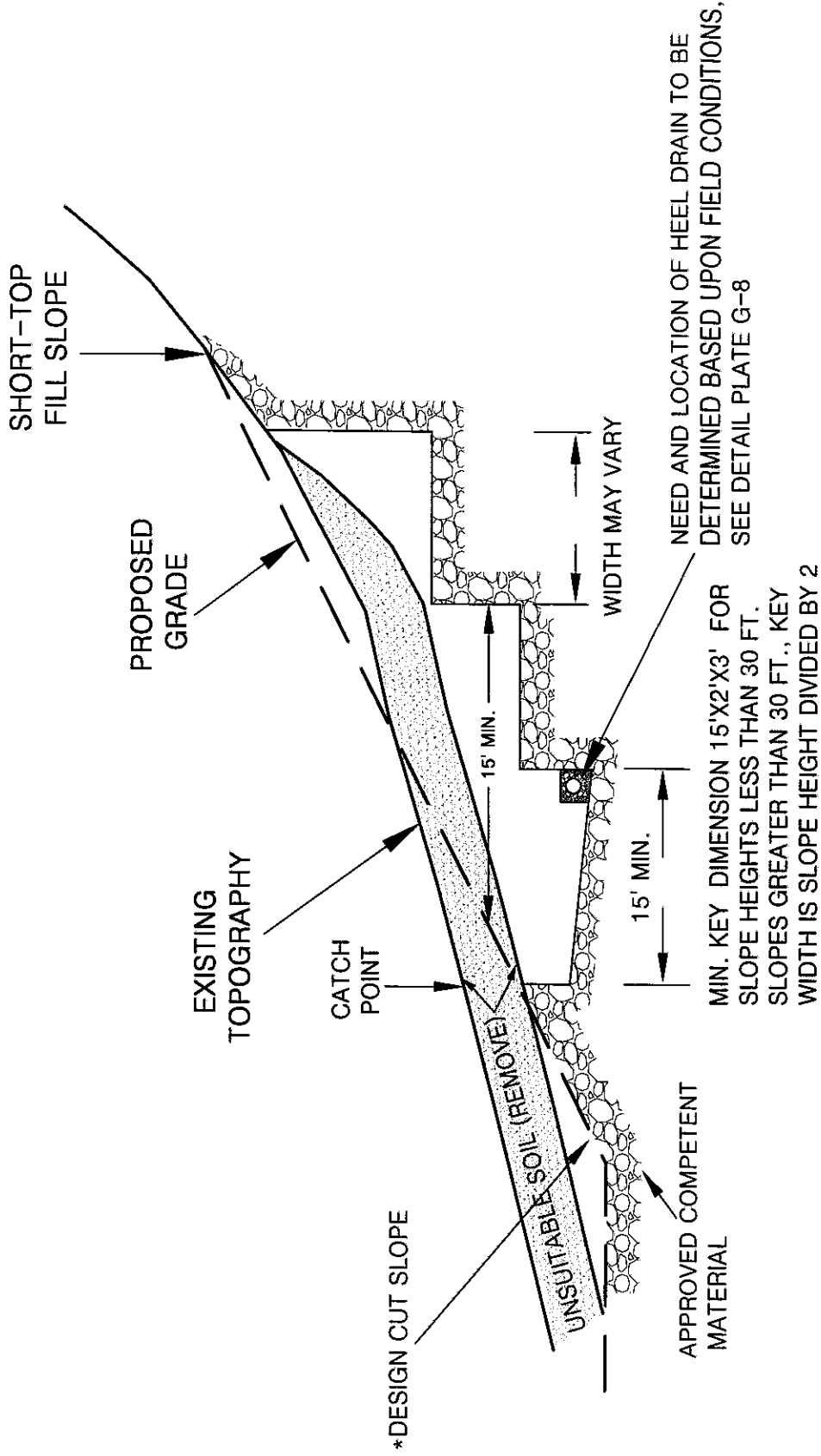

*THE CUT PORTION OF THE SLOPE SHOULD BE EXCAVATED AND EVALUATED BY THE ENGINEERING GEOLOGIST/GEO TECHNICAL ENGINEER PRIOR TO CONSTRUCTING THE FILL SLOPE



ALTA CALIFORNIA GEOTECHNICAL, INC.
VER. 1/18

PLATE G-7

STABILIZATION/BUTTRESS FILL BACKDRAIN

NOTE:

1. ASTM D2751, SDR 35, OR ASTM D3034 OR ASTM D1527, SCHD. 40 ASTM D1785, SCHD. 40
2. SOLID PIPE OUTLETS TO BE PROVIDED EVERY 100 FT. AND JOINED TO PERFORATED BACKDRAIN PIPE WITH "L" OR "T"s. MIN. 2% GRADIENT.
3. GRAVEL TRENCH TO BE FILLED WITH 3/4 IN. MAXIMUM ROCK
4. THE NECESSITY FOR UPPER TIER BACKDRAINS SHALL BE DETERMINED IN THE FIELD BY THE GEOTECHNICAL ENGINEER OR GEOLOGIST. UPPER TIER OUTLETS SHOULD DRAIN INTO PAVED TERRACE DRAINS.
5. ENGINEERED FILL PLACED BELOW DRAINS SHALL BE COMPACTED TO 93% OF THE LABORATORY MAXIMUM DRY DENSITY (ASTM:D1557)

ALTERNATIVE NO. 1

FILTER FABRIC
MIN. 6" OVERLAP

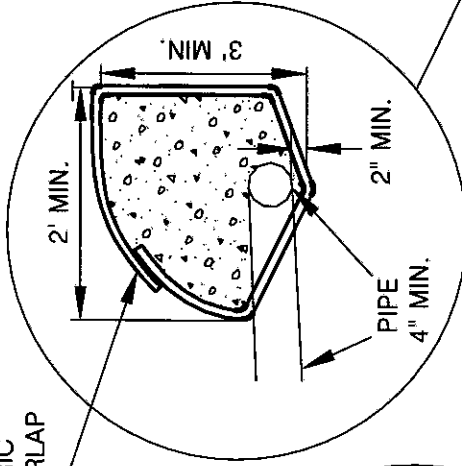

ALTERNATIVE NO. 2

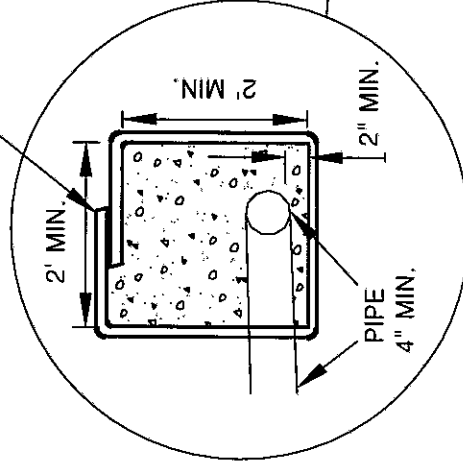

TYPICAL 2 FT. X 2 FT. 3/4 IN. MAX. ROCK FILLED TRENCH WITH 4 IN. DIA. ABS OR PVC PIPE OR APPROVED SUBSTITUTE. PROVIDE MINIMUM 8 PERFORATIONS (1/4-IN. DIA.) PER LINEAL FOOT IN BOTTOM HALF OF PIPE. PIPE IS TO EXTEND FULL LENGTH OF BUTTRESS OR STABILIZATION FILL WITH A MINIMUM GRADIENT OF 2% TO OUTLET PIPES.

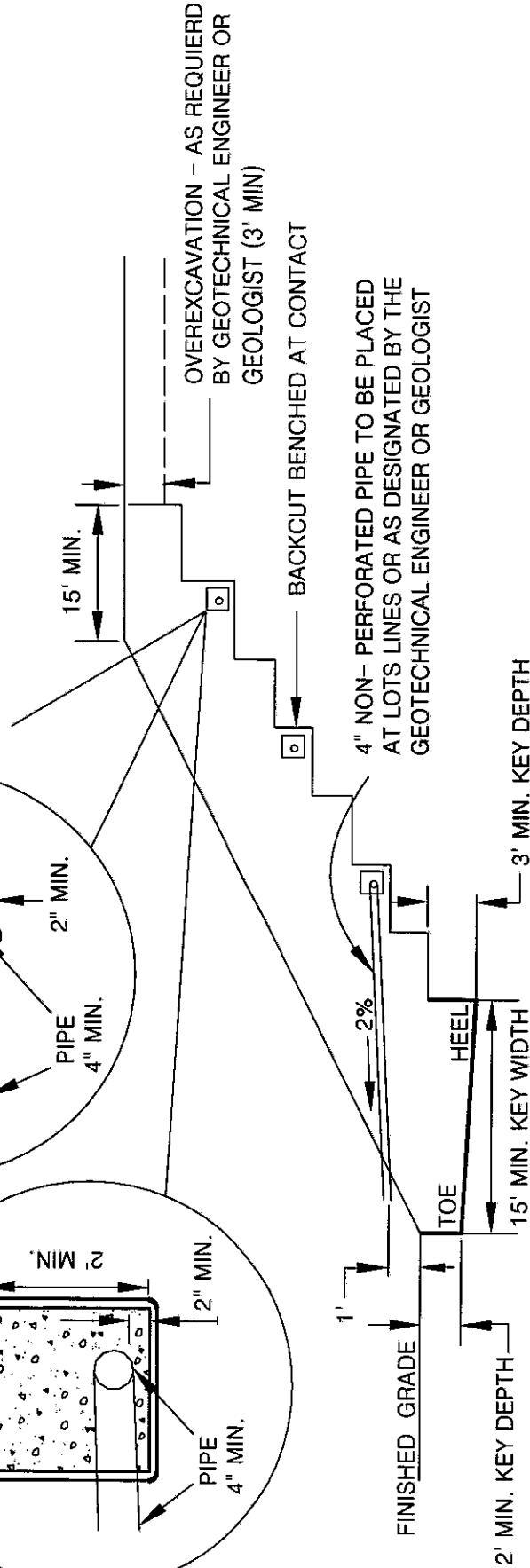

ALTA CALIFORNIA GEOTECHNICAL, INC.

VER. 3/12

STABILIZATION FILL (UPSLOPE ALLUVIATED AREA)

PROVIDE BERM, PAVED SWALE,
AND/OR STORM DRAIN PER
CIVIL ENGINEER

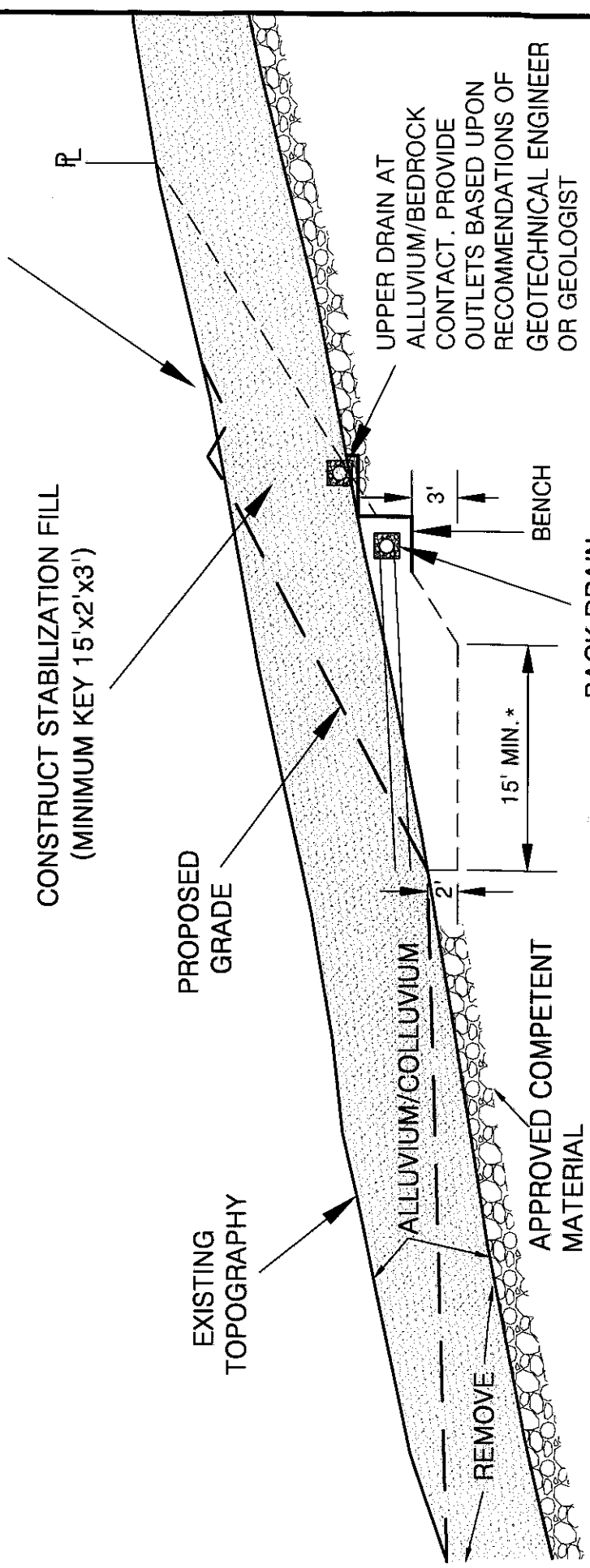

* FOR SLOPE HEIGHTS LESS THAN 30 FT.
SLOPES GREATER THAN 30 FT., KEY
WIDTH IS SLOPE HEIGHT DIVIDED BY 2

SELECTIVE GRADING DETAIL FOR STABILIZATION FILL UNSTABLE MATERIAL EXPOSED IN PORTION OF CUT SLOPE

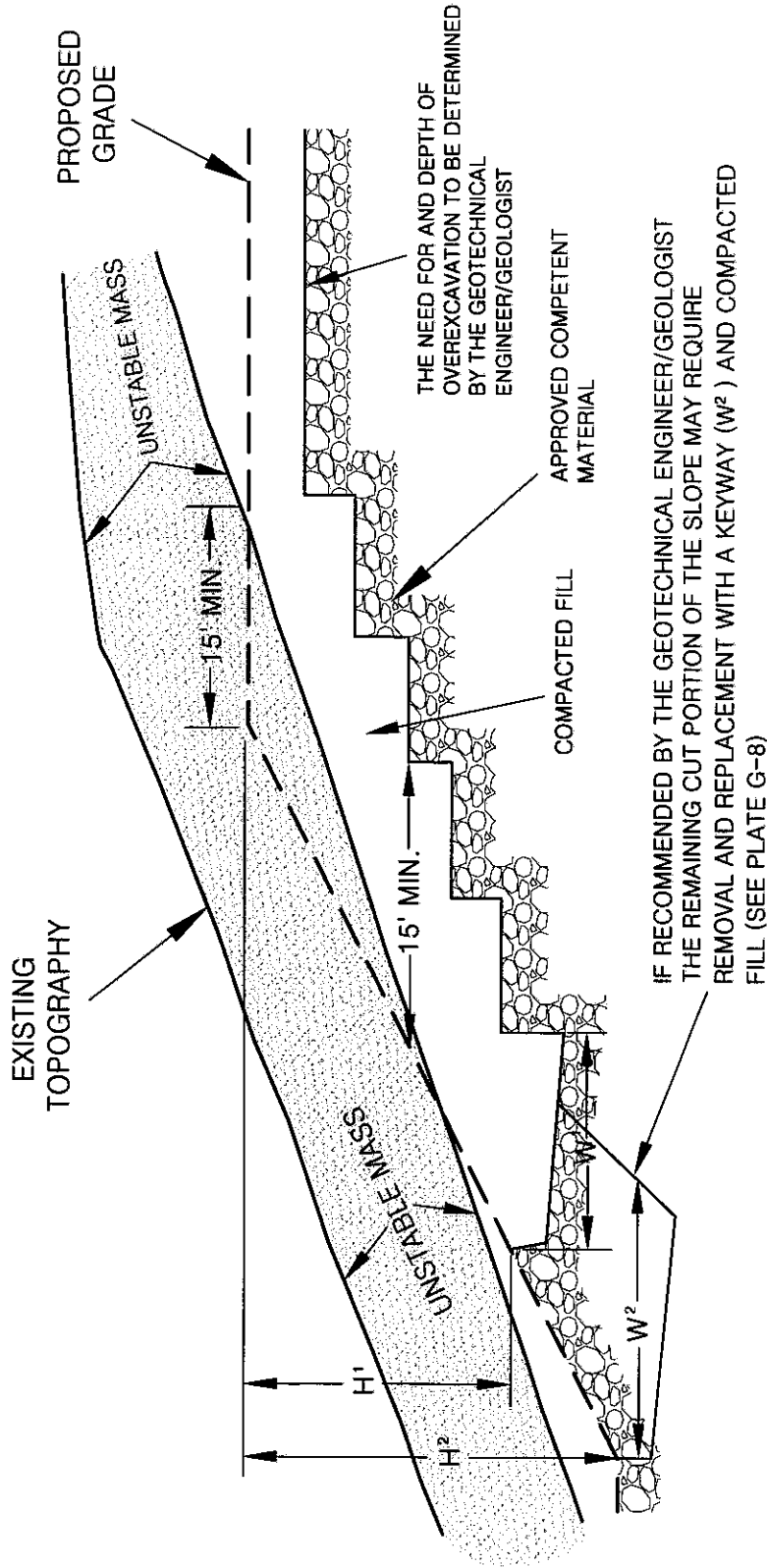

NOTES: 1. BACKDRAINS ARE NOT REQUIRED UNLESS SPECIFIED.

2. "W" SHALL BE EQUIPMENT WIDTH (15') FOR SLOPE HEIGHT LESS THAN 25 FEET. FOR SLOPES GREATER THAN 25 FEET, "W" SHALL BE DETERMINED BY THE PROJECT GEOTECHNICAL ENGINEER/GEOLOGIST. AT NO TIME SHALL "W" BE LESS THAN H/2.

SKIN FILL SLOPE OVER NATURAL GROUND

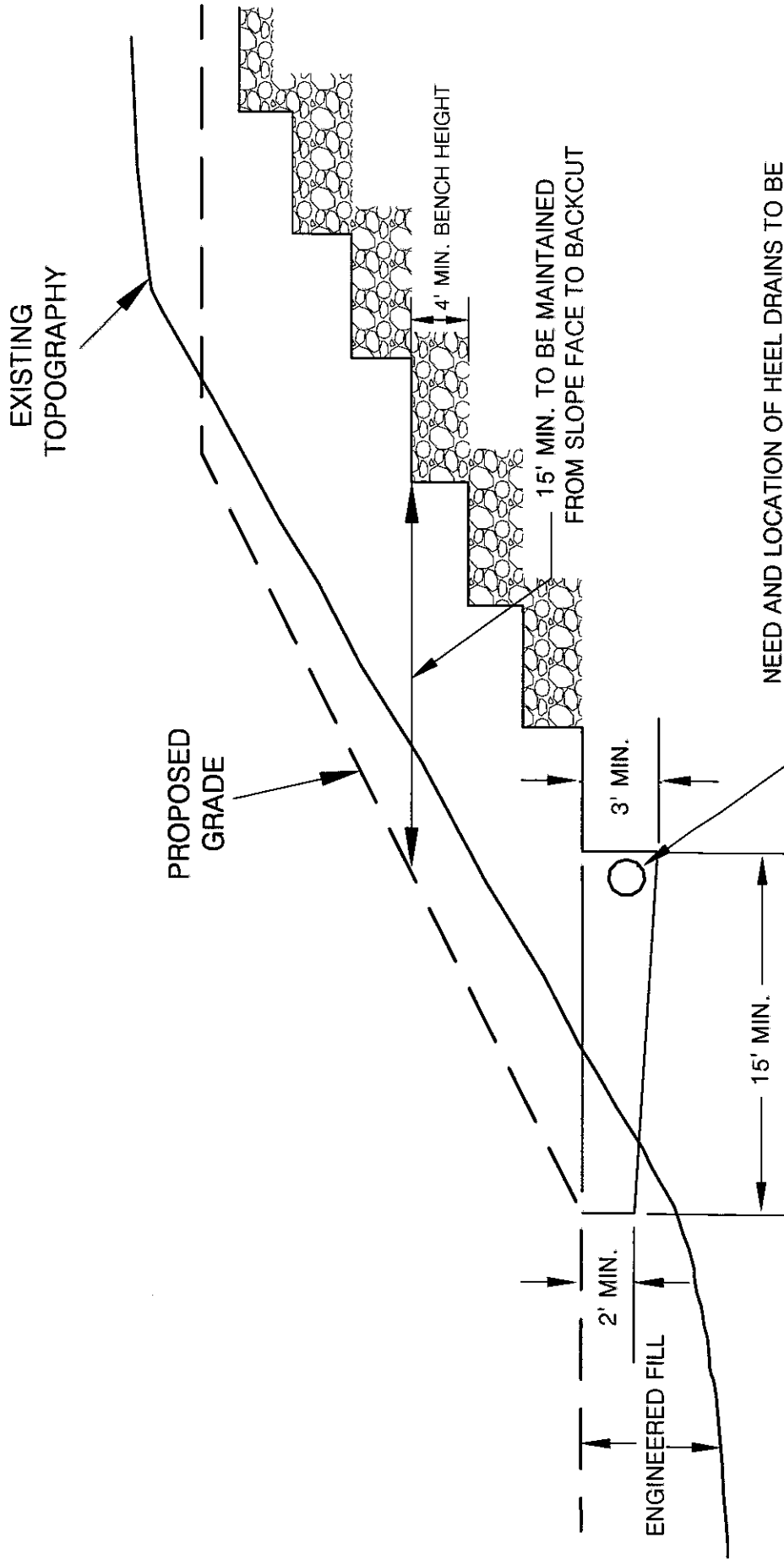

MIN. KEY DIMENSIONS 15'X2'X3' FOR SLOPE HEIGHTS LESS THAN 30 FT. SLOPES GREATER THAN 30 FT., KEY WIDTH IS SLOPE HEIGHT DIVIDED BY 2

DETAIL FOR MAXIMUM PARTICLE DIMENSION

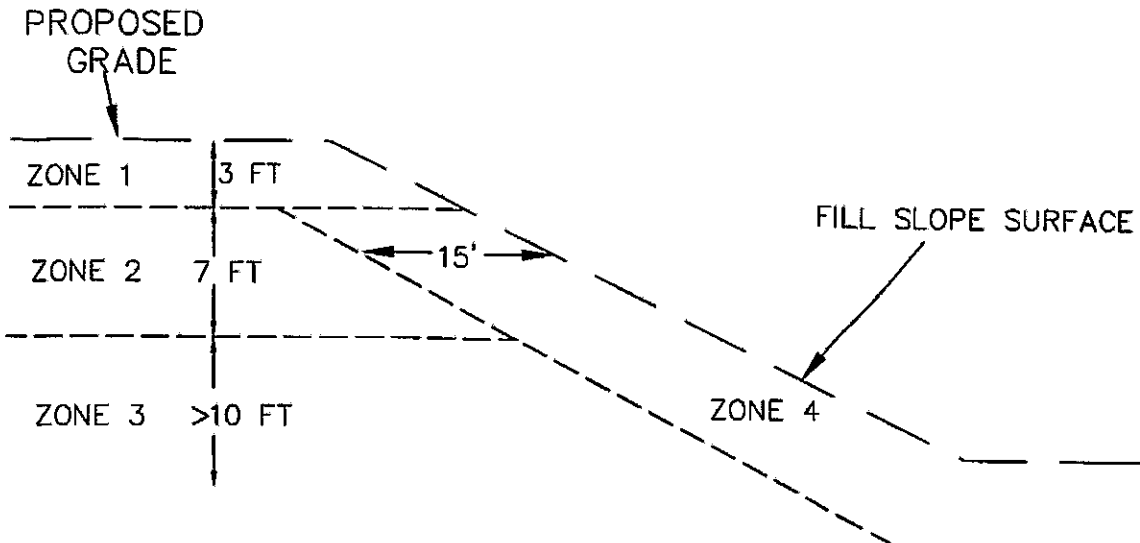

ZONE	DEPTH	PARTICLE MAX. DIMENSION	PLACEMENT METHOD
1	0-3 ft.	≤ 1.0 ft.	STANDARD OR CONVENTIONAL COMPACTION METHODS (SEE EARTHWORK SPECIFICATIONS)
2	3-10 ft.	≤ 2.0 ft.	ROCK BLANKETS (SEE PLATE G-13)
3	>10 ft.	≤ 8.0 ft.	ROCK BLANKETS (PLATE G-13) ROCK WINDROW (PLATE G-14) INDIVIDUAL ROCK BURIED (PLATE G-15)
4	15 HORIZONTAL FEET FROM FILL SLOPE FACE	≤ 1.0 ft.	STANDARD OR CONVENTIONAL COMPACTION METHODS (SEE EARTHWORK SPECIFICATIONS)



ALTA CALIFORNIA GEOTECHNICAL, INC.
VER. 2/15

PLATE G-12

ROCK BLANKET DETAILS

LOOSE PILE 1
 LOOSE, DUMPED ROCK, GRAVEL AND SAND MIXTURE REMOVE
 FRAGMENTS LARGER THAT 2 FEET FOR ISOLATED BURIAL
 (PLATE G-15) OR WINDROW (PLATE G-10)

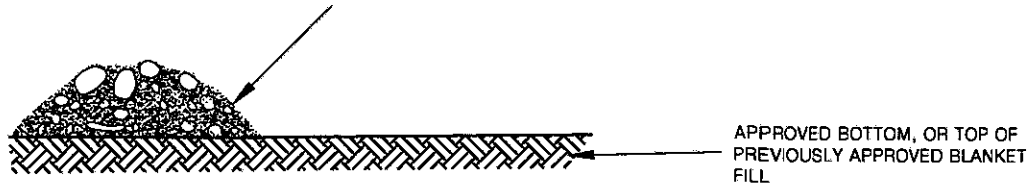

COMPACT PILE 1
 SPREAD LOOSE PILE FORWARD WITH HEAVY TRACKED DOZER (D-8
 OR LARGER). HEAVILY WATER, TRACK, AND APPLY ADDITIONAL SAND
 AND GRAVEL AS NECESSARY TO FILL VOIDS AND CREATE A DENSE
 MATRIX OF ROCK, COBBLES, GRAVEL AND SAND (2 FOOT MAXIMUM
 THICKNESS)

LOOSE PILE 2
 DUMP SUCCESSIVE PILES OF LOOSE ROCK, GRAVEL AND SAND
 MIXTURE ON FORWARD EDGE OF PREVIOUSLY COMPACTED LIFT
 WITH TRUCKS AND/OR SCRAPERS. USE PREVIOUS LIFT TO ACCESS
 AND FURTHER COMPACT PILE 1.

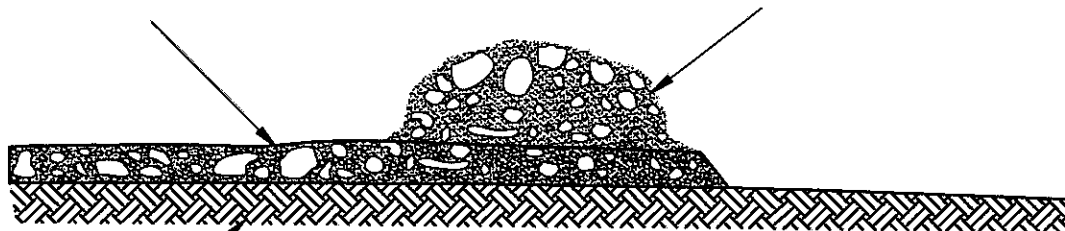

APPROVED BOTTOM, OR TOP OF
 PREVIOUSLY APPROVED BLANKET
 FILL

LOOSE PILE 3
 DUMP SUCCESSIVE PILES OF LOOSE ROCK, GRAVEL AND SAND
 MIXTURE ON FORWARD EDGE OF PREVIOUSLY COMPACTED LIFT
 WITH TRUCKS AND/OR SCRAPERS. USE PREVIOUS LIFT TO ACCESS
 AND FURTHER COMPACT EXISTING BLANKET.

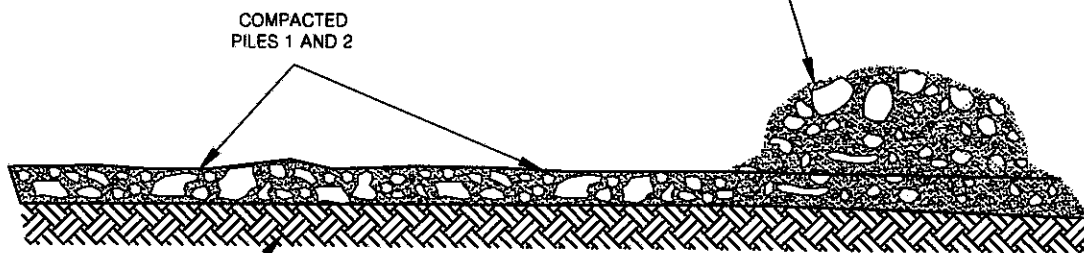

APPROVED BOTTOM, OR TOP OF
 PREVIOUSLY APPROVED BLANKET
 FILL

OBSERVATION TESTING AND APPROVAL PROCEDURES
 OBSERVE EQUIPMENT. SCRAPERS AND TRUCKS SHOULD BE FULLY SUPPORTED ON BLANKET WITHOUT SIGNIFICANT YIELDING.
 EXCAVATE TEST/OBSERVATION PITS TO CONFIRM EXISTENCE OF MIXTURE OF VARIOUS PARTICLE SIZES, WITHOUT SIGNIFICANT
 VOIDS, AND FORMING A DENSE, COMPACTED FILL MATRIX. TEST BY ASTM D1556, D2922 AND/OR D3017 WHEN APPROPRIATE.
 RECORD LIMITS AND ELEVATION OF BLANKET. ALL FILL AND COMPACTION OPERATIONS TO BE CONDUCTED UNDER THE
 OBSERVATION OF THE GEOTECHNICAL ENGINEER. SUBSEQUENT LIFTS TO BE APPLIED ONLY AFTER OBSERVATION AND
 CONFIRMATION OF SUITABILITY OF FILL AND RELEASE BY THE GEOTECHNICAL ENGINEER. BLANKETS TO BE CONSTRUCTED IN
 ACCORDANCE WITH PLATE G-12.



ROCK WINDROW DETAIL

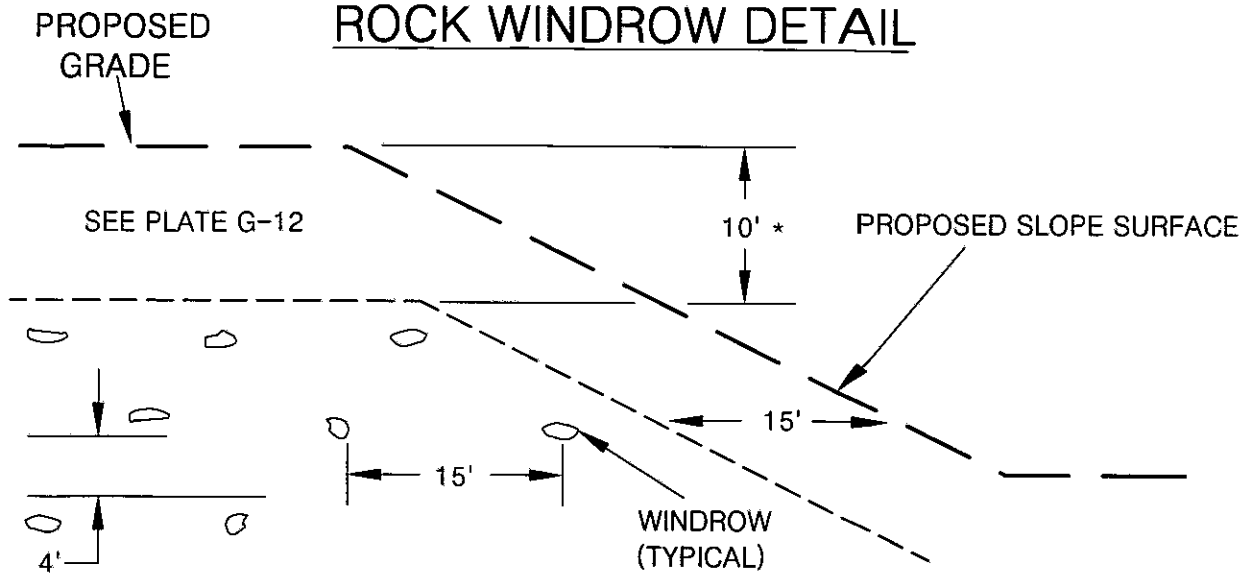

NOTE: OVERSIZED MATERIAL SHOULD BE REMOVED FROM THE 15' CLEAR ZONES WITH SPECIAL EQUIPMENT, SUCH AS A ROCK RAKE, PRIOR TO PLACING THE NEXT FILL LIFT.
*VARIANCES TO THE ABOVE ROCK HOLD DOWN MAY BE GRANTED SUBJECT TO APPROVAL BY THE OWNER, GEOTECHNICAL ENGINEER, AND GOVERNING AGENCY

TYPICAL WINDROW DETAIL (END VIEW)

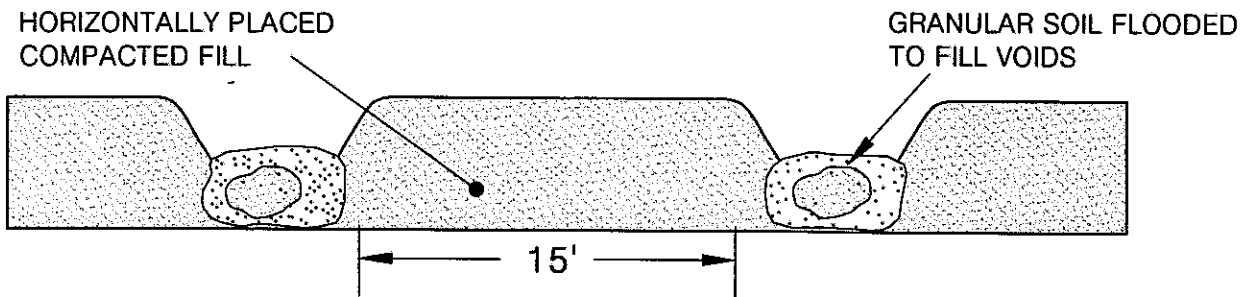

NOTE: COMPACTED FILL SHALL BE BROUGHT UP TO A HIGHER ELEVATION ALONG EACH WINDROW SO GRANULAR SOIL CAN BE FLOODED IN A "TRENCH CONDITION".

PROFILE VIEW

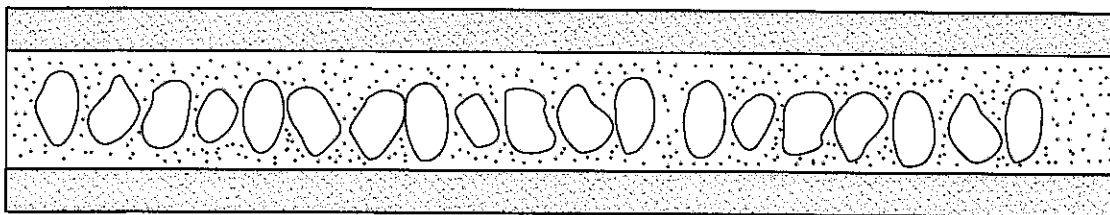

ISOLATED ROCK BURIAL DETAILS

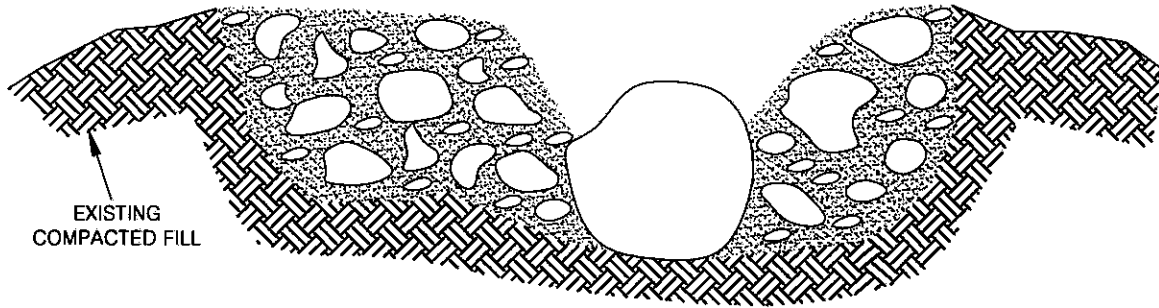

EXCAVATE HOLE INTO EXISTING FILL PRISM, PLACE BOULDER (< 8 feet in maximum dimension) INTO EXISTING COMPACTED FILL. SURROUND WITH SAND, GRAVEL, COBBLES AND WATER HEAVILY. TRACK WITH D8 OR LARGER EQUIPMENT UNTIL RESULTING FILL FULLY SUPPORTS EQUIPMENT. OBSERVE AND/OR TEST IN ACCORDANCE WITH ASTM D1556, D2922 OR D3017. ROCKS LARGER THAN 8 FEET SHALL BE FURTHER REDUCED IN SIZE BY SECONDARY BREAKING.

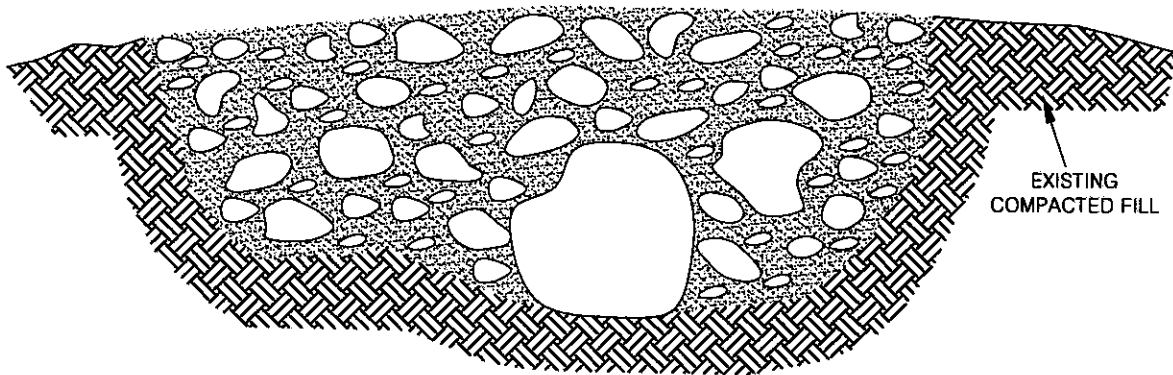

RELATIVE COMPACTION VS. DEPTH

CANYON WALL LAY BACK DIFFERENTIAL FILL OVEREXCAVATION DETAILS

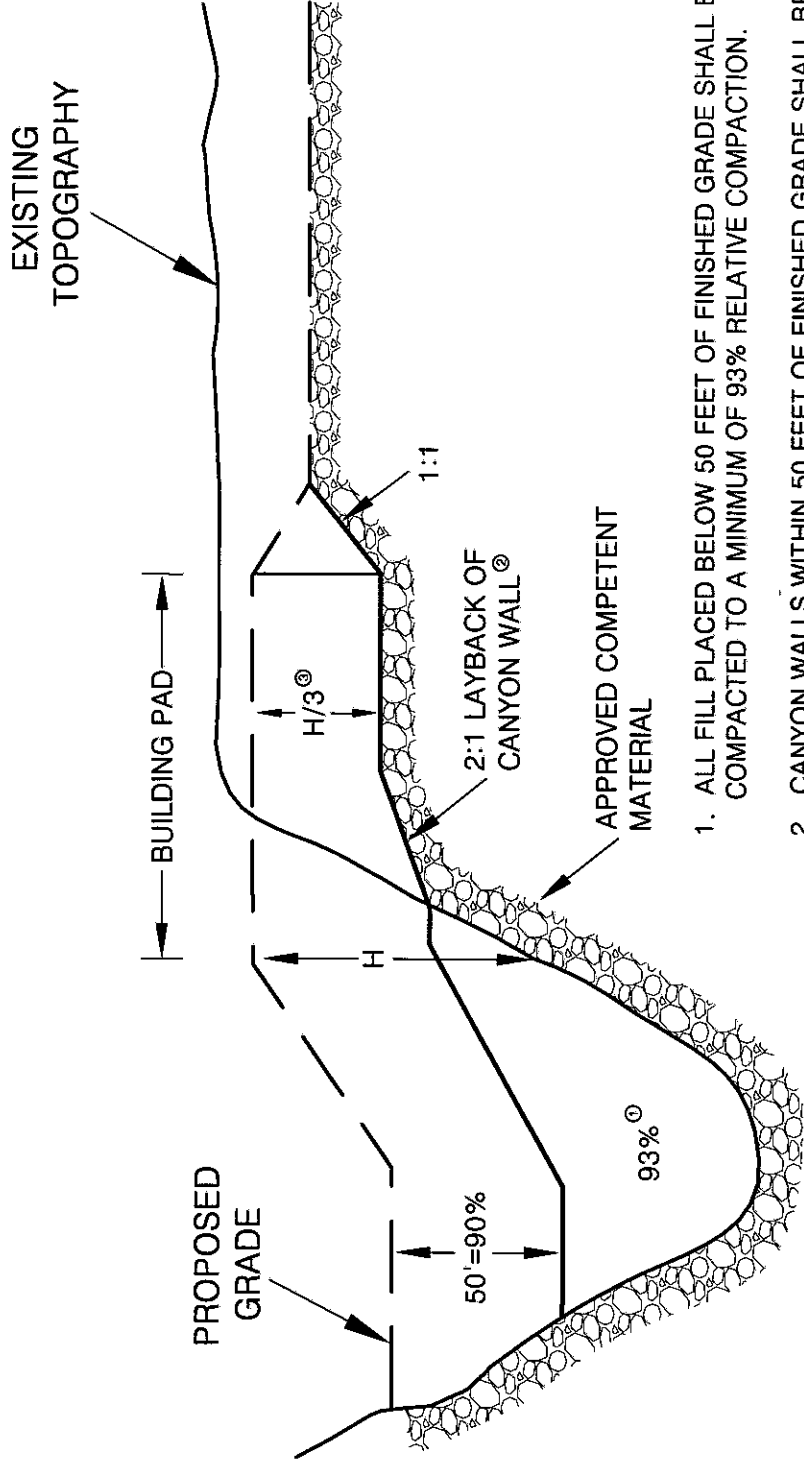

1. ALL FILL PLACED BELOW 50 FEET OF FINISHED GRADE SHALL BE COMPACTED TO A MINIMUM OF 93% RELATIVE COMPACTION.
2. CANYON WALLS WITHIN 50 FEET OF FINISHED GRADE SHALL BE LAID BACK TO A SLOPE RATIO OF 2:1 OR FLATTER.
3. ALL BUILDING PADS SHALL BE OVER EXCAVATED TO A MINIMUM OF 1/3 OF THE MAXIMUM DEPTH OF FILL BELOW THE BUILDING PAD TO A MAXIMUM OF 17 FEET.
4. IF THE 2:1 LAY BACK OF THE CANYON WALL IS IMPRACTICAL, THEN AS AN ALTERNATIVE THE INCREASED COMPACTION STANDARDS IN NOTE 1 SHOULD BE EXTENDED UP TO $H/3$ AND THE LAY BACK WILL NOT BE REQUIRED.

SETTLEMENT PLATE DETAIL

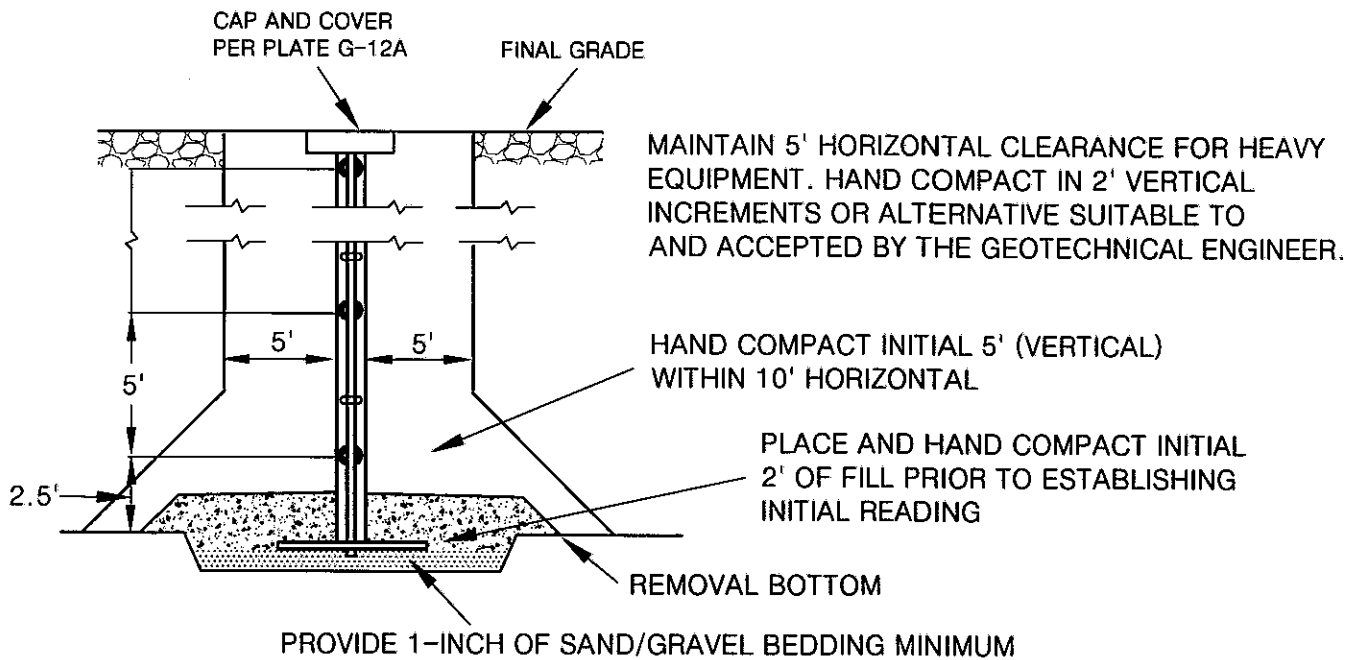
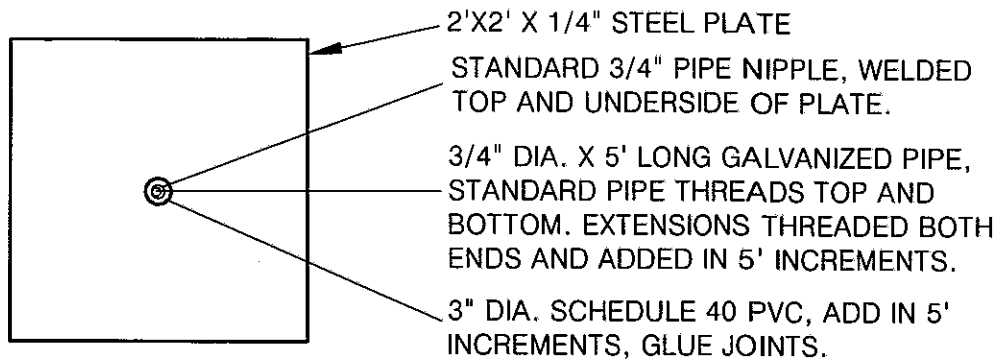

NOTES:

- 1) LOCATIONS OF SETTLEMENT PLATES SHALL BE CLEARLY MARKED AND READILY VISIBLE (RED FLAGGED) TO EQUIPMENT OPERATORS.
- 2) CONTRACTOR SHALL MAINTAIN 10' HORIZONTAL CLEARANCE FOR HEAVY EQUIPMENT WITHIN 5' (VERTICAL) OF PLATE BASE. FILL WITHIN CLEARANCE AREA SHALL BE HAND COMPACTED TO PROJECT SPECIFICATIONS OR COMPACTED BY ALTERNATIVE APPROVED BY THE GEOTECHNICAL ENGINEER.
- 3) AFTER 5' (VERTICAL) OF FILL IS IN PLACE, CONTRACTOR SHALL MAINTAIN 5' HORIZONTAL EQUIPMENT CLEARANCE. FILL IN CLEARANCE AREA SHALL BE HAND COMPACTED (OR APPROVED ALTERNATIVE) IN VERTICAL INCREMENTS NOT TO EXCEED 2 FEET.
- 4) IN THE EVENT OF DAMAGE TO SETTLEMENT PLATE OR EXTENSION RESULTING FROM EQUIPMENT OPERATING WITHIN PRESCRIBED CLEARANCE AREA, CONTRACTOR SHALL IMMEDIATELY NOTIFY GEOTECHNICAL ENGINEER AND SHALL BE RESPONSIBLE FOR RESTORING THE SETTLEMENT PLATE AND EXTENSION RODS TO WORKING ORDER.



ALTA CALIFORNIA GEOTECHNICAL, INC.
VER. 3/12

PLATE G-17

SURFACE SETTLEMENT MONUMENT DETAIL

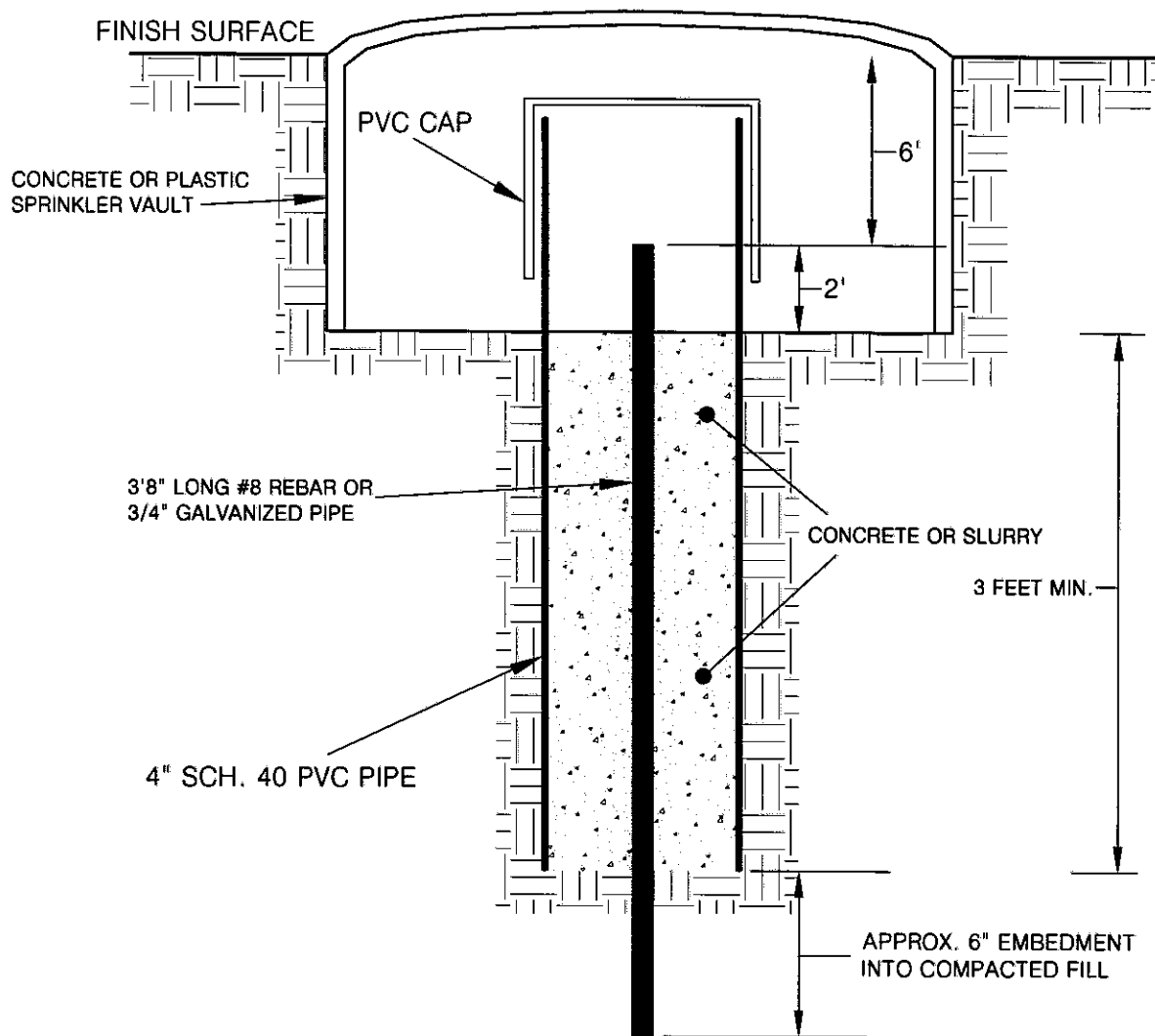

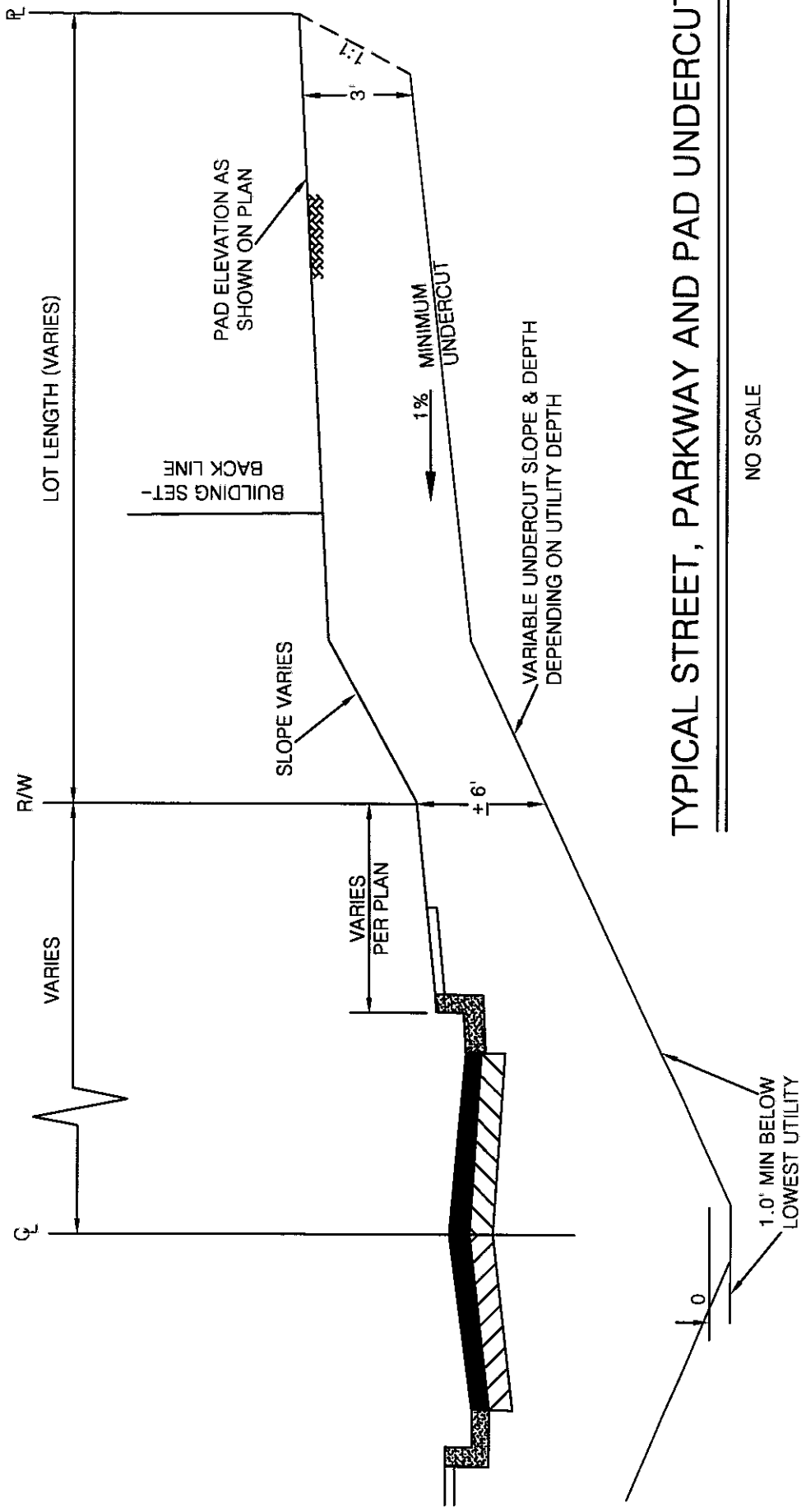

TYPICAL STREET, PARKWAY AND PAD UNDERCUT

NO SCALE

Parcel Addresses & APNs	Existing Zoning
Beltramo Ranch Road APN: 504-0-021-195	RE-1
11930-11934 West Los Angeles Ave. APN: 506-0-030-220 APN: 506-0-030-210 APN: 506-0-030-235 APN: 506-0-030-045	RE-20
11944 West Los Angeles Ave. APN: 506-0-030-255	RO

R-1* Developmental Standards:
 Density: 7 du/ac
 Front Yard Setback: 20'
 Interior Side Yard Setback: 5'
 Street Side Yard Setback: 10'
 Rear Yard Setback: 15'
 Lot Coverage: 50%
 Building Height: 35'
 Resident Parking: 2.5 sp/unit

*Conceptual Site Plan is compliant with R-1 zoning standards, however project is seeking RPD zoning and High Density Residential (R-1) zoning throughout

Site Plan Summary

Site Area: ±7.4 ac. (±323,000sf)
 Home Mix:
 47 homes - 60'x53'-6" SFD Two-Story (2000-2200sf)
 Site Density: ±6.4 du/ac
 Proposed Building Height:
 Two-Story Homes: ±26'

Parking Provided:
 94 spaces - Garage Spaces
 94 spaces - Driveway
 76 spaces - Guest On-Street Parking
 264 spaces - Total (±5.64 sp/unit)

Building Coverage: ±23%

Open Space Provided:
 ±88,000sf - Private Yards
 ±56,000sf - Open Area
 ±144,000sf - Total Open Space Provided (45% of site)

Proposed Zoning: RPD*



Architecture + Planning
 17911 Von Karman Ave,
 Suite 200
 Irvine, CA 92614
 949.851.2133
 ktgy.com



MOORPARK - BELTRAMO RANCH
 MOORPARK, CA # 2018-0860

Representative Site Plan for Road on Outer Edges
CONCEPTUAL SITE PLAN 3
 FEBRUARY 19, 2021

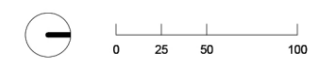

AI.0