

INITIAL STUDY AND DRAFT MITIGATED NEGATIVE DECLARATION

# North Pebble Beach Drive Public Access Point Project



**May 2022**

**Lead Agency:**  
County of Del Norte  
Community Development Department  
981 H Street, Suite 110  
Crescent City, CA 95531

## Table of Contents

<b>1.0 PROJECT INFORMATION.....</b>	<b>2</b>
<b>2.0 STATEMENT OF FINDINGS AND DETERMINATION .....</b>	<b>6</b>
<b>3.0 ENVIRONMENTAL IMPACTS EVALUATION AND CHECKLIST .....</b>	<b>7</b>
AESTHETICS .....	8
AGRICULTURE AND FOREST RESOURCES .....	9
AIR QUALITY .....	10
BIOLOGICAL RESOURCES.....	12
CULTURAL RESOURCES .....	18
ENERGY .....	20
GEOLOGY AND SOILS.....	21
GREENHOUSE GAS EMISSIONS.....	22
HAZARDS AND HAZARDOUS MATERIALS .....	24
HYDROLOGY AND WATER QUALITY .....	25
LAND USE AND PLANNING .....	27
MINERAL RESOURCES .....	27
NOISE .....	28
POPULATION AND HOUSING.....	29
PUBLIC SERVICES.....	30
RECREATION .....	30
TRANSPORTATION .....	31
TRIBAL CULTURAL RESOURCES .....	32
UTILITIES AND SERVICE SYSTEMS.....	33
WILDFIRE.....	34
MANDATORY FINDINGS OF SIGNIFICANCE.....	35

### FIGURES

Figure 1 – Project Area .....	3
-------------------------------	---

### APPENDICES

Appendix A – References

Appendix B – Existing Conditions Report which includes all Technical Memorandums prepared for the project excluding the Phase I Cultural Resource Inventory Report

## 1.0 Project Information

- PROJECT TITLE:** North Pebble Beach Public Access Point
- LEAD AGENCY:** Del Norte County Community Development Department
- CONTACT:** Heidi Kunstal, Community Development Director  
981 H Street, Suite 110  
Crescent City, CA 95531  
Phone: (707) 464-7254  
Email: hkunstal@co.del-norte.ca.us
- PROJECT LOCATION:** West side of N. Pebble Beach Drive approximately .5 mile south of the Pebble Beach Drive and Washington Boulevard intersection. The project location is developed with an existing parking lot and pathway to the beach.
- ASSESSOR'S PARCEL NUMBER:** 120-020-022
- GENERAL PLAN DESIGNATION:** Public Facility
- ZONING DESIGNATION:** A-5-C (A)(H) Agriculture General – 5 Acre Minimum – Coastal Combining District – Requirements for Coastal Bluff Hazard, Tsunami Erosion and Slope Risk Failure and Requirements for of Coastal Access.

### PROJECT DESCRIPTION:

#### Project Summary

In 2019, the County of Del Norte received funding from the State Coastal Conservancy to prepare studies needed to obtain permits and complete an environmental review as required by CEQA for public access to the Pacific Ocean at two locations including an existing public access point located along North Pebble Beach Drive in the Crescent City urban area. Pebble Beach Drive (North and South) is a scenic drive that has approximately two miles of ocean frontage. With the exception of three residences on the west side of Pebble Beach Drive, the frontage of Pebble Beach Drive on the ocean side of the street is all publicly owned either directly by the County or by the State. Pebble Beach Drive offers panoramic ocean views of numerous pocket beaches, sandy alcoves, rock outcroppings, sea stacks offshore, Castle Rock and other numerous offshore rocks. This stretch of shoreline includes coastal attractions such as seasonal whale watching, bird migration, marine life, surfing, tide pools, and views of two offshore lighthouses.

The North Pebble Beach Public Access Point was designed to be the County's only beach access in the Crescent City area compliant with the American with Disabilities Act (ADA). The project includes the construction of a ramp and regrading, paving, and striping an area of the existing parking lot to also conform to ADA requirements. Currently, there is no official access point from the parking lot to the beach other than an asphalt-paved path that is periodically covered in up to a foot of sand. It is estimated that the parking lot and path were constructed shortly after the property was acquired in 2002 based on a review of aerial imagery from Californiacoastline.org. Little to no maintenance has occurred since that time other than to clear the sand. Presently, the path is located within an area dominated by ice plant. The location of the new ramp generally follows the footprint of the older asphalt-paved path which will be removed during construction of the new North Pebble Beach Public Access Point. By having an officially designated public access point, it is more unlikely for wetland areas and rare plant habitats located in the nearby dune areas to be impacted by foot traffic.

A portion of the new ramp will parallel the parking lot to allow for ingress from the ADA loading and unloading spaces with a 90-degree turn at the eastern end to access the beach. This seaward portion will be approximately 36 feet in length and approximately 6 feet wide. The slope over most of the ramp will be at 8 percent; however, this will be shallow to 1.8 percent at the end to allow a transition to the beach surface. The ramp will be bordered on both sides with new concrete sidewalls and handrails.

The portion of the ramp that is parallel to the parking lot will be founded on 8-foot-deep concrete footings while the footing for the seaward portion of the ramp is anticipated to be approximately 5 feet deep, depending on the depth to competent dense sand observed during the geotechnical exploration.

According to FEMA, base flood elevation at the site is 24 feet msl. LACO, the County's consultants, estimated sea level rise during an economic lifespan of 50 years at approximately 3 feet. The proposed ramp is designed to withstand a design flood elevation, which includes new storm wave height in addition to sea level rise, of 28.6 feet msl. A tsunami is assumed to be likely within the lifespan of the project with runup projected to extend east nearly 1,200 feet. However, current building codes do not require that the project be built to withstand a tsunami as it is not a critical structure. LACO also evaluated bluff erosion at the project site. While the project area is expected to be subject to bluff erosion over the lifespan of the project, most of this erosion is probably due to a combination of waves and storm events, which are included to some extent in the design flood elevation. This will likely provide some hardening in the immediate vicinity of the North Pebble Beach Public Access Point.

A Public Access Program and Plan will be required as a condition of project approval that describes methods by which safe public around construction activity areas and staging area shall be maintained during project operations.

**Project Setting**

The project site is located on a 9.75 acre parcel that lies between the Pacific Ocean and the centerline of N. Pebble Beach Drive approximately .5 mile of N. Pebble Beach Drive's intersection with Washington Boulevard. The County of Del Norte acquired the property in 2002 from a private property owner for the purpose of providing public access and acquiring portions of Pebble Beach Drive which is a County Maintained Road.

The site comprises beach strand habitat with ground surface elevations ranging between 0 and 15 above mean sea level (AMSL). The topography is shoreline on the western portion of the site and irregular dune formation on the eastern portion of the site with a paved parking lot with approximately 20 parking spaces as well as an older asphalt-path to the ocean located at the south end of the parking lot. A gate is located south of the parking lot that provides limited beach access to vehicles<sup>1</sup>.

To the north and on the same parcel is another parking lot that includes an interpretative panel display. No authorized beach access is located at the parking lot due to the steep bluff face. Across N. Pebble Beach Drive to the North is the McNamara Ranch which includes portions of the Marhoffer Creek watershed. Some of the lands are used as farmed wetlands. The property is developed with several agricultural buildings and a home.

---

<sup>1</sup> Under Del Norte County Code Section 10.16.60 only to such vehicles as are duly authorized and actually used for search and rescue operations by the sheriff's department or other public authority. Additionally, an exception is granted to those specifically authorized by the property owner for access to and from the Pacific Ocean for the launching of fishing craft. The area of this exception is to lie between Marhoffer Creek, north to the access gate and to the Pacific Ocean. The project includes no changes to the gate or the need to use the access for development of the project.

Figure 1: Project Area – Biological Resources

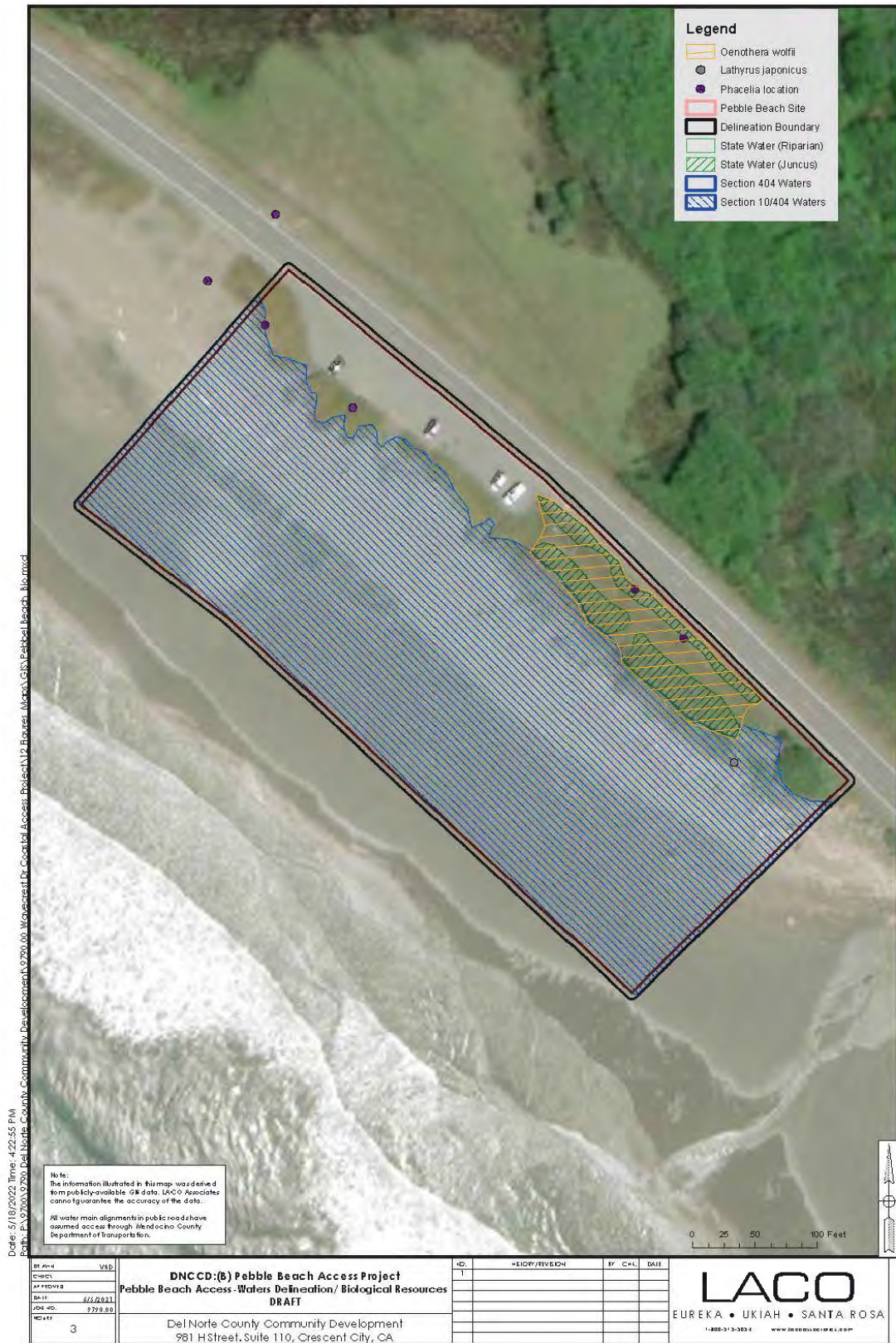
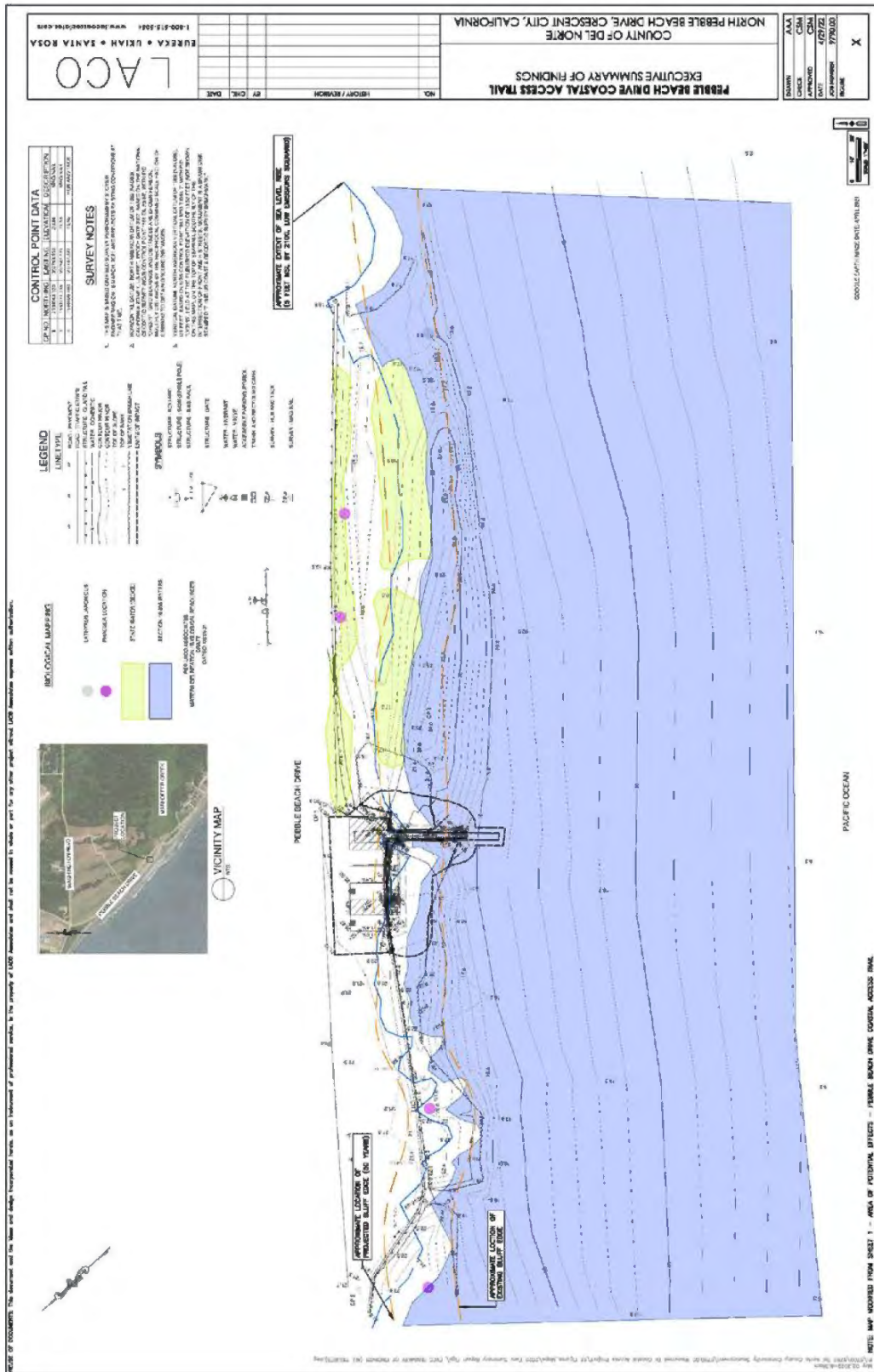

Figure 2: Project Area – Executive Summary of Findings



**Figure 3: Visual Assessment**



**Figure 3: Visual Assessment - Pebble Beach Drive**  
Wavecrest Drive and North Pebble Beach Drive Coastal Access Plan  
Del Norte County, Community Development Department  
April 25, 2022

LACO



**Approvals Required**

The project would require the following approvals and/or discretionary actions from Del Norte County:

- Planning Commission - Initial Study/Mitigated Negative Declaration Adoption & Use Permit Approval

Other review and/or approvals may be required from the following agencies:

- North Coast Regional Water Quality Control, 401 Water Quality Certification
- U.S. Army Corps of Engineers — Clean Water Act Section 404 Permit, Section 7 ESA

## 2.0 Statement of Findings and Determination

### ENVIRONMENTAL FACTORS POTENTIALLY AFFECTED:

The environmental factors checked below would be potentially affected by this project, involving at least one impact that is a "Potentially Significant Impact" as indicated by the checklist on the following pages.

- |   |  |  |
|---|--|--|
| <input type="checkbox"/> Aesthetics                         | <input type="checkbox"/> Geology/Soils                 | <input type="checkbox"/> Population/Housing        |
| <input type="checkbox"/> Agricultural & Forestry Resources  | <input type="checkbox"/> Greenhouse Gas Emissions      | <input type="checkbox"/> Public Services           |
| <input type="checkbox"/> Air Quality                        | <input type="checkbox"/> Hazards & Hazardous Materials | <input type="checkbox"/> Recreation                |
| <input type="checkbox"/> Biological Resources               | <input type="checkbox"/> Hydrology/Water Quality       | <input type="checkbox"/> Tribal Resources          |
| <input type="checkbox"/> Cultural Resources                 | <input type="checkbox"/> Land Use/Planning             | <input type="checkbox"/> Transportation            |
| <input type="checkbox"/> Energy                             | <input type="checkbox"/> Mineral Resources             | <input type="checkbox"/> Utilities/Service Systems |
| <input type="checkbox"/> Mandatory Findings of Significance | <input type="checkbox"/> Noise                         | <input type="checkbox"/> Wildfire                  |

### DETERMINATION

On the basis of this initial evaluation:

- I find that the proposed project COULD NOT have a significant effect on the environment, and a NEGATIVE DECLARATION will be prepared.
- I find that although the proposed project could have a significant effect on the environment, there will not be a significant effect in this case because revisions in the project have been made by or agreed to by the project proponent. A MITIGATED NEGATIVE DECLARATION will be prepared.
- I find that the proposed project MAY have a significant effect on the environment, and an ENVIRONMENTAL IMPACT REPORT is required.
- I find that the proposed project MAY have a "potentially significant impact" or "potentially significant unless mitigated" impact on the environment, but at least one effect 1) has been adequately analyzed in an earlier document pursuant to applicable legal standards, and 2) has been addressed by mitigation measures based on the earlier analysis as described on attached sheets. An ENVIRONMENTAL IMPACT REPORT is required, but it must analyze only the effects that remain to be addressed.
- I find that although the proposed project could have a significant effect on the environment, because all potentially significant effects (a) have been analyzed adequately in an earlier EIR or NEGATIVE DECLARATION pursuant to applicable standards, and (b) have been avoided or mitigated pursuant to that earlier EIR or NEGATIVE DECLARATION, including revisions or mitigation measures that are imposed upon the proposed project, nothing further is required.

  
 \_\_\_\_\_  
 Signature  
 Heidi Kunstal  
 \_\_\_\_\_  
 Printed Name

5-20-2022  
 \_\_\_\_\_  
 Date

### 3.0 Environmental Impacts Evaluation and Checklist

- 1) A brief explanation is required for all answers except "No Impact" answers that are adequately supported by the information sources a lead agency cites in the parentheses following each question. A "No Impact" answer is adequately supported if the referenced information sources show that the impact simply does not apply to projects like the one involved (e.g., the project falls outside a fault rupture zone). A "No Impact" answer should be explained where it is based on project-specific factors as well as general standards (e.g., the project will not expose sensitive receptors to pollutants, based on a project-specific screening analysis).
- 2) All answers must take account of the whole action involved, including off-site as well as on-site, cumulative as well as project-level, indirect as well as direct, and construction as well as operational impacts.
- 3) Once the lead agency has determined that a particular physical impact may occur, then the checklist answers must indicate whether the impact is potentially significant, less than significant with mitigation, or less than significant. "Potentially Significant Impact" is appropriate if there is substantial evidence that an effect may be significant. If there are one or more "Potentially Significant Impact" entries when the determination is made, an EIR is required.
- 4) "Negative Declaration: Less Than Significant with Mitigation Incorporated" applies where the incorporation of mitigation measures has reduced an effect from "Potentially Significant Impact" to a "Less Than Significant Impact." The lead agency must describe the mitigation measures, and briefly explain how they reduce the effect to a less than significant level (mitigation measures from "Earlier Analyses," as described in (5) below, may be cross-referenced).
- 5) Earlier analyses may be used where, pursuant to the tiering, program EIR, or other CEQA process, an effect has been adequately analyzed in an earlier EIR or negative declaration. Section 15063(c)(3)(D). In this case, a brief discussion should identify the following:
  - a) Earlier Analysis Used. Identify and state where they are available for review.
  - b) Impacts Adequately Addressed. Identify which effects from the above checklist were within the scope of and adequately analyzed in an earlier document pursuant to applicable legal standards, and state whether such effects were addressed by mitigation measures based on the earlier analysis.
  - c) Mitigation Measures. For effects that are "Less Than Significant with Mitigation Measures Incorporated," describe the mitigation measures which were incorporated or refined from the earlier document and the extent to which they address site-specific conditions for the project.
- 6) Lead agencies are encouraged to incorporate into the checklist references to information sources for potential impacts (e.g., general plans, zoning ordinances). Reference to a previously prepared or outside document should, where appropriate, include a reference to the page or pages where the statement is substantiated.
- 7) Supporting Information Sources: A source list should be attached, and other sources used or individuals contacted should be cited in the discussion.
- 8) This is only a suggested form, and lead agencies are free to use different formats; however, lead agencies should normally address the questions from this checklist that are relevant to a project's environmental effects in whatever format is selected. –
- 9) The analysis of each issue should identify:
  - a) the significance criteria or threshold used to evaluate each question; and
  - b) the mitigation measure identified, if any, to reduce the impact to less than significance.

<b>AESTHETICS</b>	<b>Potentially Significant</b>	<b>Less Than Significant With Mitigation</b>	<b>Less Than Significant</b>	<b>No Impact</b>
Except as provided in Public Resources Code Section 21099, would the project:				
a) Have a substantial adverse effect on a scenic vista?			X	
b) Substantially damage scenic resources, including, but not limited to, trees, rock outcroppings, and historic buildings within a state scenic highway?				X
c) Substantially degrade the existing visual character or quality of public views of the site and its surroundings (Public views are those that are experienced from a publicly accessible vantage point)? If the project is in an urbanized area, would the project conflict with applicable zoning and other regulations governing scenic quality?				X
d) Create a new source of substantial light or glare which would adversely affect day or nighttime views in the area?				X

### Setting

The project site is located between N. Pebble Beach Drive and the Pacific Ocean in an area previously developed with a paved parking lot and asphalt path to the beach. Viewshed characteristics at the site include views of the ocean and offshore rocks including Castle Rock to the west, north and south. To the east, is the Marhoffer Creek watershed and open grazing lands.

### Discussion

a) Pebble Beach Drive (North & South) is identified in the Visual Resource Inventory of the County's Coastal Element (Land Use Plan or LUP) as a view corridor. The project site is identified as one of three viewpoints along Pebble Beach Drive. While designated in the Visual Resource Inventory, N. Pebble Beach Drive and the project site are not designated as highly scenic coastal areas in the County's Local Coastal Program (Implementation Plan/IP or LUP) or as a scenic vista.

The project site is used as public access. The only visual change will be the construction of a low profile ramp to provide beach access compliant with the American with Disabilities Act (ADA). All other aspects of the project are in-kind improvements to the parking lot that will not create new visual impacts. There will be short term and temporary impacts while construction and rehabilitation activities are on-going. A Visual Assessment was completed by LACO for the project which is attached to this Initial Study. It provides a visual representation of what the new ramp will look like. A **less than significant** impact is expected.

b) Based on California Scenic Highway Mapping System information, no designated state scenic highways are found adjacent to or within view of the project area<sup>2</sup>. There is one officially designated State Scenic Highway section within Del Norte County along Highway 101 with scenic ocean views through Del Norte Redwoods state park, although Highway 101 for its entire length in Del Norte County

<sup>2</sup> Caltrans, California State Scenic Highway System Map. Accessed May 14, 2022.

has been identified by the State Scenic Highway Mapping System as eligible for State listing. The project site is not visible from the highway due to distance and intervening vegetation. As such, there will be **no impact** on scenic resources.

**c)** As noted under section a) above the project site is visible from N. Pebble Beach Drive and adjacent parcels. The only visual change will be the construction of a low profile ramp to provide beach access compliant with the American with Disabilities Act (ADA). All other aspects of the project are in-kind improvements to the parking lot and gate that will not create new visual impacts. There will be short term and temporary impacts while construction and rehabilitation activities are on-going. Upon project completion, the typical view will not be significantly altered from current conditions and **no impact** is expected. Figure 3 is a visual graphic of the proposed ramp.

**d)** The project will not create any lighting sources. In addition, temporary construction activities associated with the project will be conducted during daylight hours and will avoid excessive light pollution from the site. **No impact** is expected.

<b>AGRICULTURE AND FOREST RESOURCES</b>	<b>Potentially Significant</b>	<b>Less Than Significant With Mitigation</b>	<b>Less Than Significant</b>	<b>No Impact</b>
Would the project:				
a) Convert Prime Farmland, Unique Farmland, or Farmland of Statewide Importance (Farmland), as shown on the maps prepared pursuant to the Farmland Mapping and Monitoring Program of the California Resources Agency, to non-agricultural use?				X
b) Conflict with existing zoning for agricultural use, or a Williamson Act contract?				X
c) Conflict with existing zoning for, or cause rezoning of, forest land (as defined in Public Resources Code section 12220(g), timberland (as defined by PRC section 4526), or timberland zoned Timberland Production (as defined by Government Code section 51104(g))?				X
d) Result in the loss of forest land or conversion of forest land to non-forest use?				X
e) Involve other changes in the existing environment which, due to their location or nature, could result in conversion of Farmland, to non-agricultural use or conversion of forestland to non-forest use?				X

**Setting**

Maps prepared pursuant to California’s Farmland Mapping and Monitoring Program (FMMP) include Del Norte County as an “Area Not Mapped” and, therefore do not categorize the project area as having any

type of Important Farmland (California Department of Conservation 2018),. No agricultural activities exist on the parcel. Based on imagery found on the CaliforniaCoastline.org website, the property has not been used for agricultural use or for the harvesting of timbers since at least 1972. The project site is zoned for agricultural uses per the County’s Title 21 Coastal Zoning (A-5); however, the Coastal Land Use Plan Map designates the property as Public Facility which is reflective of its present use. There are no parcels under Williamson Act contract within or adjacent to the project site.

a) The project site does not include Prime Farmland, Unique Farmland, or Farmland of Statewide importance as shown on maps prepared pursuant to the FMMP. The project would not convert FMMP designated Prime Farmland, Unique Farmland, or Farmland of Statewide Importance to a non-agricultural use, therefore, **no impact** would occur.

b-d) The neither the subject parcel nor other parcels in the vicinity are under Williamson Act contract or zoned for Timberland Production (Del Norte County Web GIS). The project would not conflict with agricultural or forest land zoning or Williamson Act contracts and would not result in the loss of forest land, therefore, **no impact** would occur.

e) The project would not involve changes in the existing environment which would result in conversion of farmland to non-agricultural use or conversion of forest land to non-forest use. The project site is an existing public access point to the ocean. All planned work is within the existing parking lot and path way. No forest land or timberland exists at the project site or adjacent parcels and the project would not result in the loss or conversion of forest land Therefore, a **no impact** would occur.

<b>AIR QUALITY</b>	<b>Potentially Significant</b>	<b>Less Than Significant With Mitigation</b>	<b>Less Than Significant</b>	<b>No Impact</b>
Would the project:				
a) Conflict with or obstruct implementation of the applicable air quality plan?			X	
b) Result in a cumulatively considerable net increase of any criteria pollutant for which the project region is non-attainment under an applicable federal or state ambient air quality standard?			X	
c) Expose sensitive receptors to substantial pollutant concentrations?			X	
d) Result in other emissions (such as those leading to odors) adversely affecting a substantial number of people?			X	

**Setting**

The project site lies within the North Coast Air Basin (NCAB), under the authority of the North Coast Unified Air Quality Management District (NCAQMD) and the California Air Resources Board (CARB). The NCAB includes Humboldt County, Mendocino County, and Northern Sonoma County. In the NCAB, air quality is predominantly influenced by the climatic regimes of the Pacific. In summer, warm ground surfaces draw cool air in from the coast, creating frequent thick fogs along the coast and making

northwesterly winds common. In winter, precipitation is high, surface wind directions are highly variable, and weather is more affected by oceanic storm patterns<sup>3</sup>.

Del Norte County generally has good air quality and is in attainment for federal and state air quality standards.

The NCUAQMD has not formally adopted significance thresholds but rather recommends using the Particulate Matter Attainment Plan (1995), and the Best Available Control Technology (BACT) emission rates for stationary sources as defined and listed in the NCUAQMD Rule 110, New Source Review, and Prevention of Significant Deterioration, Section 5.1 - BACT. All projects are subject to adopted NCUAQMD rules and regulations in effect at the time of construction.

### Discussion

**a)** The project is expected to create additional vehicle trips by construction workers and delivery vehicles. It is unlikely construction trips will create a substantial increase in fugitive dust. Earth moving and other ground disturbing activity may generate fugitive dust.

In an effort to minimize the amount of fugitive dust from construction activities at the site, the contractor will employ best management practices including covering spoils and watering active construction areas as necessary. This impact will be limited to the construction phase of the project.

Additional air pollutants are expected to be generated from passenger vehicle and construction equipment exhaust. In an effort to minimize exhaust emissions, the contractor will encourage carpooling to the site when possible and utilize best management practices for construction equipment including shutting of equipment when not in use and ensuring that all equipment is fitted with required CARB exhaust systems and is in good working order.

Project equipment includes: Track and tire equipment including excavators, dump trucks, carrier crawler, bulldozers, loaders, crew trucks, and low boys.

Emissions from the project will be limited to the construction phase. Maintaining equipment in good working order, implementing applicable BMPs and complying with state regulations for exhaust systems will result in no conflict with existing air quality plans and a **less than significant** impact.

**b)** Del Norte County is in attainment for all Federal and State criteria air pollutants. The attainment status for each criteria air pollutant is based on measurements collected at monitoring stations throughout the county. Monitoring results have shown that the principal pollutant in the NCAB is PM10.

As noted above under Section (a), the project will create a temporary increase of PM10 emissions from earth moving work and vehicle exhaust.

Increase in criteria pollutants, including PM10, generated by the project will be limited and temporary. As such, there will be a **less than significant** impact.

**c, d)** The project is located between the ocean and N. Pebble Beach Drive in the Crescent City urban

---

<sup>3</sup> North Coast Unified Air Quality Management District (NCUAQMD).  
<https://www.ncuaqmd.org/index.php?page=aqplanning.ceqa> Accessed July 22, 2021.

area. Any air quality emissions will be limited and temporary and there are no project activities that are anticipated to create a substantial amount of odor. As such, there will be a **less than significant** impact related to sensitive receptors or other emissions such as odors.

<b>BIOLOGICAL RESOURCES</b>	<b>Potentially Significant</b>	<b>Less Than Significant With Mitigation</b>	<b>Less Than Significant</b>	<b>No Impact</b>
Would the project:				
a) Have a substantial adverse effect, either directly or through habitat modifications, on any species identified as a candidate, sensitive, or special status species in local or regional plans, policies, or regulations, or by the California Depart. of Fish and Wildlife or U.S. Fish and Wildlife Service?		X		
b) Have a substantial adverse effect on any riparian habitat or other sensitive natural community identified in local or regional plans, policies, and regulations or by the California Depart. of Fish and Wildlife or U.S. Fish and Wildlife Service?		X		
c) Have a substantial adverse effect on state or federally protected wetlands (including, but not limited to, marsh, vernal pool, coastal, etc.) through direct removal, filling, hydrological interruption, or other means?		X		
d) Interfere substantially with the movement of any native resident or migratory fish or wildlife species or with established native resident or migratory wildlife corridors, or impede the use of native wildlife nursery sites?			X	
e) Conflict with any local policies or ordinances protecting biological resources, such as a tree preservation policy or ordinance?		X		
f) Conflict with the provisions of an adopted Habitat Conservation Plan, Natural Community Conservation Plan, or other approved local, regional, or state habitat conservation plan?				X

**Physical Setting**

The Pebble Beach Site comprises beach strand habitat with ground surface elevations ranging between 0 and 15 feet amsl. The topography is shoreline on the western portion of the site and irregular dune formations on the eastern portion of the site, with a paved parking area (approximately 20 parking sites) and access gate adjacent to North Pebble Beach Drive. Directly south of the site is a drainage fed by a culvert passing beneath North Pebble Beach Drive, which drains Marhoffer Creek. The proposed Project area comprises primarily perennial grasses and groundcovers.



The project site is located on APN 120-020-022. The majority of the parcel is undeveloped with the exception of the project site and a second parking area with interpretative panels located 775 feet to the north. Farmed wetlands and grazing lands lie to the east of the project site, and are separated from the project site by N. Pebble Beach Drive. Lands to the south are undeveloped with irregular dune formations.

### Discussion

a) No biological resources are expected to be adversely affected by the project because the project is designed to prevent impacts to any state or federally listed species through avoidance measures.

Details on botanical and wildlife species encountered within the project area are listed below.

#### *Botanical Species*

Field surveys of the project area were conducted on May 5, 2021, and May 8, 2021. LACO's biologist and botanist, Gary Lester, conducted the surveys. U.S. Geological Survey (USGS) topographic maps, aerial photography maps, and the California Department of Fish and Wildlife (CDFW, 2021) California Natural Diversity Database (CNDDDB; for the Smith River and Crescent City Quads), relating to the Project area were reviewed prior to and during the surveys for potential sensitive species occurrence.

The biological survey was conducted following CDFW protocol (2018). An intuitively controlled, seasonally appropriate survey was conducted that sampled the identified potential habitat. Plants were identified to the lowest taxonomic level (genus or species) necessary for rare plant identification. The scientific nomenclature follows the Jepson Manual (Baldwin, et. al. 2012).

All species included on Lists 1 to 4 (herein referred to as "sensitive species") of the California Native Plant Society's (CNPS) Inventory of Rare and Endangered Vascular Plants of California (2021) were reviewed to determine potential presence in the project site in the *Technical Memorandum: Biological and Rare Plant Survey and Waters/Wetland Assessment Wavcrest Drive and North Pebble Beach Drive Access Project (Biological and Rare Plant Survey)* prepared for the project by LACO. The CNPS inventory includes species listed as rare or endangered by the Federal and State governments.

Only coastal dune habitat was present at the project site, eliminating many sensitive species specific to other types of habitats. Three (3) sensitive plant species were observed on-site, including: seaside pea (*Lathyrus japonicus*), Wolf's evening primrose (*Oenothera wolfii*), and sand dune phacelia (*Phacelia argentea*). The seaside pea is known from two (2) historical sightings in 1939, approximately 750 feet southeast of project site, adjacent to North Pebble Beach Drive and was observed on-site. The location of the on-site plant is shown in Figure 1 taken from the *Biological and Rare Plant Survey*. It is roughly 230 feet south of the limit of project impact as shown on Figure 2. No work is planned in this area. This species has a CRPR of 2B.1, defined as rare, threatened, or endangered in California, but more common elsewhere.

The next sensitive plant species identified was the Wolf's evening primrose which is known from multiple sightings in 1987, with one (1) sighting approximately 1,500 feet north of the Pebble Beach Site adjacent to North Pebble Beach Drive and was observed on-site. Figure 1 identifies the plants being immediately south of the limit of project impact within areas also designated as wetlands. No work is planned in this area. This species has a CRPR of 1B.1, defined as rare, threatened, or endangered in California and elsewhere, seriously threatened in California.

Lastly, the sand dune phacelia is known from historical sightings (1939) and a 1987 sighting approximately 500 yards south of the Pebble Beach Site adjacent to North Pebble Beach Drive and was observed on-site. Figure 1 shows the location of the plants to the north and south of the limit of project impact. The closest plant to the north is 80 feet from the limit of project impact and the closest plant to the south is 100 feet from the limit of project impact. No work is planned near the plants. This species has a CRPR of 1B.1, defined as rare, threatened, or endangered in California and elsewhere, seriously threatened in California.

The sensitive plants are considered environmentally sensitive habitat areas (ESHA) in the County's Local Coastal Program.

The County's *Coastal Land Use Plan* Marine and Water Resources Policy VI.C.6 states,

"Environmentally sensitive habitat areas shall be protected against any significant disruption of habitat values, and only uses dependent on such resources shall be allowed within such areas development in areas adjacent to environmentally sensitive habitat areas shall be sited and designed to prevent impacts which would significantly degrade such areas, and shall be compatible with the continuance of such habitat areas."

The Coastal Commission *Standards for Siting Development Adjacent to Environmentally Sensitive Habitat Areas* has been considered for the proposed project. Below is a summary of the standards to be analyzed.

1. Biological significance of adjacent lands.

With regard to the sand dune phacelia, a minimum of 80-foot setback exists, for the seaside pearl, a minimum 230-foot setback exists and for the Wolf's evening primrose, a minimum of 5-foot setback can be designed into the project. The very northeast tip of the mapped area abuts the parking lot. Access paths are allowed in buffer areas as it is seen as having a beneficial effect in the protection of habitat areas from further disturbance. Improved access at this location will limit beachgoers from making their own paths to the beach which may impair ESHA.

2. Sensitivity of species to disturbance.

The distance of the project area to the location of the plants will protect the plant from being physically disturbed. Protective fencing will be placed in the parking area to prevent disturbance to the Wolf's evening primrose which is closest in proximity to the project site. All other identified plants are well outside of areas designated for construction staging or construction activities.

3. Susceptibility of parcel to erosion.

The project will not result in any impacts to the sensitive plants identified. All drainage will be directed toward the ocean and away from sensitive plants or natural sensitive communities.

4. Use of natural topographic features to locate development.

The project area is already developed and the only "new" development is the construction of the ramp which will be located in previously disturbed areas (i.e. parking area and existing pathway).

5. Use of existing cultural features to locate buffer zones.

All buffers are to be measured from the existing developed area which includes the existing path way and the parking lot.

#### 6. Lot configuration and location of existing development.

As noted throughout this document, the only “development” is the improvement of the existing public access pathway from asphalt to an ADA compliant ramp. The footprint of the access pathway will be used. No encroachment into existing ESHA buffers is planned.

#### 7. Type and scale of development proposed.

The proposed project is relatively modest and as noted fits within the existing footprint of previously developed and disturbed areas that lack ESHA. There is need or way to design additional buffer into the project.

The project has been designed to maintain the functional capacity of ESHA by avoiding any new impacts through the maintenance of existing buffers. Additionally, the improved public access will reduce impacts to the ESHA as it will encourage beachgoers to use the ramp.

A qualified biologist shall identify all plants within 100 feet of the construction area, the contractor made aware of the sensitive plants and temporary fencing placed to protect the plants.

See Mitigation Measure BIO-1 below.

#### *Wildlife Species*

Field surveys of the project area were conducted on May 5, 2021, and May 8, 2021. LACO’s biologist and botanist, Gary Lester, conducted the surveys. U.S. Geological Survey (USGS) topographic maps, aerial photography maps, and the California Department of Fish and Wildlife (CDFW, 2021) California Natural Diversity Database (CNDDDB; for the Smith River and Crescent City Quads), relating to the Project area were reviewed prior to and during the surveys for potential sensitive species occurrence.

Sensitive animal species potentially present in the project area include the Western snowy plover (*Charadrius nivosus nivosus*), Rufous hummingbird (*Selaphosrus rufus*), Northern harrier (*Circus hudsonious*), Black-capped chickadee (*Poecile atricapilus*), Western bumble bee (*Bombus occidentalis*), Yontocket Satyr (*Coenonympha tulia*), Oregon silverspot butterfly (*Speyeria zerene hippolyta*) and the Rocky coast Pacific sideband snail (*Monadenia fidelis pronotis*). According to the results of the Biological and Rare Plant Survey, limited suitable habitat exists in the project area for Rufous hummingbird, Norther harrier, Blacked-capped Chickadee, Rocky coast Pacific sideband snail and Yontocket satyr. No protection recommendations were included in the Biological and Rare Plant Survey for any of these species. Suitable habitat was identified for the Western bumblebee but no protection recommendations were proposed. Likewise, suitable habitat for foraging for the Oregon silverspot butterfly was identified but no protection recommendations provided. Very limited broad habitat was identified in the project area for the Western snowy plover. Again, no protection recommendation was made. The County shall consult with the California Department of Fish and Wildlife to determine whether a protection mitigation measure should be added for the benefit of the Western snowy plover. If a pre-construction survey is needed, it will be incorporated into the project approval. Alternatively, the work window can be modified to avoid potential conflicts.

With the incorporation of the above referenced design features, project impacts will be **less than significant with mitigation**.

#### **Mitigation Measure BIO-1: PROTECTION OF SENSITIVE PLANT SPECIES (ESHA)**

Where construction is proposed within 100 feet of known sensitive plant population locations, each population should be clearly marked in the field by a qualified biologist and shown to the project contractor. Temporary fencing will be used to prevent accidental disturbance of the special status plants during construction.

*Timing/Implementation: Prior to project initiation.*

*Enforcement: County Community Development, California Department of Fish and Wildlife*

*Monitoring: Ongoing during construction period by County Community Development Department staff.*

### **Mitigation Measure BIO-2: Worker Environmental Awareness Program (WEAP)**

All workers performing construction activities shall receive training regarding the environmental sensitivity of the site and the need to minimize impacts. Training regarding sensitive habitats, special-status species, laws and regulations, permit conditions, BMPs, safety, and trash removal will be covered.

*Timing/Implementation: Prior to project initiation.*

*Enforcement: County Community Development, California Department of Fish and Wildlife*

*Monitoring: Ongoing during construction period by County Community Development Department staff.*

**b)** The project area does not include any riparian habitat as it is not located immediately adjacent to a creek or stream. The area immediately south of the limit of project impact does have slough sledge (*carex obnupta- Juncus lescurii*) which is identified as a California Sensitive Natural Community by the California Department of Fish and Wildlife. (Source: California Sensitive Natural Communities, California Department of Fish and Wildlife, August 18, 2021). The slough sledge is located immediately south of the limit of project area and parallels the longstanding access road to the beach and the area identified as having Wolf's evening primrose. The limit of project impact will be temporarily fenced required and is described in Mitigation Measure BIO-1. With the incorporation of the above fencing, project impacts will be **less than significant** with mitigation.

**c)** The wetland delineation was performed on March 2, 2021. No significant rainfall occurred in the week prior to the delineation. The delineation was guided by visual assessment of vegetation and potential hydrology, with soil pits dug at various locations to verify hydric soil conditions and validate wetland boundaries. No areas of potential hydrology were identified and no three-parameter wetlands required soils verification. Delineation of single parameter wetlands was verified using vegetation indicator status.

The project area was examined to determine the presence of federal jurisdictional waters (three-parameter wetlands or open waters) and the presence of CCC jurisdiction waters (one-parameter wetland or open waters). With regard to federal jurisdictional waters, one area was identified during the field survey as federal waters (See Figure 1 of *Biological and Rare Plant Survey*), identified as the Pacific Ocean, which covers the majority of the Project area and is identified as tidal waters of the U.S. The total area of waters of the U.S. observed at the Pebble Beach Site was 2.76 acres. Roughly 22 feet of the proposed ramp is located within this area.

With regard to CCC jurisdiction waters (one-parameter wetland or open waters), four (4) areas were identified during the field survey as waters of the state (See Figure 1 of *Biological and Rare Plant Survey*). They include the tidal waters of the U.S. as noted above and three (3) areas containing populations of hydrophytic vegetation. The latter are the slough sledge noted under item b) as a natural community. The total area of waters of the state observed at the project area was 2.90 acres.

The three (3) areas containing hydrophytic vegetation are located on the southeast portions of the site on slightly raised dune topography and are dominated by *Juncus lescurii* or slough sedge, a facilitative wetland species. These areas occupy 0.143 acres and are identified as one-parameter wetlands and are jurisdictional waters of the state.

The Pacific Ocean, which makes up a majority of the site and makes up the western boundary, was identified through median high tide indicators and occupies 2.76 acres of the Project area.

Marine and Water Resources VII.D.4.f states,

Development in areas adjacent to environmentally sensitive habitat areas shall be sited and designed to prevent impacts which could significantly degrade such areas, and shall be compatible with the continuance of such habitat areas. The primary tool to reduce the above impacts around wetlands between the development and the edge of the wetland shall be a buffer of one-hundred feet in width. A buffer of less than one-hundred feet may be utilized where it can be determined that there is no adverse impact on the wetland. A determination to utilize a buffer area of less than one-hundred feet shall be done in cooperation with the California Department of Fish and Game and the County's determination shall be based upon specific findings as to the adequacy of the buffer to protect the identified resource.

The County will coordinate with the California Department of Fish and Wildlife for a reduction of the wetland buffer for the slough sedge. In all cases, the slough sedge will be avoided and protected during the construction period. Mitigation Measure BIO-3 applies to the protection of the slough sedge.

The project is unable to avoid impacting the open waters of the U.S. through the construction of the ramp. As noted earlier, the ramp extends approximately 22 feet by 6 feet wide (132 square feet or .003 ac) into the mapped waters of the U.S. The area to be disturbed is already developed with an existing asphalt pathway and ice plant. Mitigation Measure BIO-4 is added to add a mitigation that would result in the planting of native plants within the impacted project area that presently has non-native ice plant.

With the implementation of the above project design elements, any impacts to wetlands will be considered **less than significant** with mitigation.

### **Mitigation Measure BIO-3: PROTECTION OF WETLANDS**

Where construction is proposed within 100 feet of mapped wetlands as shown on Figure 1, temporary fencing will be used to prevent accidental disturbance of the wetlands. An exception will be along 22 feet of the pathway which is shown as being located within Waters of the U.S. (Pacific Ocean) where impact can't be avoided.

*Timing/Implementation: Prior to project initiation.*

*Enforcement: County Community Development, California Department of Fish and Wildlife*

*Monitoring: Ongoing during construction period by County Community Development Department staff.*

**Mitigation Measure BIO-4: Native Plants Mitigation Plan.**

To mitigate for the .003 ac. (132 sq. ft. ) impact to the wetland resulting from the ramp construction, the County shall prepare a plan for the planting of native plants to replace the non-native ice plant located within the project impact area. A minimum area of 400 square feet shall be planted. Ideally, the planting will be on the north side of the ramp where the ice plant is denser and there are no conflicts with sensitive plants.

The success criterion for any seeded, planted, and/or relocated plants shall be full replacement at a 1:1 ratio after five years. Monitoring surveys of the seeded or planted individuals shall be conducted and reported on annually for a minimum of five years, to ensure that the success criterion can be achieved at year 5. If it appears the success criterion would not be met after five years, contingency measures may be applied. Such measures shall include, but not be limited to: additional seeding and planting; altering or implementing weed management activities; or, introducing or altering other management activities.

Approval of the Native Plants Mitigation Plan shall be made by the County in consultation with the California Department of Fish and Wildlife.

*Timing/Implementation: Upon completion of project construction.*

*Enforcement: County Community Development, California Department of Fish and Wildlife*

*Monitoring: Annual monitoring surveys for a minimum of five years depending on success of mitigation per success criterion provided in the Native Plant Mitigation Plan. Contingency measures will be considered if success criterion not met within five years.*

- d) Based on the *Biological and Rare Plant Survey* prepared by LACO, the project will not substantially interfere with the movement of any fish or wildlife species or with established native resident or migratory wildlife corridors, or impede the use of native wildlife nursery sites. As such, a **less than significant** impact is anticipated.
- e) The project does not conflict with any local policies or ordinances protecting biological resources that have not been identified under a-c) and addressed in Mitigation Measures BIO-1 through 4. With the incorporation of the Mitigation Measures, project impacts will **be less than significant** with mitigation.
- f) There are no adopted Habitat Conservation Plans, Natural Community Conservation Plans, or other approved conservation plans with which the project would conflict. As such, **no impact** would occur.

<b>CULTURAL RESOURCES</b>	<b>Potentially Significant</b>	<b>Less Than Significant With Mitigation</b>	<b>Less Than Significant</b>	<b>No Impact</b>
Would the project:				
a) Cause a substantial adverse change in the significance of a historical resource pursuant to §15064.5?			X	
b) Cause a substantial adverse change in the significance of an archaeological resource		X		

<b>CULTURAL RESOURCES</b>	<b>Potentially Significant</b>	<b>Less Than Significant With Mitigation</b>	<b>Less Than Significant</b>	<b>No Impact</b>
pursuant to §15064.5?				
c) Disturb any human remains, including those interred outside of dedicated cemeteries?		X		

**Setting**

The general area has a long history of human use associated with the Pacific Ocean including Native Americans and later with European settlers beginning around 1850. The project area is within the ethnographic territory of the Tolowa Dee-ni’ and the general area has high potential for archaeological sites. The Tolowa Dee-ni’ Nation and the Elk Valley Rancheria were consulted through the County’s consultant and were sent a Tribal Consultation Notification per AB 52. Comments were received from the Tolowa Dee-ni’ Nation which is incorporated into Mitigation Measures discussed below.

A *Phase 1 Cultural Resource Inventory Report* was completed by a licensed archaeologist from DZC Archaeology and Cultural Resource Management Consulting. The report recommends a finding of no impacts to historical, archaeological, or Tribal Cultural Resources as defined by CEQA, and a finding of No Effects as defined by the National Environmental Policy Act (NEPA).

**Regulatory Context**

The Del Norte County General Plan Chapter 5: Recreational and Cultural Resources includes policies for the inadvertent discovery of artifacts or human remains.

In the event that human remains are discovered, work will cease immediately in the area of the find and comply with California State Health and Safety Code 7050.5 which states that no further disturbance shall occur until the County Coroner has made the necessary findings as to the origin and disposition pursuant to California Public Resources Code, Section 5097.98. Work shall not resume in the area until proper disposition is complete as part of California Public Resources Code, Section 5097.98.

**Discussion**

**a, b)** The project site is not known to contain archaeological, historical, or tribal cultural resources and is not located on any mapped cultural sites. As mentioned above, the project area has been reviewed by local tribal groups and no archaeological sites were found. Additionally, no structures over 45 years of age will be removed as part of the project.

There is potential for subsurface excavation activities to uncover previously unknown subsurface archaeological resources. Implementation of standard cultural resource construction procedures as outlined in the Del Norte County General Plan policies noted above regarding inadvertent discovery would reduce potential impacts to a less than significant level. No significant archaeological or historic resources were observed during investigation. Based on these findings, the project’s potential to cause a substantial adverse change in the significance of a historical or archaeological resource would be **less than significant** with mitigation with regard to archeological resources and less than significant with regard to historical resources.

**Mitigation Measure CUL-1 Inadvertent Discovery Protocol**

The following inadvertent Discovery Protocol stipulations shall be included as a condition of project approval, and that these stipulations are included on all construction/design plans:

1. If buried cultural materials are encountered during construction, it is required that work stop in that immediate area until a qualified archaeologist can evaluation the nation and significance of the find (CCR 15064.5(f));
2. A list of qualified archaeologist local to the project may be obtained from the Del Norte County Community Development Department located at 981 H Street, Suite 110, Crescent City, CA.

c) There are no known human remains on the project site. Implementation of standard cultural resource construction procedures regarding inadvertent discovery, including Del Norte County General Plan policies and California Health and Safety Code §7050.5, would reduce potential impacts to a **less than significant with mitigation** level. The preparer of the Phase 1 Cultural Resource Inventory Report recommends that the following Mitigation Measure be added to the project approval.

**Mitigation Measure CUL-2 Discovery of Human Remains**

The following Inadvertent Discovery of Human Remains Protocol stipulations shall be included in all project construction/design plans:

1. If any human remains are encountered during any phase of construction, all earth-disturbing work shall stop within 50 feet of the find.
2. The county coroner shall be contacted to determine whether investigation of the cause of death is required as well as to determine whether the remains may be Native American in origin.
3. Should Native American remains be discovered, the county coroner must contact the Native American Heritage Commission (NAHC). The NAHC will then determine those persons it believes to be most likely descended from the deceased Native American(s).
4. Contact Information for the current County Coroner.

<b>ENERGY</b>	<b>Potentially Significant</b>	<b>Less Than Significant With Mitigation</b>	<b>Less Than Significant</b>	<b>No Impact</b>
Would the project:				
a) Result in potentially significant environmental impact due to wasteful, inefficient, or unnecessary consumption of energy resources, during project construction or operation?				X
b) Conflict with or obstruct a state or local plan for renewable energy or energy efficiency?				X

**Discussion**

a,b) Construction of the project will require some energy use including grading and construction of the ramp. However, as this is a public access improvement project with no long term energy use associated with it, it is not anticipated that construction will create a significant environmental impact due to wasteful consumption of energy resources.



The project will not result in potentially significant environmental impact due to wasteful, inefficient, or unnecessary consumption of energy resources, during project construction or operation; and will not conflict with or obstruct a state or local plan for renewable energy or energy efficiency. Therefore, **no impact** on energy resources will occur.

<b>GEOLOGY AND SOILS</b>	<b>Potentially Significant</b>	<b>Less Than Significant With Mitigation</b>	<b>Less Than Significant</b>	<b>No Impact</b>
Would the project:				
a) Directly or indirectly cause potential substantial adverse effects, including the risk of loss, injury, or death involving:				
i) Rupture of a known earthquake fault, as delineated on the most recent Alquist-Priolo Earthquake Fault Zoning Map issued by the State Geologist for the area or based on other substantial evidence of a known fault? Refer to Division of Mines and Geology Special Publication 42.			X	
ii) Strong seismic ground shaking?			X	
iii) Seismic-related ground failure, including liquefaction?			X	
iv) Landslides?			X	
b) Result in substantial soil erosion or the loss of topsoil?			X	
c) Be located on a geologic unit or soil that is unstable or that would become unstable as a result of the project, and potentially result in onsite or offsite landslide, lateral spreading, subsidence, liquefaction or collapse?				X
d) Be located on expansive soil, as defined in Table 18-1-B of the Uniform Building Code (1994), creating substantial direct or indirect risks to life or property?				X
e) Have soils incapable of adequately supporting the use of septic tanks or alternative wastewater disposal systems where sewers are not available for the disposal of wastewater?				X
f) Directly or indirectly destroy a unique paleontological resource or site or unique geologic feature?				X

### Setting

The Northern California coast is located in the southern portion of the Cascadia Subduction Zone and is a seismically active area noted by numerous fault zones (Clarke and Carver 1992). The region as a whole is subject to potentially strong seismic ground shaking with earthquakes of 8.4 magnitude or greater (Clarke and Carver 1992). Multiple earthquake sources capable of generating moderate to strong

earthquakes are in close proximity to the project site (as noted above) and strong seismic shaking is a regional hazard that could cause major damage to the project area.

Due to the proximity to active seismic sources, localized areas in Del Norte County may be subject to secondary seismic effects, such as liquefaction, lateral spread, and seismically-induced land sliding. Liquefaction is the sudden loss of soil shear strength due to a rapid increase of soil pore water pressures caused by cyclic loading from a seismic event.

**Discussion**

**a.i-iv)** The project will not significantly impact geology, soils or hydrology. The Project will result in improved public access to the beach. Effective erosion control measures will be in place at all times during construction, worksites will be winterized each day when heavy rainfall is forecasted and an adequate supply of erosion control materials (e.g. gravel, straw bales and shovels) will be maintained onsite to facilitate a quick response to unanticipated storm events. Disturbed soils will be restored and revegetated at project completion to prevent erosion and ensure rapid establishment of native vegetation. Based on location, geotechnical investigations, and project design elements, impacts related to rupture of faults, strong seismic ground shaking, liquefaction, and landslides will be **less than significant**.

**b)** Based on implementation of standard construction related erosion control measures and project design, impacts pertaining to soil erosion will be **less than significant**.

**c,d)** The project does not involve any construction on expansive soils and **no impact** will occur.

**e)** No septic or sewer systems are proposed as part of the project. As such, **no impact** will occur.

**f)** No unique paleontological or geological resources are known to exist at the project site. As such, there will be **no impact** on unique paleontological or geological resources.

<b>GREENHOUSE GAS EMISSIONS</b>	<b>Potentially Significant</b>	<b>Less Than Significant With Mitigation</b>	<b>Less Than Significant</b>	<b>No Impact</b>
Would the project:				
a) Generate greenhouse gas emissions, either directly or indirectly, that may have a significant impact on the environment?			X	
b) Conflict with an applicable plan, policy or regulation adopted for the purpose of reducing the emissions of greenhouse gases?				X

**Setting**

Global temperatures are affected by naturally occurring and anthropogenic-generated atmospheric gases such as water vapor, carbon dioxide, methane, and nitrous oxide. Gases that trap heat in the atmosphere are called greenhouse gases (GHGs). Emissions of GHGs from human activities such as electricity production, motor vehicle use, and agriculture, are elevating the concentration of GHGs in the atmosphere and are reported to have led to a trend of unnatural warming of the earth’s climate, known

as global warming or global climate change, and should be lessened and/or mitigated whenever possible. Other than water vapor, the primary GHGs contributing to global climate change include the following gases:

- Carbon dioxide (CO<sub>2</sub>), primarily a byproduct of fuel combustion;
- Nitrous oxide (N<sub>2</sub>O), a byproduct of fuel combustion and also associated with agricultural operations such as the fertilization of crops;
- Methane (CH<sub>4</sub>), commonly created by off-gassing from agricultural practices (e.g., livestock), wastewater treatment, and landfill operations;
- Chlorofluorocarbons (CFCs), which were used as refrigerants, propellants, and cleaning solvents, although their production has been mostly prohibited by international treaty;
- Hydrofluorocarbons (HFCs), which are now widely used as a substitute for chlorofluorocarbons in refrigeration and cooling; and
- Perfluorocarbons (PFCs) and sulfur hexafluoride (SF<sub>6</sub>) emissions, which are commonly created by industries such as aluminum production and semiconductor manufacturing.

In 2002, the California legislature declared that global climate change was a matter of increasing concern for the state's public health and environment, and enacted laws requiring the state Air Resources Board (ARB) to control GHG emissions from motor vehicles (Health & Safety Code §32018.5 et seq.). CEQA Guidelines define greenhouse gases to include carbon dioxide (CO<sub>2</sub>), nitrous oxide (N<sub>2</sub>O), hydrofluorocarbons, perfluorocarbons, and sulfur hexafluoride. The California Global Warming Solutions Act of 2006 (Assembly Bill 32) definitively established the state's climate change policy and set GHG reduction targets (Health & Safety Code §38500 et seq.). The State set its target at reducing greenhouse gases to 1990 levels by 2020. Executive Order B-30-15 and SB 32 extended the goals of AB 32 and set a 2030 goal of reducing emissions 40 percent from 2020 levels. This action keeps California on target to achieve the level of reductions scientists say is necessary to meet the Paris Agreement goals (CA Air Resources Board Climate Change Scoping Plan 2017).

In 2011, the CEQA Guidelines Section 15064.4 Appendix G was modified to include thresholds of significance for Greenhouse Gases. The project would have potential significant impacts if the project would: generate greenhouse gas emissions, either directly or indirectly, that may have a significant impact on the environment; or conflict with an applicable plan, policy or regulation adopted for the purpose of reducing the emissions of greenhouse gases.

### Discussion

a) Construction of the project would cause GHG emissions as a result of combustion of fossil fuels used in construction equipment, vehicles from workers commuting to and from the site, and the importing of construction materials. The project would require the use of several pieces of construction equipment in addition to other small engine-powered tools and equipment. The NCUAQMD has not adopted a threshold for construction-related GHG emissions against which to evaluate significance and has not established construction-generated criteria air pollutant screening levels above which quantitative air quality emissions would be required.

Parks and public lands serve an essential role in preserving natural resources, wildlife habitats, protecting clean water, as well as result in energy and resource conservation (National Recreation and Park Association, 2022). It is expected that more active transportation users and other recreationist will spend time enjoying outdoor recreation at this location. As such, the project will have a **less than significant** impact.

b) The project is expected to result in a temporary and minimal increase in GHG emissions with an ultimate decrease in GHG emissions on project completion. It does not conflict with an applicable plan or policy and **no impact** will occur.

<b>HAZARDS AND HAZARDOUS MATERIALS</b>	<b>Potentially Significant</b>	<b>Less Than Significant With Mitigation</b>	<b>Less Than Significant</b>	<b>No Impact</b>
Would the project:				
a) Create a significant hazard to the public or the environment through the routine transport, use, or disposal of hazardous materials?			X	
b) Create a significant hazard to the public or the environment through reasonably foreseeable upset and accident conditions involving the release of hazardous materials into the environment?			X	
c) Emit hazardous emissions or handle hazardous or acutely hazardous materials, substances, or waste within one-quarter mile of an existing or proposed school?				X
d) Be located on a site which is included on a list of hazardous materials sites compiled pursuant to Government Code Section 65962.5 and, as a result, would it create a significant hazard to the public or the environment?				X
e) For a project located within an airport land use plan or, where such a plan has not been adopted, within two miles of a public airport or public use airport, would the project result in a safety hazard or excessive noise for people residing or working in the project area?				X
f) Impair implementation of or physically interfere with an adopted or emergency evacuation plan?				X
g) Expose people or structures, either directly or indirectly, to a significant risk of loss, injury or death involving wildland fires?			X	

**Setting**

The project will not create a significant hazard to the public or environment. All heavy equipment will be in good condition, inspected for leaks and washed prior to working within the action area and daily to prevent spills of hazardous materials. Spill containment, absorbent cleanup materials and emergency contact numbers will be onsite at all times during project construction and all contractors and responsible parties will be trained in the appropriate steps should a spill occur. All fueling will occur at least 100 feet from any waterway or stream to prevent impacts to water quality and contamination of

hazardous materials. All machinery will be stored in designated staging areas that avoid impacts to wetlands or environmentally sensitive habitat areas.

**Discussion**

**a,b)** Construction of the project would require the use and transport of hazardous materials including fuels, oils, and other chemicals used during construction activities. Improper use and transportation of hazardous materials could result in accidental releases or spills, potentially posing health risks to workers, the public, and the environment. These activities are controlled by County code provisions and state regulations (Health and Safety Code Division 20: Miscellaneous Health and Safety Provisions). Additionally, construction activities at the project site will incorporate current best management practices (BMPs) for construction, including site housekeeping practices, hazardous material storage, inspections, maintenance, worker training in pollution prevention measures, and secondary containment of releases to prevent pollutants from being carried off-site via runoff.

The proposed project would not create a significant hazard to the public or the environment through reasonably foreseeable upset and accident conditions involving hazardous materials release into the environment. Therefore, a **less than significant** impact would occur.

**c-f)** The project is located within two miles of the of an Del Norte County Regional Airport, but is not on a site designated as hazardous, or would it create excessive noise or other safety hazards for people working or residing in the area. There are no schools located with one-quarter mile of the project site. The project is adjacent to existing access routes and will not block any existing roadways that may be used as evacuation routes. As the project will not store hazardous material onsite and is not located near schools, will not impact airport operations and will not interfere with existing evacuation plans, **no impact** will occur.

**g)** There is a small risk of an accidental spark igniting a fire and spills of fuels or other hazardous materials, but the potential for these impacts will be reduced to a less than significant level through implementation of mitigation measures outlined in a spill prevention and response plan. Based on the low potential of wildfire, there will be **less than significant impact**.

<b>HYDROLOGY AND WATER QUALITY</b>	<b>Potentially Significant</b>	<b>Less Than Significant With Mitigation</b>	<b>Less Than Significant</b>	<b>No Impact</b>
Would the project:				
a) Violate any water quality standards or waste discharge requirements or otherwise substantially degrade surface or ground water quality?				X
b) Substantially decrease groundwater supplies or interfere substantially with groundwater recharge such that the project may impede sustainable groundwater management of the basin?				X
c) Substantially alter the existing drainage pattern of the site or area, including through the alteration of a stream or river or through the addition of impervious surfaces, in a			X	

<b>HYDROLOGY AND WATER QUALITY</b>	<b>Potentially Significant</b>	<b>Less Than Significant With Mitigation</b>	<b>Less Than Significant</b>	<b>No Impact</b>
manner which would:				
(i) result in substantial erosion or siltation on or offsite;			X	
(ii) substantially increase the rate or amount of surface runoff in a manner which would result in flooding on- or offsite;			X	
(iii) create or contribute runoff water which would exceed the capacity of existing or planned stormwater drainage systems or provide substantial additional sources of polluted runoff; or			X	
d) In flood hazard, tsunami, or seiche zones, risk release of pollutants due to project inundation?			X	
e) Conflict with or obstruct implementation of a water quality control plan or sustainable groundwater management plan?				X

**Setting**

All necessary measures will be taken to minimize erosion of unfinished excavations, grading or work surfaces. The worksite will be winterized at the end of each day when significant rains are forecasted. All areas within the limit of disturbance will be mulched, seeded and planted with native plants after project implementation. All construction areas will be weatherized and treated with best management practices (BMP's) to prevent runoff of fine sediments including straw wattles. A condition of project approval will be that the project complies with established Best Management Practices.

**Discussion**

- a) The project does not involve any activities that would violate water quality standards or wastewater discharge requirements. Upon completion of project, water quality will remain the same. **No impact** is expected.
- b) The project will have **no impact** on groundwater supplies or recharge. The amount of impervious surface will be roughly the same as it is under current conditions.
- c.i-iii) The project will not result in the altering of existing drainage and is not located in close proximity to any creeks that would be impacted by the project. Any surface water will drain toward the Pacific Ocean reducing flooding impacts to private property or public infrastructure. Based on project design elements, any erosion or surface water runoff impacts will be **less than significant**.
- d) The project site is located within a tsunami runup zone. The *Technical Memorandum Tsunami Runup* was prepared by LACO for the project. The tsunami runup at the project site is anticipated to extend inland approximately 1,250 feet to an elevation of approximately 57 feet. This runup extends beyond Pebble Beach Drive and into the development to the north-east (McNamara Ranch). The risk of the projected degree of tsunami runup occurring at the site is 2 percent within 19.5 years, which correlates to approximately 5 percent over a 50-year project lifespan or 7.5

percent over a 75-year project lifespan. The project is not designed to withstand tsunami as it is a non-essential status as a structure. Loss of portions of the ramp to a tsunami should not result in a release of pollutants. The project is located in a Zone VE (FEMA FIRM 06015C0213G, Effective 8/2/2017); however the ramp is not expected to increase flooding. As such, there will be **less than significant** from potential inundation due to the project.

- e) As noted previously, the project will have no impact on groundwater resources and will therefore have no impact related to a sustainable groundwater management plan. As such, there will be no conflict with existing water quality plans, and **no impact** will occur.

<b>LAND USE AND PLANNING</b>	<b>Potentially Significant</b>	<b>Less Than Significant With Mitigation</b>	<b>Less Than Significant</b>	<b>No Impact</b>
Would the project:				
a) Physically divide an established community?				X
b) Cause a significant environmental impact due to a conflict with any land use plan, policy, or regulation adopted for the purpose of avoiding or mitigating an environmental effect?				X

**Setting**

Del Norte County Coastal Land Use designations identify permitted development types (e.g., residential, commercial, and industrial) and the density or intensity of allowed development.

**Discussion**

- a) The project involves the improvement of an existing pathway and parking lot. No project aspect would divide an existing community; therefore, **no impact** would occur.
- b) The Coastal Plan Land Use designation for the project site is Public Facility and the Coastal Zoning designation is A-5-C (A) (H) (General Agricultural District – 5-acre minimum lot size with Coastal Combining District – Requirements for Coastal Bluff Hazard, Tsunami Erosion and Slope Risk Failure and Requirements for of Coastal Access. Due to the zoning designation a Use Permit is being requested as allowed by Section 21.46.020 of Title 21 Coastal Zoning for Public Uses (i.e. parking lot and access to the beach). The project is designed to mitigate any adverse effects. As such, **no impact** would occur.

<b>MINERAL RESOURCES</b>	<b>Potentially Significant</b>	<b>Less Than Significant With Mitigation</b>	<b>Less Than Significant</b>	<b>No Impact</b>
Would the project:				
a) Result in the loss of availability of a known mineral resource that would be of value to the region and the residents of the state?				X
b) Result in the loss of availability of a locally-important mineral resource				X

<b>MINERAL RESOURCES</b>	<b>Potentially Significant</b>	<b>Less Than Significant With Mitigation</b>	<b>Less Than Significant</b>	<b>No Impact</b>
recovery site delineated on a local general plan, specific plan or other land use plan?				

**Setting**

Current mineral resource production in the County is primarily limited to sand, gravel, and rock extraction. According to planning records maintained by the County’s Planning Division, there is no mining permit issued by the County for the site.

**Discussion**

**a,b)** No mineral resources and no mineral resource extraction currently occurs within the project site. No mining is proposed. The project would not affect the availability of a known mineral resource that would be of value to the region, nor would the project result in the loss of availability of a locally important mineral resource recovery site delineated on a specific, general plan or other land use plan. Therefore, **no impact** would occur.

<b>NOISE</b>	<b>Potentially Significant</b>	<b>Less Than Significant With Mitigation</b>	<b>Less Than Significant</b>	<b>No Impact</b>
Would the project result in:				
a) Generation of a substantial temporary or permanent increase in ambient noise levels in the vicinity of the project in excess of standards established in the local general plan or noise ordinance, or applicable standards of other agencies?			X	
b) Generation of excessive ground borne vibration or ground borne noise levels?			X	
c) For a project located within the vicinity of a private airstrip or an airport land use plan or, where such a plan has not been adopted, within two miles of a public airport or public use airport, would the project expose people residing or working in the project area to excessive noise levels?				X

**Setting**

Sound can be described as the mechanical energy of a vibrating object transmitted by pressure waves through a liquid or gaseous medium (e.g., air) to a human ear. Noise is defined as loud, unexpected, annoying, or unwanted sound. Vibration is the periodic oscillation of a medium or object with respect to a given reference point. Sources of vibration include natural phenomena (e.g., earthquakes, volcanic eruptions, sea waves, landslides) and those introduced by human activity (e.g., explosions, machinery, traffic, trains, construction equipment). Vibration sources may be continuous, (e.g., operating factory machinery) or transient in nature (e.g., explosions).



Increased noise levels will be temporarily present in the area during the Project. Work will be conducted between the hours of 8:00 to 18:00 each day to minimize impacts to the nearby residential housing. Additionally, the project will be conducted expeditiously to reduce the timeframe of elevated noise levels in the project area. The Project will not result in any change in noise levels after construction is completed. Operations will comply with OSHA regulations. Internal combustion engines will be equipped with a muffler of a type recommended by the manufacturer. Equipment used for restoration will utilize the best available noise control techniques (e.g. engine enclosures, acoustically attenuating shields or shrouds, ducts, etc.) whenever feasible and necessary.

**Discussion**

- a) The construction phase of the project will include use of heavy machinery and multiple trips by construction vehicles which will increase noise levels in the local vicinity. These noise increases will be limited to permitted hours (8 a.m. – 6p.m. weekdays, 9 a.m. – 6 p.m. weekends, lower ambient noise levels within 2 hours of sunrise/sunset). Potential noise levels from construction equipment are included in the table below.

Equipment	Noise Level (dB)	Equipment	Noise Level (dB)
Jackhammer	85	Paver or Roller	85
Backhoe	80	Dump Truck	84
Mini-Excavator	85		

Source: Federal Highway Administration, 2005.

Sound from a point source is known to attenuate, or reduce, at a rate of 6 dB for each doubling of distance. For example, a noise level of 84 dB as measured at 50 feet from the noise source would attenuate to 78 dB at 100 feet from the source and to 72 dB at 200 feet from the source to the receptor. Since noise from construction activities will be limited to permitted hours, temporary in nature, and attenuated to within acceptable levels for the adjacent agricultural land designation, effects from the project will be **less than significant**.

- b) The project is not expected to generate unusual ground borne vibration or ground borne noise levels. Construction activities typically create a small increase in ground borne vibrations, but the vibration level is rarely significant and diminishes rapidly with distance from the construction equipment unless unusual geological conditions are present. Construction equipment and construction operations for the project would be similar to construction operations at many construction sites. As there are no unusual geological conditions within the project area and residential households are located approximately 850 feet or more from the project site, there will be **less than significant** impacts from ground borne vibrations.
- c) The project site is located approximately .5 mile from the Del Norte County Regional airport. The project does not entail the construction of facilities for people to reside or work. As such, the project would not expose people residing or working in the project area to excessive airport-related noise levels, and **no impact** would occur.

POPULATION AND HOUSING	Potentially Significant	Less Than Significant with Mitigation	Less Than Significant	No Impact
Would the project:				

<b>POPULATION AND HOUSING</b>	<b>Potentially Significant</b>	<b>Less Than Significant with Mitigation</b>	<b>Less Than Significant</b>	<b>No Impact</b>
a) Induce substantial unplanned population growth in the area, either directly (for example, by proposing new homes and businesses) or indirectly (for example, through extension of roads or other infrastructure)?				X
b) Displace substantial numbers of existing people or housing, necessitating the construction of replacement housing elsewhere?				X

**Discussion**

**a,b)** The Project will not result in any loss of housing. There will be no long term impacts to the population. **No impact** would occur.

<b>PUBLIC SERVICES</b>	<b>Potentially Significant</b>	<b>Less Than Significant With Mitigation</b>	<b>Less Than Significant</b>	<b>No Impact</b>
Would the project result in substantial adverse physical impacts associated with the provision of new or physically altered governmental facilities, the construction of which could cause significant environmental impacts, in order to maintain acceptable service ratios, response times or other performance objectives for any of the public services:				
a) Fire protection?				X
b) Police protection?				X
c) Schools?				X
d) Parks?				X
e) Other public facilities?				X

**Discussion**

**a-e)** As discussed in the Population and Housing section, the project would not directly or indirectly induce population growth nor create new demand for services. Therefore, the project would have no impact on the service ratios, response times, or other performance objectives of schools, parks, and other public facilities and services that are based on population growth. **No impact** would occur.

<b>RECREATION</b>	<b>Potentially Significant</b>	<b>Less Than Significant With Mitigation</b>	<b>Less Than Significant</b>	<b>No Impact</b>
Would the project:				
a) Would the project increase the use of existing neighborhood and regional parks or other recreational facilities such that substantial physical deterioration of the facility would occur or be accelerated?				X
b) Does the project include recreational facilities or require the construction or				

<b>RECREATION</b>	<b>Potentially Significant</b>	<b>Less Than Significant With Mitigation</b>	<b>Less Than Significant</b>	<b>No Impact</b>
expansion of recreational facilities which might have an adverse physical effect on the environment?				X

### Discussion

**a,b)** The project would not directly or indirectly induce substantial population growth or would the project expand services. It does make use of the beach access more appealing as it will be ADA compliant. Overall, the improvements will aid in the protection of sensitive resources currently being impacted by establishing a more definable public access to the beach. Beachgoers will be less inclined to create their own path way to the beach when they see a clearly marked pathway. Potential impacts to the environment are being mitigated as per mitigation measures identified in this Study. **No impact** would occur.

<b>TRANSPORTATION</b>	<b>Potentially Significant</b>	<b>Less Than Significant With Mitigation</b>	<b>Less Than Significant</b>	<b>No Impact</b>
Would the project:				
a) Conflict with a program, plan, ordinance or policy addressing the circulation system, including transit, roadway, bicycle, and pedestrian facilities?			X	
b) Would the project conflict or be inconsistent with CEQA Guidelines section 15064.3 subdivision (b)?			X	
c) Substantially increase hazards due to a geometric design feature (e.g., sharp curves or dangerous intersections) or incompatible uses (e.g., farm equipment)?				X
d) Result in inadequate emergency access?				X

### Summary

N. Pebble Beach Drive is a public county road. A county encroachment permit may be required in the event that N. Pebble Beach Drive has to be temporarily closed for staging of the project construction. Traffic safety rules and regulations will be followed when hauling construction materials to the project site. Project equipment will be used within the existing paved parking area for the construction of the ramp. No beach access is planned

### Discussion

**a)** There will be an increase of traffic on N. Pebble Beach Drive from construction vehicles and other necessary equipment for staging, grading, and construction activities. Increased traffic from oversized vehicles and equipment may have an impact on roadway accessibility for non-motorized users. However, this impact will be intermittent and temporary with no long term effects. Additionally,

equipment will be staged away from main roadways when possible in order to better facilitate access by non-motorized users during the construction period.

Impacts to traffic and safety along N. Pebble Beach Drive and bike path networks will be minimal and temporary. The project does not propose any alterations to existing roads, trails, or other non-vehicle paths of travel. As such, the project will not conflict with any policies regarding transportation in the Pebble Beach area and a **less than significant** impact will occur.

**b)** Construction of the access ramp will create additional VMTs due to trips from construction workers and delivery of materials. It is unknown where construction workers would be traveling from and as such it is difficult to estimate the actual number of vehicle miles that will be generated. It is also unknown how many delivery trips will be required to bring all necessary construction materials to the site. However, these trips will only last for the duration of construction which is anticipated to take approximately two weeks. After construction is completed, vehicle trips are expected to return to pre-project conditions.

The project will generate some additional VMTs during construction, however these will be limited and temporary, with VMTs impacts **less than significant**.

**c,d)** As the project does not propose any modifications to local roadways, it will also not create inadequate emergency access. During construction, access roads will be kept clear in the event of an emergency in order to facilitate adequate access. As such, there will be **no impact** from design features, incompatible uses, or inadequate emergency access.

<b>TRIBAL CULTURAL RESOURCES</b>	<b>Potentially Significant</b>	<b>Less Than Significant With Mitigation</b>	<b>Less Than Significant</b>	<b>No Impact</b>
Would the project: Cause a substantial adverse change in the significance of a tribal cultural resource, defined in Public Resources Code section 21074 as either a site, feature, place, cultural landscape, sacred place, or object with cultural value to a California Native American Tribe, and that is:				
a) Listed or eligible for listing in the California Register of Historical Resources, or in a local register of historical resources as defined in Public Resources Code section 5020.1 (k), or			X	
b) A resource determined by the lead agency, in its discretion and supported by substantial evidence, to be significant pursuant to criteria set forth in subdivision (c) of Public Resources Code Section 5024.1. In applying the criteria set forth in subdivision (c) of Public Resources Code Section 5024.1, the Lead Agency shall consider the significance of the resource to a California Native American Tribe.			X	

**Setting**

The general area has a long history of human use associated with the Pacific Ocean including Native Americans and later with European settlers beginning around 1850. The project area is within the ethnographic territory of the Tolowa Dee-ni’ and the general area has high potential for archaeological sites. The Tolowa Dee-ni’ Nation and the Elk Valley Rancheria were consulted through the County’s consultant and were sent a Tribal Consultation Notification per AB 52. Comments from the Tolowa Dee-ni’ Nation is incorporated into the Mitigation Measures in the *Cultural Resources* section.

A Phase 1 Cultural Resource Inventory Report was completed by a licensed archaeologist from DZC Archaeology and Cultural Resource Management Consulting. The report recommends a finding of no impacts to historical, archaeological, or Tribal Cultural Resources as defined by CEOA, and a finding of No Effects as defined by the National Environmental Policy Act (NEPA).

**Discussion**

**a, b)** As discussed in the *Cultural Resources* section of this document, DZC Archaeology found no evidence of tribal or other cultural resources and determined that no impact would result from the project. By following applicable policies and codes as discussed under *Cultural Resources* and Mitigation Measures, potential project impacts related to tribal cultural resources would be **less than significant**.

<b>UTILITIES AND SERVICE SYSTEMS</b>	<b>Potentially Significant</b>	<b>Less Than Significant With Mitigation</b>	<b>Less Than Significant</b>	<b>No Impact</b>
Would the project:				
a) Require or result in the relocation or construction of new or expanded water, wastewater treatment, or storm water drainage, electric power, natural gas, or telecommunications facilities, the construction or relocation of which could cause significant environmental effects?			X	
b) Have sufficient water supplies available to serve the project and reasonably foreseeable future development during normal, dry and multiple dry years?				X
c) Result in a determination by the wastewater treatment provider which serves or may serve the project that it has inadequate capacity to serve the project’s projected demand in addition to the provider’s existing commitments?				X
d) Generate solid waste in excess of State or local standards, or in excess of the capacity of local infrastructure, or otherwise impair the attainment of solid waste reduction goals?			X	
e) Comply with federal, state, and local management and reduction statutes and regulations related to solid waste?			X	

**Discussion**

a) Utility service providers will be contacted prior to the Project to ensure excavation avoids all underground service lines. Based on the existing infrastructure in place impacts will be **less than significant**.

b) The project does not involve any increase in potable water demand. As such, there will be **no impact**.

c) The project does not involve any development that would require additional wastewater capacity or construction of facilities that would increase demands from existing developments. As such, there will be **no impact**.

d,e) The project will create a temporary increase in solid waste during construction. However, operations will not increase the amount of solid waste above existing levels. During construction of the project, construction workers must comply with all County and State solid waste diversion, reduction, and recycling mandates. As such, impacts will be **less than significant**.

<b>WILDFIRE</b>	<b>Potentially Significant</b>	<b>Less Than Significant With Mitigation</b>	<b>Less Than Significant</b>	<b>No Impact</b>
If located in or near state responsibility areas or lands classified as very high fire severity zones, would the project:				
a) Substantially impair an adopted emergency response plan or emergency evacuation plan?				X
b) Due to slope, prevailing winds, and other factors, exacerbate wildfire risks, and thereby expose project occupants to, pollutants from a wildfire or the uncontrolled spread of wildfire?				X
c) Require the installation or maintenance of associated infrastructure (such as roads, fuel breaks, emergency water sources, power lines or other utilities) that may exacerbate fire risk or that may result in temporary or ongoing impacts to the environment?				X
d) Expose people or structures to significant risks, including downslope or downstream flooding or landslides, as a result of runoff, post-fire slope instability, or drainage change?				X

**Setting**

Wildland fire protection in California is the responsibility of either the State, local, or federal government. A State Responsibility Area (SRA) is a legal term defining the area where the State has financial responsibility for wildland fire protection. Incorporated cities and areas of federal ownership are not included. The prevention and suppression of fires in all areas that are not SRAs are primarily the responsibility of local or federal agencies. There are more than 31 million acres in state responsibility area with an estimated 1.7 million people and 750,000 existing homes. Local Responsibility Areas (LRAs) include incorporated cities, cultivated agriculture lands, and portions of the desert. Local responsibility area fire protection is typically provided by: city fire departments, fire protection districts, counties, and by CAL FIRE under contract to local government.

The project site is within the Crescent Fire Protection District (CFPD) and in a SRA. The CFPD provides structural fire protection and emergency services to the Crescent City urban area.

**Discussion**

a) Construction work at the project site would be temporary and N. Pebble Beach Drive would still be accessible so as to not impair an adopted emergency plan or emergency evacuation plan by ensuring access in the event of an emergency or evacuation. Therefore, there would be **no impacts**.

b-d) The project does not include site-specific modifications that would expose project occupants to pollutants from a wildfire or other uncontrolled spread of wildfire. The project would not expose people or structures to significant risks, including downslope or downstream flooding or landslides, as a result of runoff, post-fire instability, or drainage change. As such, there would be **no impacts**.

<b>MANDATORY FINDINGS OF SIGNIFICANCE</b>	<b>Potentially Significant</b>	<b>Less Than Significant With Mitigation</b>	<b>Less Than Significant</b>	<b>No Impact</b>
a) Does the project have the potential to substantially degrade the quality of the environment, substantially reduce the habitat of a fish or wildlife species, cause a fish or wildlife population to drop below self-sustaining levels, threaten to eliminate a plant or animal community, substantially reduce the number or restrict the range of a rare or endangered plant or animal, or eliminate important examples of the major periods of California history or prehistory?			X	
b) Does the project have impacts that are individually limited, but cumulatively considerable? (“Cumulatively considerable” means that the incremental effects of a project are considerable when viewed in connection with the effects of past projects, the effects of other current projects, and the effects of probable future projects.)			X	
c) Does the project have environmental effects which will cause substantial adverse effects on human beings, either directly or indirectly?			X	

**Discussion**

Certain mandatory findings of significance must be made to comply with CEQA Guidelines §15065. The proposed project has been analyzed, and it has been determined that it would not:

- Substantially degrade environmental quality;
- Substantially reduce fish or wildlife habitat;
- Cause a fish or wildlife population to fall below self-sustaining levels;

- Threaten to eliminate a plant or animal community;
- Reduce the numbers or range of a rare, threatened, or endangered species;
- Eliminate important examples of the major periods of California history or pre-history;
- Achieve short term goals to the disadvantage of long-term goals;
- Have environmental effects that will directly or indirectly cause substantial adverse effects on human beings; or
- Have possible environmental effects that are individually limited but cumulatively considerable when viewed in connection with past, current, and reasonably anticipated future projects.

The project has been evaluated in this initial study and determined to have no potentially significant unmitigated impacts. With implementation of the proposed mitigation measures all potentially significant impacts would be reduced to less than significant levels.

**a,c)** Due to the nature of the project site and surrounding land uses the project as a whole does not have the potential to significantly degrade the quality of the environment, including air quality, fish or wildlife species or their habitat, plant or animal communities, important examples of the major periods of California history or prehistory, geologic resources, hazards, water resources, land use compatibility, noise, traffic movement, or other adverse effects, directly or indirectly, on human beings. The project as would result in the construction of ADA-compliant public beach access which would enhance opportunities for no-cost enjoyment of California's coastline. Furthermore, a clearly defined access to the beach will minimize future impacts to known ESHA and wetlands from new accesses to the beach being created.

**b)** The project's individual impacts would not add appreciably to any existing or foreseeable future significant cumulative impact, such as visual quality, historic resources, traffic impacts, or air quality degradation. Incremental impacts, if any, would be small and undetectable. As reported throughout this document, any impacts to which this project would contribute would be mitigated to a less than significant level.



## Appendix A – References

- California Air Resources Board (CARB). Climate Change Scoping Plan 2017. [https://ww2.arb.ca.gov/sites/default/files/classic/cc/scopingplan/scoping\\_plan\\_2017.pdf](https://ww2.arb.ca.gov/sites/default/files/classic/cc/scopingplan/scoping_plan_2017.pdf)
- California Native Plant Society (GNPs). 2021. A Manual of California Vegetation Online. <https://vegetation.cnps.org/>
- California Coastal Commission. Statewide Guidelines: Standards for Siting Development Adjacent to Environmentally Sensitive Habitat Areas. Adopted February 4, 1981.
- Coffman Associates, Inc. , 2017. Airport Land Use Compatibility Plan, Del Norte County, California. <https://www.co.del-norte.ca.us/departments/Planning/Documents>
- DZC Archaeology & Cultural Resource Management. Phase I Cultural Resource Inventory Report for the Wavecrest Drive and North Pebble Beach Drive Beach Access Project Del Norte County, CA. June 2021.
- Del Norte County Title 21 Zoning. 1983. [https://delnortecounty.municipalcodeonline.com/book?type=ordinances#name=21\\_Coastal\\_Zoning](https://delnortecounty.municipalcodeonline.com/book?type=ordinances#name=21_Coastal_Zoning).
- Del Norte County. Local Coastal Program Land Use Plan. 1983. <https://www.co.del-norte.ca.us/departments/Planning/Documents>
- LACO. Technical Memorandum Biological and Rare Plant Survey and Waters/Wetland Assessment Wavecrest Drive and North Pebble Beach Drive Access Project, Del Norte County, California. September 2021
- LACO. Technical Memorandum Bluff Retreat Wavecrest Drive and Pebble Beach Drive Access Sites, Crescent City, California. November 2021.
- LACO. Technical Memorandum Geotechnical Exploration and Recommendations Wavecrest Drive and North Pebble Beach Drive Access Project, Del Norte County, California.
- LACO. Technical Memorandum Relative Sea Level Changes Wavecrest Drive and Pebble Beach Drive Access Sites. February 2021.
- LACO. Technical Memorandum Tsunami Runup Wavecrest Drive and Pebble Beach Coastal Access Plan Del Norte County Community Development Department. September 2021.
- Stover Engineering. Pebble Beach Drive Coastal Access Trail. Existing Topography Map. March 2021.
- Stover Engineering. Pebble Beach Drive Coast Access Planset. April 2022.
- United States Department of Agriculture (USDA). 2021. COMET Planner, Carbon and greenhouse gas evaluation for NRCS conservation practice planning. <http://Jcomet-planner.com/>
- United States Forest Service (USFS). 2008. Stream simulation: An Ecological Approach to Road Stream Crossings. USDA United States Forest Service National Technology and Development Program, San Dimas, CA.



May 16, 2022

9790.00

Del Norte County Community Development  
981 H Street, Suite 110  
Crescent City, CA 95531

Attention: Heidi Kunstal

Subject: Del Norte County Wavecrest / Pebble Beach Access Project, Existing Conditions  
Executive Summary

Dear Ms. Kunstal:

Attached is our summary of the findings of each of the technical reports and/or maps prepared during this project. The documents have been individually submitted previously; therefore, this report will only include their findings by reference. The locations of various predicted changes in conditions (such as sea level rise and bluff retreat) have been superimposed on the Area of Potential Effects maps prepared by Stover Engineering and are attached.

Please call me at (707) 443-5054 or email me at [manhartc@lacoassociates.com](mailto:manhartc@lacoassociates.com) if you have any questions.

Sincerely,  
LACO Associates

Christine S. Manhart  
Project Manager / Principal Geologist

CSM

P:\9700\9790 Del Norte County Community Development\9790.00 Wavecrest Dr Coastal Access Project\08 Geology\Reports\Existing Conditions Summary Report\9790.00 FINAL Existing Conditions Ltr Rpt rev 20220516.docx

## **PROJECT DESCRIPTION**

### **Wavecrest Access Point**

The Wavecrest Access Point (WAP) project will provide a replacement for the beach access point that is in disrepair due to wave action from storm and tsunami events over the last several years. The seaward portion of the existing ramp is currently several feet above the surface of the sand, making its use by the public dangerous. In addition, it will only continue to degrade in the future. To avoid a lengthy permitting process due to WAP's proximity to the California Coastal Commission's jurisdictional waters and a creek and identified wetland, this project is designed to fit the CCC criteria of a maintenance project. This requires that all construction occur within the footprint of the existing structure.

The existing access ramp is approximately 320 feet in length and 5.5 feet wide. To comply with the CCC restrictions, the slope at the seaward end will be approximately 12 percent. As that slope will be difficult for many members of the public to negotiate, the design includes steps with treads that are 2.5 feet deep and with 7-inch risers. The extra depth to the stair tread will make it easier for more people to use. The ramp will be bordered on both sides with new concrete sidewalks and handrails.

In order to facilitate use of the ramp to access beach areas identified as an Area of Potential Effect in the cultural assessment, bollards planned for at the landward-most end of the ramp adjacent to the parking lot will be removeable seasonally. This will allow the Native community to access these areas, that were identified outside of the planned project area. While the ramp will have stairs, the broad tread depth will allow access using a quad all-terrain vehicle by Native community members that need additional support.

In order to mitigate the ongoing impacts of the surf as well as anticipated sea level rise, the new ramp is designed with a concrete foundation generally 2 feet thick and a steel sheet pile wall on the outboard edge extending from just below the surface to an elevation of approximately 10.5 feet. The sheet pile is intended to prevent future scour. The junction of the sand surface and the ramp's foundation will be covered with riprap obtained from the destruction of the existing ramp and salvaged existing riprap, providing additional protection by dissipating wave energy.

According to FEMA, base flood elevation at WAP is 18 feet above mean sea level (msl). LACO estimated sea level rise during an economic lifespan of 50 years at approximately 3 feet. The proposed ramp is designed to withstand a design flood elevation, which includes new storm wave height in addition to sea level rise, of 22.6 feet msl. A tsunami is assumed to be likely within the lifespan of the project with runup projected to extend east nearly 700 feet. However, current building codes do not require that the project be built to withstand a tsunami as it is not a critical structure. LACO also evaluated bluff erosion at the project site. While the project area is expected to be subject to bluff erosion over the lifespan of the project, it is anticipated that the design will harden the area of the ramp minimizing the impacts.

### **Pebble Beach Access Point**

The Pebble Beach Access Point (PBAP) was designed to be the only beach access in the Crescent City area compliant with the American with Disabilities Act (ADA). In addition to the access ramp, the project includes regrading, paving, and striping an area of the existing parking lot to also conform to ADA requirements. Currently, there is no official access point from the parking lot to the beach and users have historically created a footpath that requires stepping over a guardrail and walking through

vegetated dunes. Surveys conducted during this assessment indicate the presence of wetland areas and rare plant habitats in these dunes that may be impacted by this unofficial foot traffic. The location of the new ramp generally follows an older asphalt-paved path that is currently buried under approximately 1 foot of sand. This will be removed during construction of the new PBAP.

A portion of the new ramp will parallel the parking lot to allow for ingress from the ADA loading and unloading spaces with a 90-degree turn at the eastern end to access the beach. This seaward portion will be approximately 36 feet in length and approximately 6 feet wide. The slope over most of the ramp will be at 8 percent; however, this will shallow to 1.8 percent at the end to allow a transition to the beach surface. The ramp will be bordered on both sides with new concrete sidewalls and handrails.

The portion of the ramp that is parallel to the parking lot will be founded on 8-foot-deep concrete footings while the footing for the seaward portion of the ramp is anticipated to be approximately 5 feet deep, depending on the depth to competent dense sand observed during the geotechnical exploration.

According to FEMA, base flood elevation at the site is 24 feet msl. LACO estimated sea level rise during an economic lifespan of 50 years at approximately 3 feet. The proposed ramp is designed to withstand a design flood elevation, which includes new storm wave height in addition to sea level rise, of 28.6 feet msl. A tsunami is assumed to be likely within the lifespan of the project with runup projected to extend east nearly 1,200 feet. However, current building codes do not require that the project be built to withstand a tsunami as it is not a critical structure. LACO also evaluated bluff erosion at the project site. While the project area is expected to be subject to bluff erosion over the lifespan of the project, most of this erosion is probably due to a combination of waves and storm events, which are included to some extent in the design flood elevation. This will likely provide some hardening in the immediate vicinity of the PBAP.

### **Topography and Baseline Mapping**

An existing topography map was generated for the Wavecrest Drive Coastal Access Trail site by Stover Engineering on March 26, 2021. The submittal includes legal descriptions and a grant deed for Site parcels.

### **Geotechnical Evaluation**

*Intro:* LACO submitted a geotechnical evaluation for the Wavecrest and Pebble Beach Access sites on April 26, 2021. The report evaluated “the suitability of the surface with which to construct the proposed beach accesses”.

*Findings:* Three geotechnical hand auger borings were installed at the Wavecrest Site, and two at the Pebble Beach Site. Borings encountered poorly graded sands with recommended maximum allowable bearing pressures of 1,500 pounds per square foot (psf). At the Wavecrest Site, we recommended placement of foundation elements on the iron-cemented sands of the Battery formation (about 5' bgs). At the Pebble Beach Site, we recommended placement of foundation elements on the Point St. George formation (estimated to be 5 to 8 feet bgs). These findings were used by the engineer to design foundations for both project sites.

### **Sea Level Rise Assessment**

*Intro:* LACO submitted a Relative Sea Level Changes technical memorandum on February 4, 2021. The report “reviews historical sea and land levels, projected future levels, and show those changes may

impact future tides and storm surges to inform their potential to impact the project over a proposed 50-year lifespan."

*Findings:* Using tide gauge measurements and research on changes in vertical land motion, we determined that there is a potential sea level rise of approximately 3 feet by 2070. The following effects at the Sites were identified:

- Pebble Beach Drive – shallow coastal flooding associated with high tides; and,
- Wavecrest Drive – increased water levels due to sea level rise, shallow coastal flooding associated with high tides, and marsh migration.
- Inundation due to storm events will be exacerbated at both location with rising sea levels.

The sea level rise associated with a high-emissions scenario in the year 2070 are represented in the Area of Potential Effect (APE) maps included as Figures 1 and 2.

### **Hydraulics Assessment (Tsunami Runup, Bluff Retreat)**

*Intro:* LACO submitted a tsunami runup impact assessment on September 20, 2021. The report "reviews the potential impacts of tsunami runup of two coastal access sites (Wavecrest and Pebble Beach) in the County of Del Norte." LACO also submitted a bluff retreat impact assessment on November 3, 2021. The bluff retreat report "reviews the potential impacts of bluff retreat to two coastal access sites (Wavecrest and Pebble Beach) in the County of Del Norte."

*Findings: (Tsunami Runup)* Using CGS models as guidance, LACO determined that tsunami runup at both Sites extends to an elevation of approximately 57 feet (NAVD 88). We presented the following conclusions:

- Ground surface elevation at the Wavecrest Beach Access point is 25 feet referenced to the North American Vertical Datum 1988.
- The tsunami run-up at the Wavecrest Drive Access location is anticipated to extend approximately 700 feet inland to an elevation of approximately 57 feet. This run-up extends beyond U.S. Highway 101 and into the development to the east of the highway.
- The Pebble Beach Access point was determined to have an elevation of 20 feet.
- The tsunami run-up at the Pebble Beach Drive Access location is anticipated to extend inland approximately 1,250 feet to an elevation of approximately 57 feet. This runup extends beyond Pebble Beach Drive and into the development to the north-east.
- The risk of the projected degree of tsunami run-up occurring at both locations as 2 percent within 19.5 years, which correlates to approximately 5 percent over a 50-year project lifespan or 7.5 percent over a 75-year project lifespan.

Note that as the height of anticipated tsunami runup exceeds the scale, it is not included on the APE maps.

*(Bluff Retreat)* LACO determined that the two Sites are within the Smith River and Klamath River littoral cells, with southwesterly waves dominating the bluff erosion process. We presented an estimated bluff retreat rate of 0.27 ft/yr at the Pebble Beach Site, mainly via wave action. At the Wavecrest Site, we presented a bluff retreat rate of 2.1 ft/yr via a combination of wave action and erosion from stormwater flow in the gully. Conclusions are as follows:

- The estimated bluff recession rate at the Pebble Beach Drive access walkway is 0.27 feet per year. This results in an estimated bluff retreat of approximately 13.5 feet over 50 years. This bluff retreat is probably due to a combination of waves and storm events.

- The wave climate at the sites is controlled by seas during the winter months, November through March. This period is characterized by very high energy "seas" which arrive from the south. These southwesterly waves average about 9.8 feet high and range up to 26 feet high. Winter storms combined with high tidal range result in maximizing the energy available for erosion, and thereby, bluff retreat.
- The Wavecrest Drive access walkway estimated gully erosion is 2.1 feet per year. This erosion is probably caused by a combination of wave runup and gully flow during storm events.
- The bluff north of Wavecrest Drive access does not appear to be experiencing retreat.

Extent of anticipated bluff retreat over a 50-year timeframe are represented in the APE maps included as Figures 1 and 2.

### **Biological Survey Results & Wetlands Assessment**

*Intro:* A biological and rare plant survey was submitted by LACO Associates September 2021. The purpose of the assessment was "to determine whether the two areas where the repairs and new access are proposed contain sensitive biological resources, including special status plant and wildlife species and coastal wetlands." A wetlands assessment component accompanied the report as Figures 1 and 2.

*Findings: (Biological Survey)* The biological and rare plant survey at the Wavecrest Site identified one sensitive animal species, the Bank Swallow, and two sensitive plant species, the seaside pea and Siskiyou checkerbloom. The biological and rare plant survey at the Pebble Beach Site found three sensitive plant species, the seaside pea, Wolf's evening primrose, and sand dune phacelia. LACO suggested avoiding sensitive plant populations at the greatest extent feasible and to clearly mark sensitive plant population locations in the field and show to the Project contractor if construction is proposed within 100 feet of the population. Additionally, to protect the sensitive animal species, construction should not occur within 100 feet of the bank swallow colony from May through August to avoid disrupting their mating season.

*(Wetlands Assessment)* The waters and wetland assessment revealed that both waters of the state and U.S. were present at the Wavecrest and Pebble Beach sites, which are summarized in Table 5 of the report. LACO recommends that any proposed construction at the sites have a minimum of 100 feet buffer from the identified wetlands. However, if setback reductions are required, they should be analyzed in conjunction with the specific development proposed to determine if additional mitigation measures are necessary and the California Department of Fish and Wildlife (CDFW) must concur.

Areas of currently identified biological zones are represented in the APE maps included as Figure 1 and 2.

### **Visual Impacts Assessment**

LACO used recent photographs of site conditions to prepare approximations as to how the plans prepared by Stover Engineering may look upon completion. These are attached as Figures 3 through 5.

### **Cultural Resources Assessment**

*Intro:* A Phase 1 Cultural Resource Inventory Report was prepared for LACO by DZC Archaeology & Cultural Resource Consulting (DZC) in June of 2021. From the report: "On behalf of the County of Del Norte, LACO Associates retained DZC Archaeology & Cultural Resource Consulting, LLC (DZC), to

conduct an archaeological inventory and survey for the Wavecrest Drive and North Pebble Beach Drive Beach Access Project (the Project). This project has the potential to adversely affect cultural resources. Therefore, a good faith effort was made to identify any cultural resources within and immediately adjacent to the Area of Potential Effects. This cultural resource inventory was conducted to satisfy requirements of the California Environmental Quality Act (CEQA) of 1970 (as amended). This investigation was overseen by Dimitra Zalarvis-Chase (M.A., RPA) a Secretary of the Interior-qualified Registered Professional Archaeologist, and staff archaeologist Cydney Lanthier (B.A.), both of DZC Archaeology & Cultural Resource Consulting, LLC."

**Findings:** The following findings and recommendations are presented in DZC's report:

- DZC found two resources within the project area; resource P-08-00031 Fish Camp Midden, and resource PB-DZC-01. Resource P-08-00031, also identified as *Yaa-ghii~a'~* Fish Camp, is a midden deposit that was capped in 1992 and the Project is currently designed to avoid impacts to this resource and will also improve access to the resource. A qualified archaeologist and a Tribal Monitor will be required on site to monitor ground disturbance near this resource. Resource PB-DZC-01 is a segment of North Pebble Beach Drive that is fairly fragmented and was deemed ineligible for both the National Register of Historic Place and the California Register of Historic Places. This resource does not require any additional management considerations.
- Native American Recommendations
  1. The Public Access path should be wide enough to accommodate an ATV for transporting elders, Tribal members with disabilities, and traditional fishing equipment.
  2. Placement of interpretive signage at the head of the Public Access trail reinforcing the following concepts:
    - a. The immediate area is a Marine Protected Area
    - b. Education regarding the Tribe's historic and contemporary relationship to the location.
    - c. Reminding beach goers of ecological concerns and encouraging respectful public use
  3. Placement of a trash receptacle, maintained by the County, to encourage proper waste disposal by visitors.
- Recommended CEQA mitigation measures

To avoid significant impacts to resource P-08-000331, Cultural Conditions (CUL-#) CUL-1 and CUL-2 are required during work within the NU-APE (Wavecrest Dr.):

**1. CUL-1 Cultural Resource Monitoring at P-08-000331**

- a. All ground disturbance, including the removal of overburden, cement fixtures, vegetation, and associated trail appurtenances shall be monitored by a qualified archaeologist with knowledge specific to the region.

**2. CUL-2 Native American Monitoring at P-08-000331**

- a. All ground disturbance, including the removal of overburden, cement fixtures, vegetation, and associated trail appurtenances shall be monitored by a Tribal Cultural Monitor representing the joint interests of the Tolowa Dee-ni' Nation and Elk Valley Rancheria.

In the case of an inadvertent discovery of cultural resources, or the discovery of human remains, CUL-3 and CUL-4 are applicable to both the NU-APE (Wavecrest Dr.) and the SU-APE (North Pebble Beach Drive).

3. **CUL-3 Inadvertent Discovery Protocol:** Although the API contains modern disturbance, there is potential for previously unknown cultural resources to be encountered during Project activities. It is recommended that the following Inadvertent Discovery Protocol stipulations be included as conditions of project approval, and that these stipulations be included on all project construction/design plans:

- a. If buried cultural materials are encountered during construction, it is required that work stop in that immediate area until a qualified archaeologist can evaluate the nature and significance of the find [CCR 15064.5(f)].
  - b. A qualified archaeologist local to the project may be reached at DZC Archaeology & Cultural Resource Consulting, LLC; (707) 599-9842.
4. **CUL-4 Discovery of Human Remains:** It is recommended that the following Inadvertent Discovery of human Remains Protocol stipulations be included as conditions of project approval, and that these stipulations be included on all project construction/design plans:
- a. If any human remains are encountered during any phase of construction, all earth disturbing work shall stop within 50 feet of the find.
  - b. The county coroner shall be contacted to determine whether investigation of the cause of death is required as well as to determine whether the remains may be Native American in origin.
  - c. Should Native American remains be discovered, the county coroner must contact the Native American Heritage Commission (NAHC). The NAHC will then determine those persons it believes to be most likely descended from the deceased Native American(s).
  - d. Contact information for the Chief Deputy Coroner office at the time of this report: Del Norte County Coroner; Dean Wilson– Chief Deputy Coroner, 650 5th St, Crescent City, CA 95531; Phone: 707-464-4191

Areas of mapped cultural resources identified in this assessment are outside the planned work areas and so are not included on the APE maps. However, recommendations for onsite cultural monitoring outlined above and more fully in the document must still be followed.





VICINITY MAP  
NTS

BIOLOGICAL MAPPING



PER LACO ASSOCIATES  
WATERS DELINEATION / BIOLOGICAL RESOURCES  
DRAFT  
DATED: 06/05/21

**LEGEND**

LINETYPE	SYMBOLS
--- (dashed)	PHONE - SERVICE BOX
--- (dashed)	POWER - SERVICE BOX
--- (dashed)	STORM DRAIN - INLET
--- (dashed)	STRUCTURE - BOLLARD
--- (dashed)	STRUCTURE - SIGN (SINGLE POLE)
--- (dashed)	WATER - HYDRANT
--- (dashed)	WATER - METER
--- (dashed)	WATER - VALVE
--- (dashed)	ROCK BARRIER
--- (dashed)	TRASH CAN
--- (dashed)	SURVEY - HUB AND TACK
--- (dashed)	SURVEY - REBAR
--- (dashed)	PROPERTY LINE
--- (dashed)	ROAD - ALIGNMENT CENTERLINE
--- (dashed)	ROAD - BACK OF SIDEWALK / WALKWAY
--- (dashed)	ROAD - GUTTER FLOWLINE
--- (dashed)	ROAD - PAVEMENT
--- (dashed)	ROAD - TOP OF CURB
--- (dashed)	STORM DITCH FLOWLINE
--- (dashed)	STORM DRAIN LINE
--- (dashed)	STRUCTURE - FENCE CONCRETE
--- (dashed)	STRUCTURE - RETAINING WALL
--- (dashed)	WATER - DOMESTIC
--- (dashed)	CONTOUR MAJOR
--- (dashed)	CONTOUR MINOR
--- (dashed)	TOE OF SLOPE
--- (dashed)	TOP OF BANK
--- (dashed)	VEGETATION BRUSH LINE
--- (dashed)	LIMITS OF IMPACT

**CONTROL POINT DATA**

CP NO.	NORTHING	EASTING	ELEVATION	DESCRIPTION
100	10393.061	9615.933	32.78'	FOUND 5/8"Ø REBAR W/ YPC 'LS 4931'
102	10243.551	9612.933	34.03'	FOUND 5/8"Ø REBAR W/ YPC 'LS 4931'
103	10243.582	9615.834	34.10'	FOUND 5/8"Ø REBAR MISSING CAP
153	10404.483	9586.434	33.10'	FOUND 5/8"Ø REBAR
156*	10124.41	9585.362	35.47'	FOUND 5/8"Ø REBAR W/ YPC 'LS 4931'
181	10418.955	9579.156	32.52'	HUB AND TACK
182*	10023.942	9615.901	36.31'	FOUND 5/8"Ø REBAR W/ YPC 'LS 4931'
232	10412.463	9435.896	32.47'	HUB AND TACK
271	10371.669	9343.678	25.42'	HUB AND TACK

\* - MONUMENTS NOT SHOWN ON THIS SHEET. MONUMENTS ARE LOCATED IN THE CENTERLINE OF WAVECREST DRIVE AT THE BEGINNING AND END OF RADIUS CURVE

**SURVEY NOTES**

- THIS MAP IS BASED ON FIELD SURVEY PERFORMED BY STOVER ENGINEERING ON 12 MARCH, 2021 AND REFLECTS EXISTING CONDITIONS AT THAT TIME.
- HORIZONTAL DATUM: A LINE FROM CP100 TO CP102 BEARING S 01° 08'58" W A DISTANCE OF 149.54' PER RECORDS FOUND IN BOOK 12 OF MAPS PAGE 001-004, DEL NORTE COUNTY RECORDS. HORIZONTAL DATUM IS ASSUMED COORDINATES.
- VERTICAL DATUM: NORTH AMERICAN VERTICAL DATUM OF 1988 (NAVD88); US FEET, BASED ON NGS CONTROL POINT "B 1399" WITH PID "LV0544", HELD AT THE PUBLISHED ELEVATION OF 43.62 FEET (NOT SHOWN ON THIS MAP), FROM FRED D HAIGHT DRIVE JUNCTION WITH US HIGHWAY 101 AT THE TOWN OF SMITH RIVER GO WEST THEN NORTH ON HIGHWAY 101 FOR 4.67 MI TO STATION ON THE LEFT, 73 FT SOUTH, MEASURED ALONG THE WEST EDGE OF PAVEMENT ON THE HIGHWAY. FROM THE HIGHWAY POSTMILE 44.50 MARKER, IT IS AT POST MILE 44.49. MONUMENT IS A STAINLESS STEEL ROD WITHOUT SLEEVE INSIDE 5 INCH LOGO CAP STAMPED "B 1399 1988."

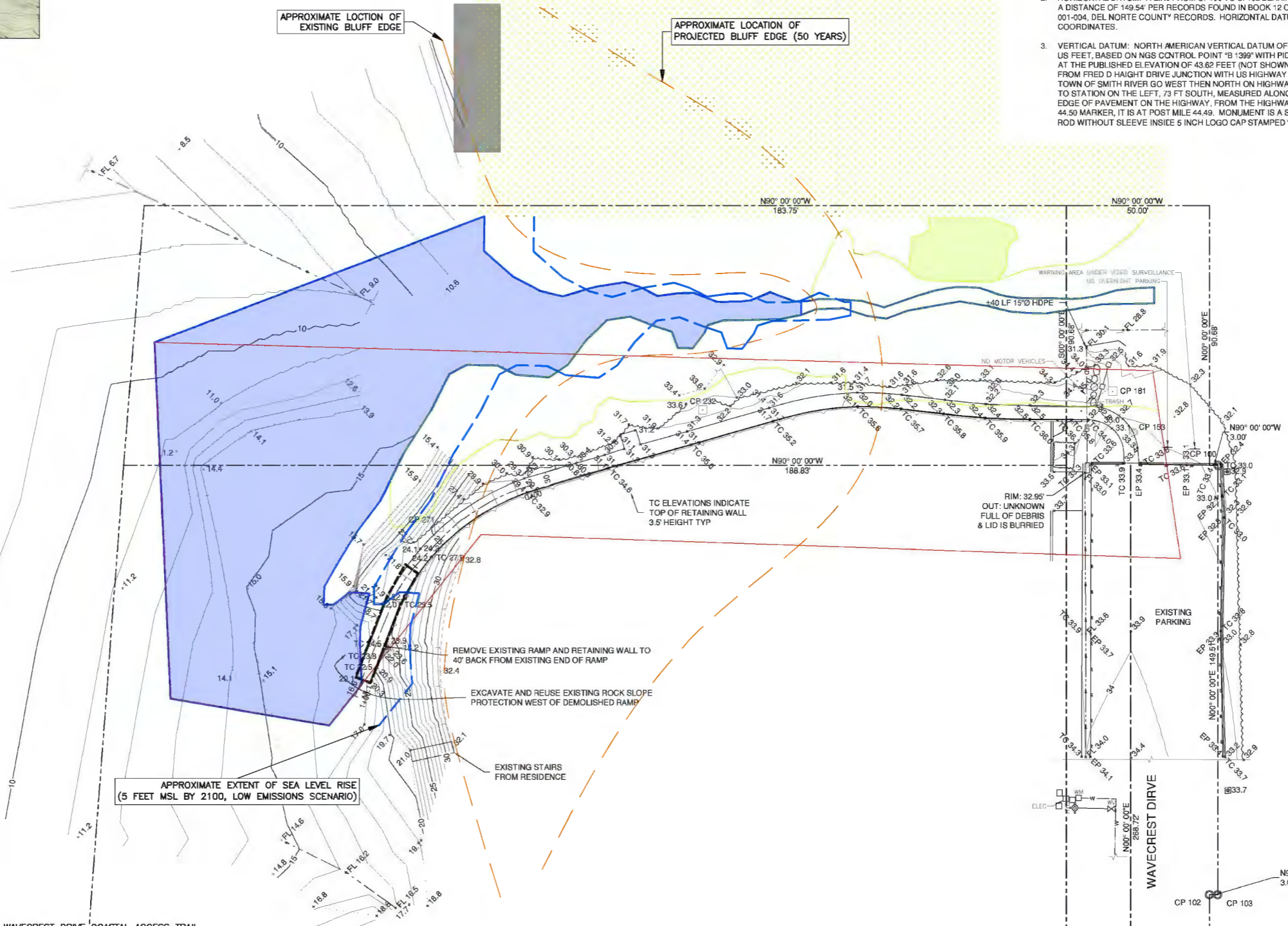

APPROXIMATE EXTENT OF SEA LEVEL RISE  
(5 FEET MSL BY 2100, LOW EMISSIONS SCENARIO)

REMOVE EXISTING RAMP AND RETAINING WALL TO  
40' BACK FROM EXISTING END OF RAMP

EXCAVATE AND REUSE EXISTING ROCK SLOPE  
PROTECTION WEST OF DEMOLISHED RAMP

RIM: 32.95'  
OUT: UNKNOWN  
FULL OF DEBRIS  
& LID IS BURIED

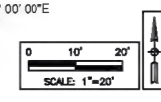

**LACO**  
EUREKA • UKIAH • SANTA ROSA  
1-800-515-5054 www.lacoassociates.com

NO.	DATE	BY	CHK.	HISTORY / REVISION

**WAVECREST DRIVE COASTAL ACCESS TRAIL**  
EXECUTIVE SUMMARY OF FINDINGS

COUNTY OF DEL NORTE  
WAVECREST DRIVE, CRESCENT CITY, CALIFORNIA

DRAWN	AAA
CHECK	CSM
APPROVED	CSM
DATE	4/29/22
JOB NUMBER	9790.00
FIGURE	X



VICINITY MAP  
NTS

**BIOLOGICAL MAPPING**

- LATHYRUS JAPONICUS
- PHACELIA LOCATION
- STATE WATER (SEDGE)
- SECTION 10/404 WATERS

PER LACO ASSOCIATES  
WATERS DELINEATION / BIOLOGICAL RESOURCES  
DRAFT  
DATED: 09/05/21

**LEGEND**

**LINETYPE**

- ROAD - PAVEMENT
- ROAD - TRAFFIC STRIPE
- STRUCTURE - GUARD RAIL
- WATER - DOMESTIC
- CONTOUR MAJOR
- CONTOUR MINOR
- TOE OF SLOPE
- TOP OF BANK
- VEGETATION BRUSH LINE
- LIMITS OF IMPACT

**SYMBOLS**

- STRUCTURE - BOLLARD
- STRUCTURE - SIGN (SINGLE POLE)
- STRUCTURE - BIKE RACK
- STRUCTURE - GATE
- WATER - HYDRANT
- WATER - VALVE
- ACCESSIBLE PARKING SYMBOL
- TRASH AND RECYCLING CANS
- SURVEY - HUB AND TACK
- SURVEY - MAG NAIL

CONTROL POINT DATA				
CP NO.	NORTHING	EASTING	ELEVATION	DESCRIPTION
1	2534543.920	592743.953	20.84'	MAG NAIL
2	2534711.236	592542.721	21.53'	MAG NAIL
3	2534469.300	592742.341	23.96'	HUB AND TACK

**SURVEY NOTES**

- THIS MAP IS BASED ON FIELD SURVEY PERFORMED BY STOVER ENGINEERING ON 16 MARCH, 2021 AND REFLECTS EXISTING CONDITIONS AT THAT TIME.
- HORIZONTAL DATUM: NORTH AMERICAN DATUM OF 1983 (NAD83), CALIFORNIA ZONE 1, US FEET, EPOCH DATE 2007, BASED ON THE NATIONAL GEODETIC SURVEY (NGS) CONTROL POINT '101 DN 23.64' WITH PID 'DH8371'. GRID BEARINGS AND DISTANCES ARE SHOWN HEREON. MULTIPLY DISTANCES BY THE RECIPROCAL COMBINED SCALE FACTOR OF 0.9999742 TO OBTAIN GROUND DISTANCES.
- VERTICAL DATUM: NORTH AMERICAN VERTICAL DATUM OF 1988 (NAVDS8), US FEET, BASED ON NGS CONTROL POINT '941 9750 TIDAL 7' WITH PID 'LV0115', HELD AT THE PUBLISHED ELEVATION OF 13.52 FEET (NOT SHOWN ON THIS MAP), ON THE TOP OF SEAWALL SOUTHERLY OF THE INTERSECTION OF FRONT AND H STREETS. MONUMENT IS A BRASS DISK STAMPED '7 1945 US COAST & GEODETIC SURVEY BENCH-MARK.'

APPROXIMATE EXTENT OF SEA LEVEL RISE  
(5 FEET MSL BY 2100, LOW EMISSIONS SCENARIO)

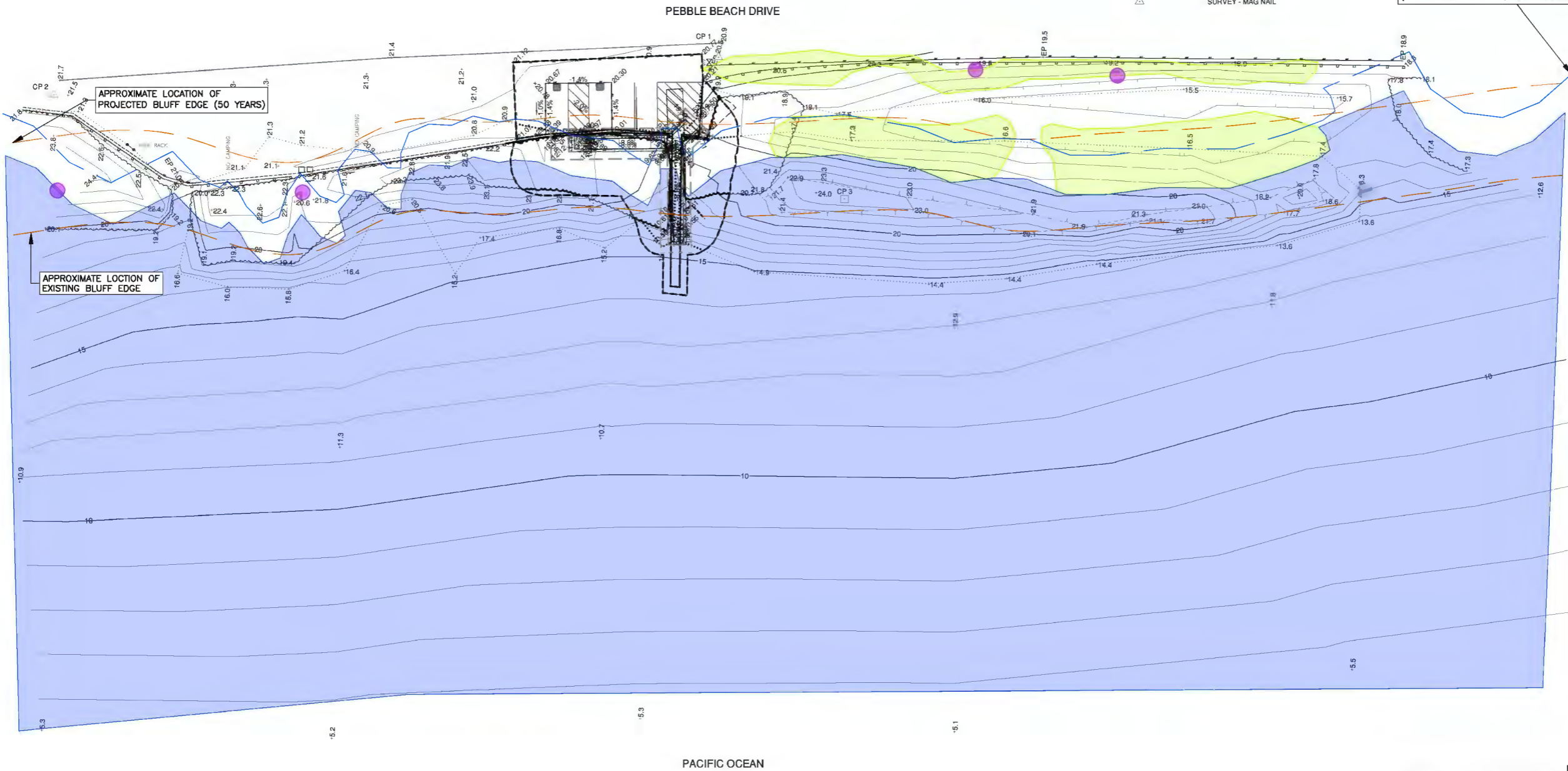

May 02, 2022 - a:35am  
 P:\9790\9790 Del Norte County Community Development\9790.00 Wavcrest Dr Coastal Access Project\12 Figures\_Maps\2022 Exec Summary Report\_Fig\ EXEC SUMMARY OF FINDINGS (ALL FIGURES).dwg

NOTE: MAP MODIFIED FROM SHEET 1 - AREA OF POTENTIAL EFFECTS - PEBBLE BEACH DRIVE COASTAL ACCESS TRAIL (STOVER ENGINEERING, DATED APRIL 27, 2022)

GOOGLE EARTH IMAGE DATE: APRIL 2021

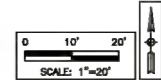

LACO

EUREKA • UKIAH • SANTA ROSA  
1-800-515-5054 www.lacoassociates.com

NO.	HISTORY / REVISION	BY	CHK.	DATE

PEBBLE BEACH DRIVE COASTAL ACCESS TRAIL

EXECUTIVE SUMMARY OF FINDINGS

COUNTY OF DEL NORTE

NORTH PEBBLE BEACH DRIVE, CRESCENT CITY, CALIFORNIA

DRAWN	AAA
CHECK	CSM
APPROVED	CSM
DATE	4/29/22
JOB NUMBER	9790.00
FIGURE	X



**Figure 4: Visual Assessment - Wavecrest Drive**  
**Wavecrest Drive and North Pebble Beach Drive Coastal Access Plan**  
**Del Norte County, Community Development Department**  
April 25, 2022



**Figure 3: Visual Assessment - Pebble Beach Drive**  
Wavecrest Drive and North Pebble Beach Drive Coastal Access Plan  
Del Norte County, Community Development Department  
April 25, 2022



**Figure 5: Visual Assessment - Wavecrest Drive Stair Section**

**Wavecrest Drive and North Pebble Beach Drive Coastal Access Plan**

**Del Norte County, Community Development Department**

April 25, 2022

S:\4737 LACO DINO Coastal Access Project\Civil\3D\FBD DWG\COPY - 26220324 - 4737 - PEBBLE BEACH DRIVE COASTAL ACCESS\FBD DWG\COPY - 26220324 - 4737 - PEBBLE BEACH DRIVE COASTAL ACCESS 7/20/22 4:53 PM STOVER ENGINEERING SHALL NOT BE RESPONSIBLE FOR THE ACCURACY OR COPY FIDELITY OF ELECTRONIC COPIES OF THIS PLAN SHEET.

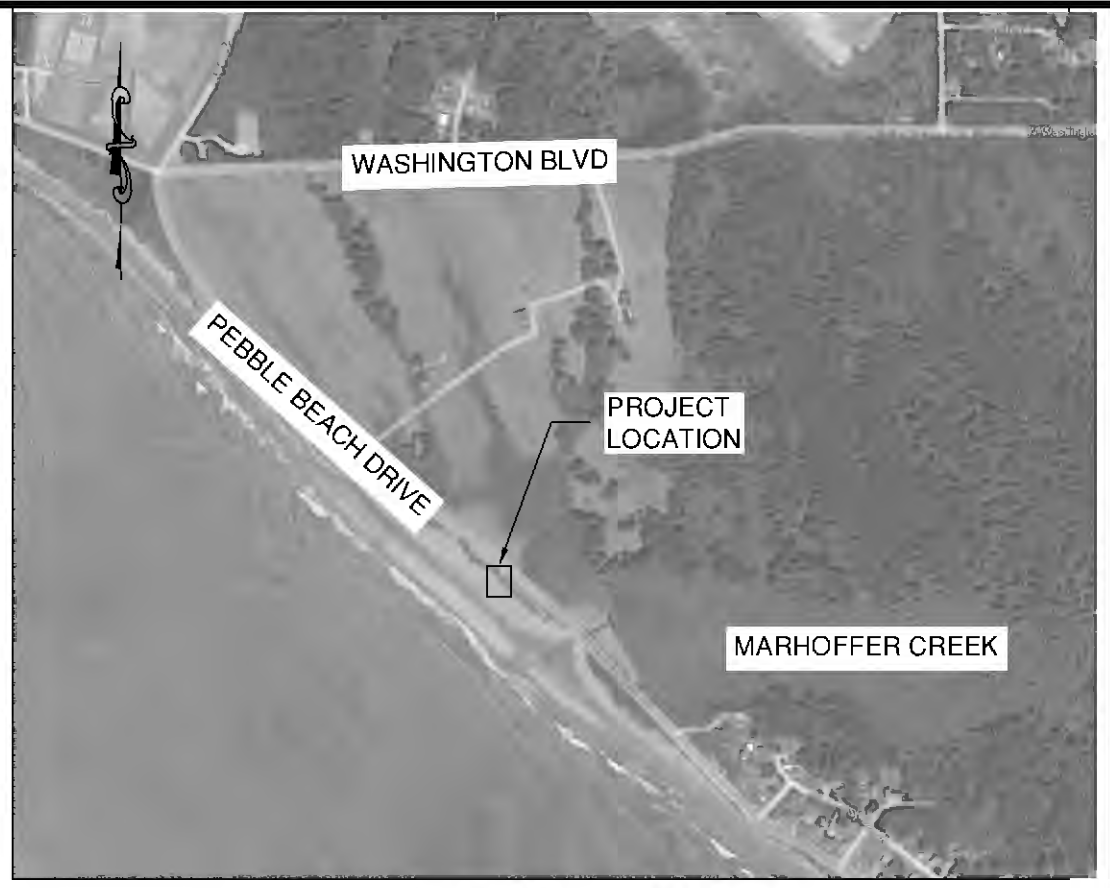
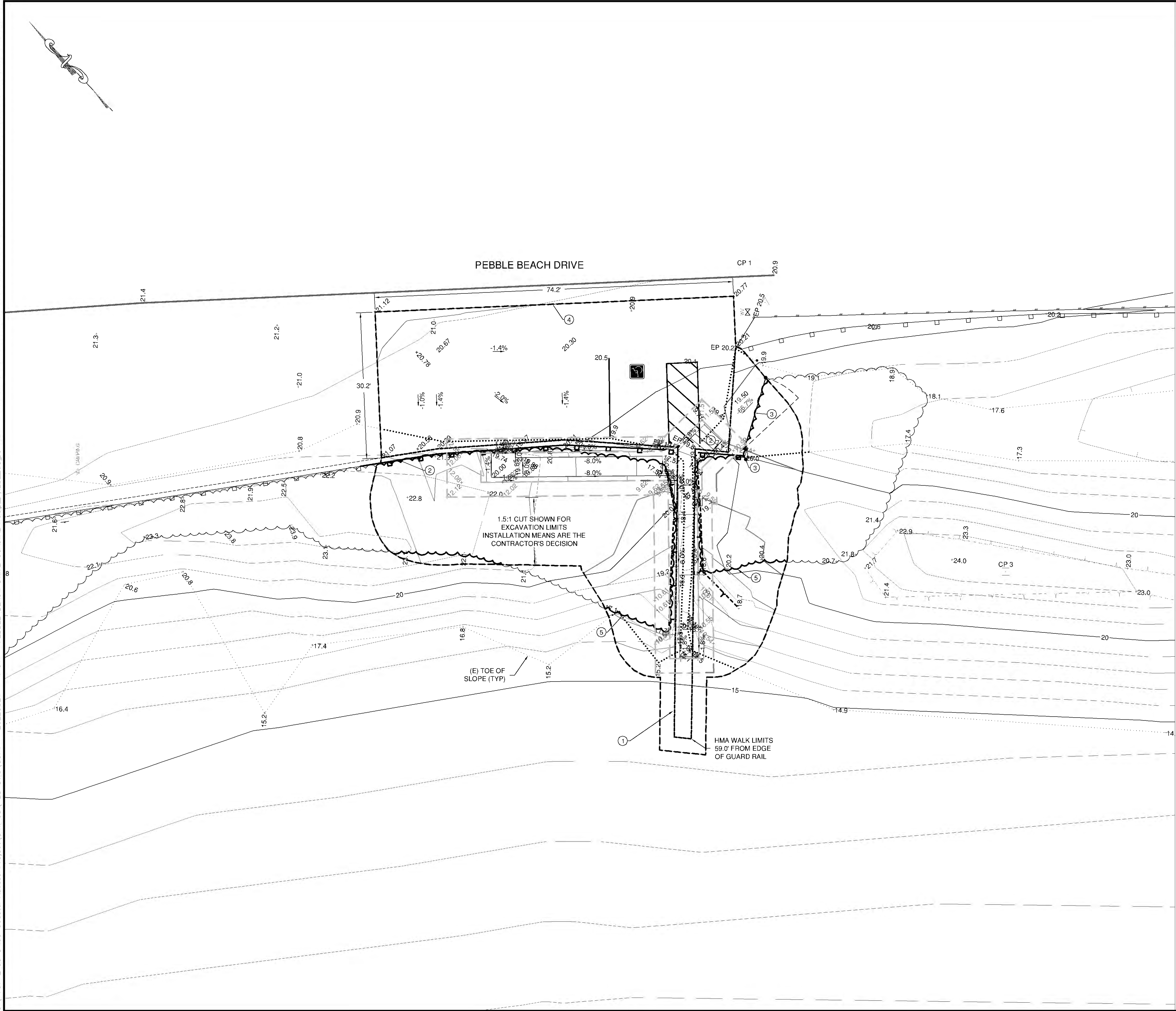

**CONTROL POINT DATA**

CP NO.	NORTHING	EASTING	ELEVATION	DESCRIPTION
1	2534543.920	592743.953	20.84'	MAG NAIL
2	2534711.236	592542.721	21.53'	MAG NAIL
3	2534469.300	592742.341	23.96'	HUB AND TACK

- SURVEY NOTES**
- THIS MAP IS BASED ON FIELD SURVEY PERFORMED BY STOVER ENGINEERING ON 16 MARCH, 2021 AND REFLECTS EXISTING CONDITIONS AT THAT TIME.
  - HORIZONTAL DATUM: NORTH AMERICAN DATUM OF 1983 (NAD83), CALIFORNIA ZONE 1, US FEET, EPOCH DATE 2007, BASED ON THE NATIONAL GEODETIC SURVEY (NGS) CONTROL POINT "101 DN 23.64", WITH PID "DH6371". GRID BEARINGS AND DISTANCES ARE SHOWN HEREON. MULTIPLY DISTANCES BY THE RECIPROCAL COMBINED SCALE FACTOR OF 0.9999742 TO OBTAIN GROUND DISTANCES.
  - VERTICAL DATUM: NORTH AMERICAN VERTICAL DATUM OF 1988 (NAVD88), US FEET, BASED ON NGS CONTROL POINT "941 9750 TIDAL 7" WITH PID "LV0115", HELD AT THE PUBLISHED ELEVATION OF 13.52 FEET (NOT SHOWN ON THIS MAP), ON THE TOP OF SEAWALL SOUTHERLY OF THE INTERSECTION OF FRONT AND H STREETS. MONUMENT IS A BRASS DISK STAMPED "7 1945 US COAST & GEODETIC SURVEY BENCHMARK."

**LEGEND**

**LINETYPE**

	ROAD - PAVEMENT
	ROAD - TRAFFIC STRIPE
	STRUCTURE - GUARD RAIL
	WATER - DOMESTIC
	CONTOUR MAJOR
	CONTOUR MINOR
	TOE OF SLOPE
	TOP OF BANK
	VEGETATION BRUSH LINE
	LIMITS OF IMPACT

**SYMBOLS**

	STRUCTURE - BOLLARD
	STRUCTURE - SIGN (SINGLE POLE)
	STRUCTURE - BIKE RACK
	STRUCTURE - GATE
	WATER - HYDRANT
	WATER - VALVE
	ACCESSIBLE PARKING SYMBOL
	TRASH AND RECYCLING CANS
	SURVEY - HUB AND TACK
	SURVEY - MAG NAIL

NOTE: THE PLAN (LEFT) DEPICTS EXISTING CONDITIONS IN DARK LINE TYPE. EXISTING LINE TYPES NOTED ABOVE APPLY TO ALL OTHER SHEETS.

- KEY NOTES**
- REMOVE (E) HMA BEACH ACCESS PATH
  - REMOVE AND REPLACE (E) GUARDRAIL
  - REMOVE AND REPLACE (E) BOLLARDS AND GATE
  - SAWCUT AND REMOVE (E) HMA
  - (E) VEGETATION REMOVAL AND REPLACEMENT PER LACO ASSOCIATES WATERS DELINEATION / BIOLOGICAL RESOURCES DRAFT DATED: 06/05/21

No.	Date	Revision	Appr'd.

DESIGNED BY: WLS DRAWN BY: GLH CHECKED BY:   
 1 BAR IS EQUAL TO ONE INCH ON ORIGINAL DRAWING. ADJUST SCALES IF DISTANCE VARIES ACCORDINGLY.

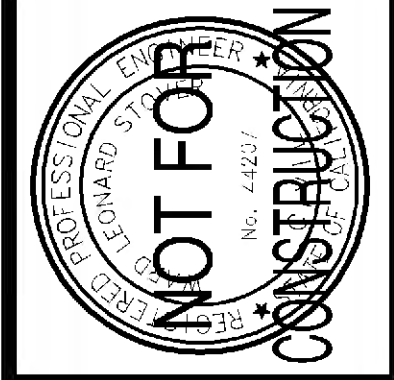

**STOVER ENGINEERING**  
 Civil Engineers and Consultants  
 PO BOX 783 - 711 H STREET  
 CRESCENT CITY, CA 95531 707-485-6742

COUNTY OF DEL NORTE  
 PEBBLE BEACH DRIVE COASTAL ACCESS  
 CRESCENT CITY, CA  
 EXISTING CONDITIONS AND DEMOLITION

JOB NO. 4737  
 SCALE: 1" = 10'  
 DATE: 04/27/22  
 SHEET  
 1 OF 2

S:\4737 LACO DMCO Coastal Access Project\Civil\3D\FBD DWG\COPY - 26220324 - 4737 - PEBBLE BEACH DRIVE COASTAL ACCESS\72002204.dwg PLOT STOVER ENG NEER NO SHALL NOT BE RESPONSIBLE FOR THE ACCURACY OR COPYWRIGHTNESS OF ELECTRONIC COPIES OF THIS PLAN SHEET

PEBBLE BEACH DRIVE

CP 1

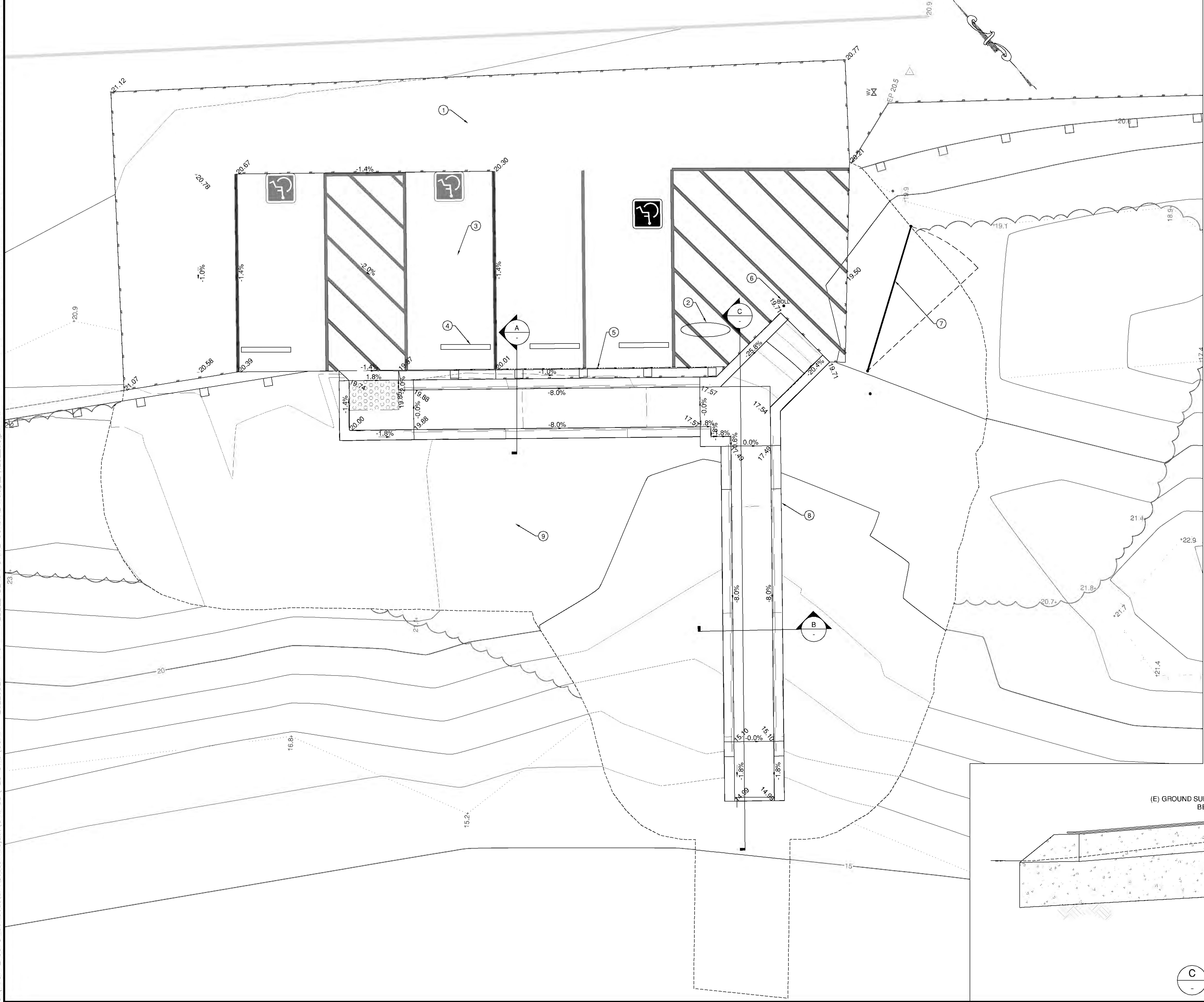

**KEY NOTES**

- ① NEW PAVING AND STRIPING
- ② NEW BIKE RACK
- ③ CONCRETE ACCESSIBLE PARKING PAD
- ④ WHEEL STOP (TYP)
- ⑤ RECONSTRUCT GUARD RAIL
- ⑥ NEW BOLLARD
- ⑦ REMOVE & REPLACE EXISTING GATE AND BOLLARDS AS NEEDED
- ⑧ NEW CONCRETE RAMP
- ⑨ REVEGETATE DISTURBED GROUND WITH NATIVE PLANTS FROM APPROVED LIST

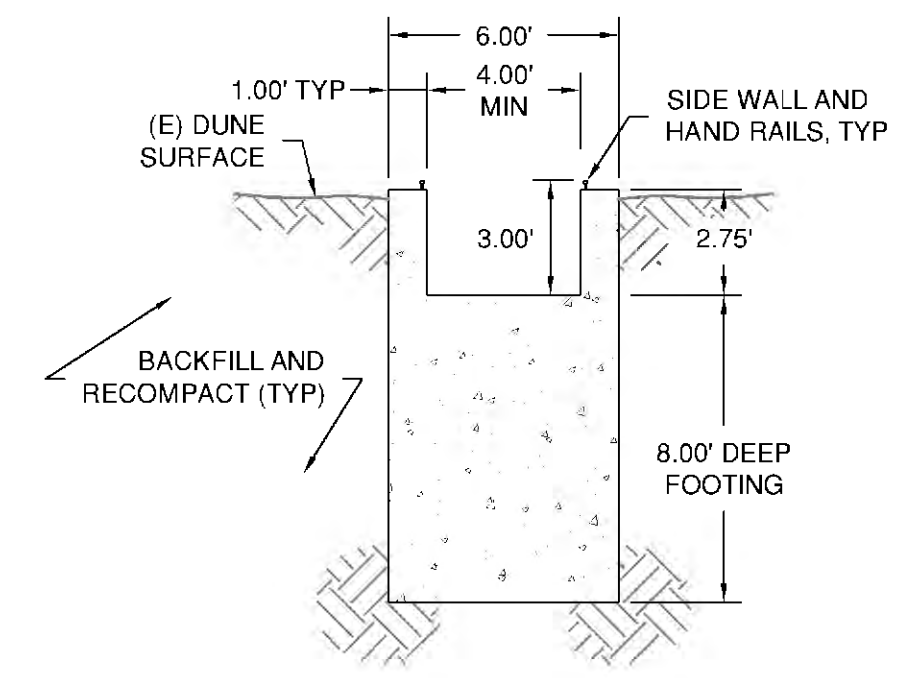

**A SECTION**  
1"=5'

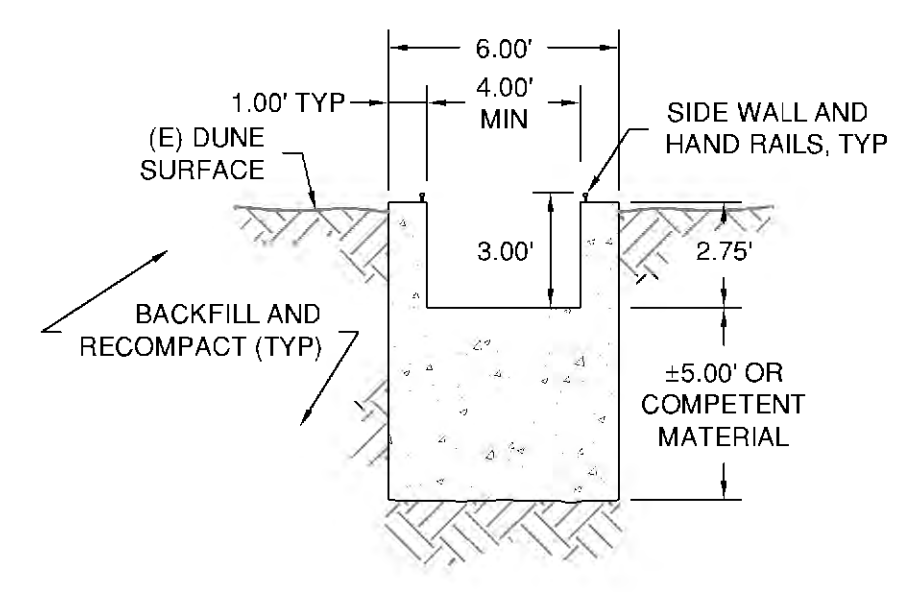

**B SECTION**  
1"=5'

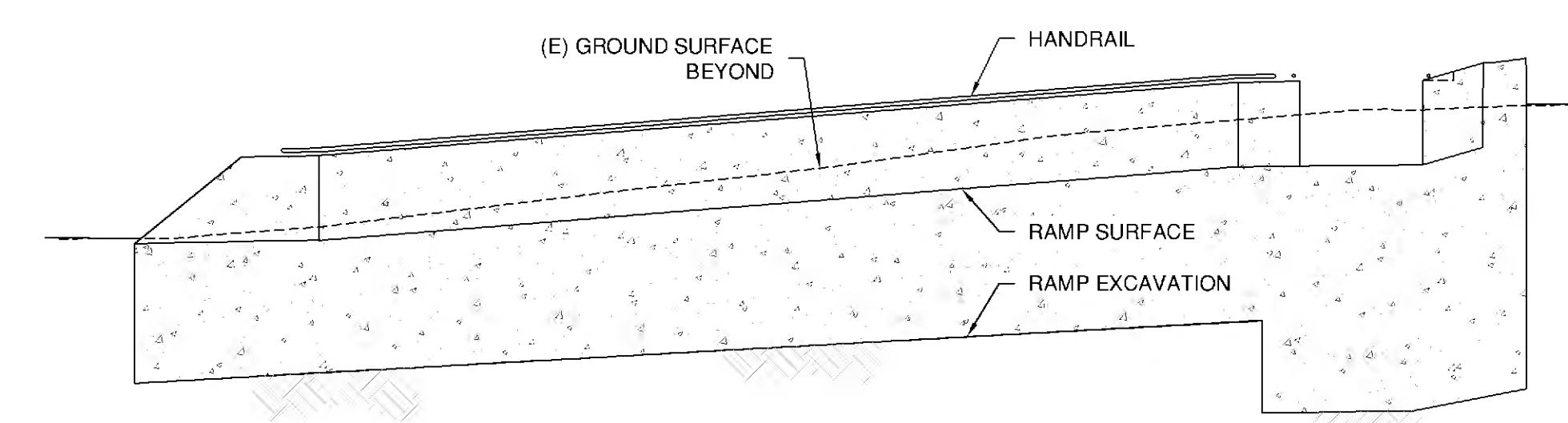

**C TYPICAL SECTION**  
1"=5'

No.	Date	Revision	Appr'd.

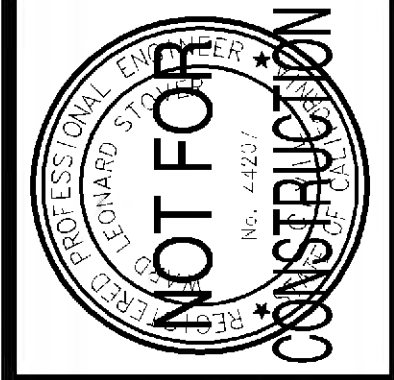

**STOVER ENGINEERING**  
Civil Engineers and Consultants  
PO BOX 783 - 711 H STREET  
CRESCENT CITY, CA 95531 707-485-6742

COUNTY OF DEL NORTE  
PEBBLE BEACH DRIVE COASTAL ACCESS  
CRESCENT CITY, CA  
IMPROVEMENT PLAN

JOB NO. 4737  
SCALE: 1"=5'  
DATE: 04/27/22  
SHEET  
**2** OF **2**

## ATTACHMENT 1

### **Topography and Baseline Mapping**





**LEGEND**

**LINETYPE**

- ROAD - PAVEMENT
- ROAD - TRAFFIC STRIPE
- STRUCTURE - GUARD RAIL
- WATER - DOMESTIC
- CONTOUR MAJOR
- CONTOUR MINOR
- TIE OF SLOPE
- TOP OF BANK
- VEGETATION BRUSH LINE

**SYMBOLS**

- STRUCTURE - BOLLARD
- STRUCTURE - SIGN (BRASS POLE)
- STRUCTURE - BIKE RACK
- STRUCTURE - GATE
- WATER - HYDRANT
- WATER - VALVE
- ACCESSIBLE PARKING SYMBOL
- TRASH AND RECYCLING CANS
- SURVEY - HUD AND TAG
- SURVEY - MAG NAIL

**CONTROL POINT DATA**

CP NO	NORTHING	EASTING	ELEVATION	DESCRIPTION
1	25844.820	58741.993	25.84	MAG NAIL
2	25872.288	58741.721	23.53	MAG NAIL
3	25844.820	58742.141	23.86	HUB AND TAG

**SURVEY NOTES**

- THIS MAP IS BASED ON FIELD SURVEY PERFORMED BY STOVER ENGINEERS ON 16 MARCH, 2021 AND REFLECTS EXISTING CONDITIONS AT THAT TIME.
- HORIZONTAL DATUM: NORTH AMERICAN DATUM OF 1983 (NAD83), CALIFORNIA ZONE 1, US FEET, EPOCH DATE 2011, BASED ON THE NATIONAL GEODETIC SURVEY (NGS) CONTROL POINT 101 042 04, WITH THE 2011 7-14-10 BEARINGS AND DISTANCES ARE SHOWN HERE. MULTIPLY OBTAINED BY THE RECIPROCAL COARED SCALE FACTOR OF 0.999942 TO OBTAIN GROUND DISTANCES.
- VERTICAL DATUM: NORTH AMERICAN VERTICAL DATUM OF 1988 (NAV88), US FEET, BASED ON NGS CONTROL POINT 941 970 TIDAL, WITH PD 1V21157, HELD AT THE PUBLISHED ELEVATION OF 13.52 FEET (401 2943MM) ON THIS MAP, ON THE TOP OF SEAWALL, NORTHERLY OF THE INTERSECTION OF FRONT AND H STREETS. MONUMENT IS A BRASS DISK STAMPED "1945 US COAST & GEODETIC SURVEY BENCHMARK".

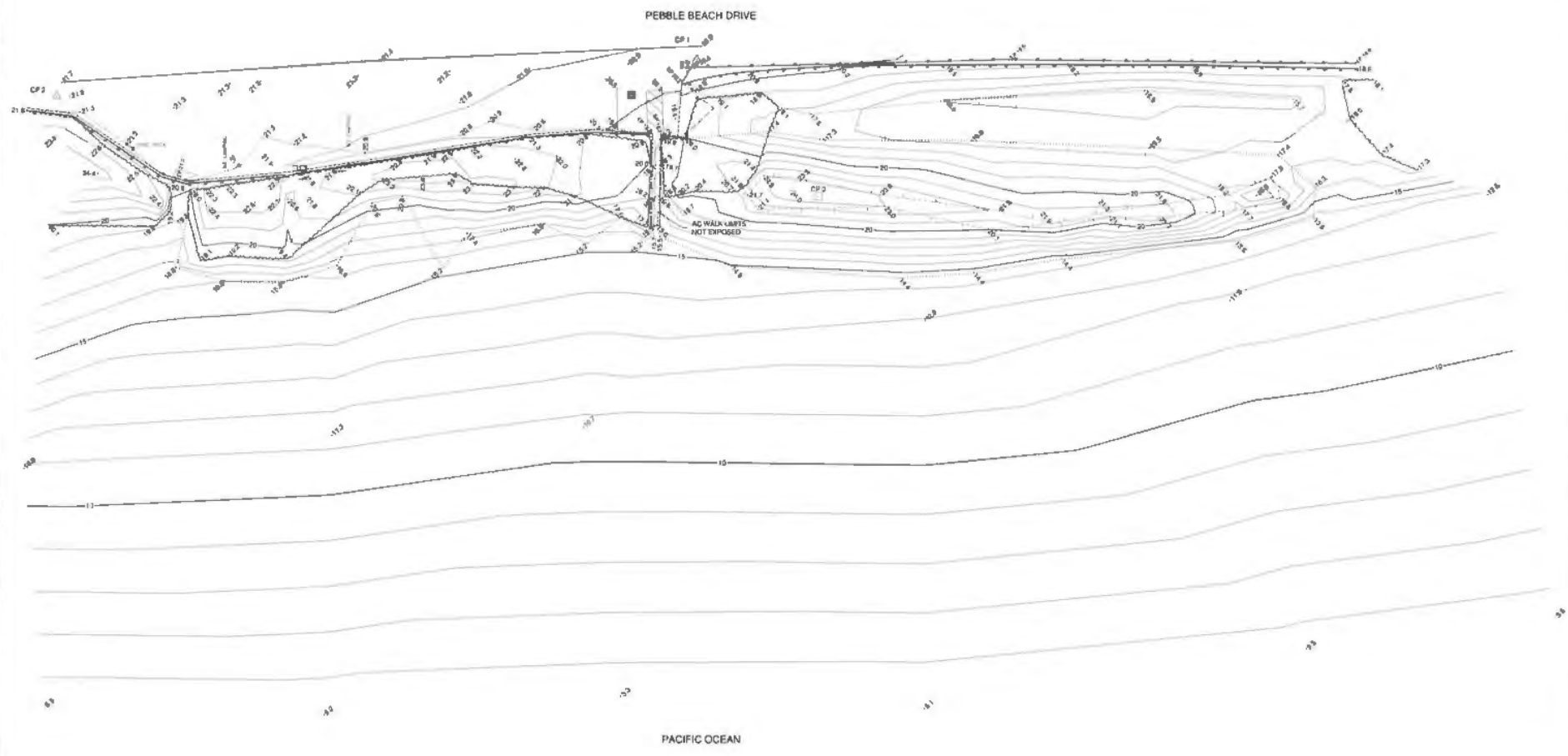

No.	Date	DESIGNED BY	CHECKED BY	SCALE	Notes



**STOVER ENGINEERING**  
Civil Engineers and Consultants  
PO BOX 780, 714 H STREET  
CRESCENT CITY, CA 95531 707-466-8742

COUNTY OF DEL NORTE  
PEBBLE BEACH DRIVE COASTAL ACCESS TRAIL  
CRESCENT CITY, CA  
EXISTING TOPOGRAPHY

JOB NO. 4737  
SCALE: 1"=20'  
DATE: 03/26/21  
SHEET  
**1** OF 1

# TECHNICAL MEMORANDUM

Revised - Biological and Rare Plant Survey and Waters/Wetland Assessment  
 Wavecrest Drive and North Pebble Beach Drive Access Project Del Norte County,  
 California

Date: May 18, 2022  
 Project No.: 9790.00

Prepared For: County of Del Norte

Prepared By: Cameron Purchio, Associate Planner



Reviewed By: Gary Lester, Senior Biologist/Botanist



Attachments:	Figure 1:	Location Map
	Figure 2:	Wavecrest Site Existing Conditions
	Figure 3:	Pebble Beach Site Existing Conditions
	Appendix A:	Plant Species Encountered During Field Survey of the Project Areas
	Appendix B:	Wetland Determination Data Forms

## 1.0 INTRODUCTION

This technical memorandum presents the results of a biological and rare plant survey and wetlands assessment performed by LACO Associates (LACO) at two coastal access sites in the County of Del Norte (Figure 1; herein referred to as “Project”). The northernmost of the two sites, Wavecrest Drive access site, is intended to repair a coastal access route that was damaged by the tsunami resulting from the 2011 Tohoku earthquake in Japan. The second site, Pebble Beach Drive access site, is in the City of Crescent City, and is a new access location that is intended to provide Americans with Disability Act (ADA)-compliant access in an area where overall beach access is limited.

The purpose of the study was to determine whether the two areas where the repairs and new access are proposed contain sensitive biological resources, including special status plant and wildlife species and coastal wetlands.

The Wavecrest Drive access site (herein referred to as “Wavecrest Site”) is located on Assessor’s Parcel Number (APN) 101-170-036, owned by the County of Del Norte, in the Smith River Area (Section 8, Township 18 North, Range 2 West of the Smith River USGS 7.5-minute quadrangle) on the west side of US Highway 101, approximately 14 miles north of Crescent City, Del Norte County, California.

The Pebble Beach Drive access site (herein referred to as "Pebble Beach Site") is located on APN 120-020-022, owned by the County of Del Norte, in the Crescent City Area (Section 19, Township 16 North, Range 1 West of the Crescent City USGS 7.5-minute quadrangle) on the west side of North Pebble Beach Drive in Crescent City, Del Norte County, California.

## 2.0 METHODOLOGY

Field surveys of the two locations were conducted on May 5, 2021, and May 8, 2021. LACO's biologist and botanist, Gary Lester, conducted the surveys. Mr. Lester is qualified to conduct biological surveys, having earned an undergraduate degree in Botany and received training in recognition of the local flora and fauna and in rare plant identification and survey protocol. Additionally, Mr. Lester has conducted sensitive plant surveys, biological site investigations, wetland delineations, and wildlife surveys for over 25 years.

U.S. Geological Survey (USGS) topographic maps, aerial photography maps, and the California Department of Fish and Wildlife (CDFW, 2021) California Natural Diversity Database (CNDDDB; for the Smith River and Crescent City Quads), relating to the Project area were reviewed prior to and during the surveys for potential sensitive species occurrence. The U.S. Fish and Wildlife Service (USFWS) National Wetlands Inventory (NWI, 2021) was reviewed for potential wetlands to provide survey location guidance.

### 2.1 Biological Survey

The biological survey was conducted following CDFW protocol (2018). An intuitively controlled, seasonally appropriate survey was conducted that sampled the identified potential habitat. Plants were identified to the lowest taxonomic level (genus or species) necessary for rare plant identification. The scientific nomenclature follows the Jepson Manual (Baldwin, et. al. 2012).

### 2.2 Waters and Wetland Assessment

On March 2, 2021, a wetland and waters delineation was conducted by LACO staff member Ms. Cameron Purchio, Associate Planner. LACO examined the Subject Properties in accordance with the United States Army Corps of Engineers Wetland Delineation Manual: Western Mountains, Valleys, and Coast Region, version 2.0 (ACOE, 2010 and ACOE, 1987). ACOE uses a three-parameter approach for making wetland determinations. It is based on the presence of indicators for: a predominance of hydrophytic vegetation (plants adapted to anaerobic conditions resulting from a prolonged inundation with water); hydric soils (soils formed under conditions of saturation, flooding, or ponding long enough during the growing season to develop anaerobic conditions in the upper part (Federal Register, 1986)); and wetland hydrology (permanent or periodic inundation or saturation of the soil to the surface at some time during the growing season of the prevalent vegetation). The ACOE (1987, 2010) identifies an area as wetland when all three parameters are present.

The ordinary high-water mark (OHWM) was determined in accordance with the United States Army Corps of Engineers Guide to Ordinary High Water Mark Delineation for Non-Perennial Streams in the Western Mountains, Valleys, and Coast Region of the United States (ACOE, 2014). OHWM is defined in federal regulations as "that line on the shore established by the fluctuations of water and indicated by physical characteristics such as a clear, natural line impressed on the bank, shelving, changes in the character of the soil, destruction of terrestrial vegetation, the presence of litter and debris, or other appropriate means that consider the characteristics of the surrounding waters" (33CFR 328.3(e)). ACOE uses the presence of

indicators and supporting features to determine the OHWM in areas with changing water elevations. The primary indicators used to determine OHWM are breaks in slope, change in sediment characteristics, and change in vegetation characteristics.

LACO examined the Subject Properties to determine the presence of wetland features in accordance with the State Water Resources Control Board (SWRCB), which defines waters of the state as "any surface water or groundwater, including saline waters, within the boundary of the state" (CCR 13050 (e)). More specifically, the SWRCB has defined a wetland to be "any area if, under normal circumstances, (1) the area has continuous or recurrent saturation of the upper substrate caused by groundwater, or shallow surface water, or both; (2) the duration of such saturation is sufficient to cause anaerobic conditions in the upper substrate; and (3) the area's vegetation is dominated by hydrophytes or the area lacks vegetation" (SWRCB, 2019).

Within the coastal zone, the California Coastal Commission (CCC) defines a wetland as "lands within the coastal zone which may be covered periodically or permanently with shallow water and include saltwater marches, freshwater marshes, open or closed brackish water marshes, swamps, mudflats, and fens" (CA Public Resource Code §30121). The implications of these regulations are such that a feature may be considered wetlands by the CCC if a single indicator (hydric soils, hydrophytic vegetation, or wetland hydrology) is present.

The delineation was guided by visual assessment of vegetation and potential hydrology. Soil pits were dug at various locations to verify hydric soil conditions and validate wetland boundaries. Please note this work was done under observation of a cultural monitor, whose report was compiled and submitted under separate cover.

## 3.0 ENVIRONMENTAL SETTING

### 3.1 Wavecrest Site

The Wavecrest Site is comprised of bluff and beach strand habitat with ground surface elevations ranging between 0 and 40 feet above mean sea level (amsl). The topography is shoreline on the western portion of the site and elevated bluff on the eastern portion of the site. The northern portion of the site contains a perennial stream with associated riparian habitat. Adjacent and south of the stream is the currently existing beach access consisting of a small parking area (approximately 15 parking sites) and a cement pathway which curves east to southwest and provides the current access to the shoreline. Directly south of the site on the bluff area is a fenced residential development. The proposed Project area comprises primarily perennial grasses and riparian vegetation. A complete list of plant species observed in the Project area is available in Appendix A.

### 3.2 Pebble Beach Site

The Pebble Beach Site comprises beach strand habitat with ground surface elevations ranging between 0 and 15 feet amsl. The topography is shoreline on the western portion of the site and irregular dune formations on the eastern portion of the site, with a paved parking area (approximately 20 parking sites) and access gate adjacent to North Pebble Beach Drive. Directly south of the site is a drainage fed by a culvert passing beneath North Pebble Beach Drive, which drains Marhoffer Creek. The proposed Project area comprises primarily perennial grasses and groundcovers. A complete list of the plant species observed in the Project area is available in Appendix A.

## 4.0 SENSITIVE SPECIES ANALYSIS

### 4.1 Sensitive Plant Species Historically Reported Nearby

All species included on Lists 1 to 4 (herein referred to as “sensitive species”) of the California Native Plant Society’s (CNPS) Inventory of Rare and Endangered Vascular Plants of California (2021) were reviewed to determine potential presence in the Site (species databases referred to in this report use the U.S. Geological Survey Smith River or Crescent City Quads as the reference point). The CNPS inventory includes species listed as rare or endangered by the Federal and State governments. Based on the species identified in the CNDDDB records, the range of habitats present, and the geographical range of the various sensitive species, the species considered most likely to occur in the vicinity of the Project area are listed in Tables 1 and 2, below.

#### 4.1.1 Wavecrest Site

Only Coastal Dune and Coast Scrub/Bluff Scrub habitats were present at the Wavecrest Site, eliminating many sensitive species specific to other types of habitats. Two (2) sensitive plant species were observed on-site, including seaside pea (*Lathyrus japonicus*) and Siskiyou checkerbloom (*Sidalcea malviflora ssp. patula*).

Table 1. Sensitive Species Potentially Present in the Project Area – Wavecrest Drive Site

Species	Common Name	CNPS List*	Preferred Habitat
<i>Hesperexav sparsiflora</i> var. <i>brevifolia</i>	Short-leaved evax	1B.2	Coastal bluff scrub, Coastal dune, Coastal prairie
<i>Gilia capitata ssp. pacifica</i>	Pacific gilia	1B.2	Coastal bluff scrub, Coastal prairie
<i>Angelica lucida</i>	Sea-watch	4.2	Coastal bluff scrub, Coastal dunes, Coastal scrub, Marshes and swamps
<i>Castilleja littoralis</i>	Oregon coast pantbrush	2B.2	Coastal bluff scrub, Coastal dunes, Coastal scrub
<i>Erysimum concinnum</i>	Bluff wallflower	1B.2	Coastal bluff scrub, Coastal dunes, Coastal scrub
<i>Gilia millefoliata</i>	Dark-eyed gilia	1B.2	Coastal dunes
<i>Lathyrus japonicus</i>	Seaside pea	2B.1	Coastal dunes
<i>Oenothera wolfii</i>	Wolf’s evening-primrose	1B.1	Coastal bluff scrub, Coastal dunes, Coastal prairie
<i>Phacelia argentea</i>	Sand dune phacelia	1B.1	Coastal dunes
<i>Sulcaria spiralifera</i>	Twisted horsehair lichen	1B.2	Coastal dunes
<i>Polemonium carneum</i>	Oregon polemonium	2B.2	Coastal prairie, Coastal scrub
<i>Sidalcea malviflora ssp. patula</i>	Siskiyou checkerbloom	1B.2	Coastal bluff scrub, Coastal prairie

\* CNPS List Codes:

- 1B.1-Rare, threatened or endangered in California and elsewhere, seriously threatened in California
- 1B.2-Rare, threatened or endangered in California and elsewhere, moderately threatened in California;
- 2B.2-Rare, threatened or endangered in California, but more common elsewhere, moderately threatened in California;
- 4.1-Plants of limited distribution, seriously threatened in California;
- 4.2-Plants of limited distribution, moderately threatened in California.

The following summaries are for the sensitive plant species shown in Table 1:

The **short-leaved evax** is known from nearby coastal bluff scrub, coastal dunes, and coastal prairie habitats. Habitat for this species occurs in the Project area. This species has a California Rare Plant Ranking (CRPR, CNPS, 2018) of 1B.2, defined as rare, threatened, or endangered in California, and elsewhere and a moderate number of the California populations are threatened.

The **Pacific gilia** is known from sightings as recently as 2017 within Tolowa Dunes State Park, approximately four (4) miles south of the Wavecrest Site. Habitat for this species occurs within the Project area. This species has a CRPR of 1B.2, defined as rare, threatened, or endangered in California and elsewhere and the majority of the California populations are seriously threatened.

The **Sea-watch** is known from nearby coastal bluff scrub, coastal dune, and coastal scrub habitats. Habitat for this species occurs within the Project area. This species has a CRPR of 4.2, defined as uncommon, moderately threatened in California.

The **Oregon coast paintbrush** is known from nearby coastal bluff scrub, coastal dunes, and coastal scrub habitats. Habitat for this species occurs within the Project area. This species has a CRPR of 2B.2, defined as rare, threatened, or endangered in California, but more common elsewhere, and fairly threatened in California.

The **bluff wallflower** is known from sightings as recently as 2014 within Tolowa Dunes State Park, approximately four (4) miles south of the Wavecrest Site and a single sighting from 1970 on Prince Island, approximately one (1) mile south of the Wavecrest Site. Habitat for this species occurs in the Project area. This species has a CRPR of 1B.2, defined as rare, threatened, or endangered in California, and elsewhere and a moderate number of the California populations are threatened.

The **dark-eyed gilia** is known from multiple sightings as recently as 2019 within the Smith River Indian Reservation, approximately one (1) mile south of the Wavecrest Site. Habitat for this species occurs in the Project area. This species has a CRPR of 1B.2, defined as rare, threatened, or endangered in California, and elsewhere and a moderate number of the California populations are threatened.

The **seaside pea** is known from two (2) sightings in 1977 at the mouth of the Smith River, approximately two (2) miles south of the Wavecrest Site and was observed on-site. Habitat for this species occurs in the Project area. This species has a CRPR of 2B.1, defined as rare, threatened, or endangered in California, but more common elsewhere, seriously threatened in California.

The **Wolf's evening primrose** is known from multiple sightings in 1987, with one (1) sighting occurring approximately one (1) mile north of the Wavecrest Site adjacent to US Highway 101, and two (2) sightings occurring approximately two (2) miles south of the Wavecrest Site near the mouth of the Smith River. Habitat for this species occurs in the Project area. This species has a CRPR of 1B.1, defined as rare, threatened, or endangered in California and elsewhere, seriously threatened in California.

The **sand dune phacelia** is known from historical sightings (1939) and a 1984 sighting approximately two (2) miles south of the Wavecrest Site near the mouth of the Smith River, and an additional 1987 sighting approximately two (2) miles north of the Wavecrest Site adjacent to US Highway 101. Habitat for this species

occurs in the Project area. This species has a CRPR of 1B.1, defined as rare, threatened, or endangered in California and elsewhere, seriously threatened in California.

The **twisted horsehair lichen** is known from nearby coastal dunes habitat. Habitat for this species occurs in the Project area. This species has a CRPR of 1B.2, defined as rare, threatened, or endangered in California, and elsewhere and a moderate number of the California populations are threatened.

**Oregon polemonium** is known locally only by two (2) collections in 1928 and 1950 from Bear River Ridge. The polemonium is not likely present due to the high non-native herbaceous component in the on-site pasture. This species has a CRPR of 2B.2, defined as rare, threatened, or endangered in California, but more common elsewhere and a moderate number of the California populations are threatened.

The **Siskiyou Checkerbloom** is known from prairies and forest edges in northern California and was observed on-site. Populations have been found in nearby Kamph Memorial Park (CNDDDB, 2018). This species has a CRPR of 1B.2, defined as rare, threatened, or endangered in California, and elsewhere and a moderate number of the California populations are threatened.

#### 4.1.2 Pebble Beach Site

Only coastal dune habitat was present at the Pebble Beach Site, eliminating many sensitive species specific to other types of habitats. Three (3) sensitive plant species were observed on-site, including: seaside pea, Wolf's evening primrose (*Oenothera wolfii*), and sanddune phacelia (*Phacelia argentea*).

Table 2. Sensitive Species Potentially Present in the Project Area – Pebble Beach Site

Species	Common Name	CNPS List*	Preferred Habitat
<i>Hesperevax sparsiflora</i> var. <i>brevifolia</i>	Short-leaved evax	1B.2	Coastal bluff scrub, Coastal dune, Coastal Prairie
<i>Castilleja littoralis</i>	Oregon coast pantbrush	2B.2	Coastal bluff scrub, Coastal dunes, Coastal scrub
<i>Oenothera wolfii</i>	Wolf's evening-primrose	1B.1	Coastal bluff scrub, Coastal dunes, Coastal prairie
<i>Phacelia argentea</i>	Sand dune phacelia	1B.1	Coastal dunes
<i>Sulcaria spiralifera</i>	Twisted horsehair lichen	1B.2	Coastal dunes
<i>Erysimum concinnum</i>	Bluff wallflower	1B.2	Coastal bluff scrub, Coastal dunes, Coastal prairie
<i>Abronia umbellata</i> var. <i>brevifolia</i>	Pink sand-verbena	1B.1	Coastal dunes
<i>Lathyrus japonicus</i>	Seaside pea	2B.1	Coastal dune
<i>Gilia millefoliata</i>	Dark-eyed gilia	1B.2	Coastal dunes
<i>Glehnia littoralis</i> ssp. <i>leiocarpa</i>	American glehnia	4.2	Coastal dunes, north coast coniferous forest

\* CNPS List Codes:

- 1B.1-Rare, threatened or endangered in California and elsewhere, seriously threatened in California
- 1B.2-Rare, threatened or endangered in California and elsewhere, moderately threatened in California;
- 2B.2-Rare, threatened or endangered in California, but more common elsewhere, moderately threatened in California;
- 4.1-Plants of limited distribution, seriously threatened in California;
- 4.2-Plants of limited distribution, moderately threatened in California.

The following summaries are for the sensitive plant species shown in Table 2:

The **short-leaved evax** is known from nearby coastal bluff scrub, coastal dunes, and coastal prairie habitats. Habitat for this species occurs in the Project area. This species has a CRPR of 1B.2, defined as rare, threatened, or endangered in California, and elsewhere and a moderate number of the California populations are threatened.

The **Oregon coast paintbrush** is known from nearby coastal bluff scrub, coastal dunes, and coastal scrub habitats. Habitat for this species occurs within the Project area. This species has a CRPR of 2B.2, defined as rare, threatened, or endangered in California, but more common elsewhere, and fairly threatened in California.

The **Wolf's evening primrose** is known from multiple sightings in 1987, with one (1) sighting approximately 500 yards north of the Pebble Beach Site adjacent to North Pebble Beach Drive and was observed on-site. Habitat for this species occurs in the Project area. This species has a CRPR of 1B.1, defined as rare, threatened, or endangered in California and elsewhere, seriously threatened in California.

The **sand dune phacelia** is known from historical sightings (1939) and a 1987 sighting approximately 500 yards south of the Pebble Beach Site adjacent to North Pebble Beach Drive and was observed on-site. Habitat for this species occurs in the Project area. This species has a CRPR of 1B.1, defined as rare, threatened, or endangered in California and elsewhere, seriously threatened in California.

The **twisted horsehair lichen** is known from nearby coastal dunes habitat. Habitat for this species occurs in the Project area. This species has a CRPR of 1B.2, defined as rare, threatened, or endangered in California, and elsewhere and a moderate number of the California populations are threatened.

The **bluff wallflower** is known from sightings as recently as 2018 east of the Del Norte County Regional Airport, approximately one (1) mile north of the Pebble Beach Site. Habitat for this species occurs in the Project area. This species has a CRPR of 1B.2, defined as rare, threatened, or endangered in California, and elsewhere and a moderate number of the California populations are threatened.

The **pink sand-verbena** is known from a historical sighting (1925) within the Project area. Habitat for this species occurs in the Project area. This species has a CRPR of 1B.1, defined as rare, threatened, or endangered in California and elsewhere, seriously threatened in California.

The **seaside pea** is known from two (2) historical sightings in 1939, approximately 250 yards southeast of the Pebble Beach Site, adjacent to North Pebble Beach Drive and was observed on-site. Habitat for this species occurs in the Project area. This species has a CRPR of 2B.1, defined as rare, threatened, or endangered in California, but more common elsewhere, seriously threatened in California.

The **dark-eyed gilia** is known from multiple sightings as recently as 2019 within the Tolowa Dunes State Park, approximately four (4) miles north of the Pebble Beach Site. Habitat for this species occurs in the Project area. This species has a CRPR of 1B.2, defined as rare, threatened, or endangered in California, and elsewhere and a moderate number of the California populations are threatened.



The **American glehnia** is known from a historical sighting (1965) northeast of the Del Norte County Regional Airport, approximately two (2) miles north of the Pebble Beach Site. Habitat for this species occurs within the Project area. This species has a CRPR of 4.2, defined as uncommon, moderately threatened in California.

## 4.2 Potential Sensitive Animal Species Present

According to CNDDDB records and the U.S. Fish and Wildlife Service (USFWS) Smith River and Crescent City Quads species list (USFWS, 2021), the range of habitats present, the geographical range of the sensitive animal species, and the species considered most likely to occur in the vicinity of the Wavecrest and Pebble Beach Sites are listed in Tables 3 and 4, respectively.

### 4.2.1 Wavecrest Site

Only Coastal Dune and Coast Scrub/Bluff Scrub habitats were present, eliminating many of the sensitive species specific to other types of habitats. Bank swallow (*Riparia riparia*) was observed directly north of the Project area.

Table 3. Sensitive Animal Species Potentially Present in the Project Area – Wavecrest Site

Species	Common Name	Fed/State List	Preferred Habitat
<i>Charadrius nivosus nivosus</i>	Western snowy plover	Federally Threatened/State species of concern	Coastal dune
<i>Riparia riparia</i>	Bank swallow	State Threatened	Coastal bluff, coastal bluff scrub, riparian lowlands
<i>Bombus occidentalis</i>	Western bumble bee	State Candidate species	Diverse: mixed woodland, grassland, prairie, urban, and others
<i>Speyeria zerene hippolyta</i>	Oregon silverspot butterfly	Federally Threatened	Coastal dune, coastal bluff scrub, coastal bluff

The following summaries are for the sensitive animal species shown in Table 3:

The **Western snowy plover** is known from a 1978 sighting at the mouth of the Smith River, approximately 1.7 miles south of the Project area. Habitat for this species occurs within the Project area. This species is federally threatened and a state species of special concern within California.

The **Bank swallow** is known from a 2011 sighting near the mouth of Lopez Creek, approximately 0.6 miles south of the Project area and was observed directly north of the Project area. Habitat for this species occurs within the Project area. This species is threatened within California.

The **Western bumble bee** is known from historical observations and is known throughout the western states. Suitable habitat occurs near the Project area. This species is a candidate species within California

The **Oregon silverspot butterfly** is known from a 1990 observation on the bluff habitat within and adjacent to the Project area. Although no *Viola adunca* was observed on-site, suitable habitat exists near the Project area. This species is federally threatened.

#### 4.2.2 Pebble Beach Site

Only Coastal Dune habitats were present, eliminating many of the sensitive species specific to other types of habitats. None of the listed sensitive animal species below were identified on-site.

Table 4. Sensitive Animal Species Potentially Present in the Project Area – Pebble Beach Site

Species	Common Name	Fed/State List	Preferred Habitat
<i>Charadrius nivosus nivosus</i>	Western snowy plover	Federally Threatened/ State species of concern	Coastal dune
<i>Selasphorus rufus</i>	Rufous hummingbird	State species of concern	Coastal bluff scrub
<i>Circus hudsonius</i>	Northern harrier	State species of concern	Marsh, grassland, prairie
<i>Poecile atricapillus</i>	Black-capped chickadee	State species of concern	Coastal riparian
<i>Bombus occidentalis</i>	Western bumble bee	Federal/State	<i>Bombus occidentalis</i>
<i>Coenonympha tullia</i>	Yontocket satyr	State species of concern	Coastal bluff scrub
<i>Speyeria zerene hippolyta</i>	Oregon silverspot butterfly	Federally Threatened	Coastal dune, coastal bluff scrub, coastal bluff
<i>Monadenia fidelis pronotis</i>	Rocky coast Pacific sideband	Federal review species, State species of concern	Coastal bluff scrub, coastal bluff

The following summaries are for the sensitive animal species shown in Table 4:

The Western snowy plover is likely a spring/summer breeder at Lake Tolowa, approximately 5 miles north of the Project area. Habitat for this species occurs within the Project area (wave slope/foraging, open sand/breeding). That said, very limited broad, open sand breeding habitat is present at the Project area. This species is federally threatened and a state species of special concern within California.

The Rufous hummingbird is a common migrant known from mixed habitats adjacent to the Project area. Limited suitable habitat for this species occurs within the Project area. This is a State species of concern within California.

The Northern harrier is known from suitable low marsh lands and grasslands adjacent to the Project area. Limited suitable habitat for this species occurs within the Project area. This is a State species of concern within California.

The Black-capped Chickadee is known from suitable coastal riparian habitats adjacent to the Project area. Limited suitable habitat for this species occurs within the Project area. This is a State species of concern within California.

The Western bumblebee is known from historical observations and is known throughout the western states. Suitable habitat occurs near the Project area. This species is a candidate species within California.

The Yontocket satyr is known from Point Saint George adjacent to the Project area. Limited suitable habitat (open grasslands) occurs in the Project area. This is a State species of concern within California.

The Oregon silverspot butterfly is known from Point Saint George adjacent to the Project area. Although no *Viola adunca* was observed on-site, suitable foraging habitat exists in the Project area. This species is federally threatened.

The Rocky coast Pacific sideband snail is known from Point Saint George adjacent to the Project area. Limited suitable habitat (rocky bluffs) occurs in the Project area. This is a State species of concern within California.

## 5.0 WATERS AND WETLAND ASSESSMENT

As noted above, within the coastal zone, under CA Public Resource Code §30121, a feature may be considered wetlands by the CCC if a single indicator (hydric soils, hydrophytic vegetation, or wetland hydrology) is present.

### Soils

Soil colors were described using Munsell Soil Color Charts (2000). Hydric soil determinations are based upon hydric soil indicators that include either a chroma color of one or a chroma color of two with oxidation-reduction (redox) features present. Redox features in the soil usually result from the presence of periodic reducing soil conditions. Soils with bright redox features and/or low matrix chroma are indicative of a fluctuating water regime. Additionally, the presence of gleyed soil in upper horizons is indicative of waterlogged conditions during at least a major part of the growing season and is used to determine wetlands. Gley is a condition in which the soil is under prolonged anaerobic conditions and iron is chemically reduced to compounds that have low-chroma (gray, bluish, or gray-green colors).

Soils with low chromas were verified as being hydric or upland utilizing the indicators outlined in the document Field Indicators of Hydric Soils in the United States, Version 7.0, 2010, Natural Resources Conservation Service, 2010.

### Hydrology

Wetland hydrology determinations were based upon the presence of at least one primary indicator (such as the presence of reduced iron or saturation in the upper 16 inches of soil) or at least two secondary indicators, in accordance with ACOE (2010) and ACOE (1987) methodologies. At least two secondary indicators are required for a wetland hydrology determination when a primary hydrology indicator is lacking. One secondary indicator is the presence of oxidized root channels (called rhizospheres) in the upper 14 inches, which suggests that soils likely fluctuate between wet and dry for significant periods of time. Another common secondary indicator is the use of the Facultative Neutral (FAC-neutral) test, wherein plant species with a facultative designation are disregarded (due to their versatility in upland and wetland environments) and the remaining dominants are considered. Hydrology determinations at the Subject Properties were based on the presence of hydric soil indicators. According to ACOE 1987, "if soils at all sampling locations lack positive hydric soil indicators, none of the area is a wetland."

## Vegetation

Herbaceous vegetation and saplings/shrubs were identified within 1 square meter of each soil pit, as per ACOE (2010) and ACOE (1987) methodologies. Determinations for dominant vegetation were made using visual estimations of percent cover for the herb stratum.

Plants reviewed during the wetland delineation were identified by their assigned wetland status indicator, taken from The National Plant List, State of California Wetland Plant List: 2018, as defined below. Taxonomy for all species listed in this report follows The Jepson Manual: Higher Plants of California, 2nd Edition (Baldwin, et. al. 2012).

- **Obligate Wetland (OBL):** Occurs in wetlands under natural conditions at an estimated probability > 99 percent
- **Facultative Wetland (FACW):** Usually occurs in wetlands (estimated probability 67%-99%), but occasionally found in non-wetlands
- **Facultative (FAC):** Equally likely to occur in wetlands or non-wetlands (estimated probability 34%-66%)
- **Facultative Upland (FACU):** Usually occurs in non-wetlands (estimated probability 67%-99%), but occasionally found in wetlands (estimated probability 1%-33%)
- **Obligate Upland (UPL):** Occur in wetlands in another region, but occur almost always (estimated probability > 99%) under natural conditions in non-wetlands in the region specified
- **Not Indicated (NI):** Recorded for those species for which insufficient information was available to determine an indicator status
- **Not Listed (NL):** Generally considered upland
- **Tentative Assignment (\*):** Due to limited information

## 5.1 Waters and Wetland Assessment Summary

### 5.1.1 Wavecrest Site

According to the California Resource Lab at University of California (U.C.) Davis (2021), the soils at the Wavecrest Drive Site are classified as Oxyaquic Udipsamments-Somoa Complex and are a common feature of beaches, dunes, and toeslopes (U.C. Davis, 2021). The UUSFWS National Wetlands Inventory shows a single feature adjacent to the Project area, a 1.21-acre Freshwater Forested/Shrub Wetland (NWI, 2021).

The wetland delineation was performed on March 2, 2021. No significant rainfall occurred in the week prior to the delineation. The delineation was guided by visual assessment of vegetation and potential hydrology, with soil pits dug at various locations to verify hydric soil conditions and validate wetland boundaries. In total, three complete sample points were taken and documented on Wetland Determination Data Forms (ACOE, 2010), which are included in Appendix B.

### 5.1.2 Pebble Beach Site

According to the California Research Lab at U.C. Davis (2021), the soils are classified as Oxyaquic Udipsamments-Somoa Complex and are a common feature of beaches, dunes, and toeslopes (U.C. Davis, 2021). The FWS National Wetlands Inventory shows no features within the project area (NWI, 2021).

The wetland delineation was performed on March 2, 2021. No significant rainfall occurred in the week prior to the delineation. The delineation was guided by visual assessment of vegetation and potential hydrology,

with soil pits dug at various locations to verify hydric soil conditions and validate wetland boundaries. No areas of potential hydrology were identified and no three-parameter wetlands required soils verification. Delineation of single parameter wetlands was verified using vegetation indicator status.

## **5.2 Waters of the United States (Three-Parameter ACOE)**

### **5.2.1 Wavecrest Site**

The Wavecrest Site was examined to determine the presence of federal jurisdictional waters (three-parameter wetlands or open waters). Two areas were identified during the field survey as federal waters (See Figure 1): the first area is a perennial creek on the north edge of the site identified as riverine waters of the U.S.; the second being the Pacific Ocean on the western boundary of the site, identified as tidal waters of the U.S. The total area of waters of the U.S. observed at the Wavecrest Site was 0.46-acres.

The perennial creek, located along the northern boundary of the Project area, runs east to west through the site before draining onto the beach/Pacific Ocean. This area occupies 0.013 acres and was identified using ordinary high-water marks and sediment sorting, bed and banks, and breaks in topography were readily observed. Riparian vegetation directly bordering the creek was also observed.

The Pacific Ocean forms the western boundary of the Wavecrest Site. The area occupies 0.33 acres of the Project area and was identified through median high tide indicators with breaks in slope and drift deposits readily observable.

### **5.2.2 Pebble Beach Site**

The Pebble Beach Site was examined to determine the presence of federal jurisdictional waters (three-parameter wetlands or open waters). One area was identified during the field survey as federal waters (See Figure 2), identified as the Pacific Ocean, which covers the majority of the Project area and is identified as tidal waters of the U.S. The total area of waters of the U.S. observed at the Pebble Beach Site was 2.76 acres.

## **5.3 Waters of the State of California (One-Parameter CCC)**

### **5.3.1 Wavecrest Site**

The Wavecrest Site was examined to determine the presence of CCC jurisdictional waters (one-parameter wetland or open waters). Three (3) areas were identified during the field survey as waters of the state (See Figure 1): the first area is a perennial creek bounded by riparian vegetation on the north edge of the site, identified as open waters / riparian waters of the state; the second is a one-parameter wetland directly north of the Project area in coastal bluff habitat identified as wetland waters of the state; and the third being the Pacific Ocean on the western boundary of the site, identified as open waters of the state. The total area of state waters observed at the Wavecrest Site was 0.56 acres.

The perennial creek bounded by riparian vegetation, located along the northern boundary of the Project area, runs east to west through the site before draining onto the beach/Pacific Ocean. This area occupies 0.20 acres and was identified by ordinary high-water indicators and riparian vegetation. The riparian vegetation is approximately 20-40 feet wide along the streambed and dominated by coastal willow (*Salix hookerian*).

The one-parameter wetland is located adjacent to and directly north of the Project area in a depressional area at the western edge of coastal bluffs and extends beyond the Project area. This area occupies 0.016 acres and was identified by the presence of hydrophytic vegetation and was dominated by *Carex obnupta* (95% coverage).

The Pacific Ocean forms the western boundary of the Wavecrest Site. This area occupies 0.33 acres of the Project area and was identified through median high tide indicators.

**5.3.2 Pebble Beach Site**

The Pebble Beach Site was examined to determine the presence of CCC jurisdiction waters (one-parameter wetland or open waters). Four (4) areas were identified during the field survey as waters of the state (See Figure 2): three (3) areas containing populations of hydrophytic vegetation and the Pacific Ocean. The total area of waters of the state observed at the Pebble Beach Site was 2.90 acres.

The three (3) areas containing hydrophytic vegetation are located on the southeast portions of the site on slightly raised dune topography and are dominated by *Juncus lescurii*, a facilitative wetland species. These areas occupy 0.143 acres and are identified as one-parameter wetlands and are jurisdictional waters of the state.

The Pacific Ocean, which makes up a majority of the site and makes up the western boundary, was identified through median high tide indicators and occupies 2.76 acres of the Project area.

**6.0 BIOLOGICAL SURVEY RESULTS**

The biological survey recorded one (1) sensitive animal species and two (2) sensitive plant species at the Wavecrest Site. Bank swallow, a state threatened animal species, was observed directly north of the Project area. Seaside pea (CNPS rank 2B.1) and Siskiyou checkerbloom (CNPS rank 1B.2) were both observed on-site.

The biological survey recorded three (3) sensitive plant species at the Pebble Beach Site. Seaside pea (CNPS rank 2B.1), Wolf’s evening primrose (CNPS rank 1B.1), and sanddune phacelia (CNPS rank 1B.1) were all observed on-site.

**7.0 WATERS AND WETLAND ASSESSMENT RESULTS**

Waters of the state and U.S. were identified at both the Wavecrest Site and the Pebble Beach Site and are summarized in the following table.

Table 5. Summary of Delineated Waters

Location	Waters Description	Waters Type	Water of U.S.	Water of State	Area (acres)
Wavecrest Site	Perennial Creek	Open Waters	X	X	
	Riparian Corridor	Riparian Waters		X	
	Carex Wetland	3-Parameter Wetland Waters	X	X	
	Pacific Ocean	Tidal/Open Waters	X	X	

Pebble Beach Site	Juncus Wetland	1-Parameter Wetland Waters		X	
	Juncus Wetland	1-Parameter Wetland Waters		X	
	Juncus Wetland	1-Parameter Wetland Waters		X	
	Pacific Ocean	Tidal/Open Waters	X	X	

## 8.0 CONCLUSIONS AND RECOMMENDATIONS

### 8.1 Sensitive Species

Sensitive plant populations should be avoided to the greatest extent feasible. If construction is proposed within 100 feet of known sensitive plant population locations, each population should be clearly marked in the field and shown to the Project contractor. Construction should not be allowed to occur within 100 feet of the bank swallow colony during breeding season (May through August).

If appropriate minimization measures and recommendations are incorporated into the proposed activities, it is the professional opinion of LACO that there will be no significant loss of biological resources at the Wavecrest and Pebble Beach Sites.

### 8.2 Wetlands

Pursuant to Policy 1.E.21 of the Del Norte County General Plan (2003) pertaining to coastal wetlands, a 100-foot buffer is required to be provided between new development and wetlands; however, a buffer of less than 100 feet may be utilized where it can be determined, in cooperation with the California Department of Fish and Wildlife (CDFW), that no adverse impacts on the wetland habitat would occur as a result of a reduced buffer.

LACO recommends that any proposed development or improvements at the Project area occur a minimum of 100 feet from identified wetlands. Setback reductions, as required, should be analyzed in conjunction with the specific development proposed to determine if mitigation plans are needed. Generally, maintaining as close to the standard setbacks as is practicable while still allowing for reasonable orderly development of the Wavecrest and Pebble Beach Sites is preferred.

## 9.0 REFERENCES

- Baldwin, B. G., D. H. Goldman, D. J. Keil, R. Patterson, T. J. Rosatti and D. H. Wilken. 2012. *The Jepson Manual: Vascular Plants of California*. University of California Press. Berkeley CA.
- California Code of Regulations, 2011. California Water Code, Division 7, Water Quality Code §13050. 2011. Sacramento, CA.
- California Department of Fish and Wildlife. May 2021. Special Animals List. Sacramento, CA.
- California Department of Fish and Wildlife. May 2021. California Natural Diversity Database (CNDDB). Smith River and Crescent City Quads. Sacramento, CA.
- California Native Plant Society. 2021. California Native Plant Society's Inventory of Rare and Endangered Vascular Plants of California, Sacramento, CA. Available online at <http://www.rareplants.cnps.org/> Smith River and Crescent City Quads.
- California Public Resource Code, 2016. Public Resource Code Division 20, California Coastal Act §30121. 2016. Sacramento, CA.
- Del Norte County General Plan. January 28, 2003. Available online at: <https://www.co.del-norte.ca.us/departments/Planning/Documents>.
- Federal Register, 1986. Department of Defense, Corps of Engineers, Department of the Army. 33 CFR 320 through 330, Regulatory Programs of the Corps of Engineers; Final Rule. November 1986.
- Natural Resource Conservation Service (NRCS), 2017. Field Indicators of Hydric Soils in the United States. A Guide for Identifying and Delineating Hydric Soils. Version 8.1. 2017.
- University of California Davis, California Soil Resource Lab. Last modified 2019. Soil Web. Accessed August 23, 2021. Available at: <https://casoilresource.lawr.ucdavis.edu/gmap/>.
- U.S. Army Corps of Engineers, 1987. Wetlands Delineation Manual. Technical Report Y-87-1, January 1987. Vicksburg, MS.
- U.S. Army Corps of Engineers, 2010. Regional Supplement to the Corps of Engineers Wetland Delineation Manual: Western Mountains, Valleys, and Coast Region (version 2.0). May 2010. Vicksburg, MS.
- U.S. Army Corps of Engineers, 2014. A Guide to Ordinary High Water Mark (OHWM) Delineation for Non-Perennial Streams in the Western Mountains, Valleys, and Coast Regions of the United States. August 2014. Vicksburg, MS.
- U.S. Fish and Wildlife Service. 2021. Smith River and Crescent City Quads Species Lists, Arcata Field Office, CA.
- U.S. Fish and Wildlife Service. 2021. National Wetlands Inventory. Available online at: <https://www.fws.gov/wetlands/data/mapper.html>.



## FIGURES

**Figure 1**

**Location Map**

**Figure 2**

**Wavecrest Site Existing Conditions**

**Figure 3**

**Pebble Beach Site Existing Conditions**

# LACO

EUREKA • UKIAH • SANTA ROSA

1-800-515-5054 www.lacoassociates.com









PROJECT	DNCCD:(B) Wavecrest Dr Coastal Access	BY	VSD	FIGURE	1
CLIENT	Del Norte County Community Development	CHECK	CSM	JOB NO.	9790.00
LOCATION	Del Norte County, California	DATE	9/1/2021		
	Location Map				

REUSE OF DOCUMENTS: This document and the ideas and design incorporated herein, as an instrument of professional service, is the property of LACO Associates and shall not be reused in whole or part for any other project without LACO Associates express written authorization.



Note:  
The information illustrated in this map was derived from publicly-available GIS data. LACO Associates cannot guarantee the accuracy of the data.

**Legend**

-  Bank Swallow colony
-  Siskiyou checkerbloom
-  Wavecrest Site
-  Delineation Boundary
-  State Water (Riparian)
-  State Water (Sedge)
-  Section 404 Waters
-  Section 10/404 Waters

population~ 1,000+ plants



Note:  
The information illustrated in this map was derived from publicly-available GIS data. LACO Associates cannot guarantee the accuracy of the data.

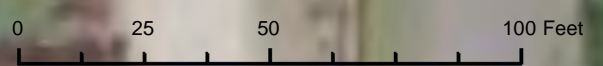

Date: 6/6/2021 Time: 7:15:25 PM  
Path: P:\9700\9790 Del Norte County Community Development\9790.00 Wavecrest Dr Coastal Access Project\12 Figures Maps\GIS\Wavecrest\_Bio.mxd

DRAWN	VSD
CHECK	
APPROVED	
DATE	6/5/2021
JOB NO.	9790.00
FIGURE	2









DNCCD:(B) Wavecrest Dr Coastal Access Project  
Wavecrest Access-Waters Delineation/ Biological Resources

Del Norte County Community Development  
981 H Street, Suite 110, Crescent City, CA

NO.	HISTORY/REVISION	BY	CHK.	DATE
1				

**LACO**  
EUREKA • UKIAH • SANTA ROSA  
1-800-515-5054 www.lacoassociates.com

**Legend**

-  Oenothera wolfii
-  Lathyrus japonicus
-  Phacelia location
-  Pebble Beach Site
-  Delineation Boundary
-  State Water (Riparian)
-  State Water (Juncus)
-  Section 404 Waters
-  Section 10/404 Waters

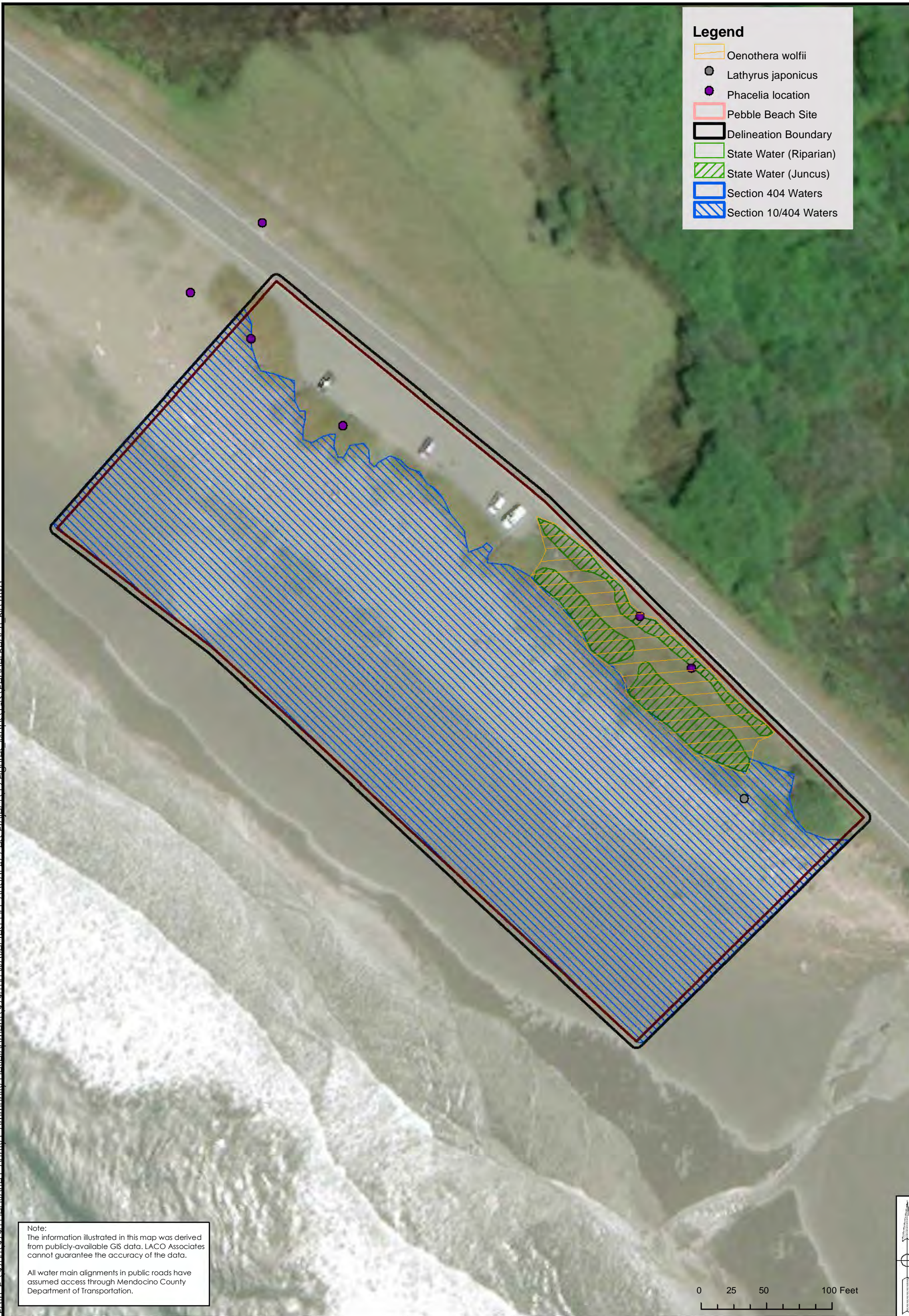

Note:  
The information illustrated in this map was derived from publicly-available GIS data. LACO Associates cannot guarantee the accuracy of the data.

All water main alignments in public roads have assumed access through Mendocino County Department of Transportation.

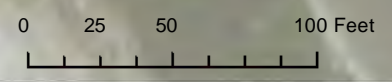

Date: 5/18/2022 Time: 4:22:55 PM  
Path: P:\9700\9790\Del Norte County Community Development\9790.00\Mapwork\Dr Coastal Access Project\12 Figures Maps\GIS\Babbal Beach\_Bio.mxd

DRAWN	VSE
CHECK	
APPROVED	
DATE	6/5/2021
JOB NO.	9790.00
FIGURE	3

DNCCD:(B) Pebble Beach Access Project  
Pebble Beach Access-Waters Delineation/ Biological Resources  
DRAFT

Del Norte County Community Development  
981 H Street, Suite 110, Crescent City, CA

NO.	HISTORY/REVISION	BY	CHK.	DATE
1				

**LACO**  
EUREKA • UKIAH • SANTA ROSA  
1-800-515-5054 www.lacoassociates.com

## APPENDIX A

### **Plant Species Encountered During Field Survey of the Project Area**

### Plant Species Encountered During Field Survey of the Project Area – Wavecrest Site

Species	Common Name	Fed/State List	Native / Non-Native
<i>Achillea millefolium</i>	yarrow	none	Native
<i>Agrostis stolonifera</i>	creeping bentgrass	none	Non-Native
<i>Aira caryophylla</i>	silver hair grass	none	Non-Native
<i>Alnus rubra</i>	red alder	none	Native
<i>Alopecurus geniculatus</i>	water foxtail	none	Native
<i>Alopecurus pratensis</i>	meadow foxtail	none	Native
<i>Ambrosia chamissonis</i>	beach-bur	none	Non-Native
<i>Ammophila arvensis</i>	European beach grass	none	Non-Native
<i>Anagallis arvensis</i>	scarlet pimpernel	none	Non-Native
<i>Anthoxanthum odoratum</i>	sweet vernal grass	none	Non-Native
<i>Armeria maritima</i>	sea thift	none	Native
<i>Arrhenatherum elatius</i>	tall oatgrass	none	Non-Native
<i>Athyrium filix-femina</i>	lady fern	none	Native
<i>Avena barbata</i>	slender oat grass	none	Non-Native
<i>Baccharis pilularis</i>	coyote brush	none	Native
<i>Bellis perennis</i>	English lawn daisy	none	Non-Native
<i>Briza maxima</i>	large quaking grass	none	Non-Native
<i>Briza minor</i>	small quaking grass	none	Non-Native
<i>Bromus catharticus</i>	rescue grass	none	Non-Native
<i>Bromus diandrus</i>	ripgut grass	none	Non-Native
<i>Bromus hordeaceus</i>	soft brome	none	Non-Native
<i>Bromus maritimus</i>	maritime brome	none	Native
<i>Brassica rapa</i>	common mustard	none	Non-Native
<i>Cakile maritima</i>	sea rocket	none	Native
<i>Cardamine oligosperma</i>	western bittercress	none	Native
<i>Carex obnupta</i>	slough sedge	none	Native
<i>Cerastium glomeratum</i>	common chickweed	none	Non-Native
<i>Cirsium arvense</i>	Canadian thistle	none	Non-Native
<i>Cirsium vulgare</i>	bull thistle	none	Non-Native
<i>Cyperus eragrostis</i>	tall-flat sedge	none	Native
<i>Dactylis glomerata</i>	orchard grass	none	Non-Native
<i>Daucus carota</i>	Queen Anne's lace	none	Non-Native
<i>Erigeron canadensis</i>	horseweed	none	Native
<i>Foeniculum vulgare</i>	fennel	none	Non-Native
<i>Festuca arundinacea</i>	tall reed fescue	none	Non-Native
<i>Festuca bromoides</i>	brome fescue	none	Non-Native
<i>Festuca perenne</i>	perennial ryegrass	none	Non-Native
<i>Fragaria chilonesis</i>	beach strawberry	none	Native
<i>Gautheria shallon</i>	salal	none	Native
<i>Geranium molle</i>	wild geranium	none	Non-Native
<i>Glyceria occidentalis</i>	western manna grass	none	Non-Native
<i>Helminthotheca echinoides</i>	ox tongue	none	Non-Native
<i>Holcus lanatus</i>	velvet grass	none	Non-Native
<i>Hypochaeris radicata</i>	perennial cat's ear	none	Non-Native
<i>Iris douglasiana</i>	Douglas iris	none	Native
<i>Juncus bufonius</i>	toad rush	none	Native
<i>Juncus effusus</i>	soft rush	none	Native

Species	Common Name	Fed/State List	Native / Non-Native
<i>Juncus lescurii</i>	salt rush	none	Native
<i>Lathyrus japonicus</i>	seaside pea	CNPS 1B.2	Native
<i>Laythrus vestitus</i>	Pacific pea	none	Native
<i>Linum bienne</i>	blue flax	none	Non-Native
<i>Lotus corniculatus</i>	bird's foot trefoil	none	Non-Native
<i>Lupinus littoralis</i>	seashore lupine	none	Native
<i>Lythrum hyssopifolia</i>	hyssop loosestrife	none	Native
<i>Medicago arabica</i>	spotted burclover	none	Non-Native
<i>Mentha pulegium</i>	penny royal	none	Non-Native
<i>Morella californica</i>	wax myrtle	none	Native
<i>Oenanthe sarmentosa</i>	water parsley	none	Native
<i>Picea sitchensis</i>	sitka spruce	none	Native
<i>Pinus radiata</i>	Monterey pine	none	Non-Native
<i>Plantago lanceolata</i>	English plantain	none	Non-Native
<i>Plantago minor</i>	common plantain	none	Non-Native
<i>Poa annua</i>	annual bluegrass	none	Non-Native
<i>Poa pratensis</i>	Kentucky bluegrass	none	Non-Native
<i>Polygonum arenastrum</i>	common knotweed	none	Non-Native
<i>Polystichum munitum</i>	sword fern	none	Native
<i>Polyogon monspelianus</i>	rabbit's foot grass	none	Non-Native
<i>Prunella vulgaris</i>	self-heal	none	Non-Native
<i>Ranunculus repens</i>	creeping buttercup	none	Non-Native
<i>Raphanus sativa</i>	wild radish	none	Non-Native
<i>Rubus ursinus</i>	California blackberry	none	Native
<i>Rumex acetocella</i>	sheep sorrel	none	Non-Native
<i>Rumex crispus</i>	curly dock	none	Non-Native
<i>Salix hookeriana</i>	coastal willow	none	Native
<i>Sambucus racemosa</i>	red elderberry	none	Native
<i>Scirpus microcarpus</i>	small-flowered bulrush	none	Native
<i>Senecio vulgaris</i>	common groundsel	none	Non-Native
<i>Sidalcea malviflora ssp. patula</i>	Siskiyou checkerbloom	CNPS 1B.2	Native
<i>Sonchus oleraceus</i>	sow thistle	none	Non-Native
<i>Stachys chamissonis</i>	coastal hedge	none	Native
<i>Taraxacum officinale</i>	common dandelion	none	Non-Native
<i>Trifolium pratense</i>	red clover	none	Non-Native
<i>Trifolium repens</i>	white clover	none	Non-Native
<i>Trifolium subterraneum</i>	subterranean clover	none	Non-Native
<i>Vicia hirsuta</i>	annual vetch	none	Non-Native
<i>Viola adunca</i>	dog-toothed violet	none	Native

**Plant Species Encountered During Field Survey of the Project Area – Pebble Beach Site**

<b>Species</b>	<b>Common Name</b>	<b>Fed/State List</b>	<b>Native / Non-Native</b>
<i>Abronia latifolia</i>	yellow sand verbena	none	Native
<i>Achillea millefolium</i>	yarrow	none	Native
<i>Agrostis stolonifera</i>	creeping bentgrass	none	Non-Native
<i>Aira caryophyllea</i>	silver hair grass	none	Non-Native
<i>Alnus rubra</i>	red alder	none	Native
<i>Alopecurus geniculatus</i>	water foxtail	none	Native
<i>Alopecurus pratensis</i>	meadow foxtail	none	Native
<i>Ambrosia chamissonis</i>	beach bur	none	Native
<i>Ammophila arvensis</i>	European beach grass	none	Non-Native
<i>Anagallis arvensis</i>	scarlet pimpernel	none	Non-Native
<i>Anthoxanthum odoratum</i>	sweet vernal grass	none	Non-Native
<i>Armeria maritima</i>	sea thrift	none	Native
<i>Arrhenatherum elatius</i>	tall oatgrass	none	Non-Native
<i>Athyrium filix-femina</i>	lady fern	none	Native
<i>Avena barbata</i>	slender oat grass	none	Non-Native
<i>Baccharis pilularis</i>	coyote brush	none	Native
<i>Bellis perennis</i>	English lawn daisy	none	Non-Native
<i>Briza maxima</i>	large quaking grass	none	Non-Native
<i>Briza minor</i>	small quaking grass	none	Non-Native
<i>Bromus catharticus</i>	rescue grass	none	Non-Native
<i>Bromus diandrus</i>	ripgut grass	none	Non-Native
<i>Bromus hordeaceus</i>	soff brome	none	Non-Native
<i>Bromus maritimus</i>	maritime brome	none	Native
<i>Brassica rapa</i>	common mustard	none	Non-Native
<i>Cakile maritima</i>	sea rocket	none	Non-Native
<i>Camissoniopsis cheiranthifolia</i>	beach evening primrose	none	Native
<i>Cardamine oligosperma</i>	western bittercress	none	Native
<i>Carex obnupta</i>	slough sedge	none	Native
<i>Cerastium glomeratum</i>	common chickweed	none	Non-Native
<i>Cirsium arvense</i>	Canadian thistle	none	Non-Native
<i>Cirsium vulgare</i>	bull thistle	none	Non-Native
<i>Convolvulus arvensis</i>	wild morning glory	none	Non-Native
<i>Cyperus eragrostis</i>	tall-flat sedge	none	Native
<i>Dactylis glomerata</i>	orchard grass	none	Non-Native
<i>Daucus carota</i>	Queen Anne's lace	none	Non-Native
<i>Erigeron canadensis</i>	horseweed	none	Native
<i>Eriogonum latifolium</i>	beach wild buckwheat	none	Native
<i>Erodium cicutarium</i>	stork's bill	none	Non-Native
<i>Foeniculum vulgare</i>	fennel	none	Non-Native
<i>Festuca arundinacea</i>	tall reed fescue	none	Non-Native
<i>Festuca bromoides</i>	brome fescue	none	Non-Native
<i>Festuca perenne</i>	perennial ryegrass	none	Non-Native
<i>Festuca rubra</i>	red fescue	none	Native
<i>Fragaria chilonesis</i>	beach strawberry	none	Native
<i>Gautheria shallon</i>	saldal	none	Native
<i>Geranium molle</i>	wild geranium	none	Non-Native
<i>Glehnia littoralis</i>	American glehnia	none	Native
<i>Glyceria occidentalis</i>	western manna grass	none	Non-Native



Species	Common Name	Fed/State List	Native / Non-Native
<i>Helminthotheca echinoides</i>	ox tongue	none	Non-Native
<i>Holcus lanatus</i>	velvet grass	none	Non-Native
<i>Hypochaeris radicata</i>	perennial cat's ear	none	Non-Native
<i>Iris douglasiana</i>	Douglas iris	none	Native
<i>Juncus bufonius</i>	toad rush	none	Native
<i>Juncus effusus</i>	soft rush	none	Native
<i>Juncus lescurii</i>	salt rush	none	Native
<i>Lathyrus japonicus</i>	seaside pea	CNPS 1B.2	Native
<i>Laythrus vestitus</i>	Pacific pea	none	Native
<i>Linum bienne</i>	blue flax	none	Non-Native
<i>Lonicera involucrata</i>	twinberry	none	Native
<i>Lotus corniculatus</i>	bird's foot trefoil	none	Non-Native
<i>Lupinus littoralis</i>	seashore lupine	none	Native
<i>Lythrum hyssopifolia</i>	hyssop loosestrife	none	Native
<i>Medicago arabica</i>	spotted burclover	none	Non-Native
<i>Mentha pulegium</i>	penny royal	none	Non-Native
<i>Mesembryanthemum nodiflorum</i>	iceplant	none	Non-Native
<i>Mimulus guttatus</i>	seep monkeyflower	none	Native
<i>Morella californica</i>	wax myrtle	none	Native
<i>Oenanthe sarmentosa</i>	water parsley	none	Native
<i>Oenothera wolfii</i>	Wolf's evening primrose	CNPS 1B.1	Native
<i>Phacelia argentea</i>	sanddune phacelia	CNPS 1B.1	Native
<i>Plantago coronopus</i>	cut-leaf plantain	none	Non-Native
<i>Plantago lanceolata</i>	English plantain	none	Non-Native
<i>Plantago maritima</i>	seaside plantain	none	Native
<i>Plantago minor</i>	common plantain	none	Non-Native
<i>Poa annua</i>	annual bluegrass	none	Non-Native
<i>Poa douglasii</i>	Douglas bluegrass	none	Native
<i>Poa pratensis</i>	Kentucky bluegrass	none	Non-Native
<i>Polygonum arenastrum</i>	common knotweed	none	Non-Native
<i>Polypogon monspelianus</i>	rabbit's foot grass	none	Non-Native
<i>Polygonum paronychium</i>	beach knotweed	none	Native
<i>Polystichum munitum</i>	sword fern	none	Native
<i>Potentilla anserina</i>	silverweed	none	Native
<i>Prunella vulgaris</i>	self-heal	none	Non-Native
<i>Pteridium aquilinum</i>	bracken fern	none	Native
<i>Ranunculus repens</i>	creeping buttercup	none	Non-Native
<i>Raphanus sativa</i>	wild radish	none	Non-Native
<i>Rubus armenicus</i>	Himalayan blackberry	none	Non-Native
<i>Rubus ursinus</i>	California blackberry	none	Native
<i>Rumex acetocella</i>	sheep sorrel	none	Non-Native
<i>Rumex crispus</i>	curly dock	none	Non-Native
<i>Salix hookeriana</i>	coastal willow	none	Native
<i>Sambucus racemosa</i>	red elderberry	none	Native
<i>Schoenoplectus americanus</i>	American three-square	none	Native
<i>Scirpus microcarpus</i>	small-flowered bulrush	none	Native
<i>Sedum album</i>	white stonecrop	none	Non-Native
<i>Senecio vulgaris</i>	common groundsel	none	Non-Native
<i>Sonchus oleraceus</i>	sow thistle	none	Non-Native

<b>Species</b>	<b>Common Name</b>	<b>Fed/State List</b>	<b>Native / Non-Native</b>
<i>Stachys chamissonis</i>	coastal hedge	none	Native
<i>Symphotrichum chilense</i>	coastal aster	none	Native
<i>Tanacetum bipinnatum</i>	coastal tansy	none	Native
<i>Taraxacum officinale</i>	common dandelion	none	Non-Native
<i>Trifolium pratense</i>	red clover	none	Non-Native
<i>Trifolium repens</i>	white clover	none	Non-Native
<i>Trifolium subterraneum</i>	subterranean clover	none	Non-Native
<i>Vicia hirsuta</i>	annual vetch	none	Non-Native

## APPENDIX B

### **Wetland Delineation Data Forms**

**WETLAND DETERMINATION DATA FORM – Western Mountains, Valleys, and Coast Region**

Project/Site: Wavecrest Access Site City/County: Del Norte Sampling Date: 3/2/2021  
 Applicant/Owner: Co. of Del Norte State: CA Sampling Point: SP-1  
 Investigator(s): Cameron Purchio Section, Township, Range: S8 T10 R2W South River  
 Landform (hillslope, terrace, etc.): bluff Local relief (concave, convex, none): slight concave Slope (%): <1%  
 Subregion (LRR): Coastal Redwood Belt Lat: 41.968328° Long: -124.203065° Datum: \_\_\_\_\_  
 Soil Map Unit Name: oxyaquic Udipsamments-Samma Complex (157) NWI classification: None  
 Are climatic / hydrologic conditions on the site typical for this time of year? Yes  No \_\_\_\_\_ (If no, explain in Remarks.)  
 Are Vegetation \_\_\_\_\_, Soil \_\_\_\_\_, or Hydrology \_\_\_\_\_ significantly disturbed? Are "Normal Circumstances" present? Yes  No \_\_\_\_\_  
 Are Vegetation \_\_\_\_\_, Soil \_\_\_\_\_, or Hydrology \_\_\_\_\_ naturally problematic? (If needed, explain any answers in Remarks.)

**SUMMARY OF FINDINGS – Attach site map showing sampling point locations, transects, important features, etc.**

Hydrophytic Vegetation Present? Yes <input checked="" type="checkbox"/> No _____ Hydric Soil Present? Yes _____ No <input checked="" type="checkbox"/> Wetland Hydrology Present? Yes _____ No <input checked="" type="checkbox"/>	Is the Sampled Area within a Wetland? Yes _____ No <input checked="" type="checkbox"/>
Remarks: <p align="center" style="font-size: 1.2em;"><u>slight drought conditions</u></p>	

**VEGETATION – Use scientific names of plants.**

Tree Stratum (Plot size: _____)	Absolute % Cover	Dominant Species?	Indicator Status	Dominance Test worksheet:
1. _____				Number of Dominant Species That Are OBL, FACW, or FAC: <u>1</u> (A)
2. _____				Total Number of Dominant Species Across All Strata: <u>1</u> (B)
3. _____				Percent of Dominant Species That Are OBL, FACW, or FAC: <u>100%</u> (A/B)
4. _____				
$\phi$ = Total Cover				
Sapling/Shrub Stratum (Plot size: _____)	Absolute % Cover	Dominant Species?	Indicator Status	Prevalence Index worksheet:
1. _____				Total % Cover of: _____ Multiply by: _____
2. _____				OBL species _____ x 1 = _____
3. _____				FACW species _____ x 2 = _____
4. _____				FAC species _____ x 3 = _____
5. _____				FACU species _____ x 4 = _____
$\phi$ = Total Cover				UPL species _____ x 5 = _____
$\phi$ = Total Cover				Column Totals: _____ (A) _____ (B)
$\phi$ = Total Cover				Prevalence Index = B/A = _____
Herb Stratum (Plot size: <u>5m</u> )	Absolute % Cover	Dominant Species?	Indicator Status	Hydrophytic Vegetation Indicators:
1. <u>Carex obnubta</u>	<u>95%</u>	<u>Y</u>	<u>OBL</u>	<input type="checkbox"/> 1 - Rapid Test for Hydrophytic Vegetation
2. _____				<input type="checkbox"/> 2 - Dominance Test is >50%
3. _____				<input type="checkbox"/> 3 - Prevalence Index is $\leq 3.0^1$
4. _____				<input type="checkbox"/> 4 - Morphological Adaptations <sup>1</sup> (Provide supporting data in Remarks or on a separate sheet)
5. _____				<input type="checkbox"/> 5 - Wetland Non-Vascular Plants <sup>1</sup>
6. _____				<input type="checkbox"/> Problematic Hydrophytic Vegetation <sup>1</sup> (Explain)
7. _____				<sup>1</sup> Indicators of hydric soil and wetland hydrology must be present, unless disturbed or problematic.
8. _____				
9. _____				
10. _____				
11. _____				
<u>95%</u> = Total Cover				
Woody Vine Stratum (Plot size: _____)	Absolute % Cover	Dominant Species?	Indicator Status	Hydrophytic Vegetation Present?
1. _____				Yes <input checked="" type="checkbox"/> No _____
2. _____				
<u>0%</u> = Total Cover				
% Bare Ground in Herb Stratum <u>5%</u>				
Remarks:				

**SOIL**

Sampling Point: \_\_\_\_\_

**Profile Description: (Describe to the depth needed to document the indicator or confirm the absence of indicators.)**

Depth (inches)	Matrix		Redox Features				Texture	Remarks
	Color (moist)	%	Color (moist)	%	Type <sup>1</sup>	Loc <sup>2</sup>		
0-16	7.5YR 3	100					Sandy	

<sup>1</sup>Type: C=Concentration, D=Depletion, RM=Reduced Matrix, CS=Covered or Coated Sand Grains.      <sup>2</sup>Location: PL=Pore Lining, M=Matrix.

**Hydric Soil Indicators: (Applicable to all LRRs, unless otherwise noted.)**

<input type="checkbox"/> Histosol (A1)	<input type="checkbox"/> Sandy Redox (S5)	<input type="checkbox"/> 2 cm Muck (A10)
<input type="checkbox"/> Histic Epipedon (A2)	<input type="checkbox"/> Stripped Matrix (S6)	<input type="checkbox"/> Red Parent Material (TF2)
<input type="checkbox"/> Black Histic (A3)	<input type="checkbox"/> Loamy Mucky Mineral (F1) (except MLRA 1)	<input type="checkbox"/> Very Shallow Dark Surface (TF12)
<input type="checkbox"/> Hydrogen Sulfide (A4)	<input type="checkbox"/> Loamy Gleyed Matrix (F2)	<input type="checkbox"/> Other (Explain in Remarks)
<input type="checkbox"/> Depleted Below Dark Surface (A11)	<input type="checkbox"/> Depleted Matrix (F3)	<sup>3</sup> Indicators of hydrophytic vegetation and wetland hydrology must be present, unless disturbed or problematic.
<input type="checkbox"/> Thick Dark Surface (A12)	<input type="checkbox"/> Redox Dark Surface (F6)	
<input type="checkbox"/> Sandy Mucky Mineral (S1)	<input type="checkbox"/> Depleted Dark Surface (F7)	
<input type="checkbox"/> Sandy Gleyed Matrix (S4)	<input type="checkbox"/> Redox Depressions (F8)	

**Restrictive Layer (if present):**

Type: \_\_\_\_\_

Depth (inches): \_\_\_\_\_

Hydric Soil Present? Yes \_\_\_\_\_ No

Remarks:

**HYDROLOGY**

**Wetland Hydrology Indicators:**

<b>Primary Indicators (minimum of one required; check all that apply)</b>		<b>Secondary Indicators (2 or more required)</b>
<input type="checkbox"/> Surface Water (A1)	<input type="checkbox"/> Water-Stained Leaves (B9) (except MLRA 1, 2, 4A, and 4B)	<input type="checkbox"/> Water-Stained Leaves (B9) (MLRA 1, 2, 4A, and 4B)
<input type="checkbox"/> High Water Table (A2)	<input type="checkbox"/> Salt Crust (B11)	<input type="checkbox"/> Drainage Patterns (B10)
<input type="checkbox"/> Saturation (A3)	<input type="checkbox"/> Aquatic Invertebrates (B13)	<input type="checkbox"/> Dry-Season Water Table (C2)
<input type="checkbox"/> Water Marks (B1)	<input type="checkbox"/> Hydrogen Sulfide Odor (C1)	<input checked="" type="checkbox"/> Saturation Visible on Aerial Imagery (C9)
<input type="checkbox"/> Sediment Deposits (B2)	<input type="checkbox"/> Oxidized Rhizospheres along Living Roots (C3)	<input type="checkbox"/> Geomorphic Position (D2)
<input type="checkbox"/> Drift Deposits (B3)	<input type="checkbox"/> Presence of Reduced Iron (C4)	<input type="checkbox"/> Shallow Aquitard (D3)
<input type="checkbox"/> Algal Mat or Crust (B4)	<input type="checkbox"/> Recent Iron Reduction in Tilled Soils (C6)	<input type="checkbox"/> FAC-Neutral Test (D5)
<input type="checkbox"/> Iron Deposits (B5)	<input type="checkbox"/> Stunted or Stressed Plants (D1) (LRR A)	<input type="checkbox"/> Raised Ant Mounds (D6) (LRR A)
<input type="checkbox"/> Surface Soil Cracks (B6)	<input type="checkbox"/> Other (Explain in Remarks)	<input type="checkbox"/> Frost-Heave Hummocks (D7)
<input type="checkbox"/> Inundation Visible on Aerial Imagery (B7)		
<input type="checkbox"/> Sparsely Vegetated Concave Surface (B8)		

**Field Observations:**

Surface Water Present? Yes \_\_\_\_\_ No  Depth (inches): \_\_\_\_\_

Water Table Present? Yes \_\_\_\_\_ No  Depth (inches): \_\_\_\_\_

Saturation Present? (includes capillary fringe) Yes \_\_\_\_\_ No  Depth (inches): \_\_\_\_\_

Wetland Hydrology Present? Yes \_\_\_\_\_ No

Describe Recorded Data (stream gauge, monitoring well, aerial photos, previous inspections), if available:

Remarks: Slight concave area

**WETLAND DETERMINATION DATA FORM – Western Mountains, Valleys, and Coast Region**

Project/Site: Wavecrest Access Site City/County: Del Norte Sampling Date: 3/2/2021  
 Applicant/Owner: Co. of Del Norte State: \_\_\_\_\_ Sampling Point: SP-2  
 Investigator(s): Cameron Purchio Section, Township, Range: S8 T18 R2W Smith River  
 Landform (hillslope, terrace, etc.): bluff Local relief (concave, convex, none): \_\_\_\_\_ Slope (%): <1-2%  
 Subregion (LRR): Coastal Redwood Belt Lat: 41.968374° Long: -124.203789 Datum: \_\_\_\_\_  
 Soil Map Unit Name: Oxyaquic Udipsamments - Samoa Complex (157) NWI classification: None  
 Are climatic / hydrologic conditions on the site typical for this time of year? Yes  No \_\_\_\_\_ (If no, explain in Remarks.)  
 Are Vegetation \_\_\_\_\_, Soil \_\_\_\_\_, or Hydrology \_\_\_\_\_ significantly disturbed? Are "Normal Circumstances" present? Yes  No \_\_\_\_\_  
 Are Vegetation \_\_\_\_\_, Soil \_\_\_\_\_, or Hydrology \_\_\_\_\_ naturally problematic? (If needed, explain any answers in Remarks.)

**SUMMARY OF FINDINGS – Attach site map showing sampling point locations, transects, important features, etc.**

Hydrophytic Vegetation Present?	Yes <input checked="" type="checkbox"/>	No <input type="checkbox"/>	Is the Sampled Area within a Wetland?	Yes _____	No <input checked="" type="checkbox"/>
Hydric Soil Present?	Yes _____	No <input checked="" type="checkbox"/>			
Wetland Hydrology Present?	Yes _____	No <input checked="" type="checkbox"/>			

Remarks:  
Sample point outside of small depression area to pair SP-1, slight drought conditions

**VEGETATION – Use scientific names of plants.**

Tree Stratum (Plot size: _____)	Absolute % Cover	Dominant Species?	Indicator Status	Dominance Test worksheet: Number of Dominant Species That Are OBL, FACW, or FAC: <u>1</u> (A) Total Number of Dominant Species Across All Strata: <u>1</u> (B) Percent of Dominant Species That Are OBL, FACW, or FAC: <u>100%</u> (A/B)
1. _____				
2. _____				
3. _____				
4. _____				
Sapling/Shrub Stratum (Plot size: _____) <u>∅</u> = Total Cover				
1. _____				<b>Hydrophytic Vegetation Indicators:</b> ___ 1 - Rapid Test for Hydrophytic Vegetation ___ 2 - Dominance Test is >50% ___ 3 - Prevalence Index is ≤3.0 <sup>1</sup> ___ 4 - Morphological Adaptations <sup>1</sup> (Provide supporting data in Remarks or on a separate sheet) ___ 5 - Wetland Non-Vascular Plants <sup>1</sup> ___ Problematic Hydrophytic Vegetation <sup>1</sup> (Explain) <sup>1</sup> Indicators of hydric soil and wetland hydrology must be present, unless disturbed or problematic.
2. _____				
3. _____				
4. _____				
5. _____				
6. _____				
7. _____				
8. _____				
9. _____				
10. _____				
11. _____				
Herb Stratum (Plot size: <u>5m</u> ) <u>∅</u> = Total Cover				
1. <u>Carex obovata</u>	<u>95%</u>	<u>Y</u>	<u>OBL</u>	<b>Hydrophytic Vegetation Present?</b> Yes <input checked="" type="checkbox"/> No _____
2. _____				
3. _____				
4. _____				
5. _____				
6. _____				
7. _____				
8. _____				
9. _____				
10. _____				
11. _____				
Woody Vine Stratum (Plot size: _____) <u>9.5%</u> = Total Cover				
1. _____				
2. _____				
% Bare Ground in Herb Stratum <u>5%</u> <u>∅</u> = Total Cover				

Remarks:

**SOIL**

Sampling Point: \_\_\_\_\_

**Profile Description: (Describe to the depth needed to document the indicator or confirm the absence of indicators.)**

Depth (inches)	Matrix		Redox Features				Texture	Remarks
	Color (moist)	%	Color (moist)	%	Type <sup>1</sup>	Loc <sup>2</sup>		
0-16	7.5 YR 3	100%					Sandy	

<sup>1</sup>Type: C=Concentration, D=Depletion, RM=Reduced Matrix, CS=Covered or Coated Sand Grains. <sup>2</sup>Location: PL=Pore Lining, M=Matrix.

**Hydric Soil Indicators: (Applicable to all LRRs, unless otherwise noted.)**

**Indicators for Problematic Hydric Soils<sup>3</sup>:**

<input type="checkbox"/> Histosol (A1)	<input type="checkbox"/> Sandy Redox (S5)	<input type="checkbox"/> 2 cm Muck (A10)
<input type="checkbox"/> Histic Epipedon (A2)	<input type="checkbox"/> Stripped Matrix (S6)	<input type="checkbox"/> Red Parent Material (TF2)
<input type="checkbox"/> Black Histic (A3)	<input type="checkbox"/> Loamy Mucky Mineral (F1) (except MLRA 1)	<input type="checkbox"/> Very Shallow Dark Surface (TF12)
<input type="checkbox"/> Hydrogen Sulfide (A4)	<input type="checkbox"/> Loamy Gleyed Matrix (F2)	<input type="checkbox"/> Other (Explain in Remarks)
<input type="checkbox"/> Depleted Below Dark Surface (A11)	<input type="checkbox"/> Depleted Matrix (F3)	
<input type="checkbox"/> Thick Dark Surface (A12)	<input type="checkbox"/> Redox Dark Surface (F6)	
<input type="checkbox"/> Sandy Mucky Mineral (S1)	<input type="checkbox"/> Depleted Dark Surface (F7)	
<input type="checkbox"/> Sandy Gleyed Matrix (S4)	<input type="checkbox"/> Redox Depressions (F8)	

<sup>3</sup>Indicators of hydrophytic vegetation and wetland hydrology must be present, unless disturbed or problematic.

**Restrictive Layer (if present):**

Type: \_\_\_\_\_

Depth (inches): \_\_\_\_\_

Hydric Soil Present? Yes  No

Remarks:

**HYDROLOGY**

**Wetland Hydrology Indicators:**

Primary Indicators (minimum of one required; check all that apply)

Secondary Indicators (2 or more required)

<input type="checkbox"/> Surface Water (A1)	<input type="checkbox"/> Water-Stained Leaves (B9) (except MLRA 1, 2, 4A, and 4B)	<input type="checkbox"/> Water-Stained Leaves (B9) (MLRA 1, 2, 4A, and 4B)
<input type="checkbox"/> High Water Table (A2)	<input type="checkbox"/> Salt Crust (B11)	<input type="checkbox"/> Drainage Patterns (B10)
<input type="checkbox"/> Saturation (A3)	<input type="checkbox"/> Aquatic Invertebrates (B13)	<input type="checkbox"/> Dry-Season Water Table (C2)
<input type="checkbox"/> Water Marks (B1)	<input type="checkbox"/> Hydrogen Sulfide Odor (C1)	<input type="checkbox"/> Saturation Visible on Aerial Imagery (C9)
<input type="checkbox"/> Sediment Deposits (B2)	<input type="checkbox"/> Oxidized Rhizospheres along Living Roots (C3)	<input type="checkbox"/> Geomorphic Position (D2)
<input type="checkbox"/> Drift Deposits (B3)	<input type="checkbox"/> Presence of Reduced Iron (C4)	<input type="checkbox"/> Shallow Aquitard (D3)
<input type="checkbox"/> Algal Mat or Crust (B4)	<input type="checkbox"/> Recent Iron Reduction in Tilled Soils (C6)	<input type="checkbox"/> FAC-Neutral Test (D5)
<input type="checkbox"/> Iron Deposits (B5)	<input type="checkbox"/> Stunted or Stressed Plants (D1) (LRR A)	<input type="checkbox"/> Raised Ant Mounds (D6) (LRR A)
<input type="checkbox"/> Surface Soil Cracks (B6)	<input type="checkbox"/> Other (Explain in Remarks)	<input type="checkbox"/> Frost-Heave Hummocks (D7)
<input type="checkbox"/> Inundation Visible on Aerial Imagery (B7)		
<input type="checkbox"/> Sparsely Vegetated Concave Surface (B8)		

**Field Observations:**

Surface Water Present? Yes  No  Depth (inches): \_\_\_\_\_

Water Table Present? Yes  No  Depth (inches): \_\_\_\_\_

Saturation Present? (includes capillary fringe) Yes  No  Depth (inches): \_\_\_\_\_

Wetland Hydrology Present? Yes  No

Describe Recorded Data (stream gauge, monitoring well, aerial photos, previous inspections), if available:

Remarks:

## ATTACHMENT 6

### **Wetlands Assessment**



# LACO

EUREKA • UKIAH • SANTA ROSA

1-800-515-5054 www.lacoassociates.com

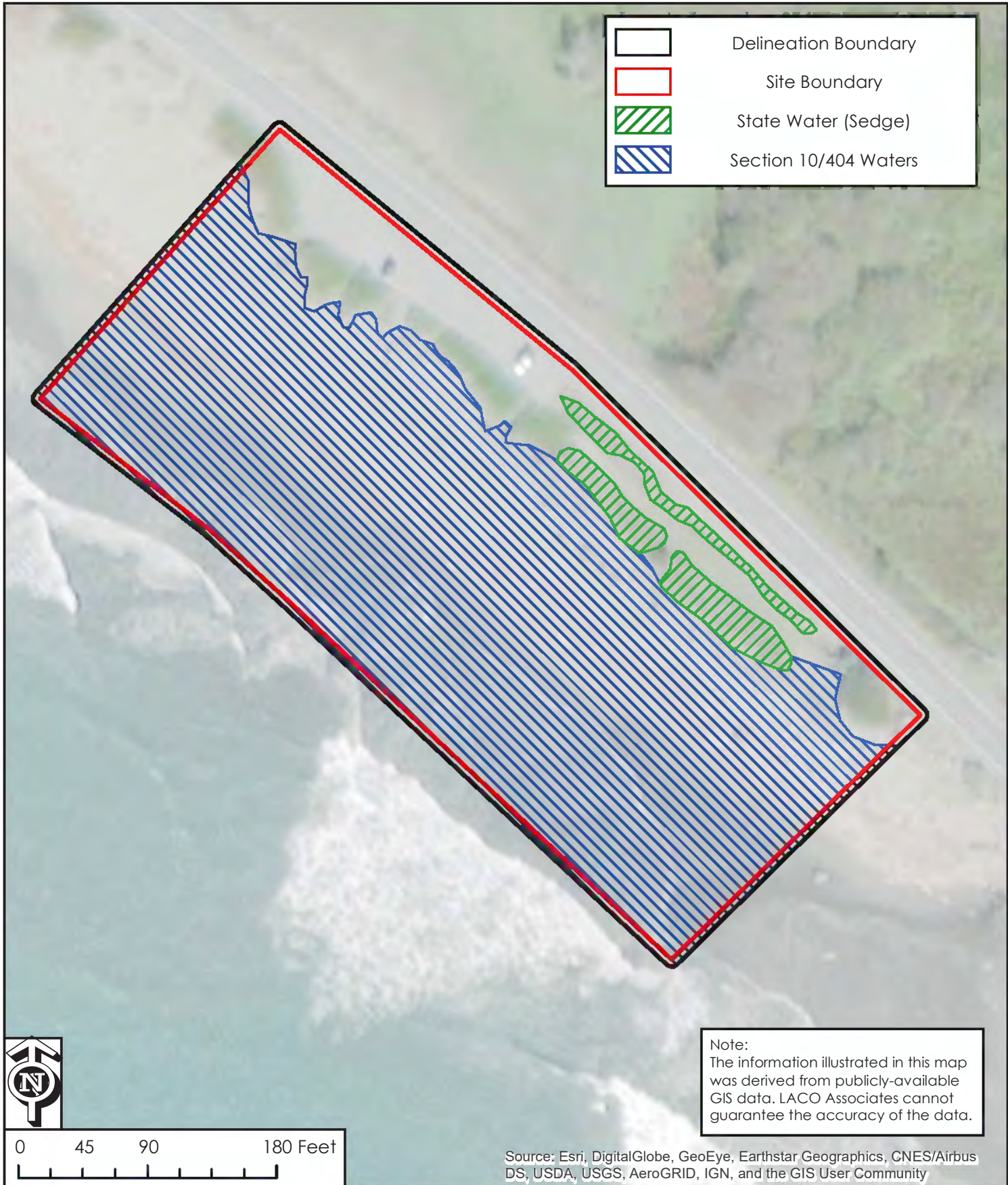

PROJECT	WAVECREST DR./N. PEBBLE BEACH DR. ACCESS	BY	CRP	FIGURE	2
CLIENT	COUNTY OF DEL NORTE	CHECK	JC		
LOCATION	NORTH PEBBLE BEACH DRIVE, DEL NORTE, CA	DATE	3/9/2021	JOB NO.	9790.00
	PEBBLE BEACH ACCESS WATERS DELINEATION				



# TECHNICAL MEMORANDUM

Geotechnical Exploration and Recommendations  
 Wavecrest Drive and North Pebble Beach Drive Access Project  
 Del Norte County, California

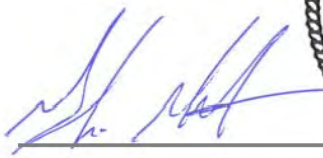
---

Date:	April 26, 2021		
Project No.:	9790.00		
Prepared For:	County of Del Norte		
Prepared By:	Gary L. Manhart, CEG Senior Engineering Geologist CEG No. 2651; Exp. 10/31/22		
Reviewed By:	Leonard Osborne Principal Engineer		
Attachments:	Figure 1: Figure 2 Figure 3 Figure 4 Appendix 1:	Locations Map Wavecrest Drive Site Map Pebble Beach Drive Site Map Geologic Map Boring Logs	

---

## 1.0 INTRODUCTION

This memorandum presents the results of a geotechnical exploration performed by LACO Associates, Inc. (LACO) at the two coastal access sites in the County of Del Norte (Figure 1). The northernmost of the two sites, Wavecrest Drive access site, is intended to repair a coastal access route that was damaged by the tsunami resulting from the 2011 Tohoku earthquake in Japan. The second site, Pebble Beach Drive access site, is in the City of Crescent City, and is a new access location that is intended to provide Americans with Disability Act (ADA)-compliant access in an area where overall beach access is limited. This geologic evaluation of the subsurface was conducted to determine suitability of the surface with which to construct the proposed beach accesses.

## 2.0 EXPLORATION

On March 2, 2021, LACO conducted a geotechnical exploration comprising a hand auger subsurface exploration program. Three hand auger borings (HB-1 wave through HB-3 wave) were installed at the

Wavecrest Drive site and two hand auger boring (HB-1 PB and HB-2 PB) at the Pebble Beach Drive site. Boring locations are shown in Figures 2 and 3. Our geologist logged the borings in general accordance with the American Society for Testing and Materials (ASTM) Test Procedure D2488 Visual-Manual. Boring logs are attached as Appendix 1. One grab sample of the partially iron-cemented Battery formation was collected from HB-1 wave.

## 3.0 GENERAL GEOLOGY

The sea cliffs in the vicinity of Wavecrest Drive and Pebble Beach Drive generally comprise an unconsolidated soil deposit overlying fine-grained marine sedimentary rock. The overlying soil has been mapped as a Pleistocene marine terrace deposit. This deposit consists of marine terrace silts and sands with interfingering dune sands and alluvial gravels. They largely comprise tan to reddish-brown, semi-consolidated, medium-grained sands alternating with blue-gray silty clay and imbricated gravels designated as the Battery formation (CGS, 2012). The sedimentary rock within the lower cliff and extending across the foreshore is a massive, poorly bedded, Pliocene marine siltstone and shale. This deposit has been designated as the St. George formation (Aalto, 2006).

## 4.0 WAVECREST DRIVE

### 4.1 Surface Conditions

The bluff height at the Wavecrest Drive site is 32 feet in elevation. The beach elevation at the end of the ramp is approximately 20 feet above mean sea level. The end of the access ramp is undermined and approximately 4 feet higher than the back shore area, which generally comprises medium to fine sand. Slope configurations at the site are currently stable; however, they are prone to episodic failure. Near vertical slopes were observed at the mouth of an unnamed creek. Slopes to the south and east of the lower portion of the access ramp were generally 1:1 and vegetated.

### 4.2 Subsurface Conditions

The beach sand was approximately 5 feet thick at the time of subsurface exploration and overlies an iron-cemented sand layer with gravels associated with the Battery formation. Hand augering below this layer was not possible due to the gravely and cemented nature of the material. Boring HB-1 wave, at the south end of the access ramp, was extended to 6 feet below ground surface and 1 foot into the Battery formation, which is acting as the wave cut bench. HB-2 wave was advanced west approximately 10 feet from the edge of the access ramp. HB-2 wave was halted at 2.5 feet after encountering riprap that was eroded and moved away from the access ramp toward the surf zone. Boring HB-3 wave encountered the Battery formation at 5 feet below the current back shore, approximately 30 feet north of the end of the access ramp, and was abandoned at 6 feet due to gravels. Our subsurface exploration indicated the depth to scour at the site is approximately 5 feet below the beach sands, which appears to be the wavecut bench.

## 5.0 PEBBLE BEACH DRIVE

### 5.1 Surface Conditions

The road height at the Pebble Beach Drive site is 20 feet in elevation. The beach elevation at the end of the access is approximately 15 feet above mean sea level. The access path is currently buried in back shore

sands and being encroached on by vegetation. The beach sand generally comprises medium to fine sand with scattered medium to fine gravel. The Pebble Beach site slopes to the west approximately 5 to 10 degrees and slope stability is not an issue.

## 5.2 Subsurface Conditions

Hand augering at this site was difficult as there was a gravel layer at approximately 3 feet below the surface below, and it was not possible to advance the hand auger. The St. George formation is estimated to be 2 to 5 feet deeper than our exploration based on observed surface outcrops near the site and the mapped and observed dip of the unit. Borings HB-1 PB and HB-2 PB were in the back shore area of the beach access, north and south of the access ramp, respectively. Borings were attempted in several locations north, south, and west of HB-1 PB and HB-2 PB, but continued to encounter the same gravel layer and were not logged. Based on our observations at the Pebble Beach Drive site, our estimation of the depth to scour at the site is approximately 5 to 8 feet below the beach sands.

## 6.0 RECOMMENDATIONS

Based on the observed soil type below the loose beach sands to the depth of our exploration, the maximum allowable bearing pressures are presented in Table 1.

*Table 1. Maximum Allowable Bearing Pressures for Shallow Spread Footings*

Loading Condition	Maximum Allowable Bearing Pressure (psf)
Dead plus long-term live loads	1,500
Total, including Wind or Seismic	2,000

Lateral load resistance may be developed via: (1) skin friction between the footing bottoms and underlying soil and (2) passive soil resistance against the vertical faces of footings. For design, use an allowable friction coefficient of 0.35, and a passive soil equivalent fluid pressure of 200 pounds per cubic foot (pcf). Passive pressure should be neglected in the upper 1 foot of soil unless confined by adjacent concrete slabs or pavements. If friction and passive resistances are to be combined, reduce the lesser value by 50 percent.

The foundation elements should be placed on undisturbed native subgrade of the Battery formation at Wavecrest Drive site or on the St. George formation at the Pebble Beach Drive site. Subsoils should be scarified and compacted as described in Table 2.

## 6.1 Earthwork

Areas to be graded should be cleared of unengineered fill, disturbed native soils, loose sand, debris, and surface vegetation. Deeper stripping and grubbing may be necessary to remove loose sand. Stripping and debris materials should be removed from the site. Areas to receive fill should be scarified to a depth of approximately 6 inches, moisture conditioned at the optimum moisture content, and compacted to at least 90 percent relative compaction utilizing a sheep's foot type roller.

### 6.2.1 Select Fill

Our exploration indicates that most of the on-site soil materials may be suitable for use as fill, provided isolated zones of organic, oversized, and/or highly plastic materials are removed. In order to achieve the required

compaction, rocks greater than 4 inches in largest dimension can be used for erosion protection, energy dissipators, on upstream embankment slopes, and/or disposed of off-site.

If imported fill is necessary to achieve planned site grades, it should not contain organic material or rocks larger than 3 inches in greatest dimension. Additionally, the material should meet the following specifications:

Plasticity Index:	less than 15 percent
Liquid Limit:	less than 40 percent
Percent passing No. 200 sieve:	50 maximum, 5 minimum

Fill should be placed in thin layers (typically 8-inch lifts, approximately 12 inches loosely placed) on a relatively flat surface, thoroughly moisture conditioned to the optimum moisture content, and compacted to at least 90 percent relative compaction. Fill should be benched into sloping ground, both parallel and transverse to the embankment crest. Benches should extend into stiff soil. Fill surfaces should be finished smooth and unyielding.

Table 2. Soil Compaction Recommendations

Fill Element	Relative Compaction	Moisture Content
General fill - raising of project site grades	90 percent	Near Optimum
Upper 6 inches of subgrade beneath hardscape	90 percent	Near Optimum
Aggregate base rock beneath hardscape	90 percent	Near Optimum

### 6.2.2 Temporary Slopes

Temporary cut slopes should be inclined no steeper than 1.5:1. A LACO geologist should observe the cut slopes during construction to check the exposed soil/rock is consistent with soil encountered in test pits and recommend modifications, as necessary. The tops of cut slopes should be flattened or rounded back to blend with the natural topography. Fill slopes should be trimmed of loose material and the downslope planted with fast growing and deeply rooted ground cover.

## 7.0 FUTURE GEOTECHNICAL SERVICES

LACO should be retained to observe and test (as necessary) the earthwork and foundation phases of construction in order to: a) check that subsurface conditions exposed during construction are substantially the same as those interpolated from our subsurface exploration, on which the analysis and design were based; b) observe compliance with the geotechnical design concepts, specifications, and recommendations; and c) allow design changes in the event that subsurface conditions differ from those anticipated. The recommendations in this memorandum are based on limited subsurface information. The nature and extent of variation across the site may not become evident until construction. If variations are then exposed, it will be necessary to re-evaluate our recommendations.

## 8.0 LIMITATIONS

This memorandum has been prepared for the exclusive use of the County of Del Norte, their agents, contractors and consultants, and appropriate public authorities for specific application to development of

the Site. LACO has exercised a standard of care equal to that generated for this industry to ensure that the information contained in this memorandum is current and accurate. The opinions presented in this memorandum are based upon information obtained from subsurface excavations, a Site reconnaissance, review of geologic maps and data available to us, and upon local experience and engineering judgment, and the opinions have been formulated in accordance with generally accepted geotechnical engineering practices that exist in California at the time this memorandum was prepared. In addition, geotechnical issues may arise that are not apparent at this time. No other warranty, expressed or implied, is made or should be inferred.

Data generated for this memorandum represent information gathered at that time and at the widely spaced locations indicated. Subsurface conditions may be highly variable and difficult to predict. As such, the recommendations included in this memorandum are based, in part, on assumptions about subsurface conditions that may only be observed and/or tested during subsequent project earthwork. Accordingly, the validity of these recommendations is contingent upon review of the subsurface conditions exposed during construction in order to check that they are consistent with those characterized in this memorandum. Upon request, LACO can discuss the extent of (and fee for) observations and tests required to check the validity of the recommendations presented herein.

The opinions presented in this memorandum are valid as of the present date for the property evaluated. Changes in the condition of the property can occur over time, whether due to natural processes or the works of people, on this or adjacent properties. In addition, changes in applicable standards of practice can occur, whether from legislation or the broadening of knowledge. Accordingly, the opinions presented in this memorandum may be invalidated, wholly or partially, by changes outside our control. Therefore, this memorandum is subject to review and should not be relied upon after a period of three years, nor should it be used, or is it applicable, for any property other than that evaluated. This memorandum is valid solely for the purpose, Site, and project described in this document. Any alteration, unauthorized distribution, or deviation from this description will invalidate this memorandum. LACO assumes no responsibility for any third-party reliance on the data presented. Additionally, the data presented should not be utilized by any third-party to represent data for any other time or location.

## 9.0 REFERENCES

- Aalto, K. R. The Klamath Peneplane: A review of J. S. Diller's Classic Erosion Surface, Geologic Society of America, Special Paper 410, 2006, p451-463.
- CGS, 2012, Preliminary Geologic Map of the Onshore Portions of the Crescent City and Orick 30' x 60' Quadrangles, California. Marc Delattre and Anne Rosinski.

## FIGURES

<b>Figure 1</b>	<b>Locations Map</b>
<b>Figure 2</b>	<b>Wavecrest Drive Site Map</b>
<b>Figure 3</b>	<b>Pebble Beach Drive Site Map</b>
<b>Figure 4</b>	<b>Geologic Map</b>



PROJECT	Geologic Report	BY	GLM	FIGURE	1
CLIENT	County of Del Norte	DATE	4/7/21		
LOCATION	Wavecrest and Pebble Beach Drives	CHECK		JOB NO.	9790.00
	Locations Map	SCALE	1" = 4000'		

REUSE OF DOCUMENTS: This document and the ideas and designs incorporated herein, as an instrument of professional service is the property of LACO Associates and shall not be reused in whole or part for any other project without LACO Associates' express written authorization.

## Wavecrest Drive Location

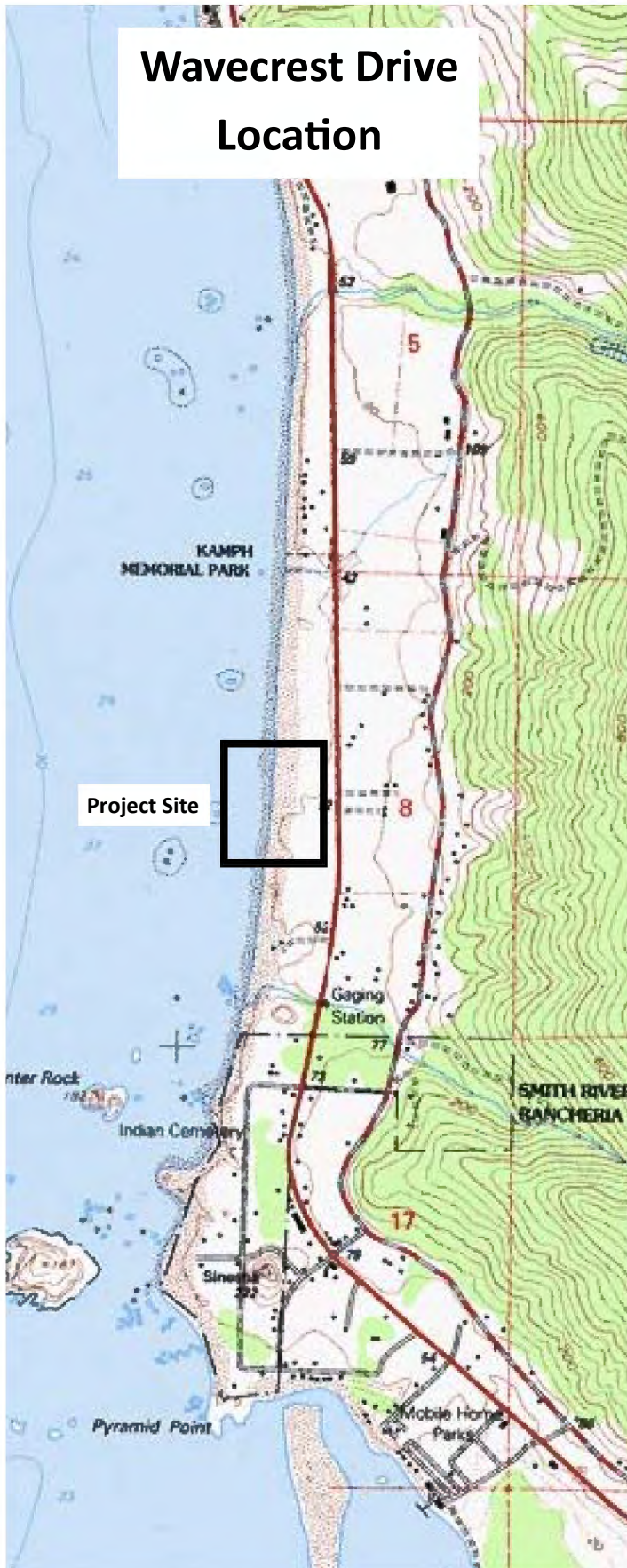

## Pebble Beach Drive Location



REUSE OF DOCUMENTS: This document and the ideas and designs incorporated herein, as an instrument of professional service is the property of LACO Associates and shall not be reused in whole or part for any other project without LACO Associates' express written authorization.

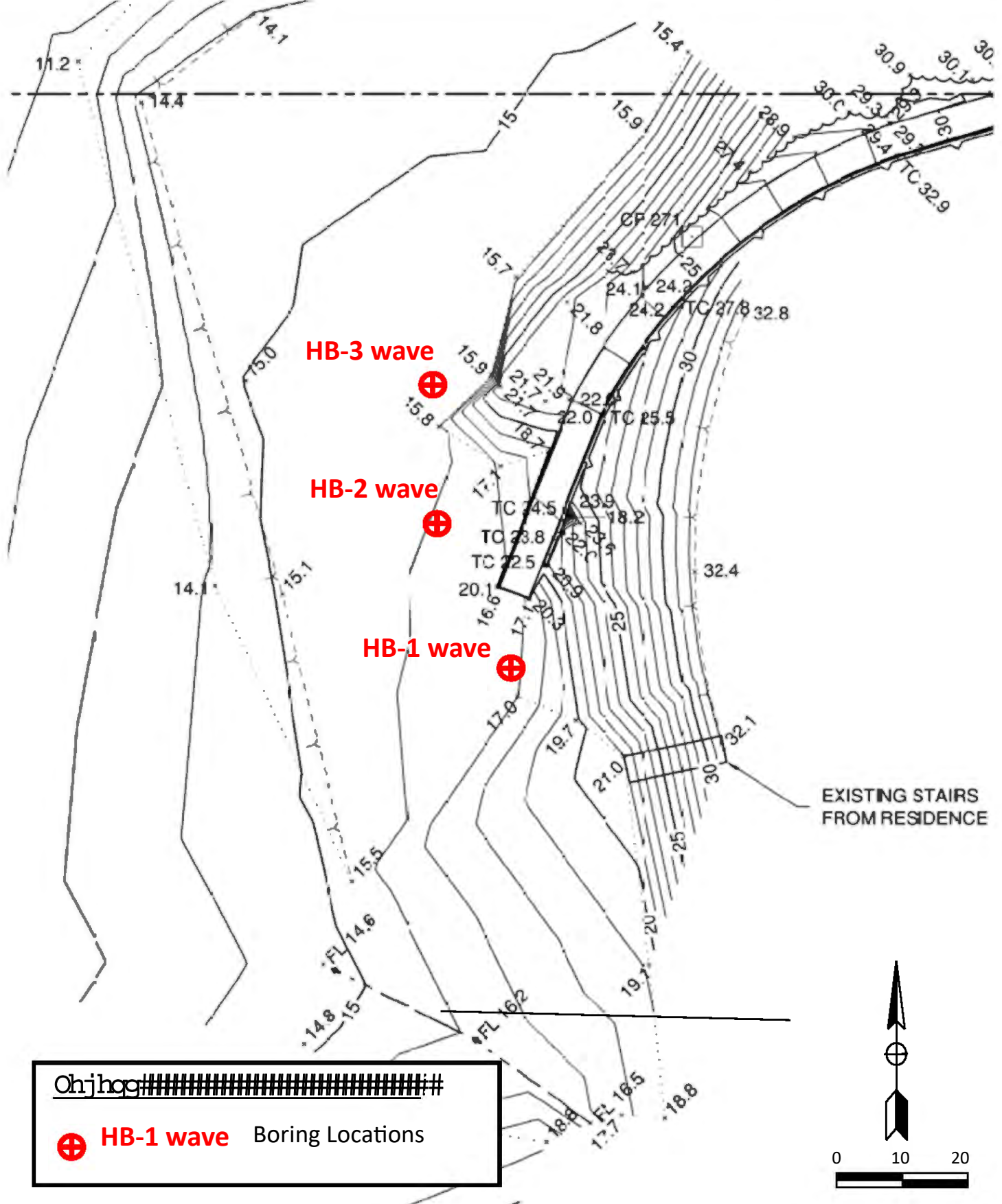

Ohjhog#####

 **HB-1 wave** Boring Locations

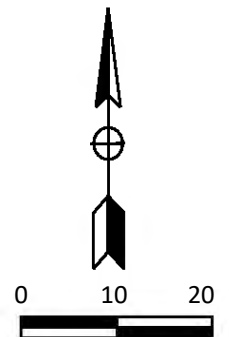

PROJECT	Geologic Report	BY	GLM
CLIENT	County of Del Norte	DATE	4/7/21
LOCATION	Pebble Beach Drive	CHECK	
	Site Map	SCALE	1" = 50'

FIGURE	3
JOB NO.	9790.00

REUSE OF DOCUMENTS: This document and the ideas and designs incorporated herein, as an instrument of professional service is the property of LACO Associates and shall not be reused in whole or part for any other project without LACO Associates' express written authorization.

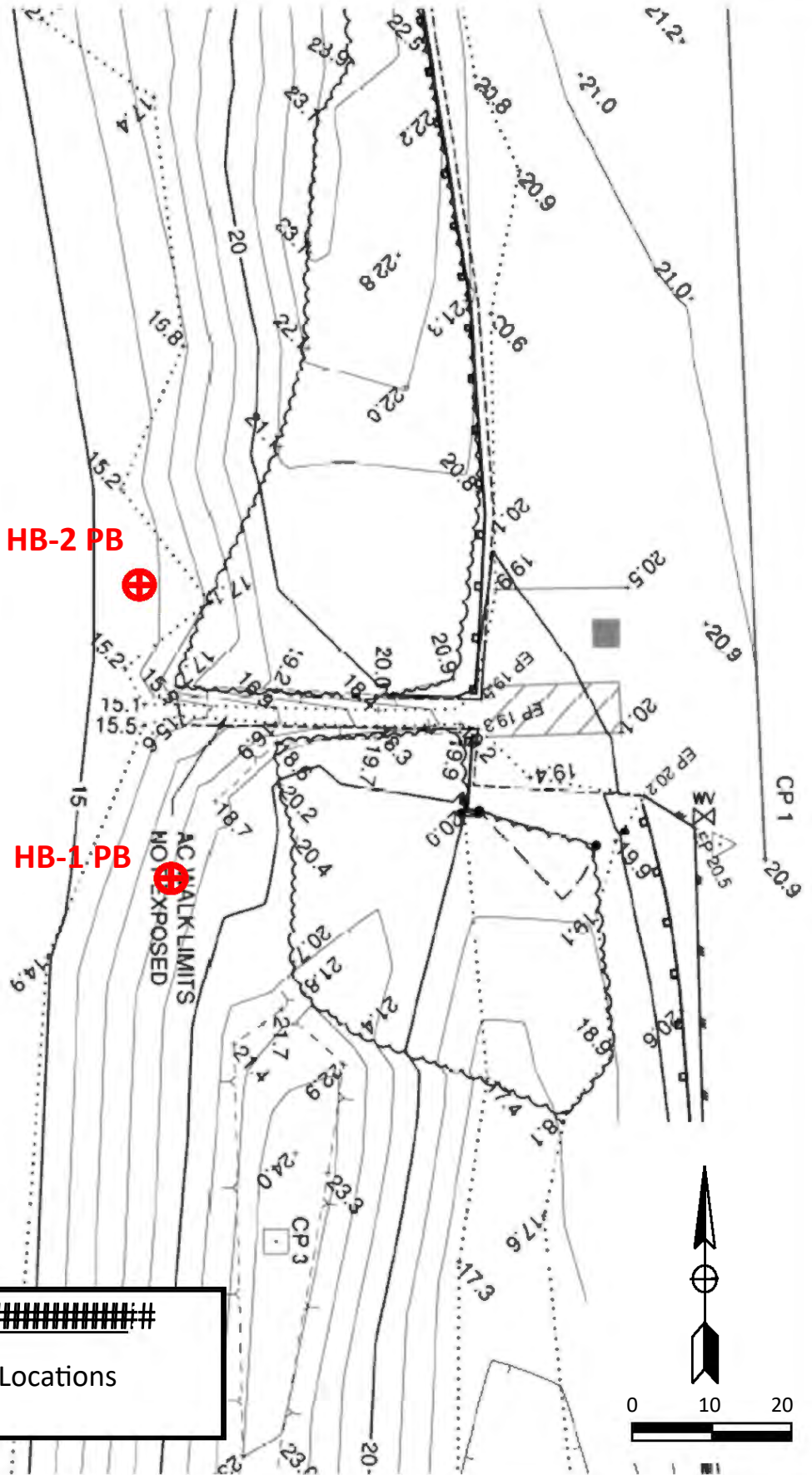

Ohjhgg#####

 **HB-1 PB** Boring Locations

PROJECT	Geologic Report	BY	GLM	FIGURE 4
CLIENT	County of Del Norte	DATE	4/7/21	
LOCATION	Wavecrest and Pebble Beach Drives	CHECK		JOB NO.
	Geologic Map	SCALE	1" = 2000'	9790.00

REUSE OF DOCUMENTS: This document and the ideas and designs incorporated herein, as an instrument of professional service is the property of LACO Associates and shall not be reused in whole or part for any other project without LACO Associates' express written authorization.

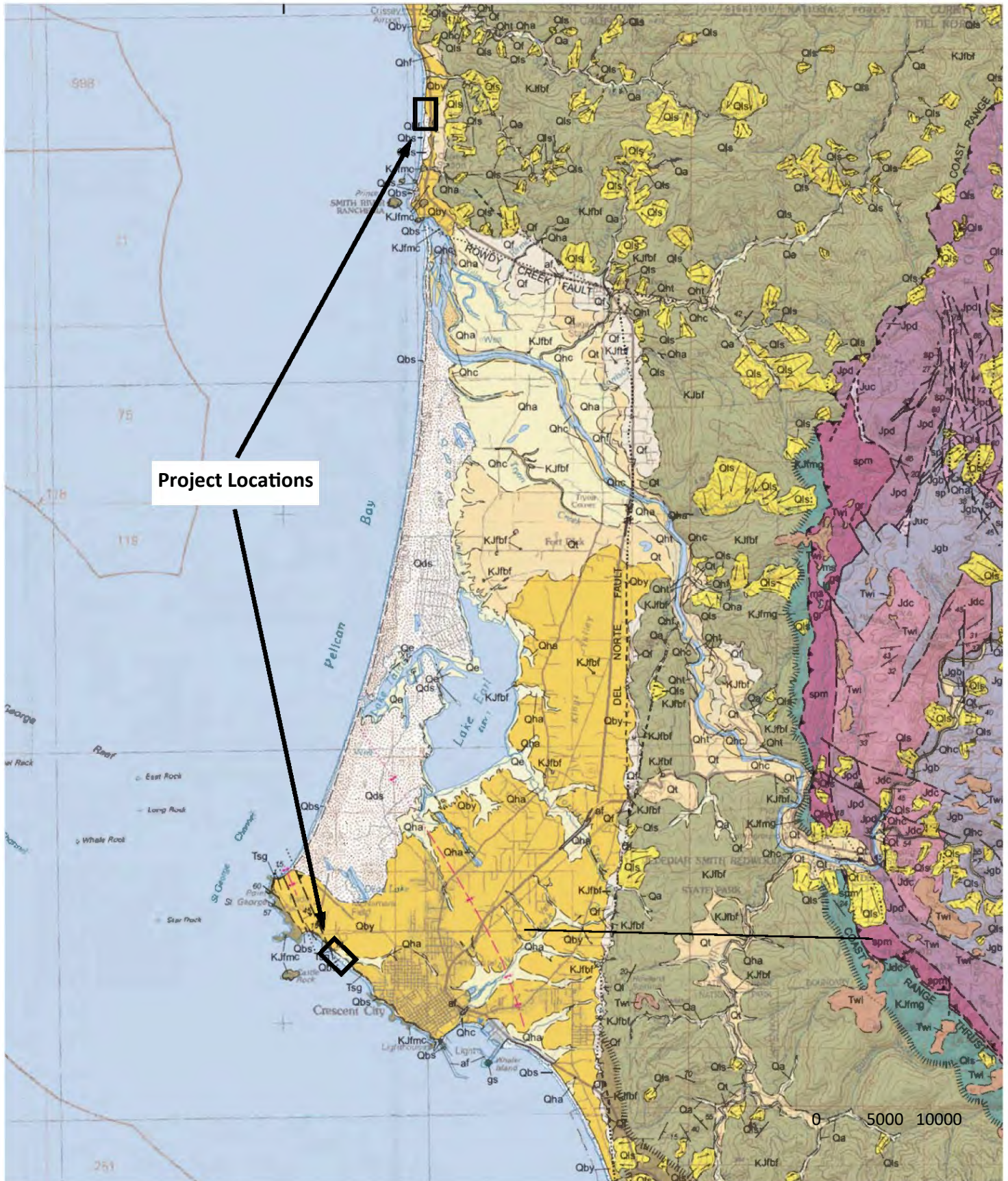

## APPENDIX 1

### **Boring Logs**

GEOTECH BORING NEW - GINT STD US LAB.GDT - 4/8/21 15:52 - P:\9700\9790 DEL NORTE COUNTY COMMUNITY DEVELOPMENT\9790.00 WAVECREST DR COASTAL ACCESS PROJECT\08 GEOLOGY\FIELD DATA\9790 GINT LOGS.GPJ

<b>CLIENT</b> <u>County of Del Norte</u>	<b>PROJECT NAME</b> <u>Coastal Access Project</u>
<b>PROJECT NUMBER</b> <u>9790.00</u>	<b>PROJECT LOCATION</b> <u>Wave Crest Drive, Crescent City, California</u>
<b>DATE STARTED</b> <u>3/2/21</u> <b>COMPLETED</b> <u>3/2/21</u>	<b>GROUND ELEVATION</b> _____ <b>HOLE SIZE</b> <u>3 inches</u>
<b>DRILLING CONTRACTOR</b> <u>LACO</u>	<b>GROUND WATER LEVELS:</b>
<b>DRILLING METHOD</b> <u>Hand Auger</u>	<b>AT TIME OF DRILLING</b> <u>--- No Groundwater Encountered</u>
<b>LOGGED BY</b> <u>GM</u> <b>CHECKED BY</b> <u>GM</u>	<b>AT END OF DRILLING</b> <u>--- No Groundwater Encountered</u>
<b>NOTES</b> _____	

DEPTH (ft)	GRAPHIC LOG	MATERIAL DESCRIPTION	SAMPLE TYPE NUMBER	RECOVERY % (RQD)	BLOW COUNTS (N VALUE)	TESTS AND REMARKS	Pocket Penetrometer (tsf)	DRY UNIT WT. (pcf)	MOISTURE CONTENT (%)	ATTERBERG LIMITS (%)			FINES CONTENT (%)
										LIQUID LIMIT	PLASTIC LIMIT	PLASTICITY INDEX	
0.0		(SP) Beach sand, gray, moist, loose											
2.5	[Dotted pattern]	Iron staining with depth, brown, moist, loose.											

Refusal at 3 feet bgs due to gravel  
Bottom of borehole at 3.0 feet.

GEOTECH BORING NEW - GINT STD US LAB.GDT - 4/8/21 15:52 - P:\19700\9790 DEL NORTE COUNTY COMMUNITY DEVELOPMENT\9790.00 WAVECREST DR COASTAL ACCESS PROJECT\08 GEOLOGY\FIELD DATA\9790 GINT LOGS.GPJ

<b>CLIENT</b> <u>County of Del Norte</u>	<b>PROJECT NAME</b> <u>Coastal Access Project</u>
<b>PROJECT NUMBER</b> <u>9790.00</u>	<b>PROJECT LOCATION</b> <u>Wave Crest Drive, Crescent City, California</u>
<b>DATE STARTED</b> <u>3/2/21</u> <b>COMPLETED</b> <u>3/2/21</u>	<b>GROUND ELEVATION</b> _____ <b>HOLE SIZE</b> <u>3 inches</u>
<b>DRILLING CONTRACTOR</b> <u>LACO</u>	<b>GROUND WATER LEVELS:</b>
<b>DRILLING METHOD</b> <u>Hand Auger</u>	<b>AT TIME OF DRILLING</b> <u>--- No Groundwater Encountered</u>
<b>LOGGED BY</b> <u>GM</u> <b>CHECKED BY</b> <u>GM</u>	<b>AT END OF DRILLING</b> <u>--- No Groundwater Encountered</u>
<b>NOTES</b> _____	

DEPTH (ft)	GRAPHIC LOG	MATERIAL DESCRIPTION	SAMPLE TYPE NUMBER	RECOVERY % (RQD)	BLOW COUNTS (N VALUE)	TESTS AND REMARKS	Pocket Penetrometer (tsf)	DRY UNIT WT. (pcf)	MOISTURE CONTENT (%)	ATTERBERG LIMITS (%)			FINES CONTENT (%)
										LIQUID LIMIT	PLASTIC LIMIT	PLASTICITY INDEX	
0.0		(SP) Beach sand, gray, moist, loose, fine grained sand											
2.5		Coarsens with depth, beach sand, moist, loose, medium to fine grained sand											
5.0		Coarsens with depth, beach sand with gravel, moist, loose, medium to fine grained sand, iron cementing											
			GB										

Refusal at 6 feet bgs due to rock and gravel, grab sample of iron cementing  
Bottom of borehole at 6.0 feet.

GEOTECH BORING NEW - GINT STD US LAB.GDT - 4/8/21 15:52 - P:\9700\9790 DEL NORTE COUNTY COMMUNITY DEVELOPMENT\9790.00 WAVECREST DR COASTAL ACCESS PROJECT\08 GEOLOGY\FIELD DATA\9790 GINT LOGS.GPJ

<b>CLIENT</b> <u>County of Del Norte</u>	<b>PROJECT NAME</b> <u>Coastal Access Project</u>
<b>PROJECT NUMBER</b> <u>9790.00</u>	<b>PROJECT LOCATION</b> <u>Wave Crest Drive, Crescent City, California</u>
<b>DATE STARTED</b> <u>3/2/21</u> <b>COMPLETED</b> <u>3/2/21</u>	<b>GROUND ELEVATION</b> _____ <b>HOLE SIZE</b> <u>3 inches</u>
<b>DRILLING CONTRACTOR</b> <u>LACO</u>	<b>GROUND WATER LEVELS:</b>
<b>DRILLING METHOD</b> <u>Hand Auger</u>	<b>AT TIME OF DRILLING</b> <u>--- No Groundwater Encountered</u>
<b>LOGGED BY</b> <u>GM</u> <b>CHECKED BY</b> <u>GM</u>	<b>AT END OF DRILLING</b> <u>--- No Groundwater Encountered</u>
<b>NOTES</b> _____	

DEPTH (ft)	GRAPHIC LOG	MATERIAL DESCRIPTION	SAMPLE TYPE NUMBER	RECOVERY % (RQD)	BLOW COUNTS (N VALUE)	TESTS AND REMARKS	Pocket Penetrometer (tsf)	DRY UNIT WT. (pcf)	MOISTURE CONTENT (%)	ATTERBERG LIMITS (%)			FINES CONTENT (%)
										LIQUID LIMIT	PLASTIC LIMIT	PLASTICITY INDEX	
0.0		(SP) Beach sand, gray, moist, loose, fine grained sand											
2.5	[Dotted pattern]	Becomes medium grained, moist, loose, some scattered gravel.											

Refusal at 3 feet bgs due to gravel  
Bottom of borehole at 3.0 feet.



GEOTECH BORING NEW - GINT STD US LAB.GDT - 4/8/21 15:52 - P:\9700\9790 DEL NORTE COUNTY COMMUNITY DEVELOPMENT\9790.00 WAVECREST DR COASTAL ACCESS PROJECT\08 GEOLOGY\FIELD DATA\9790 GINT LOGS.GPJ

**CLIENT** County of Del Norte      **PROJECT NAME** Coastal Access Project  
**PROJECT NUMBER** 9790.00      **PROJECT LOCATION** Wave Crest Drive, Crescent City, California  
**DATE STARTED** 3/2/21      **COMPLETED** 3/2/21      **GROUND ELEVATION** \_\_\_\_\_      **HOLE SIZE** 3 inches  
**DRILLING CONTRACTOR** LACO      **GROUND WATER LEVELS:**  
**DRILLING METHOD** Hand Auger      **AT TIME OF DRILLING** --- No Groundwater Encountered  
**LOGGED BY** GM      **CHECKED BY** GM      **AT END OF DRILLING** --- No Groundwater Encountered  
**NOTES** Boring located approximately 40 feet west of 2nd wall joint

DEPTH (ft)	GRAPHIC LOG	MATERIAL DESCRIPTION	SAMPLE TYPE NUMBER	RECOVERY % (RQD)	BLOW COUNTS (N VALUE)	TESTS AND REMARKS	Pocket Penetrometer (tsf)	DRY UNIT WT. (pcf)	MOISTURE CONTENT (%)	ATTERBERG LIMITS (%)			FINES CONTENT (%)
										LIQUID LIMIT	PLASTIC LIMIT	PLASTICITY INDEX	
0.0		(SP) Beach sand, gray, moist, loose											
2.5													

Refusal at 2.5 feet bgs due to loose rip rap  
Bottom of borehole at 2.5 feet.

GEOTECH BORING NEW - GINT STD US LAB.GDT - 4/8/21 15:52 - P:\9700\9790 DEL NORTE COUNTY COMMUNITY DEVELOPMENT\9790.00 WAVECREST DR COASTAL ACCESS PROJECT\08 GEOLOGY\FIELD DATA\9790 GINT LOGS.GPJ

CLIENT <u>County of Del Norte</u>	PROJECT NAME <u>Coastal Access Project</u>
PROJECT NUMBER <u>9790.00</u>	PROJECT LOCATION <u>Wave Crest Drive, Crescent City, California</u>
DATE STARTED <u>3/2/21</u> COMPLETED <u>3/2/21</u>	GROUND ELEVATION _____      HOLE SIZE <u>3 inches</u>
DRILLING CONTRACTOR <u>LACO</u>	GROUND WATER LEVELS:
DRILLING METHOD <u>Hand Auger</u>	AT TIME OF DRILLING <u>--- No Groundwater Encountered</u>
LOGGED BY <u>GM</u> CHECKED BY <u>GM</u>	AT END OF DRILLING <u>--- No Groundwater Encountered</u>
NOTES <u>Boring located approximately 40 feet off 4th wall joint</u>	

DEPTH (ft)	GRAPHIC LOG	MATERIAL DESCRIPTION	SAMPLE TYPE NUMBER	RECOVERY % (RQD)	BLOW COUNTS (N VALUE)	TESTS AND REMARKS	Pocket Penetrometer (tsf)	DRY UNIT WT. (pcf)	MOISTURE CONTENT (%)	ATTERBERG LIMITS (%)			FINES CONTENT (%)
										LIQUID LIMIT	PLASTIC LIMIT	PLASTICITY INDEX	
0.0		(SP) Beach sand, gray, moist, loose											
2.5	[Dotted pattern]												
5.0	[Dotted pattern]	Iron cemented and coated sands and fine gravels, loose, moist											
Bottom of borehole at 6.0 feet.													

# TECHNICAL MEMORANDUM

Revised - Bluff Retreat  
Wavecrest Drive and Pebble Beach Drive Access Sites  
Crescent City, California

Date: May 16, 2022  
Project No.: 9790.00  
Prepared For: County of Del Norte  
Prepared By: Christine S. Manhart, CHG  
Principal Geologist  
CHG No. 1080, Exp 3/31/23  
Reviewed By: Dr. Ronald C. Chaney, PE, GE  
Senior Geotechnical Engineer  
GE No. GE000934, Exp 3/31/23

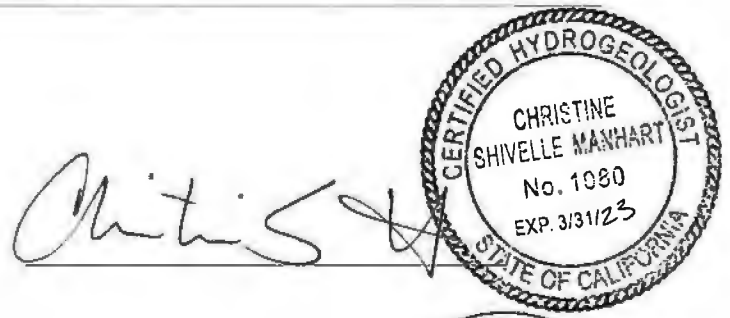

## 1.0 INTRODUCTION

This report reviews the potential impacts of bluff retreat to two coastal access sites in the County of Del Norte. The northernmost of the two sites, the Wavecrest Drive access site, is a new access location that is intended to provide Americans with Disability Act (ADA) compliant access in an area where overall beach access is limited. The second site, the Pebble Beach Drive access site, is in Crescent City and is intended to repair a coastal access route that was damaged by the tsunami resulting from the 2011 Tohoku (Fukushima) earthquake in Japan. Project implementation will require a Coastal Development Permit, partial fulfillment of which requires a review of potential bluff retreat impacts. Figure 1 shows the locations of the two access sites.

This report reviews historical bluff retreat with an associated estimated retreat rate, local geology, and beach erosional and depositional processes, and how those factors may impact bluff retreat to inform their potential to impact the project over a proposed 50-year lifespan.

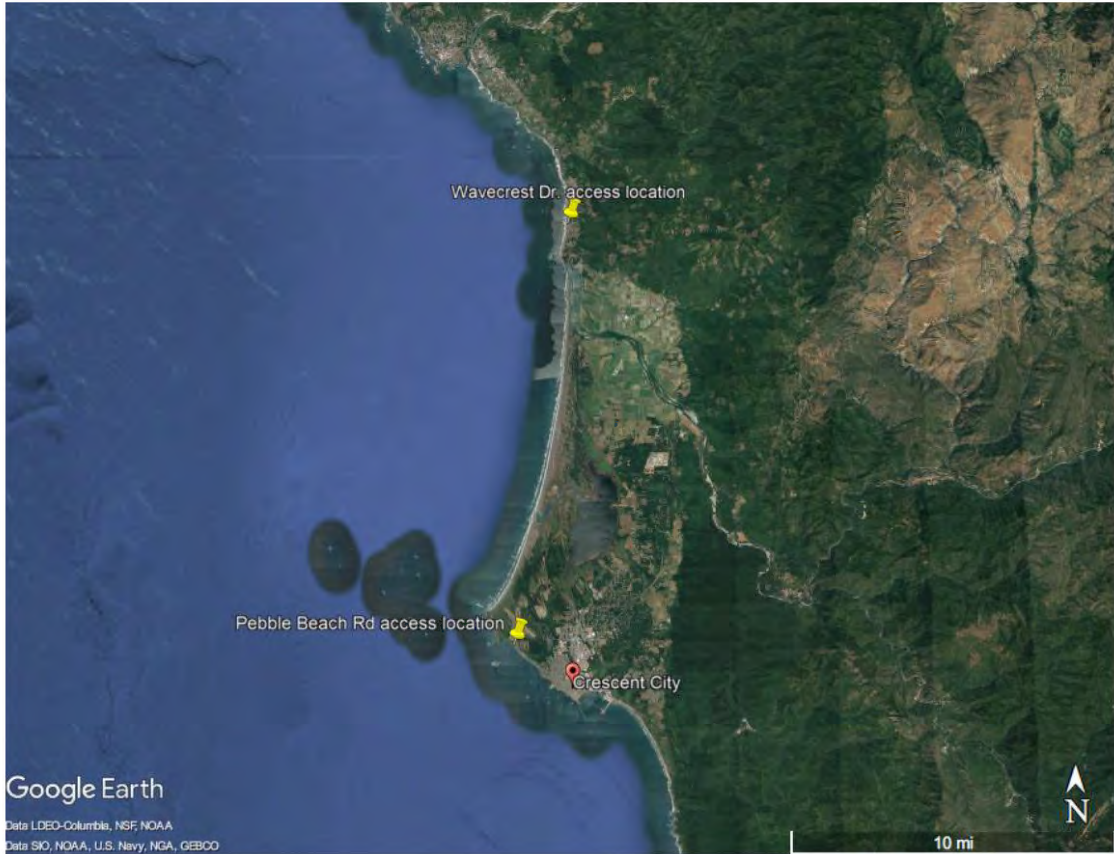

Figure 1: Access Point Location Map (Google Earth, April 2021)

## 2.0 GEOLOGY

Looking eastward from the town of Crescent City, California marine terraces and old shorelines have risen to an elevation of approximately 50 feet (15 meters) as shown in Figure 2. This is primarily the result of interseismic uplift, or uplift occurring as the land stabilizes following a seismic event. There is also evidence of successive, co-seismic increases in elevation in landmasses along this coast. Coupled with these two geological phenomena is fluctuating sea level, which has been rising since the beginning of the last ice age. Presently, relative sea level (i.e., the combined effect of the change in elevations of both the land and sea level) is rising along the north coast (Russell, 1957). The result of the rise of sea level with respect to the land is coastal erosion. The effect of coastal bluff erosion on Pebble Beach Drive, located immediately north of Crescent City, California, and Wavecrest Drive approximately 14 miles north, are the focus of this report.

Sea-level rise for Crescent City, California was discussed in LACO's *Relative Sea-level Changes, Wavecrest Drive and Pebble Beach Drive Access Sites* (2021). In summary, our report provided high and low estimates of 50-year sea level rise for the general area of 2.4 feet (relative to mean sea level, msl) based on a low greenhouse gas emissions model and 2.8 feet msl based on a model of high emissions.

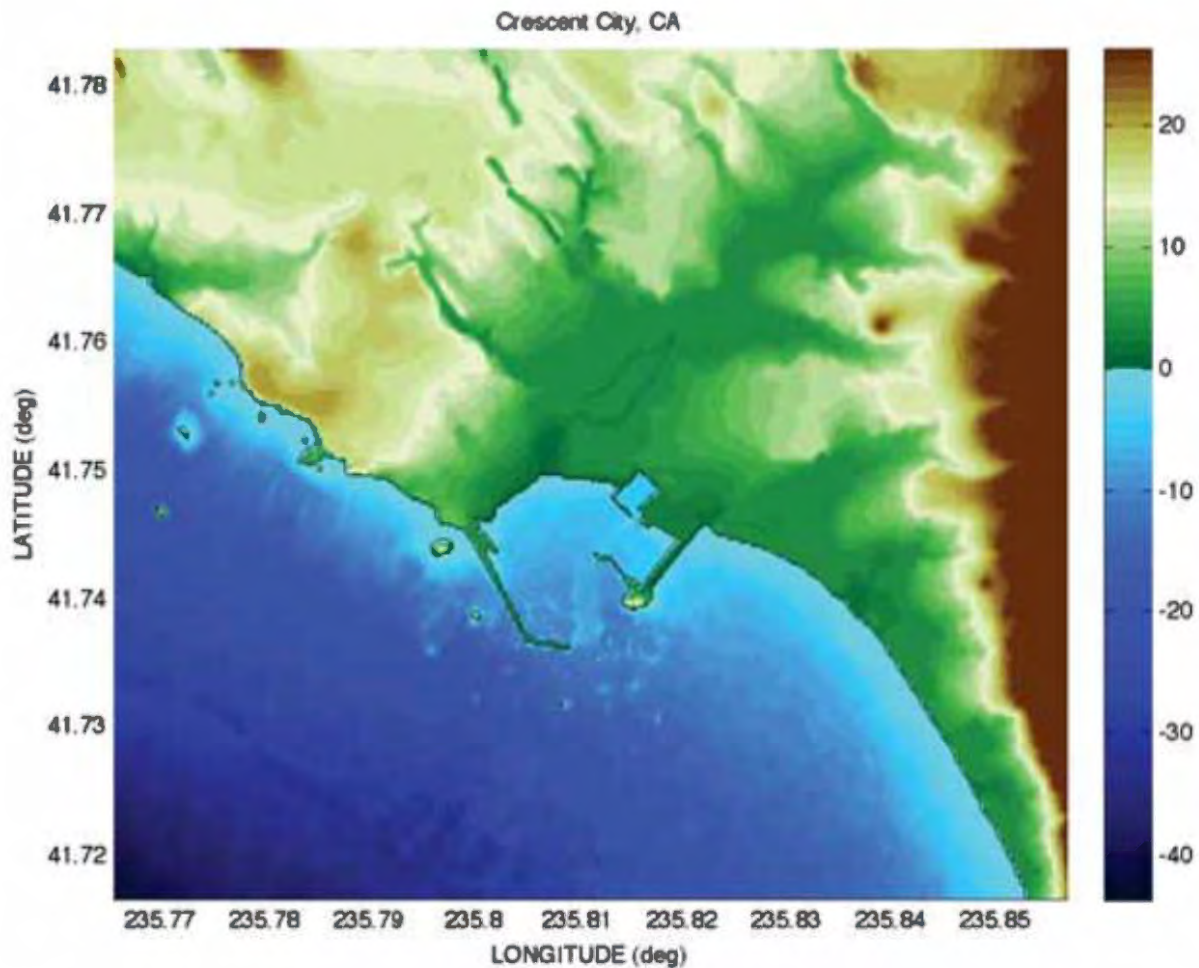

Figure 2: Color-filled surface plot of digital elevation model of Crescent City, California. Color bar units are elevation in meters (After Arcas and Uslu, 2010).

The sea cliffs in the vicinity of Crescent City comprise an unconsolidated soil deposit overlying fine-grained marine sedimentary rock. The overlying soil has been mapped as a Pleistocene marine terrace deposit. This deposit generally comprises 2 feet of dark brown silty sand (SM) overlying 6 feet of stiff sandy clay (CH) and is known as the Battery formation (Davenport, 1982). Underlying the Battery formation within the lower cliff face and extending across the foreshore is massive, poorly bedded, Pliocene marine siltstone and shale, known as the St. George formation (Davenport, 1982).

## 3.0 BLUFF RETREAT FACTORS

### 3.1 Introduction

The erosion potential of a coast varies greatly from point to point and is dependent on a number of factors, which may include the following: (1) exposure of coastline to wave attack; (2) tides; (3) coastal type; (4) type of geologic material comprising the coast; (5) offshore relief; (6) effect of man-made structures; (7) longshore movement of beach material; (8) tectonic changes; and (9) proximity of rivers carrying sediment to the ocean (Adapted from King, 1959). The basic premise is that if the beaches below a coastal bluff are subject

to sand depletion due to a lack of material transport by the longshore current, then wave action will actively attack the coastal bluffs. Conversely, if the beaches are aggrading, then wave energy is expended in the constant redistribution of sediments.

Regional coastal bluffs in Crescent City are not all vertical. This is the result of both the regional geology and the intensity of various weathering processes that control the steepness and profile of cliffs. In this case, the sea cliffs are formed through the erosion of horizontally layered sedimentary rocks with large differences in how individual layers react to weathering processes. Under these conditions, the cliff erodes unevenly. When wave erosion results in abrasion that undercuts the base of the sea cliff, the eventual failure of the upper slope results in a steep to near-vertical face. However, even where the base of the slope is not undercut by wave action there could still be bluff retreat as continued erosion of the surface of the slope reduces the angle and results in sea cliffs that are more gently inclined.

### 3.2 Wave Climate

Coastal bluff retreat, or recession, is related to the interaction between the cliff face and the sea. It is therefore necessary to determine the wave climate and tides that interact with the cliff and exposed beach. The term "wave climate" describes the height, direction, and frequency of occurrence of waves caused by local winds and swell from distant storms. Incoming wave power is distributed among three recognizable "families" of waves, each with a particular season of effect and average angle of approach (Figure 3). The significant wave height is defined as the mean of the highest one-third of waves measured over a 20-minute period.

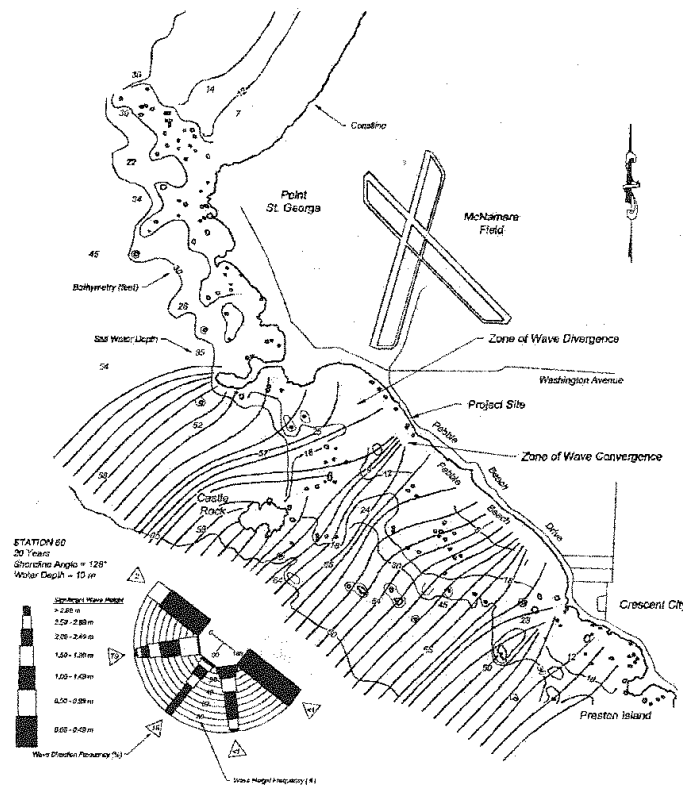

Figure 3: Significant Wave Height and Direction Crescent City, CA (after Jensen et al., 1989). Note: 1m = 3.28 ft.

From April to November, the dominant wave energy component in the Crescent City study area is the "prevailing swell". These waves are generated by storms in the north-central and northeastern Pacific. These waves are low energy wave forms, generally not higher than 9.8 feet and averaging under 3.3 feet high, and dominate the total wave power as a result of their long season of effect. The winter months, November through March, are characterized by very high energy "seas" which arrive from the south. These southwesterly waves average about 9.8 feet high and range up to 26 feet high. They are associated with winter storm fronts passing through the area. The southwesterly waves are expected to dominate bluff erosion forces.

A third group of waves arriving at the study area are seas generated by north-northwest winds, which occur most strongly in the months of May to August. This family of waves has an average deep-water approach direction of northwest to north-northwest and an average height of 3.2 to 6.4 feet with a maximum height of 16.4 feet. Southward littoral drift during the late spring and summer months is a result of this group of waves. The total wave-power of this northerly group is about equal to the total wave-power of the winter southerly waves.

### 3.3 Tides and Sea-level Rise

In contrast to the action of waves, tides describe the continual variation in the still water level (SWL, i.e., water level in the absence of waves) caused by the gravitational attraction of the sun and moon. Tides in the study area are mixed semi-diurnal, with a mean tidal range of approximately 5 feet and a maximum range of approximately 13 feet (NOAA, 2021). The tidal range influences beach processes because it determines the extent of beach exposure and inundation throughout the tidal cycle. Especially crucial to beach erosion episodes are the timing and height of the highest tides in conjunction with maximum wave height and surge developed during storms or tsunamis. A schematic illustration of the influence of the tidal cycle, waves, and tsunamis on Pebble Beach is presented in Figure 4.

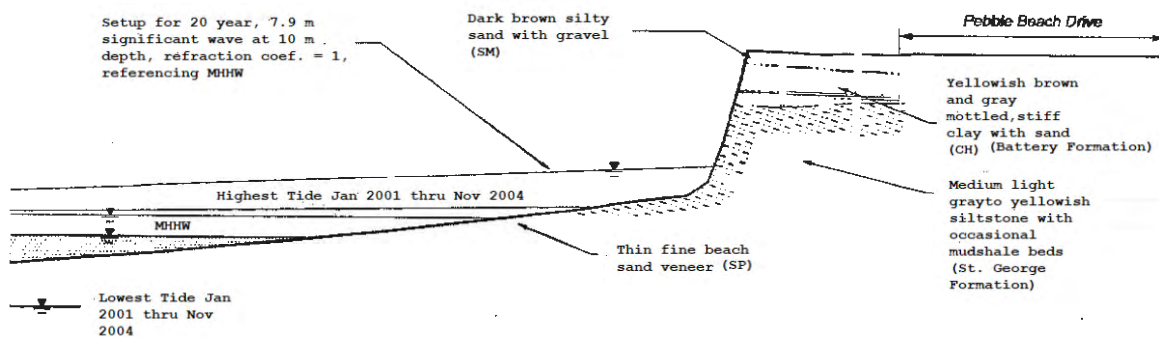

Figure 4: Typical Cliff and Foreshore Profile, Pebble Beach (Adapted from Devin, 2006. (Note that a 7.9 m "significant wave" is 26 feet, currently above the elevation of the adjacent Pebble Beach Drive.) A "significant" wave is the average height of the highest one-third of waves in the open sea.

Note that the still water level elevation will rise as sea level rises, moving the point at which waves attack the beach face closer to the base of the cliff. The beach face at both access locations is relatively shallow: approximately 4 percent at Wavecrest and 6 percent at Pebble Beach. This equates to the loss of an average of 50 feet of beach face between the two sites.

## 4.0 NORTHERN CALIFORNIA HISTORICAL BLUFF RETREAT

Sea cliff instability leading to recession is an episodic process that occurs when the driving forces exceed the resisting forces. Both the resisting forces (i.e., shear strength) and the driving forces (i.e., gravity, wave forces etc.) vary both in time and space. Due to the episodic nature of the loading conditions, recession rates in the short term (less than 5 to 10 years) are highly variable in contrast to average rates determined over the long term (greater than 50 years), which reach a steady state. In order to establish a baseline, we looked at changes in the rate of shoreline change for the northern California coast from Patrick's Point State Park to the Oregon border as presented in Figure 5 (Davenport, 1982). A review shows that the coast experiences both accretion and recession, depending on location. The Crescent City coastline (identified as Point St. George) is experiencing a recession rate varying from approximately 1.5 to 3.2 feet per year. Note that Figure 5 presents rates in meters per year. These recession rates are similar to those for the coastline adjacent to Patrick's Point state park where recession rates range from 0.8 to 2.6 feet per year (Chaney, 1988).

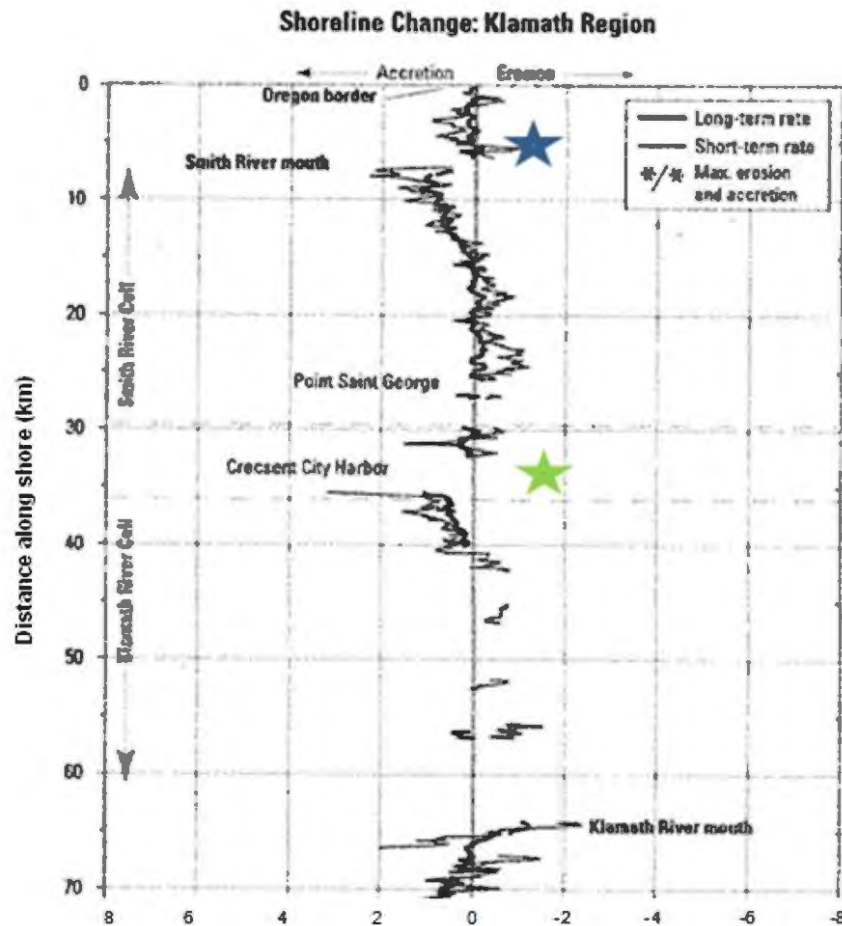

Figure 5: Shoreline Change Rates for the Klamath Region (after Davenport, 1982). Note that "accretion" indicates uplift, and "erosion" indicates recession. Blue star is the approximate location of the Wavecrest site and the green star is the approximate location of the Pebble Beach site.



An implication of a relatively stable rate of coastal bluff recession is that a constant amount of sediment is being transported along the coast by the longshore current, produced by angular wave approach to the coast. The prevailing southerly direction for California's longshore sediment transport is driven by a combination of the North Pacific swell and northwest wind waves. In addition, there are local reversals in this prevailing direction due to either the orientation of the coast and/or southerly wave events.

Sediment transport along the coast is described by looking at individual sections, termed littoral cells. Littoral cells are segments of the coast with distinct sediment sources, defined by longshore transport pathways, and sinks where the sediment is removed from the littoral system. The littoral cell boundaries delineate areas where the sediment budget can be balanced for quantitative analysis. The boundaries of littoral cells and coastal watersheds along the California coast are presented in Figure 6.

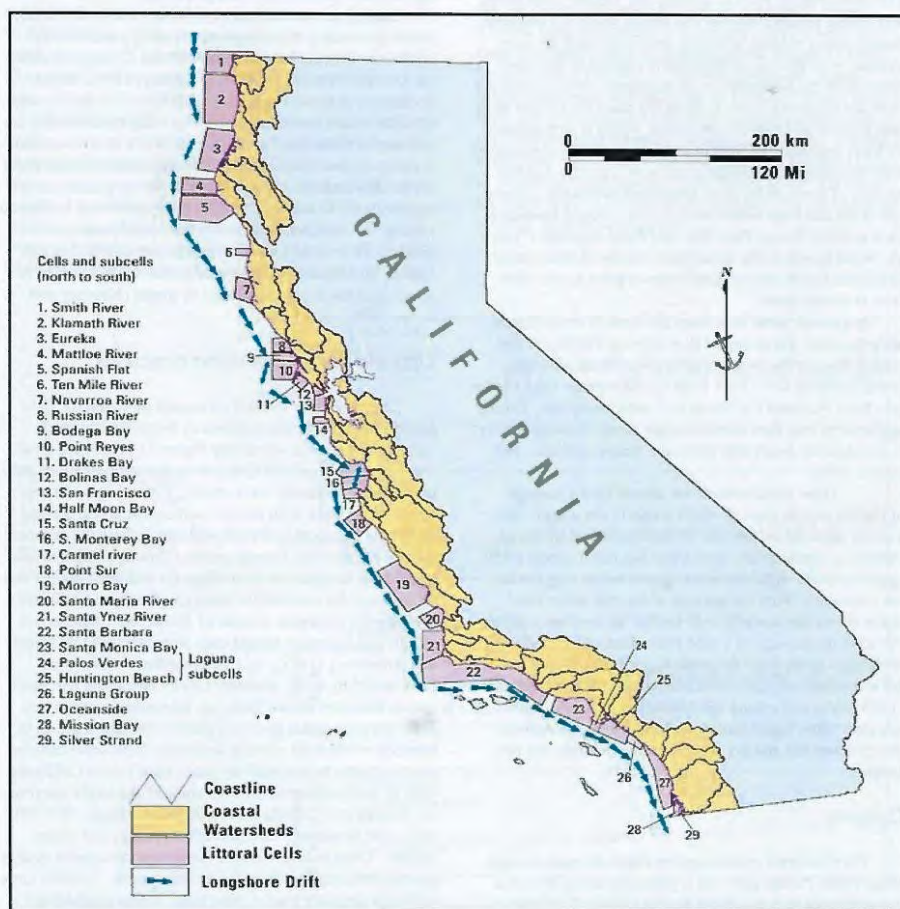

Figure 6: Major littoral cells, coastal watersheds, and conceptual net longshore drift directions for the California coast, modified from Habel and Armstrong (1977) and Hapke et al. (2006).

Figure 6 indicates that the project sites are within the Smith River (Wavecrest site) and Klamath River (Pebble Beach site) littoral cells. Longshore drift associated with the Smith and Klamath River systems is shown to flow both north and south. This combination of littoral drift and seasonal wave climate results in the generally observed pattern of beach aggradation in the winter and summer degradation.

The average annual sand and gravel discharge from the Smith River is estimated at just under 5 million cubic feet per year. (Hapke et al., 2006). In contrast, the annual sand and gravel discharge for the Klamath River is approximately 45 million cubic feet per year. (Hapke et al., 2006). The actual volume of sand and gravel entering the Smith River and Klamath River cells has not been determined.

## 5.0 BLUFF RETREAT EVALUATION

We estimated recession rates in our study areas based on scaling a combination of (1) USGS topographical maps for older time periods and (2) USGS topographical maps and Google Earth for the more recent past. Bluff retreat was estimated based on the distance from a landmark (centerline of an adjacent road) to the top of the coastal bluffs at known times. We then plotted this distance as a function of time to produce an approximate linear curve as presented in Charts 1 through 3 for our study areas. The slope of the linear plot produces an average historical recession rate that assumes that retreat has been constant over the period of time studied. In the following two sections, we discuss bluff recession at both Pebble Beach Drive Access and Wavecrest Drive Access.

### 5.1 Pebble Beach Drive Access Site

Bluff erosion at the Pebble Beach Drive access site has moved landward to an extent that threatens the stability of Pebble Beach Drive and the proposed beach access. This beach access is located between two parking areas south of McNamara Field. Sea cliffs in this area range from 20 to 25 feet in height (Figure 3).

We evaluated cliff retreat at the Pebble Beach access site using a combination of USGS topographic maps from 1956 through 2018. Results are presented in Chart 1 as the distance from the centerline of Pebble Beach Drive to the bluff edge as a function of time.

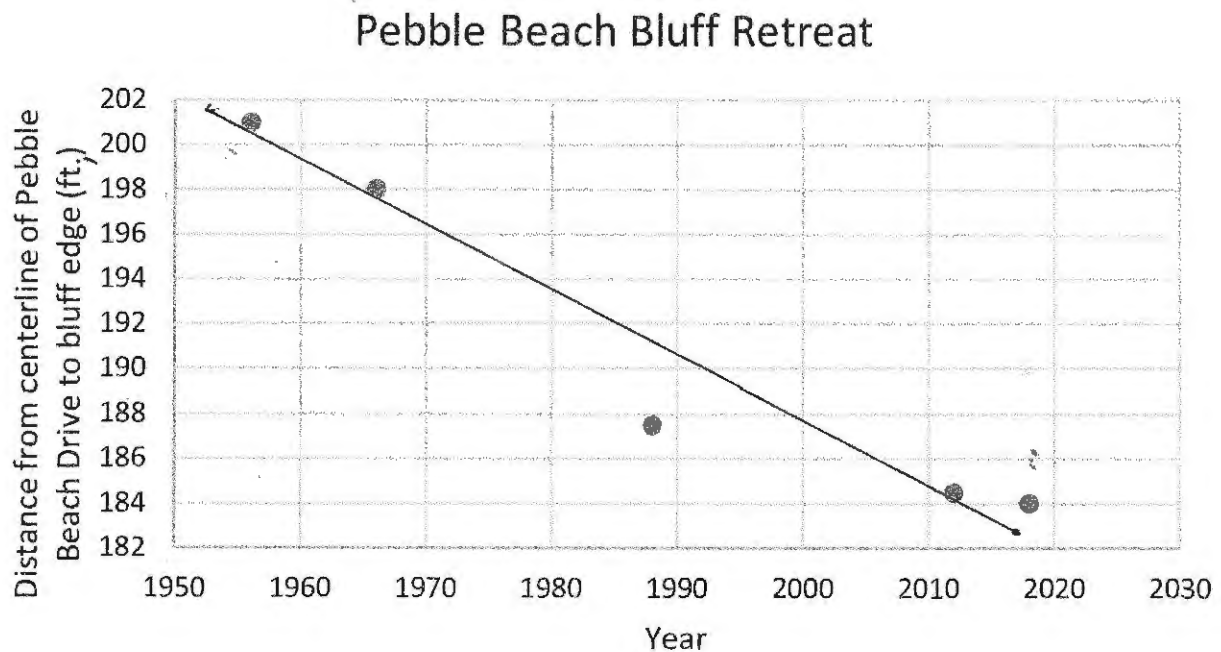

Chart 1: Distance from south shoulder of Pebble Beach Drive as a function of time, estimated retreat rate 0.27 feet per year.

Over the 62-year period of recorded data, we calculated an estimated recession rate of 0.27 feet per year. By projecting this recession rate into the future (i.e., 25 and 50 years) we can estimate the amount of bluff retreat that can be approximated. This estimate is presented in Table 1.

*Table 1. Bluff Retreat as a Function of Years at Pebble Beach Drive Access*

Recession Rate (feet per year)	Years	Total Recession (feet)
0.27	25	6.8
	50	13.5

A review of Table 1 shows that bluff retreat can potentially range up to 13.5 ft in 50 years. This is illustrated in Figure 7, which shows that by this time Pebble Beach Drive will be seriously impacted.



Figure 7: Graphic of estimated bluff retreat in 50 years. Red box is project area, blue line is existing bluff edge, yellow line is projected 50-year retreat extent.

## 5.2 Wavecrest Drive Beach Access

Bluff retreat at the Wavecrest Drive beach access site was evaluated using both USGS topographic maps and Google Earth from 1988 through 2016. Two sections were evaluated because of apparent differences in erosional behavior. The first section was along the existing access walkway that follows a gully. The second section was located approximately 330 feet north where no gully was present. Results are presented in Charts 2 and 3 as distance from the centerline of Highway 101 to the bluff edge as a function of time.

## Wavecrest Dr. Access Walkway Bluff Retreat

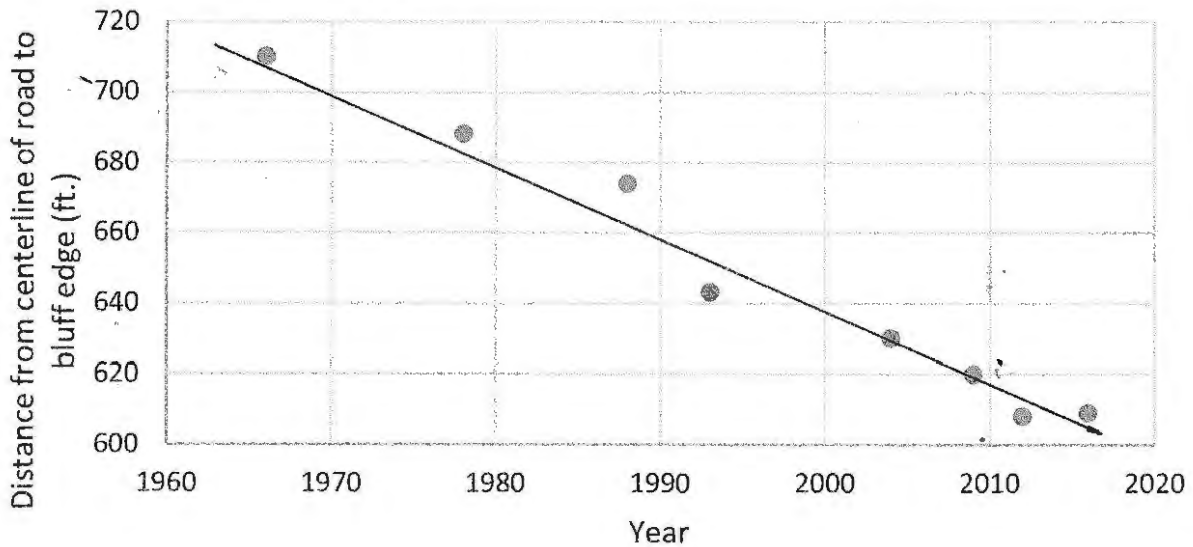

Chart 2: Wavecrest access walkway, distance from centerline of Hwy 101 as a function of time, estimated retreat 2.1 feet per year.

## Wavecrest Dr. Bluff Retreat

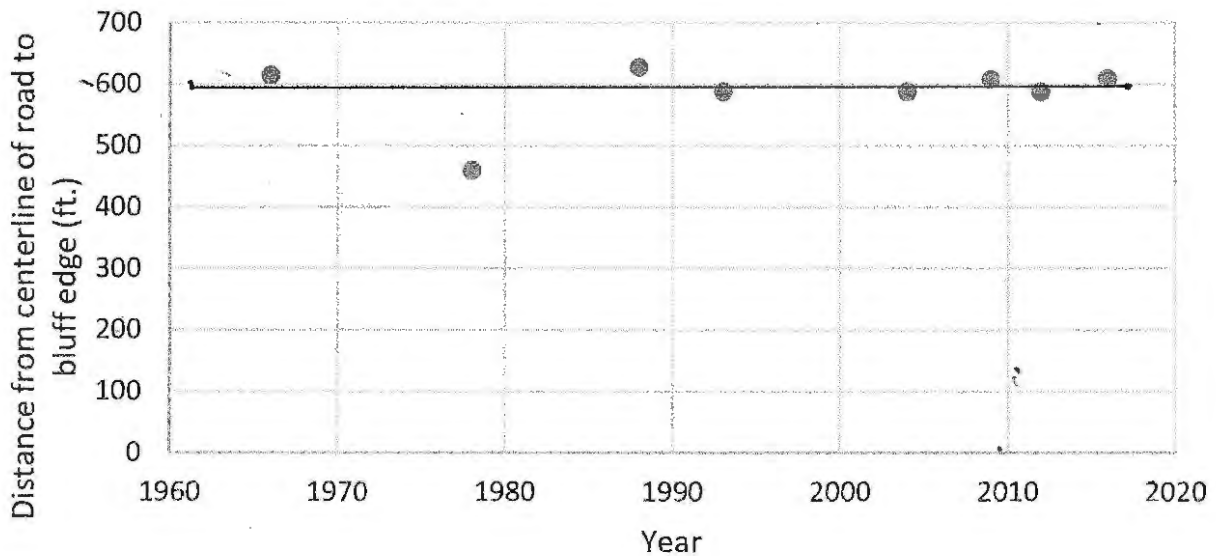

Chart 3: Wavecrest Dr. bluff, distance from centerline of Hwy 101 to edge of bluff, approximately 330 ft. north of beach access walkway. No apparent bluff retreat.

Over the 50-year period of recorded data an estimated recession rate of 2.1 feet per year was calculated for the section along the existing access walkway located in the gully (Chart 2). Projecting this recession rate into the future (i.e., 25 and 50 years) an estimate of the amount of bluff retreat can be approximated. This

estimate is presented in Table 2. A second section located approximately 330 feet north and east of the gully was also evaluated, as shown in Chart 3. A review of Chart 3 shows that there was no apparent bluff retreat at this location. Since the wave climate and overall shoreline aspect north and south of the gully are generally the same, the difference in bluff retreat rates at the two locations is believed due to the flow of water down the gully during storm events, which exacerbates erosion.

*Table 2. Bluff Retreat as a Function of Years at Wavecrest Access walkway*

Recession Rate (feet per year)	Years	Total Recession (feet)
2.1	25	52.5
	50	105

A review of Table 2 shows that bluff retreat can potentially range up to 52.5 ft in 25 years and 105 ft in 50 years. This estimate of bluff retreat is presented graphically in Figure 8, which shows that the access walkway will be impacted by bluff retreat (i.e., erosion) in the gully.



*Figure 8: Modified Google Earth image showing estimated retreat of the access walkway located in the gully in 50 years. Red outline is project area, blue line is existing bluff edge, yellow line is 50-year retreat extent. Note that the blue and yellow lines overlap north and south of the project area.*

## 6.0 DISCUSSION

As far back as geological records can be traced, there is evidence that the shorelines of the world are dynamic, subject to rises and falls in sea level, and elevations and depressions in landmasses. The project

sites are within the Smith River and Klamath River littoral cells. Longshore drift associated with both cells is shown to be going both north and south with both rivers having sand and gravel transport estimated in the ones to tens of millions of cubic feet.

The wave climate at the sites is controlled by seas during the winter months, November through March. This period is characterized by very high energy "seas" which arrive from the south. These southwesterly waves average about 9.8 feet high and significant waves up to 26 feet high. They are associated with winter storm fronts passing through the area. The southwesterly waves are expected to dominate bluff erosion processes.

Tides in the study area are mixed semi-diurnal, with a mean tide range of approximately 5 feet and a maximum tide range of approximately 13 feet (NOAA, 2021). The tidal range influences beach processes because it determines the extent of beach exposure and inundation throughout the tidal cycle. Especially crucial to beach erosion episodes are the timing and height of the highest tides in conjunction with maximum wave height and/or surge developed during storms or tsunamis.

When wave erosion results in abrasion that undercuts the base of the sea cliff, the result is eventual failure of the upper slope resulting in a steep to near-vertical face. In contrast, if the base of the slope is not undercut by wave action, then bluff retreat could result from erosion of the face of the slope. In time, continued erosion of the face of the slope reduces its angle and results in sea cliffs that are more gently inclined.

Based on sea level rise, local geology, beach erosion, and deposition, the estimated bluff retreat at Pebble Beach Drive access and Wavecrest Drive gully access is 0.27 feet per year and 2.1 feet per year, respectively. The bluffs north and south of the Wavecrest gully access do not appear to be retreating. The bluff retreat at the Pebble Beach access walkway is primarily by wave action. In contrast, the bluff retreat at the Wavecrest Drive gully access is probably controlled by a combination of wave action and erosion from flow in the gully during storm events.

## 7.0 CONCLUSIONS

- The estimated bluff recession rate at the Pebble Beach Drive access walkway is 0.27 feet per year. This results in an estimated bluff retreat of approximately 13.5 feet over 50 years. This bluff retreat is probably due to a combination of waves and storm events.
- The wave climate at the sites is controlled by seas during the winter months, November through March. This period is characterized by very high energy "seas" which arrive from the south. These southwesterly waves average about 9.8 feet high and range up to 26 feet high. Winter storms combined with high tidal range result in maximizing the energy available for erosion, and thereby, bluff retreat.
- The Wavecrest Drive access walkway estimated gully erosion is 2.1 feet per year. This erosion is probably caused by a combination of wave runup and gully flow during storm events.
- The bluff north of Wavecrest Drive access does not appear to be experiencing retreat.

## 8.0 LIMITATIONS

LACO has exercised a standard of care equal to that generated for this industry to ensure that the information contained in this technical memorandum is current and accurate. LACO disclaims any and all liability for any errors, omissions, or inaccuracies in the information and data presented in this technical memorandum and/or any consequences arising therefrom, whether attributable to inadvertence or otherwise. LACO makes no representations or warranties of any kind including, but not limited to, any implied

warranties with respect to the accuracy or interpretations of the data furnished. It is known that subsurface conditions may change with time and under anthropologic influences. LACO assumes no responsibility for any third-party reliance on the data presented. Data generated for this technical memorandum represent information gathered at that time and at the indicated locations. It should not be utilized by any third-party to represent data for any other time or location. This Technical memorandum is valid solely for the purpose, site, and project described in this document. Any alteration, unauthorized distribution, or deviation from this description will invalidate this technical memorandum.

## 9.0 REFERENCES

- Arcas, D., and Uslu, B. (2010). "A Tsunami Forecast Model for Crescent City, California," PMEL Tsunami Forecast Series: Vol. 2, NOAA.
- Chaney, R.C. (1988). "Coastal Bluff Retreat at Big Lagoon, California," Second International Conference on Case Histories in Geotechnical Engineering, June 1-5, St. Louis, Mo.: pp. 555-558.
- Davenport, C.W. (1982). "Geology and geomorphic features related to land sliding, Crescent City 7.5' Quadrangle, Del Norte County, California, California Department of Conservation, Division of Mines and Geology, OFR 82-21.
- Devin, S.C. (2006). "A Geomorphic Model for Coastal Cliff Recession near Crescent City, California," 40th Symposium on Engineering Geology and Geotechnical Engineering, Logan Utah, May 24-26: 12p.
- Google Earth (Imagery [www.google.com/maps/place/wavecrest+Dr.+California+95567](http://www.google.com/maps/place/wavecrest+Dr.+California+95567))
- Habel, JS and GA Armstrong. 1977. Assessment and Atlas Along the California Coast. Department of Navigation and Ocean Development.
- Hapke, C.J., Reid, D., Richmond, B.M., Ruggiero, P. and List, J. (2006). "National Assessment of Shore Line Change Part 3; Historical Shore Line Change and Associated Coastal Land Loss Along Sandy Shorelines of the California Coast," USGS Open-File Report 2006-1219, 72p.
- Jensen, R.E., Hubertz, J.M., and Payne, J.B. (1989) "WIS Report 17, Pacific Coast Hindcast Phase III North Wave Information. Coastal Engineering Research Center, Department of the Army, WES.
- King, C.A.M. (1959). Beaches and Coasts, Edward Arnold Publishers, London: 493 p.
- LACO Associates (2021) Sea-level Rise, Wavecrest Drive and Pebble Beach Drive Access Sites.
- NOAA (2021). [www.tidesandcurrent.noaa.gov/noaatidepredictions](http://www.tidesandcurrent.noaa.gov/noaatidepredictions). Accessed August 23, 2021.
- Russell, R.J. (1957). "Instability of Sea Level," American Scientist, Vol. 45, 5: pp 414-430.

## TECHNICAL MEMORANDUM

Revised - Relative Sea Level Changes  
Wavecrest Drive and Pebble Beach Drive Access Sites  
Crescent City, California

---

Date: May 9, 2022  
Project No.: 9790.00

Prepared For: County of Del Norte

Prepared By: Christine S. Manhart, CHG  
Principal Geologist  
CHG No. 1080, Exp 3/31/21

Reviewed By: Dr. Ronald C. Chaney, PE, GE  
Senior Geotechnical Engineer  
GE No. GE000934, Exp 3/31/21

---



*Christine S. Manhart*

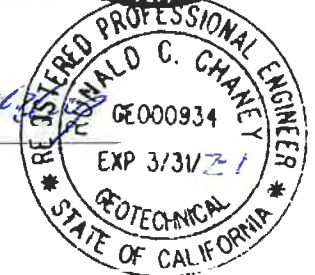

*Ronald C. Chaney*

### 1.0 INTRODUCTION

This report reviews the potential impacts of changes in global sea level to two coastal access sites in the County of Del Norte. The northernmost of the two sites, Wavecrest Drive access site, is intended to repair a coastal access route that was damaged by the tsunami resulting from the 2011 Tohoku earthquake in Japan. The second site, Pebble Beach Drive access site, is in the City of Crescent City, and is a new access location that is intended to provide Americans with Disability Act (ADA)-compliant access in an area where overall beach access is limited. Project implementation will require a Coastal Development Permit, partial fulfillment of which requires a review of potential sea level impacts. Figure 1 shows the locations of the two access sites.

This report reviews historical sea and land levels, projected future levels, and how those changes may impact future tides and storm surges to inform their potential to impact the project over a proposed 75-year lifespan.



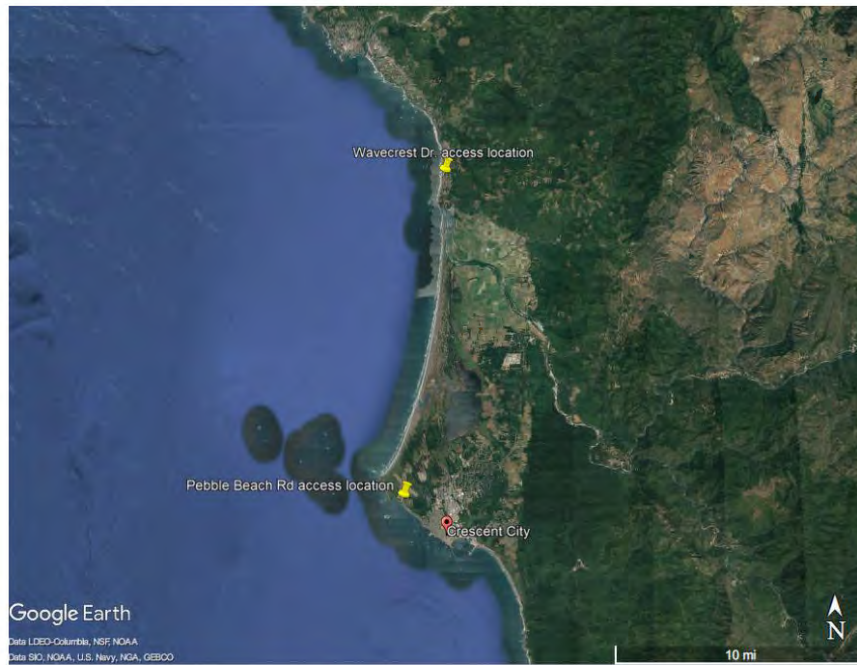

Figure 1: Access Point Location Map

## 2.0 RELATIVE SEA LEVEL CHANGES

### 2.1 Historical Relative Sea Level

Relative sea level change is a product both of changes in global sea level and those of the land surface. Global, or eustatic, sea level is affected by many factors, primarily ocean warming, which causes the seawater to expand, along with the melting of land/sea ice. Changes to the elevation of the land surface, or vertical land motion (VLM), is influenced by a combination of factors ranging from glaciers (due to the weight of the ice on the land), adjustments due to plate tectonics (seismic and inter-seismic rises and falls), and land subsidence (soil compaction, groundwater, and other fluid extraction). Relative sea level either rises if eustatic sea level is rising faster than VLM or falls if VLM rises faster than sea level.

Along the northern California coast, VLM is controlled primarily by the Cascadia subduction zone (CSZ), which ranges from Cape Mendocino to the Queen Charlotte Islands in British Columbia, Canada. The CSZ is the zone at which the North American plate is being subducted beneath the Gorda Plate offshore Northern California and the remnants of the Juan de Fuca Plate to the north. The act of subduction results in relatively little vertical land movement most of the time punctuated by a great deal during earthquakes. While the area between Cape Mendocino and approximately Humboldt Bay are generally rising as seismic stresses slowly relax during interseismic times, land levels near Crescent City are dropping. In Crescent City, this general negative VLM has resulted in falling sea levels in historical tide gauge data.

Figure 2 presents the monthly mean sea level without the regular seasonal fluctuations due to coastal ocean temperatures, salinities, winds, atmospheric pressures, and ocean currents. The plot presents the long-term linear trend as well as the 95 percent upper and lower confidence intervals.

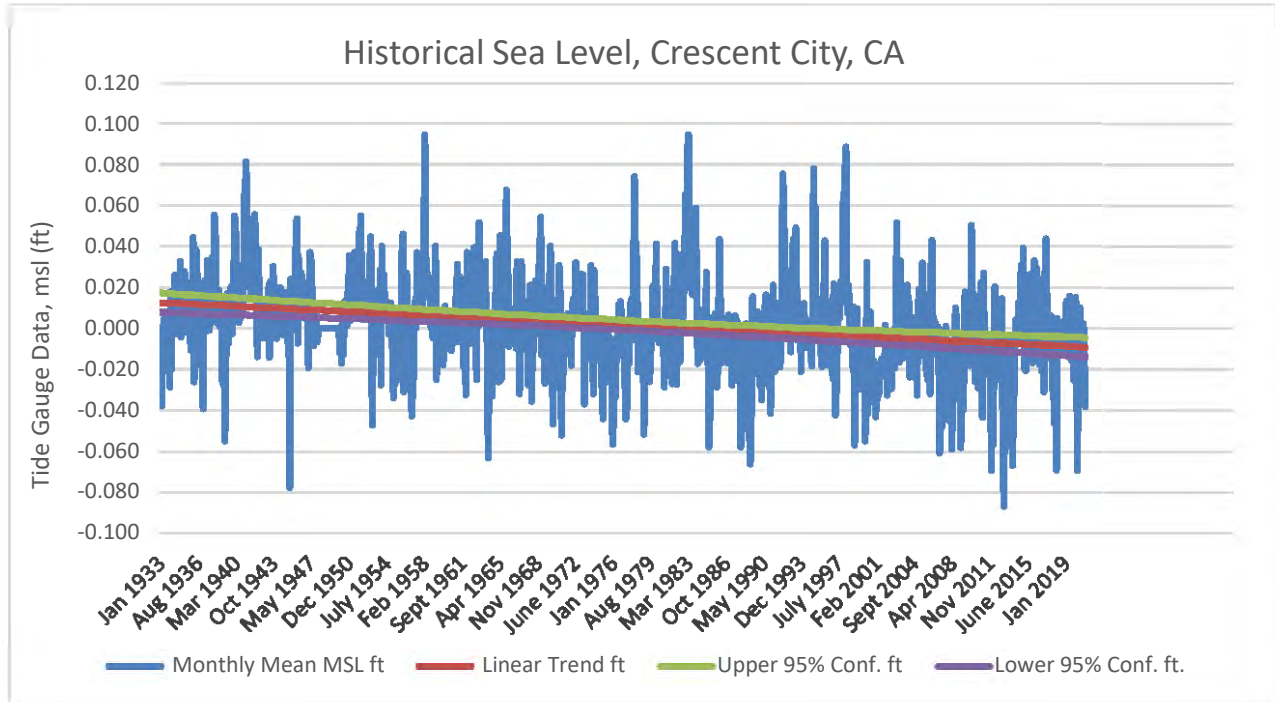

Figure 2: Monthly Mean Sea Level, Crescent City, CA (1933-2017)

Note: These data represent monthly mean sea levels with the average seasonal cycle removed. (NOAA, 2021)

As these data were collected from a land-based tide gauge, they represent relative sea level (i.e., the combination of both eustatic sea level and VLM). Over the 84 years of records, mean relative sea level change at the Crescent City tide gauge was  $-0.75 \pm 0.28$  millimeters per year (mm/yr), or  $-0.003 \pm 0.0009$  feet per year (ft/yr). This indicates an overall decline in relative sea level over the time period represented by these data.

Vertical land motion is the second part of the equation when examining changes in relative sea level. Continuous GPS (CGPS) records collected along the west coast since at least 2003 have been used to adjust tide gauge data by accounting for changes in land elevation (NAS 2012). The CGPS data station is located 10 kilometers (6.2 miles) from the Crescent City tide gauge and includes records from 1999. The VLM calculated for this time frame is  $2.60 \pm 0.40$  mm/yr ( $0.0085 \pm .001$  ft/yr).

While the VLM data include only approximately 20 years of records and tide gauge data are typically closer to 100 years, the National Academy of Science (NAS) research committee made the assumption that the rate of VLM has remained constant over the entire time frame. The tectonics that govern the behavior of the CSZ through multiple seismic events dating back 3,500 years have been studied since the 1990s (Atwater and Hemphill-Haley, 1997). The pattern of high amplitude seismic changes separated by slow elastic rebound during interseismic intervals over a timeframe of several hundred years per cycle gives validity to this assumption (Figure 3).

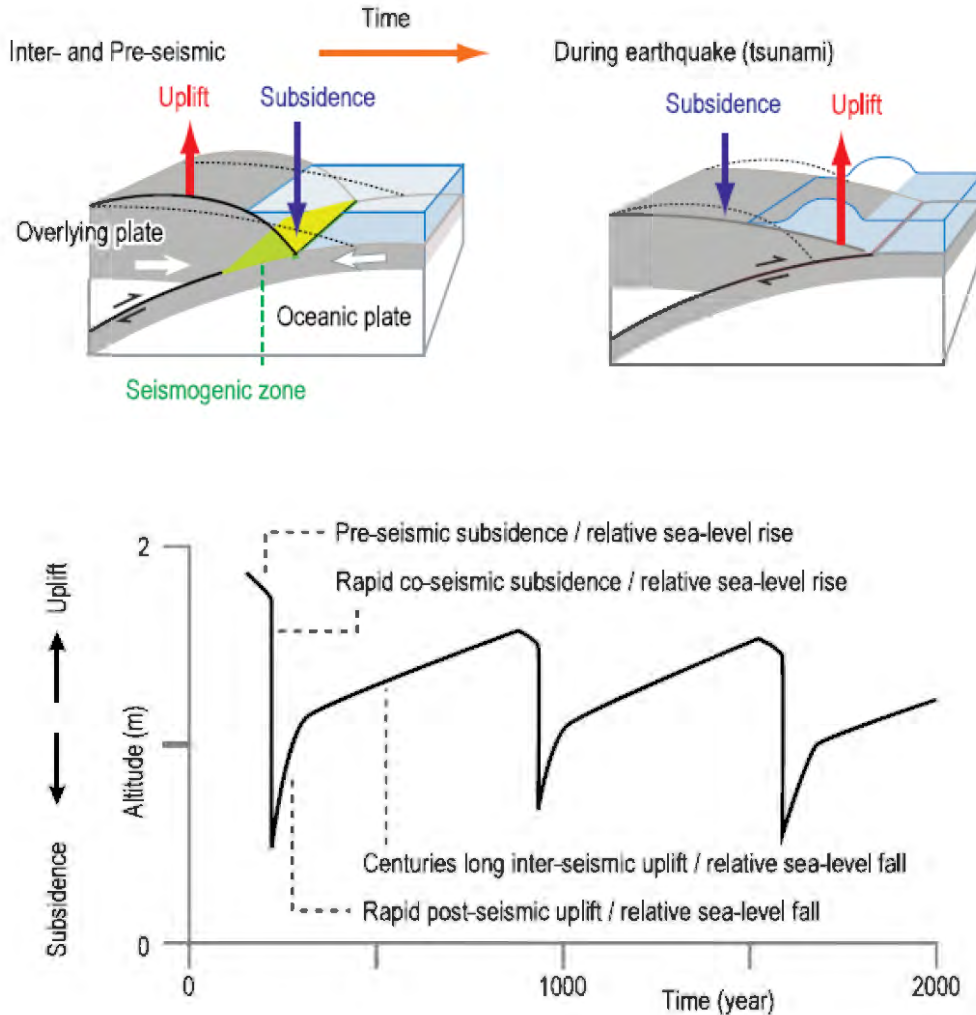

Figure 3: Historical VLM at Cascadia Subduction Zone (NAS 2012)

NAS (2012) used this deformation model to determine the rate of VLM at various locations along the U.S. west coast including Eureka, California and Coos Bay, Oregon. We interpolated between the values given for these cities and obtained a rate for Crescent City of 2.73 mm/yr (0.009 ft/yr). This falls within the range cited above using CGPS data and is the value we used in the remainder of this report.

## 2.2 Predicted Changes Due to Eustatic Sea Level Rise

The State of California Natural Resources Agency (NRC) published Sea-Level Rise Guidance (“Guidance”, 2018) to provide “a bold, science-based methodology for state and local governments to analyze and assess the risks associated with sea-level rise, and to incorporate sea-level rise into their planning, permitting, and investment decisions.” This Guidance provides potential rates of relative sea level change under a variety of scenarios. These include risk tolerance (low, medium-high, and extreme risk aversion) and greenhouse gas emissions (low and high emissions). Greenhouse gas emissions are important as the model indicates that the high emissions scenarios result in higher relative sea levels than the low emissions. The following discussion relies on data presented in the Guidance without verification of accuracy.

Relative sea levels for Crescent City were provided for the timeframe from 2030 through 2100 (NRC 2018). These values are shown in Table 1 below. Values for 2030, 2040, and 2050 include only the high emissions scenario; however, values corresponding to both high and low greenhouse gas emissions are provided for 2060 through 2150. Our evaluation of the potential sea level changes in Crescent City used the medium-high risk aversion scenario through 2100. While values are provided through 2150, the Guidance indicates that projections after 2100 should be used with caution due to increased uncertainty. We included the current values discussed above for 2020 and projections through 2100.

*Table 1: Relative Sea Level Change, 2020-2100*

Year	Relative Sea Level Change in feet (Low emissions)	Relative Sea Level Change in feet (High emissions)
2020	-0.002	-0.002
2030	0.409	0.409
2050	1.231	1.231
2070	2.400	2.800
2080	3.100	3.700
2100	4.800	5.900

From these data, the historical trend of falling relative sea levels caused by VLM outpacing changes in eustatic sea level are anticipated to reverse between 2020 and 2030. Based on these data, from that point through the end of the projection in 2100, relative sea level will continue to rise. The model diverges after 2050 to reflect the potential impacts of the two different greenhouse gas emissions scenarios. Figure 4, below, illustrates the projected changes in relative sea level.

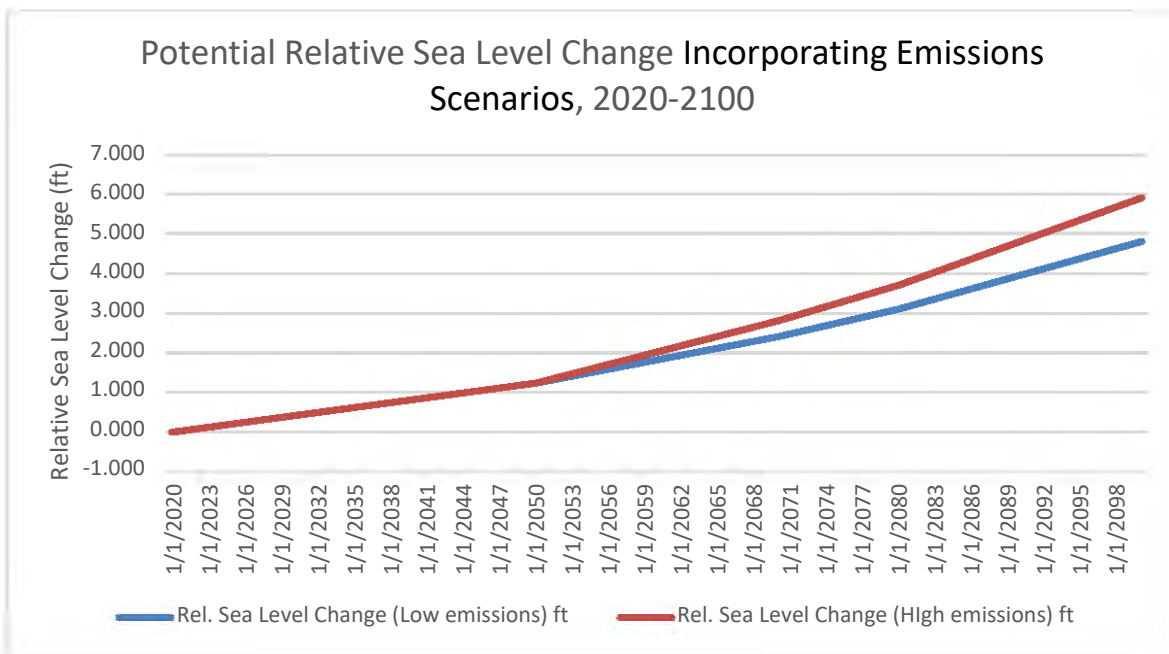

*Figure 4: Projected Relative Sea Level Changes, 2020-2100, Incorporating High and Low Emission Scenarios*

### 3.0 POTENTIAL IMPACTS

The effects of relative sea level rise locally include, among others, an increase in flooding due to seasonal storms and high tides, shoreline erosion, and saltwater intrusion, as well as an increase in the inundation zone due to tsunamis (PND 2019). Impacts due to tsunami inundation will be assessed in a separate memorandum. In order to demonstrate the potential impacts of sea level rise at the Wavecrest and Pebble Beach access points, we used an online tool created by NOAA to provide simulations of the extent of these effects for different values of sea level rise. The NOAA Sea Level Rise Viewer (Viewer) was developed by the NOAA Office for Coastal Management to allow coastal managers and planners to visualize various sea level rise scenarios both from a type of impact viewpoint as well as from a perceived level of risk. We used this tool to illustrate the potential impacts over a projected 50-year lifespan of the project and the more conservative high greenhouse gas emissions scenario and modeled a sea level rise of 2.8 feet by the year 2070.

The Viewer is limited to 10-year intervals and whole values of sea level rise. As the structures planned for in the two project locations are not habitable, we selected an intermediate-high-risk level in this assessment which yielded a 3 feet of projected sea level, rounding up from 2.8 feet, by the year 2070. In general, the areas most prone to impacts of sea level rise are the existing low-lying areas surrounding Elk Creek, Smith River, and Lake Earl.



Figure 5: Mapping Confidence (a) Pebble Beach Drive Access and (b) Wavecrest Drive Beach Access

The mapping confidence is based on the proximity of the tide gauge, in this case at the Crescent City Harbor, and the availability of continuous GPS data. At the scale of maps presented in Figures 5 through 8, the location of the tide gauge does not plot. Figure 5 illustrates the mapping confidence at the two project sites. Note that the mapping confidence is not high at either location and this may reduce the reliability of the following projections.

As described above, we are presenting the modeled impacts of a relative sea level rise of 3 feet msl by 2070. Figure 5 presents the anticipated area of impact. Degree of sea level rise is indicated by shades of blue, with lighter shades representing lower water depths. Sea level rise as visualized for both access locations indicate a fairly narrow light blue band, with a slightly higher degree of impact associated with the Wavecrest Drive location.



Figure 6: Area of Impact for Relative Sea Level Rise of 3 feet msl, (a) Pebble Beach Drive Access and (b) Wavecrest Drive Beach Access



Figure 7: Area of Impact High Tide Flooding, (a) Pebble Beach Drive Access and (b) Wavecrest Drive Beach Access

Figure 7 presents the anticipated area of impact due to high tide flooding, with those areas anticipated to experience shallow coastal flooding associated with high tides are indicated in red. Once again, the Wavecrest Drive location is predicted to experience flooding to a greater height than the Pebble Beach site. Coastal flooding due to high tide will occur more frequently as sea level rises and the magnitude of high tide increases

The highest storm surge recorded in the Crescent City tide gauge between 1951 and the present was a height of 2.17 feet above msl recorded on January 29, 1983. This storm surge, if coincident with a sea level rise of 5 feet, would result in inundation approximately 7 feet above current conditions.

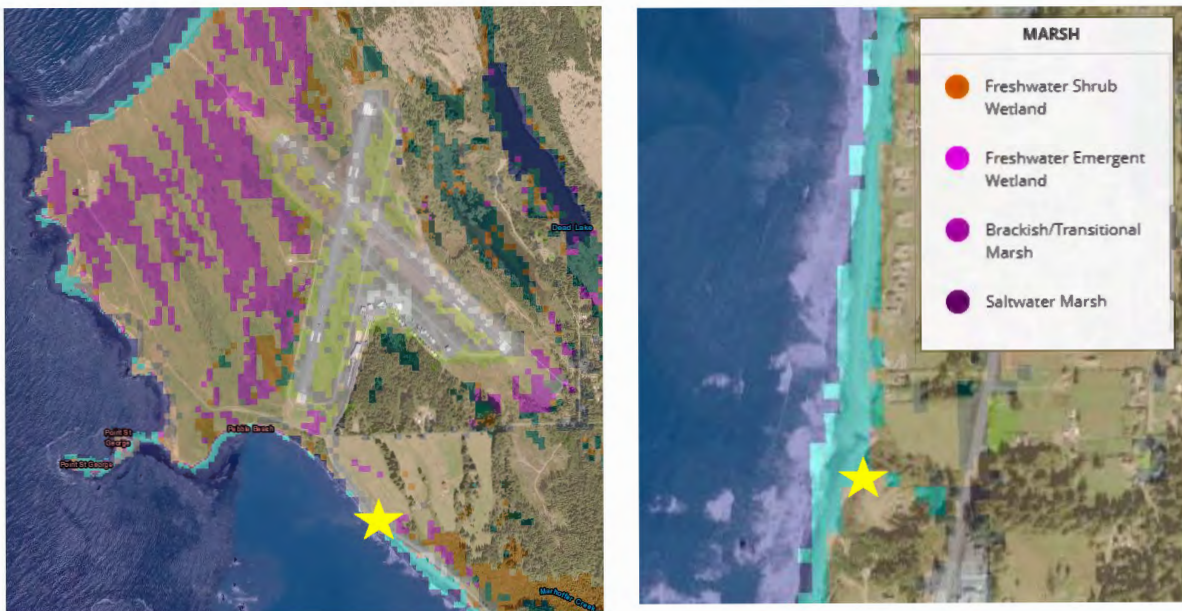

Figure 8: Areas of Marsh Migration, (a) Pebble Beach Drive Access and (b) Wavecrest Drive Beach Access Locations

Figure 8 illustrates fresh, salt, and brackish/transitional marsh migration. In this figure, light blue indicates unconsolidated beach sand. With rising sea level, freshwater marshes are pushed inland and are overtaken by brackish and saltwater marshes.

## 4.0 CONCLUSION

Historical tide gauges measurements and research on changes in VLM at the project locations, combined with future projections of sea level under low and high greenhouse gas emission scenarios, indicate a potential relative sea level rise of approximately 3 to 5 feet msl by year 2100. Assuming a project lifespan of 50 years and the data input requirements of the NOAA Sea Level Rise Visualizer, we used an expected sea level rise 3 feet by the year 2070. The primary effects of sea level rise at the project locations by 2070 are identified as the following:

- Pebble Beach Drive – shallow coastal flooding associated with high tides; and,
- Wavecrest Drive – increased water levels due to sea level rise, shallow coastal flooding associated with high tides, and marsh migration.
- Inundation due to storm events will be exacerbated at both location with rising sea levels.

## 5.0 REFERENCES

- Atwater, B. and E. Hemphill-Haley. 1997. Recurrence Intervals for Great Earthquakes of the Past 3,500 years at Northeastern Willapa Bay, Washington. US Geological Survey Professional Paper 1576. US Government Printing Office, Washington D.C., 108 pp.
- National Oceanic and Atmospheric Agency (NOAA). Tides and Currents, Crescent City California Tide Gauge No. 9419750. Accessed 1/4/2021.  
[https://tidesandcurrents.noaa.gov/sltrends/sltrends\\_station.shtml?id=9419750](https://tidesandcurrents.noaa.gov/sltrends/sltrends_station.shtml?id=9419750)
- Ibid. Sea Level Rise Viewer. Crescent City tide gauge. Accessed 1/19/21.  
<https://coast.noaa.gov/slr/#/layer/slr/0/-13795063.467339959/5125122.28856575/10/satellite/75/0.8/2050/interHigh/midAccretion>
- Ibid. Tides and Currents, Crescent City tide gauge, Extreme Water Levels. Accessed 2/3/21.  
<https://tidesandcurrents.noaa.gov/waterlevels.html?id=9419750&units=standard&bdate=19830125&edate=19830202&timezone=GMT&datum=MSL&interval=h&action=>
- National Research Council 2012. Sea-Level Rise for the Coasts of California, Oregon, and Washington: Past, Present, and Future. Washington, DC: The National Academies Press.  
<https://doi.org/10.17226/13389>.
- PND Engineers, Inc., 2019. Draft AB 691 Sea-Level Rise Assessment for Crescent City State Lands. Submitted to City of Crescent City.
- State of California Natural Resource Conservancy (NRC), Sea-Level Rise Guidance, 2018 Update. Sacramento, California.



# Revised - Tsunami Runup

## Wavecrest Drive and Pebble Beach Coastal Access Plan Del Norte County Community Development Department

May 16, 2022

Prepared for:  
DNCDD

Prepared By:  
LACO Associates, Inc.  
21 W Fourth Street  
Eureka, California 95501  
707-443-5054

Project No. 9790.00

# LACO

advancing the  
quality of life for  
generations to come

Design  
Planning  
Engineering  
Geology and Geotechnical  
Environmental Science  
Materials Testing  
Survey

800 515-5054  
www.lacoassociates.com  
Eureka | Ukiah | Santa Rosa

  
Dr. Ron C. Chaney, PE, GE  
Senior Geotechnical Engineer  
No. GE000934 Exp. 3/31/23



  
Christine S. Manhart, CHG  
Principal Geologist  
CHG No. 1080; Exp. 03/31/23



## 1.0 INTRODUCTION

This report reviews the potential impacts of Tsunami Runup of two coastal access sites in the County of Del Norte. The northernmost of the two sites, Wavecrest Drive access site, is intended to repair a coastal access route that was damaged by the tsunami resulting from the 2011 Tohoku earthquake in Japan. The second site, Pebble Beach Drive access site, is in the City of Crescent City, and is a new access location that is intended to provide Americans with Disability Act (ADA)-compliant access in an area where overall beach access is limited. Project implementation will require a Coastal Development Permit, partial fulfillment of which requires a review of potential bluff retreat impacts. Figure 1 shows the locations of the two access sites.

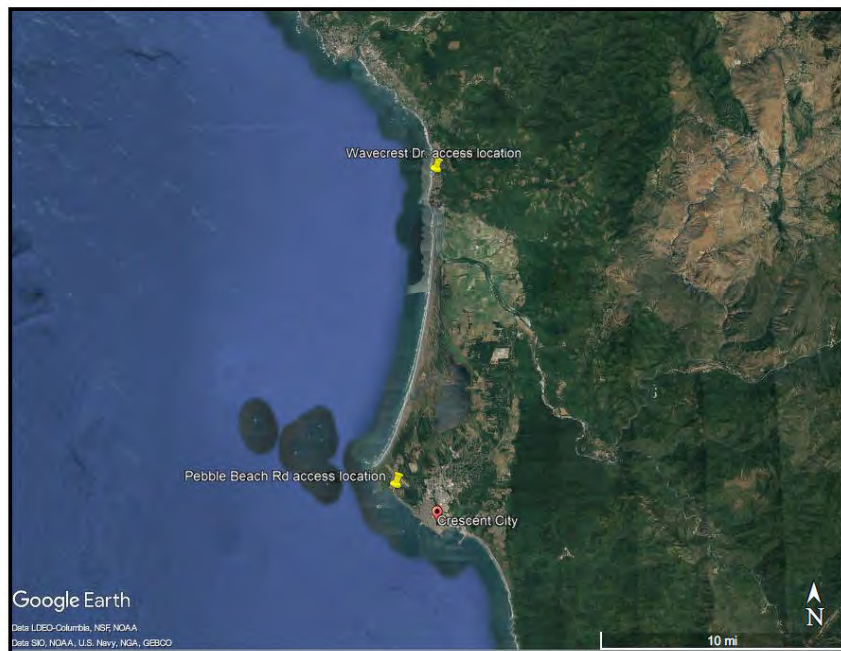

Figure 1: Access point locations

This report reviews historical tsunamis in Crescent City with regard to potential tsunami inundation zones and tsunami runup to inform their potential to impact the project over a proposed 75-year lifespan.

## 2.0 SEISMIC SEA WAVES

Tsunamis or seismic sea waves are impulsively generated, dispersive waves of relatively long period and low amplitude. These waves are typically generated by sudden large scale sea floor movements usually associated with severe, shallow focus earthquakes. Typically, an earthquake of at least 6.5 to 7.0 moment magnitude and with focal depths of less than 30 to 40 miles is required to initiate such sea floor movements. Tsunamis may also be generated by underwater landslides, volcanoes, or explosions.

An example of a largescale sea floor movement is a simple fault in which tension in the basement rock is relieved by the abrupt rupturing of the rock along an inclined plane. When such a rupture occurs, a large

mass of rock and sediment drops rapidly, and the support is consequently removed from a column of water that extends to the surface. The water surface oscillates up and down as it seeks to return to mean sea level, and a series of waves are produced. In contrast, a tsunami can also be generated if the basement rock fails in compression, the mass of rock on one side rides up and over that of the other, and a column of water is lifted.

Another mechanism is landslide or mass movement that is initiated by an earthquake. If the slide begins above the water, abruptly depositing a mass of rock and soil into the sea, waves are generated. Slides occurring well below the surface of the sea can also create waves. Tsunamis can be highly destructive, especially at certain locations prone to tsunami run-up. They are almost undetectable at sea because of their long wavelengths and with periods of a few minutes to an hour or more and heights of only 1 or 2 feet or less. However, when they approach shallow water, shoaling, refraction, and possible resonant effects can cause run-ups of from several feet to upwards of approximately 106 feet or more, depending on the tsunami's characteristics and the local topography. Tsunamis are often observed as a series of highly periodic surges that can continue over a period of several hours (Chaney, 2021; Dengler et al., 2021).

The damage due to a tsunami is normally from large hydrostatic and hydrodynamic forces along with the impact of water borne objects, overtopping with subsequent flooding and erosion caused by the highwater velocities. The characteristics of tsunami of interest are primarily those associated with the nearshore environment. These characteristics are (1) run-up heights, (2) surge or bore velocities, and (3) return period.

## 3.0 TSUNAMIS IN CRESCENT CITY

### 3.1 Historical Tsunamis

Since 1933, 31 tsunamis have been observed in Crescent City. Four of those caused damage, and one of them, in March 1964, remains the "largest and most destructive recorded tsunami to ever strike the United States Pacific Coast," (University of Southern California's Tsunami Research Center). The 1964 tsunami killed 17 people on the West Coast, 11 of them in Crescent City.

The 1964 tsunami was caused by the largest earthquake ever recorded in North America (Wilson and Torum, 1968). The so-called Good Friday Earthquake struck during late afternoon on March 29, its epicenter was just north of Alaska's Prince William Sound, registered a Moment Magnitude of 9.2 and killed 115 Alaskans, inflicting its worst damage on Anchorage. All but nine of the deaths were caused not by the earthquake itself, but by the tsunami that resulted. (The tsunami also hit Canada, but no one there was killed.)

After Alaska, the state worst-hit by the 1964 wave was California, where the tsunami hit a little before midnight. Total property damage there was \$17 million (Oregon and Washington each sustained less than \$1 million), of which fully \$15 million occurred in Crescent City. Although the earthquake killed many more people in Alaska than in Crescent City, the property damage was greater in Crescent City. A listing of recent tsunamis to hit Crescent City is presented in Table 1.

Table 1. Recent Tsunamis in Crescent City

Year	Wave Height (ft.)	Associated Earthquake	Magnitude (M <sub>w</sub> )
1960	Approx. 3	Valdivia (Chilean),	9.5
1964	21	Alaskan ("Good Friday")	9.2
Est. 2006	5.8	Kuril Islands, Japan,	8.3
2011	6.5	Tohoku (Fukushima), Japan	9.0

### 3.2 Future Tsunamis

Crescent City is presumed to be more vulnerable to tsunamis than any other city along the West Coast of the United States, based on frequency and severity of impact from past events. Tsunami waves tend to be amplified in the area around Crescent City, and the observed wave heights in Crescent City Harbor are typically an order of magnitude greater than those measured in other locations along the West Coast. The reasons for amplification of tsunami waves have not been clearly identified, though most evidence points to the combined effect of three factors: (1) The presence of the Mendocino Escarpment, an abrupt 1,000-meter seafloor depth-discontinuity immediately offshore of the Northern California coast, with the potential for channeling tsunami energy (i.e. waves) toward Crescent City and into shallower water where the waves pick up speed as they approach the mainland; (2) The tendency of the Crescent City Harbor to amplify those waves with frequencies around the 20-minute period; and (3) The combination of geology and tectonics that has thrust Point St. George out into the ocean and created a natural south facing crescent-shaped bay that funnels tsunamis from all directions into the harbor area (Dengler et al., 2015). These three factors may be the most likely cause of elevated tsunami wave heights observed in the area.

A number of studies have been conducted to look at potential flooding due to tsunami runup in Del Norte County. Figures below present the latest estimate of tsunami runup at the Wavecrest access location (Figure 2) and for the Pebble Beach access location (Figure 3). These figures were released by the California Geological Survey in 2021 and represent the results of modeling to determine which of all potential earthquake sources were the ones most likely to result in a damaging earthquake. In Crescent City, these are primarily earthquakes on the Alaskan and Cascadian subduction zones. California Geological Survey (CGS) models used an average return period of 975 years, which represents a two percent risk of recurrence every 19.5 years.

Each access site was recently surveyed as a separate scope of work under this project. To determine the extent of tsunami runup at both locations, we projected a line perpendicular to the shoreline through the access point to the edge of the projected runup and obtained an approximate elevation at that point using Google Earth. Ground surface elevation at the Wavecrest Beach access point is 25 feet referenced to the North American Vertical Datum 1988 (NAVD88). As illustrated in Figure 2, tsunami runup is anticipated to extend approximately 700 feet inland to an elevation of approximately 57 feet. This runup extends beyond U.S. Highway 101 and into the development to the east of the highway.

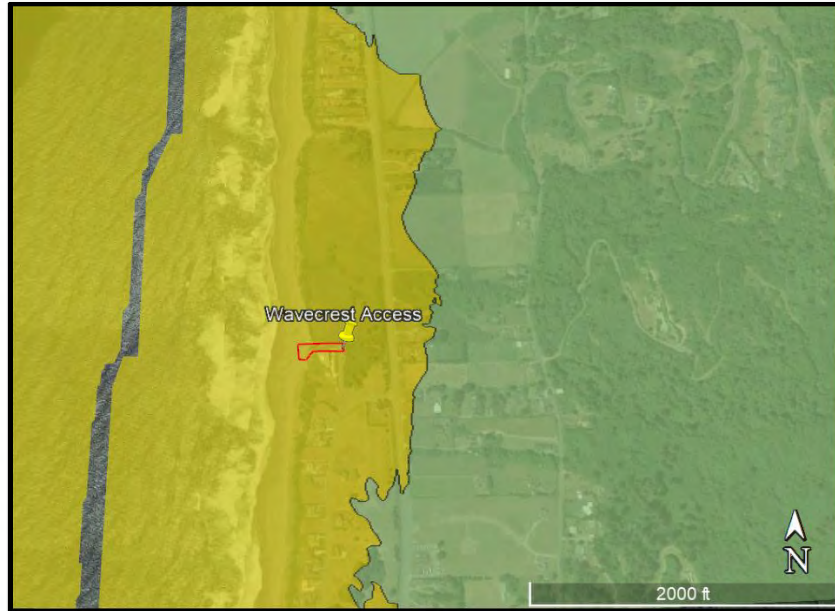

Figure 2: Projected tsunami runup, Wavecrest Beach access point (CGS, 2021)

The Pebble Beach Access point as shown in Figure 3 was determined to have an elevation of 20 feet NAVD88. Tsunami runup at this location is estimated to extend approximately 1,250 feet to an elevation of approximately 57 feet NAVD88.

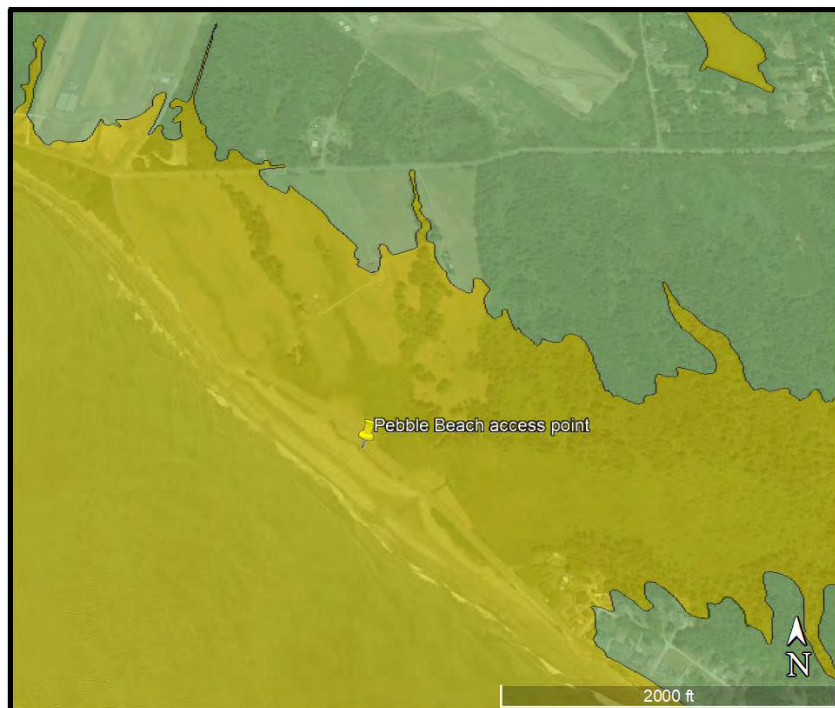

Figure 3: Projected tsunami runup, Pebble Beach access point (CGS, 2021)

## 4.0 DISCUSSION

Crescent City is presumed to be more vulnerable to tsunamis than any other city along the West Coast of the United States. This observation is based on frequency and severity of impacts from past events. Tsunami waves tend to amplify in the area around Crescent City, and the observed wave heights in Crescent City Harbor are typically an order of magnitude greater than those measured in other locations along the West Coast. This is due to a combination of regional geology and topography of the harbor area. The characteristics of a tsunami that are primarily interest are those associated with the nearshore environment. These characteristics are (1) run-up heights, (2) surge or bore velocities, and (3) return period.

Tsunami runup in both access point locations extends to an elevation of approximately 57 feet NAVD88 using CGS models as guidance. Due to variations in topography, this elevation change equates to a runup of approximately 700 feet at the Wavecrest Beach access point and 1,250 feet at the Pebble Beach access point. The CGS model calculated the risk of this degree of tsunami runup occurring as 2 percent within 19.5 years, which correlates to approximately 5 percent over a 50-year project lifespan or 7.5 percent over a 75-year project lifespan.

## 5.0 CONCLUSIONS

- Ground surface elevation at the Wavecrest Beach Access point is 25 feet referenced to the North American Vertical Datum 1988.
- The tsunami run-up at the Wavecrest Drive Access location is anticipated to extend approximately 700 feet inland to an elevation of approximately 57 feet. This run-up extends beyond U.S. Highway 101 and into the development to the east of the highway.
- The Pebble Beach Access point was determined to have an elevation of 20 feet.
- The tsunami run-up at the Pebble Beach Drive Access location is anticipated to extend inland approximately 1,250 feet to an elevation of approximately 57 feet. This runup extends beyond Pebble Beach Drive and into the development to the north-east.
- The risk of the projected degree of tsunami run-up occurring at both locations as 2 percent within 19.5 years, which correlates to approximately 5 percent over a 50-year project lifespan or 7.5 percent over a 75-year project lifespan.

## 6.0 LIMITATIONS

LACO has exercised a standard of care equal to that generated for this industry so that the information contained in this technical memorandum is current and accurate. LACO disclaims any and all liability for any errors, omissions, or inaccuracies in the information and data presented in this technical memorandum and/or any consequences arising therefrom, whether attributable to inadvertence or otherwise. LACO makes no representations or warranties of any kind including, but not limited to, any implied warranties with respect to the accuracy or interpretations of the data furnished. It is known that subsurface conditions may change with time and under anthropologic influences. LACO assumes no responsibility for any third-party reliance on the data presented. Data generated for this technical memorandum represent information gathered at that time and at the indicated locations. It should not be utilized by any third-party to represent

data for any other time or location. This Technical memorandum is valid solely for the purpose, site, and project described in this document. Any alteration, unauthorized distribution, or deviation from this description will invalidate this technical memorandum.

## 7.0 REFERENCES

- California Geological Survey (2021). [www.conservation.ca.gov/cgs/tsunami/maps/del-norte](http://www.conservation.ca.gov/cgs/tsunami/maps/del-norte)
- Chaney, R.C. (2021) Marine Geology and Geotechnology of the South China Sea and Taiwan Strait, CRC Press: 246p.
- Dengler, L. & Goltz, James & Fenton, Johanna & Miller, Kevin & Wilson, Rick. (2021). Building tsunami-resilient communities in the United States: An example from California.
- Dengler, L., Barberopoulou, A., Uslu, B., and Yim, S. (2015) Tsunami damage in Crescent City, California from the November 15, 2006 Kuril event. In: Cummins P.R., Satake K., Kong L.S.L. (eds) Tsunami Science Four Years after the 2004 Indian Ocean Tsunami. Pageoph Topical Volumes. Birkhäuser Basel. [https://doi.org/10.1007/978-3-0346-0064-4\\_3](https://doi.org/10.1007/978-3-0346-0064-4_3).
- Wilson, B.W. and Torum, A. (1968). The Alaskan Tsunami of March 1964: Engineering Evaluation Technical Memorandum No. 25, Coastal Engineering Research Center, Corps Engrs., U.S. Army, Wash., D.C., 1966.