

---

# **Appendix G**

## Storm Water Quality Management Plan (SWQMP)



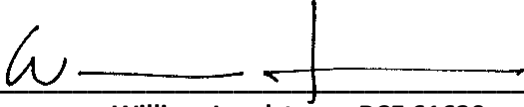
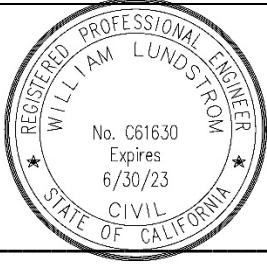

<b>CITY OF SAN MARCOS</b>	
<b>PRIORITY DEVELOPMENT PROJECT (PDP)</b>	
<b>STORM WATER QUALITY MANAGEMENT PLAN (SWQMP)</b>	
<b>FOR</b>	
<b>PACIFIC</b>	
<b>[INSERT PERMIT APPLICATION NUMBERS]</b>	
<b>Las Posas Road</b>	
<b>San Marcos, CA 92078</b>	
<b>ASSESSOR'S PARCEL NUMBER(S):</b>	
<b>219-222-01, 219-222-02, 219-222-03, 219-222-04</b>	
<b>ENGINEER OF WORK:</b>	
	
<b>William Lundstrom, RCE 61630</b>	

**PREPARED FOR:**

The Las Posas Project Owner LPV, LLC a Delaware  
Limited Liability Company.  
703 Palomar Airport Road, Suite 170  
Carlsbad, CA 92011  
760-944-7511

**PDP SWQMP PREPARED BY:**

Lundstrom Engineering & Surveying, Inc.  
3333 Camino Del Rio South, Suite 330  
San Diego, CA 92108  
619-814-1220

**DATE OF SWQMP:**  
02/16/2023

**PLANS PREPARED BY:**  
Lundstrom Engineering & Surveying, Inc. 3333  
Camino Del Rio South, Suite 330 San Diego, CA  
92108  
619-814-1220

Page intentionally blank

## **TABLE OF CONTENTS**

- Acronym Sheet
- PDP SWQMP Preparer's Certification Page
- PDP SWQMP Project Owner's Certification Page
- Submittal Record
- Project Vicinity Map
- FORM I-1 Applicability of Storm Water BMP Requirements
- FORM I-2 Project Type Determination Checklist (Standard Project or PDP)
- FORM I-3B Site Information Checklist for PDPs
- FORM I-4 Source Control BMP Checklist for All Development Projects
- FORM I-5 Site Design BMP Checklist for All Development Projects
- FORM I-6 Summary of PDP Structural BMPs
- Attachment 1: Backup for PDP Pollutant Control BMPs
  - Attachment 1a: DMA Exhibit
  - Attachment 1b: Tabular Summary of DMAs and Design Capture Volume Calculations
  - Attachment 1c: Harvest and Use Feasibility Screening (when applicable)
  - Attachment 1d: Categorization of Infiltration Feasibility Condition (when applicable)
  - Attachment 1e: Pollutant Control BMP Design Worksheets / Calculations
- Attachment 2: Backup for PDP Hydromodification Control Measures
  - Attachment 2a: Hydromodification Management Exhibit
  - Attachment 2b: Management of Critical Coarse Sediment Yield Areas
  - Attachment 2c: Geomorphic Assessment of Receiving Channels
  - Attachment 2d: Flow Control Facility Design
- Attachment 3: Structural BMP Maintenance Plan
  - Attachment 3a: B Structural BMP Maintenance Thresholds and Actions
  - Attachment 3b: Draft Maintenance Agreement (when applicable)
- Attachment 4: Copy of Plan Sheets Showing Permanent Storm Water BMPs

## ACRONYMS

APN	Assessor's Parcel Number
BMP	Best Management Practice
HMP	Hydromodification Management Plan
HSG	Hydrologic Soil Group
MS4	Municipal Separate Storm Sewer System
N/A	Not Applicable
NRCS	Natural Resources Conservation Service
PDP	Priority Development Project
PE	Professional Engineer
SC	Source Control
SD	Site Design
SDRWQCB	San Diego Regional Water Quality Control Board
SIC	Standard Industrial Classification
SWQMP	Storm Water Quality Management Plan

**PDP SWQMP PREPARER'S CERTIFICATION PAGE**

**Project Name: Pacific**  
**Permit Application Number:**

**PREPARER'S CERTIFICATION**

I hereby declare that I am the Engineer in Responsible Charge of design of storm water best management practices (BMPs) for this project, and that I have exercised responsible charge over the design of the BMPs as defined in Section 6703 of the Business and Professions Code, and that the design is consistent with the PDP requirements of the [INSERT AGENCY NAME] BMP Design Manual, which is a design manual for compliance with local [INSERT AGENCY NAME] and regional MS4 Permit (California Regional Water Quality Control Board San Diego Region Order No. R9-2015-0100) requirements for storm water management.

I have read and understand that the [City Engineer] has adopted minimum requirements for managing urban runoff, including storm water, from land development activities, as described in the BMP Design Manual. I certify that this PDP SWQMP has been completed to the best of my ability and accurately reflects the project being proposed and the applicable BMPs proposed to minimize the potentially negative impacts of this project's land development activities on water quality. I understand and acknowledge that the plan check review of this PDP SWQMP by the [City Engineer] is confined to a review and does not relieve me, as the Engineer in Responsible Charge of design of storm water BMPs for this project, of my responsibilities for project design.

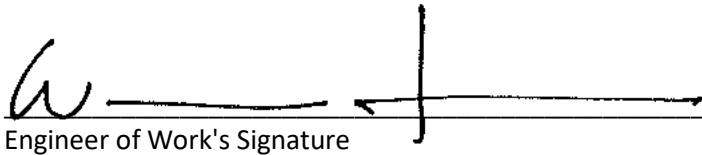
  
Engineer of Work's Signature

William Lundstrom  
Print Name

Lundstrom Engineering & Surveying, Inc.  
Company

02/16/2023  
\_ Date

Engineer's Seal:



Page intentionally blank

**PDP SWQMP PROJECT OWNER'S CERTIFICATION PAGE**

**Project Name: Pacific**

**Permit Application Number:**

**PROJECT OWNER'S CERTIFICATION**

This PDP SWQMP has been prepared for The Las Posas Project Owner LPV, LLC by Lundstrom Engineering & Surveying, Inc. The PDP SWQMP is intended to comply with the PDP requirements of the City of San Marcos BMP Design Manual, which is a design manual for compliance with local City of San Marcos and regional MS4 Permit (California Regional Water Quality Control Board San Diego Region Order No. R9-2015-0100) requirements for storm water management.

The undersigned, while it owns the subject property, is responsible for the implementation of the provisions of this plan. Once the undersigned transfers its interests in the property, its successor-in-interest shall bear the aforementioned responsibility to implement the best management practices (BMPs) described within this plan, including ensuring on-going operation and maintenance of structural BMPs. A signed copy of this document shall be available on the subject property into perpetuity.

---

Project Owner's Signature

---

Print Name

The Las Posas Project Owner LPV, LLC  
Company

---

Date

Page intentionally blank



### SUBMITTAL RECORD

Use this Table to keep a record of submittals of this PDP SWQMP. Each time the PDP SWQMP is re-submitted, provide the date and status of the project. In column 4 summarize the changes that have been made or indicate if response to plancheck comments is included. When applicable, insert response to plancheck comments behind this page.

Submittal Number	Date	Project Status	Summary of Changes
1	04/15/2022	<input checked="" type="checkbox"/> Preliminary Design / Planning/ CEQA <input type="checkbox"/> Final Design	Initial Submittal
2	08/15/2022	<input checked="" type="checkbox"/> Preliminary Design / Planning/ CEQA <input type="checkbox"/> Final Design	Resubmittal
3	11/07/2022	<input checked="" type="checkbox"/> Preliminary Design / Planning/ CEQA <input type="checkbox"/> Final Design	Resubmittal
4	02/16/2023	<input checked="" type="checkbox"/> Preliminary Design / Planning/ CEQA <input type="checkbox"/> Final Design	Resubmittal

**PROJECT VICINITY MAP**

**Project Name: Pacific**

**Permit Application Number:**

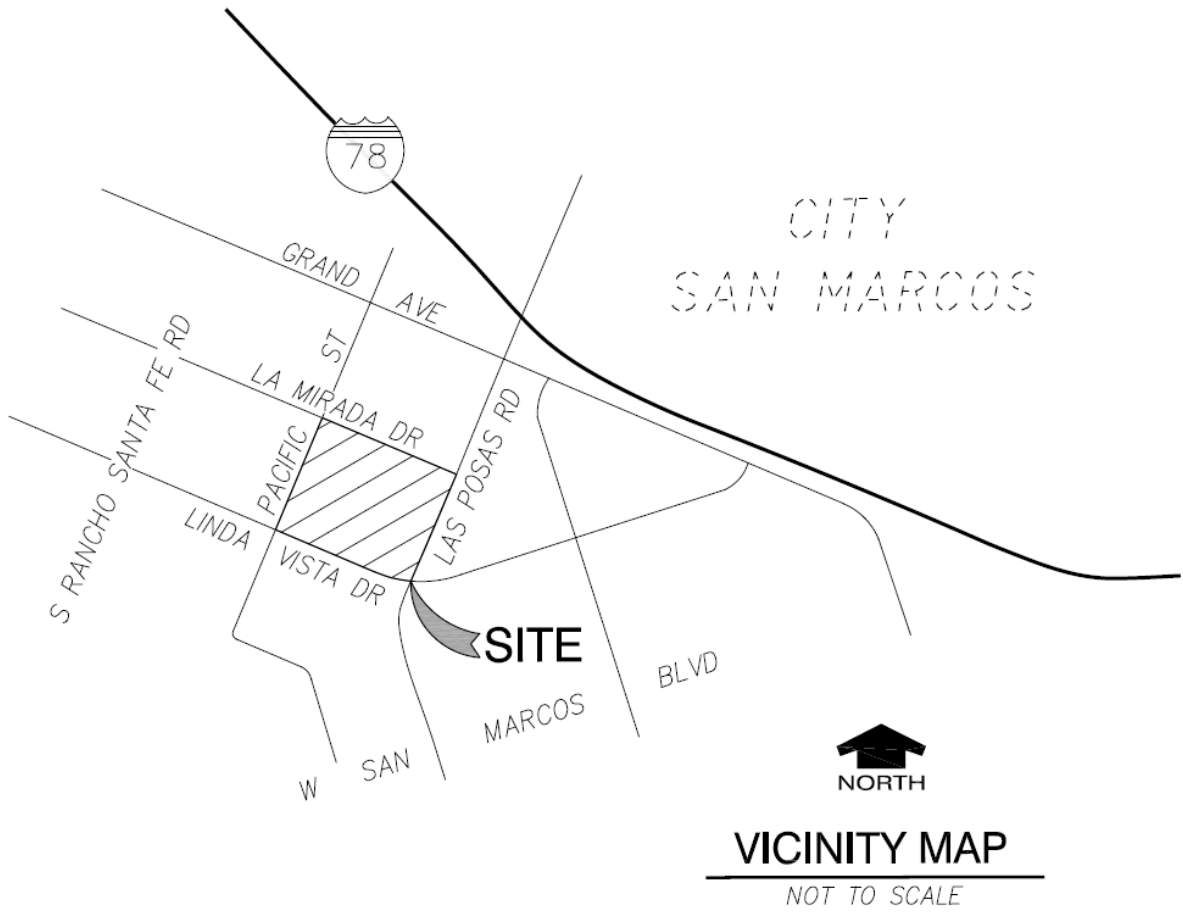

# Applicability of Storm Water Best Management Practices (BMP) Requirements

(Storm Water Intake Form for all Development Permit Applications)

For detailed information please visit:

<http://www.san-marcos.net/departments/development-services/stormwater/development-planning>

Form I-1  
[March 15, 2016]

## Project Identification

Project Name: **Pacific**

The 33.2-acre project site is an infill site located in the western portion of the City of San Marcos (City), at the northwest corner of S. Las Posas Road and Linda Vista Drive, comprised of Assessor's Parcel Numbers 219-222-01, 219-222-02, 219-222-03, and 219-222-04. La Mirada Drive abuts the site's northern boundary, while South Pacific Street abuts the property's western boundary. The Grand Plaza shopping center is located directly across Las Posas Road to the east. Light industrial uses are adjacent to the site's northern, southern, and western boundary, and Bradley Park is located across from the site's southwestern corner. Single- and multi-family residential uses are located to the west and south of Bradley Park. The project consists of 449 residential units, including a mix of apartments, rowhomes, villas, and affordable flats on approximately 15.09 acres of the 33.2-acre project site. Proposed residential units would include a mix of apartments within a five-story podium building, three-story rowhomes, three-story villas, and affordable flats within a four-story building. The project includes a total of 927 parking spaces and 134,985 square feet of common open space area. 68 of the 449 total units (15% of the total) would be designated as deed-restricted affordable units (alternatively, the project reserves the option to contribute to the affordable housing fund by paying the in-lieu fee). The proposed project also includes landscaping, bio-retention areas, and circulation improvements. The remaining 18.11 acres of the 33.2-acre project site would be preserved and restored as open space and habitat area. The proposed project would have a density of approximately 13.5 dwelling units per acre, including the open space and habitat area.

Permit Application Number (if applicable):

Date:

Project Address:

## Determination of Requirements

This form is required as part of the City's application process. The purpose of this form is to identify potential land development planning storm water requirements that apply to development projects.

**Development projects are defined as construction, rehabilitation, redevelopment, or reconstruction of any public or private projects. In addition, the identification of a development project, as it relates to storm water regulations, would truly apply to development and redevelopment activities that have the potential to contact storm water and contribute a source of pollutants, or reduce the natural absorption and infiltration abilities of the land.**

To access the BMP Design Manual, Storm Water Quality Management Plan (SWQMP) templates, and other pertinent information related to this program please refer to:

<http://www.san-marcos.net/departments/development-services/stormwater/development-planning>

Please answer each of the following steps below, starting with Step 1 and progressing through each step until reaching "Stop".

Step	Answer	Progression
<b>Step 1: Based on the above</b> , Is the project a "development project" (See definition above)? See Section 1.3 of the BMP Design Manual for further guidance if necessary.	<input checked="" type="checkbox"/> Yes	Go to Step 2.
	<input type="checkbox"/> No	Permanent BMP requirements do not apply. No SWQMP will be required. Provide brief discussion below. <b>STOP.</b>
Discussion / justification if the project is <u>not</u> a "development project" (e.g., the project includes <i>only</i> interior remodels within an existing building):		
<b>Step 2:</b> Is the project a Standard Project, Priority Development Project (PDP), or exception to PDP definitions?	<input type="checkbox"/> Standard Project	<u>Only</u> Standard Project requirements apply, including <u>Standard Project SWQMP</u> . <b>STOP.</b>
	<input checked="" type="checkbox"/> PDP	<u>Standard and PDP</u> requirements apply, including <u>PDP SWQMP</u> . <b>Go to Step 3 on the following page.</b>

<p><b>To answer this item, complete Form I-2, Project Type Determination. See Section 1.4 of the BMP Design Manual in its entirety for guidance.</b></p> <p><b>In addition to Section 1.4, please refer to the City's SWQMP Submittal Requirements form.</b></p>	<input type="checkbox"/> Exception to PDP definitions	<p>Standard Project requirements apply, and any additional requirements specific to the type of project. Provide discussion and list any additional requirements below. Prepare <u>Standard Project SWQMP</u>. <b>STOP.</b></p>
------------------------------------------------------------------------------------------------------------------------------------------------------------------------------------------------------------------------------------------------------------------	-------------------------------------------------------	---------------------------------------------------------------------------------------------------------------------------------------------------------------------------------------------------------------------------------

Discussion / justification, and additional requirements for exceptions to PDP definitions, if applicable:

**Form I-1 Page 2, Form Date: March 15, 2016**

**Step 3 (PDPs only).** Please answer the list of questions in this section to determine if hydromodification requirements apply to the proposed PDP. Does the project:

<p><b>Step 3a.</b> Discharge storm water runoff directly to the Pacific Ocean?</p>	<input type="checkbox"/> Yes <input checked="" type="checkbox"/> No	<p><b>STOP.</b> Hydromodification requirements do not apply. Continue to Step 3b.</p>
<p><b>Step 3b.</b> Discharge storm water runoff directly to an enclosed embayment, not within protected areas?</p>	<input type="checkbox"/> Yes <input checked="" type="checkbox"/> No	<p><b>STOP.</b> Hydromodification requirements do not apply. Continue to Step 3c.</p>
<p><b>Step 3c.</b> Discharge storm water runoff directly to a water storage reservoir or lake, below spillway or normal operating level?</p>	<input type="checkbox"/> Yes <input checked="" type="checkbox"/> No	<p><b>STOP.</b> Hydromodification requirements do not apply. Continue to Step 3d.</p>
<p><b>Step 3d.</b> Discharge storm water runoff directly to an area identified in WMAA?</p>	<input type="checkbox"/> Yes <input checked="" type="checkbox"/> No	<p><b>STOP.</b> Hydromodification requirements do not apply. Hydromodification requirements apply to the project. Go to Step 4.</p>

Discussion / justification if hydromodification control requirements do not apply:

<p><b>Step 4 (PDPs subject to hydromodification control requirements only).</b> Does protection of critical coarse sediment yield areas apply based on review of WMAA Potential Critical Coarse Sediment Yield Area Map? See Section 6.2 of the BMP Design Manual for guidance.</p>	<input type="checkbox"/> Yes <input checked="" type="checkbox"/> No	<p>Management measures required for protection of critical coarse sediment yield areas (Chapter 6.2). Stop.</p> <p>Management measures not required for protection of critical coarse sediment yield areas. Provide brief discussion below. Stop.</p>
-------------------------------------------------------------------------------------------------------------------------------------------------------------------------------------------------------------------------------------------------------------------------------------	------------------------------------------------------------------------	-------------------------------------------------------------------------------------------------------------------------------------------------------------------------------------------------------------------------------------------------------------------

Project Type Determination Checklist		Form I-2 [March 15, 2016]	
<b>Project Information</b>			
Project Name/Description: <b>Pacific</b>			
Permit Application Number (if applicable):		Date:	
Project Address:			
<b>Project Type Determination: Standard Project or Priority Development Project (PDP)</b>			
The project is (select one): <input checked="" type="checkbox"/> New Development <input type="checkbox"/> Redevelopment			
The total proposed newly created or replaced impervious area is: _____ ft <sup>2</sup> (11.5) acres			
Is the project in any of the following categories, (a) through (f)?			
Yes <input checked="" type="checkbox"/>	No <input type="checkbox"/>	(a)	New development projects that create 10,000 square feet or more of impervious surfaces (collectively over the entire project site). This includes commercial, industrial, residential, mixed-use, and public development projects on public or private land.
Yes <input type="checkbox"/>	No <input checked="" type="checkbox"/>	(b)	Redevelopment projects that create and/or replace 5,000 square feet or more of impervious surface (collectively over the entire project site on an existing site of 10,000 square feet or more of impervious surfaces). This includes commercial, industrial, residential, mixed-use, and public development projects on public or private land.
Yes <input type="checkbox"/>	No <input checked="" type="checkbox"/>	(c)	<p>New and redevelopment projects that create and/or replace 5,000 square feet or more of impervious surface (collectively over the entire project site), and support one or more of the following uses:</p> <ul style="list-style-type: none"> <li>(i) Restaurants. This category is defined as a facility that sells prepared foods and drinks for consumption, including stationary lunch counters and refreshment stands selling prepared foods and drinks for immediate consumption (Standard Industrial Classification (SIC) code 5812).</li> <li>(ii) Hillside development projects. This category includes development on any natural slope that is twenty-five percent or greater.</li> <li>(iii) Parking lots. This category is defined as a land area or facility for the temporary parking or storage of motor vehicles used personally, for business, or for commerce.</li> <li>(iv) Streets, roads, highways, freeways, and driveways. This category is defined as any paved impervious surface used for the transportation of automobiles, trucks, motorcycles, and other vehicles.</li> </ul>

Yes <input type="checkbox"/>	No <input checked="" type="checkbox"/>	(d)	New or redevelopment projects that create and/or replace 2,500 square feet or more of impervious surface (collectively over the entire project site), and discharging directly to an Environmentally Sensitive Area (ESA). "Discharging directly to" includes flow that is conveyed overland a distance of 200 feet or less from the project to the ESA, or conveyed in a pipe or open channel any distance as an isolated flow from the project to the ESA (i.e. not commingled with flows from adjacent lands).  <i>Note: ESAs are areas that include but are not limited to all Clean Water Act Section 303(d) impaired water bodies; areas designated as Areas of Special Biological Significance by the State Water Board and San Diego Water Board; State Water Quality Protected Areas; water bodies designated with the RARE beneficial use by the State Water Board and San Diego Water Board; and any other equivalent environmentally sensitive areas which have been identified by the Copermittees. See BMP Design Manual Section 1.4.2 for additional guidance.</i>
Yes <input type="checkbox"/>	No <input checked="" type="checkbox"/>	(e)	New development projects, or redevelopment projects that create and/or replace 5,000 square feet or more of impervious surface, that support one or more of the following uses: (i) Automotive repair shops. This category is defined as a facility that is categorized in any one of the following SIC codes: 5013, 5014, 5541, 7532-7534, or 7536-7539. (ii) Retail gasoline outlets (RGOs). This category includes RGOs that meet the following criteria: (a) 5,000 square feet or more or (b) a projected Average Daily Traffic (ADT) of 100 or more vehicles per day.
Yes <input checked="" type="checkbox"/>	No <input type="checkbox"/>	(f)	New or redevelopment projects that result in the disturbance of one or more acres of land and are expected to generate pollutants post construction.  <i>Note: See BMP Design Manual Section 1.4.2 for additional guidance.</i>

Does the project meet the definition of one or more of the Priority Development Project categories (a) through (f) listed above?

- No – the project is not a Priority Development Project (Standard Project).  
 Yes – the project is a Priority Development Project (PDP).

The following is for redevelopment PDPs only:

The area of existing (pre-project) impervious area at the project site is: \_\_\_\_\_ ft<sup>2</sup> (A)

The total proposed newly created or replaced impervious area is \_\_\_\_\_ ft<sup>2</sup> (B)

Percent impervious surface created or replaced (B/A)\*100: \_\_\_\_\_%

The percent impervious surface created or replaced is (select one based on the above calculation):

- less than or equal to fifty percent (50%) – only new impervious areas are considered PDP

OR

- greater than fifty percent (50%) – the entire project site is a PDP

<b>Site Information Checklist For PDPs</b>		<b>Form I-3B (PDPs) [March 15, 2016]</b>
<b>Project Summary Information</b>		
Project Name	Pacific	
Project Address	Northwest corner of the intersection of Las Posas Road and Linda Vista Drive.	
Assessor's Parcel Number(s) (APN(s))	<b>219-222-01, 219-222-02, 219-222-03, 219-222-04</b>	
Permit Application Number		
Project Hydrologic Unit	Select One: <input type="checkbox"/> Santa Margarita 902 <input type="checkbox"/> San Luis Rey 903 <input checked="" type="checkbox"/> Carlsbad 904 <input type="checkbox"/> San Dieguito 905 <input type="checkbox"/> Penasquitos 906 <input type="checkbox"/> San Diego 907 <input type="checkbox"/> Pueblo San Diego 908 <input type="checkbox"/> Sweetwater 909 <input type="checkbox"/> Otay 910 <input type="checkbox"/> Tijuana 911	
Project Watershed (Complete Hydrologic Unit, Area, and Subarea Name with Numeric Identifier)	HU Carlsbad, HA San Marcos, HSA 904.52 Richland	
Parcel Area (total area of Assessor's Parcel(s) associated with the project)	33.2 Acres ( _____ Square Feet)	
Area to be Disturbed by the Project (Project Area)	15.2 Acres ( _____ Square Feet)	
Project Proposed Impervious Area (subset of Project Area)	11.5 Acres ( _____ Square Feet)	
Project Proposed Pervious Area (subset of Project Area)	3.7 Acres ( _____ Square Feet)	
Note: Proposed Impervious Area + Proposed Pervious Area = Area to be Disturbed by the Project. This may be less than the Parcel Area.		

**Description of Existing Site Condition**

Current Status of the Site (select all that apply):

- Existing development
- Previously graded but not built out
- Demolition completed without new construction
- Agricultural or other non-impervious use
- Vacant, undeveloped/natural

Description / Additional Information:

The 33.2 acre property is currently undeveloped. Adjacent land use is varied with shopping centers, light industrial, and recreation.

The majority of the site flows southeasterly toward the northwest corner of Linda Vista Drive and Las Posas Road. This drainage is collected in a CMP (corrugated metal pipe) riser which drains to an 11'x7' RCB (reinforced concrete box) in Las Posas Rd. The remainder of the site surface drains to the surrounding streets. All surrounding streets drain via gutter flow to the same corner (Las Posas and Linda Vista) where runoff is collected by a pair of curb inlets which drain into the same 11'x7' RCB in Las Posas Rd. It is noted that some on-site run-off occurs from the property onto adjacent streets. The run-off is carried via the streets to the same RCB in Las Posas Road. There is no offsite run-on to the property.

Existing Land Cover Includes (select all that apply):

- Vegetative Cover
- Non-Vegetated Pervious Areas
- Impervious Areas

Description / Additional Information:

Underlying Soil belongs to Hydrologic Soil Group (select all that apply):

- NRCS Type A
- NRCS Type B
- NRCS Type C
- NRCS Type D

Approximate Depth to Groundwater (GW):

- GW Depth < 5 feet
- 5 feet < GW Depth < 10 feet
- 10 feet < GW Depth < 20 feet
- GW Depth > 20 feet



Existing Natural Hydrologic Features (select all that apply):

- Watercourses
- Seeps
- Springs
- Wetlands
- None

Description / Additional Information:

**Description of Existing Site Drainage Patterns**

How is storm water runoff conveyed from the site? At a minimum, this description should answer:

- (1) whether existing drainage conveyance is natural or urban;
- (2) Is runoff from offsite conveyed through the site? if yes, quantify all offsite drainage areas, design flows, and locations where offsite flows enter the project site, and summarize how such flows are conveyed through the site;
- (3) Provide details regarding existing project site drainage conveyance network, including any existing storm drains, concrete channels, swales, detention facilities, storm water treatment facilities, natural or constructed channels; and
- (4) Identify all discharge locations from the existing project site along with a summary of conveyance system size and capacity for each of the discharge locations. Provide summary of the pre-project drainage areas and design flows to each of the existing runoff discharge locations.

Describe existing site drainage patterns:

The majority of the site is natural overland and flows southeasterly toward the northwest corner of Linda Vista Drive and Las Posas Road. This drainage is collected in a CMP (corrugated metal pipe) riser which drains to an 11'x7' RCB (reinforced concrete box) in Las Posas Rd. The remainder of the site surface drains to the surrounding streets. All surrounding streets drain via gutter flow to the same corner (Las Posas and Linda Vista) where runoff is collected by a pair of curb inlets which drain into the same 11'x7' RCB in Las Posas Rd. It is noted that some on-site run-off occurs from the property onto adjacent streets. The run-off is carried via the streets to the same RCB in Las Posas Road. There is no offsite run-on to the property.

**Description of Proposed Site Development**

**Project Description / Proposed Land Use and/or Activities:**

The 33.2-acre project site is an infill site located in the western portion of the City of San Marcos (City), at the northwest corner of S. Las Posas Road and Linda Vista Drive, comprised of Assessor's Parcel Numbers 219-222-01, 219-222-02, 219-222-03, and 219-222-04. La Mirada Drive abuts the site's northern boundary, while South Pacific Street abuts the property's western boundary. The Grand Plaza shopping center is located directly across Las Posas Road to the east. Light industrial uses are adjacent to the site's northern, southern, and western boundary, and Bradley Park is located across from the site's southwestern corner. Single- and multi-family residential uses are located to the west and south of Bradley Park. The project consists of 449 residential units, including a mix of apartments, rowhomes, villas, and affordable flats on approximately 15.09 acres of the 33.2-acre project site. Proposed residential units would include a mix of apartments within a five-story podium building, three-story rowhomes, three-story villas, and affordable flats within a four-story building. The project includes a total of 927 parking spaces and 134,985 square feet of common open space area. 68 of the 449 total units (15% of the total) would be designated as deed-restricted affordable units (alternatively, the project reserves the option to contribute to the affordable housing fund by paying the in-lieu fee). The proposed project also includes landscaping, bio-retention areas, and circulation improvements. The remaining 17.94 acres of the 33.2-acre project site would be preserved and restored as open space and habitat area. The proposed project would have a density of approximately 13.5 dwelling units per acre, including the open space and habitat area.

**List/describe proposed impervious features of the project (e.g., buildings, roadways, parking lots, courtyards, athletic courts, other impervious features):**

The proposed site will consist of approximately 10.2 acres of impervious area in the form of a paved roads, paved driveways, paved walkways and roof areas.

**List/describe proposed pervious features of the project (e.g., landscape areas):**

The proposed site will consist of approximately 2.9 acres of pervious area in the form of landscaped yards and common use areas.

**Does the project include grading and changes to site topography?**

Yes

No

Description / Additional Information: See Attachment 1a.

**Description of Proposed Site Drainage Patterns**

Does the project include changes to site drainage (e.g., installation of new storm water conveyance systems)?

Yes

No

If yes, provide details regarding the proposed project site drainage conveyance network, including storm drains, concrete channels, swales, detention facilities, storm water treatment facilities, natural or constructed channels, and the method for conveying offsite flows through or around the proposed project site. Identify all discharge locations from the proposed project site along with a summary of the conveyance system size and capacity for each of the discharge locations. Provide a summary of pre- and post-project drainage areas and design flows to each of the runoff discharge locations. Reference the drainage study for detailed calculations.

Describe proposed site drainage patterns::

The proposed storm drain system will collect and convey stormwater runoff to biofiltration basins and underground hydromodification storage vaults. The proposed storm drain system will convey stormwater southeast to an existing public drainage system in Las Posas Road.

Identify whether any of the following features, activities, and/or pollutant source areas will be present (select all that apply):

- On-site storm drain inlets
- Interior floor drains and elevator shaft sump pumps
- Interior parking garages
- Need for future indoor & structural pest control
- Landscape/Outdoor Pesticide Use
- Pools, spas, ponds, decorative fountains, and other water features
- Food service
- Refuse areas
- Industrial processes
- Outdoor storage of equipment or materials
- Vehicle and Equipment Cleaning
- Vehicle/Equipment Repair and Maintenance
- Fuel Dispensing Areas
- Loading Docks
- Fire Sprinkler Test Water
- Miscellaneous Drain or Wash Water
- Plazas, sidewalks, and parking lots

Description / Additional Information:

**Identification and Narrative of Receiving Water and Pollutants of Concern**

Describe flow path of storm water from the project site discharge location(s), through urban storm conveyance systems as applicable, to receiving creeks, rivers, and lagoons as applicable, and ultimate discharge to the Pacific Ocean (or bay, lagoon, lake or reservoir, as applicable):

The existing public drainage system in Las Posas Road conveys stormwater approximately 700 feet downstream to San Marcos Creek and then into Lake San Marcos.

List any 303(d) impaired water bodies within the path of storm water from the project site to the Pacific Ocean (or bay, lagoon, lake or reservoir, as applicable), identify the pollutant(s)/stressor(s) causing impairment, and identify any TMDLs and/or Highest Priority Pollutants from the WQIP for the impaired water bodies:

<b>303(d) Impaired Water Body</b>	<b>Pollutant(s)/Stressor(s)</b>	<b>TMDLs / WQIP Highest Priority Pollutant</b>
San Marcos Creek	DDE, Toxicity, Benthic Community Effects, Indicator Bacteria, Phosphorus, and Selenium	nutrients, bacteria
San Marcos Lake	Ammonia as Nitrogen, Copper, Nutrients, and Phosphorus	heavy metals, nutrients

**Identification of Project Site Pollutants\***

**\*Identification of project site pollutants is only required if flow-thru treatment BMPs are implemented onsite in lieu of retention or biofiltration BMPs (note the project must also participate in an alternative compliance program unless prior lawful approval to meet earlier PDP requirements is demonstrated)**

Identify pollutants expected from the project site based on all proposed use(s) of the site (see BMP Design Manual Appendix B.6):

<b>Pollutant</b>	<b>Not Applicable to the Project Site</b>	<b>Expected from the Project Site</b>	<b>Also a Receiving Water Pollutant of Concern</b>
Sediment		X	
Nutrients		X	X
Heavy Metals		X	X
Organic Compounds		X	
Trash & Debris		X	
Oxygen Demanding Substances		X	
Oil & Grease		X	
Bacteria & Viruses		X	X
Pesticides		X	

**Hydromodification Management Requirements**

Do hydromodification management requirements apply (see Section 1.6 of the BMP Design Manual)?

- Yes, hydromodification management flow control structural BMPs required.
- No, the project will discharge runoff directly to existing underground storm drains discharging directly to water storage reservoirs, lakes, enclosed embayments, or the Pacific Ocean.
- No, the project will discharge runoff directly to conveyance channels whose bed and bank are concrete-lined all the way from the point of discharge to water storage reservoirs, lakes, enclosed embayments, or the Pacific Ocean.
- No, the project will discharge runoff directly to an area identified as appropriate for an exemption by the WMAA for the watershed in which the project resides.

Description / Additional Information (to be provided if a 'No' answer has been selected above):

**Critical Coarse Sediment Yield Areas\***

**\*This Section only required if hydromodification management requirements apply**

Based on the maps provided within the WMAA, do potential critical coarse sediment yield areas exist within the project drainage boundaries?

- Yes
- No, No critical coarse sediment yield areas to be protected based on WMAA maps

If yes, have any of the optional analyses presented in Section 6.2 of the BMP Design Manual been performed?

- 6.2.1 Verification of Geomorphic Landscape Units (GLUs) Onsite
- 6.2.2 Downstream Systems Sensitivity to Coarse Sediment
- 6.2.3 Optional Additional Analysis of Potential Critical Coarse Sediment Yield Areas Onsite
- No optional analyses performed, the project will avoid critical coarse sediment yield areas identified based on WMAA maps

If optional analyses were performed, what is the final result?

- No critical coarse sediment yield areas to be protected based on verification of GLUs onsite
- Critical coarse sediment yield areas exist but additional analysis has determined that protection is not required. Documentation attached in Attachment 2.b of the SWQMP.
- Critical coarse sediment yield areas exist and require protection. The project will implement management measures described in Sections 6.2.4 and 6.2.5 as applicable, and the areas are identified on the SWQMP Exhibit.

Discussion / Additional Information:

**Flow Control for Post-Project Runoff\***

**\*This Section only required if hydromodification management requirements apply**

List and describe point(s) of compliance (POCs) for flow control for hydromodification management (see Section 6.3.1). For each POC, provide a POC identification name or number correlating to the project's HMP Exhibit and a receiving channel identification name or number correlating to the project's HMP Exhibit.

POC#1: Existing storm drain in Las Posas Road. See Attachment 2a.

Has a geomorphic assessment been performed for the receiving channel(s)?

- No, the low flow threshold is 0.1Q2 (default low flow threshold)
- Yes, the result is the low flow threshold is 0.1Q2
- Yes, the result is the low flow threshold is 0.3Q2
- Yes, the result is the low flow threshold is 0.5Q2

If a geomorphic assessment has been performed, provide title, date, and preparer:

Discussion / Additional Information: (optional)



**Other Site Requirements and Constraints**

When applicable, list other site requirements or constraints that will influence storm water management design, such as zoning requirements including setbacks and open space, or local codes governing minimum street width, sidewalk construction, allowable pavement types, and drainage requirements.

The project is constrained by 17.8 acres of open space (self-mitigating).  
Proposed frontage improvements will have biofiltration BMPs and tree wells for stormwater treatment.

**Optional Additional Information or Continuation of Previous Sections As Needed**

This space provided for additional information or continuation of information from previous sections as needed.

<b>Source Control BMP Checklist for All Development Projects (Standard Projects and Priority Development Projects)</b>	<b>Form I-4 [March 15, 2016]</b>
--------------------------------------------------------------------------------------------------------------------------------	--------------------------------------

**Project Identification**

Project Name

Permit Application Number

**Source Control BMPs**

All development projects must implement source control BMPs SC-1 through SC-6 where applicable and feasible. See Chapter 4 and Appendix E of the Model BMP Design Manual for information to implement source control BMPs shown in this checklist.

Answer each category below pursuant to the following.

- "Yes" means the project will implement the source control BMP as described in Chapter 4 and/or Appendix E of the Model BMP Design Manual. Discussion / justification is not required.
- "No" means the BMP is applicable to the project but it is not feasible to implement. Discussion / justification must be provided.
- "N/A" means the BMP is not applicable at the project site because the project does not include the feature that is addressed by the BMP (e.g., the project has no outdoor materials storage areas). Discussion / justification may be provided.

Source Control Requirement	Applied?		
----------------------------	----------	--	--

<b>SC-1</b> Prevention of Illicit Discharges into the MS4	<input checked="" type="checkbox"/> Yes	<input type="checkbox"/> No	<input type="checkbox"/> N/A
-----------------------------------------------------------	-----------------------------------------	-----------------------------	------------------------------

Discussion / justification if SC-1 not implemented:

<b>SC-2</b> Storm Drain Stenciling or Signage	<input checked="" type="checkbox"/> Yes	<input type="checkbox"/> No	<input type="checkbox"/> N/A
-----------------------------------------------	-----------------------------------------	-----------------------------	------------------------------

Discussion / justification if SC-2 not implemented:

<b>SC-3</b> Protect Outdoor Materials Storage Areas from Rainfall, Run-On, Runoff, and Wind Dispersal	<input type="checkbox"/> Yes	<input type="checkbox"/> No	<input checked="" type="checkbox"/> N/A
-------------------------------------------------------------------------------------------------------	------------------------------	-----------------------------	-----------------------------------------

Discussion / justification if SC-3 not implemented:

<b>SC-4</b> Protect Materials Stored in Outdoor Work Areas from Rainfall, Run-On, Runoff, and Wind Dispersal	<input type="checkbox"/> Yes	<input type="checkbox"/> No	<input checked="" type="checkbox"/> N/A
--------------------------------------------------------------------------------------------------------------	------------------------------	-----------------------------	-----------------------------------------

Discussion / justification if SC-4 not implemented:

Source Control Requirement	Applied?		
<b>SC-5</b> Protect Trash Storage Areas from Rainfall, Run-On, Runoff, and Wind Dispersal	<input checked="" type="checkbox"/> Yes	<input type="checkbox"/> No	<input type="checkbox"/> N/A
Discussion / justification if SC-5 not implemented:			
<b>SC-6</b> Additional BMPs Based on Potential Sources of Runoff Pollutants (must answer for each source listed below)			
<input checked="" type="checkbox"/> On-site storm drain inlets	<input type="checkbox"/> Yes	<input type="checkbox"/> No	<input type="checkbox"/> N/A
<input checked="" type="checkbox"/> Interior floor drains and elevator shaft sump pumps	<input type="checkbox"/> Yes	<input type="checkbox"/> No	<input type="checkbox"/> N/A
<input checked="" type="checkbox"/> Interior parking garages	<input type="checkbox"/> Yes	<input type="checkbox"/> No	<input type="checkbox"/> N/A
<input checked="" type="checkbox"/> Need for future indoor & structural pest control	<input type="checkbox"/> Yes	<input type="checkbox"/> No	<input type="checkbox"/> N/A
<input checked="" type="checkbox"/> Landscape/Outdoor Pesticide Use	<input type="checkbox"/> Yes	<input type="checkbox"/> No	<input type="checkbox"/> N/A
<input checked="" type="checkbox"/> Pools, spas, ponds, decorative fountains, and other water features	<input type="checkbox"/> Yes	<input type="checkbox"/> No	<input type="checkbox"/> N/A
<input type="checkbox"/> Food service	<input type="checkbox"/> Yes	<input type="checkbox"/> No	<input checked="" type="checkbox"/> N/A
<input type="checkbox"/> Refuse areas	<input type="checkbox"/> Yes	<input type="checkbox"/> No	<input checked="" type="checkbox"/> N/A
<input type="checkbox"/> Industrial processes	<input type="checkbox"/> Yes	<input type="checkbox"/> No	<input checked="" type="checkbox"/> N/A
<input type="checkbox"/> Outdoor storage of equipment or materials	<input type="checkbox"/> Yes	<input type="checkbox"/> No	<input checked="" type="checkbox"/> N/A
<input type="checkbox"/> Vehicle and Equipment Cleaning	<input type="checkbox"/> Yes	<input type="checkbox"/> No	<input checked="" type="checkbox"/> N/A
<input type="checkbox"/> Vehicle/Equipment Repair and Maintenance	<input type="checkbox"/> Yes	<input type="checkbox"/> No	<input checked="" type="checkbox"/> N/A
<input type="checkbox"/> Fuel Dispensing Areas	<input type="checkbox"/> Yes	<input type="checkbox"/> No	<input checked="" type="checkbox"/> N/A
<input type="checkbox"/> Loading Docks	<input type="checkbox"/> Yes	<input type="checkbox"/> No	<input checked="" type="checkbox"/> N/A
<input checked="" type="checkbox"/> Fire Sprinkler Test Water	<input type="checkbox"/> Yes	<input type="checkbox"/> No	<input type="checkbox"/> N/A
<input type="checkbox"/> Miscellaneous Drain or Wash Water	<input type="checkbox"/> Yes	<input type="checkbox"/> No	<input type="checkbox"/> N/A
<input checked="" type="checkbox"/> Plazas, sidewalks, and parking lots	<input type="checkbox"/> Yes	<input type="checkbox"/> No	<input type="checkbox"/> N/A
Discussion / justification if SC-6 not implemented. Clearly identify which sources of runoff pollutants are discussed. Justification must be provided for <u>all</u> "No" answers shown above.			

<b>Site Design BMP Checklist for All Development Projects (Standard Projects and Priority Development Projects)</b>		<b>Form I-5 [March 15, 2016]</b>		
<b>Project Identification</b>				
Project Name				
Permit Application Number				
<b>Site Design BMPs</b>				
<p>All development projects must implement site design BMPs SD-1 through SD-8 where applicable and feasible. See Chapter 4 and Appendix E of the Model BMP Design Manual for information to implement site design BMPs shown in this checklist.</p> <p>Answer each category below pursuant to the following.</p> <ul style="list-style-type: none"> <li>• "Yes" means the project will implement the site design BMP as described in Chapter 4 and/or Appendix E of the Model BMP Design Manual. Discussion / justification is not required.</li> <li>• "No" means the BMP is applicable to the project but it is not feasible to implement. Discussion / justification must be provided.</li> <li>• "N/A" means the BMP is not applicable at the project site because the project does not include the feature that is addressed by the BMP (e.g., the project site has no existing natural areas to conserve). Discussion / justification may be provided.</li> </ul>				
<b>Site Design Requirement</b>		<b>Applied?</b>		
<b>SD-1</b> Maintain Natural Drainage Pathways and Hydrologic Features		<input type="checkbox"/> Yes	<input type="checkbox"/> No	<input checked="" type="checkbox"/> N/A
Discussion / justification if SD-1 not implemented:				
<b>SD-2</b> Conserve Natural Areas, Soils, and Vegetation		<input checked="" type="checkbox"/> Yes	<input type="checkbox"/> No	<input type="checkbox"/> N/A
Discussion / justification if SD-2 not implemented:				
<b>SD-3</b> Minimize Impervious Area		<input checked="" type="checkbox"/> Yes	<input type="checkbox"/> No	<input type="checkbox"/> N/A
Discussion / justification if SD-3 not implemented:				
<b>SD-4</b> Minimize Soil Compaction		<input checked="" type="checkbox"/> Yes	<input type="checkbox"/> No	<input type="checkbox"/> N/A
Discussion / justification if SD-4 not implemented:				
<b>SD-5</b> Impervious Area Dispersion		<input type="checkbox"/> Yes	<input checked="" type="checkbox"/> No	<input type="checkbox"/> N/A
Discussion / justification if SD-5 not implemented: Project runoff will be routed to tree wells and biofiltration basins.				

Site Design Requirement	Applied?		
<b>SD-6</b> Runoff Collection	<input checked="" type="checkbox"/> Yes	<input type="checkbox"/> No	<input type="checkbox"/> N/A
Discussion / justification if SD-6 not implemented:  Harvest and Reuse is not feasible for the project. Collecting runoff through permeable pavement is not feasible due to low infiltration rates.			
<b>SD-7</b> Landscaping with Native or Drought Tolerant Species	<input checked="" type="checkbox"/> Yes	<input type="checkbox"/> No	<input type="checkbox"/> N/A
Discussion / justification if SD-7 not implemented:			
<b>SD-8</b> Harvesting and Using Precipitation	<input type="checkbox"/> Yes	<input type="checkbox"/> No	<input checked="" type="checkbox"/> N/A
Discussion / justification if SD-8 not implemented:  Harvest and Reuse is not feasible for the project.			

<b>Summary of PDP Structural BMPs</b>	<b>Form I-6 (PDPs)</b> [March 15, 2016]
<b>Project Identification</b>	
Project Name: Pacific	
Permit Application Number	
<b>PDP Structural BMPs</b>	
<p>All PDPs must implement structural BMPs for storm water pollutant control (see Chapter 5 of the BMP Design Manual). Selection of PDP structural BMPs for storm water pollutant control must be based on the selection process described in Chapter 5. PDPs subject to hydromodification management requirements must also implement structural BMPs for flow control for hydromodification management (see Chapter 6 of the BMP Design Manual). Both storm water pollutant control and flow control for hydromodification management can be achieved within the same structural BMP(s).</p> <p>PDP structural BMPs must be verified by the local jurisdiction at the completion of construction. This may include requiring the project owner or project owner's representative and engineer of record to certify construction of the structural BMPs (see Section 1.12 of the BMP Design Manual). PDP structural BMPs must be maintained into perpetuity, and the local jurisdiction must confirm the maintenance (see Section 7 of the BMP Design Manual).</p> <p>Use this form to provide narrative description of the general strategy for structural BMP implementation at the project site in the box below. Then complete the PDP structural BMP summary information sheet (page 3 of this form) for each structural BMP within the project (copy the BMP summary information page as many times as needed to provide summary information for each individual structural BMP).</p>	
<p>Describe the general strategy for structural BMP implementation at the site. This information must describe how the steps for selecting and designing storm water pollutant control BMPs presented in Section 5.1 of the BMP Design Manual were followed, and the results (type of BMPs selected). For projects requiring hydromodification flow control BMPs, indicate whether pollutant control and flow control BMPs are integrated or separate.</p> <p>Infiltration is not feasible per the attached soils report.</p> <p>The project proposed biofiltration basins and tree wells with nutrient sensitive media for site design treatment BMP and modular underground detention systems for HMP for control and 100 year detention.</p> <p>The project is constrained by 17.8 acres of open space (self-mitigating). Proposed frontage improvements will have biofiltration BMPs and tree wells for stormwater treatment.</p> <p>(Continue on page 2 as necessary.)</p>	

**(Page reserved for continuation of description of general strategy for structural BMP implementation at the site)**

(Continued from page 1)

**Structural BMP Summary Information**

(Copy this page as needed to provide information for each individual proposed structural BMP)

Structural BMP ID No. <b>1A</b>	
Construction Plan Sheet No.	
Type of structural BMP: <input type="checkbox"/> Retention by harvest and use (HU-1) <input type="checkbox"/> Retention by infiltration basin (INF-1) <input type="checkbox"/> Retention by bioretention (INF-2) <input type="checkbox"/> Retention by permeable pavement (INF-3) <input type="checkbox"/> Partial retention by biofiltration with partial retention (PR-1) <input checked="" type="checkbox"/> Biofiltration (BF-1) <input type="checkbox"/> Biofiltration with Nutrient Sensitive Media Design (BF-2) <input type="checkbox"/> Proprietary Biofiltration (BF-3) meeting all requirements of Appendix F <input type="checkbox"/> Flow-thru treatment control with prior lawful approval to meet earlier PDP requirements (provide BMP type/description in discussion section below) <input type="checkbox"/> Flow-thru treatment control included as pre-treatment/forebay for an onsite retention or biofiltration BMP (provide BMP type/description and indicate which onsite retention or biofiltration BMP it serves in discussion section below) <input type="checkbox"/> Flow-thru treatment control with alternative compliance (provide BMP type/description in discussion section below) <input type="checkbox"/> Detention pond or vault for hydromodification management <input type="checkbox"/> Other (describe in discussion section below)	
Purpose: <input checked="" type="checkbox"/> Pollutant control only <input type="checkbox"/> Hydromodification control only <input type="checkbox"/> Combined pollutant control and hydromodification control <input type="checkbox"/> Pre-treatment/forebay for another structural BMP <input type="checkbox"/> Other (describe in discussion section below)	
Who will certify construction of this BMP? Provide name and contact information for the party responsible to sign BMP verification forms if required by the [City Engineer] (See Section 1.12 of the BMP Design Manual)	
Who will be the final owner of this BMP?	<b>PRIVATE OWNER</b>
Who will maintain this BMP into perpetuity?	<b>PRIVATE MAINTENANCE</b>
What is the funding mechanism for maintenance?	



**Structural BMP Summary Information**

**(Copy this page as needed to provide information for each individual proposed structural BMP)**

Structural BMP ID No. <u>1B</u>	
Construction Plan Sheet No.	
Type of structural BMP: <input type="checkbox"/> Retention by harvest and use (HU-1) <input type="checkbox"/> Retention by infiltration basin (INF-1) <input type="checkbox"/> Retention by bioretention (INF-2) <input type="checkbox"/> Retention by permeable pavement (INF-3) <input type="checkbox"/> Partial retention by biofiltration with partial retention (PR-1) <input checked="" type="checkbox"/> Biofiltration (BF-1) <input type="checkbox"/> Biofiltration with Nutrient Sensitive Media Design (BF-2) <input type="checkbox"/> Proprietary Biofiltration (BF-3) meeting all requirements of Appendix F <input type="checkbox"/> Flow-thru treatment control with prior lawful approval to meet earlier PDP requirements (provide BMP type/description in discussion section below) <input type="checkbox"/> Flow-thru treatment control included as pre-treatment/forebay for an onsite retention or biofiltration BMP (provide BMP type/description and indicate which onsite retention or biofiltration BMP it serves in discussion section below) <input type="checkbox"/> Flow-thru treatment control with alternative compliance (provide BMP type/description in discussion section below) <input type="checkbox"/> Detention pond or vault for hydromodification management <input type="checkbox"/> Other (describe in discussion section below)	
Purpose: <input checked="" type="checkbox"/> Pollutant control only <input type="checkbox"/> Hydromodification control only <input type="checkbox"/> Combined pollutant control and hydromodification control <input type="checkbox"/> Pre-treatment/forebay for another structural BMP <input type="checkbox"/> Other (describe in discussion section below)	
Who will certify construction of this BMP? Provide name and contact information for the party responsible to sign BMP verification forms if required by the [City Engineer] (See Section 1.12 of the BMP Design Manual)	
Who will be the final owner of this BMP?	<u>PRIVATE OWNER</u>
Who will maintain this BMP into perpetuity?	<u>PRIVATE MAINTENANCE</u>
What is the funding mechanism for maintenance?	

**Structural BMP Summary Information**

(Copy this page as needed to provide information for each individual proposed structural BMP)

Structural BMP ID No. <u>2</u>	
Construction Plan Sheet No.	
Type of structural BMP: <input type="checkbox"/> Retention by harvest and use (HU-1) <input type="checkbox"/> Retention by infiltration basin (INF-1) <input type="checkbox"/> Retention by bioretention (INF-2) <input type="checkbox"/> Retention by permeable pavement (INF-3) <input type="checkbox"/> Partial retention by biofiltration with partial retention (PR-1) <input type="checkbox"/> Biofiltration (BF-1) <input type="checkbox"/> Biofiltration with Nutrient Sensitive Media Design (BF-2) <input checked="" type="checkbox"/> Proprietary Biofiltration (BF-3) meeting all requirements of Appendix F <input type="checkbox"/> Flow-thru treatment control with prior lawful approval to meet earlier PDP requirements (provide BMP type/description in discussion section below) <input type="checkbox"/> Flow-thru treatment control included as pre-treatment/forebay for an onsite retention or biofiltration BMP (provide BMP type/description and indicate which onsite retention or biofiltration BMP it serves in discussion section below) <input type="checkbox"/> Flow-thru treatment control with alternative compliance (provide BMP type/description in discussion section below) <input type="checkbox"/> Detention pond or vault for hydromodification management <input type="checkbox"/> Other (describe in discussion section below)	
Purpose: <input checked="" type="checkbox"/> Pollutant control only <input type="checkbox"/> Hydromodification control only <input type="checkbox"/> Combined pollutant control and hydromodification control <input type="checkbox"/> Pre-treatment/forebay for another structural BMP <input type="checkbox"/> Other (describe in discussion section below)	
Who will certify construction of this BMP? Provide name and contact information for the party responsible to sign BMP verification forms if required by the [City Engineer] (See Section 1.12 of the BMP Design Manual)	
Who will be the final owner of this BMP?	<u>PRIVATE OWNER</u>
Who will maintain this BMP into perpetuity?	<u>PRIVATE MAINTENANCE</u>
What is the funding mechanism for maintenance?	



**Structural BMP Summary Information**

(Copy this page as needed to provide information for each individual proposed structural BMP)

Structural BMP ID No. 3A

Construction Plan Sheet No.

Type of structural BMP:

- Retention by harvest and use (HU-1)
- Retention by infiltration basin (INF-1)
- Retention by bioretention (INF-2)
- Retention by permeable pavement (INF-3)
- Partial retention by biofiltration with partial retention (PR-1)
- Biofiltration (BF-1)
- Biofiltration with Nutrient Sensitive Media Design (BF-2)
- Proprietary Biofiltration (BF-3) meeting all requirements of Appendix F
- Flow-thru treatment control with prior lawful approval to meet earlier PDP requirements (provide BMP type/description in discussion section below)
- Flow-thru treatment control included as pre-treatment/forebay for an onsite retention or biofiltration BMP (provide BMP type/description and indicate which onsite retention or biofiltration BMP it serves in discussion section below)
- Flow-thru treatment control with alternative compliance (provide BMP type/description in discussion section below)
- Detention pond or vault for hydromodification management
- Other (describe in discussion section below)

Purpose:

- Pollutant control only
- Hydromodification control only
- Combined pollutant control and hydromodification control
- Pre-treatment/forebay for another structural BMP
- Other (describe in discussion section below)

Who will certify construction of this BMP?  
Provide name and contact information for the party responsible to sign BMP verification forms if required by the [City Engineer] (See Section 1.12 of the BMP Design Manual)

Who will be the final owner of this BMP?

PRIVATE OWNER

Who will maintain this BMP into perpetuity?

PRIVATE MAINTENANCE

What is the funding mechanism for maintenance?

**Structural BMP Summary Information**

(Copy this page as needed to provide information for each individual proposed structural BMP)

Structural BMP ID No. 3B

Construction Plan Sheet No.

Type of structural BMP:

- Retention by harvest and use (HU-1)
- Retention by infiltration basin (INF-1)
- Retention by bioretention (INF-2)
- Retention by permeable pavement (INF-3)
- Partial retention by biofiltration with partial retention (PR-1)
- Biofiltration (BF-1)
- Biofiltration with Nutrient Sensitive Media Design (BF-2)
- Proprietary Biofiltration (BF-3) meeting all requirements of Appendix F
- Flow-thru treatment control with prior lawful approval to meet earlier PDP requirements (provide BMP type/description in discussion section below)
- Flow-thru treatment control included as pre-treatment/forebay for an onsite retention or biofiltration BMP (provide BMP type/description and indicate which onsite retention or biofiltration BMP it serves in discussion section below)
- Flow-thru treatment control with alternative compliance (provide BMP type/description in discussion section below)
- Detention pond or vault for hydromodification management
- Other (describe in discussion section below)

Purpose:

- Pollutant control only
- Hydromodification control only
- Combined pollutant control and hydromodification control
- Pre-treatment/forebay for another structural BMP
- Other (describe in discussion section below)

Who will certify construction of this BMP?  
Provide name and contact information for the party responsible to sign BMP verification forms if required by the [City Engineer] (See Section 1.12 of the BMP Design Manual)

Who will be the final owner of this BMP?

PRIVATE OWNER

Who will maintain this BMP into perpetuity?

PRIVATE MAINTENANCE

What is the funding mechanism for maintenance?



**Structural BMP Summary Information**

**(Copy this page as needed to provide information for each individual proposed structural BMP)**

Structural BMP ID No. 3C

Construction Plan Sheet No.

Type of structural BMP:

- Retention by harvest and use (HU-1)
- Retention by infiltration basin (INF-1)
- Retention by bioretention (INF-2)
- Retention by permeable pavement (INF-3)
- Partial retention by biofiltration with partial retention (PR-1)
- Biofiltration (BF-1)
- Biofiltration with Nutrient Sensitive Media Design (BF-2)
- Proprietary Biofiltration (BF-3) meeting all requirements of Appendix F
- Flow-thru treatment control with prior lawful approval to meet earlier PDP requirements (provide BMP type/description in discussion section below)
- Flow-thru treatment control included as pre-treatment/forebay for an onsite retention or biofiltration BMP (provide BMP type/description and indicate which onsite retention or biofiltration BMP it serves in discussion section below)
- Flow-thru treatment control with alternative compliance (provide BMP type/description in discussion section below)
- Detention pond or vault for hydromodification management
- Other (describe in discussion section below)

Purpose:

- Pollutant control only
- Hydromodification control only
- Combined pollutant control and hydromodification control
- Pre-treatment/forebay for another structural BMP
- Other (describe in discussion section below)

Who will certify construction of this BMP?  
Provide name and contact information for the party responsible to sign BMP verification forms if required by the [City Engineer] (See Section 1.12 of the BMP Design Manual)

Who will be the final owner of this BMP?

PRIVATE OWNER

Who will maintain this BMP into perpetuity?

PRIVATE MAINTENANCE

What is the funding mechanism for maintenance?

**Structural BMP Summary Information**

(Copy this page as needed to provide information for each individual proposed structural BMP)

Structural BMP ID No. <b>3D</b>	
Construction Plan Sheet No.	
Type of structural BMP: <input type="checkbox"/> Retention by harvest and use (HU-1) <input type="checkbox"/> Retention by infiltration basin (INF-1) <input type="checkbox"/> Retention by bioretention (INF-2) <input type="checkbox"/> Retention by permeable pavement (INF-3) <input type="checkbox"/> Partial retention by biofiltration with partial retention (PR-1) <input type="checkbox"/> Biofiltration (BF-1) <input type="checkbox"/> Biofiltration with Nutrient Sensitive Media Design (BF-2) <input checked="" type="checkbox"/> Proprietary Biofiltration (BF-3) meeting all requirements of Appendix F <input type="checkbox"/> Flow-thru treatment control with prior lawful approval to meet earlier PDP requirements (provide BMP type/description in discussion section below) <input type="checkbox"/> Flow-thru treatment control included as pre-treatment/forebay for an onsite retention or biofiltration BMP (provide BMP type/description and indicate which onsite retention or biofiltration BMP it serves in discussion section below) <input type="checkbox"/> Flow-thru treatment control with alternative compliance (provide BMP type/description in discussion section below) <input type="checkbox"/> Detention pond or vault for hydromodification management <input type="checkbox"/> Other (describe in discussion section below)	
Purpose: <input checked="" type="checkbox"/> Pollutant control only <input type="checkbox"/> Hydromodification control only <input type="checkbox"/> Combined pollutant control and hydromodification control <input type="checkbox"/> Pre-treatment/forebay for another structural BMP <input type="checkbox"/> Other (describe in discussion section below)	
Who will certify construction of this BMP? Provide name and contact information for the party responsible to sign BMP verification forms if required by the [City Engineer] (See Section 1.12 of the BMP Design Manual)	
Who will be the final owner of this BMP?	<b>PRIVATE OWNER</b>
Who will maintain this BMP into perpetuity?	<b>PRIVATE MAINTENANCE</b>
What is the funding mechanism for maintenance?	



**Structural BMP Summary Information**

(Copy this page as needed to provide information for each individual proposed structural BMP)

Structural BMP ID No. <u>4</u>	
Construction Plan Sheet No.	
Type of structural BMP: <input type="checkbox"/> Retention by harvest and use (HU-1) <input type="checkbox"/> Retention by infiltration basin (INF-1) <input type="checkbox"/> Retention by bioretention (INF-2) <input type="checkbox"/> Retention by permeable pavement (INF-3) <input type="checkbox"/> Partial retention by biofiltration with partial retention (PR-1) <input checked="" type="checkbox"/> Biofiltration (BF-1) <input type="checkbox"/> Biofiltration with Nutrient Sensitive Media Design (BF-2) <input type="checkbox"/> Proprietary Biofiltration (BF-3) meeting all requirements of Appendix F <input type="checkbox"/> Flow-thru treatment control with prior lawful approval to meet earlier PDP requirements (provide BMP type/description in discussion section below) <input type="checkbox"/> Flow-thru treatment control included as pre-treatment/forebay for an onsite retention or biofiltration BMP (provide BMP type/description and indicate which onsite retention or biofiltration BMP it serves in discussion section below) <input type="checkbox"/> Flow-thru treatment control with alternative compliance (provide BMP type/description in discussion section below) <input type="checkbox"/> Detention pond or vault for hydromodification management <input type="checkbox"/> Other (describe in discussion section below)	
Purpose: <input checked="" type="checkbox"/> Pollutant control only <input type="checkbox"/> Hydromodification control only <input type="checkbox"/> Combined pollutant control and hydromodification control <input type="checkbox"/> Pre-treatment/forebay for another structural BMP <input type="checkbox"/> Other (describe in discussion section below)	
Who will certify construction of this BMP? Provide name and contact information for the party responsible to sign BMP verification forms if required by the [City Engineer] (See Section 1.12 of the BMP Design Manual)	
Who will be the final owner of this BMP?	PRIVATE OWNER
Who will maintain this BMP into perpetuity?	PRIVATE MAINTENANCE
What is the funding mechanism for maintenance?	

**Structural BMP Summary Information**

(Copy this page as needed to provide information for each individual proposed structural BMP)

Structural BMP ID No. **5A**

Construction Plan Sheet No.

Type of structural BMP:

- Retention by harvest and use (HU-1)
- Retention by infiltration basin (INF-1)
- Retention by bioretention (INF-2)
- Retention by permeable pavement (INF-3)
- Partial retention by biofiltration with partial retention (PR-1)
- Biofiltration (BF-1)
- Biofiltration with Nutrient Sensitive Media Design (BF-2)
- Proprietary Biofiltration (BF-3) meeting all requirements of Appendix F
- Flow-thru treatment control with prior lawful approval to meet earlier PDP requirements (provide BMP type/description in discussion section below)
- Flow-thru treatment control included as pre-treatment/forebay for an onsite retention or biofiltration BMP (provide BMP type/description and indicate which onsite retention or biofiltration BMP it serves in discussion section below)
- Flow-thru treatment control with alternative compliance (provide BMP type/description in discussion section below)
- Detention pond or vault for hydromodification management
- Other (describe in discussion section below)

Purpose:

- Pollutant control only
- Hydromodification control only
- Combined pollutant control and hydromodification control
- Pre-treatment/forebay for another structural BMP
- Other (describe in discussion section below)

Who will certify construction of this BMP?  
Provide name and contact information for the party responsible to sign BMP verification forms if required by the [City Engineer] (See Section 1.12 of the BMP Design Manual)

Who will be the final owner of this BMP?

**PUBLIC / CITY**

Who will maintain this BMP into perpetuity?

**CITY**

What is the funding mechanism for maintenance?

**CFD**



**Structural BMP Summary Information**

(Copy this page as needed to provide information for each individual proposed structural BMP)

Structural BMP ID No. <b>EB</b>	
Construction Plan Sheet No.	
Type of structural BMP: <input type="checkbox"/> Retention by harvest and use (HU-1) <input type="checkbox"/> Retention by infiltration basin (INF-1) <input type="checkbox"/> Retention by bioretention (INF-2) <input type="checkbox"/> Retention by permeable pavement (INF-3) <input type="checkbox"/> Partial retention by biofiltration with partial retention (PR-1) <input checked="" type="checkbox"/> Biofiltration (BF-1) <input type="checkbox"/> Biofiltration with Nutrient Sensitive Media Design (BF-2) <input type="checkbox"/> Proprietary Biofiltration (BF-3) meeting all requirements of Appendix F <input type="checkbox"/> Flow-thru treatment control with prior lawful approval to meet earlier PDP requirements (provide BMP type/description in discussion section below) <input type="checkbox"/> Flow-thru treatment control included as pre-treatment/forebay for an onsite retention or biofiltration BMP (provide BMP type/description and indicate which onsite retention or biofiltration BMP it serves in discussion section below) <input type="checkbox"/> Flow-thru treatment control with alternative compliance (provide BMP type/description in discussion section below) <input type="checkbox"/> Detention pond or vault for hydromodification management <input type="checkbox"/> Other (describe in discussion section below)	
Purpose: <input checked="" type="checkbox"/> Pollutant control only <input type="checkbox"/> Hydromodification control only <input type="checkbox"/> Combined pollutant control and hydromodification control <input type="checkbox"/> Pre-treatment/forebay for another structural BMP <input type="checkbox"/> Other (describe in discussion section below)	
Who will certify construction of this BMP? Provide name and contact information for the party responsible to sign BMP verification forms if required by the [City Engineer] (See Section 1.12 of the BMP Design Manual)	
Who will be the final owner of this BMP?	<b>PUBLIC / CITY</b>
Who will maintain this BMP into perpetuity?	<b>CITY</b>
What is the funding mechanism for maintenance?	<b>CFD</b>

**Structural BMP Summary Information**

(Copy this page as needed to provide information for each individual proposed structural BMP)

Structural BMP ID No. 5C

Construction Plan Sheet No.

Type of structural BMP:

- Retention by harvest and use (HU-1)
- Retention by infiltration basin (INF-1)
- Retention by bioretention (INF-2)
- Retention by permeable pavement (INF-3)
- Partial retention by biofiltration with partial retention (PR-1)
- Biofiltration (BF-1)
- Biofiltration with Nutrient Sensitive Media Design (BF-2)
- Proprietary Biofiltration (BF-3) meeting all requirements of Appendix F
- Flow-thru treatment control with prior lawful approval to meet earlier PDP requirements (provide BMP type/description in discussion section below)
- Flow-thru treatment control included as pre-treatment/forebay for an onsite retention or biofiltration BMP (provide BMP type/description and indicate which onsite retention or biofiltration BMP it serves in discussion section below)
- Flow-thru treatment control with alternative compliance (provide BMP type/description in discussion section below)
- Detention pond or vault for hydromodification management
- Other (describe in discussion section below)

Purpose:

- Pollutant control only
- Hydromodification control only
- Combined pollutant control and hydromodification control
- Pre-treatment/forebay for another structural BMP
- Other (describe in discussion section below)

Who will certify construction of this BMP?  
Provide name and contact information for the party responsible to sign BMP verification forms if required by the [City Engineer] (See Section 1.12 of the BMP Design Manual)

Who will be the final owner of this BMP?

PUBLIC/CITY

Who will maintain this BMP into perpetuity?

CITY

What is the funding mechanism for maintenance?

CFD



**Structural BMP Summary Information**

(Copy this page as needed to provide information for each individual proposed structural BMP)

Structural BMP ID No. <i>5D</i>	
Construction Plan Sheet No.	
Type of structural BMP: <input type="checkbox"/> Retention by harvest and use (HU-1) <input type="checkbox"/> Retention by infiltration basin (INF-1) <input type="checkbox"/> Retention by bioretention (INF-2) <input type="checkbox"/> Retention by permeable pavement (INF-3) <input type="checkbox"/> Partial retention by biofiltration with partial retention (PR-1) <input checked="" type="checkbox"/> Biofiltration (BF-1) <input type="checkbox"/> Biofiltration with Nutrient Sensitive Media Design (BF-2) <input type="checkbox"/> Proprietary Biofiltration (BF-3) meeting all requirements of Appendix F <input type="checkbox"/> Flow-thru treatment control with prior lawful approval to meet earlier PDP requirements (provide BMP type/description in discussion section below) <input type="checkbox"/> Flow-thru treatment control included as pre-treatment/forebay for an onsite retention or biofiltration BMP (provide BMP type/description and indicate which onsite retention or biofiltration BMP it serves in discussion section below) <input type="checkbox"/> Flow-thru treatment control with alternative compliance (provide BMP type/description in discussion section below) <input type="checkbox"/> Detention pond or vault for hydromodification management <input type="checkbox"/> Other (describe in discussion section below)	
Purpose: <input checked="" type="checkbox"/> Pollutant control only <input type="checkbox"/> Hydromodification control only <input type="checkbox"/> Combined pollutant control and hydromodification control <input type="checkbox"/> Pre-treatment/forebay for another structural BMP <input type="checkbox"/> Other (describe in discussion section below)	
Who will certify construction of this BMP? Provide name and contact information for the party responsible to sign BMP verification forms if required by the [City Engineer] (See Section 1.12 of the BMP Design Manual)	
Who will be the final owner of this BMP?	<i>PUBLIC / CITY</i>
Who will maintain this BMP into perpetuity?	<i>CITY</i>
What is the funding mechanism for maintenance?	<i>CFD</i>

**Structural BMP Summary Information**

**(Copy this page as needed to provide information for each individual proposed structural BMP)**

Structural BMP ID No. <i>G</i>	
Construction Plan Sheet No.	
Type of structural BMP: <input type="checkbox"/> Retention by harvest and use (HU-1) <input type="checkbox"/> Retention by infiltration basin (INF-1) <input type="checkbox"/> Retention by bioretention (INF-2) <input type="checkbox"/> Retention by permeable pavement (INF-3) <input type="checkbox"/> Partial retention by biofiltration with partial retention (PR-1) <input type="checkbox"/> Biofiltration (BF-1) <input type="checkbox"/> Biofiltration with Nutrient Sensitive Media Design (BF-2) <input type="checkbox"/> Proprietary Biofiltration (BF-3) meeting all requirements of Appendix F <input type="checkbox"/> Flow-thru treatment control with prior lawful approval to meet earlier PDP requirements (provide BMP type/description in discussion section below) <input type="checkbox"/> Flow-thru treatment control included as pre-treatment/forebay for an onsite retention or biofiltration BMP (provide BMP type/description and indicate which onsite retention or biofiltration BMP it serves in discussion section below) <input type="checkbox"/> Flow-thru treatment control with alternative compliance (provide BMP type/description in discussion section below) <input checked="" type="checkbox"/> Detention pond or vault for hydromodification management <input type="checkbox"/> Other (describe in discussion section below)	
Purpose: <input type="checkbox"/> Pollutant control only <input checked="" type="checkbox"/> Hydromodification control only <input type="checkbox"/> Combined pollutant control and hydromodification control <input type="checkbox"/> Pre-treatment/forebay for another structural BMP <input type="checkbox"/> Other (describe in discussion section below)	
Who will certify construction of this BMP? Provide name and contact information for the party responsible to sign BMP verification forms if required by the [City Engineer] (See Section 1.12 of the BMP Design Manual)	
Who will be the final owner of this BMP?	<i>PRIVATE OWNER</i>
Who will maintain this BMP into perpetuity?	<i>PRIVATE MAINTENANCE</i>
What is the funding mechanism for maintenance?	



**Structural BMP Summary Information**

**(Copy this page as needed to provide information for each individual proposed structural BMP)**

Structural BMP ID No. <u>7</u>	
Construction Plan Sheet No.	
Type of structural BMP: <input type="checkbox"/> Retention by harvest and use (HU-1) <input type="checkbox"/> Retention by infiltration basin (INF-1) <input type="checkbox"/> Retention by bioretention (INF-2) <input type="checkbox"/> Retention by permeable pavement (INF-3) <input type="checkbox"/> Partial retention by biofiltration with partial retention (PR-1) <input type="checkbox"/> Biofiltration (BF-1) <input type="checkbox"/> Biofiltration with Nutrient Sensitive Media Design (BF-2) <input type="checkbox"/> Proprietary Biofiltration (BF-3) meeting all requirements of Appendix F <input type="checkbox"/> Flow-thru treatment control with prior lawful approval to meet earlier PDP requirements (provide BMP type/description in discussion section below) <input type="checkbox"/> Flow-thru treatment control included as pre-treatment/forebay for an onsite retention or biofiltration BMP (provide BMP type/description and indicate which onsite retention or biofiltration BMP it serves in discussion section below) <input type="checkbox"/> Flow-thru treatment control with alternative compliance (provide BMP type/description in discussion section below) <input checked="" type="checkbox"/> Detention pond or vault for hydromodification management <input type="checkbox"/> Other (describe in discussion section below)	
Purpose: <input type="checkbox"/> Pollutant control only <input checked="" type="checkbox"/> Hydromodification control only <input type="checkbox"/> Combined pollutant control and hydromodification control <input type="checkbox"/> Pre-treatment/forebay for another structural BMP <input type="checkbox"/> Other (describe in discussion section below)	
Who will certify construction of this BMP? Provide name and contact information for the party responsible to sign BMP verification forms if required by the [City Engineer] (See Section 1.12 of the BMP Design Manual)	
Who will be the final owner of this BMP?	<u>PRIVATE OWNER</u>
Who will maintain this BMP into perpetuity?	<u>PRIVATE MAINTENANCE</u>
What is the funding mechanism for maintenance?	

**Structural BMP Summary Information**

**(Copy this page as needed to provide information for each individual proposed structural BMP)**

Structural BMP ID No. <b>7A</b>	
Construction Plan Sheet No.	
Type of structural BMP: <input type="checkbox"/> Retention by harvest and use (HU-1) <input type="checkbox"/> Retention by infiltration basin (INF-1) <input type="checkbox"/> Retention by bioretention (INF-2) <input type="checkbox"/> Retention by permeable pavement (INF-3) <input type="checkbox"/> Partial retention by biofiltration with partial retention (PR-1) <input checked="" type="checkbox"/> Biofiltration (BF-1) <input type="checkbox"/> Biofiltration with Nutrient Sensitive Media Design (BF-2) <input type="checkbox"/> Proprietary Biofiltration (BF-3) meeting all requirements of Appendix F <input type="checkbox"/> Flow-thru treatment control with prior lawful approval to meet earlier PDP requirements (provide BMP type/description in discussion section below) <input type="checkbox"/> Flow-thru treatment control included as pre-treatment/forebay for an onsite retention or biofiltration BMP (provide BMP type/description and indicate which onsite retention or biofiltration BMP it serves in discussion section below) <input type="checkbox"/> Flow-thru treatment control with alternative compliance (provide BMP type/description in discussion section below) <input type="checkbox"/> Detention pond or vault for hydromodification management <input type="checkbox"/> Other (describe in discussion section below)	
Purpose: <input checked="" type="checkbox"/> Pollutant control only <input type="checkbox"/> Hydromodification control only <input type="checkbox"/> Combined pollutant control and hydromodification control <input type="checkbox"/> Pre-treatment/forebay for another structural BMP <input type="checkbox"/> Other (describe in discussion section below)	
Who will certify construction of this BMP? Provide name and contact information for the party responsible to sign BMP verification forms if required by the [City Engineer] (See Section 1.12 of the BMP Design Manual)	
Who will be the final owner of this BMP?	<b>PUBLIC/CITY</b>
Who will maintain this BMP into perpetuity?	<b>CITY</b>
What is the funding mechanism for maintenance?	<b>CFD</b>



**Structural BMP Summary Information**

(Copy this page as needed to provide information for each individual proposed structural BMP)

Structural BMP ID No. <b>7B</b>	
Construction Plan Sheet No.	
Type of structural BMP: <input type="checkbox"/> Retention by harvest and use (HU-1) <input type="checkbox"/> Retention by infiltration basin (INF-1) <input type="checkbox"/> Retention by bioretention (INF-2) <input type="checkbox"/> Retention by permeable pavement (INF-3) <input type="checkbox"/> Partial retention by biofiltration with partial retention (PR-1) <input checked="" type="checkbox"/> Biofiltration (BF-1) <input type="checkbox"/> Biofiltration with Nutrient Sensitive Media Design (BF-2) <input type="checkbox"/> Proprietary Biofiltration (BF-3) meeting all requirements of Appendix F <input type="checkbox"/> Flow-thru treatment control with prior lawful approval to meet earlier PDP requirements (provide BMP type/description in discussion section below) <input type="checkbox"/> Flow-thru treatment control included as pre-treatment/forebay for an onsite retention or biofiltration BMP (provide BMP type/description and indicate which onsite retention or biofiltration BMP it serves in discussion section below) <input type="checkbox"/> Flow-thru treatment control with alternative compliance (provide BMP type/description in discussion section below) <input type="checkbox"/> Detention pond or vault for hydromodification management <input type="checkbox"/> Other (describe in discussion section below)	
Purpose: <input checked="" type="checkbox"/> Pollutant control only <input type="checkbox"/> Hydromodification control only <input type="checkbox"/> Combined pollutant control and hydromodification control <input type="checkbox"/> Pre-treatment/forebay for another structural BMP <input type="checkbox"/> Other (describe in discussion section below)	
Who will certify construction of this BMP? Provide name and contact information for the party responsible to sign BMP verification forms if required by the [City Engineer] (See Section 1.12 of the BMP Design Manual)	
Who will be the final owner of this BMP?	<b>PUBLIC/CITY</b>
Who will maintain this BMP into perpetuity?	<b>CITY</b>
What is the funding mechanism for maintenance?	<b>CFD</b>

**ATTACHMENT 1  
BACKUP FOR PDP POLLUTANT CONTROL BMPS**

This is the cover sheet for Attachment 1.

**Indicate which Items are Included behind this cover sheet:**

<b>Attachment Sequence</b>	<b>Contents</b>	<b>Checklist</b>
Attachment 1a	DMA Exhibit (Required)  See DMA Exhibit Checklist on the back of this Attachment cover sheet.	Harvest and Reuse is not feasible for the project. Included
Attachment 1b	Tabular Summary of DMAs Showing DMA ID matching DMA Exhibit, DMA Area, and DMA Type (Required)*  *Provide table in this Attachment OR on DMA Exhibit in Attachment 1a	<input checked="" type="checkbox"/> Included on DMA Exhibit in Attachment 1a <input type="checkbox"/> Included as Attachment 1b, separate from DMA Exhibit
Attachment 1c	Form I-7, Harvest and Use Feasibility Screening Checklist (Required unless the entire project will use infiltration BMPs)  Refer to Appendix B.3-1 of the BMP Design Manual to complete Form I-7.	<input checked="" type="checkbox"/> Included <input type="checkbox"/> Not included because the entire project will use infiltration BMPs
Attachment 1d	Form I-8, Categorization of Infiltration Feasibility Condition (Required unless the project will use harvest and use BMPs)  Refer to Appendices C and D of the BMP Design Manual to complete Form I-8.	<input checked="" type="checkbox"/> Included <input type="checkbox"/> Not included because the entire project will use harvest and use BMPs
Attachment 1e	Pollutant Control BMP Design Worksheets / Calculations (Required)  Refer to Appendices B and E of the BMP Design Manual for structural pollutant control BMP design guidelines	<input checked="" type="checkbox"/> Included



**Use this checklist to ensure the required information has been included on the DMA Exhibit:**

The DMA Exhibit must identify:

- Underlying hydrologic soil group
- Approximate depth to groundwater
- Existing natural hydrologic features ( watercourses, seeps, springs, wetlands)
- Critical coarse sediment yield areas to be protected
- Existing topography and impervious areas
- Existing and proposed site drainage network and connections to drainage offsite
- Proposed demolition
- Proposed grading
- Proposed impervious features
- Proposed design features and surface treatments used to minimize imperviousness
- Drainage management area (DMA) boundaries, DMA ID numbers, and DMA areas (square footage or acreage), and DMA type (i.e., drains to BMP, self-retaining, or self-mitigating)
- Potential pollutant source areas and corresponding required source controls (see Chapter 4, Appendix E.1, and Form I-3B)
- Structural BMPs (identify location, type of BMP, and size/detail)



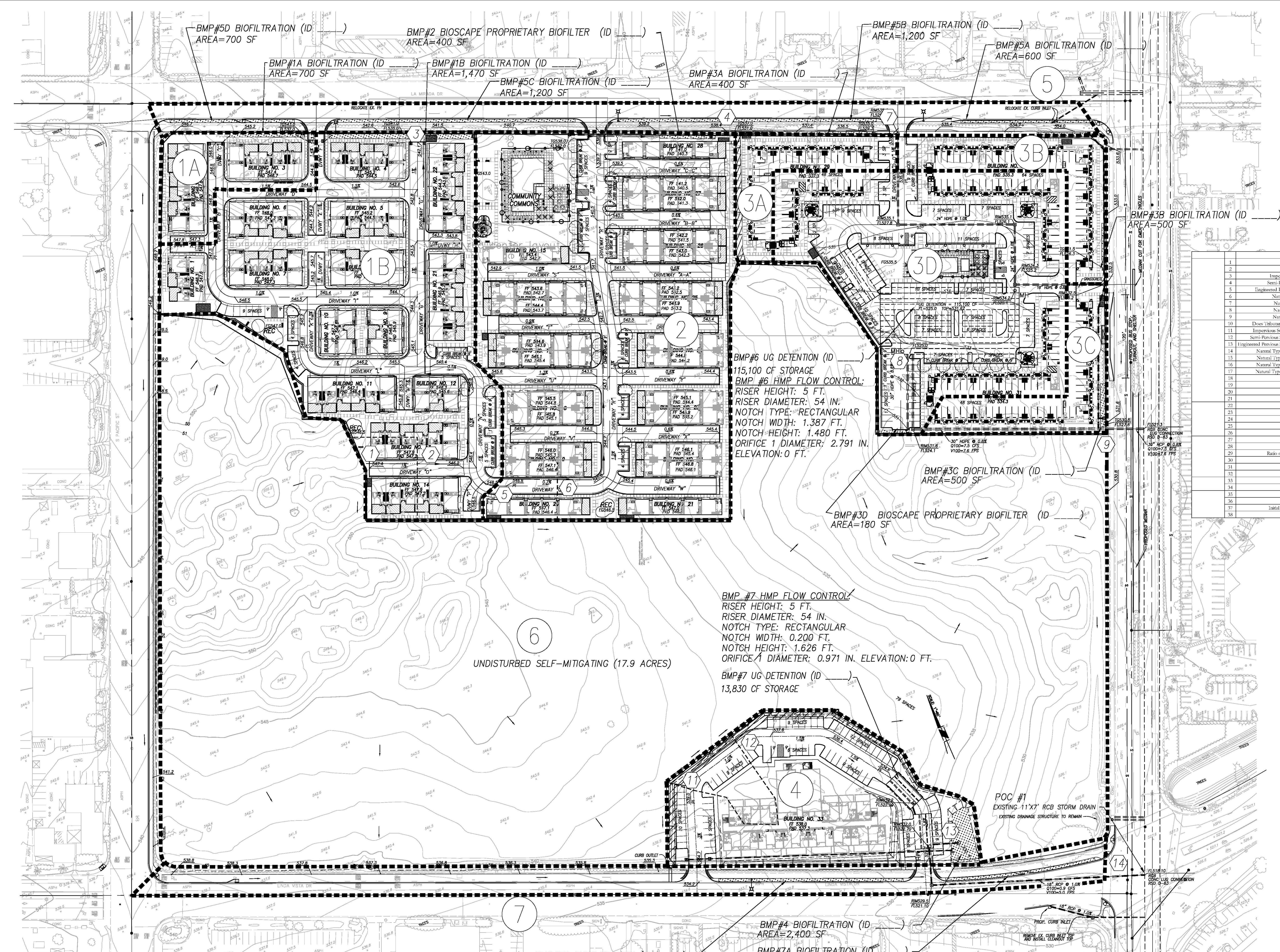

**LEGEND**

- ① DMA NUMBER
- DRAINAGE MANAGEMENT AREA (DMA)
- TREE WELL PER SD-4 (PROJECT TOTAL = 26 EA)
- STORMWATER VAULT WITH HMP FLOW CONTROL (PROJECT TOTAL = 128,930 CF)
- ▨ BIOFILTRATION BASIN (PROJECT TOTAL = 9,940 SF)
- ② AES DRAINAGE NODE

TOTAL AREA = 33.2 ACRES  
 DISTURBED AREA = 16.5 ACRES  
 HYDROLOGIC SOIL GROUP D  
 DEPTH TO GROUNDWATER > 15 FEET  
 NO EXISTING NATURAL HYDROLOGIC FEATURES  
 NO CRITICAL COARSE SEDIMENT YIELD AREAS (CCSYA) EXISTS ON SITE.

Drainage Node ID or Name	DMA 1A	DMA 1B	DMA 2	DMA 3A	DMA 3B	DMA 3C	DMA 4	DMA 5	DMA 6	inches
1. Impervious Surface, 24 hr Storm Depth	0.75	0.75	0.75	0.75	0.75	0.75	0.75	0.75	0.75	0.75
2. Semi-Pervious Surface, 24 hr Storm Depth	0.60	0.60	0.60	0.60	0.60	0.60	0.60	0.60	0.60	0.60
3. Permeable Pervious Surface, 24 hr Storm Depth	0.10	0.10	0.10	0.10	0.10	0.10	0.10	0.10	0.10	0.10
4. Natural Type A Soil, 24 hr Storm Depth	0.10	0.10	0.10	0.10	0.10	0.10	0.10	0.10	0.10	0.10
5. Natural Type B Soil, 24 hr Storm Depth	0.10	0.10	0.10	0.10	0.10	0.10	0.10	0.10	0.10	0.10
6. Natural Type C Soil, 24 hr Storm Depth	0.10	0.10	0.10	0.10	0.10	0.10	0.10	0.10	0.10	0.10
7. Natural Type D Soil, 24 hr Storm Depth	0.10	0.10	0.10	0.10	0.10	0.10	0.10	0.10	0.10	0.10
8. Impervious Surface, 24 hr Storm Depth	0.75	0.75	0.75	0.75	0.75	0.75	0.75	0.75	0.75	0.75
9. Semi-Pervious Surface, 24 hr Storm Depth	0.60	0.60	0.60	0.60	0.60	0.60	0.60	0.60	0.60	0.60
10. Permeable Pervious Surface, 24 hr Storm Depth	0.10	0.10	0.10	0.10	0.10	0.10	0.10	0.10	0.10	0.10
11. Natural Type A Soil, 24 hr Storm Depth	0.10	0.10	0.10	0.10	0.10	0.10	0.10	0.10	0.10	0.10
12. Natural Type B Soil, 24 hr Storm Depth	0.10	0.10	0.10	0.10	0.10	0.10	0.10	0.10	0.10	0.10
13. Natural Type C Soil, 24 hr Storm Depth	0.10	0.10	0.10	0.10	0.10	0.10	0.10	0.10	0.10	0.10
14. Natural Type D Soil, 24 hr Storm Depth	0.10	0.10	0.10	0.10	0.10	0.10	0.10	0.10	0.10	0.10
15. Average Annual Flow Capacity	20	20	20	20	20	20	20	20	20	20
16. Number of Rain Events per Year	5	15				6				6
17. Average Rain Rate (in/hr)	2.0	2.0				2.0				2.0
18. Total Volume of Rain (in/yr)	20	20				20				20
19. Total Volume of Rain (in/yr)	20	20				20				20
20. Total Volume of Rain (in/yr)	20	20				20				20
21. Total Volume of Rain (in/yr)	20	20				20				20
22. Total Volume of Rain (in/yr)	20	20				20				20
23. Total Volume of Rain (in/yr)	20	20				20				20
24. Total Volume of Rain (in/yr)	20	20				20				20
25. Total Volume of Rain (in/yr)	20	20				20				20
26. Total Volume of Rain (in/yr)	20	20				20				20
27. Total Volume of Rain (in/yr)	20	20				20				20
28. Total Volume of Rain (in/yr)	20	20				20				20
29. Total Volume of Rain (in/yr)	20	20				20				20
30. Total Volume of Rain (in/yr)	20	20				20				20
31. Total Volume of Rain (in/yr)	20	20				20				20
32. Total Volume of Rain (in/yr)	20	20				20				20
33. Total Volume of Rain (in/yr)	20	20				20				20
34. Total Volume of Rain (in/yr)	20	20				20				20
35. Total Volume of Rain (in/yr)	20	20				20				20
36. Total Volume of Rain (in/yr)	20	20				20				20
37. Total Volume of Rain (in/yr)	20	20				20				20
38. Total Volume of Rain (in/yr)	20	20				20				20

**SOURCE CONTROL BMPs**

SOURCE CONTROL BMPs	PROJECT IMPLEMENTATION
4.2.1 & 4.2.2 STORM DRAIN INLETS	MARK ALL INLETS WITH THE WORDS "NO DUMPING DRAINS TO WATERWAYS" IN ENGLISH AND "NO CONTAMINE" IN SPANISH. MAINTAIN AND PERIODICALLY REPLACE INLET MARKINGS. SEE APPLICABLE OPERATIONAL BMPs IN CASQA FACT SHEET SC-44, "DRAINAGE SYSTEM MAINTENANCE."
4.2.6.E LANDSCAPE/OUTDOOR PESTICIDE USE	LANDSCAPE HAS BEEN DESIGNED PER CITY OF SAN DIEGO LANDSCAPE STANDARDS TO MINIMIZE IRRIGATION AND RUNOFF, AND TO MINIMIZE THE USE OF FERTILIZERS AND PESTICIDES THAT CAN CONTRIBUTE TO STORMWATER POLLUTION. SEE APPLICABLE BMPs IN CASQA FACT SHEETS SC-41, "BUILDING AND GROUNDS MAINTENANCE."
4.2.5 TRASH BINS	TRASH BIN FOR EACH UNIT SHALL HAVE LIDS AND BE STORED IN GARAGE. SEE CASQA FACT SHEET SC-54, "WASTE HANDLING AND DISPOSAL."
4.2.6.O PLAZAS, SIDEWALKS, AND PARKING LOTS	PLAZAS, SIDEWALKS, AND PARKING LOTS SHALL BE SWEEP REGULARLY AND ONCE PRIOR TO OCTOBER 1ST TO PREVENT THE ACCUMULATION OF LITTER AND DEBRIS. SEE CASQA FACT SHEET SC-41, "BUILDING AND GROUNDS MAINTENANCE."

**SITE DESIGN BMPs**

4.3.3	4.3.3 MINIMIZE IMPERVIOUS AREA: RESIDENTIAL STREETS ARE AT THE MINIMUM REQUIRED WIDTH PER COUNTY STANDARDS.
4.3.4	4.3.4 MINIMIZE SOIL COMPACTION: RE-TILL SOILS COMPACTED BY CONSTRUCTION VEHICLES. COLLECT AND RE-USE UPPER SOIL LAYERS DEVELOPMENT SITE CONTAINING ORGANIC MATERIALS.
4.3.5	4.3.5 RUNOFF FROM WALKS AND ROOF DRAIN DOWNSPOUTS SHALL DISCHARGE ONTO SPLASH BLOCKS AND FLOW THROUGH ADJACENT LANDSCAPE AREA BEFORE ENTERING BIORETENTION BASINS.
4.3.7	4.3.7 LANDSCAPING WITH DROUGHT TOLERANT SPECIES

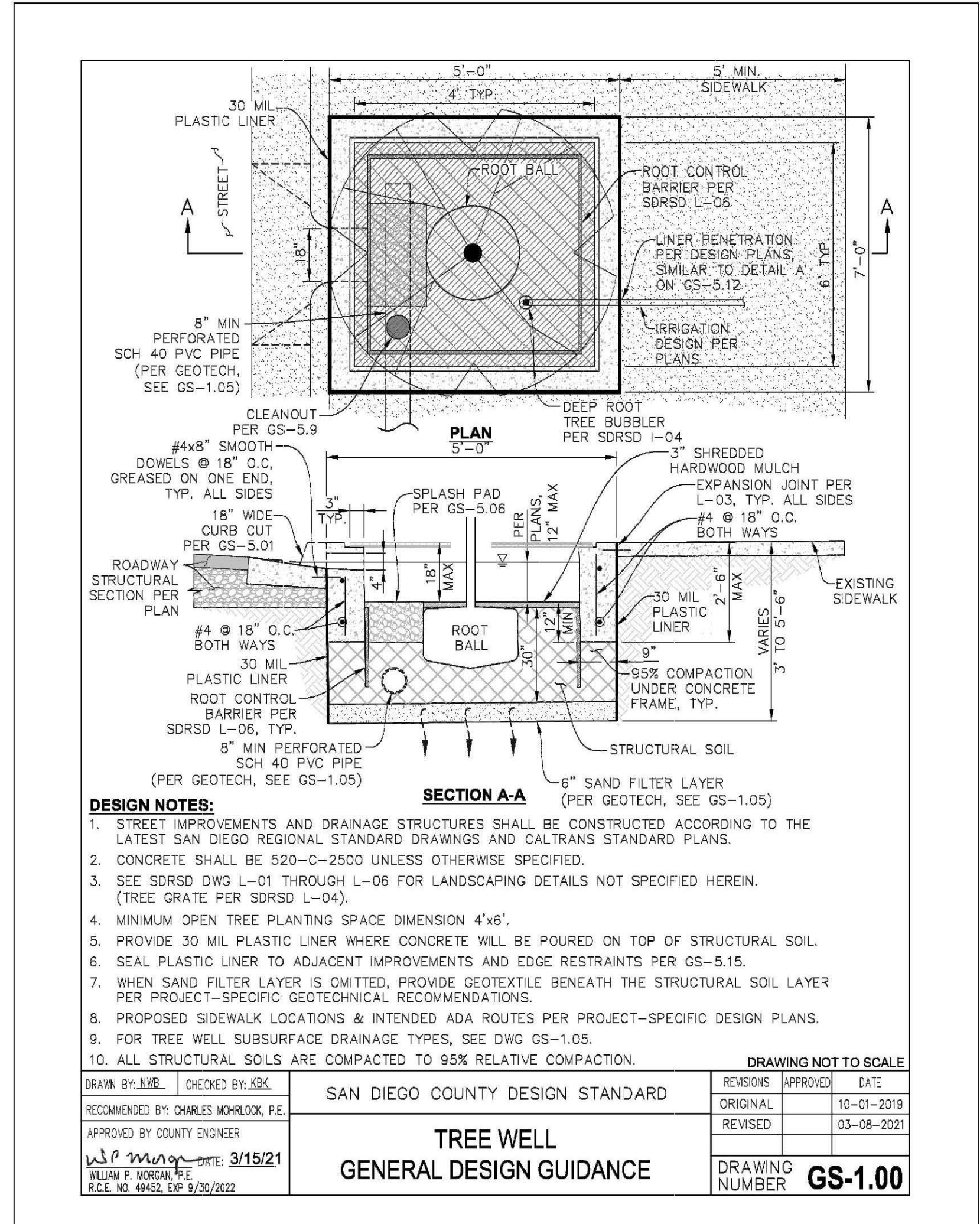
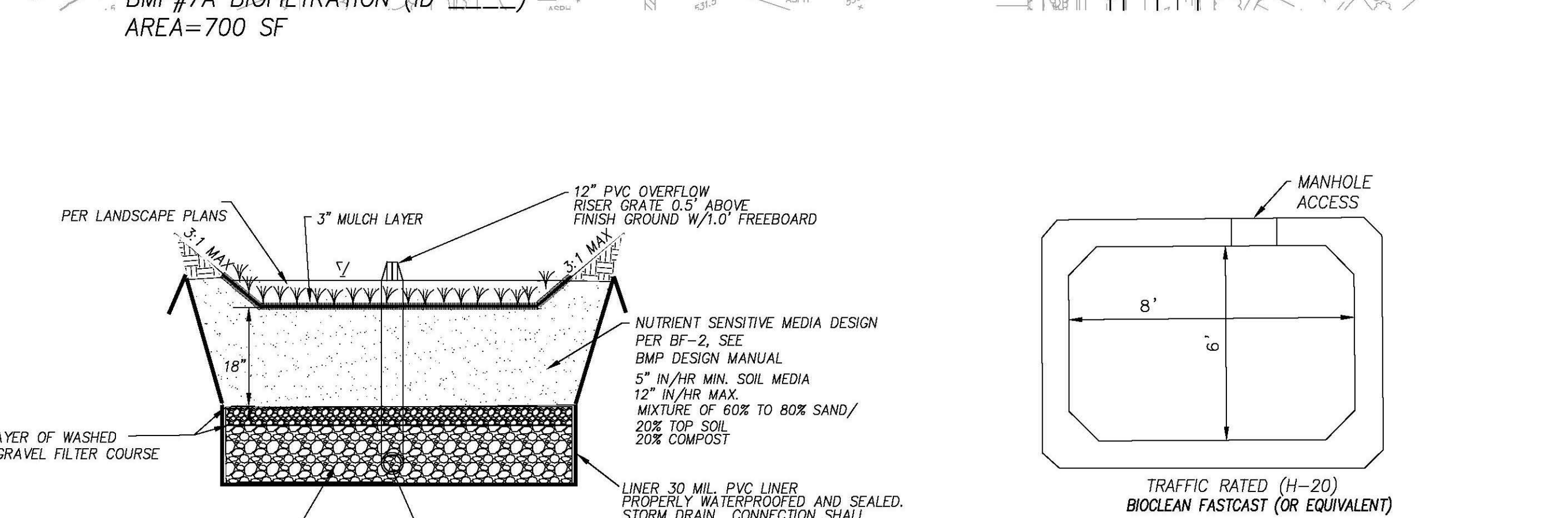



**Automated Worksheet B.1: Calculation of Design Capture Volume (V2.0)**

Category	#	Description	<i>i</i>	<i>ii</i>	<i>iii</i>	<i>iv</i>	<i>v</i>	<i>vi</i>	<i>vii</i>	<i>viii</i>	<i>ix</i>	<i>x</i>	Units
Standard Drainage Basin Inputs	1	Drainage Basin ID or Name	DMA 1A	DMA 1B	DMA 2	DMA 3A	DMA 3B	DMA 3C	DMA 3D	DMA 4	DMA 5	DMA 7	unitless
	2	85th Percentile 24-hr Storm Depth	0.75	0.75	0.75	0.75	0.75	0.75	0.75	0.75	0.75	0.75	inches
	3	Impervious Surfaces <u>Not Directed to Dispersion Area</u> (C=0.90)	19,800	125,875	190,940	12,930	16,500	15,600	80,534	40,000	51,250	57,200	sq-ft
	4	Semi-Pervious Surfaces <u>Not Serving as Dispersion Area</u> (C=0.30)											sq-ft
	5	Engineered Pervious Surfaces <u>Not Serving as Dispersion Area</u> (C=0.10)	4,900	41,960	56,400	6,370	8,100	7,600	39,666	38,600			sq-ft
	6	Natural Type A Soil <u>Not Serving as Dispersion Area</u> (C=0.10)											sq-ft
	7	Natural Type B Soil <u>Not Serving as Dispersion Area</u> (C=0.14)											sq-ft
	8	Natural Type C Soil <u>Not Serving as Dispersion Area</u> (C=0.23)											sq-ft
	9	Natural Type D Soil <u>Not Serving as Dispersion Area</u> (C=0.30)											sq-ft
Dispersion Area, Tree Well & Rain Barrel Inputs (Optional)	10	Does Tributary Incorporate Dispersion, Tree Wells, and/or Rain Barrels?	Yes	Yes	Yes	No	No	No	Yes	No	No	No	yes/no
	11	Impervious Surfaces <b>Directed to Dispersion Area</b> per SD-B (Ci=0.90)											sq-ft
	12	Semi-Pervious Surfaces <b>Serving as Dispersion Area</b> per SD-B (Ci=0.30)											sq-ft
	13	Engineered Pervious Surfaces <b>Serving as Dispersion Area</b> per SD-B (Ci=0.10)											sq-ft
	14	Natural Type A Soil <b>Serving as Dispersion Area</b> per SD-B (Ci=0.10)											sq-ft
	15	Natural Type B Soil <b>Serving as Dispersion Area</b> per SD-B (Ci=0.14)											sq-ft
	16	Natural Type C Soil <b>Serving as Dispersion Area</b> per SD-B (Ci=0.23)											sq-ft
	17	Natural Type D Soil <b>Serving as Dispersion Area</b> per SD-B (Ci=0.30)											sq-ft
	18	Number of Tree Wells Proposed per SD-A		5	15				6				#
	19	Average Mature Tree Canopy Diameter		20	20				20				ft
	20	Number of Rain Barrels Proposed per SD-E											#
Initial Runoff Factor Calculation	21	Average Rain Barrel Size											gal
	22	Total Tributary Area	24,700	167,835	247,340	19,300	24,600	23,200	120,200	78,600	51,250	57,200	sq-ft
	23	Initial Runoff Factor for Standard Drainage Areas	0.74	0.70	0.72	0.64	0.64	0.64	0.64	0.51	0.90	0.90	unitless
	24	Initial Runoff Factor for Dispersed & Dispersion Areas	0.00	0.00	0.00	0.00	0.00	0.00	0.00	0.00	0.00	0.00	unitless
	25	Initial Weighted Runoff Factor	0.74	0.70	0.72	0.64	0.64	0.64	0.64	0.51	0.90	0.90	unitless
	26	Initial Design Capture Volume	1,142	7,343	11,130	772	984	928	4,808	2,505	2,883	3,218	cubic-feet
Dispersion Area Adjustments	27	Total Impervious Area Dispersed to Pervious Surface	0	0	0	0	0	0	0	0	0	0	sq-ft
	28	Total Pervious Dispersion Area	0	0	0	0	0	0	0	0	0	0	sq-ft
	29	Ratio of Dispersed Impervious Area to Pervious Dispersion Area	n/a	n/a	n/a	n/a	n/a	n/a	n/a	n/a	n/a	n/a	ratio
	30	Adjustment Factor for Dispersed & Dispersion Areas	1.00	1.00	1.00	1.00	1.00	1.00	1.00	1.00	1.00	1.00	ratio
	31	Runoff Factor After Dispersion Techniques	0.74	0.70	0.72	0.64	0.64	0.64	0.64	0.51	0.90	0.90	unitless
	32	Design Capture Volume After Dispersion Techniques	1,142	7,343	11,130	772	984	928	4,808	2,505	2,883	3,218	cubic-feet
Tree & Barrel Adjustments	33	Total Tree Well Volume Reduction	0	900	2,700	0	0	0	1,080	0	0	0	cubic-feet
	34	Total Rain Barrel Volume Reduction	0	0	0	0	0	0	0	0	0	0	cubic-feet
Results	35	Final Adjusted Runoff Factor	0.74	0.61	0.55	0.64	0.64	0.64	0.50	0.51	0.90	0.90	unitless
	36	Final Effective Tributary Area	18,278	102,379	136,037	12,352	15,744	14,848	60,100	40,086	46,125	51,480	sq-ft
	37	Initial Design Capture Volume Retained by Site Design Elements	0	900	2,700	0	0	0	1,080	0	0	0	cubic-feet
	38	Final Design Capture Volume Tributary to BMP	1,142	6,443	8,430	772	984	928	3,728	2,505	2,883	3,218	cubic-feet

**No Warning Messages**

**Automated Worksheet B.2: Retention Requirements (V2.0)**

Category	#	Description	<i>i</i>	<i>ii</i>	<i>iii</i>	<i>iv</i>	<i>v</i>	<i>vi</i>	<i>vii</i>	<i>viii</i>	<i>ix</i>	<i>x</i>	Units	
Basic Analysis	1	Drainage Basin ID or Name	DMA 1A	DMA 1B	DMA 2	DMA 3A	DMA 3B	DMA 3C	DMA 3D	DMA 4	DMA 5	DMA 7	unitless	
	2	85th Percentile Rainfall Depth	0.75	0.75	0.75	0.75	0.75	0.75	0.75	0.75	0.75	0.75	inches	
	3	Predominant NRCS Soil Type Within BMP Location	D	D	D	D	D	D	D	D	D	D	unitless	
	4	Is proposed BMP location Restricted or Unrestricted for Infiltration Activities?	Restricted	Restricted	Restricted	Restricted	Restricted	Restricted	Restricted	Restricted	Restricted	Restricted	Restricted	unitless
	5	Nature of Restriction	Soil Type	Soil Type	Soil Type	Soil Type	Soil Type	Soil Type	Soil Type	Soil Type	Soil Type	Soil Type	Soil Type	unitless
	6	Do Minimum Retention Requirements Apply to this Project?	Yes	Yes	Yes	Yes	Yes	Yes	Yes	Yes	Yes	Yes	Yes	yes/no
	7	Are Habitable Structures Greater than 9 Stories Proposed?	No	No	No	No	No	No	No	No	No	No	No	yes/no
Advanced Analysis	8	Has Geotechnical Engineer Performed an Infiltration Analysis?	Yes	Yes	Yes	Yes	Yes	Yes	Yes	Yes	Yes	Yes	yes/no	
	9	Design Infiltration Rate Recommended by Geotechnical Engineer	0.000	0.000	0.000	0.000	0.000	0.000	0.000	0.000	0.000	0.000	0.000	in/hr
Result	10	Design Infiltration Rate Used To Determine Retention Requirements	0.000	0.000	0.000	0.000	0.000	0.000	0.000	0.000	0.000	0.000	0.000	in/hr
	11	Percent of Average Annual Runoff that Must be Retained within DMA	1.5%	1.5%	1.5%	1.5%	1.5%	1.5%	1.5%	1.5%	1.5%	1.5%	1.5%	percentage
	12	Fraction of DCV Requiring Retention	0.01	0.01	0.01	0.01	0.01	0.01	0.01	0.01	0.01	0.01	0.01	ratio
	13	Required Retention Volume	11	64	84	8	10	9	37	25	29	32	cubic-feet	

**No Warning Messages**

**Automated Worksheet B.3: BMP Performance (V2.0)**

Category	#	Description	<i>i</i>	<i>ii</i>	<i>iii</i>	<i>iv</i>	<i>v</i>	<i>vi</i>	<i>vii</i>	<i>viii</i>	<i>ix</i>	<i>x</i>	Units
BMP Inputs	1	Drainage Basin ID or Name	DMA 1A	DMA 1B	DMA 2	DMA 3A	DMA 3B	DMA 3C	DMA 3D	DMA 4	DMA 5	DMA 7	sq-ft
	2	Design Infiltration Rate Recommended	0.000	0.000	0.000	0.000	0.000	0.000	0.000	0.000	0.000	0.000	in/hr
	3	Design Capture Volume Tributary to BMP	1,142	3,068	8,430	772	984	928	3,728	2,505	2,883	3,218	cubic-feet
	4	Is BMP Vegetated or Unvegetated?	Vegetated	Vegetated	Vegetated	Vegetated	Vegetated	Vegetated	Vegetated	Vegetated	Vegetated	Vegetated	unitless
	5	Is BMP Impermeably Lined or Unlined?	Lined	Lined	Lined	Lined	Lined	Lined	Lined	Lined	Lined	Lined	unitless
	6	Does BMP Have an Underdrain?	Underdrain	Underdrain	Underdrain	Underdrain	Underdrain	Underdrain	Underdrain	Underdrain	Underdrain	Underdrain	unitless
	7	Does BMP Utilize Standard or Specialized Media?	Standard	Standard	Specialized	Standard	Standard	Standard	Specialized	Standard	Standard	Standard	unitless
	8	Provided Surface Area	700	1,470	400	400	500	500	180	2,400	3,700	1,600	sq-ft
	9	Provided Surface Ponding Depth	6	6	6	6	6	6	6	6	6	6	inches
	10	Provided Soil Media Thickness	18	18	18	18	18	18	18	18	18	18	inches
	11	Provided Gravel Thickness (Total Thickness)	18	18	18	12	18	18	18	18	18	18	inches
	12	Underdrain Offset	3	3	3	3	3	3	3	3	3	3	inches
	13	Diameter of Underdrain or Hydromod Orifice (Select Smallest)	8.00	8.00	8.00	8.00	8.00	8.00	8.00	8.00	8.00	8.00	inches
	14	Specialized Soil Media Filtration Rate			175.00				175.00				in/hr
	15	Specialized Soil Media Pore Space for Retention			0.20				0.20				unitless
	16	Specialized Soil Media Pore Space for Biofiltration			0.20				0.20				unitless
	17	Specialized Gravel Media Pore Space			0.40				0.40				unitless
Retention Calculations	18	Volume Infiltrated Over 6 Hour Storm	0	0	0	0	0	0	0	0	0	0	cubic-feet
	19	Ponding Pore Space Available for Retention	0.00	0.00	0.00	0.00	0.00	0.00	0.00	0.00	0.00	0.00	unitless
	20	Soil Media Pore Space Available for Retention	0.05	0.05	0.20	0.05	0.05	0.05	0.20	0.05	0.05	0.05	unitless
	21	Gravel Pore Space Available for Retention (Above Underdrain)	0.00	0.00	0.00	0.00	0.00	0.00	0.00	0.00	0.00	0.00	unitless
	22	Gravel Pore Space Available for Retention (Below Underdrain)	0.40	0.40	0.40	0.40	0.40	0.40	0.40	0.40	0.40	0.40	unitless
	23	Effective Retention Depth	2.10	2.10	4.80	2.10	2.10	2.10	4.80	2.10	2.10	2.10	inches
	24	Fraction of DCV Retained (Independent of Drawdown Time)	0.11	0.08	0.02	0.09	0.09	0.09	0.02	0.17	0.22	0.09	ratio
	25	Calculated Retention Storage Drawdown Time	120	120	120	120	120	120	120	120	120	120	hours
	26	Efficacy of Retention Processes	0.13	0.10	0.02	0.11	0.11	0.11	0.02	0.19	0.24	0.11	ratio
	27	Volume Retained by BMP (Considering Drawdown Time)	149	296	204	84	107	101	90	478	687	350	cubic-feet
	28	Design Capture Volume Remaining for Biofiltration	993	2,772	8,226	688	877	827	3,638	2,027	2,196	2,868	cubic-feet
Biofiltration Calculations	29	Max Hydromod Flow Rate through Underdrain	2.8704	2.8704	2.8704	2.6128	2.8704	2.8704	2.8704	2.8704	2.8704	2.8704	cfs
	30	Max Soil Filtration Rate Allowed by Underdrain Orifice	177.15	84.36	310.01	282.18	248.00	248.00	688.90	51.67	33.51	77.50	in/hr
	31	Soil Media Filtration Rate per Specifications	5.00	5.00	175.00	5.00	5.00	5.00	175.00	5.00	5.00	5.00	in/hr
	32	Soil Media Filtration Rate to be used for Sizing	5.00	5.00	175.00	5.00	5.00	5.00	175.00	5.00	5.00	5.00	in/hr
	33	Depth Biofiltered Over 6 Hour Storm	30.00	30.00	1050.00	30.00	30.00	30.00	1050.00	30.00	30.00	30.00	inches
	34	Ponding Pore Space Available for Biofiltration	1.00	1.00	1.00	1.00	1.00	1.00	1.00	1.00	1.00	1.00	unitless
	35	Soil Media Pore Space Available for Biofiltration	0.20	0.20	0.20	0.20	0.20	0.20	0.20	0.20	0.20	0.20	unitless
	36	Gravel Pore Space Available for Biofiltration (Above Underdrain)	0.40	0.40	0.40	0.40	0.40	0.40	0.40	0.40	0.40	0.40	unitless
	37	Effective Depth of Biofiltration Storage	15.60	15.60	15.60	13.20	15.60	15.60	15.60	15.60	15.60	15.60	inches
	38	Drawdown Time for Surface Ponding	1	1	0	1	1	1	0	1	1	1	hours
	39	Drawdown Time for Effective Biofiltration Depth	3	3	0	3	3	3	0	3	3	3	hours
	40	Total Depth Biofiltered	45.60	45.60	1065.60	43.20	45.60	45.60	1065.60	45.60	45.60	45.60	inches
	41	Option 1 - Biofilter 1.50 DCV: Target Volume	1,489	4,157	12,339	1,032	1,316	1,241	5,457	3,040	3,295	4,302	cubic-feet
	42	Option 1 - Provided Biofiltration Volume	1,489	4,157	12,339	1,032	1,316	1,241	5,457	3,040	3,295	4,302	cubic-feet
	43	Option 2 - Store 0.75 DCV: Target Volume	744	2,079	6,170	516	658	620	2,728	1,520	1,647	2,151	cubic-feet
	44	Option 2 - Provided Storage Volume	744	1,911	520	440	650	620	234	1,520	1,647	2,080	cubic-feet
	45	Portion of Biofiltration Performance Standard Satisfied	1.00	1.00	1.00	1.00	1.00	1.00	1.00	1.00	1.00	1.00	ratio
Result	46	Do Site Design Elements and BMPs Satisfy Annual Retention Requirements?	Yes	Yes	Yes	Yes	Yes	Yes	Yes	Yes	Yes	Yes	yes/no
	47	Overall Portion of Performance Standard Satisfied (BMP Efficacy Factor)	1.00	1.00	1.00	1.00	1.00	1.00	1.00	1.00	1.00	1.00	ratio
	48	<b>Deficit of Effectively Treated Stormwater</b>	<b>0</b>	<b>0</b>	<b>0</b>	<b>0</b>	<b>0</b>	<b>0</b>	<b>0</b>	<b>0</b>	<b>0</b>	<b>0</b>	cubic-feet

**Attention!**  
 - BMPs sized at <3% of the effective tributary areas must be accompanied by Reduced Size BMP Maintenance calculations (see last tab).

-Use of specialized or proprietary media requires submittal of supplemental information outlined in Appendix F of the BMPDM.



**Filterra Sizing Spreadsheet**  
**San Diego Region**  
**Uniform Intensity Approach**  
**Storm Intensity = 0.20 in/hr**

Filterra Infiltration Rate = 175 (in/hr)  
 Filterra Flow per Square Foot = 0.00405 (ft3/sec/ft2)

Filterra Flow Rate, Q = 0.00405 ft3/sec x Filterra Surface Area  
 Rational Method, Q = C x I x A  
 San Diego Multiplier, M = 1.5

OR Site Flowrate, Q = (C x DI x DA x M x 43560) / (12 x 3600)  
 DA = (12 x 3600 x Q) / (C x 43560 x DI x M)

where Q = Flow (ft3/sec)  
 DA = Drainage Area (acres)  
 DI = Design Intensity (in/hr)  
 C = Runoff coefficient (dimensionless)  
 M = Multiplier (dimensionless)

			DI 0.2	C 0.95	C 0.85	C 0.50
Available Filterra Box Sizes			Filterra Flow Rate, Q (ft3/sec)	100% Imperv. DA (acres)	Commercial max DA (acres)	Residential max DA (acres)
L (ft)	W (ft)	Filterra Surface Area (ft2)				
4	4	16	0.0648	0.226	0.252	0.429
6	4	24	0.0972	0.338	0.378	0.643
6.5	4	26	0.1053	0.367	0.410	0.696
8	4	32	0.1296	0.451	0.504	0.857
12	4	48	0.1944	0.677	0.756	1.286
6	6	36	0.1458	0.507	0.567	0.964
8	6	48	0.1944	0.677	0.756	1.286
10	6	60	0.2431	0.846	0.945	1.607
12	6	72	0.2917	1.015	1.134	1.928
13	7	91	0.3686	1.283	1.434	2.437
12	8	96	0.3889	1.353	1.512	2.571
14	8	112	0.4537	1.579	1.765	3.000
16	8	128	0.5185	1.804	2.017	3.428
18	8	144	0.5833	2.030	2.269	3.857
20	8	160	0.6481	2.255	2.521	4.285
22	8	176	0.7130	2.481	2.773	4.714



September 2019

**GENERAL USE LEVEL DESIGNATION FOR BASIC (TSS), ENHANCED,  
PHOSPHORUS & OIL TREATMENT**

**For**

**CONTECH Engineered Solutions Filterra®**

**Ecology's Decision:**

Based on Contech's submissions, including the Final Technical Evaluation Reports, dated August 2019, March 2014, December 2009, and additional information provided to Ecology dated October 9, 2009, Ecology hereby issues the following use level designations:

1. A General Use Level Designation for Basic, Enhanced, Phosphorus, and Oil Treatment for the Filterra® system constructed with a minimum media thickness of 21 inches (1.75 feet), at the following water quality design hydraulic loading rates:

Treatment	Infiltration Rate (in/hr) for use in Sizing
Basic	175
Phosphorus	100
Oil	50
Enhanced	175

2. The Filterra is not appropriate for oil spill-control purposes.
3. Ecology approves Filterra systems for treatment at the hydraulic loading rates listed above, to achieve the maximum water quality design flow rate. Calculate the water quality design flow rates using the following procedures:

- Western Washington: for treatment installed upstream of detention or retention, the water quality design flow rate is the peak 15-minute flow rate as calculated using the latest version of the Western Washington Hydrology Model or other Ecology-approved continuous runoff model.
- Eastern Washington: For treatment installed upstream of detention or retention, the water quality design flow rate is the peak 15-minute flow rate as calculated using one of the three flow rate based methods described in Chapter 2.2.5 of the Stormwater Management Manual for Eastern Washington (SWMMEW) or local manual.
- Entire State: For treatment installed downstream of detention, the water quality design flow rate is the full 2-year release rate of the detention facility.

4. This General Use Level Designation has no expiration date, but Ecology may revoke or amend the designation, and is subject to the conditions specified below.

**Ecology's Conditions of Use:**

Filtterra systems shall comply with these conditions shall comply with the following conditions:

1. Design, assemble, install, operate, and maintain the Filtterra systems in accordance with applicable Contech Filtterra manuals and this Ecology Decision.
2. The minimum size filter surface-area for use in Washington is determined by using the design water quality flow rate (as determined in this Ecology Decision, Item 3, above) and the Infiltration Rate from the table above (use the lowest applicable Infiltration Rate depending on the level of treatment required). Calculate the required area by dividing the water quality design flow rate (cu-ft/sec) by the Infiltration Rate (converted to ft/sec) to obtain required surface area (sq-ft) of the Filtterra unit.
3. Each site plan must undergo Contech Filtterra review before Ecology can approve the unit for site installation. This will ensure that design parameters including site grading and slope are appropriate for use of a Filtterra unit.
4. Filtterra media shall conform to the specifications submitted to and approved by Ecology and shall be sourced from Contech Engineered Solutions, LLC with no substitutions.
5. Maintenance includes removing trash, degraded mulch, and accumulated debris from the filter surface and replacing the mulch layer. Use inspections to determine the site-specific maintenance schedules and requirements. Follow maintenance procedures given in the most recent version of the Filtterra Operation and Maintenance Manual.
6. Maintenance: The required maintenance interval for stormwater treatment devices is often dependent upon the degree of pollutant loading from a particular drainage basin. Therefore, Ecology does not endorse or recommend a "one size fits all" maintenance cycle for a particular model/size of manufactured treatment device.
  - Contech designs Filtterra systems for a target maintenance interval of 6 months in the Pacific Northwest. Maintenance includes removing and replacing the mulch layer above the media along with accumulated sediment, trash, and captured organic materials therein, evaluating plant health, and pruning the plant if deemed necessary.
  - Conduct maintenance following manufacturer's guidelines.
7. Filtterra systems come in standard sizes.
8. Install the Filtterra in such a manner that flows exceeding the maximum Filtterra operating rate are conveyed around the Filtterra mulch and media and will not resuspend captured sediment.
9. Discharges from the Filtterra units shall not cause or contribute to water quality standards violations in receiving waters.



## **Approved Alternate Configurations**

### **Filtterra Internal Bypass - Pipe (FTIB-P)**

1. The Filtterra® Internal Bypass – Pipe allows for piped-in flow from area drains, grated inlets, trench drains, and/or roof drains. Design capture flows and peak flows enter the structure through an internal slotted pipe. Filtterra® inverted the slotted pipe to allow design flows to drop through to a series of splash plates that then disperse the design flows over the top surface of the Filtterra® planter area. Higher flows continue to bypass the slotted pipe and convey out the structure.
2. To select a FTIB-P unit, the designer must determine the size of the standard unit using the sizing guidance described above.

### **Filtterra Internal Bypass – Curb (FTIB-C)**

1. The Filtterra® Internal Bypass –Curb model (FTIB-C) incorporates a curb inlet, biofiltration treatment chamber, and internal high flow bypass in one single structure. Filtterra® designed the FTIB-C model for use in a “Sag” or “Sump” condition and will accept flows from both directions along a gutter line. An internal flume tray weir component directs treatment flows entering the unit through the curb inlet to the biofiltration treatment chamber. Flows in excess of the water quality treatment flow rise above the flume tray weir and discharge through a standpipe orifice; providing bypass of untreated peak flows. Americast manufactures the FTIB-C model in a variety of sizes and configurations and you may use the unit on a continuous grade when a single structure providing both treatment and high flow bypass is preferred. The FTIB-C model can also incorporate a separate junction box chamber to allow larger diameter discharge pipe connections to the structure.
2. To select a FTIB-C unit, the designer must determine the size of the standard unit using the sizing guidance described above.

### **Filtterra® Shallow**

1. The Filtterra Shallow provides additional flexibility for design engineers and designers in situations where various elevation constraints prevent application of a standard Filtterra configuration. Engineers can design this system up to six inches shallower than any of the previous Filtterra unit configurations noted above.
2. Ecology requires that the Filtterra Shallow provide a media contact time equivalent to that of the standard unit. This means that with a smaller depth of media, the surface area must increase.
3. To select a Filtterra Shallow System unit, the designer must first identify the size of the standard unit using the modeling guidance described above.
4. Once the size of the standard Filtterra unit is established using the sizing technique described above, use information from the following table to select the appropriate size Filtterra Shallow System unit.

**Shallow Unit Basic, Enhanced, and Oil Treatment Sizing**

Standard Depth	Equivalent Shallow Depth
4x4	4x6 or 6x4
4x6 or 6x4	6x6
4x8 or 8x4	6x8 or 8x6
6x6	6x10 or 10x6
6x8 or 8x6	6x12 or 12x6
6x10 or 10x6	13x7

**Notes:**

1. Shallow Depth Boxes are less than the standard depth of 3.5 feet but no less than 3.0 feet deep (TC to INV).

**Applicant:** Contech Engineered Solutions, LLC.

**Applicant's Address:** 11815 NE Glenn Widing Drive  
Portland, OR 97220

**Application Documents:**

- State of Washington Department of Ecology Application for Conditional Use Designation, Americast (September 2006)
- Quality Assurance Project Plan Filterra® Bioretention Filtration System Performance Monitoring, Americast (April 2008)
- Quality Assurance Project Plan Addendum Filterra® Bioretention Filtration System Performance Monitoring, Americast (June 2008)
- Draft Technical Evaluation Report Filterra® Bioretention Filtration System Performance Monitoring, Americast (August 2009)
- Final Technical Evaluation Report Filterra® Bioretention Filtration System Performance Monitoring, Americast (December 2009)
- Technical Evaluation Report Appendices Filterra® Bioretention Filtration System Performance Monitoring, Americast, (August 2009)
- Memorandum to Department of Ecology Dated October 9, 2009 from Americast, Inc. and Herrera Environmental Consultants
- Quality Assurance Project Plan Filterra® Bioretention System Phosphorus treatment and Supplemental Basic and Enhanced Treatment Performance Monitoring, Americast (November 2011)
- Filterra® letter August 24, 2012 regarding sizing for the Filterra® Shallow System.
- University of Virginia Engineering Department Memo by Joanna Crowe Curran, Ph. D dated March 16, 2013 concerning capacity analysis of Filterra® internal weir inlet tray.
- Terraphase Engineering letter to Jodi Mills, P.E. dated April 2, 2013 regarding Terrafume Hydraulic Test, Filterra® Bioretention System and attachments.
- Technical Evaluation Report, Filterra® System Phosphorus Treatment and Supplemental Basic Treatment Performance Monitoring. March 27<sup>th</sup>, 2014.
- State of Washington Department of Ecology Application for Conditional Use Level Designation, Contech Engineered Solutions (May 2015)

- Quality Assurance Project Plan Filterra® Bioretention System, Contech Engineered Solutions (May 2015)
- Filterra Bioretention System Armco Avenue General Use Level Designation Technical Evaluation Report, Contech Engineered Solutions (August 2019)

**Applicant’s Use Level Request:**

General Level Use Designation for Basic (175 in/hr), Enhanced (175 in/hr), Phosphorus (100 in/hr), and Oil Treatment (50 in/hr).

**Applicant’s Performance Claims:**

Field-testing and laboratory testing show that the Filterra® unit is promising as a stormwater treatment best management practice and can meet Ecology’s performance goals for basic, enhanced, phosphorus, and oil treatment.

**Findings of Fact:**

Field Testing 2015-2019

1. Contech completed field testing of a 4 ft. x 4 ft. Filterra® unit at one site in Hillsboro, Oregon from September 2015 to July 2019. Throughout the monitoring period a total of 24 individual storm events were sampled, of which 23 qualified for TAPE sampling criteria.
2. Contech encountered several unanticipated events and challenges that prevented them from collecting continuous flow and rainfall data. An analysis of the flow data from the sampled events, including both the qualifying and non-qualifying events, demonstrated the system treated over 99 % of the influent flows. Peak flows during these events ranged from 25 % to 250 % of the design flow rate of 29 gallons per minute.
3. Of the 23 TAPE qualified sample events, 13 met requirements for TSS analysis. Influent concentrations ranged from 20.8 mg/L to 83 mg/L, with a mean concentration of 46.3 mg/L. The UCL95 mean effluent concentration was 15.9 mg/L, meeting the 20 mg/L performance goal for Basic Treatment.
4. All 23 TAPE qualified sample events met requirements for dissolved zinc analysis. Influent concentrations range from 0.0384 mg/L to 0.2680 mg/L, with a mean concentration of 0.0807 mg/L. The LCL 95 mean percent removal was 62.9 %, meeting the 60 % performance goal for Enhanced Treatment.
5. Thirteen of the 23 TAPE qualified sample events met requirements for dissolved copper analysis. Influent concentrations ranged from 0.00543 mg/L to 0.01660 mg/L, with a mean concentration of 0.0103 mg/L. The LCL 95 mean percent removal was 41.2 %, meeting the 30 % performance goal for Enhanced Treatment.
6. Total zinc concentrations were analyzed for all 24 sample events. Influent EMCs for total zinc ranged from 0.048 mg/L to 5.290 mg/L with a median of 0.162 mg/L. Corresponding effluent EMCs for total zinc ranged from 0.015 mg/L to 0.067 mg/L with a median of

0.029 mg/L. Total event loadings for the study for total zinc were 316.85 g at the influent and 12.92 g at the effluent sampling location, resulting in a summation of loads removal efficiency of 95.9 %.

7. Total copper concentrations were analyzed for all 24 sample events. Influent EMCs for total copper ranged from 0.003 mg/L to 35.600 mg/L with a median value of 0.043 mg/L. Corresponding effluent EMCs for total copper ranged from 0.002 mg/L to 0.015 mg/L with a median of 0.004 mg/L. Total event loadings for total copper for the study were 1,810.06 g at the influent and 1.90 g at the effluent sampling location, resulting in a summation of loads removal efficiency of 99.9 %.

### Field Testing 2013

1. Filterra completed field-testing of a 6.5 ft x 4 ft. unit at one site in Bellingham, Washington. Continuous flow and rainfall data collected from January 1, 2013 through July 23, 2013 indicated that 59 storm events occurred. Water quality data was obtained from 22 storm events. Not all the sampled storms produced information that met TAPE criteria for storm and/or water quality data.
2. The system treated 98.9 % of the total 8-month runoff volume during the testing period. Consequently, the system achieved the goal of treating 91 % of the volume from the site. Stormwater runoff bypassed Filterra treatment during four of the 59 storm events.
3. Of the 22 sampled events, 18 qualified for TSS analysis (influent TSS concentrations ranged from 25 to 138 mg/L). The data were segregated into sample pairs with influent concentration greater than and less than 100 mg/L. The UCL95 mean effluent concentration for the data with influent less than 100 mg/L was 5.2 mg/L, below the 20-mg/L threshold. Although the TAPE guidelines do not require an evaluation of TSS removal efficiency for influent concentrations below 100 mg/L, the mean TSS removal for these samples was 90.1 %. Average removal of influent TSS concentrations greater than 100 mg/L (three events) was 85 %. In addition, the system consistently exhibited TSS removal greater than 80 % at flow rates equivalent to a 100 in/hr infiltration rate and was observed at 150 in/hr.
4. Ten of the 22 sampled events qualified for TP analysis. Americast augmented the dataset using two sample pairs from previous monitoring at the site. Influent TP concentrations ranged from 0.11 to 0.52 mg/L. The mean TP removal for these twelve events was 72.6 %. The LCL95 mean percent removal was 66.0, well above the TAPE requirement of 50 %. Treatment above 50 % was evident at 100 in/hr infiltration rate and as high as 150 in/hr. Consequently, the Filterra test system met the TAPE Phosphorus Treatment goal at 100 in/hr. Influent ortho-P concentrations ranged from 0.005 to 0.012 mg/L; effluent ortho-P concentrations ranged from 0.005 to 0.013 mg/L. The reporting limit/resolution for the ortho-P test method is 0.01 mg/L, therefore the influent and effluent ortho-P concentrations were both at and near non-detect concentrations.

## Field Testing 2008-2009

1. Filtterra completed field-testing at two sites at the Port of Tacoma. Continuous flow and rainfall data collected during the 2008-2009 monitoring period indicated that 89 storm events occurred. The monitoring obtained water quality data from 27 storm events. Not all the sampled storms produced information that met TAPE criteria for storm and/or water quality data.
2. During the testing at the Port of Tacoma, 98.96 to 99.89 % of the annual influent runoff volume passed through the POT1 and POT2 test systems respectively. Stormwater runoff bypassed the POT1 test system during nine storm events and bypassed the POT2 test system during one storm event. Bypass volumes ranged from 0.13 % to 15.3% of the influent storm volume. Both test systems achieved the 91 % water quality treatment-goal over the 1-year monitoring period.
3. Consultants observed infiltration rates as high as 133 in/hr during the various storms. Filtterra did not provide any paired data that identified percent removal of TSS, metals, oil, or phosphorus at an instantaneous observed flow rate.
4. The maximum storm average hydraulic loading rate associated with water quality data is <40 in/hr, with the majority of flow rates < 25 in/hr. The average instantaneous hydraulic loading rate ranged from 8.6 to 53 in/hr.
5. The field data showed a removal rate greater than 80 % for TSS with an influent concentration greater than 20 mg/L at an average instantaneous hydraulic loading rate up to 53 in/hr (average influent concentration of 28.8 mg/L, average effluent concentration of 4.3 mg/L).
6. The field data showed a removal rate generally greater than 54 % for dissolved zinc at an average instantaneous hydraulic loading rate up to 60 in/hr and an average influent concentration of 0.266 mg/L (average effluent concentration of 0.115 mg/L).
7. The field data showed a removal rate generally greater than 40 % for dissolved copper at an average instantaneous hydraulic loading rate up to 35 in/hr and an average influent concentration of 0.0070 mg/L (average effluent concentration of 0.0036 mg/L).
8. The field data showed an average removal rate of 93 % for total petroleum hydrocarbon (TPH) at an average instantaneous hydraulic loading rate up to 53 in/hr and an average influent concentration of 52 mg/L (average effluent concentration of 2.3 mg/L). The data also shows achievement of less than 15 mg/L TPH for grab samples. Filtterra provided limited visible sheen data due to access limitations at the outlet monitoring location.
9. The field data showed low percentage removals of total phosphorus at all storm flows at an average influent concentration of 0.189 mg/L (average effluent concentration of 0.171 mg/L). We may relate the relatively poor treatment performance of the Filtterra system at this location to influent characteristics for total phosphorus that are unique to the Port of Tacoma site. It appears that the Filtterra system will not meet the 50 % removal performance goal when the majority of phosphorus in the runoff is expected to be in the dissolved form.

### Laboratory Testing

1. Filterra performed laboratory testing on a scaled down version of the Filterra unit. The lab data showed an average removal from 83-91 % for TSS with influents ranging from 21 to 320 mg/L, 82-84 % for total copper with influents ranging from 0.94 to 2.3 mg/L, and 50-61 % for orthophosphate with influents ranging from 2.46 to 14.37 mg/L.
2. Filterra conducted permeability tests on the soil media.
3. Lab scale testing using Sil-Co-Sil 106 showed removals ranging from 70.1 % to 95.5 % with a median removal of 90.7 %, for influent concentrations ranging from 8.3 to 260 mg/L. Filterra ran these laboratory tests at an infiltration rate of 50 in/hr.
4. Supplemental lab testing conducted in September 2009 using Sil-Co-Sil 106 showed an average removal of 90.6 %. These laboratory tests were run at infiltration rates ranging from 25 to 150 in/hr for influent concentrations ranging from 41.6 to 252.5 mg/L. Regression analysis results indicate that the Filterra system's TSS removal performance is independent of influent concentration in the concentration range evaluated at hydraulic loading rates of up to 150 in/hr.

### **Contact Information:**

Applicant: Jeremiah Lehman  
Contech Engineered Solutions, LLC.  
11815 Glenn Widing Dr  
Portland, OR 97220  
(503) 258-3136  
[jlehman@conteches.com](mailto:jlehman@conteches.com)

Applicant's Website: <http://www.conteches.com>

Ecology web link: <http://www.ecy.wa.gov/programs/wq/stormwater/newtech/index.html>

Ecology: Douglas C. Howie, P.E.  
Department of Ecology  
Water Quality Program  
(360) 407-6444  
[douglas.howie@ecy.wa.gov](mailto:douglas.howie@ecy.wa.gov)

<b>Date</b>	<b>Revision</b>
December 2009	GULD for Basic, Enhanced, and Oil granted, CULD for Phosphorus
September 2011	Extended CULD for Phosphorus Treatment
September 2012	Revised design storm discussion, added Shallow System.
January 2013	Revised format to match Ecology standards, changed Filterra contact information
February 2013	Added FTIB-P system
March 2013	Added FTIB-C system
April 2013	Modified requirements for identifying appropriate size of unit

June 2013	Modified description of FTIB-C alternate configuration
March 2014	GULD awarded for Phosphorus Treatment. GULD updated for a higher flow-rate for Basic Treatment.
June 2014	Revised sizing calculation methods
March 2015	Revised Contact Information
June 2015	CULD for Basic and Enhanced at 100 in/hr infiltration rate
September 2019	GULD for Basic and Enhanced at 175 in/hr infiltration rate

Harvest and Use Feasibility Checklist		Form I-7
<p>1. Is there a demand for harvested water (check all that apply) at the project site that is reliably present during the wet season?</p> <p><input checked="" type="checkbox"/> Toilet and urinal flushing</p> <p><input checked="" type="checkbox"/> Landscape irrigation</p> <p><input type="checkbox"/> Other: _____</p>		
<p>2. If there is a demand; estimate the anticipated average wet season demand over a period of 36 hours. Guidance for planning level demand calculations for toilet/urinal flushing and landscape irrigation is provided in Section B.3.2.</p> <p style="color: blue; font-family: cursive;">TOILET FLUSHING: 192 UNITS x 18.5 x 1.5 = 5,325 gal = 713 c.f.</p> <p style="color: blue; font-family: cursive;">IRRIGATION: 390 gal/ac. x 3.75 ac. = 1,462 gal = 195 c.f.</p>		
<p>3. Calculate the DCV using worksheet B-2.1.</p> <p>DCV = <u>40,539</u> (cubic feet)</p>		
<p>3a. Is the 36 hour demand greater than or equal to the DCV?</p> <p><input type="checkbox"/> Yes / <input checked="" type="checkbox"/> No ⇒</p> <p style="text-align: center;">↓</p>	<p>3b. Is the 36 hour demand greater than 0.25DCV but less than the full DCV?</p> <p><input type="checkbox"/> Yes / <input checked="" type="checkbox"/> No ⇒</p> <p style="text-align: center;">↓</p>	<p>3c. Is the 36 hour demand less than 0.25DCV?</p> <p><input checked="" type="checkbox"/> Yes ↓</p>
<p>Harvest and use appears to be feasible. Conduct more detailed evaluation and sizing calculations to confirm that DCV can be used at an adequate rate to meet drawdown criteria.</p>	<p>Harvest and use may be feasible. Conduct more detailed evaluation and sizing calculations to determine feasibility. Harvest and use may only be able to be used for a portion of the site, or (optionally) the storage may need to be upsized to meet long term capture targets while draining in longer than 36 hours.</p>	<p>Harvest and use is considered to be infeasible.</p>
<p>Is harvest and use feasible based on further evaluation?</p> <p><input type="checkbox"/> Yes, refer to Appendix E to select and size harvest and use BMPs.</p> <p><input checked="" type="checkbox"/> No, select alternate BMPs.</p>		

Note: 36-hour demand calculations are for feasibility analysis only. Once feasibility analysis is complete the applicant may be allowed to use a different drawdown time provided they meet the 80% annual capture standard (refer to B.4.2) and 96-hour vector control drawdown requirement.



**ATTACHMENT 2  
BACKUP FOR PDP HYDROMODIFICATION CONTROL MEASURES**

This is the cover sheet for Attachment 2.

Mark this box if this attachment is empty because the project is exempt from PDP hydromodification management requirements.

**Indicate which Items are Included behind this cover sheet:**

<b>Attachment Sequence</b>	<b>Contents</b>	<b>Checklist</b>
Attachment 2a	Hydromodification Management Exhibit (Required)	<input type="checkbox"/> Included  See Hydromodification Management Exhibit Checklist on the back of this Attachment cover sheet.
Attachment 2b	Management of Critical Coarse Sediment Yield Areas (WMAA Exhibit is required, additional analyses are optional)  See Section 6.2 of the BMP Design Manual.	<input type="checkbox"/> Exhibit showing project drainage boundaries marked on WMAA Critical Coarse Sediment Yield Area Map (Required)  Optional analyses for Critical Coarse Sediment Yield Area Determination <input type="checkbox"/> 6.2.1 Verification of Geomorphic Landscape Units Onsite <input type="checkbox"/> 6.2.2 Downstream Systems Sensitivity to Coarse Sediment <input type="checkbox"/> 6.2.3 Optional Additional Analysis of Potential Critical Coarse Sediment Yield Areas Onsite
Attachment 2c	Geomorphic Assessment of Receiving Channels (Optional) See Section 6.3.4 of the BMP Design Manual.	<input type="checkbox"/> Not performed <input type="checkbox"/> Included <input type="checkbox"/> Submitted as separate stand-alone document
Attachment 2d	Flow Control Facility Design, including Structural BMP Drawdown Calculations and Overflow Design Summary (Required) See Chapter 6 and Appendix G of the BMP Design Manual	<input type="checkbox"/> Included <input type="checkbox"/> Submitted as separate stand-alone document
Attachment 2e	Vector Control Plan (Required when structural BMPs will not drain in 96 hours)	<input type="checkbox"/> Included <input type="checkbox"/> Not required because BMPs will drain in less than 96 hours

**Use this checklist to ensure the required information has been included on the Hydromodification Management Exhibit:**

The Hydromodification Management Exhibit must identify:

- Underlying hydrologic soil group
- Approximate depth to groundwater
- Existing natural hydrologic features ( watercourses, seeps, springs, wetlands)
- Critical coarse sediment yield areas to be protected
- Existing topography
- Existing and proposed site drainage network and connections to drainage offsite
- Proposed grading
- Proposed impervious features
- Proposed design features and surface treatments used to minimize imperviousness
- Point(s) of Compliance (POC) for Hydromodification Management
- Existing and proposed drainage boundary and drainage area to each POC (when necessary, create separate exhibits for pre-development and post-project conditions)
- Structural BMPs for hydromodification management (identify location, type of BMP, and size/detail)



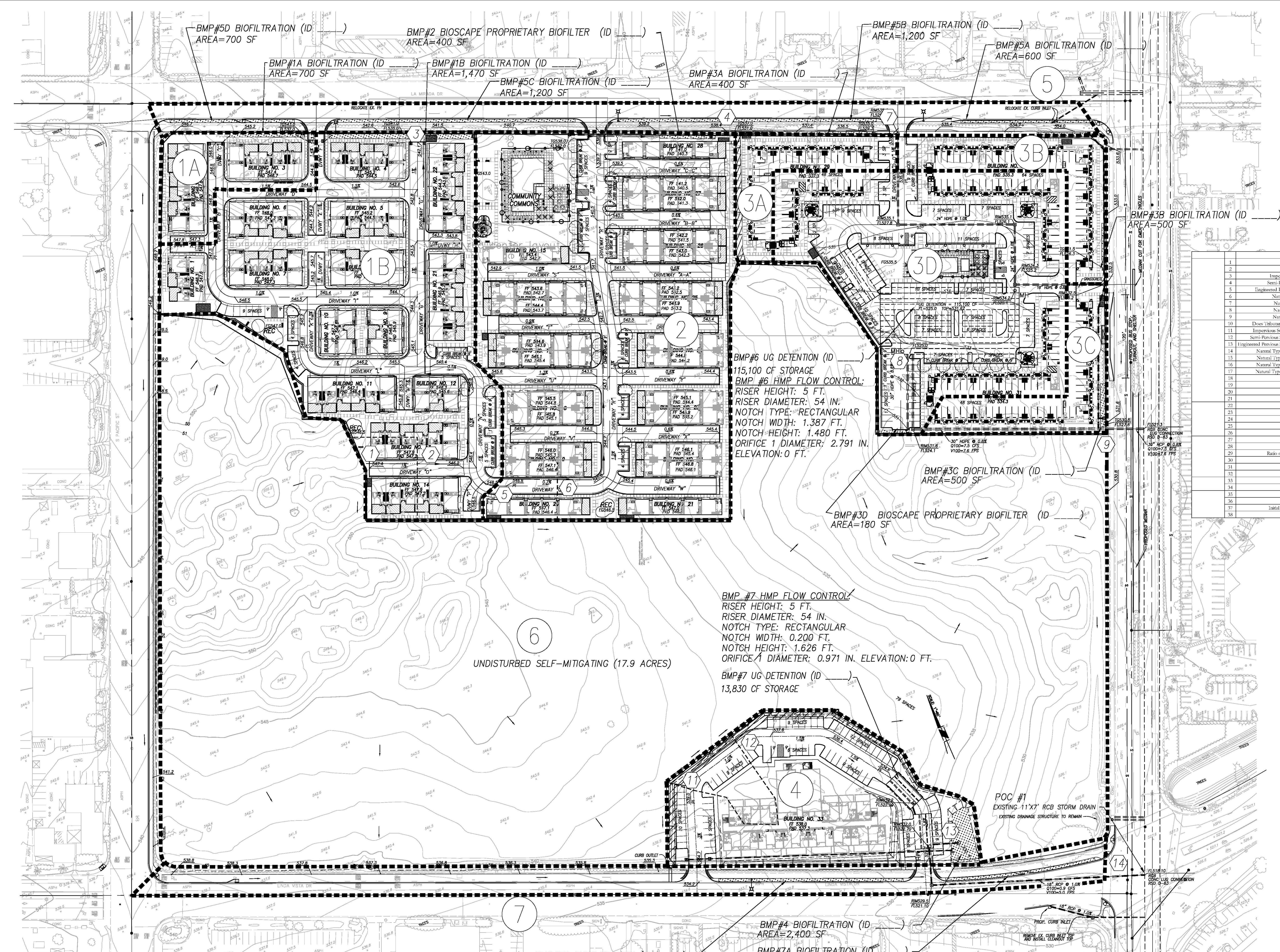

**LEGEND**

- ① DMA NUMBER
- DRAINAGE MANAGEMENT AREA (DMA)
- TREE WELL PER SD-4 (PROJECT TOTAL = 26 EA)
- STORMWATER VAULT WITH HMP FLOW CONTROL (PROJECT TOTAL = 128,930 CF)
- ▨ BIOFILTRATION BASIN (PROJECT TOTAL = 9,940 SF)
- ② AES DRAINAGE NODE

TOTAL AREA = 33.2 ACRES  
 DISTURBED AREA = 16.5 ACRES  
 HYDROLOGIC SOIL GROUP D  
 DEPTH TO GROUNDWATER > 15 FEET  
 NO EXISTING NATURAL HYDROLOGIC FEATURES  
 NO CRITICAL COARSE SEDIMENT YIELD AREAS (CCSYA) EXISTS ON SITE.

Drainage Node ID or Name	DMA 1A	DMA 1B	DMA 2	DMA 3A	DMA 3B	DMA 3C	DMA 4	DMA 5	DMA 6	inches
1. Impervious Surface, 24 hr Storm Depth	0.75	0.75	0.75	0.75	0.75	0.75	0.75	0.75	0.75	0.75
2. Semi-Pervious Surface, 24 hr Storm Depth	0.60	0.60	0.60	0.60	0.60	0.60	0.60	0.60	0.60	0.60
3. Permeable Pervious Surface, 24 hr Storm Depth	0.10	0.10	0.10	0.10	0.10	0.10	0.10	0.10	0.10	0.10
4. Natural Type A Soil, 24 hr Storm Depth	0.05	0.05	0.05	0.05	0.05	0.05	0.05	0.05	0.05	0.05
5. Natural Type B Soil, 24 hr Storm Depth	0.05	0.05	0.05	0.05	0.05	0.05	0.05	0.05	0.05	0.05
6. Natural Type C Soil, 24 hr Storm Depth	0.05	0.05	0.05	0.05	0.05	0.05	0.05	0.05	0.05	0.05
7. Natural Type D Soil, 24 hr Storm Depth	0.05	0.05	0.05	0.05	0.05	0.05	0.05	0.05	0.05	0.05
8. Impervious Surface, 24 hr Storm Depth	0.75	0.75	0.75	0.75	0.75	0.75	0.75	0.75	0.75	0.75
9. Semi-Pervious Surface, 24 hr Storm Depth	0.60	0.60	0.60	0.60	0.60	0.60	0.60	0.60	0.60	0.60
10. Permeable Pervious Surface, 24 hr Storm Depth	0.10	0.10	0.10	0.10	0.10	0.10	0.10	0.10	0.10	0.10
11. Natural Type A Soil, 24 hr Storm Depth	0.05	0.05	0.05	0.05	0.05	0.05	0.05	0.05	0.05	0.05
12. Natural Type B Soil, 24 hr Storm Depth	0.05	0.05	0.05	0.05	0.05	0.05	0.05	0.05	0.05	0.05
13. Natural Type C Soil, 24 hr Storm Depth	0.05	0.05	0.05	0.05	0.05	0.05	0.05	0.05	0.05	0.05
14. Natural Type D Soil, 24 hr Storm Depth	0.05	0.05	0.05	0.05	0.05	0.05	0.05	0.05	0.05	0.05
15. Average Storm Flow Coefficient	0.20	0.20	0.20	0.20	0.20	0.20	0.20	0.20	0.20	0.20
16. Number of Rain Events per Storm	3	3	3	3	3	3	3	3	3	3
17. Average Rain Rate	0.20	0.20	0.20	0.20	0.20	0.20	0.20	0.20	0.20	0.20
18. Total Impervious Area	24,700	167,835	24,340	19,800	34,600	23,200	130,200	78,600	33,200	37,200
19. Total Pervious Area	0.74	0.70	0.72	0.64	0.64	0.64	0.64	0.51	0.50	0.50
20. Total Runoff Volume	1,000	6,000	6,000	6,000	6,000	6,000	6,000	6,000	6,000	6,000
21. Total Runoff Volume	1,142	3,615	11,300	772	984	928	2,868	2,868	3,218	3,218
22. Total Runoff Volume	0	0	0	0	0	0	0	0	0	0
23. Total Runoff Volume	0	0	0	0	0	0	0	0	0	0
24. Total Runoff Volume	0	0	0	0	0	0	0	0	0	0
25. Total Runoff Volume	0	0	0	0	0	0	0	0	0	0
26. Total Runoff Volume	0	0	0	0	0	0	0	0	0	0
27. Total Runoff Volume	0	0	0	0	0	0	0	0	0	0
28. Total Runoff Volume	0	0	0	0	0	0	0	0	0	0
29. Total Runoff Volume	0	0	0	0	0	0	0	0	0	0
30. Total Runoff Volume	0	0	0	0	0	0	0	0	0	0
31. Total Runoff Volume	0	0	0	0	0	0	0	0	0	0
32. Total Runoff Volume	1,142	3,615	11,300	772	984	928	2,868	2,868	3,218	3,218
33. Total Runoff Volume	0	0	0	0	0	0	0	0	0	0
34. Total Runoff Volume	0	0	0	0	0	0	0	0	0	0
35. Total Runoff Volume	0	0	0	0	0	0	0	0	0	0
36. Total Runoff Volume	10,770	10,770	10,770	10,770	10,770	10,770	10,770	10,770	10,770	10,770
37. Total Runoff Volume	0	0	0	0	0	0	0	0	0	0
38. Total Runoff Volume	1,142	6,415	8,430	772	984	928	3,728	2,905	2,863	3,218

**SOURCE CONTROL BMPs**

SOURCE CONTROL BMPs	PROJECT IMPLEMENTATION
4.2.1 & 4.2.2 STORM DRAIN INLETS	MARK ALL INLETS WITH THE WORDS "NO DUMPING DRAINS TO WATERWAYS" IN ENGLISH AND "NO CONTAMINE" IN SPANISH. MAINTAIN AND PERIODICALLY REPLACE INLET MARKINGS. SEE APPLICABLE OPERATIONAL BMPs IN CASQA FACT SHEET SC-44, "DRAINAGE SYSTEM MAINTENANCE."
4.2.6.E LANDSCAPE/OUTDOOR PESTICIDE USE	LANDSCAPE HAS BEEN DESIGNED PER CITY OF SAN DIEGO LANDSCAPE STANDARDS TO MINIMIZE IRRIGATION AND RUNOFF, AND TO MINIMIZE THE USE OF FERTILIZERS AND PESTICIDES THAT CAN CONTRIBUTE TO STORMWATER POLLUTION. SEE APPLICABLE BMPs IN CASQA FACT SHEETS SC-41, "BUILDING AND GROUNDS MAINTENANCE."
4.2.5 TRASH BINS	TRASH BIN FOR EACH UNIT SHALL HAVE LIDS AND BE STORED IN GARAGE. SEE CASQA FACT SHEET SC-54, "WASTE HANDLING AND DISPOSAL."
4.2.6.O PLAZAS, SIDEWALKS, AND PARKING LOTS	PLAZAS, SIDEWALKS, AND PARKING LOTS SHALL BE SWEEP REGULARLY AND ONCE PRIOR TO OCTOBER 1ST TO PREVENT THE ACCUMULATION OF LITTER AND DEBRIS. SEE CASQA FACT SHEET SC-41, "BUILDING AND GROUNDS MAINTENANCE."

**SITE DESIGN BMPs**

4.3.3	4.3.3 MINIMIZE IMPERVIOUS AREA: RESIDENTIAL STREETS ARE AT THE MINIMUM REQUIRED WIDTH PER COUNTY STANDARDS.
4.3.4	4.3.4 MINIMIZE SOIL COMPACTION: RE-TILL SOILS COMPACTED BY CONSTRUCTION VEHICLES. COLLECT AND RE-USE UPPER SOIL LAYERS DEVELOPMENT SITE CONTAINING ORGANIC MATERIALS.
4.3.5	4.3.5 RUNOFF FROM WALKS AND ROOF DRAIN DOWNSPOUTS SHALL DISCHARGE ONTO SPLASH BLOCKS AND FLOW THROUGH ADJACENT LANDSCAPE AREA BEFORE ENTERING BIORETENTION BASINS.
4.3.7	4.3.7 LANDSCAPING WITH DROUGHT TOLERANT SPECIES

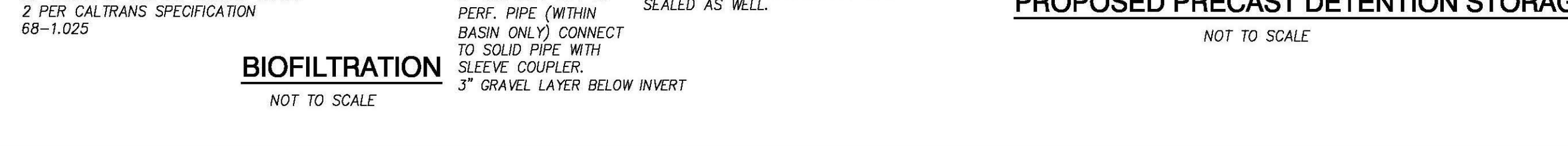
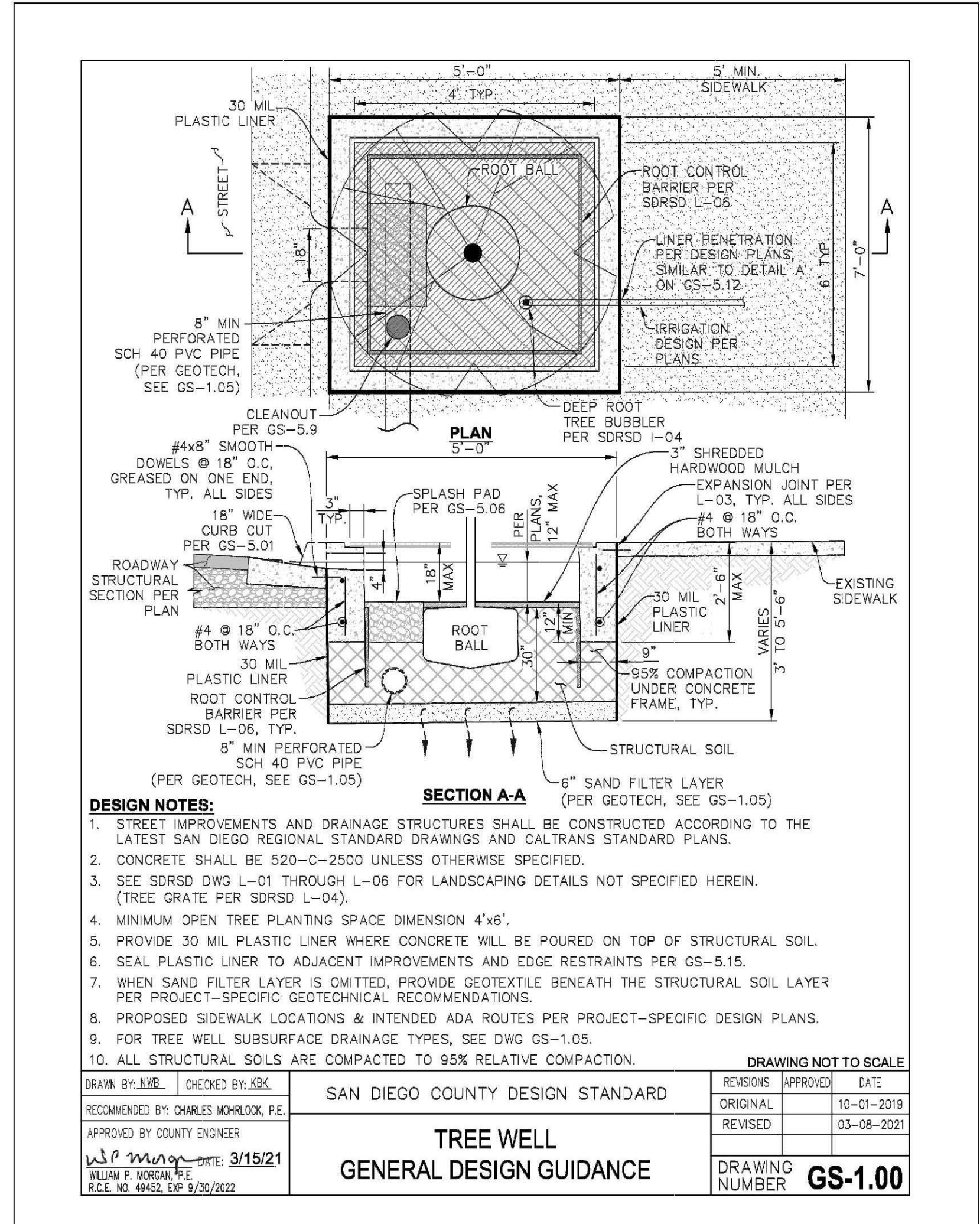
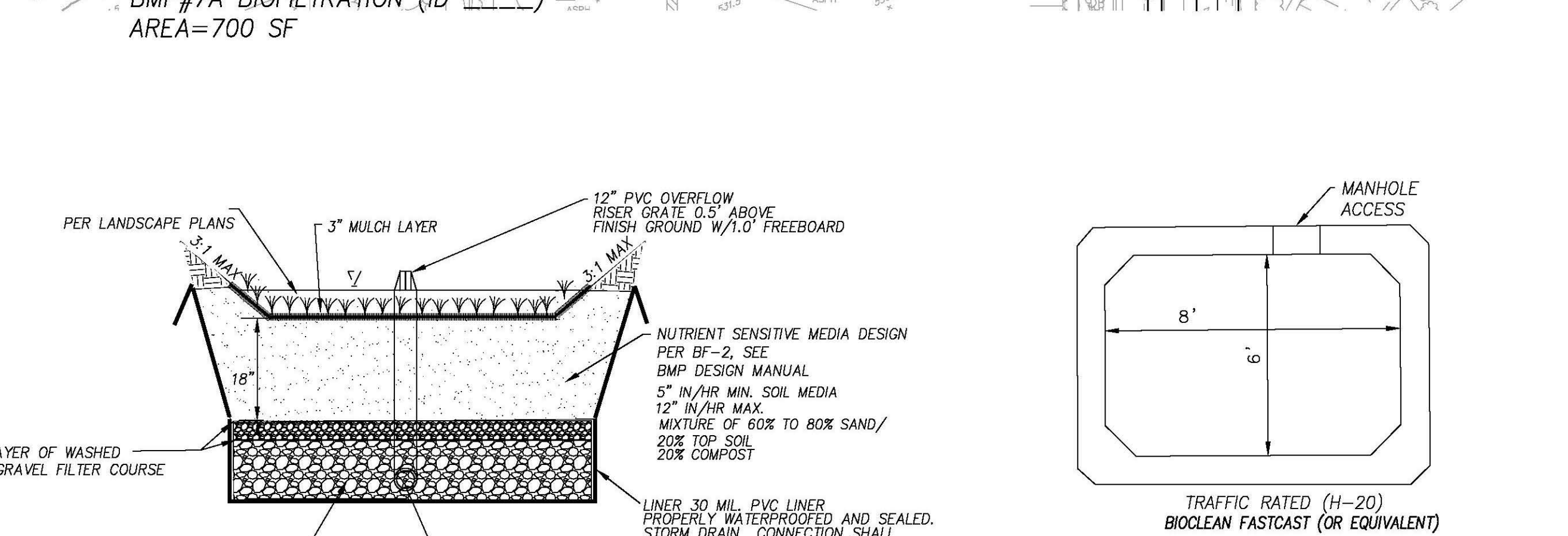



**SDHM 3.1**  
**PROJECT REPORT**

## *General Model Information*

Project Name: L300-14 Pacific 12-07-2021  
Site Name: Pacific  
Site Address:  
City:  
Report Date: 8/16/2022  
Gage: ESCONDID  
Data Start: 10/01/1964  
Data End: 09/30/2004  
Timestep: Hourly  
Precip Scale: 1.000  
Version Date: 2020/04/07

## *POC Thresholds*

---

Low Flow Threshold for POC1:	10 Percent of the 2 Year
High Flow Threshold for POC1:	10 Year

---

## Landuse Basin Data

### Predeveloped Land Use

#### Basin 1

Bypass:	No
GroundWater:	No
Pervious Land Use D,NatVeg,Flat	acre 15.14
Pervious Total	15.14
Impervious Land Use	acre
Impervious Total	0
Basin Total	15.14

Element Flows To:		
Surface	Interflow	Groundwater

## Mitigated Land Use

### Basin 1

Bypass:	No
GroundWater:	No
Pervious Land Use D,Urban,Flat	acre 2.54
Pervious Total	2.54
Impervious Land Use IMPERVIOUS-FLAT	acre 12.6
Impervious Total	12.6
Basin Total	15.14

Element Flows To:		
Surface	Interflow	Groundwater
Vault 1	Vault 1	

*Routing Elements*  
*Predeveloped Routing*



## Mitigated Routing

### Vault 1

Width: 138.498411407562 ft.  
Length: 138.498411407562 ft.  
Depth: 6 ft.  
Discharge Structure  
Riser Height: 5 ft.  
Riser Diameter: 54 in.  
Notch Type: Rectangular  
Notch Width: 1.387 ft.  
Notch Height: 1.480 ft.  
Orifice 1 Diameter: 2.791 in. Elevation:0 ft.  
Element Flows To:  
Outlet 1                      Outlet 2

Vault Hydraulic Table

Stage(feet)	Area(ac.)	Volume(ac-ft.)	Discharge(cfs)	Infilt(cfs)
0.0000	0.440	0.000	0.000	0.000
0.0667	0.440	0.029	0.054	0.000
0.1333	0.440	0.058	0.077	0.000
0.2000	0.440	0.088	0.094	0.000
0.2667	0.440	0.117	0.109	0.000
0.3333	0.440	0.146	0.122	0.000
0.4000	0.440	0.176	0.133	0.000
0.4667	0.440	0.205	0.144	0.000
0.5333	0.440	0.234	0.154	0.000
0.6000	0.440	0.264	0.163	0.000
0.6667	0.440	0.293	0.172	0.000
0.7333	0.440	0.322	0.181	0.000
0.8000	0.440	0.352	0.189	0.000
0.8667	0.440	0.381	0.196	0.000
0.9333	0.440	0.411	0.204	0.000
1.0000	0.440	0.440	0.211	0.000
1.0667	0.440	0.469	0.218	0.000
1.1333	0.440	0.499	0.225	0.000
1.2000	0.440	0.528	0.231	0.000
1.2667	0.440	0.557	0.237	0.000
1.3333	0.440	0.587	0.244	0.000
1.4000	0.440	0.616	0.250	0.000
1.4667	0.440	0.645	0.256	0.000
1.5333	0.440	0.675	0.261	0.000
1.6000	0.440	0.704	0.267	0.000
1.6667	0.440	0.733	0.272	0.000
1.7333	0.440	0.763	0.278	0.000
1.8000	0.440	0.792	0.283	0.000
1.8667	0.440	0.822	0.288	0.000
1.9333	0.440	0.851	0.293	0.000
2.0000	0.440	0.880	0.298	0.000
2.0667	0.440	0.910	0.303	0.000
2.1333	0.440	0.939	0.308	0.000
2.2000	0.440	0.968	0.313	0.000
2.2667	0.440	0.998	0.318	0.000
2.3333	0.440	1.027	0.322	0.000
2.4000	0.440	1.056	0.327	0.000

2.4667	0.440	1.086	0.332	0.000
2.5333	0.440	1.115	0.336	0.000
2.6000	0.440	1.144	0.340	0.000
2.6667	0.440	1.174	0.345	0.000
2.7333	0.440	1.203	0.349	0.000
2.8000	0.440	1.233	0.353	0.000
2.8667	0.440	1.262	0.357	0.000
2.9333	0.440	1.291	0.362	0.000
3.0000	0.440	1.321	0.366	0.000
3.0667	0.440	1.350	0.370	0.000
3.1333	0.440	1.379	0.374	0.000
3.2000	0.440	1.409	0.378	0.000
3.2667	0.440	1.438	0.382	0.000
3.3333	0.440	1.467	0.385	0.000
3.4000	0.440	1.497	0.389	0.000
3.4667	0.440	1.526	0.393	0.000
3.5333	0.440	1.555	0.404	0.000
3.6000	0.440	1.585	0.505	0.000
3.6667	0.440	1.614	0.664	0.000
3.7333	0.440	1.644	0.863	0.000
3.8000	0.440	1.673	1.096	0.000
3.8667	0.440	1.702	1.358	0.000
3.9333	0.440	1.732	1.646	0.000
4.0000	0.440	1.761	1.958	0.000
4.0667	0.440	1.790	2.293	0.000
4.1333	0.440	1.820	2.648	0.000
4.2000	0.440	1.849	3.022	0.000
4.2667	0.440	1.878	3.416	0.000
4.3333	0.440	1.908	3.827	0.000
4.4000	0.440	1.937	4.255	0.000
4.4667	0.440	1.966	4.700	0.000
4.5333	0.440	1.996	5.160	0.000
4.6000	0.440	2.025	5.636	0.000
4.6667	0.440	2.055	6.127	0.000
4.7333	0.440	2.084	6.631	0.000
4.8000	0.440	2.113	7.150	0.000
4.8667	0.440	2.143	7.683	0.000
4.9333	0.440	2.172	8.228	0.000
5.0000	0.440	2.201	8.787	0.000
5.0667	0.440	2.231	9.612	0.000
5.1333	0.440	2.260	11.11	0.000
5.2000	0.440	2.289	13.06	0.000
5.2667	0.440	2.319	15.36	0.000
5.3333	0.440	2.348	17.96	0.000
5.4000	0.440	2.377	20.83	0.000
5.4667	0.440	2.407	23.93	0.000
5.5333	0.440	2.436	27.23	0.000
5.6000	0.440	2.466	30.70	0.000
5.6667	0.440	2.495	34.33	0.000
5.7333	0.440	2.524	38.08	0.000
5.8000	0.440	2.554	41.93	0.000
5.8667	0.440	2.583	45.84	0.000
5.9333	0.440	2.612	49.79	0.000
6.0000	0.440	2.642	53.76	0.000
6.0667	0.440	2.671	57.71	0.000
6.1333	0.000	0.000	61.62	0.000

# Analysis Results

## POC 1

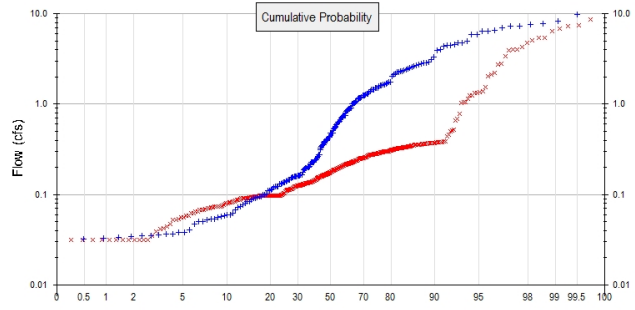
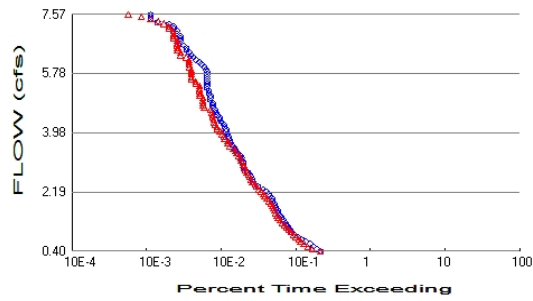

+ Predeveloped    x Mitigated

### Predeveloped Landuse Totals for POC #1

Total Pervious Area: 15.14  
Total Impervious Area: 0

### Mitigated Landuse Totals for POC #1

Total Pervious Area: 2.54  
Total Impervious Area: 12.6

Flow Frequency Method: Cunnane

### Flow Frequency Return Periods for Predeveloped. POC #1

Return Period	Flow(cfs)
2 year	3.965425
5 year	6.570597
10 year	7.571298
25 year	8.564851

### Flow Frequency Return Periods for Mitigated. POC #1

Return Period	Flow(cfs)
2 year	1.46713
5 year	5.033378
10 year	6.772941
25 year	7.686606

## Duration Flows

The Facility PASSED

Flow(cfs)	Predev	Mit	Percentage	Pass/Fail
0.3965	762	749	98	Pass
0.4690	666	580	87	Pass
0.5415	611	506	82	Pass
0.6140	541	452	83	Pass
0.6864	477	408	85	Pass
0.7589	423	383	90	Pass
0.8314	375	352	93	Pass
0.9038	334	324	97	Pass
0.9763	306	302	98	Pass
1.0488	290	282	97	Pass
1.1213	278	263	94	Pass
1.1937	265	248	93	Pass
1.2662	254	229	90	Pass
1.3387	238	217	91	Pass
1.4112	227	204	89	Pass
1.4836	215	197	91	Pass
1.5561	205	188	91	Pass
1.6286	199	182	91	Pass
1.7010	191	178	93	Pass
1.7735	184	171	92	Pass
1.8460	179	162	90	Pass
1.9185	172	151	87	Pass
1.9909	168	145	86	Pass
2.0634	159	133	83	Pass
2.1359	153	130	84	Pass
2.2083	140	120	85	Pass
2.2808	129	111	86	Pass
2.3533	109	104	95	Pass
2.4258	98	100	102	Pass
2.4982	93	91	97	Pass
2.5707	92	88	95	Pass
2.6432	87	84	96	Pass
2.7157	84	81	96	Pass
2.7881	80	78	97	Pass
2.8606	74	75	101	Pass
2.9331	72	71	98	Pass
3.0055	70	70	100	Pass
3.0780	70	68	97	Pass
3.1505	66	65	98	Pass
3.2230	66	64	96	Pass
3.2954	64	60	93	Pass
3.3679	58	56	96	Pass
3.4404	55	54	98	Pass
3.5129	53	51	96	Pass
3.5853	50	46	92	Pass
3.6578	47	43	91	Pass
3.7303	46	43	93	Pass
3.8027	44	39	88	Pass
3.8752	44	38	86	Pass
3.9477	42	36	85	Pass
4.0202	41	34	82	Pass
4.0926	41	31	75	Pass
4.1651	39	31	79	Pass

4.2376	38	29	76	Pass
4.3100	36	28	77	Pass
4.3825	34	28	82	Pass
4.4550	33	27	81	Pass
4.5275	31	27	87	Pass
4.5999	30	26	86	Pass
4.6724	29	25	86	Pass
4.7449	27	21	77	Pass
4.8174	27	20	74	Pass
4.8898	27	20	74	Pass
4.9623	25	20	80	Pass
5.0348	25	20	80	Pass
5.1072	25	18	72	Pass
5.1797	24	18	75	Pass
5.2522	24	18	75	Pass
5.3247	23	18	78	Pass
5.3971	23	18	78	Pass
5.4696	23	16	69	Pass
5.5421	23	16	69	Pass
5.6145	23	14	60	Pass
5.6870	23	14	60	Pass
5.7595	23	14	60	Pass
5.8320	23	14	60	Pass
5.9044	22	14	63	Pass
5.9769	21	13	61	Pass
6.0494	19	13	68	Pass
6.1219	18	13	72	Pass
6.1943	16	13	81	Pass
6.2668	15	12	80	Pass
6.3393	14	10	71	Pass
6.4117	13	10	76	Pass
6.4842	12	9	75	Pass
6.5567	12	9	75	Pass
6.6292	11	9	81	Pass
6.7016	10	9	90	Pass
6.7741	10	9	90	Pass
6.8466	10	8	80	Pass
6.9190	10	8	80	Pass
6.9915	9	8	88	Pass
7.0640	9	8	88	Pass
7.1365	8	7	87	Pass
7.2089	8	7	87	Pass
7.2814	7	6	85	Pass
7.3539	5	5	100	Pass
7.4264	4	4	100	Pass
7.4988	4	3	75	Pass
7.5713	4	2	50	Pass

## Water Quality

### Drawdown Time Results

Pond: Vault 1

<b>Days</b>	<b>Stage(feet)</b>	<b>Percent of Total Run Time</b>
1	0.575	4.0452
2	1.576	1.6454
3	3.039	0.3992
4	0.000	N/A
5	0.000	N/A

Maximum Stage: 5.000 Drawdown Time: 03 12:26:30



## *Model Default Modifications*

Total of 0 changes have been made.

### *PERLND Changes*

No PERLND changes have been made.

### *IMPLND Changes*

No IMPLND changes have been made.

*Appendix*  
*Predeveloped Schematic*



Basin 1  
15.14ac

Mitigated Schematic

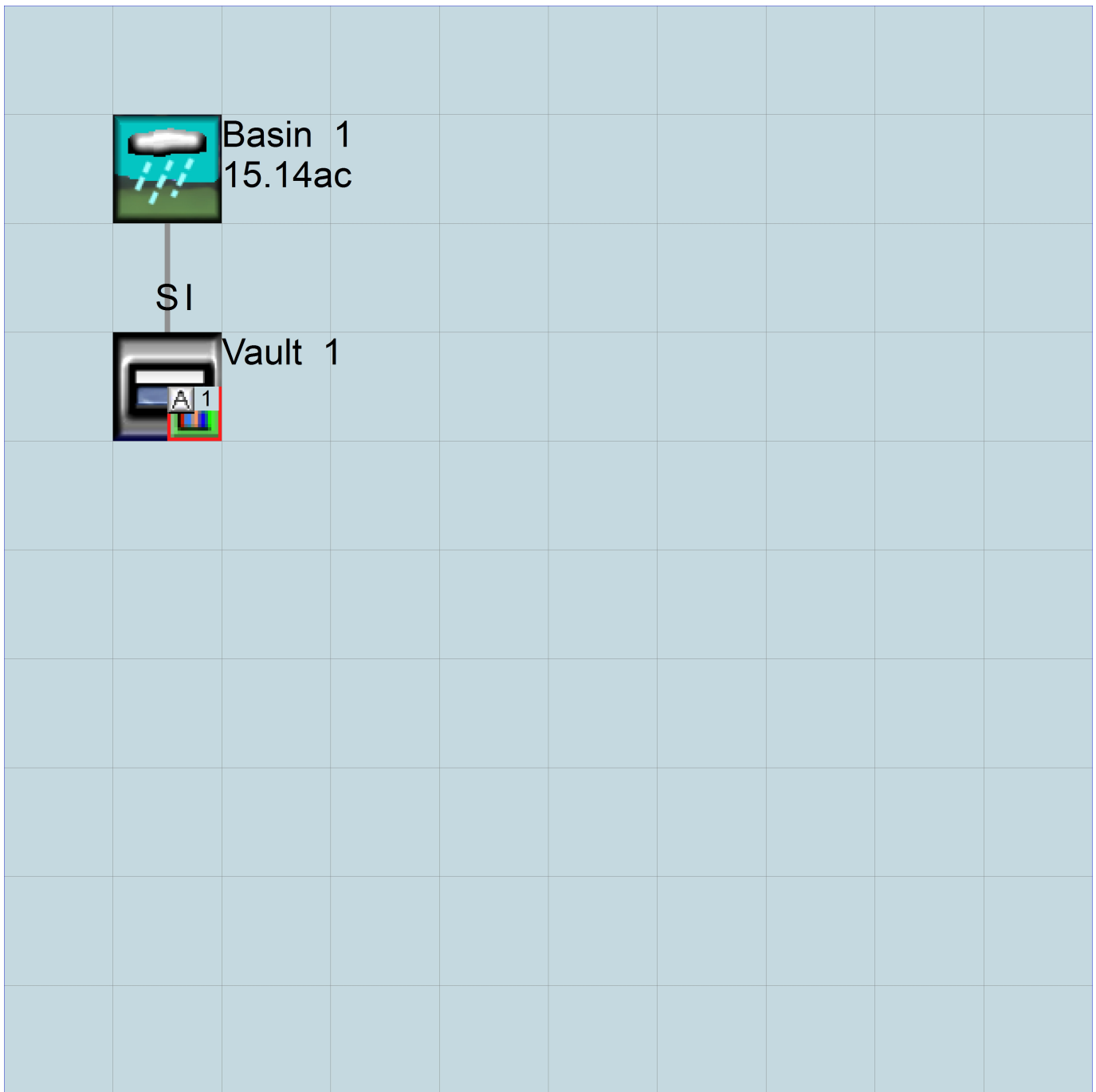

# Predeveloped UCI File

RUN

GLOBAL

```
WVHM4 model simulation
START      1964 10 01      END      2004 09 30
RUN INTERP OUTPUT LEVEL   3      0
RESUME     0 RUN         1
UNIT SYSTEM 1
```

END GLOBAL

FILES

```
<File> <Un#> <-----File Name----->***
<-ID->                                     ***
WDM      26      L300-14 Pacific 12-07-2021.wdm
MESSU    25      PreL300-14 Pacific 12-07-2021.MES
          27      PreL300-14 Pacific 12-07-2021.L61
          28      PreL300-14 Pacific 12-07-2021.L62
          30      POCL300-14 Pacific 12-07-20211.dat
```

END FILES

OPN SEQUENCE

```
INGRP          INDELT 00:60
  PERLND       28
  COPY         501
  DISPLY       1
```

END INGRP

END OPN SEQUENCE

DISPLY

DISPLY-INFO1

```
# - #<-----Title----->***TRAN PIVL DIG1 FIL1  PYR DIG2 FIL2 YRND
1      Basin 1          MAX          1      2      30      9
```

END DISPLY-INFO1

END DISPLY

COPY

TIMESERIES

```
# - # NPT NMN ***
1      1      1
501    1      1
```

END TIMESERIES

END COPY

GENER

OPCODE

```
#      # OPCD ***
```

END OPCODE

PARM

```
#      #          K ***
```

END PARM

END GENER

PERLND

GEN-INFO

```
<PLS ><-----Name----->NBLKS  Unit-systems  Printer ***
# - #          User  t-series  Engl Metr ***
          in  out          ***
```

```
28      D,NatVeg,Flat          1      1      1      1      27      0
```

END GEN-INFO

\*\*\* Section PWATER\*\*\*

ACTIVITY

```
<PLS > ***** Active Sections *****
# - # ATMP SNOW PWAT  SED  PST  PWG  PQAL MSTL PEST NITR PHOS TRAC ***
28      0      0      1      0      0      0      0      0      0      0      0      0
```

END ACTIVITY

PRINT-INFO

```
<PLS > ***** Print-flags ***** PIVL  PYR
# - # ATMP SNOW PWAT  SED  PST  PWG  PQAL MSTL PEST NITR PHOS TRAC *****
28      0      0      4      0      0      0      0      0      0      0      0      0      1      9
```

END PRINT-INFO

```

PWAT-PARM1
<PLS > PWATER variable monthly parameter value flags ***
# - # CSNO RTOP UZFG VCS VUZ VNN VIFW VIRG VLE INFC HWT ***
28 0 1 1 1 0 0 0 0 1 1 0
END PWAT-PARM1

PWAT-PARM2
<PLS > PWATER input info: Part 2 ***
# - # ***FOREST LZSN INFILT LSUR SLSUR KVARY AGWRC
28 0 3.3 0.03 100 0.05 2.5 0.915
END PWAT-PARM2

PWAT-PARM3
<PLS > PWATER input info: Part 3 ***
# - # ***PETMAX PETMIN INFEXP INFILD DEEPFR BASETP AGWETP
28 0 0 2 2 0 0.05 0.05
END PWAT-PARM3

PWAT-PARM4
<PLS > PWATER input info: Part 4 ***
# - # CEPSC UZSN NSUR INTFW IRC LZETP ***
28 0 0.6 0.04 1 0.3 0
END PWAT-PARM4

MON-LZETPARM
<PLS > PWATER input info: Part 3 ***
# - # JAN FEB MAR APR MAY JUN JUL AUG SEP OCT NOV DEC ***
28 0.4 0.4 0.4 0.4 0.6 0.6 0.6 0.6 0.4 0.4 0.4
END MON-LZETPARM

MON-INTERCEP
<PLS > PWATER input info: Part 3 ***
# - # JAN FEB MAR APR MAY JUN JUL AUG SEP OCT NOV DEC ***
28 0.1 0.1 0.1 0.1 0.06 0.06 0.06 0.06 0.1 0.1 0.1
END MON-INTERCEP

PWAT-STATE1
<PLS > *** Initial conditions at start of simulation
ran from 1990 to end of 1992 (pat 1-11-95) RUN 21 ***
# - # *** CEPS SURS UZS IFWS LZS AGWS GWVS
28 0 0 0.01 0 0.4 0.01 0
END PWAT-STATE1

END PERLND

IMPLND
GEN-INFO
<PLS ><-----Name-----> Unit-systems Printer ***
# - # User t-series Engl Metr ***
in out ***

END GEN-INFO
*** Section IWATER***

ACTIVITY
<PLS > ***** Active Sections *****
# - # ATMP SNOW IWAT SLD IWG IQAL ***
END ACTIVITY

PRINT-INFO
<ILS > ***** Print-flags ***** PIVL PYR
# - # ATMP SNOW IWAT SLD IWG IQAL *****
END PRINT-INFO

IWAT-PARM1
<PLS > IWATER variable monthly parameter value flags ***
# - # CSNO RTOP VRS VNN RTLI ***
END IWAT-PARM1

IWAT-PARM2
<PLS > IWATER input info: Part 2 ***
# - # *** LSUR SLSUR NSUR RETSC
END IWAT-PARM2

```





SPEC-ACTIONS  
 END SPEC-ACTIONS  
 FTABLES  
 END FTABLES

EXT SOURCES

<-Volume->	<Member>	SsysSgap	<--Mult-->	Tran	<-Target vols>	<-Grp>	<-Member->	***
<Name>	#	<Name>	#	tem strg	<-factor-->	strg	<Name>	# #
WDM	2	PREC		ENGL	1		PERLND	1 999 EXTNL PREC
WDM	2	PREC		ENGL	1		IMPLND	1 999 EXTNL PREC
WDM	1	EVAP		ENGL	1		PERLND	1 999 EXTNL PETINP
WDM	1	EVAP		ENGL	1		IMPLND	1 999 EXTNL PETINP

END EXT SOURCES

EXT TARGETS

<-Volume->	<-Grp>	<-Member->	<--Mult-->	Tran	<-Volume->	<Member>	Tsys	Tgap	Amd	***
<Name>	#	<Name>	#	#<-factor-->	strg	<Name>	#	<Name>	tem strg	strg***
COPY	501	OUTPUT	MEAN	1 1	12.1	WDM	501	FLOW	ENGL	REPL

END EXT TARGETS

MASS-LINK

<Volume>	<-Grp>	<-Member->	<--Mult-->	<Target>	<-Grp>	<-Member->	***
<Name>	#	<Name>	#	<-factor-->	<Name>	#	#***
MASS-LINK			12				
PERLND	PWATER	SURO		0.083333	COPY	INPUT	MEAN
END MASS-LINK			12				
MASS-LINK			13				
PERLND	PWATER	IFWO		0.083333	COPY	INPUT	MEAN
END MASS-LINK			13				

END MASS-LINK

END RUN

# Mitigated UCI File

RUN

GLOBAL

```
WVHM4 model simulation
START      1964 10 01      END      2004 09 30
RUN INTERP OUTPUT LEVEL   3      0
RESUME     0 RUN          1
UNIT SYSTEM 1
```

END GLOBAL

FILES

```
<File> <Un#> <-----File Name----->***
<-ID->                                     ***
WDM      26      L300-14 Pacific 12-07-2021.wdm
MESSU    25      MitL300-14 Pacific 12-07-2021.MES
          27      MitL300-14 Pacific 12-07-2021.L61
          28      MitL300-14 Pacific 12-07-2021.L62
          30      POCL300-14 Pacific 12-07-20211.dat
```

END FILES

OPN SEQUENCE

```
INGRP          INDELT 00:60
  PERLND        46
  IMPLND         1
  RCHRES         1
  COPY           1
  COPY          501
  DISPLY         1
```

END INGRP

END OPN SEQUENCE

DISPLY

DISPLY-INF01

```
# - #<-----Title----->***TRAN PIVL DIG1 FIL1  PYR DIG2 FIL2 YRND
1      Vault 1      MAX      1      2      30      9
```

END DISPLY-INF01

END DISPLY

COPY

TIMESERIES

```
# - # NPT NMN ***
1      1      1
501    1      1
```

END TIMESERIES

END COPY

GENER

OPCODE

```
#      # OPCODE ***
```

END OPCODE

PARAM

```
#      #      K ***
```

END PARAM

END GENER

PERLND

GEN-INFO

```
<PLS ><-----Name----->NBLKS  Unit-systems  Printer ***
# - #      User  t-series  Engl Metr ***
          in  out      ***
46      D,Urban,Flat      1      1      1      1      27      0
```

END GEN-INFO

\*\*\* Section PWATER\*\*\*

ACTIVITY

```
<PLS > ***** Active Sections *****
# - # ATMP SNOW PWAT  SED  PST  PWG  PQAL MSTL  PEST  NITR  PHOS  TRAC ***
46      0      0      1      0      0      0      0      0      0      0      0
```

END ACTIVITY

PRINT-INFO

```
<PLS > ***** Print-flags ***** PIVL  PYR
# - # ATMP SNOW PWAT  SED  PST  PWG  PQAL MSTL  PEST  NITR  PHOS  TRAC *****
```

46 0 0 4 0 0 0 0 0 0 0 0 0 0 1 9  
END PRINT-INFO

PWAT-PARM1  
<PLS > PWATER variable monthly parameter value flags \*\*\*  
# - # CSNO RTOP UZFG VCS VUZ VNN VIFW VIRG VLE INFC HWT \*\*\*  
46 0 1 1 1 0 0 0 0 1 1 0  
END PWAT-PARM1

PWAT-PARM2  
<PLS > PWATER input info: Part 2 \*\*\*  
# - # \*\*\*FOREST LZSN INFILT LSUR SLSUR KVARY AGWRC  
46 0 3.8 0.03 50 0.05 2.5 0.915  
END PWAT-PARM2

PWAT-PARM3  
<PLS > PWATER input info: Part 3 \*\*\*  
# - # \*\*\*PETMAX PETMIN INFEXP INFILD DEEPFR BASETP AGWETP  
46 0 0 2 2 0 0.05 0.05  
END PWAT-PARM3

PWAT-PARM4  
<PLS > PWATER input info: Part 4 \*\*\*  
# - # CEPSC UZSN NSUR INTFW IRC LZETP \*\*\*  
46 0 0.6 0.03 1 0.3 0  
END PWAT-PARM4

MON-LZETPARM  
<PLS > PWATER input info: Part 3 \*\*\*  
# - # JAN FEB MAR APR MAY JUN JUL AUG SEP OCT NOV DEC \*\*\*  
46 0.6 0.6 0.6 0.6 0.7 0.7 0.7 0.7 0.7 0.6 0.6 0.6  
END MON-LZETPARM

MON-INTERCEP  
<PLS > PWATER input info: Part 3 \*\*\*  
# - # JAN FEB MAR APR MAY JUN JUL AUG SEP OCT NOV DEC \*\*\*  
46 0.1 0.1 0.1 0.1 0.1 0.1 0.1 0.1 0.1 0.1 0.1 0.1  
END MON-INTERCEP

PWAT-STATE1  
<PLS > \*\*\* Initial conditions at start of simulation  
ran from 1990 to end of 1992 (pat 1-11-95) RUN 21 \*\*\*  
# - # \*\*\* CEPS SURS UZS IFWS LZS AGWS GWVS  
46 0 0 0.15 0 1 0.05 0  
END PWAT-STATE1

END PERLND

IMPLND  
GEN-INFO  
<PLS ><-----Name-----> Unit-systems Printer \*\*\*  
# - # User t-series Engl Metr \*\*\*  
in out \*\*\*  
1 IMPERVIOUS-FLAT 1 1 1 27 0  
END GEN-INFO  
\*\*\* Section IWATER\*\*\*

ACTIVITY  
<PLS > \*\*\*\*\* Active Sections \*\*\*\*\*  
# - # ATMP SNOW IWAT SLD IWG IQAL \*\*\*  
1 0 0 1 0 0 0  
END ACTIVITY

PRINT-INFO  
<ILS > \*\*\*\*\* Print-flags \*\*\*\*\* PIVL PYR  
# - # ATMP SNOW IWAT SLD IWG IQAL \*\*\*\*\*  
1 0 0 4 0 0 0 1 9  
END PRINT-INFO

IWAT-PARM1  
<PLS > IWATER variable monthly parameter value flags \*\*\*  
# - # CSNO RTOP VRS VNN RTLI \*\*\*  
1 0 0 0 0 1

END IWAT-PARM1

IWAT-PARM2
<PLS > IWATER input info: Part 2 \*\*\*
# - # \*\*\* LSUR SLSUR NSUR RETSC
1 100 0.05 0.011 0.1
END IWAT-PARM2

IWAT-PARM3
<PLS > IWATER input info: Part 3 \*\*\*
# - # \*\*\*PETMAX PETMIN
1 0 0
END IWAT-PARM3

IWAT-STATE1
<PLS > \*\*\* Initial conditions at start of simulation
# - # \*\*\* RETS SURS
1 0 0
END IWAT-STATE1

END IMPLND

SCHEMATIC
<-Source-> <--Area--> <-Target-> MBLK \*\*\*
<Name> # <-factor-> <Name> # Tbl# \*\*\*
Basin 1\*\*\*
PERLND 46 2.54 RCHRES 1 2
PERLND 46 2.54 RCHRES 1 3
IMPLND 1 12.6 RCHRES 1 5

\*\*\*\*\*Routing\*\*\*\*\*
PERLND 46 2.54 COPY 1 12
IMPLND 1 12.6 COPY 1 15
PERLND 46 2.54 COPY 1 13
RCHRES 1 1 COPY 501 16
END SCHEMATIC

NETWORK
<-Volume-> <-Grp> <-Member-><--Mult-->Tran <-Target vols> <-Grp> <-Member-> \*\*\*
<Name> # <Name> # #<-factor->strg <Name> # # <Name> # # \*\*\*
COPY 501 OUTPUT MEAN 1 1 12.1 DISPLY 1 INPUT TIMSER 1

<-Volume-> <-Grp> <-Member-><--Mult-->Tran <-Target vols> <-Grp> <-Member-> \*\*\*
<Name> # <Name> # #<-factor->strg <Name> # # <Name> # # \*\*\*
END NETWORK

RCHRES
GEN-INFO
RCHRES Name Nexits Unit Systems Printer \*\*\*
# - #<-----><----> User T-series Engl Metr LKFG \*\*\*
in out \*\*\*
1 Vault 1 1 1 1 28 0 1
END GEN-INFO
\*\*\* Section RCHRES\*\*\*

ACTIVITY
<PLS > \*\*\*\*\* Active Sections \*\*\*\*\*
# - # HYFG ADFG CNFG HTFG SDFG GQFG OXFG NUFQ PKFG PHFG \*\*\*
1 1 0 0 0 0 0 0 0 0
END ACTIVITY

PRINT-INFO
<PLS > \*\*\*\*\* Print-flags \*\*\*\*\* PIVL PYR
# - # HYDR ADCA CONS HEAT SED GQL OXRX NUTR PLNK PHCB PIVL PYR \*\*\*\*\*
1 4 0 0 0 0 0 0 0 0 0 1 9
END PRINT-INFO

HYDR-PARM1

```

RCHRES  Flags for each HYDR Section                                     ***
# - #   VC A1 A2 A3  ODFVFG for each *** ODGTFG for each  FUNCT  for each
          FG FG FG FG  possible exit *** possible exit  possible exit
          * * * *   * * * *   * * * *   * * * *
1         0 1  0  0   4 0  0  0  0   0  0  0  0  0   2  2  2  2  2
END HYDR-PARM1

```

```

HYDR-PARM2
# - #   FTABNO          LEN          DELTH          STCOR          KS          DB50          ***
<-----><-----><-----><-----><-----><-----><----->          ***
1         1          0.03          0.0          0.0          0.5          0.0

```

END HYDR-PARM2

HYDR-INIT

```

RCHRES  Initial conditions for each HYDR section                       ***
# - #   *** VOL          Initial value of COLIND          Initial value of OUTDGT
          *** ac-ft          for each possible exit          for each possible exit
<-----><----->          <-----><-----><-----><----->          *** <-----><-----><-----><-----><----->
1         0          4.0  0.0  0.0  0.0  0.0          0.0  0.0  0.0  0.0  0.0

```

END HYDR-INIT

END RCHRES

SPEC-ACTIONS

END SPEC-ACTIONS

FTABLES

```

FTABLE  1
92      4

```

Depth (ft)	Area (acres)	Volume (acre-ft)	Outflow (cfs)	Velocity (ft/sec)	Travel Time (Minutes)
0.000000	0.440354	0.000000	0.000000		
0.066667	0.440354	0.029357	0.054580		
0.133333	0.440354	0.058714	0.077188		
0.200000	0.440354	0.088071	0.094535		
0.266667	0.440354	0.117428	0.109160		
0.333333	0.440354	0.146785	0.122044		
0.400000	0.440354	0.176142	0.133693		
0.466667	0.440354	0.205498	0.144405		
0.533333	0.440354	0.234855	0.154375		
0.600000	0.440354	0.264212	0.163740		
0.666667	0.440354	0.293569	0.172597		
0.733333	0.440354	0.322926	0.181021		
0.800000	0.440354	0.352283	0.189070		
0.866667	0.440354	0.381640	0.196791		
0.933333	0.440354	0.410997	0.204219		
1.000000	0.440354	0.440354	0.211387		
1.066667	0.440354	0.469711	0.218320		
1.133333	0.440354	0.499068	0.225039		
1.200000	0.440354	0.528425	0.231563		
1.266667	0.440354	0.557781	0.237908		
1.333333	0.440354	0.587138	0.244089		
1.400000	0.440354	0.616495	0.250117		
1.466667	0.440354	0.645852	0.256002		
1.533333	0.440354	0.675209	0.261756		
1.600000	0.440354	0.704566	0.267386		
1.666667	0.440354	0.733923	0.272900		
1.733333	0.440354	0.763280	0.278304		
1.800000	0.440354	0.792637	0.283605		
1.866667	0.440354	0.821994	0.288810		
1.933333	0.440354	0.851351	0.293922		
2.000000	0.440354	0.880708	0.298946		
2.066667	0.440354	0.910064	0.303888		
2.133333	0.440354	0.939421	0.308751		
2.200000	0.440354	0.968778	0.313538		
2.266667	0.440354	0.998135	0.318253		
2.333333	0.440354	1.027492	0.322899		
2.400000	0.440354	1.056849	0.327479		
2.466667	0.440354	1.086206	0.331997		
2.533333	0.440354	1.115563	0.336453		
2.600000	0.440354	1.144920	0.340851		
2.666667	0.440354	1.174277	0.345194		
2.733333	0.440354	1.203634	0.349482		

2.800000	0.440354	1.232991	0.353718
2.866667	0.440354	1.262347	0.357904
2.933333	0.440354	1.291704	0.362042
3.000000	0.440354	1.321061	0.366133
3.066667	0.440354	1.350418	0.370179
3.133333	0.440354	1.379775	0.374181
3.200000	0.440354	1.409132	0.378141
3.266667	0.440354	1.438489	0.382059
3.333333	0.440354	1.467846	0.385938
3.400000	0.440354	1.497203	0.389778
3.466667	0.440354	1.526560	0.393581
3.533333	0.440354	1.555917	0.404498
3.600000	0.440354	1.585274	0.505665
3.666667	0.440354	1.614630	0.664281
3.733333	0.440354	1.643987	0.863602
3.800000	0.440354	1.673344	1.096421
3.866667	0.440354	1.702701	1.358398
3.933333	0.440354	1.732058	1.646547
4.000000	0.440354	1.761415	1.958644
4.066667	0.440354	1.790772	2.292955
4.133333	0.440354	1.820129	2.648074
4.200000	0.440354	1.849486	3.022832
4.266667	0.440354	1.878843	3.416240
4.333333	0.440354	1.908200	3.827442
4.400000	0.440354	1.937557	4.255693
4.466667	0.440354	1.966913	4.700331
4.533333	0.440354	1.996270	5.160769
4.600000	0.440354	2.025627	5.636478
4.666667	0.440354	2.054984	6.126976
4.733333	0.440354	2.084341	6.631829
4.800000	0.440354	2.113698	7.150634
4.866667	0.440354	2.143055	7.683024
4.933333	0.440354	2.172412	8.228658
5.000000	0.440354	2.201769	8.787220
5.066667	0.440354	2.231126	9.612449
5.133333	0.440354	2.260483	11.11726
5.200000	0.440354	2.289840	13.06307
5.266667	0.440354	2.319196	15.36334
5.333333	0.440354	2.348553	17.96570
5.400000	0.440354	2.377910	20.83171
5.466667	0.440354	2.407267	23.92960
5.533333	0.440354	2.436624	27.23080
5.600000	0.440354	2.465981	30.70821
5.666667	0.440354	2.495338	34.33519
5.733333	0.440354	2.524695	38.08506
5.800000	0.440354	2.554052	41.93076
5.866667	0.440354	2.583409	45.84483
5.933333	0.440354	2.612766	49.79941
6.000000	0.440354	2.642123	53.76636
6.066667	0.440354	2.671480	57.71754

END FTABLE 1

END FTABLES

EXT SOURCES

<-Volume->	<Member>	SsysSgap	<--Mult-->	Tran	<-Target vols>	<-Grp>	<-Member->	***	
<Name>	#	<Name>	#	tem strg	<-factor-->	strg	<Name>	# #	***
WDM	2	PREC		ENGL	1		PERLND	1 999	EXTNL PREC
WDM	2	PREC		ENGL	1		IMPLND	1 999	EXTNL PREC
WDM	1	EVAP		ENGL	1		PERLND	1 999	EXTNL PETINP
WDM	1	EVAP		ENGL	1		IMPLND	1 999	EXTNL PETINP
WDM	22	IRRG		ENGL	0.7	SAME	PERLND	46	EXTNL SURLI

END EXT SOURCES

EXT TARGETS

<-Volume->	<-Grp>	<-Member->	<--Mult-->	Tran	<-Volume->	<Member>	Tsys	Tgap	Amd	***	
<Name>	#	<Name>	#	<-factor-->	strg	<Name>	#	<Name>	tem strg	strg***	
RCHRES	1	HYDR	RO	1	1	WDM	1002	FLOW	ENGL	REPL	
RCHRES	1	HYDR	STAGE	1	1	WDM	1003	STAG	ENGL	REPL	
COPY	1	OUTPUT	MEAN	1	1	12.1	WDM	701	FLOW	ENGL	REPL

COPY 501 OUTPUT MEAN 1 1 12.1 WDM 801 FLOW ENGL REPL  
END EXT TARGETS

MASS-LINK

<Volume> <-Grp> <-Member-><--Mult--> <Target> <-Grp> <-Member->\*\*\*  
<Name> <Name> # #<-factor-> <Name> <Name> # #\*\*\*

MASS-LINK 2  
PERLND PWATER SURO 0.083333 RCHRES INFLOW IVOL  
END MASS-LINK 2

MASS-LINK 3  
PERLND PWATER IFWO 0.083333 RCHRES INFLOW IVOL  
END MASS-LINK 3

MASS-LINK 5  
IMPLND IWATER SURO 0.083333 RCHRES INFLOW IVOL  
END MASS-LINK 5

MASS-LINK 12  
PERLND PWATER SURO 0.083333 COPY INPUT MEAN  
END MASS-LINK 12

MASS-LINK 13  
PERLND PWATER IFWO 0.083333 COPY INPUT MEAN  
END MASS-LINK 13

MASS-LINK 15  
IMPLND IWATER SURO 0.083333 COPY INPUT MEAN  
END MASS-LINK 15

MASS-LINK 16  
RCHRES ROFLOW COPY INPUT MEAN  
END MASS-LINK 16

END MASS-LINK

END RUN



*Predeveloped HSPF Message File*

*Mitigated HSPF Message File*

## *Disclaimer*

### *Legal Notice*

This program and accompanying documentation are provided 'as-is' without warranty of any kind. The entire risk regarding the performance and results of this program is assumed by End User. Clear Creek Solutions Inc. and the governmental licensee or sublicensees disclaim all warranties, either expressed or implied, including but not limited to implied warranties of program and accompanying documentation. In no event shall Clear Creek Solutions Inc. be liable for any damages whatsoever (including without limitation to damages for loss of business profits, loss of business information, business interruption, and the like) arising out of the use of, or inability to use this program even if Clear Creek Solutions Inc. or their authorized representatives have been advised of the possibility of such damages. Software Copyright © by : Clear Creek Solutions, Inc. 2005-2022; All Rights Reserved.

Clear Creek Solutions, Inc.  
6200 Capitol Blvd. Ste F  
Olympia, WA. 98501  
Toll Free 1(866)943-0304  
Local (360)943-0304

[www.clearcreeksolutions.com](http://www.clearcreeksolutions.com)

**SDHM 3.1**  
**PROJECT REPORT**

## *General Model Information*

Project Name: L300-14 Pacific south 12-07-2021  
Site Name: Pacific  
Site Address:  
City:  
Report Date: 8/16/2022  
Gage: ESCONDID  
Data Start: 10/01/1964  
Data End: 09/30/2004  
Timestep: Hourly  
Precip Scale: 1.000  
Version Date: 2020/04/07

## *POC Thresholds*

---

Low Flow Threshold for POC1:	10 Percent of the 2 Year
High Flow Threshold for POC1:	10 Year

---

## *Landuse Basin Data*

### *Predeveloped Land Use*

#### Basin 1

Bypass:	No
GroundWater:	No
Pervious Land Use	acre
D,NatVeg,Flat	1.8
Pervious Total	1.8
Impervious Land Use	acre
Impervious Total	0
Basin Total	1.8

Element Flows To:		
Surface	Interflow	Groundwater



## Mitigated Land Use

### Basin 1

Bypass:	No
GroundWater:	No
Pervious Land Use D,Urban,Flat	acre 0.4
Pervious Total	0.4
Impervious Land Use IMPERVIOUS-FLAT	acre 1.4
Impervious Total	1.4
Basin Total	1.8

Element Flows To:		
Surface	Interflow	Groundwater
Vault 1	Vault 1	

*Routing Elements*  
*Predeveloped Routing*

## Mitigated Routing

### Vault 1

Width: 47.8962009473671 ft.  
 Length: 47.8962009473671 ft.  
 Depth: 6 ft.  
 Discharge Structure  
 Riser Height: 5 ft.  
 Riser Diameter: 54 in.  
 Notch Type: Rectangular  
 Notch Width: 0.200 ft.  
 Notch Height: 1.626 ft.  
 Orifice 1 Diameter: 0.971 in. Elevation:0 ft.  
 Element Flows To:  
 Outlet 1                      Outlet 2

Vault Hydraulic Table

Stage(feet)	Area(ac.)	Volume(ac-ft.)	Discharge(cfs)	Infilt(cfs)
0.0000	0.052	0.000	0.000	0.000
0.0667	0.052	0.003	0.006	0.000
0.1333	0.052	0.007	0.009	0.000
0.2000	0.052	0.010	0.011	0.000
0.2667	0.052	0.014	0.013	0.000
0.3333	0.052	0.017	0.014	0.000
0.4000	0.052	0.021	0.016	0.000
0.4667	0.052	0.024	0.017	0.000
0.5333	0.052	0.028	0.018	0.000
0.6000	0.052	0.031	0.019	0.000
0.6667	0.052	0.035	0.020	0.000
0.7333	0.052	0.038	0.021	0.000
0.8000	0.052	0.042	0.022	0.000
0.8667	0.052	0.045	0.023	0.000
0.9333	0.052	0.049	0.024	0.000
1.0000	0.052	0.052	0.025	0.000
1.0667	0.052	0.056	0.026	0.000
1.1333	0.052	0.059	0.027	0.000
1.2000	0.052	0.063	0.028	0.000
1.2667	0.052	0.066	0.028	0.000
1.3333	0.052	0.070	0.029	0.000
1.4000	0.052	0.073	0.030	0.000
1.4667	0.052	0.077	0.031	0.000
1.5333	0.052	0.080	0.031	0.000
1.6000	0.052	0.084	0.032	0.000
1.6667	0.052	0.087	0.033	0.000
1.7333	0.052	0.091	0.033	0.000
1.8000	0.052	0.094	0.034	0.000
1.8667	0.052	0.098	0.035	0.000
1.9333	0.052	0.101	0.035	0.000
2.0000	0.052	0.105	0.036	0.000
2.0667	0.052	0.108	0.036	0.000
2.1333	0.052	0.112	0.037	0.000
2.2000	0.052	0.115	0.037	0.000
2.2667	0.052	0.119	0.038	0.000
2.3333	0.052	0.122	0.039	0.000
2.4000	0.052	0.126	0.039	0.000

2.4667	0.052	0.129	0.040	0.000
2.5333	0.052	0.133	0.040	0.000
2.6000	0.052	0.136	0.041	0.000
2.6667	0.052	0.140	0.041	0.000
2.7333	0.052	0.143	0.042	0.000
2.8000	0.052	0.147	0.042	0.000
2.8667	0.052	0.151	0.043	0.000
2.9333	0.052	0.154	0.043	0.000
3.0000	0.052	0.158	0.044	0.000
3.0667	0.052	0.161	0.044	0.000
3.1333	0.052	0.165	0.045	0.000
3.2000	0.052	0.168	0.045	0.000
3.2667	0.052	0.172	0.046	0.000
3.3333	0.052	0.175	0.046	0.000
3.4000	0.052	0.179	0.049	0.000
3.4667	0.052	0.182	0.066	0.000
3.5333	0.052	0.186	0.089	0.000
3.6000	0.052	0.189	0.116	0.000
3.6667	0.052	0.193	0.148	0.000
3.7333	0.052	0.196	0.182	0.000
3.8000	0.052	0.200	0.219	0.000
3.8667	0.052	0.203	0.257	0.000
3.9333	0.052	0.207	0.298	0.000
4.0000	0.052	0.210	0.339	0.000
4.0667	0.052	0.214	0.382	0.000
4.1333	0.052	0.217	0.425	0.000
4.2000	0.052	0.221	0.469	0.000
4.2667	0.052	0.224	0.514	0.000
4.3333	0.052	0.228	0.558	0.000
4.4000	0.052	0.231	0.607	0.000
4.4667	0.052	0.235	0.662	0.000
4.5333	0.052	0.238	0.719	0.000
4.6000	0.052	0.242	0.778	0.000
4.6667	0.052	0.245	0.838	0.000
4.7333	0.052	0.249	0.899	0.000
4.8000	0.052	0.252	1.253	0.000
4.8667	0.052	0.256	1.339	0.000
4.9333	0.052	0.259	1.426	0.000
5.0000	0.052	0.263	1.515	0.000
5.0667	0.052	0.266	2.337	0.000
5.1333	0.052	0.270	3.840	0.000
5.2000	0.052	0.273	5.783	0.000
5.2667	0.052	0.277	8.080	0.000
5.3333	0.052	0.280	10.68	0.000
5.4000	0.052	0.284	13.54	0.000
5.4667	0.052	0.287	16.63	0.000
5.5333	0.052	0.291	19.93	0.000
5.6000	0.052	0.294	23.41	0.000
5.6667	0.052	0.298	27.03	0.000
5.7333	0.052	0.301	30.78	0.000
5.8000	0.052	0.305	34.62	0.000
5.8667	0.052	0.309	38.53	0.000
5.9333	0.052	0.312	42.49	0.000
6.0000	0.052	0.316	46.45	0.000
6.0667	0.052	0.319	50.40	0.000
6.1333	0.000	0.000	54.30	0.000

# Analysis Results

## POC 1

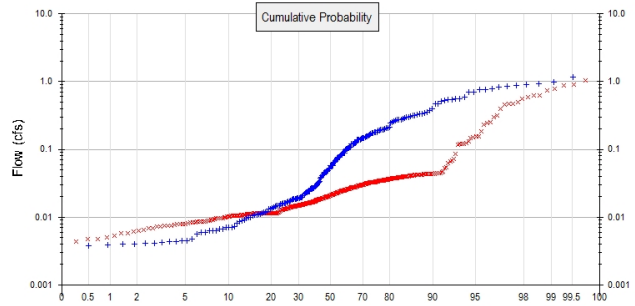
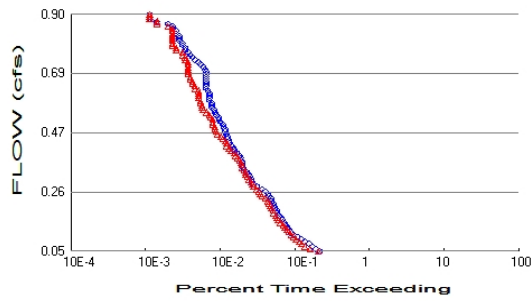

+ Predeveloped    x Mitigated

### Predeveloped Landuse Totals for POC #1

Total Pervious Area: 1.8  
Total Impervious Area: 0

### Mitigated Landuse Totals for POC #1

Total Pervious Area: 0.4  
Total Impervious Area: 1.4

Flow Frequency Method: Cunnane

### Flow Frequency Return Periods for Predeveloped. POC #1

Return Period	Flow(cfs)
2 year	0.471451
5 year	0.781181
10 year	0.900154
25 year	1.018278

### Flow Frequency Return Periods for Mitigated. POC #1

Return Period	Flow(cfs)
2 year	0.170547
5 year	0.584245
10 year	0.780762
25 year	0.944355

## Duration Flows

The Facility PASSED

Flow(cfs)	Predev	Mit	Percentage	Pass/Fail
0.0471	762	727	95	Pass
0.0558	677	563	83	Pass
0.0644	611	481	78	Pass
0.0730	546	430	78	Pass
0.0816	479	401	83	Pass
0.0902	425	365	85	Pass
0.0988	379	338	89	Pass
0.1075	335	311	92	Pass
0.1161	307	292	95	Pass
0.1247	290	276	95	Pass
0.1333	278	256	92	Pass
0.1419	265	245	92	Pass
0.1505	254	227	89	Pass
0.1592	239	211	88	Pass
0.1678	228	202	88	Pass
0.1764	216	194	89	Pass
0.1850	205	184	89	Pass
0.1936	200	180	90	Pass
0.2022	191	171	89	Pass
0.2109	184	166	90	Pass
0.2195	179	159	88	Pass
0.2281	172	151	87	Pass
0.2367	169	142	84	Pass
0.2453	159	128	80	Pass
0.2539	155	121	78	Pass
0.2626	141	117	82	Pass
0.2712	129	107	82	Pass
0.2798	109	98	89	Pass
0.2884	98	95	96	Pass
0.2970	93	91	97	Pass
0.3056	92	85	92	Pass
0.3142	87	81	93	Pass
0.3229	84	77	91	Pass
0.3315	80	77	96	Pass
0.3401	74	73	98	Pass
0.3487	72	70	97	Pass
0.3573	70	68	97	Pass
0.3659	70	67	95	Pass
0.3746	67	64	95	Pass
0.3832	66	61	92	Pass
0.3918	64	57	89	Pass
0.4004	59	55	93	Pass
0.4090	55	49	89	Pass
0.4176	53	46	86	Pass
0.4263	50	43	86	Pass
0.4349	47	43	91	Pass
0.4435	46	41	89	Pass
0.4521	44	38	86	Pass
0.4607	44	36	81	Pass
0.4693	42	32	76	Pass
0.4780	41	31	75	Pass
0.4866	41	30	73	Pass
0.4952	39	30	76	Pass



0.5038	38	28	73	Pass
0.5124	36	28	77	Pass
0.5210	34	28	82	Pass
0.5297	33	26	78	Pass
0.5383	31	25	80	Pass
0.5469	30	23	76	Pass
0.5555	29	21	72	Pass
0.5641	27	20	74	Pass
0.5727	27	20	74	Pass
0.5814	27	19	70	Pass
0.5900	25	19	76	Pass
0.5986	25	18	72	Pass
0.6072	25	18	72	Pass
0.6158	25	18	72	Pass
0.6244	24	18	75	Pass
0.6331	23	16	69	Pass
0.6417	23	16	69	Pass
0.6503	23	15	65	Pass
0.6589	23	15	65	Pass
0.6675	23	14	60	Pass
0.6761	23	14	60	Pass
0.6847	23	13	56	Pass
0.6934	23	13	56	Pass
0.7020	22	13	59	Pass
0.7106	21	13	61	Pass
0.7192	19	13	68	Pass
0.7278	18	13	72	Pass
0.7364	16	12	75	Pass
0.7451	15	12	80	Pass
0.7537	14	11	78	Pass
0.7623	13	11	84	Pass
0.7709	12	9	75	Pass
0.7795	12	9	75	Pass
0.7881	11	8	72	Pass
0.7968	11	8	72	Pass
0.8054	10	8	80	Pass
0.8140	10	8	80	Pass
0.8226	10	8	80	Pass
0.8312	9	8	88	Pass
0.8398	9	8	88	Pass
0.8485	8	8	100	Pass
0.8571	8	7	87	Pass
0.8657	7	5	71	Pass
0.8743	5	5	100	Pass
0.8829	4	4	100	Pass
0.8915	4	4	100	Pass
0.9002	4	4	100	Pass

## Water Quality

### Drawdown Time Results

Pond: Vault 1

<b>Days</b>	<b>Stage(feet)</b>	<b>Percent of Total Run Time</b>
1	1.127	2.4254
2	2.448	0.7485
3	0.000	N/A
4	0.000	N/A
5	0.000	N/A

Maximum Stage: 5.000 Drawdown Time: 02 20:37:30

## *Model Default Modifications*

Total of 0 changes have been made.

### *PERLND Changes*

No PERLND changes have been made.

### *IMPLND Changes*

No IMPLND changes have been made.

*Appendix*  
*Predeveloped Schematic*



Basin 1  
1.80ac

Mitigated Schematic



# Predeveloped UCI File

RUN

GLOBAL

```
WVHM4 model simulation
START      1964 10 01      END      2004 09 30
RUN INTERP OUTPUT LEVEL   3      0
RESUME     0 RUN          1
UNIT SYSTEM 1
```

END GLOBAL

FILES

```
<File> <Un#> <-----File Name----->***
<-ID->                                     ***
WDM      26      L300-14 Pacific south 12-07-2021.wdm
MESSU    25      PreL300-14 Pacific south 12-07-2021.MES
          27      PreL300-14 Pacific south 12-07-2021.L61
          28      PreL300-14 Pacific south 12-07-2021.L62
          30      POCL300-14 Pacific south 12-07-20211.dat
```

END FILES

OPN SEQUENCE

```
INGRP          INDELT 00:60
  PERLND       28
  COPY         501
  DISPLY       1
```

END INGRP

END OPN SEQUENCE

DISPLY

DISPLY-INFO1

```
# - #<-----Title----->***TRAN PIVL DIG1 FIL1  PYR DIG2 FIL2 YRND
1      Basin 1          MAX          1      2      30      9
```

END DISPLY-INFO1

END DISPLY

COPY

TIMESERIES

```
# - # NPT NMN ***
1      1      1
501    1      1
```

END TIMESERIES

END COPY

GENER

OPCODE

```
#      # OPCD ***
```

END OPCODE

PARM

```
#      #          K ***
```

END PARM

END GENER

PERLND

GEN-INFO

```
<PLS ><-----Name----->NBLKS  Unit-systems  Printer ***
# - #          User  t-series  Engl  Metr  ***
          in  out          ***
```

```
28      D,NatVeg,Flat          1      1      1      1      27      0
```

END GEN-INFO

\*\*\* Section PWATER\*\*\*

ACTIVITY

```
<PLS > ***** Active Sections *****
# - # ATMP SNOW PWAT  SED  PST  PWG  PQAL MSTL PEST NITR PHOS TRAC ***
28      0      0      1      0      0      0      0      0      0      0      0      0
```

END ACTIVITY

PRINT-INFO

```
<PLS > ***** Print-flags ***** PIVL  PYR
# - # ATMP SNOW PWAT  SED  PST  PWG  PQAL MSTL PEST NITR PHOS TRAC  *****
28      0      0      4      0      0      0      0      0      0      0      0      0      1      9
```

END PRINT-INFO



```

PWAT-PARM1
<PLS > PWATER variable monthly parameter value flags ***
# - # CSNO RTOP UZFG VCS VUZ VNN VIFW VIRG VLE INFC HWT ***
28 0 1 1 1 0 0 0 0 1 1 0
END PWAT-PARM1

PWAT-PARM2
<PLS > PWATER input info: Part 2 ***
# - # ***FOREST LZSN INFILT LSUR SLSUR KVARY AGWRC
28 0 3.3 0.03 100 0.05 2.5 0.915
END PWAT-PARM2

PWAT-PARM3
<PLS > PWATER input info: Part 3 ***
# - # ***PETMAX PETMIN INFEXP INFILD DEEPFR BASETP AGWETP
28 0 0 2 2 0 0.05 0.05
END PWAT-PARM3

PWAT-PARM4
<PLS > PWATER input info: Part 4 ***
# - # CEPSC UZSN NSUR INTFW IRC LZETP ***
28 0 0.6 0.04 1 0.3 0
END PWAT-PARM4

MON-LZETPARM
<PLS > PWATER input info: Part 3 ***
# - # JAN FEB MAR APR MAY JUN JUL AUG SEP OCT NOV DEC ***
28 0.4 0.4 0.4 0.4 0.6 0.6 0.6 0.6 0.4 0.4 0.4
END MON-LZETPARM

MON-INTERCEP
<PLS > PWATER input info: Part 3 ***
# - # JAN FEB MAR APR MAY JUN JUL AUG SEP OCT NOV DEC ***
28 0.1 0.1 0.1 0.1 0.06 0.06 0.06 0.06 0.1 0.1 0.1
END MON-INTERCEP

PWAT-STATE1
<PLS > *** Initial conditions at start of simulation
ran from 1990 to end of 1992 (pat 1-11-95) RUN 21 ***
# - # *** CEPS SURS UZS IFWS LZS AGWS GWVS
28 0 0 0.01 0 0.4 0.01 0
END PWAT-STATE1

END PERLND

IMPLND
GEN-INFO
<PLS ><-----Name-----> Unit-systems Printer ***
# - # User t-series Engl Metr ***
in out ***

END GEN-INFO
*** Section IWATER***

ACTIVITY
<PLS > ***** Active Sections *****
# - # ATMP SNOW IWAT SLD IWG IQAL ***
END ACTIVITY

PRINT-INFO
<ILS > ***** Print-flags ***** PIVL PYR
# - # ATMP SNOW IWAT SLD IWG IQAL *****
END PRINT-INFO

IWAT-PARM1
<PLS > IWATER variable monthly parameter value flags ***
# - # CSNO RTOP VRS VNN RTLI ***
END IWAT-PARM1

IWAT-PARM2
<PLS > IWATER input info: Part 2 ***
# - # *** LSUR SLSUR NSUR RETSC
END IWAT-PARM2

```



SPEC-ACTIONS  
 END SPEC-ACTIONS  
 FTABLES  
 END FTABLES

EXT SOURCES

<-Volume->	<Member>	SsysSgap	<--Mult-->	Tran	<-Target vols>	<-Grp>	<-Member->	***	
<Name>	#	<Name>	#	tem strg	<-factor->	strg	<Name>	# #	***
WDM	2	PREC		ENGL	1		PERLND	1 999 EXTNL	PREC
WDM	2	PREC		ENGL	1		IMPLND	1 999 EXTNL	PREC
WDM	1	EVAP		ENGL	1		PERLND	1 999 EXTNL	PETINP
WDM	1	EVAP		ENGL	1		IMPLND	1 999 EXTNL	PETINP

END EXT SOURCES

EXT TARGETS

<-Volume->	<-Grp>	<-Member->	<--Mult-->	Tran	<-Volume->	<Member>	Tsys	Tgap	Amd	***
<Name>	#	<Name>	#	#<-factor->	strg	<Name>	#	<Name>	tem strg	strg***
COPY	501	OUTPUT	MEAN	1 1	12.1	WDM	501	FLOW	ENGL	REPL

END EXT TARGETS

MASS-LINK

<Volume>	<-Grp>	<-Member->	<--Mult-->	<Target>	<-Grp>	<-Member->	***
<Name>	#	<Name>	#	<-factor->	<Name>	#	***
MASS-LINK			12				
PERLND	PWATER	SURO		0.083333	COPY	INPUT	MEAN
END MASS-LINK			12				
MASS-LINK			13				
PERLND	PWATER	IFWO		0.083333	COPY	INPUT	MEAN
END MASS-LINK			13				

END MASS-LINK

END RUN

# Mitigated UCI File

RUN

GLOBAL

```
WVHM4 model simulation
START      1964 10 01      END      2004 09 30
RUN INTERP OUTPUT LEVEL   3      0
RESUME     0 RUN         1
UNIT SYSTEM 1
```

END GLOBAL

FILES

```
<File> <Un#> <-----File Name----->***
<-ID->                                     ***
WDM      26      L300-14 Pacific south 12-07-2021.wdm
MESSU    25      MitL300-14 Pacific south 12-07-2021.MES
          27      MitL300-14 Pacific south 12-07-2021.L61
          28      MitL300-14 Pacific south 12-07-2021.L62
          30      POCL300-14 Pacific south 12-07-20211.dat
```

END FILES

OPN SEQUENCE

```
INGRP          INDELT 00:60
  PERLND        46
  IMPLND         1
  RCHRES         1
  COPY           1
  COPY          501
  DISPLY         1
```

END INGRP

END OPN SEQUENCE

DISPLY

DISPLY-INFO1

```
# - #<-----Title----->***TRAN PIVL DIG1 FIL1  PYR DIG2 FIL2 YRND
1      Vault 1      MAX      1      2      30      9
```

END DISPLY-INFO1

END DISPLY

COPY

TIMESERIES

```
# - # NPT NMN ***
1      1      1
501    1      1
```

END TIMESERIES

END COPY

GENER

OPCODE

```
# # OPCODE ***
```

END OPCODE

PARAM

```
# # K ***
```

END PARAM

END GENER

PERLND

GEN-INFO

```
<PLS ><-----Name----->NBLKS Unit-systems Printer ***
# - # User t-series Engl Metr ***
          in out ***
46      D,Urban,Flat      1      1      1      1      27      0
```

END GEN-INFO

\*\*\* Section PWATER\*\*\*

ACTIVITY

```
<PLS > ***** Active Sections *****
# - # ATMP SNOW PWAT SED PST PWG PQAL MSTL PEST NITR PHOS TRAC ***
46      0      0      1      0      0      0      0      0      0      0      0
```

END ACTIVITY

PRINT-INFO

```
<PLS > ***** Print-flags ***** PIVL PYR
# - # ATMP SNOW PWAT SED PST PWG PQAL MSTL PEST NITR PHOS TRAC *****
```

46 0 0 4 0 0 0 0 0 0 0 0 0 0 1 9  
END PRINT-INFO

PWAT-PARM1  
<PLS > PWATER variable monthly parameter value flags \*\*\*  
# - # CSNO RTOP UZFG VCS VUZ VNN VIFW VIRG VLE INFC HWT \*\*\*  
46 0 1 1 1 0 0 0 0 1 1 0  
END PWAT-PARM1

PWAT-PARM2  
<PLS > PWATER input info: Part 2 \*\*\*  
# - # \*\*\*FOREST LZSN INFILT LSUR SLSUR KVARY AGWRC  
46 0 3.8 0.03 50 0.05 2.5 0.915  
END PWAT-PARM2

PWAT-PARM3  
<PLS > PWATER input info: Part 3 \*\*\*  
# - # \*\*\*PETMAX PETMIN INFEXP INFILD DEEPFR BASETP AGWETP  
46 0 0 2 2 0 0.05 0.05  
END PWAT-PARM3

PWAT-PARM4  
<PLS > PWATER input info: Part 4 \*\*\*  
# - # CEPSC UZSN NSUR INTFW IRC LZETP \*\*\*  
46 0 0.6 0.03 1 0.3 0  
END PWAT-PARM4

MON-LZETPARM  
<PLS > PWATER input info: Part 3 \*\*\*  
# - # JAN FEB MAR APR MAY JUN JUL AUG SEP OCT NOV DEC \*\*\*  
46 0.6 0.6 0.6 0.6 0.7 0.7 0.7 0.7 0.7 0.6 0.6 0.6  
END MON-LZETPARM

MON-INTERCEP  
<PLS > PWATER input info: Part 3 \*\*\*  
# - # JAN FEB MAR APR MAY JUN JUL AUG SEP OCT NOV DEC \*\*\*  
46 0.1 0.1 0.1 0.1 0.1 0.1 0.1 0.1 0.1 0.1 0.1 0.1  
END MON-INTERCEP

PWAT-STATE1  
<PLS > \*\*\* Initial conditions at start of simulation  
ran from 1990 to end of 1992 (pat 1-11-95) RUN 21 \*\*\*  
# - # \*\*\* CEPS SURS UZS IFWS LZS AGWS GWVS  
46 0 0 0.15 0 1 0.05 0  
END PWAT-STATE1

END PERLND

IMPLND  
GEN-INFO  
<PLS ><-----Name-----> Unit-systems Printer \*\*\*  
# - # User t-series Engl Metr \*\*\*  
in out \*\*\*  
1 IMPERVIOUS-FLAT 1 1 1 27 0  
END GEN-INFO  
\*\*\* Section IWATER\*\*\*

ACTIVITY  
<PLS > \*\*\*\*\* Active Sections \*\*\*\*\*  
# - # ATMP SNOW IWAT SLD IWG IQAL \*\*\*  
1 0 0 1 0 0 0  
END ACTIVITY

PRINT-INFO  
<ILS > \*\*\*\*\* Print-flags \*\*\*\*\* PIVL PYR  
# - # ATMP SNOW IWAT SLD IWG IQAL \*\*\*\*\*  
1 0 0 4 0 0 0 1 9  
END PRINT-INFO

IWAT-PARM1  
<PLS > IWATER variable monthly parameter value flags \*\*\*  
# - # CSNO RTOP VRS VNN RTLI \*\*\*  
1 0 0 0 0 1

END IWAT-PARM1

IWAT-PARM2
<PLS > IWATER input info: Part 2 \*\*\*
# - # \*\*\* LSUR SLSUR NSUR RETSC
1 100 0.05 0.011 0.1
END IWAT-PARM2

IWAT-PARM3
<PLS > IWATER input info: Part 3 \*\*\*
# - # \*\*\*PETMAX PETMIN
1 0 0
END IWAT-PARM3

IWAT-STATE1
<PLS > \*\*\* Initial conditions at start of simulation
# - # \*\*\* RETS SURS
1 0 0
END IWAT-STATE1

END IMPLND

SCHEMATIC
<-Source-> <--Area--> <-Target-> MBLK \*\*\*
<Name> # <-factor-> <Name> # Tbl# \*\*\*
Basin 1\*\*\*
PERLND 46 0.4 RCHRES 1 2
PERLND 46 0.4 RCHRES 1 3
IMPLND 1 1.4 RCHRES 1 5

\*\*\*\*\*Routing\*\*\*\*\*
PERLND 46 0.4 COPY 1 12
IMPLND 1 1.4 COPY 1 15
PERLND 46 0.4 COPY 1 13
RCHRES 1 1 COPY 501 16
END SCHEMATIC

NETWORK
<-Volume-> <-Grp> <-Member-><--Mult-->Tran <-Target vols> <-Grp> <-Member-> \*\*\*
<Name> # <Name> # #<-factor->strg <Name> # # <Name> # # \*\*\*
COPY 501 OUTPUT MEAN 1 1 12.1 DISPLY 1 INPUT TIMSER 1

<-Volume-> <-Grp> <-Member-><--Mult-->Tran <-Target vols> <-Grp> <-Member-> \*\*\*
<Name> # <Name> # #<-factor->strg <Name> # # <Name> # # \*\*\*
END NETWORK

RCHRES
GEN-INFO
RCHRES Name Nexits Unit Systems Printer \*\*\*
# - #<-----><----> User T-series Engl Metr LKFG \*\*\*
in out \*\*\*
1 Vault 1 1 1 1 1 28 0 1
END GEN-INFO
\*\*\* Section RCHRES\*\*\*

ACTIVITY
<PLS > \*\*\*\*\* Active Sections \*\*\*\*\*
# - # HYFG ADFG CNFG HTFG SDFG GQFG OXFG NUFQ PKFG PHFG \*\*\*
1 1 0 0 0 0 0 0 0 0
END ACTIVITY

PRINT-INFO
<PLS > \*\*\*\*\* Print-flags \*\*\*\*\* PIVL PYR
# - # HYDR ADCA CONS HEAT SED GQL OXRX NUTR PLNK PHCB PIVL PYR \*\*\*\*\*
1 4 0 0 0 0 0 0 0 0 0 1 9
END PRINT-INFO

HYDR-PARM1



```

RCHRES  Flags for each HYDR Section                                     ***
# - #   VC A1 A2 A3  ODFVFG for each *** ODGTFG for each  FUNCT  for each
      FG FG FG FG  possible exit *** possible exit  possible exit
      * * * *   * * * * * * * * * * * * * * * * * * * * * * * *
1       0 1  0  0   4 0  0  0  0  0   0  0  0  0  0   2  2  2  2  2
END HYDR-PARM1

```

```

HYDR-PARM2
# - #   FTABNO      LEN      DELTH      STCOR      KS      DB50      ***
<-----><-----><-----><-----><-----><-----><----->      ***
1       1       0.01      0.0      0.0      0.5      0.0
END HYDR-PARM2

```

```

HYDR-INIT
RCHRES  Initial conditions for each HYDR section                       ***
# - #   *** VOL      Initial value of COLIND  Initial value of OUTDGT
      *** ac-ft   for each possible exit      for each possible exit
<-----><-----> <-----><-----><-----><-----> *** <-----><-----><-----><-----><----->
1       0       4.0  0.0  0.0  0.0  0.0      0.0  0.0  0.0  0.0  0.0
END HYDR-INIT
END RCHRES

```

```

SPEC-ACTIONS
END SPEC-ACTIONS

```

FTABLES

```

FTABLE      1
92      4
Depth      Area      Volume  Outflowl Velocity  Travel Time***
(ft)      (acres) (acre-ft) (cfs) (ft/sec) (Minutes)***
0.000000  0.052664  0.000000  0.000000  0.000000  0.000000
0.066667  0.052664  0.003511  0.006606  0.009343  0.009343
0.133333  0.052664  0.007022  0.011442  0.013212  0.013212
0.200000  0.052664  0.010533  0.014422  0.017555  0.017555
0.266667  0.052664  0.014044  0.018182  0.021910  0.021910
0.333333  0.052664  0.017555  0.022885  0.027333  0.027333
0.400000  0.052664  0.021066  0.028028  0.034327  0.034327
0.466667  0.052664  0.024577  0.033685  0.041818  0.041818
0.533333  0.052664  0.028087  0.039637  0.049795  0.049795
0.600000  0.052664  0.031598  0.045890  0.058227  0.058227
0.666667  0.052664  0.035109  0.052353  0.067209  0.067209
0.733333  0.052664  0.038620  0.058966  0.076641  0.076641
0.800000  0.052664  0.042131  0.065837  0.086623  0.086623
0.866667  0.052664  0.045642  0.072966  0.097155  0.097155
0.933333  0.052664  0.049153  0.080353  0.108347  0.108347
1.000000  0.052664  0.052664  0.087998  0.120199  0.120199
1.066667  0.052664  0.056175  0.095911  0.132711  0.132711
1.133333  0.052664  0.059686  0.104092  0.145884  0.145884
1.200000  0.052664  0.063197  0.112545  0.159728  0.159728
1.266667  0.052664  0.066708  0.121270  0.174243  0.174243
1.333333  0.052664  0.070219  0.130273  0.189429  0.189429
1.400000  0.052664  0.073730  0.139546  0.205286  0.205286
1.466667  0.052664  0.077241  0.149089  0.221814  0.221814
1.533333  0.052664  0.080752  0.158902  0.239023  0.239023
1.600000  0.052664  0.084262  0.168985  0.256913  0.256913
1.666667  0.052664  0.087773  0.179338  0.275484  0.275484
1.733333  0.052664  0.091284  0.189961  0.294736  0.294736
1.800000  0.052664  0.094795  0.200854  0.314669  0.314669
1.866667  0.052664  0.098306  0.212017  0.335284  0.335284
1.933333  0.052664  0.101817  0.223450  0.356581  0.356581
2.000000  0.052664  0.105328  0.235153  0.378561  0.378561
2.066667  0.052664  0.108839  0.247126  0.401224  0.401224
2.133333  0.052664  0.112350  0.259379  0.424571  0.424571
2.200000  0.052664  0.115861  0.271902  0.448602  0.448602
2.266667  0.052664  0.119372  0.284695  0.473317  0.473317
2.333333  0.052664  0.122883  0.297758  0.498716  0.498716
2.400000  0.052664  0.126394  0.311091  0.524809  0.524809
2.466667  0.052664  0.129905  0.324694  0.551596  0.551596
2.533333  0.052664  0.133416  0.338567  0.579077  0.579077
2.600000  0.052664  0.136927  0.352710  0.607252  0.607252
2.666667  0.052664  0.140437  0.367123  0.636123  0.636123
2.733333  0.052664  0.143948  0.381796  0.665690  0.665690

```

2.800000	0.052664	0.147459	0.042813
2.866667	0.052664	0.150970	0.043320
2.933333	0.052664	0.154481	0.043821
3.000000	0.052664	0.157992	0.044316
3.066667	0.052664	0.161503	0.044805
3.133333	0.052664	0.165014	0.045290
3.200000	0.052664	0.168525	0.045769
3.266667	0.052664	0.172036	0.046243
3.333333	0.052664	0.175547	0.046713
3.400000	0.052664	0.179058	0.049930
3.466667	0.052664	0.182569	0.066030
3.533333	0.052664	0.186080	0.089042
3.600000	0.052664	0.189591	0.116796
3.666667	0.052664	0.193102	0.148191
3.733333	0.052664	0.196612	0.182500
3.800000	0.052664	0.200123	0.219188
3.866667	0.052664	0.203634	0.257831
3.933333	0.052664	0.207145	0.298080
4.000000	0.052664	0.210656	0.339638
4.066667	0.052664	0.214167	0.382244
4.133333	0.052664	0.217678	0.425669
4.200000	0.052664	0.221189	0.469706
4.266667	0.052664	0.224700	0.514167
4.333333	0.052664	0.228211	0.558877
4.400000	0.052664	0.231722	0.607255
4.466667	0.052664	0.235233	0.662491
4.533333	0.052664	0.238744	0.719424
4.600000	0.052664	0.242255	0.778004
4.666667	0.052664	0.245766	0.838186
4.733333	0.052664	0.249277	0.899927
4.800000	0.052664	0.252787	1.253683
4.866667	0.052664	0.256298	1.339039
4.933333	0.052664	0.259809	1.426313
5.000000	0.052664	0.263320	1.515462
5.066667	0.052664	0.266831	2.337930
5.133333	0.052664	0.270342	3.839994
5.200000	0.052664	0.273853	5.783084
5.266667	0.052664	0.277364	8.080651
5.333333	0.052664	0.280875	10.68031
5.400000	0.052664	0.284386	13.54365
5.466667	0.052664	0.287897	16.63888
5.533333	0.052664	0.291408	19.93744
5.600000	0.052664	0.294919	23.41223
5.666667	0.052664	0.298430	27.03660
5.733333	0.052664	0.301941	30.78388
5.800000	0.052664	0.305451	34.62700
5.866667	0.052664	0.308962	38.53851
5.933333	0.052664	0.312473	42.49053
6.000000	0.052664	0.315984	46.45495
6.066667	0.052664	0.319495	50.40361

END FTABLE 1  
 END FTABLES

EXT SOURCES

<-Volume->	<Member>	SsysSgap	<--Mult-->	Tran	<-Target vols>	<-Grp>	<-Member->	***	
<Name>	#	<Name>	#	tem strg	<-factor-->	strg	<Name>	# #	***
WDM	2	PREC		ENGL	1		PERLND	1 999	EXTNL PREC
WDM	2	PREC		ENGL	1		IMPLND	1 999	EXTNL PREC
WDM	1	EVAP		ENGL	1		PERLND	1 999	EXTNL PETINP
WDM	1	EVAP		ENGL	1		IMPLND	1 999	EXTNL PETINP
WDM	22	IRRG		ENGL	0.7	SAME	PERLND	46	EXTNL SURLI

END EXT SOURCES

EXT TARGETS

<-Volume->	<-Grp>	<-Member->	<--Mult-->	Tran	<-Volume->	<Member>	Tsys	Tgap	Amd	***
<Name>	#	<Name>	#	<-factor-->	strg	<Name>	#	<Name>	tem strg	strg***
RCHRES	1	HYDR	RO	1 1	1	WDM	1002	FLOW	ENGL	REPL
RCHRES	1	HYDR	STAGE	1 1	1	WDM	1003	STAG	ENGL	REPL
COPY	1	OUTPUT	MEAN	1 1	12.1	WDM	701	FLOW	ENGL	REPL

COPY 501 OUTPUT MEAN 1 1 12.1 WDM 801 FLOW ENGL REPL  
 END EXT TARGETS

MASS-LINK

<Volume> <-Grp> <-Member-><--Mult--> <Target> <-Grp> <-Member->\*\*\*  
 <Name> <Name> # #<-factor-> <Name> <Name> # #\*\*\*

MASS-LINK 2  
 PERLND PWATER SURO 0.083333 RCHRES INFLOW IVOL  
 END MASS-LINK 2

MASS-LINK 3  
 PERLND PWATER IFWO 0.083333 RCHRES INFLOW IVOL  
 END MASS-LINK 3

MASS-LINK 5  
 IMPLND IWATER SURO 0.083333 RCHRES INFLOW IVOL  
 END MASS-LINK 5

MASS-LINK 12  
 PERLND PWATER SURO 0.083333 COPY INPUT MEAN  
 END MASS-LINK 12

MASS-LINK 13  
 PERLND PWATER IFWO 0.083333 COPY INPUT MEAN  
 END MASS-LINK 13

MASS-LINK 15  
 IMPLND IWATER SURO 0.083333 COPY INPUT MEAN  
 END MASS-LINK 15

MASS-LINK 16  
 RCHRES ROFLOW COPY INPUT MEAN  
 END MASS-LINK 16

END MASS-LINK

END RUN

*Predeveloped HSPF Message File*

*Mitigated HSPF Message File*

## *Disclaimer*

### *Legal Notice*

This program and accompanying documentation are provided 'as-is' without warranty of any kind. The entire risk regarding the performance and results of this program is assumed by End User. Clear Creek Solutions Inc. and the governmental licensee or sublicensees disclaim all warranties, either expressed or implied, including but not limited to implied warranties of program and accompanying documentation. In no event shall Clear Creek Solutions Inc. be liable for any damages whatsoever (including without limitation to damages for loss of business profits, loss of business information, business interruption, and the like) arising out of the use of, or inability to use this program even if Clear Creek Solutions Inc. or their authorized representatives have been advised of the possibility of such damages. Software Copyright © by : Clear Creek Solutions, Inc. 2005-2022; All Rights Reserved.

Clear Creek Solutions, Inc.  
6200 Capitol Blvd. Ste F  
Olympia, WA. 98501  
Toll Free 1(866)943-0304  
Local (360)943-0304

[www.clearcreeksolutions.com](http://www.clearcreeksolutions.com)



# PACIFIC

PCCSYA - NONE

### Legend

- 0
- 06073C
- 06073C
- 06073C
- Creek
- Creek
- Enterprise Rent-A-Car
- Feature 1
- Feature 2
- Feature 3
- Feature 4
- Lake
- San
- San
- San Luis Rey River
- Yes





**REVISED PRELIMINARY Geotechnical Evaluation**  
**FOR**  
**PACIFIC GPA/REZONE**  
**Northwest Corner of Linda Vista Drive & Los Posas Road**  
**SAN MARCOS, CALIFORNIA**

**PREPARED FOR**

**The Las Posas Owner LPV, LLC, a Delaware limited liability company**  
**2235 Encinitas Boulevard, Suite 216**  
**Encinitas, California 92024**

**PREPARED BY**

**GEOTEK, INC.**  
**1384 POINSETTIA AVENUE, SUITE A**  
**VISTA, CALIFORNIA 92081**



**GeoTek, Inc.**  
1384 Poinsettia Avenue, Suite A Vista, CA 92081-8505  
(760) 599-0509 Office (760) 599-0593 Fax www.geotekusa.com

January 4, 2022  
Project No. 3649-SD

**The Las Posas Owner LPV, LLC,**  
**a Delaware limited liability company**  
2235 Encinitas Boulevard, Suite 216  
Encinitas, California 92024

Attention: Mr. Greg Waite

Subject: Revised Preliminary Geotechnical Evaluation  
Pacific GPA/Rezone  
Northwest Corner of Linda Vista Drive & Los Posas Road  
San Marcos, California

Dear Mr. Waite:

We are pleased to provide herein the results of our preliminary geotechnical evaluation for the subject property located in the city of San Marcos, California. This report presents the results of our evaluation and provides preliminary geotechnical recommendations for future earthwork, foundation design, and construction. In our opinion, the property appears feasible from a geotechnical viewpoint provided that the recommendations included herein are incorporated into the future design and construction phases of property development. The opportunity to be of service is sincerely appreciated. If you should have any questions, please do not hesitate to call our office.

Respectfully submitted,  
**GeoTek, Inc.**

Bruce A. Hick  
GE 2284  
Geotechnical Engineer



Christopher D. Livesey  
CEG 2733  
Project Geologist

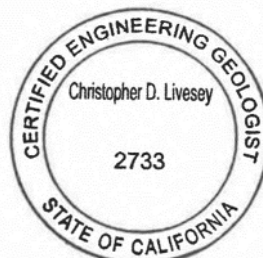

Edward LaMont  
CEG 1892  
Principal Geologist

Distribution: (I) Addressee via email

## TABLE OF CONTENTS

<b>1. PURPOSE AND SCOPE OF SERVICES</b> .....	<b>1</b>
<b>2. PROPERTY DESCRIPTION AND PROPOSED DEVELOPMENT</b> .....	<b>1</b>
2.1 Property Description .....	1
2.2 Future Development.....	2
<b>3. FIELD EXPLORATION AND LABORATORY TESTING</b> .....	<b>3</b>
3.1 Field Exploration.....	3
3.2 Laboratory Testing.....	4
<b>4. GEOLOGIC AND SOILS CONDITIONS</b> .....	<b>5</b>
4.1 Regional Setting.....	5
4.2 EARTH MATERIALS .....	5
4.2.1 Undocumented Fill (Not Mapped).....	5
4.2.2 Alluvium (Map Symbol Qal) .....	5
4.2.3 Tertiary Santiago Formation (Map Symbol Tsa) .....	6
4.3 SURFACE WATER AND GROUNDWATER.....	6
4.3.1 Surface Water.....	6
4.3.2 Groundwater.....	6
4.4 EARTHQUAKE HAZARDS .....	6
4.4.1 Surface Fault Rupture.....	6
4.4.2 Liquefaction/Seismic Settlement.....	6
4.4.3 Other Seismic Hazards.....	7
<b>5. CONCLUSIONS AND RECOMMENDATIONS</b> .....	<b>7</b>
5.1 General.....	7
5.2 EARTHWORK CONSIDERATIONS .....	7
5.2.1 General.....	7
5.2.2 Property Clearing and Preparation.....	8
5.2.3 Remedial Grading.....	8
5.2.4 Engineered Fill.....	8
5.2.5 Excavation Characteristics.....	9
5.2.6 Shrinkage and Bulking .....	9
5.2.7 Trench Excavations and Backfill .....	9
5.3 DESIGN RECOMMENDATIONS.....	10
5.3.1 Stormwater Infiltration.....	10
5.3.2 Foundation Design Criteria.....	10
5.3.3 Underslab Moisture Membrane.....	12
5.3.4 Miscellaneous Foundation Recommendations .....	13
5.3.5 Foundation Set Backs.....	13
5.3.6 Seismic Design Parameters .....	14
5.3.7 Soil Sulfate Content .....	14
5.3.8 Preliminary Pavement Design .....	14
5.4 RETAINING WALL DESIGN AND CONSTRUCTION.....	15
5.4.1 General Design Criteria.....	15
5.4.2 Restrained Retaining Walls .....	16
5.4.3 Wall Backfill and Drainage .....	17
5.5 POST CONSTRUCTION CONSIDERATIONS .....	17
5.5.1 Landscape Maintenance and Planting.....	17
5.5.2 Drainage.....	18
5.6 PLAN REVIEW AND CONSTRUCTION OBSERVATIONS .....	18



## TABLE OF CONTENTS

<b>6. LIMITATIONS .....</b>	<b>19</b>
<b>7. SELECTED REFERENCES.....</b>	<b>20</b>

### ENCLOSURES

Figure 1 – Site Location Map

Figure 2 – Boring Location Map

Appendix A – Exploratory Boring Logs and Infiltration Worksheets

Appendix B – Results of Laboratory Testing

Appendix C – General Earthwork Grading Guidelines

## **I. PURPOSE AND SCOPE OF SERVICES**

The purpose of this study was to evaluate the geotechnical conditions on the site. Services provided for this study included the following:

- Research and review of available geologic and geotechnical data, and general information pertinent to the property.
- Excavation of four (4) hollow stem auger borings onsite and collection of bulk and relatively undisturbed soil samples for subsequent laboratory testing.
- Two percolation test borings and infiltration analyses.
- Laboratory testing of the soil samples collected during the field investigation.
- Review and evaluation of seismicity, and
- Compilation of this geotechnical report which presents our findings of pertinent geotechnical conditions and geotechnical recommendations for future property development.

## **2. PROPERTY DESCRIPTION AND PROPOSED DEVELOPMENT**

### **2.1 Property Description**

The subject property is located at the northern corner of Linda Vista Drive and Los Posas Road in the City of San Marcos, San Diego County, California (see Figure 1). The property is bounded to the southwest by Linda Vista Drive, to the southeast by Los Posas Road, to the northeast by La Mirada Drive, and to the northwest by Pacific Street. Surface conditions generally consist of rolling unimproved earthen terrain, with native grasses and vegetation. The Site is relatively flat, ranging in elevation from approximately 527 feet above mean sea level (amsl) in the southeast portion of the project area to 551 feet in the northwest corner of the project Site.

## 2.2 Future Development

The approximately 33-acre Project site is an infill site located in the western portion of the City of San Marcos, at the northwest corner of Las Posas Road and Linda Vista Drive, comprised of Assessor's Parcel Numbers (APNs) 219-222-01, 219-222-02, 219-222-03, and 219-222-04. La Mirada Road abuts the site's northern boundary, while Pacific Street abuts the property's western boundary. The Grand Plaza shopping center is located directly across Las Posas Drive. Light industrial uses are adjacent to the Project site's northern, southern, and western boundary, and Bradley Park is located across from the Project site's southwestern corner. Single- and multi-family residential uses are located to the west and south of Bradley Park.

The Project would allow for the development of 495 residential units, including a mix of five-story podium apartments, three-story rowhomes, three-story villas, and four-story affordable flats on approximately 16.5 acres within the 33-acre Project site (Figure 3). 74 of the 495 total units (15 percent of the total) would be designated as deed-restricted affordable units. The proposed housing types are outlined below:

<b>Housing Type</b>	<b>Number of Units</b>	<b>Square Feet</b>
Apartments	137	740 – 1,579 sf
Rowhomes	154	1,200 - 1,890 sf
Villas	130	1,272 – 1,832 sf
Affordable Flats	74	512 – 924 sf

The Project would also include a total of 996 parking spaces and an 18,000 square foot community commons area. The proposed project also includes landscaping, bio-retention areas and circulation improvements. The remaining 16.7 acres of the 33.2-acre project site would be preserved and restored open space and habitat area.

The Project would have a density of approximately 30 dwelling units per acre (DU/AC) not including the proposed open space and habitat area. With the open space area included, the density of the proposed project would be approximately 15 DU/AC.

The Project proposes a General Plan Amendment, Rezone, Specific Plan, Tentative Map, and Multi-Family Site Development Plan. The General Plan Amendment and Rezone would change the General Plan designation and Zoning from Industrial (I) to Specific Plan Area. The Tentative Map presents specific lot configurations for the site. The Multi-Family Site Development Plan will configure the site for multi family dwelling units, street configuration, infrastructure, recreational open space, and private open space.



Structural loading information was not available at the time of this report submittal but should be provided to GeoTek once determined. For this report, we have assumed a maximum column load of 150 kips for the planned structures.

As planning progresses and additional or revised plans become available, they should be provided to GeoTek for review and comment. If plans vary significantly, additional geotechnical field exploration, laboratory testing and engineering analyses may be necessary to provide specific earthwork recommendations and geotechnical design parameters for actual development plans.

### **3. FIELD EXPLORATION AND LABORATORY TESTING**

#### **3.1 Field Exploration**

Our field study conducted on September 29, 2020 consisted of a reconnaissance, excavation of geotechnical hollow stem auger borings B-3 through B-6 to depths of about 19-½ feet below grade and 2 percolation test borings P-1 and P-2 to depths of about 3 feet below grade. The borings were drilled with a truck mounted rubber tire CME-75 drilling rig and included collection of bulk and relatively undisturbed driven soil samples for subsequent laboratory testing. Proposed borings B-1 and B-2 were not performed due to biological constraints and omitted from this report. Several variations of proposed boring locations were presented to California Fish and Wildlife (CFW), however, CFW only authorized the locations presented on Figure 2. A representative from our firm visually logged the borings and collected soil samples for laboratory analysis. Approximate locations of exploration locations are presented on the Boring Location Map, Figure 2. A description of material encountered in the borings is included in Appendix A.

#### **3.2 Percolation and Infiltration Testing**

Borings P-1 and P-2 were advanced to approximate depths of 3 feet below existing grade with an 8-inch diameter and converted to a dry well for percolation testing approximately 5-10 feet away from boring location B-6. Following completion of the boring excavations, percolation testing was performed by a representative from our firm in general conformance with the city of San Marcos BMP Design Manual. The boreholes were presoaked over-night and the testing was performed the following day. Percolation testing was performed by adding potable water to the borings, recording the initial depth to water and allowing the water to percolate for 30 minutes and the depth to water was measured. Water was generally added to each boring following each reading increment. In general, the percolation testing was performed for approximately 6 hours

to allow rates to stabilize. Results of the final percolation increment were used to calculate an infiltration rate in inches per hour via the Porchet method.

For design of shallow infiltration basins, converting percolation rates to infiltration rates via the Porchet method is generally acceptable and appropriate, as this method factors out the sidewall component of the percolation results and represents the bottom conditions of a shallow basin (infiltration). Therefore, the percolation data for borings P-1 and P-2 were converted via the Porchet method. This method is consistent with the guidelines referenced in the City of San Marcos BMP Design Manual. Results of our infiltration analysis without a factor of safety are presented in the follow table for each of the test areas.

Location	Depth (inches)	Infiltration Rate (inches per hour)*
P-1	35.75	0.07
P-2	34.75	0.07

\* Rate was converted to an infiltration rate via the Porchet method

Copies of infiltration conversion sheets are included in Appendix A.

The material exposed along the boring sidewalls and at the bottom of P-1 and P-2 were native soils. The tests performed and reported are indicative of native soils. At the time of investigation, groundwater was not encountered in the vicinity.

Over the lifetime of the storm water disposal areas, the percolation rates may be affected by silt build up and biological activities, as well as local variations in soil conditions. An appropriate factor of safety used to compute the design percolation rate should be considered at the discretion of the design engineer and acceptance of the plan reviewer.

### 3.2 Laboratory Testing

Laboratory testing was performed on bulk and relatively undisturbed soil samples collected during the field explorations. The purpose of the laboratory testing was to evaluate their physical and chemical properties for use in engineering design and analysis. Results of the laboratory testing program, along with a brief description and relevant information regarding testing procedures, are included in Appendix B.

## 4. GEOLOGIC AND SOILS CONDITIONS

### 4.1 Regional Setting

The subject property is located in the Peninsular Ranges geomorphic province. The Peninsular Ranges province is one of the largest geomorphic units in western North America. Basically, it extends roughly 975 miles from the north and northeasterly adjacent the Transverse Ranges geomorphic province to the tip of Baja California. This province varies in width from about 30 to 100 miles. It is bounded on the west by the Pacific Ocean, on the south by the Gulf of California and on the east by the Colorado Desert Province.

The Peninsular Ranges are essentially a series of northwest-southeast oriented fault blocks. Several major fault zones are found in this province. The Elsinore Fault zone and the San Jacinto Fault zones trend northwest-southeast and are found in the near the middle of the province. The San Andreas Fault zone borders the northeasterly margin of the province. The Newport-Inglewood-Rose Canyon Fault zone meanders the southwest margin of the province, but can be more appropriately defined by the Pacific Ocean. No faults are shown in the immediate vicinity on the map reviewed for the area.

### 4.2 EARTH MATERIALS

A brief description of the earth materials encountered during our subsurface exploration is presented in the following sections. Based on our field observations and review of published geologic maps the subject property is locally underlain by recent alluvium and Santiago Formation bedrock.

#### 4.2.1 Undocumented Fill (Not Mapped)

Undocumented fill soils were observed as sporadic end-dump piles from illegal dumping. These soils are not considered suitable for support of structural improvements but may be re-used as engineered fill if properly processed and placed.

#### 4.2.2 Alluvium (Map Symbol Qal)

The most recent regional geologic map reviewed showed the geology (Kennedy, 2007) for the eastern portion of the area along Los Posas Road to be alluvial deposits, however, based on our evaluation, alluvium appears to be limited to a smaller extent along a natural drainage swale along Los Posas Road. As encountered in boring B-6, the alluvium generally consisted of silty fine sands.

### **4.2.3 Tertiary Santiago Formation (Map Symbol Tsa)**

The most recently dated regional geologic map showing the overall geology (Kennedy, 2007), indicates Santiago Formation sedimentary bedrock at the surface on the western majority of the property; however, based on our evaluation the Santiago Formation appears to be near the surface across most of the property. As encountered in the borings, Santiago Formation was observed as a dark brown to black clay over sandstone.

## **4.3 SURFACE WATER AND GROUNDWATER**

### **4.3.1 Surface Water**

Surface water was not observed during our visit. If encountered during earthwork construction, surface water is likely the result of precipitation. Overall, area drainage is in a southeast direction. Provisions for surface drainage will need to be accounted for by the future project civil engineer.

### **4.3.2 Groundwater**

A static groundwater table was not encountered during drilling operations. Excavations B-5 and B-6 appears to have encountered perched water at a depth of approximately 19 and 15 feet (respectively) and cuttings in B-4 at a depth of 17 feet suggest a perch groundwater. Based on the anticipated depth of removals, groundwater is not anticipated to be a factor in future development. Localized perched groundwater may be present, but is also not anticipated to be a factor in future development with the exception that seasonal water levels are likely to impact storm water management.

## **4.4 EARTHQUAKE HAZARDS**

### **4.4.1 Surface Fault Rupture**

The geologic structure of the entire southern California area is dominated mainly by northwest-trending faults associated with the San Andreas system. The property is in a seismically active region. No active or potentially active fault is known to exist at this property nor is the property situated within an "Alquist-Priolo" Earthquake Fault Zone or a Special Studies Zone (Bryant and Hart, 2007). No faults transecting the property were identified on the readily available geologic maps reviewed. The nearest known active fault is the Newport Inglewood-Rose Canyon fault located about 11 miles to the southwest of the property.

### **4.4.2 Liquefaction/Seismic Settlement**

Liquefaction describes a phenomenon in which cyclic stresses, produced by earthquake-induced ground motion, create excess pore pressures in relatively cohesionless soils. These soils may thereby acquire a high degree of mobility, which can lead to lateral movement, sliding,

consolidation and settlement of loose sediments, sand boils and other damaging deformations. This phenomenon occurs only below the water table, but, after liquefaction has developed, the effects can propagate upward into overlying non-saturated soil as excess pore water dissipates.

The factors known to influence liquefaction potential include soil type and grain size, relative density, groundwater level, confining pressures, and both intensity and duration of ground shaking. In general, materials that are susceptible to liquefaction are loose, saturated granular soils having low fines content under low confining pressures.

The liquefaction potential and seismic settlement potential is considered negligible provided remedial grading recommendations presented herein are completed and due to the general dense to very dense nature of underlying shallow bedrock, as well as planned fill placement.

#### **4.4.3 Other Seismic Hazards**

Due to the relatively flat nature of the property, the potential for landslides and rockfall is considered negligible. The potential for secondary seismic hazards such as seiche and tsunami is remote due to property elevation and distance from an open body of water.

## **5. CONCLUSIONS AND RECOMMENDATIONS**

### **5.1 General**

Future development of the property appears feasible from a geotechnical viewpoint provided that the following recommendations are incorporated in the design and construction phases of the development. The following sections present general recommendations for currently anticipated future development. Due to the preliminary nature of this report, supplemental geotechnical evaluations of the property are anticipated at future dates once more detailed development plans are available. Those supplemental geotechnical recommendations will supersede the preliminary recommendations provided in this report.

### **5.2 EARTHWORK CONSIDERATIONS**

#### **5.2.1 General**

Earthwork and grading should be performed in accordance with the applicable grading ordinances of the city of San Marcos, the 2019 (or current) California Building Code (CBC), and recommendations contained in this report. The Grading Guidelines included in Appendix C outline general procedures and do not anticipate all specific situations. In the event of conflict,

the recommendations presented in the text of this report should supersede those contained in Appendix C.

### **5.2.2 Property Clearing and Preparation**

Property preparation should start with removal of deleterious materials and vegetation. These materials should be disposed of properly off property. Any existing underground improvements, utilities and trench backfill should also be removed or be further evaluated as part of future development operations.

### **5.2.3 Remedial Grading**

Prior to placement of fill materials and in all structural areas the upper variable, potentially compressible materials should be removed. Removals should include all existing fill, colluvium/weathered bedrock materials and we anticipate that the removals will extend approximately 5 feet below existing grade and should also extend to at least 2 feet below the bottom of proposed footings. The lateral extent of removals beyond the outside edge of all settlement sensitive structures/foundations should be equivalent to that vertically removed or five feet, whichever is greater. Depending on actual field conditions encountered during grading, locally deeper and/or shallower areas of removal may be necessary.

In pavement areas, removals should extend at least 2 feet below existing grade or one foot below finished subgrade whichever is lowest.

The bottom of all removals should be scarified to a minimum depth of six (6) inches, brought to slightly above optimum moisture content, and then compacted to at least 90% of the soil's maximum dry density, per ASTM D1557 prior to fill placement. The remedial excavation bottoms should be observed by a GeoTek representative prior to scarification. The resultant voids from remedial grading/overexcavation should be filled with materials placed in general accordance with Section 5.2.4 Engineered Fill of this report.

### **5.2.4 Engineered Fill**

Onsite materials are generally considered suitable for reuse as engineered fill provided they are free from vegetation, roots, debris, and rock/concrete or hard lumps greater than six (6) inches in maximum dimension. The earthwork contractor should have the proposed excavated materials to be used as engineered fill at this property approved by the soils engineer prior to placement.

Engineered fill materials should be moisture conditioned to at or above optimum moisture content and compacted in horizontal lifts not exceeding 8 inch in loose thickness to a minimum



relative compaction of 90% as determined in accordance with laboratory test procedure ASTM D 1557.

If fill is being placed on slopes steeper than 5:1 (h:v), the fill should be properly benched into the existing slopes and a sufficient size keyway shall be constructed in accordance with grading guidelines presented in Appendix C.

### **5.2.5 Excavation Characteristics**

Excavations can generally be accomplished with heavy-duty earthmoving or excavating equipment in good operating condition. Excavations in sedimentary bedrock may require special excavation equipment and/or techniques.

### **5.2.6 Shrinkage and Bulking**

Several factors will impact earthwork balancing, including bedrock bulking, undocumented fill and colluvium shrinkage, trench spoil from utilities and footing excavations, as well as the accuracy of topography.

Shrinkage and bulking are largely dependent upon the degree of compactive effort achieved during construction. For planning purposes, a shrinkage/bulking factor ranging of plus or minus 5 percent may be considered for surficial undocumented fill materials and alluvium. A bulking factor of 5 to 10 percent may be considered for the upper 3 feet of Santiago Formation bedrock requiring removal and re-compaction. Subsidence should not be a factor, if removals are completed as recommended.

### **5.2.7 Trench Excavations and Backfill**

Temporary excavations within should be stable at 1:1 inclinations for short durations during construction, and where cuts do not exceed 10 feet in height. Temporary cuts to a maximum height of 4 feet can be excavated vertically.

Trench excavations should conform to Cal-OSHA regulations. The contractor should have a competent person, per OSHA requirements, during construction to observe conditions and to make the appropriate recommendations.

Utility trench backfill should be compacted to at least 90% relative compaction of the maximum dry density as determined per ASTM D 1557. Under-slab trenches should also be compacted to specifications.

Onsite materials may not be suitable for use as bedding material, but should be suitable as backfill provided particles larger than 6± inches are removed.

Compaction should be achieved with a mechanical compaction device. Ponding or jetting of trench backfill is not recommended. If backfill soils have dried out, they should be thoroughly moisture conditioned prior to placement in trenches.

## 5.3 DESIGN RECOMMENDATIONS

### 5.3.1 Stormwater Infiltration

Many factors control infiltration of surface waters into the subsurface, such as consistency of native soils and bedrock, geologic structure, fill consistency, material density differences, and existing groundwater conditions. In consideration of the shallow bedrock and anticipated shallow groundwater, infiltration of stormwater into the subsurface is not recommended from a geotechnical perspective. Stormwater quality control basins should be constructed with an impermeable liner along the sides and bottom.

### 5.3.2 Foundation Design Criteria

Preliminary foundation design criteria, in general conformance with the 2019 CBC, are presented herein. These are typical design criteria and are not intended to supersede the design by the structural engineer. The preliminary recommendations presented below are based on an assumed maximum column load of 150 kips for the planned buildings. Once actual structural loads and grading concepts are known, supplemental recommendations may be warranted which may require additional test borings and laboratory testing.

Based on our visual classification of materials encountered and as verified by laboratory testing, soils near subgrade are anticipate to exhibit a “medium” ( $51 \leq EI \leq 90$ ) potential for expansion per ASTM D4829. Materials with “low” ( $21 \leq EI \leq 50$ ) expansiveness may also be encountered at depth and could be placed as engineered fill soils depending on grading logistics. Additional laboratory testing should be performed at the time of supplemental geotechnical evaluations and upon completion of grading activities to verify the expansion potential and plasticity index of the subgrade soils.

The following criteria for design of foundations are preliminary. Additional laboratory testing of the samples obtained during grading should be performed and final recommendations should be based on as-graded soil conditions.

<b>DESIGN PARAMETES FOR CONVENTIONALL REINFORCED SHALLOW FOUNDATIONS</b>		
Design Parameter	“Low” Expansion Potential ( $21 \leq EI \leq 50$ )	“Medium” Expansion Potential ( $51 \leq EI \leq 90$ )
Foundation Embedment Depth or Minimum Perimeter Beam Depth (inches below lowest adjacent finished grade)	One- and Two Story – 12 Three and Four-Story-24	One- and Two Story – 18 Three and Four-Story- 24
Minimum Foundation Width (Inches)*	One- and Two Story – 12 Three and Four Story- 18	One- and Two Story – 12 Three and Four Story- 18
Minimum Slab Thickness (actual)	4 inches	4 inches
Minimum Slab Reinforcing	No. 3 rebar 24” on-center, each way, placed in the middle one-third of the slab thickness	No. 3 rebar 18” on-center, each way, placed in the middle one-third of the slab thickness
Minimum Footing Reinforcement	Two No. 4 reinforcing bars, one top and one bottom	Four No. 4 reinforcing bars, two top and two bottom
Effective Plasticity Index**	<15	20
Presaturation of Subgrade Soil (percent of optimum moisture content)	Minimum 110% to a depth of 12 inches	Minimum 120% to a depth of 18 inches

\*Code minimums per Table 1809.7 of the 2019 CBC should be complied with.

\*\*Effective Plasticity Index should be verified at the completion of the rough grading.

It should be noted that the above recommendations are based on soil support characteristics only. The structural engineer should design the slab and beam reinforcement based on actual loading conditions.

The following recommendations should be implemented into the design:

- Preliminarily, an allowable bearing capacity of 2,500 pounds per square foot (psf) may be considered for design of continuous and perimeter footings that meet the depth and width requirements in the table above. This value may be increased by 400 psf for each additional 12 inches in depth and 100 psf for each additional 12 inches in width to a maximum value of 3,000 psf. Additionally, an increase of one-third may be applied when considering short-term live loads (e.g. seismic and wind loads). It may be possible to utilize a higher allowable soil bearing pressure for foundations directly supported by bedrock. The determination of an allowable soil bearing pressure on bedrock should be determined once foundation loads and elevations are known.
- Based on our experience in the area, structural foundations may be designed in accordance with 2019 CBC, and to withstand a total settlement of 1 inch and maximum differential settlement of one-half of the total settlement over a horizontal distance of 30 feet. Seismically induced settlement is considered to be minimal.

- The passive earth pressure may preliminarily be computed as an equivalent fluid having a density of 220 psf per foot of depth, to a maximum earth pressure of 2,500 psf for footings founded on engineered fill. A coefficient of friction between soil and concrete of 0.35 may be used with dead load forces. When combining passive pressure and frictional resistance, the passive pressure component should be reduced by one-third.
- A grade beam, a minimum of 12 inches wide and 12 inches deep, should be utilized across large entrances, however, the base of the grade beam should be at the same elevation as the bottom of the adjoining footings.
- We recommend that control joints be placed in two directions spaced the numeric equivalent roughly 24 times the thickness of the slab in inches (e.g. a 4 inch slab would have control joints at 96 inch [8 feet] centers). These joints are a widely accepted means to control cracks and should be reviewed by the structural engineer.

### 5.3.3 Underslab Moisture Membrane

A moisture and vapor retarding system should be placed below slabs-on-grade where moisture migration through the slab is undesirable. Guidelines for these are provided in the 2019 California Green Building Standards Code (CALGreen) Section 4.505.2 and the 2019 CBC Section 1907.1

It should be realized that the effectiveness of the vapor retarding membrane can be adversely impacted as a result of construction related punctures (e.g. stake penetrations, tears, punctures from walking on the vapor retarder placed atop the underlying aggregate layer, etc.). These occurrences should be limited as much as possible during construction. Thicker membranes are generally more resistant to accidental puncture than thinner ones. Products specifically designed for use as moisture/vapor retarders may also be more puncture resistant. Although the CBC specifies a 6 mil vapor retarder membrane, it is GeoTek's opinion that a minimum 10 mil membrane with joints properly overlapped and sealed should be considered, unless otherwise specified by the slab design professional.

Moisture and vapor retarding systems are intended to provide a certain level of resistance to vapor and moisture transmission through the concrete, but do not eliminate it. The acceptable level of moisture transmission through the slab is to a large extent based on the type of flooring used and environmental conditions. Ultimately, the vapor retarding system should be comprised of suitable elements to limit migration of water and reduce transmission of water vapor through the slab to acceptable levels. The selected elements should have suitable properties (i.e. thickness, composition, strength and permeability) to achieve the desired performance level.

Moisture retarders can reduce, but not eliminate, moisture vapor rise from the underlying soils up through the slab. Moisture retarder systems should be designed and constructed in accordance with applicable American Concrete Institute, Portland Cement Association, Post-Tensioning Concrete Institute, ASTM and California Building Code requirements and guidelines.

GeoTek does not practice in the field of moisture vapor transmission evaluation/migration, since that practice is not a geotechnical discipline. Therefore, we recommend that a qualified person, such as the flooring contractor, structural engineer, architect, and/or other experts specializing in moisture control within the building be consulted to evaluate the general and specific moisture and vapor transmission paths and associated potential impact on the proposed construction. That person (or persons) should provide recommendations relative to the slab moisture and vapor retarder systems and for migration of potential adverse impact of moisture vapor transmission on various components of the structures, as deemed appropriate. In addition, the recommendations in this report and our services in general are not intended to address mold prevention; since we, along with geotechnical consultants in general, do not practice in the area of mold prevention. If specific recommendations addressing potential mold issues are desired, then a professional mold prevention consultant should be contacted.

#### **5.3.4 Miscellaneous Foundation Recommendations**

- To reduce moisture penetration beneath the slab on grade areas, utility trenches should be backfilled with engineered fill, lean concrete or concrete slurry where they intercept the perimeter footing or thickened slab edge.
- Spoils from the footing excavations should not be placed in the slab-on-grade areas unless properly compacted and tested. The excavations should be free of loose/sloughed materials and be neatly trimmed at the time of concrete placement.

#### **5.3.5 Foundation Set Backs**

Where applicable, the following setbacks should apply to all foundations. Any improvements not conforming to these setbacks may be subject to lateral movements and/or differential settlements:

- The outside bottom edge of all footings should be set back a minimum of  $H/3$  (where  $H$  is the slope height) from the face of any descending slope. The setback should be at least 7 feet and need not exceed 40 feet.

- The bottom of all footings for structures near retaining walls should be deepened so as to extend below a 1:1 projection upward from the bottom inside edge of the wall stem. This applies to the existing retaining walls along the perimeter, if they are to remain.
- The bottom of any existing foundations for structures should be deepened so as to extend below a 1:1 projection upward from the bottom of the nearest excavation.

### 5.3.6 Seismic Design Parameters

The property is located at approximately 33.1394 Latitude and -117.1961 Longitude. Spectral accelerations ( $S_s$  and  $S_1$ ), for 0.2 and 1.0 second periods for a risk targeted two (2) percent probability of exceedance in 50 years (MCER) were determined using the web interface provided by SEAOC/OSHPD (<https://seismicmaps.org>) to access the USGS Seismic Design Parameters. We have selected a Site Class “C” based on the apparent density of the old alluvial deposits. The results, based on ASCE 7-16 and the 2019 CBC, are presented in the following table.

<b>SEISMIC PARAMETERS</b>	
Mapped 0.2 sec Period Spectral Acceleration, $S_s$	0.897g
Mapped 1.0 sec Period Spectral Acceleration, $S_1$	0.331g
Coefficient for Site Class “C”, $F_a$	1.2
Coefficient for Site Class “C”, $F_v$	1.5
Maximum Considered Earthquake ( $MCE_R$ ) Spectral Response Acceleration for 0.2 Second, $S_{MS}$	1.077g
Maximum Considered Earthquake ( $MCE_R$ ) Spectral Response Acceleration for 1.0 Second, $S_{M1}$	0.496g
5% Damped Design Spectral Response Acceleration Parameter at 0.2 Second, $S_{DS}$	0.718g
5% Damped Design Spectral Response Acceleration Parameter at 1 second, $S_{D1}$	0.331g
Modified Peak Ground Acceleration ( $PGA_M$ )	0.465g
Seismic Design Category	D

### 5.3.7 Soil Sulfate Content

Nearby sulfate content test results indicate water soluble sulfate is less than 0.1 percent by weight, which is considered “S0” as per Table 19.3.1.1 of ACI 318-14, as such no special recommendations for concrete are included herein.

### 5.3.8 Preliminary Pavement Design

Traffic indices have not been provided to our firm during this stage of planning. In addition, remedial graded has not been completed to evaluate specific street subgrade conditions.



Therefore, we have referenced the minimum structural sections based on the City of San Marcos' Urban Street Design for residential streets (San Marcos, 2020) and are presented below.

<b>PRELIMINARY ASPHALT PAVEMENT STRUCTURAL SECTION</b>		
Design Criteria <sup>+</sup>	Asphaltic Concrete (AC) Thickness (inches)	Aggregate Base (AB) Thickness (inches)
Residential	3.0	6.0

As noted in the Urban Street Design document, actual structural pavement design is to be determined by the geotechnical engineer's testing (R-value) of the subgrade. Thus, the actual R-value of subgrade soils can only be determined at the completion of grading for street subgrade and the above values are subject to change based laboratory testing of the as-graded soils near subgrade elevations. The final pavement design may be thicker than the City of San Marcos minimum thickness presented above.

Asphalt concrete and aggregate base should conform to current Caltrans Standard Specifications Section 39 and 26-1.02, respectively. As an alternative, asphalt concrete can conform to Section 203-6 of the current Standard Specifications for Public Work (Green Book). Crushed aggregate base or crushed miscellaneous base can conform to Section 200-2.2 and 200-2.4 of the Green Book, respectively. Pavement base should be compacted to at least 95 percent of the ASTM D1557 laboratory maximum dry density (modified proctor).

All pavement installation, including preparation and compaction of subgrade, compaction of base material, placement and rolling of asphaltic concrete, should be done in accordance with the city of San Marcos specifications, and under the observation and testing of GeoTek and a City Inspector where required. Jurisdictional minimum compaction requirements in excess of the aforementioned minimums may govern.

## **5.4 RETAINING WALL DESIGN AND CONSTRUCTION**

### **5.4.1 General Design Criteria**

Preliminary plans are not yet available, if retaining walls are added at a later date, the recommendations presented herein may apply to typical masonry or concrete vertical retaining walls to a maximum height of 10 feet. Additional review and recommendations should be requested for higher walls.

Retaining wall foundations embedded a minimum of 18 inches into engineered fill or dense formational materials should be designed using an allowable bearing capacity of 2500 psf. An increase of one-third may be applied when considering short-term live loads (e.g. seismic and wind loads). The passive earth pressure may be computed as an equivalent fluid having a density of 220 psf per foot of depth, to a maximum earth pressure of 3,000 psf. A coefficient of friction between soil and concrete of 0.35 may be used with dead load forces. When combining passive pressure and frictional resistance, the passive pressure component should be reduced by one-third.

An equivalent fluid pressure approach may be used to compute the horizontal active pressure against the wall. The appropriate fluid unit weights are given in the table below for specific slope gradients of retained materials.

Surface Slope of Retained Materials (H:V)	Equivalent Fluid Pressure (PCF) Select Backfill*
Level	35
2:1	55

\*Select backfill should consist of native or imported sand other approved materials with an  $SE > 30$  and an  $EI \leq 20$  and should be provided throughout the active zone.

The above equivalent fluid weights do not include other superimposed loading conditions such as expansive soil, vehicular traffic, structures, seismic conditions or adverse geologic conditions.

Additional lateral forces can be induced on retaining walls during an earthquake. For level backfill and a Site Class "C", a supplemental earthquake-induced equivalent fluid pressure of 14.4 pcf should be considered, where required. This force can be assumed to act as a typical fluid pressure, resulting in a triangular pressure distribution. The 2019 CBC only requires the additional earthquake induced lateral force be considered on retaining walls in excess of six (6) feet in height; however, the additional force may be applied in design of lesser walls at the discretion of the wall designer.

#### 5.4.2 Restrained Retaining Walls

Any retaining wall that will be restrained prior to placing backfill or walls that have male or reentrant corners should be designed for at-rest soil conditions using an equivalent fluid pressure of 60 pcf (select backfill), plus any applicable surcharge loading. For areas having male or reentrant corners, the restrained wall design should extend a minimum distance equal to twice the height of the wall laterally from the corner, or as otherwise determined by the structural engineer.

### 5.4.3 Wall Backfill and Drainage

Wall backfill should include a minimum one (1) foot wide section of  $\frac{3}{4}$  to 1-inch clean crushed rock (or approved equivalent). The rock should be placed immediately adjacent to the back of wall and extend up from the backdrain to within approximately 12 inches of finish grade. The upper 12 inches should consist of compacted onsite materials. If the walls are designed using the “select” backfill design parameters, then the “select” materials shall be placed within the active zone as defined by a 1:1 (H:V) projection from the back of the retaining wall footing up to the retained surface behind the wall. Presence of other materials might necessitate revision to the parameters provided and modification of wall designs.

The backfill materials should be placed in lifts no greater than 8-inches in thickness and compacted to a minimum of 90% of the maximum dry density as determined in accordance with ASTM Test Method D 1557. Proper surface drainage needs to be provided and maintained. Water should not be allowed to pond behind retaining walls. Waterproofing of walls should be performed where moisture migration through the wall is undesirable.

Retaining walls should be provided with an adequate pipe and gravel back drain system to reduce the potential for hydrostatic pressures to develop. A 4-inch diameter perforated collector pipe (Schedule 40 PVC, or approved equivalent) in a minimum of one (1) cubic foot per lineal foot of  $\frac{3}{8}$  to one (1) inch clean crushed rock or equivalent, wrapped in filter fabric should be placed near the bottom of the backfill and be directed (via a solid outlet pipe) to an appropriate disposal area.

Drain outlets should be maintained over the life of the future project and should not be obstructed or plugged by adjacent improvements.

## 5.5 POST CONSTRUCTION CONSIDERATIONS

### 5.5.1 Landscape Maintenance and Planting

Water has been shown to weaken the inherent strength of soil, and slope stability is significantly reduced by overly wet conditions. Positive surface drainage away from graded slopes should be maintained and only the amount of irrigation necessary to sustain plant life should be provided for planted slopes. Controlling surface drainage and runoff and maintaining a suitable vegetation cover can minimize erosion. Plants selected for landscaping should be lightweight, deep-rooted types that require little water and are capable of surviving the prevailing climate.

Overwatering should be avoided. The soils should be maintained in a solid to semi-solid state as defined by the materials Atterberg Limits. Care should be taken when adding soil amendments

to avoid excessive watering. Leaching as a method of soil preparation prior to planting is not recommended. An abatement program to control ground-burrowing rodents should be implemented and maintained. This is critical as burrowing rodents can decreased the long-term performance of slopes.

It is common for planting to be placed adjacent to structures in planter or lawn areas. This will result in the introduction of water into the ground adjacent to the foundation. This type of landscaping should be avoided. If used, then extreme care should be exercised with regard to the irrigation and drainage in these areas. Waterproofing of the foundation and/or subdrains may be warranted and advisable. We could discuss these issues, if desired, when plans are made available.

### **5.5.2 Drainage**

The need to maintain proper surface drainage and subsurface systems cannot be overly emphasized. Positive drainage should be maintained at all times. Drainage should not flow uncontrolled down any descending slope. Water should be directed away from foundations and not allowed to pond or seep into the ground adjacent to the footings. Property drainage should conform to Section 1804.4 of the 2019 CBC. Roof gutters and downspouts should discharge onto paved surfaces sloping away from the structure or into a closed pipe system which outfalls to the street gutter pan or directly to the storm drain system. Pad drainage should be directed toward approved areas and not be blocked by other improvements.

## **5.6 PLAN REVIEW AND CONSTRUCTION OBSERVATIONS**

We recommend that future grading, specifications, retaining wall/shoring plans and foundation plans be reviewed by this office prior to construction to check for conformance with the recommendations of this report. Additional recommendations may be necessary based on these reviews. We also recommend that GeoTek representatives be present during future grading and foundation construction to check for proper implementation of the geotechnical recommendations. The owner/developer should have GeoTek's representative perform at least the following duties:

- Observe clearing and grubbing operations for proper removal of unsuitable materials.
- Observe and test bottom of removals prior to fill placement.
- Evaluate the suitability of on-site and import materials for fill placement, and collect soil samples for laboratory testing when necessary.
- Observe the fill for uniformity during placement including utility trenches.
- Observe and test the fill for field density and relative compaction.
- Observe and probe foundation excavations to confirm suitability of bearing materials.

If requested, a construction observation and compaction report can be provided by GeoTek, which can comply with the requirements of the governmental agencies having jurisdiction over the future development. We recommend that these agencies be notified prior to commencement of construction so that necessary grading permits can be obtained.

## 6. LIMITATIONS

The scope of our evaluation is limited to the area explored that is shown on the Boring Location Map (Figure 2). This evaluation does not and should in no way be construed to encompass any areas beyond the specific area of proposed construction as indicated to us by the client. The scope is based on our understanding of the future development and the client's needs, our proposal (Proposal No. P-0300620-SD) dated March 25, 2020 and geotechnical engineering standards normally used on similar property in this region.

The materials observed on the property appear to be representative of the area; however, soil and bedrock materials vary in character between excavations and natural outcrops or conditions exposed during property construction. Property conditions may vary due to seasonal changes or other factors. GeoTek, Inc. assumes no responsibility or liability for work, testing or recommendations performed or provided by others.

Since our recommendations are based on the property conditions observed and encountered, and laboratory testing, our conclusions and recommendations are professional opinions that are limited to the extent of the available data. Observations during construction are important to allow for any change in recommendations found to be warranted. These opinions have been derived in accordance with current standards of practice and no warranty is expressed or implied. Standards of practice are subject to change with time.

## 7. SELECTED REFERENCES

- American Society of Civil Engineers (ASCE), 2016, "Minimum Design Loads for Buildings and Other Structures," ASCE/SEI 7-16.
- ASTM International (ASTM), "ASTM Volumes 4.08 and 4.09 Soil and Rock."
- Bryant, W.A., and Hart, E.W., 2007, "Fault Rupture Hazard Zones in California, Alquist-Priolo Earthquake Fault Zoning Act with Index to Earthquake Fault Zones Maps," California Geological Survey: Special Publication 42.
- California Code of Regulations, Title 24, 2019 "California Building Code," 3 volumes.
- California Geological Survey (CGS, formerly referred to as the California Division of Mines and Geology), 1977, "Geologic Map of California."
- \_\_\_\_\_, 1998, "Maps of Known Active Fault Near-Source Zones in California and Adjacent Portions of Nevada," International Conference of Building Officials.
- City of San Marcos, 2012, City of San Marcos General Plan, adopted February 14, 2012.
- \_\_\_\_\_, 2016, "City of San Marcos BMP Design Manual," dated February 2016.
- \_\_\_\_\_, 2020, "City of San Marcos Urban Street Design Criteria," <https://www.san-marcos.net/home/showdocument?id=11091> not dated, accessed October 27, 2020.
- GeoTek, Inc., In-house proprietary information.
- Kennedy, M.P., and Tan, S.S., 2007, "Geologic Map of the Oceanside 30x60-minute Quadrangle, California," California Geological Survey, Regional Geologic Map No. 2, map scale 1:100,000.
- Structural Engineers Association of California/California Office of Statewide Health Planning and Development (SEOC/OSHPD), 2019, Seismic Design Maps web interface, <https://seismicmaps.org>
- Terzaghi, K. and Peck, R., 1967, "Soil Mechanics in Engineering Practice", second edition.



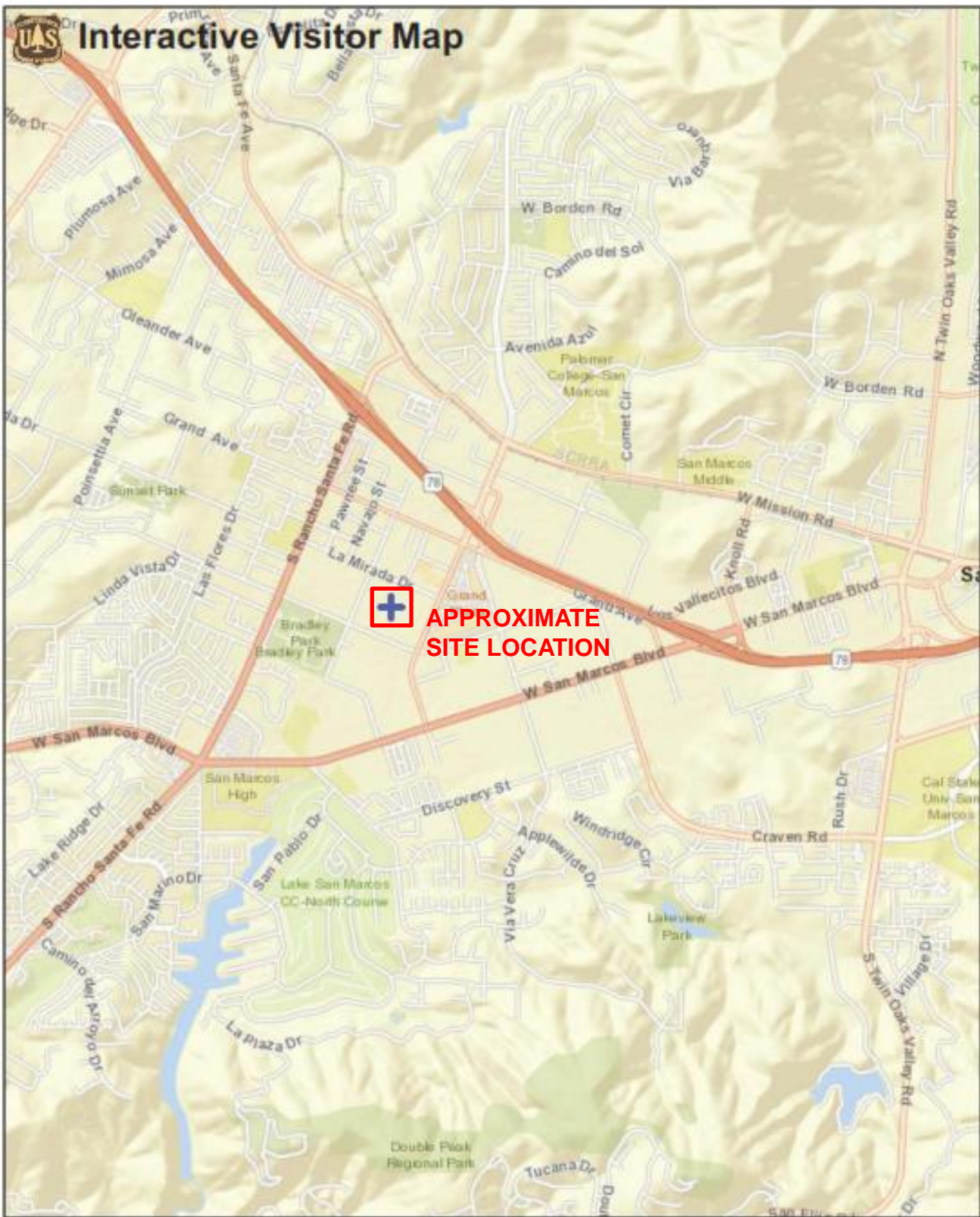

Interactive Visitor Map from US Forestry Service, 2021

NOT TO SCALE

**GEOTEK**  
 1384 Poinsettia Avenue, Suite A  
 Vista, California 92081-8505

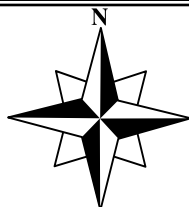

**Site Location Map**  
 Pacific GPA/Rezzone Project  
 NW Corner of Linda Vista & Las Posas Rd.  
 San Marcos, California

**Figure 1**



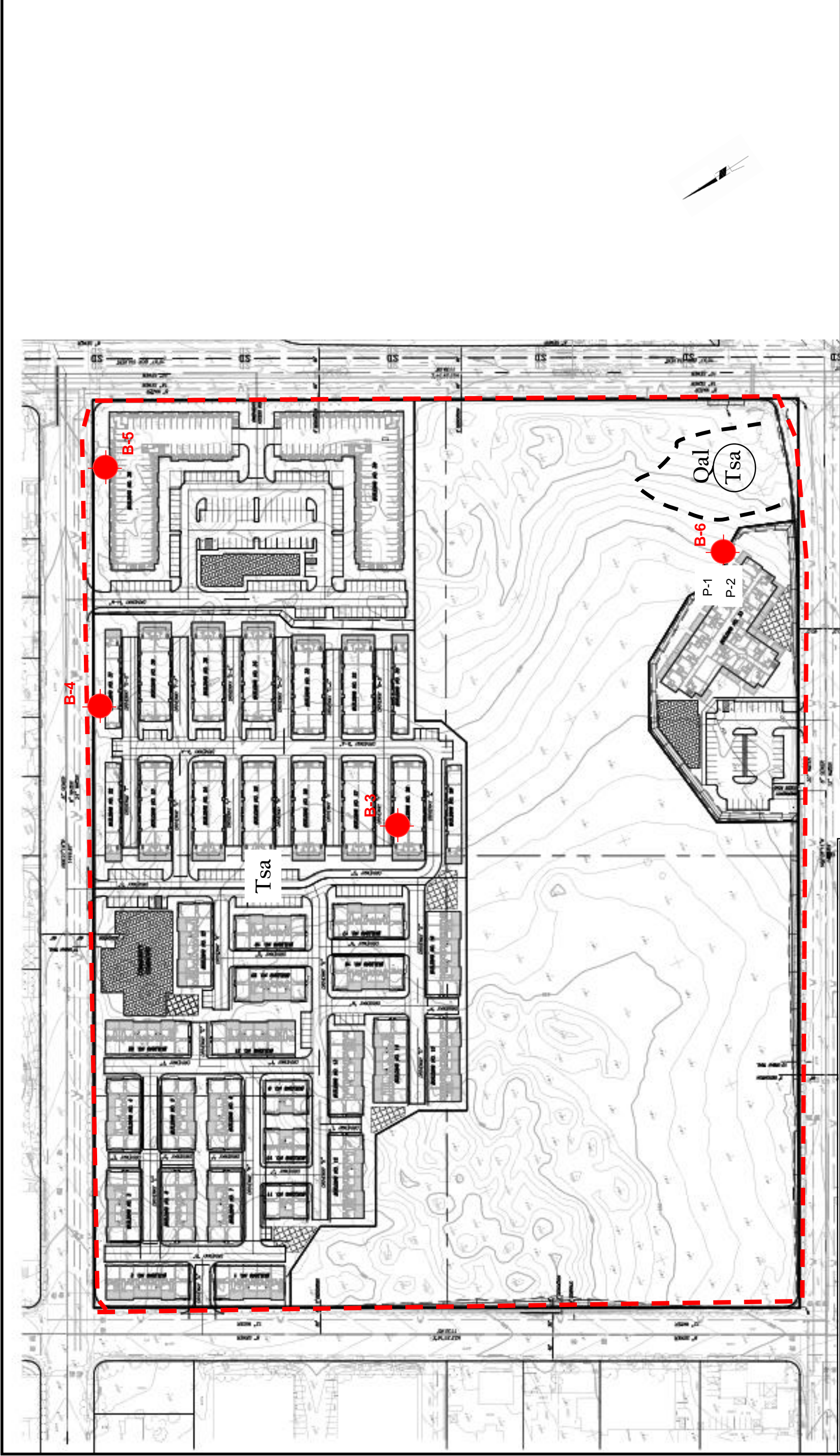

**LEGEND**

**B-6** APPROXIMATE LOCATION OF BORING TEST LOCATIONS

**Tsa** SANTIAGO FORMATION, CIRCLED WHERE BURIED

**---** LIMITS OF PROPERTY

**Qal** ALLUVIUM

The Los Posas Owner LPV, LLC  
 Pacific GPA/Rezone  
 NW Corner of Linda Vista Dr. & Las Posas  
 San Marcos, California

PN: 3649-SD

October 2021

**Figure 2**  
**Boring Location Plan**

**GEOTEK**  
 1384 Poinsettia Avenue, Suite A  
 Vista, California 92081

# **APPENDIX A**

**EXPLORATORY BORING LOGS  
AND  
INFILTRATION WORKSHEETS**

## **A - FIELD TESTING AND SAMPLING PROCEDURES**

### The Modified Split-Barrel Sampler (Ring)

The Ring sampler is driven into the ground in accordance with ASTM Test Method D 3550. The sampler, with an external diameter of 3.0 inches, is lined with 1-inch long, thin brass rings with inside diameters of approximately 2.4 inches. The sampler is typically driven into the ground 12 or 18 inches with a 140-pound hammer free falling from a height of 30 inches. Blow counts are recorded for every 6 inches of penetration as indicated on the log of boring. The samples are removed from the sample barrel in the brass rings, sealed, and transported to the laboratory for testing.

### Bulk Samples (Large)

These samples are normally large bags of earth materials over 20 pounds in weight collected from the field by means of hand digging or exploratory cuttings.

### Bulk Samples (Small)

These are plastic bag samples which are normally airtight and contain less than 5 pounds in weight of earth materials collected from the field by means of hand digging or exploratory cuttings. These samples are primarily used for determining natural moisture content and classification indices.

## **B –EXCAVATION LOG LEGEND**

The following abbreviations and symbols often appear in the classification and description of soil and rock on the logs of borings and trenches:

### SOILS

USCS            Unified Soil Classification System

f-c             Fine to coarse

f-m             Fine to medium

### GEOLOGIC

B: Attitudes    Bedding: strike/dip

J: Attitudes    Joint: strike/dip

C: Contact line

.....        Dashed line denotes USCS material change

————     Solid Line denotes unit / formational change

————     Thick solid line denotes end of boring

(Additional denotations and symbols are provided on the logs)

# GeoTek, Inc.

## LOG OF EXPLORATORY BORING

<b>CLIENT:</b>	The Las Posas Owner LPV, LLC	<b>DRILLER:</b>	Baja Exploration	<b>LOGGED BY:</b>	CDL
<b>PROJECT NAME:</b>	Pacific San Marcos	<b>DRILL METHOD:</b>	CME-75 HAS	<b>OPERATOR:</b>	
<b>PROJECT NO.:</b>	3649-SD	<b>HAMMER:</b>	140lbs/30in	<b>RIG TYPE:</b>	CME-75
<b>LOCATION:</b>	See Boring Location Map	<b>ELEVATION:</b>		<b>DATE:</b>	9/29/2020

Depth (ft)	SAMPLES			USCS Symbol	<b>BORING NO.: B-3</b>	Laboratory Testing		
	Sample Type	Blows / 6 in	Sample Number			MATERIAL DESCRIPTION AND COMMENTS	Water Content (%)	Dry Density (pcf)
0	X				<b>Dirt Road</b> Weathered Santiago/Colluvium <b>CLAY, dark brown-black, dry, trace sand</b>			
5	■	13 22 74	R-1		<b>Tertiary Santiago Formation</b> Clayey medium SANDSTONE, pale yellow, moist, very dense, transition in sample	9.4	121.9	
10	X	10 21 21	S-1		Clayey medium SANDSTONE, pale yellow, moist, very dense			
15	■	11 50/6"	R-2		Clayey medium SANDSTONE, pale yellow, moist, very dense	11.4	124.3	
20	X	12 20 24	S-2		Clayey fine SANDSTONE, orange brown and play yellow, moist, very dense, light olive gray claystone in shoe, moist, hard, bedded oxidation			
25					<b>HOLE TERMINATED AT 19.5 FEET</b>			
30					No groundwater encountered Backfilled with soil cuttings			

<b>LEGEND</b>	<b>Sample type:</b>	■ ---Ring	■ ---SPT	□ ---Small Bulk	⊗ ---Large Bulk	□ ---No Recovery	▽ ---Water Table
	<b>Lab testing:</b>	AL = Atterberg Limits	SR = Sulfate/Resistivity Test	EI = Expansion Index	SH = Shear Test	SA = Sieve Analysis	CO = Consolidation test

**GeoTek, Inc.**  
**LOG OF EXPLORATORY BORING**

<b>CLIENT:</b> The Las Posas Owner LPV, LLC	<b>DRILLER:</b> Baja Exploration	<b>LOGGED BY:</b> CDL
<b>PROJECT NAME:</b> Pacific San Marcos	<b>DRILL METHOD:</b> 8" HSA 3.75" ID	<b>OPERATOR:</b>
<b>PROJECT NO.:</b> 3649-SD	<b>HAMMER:</b> 140lbs/30in	<b>RIG TYPE:</b> CME-75
<b>LOCATION:</b> See Boring Location Map	<b>ELEVATION:</b>	<b>DATE:</b> 9/29/2020

Depth (ft)	SAMPLES			USCS Symbol	<b>BORING NO.: B-4</b>	Laboratory Testing		
	Sample Type	Blows/6 in	Sample Number			MATERIAL DESCRIPTION AND COMMENTS	Water Content (%)	Dry Density (pcf)
5	X		BB-1		<u>Vegetation over</u> <u>Weathered Santiago/Colluvium</u> Silty fine SAND, light brown, dry, loose			
15	■	15	R-1		<u>Tertiary Santiago Formation</u> Clayed medium SANDSTONE, pale yellow white, very moist, medium dense, mottled orange oxidation	8.9	124.2	
10	X	12 21 34	S-1		Clayey medium SANDSTONE, light gray, very moist, very dense, ~15% fine			
15	■	13 50/6"	R-2		Clayey medium SAND, light gray, very moist, very dense, ~15% fine  Cuttings are very wet, dark orange brown, 30-40% fine	12.5	119.1	
20	X	12 26 33			Clayey fine SANDSTONE, mottled orange, brown and pale white, very moist, very dense			
20	<b>HOLE TERMINATED AT 19.5 FEET</b>							
25					Some groundwater encountered at 17 feet Backfilled with soil cuttings			
30								

<b>LEGEND</b>	<b>Sample type:</b>	■ ---Ring	■ ---SPT	□ ---Small Bulk	⊗ ---Large Bulk	□ ---No Recovery	▽ ---Water Table
	<b>Lab testing:</b>	AL = Atterberg Limits	SR = Sulfate/Resistivity Test	EI = Expansion Index	SH = Shear Test	SA = Sieve Analysis	CO = Consolidation test



**GeoTek, Inc.**  
**LOG OF EXPLORATORY BORING**

<b>CLIENT:</b> The Las Posas Owner LPV, LLC	<b>DRILLER:</b> Baja Exploration	<b>LOGGED BY:</b> BRM
<b>PROJECT NAME:</b> Pacific San Marcos	<b>DRILL METHOD:</b> 8" HSA 3.75" ID	<b>OPERATOR:</b>
<b>PROJECT NO.:</b> 3649-SD	<b>HAMMER:</b> 140lbs/30in	<b>RIG TYPE:</b> CME 75
<b>LOCATION:</b> See Boring Location Map	<b>ELEVATION:</b>	<b>DATE:</b> 9/29/2020

Depth (ft)	SAMPLES		USCS Symbol	<b>BORING NO.: B-5</b>	Laboratory Testing			
	Sample Type	Blows/6 in			Sample Number	MATERIAL DESCRIPTION AND COMMENTS	Water Content (%)	Dry Density (pcf)
				<b>Dirt Road Patch, Slight Vegetation</b> <b>Tertiary Santiago Formation</b>				
5	X			BB-1	Clayey SAND			
5	■	12 27 54		R-1	Clayey SANDSTONE, tan-yellow, moist	7.8	129.4	
10	X			S-1	Silty fine SANDSTONE, oxidation layers tan, damp			
15	■	10 17 25		R-2	Silty fine SANDSTONE, orange brown, moist, very dense CLAYSTONE, dark brown, moist, very stiff, fine cut sandy sandstone, dark brown, moist	11.6	109.6	
20	■	19 27 41	▽	S-2	Silty medium-coarse SANDSTONE, light gray, wet, very dense			
20				<b>HOLE TERMINATED AT 19.5 FEET</b>				
25				Groundwater encountered at 18 feet Backfilled with soil cuttings				
30								

<b>LEGEND</b>	<b>Sample type:</b>	■ ---Ring	■ ---SPT	□ ---Small Bulk	⊗ ---Large Bulk	□ ---No Recovery	▽ ---Water Table
	<b>Lab testing:</b>	AL = Atterberg Limits	SR = Sulfate/Resistivity Test	EI = Expansion Index	SH = Shear Test	SA = Sieve Analysis	CO = Consolidation test

**GeoTek, Inc.**  
**LOG OF EXPLORATORY BORING**

<b>CLIENT:</b> The Las Posas Owner LPV, LLC	<b>DRILLER:</b> Baja Exploration	<b>LOGGED BY:</b> CDL
<b>PROJECT NAME:</b> Pacific San Marcos	<b>DRILL METHOD:</b> 8" HSA 3.75" ID	<b>OPERATOR:</b>
<b>PROJECT NO.:</b> 3649-SD	<b>HAMMER:</b> 140lbs/30in	<b>RIG TYPE:</b> CME-75
<b>LOCATION:</b> See Boring Location Map	<b>ELEVATION:</b>	<b>DATE:</b> 9/29/2020

Depth (ft)	SAMPLES			USCS Symbol	<b>BORING NO.: B-6</b>	Laboratory Testing		
	Sample Type	Blows / 6 in	Sample Number			Water Content (%)	Dry Density (pcf)	Others
<b>MATERIAL DESCRIPTION AND COMMENTS</b>								
					<u>Grassland Over</u> Alluvium (Qal) Silty fine SAND, light brown, dry, loose			
5	■	16 26 40	R-1		<u>Tertiary Santiago Formation</u>  Silty coarse SANDSTONE, interbedded light gray and orange brown, moist, very dense, ~15% fines	8	120.6	
10	⊠	4 7 12	S-2		CLAYSTONE, medium gray, fractured, well healed with orange oxidized fine sand			
15	■	11 27 28	R-2		Medium-coarse SANDSTONE, richly oxidized orange brown, wet, very dense, laminiated silty and clayey sandstone, ~20% fine, moist	10.7	128.8	
20	⊠	7 14 29	S-2		CLAYSTONE, dark gray, moist, hard Silty fine SANDSTONE, dark gray, moist, 40% fine, decomposed organic matter			
					<b>HOLE TERMINATED AT 19.5 FEET</b>			
					Perched groundwater encountered at 15 feet Backfilled with soil cuttings			
25								
30								

<b>LEGEND</b>	<b>Sample type:</b>	■ ---Ring	■ ---SPT	⊠ ---Small Bulk	⊠ ---Large Bulk	□ ---No Recovery	∇ ---Water Table
	<b>Lab testing:</b>	AL = Atterberg Limits	SR = Sulfate/Resistivity Test	EI = Expansion Index	SH = Shear Test	SA = Sieve Analysis	CO = Consolidation test



**Client:** The Las Posas Owner LPV, LLC  
**Project:** Pacific  
**Project No:** 3649-SD  
**Date:** 9/30/2020

**Boring No.** P-1

**Infiltration Rate (Porchet Method)**

Time Interval, $\Delta t =$	30	minutes
Final Depth to Water, $D_F =$	7.25	inches
Test Hole Radius, $r =$	4.00	inches
Initial Depth to Water, $D_O =$	6.75	inches
Total Test Hole Depth, $D_T =$	35.75	inches

Equation -  $I_t = \frac{\Delta H (60r)}{\Delta t (r+2H_{avg})}$

$H_O = D_T - D_O =$	29.00	inches
$H_F = D_T - D_F =$	28.50	inches
$\Delta H = \Delta D = H_O - H_F =$	0.50	inches
$H_{avg} = (H_O + H_F) / 2 =$	28.75	inches

$I_t =$  0.07 Inches per Hour





**Client:** The Las Posas Owner LPV, LLC  
**Project:** Pacific  
**Project No:** 3649-SD  
**Date:** 9/30/2020

**Boring No.** P-2

**Infiltration Rate (Porchet Method)**

Time Interval, $\Delta t =$	30	minutes
Final Depth to Water, $D_F =$	7.25	inches
Test Hole Radius, $r =$	4.00	inches
Initial Depth to Water, $D_O =$	6.75	inches
Total Test Hole Depth, $D_T =$	34.75	inches

Equation -  $I_t = \frac{\Delta H (60r)}{\Delta t (r+2H_{avg})}$

$H_O = D_T - D_O =$	28.00	inches
$H_F = D_T - D_F =$	27.50	inches
$\Delta H = \Delta D = H_O - H_F =$	0.50	inches
$H_{avg} = (H_O + H_F) / 2 =$	27.75	inches

$I_t =$  0.07 Inches per Hour





# **APPENDIX B**

## **RESULTS OF LABORATORY TESTING**

## SUMMARY OF LABORATORY TESTING

### Identification and Classification

Soils were identified visually in general accordance to the standard practice for description and identification of soils (ASTM D2488). The soil identifications and classifications are shown on the logs of exploratory borings in Appendix A.

### Expansion Index

Expansion Index testing was performed on one soil sample. Testing was performed in general accordance with ASTM Test Method D 4829. The results of the testing are provided below.

Boring No.	Depth (ft.)	Soil Type	Expansion Index	Classification
B-3	0-5	Dark Brown Black Clay	81	Medium

### Moisture-Density Relationship

Laboratory testing was performed on one sample collected during the subsurface exploration. The laboratory maximum dry density and optimum moisture content for the soil type was determined in general accordance with test method ASTM Test Procedure D1557. The results of the testing are provided below.

Boring No.	Depth (ft.)	Description	Maximum Dry Density (pcf)	Optimum Moisture Content (%)
B-3	0-5	Dark Brown Black Clay	114.5	15.0

# **APPENDIX C**

## **GENERAL EARTHWORK GRADING GUIDELINES**

## **GENERAL GRADING GUIDELINES**

Guidelines presented herein are intended to address general construction procedures for earthwork construction. Specific situations and conditions often arise which cannot reasonably be discussed in general guidelines, when anticipated these are discussed in the text of the report. Often unanticipated conditions are encountered which may necessitate modification or changes to these guidelines. It is our hope that these will assist the contractor to more efficiently complete the project by providing a reasonable understanding of the procedures that would be expected during earthwork and the testing and observation used to evaluate those procedures.

### **General**

Grading should be performed to at least the minimum requirements of governing agencies, Chapters 18 and 33 of the California Building Code, CBC (2019) and the guidelines presented below.

### **Preconstruction Meeting**

A preconstruction meeting should be held prior to site earthwork. Any questions the contractor has regarding our recommendations, general site conditions, apparent discrepancies between reported and actual conditions and/or differences in procedures the contractor intends to use should be brought up at that meeting. The contractor (including the main onsite representative) should review our report and these guidelines in advance of the meeting. Any comments the contractor may have regarding these guidelines should be brought up at that meeting.

### **Grading Observation and Testing**

1. Observation of the fill placement should be provided by our representative during grading. Verbal communication during the course of each day will be used to inform the contractor of test results. The contractor should receive a copy of the "Daily Field Report" indicating results of field density tests that day. If our representative does not provide the contractor with these reports, our office should be notified.
2. Testing and observation procedures are, by their nature, specific to the work or area observed and location of the tests taken, variability may occur in other locations. The contractor is responsible for the uniformity of the grading operations; our observations and test results are intended to evaluate the contractor's overall level of efforts during grading. The contractor's personnel are the only individuals participating in all aspect of site work. Compaction testing and observation should not be considered as relieving the contractor's responsibility to properly compact the fill.
3. Cleanouts, processed ground to receive fill, key excavations, and subdrains should be observed by our representative prior to placing any fill. It will be the contractor's responsibility to notify our representative or office when such areas are ready for observation.
4. Density tests may be made on the surface material to receive fill, as considered warranted by this firm.
5. In general, density tests would be made at maximum intervals of two feet of fill height or every 1,000 cubic yards of fill placed. Criteria will vary depending on soil conditions and size of the fill. More frequent testing may be performed. In any case, an adequate number of field density tests should be made to evaluate the required compaction and moisture content is generally being obtained.

6. Laboratory testing to support field test procedures will be performed, as considered warranted, based on conditions encountered (e.g. change of material sources, types, etc.) Every effort will be made to process samples in the laboratory as quickly as possible and in progress construction projects are our first priority. However, laboratory workloads may cause in delays and some soils may require a **minimum of 48 to 72 hours to complete test procedures**. Whenever possible, our representative(s) should be informed in advance of operational changes that might result in different source areas for materials.
7. Procedures for testing of fill slopes are as follows:
  - a) Density tests should be taken periodically during grading on the flat surface of the fill, three to five feet horizontally from the face of the slope.
  - b) If a method other than over building and cutting back to the compacted core is to be employed, slope compaction testing during construction should include testing the outer six inches to three feet in the slope face to determine if the required compaction is being achieved.
8. Finish grade testing of slopes and pad surfaces should be performed after construction is complete.

### Site Clearing

1. All vegetation, and other deleterious materials, should be removed from the site. If material is not immediately removed from the site it should be stockpiled in a designated area(s) well outside of all current work areas and delineated with flagging or other means. Site clearing should be performed in advance of any grading in a specific area.
2. Efforts should be made by the contractor to remove all organic or other deleterious material from the fill, as even the most diligent efforts may result in the incorporation of some materials. This is especially important when grading is occurring near the natural grade. All equipment operators should be aware of these efforts. Laborers may be required as root pickers.
3. Nonorganic debris or concrete may be placed in deeper fill areas provided the procedures used are observed and found acceptable by our representative.

### Treatment of Existing Ground

1. Following site clearing, all surficial deposits of alluvium and colluvium as well as weathered or creep effected bedrock, should be removed unless otherwise specifically indicated in the text of this report.
2. In some cases, removal may be recommended to a specified depth (e.g. flat sites where partial alluvial removals may be sufficient). The contractor should not exceed these depths unless directed otherwise by our representative.
3. Groundwater existing in alluvial areas may make excavation difficult. Deeper removals than indicated in the text of the report may be necessary due to saturation during winter months.
4. Subsequent to removals, the natural ground should be processed to a depth of six inches, moistened to near optimum moisture conditions and compacted to fill standards.
5. Exploratory back hoe or dozer trenches still remaining after site removal should be excavated and filled with compacted fill if they can be located.

### Fill Placement

1. Unless otherwise indicated, all site soil and bedrock may be reused for compacted fill; however, some special processing or handling may be required (see text of report).

2. Material used in the compacting process should be evenly spread, moisture conditioned, processed, and compacted in thin lifts six (6) to eight (8) inches in compacted thickness to obtain a uniformly dense layer. The fill should be placed and compacted on a nearly horizontal plane, unless otherwise found acceptable by our representative.
3. If the moisture content or relative density varies from that recommended by this firm, the contractor should rework the fill until it is in accordance with the following:
  - a) Moisture content of the fill should be at or above optimum moisture. Moisture should be evenly distributed without wet and dry pockets. Pre-watering of cut or removal areas should be considered in addition to watering during fill placement, particularly in clay or dry surficial soils. The ability of the contractor to obtain the proper moisture content will control production rates.
  - b) Each six-inch layer should be compacted to at least 90 percent of the maximum dry density in compliance with the testing method specified by the controlling governmental agency. In most cases, the testing method is ASTM Test Designation D 1557.
4. Rock fragments less than eight inches in diameter may be utilized in the fill, provided:
  - a) They are not placed in concentrated pockets;
  - b) There is a sufficient percentage of fine-grained material to surround the rocks;
  - c) The distribution of the rocks is observed by, and acceptable to, our representative.
5. Rocks exceeding eight (8) inches in diameter should be taken off site, broken into smaller fragments, or placed in accordance with recommendations of this firm in areas designated suitable for rock disposal. On projects where significant large quantities of oversized materials are anticipated, alternate guidelines for placement may be included. If significant oversize materials are encountered during construction, these guidelines should be requested.
6. In clay soil, dry or large chunks or blocks are common. If in excess of eight (8) inches minimum dimension, then they are considered as oversized. Sheepsfoot compactors or other suitable methods should be used to break up blocks. When dry, they should be moisture conditioned to provide a uniform condition with the surrounding fill.

### Slope Construction

1. The contractor should obtain a minimum relative compaction of 90 percent out to the finished slope face of fill slopes. This may be achieved by either overbuilding the slope and cutting back to the compacted core, or by direct compaction of the slope face with suitable equipment.
2. Slopes trimmed to the compacted core should be overbuilt by at least three (3) feet with compaction efforts out to the edge of the false slope. Failure to properly compact the outer edge results in trimming not exposing the compacted core and additional compaction after trimming may be necessary.
3. If fill slopes are built "at grade" using direct compaction methods, then the slope construction should be performed so that a constant gradient is maintained throughout construction. Soil should not be "spilled" over the slope face nor should slopes be "pushed out" to obtain grades. Compaction equipment should compact each lift along the immediate top of slope. Slopes should be back rolled or otherwise compacted at approximately every 4 feet vertically as the slope is built.
4. Corners and bends in slopes should have special attention during construction as these are the most difficult areas to obtain proper compaction.
5. Cut slopes should be cut to the finished surface. Excessive undercutting and smoothing of the face with fill may necessitate stabilization.



## UTILITY TRENCH CONSTRUCTION AND BACKFILL

Utility trench excavation and backfill is the contractor's responsibility. The geotechnical consultant typically provides periodic observation and testing of these operations. While efforts are made to make sufficient observations and tests to verify that the contractor's methods and procedures are adequate to achieve proper compaction, it is typically impractical to observe all backfill procedures. As such, it is critical that the contractor use consistent backfill procedures.

Compaction methods vary for trench compaction and experience indicates many methods can be successful. However, procedures that "worked" on previous projects may or may not prove effective on a given site. The contractor(s) should outline the procedures proposed, so that we may discuss them **prior** to construction. We will offer comments based on our knowledge of site conditions and experience.

1. Utility trench backfill in slopes, structural areas, in streets and beneath flat work or hardscape should be brought to at least optimum moisture and compacted to at least 90 percent of the laboratory standard. Soil should be moisture conditioned prior to placing in the trench.
2. Flooding and jetting are not typically recommended or acceptable for native soils. Flooding or jetting may be used with select sand having a Sand Equivalent (SE) of 30 or higher. This is typically limited to the following uses:
  - a) shallow (12 + inches) under slab interior trenches and,
  - b) as bedding in pipe zone.

The water should be allowed to dissipate prior to pouring slabs or completing trench compaction.

3. Care should be taken not to place soils at high moisture content within the upper three feet of the trench backfill in street areas, as overly wet soils may impact subgrade preparation. Moisture may be reduced to 2% below optimum moisture in areas to be paved within the upper three feet below sub grade.
4. Sand backfill should not be allowed in exterior trenches adjacent to and within an area extending below a 1:1 projection from the outside bottom edge of a footing, unless it is similar to the surrounding soil.
5. Trench compaction testing is generally at the discretion of the geotechnical consultant. Testing frequency will be based on trench depth and the contractor's procedures. A probing rod would be used to assess the consistency of compaction between tested areas and untested areas. If zones are found that are considered less compact than other areas, this would be brought to the contractor's attention.

## JOB SAFETY

### **General**

Personnel safety is a primary concern on all job sites. The following summaries are safety considerations for use by all our employees on multi-employer construction sites. On ground personnel are at highest risk of injury and possible fatality on grading construction projects. The company recognizes that construction activities will vary on each site and that job site safety is the contractor's responsibility. However, it is, imperative that all personnel be safety conscious to avoid accidents and potential injury.

In an effort to minimize risks associated with geotechnical testing and observation, the following precautions are to be implemented for the safety of our field personnel on grading and construction projects.

1. Safety Meetings: Our field personnel are directed to attend the contractor's regularly scheduled safety meetings.
2. Safety Vests: Safety vests are provided for and are to be worn by our personnel while on the job site.
3. Safety Flags: Safety flags are provided to our field technicians; one is to be affixed to the vehicle when on site, the other is to be placed atop the spoil pile on all test pits.

In the event that the contractor's representative observes any of our personnel not following the above, we request that it be brought to the attention of our office.

### **Test Pits Location, Orientation and Clearance**

The technician is responsible for selecting test pit locations. The primary concern is the technician's safety. However, it is necessary to take sufficient tests at various locations to obtain a representative sampling of the fill. As such, efforts will be made to coordinate locations with the grading contractors authorized representatives (e.g. dump man, operator, supervisor, grade checker, etc.), and to select locations following or behind the established traffic pattern, preferably outside of current traffic. The contractors authorized representative should direct excavation of the pit and safety during the test period. Again, safety is the paramount concern.

Test pits should be excavated so that the spoil pile is placed away from oncoming traffic. The technician's vehicle is to be placed next to the test pit, opposite the spoil pile. This necessitates that the fill be maintained in a drivable condition. Alternatively, the contractor may opt to park a piece of equipment in front of test pits, particularly in small fill areas or those with limited access.

A zone of non-encroachment should be established for all test pits (see diagram below). No grading equipment should enter this zone during the test procedure. The zone should extend outward to the sides approximately 50 feet from the center of the test pit and 100 feet in the direction of traffic flow. This zone is established both for safety and to avoid excessive ground vibration, which typically decreases test results.

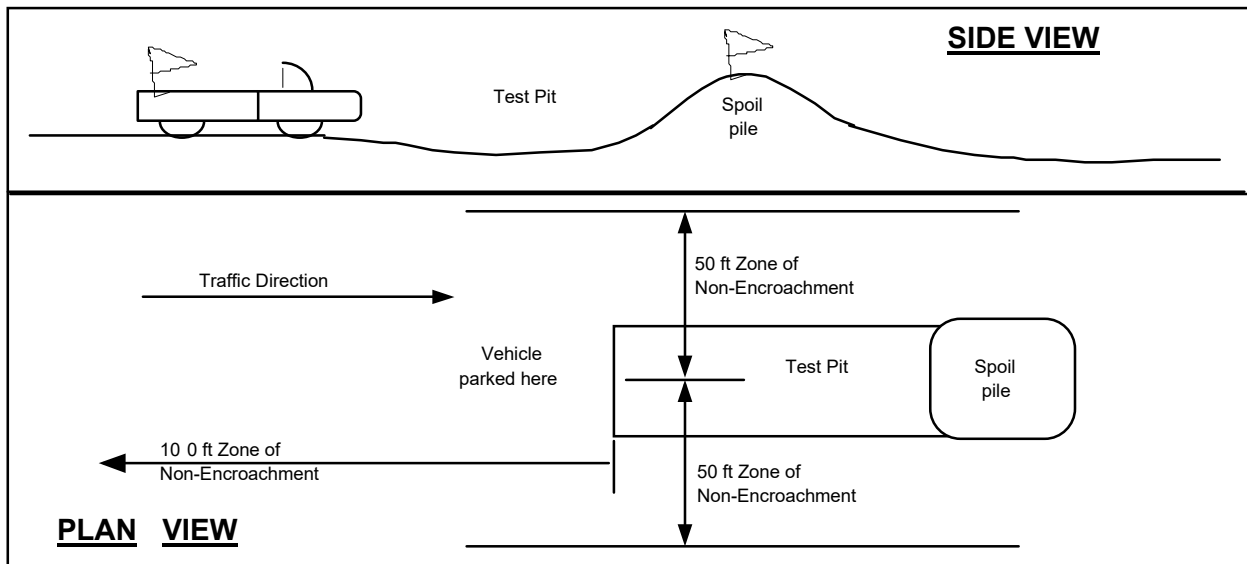
**TEST PIT SAFETY PLAN****Slope Tests**

When taking slope tests, the technician should park their vehicle directly above or below the test location on the slope. The contractor's representative should effectively keep all equipment at a safe operation distance (e.g. 50 feet) away from the slope during testing.

The technician is directed to withdraw from the active portion of the fill as soon as possible following testing. The technician's vehicle should be parked at the perimeter of the fill in a highly visible location.

**Trench Safety**

It is the contractor's responsibility to provide safe access into trenches where compaction testing is needed. Trenches for all utilities should be excavated in accordance with CAL-OSHA and any other applicable safety standards. Safe conditions will be required to enable compaction testing of the trench backfill.

All utility trench excavations in excess of 5 feet deep, which a person enters, are to be shored or laid back. Trench access should be provided in accordance with OSHA standards. Our personnel are directed not to enter any trench by being lowered or "riding down" on the equipment.

Our personnel are directed not to enter any excavation which;

1. is 5 feet or deeper unless shored or laid back,
2. exit points or ladders are not provided,
3. displays any evidence of instability, has any loose rock or other debris which could fall into the trench, or
4. displays any other evidence of any unsafe conditions regardless of depth.

If the contractor fails to provide safe access to trenches for compaction testing, our company policy requires that the soil technician withdraws and notifies their supervisor. The contractor's representative will then be contacted in an effort to effect a solution. All backfill not tested due to safety concerns or other reasons is subject to reprocessing and/or removal.

**Procedures**

In the event that the technician's safety is jeopardized or compromised as a result of the contractor's failure to comply with any of the above, the technician is directed to inform both the developer's and contractor's representatives. If the condition is not rectified, the technician is required, by company policy, to immediately withdraw and notify their supervisor. The contractor's representative will then be contacted in an effort to effect a solution. No further testing will be performed until the situation is rectified. Any fill placed in the interim can be considered unacceptable and subject to reprocessing, recompaction or removal.

In the event that the soil technician does not comply with the above or other established safety guidelines, we request that the contractor bring this to technicians attention and notify our project manager or office. Effective communication and coordination between the contractors' representative and the field technician(s) is strongly encouraged in order to implement the above safety program and safety in general.

The safety procedures outlined above should be discussed at the contractor's safety meetings. This will serve to inform and remind equipment operators of these safety procedures particularly the zone of non-encroachment.

The safety procedures outlined above should be discussed at the contractor's safety meetings. This will serve to inform and remind equipment operators of these safety procedures particularly the zone of non-encroachment.

**ATTACHMENT 3**  
**Structural BMP Maintenance Information**

This is the cover sheet for Attachment 3.

**Indicate which Items are Included behind this cover sheet:**

<b>Attachment Sequence</b>	<b>Contents</b>	<b>Checklist</b>
Attachment 3a	Structural BMP Maintenance Thresholds and Actions (Required)	<input type="checkbox"/> Included  See Structural BMP Maintenance Information Checklist on the back of this Attachment cover sheet.
Attachment 3b	Draft Maintenance Agreement (when applicable)	<input type="checkbox"/> Included <input type="checkbox"/> Not Applicable

**EXHIBIT B  
 BIOFILTRATION MAINTENANCE ACTIVITIES**

ROUTINE ACTION	MAINTENANCE INDICATOR	FIELD MEASUREMENT	MEASUREMENT FREQUENCY	MAINTENANCE ACTIVITY	Maintenance Frequency (# of times per year)	Hours per Event	Average Labor Crew Size	Labor Rate/Hr. (\$)	Equipment	Equipment Cost/Hour (\$)	Materials & Incidentals Cost or Disposal Cost/Event (\$)	Total cost per visit (\$)	Total cost per year (\$)	
Sediment Management	Accumulation of sediment, litter or debris	Visual observation	Monthly	Remove and properly dispose of accumulated materials, without damage to the vegetation or compaction of the media layer (expected once a year)	12.0	0.3	1	\$ 49.86	Utility Truck, 10-15 yd Truck, Backhoe	\$ 56.02	\$ 50.00	\$ 76	\$ 918	
Vegetation Management	Poor vegetation establishment Dead or diseased vegetation	Visual observation	Annually, prior to start of wet season	Re-seed, re-plant, or re-establish vegetation per original plans Remove dead or diseased vegetation, re-seed, re-plant or re-establish vegetation per original plans (expected every 5 years)	0.2	4.0	2	\$ 51.02	Utility Truck	\$ 14.39		\$ 466	\$ 93	x
Vegetation Management for Aesthetics (optional)	Overgrown vegetation	Visual observation	Monthly, and as needed	Mow or trim as appropriate	12.0	1.0	2	\$ 49.86	Utility Truck	\$ 14.39	\$ 50.00	\$ 164	\$ 1,969	x
Soil Repair	2/3 of mulch has decomposed, or mulch has been removed	Visual observation	Annually, and as needed	Remove decomposed fraction and top off with fresh mulch to a total depth of 3 inches	1.0	2.0	2	\$ 49.86	Utility Truck	\$ 14.39		\$ 228	\$ 228	x
Soil Repair	Evidence of erosion due to concentrated irrigation flow Evidence of erosion due to concentrated storm water runoff flow	Visual observation	Annually, prior to start of wet season	Repair/re-seed/re-plant eroded areas and adjust the irrigation system Repair/re-seed/re-plant eroded areas, and make corrective measures such as adding erosion control blankets, adding stone at flow entry points, or minor re-grading to restore proper drainage according to the original plan. If the issue is not corrected by restoring the BMP to the original plan and grade, the [City Engineer] shall be contacted prior to any additional repairs or reconstruction. (expected every 10 years)	0.1	4.0	2	\$ 51.02	Utility Truck	\$ 14.39	\$ 150.00	\$ 616	\$ 62	
Standing Water	Standing water in BMP for longer than 24 hours following a storm event. Surface ponding longer than approximately 24 hours following a storm event may be detrimental to vegetation health	Visual observation	Annually, 24 hours after a target storm event	Make appropriate corrective measures such as adjusting irrigation system, removing obstructions of debris or invasive vegetation, clearing underdrains, or repairing/replacing clogged or compacted soils. (expected every 10 years)	0.1	12.0	2	\$ 67.74	Utility Truck, 10-15 yd Truck, Backhoe	\$ 56.02		\$ 2,298	\$ 230	
General Maintenance Inspection	Underdrain clogged	Visual observation	Annually, prior to start of wet season	Clear blockage (expected every 5 years)	0.2	4.0	2	\$ 49.86	Utility Truck	\$ 14.39		\$ 456	\$ 91	
General Maintenance Inspection	Obstruction of inlet or outlet structure	Visual observation	Annually, prior to start of wet season	Clear blockage	1.0	0.5	2	\$ 49.86	Utility Truck	\$ 14.39		\$ 57	\$ 57	
General Maintenance Inspection	Damage to structural components such as weirs, inlet or outlet structures	Visual observation	Annually, prior to start of wet season	Corrective action prior to wet season. Consult engineers if immediate solution is not evident.	1.0	0.5	2	\$ 67.74	Utility Truck	\$ 14.39		\$ 75	\$ 75	
Vector Control	Presence of mosquitos/larvae	Visual observation	Annually	If mosquitos/larvae are observed; first, immediately remove any standing water by dispersing to nearby landscaping; second, make corrective measures as applicable to restore BMP drainage to prevent standing water (included in Standing Water Maintenance Activity)										
<b>Average Annual Total</b>						<b>39.4</b>							<b>\$ 3,723</b>	

<b>Large Biofiltration (1850sf)</b>	<b>98.6</b>	<b>\$ 7,028</b>
-------------------------------------	-------------	-----------------

**EXHIBIT B  
 STORAGE VAULT MAINTENANCE ACTIVITIES**

ROUTINE ACTION	MAINTENANCE INDICATOR	FIELD MEASUREMENT	MEASUREMENT FREQUENCY	MAINTENANCE ACTIVITY	Maintenance Frequency (# of times per year)	Hours per Event	Average Labor Crew Size	Labor Rate/Hr. (\$)	Equipment	Equipment Cost/Hour (\$)	Materials & Incidentals Cost or Disposal Cost/Event (\$)	Total cost per visit (\$)	Total cost per year (\$)	
Sediment Management	Accumulation of sediment, litter or debris at the inlet	Visual observation	Monthly	Remove and properly dispose of accumulated materials	12.0	0.3	1	\$ 49.86	Utility Truck	\$ 14.39		\$ 16	\$ 193	
Sediment Management	Accumulation of sediment, litter or debris in storage container	Visual observation	Semi-annually (minimum) or when debris accumulation is 25% of the total container volume, or accumulation blocks outlet, whichever is more frequent	Remove and properly dispose of accumulated materials.	2.0	1.0	2	\$ 49.86	Utility Truck, Vactor	\$ 77.09	\$ 66.67	\$ 243	\$ 487	x
Standing Water	Standing water in storage container between storm events outside of normal use timeframe for the stored water. Normal use timeframe is 36 to 96 hours following a storm event depending on the purpose and design of the cistern.	Visual observation	Annually, 96 hours after a target storm event	Use the water as intended, or disperse to landscaping.	1.0	4.0	2	\$ 49.86	Utility Truck	\$ 14.39		\$ 456	\$ 456	x
General Maintenance Inspection	Leaks or other damage to storage container	Visual observation	Annually, prior to start of wet season	Repair or replace as applicable. (expected every 5 years)	0.2	2.0	2	\$ 67.74	Utility Truck	\$ 14.39		\$ 300	\$ 60	
General Maintenance Inspection	Leaks or other damage to ancillary parts including valves, piping, screens, level indicators, and other accessories.	Visual observation	Annually, prior to start of wet season	Repair or replace as applicable. (expected every 5 years)	0.2	2.0	2	\$ 67.74	Utility Truck	\$ 56.02		\$ 383	\$ 77	
General Maintenance Inspection	Outlet blocked	Visual observation	Annually, prior to start of wet season	Clear blockage	1.0	0.1	2	\$ 49.86	Utility Truck	\$ 14.39		\$ 11	\$ 11	
General Maintenance Inspection	Cistern leaning or unstable, damage to roof, supports, anchors, or foundation	Visual observation	Annually, prior to start of wet season	Make repairs as appropriate to correct the problem and stabilize the system. (expected every 10 years)	0.1	4.0	2	\$ 67.74	Utility Truck	\$ 14.39		\$ 599	\$ 60	
Vector Control	Presence of mosquitos/larvae	Visual observation	Annually	If mosquitos/larvae are observed; first, immediately remove any standing water by using water as intended for irrigation or alternative grey water, or by dispersing to landscaping; second, check cistern outlet for blockage and clear blockage if applicable to restore drainage; third, install barriers such as screens that prevent mosquito access to storage container. (included in Standing Water Maintenance Activity)										
<b>Average Annual Total</b>						<b>17.6</b>							<b>\$ 1,344</b>	
<b>Large VAULT (9,500 cf)</b>						<b>41.6</b>							<b>\$ 2,817</b>	