

NOISE IMPACT ANALYSIS

**516 La Costa
516 La Costa Avenue
Encinitas, California 92024**

Prepared For

The Brown Studio, Inc.
Attention: Iván Zepeda
1144 North Coast Highway 101
Encinitas, California 92024
Phone: 619-577-4610

Prepared By

Eilar Associates, Inc.
Acoustical & Environmental Consulting
210 South Juniper Street, Suite 100
Escondido, California 92025
www.eilarassociates.com
Phone: 760-738-5570
Fax: 760-738-5227

Job # S200108

February 3, 2021

TABLE OF CONTENTS

	<u>Page</u>
1.0 EXECUTIVE SUMMARY	1
2.0 INTRODUCTION	2
2.1 Project Description	
2.2 Project Location	
2.3 Applicable Noise Standards	
3.0 ENVIRONMENTAL SETTING	4
3.1 Existing Noise Environment	
3.2 Future Noise Environment	
4.0 METHODOLOGY AND EQUIPMENT	10
4.1 Methodology	
4.2 Measurement Equipment	
5.0 IMPACTS AND MITIGATION	13
5.1 Traffic Noise Impacts	
5.2 Operational Noise Sources	
5.3 Temporary Construction Noise	
6.0 CONCLUSION	22
7.0 CERTIFICATION	23
8.0 REFERENCES	24

FIGURES

1. Vicinity Map
2. Assessor's Parcel Map
3. Satellite Aerial Photograph
4. Topographic Map
5. Site Plan Showing Current Traffic CNEL Contours and Noise Measurement Locations
6. Site Plan Showing Future Traffic CNEL Contours and Noise Measurement Locations
7. Site Plan Showing Outdoor Use Receiver and Barrier Locations
8. Site Plan Showing Facade Receiver Locations
9. Satellite Aerial Photograph Showing Site Plan, Daytime Project-Generated Noise Contours, and Source and Receiver Locations
10. Satellite Aerial Photograph Showing Site Plan, Nighttime Project-Generated Noise Contours, and Source and Receiver Locations

APPENDICES

- A. Project Plans
- B. Pertinent Sections of the City of Encinitas Noise Element to the General Plan and Municipal Code, California Building Code, and CALGreen
- C. Pertinent Sections of Mizuta Traffic Consulting Traffic Study
- D. Traffic Noise Model (TNM) Data and Results
- E. Manufacturer Data Sheets
- F. Acoustical Equipment Calibration Certificates
- G. Sound Insulation Prediction Results
- H. Exterior-to-Interior Noise Analysis
- I. Recommended Products
- J. Project-Generated Traffic Noise Calculations
- K. Cadna Analysis Data and Results

1.0 EXECUTIVE SUMMARY

The proposed project, known as 516 La Costa, consists of a hotel with five guest units, twelve bungalow rooms, a spa deck, and a restaurant and bar. The project site is located at 516 La Costa Avenue in the City of Encinitas, California.

The City of Encinitas Noise Element to the General Plan states that noise levels at outdoor use areas of transient lodging (hotel/motel) uses should not exceed 70 CNEL in order to be considered “conditionally acceptable.” A noise analysis was performed to determine anticipated future noise impacts at proposed outdoor use areas on the project site. In order to mitigate noise impacts at outdoor use areas, several sound attenuation barriers are required. The sound attenuation barriers were input into the noise model in locations that would provide shielding from noise associated with traffic traveling on Interstate 5, which is the primary source of noise impacting these receivers. One of the proposed sound barriers should be located toward the north end of the project site and should extend a minimum of 5 feet in height above the finished floor elevation of the restaurant outdoor seating and spa deck areas to attenuate noise levels at these areas. Additionally, a six foot tall sound attenuation barrier should be installed along the eastern property line to mitigate noise impacts to the private outdoor use areas for hotel guests. The balcony barriers on the second floors of each bungalow should also be constructed as sound attenuation barriers with a minimum height of 3.5 feet above the elevation of the balcony floor. Please refer to Section 5.1.1 for more information.

The City of Encinitas and State of California require interior noise levels of 45 CNEL or less in habitable lodging space. Exterior noise levels at many proposed building facades are shown to exceed 60 CNEL. Due to high exterior noise levels at building facades, an exterior-to-interior analysis was performed to determine building features necessary to reduce interior noise levels in residential units to 45 CNEL or less, as required by the State of California and the City of Encinitas. Calculations show that, with the proposed exterior wall assemblies and exterior windows and glass doors with a minimum STC rating of 28, interior noise levels are expected to remain below 45 CNEL in the future noise environment. As the interior noise levels of all lodging units are expected to exceed the 45 CNEL interior noise level requirement with windows open, mechanical ventilation is required in all habitable residential spaces.

The State of California requires that occupied nonresidential spaces demonstrate compliance with the requirements of the California Green Building Standards Code (known as CALGreen). CALGreen requires that where occupied nonresidential spaces are exposed to peak-hour exterior noise levels of greater than 65 dBA, the project must demonstrate building features necessary to reduce interior noise levels to 50 dBA or less in occupied areas during any hour of operation. Occupied nonresidential spaces are expected to comply with CALGreen Building Code regulations using an exterior storefront glazing system with a minimum rating of STC 28.

The City of Encinitas also requires an analysis to determine whether the proposed project will have an adverse noise impact on surrounding properties. Noise limits specified within Section 30.40 of the City of Encinitas Municipal Code must be met at neighboring property lines. The impact of project-generated traffic noise is anticipated to be insignificant at off-site noise-sensitive properties. Additionally, calculations show that noise levels generated by air conditioning units, background music, and persons gathered in proposed outdoor use areas of the project site are expected to be adequately controlled by distance attenuation at surrounding property lines and should remain in compliance with the noise requirements of the City of Encinitas. Therefore, no mitigation is deemed necessary.

Section 9.32.410 of the City of Encinitas Municipal Code restricts the operation of construction equipment to the hours of 7 a.m. to 7 p.m., Mondays through Saturdays. The Municipal Code also states that it is unlawful to operate construction equipment that exceeds a noise level of 75 dBA for more than eight hours during any 24-hour period when measured at residential property lines. Based on the currently proposed construction activities, noise levels are only expected to be 75 dBA or greater at residential property lines when activity is taking place within 35 to 65 feet of the nearest property line, and at all other times will be less than 75 dBA. Due to the large area of the site, this scenario is only expected to take place for very brief periods of time throughout the day, and for this reason, construction limited to the twelve allowable hours of operation established within the code will comply with City of Encinitas noise regulations. General good practice measures should also be followed, including reasonable maintenance of equipment, conservative planning of simultaneous equipment operation, and using equipment with effective mufflers.

2.0 INTRODUCTION

This acoustical analysis report is submitted to satisfy the noise requirements of the City of Encinitas and State of California. Its purpose is to assess noise impacts from nearby roadway traffic and to identify project features or requirements necessary to achieve exterior noise levels of 70 CNEL or less at outdoor use areas, interior noise levels of 45 CNEL or less in habitable lodging space, and interior noise levels of 50 dBA or less in occupied nonresidential space. Additionally, this report assesses noise impacts from potential on-site project-related noise sources, such as mechanical equipment, project-generated traffic, noise from patrons and hotel guests in outdoor use areas, and temporary construction, to determine if mitigation is necessary to reduce the noise impacts to levels that are less than significant or in compliance with applicable standards.

All noise level or sound level values presented herein are expressed in terms of decibels (dB), with A-weighting, abbreviated "dBA," to approximate the hearing sensitivity of humans. Time-averaged noise levels are expressed by the symbol "L_{EQ}." Unless a different time period is specified, "L_{EQ}" is implied to mean a period of one hour. Some of the data may also be presented as octave-band-filtered and/or 1/3-octave-band-filtered data, which are a series of sound spectra centered about each stated frequency, with half of the bandwidth above and half of the bandwidth below each stated frequency. This data is typically used for machinery noise analysis and barrier calculations.

The Community Noise Equivalent Level (CNEL) is a calculated 24-hour weighted average, where sound levels during evening hours of 7 p.m. to 10 p.m. have an added 5 dB weighting, and sound levels during nighttime hours of 10 p.m. to 7 a.m. have an added 10 dB weighting. This is similar to the Day-Night Sound Level (L_{DN}), which is a 24-hour average with 10 dB added weighting on the same nighttime hours but no added weighting on the evening hours. Sound levels expressed in CNEL are always based on A-weighted decibels. These data unit metrics are used to express noise levels for both measurement and municipal noise ordinances and regulations, for land use guidelines, and enforcement of noise ordinances.

Sound pressure is the actual noise experienced by a human or registered by a sound level instrument. When sound pressure is used to describe a noise source, the distance from the noise source must be specified in order to provide complete information. Sound power, on the other hand, is a specialized analytical metric used to provide information without the distance requirement, and it may be used to calculate the sound pressure at any desired distance.

2.1 Project Description

The proposed project, known as 516 La Costa, consists of a hotel with five guest units, twelve bungalow rooms, a spa deck, and a restaurant and bar, on a lot with a net area of 49,228 square feet. The site is currently occupied by a retail plant nursery.

The project site and surrounding property to the east are zoned Visitor-Serving Commercial (VSC). Properties to the west and south are zoned residential (R-3). The northern boundary of the project site is the Batiquitos Lagoon. For additional project details, please refer to the project plans provided in Appendix A.

2.2 Project Location

The project site is located at 516 La Costa Avenue in the City of Encinitas, California. The Assessor's Parcel Number (APN) for the site is 216-030-48-00. The site is currently occupied by a retail plant nursery. For a graphical representation of the site, please refer to the Vicinity Map, Assessor's Parcel Map, Satellite Aerial Photograph, and Topographic Map, provided as Figures 1 through 4, respectively.

2.3 Applicable Noise Standards

The proposed project must meet the acoustical requirements of the City of Encinitas Noise Element to the General Plan, California Building Code, CALGreen, and City of Encinitas Municipal Code in order to obtain approval.

The City of Encinitas Noise Element to the General Plan considers a noise exposure of 60 to 70 CNEL at a transient lodging (hotel/motel) property to be "Conditionally Acceptable," provided that a detailed analysis is performed to determine the required noise insulation features for the control of interior noise. Interior noise must be controlled to be 45 CNEL or less in habitable lodging space, per City of Encinitas and State of California requirements.

The State of California also requires that occupied nonresidential spaces demonstrate compliance with the requirements of the California Green Building Standards Code (known as CALGreen). CALGreen states that, if noise level readings of 65 dBA L_{EQ} or greater are documented at the proposed project site, the project must either (a) incorporate wall and roof/ceiling assemblies with an STC rating of at least 45 and exterior windows with an STC rating of at least 40, or (b) provide an acoustical analysis documenting interior noise levels do not exceed 50 dBA in occupied areas during any hour of operation. This analysis shows compliance using method b.

Additionally, Per Policy 1.1 of the City of Encinitas Noise Element to the General Plan:

If a project would cause an increase in traffic noise levels, the policy of the City of Encinitas is to accept an increase up to an L_{DN} of 55 dBA in outdoor residential use area without mitigation. If a project would increase the traffic noise level by more than 5 dBA and the resulting L_{DN} would be over 55 dBA, then mitigation measures must be evaluated. If the project, or action, would increase traffic noise levels by 3 dB or more and the resulting L_{DN} would exceed 60 dBA in outdoor use areas in residential development, noise mitigation must be similarly evaluated.

Section 30.40 of the City of Encinitas Municipal Code contains noise limits that would apply to noise sources located on the project site, including air conditioning units and persons located in outdoor use areas. The Municipal Code specifies noise limits based on the zoning of the properties in question. Properties zoned R-3 have noise limits of 50 dBA between the hours of 7 a.m. and 10

p.m. and 45 dBA between the hours of 10 p.m. and 7 a.m. Commercial zones have noise limits of 60 dBA between the hours of 7 a.m. and 10 p.m. and 55 dBA between the hours of 10 p.m. and 7 a.m. As some noise sources are expected to be present during the daytime hours only, while other noise sources are expected to be present during both daytime and nighttime hours, separate analyses of anticipated noise impacts during daytime and nighttime hours have been performed to determine compliance with applicable City of Encinitas noise limits at surrounding properties.

Section 9.32.410 of the City of Encinitas Municipal Code restricts the operation of construction equipment to the hours of 7 a.m. to 7 p.m., Mondays through Saturdays. The Municipal Code also states that it is unlawful to operate construction equipment that exceeds a noise level of 75 dBA for more than eight hours during any 24-hour period when measured at residential property lines.

Pertinent sections of the City of Encinitas Noise Element to the General Plan and Municipal Code, California Building Code, and CALGreen are provided as Appendix B.

3.0 ENVIRONMENTAL SETTING

3.1 Existing Noise Environment

The ambient noise in the vicinity of the project site and neighboring residences is primarily composed of traffic noise from Interstate 5 and associated ramps and La Costa Avenue. No other noise sources are considered significant.

3.1.1 Roadway Traffic Sources

Current traffic volumes for Interstate 5 and associated ramps are given based on information from the San Diego Association of Governments (SANDAG) Series 12 Transportation Forecast Information Center (TFIC), as well as from the Caltrans publication *2016 Traffic Volumes on California State Highways*. Current traffic volumes on La Costa Avenue were obtained from the Transportation Access Study, prepared for this project by Mizuta Traffic Consulting and dated June, 2019. Future (2035) traffic volumes are given based on information from the (SANDAG) Series 12 TFIC. Pertinent sections of the Transportation Access Study have been provided as Appendix C.

La Costa Avenue is a two-lane, two-way Collector running east-west along the south boundary of the project site. The posted speed limit is 35 mph. According to the project traffic study, the current traffic volume on La Costa Avenue in the vicinity of the project site is 15,361 Average Daily Trips (ADT) as of the year 2019.

Interstate 5 (I-5) is an eight-lane, two-way Freeway running north-south to the east of the project site. The posted speed limit is 65 mph. According to Caltrans, the current (year 2016) traffic volume on I-5 is 204,000 ADT traveling northbound and southbound combined. According to SANDAG TFIC Series 12 counts, I-5 currently (year 2008) carries a traffic volume of 88,100 ADT traveling northbound and 84,700 ADT traveling southbound. As counts provided by Caltrans exceed those provided by SANDAG, Caltrans counts have been used for this analysis.

The southbound I-5 off-ramp at La Costa Avenue is a two-lane, one-way Ramp to the east of the project site. The posted speed limit is 30 mph. According to SANDAG, the I-5 southbound off-ramp at La Costa Avenue currently carries approximately 6,700 ADT.

Traffic composition information for Interstate 5 was provided by Caltrans in the 2016 Truck Traffic on California Freeways. The truck percentage mix of 1.89% medium trucks and 2.92% heavy trucks was applied to this roadway, as well as to the associated I-5 off-ramp. No current or future truck percentages were available for La Costa Avenue; however, based on neighboring and surrounding land use, roadway classification, professional experience and on-site observations, a truck percentage mix of 2.0% medium and 1.0% heavy trucks was used for La Costa Avenue.

Current and future traffic volumes for the roadway sections near the project site are shown below in Table 1. For further roadway details and ADT traffic volumes, please refer to Appendix D: Traffic Noise Model (TNM) Data and Results.

Table 1. Overall Traffic Information					
Roadway Name	Speed Limit (mph)	Vehicle Mix (%)		Current ADT (Year)	Future ADT (2035)
		Medium	Heavy		
La Costa Avenue	35	2.0	1.0	15,361 (2019)	19,300
I-5 Southbound	65	1.89	2.92	102,000 (2016)	109,900
I-5 Northbound	65	1.89	2.92	102,000 (2016)	115,400
I-5 Southbound Ramp	30	1.89	2.92	6,700 (2008)	7,400

Traffic noise contours were calculated for the project site using Traffic Noise Model without considering project structures in the current noise environment. Noise contours are irregularly shaped due to the topography of the site and surrounding area and the noise contribution from multiple roadways. The site is exposed to traffic noise levels ranging from approximately 62 CNEL at the west boundary of the project site to 74 CNEL near the northeast corner of the site. For a graphical representation of traffic noise contours, please refer to Figure 5: Site Plan Showing Current Traffic CNEL Contours and Noise Measurement Locations.

3.1.2 Measured Noise Level

An on-site inspection and traffic noise measurement was made on the morning of Thursday, May 10, 2018. The weather conditions were as follows: partly cloudy skies, winds at 8 mph, temperature in the high 60s with moderate humidity. A noise measurement was taken at the southwest corner of the project site at approximately 25 feet north of the La Costa Avenue centerline. The microphone position was approximately five feet above the existing grade. The dominant source of noise during the measurement was traffic noise from La Costa Avenue and Interstate 5, with some noise contribution from activity in the surrounding neighborhood. The measured noise level can be seen in Table 2, and the measurement location is shown graphically on Figures 5 and 6.

Table 2. On-Site Noise Measurement Conditions and Results	
Date	Thursday, May 10, 2018
Time	10:54 a.m. – 11:10 a.m.
Conditions	Partly cloudy skies, winds at 8 mph, temperature in the high 60s with moderate humidity
Measured Noise Level	68.7 dBA L _{EQ}

In addition, long-term noise monitoring was also performed to determine the approximate ambient noise level in the vicinity of the project site. The meter was placed in a bush on the west side of the property, approximately 55 feet north of the La Costa Avenue centerline. Results of this noise monitoring are shown in Table 3, and the noise monitoring location is shown in Figures 5 and 6.

Table 3. Long-Term Measured Noise Levels on Site		
Date	Time	Hourly Average Noise Level (dBA L_{EQ})
May 10, 2018	12 p.m. – 1 p.m.	59.7
	1 p.m. – 2 p.m.	60.5
	2 p.m. – 3 p.m.	58.7
	3 p.m. – 4 p.m.	58.8
	4 p.m. – 5 p.m.	59.8
	5 p.m. – 6 p.m.	60.4
	6 p.m. – 7 p.m.	58.9
	7 p.m. – 8 p.m.	59.1
	8 p.m. – 9 p.m.	58.3
	9 p.m. – 10 p.m.	62.9
	10 p.m. – 11 p.m.	56.6
May 11, 2018	11 p.m. – 12 a.m.	55.6
	12 a.m. – 1 a.m.	51.5
	1 a.m. – 2 a.m.	61.5
	2 a.m. – 3 a.m.	53.4
	3 a.m. – 4 a.m.	51.1
	4 a.m. – 5 a.m.	58.0
	5 a.m. – 6 a.m.	57.8
	6 a.m. – 7 a.m.	60.9
	7 a.m. – 8 a.m.	61.9
	8 a.m. – 9 a.m.	61.5
	9 a.m. – 10 a.m.	59.8
	10 a.m. – 11 a.m.	60.3
11 a.m. – 12 p.m.	60.0	

Measured noise levels were observed to range from 51.1 dBA between the hours of 3 a.m. and 4 a.m. on May 11, to 62.9 dBA between 9 p.m. and 10 p.m. on May 10.

3.1.3 Calculated Noise Level

Noise levels were calculated for the site using the methodology described in Section 4.1.2 for the location, conditions, and traffic volumes counted during the noise measurements. The calculated noise levels (L_{EQ}) were compared with the measured (short-term) on-site noise level to determine if adjustments or corrections (calibration) should be applied to the traffic noise prediction model. Adjustments are intended to account for site-specific differences, such as reflection and absorption, which may be greater or lesser than accounted for in the model.

The measured noise level of 68.7 dBA L_{EQ} was compared to the calculated (modeled) noise level of 68.7 dBA L_{EQ} for the same conditions and traffic flow. According to the Federal Highway Administration’s Highway Traffic Noise: Analysis and Abatement Guide (see reference), a traffic noise model is considered validated if the measured and calculated noise impacts differ by three decibels or less. No adjustment was deemed necessary to model future noise levels for this location as the difference between the measured and calculated levels was found to be less than three decibels. The Traffic Noise Model is assumed to be representative of actual traffic noise that is experienced on site. This information is presented in Table 4.

Table 4. Calculated versus Measured Traffic Noise Data				
Location	Calculated	Measured	Difference	Correction
25 feet from La Costa Avenue centerline	68.7 dBA L_{EQ}	68.7 dBA L_{EQ}	0.0 dB	None Applied

3.2 Future Noise Environment

The future on-site noise environment will be the result of the same traffic noise sources, as well as the noise generated by the proposed uses at the project site.

3.2.1 Future Traffic Volumes

The future on-site noise environment will be the result of the same traffic noise sources. The future (year 2035) traffic volumes for surrounding roadways were provided by SANDAG Series 12.

In the vicinity of the project site, the traffic volume of La Costa Avenue is expected to increase to 19,300 ADT. The traffic volume of I-5 is expected to increase to 109,900 ADT traveling southbound (including traffic traveling on proposed HOV lanes) and 115,400 ADT traveling northbound (including traffic traveling on proposed HOV lanes) by the year 2035. The southbound I-5 ramp is expected to carry 7,400 ADT in 2035.

Future traffic noise contours were calculated for the project site using Traffic Noise Model without considering project structures. Noise contours will remain irregularly shaped in the future. The site will be exposed to traffic noise levels ranging from approximately 63 CNEL at the west boundary of the project site to 74 CNEL near the northeast corner of the site. For a graphical representation of traffic noise contours, please refer to Figure 6: Site Plan Showing Future Traffic CNEL Contours and Noise Measurement Locations.

3.2.2 Project-Generated Traffic

The existing plus project on-site noise environment is expected to consist primarily of traffic noise from La Costa Avenue and Interstate 5, in addition to traffic generated by the project. Existing plus project traffic volumes are given based on information from the Traffic Study prepared for this project by Mizuta Traffic Consulting, dated June 2019. Please refer to Appendix C for pertinent sections of the Traffic Assessment. An analysis of noise impacts from project-generated traffic is detailed in Section 5.1.4.

3.2.3 Noise from Persons Gathered in Outdoor Use Areas

The primary potential source of noise associated with the project will be from gatherings in the outdoor use areas, including outdoor restaurant seating, a spa deck, fire pit, and private balconies and patios. Access to the spa deck and private terraces and patios will be restricted to hotel guests

only. Access to the outdoor restaurant seating will be restricted to daytime hours only, while access to private terraces and patios and the spa deck will be allowed during all hours. According to project plans, the outdoor seating area of the restaurant will have a capacity of 46 persons, with 36 patrons near the restaurant and ten near the bar. According to the project proponent, the pool area will have a capacity of 60 persons; private patios located on the first floor of the bungalow and unit buildings will have a capacity of two persons per guestroom, and private balconies located on the second floor of the bungalow buildings will have a capacity of four persons per guestroom. Although unlikely, in order to represent a worst-case scenario, all outdoor use areas were modeled as being at full capacity. The project will need to adhere to the corresponding noise limits of the City of Encinitas.

In order to approximate noise levels of persons gathered in the outdoor use areas of the project, measurements shown in a study prepared by Pearsons, Bennett, and Fidell for the U.S. Environmental Protection Agency titled *Speech Levels in Various Noise Environments* (Report No. EPA-600/1-77-025) were consulted. This study shows noise levels of speech for both males and females for five different vocal efforts: casual, normal, raised, loud, and shout. Measurements for “raised” voices were considered to be appropriate for this analysis. Although a person may occasionally elevate his/her voice beyond the “raised” level, performing calculations assuming all raised voices is expected to account for the occasional loud individual combined with normal conversation. According to this study, at a distance of 3.28 feet, an average male will generate a noise level of approximately 65 dBA when speaking with a raised voice, while an average female will generate a noise level of approximately 63 dBA when speaking with a raised voice. These noise measurements have been incorporated into the analysis of noise impacts detailed in Section 5.2.

3.2.4 Noise from Outdoor Background Music System

In addition to noise associated with persons gathered in outdoor use areas, the project proposes to have outdoor speakers located in various locations on the exterior of the building. These speakers will be used solely to play low levels of background music, and their operation will be limited to during the daytime hours (7 a.m. to 10 p.m.). According to project plans, the project will have a total of eleven outdoor speakers for playing background music, with two located in the fire pit area, six located on the spa deck, and three located in the outdoor restaurant seating area.

A typical music noise spectrum was adjusted to equate to a noise level of 70 dBA, as measured at a distance of 5 feet from the source. This noise level was used to model each outdoor speaker. This noise level is considered to be a conservative estimate of the noise level produced by a background music system. Octave-band noise levels used to model each outdoor speaker are shown below in Table 5.

Table 5. Sound Power Level of Each Outdoor Speaker									
Source	Sound Power Level at Octave Band Frequency (dB)								Total (dBA)
	63	125	250	500	1K	2K	4K	8K	
Background Music	93.6	85.8	77.1	75.9	80.0	72.7	69.7	61.0	82.5

3.2.5 Mechanical Equipment

The primary sources of mechanical noise on the project site will be air conditioning units for the hotel and restaurant spaces. The manufacturer/model of air conditioning units on site is currently unknown, and for this reason, typical assumptions have been made for purposes of this noise analysis. It is assumed that each hotel room would be served by an air conditioning unit with a capacity of approximately 1.5 tons and that units would be ground-mounted. Project plans show that the units will be located at the northwest facade of the bungalow buildings and the east facade of the units. A typical 1.5-ton air conditioning unit manufactured by Carrier has been used in this analysis and is assumed to be representative of equipment that could be used on site in the future. It is assumed that the restaurant will be served by an air conditioning unit with a capacity of approximately 5 tons that would be ground-mounted in the mechanical enclosure to the west of the restaurant building. A typical 5-ton air conditioning unit manufactured by Carrier has been used in this analysis and is assumed to be representative of equipment that could be used on site in the future. Sound power levels for the representative units were provided by the manufacturer. As the summed A-weighted sound power levels do not match the sum of the manufacturer octave-band sound power levels, the octave band sound power levels were adjusted accordingly. Table 6 shows the adjusted sound power levels of the air conditioner unit. Manufacturer data sheets are provided in Appendix E.

Table 6. Sound Power Levels of Carrier 25HCC5 Performance Units								
Source	Sound Power at Octave Band Frequency (dBA)							Total (dBA)
	125	250	500	1K	2K	4K	8K	
25HCC518 (1.5-ton)	50.9	60.4	65.4	67.9	64.9	61.9	53.9	72.0
25HCC560 (5-ton)	59.8	63.8	66.3	68.3	65.3	62.3	57.8	73.0

3.2.6 Temporary Construction Equipment

Detailed construction information was not available at the time this study was prepared; therefore, a typical list of construction equipment used on similar sites has been used for this analysis. Noise impacts for the grading phase of construction are the focus of this analysis, as this stage is when the greatest quantity of heavy construction equipment would be operational on site. Therefore, noise levels at neighboring properties would be at their highest. Unless otherwise noted, construction equipment noise levels were obtained from noise measurements made by Eilar Associates on March 25, 2010 for Brutoco Engineering & Construction, Inc. for the Orange Line Extension Project, Metro Contract #C0943, City of Los Angeles, California. Noise levels are shown in Table 7.

Table 7. Typical Construction Equipment Noise Levels		
Equipment Description	Duty Cycle (%) ¹	Noise Level at 50 feet (dBA)
Front Loader ²	40	72
Backhoe ²	40	74
Grader ²	40	70
Excavator ²	40	75

Table 7. Typical Construction Equipment Noise Levels		
Equipment Description	Duty Cycle (%)¹	Noise Level at 50 feet (dBA)
Water Truck ²	40	77
Dump Truck ³	40	76

¹Source: U.S. Department of Transportation Federal Highway Administration, Construction Noise Handbook, Construction Equipment Noise Levels and Ranges.

²Source: Noise measurements made by Eilar Associates on March 25, 2010 for Brutoco Engineering & Construction, Inc. for the Orange Line Extension Project, Metro Contract #C0943, City of Los Angeles, California.

³ Source: DEFRA Update of Noise Database for Prediction of Noise on Construction and Open Sites.

4.0 METHODOLOGY AND EQUIPMENT

4.1 Methodology

4.1.1 Field Measurement

Typically, a “one-hour” equivalent sound level measurement (L_{EQ} , A-Weighted) is recorded for at least one noise-sensitive location on the site. During the on-site noise measurement, start and end times are recorded, vehicle counts are made for cars, medium trucks (double-tires/two axles), and heavy trucks (three or more axles) for the corresponding road segment(s). Supplemental sound measurements of one hour or less in duration are often made to further describe the noise environment of the site.

For measurements of less than one hour in duration, the measurement time is long enough for a representative traffic volume to occur and the noise level (L_{EQ}) to stabilize. The vehicle counts are then converted to one-hour equivalent volumes by applying an appropriate factor. Other field data gathered include measuring or estimating distances, angles-of-view, slopes, elevations, roadway grades, and vehicle speeds. This information is subsequently verified using available maps and records.

4.1.2 Roadway Noise Calculation

The Traffic Noise Model, Version 2.5 program, released by the U.S. Department of Transportation, is used to calculate the current and future daytime average CNEL contours at the project site, taking into account surrounding buildings, elevation, and additional topography. The CNEL is calculated as 9.2 percent of the ADT for surrounding roadways, based on the studies made by Wyle Laboratories (see reference). Future CNEL is calculated for desired receptor locations using future road alignment, elevations, lane configurations, projected traffic volumes, estimated truck mixes, and vehicle speeds. Noise attenuation methods may be analyzed, tested, and planned with TNM, as required.

In order to determine the estimated traffic volumes of roadways during the traffic noise measurement made on site for model calibration, the approximate percentage of the Average Daily Trips (ADT) value for the time period in which the measurement is made is incorporated into the traffic model. These percentages have been established in a study performed by Katz-Okitsu and Associates, Traffic Engineers (see reference). For purposes of calibrating the TNM, 6.2% of the

ADT values for the current environment were used in calculations (for roadways that were not manually counted) to account for traffic between the hours of 11 a.m. and 12 p.m. in the vicinity of the project site.

4.1.3 Exterior-to-Interior Analysis

The State of California and the City of Encinitas require buildings to be designed in order to attenuate, control, and maintain average interior noise levels not greater than 45 CNEL in residential space. Contemporary exterior building construction is expected to achieve at least 15 decibels of exterior-to-interior noise attenuation with windows open. As a result, exterior noise levels of more than 60 CNEL often result in interior conditions that fail to meet the 45 CNEL requirements for habitable space.

Analysis for the interior noise levels requires consideration of:

- Number of unique assemblies in the wall (doors, window/wall mount air conditioners, sliding glass doors, and windows)
- Size, number of units, and sound transmission data for each assembly type
- Length of sound impacted wall(s)
- Depth of sound impacted room
- Height of exterior wall of sound impacted room
- Exterior noise level at wall assembly or assemblies of sound impacted room

The Composite Sound Transmission data is developed for the exterior wall(s) and the calculated noise exposure is converted to octave band sound pressure levels (SPL) for a typical traffic type noise. The reduction in room noise due to absorption is calculated and subtracted from the interior octave noise levels, and the octave band noise levels are logarithmically summed to yield the overall interior room noise level. When interior noise levels exceed 45 CNEL in residential space, the noise reduction achieved by each element is reviewed to determine which changes will achieve the most cost-effective compliance. Windows are usually the first to be reviewed, followed by exterior doors, and then exterior walls.

Modeling of wall assemblies is accomplished using INSUL Version 9.0, which is a model-based computer program, developed by Marshall Day Acoustics for predicting the sound insulation of walls, floors, ceilings, and windows. It is acoustically based on theoretical models that require only minimal material information that can make reasonable estimates of the sound transmission loss (TL) and STC for use in sound insulation calculations, such as the design of common party walls and multiple-family floor-ceiling assemblies, etc. INSUL can be used to quickly evaluate new materials or systems or investigate the effects of changes to existing designs. It models individual materials using the simple mass law and coincidence frequency approach and can model more complex assembly partitions as well. It has evolved over several versions into an easy to use tool and has refined the theoretical models by continued comparison with laboratory tests to provide acceptable accuracy for a wide range of constructions. INSUL model performance comparisons with laboratory test data show that the model generally predicts the performance of a given assembly within 3 STC points.

4.1.4 Cadna Noise Modeling

Modeling of the outdoor noise environment is accomplished using Cadna Version 2019, which is a model-based computer program developed by DataKustik for predicting noise impacts in a wide variety of conditions. Cadna (Computer Aided Noise Abatement) assists in the calculation, presentation, assessment, and alleviation of noise exposure. It allows for the input of project

information such as noise source data, barriers, structures, and topography to create a detailed model and uses the most up-to-date calculation standards to predict outdoor noise impacts. Noise standards used by Cadna that are particularly relevant to this analysis include ISO 9613 (Attenuation of sound during propagation outdoors). Cadna provides results that are in line with basic acoustical calculations for distance attenuation and barrier insertion loss.

4.1.5 Formulas and Calculations

Decibel Addition

To determine the combined logarithmic noise level of two known noise source levels, the values are converted to the base values, added together, and then converted back to the final logarithmic value, using the following formula:

$$L_C = 10 \log(10^{L1/10} + 10^{L2/10} + K 10^{LN/10})$$

where L_C = the combined noise level (dB), and
 L_N = the individual noise sources (dB).

This procedure is also valid when used successively for each added noise source beyond the first two. The reverse procedure can be used to estimate the contribution of one source when the contribution of another concurrent source is known and the combined noise level is known. These methods can be used for L_{EQ} or other metrics (such as L_{DN} or CNEL), as long as the same metric is used for all components.

Attenuation Due To Distance

Attenuation due to distance is calculated by the equation:

$$SPL_2 = SPL_1 - 20 \log\left(\frac{D_2}{D_1}\right)$$

where SPL_1 = Known sound pressure level at known distance,
 SPL_2 = Calculated sound pressure level at distance,
 D_1 = Distance from source to location of known sound pressure level, and
 D_2 = Distance from source to location of calculated sound pressure level.

This is identical to the more commonly used reference of 6 dB reduction for every doubling of distance. This equation does not take into account reduction in noise due to atmospheric absorption.

Project-Generated Traffic Noise Impacts

Changes in traffic noise levels can be predicted by inputting the ratio of the two scenarios into the following logarithmic equation:

$$\Delta = 10 \log(V2/V1)$$

where: Δ = Change in sound energy,
 $V1$ = original or existing traffic volume, and
 $V2$ = future or cumulative traffic volume.

Hourly L_{EQ} Summation

To determine the hourly average noise levels (L_{EQ}) when the noise is created for less than the full hour, convert the logarithm values to the base energy value, multiply by the percentage of the hour that the noise occurs, and then convert the sum back to a logarithmic value. This is done with the following formula:

$$L_{EQ} = 10 \log(P_H \times 10^{L_P/10})$$

where P_H = the percent or fraction of the hour noise is created, and
 L_P = the partial hour noise level (dB).

4.2 Measurement Equipment

Some or all of the following equipment was used at the site to measure existing ambient noise levels:

- Larson Davis Sound Expert LxT Type 1 Sound Level Meter, Serial #4085
- Larson Davis Model CA250 Type 1 Calibrator, Serial #1081
- Tripod, microphone & windscreen
- Larson Davis Model 720 Type 2 Sound Level Meter, Serial #0309
- Larson Davis Model CAL150 Type 2 Calibrator, Serial #2056

The sound level meters were field-calibrated immediately prior to the noise measurement and checked afterwards to ensure accuracy. All sound level measurements conducted and presented in this report, in accordance with the regulations, were made with sound level meters that conform to the American National Standards Institute specifications for sound level meters (ANSI S1.4). All instruments are maintained with National Bureau of Standards traceable calibration, per the manufacturers' standards. Please refer to Appendix F for calibration certificates for equipment used to conduct noise measurements on site, which demonstrate that sound level meters and calibrators used for this project were in calibration at the time noise measurements were performed.

5.0 IMPACTS AND MITIGATION

5.1 Traffic Noise Impacts

5.1.1 Exterior Traffic Noise Impacts at Outdoor Use Areas

The City of Encinitas Noise Element to the General Plan states that noise exposure at outdoor use areas of a hotel property should not exceed 70 CNEL in order to be considered "conditionally acceptable."

Future traffic noise impacts at outdoor use areas were calculated at the restaurant outdoor seating, spa deck, fire pit, and personal decks. This analysis considers proposed site topography and building structures. Results are shown in Table 8. A graphical representation of receiver locations is provided as Figure 7.

Table 8. Future Traffic Noise Levels at Outdoor Use Areas		
Receiver	Location	Exterior Noise Level (CNEL)
OU1	Restaurant Deck	68.7
OU2	Restaurant Deck	72.9
OU3	Restaurant Deck	73.6
OU4	Spa Deck	73.0
OU5	Spa Deck	66.0
OU6	Bungalow 1, Floor 1	72.2
OU7	Bungalow 1, Floor 2	73.8
OU8	Bungalow 2, Floor 1	63.9
OU9	Bungalow 2, Floor 2	72.9
OU10	Bungalow 3, Floor 1	60.2
OU11	Bungalow 3, Floor 2	72.5
OU12	Bungalow 4, Floor 1	59.2
OU13	Bungalow 4, Floor 2	71.6
OU14	Fire Pit	60.4
OU15	Unit 5	58.4
OU16	Unit 4	53.3
OU17	Unit 3	53.5
OU18	Unit 2	53.7
OU19	Unit 1	54.9

As shown above, calculations of future noise levels at the proposed outdoor use areas on site show that noise levels are expected to exceed 70 CNEL at multiple outdoor use areas. Mitigation is required for these areas.

In order to mitigate noise impacts at outdoor use areas, several sound attenuation barriers are required. The sound attenuation barriers were input into the noise model in locations that would provide shielding from noise associated with traffic traveling on Interstate 5, which is the primary source of noise impacting these receivers. One of the proposed sound barriers should be located toward the north end of the project site and should extend a minimum of 5 feet in height above the finished floor elevation of the restaurant outdoor seating and spa deck areas to attenuate noise levels at these areas. Additionally, a six foot tall sound attenuation barrier should be installed along the eastern property line to mitigate noise impacts to the private outdoor use areas for hotel guests. The balcony barriers on the second floors of each bungalow should also be constructed as sound attenuation barriers, with a minimum height of 3.5 feet above the elevation of the balcony floor. For a graphical representation of the proposed orientation of the noise barrier walls, please refer to Figure 7. Mitigated noise levels with these barrier walls in place are shown in Table 9.

Table 9. Future Traffic Noise Levels at Outdoor Use Areas – With Barrier Mitigation		
Receiver	Location	Exterior Noise Level (CNEL)
OU2	Restaurant Deck	63.1
OU3	Restaurant Deck	63.3
OU4	Spa Deck	69.7
OU6	Bungalow 1, Floor 1	69.6
OU7	Bungalow 1, Floor 2	68.3
OU9	Bungalow 2, Floor 2	67.2
OU11	Bungalow 3, Floor 2	66.9
OU13	Bungalow 4, Floor 2	66.2

As shown above, with the recommended sound attenuation barrier walls in place, mitigated noise levels at the restaurant outdoor seating and pool areas are expected to be 70 CNEL or less in the future noise environment.

The proposed sound barriers should have the proper height and orientation as shown in Figure 7. The barriers shall be solid and constructed of masonry, wood, plastic, fiberglass, steel, or a combination of those materials, with no cracks or gaps through or below the wall. Any seams or cracks must be filled or caulked. If wood is used, it can be tongue and groove and must be at least 7/8-inch thick or have a surface density of at least 3½ pounds per square foot. Where architectural or aesthetic factors allow, glass or clear plastic may be used on the upper portion if it is desirable to preserve a view. Sheet metal of 18-gauge (minimum) may be used if it meets the other criteria and is properly supported and stiffened so that it does not rattle or create noise itself from vibration or wind. Any door or gate(s) must be designed with overlapping closures on the bottom and sides and meet the minimum specifications of the wall materials described above. The gate(s) may be of 3/4-inch thick or greater wood, solid-sheet metal of at least 18-gauge metal, or an exterior-grade solid-core steel door with prefabricated door jambs.

5.1.2 Exterior Traffic Noise Impacts at Building Facades

Future traffic noise impacts were also calculated at building facades and showed that noise levels will range from 48.3 CNEL at the northwest-facing facade of the first floor of Bungalow 2 to 74.4 CNEL at the northeast-facing facade of the second floor of the restaurant. Noise levels are shown in Table 10, and receiver locations are shown in Figure 8.

Table 10. Future Traffic Noise Levels at Building Facades			
Receiver	Location	Exterior Noise Level (CNEL)	
		Floor 1	Floor 2
F1	Restaurant, South	59.9	66.3
F2	Restaurant, West	51.6	59.1
F3	Restaurant, North	73.0	73.5
F4	Restaurant, East	73.3	74.3

Table 10. Future Traffic Noise Levels at Building Facades

Receiver	Location	Exterior Noise Level (CNEL)	
		Floor 1	Floor 2
F5	Restaurant, Northeast	73.7	74.4
F6	Restaurant, Southeast	70.3	72.4
F7	Bungalow 1, Southwest	52.6	58.7
F8	Bungalow 1, Northwest	67.3	70.0
F9	Bungalow 1, Northeast	72.9	74.2
F10	Bungalow 1, Southeast	70.3	72.2
F11	Bungalow 2, Southwest	53.1	59.3
F12	Bungalow 2, Northwest	48.3	54.9
F13	Bungalow 2, Northeast	71.0	73.0
F14	Bungalow 2, Southeast	68.4	71.5
F15	Bungalow 3, Southwest	53.0	57.6
F16	Bungalow 3, Northwest	49.1	54.6
F17	Bungalow 3, Northeast	69.6	72.3
F18	Bungalow 3, Southeast	66.9	70.7
F19	Bungalow 4, Southwest	55.4	59.3
F20	Bungalow 4, Northwest	50.8	55.7
F21	Bungalow 4, Northeast	67.9	71.5
F22	Bungalow 4, Southeast	64.7	69.6
F23	Unit 5, West	56.9	59.5
F24	Unit 5, North	66.1	69.9
F25	Unit 5, East	68.5	71.6
F26	Unit 5, South / Unit 4, North	55.8	62.0
F27	Unit 4, West	57.9	60.5
F28	Unit 4, East	68.1	71.3
F29	Unit 4, South / Unit 3, North	57.6	63.0
F30	Unit 3, West	59.1	61.3
F31	Unit 3, East	67.6	70.9
F32	Unit 3, South / Unit 2, North	56.9	61.9
F33	Unit 2, West	60.7	62.5
F34	Unit 2, East	67.3	70.6
F35	Unit 2, South / Unit 1, North	58.1	62.8
F36	Unit 1, West	63.2	64.5

Table 10. Future Traffic Noise Levels at Building Facades			
Receiver	Location	Exterior Noise Level (CNEL)	
		Floor 1	Floor 2
F37	Unit 1, East	67.8	70.6
F38	Unit 1, South	67.1	68.8

5.1.3 Interior Traffic Noise Impacts

The City of Encinitas Noise Element to the General Plan and the State of California require buildings to be designed in order to attenuate, control, and maintain interior noise levels to 45 CNEL or less in habitable lodging space. CALGreen requires that nonresidential structures that are exposed to greater than 65 dBA during any hour of operation must control interior noise levels to be 50 dBA or less in occupied nonresidential spaces. Current exterior building construction is generally expected to achieve at least 15 decibels of exterior-to-interior noise attenuation with windows opened, according to the U.S. EPA (see reference). Therefore, proposed project building structures exposed to exterior noise levels greater than 60 CNEL could be subject to interior noise levels exceeding the 45 CNEL noise limit in habitable residential or commercial space. According to the California Department of Transportation’s Technical Noise Supplement to the Traffic Noise Analysis Protocol (see reference), peak hour traffic noise levels are typically found to be close to predicted CNEL values. Therefore, CNEL values calculated in the traffic noise analysis for this project (shown in Table 10) have been considered to be representative of peak hour noise impacts that would be experienced at on-site nonresidential suites.

The proposed exterior wall assembly is expected to be constructed as a wood-framed assembly with wood, stucco, concrete, or metal on the exterior, insulation in the cavity, and one layer of 5/8-inch thick Type X gypsum board on the interior. The wood exterior wall assembly (Wall Type E) was evaluated using INSUL and was shown to achieve an STC rating of 32. The stucco exterior wall assembly (Wall Type D) was evaluated using INSUL and was shown to achieve an STC rating of 38. The concrete exterior wall assembly (Wall Type B1) was evaluated using INSUL and was shown to achieve an STC rating of 40. The metal exterior wall assembly (Wall Type A) was evaluated using INSUL and was shown to achieve an STC rating of 55. Please refer to Appendix G for more details. These proposed exterior wall assemblies were incorporated into exterior-to-interior noise calculations.

Habitable Lodging Units

Calculations show that future noise levels on site exceed 60 CNEL at many facades; therefore, interior noise levels may exceed 45 CNEL with windows open. Due to high noise levels on-site, an exterior-to-interior analysis was performed to determine building features necessary to reduce interior noise levels in occupied spaces to 45 CNEL or less in residential space. The results of the exterior-to-interior noise analysis for each room are shown in Table 11, with acoustical recommendations made therein. For more information, please refer to Appendix H: Exterior-to-Interior Noise Analysis.

Table 11. Future Interior Noise Levels with Mitigation Recommendations						
Building	Room	Maximum Exterior Facade Impact (CNEL)	Minimum STC Rating for Windows/ Glass Doors	Interior Noise Level (CNEL)		Mechanical Ventilation
				Windows Open	Windows Closed	
Bungalow	Unit Type A	72.9	28	64.2	43.9	Required
	Unit Type B	74.2	28	56.7	43.3	Required
Unit	Kitchen / Dining / Loft	71.6	28	57.6	44.4	Required
	Bedroom	68.5	28	--	38.2	Required

As shown above, all units are expected to have interior noise levels of 45 CNEL or less with the proposed exterior wall and STC 28 windows and glass doors in place. Calculations show that none of the lodging spaces will comply with the City of Encinitas and State of California interior noise regulations with windows and doors open; hence, mechanical ventilation will be required in these units. The mechanical ventilation system shall meet the criteria of the California Mechanical Code, including the capability to provide appropriate ventilation rates. The ventilation system shall not compromise the sound insulation capability of the exterior wall or be dependent on ventilation through open windows.

Exterior door installation should include all-around weather-tight door stop seals and an improved threshold closure system. The additional hardware will improve the doors' overall sound reduction properties. The transmission loss (TL) of an exterior door without weather-tight seals is largely a factor of sound leakage, particularly at the bottom of the door if excessive clearance is allowed for air transfer. By equipping exterior doors with all-around weather-tight seals and an airtight threshold closure at the bottom, a loss of up to 10 STC points can be prevented.

Additionally, it is imperative to seal and caulk between the rough opening and the finished door frame for all doors by applying an acoustically resilient, non-skinning, butyl caulking compound. Sealant application should be as generous as needed to ensure effective sound barrier isolation. The same recommendation applies to any other penetrations, cracks, or gaps through the assembly. The OSI SC175 and the Pecora AC-20 FTR acoustic sound sealants are products specifically designed for this purpose. For additional information on these products, please refer to Appendix I: Recommended Products.

The proposed residential units were analyzed for future traffic noise impacts. With the proposed exterior wall assemblies, window and door configurations specified above, and mechanical ventilation, all interior, habitable, lodging spaces are expected to comply with City of Encinitas and California Building Code noise requirements.

Nonresidential Spaces (CALGreen)

CALGreen requires that nonresidential structures that are exposed to greater than 65 dBA during any hour of operation must control interior noise levels to be 50 dBA or less. Contemporary exterior building construction is expected to achieve at least 15 decibels of exterior-to-interior noise attenuation with windows opened. As a result, exterior noise levels of more than 65 dBA can result in interior conditions that fail to meet the 50 dBA requirement for nonresidential space. According to the California Department of Transportation's Technical Noise Supplement to the Traffic Noise

Analysis Protocol (see reference), peak hour traffic noise levels are typically found to be close to predicted CNEL values. Therefore, CNEL values calculated in the traffic noise analysis for this project (shown in Appendix D) have been considered to be representative of peak hour noise impacts that would be experienced at on-site nonresidential suites.

An exterior-to-interior noise analysis was conducted for occupied nonresidential spaces located throughout the restaurant building. Proposed exterior walls detailed above were used for exterior-to-interior noise calculations. Please refer to Table 12, showing interior noise levels with these considerations taken into account, and refer to Appendix H for additional information.

Table 12. Future Interior Noise Levels with Mitigation Recommendations – Commercial Spaces			
Room	Maximum Exterior Facade Impact (CNEL)	Minimum STC Rating for Windows/Glass Doors	Interior Noise Level (CNEL)
Front Desk / Bar	74.4	28	44.1
Dining	74.3	28	45.4

As shown above, all occupied nonresidential spaces are expected to have peak-hour interior noise levels of 50 dBA L_{EQ} or less with exterior glazing with a minimum STC rating of 28.

Exterior door installation should include all-around weather-tight door stop seals and an improved threshold closure system. The additional hardware will improve the doors' overall sound reduction properties. The transmission loss (TL) of an exterior door without weather-tight seals is largely a factor of sound leakage, particularly at the bottom of the door if excessive clearance is allowed for air transfer. By equipping exterior doors with all-around weather-tight seals and an airtight threshold closure at the bottom, a loss of up to 10 STC points can be prevented.

Additionally, it is imperative to seal and caulk between the rough opening and the finished door frame for all doors by applying an acoustically resilient, non-skinning, butyl caulking compound. Sealant application should be as generous as needed to ensure effective sound barrier isolation. The same recommendation applies to any other penetrations, cracks, or gaps through the assembly. The OSI SC175 and the Pecora AC-20 FTR acoustic sound sealants are products specifically designed for this purpose. For additional information on these products, please refer to Appendix I: Recommended Products.

The proposed interior spaces were analyzed for future exterior noise impacts from roadway traffic. With the proposed exterior wall assemblies and exterior windows and glass doors meeting the minimum STC 28 rating, all occupied nonresidential space is expected to comply with CALGreen noise requirements.

5.1.4 Traffic Noise Impacts on Sensitive Receivers

Per Policy 1.1 of the City of Encinitas Noise Element to the General Plan:

If a project would cause an increase in traffic noise levels, the policy of the City of Encinitas is to accept an increase up to an L_{DN} of 55 dBA in outdoor residential use area without mitigation. If a project would increase the traffic noise level by more than 5 dBA and the resulting L_{DN} would be over 55 dBA, then mitigation measures must be evaluated. If the project, or action, would increase

traffic noise levels by 3 dB or more and the resulting L_{DN} would exceed 60 dBA in outdoor use areas in residential development, noise mitigation must be similarly evaluated.

Permanent project-generated traffic noise impacts were evaluated to determine whether the project-related traffic will increase traffic noise levels in the vicinity of the project site.

Using projected traffic volumes provided in the Traffic Study prepared by Mizuta Traffic Consulting, existing traffic volumes (peak hour) were compared to existing plus project traffic volumes (peak hour) as calculated within this transportation impact analysis to determine the projection of traffic noise impacts generated by the project.

Project-generated traffic noise impacts were calculated using the Project-Generated Traffic Noise Impacts formula shown in Section 4.1.5. Impacts were calculated at the two major intersections closest in proximity to the proposed project: the intersection of La Costa Avenue and the southbound I-5 off ramp, and the intersection of La Costa Avenue and Vulcan Avenue.

Calculations show that, at the intersection of La Costa Avenue and the southbound I-5 off ramp, there is expected to be no net increase in noise levels due to project-generated traffic. At the intersection of La Costa Avenue and Vulcan Avenue, calculations show that there is expected to be no net increase in noise levels due to project-generated traffic. For more information, please refer to Appendix J: Project-Generated Traffic Noise Calculations. As project-generated traffic is not expected to increase traffic noise levels, no mitigation is required.

5.2 Operational Noise Sources

Noise sources associated with the operation of the proposed project include mechanical equipment as well as noise from persons gathered in outdoor use areas of the project. Noise impacts from these sources were calculated at the nearest surrounding property lines using Cadna.

It is assumed that each hotel room would be served by an air conditioning unit with a capacity of approximately 1.5 tons and that units would be ground-mounted. Project plans show that the units will be located at the northwest facade of the bungalow buildings and the east facade of the units. It is also assumed that the restaurant will be served by an air conditioning unit with a capacity of approximately 5 tons that would be ground-mounted in the mechanical equipment enclosure to the west of the restaurant building. Although mechanical equipment would be expected to cycle on and off throughout the day and night, mechanical equipment was modeled as running continuously, in order to represent a worst-case analysis. As air conditioning equipment may operate during nighttime hours, noise impacts will be compared to the most restrictive nighttime noise limits to determine compliance.

In order to predict anticipated maximum noise impacts from persons gathered in outdoor use areas, all noise sources were calculated as raised voices, with half of the persons modeled as female, and the other half modeled as male. Each noise source (person) was calculated as speaking for 30 minutes out of every hour, which is considered excessive as each patron is expected to take breaks in conversation for listening, eating, drinking, et cetera. For this reason, this analysis is considered to be a conservative estimate of noise levels generated at outdoor use areas and accounts for occasional bursts of louder noise combined with times of lesser noise. Noise levels were evaluated with the outdoor use areas at the capacities listed above in Section 3.2.3.

In addition to noise associated with persons gathered in outdoor use areas, the project proposes to have outdoor speakers located in various locations on the exterior of the building. These speakers will be used solely to play low levels of background music, and their operation will be limited to during the daytime hours (7 a.m. to 10 p.m.). According to project plans, the project will have a total of eleven outdoor speakers for playing background music, with two located in the fire pit area, six

located on the spa deck, and three located in the outdoor restaurant seating area. These speakers were incorporated into plans as such. No additional outdoor amplified events are proposed at the project site.

Results are shown in Table 13 and calculation sheets are provided in Appendix K. For a graphical representation of noise contours associated with the operation of the proposed project during the daytime and nighttime hours, as well as source and receiver locations, please refer to Figures 9 and 10, respectively.

Table 13. Operational Noise Impacts					
Receiver	Description	Noise Limit (dBA L_{EQ})		Calculated Noise Level (dBA L_{EQ})	
		Daytime	Nighttime	Daytime	Nighttime
R1	South Property Line	50	45	33.4	33.3
R2	East Property Line – South	60	55	45.9	45.9
R3	East Property Line – North	60	55	40.6	41.5
R4	West Property Line – North	50	45	44.7	28.0
R5	West Property Line – South	50	45	41.8	39.2

As show above in Table 13, noise impacts associated with the operation of the proposed project are expected to comply with applicable City of Encinitas noise limits at surrounding properties. It should also be noted that these noise levels are expected to be less than the existing ambient noise environment at most receivers in the vicinity of the project site. No additional mitigation is deemed necessary for attenuating noise from the operation of the proposed facility.

5.3 Temporary Construction Noise

Temporary construction noise is expected to be at its highest during grading operations, when the greatest quantity of heavy equipment would be located on site. The City of Encinitas requires that noise levels from construction activity do not exceed 75 dBA for more than eight hours and that construction activity is limited to the hours of 7 a.m. to 7 p.m., Mondays through Saturdays. As detailed in Section 3.2.6, noise levels from construction equipment during grading activities are expected to range from 72 to 77 dBA at 50 feet from the equipment. Considering these equipment noise levels, construction activity noise levels are only expected to be 75 dBA or greater at residential property lines when activity is taking place within 35 to 65 feet of the nearest property line, and at all other times will be less than 75 dBA. Due to the large area of the site, this scenario is only expected to take place for very brief periods of time throughout the day, and for this reason, construction limited to the twelve allowable hours of operation established within the code will comply with City of Encinitas noise regulations.

No sound attenuation barriers are therefore deemed necessary to reduce temporary noise impacts. The following measures should still be practiced as a courtesy to residential neighbors.

1. Construction activity must be limited to the hours of 7 a.m. to 7 p.m., Mondays through Saturdays, as per the City of Encinitas Municipal Code.
2. Staging areas should be placed as far from occupied receivers as possible on the project site to limit any additional unnecessary noise exposure at sensitive receivers.

3. Place stationary equipment in locations that will have a lesser noise impact on nearby sensitive receivers.
4. Turn off equipment when not in use.
5. Limit the use of enunciators or public address systems, except for emergency notifications.
6. Equipment used in construction should be maintained in proper operating condition, and all loads should be properly secured to prevent rattling and banging.
7. Schedule work to avoid simultaneous construction activities that both generate high noise levels.
8. Use equipment with effective mufflers.
9. Minimize the use of backup alarms.

With work limited to those allowable by the City of Encinitas, temporary construction noise will not exceed the applicable thresholds of the City of Encinitas Municipal Code.

6.0 CONCLUSION

The City of Encinitas Noise Element to the General Plan states that noise levels at outdoor use areas of transient lodging (hotel/motel) uses should not exceed 70 CNEL in order to be considered “conditionally acceptable.” A noise analysis was performed to determine anticipated future noise impacts at proposed outdoor use areas on the project site. In order to mitigate noise impacts at outdoor use areas, several sound attenuation barriers are required. The sound attenuation barriers were input into the noise model in locations that would provide shielding from noise associated with traffic traveling on Interstate 5, which is the primary source of noise impacting these receivers. One of the proposed sound barriers should be located toward the north end of the project site and should extend a minimum of 5 feet in height above the finished floor elevation of the restaurant outdoor seating and spa deck areas to attenuate noise levels at these areas. Additionally, a six foot tall sound attenuation barrier should be installed along the eastern property line to mitigate noise impacts to the private outdoor use areas for hotel guests. The balcony barriers on the second floors of each bungalow should also be constructed as sound attenuation barriers, with a minimum height of 3.5 feet above the elevation of the balcony floor. Please refer to Section 5.1.1 for more information.

The City of Encinitas and State of California require interior noise levels of 45 CNEL or less in habitable lodging space. Calculations show that, with the proposed exterior wall assemblies and exterior windows and glass doors with minimum a minimum STC rating of 28, interior noise levels are expected to remain below 45 CNEL in the future noise environment. As the interior noise levels of all lodging units are expected to exceed the 45 CNEL interior noise level requirement with windows open, mechanical ventilation is required in all habitable residential spaces.

The State of California requires that occupied nonresidential spaces demonstrate compliance with the requirements of the California Green Building Standards Code (known as CALGreen). Occupied nonresidential spaces are expected to comply with CALGreen Building Code regulations using an exterior storefront glazing system with a minimum rating of STC 28.

The City of Encinitas also requires an analysis to determine whether the proposed project will have an adverse noise impact on surrounding properties. Noise limits specified within Section 30.40 of the City of Encinitas Municipal Code must be met at neighboring property lines. The impact of project-generated traffic noise is anticipated to be insignificant at off-site noise-sensitive properties. Additionally, calculations show that noise levels generated by air conditioning units, background music, and persons gathered in proposed outdoor use areas of the project site are expected to be adequately controlled by distance attenuation at surrounding property lines and, therefore, should remain in compliance with the noise requirements of the City of Encinitas. No mitigation is deemed necessary.

Section 9.32.410 of the City of Encinitas Municipal Code restricts the operation of construction equipment to the hours of 7 a.m. to 7 p.m., Mondays through Saturdays. The Municipal Code also states that it is unlawful to operate construction equipment that exceeds a noise level of 75 dBA for more than eight hours during any 24-hour period when measured at residential property lines. Based on the currently proposed construction activities, noise levels are only expected to be 75 dBA or greater at residential property lines when activity is taking place within 35 to 65 feet of the nearest property line, and at all other times will be less than 75 dBA. Due to the large area of the site, this scenario is only expected to take place for very brief periods of time throughout the day, and for this reason, construction limited to the twelve allowable hours of operation established within the code will comply with City of Encinitas noise regulations. General good practice measures should also be followed, including reasonable maintenance of equipment, conservative planning of simultaneous equipment operation, and using equipment with effective mufflers.

These conclusions and recommendations are based on the best and most current project-related information available at the time this study was prepared.

7.0 CERTIFICATION

All recommendations for noise control are based on the best information available at the time our consulting services are provided. However, as there are many factors involved in sound transmission, and Eilar Associates has no control over the construction, workmanship, or materials, Eilar Associates is specifically not liable for final results of any recommendations or implementation of the recommendations.

This report is based on the related project information received and measured noise levels, and represents a true and factual analysis of the acoustical issues associated with the 516 La Costa Project in the City of Encinitas, California. This report was prepared by Mo Ouwenga and Jonathan Brothers.



Mo Ouwenga, Acoustical Consultant

Jonathan Brothers, Principal Acoustical Consultant

8.0 REFERENCES

1. City of Encinitas Noise Element to the General Plan.
2. California Building Code, Based on the International Building Code, Chapter 12, Section 1207 – *Sound Transmission Control*.
3. California Green Building Code, Nonresidential Mandatory Measures.
4. City of Encinitas Municipal Code.
5. San Diego Association of Governments (SANDAG) Traffic Forecast Information Center, Series 12, <http://tfic.SANDAG.org>.
6. Caltrans Traffic Census Program, <http://www.dot.ca.gov/trafficops/census/>
7. Mizuta Traffic Consulting, 516 La Costa Development Traffic Study, June 2019.
8. Federal Highway Administration, Highway Traffic Noise: Analysis and Abatement Guide, December 2011.
9. Pearsons, K.S., Bennett, R.L., & Fidell, S., Speech Levels in Various Noise Environments (Report No. EPA-600/1-77-025), U.S. Environmental Protection Agency, 1977.
10. U.S. Department of Transportation Federal Highway Administration, Construction Noise Handbook, Construction Equipment Noise Levels and Ranges.
11. Department for Environment Food and Rural Affairs (DEFRA), Update of Noise Database for Prediction of Noise on Construction and Open Sites, 2005.
12. Federal Highway Administration, Traffic Noise Model Version 2.5.
13. Wyle Laboratories, Development of Ground Transportation Systems Noise Contours for the San Diego Region, December, 1973
14. Traffic Distribution Study, by Katz-Okitsu and Associates Traffic Engineers, 1986.
15. Marshall Day Acoustics, INSUL Version 9.0, 2017.
16. DataKustik, CadnaA (Computer Aided Noise Abatement), Version 2019.

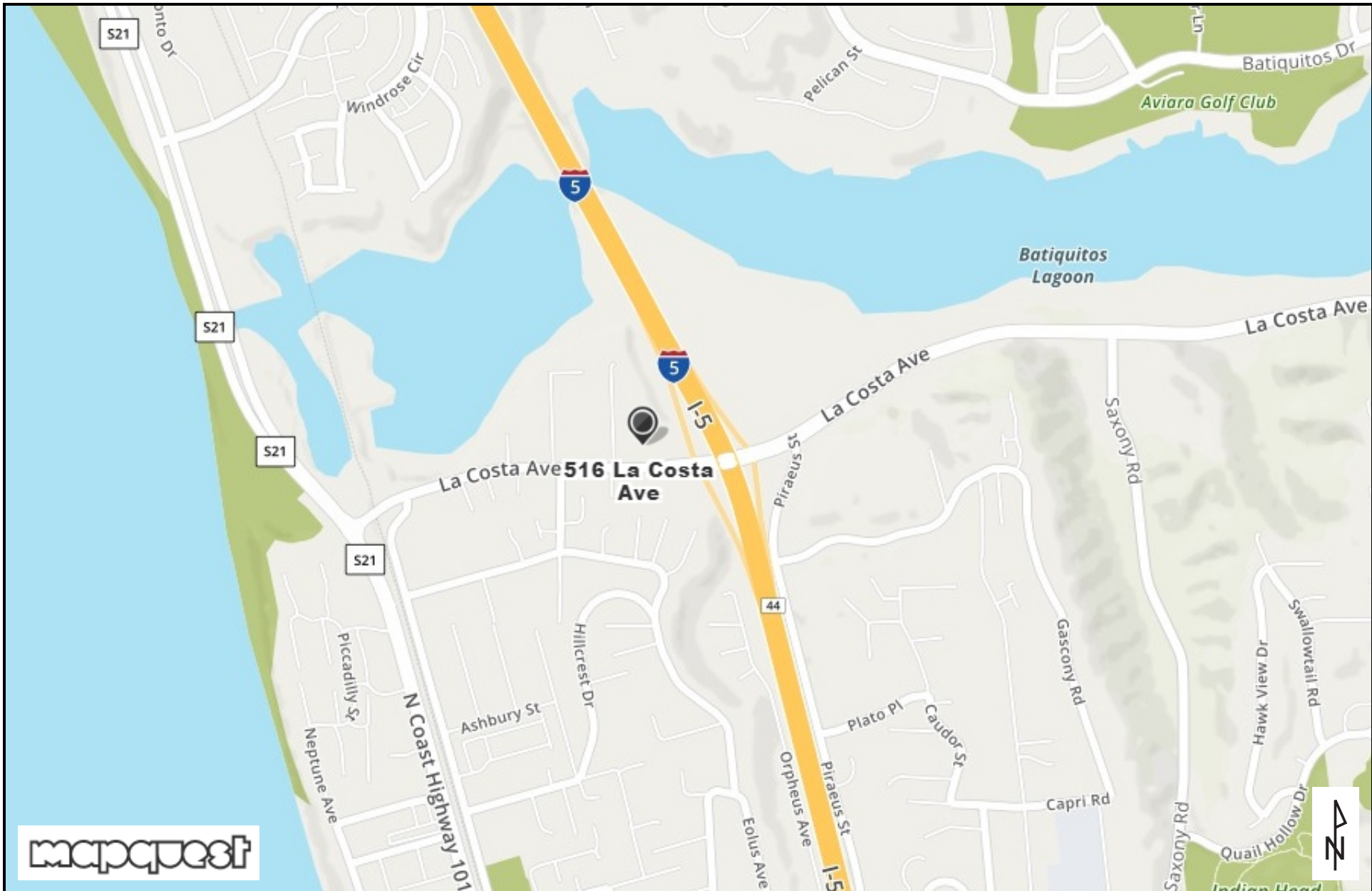
FIGURES



mapquest

Eilar Associates, Inc.
 210 South Juniper Street, Suite 100
 Escondido, California 92025
 760-738-5570

Vicinity Map
Job # S200108

Figure 1

San Diego County
Assessor's
Parcel Number:

216-030-48-00

Project Location

2160304800



Eilar Associates, Inc.
210 South Juniper Street, Suite 100
Escondido, California 92025
760-738-5570

Assessor's Parcel Map
Job # S200108

Figure 2



Google earth

Eilar Associates, Inc.
210 South Juniper Street, Suite 100
Escondido, California 92025
760-738-5570

Satellite Aerial Photograph
Job # S200108

Figure 3



Map provided by MyTopo.com

Eilar Associates, Inc.
210 South Juniper Street, Suite 100
Escondido, California 92025
760-738-5570

Topographic Map
Job # S200108

Figure 4

65 CNEL Contour
70 CNEL Contour

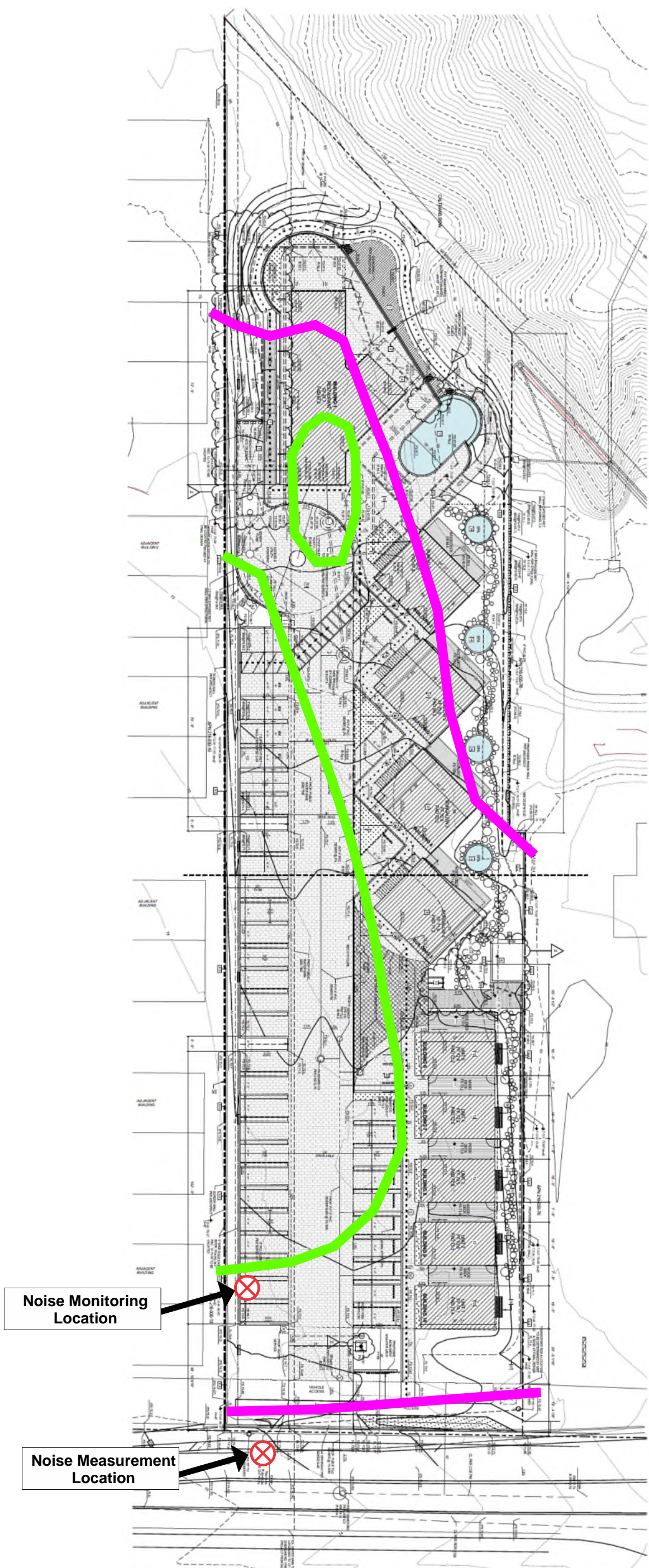

Eilar Associates, Inc.
210 South Juniper Street, Suite 100
Escondido, California 92025
760-738-5570

**Site Plan Showing Current Traffic CNEL
Contours and Noise Measurement Locations
Job # 200108**

Figure 5

65 CNEL Contour
70 CNEL Contour

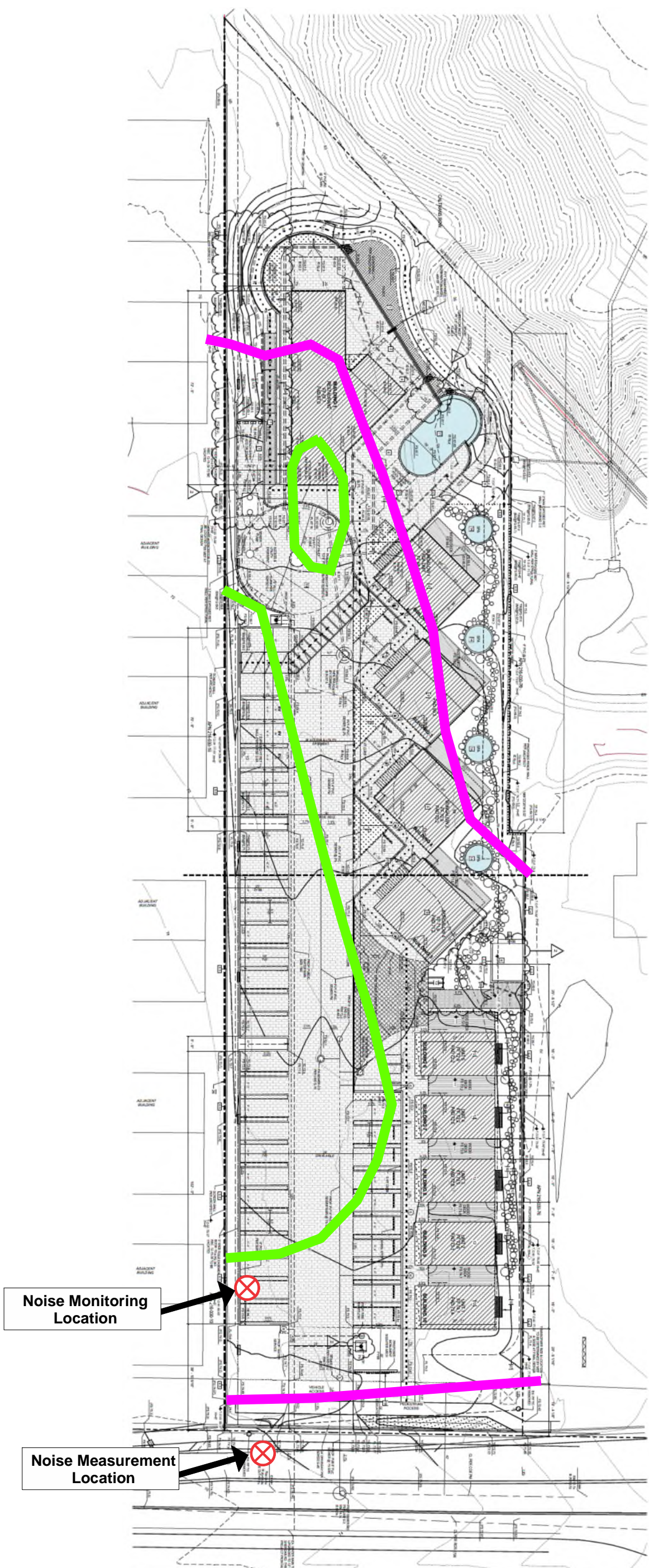

Eilar Associates, Inc.
210 South Juniper Street, Suite 100
Escondido, California 92025
760-738-5570

**Site Plan Showing Future Traffic CNEL
Contours and Noise Measurement Locations
Job # 200108**

Figure 6



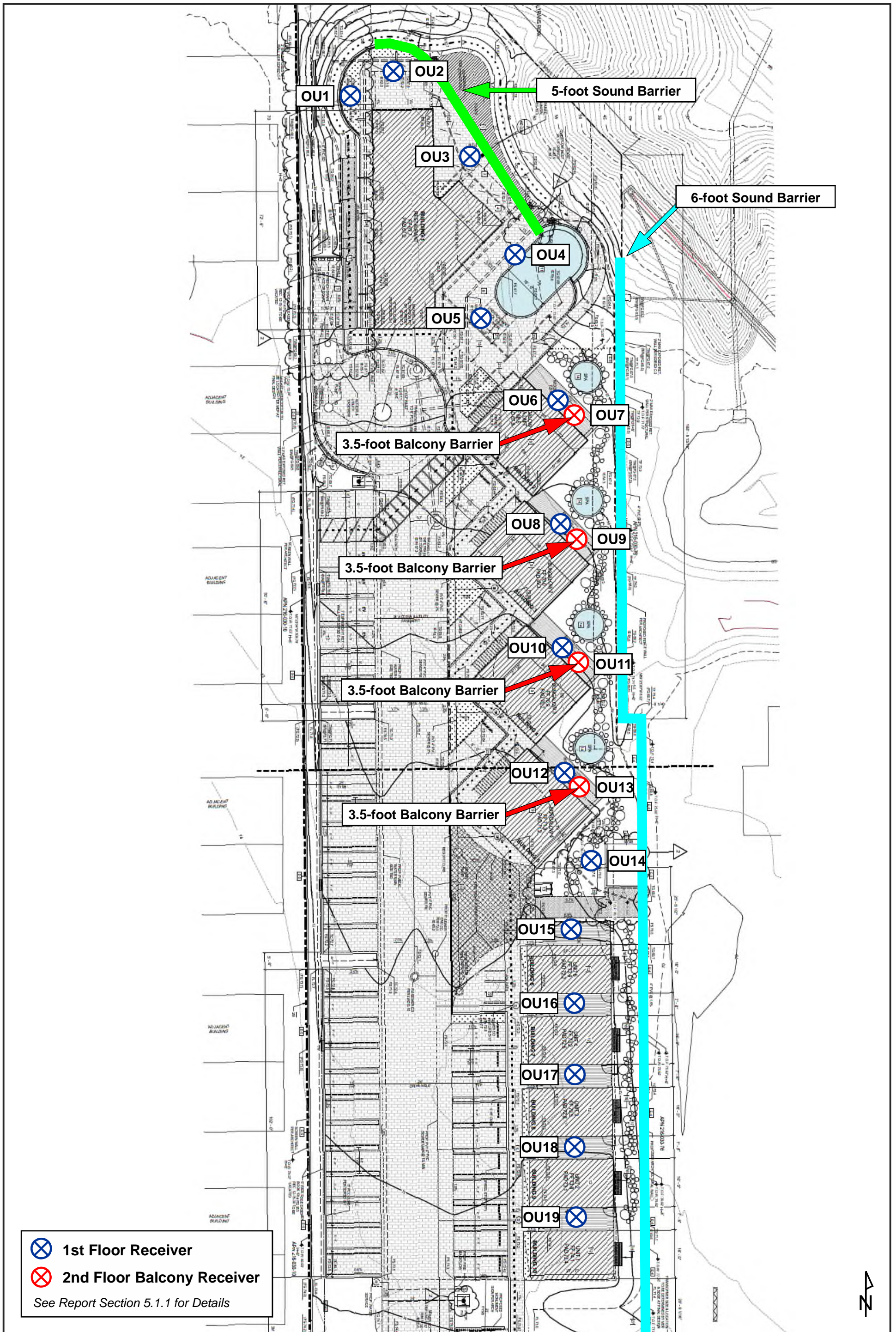

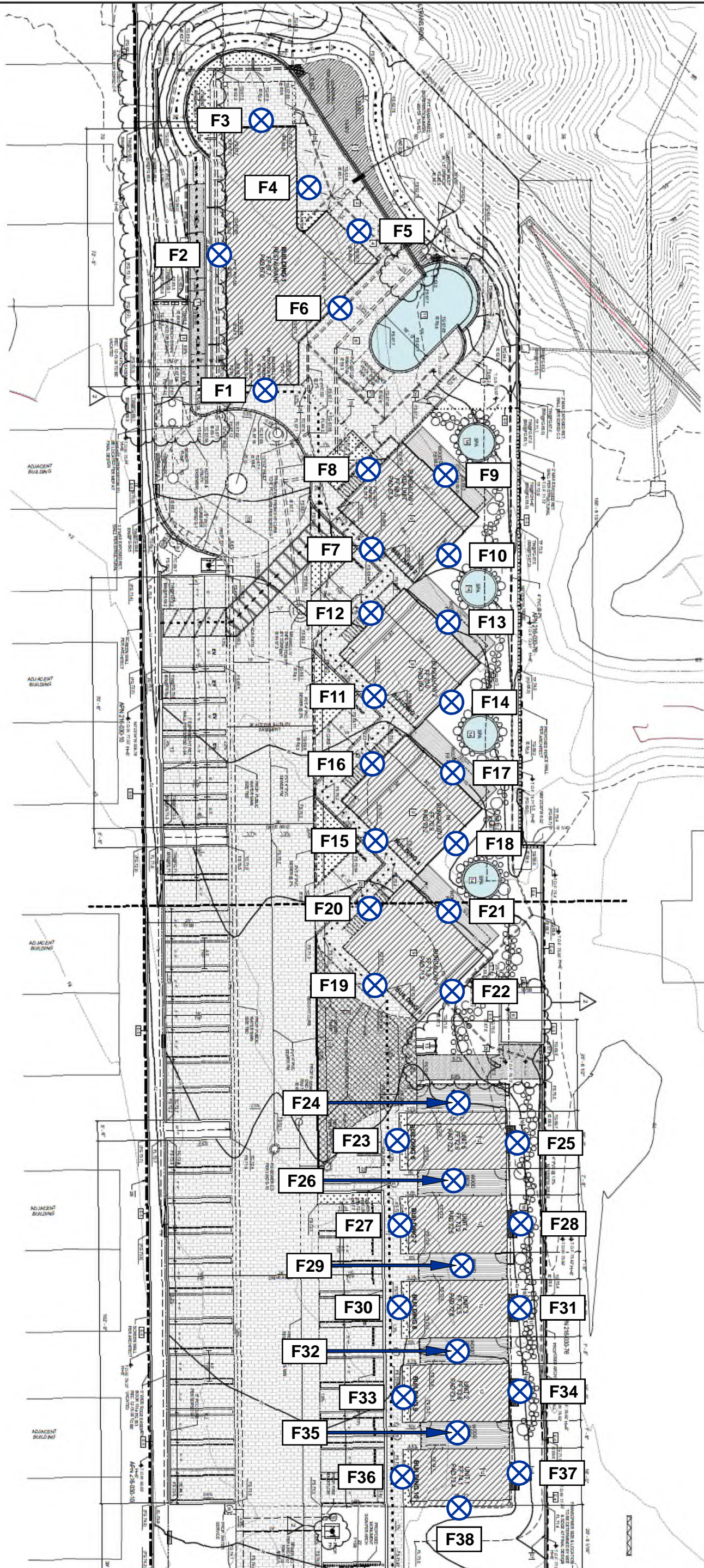

Eilar Associates, Inc.
 210 South Juniper Street, Suite 100
 Escondido, California 92025
 760-738-5570

Site Plan Showing
 Facade Receiver Locations
 Job # 200108

Figure 8



- ⊗ Receiver Location
 - ◆ 1.5-ton HVAC Unit
 - ◆ 5-ton HVAC Unit
 - ◆ Background Music Speaker
- Patrons Speaking**
- One Person on Ground Floor
 - Two People on Ground Floor
 - Two People on Ground Floor and Four People on Balcony

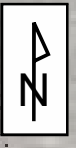
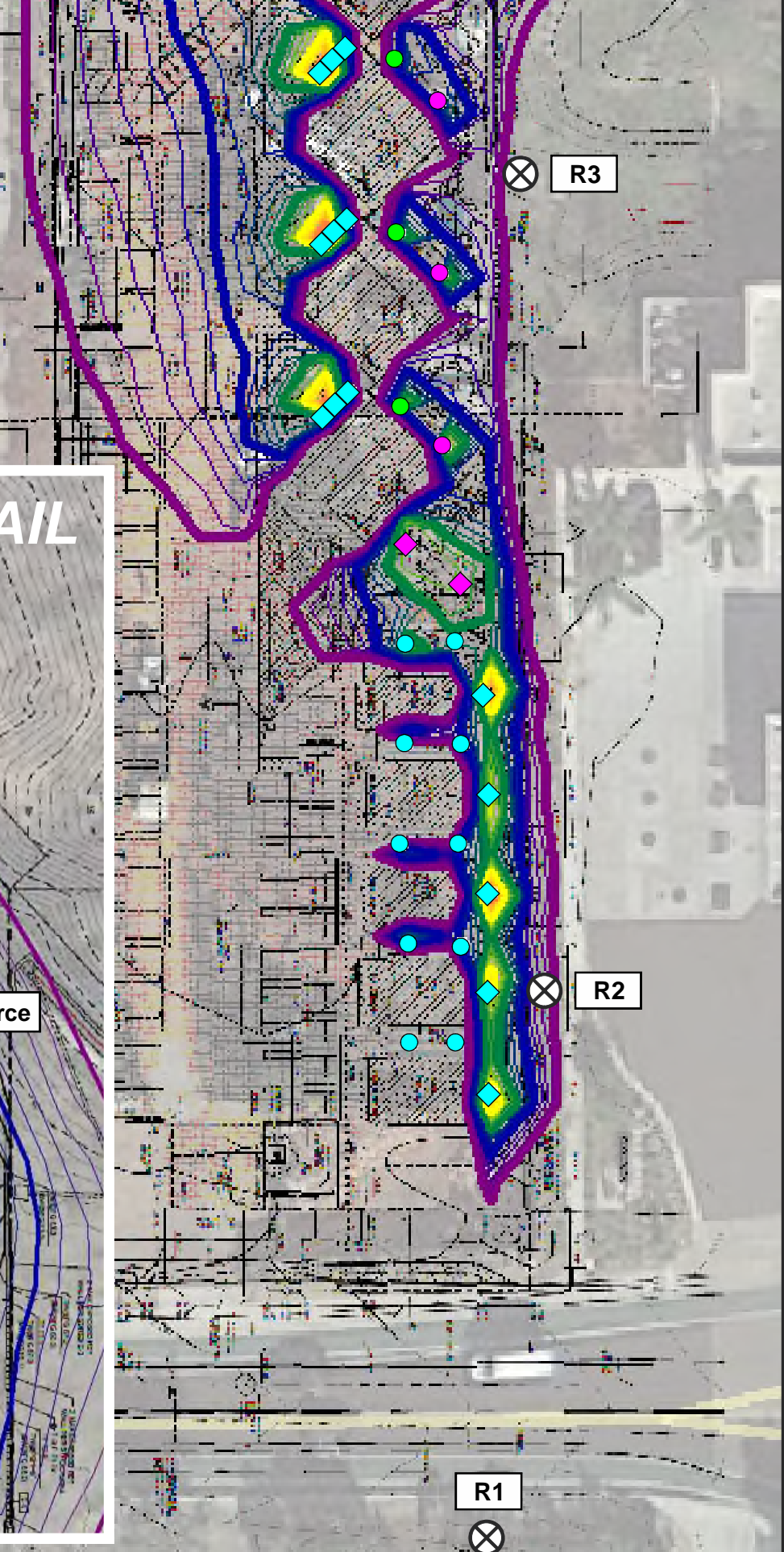
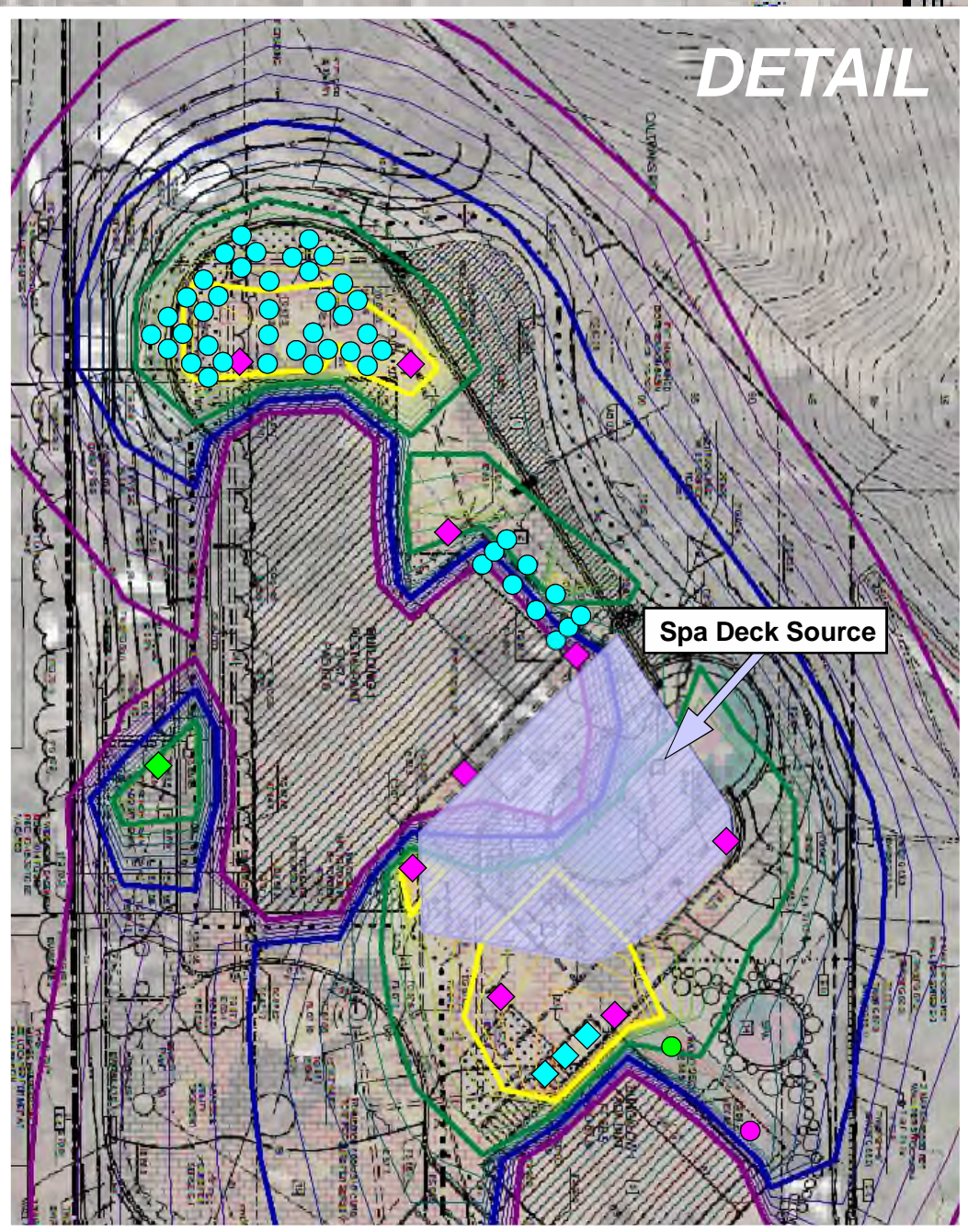
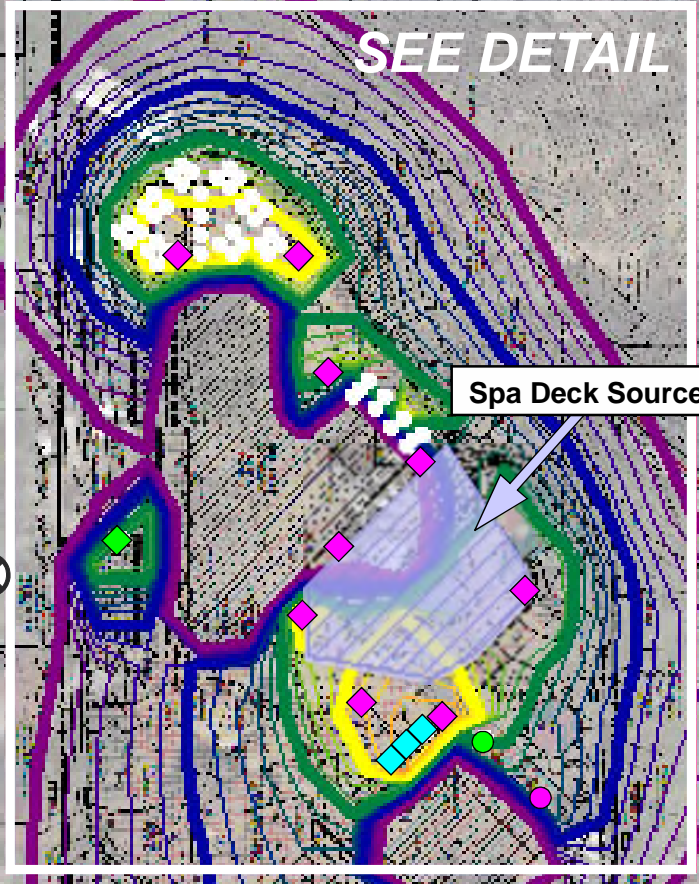

Eilar Associates, Inc.
 210 South Juniper Street, Suite 100
 Escondido, California 92025
 760-738-5570

**Satellite Aerial Photograph Showing Site Plan,
 Daytime Project-Generated Noise Contours,
 and Source and Receiver Locations**
 Job # S200108

Figure 9

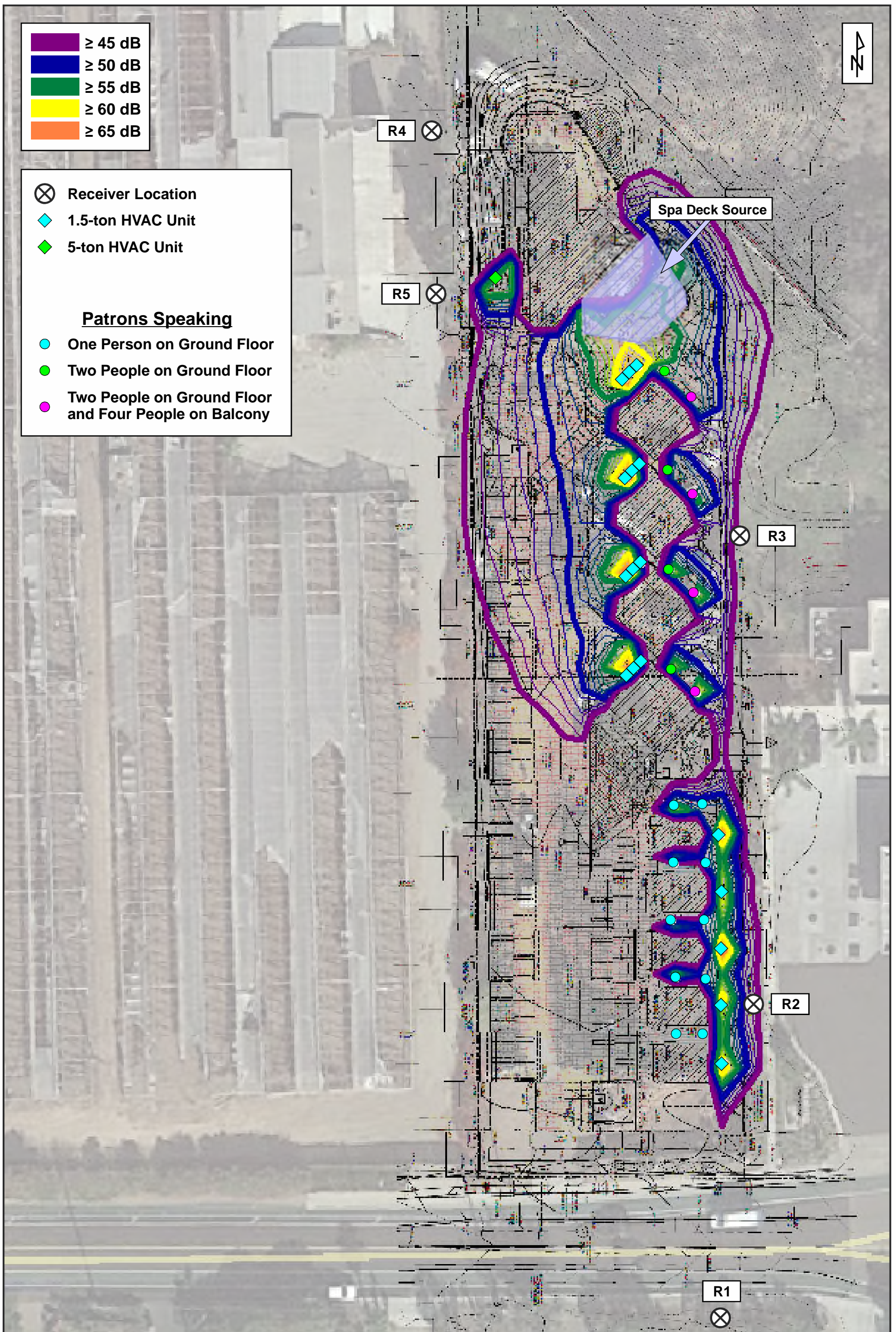

APPENDIX A

Project Plans

1 SITE PLAN
1" = 20'-0"

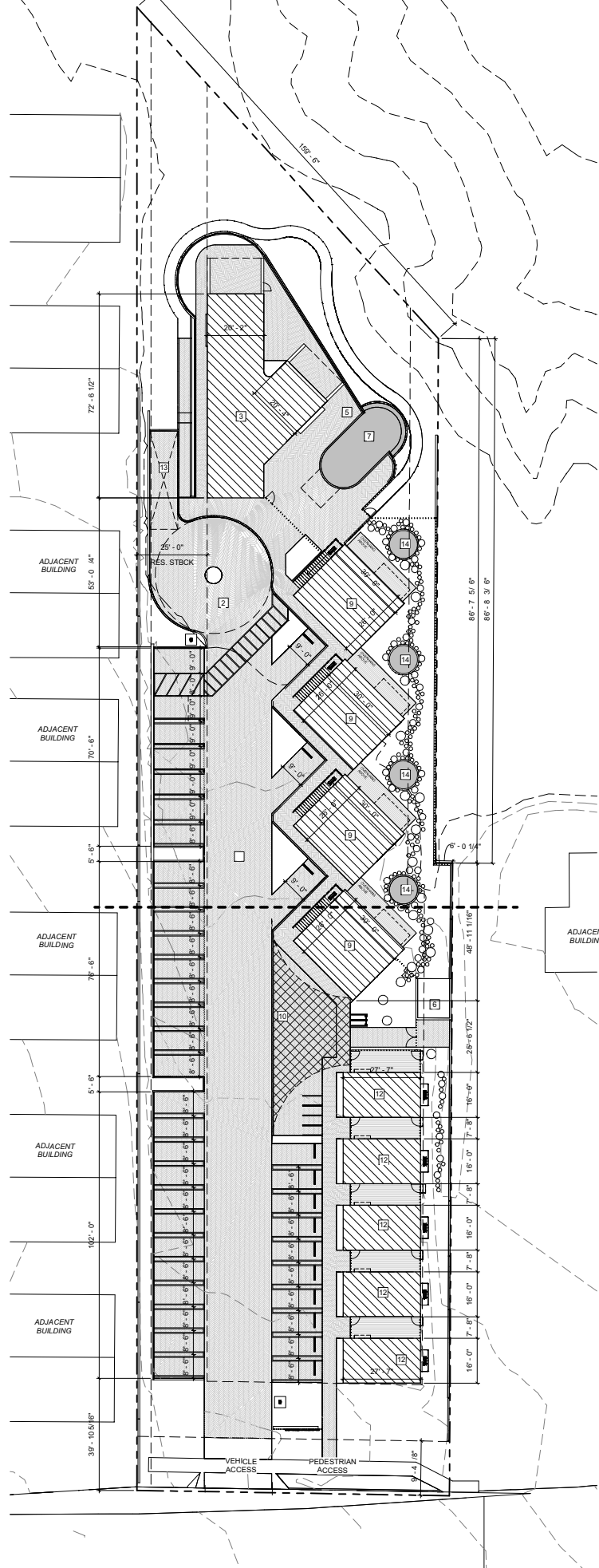

LA COSTA AVE.

PROJECT DATA

PROJECT NAME
516 LA COSTA

PROJECT ADDRESS
516 LA COSTA AVE.
ENCINITAS, CA 92024

APN #
216-030-48-00

LEGAL DESCRIPTION
A PORTION OF THE SOUTH EAST QUARTER OF SECTION 9 TOWNSHIP 13 SOUTH RANGE 4 WEST SAN BERNARDINO MERIDIAN IN THE COUNTY OF SAN DIEGO, STATE OF CALIFORNIA

LOT AREA
GROSS: 51,377 SF (1.18 ac)
EASEMENT: 2,149 SF
NET: 49,228 SF (1.13 ac)

LOT COVERAGE
ALLOWABLE: 17,982 SF (35%)
PROPOSED: 6,970 SF (13.5%)

F.A.R.
ALLOWED: 51,377 SF = 1.0
PROPOSED: 12,436 SF = 0.235

SETBACKS

	CODE	ACTUAL
FRONT YARD	20'-0"	20'-0"
SIDE YARD	10'-0"	10'-0"
SIDE YARD	25'-0"	25'-0"
ADJ. RESIDENTIAL	10'-0"	10'-0"
REAR YARD	0'-0"	0'-0"
ROW EASEMENT	22'-0"	22'-0"

LANDSCAPING
REQUIRED = 7,707 SF (15%)
PROPOSED: 16,965 SF (33%)

SCOPE OF WORK

CONSTRUCTION OF A NEW 17 ROOM BOUTIQUE HOTEL, WITH POOL AND SPA DECK AMENITY, PUBLIC RESTAURANT WITH OUTDOOR DINING AREA, ALCOHOL SERVICE LICENCES AND MONUMENT SIGN. NO ON-SITE CONSTRUCTION TRAILER PROPOSED

ABC LICENCES:
47-ON SALE GENERAL EARING PLACE
66-CONTROLLED ACCESS PERMIT
58-CATERERS
68-PORTABLE LICENCE

PERMITS REQUIRED:
MINOR USE PERMIT, DESIGN REVIEW, COASTAL DEVELOPMENT PERMIT

KEYNOTES

- 1 DRIVEWAY
- 2 MOTOR COURT
- 3 RESTAURANT
- 5 UNDERGROUND SPA QUIPMENT AREA
- 6 TRASH
- 7 MAIN SPA
- 9 QUONSET HUT UNITS
- 10 FIRE TURNAROUND
- 12 BUNGALOW UNITS
- 13 LOADING SPACE
- 14 HOTEL PRIVATE SPAS

VICINITY MAP



BUILDING CODE DATA

CONSTRUCTION TYPE
TYPE V-A

OCCUPANCY CLASS
R-1, B, S-2

FIRE SPRINKLERS
YES

WATER DISTRICT
SAN DIEGUITO WATER DISTRICT

SANITARY DISTRICT
ENCINITAS SANITATION

NUMBER OF STORIES
PROPOSED 2

MAX BUILDING HEIGHT
30'

GOVERNING CODES
2016 CA. BLDG. CODE
2016 UNIFORM PLUMBING CODE
2016 ELECTRICAL CODE
2016 UNIFORM MECHANICAL CODE

ZONING : VSC
GENERAL PLAN DESIGNATION: VISITOR SERVING COMMERCIAL
COASTAL: COASTAL APPEAL ZONE
CULTURAL RESOURCES OVERLAY ZONE

PERMIT NUMBER:
MULTI-002750-2018; DR-002670-2018; USE-002671-2018; CDPNF-002672-2020; CPP-003887-2020

I.CDP

- A0.00 CDP TITLE SHEET
- A0.01 NOTES
- A0.02 EXISTING SITE CONDITION
- A0.03a PROPOSED SITE PLAN
- A0.03b PROPOSED SITE PLAN
- A0.04 TRASH ENCLOSURE DETAILS
- A1.01a FLOOR PLAN - LEVEL 1
- A1.01b FLOOR PLAN - LEVEL 1
- A1.03a ROOF PLAN
- A1.03b ROOF PLAN
- A1.04 ENLARGED RESTAURANT/ COMMUNAL AREAS
- A1.05 ENLARGED RESTAURANT/ COMMUNAL AREAS
- A1.06 ENLARGED PLAN BUILDING TYPE A
- A1.07 ENLARGED PLAN BUILDING TYPE B
- A2.01 GENERAL ELEVATIONS
- A2.02 ELEVATIONS RESTAURANT
- A2.03 ELEVATIONS
- A2.04 ELEVATIONS
- A2.04 WALL DETAILS
- A10.1 AREA PLAN (PROPOSED)
- A10.2 PARKING DIAGRAM
- A10.3 ALCOHOL DIAGRAM
- A10.4 SEATING DIAGRAM
- A10.5 SIGNAGE
- A10.6 OUTDOOR SPEAKERS
- C1 PRELIMINARY GRADING PLAN
- C2 PRELIMINARY GRADING & DRAINAGE PLAN
- C3 PRELIMINARY GRADING & DRAINAGE PLAN
- C4 STRIPING & IMPROVEMENTS EXHIBIT
- C5 SLOPE ANALYSIS
- E1.0 EXTERIOR LIGHTING PLAN
- L1.0 PROPOSED LANDSCAPE PLAN
- MB-1 MATERIAL BOARD
- MB-2 MATERIAL BOARD
- MB-3 MATERIAL BOARD

FLOOR AREA ANALYSIS

ALLOWABLE AREA:
GROSS AREA: 51,377 SF
EASEMENT: 2,149 SF
NET LOT AREA: 49,228 SF

PROPOSED AREA BREAKDOWN:

NAME	AREA
CIRCULATION-EXTERIOR	5,312 SF
LANDSCAPE	15,975 SF
PARKING	17,375 SF
TRASH	185 SF
BAR	191 SF
CIRCULATION-INTERIOR	100 SF
HOTEL OFFICE	269 SF
HOTEL OFFICE MEZZANINE	179 SF
HOTEL SERVICE	159 SF
KITCHEN B.O.H	451 SF
DECK - UNITS	2,161 SF
SPA	933 SF
SPA LOUNGE	1,845 SF
LOBBY	184 SF
RESTAURANT	890 SF
RESTROOM-MEN	50 SF
RESTROOM-WOMENS	43 SF
LANDSCAPE	476 SF
OUTDOOR DINING	345 SF

BUNGALOW	3,211 SF
QUONSET HUT	6,708 SF

TOTAL GROSS 12,436 SF
*NO OUTDOOR AREAS INCLUDED

PERSPECTIVE VIEW

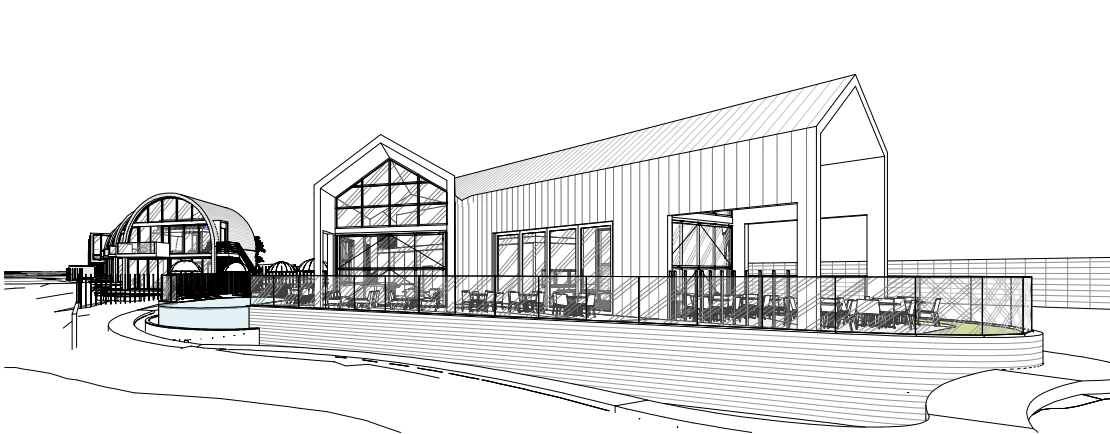

GENERAL NOTES

- COMPLIANCE WITH THE DOCUMENTATION REQUIREMENTS OF THE 2016 ENERGY EFFICIENCY STANDARDS IS NECESSARY FOR THIS PROJECT. REGISTERED, SIGNED, AND DATED COPIES OF THE APPROPRIATE CF 1R, CF2R, AND CF3R FORMS SHALL BE MADE AVAILABLE FOR THE BUILDING OWNER.
- ALL STRUCTURES SHALL BE PROVIDED WITH A CLASS "A" ROOF COVERING TO THE SATISFACTION OF THE ENCINITAS FIRE DEPARTMENT

DEFERRED SUBMITTAL

-FIRE SPRINKLER SYSTEM, FIRE ALARM SYSTEM, POOL

FIRE ALARM SYSTEM

EXISTING AUTOMATIC FIRE ALARM SYSTEM SHALL REMAIN AND BE VERIFIED FOR COMPLIANCE FIRE CODE AND WITH SECTION 901 OF CBC. AS PER N.F.P.A.72. THE MOST CURRENT EDITION SHALL BE USED & THE ENCINITAS FIRE DEPT. POLICIES. FIRE. ANY NEW FIRE ALARM INSTALLATION MUST BE BY A C10 LICENSED ALARM CONTRACTOR. CALIFORNIA FIRE CODE AND ENCINITAS FIRE DEPARTMENT REQUIREMENTS

AUTOMATIC FIRE SPRINKLER SYSTEM

EXISTING AUTOMATIC FIRE SPRINKLER SYSTEM SHALL BE VERIFIED FOR THE COMPLIANCE WITH SECTION 901 OF THE CBC. AS PER N.F.P.A. 13R. THE MOST CURRENT EDITION SHALL BE USED & THE ENCINITAS FIRE DEPT. POLICIES. SPRINKLER PLANS SHALL BE SUBMITTED TO THE PREVENTION BUREAU & APPROVED FOR COMPLIANCE IF MORE THAN 10 SPRINKLER HEADS ARE MOVED. ANY NEW SPRINKLER HEADS INSTALLATION MUST BE BY A C16 LICENSED SPRINKLER CONTRACTOR. STRUCTURES SHALL BE PROTECTED BY AN AUTOMATIC FIRE SPRINKLER SYSTEM DESIGN AND INSTALLED TO THE SATISFACTION OF THE FIRE DEPARTMENT. A CLASS I OR CLASS II COMBINED WET STANDPIPE SYSTEM IS REQUIRED. STANDPIPE SYSTEM SHALL BE DESIGNED AND INSTALLED TO THE SATISFACTION OF THE FIRE DEPARTMENT. EXISTING STANDPIPE SHALL BE VERIFIED TO MEET STANDARDS.

PROJECT TEAM

- OWNER**
DM LA COSTA, LLC
P.O. BOX 232370
ENCINITAS, CA. 92023
658.228.7116
chris@dasmod.com
- DESIGNER/ ARCHITECT**
THE BROWN STUDIO, INC.
1144 N. COAST HWY. 101
ENCINITAS, CA. 92024
619.577.4610
lindsay@thebrownstudio.com
- CIVIL ENGINEER**
PASCO LEURED SUITER & ASSOCIATES
BRIAN ARDOLINO, PE, QSD
535 N HIGHWAY 101 STE A
SOLANA BEACH, CA 92075
858.259.8212 EXT 111
bardolino@plsaengineering.com
- LANDSCAPE ARCHITECT**
DESIGN WORKSHOP
XIAOJIAN FAN
527 W. 7TH STREET, SUITE 508
LOS ANGELES, CA 90014
213.426.1763
xfan@designworkshop.com
- SOILS ENGINEER**
ENGINEERING DESIGN GROUP
ERIN RIST
2121 MONTIEL ROAD
SAN MARCOS, CA 92069
760.839.7302
erin@designgroupca.com
- ACOUSTICAL CONSULTANT**
EILAR ASSOCIATES, INC.
JONATHAN BROTHERS
210 SOUTH JUNIPER STREET, SUITE 100
ESCONDIDO, CA 92025
760.738.5570 EXT 101
jbrothers@eilarassociates.com
- ARCHIOLOGICAL CONSULTANT**
ECORP CONSULTING, INC.
Lisa Westwood, RPA
2525 WARREN DRIVE
ROCKLIN, CA 95677
916.782.9100
lwestwood@ecorpconsulting.com
- TRAFFIC ENGINEER**
MIZUTA TRAFFIC CONSULTING, INC.
MARK MIZUTA
5694 MISSION CENTER ROAD, #602-121
SAN DIEGO, CA 92108
858.752.8212
mizutatraficconsulting@gmail.com
- ENVIRONMENTAL CONSULTANT**
LEIGHTON GROUP
BRYAN E. VOSS PG
3934 MURPHY CANYON ROAD, SUITE B205
SAN DIEGO, CA 92123
858.300.8497
bvoss@leightongroup.com
- GREENHOUSE GAS CONSULTANT**
EILAR ASSOCIATES, INC.
MELISSA COUNTS
210 SOUTH JUNIPER STREET, SUITE 100
ESCONDIDO, CA 92025
760.738.5570
mcounts@eilarassociates.com

PROJECT NO. -
DRAWN BY: THE BROWN
CHECKED BY: ENCINITAS
DATE: 02/04/2021

REVISIONS:
1 03/16/2020 CDP-SUB 2

THE BROWN STUDIO INC
1144 N. COAST HWY 101
ENCINITAS, CA 92024
619.577.4610 lindsay@thebrownstudio.com

516 LA COSTA

Case No. 18-188 DR/MUP/CDP

PROJECT NO.
DRAWINGS PREPARED BY:
LINDSAY BROWN

SHEET TITLE
CDP TITLE SHEET

SHEET NUMBER

A0.00

THESE DRAWINGS, ASSOCIATED SPECIFICATIONS, RELATED PROJECT DOCUMENTS, AND OTHER INSTRUMENTS OF SERVICE ARE THE PROPERTY OF THE DESIGNER AND CONSULTANTS-OF-RECORD; THEY SHALL NEITHER BE EXECUTED NOR USED FOR ANY OTHER WORK EXCEPT BY SPECIFIC AGREEMENT WITH THE DESIGNER. (C) 2019 THE BROWN STUDIO INC.

PROJECT NO. -
 DRAWN BY: Designer
 CHECKED BY: Checker
 DATE: 02/04/2021
 REVISIONS:
 2 07/XX/2020 CDP-SUB 3

THE BROWN STUDIO INC.
 114 N. COAST HWY 101
 ENCINITAS, CA 92024
 619.577.4610 lindsay@thebrownstudio.com

516 LA COSTA

Case No. 18-188 DR/MUP/CDP

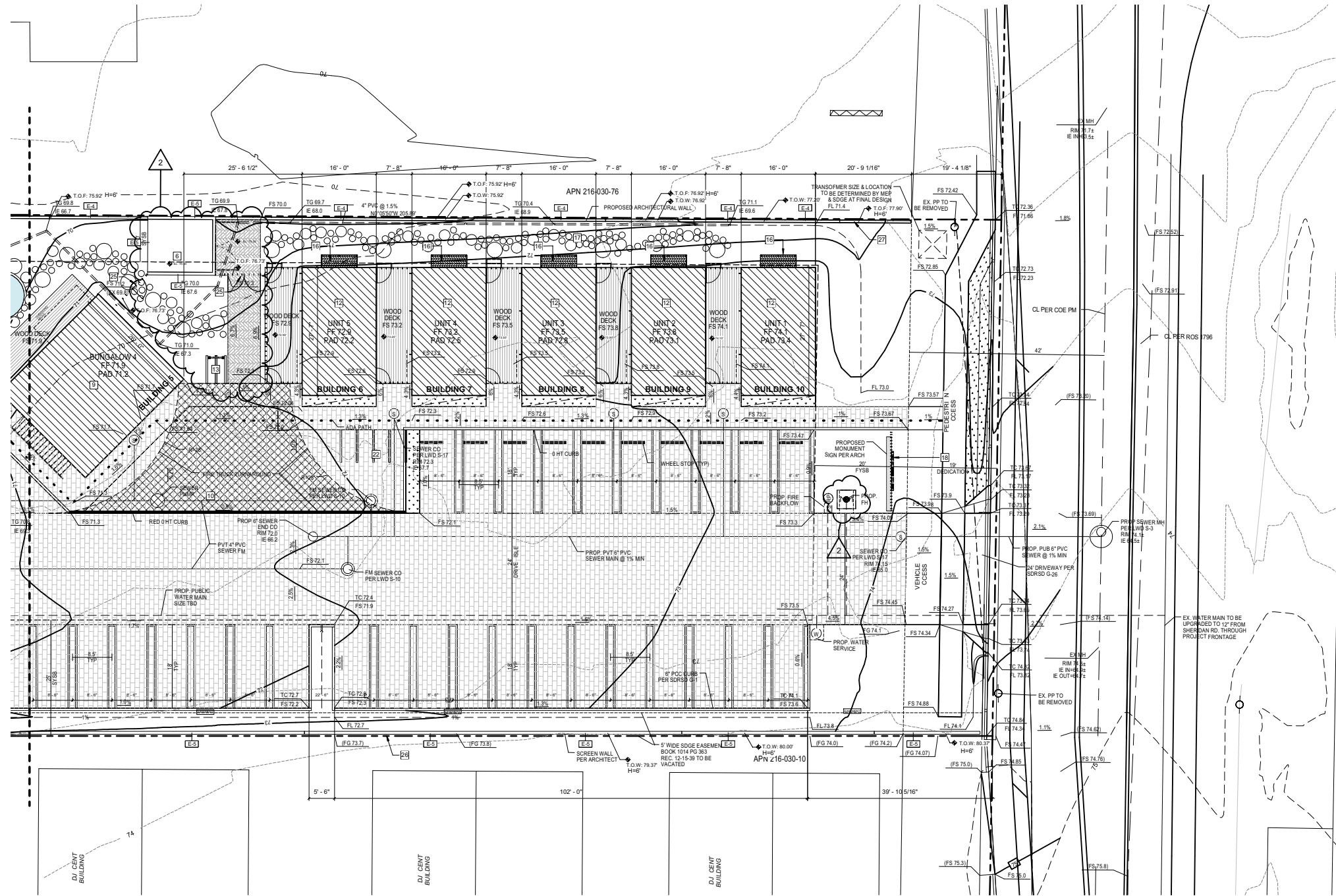

1 PROPOSED SITE PLAN

1" = 10'-0"



KEYNOTES

- 1 BMP
- 2 SOUND WALL
- 3 LOADING SPACE
- 4 OUTDOOR LOUNGE
- 5 WALKING PATH
- 6 TRASH ENCLOSURE
- 7 ADA RAMP
- 8 LOUNGE SEATING AREA
- 9 QUONSET HUT (3 UNITS)
- 10 FIRE TRUCK TURNAROUND
- 11 SPA
- 12 BUNGALOW UNITS
- 13 BICYCLE PARKING
- 14 HOTEL PLUNGE POOL
- 15 6' FENCE
- 16 SCREENED MECHANICAL EQUIPMENT
- 17 STEPSTONE WALKWAY
- 18 MONUMENT SIGN
- 19 MOTOR COURT
- 20 OUTDOOR DINING
- 21 UNDERGROUND SPA EQUIPMENT
- 22 MOTORCYCLE PARKING
- 23 SCREENED MECHANICAL EQUIPMENT UNDER STAIRS
- 24 RAISED PLANTER
- 25 GATE AT FENCE (KEY ACCESS)
- 26 CMU FENCE
- 27 WOOD FENCE 6"

NOTES

MONUMENT SIGN.
 PER EMC 30.60.C.2
ALLOWANCE: 1 SF/LF LOT FRONTAGE
LOT FRONTAGE = 111'-9" LF = 111.75' LF
MAX. ALLOWANCE: 111.75' / 1 = 111.75 SF

PROPOSED: 111 SF SEE SHEET A10.4

MATERIAL LEGEND

- E-1 EXTERIOR METAL WALL/ROOF CLADDING
- E-2 CONCRETE CLADDING
- E-3 EXTERIOR METAL WALL PANEL/BREAK METAL PAINTED BLACK
- E-4 NATURAL WOOD ELEMENTS, STAINED; ANTIQUE OAK
- E-5 EXPOSED CMU, STRAIGHT STACK
- E-6 CONCRETE RETAINING WALL
- E-7 STEEL FACIA/STRINGER, PAINTED BLACK
- FL-1 CONCRETE PERVIOUS PAVERS
- FL-3 EXTERIOR WOOD FLOORING

BUILDING AREAS

NAME	ID	AREA	LEVEL	LOT COVERAGE	FAR
BUILDING 1 - RESTAURANT					
LOBBY	2	184 SF	LEVEL 1	•	•
RESTAURANT	3	890 SF	LEVEL 1	•	•
BAR	4	191 SF	LEVEL 1	•	•
KITCHEN B.O.H	5	451 SF	LEVEL 1	•	•
RESTROOM-WOMENS	7	43 SF	LEVEL 1	•	•
RESTROOM-MEN	8	50 SF	LEVEL 1	•	•
HOTEL OFFICE	9	269 SF	LEVEL 2	•	•
HOTEL OFFICE MEZZANINE	10	179 SF	LEVEL 2	•	•
HOTEL SERVICE	11	159 SF	LEVEL 2	•	•
CIRCULATION-INTERIOR	15	100 SF	LEVEL 1	•	•
		2,517 SF			
BUILDING 2					
UNIT B	UNIT 15	360 SF	LEVEL 1	•	•
UNIT B	UNIT 16	360 SF	LEVEL 1	•	•
UNIT A	UNIT 17	720 SF	LEVEL 2	•	•
		1,440 SF			
BUILDING 3					
UNIT B	UNIT 12	360 SF	LEVEL 1	•	•
UNIT B	UNIT 13	360 SF	LEVEL 1	•	•
UNIT A	UNIT 14	720 SF	LEVEL 2	•	•
		1,440 SF			
BUILDING 4					
UNIT B	UNIT 9	360 SF	LEVEL 1	•	•
UNIT B	UNIT 10	360 SF	LEVEL 1	•	•
UNIT A	UNIT 11	720 SF	LEVEL 2	•	•
		1,440 SF			

NAME	ID	AREA	LEVEL	LOT COVERAGE	FAR
BUILDING 5					
UNIT B	UNIT 6	360 SF	LEVEL 1	•	•
UNIT B	UNIT 7	360 SF	LEVEL 1	•	•
UNIT A	UNIT 8	720 SF	LEVEL 2	•	•
		1,440 SF			
BUILDING 6					
UNIT C	UNIT 5	436 SF	LEVEL 1	•	•
UNIT C	UNIT 5	206 SF	LEVEL 2	•	•
		642 SF			
BUILDING 7					
UNIT C	UNIT 4	436 SF	LEVEL 1	•	•
UNIT C	UNIT 4	206 SF	LEVEL 2	•	•
		642 SF			
BUILDING 8					
UNIT C	UNIT 3	436 SF	LEVEL 1	•	•
UNIT C	UNIT 3	206 SF	LEVEL 2	•	•
		642 SF			
BUILDING 9					
UNIT C	UNIT 2	436 SF	LEVEL 1	•	•
UNIT C	UNIT 2	206 SF	LEVEL 2	•	•
		642 SF			
BUILDING 10					
UNIT C	UNIT 1	436 SF	LEVEL 1	•	•
UNIT C	UNIT 1	206 SF	LEVEL 2	•	•
		642 SF			
		6,970 SF			12,436 SF

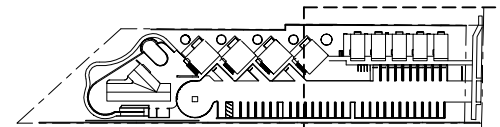

KEY PLAN

1" = 80'-0"

PROJECT NO.
 DRAWINGS PREPARED BY:
 LINDSAY BROWN

SHEET TITLE
 PROPOSED SITE PLAN

SHEET NUMBER

A0.03a

PROJECT NO. _____
 DRAWN BY: Designer
 CHECKED BY: Checker
 DATE: 02/04/2021

REVISIONS:
 1 03/16/2020 CDP-SUB 2
 2 07/XX/2020 CDP-SUB 3

THE BROWN STUDIO INC.
 114 N. C. S. G. I. H. W. Y. 101
 ENCINITAS, CA 92024
 619.577.4610 lindsay@thebrownstudio.com

516 LA COSTA

Case No. 18-188 DR/MUP/CDP

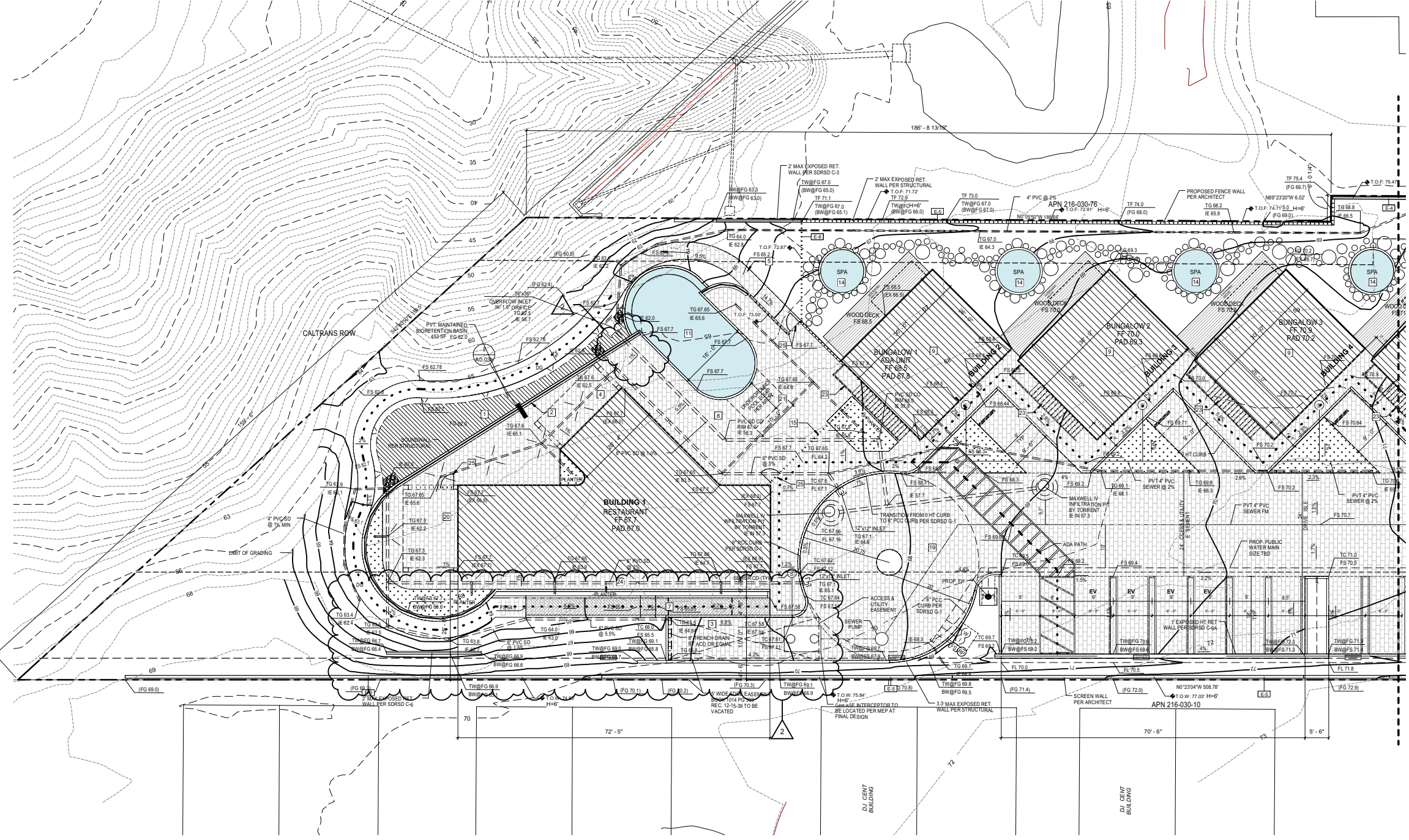

1 PROPOSED SITE PLAN
 1" = 10'-0"

KEYNOTES

- 1 BMP
- 2 SOUND WALL
- 3 LOADING SPACE
- 4 OUTDOOR LOUNGE
- 5 WALKING PATH
- 6 TRASH ENCLOSURE
- 7 ADA RAMP
- 8 LOUNGE SEATING AREA
- 9 QUONSET HUT (3 UNITS)
- 10 FIRE TRUCK TURNAROUND
- 11 SPA
- 12 BUNGALOW UNITS
- 13 BICYCLE PARKING
- 14 HOTEL PLUNGE POOL
- 15 6" FENCE
- 16 SCREENED MECHANICAL EQUIPMENT
- 17 STEPSTONE WALKWAY
- 18 MONUMENT SIGN
- 19 MOTOR COURT
- 20 OUTDOOR DINING
- 21 UNDERGROUND SPA EQUIPMENT
- 22 MOTORCYCLE PARKING
- 23 SCREENED MECHANICAL EQUIPMENT UNDER STAIRS
- 24 RAISED PLANTER
- 25 GATE AT FENCE (KEY ACCESS)
- 26 CMU FENCE
- 27 WOOD FENCE 6"

NOTES

MONUMENT SIGN.
 PER EMC 30.60.C.2

ALLOWANCE: 1 SF/1' LOT FRONTAGE
LOT FRONTAGE = 111'-9" LF = 111.75' LF
MAX. ALLOWANCE: 111.75' / 1 = 111.75 SF

PROPOSED: 111 SF SEE SHEET A10.4

MATERIAL LEGEND

E-1 EXTERIOR METAL WALL/ROOF CLADDING
 E-2 CONCRETE CLADDING
 E-3 EXTERIOR METAL WALL PANEL/BREAK METAL PAINTED BLACK
 E-4 NATURAL WOOD ELEMENTS, STAINED; ANTIQUE OAK
 E-5 EXPOSED CMU, STRAIGHT STACK
 E-6 CONCRETE RETAINING WALL
 E-7 STEEL FACIA/STRINGER, PAINTED BLACK
 FL-1 CONCRETE PERVIOUS PAVERS
 FL-3 EXTERIOR WOOD FLOORING

BUILDING AREAS

NAME	ID	AREA	LEVEL	LOT COVERAGE	FAR
BUILDING 1 - RESTAURANT					
LOBBY	2	184 SF	LEVEL 1	•	•
RESTAURANT	3	890 SF	LEVEL 1	•	•
BAR	4	191 SF	LEVEL 1	•	•
KITCHEN B.O.H	5	451 SF	LEVEL 1	•	•
RESTROOM-WOMENS	7	43 SF	LEVEL 1	•	•
RESTROOM-MEN	8	50 SF	LEVEL 1	•	•
HOTEL OFFICE	9	269 SF	LEVEL 2	•	•
HOTEL OFFICE MEZZANINE	10	179 SF	LEVEL 2	•	•
HOTEL SERVICE	11	159 SF	LEVEL 2	•	•
CIRCULATION-INTERIOR	15	100 SF	LEVEL 1	•	•
		2,517 SF			
BUILDING 2					
UNIT B	UNIT 15	360 SF	LEVEL 1	•	•
UNIT B	UNIT 16	360 SF	LEVEL 1	•	•
UNIT A	UNIT 17	720 SF	LEVEL 2	•	•
		1,440 SF			
BUILDING 3					
UNIT B	UNIT 12	360 SF	LEVEL 1	•	•
UNIT B	UNIT 13	360 SF	LEVEL 1	•	•
UNIT A	UNIT 14	720 SF	LEVEL 2	•	•
		1,440 SF			
BUILDING 4					
UNIT B	UNIT 9	360 SF	LEVEL 1	•	•
UNIT B	UNIT 10	360 SF	LEVEL 1	•	•
UNIT A	UNIT 11	720 SF	LEVEL 2	•	•
		1,440 SF			

BUILDING AREAS

NAME	ID	AREA	LEVEL	LOT COVERAGE	FAR
BUILDING 5					
UNIT B	UNIT 6	360 SF	LEVEL 1	•	•
UNIT B	UNIT 7	360 SF	LEVEL 1	•	•
UNIT A	UNIT 8	720 SF	LEVEL 2	•	•
		1,440 SF			
BUILDING 6					
UNIT C	UNIT 5	436 SF	LEVEL 1	•	•
UNIT C	UNIT 5	206 SF	LEVEL 2	•	•
		642 SF			
BUILDING 7					
UNIT C	UNIT 4	436 SF	LEVEL 1	•	•
UNIT C	UNIT 4	206 SF	LEVEL 2	•	•
		642 SF			
BUILDING 8					
UNIT C	UNIT 3	436 SF	LEVEL 1	•	•
UNIT C	UNIT 3	206 SF	LEVEL 2	•	•
		642 SF			
BUILDING 9					
UNIT C	UNIT 2	436 SF	LEVEL 1	•	•
UNIT C	UNIT 2	206 SF	LEVEL 2	•	•
		642 SF			
BUILDING 10					
UNIT C	UNIT 1	436 SF	LEVEL 1	•	•
UNIT C	UNIT 1	206 SF	LEVEL 2	•	•
		642 SF			
		6,970 SF		12,436 SF	

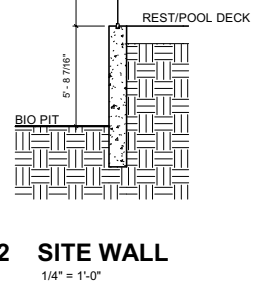

2 SITE WALL
 1/4" = 1'-0"

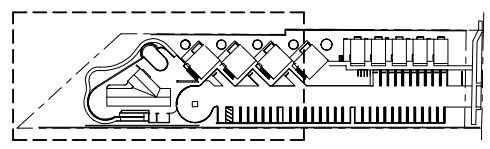

KEY PLAN
 1" = 80'-0"

PROJECT NO. _____
 DRAWINGS PREPARED BY:
 LINDSAY BROWN

SHEET TITLE
 PROPOSED SITE PLAN

SHEET NUMBER

A0.03b

THESE DRAWINGS, ASSOCIATED SPECIFICATIONS, RELATED PROJECT DOCUMENTS, AND OTHER INSTRUMENTS OF SERVICE ARE THE PROPERTY OF THE DESIGNER AND CONSULTANTS AND RECORD. THEY SHALL NEITHER BE EXECUTED NOR USED FOR ANY OTHER WORK EXCEPT BY SPECIFIC AGREEMENT WITH THE DESIGNER. (C) 2019 THE BROWN STUDIO INC.

PROJECT NO. -
 DRAWN BY: Designer
 CHECKED BY: Checker
 DATE: 02/04/2021
 REVISIONS:

THE BROWN STUDIO INC
 144 N. COGUE HWY 101
 ENCINITAS CA 92024
 619.577.4610 lindsay@thebrownstudio.com

516 LA COSTA

Case No. 18-188 DR/MUP/CDP

PROJECT NO. -
 DRAWINGS PREPARED BY:
 LINDSAY BROWN

SHEET TITLE
 TRASH ENCLOSURE DETAILS

SHEET NUMBER

A0.04

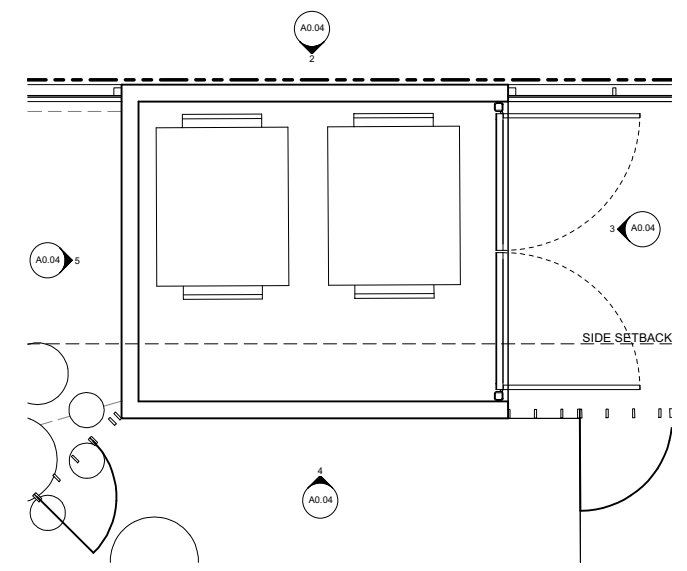

1 ENLARGED TRASH ENCLOSURE
 3/8" = 1'-0"

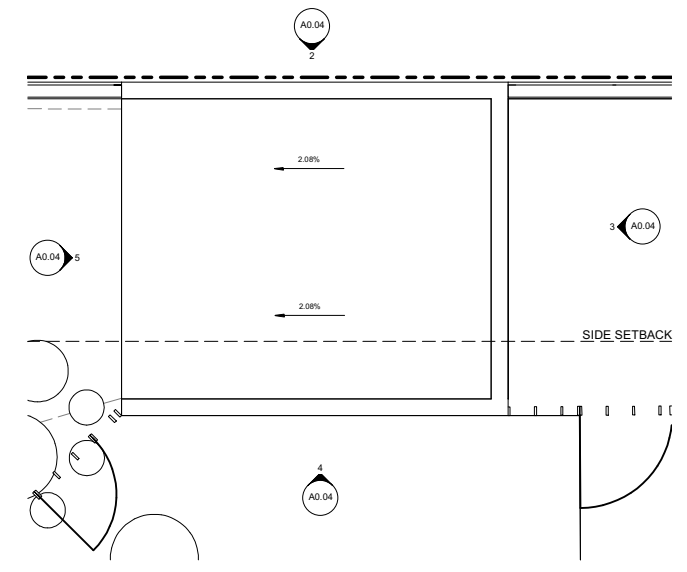

S ENLARGED TRASH ENCLOSURE - ROOF PLAN
 3/8" = 1'-0"

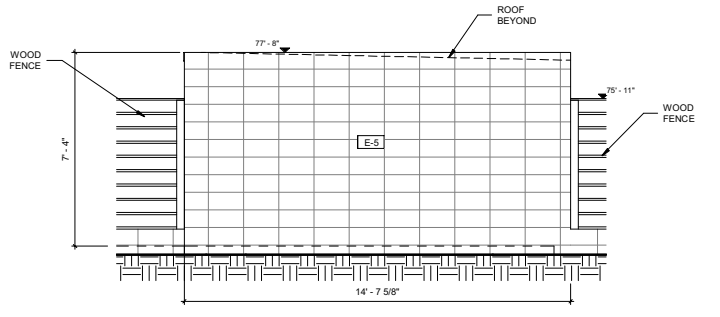

2 ELEVATION - EAST
 3/8" = 1'-0"

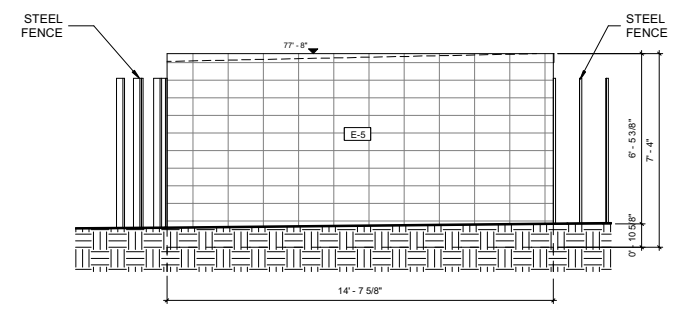

4 ELEVATION - WEST
 3/8" = 1'-0"

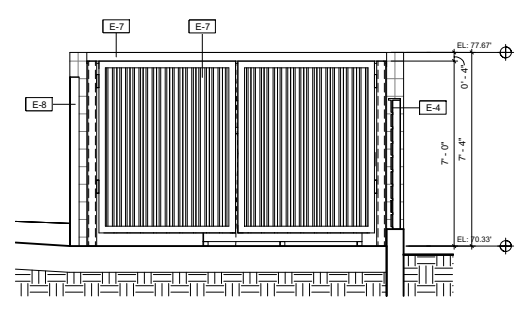

3 ELEVATION - SOUTH
 3/8" = 1'-0"

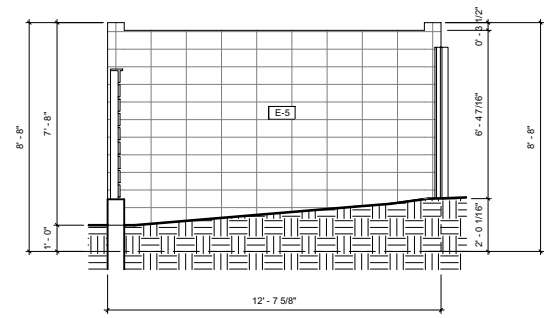

5 ELEVATION NORTH
 3/8" = 1'-0"

MATERIAL LEGEND

- E-1 EXTERIOR METAL WALL/ROOF CLADDING
- E-2 CONCRETE CLADDING
- E-3 EXTERIOR METAL WALL PANEL/BREAK METAL, PAINTED BLACK
- E-4 NATURAL WOOD ELEMENTS, STAINED: ANTIQUE OAK
- E-5 EXPOSED CMU, STRAIGHT STACK
- E-6 CONCRETE RETAINING WALL
- E-7 STEEL FACIA/STRINGER, PAINTED BLACK
- FL-1 CONCRETE PERVIOUS PAVERS
- FL-3 EXTERIOR WOOD FLOORING

KEY PLAN

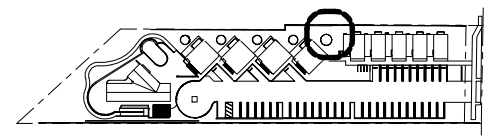

THESE DRAWINGS, ASSOCIATED SPECIFICATIONS, RELATED PROJECT DOCUMENTS, AND OTHER INSTRUMENTS OF SERVICE ARE THE PROPERTY OF THE DESIGNER AND CONSULTANTS-OF-RECORD; THEY SHALL NEITHER BE EXECUTED NOR USED FOR ANY OTHER WORK EXCEPT BY SPECIFIC AGREEMENT WITH THE DESIGNER. (C) 2019 THE BROWN STUDIO INC.

PROJECT NO. -
 DRAWN BY: Designer
 CHECKED BY: Checker
 DATE: 02/04/2021
 REVISIONS:
 2 07/XX/2020 CDP-SUB 3

THE BROWN STUDIO INC.
 144 N. Coast Highway 101
 Encinitas, CA 92024
 619.577.4610 lindsay@thebrownstudio.com

516 LA COSTA

Case No. 18-188 DR/MUP/CDP

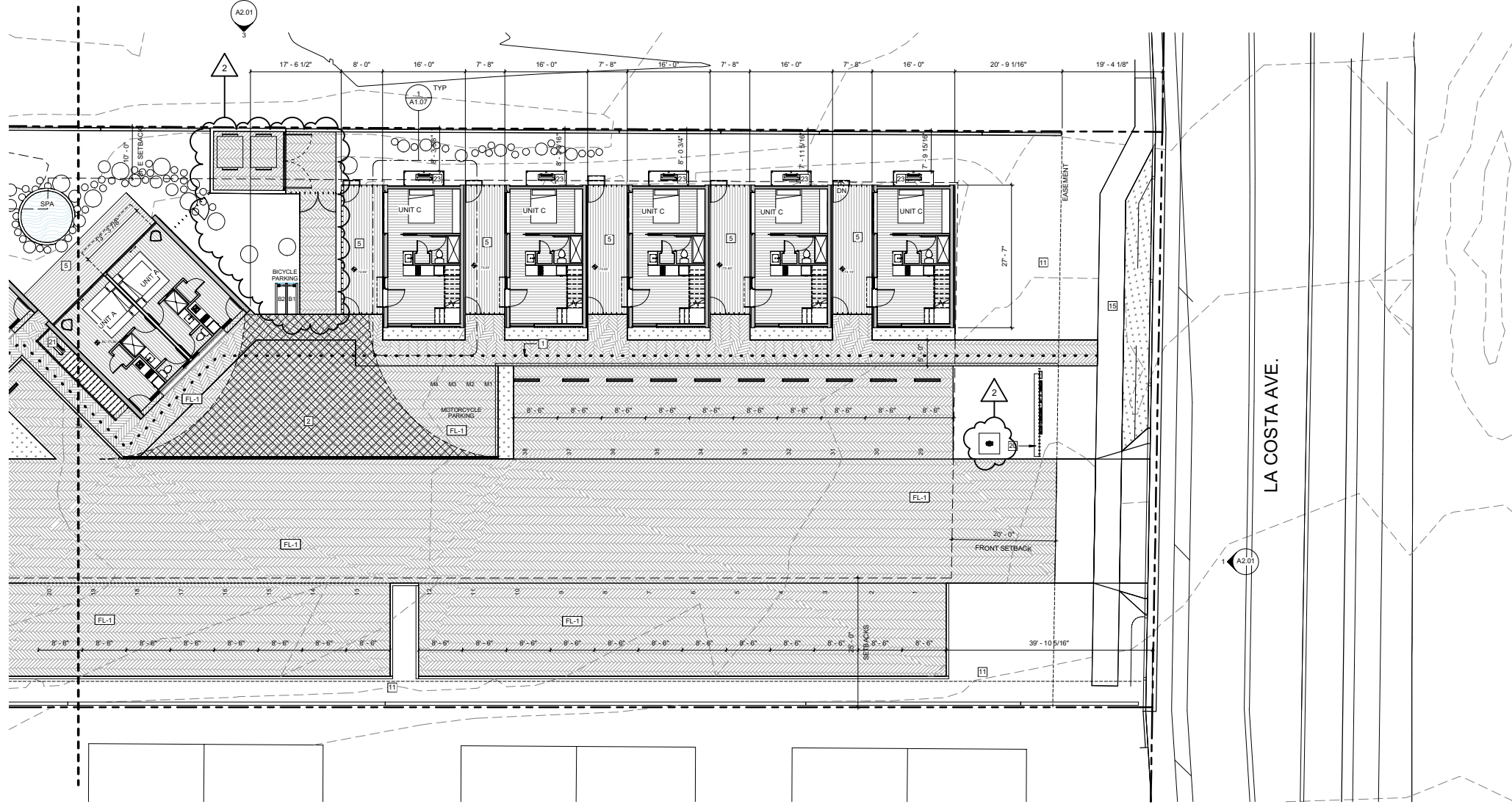

3 LEVEL 1 - FLOOR PLAN 
 1" = 10'-0"

KEYNOTES

- 1 ADA PATH OF TRAVEL
- 2 FIRE TRUCK TURNAROUND AREA
- 4 ADA RAMP
- 5 RAISED DECK
- 8 DRIVEWAY TURNAROUND
- 11 LANDSCAPE AREA
- 14 SPA DECK LOUNGE
- 15 STREET IMPROVEMENTS PER CITY OF ENCINITAS
- 16 PEDESTRIAN WALKWAY
- 17 COVERED OUTDOOR DINING AREA
- 20 MONUMENT SIGN
- 21 MECHANICAL EQUIPMENT UNDER STAIRS
- 23 MECHANICAL EQUIPMENT (SCREENED)

NOTES

PROJECT NO. -
 DRAWINGS PREPARED BY:
 LINDSAY BROWN

SHEET TITLE
 FLOOR PLAN - LEVEL 1

SHEET NUMBER

A1.01a

THESE DRAWINGS, ASSOCIATED SPECIFICATIONS, RELATED PROJECT DOCUMENTS, AND OTHER INSTRUMENTS OF SERVICE ARE THE PROPERTY OF THE DESIGNER AND CONSULTANTS-OF-RECORD. THEY SHALL NEITHER BE EXECUTED NOR USED FOR ANY OTHER WORK EXCEPT BY SPECIFIC AGREEMENT WITH THE DESIGNER. (C) 2019 THE BROWN STUDIO INC.

PROJECT NO. -
 DRAWN BY: Designer
 CHECKED BY: Checker
 DATE: 02/04/2021
 REVISIONS:
 2 07/XX/2020 CDP-SUB 3

THE BROWN STUDIO INC
 114 N Coast Hwy 101
 Encinitas CA 92024
 619.577.4610 lindsay@thebrownstudio.com

516 LA COSTA

Case No. 18-188 DR/MUP/CDP

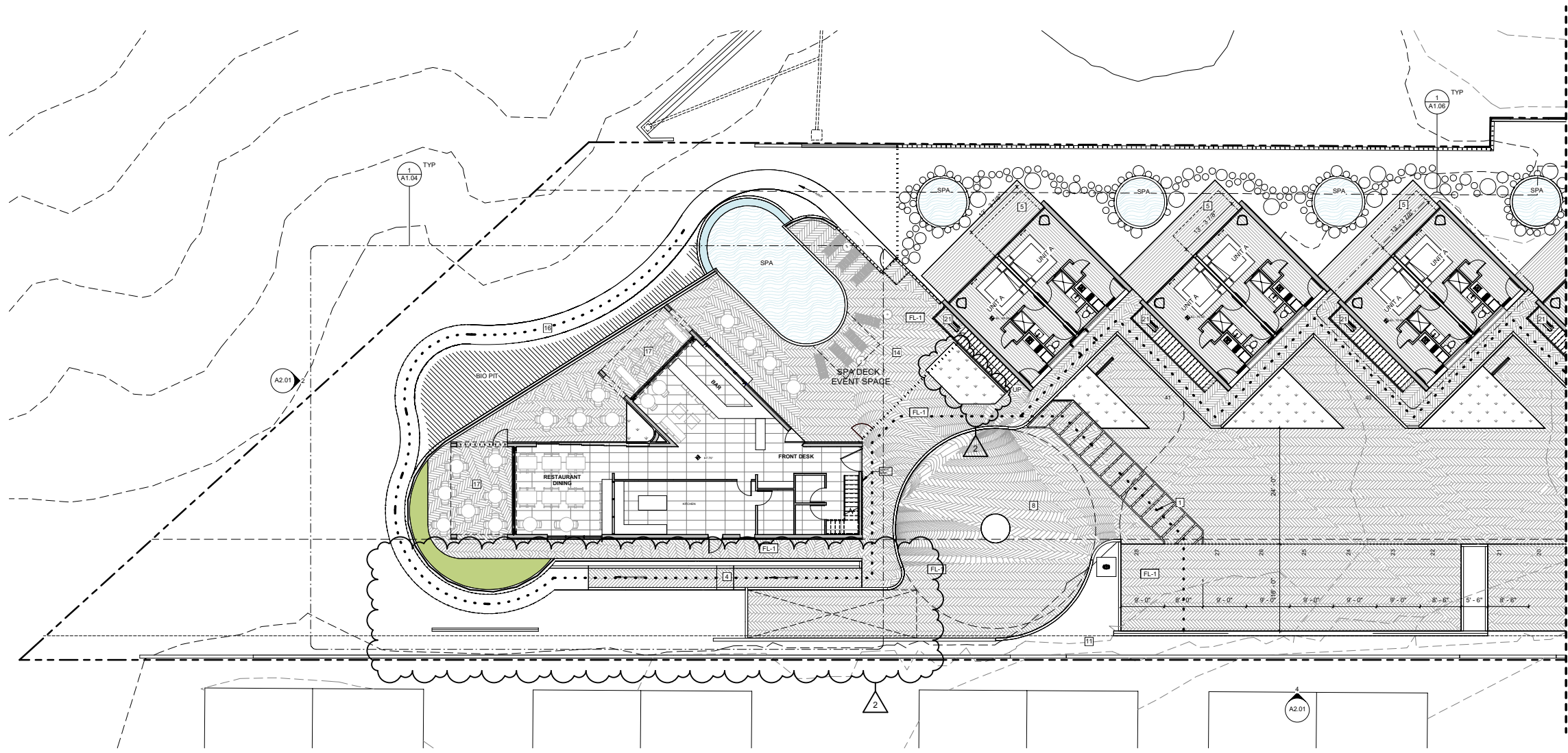

1 LEVEL 1 - FLOOR PLAN 
 1" = 10'-0"

KEYNOTES

- 1 ADA PATH OF TRAVEL
- 2 FIRE TRUCK TURNAROUND AREA
- 4 ADA RAMP
- 5 RAISED DECK
- 8 DRIVEWAY TURNAROUND
- 11 LANDSCAPE AREA
- 14 SPA DECK LOUNGE
- 15 STREET IMPROVEMENTS PER CITY OF ENCINITAS
- 16 PEDESTRIAN WALKWAY
- 17 COVERED OUTDOOR DINING AREA
- 20 MONUMENT SIGN
- 21 MECHANICAL EQUIPMENT UNDER STAIRS
- 23 MECHANICAL EQUIPMENT (SCREENED)

NOTES

PROJECT NO. -
 DRAWINGS PREPARED BY:
 LINDSAY BROWN

SHEET TITLE
 FLOOR PLAN - LEVEL 1

SHEET NUMBER

A1.01b

THESE DRAWINGS, ASSOCIATED SPECIFICATIONS, RELATED PROJECT DOCUMENTS, AND OTHER INSTRUMENTS OF SERVICE ARE THE PROPERTY OF THE DESIGNER AND CONSULTANTS-OF-RECORD; THEY SHALL NEITHER BE EXECUTED NOR USED FOR ANY OTHER WORK EXCEPT BY SPECIFIC AGREEMENT WITH THE DESIGNER. (C) 2019 THE BROWN STUDIO INC.

PROJECT NO. -
 DRAWN BY: Designer
 CHECKED BY: Checker
 DATE: 02/04/2021
 REVISIONS:

THE BROWN STUDIO INC
 144 N. Coast Hwy 101
 Encinitas, CA 92024
 619.577.4610 lindsay@thebrownstudio.com

516 LA COSTA

Case No. 18-188 DR/MUP/CDP

PROJECT NO. -
 DRAWINGS PREPARED BY:
 LINDSAY BROWN

SHEET TITLE
 FLOOR PLAN - LEVEL 2

SHEET NUMBER

A1.02a

2/1/2021 12:35:02 AM

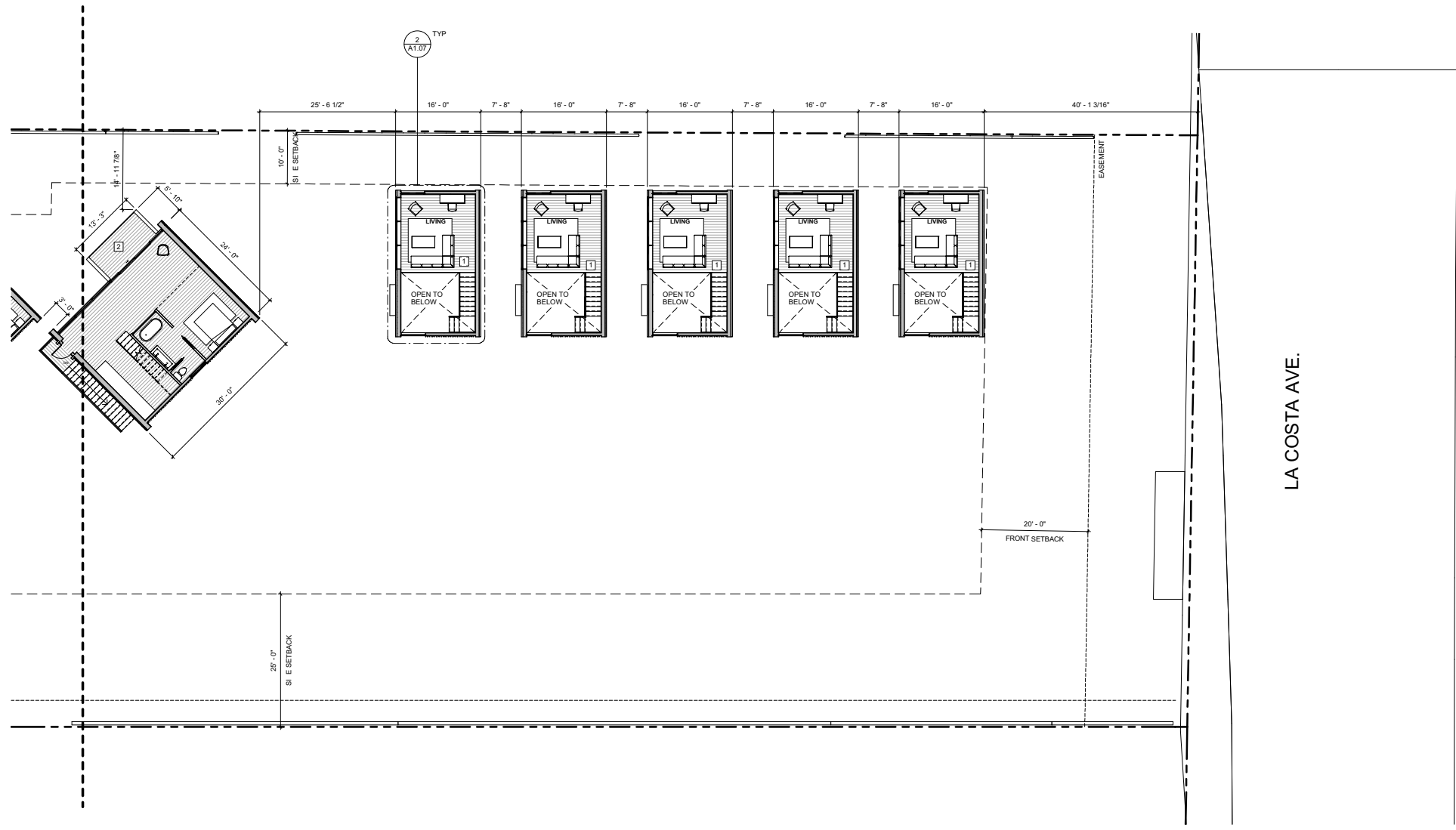

1 LEVEL 2 - FLOOR PLAN 
 1" = 10'-0"

KEYNOTES

- 1 UNIT C LOFT
- 2 BALCONY

NOTES

PROJECT NO. -
 DRAWN BY: Designer
 CHECKED BY: Checker
 DATE: 02/04/2021
 REVISIONS:

THE BROWN STUDIO INC.
 1144 N. COAST HWY 101
 ENCINITAS, CA 92024
 619.577.4610 lindsay@thebrownstudio.com

516 LA COSTA

Case No. 18-188 DR/MUP/CDP

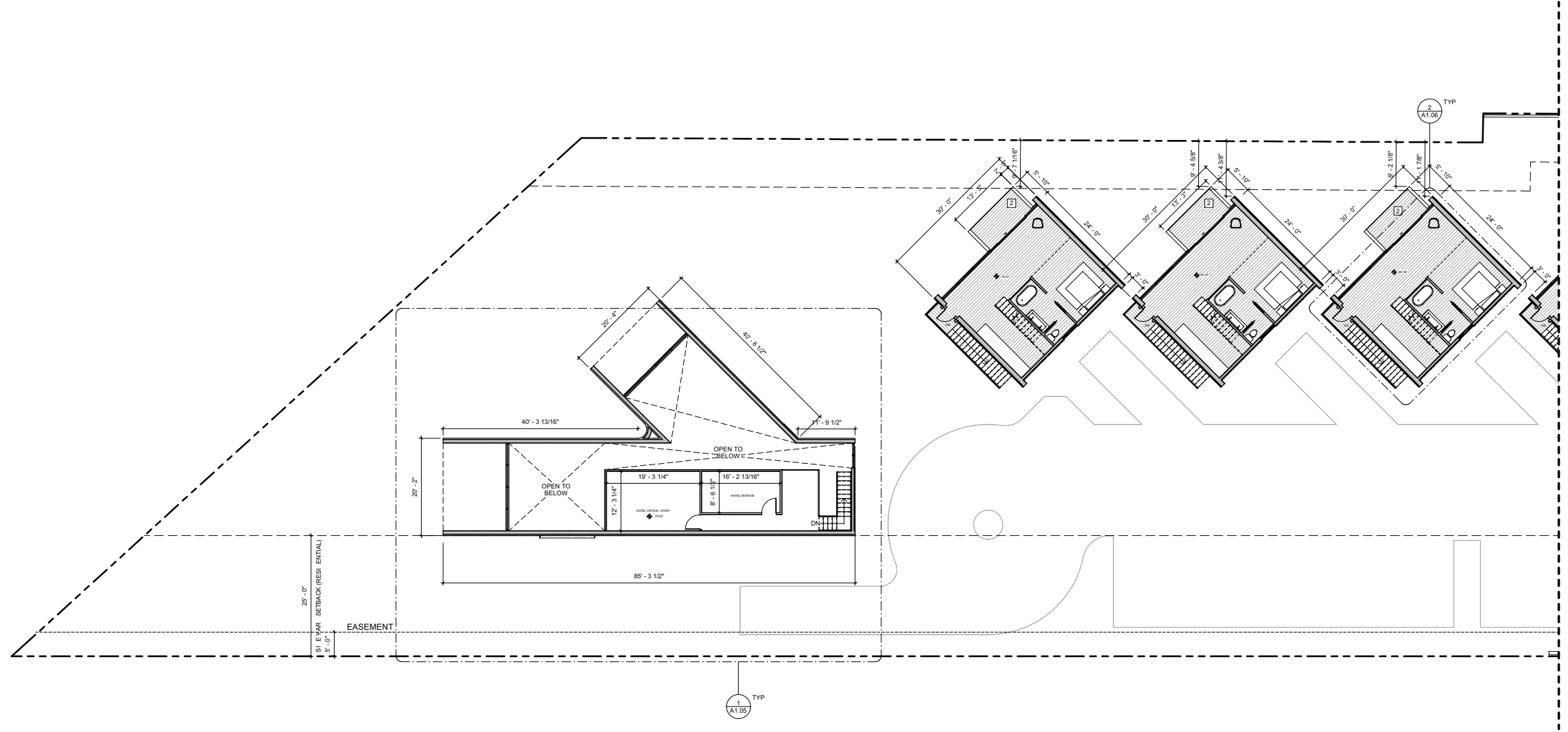

1 LEVEL 2 - FLOOR PLAN ⊕
 1" = 10'-0"

KEYNOTES

- 1 UNIT C LOFT
- 2 BALCONY

NOTES

PROJECT NO. -
 DRAWINGS PREPARED BY:
 LINDSAY BROWN

SHEET TITLE
 FLOOR PLAN - LEVEL 2

SHEET NUMBER

A1.02b

THESE DRAWINGS, ASSOCIATED SPECIFICATIONS, RELATED PROJECT DOCUMENTS, AND OTHER INSTRUMENTS OF SERVICE ARE THE PROPERTY OF THE DESIGNER AND CONSULTANTS-OF-RECORD; THEY SHALL NEITHER BE EXECUTED NOR USED FOR ANY OTHER WORK EXCEPT BY SPECIFIC AGREEMENT WITH THE DESIGNER. (C) 2019 THE BROWN STUDIO INC.

PROJECT NO. -
 DRAWN BY: Designer
 CHECKED BY: Checker
 DATE: 02/04/2021
 REVISIONS:

THE BROWN STUDIO INC.
 1144 N. COGILL HWY 101
 ENCINITAS, CA 92024
 619.577.4610 | info@thebrownstudio.com

516 LA COSTA

Case No. 18-188 DR/MUP/CDP

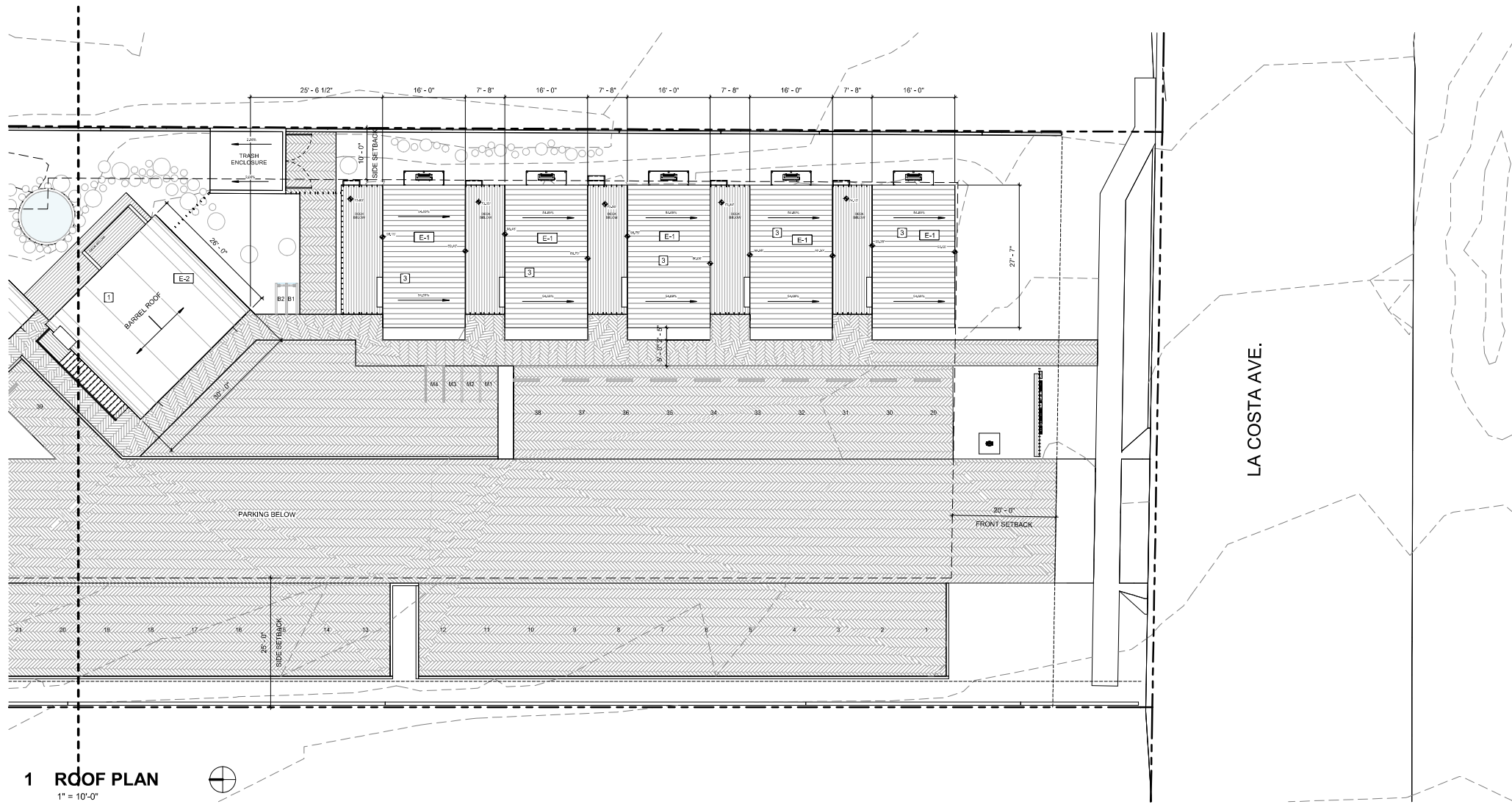

1 ROOF PLAN
 1" = 10'-0"

KEYNOTES

- 1 CONCRETE TILE BARREL ROOF
- 1 ROOF TYPE B: CONCRETE TILE BARREL ROOF
- 3 ROOF TYPE A: Fabral® Might-Rib® METAL ROOFING SYSTEM, (NON-REFLECTIVE) UL 790 CLASS A FIRE RESISTANCE RATING, UL 2218 CLASS 4 HAIL IMPACT RESISTANCE, UL 580 CLASS 90 UPLIFT TEST RATING, WITH GEORGIA-PACIFIC DENSGLASS FIREGUARD SHEATHING UNDERLAYMENT, ICC ESR-3087 OR SIMILAR; REFER TO STRUCTURAL FOR SHEATHING SIZE.
- 4 FUTURE AREA FOR SOLAR PANELS

DET.ROOF.A 1 1/2" = 1'-0"

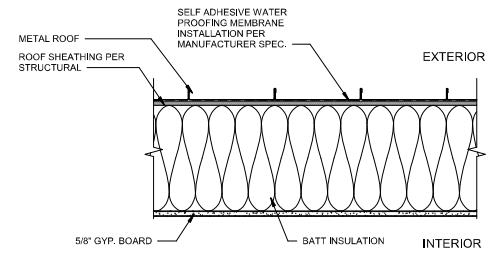

STANDING SEAM METAL ROOF
 MANUFACTURER : CUSTOM-BILT METALS
 PANELS : CB-150 OR SL-1750
 ASTM A 792
 DECK : MINIMUM 15/32" PLYWOOD
 UNDERLAYMENT : ONE LAYER OF TYPE II AND TWO LAYERS OF GAF VERSASHEILD
 FIRE RESISTANCE : ROOF DECK PROTECTION
 FIRE RESISTANCE RATING : ASTM E108 (UL 790) CLASS A

DET.ROOF.B 1 1/2" = 1'-0"

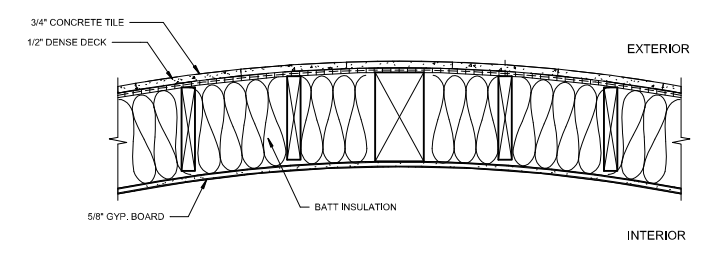

NOTES

PROJECT NO. -
 DRAWINGS PREPARED BY:
 LINDSAY BROWN

SHEET TITLE
 ROOF PLAN

SHEET NUMBER

A1.03a

THESE DRAWINGS, ASSOCIATED SPECIFICATIONS, RELATED PROJECT DOCUMENTS, AND OTHER INSTRUMENTS OF SERVICE ARE THE PROPERTY OF THE DESIGNER AND CONSULTANTS-OF-RECORD; THEY SHALL NEITHER BE EXECUTED NOR USED FOR ANY OTHER WORK EXCEPT BY SPECIFIC AGREEMENT WITH THE DESIGNER. (C) 2019 THE BROWN STUDIO INC.

PROJECT NO. -
 DRAWN BY: Designer
 CHECKED BY: Checker
 DATE: 02/04/2021
 REVISIONS:

THE BROWN STUDIO INC.
 1144 N. COAST HIGHWAY 101
 ENCINITAS, CA 92024
 619.577.4610 | Lindsay@thebrownstudio.com

516 LA COSTA

Case No. 18-188 DR/MUP/CDP

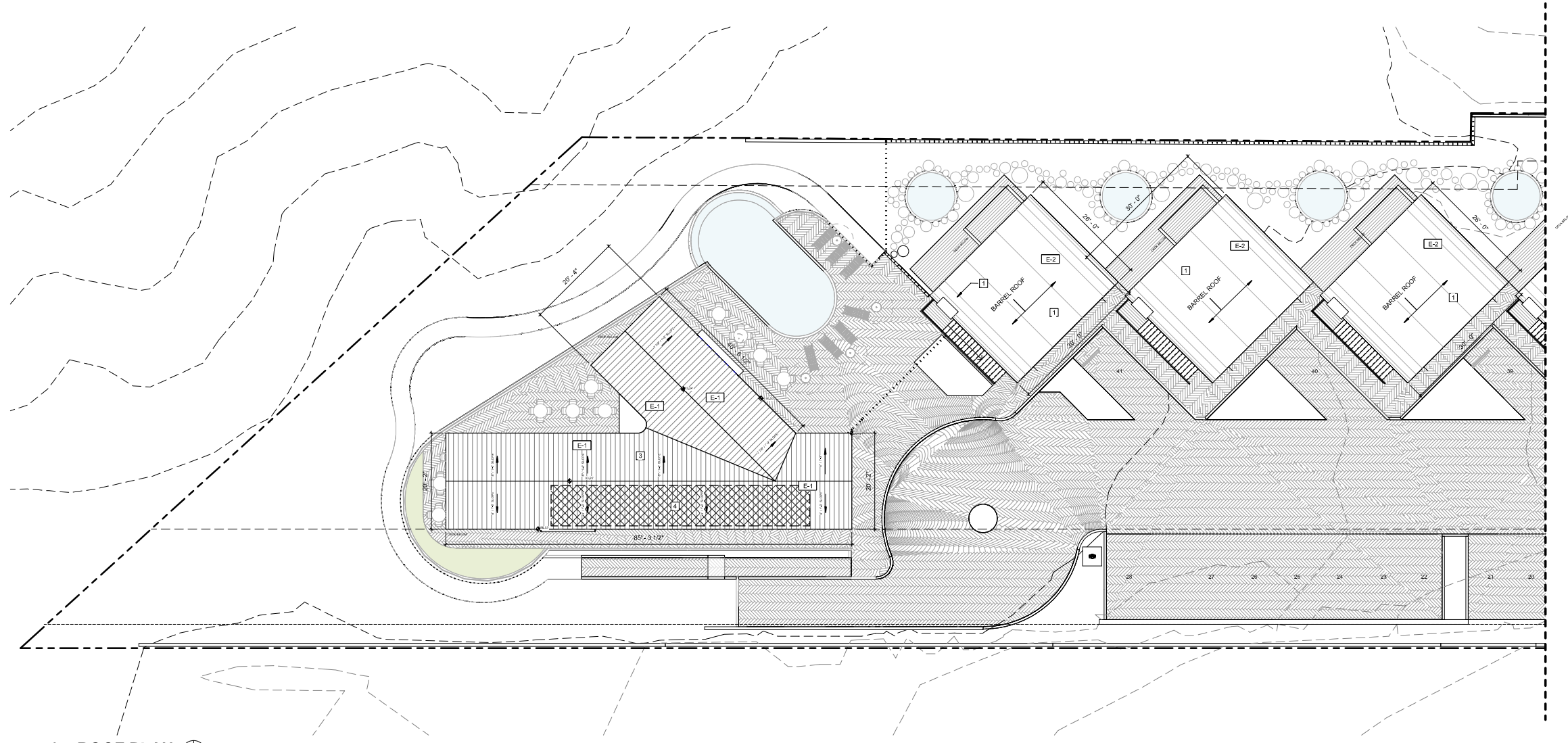

1 ROOF PLAN
 1" = 10'-0"

KEYNOTES

- 1 CONCRETE TILE BARREL ROOF
- 1 ROOF TYPE B: CONCRETE TILE BARREL ROOF
- 3 ROOF TYPE A: Fabra® Might-Rib® METAL ROOFING SYSTEM, (NON-REFLECTIVE) UL 790 CLASS A FIRE RESISTANCE RATING, UL 2218 CLASS 4 HAIL IMPACT RESISTANCE, UL 580 CLASS 90 UPLIFT TEST RATING, WITH GEORGIA-PACIFIC DENSGLOSS FIREGUARD SHEATHING UNDERLAYMENT, ICC ESR-3087 OR SIMILAR; REFER TO STRUCTURAL FOR SHEATHING SIZE.
- 4 FUTURE AREA FOR SOLAR PANELS

DET. ROOF.A
 1 1/2" = 1'-0"

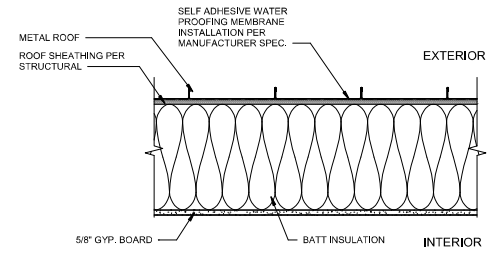

STANDING SEAM METAL ROOF
 MANUFACTURER : CUSTOM-BILT METALS
 PANELS : CB-150 OR SL-1750
 ASTM A 792
 DECK : MINIMUM 15/32" PLYWOOD
 UNDERLAYMENT : ONE LAYER OF TYPE II AND TWO LAYERS OF GAF VERSASHEILD
 FIRE RESISTANCE ROOF DECK PROTECTION
 FIRE RESISTANCE RATING : ASTM E108 (UL 790) CLASS A

DET. ROOF.B
 1 1/2" = 1'-0"

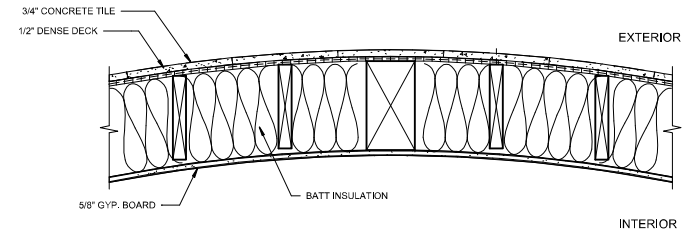

NOTES

PROJECT NO. -
 DRAWINGS PREPARED BY:
 LINDSAY BROWN

SHEET TITLE
 ROOF PLAN

SHEET NUMBER

A1.03b

THESE DRAWINGS, ASSOCIATED SPECIFICATIONS, RELATED PROJECT DOCUMENTS, AND OTHER INSTRUMENTS OF SERVICE ARE THE PROPERTY OF THE DESIGNER AND CONSULTANTS-OF-RECORD; THEY SHALL NEITHER BE EXECUTED NOR USED FOR ANY OTHER WORK EXCEPT BY SPECIFIC AGREEMENT WITH THE DESIGNER. (C) 2019 THE BROWN STUDIO INC.

PROJECT NO. -
 DRAWN BY: Designer
 CHECKED BY: Checker
 DATE: 02/04/2021
 REVISIONS:
 2 07/XX/2020 CDP-SUB 3

THE BROWN STUDIO INC.
 114 N. COGILL HWY 101
 ENCINITAS, CA 92024
 619.577.4610 | info@thebrownstudio.com

516 LA COSTA

Case No. 18-188 DR/MUP/CDP

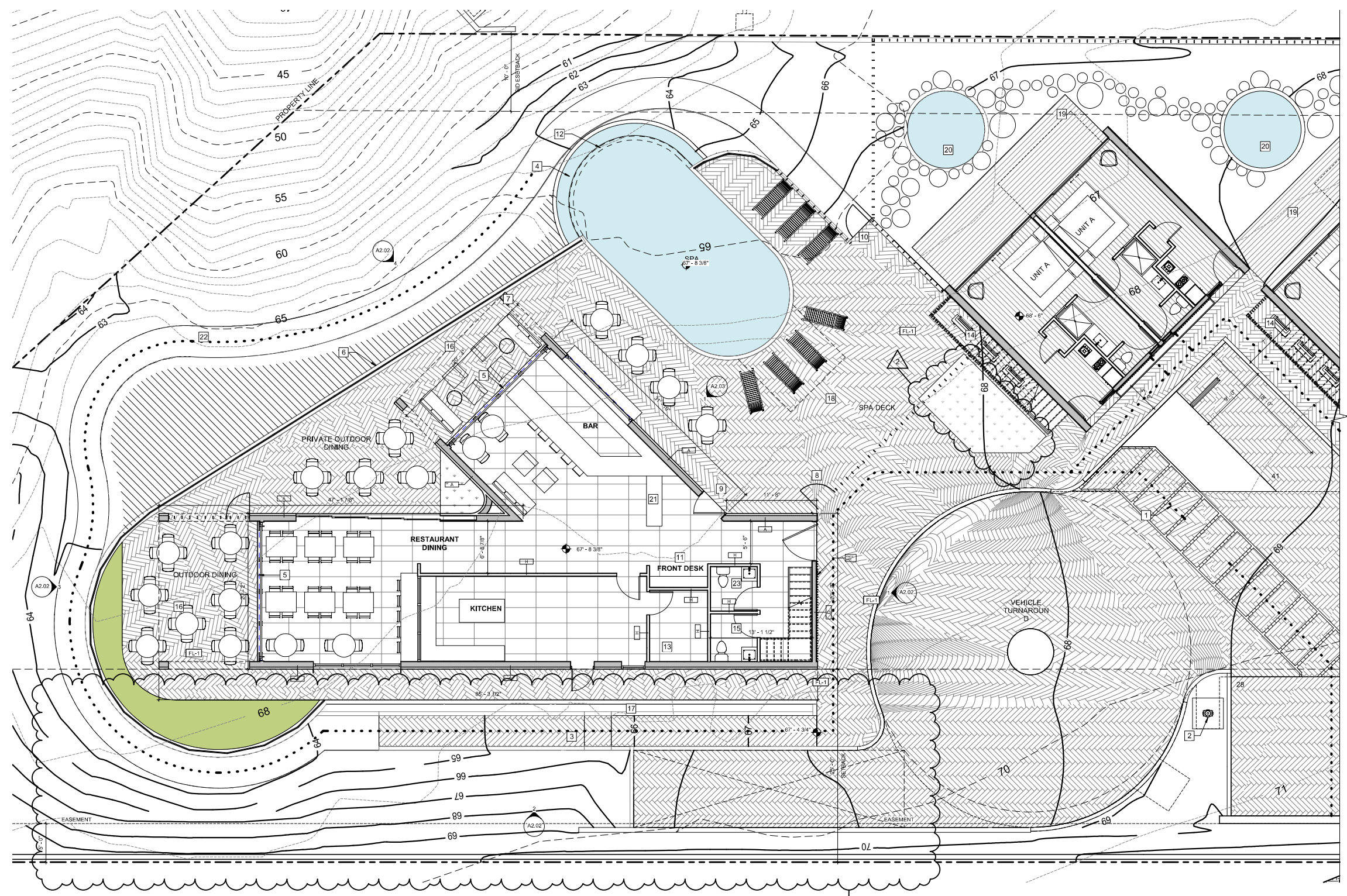

1 ENLARGED FLOOR PLAN - RESTAURANT LEVEL 1
 3/16" = 1'-0"

KEYNOTES

- | | |
|--|------------------------------|
| 1 ADA PATH OF TRAVEL | 19 PRIVATE OUTDOOR DECK |
| 2 FIRE HYDRANT | 20 PRIVATE SPA |
| 3 ADA RAMP TO WALKWAY | 21 RESTAURANT RECEPTION AREA |
| 4 CATCH BASIN | 22 WALKWAY |
| 5 FLIP UP WINDOW SYSTEM | 23 WOMENS RESTROOM |
| 6 GLASS SOUND WALL | |
| 7 HOTEL GUEST OUTDOOR DINING ACCESS (KEYCARD) | |
| 8 HOTEL GUEST PATIO ACCESS (KEYCARD) | |
| 9 HOTEL GUEST RESTAURANT ACCESS (KEYCARD) | |
| 10 HOTEL GUEST WALKWAY ACCESS (KEYCARD) | |
| 11 HOTEL SELF CHECK IN DESK | |
| 12 INFINITY EDGE SPA | |
| 13 KITCHEN STORAGE | |
| 14 MECHANICAL EQUIPMENT UNDER STAIR (SCREENED) | |
| 15 MENS RESTROOM | |
| 16 COVERED OUTDOOR DINING AREA | |
| 17 PLANTER | |
| 18 PRIVATE OUTDOOR AREA | |

WALL LEGEND

- EXTERIOR**
- TYPE A - WOOD STUD / METAL WALL CLADDING
 - TYPE B - WOOD STUD / CONCRETE WALL CLADDING
 - TYPE C - WOOD STUD / CONCRETE WALL CLADDING
 - TYPE D - WOOD STUD / WOOD WALL CLADDING
 - TYPE E - WOOD STUD / WOOD WALL CLADDING LATTICE
 - TYPE F - WOOD STUD / METAL WALL CLADDING LATTICE
- INTERIOR**
- TYPE G - WOOD STUD / DEMISING WALL DOUBLE GYP BOARD
 - TYPE H - WOOD STUD / GYP BOARD

KEY PLAN

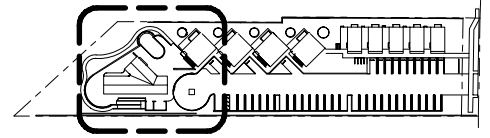

PROJECT NO. -
 DRAWINGS PREPARED BY:
 LANSAY BROWN

SHEET TITLE
 ENLARGED RESTAURANT/
 COMMUNAL AREAS

SHEET NUMBER

A1.04

THESE DRAWINGS, ASSOCIATED SPECIFICATIONS, RELATED PROJECT DOCUMENTS, AND OTHER INSTRUMENTS OF SERVICE ARE THE PROPERTY OF THE DESIGNER AND CONSULTANTS-OF-RECORD. THEY SHALL NEITHER BE EXECUTED NOR USED FOR ANY OTHER WORK EXCEPT BY SPECIFIC AGREEMENT WITH THE DESIGNER. (C) 2019 THE BROWN STUDIO INC.

PROJECT NO. -
 DRAWN BY: Designer
 CHECKED BY: Checker
 DATE: 02/04/2021
 REVISIONS:

THE BROWN STUDIO INC.
 114 H. COGILL HWY. 101
 ENCINITAS, CA 92024
 619.577.4610 Lindsay@thebrownstudio.com

516 LA COSTA

Case No. 18-188 DR/MUP/CDP

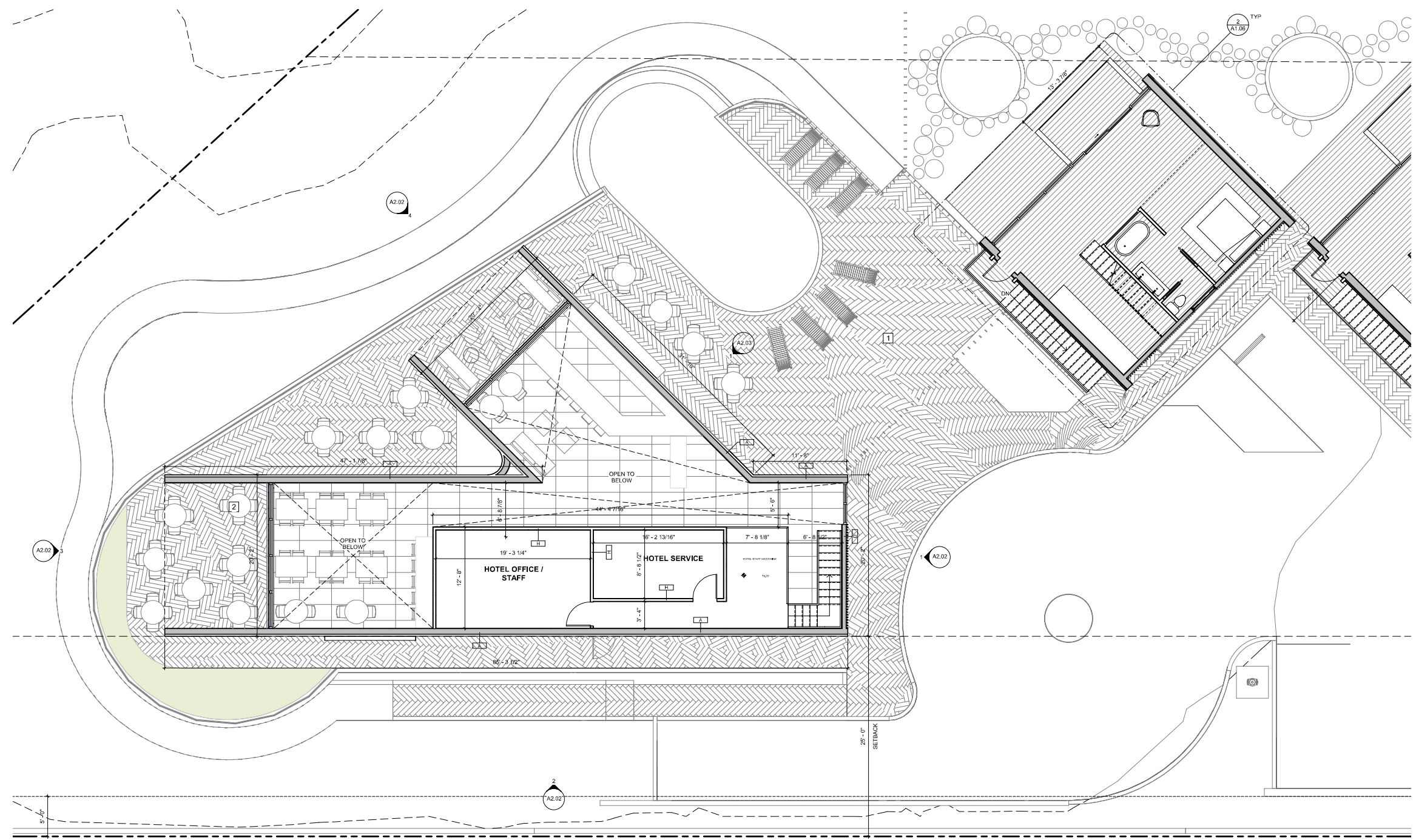

1 ENLARGED FLOOR PLAN - RESTAURANT LEVEL 2 (MEZZANINE)
 3/16" = 1'-0"

KEYNOTES

1	OUTDOOR SPA AREA BELOW
2	OUTDOOR DINING AREA BELOW

WALL LEGEND

EXTERIOR	
TYPE A	WOOD STUD / METAL WALL CLADDING
TYPE B	WOOD STUD / CONCRETE WALL CLADDING
TYPE C	WOOD STUD / CONCRETE WALL CLADDING
TYPE D	WOOD STUD / WOOD WALL CLADDING
TYPE E	WOOD STUD / WOOD WALL CLADDING LATTICE
TYPE F	WOOD STUD / METAL WALL CLADDING LATTICE
INTERIOR	
TYPE G	WOOD STUD / DEMISING WALL DOUBLE GYP BOARD
TYPE H	WOOD STUD / GYP BOARD

KEY PLAN

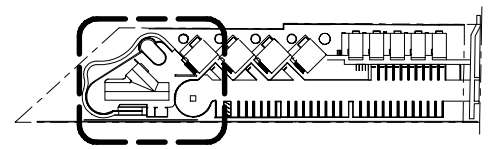

PROJECT NO. -
 DRAWINGS PREPARED BY:
 LINDSAY BROWN

SHEET TITLE
 ENLARGED RESTAURANT/
 COMMUNAL AREAS
SHEET NUMBER

A1.05

THESE DRAWINGS, ASSOCIATED SPECIFICATIONS, RELATED PROJECT DOCUMENTS, AND OTHER INSTRUMENTS OF SERVICE ARE THE PROPERTY OF THE DESIGNER AND CONSULTANTS-OF-RECORD; THEY SHALL NEITHER BE EXECUTED NOR USED FOR ANY OTHER WORK EXCEPT BY SPECIFIC AGREEMENT WITH THE DESIGNER. (C) 2019 THE BROWN STUDIO INC.

PROJECT NO. -
 DRAWN BY: Designer
 CHECKED BY: Checker
 DATE: 02/04/2021
 REVISIONS:
 2 07/XX/2020 CDP-SUB 3

THE BROWN STUDIO INC.
 1144 N. COGGI HWY 101
 ENCINITAS, CA 92024
 619.577.4610 | info@thebrownstudio.com

516 LA COSTA

Case No. 18-188 DR/MUP/CDP

PROJECT NO. -
 DRAWINGS PREPARED BY:
 LINDSAY BROWN

SHEET TITLE
 ENLARGED PLAN BUILDING TYPE A

SHEET NUMBER

A1.06

THESE DRAWINGS, ASSOCIATED SPECIFICATIONS, RELATED PROJECT DOCUMENTS, AND OTHER INSTRUMENTS OF SERVICE ARE THE PROPERTY OF THE DESIGNER AND CONSULTANTS-OF-RECORD; THEY SHALL NEITHER BE EXECUTED NOR USED FOR ANY OTHER WORK EXCEPT BY SPECIFIC AGREEMENT WITH THE DESIGNER. (C) 2019 THE BROWN STUDIO INC.

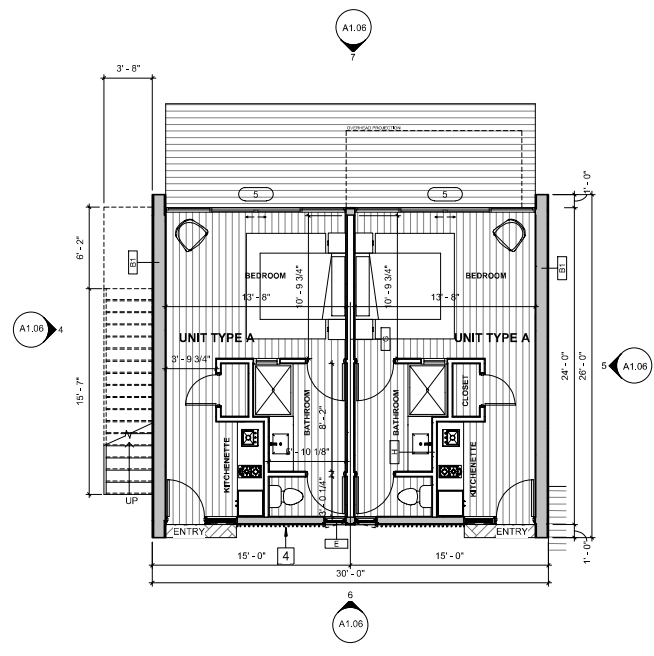

1 ENLARGED BUNGALOW A - LEVEL 1 - TYP.
 3/16" = 1'-0"

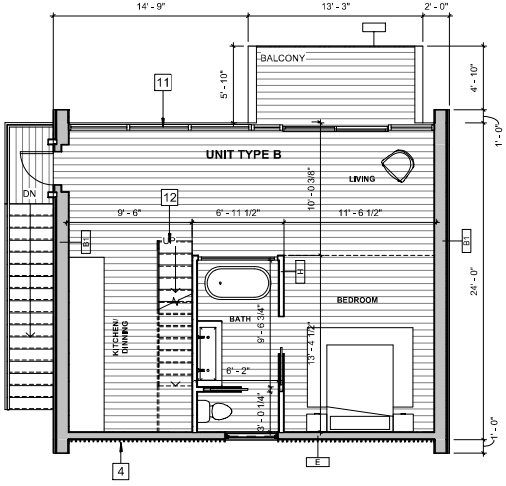

2 ENLARGED BUNGALOW A - LEVEL 2 - TYP.
 3/16" = 1'-0"

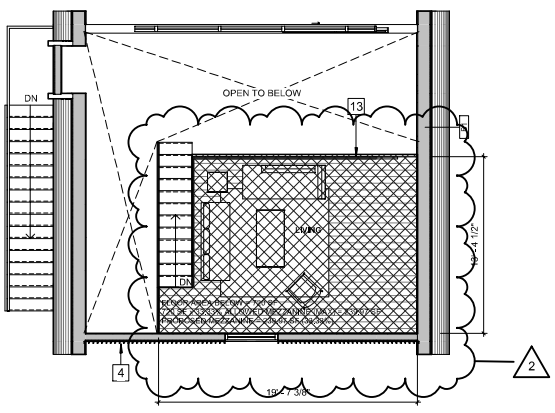

3 ENLARGED BUNGALOW A - LOFT LEVEL 2 - TYP.
 3/16" = 1'-0"

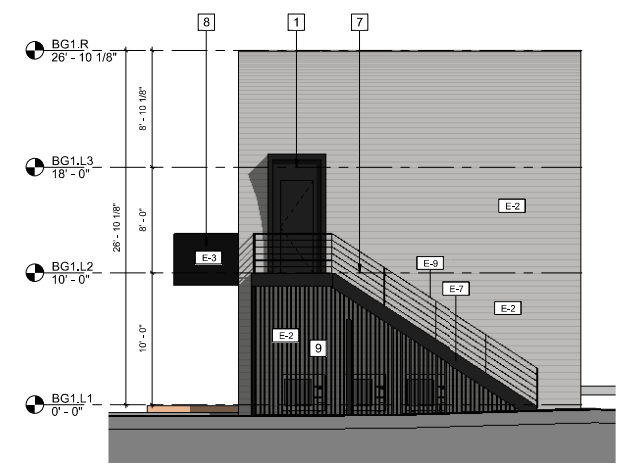

4 BUILDING 2 - WEST ELEVATION
 3/16" = 1'-0"

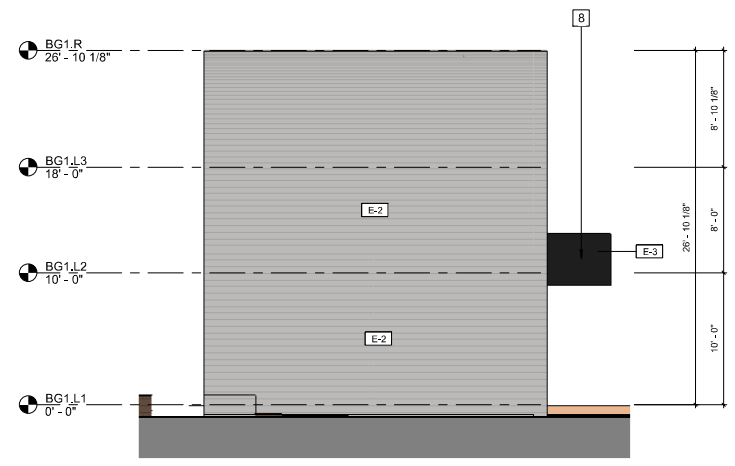

5 BUILDING 2 - EAST ELEVATION
 3/16" = 1'-0"

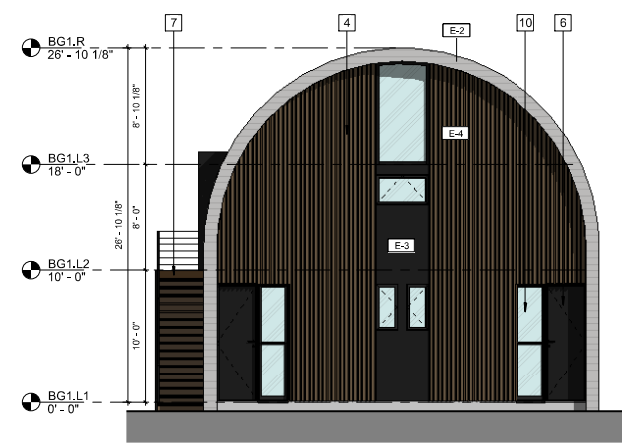

6 BUILDING 2 - SOUTH ELEVATION
 3/16" = 1'-0"

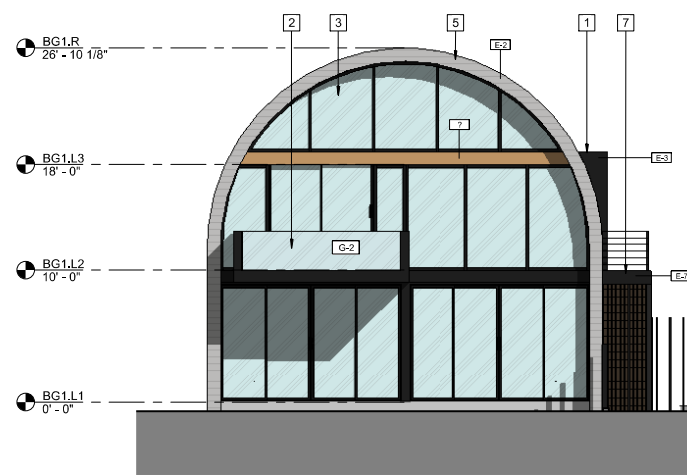

7 BUILDING 2 - NORTH ELEVATION
 3/16" = 1'-0"

KEYNOTES

- 1 DORMER/ENTRY
- 2 GLASS GUARD RAIL
- 3 CUSTOM GLAZING
- 4 WOOD LATTICE WALL CLADDING
- 5 BARREL ROOF
- 6 UNIT ENTRY DOOR
- 7 STAIR ACCESS TO UPPER LEVEL UNIT
- 8 BALCONY
- 9 WOOD SCREEN, MECHANICAL EQUIPMENT BEYOND
- 10 WINDOW
- 11 CUSTOM GLAZING
- 12 STAIR TO LOFT AREA
- 13 MEZZANINE GUARDRAIL

WALL LEGEND

- EXTERIOR**
- TYPE A - WOOD STUD / METAL WALL CLADDING
 - TYPE B - WOOD STUD / CONCRETE WALL CLADDING
 - TYPE C - WOOD STUD / CONCRETE WALL CLADDING
 - TYPE D - WOOD STUD / WOOD WALL CLADDING
 - TYPE E - WOOD STUD / WOOD WALL CLADDING LATTICE
 - TYPE F - WOOD STUD / METAL WALL CLADDING LATTICE
- INTERIOR**
- TYPE G - WOOD STUD / DEMISING WALL DOUBLE GYP BOARD
 - TYPE H - WOOD STUD / GYP BOARD

MATERIAL LEGEND

- E-1 EXTERIOR METAL WALL/ROOF CLADDING
- E-2 CONCRETE CLADDING
- E-3 EXTERIOR METAL WALL PANEL/BREAK METAL, PAINTED BLACK
- E-4 NATURAL WOOD ELEMENTS, STAINED; ANTIQUE OAK
- E-5 EXPOSED CMU, STRAIGHT STACK
- E-6 CONCRETE RETAINING WALL
- E-7 STEEL FACIA/STRINGER, PAINTED BLACK
- FL-1 CONCRETE PERVIOUS PAVERS
- FL-3 EXTERIOR WOOD FLOORING

KEY PLAN

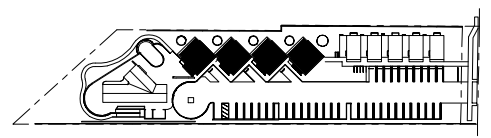

PROJECT NO. -
 DRAWN BY: Designer
 CHECKED BY: Checker
 DATE: 02/04/2021
 REVISIONS:

THE BROWN STUDIO INC.
 1144 N. COGILL HWY 101
 ENCINITAS, CA 92024
 619.577.4610 | info@thebrownstudio.com

516 LA COSTA

Case No. 18-188 DR/MUP/CDP

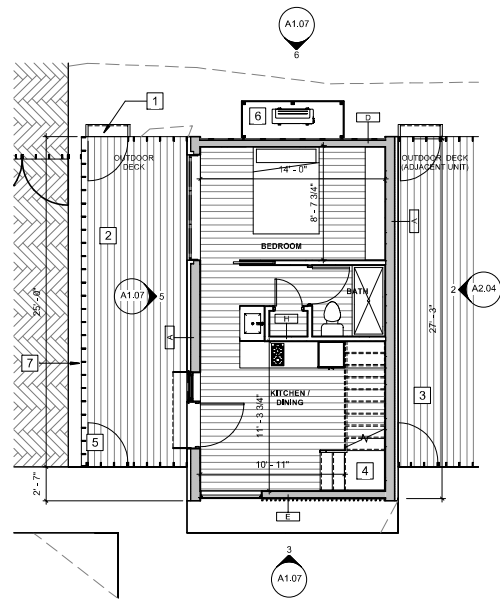

1 BUNGALOW B - ENLARGED FLOOR PLAN LEVEL 1
 3/16" = 1'-0"

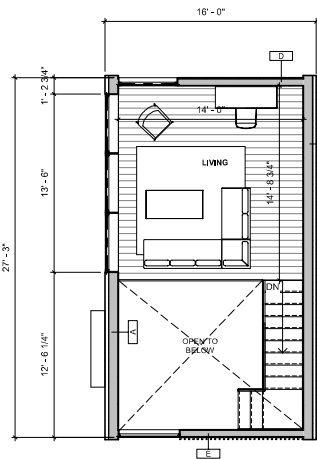

2 BUNGALOW B - ENLARGED FLOOR PLAN LOFT
 3/16" = 1'-0"

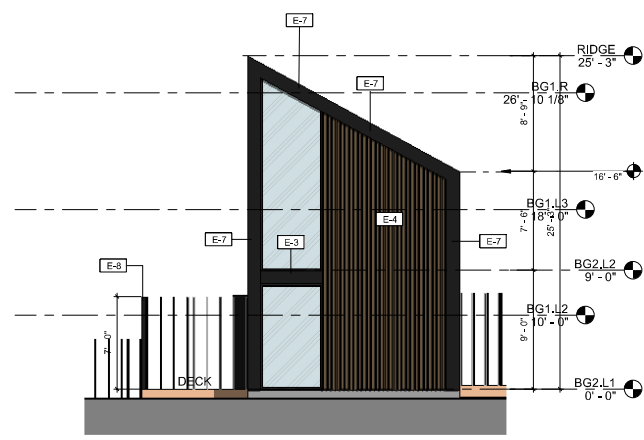

3 UNIT C - ELEVATION - WEST - TYP.
 3/16" = 1'-0"

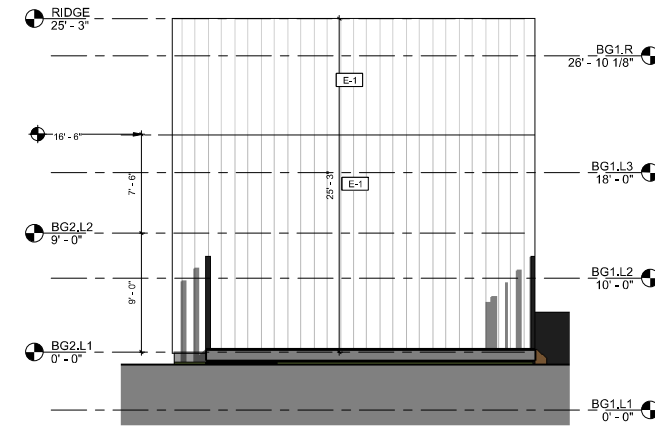

4 UNIT C - ELEVATION - SOUTH - TYP.
 3/16" = 1'-0"



5 UNIT C - ELEVATION - NORTH - TYP.
 3/16" = 1'-0"



6 UNIT C - ELEVATION - EAST - TYP.
 3/16" = 1'-0"

KEYNOTES

- 1 ACCESS TO PRIVATE SIDE YARD
- 2 PRIVATE OUTDOOR DECK
- 3 PRIVATE OUTDOOR DECK
- 4 STAIR TO LOFT AREA
- 5 UNIT GATE ACCESS
- 6 MECHANICAL EQUIPMENT (SCREENED)
- 7 VERTICAL STEEL FENCE

WALL LEGEND

- EXTERIOR**
- TYPE A - WOOD STUD / METAL WALL CLADDING
 - TYPE B - WOOD STUD / CONCRETE WALL CLADDING
 - TYPE C - WOOD STUD / CONCRETE WALL CLADDING
 - TYPE D - WOOD STUD / WOOD WALL CLADDING
 - TYPE E - WOOD STUD / WOOD WALL CLADDING LATTICE
 - TYPE F - WOOD STUD / METAL WALL CLADDING LATTICE
- INTERIOR**
- TYPE G - WOOD STUD / DEMISING WALL DOUBLE GYP BOARD
 - TYPE H - WOOD STUD / GYP BOARD

MATERIAL LEGEND

- E-1 EXTERIOR METAL WALL/ROOF CLADDING
- E-2 CONCRETE CLADDING
- E-3 EXTERIOR METAL WALL PANEL/BREAK METAL, PAINTED BLACK
- E-4 NATURAL WOOD ELEMENTS, STAINED, ANTIQUE OAK
- E-5 EXPOSED CMU, STRAIGHT STACK
- E-6 CONCRETE RETAINING WALL
- E-7 STEEL FACIA/STRINGER, PAINTED BLACK
- FL-1 CONCRETE PERVIOUS PAVERS
- FL-3 EXTERIOR WOOD FLOORING

KEY PLAN

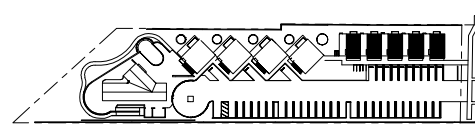

PROJECT NO. -
 DRAWINGS PREPARED BY:
 LANSAY BROWN

SHEET TITLE
 ENLARGED PLAN BUILDING TYPE B

SHEET NUMBER

A1.07

THESE DRAWINGS, ASSOCIATED SPECIFICATIONS, RELATED PROJECT DOCUMENTS, AND OTHER INSTRUMENTS OF SERVICE ARE THE PROPERTY OF THE DESIGNER AND CONSULTANTS-OF-RECORD; THEY SHALL NEITHER BE EXECUTED NOR USED FOR ANY OTHER WORK EXCEPT BY SPECIFIC AGREEMENT WITH THE DESIGNER. (C) 2019 THE BROWN STUDIO INC.

THESE DRAWINGS, ASSOCIATED SPECIFICATIONS, RELATED PROJECT DOCUMENTS, AND OTHER INSTRUMENTS OF SERVICE ARE THE PROPERTY OF THE DESIGNER AND CONSULTANTS-OF-RECORD; THEY SHALL NEITHER BE EXECUTED NOR USED FOR ANY OTHER WORK EXCEPT BY SPECIFIC AGREEMENT WITH THE DESIGNER. (C) 2019 THE BROWN STUDIO INC.

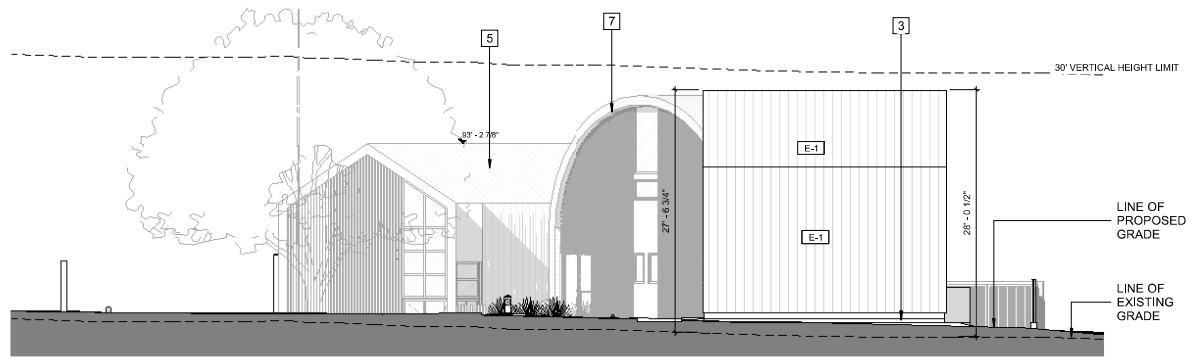

1 ELEVATION - SOUTH (LA COSTA AVE.)
1/8" = 1'-0"



2 ELEVATION - NORTH
1/8" = 1'-0"

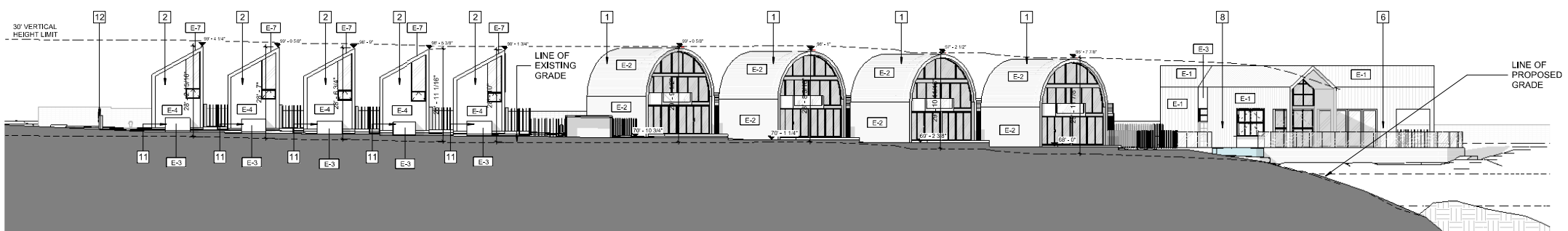

3 ELEVATION - EAST
1/16" = 1'-0"

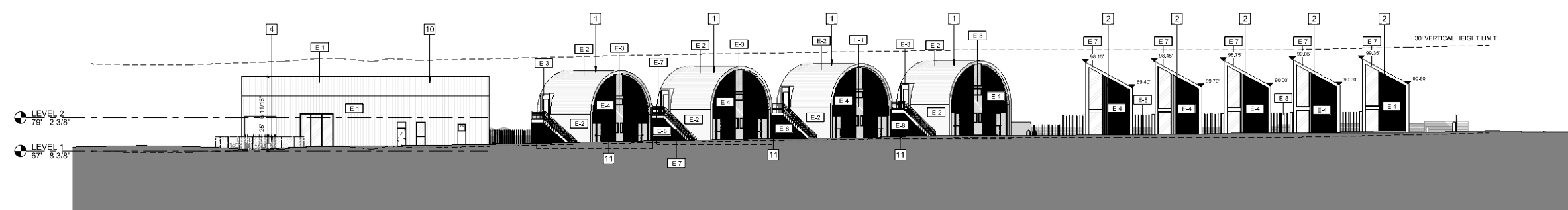

4 ELEVATION - WEST
1/16" = 1'-0"

KEYNOTES

- 1 BUNGALOW "A"
- 2 BUNGALOW "B"
- 3 FRONT LANDSCAPE AREA
- 4 OUTDOOR DINING AREA
- 5 RESTAURANT BUILDING BEYOND
- 6 GLASS SOUND WALL
- 7 BUNGALOW "A" BEYOND
- 8 PATIO DECK AREA
- 9 FLIP UP WINDOW SYSTEM
- 10 RESTURANT BUILDING
- 11 HVAC EQUIPMENT SCREEN
- 12 PROPOSED MONUMENT SIGN

MATERIAL LEGEND

- E-1 EXTERIOR METAL WALL/ROOF CLADDING
- E-2 CONCRETE CLADDING
- E-3 EXTERIOR METAL WALL PANEL/BREAK METAL, PAINTED BLACK
- E-4 NATURAL WOOD ELEMENTS, STAINED: ANTIQUE OAK
- E-5 EXPOSED CMU, STRAIGHT STACK
- E-6 CONCRETE RETAINING WALL
- E-7 STEEL FACIA/STRINGER, PAINTED BLACK
- FL-1 CONCRETE PERVIOUS PAVERS
- FL-3 EXTERIOR WOOD FLOORING

NOTES

BUILDING HEIGHT MEASUREMENT IS TAKEN AT FACE OF EXTERIOR WALL, TO THE LOWEST OF EXISTING OR PROPOSED GRADE, WHICH EVER IS LESS, PER EMC.

PROJECT NO.	-
DRAWN BY:	Designer
CHECKED BY:	Checker
DATE:	02/04/2021
REVISIONS:	

THE BROWN STUDIO INC.
114 N. COGILL HWY 101
ENCINITAS, CA 92024
619.577.4610 | info@thebrownstudio.com

516 LA COSTA

Case No. 18-188 DR/MUP/CDP

PROJECT NO.	-
DRAWINGS PREPARED BY:	LINDSAY BROWN

SHEET TITLE
GENERAL ELEVATIONS

SHEET NUMBER

A2.01

THESE DRAWINGS, ASSOCIATED SPECIFICATIONS, RELATED PROJECT DOCUMENTS, AND OTHER INSTRUMENTS OF SERVICE ARE THE PROPERTY OF THE DESIGNER AND CONSULTANTS-OF-RECORD. THEY SHALL NEITHER BE EXECUTED NOR USED FOR ANY OTHER WORK EXCEPT BY SPECIFIC AGREEMENT WITH THE DESIGNER. (C) 2019 THE BROWN STUDIO INC.

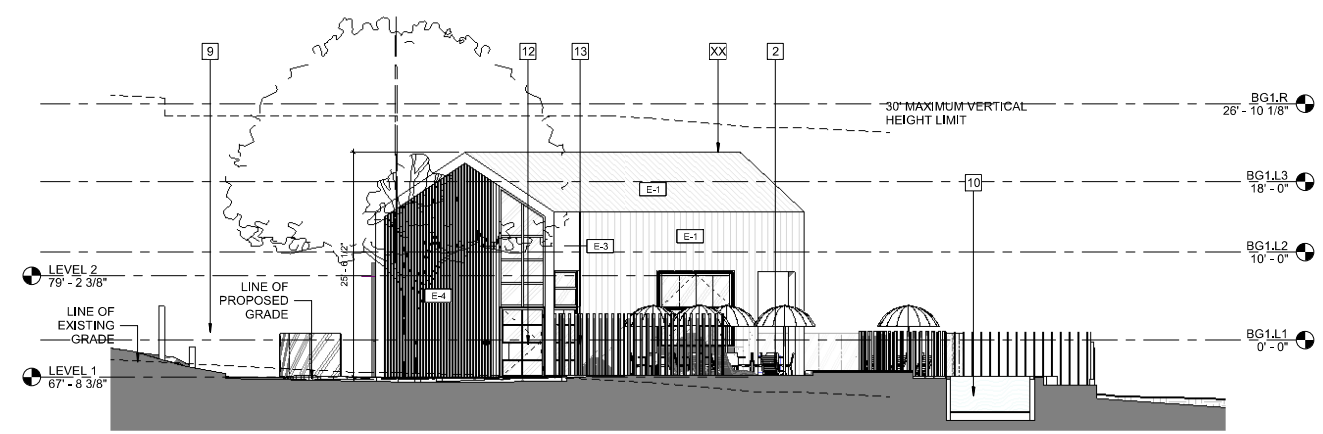

1 ELEVATION RESTAURANT - SOUTH
1/8" = 1'-0"

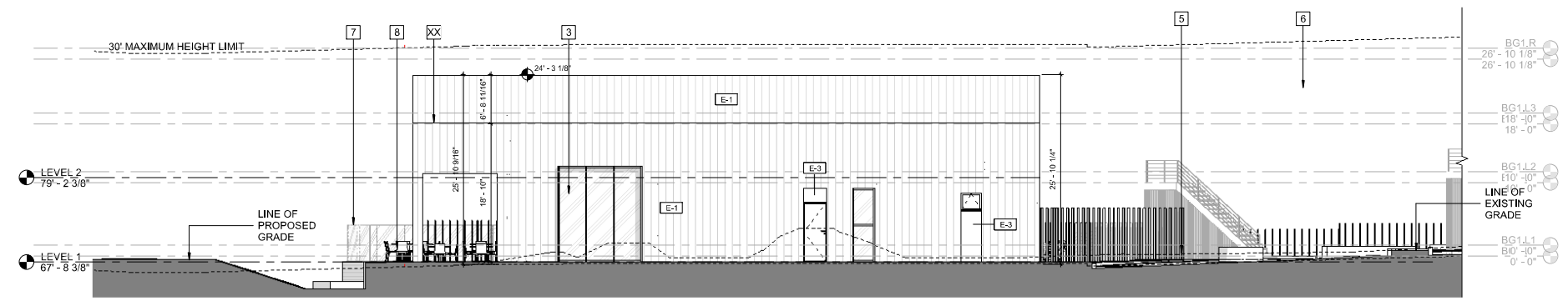

2 ELEVATION RESTAURANT - WEST
1/8" = 1'-0"

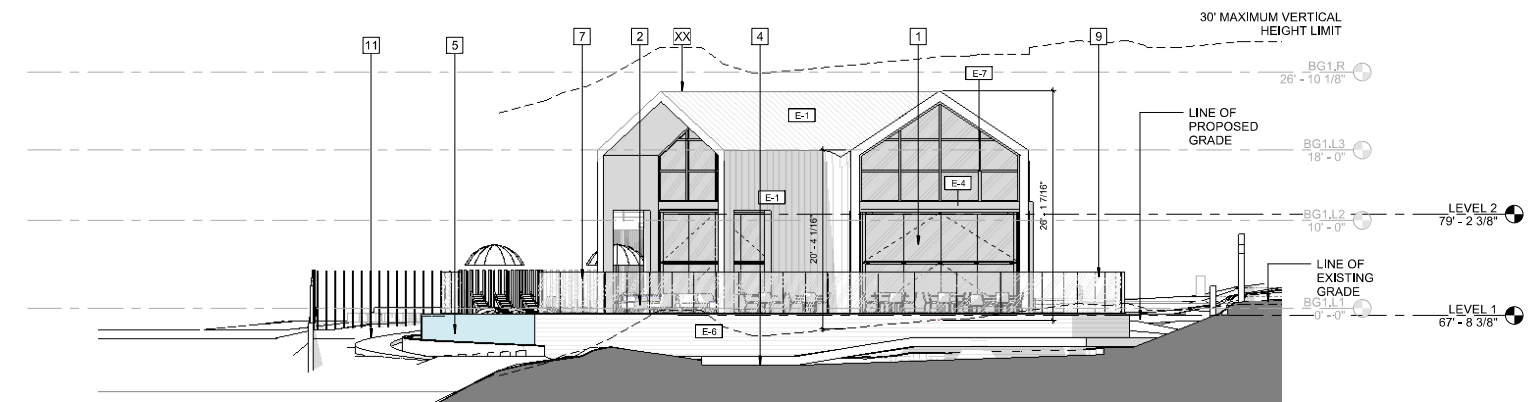

3 ELEVATION RESTAURANT - NORTH
1/8" = 1'-0"

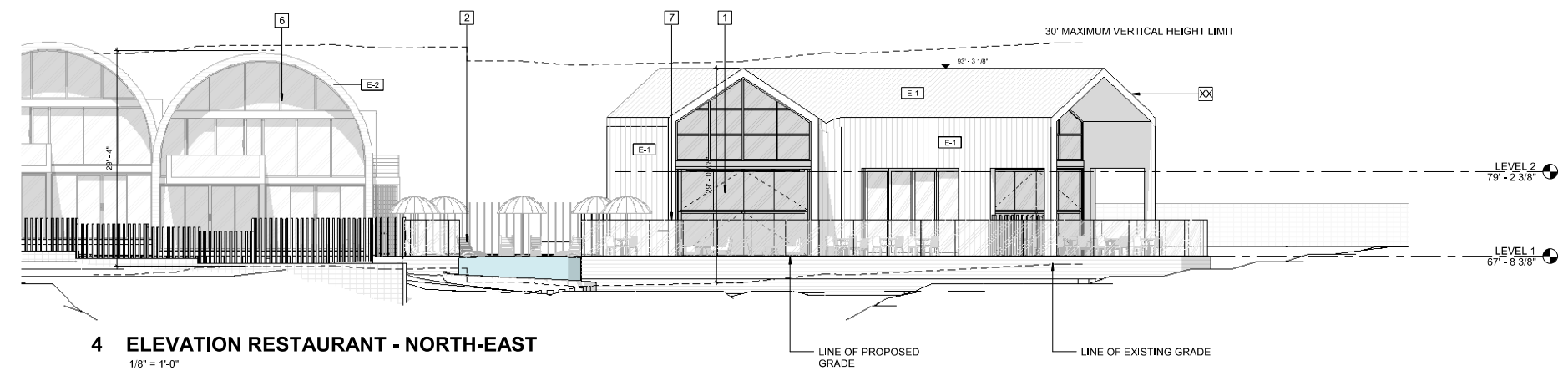

4 ELEVATION RESTAURANT - NORTH-EAST
1/8" = 1'-0"

KEYNOTES

- 1 FLIP UP WINDOW SYSTEM
- 2 PATIO DECK AREA
- 3 STOREFRONT SYSTEM
- 4 BIOPIT AREA
- 5 SPA INFINITI EDGE
- 5 VEHICLE TURNAROUND AREA
- 6 BUNGALOW "A" BEYOND
- 7 SOUND WALL
- 8 OUTDOOR DINING AREA
- 9 TRASH ENCLOSURE
- 10 SPA
- 11 WALKING TRAIL
- 12 LOBBY ENTRY
- 13 FENCE
- XX OPEN TRELLIS SHADE STRUCTURE

MATERIAL LEGEND

- E-1 EXTERIOR METAL WALL/ROOF CLADDING
- E-2 CONCRETE CLADDING
- E-3 EXTERIOR METAL WALL PANEL/BREAK METAL. PAINTED BLACK
- E-4 NATURAL WOOD ELEMENTS, STAINED: ANTIQUE OAK
- E-5 EXPOSED CMU, STRAIGHT STACK
- E-6 CONCRETE RETAINING WALL
- E-7 STEEL FACIA/STRINGER. PAINTED BLACK
- FL-1 CONCRETE PERVIOUS PAVERS
- FL-3 EXTERIOR WOOD FLOORING

NOTES

BUILDING HEIGHT MEASUREMENT IS TAKEN AT FACE OF EXTERIOR WALL, TO THE LOWEST OF EXISTING OR PROPOSED GRADE, WHICH EVER IS LESS, PER EMC.

GRADE LINE LEGEND

- EXISTING GRADE
- 1960 GRADE
- 1975 GRADE

PROJECT NO.	-
DRAWN BY:	Designer
CHECKED BY:	Checker
DATE:	02/04/2021
REVISIONS:	

THE BROWN STUDIO INC.
1144 N. COGUE HWY 101
ENCINITAS, CA 92024
619.577.4610 | info@thebrownstudio.com

516 LA COSTA

Case No. 18-188 DR/MUP/CDP

PROJECT NO.	-
DRAWINGS PREPARED BY:	LINSAY BROWN

SHEET TITLE
ELEVATIONS RESTAURANT

SHEET NUMBER

A2.02

THESE DRAWINGS, ASSOCIATED SPECIFICATIONS, RELATED PROJECT DOCUMENTS, AND OTHER INSTRUMENTS OF SERVICE ARE THE PROPERTY OF THE DESIGNER AND CONSULTANTS-OF-RECORD. THEY SHALL NEITHER BE EXECUTED NOR USED FOR ANY OTHER WORK EXCEPT BY SPECIFIC AGREEMENT WITH THE DESIGNER. (C) 2019 THE BROWN STUDIO INC.

WALL TYPE A 3" = 1'-0"			WALL TYPE B 3" = 1'-0"			WALL TYPE C 3" = 1'-0"			WALL TYPE D 3" = 1'-0"		
DESCRIPTION	WIDTH	STUD	DESCRIPTION	WIDTH	STUD	DESCRIPTION	WIDTH	STUD	DESCRIPTION	WIDTH	STUD
TYPE A	12"	DBL 5 1/2"	TYPE B1	12"	11"	TYPE C	12"	11"	TYPE D	7 3/8"	5 1/2"
			TYPE B2	12"	5 1/2"						
WALL TYPE E 3" = 1'-0"			WALL TYPE F 3" = 1'-0"			WALL TYPE G 3" = 1'-0"			WALL TYPE H 3" = 1'-0"		
DESCRIPTION	WIDTH	STUD	DESCRIPTION	WIDTH	STUD	DESCRIPTION	WIDTH	STUD	DESCRIPTION	WIDTH	STUD
TYPE E	7 1/8"	5 1/2"	TYPE F	8"	5 1/2"	TYPE G	8"	5 1/2"	TYPE H	4 3/4"	3 1/2"

NOTE

THE EXTERNAL WALL MUST HAVE A MINIMUM STC RATING OF 47

PROJECT NO.	-
DRAWN BY:	Designer
CHECKED BY:	Checker
DATE:	02/04/2021
REVISIONS:	
	05-30-2019

THE BROWN STUDIO INC.
 1144 N. COGGI HWY 101
 ENCINITAS, CA 92024
 619.577.4610 | info@thebrownstudio.com

516 LA COSTA

Case No. 18-188 DR/MUP/CDP

PROJECT NO.	-
DRAWINGS PREPARED BY:	LINDSAY BROWN

SHEET TITLE
WALL DETAILS

SHEET NUMBER

A7.04

PROJECT NO. -
 DRAWN BY: TBS
 CHECKED BY: COE
 DATE: 02/04/2021
 REVISIONS:
 2 07/XX/2020 CDP-SUB 3

THE BROWN STUDIO INC.
 144 N. COGILL HWY #101
 ENCINITAS, CA 92024
 619.577.4610 lindsay@thebrownstudio.com

LA COSTA AVE.

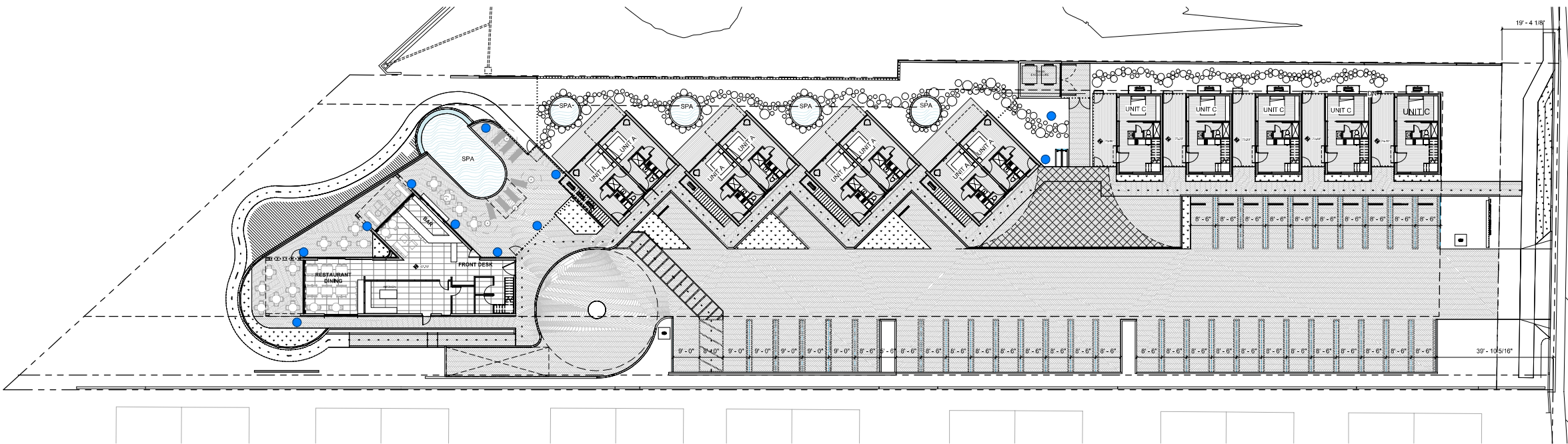

1 LEVEL 1 - FLOOR PLAN - OUTDOOR SPEAKERS
 1/16" = 1'-0"

516 LA COSTA
 Case No. 18-188 DR/MUP/CDP

LEGEND

 OUTDOOR SPEAKER LOCATIONS

NOTES

PROJECT NO. -
 DRAWINGS PREPARED BY:
 LINDSAY BROWN

SHEET TITLE
 OUTDOOR SPEAKERS

SHEET NUMBER

A10.6

THESE DRAWINGS, ASSOCIATED SPECIFICATIONS, RELATED PROJECT DOCUMENTS, AND OTHER INSTRUMENTS OF SERVICE ARE THE PROPERTY OF THE DESIGNER AND CONSULTANTS-OF-RECORD; THEY SHALL NEITHER BE EXECUTED NOR USED FOR ANY OTHER WORK EXCEPT BY SPECIFIC AGREEMENT WITH THE DESIGNER. (C) 2019 THE BROWN STUDIO INC.

PROJECT NO. -
 DRAWN BY: Designer
 CHECKED BY: Checker
 DATE: 02/04/2021
 REVISIONS:
 2 07/XX/2020 CDP-SUB 3

THE BROWN STUDIO INC.
 14 N. COGILL HWY. 101
 ENCINITAS, CA 92024
 619.577.4610 lindsay@thebrownstudio.com

516 LA COSTA

Case No. 18-188 DR/MUP/CDP

PROJECT NO. -
 DRAWINGS PREPARED BY:
 LINDSAY BROWN

SHEET TITLE
 SITE PLAN (FULL)

SHEET NUMBER

A0.03

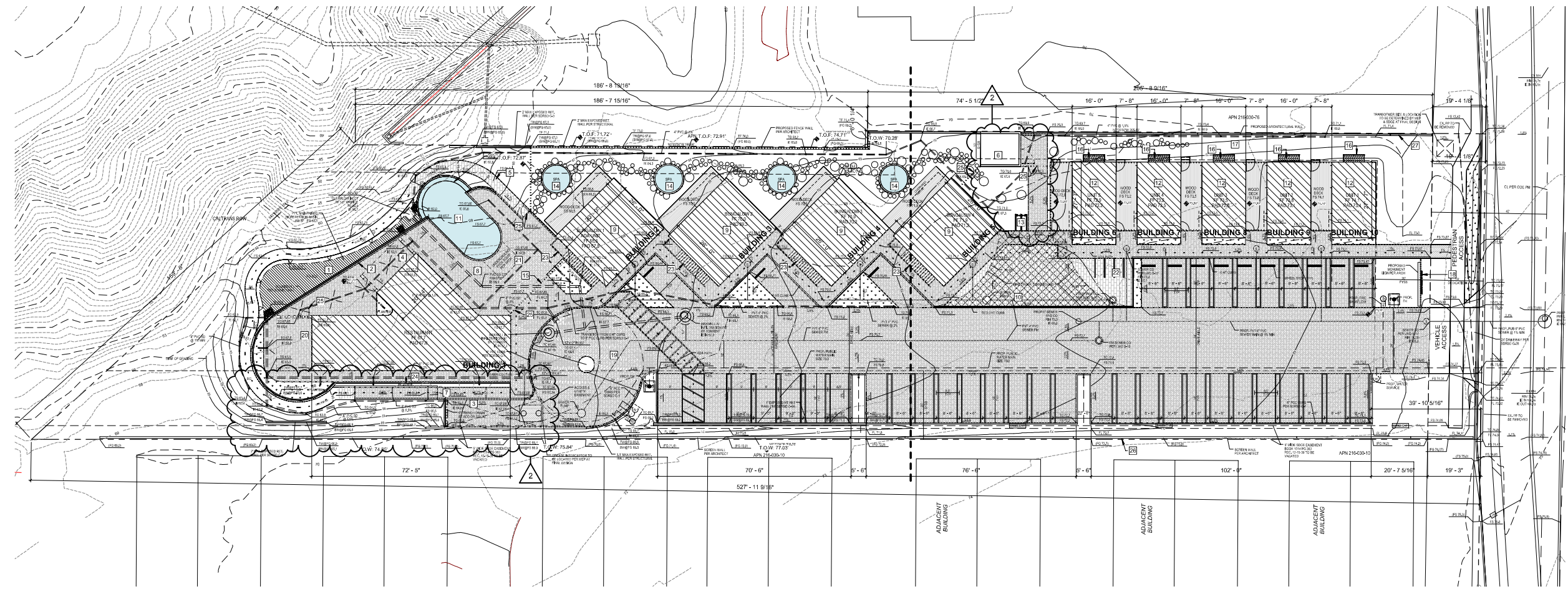

1 PROPOSED SITE PLAN
 1/16" = 1'-0"

KEYNOTES

- 1 BMP
- 2 SOUND WALL
- 3 LOADING SPACE
- 4 OUTDOOR LOUNGE
- 5 WALKING PATH
- 6 TRASH ENCLOSURE
- 7 ADA RAMP
- 8 LOUNGE SEATING AREA
- 9 QUONSET HUT (3 UNITS)
- 10 FIRE TRUCK TURNAROUND
- 11 SPA
- 12 BUNGALOW UNITS
- 13 BICYCLE PARKING
- 14 HOTEL PLUNGE POOL
- 15 6' FENCE
- 16 SCREENED MECHANICAL EQUIPMENT
- 17 STEPSTONE WALKWAY
- 18 MONUMENT SIGN
- 19 MOTOR COURT
- 20 OUTDOOR DINING
- 21 UNDERGROUND SPA EQUIPMENT
- 22 MOTORCYCLE PARKING
- 23 SCREENED MECHANICAL EQUIPMENT UNDER STAIRS
- 24 RAISED PLANTER
- 25 GATE AT FENCE (KEY ACCESS)
- 26 CMU FENCE
- 27 WOOD FENCE 6'

NOTES

THESE DRAWINGS, ASSOCIATED SPECIFICATIONS, RELATED PROJECT DOCUMENTS, AND OTHER INSTRUMENTS OF SERVICE ARE THE PROPERTY OF THE DESIGNER AND CONSULTANTS-OF-RECORD; THEY SHALL NEITHER BE EXECUTED NOR USED FOR ANY OTHER WORK EXCEPT BY SPECIFIC AGREEMENT WITH THE DESIGNER. (C) 2019 THE BROWN STUDIO INC.

PROJECT NO. -
 DRAWN BY: Designer
 CHECKED BY: Checker
 DATE: 02/04/2021
 REVISIONS:
 2 07/XX/2020 CDP-SUB 3

THE BROWN STUDIO INC.
 14 N. COGILL HWY 101
 ENCINITAS, CA 92024
 619.577.4610 lindsay@thebrownstudio.com

516 LA COSTA

Case No. 18-188 DR/MUP/CDP

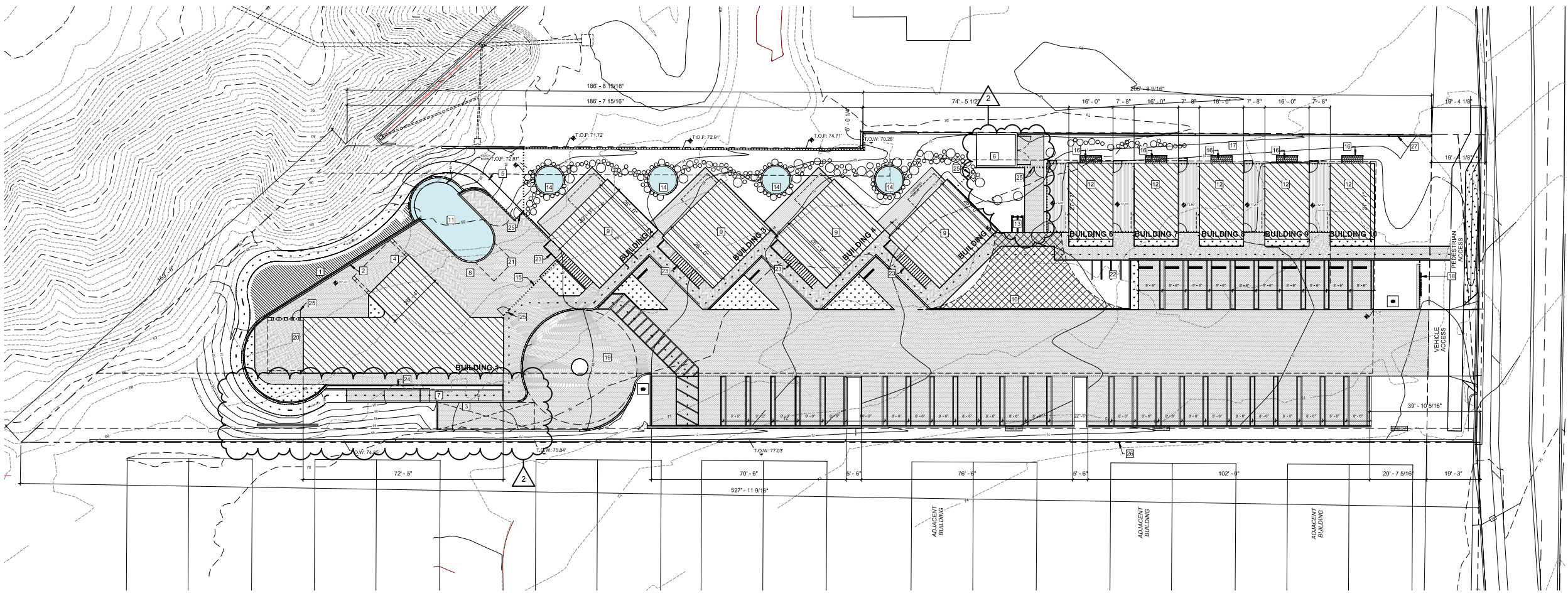

1 PROPOSED SITE PLAN
 1/16" = 1'-0"

KEYNOTES

- 1 BMP
- 2 SOUND WALL
- 3 LOADING SPACE
- 4 OUTDOOR LOUNGE
- 5 WALKING PATH
- 6 TRASH ENCLOSURE
- 7 ADA RAMP
- 8 LOUNGE SEATING AREA
- 9 QUONSET HUT (3 UNITS)
- 10 FIRE TRUCK TURNAROUND
- 11 SPA
- 12 BUNGALOW UNITS
- 13 BICYCLE PARKING
- 14 HOTEL PLUNGE POOL
- 15 6' FENCE
- 16 SCREENED MECHANICAL EQUIPMENT
- 17 STEPSTONE WALKWAY
- 18 MONUMENT SIGN
- 19 MOTOR COURT
- 20 OUTDOOR DINING
- 21 UNDERGROUND SPA EQUIPMENT
- 22 MOTORCYCLE PARKING
- 23 SCREENED MECHANICAL EQUIPMENT UNDER STAIRS
- 24 RAISED PLANTER
- 25 GATE AT FENCE (KEY ACCESS)
- 26 CMU FENCE
- 27 WOOD FENCE 6'

NOTES

PROJECT NO. -
 DRAWINGS PREPARED BY:
 LINDSAY BROWN

SHEET TITLE
 SITE PLAN (FULL)

SHEET NUMBER

A0.03

THESE DRAWINGS, ASSOCIATED SPECIFICATIONS, RELATED PROJECT DOCUMENTS, AND OTHER INSTRUMENTS OF SERVICE ARE THE PROPERTY OF THE DESIGNER AND CONSULTANTS-OF-RECORD; THEY SHALL NEITHER BE EXECUTED NOR USED FOR ANY OTHER WORK EXCEPT BY SPECIFIC AGREEMENT WITH THE DESIGNER. (C) 2019 THE BROWN STUDIO INC.

APPENDIX B

Pertinent Sections of the City of Encinitas Noise Element to the General Plan and Municipal Code, California Building Code, and CALGreen

Figure 17-1 State of California Guidelines for Noise Compatible Land Use

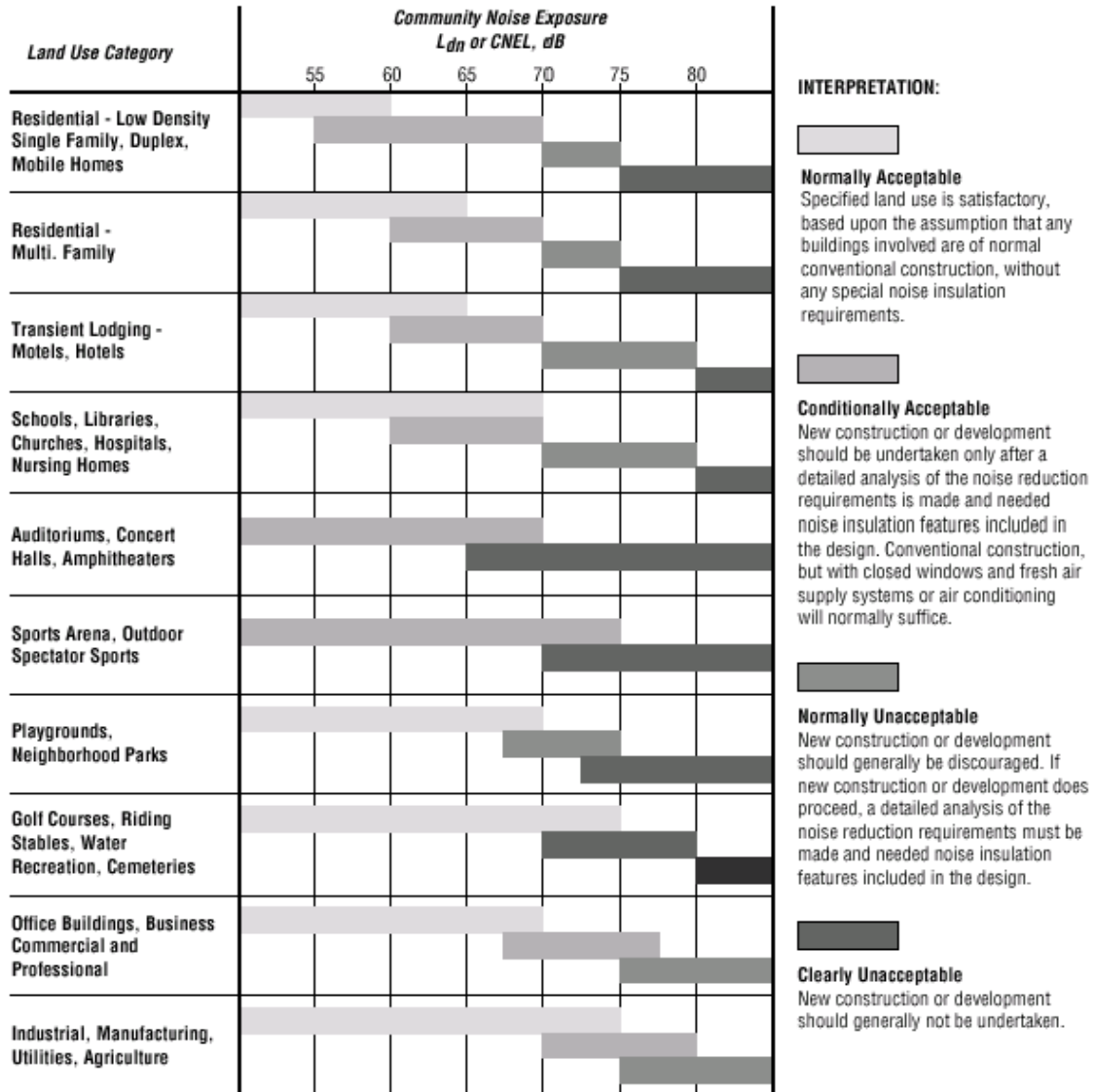

Source: State of California. (2003). *General Plan Guidelines*. Governor's Office of Planning and Research. October

- The interior noise level as required by the State of California Noise Insulation Standards [CCR Title 24] must not exceed an Ldn of 45 dB in multi-family dwellings. This interior standard shall also be applied to single family dwellings and offices in the City of Encinitas.

Other Noise Guidelines

The Collaborative for High Performance Schools (CHPS) is a non-profit organization dedicated to making schools better places to learn. CHPS was initially founded in 1999 as a collaboration of California’s major utilities to address energy efficiency in schools. The program quickly expanded to address all aspects of school design, construction and operation including noise. The CHPS *California 2009 Criteria for New Construction and Major Modernizations* specify that the maximum background noise level in unoccupied classrooms should not exceed 45 dB(A) and strongly recommends designs that would achieve background levels no greater than 35 dB(A). Background interior noise in schools is considered to be primarily due to heating, ventilation, and air conditioning (HVAC) systems and exterior noise sources such as traffic.

The Acoustical Society of America (ASA) and the American National Standards Institute (ANSI) have developed *ANSI/ASA S12.60-2010/Part 1 - Acoustical Performance Criteria, Design Requirements, and Guidelines for Schools, Part 1: Permanent Schools*. This voluntary standard specifies an interior background one-hour average noise level due to exterior sources of 35 dB(A) in classrooms.

17.5 PLANNING GOALS AND POLICIES

Applicable goals and policies contained in the existing General Plan relevant to noise are found in the Noise Element as listed in Table 17-7.

Table 17-7 Resource Management Element Policies Related to Noise

Policy	Description
Goal 1	Provide an acceptable noise environment for existing and future residents of the City of Encinitas
1.1	<p>Review actions or projects that may have noise generation potential to determine what impact they may have on existing land uses. If a project would cause an increase in traffic noise levels, the policy of the City of Encinitas is to accept an increase up to an L_{dn} of 55 dB in outdoor residential use areas without mitigation. If a project would increase the traffic noise level by more than 5 dB and the resulting L_{dn} would be over 55 dB, then mitigation measures must be evaluated. If the project, or action, would increase traffic noise levels by 3 dB or more and the resulting L_{dn} would exceed 60 dB in outdoor use areas in residential development, noise mitigation must be similarly evaluated. The impact of non-transportation projects must generally be evaluated on a case-by-case basis. The following guidelines will aid in evaluating the impacts of commercial and industrial projects.</p> <ul style="list-style-type: none"> a) <u>Performance Standards Adjacent to Residential Areas.</u> New commercial construction adjacent to residential areas should not increase noise levels in a residential area by more than 3 dB (L_{dn}) or create noise impacts which would increase noise levels to more than an L_{dn} of 60 dB at the boundary of the nearest residential area, whichever is more restrictive. b) <u>Performance Standards Adjacent to Commercial and Industrial Areas.</u> New commercial projects should not increase noise levels in a commercial area by more than 5 dB (L_{dn}) or increase noise levels to an L_{dn} in excess of 70 dB (office buildings, business and professional) or an L_{dn} of 75 dB (industrial) at the property line of an adjacent commercial/industrial use, whichever is more restrictive.

CHAPTER 30.40
PERFORMANCE STANDARDS

30.40.010. PURPOSE

In order to minimize the adverse impacts of certain nuisance factors and to provide methods of determining compatibility between uses of land and buildings, the following performance standards are established. (Ord. 90-04)

A. NOISE

1. Every use shall be so operated that the noise generated does not exceed the following levels at or beyond the lot line and does not exceed the limits of any adjacent zone.

Adjacent Zone	One Hour Average Sound Level	
	7am-10pm	10pm-7am
RR, RR-1, RR-2, R-3, R-5, R-8	50 dB	45 dB
R-11, RS-11, R-15, R-20, R-25, MHP	55 dB	50 dB
OP, LLC, LC, GC L-VSC, VSC	60 dB	55 dB
L-I, BP	60 dB	55 dB

2. ER/OS/PK - Will be governed by the limits applicable to the source of the complaint.

3. The interior noise level as required by the State of California Noise Insulation Standards must not exceed an LDN of 45 dB in multi-family dwellings. This interior standard shall also be applied to single family dwellings and offices in the City of Encinitas.

4. It shall be unlawful for any person on any property within the City to create any noise, or to allow the creation of any noise on property owned, leased,

occupied, or otherwise controlled by such person, which causes the noise level when measured on any other property to exceed the following:

- a. The noise standard for cumulative period of more than 30 minutes in any hour; or
- b. The noise standard plus 5 dB for a cumulative period of more than 15 minutes in any hour; or
- c. The noise standard plus up to 15 dB for a cumulative period of more than 1 minute in any hour; or
- d. The noise standard plus 20 dB for any period of time.

5. For the purpose of this Chapter, the peak decibel reading for a noise with a fluctuating noise level (such as live or recorded music) shall be considered as the noise level for the entire cumulative period of the noise. Likewise, the time between repetitive intermittent noises (such as banging, pounding, or hammering) shall be included in the cumulative of the noise.

B. VIBRATION

Every use shall be so operated that the ground vibration generated at any time and measured at any point along the lot line of the lot on which the use is located shall not be perceptible and shall not exceed the following:

Adjacent Zone	Vibration in Inches per Second	
	Impact	Steady-State
Residential	.006	.003
Commercial	.010	.005
Light Industrial	.040	.020
Public/Semi-Public	.010	.005

C. RADIOACTIVITY AND ELECTRICAL DISTURBANCES (Ord. 90-07)

1. Except with the prior approval of the City as to specific uses, the use of radioactive materials within any zone shall be limited to measuring, gauging, and calibration devices, as tracer elements in X-ray and like

Encinitas Municipal Code[Up](#)[Previous](#)[Next](#)[Main](#)[Search](#)[Print](#)[No Frames](#)[Title 9 PUBLIC SAFETY, PEACE, AND WELFARE](#)[Chapter 9.32 NOISE ABATEMENT AND CONTROL](#)**9.32.410 Construction Equipment.**

Except for emergency work, it shall be unlawful for any person, including the City, to operate construction equipment at any construction site, except as outlined in subsections A and B of this section:

A. It shall be unlawful for any person, including the City, to operate construction equipment at any construction site on Sundays, and days appointed by the President, Governor or the City Council for a public fast, thanksgiving or holiday. Notwithstanding the above, a person may operate construction equipment on the above-specified days between the hours of 10:00 a.m. and 5:00 p.m. in compliance with the requirements of subsection B of this section at his or her residence or for the purpose of constructing a residence for him or herself, provided such operation of construction equipment is not carried on for profit or livelihood. In addition, it shall be unlawful for any person to operate construction equipment at any construction site on Mondays through Saturdays except between the hours of 7:00 a.m. and 7:00 p.m.

B. No such equipment, or combination of equipment regardless of age or date of acquisition, shall be operated so as to cause noise at a level in excess of 75 decibels for more than eight hours during any 24-hour period when measured at or within the property lines of any property which is developed and used either in part or in whole for residential purposes.

In the event that lower noise limit standards are established for construction equipment pursuant to state or federal law, said lower limits shall be used as a basis for revising and amending the noise level limits specified in this subsection.

View the [mobile version](#).

1206.3 Courts. Courts shall be not less than 3 feet (914 mm) in width. Courts having windows opening on opposite sides shall be not less than 6 feet (1829 mm) in width. Courts shall be not less than 10 feet (3048 mm) in length unless bounded on one end by a public way or yard. For buildings more than two stories above grade plane, the court shall be increased 1 foot (305 mm) in width and 2 feet (610 mm) in length for each additional story. For buildings exceeding 14 stories above grade plane, the required dimensions shall be computed on the basis of 14 stories above grade plane.

1206.3.1 Court access. Access shall be provided to the bottom of courts for cleaning purposes.

1206.3.2 Air intake. Courts more than two stories in height shall be provided with a horizontal air intake at the bottom not less than 10 square feet (0.93 m²) in area and leading to the exterior of the building unless abutting a yard or public way.

1206.3.3 Court drainage. The bottom of every court shall be properly graded and drained to a public sewer or other approved disposal system complying with the *California Plumbing Code*.

**SECTION 1207
SOUND TRANSMISSION**

1207.1 Scope. This section shall apply to common interior walls, partitions and floor/ceiling assemblies between adjacent dwelling units and sleeping units or between dwelling units and sleeping units and adjacent public areas such as halls, corridors, stairways or service areas.

1207.2 Air-borne sound. Walls, partitions and floor/ceiling assemblies separating dwelling units and sleeping units from each other or from public or service areas shall have a sound transmission class of not less than 50, or not less than 45 if field tested, for air-borne noise when tested in accordance with ASTM E90. Penetrations or openings in construction assemblies for piping; electrical devices; recessed cabinets; bathtubs; soffits; or heating, ventilating or exhaust ducts shall be sealed, lined, insulated or otherwise treated to maintain the required ratings. This requirement shall not apply to entrance doors; however, such doors shall be tight fitting to the frame and sill.

1207.2.1 Masonry. The sound transmission class of concrete masonry and clay masonry assemblies shall be calculated in accordance with TMS 0302 or determined through testing in accordance with ASTM E90.

1207.3 Structure-borne sound. Floor/ceiling assemblies between dwelling units and sleeping units or between a dwelling unit or sleeping unit and a public or service area within the structure shall have an impact insulation class rating of not less than 50, or not less than 45 if field tested, when tested in accordance with ASTM E492.

Exception: Impact sound insulation is not required for floor-ceiling assemblies over nonhabitable rooms or spaces not designed to be occupied, such as garages, mechanical rooms or storage areas.

1207.4 Allowable interior noise levels. Interior noise levels attributable to exterior sources shall not exceed 45 dB in any

habitable room. The noise metric shall be either the day-night average sound level (*L_{dn}*) or the community noise equivalent level (*CNEL*), consistent with the noise element of the local general plan.

1207.5 Acoustical control. [BSC-CG] See *California Green Building Standards Code, Chapter 5, Division 5.5* for additional sound transmission requirements.

**SECTION 1208
INTERIOR SPACE DIMENSIONS**

1208.1 Minimum room widths. Habitable spaces, other than a kitchen, shall be not less than 7 feet (2134 mm) in any plan dimension. Kitchens shall have a clear passageway of not less than 3 feet (914 mm) between counter fronts and appliances or counter fronts and walls.

[HCD 1] For limited-density owner-built rural dwellings, there shall be no requirements for room dimensions, provided there is adequate light and ventilation and adequate means of egress.

1208.2 Minimum ceiling heights. Occupiable spaces, habitable spaces and corridors shall have a ceiling height of not less than 7 feet 6 inches (2286 mm). Bathrooms, toilet rooms, kitchens, storage rooms and laundry rooms shall have a ceiling height of not less than 7 feet (2134 mm).

Exceptions:

1. In one- and two-family dwellings, beams or girders spaced not less than 4 feet (1219 mm) on center shall be permitted to project not more than 6 inches (152 mm) below the required ceiling height.
2. If any room in a building has a sloped ceiling, the prescribed ceiling height for the room is required in one-half the area thereof. Any portion of the room measuring less than 5 feet (1524 mm) from the finished floor to the ceiling shall not be included in any computation of the minimum area thereof.
3. The height of mezzanines and spaces below mezzanines shall be in accordance with Section 505.1.
4. Corridors contained within a dwelling unit or sleeping unit in a Group R occupancy shall have a ceiling height of not less than 7 feet (2134 mm).
5. [OSHPD 1, 2 & 3] Minimum ceiling heights shall comply with Section 1224.4.10.
6. [OSHPD 4] Minimum ceiling heights shall comply with Section 1227.8

1208.2.1 Furred ceiling. Any room with a furred ceiling shall be required to have the minimum ceiling height in two-thirds of the area thereof, but in no case shall the height of the furred ceiling be less than 7 feet (2134 mm).

1208.3 Room area. Every dwelling unit shall have no fewer than one room that shall have not less than 120 square feet (13.9 m²) of net floor area. Other habitable rooms shall have a net floor area of not less than 70 square feet (6.5 m²).

Exception: Kitchens are not required to be of a minimum floor area.

5.504.7 Environmental tobacco smoke (ETS) control. Where outdoor areas are provided for smoking, prohibit smoking within 25 feet of building entries, outdoor air intakes and operable windows and within the building as already prohibited by other laws or regulations; or as enforced by ordinances, regulations or policies of any city, county, city and county, California Community College, campus of the California State University, or campus of the University of California, whichever are more stringent. When ordinances, regulations or policies are not in place, post signage to inform building occupants of the prohibitions.

SECTION 5.505 INDOOR MOISTURE CONTROL

5.505.1 Indoor moisture control. Buildings shall meet or exceed the provisions of *California Building Code*, CCR, Title 24, Part 2, Sections 1203 (Ventilation) and Chapter 14 (Exterior Walls). For additional measures not applicable to low-rise residential occupancies, see Section 5.407.2 of this code.

SECTION 5.506 INDOOR AIR QUALITY

5.506.1 Outside air delivery. For mechanically or naturally ventilated spaces in buildings, meet the minimum requirements of Section 120.1 (Requirements For Ventilation) of the 2013 *California Energy Code*, or the applicable local code, whichever is more stringent, and Division 1, Chapter 4 of CCR, Title 8.

5.506.2 Carbon dioxide (CO₂) monitoring. For buildings or additions equipped with demand control ventilation, CO₂ sensors and ventilation controls shall be specified and installed in accordance with the requirements of the 2013 *California Energy Code*, Section 120(c)(4).

SECTION 5.507 ENVIRONMENTAL COMFORT

5.507.4 Acoustical control. Employ building assemblies and components with Sound Transmission Class (STC) values determined in accordance with ASTM E90 and ASTM E413 or Outdoor-Indoor Sound Transmission Class (OITC) determined in accordance with ASTM E1332, using either the prescriptive or performance method in Section 5.507.4.1 or 5.507.4.2.

Exception: Buildings with few or no occupants or where occupants are not likely to be affected by exterior noise, as determined by the enforcement authority, such as factories, stadiums, storage, enclosed parking structures and utility buildings.

Exception: [DSA-SS] For public schools and community colleges, the requirements of this section and all subsections apply only to new construction.

5.507.4.1 Exterior noise transmission, prescriptive method. Wall and roof-ceiling assemblies exposed to the noise source making up the building or addition envelope

or altered envelope shall meet a composite STC rating of at least 50 or a composite OITC rating of no less than 40, with exterior windows of a minimum STC of 40 or OITC of 30 in the following locations:

1. Within the 65 CNEL noise contour of an airport.

Exceptions:

1. L_{dn} or CNEL for military airports shall be determined by the facility Air Installation Compatible Land Use Zone (AICUZ) plan.
2. L_{dn} or CNEL for other airports and heliports for which a land use plan has not been developed shall be determined by the local general plan noise element.
2. Within the 65 CNEL or L_{dn} noise contour of a freeway or expressway, railroad, industrial source or fixed-guideway source as determined by the Noise Element of the General Plan.

5.507.4.1.1 Noise exposure where noise contours are not readily available. Buildings exposed to a noise level of 65 dB L_{eq} -1-hr during any hour of operation shall have building, addition or alteration exterior wall and roof-ceiling assemblies exposed to the noise source meeting a composite STC rating of at least 45 (or OITC 35), with exterior windows of a minimum STC of 40 (or OITC 30).

5.507.4.2 Performance method. For buildings located as defined in Section 5.507.4.1 or 5.507.4.1.1, wall and roof-ceiling assemblies exposed to the noise source making up the building or addition envelope or altered envelope shall be constructed to provide an interior noise environment attributable to exterior sources that does not exceed an hourly equivalent noise level (L_{eq} -1Hr) of 50 dBA in occupied areas during any hour of operation.

5.507.4.2.1 Site features. Exterior features such as sound walls or earth berms may be utilized as appropriate to the building, addition or alteration project to mitigate sound migration to the interior.

5.507.4.2.2 Documentation of compliance. An acoustical analysis documenting complying interior sound levels shall be prepared by personnel approved by the architect or engineer of record.

5.507.4.3 Interior sound transmission. Wall and floor-ceiling assemblies separating tenant spaces and tenant spaces and public places shall have an STC of at least 40.

Note: Examples of assemblies and their various STC ratings may be found at the California Office of Noise Control: http://www.toolbase.org/PDF/CaseStudies/stc_icc_ratings.pdf.

SECTION 5.508 OUTDOOR AIR QUALITY

5.508.1 Ozone depletion and greenhouse gas reductions. Installations of HVAC, refrigeration and fire suppression equipment shall comply with Sections 5.508.1.1 and 5.508.1.2.

APPENDIX C

Pertinent Sections of the Mizuta Traffic Consulting Traffic Study

516 La Costa Development Traffic Study

Prepared for:

DM LaCosta Avenue LLC
1650 N Coast Highway 101
Encinitas, CA 92024

Prepared by:

Marc Mizuta, PE, TE, PTOE



5694 Mission Center Road, #602-121
San Diego, CA 92108

June 2019



xx / yy - AM / PM Peak-Hour Turning Movement Volumes
 The naming convention for intersections is North / South & East / West

N Coast Hwy 101 & La Costa Ave	Vulcan Ave & La Costa Ave	Proj Dwy & La Costa Ave	I-5 SB Ramps & La Costa Ave
<p>1</p> <p>1040 / 372 249 / 204</p> <p>71 / 220 248 / 281</p> <p>208 / 513 201 / 219</p>	<p>2</p> <p>349 / 441 261 / 123</p> <p>361 / 343 82 / 56</p> <p>33 / 58 183 / 152</p>	<p>Intersection does not exist</p>	<p>4</p> <p>287 / 163 4 / 1 508 / 451</p> <p>447 / 484 657 / 738</p> <p>617 / 507 67 / 67</p>
<p>I-5 NB Ramps & La Costa Ave</p>			
<p>5</p> <p>652 / 435 1101 / 1123</p> <p>235 / 142 859 / 816</p> <p>38 / 111 0 / 1 379 / 839</p>			



516 La Costa Development
 Existing Conditions Traffic Volumes

Figure 3-2



xx / yy - AM / PM Peak-Hour Turning Movement Volumes
 The naming convention for intersections is North / South & East / West

N Coast Hwy 101 & La Costa Ave	Vulcan Ave & La Costa Ave	Proj Dwy & La Costa Ave	I-5 SB Ramps & La Costa Ave
<p>1</p> <p>1040 / 372 250 / 205</p> <p>71 / 220 249 / 282</p> <p>208 / 513 202 / 220</p>	<p>2</p> <p>350 / 442 261 / 123</p> <p>363 / 345 82 / 56</p> <p>33 / 58 183 / 152</p>	<p>3</p> <p>1 / 1 3 / 4</p> <p>5 / 7 904 / 670</p> <p>2 / 2 684 / 574</p>	<p>4</p> <p>288 / 165 4 / 1</p> <p>508 / 451 451 / 489 657 / 738</p> <p>619 / 509 68 / 69</p>
I-5 NB Ramps & La Costa Ave			
<p>5</p> <p>652 / 435 1103 / 1125</p> <p>236 / 143 860 / 817</p> <p>40 / 114 0 / 1 379 / 839</p>			



516 La Costa Development
 Existing Plus Project Traffic Volumes

Figure 5-2

APPENDIX D

Traffic Noise Model (TNM) Data and Results

INPUT: ROADWAYS

S200108 516 La Costa

Eilar Associates					26 January 2020					
MLO					TNM 2.5					
INPUT: ROADWAYS										
PROJECT/CONTRACT:	S200108 516 La Costa								Average pavement type shall be used unless a State highway agency substantiates the use of a different type with the approval of FHWA	
RUN:	Calibration									

Roadway	Width	Points	No.	Coordinates (pavement)			Flow Control			Segment	
Name		Name		X	Y	Z	Control Device	Speed Constraint	Percent Vehicles Affected	Pvmt Type	On Struct?
	m			m	m	m		km/h	%		
I-5 NB	14.6	point1	1	633.0	-20.5	11.00				Average	
		point2	2	590.1	97.1	8.00				Average	
		point3	3	569.1	152.6	4.00				Average	
		point4	4	450.7	372.7	2.00				Average	
		point5	5	375.9	512.1	3.00					
I-5 SB	14.6	point6	6	348.2	510.4	3.00				Average	
		point7	7	427.2	366.8	2.00				Average	
		point8	8	546.5	140.8	4.00				Average	
		point9	9	569.1	86.2	8.00				Average	
		point10	10	606.1	-23.8	11.00					
EB La Costa	4.6	point11	11	-12.8	86.6	20.00				Average	
		point12	12	118.4	88.4	23.00				Average	
		point13	13	184.5	89.0	24.00				Average	
		point14	14	358.6	89.4	23.00				Average	
		point15	15	502.6	93.8	17.00				Average	Y
		point16	16	643.4	122.9	11.00				Average	
		point17	17	741.4	156.9	8.00					
WB La Costa	4.6	point18	18	731.5	171.2	8.00				Average	
		point19	19	630.2	135.2	11.00				Average	Y
		point20	20	490.8	107.2	17.00				Average	
		point21	21	362.8	94.1	23.00				Average	
		point22	22	182.3	93.8	24.00				Average	
		point23	23	116.8	93.6	23.00				Average	
		point24	24	-15.5	92.1	20.00					
Ramp	7.3	point25	25	348.2	497.0	3.00				Average	

INPUT: ROADWAYS**S200108 516 La Costa**

		point26	26	404.1	367.3	3.00				Average	
		point27	27	441.0	266.2	7.00				Average	
		point28	28	486.0	117.3	17.00					

INPUT: TRAFFIC FOR LAeq1h Volumes

S200108 516 La Costa

Eilar Associates		26 January 2020										
MLO		TNM 2.5										
INPUT: TRAFFIC FOR LAeq1h Volumes												
PROJECT/CONTRACT:		S200108 516 La Costa										
RUN:		Calibration										
Roadway	Points											
Name	Name	No.	Segment		MTrucks		HTrucks		Buses		Motorcycles	
			Autos		V	S	V	S	V	S	V	S
			V	S	veh/hr	km/h	veh/hr	km/h	veh/hr	km/h	veh/hr	km/h
I-5 NB	point1	1	6020	105	120	88	185	88	0	0	0	0
	point2	2	6020	105	120	88	185	88	0	0	0	0
	point3	3	6020	105	120	88	185	88	0	0	0	0
	point4	4	6020	105	120	88	185	88	0	0	0	0
	point5	5										
I-5 SB	point6	6	6020	105	120	88	185	88	0	0	0	0
	point7	7	6020	105	120	88	185	88	0	0	0	0
	point8	8	6020	105	120	88	185	88	0	0	0	0
	point9	9	6020	105	120	88	185	88	0	0	0	0
	point10	10										
EB La Costa	point11	11	350	64	14	64	6	64	0	0	0	0
	point12	12	350	64	14	64	6	64	0	0	0	0
	point13	13	350	64	14	64	6	64	0	0	0	0
	point14	14	350	64	14	64	6	64	0	0	0	0
	point15	15	350	64	14	64	6	64	0	0	0	0
	point16	16	350	64	14	64	6	64	0	0	0	0
	point17	17										
WB La Costa	point18	18	350	64	14	64	6	64	0	0	0	0
	point19	19	350	64	14	64	6	64	0	0	0	0
	point20	20	350	64	14	64	6	64	0	0	0	0
	point21	21	350	64	14	64	6	64	0	0	0	0
	point22	22	350	64	14	64	6	64	0	0	0	0
	point23	23	350	64	14	64	6	64	0	0	0	0

INPUT: TRAFFIC FOR LAeq1h Volumes**S200108 516 La Costa**

	point24	24										
Ramp	point25	25	395	48	8	48	12	48	0	0	0	0
	point26	26	395	48	8	48	12	48	0	0	0	0
	point27	27	395	48	8	48	12	48	0	0	0	0
	point28	28										

INPUT: RECEIVERS

S200108 516 La Costa

Eilar Associates							26 January 2020				
MLO							TNM 2.5				
INPUT: RECEIVERS											
PROJECT/CONTRACT:		S200108 516 La Costa									
RUN:		Calibration									
Receiver											
Name	No.	#DUs	Coordinates (ground)			Height	Input Sound Levels and Criteria				Active
			X	Y	Z	above	Existing	Impact Criteria		NR	in
						Ground	LAeq1h	LAeq1h	Sub'l	Goal	Calc.
			m	m	m	m	dBA	dBA	dB	dB	
calibration	246	1	360.0	100.9	22.80	1.52	0.00	66	10.0	8.0	Y

INPUT: TERRAIN LINES

S200108 516 L

Eilar Associates		27 January 2020		
MLO		TNM 2.5		
INPUT: TERRAIN LINES				
PROJECT/CONTRACT:		S200108 516 La Costa		
RUN:		Calibration		
Terrain Line	Points			
Name	No.	Coordinates (ground)		
		X	Y	Z
		m	m	m
Terrain Line1	1	338.1	492.8	3.00
	2	394.1	363.1	3.00
	3	430.9	262.0	7.00
	4	475.9	113.1	17.00
Terrain Line2	5	494.2	117.8	17.00
	6	458.2	243.1	7.00
	7	414.8	359.8	3.00
Terrain Line3	8	356.9	102.5	23.00
	9	355.3	256.5	18.00
	10	317.9	318.3	16.00
	11	293.5	385.5	17.00
	12	259.9	424.5	20.00
	13	207.3	439.2	9.00
Terrain Line4	14	449.6	125.4	19.00
	15	435.3	191.3	15.00
	16	410.1	248.4	5.00
	17	374.4	299.3	11.00
	18	378.6	349.3	3.00
	19	364.8	416.5	2.00
	20	340.5	457.7	2.00
	21	245.2	465.1	1.00
Terrain Line5	22	272.8	106.2	24.00
	23	269.5	185.5	24.00
	24	263.5	334.9	22.00
	25	261.5	389.5	21.00
	26	192.1	399.5	16.00
Terrain Line6	27	194.1	346.2	19.00
	28	241.5	306.2	23.00
	29	241.5	249.5	23.00
	30	246.8	182.8	24.00
	31	248.1	112.8	25.00
Terrain Line7	32	183.5	110.8	24.00
	33	182.8	212.9	23.00
	34	181.5	250.9	23.00
	35	179.5	335.5	19.00
	36	136.1	376.9	16.00
Terrain Line8	37	132.1	105.5	26.00

INPUT: TERRAIN LINES**S200108 516 L**

	38	120.1	339.5	19.00
	39	92.8	367.5	13.00
Terrain Line9	40	370.2	454.0	3.00
	41	419.2	364.8	2.00
	42	538.5	138.8	4.00
Terrain Line10	46	360.0	264.1	19.80
	47	365.7	255.7	19.80
	48	366.9	251.0	19.80
	49	366.6	249.4	19.80
	50	369.5	245.3	19.80
	51	374.2	242.5	19.80
	52	377.8	241.7	19.80
	53	379.9	239.8	19.80
	54	379.8	237.2	19.80
	55	378.7	235.8	19.80
	56	378.8	232.3	19.80
	57	382.0	228.4	19.80
	58	388.7	215.9	19.80
	59	389.8	212.7	19.80
Terrain Line11	60	355.9	233.5	21.30
	61	356.3	232.1	21.30
	62	356.3	226.7	21.30
	63	360.9	217.5	21.30
	64	363.7	216.7	21.30
	65	360.1	209.1	21.30
	66	368.0	184.9	21.30
	67	375.8	180.9	21.30
	68	378.0	178.6	21.30
	69	379.4	177.0	21.30
	70	378.6	171.7	21.30
	71	378.4	166.3	21.30
	72	385.3	158.1	21.30

RESULTS: SOUND LEVELS

S200108 516 La Costa

Eilar Associates										26 January 2020			
MLO										TNM 2.5			
										Calculated with TNM 2.5			
RESULTS: SOUND LEVELS													
PROJECT/CONTRACT:		S200108 516 La Costa											
RUN:		Calibration											
BARRIER DESIGN:		INPUT HEIGHTS						Average pavement type shall be used unless a State highway agency substantiates the use of a different type with approval of FHWA.					
ATMOSPHERICS:		20 deg C, 50% RH											
Receiver													
Name		No.	#DUs	Existing LAeq1h	No Barrier LAeq1h Calculated	Crit'n	Increase over existing		With Barrier				
							Calculated	Crit'n	Type Impact	Calculated LAeq1h	Noise Reduction		Calculated minus Goal
								Sub'l Inc			Calculated	Goal	Calculated minus Goal
				dB	dB	dB	dB	dB		dB	dB	dB	dB
calibration		246	1	0.0	68.7	66	68.7	10	Snd Lvl	68.7	0.0	8	-8.0
Dwelling Units			# DUs	Noise Reduction									
				Min	Avg	Max							
				dB	dB	dB							
All Selected			1	0.0	0.0	0.0							
All Impacted			1	0.0	0.0	0.0							
All that meet NR Goal			0	0.0	0.0	0.0							

INPUT: TRAFFIC FOR LAeq1h Volumes

S200108 516 La Costa

Eilar Associates		27 January 2020										
MLO		TNM 2.5										
INPUT: TRAFFIC FOR LAeq1h Volumes												
PROJECT/CONTRACT:		S200108 516 La Costa										
RUN:		Current										
Roadway	Points											
Name	Name	No.	Segment		MTrucks		HTrucks		Buses		Motorcycles	
			Autos		V	S	V	S	V	S	V	S
			V	S	veh/hr	km/h	veh/hr	km/h	veh/hr	km/h	veh/hr	km/h
I-5 NB	point1	1	8933	105	177	88	274	88	0	0	0	0
	point2	2	8933	105	177	88	274	88	0	0	0	0
	point3	3	8933	105	177	88	274	88	0	0	0	0
	point4	4	8933	105	177	88	274	88	0	0	0	0
	point5	5										
I-5 SB	point6	6	8933	105	177	88	274	88	0	0	0	0
	point7	7	8933	105	177	88	274	88	0	0	0	0
	point8	8	8933	105	177	88	274	88	0	0	0	0
	point9	9	8933	105	177	88	274	88	0	0	0	0
	point10	10										
EB La Costa	point11	11	685	64	14	64	7	64	0	0	0	0
	point12	12	685	64	14	64	7	64	0	0	0	0
	point13	13	685	64	14	64	7	64	0	0	0	0
	point14	14	685	64	14	64	7	64	0	0	0	0
	point15	15	685	64	14	64	7	64	0	0	0	0
	point16	16	685	64	14	64	7	64	0	0	0	0
	point17	17										
WB La Costa	point18	18	685	64	14	64	7	64	0	0	0	0
	point19	19	685	64	14	64	7	64	0	0	0	0
	point20	20	685	64	14	64	7	64	0	0	0	0
	point21	21	685	64	14	64	7	64	0	0	0	0
	point22	22	685	64	14	64	7	64	0	0	0	0
	point23	23	685	64	14	64	7	64	0	0	0	0

INPUT: TRAFFIC FOR LAeq1h Volumes**S200108 516 La Costa**

	point24	24										
Ramp	point25	25	587	48	12	48	18	48	0	0	0	0
	point26	26	587	48	12	48	18	48	0	0	0	0
	point27	27	587	48	12	48	18	48	0	0	0	0
	point28	28										

INPUT: RECEIVERS

S200108 516 La Costa

Eilar Associates																						
MLO																						
										27 January 2020												
										TNM 2.5												
INPUT: RECEIVERS																						
PROJECT/CONTRACT:	S200108 516 La Costa																					
RUN:	Current																					

Receiver																					
Name	No.	#DUs	Coordinates (ground)			Height	Input Sound Levels and Criteria				Active										
			X	Y	Z	above	Impact Criteria			NR	in										
						Ground	LAeq1h	LAeq1h	Sub'l	Goal	Calc.										
			m	m	m	m	dBA	dBA	dB	dB											
1	246	0	360.6	101.0	22.81	1.52	0.00	66	10.0	8.0	Y										
2	338	0	360.6	109.0	22.72	1.52	0.00	66	10.0	8.0	Y										
3	339	0	360.6	117.0	22.58	1.52	0.00	66	10.0	8.0	Y										
4	340	0	360.6	125.0	22.50	1.52	0.00	66	10.0	8.0	Y										
5	341	0	360.6	133.0	22.41	1.52	0.00	66	10.0	8.0	Y										
6	342	0	360.6	141.0	22.29	1.52	0.00	66	10.0	8.0	Y										
7	343	0	360.6	149.0	22.18	1.52	0.00	66	10.0	8.0	Y										
8	344	0	360.6	157.0	22.06	1.52	0.00	66	10.0	8.0	Y										
9	345	0	360.6	165.0	21.95	1.52	0.00	66	10.0	8.0	Y										
10	346	0	360.6	173.0	21.84	1.52	0.00	66	10.0	8.0	Y										
11	347	0	360.6	181.0	21.72	1.52	0.00	66	10.0	8.0	Y										
12	348	0	360.6	189.0	21.61	1.52	0.00	66	10.0	8.0	Y										
13	349	0	360.6	197.0	21.49	1.52	0.00	66	10.0	8.0	Y										
14	350	0	360.6	205.0	21.38	1.52	0.00	66	10.0	8.0	Y										
15	351	0	360.6	213.0	21.34	1.52	0.00	66	10.0	8.0	Y										
16	352	0	360.6	221.0	21.17	1.52	0.00	66	10.0	8.0	Y										
17	353	0	360.6	229.0	20.78	1.52	0.00	66	10.0	8.0	Y										
18	354	0	360.6	237.0	20.81	1.52	0.00	66	10.0	8.0	Y										
19	355	0	360.6	245.0	19.77	1.52	0.00	66	10.0	8.0	Y										
20	356	0	360.6	253.0	18.78	1.52	0.00	66	10.0	8.0	Y										
21	357	0	368.6	101.0	22.54	1.52	0.00	66	10.0	8.0	Y										
22	358	0	368.6	109.0	22.17	1.52	0.00	66	10.0	8.0	Y										

INPUT: RECEIVERS

S200108 516 La Costa

23	359	0	368.6	117.0	22.14	1.52	0.00	66	10.0	8.0	Y
24	360	0	368.6	125.0	22.10	1.52	0.00	66	10.0	8.0	Y
25	361	0	368.6	133.0	21.94	1.52	0.00	66	10.0	8.0	Y
26	362	0	368.6	141.0	21.74	1.52	0.00	66	10.0	8.0	Y
27	363	0	368.6	149.0	21.66	1.52	0.00	66	10.0	8.0	Y
28	364	0	368.6	157.0	21.58	1.52	0.00	66	10.0	8.0	Y
29	365	0	368.6	165.0	21.50	1.52	0.00	66	10.0	8.0	Y
30	366	0	368.6	173.0	21.42	1.52	0.00	66	10.0	8.0	Y
31	367	0	368.6	181.0	21.33	1.52	0.00	66	10.0	8.0	Y
32	368	0	368.6	189.0	21.05	1.52	0.00	66	10.0	8.0	Y
33	369	0	368.6	197.0	20.56	1.52	0.00	66	10.0	8.0	Y
34	370	0	368.6	205.0	20.06	1.52	0.00	66	10.0	8.0	Y
35	371	0	368.6	213.0	20.00	1.52	0.00	66	10.0	8.0	Y
36	372	0	368.6	221.0	20.00	1.52	0.00	66	10.0	8.0	Y
37	373	0	368.6	229.0	19.99	1.52	0.00	66	10.0	8.0	Y
38	374	0	368.6	237.0	19.97	1.52	0.00	66	10.0	8.0	Y
39	375	0	368.6	245.0	19.81	1.52	0.00	66	10.0	8.0	Y
40	376	0	376.6	101.0	22.17	1.52	0.00	66	10.0	8.0	Y
41	377	0	376.6	109.0	21.63	1.52	0.00	66	10.0	8.0	Y
42	378	0	376.6	117.0	21.59	1.52	0.00	66	10.0	8.0	Y
43	379	0	376.6	125.0	21.55	1.52	0.00	66	10.0	8.0	Y
44	380	0	376.6	133.0	21.52	1.52	0.00	66	10.0	8.0	Y
45	381	0	376.6	141.0	21.48	1.52	0.00	66	10.0	8.0	Y
46	382	0	376.6	149.0	21.33	1.52	0.00	66	10.0	8.0	Y
47	383	0	376.6	157.0	21.12	1.52	0.00	66	10.0	8.0	Y
48	384	0	376.6	165.0	21.12	1.52	0.00	66	10.0	8.0	Y
49	385	0	376.6	173.0	21.04	1.52	0.00	66	10.0	8.0	Y
50	386	0	376.6	181.0	21.26	1.52	0.00	66	10.0	8.0	Y
51	387	0	376.6	189.0	20.43	1.52	0.00	66	10.0	8.0	Y
52	388	0	376.6	197.0	20.18	1.52	0.00	66	10.0	8.0	Y
53	389	0	376.6	205.0	20.00	1.52	0.00	66	10.0	8.0	Y
54	390	0	376.6	213.0	20.00	1.52	0.00	66	10.0	8.0	Y
55	391	0	376.6	221.0	20.00	1.52	0.00	66	10.0	8.0	Y
56	392	0	376.6	229.0	19.91	1.52	0.00	66	10.0	8.0	Y
57	393	0	376.6	237.0	19.81	1.52	0.00	66	10.0	8.0	Y
58	394	0	384.6	101.0	21.80	1.52	0.00	66	10.0	8.0	Y

INPUT: RECEIVERS**S200108 516 La Costa**

59	395	0	384.6	109.0	21.13	1.52	0.00	66	10.0	8.0	Y
60	396	0	384.6	117.0	21.15	1.52	0.00	66	10.0	8.0	Y
61	397	0	384.6	125.0	21.15	1.52	0.00	66	10.0	8.0	Y
62	398	0	384.6	133.0	21.16	1.52	0.00	66	10.0	8.0	Y
63	399	0	384.6	141.0	21.16	1.52	0.00	66	10.0	8.0	Y
64	400	0	384.6	149.0	21.16	1.52	0.00	66	10.0	8.0	Y
65	401	0	384.6	157.0	21.25	1.52	0.00	66	10.0	8.0	Y
66	402	0	384.6	165.0	21.00	1.52	0.00	66	10.0	8.0	Y
67	403	0	384.6	173.0	20.95	1.52	0.00	66	10.0	8.0	Y
68	404	0	384.6	181.0	20.84	1.52	0.00	66	10.0	8.0	Y
69	405	0	384.6	189.0	20.43	1.52	0.00	66	10.0	8.0	Y
70	406	0	384.6	197.0	20.00	1.52	0.00	66	10.0	8.0	Y
71	407	0	384.6	205.0	20.00	1.52	0.00	66	10.0	8.0	Y
72	408	0	384.6	213.0	19.93	1.52	0.00	66	10.0	8.0	Y
73	409	0	384.6	221.0	19.83	1.52	0.00	66	10.0	8.0	Y
74	410	0	384.6	229.0	18.77	1.52	0.00	66	10.0	8.0	Y
75	411	0	392.6	101.0	21.43	1.52	0.00	66	10.0	8.0	Y
76	412	0	392.6	109.0	21.13	1.52	0.00	66	10.0	8.0	Y
77	413	0	392.6	117.0	21.13	1.52	0.00	66	10.0	8.0	Y
78	414	0	392.6	125.0	21.13	1.52	0.00	66	10.0	8.0	Y
79	415	0	392.6	133.0	21.13	1.52	0.00	66	10.0	8.0	Y
80	416	0	392.6	141.0	21.15	1.52	0.00	66	10.0	8.0	Y
81	417	0	392.6	149.0	21.15	1.52	0.00	66	10.0	8.0	Y
82	418	0	392.6	157.0	21.08	1.52	0.00	66	10.0	8.0	Y
83	419	0	392.6	165.0	20.68	1.52	0.00	66	10.0	8.0	Y
84	420	0	392.6	173.0	20.58	1.52	0.00	66	10.0	8.0	Y
85	421	0	392.6	181.0	20.39	1.52	0.00	66	10.0	8.0	Y
86	422	0	392.6	189.0	20.11	1.52	0.00	66	10.0	8.0	Y
87	423	0	392.6	197.0	19.85	1.52	0.00	66	10.0	8.0	Y
88	424	0	392.6	205.0	19.69	1.52	0.00	66	10.0	8.0	Y
89	425	0	392.6	213.0	18.55	1.52	0.00	66	10.0	8.0	Y
90	436	0	392.6	221.0	17.09	1.52	0.00	66	10.0	8.0	Y

RESULTS: SOUND LEVELS

S200108 516 La Costa

Eilar Associates										27 January 2020			
MLO										TNM 2.5			
										Calculated with TNM 2.5			
RESULTS: SOUND LEVELS													
PROJECT/CONTRACT:		S200108 516 La Costa											
RUN:		Current											
BARRIER DESIGN:		INPUT HEIGHTS											
		Average pavement type shall be used unless a State highway agency substantiates the use of a different type with approval of FHWA.											
ATMOSPHERICS:		20 deg C, 50% RH											

Receiver												
Name	No.	#DUs	Existing LAeq1h	No Barrier				With Barrier				
				No Barrier LAeq1h Calculated	Crit'n	Increase over existing		Type Impact	Calculated LAeq1h	Noise Reduction		
						Calculated	Crit'n			Goal	Calculated	Goal
dBA	dBA	dBA	dB	dB	dBA	dB	dB	dB	dB			
1	246	0	0.0	70.7	66	70.7	10	Snd Lvl	70.7	0.0	8	-8.0
2	338	0	0.0	67.7	66	67.7	10	Snd Lvl	67.7	0.0	8	-8.0
3	339	0	0.0	65.4	66	65.4	10	----	65.4	0.0	8	-8.0
4	340	0	0.0	63.8	66	63.8	10	----	63.8	0.0	8	-8.0
5	341	0	0.0	62.8	66	62.8	10	----	62.8	0.0	8	-8.0
6	342	0	0.0	62.1	66	62.1	10	----	62.1	0.0	8	-8.0
7	343	0	0.0	61.9	66	61.9	10	----	61.9	0.0	8	-8.0
8	344	0	0.0	62.0	66	62.0	10	----	62.0	0.0	8	-8.0
9	345	0	0.0	62.6	66	62.6	10	----	62.6	0.0	8	-8.0
10	346	0	0.0	64.1	66	64.1	10	----	64.1	0.0	8	-8.0
11	347	0	0.0	64.4	66	64.4	10	----	64.4	0.0	8	-8.0
12	348	0	0.0	64.6	66	64.6	10	----	64.6	0.0	8	-8.0
13	349	0	0.0	65.0	66	65.0	10	----	65.0	0.0	8	-8.0
14	350	0	0.0	65.6	66	65.6	10	----	65.6	0.0	8	-8.0
15	351	0	0.0	66.6	66	66.6	10	Snd Lvl	66.6	0.0	8	-8.0
16	352	0	0.0	68.9	66	68.9	10	Snd Lvl	68.9	0.0	8	-8.0
17	353	0	0.0	69.8	66	69.8	10	Snd Lvl	69.8	0.0	8	-8.0
18	354	0	0.0	72.4	66	72.4	10	Snd Lvl	72.4	0.0	8	-8.0
19	355	0	0.0	72.3	66	72.3	10	Snd Lvl	72.3	0.0	8	-8.0
20	356	0	0.0	67.4	66	67.4	10	Snd Lvl	67.4	0.0	8	-8.0
21	357	0	0.0	71.0	66	71.0	10	Snd Lvl	71.0	0.0	8	-8.0
22	358	0	0.0	67.9	66	67.9	10	Snd Lvl	67.9	0.0	8	-8.0
23	359	0	0.0	65.7	66	65.7	10	----	65.7	0.0	8	-8.0
24	360	0	0.0	64.3	66	64.3	10	----	64.3	0.0	8	-8.0

RESULTS: SOUND LEVELS

S200108 516 La Costa

25	361	0	0.0	63.4	66	63.4	10	----	63.4	0.0	8	-8.0
26	362	0	0.0	62.6	66	62.6	10	----	62.6	0.0	8	-8.0
27	363	0	0.0	62.6	66	62.6	10	----	62.6	0.0	8	-8.0
28	364	0	0.0	63.3	66	63.3	10	----	63.3	0.0	8	-8.0
29	365	0	0.0	63.8	66	63.8	10	----	63.8	0.0	8	-8.0
30	366	0	0.0	65.4	66	65.4	10	----	65.4	0.0	8	-8.0
31	367	0	0.0	66.1	66	66.1	10	Snd Lvl	66.1	0.0	8	-8.0
32	368	0	0.0	66.9	66	66.9	10	Snd Lvl	66.9	0.0	8	-8.0
33	369	0	0.0	66.2	66	66.2	10	Snd Lvl	66.2	0.0	8	-8.0
34	370	0	0.0	65.3	66	65.3	10	----	65.3	0.0	8	-8.0
35	371	0	0.0	65.0	66	65.0	10	----	65.0	0.0	8	-8.0
36	372	0	0.0	66.3	66	66.3	10	Snd Lvl	66.3	0.0	8	-8.0
37	373	0	0.0	70.8	66	70.8	10	Snd Lvl	70.8	0.0	8	-8.0
38	374	0	0.0	72.8	66	72.8	10	Snd Lvl	72.8	0.0	8	-8.0
39	375	0	0.0	73.6	66	73.6	10	Snd Lvl	73.6	0.0	8	-8.0
40	376	0	0.0	71.3	66	71.3	10	Snd Lvl	71.3	0.0	8	-8.0
41	377	0	0.0	68.3	66	68.3	10	Snd Lvl	68.3	0.0	8	-8.0
42	378	0	0.0	66.4	66	66.4	10	Snd Lvl	66.4	0.0	8	-8.0
43	379	0	0.0	65.2	66	65.2	10	----	65.2	0.0	8	-8.0
44	380	0	0.0	64.6	66	64.6	10	----	64.6	0.0	8	-8.0
45	381	0	0.0	64.3	66	64.3	10	----	64.3	0.0	8	-8.0
46	382	0	0.0	65.1	66	65.1	10	----	65.1	0.0	8	-8.0
47	383	0	0.0	65.4	66	65.4	10	----	65.4	0.0	8	-8.0
48	384	0	0.0	66.4	66	66.4	10	Snd Lvl	66.4	0.0	8	-8.0
49	385	0	0.0	67.0	66	67.0	10	Snd Lvl	67.0	0.0	8	-8.0
50	386	0	0.0	68.7	66	68.7	10	Snd Lvl	68.7	0.0	8	-8.0
51	387	0	0.0	68.5	66	68.5	10	Snd Lvl	68.5	0.0	8	-8.0
52	388	0	0.0	68.3	66	68.3	10	Snd Lvl	68.3	0.0	8	-8.0
53	389	0	0.0	68.0	66	68.0	10	Snd Lvl	68.0	0.0	8	-8.0
54	390	0	0.0	70.4	66	70.4	10	Snd Lvl	70.4	0.0	8	-8.0
55	391	0	0.0	72.7	66	72.7	10	Snd Lvl	72.7	0.0	8	-8.0
56	392	0	0.0	73.4	66	73.4	10	Snd Lvl	73.4	0.0	8	-8.0
57	393	0	0.0	73.9	66	73.9	10	Snd Lvl	73.9	0.0	8	-8.0
58	394	0	0.0	71.9	66	71.9	10	Snd Lvl	71.9	0.0	8	-8.0
59	395	0	0.0	68.7	66	68.7	10	Snd Lvl	68.7	0.0	8	-8.0
60	396	0	0.0	66.9	66	66.9	10	Snd Lvl	66.9	0.0	8	-8.0
61	397	0	0.0	66.2	66	66.2	10	Snd Lvl	66.2	0.0	8	-8.0
62	398	0	0.0	66.3	66	66.3	10	Snd Lvl	66.3	0.0	8	-8.0
63	399	0	0.0	66.7	66	66.7	10	Snd Lvl	66.7	0.0	8	-8.0
64	400	0	0.0	67.3	66	67.3	10	Snd Lvl	67.3	0.0	8	-8.0
65	401	0	0.0	68.0	66	68.0	10	Snd Lvl	68.0	0.0	8	-8.0

RESULTS: SOUND LEVELS

S200108 516 La Costa

66	402	0	0.0	68.6	66	68.6	10	Snd Lvl	68.6	0.0	8	-8.0
67	403	0	0.0	69.3	66	69.3	10	Snd Lvl	69.3	0.0	8	-8.0
68	404	0	0.0	70.2	66	70.2	10	Snd Lvl	70.2	0.0	8	-8.0
69	405	0	0.0	70.7	66	70.7	10	Snd Lvl	70.7	0.0	8	-8.0
70	406	0	0.0	71.2	66	71.2	10	Snd Lvl	71.2	0.0	8	-8.0
71	407	0	0.0	72.5	66	72.5	10	Snd Lvl	72.5	0.0	8	-8.0
72	408	0	0.0	73.1	66	73.1	10	Snd Lvl	73.1	0.0	8	-8.0
73	409	0	0.0	73.6	66	73.6	10	Snd Lvl	73.6	0.0	8	-8.0
74	410	0	0.0	73.9	66	73.9	10	Snd Lvl	73.9	0.0	8	-8.0
75	411	0	0.0	72.4	66	72.4	10	Snd Lvl	72.4	0.0	8	-8.0
76	412	0	0.0	69.1	66	69.1	10	Snd Lvl	69.1	0.0	8	-8.0
77	413	0	0.0	67.5	66	67.5	10	Snd Lvl	67.5	0.0	8	-8.0
78	414	0	0.0	66.9	66	66.9	10	Snd Lvl	66.9	0.0	8	-8.0
79	415	0	0.0	67.0	66	67.0	10	Snd Lvl	67.0	0.0	8	-8.0
80	416	0	0.0	67.7	66	67.7	10	Snd Lvl	67.7	0.0	8	-8.0
81	417	0	0.0	68.3	66	68.3	10	Snd Lvl	68.3	0.0	8	-8.0
82	418	0	0.0	69.0	66	69.0	10	Snd Lvl	69.0	0.0	8	-8.0
83	419	0	0.0	69.6	66	69.6	10	Snd Lvl	69.6	0.0	8	-8.0
84	420	0	0.0	70.3	66	70.3	10	Snd Lvl	70.3	0.0	8	-8.0
85	421	0	0.0	71.2	66	71.2	10	Snd Lvl	71.2	0.0	8	-8.0
86	422	0	0.0	71.9	66	71.9	10	Snd Lvl	71.9	0.0	8	-8.0
87	423	0	0.0	72.5	66	72.5	10	Snd Lvl	72.5	0.0	8	-8.0
88	424	0	0.0	73.3	66	73.3	10	Snd Lvl	73.3	0.0	8	-8.0
89	425	0	0.0	73.5	66	73.5	10	Snd Lvl	73.5	0.0	8	-8.0
90	436	0	0.0	73.6	66	73.6	10	Snd Lvl	73.6	0.0	8	-8.0
Dwelling Units		# DUs	Noise Reduction									
			Min	Avg	Max							
			dB	dB	dB							
All Selected		0	0.0	0.0	0.0							
All Impacted		0	0.0	0.0	0.0							
All that meet NR Goal		0	0.0	0.0	0.0							

INPUT: TRAFFIC FOR LAeq1h Volumes

S200108 516 La Costa

Eilar Associates		27 January 2020											
MLO		TNM 2.5											
INPUT: TRAFFIC FOR LAeq1h Volumes													
PROJECT/CONTRACT:		S200108 516 La Costa											
RUN:		Future											
Roadway	Points												
Name	Name	No.	Segment		MTrucks		HTrucks		Buses		Motorcycles		
			Autos		V	S	V	S	V	S	V	S	
					veh/hr	km/h	veh/hr	km/h	veh/hr	km/h	veh/hr	km/h	
I-5 NB	point1	1	10106	105	201	88	310	88	0	0	0	0	
	point2	2	10106	105	201	88	310	88	0	0	0	0	
	point3	3	10106	105	201	88	310	88	0	0	0	0	
	point4	4	10106	105	201	88	310	88	0	0	0	0	
	point5	5											
I-5 SB	point6	6	9624	105	191	88	295	88	0	0	0	0	
	point7	7	9624	105	191	88	295	88	0	0	0	0	
	point8	8	9624	105	191	88	295	88	0	0	0	0	
	point9	9	9624	105	191	88	295	88	0	0	0	0	
	point10	10											
EB La Costa	point11	11	861	64	18	64	9	64	0	0	0	0	
	point12	12	861	64	18	64	9	64	0	0	0	0	
	point13	13	861	64	18	64	9	64	0	0	0	0	
	point14	14	861	64	18	64	9	64	0	0	0	0	
	point15	15	861	64	18	64	9	64	0	0	0	0	
	point16	16	861	64	18	64	9	64	0	0	0	0	
	point17	17											
WB La Costa	point18	18	861	64	18	64	9	64	0	0	0	0	
	point19	19	861	64	18	64	9	64	0	0	0	0	
	point20	20	861	64	18	64	9	64	0	0	0	0	
	point21	21	861	64	18	64	9	64	0	0	0	0	
	point22	22	861	64	18	64	9	64	0	0	0	0	
	point23	23	861	64	18	64	9	64	0	0	0	0	

INPUT: TRAFFIC FOR LAeq1h Volumes**S200108 516 La Costa**

	point24	24										
Ramp	point25	25	648	48	13	48	20	48	0	0	0	0
	point26	26	648	48	13	48	20	48	0	0	0	0
	point27	27	648	48	13	48	20	48	0	0	0	0
	point28	28										

RESULTS: SOUND LEVELS

S200108 516 La Costa

Eilar Associates								27 January 2020					
MLO								TNM 2.5					
								Calculated with TNM 2.5					
RESULTS: SOUND LEVELS													
PROJECT/CONTRACT:		S200108 516 La Costa											
RUN:		Future											
BARRIER DESIGN:		INPUT HEIGHTS						Average pavement type shall be used unless a State highway agency substantiates the use of a different type with approval of FHWA.					
ATMOSPHERICS:		20 deg C, 50% RH											
Receiver													
Name	No.	#DUs	Existing	No Barrier				With Barrier					
			LAeq1h	LAeq1h	Crit'n	Increase over existing	Type	Calculated	Noise Reduction	Calculated	Goal	Calculated	
				Calculated	Crit'n	Calculated	Crit'n	Impact	LAeq1h	Calculated	Goal	Calculated	
							Sub'l Inc					minus	
												Goal	
			dBA	dBA	dBA	dB	dB		dBA	dB	dB	dB	
1	246	0	0.0	71.7	66	71.7	10	Snd Lvl	71.7	0.0	8	-8.0	
2	338	0	0.0	68.6	66	68.6	10	Snd Lvl	68.6	0.0	8	-8.0	
3	339	0	0.0	66.3	66	66.3	10	Snd Lvl	66.3	0.0	8	-8.0	
4	340	0	0.0	64.7	66	64.7	10	----	64.7	0.0	8	-8.0	
5	341	0	0.0	63.6	66	63.6	10	----	63.6	0.0	8	-8.0	
6	342	0	0.0	62.8	66	62.8	10	----	62.8	0.0	8	-8.0	
7	343	0	0.0	62.6	66	62.6	10	----	62.6	0.0	8	-8.0	
8	344	0	0.0	62.6	66	62.6	10	----	62.6	0.0	8	-8.0	
9	345	0	0.0	63.2	66	63.2	10	----	63.2	0.0	8	-8.0	
10	346	0	0.0	64.7	66	64.7	10	----	64.7	0.0	8	-8.0	
11	347	0	0.0	64.9	66	64.9	10	----	64.9	0.0	8	-8.0	
12	348	0	0.0	65.1	66	65.1	10	----	65.1	0.0	8	-8.0	
13	349	0	0.0	65.5	66	65.5	10	----	65.5	0.0	8	-8.0	
14	350	0	0.0	66.1	66	66.1	10	Snd Lvl	66.1	0.0	8	-8.0	
15	351	0	0.0	67.1	66	67.1	10	Snd Lvl	67.1	0.0	8	-8.0	
16	352	0	0.0	69.4	66	69.4	10	Snd Lvl	69.4	0.0	8	-8.0	
17	353	0	0.0	70.3	66	70.3	10	Snd Lvl	70.3	0.0	8	-8.0	
18	354	0	0.0	72.8	66	72.8	10	Snd Lvl	72.8	0.0	8	-8.0	
19	355	0	0.0	72.8	66	72.8	10	Snd Lvl	72.8	0.0	8	-8.0	
20	356	0	0.0	67.8	66	67.8	10	Snd Lvl	67.8	0.0	8	-8.0	
21	357	0	0.0	72.0	66	72.0	10	Snd Lvl	72.0	0.0	8	-8.0	
22	358	0	0.0	68.9	66	68.9	10	Snd Lvl	68.9	0.0	8	-8.0	
23	359	0	0.0	66.6	66	66.6	10	Snd Lvl	66.6	0.0	8	-8.0	
24	360	0	0.0	65.1	66	65.1	10	----	65.1	0.0	8	-8.0	

RESULTS: SOUND LEVELS

S200108 516 La Costa

25	361	0	0.0	64.1	66	64.1	10	----	64.1	0.0	8	-8.0
26	362	0	0.0	63.3	66	63.3	10	----	63.3	0.0	8	-8.0
27	363	0	0.0	63.2	66	63.2	10	----	63.2	0.0	8	-8.0
28	364	0	0.0	63.9	66	63.9	10	----	63.9	0.0	8	-8.0
29	365	0	0.0	64.4	66	64.4	10	----	64.4	0.0	8	-8.0
30	366	0	0.0	65.9	66	65.9	10	----	65.9	0.0	8	-8.0
31	367	0	0.0	66.6	66	66.6	10	Snd Lvl	66.6	0.0	8	-8.0
32	368	0	0.0	67.4	66	67.4	10	Snd Lvl	67.4	0.0	8	-8.0
33	369	0	0.0	66.7	66	66.7	10	Snd Lvl	66.7	0.0	8	-8.0
34	370	0	0.0	65.8	66	65.8	10	----	65.8	0.0	8	-8.0
35	371	0	0.0	65.5	66	65.5	10	----	65.5	0.0	8	-8.0
36	372	0	0.0	66.8	66	66.8	10	Snd Lvl	66.8	0.0	8	-8.0
37	373	0	0.0	71.2	66	71.2	10	Snd Lvl	71.2	0.0	8	-8.0
38	374	0	0.0	73.3	66	73.3	10	Snd Lvl	73.3	0.0	8	-8.0
39	375	0	0.0	74.0	66	74.0	10	Snd Lvl	74.0	0.0	8	-8.0
40	376	0	0.0	72.3	66	72.3	10	Snd Lvl	72.3	0.0	8	-8.0
41	377	0	0.0	69.2	66	69.2	10	Snd Lvl	69.2	0.0	8	-8.0
42	378	0	0.0	67.2	66	67.2	10	Snd Lvl	67.2	0.0	8	-8.0
43	379	0	0.0	66.0	66	66.0	10	Snd Lvl	66.0	0.0	8	-8.0
44	380	0	0.0	65.3	66	65.3	10	----	65.3	0.0	8	-8.0
45	381	0	0.0	65.0	66	65.0	10	----	65.0	0.0	8	-8.0
46	382	0	0.0	65.6	66	65.6	10	----	65.6	0.0	8	-8.0
47	383	0	0.0	66.0	66	66.0	10	Snd Lvl	66.0	0.0	8	-8.0
48	384	0	0.0	66.9	66	66.9	10	Snd Lvl	66.9	0.0	8	-8.0
49	385	0	0.0	67.5	66	67.5	10	Snd Lvl	67.5	0.0	8	-8.0
50	386	0	0.0	69.1	66	69.1	10	Snd Lvl	69.1	0.0	8	-8.0
51	387	0	0.0	69.0	66	69.0	10	Snd Lvl	69.0	0.0	8	-8.0
52	388	0	0.0	68.8	66	68.8	10	Snd Lvl	68.8	0.0	8	-8.0
53	389	0	0.0	68.5	66	68.5	10	Snd Lvl	68.5	0.0	8	-8.0
54	390	0	0.0	70.9	66	70.9	10	Snd Lvl	70.9	0.0	8	-8.0
55	391	0	0.0	73.1	66	73.1	10	Snd Lvl	73.1	0.0	8	-8.0
56	392	0	0.0	73.8	66	73.8	10	Snd Lvl	73.8	0.0	8	-8.0
57	393	0	0.0	74.3	66	74.3	10	Snd Lvl	74.3	0.0	8	-8.0
58	394	0	0.0	72.8	66	72.8	10	Snd Lvl	72.8	0.0	8	-8.0
59	395	0	0.0	69.5	66	69.5	10	Snd Lvl	69.5	0.0	8	-8.0
60	396	0	0.0	67.6	66	67.6	10	Snd Lvl	67.6	0.0	8	-8.0
61	397	0	0.0	66.9	66	66.9	10	Snd Lvl	66.9	0.0	8	-8.0
62	398	0	0.0	66.9	66	66.9	10	Snd Lvl	66.9	0.0	8	-8.0
63	399	0	0.0	67.3	66	67.3	10	Snd Lvl	67.3	0.0	8	-8.0
64	400	0	0.0	67.9	66	67.9	10	Snd Lvl	67.9	0.0	8	-8.0
65	401	0	0.0	68.5	66	68.5	10	Snd Lvl	68.5	0.0	8	-8.0

RESULTS: SOUND LEVELS

S200108 516 La Costa

66	402	0	0.0	69.2	66	69.2	10	Snd Lvl	69.2	0.0	8	-8.0
67	403	0	0.0	69.8	66	69.8	10	Snd Lvl	69.8	0.0	8	-8.0
68	404	0	0.0	70.7	66	70.7	10	Snd Lvl	70.7	0.0	8	-8.0
69	405	0	0.0	71.1	66	71.1	10	Snd Lvl	71.1	0.0	8	-8.0
70	406	0	0.0	71.7	66	71.7	10	Snd Lvl	71.7	0.0	8	-8.0
71	407	0	0.0	72.9	66	72.9	10	Snd Lvl	72.9	0.0	8	-8.0
72	408	0	0.0	73.5	66	73.5	10	Snd Lvl	73.5	0.0	8	-8.0
73	409	0	0.0	74.1	66	74.1	10	Snd Lvl	74.1	0.0	8	-8.0
74	410	0	0.0	74.4	66	74.4	10	Snd Lvl	74.4	0.0	8	-8.0
75	411	0	0.0	73.4	66	73.4	10	Snd Lvl	73.4	0.0	8	-8.0
76	412	0	0.0	70.0	66	70.0	10	Snd Lvl	70.0	0.0	8	-8.0
77	413	0	0.0	68.2	66	68.2	10	Snd Lvl	68.2	0.0	8	-8.0
78	414	0	0.0	67.5	66	67.5	10	Snd Lvl	67.5	0.0	8	-8.0
79	415	0	0.0	67.6	66	67.6	10	Snd Lvl	67.6	0.0	8	-8.0
80	416	0	0.0	68.3	66	68.3	10	Snd Lvl	68.3	0.0	8	-8.0
81	417	0	0.0	68.8	66	68.8	10	Snd Lvl	68.8	0.0	8	-8.0
82	418	0	0.0	69.5	66	69.5	10	Snd Lvl	69.5	0.0	8	-8.0
83	419	0	0.0	70.0	66	70.0	10	Snd Lvl	70.0	0.0	8	-8.0
84	420	0	0.0	70.8	66	70.8	10	Snd Lvl	70.8	0.0	8	-8.0
85	421	0	0.0	71.6	66	71.6	10	Snd Lvl	71.6	0.0	8	-8.0
86	422	0	0.0	72.3	66	72.3	10	Snd Lvl	72.3	0.0	8	-8.0
87	423	0	0.0	73.0	66	73.0	10	Snd Lvl	73.0	0.0	8	-8.0
88	424	0	0.0	73.7	66	73.7	10	Snd Lvl	73.7	0.0	8	-8.0
89	425	0	0.0	74.0	66	74.0	10	Snd Lvl	74.0	0.0	8	-8.0
90	436	0	0.0	74.0	66	74.0	10	Snd Lvl	74.0	0.0	8	-8.0
Dwelling Units		# DUs	Noise Reduction									
			Min	Avg	Max							
			dB	dB	dB							
All Selected		0	0.0	0.0	0.0							
All Impacted		0	0.0	0.0	0.0							
All that meet NR Goal		0	0.0	0.0	0.0							

INPUT: RECEIVERS

S200108 516 La Costa

Eilar Associates							27 January 2020					
MLO							TNM 2.5					
INPUT: RECEIVERS												
PROJECT/CONTRACT:		S200108 516 La Costa										
RUN:		Outdoor Use - Floor 1										
Receiver												
Name	No.	#DUs	Coordinates (ground)			Height above Ground	Input Sound Levels and Criteria				Active in Calc.	
			X	Y	Z		Existing LAeq1h	Impact Criteria LAeq1h	Sub'l	NR Goal		
			m	m	m	m	dBA	dBA	dB	dB		
OU1	246	0	363.0	234.7	20.42	1.07	0.00	66	10.0	8.0	Y	
OU2	338	0	367.4	237.3	20.42	1.07	0.00	66	10.0	8.0	Y	
OU3	339	0	375.0	228.7	20.42	1.07	0.00	66	10.0	8.0	Y	
OU4	340	0	379.6	218.7	20.42	1.07	0.00	66	10.0	8.0	Y	
OU5	341	0	376.2	212.4	20.42	1.07	0.00	66	10.0	8.0	Y	
OU6	342	0	384.1	203.9	20.67	1.07	0.00	66	10.0	8.0	Y	
OU8	345	0	384.3	191.4	21.12	1.07	0.00	66	10.0	8.0	Y	
OU10	348	0	384.5	178.9	21.40	1.07	0.00	66	10.0	8.0	Y	
OU12	351	0	384.6	166.3	21.70	1.07	0.00	66	10.0	8.0	Y	
OU14	436	0	387.3	157.4	21.82	1.07	0.00	66	10.0	8.0	Y	
OU15	441	1	385.4	150.4	22.01	1.07	0.00	66	10.0	8.0	Y	
OU16	442	1	385.7	143.0	22.10	1.07	0.00	66	10.0	8.0	Y	
OU17	443	1	385.7	135.8	22.19	1.07	0.00	66	10.0	8.0	Y	
OU18	444	1	385.7	128.5	22.28	1.07	0.00	66	10.0	8.0	Y	
OU19	445	1	385.8	121.3	22.37	1.07	0.00	66	10.0	8.0	Y	

Eilar Associates	27 January 2020
MLO	TNM 2.5

INPUT: BARRIERS

PROJECT/CONTRACT: S200108 516 La Costa
 RUN: Outdoor Use - Floor 1

Barrier									Points										
Name	Type	Height		If Wall	If Berm			Add'tnl	Name	No.	Coordinates (bottom)			Height	Segment				
		Min	Max	\$ per	\$ per	Top	Run:Rise	\$ per			X	Y	Z	at	Seg	Ht	Perturbs	On	Important
				Unit	Unit	Width		Unit						Point	Incre-	#Up	#Dn	Struct?	Reflec-
		m	m	Area	Vol.		m:m	Length			m	m	m	m	ment				tions?
				\$/sq m	\$/cu m			\$/m											
Restaurant Building	W	0.00	30.48	0.00				0.00	point1	1	365.5	211.3	20.42	5.49	0.00	0	0		
									point2	2	365.2	233.5	20.42	5.49	0.00	0	0		
									point3	3	371.4	233.5	20.42	5.49	0.00	0	0		
									point4	4	371.5	224.9	20.42	5.49	0.00	0	0		
									point5	5	371.9	224.5	20.42	5.49	0.00	0	0		
									point6	6	374.0	226.4	20.42	5.49	0.00	0	0		
									point7	7	378.3	222.0	20.42	5.49	0.00	0	0		
									point8	8	371.6	215.0	20.42	5.49	0.00	0	0		
									point9	9	371.7	211.4	20.42	5.49	0.00	0	0		
									point10	10	365.5	211.3	20.42	5.49					
Bungalow 1	W	0.00	30.48	0.00				0.00	point11	11	380.4	206.4	20.67	5.49	0.00	0	0		
									point12	12	374.9	200.8	20.67	5.49	0.00	0	0		
									point13	13	381.4	194.4	20.67	5.49	0.00	0	0		
									point14	14	386.9	200.1	20.67	5.49	0.00	0	0		
									point15	15	380.4	206.4	20.67	5.49					
Bungalow 2	W	0.00	30.48	0.00				0.00	point16	16	380.6	194.0	21.12	5.49	0.00	0	0		
									point17	17	375.2	188.3	21.12	5.49	0.00	0	0		
									point18	18	381.7	182.0	21.12	5.49	0.00	0	0		
									point19	19	387.2	187.6	21.12	5.49	0.00	0	0		
									point20	20	380.6	194.0	21.12	5.49					
Bungalow 3	W	0.00	30.48	0.00				0.00	point21	21	380.7	181.4	21.40	5.49	0.00	0	0		
									point22	22	375.2	175.8	21.40	5.49	0.00	0	0		
									point23	23	381.7	169.4	21.40	5.49	0.00	0	0		
									point24	24	387.2	175.1	21.40	5.49	0.00	0	0		
									point25	25	380.7	181.4	21.40	5.49					
Bungalow 4	W	0.00	30.48	0.00				0.00	point26	26	380.8	168.8	21.70	5.49	0.00	0	0		
									point27	27	375.4	163.2	21.70	5.49	0.00	0	0		
									point28	28	381.9	156.8	21.70	5.49	0.00	0	0		
									point29	29	387.3	162.5	21.70	5.49	0.00	0	0		
									point30	30	380.8	168.8	21.70	5.49					
Unit 5	W	0.00	30.48	0.00				0.00	point31	31	389.2	149.1	22.01	8.00	0.00	0	0		
									point32	32	380.9	149.0	22.01	8.00	0.00	0	0		
									point33	33	381.0	144.1	22.01	4.34	0.00	0	0		
									point34	34	389.3	144.2	22.01	4.34	0.00	0	0		
									point35	35	389.2	149.1	22.01	8.00					

INPUT: BARRIERS

S200108 516 La Costa

Unit 4	W	0.00	30.48	0.00				0.00	point36	36	389.3	141.9	22.10	8.00	0.00	0	0		
									point37	37	381.0	141.9	22.10	8.00	0.00	0	0		
									point38	38	381.0	137.0	22.10	4.34	0.00	0	0		
									point39	39	389.4	137.0	22.10	4.34	0.00	0	0		
									point40	40	389.3	141.9	22.10	8.00					
Unit 3	W	0.00	30.48	0.00				0.00	point41	41	389.4	134.6	22.19	8.00	0.00	0	0		
									point42	42	381.1	134.5	22.19	8.00	0.00	0	0		
									point43	43	381.2	129.6	22.19	4.34	0.00	0	0		
									point44	44	389.5	129.7	22.19	4.34	0.00	0	0		
									point45	45	389.4	134.6	22.19	8.00					
Unit 2	W	0.00	30.48	0.00				0.00	point46	46	389.5	127.4	22.28	8.00	0.00	0	0		
									point47	47	381.1	127.3	22.28	8.00	0.00	0	0		
									point48	48	381.2	122.4	22.30	4.32	0.00	0	0		
									point49	49	389.6	122.5	22.28	4.34	0.00	0	0		
									point50	50	389.5	127.4	22.28	8.00					
Unit 1	W	0.00	30.48	0.00				0.00	point51	51	389.6	120.1	22.37	8.00	0.00	0	0		
									point52	52	381.3	120.0	22.37	8.00	0.00	0	0		
									point53	53	381.4	115.1	22.37	4.34	0.00	0	0		
									point54	54	389.7	115.2	22.37	4.34	0.00	0	0		
									point55	55	389.6	120.1	22.37	8.00					
PL Barrier	W	0.00	30.48	0.00				0.00	point56	56	392.9	109.1	21.53	2.06	0.00	0	0		
									point57	57	392.8	117.7	22.21	1.38	0.00	0	0		
									point58	58	392.4	158.1	21.47	1.96	0.00	0	0		
									point59	59	392.3	171.8	21.08	2.13	0.00	0	0		
									point60	60	390.5	171.8	21.32	1.89	0.00	0	0		
									point61	61	390.4	183.2	21.04	2.02	0.00	0	0		
									point62	62	390.3	199.0	20.55	0.91	0.00	0	0		
									point63	63	390.2	209.4	19.97	0.45	0.00	0	0		
									point64	64	390.2	215.5	19.19	0.10	0.00	0	0		
									point65	65	390.2	218.4	18.73	0.56					

INPUT: TERRAIN LINES

S200108 516 L

Eilar Associates		27 January 2020		
MLO		TNM 2.5		
INPUT: TERRAIN LINES				
PROJECT/CONTRACT:		S200108 516 La Costa		
RUN:		Outdoor Use - Floor 1		
Terrain Line	Points			
Name	No.	Coordinates (ground)		
		X	Y	Z
		m	m	m
Terrain Line1	1	338.1	492.8	3.00
	2	394.1	363.1	3.00
	3	430.9	262.0	7.00
	4	475.9	113.1	17.00
Terrain Line2	5	494.2	117.8	17.00
	6	458.2	243.1	7.00
	7	414.8	359.8	3.00
Terrain Line3	8	356.9	102.5	23.00
	9	355.3	256.5	18.00
	10	317.9	318.3	16.00
	11	293.5	385.5	17.00
	12	259.9	424.5	20.00
	13	207.3	439.2	9.00
Terrain Line4	14	449.6	125.4	19.00
	15	435.3	191.3	15.00
	16	410.1	248.4	5.00
	17	374.4	299.3	11.00
	18	378.6	349.3	3.00
	19	364.8	416.5	2.00
	20	340.5	457.7	2.00
	21	245.2	465.1	1.00
Terrain Line5	22	272.8	106.2	24.00
	23	269.5	185.5	24.00
	24	263.5	334.9	22.00
	25	261.5	389.5	21.00
	26	192.1	399.5	16.00
Terrain Line6	27	194.1	346.2	19.00
	28	241.5	306.2	23.00
	29	241.5	249.5	23.00
	30	246.8	182.8	24.00
	31	248.1	112.8	25.00
Terrain Line7	32	183.5	110.8	24.00
	33	182.8	212.9	23.00
	34	181.5	250.9	23.00
	35	179.5	335.5	19.00
	36	136.1	376.9	16.00
Terrain Line8	37	132.1	105.5	26.00

INPUT: TERRAIN LINES

S200108 516 L

	38	120.1	339.5	19.00
	39	92.8	367.5	13.00
Terrain Line9	40	370.2	454.0	3.00
	41	419.2	364.8	2.00
	42	538.5	138.8	4.00
Terrain Line10	46	360.0	264.1	19.80
	47	365.7	255.7	19.80
	48	366.9	251.0	19.80
	49	366.6	249.4	19.80
	50	369.5	245.3	19.80
	51	374.2	242.5	19.80
	52	377.8	241.7	19.80
	53	379.9	239.8	19.80
	54	379.8	237.2	19.80
	55	378.7	235.8	19.80
	56	378.8	232.3	19.80
	57	382.0	228.4	19.80
	58	388.7	215.9	19.80
	59	389.8	212.7	19.80
Restaurant Pad	73	363.0	228.8	20.40
	74	361.0	231.3	20.40
	75	360.5	235.6	20.40
	76	362.2	238.6	20.40
	77	365.8	240.1	20.40
	78	369.1	239.7	20.40
	79	372.0	237.1	20.40
	80	385.6	215.8	20.40
	81	385.8	214.0	20.40
	82	382.3	210.3	20.40
	83	378.6	207.9	20.40
	84	364.5	208.9	20.40
	85	363.0	210.4	20.40
	86	363.0	228.8	20.40
Bungalow Pad 1	87	381.5	194.2	20.70
	88	388.7	201.6	20.70
	89	382.0	208.3	20.70
	90	374.7	200.9	20.70
	91	381.5	194.2	20.70
Bungalow Pad 2	92	381.6	181.7	21.10
	93	388.8	189.1	21.10
	94	382.7	195.2	21.10
	95	381.2	193.8	21.10
	96	380.8	194.2	21.10
	97	374.8	188.4	21.10
	98	381.6	181.7	21.10
Bungalow Pad 3	99	381.7	169.1	21.40
	100	388.9	176.6	21.40
	101	382.8	182.6	21.40

INPUT: TERRAIN LINES**S200108 516 L**

	102	381.4	181.2	21.40
	103	380.8	181.7	21.40
	104	375.0	175.8	21.40
	105	381.7	169.1	21.40
Bungalow Pad 4	106	381.9	156.6	21.70
	107	389.1	164.0	21.70
	108	382.9	170.1	21.70
	109	381.5	168.7	21.70
	110	380.9	169.2	21.70
	111	375.1	163.3	21.70
	112	381.9	156.6	21.70
Units Pad	113	389.7	152.1	22.00
	114	389.8	144.1	22.00
	115	389.8	143.8	22.10
	116	389.9	136.8	22.10
	117	389.9	136.5	22.20
	118	389.8	129.6	22.20
	119	389.8	129.4	22.30
	120	390.0	122.4	22.30
	121	390.0	122.1	22.40
	122	390.0	115.0	22.40
	123	380.3	114.9	22.40
	124	380.3	122.3	22.40
	125	380.2	122.5	22.30
	126	380.1	129.4	22.30
	127	380.1	129.6	22.20
	128	380.0	136.5	22.20
	129	380.0	136.8	22.10
	130	379.9	143.7	22.10
	131	379.9	143.9	22.00
	132	379.9	152.1	22.00
	133	389.7	152.1	22.00

RESULTS: SOUND LEVELS

S200108 516 La Costa

Eilar Associates	27 January 2020											
MLO	TNM 2.5											
RESULTS: SOUND LEVELS	Calculated with TNM 2.5											
PROJECT/CONTRACT:	S200108 516 La Costa											
RUN:	Outdoor Use - Floor 1											
BARRIER DESIGN:	INPUT HEIGHTS											
ATMOSPHERICS:	20 deg C, 50% RH											
	Average pavement type shall be used unless a State highway agency substantiates the use of a different type with approval of FHWA.											

Receiver														
Name	No.	#DUs	Existing	No Barrier							With Barrier			
			LAeq1h	LAeq1h	Increase over existing		Type	Calculated	Noise Reduction					
				Calculated	Crit'n	Calculated	Crit'n	Impact	LAeq1h	Calculated	Goal	Calculated		
							Sub'l Inc					minus		
			dBA	dBA	dBA		dB			dBA	dB	dB	dB	
OU1	246	0	0.0	68.7	66	68.7	10	Snd Lvl	68.7	0.0	8	-8.0		
OU2	338	0	0.0	72.9	66	72.9	10	Snd Lvl	72.9	0.0	8	-8.0		
OU3	339	0	0.0	73.6	66	73.6	10	Snd Lvl	73.6	0.0	8	-8.0		
OU4	340	0	0.0	73.0	66	73.0	10	Snd Lvl	73.0	0.0	8	-8.0		
OU5	341	0	0.0	66.0	66	66.0	10	Snd Lvl	66.0	0.0	8	-8.0		
OU6	342	0	0.0	72.2	66	72.2	10	Snd Lvl	72.2	0.0	8	-8.0		
OU8	345	0	0.0	63.9	66	63.9	10	----	63.9	0.0	8	-8.0		
OU10	348	0	0.0	60.2	66	60.2	10	----	60.2	0.0	8	-8.0		
OU12	351	0	0.0	59.2	66	59.2	10	----	59.2	0.0	8	-8.0		
OU14	436	0	0.0	60.4	66	60.4	10	----	60.4	0.0	8	-8.0		
OU15	441	1	0.0	58.4	66	58.4	10	----	58.4	0.0	8	-8.0		
OU16	442	1	0.0	53.3	66	53.3	10	----	53.3	0.0	8	-8.0		
OU17	443	1	0.0	53.5	66	53.5	10	----	53.5	0.0	8	-8.0		
OU18	444	1	0.0	53.7	66	53.7	10	----	53.7	0.0	8	-8.0		
OU19	445	1	0.0	54.9	66	54.9	10	----	54.9	0.0	8	-8.0		
Dwelling Units	# DUs	Noise Reduction												
		Min	Avg	Max										
		dB	dB	dB										
All Selected	5	0.0	0.0	0.0										
All Impacted	0	0.0	0.0	0.0										
All that meet NR Goal	0	0.0	0.0	0.0										

INPUT: RECEIVERS

S200108 516 La Costa

Eilar Associates							27 January 2020				
MLO							TNM 2.5				
INPUT: RECEIVERS											
PROJECT/CONTRACT:		S200108 516 La Costa									
RUN:		Outdoor Use - Floor 2									
Receiver											
Name	No.	#DUs	Coordinates (ground)			Height above Ground	Input Sound Levels and Criteria				Active in Calc.
			X	Y	Z		Existing LAeq1h	Impact Criteria LAeq1h	Sub'l	NR Goal	
			m	m	m	m	dBA	dBA	dB	dB	
OU7	343	0	385.6	202.5	20.67	4.11	0.00	66	10.0	8.0	Y
OU9	346	0	385.9	189.9	21.12	4.11	0.00	66	10.0	8.0	Y
OU11	349	0	386.0	177.5	21.40	4.11	0.00	66	10.0	8.0	Y
OU13	352	0	386.2	164.8	21.70	4.11	0.00	66	10.0	8.0	Y

Eilar Associates	27 January 2020
MLO	TNM 2.5

INPUT: BARRIERS

PROJECT/CONTRACT: S200108 516 La Costa
 RUN: Outdoor Use - Floor 2

Barrier									Points										
Name	Type	Height		If Wall	If Berm			Add'tnl	Name	No.	Coordinates (bottom)			Height	Segment				
		Min	Max	\$ per	\$ per	Top	Run:Rise	\$ per			X	Y	Z	at	Seg	Ht	Perturbs	On	Important
				Unit	Unit	Width		Unit						Point	Incre-	#Up	#Dn	Struct?	Reflec-
		m	m	Area	Vol.		m:m	Length			m	m	m	m	ment				tions?
				\$/sq m	\$/cu m			\$/m											
Restaurant Building	W	0.00	30.48	0.00				0.00	point1	1	365.5	211.3	20.42	5.49	0.00	0	0		
									point2	2	365.2	233.5	20.42	5.49	0.00	0	0		
									point3	3	371.4	233.5	20.42	5.49	0.00	0	0		
									point4	4	371.5	224.9	20.42	5.49	0.00	0	0		
									point5	5	371.9	224.5	20.42	5.49	0.00	0	0		
									point6	6	374.0	226.4	20.42	5.49	0.00	0	0		
									point7	7	378.3	222.0	20.42	5.49	0.00	0	0		
									point8	8	371.6	215.0	20.42	5.49	0.00	0	0		
									point9	9	371.7	211.4	20.42	5.49	0.00	0	0		
									point10	10	365.5	211.3	20.42	5.49					
Bungalow 1	W	0.00	30.48	0.00				0.00	point11	11	380.4	206.4	20.67	5.49	0.00	0	0		
									point12	12	374.9	200.8	20.67	5.49	0.00	0	0		
									point13	13	381.4	194.4	20.67	5.49	0.00	0	0		
									point14	14	386.9	200.1	20.67	5.49	0.00	0	0		
									point15	15	380.4	206.4	20.67	5.49					
Bungalow 2	W	0.00	30.48	0.00				0.00	point16	16	380.6	194.0	21.12	5.49	0.00	0	0		
									point17	17	375.2	188.3	21.12	5.49	0.00	0	0		
									point18	18	381.7	182.0	21.12	5.49	0.00	0	0		
									point19	19	387.2	187.6	21.12	5.49	0.00	0	0		
									point20	20	380.6	194.0	21.12	5.49					
Bungalow 3	W	0.00	30.48	0.00				0.00	point21	21	380.7	181.4	21.40	5.49	0.00	0	0		
									point22	22	375.2	175.8	21.40	5.49	0.00	0	0		
									point23	23	381.7	169.4	21.40	5.49	0.00	0	0		
									point24	24	387.2	175.1	21.40	5.49	0.00	0	0		
									point25	25	380.7	181.4	21.40	5.49					
Bungalow 4	W	0.00	30.48	0.00				0.00	point26	26	380.8	168.8	21.70	5.49	0.00	0	0		
									point27	27	375.4	163.2	21.70	5.49	0.00	0	0		
									point28	28	381.9	156.8	21.70	5.49	0.00	0	0		
									point29	29	387.3	162.5	21.70	5.49	0.00	0	0		
									point30	30	380.8	168.8	21.70	5.49					
Unit 5	W	0.00	30.48	0.00				0.00	point31	31	389.2	149.1	22.01	8.00	0.00	0	0		
									point32	32	380.9	149.0	22.01	8.00	0.00	0	0		
									point33	33	381.0	144.1	22.01	4.34	0.00	0	0		
									point34	34	389.3	144.2	22.01	4.34	0.00	0	0		
									point35	35	389.2	149.1	22.01	8.00					

INPUT: BARRIERS

S200108 516 La Costa

Unit 4	W	0.00	30.48	0.00				0.00	point36	36	389.3	141.9	22.10	8.00	0.00	0	0		
									point37	37	381.0	141.9	22.10	8.00	0.00	0	0		
									point38	38	381.0	137.0	22.10	4.34	0.00	0	0		
									point39	39	389.4	137.0	22.10	4.34	0.00	0	0		
									point40	40	389.3	141.9	22.10	8.00					
Unit 3	W	0.00	30.48	0.00				0.00	point41	41	389.4	134.6	22.19	8.00	0.00	0	0		
									point42	42	381.1	134.5	22.19	8.00	0.00	0	0		
									point43	43	381.2	129.6	22.19	4.34	0.00	0	0		
									point44	44	389.5	129.7	22.19	4.34	0.00	0	0		
									point45	45	389.4	134.6	22.19	8.00					
Unit 2	W	0.00	30.48	0.00				0.00	point46	46	389.5	127.4	22.28	8.00	0.00	0	0		
									point47	47	381.1	127.3	22.28	8.00	0.00	0	0		
									point48	48	381.2	122.4	22.30	4.32	0.00	0	0		
									point49	49	389.6	122.5	22.28	4.34	0.00	0	0		
									point50	50	389.5	127.4	22.28	8.00					
Unit 1	W	0.00	30.48	0.00				0.00	point51	51	389.6	120.1	22.37	8.00	0.00	0	0		
									point52	52	381.3	120.0	22.37	8.00	0.00	0	0		
									point53	53	381.4	115.1	22.37	4.34	0.00	0	0		
									point54	54	389.7	115.2	22.37	4.34	0.00	0	0		
									point55	55	389.6	120.1	22.37	8.00					
PL Barrier	W	0.00	30.48	0.00				0.00	point56	56	392.9	109.1	21.53	2.06	0.00	0	0		
									point57	57	392.8	117.7	22.21	1.38	0.00	0	0		
									point58	58	392.4	158.1	21.47	1.96	0.00	0	0		
									point59	59	392.3	171.8	21.08	2.13	0.00	0	0		
									point60	60	390.5	171.8	21.32	1.89	0.00	0	0		
									point61	61	390.4	183.2	21.04	2.02	0.00	0	0		
									point62	62	390.3	199.0	20.55	0.91	0.00	0	0		
									point63	63	390.2	209.4	19.97	0.45	0.00	0	0		
									point64	64	390.2	215.5	19.19	0.10	0.00	0	0		
									point65	65	390.2	218.4	18.73	0.56					
Bungalow Balcony 1	W	0.00	30.48	0.00				0.00	point66	66	383.6	203.4	20.67	3.96	0.00	0	0		
									point67	67	384.6	204.4	20.67	3.96	0.00	0	0		
									point68	68	387.6	201.6	20.67	3.96	0.00	0	0		
									point69	69	386.5	200.5	20.67	3.96					
Bungalow Balcony 2	W	0.00	30.48	0.00				0.00	point70	70	383.8	190.9	21.12	3.96	0.00	0	0		
									point71	71	384.8	192.0	21.12	3.96	0.00	0	0		
									point72	72	387.7	189.2	21.12	3.96	0.00	0	0		
									point73	73	386.7	188.1	21.12	3.96					
Bungalow Balcony 3	W	0.00	30.48	0.00				0.00	point74	74	383.9	178.3	21.40	3.96	0.00	0	0		
									point75	75	384.9	179.4	21.40	3.96	0.00	0	0		
									point76	76	387.8	176.6	21.40	3.96	0.00	0	0		
									point77	77	386.8	175.5	21.40	3.96					
Bungalow Balcony 4	W	0.00	30.48	0.00				0.00	point78	78	384.0	165.8	21.70	3.96	0.00	0	0		
									point79	79	385.0	166.9	21.70	3.96	0.00	0	0		
									point80	80	387.9	164.0	21.70	3.96	0.00	0	0		
									point81	81	386.9	163.0	21.70	3.96					

RESULTS: SOUND LEVELS

S200108 516 La Costa

Eilar Associates										27 January 2020			
MLO										TNM 2.5			
										Calculated with TNM 2.5			
RESULTS: SOUND LEVELS													
PROJECT/CONTRACT:		S200108 516 La Costa											
RUN:		Outdoor Use - Floor 2											
BARRIER DESIGN:		INPUT HEIGHTS						Average pavement type shall be used unless a State highway agency substantiates the use of a different type with approval of FHWA.					
ATMOSPHERICS:		20 deg C, 50% RH											
Receiver													
Name	No.	#DUs	Existing LAeq1h	No Barrier LAeq1h Calculated	Crit'n	Increase over existing		Type Impact	With Barrier				
						Calculated	Crit'n		Calculated LAeq1h	Noise Reduction		Calculated	
							Sub'l Inc			Calculated	Goal	Calculated minus Goal	
			dB	dB	dB	dB	dB		dB	dB	dB	dB	
OU7	343	0	0.0	73.8	66	73.8	10	Snd Lvl	73.8	0.0	8	-8.0	
OU9	346	0	0.0	72.9	66	72.9	10	Snd Lvl	72.9	0.0	8	-8.0	
OU11	349	0	0.0	72.5	66	72.5	10	Snd Lvl	72.5	0.0	8	-8.0	
OU13	352	0	0.0	71.6	66	71.6	10	Snd Lvl	71.6	0.0	8	-8.0	
Dwelling Units		# DUs	Noise Reduction										
			Min	Avg	Max								
			dB	dB	dB								
All Selected		0	0.0	0.0	0.0								
All Impacted		0	0.0	0.0	0.0								
All that meet NR Goal		0	0.0	0.0	0.0								

INPUT: BARRIERS

S200108 516 La Costa

Eilar Associates	27 January 2020
MLO	TNM 2.5

INPUT: BARRIERS

PROJECT/CONTRACT: S200108 516 La Costa
 RUN: Outdoor Use - Floor 1 - Mitigated

Barrier									Points										
Name	Type	Height		If Wall	If Berm			Add'tnl	Name	No.	Coordinates (bottom)			Height	Segment				
		Min	Max	\$ per	\$ per	Top	Run:Rise	\$ per			X	Y	Z	at	Seg	Ht	Perturbs	On	Important
				Unit	Unit	Width		Unit					Point	Incre-	#Up	#Dn	Struct?	Reflec-	tions?
		m	m	Area	Vol.		m:m	Length			m	m	m	m	m				
Restaurant Building	W	0.00	30.48	0.00				0.00	point1	1	365.5	211.3	20.42	5.49	0.00	0	0		
									point2	2	365.2	233.5	20.42	5.49	0.00	0	0		
									point3	3	371.4	233.5	20.42	5.49	0.00	0	0		
									point4	4	371.5	224.9	20.42	5.49	0.00	0	0		
									point5	5	371.9	224.5	20.42	5.49	0.00	0	0		
									point6	6	374.0	226.4	20.42	5.49	0.00	0	0		
									point7	7	378.3	222.0	20.42	5.49	0.00	0	0		
									point8	8	371.6	215.0	20.42	5.49	0.00	0	0		
									point9	9	371.7	211.4	20.42	5.49	0.00	0	0		
									point10	10	365.5	211.3	20.42	5.49					
Bungalow 1	W	0.00	30.48	0.00				0.00	point11	11	380.4	206.4	20.67	5.49	0.00	0	0		
									point12	12	374.9	200.8	20.67	5.49	0.00	0	0		
									point13	13	381.4	194.4	20.67	5.49	0.00	0	0		
									point14	14	386.9	200.1	20.67	5.49	0.00	0	0		
									point15	15	380.4	206.4	20.67	5.49					
Bungalow 2	W	0.00	30.48	0.00				0.00	point16	16	380.6	194.0	21.12	5.49	0.00	0	0		
									point17	17	375.2	188.3	21.12	5.49	0.00	0	0		
									point18	18	381.7	182.0	21.12	5.49	0.00	0	0		
									point19	19	387.2	187.6	21.12	5.49	0.00	0	0		
									point20	20	380.6	194.0	21.12	5.49					
Bungalow 3	W	0.00	30.48	0.00				0.00	point21	21	380.7	181.4	21.40	5.49	0.00	0	0		
									point22	22	375.2	175.8	21.40	5.49	0.00	0	0		
									point23	23	381.7	169.4	21.40	5.49	0.00	0	0		
									point24	24	387.2	175.1	21.40	5.49	0.00	0	0		
									point25	25	380.7	181.4	21.40	5.49					
Bungalow 4	W	0.00	30.48	0.00				0.00	point26	26	380.8	168.8	21.70	5.49	0.00	0	0		
									point27	27	375.4	163.2	21.70	5.49	0.00	0	0		
									point28	28	381.9	156.8	21.70	5.49	0.00	0	0		
									point29	29	387.3	162.5	21.70	5.49	0.00	0	0		
									point30	30	380.8	168.8	21.70	5.49					
Unit 5	W	0.00	30.48	0.00				0.00	point31	31	389.2	149.1	22.01	8.00	0.00	0	0		
									point32	32	380.9	149.0	22.01	8.00	0.00	0	0		
									point33	33	381.0	144.1	22.01	4.34	0.00	0	0		
									point34	34	389.3	144.2	22.01	4.34	0.00	0	0		
									point35	35	389.2	149.1	22.01	8.00					

INPUT: BARRIERS

S200108 516 La Costa

Unit 4	W	0.00	30.48	0.00				0.00	point36	36	389.3	141.9	22.10	8.00	0.00	0	0		
									point37	37	381.0	141.9	22.10	8.00	0.00	0	0		
									point38	38	381.0	137.0	22.10	4.34	0.00	0	0		
									point39	39	389.4	137.0	22.10	4.34	0.00	0	0		
									point40	40	389.3	141.9	22.10	8.00					
Unit 3	W	0.00	30.48	0.00				0.00	point41	41	389.4	134.6	22.19	8.00	0.00	0	0		
									point42	42	381.1	134.5	22.19	8.00	0.00	0	0		
									point43	43	381.2	129.6	22.19	4.34	0.00	0	0		
									point44	44	389.5	129.7	22.19	4.34	0.00	0	0		
									point45	45	389.4	134.6	22.19	8.00					
Unit 2	W	0.00	30.48	0.00				0.00	point46	46	389.5	127.4	22.28	8.00	0.00	0	0		
									point47	47	381.1	127.3	22.28	8.00	0.00	0	0		
									point48	48	381.2	122.4	22.30	4.32	0.00	0	0		
									point49	49	389.6	122.5	22.28	4.34	0.00	0	0		
									point50	50	389.5	127.4	22.28	8.00					
Unit 1	W	0.00	30.48	0.00				0.00	point51	51	389.6	120.1	22.37	8.00	0.00	0	0		
									point52	52	381.3	120.0	22.37	8.00	0.00	0	0		
									point53	53	381.4	115.1	22.37	4.34	0.00	0	0		
									point54	54	389.7	115.2	22.37	4.34	0.00	0	0		
									point55	55	389.6	120.1	22.37	8.00					
PL Barrier	W	0.00	30.48	0.00				0.00	point56	56	392.9	109.1	21.53	2.06	0.00	0	0		
									point57	57	392.8	117.7	22.21	1.38	0.00	0	0		
									point58	58	392.4	158.1	21.47	1.96	0.00	0	0		
									point59	59	392.3	171.8	21.08	2.13	0.00	0	0		
									point60	60	390.5	171.8	21.32	1.89	0.00	0	0		
									point61	61	390.4	183.2	21.04	2.02	0.00	0	0		
									point62	62	390.3	199.0	20.55	0.91	0.00	0	0		
									point63	63	390.2	209.4	19.97	0.76	0.00	0	0		
									point64	64	390.2	215.5	19.19	1.54	0.00	0	0		
									point65	65	390.2	218.4	18.73	2.00					
Miti Barrier	W	0.00	30.48	0.00				0.00	point66	66	365.8	239.9	20.42	1.52	0.00	0	0		
									point67	67	369.0	239.5	20.42	1.52	0.00	0	0		
									point68	68	371.8	237.1	20.42	1.52	0.00	0	0		
									point69	69	382.2	220.8	20.42	1.52					

RESULTS: SOUND LEVELS

S200108 516 La Costa

Eilar Associates													27 January 2020	
MLO													TNM 2.5	
													Calculated with TNM 2.5	
RESULTS: SOUND LEVELS														
PROJECT/CONTRACT:			S200108 516 La Costa											
RUN:			Outdoor Use - Floor 1 - Mitigated											
BARRIER DESIGN:			INPUT HEIGHTS						Average pavement type shall be used unless a State highway agency substantiates the use of a different type with approval of FHWA.					
ATMOSPHERICS:			20 deg C, 50% RH											
Receiver														
Name	No.	#DUs	Existing LAeq1h	No Barrier LAeq1h Calculated	Crit'n	Increase over existing Calculated	Crit'n	Type Impact	With Barrier Calculated LAeq1h	Noise Reduction Calculated	Goal	Calculated minus Goal		
			dBA	dBA	dBA	dB	dB		dBA	dB	dB	dB		
OU1	246	0	0.0	66.2	66	66.2	10	Snd Lvl	66.2	0.0	8	-8.0		
OU2	338	0	0.0	63.1	66	63.1	10	----	63.1	0.0	8	-8.0		
OU3	339	0	0.0	63.3	66	63.3	10	----	63.3	0.0	8	-8.0		
OU4	340	0	0.0	69.7	66	69.7	10	Snd Lvl	69.7	0.0	8	-8.0		
OU5	341	0	0.0	64.1	66	64.1	10	----	64.1	0.0	8	-8.0		
OU6	342	0	0.0	69.6	66	69.6	10	Snd Lvl	69.6	0.0	8	-8.0		
OU8	345	0	0.0	63.6	66	63.6	10	----	63.6	0.0	8	-8.0		
OU10	348	0	0.0	60.2	66	60.2	10	----	60.2	0.0	8	-8.0		
OU12	351	0	0.0	59.2	66	59.2	10	----	59.2	0.0	8	-8.0		
OU14	436	0	0.0	60.4	66	60.4	10	----	60.4	0.0	8	-8.0		
OU15	441	1	0.0	58.4	66	58.4	10	----	58.4	0.0	8	-8.0		
OU16	442	1	0.0	53.3	66	53.3	10	----	53.3	0.0	8	-8.0		
OU17	443	1	0.0	53.5	66	53.5	10	----	53.5	0.0	8	-8.0		
OU18	444	1	0.0	53.7	66	53.7	10	----	53.7	0.0	8	-8.0		
OU19	445	1	0.0	54.9	66	54.9	10	----	54.9	0.0	8	-8.0		
Dwelling Units		# DUs	Noise Reduction											
			Min dB	Avg dB	Max dB									
All Selected		5	0.0	0.0	0.0									
All Impacted		0	0.0	0.0	0.0									
All that meet NR Goal		0	0.0	0.0	0.0									

INPUT: BARRIERS

S200108 516 La Costa

Eilar Associates	27 January 2020
MLO	TNM 2.5

INPUT: BARRIERS

PROJECT/CONTRACT: S200108 516 La Costa
 RUN: Outdoor Use - Floor 2 - Mitigated

Barrier									Points										
Name	Type	Height		If Wall	If Berm			Add'tnl	Name	No.	Coordinates (bottom)			Height	Segment				
		Min	Max	\$ per	\$ per	Top	Run:Rise	\$ per			X	Y	Z	at	Seg	Ht	Perturbs	On	Important
				Unit	Unit	Width		Unit					Point	Incre-	#Up	#Dn	Struct?	Reflec-	
		m	m	Area	Vol.		m:m	Length			m	m	m	m	ment			tions?	
				\$/sq m	\$/cu m			\$/m											
Restaurant Building	W	0.00	30.48	0.00				0.00	point1	1	365.5	211.3	20.42	5.49	0.00	0	0		
									point2	2	365.2	233.5	20.42	5.49	0.00	0	0		
									point3	3	371.4	233.5	20.42	5.49	0.00	0	0		
									point4	4	371.5	224.9	20.42	5.49	0.00	0	0		
									point5	5	371.9	224.5	20.42	5.49	0.00	0	0		
									point6	6	374.0	226.4	20.42	5.49	0.00	0	0		
									point7	7	378.3	222.0	20.42	5.49	0.00	0	0		
									point8	8	371.6	215.0	20.42	5.49	0.00	0	0		
									point9	9	371.7	211.4	20.42	5.49	0.00	0	0		
									point10	10	365.5	211.3	20.42	5.49					
Bungalow 1	W	0.00	30.48	0.00				0.00	point11	11	380.4	206.4	20.67	5.49	0.00	0	0		
									point12	12	374.9	200.8	20.67	5.49	0.00	0	0		
									point13	13	381.4	194.4	20.67	5.49	0.00	0	0		
									point14	14	386.9	200.1	20.67	5.49	0.00	0	0		
									point15	15	380.4	206.4	20.67	5.49					
Bungalow 2	W	0.00	30.48	0.00				0.00	point16	16	380.6	194.0	21.12	5.49	0.00	0	0		
									point17	17	375.2	188.3	21.12	5.49	0.00	0	0		
									point18	18	381.7	182.0	21.12	5.49	0.00	0	0		
									point19	19	387.2	187.6	21.12	5.49	0.00	0	0		
									point20	20	380.6	194.0	21.12	5.49					
Bungalow 3	W	0.00	30.48	0.00				0.00	point21	21	380.7	181.4	21.40	5.49	0.00	0	0		
									point22	22	375.2	175.8	21.40	5.49	0.00	0	0		
									point23	23	381.7	169.4	21.40	5.49	0.00	0	0		
									point24	24	387.2	175.1	21.40	5.49	0.00	0	0		
									point25	25	380.7	181.4	21.40	5.49					
Bungalow 4	W	0.00	30.48	0.00				0.00	point26	26	380.8	168.8	21.70	5.49	0.00	0	0		
									point27	27	375.4	163.2	21.70	5.49	0.00	0	0		
									point28	28	381.9	156.8	21.70	5.49	0.00	0	0		
									point29	29	387.3	162.5	21.70	5.49	0.00	0	0		
									point30	30	380.8	168.8	21.70	5.49					
Unit 5	W	0.00	30.48	0.00				0.00	point31	31	389.2	149.1	22.01	8.00	0.00	0	0		
									point32	32	380.9	149.0	22.01	8.00	0.00	0	0		
									point33	33	381.0	144.1	22.01	4.34	0.00	0	0		
									point34	34	389.3	144.2	22.01	4.34	0.00	0	0		
									point35	35	389.2	149.1	22.01	8.00					

INPUT: BARRIERS

S200108 516 La Costa

Unit 4	W	0.00	30.48	0.00				0.00	point36	36	389.3	141.9	22.10	8.00	0.00	0	0		
									point37	37	381.0	141.9	22.10	8.00	0.00	0	0		
									point38	38	381.0	137.0	22.10	4.34	0.00	0	0		
									point39	39	389.4	137.0	22.10	4.34	0.00	0	0		
									point40	40	389.3	141.9	22.10	8.00					
Unit 3	W	0.00	30.48	0.00				0.00	point41	41	389.4	134.6	22.19	8.00	0.00	0	0		
									point42	42	381.1	134.5	22.19	8.00	0.00	0	0		
									point43	43	381.2	129.6	22.19	4.34	0.00	0	0		
									point44	44	389.5	129.7	22.19	4.34	0.00	0	0		
									point45	45	389.4	134.6	22.19	8.00					
Unit 2	W	0.00	30.48	0.00				0.00	point46	46	389.5	127.4	22.28	8.00	0.00	0	0		
									point47	47	381.1	127.3	22.28	8.00	0.00	0	0		
									point48	48	381.2	122.4	22.30	4.32	0.00	0	0		
									point49	49	389.6	122.5	22.28	4.34	0.00	0	0		
									point50	50	389.5	127.4	22.28	8.00					
Unit 1	W	0.00	30.48	0.00				0.00	point51	51	389.6	120.1	22.37	8.00	0.00	0	0		
									point52	52	381.3	120.0	22.37	8.00	0.00	0	0		
									point53	53	381.4	115.1	22.37	4.34	0.00	0	0		
									point54	54	389.7	115.2	22.37	4.34	0.00	0	0		
									point55	55	389.6	120.1	22.37	8.00					
PL Barrier	W	0.00	30.48	0.00				0.00	point56	56	392.9	109.1	21.53	2.06	0.00	0	0		
									point57	57	392.8	117.7	22.21	1.38	0.00	0	0		
									point58	58	392.4	158.1	21.47	1.96	0.00	0	0		
									point59	59	392.3	171.8	21.08	2.13	0.00	0	0		
									point60	60	390.5	171.8	21.32	1.89	0.00	0	0		
									point61	61	390.4	183.2	21.04	2.02	0.00	0	0		
									point62	62	390.3	199.0	20.55	0.91	0.00	0	0		
									point63	63	390.2	209.4	19.97	0.76	0.00	0	0		
									point64	64	390.2	215.5	19.19	1.54	0.00	0	0		
									point65	65	390.2	218.4	18.73	2.00					
Bungalow Balcony 1	W	0.00	30.48	0.00				0.00	point66	66	383.6	203.4	20.67	4.11	0.00	0	0		
									point67	67	384.6	204.4	20.67	4.11	0.00	0	0		
									point68	68	387.6	201.6	20.67	4.11	0.00	0	0		
									point69	69	386.5	200.5	20.67	4.11					
Bungalow Balcony 2	W	0.00	30.48	0.00				0.00	point70	70	383.8	190.9	21.12	4.11	0.00	0	0		
									point71	71	384.8	192.0	21.12	4.11	0.00	0	0		
									point72	72	387.7	189.2	21.12	4.11	0.00	0	0		
									point73	73	386.7	188.1	21.12	4.11					
Bungalow Balcony 3	W	0.00	30.48	0.00				0.00	point74	74	383.9	178.3	21.40	4.11	0.00	0	0		
									point75	75	384.9	179.4	21.40	4.11	0.00	0	0		
									point76	76	387.8	176.6	21.40	4.11	0.00	0	0		
									point77	77	386.8	175.5	21.40	4.11					
Bungalow Balcony 4	W	0.00	30.48	0.00				0.00	point78	78	384.0	165.8	21.70	4.11	0.00	0	0		
									point79	79	385.0	166.9	21.70	4.11	0.00	0	0		
									point80	80	387.9	164.0	21.70	4.11	0.00	0	0		
									point81	81	386.9	163.0	21.70	4.11					
Miti Barrier	W	0.00	30.48	0.00				0.00	point82	82	365.8	239.9	20.42	1.52	0.00	0	0		
									point83	83	369.0	239.5	20.42	1.52	0.00	0	0		
									point84	84	371.8	237.1	20.42	1.52	0.00	0	0		

INPUT: BARRIERS

S200108 516 La Costa

									point85	85	382.2	220.8	20.42	1.52				
--	--	--	--	--	--	--	--	--	---------	----	-------	-------	-------	------	--	--	--	--

RESULTS: SOUND LEVELS

S200108 516 La Costa

Eilar Associates					27 January 2020								
MLO					TNM 2.5								
					Calculated with TNM 2.5								
RESULTS: SOUND LEVELS													
PROJECT/CONTRACT:			S200108 516 La Costa										
RUN:			Outdoor Use - Floor 2 - Mitigated										
BARRIER DESIGN:			INPUT HEIGHTS					Average pavement type shall be used unless a State highway agency substantiates the use of a different type with approval of FHWA.					
ATMOSPHERICS:			20 deg C, 50% RH										
Receiver													
Name		No.	#DUs	Existing LAeq1h	No Barrier LAeq1h Calculated	Crit'n	Increase over existing Calculated	Crit'n Sub'l Inc	Type Impact	With Barrier Calculated LAeq1h	Noise Reduction Calculated	Goal	Calculated minus Goal
				dB	dB	dB	dB	dB		dB	dB	dB	dB
OU7		343	0	0.0	68.3	66	68.3	10	Snd Lvl	68.3	0.0	8	-8.0
OU9		346	0	0.0	67.2	66	67.2	10	Snd Lvl	67.2	0.0	8	-8.0
OU11		349	0	0.0	66.9	66	66.9	10	Snd Lvl	66.9	0.0	8	-8.0
OU13		352	0	0.0	66.2	66	66.2	10	Snd Lvl	66.2	0.0	8	-8.0
Dwelling Units			# DUs	Noise Reduction									
				Min	Avg	Max							
				dB	dB	dB							
All Selected			0	0.0	0.0	0.0							
All Impacted			0	0.0	0.0	0.0							
All that meet NR Goal			0	0.0	0.0	0.0							

INPUT: RECEIVERS

S200108 516 La Costa

Eilar Associates							29 January 2020					
MLO							TNM 2.5					
INPUT: RECEIVERS												
PROJECT/CONTRACT:			S200108 516 La Costa									
RUN:			Facades									
Receiver												
Name	No.	#DUs	Coordinates (ground)			Height above Ground	Input Sound Levels and Criteria				Active in Calc.	
			X	Y	Z		Existing LAeq1h	Impact Criteria LAeq1h	Sub'l	NR Goal		
			m	m	m	m	dBA	dBA	dB	dB		
1-F1	246	0	368.5	210.9	20.42	1.52	0.00	66	10.0	8.0	Y	
1-F2	338	0	364.7	222.5	20.42	1.52	0.00	66	10.0	8.0	Y	
1-F3	339	0	368.3	234.1	20.42	1.52	0.00	66	10.0	8.0	Y	
1-F4	340	0	372.3	228.4	20.42	1.52	0.00	66	10.0	8.0	Y	
1-F5	341	0	376.6	224.5	20.42	1.52	0.00	66	10.0	8.0	Y	
1-F6	342	0	375.0	218.0	20.42	1.52	0.00	66	10.0	8.0	Y	
1-F7	345	0	377.7	197.2	20.91	1.52	0.00	66	10.0	8.0	Y	
1-F8	348	0	377.5	204.2	20.63	1.52	0.00	66	10.0	8.0	Y	
1-F9	351	0	384.1	203.7	20.67	1.52	0.00	66	10.0	8.0	Y	
1-F10	436	0	384.3	196.7	21.00	1.52	0.00	66	10.0	8.0	Y	
1-F11	441	0	377.9	184.6	21.27	1.52	0.00	66	10.0	8.0	Y	
1-F12	442	0	377.8	191.9	21.10	1.52	0.00	66	10.0	8.0	Y	
1-F13	443	0	384.3	191.2	21.12	1.52	0.00	66	10.0	8.0	Y	
1-F14	444	0	384.6	184.3	21.32	1.52	0.00	66	10.0	8.0	Y	
1-F15	445	0	378.0	172.3	21.56	1.52	0.00	66	10.0	8.0	Y	
1-F16	446	0	377.6	179.0	21.39	1.52	0.00	66	10.0	8.0	Y	
1-F17	447	0	384.7	178.1	21.40	1.52	0.00	66	10.0	8.0	Y	
1-F18	448	0	384.8	171.9	21.61	1.52	0.00	66	10.0	8.0	Y	
1-F19	449	0	378.2	159.4	21.74	1.52	0.00	66	10.0	8.0	Y	
1-F20	450	0	377.6	166.3	21.69	1.52	0.00	66	10.0	8.0	Y	
1-F21	451	0	384.4	166.2	21.70	1.52	0.00	66	10.0	8.0	Y	
1-F22	452	0	384.8	159.2	21.71	1.52	0.00	66	10.0	8.0	Y	

INPUT: RECEIVERS

S200108 516 La Costa

1-F23	453	0	380.0	146.4	22.01	1.52	0.00	66	10.0	8.0	Y
1-F24	454	0	385.1	149.8	22.01	1.52	0.00	66	10.0	8.0	Y
1-F25	455	0	390.3	146.4	21.98	1.52	0.00	66	10.0	8.0	Y
1-F26	456	0	384.8	143.1	22.10	1.52	0.00	66	10.0	8.0	Y
1-F27	457	0	380.2	139.3	22.10	1.52	0.00	66	10.0	8.0	Y
1-F28	458	0	390.5	139.4	22.07	1.52	0.00	66	10.0	8.0	Y
1-F29	459	0	385.4	135.9	22.19	1.52	0.00	66	10.0	8.0	Y
1-F30	460	0	380.2	132.2	22.19	1.52	0.00	66	10.0	8.0	Y
1-F31	461	0	390.4	132.2	22.16	1.52	0.00	66	10.0	8.0	Y
1-F32	462	0	385.2	128.4	22.28	1.52	0.00	66	10.0	8.0	Y
1-F33	463	0	380.6	124.5	22.28	1.52	0.00	66	10.0	8.0	Y
1-F34	464	0	390.4	125.0	22.25	1.52	0.00	66	10.0	8.0	Y
1-F35	465	0	385.3	121.3	22.37	1.52	0.00	66	10.0	8.0	Y
1-F36	466	0	380.5	117.7	22.37	1.52	0.00	66	10.0	8.0	Y
1-F37	467	0	390.4	118.0	22.35	1.52	0.00	66	10.0	8.0	Y
1-F38	468	0	385.3	114.9	22.38	1.52	0.00	66	10.0	8.0	Y
2-F1	469	0	368.5	210.9	20.42	4.57	0.00	66	10.0	8.0	Y
2-F2	470	0	364.7	222.5	20.42	4.57	0.00	66	10.0	8.0	Y
2-F3	471	0	368.3	234.1	20.42	4.57	0.00	66	10.0	8.0	Y
2-F4	472	0	372.3	228.4	20.42	4.57	0.00	66	10.0	8.0	Y
2-F5	473	0	376.6	224.5	20.42	4.57	0.00	66	10.0	8.0	Y
2-F6	474	0	375.0	218.0	20.42	4.57	0.00	66	10.0	8.0	Y
2-F7	475	0	377.7	197.2	20.91	4.57	0.00	66	10.0	8.0	Y
2-F8	476	0	377.5	204.2	20.63	4.57	0.00	66	10.0	8.0	Y
2-F9	477	0	384.1	203.7	20.67	4.57	0.00	66	10.0	8.0	Y
2-F10	478	0	384.3	196.7	21.00	4.57	0.00	66	10.0	8.0	Y
2-F11	479	0	377.9	184.6	21.27	4.57	0.00	66	10.0	8.0	Y
2-F12	480	0	377.8	191.9	21.10	4.57	0.00	66	10.0	8.0	Y
2-F13	481	0	384.3	191.2	21.12	4.57	0.00	66	10.0	8.0	Y
2-F14	482	0	384.6	184.3	21.32	4.57	0.00	66	10.0	8.0	Y
2-F15	483	0	378.0	172.3	21.56	4.57	0.00	66	10.0	8.0	Y
2-F16	484	0	377.6	179.0	21.39	4.57	0.00	66	10.0	8.0	Y
2-F17	485	0	384.7	178.1	21.40	4.57	0.00	66	10.0	8.0	Y
2-F18	486	0	384.8	171.9	21.61	4.57	0.00	66	10.0	8.0	Y
2-F19	487	0	378.2	159.4	21.74	4.57	0.00	66	10.0	8.0	Y
2-F20	488	0	377.6	166.3	21.69	4.57	0.00	66	10.0	8.0	Y

INPUT: RECEIVERS**S200108 516 La Costa**

2-F21	489	0	384.4	166.2	21.70	4.57	0.00	66	10.0	8.0	Y
2-F22	490	0	384.8	159.2	21.71	4.57	0.00	66	10.0	8.0	Y
2-F23	491	0	380.0	146.4	22.01	4.27	0.00	66	10.0	8.0	Y
2-F24	492	0	385.1	149.8	22.01	4.27	0.00	66	10.0	8.0	Y
2-F25	493	0	390.3	146.4	21.98	4.27	0.00	66	10.0	8.0	Y
2-F26	494	0	384.8	143.1	22.10	4.27	0.00	66	10.0	8.0	Y
2-F27	495	0	380.2	139.3	22.10	4.27	0.00	66	10.0	8.0	Y
2-F28	496	0	390.5	139.4	22.07	4.27	0.00	66	10.0	8.0	Y
2-F29	497	0	385.4	135.9	22.19	4.27	0.00	66	10.0	8.0	Y
2-F30	498	0	380.2	132.2	22.19	4.27	0.00	66	10.0	8.0	Y
2-F31	499	0	390.4	132.2	22.16	4.27	0.00	66	10.0	8.0	Y
2-F32	500	0	385.2	128.4	22.28	4.27	0.00	66	10.0	8.0	Y
2-F33	501	0	380.6	124.5	22.28	4.27	0.00	66	10.0	8.0	Y
2-F34	502	0	390.4	125.0	22.25	4.27	0.00	66	10.0	8.0	Y
2-F35	503	0	385.3	121.3	22.37	4.27	0.00	66	10.0	8.0	Y
2-F36	504	0	380.5	117.7	22.37	4.27	0.00	66	10.0	8.0	Y
2-F37	505	0	390.3	118.0	22.35	4.27	0.00	66	10.0	8.0	Y
2-F38	517	0	385.3	114.9	22.38	4.27	0.00	66	10.0	8.0	Y

Eilar Associates	29 January 2020
MLO	TNM 2.5

INPUT: BARRIERS

PROJECT/CONTRACT: S200108 516 La Costa
 RUN: Facades

Barrier									Points										
Name	Type	Height		If Wall	If Berm			Add'tnl	Name	No.	Coordinates (bottom)			Height	Segment				
		Min	Max	\$ per	\$ per	Top	Run:Rise	\$ per			X	Y	Z	at	Seg	Ht	Perturbs	On	Important
				Unit	Unit	Width		Unit					Point	Incre-	#Up	#Dn	Struct?	Reflec-	tions?
		m	m	Area	Vol.		m:m	Length			m	m	m	m	m				
				\$/sq m	\$/cu m			\$/m											
Restaurant Building	W	0.00	30.48	0.00				0.00	point1	1	365.5	211.3	20.42	5.49	0.00	0	0		
									point2	2	365.2	233.5	20.42	5.49	0.00	0	0		
									point3	3	371.4	233.5	20.42	5.49	0.00	0	0		
									point4	4	371.5	224.9	20.42	5.49	0.00	0	0		
									point5	5	371.9	224.5	20.42	5.49	0.00	0	0		
									point6	6	374.0	226.4	20.42	5.49	0.00	0	0		
									point7	7	378.3	222.0	20.42	5.49	0.00	0	0		
									point8	8	371.6	215.0	20.42	5.49	0.00	0	0		
									point9	9	371.7	211.4	20.42	5.49	0.00	0	0		
									point10	10	365.5	211.3	20.42	5.49					
Bungalow 1	W	0.00	30.48	0.00				0.00	point11	11	380.4	206.4	20.67	5.49	0.00	0	0		
									point12	12	374.9	200.8	20.67	5.49	0.00	0	0		
									point13	13	381.4	194.4	20.67	5.49	0.00	0	0		
									point14	14	386.9	200.1	20.67	5.49	0.00	0	0		
									point15	15	380.4	206.4	20.67	5.49					
Bungalow 2	W	0.00	30.48	0.00				0.00	point16	16	380.6	194.0	21.12	5.49	0.00	0	0		
									point17	17	375.2	188.3	21.12	5.49	0.00	0	0		
									point18	18	381.7	182.0	21.12	5.49	0.00	0	0		
									point19	19	387.2	187.6	21.12	5.49	0.00	0	0		
									point20	20	380.6	194.0	21.12	5.49					
Bungalow 3	W	0.00	30.48	0.00				0.00	point21	21	380.7	181.4	21.40	5.49	0.00	0	0		
									point22	22	375.2	175.8	21.40	5.49	0.00	0	0		
									point23	23	381.7	169.4	21.40	5.49	0.00	0	0		
									point24	24	387.2	175.1	21.40	5.49	0.00	0	0		
									point25	25	380.7	181.4	21.40	5.49					
Bungalow 4	W	0.00	30.48	0.00				0.00	point26	26	380.8	168.8	21.70	5.49	0.00	0	0		
									point27	27	375.4	163.2	21.70	5.49	0.00	0	0		
									point28	28	381.9	156.8	21.70	5.49	0.00	0	0		
									point29	29	387.3	162.5	21.70	5.49	0.00	0	0		
									point30	30	380.8	168.8	21.70	5.49					
Unit 5	W	0.00	30.48	0.00				0.00	point31	31	389.2	149.1	22.01	8.00	0.00	0	0		
									point32	32	380.9	149.0	22.01	8.00	0.00	0	0		
									point33	33	381.0	144.1	22.01	4.34	0.00	0	0		
									point34	34	389.3	144.2	22.01	4.34	0.00	0	0		
									point35	35	389.2	149.1	22.01	8.00					

INPUT: BARRIERS

S200108 516 La Costa

Unit 4	W	0.00	30.48	0.00				0.00	point36	36	389.3	141.9	22.10	8.00	0.00	0	0		
									point37	37	381.0	141.9	22.10	8.00	0.00	0	0		
									point38	38	381.0	137.0	22.10	4.34	0.00	0	0		
									point39	39	389.4	137.0	22.10	4.34	0.00	0	0		
									point40	40	389.3	141.9	22.10	8.00					
Unit 3	W	0.00	30.48	0.00				0.00	point41	41	389.4	134.6	22.19	8.00	0.00	0	0		
									point42	42	381.1	134.5	22.19	8.00	0.00	0	0		
									point43	43	381.2	129.6	22.19	4.34	0.00	0	0		
									point44	44	389.5	129.7	22.19	4.34	0.00	0	0		
									point45	45	389.4	134.6	22.19	8.00					
Unit 2	W	0.00	30.48	0.00				0.00	point46	46	389.5	127.4	22.28	8.00	0.00	0	0		
									point47	47	381.1	127.3	22.28	8.00	0.00	0	0		
									point48	48	381.2	122.4	22.30	4.32	0.00	0	0		
									point49	49	389.6	122.5	22.28	4.34	0.00	0	0		
									point50	50	389.5	127.4	22.28	8.00					
Unit 1	W	0.00	30.48	0.00				0.00	point51	51	389.6	120.1	22.37	8.00	0.00	0	0		
									point52	52	381.3	120.0	22.37	8.00	0.00	0	0		
									point53	53	381.4	115.1	22.37	4.34	0.00	0	0		
									point54	54	389.7	115.2	22.37	4.34	0.00	0	0		
									point55	55	389.6	120.1	22.37	8.00					

RESULTS: SOUND LEVELS

S200108 516 La Costa

Eilar Associates	29 January 2020
MLO	TNM 2.5
	Calculated with TNM 2.5

RESULTS: SOUND LEVELS

PROJECT/CONTRACT: S200108 516 La Costa
RUN: Facades
BARRIER DESIGN: INPUT HEIGHTS

Average pavement type shall be used unless a State highway agency substantiates the use of a different type with approval of FHWA.

ATMOSPHERICS: 20 deg C, 50% RH

Receiver														
Name	No.	#DUs	Existing LAeq1h dBA	No Barrier				With Barrier						
				LAeq1h dBA	Calculated	Crit'n dBA	Increase over existing dB	Type Impact	Calculated LAeq1h dBA	Noise Reduction				
													Calculated minus Goal	
													Goal	
													Calculated minus Goal	
1-F1	246	0	0.0	59.9	66	59.9	10	----	59.9	0.0	8	-8.0		
1-F2	338	0	0.0	51.6	66	51.6	10	----	51.6	0.0	8	-8.0		
1-F3	339	0	0.0	73.0	66	73.0	10	Snd Lvl	73.0	0.0	8	-8.0		
1-F4	340	0	0.0	73.3	66	73.3	10	Snd Lvl	73.3	0.0	8	-8.0		
1-F5	341	0	0.0	73.7	66	73.7	10	Snd Lvl	73.7	0.0	8	-8.0		
1-F6	342	0	0.0	70.3	66	70.3	10	Snd Lvl	70.3	0.0	8	-8.0		
1-F7	345	0	0.0	52.6	66	52.6	10	----	52.6	0.0	8	-8.0		
1-F8	348	0	0.0	67.3	66	67.3	10	Snd Lvl	67.3	0.0	8	-8.0		
1-F9	351	0	0.0	72.9	66	72.9	10	Snd Lvl	72.9	0.0	8	-8.0		
1-F10	436	0	0.0	70.3	66	70.3	10	Snd Lvl	70.3	0.0	8	-8.0		
1-F11	441	0	0.0	53.1	66	53.1	10	----	53.1	0.0	8	-8.0		
1-F12	442	0	0.0	48.3	66	48.3	10	----	48.3	0.0	8	-8.0		
1-F13	443	0	0.0	71.0	66	71.0	10	Snd Lvl	71.0	0.0	8	-8.0		
1-F14	444	0	0.0	68.4	66	68.4	10	Snd Lvl	68.4	0.0	8	-8.0		
1-F15	445	0	0.0	53.0	66	53.0	10	----	53.0	0.0	8	-8.0		
1-F16	446	0	0.0	49.1	66	49.1	10	----	49.1	0.0	8	-8.0		
1-F17	447	0	0.0	69.6	66	69.6	10	Snd Lvl	69.6	0.0	8	-8.0		
1-F18	448	0	0.0	66.9	66	66.9	10	Snd Lvl	66.9	0.0	8	-8.0		
1-F19	449	0	0.0	55.4	66	55.4	10	----	55.4	0.0	8	-8.0		
1-F20	450	0	0.0	50.8	66	50.8	10	----	50.8	0.0	8	-8.0		
1-F21	451	0	0.0	67.9	66	67.9	10	Snd Lvl	67.9	0.0	8	-8.0		
1-F22	452	0	0.0	64.7	66	64.7	10	----	64.7	0.0	8	-8.0		
1-F23	453	0	0.0	56.9	66	56.9	10	----	56.9	0.0	8	-8.0		
1-F24	454	0	0.0	66.1	66	66.1	10	Snd Lvl	66.1	0.0	8	-8.0		

RESULTS: SOUND LEVELS

S200108 516 La Costa

1-F25	455	0	0.0	68.5	66	68.5	10	Snd Lvl	68.5	0.0	8	-8.0
1-F26	456	0	0.0	55.8	66	55.8	10	----	55.8	0.0	8	-8.0
1-F27	457	0	0.0	57.9	66	57.9	10	----	57.9	0.0	8	-8.0
1-F28	458	0	0.0	68.1	66	68.1	10	Snd Lvl	68.1	0.0	8	-8.0
1-F29	459	0	0.0	57.6	66	57.6	10	----	57.6	0.0	8	-8.0
1-F30	460	0	0.0	59.1	66	59.1	10	----	59.1	0.0	8	-8.0
1-F31	461	0	0.0	67.6	66	67.6	10	Snd Lvl	67.6	0.0	8	-8.0
1-F32	462	0	0.0	56.9	66	56.9	10	----	56.9	0.0	8	-8.0
1-F33	463	0	0.0	60.7	66	60.7	10	----	60.7	0.0	8	-8.0
1-F34	464	0	0.0	67.3	66	67.3	10	Snd Lvl	67.3	0.0	8	-8.0
1-F35	465	0	0.0	58.1	66	58.1	10	----	58.1	0.0	8	-8.0
1-F36	466	0	0.0	63.2	66	63.2	10	----	63.2	0.0	8	-8.0
1-F37	467	0	0.0	67.8	66	67.8	10	Snd Lvl	67.8	0.0	8	-8.0
1-F38	468	0	0.0	67.1	66	67.1	10	Snd Lvl	67.1	0.0	8	-8.0
2-F1	469	0	0.0	66.3	66	66.3	10	Snd Lvl	66.3	0.0	8	-8.0
2-F2	470	0	0.0	59.1	66	59.1	10	----	59.1	0.0	8	-8.0
2-F3	471	0	0.0	73.5	66	73.5	10	Snd Lvl	73.5	0.0	8	-8.0
2-F4	472	0	0.0	74.3	66	74.3	10	Snd Lvl	74.3	0.0	8	-8.0
2-F5	473	0	0.0	74.4	66	74.4	10	Snd Lvl	74.4	0.0	8	-8.0
2-F6	474	0	0.0	72.4	66	72.4	10	Snd Lvl	72.4	0.0	8	-8.0
2-F7	475	0	0.0	58.7	66	58.7	10	----	58.7	0.0	8	-8.0
2-F8	476	0	0.0	70.0	66	70.0	10	Snd Lvl	70.0	0.0	8	-8.0
2-F9	477	0	0.0	74.2	66	74.2	10	Snd Lvl	74.2	0.0	8	-8.0
2-F10	478	0	0.0	72.2	66	72.2	10	Snd Lvl	72.2	0.0	8	-8.0
2-F11	479	0	0.0	59.3	66	59.3	10	----	59.3	0.0	8	-8.0
2-F12	480	0	0.0	54.9	66	54.9	10	----	54.9	0.0	8	-8.0
2-F13	481	0	0.0	73.0	66	73.0	10	Snd Lvl	73.0	0.0	8	-8.0
2-F14	482	0	0.0	71.5	66	71.5	10	Snd Lvl	71.5	0.0	8	-8.0
2-F15	483	0	0.0	57.6	66	57.6	10	----	57.6	0.0	8	-8.0
2-F16	484	0	0.0	54.6	66	54.6	10	----	54.6	0.0	8	-8.0
2-F17	485	0	0.0	72.3	66	72.3	10	Snd Lvl	72.3	0.0	8	-8.0
2-F18	486	0	0.0	70.7	66	70.7	10	Snd Lvl	70.7	0.0	8	-8.0
2-F19	487	0	0.0	59.3	66	59.3	10	----	59.3	0.0	8	-8.0
2-F20	488	0	0.0	55.7	66	55.7	10	----	55.7	0.0	8	-8.0
2-F21	489	0	0.0	71.5	66	71.5	10	Snd Lvl	71.5	0.0	8	-8.0
2-F22	490	0	0.0	69.6	66	69.6	10	Snd Lvl	69.6	0.0	8	-8.0
2-F23	491	0	0.0	59.5	66	59.5	10	----	59.5	0.0	8	-8.0
2-F24	492	0	0.0	69.9	66	69.9	10	Snd Lvl	69.9	0.0	8	-8.0
2-F25	493	0	0.0	71.6	66	71.6	10	Snd Lvl	71.6	0.0	8	-8.0
2-F26	494	0	0.0	62.0	66	62.0	10	----	62.0	0.0	8	-8.0
2-F27	495	0	0.0	60.5	66	60.5	10	----	60.5	0.0	8	-8.0

RESULTS: SOUND LEVELS

S200108 516 La Costa

2-F28	496	0	0.0	71.3	66	71.3	10	Snd Lvl	71.3	0.0	8	-8.0
2-F29	497	0	0.0	63.0	66	63.0	10	----	63.0	0.0	8	-8.0
2-F30	498	0	0.0	61.3	66	61.3	10	----	61.3	0.0	8	-8.0
2-F31	499	0	0.0	70.9	66	70.9	10	Snd Lvl	70.9	0.0	8	-8.0
2-F32	500	0	0.0	61.9	66	61.9	10	----	61.9	0.0	8	-8.0
2-F33	501	0	0.0	62.5	66	62.5	10	----	62.5	0.0	8	-8.0
2-F34	502	0	0.0	70.6	66	70.6	10	Snd Lvl	70.6	0.0	8	-8.0
2-F35	503	0	0.0	62.8	66	62.8	10	----	62.8	0.0	8	-8.0
2-F36	504	0	0.0	64.5	66	64.5	10	----	64.5	0.0	8	-8.0
2-F37	505	0	0.0	70.6	66	70.6	10	Snd Lvl	70.6	0.0	8	-8.0
2-F38	517	0	0.0	68.8	66	68.8	10	Snd Lvl	68.8	0.0	8	-8.0
Dwelling Units		# DUs	Noise Reduction									
			Min	Avg	Max							
			dB	dB	dB							
All Selected		0	0.0	0.0	0.0							
All Impacted		0	0.0	0.0	0.0							
All that meet NR Goal		0	0.0	0.0	0.0							

APPENDIX E

Manufacturer Data Sheets

**25HCC5
Performance™ 15 Heat Pump
with Puron® Refrigerant
1–1/2 To 5 Nominal Tons**



Product Data



Performance SERIES

Carrier's heat pumps with Puron® refrigerant provide a collection of features unmatched by any other family of equipment. The 25HCC5 has been designed utilizing Carrier's Puron refrigerant. The environmentally sound refrigerant allows consumers to make a responsible decision in the protection of the earth's ozone layer. This product has been designed and manufactured to meet Energy Star® criteria for energy efficiency when matched with appropriate coil components. Refer to the combination ratings in the Product Data for system combinations that meet Energy Star® guidelines.

NOTE: Ratings contained in this document are subject to change at any time. Always refer to the AHRI directory (www.ahridirectory.org) for the most up-to-date ratings information.

INDUSTRY LEADING FEATURES / BENEFITS

Efficiency

- 15.3 SEER/ 11.0 - 13.0 EER/ 7.7 - 9.0 HSPF (Nominal)
- Microtube Technology™ refrigeration system
- Indoor air quality accessories available

Sound

- Sound level as low as 68 dBA

Comfort

- System supports Thermidistat™ or standard thermostat controls

Reliability

- Puron® refrigerant - environmentally sound, won't deplete the ozone layer and low lifetime service cost.
- Front-seating service valves
- Scroll compressor
- Internal pressure relief valve
- Internal thermal overload
- High pressure switch
- Loss of charge switch
- Filter drier
- Balanced refrigeration system for maximum reliability

Durability

WeatherArmor™ protection package:

- Solid, durable sheet metal construction
- Steel louver coil guard
- Baked-on, complete coverage, powder paint

Applications

- Long-line - up to 250 feet (76.20 m) total equivalent length, up to 200 feet (60.96 m) condenser above evaporator, or up to 80 ft. (24.38 m) evaporator above condenser (See Longline Guide for more information.)
- Low ambient (down to -20°F/-28.9°C) with accessory kit

ELECTRICAL DATA

UNIT SIZE	V/PH	OPER VOLTS*		COMPR		FAN	MCA	MIN WIRE SIZE†	MIN WIRE SIZE†	MAX LENGTH ft (m)††	MAX LENGTH ft (m)††	MAX FUSE** or CKT BRK AMPS
		MAX	MIN	LRA	RLA	FLA		60° C	75° C	60° C	75° C	
18-30	208/230/1	253	197	48.0	9.00	0.5	11.8	14	14	67 (20.4)	63 (19.2)	20
24-30				58.3	12.80	0.5	16.5	14	14	48 (14.6)	45 (13.7)	25
30-30				73.0	14.10	0.5	18.1	14	14	44 (13.4)	41 (12.5)	30
36-30				79.0	16.70	1.2	22.1	12	12	57 (17.4)	54 (16.5)	35
42-30				109.0	21.10	1.2	27.6	10	10	72 (21.9)	69 (21.0)	40
48-30				117.0	21.80	1.2	28.5	10	10	70 (21.3)	67 (20.4)	40
60-30				134.0	26.40	1.2	34.2	8	10	91 (27.7)	56 (17.1)	50

* Permissible limits of the voltage range at which the unit will operate satisfactorily

† If wire is applied at ambient greater than 30°C, consult table 310-16 of the NEC (ANSI/NFPA 70). The ampacity of non-metallic-sheathed cable (NM), trade name ROMEX, shall be that of 60°C conditions, per the NEC (ANSI/NFPA 70) Article 336-26. If other than uncoated (no-plated), 60 or 75°C insulation, copper wire (solid wire for 10 AWG or smaller, stranded wire for larger than 10 AWG) is used, consult applicable tables of the NEC (ANSI/NFPA 70).

‡ Length shown is as measured 1 way along wire path between unit and service panel for voltage drop not to exceed 2%.

** Time-Delay fuse.

FLA - Full Load Amps

LRA - Locked Rotor Amps

MCA - Minimum Circuit Amps

RLA - Rated Load Amps

NOTE: Control circuit is 24-V on all units and requires external power source. Copper wire must be used from service disconnect to unit.

All motors/compressors contain internal overload protection.

Complies with 2007 requirements of ASHRAE Standards 90.1

25HCC5

A-WEIGHTED SOUND POWER

UNIT SIZE - VOLTAGE, SERIES	STANDARD RATING (dBA)	TYPICAL OCTAVE BAND SPECTRUM (dBA, without tone adjustment)						
		125	250	500	1000	2000	4000	8000
18-30	72	50.5	60.0	65.0	67.5	64.5	61.5	53.5
24-30	68	49.5	58.5	61.5	62.0	61.0	58.5	51.5
30-30	69	50.5	58.5	61.5	64.0	61.5	58.5	51.5
36-30	70	54.5	57.5	63.0	66.0	64.0	61.0	54.0
42-30	72	56.5	64.5	66.5	66.5	64.5	61.0	54.5
48-30	72	58.5	63.0	65.5	67.0	63.5	60.0	52.0
60-30	73	58.5	62.5	65.0	67.0	64.0	61.0	56.5

NOTE: Tested in accordance with AHRI Standard 270-08 (not listed in AHRI).

CHARGING SUBCOOLING (TXV-TYPE EXPANSION DEVICE)

UNIT SIZE - VOLTAGE, SERIES	REQUIRED SUBCOOLING ° F (° C)
18-30	12 (6.7)
24-30	14 (7.8)
30-30	10 (5.6)
36-30	8 (4.4)
42-30	10 (5.6)
48-30	11 (6.1)
60-30	10 (5.6)

APPENDIX F

Acoustical Equipment Calibration Certificates

Calibration Certificate

Certificate Number 2018000194

Customer:

Eilar Associates
466 Blueridge Place
Escondido, CA 92026, United States

Model Number	LxT SE	Procedure Number	D0001.8384
Serial Number	0004085	Technician	Ron Harris
Test Results	Pass	Calibration Date	4 Jan 2018
Initial Condition	AS RECEIVED same as shipped	Calibration Due	4 Jan 2020
Description	Sound Expert LxT Class 1 Sound Level Meter Firmware Revision: 2.302	Temperature	23.33 °C ± 0.25 °C
		Humidity	51.5 %RH ± 2.0 %RH
		Static Pressure	86.97 kPa ± 0.13 kPa

Evaluation Method **Tested with:** **Data reported in dB re 20 µPa.**

Larson Davis PRMLxT1L. S/N 035963
PCB 377B02. S/N 146849
Larson Davis CAL200. S/N 9079
Larson Davis CAL291. S/N 0203

Compliance Standards Compliant to Manufacturer Specifications and the following standards when combined with Calibration Certificate from procedure D0001.8378:

IEC 60651:2001 Type 1	ANSI S1.4-2014 Class 1
IEC 60804:2000 Type 1	ANSI S1.4 (R2006) Type 1
IEC 61252:2002	ANSI S1.11 (R2009) Class 1
IEC 61260:2001 Class 1	ANSI S1.25 (R2007)
IEC 61672:2013 Class 1	ANSI S1.43 (R2007) Type 1

Issuing lab certifies that the instrument described above meets or exceeds all specifications as stated in the referenced procedure (unless otherwise noted). It has been calibrated using measurement standards traceable to the International System of Units (SI) through the National Institute of Standards and Technology (NIST), or other national measurement institutes, and meets the requirements of ISO/IEC 17025:2005.

Test points marked with a ‡ in the uncertainties column do not fall within this laboratory's scope of accreditation.

The quality system is registered to ISO 9001:2008.

This calibration is a direct comparison of the unit under test to the listed reference standards and did not involve any sampling plans to complete. No allowance has been made for the instability of the test device due to use, time, etc. Such allowances would be made by the customer as needed.

The uncertainties were computed in accordance with the ISO Guide to the Expression of Uncertainty in Measurement (GUM). A coverage factor of approximately 2 sigma ($k=2$) has been applied to the standard uncertainty to express the expanded uncertainty at approximately 95% confidence level.

This report may not be reproduced, except in full, unless permission for the publication of an approved abstract is obtained in writing from the organization issuing this report.

Correction data from Larson Davis LxT Manual for SoundTrack LxT & SoundExpert Lxt, I770.01 Rev J Supporting Firmware Version 2.301, 2015-04-30

Larson Davis, a division of PCB Piezotronics, Inc
1681 West 820 North
Provo, UT 84601, United States
716-684-0001



Certificate Number 2018000194

For 1/4" microphones, the Larson Davis ADP024 1/4" to 1/2" adaptor is used with the calibrators and the Larson Davis ADP043 1/4" to 1/2" adaptor is used with the preamplifier.

Calibration Check Frequency: 1000 Hz; Reference Sound Pressure Level: 114 dB re 20 µPa

Periodic tests were performed in accordance with procedures from IEC 61672-3:2013 / ANSI/ASA S1.4-2014/Part3.

No Pattern approval for IEC 61672-1:2013 / ANSI/ASA S1.4-2014/Part 1 available.

The sound level meter submitted for testing successfully completed the periodic tests of IEC 61672-3:2013 / ANSI/ASA S1.4-2014/Part 3, for the environmental conditions under which the tests were performed. However, no general statement or conclusion can be made about conformance of the sound level meter to the full specifications of IEC 61672-1:2013 / ANSI/ASA S1.4-2014/Part 1 because (a) evidence was not publicly available, from an independent testing organization responsible for pattern approvals, to demonstrate that the model of sound level meter fully conformed to the class 1 specifications in IEC 61672-1:2013 / ANSI/ASA S1.4-2014/Part 1 or correction data for acoustical test of frequency weighting were not provided in the Instruction Manual and (b) because the periodic tests of IEC 61672-3:2013 / ANSI/ASA S1.4-2014/Part 3 cover only a limited subset of the specifications in IEC 61672-1:2013 / ANSI/ASA S1.4-2014/Part 1.

Standards Used

Description	Cal Date	Cal Due	Cal Standard
SRS DS360 Ultra Low Distortion Generator	2017-06-23	2018-06-23	006311
Hart Scientific 2626-S Humidity/Temperature Sensor	2017-06-11	2018-06-11	006943
Larson Davis CAL200 Acoustic Calibrator	2017-07-25	2018-07-25	007027
Larson Davis Model 831	2017-03-01	2018-03-01	007182
PCB 377A13 1/2 inch Prepolarized Pressure Microphone	2017-03-08	2018-03-08	007185
Larson Davis CAL291 Residual Intensity Calibrator	2017-09-19	2018-09-19	007287

Acoustic Calibration

Measured according to IEC 61672-3:2013 10 and ANSI S1.4-2014 Part 3: 10

Measurement	Test Result [dB]	Lower Limit [dB]	Upper Limit [dB]	Expanded Uncertainty [dB]	Result
1000 Hz	114.01	113.80	114.20	0.14	Pass

As Received Level: 112.02
Adjusted Level: 114.01

-- End of measurement results--

Acoustic Signal Tests, C-weighting

Measured according to IEC 61672-3:2013 12 and ANSI S1.4-2014 Part 3: 12 using a comparison coupler with Unit Under Test (UUT) and reference SLM using slow time-weighted sound level for compliance to IEC 61672-1:2013 5.5; ANSI S1.4-2014 Part 1: 5.5

Frequency [Hz]	Test Result [dB]	Expected [dB]	Lower Limit [dB]	Upper Limit [dB]	Expanded Uncertainty [dB]	Result
125	-0.22	-0.20	-1.20	0.80	0.23	Pass
1000	0.10	0.00	-0.70	0.70	0.23	Pass
8000	-2.30	-3.00	-5.50	-1.50	0.32	Pass

-- End of measurement results--



Self-generated Noise

Measured according to IEC 61672-3:2013 11.1 and ANSI S1.4-2014 Part 3: 11.1

Measurement	Test Result [dB]
A-weighted	40.37

-- End of measurement results--

-- End of Report--

Signatory: Ron Harris

Larson Davis, a division of PCB Piezotronics, Inc
1681 West 820 North
Provo, UT 84601, United States
716-684-0001



Calibration Certificate

Certificate Number 2018000180

Customer:

Eilar Associates
466 Blueridge Place
Escondido, CA 92026, United States

Model Number	LxT SE	Procedure Number	D0001.8378
Serial Number	0004085	Technician	Ron Harris
Test Results	Pass	Calibration Date	4 Jan 2018
Initial Condition	AS RECEIVED same as shipped	Calibration Due	4 Jan 2020
Description	Sound Expert LxT Class 1 Sound Level Meter Firmware Revision: 2.302	Temperature	22.99 °C ± 0.25 °C
		Humidity	51.4 %RH ± 2.0 %RH
		Static Pressure	86.87 kPa ± 0.13 kPa

Evaluation Method Tested electrically using Larson Davis PRMLxT1L S/N 035963 and a 12.0 pF capacitor to simulate microphone capacitance. Data reported in dB re 20 µPa assuming a microphone sensitivity of 23.6 mV/Pa.

Compliance Standards Compliant to Manufacturer Specifications and the following standards when combined with Calibration Certificate from procedure D0001.8384:

IEC 60651:2001 Type 1	ANSI S1.4-2014 Class 1
IEC 60804:2000 Type 1	ANSI S1.4 (R2006) Type 1
IEC 61252:2002	ANSI S1.11 (R2009) Class 1
IEC 61260:2001 Class 1	ANSI S1.25 (R2007)
IEC 61672:2013 Class 1	ANSI S1.43 (R2007) Type 1

Issuing lab certifies that the instrument described above meets or exceeds all specifications as stated in the referenced procedure (unless otherwise noted). It has been calibrated using measurement standards traceable to the International System of Units (SI) through the National Institute of Standards and Technology (NIST), or other national measurement institutes, and meets the requirements of ISO/IEC 17025:2005. Test points marked with a ‡ in the uncertainties column do not fall within this laboratory's scope of accreditation.

The quality system is registered to ISO 9001:2008.

This calibration is a direct comparison of the unit under test to the listed reference standards and did not involve any sampling plans to complete. No allowance has been made for the instability of the test device due to use, time, etc. Such allowances would be made by the customer as needed.

The uncertainties were computed in accordance with the ISO Guide to the Expression of Uncertainty in Measurement (GUM). A coverage factor of approximately 2 sigma (k=2) has been applied to the standard uncertainty to express the expanded uncertainty at approximately 95% confidence level.

This report may not be reproduced, except in full, unless permission for the publication of an approved abstract is obtained in writing from the organization issuing this report.

Correction data from Larson Davis LxT Manual for SoundTrack LxT & SoundExpert Lxt, I770.01 Rev J Supporting Firmware Version 2.301, 2015-04-30

Calibration Check Frequency: 1000 Hz; Reference Sound Pressure Level: 114 dB re 20 µPa

Larson Davis, a division of PCB Piezotronics, Inc
1681 West 820 North
Provo, UT 84601, United States
716-684-0001



Periodic tests were performed in accordance with precedures from IEC 61672-3:2013 / ANSI/ASA S1.4-2014/Part3.

No Pattern approval for IEC 61672-1:2013 / ANSI/ASA S1.4-2014/Part 1 available.

The sound level meter submitted for testing successfully completed the periodic tests of IEC 61672-3:2013 / ANSI/ASA S1.4-2014/Part 3, for the environmental conditions under which the tests were performed. However, no general statement or conclusion can be made about conformance of the sound level meter to the full specifications of IEC 61672-1:2013 / ANSI/ASA S1.4-2014/Part 1 because (a) evidence was not publicly available, from an independent testing organization responsible for pattern approvals, to demonstrate that the model of sound level meter fully conformed to the class 1 specifications in IEC 61672-1:2013 / ANSI/ASA S1.4-2014/Part 1 or correction data for acoustical test of frequency weighting were not provided in the Instruction Manual and (b) because the periodic tests of IEC 61672-3:2013 / ANSI/ASA S1.4-2014/Part 3 cover only a limited subset of the specifications in IEC 61672-1:2013 / ANSI/ASA S1.4-2014/Part 1.

Description	Standards Used		
	Cal Date	Cal Due	Cal Standard
SRS DS360 Ultra Low Distortion Generator	2017-01-19	2018-01-19	006239
Hart Scientific 2626-S Humidity/Temperature Sensor	2017-06-11	2018-06-11	006943



A-weight Filter Response

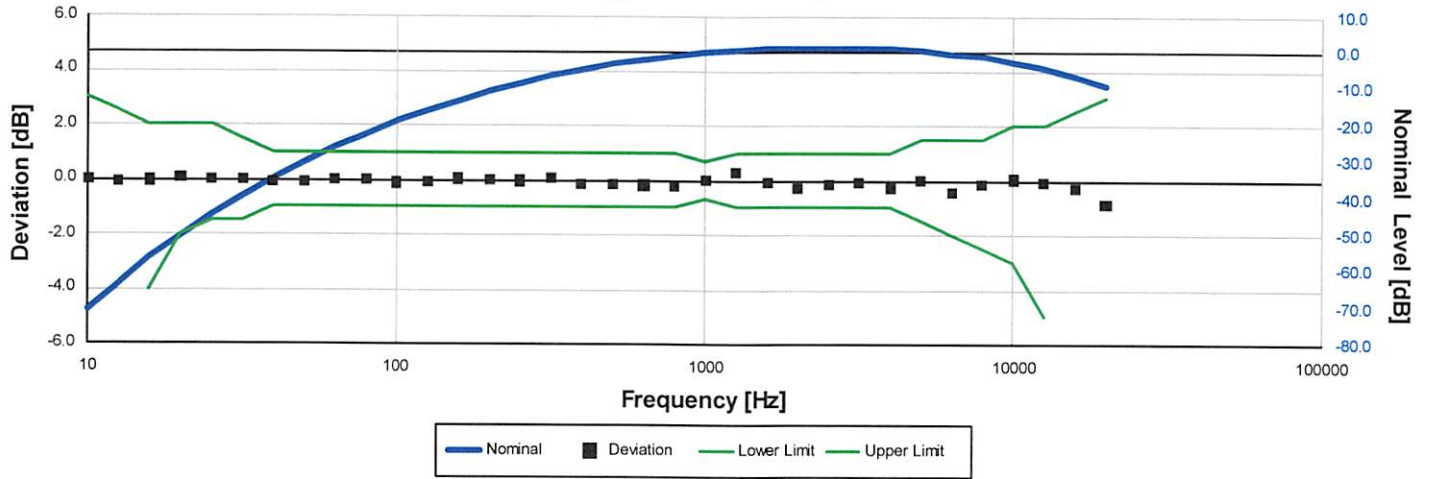

Electrical signal test of frequency weighting performed according to IEC 61672-3:2013 13 and ANSI S1.4-2014 Part 3: 13 for compliance to IEC 61672-1:2013 5.5; IEC 60651:2001 6.1 and 9.2.2; IEC 60804:2000 5; ANSI S1.4:1983 (R2006) 5.1 and 8.2.1; ANSI S1.4-2014 Part 1: 5.5

Frequency [Hz]	Test Result [dB]	Deviation [dB]	Lower limit [dB]	Upper limit [dB]	Expanded Uncertainty [dB]	Result
10.00	-70.38	0.02	-inf	3.00	0.22	Pass
12.59	-63.44	-0.04	-inf	2.50	0.22	Pass
15.85	-56.73	-0.03	-4.00	2.00	0.22	Pass
19.95	-50.42	0.08	-2.00	2.00	0.22	Pass
25.12	-44.68	0.02	-1.50	2.00	0.22	Pass
31.62	-39.42	-0.02	-1.50	1.50	0.22	Pass
39.81	-34.64	-0.04	-1.00	1.00	0.22	Pass
50.12	-30.24	-0.04	-1.00	1.00	0.22	Pass
63.10	-26.18	0.02	-1.00	1.00	0.22	Pass
79.43	-22.48	0.02	-1.00	1.00	0.22	Pass
100.00	-19.20	-0.10	-1.00	1.00	0.22	Pass
125.89	-16.17	-0.07	-1.00	1.00	0.22	Pass
158.49	-13.36	0.04	-1.00	1.00	0.22	Pass
199.53	-10.88	0.02	-1.00	1.00	0.22	Pass
251.19	-8.63	-0.03	-1.00	1.00	0.22	Pass
316.23	-6.53	0.07	-1.00	1.00	0.22	Pass
398.11	-4.94	-0.14	-1.00	1.00	0.22	Pass
501.19	-3.37	-0.17	-1.00	1.00	0.22	Pass
630.96	-2.08	-0.18	-1.00	1.00	0.22	Pass
794.33	-1.00	-0.20	-1.00	1.00	0.22	Pass
1,000.00	0.00	0.00	-0.70	0.70	0.22	Pass
1,258.93	0.91	0.31	-1.00	1.00	0.22	Pass
1,584.89	0.96	-0.04	-1.00	1.00	0.22	Pass
1,995.26	0.91	-0.29	-1.00	1.00	0.22	Pass
2,511.89	1.19	-0.11	-1.00	1.00	0.22	Pass
3,162.28	1.13	-0.07	-1.00	1.00	0.22	Pass
3,981.07	0.75	-0.25	-1.00	1.00	0.22	Pass
5,011.87	0.48	-0.02	-1.50	1.50	0.22	Pass
6,309.57	-0.51	-0.41	-2.00	1.50	0.22	Pass
7,943.28	-1.25	-0.15	-2.50	1.50	0.22	Pass
10,000.00	-2.46	0.04	-3.00	2.00	0.22	Pass
12,589.25	-4.36	-0.06	-5.00	2.00	0.22	Pass
15,848.93	-6.88	-0.28	-16.00	2.50	0.22	Pass
19,952.62	-10.15	-0.85	-inf	3.00	0.22	Pass

-- End of measurement results--

Larson Davis, a division of PCB Piezotronics, Inc
 1681 West 820 North
 Provo, UT 84601, United States
 716-684-0001



C-weight Filter Response

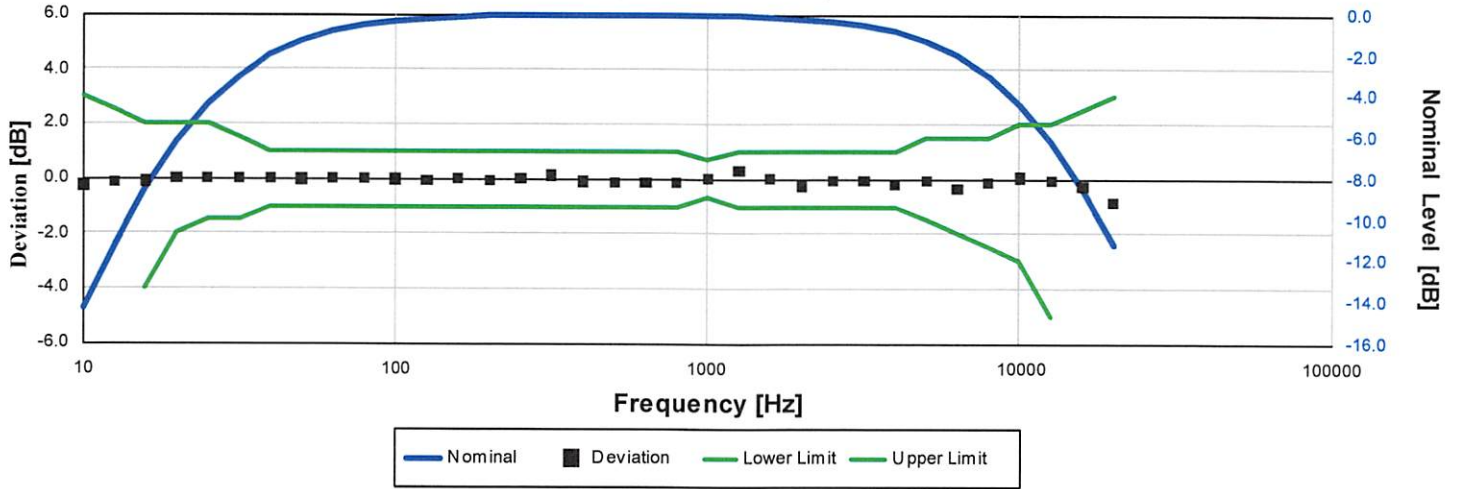

Electrical signal test of frequency weighting performed according to IEC 61672-3:2013 13 and ANSI S1.4-2014 Part 3: 13 for compliance to IEC 61672-1:2013 5.5; IEC 60651:2001 6.1 and 9.2.2; IEC 60804:2000 5; ANSI S1.4:1983 (R2006) 5.1 and 8.2.1; ANSI S1.4-2014 Part 1: 5.5

Frequency [Hz]	Test Result [dB]	Deviation [dB]	Lower limit [dB]	Upper limit [dB]	Expanded Uncertainty [dB]	Result
10.00	-14.54	-0.24	-inf	3.00	0.22	Pass
12.59	-11.36	-0.16	-inf	2.50	0.22	Pass
15.85	-8.59	-0.09	-4.00	2.00	0.22	Pass
19.95	-6.21	-0.01	-2.00	2.00	0.22	Pass
25.12	-4.40	0.00	-1.50	2.00	0.22	Pass
31.62	-3.00	0.00	-1.50	1.50	0.22	Pass
39.81	-2.00	0.00	-1.00	1.00	0.22	Pass
50.12	-1.33	-0.03	-1.00	1.00	0.22	Pass
63.10	-0.80	0.00	-1.00	1.00	0.22	Pass
79.43	-0.49	0.01	-1.00	1.00	0.22	Pass
100.00	-0.32	-0.02	-1.00	1.00	0.22	Pass
125.89	-0.24	-0.04	-1.00	1.00	0.22	Pass
158.49	-0.08	0.02	-1.00	1.00	0.22	Pass
199.53	-0.05	-0.05	-1.00	1.00	0.22	Pass
251.19	0.02	0.02	-1.00	1.00	0.22	Pass
316.23	0.12	0.12	-1.00	1.00	0.22	Pass
398.11	-0.09	-0.09	-1.00	1.00	0.22	Pass
501.19	-0.11	-0.11	-1.00	1.00	0.22	Pass
630.96	-0.14	-0.15	-1.00	1.00	0.22	Pass
794.33	-0.13	-0.13	-1.00	1.00	0.22	Pass
1,000.00	0.00	0.00	-0.70	0.70	0.22	Pass
1,258.93	0.31	0.31	-1.00	1.00	0.22	Pass
1,584.89	-0.08	0.02	-1.00	1.00	0.22	Pass
1,995.26	-0.43	-0.23	-1.00	1.00	0.22	Pass
2,511.89	-0.37	-0.07	-1.00	1.00	0.22	Pass
3,162.28	-0.56	-0.06	-1.00	1.00	0.22	Pass
3,981.07	-1.03	-0.23	-1.00	1.00	0.22	Pass
5,011.87	-1.34	-0.04	-1.50	1.50	0.22	Pass
6,309.57	-2.37	-0.37	-2.00	1.50	0.22	Pass
7,943.28	-3.13	-0.13	-2.50	1.50	0.22	Pass
10,000.00	-4.36	0.04	-3.00	2.00	0.22	Pass
12,589.25	-6.28	-0.08	-5.00	2.00	0.22	Pass
15,848.93	-8.79	-0.29	-16.00	2.50	0.22	Pass
19,952.62	-12.05	-0.85	-inf	3.00	0.22	Pass

-- End of measurement results--

Larson Davis, a division of PCB Piezotronics, Inc
 1681 West 820 North
 Provo, UT 84601, United States
 716-684-0001



Z-weight Filter Response

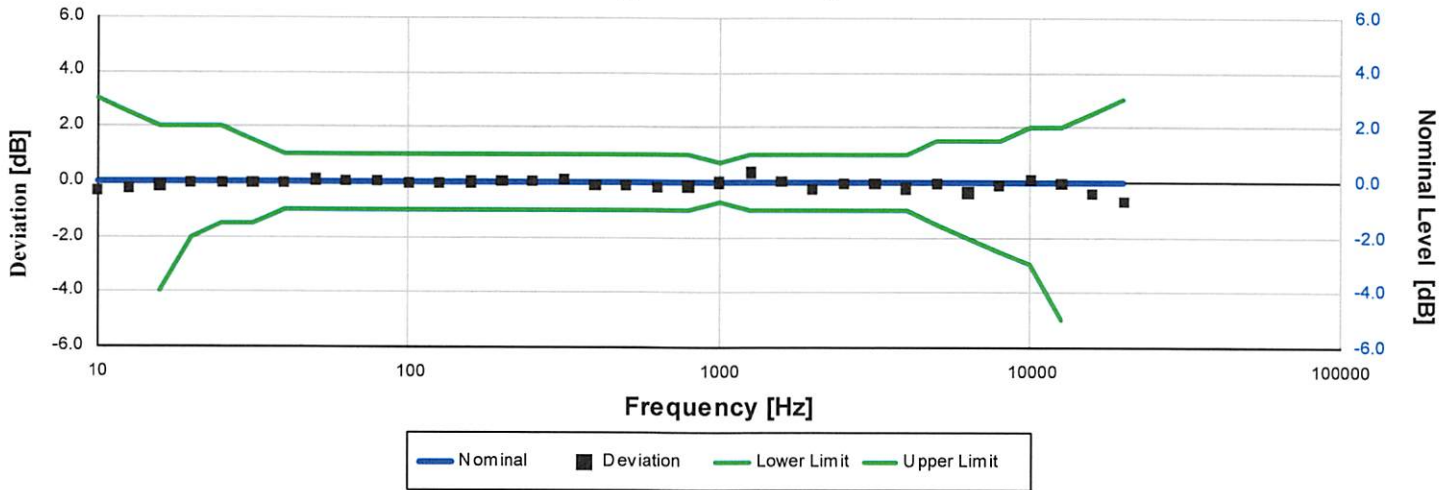

Electrical signal test of frequency weighting performed according to IEC 61672-3:2013 13 and ANSI S1.4-2014 Part 3: 13 for compliance to IEC 61672-1:2013 5.5; IEC 60651:2001 6.1 and 9.2.2; IEC 60804:2000 5; ANSI S1.4:1983 (R2006) 5.1 and 8.2.1; ANSI S1.4-2014 Part 1: 5.5

Frequency [Hz]	Test Result [dB]	Deviation [dB]	Lower limit [dB]	Upper limit [dB]	Expanded Uncertainty [dB]	Result
10.00	-0.33	-0.33	-inf	3.00	0.22	Pass
12.59	-0.26	-0.26	-inf	2.50	0.22	Pass
15.85	-0.15	-0.15	-4.00	2.00	0.22	Pass
19.95	-0.04	-0.04	-2.00	2.00	0.22	Pass
25.12	-0.04	-0.04	-1.50	2.00	0.22	Pass
31.62	-0.03	-0.03	-1.50	1.50	0.22	Pass
39.81	-0.03	-0.03	-1.00	1.00	0.22	Pass
50.12	0.06	0.06	-1.00	1.00	0.22	Pass
63.10	0.01	0.01	-1.00	1.00	0.22	Pass
79.43	0.02	0.02	-1.00	1.00	0.22	Pass
100.00	-0.05	-0.05	-1.00	1.00	0.22	Pass
125.89	-0.06	-0.06	-1.00	1.00	0.22	Pass
158.49	0.00	0.00	-1.00	1.00	0.22	Pass
199.53	0.01	0.01	-1.00	1.00	0.22	Pass
251.19	0.02	0.02	-1.00	1.00	0.22	Pass
316.23	0.11	0.11	-1.00	1.00	0.22	Pass
398.11	-0.13	-0.13	-1.00	1.00	0.22	Pass
501.19	-0.12	-0.12	-1.00	1.00	0.22	Pass
630.96	-0.16	-0.16	-1.00	1.00	0.22	Pass
794.33	-0.15	-0.15	-1.00	1.00	0.22	Pass
1,000.00	0.00	0.00	-0.70	0.70	0.22	Pass
1,258.93	0.35	0.35	-1.00	1.00	0.22	Pass
1,584.89	0.01	0.01	-1.00	1.00	0.22	Pass
1,995.26	-0.25	-0.25	-1.00	1.00	0.22	Pass
2,511.89	-0.06	-0.06	-1.00	1.00	0.22	Pass
3,162.28	-0.06	-0.06	-1.00	1.00	0.22	Pass
3,981.07	-0.22	-0.22	-1.00	1.00	0.22	Pass
5,011.87	-0.06	-0.06	-1.50	1.50	0.22	Pass
6,309.57	-0.36	-0.36	-2.00	1.50	0.22	Pass
7,943.28	-0.09	-0.09	-2.50	1.50	0.22	Pass
10,000.00	0.12	0.12	-3.00	2.00	0.22	Pass
12,589.25	-0.02	-0.02	-5.00	2.00	0.22	Pass
15,848.93	-0.38	-0.38	-16.00	2.50	0.22	Pass
19,952.62	-0.70	-0.70	-inf	3.00	0.22	Pass

-- End of measurement results--

Larson Davis, a division of PCB Piezotronics, Inc
 1681 West 820 North
 Provo, UT 84601, United States
 716-684-0001



High Level Stability

Electrical signal test of high level stability performed according to IEC 61672-3:2013 21 and ANSI S1.4-2014 Part 3: 21 for compliance to IEC 61672-1:2013 5.15 and ANSI S1.4-2014 Part 1: 5.15

Measurement	Test Result [dB]	Lower limit [dB]	Upper limit [dB]	Expanded Uncertainty [dB]	Result
High Level Stability	0.01	-0.10	0.10	0.01	Pass
-- End of measurement results--					

Long-Term Stability

Electrical signal test of long term stability performed according to IEC 61672-3:2013 15 and ANSI S1.4-2014 Part 3: 15 for compliance to IEC 61672-1:2013 5.14 and ANSI S1.4-2014 Part 1: 5.14

Test Duration [min]	Test Result [dB]	Lower limit [dB]	Upper limit [dB]	Expanded Uncertainty [dB]	Result
35	-0.02	-0.10	0.10	0.07	Pass
-- End of measurement results--					

1 kHz Reference Levels

Frequency weightings and time weightings at 1 kHz (reference is A weighted Fast) performed according to IEC 61672-3:2013 14 and ANSI S1.4-2014 Part 3: 14 for compliance to IEC 61672-1:2013 5.5.9 and 5.8.3 and ANSI S1.4-2014 Part 1: 5.5.9 and 5.8.3

Measurement	Test Result [dB]	Lower limit [dB]	Upper limit [dB]	Expanded Uncertainty [dB]	Result
C weight	95.84	95.64	96.04	0.09	Pass
Z weight	95.83	95.64	96.04	0.09	Pass
Slow	95.84	95.74	95.94	0.09	Pass
Impulse	95.84	95.74	95.94	0.09	Pass
-- End of measurement results--					



A-weighted Broadband Log Linearity: 8,000.00 Hz

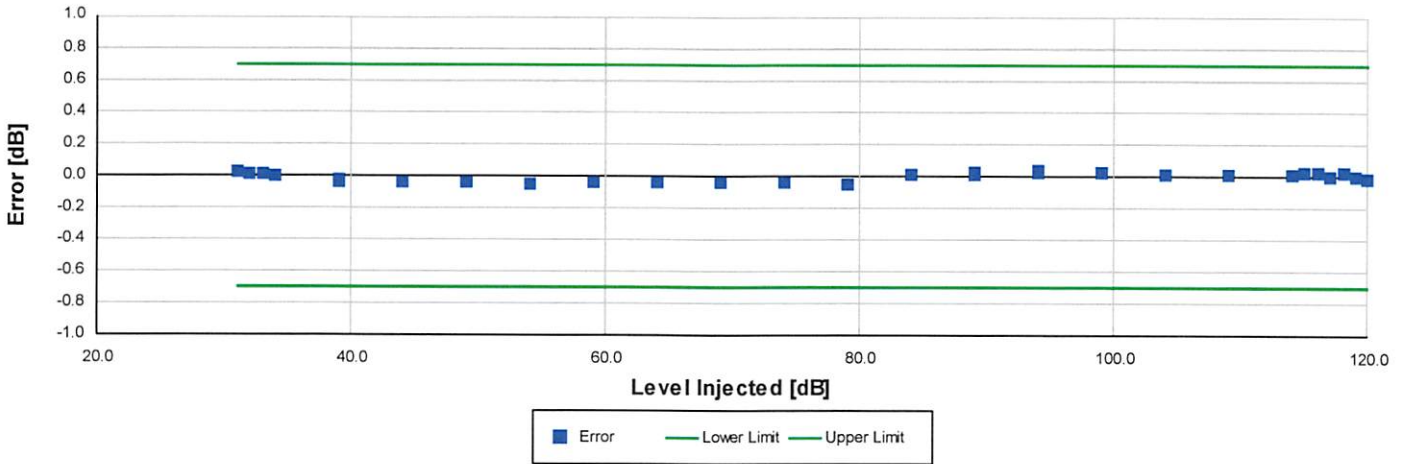

Broadband level linearity performed according to IEC 61672-3:2013 16 and ANSI S1.4-2014 Part 3: 16 for compliance to IEC 61672-1:2013 5.6, IEC 60804:2000 6.2, IEC 61252:2002 8, ANSI S1.4 (R2006) 6.9, ANSI S1.4-2014 Part 1: 5.6, ANSI S1.43 (R2007) 6.2

Level [dB]	Error [dB]	Lower limit [dB]	Upper limit [dB]	Expanded Uncertainty [dB]	Result
31.00	0.03	-0.70	0.70	0.09	Pass
32.00	0.01	-0.70	0.70	0.09	Pass
33.00	0.02	-0.70	0.70	0.09	Pass
34.00	0.00	-0.70	0.70	0.09	Pass
39.00	-0.03	-0.70	0.70	0.09	Pass
44.00	-0.04	-0.70	0.70	0.09	Pass
49.00	-0.04	-0.70	0.70	0.09	Pass
54.00	-0.05	-0.70	0.70	0.09	Pass
59.00	-0.03	-0.70	0.70	0.09	Pass
64.00	-0.04	-0.70	0.70	0.09	Pass
69.00	-0.03	-0.70	0.70	0.09	Pass
74.00	-0.04	-0.70	0.70	0.09	Pass
79.00	-0.05	-0.70	0.70	0.09	Pass
84.00	0.01	-0.70	0.70	0.09	Pass
89.00	0.02	-0.70	0.70	0.09	Pass
94.00	0.03	-0.70	0.70	0.09	Pass
99.00	0.03	-0.70	0.70	0.09	Pass
104.00	0.01	-0.70	0.70	0.09	Pass
109.00	0.01	-0.70	0.70	0.09	Pass
114.00	0.01	-0.70	0.70	0.09	Pass
115.00	0.03	-0.70	0.70	0.09	Pass
116.00	0.02	-0.70	0.70	0.09	Pass
117.00	0.00	-0.70	0.70	0.09	Pass
118.00	0.02	-0.70	0.70	0.09	Pass
119.00	0.00	-0.70	0.70	0.09	Pass
120.00	-0.01	-0.70	0.70	0.09	Pass

-- End of measurement results--

1/1 Octave Log Linearity: 1,000.00 Hz

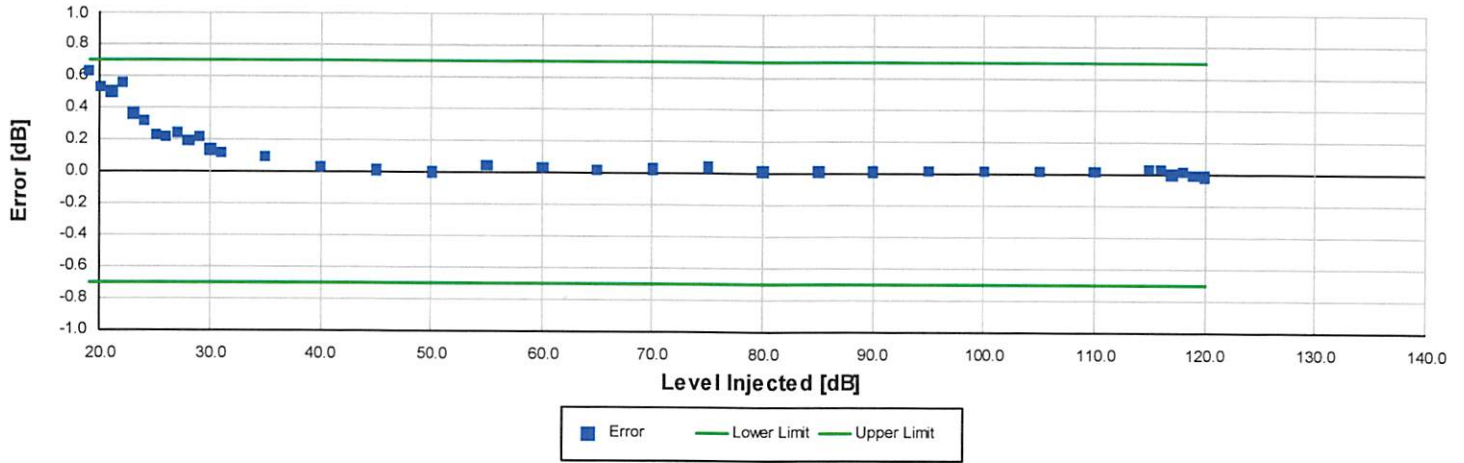

1/1 octave level linearity at normal range performed according to IEC 61260:2001 4.6, ANSI S.11 (R2009) 4.6

Level [dB]	Error [dB]	Lower limit [dB]	Upper limit [dB]	Expanded Uncertainty [dB]	Result
19.00	0.63	-0.70	0.70	0.09	Pass
20.00	0.53	-0.70	0.70	0.09	Pass
21.00	0.50	-0.70	0.70	0.09	Pass
22.00	0.56	-0.70	0.70	0.09	Pass
23.00	0.37	-0.70	0.70	0.09	Pass
24.00	0.32	-0.70	0.70	0.09	Pass
25.00	0.23	-0.70	0.70	0.09	Pass
26.00	0.22	-0.70	0.70	0.11	Pass
27.00	0.24	-0.70	0.70	0.11	Pass
28.00	0.20	-0.70	0.70	0.09	Pass
29.00	0.22	-0.70	0.70	0.10	Pass
30.00	0.14	-0.70	0.70	0.10	Pass
31.00	0.12	-0.70	0.70	0.09	Pass
35.00	0.09	-0.70	0.70	0.09	Pass
40.00	0.03	-0.70	0.70	0.09	Pass
45.00	0.01	-0.70	0.70	0.09	Pass
50.00	0.00	-0.70	0.70	0.09	Pass
55.00	0.04	-0.70	0.70	0.09	Pass
60.00	0.03	-0.70	0.70	0.09	Pass
65.00	0.02	-0.70	0.70	0.09	Pass
70.00	0.02	-0.70	0.70	0.09	Pass
75.00	0.04	-0.70	0.70	0.09	Pass
80.00	0.01	-0.70	0.70	0.09	Pass
85.00	0.01	-0.70	0.70	0.09	Pass
90.00	0.01	-0.70	0.70	0.09	Pass
95.00	0.02	-0.70	0.70	0.09	Pass
100.00	0.02	-0.70	0.70	0.09	Pass
105.00	0.02	-0.70	0.70	0.09	Pass
110.00	0.02	-0.70	0.70	0.09	Pass
115.00	0.03	-0.70	0.70	0.09	Pass
116.00	0.03	-0.70	0.70	0.09	Pass
117.00	0.00	-0.70	0.70	0.09	Pass
118.00	0.02	-0.70	0.70	0.09	Pass
119.00	-0.01	-0.70	0.70	0.09	Pass
120.00	-0.01	-0.70	0.70	0.09	Pass

-- End of measurement results--

Larson Davis, a division of PCB Piezotronics, Inc
 1681 West 820 North
 Provo, UT 84601, United States
 716-684-0001



1/3 Octave Log Linearity: 1,000.00 Hz

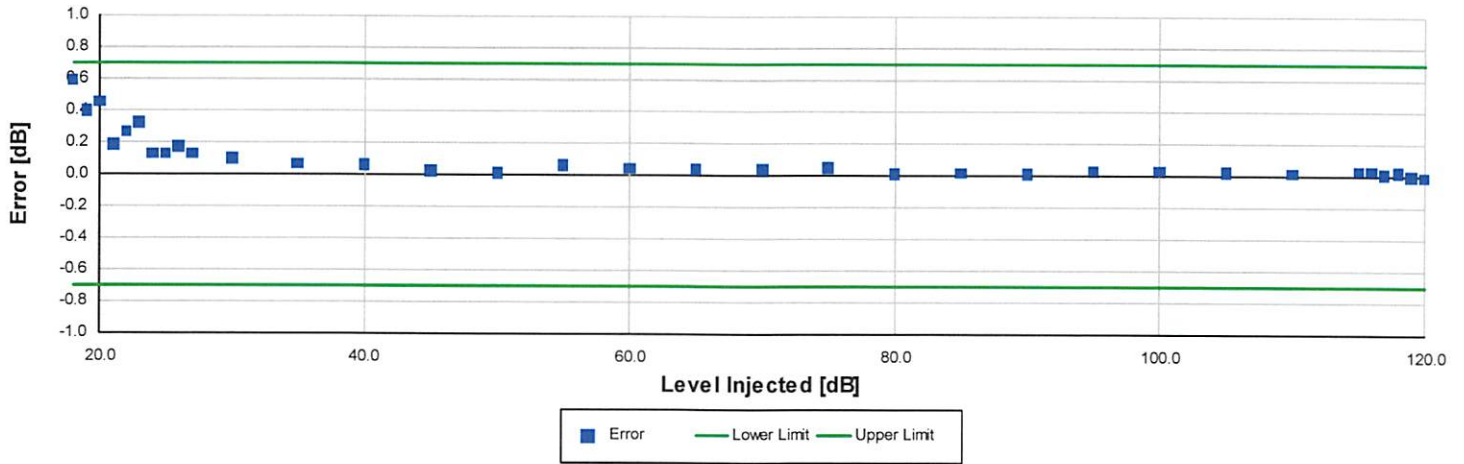

1/3 octave level linearity at normal range performed according to IEC 61260:2001 4.6, ANSI S.11 (R2009) 4.6

Level [dB]	Error [dB]	Lower limit [dB]	Upper limit [dB]	Expanded Uncertainty [dB]	Result
18.00	0.59	-0.70	0.70	0.09	Pass
19.00	0.40	-0.70	0.70	0.09	Pass
20.00	0.46	-0.70	0.70	0.09	Pass
21.00	0.19	-0.70	0.70	0.09	Pass
22.00	0.27	-0.70	0.70	0.12	Pass
23.00	0.32	-0.70	0.70	0.13	Pass
24.00	0.13	-0.70	0.70	0.11	Pass
25.00	0.13	-0.70	0.70	0.11	Pass
26.00	0.17	-0.70	0.70	0.10	Pass
27.00	0.13	-0.70	0.70	0.10	Pass
30.00	0.10	-0.70	0.70	0.10	Pass
35.00	0.06	-0.70	0.70	0.09	Pass
40.00	0.06	-0.70	0.70	0.09	Pass
45.00	0.02	-0.70	0.70	0.09	Pass
50.00	0.01	-0.70	0.70	0.09	Pass
55.00	0.06	-0.70	0.70	0.09	Pass
60.00	0.04	-0.70	0.70	0.09	Pass
65.00	0.03	-0.70	0.70	0.09	Pass
70.00	0.03	-0.70	0.70	0.09	Pass
75.00	0.05	-0.70	0.70	0.09	Pass
80.00	0.01	-0.70	0.70	0.09	Pass
85.00	0.02	-0.70	0.70	0.09	Pass
90.00	0.01	-0.70	0.70	0.09	Pass
95.00	0.03	-0.70	0.70	0.09	Pass
100.00	0.03	-0.70	0.70	0.09	Pass
105.00	0.02	-0.70	0.70	0.09	Pass
110.00	0.01	-0.70	0.70	0.09	Pass
115.00	0.03	-0.70	0.70	0.09	Pass
116.00	0.03	-0.70	0.70	0.09	Pass
117.00	0.01	-0.70	0.70	0.09	Pass
118.00	0.02	-0.70	0.70	0.09	Pass
119.00	0.00	-0.70	0.70	0.09	Pass
120.00	-0.01	-0.70	0.70	0.09	Pass

-- End of measurement results--

Slow Detector

Toneburst response performed according to IEC 61672-3:2013 18 and ANSI S1.4-2014 Part 3: 18 for compliance to IEC 61672-1:2013 5.9, IEC 60651:2001 9.4.2, ANSI S1.4:1983 (R2006) 8.4.2 and ANSI S1.4-2014 Part 1: 5.9

Amplitude [dB]	Duration [ms]	Test Result [dB]	Lower limit [dB]	Upper limit [dB]	Expanded Uncertainty [dB]	Result
113.15	200	-7.55	-7.92	-6.92	0.09	Pass
	2	-27.15	-29.99	-25.99	0.09	Pass

-- End of measurement results--

Fast Detector

Toneburst response performed according to IEC 61672-3:2013 18 and ANSI S1.4-2014 Part 3: 18 for compliance to IEC 61672-1:2013 5.9, IEC 60651:2001 9.4.2, ANSI S1.4:1983 (R2006) 8.4.2 and ANSI S1.4-2014 Part 1: 5.9

Amplitude [dB]	Duration [ms]	Test Result [dB]	Lower limit [dB]	Upper limit [dB]	Expanded Uncertainty [dB]	Result
113.15	200.00	-1.08	-1.48	-0.48	0.23	Pass
	2.00	-18.28	-19.49	-16.99	0.09	Pass
	0.25	-27.33	-29.99	-25.99	0.09	Pass

-- End of measurement results--

Sound Exposure Level

Toneburst response performed according to IEC 61672-3:2013 18 and ANSI S1.4-2014 Part 3: 18 for compliance to IEC 61672-1:2013 5.9, IEC 60651:2001 9.4.2, ANSI S1.4:1983 (R2006) 8.4.2 and ANSI S1.4-2014 Part 1: 5.9

Amplitude [dB]	Duration [ms]	Test Result [dB]	Lower limit [dB]	Upper limit [dB]	Expanded Uncertainty [dB]	Result
113.15	200.00	-7.01	-7.49	-6.49	0.09	Pass
	2.00	-27.04	-28.49	-25.99	0.09	Pass
	0.25	-36.15	-39.02	-35.02	0.09	Pass

-- End of measurement results--

Peak C-weight

C-weighted peak sound level performed according to IEC 61672-3:2013 19 and ANSI S1.4-2014 Part 3: 19 for compliance to IEC 61672-1:2013 5.13 and ANSI S1.4-2014 Part 1: 5.13

Level [dB]	Frequency [Hz]	Test Result [dB]	Lower limit [dB]	Upper limit [dB]	Expanded Uncertainty [dB]	Result
111.15	31.50	114.41	111.65	115.65	0.09	Pass
111.15	500.00	114.74	113.65	115.65	0.09	Pass
111.15	8,000.00	113.89	112.55	116.55	0.10	Pass
111.15, Negative	500.00	113.35	112.55	114.55	0.09	Pass
111.15, Positive	500.00	113.28	112.55	114.55	0.09	Pass

-- End of measurement results--

Peak Z-weight

Z-weighted peak sound level performed according to IEC 60651:2001 9.4.4 and ANSI S1.4:1983 (R2006) 8.4.4

Amplitude [dB]	Duration[μs]	Test Result [dB]	Lower limit [dB]	Upper limit [dB]	Expanded Uncertainty [dB]	Result	
112.15	100	Negative Pulse	114.40	112.05	116.05	0.09	Pass
	100	Positive Pulse	114.35	111.99	115.99	0.09	Pass
102.15	100	Negative Pulse	104.38	102.03	106.03	0.09	Pass
	100	Positive Pulse	104.34	101.99	105.99	0.09	Pass
92.15	100	Negative Pulse	94.39	92.04	96.04	0.09	Pass
	100	Positive Pulse	94.34	92.00	96.00	0.09	Pass
82.15	100	Negative Pulse	84.40	82.05	86.05	0.09	Pass
	100	Positive Pulse	84.34	82.01	86.01	0.09	Pass

-- End of measurement results--

Overload Detector

Overload indication performed according to IEC 61672-3:2013 20 and ANSI S1.4-2014 Part 3: 20 for compliance to IEC 61672-1:2013 5.11, IEC 60804:2000 9.3.5, IEC 61252:2002 11, ANSI S1.4 (R2006) 5.8, and ANSI S1.4-2014 Part 1: 5.11, ANSI S1.25 (R2007) 7.6, ANSI S1.43 (R2007) 7

Measurement	Test Result [dB]	Lower limit [dB]	Upper limit [dB]	Expanded Uncertainty [dB]	Result
Positive	119.05	118.00	120.00	0.09	Pass
Negative	118.85	118.00	120.00	0.09	Pass
Difference	0.20	-1.50	1.50	0.09	Pass

-- End of measurement results--

Peak Rise Time

Peak rise time performed according to IEC 60651:2001 9.4.4 and ANSI S1.4:1983 (R2006) 8.4.4

Amplitude [dB]	Duration [μs]	Test Result [dB]	Lower limit [dB]	Upper limit [dB]	Expanded Uncertainty [dB]	Result	
113.15	40	Negative Pulse	114.28	113.04	115.04	0.09	Pass
		Positive Pulse	114.41	112.96	114.96	0.09	Pass
	30	Negative Pulse	113.60	113.04	115.04	0.09	Pass
		Positive Pulse	113.52	112.96	114.96	0.09	Pass

-- End of measurement results--

Positive Pulse Crest Factor

200 μ s pulse tests at 2.0, 12.0, 22.0, 32.0 dB below Overload Limit

Crest Factor measured according to IEC 60651:2001 9.4.2 and ANSI S1.4:1983 (R2006) 8.4.2

Amplitude [dB]	Crest Factor	Test Result [dB]	Limits [dB]	Expanded Uncertainty [dB]	Result
114.15	3	OVLD	± 0.50	0.09	Pass
	5	OVLD	± 1.00	0.09	Pass
	10	OVLD	± 1.50	0.09	Pass
104.15	3	-0.10	± 0.50	0.09	Pass
	5	-0.11	± 1.00	0.11	Pass
	10	OVLD	± 1.50	0.09	Pass
94.15	3	-0.08	± 0.50	0.09	Pass
	5	-0.07	± 1.00	0.09	Pass
	10	-0.24	± 1.50	0.09	Pass
84.15	3	-0.08	± 0.50	0.09	Pass
	5	-0.06	± 1.00	0.09	Pass
	10	0.07	± 1.50	0.09	Pass

-- End of measurement results--

Negative Pulse Crest Factor

200 μ s pulse tests at 2.0, 12.0, 22.0, 32.0 dB below Overload Limit

Crest Factor measured according to IEC 60651:2001 9.4.2 and ANSI S1.4:1983 (R2006) 8.4.2

Amplitude [dB]	Crest Factor	Test Result [dB]	Limits [dB]	Expanded Uncertainty [dB]	Result
114.15	3	OVLD	± 0.50	0.09	Pass
	5	OVLD	± 1.00	0.09	Pass
	10	OVLD	± 1.50	0.09	Pass
104.15	3	-0.06	± 0.50	0.09	Pass
	5	-0.05	± 1.00	0.09	Pass
	10	OVLD	± 1.50	0.09	Pass
94.15	3	-0.07	± 0.50	0.09	Pass
	5	-0.06	± 1.00	0.09	Pass
	10	-0.20	± 1.50	0.09	Pass
84.15	3	-0.06	± 0.50	0.09	Pass
	5	-0.04	± 1.00	0.09	Pass
	10	0.08	± 1.50	0.09	Pass

-- End of measurement results--

Tone Burst

2kHz tone burst tests at 2.0, 12.0, 22.0, 32.0 dB below Overload Limit

Tone burst response measured according to IEC 60651:2001 9.4.2 and ANSI S1.4:1983 (R2006) 8.4.2

Amplitude [dB]	Crest Factor	Test Result [dB]	Limits [dB]	Expanded Uncertainty [dB]	Result
114.15	3	OVLD	± 0.50	0.09	Pass
	5	OVLD	± 1.00	0.09	Pass
104.15	3	-0.06	± 0.50	0.09	Pass
	5	-0.04	± 1.00	0.09	Pass
94.15	3	-0.06	± 0.50	0.09	Pass
	5	-0.05	± 1.00	0.09	Pass
84.15	3	-0.06	± 0.50	0.09	Pass
	5	-0.01	± 1.00	0.09	Pass

-- End of measurement results--

Impulse Detector - Repeat

Impulse Detector measured according to IEC 60651:2001 9.4.3 and ANSI S1.4:1983 (R2006) 8.4.3

Amplitude [dB]	Repetition Rate [Hz]	Test Result [dB]	Lower limit [dB]	Upper limit [dB]	Expanded Uncertainty [dB]	Result
116.15	100.00	-2.78	-3.71	-1.71	0.09	Pass
	20.00	-7.58	-9.57	-5.57	0.16	Pass
	2.00	-8.93	-10.76	-6.76	0.09	Pass
Step	2.00	5.00	4.00	6.00	0.09	Pass

-- End of measurement results--

Impulse Detector - Single

Impulse Detector measured according to IEC 60651:2001 9.4.3 and ANSI S1.4:1983 (R2006) 8.4.3

Amplitude [dB]	Duration [ms]	Test Result [dB]	Lower limit [dB]	Upper limit [dB]	Expanded Uncertainty [dB]	Result
116.15	20.00	-3.65	-5.11	-2.11	0.09	Pass
	5.00	-8.90	-10.76	-6.76	0.10	Pass
	2.00	-12.84	-14.55	-10.55	0.11	Pass
Step	2.00	9.72	9.00	11.00	0.11	Pass

-- End of measurement results--

Gain

Gain measured according to IEC 61672-3:2013 17.3 and 17.4 and ANSI S1.4-2014 Part 3: 17.3 and 17.4

Measurement	Test Result [dB]	Lower limit [dB]	Upper limit [dB]	Expanded Uncertainty [dB]	Result
0 dB Gain	84.02	83.90	84.10	0.09	Pass
0 dB Gain, Linearity	20.47	20.30	21.70	0.15	Pass
OBA Low Range	84.00	83.90	84.10	0.09	Pass
OBA Normal Range	84.00	83.20	84.80	0.09	Pass

-- End of measurement results--

1/3-Octave Self-Generated Noise

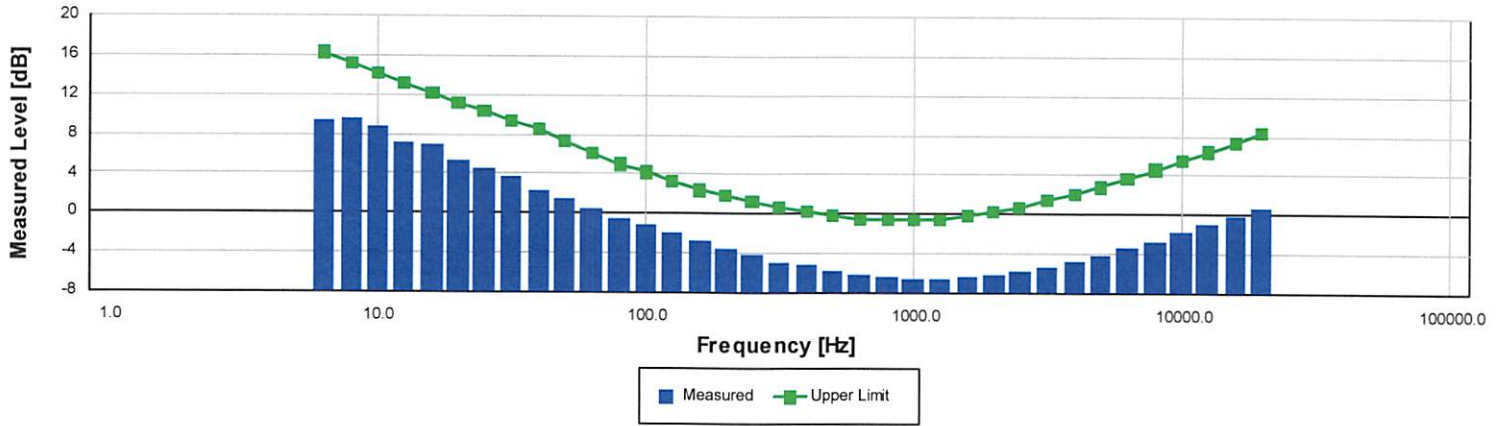

The SLM is set to low range.

Frequency [Hz]	Test Result [dB]	Upper limit [dB]	Result
6.30	9.41	16.30	Pass
8.00	9.54	15.20	Pass
10.00	8.74	14.20	Pass
12.50	7.16	13.20	Pass
16.00	6.96	12.10	Pass
20.00	5.31	11.10	Pass
25.00	4.46	10.40	Pass
31.50	3.78	9.40	Pass
40.00	2.34	8.60	Pass
50.00	1.42	7.40	Pass
63.00	0.55	6.10	Pass
80.00	-0.49	5.00	Pass
100.00	-1.15	4.20	Pass
125.00	-1.96	3.30	Pass
160.00	-2.86	2.40	Pass
200.00	-3.57	1.90	Pass
250.00	-4.19	1.20	Pass
315.00	-4.95	0.60	Pass
400.00	-5.27	0.20	Pass
500.00	-5.80	-0.10	Pass
630.00	-6.23	-0.50	Pass
800.00	-6.46	-0.50	Pass
1,000.00	-6.57	-0.60	Pass
1,250.00	-6.58	-0.60	Pass
1,600.00	-6.42	-0.20	Pass
2,000.00	-6.20	0.20	Pass
2,500.00	-5.78	0.70	Pass
3,150.00	-5.35	1.40	Pass
4,000.00	-4.78	2.10	Pass
5,000.00	-4.15	2.80	Pass
6,300.00	-3.44	3.70	Pass
8,000.00	-2.70	4.60	Pass
10,000.00	-1.83	5.50	Pass
12,500.00	-1.03	6.40	Pass
16,000.00	-0.15	7.40	Pass
20,000.00	0.73	8.30	Pass

-- End of measurement results--



Broadband Noise Floor

Self-generated noise measured according to IEC 61672-3:2013 11.2 and ANSI S1.4-2014 Part 3: 11.2

Measurement	Test Result [dB]	Upper limit [dB]	Result
A-weight Noise Floor	7.23	16.00	Pass
C-weight Noise Floor	11.77	18.00	Pass
Z-weight Noise Floor	19.85	25.00	Pass

-- End of measurement results--

Total Harmonic Distortion

Measured using 1/3-Octave filters

Measurement	Test Result [dB]	Lower Limit [dB]	Upper Limit [dB]	Expanded Uncertainty [dB]	Result
10 Hz Signal	113.03	112.35	113.95	0.09	Pass
THD	-56.65		-50.00	0.01	Pass
THD+N	-54.99		-50.00	0.01	Pass

-- End of measurement results--

1/1 Octave Filter: 8.0 Hz

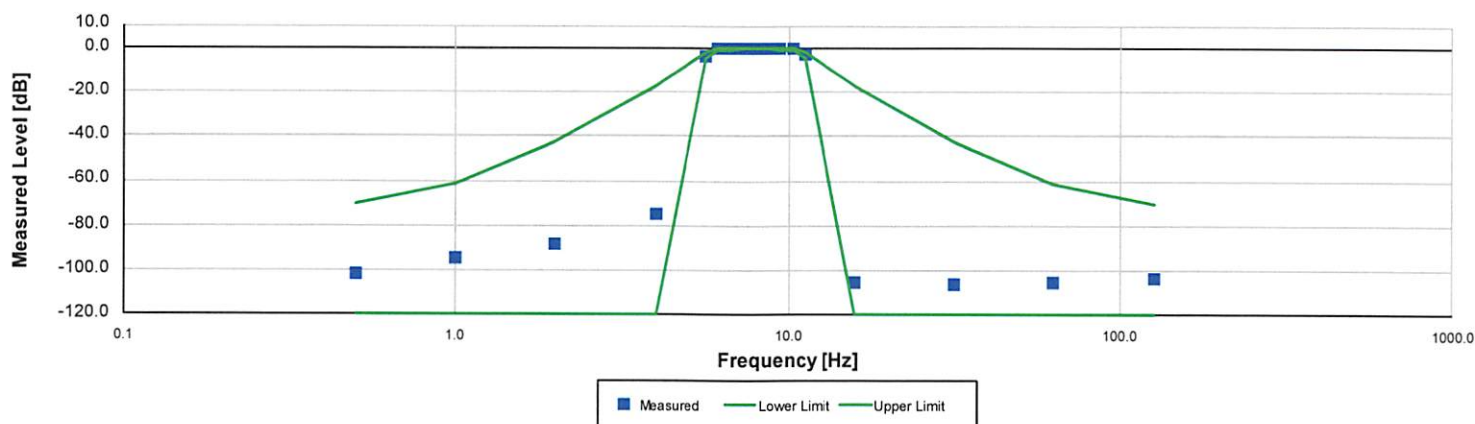
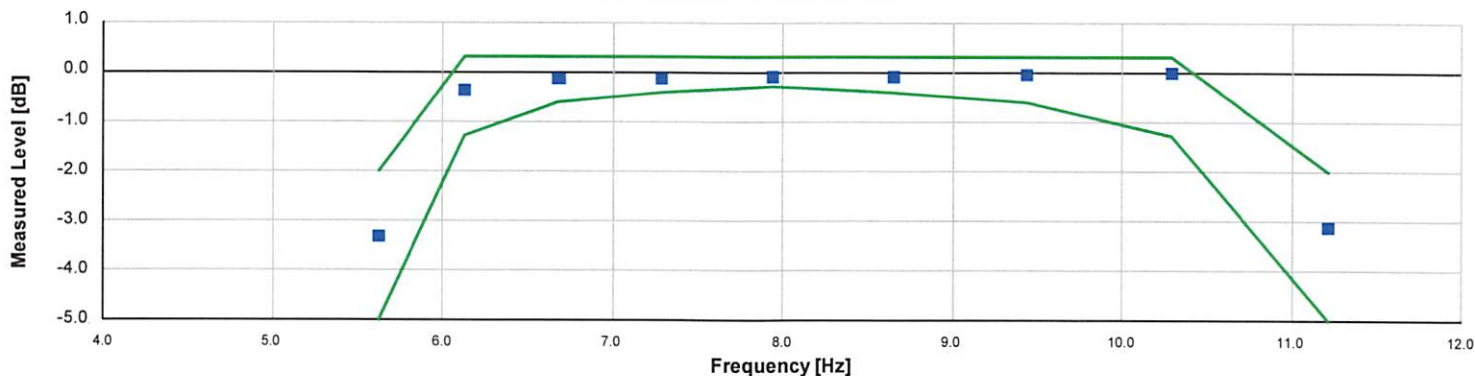

■ Measured — Lower Limit — Upper Limit

The SLM is set to normal range. Filter shape measured according to IEC 61260:2001 and ANSI S1.11:2004

Frequency [Hz]	Test Result [dB]	Lower limit [dB]	Upper limit [dB]	Expanded Uncertainty [dB]	Result
0.50	-101.58	-inf	-70.00	2.70	Pass
1.00	-94.30	-inf	-61.00	2.00	Pass
2.00	-88.18	-inf	-42.00	0.26	Pass
3.98	-74.79	-inf	-17.50	0.31	Pass
5.62	-3.32	-5.00	-2.00	0.09	Pass
6.13	-0.36	-1.30	0.30	0.09	Pass
6.68	-0.13	-0.60	0.30	0.09	Pass
7.29	-0.12	-0.40	0.30	0.09	Pass
7.94	-0.10	-0.30	0.30	0.09	Pass
8.66	-0.09	-0.40	0.30	0.09	Pass
9.44	-0.05	-0.60	0.30	0.09	Pass
10.29	-0.01	-1.30	0.30	0.09	Pass
11.22	-3.11	-5.00	-2.00	0.09	Pass
15.85	-105.02	-inf	-17.50	1.30	Pass
31.62	-106.34	-inf	-42.00	1.70	Pass
63.10	-104.96	-inf	-61.00	1.50	Pass
125.89	-103.63	-inf	-70.00	1.60	Pass

-- End of measurement results--



1/1 Octave Filter: 1 kHz

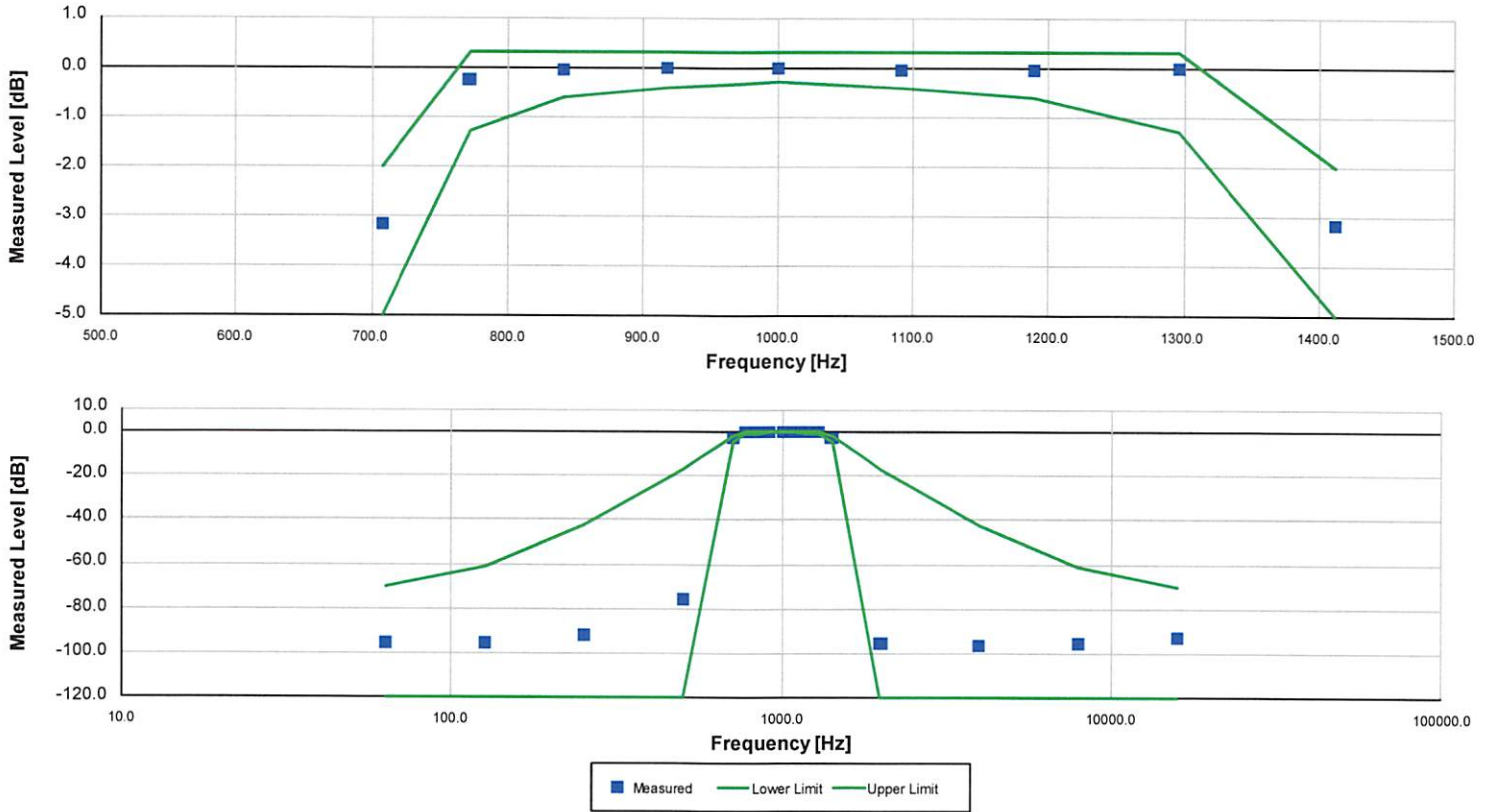

The SLM is set to normal range. Filter shape measured according to IEC 61260:2001 and ANSI S1.11:2004

Frequency [Hz]	Test Result [dB]	Lower limit [dB]	Upper limit [dB]	Expanded Uncertainty [dB]	Result
63.10	-95.58	-inf	-70.00	0.24	Pass
125.89	-95.80	-inf	-61.00	0.25	Pass
251.19	-92.00	-inf	-42.00	0.13	Pass
501.19	-75.23	-inf	-17.50	0.09	Pass
707.95	-3.17	-5.00	-2.00	0.09	Pass
771.79	-0.24	-1.30	0.30	0.09	Pass
841.40	-0.04	-0.60	0.30	0.09	Pass
917.28	-0.03	-0.40	0.30	0.09	Pass
1,000.00	-0.01	-0.30	0.30	0.09	Pass
1,090.18	-0.05	-0.40	0.30	0.09	Pass
1,188.50	-0.04	-0.60	0.30	0.09	Pass
1,295.69	-0.02	-1.30	0.30	0.09	Pass
1,412.54	-3.16	-5.00	-2.00	0.09	Pass
1,995.26	-95.56	-inf	-17.50	0.25	Pass
3,981.07	-96.49	-inf	-42.00	0.29	Pass
7,943.28	-95.70	-inf	-61.00	0.23	Pass
15,848.93	-92.60	-inf	-70.00	0.23	Pass

-- End of measurement results--



1/1 Octave Filter: 16 kHz

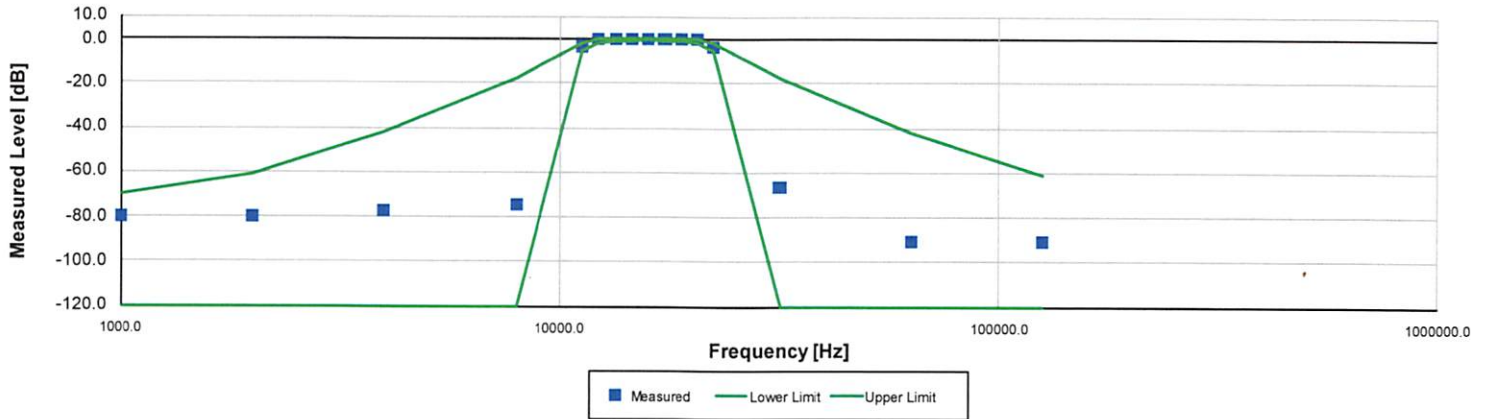
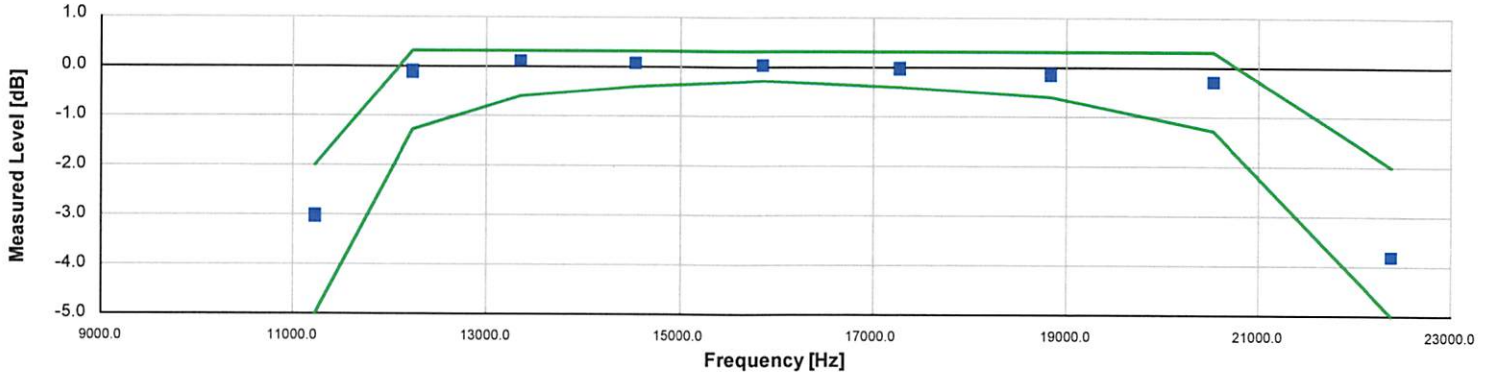

The SLM is set to normal range. Filter shape measured according to IEC 61260:2001 and ANSI S1.11:2004

Frequency [Hz]	Test Result [dB]	Lower limit [dB]	Upper limit [dB]	Expanded Uncertainty [dB]	Result
1,000.00	-79.94	-inf	-70.00	0.10	Pass
1,995.26	-79.92	-inf	-61.00	0.11	Pass
3,981.07	-77.49	-inf	-42.00	0.09	Pass
7,943.28	-74.20	-inf	-17.50	0.12	Pass
11,220.18	-3.02	-5.00	-2.00	0.09	Pass
12,232.07	-0.11	-1.30	0.30	0.09	Pass
13,335.21	0.10	-0.60	0.30	0.09	Pass
14,537.84	0.06	-0.40	0.30	0.09	Pass
15,848.93	0.02	-0.30	0.30	0.09	Pass
17,278.26	-0.03	-0.40	0.30	0.09	Pass
18,836.49	-0.16	-0.60	0.30	0.09	Pass
20,535.25	-0.28	-1.30	0.30	0.09	Pass
22,387.21	-3.79	-5.00	-2.00	0.09	Pass
31,622.78	-66.76	-inf	-17.50	0.09	Pass
63,095.73	-90.72	-inf	-42.00	0.10	Pass
125,892.54	-90.57	-inf	-61.00	0.10	Pass

-- End of measurement results--

1/3 Octave Filter: 6.3 Hz

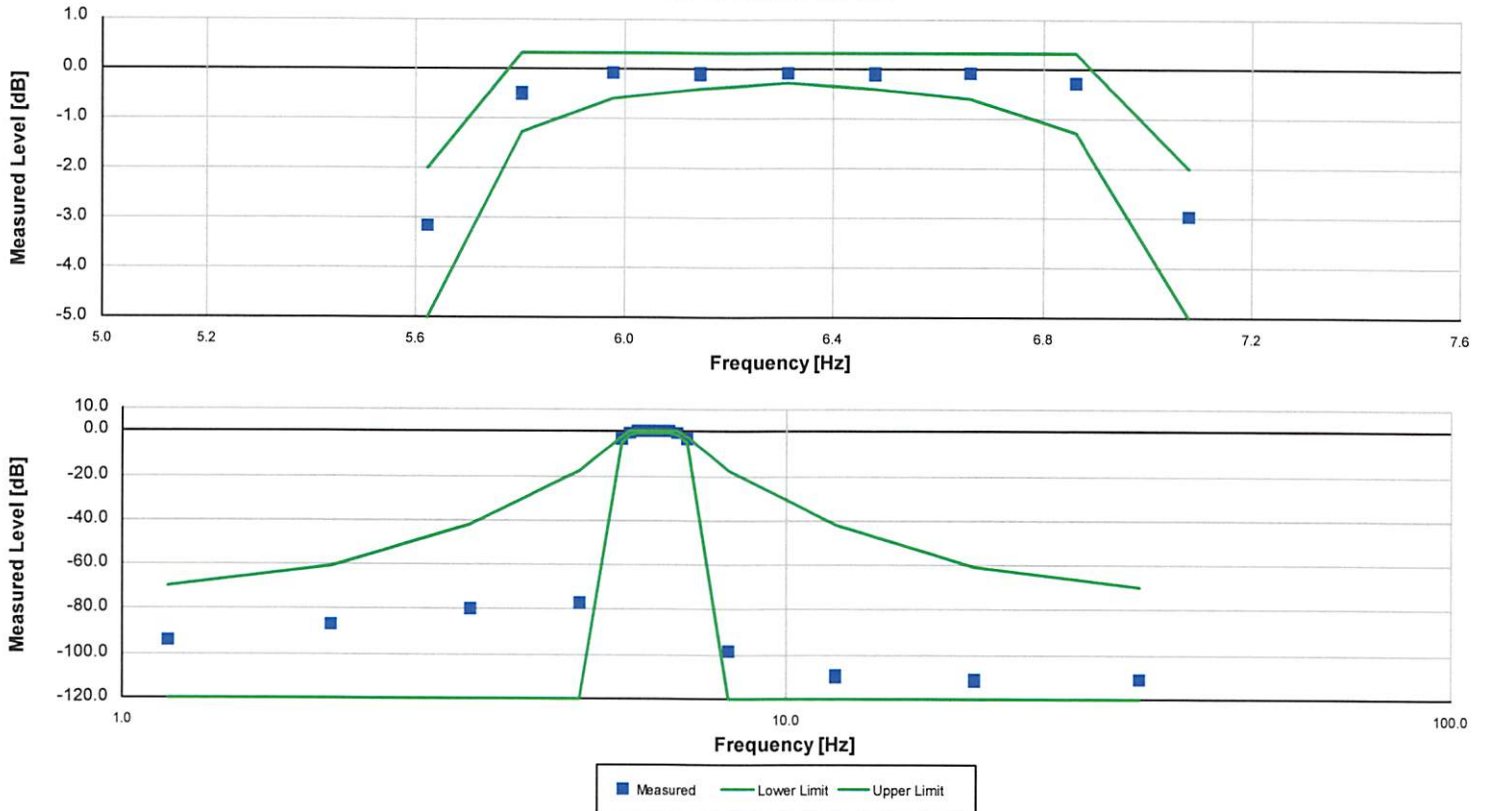

The SLM is set to normal range. Filter shape measured according to IEC 61260:2001 and ANSI S1.11:2004

Frequency [Hz]	Test Result [dB]	Lower limit [dB]	Upper limit [dB]	Expanded Uncertainty [dB]	Result
1.17	-93.89	-inf	-70.00	1.90	Pass
2.07	-87.17	-inf	-61.00	0.17	Pass
3.35	-79.47	-inf	-42.00	0.09	Pass
4.87	-76.89	-inf	-17.50	0.10	Pass
5.62	-3.15	-5.00	-2.00	0.09	Pass
5.80	-0.51	-1.30	0.30	0.09	Pass
5.98	-0.10	-0.60	0.30	0.09	Pass
6.15	-0.12	-0.40	0.30	0.09	Pass
6.31	-0.11	-0.30	0.30	0.09	Pass
6.48	-0.11	-0.40	0.30	0.09	Pass
6.66	-0.10	-0.60	0.30	0.09	Pass
6.86	-0.29	-1.30	0.30	0.09	Pass
7.08	-2.95	-5.00	-2.00	0.09	Pass
8.17	-98.70	-inf	-17.50	0.34	Pass
11.87	-109.62	-inf	-42.00	1.50	Pass
19.27	-111.43	-inf	-61.00	1.80	Pass
34.02	-110.85	-inf	-70.00	0.62	Pass

-- End of measurement results--



1/3 Octave Filter: 1 kHz

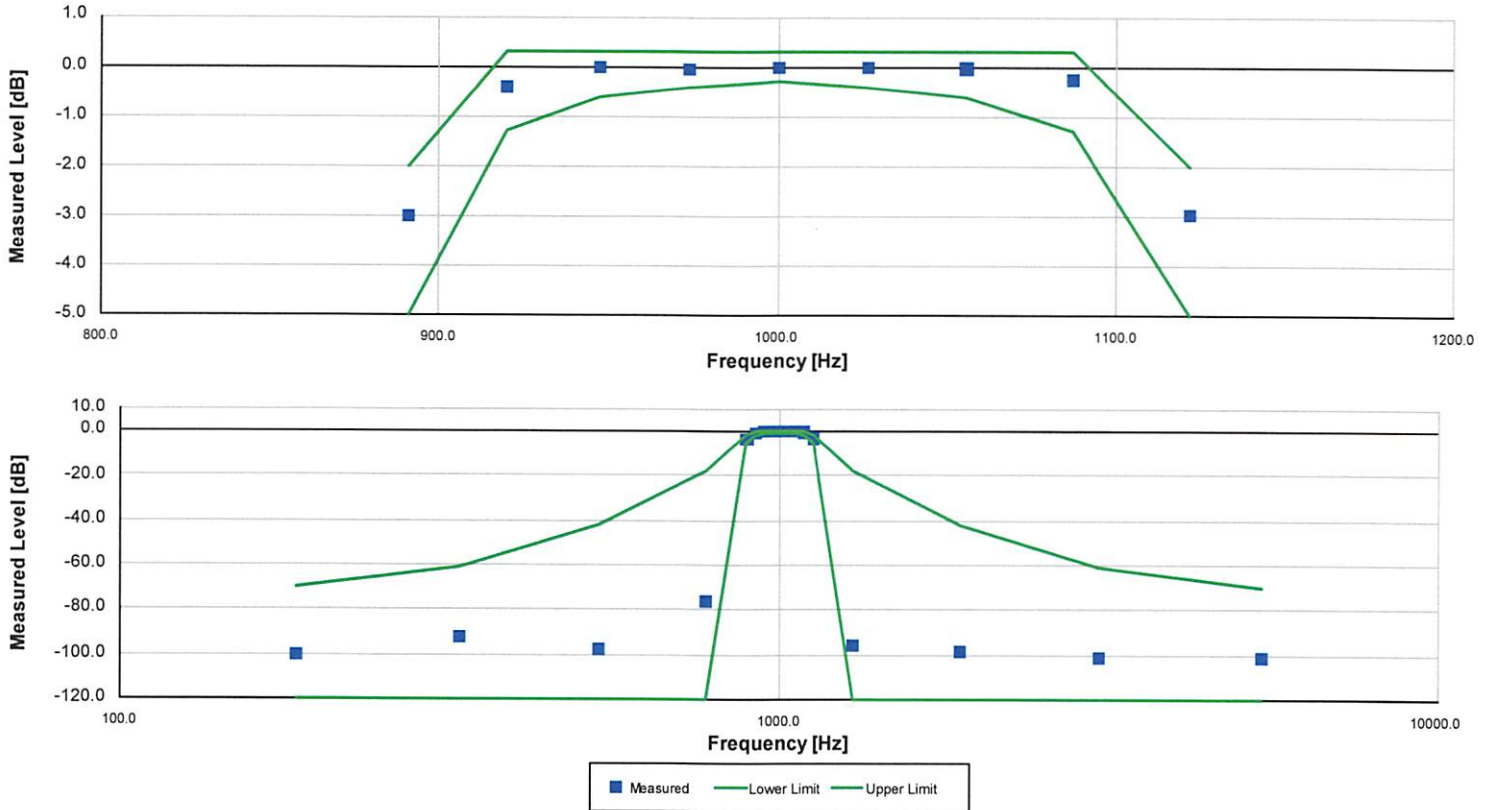

The SLM is set to normal range. Filter shape measured according to IEC 61260:2001 and ANSI S1.11:2004

Frequency [Hz]	Test Result [dB]	Lower limit [dB]	Upper limit [dB]	Expanded Uncertainty [dB]	Result
185.46	-100.01	-inf	-70.00	0.28	Pass
327.48	-92.44	-inf	-61.00	0.11	Pass
531.43	-98.12	-inf	-42.00	0.09	Pass
772.57	-76.21	-inf	-17.50	0.09	Pass
891.25	-3.01	-5.00	-2.00	0.09	Pass
919.58	-0.41	-1.30	0.30	0.09	Pass
947.19	-0.01	-0.60	0.30	0.09	Pass
974.02	-0.04	-0.40	0.30	0.09	Pass
1,000.00	-0.01	-0.30	0.30	0.09	Pass
1,026.67	-0.02	-0.40	0.30	0.09	Pass
1,055.75	-0.03	-0.60	0.30	0.09	Pass
1,087.46	-0.25	-1.30	0.30	0.09	Pass
1,122.02	-2.98	-5.00	-2.00	0.09	Pass
1,294.37	-95.80	-inf	-17.50	0.24	Pass
1,881.73	-99.01	-inf	-42.00	0.28	Pass
3,053.65	-101.64	-inf	-61.00	0.44	Pass
5,391.95	-101.62	-inf	-70.00	0.24	Pass

-- End of measurement results--

1/3 Octave Filter: 20 kHz

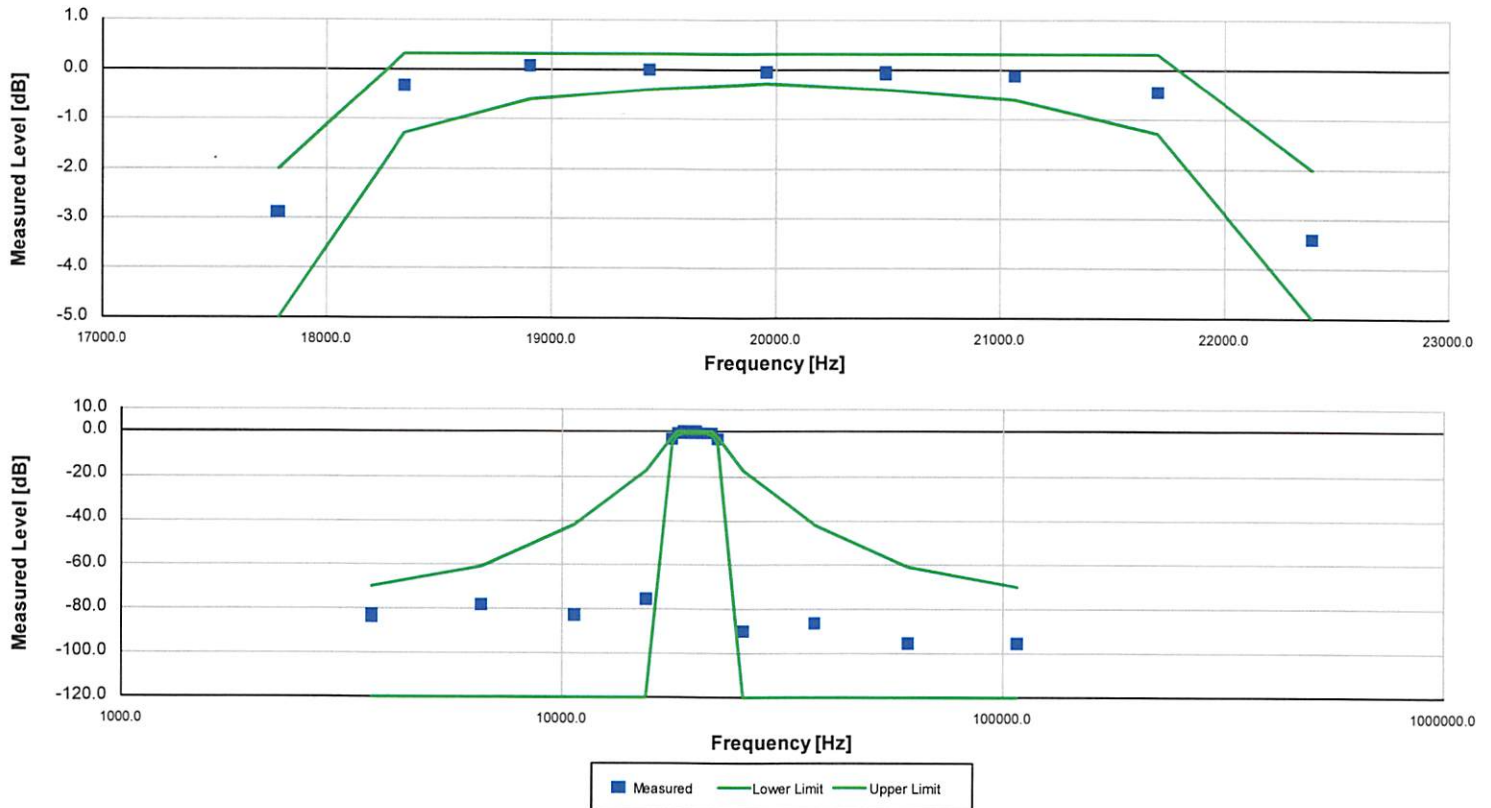

The SLM is set to normal range. Filter shape measured according to IEC 61260:2001 and ANSI S1.11:2004

Frequency [Hz]	Test Result [dB]	Lower limit [dB]	Upper limit [dB]	Expanded Uncertainty [dB]	Result
3,700.45	-83.05	-inf	-70.00	0.11	Pass
6,534.02	-78.28	-inf	-61.00	0.10	Pass
10,603.35	-82.37	-inf	-42.00	0.09	Pass
15,414.88	-75.65	-inf	-17.50	0.09	Pass
17,782.79	-2.87	-5.00	-2.00	0.09	Pass
18,347.97	-0.34	-1.30	0.30	0.09	Pass
18,898.93	0.06	-0.60	0.30	0.09	Pass
19,434.23	0.00	-0.40	0.30	0.09	Pass
19,952.62	-0.06	-0.30	0.30	0.09	Pass
20,484.85	-0.08	-0.40	0.30	0.09	Pass
21,065.07	-0.14	-0.60	0.30	0.09	Pass
21,697.62	-0.44	-1.30	0.30	0.09	Pass
22,387.21	-3.39	-5.00	-2.00	0.09	Pass
25,826.16	-89.65	-inf	-17.50	0.11	Pass
37,545.40	-86.52	-inf	-42.00	0.10	Pass
60,928.37	-95.26	-inf	-61.00	0.12	Pass
107,583.52	-95.02	-inf	-70.00	0.14	Pass

-- End of measurement results--

-- End of Report--

Signatory: Ron Harris

Larson Davis, a division of PCB Piezotronics, Inc
 1681 West 820 North
 Provo, UT 84601, United States
 716-684-0001



Calibration Certificate

Certificate Number 2018000179

Customer:

Eilar Associates
466 Blueridge Place
Escondido, CA 92026, United States

Model Number	PRMLxT1L	Procedure Number	D0001.8383
Serial Number	035963	Technician	Ron Harris
Test Results	Pass	Calibration Date	4 Jan 2018
Initial Condition	AS RECEIVED same as shipped	Calibration Due	4 Jan 2020
Description	Larson Davis 1/2" Preamplifier for LxT Class 1 -1 dB	Temperature	23.12 °C ± 0.01 °C
		Humidity	52.2 %RH ± 0.5 %RH
		Static Pressure	86.91 kPa ± 0.03 kPa
Evaluation Method	Tested electrically using a 12.0 pF capacitor to simulate microphone capacitance. Data reported in dB re 20 µPa assuming a microphone sensitivity of 50.0 mV/Pa.		
Compliance Standards	Compliant to Manufacturer Specifications		

Issuing lab certifies that the instrument described above meets or exceeds all specifications as stated in the referenced procedure (unless otherwise noted). It has been calibrated using measurement standards traceable to the SI through the National Institute of Standards and Technology (NIST), or other national measurement institutes, and meets the requirements of ISO/IEC 17025:2005.

Test points marked with a ‡ in the uncertainties column do not fall within this laboratory's scope of accreditation.

The quality system is registered to ISO 9001:2008.

This calibration is a direct comparison of the unit under test to the listed reference standards and did not involve any sampling plans to complete. No allowance has been made for the instability of the test device due to use, time, etc. Such allowances would be made by the customer as needed.

The uncertainties were computed in accordance with the ISO Guide to the Expression of Uncertainty in Measurement (GUM). A coverage factor of approximately 2 sigma (k=2) has been applied to the standard uncertainty to express the expanded uncertainty at approximately 95% confidence level.

This report may not be reproduced, except in full, unless permission for the publication of an approved abstract is obtained in writing from the organization issuing this report.

Standards Used

Description	Cal Date	Cal Due	Cal Standard
Larson Davis Model 2900 Real Time Analyzer	03/08/2017	03/08/2018	003003
Hart Scientific 2626-S Humidity/Temperature Sensor	06/11/2017	06/11/2018	006943
Agilent 34401A DMM	06/28/2017	06/28/2018	007165
SRS DS360 Ultra Low Distortion Generator	10/05/2017	10/05/2018	007167

Larson Davis, a division of PCB Piezotronics, Inc
1681 West 820 North
Provo, UT 84601, United States
716-684-0001



Frequency Response

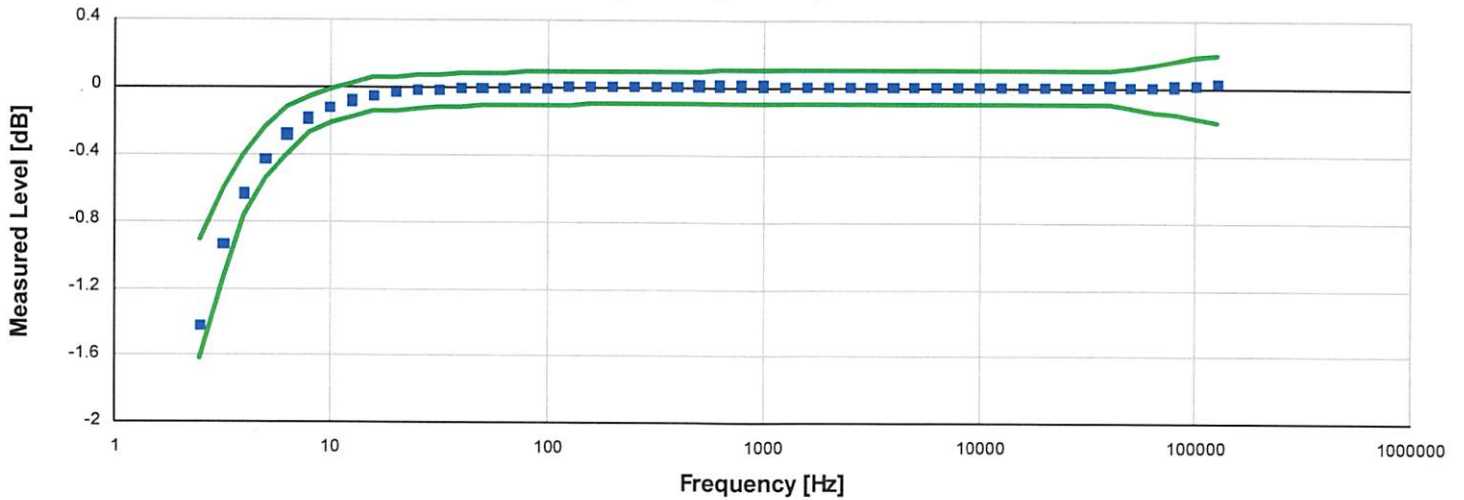

Frequency response electrically tested at 120.0 dB re 1 μ V

Frequency [Hz]	Test Result [dB re 1 kHz]	Lower limit [dB]	Upper limit [dB]	Expanded Uncertainty [dB]	Result
2.50	-1.42	-1.62	-0.91	0.07	Pass
3.20	-0.94	-1.14	-0.60	0.08	Pass
4.00	-0.64	-0.77	-0.40	0.08	Pass
5.00	-0.43	-0.54	-0.24	0.07	Pass
6.30	-0.29	-0.40	-0.12	0.07	Pass
7.90	-0.19	-0.28	-0.06	0.07	Pass
10.00	-0.13	-0.22	-0.01	0.07	Pass
12.60	-0.09	-0.18	0.02	0.07	Pass
15.80	-0.05	-0.15	0.05	0.07	Pass
20.00	-0.03	-0.14	0.06	0.07	Pass
25.10	-0.03	-0.13	0.07	0.07	Pass
31.60	-0.02	-0.12	0.07	0.07	Pass
39.80	-0.01	-0.12	0.08	0.07	Pass
50.10	-0.01	-0.11	0.08	0.07	Pass
63.10	-0.01	-0.11	0.08	0.07	Pass
79.40	-0.01	-0.11	0.09	0.07	Pass
100.00	-0.01	-0.11	0.09	0.07	Pass
125.90	0.00	-0.11	0.09	0.07	Pass
158.50	0.00	-0.10	0.09	0.07	Pass
199.50	0.00	-0.10	0.09	0.07	Pass
251.20	0.00	-0.10	0.09	0.07	Pass
316.20	0.00	-0.10	0.09	0.07	Pass
398.10	0.00	-0.10	0.09	0.07	Pass
501.20	0.01	-0.10	0.09	0.07	Pass
631.00	0.01	-0.10	0.10	0.07	Pass
794.30	0.01	-0.10	0.10	0.07	Pass
1,000.00	0.01	-0.10	0.10	0.07	Pass
1,258.90	0.00	-0.10	0.10	0.07	Pass
1,584.90	0.00	-0.10	0.10	0.07	Pass
1,995.30	0.00	-0.10	0.10	0.07	Pass
2,511.90	0.00	-0.10	0.10	0.07	Pass
3,162.30	0.00	-0.10	0.10	0.07	Pass

Larson Davis, a division of PCB Piezotronics, Inc
 1681 West 820 North
 Provo, UT 84601, United States
 716-684-0001



Frequency [Hz]	Test Result [dB re 1 kHz]	Lower limit [dB]	Upper limit [dB]	Expanded Uncertainty [dB]	Result
3,981.10	0.00	-0.10	0.10	0.07	Pass
5,011.90	0.01	-0.10	0.10	0.07	Pass
6,309.60	0.01	-0.10	0.10	0.07	Pass
7,943.30	0.01	-0.10	0.10	0.07	Pass
10,000.00	0.01	-0.10	0.10	0.07	Pass
12,589.30	0.00	-0.10	0.10	0.07	Pass
15,848.90	0.00	-0.10	0.10	0.07	Pass
19,952.60	0.00	-0.10	0.10	0.07	Pass
25,118.90	0.00	-0.10	0.10	0.07	Pass
31,622.80	0.01	-0.10	0.10	0.07	Pass
39,810.70	0.01	-0.10	0.10	0.07	Pass
50,118.70	0.00	-0.12	0.12	0.08	Pass
63,095.70	0.01	-0.14	0.14	0.08	Pass
79,432.80	0.01	-0.16	0.16	0.08	Pass
100,000.00	0.02	-0.18	0.18	0.08	Pass
125,892.50	0.03	-0.20	0.20	0.22	Pass

Gain Measurement

Measurement	Test Result [dB]	Lower limit [dB]	Upper limit [dB]	Expanded Uncertainty [dB]	Result
Output Gain @ 1 kHz	-1.83	-2.60	-1.00	0.03	Pass

-- End of measurement results--

DC Bias Measurement

Measurement	Test Result [V]	Lower limit [V]	Upper limit [V]	Expanded Uncertainty [V]	Result
DC Voltage	3.79	2.90	3.80	0.01	Pass

-- End of measurement results--



1/3-Octave Self-Generated Noise

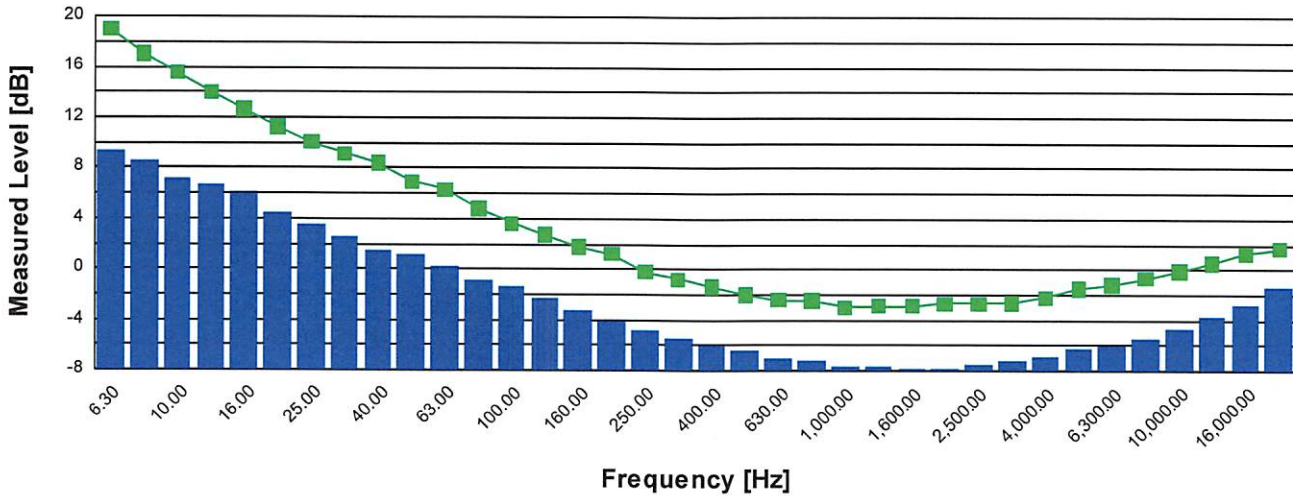

Frequency [Hz]	Test Result [dB re 1 μV]	Upper limit [dB re 1 μV]	Result
6.30	9.30	19.00	Pass
8.00	8.50	17.00	Pass
10.00	7.20	15.50	Pass
12.50	6.60	14.00	Pass
16.00	6.00	12.60	Pass
20.00	4.50	11.20	Pass
25.00	3.50	10.00	Pass
31.50	2.60	9.10	Pass
40.00	1.50	8.40	Pass
50.00	1.20	6.90	Pass
63.00	0.20	6.30	Pass
80.00	-0.90	4.80	Pass
100.00	-1.40	3.60	Pass
125.00	-2.30	2.70	Pass
160.00	-3.20	1.80	Pass
200.00	-4.00	1.20	Pass
250.00	-4.80	-0.20	Pass
315.00	-5.40	-0.80	Pass
400.00	-5.90	-1.40	Pass
500.00	-6.40	-2.00	Pass
630.00	-7.00	-2.40	Pass
800.00	-7.20	-2.50	Pass
1,000.00	-7.70	-3.00	Pass
1,250.00	-7.70	-2.90	Pass
1,600.00	-7.80	-2.90	Pass
2,000.00	-7.80	-2.70	Pass
2,500.00	-7.50	-2.70	Pass
3,150.00	-7.20	-2.60	Pass
4,000.00	-6.80	-2.20	Pass
5,000.00	-6.20	-1.50	Pass
6,300.00	-5.90	-1.20	Pass
8,000.00	-5.40	-0.70	Pass
10,000.00	-4.70	-0.10	Pass
12,500.00	-3.80	0.50	Pass
16,000.00	-2.80	1.30	Pass
20,000.00	-1.40	1.70	Pass

-- End of measurement results--

Larson Davis, a division of PCB Piezotronics, Inc
 1681 West 820 North
 Provo, UT 84601, United States
 716-684-0001



Self-generated Noise

Bandwidth	Test Result [μ V]	Test Result [dB re 1 μ V]	Upper limit [dB re 1 μ V]	Result
A-weighted (1 Hz - 20 kHz)	1.86	5.40	8.00	Pass
Broadband (1 Hz - 20 kHz)	4.03	12.10	14.00	Pass
-- End of measurement results--				

Signatory: Ron Harris

Larson Davis, a division of PCB Piezotronics, Inc
 1681 West 820 North
 Provo, UT 84601, United States
 716-684-0001



Calibration Certificate

Certificate Number 2017004816

Customer:

Eilar Associates
466 Blueridge Place
Escondido, CA 92026, United States

Model Number	CAL250	Procedure Number	D0001.8386
Serial Number	1081	Technician	Scott Montgomery
Test Results	Pass	Calibration Date	9 May 2017
Initial Condition	Adjusted	Calibration Due	9 May 2019
Description	Larson Davis CAL250 Acoustic Calibrator	Temperature	24 °C ± 0.3 °C
		Humidity	39 %RH ± 3 %RH
		Static Pressure	101.2 kPa ± 1 kPa

Evaluation Method The data is acquired by the insert voltage calibration method using the reference microphone's open circuit sensitivity. Data reported in dB re 20 µPa.

Compliance Standards Compliant to Manufacturer Specifications per D0001.8190 and the following standards:
IEC 60942:2003 ANSI S1.40-2006

Issuing lab certifies that the instrument described above meets or exceeds all specifications as stated in the referenced procedure (unless otherwise noted). It has been calibrated using measurement standards traceable to the SI through the National Institute of Standards and Technology (NIST), or other national measurement institutes, and meets the requirements of ISO/IEC 17025:2005. Test points marked with a ‡ in the uncertainties column do not fall within this laboratory's scope of accreditation.

The quality system is registered to ISO 9001:2008.

This calibration is a direct comparison of the unit under test to the listed reference standards and did not involve any sampling plans to complete. No allowance has been made for the instability of the test device due to use, time, etc. Such allowances would be made by the customer as needed.

The uncertainties were computed in accordance with the ISO Guide to the Expression of Uncertainty in Measurement (GUM). A coverage factor of approximately 2 sigma (k=2) has been applied to the standard uncertainty to express the expanded uncertainty at approximately 95% confidence level.

This report may not be reproduced, except in full, unless permission for the publication of an approved abstract is obtained in writing from the organization issuing this report.

Standards Used			
Description	Cal Date	Cal Due	Cal Standard
Agilent 34401A DMM	09/07/2016	09/07/2017	001021
Sound Level Meter / Real Time Analyzer	04/10/2017	04/10/2018	001051
Microphone Calibration System	08/17/2016	08/17/2017	005446
1/2" Preamplifier	10/06/2016	10/06/2017	006506
Larson Davis 1/2" Preamplifier 7-pin LEMO	08/22/2016	08/22/2017	006507
1/2 inch Microphone - RI - 200V	10/03/2016	10/03/2017	006511
Pressure Transducer	07/01/2016	07/01/2017	007368

Larson Davis, a division of PCB Piezotronics, Inc
1681 West 820 North
Provo, UT 84601, United States
716-684-0001



Output Level

Nominal Level [dB]	Pressure [kPa]	Test Result [dB]	Lower limit [dB]	Upper limit [dB]	Expanded Uncertainty [dB]	Result
114	101.2	114.01	113.90	114.10	0.13	Pass

-- End of measurement results--

Frequency

Nominal Level [dB]	Pressure [kPa]	Test Result [Hz]	Lower limit [Hz]	Upper limit [Hz]	Expanded Uncertainty [Hz]	Result
114	101.2	251.22	249.19	253.19	0.10	Pass

-- End of measurement results--

Total Harmonic Distortion + Noise (THD+N)

Nominal Level [dB]	Pressure [kPa]	Test Result [%]	Lower limit [%]	Upper limit [%]	Expanded Uncertainty [%]	Result
114	101.2	0.67	0.00	2.00	0.25	Pass

-- End of measurement results--

Level Change Over Pressure

Tested at: 114 dB, 23 °C, 38 %RH

Nominal Pressure [kPa]	Pressure [kPa]	Test Result [dB]	Lower limit [dB]	Upper limit [dB]	Expanded Uncertainty [dB]	Result
101.3	101.1	0.00	-0.30	0.30	0.04 ‡	Pass
74.0	74.0	0.10	-0.30	0.30	0.04 ‡	Pass
108.0	108.0	-0.02	-0.30	0.30	0.04 ‡	Pass
92.0	92.2	0.03	-0.30	0.30	0.04 ‡	Pass
83.0	83.1	0.07	-0.30	0.30	0.04 ‡	Pass
65.0	64.8	0.14	-0.30	0.30	0.04 ‡	Pass

-- End of measurement results--

Frequency Change Over Pressure

Tested at: 114 dB, 23 °C, 38 %RH

Nominal Pressure [kPa]	Pressure [kPa]	Test Result [Hz]	Lower limit [Hz]	Upper limit [Hz]	Expanded Uncertainty [Hz]	Result
101.3	101.1	0.00	-2.00	2.00	0.10 ‡	Pass
74.0	74.0	0.00	-2.00	2.00	0.10 ‡	Pass
108.0	108.0	-0.01	-2.00	2.00	0.10 ‡	Pass
92.0	92.2	-0.01	-2.00	2.00	0.10 ‡	Pass
83.0	83.1	-0.01	-2.00	2.00	0.10 ‡	Pass
65.0	64.8	-0.01	-2.00	2.00	0.10 ‡	Pass

-- End of measurement results--



Total Harmonic Distortion + Noise (THD+N) Over Pressure

Tested at: 114 dB, 23 °C, 38 %RH

Nominal Pressure [kPa]	Pressure [kPa]	Test Result [%]	Lower limit [%]	Upper limit [%]	Expanded Uncertainty [%]	Result
74.0	74.0	0.70	0.00	2.00	0.25 ‡	Pass
108.0	108.0	0.67	0.00	2.00	0.25 ‡	Pass
101.3	101.1	0.67	0.00	2.00	0.25 ‡	Pass
92.0	92.2	0.68	0.00	2.00	0.25 ‡	Pass
83.0	83.1	0.68	0.00	2.00	0.25 ‡	Pass
65.0	64.8	0.71	0.00	2.00	0.25 ‡	Pass

-- End of measurement results--

Signatory: Scott Montgomery

Larson Davis, a division of PCB Piezotronics, Inc
 1681 West 820 North
 Provo, UT 84601, United States
 716-684-0001



Initial Assessment

Certificate Number 2017004814

Customer:

Eilar Associates
466 Blueridge Place
Escondido, CA 92026, United States

Model Number	CAL250	Procedure Number	D0001.8386
Serial Number	1081	Technician	Scott Montgomery
Test Results	Pass	Calibration Date	9 May 2017
Initial Condition	As Received	Calibration Due	
Description	Larson Davis CAL250 Acoustic Calibrator	Temperature	24 °C ± 0.3 °C
		Humidity	37 %RH ± 3 %RH
		Static Pressure	101.3 kPa ± 1 kPa

Evaluation Method The data is acquired by the insert voltage calibration method using the reference microphone's open circuit sensitivity. Data reported in dB re 20 µPa.

Compliance Standards Compliant to Manufacturer Specifications per D0001.8190 and the following standards:
IEC 60942:2003 ANSI S1.40-2006

Issuing lab certifies that the instrument described above meets or exceeds all specifications as stated in the referenced procedure (unless otherwise noted). It has been calibrated using measurement standards traceable to the SI through the National Institute of Standards and Technology (NIST), or other national measurement institutes, and meets the requirements of ISO/IEC 17025:2005. Test points marked with a ‡ in the uncertainties column do not fall within this laboratory's scope of accreditation.

The quality system is registered to ISO 9001:2008.

This calibration is a direct comparison of the unit under test to the listed reference standards and did not involve any sampling plans to complete. No allowance has been made for the instability of the test device due to use, time, etc. Such allowances would be made by the customer as needed.

The uncertainties were computed in accordance with the ISO Guide to the Expression of Uncertainty in Measurement (GUM). A coverage factor of approximately 2 sigma (k=2) has been applied to the standard uncertainty to express the expanded uncertainty at approximately 95% confidence level.

This report may not be reproduced, except in full, unless permission for the publication of an approved abstract is obtained in writing from the organization issuing this report.

Standards Used			
Description	Cal Date	Cal Due	Cal Standard
Agilent 34401A DMM	09/07/2016	09/07/2017	001021
Sound Level Meter / Real Time Analyzer	04/10/2017	04/10/2018	001051
Microphone Calibration System	08/17/2016	08/17/2017	005446
1/2" Preampifier	10/06/2016	10/06/2017	006506
Larson Davis 1/2" Preampifier 7-pin LEMO	08/22/2016	08/22/2017	006507
1/2 inch Microphone - RI - 200V	10/03/2016	10/03/2017	006511
Pressure Transducer	07/01/2016	07/01/2017	007368

Larson Davis, a division of PCB Piezotronics, Inc
1681 West 820 North
Provo, UT 84601, United States
716-684-0001



Output Level

Nominal Level [dB]	Pressure [kPa]	Test Result [dB]	Lower limit [dB]	Upper limit [dB]	Expanded Uncertainty [dB]	Result
114	101.3	113.98	113.90	114.10	0.13	Pass

-- End of measurement results--

Frequency

Nominal Level [dB]	Pressure [kPa]	Test Result [Hz]	Lower limit [Hz]	Upper limit [Hz]	Expanded Uncertainty [Hz]	Result
114	101.3	249.82	249.19	253.19	0.10	Pass

-- End of measurement results--

Total Harmonic Distortion + Noise (THD+N)

Nominal Level [dB]	Pressure [kPa]	Test Result [%]	Lower limit [%]	Upper limit [%]	Expanded Uncertainty [%]	Result
114	101.3	0.66	0.00	2.00	0.25	Pass

-- End of measurement results--

Level Change Over Pressure

Tested at: 114 dB, 23 °C, 38 %RH

Nominal Pressure [kPa]	Pressure [kPa]	Test Result [dB]	Lower limit [dB]	Upper limit [dB]	Expanded Uncertainty [dB]	Result
101.3	101.1	0.00	-0.30	0.30	0.04 ‡	Pass
74.0	74.0	0.10	-0.30	0.30	0.04 ‡	Pass
108.0	108.0	-0.02	-0.30	0.30	0.04 ‡	Pass
92.0	92.2	0.03	-0.30	0.30	0.04 ‡	Pass
83.0	83.1	0.07	-0.30	0.30	0.04 ‡	Pass
65.0	64.8	0.14	-0.30	0.30	0.04 ‡	Pass

-- End of measurement results--

Frequency Change Over Pressure

Tested at: 114 dB, 23 °C, 38 %RH

Nominal Pressure [kPa]	Pressure [kPa]	Test Result [Hz]	Lower limit [Hz]	Upper limit [Hz]	Expanded Uncertainty [Hz]	Result
101.3	101.1	0.00	-2.00	2.00	0.10 ‡	Pass
74.0	74.0	0.00	-2.00	2.00	0.10 ‡	Pass
108.0	108.0	-0.01	-2.00	2.00	0.10 ‡	Pass
92.0	92.2	-0.01	-2.00	2.00	0.10 ‡	Pass
83.0	83.1	-0.01	-2.00	2.00	0.10 ‡	Pass
65.0	64.8	-0.01	-2.00	2.00	0.10 ‡	Pass

-- End of measurement results--



Total Harmonic Distortion + Noise (THD+N) Over Pressure

Tested at: 114 dB, 23 °C, 38 %RH

Nominal Pressure [kPa]	Pressure [kPa]	Test Result [%]	Lower limit [%]	Upper limit [%]	Expanded Uncertainty [%]	Result
74.0	74.0	0.70	0.00	2.00	0.25 ‡	Pass
108.0	108.0	0.67	0.00	2.00	0.25 ‡	Pass
101.3	101.1	0.67	0.00	2.00	0.25 ‡	Pass
92.0	92.2	0.68	0.00	2.00	0.25 ‡	Pass
83.0	83.1	0.68	0.00	2.00	0.25 ‡	Pass
65.0	64.8	0.71	0.00	2.00	0.25 ‡	Pass

-- End of measurement results--

Signatory: Scott Montgomery

Larson Davis, a division of PCB Piezotronics, Inc
 1681 West 820 North
 Provo, UT 84601, United States
 716-684-0001



Certificate of Calibration and Conformance

Certificate Number 2017-205701

Instrument Model 720, Serial Number 0309, was calibrated on 22 Sep 2017. The instrument meets factory specifications per Procedure D0001.8208, ANSI S1.4 1983, IEC 651-Type 2 1979, and IEC 804-Type 2 1985.

Instrument found to be in calibration as received: YES

Date Calibrated: 22 Sep 2017

Calibration due: 22 Sep 2019

Calibration Standards Used

MANUFACTURER	MODEL	SERIAL NUMBER	INTERVAL	CAL. DUE	TRACEABILITY NO.
PCB	377A13	134649	12 Months	3 Oct 2017	2016008854
Larson Davis	LDSigGn/2209	0445 / 0111	12 Months	16 Nov 2017	2016-204299
PCB	426B03	1603	12 Months	12 Apr 2018	2017003848

Reference Standards are traceable to the National Institute of Standards and Technology (NIST)

Calibration Environmental Conditions

Temperature: 23 ° Centigrade

Relative Humidity: 30 %

Affirmations

This Certificate attests that this instrument has been calibrated under the stated conditions with Measurement and Test Equipment (M&TE) Standards traceable to the U.S. National Institute of Standards and Technology (NIST). All of the Measurement Standards have been calibrated to their manufacturers' specified accuracy / uncertainty. Evidence of traceability and accuracy is on file at Provo Engineering & Manufacturing Center. An acceptable accuracy ratio between the Standard(s) and the item calibrated has been maintained. This instrument meets or exceeds the manufacturer's published specification unless noted.

The collective uncertainty of the Measurement Standard used does not exceed 25% of the applicable tolerance for each characteristic calibrated unless otherwise noted.

The results documented in this certificate relate only to the item(s) calibrated or tested. A one year calibration is recommended, however calibration interval assignment and adjustment are the responsibility of the end user. This certificate may not be reproduced, except in full, without the written approval of the issuer.

"AS RECEIVED" data same as shipped data.

Signed: _____



Technician: Eric Olson



Larson Davis Microphone and Preamp Data
Model: MIC001 Serial Number: 1029

Sensitivity @ 1 KHz: 8.08 mV/Pa

Test Conditions:

Powered by LD Spark 706RC. Compared to PCB 377A13 microphone in Larson Davis CAL291. Corrected to 0° free field response. Data taken with LD 2900.

2900 Serial Number: 0249

CAL291 Serial Number: 0128

377A13 Serial Number: 134649

Spark 706RC Serial Number: 17000

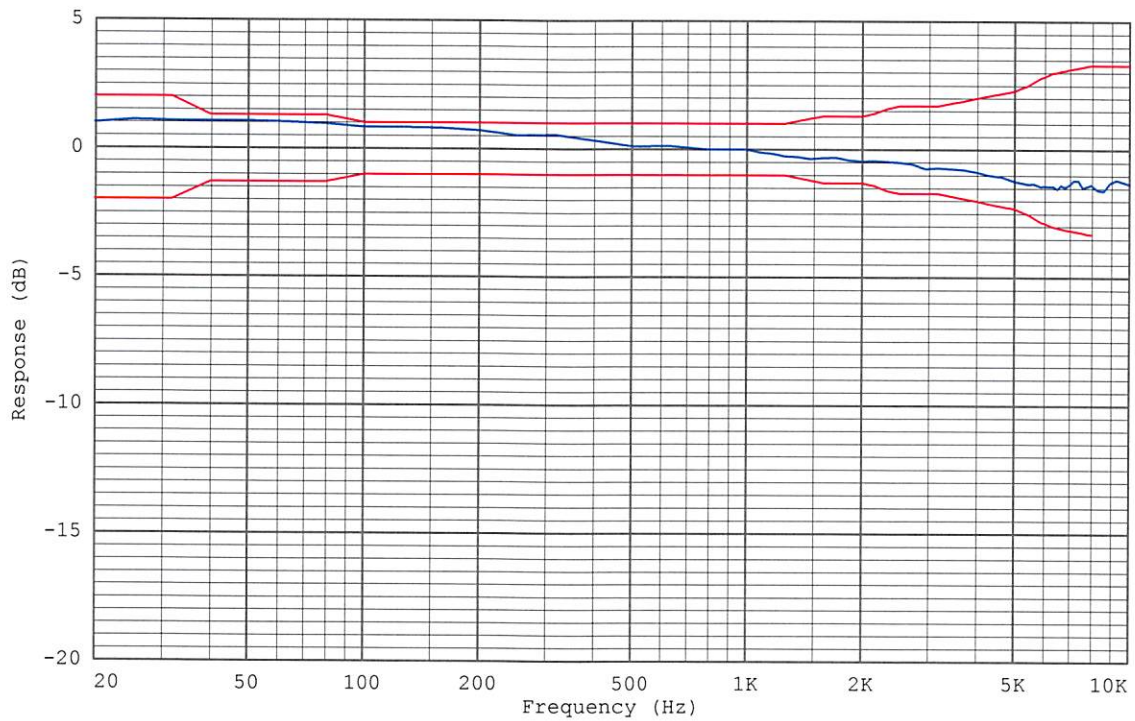

Frequency Response with reference at 1 KHz

Frequency	Response	Limits	Frequency	Response	Limits	Frequency	Response	Limits
19.95	0.98	-2.00/2.00	1258.93	-0.26	-1.00/1.00	5411.70	-1.33	-2.50/2.50
25.12	1.09	-2.00/2.00	1359.36	-0.28	-1.10/1.10	5623.41	-1.32	-2.65/2.65
31.62	1.05	-2.00/2.00	1467.80	-0.36	-1.20/1.20	5843.41	-1.41	-2.80/2.80
39.81	1.05	-1.30/1.30	1584.89	-0.32	-1.30/1.30	5994.84	-1.40	-2.86/2.86
50.12	1.05	-1.30/1.30	1711.33	-0.31	-1.30/1.30	6150.20	-1.41	-2.93/2.93
63.10	1.01	-1.30/1.30	1847.85	-0.41	-1.30/1.30	6309.57	-1.41	-3.00/3.00
79.43	0.96	-1.30/1.30	1995.26	-0.45	-1.30/1.30	6473.08	-1.52	-3.03/3.03
100.00	0.82	-1.00/1.00	2154.43	-0.43	-1.40/1.40	6640.83	-1.38	-3.07/3.07
125.89	0.82	-1.00/1.00	2326.31	-0.46	-1.60/1.60	6812.92	-1.45	-3.10/3.10
158.49	0.80	-1.00/1.00	2511.89	-0.50	-1.70/1.70	6989.47	-1.35	-3.13/3.13
199.53	0.71	-1.00/1.00	2712.27	-0.57	-1.70/1.70	7170.60	-1.19	-3.17/3.17
251.19	0.52	-1.00/1.00	2928.64	-0.73	-1.70/1.70	7356.42	-1.19	-3.20/3.20
316.23	0.55	-1.00/1.00	3162.28	-0.72	-1.70/1.70	7547.06	-1.47	-3.23/3.23
398.11	0.34	-1.00/1.00	3414.55	-0.74	-1.80/1.80	7742.64	-1.42	-3.27/3.27
501.19	0.12	-1.00/1.00	3686.95	-0.78	-1.90/1.90	7943.28	-1.36	-3.30/3.30
630.96	0.13	-1.00/1.00	3981.07	-0.86	-2.00/2.00	8254.04	-1.55	-∞ /3.30
794.33	0.00	-1.00/1.00	4298.66	-0.99	-2.10/2.10	8576.96	-1.59	-∞ /3.30
1000.00	0.00	-1.00/1.00	4641.59	-1.06	-2.20/2.20	8912.51	-1.28	-∞ /3.30
1079.78	-0.11	-1.00/1.00	5011.87	-1.23	-2.30/2.30	9261.19	-1.16	-∞ /3.30
1165.91	-0.16	-1.00/1.00	5207.95	-1.28	-2.40/2.40	10000.00	-1.31	-∞ /3.30

Sound Level Meter Model: 720 Serial Number: A0309 Log Linearity, Differential Linearity and Range Data

This Type 2 Sound Level Meter (including integral PRM789 preamplifier and ADP018 4.7 pF input adapter) was calibrated with a reference 1kHz sine wave at a level of 114.0 dB SPL. The instrument's Log Linearity A-weighted fast response was then electrically tested using a 1kHz sine wave from 26.5 dB SPL to 146.5 dB SPL in 0.5 dB increments.

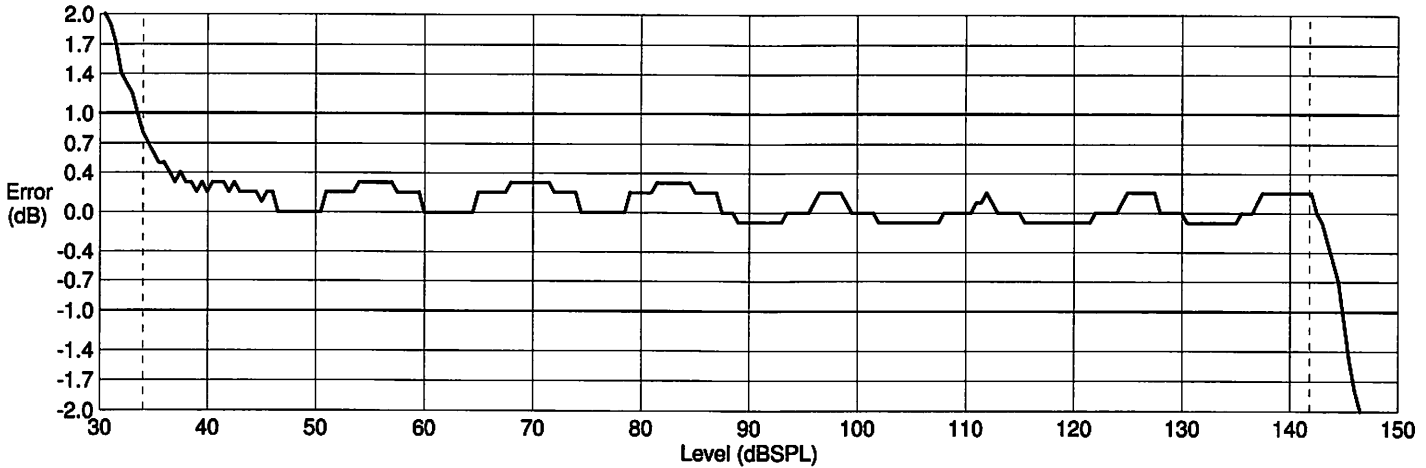

Levl dB SPL	Meas dB SPL	Err dB	Levl dB SPL	Meas dB SPL	Err dB	Levl dB SPL	Meas dB SPL	Err dB	Levl dB SPL	Meas dB SPL	Err dB	Levl dB SPL	Meas dB SPL	Err dB	Levl dB SPL	Meas dB SPL	Err dB
26.5	30.9	4.4	47.0	47.0	0.0	67.5	67.7	0.2	88.0	88.0	0.0	108.5	108.5	0.0	129.0	129.0	0.0
27.0	31.2	4.2	47.5	47.5	0.0	68.0	68.3	0.3	88.5	88.5	0.0	109.0	109.0	0.0	129.5	129.5	0.0
27.5	31.3	3.8	48.0	48.0	0.0	68.5	68.8	0.3	89.0	88.9	-0.1	109.5	109.5	0.0	130.0	130.0	0.0
28.0	31.5	3.5	48.5	48.5	0.0	69.0	69.3	0.3	89.5	89.4	-0.1	110.0	110.0	0.0	130.5	130.4	-0.1
28.5	31.7	3.2	49.0	49.0	0.0	69.5	69.8	0.3	90.0	89.9	-0.1	110.5	110.5	0.0	131.0	130.9	-0.1
29.0	31.8	2.8	49.5	49.5	0.0	70.0	70.3	0.3	90.5	90.4	-0.1	111.0	111.1	0.1	131.5	131.4	-0.1
29.5	32.1	2.6	50.0	50.0	0.0	70.5	70.8	0.3	91.0	90.9	-0.1	111.5	111.6	0.1	132.0	131.9	-0.1
30.0	32.2	2.2	50.5	50.5	0.0	71.0	71.3	0.3	91.5	91.4	-0.1	112.0	112.2	0.2	132.5	132.4	-0.1
30.5	32.6	2.1	51.0	51.2	0.2	71.5	71.8	0.3	92.0	91.9	-0.1	112.5	112.6	0.1	133.0	132.9	-0.1
31.0	32.9	1.9	51.5	51.7	0.2	72.0	72.2	0.2	92.5	92.4	-0.1	113.0	113.0	0.0	133.5	133.4	-0.1
31.5	33.2	1.7	52.0	52.2	0.2	72.5	72.7	0.2	93.0	92.9	-0.1	113.5	113.5	0.0	134.0	133.9	-0.1
32.0	33.4	1.4	52.5	52.7	0.2	73.0	73.2	0.2	93.5	93.5	0.0	114.0	114.0	0.0	134.5	134.4	-0.1
32.5	33.8	1.3	53.0	53.2	0.2	73.5	73.7	0.2	94.0	94.0	0.0	114.5	114.5	0.0	135.0	134.9	-0.1
33.0	34.2	1.2	53.5	53.7	0.2	74.0	74.2	0.2	94.5	94.5	0.0	115.0	115.0	0.0	135.5	135.5	0.0
33.5	34.5	1.0	54.0	54.3	0.3	74.5	74.5	0.0	95.0	95.0	0.0	115.5	115.4	-0.1	136.0	136.0	0.0
34.0	34.8	0.8	54.5	54.8	0.3	75.0	75.0	0.0	95.5	95.5	0.0	116.0	115.9	-0.1	136.5	136.5	0.0
34.5	35.2	0.7	55.0	55.3	0.3	75.5	75.5	0.0	96.0	96.1	0.1	116.5	116.4	-0.1	137.0	137.1	0.1
35.0	35.6	0.6	55.5	55.8	0.3	76.0	76.0	0.0	96.5	96.7	0.2	117.0	116.9	-0.1	137.5	137.7	0.2
35.5	36.0	0.5	56.0	56.3	0.3	76.5	76.5	0.0	97.0	97.2	0.2	117.5	117.4	-0.1	138.0	138.2	0.2
36.0	36.5	0.5	56.5	56.8	0.3	77.0	77.0	0.0	97.5	97.7	0.2	118.0	117.9	-0.1	138.5	138.7	0.2
36.5	36.9	0.4	57.0	57.3	0.3	77.5	77.5	0.0	98.0	98.2	0.2	118.5	118.4	-0.1	139.0	139.2	0.2
37.0	37.3	0.3	57.5	57.7	0.2	78.0	78.0	0.0	98.5	98.7	0.2	119.0	118.9	-0.1	139.5	139.7	0.2
37.5	37.9	0.4	58.0	58.2	0.2	78.5	78.5	0.0	99.0	99.1	0.1	119.5	119.4	-0.1	140.0	140.2	0.2
38.0	38.3	0.3	58.5	58.7	0.2	79.0	79.2	0.2	99.5	99.5	0.0	120.0	119.9	-0.1	140.5	140.7	0.2
38.5	38.8	0.3	59.0	59.2	0.2	79.5	79.7	0.2	100.0	100.0	0.0	120.5	120.4	-0.1	141.0	141.2	0.2
39.0	39.2	0.2	59.5	59.7	0.2	80.0	80.2	0.2	100.5	100.5	0.0	121.0	120.9	-0.1	141.5	141.7	0.2
39.5	39.8	0.3	60.0	60.0	0.0	80.5	80.7	0.2	101.0	101.0	0.0	121.5	121.4	-0.1	142.0	142.2	0.2
40.0	40.2	0.2	60.5	60.5	0.0	81.0	81.2	0.2	101.5	101.5	0.0	122.0	122.0	0.0	142.5	142.5	0.0
40.5	40.8	0.3	61.0	61.0	0.0	81.5	81.8	0.3	102.0	101.9	-0.1	122.5	122.5	0.0	143.0	142.9	-0.1
41.0	41.3	0.3	61.5	61.5	0.0	82.0	82.3	0.3	102.5	102.4	-0.1	123.0	123.0	0.0	143.5	143.2	-0.3
41.5	41.8	0.3	62.0	62.0	0.0	82.5	82.8	0.3	103.0	102.9	-0.1	123.5	123.5	0.0	144.0	143.5	-0.5
42.0	42.2	0.2	62.5	62.5	0.0	83.0	83.3	0.3	103.5	103.4	-0.1	124.0	124.0	0.0	144.5	143.8	-0.7
42.5	42.8	0.3	63.0	63.0	0.0	83.5	83.8	0.3	104.0	103.9	-0.1	124.5	124.6	0.1	145.0	143.9	-1.1
43.0	43.2	0.2	63.5	63.5	0.0	84.0	84.3	0.3	104.5	104.4	-0.1	125.0	125.2	0.2	145.5	144.0	-1.5
43.5	43.7	0.2	64.0	64.0	0.0	84.5	84.8	0.3	105.0	104.9	-0.1	125.5	125.7	0.2	146.0	144.2	-1.8
44.0	44.2	0.2	64.5	64.5	0.0	85.0	85.2	0.2	105.5	105.4	-0.1	126.0	126.2	0.2	146.5	144.2	-2.3
44.5	44.7	0.2	65.0	65.2	0.2	85.5	85.7	0.2	106.0	105.9	-0.1	126.5	126.7	0.2			
45.0	45.1	0.1	65.5	65.7	0.2	86.0	86.2	0.2	106.5	106.4	-0.1	127.0	127.2	0.2			
45.5	45.7	0.2	66.0	66.2	0.2	86.5	86.7	0.2	107.0	106.9	-0.1	127.5	127.7	0.2			
46.0	46.2	0.2	66.5	66.7	0.2	87.0	87.2	0.2	107.5	107.4	-0.1	128.0	128.0	0.0			
46.5	46.5	0.0	67.0	67.2	0.2	87.5	87.5	0.0	108.0	108.0	0.0	128.5	128.5	0.0			

Plotted per typical sensitivity of an M1 3/8" electret microphone; 16.7 mV/Pa & 4.7 pF.

Overload occurs at 141.9 dB SPL.

Primary indicator range: 107.8 dB (lower limit: 34.0 dB SPL to upper limit: 141.8 dB SPL).

Dynamic range: 112.1 dB (noise floor: 29.7 dB SPL to upper limit: 141.8 dB SPL).

This instrument is in compliance with IEC 60651 (2001-10) 7.9 and 7.10, ANSI S1.4-1983 3.2 and IEC 60804 (2001-10) 9.2.1 for Type 2 sound level meters when used with a Larson Davis Type 2 microphone.

**Sound Level Meter Model: 720 Serial Number: A0309
Certificate of A-Weight Electrical Conformance**

This Type 2 Sound Level Meter (including integral PRM789 preamplifier and ADP018 4.7 pF input adapter) was calibrated with a reference 1kHz sine wave at a level of 114.0 dB SPL. The instrument's A-weighted response was then electrically tested using a 3.0 Vrms sinewave at exact frequencies as specified in IEC 60651 (2001-10) and ANSI S1.4-1983.

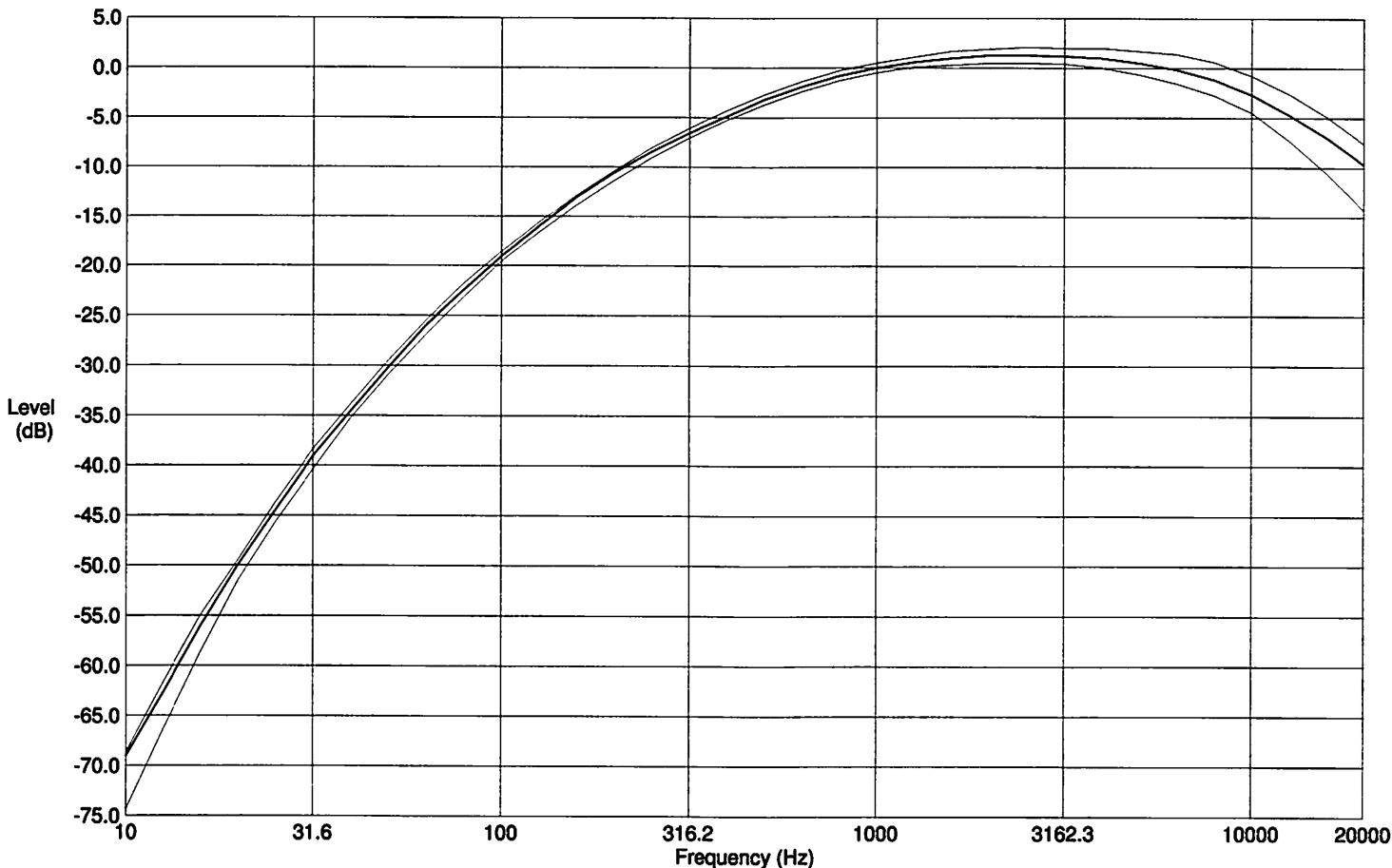

Freq (Hz)	Theor	Measured	Error	Tolerance	Freq (Hz)	Theor	Measured	Error	Tolerance
10.00	-70.4	-69.10	1.30	+1.7, -4.0	630.96	-1.9	-1.90	0.00	+0.5, -0.5
12.59	-63.4	-62.70	0.70	+1.7, -3.0	794.33	-0.8	-0.80	0.00	+0.5, -0.5
15.85	-56.7	-56.10	0.60	+1.7, -2.0	1000.00	0.0	0.00	0.00	+0.5, -0.5
19.95	-50.5	-50.00	0.50	+1.0, -1.0	1258.90	0.6	0.60	0.00	+0.5, -0.5
25.12	-44.7	-44.50	0.20	+1.0, -1.0	1584.90	1.0	1.00	0.00	+0.7, -0.7
31.62	-39.4	-39.10	0.30	+1.0, -1.0	1995.30	1.2	1.30	0.10	+0.7, -0.7
39.81	-34.6	-34.60	0.00	+0.7, -0.7	2511.90	1.3	1.30	0.00	+0.8, -0.8
50.12	-30.2	-30.20	0.00	+0.7, -0.7	3162.30	1.2	1.20	0.00	+0.8, -0.8
63.10	-26.2	-26.00	0.20	+0.7, -0.7	3981.10	1.0	1.00	0.00	+1.0, -1.0
79.43	-22.5	-22.50	0.00	+0.7, -0.7	5011.90	0.5	0.50	0.00	+1.2, -1.2
100.00	-19.1	-19.10	0.00	+0.5, -0.5	6309.60	-0.1	-0.20	-0.10	+1.5, -1.5
125.89	-16.1	-16.00	0.10	+0.5, -0.5	7943.30	-1.1	-1.20	-0.10	+1.7, -1.7
158.49	-13.4	-13.10	0.30	+0.5, -0.5	10000.00	-2.5	-2.70	-0.20	+1.7, -2.0
199.53	-10.9	-10.60	0.30	+0.5, -0.5	12589.00	-4.3	-4.70	-0.40	+1.7, -3.0
251.19	-8.6	-8.50	0.10	+0.5, -0.5	15849.00	-6.6	-7.00	-0.40	+1.7, -4.0
316.23	-6.6	-6.60	0.00	+0.5, -0.5	19953.00	-9.3	-9.70	-0.40	+1.7, -5.0
398.11	-4.8	-4.90	-0.10	+0.5, -0.5	25119.00	-12.4	-13.40	0.00	n/a n/a
501.19	-3.2	-3.20	0.00	+0.5, -0.5	31623.00	-15.8	-18.10	0.00	n/a n/a

This instrument is in compliance with IEC 60651 (2001-10) 6.1 and 9.2.2, ANSI S1.4-1983 5.1 and 8.2.1, and IEC 60804 (2001-10) 5.1 for Type 2 sound level meters when used with a Larson Davis Type 2 microphone.

**Sound Level Meter Model: 720 Serial Number: A0309
Certificate of C-Weight Electrical Conformance**

This Type 2 Sound Level Meter (including integral PRM789 preamplifier and ADP018 4.7 pF input adapter) was calibrated with a reference 1kHz sine wave at a level of 114.0 dB SPL. The instrument's C-weighted response was then electrically tested using a 3.0 Vrms sinewave at exact frequencies as specified in IEC 60651 (2001-10) and ANSI S1.4-1983.

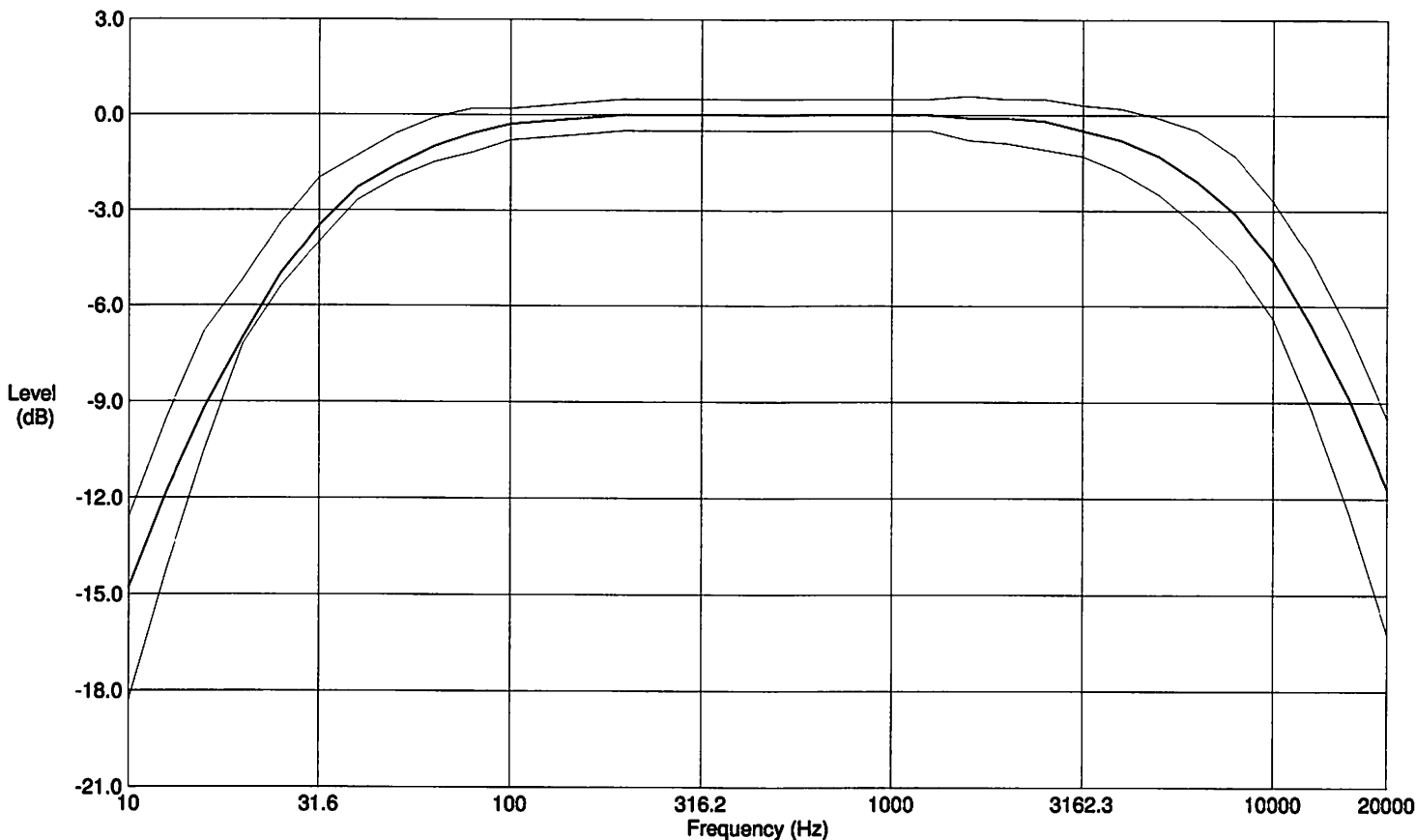

Freq (Hz)	Theor	Measured	Error	Tolerance	Freq (Hz)	Theor	Measured	Error	Tolerance
10.00	-14.3	-14.80	-0.50	+1.7, -4.0	630.96	0.0	0.00	0.00	+0.5, -0.5
12.59	-11.2	-11.80	-0.60	+1.7, -3.0	794.33	0.0	0.00	0.00	+0.5, -0.5
15.85	-8.5	-9.20	-0.70	+1.7, -2.0	1000.00	0.0	0.00	0.00	+0.5, -0.5
19.95	-6.2	-7.00	-0.80	+1.0, -1.0	1258.90	0.0	0.00	0.00	+0.5, -0.5
25.12	-4.4	-5.00	-0.60	+1.0, -1.0	1584.90	-0.1	-0.10	0.00	+0.7, -0.7
31.62	-3.0	-3.50	-0.50	+1.0, -1.0	1995.30	-0.2	-0.10	0.10	+0.7, -0.7
39.81	-2.0	-2.30	-0.30	+0.7, -0.7	2511.90	-0.3	-0.20	0.10	+0.8, -0.8
50.12	-1.3	-1.60	-0.30	+0.7, -0.7	3162.30	-0.5	-0.50	0.00	+0.8, -0.8
63.10	-0.8	-1.00	-0.20	+0.7, -0.7	3981.10	-0.8	-0.80	0.00	+1.0, -1.0
79.43	-0.5	-0.60	-0.10	+0.7, -0.7	5011.90	-1.3	-1.30	0.00	+1.2, -1.2
100.00	-0.3	-0.30	0.00	+0.5, -0.5	6309.60	-2.0	-2.10	-0.10	+1.5, -1.5
125.89	-0.2	-0.20	0.00	+0.5, -0.5	7943.30	-3.0	-3.10	-0.10	+1.7, -1.7
158.49	-0.1	-0.10	0.00	+0.5, -0.5	10000.00	-4.4	-4.60	-0.20	+1.7, -2.0
199.53	0.0	0.00	0.00	+0.5, -0.5	12589.00	-6.2	-6.60	-0.40	+1.7, -3.0
251.19	0.0	0.00	0.00	+0.5, -0.5	15849.00	-8.5	-8.90	-0.40	+1.7, -4.0
316.23	0.0	0.00	0.00	+0.5, -0.5	19953.00	-11.2	-11.70	-0.50	+1.7, -5.0
398.11	0.0	0.00	0.00	+0.5, -0.5	25119.00	-14.3	-15.20	0.00	n/a n/a
501.19	0.0	0.00	0.00	+0.5, -0.5	31623.00	-17.7	-20.10	0.00	n/a n/a

This instrument is in compliance with IEC 60651 (2001-10) 6.1 and 9.2.2, ANSI S1.4-1983 5.1 and 8.2.1, and IEC 60804 (2001-10) 5.1 for Type 2 sound level meters when used with a Larson Davis Type 2 microphone.

Technician: Eric Olson Test Date: 22SEP2017

Calibration Certificate

Certificate Number 2017004806

Customer:

Eilar Associates
466 Blueridge Place
Escondido, CA 92026, United States

Model Number	CAL150B	Procedure Number	D0001.8386
Serial Number	2056	Technician	Scott Montgomery
Test Results	Pass	Calibration Date	9 May 2017
Initial Condition	Adjusted	Calibration Due	9 May 2019
Description	Larson Davis CAL150B Calibrator	Temperature	23 °C ± 0.3 °C
		Humidity	39 %RH ± 3 %RH
		Static Pressure	101.3 kPa ± 1 kPa

Evaluation Method The data is acquired by the insert voltage calibration method using the reference microphone's open circuit sensitivity. Data reported in dB re 20 µPa.

Compliance Standards Compliant to Manufacturer Specifications per D0001.8190 and the following standards:
IEC 60942:2003 ANSI S1.40-2006

Issuing lab certifies that the instrument described above meets or exceeds all specifications as stated in the referenced procedure (unless otherwise noted). It has been calibrated using measurement standards traceable to the SI through the National Institute of Standards and Technology (NIST), or other national measurement institutes, and meets the requirements of ISO/IEC 17025:2005. Test points marked with a ‡ in the uncertainties column do not fall within this laboratory's scope of accreditation.

The quality system is registered to ISO 9001:2008.

This calibration is a direct comparison of the unit under test to the listed reference standards and did not involve any sampling plans to complete. No allowance has been made for the instability of the test device due to use, time, etc. Such allowances would be made by the customer as needed.

The uncertainties were computed in accordance with the ISO Guide to the Expression of Uncertainty in Measurement (GUM). A coverage factor of approximately 2 sigma (k=2) has been applied to the standard uncertainty to express the expanded uncertainty at approximately 95% confidence level.

This report may not be reproduced, except in full, unless permission for the publication of an approved abstract is obtained in writing from the organization issuing this report.

Standards Used:

Description	Cal Date	Cal Due	Cal Standard
Agilent 34401A DMM	09/07/2016	09/07/2017	001021
Sound Level Meter / Real Time Analyzer	04/10/2017	04/10/2018	001051
Microphone Calibration System	08/17/2016	08/17/2017	005446
1/2" Preamplifier	10/06/2016	10/06/2017	006506
Larson Davis 1/2" Preamplifier 7-pin LEMO	08/22/2016	08/22/2017	006507
1/2 inch Microphone - RI - 200V	10/03/2016	10/03/2017	006511
Pressure Transducer	07/01/2016	07/01/2017	007368

Larson Davis, a division of PCB Piezotronics, Inc
1681 West 820 North
Provo, UT 84601, United States
716-684-0001



Output Level

Nominal Level [dB]	Pressure [kPa]	Test Result [dB]	Lower limit [dB]	Upper limit [dB]	Expanded Uncertainty [dB]	Result
94	101.3	94.02	93.70	94.30	0.14	Pass
114	101.2	114.01	113.70	114.30	0.13	Pass

-- End of measurement results--

Frequency

Nominal Level [dB]	Pressure [kPa]	Test Result [Hz]	Lower limit [Hz]	Upper limit [Hz]	Expanded Uncertainty [Hz]	Result
94	101.3	1,000.18	990.00	1,010.00	0.20	Pass
114	101.2	1,000.17	990.00	1,010.00	0.20	Pass

-- End of measurement results--

Total Harmonic Distortion + Noise (THD+N)

Nominal Level [dB]	Pressure [kPa]	Test Result [%]	Lower limit [%]	Upper limit [%]	Expanded Uncertainty [%]	Result
94	101.3	0.37	0.00	2.00	0.25	Pass
114	101.2	0.35	0.00	2.00	0.25	Pass

-- End of measurement results--

Level Change Over Pressure

Tested at: 114 dB, 22 °C, 38 %RH

Nominal Pressure [kPa]	Pressure [kPa]	Test Result [dB]	Lower limit [dB]	Upper limit [dB]	Expanded Uncertainty [dB]	Result
101.3	101.2	0.00	-0.40	0.40	0.04 ‡	Pass
108.0	107.6	-0.08	-0.40	0.40	0.04 ‡	Pass
92.0	92.0	0.07	-0.40	0.40	0.04 ‡	Pass
83.0	83.1	0.06	-0.40	0.40	0.04 ‡	Pass
74.0	74.1	-0.01	-0.40	0.40	0.04 ‡	Pass
65.0	65.0	-0.12	-0.40	0.40	0.04 ‡	Pass

-- End of measurement results--

Frequency Change Over Pressure

Tested at: 114 dB, 22 °C, 38 %RH

Nominal Pressure [kPa]	Pressure [kPa]	Test Result [Hz]	Lower limit [Hz]	Upper limit [Hz]	Expanded Uncertainty [Hz]	Result
108.0	107.6	0.00	-10.00	10.00	0.20 ‡	Pass
101.3	101.2	0.00	-10.00	10.00	0.20 ‡	Pass
92.0	92.0	0.00	-10.00	10.00	0.20 ‡	Pass
83.0	83.1	0.00	-10.00	10.00	0.20 ‡	Pass
74.0	74.1	-0.01	-10.00	10.00	0.20 ‡	Pass
65.0	65.0	-0.01	-10.00	10.00	0.20 ‡	Pass

-- End of measurement results--



Total Harmonic Distortion + Noise (THD+N) Over Pressure

Tested at: 114 dB, 22 °C, 38 %RH

Nominal Pressure [kPa]	Pressure [kPa]	Test Result [%]	Lower limit [%]	Upper limit [%]	Expanded Uncertainty [%]	Result
108.0	107.6	0.34	0.00	2.00	0.25 ‡	Pass
101.3	101.2	0.34	0.00	2.00	0.25 ‡	Pass
92.0	92.0	0.35	0.00	2.00	0.25 ‡	Pass
83.0	83.1	0.37	0.00	2.00	0.25 ‡	Pass
74.0	74.1	0.39	0.00	2.00	0.25 ‡	Pass
65.0	65.0	0.42	0.00	2.00	0.25 ‡	Pass

-- End of measurement results--

Signatory: Scott Montgomery

Larson Davis, a division of PCB Piezotronics, Inc
 1681 West 820 North
 Provo, UT 84601, United States
 716-684-0001



Initial Assessment

Certificate Number 2017004805

Customer:

Eilar Associates
466 Blueridge Place
Escondido, CA 92026, United States

Model Number	CAL150B	Procedure Number	D0001.8386
Serial Number	2056	Technician	Scott Montgomery
Test Results	Pass	Calibration Date	9 May 2017
Initial Condition	As Received	Calibration Due	
Description	Larson Davis CAL150B Calibrator	Temperature	24 °C ± 0.3 °C
		Humidity	36 %RH ± 3 %RH
		Static Pressure	100.9 kPa ± 1 kPa

Evaluation Method The data is acquired by the insert voltage calibration method using the reference microphone's open circuit sensitivity. Data reported in dB re 20 µPa.

Compliance Standards Compliant to Manufacturer Specifications per D0001.8190 and the following standards:
IEC 60942:2003 ANSI S1.40-2006

Issuing lab certifies that the instrument described above meets or exceeds all specifications as stated in the referenced procedure (unless otherwise noted). It has been calibrated using measurement standards traceable to the SI through the National Institute of Standards and Technology (NIST), or other national measurement institutes, and meets the requirements of ISO/IEC 17025:2005. Test points marked with a ‡ in the uncertainties column do not fall within this laboratory's scope of accreditation.

The quality system is registered to ISO 9001:2008.

This calibration is a direct comparison of the unit under test to the listed reference standards and did not involve any sampling plans to complete. No allowance has been made for the instability of the test device due to use, time, etc. Such allowances would be made by the customer as needed.

The uncertainties were computed in accordance with the ISO Guide to the Expression of Uncertainty in Measurement (GUM). A coverage factor of approximately 2 sigma (k=2) has been applied to the standard uncertainty to express the expanded uncertainty at approximately 95% confidence level.

This report may not be reproduced, except in full, unless permission for the publication of an approved abstract is obtained in writing from the organization issuing this report.

Standards Used

Description	Cal Date	Cal Due	Cal Standard
Agilent 34401A DMM	09/07/2016	09/07/2017	001021
Sound Level Meter / Real Time Analyzer	04/10/2017	04/10/2018	001051
Microphone Calibration System	08/17/2016	08/17/2017	005446
1/2" Preamplifier	10/06/2016	10/06/2017	006506
Larson Davis 1/2" Preamplifier 7-pin LEMO	08/22/2016	08/22/2017	006507
1/2 inch Microphone - RI - 200V	10/03/2016	10/03/2017	006511
Pressure Transducer	07/01/2016	07/01/2017	007368

Larson Davis, a division of PCB Piezotronics, Inc
1681 West 820 North
Provo, UT 84601, United States
716-684-0001



Output Level

Nominal Level [dB]	Pressure [kPa]	Test Result [dB]	Lower limit [dB]	Upper limit [dB]	Expanded Uncertainty [dB]	Result
94	100.9	93.78	93.70	94.30	0.14	Pass
114	101.5	113.77	113.70	114.30	0.13	Pass

-- End of measurement results--

Frequency

Nominal Level [dB]	Pressure [kPa]	Test Result [Hz]	Lower limit [Hz]	Upper limit [Hz]	Expanded Uncertainty [Hz]	Result
94	100.9	1,001.88	990.00	1,010.00	0.20	Pass
114	101.5	1,001.87	990.00	1,010.00	0.20	Pass

-- End of measurement results--

Total Harmonic Distortion + Noise (THD+N)

Nominal Level [dB]	Pressure [kPa]	Test Result [%]	Lower limit [%]	Upper limit [%]	Expanded Uncertainty [%]	Result
94	100.9	0.38	0.00	2.00	0.25	Pass
114	101.5	0.34	0.00	2.00	0.25	Pass

-- End of measurement results--

Level Change Over Pressure

Tested at: 114 dB, 22 °C, 38 %RH

Nominal Pressure [kPa]	Pressure [kPa]	Test Result [dB]	Lower limit [dB]	Upper limit [dB]	Expanded Uncertainty [dB]	Result
101.3	101.2	0.00	-0.40	0.40	0.04 ‡	Pass
108.0	107.6	-0.08	-0.40	0.40	0.04 ‡	Pass
92.0	92.0	0.07	-0.40	0.40	0.04 ‡	Pass
83.0	83.1	0.06	-0.40	0.40	0.04 ‡	Pass
74.0	74.1	-0.01	-0.40	0.40	0.04 ‡	Pass
65.0	65.0	-0.12	-0.40	0.40	0.04 ‡	Pass

-- End of measurement results--

Frequency Change Over Pressure

Tested at: 114 dB, 22 °C, 38 %RH

Nominal Pressure [kPa]	Pressure [kPa]	Test Result [Hz]	Lower limit [Hz]	Upper limit [Hz]	Expanded Uncertainty [Hz]	Result
108.0	107.6	0.00	-10.00	10.00	0.20 ‡	Pass
101.3	101.2	0.00	-10.00	10.00	0.20 ‡	Pass
92.0	92.0	0.00	-10.00	10.00	0.20 ‡	Pass
83.0	83.1	0.00	-10.00	10.00	0.20 ‡	Pass
74.0	74.1	-0.01	-10.00	10.00	0.20 ‡	Pass
65.0	65.0	-0.01	-10.00	10.00	0.20 ‡	Pass

-- End of measurement results--

Total Harmonic Distortion + Noise (THD+N) Over Pressure

Tested at: 114 dB, 22 °C, 38 %RH

Nominal Pressure [kPa]	Pressure [kPa]	Test Result [%]	Lower limit [%]	Upper limit [%]	Expanded Uncertainty [%]	Result
108.0	107.6	0.34	0.00	2.00	0.25 ‡	Pass
101.3	101.2	0.34	0.00	2.00	0.25 ‡	Pass
92.0	92.0	0.35	0.00	2.00	0.25 ‡	Pass
83.0	83.1	0.37	0.00	2.00	0.25 ‡	Pass
74.0	74.1	0.39	0.00	2.00	0.25 ‡	Pass
65.0	65.0	0.42	0.00	2.00	0.25 ‡	Pass

-- End of measurement results--

Signatory: Scott Montgomery

Larson Davis, a division of PCB Piezotronics, Inc
 1681 West 820 North
 Provo, UT 84601, United States
 716-684-0001



APPENDIX G

Sound Insulation Prediction Results

Sound Insulation Prediction (v9.0.17)

Program copyright Marshall Day Acoustics 2017

margin of error is generally within STC +/- 3 dB

- Key No. 1866

Job Name:516 La Costa

Job No.: S200108

Date:1/29/2020

File Name:wall A.ixl

Initials:mouwenga

Notes: Wall Type A

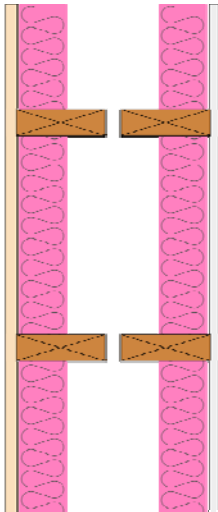

STC 55
OITC 41

Mass-air-mass resonant frequency = 41 Hz

Panel Size = 8.9 ft x 13.1 ft

Partition surface mass = 4.43 lb/ft²

System description

Panel 1 wood

Frame: Double timber stud (5.7 in x 1.8 in), Stud spacing 16 in; Cavity Width 12.32 in, 2 x fiberglass (0.6 lb/ft³) Thickness 3.0 in

Panel 2 : 1 x 0.63 in Type X Gypsum Board

freq.(Hz)	TL(dB)	TL(dB)
50	10	
63	17	14
80	24	
100	30	
125	35	33
160	40	
200	42	
250	45	45
315	49	
400	53	
500	56	55
630	59	
800	61	
1000	61	58
1250	55	
1600	57	
2000	59	57
2500	56	
3150	63	
4000	68	66
5000	74	

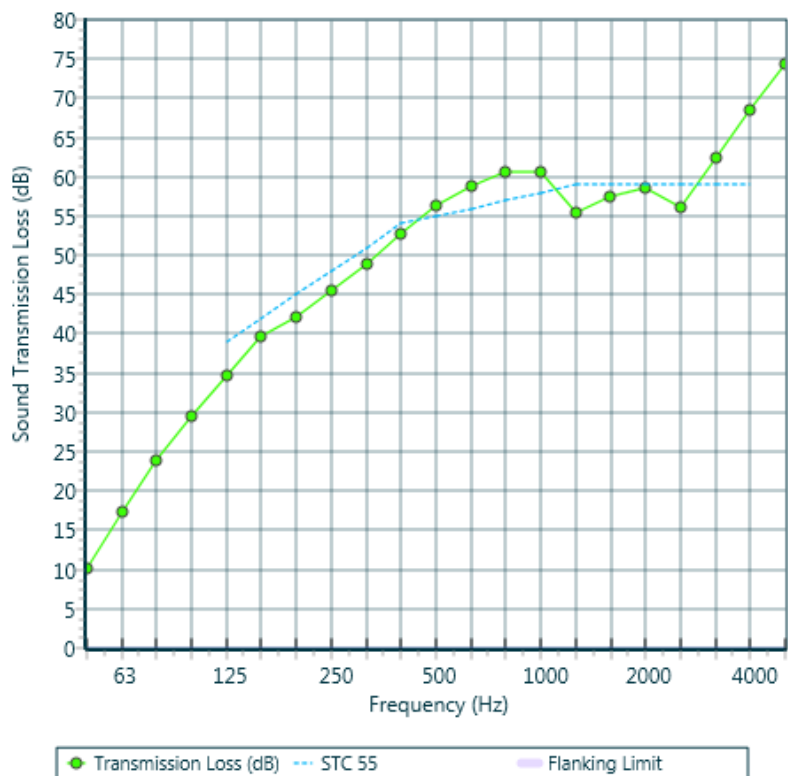

Sound Insulation Prediction (v9.0.17)

Program copyright Marshall Day Acoustics 2017

margin of error is generally within STC +/- 3 dB

- Key No. 1866

Job Name:516 La Costa

Job No.: S200108

Date:1/29/2020

File Name:wall B1.ixl

Initials:mouwenga

Notes: Wall Type B1

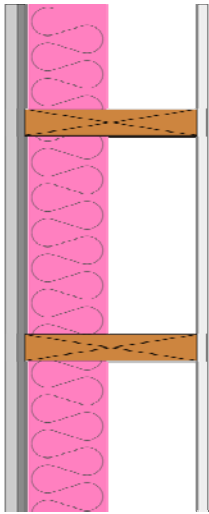

STC 40
OITC 29

Mass-air-mass resonant frequency = 32 Hz

Panel Size = 8.9 ft x 13.1 ft

Partition surface mass = 14.6 lb/ft²

System description

Panel 1 : 1 x 0.75 in Concrete

+ 1 x 0.5 in PermaBase Cement Board

Frame: Timber stud (11 in x 1.8 in), Stud spacing 16 in; Cavity Width 11 in, 1 x fiberglass (0.6 lb/ft³) Thickness 5.0 in

Panel 2 : 1 x 0.63 in Type X Gypsum Board

freq.(Hz)	TL(dB)	TL(dB)
50	24	
63	25	24
80	25	
100	24	
125	16	19
160	20	
200	36	
250	45	40
315	47	
400	49	
500	51	51
630	53	
800	54	
1000	55	55
1250	55	
1600	51	
2000	60	53
2500	53	
3150	54	
4000	57	56
5000	61	

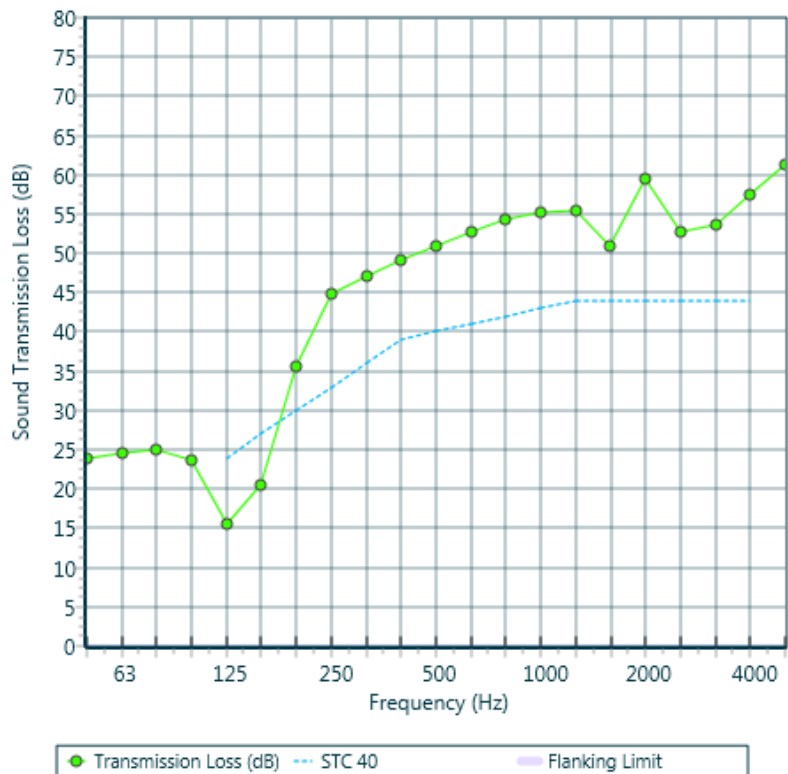

Sound Insulation Prediction (v9.0.17)

Program copyright Marshall Day Acoustics 2017

margin of error is generally within STC +/- 3 dB

- Key No. 1866

Job Name:516 La Costa

Job No.: S200108

Date:1/29/2020

File Name:wall D.ixl

Initials:mouwenga

Notes: Wall Type D

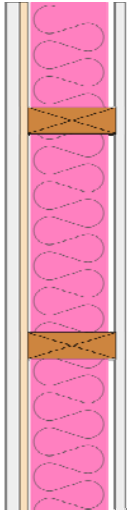

STC 38
OITC 30

Mass-air-mass resonant frequency = 45 Hz

Panel Size = 8.9 ft x 13.1 ft

Partition surface mass = 13.9 lb/ft²

System description

Panel 1 : 1 x 0.87 in -Coat Plaster (sand:gypsum =3:1)

+ 1 x 0.5 in Plywood

Frame: Timber stud (5.7 in x 1.8 in), Stud spacing 16 in ; Cavity Width 5.67 in , 1 x fiberglass (0.6 lb/ft³) Thickness 5.0 in

Panel 2 : 1 x 0.63 in Type X Gypsum Board

freq.(Hz)	TL(dB)	TL(dB)
50	23	
63	24	24
80	25	
100	25	
125	22	20
160	17	
200	29	
250	38	33
315	43	
400	47	
500	49	48
630	49	
800	50	
1000	56	53
1250	58	
1600	59	
2000	59	59
2500	58	
3150	63	
4000	67	66
5000	71	

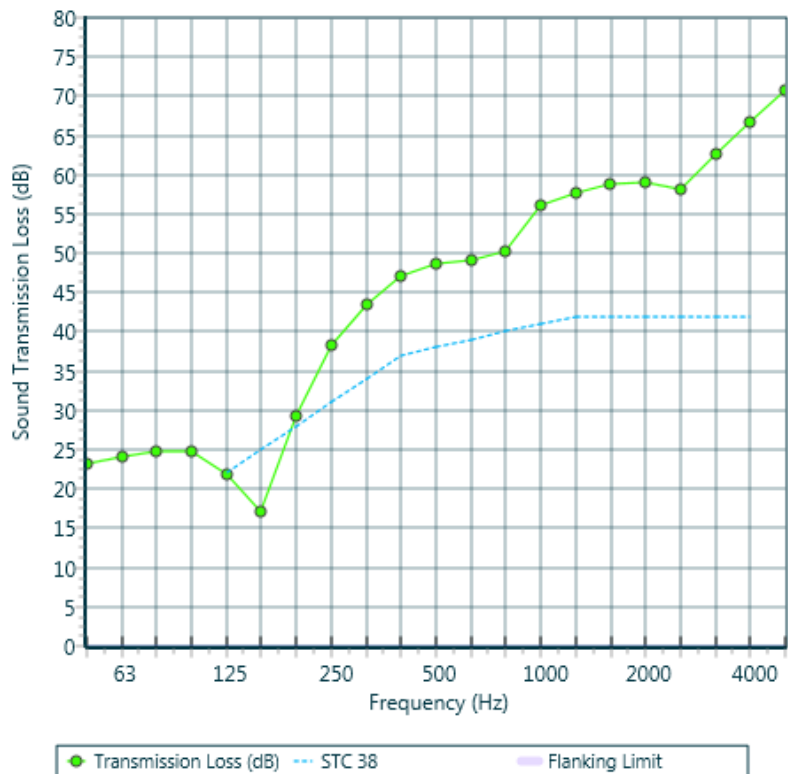

Sound Insulation Prediction (v9.0.17)

Program copyright Marshall Day Acoustics 2017

margin of error is generally within STC +/- 3 dB

- Key No. 1866

Job Name:516 La Costa

Job No.: S200108

Date:1/29/2020

File Name:wall E.ixl

Initials:mouwenga

Notes: Wall Type E

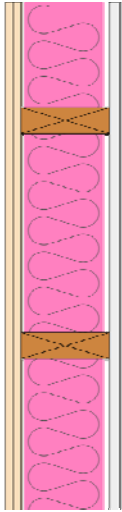

STC 32
OITC 23

Mass-air-mass resonant frequency = 56 Hz

Panel Size = 8.9 ft x 13.1 ft

Partition surface mass = 5.43 lb/ft²

System description

Panel 1 : 2 x 0.5 in Plywood

Frame: Timber stud (5.7 in x 1.8 in), Stud spacing 16 in; Cavity Width 5.67 in, 1 x fiberglass (0.6 lb/ft³) Thickness 5.0 in

Panel 2 : 1 x 0.63 in Type X Gypsum Board

freq.(Hz)	TL(dB)	TL(dB)
50	20	
63	16	17
80	17	
100	17	
125	15	13
160	11	
200	19	
250	23	
315	35	
400	39	
500	42	41
630	43	
800	45	
1000	46	46
1250	47	
1600	45	
2000	45	45
2500	44	
3150	45	
4000	49	48
5000	53	

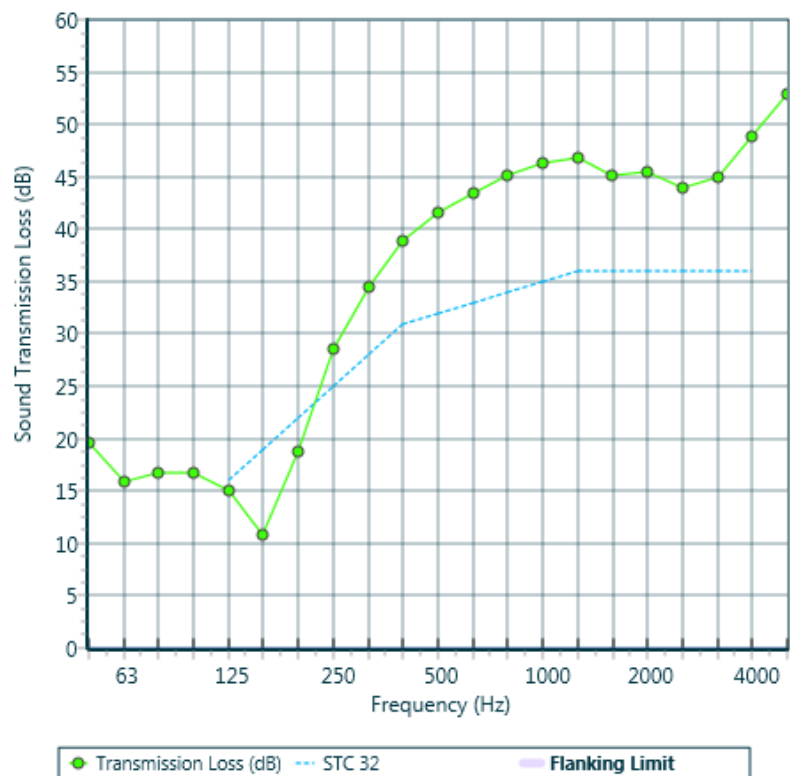

APPENDIX H

Exterior-to-Interior Noise Analysis

EXTERIOR TO INTERIOR NOISE REDUCTION ANALYSIS

Project Name: 516 La Costa
 Project #: S200108
 Room Name: Bungalow - Unit Type A

Wall 1 of 3

Room Type : Soft						
	<u>125 Hz</u>	<u>250 Hz</u>	<u>500 Hz</u>	<u>1KHz</u>	<u>2KHz</u>	<u>4KHz</u>
Reverberation Time (sec) :	0.5	0.5	0.5	0.5	0.4	0.4
Room Absorption (Sabins) :	201	201	201	201	251	251

	<u>Noise Level</u>		<u>125 Hz</u>	<u>250 Hz</u>	<u>500 Hz</u>	<u>1KHz</u>	<u>2KHz</u>	<u>4KHz</u>	
Source 1: Traffic	72.9	CNEL	56.2	61.7	64.2	68.2	68.2	62.2	: Traffic Spectrum
Source 2: <N/A>	0.0	CNEL	0.0	0.0	0.0	0.0	0.0	0.0	
Source 3: <N/A>	0.0	CNEL	0.0	0.0	0.0	0.0	0.0	0.0	
Source 4: <N/A>	0.0	CNEL	0.0	0.0	0.0	0.0	0.0	0.0	
Overall:	72.9	CNEL	56.2	61.7	64.2	68.2	68.2	62.2	: Effective Noise Spectrum

<u>Assembly Type</u>	<u>Open</u>	<u>Width</u>	<u>Height</u>	<u>Qty</u>	<u>Total Area</u>	<u>125 Hz</u>	<u>250 Hz</u>	<u>500 Hz</u>	<u>1KHz</u>	<u>2KHz</u>	<u>4KHz</u>
Exterior Wall Type B1 (S200108)	N	24	9	1	94.5	19	40	51	55	53	56
STC 28 1/2-inch Sliding Glass Door	Y	6.5	9	1	58.5	23	23	22	32	43	37
STC 28 1/2-inch Dual Insulating Window	N	7	9	1	63.0	23	23	22	32	43	37
<N/A>	N	0	0	0	0.0	0	0	0	0	0	0
<N/A>	N	0	0	0	0.0	0	0	0	0	0	0
<N/A>	N	0	0	0	0.0	0	0	0	0	0	0
<N/A>	N	0	0	0	0.0	0	0	0	0	0	0
<N/A>	N	0	0	0	0.0	0	0	0	0	0	0
<N/A>	N	0	0	0	0.0	0	0	0	0	0	0
<N/A>	N	0	0	0	0.0	0	0	0	0	0	0
<N/A>	N	0	0	0	0.0	0	0	0	0	0	0

Room Depth: 9.5 ft Overall Area: 216 ft²
 Volume: 2052 ft³

Number of Impacted Walls: 3

Windows Open		
Interior Noise Level:	64.2	CNEL
Windows Closed		
Interior Noise Level:	43.9	CNEL

<u>125 Hz</u>	<u>250 Hz</u>	<u>500 Hz</u>	<u>1KHz</u>	<u>2KHz</u>	<u>4KHz</u>	
56.2	61.7	64.2	68.2	68.2	62.2	: Exterior Wall Noise Exposure
8.4	8.6	8.6	8.7	8.7	8.7	: Transmission Loss
23.3	23.3	23.3	23.3	23.3	23.3	: Wall Surface Area Factor
23.0	23.0	23.0	23.0	24.0	24.0	: Absorption
48.1	53.4	55.9	59.8	58.9	52.9	: Noise Level
64.2	CNEL	WINDOWS OPEN				
<u>125 Hz</u>	<u>250 Hz</u>	<u>500 Hz</u>	<u>1KHz</u>	<u>2KHz</u>	<u>4KHz</u>	
56.2	61.7	64.2	68.2	68.2	62.2	: Exterior Wall Noise Exposure
20.8	25.3	24.6	34.8	44.8	39.8	: Transmission Loss
23.3	23.3	23.3	23.3	23.3	23.3	: Wall Surface Area Factor
23.0	23.0	23.0	23.0	24.0	24.0	: Absorption
35.8	36.7	39.9	33.7	22.7	21.8	: Noise Level
43.2	CNEL	WINDOWS CLOSED				

EXTERIOR TO INTERIOR NOISE REDUCTION ANALYSIS

Project Name: 516 La Costa
Project #: S200108
Room Name: Bungalow - Unit Type A

Wall 2 of 3

	<u>Noise Level</u>		<u>125 Hz</u>	<u>250 Hz</u>	<u>500 Hz</u>	<u>1KHz</u>	<u>2KHz</u>	<u>4KHz</u>	
Source 1: Traffic	70.3	CNEL	53.6	59.1	61.6	65.6	65.6	59.6	: Traffic Spectrum
Source 2: <N/A>	0.0	CNEL	0.0	0.0	0.0	0.0	0.0	0.0	
Source 3: <N/A>	0.0	CNEL	0.0	0.0	0.0	0.0	0.0	0.0	
Source 4: <N/A>	0.0	CNEL	0.0	0.0	0.0	0.0	0.0	0.0	
Overall:	70.3	CNEL	53.6	59.1	61.6	65.6	65.6	59.6	: Effective Noise Spectrum

<u>Assembly Type</u>	<u>Open</u>	<u>Width</u>	<u>Height</u>	<u>Qty</u>	<u>Total Area</u>	<u>125 Hz</u>	<u>250 Hz</u>	<u>500 Hz</u>	<u>1KHz</u>	<u>2KHz</u>	<u>4KHz</u>
Exterior Wall Type B1 (S200108)	N	24	9	1	216.0	19	40	51	55	53	56
<N/A>	N	0	0	0	0.0	0	0	0	0	0	0
<N/A>	N	0	0	0	0.0	0	0	0	0	0	0
<N/A>	N	0	0	0	0.0	0	0	0	0	0	0
<N/A>	N	0	0	0	0.0	0	0	0	0	0	0
<N/A>	N	0	0	0	0.0	0	0	0	0	0	0
<N/A>	N	0	0	0	0.0	0	0	0	0	0	0
<N/A>	N	0	0	0	0.0	0	0	0	0	0	0
<N/A>	N	0	0	0	0.0	0	0	0	0	0	0
<N/A>	N	0	0	0	0.0	0	0	0	0	0	0
<N/A>	N	0	0	0	0.0	0	0	0	0	0	0
<N/A>	N	0	0	0	0.0	0	0	0	0	0	0
<N/A>	N	0	0	0	0.0	0	0	0	0	0	0
<N/A>	N	0	0	0	0.0	0	0	0	0	0	0
<N/A>	N	0	0	0	0.0	0	0	0	0	0	0
<N/A>	N	0	0	0	0.0	0	0	0	0	0	0
<N/A>	N	0	0	0	0.0	0	0	0	0	0	0
					Overall Area:	216	ft ²				

<u>125 Hz</u>	<u>250 Hz</u>	<u>500 Hz</u>	<u>1KHz</u>	<u>2KHz</u>	<u>4KHz</u>	
53.6	59.1	61.6	65.6	65.6	59.6	: Exterior Wall Noise Exposure
19.0	40.0	51.0	55.0	53.0	56.0	: Transmission Loss
23.3	23.3	23.3	23.3	23.3	23.3	: Wall Surface Area Factor
23.0	23.0	23.0	23.0	24.0	24.0	: Absorption
34.9	19.4	10.9	10.9	11.9	2.9	: Noise Level
35.1			CNEL WINDOWS OPEN			
<u>125 Hz</u>	<u>250 Hz</u>	<u>500 Hz</u>	<u>1KHz</u>	<u>2KHz</u>	<u>4KHz</u>	
53.6	59.1	61.6	65.6	65.6	59.6	: Exterior Wall Noise Exposure
19.0	40.0	51.0	55.0	53.0	56.0	: Transmission Loss
23.3	23.3	23.3	23.3	23.3	23.3	: Wall Surface Area Factor
23.0	23.0	23.0	23.0	24.0	24.0	: Absorption
34.9	19.4	10.9	10.9	11.9	2.9	: Noise Level
35.1			CNEL WINDOWS CLOSED			

EXTERIOR TO INTERIOR NOISE REDUCTION ANALYSIS

Project Name: 516 La Costa
 Project #: S200108
 Room Name: Bungalow - Unit Type A

Wall 3 of 3

	<u>Noise Level</u>		<u>125 Hz</u>	<u>250 Hz</u>	<u>500 Hz</u>	<u>1KHz</u>	<u>2KHz</u>	<u>4KHz</u>	
Source 1: Traffic	52.6	CNEL	35.9	41.4	43.9	47.9	47.9	41.9	: Traffic Spectrum
Source 2: <N/A>	0.0	CNEL	0.0	0.0	0.0	0.0	0.0	0.0	
Source 3: <N/A>	0.0	CNEL	0.0	0.0	0.0	0.0	0.0	0.0	
Source 4: <N/A>	0.0	CNEL	0.0	0.0	0.0	0.0	0.0	0.0	
Overall:	52.6	CNEL	35.9	41.4	43.9	47.9	47.9	41.9	: Effective Noise Spectrum

<u>Assembly Type</u>	<u>Open</u>	<u>Width</u>	<u>Height</u>	<u>Qty</u>	<u>Total Area</u>	<u>125 Hz</u>	<u>250 Hz</u>	<u>500 Hz</u>	<u>1KHz</u>	<u>2KHz</u>	<u>4KHz</u>
Exterior Wall Type B1 (S200108)	N	7.5	9	1	18.0	19	40	51	55	53	56
STC 28 1/2-inch Dual Insulating Window	N	2.5	9	1	22.5	23	23	22	32	43	37
1 3/4" Thick Solid Core Door	N	3	9	1	27.0	18	22	26	24	23	20
<N/A>	N	0	0	0	0.0	0	0	0	0	0	0
<N/A>	N	0	0	0	0.0	0	0	0	0	0	0
<N/A>	N	0	0	0	0.0	0	0	0	0	0	0
<N/A>	N	0	0	0	0.0	0	0	0	0	0	0
<N/A>	N	0	0	0	0.0	0	0	0	0	0	0
<N/A>	N	0	0	0	0.0	0	0	0	0	0	0
<N/A>	N	0	0	0	0.0	0	0	0	0	0	0
<N/A>	N	0	0	0	0.0	0	0	0	0	0	0
<N/A>	N	0	0	0	0.0	0	0	0	0	0	0
<N/A>	N	0	0	0	0.0	0	0	0	0	0	0
Overall Area:					67.5	ft ²					

<u>125 Hz</u>	<u>250 Hz</u>	<u>500 Hz</u>	<u>1KHz</u>	<u>2KHz</u>	<u>4KHz</u>	
35.9	41.4	43.9	47.9	47.9	41.9	: Exterior Wall Noise Exposure
19.4	23.7	25.1	27.5	26.9	23.9	: Transmission Loss
18.3	18.3	18.3	18.3	18.3	18.3	: Wall Surface Area Factor
23.0	23.0	23.0	23.0	24.0	24.0	: Absorption
11.7	13.0	14.0	15.7	15.3	12.3	: Noise Level
21.7	CNEL WINDOWS OPEN					
<u>125 Hz</u>	<u>250 Hz</u>	<u>500 Hz</u>	<u>1KHz</u>	<u>2KHz</u>	<u>4KHz</u>	
35.9	41.4	43.9	47.9	47.9	41.9	: Exterior Wall Noise Exposure
19.4	23.7	25.1	27.5	26.9	23.9	: Transmission Loss
18.3	18.3	18.3	18.3	18.3	18.3	: Wall Surface Area Factor
23.0	23.0	23.0	23.0	24.0	24.0	: Absorption
11.7	13.0	14.0	15.7	15.3	12.3	: Noise Level
21.7	CNEL WINDOWS CLOSED					

EXTERIOR TO INTERIOR NOISE REDUCTION ANALYSIS

Project Name: 516 La Costa
 Project #: S200108
 Room Name: Bungalow - Unit Type B

Wall 1 of 4

Room Type : Soft						
	<u>125 Hz</u>	<u>250 Hz</u>	<u>500 Hz</u>	<u>1KHz</u>	<u>2KHz</u>	<u>4KHz</u>
Reverberation Time (sec) :	0.5	0.5	0.5	0.5	0.4	0.4
Room Absorption (Sabins) :	856	856	856	856	1070	1070

	<u>Noise Level</u>		<u>125 Hz</u>	<u>250 Hz</u>	<u>500 Hz</u>	<u>1KHz</u>	<u>2KHz</u>	<u>4KHz</u>	
Source 1: Traffic	74.2	CNEL	57.5	63.0	65.5	69.5	69.5	63.5	: Traffic Spectrum
Source 2: <N/A>	0.0	CNEL	0.0	0.0	0.0	0.0	0.0	0.0	
Source 3: <N/A>	0.0	CNEL	0.0	0.0	0.0	0.0	0.0	0.0	
Source 4: <N/A>	0.0	CNEL	0.0	0.0	0.0	0.0	0.0	0.0	
Overall:	74.2	CNEL	57.5	63.0	65.5	69.5	69.5	63.5	: Effective Noise Spectrum

<u>Assembly Type</u>	<u>Open</u>	<u>Width</u>	<u>Height</u>	<u>Qty</u>	<u>Total Area</u>	<u>125 Hz</u>	<u>250 Hz</u>	<u>500 Hz</u>	<u>1KHz</u>	<u>2KHz</u>	<u>4KHz</u>
Exterior Wall Type B1 (S200108)	N	28	13	1	0.0	19	40	51	55	53	56
STC 28 1/2-inch Sliding Glass Door	Y	4	8	1	32.0	23	23	22	32	43	37
STC 28 1/2-inch Sliding Glass Door	N	4	8	1	32.0	23	23	22	32	43	37
STC 28 1/2-inch Dual Insulating Window	N	25	12	1	300.0	23	23	22	32	43	37
<N/A>	N	0	0	0	0.0	0	0	0	0	0	0
<N/A>	N	0	0	0	0.0	0	0	0	0	0	0
<N/A>	N	0	0	0	0.0	0	0	0	0	0	0
<N/A>	N	0	0	0	0.0	0	0	0	0	0	0
<N/A>	N	0	0	0	0.0	0	0	0	0	0	0
<N/A>	N	0	0	0	0.0	0	0	0	0	0	0
<N/A>	N	0	0	0	0.0	0	0	0	0	0	0

Room Depth: 24 ft Overall Area: 364 ft²
 Volume: 8736 ft³

Number of Impacted Walls: 4

Windows Open		
Interior Noise Level:	56.7	CNEL
Windows Closed		
Interior Noise Level:	43.3	CNEL

<u>125 Hz</u>	<u>250 Hz</u>	<u>500 Hz</u>	<u>1KHz</u>	<u>2KHz</u>	<u>4KHz</u>	
57.5	63.0	65.5	69.5	69.5	63.5	: Exterior Wall Noise Exposure
13.1	13.1	13.0	13.5	13.6	13.6	: Transmission Loss
25.6	25.6	25.6	25.6	25.6	25.6	: Wall Surface Area Factor
29.3	29.3	29.3	29.3	30.3	30.3	: Absorption
40.7	46.2	48.8	52.3	51.3	45.3	: Noise Level
56.7	CNEL	WINDOWS OPEN				
<u>125 Hz</u>	<u>250 Hz</u>	<u>500 Hz</u>	<u>1KHz</u>	<u>2KHz</u>	<u>4KHz</u>	
57.5	63.0	65.5	69.5	69.5	63.5	: Exterior Wall Noise Exposure
22.9	22.9	22.1	32.3	42.6	37.3	: Transmission Loss
25.6	25.6	25.6	25.6	25.6	25.6	: Wall Surface Area Factor
29.3	29.3	29.3	29.3	30.3	30.3	: Absorption
30.9	36.4	39.7	33.5	22.2	21.5	: Noise Level
42.4	CNEL	WINDOWS CLOSED				

EXTERIOR TO INTERIOR NOISE REDUCTION ANALYSIS

Project Name: 516 La Costa
 Project #: S200108
 Room Name: Bungalow - Unit Type B

Wall 2 of 4

	<u>Noise Level</u>	<u>125 Hz</u>	<u>250 Hz</u>	<u>500 Hz</u>	<u>1KHz</u>	<u>2KHz</u>	<u>4KHz</u>	
Source 1: Traffic	72.2 CNEL	55.5	61.0	63.5	67.5	67.5	61.5	: Traffic Spectrum
Source 2: <N/A>	0.0 CNEL	0.0	0.0	0.0	0.0	0.0	0.0	
Source 3: <N/A>	0.0 CNEL	0.0	0.0	0.0	0.0	0.0	0.0	
Source 4: <N/A>	0.0 CNEL	0.0	0.0	0.0	0.0	0.0	0.0	
Overall:	72.2 CNEL	55.5	61.0	63.5	67.5	67.5	61.5	: Effective Noise Spectrum

<u>Assembly Type</u>	<u>Open</u>	<u>Width</u>	<u>Height</u>	<u>Qty</u>	<u>Total Area</u>	<u>125 Hz</u>	<u>250 Hz</u>	<u>500 Hz</u>	<u>1KHz</u>	<u>2KHz</u>	<u>4KHz</u>
Exterior Wall Type B1 (S200108)	N	24	16	1	384.0	19	40	51	55	53	56
<N/A>	N	0	0	0	0.0	0	0	0	0	0	0
<N/A>	N	0	0	0	0.0	0	0	0	0	0	0
<N/A>	N	0	0	0	0.0	0	0	0	0	0	0
<N/A>	N	0	0	0	0.0	0	0	0	0	0	0
<N/A>	N	0	0	0	0.0	0	0	0	0	0	0
<N/A>	N	0	0	0	0.0	0	0	0	0	0	0
<N/A>	N	0	0	0	0.0	0	0	0	0	0	0
<N/A>	N	0	0	0	0.0	0	0	0	0	0	0
<N/A>	N	0	0	0	0.0	0	0	0	0	0	0
<N/A>	N	0	0	0	0.0	0	0	0	0	0	0
<N/A>	N	0	0	0	0.0	0	0	0	0	0	0
<N/A>	N	0	0	0	0.0	0	0	0	0	0	0
Overall Area:					384	ft²					

<u>125 Hz</u>	<u>250 Hz</u>	<u>500 Hz</u>	<u>1KHz</u>	<u>2KHz</u>	<u>4KHz</u>	
55.5	61.0	63.5	67.5	67.5	61.5	: Exterior Wall Noise Exposure
19.0	40.0	51.0	55.0	53.0	56.0	: Transmission Loss
25.8	25.8	25.8	25.8	25.8	25.8	: Wall Surface Area Factor
29.3	29.3	29.3	29.3	30.3	30.3	: Absorption
33.0	17.5	9.0	9.0	10.1	1.1	: Noise Level
33.2	CNEL	WINDOWS OPEN				
<u>125 Hz</u>	<u>250 Hz</u>	<u>500 Hz</u>	<u>1KHz</u>	<u>2KHz</u>	<u>4KHz</u>	
55.5	61.0	63.5	67.5	67.5	61.5	: Exterior Wall Noise Exposure
19.0	40.0	51.0	55.0	53.0	56.0	: Transmission Loss
25.8	25.8	25.8	25.8	25.8	25.8	: Wall Surface Area Factor
29.3	29.3	29.3	29.3	30.3	30.3	: Absorption
33.0	17.5	9.0	9.0	10.1	1.1	: Noise Level
33.2	CNEL	WINDOWS CLOSED				

EXTERIOR TO INTERIOR NOISE REDUCTION ANALYSIS

Project Name: 516 La Costa
 Project #: S200108
 Room Name: Bungalow - Unit Type B

Wall 3 of 4

	<u>Noise Level</u>		<u>125 Hz</u>	<u>250 Hz</u>	<u>500 Hz</u>	<u>1KHz</u>	<u>2KHz</u>	<u>4KHz</u>	
Source 1: Traffic	70.0	CNEL	53.3	58.8	61.3	65.3	65.3	59.3	: Traffic Spectrum
Source 2: <N/A>	0.0	CNEL	0.0	0.0	0.0	0.0	0.0	0.0	
Source 3: <N/A>	0.0	CNEL	0.0	0.0	0.0	0.0	0.0	0.0	
Source 4: <N/A>	0.0	CNEL	0.0	0.0	0.0	0.0	0.0	0.0	
Overall:	70.0	CNEL	53.3	58.8	61.3	65.3	65.3	59.3	: Effective Noise Spectrum

<u>Assembly Type</u>	<u>Open</u>	<u>Width</u>	<u>Height</u>	<u>Qty</u>	<u>Total Area</u>	<u>125 Hz</u>	<u>250 Hz</u>	<u>500 Hz</u>	<u>1KHz</u>	<u>2KHz</u>	<u>4KHz</u>
Exterior Wall Type B1 (S200108)	N	24	16	1	352.5	19	40	51	55	53	56
STC 28 French Door with seals	N	3.5	9	1	31.5	23	23	22	32	43	37
<N/A>	N	0	0	0	0.0	0	0	0	0	0	0
<N/A>	N	0	0	0	0.0	0	0	0	0	0	0
<N/A>	N	0	0	0	0.0	0	0	0	0	0	0
<N/A>	N	0	0	0	0.0	0	0	0	0	0	0
<N/A>	N	0	0	0	0.0	0	0	0	0	0	0
<N/A>	N	0	0	0	0.0	0	0	0	0	0	0
<N/A>	N	0	0	0	0.0	0	0	0	0	0	0
<N/A>	N	0	0	0	0.0	0	0	0	0	0	0
<N/A>	N	0	0	0	0.0	0	0	0	0	0	0
<N/A>	N	0	0	0	0.0	0	0	0	0	0	0
Overall Area:					384	ft ²					

<u>125 Hz</u>	<u>250 Hz</u>	<u>500 Hz</u>	<u>1KHz</u>	<u>2KHz</u>	<u>4KHz</u>	
53.3	58.8	61.3	65.3	65.3	59.3	: Exterior Wall Noise Exposure
19.2	32.9	32.9	42.9	50.4	47.6	: Transmission Loss
25.8	25.8	25.8	25.8	25.8	25.8	: Wall Surface Area Factor
29.3	29.3	29.3	29.3	30.3	30.3	: Absorption
30.6	22.4	24.9	18.9	10.5	7.3	: Noise Level
32.4	CNEL	WINDOWS OPEN				
<u>125 Hz</u>	<u>250 Hz</u>	<u>500 Hz</u>	<u>1KHz</u>	<u>2KHz</u>	<u>4KHz</u>	
53.3	58.8	61.3	65.3	65.3	59.3	: Exterior Wall Noise Exposure
19.2	32.9	32.9	42.9	50.4	47.6	: Transmission Loss
25.8	25.8	25.8	25.8	25.8	25.8	: Wall Surface Area Factor
29.3	29.3	29.3	29.3	30.3	30.3	: Absorption
30.6	22.4	24.9	18.9	10.5	7.3	: Noise Level
32.4	CNEL	WINDOWS CLOSED				

EXTERIOR TO INTERIOR NOISE REDUCTION ANALYSIS

Project Name: 516 La Costa
 Project #: S200108
 Room Name: Bungalow - Unit Type B

Wall 4 of 4

	<u>Noise Level</u>		<u>125 Hz</u>	<u>250 Hz</u>	<u>500 Hz</u>	<u>1KHz</u>	<u>2KHz</u>	<u>4KHz</u>	
Source 1: Traffic	58.7	CNEL	42.0	47.5	50.0	54.0	54.0	48.0	: Traffic Spectrum
Source 2: <N/A>	0.0	CNEL	0.0	0.0	0.0	0.0	0.0	0.0	
Source 3: <N/A>	0.0	CNEL	0.0	0.0	0.0	0.0	0.0	0.0	
Source 4: <N/A>	0.0	CNEL	0.0	0.0	0.0	0.0	0.0	0.0	
Overall:	58.7	CNEL	42.0	47.5	50.0	54.0	54.0	48.0	: Effective Noise Spectrum

<u>Assembly Type</u>	<u>Open</u>	<u>Width</u>	<u>Height</u>	<u>Qty</u>	<u>Total Area</u>	<u>125 Hz</u>	<u>250 Hz</u>	<u>500 Hz</u>	<u>1KHz</u>	<u>2KHz</u>	<u>4KHz</u>
Exterior Wall Type B1 (S200108)	N	28	13	1	322.8	19	40	51	55	53	56
STC 28 1/2-inch Dual Insulating Window	N	4	8	1	32.0	23	23	22	32	43	37
STC 28 1/2-inch Dual Insulating Window	Y	4	2.3	1	9.2	23	23	22	32	43	37
<N/A>	N	0	0	0	0.0	0	0	0	0	0	0
<N/A>	N	0	0	0	0.0	0	0	0	0	0	0
<N/A>	N	0	0	0	0.0	0	0	0	0	0	0
<N/A>	N	0	0	0	0.0	0	0	0	0	0	0
<N/A>	N	0	0	0	0.0	0	0	0	0	0	0
<N/A>	N	0	0	0	0.0	0	0	0	0	0	0
<N/A>	N	0	0	0	0.0	0	0	0	0	0	0
<N/A>	N	0	0	0	0.0	0	0	0	0	0	0
<N/A>	N	0	0	0	0.0	0	0	0	0	0	0
<N/A>	N	0	0	0	0.0	0	0	0	0	0	0
Overall Area:					364	ft ²					

<u>125 Hz</u>	<u>250 Hz</u>	<u>500 Hz</u>	<u>1KHz</u>	<u>2KHz</u>	<u>4KHz</u>	
42.0	47.5	50.0	54.0	54.0	48.0	: Exterior Wall Noise Exposure
16.1	18.8	18.8	19.0	19.0	19.0	: Transmission Loss
25.6	25.6	25.6	25.6	25.6	25.6	: Wall Surface Area Factor
29.3	29.3	29.3	29.3	30.3	30.3	: Absorption
22.2	25.0	27.5	31.3	30.3	24.3	: Noise Level
35.8	CNEL WINDOWS OPEN					
<u>125 Hz</u>	<u>250 Hz</u>	<u>500 Hz</u>	<u>1KHz</u>	<u>2KHz</u>	<u>4KHz</u>	
42.0	47.5	50.0	54.0	54.0	48.0	: Exterior Wall Noise Exposure
19.3	31.7	31.5	41.6	49.7	46.3	: Transmission Loss
25.6	25.6	25.6	25.6	25.6	25.6	: Wall Surface Area Factor
29.3	29.3	29.3	29.3	30.3	30.3	: Absorption
19.0	12.1	14.8	8.7	-0.4	-3.0	: Noise Level
21.3	CNEL WINDOWS CLOSED					

EXTERIOR TO INTERIOR NOISE REDUCTION ANALYSIS

Project Name: 516 La Costa
 Project #: S200108
 Room Name: Unit - Kitchen / Dining / Loft

Wall 1 of 4

Room Type : Soft						
	<u>125 Hz</u>	<u>250 Hz</u>	<u>500 Hz</u>	<u>1KHz</u>	<u>2KHz</u>	<u>4KHz</u>
Reverberation Time (sec) :	0.5	0.5	0.5	0.5	0.4	0.4
Room Absorption (Sabins) :	329	329	329	329	412	412

	<u>Noise Level</u>		<u>125 Hz</u>	<u>250 Hz</u>	<u>500 Hz</u>	<u>1KHz</u>	<u>2KHz</u>	<u>4KHz</u>	
Source 1: Traffic	71.6	CNEL	54.9	60.4	62.9	66.9	66.9	60.9	: Traffic Spectrum
Source 2: <N/A>	0.0	CNEL	0.0	0.0	0.0	0.0	0.0	0.0	
Source 3: <N/A>	0.0	CNEL	0.0	0.0	0.0	0.0	0.0	0.0	
Source 4: <N/A>	0.0	CNEL	0.0	0.0	0.0	0.0	0.0	0.0	
Overall:	71.6	CNEL	54.9	60.4	62.9	66.9	66.9	60.9	: Effective Noise Spectrum

<u>Assembly Type</u>	<u>Open</u>	<u>Width</u>	<u>Height</u>	<u>Qty</u>	<u>Total Area</u>	<u>125 Hz</u>	<u>250 Hz</u>	<u>500 Hz</u>	<u>1KHz</u>	<u>2KHz</u>	<u>4KHz</u>
Exterior Wall Type D (S200108)	N	14	10	1	32.6	20	33	48	53	59	66
STC 28 1/2-inch Dual Insulating Window	N	9.3	8.3	1	77.2	23	23	22	32	43	37
STC 28 1/2-inch Dual Insulating Window	N	9.3	3.25	1	30.2	23	23	22	32	43	37
<N/A>	N	0	0	0	0.0	0	0	0	0	0	0
<N/A>	N	0	0	0	0.0	0	0	0	0	0	0
<N/A>	N	0	0	0	0.0	0	0	0	0	0	0
<N/A>	N	0	0	0	0.0	0	0	0	0	0	0
<N/A>	N	0	0	0	0.0	0	0	0	0	0	0
<N/A>	N	0	0	0	0.0	0	0	0	0	0	0
<N/A>	N	0	0	0	0.0	0	0	0	0	0	0
<N/A>	N	0	0	0	0.0	0	0	0	0	0	0

Room Depth: 24 ft Overall Area: 140 ft²
 Volume: 3360 ft³

Number of Impacted Walls: 4

Windows Open		
Interior Noise Level:	57.6	CNEL
Windows Closed		
Interior Noise Level:	44.4	CNEL

<u>125 Hz</u>	<u>250 Hz</u>	<u>500 Hz</u>	<u>1KHz</u>	<u>2KHz</u>	<u>4KHz</u>	
54.9	60.4	62.9	66.9	66.9	60.9	: Exterior Wall Noise Exposure
22.0	23.9	23.2	33.5	43.7	38.5	: Transmission Loss
21.5	21.5	21.5	21.5	21.5	21.5	: Wall Surface Area Factor
25.2	25.2	25.2	25.2	26.1	26.1	: Absorption
29.2	32.8	36.0	29.7	18.5	17.8	: Noise Level
38.9	CNEL	WINDOWS OPEN				
<u>125 Hz</u>	<u>250 Hz</u>	<u>500 Hz</u>	<u>1KHz</u>	<u>2KHz</u>	<u>4KHz</u>	
54.9	60.4	62.9	66.9	66.9	60.9	: Exterior Wall Noise Exposure
22.0	23.9	23.2	33.5	43.7	38.5	: Transmission Loss
21.5	21.5	21.5	21.5	21.5	21.5	: Wall Surface Area Factor
25.2	25.2	25.2	25.2	26.1	26.1	: Absorption
29.2	32.8	36.0	29.7	18.5	17.8	: Noise Level
38.9	CNEL	WINDOWS CLOSED				

EXTERIOR TO INTERIOR NOISE REDUCTION ANALYSIS

Project Name: 516 La Costa
 Project #: S200108
 Room Name: Unit - Kitchen / Dining / Loft

Wall 2 of 4

	<u>Noise Level</u>		<u>125 Hz</u>	<u>250 Hz</u>	<u>500 Hz</u>	<u>1KHz</u>	<u>2KHz</u>	<u>4KHz</u>	
Source 1: Traffic	64.5 CNEL		47.8	53.3	55.8	59.8	59.8	53.8	: Traffic Spectrum
Source 2: <N/A>	0.0 CNEL		0.0	0.0	0.0	0.0	0.0	0.0	
Source 3: <N/A>	0.0 CNEL		0.0	0.0	0.0	0.0	0.0	0.0	
Source 4: <N/A>	0.0 CNEL		0.0	0.0	0.0	0.0	0.0	0.0	
Overall:	64.5 CNEL		47.8	53.3	55.8	59.8	59.8	53.8	: Effective Noise Spectrum

<u>Assembly Type</u>	<u>Open</u>	<u>Width</u>	<u>Height</u>	<u>Qty</u>	<u>Total Area</u>	<u>125 Hz</u>	<u>250 Hz</u>	<u>500 Hz</u>	<u>1KHz</u>	<u>2KHz</u>	<u>4KHz</u>
Exterior Wall Type E (S200108)	N	14	19	1	163.6	13	23	41	46	45	48
STC 28 1/2-inch Dual Insulating Window	N	4.5	8	1	36.0	23	23	22	32	43	37
STC 28 1/2-inch Dual Insulating Window	N	4.5	11.5	1	51.8	23	23	22	32	43	37
STC 28 1/2-inch Dual Insulating Window	N	4.5	3.25	1	14.6	23	23	22	32	43	37
<N/A>	N	0	0	0	0.0	0	0	0	0	0	0
<N/A>	N	0	0	0	0.0	0	0	0	0	0	0
<N/A>	N	0	0	0	0.0	0	0	0	0	0	0
<N/A>	N	0	0	0	0.0	0	0	0	0	0	0
<N/A>	N	0	0	0	0.0	0	0	0	0	0	0
<N/A>	N	0	0	0	0.0	0	0	0	0	0	0
<N/A>	N	0	0	0	0.0	0	0	0	0	0	0
<N/A>	N	0	0	0	0.0	0	0	0	0	0	0
<N/A>	N	0	0	0	0.0	0	0	0	0	0	0
Overall Area:					266	ft ²					

<u>125 Hz</u>	<u>250 Hz</u>	<u>500 Hz</u>	<u>1KHz</u>	<u>2KHz</u>	<u>4KHz</u>	
47.8	53.3	55.8	59.8	59.8	53.8	: Exterior Wall Noise Exposure
14.8	23.0	26.1	36.2	43.9	40.9	: Transmission Loss
24.2	24.2	24.2	24.2	24.2	24.2	: Wall Surface Area Factor
25.2	25.2	25.2	25.2	26.1	26.1	: Absorption
32.0	29.4	28.7	22.7	14.0	11.0	: Noise Level
35.4	CNEL WINDOWS OPEN					
<u>125 Hz</u>	<u>250 Hz</u>	<u>500 Hz</u>	<u>1KHz</u>	<u>2KHz</u>	<u>4KHz</u>	
47.8	53.3	55.8	59.8	59.8	53.8	: Exterior Wall Noise Exposure
14.8	23.0	26.1	36.2	43.9	40.9	: Transmission Loss
24.2	24.2	24.2	24.2	24.2	24.2	: Wall Surface Area Factor
25.2	25.2	25.2	25.2	26.1	26.1	: Absorption
32.0	29.4	28.7	22.7	14.0	11.0	: Noise Level
35.4	CNEL WINDOWS CLOSED					

EXTERIOR TO INTERIOR NOISE REDUCTION ANALYSIS

Project Name: 516 La Costa
 Project #: S200108
 Room Name: Unit - Kitchen / Dining / Loft

Wall 3 of 4

	<u>Noise Level</u>	<u>125 Hz</u>	<u>250 Hz</u>	<u>500 Hz</u>	<u>1KHz</u>	<u>2KHz</u>	<u>4KHz</u>	
Source 1: Traffic	68.8 CNEL	52.1	57.6	60.1	64.1	64.1	58.1	: Traffic Spectrum
Source 2: <N/A>	0.0 CNEL	0.0	0.0	0.0	0.0	0.0	0.0	
Source 3: <N/A>	0.0 CNEL	0.0	0.0	0.0	0.0	0.0	0.0	
Source 4: <N/A>	0.0 CNEL	0.0	0.0	0.0	0.0	0.0	0.0	
Overall:	68.8 CNEL	52.1	57.6	60.1	64.1	64.1	58.1	: Effective Noise Spectrum

<u>Assembly Type</u>	<u>Open</u>	<u>Width</u>	<u>Height</u>	<u>Qty</u>	<u>Total Area</u>	<u>125 Hz</u>	<u>250 Hz</u>	<u>500 Hz</u>	<u>1KHz</u>	<u>2KHz</u>	<u>4KHz</u>
Exterior Wall Type A (S200108)	N	26	11	1	286.0	33	45	55	58	57	66
<N/A>	N	0	0	0	0.0	0	0	0	0	0	0
<N/A>	N	0	0	0	0.0	0	0	0	0	0	0
<N/A>	N	0	0	0	0.0	0	0	0	0	0	0
<N/A>	N	0	0	0	0.0	0	0	0	0	0	0
<N/A>	N	0	0	0	0.0	0	0	0	0	0	0
<N/A>	N	0	0	0	0.0	0	0	0	0	0	0
<N/A>	N	0	0	0	0.0	0	0	0	0	0	0
<N/A>	N	0	0	0	0.0	0	0	0	0	0	0
<N/A>	N	0	0	0	0.0	0	0	0	0	0	0
<N/A>	N	0	0	0	0.0	0	0	0	0	0	0
<N/A>	N	0	0	0	0.0	0	0	0	0	0	0
<N/A>	N	0	0	0	0.0	0	0	0	0	0	0
Overall Area:					286	ft ²					

<u>125 Hz</u>	<u>250 Hz</u>	<u>500 Hz</u>	<u>1KHz</u>	<u>2KHz</u>	<u>4KHz</u>	
52.1	57.6	60.1	64.1	64.1	58.1	: Exterior Wall Noise Exposure
33.0	45.0	55.0	58.0	57.0	66.0	: Transmission Loss
24.6	24.6	24.6	24.6	24.6	24.6	: Wall Surface Area Factor
25.2	25.2	25.2	25.2	26.1	26.1	: Absorption
18.5	12.0	4.5	5.5	5.5	-9.5	: Noise Level
19.8	CNEL	WINDOWS OPEN				
<u>125 Hz</u>	<u>250 Hz</u>	<u>500 Hz</u>	<u>1KHz</u>	<u>2KHz</u>	<u>4KHz</u>	
52.1	57.6	60.1	64.1	64.1	58.1	: Exterior Wall Noise Exposure
33.0	45.0	55.0	58.0	57.0	66.0	: Transmission Loss
24.6	24.6	24.6	24.6	24.6	24.6	: Wall Surface Area Factor
25.2	25.2	25.2	25.2	26.1	26.1	: Absorption
18.5	12.0	4.5	5.5	5.5	-9.5	: Noise Level
19.8	CNEL	WINDOWS CLOSED				

EXTERIOR TO INTERIOR NOISE REDUCTION ANALYSIS

Project Name: 516 La Costa
 Project #: S200108
 Room Name: Unit - Kitchen / Dining / Loft

Wall 4 of 4

	<u>Noise Level</u>		<u>125 Hz</u>	<u>250 Hz</u>	<u>500 Hz</u>	<u>1KHz</u>	<u>2KHz</u>	<u>4KHz</u>	
Source 1: Traffic	69.9	CNEL	53.2	58.7	61.2	65.2	65.2	59.2	: Traffic Spectrum
Source 2: <N/A>	0.0	CNEL	0.0	0.0	0.0	0.0	0.0	0.0	
Source 3: <N/A>	0.0	CNEL	0.0	0.0	0.0	0.0	0.0	0.0	
Source 4: <N/A>	0.0	CNEL	0.0	0.0	0.0	0.0	0.0	0.0	
Overall:	69.9	CNEL	53.2	58.7	61.2	65.2	65.2	59.2	: Effective Noise Spectrum

<u>Assembly Type</u>	<u>Open</u>	<u>Width</u>	<u>Height</u>	<u>Qty</u>	<u>Total Area</u>	<u>125 Hz</u>	<u>250 Hz</u>	<u>500 Hz</u>	<u>1KHz</u>	<u>2KHz</u>	<u>4KHz</u>
Exterior Wall Type B1 (S200108)	N	26	21	1	295.0	19	40	51	55	53	56
1 3/4" Thick Solid Core Door	N	3.5	7	1	24.5	18	22	26	24	23	20
STC 28 1/2-inch Dual Insulating Window	N	2	7	1	14.0	23	23	22	32	43	37
STC 28 1/2-inch Dual Insulating Window	N	2	5	1	10.0	23	23	22	32	43	37
STC 28 1/2-inch Dual Insulating Window	Y	13.5	3	1	40.5	23	23	22	32	43	37
STC 28 1/2-inch Dual Insulating Window	N	13.5	12	1	162.0	23	23	22	32	43	37
<N/A>	N	0	0	0	0.0	0	0	0	0	0	0
<N/A>	N	0	0	0	0.0	0	0	0	0	0	0
<N/A>	N	0	0	0	0.0	0	0	0	0	0	0
<N/A>	N	0	0	0	0.0	0	0	0	0	0	0
<N/A>	N	0	0	0	0.0	0	0	0	0	0	0
<N/A>	N	0	0	0	0.0	0	0	0	0	0	0
Overall Area:					546	ft ²					

<u>125 Hz</u>	<u>250 Hz</u>	<u>500 Hz</u>	<u>1KHz</u>	<u>2KHz</u>	<u>4KHz</u>	
53.2	58.7	61.2	65.2	65.2	59.2	: Exterior Wall Noise Exposure
13.3	14.0	14.0	14.3	14.3	14.2	: Transmission Loss
27.4	27.4	27.4	27.4	27.4	27.4	: Wall Surface Area Factor
25.2	25.2	25.2	25.2	26.1	26.1	: Absorption
42.1	46.9	49.4	53.1	52.2	46.2	: Noise Level
57.5	CNEL WINDOWS OPEN					
<u>125 Hz</u>	<u>250 Hz</u>	<u>500 Hz</u>	<u>1KHz</u>	<u>2KHz</u>	<u>4KHz</u>	
53.2	58.7	61.2	65.2	65.2	59.2	: Exterior Wall Noise Exposure
20.2	26.1	25.7	33.7	36.0	32.8	: Transmission Loss
27.4	27.4	27.4	27.4	27.4	27.4	: Wall Surface Area Factor
25.2	25.2	25.2	25.2	26.1	26.1	: Absorption
35.2	34.8	37.7	33.7	30.4	27.7	: Noise Level
42.1	CNEL WINDOWS CLOSED					

EXTERIOR TO INTERIOR NOISE REDUCTION ANALYSIS

Project Name: 516 La Costa
 Project #: S200108
 Room Name: Unit - Bedroom

Wall 1 of 3

Room Type : Soft						
	<u>125 Hz</u>	<u>250 Hz</u>	<u>500 Hz</u>	<u>1KHz</u>	<u>2KHz</u>	<u>4KHz</u>
Reverberation Time (sec) :	0.5	0.5	0.5	0.5	0.4	0.4
Room Absorption (Sabins) :	109	109	109	109	136	136

	<u>Noise Level</u>		<u>125 Hz</u>	<u>250 Hz</u>	<u>500 Hz</u>	<u>1KHz</u>	<u>2KHz</u>	<u>4KHz</u>	
Source 1: Traffic	68.5	CNEL	51.8	57.3	59.8	63.8	63.8	57.8	: Traffic Spectrum
Source 2: <N/A>	0.0	CNEL	0.0	0.0	0.0	0.0	0.0	0.0	
Source 3: <N/A>	0.0	CNEL	0.0	0.0	0.0	0.0	0.0	0.0	
Source 4: <N/A>	0.0	CNEL	0.0	0.0	0.0	0.0	0.0	0.0	
Overall:	68.5	CNEL	51.8	57.3	59.8	63.8	63.8	57.8	: Effective Noise Spectrum

<u>Assembly Type</u>	<u>Open</u>	<u>Width</u>	<u>Height</u>	<u>Qty</u>	<u>Total Area</u>	<u>125 Hz</u>	<u>250 Hz</u>	<u>500 Hz</u>	<u>1KHz</u>	<u>2KHz</u>	<u>4KHz</u>
Exterior Wall Type D (S200108)	N	14.5	9	1	130.5	20	33	48	53	59	66
<N/A>	N	0	0	0	0.0	0	0	0	0	0	0
<N/A>	N	0	0	0	0.0	0	0	0	0	0	0
<N/A>	N	0	0	0	0.0	0	0	0	0	0	0
<N/A>	N	0	0	0	0.0	0	0	0	0	0	0
<N/A>	N	0	0	0	0.0	0	0	0	0	0	0
<N/A>	N	0	0	0	0.0	0	0	0	0	0	0
<N/A>	N	0	0	0	0.0	0	0	0	0	0	0
<N/A>	N	0	0	0	0.0	0	0	0	0	0	0
<N/A>	N	0	0	0	0.0	0	0	0	0	0	0
<N/A>	N	0	0	0	0.0	0	0	0	0	0	0

Room Depth: 8.5 ft Overall Area: 130.5 ft²
 Volume: 1109 ft³

Number of Impacted Walls: 3

Windows Open		
Interior Noise Level:	38.2	CNEL
Windows Closed		
Interior Noise Level:	38.2	CNEL

<u>125 Hz</u>	<u>250 Hz</u>	<u>500 Hz</u>	<u>1KHz</u>	<u>2KHz</u>	<u>4KHz</u>	
51.8	57.3	59.8	63.8	63.8	57.8	: Exterior Wall Noise Exposure
20.0	33.0	48.0	53.0	59.0	66.0	: Transmission Loss
21.2	21.2	21.2	21.2	21.2	21.2	: Wall Surface Area Factor
20.4	20.4	20.4	20.4	21.3	21.3	: Absorption
32.6	25.1	12.6	11.6	4.6	-8.4	: Noise Level
33.4	CNEL	WINDOWS OPEN				
<u>125 Hz</u>	<u>250 Hz</u>	<u>500 Hz</u>	<u>1KHz</u>	<u>2KHz</u>	<u>4KHz</u>	
51.8	57.3	59.8	63.8	63.8	57.8	: Exterior Wall Noise Exposure
20.0	33.0	48.0	53.0	59.0	66.0	: Transmission Loss
21.2	21.2	21.2	21.2	21.2	21.2	: Wall Surface Area Factor
20.4	20.4	20.4	20.4	21.3	21.3	: Absorption
32.6	25.1	12.6	11.6	4.6	-8.4	: Noise Level
33.4	CNEL	WINDOWS CLOSED				

EXTERIOR TO INTERIOR NOISE REDUCTION ANALYSIS

Project Name: 516 La Costa
 Project #: S200108
 Room Name: Unit - Bedroom

Wall 2 of 3

	<u>Noise Level</u>	<u>125 Hz</u>	<u>250 Hz</u>	<u>500 Hz</u>	<u>1KHz</u>	<u>2KHz</u>	<u>4KHz</u>	
Source 1: Traffic	66.1 CNEL	49.4	54.9	57.4	61.4	61.4	55.4	: Traffic Spectrum
Source 2: <N/A>	0.0 CNEL	0.0	0.0	0.0	0.0	0.0	0.0	
Source 3: <N/A>	0.0 CNEL	0.0	0.0	0.0	0.0	0.0	0.0	
Source 4: <N/A>	0.0 CNEL	0.0	0.0	0.0	0.0	0.0	0.0	
Overall:	66.1 CNEL	49.4	54.9	57.4	61.4	61.4	55.4	: Effective Noise Spectrum

<u>Assembly Type</u>	<u>Open</u>	<u>Width</u>	<u>Height</u>	<u>Qty</u>	<u>Total Area</u>	<u>125 Hz</u>	<u>250 Hz</u>	<u>500 Hz</u>	<u>1KHz</u>	<u>2KHz</u>	<u>4KHz</u>
Exterior Wall Type E (S200108)	N	8.5	9	1	20.5	13	23	41	46	45	48
STC 28 1/2-inch Dual Insulating Window	N	8	7	1	56.0	23	23	22	32	43	37
<N/A>	N	0	0	0	0.0	0	0	0	0	0	0
<N/A>	N	0	0	0	0.0	0	0	0	0	0	0
<N/A>	N	0	0	0	0.0	0	0	0	0	0	0
<N/A>	N	0	0	0	0.0	0	0	0	0	0	0
<N/A>	N	0	0	0	0.0	0	0	0	0	0	0
<N/A>	N	0	0	0	0.0	0	0	0	0	0	0
<N/A>	N	0	0	0	0.0	0	0	0	0	0	0
<N/A>	N	0	0	0	0.0	0	0	0	0	0	0
<N/A>	N	0	0	0	0.0	0	0	0	0	0	0
<N/A>	N	0	0	0	0.0	0	0	0	0	0	0
<N/A>	N	0	0	0	0.0	0	0	0	0	0	0
<N/A>	N	0	0	0	0.0	0	0	0	0	0	0
	Overall Area: 76.5					ft²					

<u>125 Hz</u>	<u>250 Hz</u>	<u>500 Hz</u>	<u>1KHz</u>	<u>2KHz</u>	<u>4KHz</u>	
49.4	54.9	57.4	61.4	61.4	55.4	: Exterior Wall Noise Exposure
17.6	22.9	23.4	33.6	43.1	38.5	: Transmission Loss
18.8	18.8	18.8	18.8	18.8	18.8	: Wall Surface Area Factor
20.4	20.4	20.4	20.4	21.3	21.3	: Absorption
30.2	30.5	32.5	26.3	15.8	14.4	: Noise Level
36.5	CNEL	WINDOWS OPEN				
<u>125 Hz</u>	<u>250 Hz</u>	<u>500 Hz</u>	<u>1KHz</u>	<u>2KHz</u>	<u>4KHz</u>	
49.4	54.9	57.4	61.4	61.4	55.4	: Exterior Wall Noise Exposure
17.6	22.9	23.4	33.6	43.1	38.5	: Transmission Loss
18.8	18.8	18.8	18.8	18.8	18.8	: Wall Surface Area Factor
20.4	20.4	20.4	20.4	21.3	21.3	: Absorption
30.2	30.5	32.5	26.3	15.8	14.4	: Noise Level
36.5	CNEL	WINDOWS CLOSED				

EXTERIOR TO INTERIOR NOISE REDUCTION ANALYSIS

Project Name: 516 La Costa
 Project #: S200108
 Room Name: Unit - Bedroom

Wall 3 of 3

	<u>Noise Level</u>		<u>125 Hz</u>	<u>250 Hz</u>	<u>500 Hz</u>	<u>1KHz</u>	<u>2KHz</u>	<u>4KHz</u>	
Source 1: Traffic	67.1 CNEL		50.4	55.9	58.4	62.4	62.4	56.4	: Traffic Spectrum
Source 2: <N/A>	0.0 CNEL		0.0	0.0	0.0	0.0	0.0	0.0	
Source 3: <N/A>	0.0 CNEL		0.0	0.0	0.0	0.0	0.0	0.0	
Source 4: <N/A>	0.0 CNEL		0.0	0.0	0.0	0.0	0.0	0.0	
Overall:	67.1 CNEL		50.4	55.9	58.4	62.4	62.4	56.4	: Effective Noise Spectrum

<u>Assembly Type</u>	<u>Open</u>	<u>Width</u>	<u>Height</u>	<u>Qty</u>	<u>Total Area</u>	<u>125 Hz</u>	<u>250 Hz</u>	<u>500 Hz</u>	<u>1KHz</u>	<u>2KHz</u>	<u>4KHz</u>
Exterior Wall Type A (S200108)	N	8.5	9	1	76.5	33	45	55	58	57	66
<N/A>	N	0	0	0	0.0	0	0	0	0	0	0
<N/A>	N	0	0	0	0.0	0	0	0	0	0	0
<N/A>	N	0	0	0	0.0	0	0	0	0	0	0
<N/A>	N	0	0	0	0.0	0	0	0	0	0	0
<N/A>	N	0	0	0	0.0	0	0	0	0	0	0
<N/A>	N	0	0	0	0.0	0	0	0	0	0	0
<N/A>	N	0	0	0	0.0	0	0	0	0	0	0
<N/A>	N	0	0	0	0.0	0	0	0	0	0	0
<N/A>	N	0	0	0	0.0	0	0	0	0	0	0
<N/A>	N	0	0	0	0.0	0	0	0	0	0	0
<N/A>	N	0	0	0	0.0	0	0	0	0	0	0
Overall Area:					76.5						ft ²

<u>125 Hz</u>	<u>250 Hz</u>	<u>500 Hz</u>	<u>1KHz</u>	<u>2KHz</u>	<u>4KHz</u>	
50.4	55.9	58.4	62.4	62.4	56.4	: Exterior Wall Noise Exposure
33.0	45.0	55.0	58.0	57.0	66.0	: Transmission Loss
18.8	18.8	18.8	18.8	18.8	18.8	: Wall Surface Area Factor
20.4	20.4	20.4	20.4	21.3	21.3	: Absorption
15.9	9.4	1.9	2.9	2.9	-12.1	: Noise Level
17.2	CNEL	WINDOWS OPEN				
<u>125 Hz</u>	<u>250 Hz</u>	<u>500 Hz</u>	<u>1KHz</u>	<u>2KHz</u>	<u>4KHz</u>	
50.4	55.9	58.4	62.4	62.4	56.4	: Exterior Wall Noise Exposure
33.0	45.0	55.0	58.0	57.0	66.0	: Transmission Loss
18.8	18.8	18.8	18.8	18.8	18.8	: Wall Surface Area Factor
20.4	20.4	20.4	20.4	21.3	21.3	: Absorption
15.9	9.4	1.9	2.9	2.9	-12.1	: Noise Level
17.2	CNEL	WINDOWS CLOSED				

EXTERIOR TO INTERIOR NOISE REDUCTION ANALYSIS

Project Name: 516 La Costa
 Project #: S200108
 Room Name: Restaurant - Front Desk / Bar

Wall 1 of 3

Room Type : Medium Hard						
	<u>125 Hz</u>	<u>250 Hz</u>	<u>500 Hz</u>	<u>1KHz</u>	<u>2KHz</u>	<u>4KHz</u>
Reverberation Time (sec) :	0.8	0.8	0.8	0.8	0.7	0.7
Room Absorption (Sabins) :	832	832	832	832	1040	1040

	<u>Noise Level</u>		<u>125 Hz</u>	<u>250 Hz</u>	<u>500 Hz</u>	<u>1KHz</u>	<u>2KHz</u>	<u>4KHz</u>	
Source 1: Traffic	72.4	CNEL	55.7	61.2	63.7	67.7	67.7	61.7	: Traffic Spectrum
Source 2: <N/A>	0.0	CNEL	0.0	0.0	0.0	0.0	0.0	0.0	
Source 3: <N/A>	0.0	CNEL	0.0	0.0	0.0	0.0	0.0	0.0	
Source 4: <N/A>	0.0	CNEL	0.0	0.0	0.0	0.0	0.0	0.0	
Overall:	72.4	CNEL	55.7	61.2	63.7	67.7	67.7	61.7	: Effective Noise Spectrum

<u>Assembly Type</u>	<u>Open</u>	<u>Width</u>	<u>Height</u>	<u>Qty</u>	<u>Total Area</u>	<u>125 Hz</u>	<u>250 Hz</u>	<u>500 Hz</u>	<u>1KHz</u>	<u>2KHz</u>	<u>4KHz</u>
Exterior Wall Type A (S200108)	N	44	21	1	776.0	33	45	55	58	57	66
STC 28 1/2-inch Dual Insulating Window	N	12	8.5	1	102.0	23	23	22	32	43	37
STC 28 1/2-inch Dual Insulating Window	N	4	4	1	16.0	23	23	22	32	43	37
STC 28 French Door with seals	N	4	7.5	1	30.0	23	23	22	32	43	37
<N/A>	N	0	0	0	0.0	0	0	0	0	0	0
<N/A>	N	0	0	0	0.0	0	0	0	0	0	0
<N/A>	N	0	0	0	0.0	0	0	0	0	0	0
<N/A>	N	0	0	0	0.0	0	0	0	0	0	0
<N/A>	N	0	0	0	0.0	0	0	0	0	0	0
<N/A>	N	0	0	0	0.0	0	0	0	0	0	0
<N/A>	N	0	0	0	0.0	0	0	0	0	0	0

Room Depth: 15 ft Overall Area: 924 ft²
 Volume: 13860 ft³

Number of Impacted Walls: 3

Windows Open		
Interior Noise Level:	44.1	CNEL
Windows Closed		
Interior Noise Level:	44.1	CNEL

<u>125 Hz</u>	<u>250 Hz</u>	<u>500 Hz</u>	<u>1KHz</u>	<u>2KHz</u>	<u>4KHz</u>	
55.7	61.2	63.7	67.7	67.7	61.7	: Exterior Wall Noise Exposure
29.0	30.7	30.0	40.2	49.8	45.2	: Transmission Loss
29.7	29.7	29.7	29.7	29.7	29.7	: Wall Surface Area Factor
29.2	29.2	29.2	29.2	30.2	30.2	: Absorption
27.1	31.0	34.1	27.9	17.4	15.9	: Noise Level
37.1	CNEL WINDOWS OPEN					
<u>125 Hz</u>	<u>250 Hz</u>	<u>500 Hz</u>	<u>1KHz</u>	<u>2KHz</u>	<u>4KHz</u>	
55.7	61.2	63.7	67.7	67.7	61.7	: Exterior Wall Noise Exposure
29.0	30.7	30.0	40.2	49.8	45.2	: Transmission Loss
29.7	29.7	29.7	29.7	29.7	29.7	: Wall Surface Area Factor
29.2	29.2	29.2	29.2	30.2	30.2	: Absorption
27.1	31.0	34.1	27.9	17.4	15.9	: Noise Level
37.1	CNEL WINDOWS CLOSED					

EXTERIOR TO INTERIOR NOISE REDUCTION ANALYSIS

Project Name: 516 La Costa
 Project #: S200108
 Room Name: Restaurant - Front Desk / Bar

Wall 2 of 3

	<u>Noise Level</u>	<u>125 Hz</u>	<u>250 Hz</u>	<u>500 Hz</u>	<u>1KHz</u>	<u>2KHz</u>	<u>4KHz</u>	
Source 1: Traffic	74.4 CNEL	57.7	63.2	65.7	69.7	69.7	63.7	: Traffic Spectrum
Source 2: <N/A>	0.0 CNEL	0.0	0.0	0.0	0.0	0.0	0.0	
Source 3: <N/A>	0.0 CNEL	0.0	0.0	0.0	0.0	0.0	0.0	
Source 4: <N/A>	0.0 CNEL	0.0	0.0	0.0	0.0	0.0	0.0	
Overall:	74.4 CNEL	57.7	63.2	65.7	69.7	69.7	63.7	: Effective Noise Spectrum

<u>Assembly Type</u>	<u>Open</u>	<u>Width</u>	<u>Height</u>	<u>Qty</u>	<u>Total Area</u>	<u>125 Hz</u>	<u>250 Hz</u>	<u>500 Hz</u>	<u>1KHz</u>	<u>2KHz</u>	<u>4KHz</u>
Exterior Wall Type A (S200108)	N	18	21	1	0.0	33	45	55	58	57	66
STC 28 1/2-inch Dual Insulating Window	N	18	21	1	378.0	23	23	22	32	43	37
<N/A>	N	0	0	0	0.0	0	0	0	0	0	0
<N/A>	N	0	0	0	0.0	0	0	0	0	0	0
<N/A>	N	0	0	0	0.0	0	0	0	0	0	0
<N/A>	N	0	0	0	0.0	0	0	0	0	0	0
<N/A>	N	0	0	0	0.0	0	0	0	0	0	0
<N/A>	N	0	0	0	0.0	0	0	0	0	0	0
<N/A>	N	0	0	0	0.0	0	0	0	0	0	0
<N/A>	N	0	0	0	0.0	0	0	0	0	0	0
<N/A>	N	0	0	0	0.0	0	0	0	0	0	0
<N/A>	N	0	0	0	0.0	0	0	0	0	0	0
<N/A>	N	0	0	0	0.0	0	0	0	0	0	0
<N/A>	N	0	0	0	0.0	0	0	0	0	0	0
<N/A>	N	0	0	0	0.0	0	0	0	0	0	0
Overall Area:					378						ft ²

<u>125 Hz</u>	<u>250 Hz</u>	<u>500 Hz</u>	<u>1KHz</u>	<u>2KHz</u>	<u>4KHz</u>	
57.7	63.2	65.7	69.7	69.7	63.7	: Exterior Wall Noise Exposure
22.9	22.9	22.1	32.3	42.6	37.3	: Transmission Loss
25.8	25.8	25.8	25.8	25.8	25.8	: Wall Surface Area Factor
29.2	29.2	29.2	29.2	30.2	30.2	: Absorption
31.4	36.9	40.2	33.9	22.7	22.0	: Noise Level
42.9	CNEL	WINDOWS OPEN				
<u>125 Hz</u>	<u>250 Hz</u>	<u>500 Hz</u>	<u>1KHz</u>	<u>2KHz</u>	<u>4KHz</u>	
57.7	63.2	65.7	69.7	69.7	63.7	: Exterior Wall Noise Exposure
22.9	22.9	22.1	32.3	42.6	37.3	: Transmission Loss
25.8	25.8	25.8	25.8	25.8	25.8	: Wall Surface Area Factor
29.2	29.2	29.2	29.2	30.2	30.2	: Absorption
31.4	36.9	40.2	33.9	22.7	22.0	: Noise Level
42.9	CNEL	WINDOWS CLOSED				

EXTERIOR TO INTERIOR NOISE REDUCTION ANALYSIS

Project Name: 516 La Costa
 Project #: S200108
 Room Name: Restaurant - Front Desk / Bar

Wall 3 of 3

	<u>Noise Level</u>	<u>125 Hz</u>	<u>250 Hz</u>	<u>500 Hz</u>	<u>1KHz</u>	<u>2KHz</u>	<u>4KHz</u>	
Source 1: Traffic	66.3 CNEL	49.6	55.1	57.6	61.6	61.6	55.6	: Traffic Spectrum
Source 2: <N/A>	0.0 CNEL	0.0	0.0	0.0	0.0	0.0	0.0	
Source 3: <N/A>	0.0 CNEL	0.0	0.0	0.0	0.0	0.0	0.0	
Source 4: <N/A>	0.0 CNEL	0.0	0.0	0.0	0.0	0.0	0.0	
Overall:	66.3 CNEL	49.6	55.1	57.6	61.6	61.6	55.6	: Effective Noise Spectrum

<u>Assembly Type</u>	<u>Open</u>	<u>Width</u>	<u>Height</u>	<u>Qty</u>	<u>Total Area</u>	<u>125 Hz</u>	<u>250 Hz</u>	<u>500 Hz</u>	<u>1KHz</u>	<u>2KHz</u>	<u>4KHz</u>
Exterior Wall Type D (S200108)	N	5	19	1	0.0	20	33	48	53	59	66
STC 28 1/2-inch Dual Insulating Window	N	5	19	1	95.0	23	23	22	32	43	37
<N/A>	N	0	0	0	0.0	0	0	0	0	0	0
<N/A>	N	0	0	0	0.0	0	0	0	0	0	0
<N/A>	N	0	0	0	0.0	0	0	0	0	0	0
<N/A>	N	0	0	0	0.0	0	0	0	0	0	0
<N/A>	N	0	0	0	0.0	0	0	0	0	0	0
<N/A>	N	0	0	0	0.0	0	0	0	0	0	0
<N/A>	N	0	0	0	0.0	0	0	0	0	0	0
<N/A>	N	0	0	0	0.0	0	0	0	0	0	0
<N/A>	N	0	0	0	0.0	0	0	0	0	0	0
<N/A>	N	0	0	0	0.0	0	0	0	0	0	0
<N/A>	N	0	0	0	0.0	0	0	0	0	0	0
Overall Area:					95	ft²					

<u>125 Hz</u>	<u>250 Hz</u>	<u>500 Hz</u>	<u>1KHz</u>	<u>2KHz</u>	<u>4KHz</u>	
49.6	55.1	57.6	61.6	61.6	55.6	: Exterior Wall Noise Exposure
22.9	22.9	22.1	32.3	42.6	37.3	: Transmission Loss
19.8	19.8	19.8	19.8	19.8	19.8	: Wall Surface Area Factor
29.2	29.2	29.2	29.2	30.2	30.2	: Absorption
17.3	22.8	26.1	19.9	8.6	7.9	: Noise Level
28.8	CNEL	WINDOWS OPEN				
<u>125 Hz</u>	<u>250 Hz</u>	<u>500 Hz</u>	<u>1KHz</u>	<u>2KHz</u>	<u>4KHz</u>	
49.6	55.1	57.6	61.6	61.6	55.6	: Exterior Wall Noise Exposure
22.9	22.9	22.1	32.3	42.6	37.3	: Transmission Loss
19.8	19.8	19.8	19.8	19.8	19.8	: Wall Surface Area Factor
29.2	29.2	29.2	29.2	30.2	30.2	: Absorption
17.3	22.8	26.1	19.9	8.6	7.9	: Noise Level
28.8	CNEL	WINDOWS CLOSED				

EXTERIOR TO INTERIOR NOISE REDUCTION ANALYSIS

Project Name: 516 La Costa
 Project #: S200108
 Room Name: Restaurant - Dining

Wall 1 of 3

Room Type : Medium Hard						
	<u>125 Hz</u>	<u>250 Hz</u>	<u>500 Hz</u>	<u>1KHz</u>	<u>2KHz</u>	<u>4KHz</u>
Reverberation Time (sec) :	0.8	0.8	0.8	0.8	0.7	0.7
Room Absorption (Sabins) :	582	582	582	582	728	728

	<u>Noise Level</u>		<u>125 Hz</u>	<u>250 Hz</u>	<u>500 Hz</u>	<u>1KHz</u>	<u>2KHz</u>	<u>4KHz</u>	
Source 1: Traffic	74.3	CNEL	57.6	63.1	65.6	69.6	69.6	63.6	: Traffic Spectrum
Source 2: <N/A>	0.0	CNEL	0.0	0.0	0.0	0.0	0.0	0.0	
Source 3: <N/A>	0.0	CNEL	0.0	0.0	0.0	0.0	0.0	0.0	
Source 4: <N/A>	0.0	CNEL	0.0	0.0	0.0	0.0	0.0	0.0	
Overall:	74.3	CNEL	57.6	63.1	65.6	69.6	69.6	63.6	: Effective Noise Spectrum

<u>Assembly Type</u>	<u>Open</u>	<u>Width</u>	<u>Height</u>	<u>Qty</u>	<u>Total Area</u>	<u>125 Hz</u>	<u>250 Hz</u>	<u>500 Hz</u>	<u>1KHz</u>	<u>2KHz</u>	<u>4KHz</u>
Exterior Wall Type A (S200108)	N	28	21	1	432.0	33	45	55	58	57	66
STC 28 1/2-inch Dual Insulating Window	N	12	13	1	156.0	23	23	22	32	43	37
<N/A>	N	0	0	0	0.0	0	0	0	0	0	0
<N/A>	N	0	0	0	0.0	0	0	0	0	0	0
<N/A>	N	0	0	0	0.0	0	0	0	0	0	0
<N/A>	N	0	0	0	0.0	0	0	0	0	0	0
<N/A>	N	0	0	0	0.0	0	0	0	0	0	0
<N/A>	N	0	0	0	0.0	0	0	0	0	0	0
<N/A>	N	0	0	0	0.0	0	0	0	0	0	0
<N/A>	N	0	0	0	0.0	0	0	0	0	0	0
<N/A>	N	0	0	0	0.0	0	0	0	0	0	0

Room Depth: 16.5 ft Overall Area: 588 ft²
 Volume: 9702 ft³

Number of Impacted Walls: 3

Windows Open		
Interior Noise Level:	45.4	CNEL
Windows Closed		
Interior Noise Level:	45.4	CNEL

<u>125 Hz</u>	<u>250 Hz</u>	<u>500 Hz</u>	<u>1KHz</u>	<u>2KHz</u>	<u>4KHz</u>	
57.6	63.1	65.6	69.6	69.6	63.6	: Exterior Wall Noise Exposure
27.6	28.6	27.8	38.1	47.9	43.1	: Transmission Loss
27.7	27.7	27.7	27.7	27.7	27.7	: Wall Surface Area Factor
27.7	27.7	27.7	27.7	28.6	28.6	: Absorption
30.0	34.6	37.8	31.6	20.7	19.6	: Noise Level
40.6	CNEL	WINDOWS OPEN				
<u>125 Hz</u>	<u>250 Hz</u>	<u>500 Hz</u>	<u>1KHz</u>	<u>2KHz</u>	<u>4KHz</u>	
57.6	63.1	65.6	69.6	69.6	63.6	: Exterior Wall Noise Exposure
27.6	28.6	27.8	38.1	47.9	43.1	: Transmission Loss
27.7	27.7	27.7	27.7	27.7	27.7	: Wall Surface Area Factor
27.7	27.7	27.7	27.7	28.6	28.6	: Absorption
30.0	34.6	37.8	31.6	20.7	19.6	: Noise Level
40.6	CNEL	WINDOWS CLOSED				

EXTERIOR TO INTERIOR NOISE REDUCTION ANALYSIS

Project Name: 516 La Costa
 Project #: S200108
 Room Name: Restaurant - Dining

Wall 2 of 3

	<u>Noise Level</u>	<u>125 Hz</u>	<u>250 Hz</u>	<u>500 Hz</u>	<u>1KHz</u>	<u>2KHz</u>	<u>4KHz</u>	
Source 1: Traffic	73.5 CNEL	56.8	62.3	64.8	68.8	68.8	62.8	: Traffic Spectrum
Source 2: <N/A>	0.0 CNEL	0.0	0.0	0.0	0.0	0.0	0.0	
Source 3: <N/A>	0.0 CNEL	0.0	0.0	0.0	0.0	0.0	0.0	
Source 4: <N/A>	0.0 CNEL	0.0	0.0	0.0	0.0	0.0	0.0	
Overall:	73.5 CNEL	56.8	62.3	64.8	68.8	68.8	62.8	: Effective Noise Spectrum

<u>Assembly Type</u>	<u>Open</u>	<u>Width</u>	<u>Height</u>	<u>Qty</u>	<u>Total Area</u>	<u>125 Hz</u>	<u>250 Hz</u>	<u>500 Hz</u>	<u>1KHz</u>	<u>2KHz</u>	<u>4KHz</u>
Exterior Wall Type A (S200108)	N	18	21	1	0.0	33	45	55	58	57	66
STC 28 1/2-inch Dual Insulating Window	N	18	21	1	378.0	23	23	22	32	43	37
<N/A>	N	0	0	0	0.0	0	0	0	0	0	0
<N/A>	N	0	0	0	0.0	0	0	0	0	0	0
<N/A>	N	0	0	0	0.0	0	0	0	0	0	0
<N/A>	N	0	0	0	0.0	0	0	0	0	0	0
<N/A>	N	0	0	0	0.0	0	0	0	0	0	0
<N/A>	N	0	0	0	0.0	0	0	0	0	0	0
<N/A>	N	0	0	0	0.0	0	0	0	0	0	0
<N/A>	N	0	0	0	0.0	0	0	0	0	0	0
<N/A>	N	0	0	0	0.0	0	0	0	0	0	0
<N/A>	N	0	0	0	0.0	0	0	0	0	0	0
<N/A>	N	0	0	0	0.0	0	0	0	0	0	0
Overall Area:					378	ft²					

<u>125 Hz</u>	<u>250 Hz</u>	<u>500 Hz</u>	<u>1KHz</u>	<u>2KHz</u>	<u>4KHz</u>	
56.8	62.3	64.8	68.8	68.8	62.8	: Exterior Wall Noise Exposure
22.9	22.9	22.1	32.3	42.6	37.3	: Transmission Loss
25.8	25.8	25.8	25.8	25.8	25.8	: Wall Surface Area Factor
27.7	27.7	27.7	27.7	28.6	28.6	: Absorption
32.1	37.6	40.8	34.6	23.4	22.6	: Noise Level
43.6	CNEL	WINDOWS OPEN				
<u>125 Hz</u>	<u>250 Hz</u>	<u>500 Hz</u>	<u>1KHz</u>	<u>2KHz</u>	<u>4KHz</u>	
56.8	62.3	64.8	68.8	68.8	62.8	: Exterior Wall Noise Exposure
22.9	22.9	22.1	32.3	42.6	37.3	: Transmission Loss
25.8	25.8	25.8	25.8	25.8	25.8	: Wall Surface Area Factor
27.7	27.7	27.7	27.7	28.6	28.6	: Absorption
32.1	37.6	40.8	34.6	23.4	22.6	: Noise Level
43.6	CNEL	WINDOWS CLOSED				

EXTERIOR TO INTERIOR NOISE REDUCTION ANALYSIS

Project Name: 516 La Costa
 Project #: S200108
 Room Name: Restaurant - Dining

Wall 3 of 3

	<u>Noise Level</u>	<u>125 Hz</u>	<u>250 Hz</u>	<u>500 Hz</u>	<u>1KHz</u>	<u>2KHz</u>	<u>4KHz</u>	
Source 1: Traffic	59.1 CNEL	42.4	47.9	50.4	54.4	54.4	48.4	: Traffic Spectrum
Source 2: <N/A>	0.0 CNEL	0.0	0.0	0.0	0.0	0.0	0.0	
Source 3: <N/A>	0.0 CNEL	0.0	0.0	0.0	0.0	0.0	0.0	
Source 4: <N/A>	0.0 CNEL	0.0	0.0	0.0	0.0	0.0	0.0	
Overall:	59.1 CNEL	42.4	47.9	50.4	54.4	54.4	48.4	: Effective Noise Spectrum

<u>Assembly Type</u>	<u>Open</u>	<u>Width</u>	<u>Height</u>	<u>Qty</u>	<u>Total Area</u>	<u>125 Hz</u>	<u>250 Hz</u>	<u>500 Hz</u>	<u>1KHz</u>	<u>2KHz</u>	<u>4KHz</u>
Exterior Wall Type A (S200108)	N	20	21	1	270.5	33	45	55	58	57	66
STC 28 1/2-inch Dual Insulating Window	N	11.5	13	1	149.5	23	23	22	32	43	37
<N/A>	N	0	0	0	0.0	0	0	0	0	0	0
<N/A>	N	0	0	0	0.0	0	0	0	0	0	0
<N/A>	N	0	0	0	0.0	0	0	0	0	0	0
<N/A>	N	0	0	0	0.0	0	0	0	0	0	0
<N/A>	N	0	0	0	0.0	0	0	0	0	0	0
<N/A>	N	0	0	0	0.0	0	0	0	0	0	0
<N/A>	N	0	0	0	0.0	0	0	0	0	0	0
<N/A>	N	0	0	0	0.0	0	0	0	0	0	0
<N/A>	N	0	0	0	0.0	0	0	0	0	0	0
<N/A>	N	0	0	0	0.0	0	0	0	0	0	0
Overall Area:					420	ft²					

<u>125 Hz</u>	<u>250 Hz</u>	<u>500 Hz</u>	<u>1KHz</u>	<u>2KHz</u>	<u>4KHz</u>	
42.4	47.9	50.4	54.4	54.4	48.4	: Exterior Wall Noise Exposure
26.7	27.3	26.6	36.8	46.8	41.8	: Transmission Loss
26.2	26.2	26.2	26.2	26.2	26.2	: Wall Surface Area Factor
27.7	27.7	27.7	27.7	28.6	28.6	: Absorption
14.3	19.2	22.4	16.2	5.2	4.2	: Noise Level
25.2	CNEL	WINDOWS OPEN				
<u>125 Hz</u>	<u>250 Hz</u>	<u>500 Hz</u>	<u>1KHz</u>	<u>2KHz</u>	<u>4KHz</u>	
42.4	47.9	50.4	54.4	54.4	48.4	: Exterior Wall Noise Exposure
26.7	27.3	26.6	36.8	46.8	41.8	: Transmission Loss
26.2	26.2	26.2	26.2	26.2	26.2	: Wall Surface Area Factor
27.7	27.7	27.7	27.7	28.6	28.6	: Absorption
14.3	19.2	22.4	16.2	5.2	4.2	: Noise Level
25.2	CNEL	WINDOWS CLOSED				

APPENDIX I

Recommended Products

THRESHOLDS AND GASKETING

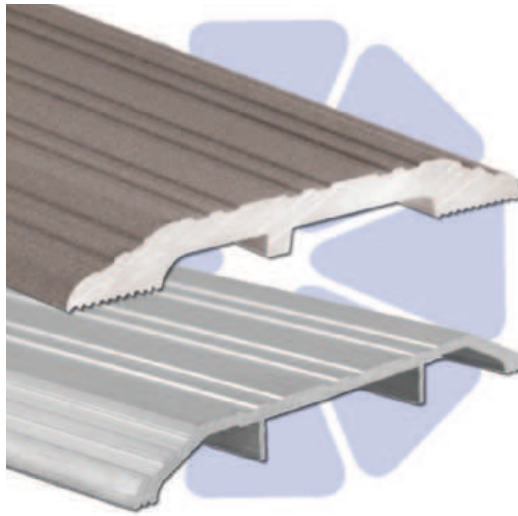

VENTURA, CA (USA)
P.O. Box 3780
Ventura, CA 93006
PH: 800.283.9988
FAX: 800.283.4050

MEMPHIS, TN (USA)
P.O. Box 18966
Memphis, TN 38181
PH: 800.824.3018
FAX: 800.243.3656

VANCOUVER, BC (CANADA)
103-2480 Mt. Lehman Rd.
Abbotsford, BC V2T 6W3 Canada
PH: 877.535.7888
FAX: 877.535.7444

TORONTO, ON (CANADA)
160 Four Valley Rd.
Concord, ON L4K 4T9 Canada
PH: 866.243.9816
FAX: 866.243.9817

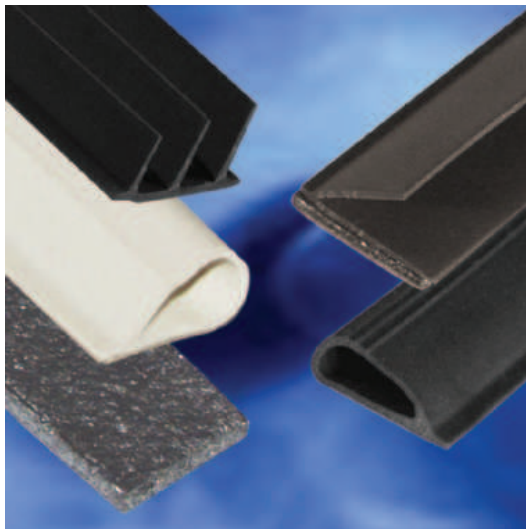

ASSA ABLOY is the global leader in door opening solutions, dedicated to satisfying end-user needs for security, safety and convenience.

COMMERCIAL THRESHOLDS

Saddle Thresholds

170_

AVAILABLE FINISHES: A, B, BDG, D, G

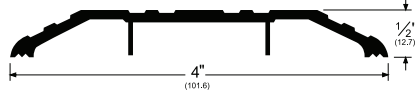

171_

AVAILABLE FINISHES: A, B, BDG, D, G, SN

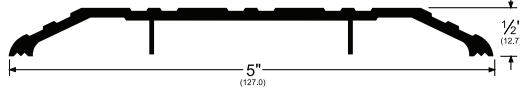

172_

AVAILABLE FINISHES: A, B, D, G, SN

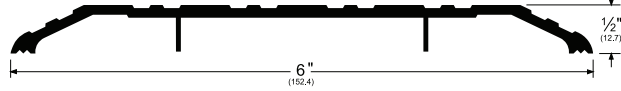

175SS_

AVAILABLE FINISH: SS (#4 Finish)

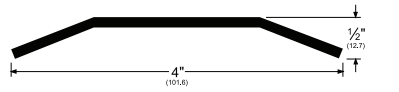

270_

AVAILABLE FINISHES: A, B, D, G

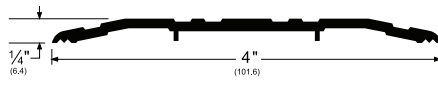

271_

AVAILABLE FINISHES: A, B, D, G, SN

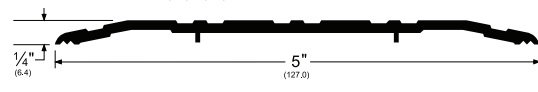

272_

AVAILABLE FINISHES: A, B, D, G, SN

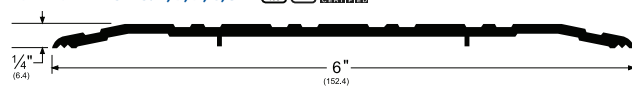

Heavy Duty Thresholds

1715_

AVAILABLE FINISHES: A, AK, D

Allow 5/8" door clearance.

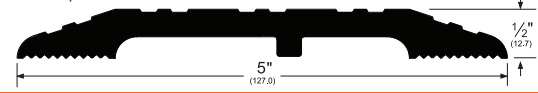

Modular Heavy Duty Thresholds

1716_

AVAILABLE FINISHES: A, AK, D

Allow 5/8" door clearance.

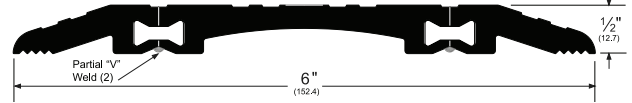

Thermal Barrier Thresholds

253X3_FG

AVAILABLE FINISHES: A, B, D, G

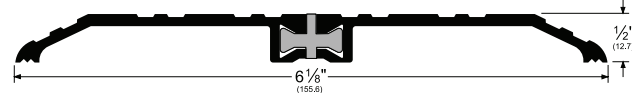

252SSx2FG_

AVAILABLE FINISH: SS (#4 Finish)

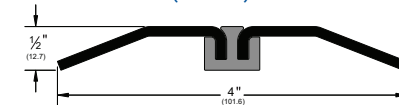

Also Available (Not Shown)

253SSx3FG_

252SSx3FG_

Latching Panic Exit Saddle Thresholds

2005_T

AVAILABLE FINISHES: A, B, D, G

Allow 3/8" door clearance.

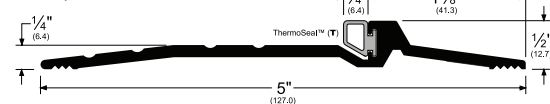

179_T

AVAILABLE FINISHES: A, B, D, G

Allow 1/2" door clearance.

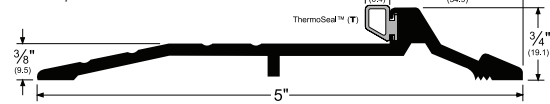

ALTERNATE INSERTS

<p>2005_P pile (P)</p> <p>179_P pile (P)</p>	<p>2005_V vinyl (V)</p> <p>179_V vinyl (V)</p>
--	--

HOSPITALITY PRODUCTS

Vinyl Thresholds

V232_

AVAILABLE COLORS: BL

AVAILABLE LENGTHS: 36", 48", 73"

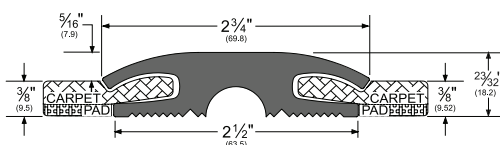

V2325_

AVAILABLE COLORS: BL

AVAILABLE LENGTHS: 36", 48", 73"

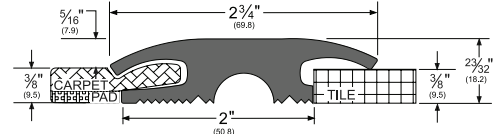

V2320_

AVAILABLE COLORS: BL

AVAILABLE LENGTHS: 36", 48", 73"

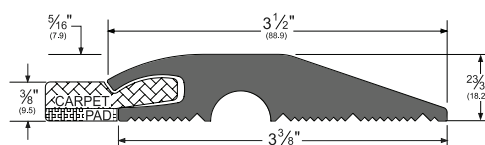

V2322_

AVAILABLE COLORS: BL

AVAILABLE LENGTHS: 36", 48", 73"

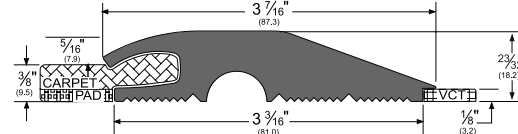

Privacy Door Latch

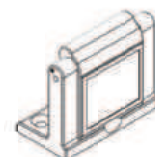
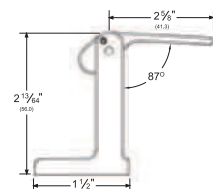

PDL_

AVAILABLE FINISHES:
US3, 4, 26, 26D/15

DOOR BOTTOMS

Automatic Door Bottoms

4131_RL

AVAILABLE FINISHES: BDG, C, D, SN

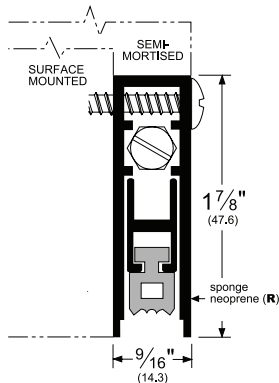

4301_RL

AVAILABLE FINISHES: C, D

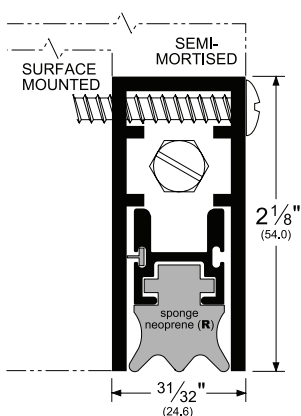

411_RL

AVAILABLE FINISHES: A

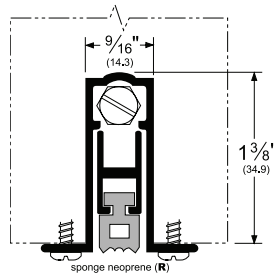

434_RL

AVAILABLE FINISHES: A

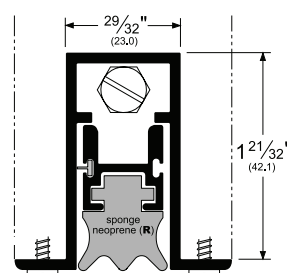

Door Shoes

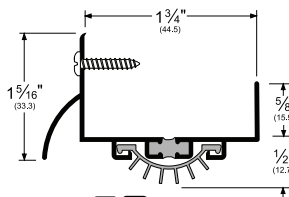

216_V
216_PK

AVAILABLE FINISHES:
A, B, BDG, D, G, PW, SN

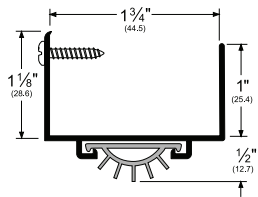

217_V
217_PK

AVAILABLE FINISHES:
A, BDG, D, G, PW, SN

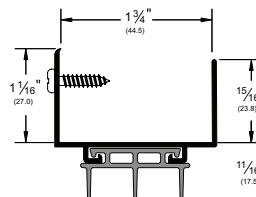

2173_V

AVAILABLE FINISHES:
A, BDG, D, PW
Also available unnotched:
2173_V36UN
2173_V48UN

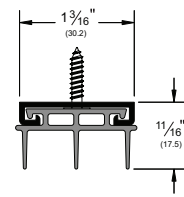

2343_V

AVAILABLE FINISHES:
A, D
Also available unnotched:
2343_V36UN
2343_V48UN

Door Bottom Sweeps

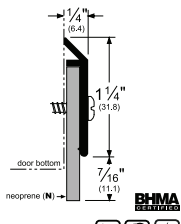

315_N

AVAILABLE FINISHES:
B, C, D, G, SN

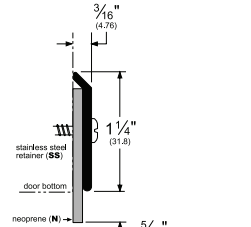

315SSN

AVAILABLE FINISH:
SS (#4 Finish)

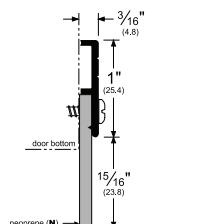

321_N

AVAILABLE FINISHES:
C, D, G

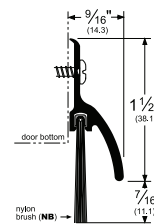

345_NB

AVAILABLE FINISHES:
A, BDG, D, G, PW

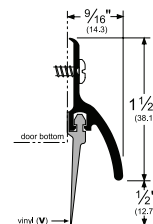

345_V

AVAILABLE FINISHES:
A, BDG, D, G, PW

BRUSH GASKETING

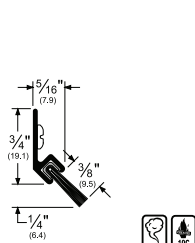

45041_NB

AVAILABLE FINISHES:
C, D, G, SN

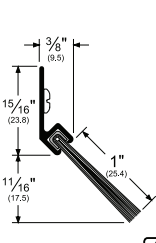

45100_NB

AVAILABLE FINISHES:
C, D, G, SN

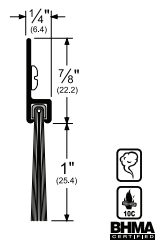

18100_NB

AVAILABLE FINISHES:
C, D, G, PW

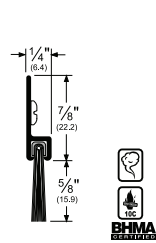

18062_NB

AVAILABLE FINISHES:
C, D, G, PW

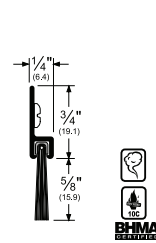

18061_NB

AVAILABLE FINISHES:
C, D, G, SN

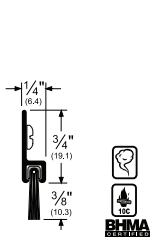

18041_NB

AVAILABLE FINISHES:
C, D, G, SN

NOTE: ALTERNATE INSERTS MAY CARRY DIFFERENT RATINGS. SEE FULL LINE CATALOG OR WEBSITE FOR MORE INFORMATION.

ADHESIVE GASKETING

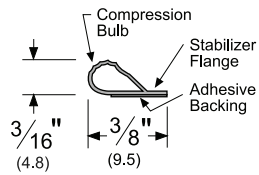

PK33_

AVAILABLE FINISHES:
BL, D, W
AVAILABLE LENGTHS:
17', 18', 20', 21', 25', 510'

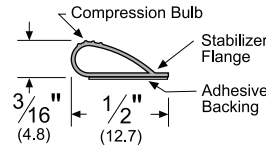

PK55_

AVAILABLE FINISHES:
BL, D, W
AVAILABLE LENGTHS:
17', 18', 20', 21', 25', 510'

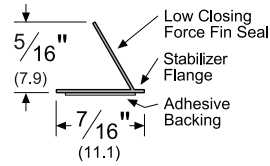

S44_

AVAILABLE FINISHES:
BL, D, W
AVAILABLE LENGTHS:
17', 18', 20', 21', 25', 510'

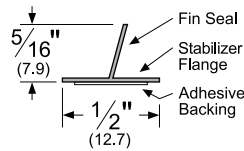

S77_

AVAILABLE FINISHES:
C, D, W
AVAILABLE LENGTHS:
17', 18', 20', 21', 25'

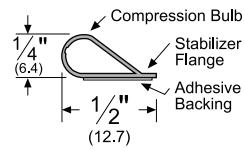

S88_

AVAILABLE FINISHES:
BL, C, D, GR, TAN, W
AVAILABLE LENGTHS:
17', 18', 20', 21', 25', 30', 204', 510'

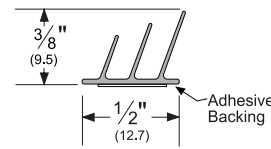

S773_

AVAILABLE FINISHES: D, W
AVAILABLE LENGTHS: 17', 18', 20', 21', 25'

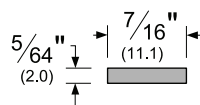

HSS1000_

AVAILABLE FINISHES:
Graphite (no code), W
AVAILABLE LENGTHS:
7', 8', 10', 18', 21', 24'

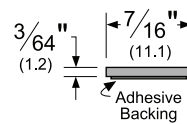

HSS2000_

AVAILABLE FINISHES:
Graphite (no code), W
AVAILABLE LENGTHS:
7', 8', 10', 18', 21', 24'

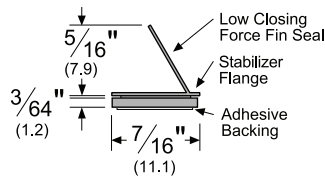

HSS2000xS44_

AVAILABLE FINISHES:
BL, D, W
AVAILABLE LENGTHS:
18', 20', 21', 24'

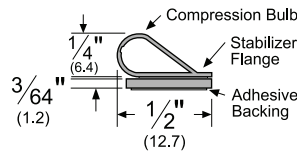

HSS2000xS88_

AVAILABLE FINISHES:
BL, C, D, GR, TAN, W
AVAILABLE LENGTHS:
18', 20', 21', 24'

PERIMETER GASKETING

Adjustable Jamb Weatherstrip

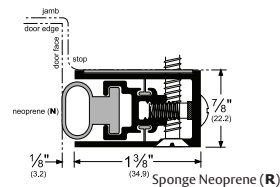

322_SN

AVAILABLE FINISHES: C, D, G

Snap Cover - Concealed Fasteners

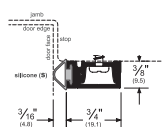

29310_S

AVAILABLE FINISHES: C, D, G
ADDITIONAL INSERTS: P, PK, V

Heavy Duty-Head Section

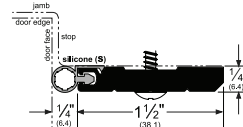

2891_S

AVAILABLE FINISHES: A, D, G
ADDITIONAL INSERTS: PK, V

Heavy Duty-Standard Jamb

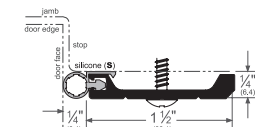

290_S

AVAILABLE FINISHES: A, D, G
ADDITIONAL INSERTS: PK, V

Standard Perimeter Gasketing

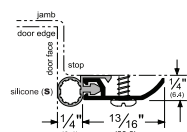

297_S

AVAILABLE FINISHES: A, BDG, D, G, PW, SN
ADDITIONAL INSERTS: PK, V

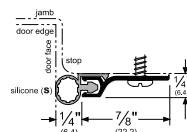

303_S

AVAILABLE FINISHES: A, BDG, D, G, PW, SN
ADDITIONAL INSERTS: PK, V

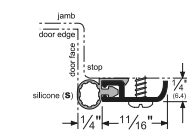

316_S

AVAILABLE FINISHES: A, BDG, D, G
ADDITIONAL INSERTS: PK, V

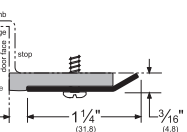

315SSR

AVAILABLE FINISH: SS (#4 Finish)

NOTE: ALTERNATE INSERTS MAY CARRY DIFFERENT RATINGS. SEE FULL LINE CATALOG OR WEBSITE FOR MORE INFORMATION.

 **Reese**



**WEATHERSTRIPS
& THRESHOLDS**

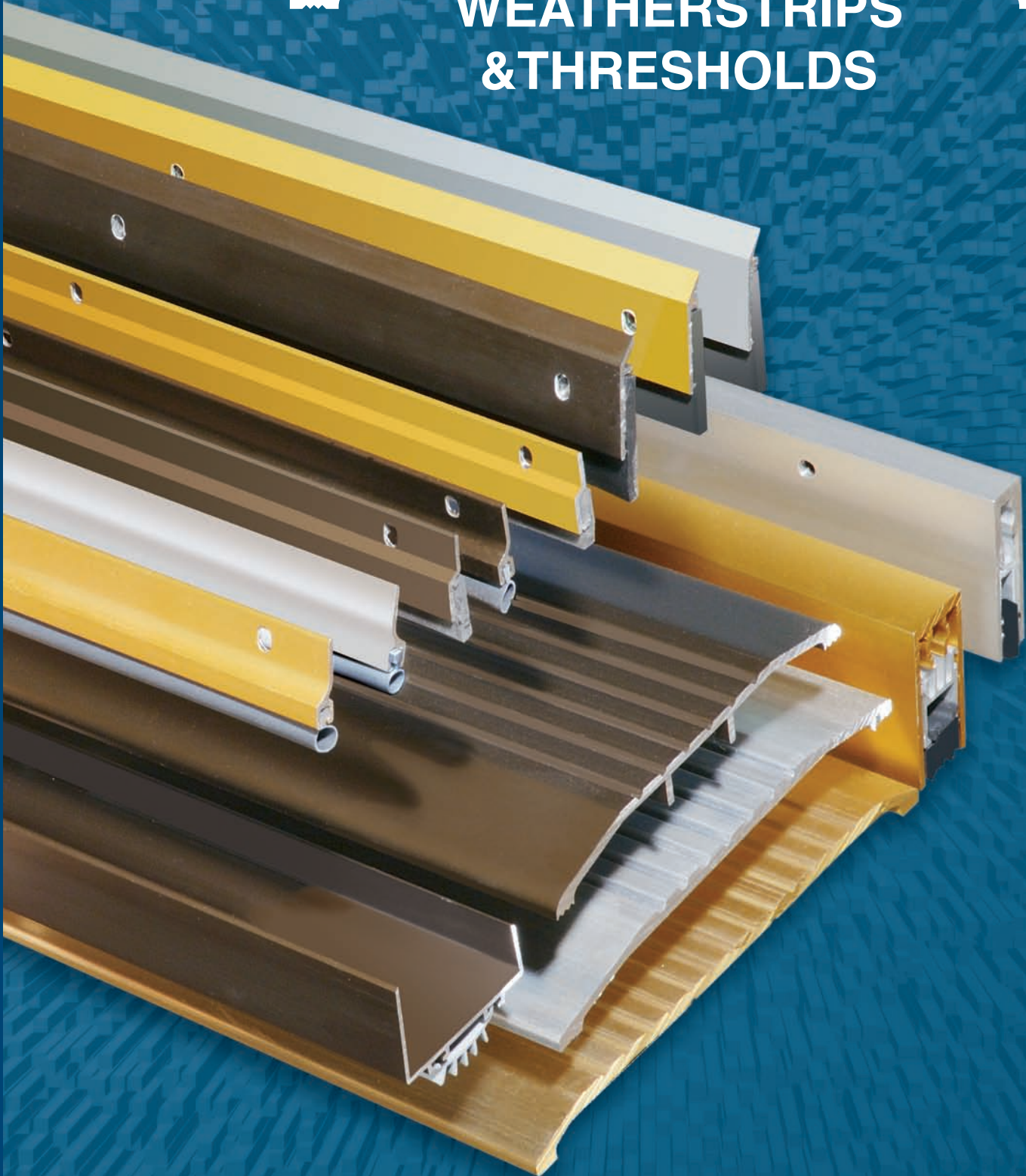

Phone 1-800-328-0953
Fax 1-800-334-8823
www.reeseusa.com

Continuous Service and Quality

Reese Enterprises, Inc. has more than 80 years experience in manufacturing weatherstrips along with many other door & floor products. During that time, we have devoted both time and dollars to product development, research and testing. Our highest valued asset, however, is you — our customer. That's why you'll talk to a pleasant, helpful person when you call Reese. No answering machines or recorded menus. Call us and hear for yourself.



THRESHOLDS

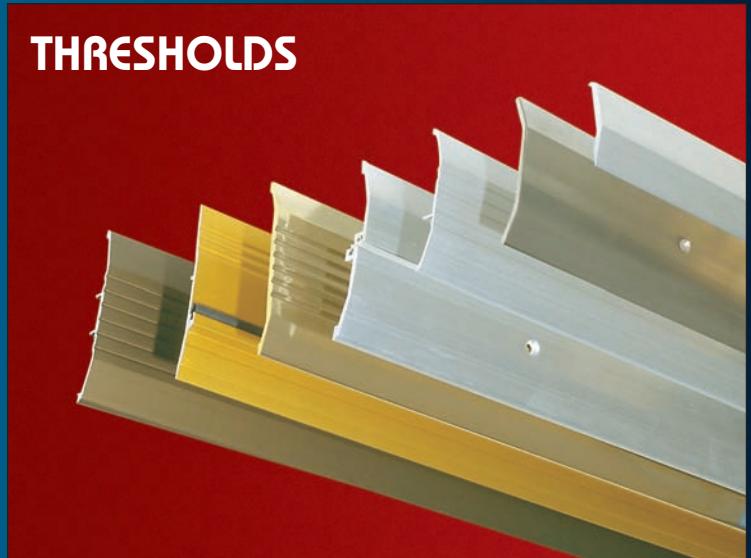

WEATHERSTRIPS

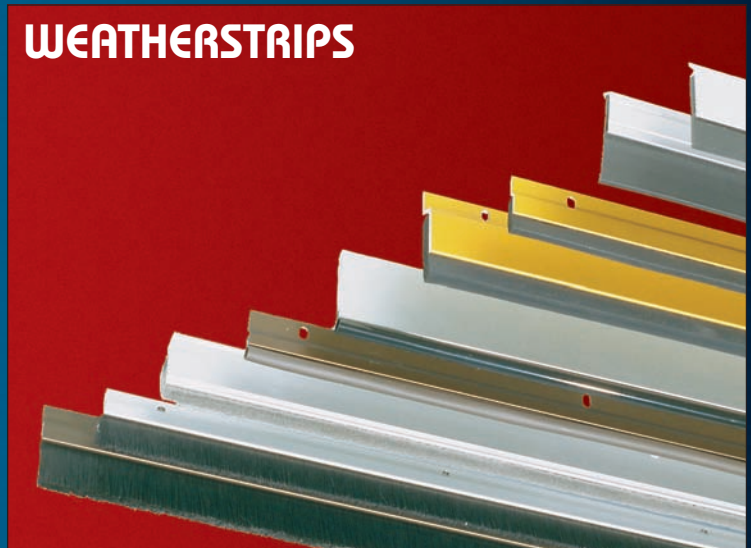

DOOR BOTTOMS

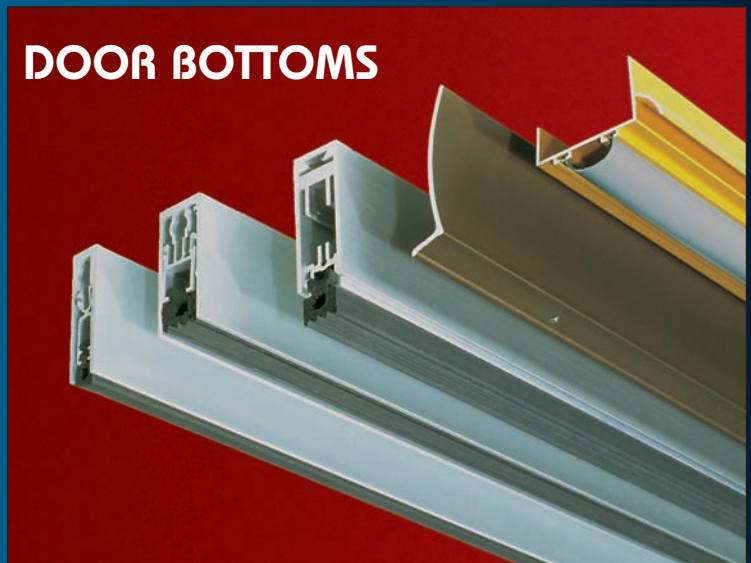



TECHNICAL DATA SHEET

Revision: August 7, 2018
Supersedes: November 13, 2015
Ref. #: 518327

DRAFT & ACOUSTICAL SOUND SEALANT

SC175

DESIGNED FOR USE ON SOUND-RATED WALL SYSTEMS

OSI SC175 Draft & Acoustical Sound Sealant is a non-flammable, latex-based sealant specially designed to reduce sound transmissions and drafts in all types of wall systems where a sound-rated assembly is required. Its primary function is to achieve and maintain the specific STC (Sound Transmission Class) value of the system designed. This paintable sealant remains flexible and adheres firmly to wood, metal studs, concrete, gypsum board and most other building materials. It is easy-to-use and cleans up easily with soap and water.

Available As:

Item #	Size	Color
1496542	28 fl oz (828 ml) cartridge	White

FEATURES & BENEFITS

- Designed for Use on Sound-Rated Wall Systems
- Reduces Draft & Sound Transmission
- Tested to UL 1479 and UL 2079 *
- Tested to ASTM E84
- Stays Permanently Flexible
- VOC Compliant

RECOMMENDED FOR

- Developed primarily for commercial construction utilizing light weight cavity walls and floor systems
- Used for exposed and unexposed applications at perimeter joints, floor and ceiling runners, cutouts in gypsum board, veneer plaster systems and other areas where a sound rated assembly is required
- Sealant can also be applied or buttered around all electrical boxes and outlets, cold air returns, heating and air conditioning ducts and other utility equipment penetrating wall surfaces for increased acoustical performance
- Works well for sealing sill and base plates in residential construction and non-fire rated systems

LIMITATIONS

- SC175 must be applied in accordance with ASTM C919 (Standard Practice for Use of Sealants in Acoustical Applications)
- Non-fire rated and fire rated systems. Refer to UL Fire Resistance Directory for testing details *
- Not for use in underwater applications or permanent water immersion
- Do not use in applications requiring temperature resistance greater than 170°F
- Do not use on metals that will corrode
- Consult with manufacturer of adjoining materials for compatibility, including CPVC materials
- Not recommended for bonding two non-porous surfaces
- Not recommended for use with polyethylene, polypropylene, polytetrafluoroethylene (PTFE)/Teflon® or nylon

COVERAGE

For a 28 fl. oz. (825 ml) cartridge:

• A 1/4" (6 mm) bead extrudes approximately 86 ft. (26 m)

• A 3/8" (9.5 mm) bead extrudes approximately 38 ft. (12 m)



TECHNICAL DATA SHEET

Revision: August 7, 2018
 Supersedes: November 13, 2015
 Ref. #: 518327

TECHNICAL DATA

Typical Uncured Physical Properties:

Color:	White	VOC Content:	<1.0% by weight	CARB
Appearance:	Non-slumping paste		45 g/l	SCAQMD rule 1168
Base:	Synthetic latex rubber	Shelf Life:	24 months from date of manufacture (unopened)	
Odor:	Mild acrylic odor	Lot Code	YYDDD	
Specific Gravity:	1.59	Explanation	YY = Last two digits of year of manufacture DDD = Day of manufacture based on 365 days in a year	
Flashpoint:	800.6° F (427°C)	Example:	18061 = 61 st day of 2018 = March 2, 2018	
Freeze/Thaw Stability	3 Freeze/Thaw Cycles Unaffected by freezing once cured			

Typical Application Properties:

Application Temperature:	Above 40°F (4°C)		
Open/Tooling Time	15 minutes*		
Tack-free Time:	30 minutes		
Cure Time:	2-7 days or longer*	* Cure time is dependent on temperature, humidity and depth of sealant applied	
Sag or Slump:	0.10 inches		ASTM D2202

Typical Cured Performance Properties:

Color:	White		
Service Temperature:	-5°F (-21°C) to 170°F (77°C)		
Water Resistant:	Yes		
Paintable:	Yes, after 24 hours		
Surface Burning Characteristics:	Flame Spread Index: 0		ASTM E 84
	Smoke Development: 0		Inorganic reinforced cement board
Sound Transmission Class:	Unsealed partition: STC = 15		ASTM E 90
	Single bead of sealant used at top and bottom runners only – both sides of partition system: STC = 24		
	Single bead of sealant used at top, bottom and perimeter joints – both sides of system: STC = 45		
	Double Bead of Sealant used at top, bottom, and all perimeter edges - both sides of partition system: STC = 55		
Low Temperature Flexibility After Artificial Weathering:	Pass with no cracking or adhesion loss		ASTM C734
Consistency Test:	300		ASTM D217
180° Peel Adhesion:			ASTM C794
Aluminum:	10.0 pli		7day cure @ 73°F & day cure @ 122°F
Wood:	8.0 pli		



TECHNICAL DATA SHEET

Revision: August 7, 2018
Supersedes: November 13, 2015
Ref. #: 518327

TECHNICAL DATA

Specifications:

UL File Number R39256



FILL, VOID OR CAVITY MATERIAL
FOR USE IN THROUGH-PENETRATION FIRESTOP
SYSTEMS & JOINT SYSTEMS
SEE UL FIRE RESISTANCE DIRECTORY
Control No. # R39256

Tested to or conforms to:

- **ASTM C834** – Standard Specification for Latex Sealants
- **ASTM E84, Class A** – Standard Test Method for Surface Burning Characteristics of Building Materials (Tested at UL under research project)
- **ASTM E90** – Standard Test Method for Laboratory Measurement of Airborne Sound Transmission Loss of Building Partitions and Elements
- **ASTM C919** – Standard Practice for Use of Sealants in Acoustical Applications
- **ASTM D217** – Standard Test Methods for Cone Penetration of Lubricating Grease
- * **UL 1479** (ASTM E814) – Standard for Fire Tests of Penetration Firestops
- * **UL 2079** (ASTM E1966) – Standard for Tests for Fire Resistance of Building Joint Systems
- GreenGuard® Certified
- * Refer to UL Fire Resistance Directory for design systems

DIRECTIONS

Tools Typically Required:

Utility knife, caulking gun and tool to puncture inside seal of cartridge.

Safety Precautions:

Wear gloves.

Preparation:

The temperature of the product, the surfaces and the working area must be above 40°F (4°C). For best performance, apply sealant at 70°F (21°C). Ensure surfaces to be sealed are clean, dry, structurally sound and free of dust, grease, oil, and other foreign contaminants. Cut off tip of cartridge at a 45° angle to desired bead size (3/8" recommended). Puncture inside seal of cartridge.

Application:

Sealant should be applied as specified in the sound-rated system being installed (either wood or metal studs). Sealant must be applied in accordance with ASTM C 919. Maximum joint size should not exceed 5/8" (15.9 mm) width x 1/2" (12.7 mm) depth. If necessary, sealant can be painted as applicable to meet project requirements after 24 hours.

Bottom and Top Runners:

Apply a continuous 3/8" (9.5 mm) round bead of sealant on runners before setting gypsum board. Press gypsum board firmly into sealant, ensuring complete contact with adjacent materials. Fill joint on top runners to complete the seal. Repeat procedure for double-layer applications.

Cut-Outs and Perimeter Joints:

Backs of electrical boxes, pipes, duct systems and other types of utility equipment penetrating wall surfaces shall be buttered with sealant. Seal all joints at perimeter edges including abutting surfaces and corner joints.

For further application information, refer to ASTM C919 - Standard Practice for Use of Sealants in Acoustical Applications.

Clean-up:

Clean tools and uncured adhesive residue immediately with warm water and soap. Cured sealant may be carefully cut away with a sharp-edged tool.

STORAGE & DISPOSAL

DAMAGED BY FREEZING. Store in a cool, dry location at room temperature. For maximum shelf life store at 75°F (24°C). Take unwanted product to an approved household hazardous waste transfer facility. Hardened material may be disposed of with

LABEL PRECAUTIONS

CAUTION! Contains ethylene glycol, mineral spirits, and crystalline silica. May cause skin, eye and respiratory irritation. Avoid contact with eyes and skin. Avoid breathing vapors. Use with adequate ventilation. Do not swallow. **FIRST AID:** If swallowed do not induce vomiting, call a physician or Poison Control center immediately. For eye contact, flush with water for 15 minutes, call a physician. For skin contact, wash thoroughly with soap and water. **KEEP OUT OF REACH OF CHILDREN.**



WARNING: Cancer and Reproductive Harm – www.P65Warnings.ca.gov.

Refer to the Safety Data Sheet (SDS) for further information.



TECHNICAL DATA SHEET

Revision: August 7, 2018
Supersedes: November 13, 2015
Ref. #: 518327

LIMITED WARRANTY

This product is warranted to be free from defects in materials when used as directed. Henkel's sole obligation shall be, at its option, to replace or refund the purchase price of product proven to be defective. Henkel makes no other warranty, express or implied, including warranties of MERCHANTABILITY and FITNESS FOR A PARTICULAR PURPOSE and will not be liable for consequential or incidental damages. This limited warranty gives you specific legal rights, which vary from state to state

DISCLAIMER

The information and recommendations contained herein are based on our research and are believed to be accurate, but no warranty, express or implied, is made or should be inferred. Henkel recommends purchasers/users should test the products to determine acceptable quality and suitability for the intended use. All adhesive/sealant applications should be tested under simulated or actual end use conditions to ensure the adhesive/sealant meets or exceeds all required project specifications. Since assembly conditions may be critical to adhesive/sealant performance, it is also recommended that testing be performed on specimens assembled under simulated or actual production conditions. Nothing contained herein shall be construed to imply the nonexistence of any relevant patents or to constitute a permission, inducement or recommendation to practice any invention covered by any patent, without authority from the owner of the patent.



OSI Tougher than the Elements. For Professional Use Only. The Battle will be Fierce.

OSI works side by side with residential builders, contractors and remodeling professionals who use our products every day on their jobsites. OSI combines this deep understanding with the sophisticated global innovation and manufacturing excellence of Henkel to make the world's best professional-grade caulks, sealants and adhesives.

For Technical Assistance call: 1-800-624-7767 – Mon-Fri - 9:00a – 4:00p ET

www.ositough.com



OSI Brand is part of the Henkel family of brands. Founded in 1876, Henkel is a global leader in the consumer and industrial businesses. Henkel operates worldwide with leading brands and technologies in three business areas: Laundry & Home Care, Beauty Care and Adhesive Technologies.

Henkel Corporation - Professional & Consumer Adhesives Headquarters - Rocky Hill, CT 06067

www.henkeln.com

AC-20 FTR®

(Fire & Temperature Rated) Acoustical & Insulation Sealant

Specification Data Sheet



BASIC USES

• AC-20 FTR® fire-rated systems are suitable for applications in schools, hospitals, churches, high-rise office buildings and hotels, prisons, sports arenas, and other public-use buildings to ensure a safe and orderly evacuation in the event of a fire.

2. MANUFACTURER

Pecora Corporation
165 Wambold Road
Harleysville, PA 19438
Phone: 215-723-6051
800-523-6688
Fax: 215-721-0286
Website: www.pecora.com

3. PRODUCT DESCRIPTION

AC-20 FTR® is a unique acrylic latex sealant that is UL® Classified in firestopping systems for expansion joints and through penetrations. When properly installed, these systems effectively contain fire, smoke, toxic fumes, and water within a given area surrounded by firewalls for a two, three, or four hour period, depending on the design specifications.

Other Uses: Excellent adhesive, flexibility and durability qualities make AC-20 FTR® ideal for insulating and weatherproofing around windows, doors, panels, siding, duct work, base plates, etc. It is compatible with all common building materials including specialties such as polystyrene, polyurethane, cork, vinyl, foamed and fibrous glass.

Used as an acoustical sealant, AC-20 FTR® reduces sound transmission in partition systems to achieve specific STC values by sealing spaces around cut-outs and at perimeters of partitions. The sealant cures to a tough rubber to form a long-lasting acoustical seal.

PACKAGING

- 30 fl. oz. (.887 liter) fiber cartridges
- 5-gallon (18.9 liter) pails

COLOR

- White, Beige-Gray
- Special colors available in 250-gallon (946 liter) batches.

4. TECHNICAL DATA

Applicable Standards: ASTM C-834-86 specification for latex sealing compounds.

Fire Rated System: Two-hour Fire and Temperature Rated wall and floor joint systems up to 7" (178mm) wide and four-hour systems up to 4" wide can be designed with AC-20 FTR® in conjunction with Ultra Block fire blocking material in fire-rated walls and floors. Reference: ANSI/UL 263, ASTM E-119, NFPA No. 251.



UNDERWRITERS
LABORATORIES INC.®
CLASSIFIED

JOINT TREATMENT MATERIALS
FIRE RESISTANCE
CLASSIFICATION

DESIGNS J900H (FFS 0006) & U900 "O"
(WWS 0010), J900Z (FFS 2002), U900Z-
009 (WWS 2008), J900Z-007 (FFS 1010),
U900Z-015 (WWS 1012)

AC-20 FTR® in conjunction with Ultra Block® achieves a 2-hour fire rating when sealing around steel or copper pipe and electrical metallic tubing or steel conduit in through penetration systems. Reference: ANSI/UL 1479, ASTM E-814.

FILL, VOID OR CAVITY MATERIALS

CLASSIFIED BY
UNDERWRITERS

LABORATORIES INC.

FOR USE IN

THROUGH-PENETRATION

FIRESTOP SYSTEM NO. CAJ 1093

In addition to its fire-blocking value, Ultra Block® is very efficient acoustically, having a noise reduction coefficient of .75 and sound transmission coefficient of .5 (Ultra Block® is a registered trademark of Backer Rod Mfg. and Supply Co., Denver, CO, USA.)

5. INSTALLATION

Surface Preparation: Surfaces must be free of all contamination. Sealant may be applied to damp, porous surfaces. No priming is required.

Application: Refer to Pecora Firestopping Manual 07270 and UL Fire Resistance Directory for installation details on fire-rated joint and through penetration systems. For insulating and weatherproofing purposes, fill all window, door, and panel perimeter joints using a resilient backer rod to control sealant depth to 1/2" (13mm) maximum. For best results, protect sealant from excessive low temperatures and apply above 40°F (4°C). For acoustical purposes, apply continuous

TYPICAL PHYSICAL PROPERTIES

Test Property	Value	Procedure
Modulus @ 100% (psi)	15-20	ASTM D412
Ultimate Tensile (psi)	30-40	ASTM D412
Ultimate Elongation (%)	400-500	ASTM D412
Movement Capability (%)	±7 1/2	ASTM D412
VOC Content	31 g/L	

beads of sealant to seal perimeters of all sound-rated partitions. Apply sealant in the angles formed by metal components or base-layer panels and abutting surfaces. Apply sealant around all openings formed for outlets; electrical, telephone, light fixtures, etc.

Tooling: Tool material flush with surfaces to allow for expected shrinkage and insure good contact and adhesion to the substrate.

Cleaning: Remove excess material with water or a damp cloth before it cures. Sealant may be painted within 30 minutes after application with a good grade of latex paint.

Shelf Life: AC-20 FTR® has a shelf life well in excess of one year when stored in unopened containers below 80° F (27°C).

Precautions: AC-20 FTR® is non-flammable, non-toxic, non-irritating and environmentally safe. However, do not take internally. Refer to Material Safety Data Sheet for additional information.

Ultra Block® is a non-carcinogenic processed continuous filament textile glass fiber that may cause skin, eye and respiratory irritation. When applying, wear long sleeves, gloves, cap, goggles or safety glasses and NIOSH/MSHA-approved dust respirator. After use bathe with soap and warm water. Wash clothes separately and rinse after use. Refer to Material Safety Data Sheet for additional information.

**FOR PROFESSIONAL USE ONLY.
KEEP OUT OF THE REACH
OF CHILDREN.**

6. AVAILABILITY AND COST

Pecora products are available from our stocking distributors in all major cities. For the name and telephone number of your nearest representative call one of our locations listed below or visit our website at www.pecora.com.

7. WARRANTY

Pecora Corporation warrants its products to be free of defects. Under this warranty, we will provide, at no charge, replacement materials for, or refund the purchase price of, any product proven to be defective when installed in accordance with our published recommendations and in applications considered by us as suitable from this product. This warranty in lieu of any and all other warranties expressed or implied, and in no case will Pecora be liable for incidental or consequential damages.

8. MAINTENANCE

If the sealant is damaged and the bond is intact, cut out the damaged area and recaulk. No primer is required. If the bond has been affected, remove the sealant, clean and prepare the joint in accordance with instructions under "Installation".

9. TECHNICAL SERVICES

Pecora representatives are available to assist you in selecting an appropriate product and to provide on-site application instructions or to conduct jobsite inspections. For further assistance call our Technical Service Department at 800-523-6688.



PEOPLE • PRODUCTS • PERFORMANCE

www.pecora.com

HARLEYSVILLE, PA
165 Wambold Road, Harleysville, PA 19438
Phone: 800-523-6688 • 215-723-6051 • FAX: 215-721-0286

DALLAS, TX
11501 Hillguard Road, Dallas, TX 75243
Phone: 800-233-9754 • 214-348-5313 • FAX: 214-348-5421

APPENDIX J

Project-Generated Traffic Noise Calculations

EILAR ASSOCIATES, INC.

Acoustical and Environmental Consulting

Project-Generated Traffic Noise Impact Calculations

Project: 516 La Costa
Project #: S200108
Date: 1/30/2020

Intersection: La Costa Ave and I-5 SB Off Ramp

AM Peak Hour Traffic

Approach	Existing		Existing + Project	
	<i>Volume</i>	<i>Total</i>	<i>Volume</i>	<i>Total</i>
North Right	0	728	0	729
North Straight	0		0	
North Left	0		0	
East Right	67	1418	68	1426
East Straight	617		619	
East Left	0		0	
South Right	287	799	288	800
South Straight	4		4	
South Left	508		508	
West Right	0	2229	0	2235
West Straight	447		451	
West Left	657		657	

Direct: Existing vs. Existing + Project	
North	0.0
East	0.0
South	0.0
West	0.0

AM Peak Hour

EILAR ASSOCIATES, INC.

Acoustical and Environmental Consulting

Project-Generated Traffic Noise Impact Calculations

Project: 516 La Costa
Project #: S200108
Date: 1/30/2020

Intersection: La Costa Ave and I-5 SB Off Ramp

PM Peak Hour Traffic

Approach	Existing		Existing + Project	
	<i>Volume</i>	<i>Total</i>	<i>Volume</i>	<i>Total</i>
North Right	0	806	0	808
North Straight	0		0	
North Left	0		0	
East Right	67	1221	69	1232
East Straight	507		509	
East Left	0		0	
South Right	163	615	165	617
South Straight	1		1	
South Left	451		451	
West Right		2180	0	2187
West Straight	484		489	
West Left	738		738	

Direct: Existing vs. Existing + Project	
North	0.0
East	0.0
South	0.0
West	0.0

PM Peak Hour

EILAR ASSOCIATES, INC.

Acoustical and Environmental Consulting

Project-Generated Traffic Noise Impact Calculations

Project: 516 La Costa
Project #: S200108
Date: 1/30/2020

Intersection: La Costa Ave and Vulcan

AM Peak Hour Traffic

Approach	Existing		Existing + Project	
	<i>Volume</i>	<i>Total</i>	<i>Volume</i>	<i>Total</i>
North Right	183	562	183	559
North Straight	0		0	
North Left	33		33	
East Right	85	828	82	828
East Straight	361		363	
East Left	0		0	
South Right	0	0	0	0
South Straight	0		0	
South Left	0		0	
West Right	0	1154	0	1157
West Straight	349		350	
West Left	261		261	

Direct: Existing vs. Existing + Project	
North	0.0
East	0.0
South	0.0
West	0.0

AM Peak Hour

EILAR ASSOCIATES, INC.

Acoustical and Environmental Consulting

Project-Generated Traffic Noise Impact Calculations

Project: 516 La Costa
Project #: S200108
Date: 1/30/2020

Intersection: La Costa Ave and Vulcan

PM Peak Hour Traffic

Approach	Existing		Existing + Project	
	<i>Volume</i>	<i>Total</i>	<i>Volume</i>	<i>Total</i>
North Right	152	389	152	389
North Straight	0		0	
North Left	58		58	
East Right	56	898	56	901
East Straight	343		345	
East Left	0		0	
South Right	0	0	0	0
South Straight	0		0	
South Left	0		0	
West Right	0	1059	0	1062
West Straight	441		442	
West Left	123		123	

Direct: Existing vs. Existing + Project	
North	0.0
East	0.0
South	0.0
West	0.0

PM Peak Hour

APPENDIX K

Cadna Analysis Data and Results

Eilar Associates, Inc.

210 South Juniper Street, Suite 100
 Escondido, California 92025-4230
 Phone: (760) 738-5570
 Date: 30 Jan 2020

Calculation Configuration

Configuration	
Parameter	Value
General	
Country	(user defined)
Max. Error (dB)	0.00
Max. Search Radius #(Unit,LEN)	2000.00
Min. Dist Src to Rcvr	0.00
Partition	
Raster Factor	0.50
Max. Length of Section #(Unit,LEN)	1000.00
Min. Length of Section #(Unit,LEN)	1.00
Min. Length of Section (%)	0.00
Proj. Line Sources	On
Proj. Area Sources	On
Ref. Time	
Reference Time Day (min)	960.00
Reference Time Night (min)	480.00
Daytime Penalty (dB)	0.00
Recr. Time Penalty (dB)	6.00
Night-time Penalty (dB)	10.00
DTM	
Standard Height (m)	0.00
Model of Terrain	Triangulation
Reflection	
max. Order of Reflection	0
Search Radius Src	100.00
Search Radius Rcvr	100.00
Max. Distance Source - Rcvr	1000.00 1000.00
Min. Distance Rvcr - Reflector	1.00 1.00
Min. Distance Source - Reflector	0.10
Industrial (ISO 9613)	
Lateral Diffraction	some Obj
Obst. within Area Src do not shield	On
Screening	Excl. Ground Att. over Barrier
	Dz with limit (20/25)
Barrier Coefficients C1,2,3	3.0 20.0 0.0
Temperature #(Unit,TEMP)	10
rel. Humidity (%)	70
Ground Absorption G	0.50
Wind Speed for Dir. #(Unit,SPEED)	3.0
Roads (TNM)	
Railways (Schall 03 (1990))	
Strictly acc. to Schall 03 / Schall-Transrapid	
Aircraft (???)	
Strictly acc. to AzB	

Receivers

Name	M.	ID	Level Lr		Limit. Value		Land Use			Height (m)	Coordinates		
			Day (dBA)	Night (dBA)	Day (dBA)	Night (dBA)	Type	Auto	Noise Type		X (m)	Y (m)	Z (m)
R1			33.4	33.3	50.0	45.0				1.52 r	389.94	85.21	22.67
R2			45.9	45.9	60.0	55.0				1.52 r	393.93	124.97	23.58
R3			40.6	41.5	60.0	55.0				1.52 r	392.29	184.72	22.28
R4			44.7	28.0	50.0	45.0				1.52 r	353.31	236.09	20.29
R5			41.8	39.2	50.0	45.0				1.52 r	353.64	215.31	20.96

Name	M.	ID	Result. PWL			Lw / Li		Correction			Sound Reduction		Attenuation	Operating Time			K0	Freq.	Direct.	Height	Coordinates			
			Day (dBA)	Evening (dBA)	Night (dBA)	Type	Value dB(A)	norm. dB(A)	Day dB(A)	Evening dB(A)	Night dB(A)	R		Area (m²)	Day (min)	Special (min)					Night (min)	(dB)	(Hz)	(m)
M10			74.6	74.6	74.6	Lw	L1		0.0	0.0	0.0				30.00	0.00	0.00	0.0	(none)	1.07	r	366.03	235.42	21.49
M11			74.6	74.6	74.6	Lw	L1		0.0	0.0	0.0				30.00	0.00	0.00	0.0	(none)	1.07	r	367.67	239.31	21.49
M13			74.6	74.6	74.6	Lw	L1		0.0	0.0	0.0				30.00	0.00	0.00	0.0	(none)	1.07	r	367.90	235.43	21.49
M14			74.6	74.6	74.6	Lw	L1		0.0	0.0	0.0				30.00	0.00	0.00	0.0	(none)	1.07	r	367.90	234.23	21.49
M15			74.6	74.6	74.6	Lw	L1		0.0	0.0	0.0				30.00	0.00	0.00	0.0	(none)	1.07	r	369.14	237.47	21.49
M16			74.6	74.6	74.6	Lw	L1		0.0	0.0	0.0				30.00	0.00	0.00	0.0	(none)	1.07	r	369.18	236.26	21.49
M17			74.6	74.6	74.6	Lw	L1		0.0	0.0	0.0				30.00	0.00	0.00	0.0	(none)	1.07	r	370.10	235.36	21.49
M18			74.6	74.6	74.6	Lw	L1		0.0	0.0	0.0				30.00	0.00	0.00	0.0	(none)	1.07	r	370.08	234.23	21.49
M19			74.6	74.6	74.6	Lw	L1		0.0	0.0	0.0				30.00	0.00	0.00	0.0	(none)	1.07	r	375.02	225.92	21.49
M20			74.6	74.6	74.6	Lw	L1		0.0	0.0	0.0				30.00	0.00	0.00	0.0	(none)	1.07	r	375.87	226.77	21.49
M21			74.6	74.6	74.6	Lw	L1		0.0	0.0	0.0				30.00	0.00	0.00	0.0	(none)	1.07	r	376.88	225.82	21.49
M22			74.6	74.6	74.6	Lw	L1		0.0	0.0	0.0				30.00	0.00	0.00	0.0	(none)	1.07	r	378.01	224.59	21.49
M23			74.6	74.6	74.6	Lw	L1		0.0	0.0	0.0				30.00	0.00	0.00	0.0	(none)	1.07	r	378.55	223.20	21.49
W01			72.9	72.9	72.9	Lw	L2		0.0	0.0	0.0				30.00	0.00	0.00	0.0	(none)	1.07	r	364.06	234.36	21.49
W02			72.9	72.9	72.9	Lw	L2		0.0	0.0	0.0				30.00	0.00	0.00	0.0	(none)	1.07	r	362.85	234.30	21.49
W03			72.9	72.9	72.9	Lw	L2		0.0	0.0	0.0				30.00	0.00	0.00	0.0	(none)	1.07	r	362.48	235.49	21.49
W04			72.9	72.9	72.9	Lw	L2		0.0	0.0	0.0				30.00	0.00	0.00	0.0	(none)	1.07	r	361.25	235.47	21.49
W05			72.9	72.9	72.9	Lw	L2		0.0	0.0	0.0				30.00	0.00	0.00	0.0	(none)	1.07	r	364.00	237.07	21.49
W06			72.9	72.9	72.9	Lw	L2		0.0	0.0	0.0				30.00	0.00	0.00	0.0	(none)	1.07	r	362.74	237.03	21.49
W07			72.9	72.9	72.9	Lw	L2		0.0	0.0	0.0				30.00	0.00	0.00	0.0	(none)	1.07	r	365.49	238.95	21.49
W08			72.9	72.9	72.9	Lw	L2		0.0	0.0	0.0				30.00	0.00	0.00	0.0	(none)	1.07	r	364.36	238.86	21.49
W09			72.9	72.9	72.9	Lw	L2		0.0	0.0	0.0				30.00	0.00	0.00	0.0	(none)	1.07	r	366.09	236.47	21.49
W10			72.9	72.9	72.9	Lw	L2		0.0	0.0	0.0				30.00	0.00	0.00	0.0	(none)	1.07	r	366.03	234.25	21.49
W11			72.9	72.9	72.9	Lw	L2		0.0	0.0	0.0				30.00	0.00	0.00	0.0	(none)	1.07	r	368.31	238.73	21.49
W12			72.9	72.9	72.9	Lw	L2		0.0	0.0	0.0				30.00	0.00	0.00	0.0	(none)	1.07	r	367.71	238.13	21.49
W12			72.9	72.9	72.9	Lw	L2		0.0	0.0	0.0				30.00	0.00	0.00	0.0	(none)	1.07	r	367.09	238.69	21.49
W13			72.9	72.9	72.9	Lw	L2		0.0	0.0	0.0				30.00	0.00	0.00	0.0	(none)	1.07	r	368.50	234.81	21.49
W14			72.9	72.9	72.9	Lw	L2		0.0	0.0	0.0				30.00	0.00	0.00	0.0	(none)	1.07	r	367.26	234.83	21.49
W15			72.9	72.9	72.9	Lw	L2		0.0	0.0	0.0				30.00	0.00	0.00	0.0	(none)	1.07	r	369.76	236.85	21.49
W16			72.9	72.9	72.9	Lw	L2		0.0	0.0	0.0				30.00	0.00	0.00	0.0	(none)	1.07	r	368.52	236.92	21.49
W17			72.9	72.9	72.9	Lw	L2		0.0	0.0	0.0				30.00	0.00	0.00	0.0	(none)	1.07	r	370.74	234.83	21.49
W18			72.9	72.9	72.9	Lw	L2		0.0	0.0	0.0				30.00	0.00	0.00	0.0	(none)	1.07	r	369.53	234.81	21.49
W19			72.9	72.9	72.9	Lw	L2		0.0	0.0	0.0				30.00	0.00	0.00	0.0	(none)	1.07	r	375.40	226.26	21.49
W20			72.9	72.9	72.9	Lw	L2		0.0	0.0	0.0				30.00	0.00	0.00	0.0	(none)	1.07	r	376.23	225.02	21.49
W21			72.9	72.9	72.9	Lw	L2		0.0	0.0	0.0				30.00	0.00	0.00	0.0	(none)	1.07	r	377.19	223.98	21.49
W22			72.9	72.9	72.9	Lw	L2		0.0	0.0	0.0				30.00	0.00	0.00	0.0	(none)	1.07	r	378.10	222.81	21.49
W23			72.9	72.9	72.9	Lw	L2		0.0	0.0	0.0				30.00	0.00	0.00	0.0	(none)	1.07	r	379.01	223.66	21.49
S1		M1	82.5	82.5	82.5	Lw	M1		0.0	0.0	0.0				60.00	0.00	0.00	0.0	(none)	2.44	r	364.84	234.33	22.86
S2		M1	82.5	82.5	82.5	Lw	M1		0.0	0.0	0.0				60.00	0.00	0.00	0.0	(none)	2.44	r	371.92	234.30	22.86
S3		M1	82.5	82.5	82.5	Lw	M1		0.0	0.0	0.0				60.00	0.00	0.00	0.0	(none)	2.44	r	373.62	227.24	22.86
S4		M1	82.5	82.5	82.5	Lw	M1		0.0	0.0	0.0				60.00	0.00	0.00	0.0	(none)	2.44	r	378.96	222.05	22.86
S5		M1	82.5	82.5	82.5	Lw	M1		0.0	0.0	0.0				60.00	0.00	0.00	0.0	(none)	2.44	r	374.30	217.10	22.86
S6		M1	82.5	82.5	82.5	Lw	M1		0.0	0.0	0.0				60.00	0.00	0.00	0.0	(none)	2.44	r	372.09	213.09	22.86
S7		M1	82.5	82.5	82.5	Lw	M1		0.0	0.0	0.0				60.00	0.00	0.00	0.0	(none)	2.44	r	375.71	207.81	22.87
S8		M1	82.5	82.5	82.5	Lw	M1		0.0	0.0	0.0				60.00	0.00	0.00	0.0	(none)	2.44	r	380.45	207.04	23.09
S9		M1	82.5	82.5	82.5	Lw	M1		0.0	0.0	0.0				60.00	0.00	0.00	0.0	(none)	2.44	r	385.23	214.40	22.86
S10		M1	82.5	82.5	82.5	Lw	M1		0.0	0.0	0.0				60.00	0.00	0.00	0.0	(none)	2.44	r	384.10	157.59	24.17
S11		M1	82.5	82.5	82.5	Lw	M1		0.0	0.0	0.0				60.00	0.00	0.00	0.0	(none)	2.44	r	388.07	154.58	24.35

Area Sources

Name	M.	ID	Result. PWL			Result. PWL"			Lw / Li			Correction			Sound Reduction		Attenuation	Operating Time			K0	Freq.	Direct.	Moving Pt. Src		
			Day	Evening	Night	Day	Evening	Night	Type	Value	norm.	Day	Evening	Night	R	Area		Day	Special	Night				Number		
			(dBA)	(dBA)	(dBA)	(dBA)	(dBA)	(dBA)				(dBA)	(dBA)	(dBA)		(m²)		(min)	(min)	(min)				(dB)	(Hz)	Day
Pool Deck - Male Voices			89.4	-25.4	89.4	69.0	-45.7	69.0	PWL-Pt	L1		0.0	0.0	0.0				30.00	0.00	30.00	0.0		(none)	30.0	0.0	30.0
Pool Deck - Female Voices			87.7	-27.1	87.7	67.4	-47.4	67.4	PWL-Pt	L2		0.0	0.0	0.0				30.00	0.00	30.00	0.0		(none)	30.0	0.0	30.0

Geometry - Area Sources

Name	Height		Coordinates			
	Begin	End	x	y	z	Ground
	(m)	(m)	(m)	(m)	(m)	(m)
Pool Deck - Male Voices	1.07	r	372.42	214.66	21.49	20.42
			372.49	210.54	21.49	20.42
			379.65	209.23	21.49	20.42
			382.29	210.72	21.49	20.42
			385.46	214.12	21.49	20.42
			385.25	215.61	21.49	20.42
			380.60	222.87	21.49	20.42
Pool Deck - Female Voices	1.07	r	372.42	214.66	21.49	20.42
			372.49	210.54	21.49	20.42
			379.65	209.23	21.49	20.42
			382.29	210.72	21.49	20.42
			385.46	214.12	21.49	20.42
			385.25	215.61	21.49	20.42
			380.60	222.87	21.49	20.42

Barriers

Name	M.	ID	Absorption		Z-Ext. (m)	Cantilever		Height	
			left	right		horz. (m)	vert. (m)	Begin (m)	End (m)
Restaurant	+							5.49	r
Bungalow 1	+							5.49	r
Bungalow 2	+							5.49	r
Bungalow 3	+							5.49	r
Bungalow 4	+							5.49	r
Unit 5	+								
Unit 4	+								
Unit 3	+								
Unit 2	+								
Unit 1	+								
Currently Proposed PL Barrier	+								
Mech Enclosure	+							1.83	r

Geometry - Barriers

Name	M.	ID	Absorption		Z-Ext. (m)	Cantilever		Height		Coordinates			
			left	right		horz. (m)	vert. (m)	Begin (m)	End (m)	x (m)	y (m)	z (m)	Ground (m)
Restaurant	+							5.49	r	365.45	211.33	25.91	20.42
										365.17	233.52	25.91	20.42
										371.41	233.52	25.91	20.42
										371.48	224.88	25.91	20.42
										371.91	224.46	25.91	20.42
										374.03	226.36	25.91	20.42
										378.33	222.02	25.91	20.42
										371.59	215.00	25.91	20.42
										371.73	211.37	25.91	20.42
										365.45	211.33	25.91	20.42
Bungalow 1	+							5.49	r	380.38	206.44	26.16	20.67
										374.94	200.82	26.16	20.67
										381.43	194.44	26.16	20.67
										386.92	200.11	26.16	20.67
										380.38	206.44	26.16	20.67
Bungalow 2	+							5.49	r	380.61	193.95	26.61	21.12
										375.16	188.33	26.61	21.12
										381.65	181.95	26.61	21.12
										387.15	187.62	26.61	21.12
										380.61	193.95	26.61	21.12
Bungalow 3	+							5.49	r	380.69	181.38	26.89	21.40
										375.24	175.75	26.89	21.40
										381.74	169.38	26.89	21.40
										387.23	175.05	26.89	21.40
										380.69	181.38	26.89	21.40
Bungalow 4	+							5.49	r	380.80	168.80	27.19	21.70
										375.36	163.18	27.19	21.70
										381.85	156.80	27.19	21.70
										387.34	162.47	27.19	21.70
										380.80	168.80	27.19	21.70
Unit 5	+									389.23	149.05	30.01	22.01
										380.92	148.96	30.01	22.01
										380.98	144.06	26.35	22.01
										389.34	144.15	26.35	22.01
										389.23	149.05	30.01	22.01
Unit 4	+									389.28	141.93	30.10	22.10
										380.97	141.85	30.10	22.10
										381.04	136.95	26.44	22.10
										389.40	137.03	26.44	22.10
										389.28	141.93	30.10	22.10
Unit 3	+									389.40	134.60	30.19	22.19
										381.08	134.51	30.19	22.19
										381.15	129.61	26.53	22.19

Name	M.	ID	Absorption		Z-Ext. (m)	Cantilever		Height		Coordinates			
			left	right		horz. (m)	vert. (m)	Begin (m)	End (m)	x (m)	y (m)	z (m)	Ground (m)
										389.51	129.70	26.53	22.19
										389.40	134.60	30.19	22.19
Unit 2	+									389.45	127.40	30.28	22.28
										381.14	127.31	30.28	22.28
										381.21	122.41	26.62	22.30
										389.56	122.50	26.62	22.28
										389.45	127.40	30.28	22.28
Unit 1	+									389.59	120.12	30.37	22.37
										381.28	120.03	30.37	22.37
										381.35	115.13	26.71	22.37
										389.70	115.22	26.71	22.37
										389.59	120.12	30.37	22.37
Currently Proposed PL Barrier	+									392.94	109.08	23.59	21.53
										392.81	117.74	23.59	22.21
										392.42	158.09	23.43	21.47
										392.29	171.78	23.21	21.08
										390.45	171.76	23.21	21.32
										390.42	183.23	23.06	21.04
										390.34	199.02	21.46	20.55
										390.23	209.38	20.42	19.97
										390.23	215.50	19.29	19.19
										390.22	218.40	19.29	18.73
Mech Enclosure	+							1.83	r	362.86	219.00	22.25	20.42
										359.66	219.00	22.25	20.42
										359.72	211.64	22.25	20.42
										362.88	211.57	22.25	20.42

Terrain Contours

Name	M.	ID	OnlyPts	Height		Coordinates		
				Begin (m)	End (m)	x (m)	y (m)	z (m)
TL1						338.14	492.77	3.00
						394.06	363.14	3.00
						430.87	261.99	7.00
						475.90	113.08	17.00
TL2						494.17	117.75	17.00
						458.16	243.10	7.00
						414.82	359.78	3.00
TL3						356.87	102.87	23.00
						355.28	256.86	18.00
						317.90	318.61	16.00
						293.54	385.81	17.00
						259.93	424.87	20.00
TL4						207.26	439.54	9.00
						449.55	125.37	19.00
						435.27	191.32	15.00
						410.07	248.44	5.00
						374.36	299.26	11.00
						378.56	349.25	3.00
						364.81	416.46	2.00
TL5						340.46	457.73	2.00
						245.21	465.14	1.00
						272.81	106.17	24.00
						269.47	185.51	24.00
						263.47	334.86	22.00
						261.47	389.54	21.00
						192.13	399.54	16.00
TL6						194.13	346.20	19.00
						241.47	306.19	23.00
						241.47	249.52	23.00
						246.80	182.84	24.00
						248.14	112.83	25.00
TL7						183.46	110.83	24.00
						182.79	212.85	23.00
						181.46	250.85	23.00
						179.46	335.53	19.00
TL8						136.12	376.87	16.00
						132.12	105.50	26.00
						120.12	339.53	19.00
TL9						92.78	367.54	13.00
						340.21	508.41	3.00
						419.18	364.77	2.00
TL10				19.81		538.46	138.80	4.00
						360.04	264.08	19.81
						365.65	255.72	19.81
						366.85	251.03	19.81
						366.56	249.43	19.81
						369.54	245.31	19.81
						374.17	242.50	19.81
						377.83	241.70	19.81
						379.89	239.81	19.81
						379.84	237.24	19.81
						378.69	235.81	19.81
pad 67.0				20.42		378.81	232.32	19.81
						381.96	228.43	19.81
						388.74	215.89	19.81
						389.83	212.71	19.81
						362.95	228.79	20.42
						360.95	231.26	20.42
						360.46	235.61	20.42
					362.24	238.59	20.42	
					365.75	240.10	20.42	

Name	M.	ID	OnlyPts	Height		Coordinates		
				Begin (m)	End (m)	x (m)	y (m)	z (m)
						369.09	239.70	20.42
						372.02	237.08	20.42
						385.58	215.79	20.42
						385.80	214.01	20.42
						382.33	210.28	20.42
						378.55	207.92	20.42
						364.51	208.90	20.42
						363.00	210.41	20.42
						363.01	211.46	20.42
						359.66	211.56	20.42
						359.59	219.13	20.42
						362.97	219.21	20.42
						362.95	228.79	20.42
pad 67.8				20.67		381.45	194.21	20.67
						388.67	201.63	20.67
						381.96	208.30	20.67
						374.71	200.86	20.67
						381.45	194.21	20.67
pad 69.3				21.12		381.58	181.65	21.12
						388.76	189.07	21.12
						382.65	195.17	21.12
						381.21	193.81	21.12
						380.75	194.20	21.12
						374.84	188.38	21.12
						381.58	181.65	21.12
pad 70.2				21.40		381.74	169.08	21.40
						388.86	176.64	21.40
						382.81	182.60	21.40
						381.37	181.24	21.40
						380.77	181.70	21.40
						375.00	175.81	21.40
						381.74	169.08	21.40
pad 71.2				21.70		381.85	156.56	21.70
						389.09	164.03	21.70
						382.92	170.08	21.70
						381.48	168.72	21.70
						380.88	169.18	21.70
						375.08	163.29	21.70
						381.85	156.56	21.70
lower pads						389.68	152.13	22.01
						389.81	144.13	22.01
						389.81	143.82	22.10
						389.86	136.84	22.10
						389.86	136.48	22.19
						389.81	129.64	22.19
						389.81	129.37	22.28
						389.95	122.39	22.28
						389.95	122.08	22.37
						390.03	115.01	22.37
						380.26	114.92	22.37
						380.26	122.26	22.37
						380.21	122.48	22.28
						380.12	129.41	22.28
						380.12	129.59	22.19
						379.99	136.53	22.19
						380.03	136.84	22.10
						379.94	143.73	22.10
						379.90	143.91	22.01
						379.86	152.13	22.01
						389.68	152.13	22.01

Sound Level Spectra

Name	ID	Type	Oktave Spectrum (dB)											Source	
			Weight.	31.5	63	125	250	500	1000	2000	4000	8000	A		lin
Male Raised Voice	L1	Lw (c)				64.1	70.2	74.5	69.5	64.5	59.7	53.8	74.6	77.3	Pearsons et al. (1977)
Female Raised Voice	L2	Lw (c)				46.4	66.3	71.1	68.8	64.8	60.0	53.5	72.9	74.6	Pearsons et al. (1977)
Carrier 25HCCS1830	AC1	Lw	A			50.9	60.4	65.4	67.9	64.9	61.9	53.9	72.0	74.8	Manufacturer
Carrier 25HCCS6030	AC2	Lw	A			59.8	63.8	66.3	68.3	65.3	62.3	57.8	73.0	78.8	Manufacturer
Background Music	M1	Lw			93.6	85.8	77.1	75.9	80.0	72.7	69.7	61.0	82.5	94.6	Measurement