



11.4 Geotechnical Investigation

This page intentionally left blank.

PRELIMINARY GEOTECHNICAL INVESTIGATION
PROPOSED NORWALK TRANSIT VILLAGE
FORMER CORRECTIONAL YOUTH
AUTHORITY FACILITY
13200 BLOOMFIELD AVENUE
NORWALK, CALIFORNIA

Prepared For:

Rincon Consultants, Inc.

180 N. Ashwood Avenue
Ventura, California 93003

Project No. 13109.001

June 17, 2021



Leighton and Associates, Inc.

A LEIGHTON GROUP COMPANY



Leighton and Associates, Inc.
A LEIGHTON GROUP COMPANY

June 17, 2021

Project No. 13109.001

Rincon Consultants, Inc.
180 N. Ashwood Avenue
Ventura, California 93003

Attention: Danielle Griffith, Supervising Planner

**Subject: Preliminary Geotechnical Investigation
Proposed Norwalk Transit Village
Former Correctional Youth Authority Facility
13200 Bloomfield Avenue
Norwalk, California**

In accordance with our March 2, 2021 proposal and your authorization, Leighton and Associates, Inc. (Leighton) has conducted this preliminary geotechnical investigation for the proposed commercial/residential development at the site of the former Correctional Youth Authority Facility, located at 13200 Bloomfield Avenue in the City of Norwalk, Los Angeles County, California. The purpose of this study has been to collect subsurface data for the site, to evaluate the proposed Norwalk Transit Village conceptual development dated March 4, 2020 with respect to the site conditions, and to provide preliminary geotechnical recommendations for design and construction of the proposed development as currently conceived.

Based on the results of our exploration and analysis, it is our opinion that the site is suitable for the intended use from a geotechnical perspective, provided our recommendations included herein are properly incorporated during design and construction. However, these recommendations should be further evaluated once final grading and foundation plans become available.

We appreciate the opportunity to work with you on the development of this project. If you have any questions regarding this report, please call us at your convenience at **(866) LEIGHTON**, direct at the phone extensions or e-mail addresses listed below.



Respectfully submitted,

LEIGHTON AND ASSOCIATES, INC.

A handwritten signature in blue ink, appearing to read "Jason D. Hertzberg".

Jason D. Hertzberg, GE 2711
Principal Engineer
Ext. 8772, jhertzberg@leightongroup.com

A handwritten signature in blue ink, appearing to read "Joe Roe".

Joe Roe, PG, CEG 2456
Principal Geologist
Ext. 4263, jroe@leightongroup.com

JB/JAR/LP/JDH/lr

Distribution: (1) Addressee

TABLE OF CONTENTS

<u>Section</u>	<u>Page</u>
1.0 EXECUTIVE SUMMARY.....	1
2.0 INTRODUCTION.....	3
2.1 Site Location and Description	3
2.2 Proposed Development	3
2.3 Purpose of Investigation	3
2.4 Scope of Investigation.....	4
3.0 FINDINGS	7
3.1 Regional Geologic Conditions.....	7
3.2 Subsurface Soil Conditions.....	7
3.2.1 Organic Content	8
3.2.2 Compressible and Collapsible Soil.....	8
3.2.3 Expansive Soils.....	8
3.2.4 Geochemical Characteristics	9
3.3 Groundwater	11
3.4 Faulting and Seismicity	12
3.5 Secondary Seismic Hazards.....	14
3.5.1 Liquefaction Potential.....	14
3.5.2 Lateral Displacement/Spread.....	15
3.5.3 Seismically Induced Settlement	15
3.6 Erosion.....	17
3.7 Flooding.....	17
3.8 Seiches and Tsunamis.....	17
3.9 Methane.....	17
4.0 CONCLUSIONS AND RECOMMENDATIONS.....	19
4.1 General Earthwork and Grading	19
4.1.1 Site Preparation	19
4.1.2 Overexcavation and Recompanction	20
4.1.3 Reuse of Concrete and Asphalt In Fill.....	21
4.1.4 Temporary Excavations	21
4.1.5 Fill Placement and Compaction.....	22
4.1.6 Shrinkage/Bulking	23
4.1.7 Import Fill Soil	23
4.2 Shallow Foundation Recommendations.....	23
4.2.1 Minimum Embedment and Width	24
4.2.2 Allowable Bearing	24

4.2.3 Lateral Load Resistance 24

4.2.4 Increase in Bearing and Friction - Short Duration Loads..... 25

4.2.5 Settlement Estimates 25

4.3 Recommendations for Slabs-On-Grade..... 25

4.4 Seismic Design Parameters..... 27

4.5 Retaining Walls..... 28

4.5.1 Drainage 29

4.6 Preliminary Pavement Design..... 30

4.6.1 Asphalt Concrete..... 30

4.6.2 Portland Cement Concrete Paving..... 31

4.6.3 Base Course 32

4.6.4 Concrete Flatwork 32

4.7 Trench Backfill 33

4.8 Surface Drainage 34

4.9 Additional Geotechnical Services 34

5.0 LIMITATIONS..... 36

6.0 REFERENCES 37

ATTACHMENTS:

Figures (Rear of Text)

- Figure 1 – Site Location Map
- Figure 2 – Exploration Location Map
- Figure 3 – Regional Geology Map
- Figure 4 – Regional Fault and Historical Seismicity Map
- Figure 5 – Seismic Hazard Map
- Figure 6 – Flood Hazard Zone Map
- Figure 7 – Dam Inundation Map
- Figure 8 – Retaining Wall Backfill Detail EI<50

Appendices

- Appendix A – Field Exploration Logs
- Appendix B – Geotechnical Laboratory Testing
- Appendix C – Summary of Seismic and Secondary Seismic Analyses
- Appendix D – General Earthwork Recommendations
- Appendix E – GBA’s Information About This Geotechnical-Engineering Report



1.0 EXECUTIVE SUMMARY

This geotechnical report provides geotechnical findings and recommendations for the preliminary residential mixed-use design concept for the proposed Norwalk Transit Village. The project as currently conceived appears feasible from a geotechnical perspective. Presented below is a summary of findings based upon the results of our geotechnical exploration of the site.

The site is underlain by undocumented artificial fill to a depth of approximately 5 feet below the existing ground surface, requiring removal and recompaction. Below the artificial fill, quaternary young alluvial fan deposits consisting of relatively unconsolidated and interbedded layers of sand, clayey sand, silty sand, sandy silt, silt, and clay were encountered to the maximum depth explored. Site soils are characterized as having a low expansion potential. Onsite soils are geotechnically suitable for reuse onsite as engineered fill provided they are free from hazardous materials of any kind.

Results of laboratory testing indicate that onsite soils at shallow depth have “negligible” soluble sulfate content. Concrete structures in contact with the on-site soils may be designed for an Exposure Class S0. If the concrete is expected to be in contact with reclaimed water, Type V cement and a water/cement ratio of 0.45 should be used. Soils are severely corrosive to ferrous iron in contact with site soil.

Groundwater was not encountered to the maximum depth explored of 75 feet below ground surface. Historic high groundwater at the project site as reported by the California Geological Survey is on the order of 9 feet below ground surface. Groundwater is not anticipated to be a constraint to site grading or construction.

No active faults are known or mapped to cross the site. The active fault nearest to the site with a potential for surface rupture and generation of strong ground shaking during the life of the project is the Whittier fault; located approximately 5.4 miles from the site. The site **is** located within an area that is susceptible to liquefaction. Liquefaction evaluation was performed utilizing a maximum credible earthquake of 7.3M_w and a historic high groundwater depth of 9 feet. Results of settlement analysis under these conditions indicate a maximum total seismically induced settlement of up to approximately 6 ³/₄ inches. Based on our findings, total seismically induced settlement poses a design constraint from a geotechnical perspective.

Remedial site grading is recommended to reduce the impact of seismically induced settlement for wood-framed structures and includes overexcavation of soils beneath proposed structure footprints to a minimum depth of 12 feet below the existing ground

surface or 8 feet below the bottom of planned foundations, whichever is deeper. Shoring would likely be required unless adequate space from property lines is available to allow backcutting to subgrade elevation. Alternatively, ground improvement methods consisting of deep soil mixing, short cement columns, geogrid reinforcement, and/or Geopiers® may be used to minimize remedial grading and overexcavation. Additional mitigation measures may be warranted for masonry or concrete structures, if proposed.

Assuming that proper remedial grading and/or approved ground improvement methods are implemented, the proposed structures may be supported by a shallow foundation system supported on structural compacted fill.

2.0 INTRODUCTION

2.1 Site Location and Description

The subject property (site) is a 32-acre, roughly rectangular, plot of land located at 13200 Bloomfield Avenue in the City of Norwalk, California. The site location (latitude 33.9124°, longitude -118.0618°) and surrounding vicinity are shown on Figure 1, *Site Location Map*. The site is bounded by a residential development and Los Angeles Community Hospital at Norwalk to the south, John Zimmerman Park to the east, and Navajo Lane to the north and Bloomfield Avenue to the west. Currently the site is occupied by the former Southern Youth Correctional Reception Center and Clinic also known as the Correctional Youth Authority, which has been closed since 2011. It is our understanding the facility has since been reopened to house COVID-negative patients. Based on review of the United States Geological Survey (USGS) 7.5-Minute Whittier Quadrangle, the site is relatively flat with an approximate surface elevation ranging from El. +94 feet above mean sea-level (msl) to El. +101 feet msl.

2.2 Proposed Development

The project is currently in the early conceptual phase and subject to change, however, we understand, based on review of the City of Norwalk March 4, 2020 document, the 32-acre site is planned to be developed with an integrated mixed-use development of medium and high density residential (townhomes and apartments), office and retail space, and a 1.25-acre central park. Project plans beyond the initial conceptual land use are currently not available. We have assumed that the proposed buildings will be wood or steel framed all constructed at grade. Parking structures will likely be considered to accommodate the development. Once the concept is developed the recommendations provided herein should be reviewed to ensure compatibility with future design.

2.3 Purpose of Investigation

The purpose of this study has been to evaluate the proposed development with respect to the site conditions and to provide preliminary geotechnical recommendations for design and construction of the development as currently conceived (March, 2020).

Our geotechnical exploration included hollow-stem auger soil borings, cone penetration test (CPT) soundings, laboratory testing, and geotechnical analysis to evaluate existing geotechnical conditions and to develop the preliminary recommendations contained in this report.

2.4 Scope of Investigation

Our scope of services for this exploration included the following:

- **Pre Field Activities:** We reviewed available, relevant geotechnical/ geologic maps and reports and aerial photographs available from our in-house library or in the public domain (see *References* at the end of this report).
- **Utility Coordination:** Geologic reconnaissance and visual observations of surface conditions at the site. Exploration locations were marked in the field for utility clearance. Underground Service Alert (USA) was notified to mark known utilities in the project vicinity.
- **Field Exploration:** Our field exploration included drilling of hollow-stem auger borings and cone penetration tests. Logs of the geotechnical borings and cone penetration test soundings are presented in Appendix A, *Field Exploration Logs*.
 - A total of six (6) exploratory soil borings (LB-1 through LB-6) were logged and sampled onsite to evaluate subsurface conditions. The borings were drilled to an approximate depth of 51.5 feet below the existing ground surface (bgs). During hollow stem auger drilling, bulk samples and driven ring samples were collected from the borings for further laboratory testing and evaluation. The driven samples were obtained using a 3-inch outside diameter modified California drive sampler (2³/₈-inch inside diameter) driven 18 inches in general accordance with ASTM Test Method D 3550. Standard penetration tests (SPT) were also performed using a 2-inch outside diameter (1³/₈-inch inside diameter) sampler without liners (though the samplers contained room for liners, as is common in this region) driven 18 inches in general accordance with ASTM Test Method D 1586. The number of blows to drive the samplers were recorded on the boring logs for each 6-inch increment (unless encountering refusal or >50 blows per 6 inches). After logging and sampling, the borings were backfilled with the soil cuttings generated during drilling.

- Six (6) cone penetration test (CPT) soundings (CPT-1 through CPT-6) were advanced to depths ranging from approximately 58 to 75 feet bgs.

All excavations were backfilled with the soil cuttings. Approximate locations of hollow-stem auger borings and CPT soundings are presented on Figure 2, *Exploration Location Map*.

- **Geotechnical Laboratory Testing:** Geotechnical laboratory tests were conducted on selected relatively undisturbed and bulk soil samples obtained during our field investigation. Laboratory tests were performed on representative bulk and drive samples to provide a basis for development of remedial earthwork and geotechnical design parameters. Laboratory tests conducted during this investigation include:

- Grain Size Distribution (ASTM D6913);
- Expansion Index (ASTM D4829);
- Atterberg Limits (D4318);
- Maximum dry Density and Moisture Determination (ASTM D1557);
- Consolidation (ASTM D2435);
- Swell and Settlement (ASTM D4546);
- Organic Matter Content (ASTM D2974);
- Corrosion potential (DOT 417, 422, 463 and 463); and
- R-Value (DOT CA 301)

Results of our soil laboratory testing are provided in Appendix B, *Geotechnical Laboratory Testing*.

- **Shear Wave Velocity:** Shear wave velocities were profiled at 10-foot intervals to a depth of 70 feet bgs in CPT-1 (Figure 2) to estimate average S-wave velocities of the upper 100 feet (V_{s100}) and 30 meters (V_{s30}). The shear wave velocity report is included in Appendix A.
- **Engineering Analysis:** Data obtained from our field exploration and geotechnical laboratory testing was evaluated and analyzed to develop geotechnical conclusions and provide preliminary recommendations presented in this report.

- **Report Preparation:** Results of our preliminary geotechnical investigation have been summarized in this report, presenting our findings, conclusions and preliminary geotechnical recommendations for design and construction of the proposed development. *These recommendations should be further evaluated once final grading and foundations plans become available.*

3.0 FINDINGS

3.1 Regional Geologic Conditions

The project site is located approximately 2.7 miles easterly of the concrete lined San Gabriel River channel within the Coastal Plain of Los Angeles County, California, a part of the Peninsular Ranges geomorphic province. Elongated northwest trending ridges separated by alluvial filled valleys characterize the province. The dominant geologic structures of the province are the west-northwest trending folds and fault zones, including the Whittier Fault and the Newport-Inglewood fault zone (NIFZ) located north and southwest of the project site, respectively.

Geological mapping of the area (Dibblee, Jr., 2001) indicates near-surficial native soil deposits at the subject site consist of Holocene age undissected alluvial deposits comprised of varying proportions of sand, gravel, silt, and clay deposited along the ancestral floodplains of the San Gabriel and Rio Hondo River systems (Figure 3, *Regional Geology Map*). These deposits are anticipated to be on the order of several hundred feet in thickness, where they are subsequently underlain by several thousand feet of sedimentary rock formations.

3.2 Subsurface Soil Conditions

Artificial Fill, Undocumented (Map Symbol: Afu): The field explorations (Appendix A) indicate the site is underlain by undocumented artificial fill overlying Quaternary age (Holocene) alluvial deposits. Artificial fill characterized as light brown to orange brown, fine to medium grained, sand, silty sand, and sandy silt was encountered in borings LB-1 through LB-4 to a maximum depth of about 5 feet.

Quaternary Young Alluvium (Map Symbol: Qyf): The alluvial soil encountered within our excavations generally consisted of combinations of sand, silt, and clay laid down along the ancestral course of the San Gabriel and Rio Hondo river systems. Interbedded layers of sand, clayey sand, silty sand, sandy silt, silt, sandy clay, silty clay, and clay varied in both stiffness and moisture content greatly throughout the borings. In general, the alluvial soil becomes oxidized with iron oxide and manganese with greater depth. More detailed descriptions of the subsurface soil are presented on the boring logs (Appendix A).

3.2.1 Organic Content

One sample of silty clay (CL-ML) was collected (Sample No. S-3 from boring LB-5 at a depth of 35 feet for total organic carbon (ASTM D2974 Methods A and C). The test yielded total organic carbon in the sample of 1.5 percent. The test results are included in Appendix B.

3.2.2 Compressible and Collapsible Soil

The onsite soils are generally considered moderately compressible at shallow depths and decrease to low compressibility at depth.

Soil collapse, or hydro-consolidation, occurs when soil units upon saturation undergo a rearrangement of their grains and a loss of cohesion or cementation, potentially resulting in substantial and rapid settlement under relatively light loads. Soil collapse is generally associated with recently deposited, Holocene-age soils that have accumulated in an arid or semi-arid environment. Wind-deposited sands and silts, and alluvial fan and debris flow sediments deposited during flash floods represent soils that may be susceptible to collapse.

Surface water infiltration when combined with the weight of a structure, can start rapid settlement and cause foundations to crack. Based on review of laboratory testing results, the site soils generally possess low collapse potential. Proper surface drainage design, excavation, recompaction and moisture conditioning during preparation of the subgrade will reduce the risks associated with collapse.

Engineered fills are generally not considered susceptible to hydro-collapse. The potential for hydro-consolidation to affect the project upon completion of grading as recommended herein is considered low.

3.2.3 Expansive Soils

Expansive soils contain significant amounts of clay particles that swell considerably when wetted and which shrink when dried. Foundations constructed on these soils are subject to uplifting forces caused by the swelling. Without proper mitigation measures, heaving and cracking of both building foundations and slabs-on-grade could result.

Two (2) near-surface (upper 5 feet) bulk soil samples obtained during our subsurface exploration were tested for expansion potential, and seven (7) deeper samples of sandy lean clay (CL), sandy silt (ML) and fat clay (CH) were tested for Atterberg limits. The test results indicate an Expansion Index (EI) value of 17 and 20 and plasticity index ranging from non-plastic and 9 to 32. Expansion index test results show that onsite near-surface soils have a very low expansion potential. The Expansion Index and Atterberg limit laboratory test results are included in Appendix B of this report.

Variance in expansion potential of near-surface onsite soil is anticipated, therefore, additional testing is recommended upon completion of site grading and excavation to confirm the expansion potential presented in this report. Standard engineering and earthwork construction practices, such as proper foundation design and controlled moisture conditioning or mixing with non-expansive soils will reduce the impacts associated with expansive soils. For purposes of this report, near surface materials should consider low expansion ($20 \leq EI \leq 50$) in preliminary design.

3.2.4 Geochemical Characteristics

Soil Resistivity: A major factor in determining soil corrosivity is electrical resistivity. The electrical resistivity of a soil is a measure of its resistance to the flow of electrical current. Corrosion of buried metal is an electrochemical process in which the amount of metal loss due to corrosion is directly proportional to the flow of electrical current (DC) from the metal into the soil. Corrosion currents, following Ohm's Law, are inversely proportional to soil resistivity. Lower electrical resistivity results from higher moisture and soluble salt contents and indicates corrosive soil. A correlation between electrical resistivity and corrosivity toward ferrous metals is shown in Table below.

Soil Corrosivity as a Function of Resistivity

Soil Resistivity (ohm-cm)	Classification of Soil Corrosiveness
0 to 900	Very severe corrosion
900 to 2,300	Severely corrosive
2,300 to 5,000	Moderately corrosive
5,000 to 10,000	Mildly corrosive
10,000 to >100,000	Very mildly corrosive

For preliminary screening purposes, the corrosivity of shallow site soils (0 to 5 feet) were tested in our laboratory on representative composite samples collected within boring LB-2 and LB-5. The results of corrosion screening (sulfate concentration, chloride content, pH and resistivity) are shown below.

Corrosion Testing Results

Test Parameter	Test Result LB-2	Test Results LB-5	General Classification of Hazard
Water-Soluble Sulfate in Soil (ppm)	62	111	Negligible sulfate exposure to buried concrete, Exposure Class S0
Water-Soluble Chloride in Soil (ppm)	80	160	Non-corrosive to buried reinforced concrete
pH	7.4	7.2	Mildly alkaline
Minimum Resistivity (saturated, ohm-cm)	600	1,997	Very Severely Corrosive

Sulfate Exposure: Sulfate ions in the soil can lower the soil resistivity and can be highly aggressive to Portland cement concrete by combining chemically with certain constituents of the concrete, principally tricalcium aluminate. This reaction is accompanied by expansion and eventual disruption of the concrete matrix. A potentially high sulfate content could also cause corrosion of reinforcing steel in concrete. Section 1904A of the 2019 California Building Code (CBC) defers to the American Concrete Institute’s (ACI’s) ACI 318-14 for concrete durability requirements. Table



19.3.1.1 of ACI 318-14 lists “*Exposure categories and classes*,” including sulfate exposure as follows:

Sulfate Concentration and Exposure

Soluble Sulfate in Water (parts-per-million)	Water-Soluble Sulfate (SO ₄) in soil (percentage by weight)	ACI 318-14 Sulfate Class
0-150	0.00 - 0.10	S0 (negligible)
150-1,500	0.10 - 0.20	S1 (moderate*)
1,500-10,000	0.20 - 2.00	S2 (severe)
>10,000	>2.00	S3 (very severe)

*or seawater

Results of our recent field exploration and laboratory testing (Appendix B) indicate that onsite soils at shallow depth have “negligible” soluble sulfate content (per Section 4.3 of ACI 318). Concrete structures in contact with the on-site soils may be designed for an Exposure Class S0. If the concrete is expected to be in contact with reclaimed water, Type V cement and a water/cement ratio of 0.45 should be used.

3.3 Groundwater

Groundwater was not encountered in any of our boring to a maximum depth explored of 51.5 feet bgs. Review of the *Seismic Hazard Zone Report for the Whittier 7.5 Minute Quadrangle* (CGS, 1998) indicates historic high groundwater level at the site is approximately 9 feet bgs. The groundwater table is expected to be below the anticipated depth of excavation for the proposed project.

The State Water Resources Control Board GeoTracker Database (SWRCB, 2021) contained groundwater data from sites within close proximity to the project site. Groundwater data from these sites is summarized below.

LUST Cleanup Site EXXONMOBIL #18-F2Q (T0603770616) is located at the southeast corner of Imperial Highway and Bloomfield Avenue, approximately 1,400 feet north of the northwest corner of the project site. Depth to groundwater in 7 wells at this site has been measured approximately quarterly beginning in February, 2005. These wells are screened from 85 to 115 feet bgs and may preclude shallower/perched aquifers. The shallowest groundwater measurement occurred on April 16, 2007 at a depth of approximately 94 feet bgs. The most



recent groundwater measurements occurred on August 25, 2020 and indicated groundwater depths of approximately 116 feet bgs or deeper.

The California Department of Water Resources Water Data Library (CDWR, 2021) contained data for one well located on Shoemaker Avenue, east of Zimmerman Park, approximately 800 feet east of the project site. Groundwater in this well has been measured since 2011 at depths between approximately 90 to 131 feet.

State Well No. 3S11W18G05 located approximately 0.4 mile west of the site with water measurement readings from 1959 through 2017 showed a high groundwater of 71 feet deep in 1997.

3.4 **Faulting and Seismicity**

Our review of available in-house literature, geologic maps and aerial photos indicates that there are no lineaments or known active faults traversing the site. The closest known active or potentially active fault is the Whittier fault, located approximately 5 miles northeast of the site.

Numerous active and potentially active faults have been mapped within the southern California region, several of which are within close proximity to the site. Faults in the vicinity of the site are shown on Figure 4, *Regional Fault and Historical Seismicity Map*. Nearby active and potentially active fault systems that could produce significant ground shaking at the site include the Puente Hills fault (Santa Fe Springs), the Whittier fault, the Elysian Park fault, and the Newport-Inglewood fault zone, among others. The distance of these faults and the estimated slip rates, if known, are discussed below.

Puente Hills Fault (Santa Fe Springs): Movement on the Puente Hills Blind-Thrust Fault (PHT) caused the 1987 magnitude 6.0 Whittier Narrows earthquake. The hypocenter of the 1987 event was at depth of approximately 13 km (8 miles) below the San Gabriel Valley. From the hypocentral region, the fault shallows southward toward the surface. The PHT has a subsurface extent of 44 km (27 miles), from west of downtown Los Angeles to near Brea, California. This fault does not reach the surface but instead a fold is formed above the fault and is expressed as a fold-scarp at or just below the surface (Shaw *et al*, 1996 and 2002, Christofferson *et al.*, 2002). To the north of the 1987 hypocenter, the fault flattens and continues beneath the San Gabriel mountains and merges with the Sierra Madre-Cucamonga fault system (Fuis *et al*, 2001). Buried fold scarps along the

Santa Fe Springs segment reveal evidence for 4 major earthquakes ($M_w > 7.0$) generated by the PHT in the past 11,000 years (Dolan et al., 2003). Late Quaternary slip rates range from 0.3 – 1.1 mm/yr; however, minimum Holocene slip rates range from 1.1 to 1.6 mm/yr (Dolan et al, 2003; Frankel et al., 2002). The estimated maximum earthquake magnitude on this fault is $M_w 7.1$. The PHT is considered a Class B fault (Frankel et al., 2002; CBC, 2001). The closest segment of PHT is located approximately 0.5 miles from the site.

Whittier Fault: The Whittier fault is the northwestward extension of the Elsinore fault-Glen Ivy Segment. The Whittier fault is considered a strike slip along most of its length with a component of vertical thrust, is approximately 40 km (25 miles) long, and extends from the Whittier Narrows section of the San Gabriel River southeastward to the Santa Ana River where it is concealed beneath the alluvium. The Whittier fault separates the Puente Hills in the north from the Santa Ana Mountains to the south. In the area of the Santa Ana River, based on offset of stream terrace deposits (Gath, 1997; Gath et al, 1992; Rockwell et al, 1988, 1991), the Whittier fault is considered to have a slip rate of approximately 2-3 mm/yr. The estimated maximum earthquake to occur along the Whittier fault segment is $M_w 6.8$ (Petersen et al., 1996). The fault is classified as a Class A fault by the California Division of Mines and Geology, CDMG (Frankel et al., 2002; Petersen et al., 1996), and a Class B fault by the California Building Code (CBC, 2001). The closest segment of the Whittier fault is located approximately 5.4 miles from the site.

Elysian Park Fault: Blind thrust faults are not included in mapped fault zones. The Elysian Park Anticline is the surface expression of low angle blind thrust faulting at depth and inferred to overlie the Elysian Park Blind Thrust (Oskin et al, 2000). Slip-rates along the Elysian Park Blind Thrust have been estimated at 0.8-2.2 mm/yr with a maximum capable earthquake of $M_w 6.2$ to 6.7. The closest segment of Elysian Park fault is located approximately 10.9 miles from the site.

Newport-Inglewood Fault Zone: The onshore southeast-trending Newport-Inglewood fault zone (NIFZ) is discontinuous at the surface, consisting of a series of primarily left-stepping *en echelon* fault strands, each up to 6.5 km (4 miles) long that extend from near Beverly Hills south to Newport Beach, a distance of approximately 65 km (41 miles). At Newport Beach, the fault continues offshore where it lines up with the deeply incised Newport Submarine Canyon and is comprised of five strands and three step overs. To the south, back onshore, the fault continues as the Rose Canyon fault, extending in a southeasterly direction

through San Diego and the international border to Baja California, where it continues as the Agua Blanca fault. Overall, from Beverly Hills to Baja California, the fault zone is more than 300 km (185 miles) long. The closest segment of Newport Inglewood fault is located approximately 9.8 miles from the site.

3.5 Secondary Seismic Hazards

In general, secondary seismic hazards for sites in the region could include soil liquefaction, earthquake-induced settlement, lateral displacement, landsliding, and earthquake-induced flooding. The potential for secondary seismic hazards at the site is discussed below.

3.5.1 Liquefaction Potential

Liquefaction is the loss of soil strength or stiffness due to a buildup of pore-water pressure during severe ground shaking. Liquefaction is associated primarily with loose (low density), saturated, fine-to-medium grained, cohesionless soils. Effects of liquefaction can include sand boils, settlement, and bearing capacity failures below structural foundations.

Review of the California Geological Survey (CGS) *Earthquake Zones of Required Investigation for the Whittier 7.5 Minute Series Quadrangle* (CGS, 1999) indicates the site in an area designated as having a liquefaction potential (Figure 5, *Seismic Hazard Map*). However, groundwater was not encountered in any of our exploratory borings to a maximum depth of 51.5 feet bgs. Based on well data, current groundwater is estimated to be deeper than 100 feet below the ground surface and available data near the site with readings since 1959 indicated that groundwater has been deeper than 71 feet.

We have analyzed the liquefaction potential based on the modified Seed Simplified Procedure as detailed by Youd et al. (2001) and Martin and Lew (1999), and utilizing an estimated historic high groundwater level deeper than 50 feet based on available well data. This analysis shows that the onsite soils are not susceptible to liquefaction due to the absence of groundwater. However, we have also analyzed the liquefaction potential utilizing a high groundwater level of 9 feet based on the Whittier Seismic Hazard Zone Report. This analysis results in soil layers susceptible to liquefaction at depths as shallow as 10 feet.

We performed further liquefaction analysis of the site based on the CPT results. Our analysis of CPT data was based on the NCEER (1998) method as detailed by Youd et al. (2001). Software developed by GeoLogismiki Geotechnical Software (2006) was utilized for the analysis.

Based on our CPT soundings, potentially liquefiable soils are generally limited to 4-foot-thick layers or less, with the thickest layer being an 8-foot-thick layer in CPT-5 below a depth of approximately 10 feet. With this analysis, the potential for surface manifestations of liquefaction, such as bearing failures and sand boils, is a design consideration.

A summary of the liquefaction analysis is included in Appendix C, *Summary of Seismic and Secondary seismic Analyses*.

3.5.2 Lateral Displacement/Spread

We performed lateral spreading analysis based on the Youd (2002) empirical method. In our analysis, we considered sloping ground conditions (0.5% slope), but not a free-face condition, since free-face conditions in the area of the site were not identified. Lateral displacement is negligible when considering a deep groundwater level based on available well data. However, when analyzing the site using a historic high groundwater of 9 feet, the lateral displacements range from 0 to 7 inches considering the data from the borings. Lateral spreading is not considered a significant constraint for the project. Based on Youd, 2009, the factor of safety against lateral spreading based on CPT data is estimated to be more than 1.3. After implementation of our recommendations that consider mitigation of potential seismic settlement and liquefaction, lateral spreading is not considered a significant constraint to the project.

3.5.3 Seismically Induced Settlement

Seismically induced settlement consists of dry dynamic settlement (above groundwater) and liquefaction-induced settlement (below groundwater). During a strong seismic event, seismically induced settlement can occur within loose to moderately dense sandy soil due to reduction in volume during and shortly after an earthquake event. Settlement caused by ground shaking is often nonuniformly distributed, which can result in differential settlement.

We have performed analyses to estimate the potential for seismically induced settlement using the method of Tokimatsu and Seed, and based on Martin and Lew (1999) for hollow-stem auger boring data, and procedures by Robertson for CPT data.

Analyses with Groundwater at 8 feet bgs: We have analyzed the potential for seismic settlement using the **historic high groundwater** level of 9 feet as prescribed by the California Building Code (CBC, 2019). This analysis results in a maximum total seismic settlement of 6¾ for borings, and 5 inches for CPT soundings. For a shallow foundation system with the recommended earthwork overexcavation (Section 3.1.2), the total seismic settlement is reduced to 4 inches. If we estimate the potential differential settlement is half of the total seismic settlement over a horizontal distance of 30 feet, this would result in approximately 2 inches differential in 30 feet, or angular distortion of 0.006L. This would be within the differential settlement threshold value of 0.015L for “other single-story structures” and 0.010L for “other multistory structures” of Risk Category I or II, as listed in Table 12.13-3 of ASCE 7 16. “Other” buildings are those not constructed with concrete or masonry wall systems (i.e. wood- or steel-framed).

Alternate Analyses with Groundwater at 60 feet bgs: We have evaluated seismic settlement utilizing a groundwater level of 60 feet bgs based on available data, current infield data collected during drilling and sampling, and the Maximum Considered Earthquake (M_w) of 7.3 with site modified peak ground acceleration (PGA_M) of 0.76g.

This alternate analysis using actual groundwater depth results in a total seismic settlement ranging from 1½ to 4¼ inches for borings. Due to the discrete nature of the samples obtained from borings and the frequent transitions of soil layers onsite between those obtained samples, we believe that the boring data tends to overestimate the total seismic settlement onsite. Based on data obtained from CPT soundings, the total seismic settlement ranges from ½ to 2¾ inches. Differential settlement is estimated to be half of the total settlement over a horizontal distance of 30 feet.

The State of California Special Publication 117 Guidelines for Evaluating and Mitigating Liquefaction prescribes using historic high groundwater in liquefaction analyses. While historic groundwater levels are not likely to return to nine feet below ground surface, using deeper groundwater data

requires substantial historical well data collected over decades within unconfined aquifer(s) to show groundwater levels over time to demonstrate liquefaction is not a constraint for development.

A summary of seismic settlement analysis is included in Appendix C.

3.6 Erosion

The project site is subject to erosion, runoff, and sedimentation due to the granular nature of the site soil. Climate, topography, soil types and vegetation are key factors to erosion, runoff, and sedimentation processes. Upon completion of earthwork construction and drainage improvements, erosion of silt materials will be less than significant. Best Management Practices during construction can reduce the potential for loss of onsite material into surrounding community.

3.7 Flooding

According to a Federal Emergency Management Agency (FEMA) flood insurance rate map, as depicted in Figure 6 *Flood Hazard Zone Map*, the project site is not located within a 100-year or 500-year flood hazard zone.

Earthquake-induced flooding can be caused by failure of dams or other water-retaining structures as a result of earthquakes. The site is not downstream of any retained bodies of water, therefore the risk of seismically-induced flooding due to dam failure is not a consideration.

3.8 Seiches and Tsunamis

Seiches are large waves generated in enclosed bodies of water in response to ground shaking. Tsunamis are waves generated in large bodies of water by fault displacement or major ground movement. Based on the absence of an enclosed water body near the site and the inland location of the site, seiche and tsunami risks at the site are not a consideration.

3.9 Methane

Based on review of State of California Geologic Energy Management Division (CalGEM) records, formerly DOGGR, the project site is not located within an oil field boundary (CalGEM, 2021). In addition, the nearest documented oil well to the site is located approximately 0.25 mile north of the site (API# 0403705384;

Equitable Oil Syndicate No. 1 Lease, Well No. 1-A) and is reported as idle (CalGEM, 2021). Based on these findings, a methane study is not required for the site.

4.0 CONCLUSIONS AND RECOMMENDATIONS

Based on the results of this study, it is our opinion that the subject site is suitable for the proposed project from a geotechnical viewpoint. Geotechnical recommendations for the conceptually proposed development are presented in the following sections and are intended to provide sufficient geotechnical information to develop the project plans in accordance with the 2019 edition of the California Building Code (CBC) requirements. The following recommendations may be superseded by more restrictive requirements of the structural engineer and the local reviewing agency.

The recommendations presented below are based upon the results of laboratory analyses and observed geotechnical engineering properties of the soils and their anticipated response both during and after construction. The recommendations are also predicated upon proper field observation and testing during construction. The project geotechnical engineer should be notified of suspected variances in field conditions to evaluate the effect upon the recommendations presented herein.

The geotechnical consultant should review the grading plan, foundation plan, structural loads and specifications as they become available to confirm that the recommendations presented in this report have been properly interpreted and incorporated into the plans prepared for the project.

These recommendations assume wood- or steel-framed structures. If masonry or concrete structures are planned, additional evaluation or exploration may be required. Parking structures, while not indicated are presumably required to accommodate parking. Once plans are further developed they should be provided to the geotechnical engineer for evaluation in consideration of the preliminary recommendations provided herein.

4.1 **General Earthwork and Grading**

All grading should be performed in accordance with the General Earthwork and Grading Specifications presented in Appendix D, unless specifically revised or amended below or by future recommendations based on final development plans.

4.1.1 **Site Preparation**

Prior to construction, the site should be cleared of debris, which should be disposed of offsite. Any underground obstructions should be removed. Resulting cavities should be properly backfilled and compacted. Efforts

should be made to locate existing utility lines. Those lines should be removed or rerouted if they interfere with the proposed construction, and the resulting cavities should be properly backfilled and compacted.

Although not identified during this investigation, abandoned septic tanks, seepage pits, or other buried structures, trash pits, or items related to past site uses are probably present. As such items are generally encountered during grading, they may require further evaluation and special consideration.

4.1.2 Overexcavation and Recompaction

To mitigate potential adverse seismic settlement and potential surface manifestations of liquefaction, the onsite soils should be overexcavated below the proposed structure footprints to a minimum depth of 12 feet below the existing ground surface or 8 feet below bottom of planned foundations, whichever is deeper. Overexcavation and recompaction should extend a minimum horizontal distance of 10 feet beyond the footing edges. During overexcavation, the soil conditions should be observed by Leighton to further evaluate these recommendations based on actual field conditions encountered. Although the planned depth of removals based on the remedial grading recommendations are expected to expose suitable/ dense alluvium, the exposed bottom will be “*quantitatively and/or qualitatively*” verified to ensure a minimum relative compaction of 85 percent based on ASTM D 1557 and/or a minimum dry density of 110 pounds per cubic foot. The removal bottom elevations, methodology of testing alluvium and test results should be documented in the as-graded geotechnical report.

Ancillary Structures and Pavement: For any auxiliary structure foundation (i.e. retaining walls/screen walls 3' or less) and any site pavement, the upper 2 feet of soils should be removed and recompacted. In cut areas deeper than 2 feet, scarification and recompaction may be sufficient depending on further verification by the geotechnical consultant during construction. Acceptability of all removal bottoms should be reviewed by an engineering geologist or geotechnical engineer and documented in an as-graded geotechnical report. The removal limit should be established by a 1:1 (horizontal:vertical) projection from the edge of fill soils supporting settlement-sensitive structures downward and outward to competent material identified by the geotechnical

consultant. Removals will also include benching into competent material as the fills rise.

After completion of the overexcavation and prior to fill placement, the exposed soils should be scarified to a minimum depth of 8 inches, moisture conditioned and compacted to at least 90 percent relative compaction based on ASTM Test Method D 1557 laboratory maximum density. Pavement subgrade and aggregate base should be compacted to a minimum of 95 percent relative compaction.

The onsite soils, less any deleterious material or organic matter, may be used for required fills. Cobbles larger than 8 inches in largest diameter should not be used in the fill. All proposed import materials should be approved by the geotechnical engineer of record prior to being placed at the site.

Ground Improvement: As an alternative to deep overexcavation ground improvement may be considered to mitigate the liquefaction potential of site soils. Methods such as soil mixing, short cement columns, Geopiers, and removal and recompaction, may be suitable ground improvement methods. The selection of ground improvement method may depend on the construction sequence and stage at which the ground improvement is installed. Design of the ground improvement system, preparation of plans and specifications, and field installation and quality control should be performed by an experienced specialty contractor.

4.1.3 Reuse of Concrete and Asphalt In Fill

Pulverized demolition concrete free of rebar and other materials and demolished asphalt pavement can be pulverized to particles no-larger-than (\leq) 3-inches, and mixed with site soils for use in compacted fill. Blended pulverized concrete and asphalt should be mixed with at least 25% soils by weight. Such materials must be free of and segregated from any hazardous materials and/or organic material of any kind.

4.1.4 Temporary Excavations

All temporary excavations, including utility trenches, foundation excavations, and other excavations should be performed in accordance with project plans, specifications and all Occupational Safety and Health Administration (OSHA)

requirements. The contractor is responsible for all temporary slopes and trenches excavated at the site and the design of any required temporary shoring. Shoring, bracing and benching should be performed by the contractor in accordance with the *California Construction Safety Orders*, current edition: <http://www.dir.ca.gov/title8/sb4a6.html>

During construction, exposed earth material conditions should be regularly evaluated to verify that conditions are as anticipated. The contractor is responsible for providing the "competent person" required by OSHA standards to evaluate soil conditions. Close coordination between the competent person and geotechnical consultant should be maintained to facilitate construction while providing safe excavations. Existing alluvial soils encountered may be subject to caving and are anticipated to be classified as OSHA soil Type C. Therefore, unshored temporary cut slopes should be no steeper than 1½:1 (horizontal:vertical), for a height no-greater-than (\leq) 20 feet (*California Construction Safety Orders*, Appendix B to Section 1541.1, Table B-1). Unshored cut slopes deeper than 20 feet should be sloped back at 2:1.

These recommended temporary cut slopes assume a level ground surface for a distance equal to one-and-a-half (x1.5) the depth of excavation. For steeper temporary slopes, appropriate shoring methods or flatter slopes may be required to protect the workers in the excavation and adjacent improvements. Such methods should be implemented by the contractor and approved by the geotechnical consultant.

No surcharge loads should be permitted within a horizontal distance equal to the height of cut or 5 feet, whichever is greater from the top of the slope, unless the cut is shored appropriately.

4.1.5 Fill Placement and Compaction

Onsite soil to be used for compacted structural fill should be free of debris and oversized material (greater than 8 inches in largest dimension). Any soil to be placed as fill, whether onsite or imported material, should be reviewed and tested by the geotechnical engineer.

All fill soil should be placed in thin, loose lifts, moisture conditioned, as necessary to near optimum moisture content, and compacted to a minimum 93 percent relative compaction. However, all fill under the buildings should

be compacted to a minimum of 95 percent relative compaction. Relative compaction should be determined in accordance with ASTM Test Method D1557. Aggregate base for pavement should be compacted to a minimum of 95 percent relative compaction.

4.1.6 Shrinkage/Bulking

The volume change of excavated onsite materials upon compaction is expected to vary with materials, density, in-situ moisture content, location, and compaction effort. The in-place and compacted densities of soil materials vary and accurate overall determination of shrinkage and bulking cannot be made. Therefore, we recommend site grading include, if possible, a balance area or ability to adjust quantities to accommodate some variation. Based on our experience with similar materials, we anticipate 15-20 percent shrinkage in the on-site topsoil/alluvium.

4.1.7 Import Fill Soil

Import soil to be placed as fill should be geotechnically accepted by Leighton. Any required import material should consist of relatively non-expansive soils with an Expansion Index (EI) less than 20. The imported materials should contain sufficient fines (binder material) so as to result in a stable subgrade when compacted. Preferably at least 3 working days prior to proposed import to the site, the contractor should provide Leighton pertinent information of the proposed import soil, such as location of the soil, whether stockpiled or native in place, and pertinent geotechnical reports if available. We recommend that a Leighton representative visit the proposed import site to observe the soil conditions and obtain representative soil samples. Potential issues may include soil that is more expansive than onsite soil, soil that is too wet, soil that is too rocky or too dissimilar to onsite soils, oversize material, organics, debris, etc.

4.2 Shallow Foundation Recommendations

Building layout, maximum column loading and wall loading is not available at the time of this report. We have anticipated that the proposed buildings will be wood-framed and lightly loaded. We assume a maximum column load of 50 kips and maximum wall load of 2.5 kips per lineal foot are generally applicable for the

buildings. Structural loading information should be provided to us when available for review.

Near-surface soils at the site were classified to have “very low” expansion potential based on laboratory expansion index tests. The proposed residential, commercial, and hotel building can be supported on conventional shallow foundations. Post-tension foundation design parameters can be provided upon request if designing the foundation by Post-Tensioning Institute methodologies.

Overexcavation and recompaction of the building pad areas should be performed as detailed in Section 3.1. The following recommendations are based on the onsite soil conditions and soils with very low expansion potential.

4.2.1 Minimum Embedment and Width

Based on our preliminary investigation, footings should have a minimum embedment per code requirements, with a minimum width of 24 and 12 inches for isolated and continuous footings, respectively.

4.2.2 Allowable Bearing

An allowable bearing pressure of 1,800 pounds-per-square-foot (psf) may be used, based on the minimum embedment depth and width above. This allowable bearing value may be increased by 200 psf per foot increase in depth or width to a maximum allowable bearing pressure of 2,500 psf. If higher bearing pressures are required, this should be reviewed on a case-by-case basis and may include additional overexcavation and/or soil reinforcement. These allowable bearing pressures are for total dead load and sustained live loads. Footing reinforcement should be designed by the structural engineer. However, as a minimum, footing reinforcement should consist of two No. 5 rebar at the top and bottom of the footing and No. 4 rebar spaced at 18 inches on center in each direction for isolated footings.

4.2.3 Lateral Load Resistance

Soil resistance available to withstand lateral loads on a shallow foundation is a function of the frictional resistance along the base of the footing and the passive resistance that may develop as the face of the structure tends to move into the soil. The frictional resistance between the base of the

foundation and the subgrade soil may be computed using a coefficient of friction of 0.35. The passive resistance may be computed using an allowable equivalent fluid pressure of 240 pounds per cubic foot (pcf), assuming there is constant contact between the footing and undisturbed soil. The coefficient of friction and passive resistance may be combined without further reduction.

4.2.4 Increase in Bearing and Friction - Short Duration Loads

The allowable bearing pressure and coefficient of friction values may be increased by one-third when considering loads of short duration, such as those imposed by wind and seismic forces.

4.2.5 Settlement Estimates

The recommended allowable bearing pressure is generally based on a total allowable, post-construction static settlement of 1.0 inches. Differential settlement due to static loading is estimated at 1/2 inch over a horizontal distance of 30 feet. Since settlement is a function of footing sustained load, size and contact bearing pressure, differential settlement can be expected between adjacent columns or walls where a large differential loading condition exists. Seismic settlement is anticipated to be approximately 2 inches over a horizontal distance of 30 feet. Structural design of the buildings should consider these settlement estimates.

4.3 Recommendations for Slabs-On-Grade

Concrete slabs-on-grade should be designed by the structural engineer in accordance with the current CBC for soil with a very low expansion potential and considering the potential for liquefaction and seismic settlement. Where conventional light floor loading conditions exist, the following minimum recommendations should be used. More stringent requirements may be required by local agencies, the structural engineer, the architect, or the CBC. Laboratory testing should be conducted at finish grade to evaluate the expansion index of near-surface subgrade soils. In addition, slabs-on-grade should have the following minimum recommended components:

- ***Subgrade Moisture Conditioning:*** The subgrade soil should be moisture conditioned to at least 2 percentage points above optimum moisture content to a minimum depth of 12 inches prior to placing the moisture vapor retarder, steel or concrete.

- **Moisture Retarder:** The following recommendations are for informational purposes since they are unrelated to the geotechnical performance of the foundation. Post-construction moisture migration should be expected below the foundation.

In general, interior floor slabs at or near the existing ground surface with moisture sensitive floor coverings are recommended to be underlain by a minimum 10-mil thick vapor retarder that has a permeance of less than 0.3 perms, as determined by ASTM E 96, and meets the applicable code requirements (ASTM E1745). The use of a capillary moisture break (crushed gravel layer) in conjunction with a vapor retarder is not considered to be necessary due to the lack of shallow groundwater conditions unless required by code. A sand layer below the synthetic sheeting will, however, serve to protect the sheeting from punctures if the underlying soils or gravel layer contain sharp, angular particles. Sand layer thickness above the barrier should be determined by the engineer/architect as they deem necessary. Sand layers should be installed where applicable in accordance with ACI Publication 302 Guide for Concrete Floor and Slab Construction.

Leighton does not practice in the field of moisture vapor transmission evaluation, since this is not specifically a geotechnical issue. Therefore, we recommend that a qualified person, such as the flooring subcontractor and/or structural engineer, be consulted to evaluate the general and specific moisture vapor transmission paths and any impact on the proposed construction. That person should provide recommendations for mitigation of potential adverse impact of moisture vapor transmission on various components of the structures as deemed appropriate.

Minor cracking of the concrete as it cures, due to drying and shrinkage, is normal and should be expected. However, cracking is often aggravated by a high water/cement ratio, high concrete temperature at the time of placement, small nominal aggregate size, and rapid moisture loss due to hot, dry, and/or windy weather conditions during placement and curing. Cracking due to temperature and moisture fluctuations can also be expected. Low slump concrete can reduce the potential for shrinkage cracking. Additionally, our experience indicates that reinforcement in slabs and foundations can generally reduce the potential for concrete cracking. The structural engineer should consider these components in slab design and specifications.

4.4 Seismic Design Parameters

The principal seismic hazard to the site is ground shaking resulting from an earthquake occurring along any of several major active and potentially active faults in southern California (Figure 4). The intensity of ground shaking at a given location depends primarily upon the earthquake magnitude, the distance from the source, and the site response characteristics.

Accordingly, design of the project should be performed in accordance with all applicable current codes and standards utilizing the appropriate seismic design parameters to reduce seismic risk as defined by California Geological Survey (CGS) Chapter 2 of Special Publication 117A (CGS, 2008). The 2019 edition of the California Building Code (CBC) is the current edition of the code. Through compliance with these regulatory requirements and the utilization of appropriate seismic design parameters selected by the design professionals, potential effects relating to seismic shaking can be reduced.

The following data should be considered for the seismic analysis of the subject site:

2019 CBC Categorization/Coefficient	Design Value
Site Longitude (decimal degrees)	-118.0618
Site Latitude (decimal degrees)	33.9124
Site Class Definition (ASCE 7 Table 20.3-1)	D**
Mapped Spectral Response Acceleration at 0.2s Period, S_s (Figure 1613.3.1(1))	1.644g
Mapped Spectral Response Acceleration at 1s Period, S_1 (Figure 1613.3.1(2))	0.588g
Short Period Site Coefficient at 0.2s Period, F_a (Table 1613.3.3(1))	1.000
Long Period Site Coefficient at 1s Period, F_v (Table 1613.3.3(2))	1.712*
Adjusted Spectral Response Acceleration at 0.2s Period, S_{Ms} (Eq. 16-37)	1.644g
Adjusted Spectral Response Acceleration at 1s Period, S_{M1} (Eq. 16-38)	1.007g*
Design Spectral Response Acceleration at 0.2s Period, S_{Ds} (Eq. 16-39)	1.096g
Design Spectral Response Acceleration at 1s Period, S_{D1} (Eq. 16-40)	0.671g*
Design Peak Ground Acceleration, PGA_M	0.775g

*Per Table 11.4-2 of Supplement 1 of ASCE 7-16, this value of F_v may only be used to calculate T_s [that note is not included in Table 1613.2.3(2)]; note that S_{D1} and S_{M1} are functions of F_v . In addition, per Exception 2 of 11.4.8 of ASCE 7-16, special equations for C_s are required. This is in lieu of a site-specific ground motion hazard analysis per ASCE 7-16 Chapter 21.2.

**Site Class D, and all of the resulting parameters in this table, may only be used for structures without seismic isolation or seismic damping systems.

Based on the 2019 CBC Table 1613.2.3(2) footnote c., F_v should be determined in accordance with Section 11.4.8 of ASCE 7-16, since the mapped spectral response acceleration at 1 second is greater than 0.2g for Site Class D; in accordance with Section 11.4.8 of ASCE 7-16, a site-specific seismic analysis is required. However, the values provided in the table above may be utilized if design is performed in accordance with Exception (2) in Section 11.4.8 of ASCE 7-16, with special requirements for the seismic response coefficient (C_s), and F_v is only used for calculation of T_s . This exception does not apply (and the values in the table above would not be applicable) for structures with seismic isolation or seismic damping systems. The project structural engineer should review the seismic parameters. A site-specific seismic ground motion analysis can be performed upon request.

Hazard deaggregation was estimated using the USGS Interactive Deaggregations utility. The results of this analysis indicate that the predominant modal earthquake has a magnitude of approximately 7.3 (M_w) at a distance on the order of 9.8 kilometers for the Maximum Considered Earthquake (2% probability of exceedance in 50 years).

4.5 Retaining Walls

We have assumed that retaining walls will have a retained soil height of less than 6 feet. We recommend that retaining walls be backfilled with very low expansive soil and constructed with a backdrain in accordance with the recommendations provided on Figure 8 (rear of text). Using expansive soil as retaining wall backfill will result in higher lateral earth pressures exerted on the wall. Based on these recommendations, the following parameters may be used for the design of conventional retaining walls:

Static Equivalent Fluid Weight (pcf)	
Condition	Level Backfill
Active	40 pcf
At-Rest	60 pcf
Passive	240 pcf (allowable) (Maximum of 4,000 psf)

The above values do not contain an appreciable factor of safety unless noted, so the structural engineer should apply the applicable factors of safety and/or load factors during design, as specified by the California Building Code.



Cantilever walls that are designed to yield at least $0.001H$, where H is equal to the wall height, may be designed using the active condition. Rigid walls and walls braced at the top should be designed using the at-rest condition.

Passive pressure is used to compute soil resistance to lateral structural movement. In addition, for sliding resistance, a frictional resistance coefficient of 0.35 may be used at the concrete and soil interface. The lateral passive resistance should be taken into account only if it is ensured that the soil providing passive resistance, embedded against the foundation elements, will remain intact with time.

In addition to the above lateral forces due to retained earth, surcharge due to improvements, such as an adjacent structure or traffic loading, should be considered in the design of the retaining wall. Loads applied within a 1:1 projection from the surcharging structure on the stem of the wall should be considered in the design.

A soil unit weight of 120 pcf may be assumed for calculating the actual weight of the soil over the wall footing.

Walls over 6 feet tall should be reviewed on a case-by-case basis, and will require a seismic increment load.

4.5.1 Drainage

Adequate drainage may be provided by a subdrain system positioned behind earth retaining walls. Typically, this system consists of a 4-inch minimum diameter perforated pipe placed near the base of the wall (perforations placed downward). The pipe should be bedded and backfilled with pervious backfill material described in Section 300-3.5.2 of the *Standard Specifications for Public Works Construction* (Green Book), 2018 Edition. This pervious backfill should extend at least 2 feet horizontally from the back face of the wall and to within 2 feet of backfilled finished grade. This pervious backfill and pipe should also be wrapped in filter fabric, such as Mirafi 140N or equivalent, placed as described in Section 300-8.1 of the *Standard Specifications for Public Works Construction* (Green Book), 2018 Edition. The subdrain outlet should be connected to a free-draining outlet or sump.

Miradrain, Geotech Drainage Panels, or Enkadrain drainage geocomposites, or similar, may be used for wall drainage as an alternative

to the Class 2 Permeable Material or drain rock backfill, particularly where horizontal space is limited adjacent to shoring (where walls are cast against shoring). However, sandy soils with a sand equivalent of 30 or greater should be backfilled against these drainage panels. These drainage panels should be constructed in accordance with the manufacturer’s recommendation and connected to the perforated drainpipe at the base of the wall.

4.6 Preliminary Pavement Design

To provide support for paving, the subgrade soils should be prepared as recommended in the Section 3.1. Compaction of the subgrade, including trench backfills, to at least 95 percent of the maximum dry density as determined by ASTM Test Method D 1557, and achieving a firm, hard, and unyielding surface will be important for paving support. The preparation of the paving area subgrade should be performed immediately prior to placement of the base course. Proper drainage of the paved areas should be provided since this will reduce moisture infiltration into the subgrade and increase the life of the paving.

4.6.1 Asphalt Concrete

The required paving and base thicknesses will depend on the expected wheel loads and volume of traffic (Traffic Index or TI). Assuming that the paving subgrade will consist of engineered fill with an R-value greater than 50, compacted to at least 95 percent as recommended, the minimum recommended paving thicknesses are presented in the following table. Results of R-value testing on a near surface sample of existing onsite soils indicate an R-value of 59.

Asphalt Concrete Pavement Sections

Traffic Index	Asphalt Concrete (inches)	Base Course (inches)
5 or less	3.0	4.0
6	3.5	4.0
7	4.0	4.5

The asphalt paving sections were determined using the Caltrans design method. We can determine the recommended paving and base course thicknesses for other Traffic Indices if required. Careful inspection is recommended to verify that the recommended thicknesses or greater are achieved, and that proper construction procedures are followed.

4.6.2 Portland Cement Concrete Paving

For light axle loads, fire lanes subject to outrigger loads, trash corral aprons, or other areas where point loads are possible, should be paved with Portland Cement Concrete (PCC) with a minimum thickness of 7 inches over properly compacted fill. We have assumed that the subgrade below paving will have an R-value of at least 50. Portland cement concrete (PCC) paving sections were determined in accordance with procedures developed by the Portland Cement Association. Concrete paving sections for a range of Traffic Indices are presented in the following table. All PCC pavements should have a minimum 28-day concrete compressive strength of 3,000 pounds-per-square-inch (psi), and have appropriate joints and saw cuts in accordance with either Portland Cement Association (PCA) or American Concrete Institute (ACI) guidelines. PCC subgrades supporting axle loads are recommended to be compacted to 95 percent relative compaction in the upper 12 inches.

PCC Pavement Sections

Traffic Index	PCC (inches)
5 or less (auto parking)	5.0
6	6.5

The PCC pavement section may be placed on compacted fill. The paving should be provided with crack control joints at regular intervals no more than 10 and 12 feet in each direction for 5 and 6.5-inch-thick PCC, respectively. Crack control joints should be oriented to form square panels (closer spacing may be required to form squares, depending on the layout of the concrete). Load transfer devices, such as dowels or keys, at joints in the paving can reduce possible offsets. The paving sections in the above table have been developed based on the strength of unreinforced concrete. Steel reinforcing

may be added to the paving to reduce cracking and to prolong the life of the paving.

Landscape areas must be separated from pavements with concrete curbs and/or edge drains. Excessive over-irrigation will have an adverse effect on adjacent pavements. Irrigation adjacent to pavements, without a deep curb or other cutoff to separate landscaping from paving will result in premature pavement distress.

4.6.3 Base Course

The base course for asphalt concrete paving should meet the specifications for Class 2 Aggregate Base as defined in Section 26 of the latest edition of the *State of California, Department of Transportation, Standard Specifications*. Alternatively, the base course could meet the specifications for untreated base as defined in Section 200-2 of the latest edition of the *Standard Specifications for Public Works Construction*. The base course should be compacted to a minimum of 95 percent of the maximum dry density as determined by ASTM Test Method D 1557.

4.6.4 Concrete Flatwork

Exterior concrete slabs-on-grade should have a minimum thickness of 4 inches. Common Type II cement should be adequate for concrete flatwork not exposed to recycled water. Type V cement and a water:cement ratio of 0.45 should be used for concrete exposed to recycled water.

Concrete flatwork should be placed on compacted fill. If this material has been disturbed or become dry or desiccated, the subgrade soil to a depth of 12 inches should be moisture conditioned to approximately 2 percentage points above optimum moisture content and recompacted to a minimum of 95 percent relative compaction. Moisture content should be checked 48 hours prior to placing concrete.

As discussed in conjunction with floor slabs, minor cracking of concrete after curing due to expansion, drying and shrinkage is normal and should be expected. However, cracking is often aggravated by a high water-to-cement ratio, high concrete temperature at the time of placement, small nominal

aggregate size, and rapid moisture loss due to hot, dry, and/or windy weather conditions during placement and curing. Cracking due to temperature and moisture fluctuations can also be expected.

The use of low-slump concrete or low water/cement ratios can reduce the potential for shrinkage cracking. Inclusion of joints at frequent intervals forming square patterns, and reinforcement will help control the locations of cracking, and improve aesthetics. Control joints should be spaced at regular intervals no greater than 6 feet on-center and have appropriate joints and saw cuts in accordance with either Portland Cement Association (PCA) or American Concrete Institute (ACI) guidelines. If cracking occurs, repairs may be needed to mitigate a trip hazard (should it develop) and/or improve the appearance.

Landscape areas should be separated from pavements with concrete curbs and/or edge drains. Excessive over-irrigation will have an adverse effect on adjacent pavements. Irrigation adjacent to pavements, without a deep curb or other cutoff to separate landscaping from paving will result in premature pavement distress.

4.7 **Trench Backfill**

Utility trenches should be backfilled with compacted fill in accordance with Sections 306-1.2 and 306-1.3 of the *Standard Specifications for Public Works Construction*, (SSPWC, "Greenbook"), 2018 Edition. Utility trenches can be backfilled with onsite material free of rubble, debris, organic and oversized material up to 3 inches in largest dimension. Prior to backfilling trenches, pipes should be bedded in and covered with either:

- **Granular Bedding:** a) ½-inch open grade aggregate; or b) a uniform sand material with a Sand Equivalent (SE) greater-than-or-equal-to (\geq) 30, passing the No. 4 U.S. Standard Sieve (or as specified by the pipe manufacturer).
- **CLSM:** Controlled Low Strength Material (CLSM) should conform to Section 201-6 of the SSPWC 2018 Edition. CLSM bedding should be placed to 1-foot (0.3 m) over the top of the conduit and vibrated. CLSM should **not** be jetted.

Pipe bedding should extend at least 4-inches below the pipeline invert and at least 12 inches over the top of the pipeline. The bedding and shading sand is

recommended to be densified in place by vibratory, lightweight compaction equipment and not by water jetting.

Trench backfill over the pipe bedding zone may consist of native and clean fill soils. All backfill should be placed in thin lifts (appropriate for the type of compaction equipment), moisture conditioned above optimum, and mechanically compacted to at least 90 percent relative compaction, relative to the ASTM D1557 laboratory maximum density).

4.8 Surface Drainage

Inadequate control of runoff water and/or poorly controlled irrigation can cause the onsite soils to expand and/or shrink, producing heaving and/or settlement of foundations, flatwork, walls, and other improvements. Maintaining adequate surface drainage, proper disposal of runoff water, and control of irrigation should help reduce the potential for future soil moisture problems.

Positive surface drainage should be designed to be directed away from foundations and toward approved drainage devices, such as gutters, paved drainage swales, or watertight area drains and collector pipes.

Surface drainage should be provided to prevent ponding of water adjacent to the structures. In general, the area around the buildings should slope away from the building. We recommend that unpaved landscaped areas adjacent to the buildings be avoided. Roof runoff should be carried to suitable drainage outlets by watertight drain pipes or over paved areas.

4.9 Additional Geotechnical Services

The preliminary geotechnical recommendations presented in this report are based on subsurface conditions as interpreted from limited subsurface explorations and limited laboratory testing. Our supplemental geotechnical recommendations provided in this report are based on information available at the time the report was prepared and may change as plans are developed. Additional geotechnical investigation and analysis may be required based on final improvement plans. Leighton should review the site and grading plans when available and comment further on the geotechnical aspects of the project. Geotechnical observation and testing should be conducted during excavation and all phases of grading operations. Our conclusions and preliminary recommendations should be

reviewed and verified by Leighton during construction and revised accordingly if geotechnical conditions encountered vary from our preliminary findings and interpretations.

Geotechnical observation and testing should be provided:

- After completion of site clearing.
- During overexcavation of compressible soil.
- During compaction of all fill materials.
- After excavation of all footings and prior to placement of concrete.
- During utility trench backfilling and compaction.
- During pavement subgrade and base preparation.
- When any unusual conditions are encountered.

5.0 LIMITATIONS

This report does not address the potential for encountering hazardous materials in site soils nor groundwater.

This report was necessarily based in part upon data obtained from a limited number of observances, site visits, soil samples, tests, analyses, histories of occurrences, spaced subsurface explorations and limited information on historical events and observations. Such information is necessarily incomplete. The nature of many sites is such that differing characteristics can be experienced within small distances and under various climatic conditions. Changes in subsurface conditions can and do occur over time. Important information about limitations of geotechnical reports in general is presented in Appendix E, *GBA's Important Information About This Geotechnical-Engineering Report*.

This report was prepared for Rincon Consultants based on their needs, directions and requirements at the time of our exploration, in accordance with generally accepted geotechnical engineering practices at this time in California. This report is not authorized for use by, and is not to be relied upon by, any party except Rincon Consultants and their design and construction management team, with whom Leighton and Associates Inc. has contracted for this work. Use of or reliance on this report by any other party is at that party's risk. Unauthorized use of or reliance on this report constitutes an agreement to defend and indemnify Leighton and Associates, Inc. from and against any liability which may arise as a result of such use or reliance, regardless of any fault, negligence, and/or strict liability of Leighton and Associates, Inc.

6.0 REFERENCES

- American Concrete Institute (ACI), 2008, Building Code Requirements for Structural Concrete (ACI 318-08) and Commentary (ACI 318R-08), an ACI Standard, 2008.
- Blake, T.F., 2000, EQFAULT, A Computer Program for estimating a maximum earthquake event, Version 3.00b, earthquake database updated January, 2011.
- California Building Standards Commission, 2013, 2013 California Building Code, California Code of Regulations, Title 24, Part 2, Volume 2 of 2, Based on 2012 International Building Code, Effective January 1, 2014.
- California Department of Water Resources (CDWR), 2021, California Statewide Groundwater Elevation Monitoring (CASGEM).
- California Geological Survey (formerly California Division of Mines and Geology), 1998, Seismic Hazard Zone Report for the Whittier 7.5-Minute Quadrangle, Los Angeles and Orange Counties, California, Seismic Hazard Zone Report 037, 1998.
- _____, 2000, CD-ROM containing digital images of Official Maps of Alquist-Priolo Earthquake Fault Zones that affect the Southern Region, DMG CD 2000-003 2000.
- _____, 2008, Guidelines for Evaluating and Mitigating Seismic Hazards in California, Special Publication 117A, Revised and Re-adopted September 11, 2008.
- City of Santa Fe Springs, The General Plan of The City of Santa Fe Springs, California, 1991-2014, Safety Element, Hazard Maps, 1994.
- CivilTech Software, 2008, LiquefyPro, Version 5.5j
- Dibblee, T.W., and Ehrenspeck, H.E., Geologic Map of the Whittier and La Habra Quadrangles (Western Puente Hills) Los Angeles and Orange Counties, California, 2001.
- GeoLogismiki, 2006, CLiq, Version 1.5.1.26.
- Idriss, I. M., and Boulanger, R. W., "Soil Liquefaction During Earthquakes", Earthquake Engineering Research Institute, 2008.
- Ishihara, K., 1995, Effects of At-Depth Liquefaction on Embedded Foundations During Earthquakes, Proceedings of 11th Asian Regional Conference on Soil Mechanics and Foundation Engineering, Vol. 2, 1995.

- Martin, G. R., and Lew, M., ed., 1999, "Recommended Procedures for Implementation of DMG Special Publication 117, Guidelines for Analyzing and Mitigating Liquefaction Hazards in California," Southern California Earthquake Center, dated March 1999.
- Page, A.L.; Miller, R. H. and Keeney, D. R., 1989, Methods of Soil Analysis. Part-2, 2nd ed. American Society Agronomy Inc.
- Public Works Standard, Inc., 2015, Greenbook, Standard Specifications for Public Works Construction: BNI Building News, Anaheim, California.
- State Water Resources Control Board (SWRCB) of California, 2021, Geotracker Website, < http://waterboards.ca.gov/about_us/>.
- United States Geological Survey (USGS), 2011, Ground Motion Parameter Calculator, Seismic Hazard Curves and Uniform Hazard Response Spectrum, Java Application, Version 5.1.0, February 10, 2011, downloaded from <http://earthquake.usgs.gov/hazards/designmaps/javacalc.php>
- Youd, T.L., DeDen, D.W., Bray, J.D., Sancio, R., Cetin, K.O., Gerber, T.M., 2009, "Zero-Displacement Lateral Spreads, 1999 Kocaeli, Turkey, Earthquake", ASCE Journal of Geotechnical and Geoenvironmental Engineering, January 2009.
- Youd, T.L., Idriss, I.M., Andrus, R.D., Arango, I., Castro, G., Christian, J.T., Dobry, R., Finn, L., Harder, L.F., Hynes, M.E., Ishihara, K., Koester, J.P., Liao, S.C., Marcuson, W.F. III, Martin, G.R., Mitchell, J.K., Moriwaki, Y., Power, M.S., Robertson, P.K., Seed, R.B., Stokoe, K.H. II, 2001, "Liquefaction Resistance of Soils: Summary Report from the 1996 NCEER and 1998 NCEER/NSF Workshops on Evaluation of Liquefaction Resistance of Soils", Journal of Geotechnical and Geoenvironmental Engineering, Vol. 127, No. 10, October 2001.
- Youd, T.L., Hansen, C.M., Bartlett, S.F., 2002, Revised Multilinear Regression Equations for Prediction of Lateral Spread Displacement, ASCE Journal of Geotechnical and Geoenvironmental Engineering, December 2002.

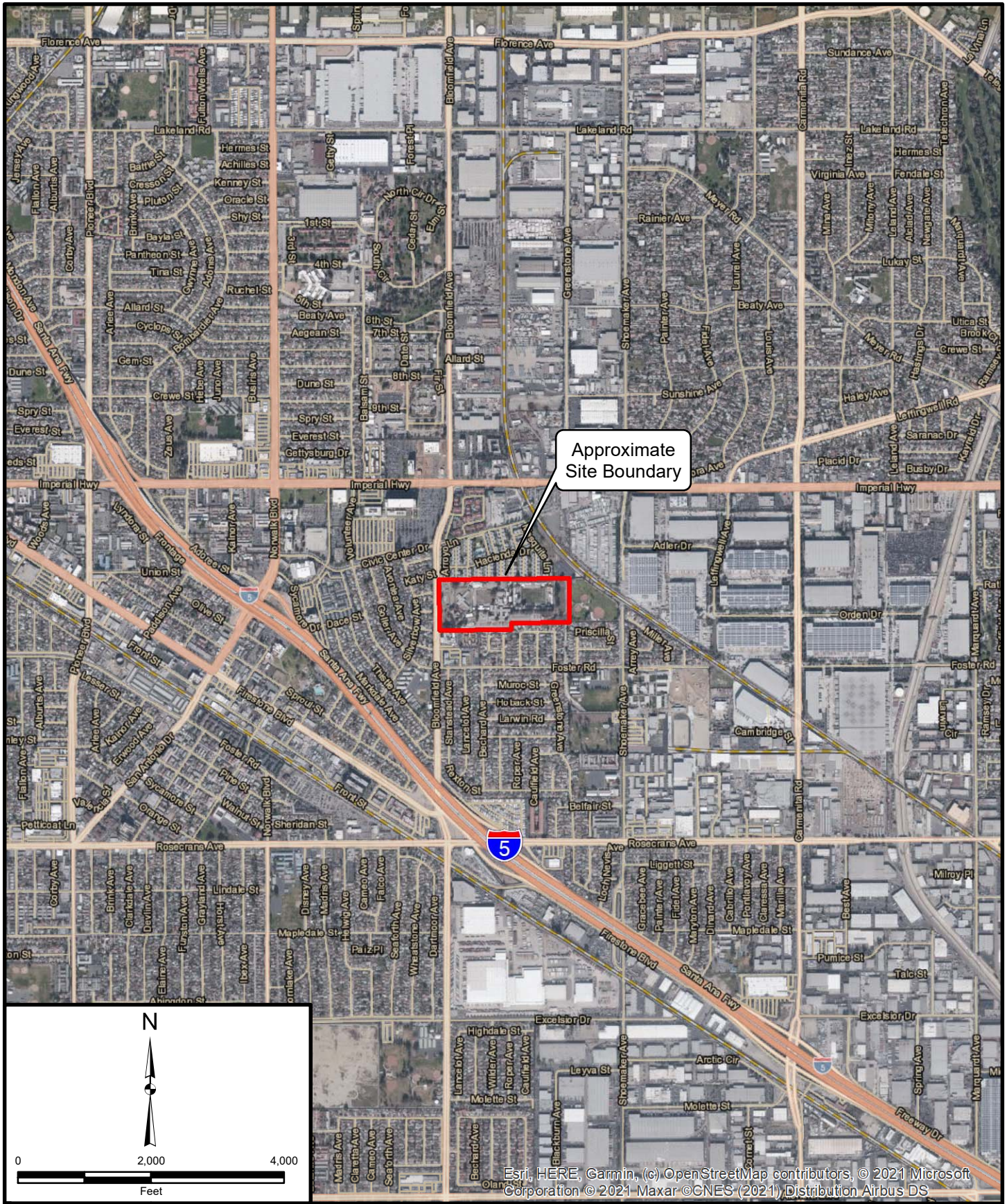

Esri, HERE, Garmin, (c) OpenStreetMap contributors, © 2021 Microsoft Corporation © 2021 Maxar ©GNES (2021) Distribution Airbus DS

Project: 13109.001	Eng/Geol: JAR
Scale: 1" = 2,000'	Date: April 2021
Base Map: ESRI ArcGIS Online 2021	
Thematic Information: Leighton	
Author: Leighton Geomatics (btran)	

SITE LOCATION MAP

Norwalk Transit Village
13200 Bloomfield Avenue
Norwalk, California

Figure 1

Leighton

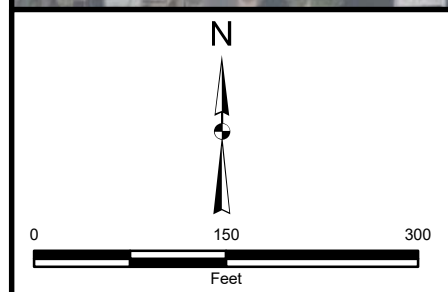

Project: 13109.001	Eng/Geol: JAR
Scale: 1" = 150'	Date: May 2021
Base Map: ESRI ArcGIS Online 2021 Thematic Information: Leighton Author: Leighton Geomatics (btran)	



EXPLORATION LOCATION MAP

Norwalk Transit Village
13200 Bloomfield Avenue
Norwalk, California

Figure 2



Legend

-  Qof, Old Alluvial Fan Deposits
-  Qyf, Young Alluvial Fan Deposits

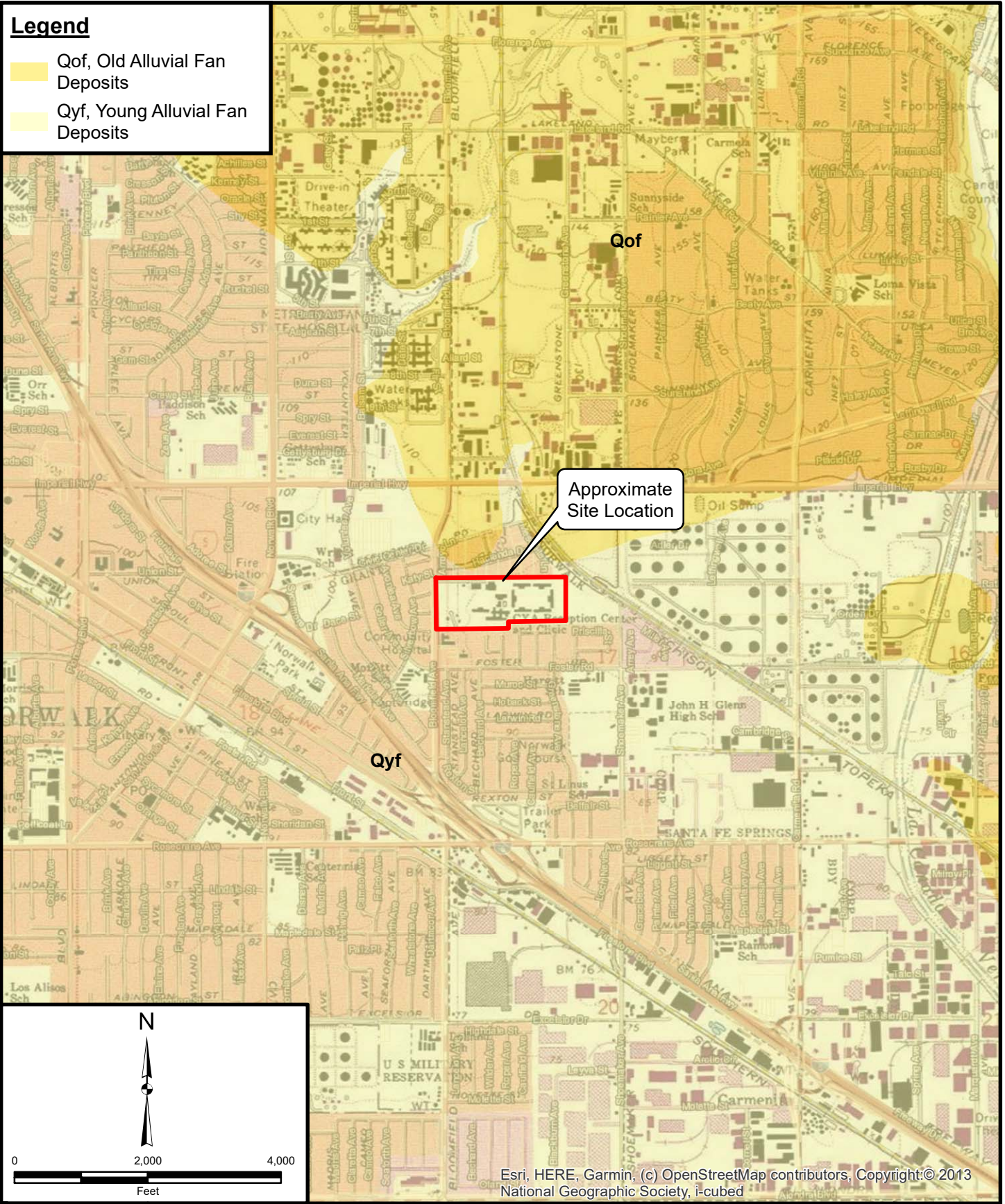

Project: 13109.001

Eng/Geol: JAR

Scale: 1" = 2,000'

Date: April 2021

Base Map: ESRI ArcGIS Online 2021
 Thematic Information: Leighton, USGS
 Author: Leighton Geomatics (btran)

REGIONAL GEOLOGY MAP
 Norwalk Transit Village
 13200 Bloomfield Avenue
 Norwalk, California

Figure 3



Leighton

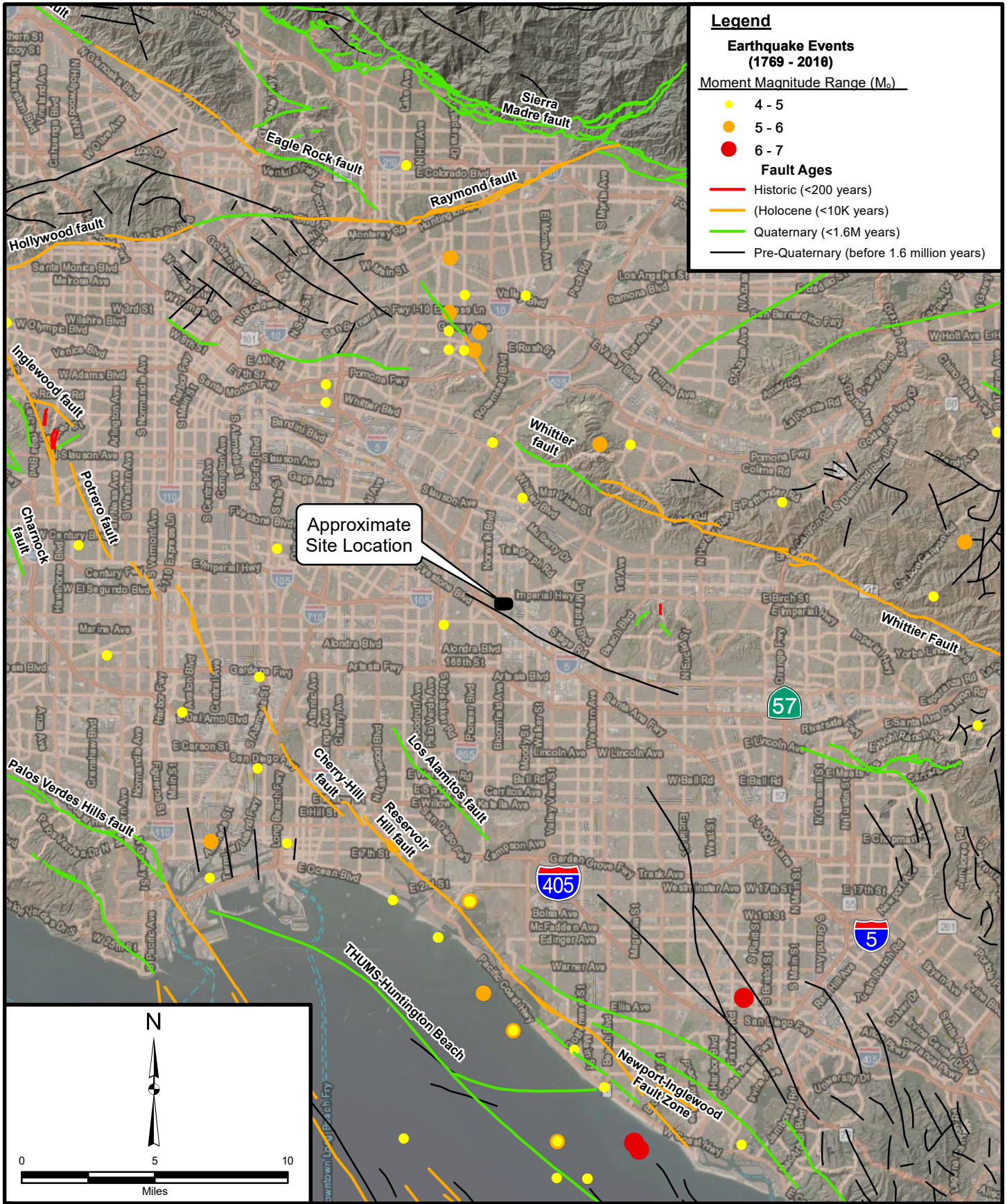

Legend

Earthquake Events (1769 - 2016)

Moment Magnitude Range (M_w)

- 4 - 5
- 5 - 6
- 6 - 7

Fault Ages

- Historic (<200 years)
- (Holocene (<10K years))
- Quaternary (<1.6M years)
- Pre-Quaternary (before 1.6 million years)

Approximate Site Location

N

0 5 10

Miles

Project: 13109.001 Eng/Geol: JAR

Scale: 1" = 5 miles Date: April 2021

Base Map: ESRI ArcGIS Online 2021
 Thematic Information: Leighton, Bryant, W. A. (compiler), 2005, Digital Database of Quaternary and Younger Faults from the Fault Activity Map of California, version 2.0: CGS, USGS, SCEC.
 Author: Leighton Geomatics (btran)

REGIONAL FAULT AND HISTORICAL SEISMICITY MAP

Norwalk Transit Village
 13200 Bloomfield Avenue
 Norwalk, California

Figure 4

Leighton

Legend

 Liquefaction Susceptibility Zone

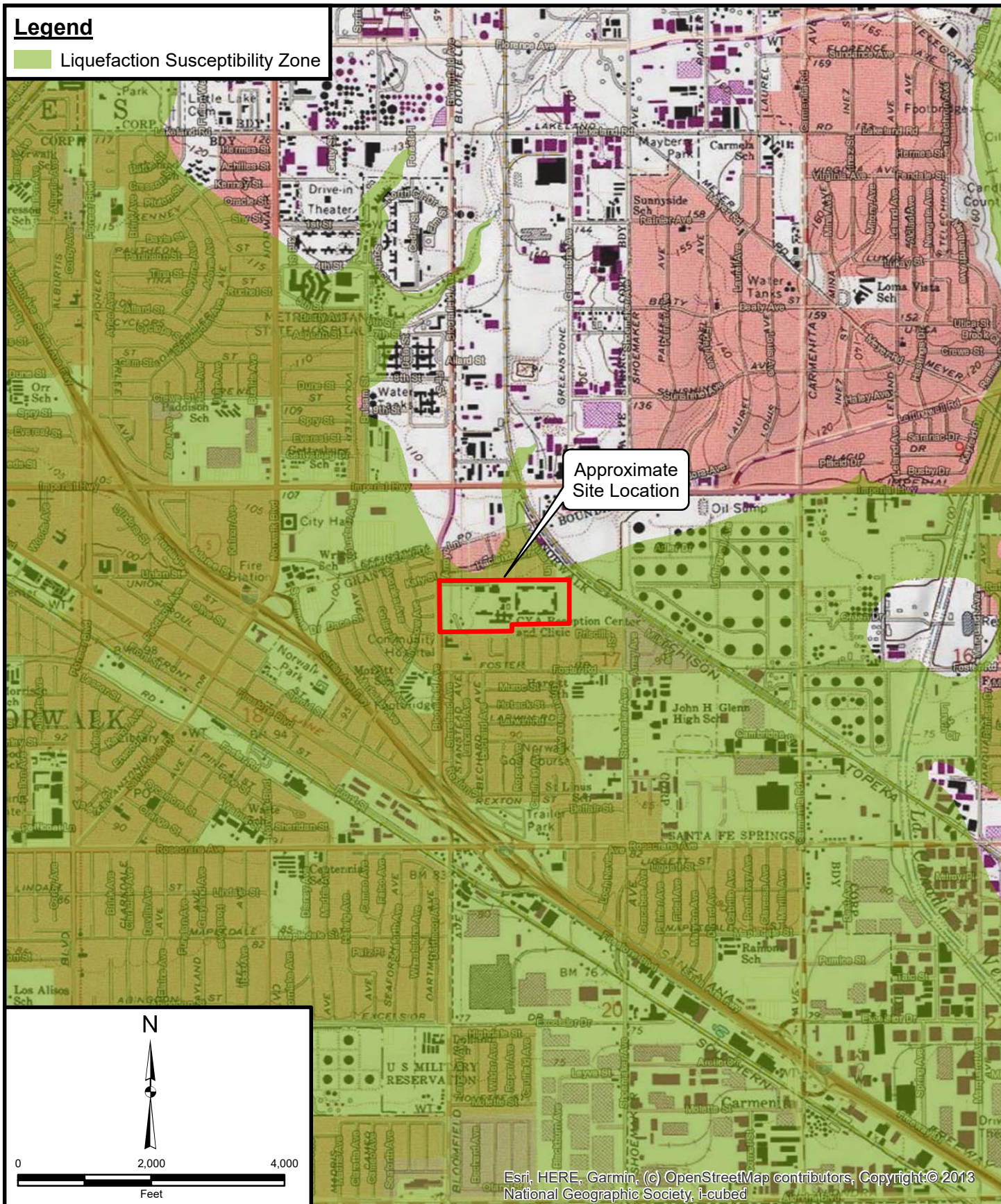

Project: 13109.001	Eng/Geol: JAR
Scale: 1" = 2,000'	Date: April 2021
Base Map: ESRI ArcGIS Online 2021 Thematic Information: Leighton, CGS Author: Leighton Geomatics (btran)	

SEISMIC HAZARD MAP
 Norwalk Transit Village
 13200 Bloomfield Avenue
 Norwalk, California

Figure 5

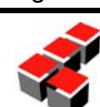

Leighton

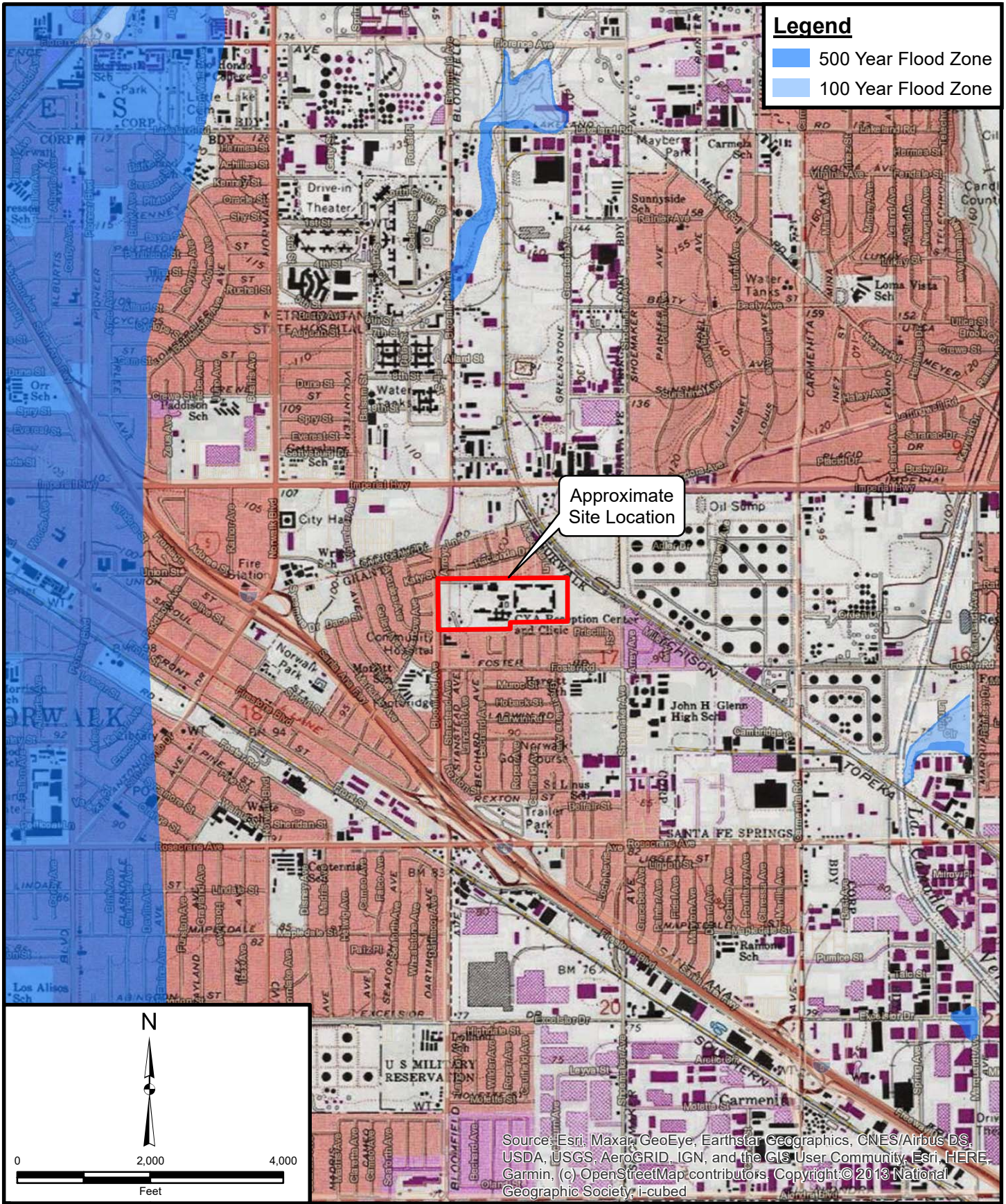

Legend

- 500 Year Flood Zone
- 100 Year Flood Zone

Approximate Site Location

Source: Esri, Maxar, GeoEye, Earthstar Geographics, CNES/Airbus DS, USDA, USGS, AeroGRID, IGN, and the GIS User Community, Esri, HERE, Garmin, (c) OpenStreetMap contributors, Copyright © 2013 National Geographic Society, i-cubed

Project: 13109.001	Eng/Geol: JAR
Scale: 1" = 2,000'	Date: April 2021
Base Map: ESRI ArcGIS Online 2021 Thematic Information: Leighton, CA DWR, FEMA Author: Leighton Geomatics (btran)	

FLOOD HAZARD ZONE MAP

Norwalk Transit Village 13200 Bloomfield Avenue Norwalk, California

Figure 6

Leighton

Legend

Prado

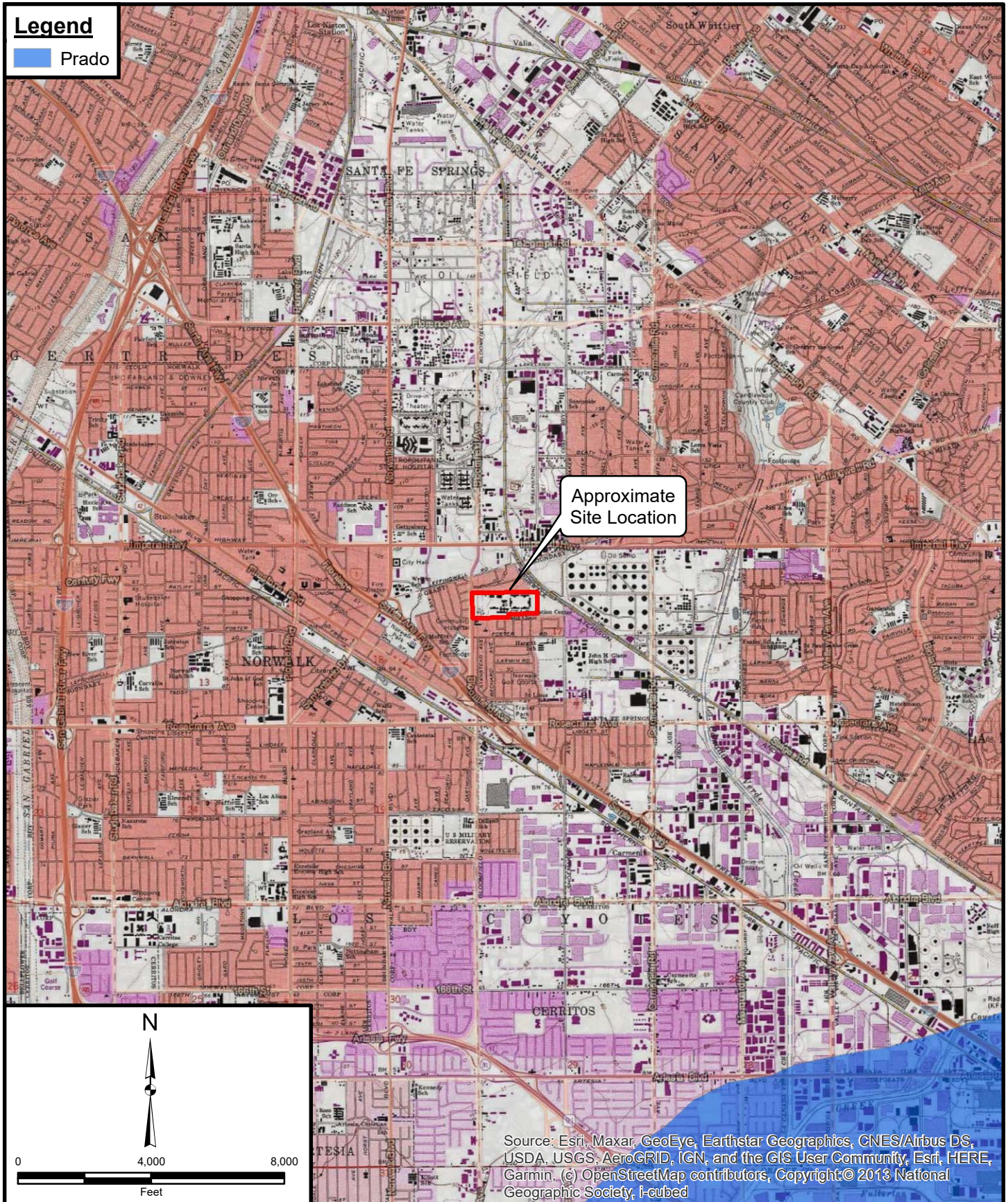

Project: 13109.001	Eng/Geol: JAR
Scale: 1" = 4,000'	Date: April 2021
Base Map: ESRI ArcGIS Online 2021 Thematic Information: Leighton, CA DWR, FEMA Author: Leighton Geomatics (btran)	

DAM INUNDATION MAP

Norwalk Transit Village
13200 Bloomfield Avenue
Norwalk, California

Figure 7



Leighton

SUBDRAIN OPTIONS AND BACKFILL WHEN NATIVE MATERIAL HAS EXPANSION INDEX OF ≤ 50

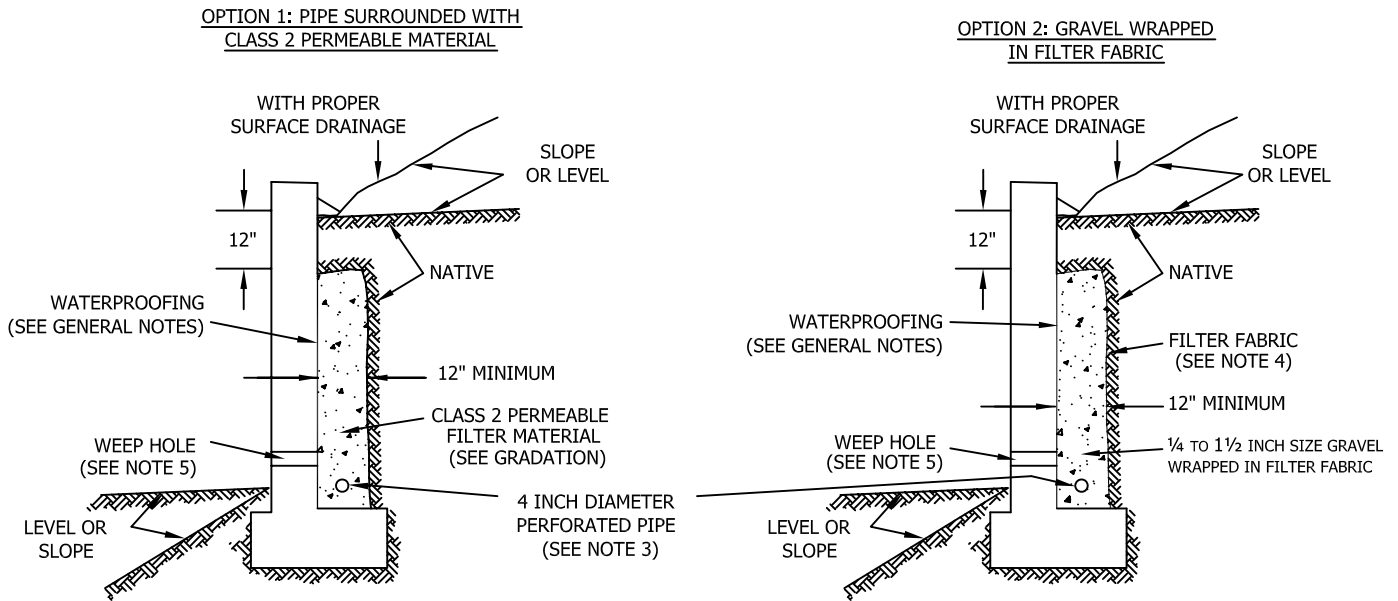

Class 2 Filter Permeable Material Gradation
Per Caltrans Specifications

Sieve Size	Percent Passing
1"	100
3/4"	90-100
3/8"	40-100
No. 4	25-40
No. 8	18-33
No. 30	5-15
No. 50	0-7
No. 200	0-3

GENERAL NOTES:

- * Waterproofing should be provided where moisture nuisance problem through the wall is undesirable.
- * Water proofing of the walls is not under purview of the geotechnical engineer
- * All drains should have a gradient of 1 percent minimum
- * Outlet portion of the subdrain should have a 4-inch diameter solid pipe discharged into a suitable disposal area designed by the project engineer. The subdrain pipe should be accessible for maintenance (rodding)
- * Other subdrain backfill options are subject to the review by the geotechnical engineer and modification of design parameters.

Notes:

- 1) Sand should have a sand equivalent of 30 or greater and may be densified by water jetting.
- 2) 1 Cu. ft. per ft. of 1/4- to 1 1/2-inch size gravel wrapped in filter fabric
- 3) Pipe type should be ASTM D1527 Acrylonitrile Butadiene Styrene (ABS) SDR35 or ASTM D1785 Polyvinyl Chloride plastic (PVC), Schedule 40, Armco A2000 PVC, or approved equivalent. Pipe should be installed with perforations down. Perforations should be 3/8 inch in diameter placed at the ends of a 120-degree arc in two rows at 3-inch on center (staggered)
- 4) Filter fabric should be Mirafi 140NC or approved equivalent.
- 5) Weepholes should be 3-inch minimum diameter and provided at 10-foot maximum intervals. If exposure is permitted, weepholes should be located 12 inches above finished grade. If exposure is not permitted such as for a wall adjacent to a sidewalk/curb, a pipe under the sidewalk to be discharged through the curb face or equivalent should be provided. For a basement-type wall, a proper subdrain outlet system should be provided.
- 6) Retaining wall plans should be reviewed and approved by the geotechnical engineer.
- 7) Walls over six feet in height are subject to a special review by the geotechnical engineer and modifications to the above requirements.

RETAINING WALL BACKFILL AND SUBDRAIN DETAIL FOR WALLS 6 FEET OR LESS IN HEIGHT

WHEN NATIVE MATERIAL HAS EXPANSION INDEX OF ≤ 50



Leighton
FIGURE 8

APPENDIX A
FIELD EXPLORATION LOGS

APPENDIX A

FIELD EXPLORATION

Our field investigation consisted of a surface reconnaissance and a subsurface exploration program. Six borings (LB-1 through LB-6) were excavated and logged to a maximum depth of approximately 51.5 feet below the existing ground surface. Six cone penetration test (CPT) sounds were conducted to a maximum depth of approximately 75 feet below the existing ground surface. Logs of these subsurface explorations are included as part of this appendix. Approximate soil boring locations are shown on Figure 2, *Test Location Map*.

Borings: On April 20, 2021, 6 hollow-stem-auger borings were drilled, logged and sampled to depths ranging from 51.3 to 51.5 feet below the ground surface. Encountered soils were logged in the field by our representative and described in accordance with the Unified Soil Classification System (ASTM D 2488). Relatively undisturbed soil samples were obtained at selected intervals within these borings using both a California ring-lined and Standard Penetration Test (SPT) split-spoon sampler. Standard Penetration Test (SPT) resistance blow counts were obtained by dropping a 140-pound hammer through a 30-inch free fall (the SPT samplers had room for a liner, but no liner was used, as is common in this region). The 2-inch outside diameter split-spoon sampler was driven 18 inches and the number of blows was recorded for each 6 inches of penetration (ASTM D 1586). In addition, 2.4-inch inside diameter brass ring samples were obtained using a Modified California sampler driven into the soil with the 140-pound hammer. Near surface bulk soil samples were also collected from the borings. Borings were backfilled with soil cuttings obtained during the exploration. Representative earth-material samples obtained from these subsurface explorations were transported to our geotechnical laboratory for evaluation and appropriate testing.

Cone Penetrometer Test (CPT): Six (6) cone penetrometer test (CPT) soundings were advanced to between approximately 58 to 75 feet below the ground surface in general accordance with ASTM D 3441, using a truck-mounted electric cone penetrometer. Unlike soil borings, in which drive samples are typically driven at discrete depth intervals (e.g. 5 feet), CPTs provide a continuous analog record of soil properties with depth. Hence, CPTs can define a subsurface soil profile with higher resolution than soil borings, often detecting thin layers that can be missed with conventional drilling and sampling; thereby more accurately defining thickness of weak or liquefiable soil layers. CPT results are presented in Appendix B.

The attached subsurface exploration logs and related information depict subsurface conditions only at the locations indicated and at the particular date designated on the logs. Subsurface conditions at other locations may differ from conditions occurring at these locations. The passage of time may result in altered subsurface conditions due to environmental changes. In addition, any stratification lines on the logs represent the approximate boundary between soil types and the transition may be gradual.

GEOTECHNICAL BORING LOG LB-1

Project No. 13109.001
Project Norwalk Transit Village
Drilling Co. Martini Drilling
Drilling Method Hollow Stem Auger - 140lb - Autohammer - 30" Drop
Location See Figure 2, Exploration Location Map

Date Drilled 4-19-21
Logged By KMD
Hole Diameter 8"
Ground Elevation '
Sampled By KMD

Elevation Feet	Depth Feet	Graphic Log	Attitudes	Sample No.	Blows Per 6 Inches	Dry Density pcf	Moisture Content, %	Soil Class. (U.S.C.S.)	SOIL DESCRIPTION	Type of Tests
	0	N S							This Soil Description applies only to a location of the exploration at the time of sampling. Subsurface conditions may differ at other locations and may change with time. The description is a simplification of the actual conditions encountered. Transitions between soil types may be gradual.	
				B-1				SM	@0': 3-inches Asphalt Concrete over 3-inches Aggregate Base. Artificial Fill, undocumented (Afu): @0.67': Silty SAND with gravel, brown, moist, fine to medium sand, fine to coarse gravels.	
	5			R-1	4 6 10	108	5	SP	Quaternary Young Alluvial Fan Deposits (Qyf): @5': SAND with gravel, brown, moist, medium dense, predominantly fine sand, some medium to coarse sand, some fine gravels, oxidation stains.	
				R-2	5 9 13			SP	@7': SAND, light grey brown, slightly moist, medium dense, fine sand, micaceous, oxidation stains.	CO
	10			S-1	4 2 2		8	SP-SM CL	@10': SAND with silt, light grey brown, slightly moist, loose, fine sand, few medium sand, poorly graded, oxidation stains, sharp contact below. @11.4': Sandy CLAY to CLAY with sand, dark brown, very moist, medium stiff, predominantly very fine sand, few medium to coarse sand, few silt, FeO veins.	-200
	15			S-2	2 4 6			SC-CL	@15': Sandy CLAY to Clayey SAND, reddish brown, very moist, stiff/medium dense, fine sand, trace to few medium sand, trace coarse sand, pervasive FeO veins and blebs, massive.	
	20			S-3	3 6 7		18	ML	@20': Sandy SILT with clay, dark yellowish brown, moist to very moist, predominantly very fine to fine sand, trace medium and coarse sand, with yellow silt-filled root voids, micaceous, weak FeO and MnO oxidation.	
	25			S-4	6 8 10			SP-SM CL SP	@25': SAND with silt, brown, moist, medium dense, predominantly fine sand, few to some medium sand. @25.25': 1.5-inch bed of Silty CLAY, mottled olive grey and reddish brown, moist to very moist, pervasive FeO and MnO spots and stains, CaCO3 veins. @25.38': SAND, grey, moist, medium dense, fine to medium sand, grading finer and more brown in color, micaceous, with few very micaceous laminations.	-200
	30									

SAMPLE TYPES:

- B BULK SAMPLE
- C CORE SAMPLE
- G GRAB SAMPLE
- R RING SAMPLE
- S SPLIT SPOON SAMPLE
- T TUBE SAMPLE

TYPE OF TESTS:

- 200 % FINES PASSING
- AL ATTERBERG LIMITS
- CN CONSOLIDATION
- CO COLLAPSE
- CR CORROSION
- CU UNDRAINED TRIAXIAL

- DS DIRECT SHEAR
- EI EXPANSION INDEX
- H HYDROMETER
- MD MAXIMUM DENSITY
- PP POCKET PENETROMETER
- RV R VALUE

- SA SIEVE ANALYSIS
- SE SAND EQUIVALENT
- SG SPECIFIC GRAVITY
- UC UNCONFINED COMPRESSIVE STRENGTH



GEOTECHNICAL BORING LOG LB-1

Project No. 13109.001
Project Norwalk Transit Village
Drilling Co. Martini Drilling
Drilling Method Hollow Stem Auger - 140lb - Autohammer - 30" Drop
Location See Figure 2, Exploration Location Map

Date Drilled 4-19-21
Logged By KMD
Hole Diameter 8"
Ground Elevation '
Sampled By KMD

Elevation Feet	Depth Feet	Graphic Log	Attitudes	Sample No.	Blows Per 6 Inches	Dry Density pcf	Moisture Content, %	Soil Class. (U.S.C.S.)	SOIL DESCRIPTION	Type of Tests
		N S							This Soil Description applies only to a location of the exploration at the time of sampling. Subsurface conditions may differ at other locations and may change with time. The description is a simplification of the actual conditions encountered. Transitions between soil types may be gradual.	
30				S-5	5 8 10		16	CL SM-ML SP CL SM-ML	@30': Interbedded CLAY with silt and Sandy SILT to Silty SAND: CLAY with silt, grey-brown, very moist, very stiff, CaCO3-impacted, micaceous, plastic, with some FeO veins; and Sandy SILT to Silty SAND, mottled reddish brown and olive, very moist, very stiff/medium dense, very fine sand, very micaceous, with a 3-inch bed of fine white SAND at approximately 31'.	
35				S-6	3 5 10			CL	@35': Sandy Lean CLAY, mottled olive brown and reddish brown, moist to very moist, very stiff, very fine sand, very micaceous, with trace white sand-filled burrow-holes, trace fine gravel.	-200, AL
40				S-7	7 14 24		4	SP	@40': SAND, reddish brown, moist, very dense, predominantly fine sand, micaceous, grading lighter grey and slightly coarser, to include some fine sand and trace fine gravel.	
45				S-8	10 16 21			SP	@45': SAND with gravel, grey-brown, moist, very dense, predominantly fine sand, some medium to coarse sand, some fine subrounded gravels.	
50				S-9	7 10 14		22	ML SM ML	@50': Sandy SILT, olive brown, very moist, hard, very fine sand, micaceous. @50.75': Silty SAND, grey-brown with reddish brown (FeO-stained) laminations, moist, medium dense, very fine sand. @50.83': SILT, olive with reddish brown FeO stains, very moist, hard, micaceous, grading more clayey to become Clayey SILT by 51.25'.	
55									Total Depth: 51.5' bgs No groundwater encountered during drilling Boring backfilled with soil cuttings and surface patched to match existing conditions.	
60										

SAMPLE TYPES:

- B BULK SAMPLE
- C CORE SAMPLE
- G GRAB SAMPLE
- R RING SAMPLE
- S SPLIT SPOON SAMPLE
- T TUBE SAMPLE

TYPE OF TESTS:

- 200 % FINES PASSING
- AL ATTERBERG LIMITS
- CN CONSOLIDATION
- CO COLLAPSE
- CR CORROSION
- CU UNDRAINED TRIAXIAL

- DS DIRECT SHEAR
- EI EXPANSION INDEX
- H HYDROMETER
- MD MAXIMUM DENSITY
- PP POCKET PENETROMETER
- RV R VALUE

- SA SIEVE ANALYSIS
- SE SAND EQUIVALENT
- SG SPECIFIC GRAVITY
- UC UNCONFINED COMPRESSIVE STRENGTH



GEOTECHNICAL BORING LOG LB-2

Project No. 13109.001
Project Norwalk Transit Village
Drilling Co. Martini Drilling
Drilling Method Hollow Stem Auger - 140lb - Autohammer - 30" Drop
Location See Figure 2, Exploration Location Map

Date Drilled 4-19-21
Logged By KMD
Hole Diameter 8"
Ground Elevation '
Sampled By KMD

Elevation Feet	Depth Feet	Graphic Log	Attitudes	Sample No.	Blows Per 6 Inches	Dry Density pcf	Moisture Content, %	Soil Class. (U.S.C.S.)	SOIL DESCRIPTION	Type of Tests
	0	N S		B-1					This Soil Description applies only to a location of the exploration at the time of sampling. Subsurface conditions may differ at other locations and may change with time. The description is a simplification of the actual conditions encountered. Transitions between soil types may be gradual. @0': 4.5-inches Asphalt Concrete over 3-inches Aggregate Base. SM Artificial Fill, undocumented: (Afu) @7.5-inches: Silty SAND, dark orange brown, moist, predominantly fine sand, few medium sand, trace coarse sand.	CR, EI, MD, SA
								ML	Quaternary Young Alluvial Fan Deposits (Qyf): @2': Sandy SILT, olive brown, tighter, very fine sand, few clay.	
	5			R-1	5 9 12	107	3	SM	@5': Silty SAND, light olive brown, slightly moist to moist, medium dense, predominantly fine sand, few to some medium sand, trace coarse sand, pinhole pores, little CaCO ₃ , sparse FeO staining. PP = 3.00 tsf	-200
				R-2	4 6 10			SP	@7': SAND, light grey, slightly moist, medium dense, unconsolidated, fine to medium sand, trace to few coarse sand.	
	10			R-3	8 12 16	99	1		@10': With predominantly fine sand, some medium sand, trace coarse sand. PP = N/A (Described as loose)	
	15			R-4	11 16 23		1			
	20			S-1	8 9 12				@20': SAND, greyish brown, slightly moist, medium dense, predominantly fine sand, some medium to coarse sand, trace to few silt, trace fine to medium gravel.	
	25			R-5	7 10 12	102	12	ML	@25': Sandy SILT, grey brown, moist, stiff, very fine sand, abundant CaCO ₃ nodules, many FeO-filled pinhole pores, trace fine rootlets, trace medium sand. PP > 4.50 tsf	
	30									

SAMPLE TYPES:

- B BULK SAMPLE
- C CORE SAMPLE
- G GRAB SAMPLE
- R RING SAMPLE
- S SPLIT SPOON SAMPLE
- T TUBE SAMPLE

TYPE OF TESTS:

- 200 % FINES PASSING
- AL ATTERBERG LIMITS
- CN CONSOLIDATION
- CO COLLAPSE
- CR CORROSION
- CU UNDRAINED TRIAXIAL

- DS DIRECT SHEAR
- EI EXPANSION INDEX
- H HYDROMETER
- MD MAXIMUM DENSITY
- PP POCKET PENETROMETER
- RV R VALUE

- SA SIEVE ANALYSIS
- SE SAND EQUIVALENT
- SG SPECIFIC GRAVITY
- UC UNCONFINED COMPRESSIVE STRENGTH



GEOTECHNICAL BORING LOG LB-2

Project No. 13109.001
Project Norwalk Transit Village
Drilling Co. Martini Drilling
Drilling Method Hollow Stem Auger - 140lb - Autohammer - 30" Drop
Location See Figure 2, Exploration Location Map

Date Drilled 4-19-21
Logged By KMD
Hole Diameter 8"
Ground Elevation '
Sampled By KMD

Elevation Feet	Depth Feet	Graphic Log	Attitudes	Sample No.	Blows Per 6 Inches	Dry Density pcf	Moisture Content, %	Soil Class. (U.S.C.S.)	SOIL DESCRIPTION	Type of Tests
		N S							<i>This Soil Description applies only to a location of the exploration at the time of sampling. Subsurface conditions may differ at other locations and may change with time. The description is a simplification of the actual conditions encountered. Transitions between soil types may be gradual.</i>	
30				S-2	5 8 7			SP-SM	@30': SAND with silt, grey brown, slightly moist, medium dense, poorly graded, predominantly fine sand, trace medium sand, trace coarse sand, massive, uncemented, micaceous.	-200
35				R-6	8 8 15	100	12	SM-ML	@35': Interbedded Sandy SILT/Silty SAND, brownish grey, moist, very stiff/medium dense, very fine sand, weak FeO staining, micaceous. PP > 4.50 tsf	AL
40				S-3	5 8 10			ML	@40': Sandy SILT, dark steel grey, very moist, very stiff, very fine sand, massive, micaceous, grades to very fine fine Silty SAND, medium dense @40.75'.	
45				R-7	9 10 15	90	33		@45': SILT, steel gray, very moist, very stiff, micaceous, trace FeO staining @46.5': CLAY, black, with charcoal over dark grey Sandy CLAY.	
50				S-4	6 7 10			CL	@50': Sandy CLAY, brown to reddish brown, moist to very moist, fine to medium sand, trace coarse sand, massive.	
									Total Depth: 51.5' bgs No groundwater encountered during drilling Boring backfilled with soil cuttings and surface patched to match existing conditions.	
55										
60										

SAMPLE TYPES:

- B BULK SAMPLE
- C CORE SAMPLE
- G GRAB SAMPLE
- R RING SAMPLE
- S SPLIT SPOON SAMPLE
- T TUBE SAMPLE

TYPE OF TESTS:

- 200 % FINES PASSING
- AL ATTERBERG LIMITS
- CN CONSOLIDATION
- CO COLLAPSE
- CR CORROSION
- CU UNDRAINED TRIAXIAL

- DS DIRECT SHEAR
- EI EXPANSION INDEX
- H HYDROMETER
- MD MAXIMUM DENSITY
- PP POCKET PENETROMETER
- RV R VALUE

- SA SIEVE ANALYSIS
- SE SAND EQUIVALENT
- SG SPECIFIC GRAVITY
- UC UNCONFINED COMPRESSIVE STRENGTH



GEOTECHNICAL BORING LOG LB-3

Project No. 13109.001
Project Norwalk Transit Village
Drilling Co. Martini Drilling
Drilling Method Hollow Stem Auger - 140lb - Autohammer - 30" Drop
Location See Figure 2, Exploration Location Map

Date Drilled 4-19-21
Logged By KMD
Hole Diameter 8"
Ground Elevation '
Sampled By KMD

Elevation Feet	Depth Feet	Graphic Log	Attitudes	Sample No.	Blows Per 6 Inches	Dry Density pcf	Moisture Content, %	Soil Class. (U.S.C.S.)	SOIL DESCRIPTION	Type of Tests
0		N S		B-1				SM	@0': 3-inches Asphalt Concrete over 6-inches Aggregate Base.	-200, RV
								ML	Artificial Fill, undocumented: (Afu) @0.75': Silty SAND, light brown, slightly moist, very fine sand.	
5				R-1	8 8 10	96	4	SM	Quaternary Young Alluvial Fan Deposits (Qyf): @5': Silty SAND, light brown, slightly moist, medium dense, very fine to fine sand, rootlets and rootlet voids, sparse FeO staining, fine sand. PP > 4.50 tsf	CO
				R-2	5 8 16	94	1	SP		
				R-3	7 9 16			NR		
15				S-1	9 11 14			SP SM	@15': SAND, light grey brown, slightly moist, medium dense, fine to medium sand, some coarse sand, trace fine gravel. @15.5': Silty SAND, light brown, slightly moist, medium dense, very fine to fine sand.	
20				R-3	8 19 23	98	4	ML SM	@20': Sandy SILT, grey brown, slightly moist, very stiff, very fine sand, slightly micaceous, some FeO stained patches, trace pinhole pores, trace MnO spots, slightly micaceous. PP > 4.50 tsf @21.25': Thin bed of Silty SAND.	AL, CN
25				S-2	6 9 10			SM SP	@25': Silty SAND, light grey brown, slightly moist, very stiff/medium dense, very fine sand, FeO veins, cemented. @25.75': Grades to SAND, light brown, slightly moist, medium dense, uncemented, predominantly fine sand, few medium sand, micaceous, few to some silt.	-200
30										

SAMPLE TYPES:

- B BULK SAMPLE
- C CORE SAMPLE
- G GRAB SAMPLE
- R RING SAMPLE
- S SPLIT SPOON SAMPLE
- T TUBE SAMPLE

TYPE OF TESTS:

- 200 % FINES PASSING
- AL ATTERBERG LIMITS
- CN CONSOLIDATION
- CO COLLAPSE
- CR CORROSION
- CU UNDRAINED TRIAXIAL

- DS DIRECT SHEAR
- EI EXPANSION INDEX
- H HYDROMETER
- MD MAXIMUM DENSITY
- PP POCKET PENETROMETER
- RV R VALUE

- SA SIEVE ANALYSIS
- SE SAND EQUIVALENT
- SG SPECIFIC GRAVITY
- UC UNCONFINED COMPRESSIVE STRENGTH



GEOTECHNICAL BORING LOG LB-3

Project No. 13109.001
Project Norwalk Transit Village
Drilling Co. Martini Drilling
Drilling Method Hollow Stem Auger - 140lb - Autohammer - 30" Drop
Location See Figure 2, Exploration Location Map

Date Drilled 4-19-21
Logged By KMD
Hole Diameter 8"
Ground Elevation '
Sampled By KMD

Elevation Feet	Depth Feet	Graphic Log	Attitudes	Sample No.	Blows Per 6 Inches	Dry Density pcf	Moisture Content, %	Soil Class. (U.S.C.S.)	SOIL DESCRIPTION	Type of Tests
		N S							This Soil Description applies only to a location of the exploration at the time of sampling. Subsurface conditions may differ at other locations and may change with time. The description is a simplification of the actual conditions encountered. Transitions between soil types may be gradual.	
30		•••••		R-4	8 13 17	92	6	SM-ML	@30': Sandy SILT to very fine Silty SAND, light grey brown, slightly moist, very stiff/medium dense, laminated, very micaceous (muscovite), FeO stained lams, very fine sand. PP = 3.75 tsf	
35		•••••		S-3	6 6 4			CL SM	@35': CLAY, steel grey, very moist, stiff, laminated, moderate plasticity, pockets of very fine grey sand, oxidized zones around rootlets. @35.3': Silty SAND, grey, moist, loose, very fine sand, micaceous, FeO stains. @36': CLAY, dark grey, very moist, stiff, massive, blocky structure, FeO stained zones, micaceous. @36.25': Sandy CLAY, black, very moist, stiff, very fine sand, micaceous, many fine rootlets, tine shell (<1 mm).	
40		•••••		R-5	23 27 40	130	7	SM-SC	@40': Silty Clayey SAND, very dark grey to brown to black, dense, predominantly fine sand, few medium sand, trace pinhole pores, sparse pieces of organic matter, weakly bedded. PP > 4.50 tsf	
45		•••••		S-4	6 9 15			CL	@45': Sandy CLAY, reddish brown to strong brown, moist to very moist, very stiff, massive, fine sand, blocky structure, with few thin interbeds of very fine clayey sand.	
50		•••••		R-6	7 20 28	107	23		@50': Sandy SILT with Clay, dark yellow brown, moist to very moist, hard, very fine sand, micaceous.	
									Total Depth: 51.5' bgs No groundwater encountered during drilling Boring backfilled with soil cuttings and surface patched to match existing conditions.	
55										
60										

SAMPLE TYPES:

- B BULK SAMPLE
- C CORE SAMPLE
- G GRAB SAMPLE
- R RING SAMPLE
- S SPLIT SPOON SAMPLE
- T TUBE SAMPLE

TYPE OF TESTS:

- 200 % FINES PASSING
- AL ATTERBERG LIMITS
- CN CONSOLIDATION
- CO COLLAPSE
- CR CORROSION
- CU UNDRAINED TRIAXIAL

- DS DIRECT SHEAR
- EI EXPANSION INDEX
- H HYDROMETER
- MD MAXIMUM DENSITY
- PP POCKET PENETROMETER
- RV R VALUE

- SA SIEVE ANALYSIS
- SE SAND EQUIVALENT
- SG SPECIFIC GRAVITY
- UC UNCONFINED COMPRESSIVE STRENGTH



GEOTECHNICAL BORING LOG LB-4

Project No. 13109.001
Project Norwalk Transit Village
Drilling Co. Martini Drilling
Drilling Method Hollow Stem Auger - 140lb - Autohammer - 30" Drop
Location See Figure 2, Exploration Location Map

Date Drilled 4-19-21
Logged By KMD
Hole Diameter 8"
Ground Elevation '
Sampled By KMD

Elevation Feet	Depth Feet	Graphic Log	Attitudes	Sample No.	Blows Per 6 Inches	Dry Density pcf	Moisture Content, %	Soil Class. (U.S.C.S.)	SOIL DESCRIPTION	Type of Tests
		N S							This Soil Description applies only to a location of the exploration at the time of sampling. Subsurface conditions may differ at other locations and may change with time. The description is a simplification of the actual conditions encountered. Transitions between soil types may be gradual.	
0	0	[Asphalt Concrete]		B-1				SM	@0': 3-inches Asphalt Concrete over Aggregate Base. Artificial Fill, undocumented: (Afu) @5': SAND, light tan, slightly moist, medium dense, fine sand, becomes sand with silt to silty sand.	
5	5	[Sandy SILT]		R-1	2 6 8	96	3	SP	Quaternary Young Alluvial Fan Deposits (Qyf): @5': SAND, light tan, slightly moist, medium dense, fine sand, becomes sand with silt to silty sand.	
		[Silty SAND]		R-2	5 5 7	88	10	SM-ML	@7': Interbedded Sandy SILT to Silty SAND, greyish brown, moist, medium dense/stiff, very fine sand, patchy FeO and MnO staining and spotting.	
10	10	[Sandy SILT]		R-3	4 10 16	99	9	ML	@10': Sandy SILT, very stiff, grading to sand with silt, grey brown, moist, medium dense, fine sand, FeO stains.	
15	15	[SAND with Silt]		R-4	8 10 21	106	3	SP-SM	@15': SAND with Silt, brown, moist, medium dense, very fine to fine sand, weak FeO staining, micaceous.	CO
		[SAND]						SP	@16.25': SAND, light grey, moist, medium dense, fine sand.	
20	20	[SAND]		S-1	4 4 5			CL	@20': SAND, light brown, moist, loose, fine sand, erosional contact below. @20.2': Sandy SILT, mottled olive reddish brown, moist, stiff, very micaceous. @21.4': Grey laminated Sandy SILT / Silty SAND, moist, stiff, very fine sand. @21.5': CLAY, grey, very moist, stiff, plastic	
25	25	[CLAY]		R-5	6 10 12	105	8	SP-SM	@25': Silty SAND to SAND with Silt, brown, moist, medium dense, very fine to fine sand, micaceous, sparse FeO spotting.	AL, CN
30	30	[CLAY]								

SAMPLE TYPES:

- B BULK SAMPLE
- C CORE SAMPLE
- G GRAB SAMPLE
- R RING SAMPLE
- S SPLIT SPOON SAMPLE
- T TUBE SAMPLE

TYPE OF TESTS:

- 200 % FINES PASSING
- AL ATTERBERG LIMITS
- CN CONSOLIDATION
- CO COLLAPSE
- CR CORROSION
- CU UNDRAINED TRIAXIAL

- DS DIRECT SHEAR
- EI EXPANSION INDEX
- H HYDROMETER
- MD MAXIMUM DENSITY
- PP POCKET PENETROMETER
- RV R VALUE

- SA SIEVE ANALYSIS
- SE SAND EQUIVALENT
- SG SPECIFIC GRAVITY
- UC UNCONFINED COMPRESSIVE STRENGTH



GEOTECHNICAL BORING LOG LB-4

Project No. 13109.001
Project Norwalk Transit Village
Drilling Co. Martini Drilling
Drilling Method Hollow Stem Auger - 140lb - Autohammer - 30" Drop
Location See Figure 2, Exploration Location Map

Date Drilled 4-19-21
Logged By KMD
Hole Diameter 8"
Ground Elevation '
Sampled By KMD

Elevation Feet	Depth Feet	Graphic Log	Attitudes	Sample No.	Blows Per 6 Inches	Dry Density pcf	Moisture Content, %	Soil Class. (U.S.C.S.)	SOIL DESCRIPTION	Type of Tests
		N S							This Soil Description applies only to a location of the exploration at the time of sampling. Subsurface conditions may differ at other locations and may change with time. The description is a simplification of the actual conditions encountered. Transitions between soil types may be gradual.	
30				S-2	5 7 5			CL	@30': CLAY, dark gray, very moist, stiff, very micaceous, with charcoal, some tiny shells, few fine sand	
35				R-6	5 8 11	81	35	ML CL CL	@35': CLAY, dark grey, moist, stiff, micaceous. @36': CLAY, grey with many light tan patchy inclusions, charcoal and sporatically burned wood, thinly laminated. @36.5': Silty Sandy CLAY, black, very moist, stiff.	
40				S-3	9 18 20			SC-CL	@40': Clayey SAND to Sandy CLAY, reddish brown, moist, dense/hard, massive, fine sand.	
45				R-7	16 28 38	127	11	CL	@45': Sandy CLAY, mottled orangish reddish brown, moist, hard, predominantly fine sand, trace medium sand.	
50				S-4	4 7 13			CL	@50': CLAY with Sand, olive brown, very moist, very stiff, fine sand, MnO spotting, some FeO staining (weak), massive.	
									Total Depth: 51.5' bgs No groundwater encountered during drilling Boring backfilled with soil cuttings and surface patched to match existing conditions.	
55										
60										

SAMPLE TYPES:

- B BULK SAMPLE
- C CORE SAMPLE
- G GRAB SAMPLE
- R RING SAMPLE
- S SPLIT SPOON SAMPLE
- T TUBE SAMPLE

TYPE OF TESTS:

- 200 % FINES PASSING
- AL ATTERBERG LIMITS
- CN CONSOLIDATION
- CO COLLAPSE
- CR CORROSION
- CU UNDRAINED TRIAXIAL
- DS DIRECT SHEAR
- EI EXPANSION INDEX
- H HYDROMETER
- MD MAXIMUM DENSITY
- PP POCKET PENETROMETER
- RV R VALUE
- SA SIEVE ANALYSIS
- SE SAND EQUIVALENT
- SG SPECIFIC GRAVITY
- UC UNCONFINED COMPRESSIVE STRENGTH



GEOTECHNICAL BORING LOG LB-5

Project No. 13109.001
Project Norwalk Transit Village
Drilling Co. Martini Drilling
Drilling Method Hollow Stem Auger - 140lb - Autohammer - 30" Drop
Location See Figure 2, Exploration Location Map

Date Drilled 4-20-21
Logged By KMD
Hole Diameter 8"
Ground Elevation '
Sampled By KMD

Elevation Feet	Depth Feet	Graphic Log	Attitudes	Sample No.	Blows Per 6 Inches	Dry Density pcf	Moisture Content, %	Soil Class. (U.S.C.S.)	SOIL DESCRIPTION	Type of Tests
		N S							This Soil Description applies only to a location of the exploration at the time of sampling. Subsurface conditions may differ at other locations and may change with time. The description is a simplification of the actual conditions encountered. Transitions between soil types may be gradual.	
0		•••••		B-1				SM	Quaternary Young Alluvial Fan Deposits (Qyf): @0': Tall grass over Silty SAND, medium brown, moist, predominantly fine sand, some medium to coarse sand, some fine to coarse gravels.	CR, EI, MD SA
5		•••••		R-1	4 6 9	97	3	SP	@5': SAND, grey brown, slightly moist, medium dense, predominantly very fine to fine sand, with trace medium to coarse sand, weak FeO staining, few silt. PP = 1.75 tsf	
		•••••		R-2	5 7 10				@7': With stronger FeO staining, few thin lams of sandy CLAY, grey-brown @8.5'.	
10		•••••		R-3	6 8 14	93	1		@10': SAND, orange tan, slightly moist, medium dense, predominantly fine sand, trace medium sand, strong oxidation (FeO).	
15		•••••		S-1	5 7 7			SP-SM	@15': SAND with silt, grey brown, slightly moist, medium dense, very fine sand, few to some silt. @15.2': ~0.25-inches of light olive grey SILT over ~0.25-inches of grey-brown CLAY, then very fine SAND, grading slightly less silty with depth.	-200
20		▨▨▨▨▨		R-4	6 11 22	101	25	ML-CL	@20': CLAY with Silt, grey brown, moist, very stiff, with pinhole pores, abundant CaCO ₃ , trace fine rootlets.	
		▨▨▨▨▨						ML	@21.25': CLAY with Sand, lighter grey brown, moist, micaceous, very fine sand, few to some CLAY, CaCO ₃ .	
25		▨▨▨▨▨		S-2	5 6 8			CL	@25': Sandy lean CLAY, olive brown, slightly moist, stiff, some laminated regions, some FeO staining, very fine sand, becomes SILT to SILT with Sand @26.5'.	-200, AL
30		▨▨▨▨▨								

SAMPLE TYPES:

- B BULK SAMPLE
- C CORE SAMPLE
- G GRAB SAMPLE
- R RING SAMPLE
- S SPLIT SPOON SAMPLE
- T TUBE SAMPLE

TYPE OF TESTS:

- 200 % FINES PASSING
- AL ATTERBERG LIMITS
- CN CONSOLIDATION
- CO COLLAPSE
- CR CORROSION
- CU UNDRAINED TRIAXIAL

- DS DIRECT SHEAR
- EI EXPANSION INDEX
- H HYDROMETER
- MD MAXIMUM DENSITY
- PP POCKET PENETROMETER
- RV R VALUE

- SA SIEVE ANALYSIS
- SE SAND EQUIVALENT
- SG SPECIFIC GRAVITY
- UC UNCONFINED COMPRESSIVE STRENGTH



GEOTECHNICAL BORING LOG LB-5

Project No. 13109.001
Project Norwalk Transit Village
Drilling Co. Martini Drilling
Drilling Method Hollow Stem Auger - 140lb - Autohammer - 30" Drop
Location See Figure 2, Exploration Location Map

Date Drilled 4-20-21
Logged By KMD
Hole Diameter 8"
Ground Elevation '
Sampled By KMD

Elevation Feet	Depth Feet	Graphic Log	Attitudes	Sample No.	Blows Per 6 Inches	Dry Density pcf	Moisture Content, %	Soil Class. (U.S.C.S.)	SOIL DESCRIPTION	Type of Tests
		N S							This Soil Description applies only to a location of the exploration at the time of sampling. Subsurface conditions may differ at other locations and may change with time. The description is a simplification of the actual conditions encountered. Transitions between soil types may be gradual.	
30		••••• ••••• ••••• ••••• •••••		R-5	9 14 22	105	12	SM	@30': Silty SAND, dark grey brown, moist to very moist, medium dense, very fine sand with few fine sand, few rootlets	AL, SA
35		/ /		S-3	1 1 2		CL	@35': CLAY, black, strong organic odor on first breaking, soft, possible charcoal, blue green patches and tiny shells, grading in ~3-inches to dominantly blue-green with black patches, organic odor.		
40		/ /		R-6	5 11 17	108	21	CL	@40': CLAY, blue-grey, very moist, very stiff, blocky structure, CaCO ₃ -impacted, decomposed root fragments, trace medium sand, becoming light blue grey Silty CLAY by 41.5'. PP = 3.00 tsf	
45		/ /		S-4	2 4 10		ML SM-ML	@45': Clayey SILT, dark blue grey, very moist, stiff, micaceous, with trace coarse sand. @46.3': Silty SAND to Sandy SILT with gravel, blue grey, moist, stiff/medium dense, fine to medium sand, some coarse sand and fine gravel.		
50		••••• ••••• ••••• ••••• •••••		R-7	18 31 50/2"		SM	@50': Silty SAND, dark blue grey, very moist, very dense, very fine sand, grades by 51' to Sandy SILT, hard, very fine sand. @51.5': SAND, grey, very moist, fine sand with few medium sand.		
									Total Depth: 51.5' bgs No groundwater encountered during drilling Boring backfilled with soil cuttings and surface patched to match existing conditions.	
55										
60										

- | | | | |
|---|--|---|--|
| SAMPLE TYPES:
B BULK SAMPLE
C CORE SAMPLE
G GRAB SAMPLE
R RING SAMPLE
S SPLIT SPOON SAMPLE
T TUBE SAMPLE | TYPE OF TESTS:
-200 % FINES PASSING
AL ATTERBERG LIMITS
CN CONSOLIDATION
CO COLLAPSE
CR CORROSION
CU UNDRAINED TRIAXIAL | DS DIRECT SHEAR
EI EXPANSION INDEX
H HYDROMETER
MD MAXIMUM DENSITY
PP POCKET PENETROMETER
RV R VALUE | SA SIEVE ANALYSIS
SE SAND EQUIVALENT
SG SPECIFIC GRAVITY
UC UNCONFINED COMPRESSIVE STRENGTH |
|---|--|---|--|



GEOTECHNICAL BORING LOG LB-6

Project No. 13109.001
Project Norwalk Transit Village
Drilling Co. Martini Drilling
Drilling Method Hollow Stem Auger - 140lb - Autohammer - 30" Drop
Location See Figure 2, Exploration Location Map

Date Drilled 4-20-21
Logged By KMD
Hole Diameter 8"
Ground Elevation '
Sampled By KMD

Elevation Feet	Depth Feet	Graphic Log	Attitudes	Sample No.	Blows Per 6 Inches	Dry Density pcf	Moisture Content, %	Soil Class. (U.S.C.S.)	SOIL DESCRIPTION	Type of Tests				
		N S							This Soil Description applies only to a location of the exploration at the time of sampling. Subsurface conditions may differ at other locations and may change with time. The description is a simplification of the actual conditions encountered. Transitions between soil types may be gradual.					
0				B-1				SM	Quaternary Young Alluvial Fan Deposits (Qyf): @0': Tall Grass over Silty SAND, light brown, slightly moist, predominantly fine sand, some medium sand.					
5				R-1	6 12 18	103	1	SP	@5': Medium dense @6': Grades to SAND, brownish grey, slightly moist, medium dense, fine sand, with few medium sand, few silt, grading less silty with depth. @7': SAND, light grey brown, slightly moist to moists, medium dense, fine sand, trace silt.					
10				R-2	8 9 13									
15				R-3	7 9 18	98	1	SM	@10': With very fine sand, few silt. @11.5': Grades to Silty SAND, grey brown, slightly moist, medium dense, very fine sand.	CO				
20				R-4	11 14 14			CL-ML SP	@15': Silty CLAY, mottled dark olive and reddish brown, very moist, very stiff, with wood fragments, CaCO ₃ , FeO and MnO stains, pockets of fine sand. @15.2': SAND, light grey brown, slightly moist to moists, medium dense, fine sand, trace silt.					
25				S-1	3 4 4			CL	@20': Sandy lean CLAY, loose, grades quickly to Silty SAND, brown, moist, very fine sand, grading by 21' to Silty CLAY, mottled light olive and dark brown, moist, firm, blocky structure, pinhole pores, trace to few charcoal fragments, some CaCO ₃ , few fine sand.	-200				
30				R-5	6 10 12	96	7	ML	@25': SILT, mottled light grey and light orange, moist, stiff, nonplastic, few very fine sand, FeO spotting, micaceous, trace MnO spotting, few clay by 26.5'.	CN				
<table style="width: 100%; font-size: x-small;"> <tr> <td style="width: 25%;"> SAMPLE TYPES: B BULK SAMPLE C CORE SAMPLE G GRAB SAMPLE R RING SAMPLE S SPLIT SPOON SAMPLE T TUBE SAMPLE </td> <td style="width: 25%;"> TYPE OF TESTS: -200 % FINES PASSING AL ATTERBERG LIMITS CN CONSOLIDATION CO COLLAPSE CR CORROSION CU UNDRAINED TRIAXIAL </td> <td style="width: 25%;"> DS DIRECT SHEAR EI EXPANSION INDEX H HYDROMETER MD MAXIMUM DENSITY PP POCKET PENETROMETER RV R VALUE </td> <td style="width: 25%;"> SA SIEVE ANALYSIS SE SAND EQUIVALENT SG SPECIFIC GRAVITY UC UNCONFINED COMPRESSIVE STRENGTH </td> </tr> </table>											SAMPLE TYPES: B BULK SAMPLE C CORE SAMPLE G GRAB SAMPLE R RING SAMPLE S SPLIT SPOON SAMPLE T TUBE SAMPLE	TYPE OF TESTS: -200 % FINES PASSING AL ATTERBERG LIMITS CN CONSOLIDATION CO COLLAPSE CR CORROSION CU UNDRAINED TRIAXIAL	DS DIRECT SHEAR EI EXPANSION INDEX H HYDROMETER MD MAXIMUM DENSITY PP POCKET PENETROMETER RV R VALUE	SA SIEVE ANALYSIS SE SAND EQUIVALENT SG SPECIFIC GRAVITY UC UNCONFINED COMPRESSIVE STRENGTH
SAMPLE TYPES: B BULK SAMPLE C CORE SAMPLE G GRAB SAMPLE R RING SAMPLE S SPLIT SPOON SAMPLE T TUBE SAMPLE	TYPE OF TESTS: -200 % FINES PASSING AL ATTERBERG LIMITS CN CONSOLIDATION CO COLLAPSE CR CORROSION CU UNDRAINED TRIAXIAL	DS DIRECT SHEAR EI EXPANSION INDEX H HYDROMETER MD MAXIMUM DENSITY PP POCKET PENETROMETER RV R VALUE	SA SIEVE ANALYSIS SE SAND EQUIVALENT SG SPECIFIC GRAVITY UC UNCONFINED COMPRESSIVE STRENGTH											



GEOTECHNICAL BORING LOG LB-6

Project No. 13109.001
Project Norwalk Transit Village
Drilling Co. Martini Drilling
Drilling Method Hollow Stem Auger - 140lb - Autohammer - 30" Drop
Location See Figure 2, Exploration Location Map

Date Drilled 4-20-21
Logged By KMD
Hole Diameter 8"
Ground Elevation '
Sampled By KMD

Elevation Feet	Depth Feet	Graphic Log	Attitudes	Sample No.	Blows Per 6 Inches	Dry Density pcf	Moisture Content, %	Soil Class. (U.S.C.S.)	SOIL DESCRIPTION	Type of Tests
		N S							This Soil Description applies only to a location of the exploration at the time of sampling. Subsurface conditions may differ at other locations and may change with time. The description is a simplification of the actual conditions encountered. Transitions between soil types may be gradual.	
30				S-2	5 7 9			CL	@30': Sandy CLAY with Silt, dark brown, moist, very stiff, very fine sand, micaceous, with FeO stained rootlet voids	
35				R-6	8 19 25	118	11	SC-CL	@35': Sandy CLAY and Clayey SAND, mottled dark olive brown and reddish brown, moist, medium dense to dense, very stiff/hard, fine sand, heavily oxidized (rings, veins, blebs), CaCO ₃ , trace medium sand.	
40				S-3	2 3 6			CH	@40': fat CLAY with sand, olive brown, moist to very moist, stiff, large CaCO ₃ nodules, coarse sand to fine gravel, pervasive fine FeO veins, well developed blocky structure, slightly micaceous, grades fairly quickly to heavily CaCO ₃ -impacted light blue grey CLAY.	AL
45				R-7	7 14 20	103	20	ML	@45': SILT, dark bluish grey, moist to very moist, very stiff, organic odor, micaceous, hackly structure, with some thin laminations of blue grey very fine silty sand. PP > 4.50 tsf	
50				S-4	5 50/4"			ML SPg	@50': Silty SAND, dark grey, moist, very dense, very fine sand. @50.25': Grades to SILT, dark bluish grey, very moist, hard, zones with very fine sand. @51': Some fine to coarse sand and fine gravel. @51.1': Gravelly SAND, light grey, moist, very dense, fine to coarse sand, fine gravels.	
55									Total Depth: 51.3' bgs No groundwater encountered during drilling Boring backfilled with soil cuttings and surface patched to match existing conditions.	
60										

SAMPLE TYPES:

- B BULK SAMPLE
- C CORE SAMPLE
- G GRAB SAMPLE
- R RING SAMPLE
- S SPLIT SPOON SAMPLE
- T TUBE SAMPLE

TYPE OF TESTS:

- 200 % FINES PASSING
- AL ATTERBERG LIMITS
- CN CONSOLIDATION
- CO COLLAPSE
- CR CORROSION
- CU UNDRAINED TRIAXIAL

- DS DIRECT SHEAR
- EI EXPANSION INDEX
- H HYDROMETER
- MD MAXIMUM DENSITY
- PP POCKET PENETROMETER
- RV R VALUE

- SA SIEVE ANALYSIS
- SE SAND EQUIVALENT
- SG SPECIFIC GRAVITY
- UC UNCONFINED COMPRESSIVE STRENGTH



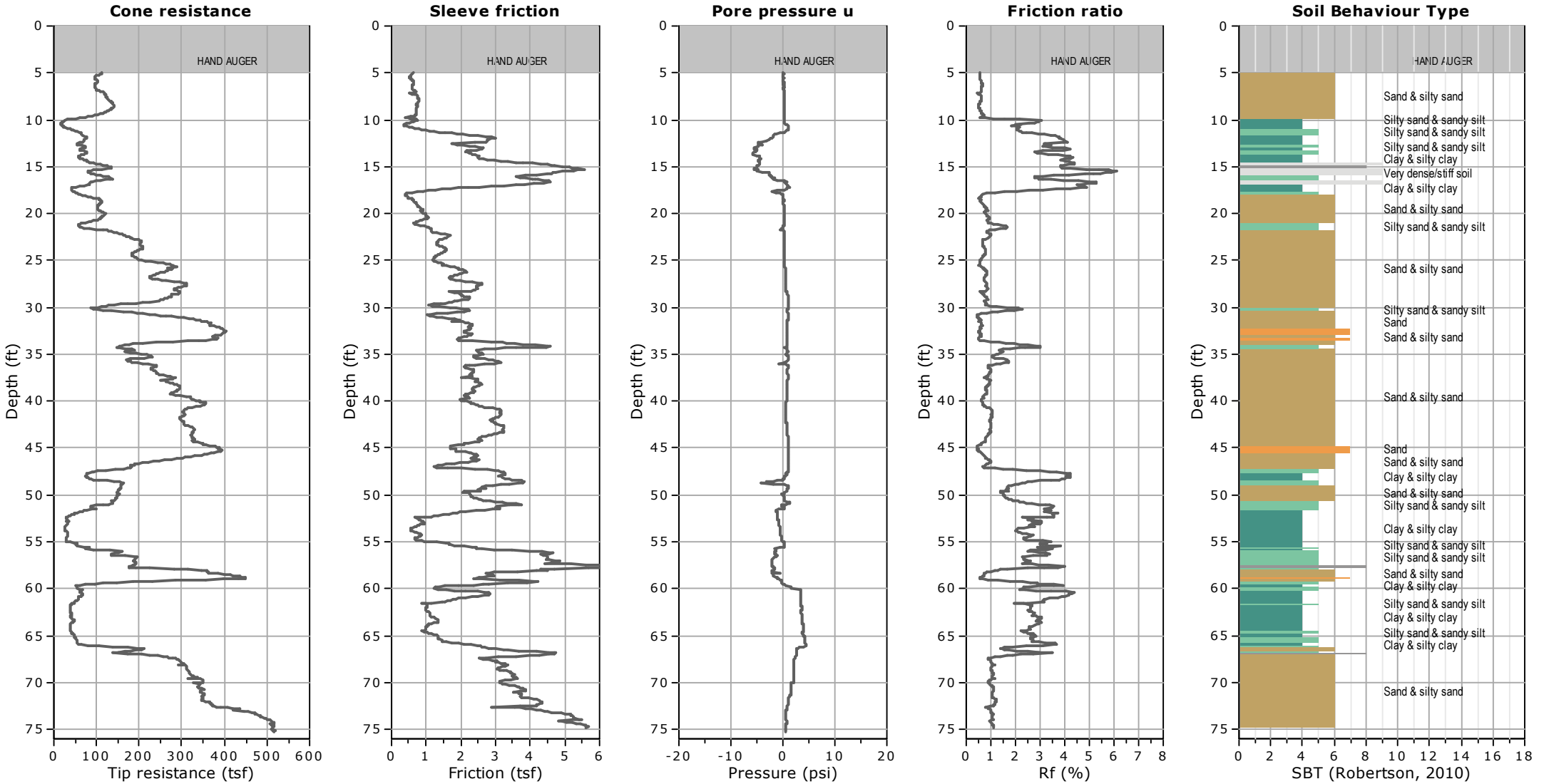

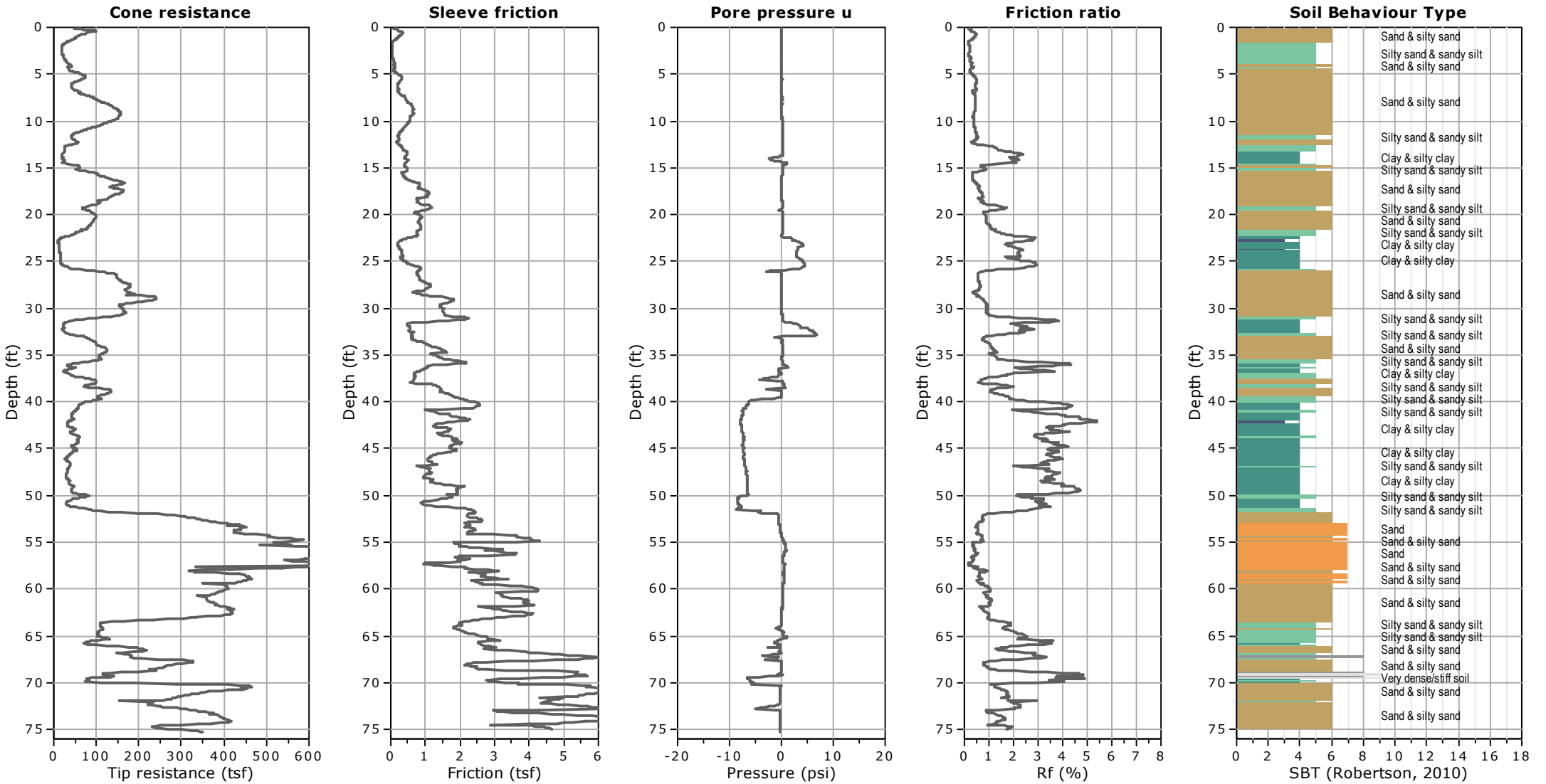

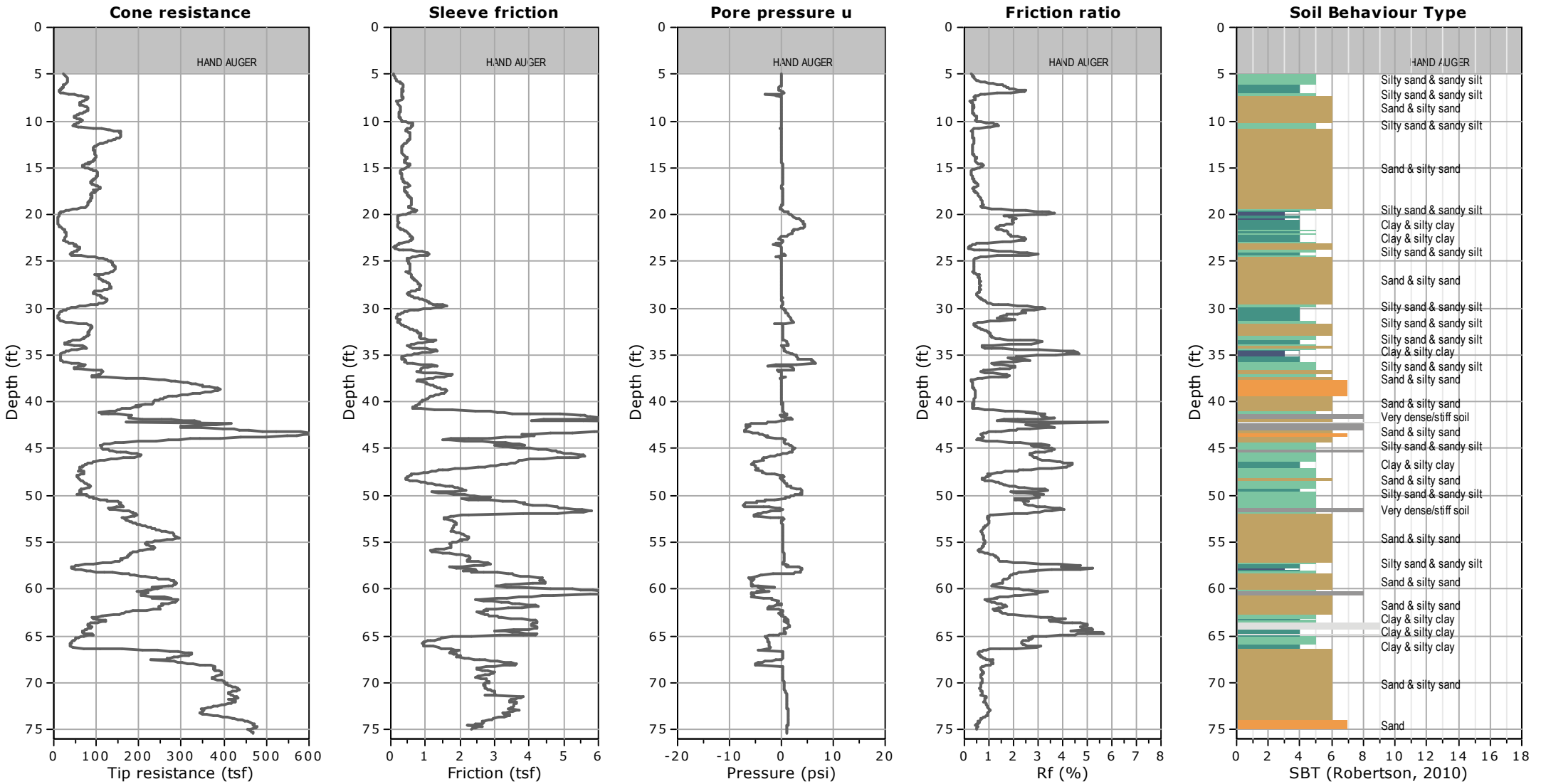

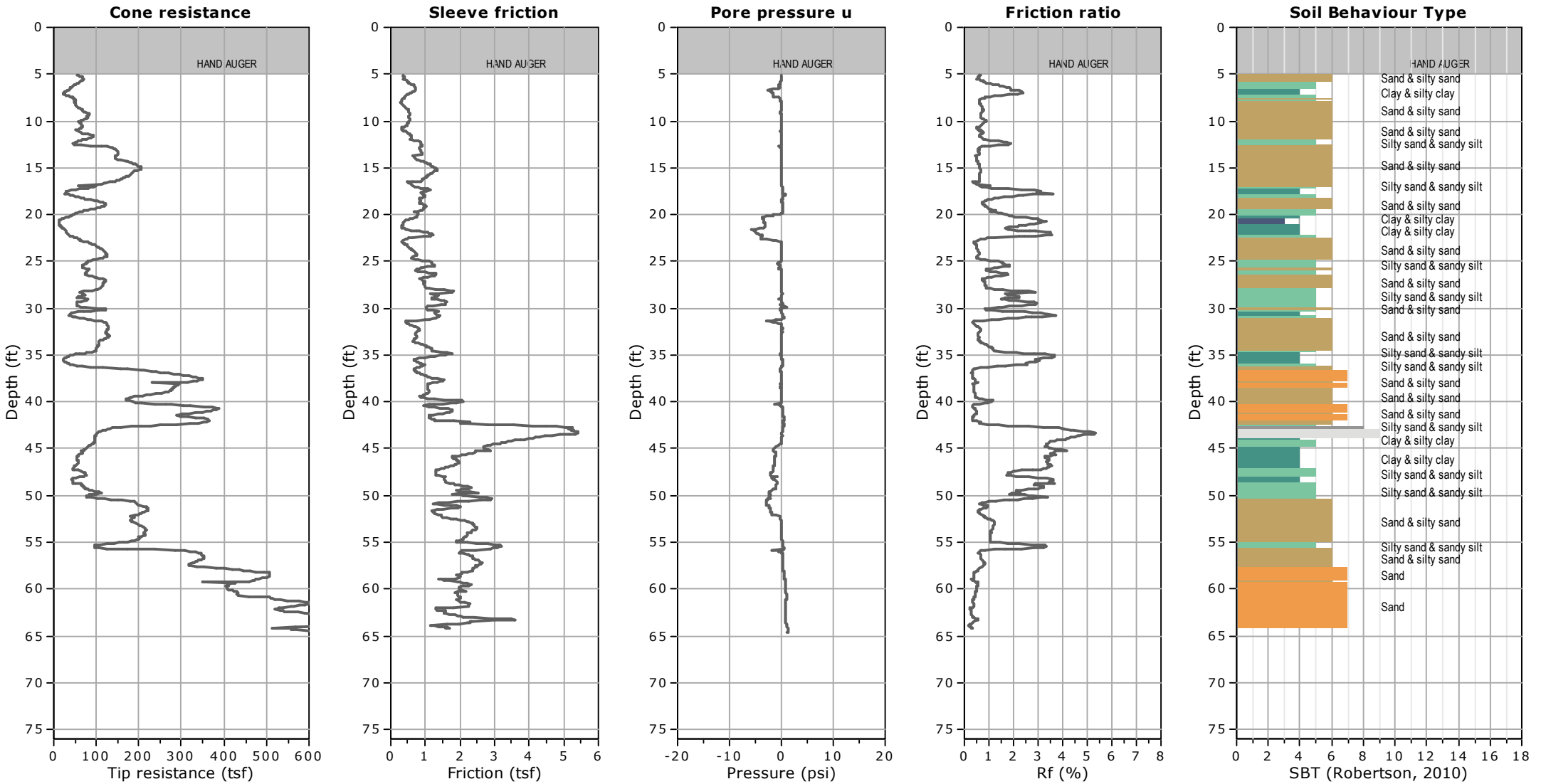

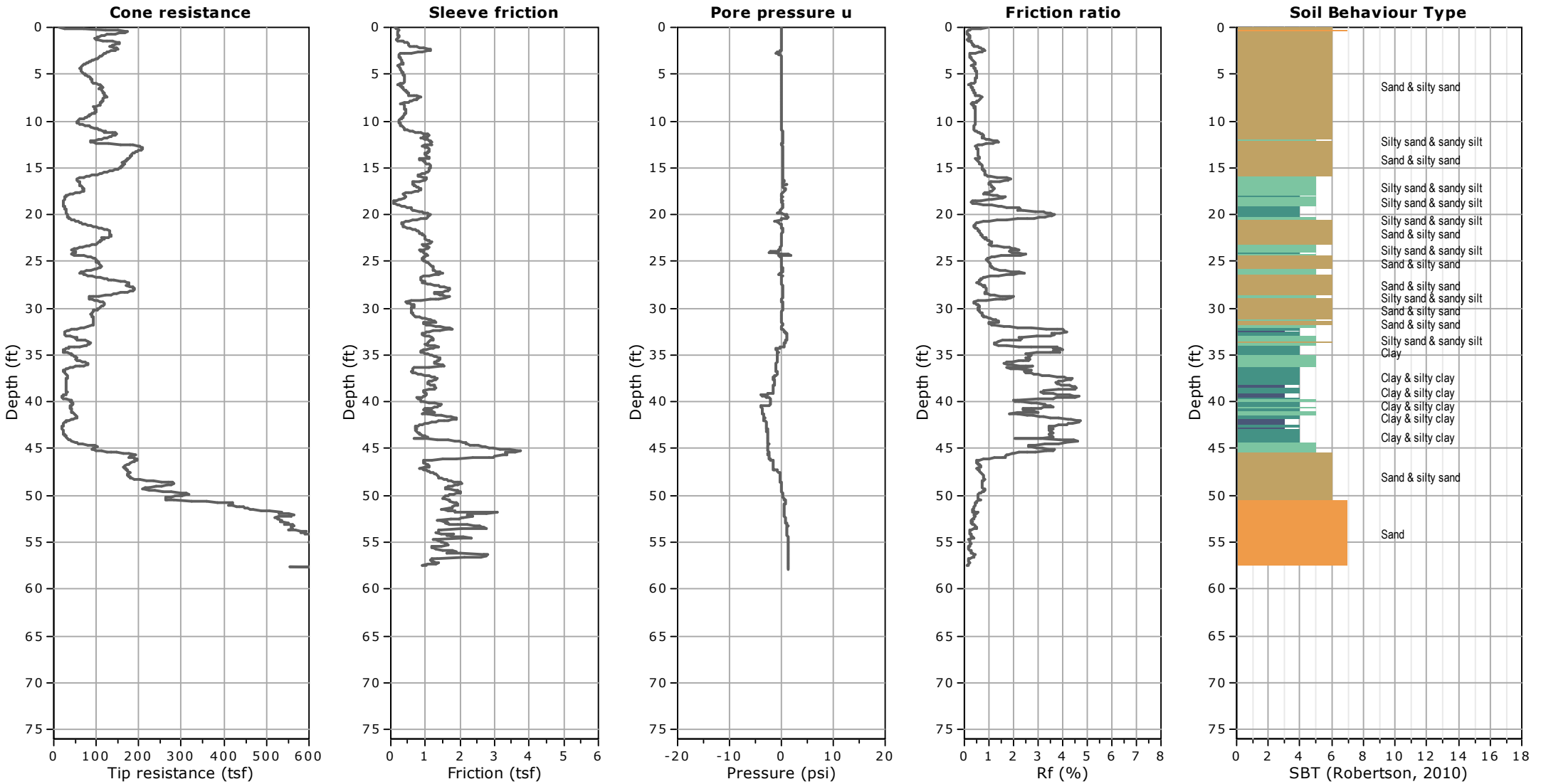

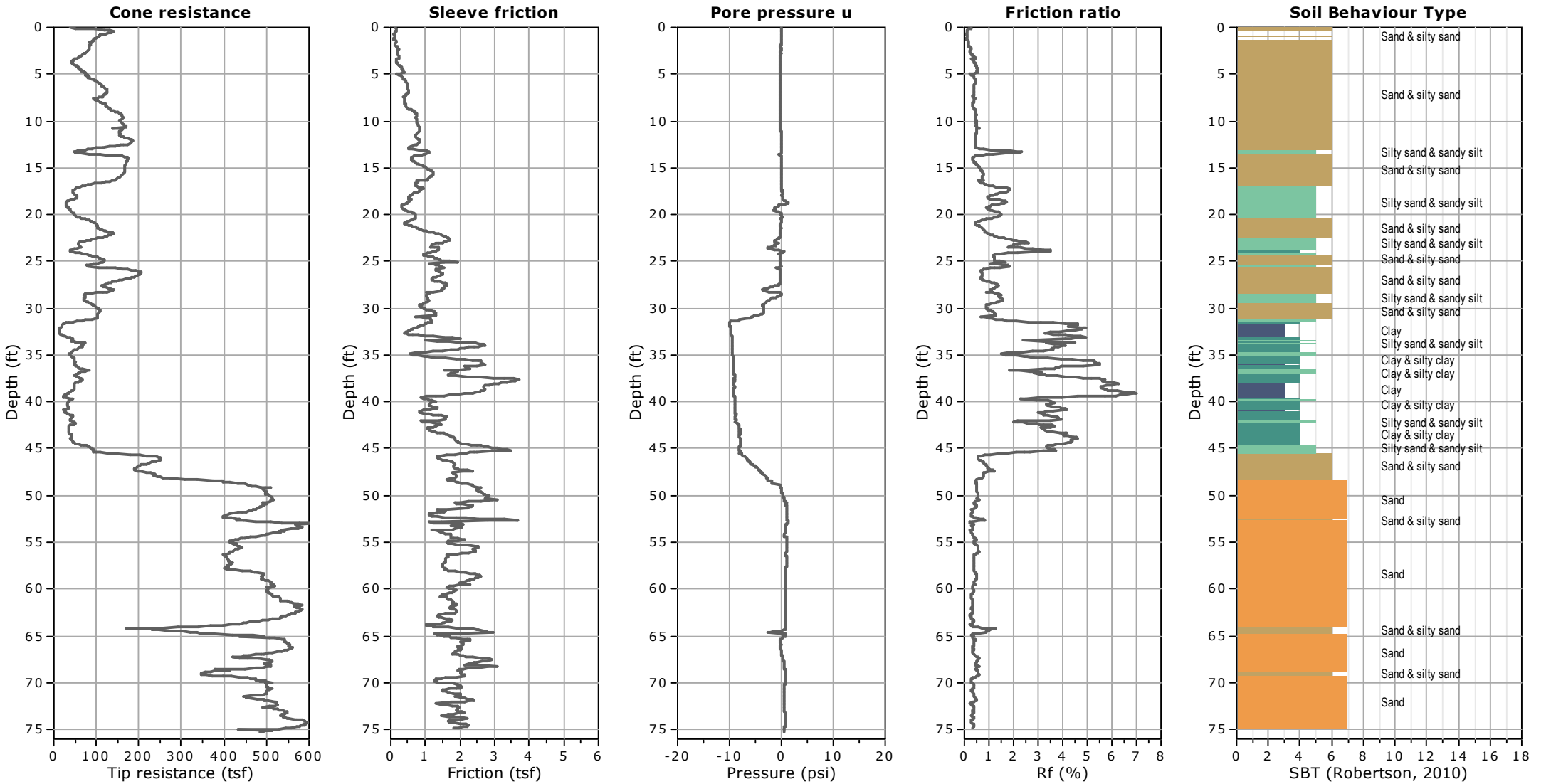

APPENDIX B
GEOTECHNICAL LABORATORY TESTING



Leighton

APPENDIX B

GEOTECHNICAL LABORATORY TESTING

The geotechnical laboratory testing program was directed toward a quantitative and qualitative evaluation of the physical and mechanical properties of the soils underlying the site and to aid in verifying soil classification.

In-Situ Moisture and Density: The natural water content (ASTM D 2216) and in-situ dry density (ASTM D 2937) were determined for recovered relatively undisturbed ring-lined barrel drive samples, from our subsurface explorations. Results of these tests are shown on the logs at the appropriate sample depths, in Appendix B.

Sieve Analysis: Sieve analyses (ASTM D 422) were performed on selected subsurface soil samples. These tests were performed to assist in the classification of the soil. Results of these tests are presented on the “*Particle Size Analysis of Soils*” figures.

Atterberg Limits: The Atterberg Limits were determined in accordance with ASTM Test Method D4318 for engineering classification of fine-grained materials. Test results are presented in this appendix.

Modified Proctor compaction Curve: A laboratory modified Proctor compaction test (ASTM D 1557) was performed on a bulk soil sample to determine maximum laboratory dry density and optimum moisture content. Result of this test is presented on the following “*Modified Proctor Compaction Test*” plot in this appendix.

Collapse Potential: Collapse potential tests were performed on selected soil samples in general accordance with ASTM Standard Test Method D 4546. Test results are presented on the “*One Dimensional Consolidation Properties of Soils*” figures.

Expansion Index: Expansion Index of a representative bulk sample was determined by the ASTM D 4829 standard test method to identify expansion potential. The expansion index is presented in this appendix.

Corrosivity Tests: To evaluate the corrosion potential of the subsurface soils at the site, we tested representative bulk samples collected during our subsurface investigation for pH, resistivity and soluble sulfate and chloride content testing. Results of these tests are presented at the end of this appendix.

Boring No.	LB-1	LB-1	LB-1	LB-2	LB-2	LB-3	LB-3	
Sample No.	S-1	S-4	S-6	R-3	S-2	B-1	S-2	
Depth (ft.)	10.0	25.0	35.0	10	30	0-5	25	
Sample Type	SPT	SPT	SPT	Ring	SPT	Bulk	SPT	
Soil Identification	Grayish brown poorly-graded sand with silt (SP-SM)	Grayish brown poorly-graded sand with silt (SP-SM)	Grayish brown sandy lean clay s(CL)	Gray poorly-graded sand (SP)	Grayish brown poorly-graded sand with silt (SP-SM)	Grayish brown silty sand (SM)	Olive brown silty sand (SM)	
Moisture Correction								
Wet Weight of Soil + Container (g)	0.00	0.00	0.00	0.00	0.00	0.00	0.00	
Dry Weight of Soil + Container (g)	0.00	0.00	0.00	0.00	0.00	0.00	0.00	
Weight of Container (g)	1.00	1.00	1.00	1.00	1.00	1.00	1.00	
Moisture Content (%)	0.00	0.00	0.00	0.00	0.00	0.00	0.00	
Sample Dry Weight Determination								
Weight of Sample + Container (g)	663.80	700.80	540.80	823.40	709.20	1119.90	754.80	
Weight of Container (g)	108.60	107.60	108.10	110.20	107.30	106.50	107.50	
Weight of Dry Sample (g)	555.20	593.20	432.70	713.20	601.90	1013.40	647.30	
Container No.:								
After Wash								
Method (A or B)	A	A	A	A	A	A	A	
Dry Weight of Sample + Cont. (g)	606.90	638.90	272.40	805.10	673.40	708.10	556.70	
Weight of Container (g)	108.60	107.60	108.10	110.20	107.30	106.50	107.50	
Dry Weight of Sample (g)	498.30	531.30	164.30	694.90	566.10	601.60	449.20	
% Passing No. 200 Sieve	10.2	10.4	62.0	2.6	5.9	40.6	30.6	
% Retained No. 200 Sieve	89.8	89.6	38.0	97.4	94.1	59.4	69.4	
 Leighton	PERCENT PASSING No. 200 SIEVE ASTM D 1140			Project Name: <u>Norwalk Transit Village</u>				
				Project No.: <u>13109.001</u>				
				Client Name: _____				
				Tested By: <u>S. Felter</u> Date: <u>05/06/21</u>				

Boring No.	LB-5	LB-5	LB-6	LB-6	LB-6			
Sample No.	S-1	S-2	B-1	S-1	S-3			
Depth (ft.)	15.0	25.0	0-5	20	40			
Sample Type	SPT	SPT	Bulk	SPT	SPT			
Soil Identification	Brown poorly-graded sand with silt (SP-SM)	Olive brown sandy lean clay s(CL)	Brown silty sand (SM)	Olive gray sandy lean clay s(CL)	Olive gray fat clay with sand (CH)s			
Moisture Correction								
Wet Weight of Soil + Container (g)	0.00	0.00	0.00	0.00	0.00			
Dry Weight of Soil + Container (g)	0.00	0.00	0.00	0.00	0.00			
Weight of Container (g)	1.00	1.00	1.00	1.00	1.00			
Moisture Content (%)	0.00	0.00	0.00	0.00	0.00			
Sample Dry Weight Determination								
Weight of Sample + Container (g)	735.80	446.80	1142.10	710.90	654.90			
Weight of Container (g)	109.40	108.20	110.10	109.10	159.60			
Weight of Dry Sample (g)	626.40	338.60	1032.00	601.80	495.30			
Container No.:								
After Wash								
Method (A or B)	A	A	A	A	A			
Dry Weight of Sample + Cont. (g)	658.10	222.10	805.70	313.00	305.80			
Weight of Container (g)	109.40	108.20	110.10	109.10	159.60			
Dry Weight of Sample (g)	548.70	113.90	695.60	203.90	146.20			
% Passing No. 200 Sieve	12.4	66.4	32.6	66.1	70.5			
% Retained No. 200 Sieve	87.6	33.6	67.4	33.9	29.5			
 Leighton	PERCENT PASSING No. 200 SIEVE ASTM D 1140				Project Name: <u>Norwalk Transit Village</u> Project No.: <u>13109.001</u> Client Name: _____ Tested By: <u>S. Felter</u> Date: <u>05/06/21</u>			



**PARTICLE-SIZE DISTRIBUTION (GRADATION)
of SOILS USING SIEVE ANALYSIS
ASTM D 6913**

Project Name: Norwalk Transit Village

Tested By: Y. Nguyen Date: 05/12/21

Project No.: 13109.001

Checked By: A. Santos Date: 05/20/21

Boring No.: LB-2

Depth (feet): 0-5

Sample No.: B-1

Soil Identification: Grayish brown sandy silty clay s(CL-ML)

Calculation of Dry Weights	Whole Sample	Sample Passing #4	Moisture Contents	Whole Sample	Sample passing #4
Container No.:	SP-1	SP-1	Wt. of Air-Dry Soil + Cont.(g)	0.0	0.0
Wt. Air-Dried Soil + Cont.(g)	2192.7	745.5	Wt. of Dry Soil + Cont. (g)	0.0	0.0
Wt. of Container (g)	230.0	230.0	Wt. of Container No.____(g)	1.0	1.0
Dry Wt. of Soil (g)	1962.7	515.5	Moisture Content (%)	0.0	0.0

Passing #4 Material After Wet Sieve	Container No.	SP-1
	Wt. of Dry Soil + Container (g)	491.2
	Wt. of Container (g)	230.0
	Dry Wt. of Soil Retained on # 200 Sieve (g)	261.2

U. S. Sieve Size		Cumulative Weight of Dry Soil Retained (g)		Percent Passing (%)
	(mm.)	Whole Sample	Sample Passing #4	
3"	75.0			
1 1/2"	37.5			
1"	25.0			
3/4"	19.0	0.0		100.0
1/2"	12.5	3.7		99.8
3/8"	9.5	6.5		99.7
#4	4.75	11.5		99.4
#8	2.36		2.4	98.9
#16	1.18		6.7	98.1
#30	0.600		18.0	95.9
#50	0.300		70.9	85.7
#100	0.150		153.2	69.9
#200	0.075		248.0	51.6
PAN				

GRAVEL: **1 %**

SAND: **47 %**

FINES: **52 %**

GROUP SYMBOL: **s(CL-ML)**

Cu = D60/D10 = _____

Cc = (D30)²/(D60*D10) = _____

Remarks: _____

GRAVEL				SAND						FINES		
COARSE		FINE		COARSE	MEDIUM		FINE		SILT		CLAY	
U.S. STANDARD SIEVE OPENING				U.S. STANDARD SIEVE NUMBER						HYDROMETER		
3.0"	1 1/2"	3/4"	3/8"	#4	#8	#16	#30	#50	#100	#200		

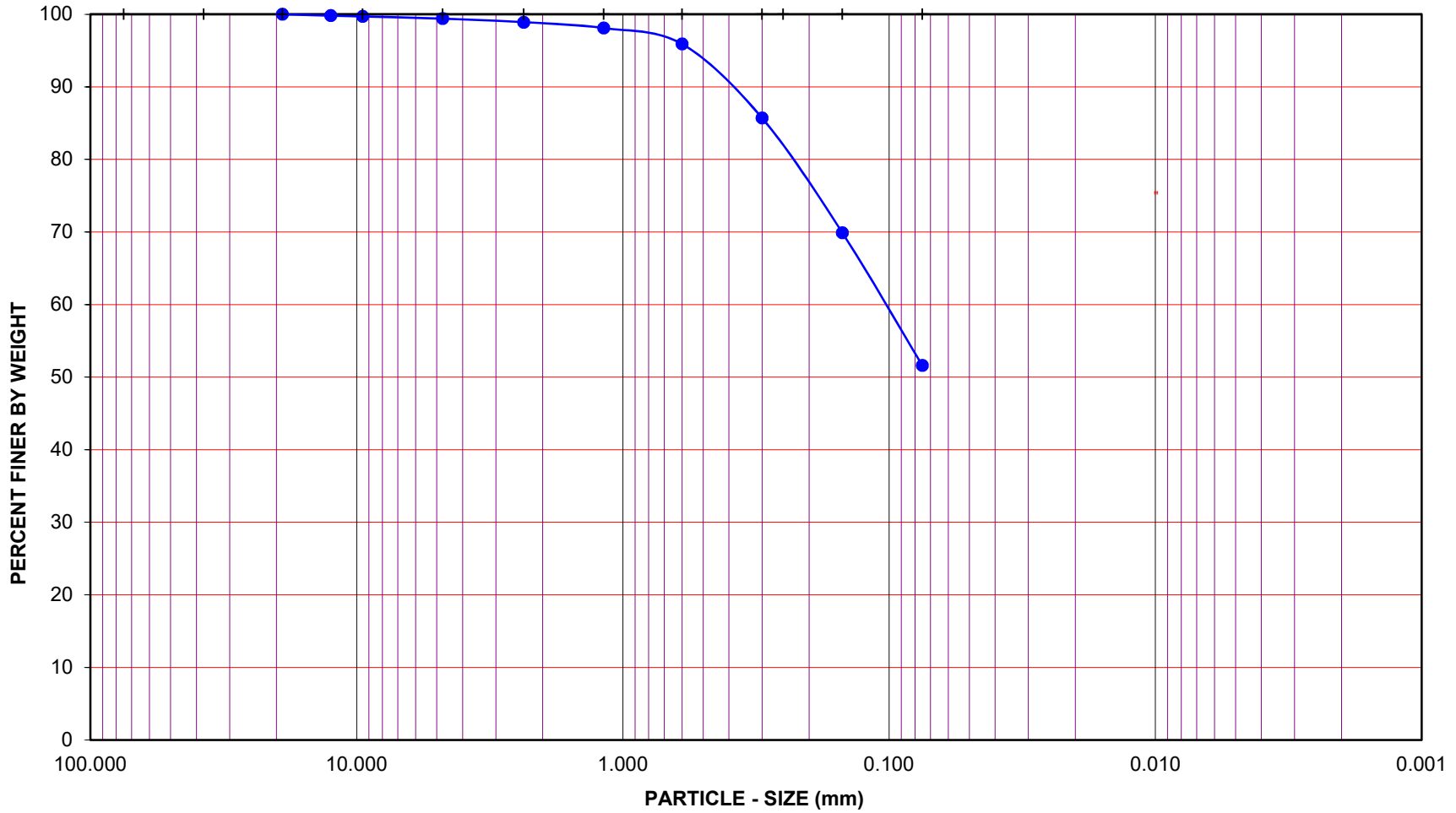

Project Name: Norwalk Transit Village

Project No.: 13109.001

Boring No.: LB-2

Sample No.: B-1

Depth (feet): 0-5

Soil Type : s(CL-ML)

Soil Identification: Grayish brown sandy silty clay s(CL-ML)

GR:SA:FI : (%) 1 : 47 : 52



Leighton

**PARTICLE - SIZE
DISTRIBUTION
ASTM D 6913**

May-21



**PARTICLE-SIZE DISTRIBUTION (GRADATION)
of SOILS USING SIEVE ANALYSIS
ASTM D 6913**

Project Name: [Norwalk Transit Village](#)

Tested By: [Y. Nguyen](#) Date: [05/12/21](#)

Project No.: [13109.001](#)

Checked By: [A. Santos](#) Date: [05/20/21](#)

Boring No.: [LB-5](#)

Depth (feet): [0-5](#)

Sample No.: [B-1](#)

Soil Identification: [Olive brown clayey sand \(SC\)](#)

Calculation of Dry Weights	Whole Sample	Sample Passing #4	Moisture Contents	Whole Sample	Sample passing #4
Container No.:	A-1A	A-1A	Wt. of Air-Dry Soil + Cont.(g)	0.0	0.0
Wt. Air-Dried Soil + Cont.(g)	3866.3	753.2	Wt. of Dry Soil + Cont. (g)	0.0	0.0
Wt. of Container (g)	237.6	237.6	Wt. of Container No.____(g)	1.0	1.0
Dry Wt. of Soil (g)	3628.7	515.6	Moisture Content (%)	0.0	0.0

Passing #4 Material After Wet Sieve	Container No.	A-1A
	Wt. of Dry Soil + Container (g)	523.5
	Wt. of Container (g)	237.6
	Dry Wt. of Soil Retained on # 200 Sieve (g)	285.9

U. S. Sieve Size		Cumulative Weight of Dry Soil Retained (g)		Percent Passing (%)
	(mm.)	Whole Sample	Sample Passing #4	
3"	75.0			
1 1/2"	37.5			
1"	25.0			
3/4"	19.0			
1/2"	12.5	0.0		100.0
3/8"	9.5	5.4		99.9
#4	4.75	14.8		99.6
#8	2.36		0.9	99.4
#16	1.18		3.9	98.8
#30	0.600		16.0	96.5
#50	0.300		75.3	85.1
#100	0.150		201.8	60.6
#200	0.075		276.1	46.3
PAN				

GRAVEL: **0 %**

SAND: **54 %**

FINES: **46 %**

GROUP SYMBOL: **SC**

Cu = D60/D10 = _____

Cc = (D30)²/(D60*D10) = _____

Remarks: _____

GRAVEL				SAND						FINES		
COARSE		FINE		COARSE	MEDIUM		FINE		SILT		CLAY	
U.S. STANDARD SIEVE OPENING				U.S. STANDARD SIEVE NUMBER						HYDROMETER		
3.0"	1 1/2"	3/4"	3/8"	#4	#8	#16	#30	#50	#100	#200		

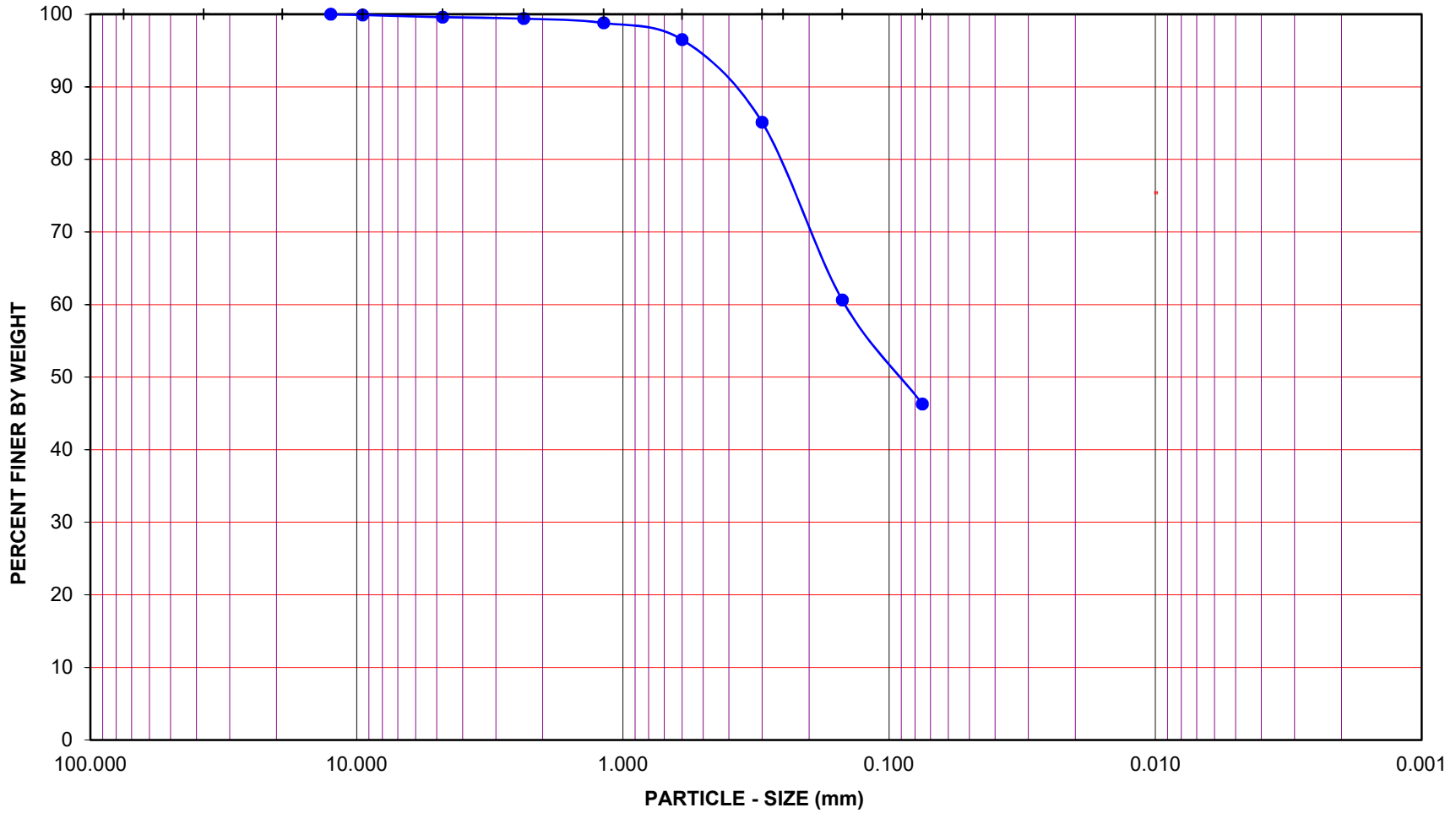

Project Name: Norwalk Transit Village

Project No.: 13109.001

Boring No.: LB-5

Sample No.: B-1

Depth (feet): 0-5

Soil Type : SC

Soil Identification: Olive brown clayey sand (SC)

GR:SA:FI : (%) 0 : 54 : 46



Leighton

**PARTICLE - SIZE
DISTRIBUTION
ASTM D 6913**

May-21



PARTICLE-SIZE ANALYSIS OF SOILS

ASTM D 422

Project Name: Norwalk Transit Village

Tested By: GB/GEB

Date: 05/10/21

Project No.: 13109.001

Checked By: A. Santos

Date: 05/20/21

Boring No.: LB-5

Sample No.: R-6

Depth (feet): 40.0

Soil Identification: Olive gray sandy lean clay s(CL), noted caliche

% Gravel	3	Soil Type s(CL)	Moisture Content of Total Air-Dry Soil	Moisture Content of Air-Dry Soil Passing #10	After Hydrometer & Wet Sieve ret. in #200 Sieve
% Sand	30				
% Fines	67				

Specific Gravity (Assumed)	2.70	Wt. of Air-Dry Soil + Cont. (g)	0.00	121.95	
Correction for Specific Gravity	0.99	Dry Wt. of Soil + Cont. (g)	0.00	121.13	90.69
Wt. of Air-Dry Soil + Cont. (g)	751.47	Wt. of Container No. ____ (g)	1.00	61.02	77.79
Wt. of Container	248.64	Moisture Content (%)	0.00	1.36	
Dry Wt. of Soil (g)	502.83	Wt. of Dry Soil (g)			12.90

Coarse Sieve		
U.S. Sieve	Cumulative Wt. Of Dry Soil Retained (g)	% Passing
3"	0.00	100.0
1½"	0.00	100.0
¾"	0.00	100.0
⅜"	4.72	99.1
No. 4	16.55	96.7
No. 10	35.45	92.9
Pan		

Sieve after Hydrometer & Wet Sieve			
U.S. Sieve Size	Cumulative Wt. Of Dry Soil Retained (g)	% Passing	% Total Sample
No. 10	0.00	100.0	92.9
No. 16	1.99	95.6	88.8
No. 30	4.61	89.8	83.4
No. 50	7.64	83.0	77.2
No. 100	10.27	77.2	71.7
No. 200	12.66	71.9	66.8
Pan			

Hydrometer

Wt. of Air-Dry Soil (g)

45.60

Wt. of Dry Soil (g)

44.99

Deflocculant 125 cc of 4% Solution

Date	Time	Elapsed Time (min)	Water Temperature (°C)	Composite Correction 152H	Actual Hydrometer Readings	% Total Sample (%)	Soil Particle Diameter (mm)
12-May-21	7:34	0		9.0			
	7:36	2	24.2	9.0	37.0	57.4	0.0289
	7:39	5	24.1	9.0	33.0	49.2	0.0189
	7:49	15	24.0	9.0	30.0	43.0	0.0112
	8:04	30	23.9	9.0	28.0	38.9	0.0081
	8:34	60	23.7	9.0	26.0	34.8	0.0058
	9:34	120	23.7	9.0	24.0	30.7	0.0042
	11:44	250	24.0	9.0	22.0	26.6	0.0029
13-May-21	7:34	1440	23.2	9.0	17.5	17.4	0.0013

GRAVEL				SAND				FINES			
COARSE		FINE		CRSE	MEDIUM		FINE	SILT		CLAY	

U.S. STANDARD SIEVE OPENING

3.0" 1 1/2" 3/4" 3/8"

U.S. STANDARD SIEVE NUMBER

#4 #8 #16 #30 #50 #100 #200

HYDROMETER

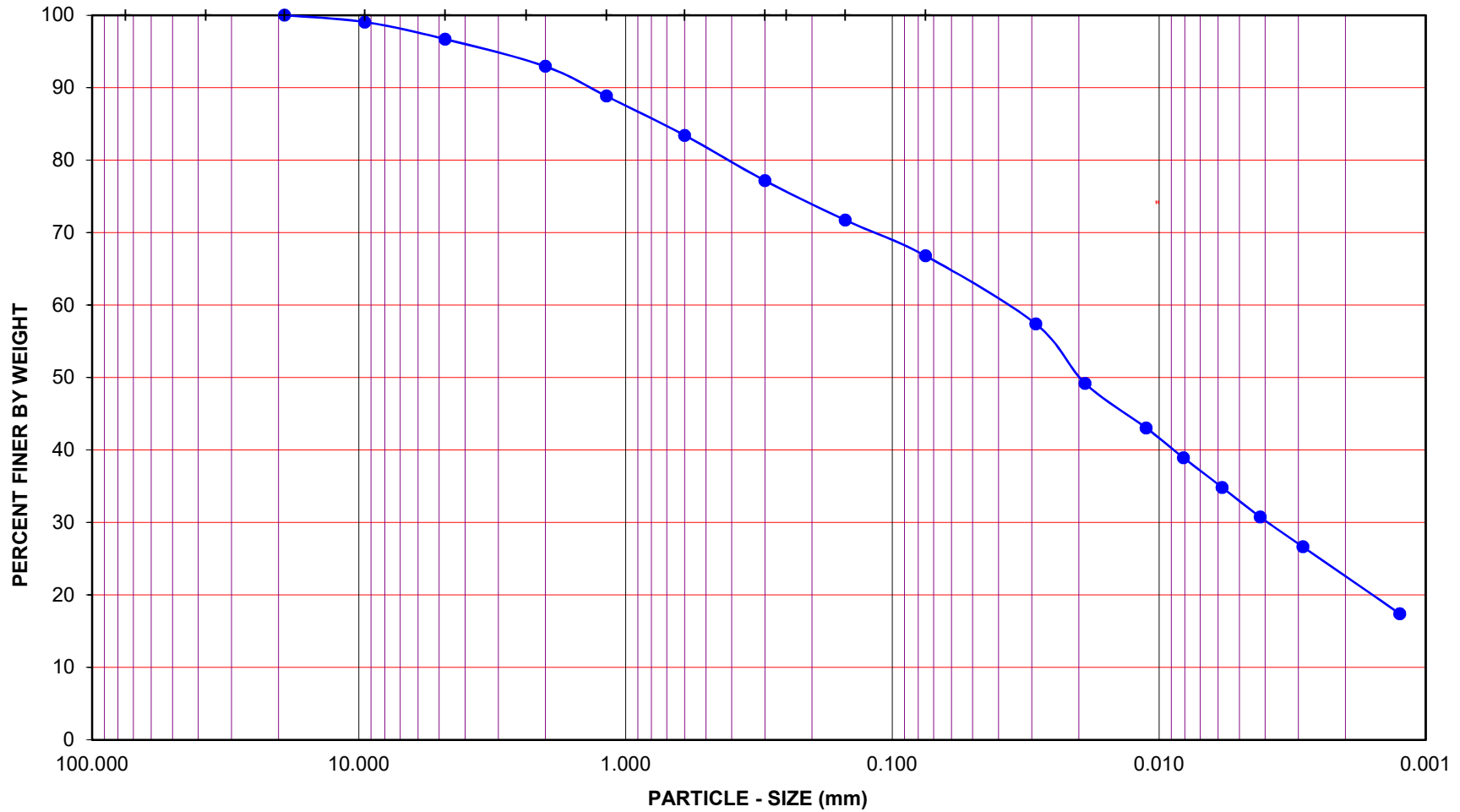

Project Name: Norwalk Transit Village

Project No.: 13109.001

Boring No.: LB-5

Sample No.: R-6

Depth (feet): 40.0

Soil Type : s(CL)

Soil Identification: Olive gray sandy lean clay s(CL), noted caliche

GR:SA:FI : (%) 3 : 30 : 67



**PARTICLE - SIZE
DISTRIBUTION
ASTM D 422**

May-21



EXPANSION INDEX of SOILS
ASTM D 4829

Project Name: Norwalk Transit Village Tested By: GEB/GB Date: 05/07/21
 Project No.: 13109.001 Checked By: A. Santos Date: 05/18/21
 Boring No.: LB-2 Depth (ft.): 0-5
 Sample No.: B-1
 Soil Identification: Grayish brown sandy silty clay s(CL-ML)

Dry Wt. of Soil + Cont.	(g)	1000.00
Wt. of Container No.	(g)	0.00
Dry Wt. of Soil	(g)	1000.00
Weight Soil Retained on #4 Sieve		0.00
Percent Passing # 4		100.00

MOLDED SPECIMEN	Before Test	After Test
Specimen Diameter (in.)	4.01	4.01
Specimen Height (in.)	1.0000	1.0190
Wt. Comp. Soil + Mold (g)	615.00	442.00
Wt. of Mold (g)	204.30	0.00
Specific Gravity (Assumed)	2.70	2.70
Container No.	0	0
Wet Wt. of Soil + Cont. (g)	819.60	646.30
Dry Wt. of Soil + Cont. (g)	751.90	581.09
Wt. of Container (g)	0.00	204.30
Moisture Content (%)	9.00	17.31
Wet Density (pcf)	123.9	130.8
Dry Density (pcf)	113.7	111.5
Void Ratio	0.483	0.511
Total Porosity	0.326	0.338
Pore Volume (cc)	67.4	71.4
Degree of Saturation (%) [S _{meas}]	50.3	91.4

SPECIMEN INUNDATION in distilled water for the period of 24 h or expansion rate < 0.0002 in./h

Date	Time	Pressure (psi)	Elapsed Time (min.)	Dial Readings (in.)
05/07/21	11:45	1.0	0	0.6365
05/07/21	11:55	1.0	10	0.6360
Add Distilled Water to the Specimen				
05/07/21	12:16	1.0	21	0.6510
05/08/21	6:32	1.0	1117	0.6555
05/08/21	8:40	1.0	1245	0.6555

Expansion Index (EI _{meas}) = ((Final Rdg - Initial Rdg) / Initial Thick.) x 1000	20
---	-----------



EXPANSION INDEX of SOILS
ASTM D 4829

Project Name: Norwalk Transit Village Tested By: ACS/GEB Date: 05/12/21
 Project No.: 13109.001 Checked By: A. Santos Date: 05/18/21
 Boring No.: LB-5 Depth (ft.): 0-5
 Sample No.: B-1
 Soil Identification: Olive brown clayey sand (SC)

Dry Wt. of Soil + Cont.	(g)	1000.00
Wt. of Container No.	(g)	0.00
Dry Wt. of Soil	(g)	1000.00
Weight Soil Retained on #4 Sieve		0.00
Percent Passing # 4		100.00

MOLDED SPECIMEN	Before Test	After Test
Specimen Diameter (in.)	4.01	4.01
Specimen Height (in.)	1.0000	1.0160
Wt. Comp. Soil + Mold (g)	607.50	449.30
Wt. of Mold (g)	184.40	0.00
Specific Gravity (Assumed)	2.70	2.70
Container No.	0	0
Wet Wt. of Soil + Cont. (g)	842.70	633.70
Dry Wt. of Soil + Cont. (g)	780.30	576.16
Wt. of Container (g)	0.00	184.40
Moisture Content (%)	8.00	14.69
Wet Density (pcf)	127.6	133.4
Dry Density (pcf)	118.2	116.3
Void Ratio	0.427	0.449
Total Porosity	0.299	0.310
Pore Volume (cc)	61.9	65.2
Degree of Saturation (%) [S _{meas}]	50.6	88.2

SPECIMEN INUNDATION in distilled water for the period of 24 h or expansion rate < 0.0002 in./h

Date	Time	Pressure (psi)	Elapsed Time (min.)	Dial Readings (in.)
05/12/21	14:20	1.0	0	0.5460
05/12/21	14:30	1.0	10	0.5450
Add Distilled Water to the Specimen				
05/12/21	14:32	1.0	2	0.5470
05/13/21	7:35	1.0	1025	0.5620
05/13/21	10:10	1.0	1180	0.5620

Expansion Index (EI _{meas}) = ((Final Rdg - Initial Rdg) / Initial Thick.) x 1000	17
---	-----------



ATTERBERG LIMITS

ASTM D 4318

Project Name: <u>Norwalk Transit Village</u>	Tested By: <u>S. Felter</u>	Date: <u>05/08/21</u>
Project No. : <u>13109.001</u>	Input By: <u>G. Bathala</u>	Date: <u>05/18/21</u>
Boring No.: <u>LB-1</u>	Checked By: <u>A. Santos</u>	
Sample No.: <u>S-6</u>	Depth (ft.) <u>35.0</u>	
Soil Identification: <u>Grayish brown sandy lean clay s(CL)</u>		

TEST NO.	PLASTIC LIMIT		LIQUID LIMIT			
	1	2	1	2	3	4
Number of Blows [N]			27	22	16	
Wet Wt. of Soil + Cont. (g)	10.29	10.52	20.07	20.16	20.59	
Dry Wt. of Soil + Cont. (g)	8.89	9.08	15.83	15.84	16.04	
Wt. of Container (g)	1.06	1.02	1.05	1.04	1.04	
Moisture Content (%) [W _n]	17.88	17.87	28.69	29.19	30.33	

Liquid Limit	29
Plastic Limit	18
Plasticity Index	11
Classification	CL

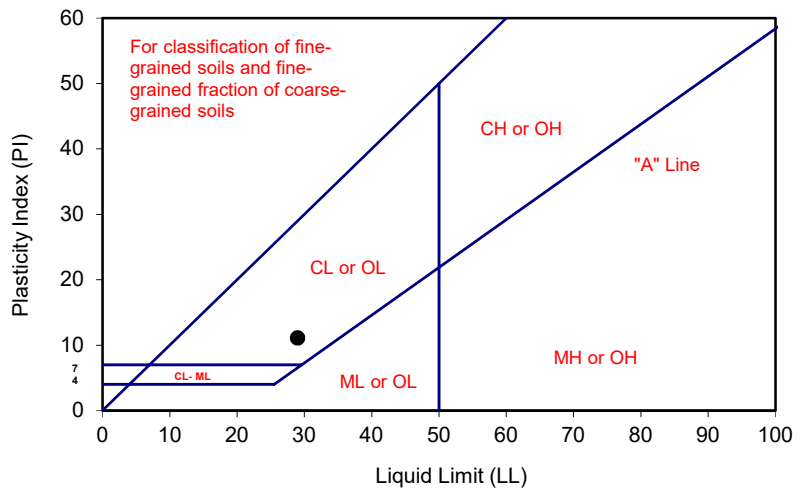

PI at "A" - Line = $0.73(LL-20)$ 6.57

One - Point Liquid Limit Calculation

$$LL = W_n(N/25)^{0.121}$$

PROCEDURES USED

- Wet Preparation
Multipoint - Wet
- Dry Preparation
Multipoint - Dry
- Procedure A
Multipoint Test
- Procedure B
One-point Test

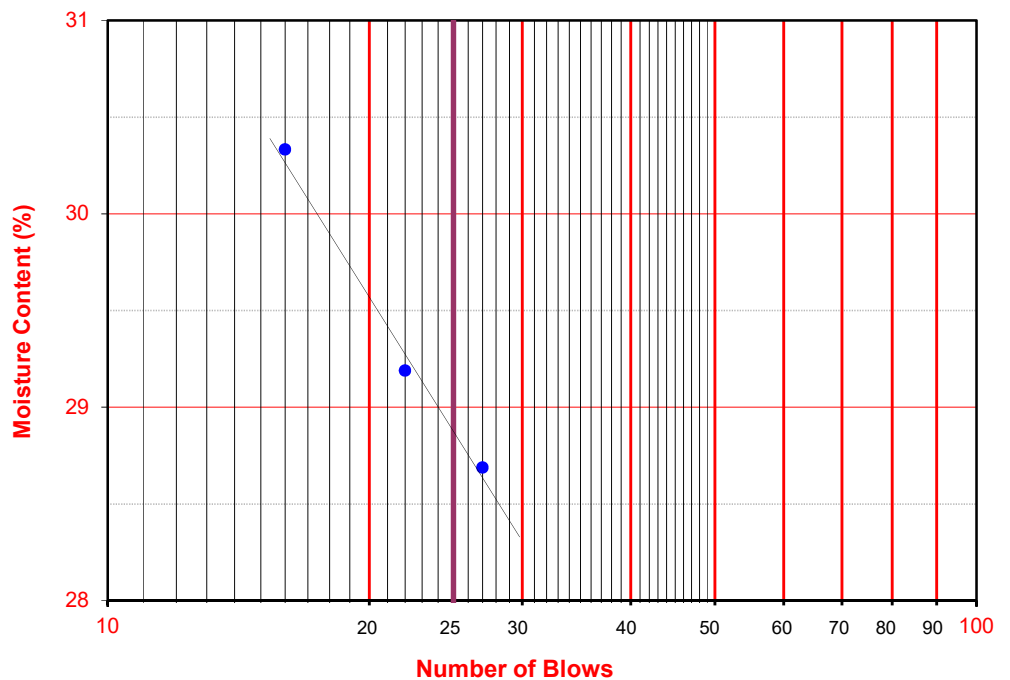



ATTERBERG LIMITS

ASTM D 4318

Project Name: <u>Norwalk Transit Village</u>	Tested By: <u>S. Felter</u>	Date: <u>05/08/21</u>
Project No. : <u>13109.001</u>	Input By: <u>G. Bathala</u>	Date: <u>05/18/21</u>
Boring No.: <u>LB-2</u>	Checked By: <u>A. Santos</u>	
Sample No.: <u>R-6</u>	Depth (ft.) <u>35.0</u>	
Soil Identification: <u>Gray silt sand (SM)</u>		

TEST NO.	PLASTIC LIMIT		LIQUID LIMIT			
	1	2	1	2	3	4
Number of Blows [N]			4			
Wet Wt. of Soil + Cont. (g)	Cannot be rolled:		22.35	Cannot get more than 4 blows:		
Dry Wt. of Soil + Cont. (g)	NonPlastic		16.55	NonPlastic		
Wt. of Container (g)			1.02			
Moisture Content (%) [Wn]			37.35			

Liquid Limit	NP
Plastic Limit	NP
Plasticity Index	NP
Classification	NP

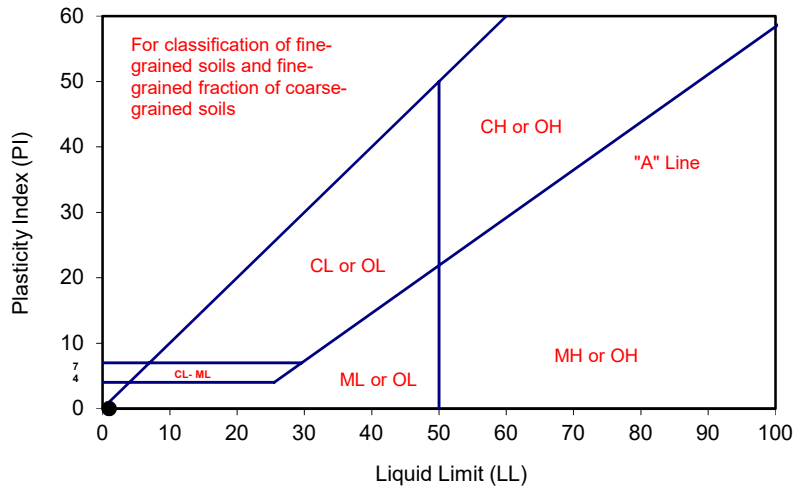

PI at "A" - Line = $0.73(LL-20)$ =

One - Point Liquid Limit Calculation

$$LL = Wn(N/25)^{0.121}$$

PROCEDURES USED

- Wet Preparation
Multipoint - Wet
- Dry Preparation
Multipoint - Dry
- Procedure A
Multipoint Test
- Procedure B
One-point Test

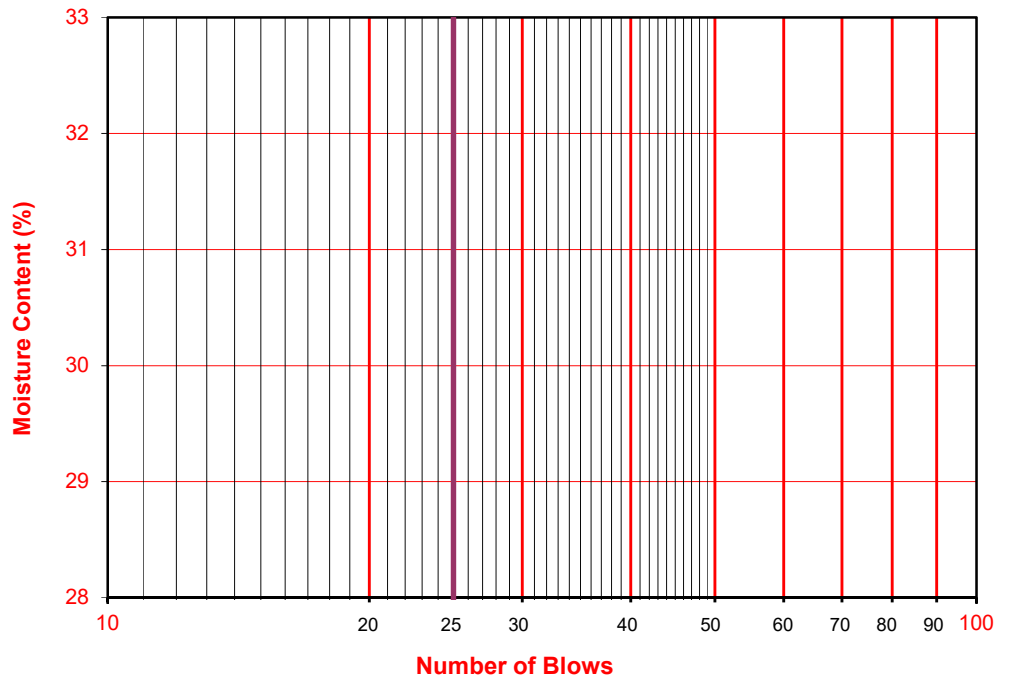



ATTERBERG LIMITS

ASTM D 4318

Project Name: <u>Norwalk Transit Village</u>	Tested By: <u>Y. Nguyen</u>	Date: <u>05/05/21</u>
Project No. : <u>13109.001</u>	Input By: <u>G. Bathala</u>	Date: <u>05/18/21</u>
Boring No.: <u>LB-3</u>	Checked By: <u>A. Santos</u>	
Sample No.: <u>R-3</u>	Depth (ft.) <u>20.0</u>	
Soil Identification: <u>Olive gray silt with sand (ML)s</u>		

TEST NO.	PLASTIC LIMIT		LIQUID LIMIT			
	1	2	1	2	3	4
Number of Blows [N]			9			
Wet Wt. of Soil + Cont. (g)	Cannot be rolled:		21.59	Cannot get more than 9 blows:		
Dry Wt. of Soil + Cont. (g)	NonPlastic		17.46	NonPlastic		
Wt. of Container (g)			1.02			
Moisture Content (%) [Wn]			25.12			

Liquid Limit	NP
Plastic Limit	NP
Plasticity Index	NP
Classification	NP

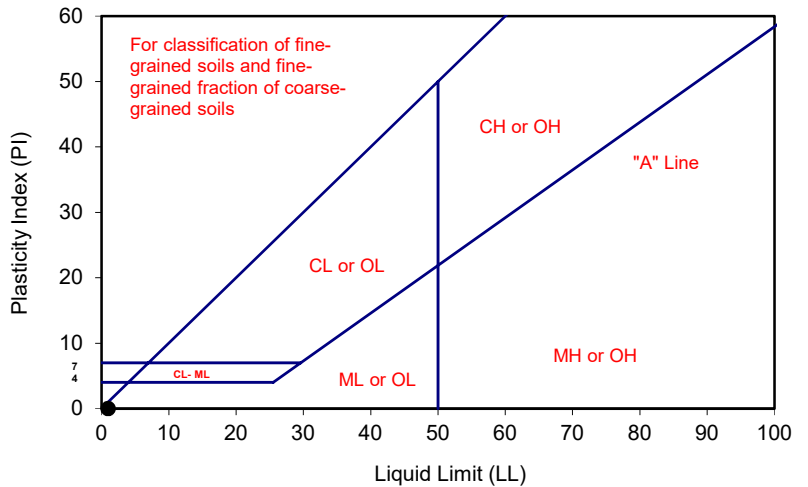

PI at "A" - Line = $0.73(LL-20)$ =

One - Point Liquid Limit Calculation

$$LL = Wn(N/25)^{0.121}$$

PROCEDURES USED

- Wet Preparation
Multipoint - Wet
- Dry Preparation
Multipoint - Dry
- Procedure A
Multipoint Test
- Procedure B
One-point Test

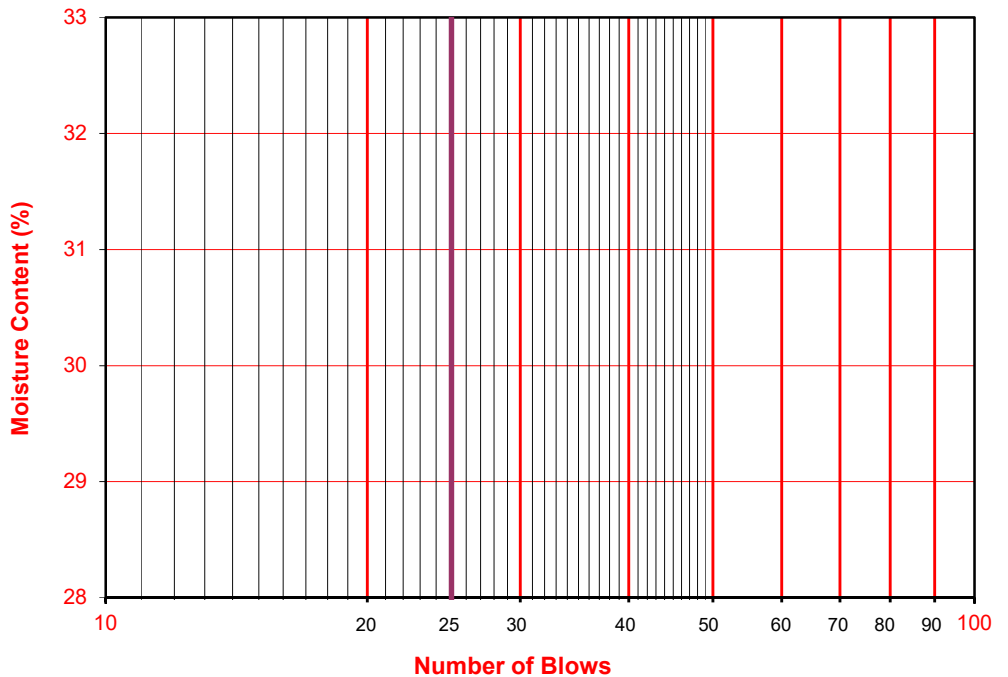



ATTERBERG LIMITS

ASTM D 4318

Project Name: <u>Norwalk Transit Village</u>	Tested By: <u>Y. Nguyen</u>	Date: <u>05/05/21</u>
Project No. : <u>13109.001</u>	Input By: <u>G. Bathala</u>	Date: <u>05/18/21</u>
Boring No.: <u>LB-4</u>	Checked By: <u>A. Santos</u>	
Sample No.: <u>R-5</u>	Depth (ft.) <u>25.0</u>	
Soil Identification: <u>Olive sandy silt s(ML)</u>		

TEST NO.	PLASTIC LIMIT		LIQUID LIMIT			
	1	2	1	2	3	4
Number of Blows [N]			7			
Wet Wt. of Soil + Cont. (g)	Cannot be rolled:		19.82 Cannot get more than 7 blows:			
Dry Wt. of Soil + Cont. (g)	NonPlastic		16.34 NonPlastic			
Wt. of Container (g)			1.10			
Moisture Content (%) [Wn]			22.83			

Liquid Limit	NP
Plastic Limit	NP
Plasticity Index	NP
Classification	NP

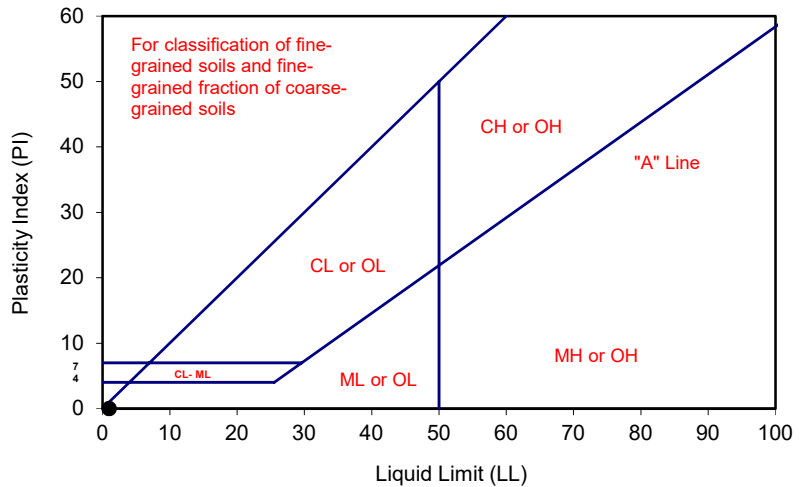

PI at "A" - Line = $0.73(LL-20)$ =

One - Point Liquid Limit Calculation

$$LL = Wn(N/25)^{0.121}$$

PROCEDURES USED

- Wet Preparation
Multipoint - Wet
- Dry Preparation
Multipoint - Dry
- Procedure A
Multipoint Test
- Procedure B
One-point Test

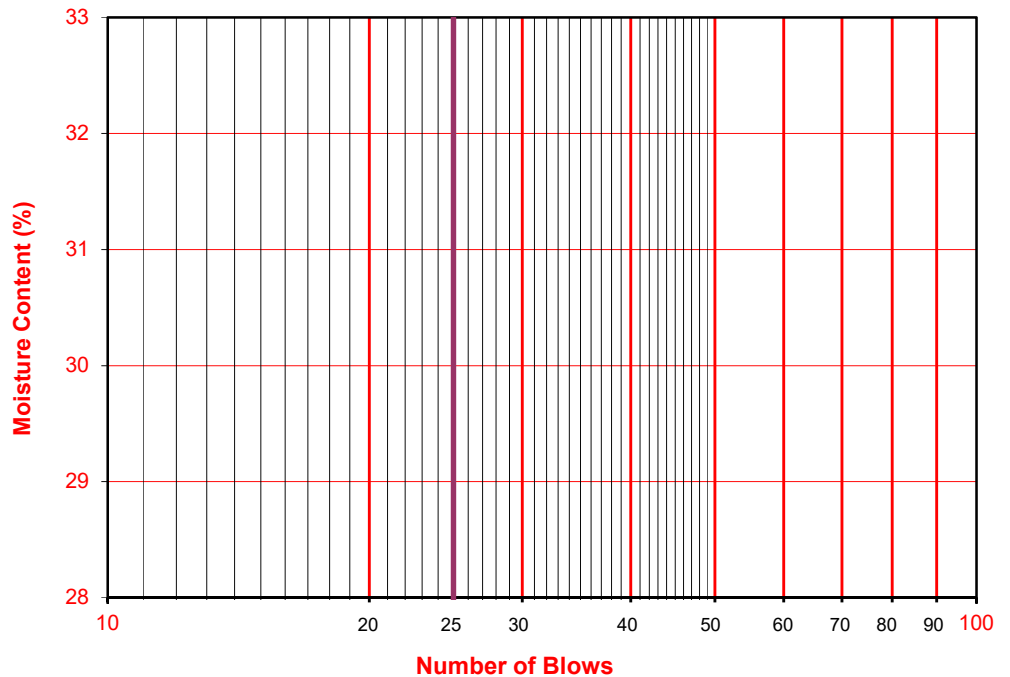



ATTERBERG LIMITS

ASTM D 4318

Project Name: Norwalk Transit Village Tested By: S. Felter Date: 05/08/21
 Project No. : 13109.001 Input By: G. Bathala Date: 05/18/21
 Boring No.: LB-5 Checked By: A. Santos
 Sample No.: S-2 Depth (ft.) 25.0
 Soil Identification: Olive brown sandy lean clay s(CL)

TEST NO.	PLASTIC LIMIT		LIQUID LIMIT			
	1	2	1	2	3	4
Number of Blows [N]			32	25	17	
Wet Wt. of Soil + Cont. (g)	10.21	10.23	21.35	20.16	20.30	
Dry Wt. of Soil + Cont. (g)	8.51	8.53	16.62	15.52	15.34	
Wt. of Container (g)	1.08	1.07	1.06	1.03	1.02	
Moisture Content (%) [Wn]	22.88	22.79	30.40	32.02	34.64	

Liquid Limit	32
Plastic Limit	23
Plasticity Index	9
Classification	CL

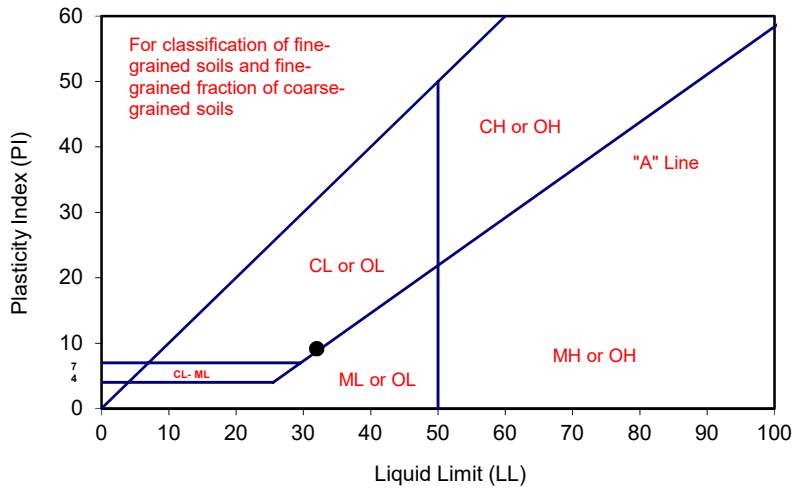

PI at "A" - Line = $0.73(LL-20)$ 8.76

One - Point Liquid Limit Calculation

$$LL = Wn(N/25)^{0.121}$$

PROCEDURES USED

- Wet Preparation
Multipoint - Wet
- Dry Preparation
Multipoint - Dry
- Procedure A
Multipoint Test
- Procedure B
One-point Test

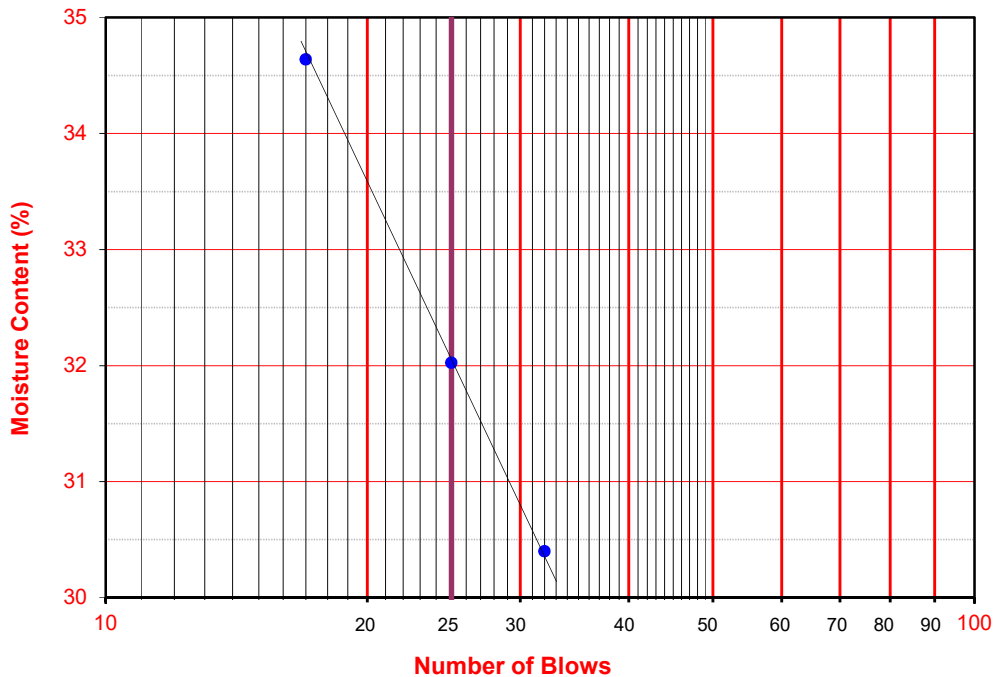



ATTERBERG LIMITS

ASTM D 4318

Project Name: <u>Norwalk Transit Village</u>	Tested By: <u>A Santos</u>	Date: <u>05/17/21</u>
Project No. : <u>13109.001</u>	Input By: <u>G. Bathala</u>	Date: <u>05/18/21</u>
Boring No.: <u>LB-5</u>	Checked By: <u>A. Santos</u>	
Sample No.: <u>R-6</u>	Depth (ft.) <u>40.0</u>	
Soil Identification: <u>Olive gray sandy lean clay s(CL)</u>		

TEST NO.	PLASTIC LIMIT		LIQUID LIMIT			
	1	2	1	2	3	4
Number of Blows [N]			31	24	19	
Wet Wt. of Soil + Cont. (g)	12.74	10.15	24.58	22.25	27.42	
Dry Wt. of Soil + Cont. (g)	11.12	8.90	18.77	16.93	20.72	
Wt. of Container (g)	1.06	1.07	1.00	0.98	1.08	
Moisture Content (%) [Wn]	16.10	15.96	32.70	33.35	34.11	

Liquid Limit	33
Plastic Limit	16
Plasticity Index	17
Classification	CL

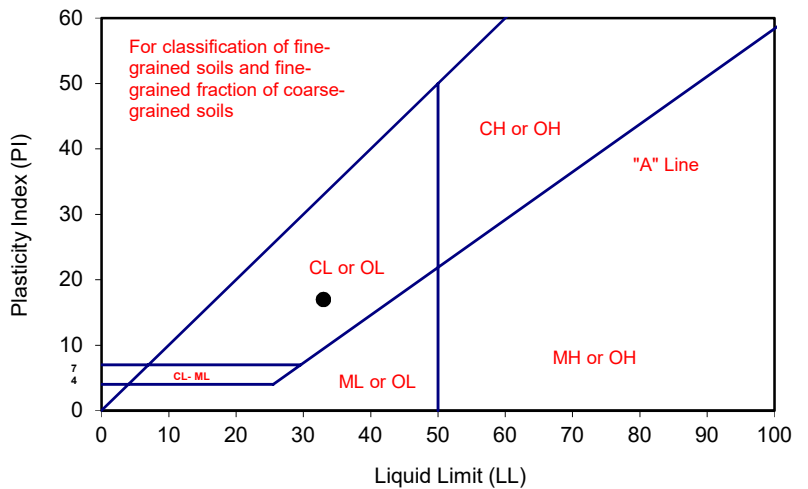

PI at "A" - Line = $0.73(LL-20)$ 9.49

One - Point Liquid Limit Calculation

$$LL = Wn(N/25)^{0.121}$$

PROCEDURES USED

- Wet Preparation
Multipoint - Wet
- Dry Preparation
Multipoint - Dry
- Procedure A
Multipoint Test
- Procedure B
One-point Test

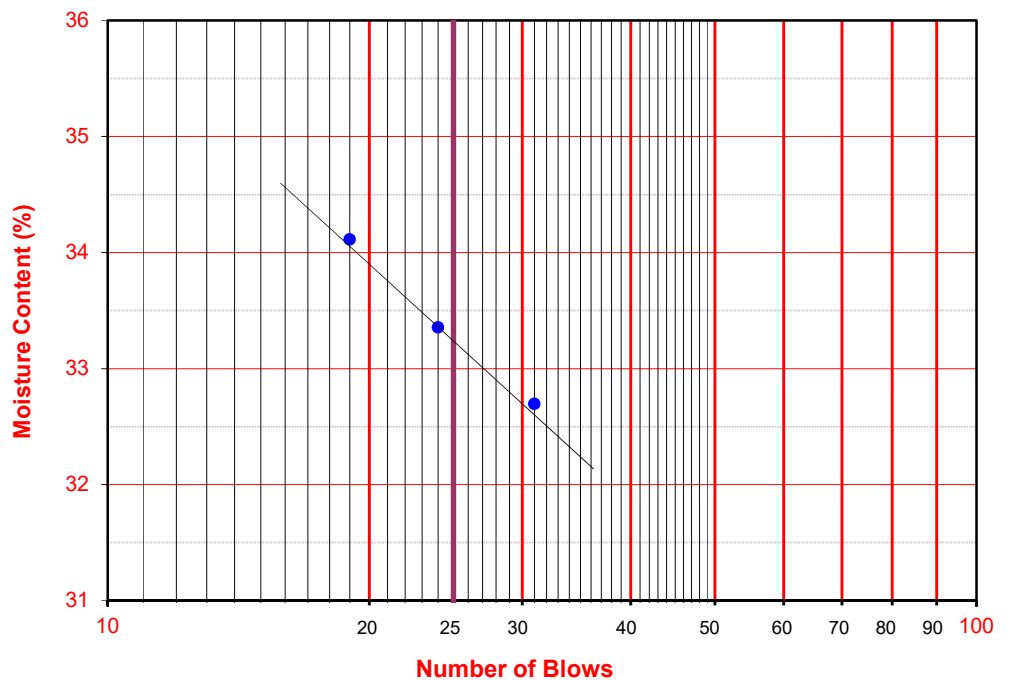



ATTERBERG LIMITS

ASTM D 4318

Project Name: Norwalk Transit Village Tested By: S. Felter Date: 05/09/21
 Project No. : 13109.001 Input By: G. Bathala Date: 05/18/21
 Boring No.: LB-6 Checked By: A. Santos
 Sample No.: S-3 Depth (ft.) 40.0
 Soil Identification: Olive gray fat clay with sand (CH)s

TEST NO.	PLASTIC LIMIT		LIQUID LIMIT			
	1	2	1	2	3	4
Number of Blows [N]			35	27	20	
Wet Wt. of Soil + Cont. (g)	10.16	10.25	21.40	20.28	20.86	
Dry Wt. of Soil + Cont. (g)	8.51	8.57	14.50	13.64	13.75	
Wt. of Container (g)	1.04	1.07	1.08	1.10	1.02	
Moisture Content (%) [W _n]	22.09	22.40	51.42	52.95	55.85	

Liquid Limit	54
Plastic Limit	22
Plasticity Index	32
Classification	CH

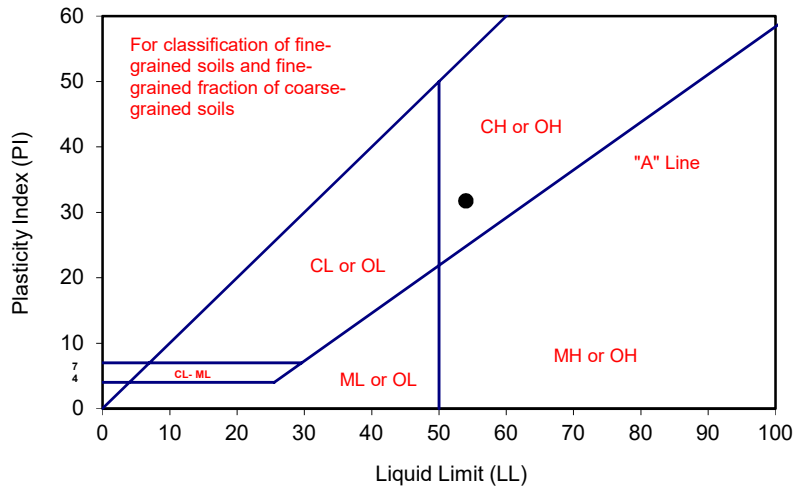

PI at "A" - Line = $0.73(LL-20)$ 24.82

One - Point Liquid Limit Calculation

$$LL = W_n(N/25)^{0.121}$$

PROCEDURES USED

- Wet Preparation
Multipoint - Wet
- Dry Preparation
Multipoint - Dry
- Procedure A
Multipoint Test
- Procedure B
One-point Test

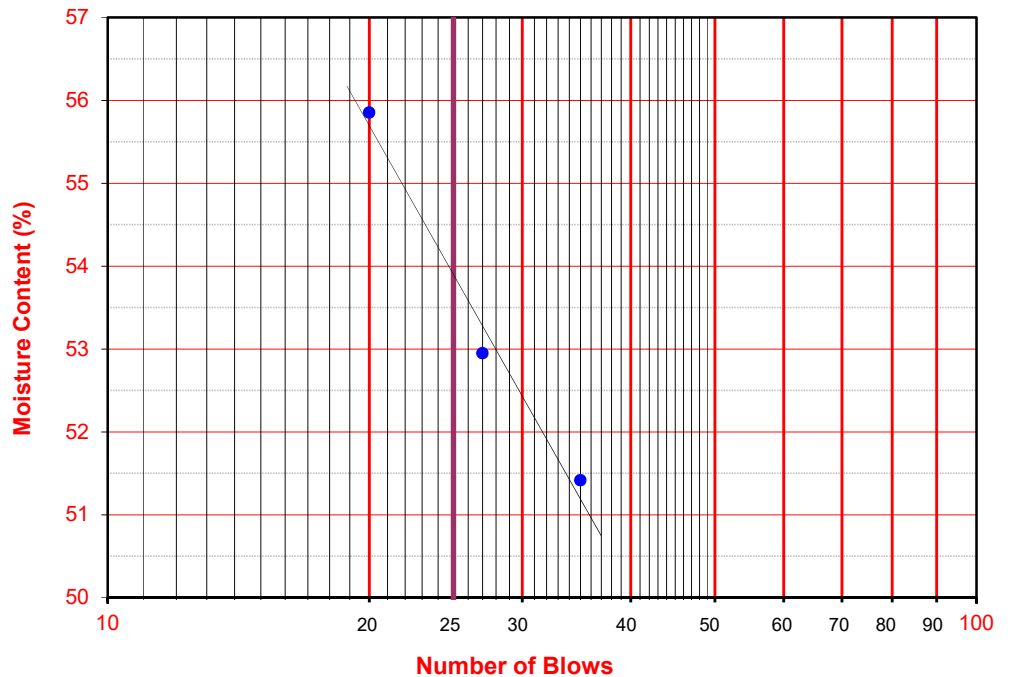



ONE-DIMENSIONAL SWELL OR SETTLEMENT POTENTIAL OF COHESIVE SOILS ASTM D 4546

Project Name: Norwalk Transit Village
 Project No.: 13109.001
 Boring No.: LB-1
 Sample No.: R-2
 Sample Description: Light olive gray poorly-graded sand (SP)

Tested By: G. Bathala Date: 05/05/21
 Checked By: A. Santos Date: 05/18/21
 Sample Type: Ring
 Depth (ft.): 7.0

Initial Dry Density (pcf):	97.1
Initial Moisture (%):	2.52
Initial Length (in.):	1.0000
Initial Dial Reading:	0.1747
Diameter(in):	2.415

Final Dry Density (pcf):	98.3
Final Moisture (%) :	23.4
Initial Void ratio:	0.7360
Specific Gravity(assumed):	2.70
Initial Saturation (%)	9.2

Pressure (p) (ksf)	Final Reading (in)	Apparent Thickness (in)	Load Compliance (%)	Swell (+) Settlement (-) % of Sample Thickness	Void Ratio	Corrected Deformation (%)
0.100	0.1749	0.9998	0.00	-0.02	0.7357	-0.02
0.900	0.1836	0.9911	0.13	-0.89	0.7228	-0.76
H2O	0.1857	0.9890	0.13	-1.10	0.7192	-0.97

Percent Swell (+) / Settlement (-) After Inundation = -0.21

Void Ratio - Log Pressure Curve

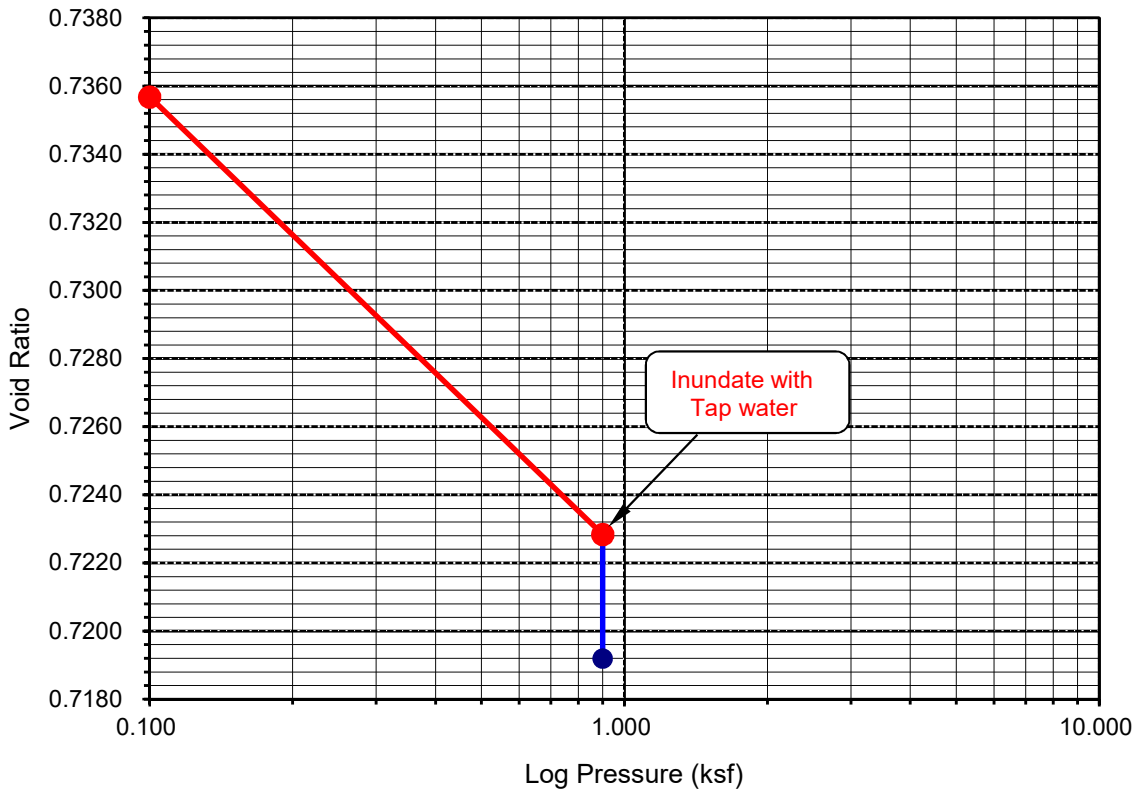



ONE-DIMENSIONAL SWELL OR SETTLEMENT POTENTIAL OF COHESIVE SOILS ASTM D 4546

Project Name: Norwalk Transit Village
 Project No.: 13109.001
 Boring No.: LB-3
 Sample No.: R-2
 Sample Description: Light olive gray poorly-graded sand (SP)

Tested By: G. Bathala Date: 05/06/21
 Checked By: A. Santos Date: 05/18/21
 Sample Type: Ring
 Depth (ft.): 7.0

Initial Dry Density (pcf):	95.5
Initial Moisture (%):	1.11
Initial Length (in.):	1.0000
Initial Dial Reading:	0.2523
Diameter(in):	2.415

Final Dry Density (pcf):	97.1
Final Moisture (%):	24.5
Initial Void ratio:	0.7642
Specific Gravity(assumed):	2.70
Initial Saturation (%):	3.9

Pressure (p) (ksf)	Final Reading (in)	Apparent Thickness (in)	Load Compliance (%)	Swell (+) Settlement (-) % of Sample Thickness	Void Ratio	Corrected Deformation (%)
0.100	0.2525	0.9998	0.00	-0.02	0.7639	-0.02
0.900	0.2606	0.9917	0.13	-0.83	0.7519	-0.70
H2O	0.2668	0.9855	0.13	-1.45	0.7409	-1.32

Percent Swell (+) / Settlement (-) After Inundation = -0.62

Void Ratio - Log Pressure Curve

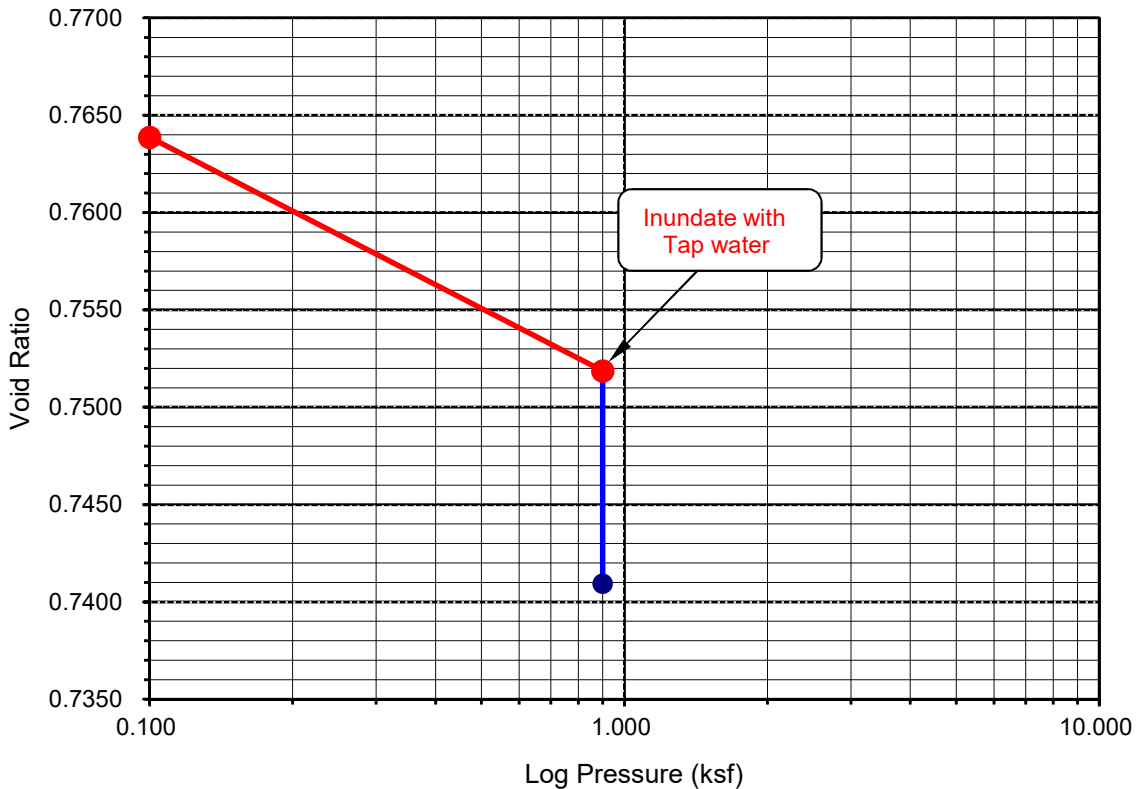



ONE-DIMENSIONAL SWELL OR SETTLEMENT POTENTIAL OF COHESIVE SOILS ASTM D 4546

Project Name: Norwalk Transit Village
 Project No.: 13109.001
 Boring No.: LB-4
 Sample No.: R-4
 Sample Description: Light olive brown poorly-graded sand with silt (SP-SM)

Tested By: G. Bathala Date: 05/05/21
 Checked By: A. Santos Date: 05/18/21
 Sample Type: Ring
 Depth (ft.): 15.0

Initial Dry Density (pcf):	110.5
Initial Moisture (%):	3.01
Initial Length (in.):	1.0000
Initial Dial Reading:	0.1897
Diameter(in):	2.415

Final Dry Density (pcf):	112.1
Final Moisture (%) :	17.0
Initial Void ratio:	0.5248
Specific Gravity(assumed):	2.70
Initial Saturation (%)	15.5

Pressure (p) (ksf)	Final Reading (in)	Apparent Thickness (in)	Load Compliance (%)	Swell (+) Settlement (-) % of Sample Thickness	Void Ratio	Corrected Deformation (%)
0.100	0.1898	0.9999	0.00	-0.01	0.5246	-0.01
1.800	0.1995	0.9902	0.26	-0.98	0.5138	-0.72
H2O	0.2011	0.9886	0.26	-1.14	0.5114	-0.88

Percent Swell (+) / Settlement (-) After Inundation = -0.16

Void Ratio - Log Pressure Curve

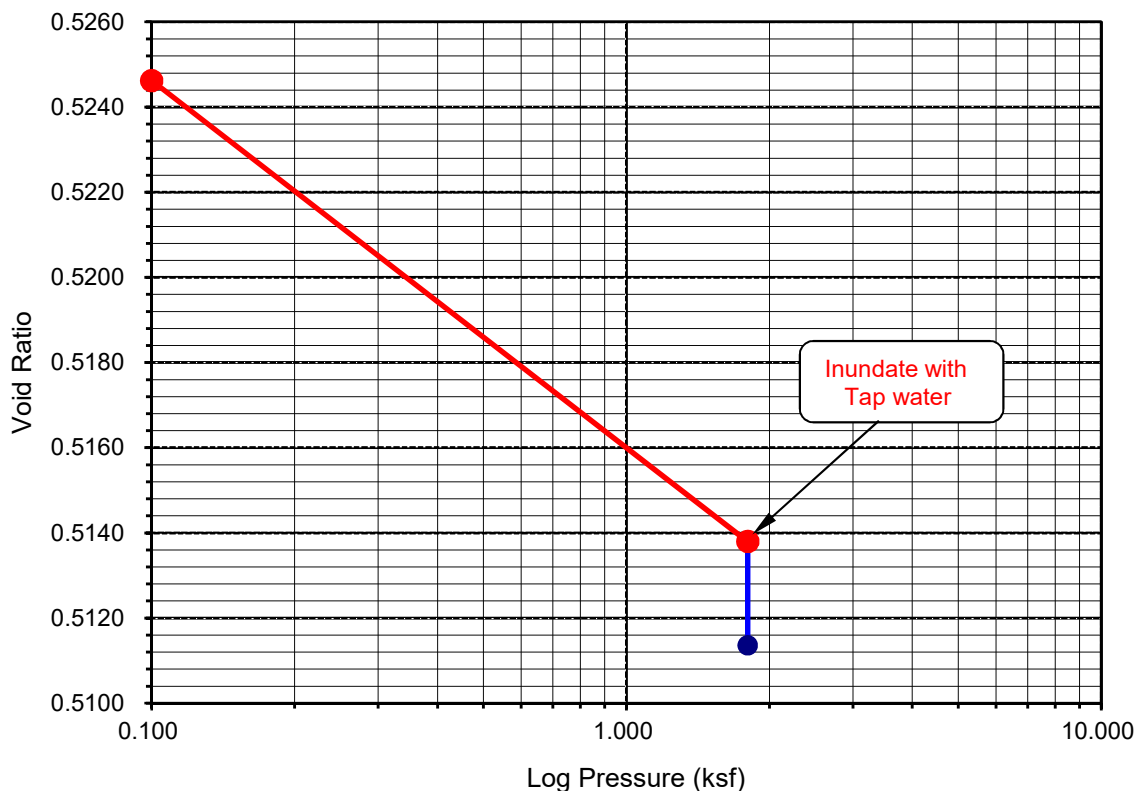



ONE-DIMENSIONAL SWELL OR SETTLEMENT POTENTIAL OF COHESIVE SOILS ASTM D 4546

Project Name: Norwalk Transit Village
 Project No.: 13109.001
 Boring No.: LB-6
 Sample No.: R-3
 Sample Description: Gray poorly-graded sand (SP)

Tested By: G. Bathala Date: 05/06/21
 Checked By: A. Santos Date: 05/18/21
 Sample Type: Ring
 Depth (ft.): 10.0

Initial Dry Density (pcf):	101.0
Initial Moisture (%):	1.18
Initial Length (in.):	1.0000
Initial Dial Reading:	0.1715
Diameter(in):	2.415

Final Dry Density (pcf):	102.1
Final Moisture (%) :	23.9
Initial Void ratio:	0.6696
Specific Gravity(assumed):	2.70
Initial Saturation (%)	4.7

Pressure (p) (ksf)	Final Reading (in)	Apparent Thickness (in)	Load Compliance (%)	Swell (+) Settlement (-) % of Sample Thickness	Void Ratio	Corrected Deformation (%)
0.100	0.1716	0.9999	0.00	-0.01	0.6695	-0.01
1.200	0.1785	0.9930	0.19	-0.70	0.6611	-0.51
H2O	0.1804	0.9911	0.19	-0.89	0.6579	-0.70

Percent Swell (+) / Settlement (-) After Inundation = -0.19

Void Ratio - Log Pressure Curve

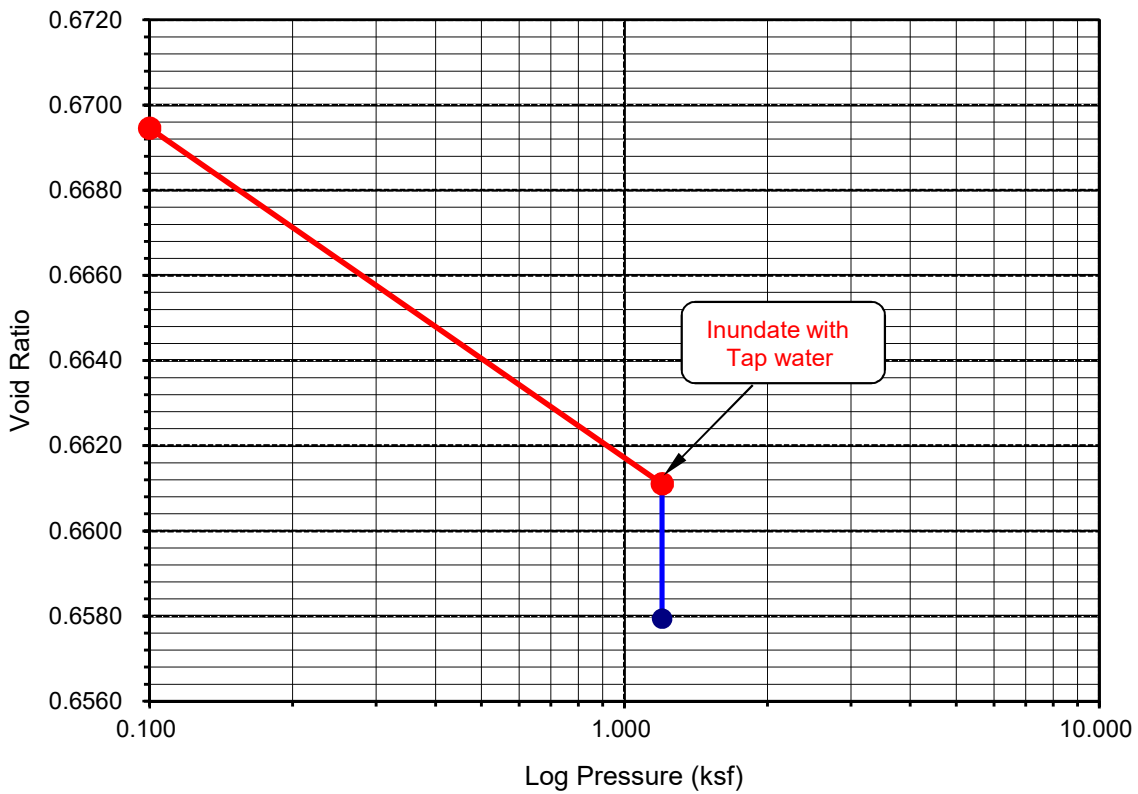

Time Readings

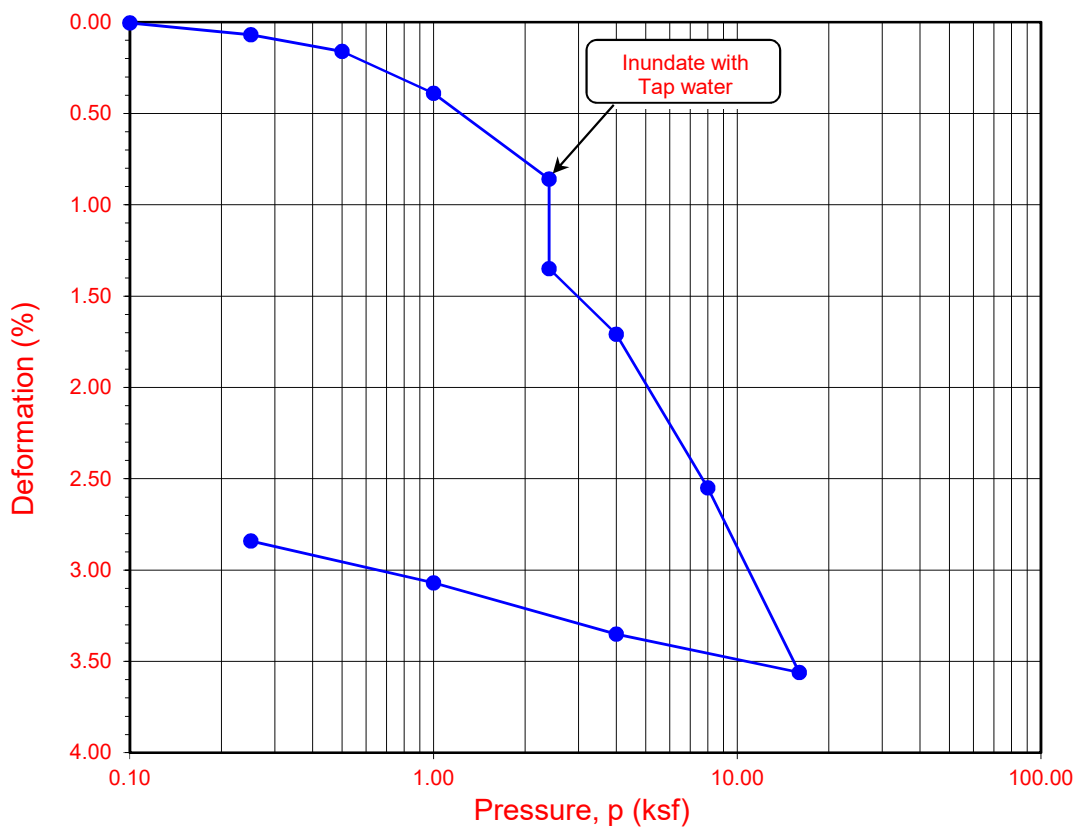
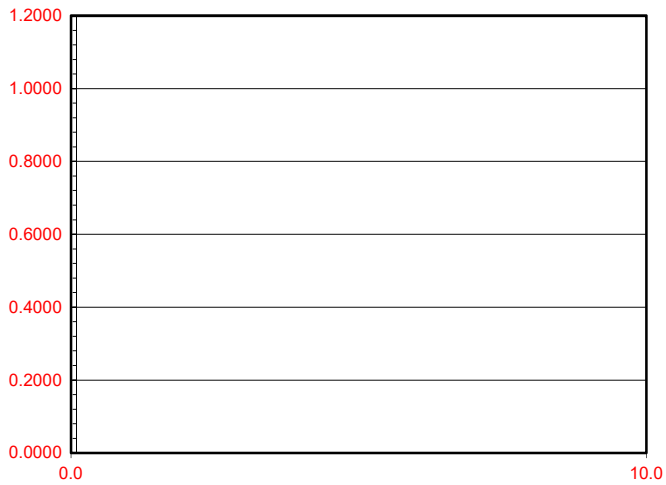
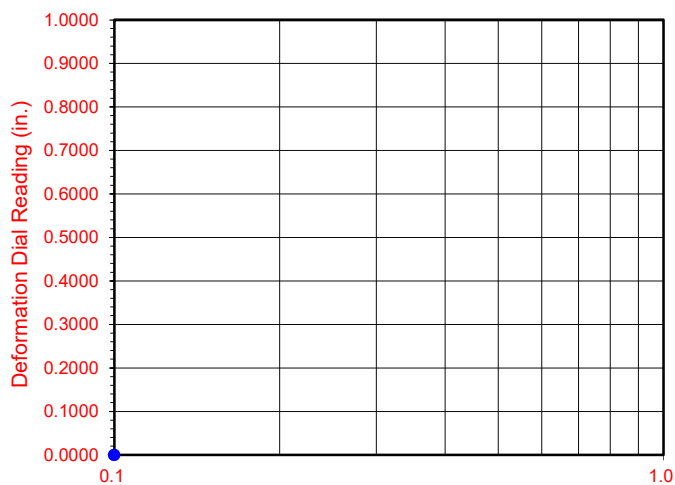

Boring No.	Sample No.	Depth (ft.)	Moisture Content (%)		Dry Density (pcf)		Void Ratio		Degree of Saturation (%)	
			Initial	Final	Initial	Final	Initial	Final	Initial	Final
LB-3	R-3	20.0	4.1	23.6	95.9	98.5	0.757	0.707	15	89

Soil Identification: Olive gray silt with sand (ML)s



**ONE-DIMENSIONAL CONSOLIDATION
PROPERTIES of SOILS
ASTM D 2435**

Project No.: 13109.001

Norwalk Transit Village

Time Readings

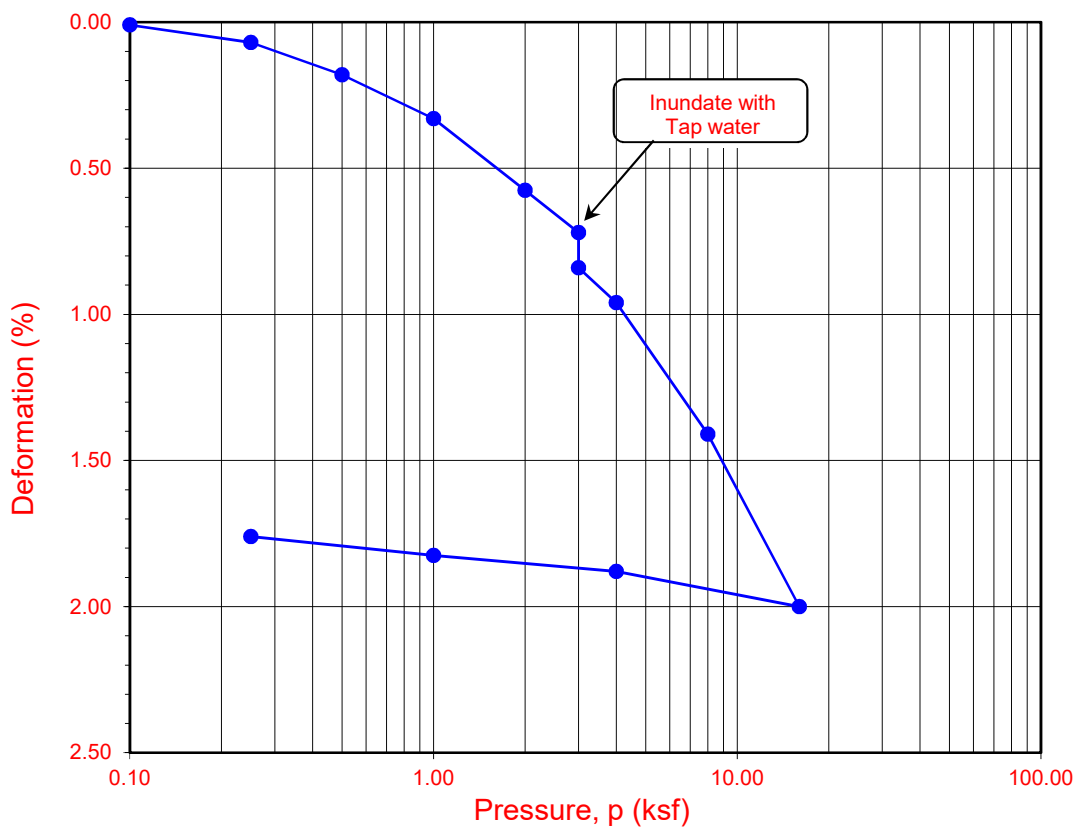
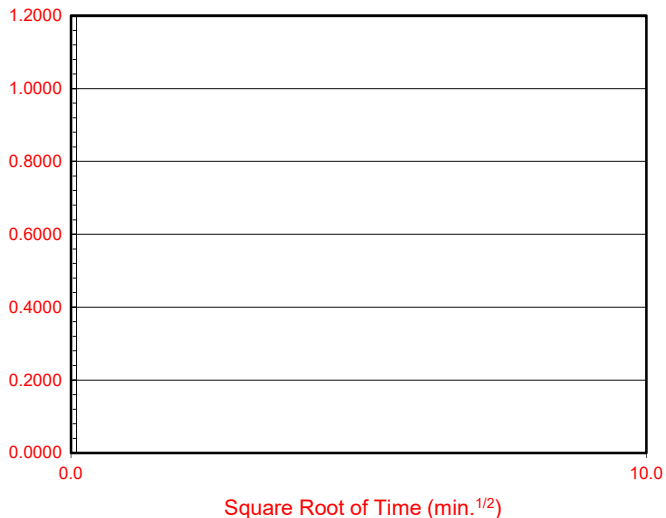
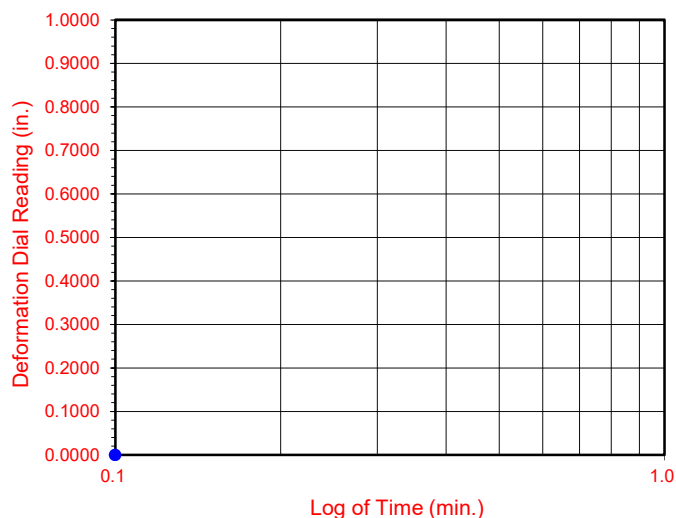

Boring No.	Sample No.	Depth (ft.)	Moisture Content (%)		Dry Density (pcf)		Void Ratio		Degree of Saturation (%)	
			Initial	Final	Initial	Final	Initial	Final	Initial	Final
LB-4	R-5	25.0	7.6	18.9	103.0	104.6	0.636	0.607	32	83

Soil Identification: Olive sandy silt s(ML)



ONE-DIMENSIONAL CONSOLIDATION PROPERTIES of SOILS ASTM D 2435

Project No.: 13109.001

Norwalk Transit Village

Time Readings

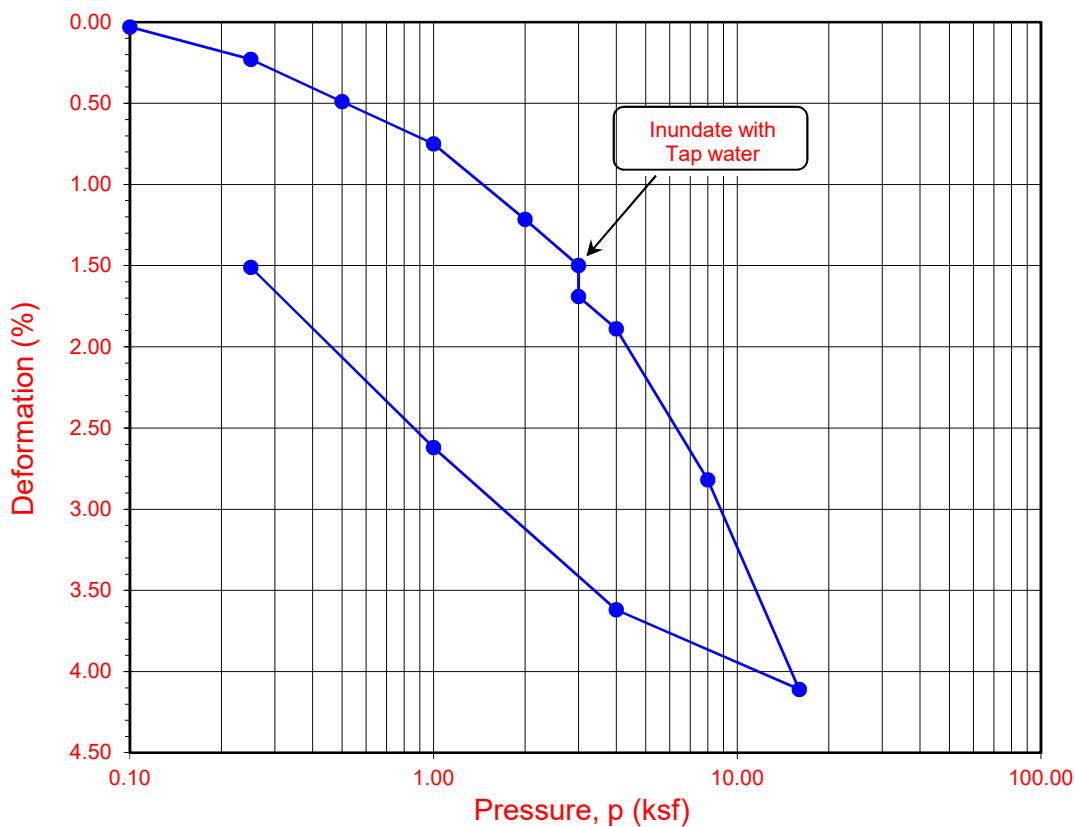
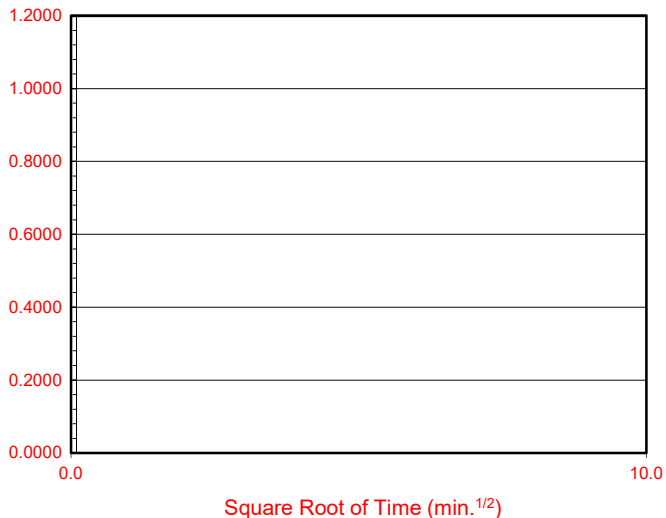
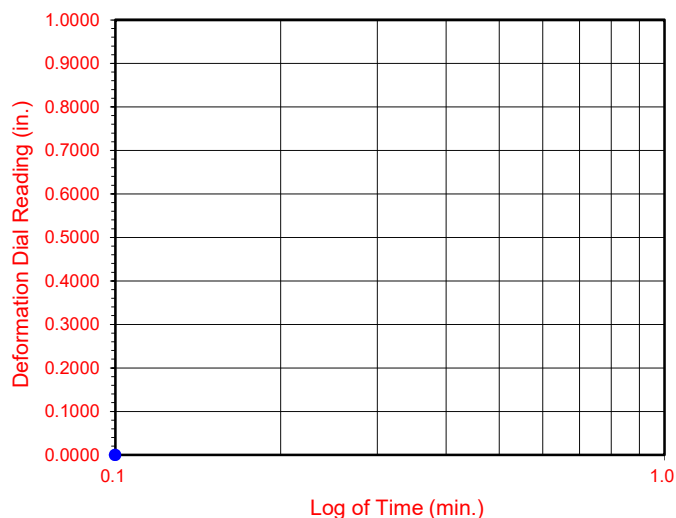

Boring No.	Sample No.	Depth (ft.)	Moisture Content (%)		Dry Density (pcf)		Void Ratio		Degree of Saturation (%)	
			Initial	Final	Initial	Final	Initial	Final	Initial	Final
LB-6	R-5	25.0	6.7	26.9	95.6	96.5	0.764	0.737	24	97

Soil Identification: Olive gray silt (ML)



ONE-DIMENSIONAL CONSOLIDATION PROPERTIES of SOILS ASTM D 2435

Project No.: 13109.001

Norwalk Transit Village



TESTS for SULFATE CONTENT CHLORIDE CONTENT and pH of SOILS

Project Name: Norwalk Transit Village Tested By : GEB/GB Date: 05/12/21
 Project No. : 13109.001 Checked By: A. Santos Date: 05/18/21

Boring No.	LB-2	LB-5		
Sample No.	B-1	B-1		
Sample Depth (ft)	0-5	0-5		
Soil Identification:				
	Grayish brown s(CL-ML)	Olive brown (SC)		
Wet Weight of Soil + Container (g)	0.00	0.00		
Dry Weight of Soil + Container (g)	0.00	0.00		
Weight of Container (g)	1.00	1.00		
Moisture Content (%)	0.00	0.00		
Weight of Soaked Soil (g)	100.71	100.29		

SULFATE CONTENT, DOT California Test 417, Part II

Beaker No.	306	310		
Crucible No.	4	19		
Furnace Temperature (°C)	860	860		
Time In / Time Out	12:25/13:10	12:25/13:10		
Duration of Combustion (min)	45	45		
Wt. of Crucible + Residue (g)	21.0606	19.8600		
Wt. of Crucible (g)	21.0591	19.8573		
Wt. of Residue (g) (A)	0.0015	0.0027		
PPM of Sulfate (A) x 41150	61.73	111.11		
PPM of Sulfate, Dry Weight Basis	62	111		

CHLORIDE CONTENT, DOT California Test 422

ml of Extract For Titration (B)	15	15		
ml of AgNO ₃ Soln. Used in Titration (C)	0.6	1.0		
PPM of Chloride (C -0.2) * 100 * 30 / B	80	160		
PPM of Chloride, Dry Wt. Basis	80	160		

pH TEST, DOT California Test 643

pH Value	7.41	7.22		
Temperature °C	22.6	22.7		



SOIL RESISTIVITY TEST

DOT CA TEST 643

Project Name: Norwalk Transit Village
 Project No. : 13109.001
 Boring No.: LB-2
 Sample No. : B-1

Tested By : G. Berdy Date: 05/13/21
 Checked By: A. Santos Date: 05/18/21
 Depth (ft.) : 0-5

Soil Identification:* Grayish brown s(CL-ML)

*California Test 643 requires soil specimens to consist only of portions of samples passing through the No. 8 US Standard Sieve before resistivity testing. Therefore, this test method may not be representative for coarser materials.

Specimen No.	Water Added (ml) (Wa)	Adjusted Moisture Content (MC)	Resistance Reading (ohm)	Soil Resistivity (ohm-cm)
1	20	15.35	2600	2600
2	30	23.02	730	730
3	40	30.69	740	740
4				
5				

Moisture Content (%) (Mci)	0.00
Wet Wt. of Soil + Cont. (g)	0.00
Dry Wt. of Soil + Cont. (g)	0.00
Wt. of Container (g)	1.00
Container No.	
Initial Soil Wt. (g) (Wt)	130.32
Box Constant	1.000
$MC = (((1 + Mci / 100) \times (Wa / Wt + 1)) - 1) \times 100$	

Min. Resistivity (ohm-cm)	Moisture Content (%)	Sulfate Content (ppm)	Chloride Content (ppm)	Soil pH	
				pH	Temp. (°C)
DOT CA Test 643		DOT CA Test 417 Part II		DOT CA Test 643	
600	26.0	62	80	7.41	22.6

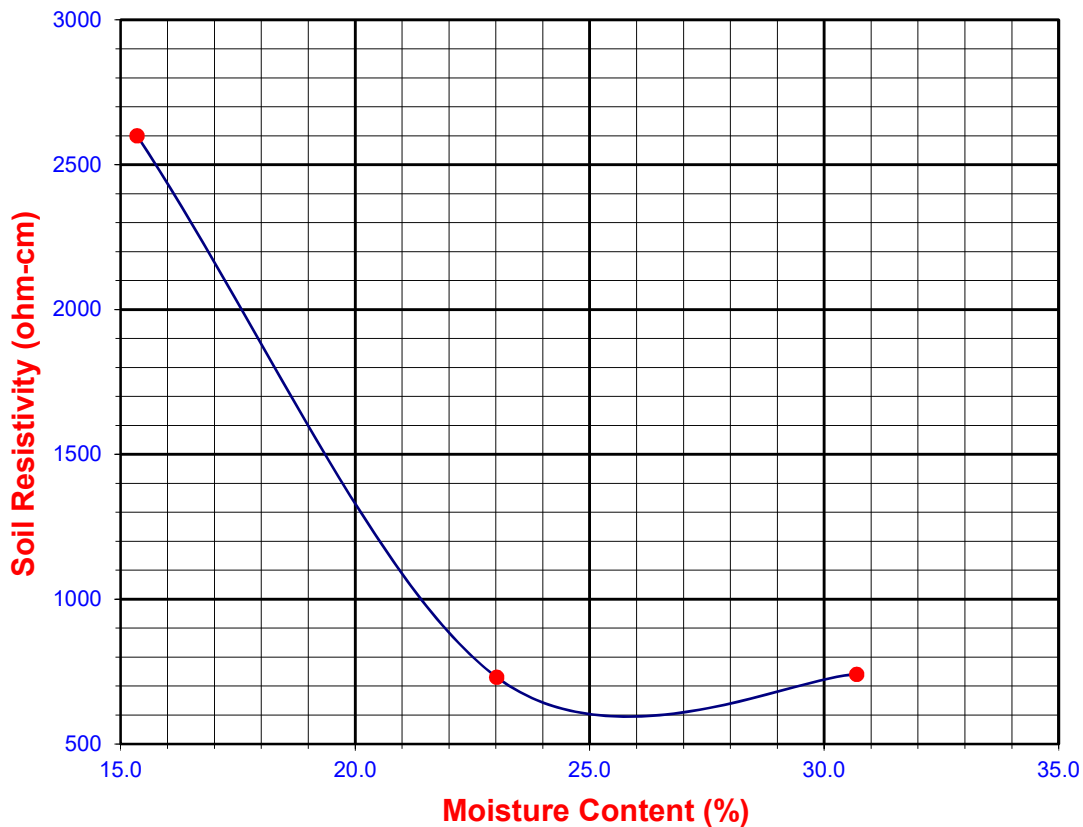



SOIL RESISTIVITY TEST

DOT CA TEST 643

Project Name: Norwalk Transit Village
 Project No. : 13109.001
 Boring No.: LB-5
 Sample No. : B-1

Tested By : G. Berdy Date: 05/13/21
 Checked By: A. Santos Date: 05/18/21
 Depth (ft.) : 0-5

Soil Identification:* Olive brown (SC)

*California Test 643 requires soil specimens to consist only of portions of samples passing through the No. 8 US Standard Sieve before resistivity testing. Therefore, this test method may not be representative for coarser materials.

Specimen No.	Water Added (ml) (Wa)	Adjusted Moisture Content (MC)	Resistance Reading (ohm)	Soil Resistivity (ohm-cm)
1	40	30.75	2300	2300
2	50	38.44	2000	2000
3	60	46.13	2150	2150
4				
5				

Moisture Content (%) (Mci)	0.00
Wet Wt. of Soil + Cont. (g)	0.00
Dry Wt. of Soil + Cont. (g)	0.00
Wt. of Container (g)	1.00
Container No.	
Initial Soil Wt. (g) (Wt)	130.07
Box Constant	1.000
$MC = (((1 + Mci / 100) \times (Wa / Wt + 1)) - 1) \times 100$	

Min. Resistivity (ohm-cm)	Moisture Content (%)	Sulfate Content (ppm)	Chloride Content (ppm)	Soil pH	
				pH	Temp. (°C)
DOT CA Test 643		DOT CA Test 417 Part II		DOT CA Test 643	
1997	39.0	111	160	7.22	22.7

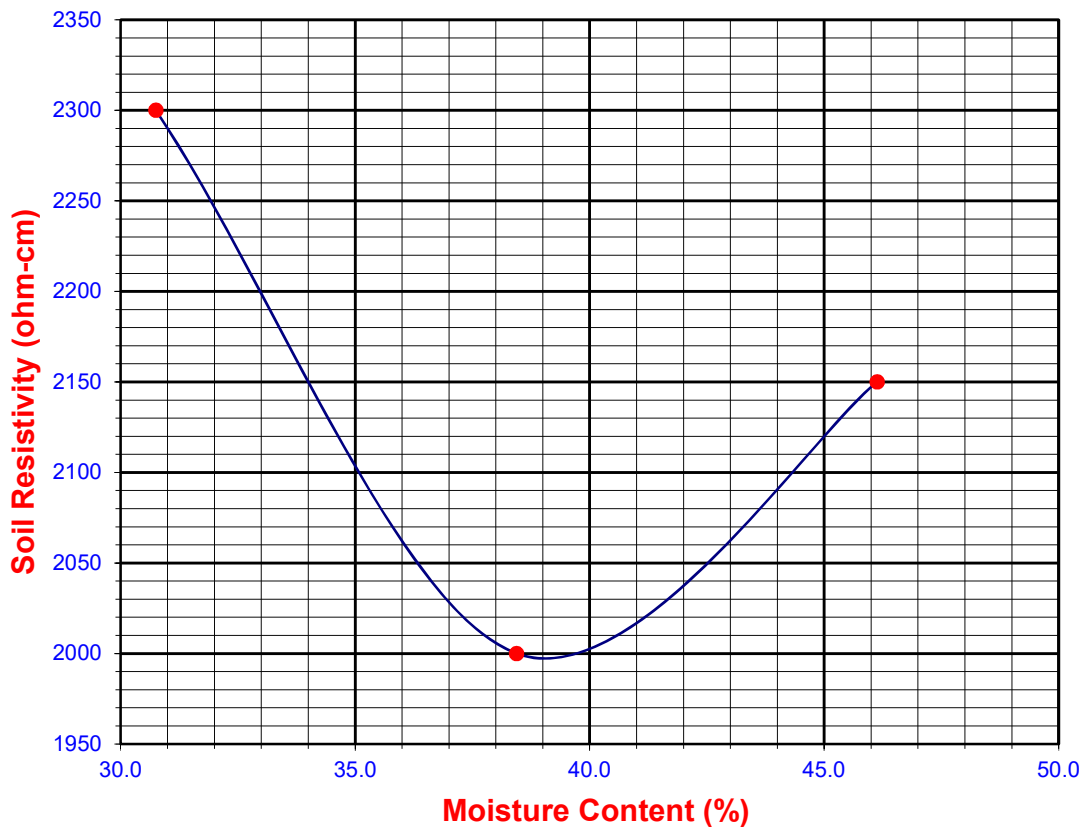



MODIFIED PROCTOR COMPACTION TEST

ASTM D 1557

Project Name: Norwalk Transit Village Tested By: J. Gonzalez Date: 05/12/21
 Project No.: 13109.001 Checked By: A. Santos Date: 05/18/21
 Boring No.: LB-2 Depth (ft.): 0-5
 Sample No.: B-1
 Soil Identification: Grayish brown sandy silty clay s(CL-ML)

Preparation Method: Moist Mechanical Ram
 Dry Manual Ram
Mold Volume (ft³) 0.03330 *Ram Weight = 10 lb.; Drop = 18 in.*

TEST NO.	1	2	3	4	5	6
Wt. Compacted Soil + Mold (g)	3867	3962	3873			
Weight of Mold (g)	1850	1850	1850			
Net Weight of Soil (g)	2017	2112	2023			
Wet Weight of Soil + Cont. (g)	403.7	443.4	427.9			
Dry Weight of Soil + Cont. (g)	374.6	402.5	380.4			
Weight of Container (g)	39.1	38.1	38.7			
Moisture Content (%)	8.67	11.22	13.90			
Wet Density (pcf)	133.5	139.8	133.9			
Dry Density (pcf)	122.9	125.7	117.6			

Maximum Dry Density (pcf) 126.0 **Optimum Moisture Content (%)** 10.5

PROCEDURE USED

Procedure A
 Soil Passing No. 4 (4.75 mm) Sieve
 Mold : 4 in. (101.6 mm) diameter
 Layers : 5 (Five)
 Blows per layer : 25 (twenty-five)
 May be used if + #4 is 20% or less

Procedure B
 Soil Passing 3/8 in. (9.5 mm) Sieve
 Mold : 4 in. (101.6 mm) diameter
 Layers : 5 (Five)
 Blows per layer : 25 (twenty-five)
 Use if + #4 is >20% and +3/8 in. is 20% or less

Procedure C
 Soil Passing 3/4 in. (19.0 mm) Sieve
 Mold : 6 in. (152.4 mm) diameter
 Layers : 5 (Five)
 Blows per layer : 56 (fifty-six)
 Use if +3/8 in. is >20% and +3/4 in. is <30%

Particle-Size Distribution:

GR:SA:FI

Atterberg Limits:

LL, PL, PI

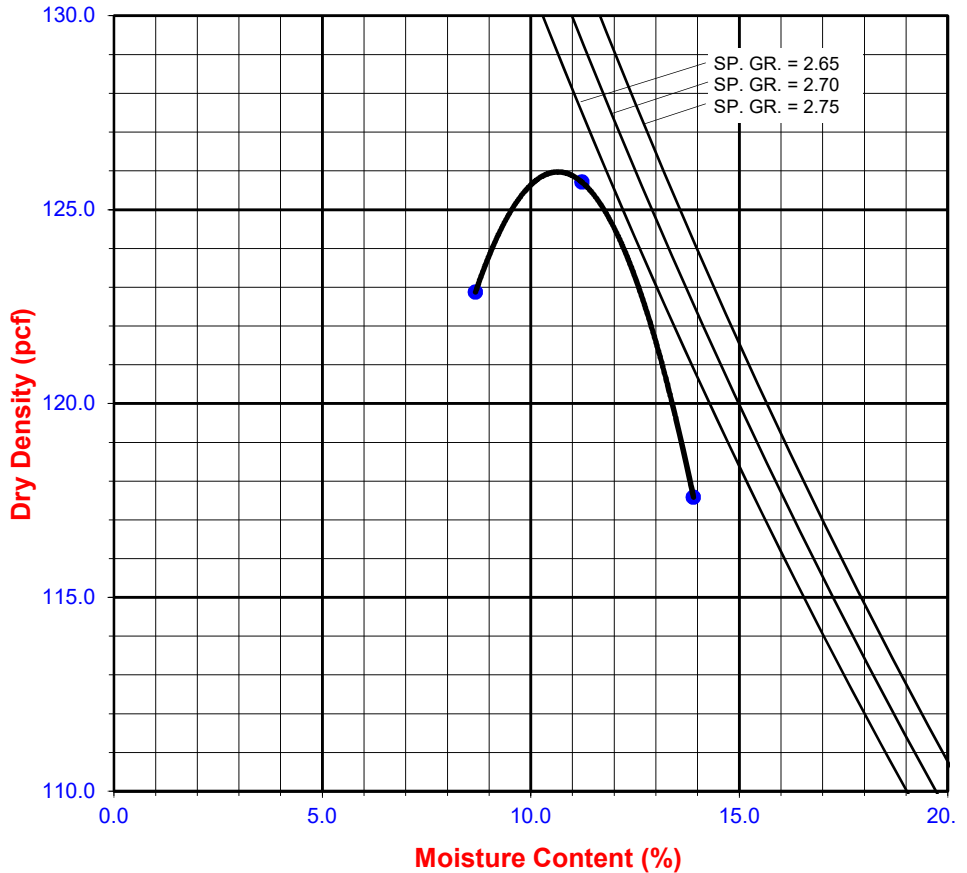



MODIFIED PROCTOR COMPACTION TEST

ASTM D 1557

Project Name: Norwalk Transit Village Tested By: J. Gonzalez Date: 05/11/21
 Project No.: 13109.001 Checked By: A. Santos Date: 05/18/21
 Boring No.: LB-5 Depth (ft.): 0-5
 Sample No.: B-1
 Soil Identification: Olive brown clayey sand (SC)

Preparation Method: Moist Mechanical Ram
 Dry Manual Ram
Mold Volume (ft³) 0.03330 *Ram Weight = 10 lb.; Drop = 18 in.*

TEST NO.	1	2	3	4	5	6
Wt. Compacted Soil + Mold (g)	3800	3931	3923			
Weight of Mold (g)	1850	1850	1850			
Net Weight of Soil (g)	1950	2081	2073			
Wet Weight of Soil + Cont. (g)	503.5	426.9	424.8			
Dry Weight of Soil + Cont. (g)	476.1	395.5	384.0			
Weight of Container (g)	39.1	39.3	38.5			
Moisture Content (%)	6.27	8.82	11.81			
Wet Density (pcf)	129.1	137.8	137.2			
Dry Density (pcf)	121.5	126.6	122.7			

Maximum Dry Density (pcf) 126.7 **Optimum Moisture Content (%)** 9.3

PROCEDURE USED

Procedure A
 Soil Passing No. 4 (4.75 mm) Sieve
 Mold : 4 in. (101.6 mm) diameter
 Layers : 5 (Five)
 Blows per layer : 25 (twenty-five)
 May be used if + #4 is 20% or less

Procedure B
 Soil Passing 3/8 in. (9.5 mm) Sieve
 Mold : 4 in. (101.6 mm) diameter
 Layers : 5 (Five)
 Blows per layer : 25 (twenty-five)
 Use if + #4 is >20% and +3/8 in. is 20% or less

Procedure C
 Soil Passing 3/4 in. (19.0 mm) Sieve
 Mold : 6 in. (152.4 mm) diameter
 Layers : 5 (Five)
 Blows per layer : 56 (fifty-six)
 Use if +3/8 in. is >20% and +3/4 in. is <30%

Particle-Size Distribution:

GR:SA:FI

Atterberg Limits:

LL,PL,PI

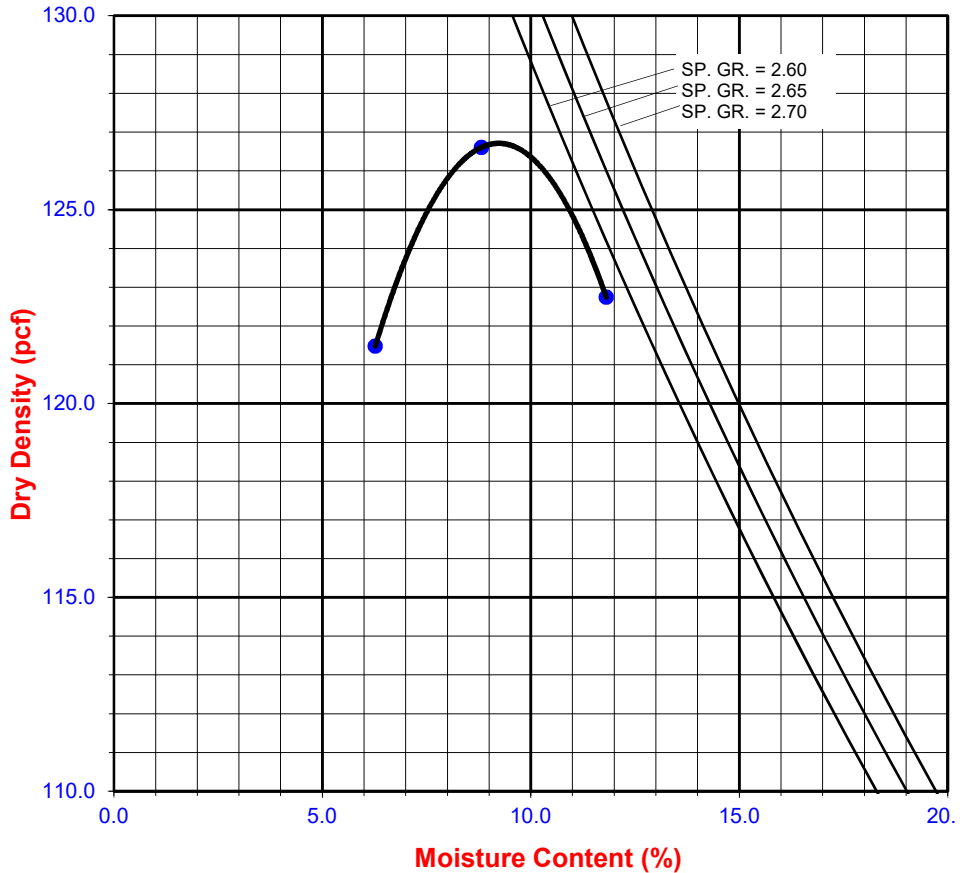



**MOISTURE, ORGANIC MATTER and
ASH CONTENT of SOILS
ASTM D 2974 (Test Methods A & C)**

Project Name: Norwalk Transit Village Tested By: G. Berdy Date: 05/04/21
 Project No. : 13109.00 Input By: A. Santos Date: 05/18/21
 Client: _____

Boring No.	LB-5				
Sample No.	S-3				
Depth (ft)	35.0				
Soil Description	Gray Clay (CL)				
Wt. of Moist Soil + Container (gm)	962.00				
Wt. of Dried Soil + Container (gm)	765.93				
Wt. Container (gm)	108.69				
Crucible No.	1, 16				
Furnace Temperature (°C)	440				
Time In / Time Out	11:08 / 13:44				
Duration of Combustion (hr)	2hr. 36m				
Wt. of Dried Soil + Crucible (gm)	84.24				
Wt. of Ash + Crucible (gm)	83.56				
Wt. of Crucible (gm)	40.20				
Moisture Content @ 105 °C (%) "as received"	29.8				
Dry wt. of Soil (gm) (1)	44.04				
Wt. of Ash (gm) (2)	43.36				
Ash Content (%) = [(2) / (1)] x 100 (3)	98.5				
Organic Matter (%) = 100 - (3)	1.5				

Remarks: Moisture, ash & organic contents are calculated as percentages of oven-dried mass of test specimen.



R-VALUE TEST RESULTS

DOT CA Test 301

PROJECT NAME: Norwalk Transit Village PROJECT NUMBER: 13109.001
 BORING NUMBER: LB-3 DEPTH (FT.): 0-5
 SAMPLE NUMBER: B-1 TECHNICIAN: O. Figueroa
 SAMPLE DESCRIPTION: Grayish brown silty sand (SM) DATE COMPLETED: 5/13/2021

TEST SPECIMEN	a	b	c
MOISTURE AT COMPACTION %	10.4	11.3	12.2
HEIGHT OF SAMPLE, Inches	2.49	2.50	2.48
DRY DENSITY, pcf	124.0	122.4	121.8
COMPACTOR PRESSURE, psi	300	225	175
EXUDATION PRESSURE, psi	562	236	140
EXPANSION, Inches x 10exp-4	44	23	10
STABILITY Ph 2,000 lbs (160 psi)	24	35	45
TURNS DISPLACEMENT	4.85	5.15	5.45
R-VALUE UNCORRECTED	74	63	54
R-VALUE CORRECTED	74	63	54

DESIGN CALCULATION DATA	a	b	c
GRAVEL EQUIVALENT FACTOR	1.0	1.0	1.0
TRAFFIC INDEX	5.0	5.0	5.0
STABILOMETER THICKNESS, ft.	0.42	0.59	0.74
EXPANSION PRESSURE THICKNESS, ft.	1.47	0.77	0.33

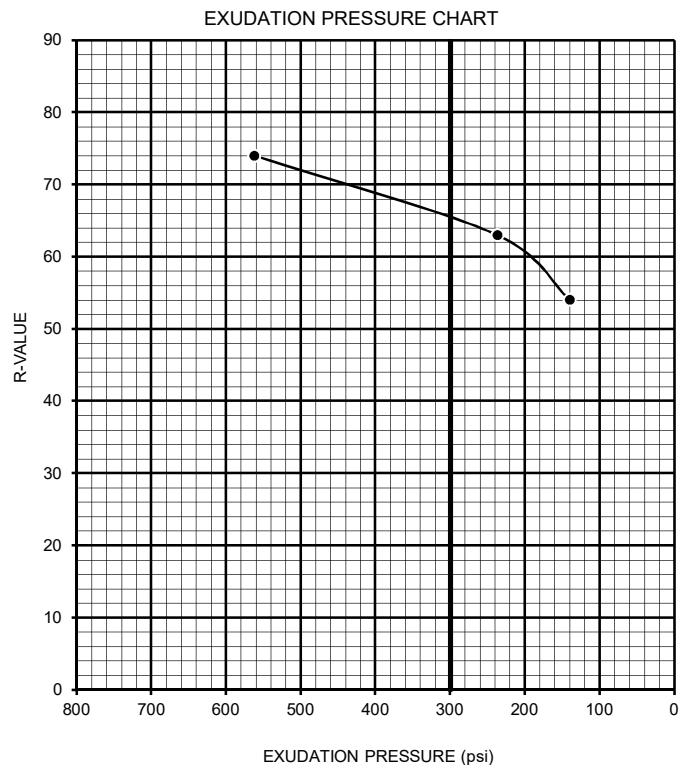
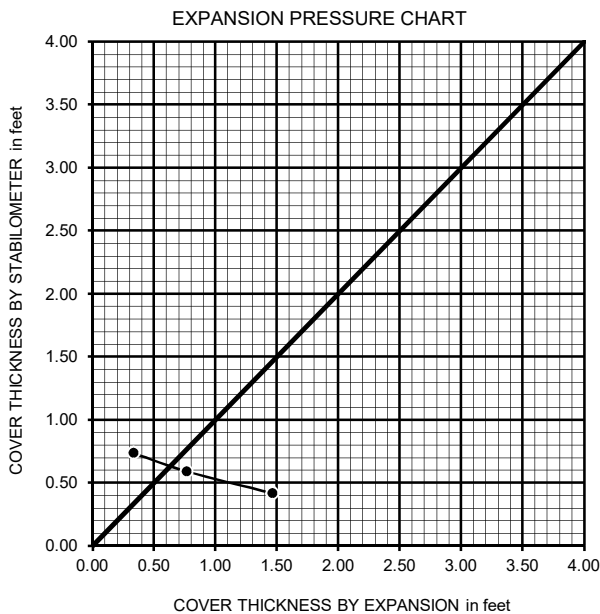

R-VALUE BY EXPANSION: 59
 R-VALUE BY EXUDATION: 65
 EQUILIBRIUM R-VALUE: 59

APPENDIX C

SUMMARY OF SEISMIC AND SECONDARY SEISMIC ANALYSES



Leighton



13109.001

Latitude, Longitude: 33.91238, -118.06177

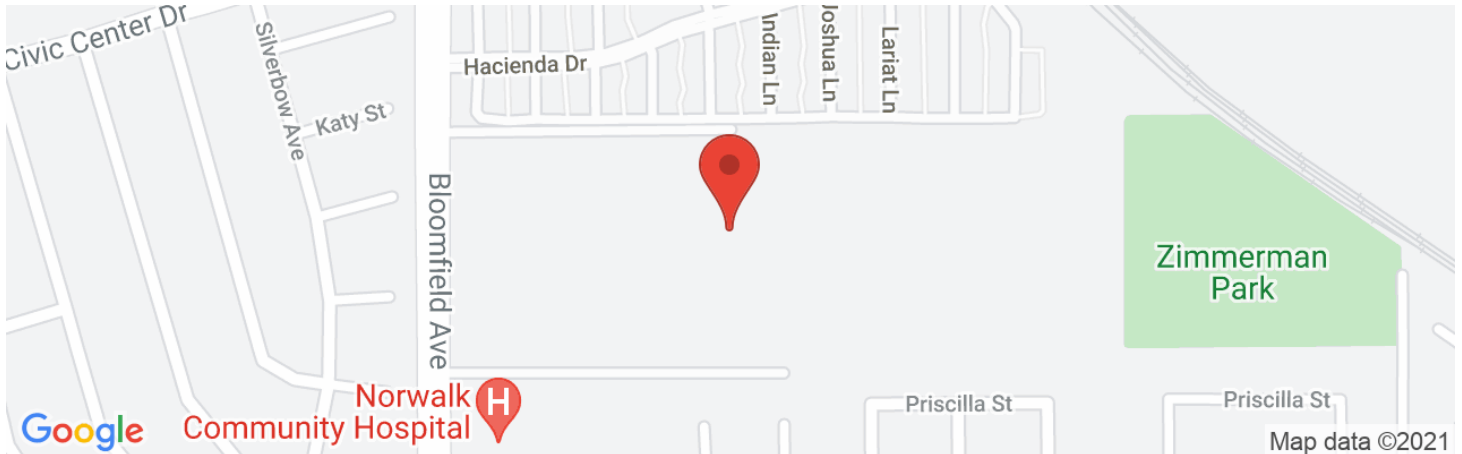

Date	4/29/2021, 2:34:04 PM
Design Code Reference Document	ASCE7-16
Risk Category	II
Site Class	D - Stiff Soil

Type	Value	Description
S_S	1.644	MCE_R ground motion. (for 0.2 second period)
S_1	0.588	MCE_R ground motion. (for 1.0s period)
S_{MS}	1.644	Site-modified spectral acceleration value
S_{M1}	null -See Section 11.4.8	Site-modified spectral acceleration value
S_{DS}	1.096	Numeric seismic design value at 0.2 second SA
S_{D1}	null -See Section 11.4.8	Numeric seismic design value at 1.0 second SA

Type	Value	Description
SDC	null -See Section 11.4.8	Seismic design category
F_a	1	Site amplification factor at 0.2 second
F_v	null -See Section 11.4.8	Site amplification factor at 1.0 second
PGA	0.705	MCE_C peak ground acceleration
F_{PGA}	1.1	Site amplification factor at PGA
PGA_M	0.775	Site modified peak ground acceleration
T_L	8	Long-period transition period in seconds
$SsRT$	1.644	Probabilistic risk-targeted ground motion. (0.2 second)
$SsUH$	1.813	Factored uniform-hazard (2% probability of exceedance in 50 years) spectral acceleration
SsD	2.384	Factored deterministic acceleration value. (0.2 second)
$S1RT$	0.588	Probabilistic risk-targeted ground motion. (1.0 second)
$S1UH$	0.651	Factored uniform-hazard (2% probability of exceedance in 50 years) spectral acceleration.
$S1D$	0.798	Factored deterministic acceleration value. (1.0 second)
$PGAd$	0.962	Factored deterministic acceleration value. (Peak Ground Acceleration)
C_{RS}	0.907	Mapped value of the risk coefficient at short periods
C_{R1}	0.903	Mapped value of the risk coefficient at a period of 1 s

DISCLAIMER

While the information presented on this website is believed to be correct, SEAOC / OSHPD and its sponsors and contributors assume no responsibility or liability for its accuracy. The material presented in this web application should not be used or relied upon for any specific application without competent examination and verification of its accuracy, suitability and applicability by engineers or other licensed professionals. SEAOC / OSHPD do not intend that the use of this information replace the sound judgment of such competent professionals, having experience and knowledge in the field of practice, nor to substitute for the standard of care required of such professionals in interpreting and applying the results of the seismic data provided by this website. Users of the information from this website assume all liability arising from such use. Use of the output of this website does not imply approval by the governing building code bodies responsible for building code approval and interpretation for the building site described by latitude/longitude location in the search results of this website.

Unified Hazard Tool



Please do not use this tool to obtain ground motion parameter values for the design code reference documents covered by the [U.S. Seismic Design Maps web tools](#) (e.g., the International Building Code and the ASCE 7 or 41 Standard). The values returned by the two applications are not identical.

^ Input

Edition

Spectral Period

Latitude

Decimal degrees

Time Horizon

Return period in years

Longitude

Decimal degrees, negative values for western longitudes

Site Class

^ Hazard Curve

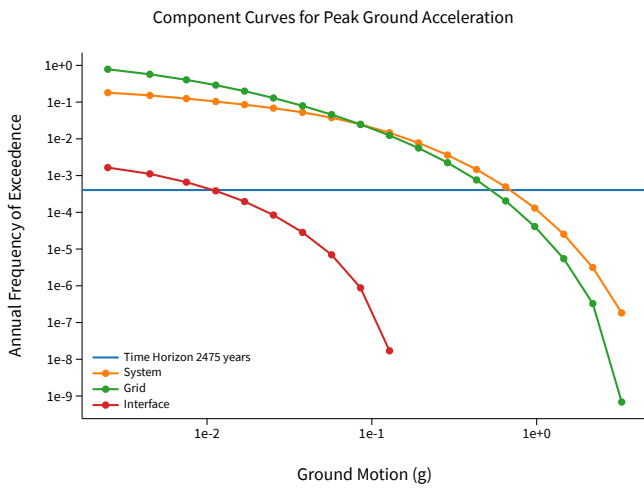
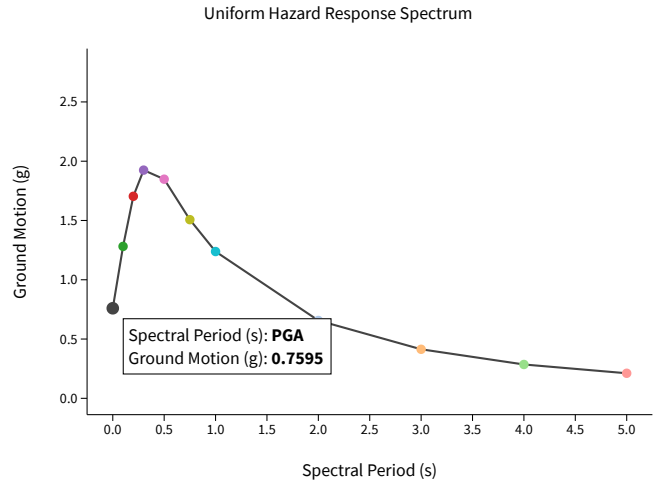
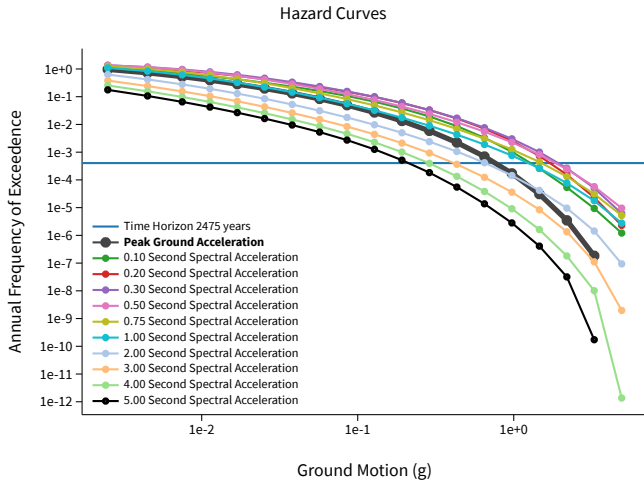

[View Raw Data](#)

^ Deaggregation

Component

Total

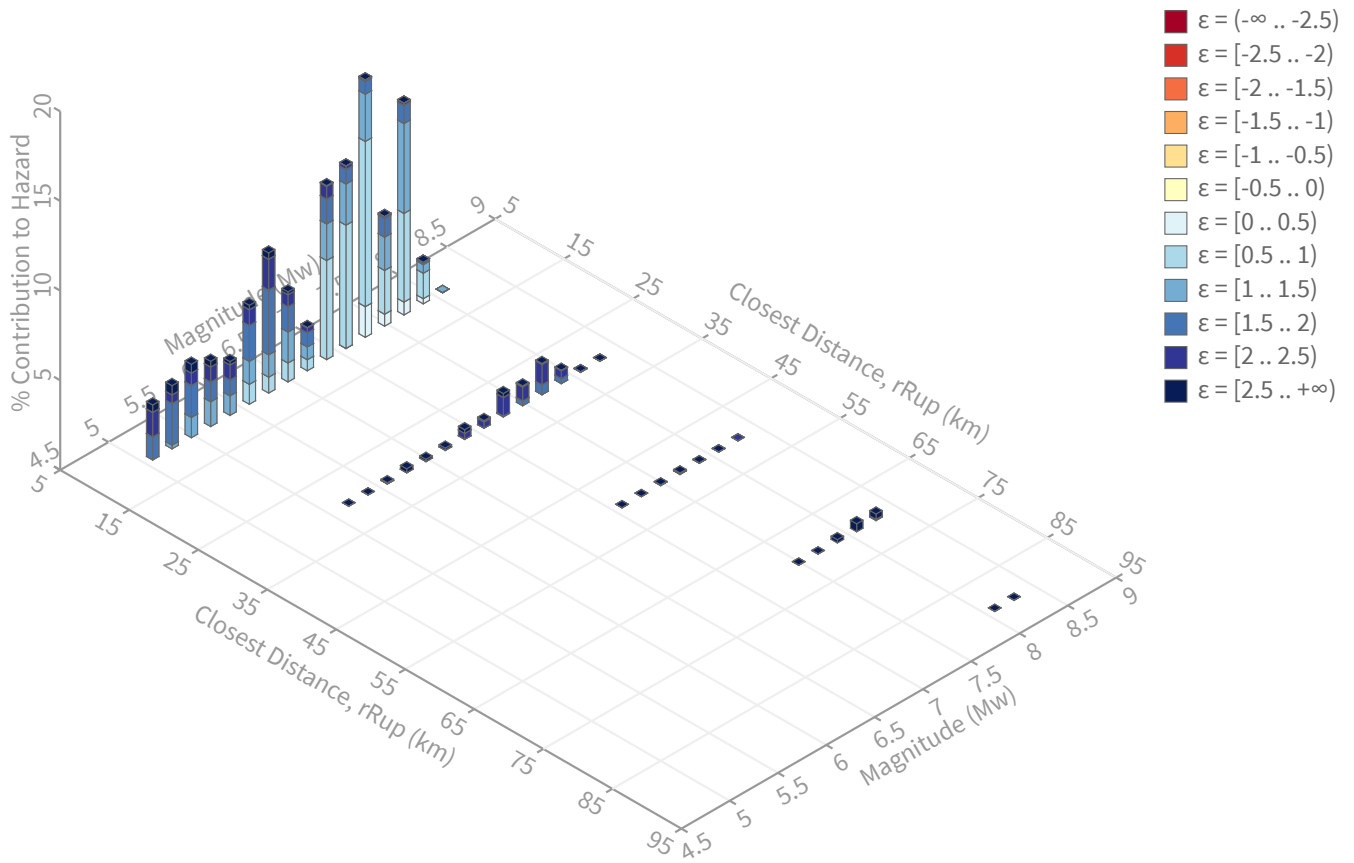

Summary statistics for, Deaggregation: Total

Deaggregation targets

Return period: 2475 yrs

Exceedance rate: 0.0004040404 yr⁻¹

PGA ground motion: 0.75953533 g

Recovered targets

Return period: 2896.6941 yrs

Exceedance rate: 0.00034522113 yr⁻¹

Totals

Binned: 100 %

Residual: 0 %

Trace: 0.06 %

Mean (over all sources)

m: 6.82

r: 10.75 km

ε₀: 1.34 σ

Mode (largest m-r bin)

m: 7.3

r: 9.79 km

ε₀: 0.81 σ

Contribution: 14.35 %

Mode (largest m-r-ε₀ bin)

m: 7.29

r: 9.11 km

ε₀: 0.68 σ

Contribution: 9.21 %

Discretization

r: min = 0.0, max = 1000.0, Δ = 20.0 km

m: min = 4.4, max = 9.4, Δ = 0.2

ε: min = -3.0, max = 3.0, Δ = 0.5 σ

Epsilon keys

ε0: [-∞ .. -2.5)

ε1: [-2.5 .. -2.0)

ε2: [-2.0 .. -1.5)

ε3: [-1.5 .. -1.0)

ε4: [-1.0 .. -0.5)

ε5: [-0.5 .. 0.0)

ε6: [0.0 .. 0.5)

ε7: [0.5 .. 1.0)

ε8: [1.0 .. 1.5)

ε9: [1.5 .. 2.0)

ε10: [2.0 .. 2.5)

ε11: [2.5 .. +∞]

Deaggregation Contributors

Source Set ↵ Source	Type	r	m	ϵ_0	lon	lat	az	%
UC33brAvg_FM32	System							39.90
Pueente Hills (Coyote Hills) [1]		4.30	7.24	0.80	118.044°W	33.915°N	81.46	9.53
Compton [1]		12.39	7.29	0.69	118.161°W	33.764°N	209.12	7.93
Pueente Hills (Santa Fe Springs) [0]		5.02	7.19	0.93	118.073°W	33.938°N	340.12	6.89
Pueente Hills (LA) [0]		10.59	7.16	1.43	118.116°W	33.990°N	329.82	2.55
Anaheim [2]		6.00	7.11	0.76	118.063°W	33.881°N	181.11	2.39
Whittier alt 2 [6]		9.24	7.11	1.47	118.019°W	33.986°N	25.56	2.12
Newport-Inglewood alt 2 [4]		15.78	7.51	1.54	118.171°W	33.804°N	219.98	1.92
UC33brAvg_FM31	System							33.31
Compton [1]		12.39	7.24	0.70	118.161°W	33.764°N	209.12	7.62
Pueente Hills [2]		7.17	7.33	0.99	118.052°W	33.949°N	12.72	6.57
Whittier alt 1 [7]		9.29	6.89	1.58	118.018°W	33.987°N	25.92	4.11
Newport-Inglewood alt 1 [4]		15.83	7.52	1.53	118.172°W	33.804°N	220.23	2.54
Anaheim [2]		6.00	7.06	0.78	118.063°W	33.881°N	181.11	2.35
Pueente Hills [1]		7.17	7.21	1.08	118.052°W	33.949°N	12.72	1.49
Pueente Hills [3]		11.58	6.86	1.58	118.143°W	33.972°N	311.82	1.09
Whittier alt 1 [6]		9.67	6.52	1.80	117.990°W	33.975°N	43.45	1.09
UC33brAvg_FM32 (opt)	Grid							14.14
PointSourceFinite: -118.062, 33.944		6.16	5.67	1.47	118.062°W	33.944°N	0.00	2.57
PointSourceFinite: -118.062, 33.944		6.16	5.67	1.47	118.062°W	33.944°N	0.00	2.57
PointSourceFinite: -118.062, 33.962		7.34	5.70	1.65	118.062°W	33.962°N	0.00	2.21
PointSourceFinite: -118.062, 33.962		7.34	5.70	1.65	118.062°W	33.962°N	0.00	2.21
UC33brAvg_FM31 (opt)	Grid							12.65
PointSourceFinite: -118.062, 33.944		6.13	5.69	1.46	118.062°W	33.944°N	0.00	2.27
PointSourceFinite: -118.062, 33.944		6.13	5.69	1.46	118.062°W	33.944°N	0.00	2.27
PointSourceFinite: -118.062, 33.962		7.36	5.68	1.67	118.062°W	33.962°N	0.00	1.83
PointSourceFinite: -118.062, 33.962		7.36	5.68	1.67	118.062°W	33.962°N	0.00	1.83

Liquefaction Susceptibility Analysis: SPT Method

Youd and Idriss (2001), Martin and Lew (1999)

Description: Norwalk Transit Village; Case 1; PGAm= 0.76; design GW9; Overex 12'

Project No.: 13109.001

Jun 2021

General Boring Information:

Boring No.	Existing	Design	Design	Overex.	Ground	Boring Location	
	GW	GW	Fill Height	depth bgs	Surface	X (ft)	Y (ft)
	Depth (ft)	Depth (ft)	(ft)	(ft)	Elev (ft)		
LB-1	116	9		0	0		
LB-2	116	9		0	0		
LB-3	116	9		0	0		
LB-4	116	9		0	0		
LB-5	116	9		0	0		
LB-6	116	9		0	0		

Summary of Liquefaction Susceptibility Analysis: SPT Method

Leighton

Liquefaction Method: Youd and Idriss (2001). Seismic Settlement Method: Tokimatsu and Seed (1987) and Martin and Lew (1999).

Project: Norwalk Transit Village; Case 3; PGAm= 0.76; design GW9; Overex 12

Project No.: 13109.001

Leighton

Boring No.	Approx. Layer Depth (ft)	SPT Depth (ft)	Approx Layer Thickness (ft)	Plasticity ("n"=non susc. to liq.)	Estimated Fines Cont (%)	γ_t (pcf)	N_m or B (blows/ft)	Sampler Type (enter 2 if mod CA Ring)	Cs	N_m (corrected for Cs and ring->SPT) (blows/ft)	Exist σ_{vo}' (psf)	$(N_1)_{60}$	$(N_1)_{60CS}$	$CRR_{7.5}$	Design σ_{vo}' (psf)	$CSR_{7.5}$	CSR_M	Liquefaction Factor of Safety	$(N_1)_{60CS}$ (for Settlement) (blows/ft)	Dry Sand Strain (%) (Tok/ Seed 87)	Sat Sand Strain (%) (Tok/ Seed 87)	Seismic Sett. of Layer (in.)	Cummulative Seismic Settlement (in.)
LB-1	0 to 6.0	5	6.0	0	5	113	40	2	1	26.0	565	45.9	45.9	>Range	565	0.49	0.46	NonLiq	45.9	0.04		0.03	3.6
LB-1	6.0 to 8.5	7	2.5	0	5	115	40	2	1	26.0	793	46.7	46.7	>Range	793	0.49	0.45	NonLiq	46.7	0.02		0.01	3.5
LB-1	8.5 to 9.0	10	0.5	0	10	115	40	0	1.3	52.0	1138	82.8	85.5	>Range	1075.6	0.51	0.48	NonLiq	85.5	0.02		0.00	3.5
LB-1	9.0 to 12.0	10	3.0	0	10	115	40	0	1.3	52.0	1138	82.8	85.5	>Range	1075.6	0.51	0.48	NonLiq	85.5			0.00	3.5
LB-1	12.0 to 12.5	10	0.5	0	10	115	4	0	1.1	4.4	1138	7.0	8.0	0.096	1075.6	0.51	0.48	0.20	8.0		2.9	0.17	3.5
LB-1	12.5 to 17.5	15	5.0	0	60	115	10	0	1.15	11.5	1713	14.9	22.9	0.255	1338.6	0.61	0.57	0.45	18.9		1.63	0.98	3.3
LB-1	17.5 to 22.5	20	5.0	0	55	115	13	0	1.19	15.5	2288	19.5	28.4	0.384	1601.6	0.67	0.63	0.61	23.5		1.35	0.81	2.4
LB-1	22.5 to 27.5	25	5.0	0	10	115	18	0	1.25	22.6	2863	25.3	26.7	0.331	1864.6	0.71	0.67	0.50	26.3		1.08	0.65	1.6
LB-1	27.5 to 32.5	30	5.0	0	60	115	18	0	1.24	22.3	3438	24.1	33.9	>Range	2127.6	0.74	0.69	NonLiq	33.9			0.00	0.9
LB-1	32.5 to 37.5	35	5.0	0	62	120	15	0	1.18	17.6	4026	17.6	26.1	0.315	2403.1	0.74	0.69	0.46	21.6		1.51	0.91	0.9
LB-1	37.5 to 42.5	40	5.0	0	5	115	38	0	1.3	49.4	4613	46.0	46.0	>Range	2678.6	0.72	0.67	NonLiq	46.0			0.00	0.0
LB-1	42.5 to 47.5	45	5.0	0	5	115	37	0	1.3	48.1	5188	42.2	42.2	>Range	2941.6	0.70	0.66	NonLiq	42.2			0.00	0.0
LB-1	47.5 to 52.0	50	4.5	0	55	125	24	0	1.25	29.9	5788	24.9	34.9	>Range	3229.6	0.68	0.63	NonLiq	34.9			0.00	0.0
LB-2	0 to 6.0	5	6.0	0	52	110	40	2	1	26.0	550	45.9	60.0	>Range	550	0.49	0.46	NonLiq	60.0	0.03		0.02	4.0
LB-2	6.0 to 8.5	7	2.5	0	5	110	40	2	1	26.0	770	47.4	47.4	>Range	770	0.49	0.45	NonLiq	47.4	0.02		0.01	4.0
LB-2	8.5 to 9.0	10	0.5	0	3	100	40	2	1	26.0	1085	42.4	42.4	>Range	1022.6	0.51	0.48	NonLiq	42.4	0.04		0.00	4.0
LB-2	9.0 to 12.0	10	3.0	0	3	100	40	2	1	26.0	1085	42.4	42.4	>Range	1022.6	0.51	0.48	NonLiq	42.4			0.00	3.9
LB-2	12.0 to 12.5	10	0.5	0	3	100	28	2	1	18.2	1085	29.7	29.7	0.447	1022.6	0.51	0.48	0.94	29.7		0.83	0.05	3.9
LB-2	12.5 to 17.5	15	5.0	0	5	110	39	2	1	25.4	1610	33.9	33.9	>Range	1235.6	0.62	0.58	NonLiq	33.9			0.00	3.9
LB-2	17.5 to 22.5	20	5.0	0	5	110	21	0	1.3	27.3	2160	35.3	35.3	>Range	1473.6	0.69	0.64	NonLiq	35.3			0.00	3.9
LB-2	22.5 to 27.5	25	5.0	0	55	114	22	2	1	14.3	2720	16.5	24.8	0.287	1721.6	0.73	0.69	0.42	20.5		1.54	0.92	3.9
LB-2	27.5 to 32.5	30	5.0	0	6	110	15	0	1.2	18.0	3280	19.8	20.0	0.215	1969.6	0.77	0.71	0.30	19.8		1.56	0.94	3.0
LB-2	32.5 to 37.5	35	5.0	0	25	112	23	2	1	15.0	3835	15.3	21.3	0.232	2212.6	0.76	0.71	0.33	17.3		1.74	1.04	2.0
LB-2	37.5 to 42.5	40	5.0	0	55	115	24	0	1.3	31.1	4403	29.6	40.6	>Range	2468.1	0.75	0.70	NonLiq	40.6			0.00	1.0
LB-2	42.5 to 47.5	45	5.0	0	55	125	25	2	1	16.3	5003	14.5	22.4	0.248	2756.1	0.72	0.68	0.37	18.5		1.66	1.00	1.0
LB-2	47.5 to 52.0	50	4.5	n	60	125	17	0	1.17	19.8	5628	16.7	25.1	>Range	3069.1	0.69	0.65	NonLiq	25.1			0.00	0.0
LB-3	0 to 6.0	5	6.0	0	41	100	40	2	1	26.0	500	45.9	60.0	>Range	500	0.49	0.46	NonLiq	60.0	0.02		0.02	1.2
LB-3	6.0 to 8.5	7	2.5	0	5	100	40	2	1	26.0	700	48.9	48.9	>Range	700	0.49	0.45	NonLiq	48.9	0.02		0.01	1.2
LB-3	8.5 to 9.0	10	0.5	0	5	110	40	2	1	26.0	1015	43.8	43.8	>Range	952.6	0.51	0.48	NonLiq	43.8	0.03		0.00	1.2
LB-3	9.0 to 12.0	10	3.0	0	5	110	40	2	1	26.0	1015	43.8	43.8	>Range	952.6	0.51	0.48	NonLiq	43.8			0.00	1.2
LB-3	12.0 to 12.5	10	0.5	0	5	110	24	2	1	15.6	1015	26.3	26.3	0.320	952.6	0.51	0.48	0.67	26.3		1.08	0.06	1.2
LB-3	12.5 to 17.5	15	5.0	0	15	110	25	0	1.3	32.5	1565	44.1	48.8	>Range	1190.6	0.63	0.58	NonLiq	48.8			0.00	1.1
LB-3	17.5 to 22.5	20	5.0	0	55	101	42	2	1	27.3	2093	35.8	48.0	>Range	1406.1	0.70	0.65	NonLiq	48.0			0.00	1.1

Boring No.	Approx. Layer Depth (ft)	SPT Depth (ft)	Approx Layer Thickness (ft)	Plasticity ("n"=non susc. to liq.)	Estimated Fines Cont (%)	γ_t (pcf)	N_m or B (blows/ft)	Sampler Type (enter 2 if mod CA Ring)	N_m (corrected for Cs and ring->SPT) (blows/ft)	Exist σ_{vo}' (psf)	$(N_1)_{60}$	$(N_1)_{60CS}$	$CRR_{7.5}$	Design σ_{vo}' (psf)	$CSR_{7.5}$	CSR_M	Liquefaction Factor of Safety	$(N_1)_{60CS}$ (for Settlement) (blows/ft)	Dry Sand Strain (%) (Tok/ Seed 87)	Sat Sand Strain (%) (Tok/ Seed 87)	Seismic Sett. of Layer (in.)	Cummulative Seismic Settlement (in.)
LB-3	22.5 to 27.5	25	5.0	0	31	100	19	0	1.29	24.5	2595	28.9	38.3	>Range	1596.6	0.76	0.71	NonLiq	38.3		0.00	1.1
LB-3	27.5 to 32.5	30	5.0	0	55	98	30	2	1	19.5	3090	22.2	31.6	>Range	1779.6	0.80	0.74	NonLiq	31.6		0.00	1.1
LB-3	32.5 to 37.5	35	5.0	0	60	125	10	0	1.12	11.2	3648	11.7	19.0	0.204	2025.1	0.79	0.74	0.28	15.7	1.83	1.10	1.1
LB-3	37.5 to 42.5	40	5.0	0	30	139	67	2	1	43.6	4308	41.9	53.1	>Range	2373.1	0.76	0.71	NonLiq	53.1		0.00	0.0
LB-3	42.5 to 47.0	45	4.5	0	60	130	24	0	1.27	30.6	4980	27.4	37.9	>Range	2733.6	0.73	0.68	NonLiq	37.9		0.00	0.0
LB-4	0 to 6.0	5	6.0	0	5	99	40	2	1	26.0	495	45.9	45.9	>Range	495	0.49	0.46	NonLiq	45.9	0.03	0.02	3.3
LB-4	6.0 to 8.5	7	2.5	0	40	97	40	2	1	26.0	691	48.9	63.7	>Range	691	0.49	0.45	NonLiq	63.7	0.01	0.00	3.3
LB-4	8.5 to 9.0	10	0.5	0	55	108	40	2	1	26.0	999	44.2	58.1	>Range	936.1	0.51	0.48	NonLiq	58.1	0.02	0.00	3.3
LB-4	9.0 to 12.0	10	3.0	0	55	108	40	2	1	26.0	999	44.2	58.1	>Range	936.1	0.51	0.48	NonLiq	58.1		0.00	3.3
LB-4	12.0 to 12.5	10	0.5	0	55	108	26	2	1	16.9	999	28.7	39.5	>Range	936.1	0.51	0.48	NonLiq	39.5		0.00	3.3
LB-4	12.5 to 17.5	15	5.0	0	5	109	31	2	1	20.2	1541	27.6	27.6	0.356	1166.6	0.63	0.59	0.60	27.6	1.02	0.61	3.3
LB-4	17.5 to 22.5	20	5.0	0	60	110	9	0	1.13	10.2	2089	13.4	21.1	0.229	1402.1	0.70	0.65	0.35	17.4	1.73	1.04	2.7
LB-4	22.5 to 27.5	25	5.0	0	50	113	22	2	1	14.3	2646	16.7	25.0	0.293	1647.6	0.75	0.70	0.42	20.7	1.53	0.92	1.6
LB-4	27.5 to 32.5	30	5.0	n	80	115	12	0	1.15	13.8	3216	15.4	23.5	>Range	1905.6	0.78	0.72	NonLiq	23.5		0.00	0.7
LB-4	32.5 to 37.5	35	5.0	n	55	109	19	2	1	12.4	3776	12.7	20.2	>Range	2153.6	0.77	0.72	NonLiq	20.2		0.00	0.7
LB-4	37.5 to 42.5	40	5.0	0	40	120	30	0	1.3	39.0	4349	37.4	49.9	>Range	2414.1	0.76	0.70	NonLiq	49.9		0.00	0.7
LB-4	42.5 to 47.5	45	5.0	0	60	140	64	2	1	41.6	4999	37.2	49.6	>Range	2752.1	0.72	0.68	NonLiq	49.6		0.00	0.7
LB-4	47.5 to 52.0	50	4.5	0	60	135	20	0	1.2	24.0	5686	20.1	29.2	0.418	3127.6	0.69	0.64	0.65	24.1	1.29	0.70	0.7
LB-5	0 to 6.0	5	6.0	0	46	100	40	2	1	26.0	500	45.9	60.0	>Range	500	0.49	0.46	NonLiq	60.0	0.02	0.02	2.7
LB-5	6.0 to 8.5	7	2.5	0	5	100	40	2	1	26.0	700	48.9	48.9	>Range	700	0.49	0.45	NonLiq	48.9	0.02	0.01	2.6
LB-5	8.5 to 9.0	10	0.5	0	5	94	40	2	1	26.0	991	44.4	44.4	>Range	928.6	0.51	0.48	NonLiq	44.4	0.03	0.00	2.6
LB-5	9.0 to 12.0	10	3.0	0	5	94	40	2	1	26.0	991	44.4	44.4	>Range	928.6	0.51	0.48	NonLiq	44.4		0.00	2.6
LB-5	12.0 to 12.5	10	0.5	0	5	94	22	2	1	14.3	991	24.4	24.4	0.281	928.6	0.51	0.48	0.58	24.4	1.26	0.08	2.6
LB-5	12.5 to 17.5	15	5.0	0	12	110	14	0	1.24	17.4	1501	24.1	26.4	0.322	1126.6	0.64	0.59	0.54	25.1	1.19	0.71	2.6
LB-5	17.5 to 22.5	20	5.0	0	60	126	33	2	1	21.5	2091	28.2	38.8	>Range	1404.6	0.70	0.65	NonLiq	38.8		0.00	1.8
LB-5	22.5 to 27.5	25	5.0	0	66	120	14	0	1.19	16.7	2706	19.3	28.1	0.374	1707.6	0.74	0.69	0.54	23.3	1.37	0.82	1.8
LB-5	27.5 to 32.5	30	5.0	0	55	118	36	2	1	23.4	3301	25.7	35.9	>Range	1990.6	0.76	0.71	NonLiq	35.9		0.00	1.0
LB-5	32.5 to 37.5	35	5.0	n	50	120	3	0	1.1	3.3	3896	3.3	9.0	>Range	2273.6	0.75	0.70	NonLiq	9.0		0.00	1.0
LB-5	37.5 to 42.5	40	5.0	n	67	131	28	2	1	18.2	4524	17.1	25.5	>Range	2589.1	0.73	0.68	NonLiq	25.5		0.00	1.0
LB-5	42.5 to 47.5	45	5.0	0	60	130	14	0	1.14	16.0	5176	14.0	21.8	0.239	2929.6	0.71	0.66	0.36	18.0	1.7	1.02	1.0
LB-5	47.5 to 52.0	50	4.5	0	30	120	100	2	1	65.0	5801	53.9	67.0	>Range	3242.6	0.68	0.63	NonLiq	67.0		0.00	0.0
LB-6	0 to 6.0	5	6.0	0	33	104	40	2	1	26.0	520	45.9	59.0	>Range	520	0.49	0.46	NonLiq	59.0	0.02	0.02	4.3
LB-6	6.0 to 8.5	7	2.5	0	5	105	40	2	1	26.0	729	48.7	48.7	>Range	729	0.49	0.45	NonLiq	48.7	0.02	0.01	4.2
LB-6	8.5 to 9.0	10	0.5	0	20	99	40	2	1	26.0	1035	43.4	50.5	>Range	972.6	0.51	0.48	NonLiq	50.5	0.03	0.00	4.2
LB-6	9.0 to 12.0	10	3.0	0	20	99	40	2	1	26.0	1035	43.4	50.5	>Range	972.6	0.51	0.48	NonLiq	50.5		0.00	4.2
LB-6	12.0 to 12.5	10	0.5	0	20	99	27	2	1	17.6	1035	29.3	35.3	>Range	972.6	0.51	0.48	NonLiq	35.3		0.00	4.2

Liquefaction Susceptibility Analysis: SPT Method

Youd and Idriss (2001), Martin and Lew (1999)

Description: Norwalk Transit Village; Case 2; PGAm= 0.76; existing GW60; Overex 12'

Project No.: 13109.001

Jun 2021

General Boring Information:

Boring No.	Existing	Design	Design	Overex.	Ground	Boring Location	
	GW	GW	Fill Height	depth bgs	Surface	X (ft)	Y (ft)
	Depth (ft)	Depth (ft)	(ft)	(ft)	Elev (ft)		
LB-1	116	60		0	0	-60	
LB-2	116	60		0	0	-60	
LB-3	116	60		0	0	-60	
LB-4	116	60		0	0	-60	
LB-5	116	60		0	0	-60	
LB-6	116	60		0	0	-60	
						0	

Summary of Liquefaction Susceptibility Analysis: SPT Method

Leighton

Liquefaction Method: Youd and Idriss (2001). Seismic Settlement Method: Tokimatsu and Seed (1987) and Martin and Lew (1999).

Project: Norwalk Transit Village; Case 2; PGAm= 0.76; existing GW60; No overex 12
 Project No.: 13109.001

Leighton

Boring No.	Approx. Layer Depth (ft)	SPT Depth (ft)	Approx Layer Thickness (ft)	Plasticity ("n"=non susc. to liq.)	Estimated Fines Cont (%)	γ_t (pcf)	N_m or B (blows/ft)	Sampler Type (enter 2 if mod CA Ring)	Cs	N_m (corrected for Cs and ring->SPT) (blows/ft)	Exist σ_{vo}' (psf)	$(N_1)_{60}$	$(N_1)_{60CS}$	$CRR_{7.5}$	Design σ_{vo}' (psf)	$CSR_{7.5}$	CSR_M	Liquefaction Factor of Safety	$(N_1)_{60CS}$ (for Settlement) (blows/ft)	Dry Sand Strain (%) (Tok/ Seed 87)	Sat Sand Strain (%) (Tok/ Seed 87)	Seismic Sett. of Layer (in.)	Cummulative Seismic Settlement (in.)
LB-1	0 to 6.0	5	6.0	0	5	113	40	2	1	26.0	565	45.9	45.9	>Range	565	0.49	0.46	NonLiq	45.9	0.04		0.03	1.6
LB-1	6.0 to 8.5	7	2.5	0	5	115	40	2	1	26.0	793	46.7	46.7	>Range	793	0.49	0.45	NonLiq	46.7	0.02		0.01	1.6
LB-1	8.5 to 12.0	10	3.5	0	10	115	40	0	1.3	52.0	1138	82.8	85.5	>Range	1138	0.48	0.45	NonLiq	85.5	0.02		0.01	1.6
LB-1	12.0 to 12.5	10	0.5	0	10	115	4	0	1.1	4.4	1138	7.0	8.0	0.096	1138	0.48	0.45	NonLiq	8.0	3.76		0.23	1.6
LB-1	12.5 to 17.5	15	5.0	0	60	115	10	0	1.15	11.5	1713	14.9	22.9	0.255	1713	0.48	0.45	NonLiq	22.9	0.33		0.20	1.3
LB-1	17.5 to 22.5	20	5.0	0	55	115	13	0	1.19	15.5	2288	19.5	28.4	0.384	2288	0.47	0.44	NonLiq	28.4	0.43		0.26	1.1
LB-1	22.5 to 27.5	25	5.0	0	10	115	18	0	1.25	22.6	2863	25.3	26.7	0.331	2863	0.47	0.43	NonLiq	26.7	0.69		0.41	0.9
LB-1	27.5 to 32.5	30	5.0	0	60	115	18	0	1.24	22.3	3438	24.1	33.9	>Range	3438	0.46	0.43	NonLiq	33.9	0.14		0.08	0.5
LB-1	32.5 to 37.5	35	5.0	0	62	120	15	0	1.18	17.6	4026	17.6	26.1	0.315	4025.5	0.44	0.41	NonLiq	26.1	0.38		0.23	0.4
LB-1	37.5 to 42.5	40	5.0	0	5	115	38	0	1.3	49.4	4613	46.0	46.0	>Range	4613	0.42	0.39	NonLiq	46.0	0.04		0.02	0.1
LB-1	42.5 to 47.5	45	5.0	0	5	115	37	0	1.3	48.1	5188	42.2	42.2	>Range	5188	0.40	0.37	NonLiq	42.2	0.05		0.03	0.1
LB-1	47.5 to 52.0	50	4.5	0	55	125	24	0	1.25	29.9	5788	24.9	34.9	>Range	5788	0.38	0.35	NonLiq	34.9	0.17		0.09	0.1
LB-2	0 to 6.0	5	6.0	0	52	110	40	2	1	26.0	550	45.9	60.0	>Range	550	0.49	0.46	NonLiq	60.0	0.03		0.02	1.6
LB-2	6.0 to 8.5	7	2.5	0	5	110	40	2	1	26.0	770	47.4	47.4	>Range	770	0.49	0.45	NonLiq	47.4	0.02		0.01	1.6
LB-2	8.5 to 12.0	10	3.5	0	3	100	40	2	1	26.0	1085	42.4	42.4	>Range	1085	0.48	0.45	NonLiq	42.4	0.05		0.02	1.6
LB-2	12.0 to 12.5	10	0.5	0	3	100	28	2	1	18.2	1085	29.7	29.7	0.447	1085	0.48	0.45	NonLiq	29.7	0.39		0.02	1.6
LB-2	12.5 to 17.5	15	5.0	0	5	110	39	2	1	25.4	1610	33.9	33.9	>Range	1610	0.48	0.45	NonLiq	33.9	0.10		0.06	1.6
LB-2	17.5 to 22.5	20	5.0	0	5	110	21	0	1.3	27.3	2160	35.3	35.3	>Range	2160	0.47	0.44	NonLiq	35.3	0.16		0.09	1.5
LB-2	22.5 to 27.5	25	5.0	0	55	114	22	2	1	14.3	2720	16.5	24.8	0.287	2720	0.47	0.43	NonLiq	24.8	0.69		0.41	1.4
LB-2	27.5 to 32.5	30	5.0	0	6	110	15	0	1.2	18.0	3280	19.8	20.0	0.215	3280	0.46	0.43	NonLiq	20.0	0.69		0.41	1.0
LB-2	32.5 to 37.5	35	5.0	0	25	112	23	2	1	15.0	3835	15.3	21.3	0.232	3835	0.44	0.41	NonLiq	21.3	0.44		0.26	0.6
LB-2	37.5 to 42.5	40	5.0	0	55	115	24	0	1.3	31.1	4403	29.6	40.6	>Range	4402.5	0.42	0.39	NonLiq	40.6	0.04		0.03	0.3
LB-2	42.5 to 47.5	45	5.0	0	55	125	25	2	1	16.3	5003	14.5	22.4	0.248	5002.5	0.40	0.37	NonLiq	22.4	0.47		0.28	0.3
LB-2	47.5 to 52.0	50	4.5	n	60	125	17	0	1.17	19.8	5628	16.7	25.1	>Range	5627.5	0.38	0.35	NonLiq	25.1	0.00		0.00	0.0
LB-3	0 to 6.0	5	6.0	0	41	100	40	2	1	26.0	500	45.9	60.0	>Range	500	0.49	0.46	NonLiq	60.0	0.02		0.02	1.0
LB-3	6.0 to 8.5	7	2.5	0	5	100	40	2	1	26.0	700	48.9	48.9	>Range	700	0.49	0.45	NonLiq	48.9	0.02		0.01	1.0
LB-3	8.5 to 12.0	10	3.5	0	5	110	40	2	1	26.0	1015	43.8	43.8	>Range	1015	0.48	0.45	NonLiq	43.8	0.04		0.02	1.0
LB-3	12.0 to 12.5	10	0.5	0	5	110	24	2	1	15.6	1015	26.3	26.3	0.320	1015	0.48	0.45	NonLiq	26.3	0.40		0.02	0.9
LB-3	12.5 to 17.5	15	5.0	0	15	110	25	0	1.3	32.5	1565	44.1	48.8	>Range	1565	0.48	0.45	NonLiq	48.8	0.02		0.01	0.9
LB-3	17.5 to 22.5	20	5.0	0	55	101	42	2	1	27.3	2093	35.8	48.0	>Range	2092.5	0.47	0.44	NonLiq	48.0	0.04		0.02	0.9
LB-3	22.5 to 27.5	25	5.0	0	31	100	19	0	1.29	24.5	2595	28.9	38.3	>Range	2595	0.47	0.43	NonLiq	38.3	0.20		0.12	0.9
LB-3	27.5 to 32.5	30	5.0	0	55	98	30	2	1	19.5	3090	22.2	31.6	>Range	3090	0.46	0.43	NonLiq	31.6	0.36		0.22	0.8
LB-3	32.5 to 37.5	35	5.0	0	60	125	10	0	1.12	11.2	3648	11.7	19.0	0.204	3647.5	0.44	0.41	NonLiq	19.0	0.75		0.45	0.5

Boring No.	Approx. Layer Depth (ft)	SPT Depth (ft)	Approx Layer Thickness (ft)	Plasticity ("n"=non susc. to liq.)	Estimated Fines Cont (%)	γ_t (pcf)	N_m or B (blows/ft)	Sampler Type (enter 2 if mod CA Ring)	Cs	N_m (corrected for Cs and ring->SPT) (blows/ft)	Exist σ_{vo}' (psf)	$(N_1)_{60}$	$(N_1)_{60CS}$	$CRR_{7.5}$	Design σ_{vo}' (psf)	$CSR_{7.5}$	CSR_M	Liquefaction Factor of Safety	$(N_1)_{60CS}$ (for Settlement) (blows/ft)	Dry Sand Strain (%) (Tok/ Seed 87)	Sat Sand Strain (%) (Tok/ Seed 87)	Seismic Sett. of Layer (in.)	Cummulative Seismic Settlement (in.)
LB-3	37.5 to 42.5	40	5.0	0	30	139	67	2	1	43.6	4308	41.9	53.1	>Range	4307.5	0.42	0.39	NonLiq	53.1	0.03		0.02	0.1
LB-3	42.5 to 47.0	45	4.5	0	60	130	24	0	1.27	30.6	4980	27.4	37.9	>Range	4980	0.40	0.37	NonLiq	37.9	0.15		0.08	0.1
LB-4	0 to 6.0	5	6.0	0	5	99	40	2	1	26.0	495	45.9	45.9	>Range	495	0.49	0.46	NonLiq	45.9	0.03		0.02	1.4
LB-4	6.0 to 8.5	7	2.5	0	40	97	40	2	1	26.0	691	48.9	63.7	>Range	691	0.49	0.45	NonLiq	63.7	0.01		0.00	1.4
LB-4	8.5 to 12.0	10	3.5	0	55	108	40	2	1	26.0	999	44.2	58.1	>Range	998.5	0.48	0.45	NonLiq	58.1	0.03		0.01	1.4
LB-4	12.0 to 12.5	10	0.5	0	55	108	26	2	1	16.9	999	28.7	39.5	>Range	998.5	0.48	0.45	NonLiq	39.5	0.13		0.01	1.4
LB-4	12.5 to 17.5	15	5.0	0	5	109	31	2	1	20.2	1541	27.6	27.6	0.356	1541	0.48	0.45	NonLiq	27.6	0.63		0.38	1.3
LB-4	17.5 to 22.5	20	5.0	0	60	110	9	0	1.13	10.2	2089	13.4	21.1	0.229	2088.5	0.47	0.44	NonLiq	21.1	0.55		0.33	1.0
LB-4	22.5 to 27.5	25	5.0	0	50	113	22	2	1	14.3	2646	16.7	25.0	0.293	2646	0.47	0.43	NonLiq	25.0	0.66		0.39	0.6
LB-4	27.5 to 32.5	30	5.0	n	80	115	12	0	1.15	13.8	3216	15.4	23.5	>Range	3216	0.46	0.43	NonLiq	23.5	0.00		0.00	0.2
LB-4	32.5 to 37.5	35	5.0	n	55	109	19	2	1	12.4	3776	12.7	20.2	>Range	3776	0.44	0.41	NonLiq	20.2	0.00		0.00	0.2
LB-4	37.5 to 42.5	40	5.0	0	40	120	30	0	1.3	39.0	4349	37.4	49.9	>Range	4348.5	0.42	0.39	NonLiq	49.9	0.04		0.02	0.2
LB-4	42.5 to 47.5	45	5.0	0	60	140	64	2	1	41.6	4999	37.2	49.6	>Range	4998.5	0.40	0.37	NonLiq	49.6	0.04		0.02	0.2
LB-4	47.5 to 52.0	50	4.5	0	60	135	20	0	1.2	24.0	5686	20.1	29.2	0.418	5686	0.38	0.35	NonLiq	29.2	0.36		0.20	0.2
LB-5	0 to 6.0	5	6.0	0	46	100	40	2	1	26.0	500	45.9	60.0	>Range	500	0.49	0.46	NonLiq	60.0	0.02		0.02	1.3
LB-5	6.0 to 8.5	7	2.5	0	5	100	40	2	1	26.0	700	48.9	48.9	>Range	700	0.49	0.45	NonLiq	48.9	0.02		0.01	1.3
LB-5	8.5 to 12.0	10	3.5	0	5	94	40	2	1	26.0	991	44.4	44.4	>Range	991	0.48	0.45	NonLiq	44.4	0.04		0.02	1.3
LB-5	12.0 to 12.5	10	0.5	0	5	94	22	2	1	14.3	991	24.4	24.4	0.281	991	0.48	0.45	NonLiq	24.4	0.41		0.02	1.3
LB-5	12.5 to 17.5	15	5.0	0	12	110	14	0	1.24	17.4	1501	24.1	26.4	0.322	1501	0.48	0.45	NonLiq	26.4	0.64		0.38	1.2
LB-5	17.5 to 22.5	20	5.0	0	60	126	33	2	1	21.5	2091	28.2	38.8	>Range	2091	0.47	0.44	NonLiq	38.8	0.13		0.08	0.9
LB-5	22.5 to 27.5	25	5.0	0	66	120	14	0	1.19	16.7	2706	19.3	28.1	0.374	2706	0.47	0.43	NonLiq	28.1	0.61		0.37	0.8
LB-5	27.5 to 32.5	30	5.0	0	55	118	36	2	1	23.4	3301	25.7	35.9	>Range	3301	0.46	0.43	NonLiq	35.9	0.12		0.07	0.4
LB-5	32.5 to 37.5	35	5.0	n	80	120	3	0	1.1	3.3	3896	3.3	9.0	>Range	3896	0.44	0.41	NonLiq	9.0	0.00		0.00	0.3
LB-5	37.5 to 42.5	40	5.0	n	67	131	28	2	1	18.2	4524	17.1	25.5	>Range	4523.5	0.42	0.39	NonLiq	25.5	0.00		0.00	0.3
LB-5	42.5 to 47.5	45	5.0	0	60	130	14	0	1.14	16.0	5176	14.0	21.8	0.239	5176	0.40	0.37	NonLiq	21.8	0.53		0.32	0.3
LB-5	47.5 to 52.0	50	4.5	0	30	120	100	2	1	65.0	5801	53.9	67.0	>Range	5801	0.38	0.35	NonLiq	67.0	0.03		0.02	0.0
LB-6	0 to 6.0	5	6.0	0	50	104	40	2	1	26.0	520	45.9	60.0	>Range	520	0.49	0.46	NonLiq	60.0	0.02		0.02	2.9
LB-6	6.0 to 8.5	7	2.5	0	5	105	40	2	1	26.0	729	48.7	48.7	>Range	729	0.49	0.45	NonLiq	48.7	0.02		0.01	2.8
LB-6	8.5 to 12.0	10	3.5	0	20	99	40	2	1	26.0	1035	43.4	50.5	>Range	1035	0.48	0.45	NonLiq	50.5	0.03		0.01	2.8
LB-6	12.0 to 12.5	10	0.5	0	20	99	27	2	1	17.6	1035	29.3	35.3	>Range	1035	0.48	0.45	NonLiq	35.3	0.16		0.01	2.8
LB-6	12.5 to 17.5	15	5.0	0	30	105	28	0	1.3	36.4	1545	49.8	62.1	>Range	1545	0.48	0.45	NonLiq	62.1	0.05		0.03	2.8
LB-6	17.5 to 22.5	20	5.0	0	66	110	8	2	1	5.2	2083	6.8	13.2	0.143	2082.5	0.47	0.44	NonLiq	13.2	1.80		1.08	2.8
LB-6	22.5 to 27.5	25	5.0	0	55	103	22	0	1.3	28.6	2615	33.6	45.3	>Range	2615	0.47	0.43	NonLiq	45.3	0.05		0.03	1.7
LB-6	27.5 to 32.5	30	5.0	0	60	130	15	2	1	9.8	3198	10.9	18.1	0.193	3197.5	0.46	0.43	NonLiq	18.1	0.74		0.44	1.7
LB-6	32.5 to 37.5	35	5.0	0	60	131	44	0	1.3	57.2	3850	58.3	74.9	>Range	3850	0.44	0.41	NonLiq	74.9	0.03		0.02	1.2
LB-6	37.5 to 42.5	40	5.0	0	71	130	9	2	1	5.9	4503	5.5	11.6	0.128	4502.5	0.42	0.39	NonLiq	11.6	1.94		1.17	1.2



Overall vertical settlements report

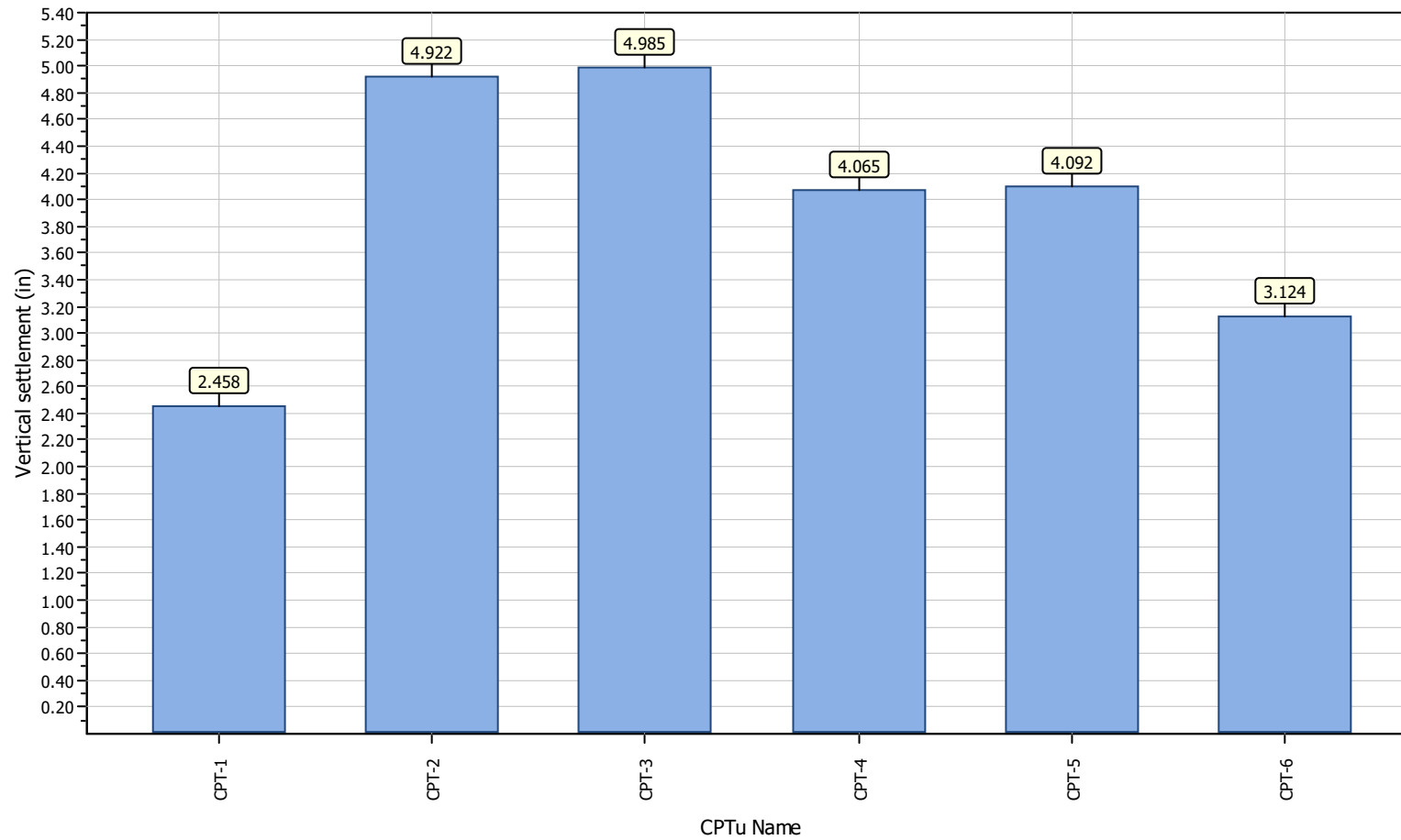



LIQUEFACTION ANALYSIS REPORT

Project title : Leighton Consulting / Norwalk Transit Village Location : Norwalk, CA
 CPT file : CPT-1

Input parameters and analysis data

Analysis method:	NCEER (1998)	G.W.T. (in-situ):	116.00 ft	Use fill:	No	Clay like behavior applied:	Sands only
Fines correction method:	NCEER (1998)	G.W.T. (earthq.):	9.00 ft	Fill height:	N/A	Limit depth applied:	Yes
Points to test:	Based on Ic value	Average results interval:	1	Fill weight:	N/A	Limit depth:	50.00 ft
Earthquake magnitude M_w :	7.30	Ic cut-off value:	2.60	Trans. detect. applied:	No	MSF method:	Method based
Peak ground acceleration:	0.76	Unit weight calculation:	Based on SBT	K_o applied:	Yes		

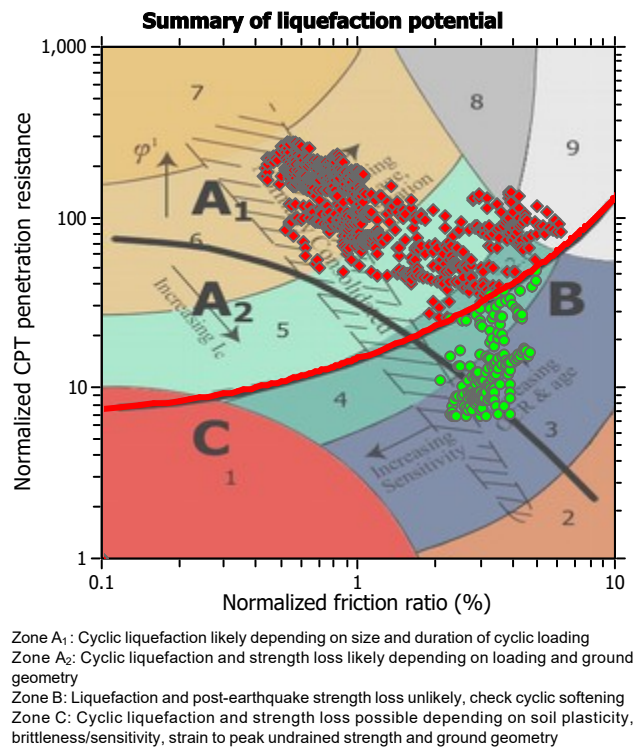
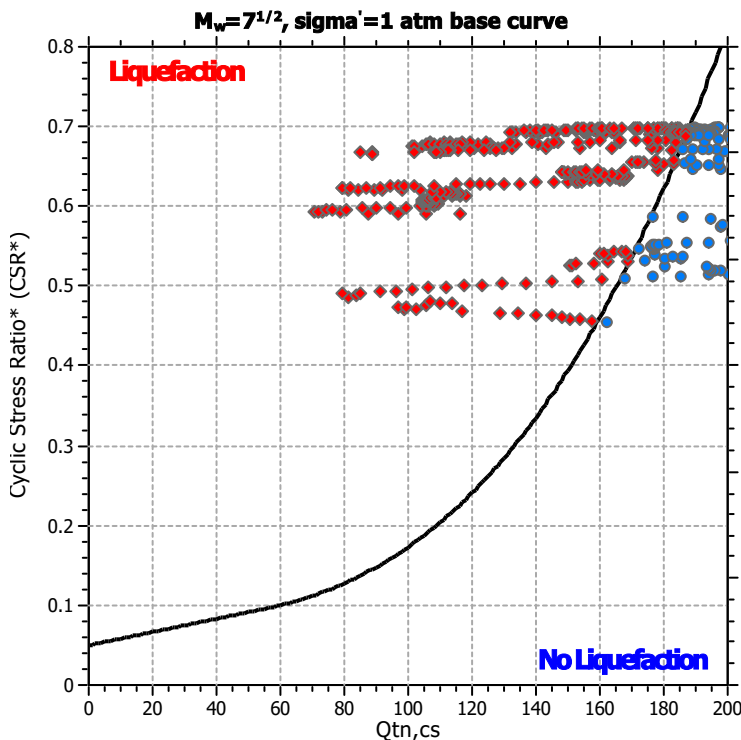
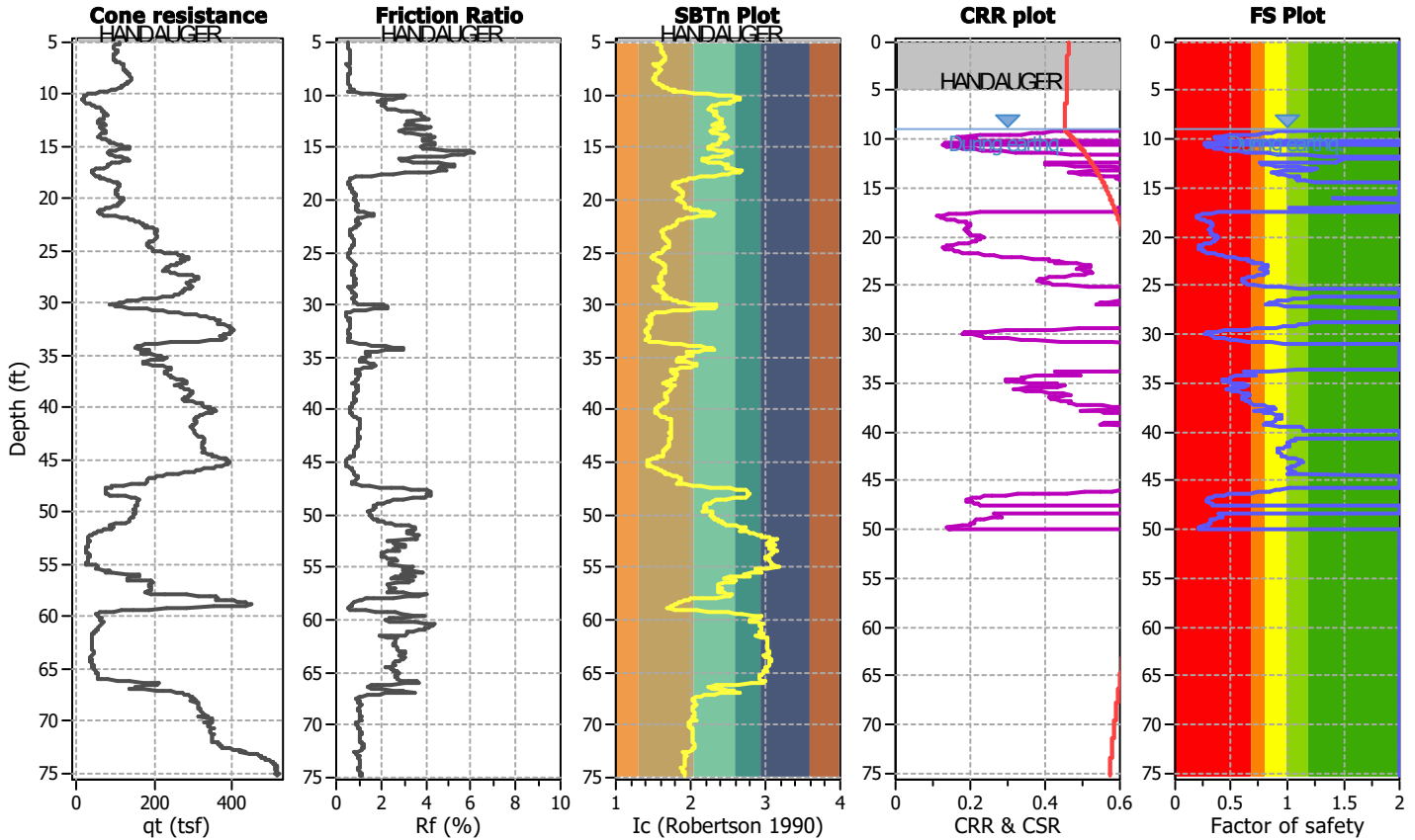

Liquefaction analysis overall plots

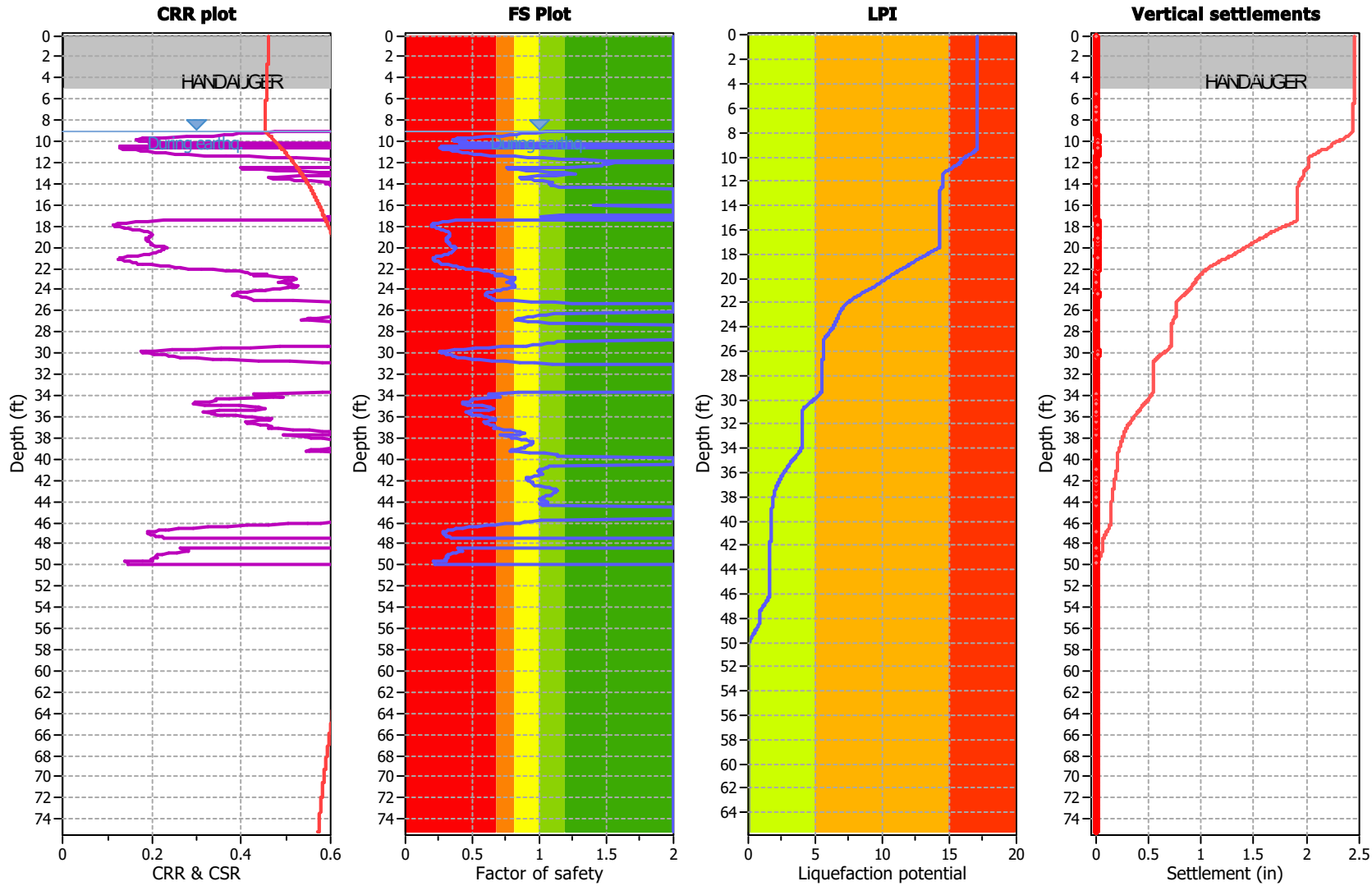

Input parameters and analysis data

Analysis method:	NCEER (1998)	Depth to water table (erthq.):	9.00 ft	Fill weight:	N/A
Fines correction method:	NCEER (1998)	Average results interval:	1	Transition detect. applied:	No
Points to test:	Based on Ic value	Ic cut-off value:	2.60	K_0 applied:	Yes
Earthquake magnitude M_w :	7.30	Unit weight calculation:	Based on SBT	Clay like behavior applied:	Sands only
Peak ground acceleration:	0.76	Use fill:	No	Limit depth applied:	Yes
Depth to water table (insitu):	116.00 ft	Fill height:	N/A	Limit depth:	50.00 ft

F.S. color scheme

- Almost certain it will liquefy
- Very likely to liquefy
- Liquefaction and no liq. are equally likely
- Unlike to liquefy
- Almost certain it will not liquefy

LPI color scheme

- Very high risk
- High risk
- Low risk



LIQUEFACTION ANALYSIS REPORT

Project title : Leighton Consulting / Norwalk Transit Village Location : Norwalk, CA
 CPT file : CPT-2

Input parameters and analysis data

Analysis method:	NCEER (1998)	G.W.T. (in-situ):	116.00 ft	Use fill:	No	Clay like behavior applied:	Sands only
Fines correction method:	NCEER (1998)	G.W.T. (earthq.):	9.00 ft	Fill height:	N/A	Limit depth applied:	Yes
Points to test:	Based on Ic value	Average results interval:	1	Fill weight:	N/A	Limit depth:	50.00 ft
Earthquake magnitude M_w :	7.30	Ic cut-off value:	2.60	Trans. detect. applied:	No	MSF method:	Method based
Peak ground acceleration:	0.76	Unit weight calculation:	Based on SBT	K_0 applied:	Yes		

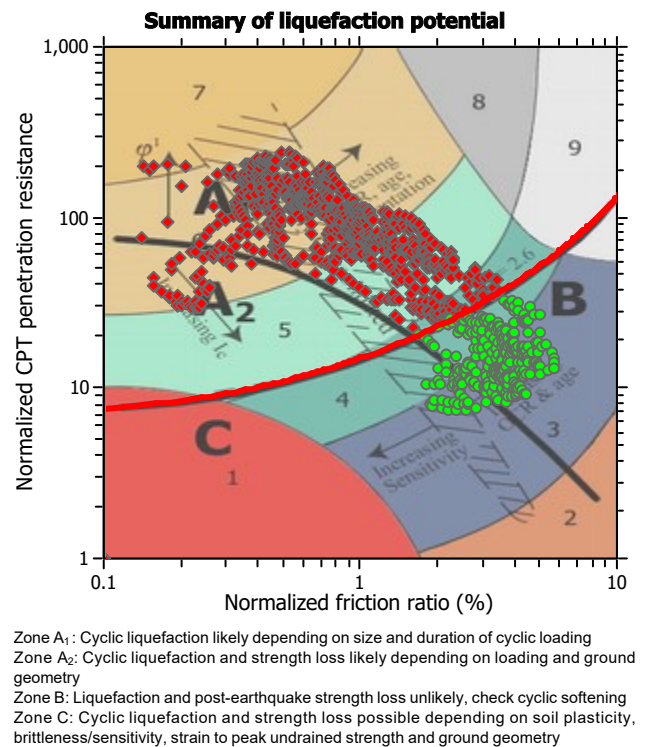
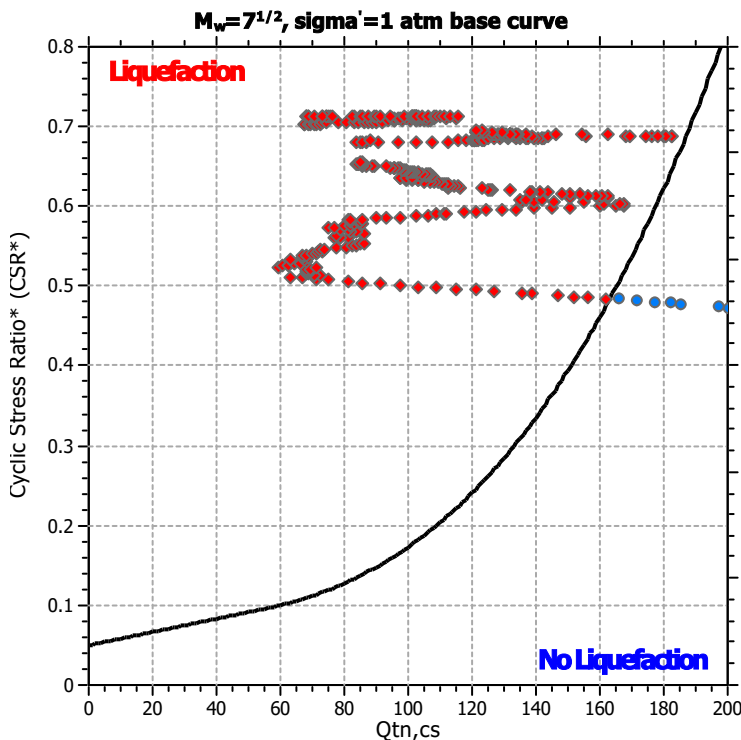
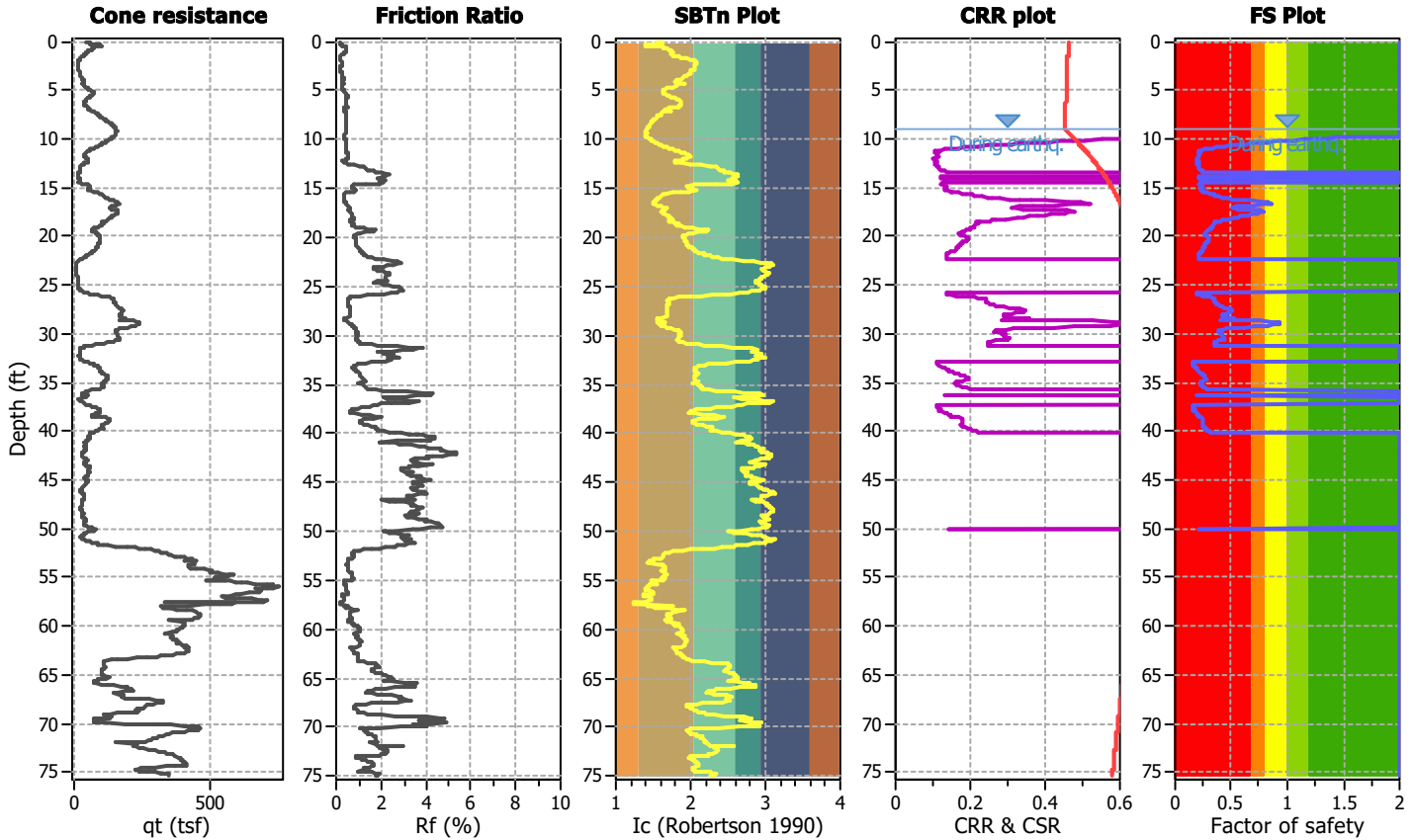

Zone A₁: Cyclic liquefaction likely depending on size and duration of cyclic loading
 Zone A₂: Cyclic liquefaction and strength loss likely depending on loading and ground geometry
 Zone B: Liquefaction and post-earthquake strength loss unlikely, check cyclic softening
 Zone C: Cyclic liquefaction and strength loss possible depending on soil plasticity, brittleness/sensitivity, strain to peak undrained strength and ground geometry

Liquefaction analysis overall plots

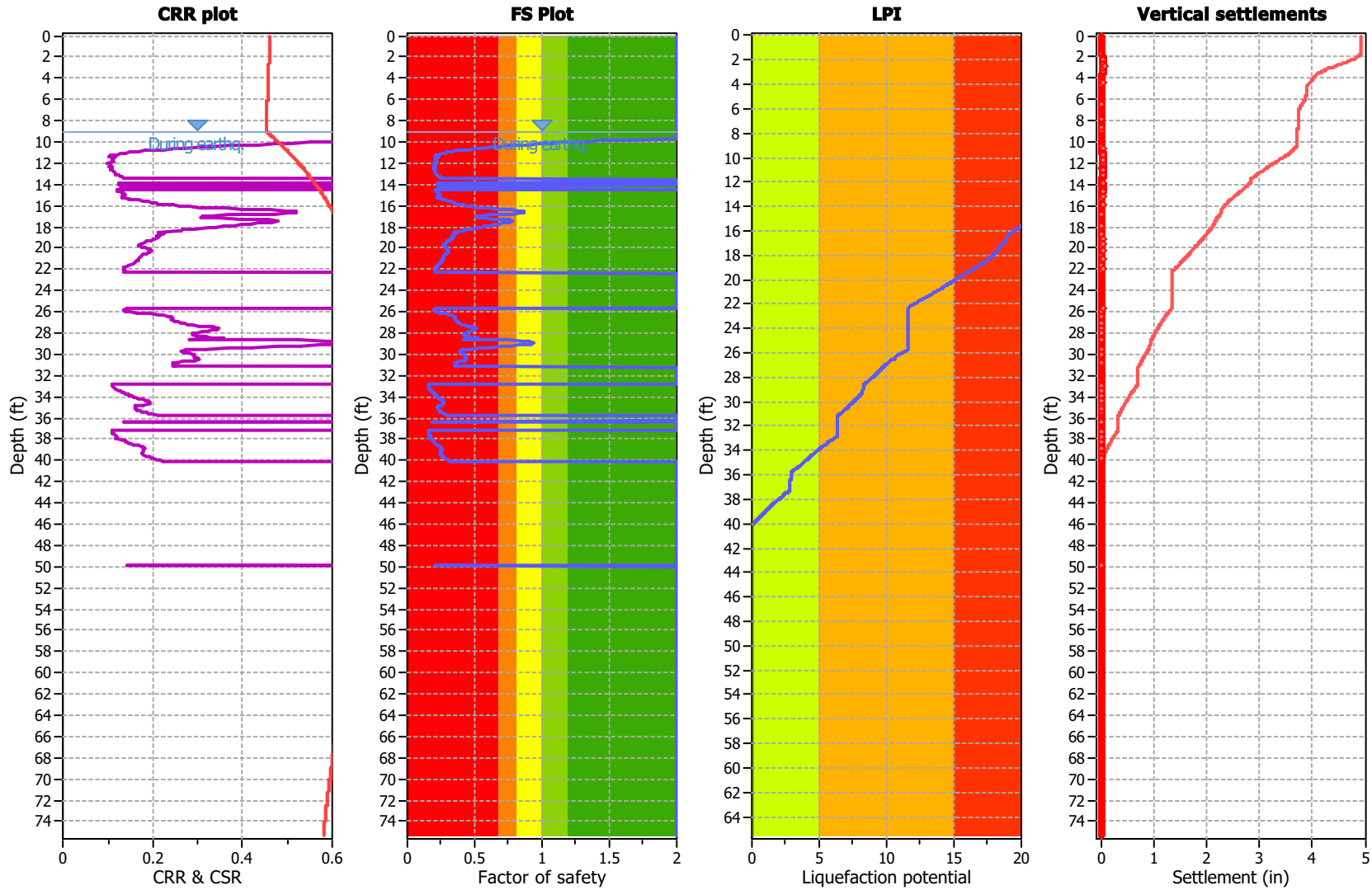

Input parameters and analysis data

Analysis method:	NCEER (1998)	Depth to water table (earthq.):	9.00 ft	Fill weight:	N/A
Fines correction method:	NCEER (1998)	Average results interval:	1	Transition detect. applied:	No
Points to test:	Based on Ic value	Ic cut-off value:	2.60	K_0 applied:	Yes
Earthquake magnitude M_w :	7.30	Unit weight calculation:	Based on SBT	Clay like behavior applied:	Sands only
Peak ground acceleration:	0.76	Use fill:	No	Limit depth applied:	Yes
Depth to water table (insitu):	116.00 ft	Fill height:	N/A	Limit depth:	50.00 ft

F.S. color scheme

- Almost certain it will liquefy
- Very likely to liquefy
- Liquefaction and no liq. are equally likely
- Unlike to liquefy
- Almost certain it will not liquefy

LPI color scheme

- Very high risk
- High risk
- Low risk



LIQUEFACTION ANALYSIS REPORT

Project title : Leighton Consulting / Norwalk Transit Village Location : Norwalk, CA
 CPT file : CPT-3

Input parameters and analysis data

Analysis method:	NCEER (1998)	G.W.T. (in-situ):	116.00 ft	Use fill:	No	Clay like behavior applied:	Sands only
Fines correction method:	NCEER (1998)	G.W.T. (earthq.):	9.00 ft	Fill height:	N/A	Limit depth applied:	Yes
Points to test:	Based on Ic value	Average results interval:	1	Fill weight:	N/A	Limit depth:	50.00 ft
Earthquake magnitude M_w :	7.30	Ic cut-off value:	2.60	Trans. detect. applied:	No	MSF method:	Method based
Peak ground acceleration:	0.76	Unit weight calculation:	Based on SBT	K_o applied:	Yes		

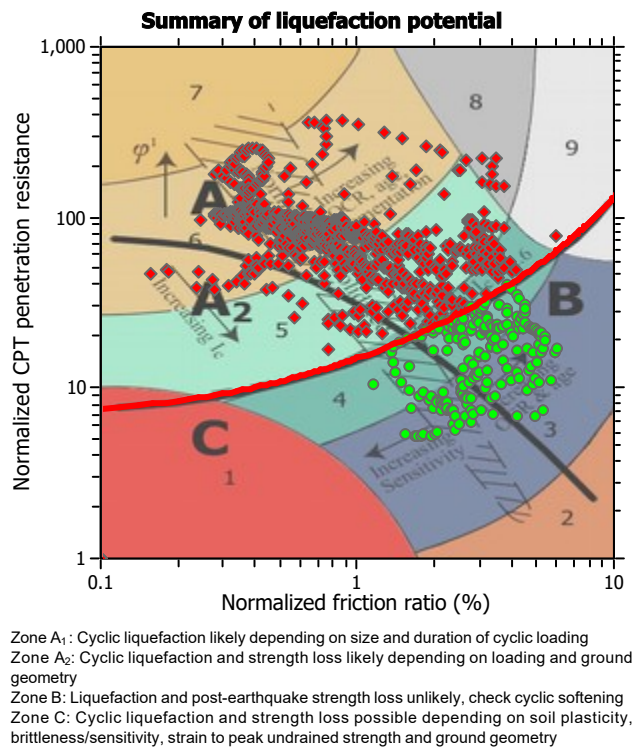
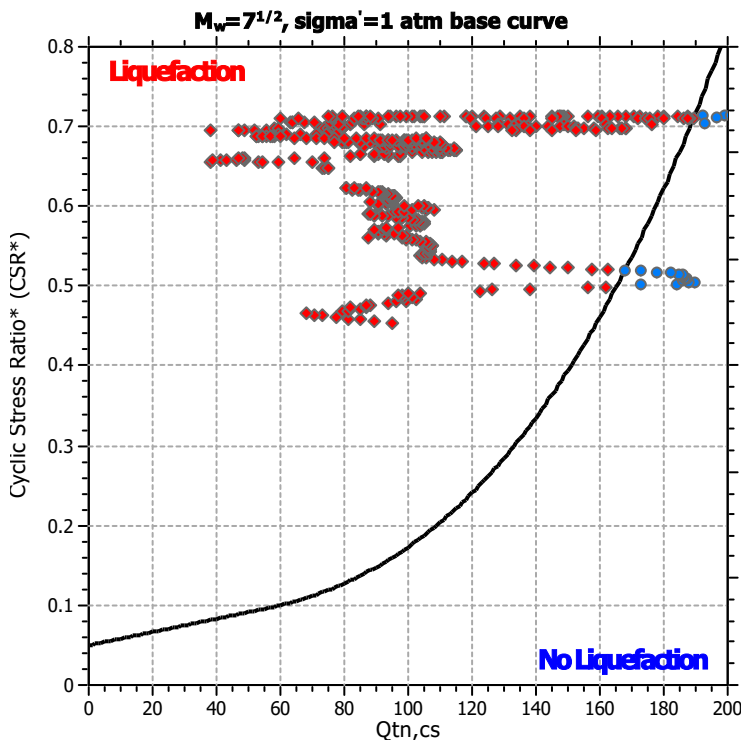
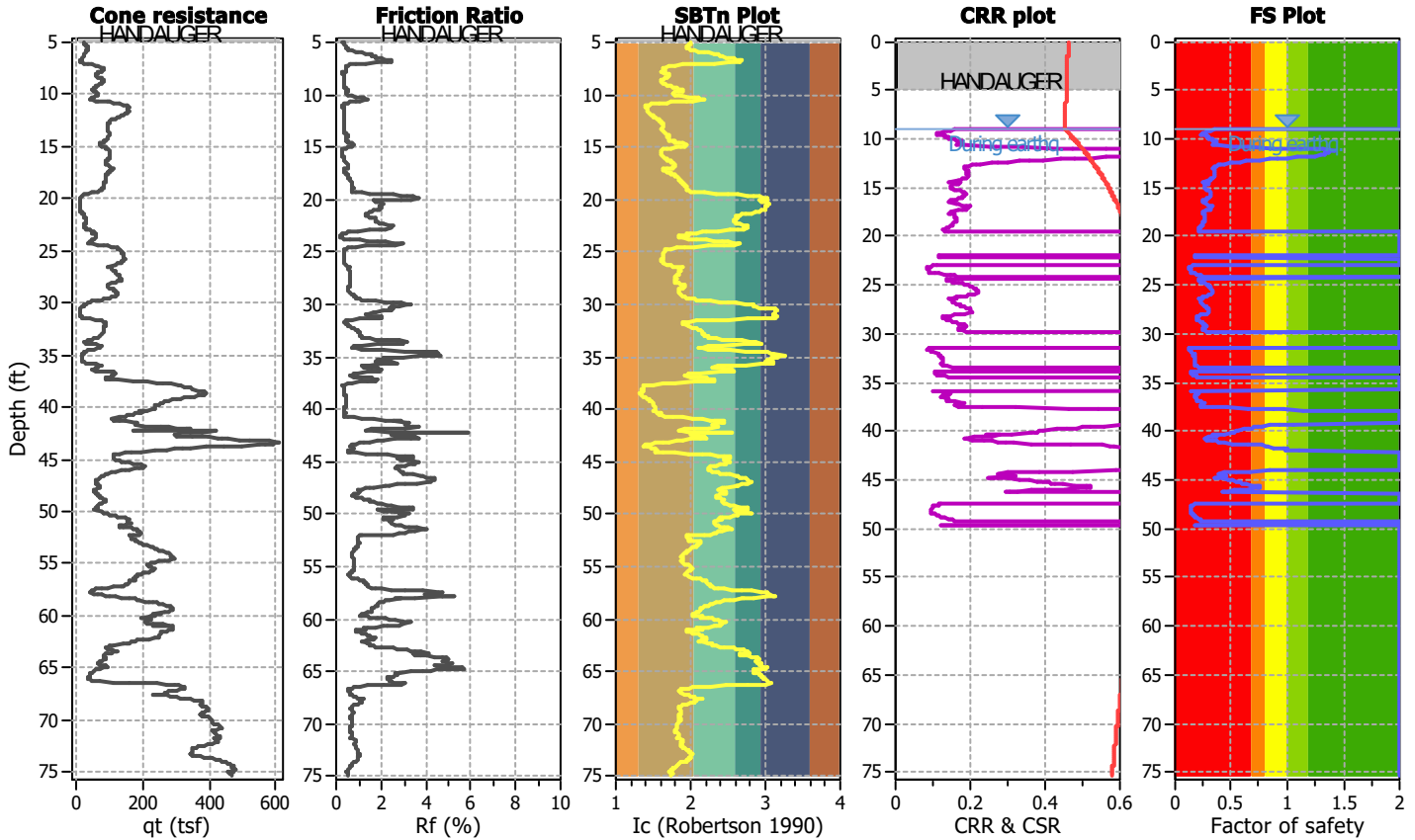

Liquefaction analysis overall plots

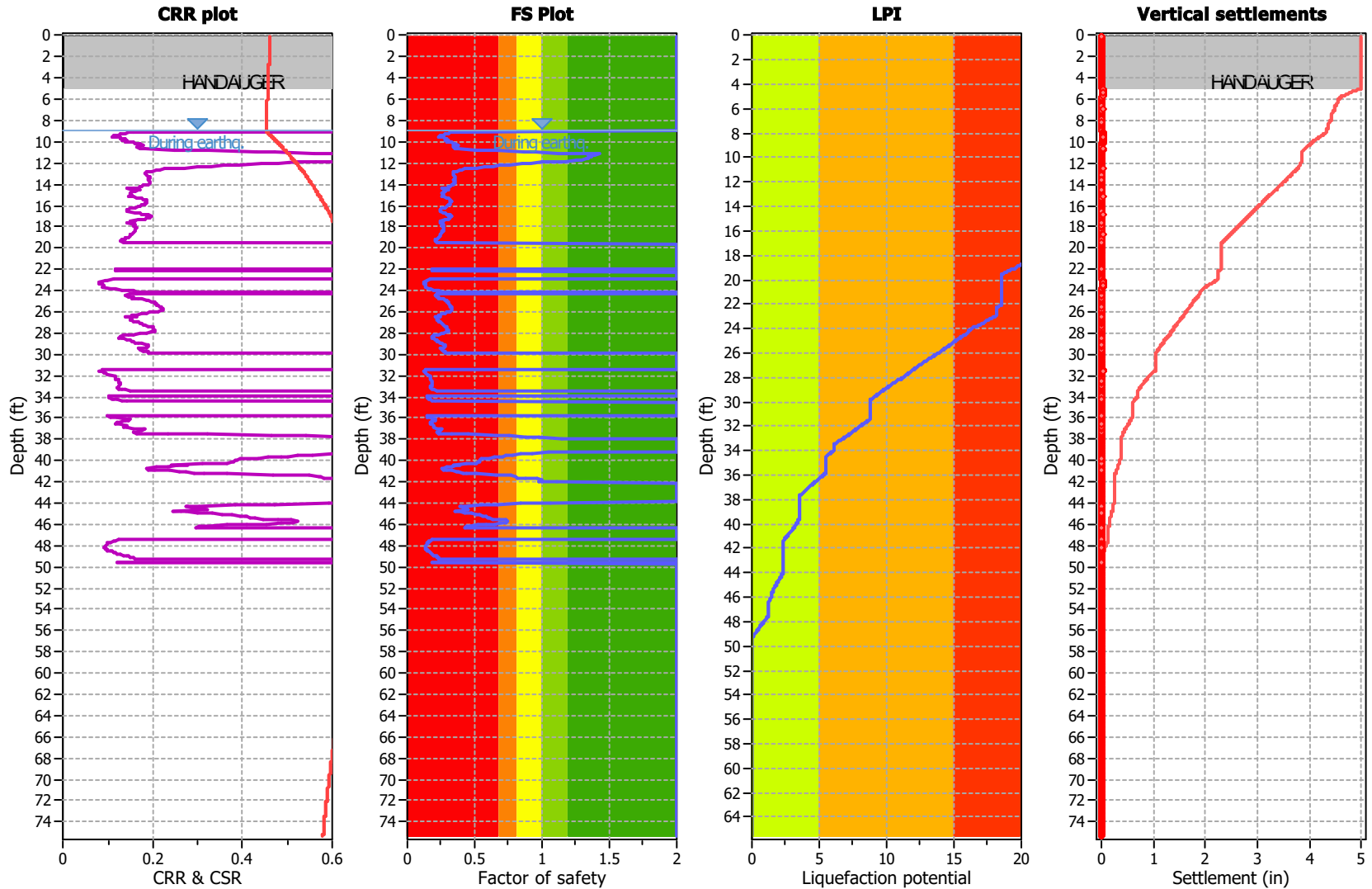

Input parameters and analysis data

Analysis method:	NCEER (1998)	Depth to water table (earthq.):	9.00 ft	Fill weight:	N/A
Fines correction method:	NCEER (1998)	Average results interval:	1	Transition detect. applied:	No
Points to test:	Based on Ic value	Ic cut-off value:	2.60	K_0 applied:	Yes
Earthquake magnitude M_w :	7.30	Unit weight calculation:	Based on SBT	Clay like behavior applied:	Sands only
Peak ground acceleration:	0.76	Use fill:	No	Limit depth applied:	Yes
Depth to water table (insitu):	116.00 ft	Fill height:	N/A	Limit depth:	50.00 ft

F.S. color scheme

- Almost certain it will liquefy
- Very likely to liquefy
- Liquefaction and no liq. are equally likely
- Unlike to liquefy
- Almost certain it will not liquefy

LPI color scheme

- Very high risk
- High risk
- Low risk



LIQUEFACTION ANALYSIS REPORT

Project title : Leighton Consulting / Norwalk Transit Village Location : Norwalk, CA
 CPT file : CPT-4

Input parameters and analysis data

Analysis method:	NCEER (1998)	G.W.T. (in-situ):	116.00 ft	Use fill:	No	Clay like behavior applied:	Sands only
Fines correction method:	NCEER (1998)	G.W.T. (earthq.):	9.00 ft	Fill height:	N/A	Limit depth applied:	Yes
Points to test:	Based on Ic value	Average results interval:	1	Fill weight:	N/A	Limit depth:	50.00 ft
Earthquake magnitude M_w :	7.30	Ic cut-off value:	2.60	Trans. detect. applied:	No	MSF method:	Method based
Peak ground acceleration:	0.76	Unit weight calculation:	Based on SBT	K_o applied:	Yes		

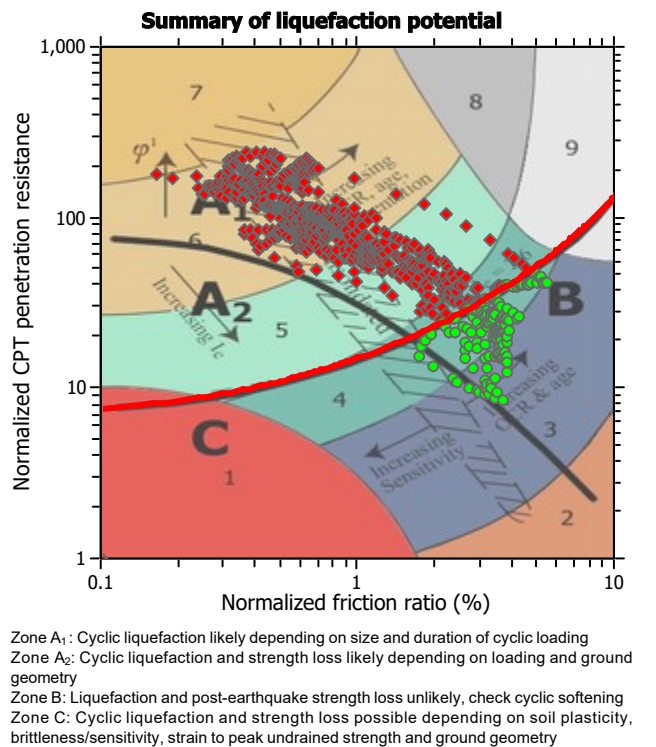
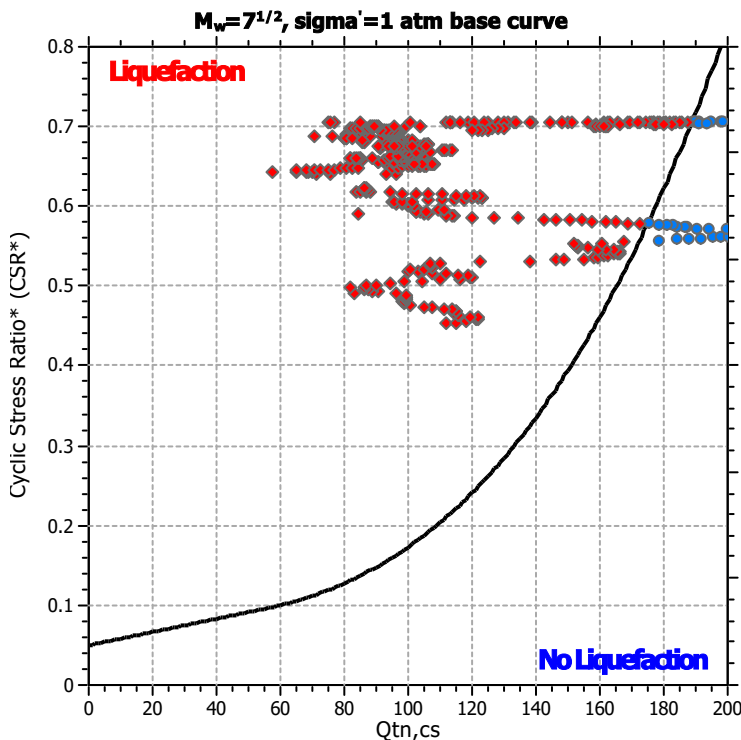
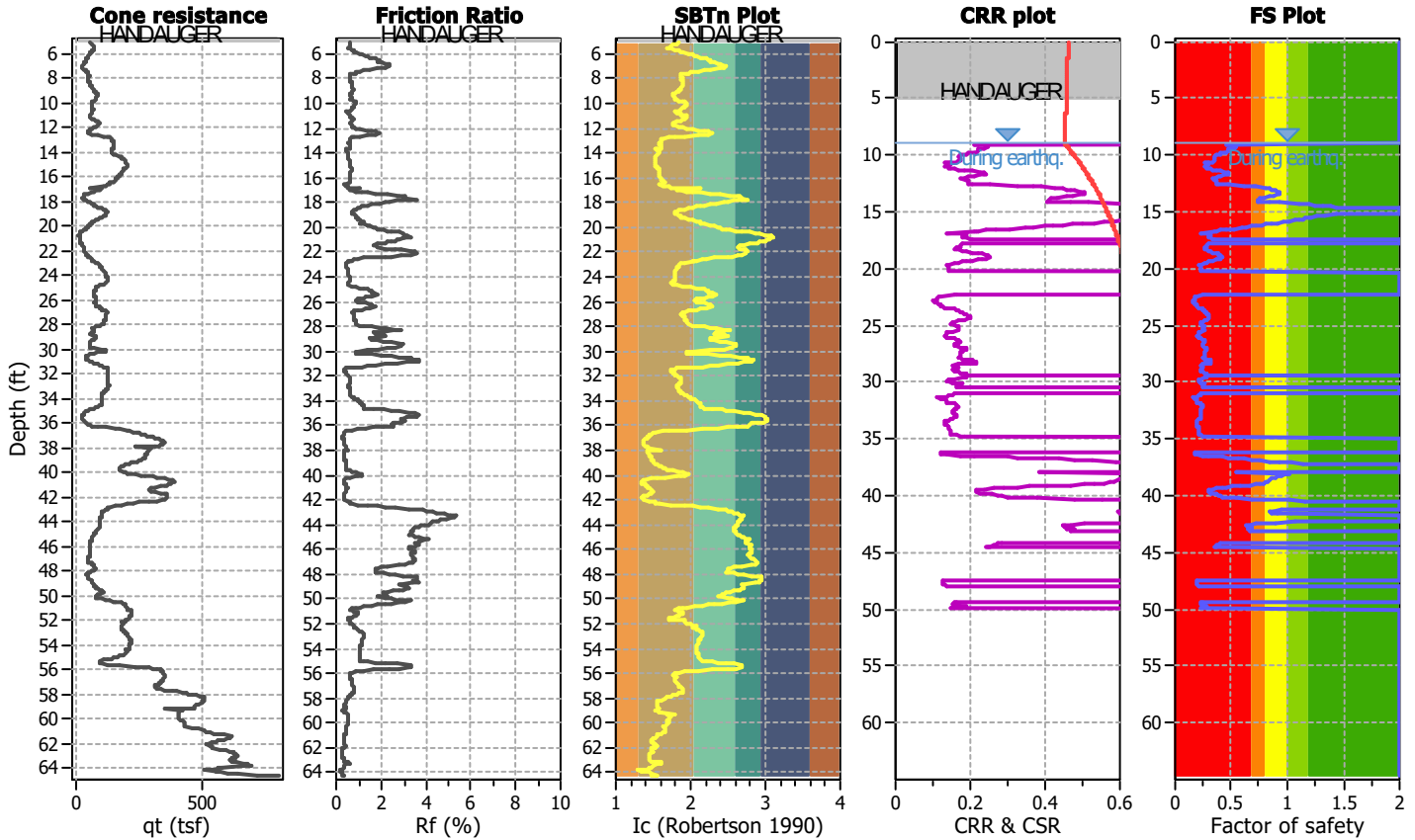

Liquefaction analysis overall plots

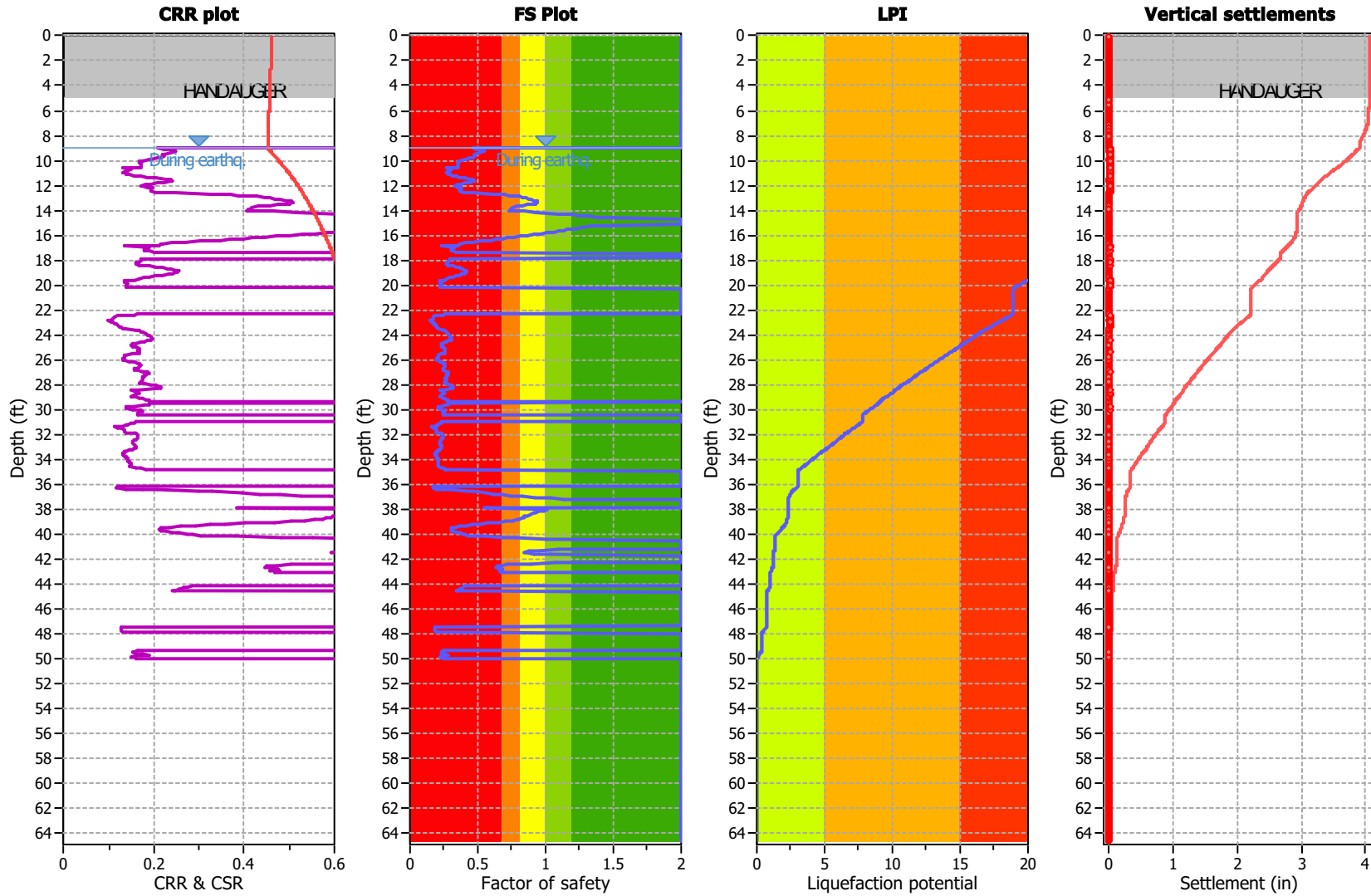

Input parameters and analysis data

Analysis method:	NCEER (1998)	Depth to water table (earthq.):	9.00 ft	Fill weight:	N/A
Fines correction method:	NCEER (1998)	Average results interval:	1	Transition detect. applied:	No
Points to test:	Based on Ic value	Ic cut-off value:	2.60	K_0 applied:	Yes
Earthquake magnitude M_w :	7.30	Unit weight calculation:	Based on SBT	Clay like behavior applied:	Sands only
Peak ground acceleration:	0.76	Use fill:	No	Limit depth applied:	Yes
Depth to water table (insitu):	116.00 ft	Fill height:	N/A	Limit depth:	50.00 ft

F.S. color scheme

- Almost certain it will liquefy
- Very likely to liquefy
- Liquefaction and no liq. are equally likely
- Unlike to liquefy
- Almost certain it will not liquefy

LPI color scheme

- Very high risk
- High risk
- Low risk



LIQUEFACTION ANALYSIS REPORT

Project title : Leighton Consulting / Norwalk Transit Village Location : Norwalk, CA
 CPT file : CPT-5

Input parameters and analysis data

Analysis method:	NCEER (1998)	G.W.T. (in-situ):	116.00 ft	Use fill:	No	Clay like behavior applied:	Sands only
Fines correction method:	NCEER (1998)	G.W.T. (earthq.):	9.00 ft	Fill height:	N/A	Limit depth applied:	Yes
Points to test:	Based on Ic value	Average results interval:	1	Fill weight:	N/A	Limit depth:	50.00 ft
Earthquake magnitude M_w :	7.30	Ic cut-off value:	2.60	Trans. detect. applied:	No	MSF method:	Method based
Peak ground acceleration:	0.76	Unit weight calculation:	Based on SBT	K_o applied:	Yes		

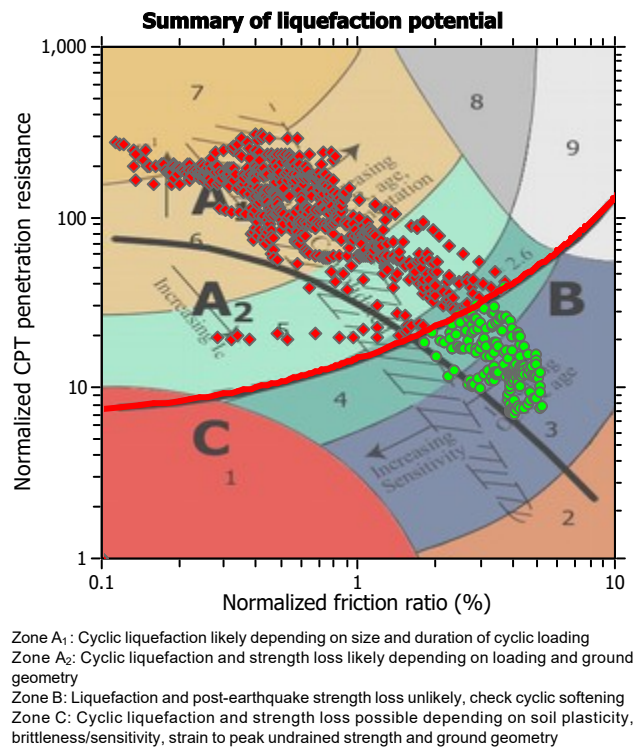
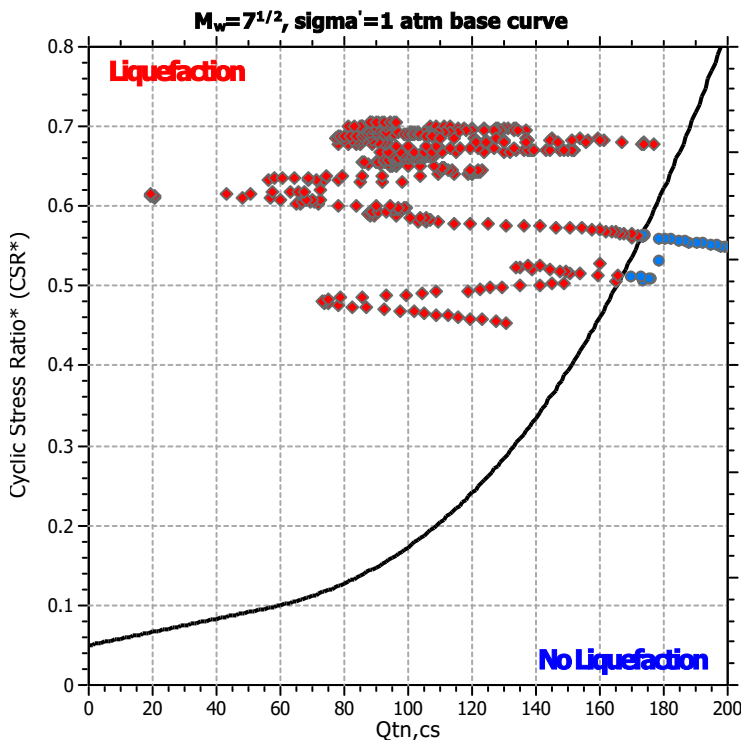
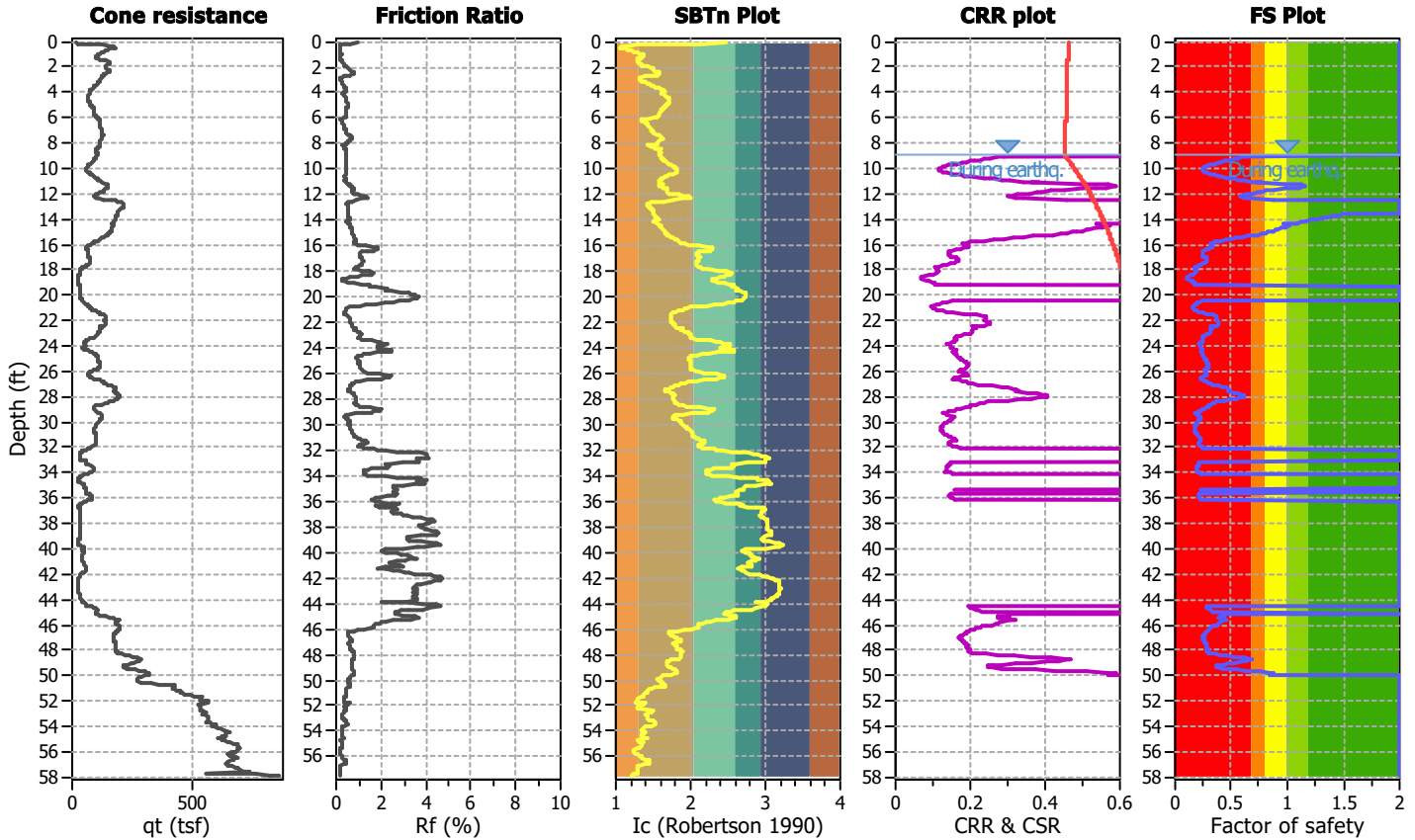

Liquefaction analysis overall plots

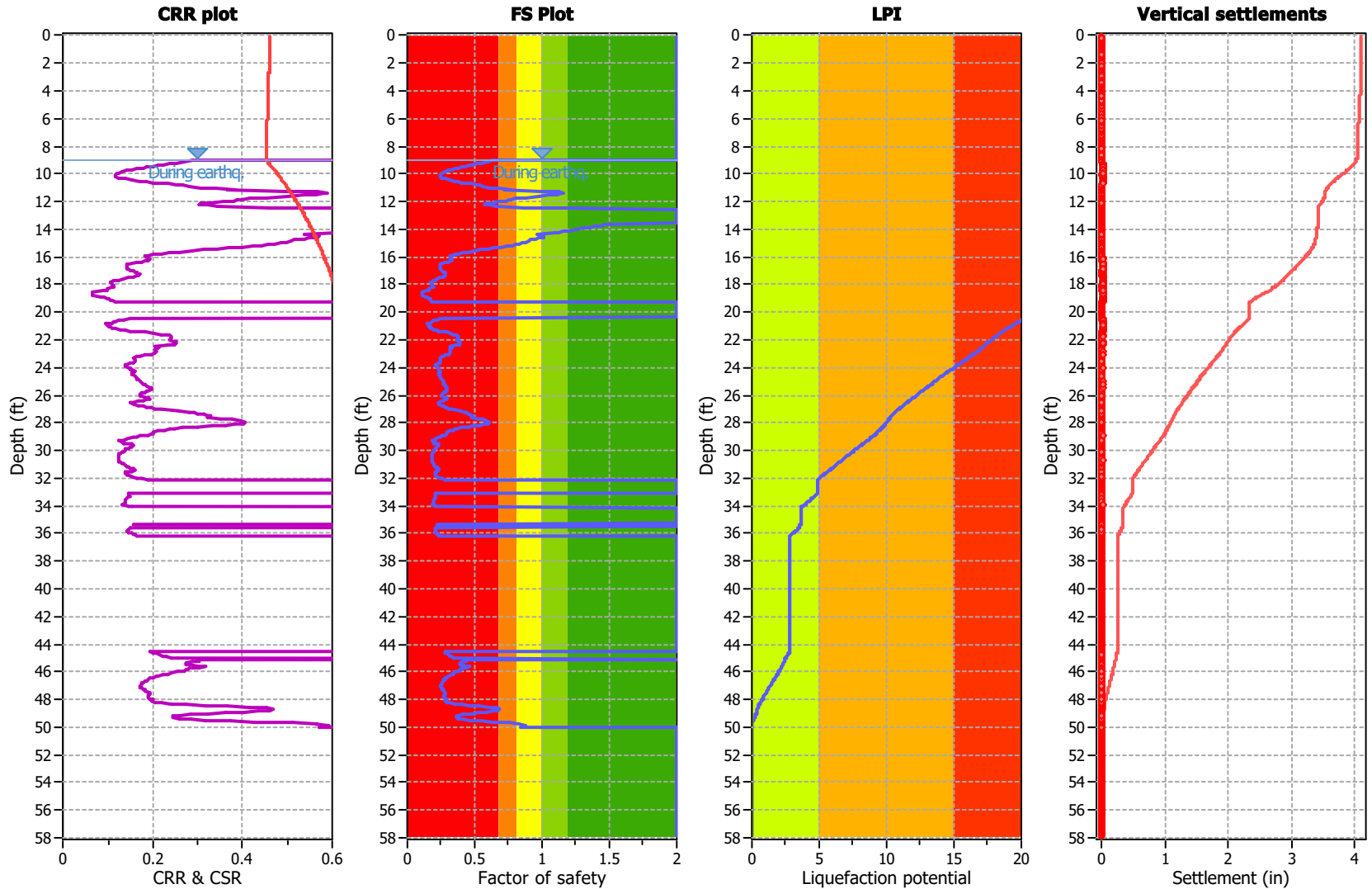

Input parameters and analysis data

Analysis method:	NCEER (1998)	Depth to water table (earthq.):	9.00 ft	Fill weight:	N/A
Fines correction method:	NCEER (1998)	Average results interval:	1	Transition detect. applied:	No
Points to test:	Based on Ic value	Ic cut-off value:	2.60	K _o applied:	Yes
Earthquake magnitude M _w :	7.30	Unit weight calculation:	Based on SBT	Clay like behavior applied:	Sands only
Peak ground acceleration:	0.76	Use fill:	No	Limit depth applied:	Yes
Depth to water table (insitu):	116.00 ft	Fill height:	N/A	Limit depth:	50.00 ft

F.S. color scheme

- Almost certain it will liquefy
- Very likely to liquefy
- Liquefaction and no liq. are equally likely
- Unlike to liquefy
- Almost certain it will not liquefy

LPI color scheme

- Very high risk
- High risk
- Low risk



LIQUEFACTION ANALYSIS REPORT

Project title : Leighton Consulting / Norwalk Transit Village Location : Norwalk, CA
 CPT file : CPT-6

Input parameters and analysis data

Analysis method:	NCEER (1998)	G.W.T. (in-situ):	116.00 ft	Use fill:	No	Clay like behavior applied:	Sands only
Fines correction method:	NCEER (1998)	G.W.T. (earthq.):	9.00 ft	Fill height:	N/A	Limit depth applied:	Yes
Points to test:	Based on Ic value	Average results interval:	1	Fill weight:	N/A	Limit depth:	50.00 ft
Earthquake magnitude M_w :	7.30	Ic cut-off value:	2.60	Trans. detect. applied:	No	MSF method:	Method based
Peak ground acceleration:	0.76	Unit weight calculation:	Based on SBT	K_o applied:	Yes		

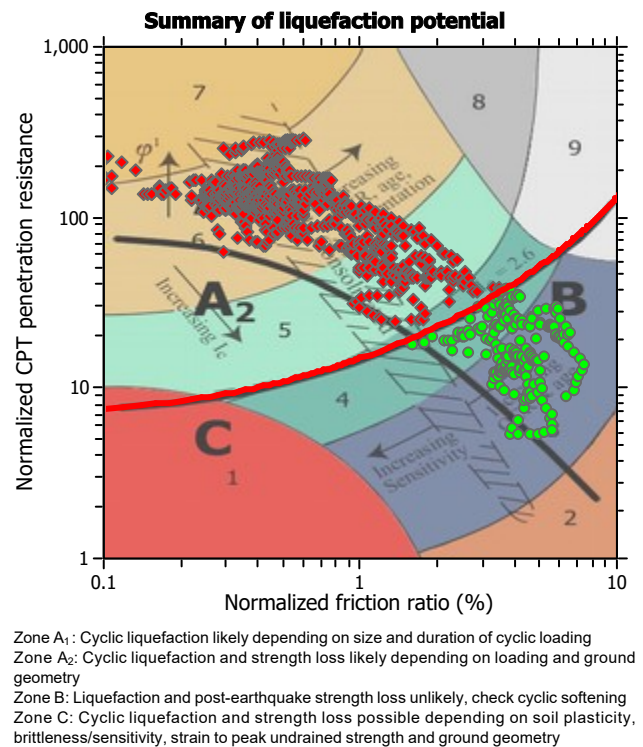
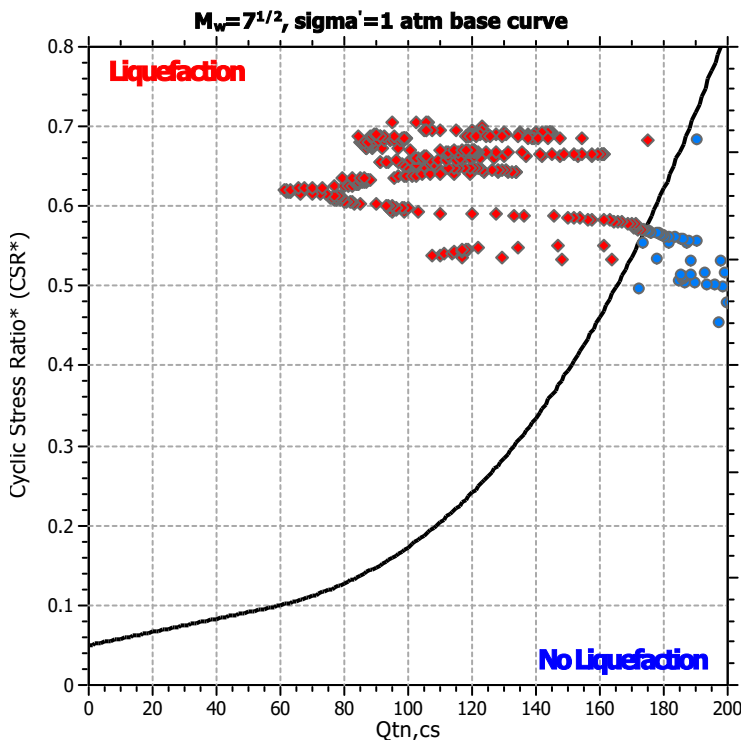
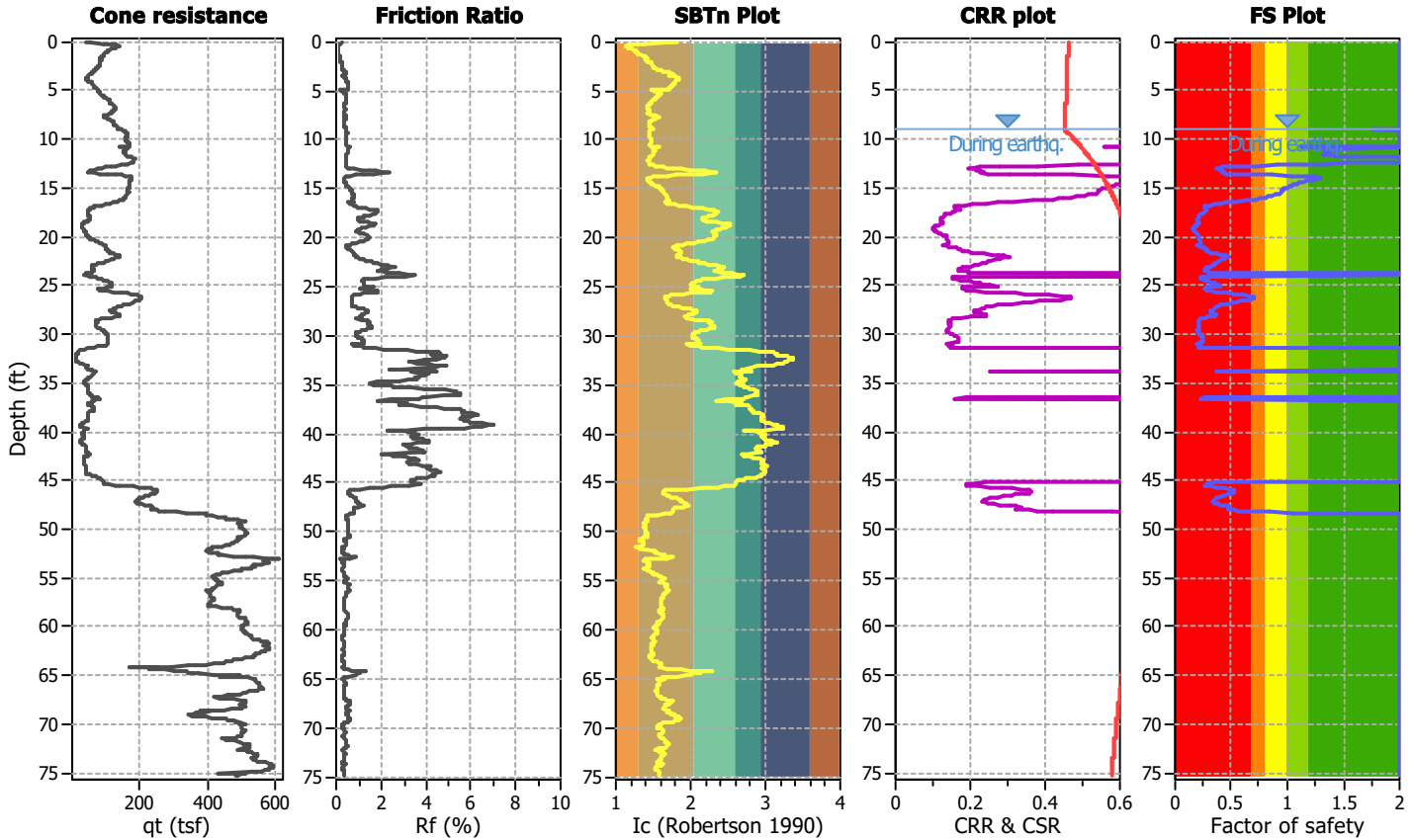

Liquefaction analysis overall plots

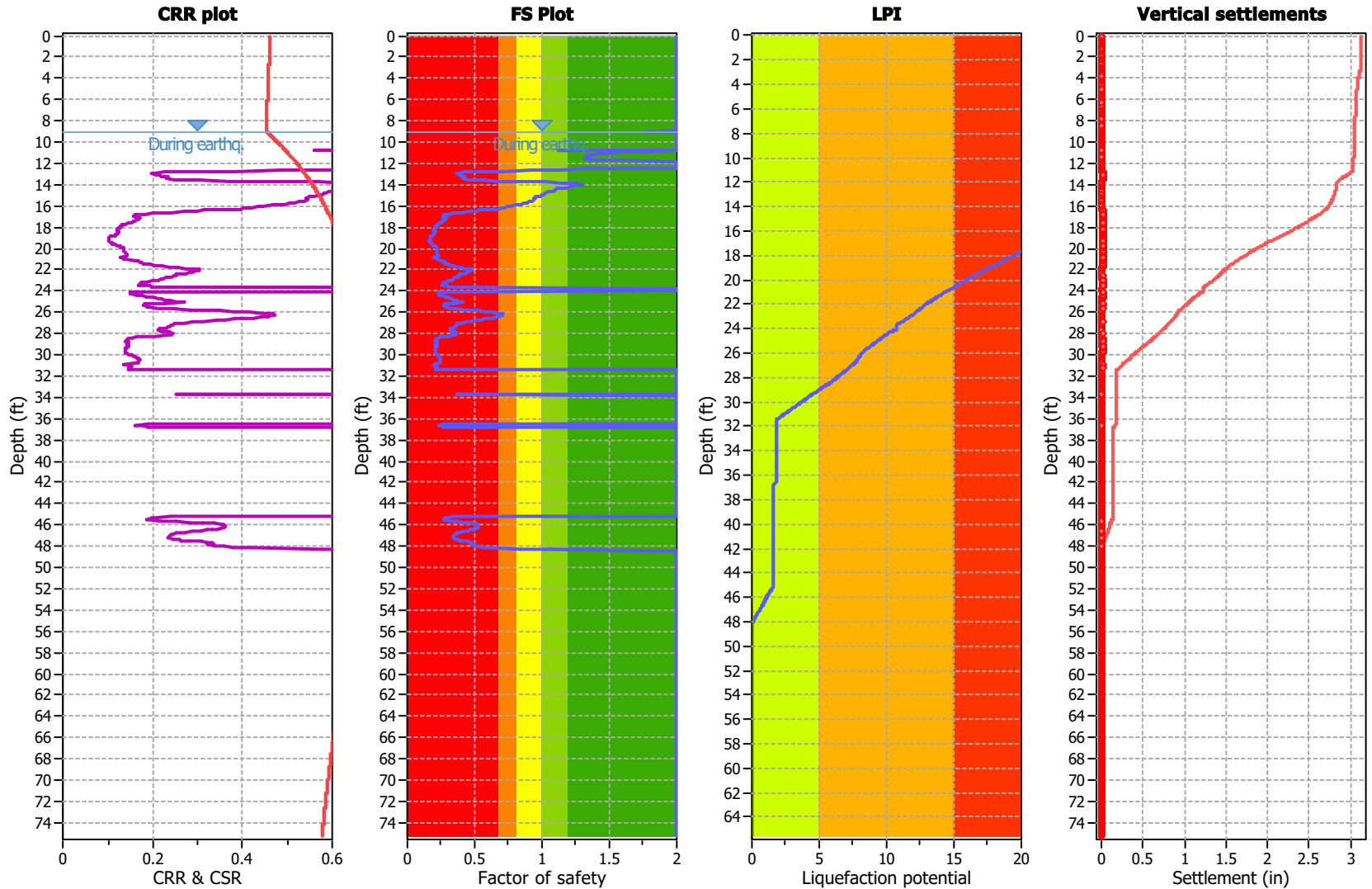

Input parameters and analysis data

Analysis method:	NCEER (1998)	Depth to water table (earthq.):	9.00 ft	Fill weight:	N/A
Fines correction method:	NCEER (1998)	Average results interval:	1	Transition detect. applied:	No
Points to test:	Based on Ic value	Ic cut-off value:	2.60	K_0 applied:	Yes
Earthquake magnitude M_w :	7.30	Unit weight calculation:	Based on SBT	Clay like behavior applied:	Sands only
Peak ground acceleration:	0.76	Use fill:	No	Limit depth applied:	Yes
Depth to water table (insitu):	116.00 ft	Fill height:	N/A	Limit depth:	50.00 ft

F.S. color scheme

- Almost certain it will liquefy
- Very likely to liquefy
- Liquefaction and no liq. are equally likely
- Unlike to liquefy
- Almost certain it will not liquefy

LPI color scheme

- Very high risk
- High risk
- Low risk



Project title : Leighton Consulting / Norwalk Transit Village
Location : Norwalk, CA

Overall vertical settlements report

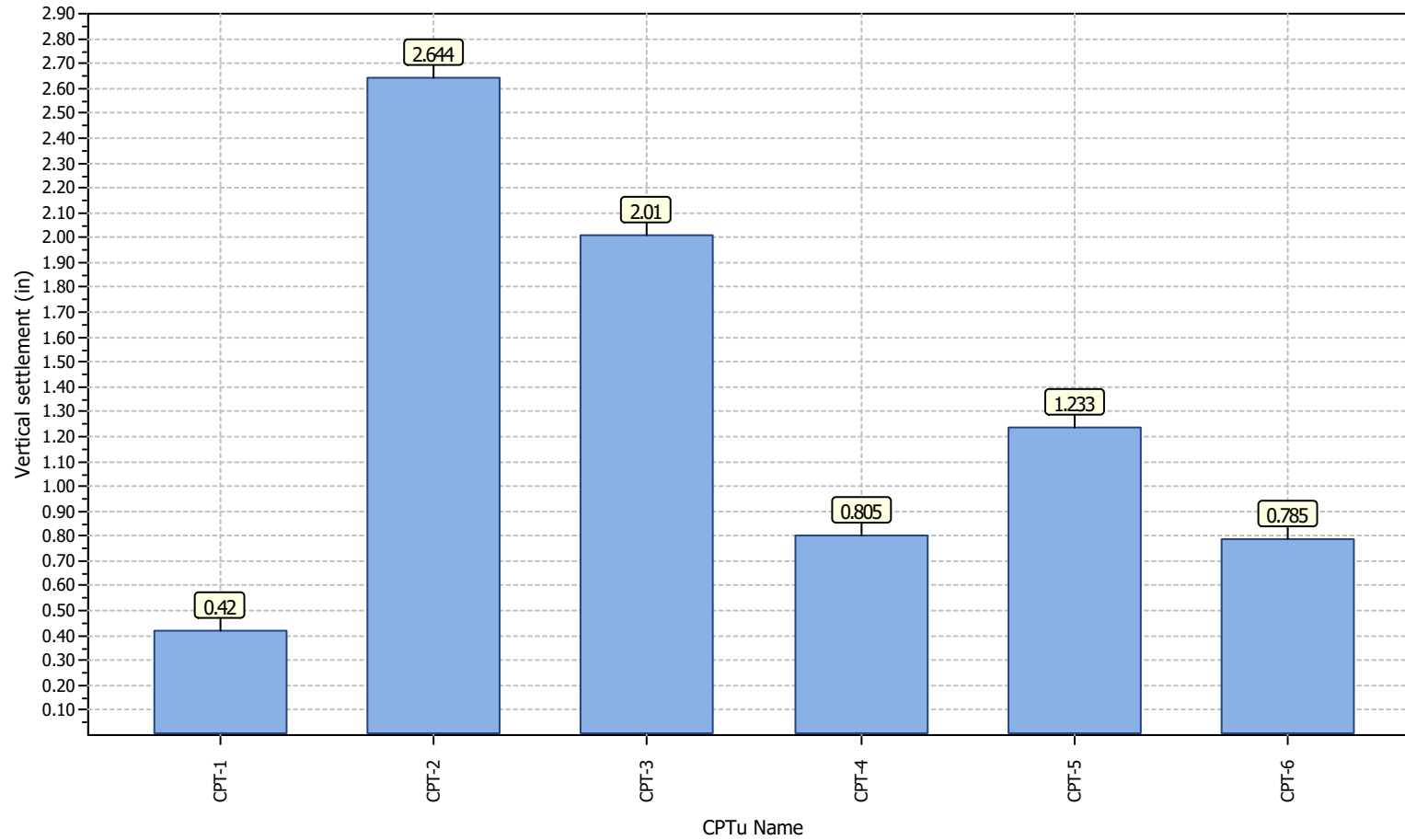



LIQUEFACTION ANALYSIS REPORT

Project title : Leighton Consulting / Norwalk Transit Village Location : Norwalk, CA

CPT file : CPT-1

Input parameters and analysis data

Analysis method:	NCEER (1998)	G.W.T. (in-situ):	116.00 ft	Use fill:	No	Clay like behavior applied:	Sands only
Fines correction method:	NCEER (1998)	G.W.T. (earthq.):	60.00 ft	Fill height:	N/A	Limit depth applied:	Yes
Points to test:	Based on Ic value	Average results interval:	1	Fill weight:	N/A	Limit depth:	50.00 ft
Earthquake magnitude M_w :	7.30	Ic cut-off value:	2.60	Trans. detect. applied:	No	MSF method:	Method based
Peak ground acceleration:	0.76	Unit weight calculation:	Based on SBT	K_0 applied:	Yes		

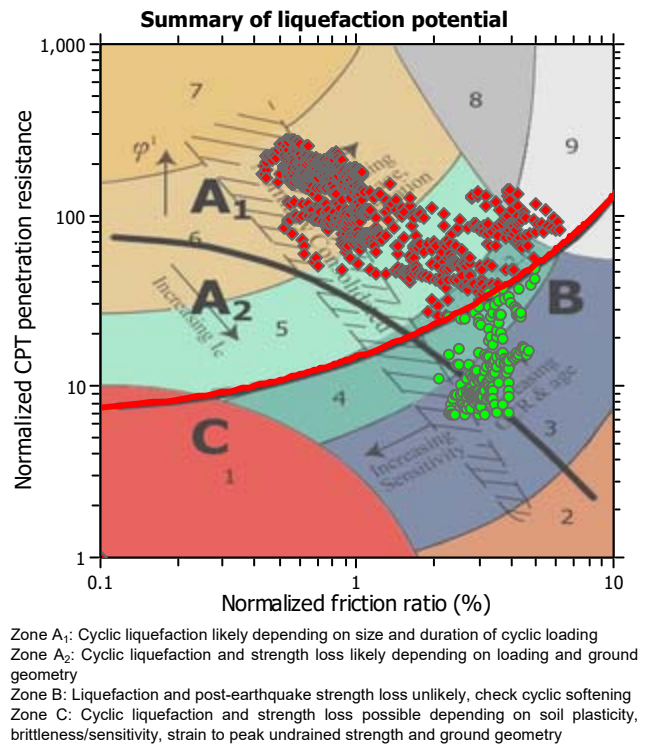
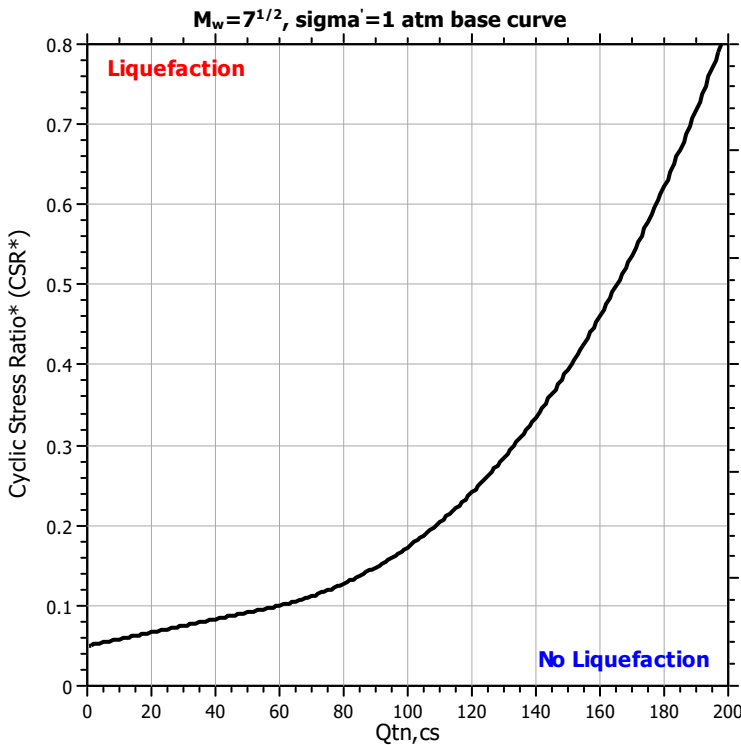
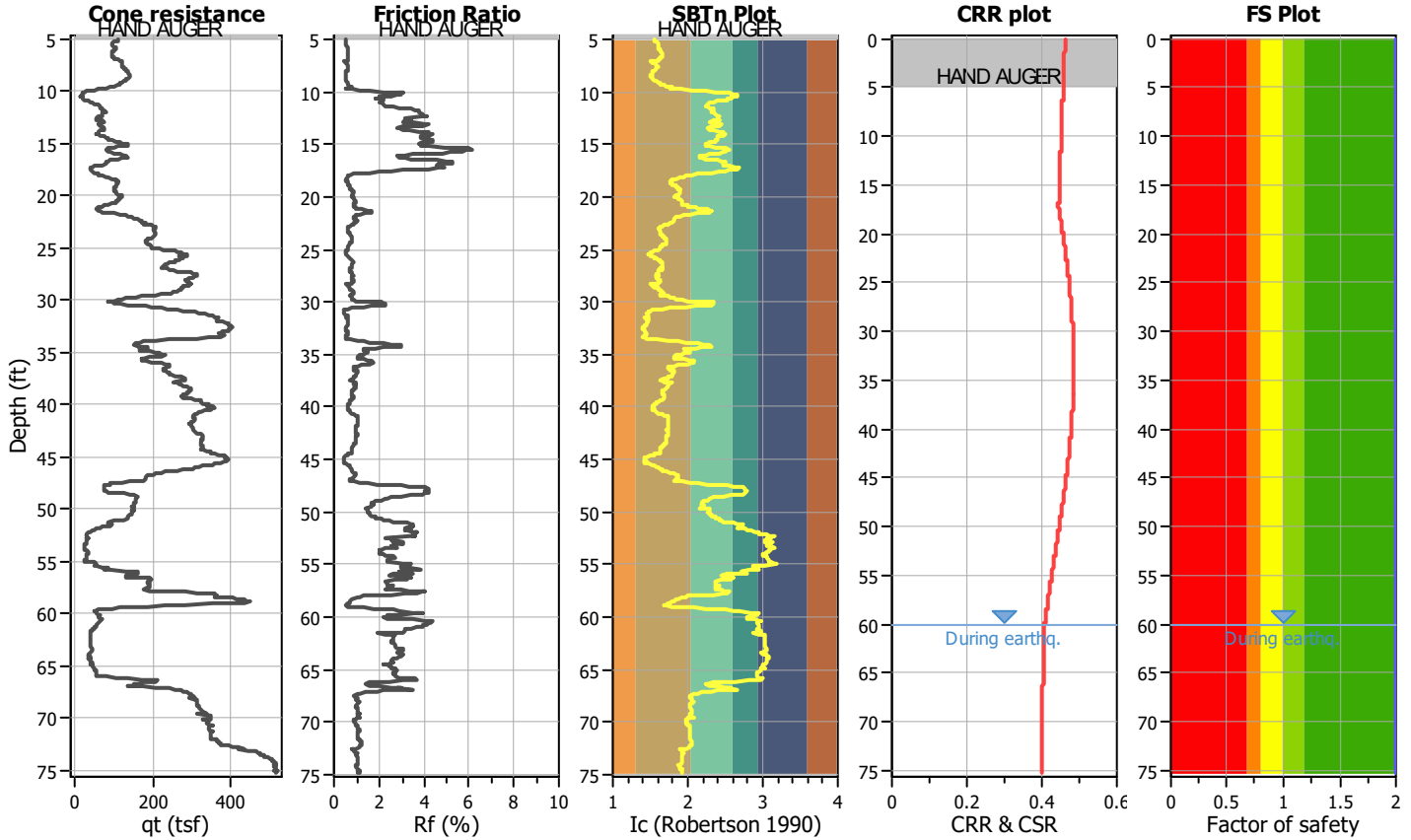

Liquefaction analysis overall plots

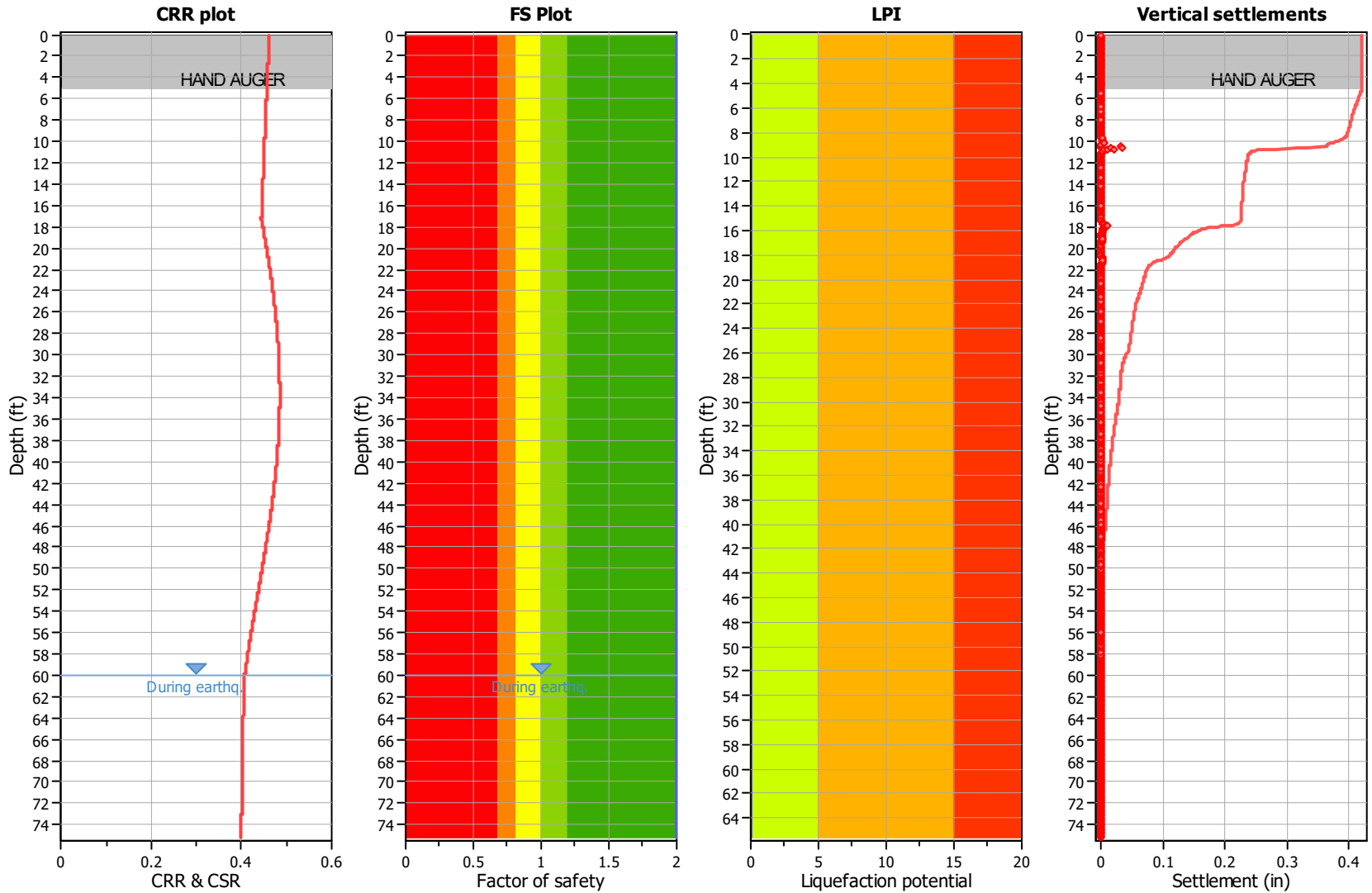

Input parameters and analysis data

Analysis method:	NCEER (1998)	Depth to water table (earthq.):	60.00 ft	Fill weight:	N/A
Fines correction method:	NCEER (1998)	Average results interval:	1	Transition detect. applied:	No
Points to test:	Based on Ic value	Ic cut-off value:	2.60	K_{σ} applied:	Yes
Earthquake magnitude M_w :	7.30	Unit weight calculation:	Based on SBT	Clay like behavior applied:	Sands only
Peak ground acceleration:	0.76	Use fill:	No	Limit depth applied:	Yes
Depth to water table (insitu):	116.00 ft	Fill height:	N/A	Limit depth:	50.00 ft

F.S. color scheme

- Almost certain it will liquefy
- Very likely to liquefy
- Liquefaction and no liq. are equally likely
- Unlike to liquefy
- Almost certain it will not liquefy

LPI color scheme

- Very high risk
- High risk
- Low risk



LIQUEFACTION ANALYSIS REPORT

Project title : Leighton Consulting / Norwalk Transit Village Location : Norwalk, CA

CPT file : CPT-2

Input parameters and analysis data

Analysis method:	NCEER (1998)	G.W.T. (in-situ):	116.00 ft	Use fill:	No	Clay like behavior applied:	Sands only
Fines correction method:	NCEER (1998)	G.W.T. (earthq.):	60.00 ft	Fill height:	N/A	Limit depth applied:	Yes
Points to test:	Based on Ic value	Average results interval:	1	Fill weight:	N/A	Limit depth:	50.00 ft
Earthquake magnitude M_w :	7.30	Ic cut-off value:	2.60	Trans. detect. applied:	No	MSF method:	Method based
Peak ground acceleration:	0.76	Unit weight calculation:	Based on SBT	K_0 applied:	Yes		

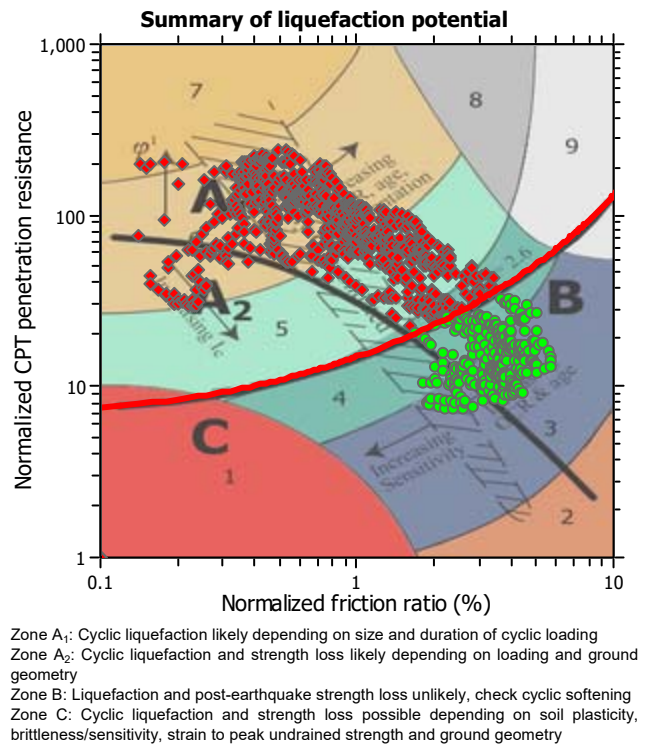
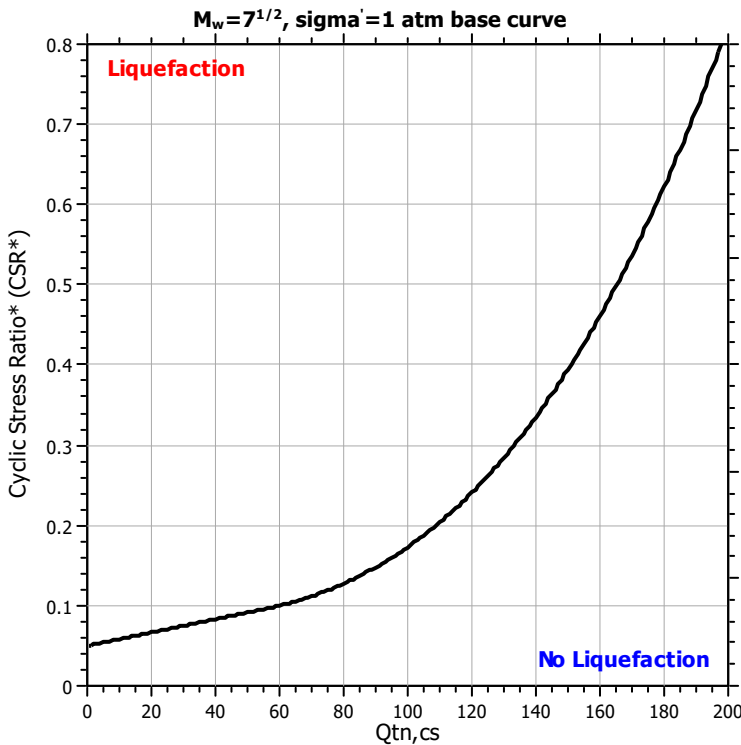
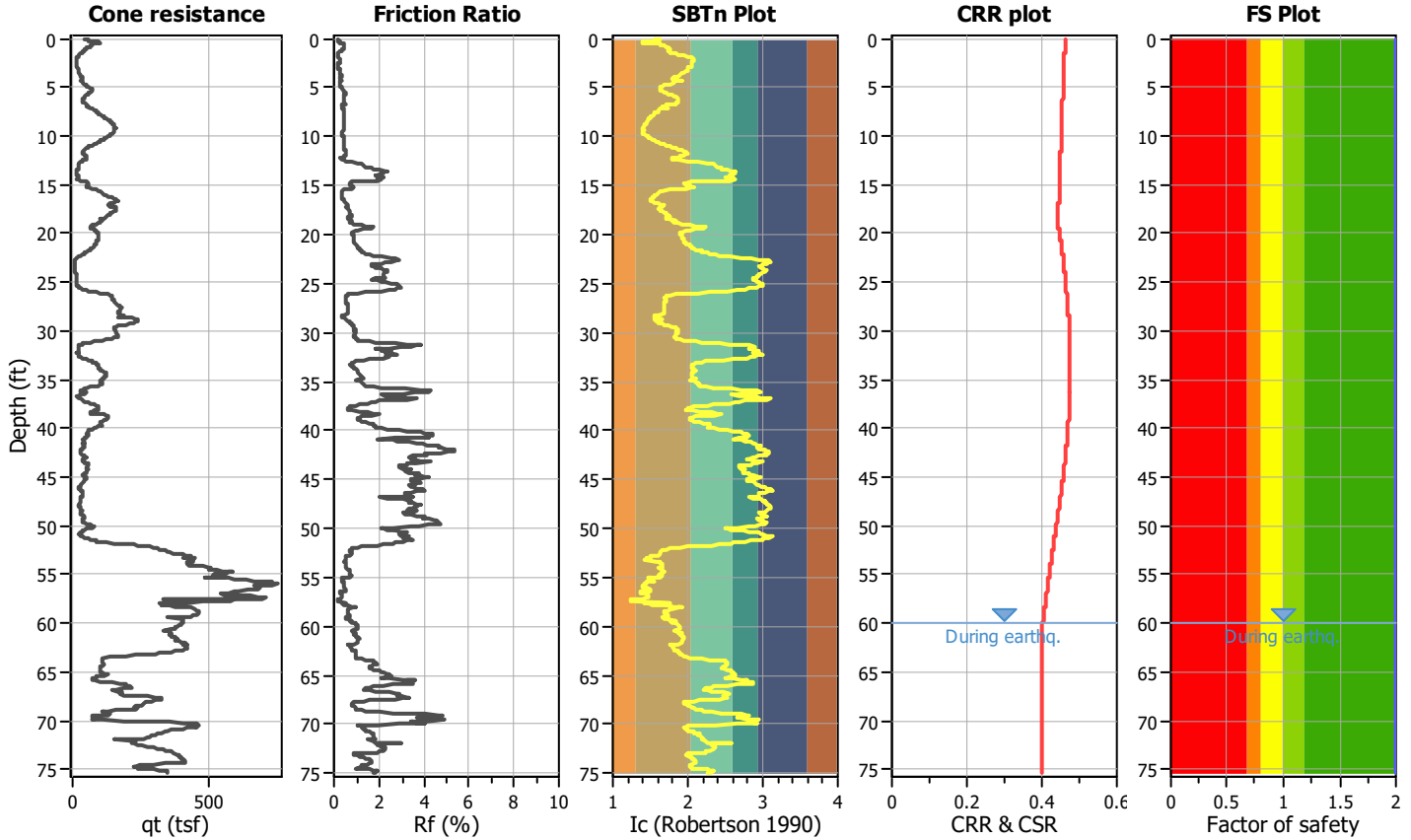

Liquefaction analysis overall plots

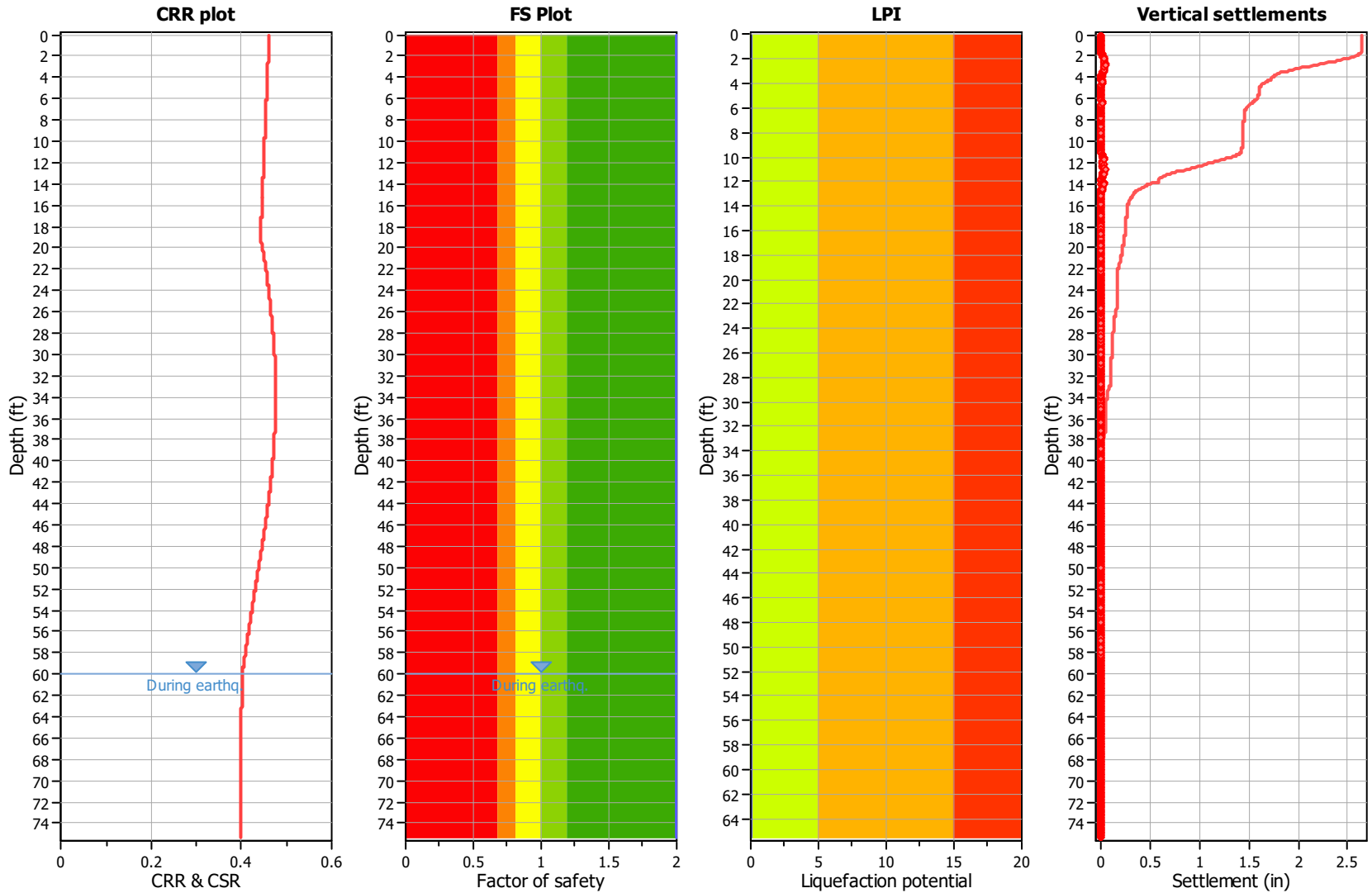

Input parameters and analysis data

Analysis method:	NCEER (1998)	Depth to water table (earthq.):	60.00 ft	Fill weight:	N/A
Fines correction method:	NCEER (1998)	Average results interval:	1	Transition detect. applied:	No
Points to test:	Based on Ic value	Ic cut-off value:	2.60	K_{σ} applied:	Yes
Earthquake magnitude M_w :	7.30	Unit weight calculation:	Based on SBT	Clay like behavior applied:	Sands only
Peak ground acceleration:	0.76	Use fill:	No	Limit depth applied:	Yes
Depth to water table (insitu):	116.00 ft	Fill height:	N/A	Limit depth:	50.00 ft

F.S. color scheme

- Almost certain it will liquefy
- Very likely to liquefy
- Liquefaction and no liq. are equally likely
- Unlike to liquefy
- Almost certain it will not liquefy

LPI color scheme

- Very high risk
- High risk
- Low risk



LIQUEFACTION ANALYSIS REPORT

Project title : Leighton Consulting / Norwalk Transit Village Location : Norwalk, CA

CPT file : CPT-3

Input parameters and analysis data

Analysis method:	NCEER (1998)	G.W.T. (in-situ):	116.00 ft	Use fill:	No	Clay like behavior applied:	Sands only
Fines correction method:	NCEER (1998)	G.W.T. (earthq.):	60.00 ft	Fill height:	N/A	Limit depth applied:	Yes
Points to test:	Based on Ic value	Average results interval:	1	Fill weight:	N/A	Limit depth:	50.00 ft
Earthquake magnitude M_w :	7.30	Ic cut-off value:	2.60	Trans. detect. applied:	No	MSF method:	Method based
Peak ground acceleration:	0.76	Unit weight calculation:	Based on SBT	K_0 applied:	Yes		

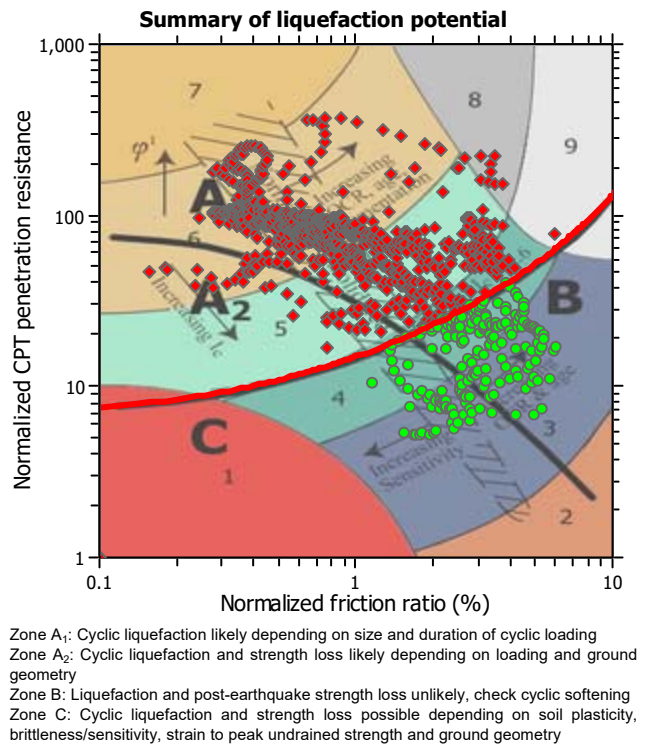
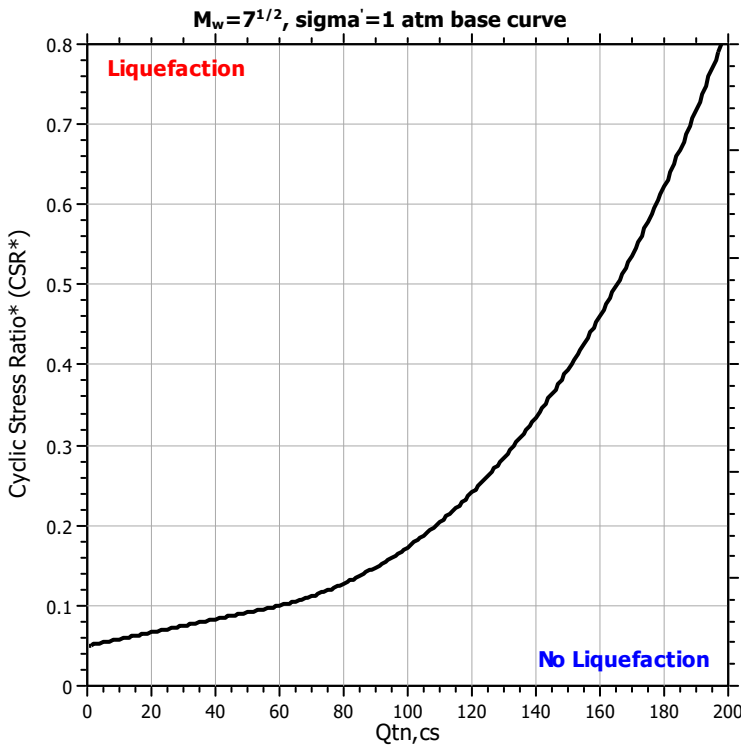
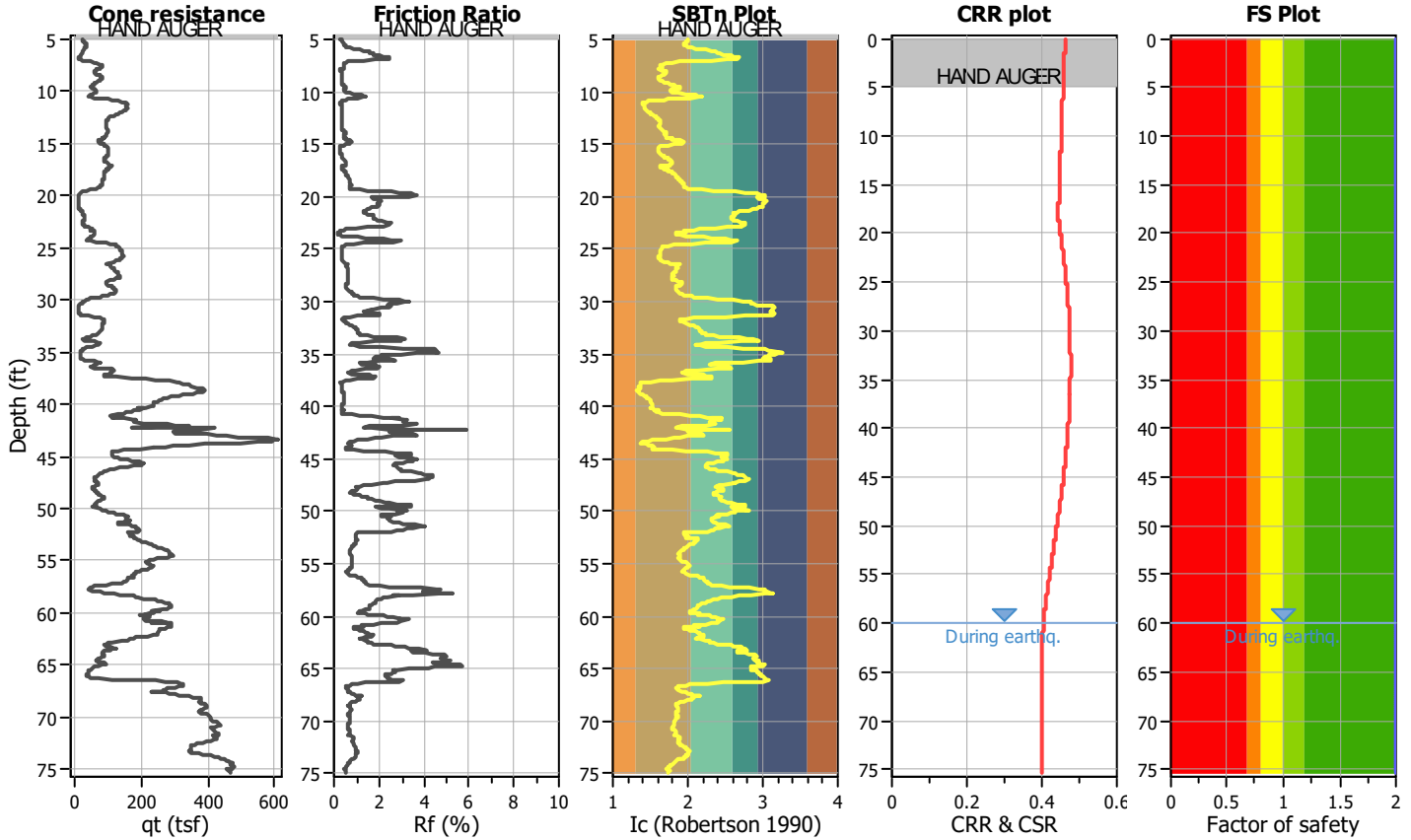

Liquefaction analysis overall plots

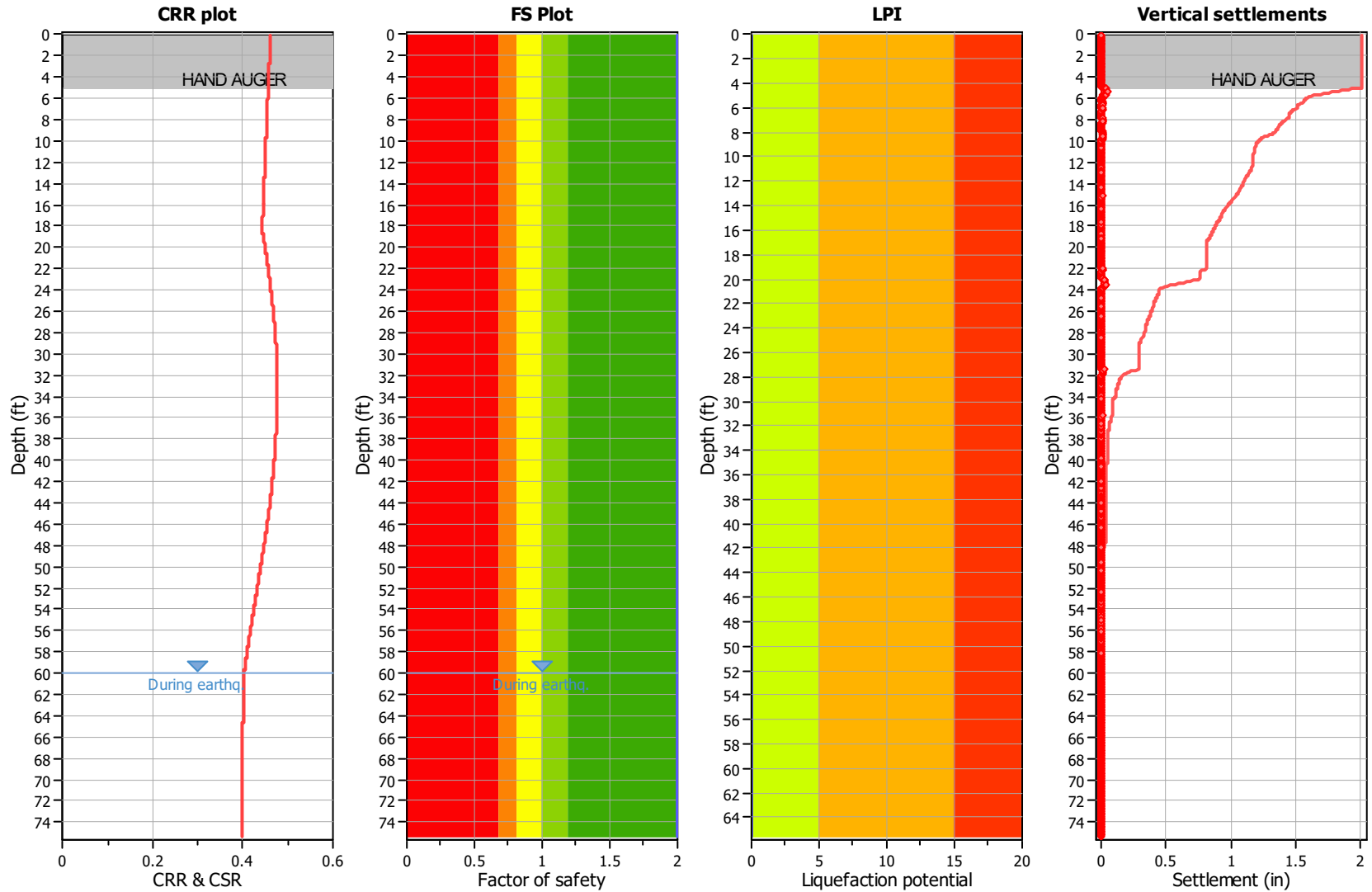

Input parameters and analysis data

Analysis method:	NCEER (1998)	Depth to water table (earthq.):	60.00 ft	Fill weight:	N/A
Fines correction method:	NCEER (1998)	Average results interval:	1	Transition detect. applied:	No
Points to test:	Based on Ic value	Ic cut-off value:	2.60	K_{σ} applied:	Yes
Earthquake magnitude M_w :	7.30	Unit weight calculation:	Based on SBT	Clay like behavior applied:	Sands only
Peak ground acceleration:	0.76	Use fill:	No	Limit depth applied:	Yes
Depth to water table (insitu):	116.00 ft	Fill height:	N/A	Limit depth:	50.00 ft

F.S. color scheme

- Almost certain it will liquefy
- Very likely to liquefy
- Liquefaction and no liq. are equally likely
- Unlike to liquefy
- Almost certain it will not liquefy

LPI color scheme

- Very high risk
- High risk
- Low risk



LIQUEFACTION ANALYSIS REPORT

Project title : Leighton Consulting / Norwalk Transit Village Location : Norwalk, CA

CPT file : CPT-4

Input parameters and analysis data

Analysis method:	NCEER (1998)	G.W.T. (in-situ):	116.00 ft	Use fill:	No	Clay like behavior applied:	Sands only
Fines correction method:	NCEER (1998)	G.W.T. (earthq.):	60.00 ft	Fill height:	N/A	Limit depth applied:	Yes
Points to test:	Based on Ic value	Average results interval:	1	Fill weight:	N/A	Limit depth:	50.00 ft
Earthquake magnitude M_w :	7.30	Ic cut-off value:	2.60	Trans. detect. applied:	No	MSF method:	Method based
Peak ground acceleration:	0.76	Unit weight calculation:	Based on SBT	K_0 applied:	Yes		

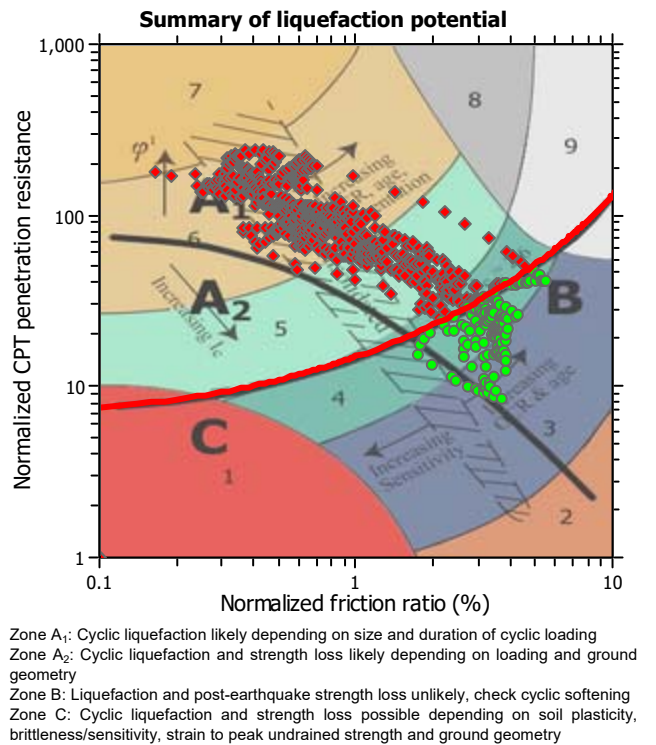
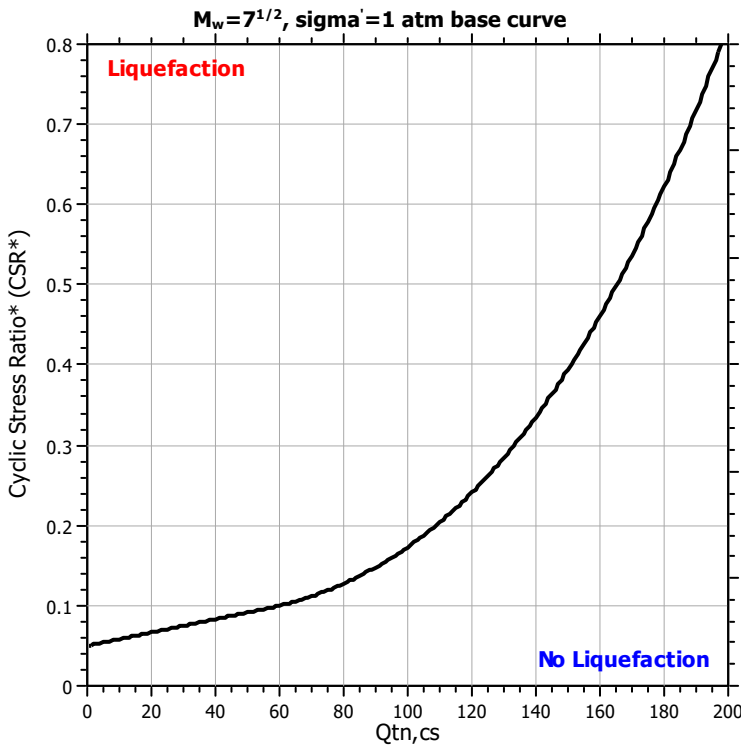
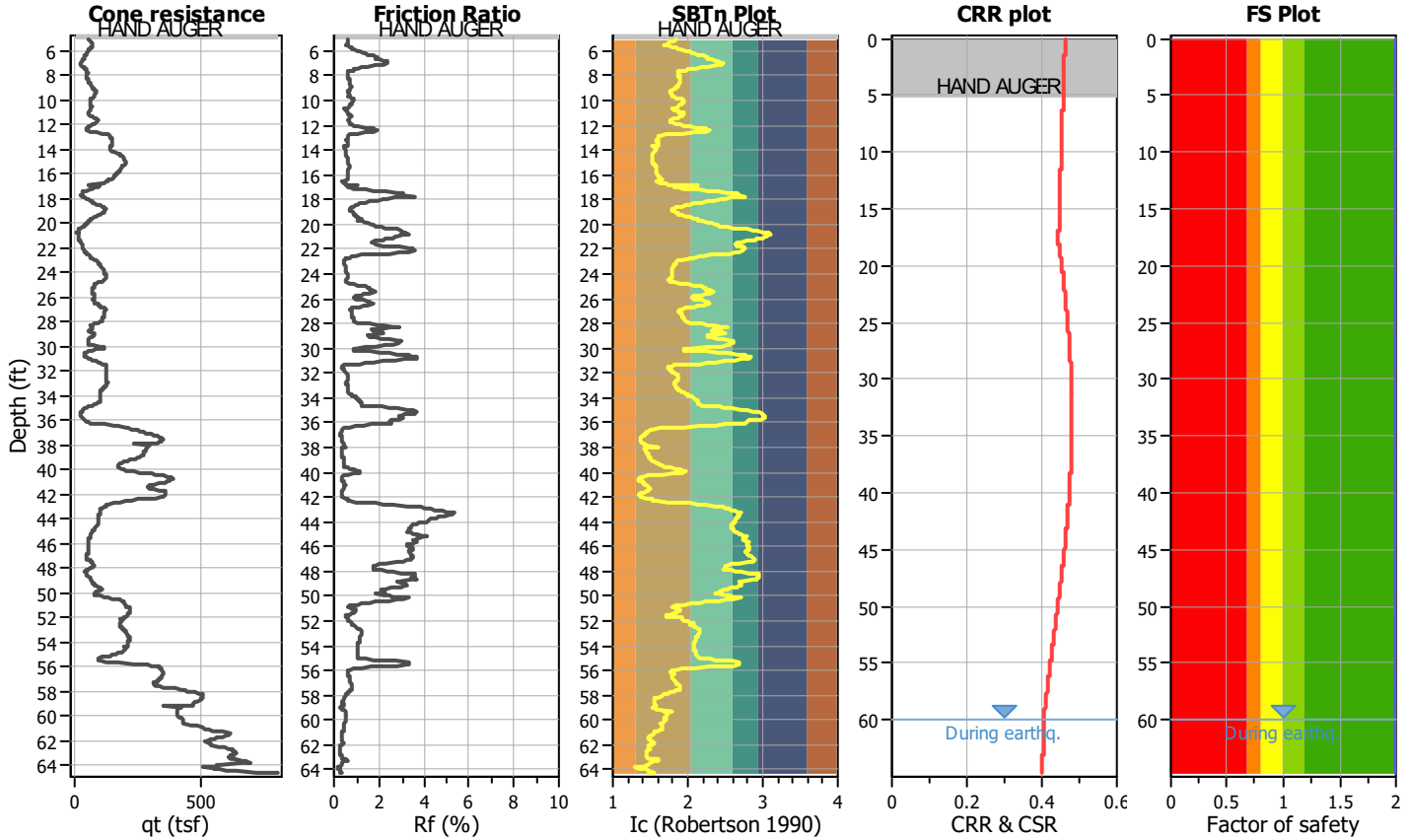

Liquefaction analysis overall plots

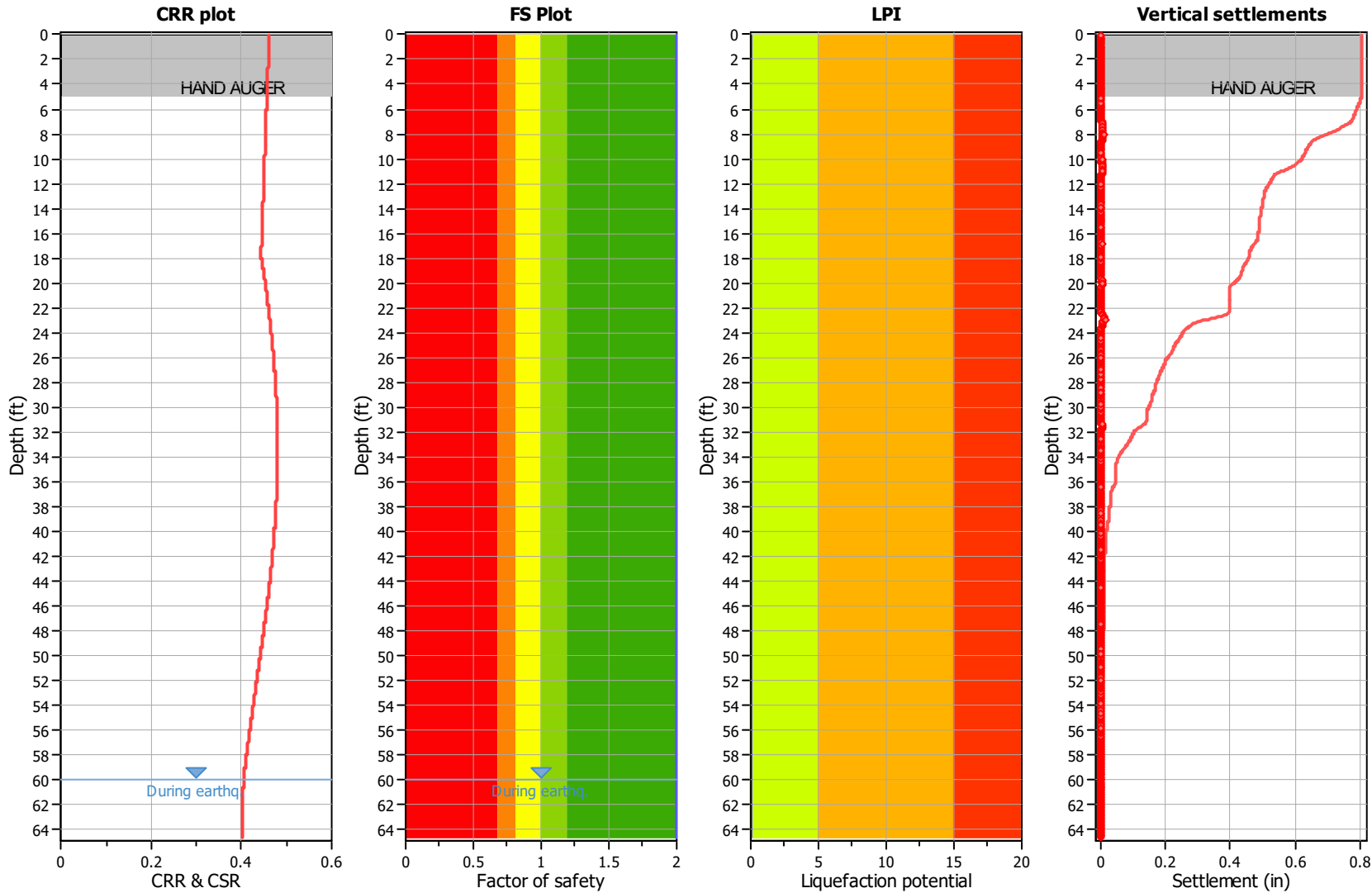

Input parameters and analysis data

Analysis method:	NCEER (1998)	Depth to water table (earthq.):	60.00 ft	Fill weight:	N/A
Fines correction method:	NCEER (1998)	Average results interval:	1	Transition detect. applied:	No
Points to test:	Based on Ic value	Ic cut-off value:	2.60	K_{σ} applied:	Yes
Earthquake magnitude M_w :	7.30	Unit weight calculation:	Based on SBT	Clay like behavior applied:	Sands only
Peak ground acceleration:	0.76	Use fill:	No	Limit depth applied:	Yes
Depth to water table (insitu):	116.00 ft	Fill height:	N/A	Limit depth:	50.00 ft

F.S. color scheme

- Almost certain it will liquefy
- Very likely to liquefy
- Liquefaction and no liq. are equally likely
- Unlike to liquefy
- Almost certain it will not liquefy

LPI color scheme

- Very high risk
- High risk
- Low risk



LIQUEFACTION ANALYSIS REPORT

Project title : Leighton Consulting / Norwalk Transit Village Location : Norwalk, CA

CPT file : CPT-5

Input parameters and analysis data

Analysis method:	NCEER (1998)	G.W.T. (in-situ):	116.00 ft	Use fill:	No	Clay like behavior applied:	Sands only
Fines correction method:	NCEER (1998)	G.W.T. (earthq.):	60.00 ft	Fill height:	N/A	Limit depth applied:	Yes
Points to test:	Based on Ic value	Average results interval:	1	Fill weight:	N/A	Limit depth:	50.00 ft
Earthquake magnitude M_w :	7.30	Ic cut-off value:	2.60	Trans. detect. applied:	No	MSF method:	Method based
Peak ground acceleration:	0.76	Unit weight calculation:	Based on SBT	K_0 applied:	Yes		

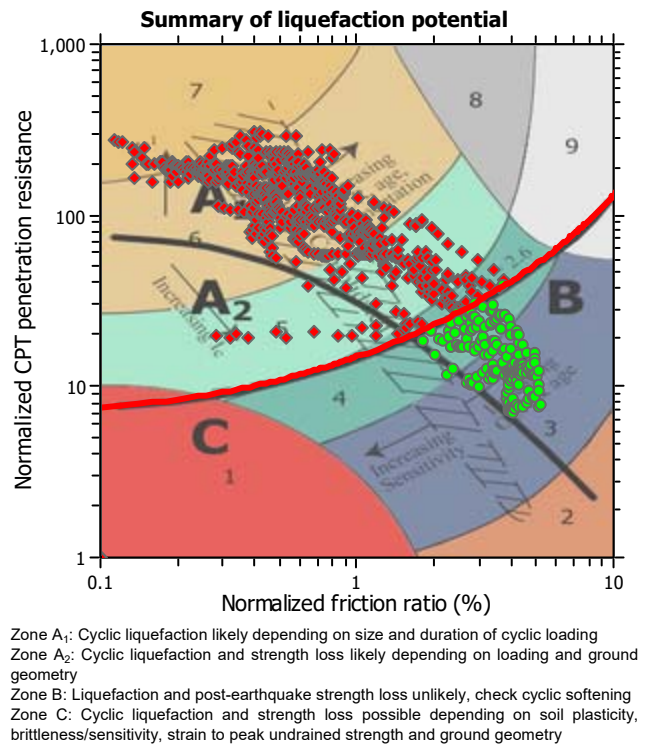
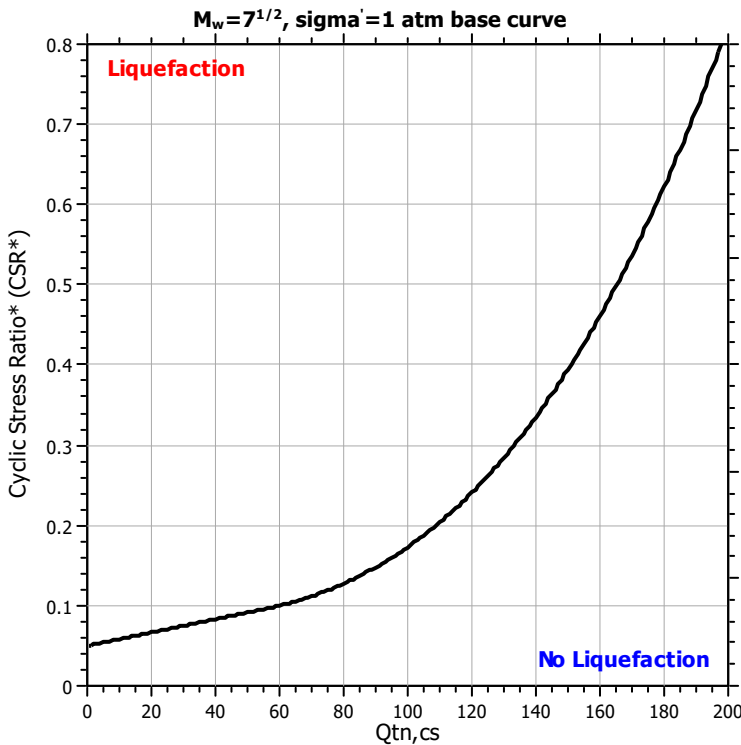
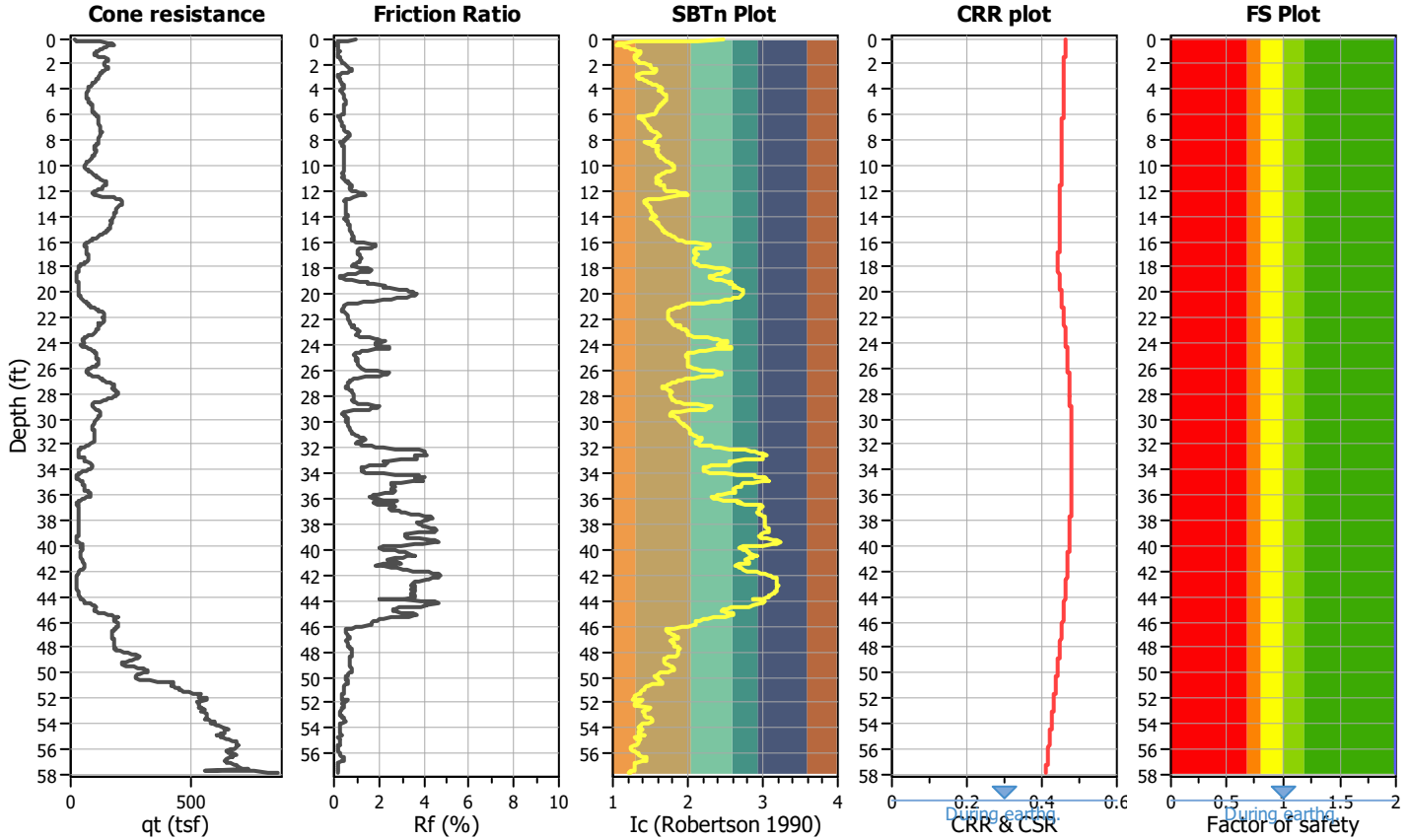

Liquefaction analysis overall plots

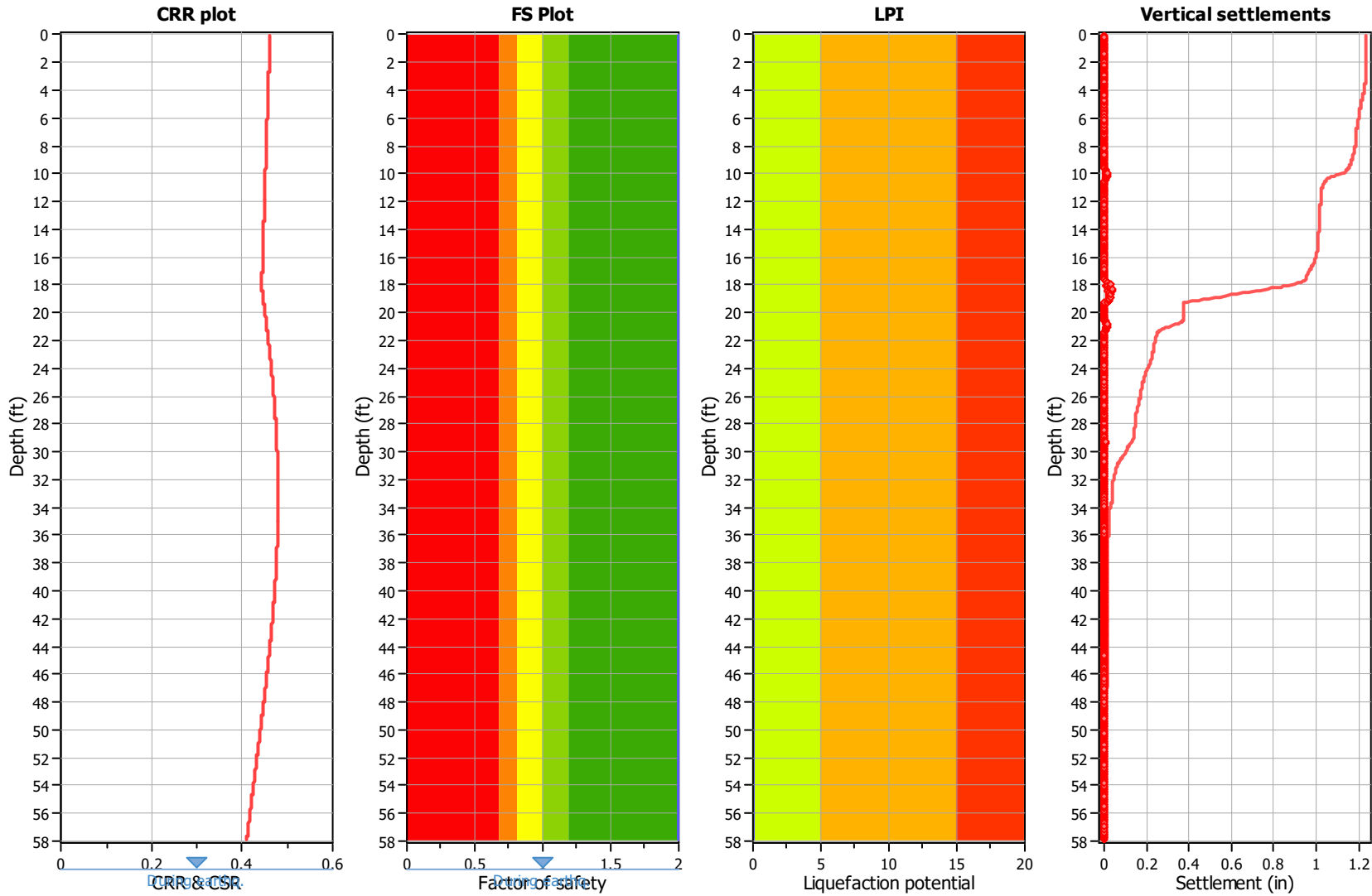

Input parameters and analysis data

Analysis method:	NCEER (1998)	Depth to water table (erthq.):	60.00 ft	Fill weight:	N/A
Fines correction method:	NCEER (1998)	Average results interval:	1	Transition detect. applied:	No
Points to test:	Based on Ic value	Ic cut-off value:	2.60	K_{σ} applied:	Yes
Earthquake magnitude M_w :	7.30	Unit weight calculation:	Based on SBT	Clay like behavior applied:	Sands only
Peak ground acceleration:	0.76	Use fill:	No	Limit depth applied:	Yes
Depth to water table (insitu):	116.00 ft	Fill height:	N/A	Limit depth:	50.00 ft

F.S. color scheme

- Almost certain it will liquefy
- Very likely to liquefy
- Liquefaction and no liq. are equally likely
- Unlike to liquefy
- Almost certain it will not liquefy

LPI color scheme

- Very high risk
- High risk
- Low risk



LIQUEFACTION ANALYSIS REPORT

Project title : Leighton Consulting / Norwalk Transit Village Location : Norwalk, CA

CPT file : CPT-6

Input parameters and analysis data

Analysis method:	NCEER (1998)	G.W.T. (in-situ):	116.00 ft	Use fill:	No	Clay like behavior applied:	Sands only
Fines correction method:	NCEER (1998)	G.W.T. (earthq.):	60.00 ft	Fill height:	N/A	Limit depth applied:	Yes
Points to test:	Based on Ic value	Average results interval:	1	Fill weight:	N/A	Limit depth:	50.00 ft
Earthquake magnitude M_w :	7.30	Ic cut-off value:	2.60	Trans. detect. applied:	No	MSF method:	Method based
Peak ground acceleration:	0.76	Unit weight calculation:	Based on SBT	K_0 applied:	Yes		

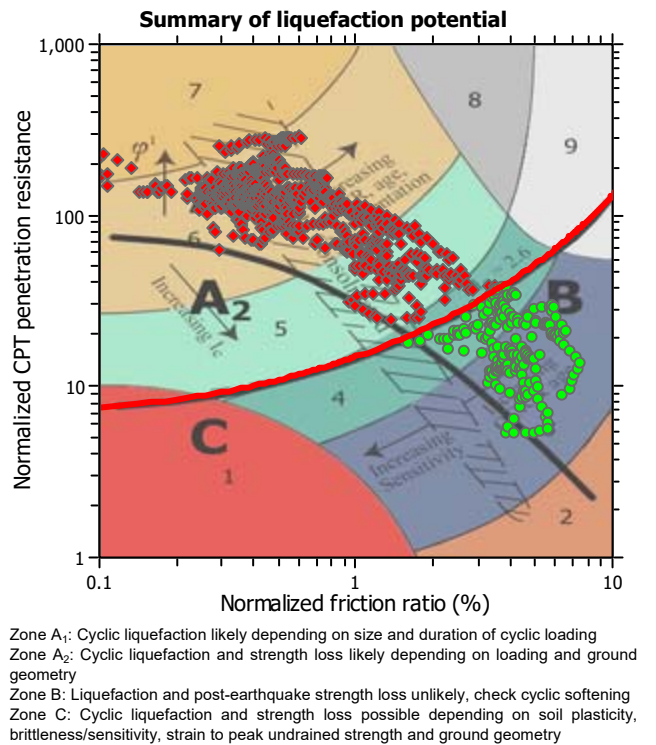
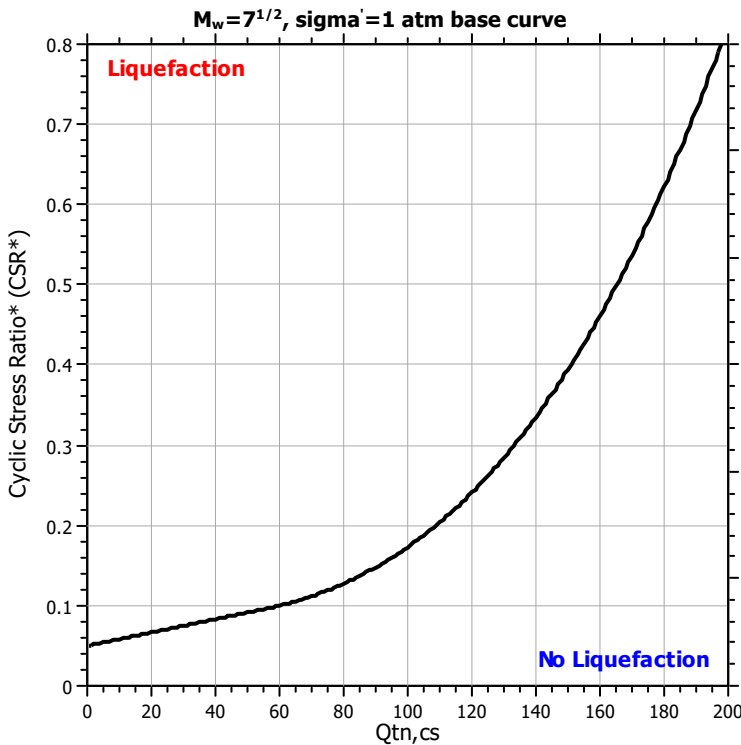
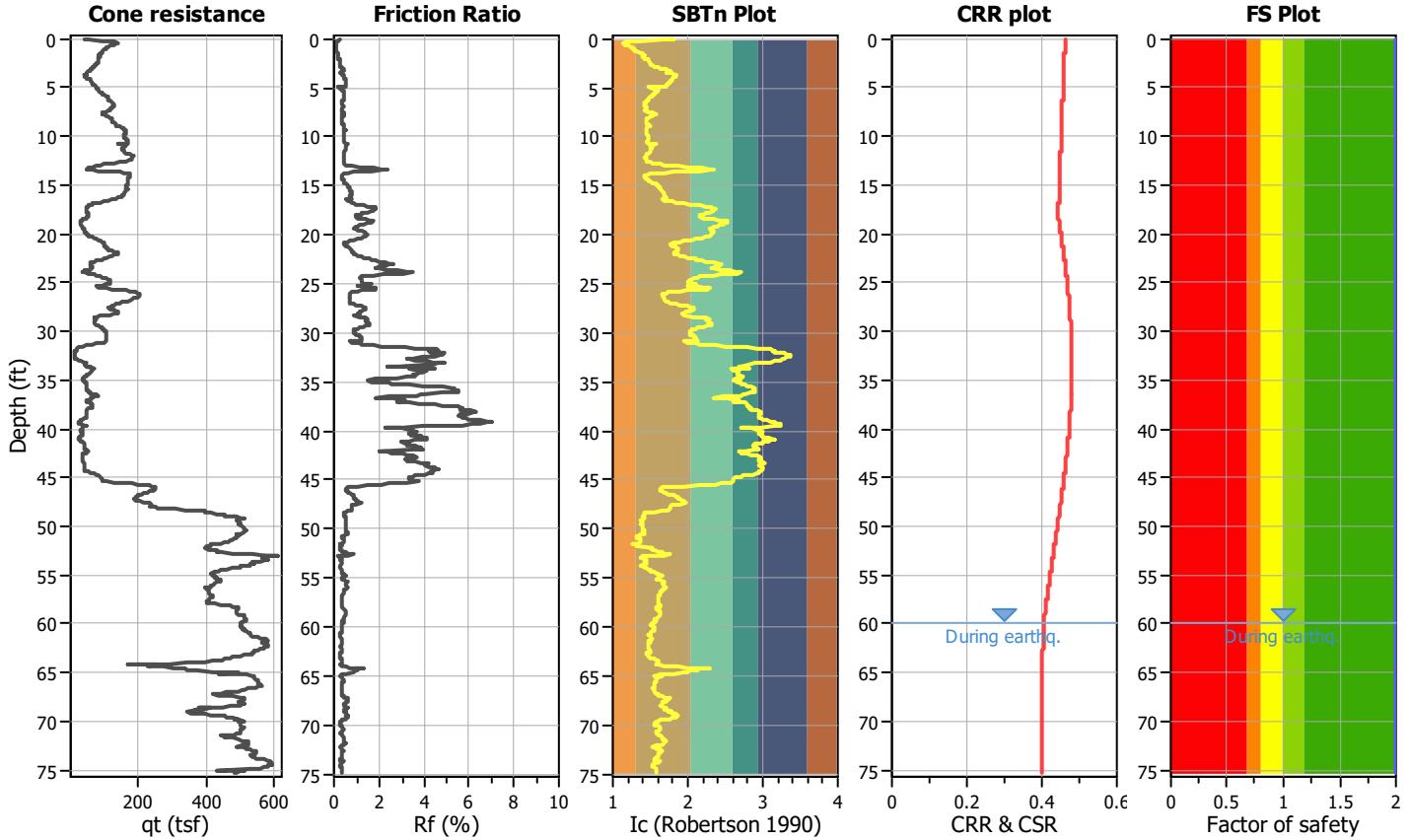

Liquefaction analysis overall plots

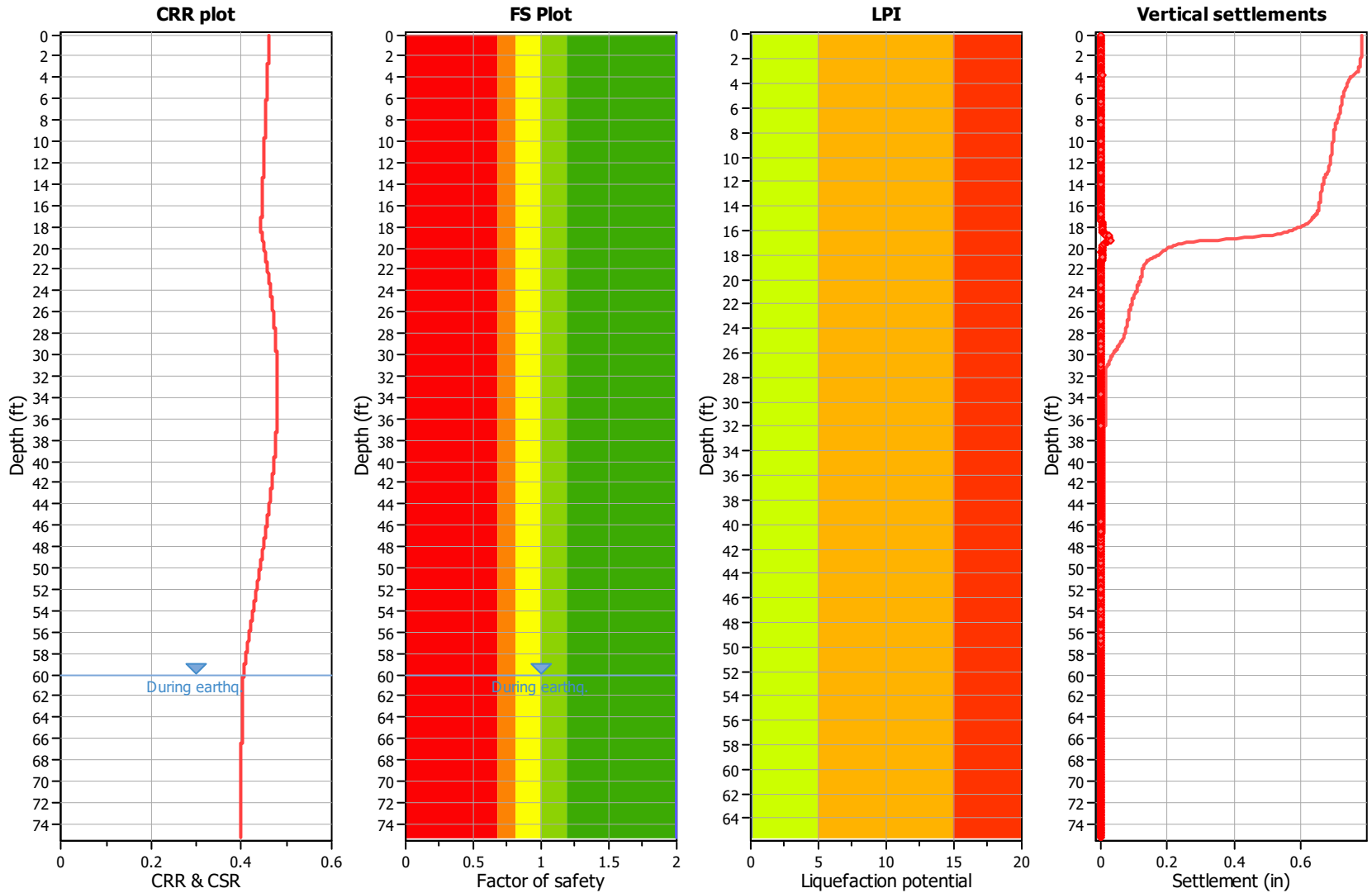

Input parameters and analysis data

Analysis method:	NCEER (1998)	Depth to water table (earthq.):	60.00 ft	Fill weight:	N/A
Fines correction method:	NCEER (1998)	Average results interval:	1	Transition detect. applied:	No
Points to test:	Based on Ic value	Ic cut-off value:	2.60	K_{σ} applied:	Yes
Earthquake magnitude M_w :	7.30	Unit weight calculation:	Based on SBT	Clay like behavior applied:	Sands only
Peak ground acceleration:	0.76	Use fill:	No	Limit depth applied:	Yes
Depth to water table (insitu):	116.00 ft	Fill height:	N/A	Limit depth:	50.00 ft

F.S. color scheme

- Almost certain it will liquefy
- Very likely to liquefy
- Liquefaction and no liq. are equally likely
- Unlike to liquefy
- Almost certain it will not liquefy

LPI color scheme

- Very high risk
- High risk
- Low risk

APPENDIX D

GENERAL EARTHWORK AND GRADING SPECIFICATIONS



Leighton

APPENDIX D
 LEIGHTON AND ASSOCIATES, INC.
 GENERAL EARTHWORK AND GRADING SPECIFICATIONS FOR ROUGH GRADING

TABLE OF CONTENTS

<u>Section</u>	<u>Appendix D Page</u>
1.0 GENERAL	1
1.1 Intent.....	1
1.2 The Geotechnical Consultant of Record	1
1.3 The Earthwork Contractor.....	2
2.0 PREPARATION OF AREAS TO BE FILLED.....	2
2.1 Clearing and Grubbing.....	2
2.2 Processing.....	3
2.3 Overexcavation.....	3
2.4 Benching.....	3
2.5 Evaluation/Acceptance of Fill Areas	4
3.0 FILL MATERIAL	4
3.1 General.....	4
3.2 Oversize.....	4
3.3 Import.....	4
4.0 FILL PLACEMENT AND COMPACTION.....	5
4.1 Fill Layers	5
4.2 Fill Moisture Conditioning.....	5
4.3 Compaction of Fill	5
4.4 Compaction of Fill Slopes	5
4.5 Compaction Testing.....	5
4.6 Frequency of Compaction Testing	6
4.7 Compaction Test Locations	6
5.0 SUBDRAIN INSTALLATION.....	6
6.0 EXCAVATION	6
7.0 TRENCH BACKFILLS	7
7.1 Safety.....	7
7.2 Bedding and Backfill	7
7.3 Lift Thickness.....	7
7.4 Observation and Testing.....	7



LEIGHTON AND ASSOCIATES, INC.

GENERAL EARTHWORK AND GRADING SPECIFICATIONS FOR ROUGH GRADING

TABLE OF CONTENTS (CONT'D)

Standard Details

A - Keying and Benching	Rear of Text
B - Oversize Rock Disposal	Rear of Text
C - Canyon Subdrains	Rear of Text
D - Buttress or Replacement Fill Subdrains	Rear of Text
E - Transition Lot Fills and Side Hill Fills	Rear of Text

1.0 GENERAL

1.1 Intent

These General Earthwork and Grading Specifications are for the grading and earthwork shown on the approved grading plan(s) and/or indicated in the geotechnical report(s). These Specifications are a part of the recommendations contained in the geotechnical report(s). In case of conflict, the specific recommendations in the geotechnical report shall supersede these more general Specifications. Observations of the earthwork by the project Geotechnical Consultant during the course of grading may result in new or revised recommendations that could supersede these specifications or the recommendations in the geotechnical report(s).

1.2 The Geotechnical Consultant of Record

Prior to commencement of work, the owner shall employ the Geotechnical Consultant of Record (Geotechnical Consultant). The Geotechnical Consultants shall be responsible for reviewing the approved geotechnical report(s) and accepting the adequacy of the preliminary geotechnical findings, conclusions, and recommendations prior to the commencement of the grading.

Prior to commencement of grading, the Geotechnical Consultant shall review the "work plan" prepared by the Earthwork Contractor (Contractor) and schedule sufficient personnel to perform the appropriate level of observation, mapping, and compaction testing.

During the grading and earthwork operations, the Geotechnical Consultant shall observe, map, and document the subsurface exposures to verify the geotechnical design assumptions. If the observed conditions are found to be significantly different than the interpreted assumptions during the design phase, the Geotechnical Consultant shall inform the owner, recommend appropriate changes in design to accommodate the observed conditions, and notify the review agency where required. Subsurface areas to be geotechnically observed, mapped, elevations recorded, and/or tested include natural ground after it has been cleared for receiving fill but before fill is placed, bottoms of all "remedial removal" areas, all key bottoms, and benches made on sloping ground to receive fill.

The Geotechnical Consultant shall observe the moisture-conditioning and processing of the subgrade and fill materials and perform relative compaction testing of fill to determine the attained level of compaction.

The Geotechnical Consultant shall provide the test results to the owner and the Contractor on a routine and frequent basis.

1.3 The Earthwork Contractor

The Earthwork Contractor (Contractor) shall be qualified, experienced, and knowledgeable in earthwork logistics, preparation and processing of ground to receive fill, moisture-conditioning and processing of fill, and compacting fill. The Contractor shall review and accept the plans, geotechnical report(s), and these Specifications prior to commencement of grading. The Contractor shall be solely responsible for performing the grading in accordance with the plans and specifications.

The Contractor shall prepare and submit to the owner and the Geotechnical Consultant a work plan that indicates the sequence of earthwork grading, the number of "spreads" of work and the estimated quantities of daily earthwork contemplated for the site prior to commencement of grading. The Contractor shall inform the owner and the Geotechnical Consultant of changes in work schedules and updates to the work plan at least 24 hours in advance of such changes so that appropriate observations and tests can be planned and accomplished. The Contractor shall not assume that the Geotechnical Consultant is aware of all grading operations.

The Contractor shall have the sole responsibility to provide adequate equipment and methods to accomplish the earthwork in accordance with the applicable grading codes and agency ordinances, these Specifications, and the recommendations in the approved geotechnical report(s) and grading plan(s). If, in the opinion of the Geotechnical Consultant, unsatisfactory conditions, such as unsuitable soil, improper moisture condition, inadequate compaction, insufficient buttress key size, adverse weather, etc., are resulting in a quality of work less than required in these specifications, the Geotechnical Consultant shall reject the work and may recommend to the owner that construction be stopped until the conditions are rectified.

2.0 PREPARATION OF AREAS TO BE FILLED

2.1 Clearing and Grubbing

Vegetation, such as brush, grass, roots, and other deleterious material shall be sufficiently removed and properly disposed of in a method acceptable to the owner, governing agencies, and the Geotechnical Consultant.

The Geotechnical Consultant shall evaluate the extent of these removals depending on specific site conditions. Earth fill material shall not contain more than 1 percent of organic materials (by volume). No fill lift shall contain more than 5 percent of organic matter. Nesting of the organic materials shall not be allowed.

If potentially hazardous materials are encountered, the Contractor shall stop work in the affected area, and a hazardous material specialist shall be informed immediately for proper evaluation and handling of these materials prior to continuing to work in that area.

As presently defined by the State of California, most refined petroleum products (gasoline, diesel fuel, motor oil, grease, coolant, etc.) have chemical constituents that are considered to be hazardous waste. As such, the indiscriminate dumping or spillage of these fluids onto the ground may constitute a misdemeanor, punishable by fines and/or imprisonment, and shall not be allowed.

2.2 Processing

Existing ground that has been declared satisfactory for support of fill by the Geotechnical Consultant shall be scarified to a minimum depth of 6 inches. Existing ground that is not satisfactory shall be overexcavated as specified in the following section. Scarification shall continue until soils are broken down and free of large clay lumps or clods and the working surface is reasonably uniform, flat, and free of uneven features that would inhibit uniform compaction.

2.3 Overexcavation

In addition to removals and overexcavations recommended in the approved geotechnical report(s) and the grading plan, soft, loose, dry, saturated, spongy, organic-rich, highly fractured or otherwise unsuitable ground shall be overexcavated to competent ground as evaluated by the Geotechnical Consultant during grading.

2.4 Benching

Where fills are to be placed on ground with slopes steeper than 5:1 (horizontal to vertical units), the ground shall be stepped or benched. Please see the Standard Details for a graphic illustration. The lowest bench or key shall be a minimum of 15 feet wide and at least 2 feet deep, into competent material as evaluated by the Geotechnical Consultant. Other benches shall be excavated a minimum height of 4 feet into competent material or as otherwise recommended by the Geotechnical

Consultant. Fill placed on ground sloping flatter than 5:1 shall also be benched or otherwise overexcavated to provide a flat subgrade for the fill.

2.5 Evaluation/Acceptance of Fill Areas

All areas to receive fill, including removal and processed areas, key bottoms, and benches, shall be observed, mapped, elevations recorded, and/or tested prior to being accepted by the Geotechnical Consultant as suitable to receive fill. The Contractor shall obtain a written acceptance from the Geotechnical Consultant prior to fill placement. A licensed surveyor shall provide the survey control for determining elevations of processed areas, keys, and benches.

3.0 FILL MATERIAL

3.1 General

Material to be used as fill shall be essentially free of organic matter and other deleterious substances evaluated and accepted by the Geotechnical Consultant prior to placement. Soils of poor quality, such as those with unacceptable gradation, high expansion potential, or low strength shall be placed in areas acceptable to the Geotechnical Consultant or mixed with other soils to achieve satisfactory fill material.

3.2 Oversize

Oversize material defined as rock, or other irreducible material with a maximum dimension greater than 8 inches, shall not be buried or placed in fill unless location, materials, and placement methods are specifically accepted by the Geotechnical Consultant. Placement operations shall be such that nesting of oversized material does not occur and such that oversize material is completely surrounded by compacted or densified fill. Oversize material shall not be placed within 10 vertical feet of finish grade or within 2 feet of future utilities or underground construction.

3.3 Import

If importing of fill material is required for grading, proposed import material shall meet the requirements of Section 3.1. The potential import source shall be given to the Geotechnical Consultant at least 48 hours (2 working days) before importing begins so that its suitability can be determined and appropriate tests performed.

4.0 FILL PLACEMENT AND COMPACTION

4.1 Fill Layers

Approved fill material shall be placed in areas prepared to receive fill (per Section 3.0) in near-horizontal layers not exceeding 8 inches in loose thickness. The Geotechnical Consultant may accept thicker layers if testing indicates the grading procedures can adequately compact the thicker layers. Each layer shall be spread evenly and mixed thoroughly to attain relative uniformity of material and moisture throughout.

4.2 Fill Moisture Conditioning

Fill soils shall be watered, dried back, blended, and/or mixed, as necessary to attain a relatively uniform moisture content at or slightly over optimum. Maximum density and optimum soil moisture content tests shall be performed in accordance with the American Society of Testing and Materials (ASTM Test Method D1557).

4.3 Compaction of Fill

After each layer has been moisture-conditioned, mixed, and evenly spread, it shall be uniformly compacted to not less than 90 percent of maximum dry density (ASTM Test Method D1557). Compaction equipment shall be adequately sized and be either specifically designed for soil compaction or of proven reliability to efficiently achieve the specified level of compaction with uniformity.

4.4 Compaction of Fill Slopes

In addition to normal compaction procedures specified above, compaction of slopes shall be accomplished by backrolling of slopes with sheepfoot rollers at increments of 3 to 4 feet in fill elevation, or by other methods producing satisfactory results acceptable to the Geotechnical Consultant. Upon completion of grading, relative compaction of the fill, out to the slope face, shall be at least 90 percent of maximum density per ASTM Test Method D1557.

4.5 Compaction Testing

Field-tests for moisture content and relative compaction of the fill soils shall be performed by the Geotechnical Consultant. Location and frequency of tests shall be at the Consultant's discretion based on field conditions encountered. Compaction test locations will not necessarily be selected on a random basis. Test locations shall be selected to verify

adequacy of compaction levels in areas that are judged to be prone to inadequate compaction (such as close to slope faces and at the fill/bedrock benches).

4.6 Frequency of Compaction Testing

Tests shall be taken at intervals not exceeding 2 feet in vertical rise and/or 1,000 cubic yards of compacted fill soils embankment. In addition, as a guideline, at least one test shall be taken on slope faces for each 5,000 square feet of slope face and/or each 10 feet of vertical height of slope. The Contractor shall assure that fill construction is such that the testing schedule can be accomplished by the Geotechnical Consultant. The Contractor shall stop or slow down the earthwork construction if these minimum standards are not met.

4.7 Compaction Test Locations

The Geotechnical Consultant shall document the approximate elevation and horizontal coordinates of each test location. The Contractor shall coordinate with the project surveyor to assure that sufficient grade stakes are established so that the Geotechnical Consultant can determine the test locations with sufficient accuracy. At a minimum, two grade stakes within a horizontal distance of 100 feet and vertically less than 5 feet apart from potential test locations shall be provided.

5.0 SUBDRAIN INSTALLATION

Subdrain systems shall be installed in accordance with the approved geotechnical report(s), the grading plan, and the Standard Details. The Geotechnical Consultant may recommend additional subdrains and/or changes in subdrain extent, location, grade, or material depending on conditions encountered during grading. All subdrains shall be surveyed by a land surveyor/civil engineer for line and grade after installation and prior to burial. Sufficient time should be allowed by the Contractor for these surveys.

6.0 EXCAVATION

Excavations, as well as over-excavation for remedial purposes, shall be evaluated by the Geotechnical Consultant during grading. Remedial removal depths shown on geotechnical plans are estimates only. The actual extent of removal shall be determined by the Geotechnical Consultant based on the field evaluation of exposed conditions during grading. Where fill-over-cut slopes are to be graded, the cut portion of the slope shall be made, evaluated, and accepted by the Geotechnical Consultant prior to placement of materials for construction of

the fill portion of the slope, unless otherwise recommended by the Geotechnical Consultant.

7.0 TRENCH BACKFILLS

7.1 Safety

The Contractor shall follow all OSHA and Cal/OSHA requirements for safety of trench excavations.

7.2 Bedding and Backfill

All bedding and backfill of utility trenches shall be performed in accordance with the applicable provisions of Standard Specifications of Public Works Construction. Bedding material shall have a Sand Equivalent greater than 30 (SE>30). The bedding shall be placed to 1 foot over the top of the conduit and densified by jetting. Backfill shall be placed and densified to a minimum of 90 percent of relative compaction from 1 foot above the top of the conduit to the surface.

The Geotechnical Consultant shall test the trench backfill for relative compaction. At least one test should be made for every 300 feet of trench and 2 feet of fill.

7.3 Lift Thickness

Lift thickness of trench backfill shall not exceed those allowed in the Standard Specifications of Public Works Construction unless the Contractor can demonstrate to the Geotechnical Consultant that the fill lift can be compacted to the minimum relative compaction by his alternative equipment and method.

7.4 Observation and Testing

The jetting of the bedding around the conduits shall be observed by the Geotechnical Consultant.

FILL SLOPE

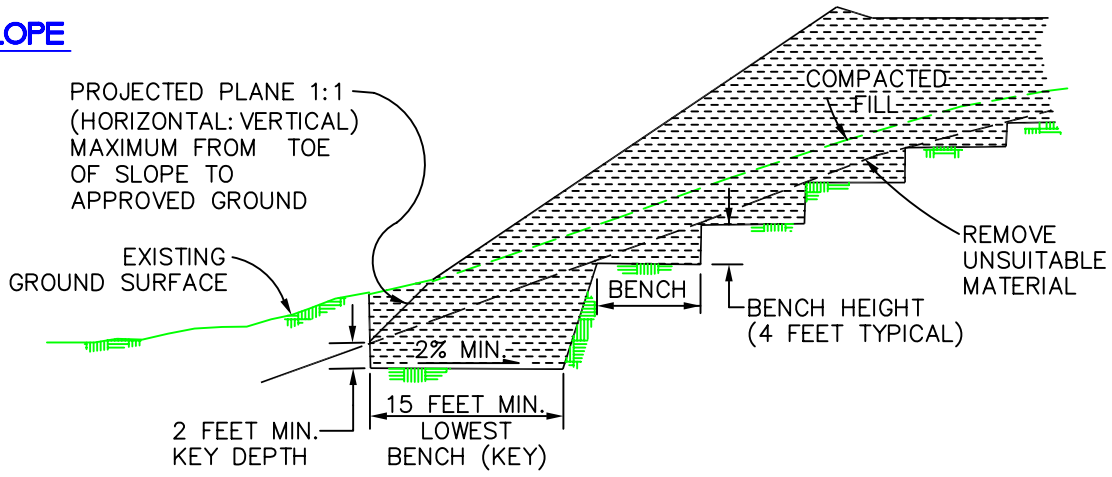

FILL-OVER-CUT SLOPE

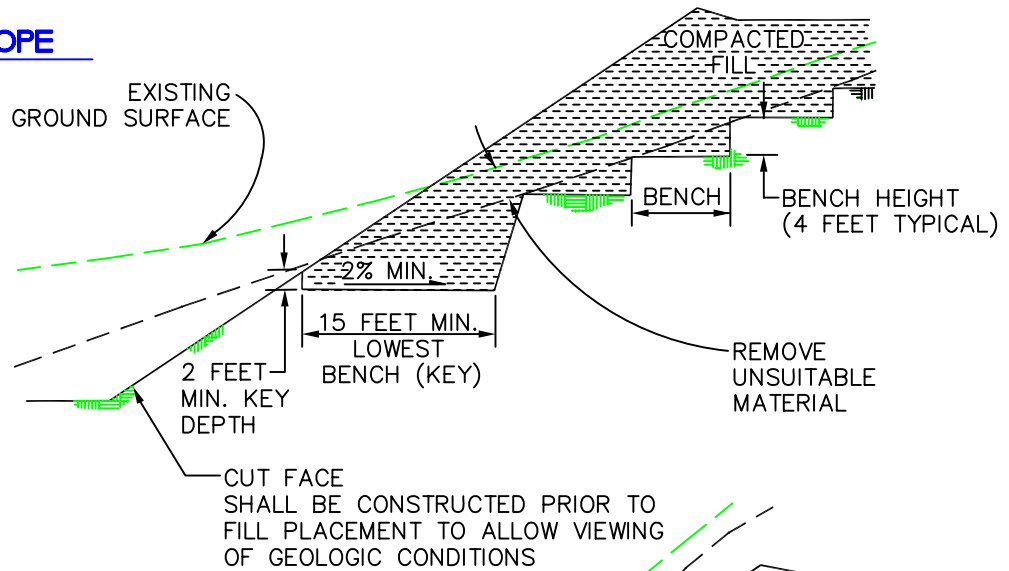

CUT-OVER-FILL SLOPE

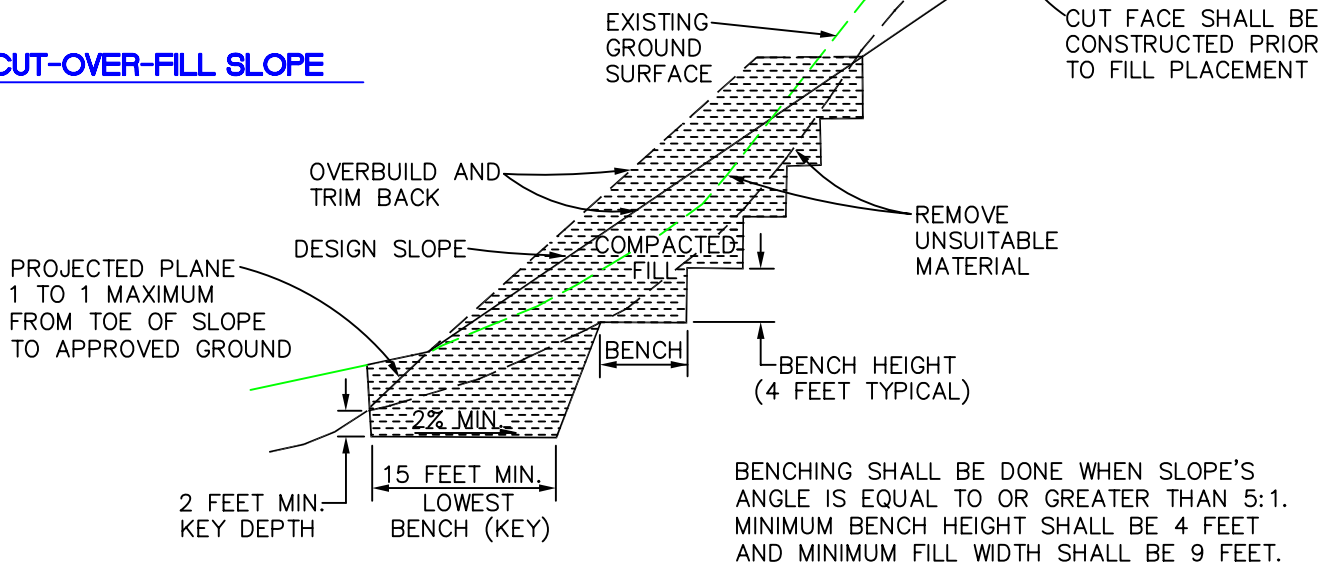

BENCHING SHALL BE DONE WHEN SLOPE'S ANGLE IS EQUAL TO OR GREATER THAN 5:1. MINIMUM BENCH HEIGHT SHALL BE 4 FEET AND MINIMUM FILL WIDTH SHALL BE 9 FEET.

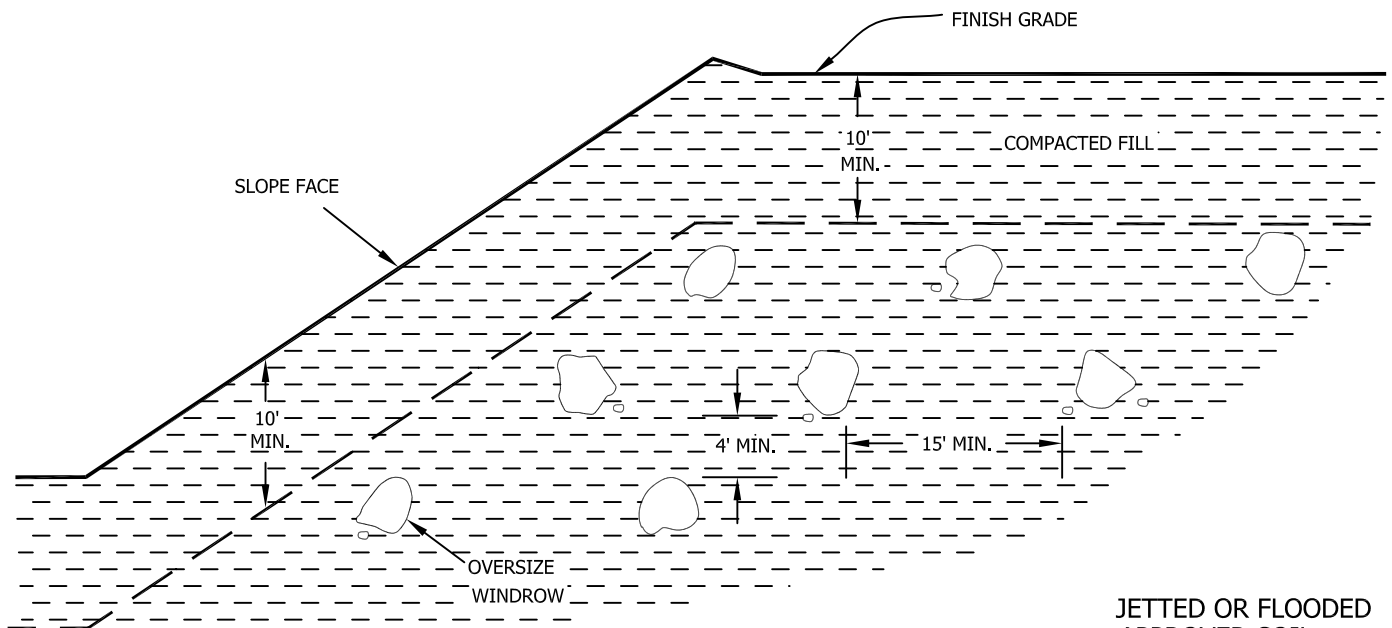

- Oversize rock is larger than 8 inches in largest dimension.
- Backfill with approved soil jetted or flooded in place to fill all the voids.
- Do not bury rock within 10 feet of finish grade.
- Windrow of buried rock shall be parallel to the finished slope face.

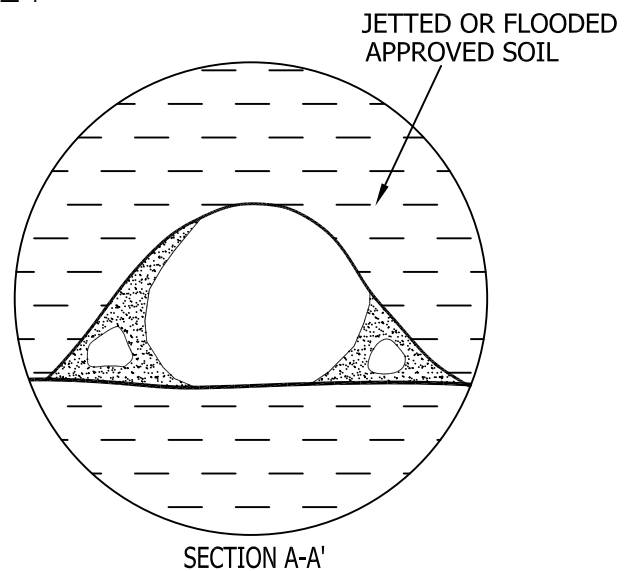

PROFILE ALONG WINDROW

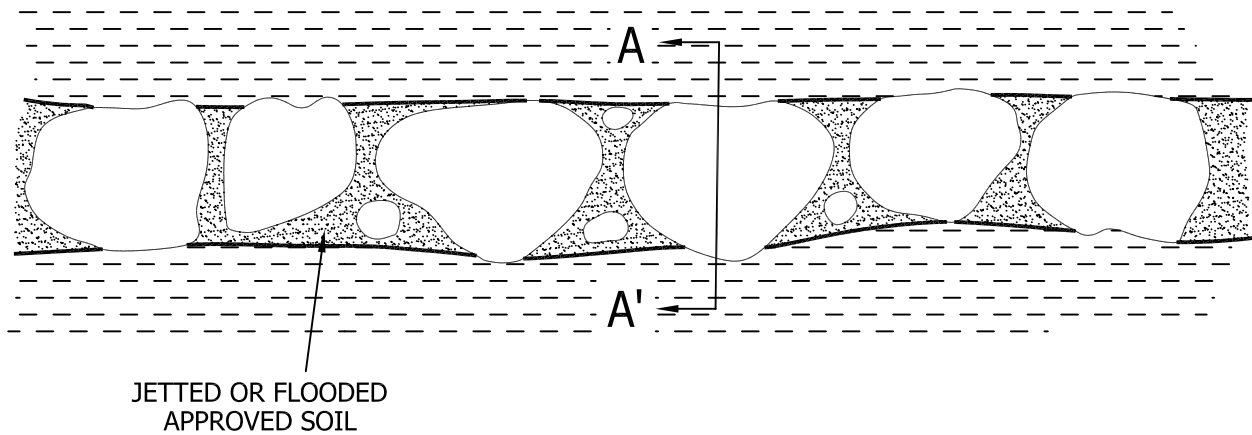

OVERSIZE ROCK DISPOSAL

GENERAL EARTHWORK AND GRADING
SPECIFICATIONS
STANDARD DETAILS B



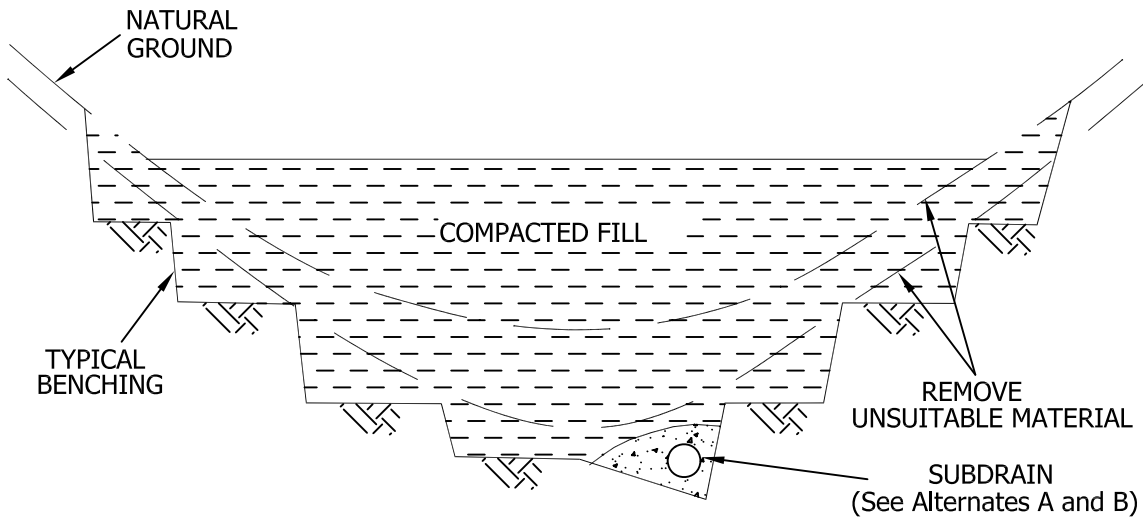

SUBDRAIN ALTERNATE A

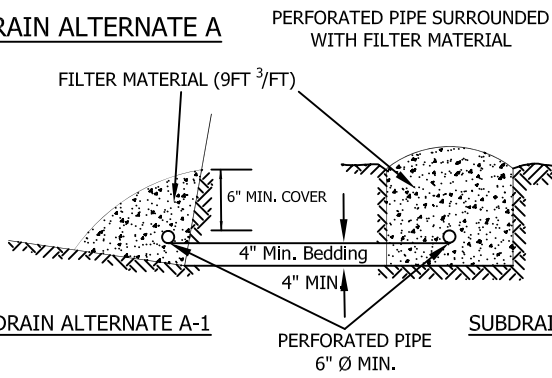

FILTER MATERIAL
 FILTER MATERIAL SHALL BE CLASS 2 PERMEABLE MATERIAL PER STATE OF CALIFORNIA STANDARD SPECIFICATION, OR APPROVED ALTERNATE.
 CLASS 2 GRADING AS FOLLOWS:

Sieve Size	Percent Passing
1"	100
3/4"	90-100
3/8"	40-100
No. 4	25-40
No. 8	18-33
No. 30	5-15
No. 50	0-7
No. 200	0-3

SUBDRAIN ALTERNATE B

DETAIL OF CANYON SUBDRAIN TERMINAL

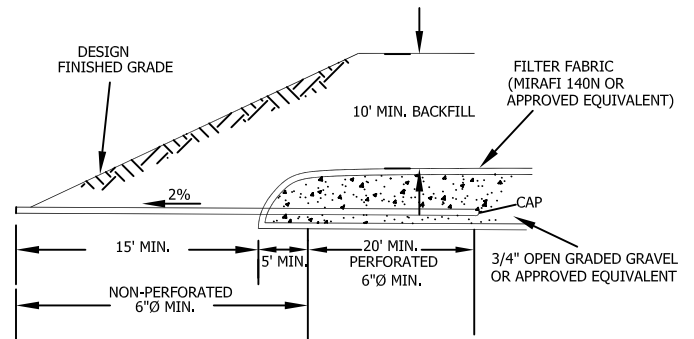
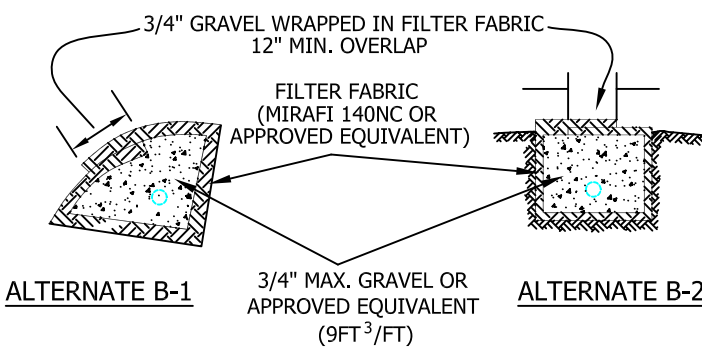

○ PERFORATED PIPE IS OPTIONAL PER GOVERNING AGENCY'S REQUIREMENTS

CANYON
SUBDRAIN

GENERAL EARTHWORK AND GRADING
SPECIFICATIONS
STANDARD DETAILS C



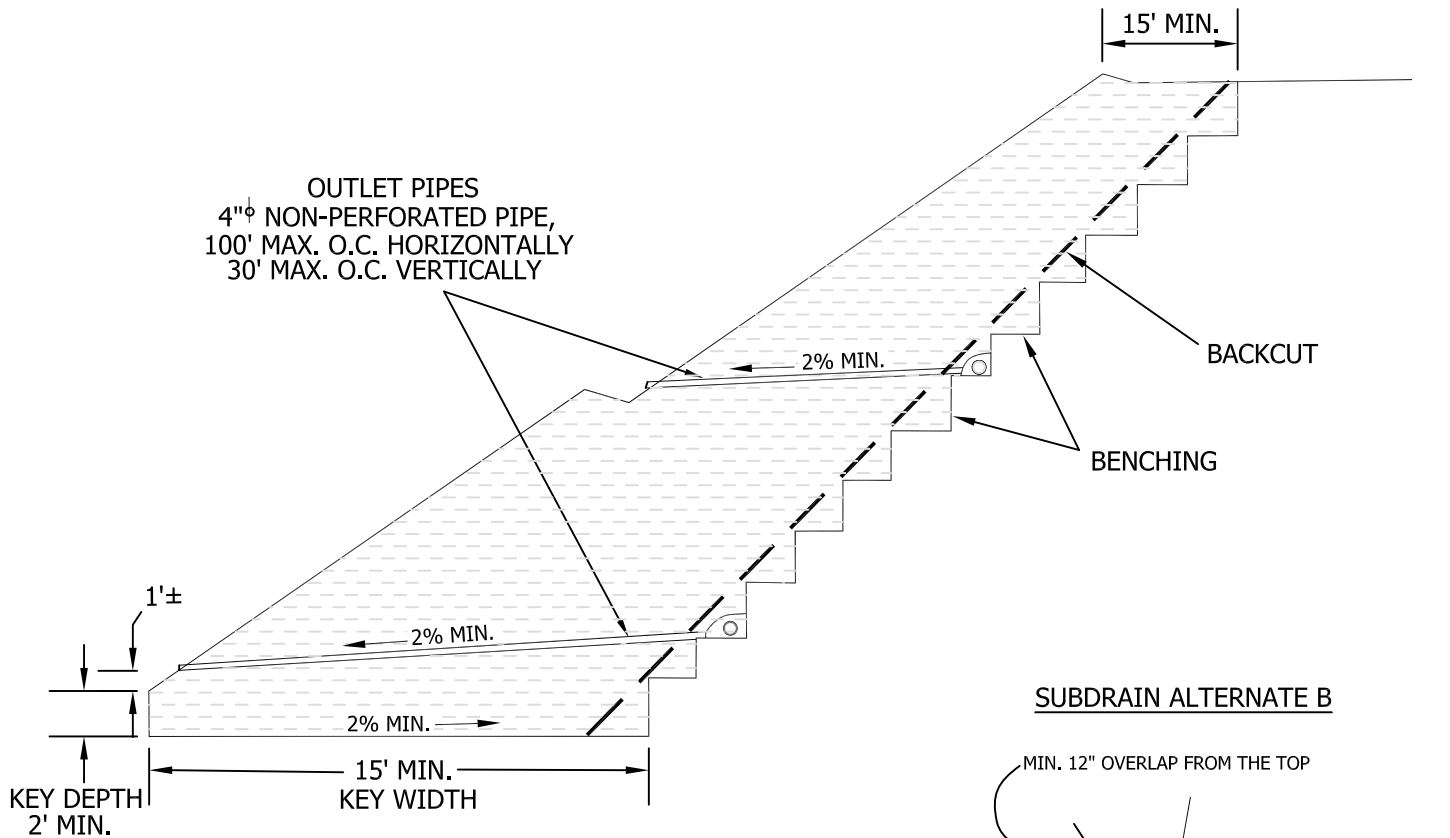

SUBDRAIN ALTERNATE A

SUBDRAIN ALTERNATE B

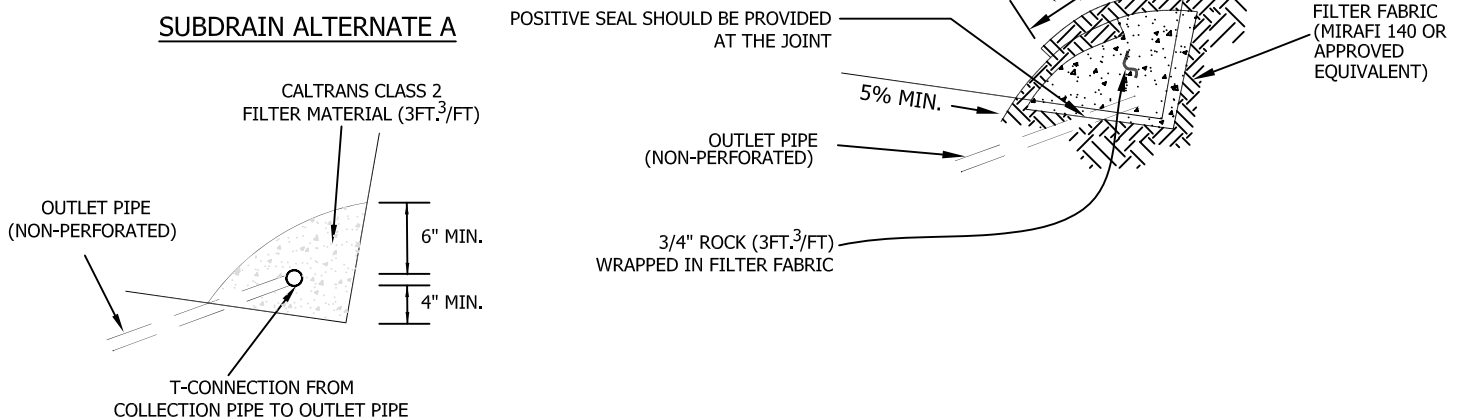

- **SUBDRAIN INSTALLATION** - Subdrain collector pipe shall be installed with perforations down or, unless otherwise designated by the geotechnical consultant. Outlet pipes shall be non-perforated pipe. The subdrain pipe shall have at least 8 perforations uniformly spaced per foot. Perforation shall be 1/4" to 1/2" if drilled holes are used. All subdrain pipes shall have a gradient at least 2% towards the outlet.
- **SUBDRAIN PIPE** - Subdrain pipe shall be ASTM D2751, ASTM D1527 (Schedule 40) or SDR 23.5 ABS pipe or ASTM D3034 (Schedule 40) or SDR 23.5 PVC pipe.
- All outlet pipe shall be placed in a trench and, after fill is placed above it, rodded to verify integrity.

**BUTTRESS OR
REPLACEMENT FILL
SUBDRAINS**

**GENERAL EARTHWORK AND GRADING
SPECIFICATIONS
STANDARD DETAILS D**



CUT-FILL TRANSITION LOT OVEREXCAVATION

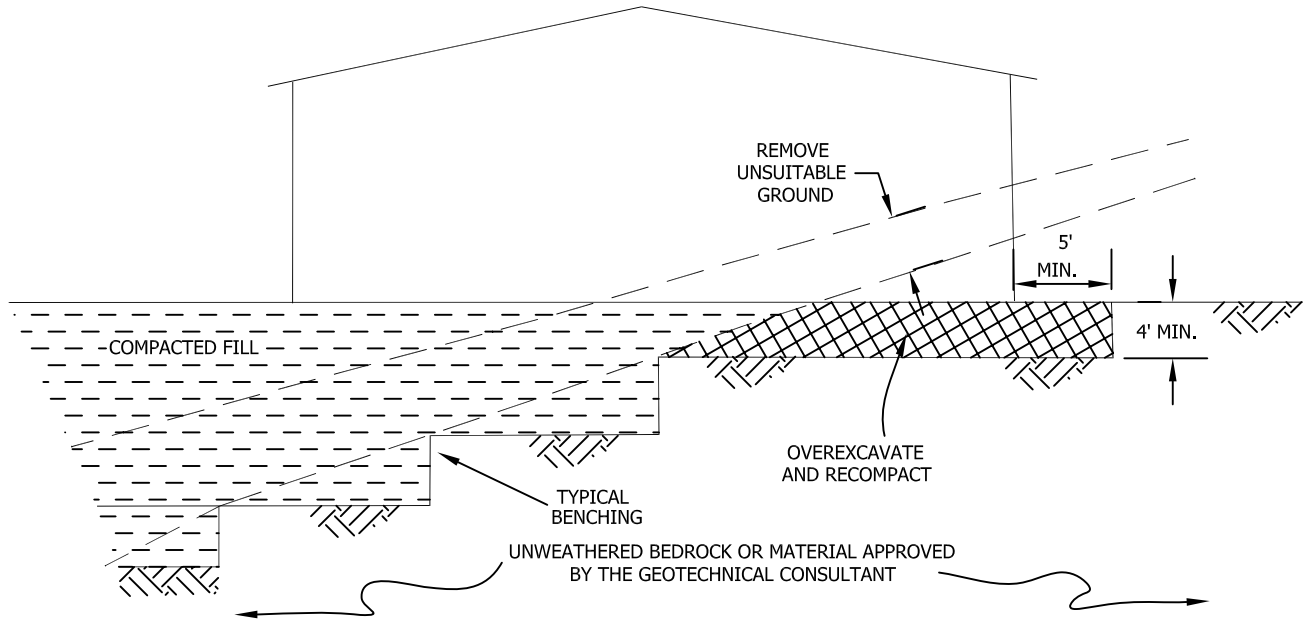

SIDE HILL FILL FOR CUT PAD

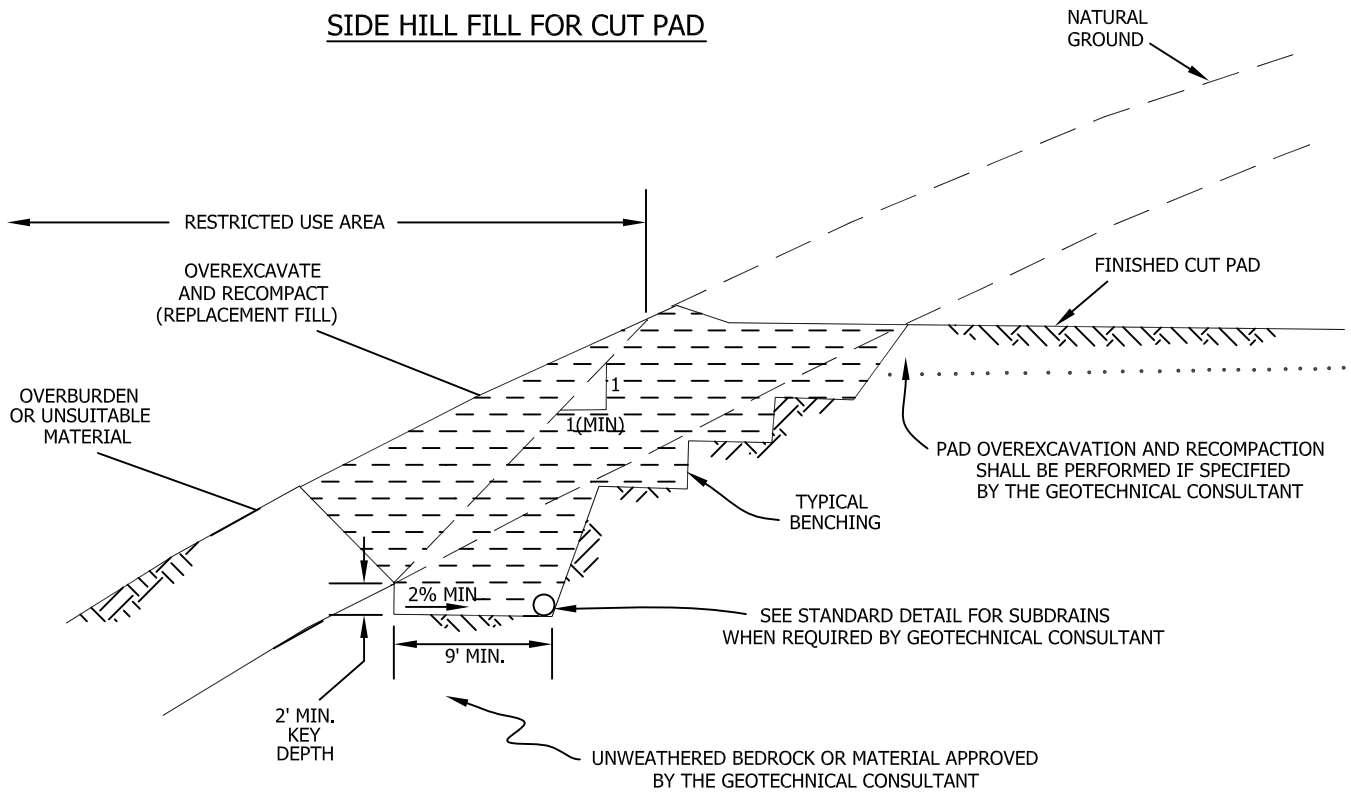

**TRANSITION LOT FILLS
AND SIDE HILL FILLS**

**GENERAL EARTHWORK AND GRADING
SPECIFICATIONS
STANDARD DETAILS E**



APPENDIX E

GBA'S INFORMATION ABOUT THIS GEOTECHNICAL- ENGINEERING REPORT



Leighton

Important Information about This

Geotechnical-Engineering Report

Subsurface problems are a principal cause of construction delays, cost overruns, claims, and disputes.

While you cannot eliminate all such risks, you can manage them. The following information is provided to help.

The Geoprofessional Business Association (GBA) has prepared this advisory to help you – assumedly a client representative – interpret and apply this geotechnical-engineering report as effectively as possible. In that way, you can benefit from a lowered exposure to problems associated with subsurface conditions at project sites and development of them that, for decades, have been a principal cause of construction delays, cost overruns, claims, and disputes. If you have questions or want more information about any of the issues discussed herein, contact your GBA-member geotechnical engineer. Active engagement in GBA exposes geotechnical engineers to a wide array of risk-confrontation techniques that can be of genuine benefit for everyone involved with a construction project.

Understand the Geotechnical-Engineering Services Provided for this Report

Geotechnical-engineering services typically include the planning, collection, interpretation, and analysis of exploratory data from widely spaced borings and/or test pits. Field data are combined with results from laboratory tests of soil and rock samples obtained from field exploration (if applicable), observations made during site reconnaissance, and historical information to form one or more models of the expected subsurface conditions beneath the site. Local geology and alterations of the site surface and subsurface by previous and proposed construction are also important considerations. Geotechnical engineers apply their engineering training, experience, and judgment to adapt the requirements of the prospective project to the subsurface model(s). Estimates are made of the subsurface conditions that will likely be exposed during construction as well as the expected performance of foundations and other structures being planned and/or affected by construction activities.

The culmination of these geotechnical-engineering services is typically a geotechnical-engineering report providing the data obtained, a discussion of the subsurface model(s), the engineering and geologic engineering assessments and analyses made, and the recommendations developed to satisfy the given requirements of the project. These reports may be titled investigations, explorations, studies, assessments, or evaluations. Regardless of the title used, the geotechnical-engineering report is an engineering interpretation of the subsurface conditions within the context of the project and does not represent a close examination, systematic inquiry, or thorough investigation of all site and subsurface conditions.

Geotechnical-Engineering Services are Performed for Specific Purposes, Persons, and Projects, and At Specific Times

Geotechnical engineers structure their services to meet the specific needs, goals, and risk management preferences of their clients. A geotechnical-engineering study conducted for a given civil engineer

will not likely meet the needs of a civil-works constructor or even a different civil engineer. Because each geotechnical-engineering study is unique, each geotechnical-engineering report is unique, prepared *solely* for the client.

Likewise, geotechnical-engineering services are performed for a specific project and purpose. For example, it is unlikely that a geotechnical-engineering study for a refrigerated warehouse will be the same as one prepared for a parking garage; and a few borings drilled during a preliminary study to evaluate site feasibility will not be adequate to develop geotechnical design recommendations for the project.

Do not rely on this report if your geotechnical engineer prepared it:

- for a different client;
- for a different project or purpose;
- for a different site (that may or may not include all or a portion of the original site); or
- before important events occurred at the site or adjacent to it; e.g., man-made events like construction or environmental remediation, or natural events like floods, droughts, earthquakes, or groundwater fluctuations.

Note, too, the reliability of a geotechnical-engineering report can be affected by the passage of time, because of factors like changed subsurface conditions; new or modified codes, standards, or regulations; or new techniques or tools. *If you are the least bit uncertain about the continued reliability of this report, contact your geotechnical engineer before applying the recommendations in it.* A minor amount of additional testing or analysis after the passage of time – if any is required at all – could prevent major problems.

Read this Report in Full

Costly problems have occurred because those relying on a geotechnical-engineering report did not read the report in its entirety. Do not rely on an executive summary. Do not read selective elements only. *Read and refer to the report in full.*

You Need to Inform Your Geotechnical Engineer About Change

Your geotechnical engineer considered unique, project-specific factors when developing the scope of study behind this report and developing the confirmation-dependent recommendations the report conveys. Typical changes that could erode the reliability of this report include those that affect:

- the site's size or shape;
- the elevation, configuration, location, orientation, function or weight of the proposed structure and the desired performance criteria;
- the composition of the design team; or
- project ownership.

As a general rule, *always* inform your geotechnical engineer of project or site changes – even minor ones – and request an assessment of their impact. *The geotechnical engineer who prepared this report cannot accept*

responsibility or liability for problems that arise because the geotechnical engineer was not informed about developments the engineer otherwise would have considered.

Most of the “Findings” Related in This Report Are Professional Opinions

Before construction begins, geotechnical engineers explore a site’s subsurface using various sampling and testing procedures. *Geotechnical engineers can observe actual subsurface conditions only at those specific locations where sampling and testing is performed.* The data derived from that sampling and testing were reviewed by your geotechnical engineer, who then applied professional judgement to form opinions about subsurface conditions throughout the site. Actual sitewide-subsurface conditions may differ – maybe significantly – from those indicated in this report. Confront that risk by retaining your geotechnical engineer to serve on the design team through project completion to obtain informed guidance quickly, whenever needed.

This Report’s Recommendations Are Confirmation-Dependent

The recommendations included in this report – including any options or alternatives – are confirmation-dependent. In other words, they are not final, because the geotechnical engineer who developed them relied heavily on judgement and opinion to do so. Your geotechnical engineer can finalize the recommendations *only after observing actual subsurface conditions* exposed during construction. If through observation your geotechnical engineer confirms that the conditions assumed to exist actually do exist, the recommendations can be relied upon, assuming no other changes have occurred. *The geotechnical engineer who prepared this report cannot assume responsibility or liability for confirmation-dependent recommendations if you fail to retain that engineer to perform construction observation.*

This Report Could Be Misinterpreted

Other design professionals’ misinterpretation of geotechnical-engineering reports has resulted in costly problems. Confront that risk by having your geotechnical engineer serve as a continuing member of the design team, to:

- confer with other design-team members;
- help develop specifications;
- review pertinent elements of other design professionals’ plans and specifications; and
- be available whenever geotechnical-engineering guidance is needed.

You should also confront the risk of constructors misinterpreting this report. Do so by retaining your geotechnical engineer to participate in prebid and preconstruction conferences and to perform construction-phase observations.

Give Constructors a Complete Report and Guidance

Some owners and design professionals mistakenly believe they can shift unanticipated-subsurface-conditions liability to constructors by limiting the information they provide for bid preparation. To help prevent the costly, contentious problems this practice has caused, include the complete geotechnical-engineering report, along with any attachments or appendices, with your contract documents, *but be certain to note*

conspicuously that you’ve included the material for information purposes only. To avoid misunderstanding, you may also want to note that “informational purposes” means constructors have no right to rely on the interpretations, opinions, conclusions, or recommendations in the report. Be certain that constructors know they may learn about specific project requirements, including options selected from the report, *only* from the design drawings and specifications. Remind constructors that they may perform their own studies if they want to, and *be sure to allow enough time* to permit them to do so. Only then might you be in a position to give constructors the information available to you, while requiring them to at least share some of the financial responsibilities stemming from unanticipated conditions. Conducting prebid and preconstruction conferences can also be valuable in this respect.

Read Responsibility Provisions Closely

Some client representatives, design professionals, and constructors do not realize that geotechnical engineering is far less exact than other engineering disciplines. This happens in part because soil and rock on project sites are typically heterogeneous and not manufactured materials with well-defined engineering properties like steel and concrete. That lack of understanding has nurtured unrealistic expectations that have resulted in disappointments, delays, cost overruns, claims, and disputes. To confront that risk, geotechnical engineers commonly include explanatory provisions in their reports. Sometimes labeled “limitations,” many of these provisions indicate where geotechnical engineers’ responsibilities begin and end, to help others recognize their own responsibilities and risks. *Read these provisions closely.* Ask questions. Your geotechnical engineer should respond fully and frankly.

Geoenvironmental Concerns Are Not Covered

The personnel, equipment, and techniques used to perform an environmental study – e.g., a “phase-one” or “phase-two” environmental site assessment – differ significantly from those used to perform a geotechnical-engineering study. For that reason, a geotechnical-engineering report does not usually provide environmental findings, conclusions, or recommendations; e.g., about the likelihood of encountering underground storage tanks or regulated contaminants. *Unanticipated subsurface environmental problems have led to project failures.* If you have not obtained your own environmental information about the project site, ask your geotechnical consultant for a recommendation on how to find environmental risk-management guidance.

Obtain Professional Assistance to Deal with Moisture Infiltration and Mold

While your geotechnical engineer may have addressed groundwater, water infiltration, or similar issues in this report, the engineer’s services were not designed, conducted, or intended to prevent migration of moisture – including water vapor – from the soil through building slabs and walls and into the building interior, where it can cause mold growth and material-performance deficiencies. Accordingly, *proper implementation of the geotechnical engineer’s recommendations will not of itself be sufficient to prevent moisture infiltration.* **Confront the risk of moisture infiltration** by including building-envelope or mold specialists on the design team. **Geotechnical engineers are not building-envelope or mold specialists.**



Telephone: 301/565-2733
e-mail: info@geoprofessional.org www.geoprofessional.org

Copyright 2019 by Geoprofessional Business Association (GBA). Duplication, reproduction, or copying of this document, in whole or in part, by any means whatsoever, is strictly prohibited, except with GBA’s specific written permission. Excerpting, quoting, or otherwise extracting wording from this document is permitted only with the express written permission of GBA, and only for purposes of scholarly research or book review. Only members of GBA may use this document or its wording as a complement to or as an element of a report of any kind. Any other firm, individual, or other entity that so uses this document without being a GBA member could be committing negligent or intentional (fraudulent) misrepresentation.