



PDP SWQMP

PRIORITY DEVELOPMENT PROJECT (PDP) STORM WATER QUALITY MANAGEMENT PLAN (SWQMP)

Project Name Shinohara Business Center

Assessor's Parcel Number(s) 644-040-01

Permit Application Number DR-21-0032

Drawing Numbers _____

CIVIL ENGINEER NAME: Gregory W. Lang ; PE # 68075

Wet Signature and Stamp



PREPARED FOR: Applicant Name: VWP-OP Shinohara Owner, LLC
Address: 2950 East Camelback Road, Suite 305
Phoenix, AZ 85016
Telephone # (213) 362-9300

PREPARED BY: Company Name: Pasco Laret Suiter & Associates
Address: 119 Aberdeen Drive
Cardiff, CA 92007
Telephone # (858) 259-8212

DATE: May 20, 2022

Approved By: City of Chula Vista
(print Name & Sign)

Date: _____

Page intentionally left blank for double-sided printing

TABLE OF CONTENTS

The checklist on this page summarized the table and attachments to be included with this PDP SWQMP Submittal. Tables & attachments with boxes already checked (✓) are required for all Projects

- Acronym Sheet**
- Certification Page**
- Submittal Record**
- Project Vicinity Map**
- Attach a copy of the Intake Form: Storm Water Requirements Applicability Checklist**
- HMP Exemption Exhibit (if Applicable)**
- FORM I-3B Site Information Checklist for PDPs**
- FORM I-4: Source Control BMP Checklist for All Development Projects**
- FORM I-5: Site Design BMP Checklist for All Development Projects**
- FORM I-6: Summary of PDP Structural BMPs**
- ATTACHEMNT 1: Backup for PDP Pollutant Control BMPs**
 - Attachment 1A: DMA Exhibit
 - Attachment 1B: Tabular Summary of DMAs and Design Capture Volume Calculations
 - Attachment 1C: FORM I-7 Harvest and Use Feasibility Screening (when applicable)
 - Attachment 1D: Infiltration Information Attachment 1E: Pollutant Control BMP Design Worksheets / Calculations for each DMA and Structural BMP Worksheets from Appendix B, as applicable
- ATTACHMENT 2: Backup for PDP Hydromodification Control Measures**
 - Attachment 2A: Hydromodification Management Exhibit
 - Attachment 2B: Management of Critical Coarse Sediment Yield Areas
 - Attachment 2C: Geomorphic Assessment of Receiving Channels
 - Attachment 2D: Flow Control Facility Design; Overflow Design Summary for each structural BMP
- ATTACHMENT 3: Structural BMP Maintenance Plan**
- ATTACHMENT 4: Copy of Plan Sheets Showing Permanent Storm Water BMPs**
- ATTACHMENT 5: Project's Drainage Report**
- ATTACHMENT 6: Project's Geotechnical and Groundwater Investigation Report**

ACRONYMS

APN	Assessor's Parcel Number
BMP	Best Management Practice
HMP	Hydromodification Management Plan
HSG	Hydrologic Soil Group
MS4	Municipal Separate Storm Sewer System
N/A	Not Applicable
NRCS	Natural Resources Conservation Service
PDP	Priority Development Project
PE	Professional Engineer
SC	Source Control
SD	Site Design
SDRWQCB	San Diego Regional Water Quality Control Board
SIC	Standard Industrial Classification
SWQMP	Storm Water Quality Management Plan

Shinohara Business Center

Project Name/_____

Certification Page

Project Name: Shinohara Business Center

Permit Application Number: DR21-0032

I hereby declare that I am the Engineer in Responsible Charge of design of storm water best management practices (BMPs) for this project, and that I have exercised responsible charge over the design of the BMPs as defined in Section 6703 of the Business and Professions Code, and that the design is consistent with the PDP requirements of the City of Chula Vista BMP Design Manual, which is based on the requirements of the San Diego Regional Water Quality Control Board Order No. R9-2013-0001 as amended by R9-2015-0001 and R9-2015-0100 (MS4 Permit).

I have read and understand that the City Engineer has adopted minimum requirements for managing urban runoff, including storm water, from land development activities, as described in the BMP Design Manual. I certify that this PDP SWQMP has been completed to the best of my ability and accurately reflects the project being proposed and the applicable BMPs proposed to minimize the potentially negative impacts of this project's land development activities on water quality. I understand and acknowledge that the plan check review of this PDP SWQMP by the City Engineer is confined to a review and does not relieve me, as the Engineer in Responsible Charge of design of storm water BMPs for this project, of my responsibilities for project design.

Gregory W. Lang
Engineer of Work's Signature

05/20/22
Date

68075, 6/30/2023
PE #, Expiration Date

Gregory W. Lang
Print Name

Pasco Laret Suiter & Associates
Company



Shinohara Business Center

Project Name/ _____

SUBMITTAL RECORD

Use this Table to keep a record of submittals of this PDP SWQMP. Each time the PDP SWQMP is re-submitted, provide the date and status of the project. In column 4 summarize the changes that have been made or indicate if response to plancheck comments is included. When applicable, insert response to plancheck comments behind this page.

Submittal Number	Date	Project Status	Summary of Changes
1	11/19/2021	<input checked="" type="checkbox"/> Preliminary Design / Planning/ CEQA <input checked="" type="checkbox"/> Final Design	Initial Submittal
2	2/14/2022	<input checked="" type="checkbox"/> Preliminary Design / Planning/ CEQA <input type="checkbox"/> Final Design	Revision to disturbed area
3	5/20/2022	<input checked="" type="checkbox"/> Preliminary Design / Planning/ CEQA <input type="checkbox"/> Final Design	Revision to DMAs and BMPs
4		<input type="checkbox"/> Preliminary Design / Planning/ CEQA <input type="checkbox"/> Final Design	

Project Vicinity Map

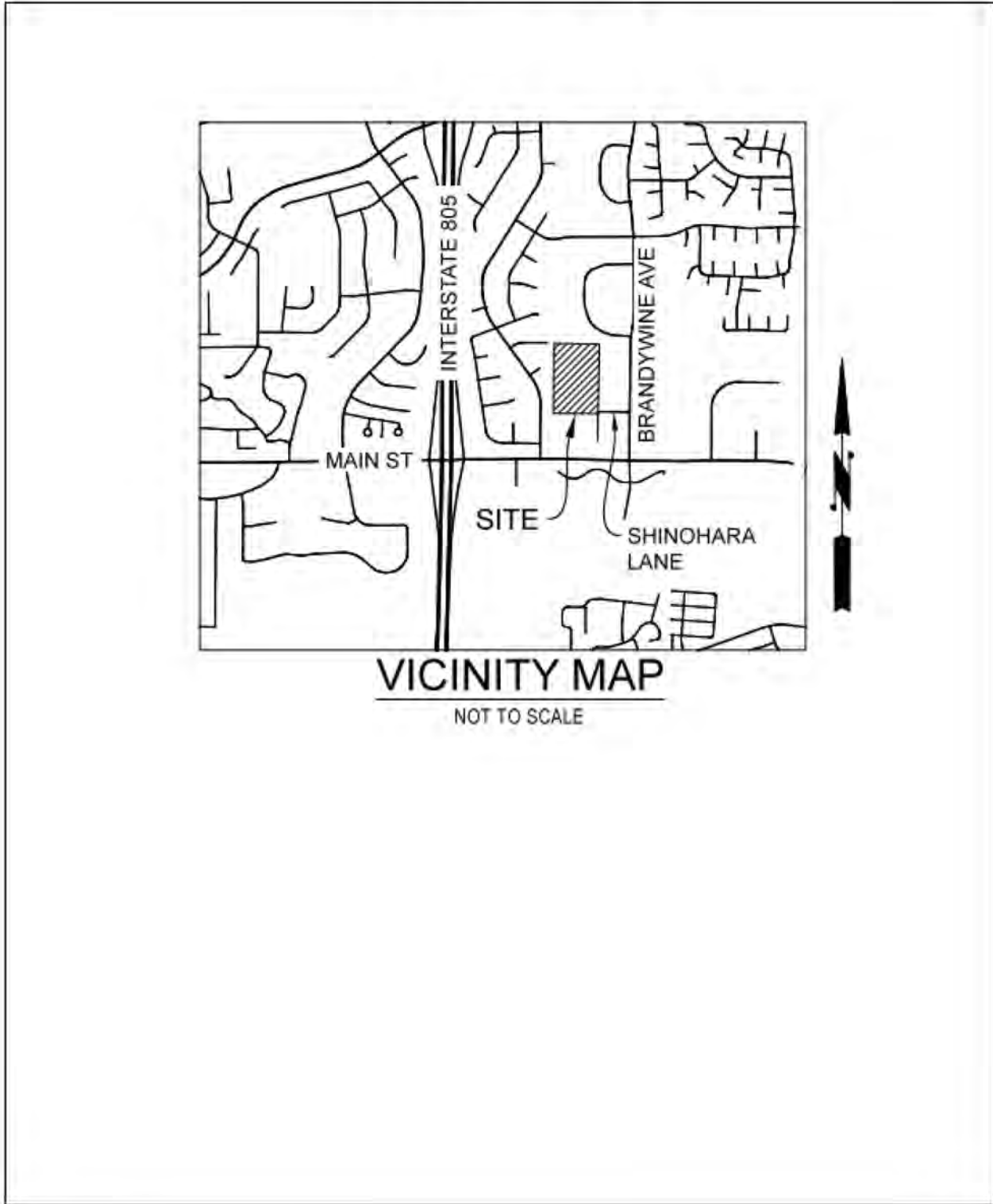

Project Name/_____

**Insert Completed Intake Form (Storm Water Requirements
Applicability Checklist)**

<https://www.chulavistaca.gov/departments/public-works/services/storm-water-pollution-prevention/documents-and-reports>



Storm Water Requirements Applicability Checklist for All Permit Applications

Intake Form

March 2019 Update

Project Information

Project Address: 517 Shinohara Lane, Chula Vista, CA 91911	Project Application # DR21-0032
Project Name: Shinohara Business Center	APN(s) 644-040-01
Brief Description of Work Proposed: Proposed industrial development	

The project is (select one):

- New Development Total Impervious Area 349,912 ft²
- Redevelopment Total new and/or replaced Impervious Area _____ ft²
(Redevelopment is the creation and/or replacement of impervious surface on an already developed site).
- Others _____

Name of Person Completing this Form: Gregory W. Lang

Role: Property Owner Contractor Architect Engineer Other _____

Email: glang@plsaengineering.com Phone: (858) 259-8212

Signature: *Gregory W. Lang* Date Completed: 05/20/2022

Answer each section below, starting with Section 1 and progressing through each section. Additional information for determining the requirements is found in the Chula Vista BMP Design Manual available on the City's website at <http://www.chulavistaca.gov/departments/public-works/services/storm-water-pollution-prevention/documents-and-reports>.

SECTION 1: Storm Water BMP Requirements

Does the project consist of **one or both** of the following:

- Repair or improvements to an existing building or structure that don't alter the size such as: tenant improvements, interior remodeling, electrical work, fire alarm, fire sprinkler system, HVAC work, Gas, plumbing, etc.
- Routine maintenance activities such as: roof or exterior structure surface replacement; resurfacing existing roadways and parking lots including dig outs, slurry seal, overlay and restriping; repair damaged sidewalks or pedestrian ramps on existing roads without expanding the impervious footprint; routine replacement of damaged pavement, trenching and resurfacing associated with utility work (i.e. sewer, water, gas or electrical laterals, etc.) and pot holing or geotechnical investigation borings.

Yes **Project is NOT Subject to Permanent Storm Water BMP requirements.**
BUT IS subject to Construction BMP requirements. Review & sign "Construction Storm Water BMP Certification Statement" on page 2.

No **Continue to Section 2, page 3.**

Construction Storm Water BMP Certification Statement

The following stormwater quality protection measures are required by City Chula Vista Municipal Code Chapter 14.20 and the City's Jurisdictional Runoff Management Program.

1. All applicable construction BMPs and non-stormwater discharge BMPs shall be installed and maintained for the duration of the project in accordance with the Appendix K "Construction BMP Standards" of the Chula Vista BMP Design Manual.
2. Erosion control BMPs shall be implemented for all portions of the project area in which no work has been done or is planned to be done over a period of 14 or more days. All onsite drainage pathways that convey concentrated flows shall be stabilized to prevent erosion.
3. Run-on from areas outside the project area shall be diverted around work areas to the extent feasible. Run-on that cannot be diverted shall be managed using appropriate erosion and sediment control BMPs.
4. Sediment control BMPs shall be implemented, including providing fiber rolls, gravel bags, or other equally effective BMPs around the perimeter of the project to prevent transport of soil and sediment offsite. Any sediment tracked onto offsite paved areas shall be removed via sweeping at least daily.
5. Trash and other construction wastes shall be placed in a designated area at least daily and shall be disposed of in accordance with applicable requirements.
6. Materials shall be stored to avoid being transported in storm water runoff and non-storm water discharges. Concrete washout shall be directed to a washout area and shall not be washed out to the ground.
7. Stockpiles and other sources of pollutants shall be covered when the chance of rain within the next 48 hours is at least 50%.

I certify that the stormwater quality protection measures listed above will be implemented at the project described on Intake Form. I understand that failure to implement these measures may result in monetary penalties or other enforcement actions. This certification is signed under penalty of perjury and does not require notarization.

Name: Gregory W. Lang Title: Principal Engineer

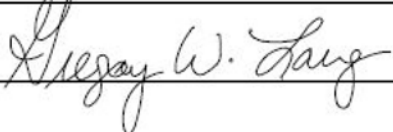
Signature:  Date: 05/20/2022

Section 2: Determine if Project is a Standard Project or Priority Development Project

Is the project in any of the following categories, (a) through (j)?

(a) New development that **creates 10,000 square feet** or more of impervious surfaces (collectively over the entire project site). This includes commercial, industrial, residential, mixed-use, and public development projects on public or private land. Yes No

(b) Redevelopment project that **creates and/or replaces 5,000 square feet** or more of impervious surface (collectively over the entire project site on an existing site of 10,000 square feet or more of impervious surfaces). This includes commercial, industrial, residential, mixed-use, and public development projects on public or private land. Yes No

(c) New development or redevelopment projects that **creates and/or replaces a combined total of 5,000 square feet** or more of impervious surface (collectively over the entire project site) and support one or more of the following uses: Yes No

(i) **Restaurant.** This category is defined as a facility that sells prepared foods and drinks for consumption, including stationary lunch counters and refreshment stands selling prepared foods and drinks for immediate consumption (Standard Industrial Classification Code 5812).

(ii) **Hillside development projects.** This category includes development on any natural slope that is twenty-five percent or greater.

(iii) **Parking Lots.** This category is defined as a land area or facility for the temporary parking or storage of motor vehicles used personally, for business, or for commerce.

(iv) **Streets, roads, highways, freeways, and driveways.** This category is defined as any paved impervious surface used for the transportation of automobiles, trucks, motorcycles, and other vehicles.

(d) New development or redevelopment project that **creates and/or replaces 2,500 square feet** or more of impervious surface (collectively over the entire project site), discharging directly to an Environmentally Sensitive Area (ESA). "Discharging directly to" includes flow that is conveyed overland a distance of 200 feet or less from the project to the ESA, or conveyed in a pipe or open channel any distance as an isolated flow from the project to the ESA (i.e. not commingled with flows from adjacent lands). Yes No

(e) New development or redevelopment project that creates and/or replaces a combined total of 5,000 square feet or more of impervious surface, that support one or more of the following used: Yes No

(i) Automotive repair shops. This category is defined as a facility that is categorized in any one of the following Standard Industrial Classification (SIC) codes: 5013, 5014, 5541, 7532-7534, or 7536-7539.

(ii) Retail gasoline outlets. This category includes retail gasoline outlets that meet the meet one of the following criteria: (a) 5,000 square feet or more or (b) a projected Average Daily Traffic (ADT) of 100 or more vehicles per day.

(f) New development or redevelopment that result in the disturbance of **one or more acres** of land and are expected to generate pollutants post construction. This does not include projects creating less than 5,000 sf of impervious surface and where added landscaping does not require regular use of pesticides and fertilizers, such as slope stabilization using native plants. Calculation of the square footage of impervious surface need not include linear pathways that are for infrequent vehicle use, such as emergency maintenance access or bicycle pedestrian use, if they are built with pervious surfaces or if they sheet flow to surrounding pervious surfaces. Yes No

The project is (select one):

If "No" is checked for every category in Section 2, **Project is "Standard Development Project"**. Site design and source control BMP requirements apply. **Complete and submit Standard SWQMP** (refer to Chapter 4 & Appendix E of the BMP Design Manual for guidance). Continue to Section 4.

If "Yes" is checked for ANY category in Section 2, **Project is "Priority Development Project (PDP)"**. Complete below, if applicable, and continue to Section 3.

Complete for PDP Redevelopment Projects ONLY:

The total existing (pre-project) impervious area at the project site is: _____ ft² (A)

The total proposed newly created or replaced impervious area is _____ ft² (B)

Percent impervious surface created or replaced (B/A)*100: _____%

The percent impervious surface created or replaced is (select one based on the above calculation):

- less than or equal to fifty percent (50%) – **only new impervious areas are considered a PDP**
OR
- greater than fifty percent (50%) – **the entire project site is considered a PDP**
- Continue to Section 3**

Section 3: Determine if project is PDP Exempt

1. Does the project ONLY include new or retrofit sidewalk, bicycle lane or trails that:

- Are designed and constructed to direct storm water runoff to adjacent vegetated areas, or other non-erodible permeable areas? Or;
- Are designed and constructed to be hydraulically disconnected from paved streets or roads? Or;
- Are designed and constructed with permeable pavements or surfaces in accordance with USEPA Green Streets guidance?

Yes. Project is PDP Exempt.

No. Next question

Complete and submit **Standard SWQMP**
(refer to Chapter 4 of the BMP Design Manual
for guidance). **Continue to Section 4.**

2. Does the project ONLY include retrofitting or redevelopment of existing paved alleys, streets or roads designed and constructed in accordance with the Green Streets standards?

**Yes.
Project is PDP Exempt.**

**No.
Project is PDP.**

Complete and submit Standard SWQMP (refer
to Chapter 4 of the BMP Design Manual for
guidance). **Continue to Section 4.**

Site design, source control and structural
pollutant control BMPs apply. Complete
and submit PDP SWQMP (refer to
Chapters 4, 5 & 6 of the BMP Design
Manual for guidance). **Continue to
Section 4.**

SECTION 4: Construction Storm Water BMP Requirements:

All construction sites are required to implement construction BMPs in accordance with the performance standards in the BMP Design Manual. Some sites are additionally required to obtain coverage under the State Construction General Permit (CGP), which is administered by the State Water Resource Control Board.

1. Does the project include Building/Grading/Construction permits proposing less than 5,000 square feet of ground disturbance and has less than 5-foot elevation change over the entire project area?

- Yes; review & sign Construction Storm Water Certification Statement, skip questions 2-4
- No; next question

2. Does the project propose construction or demolition activity, including but not limited to, clearing grading, grubbing, excavation, or other activity that results in ground disturbance of less than one acre and more than 5,000 square feet?

- Yes. complete & submit Construction Storm Water Pollution Control Plan (CSWPCP), skip questions 3-4
- No; next question

3. Does the project results in disturbance of an acre or more of total land area and are considered regular maintenance projects performed to maintain original line and grade, hydraulic capacity, or original purpose of the facility? (Projects such as sewer/storm drain/utility replacement)

- Yes. complete & submit Construction Storm Water Pollution Control Plan (CSWPCP), skip question 4
- No; next question

4. Is the project proposing land disturbance greater than or equal to one acre OR the project is part of a larger common plan of development disturbing 1 acre or more?

- Yes; Storm Water Pollution Prevention Plan (SWPPP) is required. Refer to online CASQA or Caltrans Template. Visit the SWRCB web site at http://www.waterboards.ca.gov/water_issues/programs/stormwater/construction.shtml.

Note: for Projects that result in disturbance of one to five acres of total land area and can demonstrate that there will be no adverse water quality impacts by applying for a Construction Rainfall Erosivity Waiver, may be allowed to submit a CSWPCP in lieu of a SWPPP.

Project Name/ _____

HMP Exemption Exhibit

Attach this Exhibit (if Applicable) that shows direct storm water runoff discharge from the project site to HMP exempt area. Include project area, applicable underground storm drains line and/or concrete lined channels, outfall information and exempt waterbody. Reference applicable drawing number(s). **Exhibit must be provided on 11"x17" or larger paper.**

Receiving Waters and Conveyance Systems Exempt from HYDROMODIFICATION MANAGEMENT REQUIREMENTS

September, 2018

LEGEND

- Exempt_Systems
- Exempt_Bodies
- SWMains
- Creeks
- River
- CityLimit

PROJECT SITE DISCHARGES DIRECTLY TO EXEMPT WATERBODY (OTAY RIVER) THROUGH EXIST. UNDERGROUND STORM DRAIN SYSTEMS AND CONCRETE-LINED CONVEYANCE CHANNELS

EXIST. STORM DRAIN INLET, DRAINS DIRECTLY TO MAIN STREET

EXIST. CONCRETE DRAINAGE CHANNEL, DRAINS DIRECTLY TO MAIN STREET

EXIST. STORM DRAIN OUTLETS IN OTAY RIVER

MAIN STREET: FLOW TRAVELS WEST VIA EXIST. CONCRETE CURB & GUTTER TO EXIST. CURB INLET

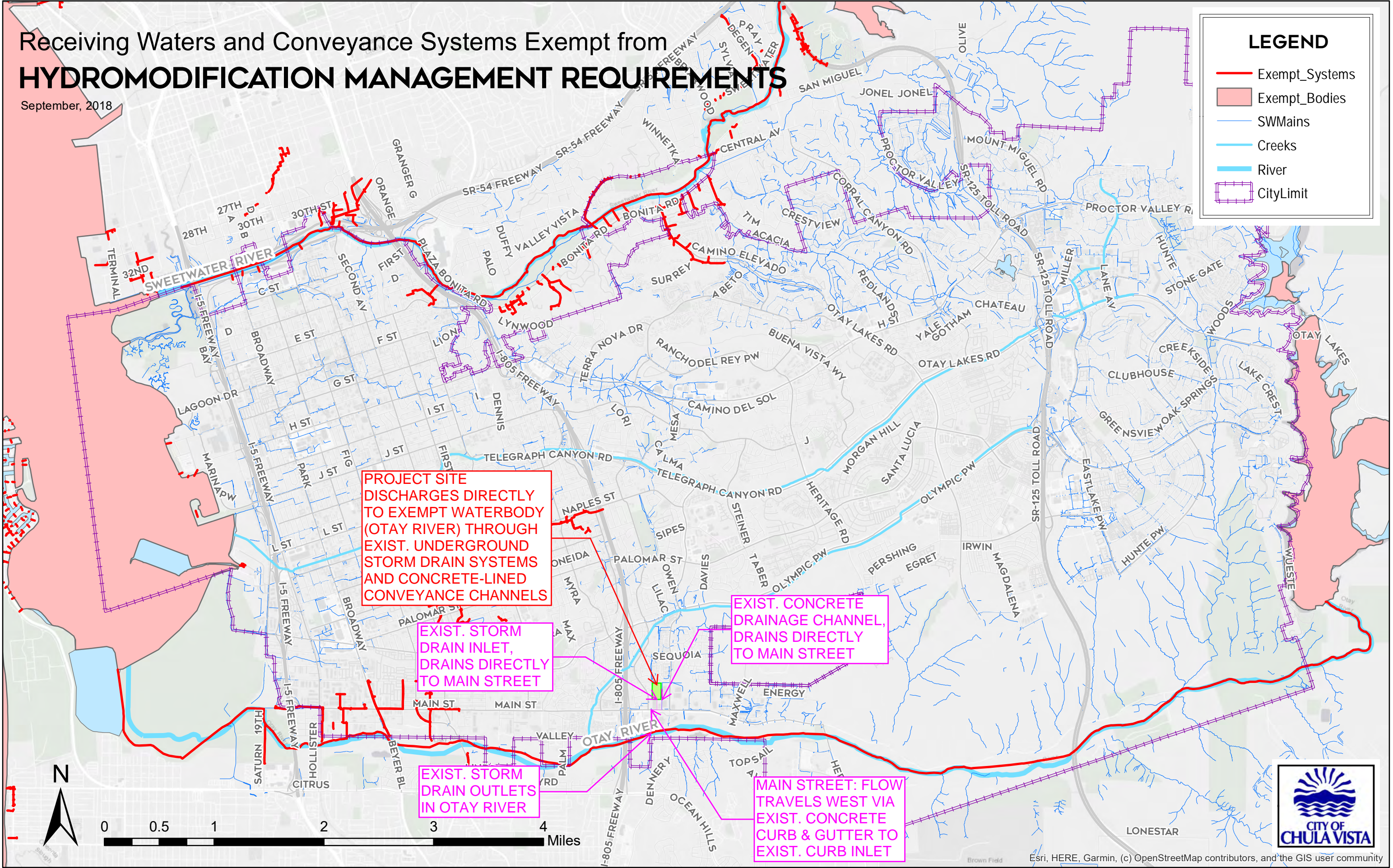

Project Name/_____

Insert Completed Form I-3B: Site Information Checklist for PDPs

<https://www.chulavistaca.gov/departments/public-works/services/storm-water-pollution-prevention/documents-and-reports>

Shinohara Business Center

Project Name: _____

Site Information Checklist		Form I-3B
Project Summary Information		
Project Name	Shinohara Business Center	
Project Address	517 Shinohara Lane Chula Vista, CA 91911	
Assessor's Parcel Number(s) (APN(s))	644-040-01	
Permit Application Number	DR21-0032	
Project Watershed	<input checked="" type="checkbox"/> San Diego Bay	
Hydrologic Subarea name with Numeric Identifier up to two decimal places	Select One: <input type="checkbox"/> Pueblo San Diego 908 <input type="checkbox"/> Sweetwater 909 <input checked="" type="checkbox"/> Otay 910	
Project Area (total area of Assessor's Parcel(s) associated with the project or total area of the right-of-way)	9.73 Acres (423,779 Square Feet)	
Area to be Disturbed by the Project (Project Footprint)	9.67 Acres (421,173 Square Feet)	
Project Proposed Impervious Area (subset of Project Footprint)	8.03 Acres (349,912 Square Feet)	
Project Proposed Pervious Area (subset of Project Footprint)	1.64 Acres (71,261 Square Feet)	
Note: Proposed Impervious Area + Proposed Pervious Area = Area to be Disturbed by the Project. This may be less than the Parcel Area.		
The proposed increase or decrease in impervious area in the proposed condition as compared to the pre-project condition	100 %	

Shinohara Business Center

Project Name: _____

Form I-3B Page 3 of 10	
Description of Existing Site Condition and Drainage Patterns	
Current Status of the Site (select all that apply):	<ul style="list-style-type: none"><input checked="" type="checkbox"/> Existing development<input type="checkbox"/> Previously graded but not built out<input type="checkbox"/> Demolition completed without new construction<input type="checkbox"/> Agricultural or other non-impervious use<input checked="" type="checkbox"/> Vacant, undeveloped/natural
Description / Additional Information:	<p>The existing site is currently undeveloped except for minor concrete drainage channels located onsite and along the eastern and southern property boundaries.</p>
Existing Land Cover Includes (select all that apply):	<ul style="list-style-type: none"><input type="checkbox"/> Vegetative Cover<input checked="" type="checkbox"/> Non-Vegetated Pervious Areas<input type="checkbox"/> Impervious Areas
Description / Additional Information:	
Underlying Soil belongs to Hydrologic Soil Group (select all that apply):	<ul style="list-style-type: none"><input type="checkbox"/> NRCS Type A<input type="checkbox"/> NRCS Type B<input checked="" type="checkbox"/> NRCS Type C<input checked="" type="checkbox"/> NRCS Type D
Approximate Depth to Groundwater (GW):	<ul style="list-style-type: none"><input type="checkbox"/> GW Depth < 5 feet<input type="checkbox"/> 5 feet < GW Depth < 10 feet<input type="checkbox"/> 10 feet < GW Depth < 20 feet<input checked="" type="checkbox"/> GW Depth > 20 feet
Existing Natural Hydrologic Features (select all that apply):	<ul style="list-style-type: none"><input type="checkbox"/> Watercourses<input type="checkbox"/> Seeps<input type="checkbox"/> Springs<input type="checkbox"/> Wetlands<input checked="" type="checkbox"/> None
Description / Additional Information:	

Project Name: _____

Form I-3B Page 3 of 10

Description of Existing Site Drainage Patterns

How is storm water runoff conveyed from the site? At a minimum, this description should answer:

1. whether existing drainage conveyance is natural or urban;
2. Is runoff from offsite conveyed through the site? if yes, quantify all offsite drainage areas, design flows, and locations where offsite flows enter the project site, and summarize how such flows are conveyed through the site;
3. Provide details regarding existing project site drainage conveyance network, including any existing storm drains, concrete channels, swales, detention facilities, storm water treatment facilities, natural or constructed channels; and
4. Identify all discharge locations from the existing project site along with a summary of conveyance system size and capacity for each of the discharge locations. Provide summary of the pre-project drainage areas and design flows to each of the existing runoff discharge locations.

Describe existing site drainage patterns:

Topographically, the site slopes steeply to the south from the northern property boundary, forming three (3) drainage basins with three (3) discharge locations. See project Drainage Study for depiction of major drainage basins. Existing Drainage Basin A comprises the western portion of the site. Runoff drains via overland flow to an existing concrete swale located at the southern property boundary. The drainage swale carries flow east to an existing Type F catch basin at the southern property boundary. The catch basin connects to an existing private storm drain pipe that outlets via curb outlet onto Main Street.

Existing Drainage Basin B comprises the eastern portion of the site. Runoff is conveyed via overland surface flow to an existing concrete drainage channel located at the southeastern corner of the site. The drainage channel conveys runoff south and outlets via curb outlet onto Main Street. From Main Street, flow travels west via concrete curb and gutter to an existing curb inlet. Stormwater is then conveyed south through an existing storm drain pipe and outlets over headwall into the Otay River.

Existing Drainage Basin C comprises the northwesterly portion of the site. Runoff is conveyed via overland surface flow to an existing swale west of the project site. Local surface runoff from the project site and surrounding properties collect in this area and flow to the south to an existing concrete drainage channel located in the rear yard of an existing single family residence at the end of Tanoak Court. The existing concrete channel flows to the south and then turns and flows to the west and discharges into Tanoak Court through two existing Type A curb outlets.



Shinohara Business Center

Project Name: _____

Form I-3B Page 4 of 10	
Description of Proposed Site Development and Drainage Patterns	
Project Description / Proposed Land Use and/or Activities:	<p>The project will include the construction of an industrial building, paved drive aisles and parking areas, retaining walls, and other associated improvements. Drainage improvements will consist of catch basins, curb inlets and storm drain pipes. A proprietary Modular Wetland System is proposed for storm water treatment. An underground detention vault is proposed for peak flow attenuation. The project will be accessed by a proposed driveway off Shinohara Lane. The proposed land use is ILP-Limited Industrial.</p>
List/describe proposed impervious features of the project (e.g., buildings, roadways, parking lots, courtyards, athletic courts, other impervious features):	<p>The proposed impervious features of the project consist of an industrial building, asphalt drive aisles and parking lots, and concrete hardscape.</p>
List/describe proposed pervious features of the project (e.g., landscape areas):	<p>The proposed pervious features of the project include landscape areas and slopes.</p>
Does the project include grading and changes to site topography?	<p><input checked="" type="checkbox"/> Yes <input type="checkbox"/> No</p>
Description / Additional Information:	<p>Grading is proposed to accommodate the proposed development. Cuts of approximately 13 feet will be made across building pad areas. Fills of approximately 23 feet will be made to reach planned grades along the southern portion of the site where driveways and parking lots will be extended into the existing slope area. Geogrid retaining walls are proposed along the southwestern and southern portions of the site. Soil nail retaining walls are proposed along the northern, northwestern and northeastern portions of the site.</p>

Project Name: _____

Form I-3B Page 5 of 10

Does the project include changes to site drainage (e.g., installation of new storm water conveyance systems)?

- Yes
 No

If yes, provide details regarding the proposed project site drainage conveyance network, including storm drains, concrete channels, swales, detention facilities, storm water treatment facilities, natural or constructed channels, and the method for conveying offsite flows through or around the proposed project site. Identify all discharge locations from the proposed project site along with a summary of the conveyance system size and capacity for each of the discharge locations. Provide a summary of pre- and post-project drainage areas and design flows to each of the runoff discharge locations. Reference the drainage study for detailed calculations.

Describe proposed site drainage patterns:

The proposed site will consist of two (2) major drainage basins with two (2) discharge locations to mimic existing conditions. See project Drainage Study for depiction of major drainage basins. The site will consist of three (3) Drainage Management Areas (DMAs) based on onsite drainage patterns and BMP locations. The site will be accessed by a proposed driveway off Shinohara Lane.

Storm water runoff from a majority of the proposed development (DMA-A) is routed to a series of BMPs including an OldCastle NSBB trash capture device, an OldCastle StormCapture underground detention system, and a BioClean Modular Wetland System (MWS). The underground detention vault has been designed to meet 100-year peak flow detention requirements. The Modular Wetland System is designed as a proprietary biofiltration BMP for storm water treatment. Outflows from the detention vault and MWS are discharged through a proposed storm drain pipe to the existing Type F catch basin at the southern property boundary. Stormwater is then conveyed through the neighboring property to the south through an existing private storm drain and outlets onto Main Street as in existing conditions.

Storm water runoff from the proposed driveway (DMA-B) will be drained to a Modular Wetland System for storm water treatment. The MWS will be designed with a 3-foot-wide curb inlet opening and a 1-inch local curb depression to capture the required water quality flow. Runoff that exceeds the water quality flow rate or capacity of the MWS will flow by the MWS and drain to the existing concrete drainage channel at the southeast corner of the project site. Outflows from the MWS will be pumped to a proposed curb outlet along the southern property boundary and discharged to the existing concrete drainage channel. The concrete drainage channel discharges onto Main Street via curb outlet as in existing conditions.

(Continued on following page)



Project Name: _____

Form I-3B Page 5 of 10

Does the project include changes to site drainage (e.g., installation of new storm water conveyance systems)?

- Yes
 No

If yes, provide details regarding the proposed project site drainage conveyance network, including storm drains, concrete channels, swales, detention facilities, storm water treatment facilities, natural or constructed channels, and the method for conveying offsite flows through or around the proposed project site. Identify all discharge locations from the proposed project site along with a summary of the conveyance system size and capacity for each of the discharge locations. Provide a summary of pre- and post-project drainage areas and design flows to each of the runoff discharge locations. Reference the drainage study for detailed calculations.

Describe proposed site drainage patterns:

(Continued from previous page)

Runoff from the cut slope at the northwest portion of the project site will be conveyed via proposed brow ditch to the existing Type F catch basin at the southern property boundary. This area (DMA-C) is considered a Self-Mitigating DMA per Chapter 5.2.1 of the City of Chula Vista BMP Design Manual.

All project site runoff is discharged onto Main Street as in existing conditions. From Main Street, flow travels west via concrete curb and gutter to an existing curb inlet. Stormwater is then conveyed south through an existing storm drain and outlets over headwall into the Otay River. The Otay River travels west and outlets at the San Diego Bay and ultimately the Pacific Ocean. The Otay River is considered an exempt river reach per the WMAA; therefore, the project is exempt from hydromodification management requirements.

The underground detention vault has been designed to provide flow control in the form of volume reduction and peak flow attenuation. The vault has been modified to include a low-flow and mid-flow orifice outlet and an overflow weir to control peak flows. The required water quality treatment flow is diverted to the downstream Modular Wetland System in accordance with Worksheet B.5-5 of the City of Chula Vista BMP Design Manual. Overflow relief for the 100-year storm event is provided with a partition weir installed within the vault and discharged directly to the existing Type F catch basin at the southern property boundary.

The undetained peak flow for Basin A is 33.5 cfs. The detained peak flow for Basin A is 7.2 cfs, which is equal to the existing peak flow of 7.2 cfs. The undetained peak flow for Basin B is 5.8 cfs, which is less than the existing peak flow of 15.3 cfs.

Shinohara Business Center

Project Name: _____

Form I-3B Page 6 of 10

Identify whether any of the following features, activities, and/or pollutant source areas will be present (select all that apply):

- On-site storm drain inlets
- Interior floor drains and elevator shaft sump pumps
- Interior parking garages
- Need for future indoor & structural pest control
- Landscape/Outdoor Pesticide Use
- Pools, spas, ponds, decorative fountains, and other water features
- Food service
- Refuse areas
- Industrial processes
- Outdoor storage of equipment or materials
- Vehicle and Equipment Cleaning
- Vehicle/Equipment Repair and Maintenance
- Fuel Dispensing Areas
- Loading Docks
- Fire Sprinkler Test Water
- Miscellaneous Drain or Wash Water
- Plazas, sidewalks, and parking lots

Description / Additional Information:

Project Name: _____

Form I-3B Page 7 of 10

Identification and Narrative of Receiving Water and Pollutants of Concern

Describe flow path of storm water from the project site discharge location(s), through urban storm conveyance systems as applicable, to receiving creeks, rivers, and lagoons as applicable, and ultimate discharge to the Pacific Ocean (or bay, lagoon, lake or reservoir, as applicable):

There are two (2) discharge locations from the project site. Discharges to the existing Type F catch basin at the southern property boundary are routed to Main Street through an existing underground storm drain pipe. Discharges to the existing concrete drainage channel at the southeast corner of the site flows to Main Street. From Main Street, flow travels west via concrete curb and gutter to an existing curb inlet. Stormwater is then conveyed south through an existing storm drain pipe and outlets over headwall into the Otay River, an exempt river reach per the WMAA. The Otay River travels west and outlets at the San Diego Bay and ultimately the Pacific Ocean.

List any 303(d) impaired water bodies within the path of storm water from the project site to the Pacific Ocean (or bay, lagoon, lake or reservoir, as applicable), identify the pollutant(s)/stressor(s) causing impairment, and identify any TMDLs and/or Highest Priority Pollutants from the WQIP for the impaired water bodies:

303(d) Impaired Water Body	Pollutant(s)/Stressor(s)	TMDLs / WQIP Highest Priority Pollutant
San Diego Bay	PCBs (Polychlorinated biphenyls)	WQIP Highest Priority Pollutant:
		Indicator Bacteria,
		Dissolved Copper, Lead
		Zinc (wet weather)

Identification of Project Site Pollutants*

*Identification of project site pollutants is only required if flow-thru treatment BMPs are implemented onsite in lieu of retention or biofiltration BMPs (note the project must also participate in an alternative compliance program unless prior lawful approval to meet earlier PDP requirements is demonstrated)

Identify pollutants expected from the project site based on all proposed use(s) of the site (see BMP Design Manual Appendix B.6):

Pollutant	Not Applicable to the Project Site	Expected from the Project Site	Also a Receiving Water Pollutant of Concern
Sediment	<input type="checkbox"/>	<input type="checkbox"/>	<input type="checkbox"/>
Nutrients	<input type="checkbox"/>	<input type="checkbox"/>	<input type="checkbox"/>
Heavy Metals	<input type="checkbox"/>	<input type="checkbox"/>	<input type="checkbox"/>
Organic Compounds	<input type="checkbox"/>	<input type="checkbox"/>	<input type="checkbox"/>
Trash & Debris	<input type="checkbox"/>	<input type="checkbox"/>	<input type="checkbox"/>
Oxygen Demanding Substances	<input type="checkbox"/>	<input type="checkbox"/>	<input type="checkbox"/>
Oil & Grease	<input type="checkbox"/>	<input type="checkbox"/>	<input type="checkbox"/>
Bacteria & Viruses	<input type="checkbox"/>	<input type="checkbox"/>	<input type="checkbox"/>
Pesticides	<input type="checkbox"/>	<input type="checkbox"/>	<input type="checkbox"/>



Form I-3B Page 8 of 10

Hydromodification Management Requirements

Do hydromodification management requirements apply (see Section 1.6)?

- Yes, hydromodification management flow control structural BMPs required.
- No, the project will discharge runoff directly to existing underground storm drains discharging directly to water storage reservoirs, lakes, enclosed embayments, or the Pacific Ocean.
- No, the project will discharge runoff directly to conveyance channels whose bed and bank are concrete-lined all the way from the point of discharge to water storage reservoirs, lakes, enclosed embayments, or the Pacific Ocean.
- No, the project will discharge runoff directly to an area identified as appropriate for an exemption by the WMAA for the watershed in which the project resides.

Description / Additional Information (to be provided if a 'No' answer has been selected above):

There are two (2) discharge locations from the project site. All locations discharge through existing underground storm drain systems and concrete-lined drainage channels and outlet at the Otay River, an exempt river reach per the WMAA. Since the project discharges to an exempt river reach, the project is exempt from PDP hydromodification management requirements. Refer to the HMP Exemption Exhibit in the project SWQMP.

Note: If "No" answer has been selected the SWQMP must include an exhibit that shows the storm water conveyance system from the project site to an exempt water body. The exhibit should include details about the conveyance system and the outfall to the exempt water body.

Critical Coarse Sediment Yield Areas*

***This Section only required if hydromodification management requirements apply**

Based on Section 6.2 and Appendix H does CCSYA exist on the project footprint or in the upstream area draining through the project footprint?

- Yes
- No

Description / Additional Information:

Not applicable since hydromodification management requirements do not apply.

Project Name: _____

Form I-3B Page 9 of 10

Flow Control for Post-Project Runoff*

***This Section only required if hydromodification management requirements apply**

List and describe point(s) of compliance (POCs) for flow control for hydromodification management (see Section 6.3.1). For each POC, provide a POC identification name or number correlating to the project's HMP Exhibit and a receiving channel identification name or number correlating to the project HMP Exhibit.

Not applicable since hydromodification management requirements do not apply.

Has a geomorphic assessment been performed for the receiving channel(s)?

- No, the low flow threshold is 0.1Q2 (default low flow threshold)
- Yes, the result is the low flow threshold is 0.1Q2
- Yes, the result is the low flow threshold is 0.3Q2
- Yes, the result is the low flow threshold is 0.5Q2

If a geomorphic assessment has been performed, provide title, date, and preparer:

Discussion / Additional Information: (optional)

Project Name: _____

Form I-3B Page 10 of 10

Other Site Requirements and Constraints

When applicable, list other site requirements or constraints that will influence storm water management design, such as zoning requirements including setbacks and open space, or local codes governing minimum street width, sidewalk construction, allowable pavement types, and drainage requirements.

Optional Additional Information or Continuation of Previous Sections As Needed

This space provided for additional information or continuation of information from previous sections as needed.

Project Name/_____

**Insert Completed Form I-4: Source Control BMP Checklist for All
Development Projects**

<https://www.chulavistaca.gov/departments/public-works/services/storm-water-pollution-prevention/documents-and-reports>

Project Name: _____

Source Control BMP Checklist for All Development Projects		Form I-4	
<p>All development projects must implement source control BMPs. Refer to Chapter 4 and Appendix E of the BMP Design Manual for information to implement BMPs shown in this checklist.</p> <p>Note: All selected BMPs must be shown on the site/construction plans.</p> <p>Answer each category below pursuant to the following:</p> <ul style="list-style-type: none"> • "Yes" means the project will implement the source control BMP as described in Chapter 4 and/or Appendix E of the BMP Design Manual. Discussion / justification is not required. • "No" means the BMP is applicable to the project but it is not feasible to implement. Discussion / justification must be provided. • "N/A" means the BMP is not applicable at the project site because the project does not include the feature that is addressed by the BMP (e.g., the project has no outdoor materials storage areas). Discussion / justification may be provided. 			
Source Control Requirement	Applied?		
4.2.1 Prevention of Illicit Discharges into the MS4	<input checked="" type="checkbox"/> Yes	<input type="checkbox"/> No	<input type="checkbox"/> N/A
Discussion / justification if 4.2.1 not implemented:			
4.2.2 Storm Drain Stenciling or Signage	<input checked="" type="checkbox"/> Yes	<input type="checkbox"/> No	<input type="checkbox"/> N/A
Discussion / justification if 4.2.2 not implemented:			
4.2.3 Protect Outdoor Materials Storage Areas from Rainfall, Run-On, Runoff, and Wind Dispersal	<input type="checkbox"/> Yes	<input type="checkbox"/> No	<input checked="" type="checkbox"/> N/A
Discussion / justification if 4.2.3 not implemented:			
4.2.4 Protect Materials Stored in Outdoor Work Areas from Rainfall, Run-On, Runoff, and Wind Dispersal	<input type="checkbox"/> Yes	<input type="checkbox"/> No	<input checked="" type="checkbox"/> N/A
Discussion / justification if 4.2.4 not implemented:			
4.2.5 Protect Trash Storage Areas from Rainfall, Run-On, Runoff, and Wind Dispersal	<input checked="" type="checkbox"/> Yes	<input type="checkbox"/> No	<input type="checkbox"/> N/A
Discussion / justification if 4.2.5 not implemented:			

Shinohara Business Center

Project Name: _____

Source Control BMP Checklist for All Development Projects	Form I-4 (Page 2 of 2)		
4.2.6 Additional BMPs Based on Potential Sources of Runoff Pollutants (must answer for each source listed below)	<input checked="" type="checkbox"/> Yes	<input type="checkbox"/> No	<input type="checkbox"/> N/A
SC-A Onsite storm drain inlets	<input checked="" type="checkbox"/> Yes	<input type="checkbox"/> No	<input type="checkbox"/> N/A
SC-B Interior floor drains and elevator shaft sump pumps	<input type="checkbox"/> Yes	<input type="checkbox"/> No	<input checked="" type="checkbox"/> N/A
SC-C Interior parking garages	<input type="checkbox"/> Yes	<input type="checkbox"/> No	<input checked="" type="checkbox"/> N/A
SC-D1 Need for future indoor & structural pest control	<input checked="" type="checkbox"/> Yes	<input type="checkbox"/> No	<input type="checkbox"/> N/A
SD-D2 Landscape/outdoor pesticide use	<input checked="" type="checkbox"/> Yes	<input type="checkbox"/> No	<input type="checkbox"/> N/A
SC-E Pools, spas, ponds, decorative fountains, and other water features	<input type="checkbox"/> Yes	<input type="checkbox"/> No	<input checked="" type="checkbox"/> N/A
SC-F Food Service	<input type="checkbox"/> Yes	<input type="checkbox"/> No	<input checked="" type="checkbox"/> N/A
SC-G Refuse areas	<input checked="" type="checkbox"/> Yes	<input type="checkbox"/> No	<input type="checkbox"/> N/A
SC-H Industrial processes	<input checked="" type="checkbox"/> Yes	<input type="checkbox"/> No	<input type="checkbox"/> N/A
SC-I Outdoor storage of equipment or materials	<input type="checkbox"/> Yes	<input type="checkbox"/> No	<input checked="" type="checkbox"/> N/A
SC-J Vehicle and equipment cleaning	<input type="checkbox"/> Yes	<input type="checkbox"/> No	<input checked="" type="checkbox"/> N/A
SC-K Vehicle/equipment repair and maintenance	<input type="checkbox"/> Yes	<input type="checkbox"/> No	<input checked="" type="checkbox"/> N/A
SC-L Fuel dispensing areas	<input type="checkbox"/> Yes	<input type="checkbox"/> No	<input checked="" type="checkbox"/> N/A
SC-M Loading docks	<input checked="" type="checkbox"/> Yes	<input type="checkbox"/> No	<input type="checkbox"/> N/A
SC-N Fire sprinkler test water	<input checked="" type="checkbox"/> Yes	<input type="checkbox"/> No	<input type="checkbox"/> N/A
SC-O Miscellaneous drain or wash water	<input checked="" type="checkbox"/> Yes	<input type="checkbox"/> No	<input type="checkbox"/> N/A
SC-P Plazas, sidewalks, and parking lots	<input checked="" type="checkbox"/> Yes	<input type="checkbox"/> No	<input type="checkbox"/> N/A
SC-Q: Large Trash Generating Facilities	<input type="checkbox"/> Yes	<input type="checkbox"/> No	<input checked="" type="checkbox"/> N/A
SC-R: Animal Facilities	<input type="checkbox"/> Yes	<input type="checkbox"/> No	<input checked="" type="checkbox"/> N/A
SC-S: Plant Nurseries and Garden Centers	<input type="checkbox"/> Yes	<input type="checkbox"/> No	<input checked="" type="checkbox"/> N/A
SC-T: Automotive Facilities	<input type="checkbox"/> Yes	<input type="checkbox"/> No	<input checked="" type="checkbox"/> N/A
Discussion / justification if 4.2.6 not implemented. Justification must be provided for all "No" answers shown above.			

Project Name/ _____

**Insert Completed Form I-5: Site Design BMP Checklist for All
Development Projects**

<https://www.chulavistaca.gov/departments/public-works/services/storm-water-pollution-prevention/documents-and-reports>

Shinohara Business Center

Project Name.: _____

Site Design BMP Checklist for All Development Projects		Form I-5	
<p>All development projects must implement site design BMPs where applicable and feasible. See Chapter 4 and Appendix E of the manual for information to implement site design BMPs shown in this checklist. Note: All selected BMPs must be shown on the site/construction plans.</p> <p>Answer each category below pursuant to the following.</p> <ul style="list-style-type: none"> • "Yes" means the project will implement the site design BMP as described in Chapter 4 and/or Appendix E of the manual. Discussion / justification is not required. • "No" means the BMP is applicable to the project but it is not feasible to implement. Discussion / justification must be provided. • "N/A" means the BMP is not applicable at the project site because the project does not include the feature that is addressed by the BMP (e.g., the project site has no existing natural areas to conserve). Discussion / justification may be provided. 			
Site Design Requirement	Applied?		
4.3.1 Maintain Natural Drainage Pathways and Hydrologic Features	<input checked="" type="checkbox"/> Yes	<input type="checkbox"/> No	<input type="checkbox"/> N/A
<p>Project will conserve vegetation within the open space easement along the northerly property line.</p>			
4.3.2 Conserve Natural Areas, Soils, and Vegetation	<input checked="" type="checkbox"/> Yes	<input type="checkbox"/> No	<input type="checkbox"/> N/A
<p>Project will conserve vegetation within the open space easement along the northerly property line.</p>			
4.3.3 Minimize Impervious Area	<input checked="" type="checkbox"/> Yes	<input type="checkbox"/> No	<input type="checkbox"/> N/A
<p>Driveways and parking lots are constructed to minimum widths necessary.</p>			
4.3.4 Minimize Soil Compaction	<input checked="" type="checkbox"/> Yes	<input type="checkbox"/> No	<input type="checkbox"/> N/A
<p>Soil compaction is minimized in all landscape areas.</p>			
4.3.5 Impervious Area Dispersion	<input checked="" type="checkbox"/> Yes	<input type="checkbox"/> No	<input type="checkbox"/> N/A
<p>Sidewalks are disconnected through distributed pervious areas.</p>			

Project Name/Address/N _____

Site Design BMP Checklist for All Development Projects		Form I-5	
Site Design Requirement	Applied?		
4.3.6 Runoff Collection	<input type="checkbox"/> Yes	<input checked="" type="checkbox"/> No	<input type="checkbox"/> N/A
Green roofs and permeable pavements are not applicable BMPs for this project. The site requires rigid pavement suitable for heavy trucks and fire lanes.			
4.3.7 Landscaping with Native or Drought Tolerant Species	<input checked="" type="checkbox"/> Yes	<input type="checkbox"/> No	<input type="checkbox"/> N/A
Native or drought tolerant species are used in all landscape areas.			
4.3.8 Harvesting and Using Precipitation	<input type="checkbox"/> Yes	<input type="checkbox"/> No	<input checked="" type="checkbox"/> N/A
Discussion / justification for all "No" answers shown above: Harvest and use is considered infeasible per Worksheet B.3-1: Form I-7 (Attachment 1c).			

Project Name/_____

Insert Completed Form I-6: Summary of PDP Structural BMPs

<https://www.chulavistaca.gov/departments/public-works/services/storm-water-pollution-prevention/documents-and-reports>

Project Name: _____

Summary of PDP Structural BMPs	Form I-6
PDP Structural BMPs	
<p>All PDPs must implement structural BMPs for storm water pollutant control (see Chapter 5 of the manual). Selection of PDP structural BMPs for storm water pollutant control must be based on the selection process described in Chapter 5. PDPs subject to hydromodification management requirements must also implement structural BMPs for flow control for hydromodification management (see Chapter 6 of the manual). Both storm water pollutant control and flow control for hydromodification management can be achieved within the same structural BMP(s).</p> <p>PDP structural BMPs must be verified by City at the completion of construction. This may include requiring the project owner or project owner's representative to certify construction of the structural BMPs (see Section 1.12 of the manual). PDP structural BMPs must be maintained into perpetuity (see Section 7 of the manual).</p> <p>Use this form to provide narrative description of the general strategy for structural BMP implementation at the project site in the box below. Then complete the PDP structural BMP summary information sheet (page 3 of this form) for each structural BMP within the project (copy the BMP summary information page as many times as needed to provide summary information for each individual structural BMP).</p>	
<p>Describe the general strategy for structural BMP implementation at the site. This information must describe how the steps for selecting and designing storm water pollutant control BMPs presented in Section 5.1 of the manual were followed, and the results (type of BMPs selected). For projects requiring hydromodification flow control BMPs, indicate whether pollutant control and flow control BMPs are integrated or separate.</p> <p>For the purpose of this SWQMP, the proposed site condition has been divided into two (2) Drainage Management Areas (DMAs) draining to structural BMPs and two (2) Self-Mitigating DMAs. The DMAs have been delineated based on on-site drainage patterns and BMP locations.</p> <p>The types of structural BMPs chosen for the project were based on the flow chart presented in Figures 5-1 and 5-2 of the City of Chula Vista BMP Design Manual (March 2019). Using Form I-7 (Worksheet B.3-1) to gauge the feasibility of implementing capture and use techniques for the project site, it was determined that harvest and use BMPs are considered infeasible. See Attachment 1C.</p> <p>A feasibility study was then conducted for infiltration and if infiltration is fully or partially feasible for the project's structural BMPs. The negative impacts associated with retention were identified and substantiated through the completion of Form I-8A (Worksheet C.4-1). An Infiltration Feasibility Condition Letter has also been provided by the geotechnical engineer that concurs with the no infiltration condition for the site. Please refer to Attachment 1D.</p> <p>Based on site geologic conditions and existing fill material, it has been determined that full or partial infiltration of storm water is considered infeasible. Since infiltration is considered infeasible, a cistern (HU-1) and proprietary biofiltration BMPs (BF-3) were chosen as the types of structural BMPs for DMA-A and DMA-B. (Continued on following page)</p>	

Project Name: _____

Summary of PDP Structural BMPs	Form I-6
PDP Structural BMPs	
<p>All PDPs must implement structural BMPs for storm water pollutant control (see Chapter 5 of the manual). Selection of PDP structural BMPs for storm water pollutant control must be based on the selection process described in Chapter 5. PDPs subject to hydromodification management requirements must also implement structural BMPs for flow control for hydromodification management (see Chapter 6 of the manual). Both storm water pollutant control and flow control for hydromodification management can be achieved within the same structural BMP(s).</p> <p>PDP structural BMPs must be verified by City at the completion of construction. This may include requiring the project owner or project owner's representative to certify construction of the structural BMPs (see Section 1.12 of the manual). PDP structural BMPs must be maintained into perpetuity (see Section 7 of the manual).</p> <p>Use this form to provide narrative description of the general strategy for structural BMP implementation at the project site in the box below. Then complete the PDP structural BMP summary information sheet (page 3 of this form) for each structural BMP within the project (copy the BMP summary information page as many times as needed to provide summary information for each individual structural BMP).</p>	
<p>Describe the general strategy for structural BMP implementation at the site. This information must describe how the steps for selecting and designing storm water pollutant control BMPs presented in Section 5.1 of the manual were followed, and the results (type of BMPs selected). For projects requiring hydromodification flow control BMPs, indicate whether pollutant control and flow control BMPs are integrated or separate.</p> <p>DMA-A: The type of underground detention vault is an OldCastle StormCapture and identified as BMP-1. Prior to entering the detention vault, storm water will be drained through an OldCastle NSBB (BMP-3) to capture trash and particles up to 5mm in size. Once flows enter the vault, the required pollutant control treatment volume, or DCV, will be drained a downstream Modular Wetland System (BMP-2) through a 4"-dia flow control orifice located at the invert of the vault (elev=182.75). A partition weir will be constructed within the vault with a 2.75'L X 0.25'H slot orifice set 2 feet above the invert of the vault (elev=184.75) and a 14'L weir set 5.5 feet above the invert of the vault (elev=188.25), such that peak flows can be safely discharged to the storm drain system.</p> <p>Since the Modular Wetland System is downstream of the storage unit, the required treatment volume is based on the project DCV and drawdown time of the storage unit, in accordance with Table B.5-5 of the City of Chula Vista BMP Design Manual. The drawdown time of the storage unit is 12 hours; therefore, the required treatment volume of the downstream biofiltration BMP is 0.85DCV. See BMP-1 vault drawdown calculation provided in Attachment 1D. The type of downstream Modular Wetland System is a MWS-L-8-24 unit.</p> <p>The volume retention requirement for DMA-A has been calculated using Worksheet B.5-2. See volume retention summary on following page.</p>	

Project Name: _____

Summary of PDP Structural BMPs	Form I-6
PDP Structural BMPs	
<p>All PDPs must implement structural BMPs for storm water pollutant control (see Chapter 5 of the manual). Selection of PDP structural BMPs for storm water pollutant control must be based on the selection process described in Chapter 5. PDPs subject to hydromodification management requirements must also implement structural BMPs for flow control for hydromodification management (see Chapter 6 of the manual). Both storm water pollutant control and flow control for hydromodification management can be achieved within the same structural BMP(s).</p> <p>PDP structural BMPs must be verified by City at the completion of construction. This may include requiring the project owner or project owner's representative to certify construction of the structural BMPs (see Section 1.12 of the manual). PDP structural BMPs must be maintained into perpetuity (see Section 7 of the manual).</p> <p>Use this form to provide narrative description of the general strategy for structural BMP implementation at the project site in the box below. Then complete the PDP structural BMP summary information sheet (page 3 of this form) for each structural BMP within the project (copy the BMP summary information page as many times as needed to provide summary information for each individual structural BMP).</p>	
<p>Describe the general strategy for structural BMP implementation at the site. This information must describe how the steps for selecting and designing storm water pollutant control BMPs presented in Section 5.1 of the manual were followed, and the results (type of BMPs selected). For projects requiring hydromodification flow control BMPs, indicate whether pollutant control and flow control BMPs are integrated or separate.</p> <p>(Continued from previous page)</p> <p>DMA-B: Storm water will be drained to BMP-4, a planted Modular Wetland System MWS-L-4-15, for stormwater pollutant control. This MWS is considered a flow-based compact biofiltration BMP and sized in accordance with Appendix F.2.2 of the BMP DM. The MWS is sized to treat the required flow rate of 1.5 times the DCV. The MWS will be designed with a 3-foot-wide curb inlet opening and a 1-inch local curb depression to capture the required water quality flow. Runoff that exceeds the water quality flow rate or capacity of the MWS will flow by the MWS and drain to the existing concrete drainage channel at the southeast corner of the project site. Outflows from the MWS will be pumped to a proposed curb outlet along the southern property boundary and discharged to the existing concrete drainage channel.</p> <p>The volume retention requirement for DMA-B has been calculated using Worksheet B.5-2. See volume retention summary on the following page.</p> <p>(Continued on following page)</p>	

Project Name: _____

Summary of PDP Structural BMPs	Form I-6
PDP Structural BMPs	
<p>All PDPs must implement structural BMPs for storm water pollutant control (see Chapter 5 of the manual). Selection of PDP structural BMPs for storm water pollutant control must be based on the selection process described in Chapter 5. PDPs subject to hydromodification management requirements must also implement structural BMPs for flow control for hydromodification management (see Chapter 6 of the manual). Both storm water pollutant control and flow control for hydromodification management can be achieved within the same structural BMP(s).</p>	
<p>PDP structural BMPs must be verified by City at the completion of construction. This may include requiring the project owner or project owner's representative to certify construction of the structural BMPs (see Section 1.12 of the manual). PDP structural BMPs must be maintained into perpetuity (see Section 7 of the manual).</p>	
<p>Use this form to provide narrative description of the general strategy for structural BMP implementation at the project site in the box below. Then complete the PDP structural BMP summary information sheet (page 3 of this form) for each structural BMP within the project (copy the BMP summary information page as many times as needed to provide summary information for each individual structural BMP).</p>	
<p>Describe the general strategy for structural BMP implementation at the site. This information must describe how the steps for selecting and designing storm water pollutant control BMPs presented in Section 5.1 of the manual were followed, and the results (type of BMPs selected). For projects requiring hydromodification flow control BMPs, indicate whether pollutant control and flow control BMPs are integrated or separate.</p>	
<p>(Continued from previous page)</p>	
<p>Volume Retention Requirement: The required volume retention for DMA-A is 291 cu.ft. The required volume retention for DMA-B is 29 cu.ft. The total required volume retention for DMA-A and DMA-B is 320 cu.ft.</p>	
<p>Two (2) tree wells with an underdrain are proposed to meet the volume retention requirement for DMA-A and DMA-B, as documented in Worksheet B.5-6. Since an underdrain is proposed, the tree credit volume (TCV) has been adjusted in accordance with Equation B.2-1 of the BMP DM. The tree well BMP-5 is designed with a soil area of 475 sq.ft., a depth of 4 feet, and a soil volume of 1,900 cu.ft. to provide a tree credit volume of 190 cu.ft. The tree well BMP-6 is designed with a soil area of 415 sq.ft., a depth of 4 feet, a soil volume of 1,660 cu.ft. to provide a tree credit volume of 166 cu.ft. The sum of volume retention benefits (total TCV) is 356 cu.ft. Therefore, the TCV provided by BMP-5 and BMP-6 is greater than the required retention volume for DMA-A and DMA-B, and the project meets volume retention requirements.</p>	



Shinohara Business Center

Project Name: _____

Form I-6 Page 2 of _____ (Copy and attach as many as needed)	
Structural BMP ID No. BMP-1	
Construction Plan Sheet No.	
<p>Type of structural BMP:</p> <ul style="list-style-type: none"> <input type="checkbox"/> Retention by harvest and use (e.g. HU-1, cistern) <input type="checkbox"/> Retention by infiltration basin (INF-1) <input type="checkbox"/> Retention by bioretention (INF-2) <input type="checkbox"/> Retention by permeable pavement (INF-3) <input type="checkbox"/> Partial retention by biofiltration with partial retention (PR-1) <input type="checkbox"/> Biofiltration (BF-1) <input type="checkbox"/> Flow-thru treatment control with prior lawful approval to meet earlier PDP requirements (provide BMP type/description in discussion section below) <input type="checkbox"/> Flow-thru treatment control included as pre-treatment/forebay for an onsite retention or biofiltration BMP (provide BMP type/description and indicate which onsite retention or biofiltration BMP it serves in discussion section below) <input type="checkbox"/> Flow-thru treatment control with alternative compliance (provide BMP type/description in discussion section below) <input type="checkbox"/> Detention pond or vault for hydromodification management <input checked="" type="checkbox"/> Other (describe in discussion section below) 	
<p>Purpose:</p> <ul style="list-style-type: none"> <input type="checkbox"/> Pollutant control only <input type="checkbox"/> Hydromodification control only <input type="checkbox"/> Combined pollutant control and hydromodification control <input type="checkbox"/> Pre-treatment/forebay for another structural BMP <input checked="" type="checkbox"/> Other (describe in discussion section below) 	
<p>Who will certify construction of this BMP? Provide name and contact information for the party responsible to sign BMP verification forms if required by the City Engineer (See Section 1.12 of the manual)</p>	<p>Gregory W. Lang, RCE 68075 119 Aberdeen Drive Cardiff, CA 92007 (858) 259-8212</p>
<p>Who will be the final owner of this BMP?</p>	<p>VWP-OP, Shinohara Owner LLC, 2950 E. Camelback Rd, Ste. 305, Phoenix, AZ 85016</p>
<p>Who will maintain this BMP into perpetuity?</p>	<p>VWP-OP, Shinohara Owner LLC, 2950 E. Camelback Rd, Ste. 305, Phoenix, AZ 85016</p>
<p>What is the funding mechanism for maintenance?</p>	<p>VWP-OP, Shinohara Owner LLC, 2950 E. Camelback Rd, Ste. 305, Phoenix, AZ 85016</p>



Shinohara Business Center

Project Name: _____

Form I-6 Page 3 of *(Copy and attach as many as needed)*

Structural BMP ID No. BMP-1

Construction Plan Sheet No.

Discussion (as needed, must include worksheets showing BMP sizing calculations in the SWQMP):

The StormCapture underground detention vault, BMP-1, is responsible for handling peak flow reduction requirements for the project site.

Shinohara Business Center

Project Name: _____

Form I-6 Page 2 of _____ (Copy and attach as many as needed)	
Structural BMP ID No. BMP-2	
Construction Plan Sheet No.	
<p>Type of structural BMP:</p> <ul style="list-style-type: none"> <input type="checkbox"/> Retention by harvest and use (e.g. HU-1, cistern) <input type="checkbox"/> Retention by infiltration basin (INF-1) <input type="checkbox"/> Retention by bioretention (INF-2) <input type="checkbox"/> Retention by permeable pavement (INF-3) <input type="checkbox"/> Partial retention by biofiltration with partial retention (PR-1) <input type="checkbox"/> Biofiltration (BF-1) <input type="checkbox"/> Flow-thru treatment control with prior lawful approval to meet earlier PDP requirements (provide BMP type/description in discussion section below) <input type="checkbox"/> Flow-thru treatment control included as pre-treatment/forebay for an onsite retention or biofiltration BMP (provide BMP type/description and indicate which onsite retention or biofiltration BMP it serves in discussion section below) <input type="checkbox"/> Flow-thru treatment control with alternative compliance (provide BMP type/description in discussion section below) <input type="checkbox"/> Detention pond or vault for hydromodification management <input checked="" type="checkbox"/> Other (describe in discussion section below) 	
<p>Purpose:</p> <ul style="list-style-type: none"> <input checked="" type="checkbox"/> Pollutant control only <input type="checkbox"/> Hydromodification control only <input type="checkbox"/> Combined pollutant control and hydromodification control <input type="checkbox"/> Pre-treatment/forebay for another structural BMP <input type="checkbox"/> Other (describe in discussion section below) 	
<p>Who will certify construction of this BMP? Provide name and contact information for the party responsible to sign BMP verification forms if required by the City Engineer (See Section 1.12 of the manual)</p>	<p>Gregory W. Lang, RCE 68075 119 Aberdeen Drive Cardiff, CA 92007 (858) 259-8212</p>
<p>Who will be the final owner of this BMP?</p>	<p>VWP-OP, Shinohara Owner LLC, 2950 E. Camelback Rd, Ste. 305, Phoenix, AZ 85016</p>
<p>Who will maintain this BMP into perpetuity?</p>	<p>VWP-OP, Shinohara Owner LLC, 2950 E. Camelback Rd, Ste. 305, Phoenix, AZ 85016</p>
<p>What is the funding mechanism for maintenance?</p>	<p>VWP-OP, Shinohara Owner LLC, 2950 E. Camelback Rd, Ste. 305, Phoenix, AZ 85016</p>



Project Name: _____

Form I-6 Page 3 of *(Copy and attach as many as needed)***Structural BMP ID No.** BMP-2**Construction Plan Sheet No.**

Discussion (as needed, must include worksheets showing BMP sizing calculations in the SWQMP):

The BioClean Modular Wetland System, BMP-2, is a proprietary biofiltration BMP (BF-3) responsible for handling pollutant control requirements for a portion of the project site (DMA-A).

Since the Modular Wetland System is downstream of the storage unit, the required treatment volume is based on the project DCV and drawdown time of the storage unit, in accordance with Table B.5-5 of the City of Chula Vista BMP Design Manual.

DMA-A DCV = 12,668 cu.ft.

BMP-1 vault volume = 35,824 cu.ft..

BMP-1 vault depth = 6 ft

BMP-1 low flow orifice size = 4"-dia

BMP-1 mid-flow orifice height = 2 ft

Drawdown time of storage unit, BMP-1 = 12 hr

Fraction required to achieve greater than 92 percent capture (per Table B.5-5) = 0.85

Storage required = 10,768 cu.ft.

Storage provided = 11,941 cu.ft.

Shinohara Business Center

Project Name: _____

Form I-6 Page 2 of _____ (Copy and attach as many as needed)	
Structural BMP ID No. BMP-3	
Construction Plan Sheet No.	
<p>Type of structural BMP:</p> <ul style="list-style-type: none"> <input type="checkbox"/> Retention by harvest and use (e.g. HU-1, cistern) <input type="checkbox"/> Retention by infiltration basin (INF-1) <input type="checkbox"/> Retention by bioretention (INF-2) <input type="checkbox"/> Retention by permeable pavement (INF-3) <input type="checkbox"/> Partial retention by biofiltration with partial retention (PR-1) <input type="checkbox"/> Biofiltration (BF-1) <input type="checkbox"/> Flow-thru treatment control with prior lawful approval to meet earlier PDP requirements (provide BMP type/description in discussion section below) <input checked="" type="checkbox"/> Flow-thru treatment control included as pre-treatment/forebay for an onsite retention or biofiltration BMP (provide BMP type/description and indicate which onsite retention or biofiltration BMP it serves in discussion section below) <input type="checkbox"/> Flow-thru treatment control with alternative compliance (provide BMP type/description in discussion section below) <input type="checkbox"/> Detention pond or vault for hydromodification management <input type="checkbox"/> Other (describe in discussion section below) 	
<p>Purpose:</p> <ul style="list-style-type: none"> <input type="checkbox"/> Pollutant control only <input type="checkbox"/> Hydromodification control only <input type="checkbox"/> Combined pollutant control and hydromodification control <input checked="" type="checkbox"/> Pre-treatment/forebay for another structural BMP <input type="checkbox"/> Other (describe in discussion section below) 	
<p>Who will certify construction of this BMP? Provide name and contact information for the party responsible to sign BMP verification forms if required by the City Engineer (See Section 1.12 of the manual)</p>	<p>Gregory W. Lang, RCE 68075 119 Aberdeen Drive Cardiff, CA 92007 (858) 259-8212</p>
<p>Who will be the final owner of this BMP?</p>	<p>VWP-OP, Shinohara Owner LLC, 2950 E. Camelback Rd, Ste. 305, Phoenix, AZ 85016</p>
<p>Who will maintain this BMP into perpetuity?</p>	<p>VWP-OP, Shinohara Owner LLC, 2950 E. Camelback Rd, Ste. 305, Phoenix, AZ 85016</p>
<p>What is the funding mechanism for maintenance?</p>	<p>VWP-OP, Shinohara Owner LLC, 2950 E. Camelback Rd, Ste. 305, Phoenix, AZ 85016</p>



Project Name: _____

Form I-6 Page 3 of *(Copy and attach as many as needed)*

Structural BMP ID No. **BMP-3**

Construction Plan Sheet No.

Discussion (as needed, must include worksheets showing BMP sizing calculations in the SWQMP):

The OldCastle NSBB, BMP-3, is a high-flow capacity trash capture BMP for the StormCapture detention system, BMP-1, and the Modular Wetland, BMP-2.

Shinohara Business Center

Project Name: _____

Form I-6 Page 2 of _____ (Copy and attach as many as needed)	
Structural BMP ID No. BMP-4	
Construction Plan Sheet No.	
<p>Type of structural BMP:</p> <ul style="list-style-type: none"> <input type="checkbox"/> Retention by harvest and use (e.g. HU-1, cistern) <input type="checkbox"/> Retention by infiltration basin (INF-1) <input type="checkbox"/> Retention by bioretention (INF-2) <input type="checkbox"/> Retention by permeable pavement (INF-3) <input type="checkbox"/> Partial retention by biofiltration with partial retention (PR-1) <input type="checkbox"/> Biofiltration (BF-1) <input type="checkbox"/> Flow-thru treatment control with prior lawful approval to meet earlier PDP requirements (provide BMP type/description in discussion section below) <input type="checkbox"/> Flow-thru treatment control included as pre-treatment/forebay for an onsite retention or biofiltration BMP (provide BMP type/description and indicate which onsite retention or biofiltration BMP it serves in discussion section below) <input type="checkbox"/> Flow-thru treatment control with alternative compliance (provide BMP type/description in discussion section below) <input type="checkbox"/> Detention pond or vault for hydromodification management <input checked="" type="checkbox"/> Other (describe in discussion section below) 	
<p>Purpose:</p> <ul style="list-style-type: none"> <input checked="" type="checkbox"/> Pollutant control only <input type="checkbox"/> Hydromodification control only <input type="checkbox"/> Combined pollutant control and hydromodification control <input type="checkbox"/> Pre-treatment/forebay for another structural BMP <input type="checkbox"/> Other (describe in discussion section below) 	
<p>Who will certify construction of this BMP? Provide name and contact information for the party responsible to sign BMP verification forms if required by the City Engineer (See Section 1.12 of the manual)</p>	<p>Gregory W. Lang, RCE 68075 119 Aberdeen Drive Cardiff, CA 92007 (858) 259-8212</p>
<p>Who will be the final owner of this BMP?</p>	<p>VWP-OP, Shinohara Owner LLC, 2950 E. Camelback Rd, Ste. 305, Phoenix, AZ 85016</p>
<p>Who will maintain this BMP into perpetuity?</p>	<p>VWP-OP, Shinohara Owner LLC, 2950 E. Camelback Rd, Ste. 305, Phoenix, AZ 85016</p>
<p>What is the funding mechanism for maintenance?</p>	<p>VWP-OP, Shinohara Owner LLC, 2950 E. Camelback Rd, Ste. 305, Phoenix, AZ 85016</p>



Project Name: _____

Form I-6 Page 3 of *(Copy and attach as many as needed)***Structural BMP ID No.** BMP-4**Construction Plan Sheet No.**

Discussion (as needed, must include worksheets showing BMP sizing calculations in the SWQMP):

The BioClean Modular Wetland System, BMP-4, is a proprietary biofiltration BMP (BF-3) responsible for handling pollutant control requirements for a portion of the project site (DMA-B).

This MWS is considered a flow-based compact biofiltration BMP and sized in accordance with Appendix F.2.2 of the BMP DM. The MWS is sized to treat the required flow rate of 1.5 times the DCV.

DMA-B:

DCV = 1,249 cu.ft.

Tributary area = 1.19 ac

Runoff coefficient = 0.5542

Intensity = 0.2 in/hr

Required flow rate = $1.5 \times 1.19 \times 0.5542 \times 0.2 = 0.198$ cfs

Provided MWS L-4-15 flow rate = 0.199 cfs

Operating head = 3.9 feet

3'-wide curb inlet opening with 1" local depression designed to capture the water quality flow rate.

Project Name/_____

ATTACHMENT 1

Backup for PDP Pollutant Control BMPs

Indicate which Items are Included:

Attachment Sequence	Contents	Checklist
Attachment 1A	DMA Exhibit (Required) See DMA Exhibit Checklist.	<input checked="" type="checkbox"/> Included
Attachment 1B	Tabular Summary of DMAs Showing DMA ID matching DMA Exhibit, DMA Area, and DMA Type (Required)* *Provide table in this Attachment OR on DMA Exhibit in Attachment 1a	<input type="checkbox"/> Included on DMA Exhibit in Attachment 1A <input checked="" type="checkbox"/> Included as Attachment 1B, separate from DMA Exhibit
Attachment 1C	Form I-7, Harvest and Use Feasibility Screening Checklist (Required unless the entire project will use infiltration BMPs) Refer to Appendix B.3-1 of the BMP Design Manual to complete Form I-7.	<input checked="" type="checkbox"/> Included <input type="checkbox"/> Not included because the entire project will use infiltration BMPs
Attachment 1D	Infiltration Feasibility Information. Contents of Attachment 1D depend on the infiltration condition: <input checked="" type="checkbox"/> No Infiltration Condition: <input checked="" type="checkbox"/> Infiltration Feasibility Condition <input checked="" type="checkbox"/> Letter (<i>Note: must be stamped & signed by licensed geotechnical engineer</i>) <input type="checkbox"/> Form I-8A (optional) <input type="checkbox"/> Form I-8B (optional) <input type="checkbox"/> Partial Infiltration Condition: <input type="checkbox"/> Infiltration Feasibility Condition <input type="checkbox"/> Letter (<i>Note: must be stamped & signed by licensed geotechnical engineer</i>) <input type="checkbox"/> Form I-8A <input type="checkbox"/> Form I-8B <input type="checkbox"/> Full Infiltration Condition: <input type="checkbox"/> Form I-8A <input type="checkbox"/> Form I-8B <input type="checkbox"/> Worksheet C.4-3 <input type="checkbox"/> Form I-9 Refer to Appendices C and D of the BMP Design Manual for guidance.	<input checked="" type="checkbox"/> Included <input type="checkbox"/> Not included because the entire project will use harvest and use BMPs
Attachment 1E	Pollutant Control BMP Design Worksheets/ Calculations (Required) Refer to Appendices B and E of the BMP Design Manual for structural pollutant control BMP design guidelines	<input checked="" type="checkbox"/> Included

Use this checklist to ensure the required information has been included on the DMA Exhibit:

The DMA Exhibit must identify all the following:

- Underlying hydrologic soil group
- Approximate depth to groundwater
- Existing natural hydrologic features (watercourses, seeps, springs, wetlands)
- Critical coarse sediment yield areas to be protected
- Existing topography and impervious areas
- Existing and proposed site drainage network and connections to drainage offsite
- Proposed grading
- Proposed impervious features
- Proposed design features and surface treatments used to minimize imperviousness
- Drainage management area (DMA) boundaries, DMA ID numbers, and DMA areas (square footage or acreage), and DMA type (i.e., drains to BMP, self-retaining, or self-mitigating)
- Potential pollutant source areas and corresponding required source controls (see Chapter 4, Appendix E.1, and Form I-3B)
- Structural BMPs (identify location, type of BMP, and size/detail, and include cross-sections)

Attachment 1A

DMA Exhibit

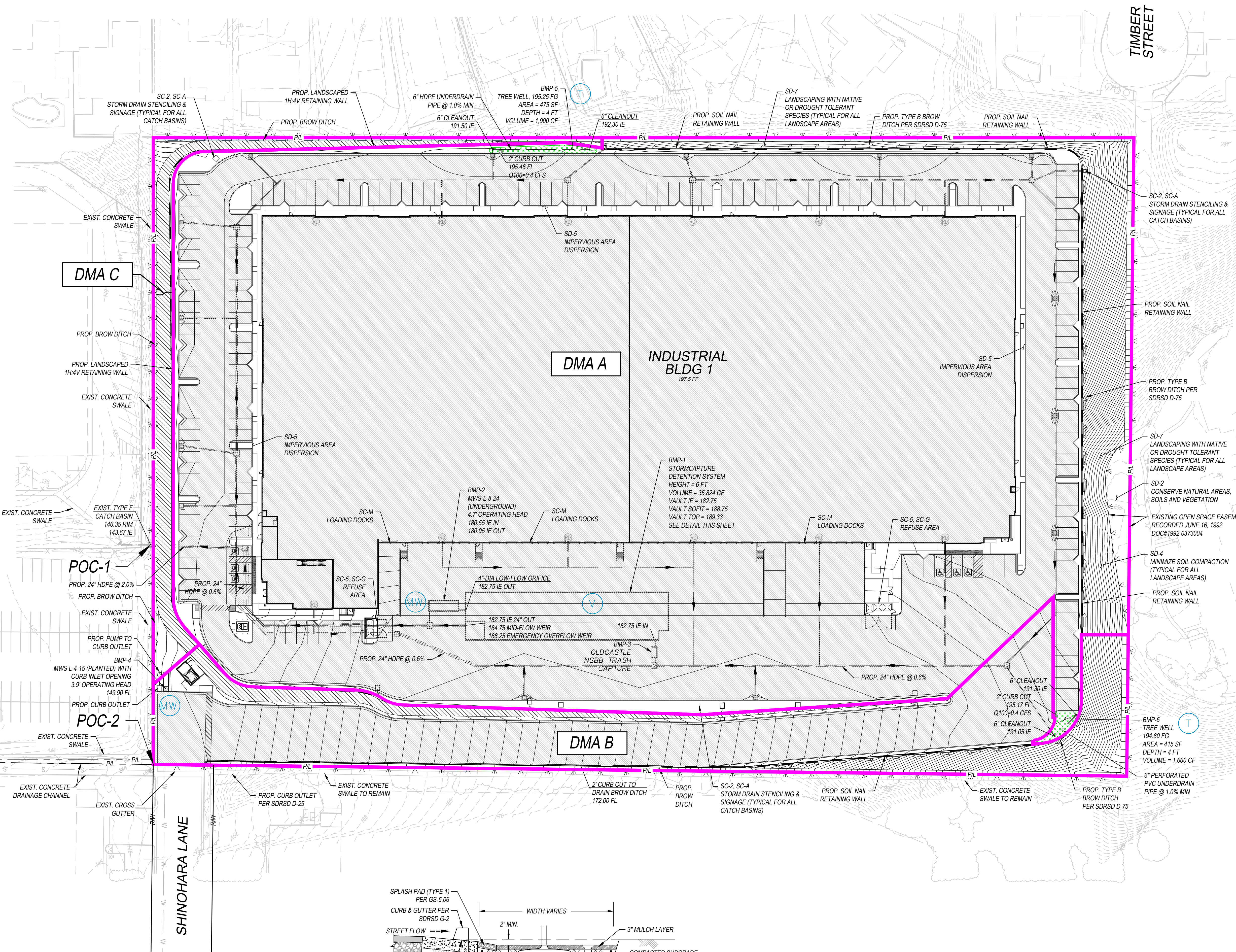

LEGEND

DESCRIPTION	SYMBOL
RIGHT-OF-WAY	—RW—
PROPERTY LINE	—PL—
DMA BOUNDARY	—
PROPOSED IMPERVIOUS AREA	[Hatched Box]
PROPOSED TREE WELL	[Green Checkered Box]
DIRECTION OF FLOW	→

HYDROLOGIC SOIL GROUP
HYDROLOGIC SOIL TYPE: C & D

DEPTH TO GROUNDWATER
DEPTH TO GROUNDWATER > 20 FT

PROJECT CHARACTERISTICS

PARCEL AREA:	9.73 AC
PROPOSED DISTURBED AREA:	9.67 AC
PROPOSED IMPERVIOUS AREA:	8.03 AC
PROPOSED PERVIOUS / LANDSCAPE AREA:	1.64 AC

- STRUCTURAL BMPs**
- UNDERGROUND DETENTION VAULT (HU-1) [V]
 - MODULAR WETLAND, PROPRIETARY BIOFILTRATION (BF-3) [MW]
- SITE DESIGN BMPs**
- TREE WELL (SD-A) [T]

CCSYAS
THE PROJECT IS EXEMPT FROM HYDROMODIFICATION REQUIREMENTS; THEREFORE PROTECTION OF CRITICAL COARSE SEDIMENT YIELD AREAS DOES NOT APPLY.
REFER TO THE HMP EXEMPTION EXHIBIT INCLUDED IN THE "CITY OF CHULA VISTA PRIORITY DEVELOPMENT PROJECT (PDP) SWQMP FOR PROJECT SHINOHARA, ONPOINT DEVELOPMENT" DATED MAY 2022.

- SITE DESIGN BMPs**
- SD-2 CONSERVE NATURAL AREAS, SOILS AND VEGETATION
 - SD-3 MINIMIZE IMPERVIOUS AREAS
 - SD-4 MINIMIZE SOIL COMPACTION
 - SD-5 IMPERVIOUS AREA DISPERSION
 - SD-7 LANDSCAPING WITH NATIVE OR DROUGHT TOLERANT SPECIES

- SOURCE CONTROL BMPs**
- SC-1 PREVENTION OF ILLICIT DISCHARGES TO THE MS4
 - SC-2 STORM DRAIN STENCILING AND SIGNAGE
 - SC-5 PROTECT TRASH STORAGE AREAS FROM RAINFALL, RUN-ON, AND WIND DISPERSAL
 - SC-6 ADDITIONAL BMPs BASED ON POTENTIAL RUNOFF POLLUTANTS:

- SC-A ONSITE STORM DRAIN INLETS
- SC-D1 NEED FOR FUTURE INDOOR & STRUCTURAL PEST CONTROL
- SC-D2 LANDSCAPE/OUTDOOR PESTICIDE USE
- SC-G REFUSE AREAS
- SC-H INDUSTRIAL PROCESSES
- SC-M LOADING DOCKS
- SC-N FIRE SPRINKLER TEST WATER
- SC-O MISCELLANEOUS DRAIN OR WASH WATER
- SC-P PLAZAS, SIDEWALKS, AND PARKING LOTS

RETENTION REQUIREMENTS

DMA-A TARGET VOLUME RETENTION = 291 CU. FT.
DMA-B TARGET VOLUME RETENTION = 29 CU. FT.
TOTAL TARGET VOLUME RETENTION = 320 CU. FT.

SITE DESIGN BMP USED:

- BMP-5, TREE WELL W/ UNDERDRAIN
SOIL AREA = 475 SQ. FT.
SOIL DEPTH = 4 FT
SOIL VOLUME (SV) = 1,900 CU. FT.
TCV = 190 CU. FT.
- BMP-6, TREE WELL W/ UNDERDRAIN
SOIL AREA = 415 SQ. FT.
SOIL DEPTH = 4 FT
SOIL VOLUME (SV) = 1,660 CU. FT.
TCV = 166 CU. FT.

SUM OF VOLUME RETENTION BENEFITS = 356 CU. FT.
SEE DETAIL 'A' THIS SHEET FOR TYPICAL TREE WELL DETAIL.

INDUSTRIAL PROCESSES NOTE
ALL PROCESS ACTIVITIES TO BE PERFORMED INDOORS. NO PROCESSES TO DRAIN TO EXTERIOR OR TO STORM DRAIN SYSTEM.

SUMMARY OF DRAINAGE MANAGEMENT AREAS

DMA	DRAINAGE AREA (AC)	IMPERVIOUS AREA (AC)	% IMP	DMA RUNOFF COEFFICIENT, C	DCV (CU.FT.)	TREATED BY (BMP ID)	POLLUTANT CONTROL TYPE
DMA-A	8.27	7.36	88.9%	0.81	12,668	BMP-2	PROPRIETARY BIOFILTRATION (BF-3)
DMA-B	1.19	0.68	56.8%	0.55	1,249	BMP-4	PROPRIETARY BIOFILTRATION (BF-3)
DMA-C	0.25	0.00	0%	--	--	NA - SELF-MITIGATING	--
TOTAL	9.71	8.03	82.7%	0.76	13,917	--	--

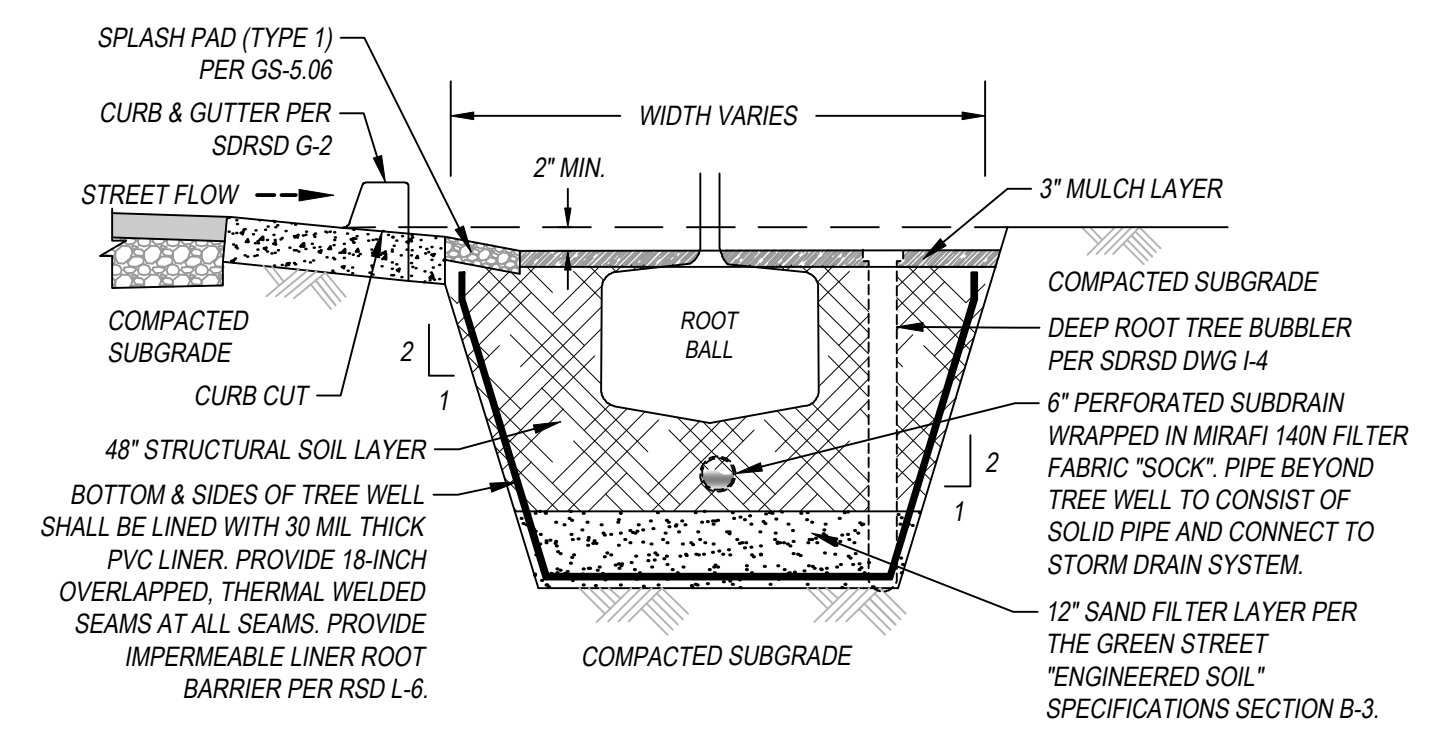

TYPICAL TREE WELL DETAIL
NOT TO SCALE

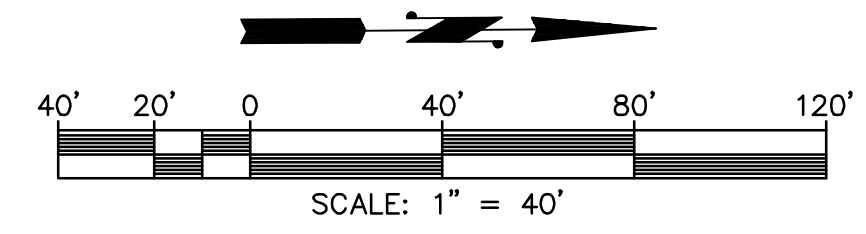

PASCO LARET SUITER & ASSOCIATES
San Diego | Encinitas | Orange County
Phone 858.259.8212 | www.plsaengineering.com

DRAINAGE MANAGEMENT AREA EXHIBIT
SHINOHARA BUSINESS PARK
DR-21-0032
517 SHINOHARA LANE
CHULA VISTA, CA 91911
PLSA JOB NO. 3690
MAY 2022

Attachment 1B

DMA Summary

Project Name: Shinohara Business Center

Tabular Summary of DMAs							Worksheet B-1		
DMA Unique Identifier	Area (acres)	Impervious Area (acres)	% Imp	HSG	Area Weighted Runoff Coefficient	DCV (Cubic feet)	Treated by (BMP ID)	Pollutant Control Type	Drains to (POC ID)
DMA-A	8.27	7.36	88.9%	C & D	0.8112	12,668	BMP-2	Biof.(BF-3)	POC-1
DMA-B	1.19	0.68	56.8%	C & D	0.5542	1,249	BMP-4	Biof.(BF-3)	POC-2
DMA-C	0.25	0.00	0%	C & D	N/A	N/A	N/A-Self-Mit.	N/A-Self-Mi	POC-1
Summary of DMA Information (Must match Project description and SWQMP narrative)									
No. of DMAs	Total DMA Area (acres)	Total Impervious Area (acres)	% Impervious		Area Weighted Runoff Coefficient	DCV (Cubic feet)	Total Area Treated (acres)		No. of POCs
3	9.71	8.03	82.7%		0.7615	13,917	9.71		2

Where: DMA = Drainage Management Area Imp = Imperviousness ID = identifier
 HSG = Hydrologic Soil Group DCV= Design Capture Volume No. = Number
 BMP = Best Management Practice POC = Point of Compliance



Attachment 1C

Harvest and Use Feasibility (Form I-7)

Project Name: _____

Harvest and Use Feasibility Screening		FORM I-7 (Worksheet B.3-1)
<p>1. Is there a demand for harvested water (check all that apply) at the project site that is reliably present during the wet season?</p> <p><input type="checkbox"/> Toilet and urinal flushing</p> <p><input checked="" type="checkbox"/> Landscape irrigation</p> <p><input type="checkbox"/> Other: _____</p>		
<p>2. If there is a demand; estimate the anticipated average wet season demand over a period of 36 hours. Guidance for planning level demand calculations for toilet/urinal flushing and landscape irrigation is provided in Section B.3.2.</p> <p>[Provide a summary of calculations here]</p> <p>Landscape Irrigation $(1.64 \text{ ac irrigated}) \times (390 \text{ gal/ac-36hr}) \times (0.13368 \text{ cu-ft/gal}) = 85.5 \text{ cu-ft/36hr}$</p>		
<p>3. Calculate the DCV using worksheet B-2.1.</p> <p>[Provide a result here]</p> <p>Total DCV = 13,917 cu-ft 0.25DCV = 3,479 cu-ft</p>		
<p>3a. Is the 36-hour demand greater than or equal to the DCV?</p> <p>Yes / No ⇨</p> <p>⇩</p>	<p>3b. Is the 36-hour demand greater than 0.25DCV but less than the full DCV?</p> <p>Yes / No ⇨</p> <p>⇩</p>	<p>3c. Is the 36-hour demand less than 0.25DCV?</p> <p>Yes</p> <p>⇩</p>
<p>Harvest and use appears to be feasible. Conduct more detailed evaluation and sizing calculations to confirm that DCV can be used at an adequate rate to meet drawdown criteria.</p>	<p>Harvest and use may be feasible. Conduct more detailed evaluation and sizing calculations to determine feasibility. Harvest and use may only be able to be used for a portion of the site, or (optionally) the storage may need to be upsized to meet long term capture targets while draining in longer than 36 hours.</p>	<p>Harvest and use is considered to be infeasible.</p>

Note: 36-hour demand calculations are for feasibility analysis only, once the feasibility analysis is complete the applicant may be allowed to use a different drawdown time provided they meet the 80 percent of average annual (long term) runoff volume performance standard.



Attachment 1D

Infiltration Feasibility

Project Name: _____

Categorization of Infiltration Feasibility Condition based on Geotechnical Conditions		Form I-8A' (Worksheet C.4-1)
Part 1 - Full Infiltration Feasibility Screening Criteria		
DMA(s) Being Analyzed:		Project Phase:
DMA-A & DMA-B		Preliminary Design
Criteria 1: Infiltration Rate Screening		
1A	<p>Is the mapped hydrologic soil group according to the NRCS Web Soil Survey or UC Davis Soil Web Mapper Type A or B and corroborated by available site soil data²?</p> <p><input type="checkbox"/> Yes; the DMA may feasibly support full infiltration. Answer "Yes" to Criteria 1 Result or continue to Step 1B if the applicant elects to perform infiltration testing.</p> <p><input type="checkbox"/> No; the mapped soil types are A or B but is not corroborated by available site soil data (continue to Step 1B).</p> <p><input checked="" type="checkbox"/> No; the mapped soil types are C, D, or "urban/unclassified" and is corroborated by available site soil data. Answer "No" to Criteria 1 Result.</p> <p><input type="checkbox"/> No; the mapped soil types are C, D, or "urban/unclassified" but is not corroborated by available site soil data (continue to Step 1B).</p>	
1B	<p>Is the reliable infiltration rate calculated using planning phase methods from Table D.3-1²?</p> <p><input type="checkbox"/> Yes; Continue to Step 1C.</p> <p><input type="checkbox"/> No; Skip to Step 1D.</p>	
1C	<p>Is the reliable infiltration rate calculated using planning phase methods from Table D.3-1 greater than 0.5 inches per hour?</p> <p><input type="checkbox"/> Yes; the DMA may feasibly support full infiltration. Answer "Yes" to Criteria 1 Result.</p> <p><input type="checkbox"/> No; full infiltration is not required. Answer "No" to Criteria 1 Result.</p>	
1D	<p>Infiltration Testing Method. Is the selected infiltration testing method suitable during the design phase (see Appendix D.3)? Note: Alternative testing standards may be allowed with appropriate rationales and documentation.</p> <p><input type="checkbox"/> Yes; continue to Step 1E.</p> <p><input type="checkbox"/> No; select an appropriate infiltration testing method.</p>	
1E	<p>Number of Percolation/Infiltration Tests. Does the infiltration testing method performed satisfy the minimum number of tests specified in Table D.3-2?</p> <p><input type="checkbox"/> Yes; continue to Step 1F.</p> <p><input type="checkbox"/> No; conduct appropriate number of tests.</p>	

¹ This form must be completed each time there is a change to the site layout that would affect the infiltration feasibility condition. Previously completed forms shall be retained to document the evolution of the site storm water design.

² Available data includes site-specific sampling or observation of soil types or texture classes, such as obtained from borings or test pits necessary to support other design elements.

Shinohara Business Center

Project Name: _____

Categorization of Infiltration Feasibility Condition based on Geotechnical Conditions		Form I-8A' (Worksheet C.4-1)
IF	<p>Factor of Safety. Is the suitable Factor of Safety selected for full infiltration design? See guidance in D.5; Tables D.5-1 and D.5-2; and Worksheet D.5-1 (Form I-9).</p> <p><input type="checkbox"/> Yes; continue to Step 1G. <input type="checkbox"/> No; select appropriate factor of safety.</p>	
1G	<p>Full Infiltration Feasibility. Is the average measured infiltration rate divided by the Factor of Safety greater than 0.5 inches per hour?</p> <p><input type="checkbox"/> Yes; answer "Yes" to Criteria 1 Result. <input type="checkbox"/> No; answer "No" to Criteria 1 Result.</p>	
Criteria 1 Result	<p>Is the estimated reliable infiltration rate greater than 0.5 inches per hour within the DMA where runoff can reasonably be routed to a BMP?</p> <p><input type="checkbox"/> Yes; the DMA may feasibly support full infiltration. Continue to Criteria 2. <input checked="" type="checkbox"/> No; full infiltration is not required. Skip to Part 1 Result.</p>	
<p>Summarize infiltration testing methods, testing locations, replicates, and results and summarize estimates of reliable infiltration rates according to procedures outlined in D.5. Documentation should be included in project geotechnical report.</p> <p>See "Infiltration Feasibility Condition Letter, Shinohara Industrial Building, 517 Shinohara Lane, Chula Vista, California" prepared by Geocon, Inc., dated November 16, 2021 (Project No. G2762-42-01). A copy of the report is included in Attachment 1D of this SWQMP.</p>		
Criteria 2: Geologic/Geotechnical Screening		
2A	<p>If all questions in Step 2A are answered "Yes," continue to Step 2B.</p> <p>For any "No" answer in Step 2A answer "No" to Criteria 2 and submit an "Infiltration Feasibility Condition Letter" that meets the requirements in Appendix C.1.1.</p> <p>The geologic/geotechnical analyses listed in Appendix C.2.1 do not apply to the DMA because one of the following setbacks cannot be avoided and therefore result in the DMA being in a no infiltration condition. The setbacks must be the closest horizontal radial distance from the surface edge (at the overflow elevation) of the BMP.</p>	



Project Name: _____

Categorization of Infiltration Feasibility Condition based on Geotechnical Conditions		Form I-8A' (Worksheet C.4-1)	
2A-1	Can the proposed full infiltration BMP(s) avoid areas with existing fill materials greater than 5 feet thick below the infiltrating surface?	<input type="checkbox"/> Yes	<input type="checkbox"/> No
2A-2	Can the proposed full infiltration BMP(s) avoid placement within 10 feet of existing underground utilities, structures, or retaining walls?	<input type="checkbox"/> Yes	<input type="checkbox"/> No
2A-3	Can the proposed full infiltration BMP(s) avoid placement within 50 feet of a natural slope (>25%) or within a distance of 1.5H from fill slopes where H is the height of the fill slope?	<input type="checkbox"/> Yes	<input type="checkbox"/> No
2B	When full infiltration is determined to be feasible, a geotechnical investigation report must be prepared that considers the relevant factors identified in Appendix C.2.1. If all questions in Step 2B are answered "Yes," then answer "Yes" to Criteria 2 Result. If there are "No" answers continue to Step 2C.		
2B-1	Hydroconsolidation. Analyze hydroconsolidation potential per approved ASTM standard due to a proposed full infiltration BMP. Can full infiltration BMPs be proposed within the DMA without increasing hydroconsolidation risks?	<input type="checkbox"/> Yes	<input type="checkbox"/> No
2B-2	Expansive Soils. Identify expansive soils (soils with an expansion index greater than 20) and the extent of such soils due to proposed full infiltration BMPs. Can full infiltration BMPs be proposed within the DMA without increasing expansive soil risks?	<input type="checkbox"/> Yes	<input type="checkbox"/> No
2B-3	Liquefaction. If applicable, identify mapped liquefaction areas. Evaluate liquefaction hazards in accordance with Section 6.4.2 of the City of San Diego's Guidelines for Geotechnical Reports (2011 or most recent edition). Liquefaction hazard assessment shall take into account any increase in groundwater elevation or groundwater mounding that could occur as a result of proposed infiltration or percolation facilities. Can full infiltration BMPs be proposed within the DMA without increasing liquefaction risks?	<input type="checkbox"/> Yes	<input type="checkbox"/> No
2B-4	Slope Stability. If applicable, perform a slope stability analysis in accordance with the ASCE and Southern California Earthquake Center (2002) Recommended Procedures for Implementation of DMG Special Publication 117, Guidelines for Analyzing and Mitigating Landslide Hazards in California to determine minimum slope setbacks for full infiltration BMPs. See the City of San Diego's Guidelines for Geotechnical Reports (2011) to determine which type of slope stability analysis is required. Can full infiltration BMPs be proposed within the DMA without increasing slope stability risks?	<input type="checkbox"/> Yes	<input type="checkbox"/> No
2B-5	Other Geotechnical Hazards. Identify site-specific geotechnical hazards not already mentioned (refer to Appendix C.2.1). Can full infiltration BMPs be proposed within the DMA without increasing risk of geologic or geotechnical hazards not already mentioned?	<input type="checkbox"/> Yes	<input type="checkbox"/> No

Project Name: _____

Categorization of Infiltration Feasibility Condition based on Geotechnical Conditions		Form I-8A' (Worksheet C.4-1)	
2B-6	<p>Setbacks. Establish setbacks from underground utilities, structures, and/or retaining walls. Reference applicable ASTM or other recognized standard in the geotechnical report.</p> <p>Can full infiltration BMPs be proposed within the DMA using established setbacks from underground utilities, structures, and/or retaining walls?</p>	<input type="checkbox"/> Yes	<input type="checkbox"/> No
2C	<p>Mitigation Measures. Propose mitigation measures for each geologic/geotechnical hazard identified in Step 2B. Provide a discussion of geologic/geotechnical hazards that would prevent full infiltration BMPs that cannot be reasonably mitigated in the geotechnical report. See Appendix C.2.1.8 for a list of typically reasonable and typically unreasonable mitigation measures.</p> <p>Can mitigation measures be proposed to allow for full infiltration BMPs? If the question in Step 2 is answered “Yes,” then answer “Yes” to Criteria 2 Result.</p> <p>If the question in Step 2C is answered “No,” then answer “No” to Criteria 2 Result.</p>	<input type="checkbox"/> Yes	<input type="checkbox"/> No
Criteria 2 Result	Can infiltration greater than 0.5 inches per hour be allowed without increasing risk of geologic or geotechnical hazards that cannot be reasonably mitigated to an acceptable level?	<input type="checkbox"/> Yes	<input type="checkbox"/> No
Summarize findings and basis; provide references to related reports or exhibits.			
Part 1 Result – Full Infiltration Geotechnical Screening ³		Result	
<p>If answers to both Criteria 1 and Criteria 2 are “Yes”, a full infiltration design is potentially feasible based on Geotechnical conditions only.</p> <p>If either answer to Criteria 1 or Criteria 2 is “No”, a full infiltration design is not required.</p>		<input type="checkbox"/> Full infiltration Condition <input checked="" type="checkbox"/> Complete Part 2	

³ To be completed using gathered site information and best professional judgement considering the definition of MEP in the MS4 Permit. Additional testing and/or studies may be required by City Engineer to substantiate findings.



Project Name: _____

Categorization of Infiltration Feasibility Condition based on Geotechnical Conditions		Form I-8A' (Worksheet C.4-1)
Part 2 – Partial vs. No Infiltration Feasibility Screening Criteria		
DMA(s) Being Analyzed:		Project Phase:
DMA-A & DMA-B		Preliminary Design
Criteria 3 : Infiltration Rate Screening		
3A	<p>NRCS Type C, D, or “urban/unclassified”: Is the mapped hydrologic soil group according to the NRCS Web Soil Survey or UC Davis Soil Web Mapper is Type C, D, or “urban/unclassified” and corroborated by available site soil data?</p> <p><input checked="" type="checkbox"/> Yes; the site is mapped as C soils and a reliable infiltration rate of 0.15 in/hr. is used to size partial infiltration BMPS. Answer “Yes” to Criteria 3 Result.</p> <p><input checked="" type="checkbox"/> Yes; the site is mapped as D soils or “urban/unclassified” and a reliable infiltration rate of 0.05 in/hr. is used to size partial infiltration BMPS. Answer “Yes” to Criteria 3 Result.</p> <p><input type="checkbox"/> No; infiltration testing is conducted (refer to Table D.3-1), continue to Step 3B.</p>	
3B	<p>Infiltration Testing Result: Is the reliable infiltration rate (i.e. average measured infiltration rate/2) greater than 0.05 in/hr. and less than or equal to 0.5 in/hr?</p> <p><input type="checkbox"/> Yes; the site may support partial infiltration. Answer “Yes” to Criteria 3 Result.</p> <p><input type="checkbox"/> No; the reliable infiltration rate (i.e. average measured rate/2) is less than 0.05 in/hr., partial infiltration is not required. Answer “No” to Criteria 3 Result.</p>	
Criteria 3 Result	<p>Is the estimated reliable infiltration rate (i.e., average measured infiltration rate/2) greater than or equal to 0.05 inches/hour and less than or equal to 0.5 inches/hour at any location within each DMA where runoff can reasonably be routed to a BMP?</p> <p><input type="checkbox"/> Yes; Continue to Criteria 4.</p> <p><input type="checkbox"/> No; Skip to Part 2 Result.</p>	
<p>Summarize infiltration testing and/or mapping results (i.e. soil maps and series description used for infiltration rate).</p> <p>A review of the soil survey maps indicates Type C & D soils in the location of the project site. According to NRCS web soil survey, Type C soils are generally rated for low infiltration capacity (approximatley 0.15 in/hr). Type D soils are generally rated for very low infiltration capacity (approximately 0.05 in/hr).</p>		

Project Name: _____

Categorization of Infiltration Feasibility Condition based on Geotechnical Conditions		Form I-8A' (Worksheet C.4-1)	
Criteria 4: Geologic/Geotechnical Screening			
4A	<p>If all questions in Step 4A are answered “Yes,” continue to Step 2B.</p> <p>For any “No” answer in Step 4A answer “No” to Criteria 4 Result, and submit an “Infiltration Feasibility Condition Letter” that meets the requirements in Appendix C.1.1. The geologic/geotechnical analyses listed in Appendix C.2.1 do not apply to the DMA because one of the following setbacks cannot be avoided and therefore result in the DMA being in a no infiltration condition. The setbacks must be the closest horizontal radial distance from the surface edge (at the overflow elevation) of the BMP.</p>		
4A-1	Can the proposed partial infiltration BMP(s) avoid areas with existing fill materials greater than 5 feet thick?	<input type="checkbox"/> Yes	<input checked="" type="checkbox"/> No
4A-2	Can the proposed partial infiltration BMP(s) avoid placement within 10 feet of existing underground utilities, structures, or retaining walls?	<input type="checkbox"/> Yes	<input type="checkbox"/> No
4A-3	Can the proposed partial infiltration BMP(s) avoid placement within 50 feet of a natural slope (>25%) or within a distance of 1.5H from fill slopes where H is the height of the fill slope?	<input type="checkbox"/> Yes	<input checked="" type="checkbox"/> No
4B	<p>When full infiltration is determined to be feasible, a geotechnical investigation report must be prepared that considers the relevant factors identified in Appendix C.2.1.</p> <p>If all questions in Step 4B are answered “Yes,” then answer “Yes” to Criteria 4 Result. If there are any “No” answers continue to Step 4C.</p>		
4B-1	<p>Hydroconsolidation. Analyze hydroconsolidation potential per approved ASTM standard due to a proposed full infiltration BMP.</p> <p>Can partial infiltration BMPs be proposed within the DMA without increasing hydroconsolidation risks?</p>	<input type="checkbox"/> Yes	<input type="checkbox"/> No
4B-2	<p>Expansive Soils. Identify expansive soils (soils with an expansion index greater than 20) and the extent of such soils due to proposed full infiltration BMPs.</p> <p>Can partial infiltration BMPs be proposed within the DMA without increasing expansive soil risks?</p>	<input type="checkbox"/> Yes	<input type="checkbox"/> No
4B-3	<p>Liquefaction. If applicable, identify mapped liquefaction areas. Evaluate liquefaction hazards in accordance with Section 6.4.2 of the City of San Diego's Guidelines for Geotechnical Reports (2011). Liquefaction hazard assessment shall take into account any increase in groundwater elevation or groundwater mounding that could occur as a result of proposed infiltration or percolation facilities.</p> <p>Can partial infiltration BMPs be proposed within the DMA without increasing liquefaction risks?</p>	<input type="checkbox"/> Yes	<input type="checkbox"/> No

Project Name: _____

Categorization of Infiltration Feasibility Condition based on Geotechnical Conditions		Form I-8A' (Worksheet C.4-1)	
4B-4	<p>Slope Stability. If applicable, perform a slope stability analysis in accordance with the ASCE and Southern California Earthquake Center (2002) Recommended Procedures for Implementation of DMG Special Publication 117, Guidelines for Analyzing and Mitigating Landslide Hazards in California to determine minimum slope setbacks for full infiltration BMPs. See the City of San Diego's Guidelines for Geotechnical Reports (2011) to determine which type of slope stability analysis is required.</p> <p>Can partial infiltration BMPs be proposed within the DMA without increasing slope stability risks?</p>	<input type="checkbox"/> Yes	<input type="checkbox"/> No
4B-5	<p>Other Geotechnical Hazards. Identify site-specific geotechnical hazards not already mentioned (refer to Appendix C.2.1).</p> <p>Can partial infiltration BMPs be proposed within the DMA without increasing risk of geologic or geotechnical hazards not already mentioned?</p>	<input type="checkbox"/> Yes	<input type="checkbox"/> No
4B-6	<p>Setbacks. Establish setbacks from underground utilities, structures, and/or retaining walls. Reference applicable ASTM or other recognized standard in the geotechnical report.</p> <p>Can partial infiltration BMPs be proposed within the DMA using recommended setbacks from underground utilities, structures, and/or retaining walls?</p>	<input type="checkbox"/> Yes	<input type="checkbox"/> No
4C	<p>Mitigation Measures. Propose mitigation measures for each geologic/geotechnical hazard identified in Step 4B. Provide a discussion on geologic/geotechnical hazards that would prevent partial infiltration BMPs that cannot be reasonably mitigated in the geotechnical report. See Appendix C.2.1.8 for a list of typically reasonable and typically unreasonable mitigation measures.</p> <p>Can mitigation measures be proposed to allow for partial infiltration BMPs? If the question in Step 4C is answered "Yes," then answer "Yes" to Criteria 4 Result.</p> <p>If the question in Step 4C is answered "No," then answer "No" to Criteria 4 Result.</p>	<input type="checkbox"/> Yes	<input type="checkbox"/> No
Criteria 4 Result	<p>Can infiltration of greater than or equal to 0.05 inches/hour and less than or equal to 0.5 inches/hour be allowed without increasing the risk of geologic or geotechnical hazards that cannot be reasonably mitigated to an acceptable level?</p>	<input type="checkbox"/> Yes	<input type="checkbox"/> No

Shinohara Business Center

Project Name: _____

Categorization of Infiltration Feasibility Condition based on Geotechnical Conditions	Form I-8A ¹ (Worksheet C.4-1)
<p>Summarize findings and basis; provide references to related reports or exhibits.</p> <p>See "Infiltration Feasibility Condition Letter, Shinohara Industrial Building, 517 Shinohara Lane, Chula Vista, California" prepared by Geocon, Inc., dated November 16, 2021 (Project No. G2762-42-01). A copy of the report is included in Attachment 1D of this SWQMP.</p>	
Part 2 – Partial Infiltration Geotechnical Screening Result ⁴	Result
<p>If answers to both Criteria 3 and Criteria 4 are “Yes”, a partial infiltration design is potentially feasible based on geotechnical conditions only.</p> <p>If answers to either Criteria 3 or Criteria 4 is “No”, then infiltration of any volume is considered to be infeasible within the site.</p>	<p><input type="checkbox"/> Partial Infiltration Condition</p> <p><input checked="" type="checkbox"/> No Infiltration Condition</p>

⁴ To be completed using gathered site information and best professional judgement considering the definition of MEP in the MS4 Permit. Additional testing and/or studies may be required by City Engineer to substantiate findings.



**INFILTRATION FEASIBILITY
CONDITION LETTER**

**SHINOHARA INDUSTRIAL BUILDING
517 SHINOHARA LANE
CHULA VISTA, CALIFORNIA**



GEOCON
INCORPORATED

GEOTECHNICAL
ENVIRONMENTAL
MATERIALS

PREPARED FOR

**ONPOINT DEVELOPMENT
LA JOLLA, CALIFORNIA**

**NOVEMBER 16, 2021
PROJECT NO. G2762-42-01**



Project No. G2762-42-01
November 16, 2021

OnPoint Development
7514 Girard Street, Suite 1515
La Jolla, California 92037

Attention: Mr. Todd Dwyer

Subject: INFILTRATION FEASIBILITY CONDITION LETTER
SHINOHARA INDUSTRIAL BUILDING
517 SHINOHARA LANE
CHULA VISTA, CALIFORNIA

- References:
1. *Geotechnical Investigation, Shinohara Industrial Building, 517 Shinohara Lane, Chula Vista, California*, prepared by Geocon Incorporated, dated July 28, 2021 (Geocon Project No. G2762-42-01).
 2. *Preliminary Grading Study for: Shinohara Industrial Building, 517 Shinohara Lane, Chula Vista*, prepared by Pasco Laret Suiter & Associates, undated.
 3. *DMA Exhibit, Shinohara Industrial Building, 517 Shinohara Lane, Chula Vista*, prepared by prepared by Pasco Laret Suiter & Associates, November 2021.

Dear Mr. Dwyer:

In accordance with the request of Pasco Laret Suiter & Associates (PLSA), we prepared this *Infiltration Feasibility Condition Letter* for the subject project located in Chula Vista, California (see Vicinity Map).



Vicinity Map

SITE DESCRIPTION

The approximately 10-acre parcel is currently undeveloped except for minor surface drainage improvements. The property is fenced with gated access via Shinohara Lane at the southeast corner. Based on review of historical aerial photographs, the site was partially graded circa 1992 when it was used as a borrow site. Except for the graded area in the north-central area of the property, the site slopes moderately to steeply from north to south. Site elevations range from approximately 250 feet mean sea level (MSL) at the north end to 145 feet MSL at the south end. The site is boarded by residential developments to the north and west, and commercial/industrial buildings to the south and east.

PROPOSED DEVELOPMENT

The proposed improvements consist of a single-story approximately 190,000 square-foot industrial warehouse building with associated improvements including utilities, paving, storm water management devices, and landscape improvements. Proposed cuts and fills are estimated to be up to 50 feet, with new slopes being up to approximately 10 feet in height. Retaining walls will be required along the perimeter of the site to reach pad grade. The walls will likely be soil nail walls and mechanically stabilized earth (MSE) walls.

STORM WATER MANAGEMENT DISCUSSION

We understand storm water management devices are being proposed in accordance with City of Chula Vista BMP Design Manual (March 2019 Update). If not properly constructed, there is a potential for distress to improvements and properties located hydrologically down gradient or adjacent to these devices. Factors such as the amount of water to be detained, its residence time, and soil permeability have an important effect on seepage transmission and the potential adverse impacts that may occur if the storm water management features are not properly designed and constructed. We have not performed a hydrogeological study at the site. If infiltration of storm water runoff occurs, downstream properties may be subjected to seeps, springs, slope instability, raised groundwater, movement of foundations and slabs, or other undesirable impacts as a result of water infiltration.

Presented below is a discussion for each item requested in Appendix C.1.1 of the BMP Design Manual.

- ***The phase of the project in which the geotechnical engineer first analyzed the site for infiltration feasibility.***

We analyzed for infiltration feasibility in the preliminary/planning phase.

- ***Results of previous geotechnical analyses conducted in the project area, if any.***

We prepared geotechnical report dated July 28, 2021 (Reference No. 1) as part of the planning phase of development. As indicated in the geotechnical report, the approximately 10-acre parcel is currently undeveloped except for minor surface drainage improvements. Except for the graded area in the north-central area of the property, the site slopes moderately to steeply from north to south. Residential developments to the north and west, and commercial/industrial buildings to the south and east border the site. Based on the results of the field investigation, the site is underlain by dense Tertiary San Diego Formation that is capped by compressible surficial deposits (i.e., undocumented fill, topsoil, alluvium), previously placed fill and dense Very Old Paralic Deposits. The surficial deposits generally consists of silty to clayey, sand and sandy clay. The Very Old Paralic Deposits are generally medium dense to very dense, silty to clayey sand with gravel and cobble. The dense San Diego Formation generally consists of silty, fine to medium coarse sandstone, with occasional gravel and cobble beds.

- ***The development status of the site prior to the project application (i.e., new development with raw ungraded land, or redevelopment with existing graded conditions.)***

The project is new development with generally raw ungraded land. As discussed above, minor areas of the property have been graded resulting in compressible undocumented fill.

- ***The history of designs discussions for the project footprint, resulting in the final design determination.***

There were no locations on the property where the storm water basins could be located that would be outside of graded areas. Final design determination was based on estimated ultimate as-graded

conditions (deep fills), planned improvements (i.e., underground utilities, surface improvements, retaining wall structures) and bordering developments.

- ***Full/partial infiltration BMP standard setbacks to underground utilities, structures, retaining walls, fill slopes, and natural slopes applicable to the DMA that prevent full/partial infiltration.***

We estimate that the project will be underlain by compacted fill, Very Old Paralic Deposits and San Diego Formation after planned grading is completed. Based on our grading recommendations, we assume that the upper 5 feet of fill and cut areas may consist of very low to low expansive soils. We expect that medium to very high expansive soils will be located at least 5 feet below proposed design grades. Deep fills and MSE retaining walls up to 50 feet thick and 45 feet in height, respectively, are planned along the south and east margins of the property to achieve design grades. Infiltration into compacted fill could result in soil movement resulting in either heave or settlement and retaining wall instability. Residential development and commercial/industrial buildings border the project. Full or partial infiltration near planned and existing improvements (i.e., building foundations, retaining walls, underground utilities, surface improvements) is not recommended. Infiltration near existing and planned improvements will likely result in lateral water migration and soil movement (heave and/or settlement) which could result in structural distress.

- ***The physical impairments (i.e., fire road egress, public safety considerations, etc.) that prevent full/partial infiltration.***

The property consists of natural, sloping terrain with surface runoff flowing in a north to south direction. Surficial soils generally exhibit a low to high expansion potential. Additional physical impairments are the existing buildings (residential, commercial/industrial) and, existing surface and underground improvements bordering the property.

- ***The consideration of site design alternatives to achieve partial/full infiltration within the DMA.***

A site design alternative to include full or partial infiltration would be limited to a lined, deep dry well system founded in the underlying San Diego Formation. However, it is estimated that the infiltration zone would extend at least 70 feet below proposed finish grade and is considered practically infeasible.

- ***The extent site design BMP's requirements were included in the overall design.***

This question is best answered by the project Civil engineer, if needed.

- ***Conclusion or recommendation from the geotechnical engineer regarding the DMA's infiltration condition.***

Based on the responses provided above, it is our professional opinion that entire site (planned DMA's) is not feasible for partial or full infiltration and the property should be considered to possess a *No Infiltration* condition in accordance with Appendix C of the City of Chula Vista BMP Design Manual (March 2019 Update). Infiltration would create an un-mitigatable risk of soil expansion, impact to improvements, slope instability, and lateral seepage migration that could adversely impact public and private improvements.

Where applicable, liners and subdrains are recommended in the design and construction of bio-filtration systems. The liners should be impermeable (e.g. High-density polyethylene, HDPE, with a thickness of about 30 mil or equivalent Polyvinyl Chloride, PVC). The subdrains should be perforated within the liner area, installed at the base and above the liner, be at least 4 inches in diameter. The subdrains outside of the liner should consist of solid pipe. The penetration of the liners at the subdrains should be properly waterproofed. The subdrains should be connected to the project storm-drain system. The devices should also be installed in accordance with the manufacturer's recommendations.

- ***An Exhibit for all applicable DMA's that clearly labels:***

Figure 1 (geologic map) and Figure 2 (DMA exhibit) are attached. The geologic map shows existing geologic conditions. Figure 2 shows planned DMA's. The project grading plan (Reference No. 2; not included) shows existing and planned improvements.

As previously discussed, there are no locations on the property where structural BMPs can be located or where full/partial infiltration can be proposed due to existing sloping terrain, geologic condition and, existing improvements bordering the project. Infiltration would create an un-mitigatable risk of soil expansion, impacted to improvements, slope instability and lateral seepage migration that could adversely affect existing improvements (residential development, commercial/industrial buildings and, adjacent underground and surface improvements).

If you have any questions regarding this letter, or if we may be of further service, please contact the undersigned at your convenience.

Very truly yours,

GEOCON INCORPORATED



Rodney C. Mikesell
GE 2533

RCM:arm

(e-mail) Addressee



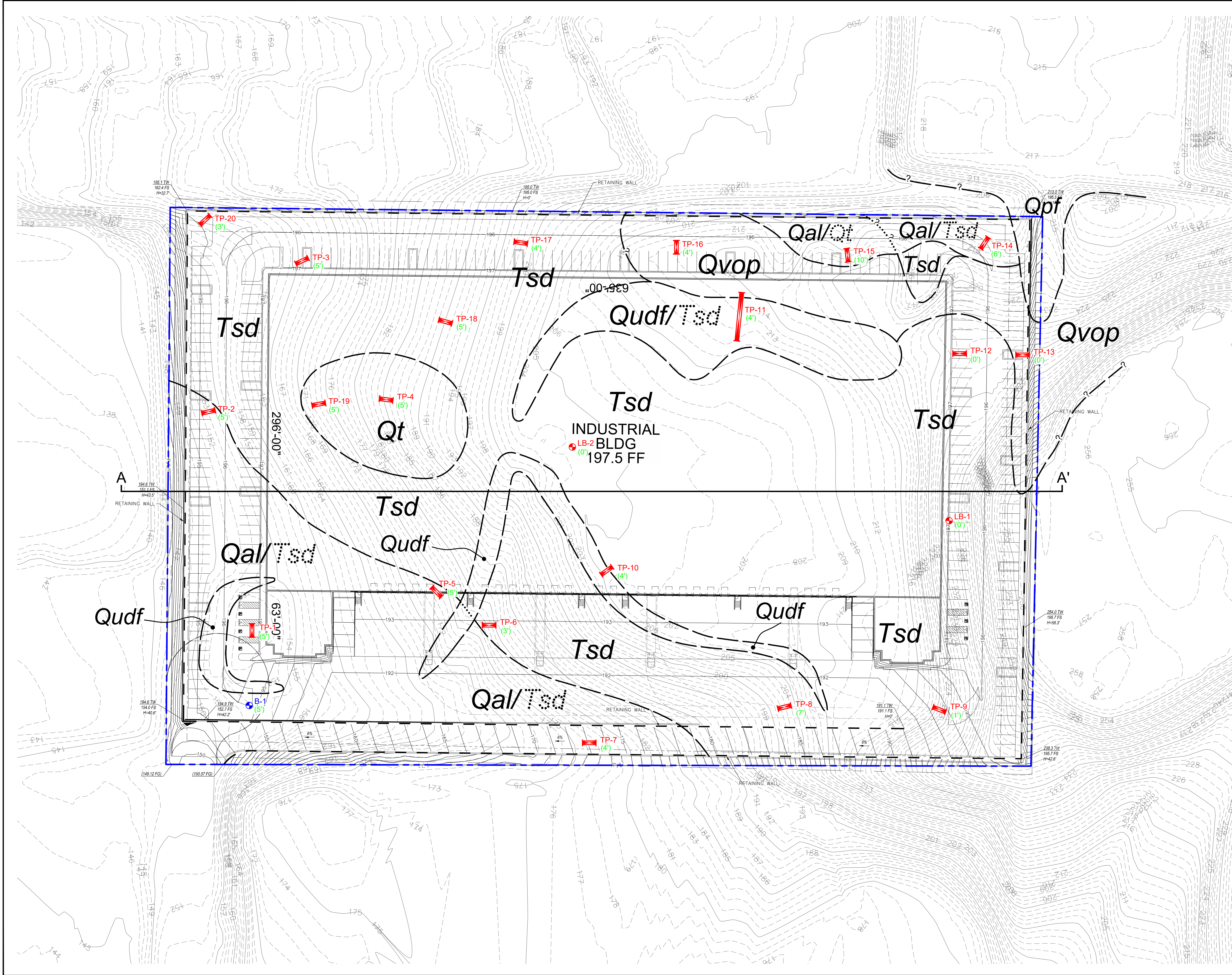
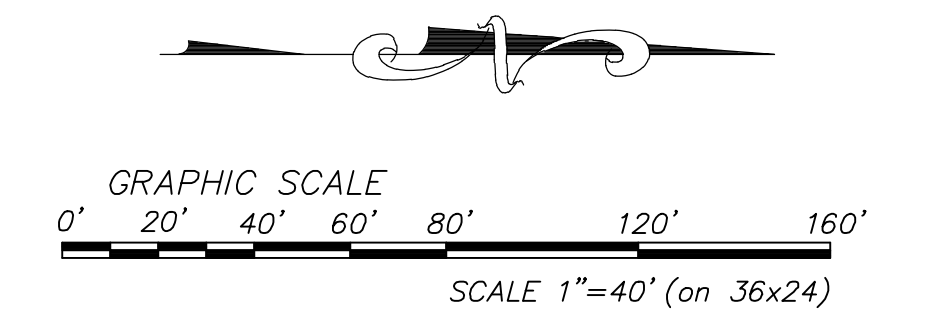

- GEOCON LEGEND**
- Qudf**.....UNDOCUMENTED FILL
 - Qpf**.....PREVIOUSLY PLACED FILL
 - Qal**.....ALLUVIUM
 - Qvop**.....VERY OLD PARALIC DEPOSITS
 - Qt**.....TERRACE DEPOSITS
(Dotted Where Buried)
 - Tsd**.....SAN DIEGO FORMATION
(Dotted Where Buried)
 -APPROX. LOCATION OF GEOLOGIC CONTACT
(Dotted Where Buried, Queried Where Uncertain)
 - B-1**.....APPROX. LOCATION OF BORING
 - LB-2**.....APPROX. LOCATION OF LARGE DIAMETER BORING
 - TP-20**.....APPROX. LOCATION OF TRENCH
 - (5)**.....APPROX. DEPTH OF REMEDIAL GRADING (In Feet)
 - A-A'**.....APPROX. LOCATION OF GEOLOGIC CROSS SECTION

GEOLOGIC MAP
SHINOHARA INDUSTRIAL BUILDING
517 SHINOHARA LANE
SAN DIEGO, CALIFORNIA

GEOCON INCORPORATED GEO TECHNICAL ■ ENVIRONMENTAL ■ MATERIALS 6960 FLANDERS DRIVE - SAN DIEGO, CALIFORNIA 92121-2974 PHONE 619-558-6900 - FAX 619-558-6159	 PROJECT NO. G2762 - 42 - 01 SHEET 1 OF 1	SCALE 1" = 40' DATE 11 - 16 - 2021 FIGURE 1
-------------------------------------------------------------------------------------------------------------------------------------------------------------------------------	-------------------------------------------------	---------------------------------------------------

Plotted 11/16/2021 12:44PM | By: JONATHAN WILKINS | File Location: \\PROJECTS\G2762-42-01\517 Shinohara Lane\SHR\G2762-42-01 Geo Map.dwg

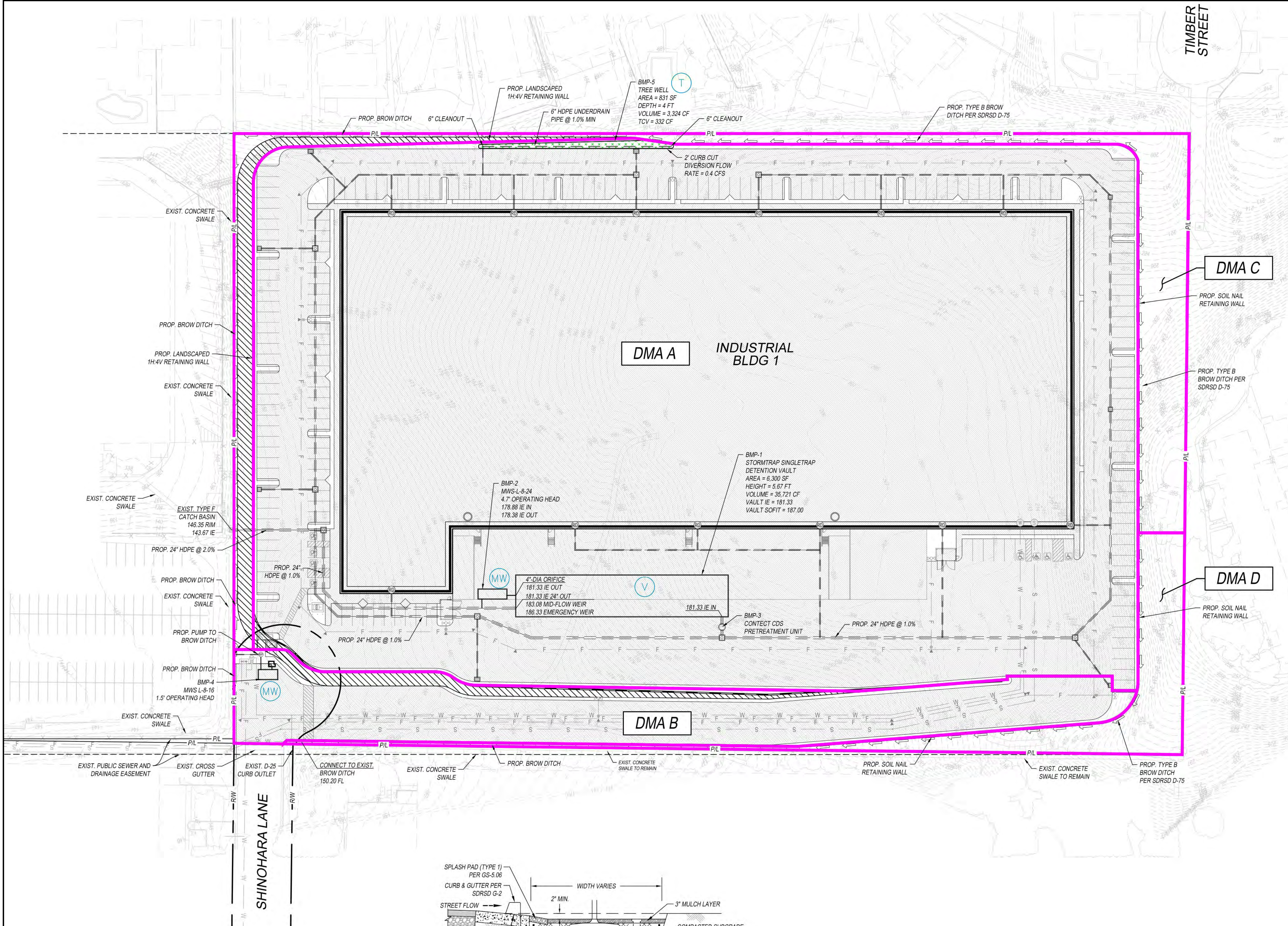

LEGEND

DESCRIPTION	SYMBOL
RIGHT-OF-WAY	—RW—
PROPERTY LINE	—P/L—
DMA BOUNDARY	—
PROPOSED IMPERVIOUS AREA	▨
PROPOSED TREE WELL	▤
DIRECTION OF FLOW	→

HYDROLOGIC SOIL GROUP
 HYDROLOGIC SOIL TYPE: C & D

DEPTH TO GROUNDWATER
 DEPTH TO GROUNDWATER > 20 FT

PROJECT CHARACTERISTICS

PARCEL AREA:	9.73 AC
PROPOSED DISTURBED AREA:	9.71 AC
PROPOSED IMPERVIOUS AREA:	8.18 AC
PROPOSED PERVIOUS / LANDSCAPE AREA:	1.54 AC

STRUCTURAL BMPs

UNDERGROUND DETENTION VAULT (HU-1)	(V)
MODULAR WETLAND, PROPRIETARY BIOFILTRATION (BF-3)	(MW)

SITE DESIGN BMPs

TREE WELL (SD-A)	(T)
------------------	-----

CCSYAS
 THE PROJECT IS EXEMPT FROM HYDROMODIFICATION REQUIREMENTS; THEREFORE PROTECTION OF CRITICAL COARSE SEDIMENT YIELD AREAS DOES NOT APPLY.
 REFER TO THE HMP EXEMPTION EXHIBIT INCLUDED IN THE "CITY OF CHULA VISTA PRIORITY DEVELOPMENT PROJECT (POP) SWOMP FOR PROJECT SHINOHARA, ONPOINT DEVELOPMENT" DATED NOVEMBER 2021.

SITE DESIGN BMPs

SD-3	MINIMIZE IMPERVIOUS AREAS
SD-4	MINIMIZE SOIL COMPACTION
SD-5	IMPERVIOUS AREA DISPERSION
SD-7	LANDSCAPING WITH NATIVE OR DROUGHT TOLERANT SPECIES

SOURCE CONTROL BMPs

SC-1	PREVENTION OF ILLICIT DISCHARGES TO THE MS4
SC-2	STORM DRAIN STENCILING AND SIGNAGE
SC-5	PROTECT TRASH STORAGE AREAS FROM RAINFALL, RUN-ON, AND WIND DISPERSAL
SC-6	ADDITIONAL BMPs BASED ON POTENTIAL RUNOFF POLLUTANTS:
SC-A	ONSITE STORM DRAIN INLETS
SC-D1	NEED FOR FUTURE INDOOR & STRUCTURAL PEST CONTROL
SC-D2	LANDSCAPE/OUTDOOR PESTICIDE USE
SC-G	REFUSE AREAS
SC-H	INDUSTRIAL PROCESSES
SC-M	LOADING DOCKS
SC-N	FIRE SPRINKLER TEST WATER
SC-O	MISCELLANEOUS DRAIN OR WASH WATER
SC-P	PLAZAS, SIDEWALKS, AND PARKING LOTS

RETENTION REQUIREMENTS

DMA-A TARGET VOLUME RETENTION = 294 CU. FT.
 DMA-B TARGET VOLUME RETENTION = 28 CU. FT.
 TOTAL TARGET VOLUME RETENTION = 322 CU. FT.

SITE DESIGN BMP USED: BMP-5, TREE WELL W/ UNDERDRAIN
 SOIL AREA = 831 SQ. FT.
 SOIL DEPTH = 4 FT.
 SOIL VOLUME (SV) = 3,324 CU. FT.
 TCV = 332 CU. FT.

SUM OF VOLUME RETENTION BENEFITS = 332 CU. FT.
 SEE DETAIL 'A' THIS SHEET FOR TYPICAL TREE WELL DETAIL

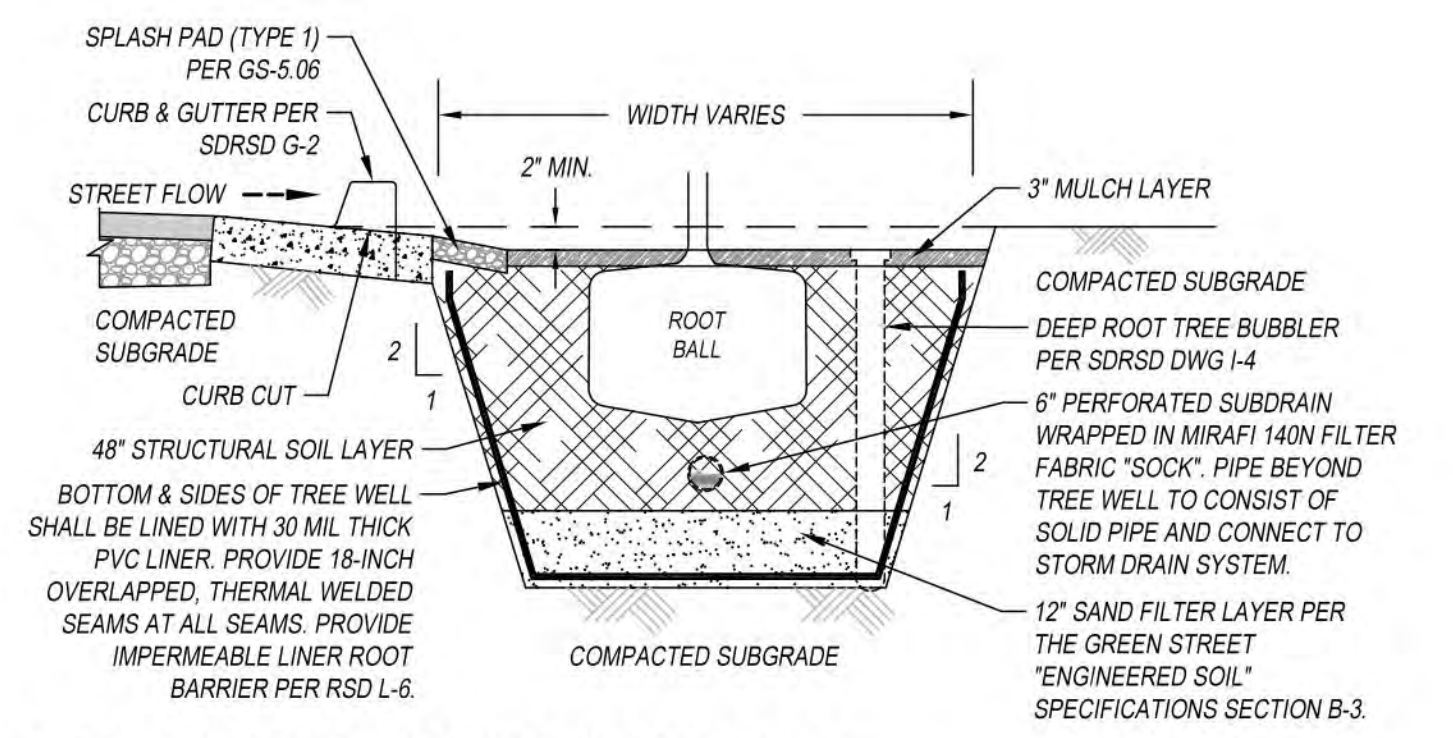

(A) TYPICAL TREE WELL DETAIL
 NOT TO SCALE

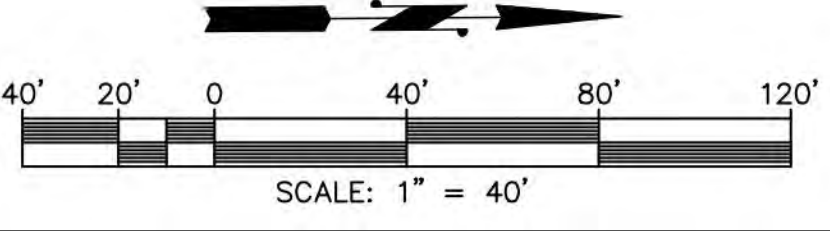

DMA EXHIBIT
 SHINOHARA INDUSTRIAL BUILDING
 517 SHINOHARA LANE
 SAN DIEGO, CALIFORNIA

SCALE	1" = 40'	DATE	11 - 16 - 2021
PROJECT NO.	G2762 - 42 - 01	FIGURE	2
SHEET	1 OF 1		

GEOCON
 INCORPORATED
 GEOTECHNICAL ■ ENVIRONMENTAL ■ MATERIALS
 6960 FLANDERS DRIVE - SAN DIEGO, CALIFORNIA 92121 - 2974
 PHONE 619-538-6900 - FAX 619-538-6159

PASCO LARET SUITER
 & ASSOCIATES
 San Diego | Solana Beach | Orange County
 Phone 858.259.8212 | www.plsaengineering.com

DRAINAGE MANAGEMENT
AREA EXHIBIT
 PROJECT SHINOHARA
 517 SHINOHARA LANE
 CHULA VISTA, CA 91911
 PLSA JOB NO. 3690
 NOVEMBER 2021

Attachment 1E

BMP Design Worksheets

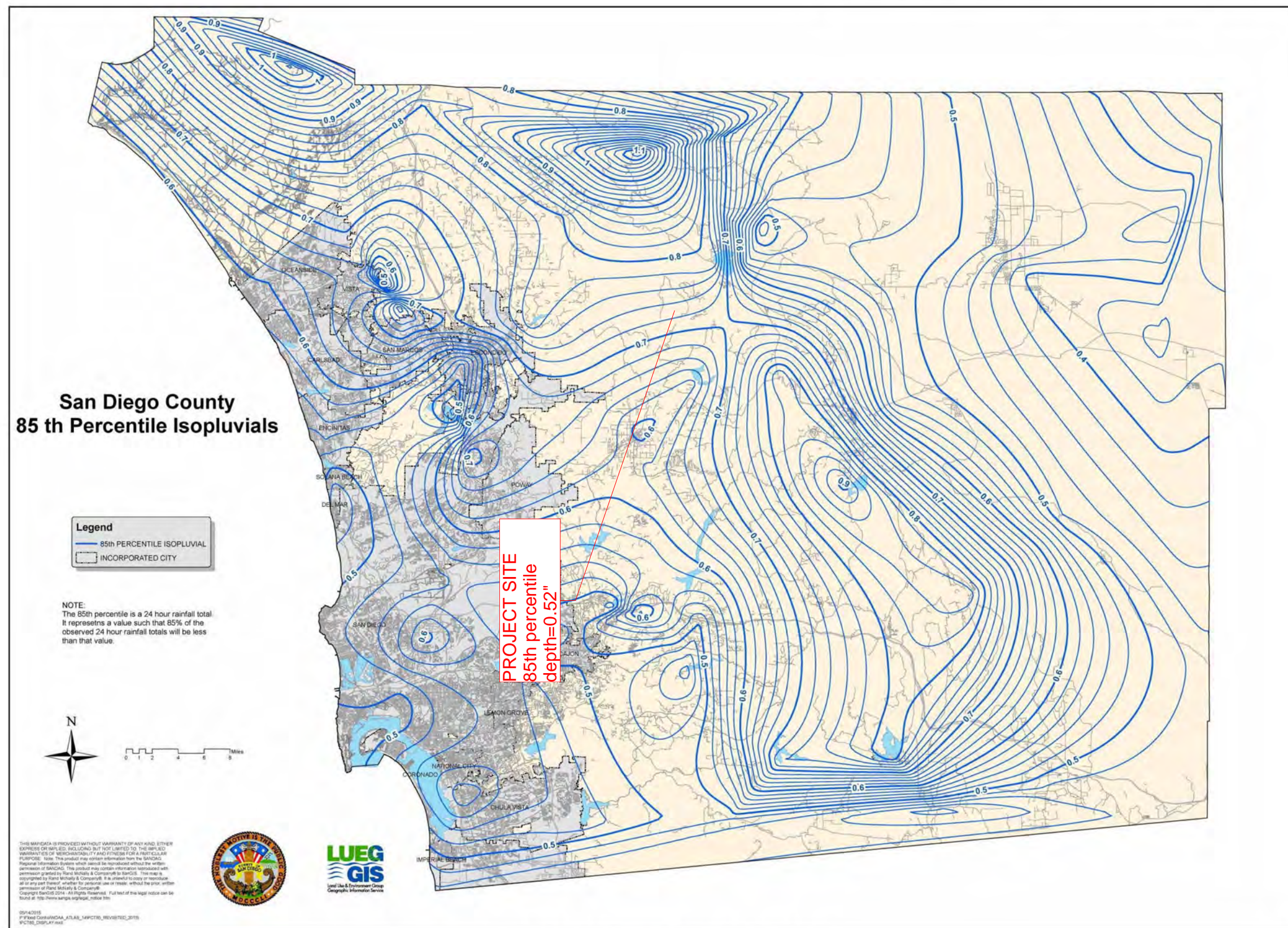



Figure B.1-1: 85th Percentile 24-hour Isopluvial Map

		Project Name	Project Shinohara	
		BMP ID	BMP-2	
Sizing Method for Volume Retention Criteria		Worksheet B.5-2		
1	Area draining to the BMP	360384	sq. ft.	
2	Adjusted runoff factor for drainage area (Refer to Appendix B.1 and B.2)	0.8112		
3	85 th percentile 24-hour rainfall depth	0.52	inches	
4	Design capture volume [Line 1 x Line 2 x (Line 3/12)]	12668	cu. ft.	
Volume Retention Requirement				
5	Measured infiltration rate in the DMA Note: When mapped hydrologic soil groups are used enter 0.10 for NRCS Type D soils and for NRCS Type C soils enter 0.30 When in no infiltration condition and the actual measured infiltration rate is unknown enter 0.0 if there are geotechnical and/or groundwater hazards identified in Appendix C	0	in/hr.	
6	Factor of safety	2		
7	Reliable infiltration rate, for biofiltration BMP sizing [Line 5 / Line 6]	0	in/hr.	
8	Average annual volume reduction target (Figure B.5-2) When Line 7 > 0.01 in/hr. = Minimum (40, 166.9 x Line 7 + 6.62) When Line 7 ≤ 0.01 in/hr. = 3.5%	3.5	%	
9	Fraction of DCV to be retained (Figure B.5-3) When Line 8 > 8% = $0.0000013 \times \text{Line } 8^3 - 0.000057 \times \text{Line } 8^2 + 0.0086 \times \text{Line } 8 - 0.014$ When Line 8 ≤ 8% = 0.023	0.023		
10	Target volume retention [Line 9 x Line 4]	291	cu. ft.	



		Project Name	Project Shinohara	
		BMP ID	BMP-2	
Optimized Biofiltration BMP Footprint when Downstream of a Storage Unit			Worksheet B.5-5	
1	Area draining to the storage unit and biofiltration BMP	360,384	sq. ft.	
2	Adjusted runoff factor for drainage area (Refer to Appendix B.1 and B.2)	0.8112		
3	Effective impervious area draining to the storage unit and biofiltration BMP [Line 1 x Line 2]	292343.5008	sq. ft.	
4	Remaining DCV after implementing retention BMPs	12668	cu. ft.	
5	Design infiltration rate (measured infiltration rate / 2)	0	ft./hr.	
6	Media thickness [1.5 feet minimum], also add mulch layer and washed ASTM 33 fine aggregate sand thickness to this line for sizing calculations	0	ft.	
7	Media filtration rate to be used for sizing (0.42 ft/hr. with no outlet control; if the filtration rate is controlled by the outlet use the outlet controlled rate)	0	ft./hr.	
8	Media retained pore space	0.05	in/in	
Storage Unit Requirement				
9	Drawdown time of the storage unit, minimum(from the elevation that bypasses the biofiltration BMP, overflow elevation)	12	hours	
10	Storage required to achieve greater than 92 percent capture (see Table B.5-5)	0.85	fraction	
11	Storage required in cubic feet (Line 4 x Line 10)	10767.98561	cu. ft.	
12	Storage provided in the design, minimum(from the elevation that bypasses the biofiltration BMP, overflow elevation)	11941	cu. ft.	
13	Is Line 12 \geq Line 11?	Storage Requirement is Met		
Criteria 1: BMP Footprint Biofiltration Capacity				
14	Peak flow from the storage unit to the biofiltration BMP (using the elevation used to evaluate the percent capture)		cfs	
15	Required biofiltration footprint [(3,600 x Line 14)/Line 7]	0	sq. ft.	
Criteria 2: Alternative Minimum Sizing Factor (Clogging)				
16	Alternative Minimum Footprint Sizing Factor [Line 11 of Worksheet B.5-4]		fraction	
17	Required biofiltration footprint [Line 3 x Line 16]	0	sq. ft.	
Criteria 3: Retention requirement [Not applicable for No Infiltration Condition]				
18	Retention Target (Line 10 in Worksheet B.5-2)		cu. ft.	
19	Average discharge rate from the storage unit to the biofiltration BMP		cfs	
20	Depth retained in the optimized biofiltration BMP {Line 6 x Line 8} + {(Line 4)/(2400 x Line 19)} x Line 5	0	ft	
21	Required optimized biofiltration footprint (Line 18/Line 20)	0	sq. ft.	
Optimized Biofiltration Footprint				
22	Optimized biofiltration footprint, maximum(Line 15, Line 17, Line 21)	0	sq. ft.	

Table B.5-5

Drawdown Time (hours)	Storage requirement (below the overflow elevation, or below outlet elevation that bypass the biofiltration BMP)
12	0.85 DCV
24	1.25 DCV
36	1.50 DCV
48	1.80 DCV
72	2.20 DCV
96	2.60 DCV
120	2.80 DCV

		Project Name Project Shinohara				
		BMP ID BMP-2				
Volume Retention for No Infiltration Condition			Worksheet B.5-6			
1	Area draining to the biofiltration BMP	360384	sq. ft.			
2	Adjusted runoff factor for drainage area (Refer to Appendix B.1 and B.2)	0.8112				
3	Effective impervious area draining to the BMP [Line 1 x Line 2]	292344	sq. ft.			
4	Required area for Evapotranspiration [Line 3 x 0.03]	8770	sq. ft.			
5	Biofiltration BMP Footprint	0	sq. ft.			
Landscape Area (must be identified on DS-3247)						
	Identification	1	2	3	4	5
6	Landscape area that meet the requirements in SD-B and SD-F Fact Sheet (sq. ft.)					
7	Impervious area draining to the landscape area (sq. ft.)					
8	Impervious to Pervious Area ratio [Line 7/Line 6]	0.00	0.00	0.00	0.00	0.00
9	Effective Credit Area If (Line 8 >1.5, Line 6, Line 7/1.5)	0	0	0	0	0
10	Sum of Landscape area [sum of Line 9 Id's 1 to 5]	0			sq. ft.	
11	Provided footprint for evapotranspiration [Line 5 + Line 10]	0			sq. ft.	
Volume Retention Performance Standard						
12	Is Line 11 ≥ Line 4?	No, Proceed to Line 13				
13	Fraction of the performance standard met through the BMP footprint and/or landscaping [Line 11/Line 4]	0				
14	Target Volume Retention [Line 10 from Worksheet B.5.2]	291			cu. ft.	
15	Volume retention required from other site design BMPs [(1-Line 13) x Line 14]	291.3690225			cu. ft.	
Site Design BMP						
	Identification	Site Design Type		Credit		
16	1	BMP-5 Tree Well w/ Underdrain (A=475 sq.ft, SV=1,900 cu.ft.)		190	cu. ft.	
	2	BMP-6 Tree Well w/ Underdrain (A=415 sq.ft, SV=1,660 cu.ft.)		166	cu. ft.	
	3				cu. ft.	
	4				cu. ft.	
	5				cu. ft.	
	Sum of volume retention benefits from other site design BMPs (e.g. trees; rain barrels etc.). [sum of Line 16 Credits for Id's 1 to 5] Provide documentation of how the site design credit is calculated in the PDP SWQMP.			356	cu. ft.	
17	Is Line 16 ≥ Line 15?	Volume Retention Performance Standard is Met				

Vault Drawdown Calculation - BMP-1

Project Name Project Shinohara

PLSA Project No. 3690

Vault Drawdown	12.0	hrs
-----------------------	-------------	------------

Vault Dimensions

Vault Volume	35,824	cf
Chamber Height	6	ft
Vault Area	5,971	sf

Note: Drawdown time is calculated assuming an initial water surface depth equal to the invert of the lowest surface discharge opening in the basin outlet structure.

Underdrain Orifice Diameter:	4	in		
C:	0.6			
Surface Depth (ft)	Volume (cf)	Qorifice (cfs)	ΔT (hr)	Total Time (hr)
2.00	11941	0.581	0	0
1.75	10449	0.542	0.74	0.74
1.50	8956	0.500	0.80	1.53
1.25	7463	0.454	0.87	2.40
1.00	5971	0.402	0.97	3.37
0.75	4478	0.343	1.11	4.49
0.50	2985	0.271	1.35	5.84
0.00	0	0.00	6.12	11.95

Storage Unit Requirement

DCV	12,668
0.85DCV	10,768
Storage provided in the design	11,941
Is storage requirement met?	yes

MODULE NOTES		
TYPE	QUANTITY	HEIGHT
A	14	6'
B	17	6'
C	2	6'
D	3	6'
F	1	6'
G	2	6'
LINK SLABS		
TOTAL	52	
VOLUME =	35,824	CUBIC FEET

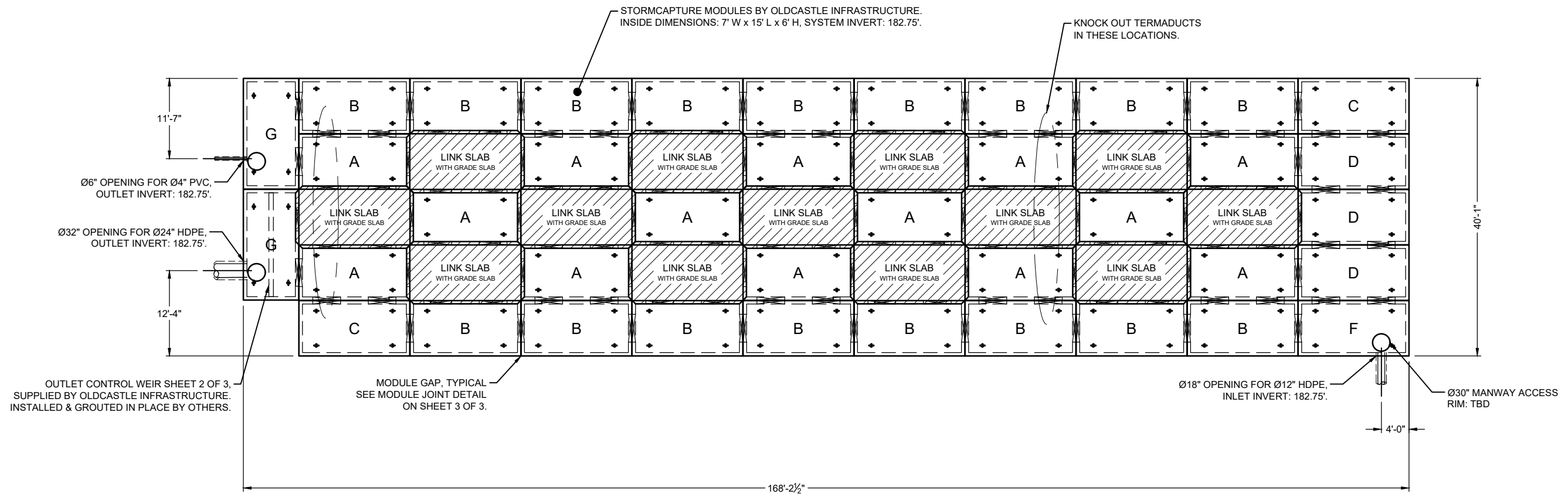

PLAN VIEW
SCALE: 1/16" = 1'

DESIGN NOTES

- LIVE LOADING CRITERIA:
 - AASHTO HS-20-44 DESIGN TRUCK (WITH IMPACT AT 0.50FT MINIMUM COVER)
 - LATERAL LIVE LOAD SURCHARGE: 80 PSF (TO 8.00FT DEPTH)
 - NO LATERAL SURCHARGE(S) FROM ANY ADJACENT BUILDINGS, WALLS, FOUNDATIONS, OR ANY ADDITIONAL SITE ELEMENTS.
- SOIL LOADING CRITERIA:
 - SOIL COVER DEPTH: 0.5FT (MIN.) - 5FT (MAX.)
 - SOIL UNIT WEIGHT: 120 PCF
 - ASSUMED WATER TABLE ELEVATION: BELOW BOTTOM OF PRECAST
 - REQUIRED ALLOWABLE BEARING PRESSURE: 2,500 PSF
 - EQUIVALENT LATERAL FLUID PRESSURE, ACTIVE: 45 PCF (DRAINED)
 - EQUIVALENT LATERAL FLUID PRESSURE, AT-REST: 60 PCF (DRAINED)
 - EQUIVALENT LATERAL FLUID PRESSURE, PASSIVE: 150 PCF (DRAINED)
 - ASSUMED COEFFICIENT OF FRICTION: 0.40
 - SEISMIC LATERAL EARTH PRESSURES: NOT APPLICABLE
- STORMCAPTURE MODULE TYPE: DETENTION (SOILTIGHT).
- CONCRETE (NORMALWEIGHT):
 - MIN. 28-DAY COMPRESSIVE STRENGTH: 6,000 PSI
 - CEMENT: ASTM C150
- STEEL REINFORCEMENT: ASTM A615 / A706 (GRADE 60), ASTM A1064 (GRADE 80)
- REFERENCE STANDARDS: ASTM C913 & C890, ACI 318-14

REV	DESCRIPTION	DATE

Oldcastle Infrastructure
A CEM COMPANY

Ph: 800.579.8819 | www.oldcastleinfrastructure.com/stormwater

THIS DOCUMENT IS THE PROPERTY OF OLDCASTLE INFRASTRUCTURE, INC. IT IS CONFIDENTIAL, SUBMITTED FOR REFERENCE PURPOSES ONLY AND SHALL NOT BE USED IN ANY WAY INJURIOUS TO THE INTERESTS OF, OR WITHOUT THE WRITTEN PERMISSION OF OLDCASTLE INFRASTRUCTURE, INC. COPYRIGHT © 2022 OLDCASTLE INFRASTRUCTURE, INC. ALL RIGHTS RESERVED.

STORMCAPTURE @ DETENTION SYSTEM	SYSTEM ID BMP-1	PLAN-N
CUSTOMER: Pasco Laret Suiter		JOB NUMBER: 22-725626
JOB NAME: Shinohara - Chula Vista, CA		SALES ORDER -
DATE 5/9/22	MFG 070-FO	DRAWN PPS
ENGINEER CDH	CHECKED CDH	SHEET -
DRAWING NAME 22-725626-SC2 3-3_BMP-1		SHEET 1 OF 3



REVIEWING NOTES

1. THIS SYSTEM HAS BEEN DESIGNED PER THE DESIGN PARAMETERS SPECIFIED IN THE DESIGN NOTES. REVIEWING ENGINEER SHALL VERIFY THAT THESE PARAMETERS MEET OR EXCEED PROJECT SPECIFIC REQUIREMENTS. IF SITE CONDITIONS DIFFER FROM NOTED DESIGN PARAMETERS, REVIEWING ENGINEER SHALL NOTIFY OLDCASTLE FOR POTENTIAL REDESIGN AND/OR PRICING ADJUSTMENTS.
2. REVIEWING ENGINEER SHALL VERIFY ALL PIPE PENETRATION LOCATIONS, SIZES, AND INVERTS.
3. REVIEWING ENGINEER SHALL VERIFY ALL MANWAY ACCESS LOCATIONS AND RIM ELEVATIONS.
4. THIS SYSTEM IS DESIGNED FOR A GROUNDWATER TABLE ELEVATION PER DESIGN NOTE 2C, SHEET 1. REVIEWING ENGINEER SHALL VERIFY THAT THE DESIGN GROUNDWATER ELEVATION MEETS OR EXCEEDS SITE CONDITION REQUIREMENTS. NOTIFY OLDCASTLE IF SITE CONDITIONS VARY FROM WHAT HAS BEEN SPECIFIED FOR POTENTIAL SYSTEM DESIGN CHANGES AND/OR PRICING ADJUSTMENTS.

5. STORMCAPTURE MODULES ARE NOT WATERTIGHT. IF A WATERTIGHT SOLUTION IS REQUIRED, CONTACT OLDCASTLE FOR RECOMMENDATIONS. THE WATERTIGHT APPLICATION TO BE PROVIDED AND IMPLEMENTED BY THE CONTRACTOR. THE CONTRACTOR IS RESPONSIBLE TO ENSURE THAT THE SELECTED WATERTIGHT SOLUTION PERFORMS AS SPECIFIED BY THE MANUFACTURER.
6. DESIGN OF THE STORMCAPTURE PRECAST MODULE SYSTEM ASSUMES NO ADJACENT BUILDING(S), WALL(S), OR STRUCTURAL FOUNDATION(S) WITHIN A 1:1 INFLUENCE LINE FROM THE BOTTOM EDGE OF ANY SYSTEM MODULE. ANY SITE ELEMENTS BEYOND THIS ZONE OF INFLUENCE ARE ASSUMED TO HAVE NO IMPACT ON THE SYSTEM AND EXERT ZERO LATERAL SURCHARGE ONTO THE MODULES. THE CONTRACTOR SHALL VERIFY THAT ANY ADJACENT BUILDING(S), WALL(S), OR STRUCTURAL FOUNDATION(S) DO NOT LIE WITHIN THIS INFLUENCE ZONE OR DO NOT SURCHARGE THE PRECAST MODULES.
7. WRITTEN APPROVAL OF SUBMITTAL DRAWINGS ALONG WITH SIGNED PURCHASE ORDER REQUIRED FOR BEGINNING OF PRODUCT FABRICATION. ANY SYSTEM MODIFICATION POST-APPROVAL MAY RESULT IN CHANGE ORDER(S) AND/OR POTENTIAL DELIVERY DELAYS.

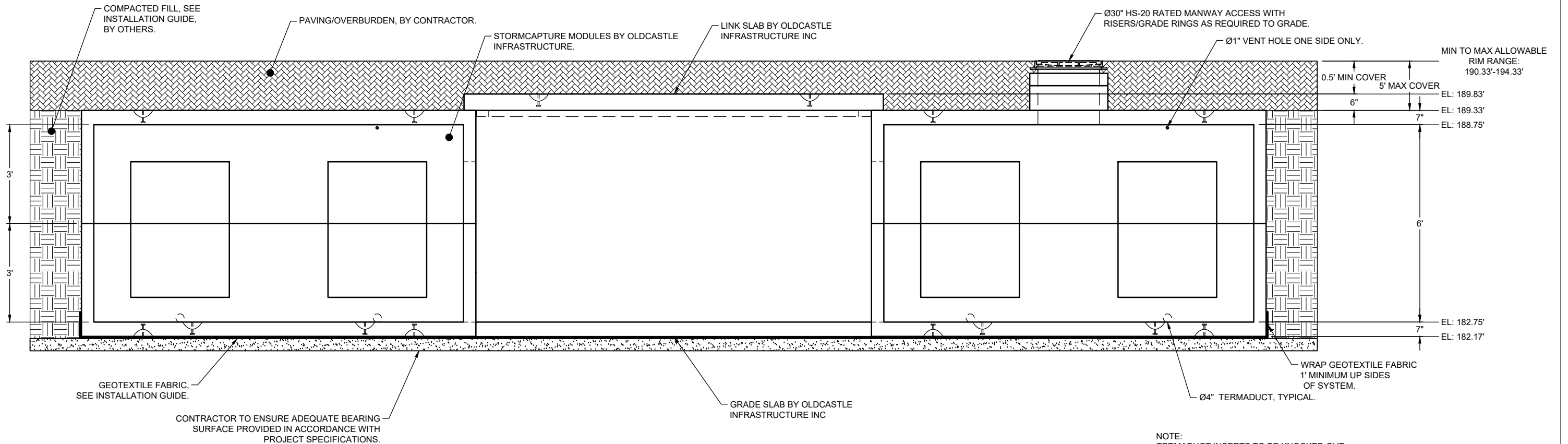
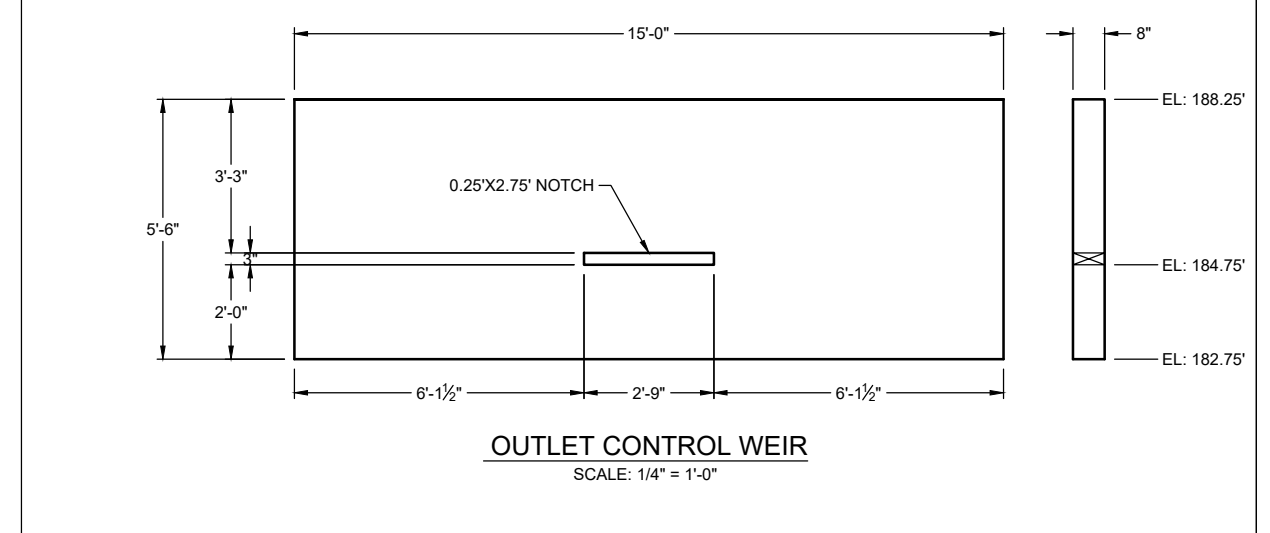

NOTE:
TERMADUCT INSERTS TO BE KNOCKED OUT
AT SPECIFIED LOCATIONS ONLY (BY
OTHERS).

REV	DESCRIPTION	DATE
 Oldcastle Infrastructure A CIBI COMPANY Ph: 800.579.8819 www.oldcastleinfrastructure.com/stormwater		
THIS DOCUMENT IS THE PROPERTY OF OLDCASTLE INFRASTRUCTURE, INC. IT IS CONFIDENTIAL, SUBMITTED FOR REFERENCE PURPOSES ONLY AND SHALL NOT BE USED IN ANY WAY INJURIOUS TO THE INTERESTS OF, OR WITHOUT THE WRITTEN PERMISSION OF OLDCASTLE INFRASTRUCTURE, INC. COPYRIGHT © 2022 OLDCASTLE INFRASTRUCTURE, INC. ALL RIGHTS RESERVED.		
STORMCAPTURE ® DETENTION SYSTEM		SYSTEM ID BMP-1
CUSTOMER: Pasco Laret Suiter		
JOB NAME: Shinohara - Chula Vista, CA		JOB NUMBER: 22-725626
DATE	MFG	DRAWN
5/9/22	070-FO	PPS
ENGINEER	CHECKED	SALES ORDER
CDH	CDH	-
DRAWING NAME 22-725626-SC2 3-3_BMP-1		
SHEET 2 OF 3		



INSTALLATION NOTES

1. UNDERGROUND PRECAST CONCRETE SYSTEM INSTALLATION SHALL BE PER ASTM C891, "STANDARD PRACTICE FOR INSTALLATION OF UNDERGROUND PRECAST CONCRETE UTILITY STRUCTURES" AND PER OLDCASTLE.
2. MODULE SUBBASE OR SUBGRADE SHALL BE LEVEL/SCREEDED AND COMPACTED ADEQUATELY FOR REQUIRED BEARING CAPACITY PER DESIGN NOTE 2D, SHEET 1. CONTRACTOR AND/OR INSTALLING SUB-CONTRACTOR SHALL VERIFY THAT SOIL BEARING CONDITIONS MEET OR EXCEED DESIGN REQUIRED MINIMUMS PRIOR TO PLACEMENT AND INSTALLATION OF MODULES.
3. ANY CONSTRUCTION EQUIPMENT EXCEEDING NOTED DESIGN LOADING IS NOT PERMITTED OVER OR ADJACENT TO ANY MODULE WITHOUT FORMAL REVIEW AND WRITTEN APPROVAL BY OLDCASTLE ENGINEERING, ELSE PRODUCT WARRANTY MAY BE VOIDED. ANY DESIGN CONSTRAINT EXCEEDING THE DESIGN PARAMETERS NOTED ABOVE MAY REQUIRE CUSTOM STRUCTURAL DESIGN, SUBGRADE REVISIONS, AND/OR PRICING ADJUSTMENTS.
4. HEAVY VIBRATORY COMPACTION EQUIPMENT SHALL NOT BE OPERATED WITHIN 10 FEET OF MODULE EXTERIOR.
5. MINIMUM OF 0.50FT OF SOIL COVER REQUIRED FOR CONSTRUCTION EQUIPMENT OPERATION ON TOP OF SYSTEM. IT IS THE RESPONSIBILITY OF THE CONTRACTOR AND INSTALLING SUB-CONTRACTOR TO ENSURE THAT NO MODULES ARE DAMAGED DURING CONSTRUCTION.
6. UNLESS NOTED OTHERWISE, ALL PIPE SUPPLIED AND INSTALLED BY OTHERS.
7. CONTRACTOR MAY MODIFY AT RISK ANY OLDCASTLE PRODUCT(S) IN THE FIELD OR AFTER DELIVERY WITHOUT FORMAL REVIEW AND WRITTEN APPROVAL BY OLDCASTLE ENGINEERING. THE CONTRACTOR SHALL BE RESPONSIBLE FOR VERIFYING THAT ANY PRODUCT MODIFICATIONS DO NOT INVALIDATE THE PRODUCT WARRANTY.
8. MODULE PLACEMENT FIELD TOLERANCES SHALL NOT EXCEED 3/4" BETWEEN ADJACENT MODULES. IF MODULE GAP EXCEEDS 3/4", CONTRACTOR SHALL MAKE NECESSARY ADJUSTMENTS AND RESET MODULE(S) TO BRING WITHIN NOTED TOLERANCES.
9. CONTRACTOR IS RESPONSIBLE FOR PRODUCTS ONCE DELIVERED TO THE SITE. OLDCASTLE IS NOT RESPONSIBLE FOR OFFLOADING PRODUCTS, MAINTENANCE, AND INSTALLATION OF PRODUCTS ONCE THEY ARRIVE TO THE SITE.
10. CONTRACTOR SHALL INSTALL SYSTEM PER PROJECT WATERPROOFING AND SOILTIGHTNESS REQUIREMENTS. WATERPROOFING AND SOILTIGHTNESS INSTALLATION IS NOT BY OLDCASTLE AND OLDCASTLE WILL PROVIDE NO GUARANTEE FOR THIS COMPONENT OF SYSTEM INSTALLATION.

KEYWAYS MUST BE FREE OF DIRT, ROCKS, AND WATER. ROCKS AND DIRT PREVENT THE VAULT SECTIONS FROM SEATING AND SEALING PROPERLY. REMOVE ALL PROTECTIVE PAPER FROM RUBBER SEALANT MATERIAL. SPLICE RUBBER SEALANT MATERIAL WITH A "SIDE BY SIDE" JOINT, AWAY FROM CORNERS. CORNER SPLICING WILL NOT SEAL PROPERLY.

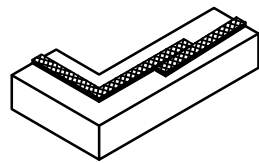

CORRECT - INSTALL RUBBER SEALANT MATERIAL AT THE OUTER EDGE OF THE KEYWAY. RUBBER SEALANT SHOULD BE CONTINUOUS AROUND CORNERS.

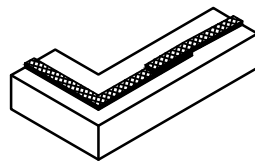

INCORRECT - DO NOT OVERLAP THE RUBBER SEALANT MATERIAL AT SPLICE.

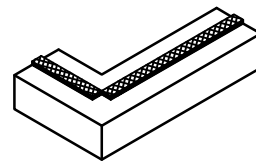

INCORRECT - DO NOT SPLICE RUBBER SEALANT MATERIAL AT A CORNER. RUBBER SEALANT SHOULD BE CONTINUOUS AROUND CORNERS.

**BUTYL RUBBER SEALANT (CONSEAL CS-102 OR EQUAL)
PLACEMENT DETAIL**
NTS

MAXIMUM EQUIPMENT OPERATING WEIGHT (OW) BY TRACK WIDTH				
TRACK WIDTH	12"	18"	24"	30"
MIN TRACK LENGTH	8'-0"	10'-0"	12'-0"	14'-0"
FILL DEPTH	OW (LBS)	OW (LBS)	OW (LBS)	OW (LBS)
0	35,000	45,000	52,500	54,500
1	35,000	45,000	56,000	60,500
2	35,000	45,000	56,000	64,000
3	76,000	78,500	83,500	88,000
4	94,000	100,000	106,000	113,000
5	100,000	116,000	132,000	149,000

NOTES:

1. IF CONSTRUCTION EQUIPMENT EXCEEDS THE ABOVE OPERATING WEIGHT LIMITS REFER TO INSTALLATION NOTE 3.
2. FOR WHEELED CONSTRUCTION EQUIPMENT LIMITS REFER TO INSTALLATION NOTE 3.
3. MINIMUM AXLE SPACING FOR ALL TRACK WIDTHS IS 6'-0".

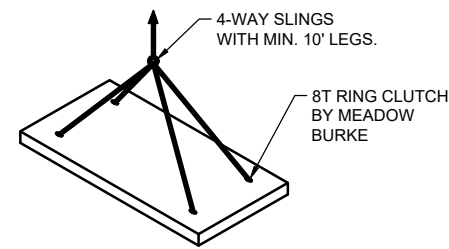

LINK/ GRADE SLAB LIFTING DETAIL
N.T.S.

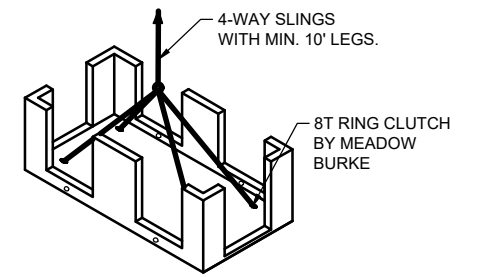

BOTTOM MODULE LIFTING DETAIL
N.T.S.

HEAVIEST PICK WEIGHT = 20,650 LBS

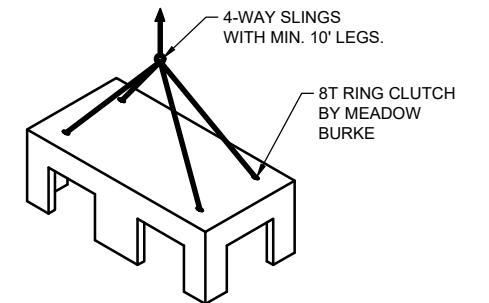

TOP MODULE LIFTING DETAIL
N.T.S.

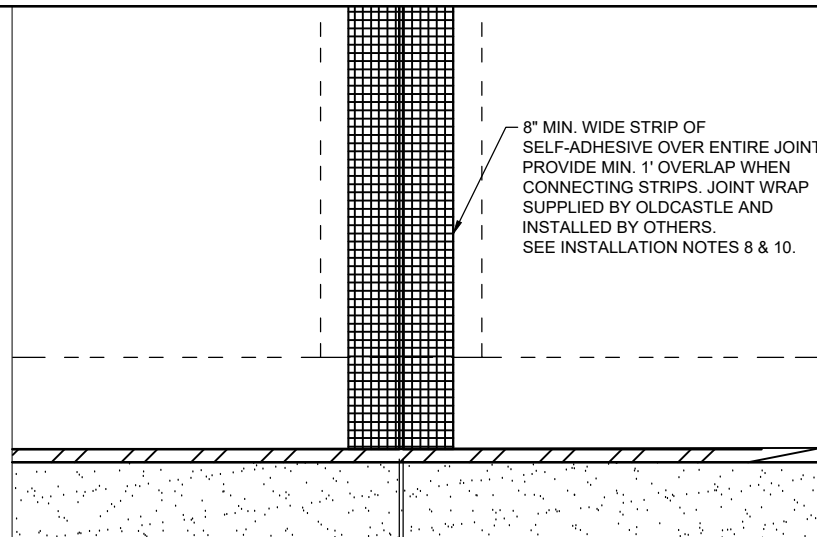

8" MIN. WIDE STRIP OF SELF-ADHESIVE OVER ENTIRE JOINT PROVIDE MIN. 1' OVERLAP WHEN CONNECTING STRIPS. JOINT WRAP SUPPLIED BY OLDCASTLE AND INSTALLED BY OTHERS. SEE INSTALLATION NOTES 8 & 10.

1/4" GAP MIN. (3/4" MAX) BETWEEN STRUCTURES

MODULE JOINT DETAIL
SCALE: 1/2" = 1'-0"

REV	DESCRIPTION	DATE

Oldcastle Infrastructure
A CIBI COMPANY
Ph: 800.579.8819 | www.oldcastleinfrastructure.com/stormwater

THIS DOCUMENT IS THE PROPERTY OF OLDCASTLE INFRASTRUCTURE, INC. IT IS CONFIDENTIAL, SUBMITTED FOR REFERENCE PURPOSES ONLY AND SHALL NOT BE USED IN ANY WAY INJURIOUS TO THE INTERESTS OF, OR WITHOUT THE WRITTEN PERMISSION OF OLDCASTLE INFRASTRUCTURE, INC. COPYRIGHT © 2022 OLDCASTLE INFRASTRUCTURE, INC. ALL RIGHTS RESERVED.

STORMCAPTURE® DETENTION SYSTEM	SYSTEM ID BMP-1
-----------------------------------	--------------------

CUSTOMER:
Pasco Laret Suiter

JOB NAME:
Shinohara - Chula Vista, CA

DATE: 5/9/22 | MFG: 070-FO | DRAWN: PPS | ENGINEER: CDH | CHECKED: CDH | SALES ORDER: -

DRAWING NAME:
22-725626-SC2 3-3_BMP-1

SHEET:
3 OF 3



SITE SPECIFIC DATA			
PROJECT NUMBER	14354		
PROJECT NAME	PROJECT SHINOHARA		
PROJECT LOCATION	CHULA VISTA, CA		
STRUCTURE ID	BMP 2		
TREATMENT REQUIRED			
VOLUME BASED (CF)	FLOW BASED (CFS)		
10,768	N/A		
TREATMENT HGL AVAILABLE (FT)	N/K		
PEAK BYPASS REQUIRED (CFS) – IF APPLICABLE	OFFLINE		
PIPE DATA	I.E.	MATERIAL	DIAMETER
INLET PIPE 1	180.55	PVC	4"
INLET PIPE 2	N/A	N/A	N/A
OUTLET PIPE	180.05	PVC	6"
	PRETREATMENT	BIOFILTRATION	DISCHARGE
RIM ELEVATION	192.96	192.96	192.96
SURFACE LOAD	H20	H20	H20
FRAME & COVER	ø30"	3EA 36" X 60"	ø30"
WETLANDMEDIA VOLUME (CY)	14.45		
ORIFICE SIZE (DIA. INCHES)	ø1.45 EA		
NOTES: PRELIMINARY NOT FOR CONSTRUCTION.			

INSTALLATION NOTES

- CONTRACTOR TO PROVIDE ALL LABOR, EQUIPMENT, MATERIALS AND INCIDENTALS REQUIRED TO OFFLOAD AND INSTALL THE SYSTEM AND APPURTENANCES IN ACCORDANCE WITH THIS DRAWING AND THE MANUFACTURERS' SPECIFICATIONS, UNLESS OTHERWISE STATED IN MANUFACTURER'S CONTRACT.
- UNIT MUST BE INSTALLED ON LEVEL BASE. MANUFACTURER RECOMMENDS A MINIMUM 6" LEVEL ROCK BASE UNLESS SPECIFIED BY THE PROJECT ENGINEER. CONTRACTOR IS RESPONSIBLE FOR VERIFYING PROJECT ENGINEER'S RECOMMENDED BASE SPECIFICATIONS.
- CONTRACTOR TO SUPPLY AND INSTALL ALL EXTERNAL CONNECTING PIPES. ALL PIPES MUST BE FLUSH WITH INSIDE SURFACE OF CONCRETE (PIPES CANNOT INTRUDE BEYOND FLUSH). INVERT OF OUTFLOW PIPE MUST BE FLUSH WITH DISCHARGE CHAMBER FLOOR. ALL PIPES SHALL BE SEALED WATERTIGHT PER MANUFACTURER'S STANDARD CONNECTION DETAIL.
- CONTRACTOR RESPONSIBLE FOR INSTALLATION OF ALL PIPES, RISERS, MANHOLES, AND HATCHES. CONTRACTOR TO GROUT ALL MANHOLES AND HATCHES TO MATCH FINISHED SURFACE UNLESS SPECIFIED OTHERWISE.
- VEGETATION SUPPLIED AND INSTALLED BY OTHERS. ALL UNITS WITH VEGETATION MUST HAVE DRIP OR SPRAY IRRIGATION SUPPLIED AND INSTALLED BY OTHERS.
- CONTRACTOR RESPONSIBLE FOR CONTACTING BIO CLEAN FOR ACTIVATION OF UNIT. MANUFACTURER'S WARRANTY IS VOID WITHOUT PROPER ACTIVATION BY A BIO CLEAN REPRESENTATIVE.

GENERAL NOTES

- MANUFACTURER TO PROVIDE ALL MATERIALS UNLESS OTHERWISE NOTED.
- ALL DIMENSIONS, ELEVATIONS, SPECIFICATIONS AND CAPACITIES ARE SUBJECT TO CHANGE. FOR PROJECT SPECIFIC DRAWINGS DETAILING EXACT DIMENSIONS, WEIGHTS AND ACCESSORIES PLEASE CONTACT BIO CLEAN.

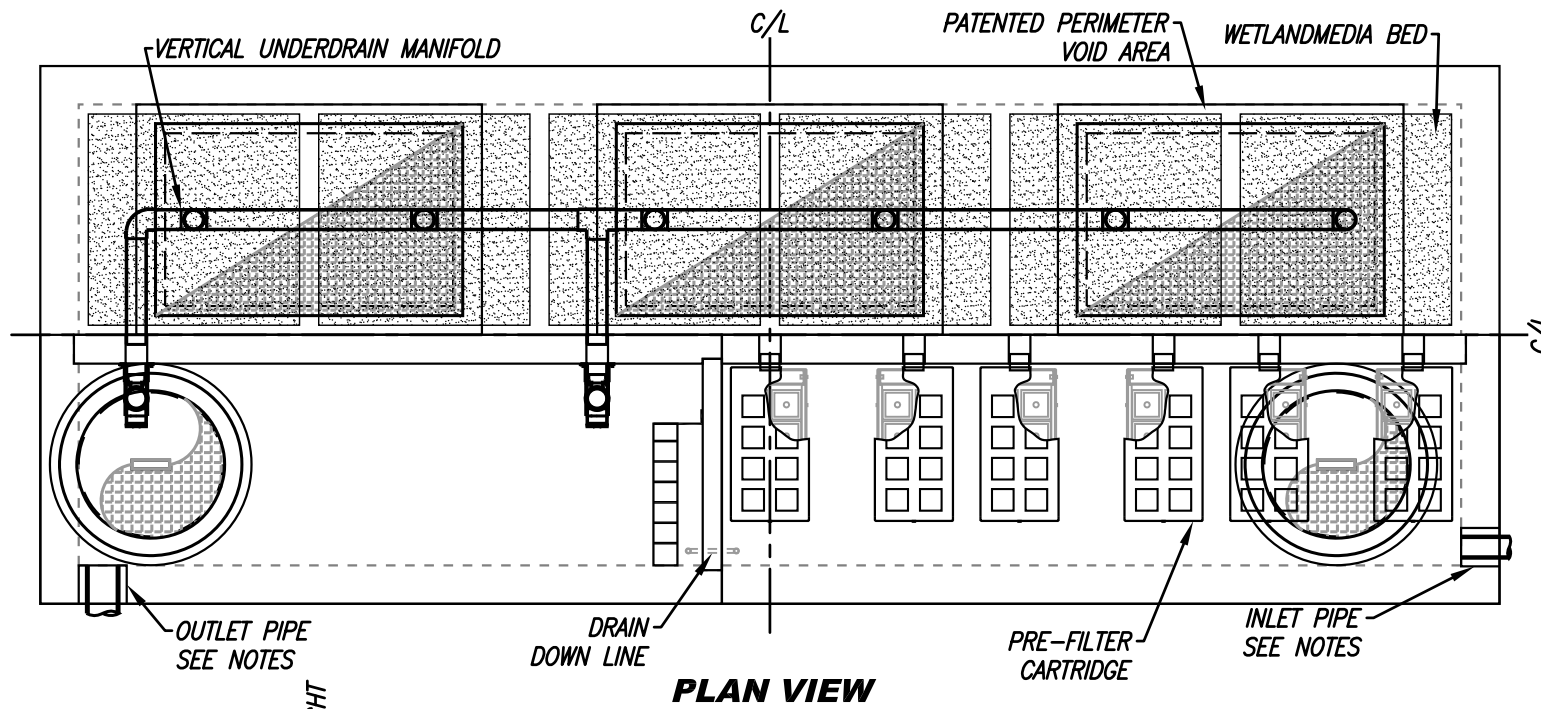

PLAN VIEW

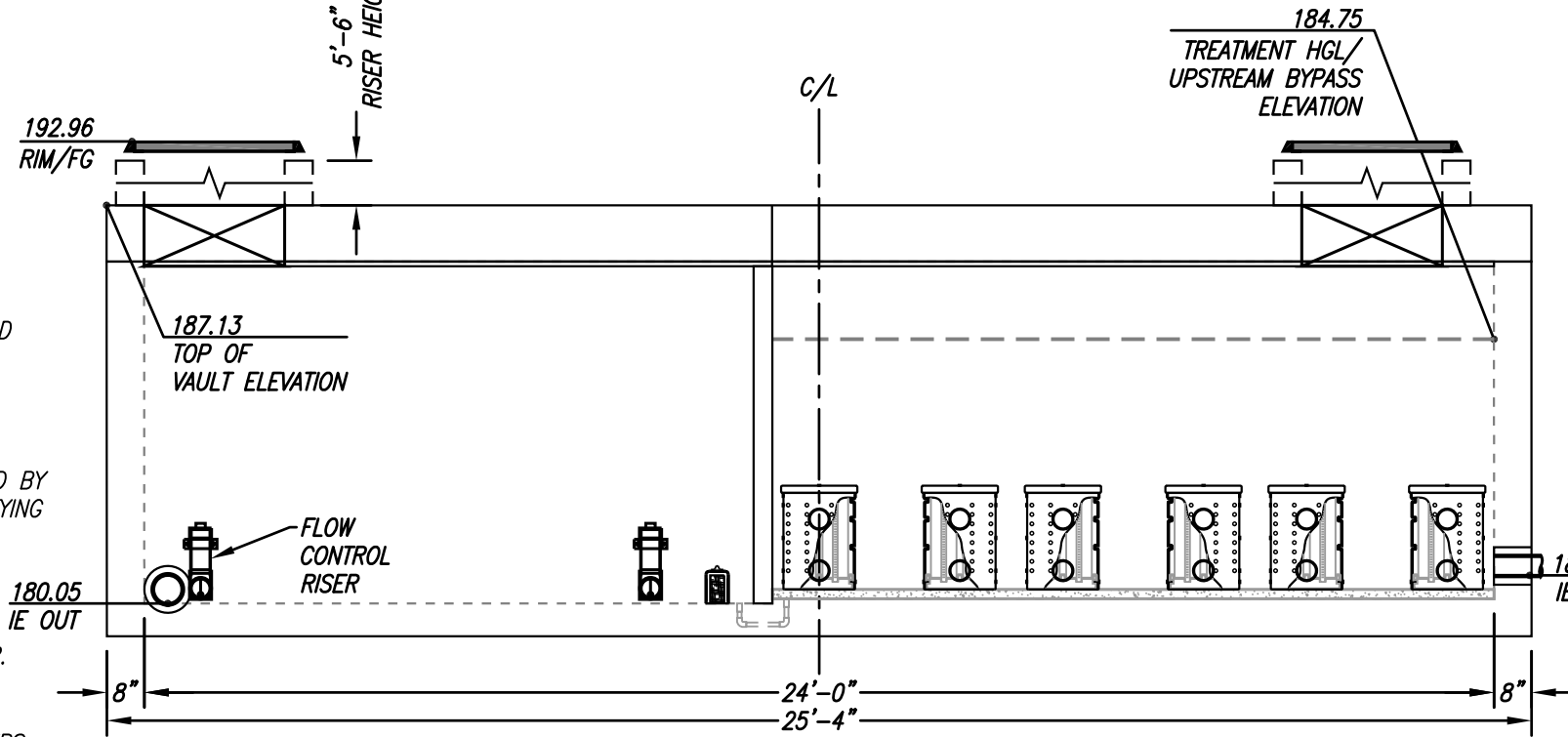

ELEVATION VIEW

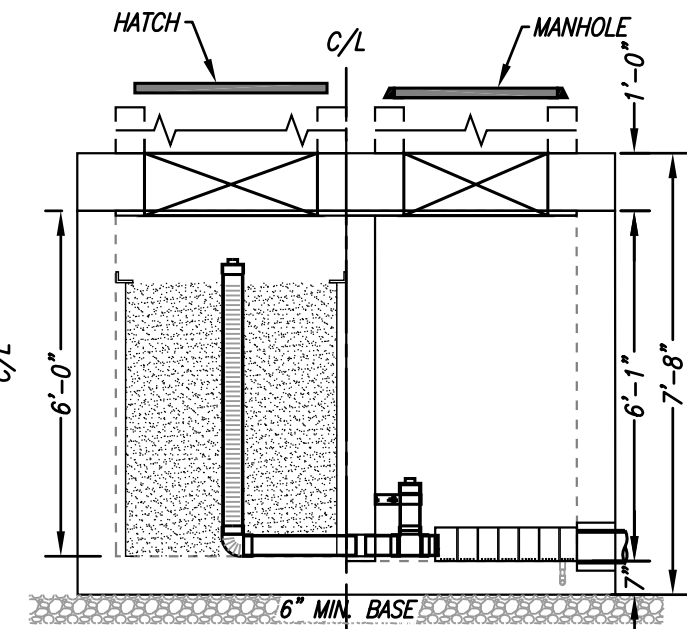

LEFT END VIEW

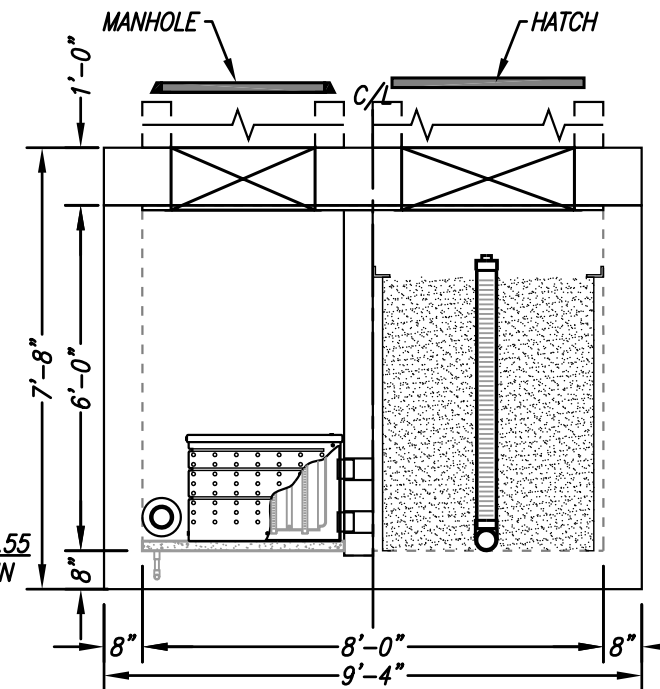

RIGHT END VIEW

REQUIRED TREATMENT VOLUME (CF)	10,768
DRAINDOWN DURATION (HOURS)	12
AVERAGE DISCHARGE RATE PER MWS UNIT(GPM)	108.51
OPERATING HEAD (FT)	4.7
WETLANDMEDIA INFILTRATION RATE (IN/HR)	26
WETLANDMEDIA LOADING RATE (GPM/SF)	OR 0.26

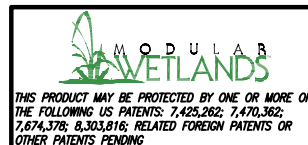

PROPRIETARY AND CONFIDENTIAL:
THE INFORMATION CONTAINED IN THIS DOCUMENT IS THE SOLE PROPERTY OF FORTERRA AND ITS COMPANIES. THIS DOCUMENT, NOR ANY PART THEREOF, MAY BE USED, REPRODUCED OR MODIFIED IN ANY MANNER WITHOUT THE WRITTEN CONSENT OF FORTERRA.



MWS-L-8-24-6'-0"-V-UG
STORMWATER BIOFILTRATION SYSTEM
STANDARD DETAIL

		Project Name	Project Shinohara, OnPoint Development	
		BMP ID	BMP-B	
Sizing Method for Volume Retention Criteria		Worksheet B.5-2		
1	Area draining to the BMP	49086	sq. ft.	
2	Adjusted runoff factor for drainage area (Refer to Appendix B.1 and B.2)	0.58742		
3	85 th percentile 24-hour rainfall depth	0.52	inches	
4	Design capture volume [Line 1 x Line 2 x (Line 3/12)]	1249	cu. ft.	
Volume Retention Requirement				
5	Measured infiltration rate in the DMA Note: When mapped hydrologic soil groups are used enter 0.10 for NRCS Type D soils and for NRCS Type C soils enter 0.30 When in no infiltration condition and the actual measured infiltration rate is unknown enter 0.0 if there are geotechnical and/or groundwater hazards identified in Appendix C or	0	in/hr.	
6	Factor of safety	2		
7	Reliable infiltration rate, for biofiltration BMP sizing [Line 5 / Line 6]	0	in/hr.	
8	Average annual volume reduction target (Figure B.5-2) When Line 7 > 0.01 in/hr. = Minimum (40, 166.9 x Line 7 + 6.62) When Line 7 ≤ 0.01 in/hr. = 3.5%	3.5	%	
9	Fraction of DCV to be retained (Figure B.5-3) When Line 8 > 8% = $0.000013 \times \text{Line } 8^3 - 0.000057 \times \text{Line } 8^2 + 0.0086 \times \text{Line } 8 - 0.014$ When Line 8 ≤ 8% = 0.023	0.023		
10	Target volume retention [Line 9 x Line 4]	29	cu. ft.	

		Project Name Project Shinohara, OnPoint Development	
		BMP ID BMP-4	
Volume Retention for No Infiltration Condition			Worksheet B.5-6
1	Area draining to the biofiltration BMP	49086	sq. ft.
2	Adjusted runoff factor for drainage area (Refer to Appendix B.1 and B.2)	0.58742	
3	Effective impervious area draining to the BMP [Line 1 x Line 2]	28834	sq. ft.
4	Required area for Evapotranspiration [Line 3 x 0.03]	865	sq. ft.
5	Biofiltration BMP Footprint	0	sq. ft.
Landscape Area (must be identified on DS-3247)			
	Identification	1	2
		3	4
		5	
6	Landscape area that meet the requirements in SD-B and SD-F Fact Sheet (sq. ft.)		
7	Impervious area draining to the landscape area (sq. ft.)		
8	Impervious to Pervious Area ratio [Line 7/Line 6]	0.00	0.00
9	Effective Credit Area If (Line 8 >1.5, Line 6, Line 7/1.5)	0	0
10	Sum of Landscape area [sum of Line 9 Id's 1 to 5]	0	sq. ft.
11	Provided footprint for evapotranspiration [Line 5 + Line 10]	0	sq. ft.
Volume Retention Performance Standard			
12	Is Line 11 ≥ Line 4?	No, Proceed to Line 13	
13	Fraction of the performance standard met through the BMP footprint and/or landscaping [Line 11/Line 4]	0	
14	Target Volume Retention [Line 10 from Worksheet B.5.2]	29	cu. ft.
15	Volume retention required from other site design BMPs [(1-Line 13) x Line 14]	28.73798446	cu. ft.
Site Design BMP			
	Identification	Site Design Type	Credit
16	1	(1) Tree Well w/ Underdrain (Area=831 sq-ft, SV=3,324 cu-ft)	332
	2		
	3		
	4		
	5		
	Sum of volume retention benefits from other site design BMPs (e.g. trees; rain barrels etc.) [sum of Line 16 Credits for Id's 1 to 5]		332
Provide documentation of how the site design credit is calculated in the PDP SWQMP.			
17	Is Line 16 ≥ Line 15?	Volume Retention Performance Standard is Met	

Worksheet B.6-1: Flow-Thru Design Flows

Flow-thru Design Flows		Worksheet B.6-1		
1	DCV	DCV	1,249	cubic-feet
2	DCV retained	DCV _{retained}	0	cubic-feet
3	DCV biofiltered	DCV _{biofiltered}	0	cubic-feet
4	DCV requiring flow-thru (Line 1 – Line 2 – 0.67*Line 3)	DCV _{flow-thru}	1,249	cubic-feet
5	Adjustment factor (Line 4 / Line 1)*	AF=	1	unitless
6	Design rainfall intensity	i=	0.20	in/hr
7	Area tributary to BMP (s)	A=	0.68	acres
8	Area-weighted runoff factor (estimate using Appendix B.2)	C=	0.5542	unitless
9	Calculate Flow Rate = AF x (C x i x A)	Q=	0.132	cfs

- 1) Adjustment factor shall be estimated considering only retention and biofiltration BMPs located upstream of flow-thru BMPs. That is, if the flow-thru BMP is upstream of the project's retention and biofiltration BMPs then the flow-thru BMP shall be sized using an adjustment factor of 1.
- 2) Volume based (e.g., dry extended detention basin) flow-thru treatment control BMPs shall be sized to the volume in Line 4 and flow based (e.g., vegetated swales) shall be sized to flow rate in Line 9. Sand filter and media filter can be designed either by volume in Line 4 or flow rate in Line 9.
- 3) Proprietary BMPs, if used, shall provide certified treatment capacity equal to or greater than the calculated flow rate in Line 9; certified treatment capacity per unit shall be consistent with third party certifications.

Per Appendix F.2.2 of the City of Chula Vista BMP Design Manual (August 2021):

Design Flow Rate = 1.5 x DCV

Design Flow Rate = 1.5 x 0.132 cfs

Design Flow Rate = 0.198 cfs

SITE SPECIFIC DATA			
PROJECT NUMBER	14354		
PROJECT NAME	PROJECT SHINOHARA		
PROJECT LOCATION	CHULA VISTA, CA		
STRUCTURE ID	BMP 4		
TREATMENT REQUIRED			
VOLUME BASED (CF)	FLOW BASED (CFS)		
N/A	0.199		
TREATMENT HGL AVAILABLE (FT)	N/K		
PEAK BYPASS REQUIRED (CFS) - IF APPLICABLE	FLOW BY		
PIPE DATA	I.E.	MATERIAL	DIAMETER
INLET PIPE 1	N/A	N/A	N/A
INLET PIPE 2	N/A	N/A	N/A
OUTLET PIPE	145.32	PVC	8"
	PRETREATMENT	BIOFILTRATION	DISCHARGE
RIM ELEVATION	150.40	150.40	150.40
SURFACE LOAD	PEDESTRIAN	N/A	PEDESTRIAN
FRAME & COVER	Ø30"	OPEN PLANTER	Ø24"
WETLAND MEDIA VOLUME (CY)	5.14		
ORIFICE SIZE (DIA. INCHES)	Ø1.95"		
NOTES: PRELIMINARY NOT FOR CONSTRUCTION.			

INSTALLATION NOTES

- CONTRACTOR TO PROVIDE ALL LABOR, EQUIPMENT, MATERIALS AND INCIDENTALS REQUIRED TO OFFLOAD AND INSTALL THE SYSTEM AND APPURTENANCES IN ACCORDANCE WITH THIS DRAWING AND THE MANUFACTURERS' SPECIFICATIONS, UNLESS OTHERWISE STATED IN MANUFACTURER'S CONTRACT.
- UNIT MUST BE INSTALLED ON LEVEL BASE. MANUFACTURER RECOMMENDS A MINIMUM 6" LEVEL ROCK BASE UNLESS SPECIFIED BY THE PROJECT ENGINEER. CONTRACTOR IS RESPONSIBLE FOR VERIFYING PROJECT ENGINEER'S RECOMMENDED BASE SPECIFICATIONS.
- CONTRACTOR TO SUPPLY AND INSTALL ALL EXTERNAL CONNECTING PIPES. ALL PIPES MUST BE FLUSH WITH INSIDE SURFACE OF CONCRETE (PIPES CANNOT INTRUDE BEYOND FLUSH). INVERT OF OUTFLOW PIPE MUST BE FLUSH WITH DISCHARGE CHAMBER FLOOR. ALL PIPES SHALL BE SEALED WATERTIGHT PER MANUFACTURER'S STANDARD CONNECTION DETAIL.
- CONTRACTOR RESPONSIBLE FOR INSTALLATION OF ALL PIPES, RISERS, MANHOLES, AND HATCHES. CONTRACTOR TO GROUT ALL MANHOLES AND HATCHES TO MATCH FINISHED SURFACE UNLESS SPECIFIED OTHERWISE.
- VEGETATION SUPPLIED AND INSTALLED BY OTHERS. ALL UNITS WITH VEGETATION MUST HAVE DRIP OR SPRAY IRRIGATION SUPPLIED AND INSTALLED BY OTHERS.
- CONTRACTOR RESPONSIBLE FOR CONTACTING BIO CLEAN FOR ACTIVATION OF UNIT. MANUFACTURER'S WARRANTY IS VOID WITHOUT PROPER ACTIVATION BY A BIO CLEAN REPRESENTATIVE.

GENERAL NOTES

- MANUFACTURER TO PROVIDE ALL MATERIALS UNLESS OTHERWISE NOTED.
- ALL DIMENSIONS, ELEVATIONS, SPECIFICATIONS AND CAPACITIES ARE SUBJECT TO CHANGE. FOR PROJECT SPECIFIC DRAWINGS DETAILING EXACT DIMENSIONS, WEIGHTS AND ACCESSORIES PLEASE CONTACT BIO CLEAN.

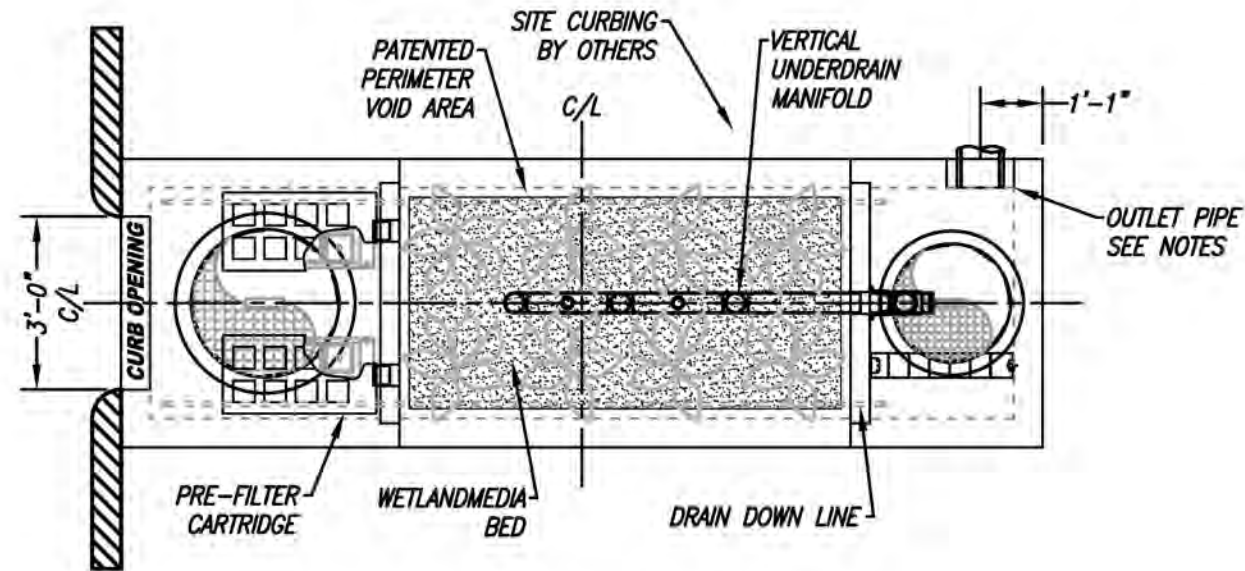

PLAN VIEW

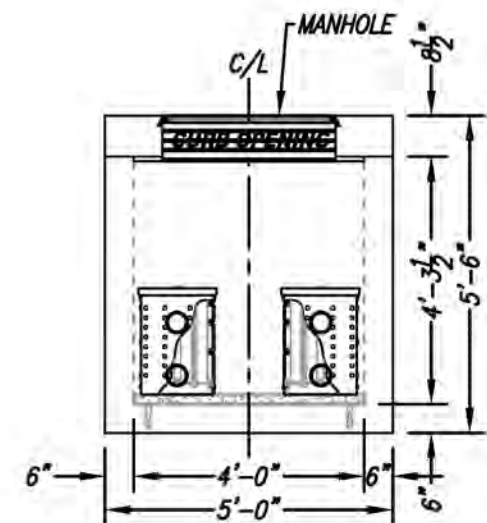

LEFT END VIEW

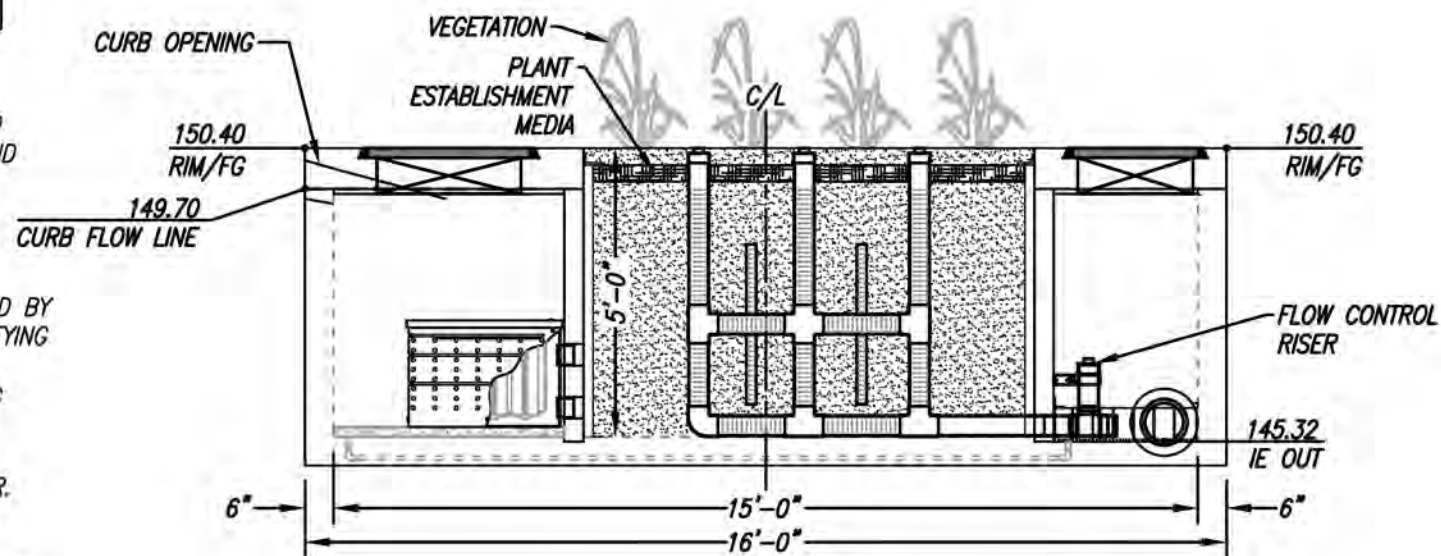

ELEVATION VIEW

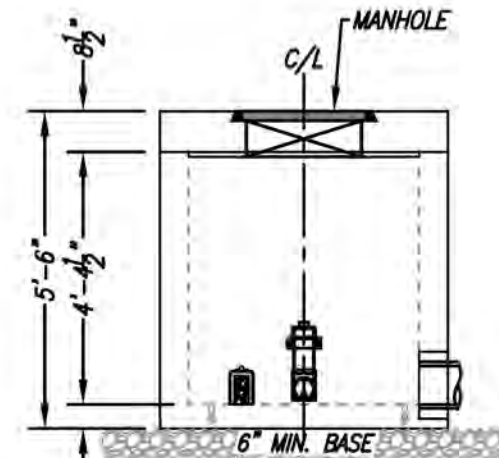

RIGHT END VIEW

TREATMENT FLOW (CFS)	0.199
OPERATING HEAD (FT)	3.9
PRETREATMENT LOADING RATE (GPM/SF)	1.7
WETLAND MEDIA LOADING RATE (GPM/SF)	1.0



PROPRIETARY AND CONFIDENTIAL:
THE INFORMATION CONTAINED IN THIS DOCUMENT IS THE SOLE PROPERTY OF FORTERRA AND ITS COMPANIES. THIS DOCUMENT, NOR ANY PART THEREOF, MAY BE USED, REPRODUCED OR MODIFIED IN ANY MANNER WITHOUT THE WRITTEN CONSENT OF FORTERRA.



MWS-L-4-15-5'-0"-C-HC
STORMWATER BIOFILTRATION SYSTEM
STANDARD DETAIL

Inlet Report

BMP-4 MWS Curb Opening Capacity Calculations

Curb Inlet

Location	=	On grade
Curb Length (ft)	=	3.00
Throat Height (in)	=	6.00
Grate Area (sqft)	=	-0-
Grate Width (ft)	=	-0-
Grate Length (ft)	=	-0-

Gutter

Slope, Sw (ft/ft)	=	0.083
Slope, Sx (ft/ft)	=	0.020
Local Depr (in)	=	1.00
Gutter Width (ft)	=	1.50
Gutter Slope (%)	=	0.80
Gutter n-value	=	0.015

Calculations

Compute by:	Known Q
Q (cfs)	= 0.20

Highlighted

Q Total (cfs)	= 0.20
Q Capt (cfs)	= 0.20
Q Bypass (cfs)	= -0-
Depth at Inlet (in)	= 2.64
Efficiency (%)	= 100
Gutter Spread (ft)	= 2.11
Gutter Vel (ft/s)	= 1.74
Bypass Spread (ft)	= -0-
Bypass Depth (in)	= -0-

All dimensions in feet

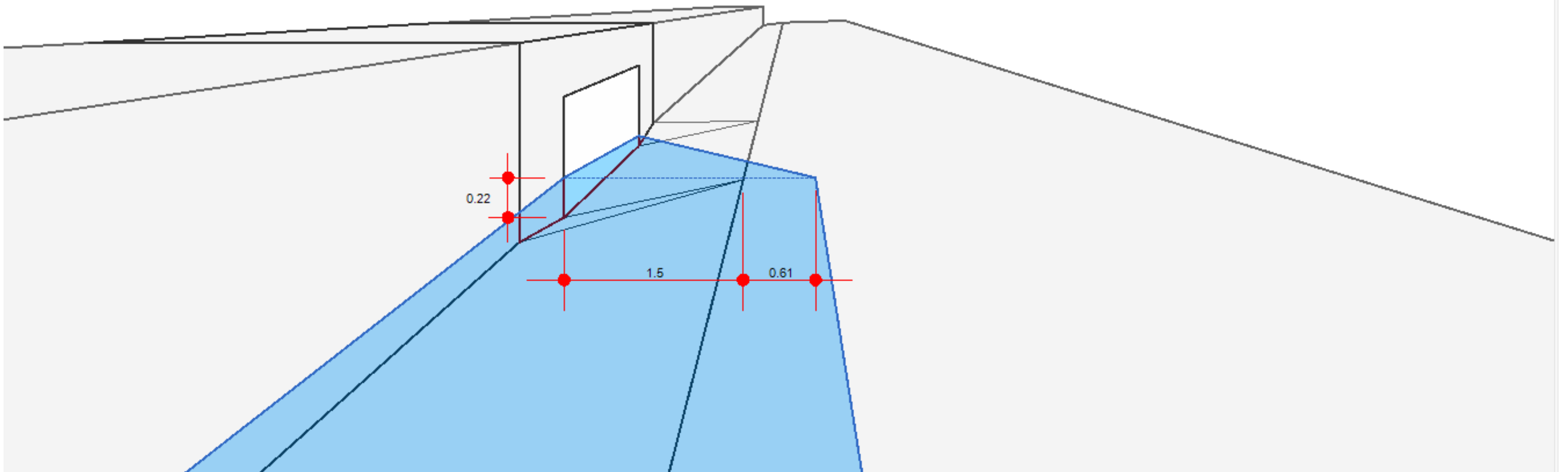

BMP-3 Trash Capture Sizing

Project Name Shinohara Business Center
PLSA Project No. 3690

Trash Capture Requirement - Certified Full Capture Devices shall be sized to treat the peak flowrate from a one-year, one-hour storm event (design storm)

(per State Water Resources Control Board Certified Full Capture System List of Trash Treatment Control Devices, Updated September 2021)

Runoff Coefficient, C= 0.8112 *(DMA-A)*
Intensity, i= 0.364 in/hr *(per NOAA Precipitation Frequency Data Server)*
Area, A= 8.27 ac *(DMA-A)*
Design Flow Rate, Q=CiA

Q=	2.44 cfs
----	----------

SITE SPECIFIC DATA			
Structure ID	BMP3		
Water Quality Flow Rate (cfs)	2.50		
Peak Flow Rate (cfs)	31.00		
Rim Elevation	192.21'		
Top of Vault Elevation	190.54'		
Pipe Data	Pipe Size	Pipe Type	Invert Elevation
Inlet	12"	HDPE	183.00'
Outlet	12"	HDPE	182.83'
Notes:			
TRASH CAPTURE PERFORMANCE SPECIFICATIONS			
Screen System Storage Volume	54.51 cf		
Total Sump Volume	204.00 cf		
Peak Flow Capacity* (100% Full Screen)	56.22 cfs		
Treatment Flow (Trash Capture)*	42.80 cfs		
Certifications			
California State Water Resources Control Board	Certified Full Capture		
Mosquito Vector Control Association of California	Accessibility Verified		
*Contact Oldcastle for additional treatment and peak flow capacities.			

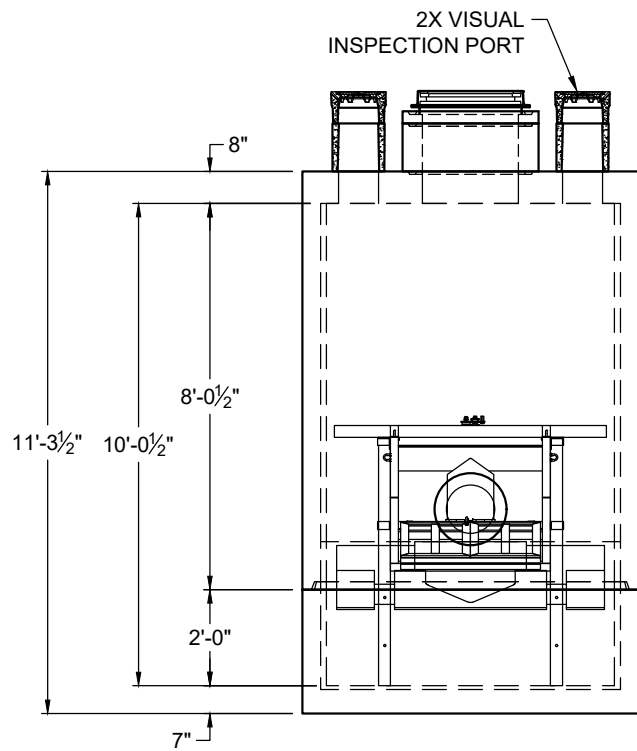

LEFT END VIEW

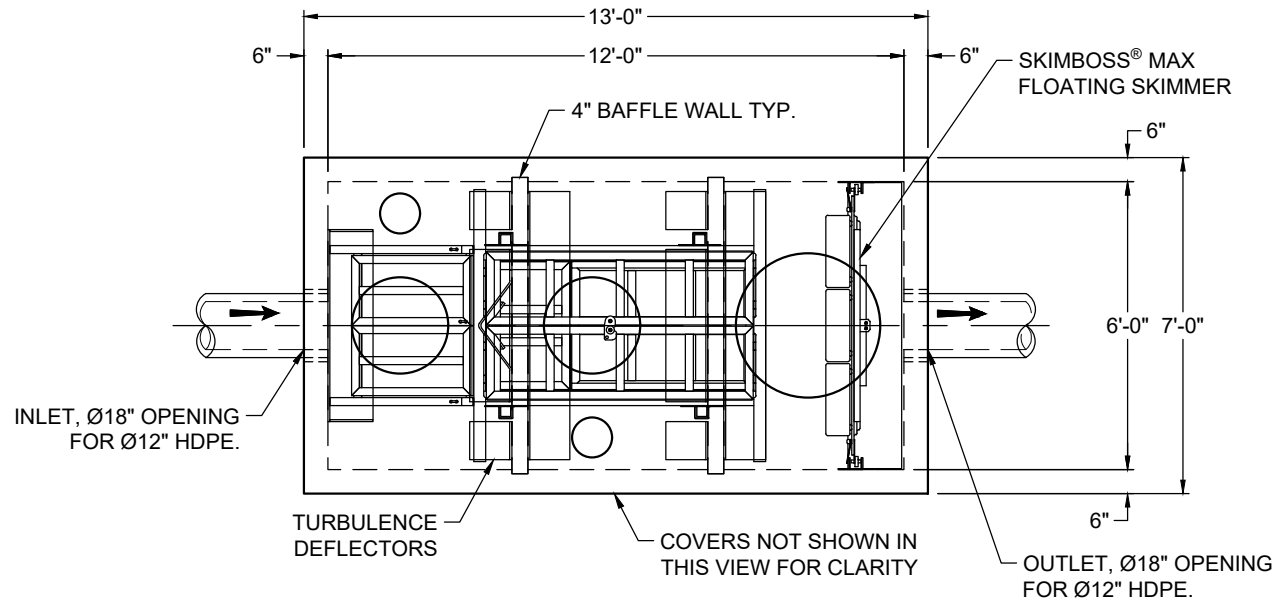

PLAN VIEW

2X Ø24" BOLTED & GASKETED ACCESS COVERS. WITH 2X Ø24"x12" GRADE RING & 2X Ø24"x3" GRADE RING. FIELD GROUT AS NEEDED TO MEET GRADE, BY OTHERS.

Ø36" ACCESS COVER. WITH 1X Ø36"x12" GRADE RING & 1X Ø36"x3" GRADE RING. FIELD GROUT AS NEEDED TO MEET GRADE, BY OTHERS.

SCREEN SYSTEM WITH SUNGLIDE™ LIDS (TRASH CAPTURE COMPLIANT)

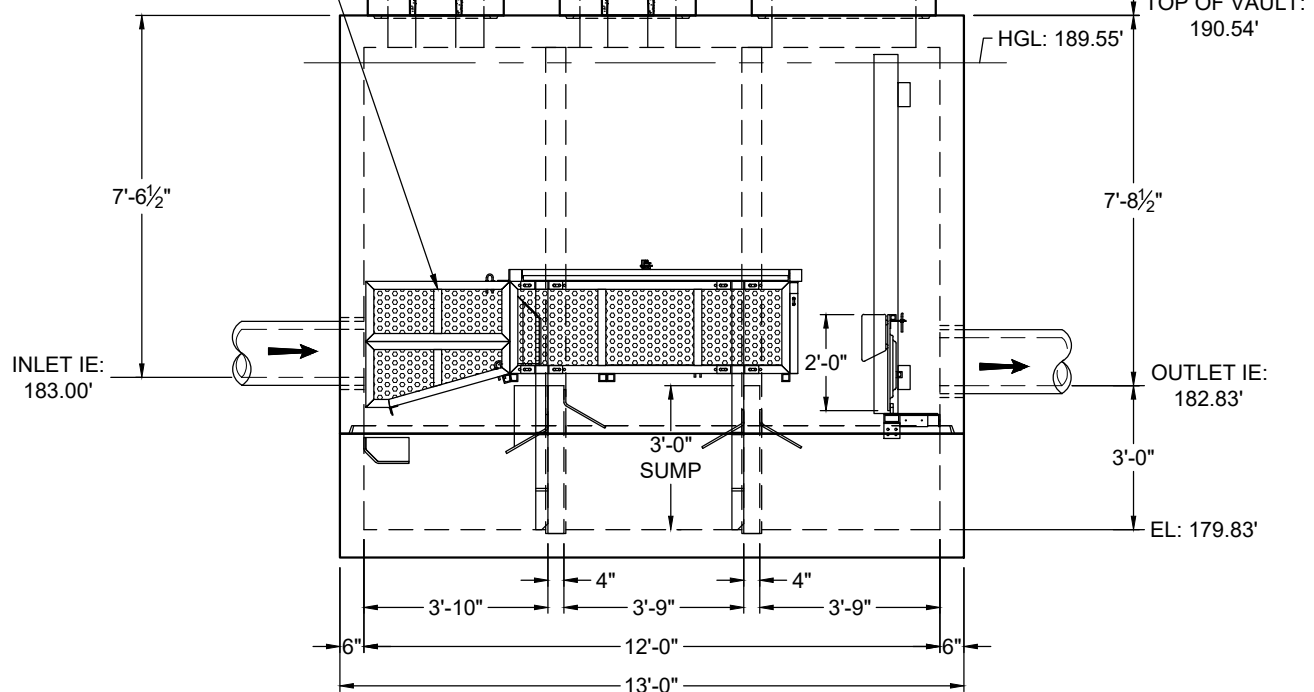

ELEVATION VIEW

NOTES:

- DESIGN LOADINGS:
 - AASHTO HS-20-44 (WITH IMPACT)
 - DESIGN SOIL COVER: 5'-0" MAXIMUM
 - ASSUMED WATER TABLE: BELOW BASE OF PRECAST (ENGINEER-OF-RECORD TO CONFIRM SITE WATER TABLE ELEVATION)
 - LATERAL EARTH PRESSURE: 45 PCF (DRAINED)
 - LATERAL LIVE LOAD SURCHARGE: 80 PSF (APPLIED TO 8'-0" BELOW GRADE)
 - NO LATERAL SURCHARGE FROM ADJACENT BUILDINGS, WALLS, PIERS, OR FOUNDATIONS.
- CONCRETE 28-DAY MINIMUM COMPRESSIVE STRENGTH: 5,000 PSI MINIMUM.
- REINFORCING: REBAR, ASTM A615/A706, GRADE 60
- CEMENT: ASTM C150
- REQ'D ALLOWABLE SOIL BEARING CAPACITY: 2,500 PSF
- REFERENCE STANDARD:
 - ASTM C890
 - ASTM C913
 - ACI 318-14
- THIS STRUCTURE IS DESIGNED TO THE PARAMETERS NOTED HEREIN. ENGINEER-OF-RECORD SHALL VERIFY THAT NOTED PARAMETERS MEET OR EXCEED PROJECT REQUIREMENTS. IF DESIGN PARAMETERS ARE INCORRECT, REVIEWING ENGINEER/AUTHORITY SHALL NOTIFY OLDCASTLE INFRASTRUCTURE UPON REVIEW OF THIS SUBMITTAL.
- OVERSIZED HOLES TO ACCOMMODATE SPECIFIC PIPE TYPE MUST BE CONCENTRIC TO PIPE ID. AFTER PIPES ARE INSTALLED, ALL ANNULAR SPACES SHALL BE FILLED WITH A MINIMUM OF 3,000 PSI CONCRETE FOR FULL THICKNESS OF PRECAST WALLS. PIPES ARE TO BE FLUSH WITH THE INSIDE SURFACE OF THE CONCRETE STRUCTURE.
- CONTRACTOR RESPONSIBLE TO VERIFY ALL SIZES, LOCATIONS, AND ELEVATIONS OF OPENINGS.
- CONTRACTOR RESPONSIBLE TO ENSURE ADEQUATE BEARING SURFACE IS PROVIDED (I.E. COMPACTED AND LEVEL PER PROJECT SPECIFICATIONS).
- SECTION HEIGHTS, SLAB/WALL THICKNESSES, AND KEYWAYS ARE SUBJECT TO CHANGE AS REQUIRED FOR SITE REQUIREMENTS AND/OR DUE TO PRODUCT AVAILABILITY AND PRODUCTION FACILITY CONSTRAINTS.
- FOR SITE SPECIFIC DRAWINGS WITH DETAILED STRUCTURE DIMENSIONS AND WEIGHTS, PLEASE CONTACT OLDCASTLE INFRASTRUCTURE.
- MAXIMUM PICK WEIGHT: 19,750 LBS. (* COMBINED WEIGHT INCLUDES BAFFLE WALLS AND PRODUCT INTERNALS.)
- INTERNAL SHALL CONSIST OF A FLOATING SKIMMER, FLOW DEFLECTORS, ELEVATED CENTRAL SCREEN SYSTEM AND SLIDING LIDS. THESE COMPONENTS EFFECTIVELY REDUCE HEAD LOSS, INCREASE POLLUTANT REMOVAL AND SIMPLIFY MAINTENANCE.

- PRELIMINARY -
NOT FOR CONSTRUCTION



Ph: 800.579.8819 | www.oldcastleinfrastructure.com/stormwater
THIS DOCUMENT IS THE PROPERTY OF OLDCASTLE INFRASTRUCTURE, INC. IT IS CONFIDENTIAL, SUBMITTED FOR REFERENCE PURPOSES ONLY AND SHALL NOT BE USED IN ANY WAY INJURIOUS TO THE INTERESTS OF, OR WITHOUT THE WRITTEN PERMISSION OF OLDCASTLE INFRASTRUCTURE, INC. COPYRIGHT © 2022 OLDCASTLE INFRASTRUCTURE, INC. ALL RIGHTS RESERVED.

Nutrient Separating Baffle Box®
Trash Capture

CUSTOMER					
Pasco Laret Suiter & Associates					
PROJECT NAME					
Shinohara - Chula Vista, CA					
DATE	MFG	DRAWN	ENGINEER	CHECKED	SALES ORDER
5/10/22	070-FO	PPS	CDH	CDH	-
SHEET NAME				REVISION	SHEET
22-725632-NSBB-612-TC				1	1 OF 1
REV DATE				REV DATE	
5/20/22				5/20/22	

THIS PRODUCT IS PROTECTED BY ONE OR MORE OF THE FOLLOWING US PATENT(S): 6,428,692; 7,270,747; 7,981,283; 8,142,666; 8,366,923; 8,491,797; 7,846,327; 8,034,236; RELATED FOREIGN PATENTS, OR OTHER PATENTS PENDING.



NOAA Atlas 14, Volume 6, Version 2
Location name: Chula Vista, California, USA*
Latitude: 32.5966°, Longitude: -117.0313°
Elevation: 154.94 ft**



* source: ESRI Maps
 ** source: USGS

POINT PRECIPITATION FREQUENCY ESTIMATES

Sanja Perica, Sarah Dietz, Sarah Heim, Lillian Hiner, Kazungu Maitaria, Deborah Martin, Sandra Pavlovic, Ishani Roy, Carl Trypaluk, Dale Unruh, Fenglin Yan, Michael Yekta, Tan Zhao, Geoffrey Bonnin, Daniel Brewer, Li-Chuan Chen, Tye Parzybok, John Yarchoan

NOAA, National Weather Service, Silver Spring, Maryland

[PF tabular](#) | [PF graphical](#) | [Maps & aerals](#)

PF tabular

PDS-based point precipitation frequency estimates with 90% confidence intervals (in inches)¹										
Duration	Average recurrence interval (years)									
	1	2	5	10	25	50	100	200	500	1000
5-min	0.108 (0.090-0.131)	0.136 (0.113-0.164)	0.173 (0.144-0.210)	0.204 (0.169-0.250)	0.248 (0.198-0.315)	0.284 (0.221-0.367)	0.320 (0.244-0.425)	0.359 (0.266-0.491)	0.414 (0.293-0.590)	0.458 (0.313-0.677)
10-min	0.155 (0.130-0.187)	0.194 (0.162-0.235)	0.248 (0.206-0.301)	0.293 (0.242-0.358)	0.356 (0.284-0.451)	0.406 (0.317-0.526)	0.459 (0.349-0.609)	0.515 (0.381-0.704)	0.593 (0.420-0.846)	0.656 (0.449-0.970)
15-min	0.187 (0.157-0.226)	0.235 (0.196-0.284)	0.300 (0.250-0.364)	0.354 (0.292-0.433)	0.431 (0.343-0.545)	0.491 (0.384-0.636)	0.555 (0.423-0.737)	0.623 (0.461-0.851)	0.718 (0.508-1.02)	0.794 (0.543-1.17)
30-min	0.262 (0.219-0.316)	0.328 (0.274-0.397)	0.418 (0.348-0.508)	0.494 (0.408-0.605)	0.601 (0.480-0.761)	0.686 (0.536-0.888)	0.775 (0.590-1.03)	0.870 (0.643-1.19)	1.00 (0.710-1.43)	1.11 (0.758-1.64)
60-min	0.364 (0.304-0.440)	0.457 (0.381-0.552)	0.582 (0.485-0.706)	0.688 (0.568-0.841)	0.836 (0.667-1.06)	0.955 (0.745-1.24)	1.08 (0.821-1.43)	1.21 (0.895-1.65)	1.39 (0.987-1.99)	1.54 (1.05-2.28)
2-hr	0.504 (0.421-0.609)	0.632 (0.528-0.765)	0.803 (0.669-0.975)	0.945 (0.781-1.16)	1.14 (0.911-1.45)	1.30 (1.01-1.68)	1.45 (1.11-1.93)	1.62 (1.20-2.21)	1.85 (1.31-2.64)	2.03 (1.39-3.00)
3-hr	0.611 (0.510-0.738)	0.767 (0.641-0.928)	0.974 (0.812-1.18)	1.15 (0.946-1.40)	1.38 (1.10-1.75)	1.56 (1.22-2.02)	1.75 (1.33-2.33)	1.95 (1.44-2.66)	2.22 (1.57-3.16)	2.43 (1.66-3.59)
6-hr	0.799 (0.668-0.965)	1.01 (0.840-1.22)	1.28 (1.07-1.55)	1.50 (1.24-1.84)	1.81 (1.45-2.29)	2.05 (1.60-2.65)	2.30 (1.75-3.05)	2.55 (1.89-3.48)	2.90 (2.05-4.14)	3.17 (2.17-4.69)
12-hr	1.03 (0.865-1.25)	1.30 (1.09-1.58)	1.66 (1.39-2.02)	1.96 (1.62-2.40)	2.37 (1.89-3.00)	2.70 (2.10-3.49)	3.03 (2.31-4.02)	3.38 (2.50-4.62)	3.86 (2.74-5.51)	4.25 (2.91-6.28)
24-hr	1.29 (1.13-1.51)	1.64 (1.43-1.91)	2.10 (1.83-2.46)	2.49 (2.15-2.93)	3.02 (2.54-3.67)	3.45 (2.85-4.27)	3.89 (3.14-4.92)	4.36 (3.43-5.65)	5.01 (3.80-6.75)	5.54 (4.07-7.69)
2-day	1.58 (1.39-1.85)	2.04 (1.78-2.38)	2.64 (2.30-3.09)	3.14 (2.72-3.70)	3.82 (3.21-4.64)	4.36 (3.60-5.39)	4.91 (3.96-6.21)	5.49 (4.32-7.12)	6.29 (4.76-8.46)	6.92 (5.08-9.61)
3-day	1.77 (1.55-2.07)	2.30 (2.02-2.69)	3.01 (2.62-3.52)	3.58 (3.10-4.22)	4.37 (3.67-5.31)	4.98 (4.11-6.16)	5.61 (4.52-7.09)	6.25 (4.92-8.11)	7.14 (5.41-9.61)	7.83 (5.75-10.9)
4-day	1.92 (1.68-2.24)	2.51 (2.19-2.93)	3.28 (2.86-3.84)	3.92 (3.39-4.62)	4.78 (4.02-5.81)	5.45 (4.50-6.75)	6.14 (4.95-7.76)	6.84 (5.38-8.87)	7.80 (5.91-10.5)	8.55 (6.28-11.9)
7-day	2.23 (1.95-2.59)	2.91 (2.55-3.40)	3.82 (3.33-4.47)	4.56 (3.95-5.38)	5.58 (4.69-6.77)	6.36 (5.24-7.87)	7.16 (5.77-9.05)	7.98 (6.28-10.4)	9.10 (6.90-12.3)	9.98 (7.33-13.9)
10-day	2.45 (2.14-2.85)	3.21 (2.80-3.74)	4.21 (3.67-4.93)	5.03 (4.35-5.93)	6.14 (5.16-7.46)	7.00 (5.78-8.66)	7.88 (6.36-9.96)	8.78 (6.91-11.4)	10.0 (7.59-13.5)	11.0 (8.06-15.2)
20-day	2.95 (2.58-3.44)	3.90 (3.41-4.55)	5.12 (4.47-6.00)	6.12 (5.30-7.21)	7.45 (6.26-9.05)	8.47 (6.99-10.5)	9.50 (7.66-12.0)	10.5 (8.30-13.7)	11.9 (9.06-16.1)	13.0 (9.57-18.1)
30-day	3.55 (3.10-4.14)	4.69 (4.10-5.48)	6.17 (5.38-7.22)	7.35 (6.36-8.66)	8.92 (7.50-10.8)	10.1 (8.33-12.5)	11.3 (9.10-14.3)	12.5 (9.82-16.2)	14.1 (10.7-18.9)	15.3 (11.2-21.2)
45-day	4.17 (3.65-4.86)	5.51 (4.82-6.43)	7.22 (6.29-8.44)	8.57 (7.42-10.1)	10.3 (8.69-12.6)	11.7 (9.61-14.4)	13.0 (10.5-16.4)	14.3 (11.2-18.5)	15.9 (12.1-21.5)	17.2 (12.6-23.9)
60-day	4.83 (4.22-5.63)	6.37 (5.57-7.43)	8.30 (7.24-9.71)	9.81 (8.49-11.6)	11.8 (9.89-14.3)	13.2 (10.9-16.3)	14.6 (11.8-18.5)	16.0 (12.6-20.8)	17.8 (13.5-24.0)	19.1 (14.0-26.6)

¹ Precipitation frequency (PF) estimates in this table are based on frequency analysis of partial duration series (PDS). Numbers in parenthesis are PF estimates at lower and upper bounds of the 90% confidence interval. The probability that precipitation frequency estimates (for a given duration and average recurrence interval) will be greater than the upper bound (or less than the lower bound) is 5%. Estimates at upper bounds are not checked against probable maximum precipitation (PMP) estimates and may be higher than currently valid PMP values. Please refer to NOAA Atlas 14 document for more information.

[Back to Top](#)

PF graphical

PDS-based depth-duration-frequency (DDF) curves
 Latitude: 32.5966°, Longitude: -117.0313°

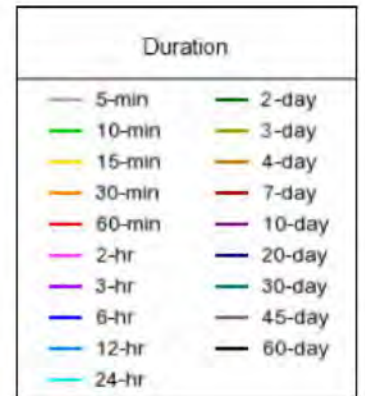
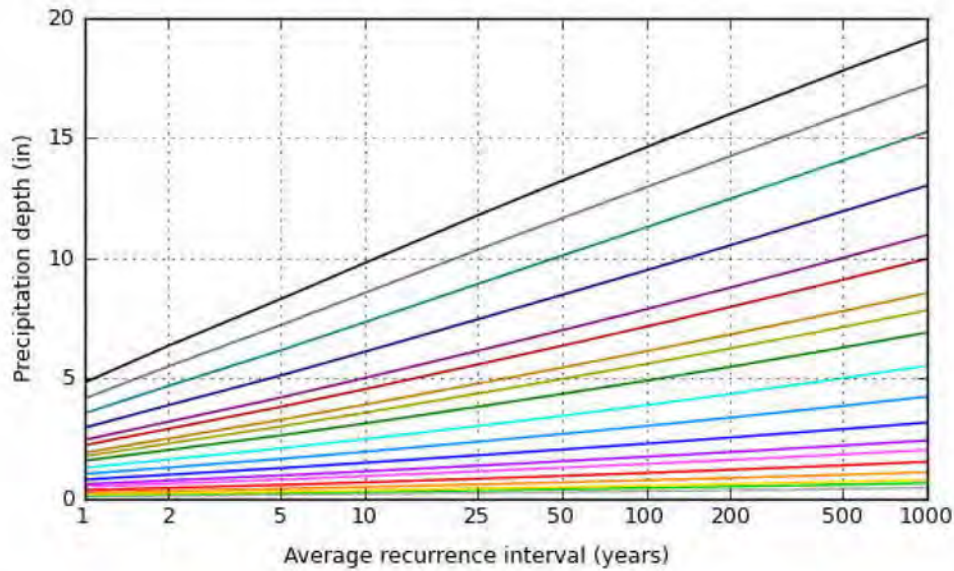
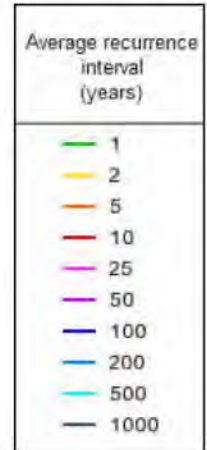
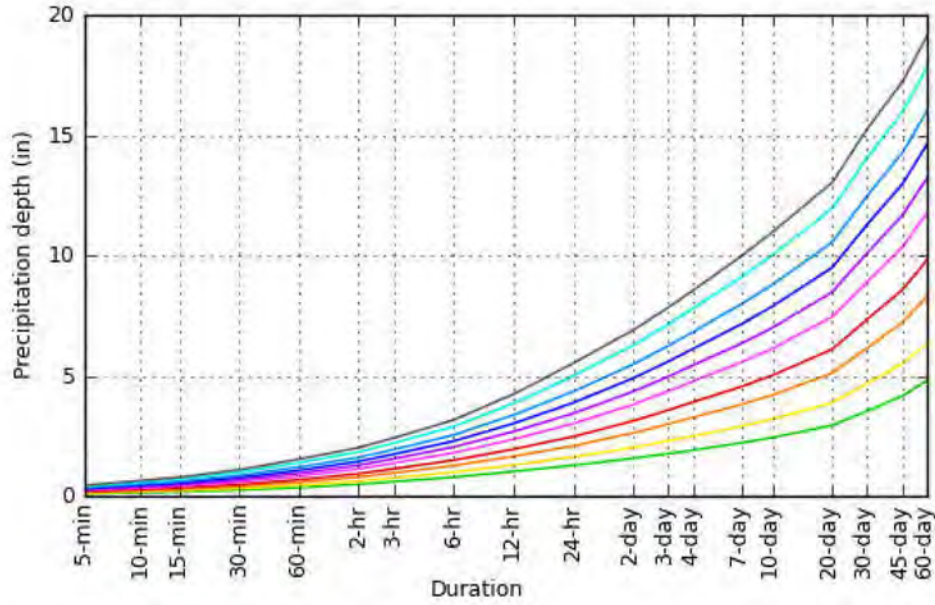

[Back to Top](#)

Maps & aerials

Small scale terrain



Large scale terrain

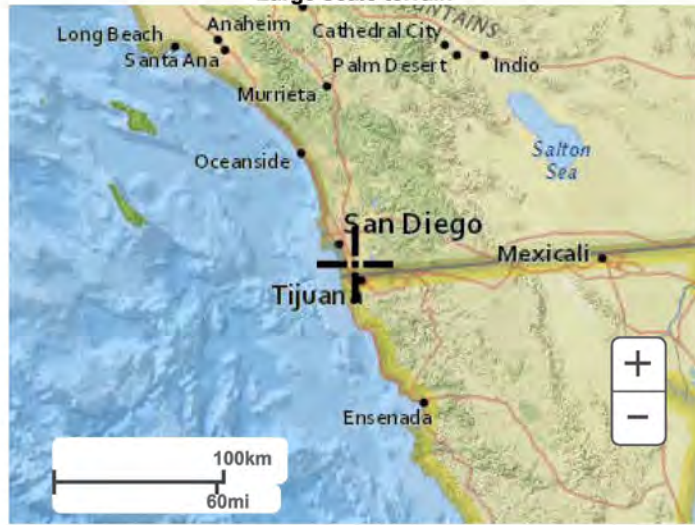

Large scale map



Large scale aerial



[Back to Top](#)

[US Department of Commerce](#)
[National Oceanic and Atmospheric Administration](#)
[National Weather Service](#)
[National Water Center](#)
1325 East West Highway
Silver Spring, MD 20910
Questions?: HDSC.Questions@noaa.gov

[Disclaimer](#)

State Water Resources Control Board

CERTIFIED FULL CAPTURE SYSTEM LIST OF TRASH TREATMENT CONTROL DEVICES (Updated September 2021)

Trash Provisions

In accordance with the Trash Provisions,¹ all trash treatment control devices (Devices) installed after December 2, 2015 shall meet the Full Capture System definition² and be certified by the State Water Resources Control Board (State Water Board) Executive Director, or designee, prior to installation. The Devices included on this list are either: 1) new Device applications certified by the State Water Board after adoption of the Trash Provisions, or 2) grandfathered device fact sheets listed by the San Francisco Regional Water Board prior to the adoption of the Trash Provisions.

The Trash Provisions require that only Certified Full Capture Devices may be installed, and that the Devices be designed according to the following criteria:

1. Appropriately sized to treat not less than the peak flowrate resulting from a one--year, one-hour storm event (design storm) or at least the same peak flows from the corresponding storm drain;
2. Do not bypass trash below the design storm under maximum operational loading conditions; and
3. Trap all particles that are 5 mm or greater up to the design flow³ or at least the same peak flows from the corresponding storm drain; and do not have a

¹ Amendment to the Water Quality Control Plan for Ocean Waters of California to Control Trash and Part 1 Trash Provisions of the Water Quality Control Plan for Inland Surface Waters, Enclosed Bays, And Estuaries of California adopted by the State Water Board.

² A Full Capture System is a treatment control, or series of treatment controls, including but not limited to, a multi-benefit project or a low-impact development control that traps all particles that are 5 mm or greater, and has a design treatment capacity that is either: of not less than the peak flow rate, Q, resulting from a one-year, one-hour storm in the subdrainage area, or b) appropriately sized to, and designed to carry at least the same flows as, the corresponding storm drain.

³ The region specific one-year, one-hour storm (or design flow) may be obtained from the [National Oceanic and Atmospheric Precipitation Estimates](https://www.weather.gov/media/owp/oh/hdsc/docs/Atlas14_Volume6.pdf) (https://www.weather.gov/media/owp/oh/hdsc/docs/Atlas14_Volume6.pdf)

CERTIFIED FULL CAPTURE SYSTEM LIST OF TRASH TREATMENT CONTROL DEVICES

diversion structure present upstream such that a portion of the peak flow is not treated to trap all particles 5-millimeter or greater.

Vector Control Accessibility

According to the California Health and Safety Code⁴, California landowners are legally responsible to abate (eliminate the source of) a public nuisance arising from their property, including mosquitoes. Mosquito vector control districts have substantial authority to access public and private property, inspect known or suspected sources of mosquitoes, abate mosquito sources, and charge the landowner for work performed and/or charge fees if a landowner is unwilling or unable to address a mosquito source arising from their property.

Depending on its design, certain Devices may impede the mosquito vector control district's ability to (1) visually inspect the Device and/or storm vault for mosquito breeding, and (2) apply the appropriate chemical treatment. Moreover, some devices may create a habitat for mosquitoes. Prior to installation of any certified Device, the local mosquito vector control district should be contacted to ensure the installation conforms to the district's visual inspection, treatment, and vector breeding minimizing guidelines. The Mosquito Vector Control Association of California may also be contacted via email at Trashtreatment@mvcac.org.

New Device Application Certification or Fact Sheet Update

To apply for certification of a new Device, or to update a grandfathered Device fact sheet, the Device owner shall submit an application/fact sheet in accordance with the *Trash Treatment Control Device Certification and Fact Sheet Update Requirements*. Upon determining that a Device application is complete and meets the definition of a trash full capture system and is approved by the Mosquito Vector Control Association of California, the Executive Director will place the Device on the State Water Board's *Certified Full Capture System List of Trash Treatment Control Devices*.

The Trash Treatment Control Device Certification and Fact Sheet Update Requirements is found on the [Trash Implementation Program webpage](https://www.waterboards.ca.gov/water_issues/programs/stormwater/trash_implementation.html) (https://www.waterboards.ca.gov/water_issues/programs/stormwater/trash_implementation.html).

Certification of any Device does not constitute an endorsement by the State Water Board. The Executive Director reserves the right to de-certify and remove any Device from this list that does not satisfy the requirements of the Trash Provisions, such as but not limited to when a Device is discontinued, found to not trap trash in accordance with the Trash Provisions, or no longer has Mosquito Vector Control Association of California approval.

⁴ Health & Safety Code sections 2001- 4(d); 2002; 2060 (b) and Health & Safety Code sections 2060-2067, 100170, and 100175.

CERTIFIED FULL CAPTURE SYSTEM LIST OF TRASH TREATMENT CONTROL DEVICES

Device applications and fact sheets may be obtained at:

<https://www.casqa.org/resources/trash/certified-full-capture-system-trash-treatment-control-devices>.

Questions regarding certification should be directed to Leo Cosentini at (916) 341-5524 or email address (leo.cosentini@waterboards.ca.gov).

CERTIFIED FULL CAPTURE SYSTEM LIST OF TRASH TREATMENT CONTROL DEVICES

Owner	Full Capture System Trash Device Brand Name	Date Application Certified or Fact Sheet Updated	Date Vector Control Accessibility Verified
Hydro International	Hydro Up-Flo Filter®	Application 11 07/18/18	03/16/20
Hydro International	Hydro DryScreen	Application 10 07/10/18 Updated 05/05/21	04/29/21
Oldcastle Infrastructure	FloGard® NetTech	OI-11HF Updated 12/08/20	12/03/20
Oldcastle Infrastructure	Nutrient Separating Baffle Box®	Application 17 10/12/18 Updated 07/21/20	05/01/20
Roscoe Moss Company ²⁵	Storm Flo® Trash Screen – Linear Radial Gross Solids Removal Device	RMC-1HF Updated 03/30/21	03/11/21

²⁵ Roscoe Moss Company website: <https://roscoemoss.com/products/stormwater-gross-solids-removal-device/>

ATTACHMENT 2

Backup for PDP Hydromodification Control Measures

- Mark this box if this attachment is empty because the project is exempt from PDP hydromodification management requirements.

Project Name/_____

ATTACHMENT 3

Structural BMP Maintenance Information Hydromodification Control Measures

Project Name/_____

Use this checklist to ensure the required information has been included in the Structural BMP Maintenance Information Attachment:

Attachment 3: For private entity operation and maintenance, Attachment 3 must include a Storm Water Management Facilities Maintenance Agreement with Grant of Access and Covenant's ("Maintenance Agreement") Template can be found at the following link (also refer to Chapter 8.2.1 for more information's):

The following information must be included in the exhibits attached to the Maintenance Agreement:

- Vicinity map (Depiction of Project Site)
- Legal Description for Project Site
- Site design BMPs for which DCV reduction is claimed for meeting the pollutant
- control obligations.
- BMP and HMP type, location, type, manufacture model, and dimensions, specifications, cross section
- LID features such as (permeable paver and LS location, dim, SF).
- Maintenance recommendations and frequency

RECORDING REQUESTED BY AND
WHEN RECORDED RETURN TO:

CITY OF CHULA VISTA
OFFICE OF THE CITY CLERK
276 FOURTH AVENUE
CHULA VISTA, CA 91910

*This Instrument Benefits City Only.
No Fee Required.*

Above Space for Recorder's Use

CCV File No. _____

**STORM WATER MANAGEMENT FACILITIES MAINTENANCE
AGREEMENT WITH GRANT OF ACCESS AND COVENANTS**

[INSERT PROJECT NAME]

THIS STORM WATER MANAGEMENT FACILITIES MAINTENANCE AGREEMENT ("Agreement"), dated _____, 20__ for the purpose of reference only and effective the date on which the last party hereto affixes his/her signature ("Effective Date"), is entered into between **[Enter Name of Owner(s)], [Enter Type of Corporation/Partnership]**, ("Owner(s)") and the City of Chula Vista, a municipal corporation, ("City") (individually, each may be referred to as "Party" and collectively as "Parties") with reference to the following facts:

RECITALS

WHEREAS, Owner(s) has(have) **[? Applied for x permit/ obtained a permit/ intends to file map/ etc]** for the development of **[Name of Subdivision/type of project]** ("Project"), located on parcels **[Insert]** "Project Site" as depicted in Exhibit "A" and more particularly described in Exhibit "B" , both attached hereto and incorporated herein by reference; and

WHEREAS, as a condition of (or condition # x of y) **[Insert]**, Owner(s) is(are) required to implement and maintain structural or non-structural pollution prevention measures, such as site design, source control, treatment control, and hydromodification control (where applicable) methods required to minimize polluted runoff and any other environmental impacts from Project during the post-development phase (collectively "BMPs"); and

WHEREAS, pursuant to City's urban runoff regulations, including Chula Vista Municipal Code, Chapter 14.20 (the "Storm Water Management and Discharge Control Ordinance) and the Chula Vista BMP Design Manual, Owner(s) is(are) required to prepare and submit a Stormwater Quality Management Plan (SWQMP), which includes an Inspection, Operation, and Maintenance Plan (IOMP); and

WHEREAS, the Owner(s) has(have) submitted SWQMP, which is on file in the office of the City Engineer; and

WHEREAS, the SWQMP proposes that storm water runoff from Project be detained and treated by the use of permanent Storm Water Management Facilities (“SWMFs”); and

WHEREAS, the SWMFs are classified in the SWQMP as site design, treatment control, and hydromodification control BMPs; and

WHEREAS, the SWQMP specifies the manner and standards by which the SWMFs must be inspected, maintained, and repaired in order to retain their effectiveness; and

WHEREAS, prior to the issuance of any construction permits for Project, City requires Owner(s) to enter into Agreement to ensure the installation, inspection, maintenance, and repair of permanent SWMFs.

NOW, THEREFORE, for good and valuable consideration, the receipt and sufficiency of which are hereby acknowledged, the parties agree to the following covenants, terms, and conditions:

ARTICLE I. DEFINITIONS

1.1 Unless context indicates otherwise, for the purpose of this Agreement, all the below-listed terms shall be defined as follows:

“Agreement” means this Storm Water Management Facilities Maintenance Agreement.

“Best Management Practices, or BMPs” means structural or non-structural pollution prevention measures, such as site design, source control, treatment control, and hydromodification control methods required to minimize polluted runoff from Project during the post-development phase. BMPs include, but are not limited to, Storm Water Management Facilities.

“City” means the City of Chula Vista, an official of the City, or any staff member authorized to act on behalf of the City.

“Inspection, Operation, and Maintenance Plan, or IOMP” means a description of inspection, operation, and maintenance activities and schedules required to ensure proper operation and effectiveness of the SWMFs into perpetuity.

“Owner(s)” means the land owner(s) of Project Site, which is the subject of this Agreement, anyone authorized to act on behalf of the land owner(s) of Project Site, and any and all of owner’s successors in interest, whether individual, partnership, corporation, or other entity such as a Home Owners’ Association, regardless of the manner of transfer, including purchase, devise, or gift. If land owner of SWMFs is different from development land owner (as may be in the case of offsite SWMFs), both owners are parties to Agreement and shall sign the Signature Page as Owner(s)

“Project” means all improvements and land dedicated to the development, which is the subject of Agreement, including any offsite water quality facilities.

“Project Site” means the land dedicated to the development, which is the subject of Agreement, including any offsite water quality facilities.

“Responsible Party” means Owner(s) and any other person, corporation, or legal entity accepting, in writing and in City approved form, responsibility on behalf of Owner(s).

“Security” means any Bond, Cash Deposit, or Letter of Credit that City may require from Owner(s) to assure the faithful performance of the obligations of Agreement.

“Storm Water Management Facilities” (“SWMFs”) means all onsite and offsite structural facilities constructed as Project’s site design, treatment control, or hydromodification control BMPs, proposed as part of the development project submittals, and as approved by City prior to the issuance of a development permit, or as amended with City’s approval after the development is complete.

“Water Quality Technical Report” (“SWQMP”) means a document prepared in accordance with the requirements of the Chula Vista Development Storm Water Manual, and submitted to the City as part of Project’s permit application documents.

ARTICLE II. – OWNER’S OBLIGATIONS

2.1 **Maintenance of Stormwater Management Facilities.** Owner(s) shall install, inspect, maintain, repair, and replace all SWMFs for the Project as required by the Director of Public Works, or his/her designated representative (“Director”).

2.1.1 Scope of Maintenance. Maintenance shall include inspection and servicing of SWMFs on the schedule determined necessary to ensure the SWMFs retain their effectiveness.

2.1.2 Duration of Obligation. Owner’s obligation to maintain, repair and replace the SWMFs shall continue in perpetuity until all obligations under this Agreement are transferred to, and assumed by, another owner or entity approved by City (“Responsible Party”).

2.2 **Grant of Right of Entry.** Owner(s) shall grant to the City, its representatives, or contractors, or any Responsible Party, the right to enter the Project to inspect SWMFs, or perform any permitted acts or obligations under this Agreement, including maintenance of said facilities in the event the Owner(s) fails(fail) to fulfill its(their) maintenance obligations after proper notice.

2.2.1 No Prior Notice. City shall have the right, at any time and without prior notice to Owner(s), to enter upon any part of Project as may be necessary or convenient for any acts permitted hereunder.

2.2.2 Unobstructed Access. Owner(s) shall at all times maintain Project so as to make City's access clear and unobstructed.

2.3 **Modification of IOMP**. Owner(s) shall, at the City's request, in City's sole discretion, amend the IOMP. The Owner(s) may amend the IOMP from time-to-time, subject to City approval. The IOMP is attached hereto as Exhibit "C."

2.3.1 Part of Owner's Obligations. Any obligations, conditions, or requirements of an amended IOMP shall become part of this Agreement immediately as if originally included herein, and the Owner(s) shall be responsible for such amended obligations, conditions, or requirements. The amended IOMP shall not be applied retroactively.

The IOMP shall describe employee training programs and duties, routine inspection, service and operating schedules, maintenance frequency, and specific maintenance activities.

2.4 **Submission of Documents**. Owner(s) shall include a copy of the Inspection, Operation, and Maintenance Plan ("IOMP") for the SWMFs in the SWQMP for Project and submit a copy to City, at the time Agreement is executed.

ARTICLE III. – CITY'S RIGHTS

3.1 **Perform Maintenance**. City shall have the right, but not the obligation, to elect to perform any or all of the maintenance activities

3.1.1 Notice. Except in the Case of an emergency, prior to performing any maintenance activities, City shall provide Owner(s) with a written notice, informing Owner(s) of its (their) failure to satisfactorily perform its (their) obligations under Agreement.

3.1.1.1 *Emergencies*. In the event of an emergency, as determined by City, City shall not be required to provide Owner(s) with notice in advance of performing any and all maintenance activities it deems necessary.

3.1.2 Time to Cure. Owner(s) shall have a reasonable time, as defined in the Notice, to cure any failure to perform its (their) maintenance obligations. If a cure cannot be completed within the time limit identified in the Notice, Owner(s) shall provide City with a written request for additional time, which shall include sufficiently detailed explanation as to why the cure cannot be completed within such timeframe. If the City approves a request for additional time, Owner(s) shall immediately commence such cure and diligently pursue to completion.

3.1.3 Costs of Maintenance. In the event City performs any maintenance under this Article III, then Owner(s) shall pay all costs City incurred in performing said maintenance activities. Payment shall be subject to the following terms:

3.1.3.1 *Due Date*. Net 30.

3.1.3.2 *Interest.* Any late payment shall be subject to a rate of eight percent (8%) interest per annum.

3.1.3.3 *Use of Security.* If payment is not received by the Due Date, City may, at its option, recover its costs through use of any security provided by Owner(s). Any costs associated with recovery shall be charged to and be an obligation of Owner(s).

3.2 **City Inspections.** City shall have the right to conduct inspections of the SWMFs from time-to-time as required by the National Pollutant Discharge Elimination System **Municipal Permit, Order No. R9-2013-0001 and** any re-issuances thereof, to ensure adequate maintenance and effectiveness of the SWMFs. Owner(s) agrees (agree) to pay all inspection fees as may be established by City.

ARTICLE IV. INDEMNITY

4.1 **General Requirement.** Owner(s) shall defend, indemnify, protect and hold harmless the City, its elected and appointed officers, agents, employees, and volunteers (“Indemnitees”) from and against any and all claims, demands, causes of action, costs, expenses, liability, loss, damage or injury, in law or equity, to property or persons, including wrongful death, in any manner arising out of or incident to any alleged acts, omissions, negligence, or willful misconduct of Owner(s), its officials, officers, employees, agents, and contractors (“Indemnitors”), arising out of or related to the installation, inspection, maintenance, repair, or replacement of the BMPs or this Agreement. This indemnity provision does not include any claims, damages, liability, costs and expenses (including without limitations, attorneys fees) arising from the sole negligence or sole willful misconduct of the Indemnitees. Also covered is under the indemnity obligations is liability arising from, connected with, caused by or claimed to be caused by the active or passive negligent acts or omissions of the Indemnitees, which may be in combination with the active or passive negligent acts or omissions of the Indemnitors.

4.2 **Costs of Defense and Award.** Included in the obligations in Section 4.1, above, is the Owner’s obligation to defend, at Owner’s own cost, expense and risk, any and all aforesaid suits, actions or other legal proceedings of every kind that may be brought or instituted against the Indemnitees. Owner(s) shall pay and satisfy any judgment, award or decree that may be rendered against Indemnitees for any and all legal expense and cost incurred by each of them in connection therewith.

4.3 **Conduct Own Defense.** If City elects, at its sole discretion, to conduct its own defense, participate in its own defense, or obtain independent legal counsel in defense on any claim related to the installation, inspection, maintenance, repair or replacement of the SWMFs, Owner(s) agrees (agree) to pay the reasonable value of attorney’s fees and all of City’s reasonable costs.

4.4 **Insurance Proceeds.** Owner’s obligation to indemnify shall not be restricted to insurance proceeds, if any, received by Indemnitees.

- 4.5 **Declarations.** Owner's obligations under this Article IV shall not be limited by any prior or subsequent declaration by the Owner(s).
- 4.6 **Enforcement Costs.** Owner(s) agrees (agree) to pay any and all costs Indemnitees incur enforcing the indemnity and defense provisions set forth in this Article IV.
- 4.7 **Survival.** Owner's obligations under this Article IV shall survive the termination of this Agreement.

ARTICLE V. INSURANCE

- 5.1 **Insurance.** In the event that insurance is required by City, Owner(s) shall not begin work under this Agreement until it has (they have) : (i) obtained, and upon the City's request provided to the City, insurance certificates reflecting evidence of all insurance required in this Article V; (ii) obtained City approval of each company or companies; and (iii) confirmed that all policies contain the specific provisions required by this Section.
- 5.2 **Types of Insurance.** At all times during the term of this Agreement, Owner(s) shall maintain those types of insurance coverage and amounts of coverage required by City to protect the City from any potential claims, which may arise from the installation, inspection, maintenance, repair or replacement of the SWMFs or any other obligations under this Agreement.
- 5.3 **Policy Endorsements Required.**
- 5.3.1 Additional Insureds. City of Chula Vista, its officers, officials, employees, agents and volunteers are to be named as additional insureds with respect all required policies of insurance with respect to liability arising out of obligations under this Agreement performed by or on behalf of the Owner(s).
- 5.3.2 Primary Insurance. The Owner's General Liability insurance coverage must be primary insurance as it pertains to the City, its officers, officials, employees, agents, and volunteers. Any insurance or self-insurance maintained by the City, its officers, officials, employees, or volunteers is wholly separate from the insurance of the Owner(s) and in no way relieves the Owner(s) from its (their) responsibility to provide insurance.
- 5.3.3 Waiver of Subrogation. Owner's insurer will provide a Waiver of Subrogation in favor of the City for each required policy providing coverage for the term required by this Agreement.
- 5.3.4 Cancellation. The insurance policies required must be endorsed to state that coverage will not be canceled by either party, except after thirty (30) days' prior written notice to the City by certified mail, return receipt requested. The words "will endeavor" and "but failure to mail such notice shall impose no obligation or liability of any kind upon the company, its agents, or representatives" shall be deleted from all certificates.

- 5.4 **Proof of Insurance Coverage.** Owner(s) shall furnish the City with original certificates and amendatory endorsements affecting coverage required. The endorsements should be on insurance industry forms, provided those endorsements or policies conform to the contract requirements. All certificates and endorsements are to be received and approved by the City before work commences on the Project. The City reserves the right to require, at any time, complete, certified copies of all required insurance policies, including endorsements evidencing the coverage required by these specifications.
- 5.5 **Deductibles and Self-Insured Retentions.** Any deductibles or self-insured retentions must be declared to and approved by the City. At the option of the City, either the insurer will reduce or eliminate such deductibles or self-insured retentions as they pertain to the City, its officers, officials, employees and volunteers; or the Owner(s) will provide a financial guarantee satisfactory to the City guaranteeing payment of losses and related investigations, claim administration, and defense expenses.
- 5.6 **Active Negligence.** Coverage shall not extend to any indemnity coverage for the active negligence of the additional insureds in any case where an agreement to indemnify the additional insured would be invalid under Subdivision (b) of Section 2782 of the Civil Code.
- 5.7 **Not a Limitation of Other Obligations.** Insurance provisions under this Article shall not be construed to limit the Owner's obligations under this Agreement, including Indemnity.

ARTICLE VI. SECURITY

- 6.1 **Security Required.** If within any five-year period, City inspectors determine on two occasions that Owner(s) has (have) failed to effectively operate, maintain, or repair the SWMFs, City may require Owner(s) to provide City with Security to assure the faithful performance of the obligations of this Agreement.
- 6.1.1 **Amount of Security.** The amount of the security shall equal the cost to maintain the SWMFs for two (2) years, which cost shall be determined as identified in the Project SWQMP ("Security Amount").
- 6.1.2 **Type of Security.** Security may be of any of the following types:
- 6.1.2.1 **Performance Bond.** Owner(s) shall provide to the City a performance bond in favor of the City in the Security Amount and subject to the provisions below.
- a. **Certificate of Agency.** All bonds signed by an agent must be accompanied by a certified copy of such agent's authority to act.
 - b. **Licensing and Rating.** The bonds shall be from surety companies admitted to do business in the State of California, licensed or authorized in the jurisdiction in which the Project is located to issue bonds for the limits required by this agreement, listed as approved by the United States

Department of Treasury Circular 570, <http://www.fms.treas.gov/c570>, and which also satisfy the requirements stated in Section 995.660 of the Code of Civil Procedure, except as provided otherwise by laws or regulation, and have a minimum AM Best rating of “A-” to an amount not to exceed ten percent (10%) of its capital and surplus.

- c. Insolvency or Bankruptcy. If the surety on any bond furnished by the Owner(s) is declared bankrupt or becomes insolvent or its right to do business is terminated in any state where any part of the Project is located, Owner(s) shall within seven (7) days thereafter substitute or require the substitution of another bond and surety, acceptable to the City.

6.1.2.2 *Letter of Credit.* As security for Owner’s obligations under this Agreement, Owner(s) shall cause an irrevocable letter of credit in the Security Amount (“Letter of Credit”) to be issued in favor of the City by a reputable state or national financial institution with a branch located in Chula Vista.

- a. Draw on Letter of Credit. The City may draw upon the Letter of Credit for the full amount or any series of partial amounts as necessary by means of a sight draft accompanied by a statement from the City Manager, Deputy City Manager, Business Center Manager, that the Owner(s) has(have) not satisfied Owner’s obligations hereunder.

6.1.2.3 *Cash Deposit.* In lieu of a Performance Bond or Letter of Credit, Owner(s) may deposit the Security Amount with the City.

- a. Return of Security. Any unused balance of the Security at the end of the Term shall be returned to the Owner(s) in accordance with City’s accounting procedures.

6.1.3 Adjustment for Inflation. The Security Amount shall be adjusted at a rate of 5% per annum.

6.1.4 Term. Security shall remain in full force and effect for two (2) years from the date it is received by the City provided no further failures are identified by City Inspectors during the initial two (2) year period. In the event additional violations occur, the City shall retain the Security until such time as the City Manager, in his sole discretion, deems appropriate to ensure the Owner’s obligations will be satisfied.

6.1.5 Form of Security. Security required under this Article shall be in a form satisfactory to the City Manager and City Attorney.

6.1.6 Use of Security. In accordance with Article III, City may use all or any portion of this Security to fund the costs associated with the City’s performance of any of the maintenance activities for the Project’s SWMFs.

6.1.7 Replenish Security. If at any time the Security Amount shall drop below the amount required under Section 6.1.1, Owner(s) shall deposit additional funds, provide an additional Letter of Credit to City, or provide an additional bond within thirty (30) days, such that the total amount of Security available to the City is equal to the amount required in Section 6.1.1.

ARTICLE VII. RECORDS

7.1 **Record Keeping.** The designation of a Responsible Party to maintain the SWMFs does not relieve Owner(s) of any of the obligations or duties under this Agreement. Owner(s), its (their) successors, or a designated Responsible Party, shall retain records of the IOMP and maintenance and inspection activities for at least five years. Said records shall be made available within 5 days, upon request by City.

ARTICLE VIII. STANDARD PROVISIONS

8.1 **Headings.** All headings are for convenience only and shall not affect the interpretation of this Agreement.

8.2 **Gender & Number.** Whenever the context requires, the use herein of (i) the neuter gender includes the masculine and the feminine genders and (ii) the singular number includes the plural number.

8.3 **Reference to Paragraphs.** Each reference in this Agreement to an Article or Section refers, unless otherwise stated, to an Article or Section in this Agreement.

8.4 **Incorporation of Recitals.** All recitals herein are incorporated into this Agreement and are made a part hereof.

8.5 **Covenants and Conditions.** All provisions of this Agreement expressed as either covenants or conditions on the part of the City or the Owner(s), shall be deemed to be both covenants and conditions.

8.6 **Integration.** This Agreement and the Exhibits and references incorporated into this Agreement fully express all understandings of the Parties concerning the matters covered in this Agreement. No change, alteration, or modification of the terms or conditions of this Agreement, and no verbal understanding of the Parties, their officers, agents, or employees shall be valid unless made in the form of a written change agreed to in writing by both Parties or an amendment to this Agreement agreed to by both Parties. All prior negotiations and agreements are merged into this Agreement.

8.7 **Severability.** The unenforceability, invalidity, or illegality of any provision of this Agreement shall not render any other provision of this Agreement unenforceable, invalid, or illegal. In the event that any provision of this Agreement shall for any reason, be determined to be invalid, illegal, or unenforceable in any respect, the remainder of this Agreement shall remain in full force and effect and the parties hereto shall negotiate in good faith and agree to such amendments, modifications, or supplements to this Agreement

or such other appropriate action as shall, to the maximum extent practicable in light of such determination, implement and give effect to the intentions of the parties as reflected herein.

- 8.8 **Drafting Ambiguities.** The Parties agree that they are aware that they have the right to be advised by counsel with respect to the negotiations, terms and conditions of this Agreement, and the decision of whether or not to seek advice of counsel with respect to this Agreement is a decision that is the sole responsibility of each Party. This Agreement shall not be construed in favor of or against either Party by reason of the extent to which each Party participated in the drafting of the Agreement.
- 8.9 **Conflicts Between Terms.** If an apparent conflict or inconsistency exists between the main body of this Agreement and the Exhibits, the main body of this Agreement shall control. If a conflict exists between an applicable federal, state, or local law, rule, regulation, order, or code and this Agreement, the law, rule, regulation, order, or code shall control. Varying degrees of stringency among the main body of this Agreement, the Exhibits, and laws, rules, regulations, orders, or codes are not deemed conflicts, and the most stringent requirement shall control. Each Party shall notify the other immediately upon the identification of any apparent conflict or inconsistency concerning this Agreement.
- 8.10 **Prompt Performance.** Time is of the essence of each covenant and condition set forth in this Agreement.
- 8.11 **Good Faith Performance.** The Parties shall cooperate with each other in good faith, and assist each other in the performance of the provisions of this Agreement.
- 8.12 **Further Assurances.** City and Owner each agree to execute and deliver such additional documents as may be required to effectuate the purposes of this Agreement.
- 8.13 **Exhibits.** Each of the following Exhibits is attached hereto and incorporated herein by this reference:
- Exhibit A: Vicinity map
 - Exhibit B: Legal Description for Project
 - Exhibit C: BMP and HMP type, location and dimensions
 - Exhibit D: Maintenance recommendations and frequency. Inspection, Operation, and Maintenance Plan (IOMP)
- 8.14 **Compliance with Controlling Law.** The Owner(s) shall comply with all laws, ordinances, regulations, and policies of the federal, state, and local governments applicable to this Agreement. In addition, the Owner(s) shall comply immediately with all directives issued by the City or its authorized representatives under authority of any laws, statutes, ordinances, rules, or regulations.
- 8.15 **Enforcement.** Failure to comply with the terms of this Agreement constitutes a violation of the Chula Vista Municipal Code Chapter 14.20 “Storm Water Management and Discharge Control” and may result in enforcement action pursuant to City’s storm water regulations and administrative procedures.

- 8.16 **Jurisdiction, Venue, and Attorney Fees.** This Agreement shall be governed by and construed in accordance with the laws of the State of California. Any action arising under or relating to this Agreement shall be brought only in the federal or state courts located in San Diego County, State of California, and if applicable, the City of Chula Vista, or as close thereto as possible. Venue for this Agreement, and performance hereunder, shall be the City of Chula Vista. The prevailing Party in any such suit or proceeding shall be entitled to a reasonable award of attorney fees in addition to any other award made in such suit or proceeding.
- 8.17 **Administrative Claims Requirement and Procedures.** No suit shall be brought arising out of this agreement, against the City, unless a claim has first been presented in writing and filed with the City of Chula Vista and acted upon by the City of Chula Vista in accordance with the procedures set forth in Chapter 1.34 of the Chula Vista Municipal Code, the provisions of which are incorporated by this reference as if fully set forth herein.
- 8.18 **Third Party Relationships.** Nothing in this Agreement shall create a contractual relationship between City and any individual, entity, or other not a party to this Agreement.
- 8.19 **Non-Assignment.** The Owner(s) shall not assign the obligations under this Agreement, whether by express assignment, by sale of the company, or any monies due or to become due, without the City's prior written approval. Any assignment in violation of this paragraph shall constitute a Default. In no event shall any putative assignment create a contractual relationship between the City and any putative assignee.
- 8.20 **Successors in Interest.** This Agreement and all rights and obligations created by this Agreement shall be in force and effect whether or not any Parties to the Agreement have been succeeded by another entity, and all rights and obligations created by this Agreement shall be vested and binding on any Party's successor in interest.
- 8.21 **Agreement Runs with Project.** The terms, covenants and conditions contained in this Agreement shall constitute covenants running with the land and shall be binding upon the heirs, executors, administrators, successors and assigns of Owner(s) and City and shall be deemed to be for the benefit of all persons owning any interest in Project, the City, and the Public. It is the intent of the Parties that this Agreement be recorded and be binding upon all persons purchasing or otherwise acquiring all or any lot, unit or other portion of Project, who shall be deemed to have consented to and become bound by all the provisions of this Agreement. This Agreement shall commence upon execution of this Agreement by all Parties named in the Agreement.
- 8.22 **Independent Contractors.** The Owner(s), any contractors, subcontractors, and any other individuals employed by the Owner(s) shall be independent contractors and not agents of the City. Any provisions of this Agreement that may appear to give the City any right to direct the Owner(s) concerning the details of performing the Services under this Agreement, or to exercise any control over such performance, shall mean only that the Owner(s) shall follow the direction of the City concerning the end results of the performance.

- 8.23 **No Waiver.** No failure of either the City or Owner(s) to insist upon the strict performance by the other of any covenant, term or condition of this Agreement, nor any failure to exercise any right or remedy consequent upon a breach of any covenant, term, or condition of this Agreement, shall constitute a waiver of any such breach of such covenant, term or condition. No waiver of any breach shall affect or alter this Agreement, and each and every covenant, condition, and term hereof shall continue in full force and effect to any existing or subsequent breach.
- 8.24 **Notices.** Owner(s) agrees(agree) that it shall, prior to transferring ownership of any land on which any part of the Project covered by this Agreement are located, and also prior to transferring ownership of any such SWMFs, provide clear written notice of the above maintenance obligations associated with that SWMF to the transferee. Owner(s) further agrees(agree) to provide evidence that Owner(s) has(have) requested the California Department of Real Estate to include in the public report issued for the development of Project, a notification regarding the SWMF maintenance requirements described in this Agreement.
- 8.24.1 Serving Notice. All notices, demands or requests provided for or permitted to be given pursuant to this Agreement must be in writing. All notices, demands and requests to be sent to any Party shall be deemed to have been properly given or served if personally served or deposited in the United States mail, addressed to such party, postage prepaid, registered or certified, with return receipt requested
- 8.25 **Entitlement to Subsequent Notices.** No notice to or demand on the Parties for notice of an event not herein legally required to be given shall in itself create the right in the Parties to any other or further notice or demand in the same, similar or other circumstances.
- 8.26 **Remedies.** The rights of the Parties under this Agreement are cumulative and not exclusive of any rights or remedies that the Parties might otherwise have unless this Agreement provides to the contrary.
- 8.27 **Counterparts.** This Agreement may be executed in more than one counterpart, each of which shall be deemed to be an original but all of which, when taken together shall constitute but one instrument.
- 8.28 **Signing Authority.** Each signatory and party hereto hereby warrants and represents to the other party that it has legal authority and capacity and direction from its principal to enter into this Agreement; that all resolutions or other actions have been taken so as to enable it to enter into this Agreement and agrees to hold the other Party or Parties hereto harmless if it is later determined that such authority does not exist.

End of page (next page is signature page)

SIGNATURE PAGE FOR
STORM WATER MANAGEMENT FACILITIES MAINTENANCE
AGREEMENT WITH GRANT OF ACCESS AND COVENANTS

(INSERT PROJECT)

IN WITNESS WHEREOF, the parties have executed this Agreement on the ____ day of _____, 20__.

OWNER:

By: _____

Its: _____

By: _____

Its: _____

CITY OF CHULA VISTA:

City Engineer

APPROVED AS TO FORM:

City Attorney

ATTEST:

City Clerk

Dated: _____

*(Notary to attach acknowledgment for each signature.)
(Corporate Authority required for each Signatory, if applicable.)*

Attachments:

1. Exhibit A: Depiction of Project Site
2. Exhibit B: Legal Description for Project Site
3. Exhibit C: BMP and HMP type, location and dimensions
4. Exhibit D: Maintenance recommendations and frequency. Inspection, Operation, and Maintenance Plan (IOMP)

J:\Engineer\LANDDEV\NPDES(LANDDEV ONLY)\STORM WATER AGREEMENTS\SSW Main Agree_VERSION 2015.doc

EXHIBIT A



NOT TO SCALE

EXHIBIT A

VICINITY MAP

SHINOHARA BUSINESS PARK
517 SHINOHARA LANE
CHULA VISTA, CA 91911

PERMIT APPLICATION NO. DR-21-0032

EXHIBIT B

LEGAL DESCRIPTION

THAT PORTION OF LOT 1, SECTION 19, TOWNSHIP 18 SOUTH, RANGE 1 WEST, SAN BERNARDINO MERIDIAN, IN THE CITY OF CHULA VISTA, COUNTY OF SAN DIEGO, STATE OF CALIFORNIA, ACCORDING TO THE OFFICIAL PLAT THEREOF, DESCRIBED AS FOLLOWS:

BEGINNING AT THE NORTHWEST CORNER OF SAID SECTION 19; THENCE SOUTH ALONG THE WEST LINE OF SAID SECTION, 812 FEET; THENCE EASTERLY AT RIGHT ANGLES TO SAID WEST LINE, 515 FEET; THENCE SOUTHERLY PARALLEL WITH SAID WEST LINE 508 FEET; THENCE EASTERLY AT RIGHT ANGLES 13 FEET; THENCE NORTHERLY PARALLEL WITH THE WEST LINE OF SAID SECTION, 1320 FEET TO THE NORTH LINE OF SAID SECTION; THENCE WEST ALONG SAID NORTH LINE, 528 FEET TO THE POINT OF BEGINNING.

APN 644-040-01

EXHIBIT B

LEGAL DESCRIPTION

SHINOHARA BUSINESS PARK

517 SHINOHARA LANE

CHULA VISTA, CA 91911

PERMIT APPLICATION NO. DR-21-0032

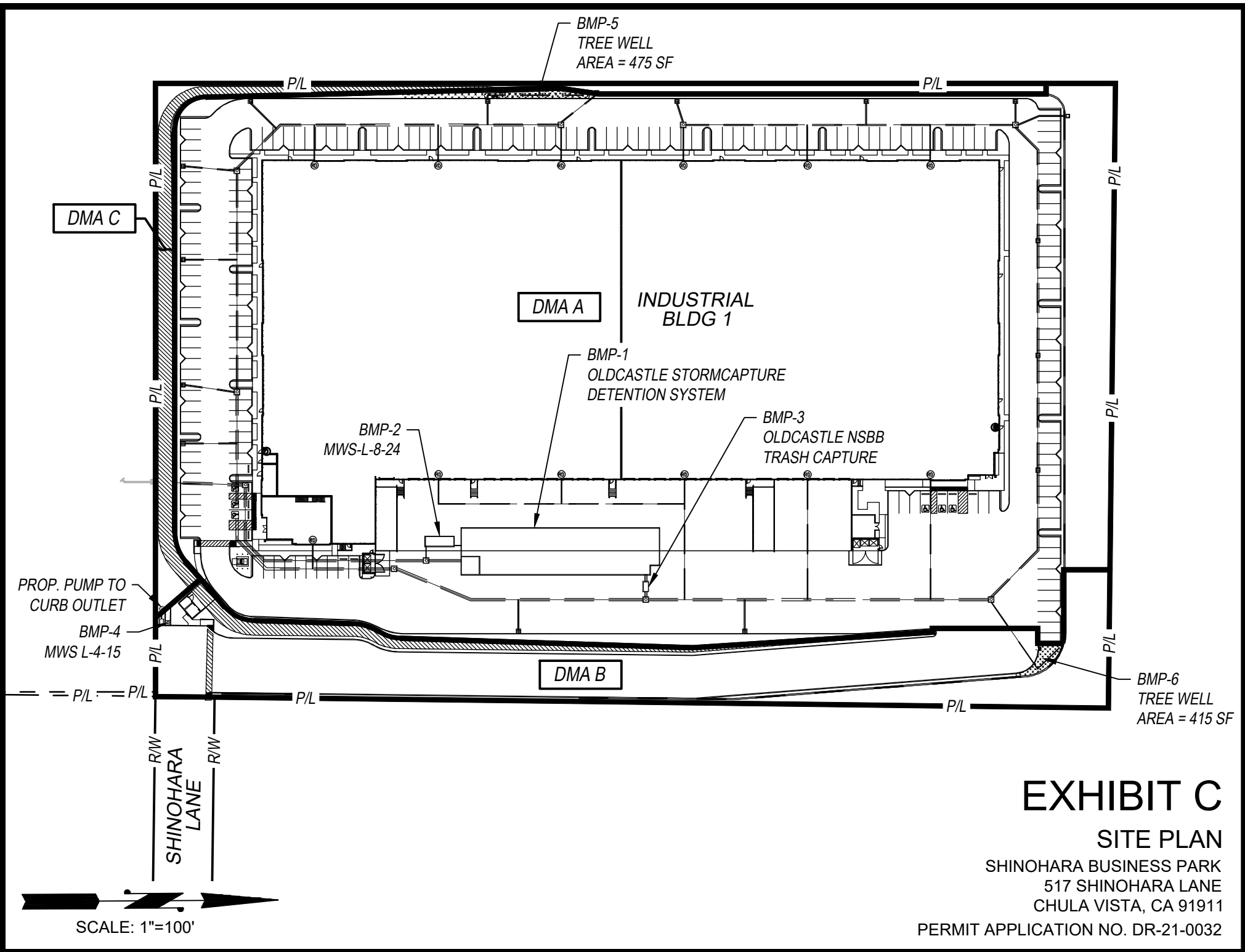

EXHIBIT C

SITE PLAN

SHINOHARA BUSINESS PARK
517 SHINOHARA LANE
CHULA VISTA, CA 91911

PERMIT APPLICATION NO. DR-21-0032

EXHIBIT D

HU-1 Cistern

BMP MAINTENANCE FACT SHEET FOR STRUCTURAL BMP HU-1 CISTERN

Cisterns are containers that capture runoff (typically rooftop runoff) and store it for future use such as irrigation or alternative grey water between storm events. Cisterns can be aboveground or below ground systems. Typical cistern components include:

- Storage container, barrel or tank for holding captured flows
- Inlet and associated valves and piping
- Outlet and associated valves and piping
- Overflow outlet
- Access riser or tank serviceway (i.e., access for underground and above-ground cisterns)
- Optional pump
- Optional first flush diverters
- Optional debris screen or pretreatment BMP (e.g., roof drain filter, drainage inlet insert)
- Optional roof, supports, foundation, level indicator, and other accessories

Normal Expected Maintenance

Cisterns can be expected to accumulate sediment and debris that is small enough to pass through the inlet into the storage container. Larger debris such as leaves or trash may accumulate at the inlet. While the storage container is generally a permanent structure, ancillary parts including valves, piping, screens, level indicators, and other accessories will wear and require occasional replacement. Maintenance of a cistern generally involves: removing accumulated sediment and debris from the inlet and storage container on a routine basis; and replacement of ancillary parts on an as-needed basis. A summary table of standard inspection and maintenance indicators is provided within this Fact Sheet. If the system as a whole includes a pump or other electrical equipment, maintenance of the equipment shall be based on the manufacturer's recommended maintenance plan.

Non-Standard Maintenance or BMP Failure

If any of the following scenarios are observed, the BMP is not performing as intended to protect downstream waterways from pollution and/or erosion. Corrective maintenance, increased inspection and maintenance, BMP replacement, or a different BMP type will be required.

- The inlet is found to be obstructed at every inspection such that storm water bypasses the cistern. The cistern is not functioning properly if it is not capturing storm water. This would require addition of ancillary features to protect the inlet, or pretreatment measures within the watershed draining to the cistern to intercept larger debris, such as screens on roof gutters, or drainage inserts within catch basins. Increase the frequency of inspection until the issue is resolved.
- Accumulation of sediment within one year is greater than 25% of the volume of the cistern. This means the sediment load from the tributary drainage area has diminished the storage volume of the cistern and the cistern will not capture the required volume of storm water. This would require pretreatment measures within the tributary area draining to the cistern to intercept sediment.
- The cistern is not drained between storm events. If the cistern is not drained between storm events, the storage volume will be diminished and the cistern will not capture the required volume of storm water from subsequent storms. This would require implementation of practices onsite to drain and use the stored water, or a different BMP if onsite use cannot be reliably sustained.

HU-1 Cistern

SUMMARY OF STANDARD INSPECTION AND MAINTENANCE FOR HU-1 CISTERN

The property owner is responsible to ensure inspection, operation and maintenance of permanent BMPs on their property unless responsibility has been formally transferred to an agency, community facilities district, homeowners association, property owners association, or other special district.

Maintenance frequencies listed in this table are average/typical frequencies. Actual maintenance needs are site-specific, and maintenance may be required more frequently. Maintenance must be performed whenever needed, based on maintenance indicators presented in this table. The BMP owner is responsible for conducting regular inspections to see when maintenance is needed based on the maintenance indicators. During the first year of operation of a structural BMP, inspection is recommended at least once prior to August 31 and then monthly from September through May. Inspection during a storm event is also recommended. After the initial period of frequent inspections, the minimum inspection and maintenance frequency can be determined based on the results of the first year inspections.

Threshold/Indicator	Maintenance Action	Typical Inspection and Maintenance Frequency
Accumulation of sediment, litter, or debris at the inlet	Remove and properly dispose of accumulated materials.	<ul style="list-style-type: none"> Inspect monthly and after every 0.5-inch or larger storm event. Remove any accumulated materials found at each inspection.
Outlet blocked	Clear blockage.	<ul style="list-style-type: none"> Inspect monthly and after every 0.5-inch or larger storm event. Remove any accumulated materials found at each inspection.
Accumulation of sediment, litter, or debris in the storage container	Remove and properly dispose of accumulated materials.	<ul style="list-style-type: none"> Inspect monthly. If the BMP is 25% full* or more in one month, increase inspection frequency to monthly plus after every 0.1-inch or larger storm event. Remove materials annually (minimum), or more frequently when BMP is 25% full* (or at manufacturer threshold if manufacturer threshold is less than 25% full*) in less than one year, or if accumulation blocks outlet
Standing water in storage container between storm events outside of normal use timeframe for the stored water. Normal use timeframe is 36 to 96 hours following a storm event depending on the purpose and design of the cistern.	<p>Use the water as intended, or disperse to landscaping.</p> <p>Implement practices onsite to drain and use the stored water.</p> <p>Contact the [City Engineer] to determine a solution if onsite use cannot be reliably sustained.</p>	<ul style="list-style-type: none"> Inspect monthly and after every 0.5-inch or larger storm event. If standing water is observed, increase inspection frequency to after every 0.1-inch or larger storm event. Maintenance when needed.

*"25% full" is defined as $\frac{1}{4}$ of the depth from the design bottom elevation to the crest of the outflow structure (e.g., if the height to the outflow opening is 12 inches from the bottom elevation, then the materials must be removed when there is 3 inches of accumulation – this should be marked on the outflow structure)

HU-1 Cistern

SUMMARY OF STANDARD INSPECTION AND MAINTENANCE FOR HU-1 CISTERN (Continued from previous page)		
Threshold/Indicator	Maintenance Action	Typical Inspection and Maintenance Frequency
Presence of mosquitos/larvae For images of egg rafts, larva, pupa, and adult mosquitos, see http://www.mosquito.org/biology	If mosquitos/larvae are observed: first, immediately remove any standing water by using the water as intended for irrigation or alternative grey water, or by dispersing to landscaping; second, check cistern outlet for blockage and clear blockage if applicable to restore drainage; third, install barriers such as screens that prevent mosquito access to the storage container.	<ul style="list-style-type: none"> • Inspect monthly and after every 0.5-inch or larger storm event. If mosquitos are observed, increase inspection frequency to after every 0.1-inch or larger storm event. • Maintenance when needed.
Leaks or other damage to ancillary parts including valves, piping, screens, level indicators, and other accessories	Repair or replace as applicable.	<ul style="list-style-type: none"> • Inspect twice per year. • Maintenance when needed.
Leaks or other damage to storage container	Repair or replace as applicable.	<ul style="list-style-type: none"> • Inspect twice per year. • Maintenance when needed.
Cistern leaning or unstable, damage to roof, supports, anchors, or foundation	Make repairs as appropriate to correct the problem and stabilize the system.	<ul style="list-style-type: none"> • Inspect twice per year. • Maintenance when needed.

References

American Mosquito Control Association.

<http://www.mosquito.org/>

California Storm Water Quality Association (CASQA). 2003. Municipal BMP Handbook.

<https://www.casqa.org/resources/bmp-handbooks/municipal-bmp-handbook>

County of San Diego. 2014. Low Impact Development Handbook.

<http://www.sandiegocounty.gov/content/sdc/dpw/watersheds/susmp/lid.html>

San Diego County Copermittees. 2016. Model BMP Design Manual, Appendix E, Fact Sheet HU-1.

http://www.projectcleanwater.org/index.php?option=com_content&view=article&id=250&Itemid=220

HU-1 Cistern

Page Intentionally Blank for Double-Sided Printing

HU-1 Cistern

Date:	Inspector:	BMP ID No.:
Permit No.:	APN(s):	
Property / Development Name:		Responsible Party Name and Phone Number:
Property Address of BMP:		Responsible Party Address:

INSPECTION AND MAINTENANCE CHECKLIST FOR HU-1 CISTERN PAGE 1 of 4			
Threshold/Indicator	Maintenance Recommendation	Date	Description of Maintenance Conducted
Accumulation of sediment, litter, or debris at the inlet Maintenance Needed? <input type="checkbox"/> YES <input type="checkbox"/> NO <input type="checkbox"/> N/A	<input type="checkbox"/> Remove and properly dispose of accumulated materials <input type="checkbox"/> If the inlet is found to be obstructed at every inspection, add features to protect the inlet, or pretreatment measures within the watershed <input type="checkbox"/> Other / Comments:		
Outlet blocked Maintenance Needed? <input type="checkbox"/> YES <input type="checkbox"/> NO <input type="checkbox"/> N/A	<input type="checkbox"/> Clear blockage <input type="checkbox"/> Other / Comments:		

HU-1 Cistern

Date:	Inspector:	BMP ID No.:
Permit No.:	APN(s):	

INSPECTION AND MAINTENANCE CHECKLIST FOR HU-1 CISTERN PAGE 2 of 4			
Threshold/Indicator	Maintenance Recommendation	Date	Description of Maintenance Conducted
<p>Standing water in storage container between storm events outside of normal use timeframe for the stored water. Normal use timeframe is 36 to 96 hours following a storm event depending on the purpose and design of the cistern.</p> <p>Maintenance Needed?</p> <p><input type="checkbox"/> YES <input type="checkbox"/> NO <input type="checkbox"/> N/A</p>	<p><input type="checkbox"/> Use the water as intended, or disperse to landscaping</p> <p><input type="checkbox"/> Implement practices onsite to drain and use the stored water</p> <p><input type="checkbox"/> Contact the [City Engineer] to determine a solution if onsite use cannot be reliably sustained</p> <p><input type="checkbox"/> Other / Comments:</p>		
<p>Presence of mosquitos/larvae</p> <p>For images of egg rafts, larva, pupa, and adult mosquitos, see http://www.mosquito.org/biology</p> <p>Maintenance Needed?</p> <p><input type="checkbox"/> YES <input type="checkbox"/> NO <input type="checkbox"/> N/A</p>	<p><input type="checkbox"/> Use the water as intended, or disperse to landscaping</p> <p><input type="checkbox"/> Install barriers such as screens that prevent mosquito access to the storage container</p> <p><input type="checkbox"/> Other / Comments:</p>		

HU-1 Cistern

Date:	Inspector:	BMP ID No.:
Permit No.:	APN(s):	

INSPECTION AND MAINTENANCE CHECKLIST FOR HU-1 CISTERN PAGE 3 of 4			
Threshold/Indicator	Maintenance Recommendation	Date	Description of Maintenance Conducted
Accumulation of sediment, litter, or debris in the storage container – to be cleared once per year or when debris accumulation is 25% of the total container volume, or accumulation blocks outlet, whichever is more frequent Maintenance Needed? <input type="checkbox"/> YES <input type="checkbox"/> NO <input type="checkbox"/> N/A	<input type="checkbox"/> Remove and properly dispose of accumulated materials <input type="checkbox"/> If accumulation of sediment within one year is >25% of the volume of the cistern, add pretreatment measures within the watershed <input type="checkbox"/> Other / Comments:		
Leaks or other damage to storage container Maintenance Needed? <input type="checkbox"/> YES <input type="checkbox"/> NO <input type="checkbox"/> N/A	<input type="checkbox"/> Repair or replace as applicable <input type="checkbox"/> Other / Comments:		

HU-1 Cistern

Date:	Inspector:	BMP ID No.:
Permit No.:	APN(s):	

INSPECTION AND MAINTENANCE CHECKLIST FOR HU-1 CISTERN PAGE 4 of 4			
Threshold/Indicator	Maintenance Recommendation	Date	Description of Maintenance Conducted
Leaks or other damage to ancillary parts including valves, piping, screens, level indicators, and other accessories Maintenance Needed? <input type="checkbox"/> YES <input type="checkbox"/> NO <input type="checkbox"/> N/A	<input type="checkbox"/> Repair or replace as applicable <input type="checkbox"/> Other / Comments:		
Cistern leaning or unstable, damage to roof, supports, anchors, or foundation Maintenance Needed? <input type="checkbox"/> YES <input type="checkbox"/> NO <input type="checkbox"/> N/A	<input type="checkbox"/> Make repairs as appropriate to correct the problem and stabilize the system <input type="checkbox"/> Other / Comments:		

SD-1

Tree Wells

BMP MAINTENANCE FACT SHEET FOR SITE DESIGN BMP SD-1 TREE WELLS

Tree wells as site design BMPs are trees planted in configurations that allow storm water runoff to be directed into the soil immediately surrounding the tree. The tree may be contained within a planter box or structural cells. The surrounding area will be graded to direct runoff to the tree well. There may be features such as tree grates, suspended pavement design, or shallow surface depressions designed to allow runoff into the tree well. Typical tree well components include:

- Trees of the appropriate species for site conditions and constraints
- Available growing space based on tree species, soil type, water availability, surrounding land uses, and project goals
- Entrance/opening that allows storm water runoff to flow into the tree well (e.g., a curb opening, tree grate, or surface depression)
- Optional suspended pavement design to provide structural support for adjacent pavement without requiring compaction of underlying layers
- Optional root barrier devices as needed; a root barrier is a device installed in the ground, between a tree and the sidewalk, intended to guide roots down and away from the sidewalk in order to prevent sidewalk lifting from tree roots
- Optional tree grates; to be considered to maximize available space for pedestrian circulation and to protect tree roots from compaction related to pedestrian circulation; tree grates are typically made up of porous material that will allow the runoff to soak through
- Optional shallow surface depression for ponding of excess runoff
- Optional planter box drain

Normal Expected Maintenance

Tree health shall be maintained as part of normal landscape maintenance. Additionally, ensure that storm water runoff can be conveyed into the tree well as designed. That is, the opening that allows storm water runoff to flow into the tree well (e.g., a curb opening, tree grate, or surface depression) shall not be blocked, filled, re-graded, or otherwise changed in a manner that prevents storm water from draining into the tree well. A summary table of standard inspection and maintenance indicators is provided within this Fact Sheet.

Non-Standard Maintenance or BMP Failure

Tree wells are site design BMPs that normally do not require maintenance actions beyond routine landscape maintenance. The normal expected maintenance described above ensures the BMP functionality. If changes have been made to the tree well entrance / opening such that runoff is prevented from draining into the tree well (e.g., a curb inlet opening is blocked by debris or a grate is clogged causing runoff to flow around instead of into the tree well, or a surface depression has been filled so runoff flows away from the tree well), the BMP is not performing as intended to protect downstream waterways from pollution and/or erosion. Corrective maintenance will be required to restore drainage into the tree well as designed.

Surface ponding of runoff directed into tree wells is expected to infiltrate/evapotranspire within 24-96 hours following a storm event. Surface ponding longer than approximately 24 hours following a storm event may be detrimental to vegetation health, and surface ponding longer than approximately 96 hours following a storm event poses a risk of vector (mosquito) breeding. Poor drainage can result from clogging or compaction of the soils surrounding the tree. Loosen or replace the soils to restore drainage.

SD-1

Tree Wells

Other Special Considerations

Site design BMPs, such as tree wells, installed within a new development or redevelopment project are components of an overall storm water management strategy for the project. The presence of site design BMPs within a project is usually a factor in the determination of the amount of runoff to be managed with structural BMPs (i.e., the amount of runoff expected to reach downstream retention or biofiltration basins that process storm water runoff from the project as a whole). When site design BMPs are not maintained or are removed, this can lead to clogging or failure of downstream structural BMPs due to greater delivery of runoff and pollutants than intended for the structural BMP. Therefore, the [City Engineer] may require confirmation of maintenance of site design BMPs as part of their structural BMP maintenance documentation requirements. Site design BMPs that have been installed as part of the project should not be removed, nor should they be bypassed by re-routing roof drains or re-grading surfaces within the project. If changes are necessary, consult the [City Engineer] to determine requirements.

SD-1 Tree Wells

SUMMARY OF STANDARD INSPECTION AND MAINTENANCE FOR SD-1 TREE WELLS		
<p>The property owner is responsible to ensure inspection, operation and maintenance of permanent BMPs on their property unless responsibility has been formally transferred to an agency, community facilities district, homeowners association, property owners association, or other special district.</p> <p>Maintenance frequencies listed in this table are average/typical frequencies. Actual maintenance needs are site-specific, and maintenance may be required more frequently. Maintenance must be performed whenever needed, based on maintenance indicators presented in this table. The BMP owner is responsible for conducting regular inspections to see when maintenance is needed based on the maintenance indicators. During the first year of operation of a structural BMP, inspection is recommended at least once prior to August 31 and then monthly from September through May. Inspection during a storm event is also recommended. After the initial period of frequent inspections, the minimum inspection and maintenance frequency can be determined based on the results of the first year inspections.</p>		
Threshold/Indicator	Maintenance Action	Typical Maintenance Frequency
Tree health	Routine actions as necessary to maintain tree health.	<ul style="list-style-type: none"> • Inspect monthly. • Maintenance when needed.
Dead or diseased tree	Remove dead or diseased tree. Replace per original plans.	<ul style="list-style-type: none"> • Inspect monthly. • Maintenance when needed.
<p>Standing water in tree well for longer than 24 hours following a storm event</p> <p>Surface ponding longer than approximately 24 hours following a storm event may be detrimental to tree health</p>	Loosen or replace soils surrounding the tree to restore drainage.	<ul style="list-style-type: none"> • Inspect monthly and after every 0.5-inch or larger storm event. If standing water is observed, increase inspection frequency to after every 0.1-inch or larger storm event. • Maintenance when needed.
<p>Presence of mosquitos/larvae</p> <p>For images of egg rafts, larva, pupa, and adult mosquitos, see http://www.mosquito.org/biology</p>	Disperse any standing water from the tree well to nearby landscaping. Loosen or replace soils surrounding the tree to restore drainage (and prevent standing water).	<ul style="list-style-type: none"> • Inspect monthly and after every 0.5-inch or larger storm event. If mosquitos are observed, increase inspection frequency to after every 0.1-inch or larger storm event. • Maintenance when needed
Entrance / opening to the tree well is blocked such that storm water will not drain into the tree well (e.g., a curb inlet opening is blocked by debris or a grate is clogged causing runoff to flow around instead of into the tree well; or a surface depression is filled such that runoff drains away from the tree well)	Make repairs as appropriate to restore drainage into the tree well.	<ul style="list-style-type: none"> • Inspect monthly. • Maintenance when needed.

SD-1 Tree Wells

References

American Mosquito Control Association.

<http://www.mosquito.org/>

County of San Diego. 2014. Low Impact Development Handbook.

<http://www.sandiegocounty.gov/content/sdc/dpw/watersheds/susmp/lid.html>

San Diego County Copermittees. 2016. Model BMP Design Manual, Appendix E, Fact Sheet SD-1.

http://www.projectcleanwater.org/index.php?option=com_content&view=article&id=250&Itemid=220

SD-1 Tree Wells

Date:	Inspector:	BMP ID No.:
Permit No.:	APN(s):	
Property / Development Name:		Responsible Party Name and Phone Number:
Property Address of BMP:		Responsible Party Address:

INSPECTION AND MAINTENANCE CHECKLIST FOR SD-1 TREE WELLS PAGE 1 of 2			
Threshold/Indicator	Maintenance Recommendation	Date	Description of Maintenance Conducted
Dead or diseased tree Maintenance Needed? <input type="checkbox"/> YES <input type="checkbox"/> NO <input type="checkbox"/> N/A	<input type="checkbox"/> Remove dead or diseased tree <input type="checkbox"/> Replace per original plans <input type="checkbox"/> Other / Comments:		
Standing water in tree well for longer than 24 hours following a storm event Surface ponding longer than approximately 24 hours following a storm event may be detrimental to tree health Maintenance Needed? <input type="checkbox"/> YES <input type="checkbox"/> NO <input type="checkbox"/> N/A	<input type="checkbox"/> Loosen or replace soils surrounding the tree to restore drainage <input type="checkbox"/> Other / Comments:		

SD-1 Tree Wells

Date:	Inspector:	BMP ID No.:
Permit No.:	APN(s):	

INSPECTION AND MAINTENANCE CHECKLIST FOR SD-1 TREE WELLS PAGE 2 of 2			
Threshold/Indicator	Maintenance Recommendation	Date	Description of Maintenance Conducted
<p>Presence of mosquitos/larvae</p> <p>For images of egg rafts, larva, pupa, and adult mosquitos, see http://www.mosquito.org/biology</p> <p>Maintenance Needed?</p> <p><input type="checkbox"/> YES <input type="checkbox"/> NO <input type="checkbox"/> N/A</p>	<p><input type="checkbox"/> Disperse any standing water from the tree well to nearby landscaping</p> <p><input type="checkbox"/> Loosen or replace soils surrounding the tree to restore drainage (and prevent standing water)</p> <p><input type="checkbox"/> Other / Comments:</p>		
<p>Entrance / opening to the tree well is blocked such that storm water will not drain into the tree well (e.g., a curb inlet opening is blocked by debris or a grate is clogged causing runoff to flow around instead of into the tree well; or a surface depression is filled such that runoff drains away from the tree well)</p> <p>Maintenance Needed?</p> <p><input type="checkbox"/> YES <input type="checkbox"/> NO <input type="checkbox"/> N/A</p>	<p><input type="checkbox"/> Make repairs as appropriate to restore drainage into the tree well</p> <p><input type="checkbox"/> Other / Comments:</p>		

Maintenance Guidelines for Modular Wetland System - Linear

Maintenance Summary

- Remove Trash from Screening Device – average maintenance interval is 6 to 12 months.
 - *(5 minute average service time).*
- Remove Sediment from Separation Chamber – average maintenance interval is 12 to 24 months.
 - *(10 minute average service time).*
- Replace Cartridge Filter Media – average maintenance interval 12 to 24 months.
 - *(10-15 minute per cartridge average service time).*
- Replace Drain Down Filter Media – average maintenance interval is 12 to 24 months.
 - *(5 minute average service time).*
- Trim Vegetation – average maintenance interval is 6 to 12 months.
 - *(Service time varies).*

System Diagram

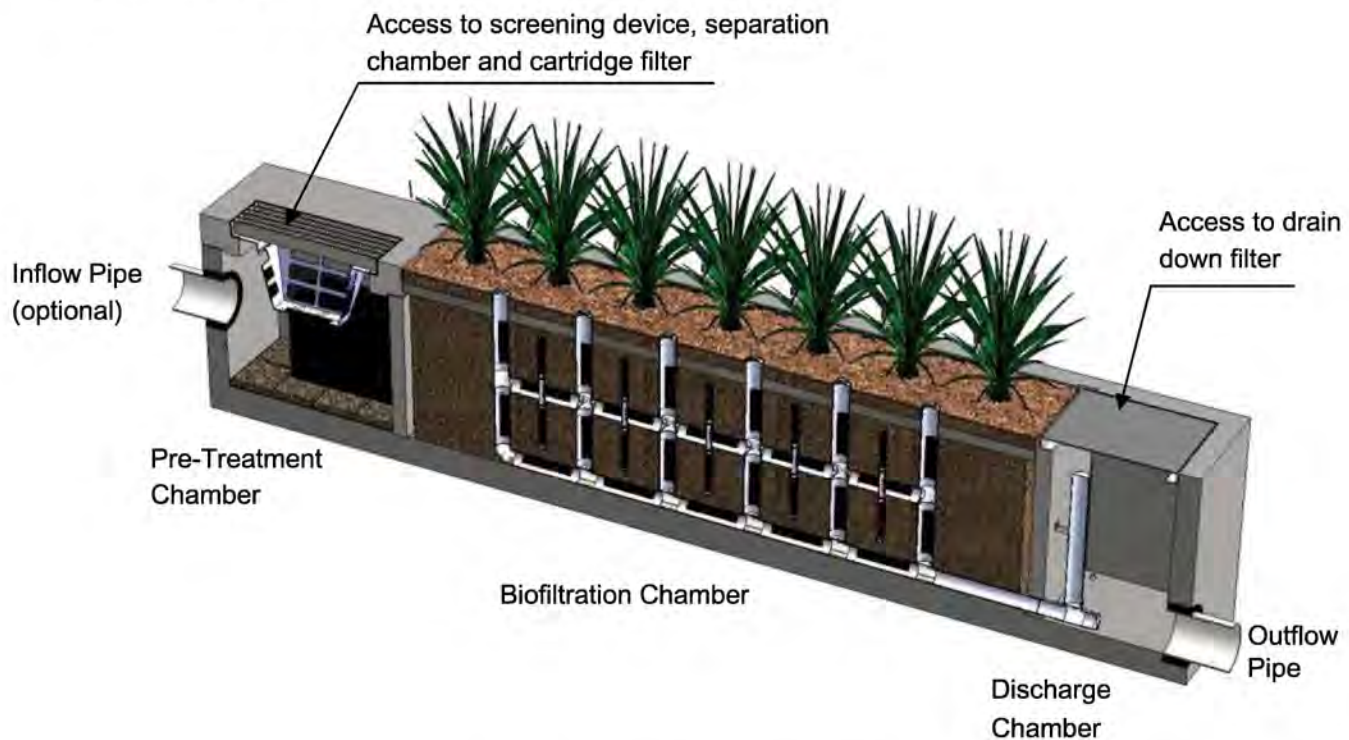

Maintenance Procedures

Screening Device

1. Remove grate or manhole cover to gain access to the screening device in the Pre-Treatment Chamber. Vault type units do not have screening device. Maintenance can be performed without entry.
2. Remove all pollutants collected by the screening device. Removal can be done manually or with the use of a vacuum truck. The hose of the vacuum truck will not damage the screening device.
3. Screening device can easily be removed from the Pre-Treatment Chamber to gain access to separation chamber and media filters below. Replace grate or manhole cover when completed.

Separation Chamber

1. Perform maintenance procedures of screening device listed above before maintaining the separation chamber.
2. With a pressure washer spray down pollutants accumulated on walls and cartridge filters.
3. Vacuum out Separation Chamber and remove all accumulated pollutants. Replace screening device, grate or manhole cover when completed.

Cartridge Filters

1. Perform maintenance procedures on screening device and separation chamber before maintaining cartridge filters.
2. Enter separation chamber.
3. Unscrew the two bolts holding the lid on each cartridge filter and remove lid.
4. Remove each of 4 to 8 media cages holding the media in place.
5. Spray down the cartridge filter to remove any accumulated pollutants.
6. Vacuum out old media and accumulated pollutants.
7. Reinstall media cages and fill with new media from manufacturer or outside supplier. Manufacturer will provide specification of media and sources to purchase.
8. Replace the lid and tighten down bolts. Replace screening device, grate or manhole cover when completed.

Drain Down Filter

1. Remove hatch or manhole cover over discharge chamber and enter chamber.
2. Unlock and lift drain down filter housing and remove old media block. Replace with new media block. Lower drain down filter housing and lock into place.
3. Exit chamber and replace hatch or manhole cover.



Maintenance Notes

1. Following maintenance and/or inspection, it is recommended the maintenance operator prepare a maintenance/inspection record. The record should include any maintenance activities performed, amount and description of debris collected, and condition of the system and its various filter mechanisms.
2. The owner should keep maintenance/inspection record(s) for a minimum of five years from the date of maintenance. These records should be made available to the governing municipality for inspection upon request at any time.
3. Transport all debris, trash, organics and sediments to approved facility for disposal in accordance with local and state requirements.
4. Entry into chambers may require confined space training based on state and local regulations.
5. No fertilizer shall be used in the Biofiltration Chamber.
6. Irrigation should be provided as recommended by manufacturer and/or landscape architect. Amount of irrigation required is dependent on plant species. Some plants may require irrigation.

Maintenance Procedure Illustration

Screening Device

The screening device is located directly under the manhole or grate over the Pre-Treatment Chamber. It's mounted directly underneath for easy access and cleaning. Device can be cleaned by hand or with a vacuum truck.



Separation Chamber

The separation chamber is located directly beneath the screening device. It can be quickly cleaned using a vacuum truck or by hand. A pressure washer is useful to assist in the cleaning process.



Cartridge Filters

The cartridge filters are located in the Pre-Treatment chamber connected to the wall adjacent to the biofiltration chamber. The cartridges have removable tops to access the individual media filters. Once the cartridge is open media can be easily removed and replaced by hand or a vacuum truck.



Drain Down Filter

The drain down filter is located in the Discharge Chamber. The drain filter unlocks from the wall mount and hinges up. Remove filter block and replace with new block.



Trim Vegetation

Vegetation should be maintained in the same manner as surrounding vegetation and trimmed as needed. No fertilizer shall be used on the plants. Irrigation per the recommendation of the manufacturer and or landscape architect. Different types of vegetation requires different amounts of irrigation.





Inspection Form



Modular Wetland System, Inc.

P. 760.433-7640

F. 760-433-3176

E. Info@modularwetlands.com

www.modularwetlands.com



Inspection Report Modular Wetlands System



Project Name _____

Project Address _____ (city) (Zip Code)

Owner / Management Company _____

Contact _____

Phone () -

Inspector Name _____

Date ____ / ____ / ____

Time _____ AM / PM

Type of Inspection Routine Follow Up Complaint

Storm

Storm Event in Last 72-hours? No Yes

Weather Condition _____

Additional Notes _____

For Office Use Only

(Reviewed By)

(Date)
Office personnel to complete section to the left.

Inspection Checklist

Modular Wetland System Type (Curb, Grate or UG Vault): _____

Size (22', 14' or etc.): _____

Structural Integrity:	Yes	No	Comments
Damage to pre-treatment access cover (manhole cover/grate) or cannot be opened using normal lifting pressure?			
Damage to discharge chamber access cover (manhole cover/grate) or cannot be opened using normal lifting pressure?			
Does the MWS unit show signs of structural deterioration (cracks in the wall, damage to frame)?			
Is the inlet/outlet pipe or drain down pipe damaged or otherwise not functioning properly?			
Working Condition:			
Is there evidence of illicit discharge or excessive oil, grease, or other automobile fluids entering and clogging the unit?			
Is there standing water in inappropriate areas after a dry period?			
Is the filter insert (if applicable) at capacity and/or is there an accumulation of debris/trash on the shelf system?			
Does the depth of sediment/trash/debris suggest a blockage of the inflow pipe, bypass or cartridge filter? If yes specify which one in the comments section. Note depth of accumulation in in pre-treatment chamber.			Depth:
Does the cartridge filter media need replacement in pre-treatment chamber and/or discharge chamber?			Chamber:
Any signs of improper functioning in the discharge chamber? Note issues in comments section.			
Other Inspection Items:			
Is there an accumulation of sediment/trash/debris in the wetland media (if applicable)?			
Is it evident that the plants are alive and healthy (if applicable)? Please note Plant Information below.			
Is there a septic or foul odor coming from inside the system?			

Waste:	Yes	No
Sediment / Silt / Clay		
Trash / Bags / Bottles		
Green Waste / Leaves / Foliage		

Recommended Maintenance	
No Cleaning Needed	
Schedule Maintenance as Planned	
Needs Immediate Maintenance	

Plant Information	
Damage to Plants	
Plant Replacement	
Plant Trimming	

Additional Notes: _____

Maintenance Report



Modular Wetland System, Inc.

P. 760.433-7640

F. 760-433-3176

E. Info@modularwetlands.com

www.modularwetlands.com



Cleaning and Maintenance Report Modular Wetlands System



Project Name _____

For Office Use Only

Project Address _____
(city) (Zip Code)

(Reviewed By)

Owner / Management Company _____

(Date)

Office personnel to complete section to the left.

Contact _____

Phone () _____

Inspector Name _____

Date ____ / ____ / ____ Time _____ AM / PM

Type of Inspection Routine Follow Up Complaint Storm Storm Event in Last 72-hours? No Yes

Weather Condition _____

Additional Notes _____

Site Map #	GPS Coordinates of Insert	Manufacturer / Description / Sizing	Trash Accumulation	Foliage Accumulation	Sediment Accumulation	Total Debris Accumulation	Condition of Media 25/50/75/100 (will be changed @ 75%)	Operational Per Manufactures' Specifications (If not, why?)
	Lat: Long:	MWS Catch Basins						
		MWS Sedimentation Basin						
		Media Filter Condition						
		Plant Condition						
		Drain Down Media Condition						
		Discharge Chamber Condition						
		Drain Down Pipe Condition						
		Inlet and Outlet Pipe Condition						

Comments:

ATTACHMENT 4

Copy of Plan Sheets Showing Permanent Storm Water BMPs

Project Name/_____

Use this checklist to ensure the required information has been included on the plans:

The plans must identify:

- Structural BMP(s) with ID numbers matching Form I-6 Summary of PDP Structural BMPs
- The grading and drainage design shown on the plans must be consistent with the delineation of DMAs shown on the DMA exhibit
- Details and specifications for construction of structural BMP(s)
- Signage indicating the location and boundary of structural BMP(s) as required by the City Engineer
- How to access the structural BMP(s) to inspect and perform maintenance
- Features that are provided to facilitate inspection (e.g., observation ports, cleanouts, silt posts, or other features that allow the inspector to view necessary components of the structural BMP and compare to maintenance thresholds)
- Manufacturer and part number for proprietary parts of structural BMP(s) when applicable
- Maintenance thresholds specific to the structural BMP(s), with a location-specific frame of reference (e.g., level of accumulated materials that triggers removal of the materials, to be identified based on viewing marks on silt posts or measured with a survey rod with respect to a fixed benchmark within the BMP)
- Recommended equipment to perform maintenance
- When applicable, necessary special training or certification requirements for inspection and maintenance personnel such as confined space entry or hazardous waste management
- Include landscaping plan sheets showing vegetation requirements for vegetated structural BMP(s)
- All BMPs must be fully dimensioned on the plans
- When proprietary BMPs are used, site specific cross section with outflow, inflow and model number shall be provided. Broucher photocopies are not allowed.

MAP 5729

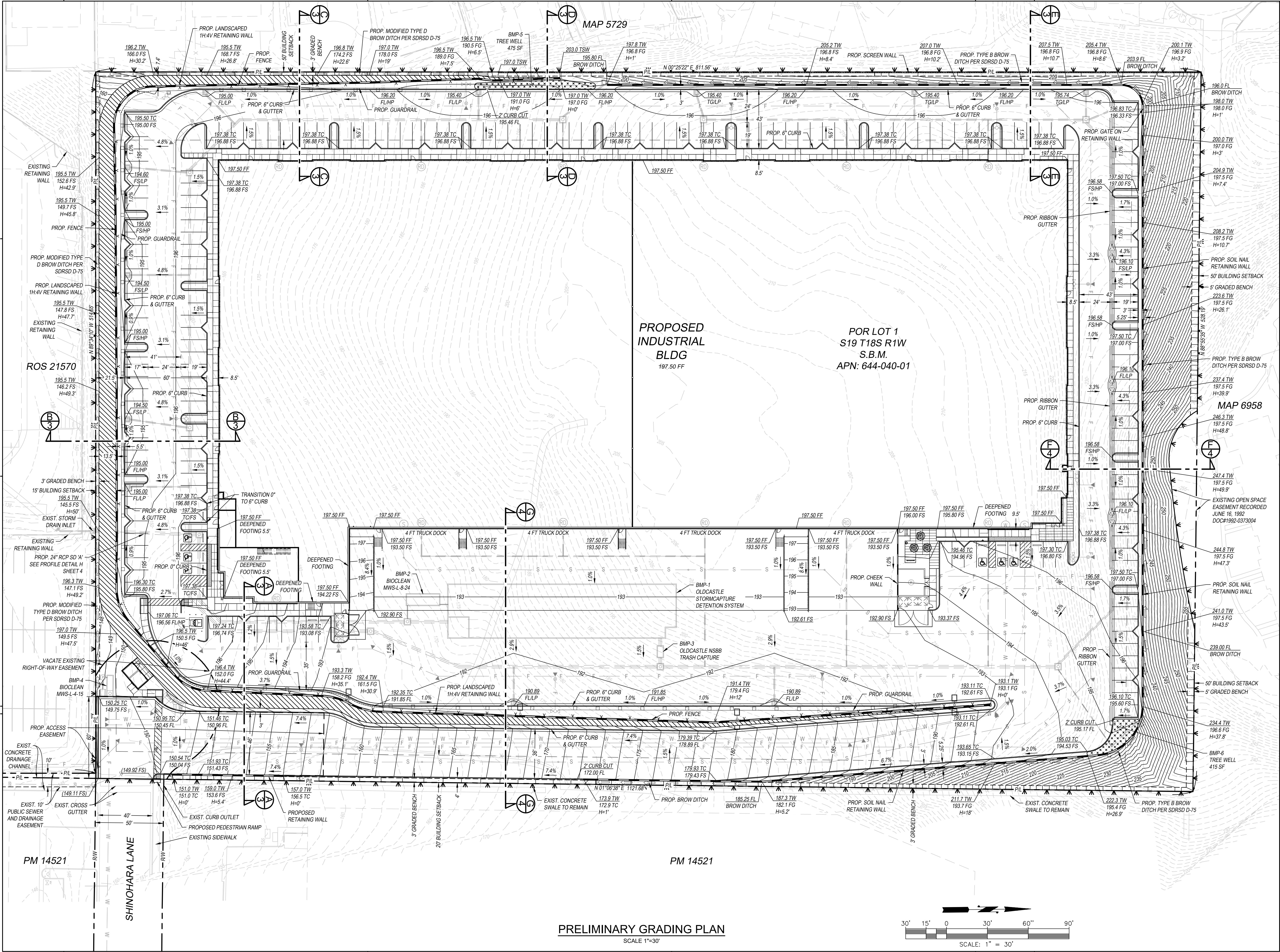

PROPOSED INDUSTRIAL BLDG
197.50 FF

POR LOT 1
S19 T18S R1W
S.B.M.
APN: 644-040-01

MAP 6958

PASCO LARET SUITER & ASSOCIATES
San Diego | Selma Beach | Orange County
Phone 658.259.8212 | www.plsaeengineering.com



SHINOHARA BUSINESS CENTER
517 SHINOHARA LANE
CHULA VISTA, CA 91911

PRELIMINARY GRADING PLAN

DATE	REVISIONS
11/22/2021	DESIGN REVIEW SUBMITTAL
02/14/2022	DESIGN REVIEW RESUBMITTAL
05/20/2022	DESIGN REVIEW RESUBMITTAL

PA/PM:	GL
DRAWN BY:	MM
JOB NO.:	3690

SHEET
C6.0

PRELIMINARY GRADING PLAN
SCALE 1"=30'

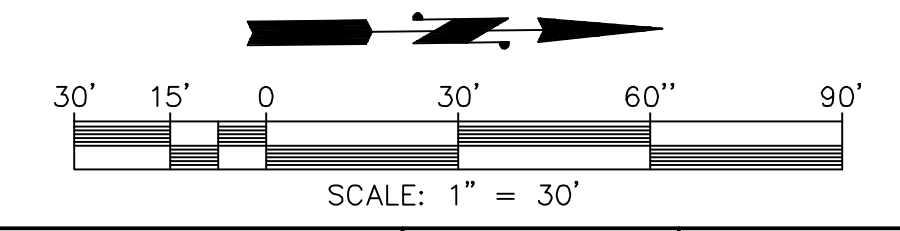

THESE DRAWINGS AND SPECIFICATIONS ARE THE PROPERTY AND COPYRIGHT OF WADE WALCUMB AND SHALL NOT BE USED ON ANY OTHER WORK EXCEPT BY AGREEMENT WITH WADE WALCUMB. WRITTEN DIMENSIONS SHALL TAKE PRECEDENCE OVER SCALED DIMENSIONS AND SHALL BE KEPT ON THE JOB SITE. ANY DISCREPANCY SHALL BE BROUGHT TO THE NOTICE OF WADE WALCUMB PRIOR TO THE COMMENCEMENT OF ANY WORK.

MAP 5729

POR LOT 1
S19 T18S R1W
S.B.M.
APN: 644-040-01

PROPOSED INDUSTRIAL BLDG
197.50 FF

ROS 21570

MAP 6958

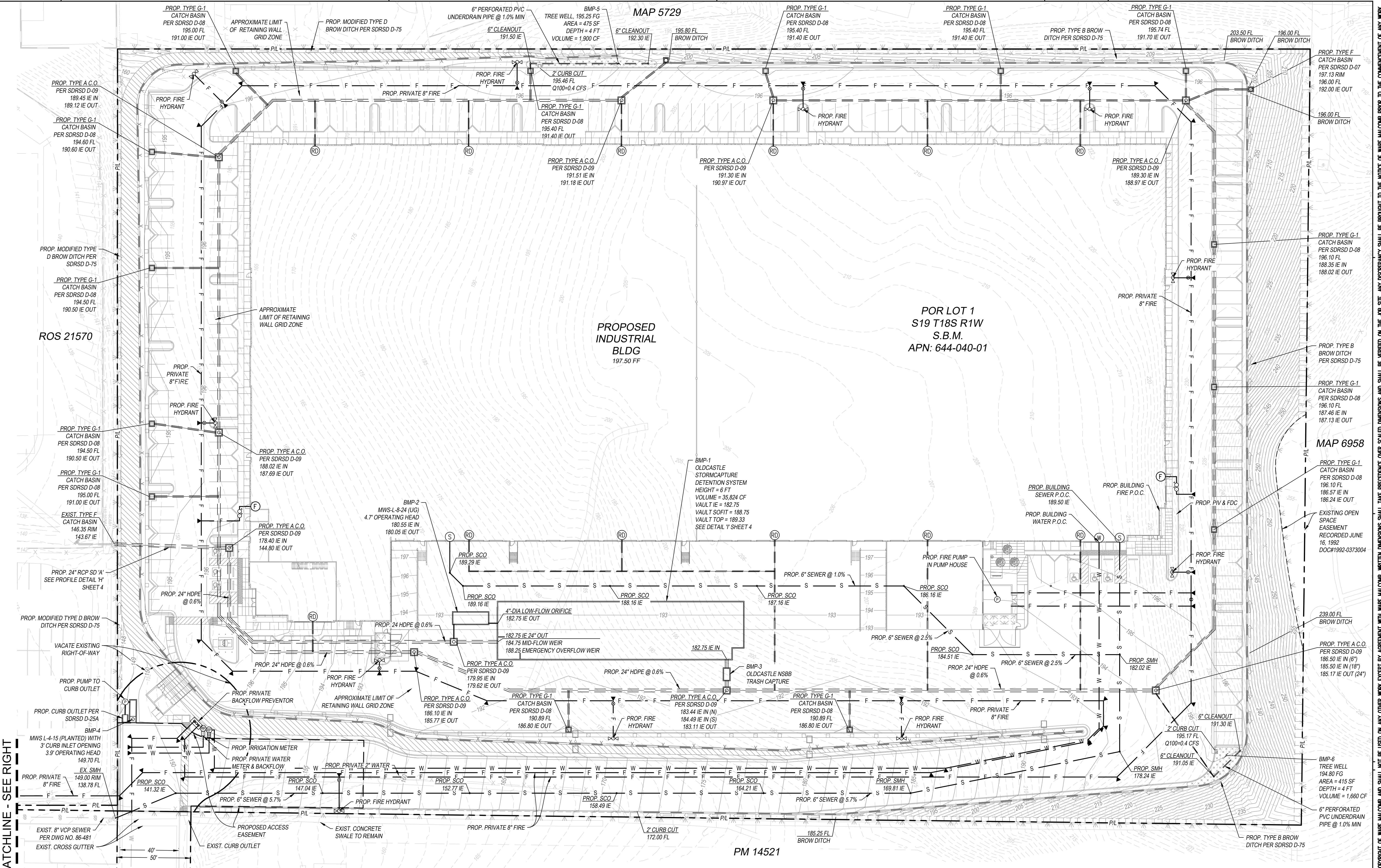

PRELIMINARY UTILITY PLAN

SCALE 1"=30'

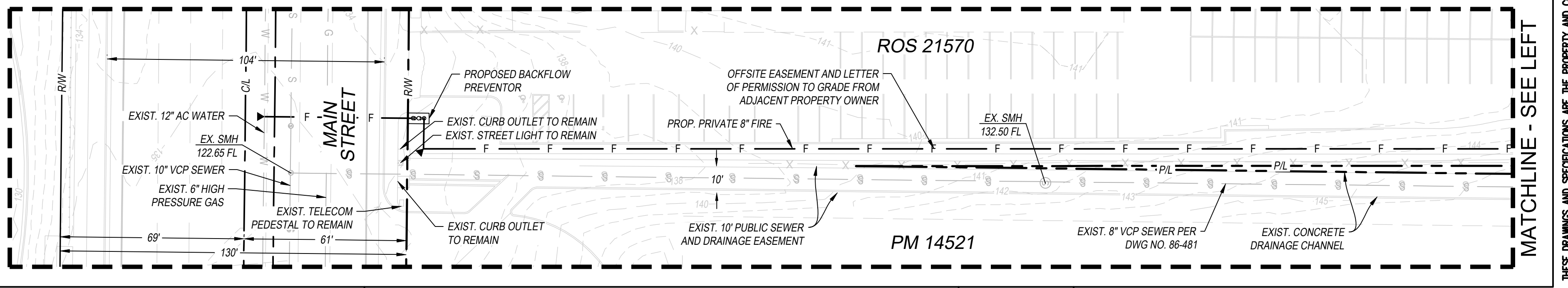
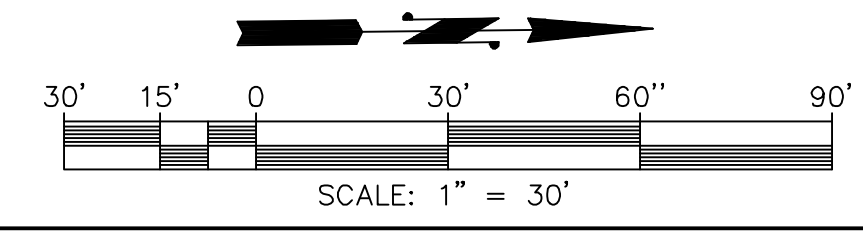

THESE DRAWINGS AND SPECIFICATIONS ARE THE PROPERTY AND COPYRIGHT OF WARE MALCOLM AND SHALL NOT BE USED ON ANY OTHER WORK EXCEPT BY AGREEMENT WITH WARE MALCOLM. WRITTEN DIMENSIONS SHALL TAKE PRECEDENCE OVER SCALED DIMENSIONS AND SHALL BE VERIFIED ON THE JOB SITE. ANY DISCREPANCY SHALL BE BROUGHT TO THE NOTICE OF WARE MALCOLM PRIOR TO THE COMMENCEMENT OF ANY WORK.

PASCO LARET SUITER & ASSOCIATES
San Diego | Seaboard Beach | Orange County
Phone 658.259.8212 | www.plaengineering.com

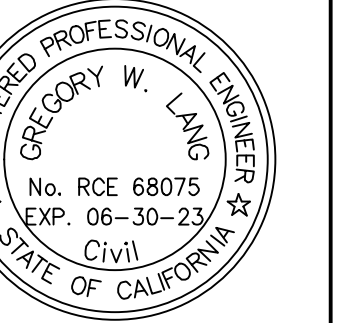

SHINOHARA BUSINESS CENTER
517 SHINOHARA LANE
CHULA VISTA, CA 91911

PRELIMINARY UTILITY PLAN

DATE	REMARKS
11/22/2021	DESIGN REVIEW SUBMITTAL
02/14/2022	DESIGN REVIEW RESUBMITTAL
05/20/2022	DESIGN REVIEW RESUBMITTAL

PA/PM:	GL
DRAWN BY:	MM
JOB NO.:	3690

SHEET
C7.0

Project Name/_____

ATTACHMENT 5

Drainage Report

Attach project's drainage report. Refer to the Subdivision Manual to determine the reporting requirements.

PRELIMINARY DRAINAGE STUDY

For:

Shinohara Business Center

517 Shinohara Lane
Chula Vista, CA 91911

APN: 644-040-01
Project Permit # DR21-0032

Prepared By:

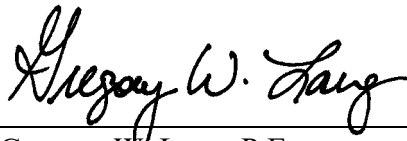

Gregory W. Lang, P.E.
Pasco Laret Suiter & Associates, Inc.
119 Aberdeen Drive
Cardiff By The Sea, CA 92007

RCE 68075

5-20-2022

EXP: 06-30-23

PASCO LARET SUITER
 & ASSOCIATES
CIVIL ENGINEERING + LAND PLANNING + LAND SURVEYING



Prepared for:

VWP-OP Shinohara Owner, LLC
2390 East Camelback Road, Suite 305
Phoenix, AZ 85016

May 20, 2022

PLSA Job No. 3690

DECLARATION OF RESPONSIBLE CHARGE

I, hereby declare that I am the Engineer of Work for this project. That I have exercised responsible charge over the design of the project as defined in section 6703 of the business and professions code, and that the design is consistent with current standards.

I understand that the check of project drawings and specifications by the County of San Diego is confined to a review only and does not relieve me, as engineer of work, of my responsibilities for project design.

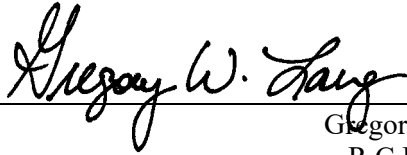

Gregory W. Lang
R.C.E. 68075
EXP. 6-30-23

05/20/2022

DATE

TABLE OF CONTENTS

1. INTRODUCTION	4
1.1 Project Description	5
1.2 Pre-Project Conditions.....	5
1.3 Post-Project Conditions	6
2. METHODOLOGY	8
2.1 Rational Method	8
2.2 Runoff Coefficient.....	9
2.3 Rainfall Intensity	11
2.4 Tributary Areas.....	11
2.5 Hydraulics	11
2.6 Curb Inlet and Catch Basin Sizing	11
2.7 Detention Basin Routing	11
3. CALCULATIONS/RESULTS.....	13
3.1 Pre- & Post-Development Peak Flow Comparison	13
3.2 Storm Water Quality.....	14
3.3 Hydromodification	14
4. CONCLUSION	15
Appendix 1	Pre-Project Condition Hydrology Node Map
Appendix 2.....	Post-Project Condition Hydrology Node Map
Appendix 3.....	Hydrology Design Summary
Appendix 4.....	AES Rational Method Calculations
Appendix 5.....	Modified-Puls Detention Routing

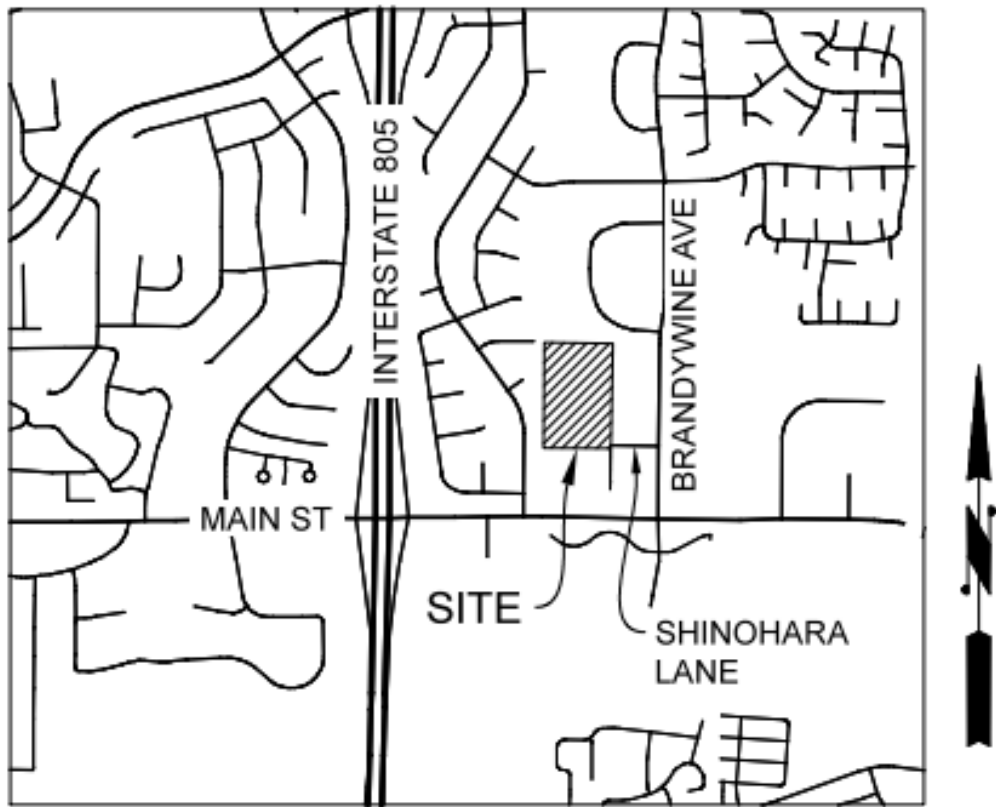

VICINITY MAP

NOT TO SCALE

1. INTRODUCTION

This Preliminary Drainage Study for the proposed Project Shinohara has been prepared to analyze the hydrologic characteristics of the existing and proposed project site. This report presents both the methodology and the calculations used for determining the storm water runoff from the project site in the existing and proposed conditions produced by the 100-year, 6-hour storm event.

1.1 Project Description

The 9.73-acre project site consists of undeveloped land located northwest of the intersection of Brandywine Avenue and Shinohara Lane, at the end of Shinohara Lane in the City of Chula Vista, San Diego County, California. The property is defined as a portion of Lot 1, Section 19, Township 18 South, Range 1 West, San Bernardino Meridian, and identified by the Assessor's Parcel Number (APN) 644-040-01.

The existing site is currently undeveloped except for minor concrete drainage channels located on site and along the eastern and southern property boundaries. The site is bounded on the north and west by residential properties, and on the east and south by industrial buildings.

The existing site condition is divided into three (3) drainage basins, Basins Am B, and C, and three (3) separate discharge locations across the project site.

Treatment of storm water runoff from the site has been addressed in a separate report- *Storm Water Quality Management Plan for OnPoint Development, Project Shinohara by PLSA*, dated May 20, 2022.

Per City of Chula Vista general design criteria, the Modified Rational Method should be used to determine peak flowrates when the contributing drainage area is up to 1.0 square mile in size. All public and private drainage facilities shall be designed for a 100-year frequency storm.

Methodology used for the computation of design rainfall events, runoff coefficients, and rainfall intensity values are consistent with the criteria set forth in Section 3 – General Design Criteria of the City of Chula Vista Subdivision Manual, revised March 2012.

1.2 Pre-Project Conditions

Topographically, the site slopes steeply to the south from the northern property boundary, forming three (3) drainage basins with three (3) discharge locations. Existing Drainage Basin A comprises the western portion of the site. Runoff drains via overland flow to an existing concrete swale located at the southern property boundary. The drainage swale carries flow east to an existing Type F catch basin at the southern property boundary. The catch basin connects to an existing private storm drain pipe that outlets via curb outlet onto Main Street.

Existing Drainage Basin B comprises the eastern portion of the site. Runoff is conveyed via overland surface flow to an existing concrete drainage channel located at the southeastern corner of the site. The drainage channel conveys runoff south and outlets via curb outlet onto Main Street.

From Main Street, flow travels west via concrete curb and gutter to an existing curb inlet. Stormwater is then conveyed south through an existing storm drain pipe and outlets over headwall into the Otay River. The Otay River travels west and outlets at the San Diego Bay and ultimately the Pacific Ocean.

The site is not within a FEMA 100-year floodplain boundary or regulatory floodway.

Existing Drainage Basin C comprises the northwesterly portion of the site. Runoff is conveyed via overland surface flow to an existing swale west of the project site. Local surface runoff from the project site and surrounding properties collect in this area and flow to the south to an existing concrete drainage channel located in the rear yard of an existing single family residence at the end of Tanoak Court. The existing concrete channel flows to the south and then turns and flows to the west and discharges into Tanoak Court through two existing Type A curb outlets.

Per the United States Department of Agriculture (USDA) Web Soil Survey, the project site is Hydrologic Soil Group C and D. Refer to Appendix C of this report for the USDA Web Soil Survey and geotechnical findings.

Table 1.1 below summarizes the pre-project condition 100-year peak flows at the project’s discharge locations. For delineated basin details, please refer to the Pre-Project Condition Hydrology Node Map included in Appendix 1 of this report.

TABLE 1.1 – Summary of Pre-Project Conditions

Existing Drainage Basin	Drainage Area (ac)	Runoff Coefficient, C	Time of Concentration, T _c (min)	Intensity, I (in/hr)	Pre-Project Q ₁₀₀ (cfs)
Basin A	2.79	0.55	9.15	4.70	7.20
Basin B	6.13	0.55	8.86	4.57	15.42
Basin C	0.79	0.55	4.77	6.32	2.78
Total	9.71	0.55			25.40

1.3 Post-Project Conditions

The project will include the construction of an industrial building, paved drive aisles and parking areas, retaining walls, and other associated improvements. Private drainage improvements will consist of catch basins, curb inlets and storm drain pipes. Proprietary Modular Wetland Systems are proposed for storm water treatment. An underground detention vault is proposed for peak flow attenuation. The project will be accessed by a proposed driveway off Shinohara Lane. The proposed land use is ILP- Limited Industrial.

The proposed site will consist of two (2) major drainage basins with two (2) discharge locations which match the existing drainage discharge points and pre-project peak flow rates for Existing Drainage Basins A and B. The proposed project’s area in the northwesterly corner of the project site that comprised Existing Drainage Basin C is proposed to be included in Proposed Drainage Basin A. This will enable the proposed project to collect and convey runoff from this location to the project’s peak flow detention facility and storm water treatment and no longer discharge runoff on an existing single family residential property. While the size of Proposed Drainage Basin A is larger than the size of Existing Drainage Basin A when comparing areas, the proposed project will provide peak flow detention so the peak flow runoff rate from this basin for the post-project condition will be equal to or less than the pre-project condition.

Storm water runoff from a majority of the proposed development (DMA-A) is routed to a series of BMPs including a Contech CDS pretreatment unit, a StormTrap underground detention vault and a BioClean Modular Wetland System (MWS). The underground detention vault has been designed to meet 100-year peak flow detention requirements. The Modular Wetland System is designed as a proprietary biofiltration

BMP for storm water treatment. Outflows from the detention vault and MWS are discharged through a proposed storm drain pipe to the existing Type F catch basin at the southern property boundary. Stormwater is then conveyed through the neighboring property to the south through an existing private storm drain and outlets onto Main Street as in existing conditions.

Storm water runoff from the proposed driveway (DMA-B) will be drained to a Modular Wetland System for storm water treatment. The MWS will be designed with a 3-foot-wide curb inlet opening and a 1-inch local curb depression to capture the required water quality flow. Runoff that exceeds the water quality flow rate or capacity of the MWS will flow by the MWS and drain to the existing concrete drainage channel at the southeast corner of the project site. Outflows from the MWS will be pumped to a proposed curb outlet along the southern property boundary and discharged to the existing concrete drainage channel. The concrete drainage channel discharges onto Main Street via curb outlet as in existing conditions. The characteristics of existing stormwater flows through the neighboring property will not change as a result of the proposed project.

Runoff from the cut slope at the northwest portion of the project site will be conveyed via proposed brow ditch to the existing Type F catch basin at the southern property boundary. This area (DMA-C) is considered a Self-Mitigating DMA per Chapter 5.2.1 of the City of Chula Vista BMP Design Manual.

All project site runoff is discharged onto Main Street as in existing conditions. From Main Street, flow travels west via concrete curb and gutter to an existing curb inlet. Stormwater is then conveyed south through an existing storm drain and outlets over headwall into the Otay River. The Otay River travels west and outlets at the San Diego Bay and ultimately the Pacific Ocean. The Otay River is considered an exempt river reach per the WMAA; therefore, the project is exempt from hydromodification management requirements.

The underground detention vault has been designed to provide flow control in the form of volume reduction and peak flow attenuation. The vault has been modified to include a low-flow and mid-flow orifice outlet and an overflow weir to control peak flows. The required water quality treatment flow is diverted to the downstream Modular Wetland System in accordance with Worksheet B.5-5 of the City of Chula Vista BMP Design Manual. Overflow relief for the 100-year storm event is provided with a partition weir installed within the vault and discharged directly to the existing Type F catch basin at the southern property boundary.

Table 1.2 below summarizes the post-project condition 100-year peak flows at the project’s discharge locations. For delineated basin details, please refer to the Post-Project Condition Hydrology Node Map included as an Attachment of this report.

TABLE 1.2 – Summary of Post-Project Conditions

Proposed Drainage Basin	Drainage Area (ac)	Runoff Coefficient, C	Time of Concentration, Tc (min)	Intensity, I (in/hr)	Post-Project Q100 (cfs)	Required Detention (cfs)
Basin A	8.52	0.79	8.78	4.60	33.45	26.25
Basin B	1.19	0.80	5.55	6.07	5.77	--
Total	9.71	0.79			39.22	26.25

2. METHODOLOGY

Runoff calculations for Project Shinohara have been performed in accordance with Section 3 – General Design Criteria of the City of Chula Vista Subdivision Manual dated March 2012. Per City of City of Chula Vista design criteria, the Modified Rational Method should be used to determine peak flowrates for local drainage basins. Advanced Engineering Software (AES) were used to calculate the peak runoff from the 100-year, 6-hour storm event using the Rational Method. Please refer to this report's Appendix for the results of these calculations.

2.1 Rational Method

As mentioned above, runoff from the project site was calculated for the 100-year storm event. Runoff was calculated using the Rational Method which is given by the following equation:

$$Q = C \times I \times A$$

Where:

Q = Flow rate in cubic feet per second (cfs)

C = Runoff coefficient

I = Rainfall Intensity in inches per hour (in/hr)

A = Drainage basin area in acres, (ac)

Rational Method calculations were performed using the AES 2008 computer program. To perform the hydrology routing, the total watershed area is divided into sub-areas which discharge at designated nodes. The procedure for the sub-area summation model is as follows:

- (1) Subdivide the watershed into an initial sub-areas and subsequent sub-areas, which are generally less than 10 acres in size. Assign upstream and downstream node numbers to each sub-area.
- (2) Estimate an initial T_c by using the appropriate nomograph or overland flow velocity estimation. The minimum T_c considered is 5.0 minutes. All T_c values for the proposed project were assumed to be 5 minutes due to the small size of each contributing drainage area.
- (3) Using the initial T_c , determine the corresponding values of I. Then $Q = CIA$.
- (4) Using Q, estimate the travel time between this node and the next by Manning's equation as applied to particular channel or conduit linking the two nodes. Then, repeat the calculation for Q based on the revised intensity (which is a function of the revised time of concentration)

2.2 Runoff Coefficient

In accordance with City of Chula Vista design standards, runoff coefficients were based on land use. An appropriate runoff coefficient (C) for each type of land use in the subarea was selected from Section 3-203.3 of the City of Chula Vista Subdivision Manual and multiplied by the percentage of total area (A) included in that class. The sum of products for all land uses is the weighted runoff coefficient ($\sum[C]$). See Tables 2.1 and 2.2 below for weighted runoff coefficient “C” calculations. The Pre-Project and Post-Project Condition Hydrology Node Maps show the drainage basin subareas, on-site drainage system and nodal points.

Runoff coefficients of 0.55 and 0.60 were selected from Section 3-203.3 for hilly and steep vegetated slopes, consistent with existing conditions. The existing site is assumed to be 0% impervious. See Table 2.1 below for pre-project condition weighted runoff coefficient “C” calculations.

In the post-project condition, the developed site was assigned a runoff coefficient of 0.85 for commercial area. Developed slopes along the northern and southern property boundary were classified as steep per Section 3-203.3 and assigned a runoff coefficient of 0.60. See Table 2.2 on the following page for post-project condition weighted runoff coefficient “C” calculations.

TABLE 2.1- Summary of Pre-Project Condition Weighted Runoff Coefficient Calculations

Pre-Project Condition - Weighted Runoff Coefficient							
Up Node	Down Node	Area (ac)	C ₁	A ₁	C ₂	A ₂	C
10	11	0.04	0.55	0.04	0.60	0.00	0.55
11	12	2.75	0.55	2.75	0.60	0.00	0.55
20	21	0.09	0.55	0.09	0.60	0.00	0.55
21	22	6.01	0.55	6.01	0.60	0.00	0.55
30	31	0.08	0.55	0.08	0.60	0.00	0.55
31	32	0.72	0.55	0.72	0.60	0.00	0.55

Note: C values taken from Section 3-203.3 of the City of Chula Vista Subdivision Manual
 Runoff Coefficient of 0.55 for Vegetated Slopes, Hilly
 Runoff Coefficient of 0.60 for Vegetated Slopes, Steep

TABLE 2.2- Summary of Post-Project Condition Weighted Runoff Coefficient Calculations

Post-Project Condition - Weighted Runoff Coefficient							
Up Node	Down Node	Area (ac)	C ₁	A ₁	C ₂	A ₂	C
100	101	0.04	0.85	0.04	0.60	0.00	0.85
101	102	0.34	0.85	0.34	0.60	0.00	0.85
103	103	0.20	0.85	0.20	0.60	0.00	0.85
104	104	0.38	0.85	0.38	0.60	0.00	0.85
105	105	0.20	0.85	0.20	0.60	0.00	0.85
106	106	0.41	0.85	0.41	0.60	0.00	0.85
107	107	0.14	0.85	0.14	0.60	0.00	0.85
107	107	0.39	0.85	0.00	0.60	0.39	0.60
108	108	0.12	0.85	0.12	0.60	0.00	0.85
109	109	0.12	0.85	0.12	0.60	0.00	0.85
110	110	0.11	0.85	0.11	0.60	0.00	0.85
111	111	0.06	0.85	0.06	0.60	0.00	0.85
112	112	0.29	0.85	0.29	0.60	0.00	0.85
113	113	0.27	0.85	0.27	0.60	0.00	0.85
114	114	0.94	0.85	0.94	0.60	0.00	0.85
115	115	0.80	0.85	0.80	0.60	0.00	0.85
117	118	0.04	0.85	0.04	0.60	0.00	0.85
118	119	0.34	0.85	0.34	0.60	0.00	0.85
120	120	0.08	0.85	0.08	0.60	0.00	0.85
121	121	0.22	0.85	0.22	0.60	0.00	0.85
122	122	0.38	0.85	0.38	0.60	0.00	0.85
123	123	0.35	0.85	0.35	0.60	0.00	0.85
124	124	0.19	0.85	0.19	0.60	0.00	0.85
125	125	0.11	0.85	0.11	0.60	0.00	0.85
126	126	0.16	0.85	0.16	0.60	0.00	0.85
127	127	0.16	0.85	0.16	0.60	0.00	0.85
128	128	0.20	0.85	0.20	0.60	0.00	0.85
129	129	0.37	0.85	0.37	0.60	0.00	0.85
131	131	0.84	0.85	0.00	0.60	0.84	0.60
136	136	0.25	0.85	0.00	0.60	0.25	0.60
200	201	0.16	0.85	0.16	0.60	0.00	0.85
201	202	1.03	0.85	0.79	0.60	0.24	0.79

Note: C values taken from Section 3-203.3 of the City of Chula Vista Subdivision Manual
 Runoff Coefficient of 0.85 for Commercial Area
 Runoff Coefficient of 0.60 for Vegetated Slopes, Steep

2.3 Rainfall Intensity

Rainfall intensity is calculated per Section 3-203.3 of the City of Chula Vista Subdivision Manual, which is given by the following equation:

$$I = 7.44P_6D^{-0.645}$$

Where:

I = Rainfall Intensity in inches per hour (in/hr)

P₆ = Adjusted 6-hour storm precipitation

D = Duration in minutes (use T_c)

The intensity values for varying time of concentrations were input manually into the AES computer program where runoff calculations were performed. The 6-hour storm rainfall amount (P₆) for the 100-year storm frequency was determined using City of Chula Vista Isopluvial Maps provided from Figure 7 of the City of Chula Vista Drainage Master Plan. The P₆ for the 100-year storm frequency was found as 2.4 inches. See Appendix 3 of this report for Isopluvial maps for the 100-year rainfall event.

2.4 Tributary Areas

Drainage basins for the existing and proposed project site are delineated in the Pre-Project and Post-Project Condition Hydrology Node Maps located in Appendix 1 and 2 of this report and graphically portray the tributary area for each drainage basin.

2.5 Hydraulics

The hydraulics of existing and proposed storm drain pipes were analyzed using the AES computer program. For pipe flow, a Manning's N value of 0.011 was used to reflect the use of HDPE pipe. A Manning's N value of 0.013 was used to reflect the use of RCP pipe.

2.6 Curb Inlet and Catch Basin Sizing

Curb inlets and catch basins will be sized in accordance with City of Chula Vista Subdivision Manual (March 2012) upon final engineering.

2.7 Detention Basin Routing

The detention facility was modeled using the Army Corps of Engineers HEC-HMS 4.3 software. Hydraulic Modified-Puls detention routing was performed to analyze the developed condition 100-year peak flow rate at the project's detention system. Stage-storage-discharge tables were generated and input into HEC-HMS to model the design of the vault outlet structure. This procedure was selected in order to model the flow control requirements and to accurately represent the middle stages of the BMP for accurate mid-flow orifice and emergency weir sizing. The stage-storage-discharge tables have been provided in Appendix 5. The HEC-HMS Modified-Puls results are summarized in Table 2.3 on the following page.

TABLE 2.3- Summary of Detention Basin Routing

Detention Basin	Tributary Area (ac)	Runoff Coefficient, C	Inflow Tc (min) ¹	100-Year Peak Inflow (cfs)	Outflow Tc (min)	100-Year Peak Outflow (cfs)	Peak Elevation (ft) ²
BMP-1	8.27	0.85	10	33.45	19	6.99	5.37

Notes: (1) Inflow time of concentration rounded to the nearest time interval that HEC-HMS could accept
(2) Peak elevation measured from the invert of the mid-flow orifice

A Rational method inflow hydrograph was generated using RickRat Hydro software from Rick Engineering. The parameters of the drainage area were entered into RickRat Hydro software to generate an inflow hydrograph. The data from this hydrograph was then entered into HEC-HMS software to model the release rates from the detention system.

HEC-HMS allows for hydrology input time steps of 1, 2, 3, 4, 5, 6, 10, 15 & 20 minutes. Rick Rat Hydro requires a minimum time of concentration (Tc) of 5 minutes. Therefore, the time of concentration (Tc) used for the concentration of the hydrograph was rounded to the nearest time interval that RickRat Hydro and HEC-HMS could accept. The time of concentration used is 10 minutes. The peak flow remains as per the modified Rational Method analysis and is not reduced (or increased) from this hydrograph development accordingly.

Rational method hydrographs, stage-storage-discharge relationships and HEC-HMS model output is provided in Appendix 5 of this report.

3. CALCULATIONS/RESULTS

3.1 Pre- & Post-Development Peak Flow Comparison

Below are a series of tables which summarize the calculations provided in the appendices of this report.

Table 3.1 itemizes the pre-project condition peak flow rates for the 100-year storm event at the project's discharge locations.

TABLE 3.1- Pre-Project Condition Peak Flow Summary

Drainage Basin	Drainage Area (ac)	Runoff Coefficient, C	Pre-Project Q100 (cfs)
Basin A	2.79	0.55	7.20
Basin B	6.13	0.55	15.42
Basin C	0.79	0.55	2.78
Total	9.71	0.55	25.40

Table 3.2 itemizes the post-project and detained condition peak flow rates for the 100-year storm event at the project's discharge locations.

TABLE 3.2- Proposed Post-Project Condition Peak Flow Summary

Drainage Basin	Drainage Area (ac)	Runoff Coefficient, C	Post-Project Condition Q100 (cfs)	Detained Condition Q100 (cfs)
Basin A	8.52	0.79	33.45	7.17
Basin B	1.19	0.80	5.77	5.77
Total	9.71	0.79	39.22	12.94

Table 3.3 shows that the total storm water peak flow for the proposed development is less than the existing storm water peak flow for the 100-year rainfall event.

TABLE 3.3- Pre-Project Vs. Post-Project Detained Condition Peak Flow Summary

Pre-Project Condition Q100 (cfs)	Post-Project Detained Condition Q100 (cfs)	Pre-Project Vs. Post-Project Detained Condition Q100 (cfs)
25.40	12.94	-12.46

3.2 Storm Water Quality

The proposed site will include Modular Wetland Systems that will provide the required storm water quality treatment for the project. For information regarding BMP sizing and the water quality design, refer to the *Storm Water Quality Management Plan for Project Shinohara, OnPoint Development by PLSA*, dated May 20, 2022, under separate cover.

3.3 Hydromodification

The project is exempt from hydromodification management requirements. For additional information regarding hydromodification exemption, refer to the *Storm Water Quality Management Plan for Project Shinohara, OnPoint Development by PLSA*, dated May 20, 2022, under separate cover.

4. CONCLUSION

This report analyzed the 100-year storm event hydrology for the proposed site using the Advanced Engineering Software (AES) and demonstrates that the post-developed peak flow rates are less than the pre-developed peak flow rates at the project's two existing discharge locations. In addition, the proposed storm drain system was sized adequately to convey the proposed project's runoff and supporting calculations can be found in the appendices of this report.

The proposed project will not substantially alter the existing drainage pattern of the site or area, including through the alteration of the course of a stream or river, in a manner that would result in substantial erosion or siltation on or off-site. In addition, the proposed project will not increase the peak runoff rate for the post-project condition when compared to the pre-project condition.

The project is not within the FEMA 100-year floodplain boundary as mapped on the Flood Insurance Rate Map.



Appendix 1
Pre-Project Condition Hydrology Node Map



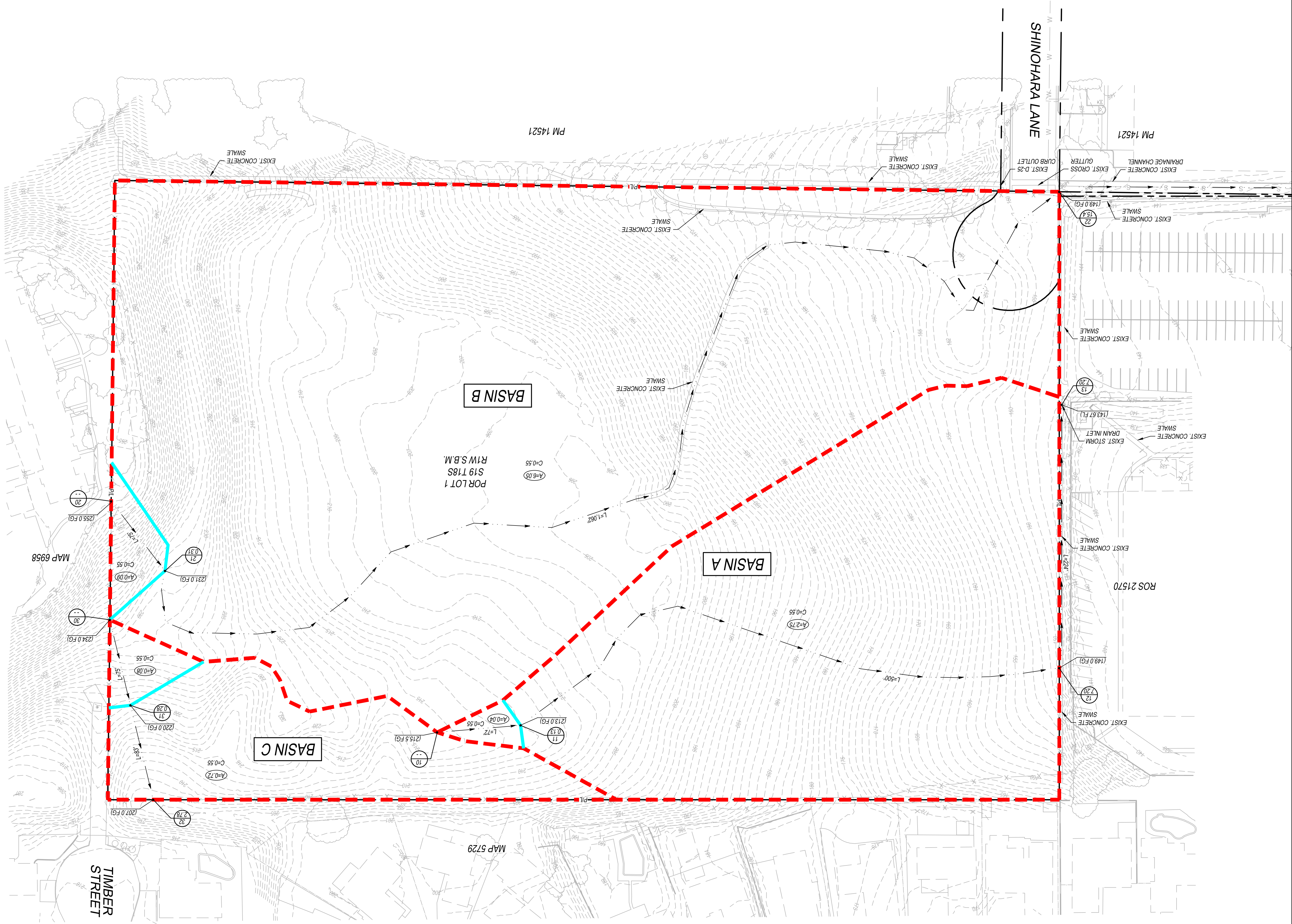
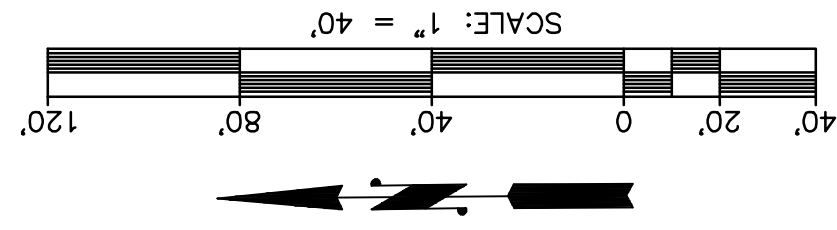

SUMMARY OF EXISTING CONDITION 100-YEAR PEAK FLOWS

DRAINAGE BASIN	DRAINAGE AREA (AC)	% IMP	WEIGHTED RUNOFF COEFFICIENT, C	EXISTING PEAK FLOW (CFS)	100-YEAR PEAK FLOWS
BASIN A	2.79	0.00	0.00	2.79	7.20
BASIN B	6.13	0.00	0.00	6.13	15.42
BASIN C	0.79	0.00	0.00	0.79	2.78
TOTAL	9.71	0.00	0.00	9.71	25.40

PASCO LARET SUTTER & ASSOCIATES
 San Diego | Solana Beach | Orange County
 Phone 858.259.8212 | www.plsaengineering.com

PRE-PROJECT CONDITION
 HYDROLOGY NODE MAP
 SHINOHARA BUSINESS PARK
 517 SHINOHARA LANE
 CHULA VISTA, CA 91911
 PLSA JOB NO. 3690
 MAY 2022

LEGEND

SYMBOL	DESCRIPTION
	HYDROLOGY NODE
	Q100 (CFS)
	SUB-BASIN AREA
	WEIGHTED RUNOFF COEFFICIENT
	RIGHT-OF-WAY
	PROPERTY LINE
	BASIN BOUNDARY
	SUB-BASIN BOUNDARY
	FLOWLINE

PROJECT CHARACTERISTICS

PARCEL AREA:	9.73 AC
EXISTING DRAINAGE BOUNDARY:	9.71 AC
EXISTING IMPERVIOUS AREA:	0 AC
EXISTING PERVIOUS / LANDSCAPE AREA:	9.71 AC

RUNOFF COEFFICIENT

IN ACCORDANCE WITH SECTION 3 - GENERAL DESIGN CRITERIA OF THE CITY OF CHULA VISTA SUBDIVISION MANUAL, RUNOFF COEFFICIENTS WERE BASED ON LAND USE. AN APPROPRIATE RUNOFF COEFFICIENT WAS SELECTED FROM SECTION 3-203.3 AND MULTIPLIED BY THE PERCENTAGE OF TOTAL AREA IN THAT CLASS. THE SUM OF THE PRODUCTS FOR ALL LAND USES IS THE WEIGHTED RUNOFF COEFFICIENT.

SEE TABLE 2.1 OF THE PRELIMINARY DRAINAGE STUDY FOR PROJECT SHINOHARA BY PLSA DATED FEBRUARY 2022 FOR PRE-PROJECT CONDITION WEIGHTED RUNOFF COEFFICIENT 'C' CALCULATIONS.

DEPTH TO GROUNDWATER

DEPTH TO GROUNDWATER > 20 FT

HYDROLOGIC SOIL GROUP

HYDROLOGIC SOIL TYPE: C & D



Appendix 2

Post-Project Condition Hydrology Node Map



LEGEND	SYMBOL
DESCRIPTION	
HYDROLOGY NODE	
POST-PROJECT DETAINED Q100 (CFS)	
SUB-BASIN AREA	
WEIGHTED RUNOFF COEFFICIENT	C=0.85
RIGHT-OF-WAY	
PROPERTY LINE	
BASIN BOUNDARY	
SUB-BASIN BOUNDARY	
FLOWLINE	

HYDROLOGIC SOIL GROUP
HYDROLOGIC SOIL TYPE: C & D

DEPTH TO GROUNDWATER
DEPTH TO GROUNDWATER > 20 FT

PROJECT CHARACTERISTICS

PARCEL AREA:	9.73 AC
PROPOSED DRAINAGE BOUNDARY:	9.71 AC
PROPOSED DISTURBED AREA:	9.67 AC
PROPOSED IMPERVIOUS AREA:	8.03 AC
PROPOSED PERVIOUS / LANDSCAPE AREA:	1.64 AC

RUNOFF COEFFICIENT
IN ACCORDANCE WITH SECTION 3-GENERAL DESIGN CRITERIA OF THE CITY OF CHULA VISTA SUBDIVISION MANUAL, RUNOFF COEFFICIENTS WERE BASED ON LAND USE. AN APPROPRIATE RUNOFF COEFFICIENT WAS SELECTED FROM SECTION 3-203.3 AND MULTIPLIED BY THE PERCENTAGE OF TOTAL AREA IN THAT CLASS. THE SUM OF THE PRODUCTS FOR ALL LAND USES IS THE WEIGHTED RUNOFF COEFFICIENT.
SEE TABLE 2.2 OF THE "PRELIMINARY DRAINAGE STUDY FOR PROJECT SHINOHARA, ONPOINT DEVELOPMENT" BY PLSA DATED MAY 2022 FOR POST-PROJECT CONDITION WEIGHTED RUNOFF COEFFICIENT "C" CALCULATIONS.

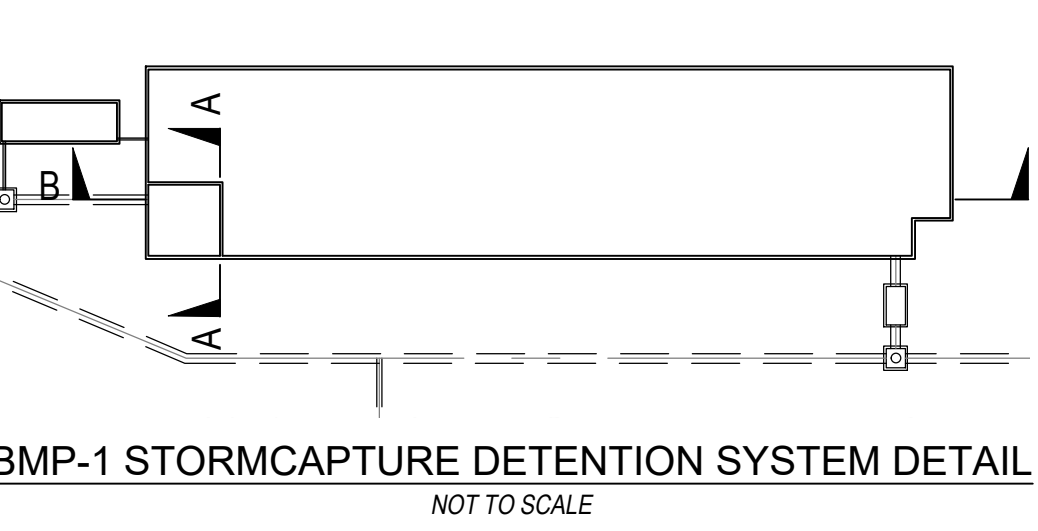
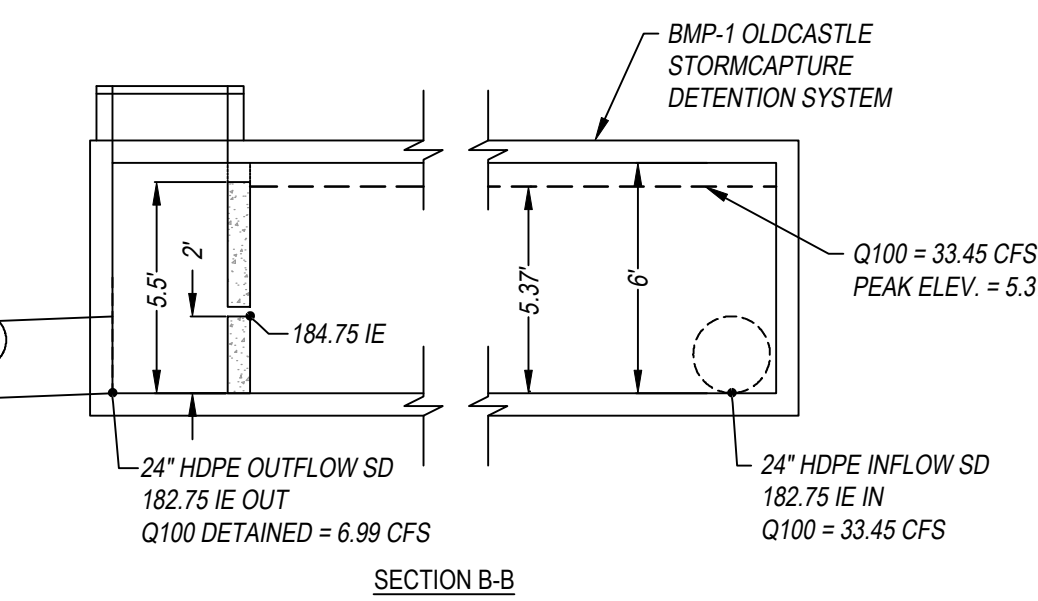
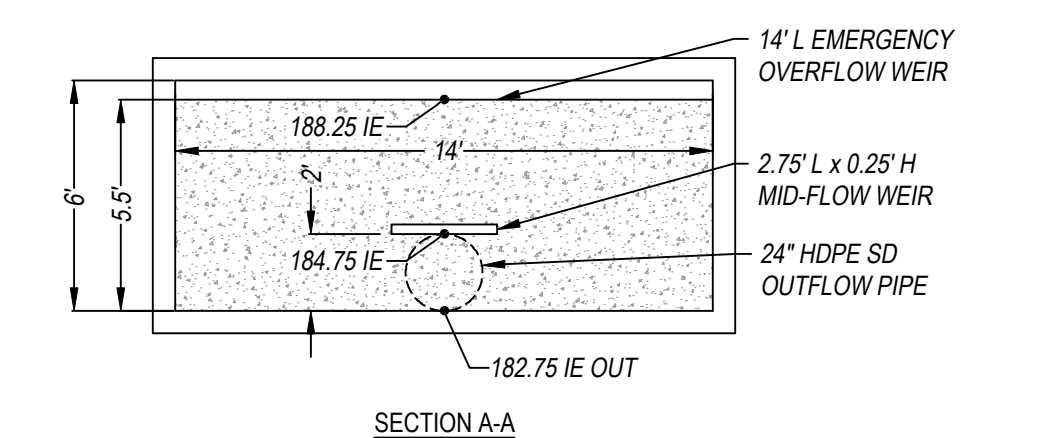
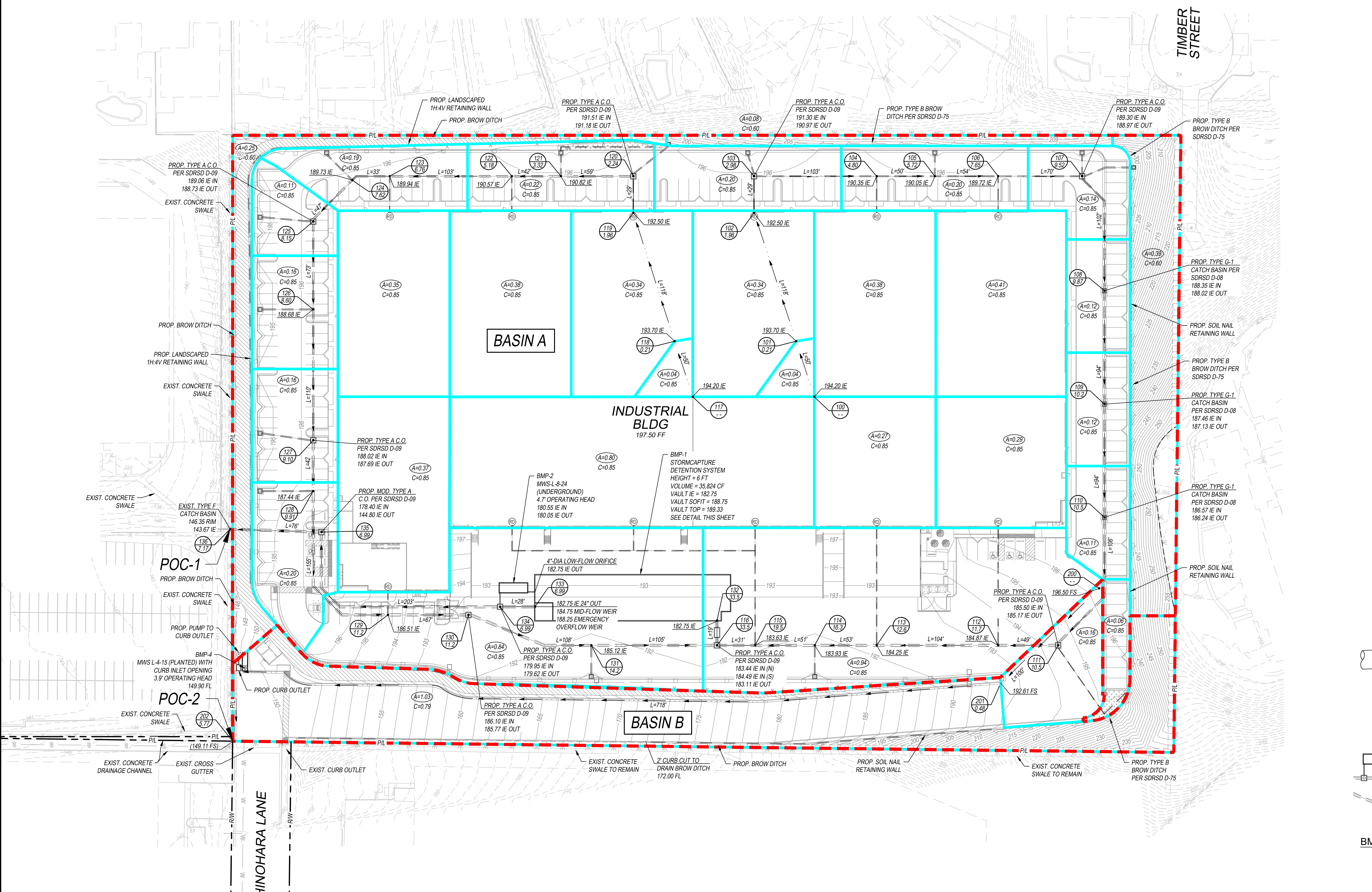

SUMMARY OF PROPOSED CONDITION 100-YEAR PEAK FLOWS

DRAINAGE BASIN	POC	DRAINAGE AREA (AC)	IMPERVIOUS AREA (AC)	% IMP	WEIGHTED RUNOFF COEFFICIENT, C	POST-PROJECT Q100 (CFS)	POST-PROJECT DETAINED Q100 (CFS)
BASIN A	POC-1	8.52	7.36	86.4%	0.83	33.45	7.17
BASIN B	POC-2	1.19	0.68	56.8%	0.80	5.77	5.77
TOTAL	-	9.71	8.03	82.7%	0.83	39.22	12.94

NOTE: UNMITIGATED PEAK FLOW IS THE POST-PROJECT PEAK FLOW THAT HAS NOT BEEN REDUCED FROM DETENTION ROUTING.
MITIGATED PEAK FLOW IS THE POST-PROJECT PEAK FLOW THAT HAS BEEN REDUCED BY ROUTING FLOW THROUGH THE PROJECT'S DETENTION FACILITY.

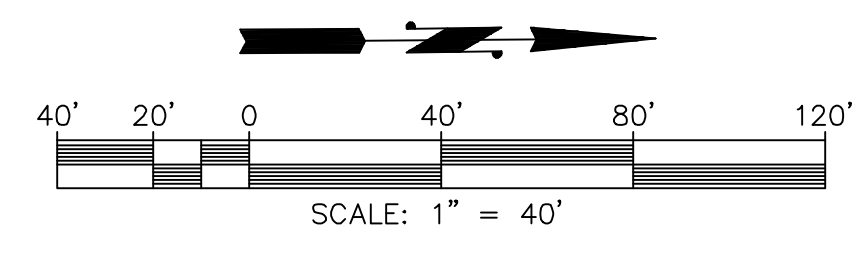

PASCO LARET SUITER & ASSOCIATES
San Diego | Encinitas | Orange County
Phone 858.259.8212 | www.plsaengineering.com

POST-PROJECT CONDITION HYDROLOGY NODE MAP
SHINOHARA BUSINESS PARK
517 SHINOHARA LANE
CHULA VISTA, CA 91911
PLSA JOB NO. 3690
MAY 2022

Appendix 3

Hydrology Design Summary

Hydrologic Soil Group—San Diego County Area, California



Soil Map may not be valid at this scale.

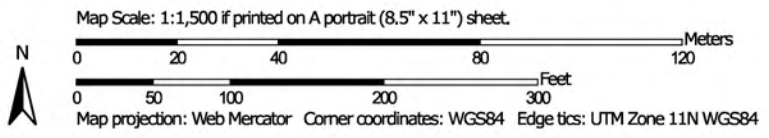



MAP LEGEND

Area of Interest (AOI)









 Area of Interest (AOI)

Soils

Soil Rating Polygons





 A
 A/D
 B
 B/D
 C
 C/D
 D
 Not rated or not available

Soil Rating Lines

 A
 A/D
 B
 B/D
 C
 C/D
 D
 Not rated or not available

Soil Rating Points

 A
 A/D
 B
 B/D

 C
 C/D
 D
 Not rated or not available

Water Features

 Streams and Canals

Transportation

 Rails
 Interstate Highways
 US Routes
 Major Roads
 Local Roads

Background

 Aerial Photography

MAP INFORMATION

The soil surveys that comprise your AOI were mapped at 1:24,000.

Warning: Soil Map may not be valid at this scale.

Enlargement of maps beyond the scale of mapping can cause misunderstanding of the detail of mapping and accuracy of soil line placement. The maps do not show the small areas of contrasting soils that could have been shown at a more detailed scale.

Please rely on the bar scale on each map sheet for map measurements.

Source of Map: Natural Resources Conservation Service
 Web Soil Survey URL:
 Coordinate System: Web Mercator (EPSG:3857)

Maps from the Web Soil Survey are based on the Web Mercator projection, which preserves direction and shape but distorts distance and area. A projection that preserves area, such as the Albers equal-area conic projection, should be used if more accurate calculations of distance or area are required.

This product is generated from the USDA-NRCS certified data as of the version date(s) listed below.

Soil Survey Area: San Diego County Area, California
 Survey Area Data: Version 15, May 27, 2020

Soil map units are labeled (as space allows) for map scales 1:50,000 or larger.

Date(s) aerial images were photographed: Aug 22, 2018—Aug 31, 2018

The orthophoto or other base map on which the soil lines were compiled and digitized probably differs from the background imagery displayed on these maps. As a result, some minor shifting of map unit boundaries may be evident.

Hydrologic Soil Group

Map unit symbol	Map unit name	Rating	Acres in AOI	Percent of AOI
OhE	Olivenhain cobbly loam, 9 to 30 percent slopes	D	7.5	71.3%
SbC	Salinas clay loam, 2 to 9 percent slopes	C	3.0	28.7%
Totals for Area of Interest			10.5	100.0%

Description

Hydrologic soil groups are based on estimates of runoff potential. Soils are assigned to one of four groups according to the rate of water infiltration when the soils are not protected by vegetation, are thoroughly wet, and receive precipitation from long-duration storms.

The soils in the United States are assigned to four groups (A, B, C, and D) and three dual classes (A/D, B/D, and C/D). The groups are defined as follows:

Group A. Soils having a high infiltration rate (low runoff potential) when thoroughly wet. These consist mainly of deep, well drained to excessively drained sands or gravelly sands. These soils have a high rate of water transmission.

Group B. Soils having a moderate infiltration rate when thoroughly wet. These consist chiefly of moderately deep or deep, moderately well drained or well drained soils that have moderately fine texture to moderately coarse texture. These soils have a moderate rate of water transmission.

Group C. Soils having a slow infiltration rate when thoroughly wet. These consist chiefly of soils having a layer that impedes the downward movement of water or soils of moderately fine texture or fine texture. These soils have a slow rate of water transmission.

Group D. Soils having a very slow infiltration rate (high runoff potential) when thoroughly wet. These consist chiefly of clays that have a high shrink-swell potential, soils that have a high water table, soils that have a claypan or clay layer at or near the surface, and soils that are shallow over nearly impervious material. These soils have a very slow rate of water transmission.

If a soil is assigned to a dual hydrologic group (A/D, B/D, or C/D), the first letter is for drained areas and the second is for undrained areas. Only the soils that in their natural condition are in group D are assigned to dual classes.

Rating Options

Aggregation Method: Dominant Condition

Component Percent Cutoff: None Specified

Tie-break Rule: Higher

Chula Vista Drainage Master Plan Figure 7: Rainfall Isopluvials

100 Year Rainfall Event

- 6 Hour Isopluvial
- 24 Hour Isopluvial

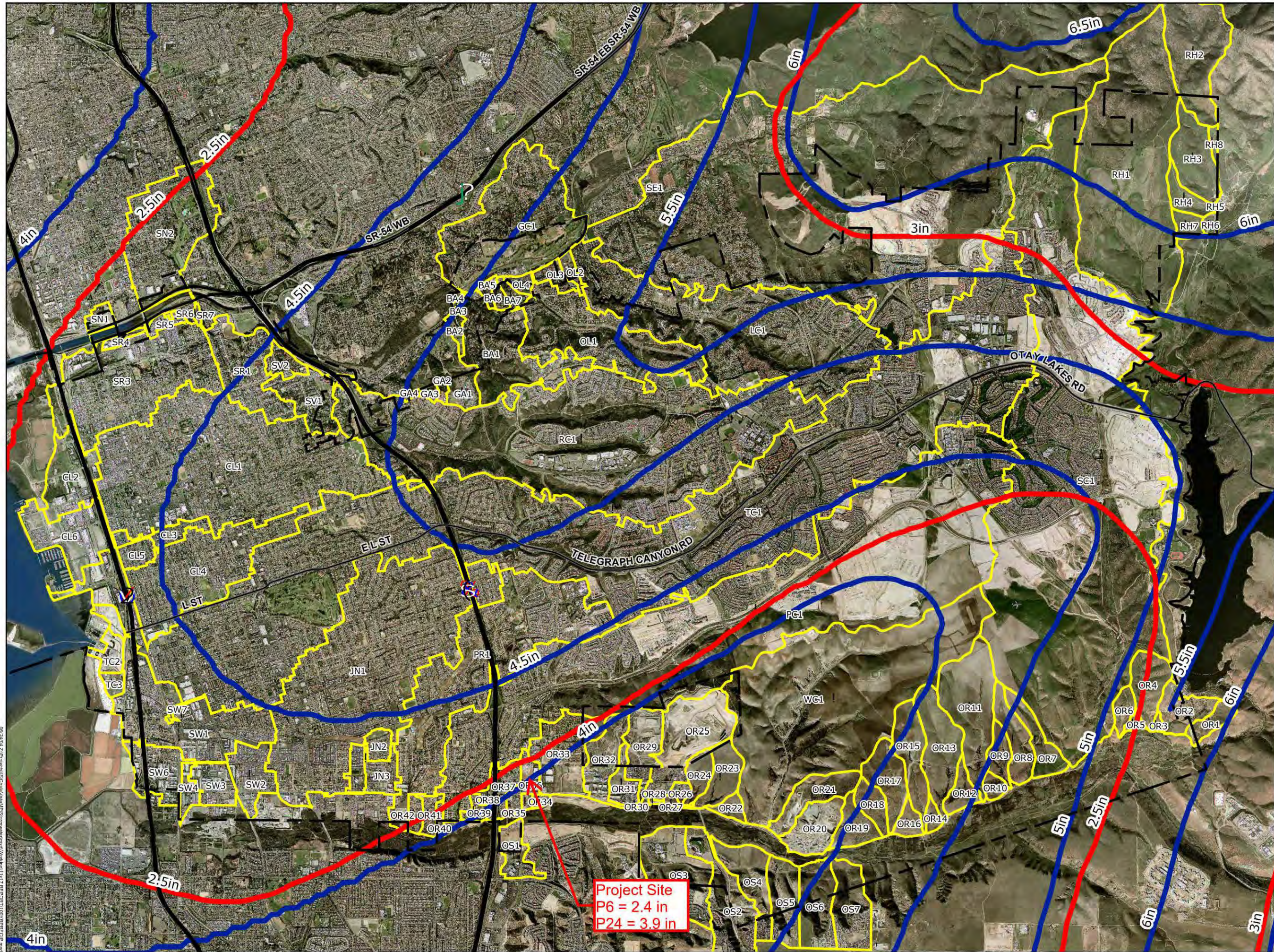

1 inch equals 4,200 feet



Map Date: Feb 12, 2004
 Projection: State Plane
 Datum: NAD 83
 Zone: California VI
 Units: Feet

Project Site
 P6 = 2.4 in
 P24 = 3.9 in

06/24/04 2:10pm GIS/Chula Vista/Map/Stormwater/Working/13/17/REP/01/100YR/REP/01.mxd

Appendix 4

AES Rational Method Calculations

100-YEAR PRE-PROJECT CONDITION

RATIONAL METHOD HYDROLOGY COMPUTER PROGRAM PACKAGE
Reference: SAN DIEGO COUNTY FLOOD CONTROL DISTRICT
2003,1985,1981 HYDROLOGY MANUAL
(c) Copyright 1982-2008 Advanced Engineering Software (aes)
Ver. 15.0 Release Date: 04/01/2008 License ID 1452

Analysis prepared by:

PASCO LARET SUITER & ASSOCIATES
535 NORTH HIGHWAY 101
SUITE A
SOLANA BEACH CA 92705

FILE NAME: 3690E100.DAT
TIME/DATE OF STUDY: 12:51 02/24/2022

USER SPECIFIED HYDROLOGY AND HYDRAULIC MODEL INFORMATION:

USER SPECIFIED STORM EVENT(YEAR) = 100.00
SPECIFIED MINIMUM PIPE SIZE(INCH) = 4.00
SPECIFIED PERCENT OF GRADIENTS(DECIMAL) TO USE FOR FRICTION SLOPE = 0.95
RAINFALL-INTENSITY ADJUSTMENT FACTOR = 1.000

*USER SPECIFIED:

NUMBER OF [TIME,INTENSITY] DATA PAIRS = 9

- 1) 5.000; 6.323
- 2) 10.000; 4.044
- 3) 15.000; 3.113
- 4) 20.000; 2.586
- 5) 25.000; 2.239
- 6) 30.000; 1.991
- 7) 40.000; 1.654
- 8) 50.000; 1.432
- 9) 60.000; 1.273

SAN DIEGO HYDROLOGY MANUAL "C"-VALUES USED FOR RATIONAL METHOD

NOTE: ONLY PEAK CONFLUENCE VALUES CONSIDERED

USER-DEFINED STREET-SECTIONS FOR COUPLED PIPEFLOW AND STREETFLOW MODEL

NO.	HALF- WIDTH (FT)	CROWN TO CROSSFALL (FT)	STREET-CROSSFALL: IN- / OUT-/ SIDE / SIDE/ WAY	CURB HEIGHT (FT)	GUTTER-GEOMETRIES: WIDTH (FT)	LIP (FT)	HIKE (FT)	MANNING FACTOR (n)
1	30.0	20.0	0.018/0.018/0.020	0.67	2.00	0.0312	0.167	0.0150

GLOBAL STREET FLOW-DEPTH CONSTRAINTS:

- 1. Relative Flow-Depth = 0.00 FEET
as (Maximum Allowable Street Flow Depth) - (Top-of-Curb)
- 2. (Depth)*(Velocity) Constraint = 6.0 (FT*FT/S)

*SIZE PIPE WITH A FLOW CAPACITY GREATER THAN
OR EQUAL TO THE UPSTREAM TRIBUTARY PIPE.*

FLOW PROCESS FROM NODE 10.00 TO NODE 11.00 IS CODE = 21

>>>>RATIONAL METHOD INITIAL SUBAREA ANALYSIS<<<<<

*USER SPECIFIED(SUBAREA):

USER-SPECIFIED RUNOFF COEFFICIENT = .5500
S.C.S. CURVE NUMBER (AMC II) = 0
INITIAL SUBAREA FLOW-LENGTH(FEET) = 72.00
UPSTREAM ELEVATION(FEET) = 215.50

DOWNSTREAM ELEVATION(FEET) = 213.00
ELEVATION DIFFERENCE(FEET) = 2.50
URBAN SUBAREA OVERLAND TIME OF FLOW(MIN.) = 5.548
100 YEAR RAINFALL INTENSITY(INCH/HOUR) = 6.073
SUBAREA RUNOFF(CFS) = 0.13
TOTAL AREA(ACRES) = 0.04 TOTAL RUNOFF(CFS) = 0.13

FLOW PROCESS FROM NODE 11.00 TO NODE 12.00 IS CODE = 51

>>>>COMPUTE TRAPEZOIDAL CHANNEL FLOW<<<<<
>>>>TRAVELTIME THRU SUBAREA (EXISTING ELEMENT)<<<<<

=====

ELEVATION DATA: UPSTREAM(FEET) = 213.00 DOWNSTREAM(FEET) = 149.00
CHANNEL LENGTH THRU SUBAREA(FEET) = 500.00 CHANNEL SLOPE = 0.1280
CHANNEL BASE(FEET) = 10.00 "Z" FACTOR = 20.000
MANNING'S FACTOR = 0.040 MAXIMUM DEPTH(FEET) = 1.00
100 YEAR RAINFALL INTENSITY(INCH/HOUR) = 4.695
*USER SPECIFIED(SUBAREA):
USER-SPECIFIED RUNOFF COEFFICIENT = .5500
S.C.S. CURVE NUMBER (AMC II) = 0
TRAVEL TIME COMPUTED USING ESTIMATED FLOW(CFS) = 3.76
TRAVEL TIME THRU SUBAREA BASED ON VELOCITY(FEET/SEC.) = 2.76
AVERAGE FLOW DEPTH(FEET) = 0.11 TRAVEL TIME(MIN.) = 3.02
Tc(MIN.) = 8.57
SUBAREA AREA(ACRES) = 2.75 SUBAREA RUNOFF(CFS) = 7.10
AREA-AVERAGE RUNOFF COEFFICIENT = 0.550
TOTAL AREA(ACRES) = 2.8 PEAK FLOW RATE(CFS) = 7.20

END OF SUBAREA CHANNEL FLOW HYDRAULICS:
DEPTH(FEET) = 0.16 FLOW VELOCITY(FEET/SEC.) = 3.33
LONGEST FLOWPATH FROM NODE 10.00 TO NODE 12.00 = 572.00 FEET.

FLOW PROCESS FROM NODE 12.00 TO NODE 13.00 IS CODE = 51

>>>>COMPUTE TRAPEZOIDAL CHANNEL FLOW<<<<<
>>>>TRAVELTIME THRU SUBAREA (EXISTING ELEMENT)<<<<<

=====

ELEVATION DATA: UPSTREAM(FEET) = 149.00 DOWNSTREAM(FEET) = 143.67
CHANNEL LENGTH THRU SUBAREA(FEET) = 224.00 CHANNEL SLOPE = 0.0238
CHANNEL BASE(FEET) = 2.50 "Z" FACTOR = 2.000
MANNING'S FACTOR = 0.015 MAXIMUM DEPTH(FEET) = 1.00
CHANNEL FLOW THRU SUBAREA(CFS) = 7.20
FLOW VELOCITY(FEET/SEC.) = 6.48 FLOW DEPTH(FEET) = 0.35
TRAVEL TIME(MIN.) = 0.58 Tc(MIN.) = 9.15
LONGEST FLOWPATH FROM NODE 10.00 TO NODE 13.00 = 796.00 FEET.

FLOW PROCESS FROM NODE 20.00 TO NODE 21.00 IS CODE = 21

>>>>RATIONAL METHOD INITIAL SUBAREA ANALYSIS<<<<<

=====

*USER SPECIFIED(SUBAREA):
USER-SPECIFIED RUNOFF COEFFICIENT = .5500
S.C.S. CURVE NUMBER (AMC II) = 0
INITIAL SUBAREA FLOW-LENGTH(FEET) = 75.00
UPSTREAM ELEVATION(FEET) = 255.00
DOWNSTREAM ELEVATION(FEET) = 231.00
ELEVATION DIFFERENCE(FEET) = 24.00
URBAN SUBAREA OVERLAND TIME OF FLOW(MIN.) = 3.980
WARNING: THE MAXIMUM OVERLAND FLOW SLOPE, 10.%, IS USED IN Tc CALCULATION!
100 YEAR RAINFALL INTENSITY(INCH/HOUR) = 6.323

NOTE: RAINFALL INTENSITY IS BASED ON Tc = 5-MINUTE.
SUBAREA RUNOFF(CFS) = 0.31
TOTAL AREA(ACRES) = 0.09 TOTAL RUNOFF(CFS) = 0.31

FLOW PROCESS FROM NODE 21.00 TO NODE 22.00 IS CODE = 51

>>>>COMPUTE TRAPEZOIDAL CHANNEL FLOW<<<<<
>>>>TRAVELTIME THRU SUBAREA (EXISTING ELEMENT)<<<<<

=====

ELEVATION DATA: UPSTREAM(FEET) =	231.00	DOWNSTREAM(FEET) =	149.00
CHANNEL LENGTH THRU SUBAREA(FEET) =	1062.00	CHANNEL SLOPE =	0.0772
CHANNEL BASE(FEET) =	5.00	"Z" FACTOR =	10.000
MANNING'S FACTOR =	0.040	MAXIMUM DEPTH(FEET) =	1.00
100 YEAR RAINFALL INTENSITY(INCH/HOUR) =	4.565		

*USER SPECIFIED(SUBAREA):
USER-SPECIFIED RUNOFF COEFFICIENT = .5500
S.C.S. CURVE NUMBER (AMC II) = 0
TRAVEL TIME COMPUTED USING ESTIMATED FLOW(CFS) = 8.20
TRAVEL TIME THRU SUBAREA BASED ON VELOCITY(FEET/SEC.) = 3.63
AVERAGE FLOW DEPTH(FEET) = 0.29 TRAVEL TIME(MIN.) = 4.88
Tc(MIN.) = 8.86
SUBAREA AREA(ACRES) = 6.05 SUBAREA RUNOFF(CFS) = 15.19
AREA-AVERAGE RUNOFF COEFFICIENT = 0.550
TOTAL AREA(ACRES) = 6.1 PEAK FLOW RATE(CFS) = 15.42

END OF SUBAREA CHANNEL FLOW HYDRAULICS:
DEPTH(FEET) = 0.39 FLOW VELOCITY(FEET/SEC.) = 4.38
LONGEST FLOWPATH FROM NODE 20.00 TO NODE 22.00 = 1137.00 FEET.

FLOW PROCESS FROM NODE 30.00 TO NODE 31.00 IS CODE = 21

>>>>RATIONAL METHOD INITIAL SUBAREA ANALYSIS<<<<<

=====

*USER SPECIFIED(SUBAREA):
USER-SPECIFIED RUNOFF COEFFICIENT = .5500
S.C.S. CURVE NUMBER (AMC II) = 0
INITIAL SUBAREA FLOW-LENGTH(FEET) = 75.00
UPSTREAM ELEVATION(FEET) = 234.00
DOWNSTREAM ELEVATION(FEET) = 220.00
ELEVATION DIFFERENCE(FEET) = 14.00
URBAN SUBAREA OVERLAND TIME OF FLOW(MIN.) = 3.980
WARNING: THE MAXIMUM OVERLAND FLOW SLOPE, 10.%, IS USED IN Tc CALCULATION!
100 YEAR RAINFALL INTENSITY(INCH/HOUR) = 6.323
NOTE: RAINFALL INTENSITY IS BASED ON Tc = 5-MINUTE.
SUBAREA RUNOFF(CFS) = 0.28
TOTAL AREA(ACRES) = 0.08 TOTAL RUNOFF(CFS) = 0.28

FLOW PROCESS FROM NODE 31.00 TO NODE 32.00 IS CODE = 51

>>>>COMPUTE TRAPEZOIDAL CHANNEL FLOW<<<<<
>>>>TRAVELTIME THRU SUBAREA (EXISTING ELEMENT)<<<<<

=====

ELEVATION DATA: UPSTREAM(FEET) =	220.00	DOWNSTREAM(FEET) =	207.00
CHANNEL LENGTH THRU SUBAREA(FEET) =	83.00	CHANNEL SLOPE =	0.1566
CHANNEL BASE(FEET) =	20.00	"Z" FACTOR =	8.000
MANNING'S FACTOR =	0.040	MAXIMUM DEPTH(FEET) =	1.00
100 YEAR RAINFALL INTENSITY(INCH/HOUR) =	6.323		

NOTE: RAINFALL INTENSITY IS BASED ON Tc = 5-MINUTE.

*USER SPECIFIED(SUBAREA):
USER-SPECIFIED RUNOFF COEFFICIENT = .5500

S.C.S. CURVE NUMBER (AMC II) = 0
TRAVEL TIME COMPUTED USING ESTIMATED FLOW (CFS) = 1.53
TRAVEL TIME THRU SUBAREA BASED ON VELOCITY (FEET/SEC.) = 1.75
AVERAGE FLOW DEPTH (FEET) = 0.04 TRAVEL TIME (MIN.) = 0.79
Tc (MIN.) = 4.77
SUBAREA AREA (ACRES) = 0.72 SUBAREA RUNOFF (CFS) = 2.50
AREA-AVERAGE RUNOFF COEFFICIENT = 0.550
TOTAL AREA (ACRES) = 0.8 PEAK FLOW RATE (CFS) = 2.78

END OF SUBAREA CHANNEL FLOW HYDRAULICS:

DEPTH (FEET) = 0.06 FLOW VELOCITY (FEET/SEC.) = 2.34
LONGEST FLOWPATH FROM NODE 30.00 TO NODE 32.00 = 158.00 FEET.

=====
END OF STUDY SUMMARY:

TOTAL AREA (ACRES) = 0.8 TC (MIN.) = 4.77
PEAK FLOW RATE (CFS) = 2.78
=====

=====
END OF RATIONAL METHOD ANALYSIS

100-YEAR POST-PROJECT CONDITION

RATIONAL METHOD HYDROLOGY COMPUTER PROGRAM PACKAGE
Reference: SAN DIEGO COUNTY FLOOD CONTROL DISTRICT
2003,1985,1981 HYDROLOGY MANUAL
(c) Copyright 1982-2016 Advanced Engineering Software (aes)
Ver. 23.0 Release Date: 07/01/2016 License ID 1452

Analysis prepared by:

FILE NAME: 3690P100.DAT
TIME/DATE OF STUDY: 09:19 05/20/2022

USER SPECIFIED HYDROLOGY AND HYDRAULIC MODEL INFORMATION:

USER SPECIFIED STORM EVENT(YEAR) = 100.00
SPECIFIED MINIMUM PIPE SIZE(INCH) = 4.00
SPECIFIED PERCENT OF GRADIENTS(DECIMAL) TO USE FOR FRICTION SLOPE = 0.95
RAINFALL-INTENSITY ADJUSTMENT FACTOR = 1.000

*USER SPECIFIED:

NUMBER OF [TIME,INTENSITY] DATA PAIRS = 9

1) 5.000; 6.323
2) 10.000; 4.044
3) 15.000; 3.113
4) 20.000; 2.586
5) 25.000; 2.239
6) 30.000; 1.991
7) 40.000; 1.654
8) 50.000; 1.432
9) 60.000; 1.273

SAN DIEGO HYDROLOGY MANUAL "C"-VALUES USED FOR RATIONAL METHOD

NOTE: ONLY PEAK CONFLUENCE VALUES CONSIDERED

USER-DEFINED STREET-SECTIONS FOR COUPLED PIPEFLOW AND STREETFLOW MODEL

NO.	HALF- WIDTH (FT)	CROWN TO CROSSFALL (FT)	STREET-CROSSFALL: IN- / OUT-/ SIDE / SIDE/ WAY	CURB HEIGHT (FT)	GUTTER-GEOMETRIES: WIDTH LIP (FT) (FT)	HIKE (FT)	MANNING FACTOR (n)
1	30.0	20.0	0.018/0.018/0.020	0.67	2.00 0.0312	0.167	0.0150

GLOBAL STREET FLOW-DEPTH CONSTRAINTS:

1. Relative Flow-Depth = 0.00 FEET
as (Maximum Allowable Street Flow Depth) - (Top-of-Curb)
2. (Depth)*(Velocity) Constraint = 6.0 (FT*FT/S)

*SIZE PIPE WITH A FLOW CAPACITY GREATER THAN
OR EQUAL TO THE UPSTREAM TRIBUTARY PIPE.*

FLOW PROCESS FROM NODE 100.00 TO NODE 101.00 IS CODE = 21

>>>>RATIONAL METHOD INITIAL SUBAREA ANALYSIS<<<<<

*USER SPECIFIED(SUBAREA):

USER-SPECIFIED RUNOFF COEFFICIENT = .8500
S.C.S. CURVE NUMBER (AMC II) = 0
INITIAL SUBAREA FLOW-LENGTH(FEET) = 50.00
UPSTREAM ELEVATION(FEET) = 194.20

DOWNSTREAM ELEVATION(FEET) = 193.70
ELEVATION DIFFERENCE(FEET) = 0.50
URBAN SUBAREA OVERLAND TIME OF FLOW(MIN.) = 3.182
100 YEAR RAINFALL INTENSITY(INCH/HOUR) = 6.323
NOTE: RAINFALL INTENSITY IS BASED ON Tc = 5-MINUTE.
SUBAREA RUNOFF(CFS) = 0.21
TOTAL AREA(ACRES) = 0.04 TOTAL RUNOFF(CFS) = 0.21

FLOW PROCESS FROM NODE 101.00 TO NODE 102.00 IS CODE = 51

>>>>COMPUTE TRAPEZOIDAL CHANNEL FLOW<<<<<
>>>>TRAVELTIME THRU SUBAREA (EXISTING ELEMENT)<<<<<

=====

ELEVATION DATA: UPSTREAM(FEET) = 193.70 DOWNSTREAM(FEET) = 192.50
CHANNEL LENGTH THRU SUBAREA(FEET) = 118.00 CHANNEL SLOPE = 0.0102
CHANNEL BASE(FEET) = 50.00 "Z" FACTOR = 50.000
MANNING'S FACTOR = 0.015 MAXIMUM DEPTH(FEET) = 1.00
100 YEAR RAINFALL INTENSITY(INCH/HOUR) = 6.072
*USER SPECIFIED(SUBAREA):
USER-SPECIFIED RUNOFF COEFFICIENT = .8500
S.C.S. CURVE NUMBER (AMC II) = 0
TRAVEL TIME COMPUTED USING ESTIMATED FLOW(CFS) = 1.10
TRAVEL TIME THRU SUBAREA BASED ON VELOCITY(FEET/SEC.) = 0.83
AVERAGE FLOW DEPTH(FEET) = 0.03 TRAVEL TIME(MIN.) = 2.37
Tc(MIN.) = 5.55
SUBAREA AREA(ACRES) = 0.34 SUBAREA RUNOFF(CFS) = 1.75
AREA-AVERAGE RUNOFF COEFFICIENT = 0.850
TOTAL AREA(ACRES) = 0.4 PEAK FLOW RATE(CFS) = 1.96

END OF SUBAREA CHANNEL FLOW HYDRAULICS:
DEPTH(FEET) = 0.04 FLOW VELOCITY(FEET/SEC.) = 1.07
LONGEST FLOWPATH FROM NODE 100.00 TO NODE 102.00 = 168.00 FEET.

FLOW PROCESS FROM NODE 102.00 TO NODE 103.00 IS CODE = 31

>>>>COMPUTE PIPE-FLOW TRAVEL TIME THRU SUBAREA<<<<<
>>>>USING COMPUTER-ESTIMATED PIPESIZE (NON-PRESSURE FLOW)<<<<<

=====

ELEVATION DATA: UPSTREAM(FEET) = 192.50 DOWNSTREAM(FEET) = 191.30
FLOW LENGTH(FEET) = 29.00 MANNING'S N = 0.011
DEPTH OF FLOW IN 9.0 INCH PIPE IS 4.5 INCHES
PIPE-FLOW VELOCITY(FEET/SEC.) = 8.79
ESTIMATED PIPE DIAMETER(INCH) = 9.00 NUMBER OF PIPES = 1
PIPE-FLOW(CFS) = 1.96
PIPE TRAVEL TIME(MIN.) = 0.05 Tc(MIN.) = 5.60
LONGEST FLOWPATH FROM NODE 100.00 TO NODE 103.00 = 197.00 FEET.

FLOW PROCESS FROM NODE 103.00 TO NODE 103.00 IS CODE = 81

>>>>ADDITION OF SUBAREA TO MAINLINE PEAK FLOW<<<<<

=====

100 YEAR RAINFALL INTENSITY(INCH/HOUR) = 6.047
*USER SPECIFIED(SUBAREA):
USER-SPECIFIED RUNOFF COEFFICIENT = .8500
S.C.S. CURVE NUMBER (AMC II) = 0
AREA-AVERAGE RUNOFF COEFFICIENT = 0.8500
SUBAREA AREA(ACRES) = 0.20 SUBAREA RUNOFF(CFS) = 1.03
TOTAL AREA(ACRES) = 0.6 TOTAL RUNOFF(CFS) = 2.98
TC(MIN.) = 5.60

```

*****
FLOW PROCESS FROM NODE    103.00 TO NODE    104.00 IS CODE = 31
-----
>>>>COMPUTE PIPE-FLOW TRAVEL TIME THRU SUBAREA<<<<
>>>>USING COMPUTER-ESTIMATED PIPESIZE (NON-PRESSURE FLOW)<<<<
=====
ELEVATION DATA: UPSTREAM(FEET) = 190.97  DOWNSTREAM(FEET) = 190.35
FLOW LENGTH(FEET) = 103.00  MANNING'S N = 0.011
DEPTH OF FLOW IN 12.0 INCH PIPE IS 9.2 INCHES
PIPE-FLOW VELOCITY(FEET/SEC.) = 4.61
ESTIMATED PIPE DIAMETER(INCH) = 12.00  NUMBER OF PIPES = 1
PIPE-FLOW(CFS) = 2.98
PIPE TRAVEL TIME(MIN.) = 0.37  Tc(MIN.) = 5.98
LONGEST FLOWPATH FROM NODE 100.00 TO NODE 104.00 = 300.00 FEET.

*****
FLOW PROCESS FROM NODE    104.00 TO NODE    104.00 IS CODE = 81
-----
>>>>ADDITION OF SUBAREA TO MAINLINE PEAK FLOW<<<<
=====
100 YEAR RAINFALL INTENSITY(INCH/HOUR) = 5.877
*USER SPECIFIED(SUBAREA):
USER-SPECIFIED RUNOFF COEFFICIENT = .8500
S.C.S. CURVE NUMBER (AMC II) = 0
AREA-AVERAGE RUNOFF COEFFICIENT = 0.8500
SUBAREA AREA(ACRES) = 0.38  SUBAREA RUNOFF(CFS) = 1.90
TOTAL AREA(ACRES) = 1.0  TOTAL RUNOFF(CFS) = 4.80
TC(MIN.) = 5.98

*****
FLOW PROCESS FROM NODE    104.00 TO NODE    105.00 IS CODE = 31
-----
>>>>COMPUTE PIPE-FLOW TRAVEL TIME THRU SUBAREA<<<<
>>>>USING COMPUTER-ESTIMATED PIPESIZE (NON-PRESSURE FLOW)<<<<
=====
ELEVATION DATA: UPSTREAM(FEET) = 190.35  DOWNSTREAM(FEET) = 190.05
FLOW LENGTH(FEET) = 50.00  MANNING'S N = 0.011
DEPTH OF FLOW IN 15.0 INCH PIPE IS 10.4 INCHES
PIPE-FLOW VELOCITY(FEET/SEC.) = 5.26
ESTIMATED PIPE DIAMETER(INCH) = 15.00  NUMBER OF PIPES = 1
PIPE-FLOW(CFS) = 4.80
PIPE TRAVEL TIME(MIN.) = 0.16  Tc(MIN.) = 6.14
LONGEST FLOWPATH FROM NODE 100.00 TO NODE 105.00 = 350.00 FEET.

*****
FLOW PROCESS FROM NODE    105.00 TO NODE    105.00 IS CODE = 81
-----
>>>>ADDITION OF SUBAREA TO MAINLINE PEAK FLOW<<<<
=====
100 YEAR RAINFALL INTENSITY(INCH/HOUR) = 5.805
*USER SPECIFIED(SUBAREA):
USER-SPECIFIED RUNOFF COEFFICIENT = .8500
S.C.S. CURVE NUMBER (AMC II) = 0
AREA-AVERAGE RUNOFF COEFFICIENT = 0.8500
SUBAREA AREA(ACRES) = 0.20  SUBAREA RUNOFF(CFS) = 0.99
TOTAL AREA(ACRES) = 1.2  TOTAL RUNOFF(CFS) = 5.72
TC(MIN.) = 6.14

*****
FLOW PROCESS FROM NODE    105.00 TO NODE    106.00 IS CODE = 31
-----
>>>>COMPUTE PIPE-FLOW TRAVEL TIME THRU SUBAREA<<<<
>>>>USING COMPUTER-ESTIMATED PIPESIZE (NON-PRESSURE FLOW)<<<<

```

=====
ELEVATION DATA: UPSTREAM(FEET) = 190.05 DOWNSTREAM(FEET) = 189.72
FLOW LENGTH(FEET) = 54.00 MANNING'S N = 0.011
DEPTH OF FLOW IN 15.0 INCH PIPE IS 12.1 INCHES
PIPE-FLOW VELOCITY(FEET/SEC.) = 5.40
ESTIMATED PIPE DIAMETER(INCH) = 15.00 NUMBER OF PIPES = 1
PIPE-FLOW(CFS) = 5.72
PIPE TRAVEL TIME(MIN.) = 0.17 Tc(MIN.) = 6.30
LONGEST FLOWPATH FROM NODE 100.00 TO NODE 106.00 = 404.00 FEET.

FLOW PROCESS FROM NODE 106.00 TO NODE 106.00 IS CODE = 81

>>>>ADDITION OF SUBAREA TO MAINLINE PEAK FLOW<<<<

=====
100 YEAR RAINFALL INTENSITY(INCH/HOUR) = 5.729
*USER SPECIFIED(SUBAREA):
USER-SPECIFIED RUNOFF COEFFICIENT = .8500
S.C.S. CURVE NUMBER (AMC II) = 0
AREA-AVERAGE RUNOFF COEFFICIENT = 0.8500
SUBAREA AREA(ACRES) = 0.41 SUBAREA RUNOFF(CFS) = 2.00
TOTAL AREA(ACRES) = 1.6 TOTAL RUNOFF(CFS) = 7.65
TC(MIN.) = 6.30

FLOW PROCESS FROM NODE 106.00 TO NODE 107.00 IS CODE = 31

>>>>COMPUTE PIPE-FLOW TRAVEL TIME THRU SUBAREA<<<<
>>>>USING COMPUTER-ESTIMATED PIPESIZE (NON-PRESSURE FLOW)<<<<

=====
ELEVATION DATA: UPSTREAM(FEET) = 189.72 DOWNSTREAM(FEET) = 189.30
FLOW LENGTH(FEET) = 70.00 MANNING'S N = 0.011
DEPTH OF FLOW IN 18.0 INCH PIPE IS 12.4 INCHES
PIPE-FLOW VELOCITY(FEET/SEC.) = 5.91
ESTIMATED PIPE DIAMETER(INCH) = 18.00 NUMBER OF PIPES = 1
PIPE-FLOW(CFS) = 7.65
PIPE TRAVEL TIME(MIN.) = 0.20 Tc(MIN.) = 6.50
LONGEST FLOWPATH FROM NODE 100.00 TO NODE 107.00 = 474.00 FEET.

FLOW PROCESS FROM NODE 107.00 TO NODE 107.00 IS CODE = 81

>>>>ADDITION OF SUBAREA TO MAINLINE PEAK FLOW<<<<

=====
100 YEAR RAINFALL INTENSITY(INCH/HOUR) = 5.639
*USER SPECIFIED(SUBAREA):
USER-SPECIFIED RUNOFF COEFFICIENT = .8500
S.C.S. CURVE NUMBER (AMC II) = 0
AREA-AVERAGE RUNOFF COEFFICIENT = 0.8500
SUBAREA AREA(ACRES) = 0.14 SUBAREA RUNOFF(CFS) = 0.67
TOTAL AREA(ACRES) = 1.7 TOTAL RUNOFF(CFS) = 8.20
TC(MIN.) = 6.50

FLOW PROCESS FROM NODE 107.00 TO NODE 107.00 IS CODE = 81

>>>>ADDITION OF SUBAREA TO MAINLINE PEAK FLOW<<<<

=====
100 YEAR RAINFALL INTENSITY(INCH/HOUR) = 5.639
*USER SPECIFIED(SUBAREA):
USER-SPECIFIED RUNOFF COEFFICIENT = .6000
S.C.S. CURVE NUMBER (AMC II) = 0
AREA-AVERAGE RUNOFF COEFFICIENT = 0.8036

SUBAREA AREA(ACRES) = 0.39 SUBAREA RUNOFF(CFS) = 1.32
TOTAL AREA(ACRES) = 2.1 TOTAL RUNOFF(CFS) = 9.52
TC(MIN.) = 6.50

FLOW PROCESS FROM NODE 107.00 TO NODE 108.00 IS CODE = 31

>>>>COMPUTE PIPE-FLOW TRAVEL TIME THRU SUBAREA<<<<<
>>>>USING COMPUTER-ESTIMATED PIPESIZE (NON-PRESSURE FLOW)<<<<<

=====

ELEVATION DATA: UPSTREAM(FEET) =	188.97	DOWNSTREAM(FEET) =	188.35
FLOW LENGTH(FEET) =	102.00	MANNING'S N =	0.011
DEPTH OF FLOW IN 21.0 INCH PIPE IS	12.6 INCHES		
PIPE-FLOW VELOCITY(FEET/SEC.) =	6.34		
ESTIMATED PIPE DIAMETER(INCH) =	21.00	NUMBER OF PIPES =	1
PIPE-FLOW(CFS) =	9.52		
PIPE TRAVEL TIME(MIN.) =	0.27	Tc(MIN.) =	6.77
LONGEST FLOWPATH FROM NODE 100.00 TO NODE 108.00 =	576.00 FEET.		

FLOW PROCESS FROM NODE 108.00 TO NODE 108.00 IS CODE = 81

>>>>ADDITION OF SUBAREA TO MAINLINE PEAK FLOW<<<<<

=====

100 YEAR RAINFALL INTENSITY(INCH/HOUR) =	5.517		
*USER SPECIFIED(SUBAREA):			
USER-SPECIFIED RUNOFF COEFFICIENT =	.8500		
S.C.S. CURVE NUMBER (AMC II) =	0		
AREA-AVERAGE RUNOFF COEFFICIENT =	0.8061		
SUBAREA AREA(ACRES) =	0.12	SUBAREA RUNOFF(CFS) =	0.56
TOTAL AREA(ACRES) =	2.2	TOTAL RUNOFF(CFS) =	9.87
TC(MIN.) =	6.77		

FLOW PROCESS FROM NODE 108.00 TO NODE 109.00 IS CODE = 31

>>>>COMPUTE PIPE-FLOW TRAVEL TIME THRU SUBAREA<<<<<
>>>>USING COMPUTER-ESTIMATED PIPESIZE (NON-PRESSURE FLOW)<<<<<

=====

ELEVATION DATA: UPSTREAM(FEET) =	188.02	DOWNSTREAM(FEET) =	187.46
FLOW LENGTH(FEET) =	94.00	MANNING'S N =	0.011
DEPTH OF FLOW IN 21.0 INCH PIPE IS	13.0 INCHES		
PIPE-FLOW VELOCITY(FEET/SEC.) =	6.34		
ESTIMATED PIPE DIAMETER(INCH) =	21.00	NUMBER OF PIPES =	1
PIPE-FLOW(CFS) =	9.87		
PIPE TRAVEL TIME(MIN.) =	0.25	Tc(MIN.) =	7.02
LONGEST FLOWPATH FROM NODE 100.00 TO NODE 109.00 =	670.00 FEET.		

FLOW PROCESS FROM NODE 109.00 TO NODE 109.00 IS CODE = 81

>>>>ADDITION OF SUBAREA TO MAINLINE PEAK FLOW<<<<<

=====

100 YEAR RAINFALL INTENSITY(INCH/HOUR) =	5.404		
*USER SPECIFIED(SUBAREA):			
USER-SPECIFIED RUNOFF COEFFICIENT =	.8500		
S.C.S. CURVE NUMBER (AMC II) =	0		
AREA-AVERAGE RUNOFF COEFFICIENT =	0.8083		
SUBAREA AREA(ACRES) =	0.12	SUBAREA RUNOFF(CFS) =	0.55
TOTAL AREA(ACRES) =	2.3	TOTAL RUNOFF(CFS) =	10.22
TC(MIN.) =	7.02		

FLOW PROCESS FROM NODE 109.00 TO NODE 110.00 IS CODE = 31

>>>>COMPUTE PIPE-FLOW TRAVEL TIME THRU SUBAREA<<<<<
>>>>USING COMPUTER-ESTIMATED PIPESIZE (NON-PRESSURE FLOW)<<<<<
=====

ELEVATION DATA: UPSTREAM(FEET) =	187.13	DOWNSTREAM(FEET) =	186.57
FLOW LENGTH(FEET) =	94.00	MANNING'S N =	0.011
DEPTH OF FLOW IN 21.0 INCH PIPE IS	13.3	INCHES	
PIPE-FLOW VELOCITY(FEET/SEC.) =	6.38		
ESTIMATED PIPE DIAMETER(INCH) =	21.00	NUMBER OF PIPES =	1
PIPE-FLOW(CFS) =	10.22		
PIPE TRAVEL TIME(MIN.) =	0.25	Tc(MIN.) =	7.26
LONGEST FLOWPATH FROM NODE	100.00	TO NODE	110.00 =
			764.00 FEET.

FLOW PROCESS FROM NODE 110.00 TO NODE 110.00 IS CODE = 81

>>>>ADDITION OF SUBAREA TO MAINLINE PEAK FLOW<<<<<
=====

100 YEAR RAINFALL INTENSITY(INCH/HOUR) =	5.293
------------------------------------------	-------

*USER SPECIFIED(SUBAREA):
USER-SPECIFIED RUNOFF COEFFICIENT = .8500
S.C.S. CURVE NUMBER (AMC II) = 0
AREA-AVERAGE RUNOFF COEFFICIENT = 0.8102
SUBAREA AREA(ACRES) = 0.11 SUBAREA RUNOFF(CFS) = 0.49
TOTAL AREA(ACRES) = 2.4 TOTAL RUNOFF(CFS) = 10.51
TC(MIN.) = 7.26

FLOW PROCESS FROM NODE 110.00 TO NODE 111.00 IS CODE = 31

>>>>COMPUTE PIPE-FLOW TRAVEL TIME THRU SUBAREA<<<<<
>>>>USING COMPUTER-ESTIMATED PIPESIZE (NON-PRESSURE FLOW)<<<<<
=====

ELEVATION DATA: UPSTREAM(FEET) =	186.24	DOWNSTREAM(FEET) =	185.50
FLOW LENGTH(FEET) =	106.00	MANNING'S N =	0.011
DEPTH OF FLOW IN 21.0 INCH PIPE IS	12.8	INCHES	
PIPE-FLOW VELOCITY(FEET/SEC.) =	6.83		
ESTIMATED PIPE DIAMETER(INCH) =	21.00	NUMBER OF PIPES =	1
PIPE-FLOW(CFS) =	10.51		
PIPE TRAVEL TIME(MIN.) =	0.26	Tc(MIN.) =	7.52
LONGEST FLOWPATH FROM NODE	100.00	TO NODE	111.00 =
			870.00 FEET.

FLOW PROCESS FROM NODE 111.00 TO NODE 111.00 IS CODE = 81

>>>>ADDITION OF SUBAREA TO MAINLINE PEAK FLOW<<<<<
=====

100 YEAR RAINFALL INTENSITY(INCH/HOUR) =	5.175
------------------------------------------	-------

*USER SPECIFIED(SUBAREA):
USER-SPECIFIED RUNOFF COEFFICIENT = .8500
S.C.S. CURVE NUMBER (AMC II) = 0
AREA-AVERAGE RUNOFF COEFFICIENT = 0.8112
SUBAREA AREA(ACRES) = 0.06 SUBAREA RUNOFF(CFS) = 0.26
TOTAL AREA(ACRES) = 2.5 TOTAL RUNOFF(CFS) = 10.54
TC(MIN.) = 7.52

FLOW PROCESS FROM NODE 111.00 TO NODE 112.00 IS CODE = 31

>>>>COMPUTE PIPE-FLOW TRAVEL TIME THRU SUBAREA<<<<<
>>>>USING COMPUTER-ESTIMATED PIPESIZE (NON-PRESSURE FLOW)<<<<<
=====

ELEVATION DATA: UPSTREAM(FEET) = 185.17 DOWNSTREAM(FEET) = 184.87
FLOW LENGTH(FEET) = 49.00 MANNING'S N = 0.011
DEPTH OF FLOW IN 21.0 INCH PIPE IS 13.4 INCHES
PIPE-FLOW VELOCITY(FEET/SEC.) = 6.50
ESTIMATED PIPE DIAMETER(INCH) = 21.00 NUMBER OF PIPES = 1
PIPE-FLOW(CFS) = 10.54
PIPE TRAVEL TIME(MIN.) = 0.13 Tc(MIN.) = 7.64
LONGEST FLOWPATH FROM NODE 100.00 TO NODE 112.00 = 919.00 FEET.

FLOW PROCESS FROM NODE 112.00 TO NODE 112.00 IS CODE = 81

>>>>ADDITION OF SUBAREA TO MAINLINE PEAK FLOW<<<<<

=====

100 YEAR RAINFALL INTENSITY(INCH/HOUR) = 5.117
*USER SPECIFIED(SUBAREA):
USER-SPECIFIED RUNOFF COEFFICIENT = .8500
S.C.S. CURVE NUMBER (AMC II) = 0
AREA-AVERAGE RUNOFF COEFFICIENT = 0.8152
SUBAREA AREA(ACRES) = 0.29 SUBAREA RUNOFF(CFS) = 1.26
TOTAL AREA(ACRES) = 2.8 TOTAL RUNOFF(CFS) = 11.68
TC(MIN.) = 7.64

FLOW PROCESS FROM NODE 112.00 TO NODE 113.00 IS CODE = 31

>>>>COMPUTE PIPE-FLOW TRAVEL TIME THRU SUBAREA<<<<<
>>>>USING COMPUTER-ESTIMATED PIPESIZE (NON-PRESSURE FLOW)<<<<<

=====

ELEVATION DATA: UPSTREAM(FEET) = 184.87 DOWNSTREAM(FEET) = 184.25
FLOW LENGTH(FEET) = 104.00 MANNING'S N = 0.011
DEPTH OF FLOW IN 21.0 INCH PIPE IS 14.6 INCHES
PIPE-FLOW VELOCITY(FEET/SEC.) = 6.55
ESTIMATED PIPE DIAMETER(INCH) = 21.00 NUMBER OF PIPES = 1
PIPE-FLOW(CFS) = 11.68
PIPE TRAVEL TIME(MIN.) = 0.26 Tc(MIN.) = 7.91
LONGEST FLOWPATH FROM NODE 100.00 TO NODE 113.00 = 1023.00 FEET.

FLOW PROCESS FROM NODE 113.00 TO NODE 113.00 IS CODE = 81

>>>>ADDITION OF SUBAREA TO MAINLINE PEAK FLOW<<<<<

=====

100 YEAR RAINFALL INTENSITY(INCH/HOUR) = 4.997
*USER SPECIFIED(SUBAREA):
USER-SPECIFIED RUNOFF COEFFICIENT = .8500
S.C.S. CURVE NUMBER (AMC II) = 0
AREA-AVERAGE RUNOFF COEFFICIENT = 0.8182
SUBAREA AREA(ACRES) = 0.27 SUBAREA RUNOFF(CFS) = 1.15
TOTAL AREA(ACRES) = 3.1 TOTAL RUNOFF(CFS) = 12.55
TC(MIN.) = 7.91

FLOW PROCESS FROM NODE 113.00 TO NODE 114.00 IS CODE = 31

>>>>COMPUTE PIPE-FLOW TRAVEL TIME THRU SUBAREA<<<<<
>>>>USING COMPUTER-ESTIMATED PIPESIZE (NON-PRESSURE FLOW)<<<<<

=====

ELEVATION DATA: UPSTREAM(FEET) = 184.25 DOWNSTREAM(FEET) = 183.93
FLOW LENGTH(FEET) = 53.00 MANNING'S N = 0.011
DEPTH OF FLOW IN 21.0 INCH PIPE IS 15.4 INCHES
PIPE-FLOW VELOCITY(FEET/SEC.) = 6.66
ESTIMATED PIPE DIAMETER(INCH) = 21.00 NUMBER OF PIPES = 1

```

PIPE-FLOW(CFS) =      12.55
PIPE TRAVEL TIME(MIN.) = 0.13    Tc(MIN.) =      8.04
LONGEST FLOWPATH FROM NODE    100.00 TO NODE    114.00 =    1076.00 FEET.

*****
FLOW PROCESS FROM NODE    114.00 TO NODE    114.00 IS CODE = 81
-----
>>>>ADDITION OF SUBAREA TO MAINLINE PEAK FLOW<<<<
=====
100 YEAR RAINFALL INTENSITY(INCH/HOUR) = 4.936
*USER SPECIFIED(SUBAREA):
USER-SPECIFIED RUNOFF COEFFICIENT = .8500
S.C.S. CURVE NUMBER (AMC II) = 0
AREA-AVERAGE RUNOFF COEFFICIENT = 0.8257
SUBAREA AREA(ACRES) = 0.94    SUBAREA RUNOFF(CFS) = 3.94
TOTAL AREA(ACRES) = 4.0    TOTAL RUNOFF(CFS) = 16.34
TC(MIN.) = 8.04

*****
FLOW PROCESS FROM NODE    114.00 TO NODE    115.00 IS CODE = 31
-----
>>>>COMPUTE PIPE-FLOW TRAVEL TIME THRU SUBAREA<<<<
>>>>USING COMPUTER-ESTIMATED PIPESIZE (NON-PRESSURE FLOW)<<<<
=====
ELEVATION DATA: UPSTREAM(FEET) = 183.93    DOWNSTREAM(FEET) = 183.63
FLOW LENGTH(FEET) = 51.00    MANNING'S N = 0.011
DEPTH OF FLOW IN 24.0 INCH PIPE IS 16.5 INCHES
PIPE-FLOW VELOCITY(FEET/SEC.) = 7.09
ESTIMATED PIPE DIAMETER(INCH) = 24.00    NUMBER OF PIPES = 1
PIPE-FLOW(CFS) = 16.34
PIPE TRAVEL TIME(MIN.) = 0.12    Tc(MIN.) = 8.16
LONGEST FLOWPATH FROM NODE    100.00 TO NODE    115.00 =    1127.00 FEET.

*****
FLOW PROCESS FROM NODE    115.00 TO NODE    115.00 IS CODE = 81
-----
>>>>ADDITION OF SUBAREA TO MAINLINE PEAK FLOW<<<<
=====
100 YEAR RAINFALL INTENSITY(INCH/HOUR) = 4.882
*USER SPECIFIED(SUBAREA):
USER-SPECIFIED RUNOFF COEFFICIENT = .8500
S.C.S. CURVE NUMBER (AMC II) = 0
AREA-AVERAGE RUNOFF COEFFICIENT = 0.8297
SUBAREA AREA(ACRES) = 0.80    SUBAREA RUNOFF(CFS) = 3.32
TOTAL AREA(ACRES) = 4.8    TOTAL RUNOFF(CFS) = 19.48
TC(MIN.) = 8.16

*****
FLOW PROCESS FROM NODE    115.00 TO NODE    116.00 IS CODE = 31
-----
>>>>COMPUTE PIPE-FLOW TRAVEL TIME THRU SUBAREA<<<<
>>>>USING COMPUTER-ESTIMATED PIPESIZE (NON-PRESSURE FLOW)<<<<
=====
ELEVATION DATA: UPSTREAM(FEET) = 183.63    DOWNSTREAM(FEET) = 183.44
FLOW LENGTH(FEET) = 31.00    MANNING'S N = 0.011
DEPTH OF FLOW IN 24.0 INCH PIPE IS 18.8 INCHES
PIPE-FLOW VELOCITY(FEET/SEC.) = 7.39
ESTIMATED PIPE DIAMETER(INCH) = 24.00    NUMBER OF PIPES = 1
PIPE-FLOW(CFS) = 19.48
PIPE TRAVEL TIME(MIN.) = 0.07    Tc(MIN.) = 8.23
LONGEST FLOWPATH FROM NODE    100.00 TO NODE    116.00 =    1158.00 FEET.

*****

```

```

FLOW PROCESS FROM NODE      116.00 TO NODE      116.00 IS CODE = 10
-----
>>>>MAIN-STREAM MEMORY COPIED ONTO MEMORY BANK # 1 <<<<<
=====
*****
FLOW PROCESS FROM NODE      117.00 TO NODE      118.00 IS CODE = 21
-----
>>>>RATIONAL METHOD INITIAL SUBAREA ANALYSIS<<<<<
=====
*USER SPECIFIED(SUBAREA):
USER-SPECIFIED RUNOFF COEFFICIENT = .8500
S.C.S. CURVE NUMBER (AMC II) = 0
INITIAL SUBAREA FLOW-LENGTH(FEET) = 50.00
UPSTREAM ELEVATION(FEET) = 194.20
DOWNSTREAM ELEVATION(FEET) = 193.70
ELEVATION DIFFERENCE(FEET) = 0.50
URBAN SUBAREA OVERLAND TIME OF FLOW(MIN.) = 3.182
100 YEAR RAINFALL INTENSITY(INCH/HOUR) = 6.323
NOTE: RAINFALL INTENSITY IS BASED ON Tc = 5-MINUTE.
SUBAREA RUNOFF(CFS) = 0.21
TOTAL AREA(ACRES) = 0.04 TOTAL RUNOFF(CFS) = 0.21
*****
FLOW PROCESS FROM NODE      118.00 TO NODE      119.00 IS CODE = 51
-----
>>>>COMPUTE TRAPEZOIDAL CHANNEL FLOW<<<<<
>>>>TRAVELTIME THRU SUBAREA (EXISTING ELEMENT)<<<<<
=====
ELEVATION DATA: UPSTREAM(FEET) = 193.70 DOWNSTREAM(FEET) = 192.50
CHANNEL LENGTH THRU SUBAREA(FEET) = 118.00 CHANNEL SLOPE = 0.0102
CHANNEL BASE(FEET) = 50.00 "Z" FACTOR = 50.000
MANNING'S FACTOR = 0.015 MAXIMUM DEPTH(FEET) = 1.00
100 YEAR RAINFALL INTENSITY(INCH/HOUR) = 6.072
*USER SPECIFIED(SUBAREA):
USER-SPECIFIED RUNOFF COEFFICIENT = .8500
S.C.S. CURVE NUMBER (AMC II) = 0
TRAVEL TIME COMPUTED USING ESTIMATED FLOW(CFS) = 1.10
TRAVEL TIME THRU SUBAREA BASED ON VELOCITY(FEET/SEC.) = 0.83
AVERAGE FLOW DEPTH(FEET) = 0.03 TRAVEL TIME(MIN.) = 2.37
Tc(MIN.) = 5.55
SUBAREA AREA(ACRES) = 0.34 SUBAREA RUNOFF(CFS) = 1.75
AREA-AVERAGE RUNOFF COEFFICIENT = 0.850
TOTAL AREA(ACRES) = 0.4 PEAK FLOW RATE(CFS) = 1.96

END OF SUBAREA CHANNEL FLOW HYDRAULICS:
DEPTH(FEET) = 0.04 FLOW VELOCITY(FEET/SEC.) = 1.07
LONGEST FLOWPATH FROM NODE 117.00 TO NODE 119.00 = 168.00 FEET.
*****
FLOW PROCESS FROM NODE      119.00 TO NODE      120.00 IS CODE = 31
-----
>>>>COMPUTE PIPE-FLOW TRAVEL TIME THRU SUBAREA<<<<<
>>>>USING COMPUTER-ESTIMATED PIPESIZE (NON-PRESSURE FLOW)<<<<<
=====
ELEVATION DATA: UPSTREAM(FEET) = 192.50 DOWNSTREAM(FEET) = 191.51
FLOW LENGTH(FEET) = 29.00 MANNING'S N = 0.011
DEPTH OF FLOW IN 9.0 INCH PIPE IS 4.8 INCHES
PIPE-FLOW VELOCITY(FEET/SEC.) = 8.20
ESTIMATED PIPE DIAMETER(INCH) = 9.00 NUMBER OF PIPES = 1
PIPE-FLOW(CFS) = 1.96
PIPE TRAVEL TIME(MIN.) = 0.06 Tc(MIN.) = 5.61
LONGEST FLOWPATH FROM NODE 117.00 TO NODE 120.00 = 197.00 FEET.

```

```

*****
FLOW PROCESS FROM NODE      120.00 TO NODE      120.00 IS CODE = 81
-----
>>>>ADDITION OF SUBAREA TO MAINLINE PEAK FLOW<<<<
=====
  100 YEAR RAINFALL INTENSITY(INCH/HOUR) = 6.045
*USER SPECIFIED(SUBAREA):
USER-SPECIFIED RUNOFF COEFFICIENT = .6000
S.C.S. CURVE NUMBER (AMC II) = 0
AREA-AVERAGE RUNOFF COEFFICIENT = 0.8065
SUBAREA AREA(ACRES) = 0.08  SUBAREA RUNOFF(CFS) = 0.29
TOTAL AREA(ACRES) = 0.5  TOTAL RUNOFF(CFS) = 2.24
TC(MIN.) = 5.61

*****
FLOW PROCESS FROM NODE      120.00 TO NODE      121.00 IS CODE = 31
-----
>>>>COMPUTE PIPE-FLOW TRAVEL TIME THRU SUBAREA<<<<
>>>>USING COMPUTER-ESTIMATED PIPESIZE (NON-PRESSURE FLOW)<<<<
=====
ELEVATION DATA: UPSTREAM(FEET) = 191.18  DOWNSTREAM(FEET) = 190.82
FLOW LENGTH(FEET) = 59.00  MANNING'S N = 0.011
DEPTH OF FLOW IN 12.0 INCH PIPE IS 7.4 INCHES
PIPE-FLOW VELOCITY(FEET/SEC.) = 4.42
ESTIMATED PIPE DIAMETER(INCH) = 12.00  NUMBER OF PIPES = 1
PIPE-FLOW(CFS) = 2.24
PIPE TRAVEL TIME(MIN.) = 0.22  Tc(MIN.) = 5.83
LONGEST FLOWPATH FROM NODE 117.00 TO NODE 121.00 = 256.00 FEET.

*****
FLOW PROCESS FROM NODE      121.00 TO NODE      121.00 IS CODE = 81
-----
>>>>ADDITION OF SUBAREA TO MAINLINE PEAK FLOW<<<<
=====
  100 YEAR RAINFALL INTENSITY(INCH/HOUR) = 5.944
*USER SPECIFIED(SUBAREA):
USER-SPECIFIED RUNOFF COEFFICIENT = .8500
S.C.S. CURVE NUMBER (AMC II) = 0
AREA-AVERAGE RUNOFF COEFFICIENT = 0.8206
SUBAREA AREA(ACRES) = 0.22  SUBAREA RUNOFF(CFS) = 1.11
TOTAL AREA(ACRES) = 0.7  TOTAL RUNOFF(CFS) = 3.32
TC(MIN.) = 5.83

*****
FLOW PROCESS FROM NODE      121.00 TO NODE      122.00 IS CODE = 31
-----
>>>>COMPUTE PIPE-FLOW TRAVEL TIME THRU SUBAREA<<<<
>>>>USING COMPUTER-ESTIMATED PIPESIZE (NON-PRESSURE FLOW)<<<<
=====
ELEVATION DATA: UPSTREAM(FEET) = 190.82  DOWNSTREAM(FEET) = 190.57
FLOW LENGTH(FEET) = 42.00  MANNING'S N = 0.011
DEPTH OF FLOW IN 15.0 INCH PIPE IS 8.2 INCHES
PIPE-FLOW VELOCITY(FEET/SEC.) = 4.85
ESTIMATED PIPE DIAMETER(INCH) = 15.00  NUMBER OF PIPES = 1
PIPE-FLOW(CFS) = 3.32
PIPE TRAVEL TIME(MIN.) = 0.14  Tc(MIN.) = 5.98
LONGEST FLOWPATH FROM NODE 117.00 TO NODE 122.00 = 298.00 FEET.

*****
FLOW PROCESS FROM NODE      122.00 TO NODE      122.00 IS CODE = 81
-----
>>>>ADDITION OF SUBAREA TO MAINLINE PEAK FLOW<<<<

```



```
=====
 100 YEAR RAINFALL INTENSITY(INCH/HOUR) = 5.878
*USER SPECIFIED(SUBAREA):
USER-SPECIFIED RUNOFF COEFFICIENT = .8500
S.C.S. CURVE NUMBER (AMC II) = 0
AREA-AVERAGE RUNOFF COEFFICIENT = 0.8311
SUBAREA AREA(ACRES) = 0.38 SUBAREA RUNOFF(CFS) = 1.90
TOTAL AREA(ACRES) = 1.1 TOTAL RUNOFF(CFS) = 5.18
TC(MIN.) = 5.98
```

```
*****
FLOW PROCESS FROM NODE 122.00 TO NODE 123.00 IS CODE = 31
```

```
-----
>>>>COMPUTE PIPE-FLOW TRAVEL TIME THRU SUBAREA<<<<
>>>>USING COMPUTER-ESTIMATED PIPESIZE (NON-PRESSURE FLOW)<<<<
```

```
=====
ELEVATION DATA: UPSTREAM(FEET) = 190.57 DOWNSTREAM(FEET) = 189.94
FLOW LENGTH(FEET) = 103.00 MANNING'S N = 0.011
DEPTH OF FLOW IN 15.0 INCH PIPE IS 11.0 INCHES
PIPE-FLOW VELOCITY(FEET/SEC.) = 5.35
ESTIMATED PIPE DIAMETER(INCH) = 15.00 NUMBER OF PIPES = 1
PIPE-FLOW(CFS) = 5.18
PIPE TRAVEL TIME(MIN.) = 0.32 Tc(MIN.) = 6.30
LONGEST FLOWPATH FROM NODE 117.00 TO NODE 123.00 = 401.00 FEET.
```

```
*****
FLOW PROCESS FROM NODE 123.00 TO NODE 123.00 IS CODE = 81
```

```
-----
>>>>ADDITION OF SUBAREA TO MAINLINE PEAK FLOW<<<<
```

```
=====
 100 YEAR RAINFALL INTENSITY(INCH/HOUR) = 5.732
*USER SPECIFIED(SUBAREA):
USER-SPECIFIED RUNOFF COEFFICIENT = .8500
S.C.S. CURVE NUMBER (AMC II) = 0
AREA-AVERAGE RUNOFF COEFFICIENT = 0.8358
SUBAREA AREA(ACRES) = 0.35 SUBAREA RUNOFF(CFS) = 1.71
TOTAL AREA(ACRES) = 1.4 TOTAL RUNOFF(CFS) = 6.76
TC(MIN.) = 6.30
```

```
*****
FLOW PROCESS FROM NODE 123.00 TO NODE 124.00 IS CODE = 31
```

```
-----
>>>>COMPUTE PIPE-FLOW TRAVEL TIME THRU SUBAREA<<<<
>>>>USING COMPUTER-ESTIMATED PIPESIZE (NON-PRESSURE FLOW)<<<<
```

```
=====
ELEVATION DATA: UPSTREAM(FEET) = 189.94 DOWNSTREAM(FEET) = 189.73
FLOW LENGTH(FEET) = 33.00 MANNING'S N = 0.011
DEPTH OF FLOW IN 18.0 INCH PIPE IS 11.1 INCHES
PIPE-FLOW VELOCITY(FEET/SEC.) = 5.91
ESTIMATED PIPE DIAMETER(INCH) = 18.00 NUMBER OF PIPES = 1
PIPE-FLOW(CFS) = 6.76
PIPE TRAVEL TIME(MIN.) = 0.09 Tc(MIN.) = 6.39
LONGEST FLOWPATH FROM NODE 117.00 TO NODE 124.00 = 434.00 FEET.
```

```
*****
FLOW PROCESS FROM NODE 124.00 TO NODE 124.00 IS CODE = 81
```

```
-----
>>>>ADDITION OF SUBAREA TO MAINLINE PEAK FLOW<<<<
```

```
=====
 100 YEAR RAINFALL INTENSITY(INCH/HOUR) = 5.690
*USER SPECIFIED(SUBAREA):
USER-SPECIFIED RUNOFF COEFFICIENT = .8500
S.C.S. CURVE NUMBER (AMC II) = 0
```

AREA-AVERAGE RUNOFF COEFFICIENT = 0.8375
SUBAREA AREA(ACRES) = 0.19 SUBAREA RUNOFF(CFS) = 0.92
TOTAL AREA(ACRES) = 1.6 TOTAL RUNOFF(CFS) = 7.62
TC(MIN.) = 6.39

FLOW PROCESS FROM NODE 124.00 TO NODE 125.00 IS CODE = 31

>>>>COMPUTE PIPE-FLOW TRAVEL TIME THRU SUBAREA<<<<<
>>>>USING COMPUTER-ESTIMATED PIPESIZE (NON-PRESSURE FLOW)<<<<<

=====

ELEVATION DATA: UPSTREAM(FEET) =	1289.73	DOWNSTREAM(FEET) =	189.06
FLOW LENGTH(FEET) =	47.00	MANNING'S N =	0.011
DEPTH OF FLOW IN	6.0 INCH PIPE IS	2.0 INCHES	
PIPE-FLOW VELOCITY(FEET/SEC.) =	131.47		
ESTIMATED PIPE DIAMETER(INCH) =	6.00	NUMBER OF PIPES =	1
PIPE-FLOW(CFS) =	7.62		
PIPE TRAVEL TIME(MIN.) =	0.01	Tc(MIN.) =	6.40
LONGEST FLOWPATH FROM NODE	117.00 TO NODE	125.00 =	481.00 FEET.

FLOW PROCESS FROM NODE 125.00 TO NODE 125.00 IS CODE = 81

>>>>ADDITION OF SUBAREA TO MAINLINE PEAK FLOW<<<<<

=====

100 YEAR RAINFALL INTENSITY(INCH/HOUR) =	5.687
*USER SPECIFIED(SUBAREA):	
USER-SPECIFIED RUNOFF COEFFICIENT =	.8500
S.C.S. CURVE NUMBER (AMC II) =	0
AREA-AVERAGE RUNOFF COEFFICIENT =	0.8383
SUBAREA AREA(ACRES) =	0.11 SUBAREA RUNOFF(CFS) = 0.53
TOTAL AREA(ACRES) =	1.7 TOTAL RUNOFF(CFS) = 8.15
TC(MIN.) =	6.40

FLOW PROCESS FROM NODE 125.00 TO NODE 126.00 IS CODE = 31

>>>>COMPUTE PIPE-FLOW TRAVEL TIME THRU SUBAREA<<<<<
>>>>USING COMPUTER-ESTIMATED PIPESIZE (NON-PRESSURE FLOW)<<<<<

=====

ELEVATION DATA: UPSTREAM(FEET) =	188.73	DOWNSTREAM(FEET) =	188.68
FLOW LENGTH(FEET) =	73.00	MANNING'S N =	0.011
DEPTH OF FLOW IN	27.0 INCH PIPE IS	19.5 INCHES	
PIPE-FLOW VELOCITY(FEET/SEC.) =	2.65		
ESTIMATED PIPE DIAMETER(INCH) =	27.00	NUMBER OF PIPES =	1
PIPE-FLOW(CFS) =	8.15		
PIPE TRAVEL TIME(MIN.) =	0.46	Tc(MIN.) =	6.86
LONGEST FLOWPATH FROM NODE	117.00 TO NODE	126.00 =	554.00 FEET.

FLOW PROCESS FROM NODE 126.00 TO NODE 126.00 IS CODE = 81

>>>>ADDITION OF SUBAREA TO MAINLINE PEAK FLOW<<<<<

=====

100 YEAR RAINFALL INTENSITY(INCH/HOUR) =	5.477
*USER SPECIFIED(SUBAREA):	
USER-SPECIFIED RUNOFF COEFFICIENT =	.8500
S.C.S. CURVE NUMBER (AMC II) =	0
AREA-AVERAGE RUNOFF COEFFICIENT =	0.8393
SUBAREA AREA(ACRES) =	0.16 SUBAREA RUNOFF(CFS) = 0.74
TOTAL AREA(ACRES) =	1.9 TOTAL RUNOFF(CFS) = 8.60
TC(MIN.) =	6.86

```

*****
FLOW PROCESS FROM NODE    126.00 TO NODE    127.00 IS CODE = 31
-----
>>>>COMPUTE PIPE-FLOW TRAVEL TIME THRU SUBAREA<<<<
>>>>USING COMPUTER-ESTIMATED PIPESIZE (NON-PRESSURE FLOW)<<<<
=====
ELEVATION DATA: UPSTREAM(FEET) = 188.68  DOWNSTREAM(FEET) = 188.02
FLOW LENGTH(FEET) = 110.00  MANNING'S N = 0.011
DEPTH OF FLOW IN 18.0 INCH PIPE IS 13.6 INCHES
PIPE-FLOW VELOCITY(FEET/SEC.) = 6.02
ESTIMATED PIPE DIAMETER(INCH) = 18.00  NUMBER OF PIPES = 1
PIPE-FLOW(CFS) = 8.60
PIPE TRAVEL TIME(MIN.) = 0.30  Tc(MIN.) = 7.16
LONGEST FLOWPATH FROM NODE    117.00 TO NODE    127.00 = 664.00 FEET.

*****
FLOW PROCESS FROM NODE    127.00 TO NODE    127.00 IS CODE = 81
-----
>>>>ADDITION OF SUBAREA TO MAINLINE PEAK FLOW<<<<
=====
100 YEAR RAINFALL INTENSITY(INCH/HOUR) = 5.338
*USER SPECIFIED(SUBAREA):
USER-SPECIFIED RUNOFF COEFFICIENT = .8500
S.C.S. CURVE NUMBER (AMC II) = 0
AREA-AVERAGE RUNOFF COEFFICIENT = 0.8401
SUBAREA AREA(ACRES) = 0.16  SUBAREA RUNOFF(CFS) = 0.73
TOTAL AREA(ACRES) = 2.0  TOTAL RUNOFF(CFS) = 9.10
TC(MIN.) = 7.16

*****
FLOW PROCESS FROM NODE    127.00 TO NODE    128.00 IS CODE = 31
-----
>>>>COMPUTE PIPE-FLOW TRAVEL TIME THRU SUBAREA<<<<
>>>>USING COMPUTER-ESTIMATED PIPESIZE (NON-PRESSURE FLOW)<<<<
=====
ELEVATION DATA: UPSTREAM(FEET) = 187.69  DOWNSTREAM(FEET) = 187.44
FLOW LENGTH(FEET) = 42.00  MANNING'S N = 0.011
DEPTH OF FLOW IN 18.0 INCH PIPE IS 14.4 INCHES
PIPE-FLOW VELOCITY(FEET/SEC.) = 6.02
ESTIMATED PIPE DIAMETER(INCH) = 18.00  NUMBER OF PIPES = 1
PIPE-FLOW(CFS) = 9.10
PIPE TRAVEL TIME(MIN.) = 0.12  Tc(MIN.) = 7.28
LONGEST FLOWPATH FROM NODE    117.00 TO NODE    128.00 = 706.00 FEET.

*****
FLOW PROCESS FROM NODE    128.00 TO NODE    128.00 IS CODE = 81
-----
>>>>ADDITION OF SUBAREA TO MAINLINE PEAK FLOW<<<<
=====
100 YEAR RAINFALL INTENSITY(INCH/HOUR) = 5.286
*USER SPECIFIED(SUBAREA):
USER-SPECIFIED RUNOFF COEFFICIENT = .8500
S.C.S. CURVE NUMBER (AMC II) = 0
AREA-AVERAGE RUNOFF COEFFICIENT = 0.8410
SUBAREA AREA(ACRES) = 0.20  SUBAREA RUNOFF(CFS) = 0.90
TOTAL AREA(ACRES) = 2.2  TOTAL RUNOFF(CFS) = 9.91
TC(MIN.) = 7.28

*****
FLOW PROCESS FROM NODE    128.00 TO NODE    129.00 IS CODE = 31
-----
>>>>COMPUTE PIPE-FLOW TRAVEL TIME THRU SUBAREA<<<<
>>>>USING COMPUTER-ESTIMATED PIPESIZE (NON-PRESSURE FLOW)<<<<

```

=====
ELEVATION DATA: UPSTREAM(FEET) = 187.44 DOWNSTREAM(FEET) = 186.51
FLOW LENGTH(FEET) = 155.00 MANNING'S N = 0.011
DEPTH OF FLOW IN 21.0 INCH PIPE IS 13.0 INCHES
PIPE-FLOW VELOCITY(FEET/SEC.) = 6.36
ESTIMATED PIPE DIAMETER(INCH) = 21.00 NUMBER OF PIPES = 1
PIPE-FLOW(CFS) = 9.91
PIPE TRAVEL TIME(MIN.) = 0.41 Tc(MIN.) = 7.68
LONGEST FLOWPATH FROM NODE 117.00 TO NODE 129.00 = 861.00 FEET.

FLOW PROCESS FROM NODE 129.00 TO NODE 129.00 IS CODE = 81

>>>>ADDITION OF SUBAREA TO MAINLINE PEAK FLOW<<<<

=====
100 YEAR RAINFALL INTENSITY(INCH/HOUR) = 5.100
*USER SPECIFIED(SUBAREA):
USER-SPECIFIED RUNOFF COEFFICIENT = .8500
S.C.S. CURVE NUMBER (AMC II) = 0
AREA-AVERAGE RUNOFF COEFFICIENT = 0.8423
SUBAREA AREA(ACRES) = 0.37 SUBAREA RUNOFF(CFS) = 1.60
TOTAL AREA(ACRES) = 2.6 TOTAL RUNOFF(CFS) = 11.17
TC(MIN.) = 7.68

FLOW PROCESS FROM NODE 129.00 TO NODE 130.00 IS CODE = 31

>>>>COMPUTE PIPE-FLOW TRAVEL TIME THRU SUBAREA<<<<
>>>>USING COMPUTER-ESTIMATED PIPESIZE (NON-PRESSURE FLOW)<<<<

=====
ELEVATION DATA: UPSTREAM(FEET) = 186.51 DOWNSTREAM(FEET) = 186.10
FLOW LENGTH(FEET) = 67.00 MANNING'S N = 0.011
DEPTH OF FLOW IN 21.0 INCH PIPE IS 14.0 INCHES
PIPE-FLOW VELOCITY(FEET/SEC.) = 6.57
ESTIMATED PIPE DIAMETER(INCH) = 21.00 NUMBER OF PIPES = 1
PIPE-FLOW(CFS) = 11.17
PIPE TRAVEL TIME(MIN.) = 0.17 Tc(MIN.) = 7.85
LONGEST FLOWPATH FROM NODE 117.00 TO NODE 130.00 = 928.00 FEET.

FLOW PROCESS FROM NODE 130.00 TO NODE 131.00 IS CODE = 31

>>>>COMPUTE PIPE-FLOW TRAVEL TIME THRU SUBAREA<<<<
>>>>USING COMPUTER-ESTIMATED PIPESIZE (NON-PRESSURE FLOW)<<<<

=====
ELEVATION DATA: UPSTREAM(FEET) = 185.77 DOWNSTREAM(FEET) = 185.12
FLOW LENGTH(FEET) = 108.00 MANNING'S N = 0.011
DEPTH OF FLOW IN 21.0 INCH PIPE IS 14.1 INCHES
PIPE-FLOW VELOCITY(FEET/SEC.) = 6.52
ESTIMATED PIPE DIAMETER(INCH) = 21.00 NUMBER OF PIPES = 1
PIPE-FLOW(CFS) = 11.17
PIPE TRAVEL TIME(MIN.) = 0.28 Tc(MIN.) = 8.13
LONGEST FLOWPATH FROM NODE 117.00 TO NODE 131.00 = 1036.00 FEET.

FLOW PROCESS FROM NODE 131.00 TO NODE 131.00 IS CODE = 81

>>>>ADDITION OF SUBAREA TO MAINLINE PEAK FLOW<<<<

=====
100 YEAR RAINFALL INTENSITY(INCH/HOUR) = 4.897
*USER SPECIFIED(SUBAREA):
USER-SPECIFIED RUNOFF COEFFICIENT = .8500
S.C.S. CURVE NUMBER (AMC II) = 0

AREA-AVERAGE RUNOFF COEFFICIENT = 0.8442
SUBAREA AREA(ACRES) = 0.84 SUBAREA RUNOFF(CFS) = 3.50
TOTAL AREA(ACRES) = 3.4 TOTAL RUNOFF(CFS) = 14.22
TC(MIN.) = 8.13

FLOW PROCESS FROM NODE 131.00 TO NODE 116.00 IS CODE = 31

>>>>COMPUTE PIPE-FLOW TRAVEL TIME THRU SUBAREA<<<<<
>>>>USING COMPUTER-ESTIMATED PIPESIZE (NON-PRESSURE FLOW)<<<<<

=====

ELEVATION DATA: UPSTREAM(FEET) =	185.12	DOWNSTREAM(FEET) =	184.49
FLOW LENGTH(FEET) =	105.00	MANNING'S N =	0.011
DEPTH OF FLOW IN	24.0 INCH PIPE IS	14.9	INCHES
PIPE-FLOW VELOCITY(FEET/SEC.) =	6.96		
ESTIMATED PIPE DIAMETER(INCH) =	24.00	NUMBER OF PIPES =	1
PIPE-FLOW(CFS) =	14.22		
PIPE TRAVEL TIME(MIN.) =	0.25	Tc(MIN.) =	8.38
LONGEST FLOWPATH FROM NODE	117.00 TO NODE	116.00 =	1141.00 FEET.

FLOW PROCESS FROM NODE 116.00 TO NODE 116.00 IS CODE = 11

>>>>CONFLUENCE MEMORY BANK # 1 WITH THE MAIN-STREAM MEMORY<<<<<

** MAIN STREAM CONFLUENCE DATA **

STREAM NUMBER	RUNOFF (CFS)	Tc (MIN.)	INTENSITY (INCH/HOUR)	AREA (ACRE)
1	14.22	8.38	4.783	3.44

LONGEST FLOWPATH FROM NODE 117.00 TO NODE 116.00 = 1141.00 FEET.

** MEMORY BANK # 1 CONFLUENCE DATA **

STREAM NUMBER	RUNOFF (CFS)	Tc (MIN.)	INTENSITY (INCH/HOUR)	AREA (ACRE)
1	19.48	8.23	4.850	4.81

LONGEST FLOWPATH FROM NODE 100.00 TO NODE 116.00 = 1158.00 FEET.

** PEAK FLOW RATE TABLE **

STREAM NUMBER	RUNOFF (CFS)	Tc (MIN.)	INTENSITY (INCH/HOUR)
1	33.45	8.23	4.850
2	33.43	8.38	4.783

COMPUTED CONFLUENCE ESTIMATES ARE AS FOLLOWS:

PEAK FLOW RATE(CFS) = 33.45 Tc(MIN.) = 8.23
TOTAL AREA(ACRES) = 8.2

FLOW PROCESS FROM NODE 116.00 TO NODE 132.00 IS CODE = 31

>>>>COMPUTE PIPE-FLOW TRAVEL TIME THRU SUBAREA<<<<<
>>>>USING COMPUTER-ESTIMATED PIPESIZE (NON-PRESSURE FLOW)<<<<<

=====

ELEVATION DATA: UPSTREAM(FEET) =	183.11	DOWNSTREAM(FEET) =	182.75
FLOW LENGTH(FEET) =	19.00	MANNING'S N =	0.011
DEPTH OF FLOW IN	24.0 INCH PIPE IS	18.4	INCHES
PIPE-FLOW VELOCITY(FEET/SEC.) =	12.97		
ESTIMATED PIPE DIAMETER(INCH) =	24.00	NUMBER OF PIPES =	1
PIPE-FLOW(CFS) =	33.45		
PIPE TRAVEL TIME(MIN.) =	0.02	Tc(MIN.) =	8.26
LONGEST FLOWPATH FROM NODE	100.00 TO NODE	132.00 =	1177.00 FEET.

```

*****
FLOW PROCESS FROM NODE    133.00 TO NODE    134.00 IS CODE = 31
-----
>>>>COMPUTE PIPE-FLOW TRAVEL TIME THRU SUBAREA<<<<
>>>>USING COMPUTER-ESTIMATED PIPESIZE (NON-PRESSURE FLOW)<<<<
=====
ELEVATION DATA: UPSTREAM(FEET) = 182.75  DOWNSTREAM(FEET) = 179.95
FLOW LENGTH(FEET) = 28.00  MANNING'S N = 0.011
DEPTH OF FLOW IN 18.0 INCH PIPE IS 13.0 INCHES
PIPE-FLOW VELOCITY(FEET/SEC.) = 24.40
ESTIMATED PIPE DIAMETER(INCH) = 18.00  NUMBER OF PIPES = 1
PIPE-FLOW(CFS) = 33.45
PIPE TRAVEL TIME(MIN.) = 0.02  Tc(MIN.) = 8.28
LONGEST FLOWPATH FROM NODE    100.00 TO NODE    134.00 = 1205.00 FEET.

*****
FLOW PROCESS FROM NODE    134.00 TO NODE    135.00 IS CODE = 31
-----
>>>>COMPUTE PIPE-FLOW TRAVEL TIME THRU SUBAREA<<<<
>>>>USING COMPUTER-ESTIMATED PIPESIZE (NON-PRESSURE FLOW)<<<<
=====
ELEVATION DATA: UPSTREAM(FEET) = 179.62  DOWNSTREAM(FEET) = 178.40
FLOW LENGTH(FEET) = 203.00  MANNING'S N = 0.011
DEPTH OF FLOW IN 30.0 INCH PIPE IS 22.5 INCHES
PIPE-FLOW VELOCITY(FEET/SEC.) = 8.46
ESTIMATED PIPE DIAMETER(INCH) = 30.00  NUMBER OF PIPES = 1
PIPE-FLOW(CFS) = 33.45
PIPE TRAVEL TIME(MIN.) = 0.40  Tc(MIN.) = 8.68
LONGEST FLOWPATH FROM NODE    100.00 TO NODE    135.00 = 1408.00 FEET.

*****
FLOW PROCESS FROM NODE    135.00 TO NODE    136.00 IS CODE = 31
-----
>>>>COMPUTE PIPE-FLOW TRAVEL TIME THRU SUBAREA<<<<
>>>>USING COMPUTER-ESTIMATED PIPESIZE (NON-PRESSURE FLOW)<<<<
=====
ELEVATION DATA: UPSTREAM(FEET) = 144.80  DOWNSTREAM(FEET) = 143.67
FLOW LENGTH(FEET) = 76.00  MANNING'S N = 0.011
DEPTH OF FLOW IN 27.0 INCH PIPE IS 17.8 INCHES
PIPE-FLOW VELOCITY(FEET/SEC.) = 12.06
ESTIMATED PIPE DIAMETER(INCH) = 27.00  NUMBER OF PIPES = 1
PIPE-FLOW(CFS) = 33.45
PIPE TRAVEL TIME(MIN.) = 0.11  Tc(MIN.) = 8.78
LONGEST FLOWPATH FROM NODE    100.00 TO NODE    136.00 = 1484.00 FEET.

*****
FLOW PROCESS FROM NODE    136.00 TO NODE    136.00 IS CODE = 81
-----
>>>>ADDITION OF SUBAREA TO MAINLINE PEAK FLOW<<<<
=====
100 YEAR RAINFALL INTENSITY(INCH/HOUR) = 4.600
*USER SPECIFIED(SUBAREA):
USER-SPECIFIED RUNOFF COEFFICIENT = .6000
S.C.S. CURVE NUMBER (AMC II) = 0
AREA-AVERAGE RUNOFF COEFFICIENT = 0.8288
SUBAREA AREA(ACRES) = 0.25  SUBAREA RUNOFF(CFS) = 0.69
TOTAL AREA(ACRES) = 8.5  TOTAL RUNOFF(CFS) = 33.45
TC(MIN.) = 8.78
NOTE: PEAK FLOW RATE DEFAULTED TO UPSTREAM VALUE

*****
FLOW PROCESS FROM NODE    200.00 TO NODE    201.00 IS CODE = 21
-----

```

>>>>RATIONAL METHOD INITIAL SUBAREA ANALYSIS<<<<<

=====

*USER SPECIFIED(SUBAREA):

USER-SPECIFIED RUNOFF COEFFICIENT = .8500
S.C.S. CURVE NUMBER (AMC II) = 0
INITIAL SUBAREA FLOW-LENGTH(FEET) = 100.00
UPSTREAM ELEVATION(FEET) = 196.50
DOWNSTREAM ELEVATION(FEET) = 192.61
ELEVATION DIFFERENCE(FEET) = 3.89
URBAN SUBAREA OVERLAND TIME OF FLOW(MIN.) = 2.861
100 YEAR RAINFALL INTENSITY(INCH/HOUR) = 6.323
NOTE: RAINFALL INTENSITY IS BASED ON Tc = 5-MINUTE.
SUBAREA RUNOFF(CFS) = 0.86
TOTAL AREA(ACRES) = 0.16 TOTAL RUNOFF(CFS) = 0.86

FLOW PROCESS FROM NODE 201.00 TO NODE 202.00 IS CODE = 61

>>>>COMPUTE STREET FLOW TRAVEL TIME THRU SUBAREA<<<<<

>>>>(STANDARD CURB SECTION USED)<<<<<

=====

UPSTREAM ELEVATION(FEET) = 192.61 DOWNSTREAM ELEVATION(FEET) = 149.11
STREET LENGTH(FEET) = 718.00 CURB HEIGHT(INCHES) = 6.0
STREET HALFWIDTH(FEET) = 36.00

DISTANCE FROM CROWN TO CROSSFALL GRADEBREAK(FEET) = 1.00
INSIDE STREET CROSSFALL(DECIMAL) = 0.015
OUTSIDE STREET CROSSFALL(DECIMAL) = 0.015

SPECIFIED NUMBER OF HALFSTREETS CARRYING RUNOFF = 1
STREET PARKWAY CROSSFALL(DECIMAL) = 0.015
Manning's FRICTION FACTOR for Streetflow Section(curbs-to-curbs) = 0.0150
Manning's FRICTION FACTOR for Back-of-Walk Flow Section = 0.0200

**TRAVEL TIME COMPUTED USING ESTIMATED FLOW(CFS) = 3.35
STREETFLOW MODEL RESULTS USING ESTIMATED FLOW:
STREET FLOW DEPTH(FEET) = 0.27
HALFSTREET FLOOD WIDTH(FEET) = 9.16
AVERAGE FLOW VELOCITY(FEET/SEC.) = 4.45
PRODUCT OF DEPTH&VELOCITY(FT*FT/SEC.) = 1.21
STREET FLOW TRAVEL TIME(MIN.) = 2.69 Tc(MIN.) = 5.55
100 YEAR RAINFALL INTENSITY(INCH/HOUR) = 6.071

*USER SPECIFIED(SUBAREA):

USER-SPECIFIED RUNOFF COEFFICIENT = .7900
S.C.S. CURVE NUMBER (AMC II) = 0
AREA-AVERAGE RUNOFF COEFFICIENT = 0.798
SUBAREA AREA(ACRES) = 1.03 SUBAREA RUNOFF(CFS) = 4.94
TOTAL AREA(ACRES) = 1.2 PEAK FLOW RATE(CFS) = 5.77

END OF SUBAREA STREET FLOW HYDRAULICS:

DEPTH(FEET) = 0.31 HALFSTREET FLOOD WIDTH(FEET) = 11.64
FLOW VELOCITY(FEET/SEC.) = 5.06 DEPTH*VELOCITY(FT*FT/SEC.) = 1.56
LONGEST FLOWPATH FROM NODE 200.00 TO NODE 202.00 = 818.00 FEET.

=====

END OF STUDY SUMMARY:

TOTAL AREA(ACRES) = 1.2 TC(MIN.) = 5.55
PEAK FLOW RATE(CFS) = 5.77

=====

END OF RATIONAL METHOD ANALYSIS

100-YEAR POST-PROJECT CONDITION - DETAINED

RATIONAL METHOD HYDROLOGY COMPUTER PROGRAM PACKAGE
Reference: SAN DIEGO COUNTY FLOOD CONTROL DISTRICT
2003,1985,1981 HYDROLOGY MANUAL
(c) Copyright 1982-2016 Advanced Engineering Software (aes)
Ver. 23.0 Release Date: 07/01/2016 License ID 1452

Analysis prepared by:

FILE NAME: 3690D100.DAT
TIME/DATE OF STUDY: 09:19 05/20/2022

USER SPECIFIED HYDROLOGY AND HYDRAULIC MODEL INFORMATION:

USER SPECIFIED STORM EVENT(YEAR) = 100.00
SPECIFIED MINIMUM PIPE SIZE(INCH) = 4.00
SPECIFIED PERCENT OF GRADIENTS(DECIMAL) TO USE FOR FRICTION SLOPE = 0.95
RAINFALL-INTENSITY ADJUSTMENT FACTOR = 1.000

*USER SPECIFIED:

NUMBER OF [TIME,INTENSITY] DATA PAIRS = 9

1) 5.000; 6.323
2) 10.000; 4.044
3) 15.000; 3.113
4) 20.000; 2.586
5) 25.000; 2.239
6) 30.000; 1.991
7) 40.000; 1.654
8) 50.000; 1.432
9) 60.000; 1.273

SAN DIEGO HYDROLOGY MANUAL "C"-VALUES USED FOR RATIONAL METHOD

NOTE: ONLY PEAK CONFLUENCE VALUES CONSIDERED

USER-DEFINED STREET-SECTIONS FOR COUPLED PIPEFLOW AND STREETFLOW MODEL

NO.	HALF- WIDTH (FT)	CROWN TO CROSSFALL (FT)	STREET-CROSSFALL: IN- / OUT-/ SIDE / SIDE/ WAY	CURB HEIGHT (FT)	GUTTER-GEOMETRIES: WIDTH (FT)	LIP (FT)	HIKE (FT)	MANNING FACTOR (n)
1	30.0	20.0	0.018/0.018/0.020	0.67	2.00	0.0312	0.167	0.0150

GLOBAL STREET FLOW-DEPTH CONSTRAINTS:

1. Relative Flow-Depth = 0.00 FEET
as (Maximum Allowable Street Flow Depth) - (Top-of-Curb)
2. (Depth)*(Velocity) Constraint = 6.0 (FT*FT/S)

*SIZE PIPE WITH A FLOW CAPACITY GREATER THAN
OR EQUAL TO THE UPSTREAM TRIBUTARY PIPE.*

FLOW PROCESS FROM NODE 100.00 TO NODE 101.00 IS CODE = 21

>>>>RATIONAL METHOD INITIAL SUBAREA ANALYSIS<<<<<

*USER SPECIFIED(SUBAREA):

USER-SPECIFIED RUNOFF COEFFICIENT = .8500
S.C.S. CURVE NUMBER (AMC II) = 0
INITIAL SUBAREA FLOW-LENGTH(FEET) = 50.00
UPSTREAM ELEVATION(FEET) = 194.20

DOWNSTREAM ELEVATION(FEET) = 193.70
ELEVATION DIFFERENCE(FEET) = 0.50
URBAN SUBAREA OVERLAND TIME OF FLOW(MIN.) = 3.182
100 YEAR RAINFALL INTENSITY(INCH/HOUR) = 6.323
NOTE: RAINFALL INTENSITY IS BASED ON Tc = 5-MINUTE.
SUBAREA RUNOFF(CFS) = 0.21
TOTAL AREA(ACRES) = 0.04 TOTAL RUNOFF(CFS) = 0.21

FLOW PROCESS FROM NODE 101.00 TO NODE 102.00 IS CODE = 51

>>>>COMPUTE TRAPEZOIDAL CHANNEL FLOW<<<<<
>>>>TRAVELTIME THRU SUBAREA (EXISTING ELEMENT)<<<<<

=====

ELEVATION DATA: UPSTREAM(FEET) = 193.70 DOWNSTREAM(FEET) = 192.50
CHANNEL LENGTH THRU SUBAREA(FEET) = 118.00 CHANNEL SLOPE = 0.0102
CHANNEL BASE(FEET) = 50.00 "Z" FACTOR = 50.000
MANNING'S FACTOR = 0.015 MAXIMUM DEPTH(FEET) = 1.00
100 YEAR RAINFALL INTENSITY(INCH/HOUR) = 6.072
*USER SPECIFIED(SUBAREA):
USER-SPECIFIED RUNOFF COEFFICIENT = .8500
S.C.S. CURVE NUMBER (AMC II) = 0
TRAVEL TIME COMPUTED USING ESTIMATED FLOW(CFS) = 1.10
TRAVEL TIME THRU SUBAREA BASED ON VELOCITY(FEET/SEC.) = 0.83
AVERAGE FLOW DEPTH(FEET) = 0.03 TRAVEL TIME(MIN.) = 2.37
Tc(MIN.) = 5.55
SUBAREA AREA(ACRES) = 0.34 SUBAREA RUNOFF(CFS) = 1.75
AREA-AVERAGE RUNOFF COEFFICIENT = 0.850
TOTAL AREA(ACRES) = 0.4 PEAK FLOW RATE(CFS) = 1.96

END OF SUBAREA CHANNEL FLOW HYDRAULICS:
DEPTH(FEET) = 0.04 FLOW VELOCITY(FEET/SEC.) = 1.07
LONGEST FLOWPATH FROM NODE 100.00 TO NODE 102.00 = 168.00 FEET.

FLOW PROCESS FROM NODE 102.00 TO NODE 103.00 IS CODE = 31

>>>>COMPUTE PIPE-FLOW TRAVEL TIME THRU SUBAREA<<<<<
>>>>USING COMPUTER-ESTIMATED PIPESIZE (NON-PRESSURE FLOW)<<<<<

=====

ELEVATION DATA: UPSTREAM(FEET) = 192.50 DOWNSTREAM(FEET) = 191.30
FLOW LENGTH(FEET) = 29.00 MANNING'S N = 0.011
DEPTH OF FLOW IN 9.0 INCH PIPE IS 4.5 INCHES
PIPE-FLOW VELOCITY(FEET/SEC.) = 8.79
ESTIMATED PIPE DIAMETER(INCH) = 9.00 NUMBER OF PIPES = 1
PIPE-FLOW(CFS) = 1.96
PIPE TRAVEL TIME(MIN.) = 0.05 Tc(MIN.) = 5.60
LONGEST FLOWPATH FROM NODE 100.00 TO NODE 103.00 = 197.00 FEET.

FLOW PROCESS FROM NODE 103.00 TO NODE 103.00 IS CODE = 81

>>>>ADDITION OF SUBAREA TO MAINLINE PEAK FLOW<<<<<

=====

100 YEAR RAINFALL INTENSITY(INCH/HOUR) = 6.047
*USER SPECIFIED(SUBAREA):
USER-SPECIFIED RUNOFF COEFFICIENT = .8500
S.C.S. CURVE NUMBER (AMC II) = 0
AREA-AVERAGE RUNOFF COEFFICIENT = 0.8500
SUBAREA AREA(ACRES) = 0.20 SUBAREA RUNOFF(CFS) = 1.03
TOTAL AREA(ACRES) = 0.6 TOTAL RUNOFF(CFS) = 2.98
TC(MIN.) = 5.60

```

*****
FLOW PROCESS FROM NODE    103.00 TO NODE    104.00 IS CODE = 31
-----
>>>>COMPUTE PIPE-FLOW TRAVEL TIME THRU SUBAREA<<<<
>>>>USING COMPUTER-ESTIMATED PIPESIZE (NON-PRESSURE FLOW)<<<<
=====
ELEVATION DATA: UPSTREAM(FEET) = 190.97  DOWNSTREAM(FEET) = 190.35
FLOW LENGTH(FEET) = 103.00  MANNING'S N = 0.011
DEPTH OF FLOW IN 12.0 INCH PIPE IS 9.2 INCHES
PIPE-FLOW VELOCITY(FEET/SEC.) = 4.61
ESTIMATED PIPE DIAMETER(INCH) = 12.00  NUMBER OF PIPES = 1
PIPE-FLOW(CFS) = 2.98
PIPE TRAVEL TIME(MIN.) = 0.37  Tc(MIN.) = 5.98
LONGEST FLOWPATH FROM NODE 100.00 TO NODE 104.00 = 300.00 FEET.

*****
FLOW PROCESS FROM NODE    104.00 TO NODE    104.00 IS CODE = 81
-----
>>>>ADDITION OF SUBAREA TO MAINLINE PEAK FLOW<<<<
=====
100 YEAR RAINFALL INTENSITY(INCH/HOUR) = 5.877
*USER SPECIFIED(SUBAREA):
USER-SPECIFIED RUNOFF COEFFICIENT = .8500
S.C.S. CURVE NUMBER (AMC II) = 0
AREA-AVERAGE RUNOFF COEFFICIENT = 0.8500
SUBAREA AREA(ACRES) = 0.38  SUBAREA RUNOFF(CFS) = 1.90
TOTAL AREA(ACRES) = 1.0  TOTAL RUNOFF(CFS) = 4.80
TC(MIN.) = 5.98

*****
FLOW PROCESS FROM NODE    104.00 TO NODE    105.00 IS CODE = 31
-----
>>>>COMPUTE PIPE-FLOW TRAVEL TIME THRU SUBAREA<<<<
>>>>USING COMPUTER-ESTIMATED PIPESIZE (NON-PRESSURE FLOW)<<<<
=====
ELEVATION DATA: UPSTREAM(FEET) = 190.35  DOWNSTREAM(FEET) = 190.05
FLOW LENGTH(FEET) = 50.00  MANNING'S N = 0.011
DEPTH OF FLOW IN 15.0 INCH PIPE IS 10.4 INCHES
PIPE-FLOW VELOCITY(FEET/SEC.) = 5.26
ESTIMATED PIPE DIAMETER(INCH) = 15.00  NUMBER OF PIPES = 1
PIPE-FLOW(CFS) = 4.80
PIPE TRAVEL TIME(MIN.) = 0.16  Tc(MIN.) = 6.14
LONGEST FLOWPATH FROM NODE 100.00 TO NODE 105.00 = 350.00 FEET.

*****
FLOW PROCESS FROM NODE    105.00 TO NODE    105.00 IS CODE = 81
-----
>>>>ADDITION OF SUBAREA TO MAINLINE PEAK FLOW<<<<
=====
100 YEAR RAINFALL INTENSITY(INCH/HOUR) = 5.805
*USER SPECIFIED(SUBAREA):
USER-SPECIFIED RUNOFF COEFFICIENT = .8500
S.C.S. CURVE NUMBER (AMC II) = 0
AREA-AVERAGE RUNOFF COEFFICIENT = 0.8500
SUBAREA AREA(ACRES) = 0.20  SUBAREA RUNOFF(CFS) = 0.99
TOTAL AREA(ACRES) = 1.2  TOTAL RUNOFF(CFS) = 5.72
TC(MIN.) = 6.14

*****
FLOW PROCESS FROM NODE    105.00 TO NODE    106.00 IS CODE = 31
-----
>>>>COMPUTE PIPE-FLOW TRAVEL TIME THRU SUBAREA<<<<
>>>>USING COMPUTER-ESTIMATED PIPESIZE (NON-PRESSURE FLOW)<<<<

```

=====
ELEVATION DATA: UPSTREAM(FEET) = 190.05 DOWNSTREAM(FEET) = 189.72
FLOW LENGTH(FEET) = 54.00 MANNING'S N = 0.011
DEPTH OF FLOW IN 15.0 INCH PIPE IS 12.1 INCHES
PIPE-FLOW VELOCITY(FEET/SEC.) = 5.40
ESTIMATED PIPE DIAMETER(INCH) = 15.00 NUMBER OF PIPES = 1
PIPE-FLOW(CFS) = 5.72
PIPE TRAVEL TIME(MIN.) = 0.17 Tc(MIN.) = 6.30
LONGEST FLOWPATH FROM NODE 100.00 TO NODE 106.00 = 404.00 FEET.

FLOW PROCESS FROM NODE 106.00 TO NODE 106.00 IS CODE = 81

>>>>ADDITION OF SUBAREA TO MAINLINE PEAK FLOW<<<<

=====
100 YEAR RAINFALL INTENSITY(INCH/HOUR) = 5.729
*USER SPECIFIED(SUBAREA):
USER-SPECIFIED RUNOFF COEFFICIENT = .8500
S.C.S. CURVE NUMBER (AMC II) = 0
AREA-AVERAGE RUNOFF COEFFICIENT = 0.8500
SUBAREA AREA(ACRES) = 0.41 SUBAREA RUNOFF(CFS) = 2.00
TOTAL AREA(ACRES) = 1.6 TOTAL RUNOFF(CFS) = 7.65
TC(MIN.) = 6.30

FLOW PROCESS FROM NODE 106.00 TO NODE 107.00 IS CODE = 31

>>>>COMPUTE PIPE-FLOW TRAVEL TIME THRU SUBAREA<<<<
>>>>USING COMPUTER-ESTIMATED PIPESIZE (NON-PRESSURE FLOW)<<<<

=====
ELEVATION DATA: UPSTREAM(FEET) = 189.72 DOWNSTREAM(FEET) = 189.30
FLOW LENGTH(FEET) = 70.00 MANNING'S N = 0.011
DEPTH OF FLOW IN 18.0 INCH PIPE IS 12.4 INCHES
PIPE-FLOW VELOCITY(FEET/SEC.) = 5.91
ESTIMATED PIPE DIAMETER(INCH) = 18.00 NUMBER OF PIPES = 1
PIPE-FLOW(CFS) = 7.65
PIPE TRAVEL TIME(MIN.) = 0.20 Tc(MIN.) = 6.50
LONGEST FLOWPATH FROM NODE 100.00 TO NODE 107.00 = 474.00 FEET.

FLOW PROCESS FROM NODE 107.00 TO NODE 107.00 IS CODE = 81

>>>>ADDITION OF SUBAREA TO MAINLINE PEAK FLOW<<<<

=====
100 YEAR RAINFALL INTENSITY(INCH/HOUR) = 5.639
*USER SPECIFIED(SUBAREA):
USER-SPECIFIED RUNOFF COEFFICIENT = .8500
S.C.S. CURVE NUMBER (AMC II) = 0
AREA-AVERAGE RUNOFF COEFFICIENT = 0.8500
SUBAREA AREA(ACRES) = 0.14 SUBAREA RUNOFF(CFS) = 0.67
TOTAL AREA(ACRES) = 1.7 TOTAL RUNOFF(CFS) = 8.20
TC(MIN.) = 6.50

FLOW PROCESS FROM NODE 107.00 TO NODE 107.00 IS CODE = 81

>>>>ADDITION OF SUBAREA TO MAINLINE PEAK FLOW<<<<

=====
100 YEAR RAINFALL INTENSITY(INCH/HOUR) = 5.639
*USER SPECIFIED(SUBAREA):
USER-SPECIFIED RUNOFF COEFFICIENT = .6000
S.C.S. CURVE NUMBER (AMC II) = 0
AREA-AVERAGE RUNOFF COEFFICIENT = 0.8036

SUBAREA AREA(ACRES) = 0.39 SUBAREA RUNOFF(CFS) = 1.32
TOTAL AREA(ACRES) = 2.1 TOTAL RUNOFF(CFS) = 9.52
TC(MIN.) = 6.50

FLOW PROCESS FROM NODE 107.00 TO NODE 108.00 IS CODE = 31

>>>>COMPUTE PIPE-FLOW TRAVEL TIME THRU SUBAREA<<<<<
>>>>USING COMPUTER-ESTIMATED PIPESIZE (NON-PRESSURE FLOW)<<<<<

=====

ELEVATION DATA: UPSTREAM(FEET) =	188.97	DOWNSTREAM(FEET) =	188.35
FLOW LENGTH(FEET) =	102.00	MANNING'S N =	0.011
DEPTH OF FLOW IN 21.0 INCH PIPE IS	12.6 INCHES		
PIPE-FLOW VELOCITY(FEET/SEC.) =	6.34		
ESTIMATED PIPE DIAMETER(INCH) =	21.00	NUMBER OF PIPES =	1
PIPE-FLOW(CFS) =	9.52		
PIPE TRAVEL TIME(MIN.) =	0.27	Tc(MIN.) =	6.77
LONGEST FLOWPATH FROM NODE 100.00 TO NODE 108.00 =	576.00 FEET.		

FLOW PROCESS FROM NODE 108.00 TO NODE 108.00 IS CODE = 81

>>>>ADDITION OF SUBAREA TO MAINLINE PEAK FLOW<<<<<

=====

100 YEAR RAINFALL INTENSITY(INCH/HOUR) =	5.517		
*USER SPECIFIED(SUBAREA):			
USER-SPECIFIED RUNOFF COEFFICIENT =	.8500		
S.C.S. CURVE NUMBER (AMC II) =	0		
AREA-AVERAGE RUNOFF COEFFICIENT =	0.8061		
SUBAREA AREA(ACRES) =	0.12	SUBAREA RUNOFF(CFS) =	0.56
TOTAL AREA(ACRES) =	2.2	TOTAL RUNOFF(CFS) =	9.87
TC(MIN.) =	6.77		

FLOW PROCESS FROM NODE 108.00 TO NODE 109.00 IS CODE = 31

>>>>COMPUTE PIPE-FLOW TRAVEL TIME THRU SUBAREA<<<<<
>>>>USING COMPUTER-ESTIMATED PIPESIZE (NON-PRESSURE FLOW)<<<<<

=====

ELEVATION DATA: UPSTREAM(FEET) =	188.02	DOWNSTREAM(FEET) =	187.46
FLOW LENGTH(FEET) =	94.00	MANNING'S N =	0.011
DEPTH OF FLOW IN 21.0 INCH PIPE IS	13.0 INCHES		
PIPE-FLOW VELOCITY(FEET/SEC.) =	6.34		
ESTIMATED PIPE DIAMETER(INCH) =	21.00	NUMBER OF PIPES =	1
PIPE-FLOW(CFS) =	9.87		
PIPE TRAVEL TIME(MIN.) =	0.25	Tc(MIN.) =	7.02
LONGEST FLOWPATH FROM NODE 100.00 TO NODE 109.00 =	670.00 FEET.		

FLOW PROCESS FROM NODE 109.00 TO NODE 109.00 IS CODE = 81

>>>>ADDITION OF SUBAREA TO MAINLINE PEAK FLOW<<<<<

=====

100 YEAR RAINFALL INTENSITY(INCH/HOUR) =	5.404		
*USER SPECIFIED(SUBAREA):			
USER-SPECIFIED RUNOFF COEFFICIENT =	.8500		
S.C.S. CURVE NUMBER (AMC II) =	0		
AREA-AVERAGE RUNOFF COEFFICIENT =	0.8083		
SUBAREA AREA(ACRES) =	0.12	SUBAREA RUNOFF(CFS) =	0.55
TOTAL AREA(ACRES) =	2.3	TOTAL RUNOFF(CFS) =	10.22
TC(MIN.) =	7.02		

FLOW PROCESS FROM NODE 109.00 TO NODE 110.00 IS CODE = 31

>>>>COMPUTE PIPE-FLOW TRAVEL TIME THRU SUBAREA<<<<<
>>>>USING COMPUTER-ESTIMATED PIPESIZE (NON-PRESSURE FLOW)<<<<<
=====

ELEVATION DATA: UPSTREAM(FEET) =	187.13	DOWNSTREAM(FEET) =	186.57
FLOW LENGTH(FEET) =	94.00	MANNING'S N =	0.011
DEPTH OF FLOW IN 21.0 INCH PIPE IS	13.3	INCHES	
PIPE-FLOW VELOCITY(FEET/SEC.) =	6.38		
ESTIMATED PIPE DIAMETER(INCH) =	21.00	NUMBER OF PIPES =	1
PIPE-FLOW(CFS) =	10.22		
PIPE TRAVEL TIME(MIN.) =	0.25	Tc(MIN.) =	7.26
LONGEST FLOWPATH FROM NODE	100.00	TO NODE	110.00 =
			764.00 FEET.

FLOW PROCESS FROM NODE 110.00 TO NODE 110.00 IS CODE = 81

>>>>ADDITION OF SUBAREA TO MAINLINE PEAK FLOW<<<<<
=====

100 YEAR RAINFALL INTENSITY(INCH/HOUR) =	5.293		
*USER SPECIFIED(SUBAREA):			
USER-SPECIFIED RUNOFF COEFFICIENT =	.8500		
S.C.S. CURVE NUMBER (AMC II) =	0		
AREA-AVERAGE RUNOFF COEFFICIENT =	0.8102		
SUBAREA AREA(ACRES) =	0.11	SUBAREA RUNOFF(CFS) =	0.49
TOTAL AREA(ACRES) =	2.4	TOTAL RUNOFF(CFS) =	10.51
TC(MIN.) =	7.26		

FLOW PROCESS FROM NODE 110.00 TO NODE 111.00 IS CODE = 31

>>>>COMPUTE PIPE-FLOW TRAVEL TIME THRU SUBAREA<<<<<
>>>>USING COMPUTER-ESTIMATED PIPESIZE (NON-PRESSURE FLOW)<<<<<
=====

ELEVATION DATA: UPSTREAM(FEET) =	186.24	DOWNSTREAM(FEET) =	185.50
FLOW LENGTH(FEET) =	106.00	MANNING'S N =	0.011
DEPTH OF FLOW IN 21.0 INCH PIPE IS	12.8	INCHES	
PIPE-FLOW VELOCITY(FEET/SEC.) =	6.83		
ESTIMATED PIPE DIAMETER(INCH) =	21.00	NUMBER OF PIPES =	1
PIPE-FLOW(CFS) =	10.51		
PIPE TRAVEL TIME(MIN.) =	0.26	Tc(MIN.) =	7.52
LONGEST FLOWPATH FROM NODE	100.00	TO NODE	111.00 =
			870.00 FEET.

FLOW PROCESS FROM NODE 111.00 TO NODE 111.00 IS CODE = 81

>>>>ADDITION OF SUBAREA TO MAINLINE PEAK FLOW<<<<<
=====

100 YEAR RAINFALL INTENSITY(INCH/HOUR) =	5.175		
*USER SPECIFIED(SUBAREA):			
USER-SPECIFIED RUNOFF COEFFICIENT =	.8500		
S.C.S. CURVE NUMBER (AMC II) =	0		
AREA-AVERAGE RUNOFF COEFFICIENT =	0.8112		
SUBAREA AREA(ACRES) =	0.06	SUBAREA RUNOFF(CFS) =	0.26
TOTAL AREA(ACRES) =	2.5	TOTAL RUNOFF(CFS) =	10.54
TC(MIN.) =	7.52		

FLOW PROCESS FROM NODE 111.00 TO NODE 112.00 IS CODE = 31

>>>>COMPUTE PIPE-FLOW TRAVEL TIME THRU SUBAREA<<<<<
>>>>USING COMPUTER-ESTIMATED PIPESIZE (NON-PRESSURE FLOW)<<<<<
=====

ELEVATION DATA: UPSTREAM(FEET) = 185.17 DOWNSTREAM(FEET) = 184.87
FLOW LENGTH(FEET) = 49.00 MANNING'S N = 0.011
DEPTH OF FLOW IN 21.0 INCH PIPE IS 13.4 INCHES
PIPE-FLOW VELOCITY(FEET/SEC.) = 6.50
ESTIMATED PIPE DIAMETER(INCH) = 21.00 NUMBER OF PIPES = 1
PIPE-FLOW(CFS) = 10.54
PIPE TRAVEL TIME(MIN.) = 0.13 Tc(MIN.) = 7.64
LONGEST FLOWPATH FROM NODE 100.00 TO NODE 112.00 = 919.00 FEET.

FLOW PROCESS FROM NODE 112.00 TO NODE 112.00 IS CODE = 81

>>>>ADDITION OF SUBAREA TO MAINLINE PEAK FLOW<<<<<

=====

100 YEAR RAINFALL INTENSITY(INCH/HOUR) = 5.117
*USER SPECIFIED(SUBAREA):
USER-SPECIFIED RUNOFF COEFFICIENT = .8500
S.C.S. CURVE NUMBER (AMC II) = 0
AREA-AVERAGE RUNOFF COEFFICIENT = 0.8152
SUBAREA AREA(ACRES) = 0.29 SUBAREA RUNOFF(CFS) = 1.26
TOTAL AREA(ACRES) = 2.8 TOTAL RUNOFF(CFS) = 11.68
TC(MIN.) = 7.64

FLOW PROCESS FROM NODE 112.00 TO NODE 113.00 IS CODE = 31

>>>>COMPUTE PIPE-FLOW TRAVEL TIME THRU SUBAREA<<<<<
>>>>USING COMPUTER-ESTIMATED PIPESIZE (NON-PRESSURE FLOW)<<<<<

=====

ELEVATION DATA: UPSTREAM(FEET) = 184.87 DOWNSTREAM(FEET) = 184.25
FLOW LENGTH(FEET) = 104.00 MANNING'S N = 0.011
DEPTH OF FLOW IN 21.0 INCH PIPE IS 14.6 INCHES
PIPE-FLOW VELOCITY(FEET/SEC.) = 6.55
ESTIMATED PIPE DIAMETER(INCH) = 21.00 NUMBER OF PIPES = 1
PIPE-FLOW(CFS) = 11.68
PIPE TRAVEL TIME(MIN.) = 0.26 Tc(MIN.) = 7.91
LONGEST FLOWPATH FROM NODE 100.00 TO NODE 113.00 = 1023.00 FEET.

FLOW PROCESS FROM NODE 113.00 TO NODE 113.00 IS CODE = 81

>>>>ADDITION OF SUBAREA TO MAINLINE PEAK FLOW<<<<<

=====

100 YEAR RAINFALL INTENSITY(INCH/HOUR) = 4.997
*USER SPECIFIED(SUBAREA):
USER-SPECIFIED RUNOFF COEFFICIENT = .8500
S.C.S. CURVE NUMBER (AMC II) = 0
AREA-AVERAGE RUNOFF COEFFICIENT = 0.8182
SUBAREA AREA(ACRES) = 0.27 SUBAREA RUNOFF(CFS) = 1.15
TOTAL AREA(ACRES) = 3.1 TOTAL RUNOFF(CFS) = 12.55
TC(MIN.) = 7.91

FLOW PROCESS FROM NODE 113.00 TO NODE 114.00 IS CODE = 31

>>>>COMPUTE PIPE-FLOW TRAVEL TIME THRU SUBAREA<<<<<
>>>>USING COMPUTER-ESTIMATED PIPESIZE (NON-PRESSURE FLOW)<<<<<

=====

ELEVATION DATA: UPSTREAM(FEET) = 184.25 DOWNSTREAM(FEET) = 183.93
FLOW LENGTH(FEET) = 53.00 MANNING'S N = 0.011
DEPTH OF FLOW IN 21.0 INCH PIPE IS 15.4 INCHES
PIPE-FLOW VELOCITY(FEET/SEC.) = 6.66
ESTIMATED PIPE DIAMETER(INCH) = 21.00 NUMBER OF PIPES = 1

```

PIPE-FLOW(CFS) = 12.55
PIPE TRAVEL TIME(MIN.) = 0.13 Tc(MIN.) = 8.04
LONGEST FLOWPATH FROM NODE 100.00 TO NODE 114.00 = 1076.00 FEET.
*****
FLOW PROCESS FROM NODE 114.00 TO NODE 114.00 IS CODE = 81
-----
>>>>ADDITION OF SUBAREA TO MAINLINE PEAK FLOW<<<<
=====
100 YEAR RAINFALL INTENSITY(INCH/HOUR) = 4.936
*USER SPECIFIED(SUBAREA):
USER-SPECIFIED RUNOFF COEFFICIENT = .8500
S.C.S. CURVE NUMBER (AMC II) = 0
AREA-AVERAGE RUNOFF COEFFICIENT = 0.8257
SUBAREA AREA(ACRES) = 0.94 SUBAREA RUNOFF(CFS) = 3.94
TOTAL AREA(ACRES) = 4.0 TOTAL RUNOFF(CFS) = 16.34
TC(MIN.) = 8.04
*****
FLOW PROCESS FROM NODE 114.00 TO NODE 115.00 IS CODE = 31
-----
>>>>COMPUTE PIPE-FLOW TRAVEL TIME THRU SUBAREA<<<<
>>>>USING COMPUTER-ESTIMATED PIPESIZE (NON-PRESSURE FLOW)<<<<
=====
ELEVATION DATA: UPSTREAM(FEET) = 183.93 DOWNSTREAM(FEET) = 183.63
FLOW LENGTH(FEET) = 51.00 MANNING'S N = 0.011
DEPTH OF FLOW IN 24.0 INCH PIPE IS 16.5 INCHES
PIPE-FLOW VELOCITY(FEET/SEC.) = 7.09
ESTIMATED PIPE DIAMETER(INCH) = 24.00 NUMBER OF PIPES = 1
PIPE-FLOW(CFS) = 16.34
PIPE TRAVEL TIME(MIN.) = 0.12 Tc(MIN.) = 8.16
LONGEST FLOWPATH FROM NODE 100.00 TO NODE 115.00 = 1127.00 FEET.
*****
FLOW PROCESS FROM NODE 115.00 TO NODE 115.00 IS CODE = 81
-----
>>>>ADDITION OF SUBAREA TO MAINLINE PEAK FLOW<<<<
=====
100 YEAR RAINFALL INTENSITY(INCH/HOUR) = 4.882
*USER SPECIFIED(SUBAREA):
USER-SPECIFIED RUNOFF COEFFICIENT = .8500
S.C.S. CURVE NUMBER (AMC II) = 0
AREA-AVERAGE RUNOFF COEFFICIENT = 0.8297
SUBAREA AREA(ACRES) = 0.80 SUBAREA RUNOFF(CFS) = 3.32
TOTAL AREA(ACRES) = 4.8 TOTAL RUNOFF(CFS) = 19.48
TC(MIN.) = 8.16
*****
FLOW PROCESS FROM NODE 115.00 TO NODE 116.00 IS CODE = 31
-----
>>>>COMPUTE PIPE-FLOW TRAVEL TIME THRU SUBAREA<<<<
>>>>USING COMPUTER-ESTIMATED PIPESIZE (NON-PRESSURE FLOW)<<<<
=====
ELEVATION DATA: UPSTREAM(FEET) = 183.63 DOWNSTREAM(FEET) = 183.44
FLOW LENGTH(FEET) = 31.00 MANNING'S N = 0.011
DEPTH OF FLOW IN 24.0 INCH PIPE IS 18.8 INCHES
PIPE-FLOW VELOCITY(FEET/SEC.) = 7.39
ESTIMATED PIPE DIAMETER(INCH) = 24.00 NUMBER OF PIPES = 1
PIPE-FLOW(CFS) = 19.48
PIPE TRAVEL TIME(MIN.) = 0.07 Tc(MIN.) = 8.23
LONGEST FLOWPATH FROM NODE 100.00 TO NODE 116.00 = 1158.00 FEET.
*****

```



```

FLOW PROCESS FROM NODE      116.00 TO NODE      116.00 IS CODE = 10
-----
>>>>MAIN-STREAM MEMORY COPIED ONTO MEMORY BANK # 1 <<<<
=====
*****
FLOW PROCESS FROM NODE      117.00 TO NODE      118.00 IS CODE = 21
-----
>>>>RATIONAL METHOD INITIAL SUBAREA ANALYSIS<<<<
=====
*USER SPECIFIED(SUBAREA):
USER-SPECIFIED RUNOFF COEFFICIENT = .8500
S.C.S. CURVE NUMBER (AMC II) = 0
INITIAL SUBAREA FLOW-LENGTH(FEET) = 50.00
UPSTREAM ELEVATION(FEET) = 194.20
DOWNSTREAM ELEVATION(FEET) = 193.70
ELEVATION DIFFERENCE(FEET) = 0.50
URBAN SUBAREA OVERLAND TIME OF FLOW(MIN.) = 3.182
100 YEAR RAINFALL INTENSITY(INCH/HOUR) = 6.323
NOTE: RAINFALL INTENSITY IS BASED ON Tc = 5-MINUTE.
SUBAREA RUNOFF(CFS) = 0.21
TOTAL AREA(ACRES) = 0.04 TOTAL RUNOFF(CFS) = 0.21
*****
FLOW PROCESS FROM NODE      118.00 TO NODE      119.00 IS CODE = 51
-----
>>>>COMPUTE TRAPEZOIDAL CHANNEL FLOW<<<<
>>>>TRAVELTIME THRU SUBAREA (EXISTING ELEMENT)<<<<
=====
ELEVATION DATA: UPSTREAM(FEET) = 193.70 DOWNSTREAM(FEET) = 192.50
CHANNEL LENGTH THRU SUBAREA(FEET) = 118.00 CHANNEL SLOPE = 0.0102
CHANNEL BASE(FEET) = 50.00 "Z" FACTOR = 50.000
MANNING'S FACTOR = 0.015 MAXIMUM DEPTH(FEET) = 1.00
100 YEAR RAINFALL INTENSITY(INCH/HOUR) = 6.072
*USER SPECIFIED(SUBAREA):
USER-SPECIFIED RUNOFF COEFFICIENT = .8500
S.C.S. CURVE NUMBER (AMC II) = 0
TRAVEL TIME COMPUTED USING ESTIMATED FLOW(CFS) = 1.10
TRAVEL TIME THRU SUBAREA BASED ON VELOCITY(FEET/SEC.) = 0.83
AVERAGE FLOW DEPTH(FEET) = 0.03 TRAVEL TIME(MIN.) = 2.37
Tc(MIN.) = 5.55
SUBAREA AREA(ACRES) = 0.34 SUBAREA RUNOFF(CFS) = 1.75
AREA-AVERAGE RUNOFF COEFFICIENT = 0.850
TOTAL AREA(ACRES) = 0.4 PEAK FLOW RATE(CFS) = 1.96

END OF SUBAREA CHANNEL FLOW HYDRAULICS:
DEPTH(FEET) = 0.04 FLOW VELOCITY(FEET/SEC.) = 1.07
LONGEST FLOWPATH FROM NODE 117.00 TO NODE 119.00 = 168.00 FEET.
*****
FLOW PROCESS FROM NODE      119.00 TO NODE      120.00 IS CODE = 31
-----
>>>>COMPUTE PIPE-FLOW TRAVEL TIME THRU SUBAREA<<<<
>>>>USING COMPUTER-ESTIMATED PIPESIZE (NON-PRESSURE FLOW)<<<<
=====
ELEVATION DATA: UPSTREAM(FEET) = 192.50 DOWNSTREAM(FEET) = 191.51
FLOW LENGTH(FEET) = 29.00 MANNING'S N = 0.011
DEPTH OF FLOW IN 9.0 INCH PIPE IS 4.8 INCHES
PIPE-FLOW VELOCITY(FEET/SEC.) = 8.20
ESTIMATED PIPE DIAMETER(INCH) = 9.00 NUMBER OF PIPES = 1
PIPE-FLOW(CFS) = 1.96
PIPE TRAVEL TIME(MIN.) = 0.06 Tc(MIN.) = 5.61
LONGEST FLOWPATH FROM NODE 117.00 TO NODE 120.00 = 197.00 FEET.

```

```

*****
FLOW PROCESS FROM NODE      120.00 TO NODE      120.00 IS CODE = 81
-----
>>>>ADDITION OF SUBAREA TO MAINLINE PEAK FLOW<<<<
=====
  100 YEAR RAINFALL INTENSITY(INCH/HOUR) = 6.045
*USER SPECIFIED(SUBAREA):
USER-SPECIFIED RUNOFF COEFFICIENT = .6000
S.C.S. CURVE NUMBER (AMC II) = 0
AREA-AVERAGE RUNOFF COEFFICIENT = 0.8065
SUBAREA AREA(ACRES) = 0.08 SUBAREA RUNOFF(CFS) = 0.29
TOTAL AREA(ACRES) = 0.5 TOTAL RUNOFF(CFS) = 2.24
TC(MIN.) = 5.61

*****
FLOW PROCESS FROM NODE      120.00 TO NODE      121.00 IS CODE = 31
-----
>>>>COMPUTE PIPE-FLOW TRAVEL TIME THRU SUBAREA<<<<
>>>>USING COMPUTER-ESTIMATED PIPESIZE (NON-PRESSURE FLOW)<<<<
=====
ELEVATION DATA: UPSTREAM(FEET) = 191.18 DOWNSTREAM(FEET) = 190.82
FLOW LENGTH(FEET) = 59.00 MANNING'S N = 0.011
DEPTH OF FLOW IN 12.0 INCH PIPE IS 7.4 INCHES
PIPE-FLOW VELOCITY(FEET/SEC.) = 4.42
ESTIMATED PIPE DIAMETER(INCH) = 12.00 NUMBER OF PIPES = 1
PIPE-FLOW(CFS) = 2.24
PIPE TRAVEL TIME(MIN.) = 0.22 Tc(MIN.) = 5.83
LONGEST FLOWPATH FROM NODE 117.00 TO NODE 121.00 = 256.00 FEET.

*****
FLOW PROCESS FROM NODE      121.00 TO NODE      121.00 IS CODE = 81
-----
>>>>ADDITION OF SUBAREA TO MAINLINE PEAK FLOW<<<<
=====
  100 YEAR RAINFALL INTENSITY(INCH/HOUR) = 5.944
*USER SPECIFIED(SUBAREA):
USER-SPECIFIED RUNOFF COEFFICIENT = .8500
S.C.S. CURVE NUMBER (AMC II) = 0
AREA-AVERAGE RUNOFF COEFFICIENT = 0.8206
SUBAREA AREA(ACRES) = 0.22 SUBAREA RUNOFF(CFS) = 1.11
TOTAL AREA(ACRES) = 0.7 TOTAL RUNOFF(CFS) = 3.32
TC(MIN.) = 5.83

*****
FLOW PROCESS FROM NODE      121.00 TO NODE      122.00 IS CODE = 31
-----
>>>>COMPUTE PIPE-FLOW TRAVEL TIME THRU SUBAREA<<<<
>>>>USING COMPUTER-ESTIMATED PIPESIZE (NON-PRESSURE FLOW)<<<<
=====
ELEVATION DATA: UPSTREAM(FEET) = 190.82 DOWNSTREAM(FEET) = 190.57
FLOW LENGTH(FEET) = 42.00 MANNING'S N = 0.011
DEPTH OF FLOW IN 15.0 INCH PIPE IS 8.2 INCHES
PIPE-FLOW VELOCITY(FEET/SEC.) = 4.85
ESTIMATED PIPE DIAMETER(INCH) = 15.00 NUMBER OF PIPES = 1
PIPE-FLOW(CFS) = 3.32
PIPE TRAVEL TIME(MIN.) = 0.14 Tc(MIN.) = 5.98
LONGEST FLOWPATH FROM NODE 117.00 TO NODE 122.00 = 298.00 FEET.

*****
FLOW PROCESS FROM NODE      122.00 TO NODE      122.00 IS CODE = 81
-----
>>>>ADDITION OF SUBAREA TO MAINLINE PEAK FLOW<<<<

```

```
=====
 100 YEAR RAINFALL INTENSITY(INCH/HOUR) = 5.878
*USER SPECIFIED(SUBAREA):
USER-SPECIFIED RUNOFF COEFFICIENT = .8500
S.C.S. CURVE NUMBER (AMC II) = 0
AREA-AVERAGE RUNOFF COEFFICIENT = 0.8311
SUBAREA AREA(ACRES) = 0.38 SUBAREA RUNOFF(CFS) = 1.90
TOTAL AREA(ACRES) = 1.1 TOTAL RUNOFF(CFS) = 5.18
TC(MIN.) = 5.98
```

```
*****
FLOW PROCESS FROM NODE 122.00 TO NODE 123.00 IS CODE = 31
```

```
-----
>>>>COMPUTE PIPE-FLOW TRAVEL TIME THRU SUBAREA<<<<
>>>>USING COMPUTER-ESTIMATED PIPESIZE (NON-PRESSURE FLOW)<<<<
```

```
=====
ELEVATION DATA: UPSTREAM(FEET) = 190.57 DOWNSTREAM(FEET) = 189.94
FLOW LENGTH(FEET) = 103.00 MANNING'S N = 0.011
DEPTH OF FLOW IN 15.0 INCH PIPE IS 11.0 INCHES
PIPE-FLOW VELOCITY(FEET/SEC.) = 5.35
ESTIMATED PIPE DIAMETER(INCH) = 15.00 NUMBER OF PIPES = 1
PIPE-FLOW(CFS) = 5.18
PIPE TRAVEL TIME(MIN.) = 0.32 Tc(MIN.) = 6.30
LONGEST FLOWPATH FROM NODE 117.00 TO NODE 123.00 = 401.00 FEET.
```

```
*****
FLOW PROCESS FROM NODE 123.00 TO NODE 123.00 IS CODE = 81
```

```
-----
>>>>ADDITION OF SUBAREA TO MAINLINE PEAK FLOW<<<<
```

```
=====
 100 YEAR RAINFALL INTENSITY(INCH/HOUR) = 5.732
*USER SPECIFIED(SUBAREA):
USER-SPECIFIED RUNOFF COEFFICIENT = .8500
S.C.S. CURVE NUMBER (AMC II) = 0
AREA-AVERAGE RUNOFF COEFFICIENT = 0.8358
SUBAREA AREA(ACRES) = 0.35 SUBAREA RUNOFF(CFS) = 1.71
TOTAL AREA(ACRES) = 1.4 TOTAL RUNOFF(CFS) = 6.76
TC(MIN.) = 6.30
```

```
*****
FLOW PROCESS FROM NODE 123.00 TO NODE 124.00 IS CODE = 31
```

```
-----
>>>>COMPUTE PIPE-FLOW TRAVEL TIME THRU SUBAREA<<<<
>>>>USING COMPUTER-ESTIMATED PIPESIZE (NON-PRESSURE FLOW)<<<<
```

```
=====
ELEVATION DATA: UPSTREAM(FEET) = 189.94 DOWNSTREAM(FEET) = 189.73
FLOW LENGTH(FEET) = 33.00 MANNING'S N = 0.011
DEPTH OF FLOW IN 18.0 INCH PIPE IS 11.1 INCHES
PIPE-FLOW VELOCITY(FEET/SEC.) = 5.91
ESTIMATED PIPE DIAMETER(INCH) = 18.00 NUMBER OF PIPES = 1
PIPE-FLOW(CFS) = 6.76
PIPE TRAVEL TIME(MIN.) = 0.09 Tc(MIN.) = 6.39
LONGEST FLOWPATH FROM NODE 117.00 TO NODE 124.00 = 434.00 FEET.
```

```
*****
FLOW PROCESS FROM NODE 124.00 TO NODE 124.00 IS CODE = 81
```

```
-----
>>>>ADDITION OF SUBAREA TO MAINLINE PEAK FLOW<<<<
```

```
=====
 100 YEAR RAINFALL INTENSITY(INCH/HOUR) = 5.690
*USER SPECIFIED(SUBAREA):
USER-SPECIFIED RUNOFF COEFFICIENT = .8500
S.C.S. CURVE NUMBER (AMC II) = 0
```

AREA-AVERAGE RUNOFF COEFFICIENT = 0.8375
SUBAREA AREA(ACRES) = 0.19 SUBAREA RUNOFF(CFS) = 0.92
TOTAL AREA(ACRES) = 1.6 TOTAL RUNOFF(CFS) = 7.62
TC(MIN.) = 6.39

FLOW PROCESS FROM NODE 124.00 TO NODE 125.00 IS CODE = 31

>>>>COMPUTE PIPE-FLOW TRAVEL TIME THRU SUBAREA<<<<<
>>>>USING COMPUTER-ESTIMATED PIPESIZE (NON-PRESSURE FLOW)<<<<<

=====

ELEVATION DATA: UPSTREAM(FEET) =	1289.73	DOWNSTREAM(FEET) =	189.06
FLOW LENGTH(FEET) =	47.00	MANNING'S N =	0.011
DEPTH OF FLOW IN	6.0 INCH PIPE IS	2.0 INCHES	
PIPE-FLOW VELOCITY(FEET/SEC.) =	131.47		
ESTIMATED PIPE DIAMETER(INCH) =	6.00	NUMBER OF PIPES =	1
PIPE-FLOW(CFS) =	7.62		
PIPE TRAVEL TIME(MIN.) =	0.01	Tc(MIN.) =	6.40
LONGEST FLOWPATH FROM NODE	117.00 TO NODE	125.00 =	481.00 FEET.

FLOW PROCESS FROM NODE 125.00 TO NODE 125.00 IS CODE = 81

>>>>ADDITION OF SUBAREA TO MAINLINE PEAK FLOW<<<<<

=====

100 YEAR RAINFALL INTENSITY(INCH/HOUR) =	5.687
*USER SPECIFIED(SUBAREA):	
USER-SPECIFIED RUNOFF COEFFICIENT =	.8500
S.C.S. CURVE NUMBER (AMC II) =	0
AREA-AVERAGE RUNOFF COEFFICIENT =	0.8383
SUBAREA AREA(ACRES) =	0.11 SUBAREA RUNOFF(CFS) = 0.53
TOTAL AREA(ACRES) =	1.7 TOTAL RUNOFF(CFS) = 8.15
TC(MIN.) =	6.40

FLOW PROCESS FROM NODE 125.00 TO NODE 126.00 IS CODE = 31

>>>>COMPUTE PIPE-FLOW TRAVEL TIME THRU SUBAREA<<<<<
>>>>USING COMPUTER-ESTIMATED PIPESIZE (NON-PRESSURE FLOW)<<<<<

=====

ELEVATION DATA: UPSTREAM(FEET) =	188.73	DOWNSTREAM(FEET) =	188.68
FLOW LENGTH(FEET) =	73.00	MANNING'S N =	0.011
DEPTH OF FLOW IN	27.0 INCH PIPE IS	19.5 INCHES	
PIPE-FLOW VELOCITY(FEET/SEC.) =	2.65		
ESTIMATED PIPE DIAMETER(INCH) =	27.00	NUMBER OF PIPES =	1
PIPE-FLOW(CFS) =	8.15		
PIPE TRAVEL TIME(MIN.) =	0.46	Tc(MIN.) =	6.86
LONGEST FLOWPATH FROM NODE	117.00 TO NODE	126.00 =	554.00 FEET.

FLOW PROCESS FROM NODE 126.00 TO NODE 126.00 IS CODE = 81

>>>>ADDITION OF SUBAREA TO MAINLINE PEAK FLOW<<<<<

=====

100 YEAR RAINFALL INTENSITY(INCH/HOUR) =	5.477
*USER SPECIFIED(SUBAREA):	
USER-SPECIFIED RUNOFF COEFFICIENT =	.8500
S.C.S. CURVE NUMBER (AMC II) =	0
AREA-AVERAGE RUNOFF COEFFICIENT =	0.8393
SUBAREA AREA(ACRES) =	0.16 SUBAREA RUNOFF(CFS) = 0.74
TOTAL AREA(ACRES) =	1.9 TOTAL RUNOFF(CFS) = 8.60
TC(MIN.) =	6.86

```

*****
FLOW PROCESS FROM NODE    126.00 TO NODE    127.00 IS CODE = 31
-----
>>>>COMPUTE PIPE-FLOW TRAVEL TIME THRU SUBAREA<<<<
>>>>USING COMPUTER-ESTIMATED PIPESIZE (NON-PRESSURE FLOW)<<<<
=====
ELEVATION DATA: UPSTREAM(FEET) = 188.68  DOWNSTREAM(FEET) = 188.02
FLOW LENGTH(FEET) = 110.00  MANNING'S N = 0.011
DEPTH OF FLOW IN 18.0 INCH PIPE IS 13.6 INCHES
PIPE-FLOW VELOCITY(FEET/SEC.) = 6.02
ESTIMATED PIPE DIAMETER(INCH) = 18.00  NUMBER OF PIPES = 1
PIPE-FLOW(CFS) = 8.60
PIPE TRAVEL TIME(MIN.) = 0.30  Tc(MIN.) = 7.16
LONGEST FLOWPATH FROM NODE    117.00 TO NODE    127.00 = 664.00 FEET.

*****
FLOW PROCESS FROM NODE    127.00 TO NODE    127.00 IS CODE = 81
-----
>>>>ADDITION OF SUBAREA TO MAINLINE PEAK FLOW<<<<
=====
100 YEAR RAINFALL INTENSITY(INCH/HOUR) = 5.338
*USER SPECIFIED(SUBAREA):
USER-SPECIFIED RUNOFF COEFFICIENT = .8500
S.C.S. CURVE NUMBER (AMC II) = 0
AREA-AVERAGE RUNOFF COEFFICIENT = 0.8401
SUBAREA AREA(ACRES) = 0.16  SUBAREA RUNOFF(CFS) = 0.73
TOTAL AREA(ACRES) = 2.0  TOTAL RUNOFF(CFS) = 9.10
TC(MIN.) = 7.16

*****
FLOW PROCESS FROM NODE    127.00 TO NODE    128.00 IS CODE = 31
-----
>>>>COMPUTE PIPE-FLOW TRAVEL TIME THRU SUBAREA<<<<
>>>>USING COMPUTER-ESTIMATED PIPESIZE (NON-PRESSURE FLOW)<<<<
=====
ELEVATION DATA: UPSTREAM(FEET) = 187.69  DOWNSTREAM(FEET) = 187.44
FLOW LENGTH(FEET) = 42.00  MANNING'S N = 0.011
DEPTH OF FLOW IN 18.0 INCH PIPE IS 14.4 INCHES
PIPE-FLOW VELOCITY(FEET/SEC.) = 6.02
ESTIMATED PIPE DIAMETER(INCH) = 18.00  NUMBER OF PIPES = 1
PIPE-FLOW(CFS) = 9.10
PIPE TRAVEL TIME(MIN.) = 0.12  Tc(MIN.) = 7.28
LONGEST FLOWPATH FROM NODE    117.00 TO NODE    128.00 = 706.00 FEET.

*****
FLOW PROCESS FROM NODE    128.00 TO NODE    128.00 IS CODE = 81
-----
>>>>ADDITION OF SUBAREA TO MAINLINE PEAK FLOW<<<<
=====
100 YEAR RAINFALL INTENSITY(INCH/HOUR) = 5.286
*USER SPECIFIED(SUBAREA):
USER-SPECIFIED RUNOFF COEFFICIENT = .8500
S.C.S. CURVE NUMBER (AMC II) = 0
AREA-AVERAGE RUNOFF COEFFICIENT = 0.8410
SUBAREA AREA(ACRES) = 0.20  SUBAREA RUNOFF(CFS) = 0.90
TOTAL AREA(ACRES) = 2.2  TOTAL RUNOFF(CFS) = 9.91
TC(MIN.) = 7.28

*****
FLOW PROCESS FROM NODE    128.00 TO NODE    129.00 IS CODE = 31
-----
>>>>COMPUTE PIPE-FLOW TRAVEL TIME THRU SUBAREA<<<<
>>>>USING COMPUTER-ESTIMATED PIPESIZE (NON-PRESSURE FLOW)<<<<

```

=====
ELEVATION DATA: UPSTREAM(FEET) = 187.44 DOWNSTREAM(FEET) = 186.51
FLOW LENGTH(FEET) = 155.00 MANNING'S N = 0.011
DEPTH OF FLOW IN 21.0 INCH PIPE IS 13.0 INCHES
PIPE-FLOW VELOCITY(FEET/SEC.) = 6.36
ESTIMATED PIPE DIAMETER(INCH) = 21.00 NUMBER OF PIPES = 1
PIPE-FLOW(CFS) = 9.91
PIPE TRAVEL TIME(MIN.) = 0.41 Tc(MIN.) = 7.68
LONGEST FLOWPATH FROM NODE 117.00 TO NODE 129.00 = 861.00 FEET.

FLOW PROCESS FROM NODE 129.00 TO NODE 129.00 IS CODE = 81

>>>>ADDITION OF SUBAREA TO MAINLINE PEAK FLOW<<<<

=====
100 YEAR RAINFALL INTENSITY(INCH/HOUR) = 5.100
*USER SPECIFIED(SUBAREA):
USER-SPECIFIED RUNOFF COEFFICIENT = .8500
S.C.S. CURVE NUMBER (AMC II) = 0
AREA-AVERAGE RUNOFF COEFFICIENT = 0.8423
SUBAREA AREA(ACRES) = 0.37 SUBAREA RUNOFF(CFS) = 1.60
TOTAL AREA(ACRES) = 2.6 TOTAL RUNOFF(CFS) = 11.17
TC(MIN.) = 7.68

FLOW PROCESS FROM NODE 129.00 TO NODE 130.00 IS CODE = 31

>>>>COMPUTE PIPE-FLOW TRAVEL TIME THRU SUBAREA<<<<
>>>>USING COMPUTER-ESTIMATED PIPESIZE (NON-PRESSURE FLOW)<<<<

=====
ELEVATION DATA: UPSTREAM(FEET) = 186.51 DOWNSTREAM(FEET) = 186.10
FLOW LENGTH(FEET) = 67.00 MANNING'S N = 0.011
DEPTH OF FLOW IN 21.0 INCH PIPE IS 14.0 INCHES
PIPE-FLOW VELOCITY(FEET/SEC.) = 6.57
ESTIMATED PIPE DIAMETER(INCH) = 21.00 NUMBER OF PIPES = 1
PIPE-FLOW(CFS) = 11.17
PIPE TRAVEL TIME(MIN.) = 0.17 Tc(MIN.) = 7.85
LONGEST FLOWPATH FROM NODE 117.00 TO NODE 130.00 = 928.00 FEET.

FLOW PROCESS FROM NODE 130.00 TO NODE 131.00 IS CODE = 31

>>>>COMPUTE PIPE-FLOW TRAVEL TIME THRU SUBAREA<<<<
>>>>USING COMPUTER-ESTIMATED PIPESIZE (NON-PRESSURE FLOW)<<<<

=====
ELEVATION DATA: UPSTREAM(FEET) = 185.77 DOWNSTREAM(FEET) = 185.12
FLOW LENGTH(FEET) = 108.00 MANNING'S N = 0.011
DEPTH OF FLOW IN 21.0 INCH PIPE IS 14.1 INCHES
PIPE-FLOW VELOCITY(FEET/SEC.) = 6.52
ESTIMATED PIPE DIAMETER(INCH) = 21.00 NUMBER OF PIPES = 1
PIPE-FLOW(CFS) = 11.17
PIPE TRAVEL TIME(MIN.) = 0.28 Tc(MIN.) = 8.13
LONGEST FLOWPATH FROM NODE 117.00 TO NODE 131.00 = 1036.00 FEET.

FLOW PROCESS FROM NODE 131.00 TO NODE 131.00 IS CODE = 81

>>>>ADDITION OF SUBAREA TO MAINLINE PEAK FLOW<<<<

=====
100 YEAR RAINFALL INTENSITY(INCH/HOUR) = 4.897
*USER SPECIFIED(SUBAREA):
USER-SPECIFIED RUNOFF COEFFICIENT = .8500
S.C.S. CURVE NUMBER (AMC II) = 0

AREA-AVERAGE RUNOFF COEFFICIENT = 0.8442
SUBAREA AREA(ACRES) = 0.84 SUBAREA RUNOFF(CFS) = 3.50
TOTAL AREA(ACRES) = 3.4 TOTAL RUNOFF(CFS) = 14.22
TC(MIN.) = 8.13

FLOW PROCESS FROM NODE 131.00 TO NODE 116.00 IS CODE = 31

>>>>COMPUTE PIPE-FLOW TRAVEL TIME THRU SUBAREA<<<<<
>>>>USING COMPUTER-ESTIMATED PIPESIZE (NON-PRESSURE FLOW)<<<<<

=====

ELEVATION DATA: UPSTREAM(FEET) =	185.12	DOWNSTREAM(FEET) =	184.49
FLOW LENGTH(FEET) =	105.00	MANNING'S N =	0.011
DEPTH OF FLOW IN	24.0 INCH PIPE IS	14.9 INCHES	
PIPE-FLOW VELOCITY(FEET/SEC.) =	6.96		
ESTIMATED PIPE DIAMETER(INCH) =	24.00	NUMBER OF PIPES =	1
PIPE-FLOW(CFS) =	14.22		
PIPE TRAVEL TIME(MIN.) =	0.25	Tc(MIN.) =	8.38
LONGEST FLOWPATH FROM NODE	117.00 TO NODE	116.00 =	1141.00 FEET.

FLOW PROCESS FROM NODE 116.00 TO NODE 116.00 IS CODE = 11

>>>>CONFLUENCE MEMORY BANK # 1 WITH THE MAIN-STREAM MEMORY<<<<<

** MAIN STREAM CONFLUENCE DATA **

STREAM NUMBER	RUNOFF (CFS)	Tc (MIN.)	INTENSITY (INCH/HOUR)	AREA (ACRE)
1	14.22	8.38	4.783	3.44

LONGEST FLOWPATH FROM NODE 117.00 TO NODE 116.00 = 1141.00 FEET.

** MEMORY BANK # 1 CONFLUENCE DATA **

STREAM NUMBER	RUNOFF (CFS)	Tc (MIN.)	INTENSITY (INCH/HOUR)	AREA (ACRE)
1	19.48	8.23	4.850	4.81

LONGEST FLOWPATH FROM NODE 100.00 TO NODE 116.00 = 1158.00 FEET.

** PEAK FLOW RATE TABLE **

STREAM NUMBER	RUNOFF (CFS)	Tc (MIN.)	INTENSITY (INCH/HOUR)
1	33.45	8.23	4.850
2	33.43	8.38	4.783

COMPUTED CONFLUENCE ESTIMATES ARE AS FOLLOWS:
PEAK FLOW RATE(CFS) = 33.45 Tc(MIN.) = 8.23
TOTAL AREA(ACRES) = 8.2

FLOW PROCESS FROM NODE 116.00 TO NODE 132.00 IS CODE = 31

>>>>COMPUTE PIPE-FLOW TRAVEL TIME THRU SUBAREA<<<<<
>>>>USING COMPUTER-ESTIMATED PIPESIZE (NON-PRESSURE FLOW)<<<<<

=====

ELEVATION DATA: UPSTREAM(FEET) =	183.11	DOWNSTREAM(FEET) =	182.75
FLOW LENGTH(FEET) =	19.00	MANNING'S N =	0.011
DEPTH OF FLOW IN	24.0 INCH PIPE IS	18.4 INCHES	
PIPE-FLOW VELOCITY(FEET/SEC.) =	12.97		
ESTIMATED PIPE DIAMETER(INCH) =	24.00	NUMBER OF PIPES =	1
PIPE-FLOW(CFS) =	33.45		
PIPE TRAVEL TIME(MIN.) =	0.02	Tc(MIN.) =	8.26
LONGEST FLOWPATH FROM NODE	100.00 TO NODE	132.00 =	1177.00 FEET.

```

*****
FLOW PROCESS FROM NODE    133.00 TO NODE    133.00 IS CODE =    7
-----
>>>>USER SPECIFIED HYDROLOGY INFORMATION AT NODE<<<<
=====
USER-SPECIFIED VALUES ARE AS FOLLOWS:
TC(MIN) = 19.00    RAIN INTENSITY(INCH/HOUR) = 2.69
TOTAL AREA(ACRES) =    8.27    TOTAL RUNOFF(CFS) =    6.99
*****

FLOW PROCESS FROM NODE    133.00 TO NODE    134.00 IS CODE = 31
-----
>>>>COMPUTE PIPE-FLOW TRAVEL TIME THRU SUBAREA<<<<
>>>>USING COMPUTER-ESTIMATED PIPESIZE (NON-PRESSURE FLOW)<<<<
=====
ELEVATION DATA: UPSTREAM(FEET) = 182.75    DOWNSTREAM(FEET) = 179.95
FLOW LENGTH(FEET) = 28.00    MANNING'S N = 0.011
DEPTH OF FLOW IN 12.0 INCH PIPE IS 6.3 INCHES
PIPE-FLOW VELOCITY(FEET/SEC.) = 16.82
ESTIMATED PIPE DIAMETER(INCH) = 12.00    NUMBER OF PIPES = 1
PIPE-FLOW(CFS) = 6.99
PIPE TRAVEL TIME(MIN.) = 0.03    Tc(MIN.) = 19.03
LONGEST FLOWPATH FROM NODE 100.00 TO NODE 134.00 = 1205.00 FEET.
*****

FLOW PROCESS FROM NODE    134.00 TO NODE    135.00 IS CODE = 31
-----
>>>>COMPUTE PIPE-FLOW TRAVEL TIME THRU SUBAREA<<<<
>>>>USING COMPUTER-ESTIMATED PIPESIZE (NON-PRESSURE FLOW)<<<<
=====
ELEVATION DATA: UPSTREAM(FEET) = 179.62    DOWNSTREAM(FEET) = 178.40
FLOW LENGTH(FEET) = 203.00    MANNING'S N = 0.011
DEPTH OF FLOW IN 18.0 INCH PIPE IS 11.6 INCHES
PIPE-FLOW VELOCITY(FEET/SEC.) = 5.82
ESTIMATED PIPE DIAMETER(INCH) = 18.00    NUMBER OF PIPES = 1
PIPE-FLOW(CFS) = 6.99
PIPE TRAVEL TIME(MIN.) = 0.58    Tc(MIN.) = 19.61
LONGEST FLOWPATH FROM NODE 100.00 TO NODE 135.00 = 1408.00 FEET.
*****

FLOW PROCESS FROM NODE    135.00 TO NODE    136.00 IS CODE = 31
-----
>>>>COMPUTE PIPE-FLOW TRAVEL TIME THRU SUBAREA<<<<
>>>>USING COMPUTER-ESTIMATED PIPESIZE (NON-PRESSURE FLOW)<<<<
=====
ELEVATION DATA: UPSTREAM(FEET) = 144.80    DOWNSTREAM(FEET) = 143.67
FLOW LENGTH(FEET) = 76.00    MANNING'S N = 0.011
DEPTH OF FLOW IN 15.0 INCH PIPE IS 9.9 INCHES
PIPE-FLOW VELOCITY(FEET/SEC.) = 8.16
ESTIMATED PIPE DIAMETER(INCH) = 15.00    NUMBER OF PIPES = 1
PIPE-FLOW(CFS) = 6.99
PIPE TRAVEL TIME(MIN.) = 0.16    Tc(MIN.) = 19.76
LONGEST FLOWPATH FROM NODE 100.00 TO NODE 136.00 = 1484.00 FEET.
*****

FLOW PROCESS FROM NODE    136.00 TO NODE    136.00 IS CODE = 81
-----
>>>>ADDITION OF SUBAREA TO MAINLINE PEAK FLOW<<<<
=====
100 YEAR RAINFALL INTENSITY(INCH/HOUR) = 2.611
*USER SPECIFIED(SUBAREA):
USER-SPECIFIED RUNOFF COEFFICIENT = .6000
S.C.S. CURVE NUMBER (AMC II) = 0

```

AREA-AVERAGE RUNOFF COEFFICIENT = 0.3224
SUBAREA AREA(ACRES) = 0.25 SUBAREA RUNOFF(CFS) = 0.39
TOTAL AREA(ACRES) = 8.5 TOTAL RUNOFF(CFS) = 7.17
TC(MIN.) = 19.76

FLOW PROCESS FROM NODE 200.00 TO NODE 201.00 IS CODE = 21

>>>>RATIONAL METHOD INITIAL SUBAREA ANALYSIS<<<<<

=====

*USER SPECIFIED(SUBAREA):

USER-SPECIFIED RUNOFF COEFFICIENT = .8500
S.C.S. CURVE NUMBER (AMC II) = 0
INITIAL SUBAREA FLOW-LENGTH(FEET) = 100.00
UPSTREAM ELEVATION(FEET) = 196.50
DOWNSTREAM ELEVATION(FEET) = 192.61
ELEVATION DIFFERENCE(FEET) = 3.89
URBAN SUBAREA OVERLAND TIME OF FLOW(MIN.) = 2.861
100 YEAR RAINFALL INTENSITY(INCH/HOUR) = 6.323
NOTE: RAINFALL INTENSITY IS BASED ON Tc = 5-MINUTE.
SUBAREA RUNOFF(CFS) = 0.86
TOTAL AREA(ACRES) = 0.16 TOTAL RUNOFF(CFS) = 0.86

FLOW PROCESS FROM NODE 201.00 TO NODE 202.00 IS CODE = 61

>>>>COMPUTE STREET FLOW TRAVEL TIME THRU SUBAREA<<<<<

>>>>(STANDARD CURB SECTION USED)<<<<<

=====

UPSTREAM ELEVATION(FEET) = 192.61 DOWNSTREAM ELEVATION(FEET) = 149.11
STREET LENGTH(FEET) = 718.00 CURB HEIGHT(INCHES) = 6.0
STREET HALFWIDTH(FEET) = 36.00

DISTANCE FROM CROWN TO CROSSFALL GRADEBREAK(FEET) = 1.00
INSIDE STREET CROSSFALL(DECIMAL) = 0.015
OUTSIDE STREET CROSSFALL(DECIMAL) = 0.015

SPECIFIED NUMBER OF HALFSTREETS CARRYING RUNOFF = 1
STREET PARKWAY CROSSFALL(DECIMAL) = 0.015
Manning's FRICTION FACTOR for Streetflow Section(curbs-to-curbs) = 0.0150
Manning's FRICTION FACTOR for Back-of-Walk Flow Section = 0.0200

**TRAVEL TIME COMPUTED USING ESTIMATED FLOW(CFS) = 3.35
STREETFLOW MODEL RESULTS USING ESTIMATED FLOW:
STREET FLOW DEPTH(FEET) = 0.27
HALFSTREET FLOOD WIDTH(FEET) = 9.16
AVERAGE FLOW VELOCITY(FEET/SEC.) = 4.45
PRODUCT OF DEPTH&VELOCITY(FT*FT/SEC.) = 1.21
STREET FLOW TRAVEL TIME(MIN.) = 2.69 Tc(MIN.) = 5.55
100 YEAR RAINFALL INTENSITY(INCH/HOUR) = 6.071

*USER SPECIFIED(SUBAREA):

USER-SPECIFIED RUNOFF COEFFICIENT = .7900
S.C.S. CURVE NUMBER (AMC II) = 0
AREA-AVERAGE RUNOFF COEFFICIENT = 0.798
SUBAREA AREA(ACRES) = 1.03 SUBAREA RUNOFF(CFS) = 4.94
TOTAL AREA(ACRES) = 1.2 PEAK FLOW RATE(CFS) = 5.77

END OF SUBAREA STREET FLOW HYDRAULICS:

DEPTH(FEET) = 0.31 HALFSTREET FLOOD WIDTH(FEET) = 11.64
FLOW VELOCITY(FEET/SEC.) = 5.06 DEPTH*VELOCITY(FT*FT/SEC.) = 1.56
LONGEST FLOWPATH FROM NODE 200.00 TO NODE 202.00 = 818.00 FEET.

=====

END OF STUDY SUMMARY:

TOTAL AREA(ACRES) = 1.2 TC(MIN.) = 5.55
PEAK FLOW RATE(CFS) = 5.77

=====

END OF RATIONAL METHOD ANALYSIS

Appendix 5

Modified-Puls Detention Routing

RUN DATE 5/20/2022
HYDROGRAPH FILE NAME Text1
TIME OF CONCENTRATION 10 MIN.
6 HOUR RAINFALL 2.4 INCHES
BASIN AREA 8.27 ACRES
RUNOFF COEFFICIENT 0.85
PEAK DISCHARGE 33.45 CFS

TIME (MIN) = 0	DISCHARGE (CFS) = 0
TIME (MIN) = 10	DISCHARGE (CFS) = 1
TIME (MIN) = 20	DISCHARGE (CFS) = 1
TIME (MIN) = 30	DISCHARGE (CFS) = 1.1
TIME (MIN) = 40	DISCHARGE (CFS) = 1.1
TIME (MIN) = 50	DISCHARGE (CFS) = 1.1
TIME (MIN) = 60	DISCHARGE (CFS) = 1.2
TIME (MIN) = 70	DISCHARGE (CFS) = 1.2
TIME (MIN) = 80	DISCHARGE (CFS) = 1.2
TIME (MIN) = 90	DISCHARGE (CFS) = 1.3
TIME (MIN) = 100	DISCHARGE (CFS) = 1.4
TIME (MIN) = 110	DISCHARGE (CFS) = 1.4
TIME (MIN) = 120	DISCHARGE (CFS) = 1.5
TIME (MIN) = 130	DISCHARGE (CFS) = 1.6
TIME (MIN) = 140	DISCHARGE (CFS) = 1.7
TIME (MIN) = 150	DISCHARGE (CFS) = 1.8
TIME (MIN) = 160	DISCHARGE (CFS) = 1.9
TIME (MIN) = 170	DISCHARGE (CFS) = 2.1
TIME (MIN) = 180	DISCHARGE (CFS) = 2.2
TIME (MIN) = 190	DISCHARGE (CFS) = 2.5
TIME (MIN) = 200	DISCHARGE (CFS) = 2.8
TIME (MIN) = 210	DISCHARGE (CFS) = 3.4
TIME (MIN) = 220	DISCHARGE (CFS) = 3.8
TIME (MIN) = 230	DISCHARGE (CFS) = 5.6
TIME (MIN) = 240	DISCHARGE (CFS) = 2.9
TIME (MIN) = 250	DISCHARGE (CFS) = 33.45
TIME (MIN) = 260	DISCHARGE (CFS) = 4.5
TIME (MIN) = 270	DISCHARGE (CFS) = 3
TIME (MIN) = 280	DISCHARGE (CFS) = 2.4
TIME (MIN) = 290	DISCHARGE (CFS) = 2
TIME (MIN) = 300	DISCHARGE (CFS) = 1.7
TIME (MIN) = 310	DISCHARGE (CFS) = 1.5
TIME (MIN) = 320	DISCHARGE (CFS) = 1.4
TIME (MIN) = 330	DISCHARGE (CFS) = 1.3
TIME (MIN) = 340	DISCHARGE (CFS) = 1.2
TIME (MIN) = 350	DISCHARGE (CFS) = 1.1
TIME (MIN) = 360	DISCHARGE (CFS) = 1
TIME (MIN) = 370	DISCHARGE (CFS) = 0

Outlet Structure for Discharge of BMP-1

Discharge vs. Elevation Table

<u>Low-flow orifice</u>		<u>Slot orifice</u>		<u>Emergency Overflow</u>	
No.:	1	No.:	1	Invert:	5.5 ft
Invert:	0 ft	Invert:	2.00 ft	L:	14 ft
Dia:	4 in	Length:	2.75 ft	C _w :	3.1
Dia:	0.33 ft	Height:	0.25 ft	<u>Tank Dimensions</u>	
A:	0.087 sq.ft.	A:	0.69 sq.ft	Area:	5,971 sq.ft.
C _o :	0.6	C _o :	0.6	Height:	6 ft
				Total Vol:	35,824 cu.ft.

***Note: h = head above the invert of the lowest surface discharge opening.**

Elev (ft)	h* (ft)	Volume (ac-ft)	Q _{orifice-low} (cfs)	Q _{slot-mid} (cfs)	Q _{emerg} (cfs)	Q _{total} (cfs)
182.75	0.00	0.0000	0.0000	0.000	0.000	0.0000
183.00	0.25	0.0343	0.1292	0.000	0.000	0.1292
183.25	0.50	0.0685	0.2712	0.000	0.000	0.2712
183.50	0.75	0.1028	0.3431	0.000	0.000	0.3431
183.75	1.00	0.1371	0.4023	0.000	0.000	0.4023
184.00	1.25	0.1713	0.4539	0.000	0.000	0.4539
184.25	1.50	0.2056	0.5001	0.000	0.000	0.5001
184.50	1.75	0.2399	0.5425	0.000	0.000	0.5425
184.75	2.00	0.2741	0.5817	0.000	0.000	0.5817
185.00	2.25	0.3084	0.6185	1.433	0.000	2.0519
185.25	2.50	0.3427	0.6532	2.190	0.000	2.8428
185.50	2.75	0.3769	0.6862	2.745	0.000	3.4309
185.75	3.00	0.4112	0.7176	3.205	0.000	3.9228
186.00	3.25	0.4455	0.7477	3.607	0.000	4.3550
186.25	3.50	0.4797	0.7767	3.969	0.000	4.7456
186.50	3.75	0.5140	0.8046	4.300	0.000	5.1048
186.75	4.00	0.5483	0.8316	4.608	0.000	5.4393
187.00	4.25	0.5825	0.8577	4.896	0.000	5.7537
187.25	4.50	0.6168	0.8831	5.168	0.000	6.0513
187.50	4.75	0.6511	0.9077	5.427	0.000	6.3345
187.75	5.00	0.6853	0.9317	5.674	0.000	6.6053
188.00	5.25	0.7196	0.9551	5.910	0.000	6.8652
188.25	5.50	0.7539	0.9779	6.137	0.000	7.1154
188.50	5.75	0.7881	1.0002	6.357	5.425	12.7820
188.75	6.00	0.8224	1.0221	6.569	15.344	22.9350

Note:

1. Weir equation, $Q=C_w L_e (h)^{3/2}$
2. Orifice equation, $Q=C_o A_e (2gh)^{1/2}$
3. Slot orifice acts as a weir when $h^* < h_{slot}$; slot orifice acts as an orifice when $h^* \geq h_{slot}$

HEC-HMS Detention Routing Summary
Project Shinohara

DMA.A

BMP-1



Summary Results for Reservoir "BMP-1"

Project: Shinohara Simulation Run: Q100
Reservoir: BMP-1

Start of Run: 01Jan2000, 00:00 Basin Model: Post_Dev
End of Run: 01Jan2000, 06:05 Meteorologic Model: Met 1
Compute Time: DATA CHANGED, RECOMPUTE Control Specifications: Control 1

Volume Units: IN ACRE-FT

Computed Results

Peak Inflow: 33.45 (CFS)	Date/Time of Peak Inflow: 01Jan2000, 04:10
Peak Discharge: 6.99 (CFS)	Date/Time of Peak Discharge: 01Jan2000, 04:19
Inflow Volume: n/a	Peak Storage: 0.74 (ACRE-FT)
Discharge Volume: n/a	Peak Elevation: 5.37 (FT)

Observed Flow Gage BMP 1

Peak Discharge: 33.45 (CFS)	Date/Time of Peak Discharge: 01Jan2000, 04:10
Volume: n/a	
RMSE Std Dev: 0.93	Nash-Sutcliffe: 0.126
Percent Bias: -22.43 %	

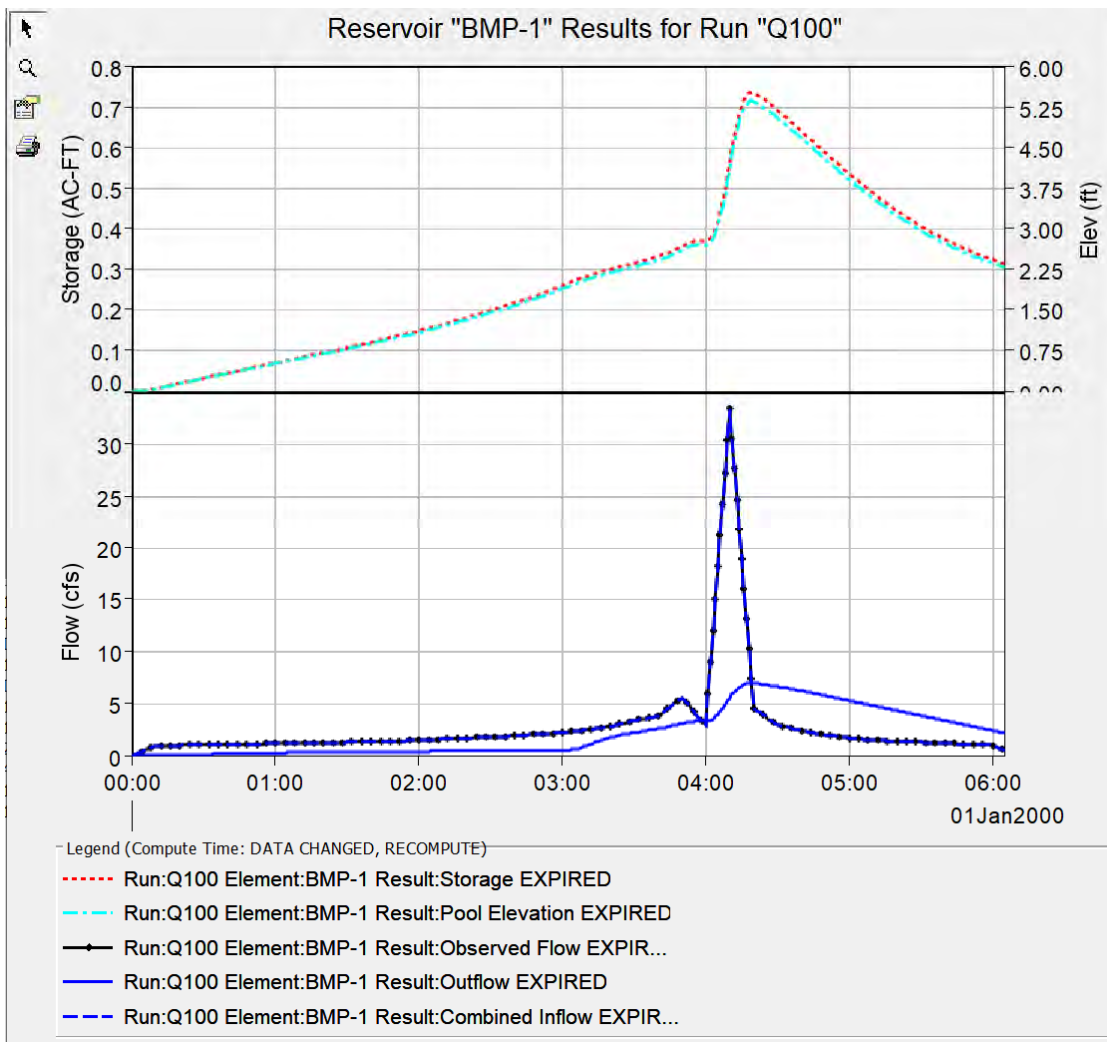

PRELIMINARY DRAINAGE STUDY

For:

Shinohara Business Center

517 Shinohara Lane
Chula Vista, CA 91911

APN: 644-040-01
Project Permit # DR21-0032

Prepared By:

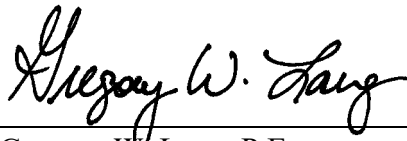

Gregory W. Lang, P.E.
Pasco Laret Suiter & Associates, Inc.
119 Aberdeen Drive
Cardiff By The Sea, CA 92007

RCE 68075

5-20-2022

EXP: 06-30-23

PASCO LARET SUITER
 & ASSOCIATES
CIVIL ENGINEERING + LAND PLANNING + LAND SURVEYING



Prepared for:

VWP-OP Shinohara Owner, LLC
2390 East Camelback Road, Suite 305
Phoenix, AZ 85016

May 20, 2022

PLSA Job No. 3690

DECLARATION OF RESPONSIBLE CHARGE

I, hereby declare that I am the Engineer of Work for this project. That I have exercised responsible charge over the design of the project as defined in section 6703 of the business and professions code, and that the design is consistent with current standards.

I understand that the check of project drawings and specifications by the County of San Diego is confined to a review only and does not relieve me, as engineer of work, of my responsibilities for project design.

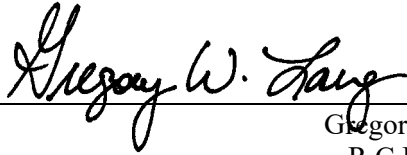

Gregory W. Lang
R.C.E. 68075
EXP. 6-30-23

05/20/2022

DATE

TABLE OF CONTENTS

1. INTRODUCTION	4
1.1 Project Description	5
1.2 Pre-Project Conditions.....	5
1.3 Post-Project Conditions	6
2. METHODOLOGY	8
2.1 Rational Method	8
2.2 Runoff Coefficient.....	9
2.3 Rainfall Intensity	11
2.4 Tributary Areas.....	11
2.5 Hydraulics	11
2.6 Curb Inlet and Catch Basin Sizing	11
2.7 Detention Basin Routing	11
3. CALCULATIONS/RESULTS.....	13
3.1 Pre- & Post-Development Peak Flow Comparison	13
3.2 Storm Water Quality.....	14
3.3 Hydromodification	14
4. CONCLUSION	15
Appendix 1	Pre-Project Condition Hydrology Node Map
Appendix 2.....	Post-Project Condition Hydrology Node Map
Appendix 3.....	Hydrology Design Summary
Appendix 4.....	AES Rational Method Calculations
Appendix 5.....	Modified-Puls Detention Routing

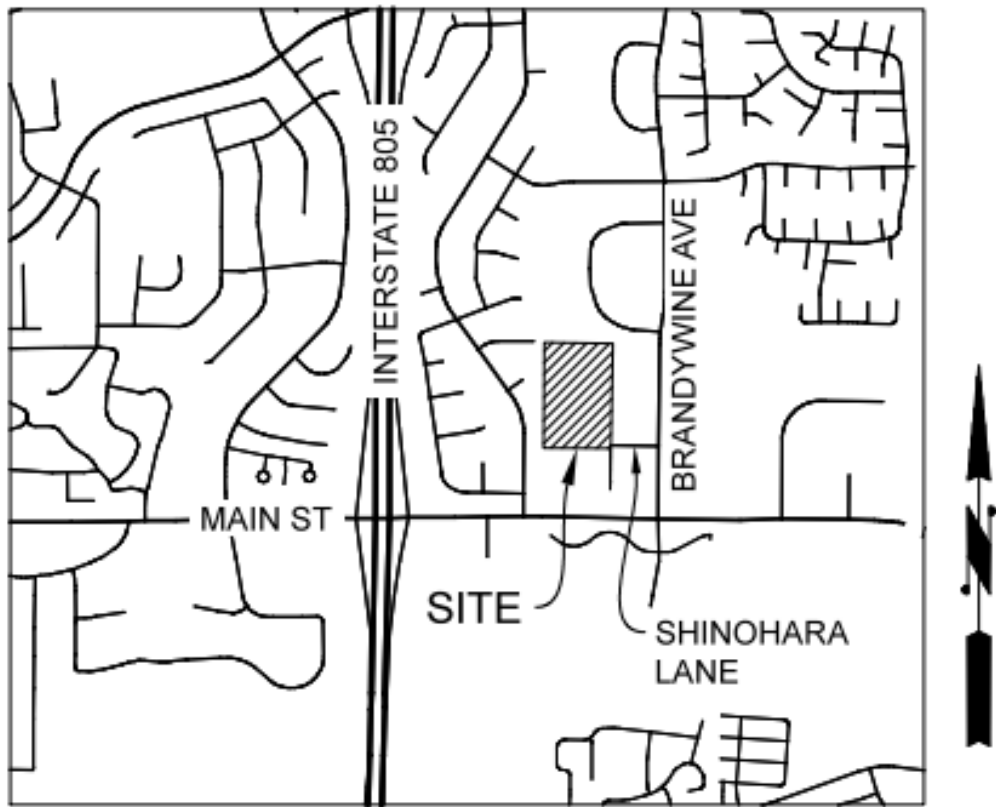

VICINITY MAP

NOT TO SCALE

1. INTRODUCTION

This Preliminary Drainage Study for the proposed Project Shinohara has been prepared to analyze the hydrologic characteristics of the existing and proposed project site. This report presents both the methodology and the calculations used for determining the storm water runoff from the project site in the existing and proposed conditions produced by the 100-year, 6-hour storm event.

1.1 Project Description

The 9.73-acre project site consists of undeveloped land located northwest of the intersection of Brandywine Avenue and Shinohara Lane, at the end of Shinohara Lane in the City of Chula Vista, San Diego County, California. The property is defined as a portion of Lot 1, Section 19, Township 18 South, Range 1 West, San Bernardino Meridian, and identified by the Assessor's Parcel Number (APN) 644-040-01.

The existing site is currently undeveloped except for minor concrete drainage channels located on site and along the eastern and southern property boundaries. The site is bounded on the north and west by residential properties, and on the east and south by industrial buildings.

The existing site condition is divided into three (3) drainage basins, Basins Am B, and C, and three (3) separate discharge locations across the project site.

Treatment of storm water runoff from the site has been addressed in a separate report- *Storm Water Quality Management Plan for OnPoint Development, Project Shinohara by PLSA*, dated May 20, 2022.

Per City of Chula Vista general design criteria, the Modified Rational Method should be used to determine peak flowrates when the contributing drainage area is up to 1.0 square mile in size. All public and private drainage facilities shall be designed for a 100-year frequency storm.

Methodology used for the computation of design rainfall events, runoff coefficients, and rainfall intensity values are consistent with the criteria set forth in Section 3 – General Design Criteria of the City of Chula Vista Subdivision Manual, revised March 2012.

1.2 Pre-Project Conditions

Topographically, the site slopes steeply to the south from the northern property boundary, forming three (3) drainage basins with three (3) discharge locations. Existing Drainage Basin A comprises the western portion of the site. Runoff drains via overland flow to an existing concrete swale located at the southern property boundary. The drainage swale carries flow east to an existing Type F catch basin at the southern property boundary. The catch basin connects to an existing private storm drain pipe that outlets via curb outlet onto Main Street.

Existing Drainage Basin B comprises the eastern portion of the site. Runoff is conveyed via overland surface flow to an existing concrete drainage channel located at the southeastern corner of the site. The drainage channel conveys runoff south and outlets via curb outlet onto Main Street.

From Main Street, flow travels west via concrete curb and gutter to an existing curb inlet. Stormwater is then conveyed south through an existing storm drain pipe and outlets over headwall into the Otay River. The Otay River travels west and outlets at the San Diego Bay and ultimately the Pacific Ocean.

The site is not within a FEMA 100-year floodplain boundary or regulatory floodway.

Existing Drainage Basin C comprises the northwesterly portion of the site. Runoff is conveyed via overland surface flow to an existing swale west of the project site. Local surface runoff from the project site and surrounding properties collect in this area and flow to the south to an existing concrete drainage channel located in the rear yard of an existing single family residence at the end of Tanoak Court. The existing concrete channel flows to the south and then turns and flows to the west and discharges into Tanoak Court through two existing Type A curb outlets.

Per the United States Department of Agriculture (USDA) Web Soil Survey, the project site is Hydrologic Soil Group C and D. Refer to Appendix C of this report for the USDA Web Soil Survey and geotechnical findings.

Table 1.1 below summarizes the pre-project condition 100-year peak flows at the project’s discharge locations. For delineated basin details, please refer to the Pre-Project Condition Hydrology Node Map included in Appendix 1 of this report.

TABLE 1.1 – Summary of Pre-Project Conditions

Existing Drainage Basin	Drainage Area (ac)	Runoff Coefficient, C	Time of Concentration, Tc (min)	Intensity, I (in/hr)	Pre-Project Q100 (cfs)
Basin A	2.79	0.55	9.15	4.70	7.20
Basin B	6.13	0.55	8.86	4.57	15.42
Basin C	0.79	0.55	4.77	6.32	2.78
Total	9.71	0.55			25.40

1.3 Post-Project Conditions

The project will include the construction of an industrial building, paved drive aisles and parking areas, retaining walls, and other associated improvements. Private drainage improvements will consist of catch basins, curb inlets and storm drain pipes. Proprietary Modular Wetland Systems are proposed for storm water treatment. An underground detention vault is proposed for peak flow attenuation. The project will be accessed by a proposed driveway off Shinohara Lane. The proposed land use is ILP- Limited Industrial.

The proposed site will consist of two (2) major drainage basins with two (2) discharge locations which match the existing drainage discharge points and pre-project peak flow rates for Existing Drainage Basins A and B. The proposed project’s area in the northwesterly corner of the project site that comprised Existing Drainage Basin C is proposed to be included in Proposed Drainage Basin A. This will enable the proposed project to collect and convey runoff from this location to the project’s peak flow detention facility and storm water treatment and no longer discharge runoff on an existing single family residential property. While the size of Proposed Drainage Basin A is larger than the size of Existing Drainage Basin A when comparing areas, the proposed project will provide peak flow detention so the peak flow runoff rate from this basin for the post-project condition will be equal to or less than the pre-project condition.

Storm water runoff from a majority of the proposed development (DMA-A) is routed to a series of BMPs including a Contech CDS pretreatment unit, a StormTrap underground detention vault and a BioClean Modular Wetland System (MWS). The underground detention vault has been designed to meet 100-year peak flow detention requirements. The Modular Wetland System is designed as a proprietary biofiltration

BMP for storm water treatment. Outflows from the detention vault and MWS are discharged through a proposed storm drain pipe to the existing Type F catch basin at the southern property boundary. Stormwater is then conveyed through the neighboring property to the south through an existing private storm drain and outlets onto Main Street as in existing conditions.

Storm water runoff from the proposed driveway (DMA-B) will be drained to a Modular Wetland System for storm water treatment. The MWS will be designed with a 3-foot-wide curb inlet opening and a 1-inch local curb depression to capture the required water quality flow. Runoff that exceeds the water quality flow rate or capacity of the MWS will flow by the MWS and drain to the existing concrete drainage channel at the southeast corner of the project site. Outflows from the MWS will be pumped to a proposed curb outlet along the southern property boundary and discharged to the existing concrete drainage channel. The concrete drainage channel discharges onto Main Street via curb outlet as in existing conditions. The characteristics of existing stormwater flows through the neighboring property will not change as a result of the proposed project.

Runoff from the cut slope at the northwest portion of the project site will be conveyed via proposed brow ditch to the existing Type F catch basin at the southern property boundary. This area (DMA-C) is considered a Self-Mitigating DMA per Chapter 5.2.1 of the City of Chula Vista BMP Design Manual.

All project site runoff is discharged onto Main Street as in existing conditions. From Main Street, flow travels west via concrete curb and gutter to an existing curb inlet. Stormwater is then conveyed south through an existing storm drain and outlets over headwall into the Otay River. The Otay River travels west and outlets at the San Diego Bay and ultimately the Pacific Ocean. The Otay River is considered an exempt river reach per the WMAA; therefore, the project is exempt from hydromodification management requirements.

The underground detention vault has been designed to provide flow control in the form of volume reduction and peak flow attenuation. The vault has been modified to include a low-flow and mid-flow orifice outlet and an overflow weir to control peak flows. The required water quality treatment flow is diverted to the downstream Modular Wetland System in accordance with Worksheet B.5-5 of the City of Chula Vista BMP Design Manual. Overflow relief for the 100-year storm event is provided with a partition weir installed within the vault and discharged directly to the existing Type F catch basin at the southern property boundary.

Table 1.2 below summarizes the post-project condition 100-year peak flows at the project’s discharge locations. For delineated basin details, please refer to the Post-Project Condition Hydrology Node Map included as an Attachment of this report.

TABLE 1.2 – Summary of Post-Project Conditions

Proposed Drainage Basin	Drainage Area (ac)	Runoff Coefficient, C	Time of Concentration, Tc (min)	Intensity, I (in/hr)	Post-Project Q100 (cfs)	Required Detention (cfs)
Basin A	8.52	0.79	8.78	4.60	33.45	26.25
Basin B	1.19	0.80	5.55	6.07	5.77	--
Total	9.71	0.79			39.22	26.25

2. METHODOLOGY

Runoff calculations for Project Shinohara have been performed in accordance with Section 3 – General Design Criteria of the City of Chula Vista Subdivision Manual dated March 2012. Per City of City of Chula Vista design criteria, the Modified Rational Method should be used to determine peak flowrates for local drainage basins. Advanced Engineering Software (AES) were used to calculate the peak runoff from the 100-year, 6-hour storm event using the Rational Method. Please refer to this report's Appendix for the results of these calculations.

2.1 Rational Method

As mentioned above, runoff from the project site was calculated for the 100-year storm event. Runoff was calculated using the Rational Method which is given by the following equation:

$$Q = C \times I \times A$$

Where:

Q = Flow rate in cubic feet per second (cfs)

C = Runoff coefficient

I = Rainfall Intensity in inches per hour (in/hr)

A = Drainage basin area in acres, (ac)

Rational Method calculations were performed using the AES 2008 computer program. To perform the hydrology routing, the total watershed area is divided into sub-areas which discharge at designated nodes. The procedure for the sub-area summation model is as follows:

- (1) Subdivide the watershed into an initial sub-areas and subsequent sub-areas, which are generally less than 10 acres in size. Assign upstream and downstream node numbers to each sub-area.
- (2) Estimate an initial T_c by using the appropriate nomograph or overland flow velocity estimation. The minimum T_c considered is 5.0 minutes. All T_c values for the proposed project were assumed to be 5 minutes due to the small size of each contributing drainage area.
- (3) Using the initial T_c , determine the corresponding values of I. Then $Q = CIA$.
- (4) Using Q, estimate the travel time between this node and the next by Manning's equation as applied to particular channel or conduit linking the two nodes. Then, repeat the calculation for Q based on the revised intensity (which is a function of the revised time of concentration)

2.2 Runoff Coefficient

In accordance with City of Chula Vista design standards, runoff coefficients were based on land use. An appropriate runoff coefficient (C) for each type of land use in the subarea was selected from Section 3-203.3 of the City of Chula Vista Subdivision Manual and multiplied by the percentage of total area (A) included in that class. The sum of products for all land uses is the weighted runoff coefficient ($\sum[C]$). See Tables 2.1 and 2.2 below for weighted runoff coefficient “C” calculations. The Pre-Project and Post-Project Condition Hydrology Node Maps show the drainage basin subareas, on-site drainage system and nodal points.

Runoff coefficients of 0.55 and 0.60 were selected from Section 3-203.3 for hilly and steep vegetated slopes, consistent with existing conditions. The existing site is assumed to be 0% impervious. See Table 2.1 below for pre-project condition weighted runoff coefficient “C” calculations.

In the post-project condition, the developed site was assigned a runoff coefficient of 0.85 for commercial area. Developed slopes along the northern and southern property boundary were classified as steep per Section 3-203.3 and assigned a runoff coefficient of 0.60. See Table 2.2 on the following page for post-project condition weighted runoff coefficient “C” calculations.

TABLE 2.1- Summary of Pre-Project Condition Weighted Runoff Coefficient Calculations

Pre-Project Condition - Weighted Runoff Coefficient							
Up Node	Down Node	Area (ac)	C ₁	A ₁	C ₂	A ₂	C
10	11	0.04	0.55	0.04	0.60	0.00	0.55
11	12	2.75	0.55	2.75	0.60	0.00	0.55
20	21	0.09	0.55	0.09	0.60	0.00	0.55
21	22	6.01	0.55	6.01	0.60	0.00	0.55
30	31	0.08	0.55	0.08	0.60	0.00	0.55
31	32	0.72	0.55	0.72	0.60	0.00	0.55

Note: C values taken from Section 3-203.3 of the City of Chula Vista Subdivision Manual
 Runoff Coefficient of 0.55 for Vegetated Slopes, Hilly
 Runoff Coefficient of 0.60 for Vegetated Slopes, Steep

TABLE 2.2- Summary of Post-Project Condition Weighted Runoff Coefficient Calculations

Post-Project Condition - Weighted Runoff Coefficient							
Up Node	Down Node	Area (ac)	C ₁	A ₁	C ₂	A ₂	C
100	101	0.04	0.85	0.04	0.60	0.00	0.85
101	102	0.34	0.85	0.34	0.60	0.00	0.85
103	103	0.20	0.85	0.20	0.60	0.00	0.85
104	104	0.38	0.85	0.38	0.60	0.00	0.85
105	105	0.20	0.85	0.20	0.60	0.00	0.85
106	106	0.41	0.85	0.41	0.60	0.00	0.85
107	107	0.14	0.85	0.14	0.60	0.00	0.85
107	107	0.39	0.85	0.00	0.60	0.39	0.60
108	108	0.12	0.85	0.12	0.60	0.00	0.85
109	109	0.12	0.85	0.12	0.60	0.00	0.85
110	110	0.11	0.85	0.11	0.60	0.00	0.85
111	111	0.06	0.85	0.06	0.60	0.00	0.85
112	112	0.29	0.85	0.29	0.60	0.00	0.85
113	113	0.27	0.85	0.27	0.60	0.00	0.85
114	114	0.94	0.85	0.94	0.60	0.00	0.85
115	115	0.80	0.85	0.80	0.60	0.00	0.85
117	118	0.04	0.85	0.04	0.60	0.00	0.85
118	119	0.34	0.85	0.34	0.60	0.00	0.85
120	120	0.08	0.85	0.08	0.60	0.00	0.85
121	121	0.22	0.85	0.22	0.60	0.00	0.85
122	122	0.38	0.85	0.38	0.60	0.00	0.85
123	123	0.35	0.85	0.35	0.60	0.00	0.85
124	124	0.19	0.85	0.19	0.60	0.00	0.85
125	125	0.11	0.85	0.11	0.60	0.00	0.85
126	126	0.16	0.85	0.16	0.60	0.00	0.85
127	127	0.16	0.85	0.16	0.60	0.00	0.85
128	128	0.20	0.85	0.20	0.60	0.00	0.85
129	129	0.37	0.85	0.37	0.60	0.00	0.85
131	131	0.84	0.85	0.00	0.60	0.84	0.60
136	136	0.25	0.85	0.00	0.60	0.25	0.60
200	201	0.16	0.85	0.16	0.60	0.00	0.85
201	202	1.03	0.85	0.79	0.60	0.24	0.79

Note: C values taken from Section 3-203.3 of the City of Chula Vista Subdivision Manual
 Runoff Coefficient of 0.85 for Commercial Area
 Runoff Coefficient of 0.60 for Vegetated Slopes, Steep

2.3 Rainfall Intensity

Rainfall intensity is calculated per Section 3-203.3 of the City of Chula Vista Subdivision Manual, which is given by the following equation:

$$I = 7.44P_6D^{-0.645}$$

Where:

I = Rainfall Intensity in inches per hour (in/hr)

P₆ = Adjusted 6-hour storm precipitation

D = Duration in minutes (use T_c)

The intensity values for varying time of concentrations were input manually into the AES computer program where runoff calculations were performed. The 6-hour storm rainfall amount (P₆) for the 100-year storm frequency was determined using City of Chula Vista Isopluvial Maps provided from Figure 7 of the City of Chula Vista Drainage Master Plan. The P₆ for the 100-year storm frequency was found as 2.4 inches. See Appendix 3 of this report for Isopluvial maps for the 100-year rainfall event.

2.4 Tributary Areas

Drainage basins for the existing and proposed project site are delineated in the Pre-Project and Post-Project Condition Hydrology Node Maps located in Appendix 1 and 2 of this report and graphically portray the tributary area for each drainage basin.

2.5 Hydraulics

The hydraulics of existing and proposed storm drain pipes were analyzed using the AES computer program. For pipe flow, a Manning's N value of 0.011 was used to reflect the use of HDPE pipe. A Manning's N value of 0.013 was used to reflect the use of RCP pipe.

2.6 Curb Inlet and Catch Basin Sizing

Curb inlets and catch basins will be sized in accordance with City of Chula Vista Subdivision Manual (March 2012) upon final engineering.

2.7 Detention Basin Routing

The detention facility was modeled using the Army Corps of Engineers HEC-HMS 4.3 software. Hydraulic Modified-Puls detention routing was performed to analyze the developed condition 100-year peak flow rate at the project's detention system. Stage-storage-discharge tables were generated and input into HEC-HMS to model the design of the vault outlet structure. This procedure was selected in order to model the flow control requirements and to accurately represent the middle stages of the BMP for accurate mid-flow orifice and emergency weir sizing. The stage-storage-discharge tables have been provided in Appendix 5. The HEC-HMS Modified-Puls results are summarized in Table 2.3 on the following page.

TABLE 2.3- Summary of Detention Basin Routing

Detention Basin	Tributary Area (ac)	Runoff Coefficient, C	Inflow Tc (min) ¹	100-Year Peak Inflow (cfs)	Outflow Tc (min)	100-Year Peak Outflow (cfs)	Peak Elevation (ft) ²
BMP-1	8.27	0.85	10	33.45	19	6.99	5.37

Notes: (1) Inflow time of concentration rounded to the nearest time interval that HEC-HMS could accept
(2) Peak elevation measured from the invert of the mid-flow orifice

A Rational method inflow hydrograph was generated using RickRat Hydro software from Rick Engineering. The parameters of the drainage area were entered into RickRat Hydro software to generate an inflow hydrograph. The data from this hydrograph was then entered into HEC-HMS software to model the release rates from the detention system.

HEC-HMS allows for hydrology input time steps of 1, 2, 3, 4, 5, 6, 10, 15 & 20 minutes. Rick Rat Hydro requires a minimum time of concentration (Tc) of 5 minutes. Therefore, the time of concentration (Tc) used for the concentration of the hydrograph was rounded to the nearest time interval that RickRat Hydro and HEC-HMS could accept. The time of concentration used is 10 minutes. The peak flow remains as per the modified Rational Method analysis and is not reduced (or increased) from this hydrograph development accordingly.

Rational method hydrographs, stage-storage-discharge relationships and HEC-HMS model output is provided in Appendix 5 of this report.

3. CALCULATIONS/RESULTS

3.1 Pre- & Post-Development Peak Flow Comparison

Below are a series of tables which summarize the calculations provided in the appendices of this report.

Table 3.1 itemizes the pre-project condition peak flow rates for the 100-year storm event at the project's discharge locations.

TABLE 3.1- Pre-Project Condition Peak Flow Summary

Drainage Basin	Drainage Area (ac)	Runoff Coefficient, C	Pre-Project Q100 (cfs)
Basin A	2.79	0.55	7.20
Basin B	6.13	0.55	15.42
Basin C	0.79	0.55	2.78
Total	9.71	0.55	25.40

Table 3.2 itemizes the post-project and detained condition peak flow rates for the 100-year storm event at the project's discharge locations.

TABLE 3.2- Proposed Post-Project Condition Peak Flow Summary

Drainage Basin	Drainage Area (ac)	Runoff Coefficient, C	Post-Project Condition Q100 (cfs)	Detained Condition Q100 (cfs)
Basin A	8.52	0.79	33.45	7.17
Basin B	1.19	0.80	5.77	5.77
Total	9.71	0.79	39.22	12.94

Table 3.3 shows that the total storm water peak flow for the proposed development is less than the existing storm water peak flow for the 100-year rainfall event.

TABLE 3.3- Pre-Project Vs. Post-Project Detained Condition Peak Flow Summary

Pre-Project Condition Q100 (cfs)	Post-Project Detained Condition Q100 (cfs)	Pre-Project Vs. Post-Project Detained Condition Q100 (cfs)
25.40	12.94	-12.46

3.2 Storm Water Quality

The proposed site will include Modular Wetland Systems that will provide the required storm water quality treatment for the project. For information regarding BMP sizing and the water quality design, refer to the *Storm Water Quality Management Plan for Project Shinohara, OnPoint Development by PLSA*, dated May 20, 2022, under separate cover.

3.3 Hydromodification

The project is exempt from hydromodification management requirements. For additional information regarding hydromodification exemption, refer to the *Storm Water Quality Management Plan for Project Shinohara, OnPoint Development by PLSA*, dated May 20, 2022, under separate cover.

4. CONCLUSION

This report analyzed the 100-year storm event hydrology for the proposed site using the Advanced Engineering Software (AES) and demonstrates that the post-developed peak flow rates are less than the pre-developed peak flow rates at the project's two existing discharge locations. In addition, the proposed storm drain system was sized adequately to convey the proposed project's runoff and supporting calculations can be found in the appendices of this report.

The proposed project will not substantially alter the existing drainage pattern of the site or area, including through the alteration of the course of a stream or river, in a manner that would result in substantial erosion or siltation on or off-site. In addition, the proposed project will not increase the peak runoff rate for the post-project condition when compared to the pre-project condition.

The project is not within the FEMA 100-year floodplain boundary as mapped on the Flood Insurance Rate Map.



Appendix 1
Pre-Project Condition Hydrology Node Map



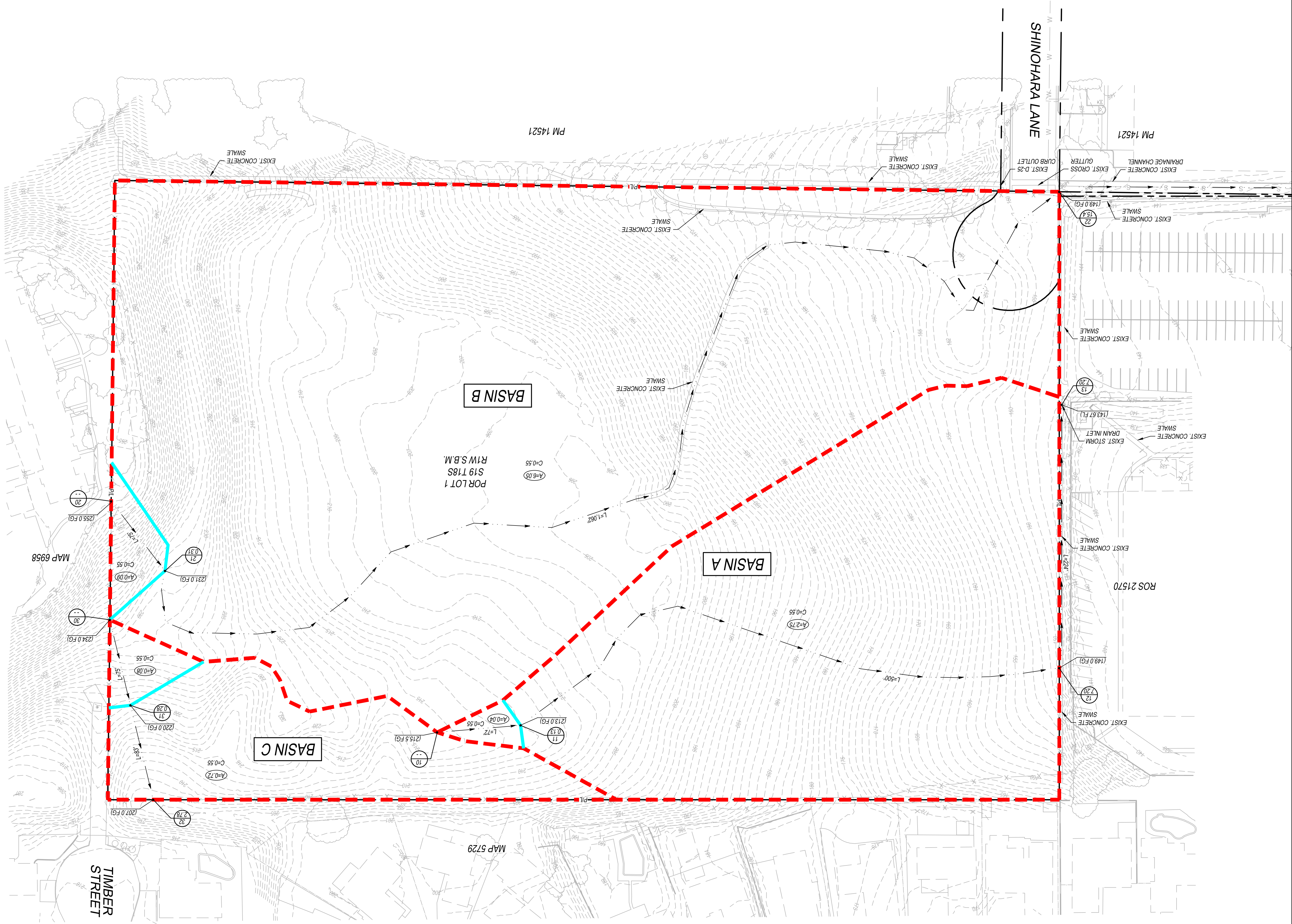
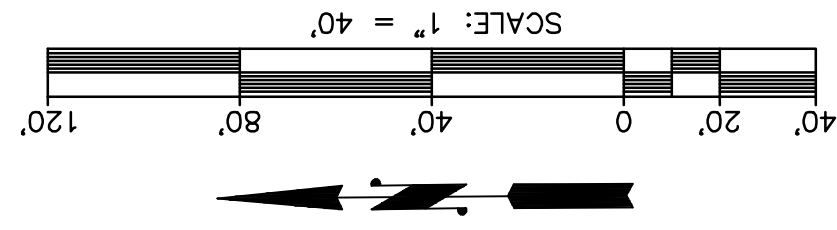

SUMMARY OF EXISTING CONDITION 100-YEAR PEAK FLOWS

DRAINAGE BASIN	DRAINAGE AREA (AC)	% IMP	WEIGHTED RUNOFF COEFFICIENT, C	EXISTING PEAK FLOW (CFS)	100-YEAR PEAK FLOW (CFS)
BASIN A	2.79	0.0%	0.55	7.20	7.20
BASIN B	6.13	0.0%	0.55	15.42	15.42
BASIN C	0.79	0.0%	0.55	2.78	2.78
TOTAL	9.71	0.0%	0.55	25.40	25.40

PASCO LARET SUTTER & ASSOCIATES
 San Diego | Solana Beach | Orange County
 Phone 858.259.8212 | www.plsaeengineering.com

PRE-PROJECT CONDITION
 HYDROLOGY NODE MAP
 SHINOHARA BUSINESS PARK
 517 SHINOHARA LANE
 CHULA VISTA, CA 91911
 PLSA JOB NO. 3690
 MAY 2022

LEGEND

SYMBOL	DESCRIPTION
	HYDROLOGY NODE
	Q100 (CFS)
	SUB-BASIN AREA
	WEIGHTED RUNOFF COEFFICIENT
	RIGHT-OF-WAY
	PROPERTY LINE
	BASIN BOUNDARY
	SUB-BASIN BOUNDARY
	FLOWLINE

PROJECT CHARACTERISTICS

PARCEL AREA:	9.73 AC
EXISTING DRAINAGE BOUNDARY:	9.71 AC
EXISTING IMPERVIOUS AREA:	0 AC
EXISTING PERVIOUS / LANDSCAPE AREA:	9.71 AC

RUNOFF COEFFICIENT

IN ACCORDANCE WITH SECTION 3 - GENERAL DESIGN CRITERIA OF THE CITY OF CHULA VISTA SUBDIVISION MANUAL, RUNOFF COEFFICIENTS WERE BASED ON LAND USE. AN APPROPRIATE RUNOFF COEFFICIENT WAS SELECTED FROM SECTION 3-203.3 AND MULTIPLIED BY THE PERCENTAGE OF TOTAL AREA IN THAT CLASS. THE SUM OF THE PRODUCTS FOR ALL LAND USES IS THE WEIGHTED RUNOFF COEFFICIENT.

SEE TABLE 2.1 OF THE PRELIMINARY DRAINAGE STUDY FOR PROJECT SHINOHARA BY PLSA DATED FEBRUARY 2022 FOR PRE-PROJECT CONDITION WEIGHTED RUNOFF COEFFICIENT 'C' CALCULATIONS.

DEPTH TO GROUNDWATER

DEPTH TO GROUNDWATER > 20 FT

HYDROLOGIC SOIL GROUP

HYDROLOGIC SOIL TYPE: C & D



Appendix 2

Post-Project Condition Hydrology Node Map



LEGEND	SYMBOL
DESCRIPTION	
HYDROLOGY NODE	
POST-PROJECT DETAINED Q100 (CFS)	
SUB-BASIN AREA	
WEIGHTED RUNOFF COEFFICIENT	C=0.85
RIGHT-OF-WAY	
PROPERTY LINE	
BASIN BOUNDARY	
SUB-BASIN BOUNDARY	
FLOWLINE	

HYDROLOGIC SOIL GROUP
HYDROLOGIC SOIL TYPE: C & D

DEPTH TO GROUNDWATER
DEPTH TO GROUNDWATER > 20 FT

PROJECT CHARACTERISTICS

PARCEL AREA:	9.73 AC
PROPOSED DRAINAGE BOUNDARY:	9.71 AC
PROPOSED DISTURBED AREA:	9.67 AC
PROPOSED IMPERVIOUS AREA:	8.03 AC
PROPOSED PERVIOUS / LANDSCAPE AREA:	1.64 AC

RUNOFF COEFFICIENT
IN ACCORDANCE WITH SECTION 3-GENERAL DESIGN CRITERIA OF THE CITY OF CHULA VISTA SUBDIVISION MANUAL, RUNOFF COEFFICIENTS WERE BASED ON LAND USE. AN APPROPRIATE RUNOFF COEFFICIENT WAS SELECTED FROM SECTION 3-203.3 AND MULTIPLIED BY THE PERCENTAGE OF TOTAL AREA IN THAT CLASS. THE SUM OF THE PRODUCTS FOR ALL LAND USES IS THE WEIGHTED RUNOFF COEFFICIENT.
SEE TABLE 2.2 OF THE "PRELIMINARY DRAINAGE STUDY FOR PROJECT SHINOHARA, ONPOINT DEVELOPMENT" BY PLSA DATED MAY 2022 FOR POST-PROJECT CONDITION WEIGHTED RUNOFF COEFFICIENT "C" CALCULATIONS.

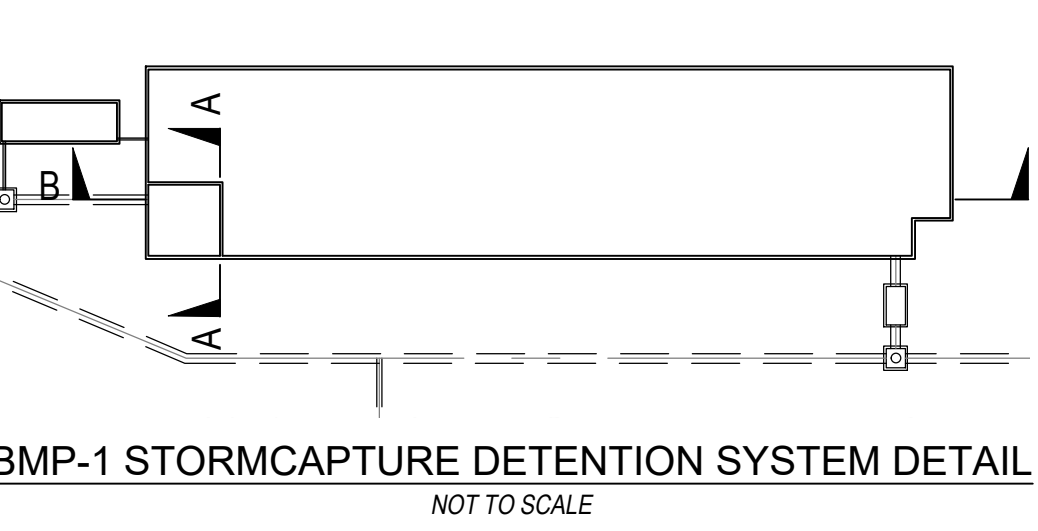
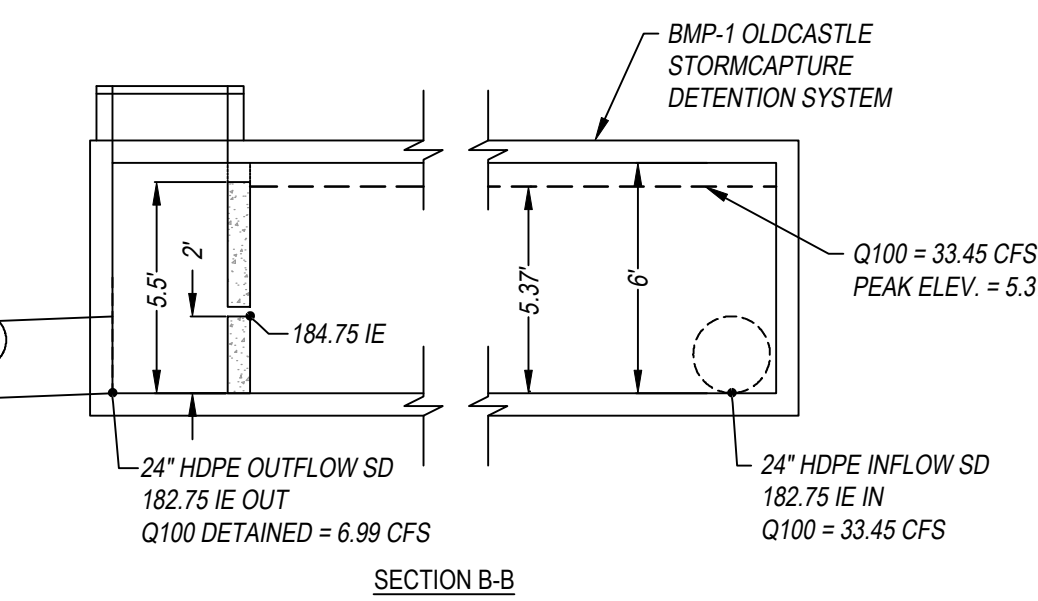
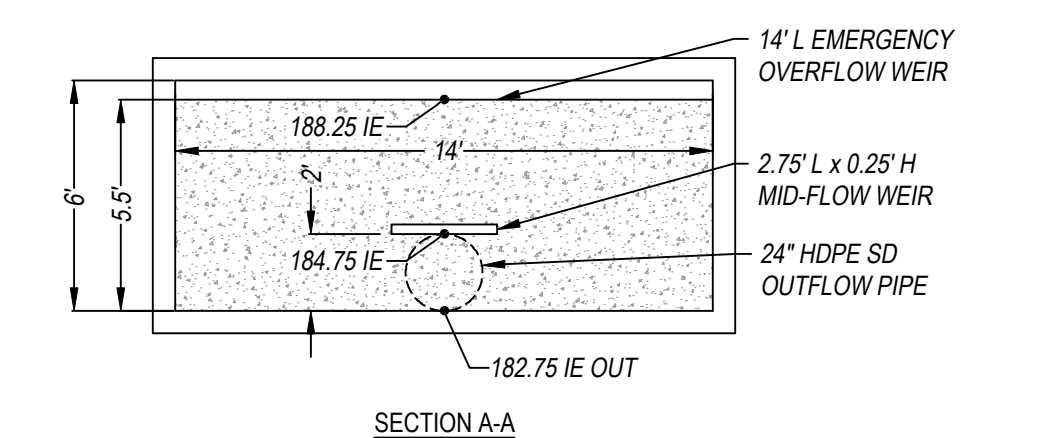
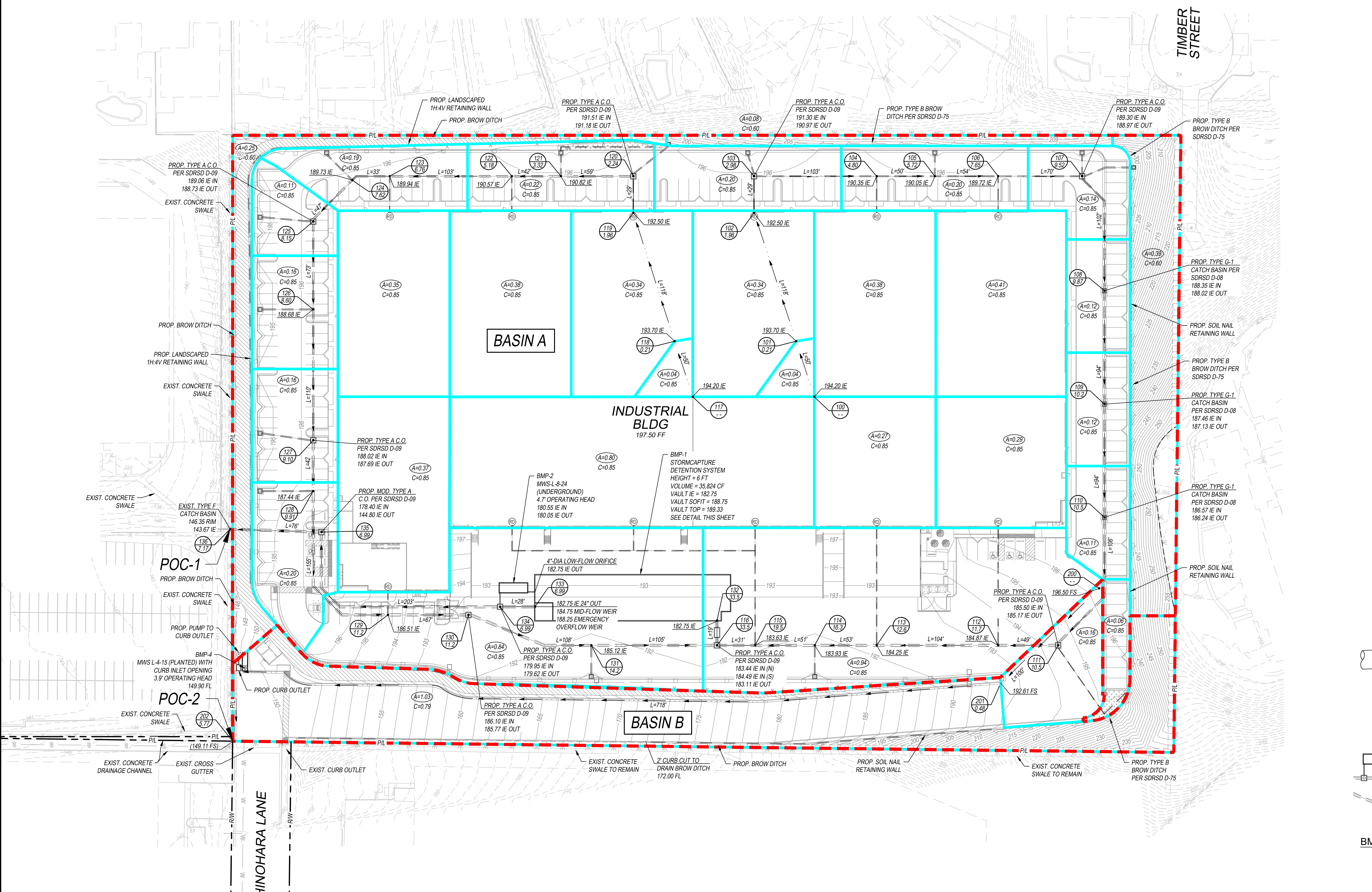

SUMMARY OF PROPOSED CONDITION 100-YEAR PEAK FLOWS

DRAINAGE BASIN	POC	DRAINAGE AREA (AC)	IMPERVIOUS AREA (AC)	% IMP	WEIGHTED RUNOFF COEFFICIENT, C	POST-PROJECT Q100 (CFS)	POST-PROJECT DETAINED Q100 (CFS)
BASIN A	POC-1	8.52	7.36	86.4%	0.83	33.45	7.17
BASIN B	POC-2	1.19	0.68	56.8%	0.80	5.77	5.77
TOTAL	-	9.71	8.03	82.7%	0.83	39.22	12.94

NOTE: UNMITIGATED PEAK FLOW IS THE POST-PROJECT PEAK FLOW THAT HAS NOT BEEN REDUCED FROM DETENTION ROUTING.
MITIGATED PEAK FLOW IS THE POST-PROJECT PEAK FLOW THAT HAS BEEN REDUCED BY ROUTING FLOW THROUGH THE PROJECT'S DETENTION FACILITY.

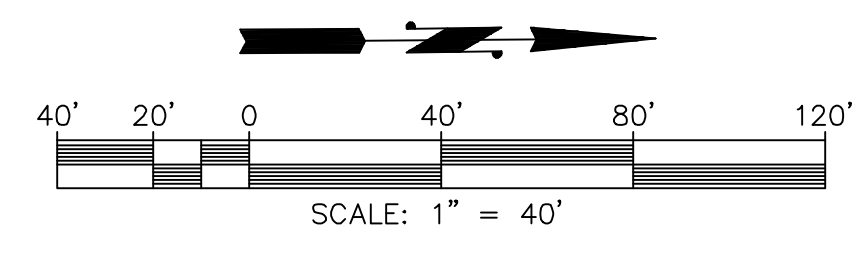

PASCO LARET SUITER & ASSOCIATES
San Diego | Encinitas | Orange County
Phone 858.259.8212 | www.plsaengineering.com

POST-PROJECT CONDITION HYDROLOGY NODE MAP
SHINOHARA BUSINESS PARK
517 SHINOHARA LANE
CHULA VISTA, CA 91911
PLSA JOB NO. 3690
MAY 2022

Appendix 3

Hydrology Design Summary

Hydrologic Soil Group—San Diego County Area, California



Soil Map may not be valid at this scale.

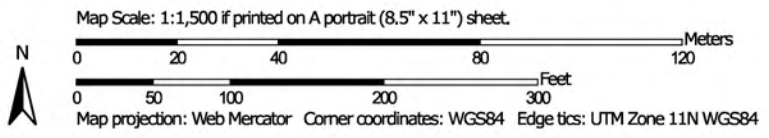





MAP LEGEND

Area of Interest (AOI)









 Area of Interest (AOI)

Soils

Soil Rating Polygons





 A
 A/D
 B
 B/D
 C
 C/D
 D
 Not rated or not available

Soil Rating Lines

 A
 A/D
 B
 B/D
 C
 C/D
 D
 Not rated or not available

Soil Rating Points

 A
 A/D
 B
 B/D

 C
 C/D
 D
 Not rated or not available

Water Features

 Streams and Canals

Transportation

 Rails
 Interstate Highways
 US Routes
 Major Roads
 Local Roads

Background

 Aerial Photography

MAP INFORMATION

The soil surveys that comprise your AOI were mapped at 1:24,000.

Warning: Soil Map may not be valid at this scale.

Enlargement of maps beyond the scale of mapping can cause misunderstanding of the detail of mapping and accuracy of soil line placement. The maps do not show the small areas of contrasting soils that could have been shown at a more detailed scale.

Please rely on the bar scale on each map sheet for map measurements.

Source of Map: Natural Resources Conservation Service
 Web Soil Survey URL:
 Coordinate System: Web Mercator (EPSG:3857)

Maps from the Web Soil Survey are based on the Web Mercator projection, which preserves direction and shape but distorts distance and area. A projection that preserves area, such as the Albers equal-area conic projection, should be used if more accurate calculations of distance or area are required.

This product is generated from the USDA-NRCS certified data as of the version date(s) listed below.

Soil Survey Area: San Diego County Area, California
 Survey Area Data: Version 15, May 27, 2020

Soil map units are labeled (as space allows) for map scales 1:50,000 or larger.

Date(s) aerial images were photographed: Aug 22, 2018—Aug 31, 2018

The orthophoto or other base map on which the soil lines were compiled and digitized probably differs from the background imagery displayed on these maps. As a result, some minor shifting of map unit boundaries may be evident.

Hydrologic Soil Group

Map unit symbol	Map unit name	Rating	Acres in AOI	Percent of AOI
OhE	Olivenhain cobbly loam, 9 to 30 percent slopes	D	7.5	71.3%
SbC	Salinas clay loam, 2 to 9 percent slopes	C	3.0	28.7%
Totals for Area of Interest			10.5	100.0%

Description

Hydrologic soil groups are based on estimates of runoff potential. Soils are assigned to one of four groups according to the rate of water infiltration when the soils are not protected by vegetation, are thoroughly wet, and receive precipitation from long-duration storms.

The soils in the United States are assigned to four groups (A, B, C, and D) and three dual classes (A/D, B/D, and C/D). The groups are defined as follows:

Group A. Soils having a high infiltration rate (low runoff potential) when thoroughly wet. These consist mainly of deep, well drained to excessively drained sands or gravelly sands. These soils have a high rate of water transmission.

Group B. Soils having a moderate infiltration rate when thoroughly wet. These consist chiefly of moderately deep or deep, moderately well drained or well drained soils that have moderately fine texture to moderately coarse texture. These soils have a moderate rate of water transmission.

Group C. Soils having a slow infiltration rate when thoroughly wet. These consist chiefly of soils having a layer that impedes the downward movement of water or soils of moderately fine texture or fine texture. These soils have a slow rate of water transmission.

Group D. Soils having a very slow infiltration rate (high runoff potential) when thoroughly wet. These consist chiefly of clays that have a high shrink-swell potential, soils that have a high water table, soils that have a claypan or clay layer at or near the surface, and soils that are shallow over nearly impervious material. These soils have a very slow rate of water transmission.

If a soil is assigned to a dual hydrologic group (A/D, B/D, or C/D), the first letter is for drained areas and the second is for undrained areas. Only the soils that in their natural condition are in group D are assigned to dual classes.

Rating Options

Aggregation Method: Dominant Condition

Component Percent Cutoff: None Specified

Tie-break Rule: Higher

Chula Vista Drainage Master Plan Figure 7: Rainfall Isopluvials

100 Year Rainfall Event

- 6 Hour Isopluvial
- 24 Hour Isopluvial

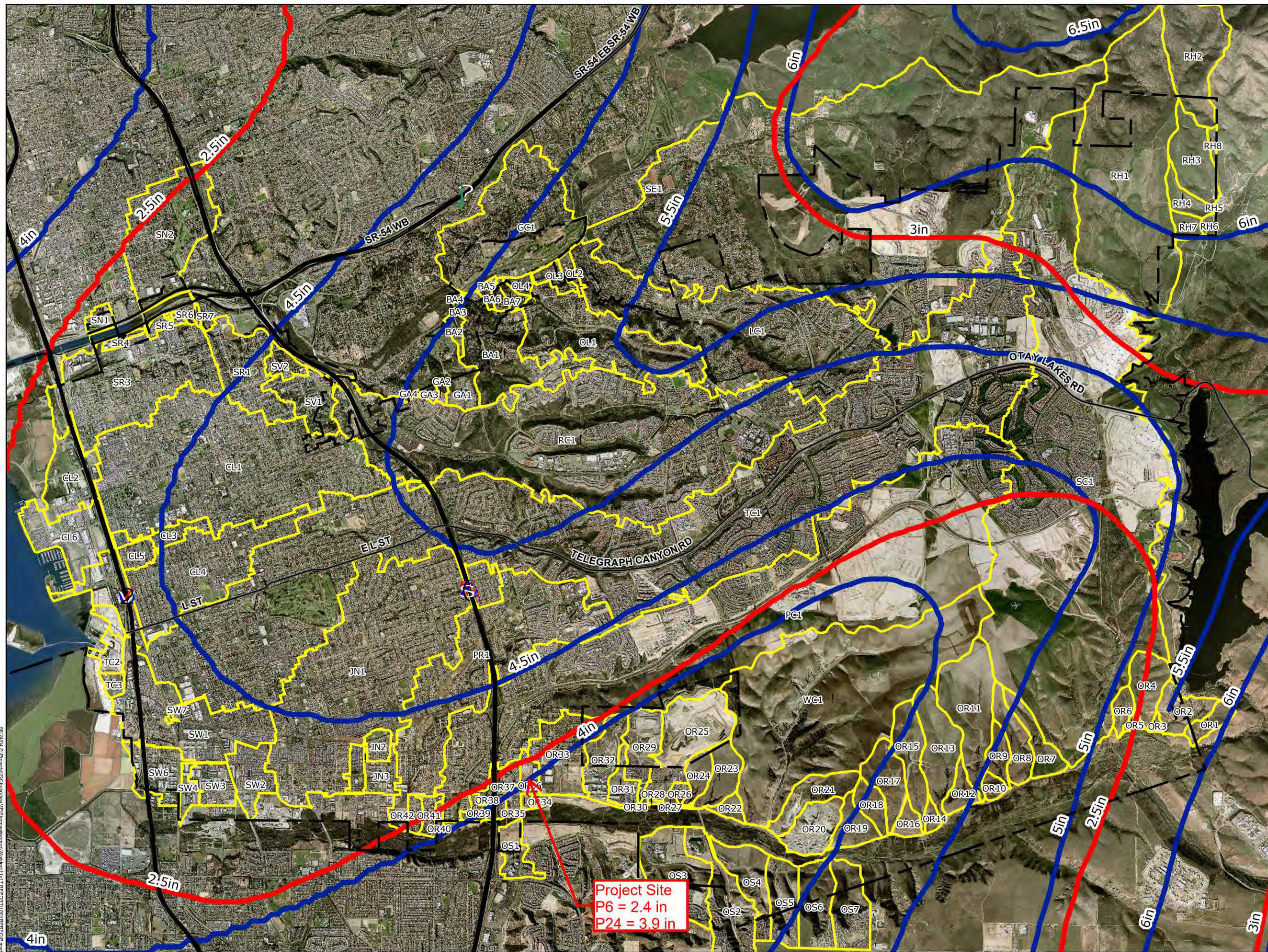

1 inch equals 4,200 feet



Map Date: Feb 12, 2004
 Projection: State Plane
 Datum: NAD 83
 Zone: California VI
 Units: Feet

Project Site
 P6 = 2.4 in
 P24 = 3.9 in

06/24/04 2:10pm GIS/Chula Vista/Map/Stormwater/Working/13177_Report/100YR/RR/CP/Map

Appendix 4

AES Rational Method Calculations

100-YEAR PRE-PROJECT CONDITION

RATIONAL METHOD HYDROLOGY COMPUTER PROGRAM PACKAGE
Reference: SAN DIEGO COUNTY FLOOD CONTROL DISTRICT
2003,1985,1981 HYDROLOGY MANUAL
(c) Copyright 1982-2008 Advanced Engineering Software (aes)
Ver. 15.0 Release Date: 04/01/2008 License ID 1452

Analysis prepared by:

PASCO LARET SUITER & ASSOCIATES
535 NORTH HIGHWAY 101
SUITE A
SOLANA BEACH CA 92705

FILE NAME: 3690E100.DAT
TIME/DATE OF STUDY: 12:51 02/24/2022

USER SPECIFIED HYDROLOGY AND HYDRAULIC MODEL INFORMATION:

USER SPECIFIED STORM EVENT(YEAR) = 100.00
SPECIFIED MINIMUM PIPE SIZE(INCH) = 4.00
SPECIFIED PERCENT OF GRADIENTS(DECIMAL) TO USE FOR FRICTION SLOPE = 0.95
RAINFALL-INTENSITY ADJUSTMENT FACTOR = 1.000

*USER SPECIFIED:

NUMBER OF [TIME,INTENSITY] DATA PAIRS = 9

1) 5.000; 6.323
2) 10.000; 4.044
3) 15.000; 3.113
4) 20.000; 2.586
5) 25.000; 2.239
6) 30.000; 1.991
7) 40.000; 1.654
8) 50.000; 1.432
9) 60.000; 1.273

SAN DIEGO HYDROLOGY MANUAL "C"-VALUES USED FOR RATIONAL METHOD

NOTE: ONLY PEAK CONFLUENCE VALUES CONSIDERED

USER-DEFINED STREET-SECTIONS FOR COUPLED PIPEFLOW AND STREETFLOW MODEL

NO.	HALF- WIDTH (FT)	CROWN TO CROSSFALL (FT)	STREET-CROSSFALL: IN- / OUT-/ SIDE / SIDE/ WAY	CURB HEIGHT (FT)	GUTTER-GEOMETRIES: WIDTH (FT)	LIP (FT)	HIKE (FT)	MANNING FACTOR (n)
1	30.0	20.0	0.018/0.018/0.020	0.67	2.00	0.0312	0.167	0.0150

GLOBAL STREET FLOW-DEPTH CONSTRAINTS:

1. Relative Flow-Depth = 0.00 FEET
as (Maximum Allowable Street Flow Depth) - (Top-of-Curb)
2. (Depth)*(Velocity) Constraint = 6.0 (FT*FT/S)

*SIZE PIPE WITH A FLOW CAPACITY GREATER THAN
OR EQUAL TO THE UPSTREAM TRIBUTARY PIPE.*

FLOW PROCESS FROM NODE 10.00 TO NODE 11.00 IS CODE = 21

>>>>RATIONAL METHOD INITIAL SUBAREA ANALYSIS<<<<<
=====

*USER SPECIFIED(SUBAREA):

USER-SPECIFIED RUNOFF COEFFICIENT = .5500
S.C.S. CURVE NUMBER (AMC II) = 0
INITIAL SUBAREA FLOW-LENGTH(FEET) = 72.00
UPSTREAM ELEVATION(FEET) = 215.50

DOWNSTREAM ELEVATION(FEET) = 213.00
ELEVATION DIFFERENCE(FEET) = 2.50
URBAN SUBAREA OVERLAND TIME OF FLOW(MIN.) = 5.548
100 YEAR RAINFALL INTENSITY(INCH/HOUR) = 6.073
SUBAREA RUNOFF(CFS) = 0.13
TOTAL AREA(ACRES) = 0.04 TOTAL RUNOFF(CFS) = 0.13

FLOW PROCESS FROM NODE 11.00 TO NODE 12.00 IS CODE = 51

>>>>COMPUTE TRAPEZOIDAL CHANNEL FLOW<<<<<
>>>>TRAVELTIME THRU SUBAREA (EXISTING ELEMENT)<<<<<

=====

ELEVATION DATA: UPSTREAM(FEET) =	213.00	DOWNSTREAM(FEET) =	149.00
CHANNEL LENGTH THRU SUBAREA(FEET) =	500.00	CHANNEL SLOPE =	0.1280
CHANNEL BASE(FEET) =	10.00	"Z" FACTOR =	20.000
MANNING'S FACTOR =	0.040	MAXIMUM DEPTH(FEET) =	1.00
100 YEAR RAINFALL INTENSITY(INCH/HOUR) =	4.695		

*USER SPECIFIED(SUBAREA):
USER-SPECIFIED RUNOFF COEFFICIENT = .5500
S.C.S. CURVE NUMBER (AMC II) = 0
TRAVEL TIME COMPUTED USING ESTIMATED FLOW(CFS) = 3.76
TRAVEL TIME THRU SUBAREA BASED ON VELOCITY(FEET/SEC.) = 2.76
AVERAGE FLOW DEPTH(FEET) = 0.11 TRAVEL TIME(MIN.) = 3.02
Tc(MIN.) = 8.57
SUBAREA AREA(ACRES) = 2.75 SUBAREA RUNOFF(CFS) = 7.10
AREA-AVERAGE RUNOFF COEFFICIENT = 0.550
TOTAL AREA(ACRES) = 2.8 PEAK FLOW RATE(CFS) = 7.20

END OF SUBAREA CHANNEL FLOW HYDRAULICS:
DEPTH(FEET) = 0.16 FLOW VELOCITY(FEET/SEC.) = 3.33
LONGEST FLOWPATH FROM NODE 10.00 TO NODE 12.00 = 572.00 FEET.

FLOW PROCESS FROM NODE 12.00 TO NODE 13.00 IS CODE = 51

>>>>COMPUTE TRAPEZOIDAL CHANNEL FLOW<<<<<
>>>>TRAVELTIME THRU SUBAREA (EXISTING ELEMENT)<<<<<

=====

ELEVATION DATA: UPSTREAM(FEET) =	149.00	DOWNSTREAM(FEET) =	143.67
CHANNEL LENGTH THRU SUBAREA(FEET) =	224.00	CHANNEL SLOPE =	0.0238
CHANNEL BASE(FEET) =	2.50	"Z" FACTOR =	2.000
MANNING'S FACTOR =	0.015	MAXIMUM DEPTH(FEET) =	1.00
CHANNEL FLOW THRU SUBAREA(CFS) =	7.20		
FLOW VELOCITY(FEET/SEC.) =	6.48	FLOW DEPTH(FEET) =	0.35
TRAVEL TIME(MIN.) =	0.58	Tc(MIN.) =	9.15

LONGEST FLOWPATH FROM NODE 10.00 TO NODE 13.00 = 796.00 FEET.

FLOW PROCESS FROM NODE 20.00 TO NODE 21.00 IS CODE = 21

>>>>RATIONAL METHOD INITIAL SUBAREA ANALYSIS<<<<<

=====

*USER SPECIFIED(SUBAREA):
USER-SPECIFIED RUNOFF COEFFICIENT = .5500
S.C.S. CURVE NUMBER (AMC II) = 0
INITIAL SUBAREA FLOW-LENGTH(FEET) = 75.00
UPSTREAM ELEVATION(FEET) = 255.00
DOWNSTREAM ELEVATION(FEET) = 231.00
ELEVATION DIFFERENCE(FEET) = 24.00
URBAN SUBAREA OVERLAND TIME OF FLOW(MIN.) = 3.980
WARNING: THE MAXIMUM OVERLAND FLOW SLOPE, 10.%, IS USED IN Tc CALCULATION!
100 YEAR RAINFALL INTENSITY(INCH/HOUR) = 6.323

NOTE: RAINFALL INTENSITY IS BASED ON Tc = 5-MINUTE.
SUBAREA RUNOFF(CFS) = 0.31
TOTAL AREA(ACRES) = 0.09 TOTAL RUNOFF(CFS) = 0.31

FLOW PROCESS FROM NODE 21.00 TO NODE 22.00 IS CODE = 51

>>>>COMPUTE TRAPEZOIDAL CHANNEL FLOW<<<<<
>>>>TRAVELTIME THRU SUBAREA (EXISTING ELEMENT)<<<<<

=====

ELEVATION DATA: UPSTREAM(FEET) =	231.00	DOWNSTREAM(FEET) =	149.00
CHANNEL LENGTH THRU SUBAREA(FEET) =	1062.00	CHANNEL SLOPE =	0.0772
CHANNEL BASE(FEET) =	5.00	"Z" FACTOR =	10.000
MANNING'S FACTOR =	0.040	MAXIMUM DEPTH(FEET) =	1.00
100 YEAR RAINFALL INTENSITY(INCH/HOUR) =	4.565		

*USER SPECIFIED(SUBAREA):
USER-SPECIFIED RUNOFF COEFFICIENT = .5500
S.C.S. CURVE NUMBER (AMC II) = 0
TRAVEL TIME COMPUTED USING ESTIMATED FLOW(CFS) = 8.20
TRAVEL TIME THRU SUBAREA BASED ON VELOCITY(FEET/SEC.) = 3.63
AVERAGE FLOW DEPTH(FEET) = 0.29 TRAVEL TIME(MIN.) = 4.88
Tc(MIN.) = 8.86
SUBAREA AREA(ACRES) = 6.05 SUBAREA RUNOFF(CFS) = 15.19
AREA-AVERAGE RUNOFF COEFFICIENT = 0.550
TOTAL AREA(ACRES) = 6.1 PEAK FLOW RATE(CFS) = 15.42

END OF SUBAREA CHANNEL FLOW HYDRAULICS:
DEPTH(FEET) = 0.39 FLOW VELOCITY(FEET/SEC.) = 4.38
LONGEST FLOWPATH FROM NODE 20.00 TO NODE 22.00 = 1137.00 FEET.

FLOW PROCESS FROM NODE 30.00 TO NODE 31.00 IS CODE = 21

>>>>RATIONAL METHOD INITIAL SUBAREA ANALYSIS<<<<<

=====

*USER SPECIFIED(SUBAREA):
USER-SPECIFIED RUNOFF COEFFICIENT = .5500
S.C.S. CURVE NUMBER (AMC II) = 0
INITIAL SUBAREA FLOW-LENGTH(FEET) = 75.00
UPSTREAM ELEVATION(FEET) = 234.00
DOWNSTREAM ELEVATION(FEET) = 220.00
ELEVATION DIFFERENCE(FEET) = 14.00
URBAN SUBAREA OVERLAND TIME OF FLOW(MIN.) = 3.980
WARNING: THE MAXIMUM OVERLAND FLOW SLOPE, 10.%, IS USED IN Tc CALCULATION!
100 YEAR RAINFALL INTENSITY(INCH/HOUR) = 6.323
NOTE: RAINFALL INTENSITY IS BASED ON Tc = 5-MINUTE.
SUBAREA RUNOFF(CFS) = 0.28
TOTAL AREA(ACRES) = 0.08 TOTAL RUNOFF(CFS) = 0.28

FLOW PROCESS FROM NODE 31.00 TO NODE 32.00 IS CODE = 51

>>>>COMPUTE TRAPEZOIDAL CHANNEL FLOW<<<<<
>>>>TRAVELTIME THRU SUBAREA (EXISTING ELEMENT)<<<<<

=====

ELEVATION DATA: UPSTREAM(FEET) =	220.00	DOWNSTREAM(FEET) =	207.00
CHANNEL LENGTH THRU SUBAREA(FEET) =	83.00	CHANNEL SLOPE =	0.1566
CHANNEL BASE(FEET) =	20.00	"Z" FACTOR =	8.000
MANNING'S FACTOR =	0.040	MAXIMUM DEPTH(FEET) =	1.00
100 YEAR RAINFALL INTENSITY(INCH/HOUR) =	6.323		

NOTE: RAINFALL INTENSITY IS BASED ON Tc = 5-MINUTE.

*USER SPECIFIED(SUBAREA):
USER-SPECIFIED RUNOFF COEFFICIENT = .5500

S.C.S. CURVE NUMBER (AMC II) = 0
TRAVEL TIME COMPUTED USING ESTIMATED FLOW (CFS) = 1.53
TRAVEL TIME THRU SUBAREA BASED ON VELOCITY (FEET/SEC.) = 1.75
AVERAGE FLOW DEPTH (FEET) = 0.04 TRAVEL TIME (MIN.) = 0.79
Tc (MIN.) = 4.77
SUBAREA AREA (ACRES) = 0.72 SUBAREA RUNOFF (CFS) = 2.50
AREA-AVERAGE RUNOFF COEFFICIENT = 0.550
TOTAL AREA (ACRES) = 0.8 PEAK FLOW RATE (CFS) = 2.78

END OF SUBAREA CHANNEL FLOW HYDRAULICS:

DEPTH (FEET) = 0.06 FLOW VELOCITY (FEET/SEC.) = 2.34
LONGEST FLOWPATH FROM NODE 30.00 TO NODE 32.00 = 158.00 FEET.

=====
END OF STUDY SUMMARY:

TOTAL AREA (ACRES) = 0.8 TC (MIN.) = 4.77
PEAK FLOW RATE (CFS) = 2.78
=====

=====
END OF RATIONAL METHOD ANALYSIS

100-YEAR POST-PROJECT CONDITION

RATIONAL METHOD HYDROLOGY COMPUTER PROGRAM PACKAGE
Reference: SAN DIEGO COUNTY FLOOD CONTROL DISTRICT
2003,1985,1981 HYDROLOGY MANUAL
(c) Copyright 1982-2016 Advanced Engineering Software (aes)
Ver. 23.0 Release Date: 07/01/2016 License ID 1452

Analysis prepared by:

FILE NAME: 3690P100.DAT
TIME/DATE OF STUDY: 09:19 05/20/2022

USER SPECIFIED HYDROLOGY AND HYDRAULIC MODEL INFORMATION:

USER SPECIFIED STORM EVENT(YEAR) = 100.00
SPECIFIED MINIMUM PIPE SIZE(INCH) = 4.00
SPECIFIED PERCENT OF GRADIENTS(DECIMAL) TO USE FOR FRICTION SLOPE = 0.95
RAINFALL-INTENSITY ADJUSTMENT FACTOR = 1.000

*USER SPECIFIED:

NUMBER OF [TIME,INTENSITY] DATA PAIRS = 9

1) 5.000; 6.323
2) 10.000; 4.044
3) 15.000; 3.113
4) 20.000; 2.586
5) 25.000; 2.239
6) 30.000; 1.991
7) 40.000; 1.654
8) 50.000; 1.432
9) 60.000; 1.273

SAN DIEGO HYDROLOGY MANUAL "C"-VALUES USED FOR RATIONAL METHOD

NOTE: ONLY PEAK CONFLUENCE VALUES CONSIDERED

USER-DEFINED STREET-SECTIONS FOR COUPLED PIPEFLOW AND STREETFLOW MODEL

NO.	HALF- WIDTH (FT)	CROWN TO CROSSFALL (FT)	STREET-CROSSFALL: IN- / OUT-/ SIDE / SIDE/ WAY	CURB HEIGHT (FT)	GUTTER-GEOMETRIES: WIDTH (FT)	LIP (FT)	HIKE (FT)	MANNING FACTOR (n)
1	30.0	20.0	0.018/0.018/0.020	0.67	2.00	0.0312	0.167	0.0150

GLOBAL STREET FLOW-DEPTH CONSTRAINTS:

1. Relative Flow-Depth = 0.00 FEET
as (Maximum Allowable Street Flow Depth) - (Top-of-Curb)
2. (Depth)*(Velocity) Constraint = 6.0 (FT*FT/S)

*SIZE PIPE WITH A FLOW CAPACITY GREATER THAN
OR EQUAL TO THE UPSTREAM TRIBUTARY PIPE.*

FLOW PROCESS FROM NODE 100.00 TO NODE 101.00 IS CODE = 21

>>>>RATIONAL METHOD INITIAL SUBAREA ANALYSIS<<<<<

*USER SPECIFIED(SUBAREA):

USER-SPECIFIED RUNOFF COEFFICIENT = .8500
S.C.S. CURVE NUMBER (AMC II) = 0
INITIAL SUBAREA FLOW-LENGTH(FEET) = 50.00
UPSTREAM ELEVATION(FEET) = 194.20

DOWNSTREAM ELEVATION(FEET) = 193.70
ELEVATION DIFFERENCE(FEET) = 0.50
URBAN SUBAREA OVERLAND TIME OF FLOW(MIN.) = 3.182
100 YEAR RAINFALL INTENSITY(INCH/HOUR) = 6.323
NOTE: RAINFALL INTENSITY IS BASED ON Tc = 5-MINUTE.
SUBAREA RUNOFF(CFS) = 0.21
TOTAL AREA(ACRES) = 0.04 TOTAL RUNOFF(CFS) = 0.21

FLOW PROCESS FROM NODE 101.00 TO NODE 102.00 IS CODE = 51

>>>>COMPUTE TRAPEZOIDAL CHANNEL FLOW<<<<<
>>>>TRAVELTIME THRU SUBAREA (EXISTING ELEMENT)<<<<<

=====

ELEVATION DATA: UPSTREAM(FEET) = 193.70 DOWNSTREAM(FEET) = 192.50
CHANNEL LENGTH THRU SUBAREA(FEET) = 118.00 CHANNEL SLOPE = 0.0102
CHANNEL BASE(FEET) = 50.00 "Z" FACTOR = 50.000
MANNING'S FACTOR = 0.015 MAXIMUM DEPTH(FEET) = 1.00
100 YEAR RAINFALL INTENSITY(INCH/HOUR) = 6.072
*USER SPECIFIED(SUBAREA):
USER-SPECIFIED RUNOFF COEFFICIENT = .8500
S.C.S. CURVE NUMBER (AMC II) = 0
TRAVEL TIME COMPUTED USING ESTIMATED FLOW(CFS) = 1.10
TRAVEL TIME THRU SUBAREA BASED ON VELOCITY(FEET/SEC.) = 0.83
AVERAGE FLOW DEPTH(FEET) = 0.03 TRAVEL TIME(MIN.) = 2.37
Tc(MIN.) = 5.55
SUBAREA AREA(ACRES) = 0.34 SUBAREA RUNOFF(CFS) = 1.75
AREA-AVERAGE RUNOFF COEFFICIENT = 0.850
TOTAL AREA(ACRES) = 0.4 PEAK FLOW RATE(CFS) = 1.96

END OF SUBAREA CHANNEL FLOW HYDRAULICS:
DEPTH(FEET) = 0.04 FLOW VELOCITY(FEET/SEC.) = 1.07
LONGEST FLOWPATH FROM NODE 100.00 TO NODE 102.00 = 168.00 FEET.

FLOW PROCESS FROM NODE 102.00 TO NODE 103.00 IS CODE = 31

>>>>COMPUTE PIPE-FLOW TRAVEL TIME THRU SUBAREA<<<<<
>>>>USING COMPUTER-ESTIMATED PIPESIZE (NON-PRESSURE FLOW)<<<<<

=====

ELEVATION DATA: UPSTREAM(FEET) = 192.50 DOWNSTREAM(FEET) = 191.30
FLOW LENGTH(FEET) = 29.00 MANNING'S N = 0.011
DEPTH OF FLOW IN 9.0 INCH PIPE IS 4.5 INCHES
PIPE-FLOW VELOCITY(FEET/SEC.) = 8.79
ESTIMATED PIPE DIAMETER(INCH) = 9.00 NUMBER OF PIPES = 1
PIPE-FLOW(CFS) = 1.96
PIPE TRAVEL TIME(MIN.) = 0.05 Tc(MIN.) = 5.60
LONGEST FLOWPATH FROM NODE 100.00 TO NODE 103.00 = 197.00 FEET.

FLOW PROCESS FROM NODE 103.00 TO NODE 103.00 IS CODE = 81

>>>>ADDITION OF SUBAREA TO MAINLINE PEAK FLOW<<<<<

=====

100 YEAR RAINFALL INTENSITY(INCH/HOUR) = 6.047
*USER SPECIFIED(SUBAREA):
USER-SPECIFIED RUNOFF COEFFICIENT = .8500
S.C.S. CURVE NUMBER (AMC II) = 0
AREA-AVERAGE RUNOFF COEFFICIENT = 0.8500
SUBAREA AREA(ACRES) = 0.20 SUBAREA RUNOFF(CFS) = 1.03
TOTAL AREA(ACRES) = 0.6 TOTAL RUNOFF(CFS) = 2.98
TC(MIN.) = 5.60

```

*****
FLOW PROCESS FROM NODE    103.00 TO NODE    104.00 IS CODE = 31
-----
>>>>COMPUTE PIPE-FLOW TRAVEL TIME THRU SUBAREA<<<<
>>>>USING COMPUTER-ESTIMATED PIPESIZE (NON-PRESSURE FLOW)<<<<
=====
ELEVATION DATA: UPSTREAM(FEET) = 190.97  DOWNSTREAM(FEET) = 190.35
FLOW LENGTH(FEET) = 103.00  MANNING'S N = 0.011
DEPTH OF FLOW IN 12.0 INCH PIPE IS 9.2 INCHES
PIPE-FLOW VELOCITY(FEET/SEC.) = 4.61
ESTIMATED PIPE DIAMETER(INCH) = 12.00  NUMBER OF PIPES = 1
PIPE-FLOW(CFS) = 2.98
PIPE TRAVEL TIME(MIN.) = 0.37  Tc(MIN.) = 5.98
LONGEST FLOWPATH FROM NODE    100.00 TO NODE    104.00 = 300.00 FEET.

*****
FLOW PROCESS FROM NODE    104.00 TO NODE    104.00 IS CODE = 81
-----
>>>>ADDITION OF SUBAREA TO MAINLINE PEAK FLOW<<<<
=====
100 YEAR RAINFALL INTENSITY(INCH/HOUR) = 5.877
*USER SPECIFIED(SUBAREA):
USER-SPECIFIED RUNOFF COEFFICIENT = .8500
S.C.S. CURVE NUMBER (AMC II) = 0
AREA-AVERAGE RUNOFF COEFFICIENT = 0.8500
SUBAREA AREA(ACRES) = 0.38  SUBAREA RUNOFF(CFS) = 1.90
TOTAL AREA(ACRES) = 1.0  TOTAL RUNOFF(CFS) = 4.80
TC(MIN.) = 5.98

*****
FLOW PROCESS FROM NODE    104.00 TO NODE    105.00 IS CODE = 31
-----
>>>>COMPUTE PIPE-FLOW TRAVEL TIME THRU SUBAREA<<<<
>>>>USING COMPUTER-ESTIMATED PIPESIZE (NON-PRESSURE FLOW)<<<<
=====
ELEVATION DATA: UPSTREAM(FEET) = 190.35  DOWNSTREAM(FEET) = 190.05
FLOW LENGTH(FEET) = 50.00  MANNING'S N = 0.011
DEPTH OF FLOW IN 15.0 INCH PIPE IS 10.4 INCHES
PIPE-FLOW VELOCITY(FEET/SEC.) = 5.26
ESTIMATED PIPE DIAMETER(INCH) = 15.00  NUMBER OF PIPES = 1
PIPE-FLOW(CFS) = 4.80
PIPE TRAVEL TIME(MIN.) = 0.16  Tc(MIN.) = 6.14
LONGEST FLOWPATH FROM NODE    100.00 TO NODE    105.00 = 350.00 FEET.

*****
FLOW PROCESS FROM NODE    105.00 TO NODE    105.00 IS CODE = 81
-----
>>>>ADDITION OF SUBAREA TO MAINLINE PEAK FLOW<<<<
=====
100 YEAR RAINFALL INTENSITY(INCH/HOUR) = 5.805
*USER SPECIFIED(SUBAREA):
USER-SPECIFIED RUNOFF COEFFICIENT = .8500
S.C.S. CURVE NUMBER (AMC II) = 0
AREA-AVERAGE RUNOFF COEFFICIENT = 0.8500
SUBAREA AREA(ACRES) = 0.20  SUBAREA RUNOFF(CFS) = 0.99
TOTAL AREA(ACRES) = 1.2  TOTAL RUNOFF(CFS) = 5.72
TC(MIN.) = 6.14

*****
FLOW PROCESS FROM NODE    105.00 TO NODE    106.00 IS CODE = 31
-----
>>>>COMPUTE PIPE-FLOW TRAVEL TIME THRU SUBAREA<<<<
>>>>USING COMPUTER-ESTIMATED PIPESIZE (NON-PRESSURE FLOW)<<<<

```

=====
ELEVATION DATA: UPSTREAM(FEET) = 190.05 DOWNSTREAM(FEET) = 189.72
FLOW LENGTH(FEET) = 54.00 MANNING'S N = 0.011
DEPTH OF FLOW IN 15.0 INCH PIPE IS 12.1 INCHES
PIPE-FLOW VELOCITY(FEET/SEC.) = 5.40
ESTIMATED PIPE DIAMETER(INCH) = 15.00 NUMBER OF PIPES = 1
PIPE-FLOW(CFS) = 5.72
PIPE TRAVEL TIME(MIN.) = 0.17 Tc(MIN.) = 6.30
LONGEST FLOWPATH FROM NODE 100.00 TO NODE 106.00 = 404.00 FEET.

FLOW PROCESS FROM NODE 106.00 TO NODE 106.00 IS CODE = 81

>>>>ADDITION OF SUBAREA TO MAINLINE PEAK FLOW<<<<

=====
100 YEAR RAINFALL INTENSITY(INCH/HOUR) = 5.729
*USER SPECIFIED(SUBAREA):
USER-SPECIFIED RUNOFF COEFFICIENT = .8500
S.C.S. CURVE NUMBER (AMC II) = 0
AREA-AVERAGE RUNOFF COEFFICIENT = 0.8500
SUBAREA AREA(ACRES) = 0.41 SUBAREA RUNOFF(CFS) = 2.00
TOTAL AREA(ACRES) = 1.6 TOTAL RUNOFF(CFS) = 7.65
TC(MIN.) = 6.30

FLOW PROCESS FROM NODE 106.00 TO NODE 107.00 IS CODE = 31

>>>>COMPUTE PIPE-FLOW TRAVEL TIME THRU SUBAREA<<<<
>>>>USING COMPUTER-ESTIMATED PIPESIZE (NON-PRESSURE FLOW)<<<<

=====
ELEVATION DATA: UPSTREAM(FEET) = 189.72 DOWNSTREAM(FEET) = 189.30
FLOW LENGTH(FEET) = 70.00 MANNING'S N = 0.011
DEPTH OF FLOW IN 18.0 INCH PIPE IS 12.4 INCHES
PIPE-FLOW VELOCITY(FEET/SEC.) = 5.91
ESTIMATED PIPE DIAMETER(INCH) = 18.00 NUMBER OF PIPES = 1
PIPE-FLOW(CFS) = 7.65
PIPE TRAVEL TIME(MIN.) = 0.20 Tc(MIN.) = 6.50
LONGEST FLOWPATH FROM NODE 100.00 TO NODE 107.00 = 474.00 FEET.

FLOW PROCESS FROM NODE 107.00 TO NODE 107.00 IS CODE = 81

>>>>ADDITION OF SUBAREA TO MAINLINE PEAK FLOW<<<<

=====
100 YEAR RAINFALL INTENSITY(INCH/HOUR) = 5.639
*USER SPECIFIED(SUBAREA):
USER-SPECIFIED RUNOFF COEFFICIENT = .8500
S.C.S. CURVE NUMBER (AMC II) = 0
AREA-AVERAGE RUNOFF COEFFICIENT = 0.8500
SUBAREA AREA(ACRES) = 0.14 SUBAREA RUNOFF(CFS) = 0.67
TOTAL AREA(ACRES) = 1.7 TOTAL RUNOFF(CFS) = 8.20
TC(MIN.) = 6.50

FLOW PROCESS FROM NODE 107.00 TO NODE 107.00 IS CODE = 81

>>>>ADDITION OF SUBAREA TO MAINLINE PEAK FLOW<<<<

=====
100 YEAR RAINFALL INTENSITY(INCH/HOUR) = 5.639
*USER SPECIFIED(SUBAREA):
USER-SPECIFIED RUNOFF COEFFICIENT = .6000
S.C.S. CURVE NUMBER (AMC II) = 0
AREA-AVERAGE RUNOFF COEFFICIENT = 0.8036

SUBAREA AREA(ACRES) = 0.39 SUBAREA RUNOFF(CFS) = 1.32
TOTAL AREA(ACRES) = 2.1 TOTAL RUNOFF(CFS) = 9.52
TC(MIN.) = 6.50

FLOW PROCESS FROM NODE 107.00 TO NODE 108.00 IS CODE = 31

>>>>COMPUTE PIPE-FLOW TRAVEL TIME THRU SUBAREA<<<<<
>>>>USING COMPUTER-ESTIMATED PIPESIZE (NON-PRESSURE FLOW)<<<<<

=====

ELEVATION DATA: UPSTREAM(FEET) =	188.97	DOWNSTREAM(FEET) =	188.35
FLOW LENGTH(FEET) =	102.00	MANNING'S N =	0.011
DEPTH OF FLOW IN 21.0 INCH PIPE IS	12.6 INCHES		
PIPE-FLOW VELOCITY(FEET/SEC.) =	6.34		
ESTIMATED PIPE DIAMETER(INCH) =	21.00	NUMBER OF PIPES =	1
PIPE-FLOW(CFS) =	9.52		
PIPE TRAVEL TIME(MIN.) =	0.27	Tc(MIN.) =	6.77
LONGEST FLOWPATH FROM NODE 100.00 TO NODE 108.00 =	576.00 FEET.		

FLOW PROCESS FROM NODE 108.00 TO NODE 108.00 IS CODE = 81

>>>>ADDITION OF SUBAREA TO MAINLINE PEAK FLOW<<<<<

=====

100 YEAR RAINFALL INTENSITY(INCH/HOUR) =	5.517		
*USER SPECIFIED(SUBAREA):			
USER-SPECIFIED RUNOFF COEFFICIENT =	.8500		
S.C.S. CURVE NUMBER (AMC II) =	0		
AREA-AVERAGE RUNOFF COEFFICIENT =	0.8061		
SUBAREA AREA(ACRES) =	0.12	SUBAREA RUNOFF(CFS) =	0.56
TOTAL AREA(ACRES) =	2.2	TOTAL RUNOFF(CFS) =	9.87
TC(MIN.) =	6.77		

FLOW PROCESS FROM NODE 108.00 TO NODE 109.00 IS CODE = 31

>>>>COMPUTE PIPE-FLOW TRAVEL TIME THRU SUBAREA<<<<<
>>>>USING COMPUTER-ESTIMATED PIPESIZE (NON-PRESSURE FLOW)<<<<<

=====

ELEVATION DATA: UPSTREAM(FEET) =	188.02	DOWNSTREAM(FEET) =	187.46
FLOW LENGTH(FEET) =	94.00	MANNING'S N =	0.011
DEPTH OF FLOW IN 21.0 INCH PIPE IS	13.0 INCHES		
PIPE-FLOW VELOCITY(FEET/SEC.) =	6.34		
ESTIMATED PIPE DIAMETER(INCH) =	21.00	NUMBER OF PIPES =	1
PIPE-FLOW(CFS) =	9.87		
PIPE TRAVEL TIME(MIN.) =	0.25	Tc(MIN.) =	7.02
LONGEST FLOWPATH FROM NODE 100.00 TO NODE 109.00 =	670.00 FEET.		

FLOW PROCESS FROM NODE 109.00 TO NODE 109.00 IS CODE = 81

>>>>ADDITION OF SUBAREA TO MAINLINE PEAK FLOW<<<<<

=====

100 YEAR RAINFALL INTENSITY(INCH/HOUR) =	5.404		
*USER SPECIFIED(SUBAREA):			
USER-SPECIFIED RUNOFF COEFFICIENT =	.8500		
S.C.S. CURVE NUMBER (AMC II) =	0		
AREA-AVERAGE RUNOFF COEFFICIENT =	0.8083		
SUBAREA AREA(ACRES) =	0.12	SUBAREA RUNOFF(CFS) =	0.55
TOTAL AREA(ACRES) =	2.3	TOTAL RUNOFF(CFS) =	10.22
TC(MIN.) =	7.02		

FLOW PROCESS FROM NODE 109.00 TO NODE 110.00 IS CODE = 31

>>>>COMPUTE PIPE-FLOW TRAVEL TIME THRU SUBAREA<<<<<
>>>>USING COMPUTER-ESTIMATED PIPESIZE (NON-PRESSURE FLOW)<<<<<
=====

ELEVATION DATA: UPSTREAM(FEET) =	187.13	DOWNSTREAM(FEET) =	186.57
FLOW LENGTH(FEET) =	94.00	MANNING'S N =	0.011
DEPTH OF FLOW IN 21.0 INCH PIPE IS	13.3	INCHES	
PIPE-FLOW VELOCITY(FEET/SEC.) =	6.38		
ESTIMATED PIPE DIAMETER(INCH) =	21.00	NUMBER OF PIPES =	1
PIPE-FLOW(CFS) =	10.22		
PIPE TRAVEL TIME(MIN.) =	0.25	Tc(MIN.) =	7.26
LONGEST FLOWPATH FROM NODE	100.00	TO NODE	110.00 =
			764.00 FEET.

FLOW PROCESS FROM NODE 110.00 TO NODE 110.00 IS CODE = 81

>>>>ADDITION OF SUBAREA TO MAINLINE PEAK FLOW<<<<<
=====

100 YEAR RAINFALL INTENSITY(INCH/HOUR) =	5.293
------------------------------------------	-------

*USER SPECIFIED(SUBAREA):
USER-SPECIFIED RUNOFF COEFFICIENT = .8500
S.C.S. CURVE NUMBER (AMC II) = 0
AREA-AVERAGE RUNOFF COEFFICIENT = 0.8102
SUBAREA AREA(ACRES) = 0.11 SUBAREA RUNOFF(CFS) = 0.49
TOTAL AREA(ACRES) = 2.4 TOTAL RUNOFF(CFS) = 10.51
TC(MIN.) = 7.26

FLOW PROCESS FROM NODE 110.00 TO NODE 111.00 IS CODE = 31

>>>>COMPUTE PIPE-FLOW TRAVEL TIME THRU SUBAREA<<<<<
>>>>USING COMPUTER-ESTIMATED PIPESIZE (NON-PRESSURE FLOW)<<<<<
=====

ELEVATION DATA: UPSTREAM(FEET) =	186.24	DOWNSTREAM(FEET) =	185.50
FLOW LENGTH(FEET) =	106.00	MANNING'S N =	0.011
DEPTH OF FLOW IN 21.0 INCH PIPE IS	12.8	INCHES	
PIPE-FLOW VELOCITY(FEET/SEC.) =	6.83		
ESTIMATED PIPE DIAMETER(INCH) =	21.00	NUMBER OF PIPES =	1
PIPE-FLOW(CFS) =	10.51		
PIPE TRAVEL TIME(MIN.) =	0.26	Tc(MIN.) =	7.52
LONGEST FLOWPATH FROM NODE	100.00	TO NODE	111.00 =
			870.00 FEET.

FLOW PROCESS FROM NODE 111.00 TO NODE 111.00 IS CODE = 81

>>>>ADDITION OF SUBAREA TO MAINLINE PEAK FLOW<<<<<
=====

100 YEAR RAINFALL INTENSITY(INCH/HOUR) =	5.175
------------------------------------------	-------

*USER SPECIFIED(SUBAREA):
USER-SPECIFIED RUNOFF COEFFICIENT = .8500
S.C.S. CURVE NUMBER (AMC II) = 0
AREA-AVERAGE RUNOFF COEFFICIENT = 0.8112
SUBAREA AREA(ACRES) = 0.06 SUBAREA RUNOFF(CFS) = 0.26
TOTAL AREA(ACRES) = 2.5 TOTAL RUNOFF(CFS) = 10.54
TC(MIN.) = 7.52

FLOW PROCESS FROM NODE 111.00 TO NODE 112.00 IS CODE = 31

>>>>COMPUTE PIPE-FLOW TRAVEL TIME THRU SUBAREA<<<<<
>>>>USING COMPUTER-ESTIMATED PIPESIZE (NON-PRESSURE FLOW)<<<<<
=====

ELEVATION DATA: UPSTREAM(FEET) = 185.17 DOWNSTREAM(FEET) = 184.87
FLOW LENGTH(FEET) = 49.00 MANNING'S N = 0.011
DEPTH OF FLOW IN 21.0 INCH PIPE IS 13.4 INCHES
PIPE-FLOW VELOCITY(FEET/SEC.) = 6.50
ESTIMATED PIPE DIAMETER(INCH) = 21.00 NUMBER OF PIPES = 1
PIPE-FLOW(CFS) = 10.54
PIPE TRAVEL TIME(MIN.) = 0.13 Tc(MIN.) = 7.64
LONGEST FLOWPATH FROM NODE 100.00 TO NODE 112.00 = 919.00 FEET.

FLOW PROCESS FROM NODE 112.00 TO NODE 112.00 IS CODE = 81

>>>>ADDITION OF SUBAREA TO MAINLINE PEAK FLOW<<<<<

=====

100 YEAR RAINFALL INTENSITY(INCH/HOUR) = 5.117
*USER SPECIFIED(SUBAREA):
USER-SPECIFIED RUNOFF COEFFICIENT = .8500
S.C.S. CURVE NUMBER (AMC II) = 0
AREA-AVERAGE RUNOFF COEFFICIENT = 0.8152
SUBAREA AREA(ACRES) = 0.29 SUBAREA RUNOFF(CFS) = 1.26
TOTAL AREA(ACRES) = 2.8 TOTAL RUNOFF(CFS) = 11.68
TC(MIN.) = 7.64

FLOW PROCESS FROM NODE 112.00 TO NODE 113.00 IS CODE = 31

>>>>COMPUTE PIPE-FLOW TRAVEL TIME THRU SUBAREA<<<<<
>>>>USING COMPUTER-ESTIMATED PIPESIZE (NON-PRESSURE FLOW)<<<<<

=====

ELEVATION DATA: UPSTREAM(FEET) = 184.87 DOWNSTREAM(FEET) = 184.25
FLOW LENGTH(FEET) = 104.00 MANNING'S N = 0.011
DEPTH OF FLOW IN 21.0 INCH PIPE IS 14.6 INCHES
PIPE-FLOW VELOCITY(FEET/SEC.) = 6.55
ESTIMATED PIPE DIAMETER(INCH) = 21.00 NUMBER OF PIPES = 1
PIPE-FLOW(CFS) = 11.68
PIPE TRAVEL TIME(MIN.) = 0.26 Tc(MIN.) = 7.91
LONGEST FLOWPATH FROM NODE 100.00 TO NODE 113.00 = 1023.00 FEET.

FLOW PROCESS FROM NODE 113.00 TO NODE 113.00 IS CODE = 81

>>>>ADDITION OF SUBAREA TO MAINLINE PEAK FLOW<<<<<

=====

100 YEAR RAINFALL INTENSITY(INCH/HOUR) = 4.997
*USER SPECIFIED(SUBAREA):
USER-SPECIFIED RUNOFF COEFFICIENT = .8500
S.C.S. CURVE NUMBER (AMC II) = 0
AREA-AVERAGE RUNOFF COEFFICIENT = 0.8182
SUBAREA AREA(ACRES) = 0.27 SUBAREA RUNOFF(CFS) = 1.15
TOTAL AREA(ACRES) = 3.1 TOTAL RUNOFF(CFS) = 12.55
TC(MIN.) = 7.91

FLOW PROCESS FROM NODE 113.00 TO NODE 114.00 IS CODE = 31

>>>>COMPUTE PIPE-FLOW TRAVEL TIME THRU SUBAREA<<<<<
>>>>USING COMPUTER-ESTIMATED PIPESIZE (NON-PRESSURE FLOW)<<<<<

=====

ELEVATION DATA: UPSTREAM(FEET) = 184.25 DOWNSTREAM(FEET) = 183.93
FLOW LENGTH(FEET) = 53.00 MANNING'S N = 0.011
DEPTH OF FLOW IN 21.0 INCH PIPE IS 15.4 INCHES
PIPE-FLOW VELOCITY(FEET/SEC.) = 6.66
ESTIMATED PIPE DIAMETER(INCH) = 21.00 NUMBER OF PIPES = 1

```

PIPE-FLOW(CFS) = 12.55
PIPE TRAVEL TIME(MIN.) = 0.13 Tc(MIN.) = 8.04
LONGEST FLOWPATH FROM NODE 100.00 TO NODE 114.00 = 1076.00 FEET.
*****
FLOW PROCESS FROM NODE 114.00 TO NODE 114.00 IS CODE = 81
-----
>>>>ADDITION OF SUBAREA TO MAINLINE PEAK FLOW<<<<
=====
100 YEAR RAINFALL INTENSITY(INCH/HOUR) = 4.936
*USER SPECIFIED(SUBAREA):
USER-SPECIFIED RUNOFF COEFFICIENT = .8500
S.C.S. CURVE NUMBER (AMC II) = 0
AREA-AVERAGE RUNOFF COEFFICIENT = 0.8257
SUBAREA AREA(ACRES) = 0.94 SUBAREA RUNOFF(CFS) = 3.94
TOTAL AREA(ACRES) = 4.0 TOTAL RUNOFF(CFS) = 16.34
TC(MIN.) = 8.04
*****
FLOW PROCESS FROM NODE 114.00 TO NODE 115.00 IS CODE = 31
-----
>>>>COMPUTE PIPE-FLOW TRAVEL TIME THRU SUBAREA<<<<
>>>>USING COMPUTER-ESTIMATED PIPESIZE (NON-PRESSURE FLOW)<<<<
=====
ELEVATION DATA: UPSTREAM(FEET) = 183.93 DOWNSTREAM(FEET) = 183.63
FLOW LENGTH(FEET) = 51.00 MANNING'S N = 0.011
DEPTH OF FLOW IN 24.0 INCH PIPE IS 16.5 INCHES
PIPE-FLOW VELOCITY(FEET/SEC.) = 7.09
ESTIMATED PIPE DIAMETER(INCH) = 24.00 NUMBER OF PIPES = 1
PIPE-FLOW(CFS) = 16.34
PIPE TRAVEL TIME(MIN.) = 0.12 Tc(MIN.) = 8.16
LONGEST FLOWPATH FROM NODE 100.00 TO NODE 115.00 = 1127.00 FEET.
*****
FLOW PROCESS FROM NODE 115.00 TO NODE 115.00 IS CODE = 81
-----
>>>>ADDITION OF SUBAREA TO MAINLINE PEAK FLOW<<<<
=====
100 YEAR RAINFALL INTENSITY(INCH/HOUR) = 4.882
*USER SPECIFIED(SUBAREA):
USER-SPECIFIED RUNOFF COEFFICIENT = .8500
S.C.S. CURVE NUMBER (AMC II) = 0
AREA-AVERAGE RUNOFF COEFFICIENT = 0.8297
SUBAREA AREA(ACRES) = 0.80 SUBAREA RUNOFF(CFS) = 3.32
TOTAL AREA(ACRES) = 4.8 TOTAL RUNOFF(CFS) = 19.48
TC(MIN.) = 8.16
*****
FLOW PROCESS FROM NODE 115.00 TO NODE 116.00 IS CODE = 31
-----
>>>>COMPUTE PIPE-FLOW TRAVEL TIME THRU SUBAREA<<<<
>>>>USING COMPUTER-ESTIMATED PIPESIZE (NON-PRESSURE FLOW)<<<<
=====
ELEVATION DATA: UPSTREAM(FEET) = 183.63 DOWNSTREAM(FEET) = 183.44
FLOW LENGTH(FEET) = 31.00 MANNING'S N = 0.011
DEPTH OF FLOW IN 24.0 INCH PIPE IS 18.8 INCHES
PIPE-FLOW VELOCITY(FEET/SEC.) = 7.39
ESTIMATED PIPE DIAMETER(INCH) = 24.00 NUMBER OF PIPES = 1
PIPE-FLOW(CFS) = 19.48
PIPE TRAVEL TIME(MIN.) = 0.07 Tc(MIN.) = 8.23
LONGEST FLOWPATH FROM NODE 100.00 TO NODE 116.00 = 1158.00 FEET.
*****

```



```

FLOW PROCESS FROM NODE      116.00 TO NODE      116.00 IS CODE = 10
-----
>>>>MAIN-STREAM MEMORY COPIED ONTO MEMORY BANK # 1 <<<<
=====
*****
FLOW PROCESS FROM NODE      117.00 TO NODE      118.00 IS CODE = 21
-----
>>>>RATIONAL METHOD INITIAL SUBAREA ANALYSIS<<<<
=====
*USER SPECIFIED(SUBAREA):
USER-SPECIFIED RUNOFF COEFFICIENT = .8500
S.C.S. CURVE NUMBER (AMC II) = 0
INITIAL SUBAREA FLOW-LENGTH(FEET) = 50.00
UPSTREAM ELEVATION(FEET) = 194.20
DOWNSTREAM ELEVATION(FEET) = 193.70
ELEVATION DIFFERENCE(FEET) = 0.50
URBAN SUBAREA OVERLAND TIME OF FLOW(MIN.) = 3.182
100 YEAR RAINFALL INTENSITY(INCH/HOUR) = 6.323
NOTE: RAINFALL INTENSITY IS BASED ON Tc = 5-MINUTE.
SUBAREA RUNOFF(CFS) = 0.21
TOTAL AREA(ACRES) = 0.04 TOTAL RUNOFF(CFS) = 0.21
*****
FLOW PROCESS FROM NODE      118.00 TO NODE      119.00 IS CODE = 51
-----
>>>>COMPUTE TRAPEZOIDAL CHANNEL FLOW<<<<
>>>>TRAVELTIME THRU SUBAREA (EXISTING ELEMENT)<<<<
=====
ELEVATION DATA: UPSTREAM(FEET) = 193.70 DOWNSTREAM(FEET) = 192.50
CHANNEL LENGTH THRU SUBAREA(FEET) = 118.00 CHANNEL SLOPE = 0.0102
CHANNEL BASE(FEET) = 50.00 "Z" FACTOR = 50.000
MANNING'S FACTOR = 0.015 MAXIMUM DEPTH(FEET) = 1.00
100 YEAR RAINFALL INTENSITY(INCH/HOUR) = 6.072
*USER SPECIFIED(SUBAREA):
USER-SPECIFIED RUNOFF COEFFICIENT = .8500
S.C.S. CURVE NUMBER (AMC II) = 0
TRAVEL TIME COMPUTED USING ESTIMATED FLOW(CFS) = 1.10
TRAVEL TIME THRU SUBAREA BASED ON VELOCITY(FEET/SEC.) = 0.83
AVERAGE FLOW DEPTH(FEET) = 0.03 TRAVEL TIME(MIN.) = 2.37
Tc(MIN.) = 5.55
SUBAREA AREA(ACRES) = 0.34 SUBAREA RUNOFF(CFS) = 1.75
AREA-AVERAGE RUNOFF COEFFICIENT = 0.850
TOTAL AREA(ACRES) = 0.4 PEAK FLOW RATE(CFS) = 1.96

END OF SUBAREA CHANNEL FLOW HYDRAULICS:
DEPTH(FEET) = 0.04 FLOW VELOCITY(FEET/SEC.) = 1.07
LONGEST FLOWPATH FROM NODE 117.00 TO NODE 119.00 = 168.00 FEET.
*****
FLOW PROCESS FROM NODE      119.00 TO NODE      120.00 IS CODE = 31
-----
>>>>COMPUTE PIPE-FLOW TRAVEL TIME THRU SUBAREA<<<<
>>>>USING COMPUTER-ESTIMATED PIPESIZE (NON-PRESSURE FLOW)<<<<
=====
ELEVATION DATA: UPSTREAM(FEET) = 192.50 DOWNSTREAM(FEET) = 191.51
FLOW LENGTH(FEET) = 29.00 MANNING'S N = 0.011
DEPTH OF FLOW IN 9.0 INCH PIPE IS 4.8 INCHES
PIPE-FLOW VELOCITY(FEET/SEC.) = 8.20
ESTIMATED PIPE DIAMETER(INCH) = 9.00 NUMBER OF PIPES = 1
PIPE-FLOW(CFS) = 1.96
PIPE TRAVEL TIME(MIN.) = 0.06 Tc(MIN.) = 5.61
LONGEST FLOWPATH FROM NODE 117.00 TO NODE 120.00 = 197.00 FEET.

```

```

*****
FLOW PROCESS FROM NODE      120.00 TO NODE      120.00 IS CODE = 81
-----
>>>>ADDITION OF SUBAREA TO MAINLINE PEAK FLOW<<<<
=====
  100 YEAR RAINFALL INTENSITY(INCH/HOUR) = 6.045
*USER SPECIFIED(SUBAREA):
USER-SPECIFIED RUNOFF COEFFICIENT = .6000
S.C.S. CURVE NUMBER (AMC II) = 0
AREA-AVERAGE RUNOFF COEFFICIENT = 0.8065
SUBAREA AREA(ACRES) = 0.08  SUBAREA RUNOFF(CFS) = 0.29
TOTAL AREA(ACRES) = 0.5  TOTAL RUNOFF(CFS) = 2.24
TC(MIN.) = 5.61

*****
FLOW PROCESS FROM NODE      120.00 TO NODE      121.00 IS CODE = 31
-----
>>>>COMPUTE PIPE-FLOW TRAVEL TIME THRU SUBAREA<<<<
>>>>USING COMPUTER-ESTIMATED PIPESIZE (NON-PRESSURE FLOW)<<<<
=====
ELEVATION DATA: UPSTREAM(FEET) = 191.18  DOWNSTREAM(FEET) = 190.82
FLOW LENGTH(FEET) = 59.00  MANNING'S N = 0.011
DEPTH OF FLOW IN 12.0 INCH PIPE IS 7.4 INCHES
PIPE-FLOW VELOCITY(FEET/SEC.) = 4.42
ESTIMATED PIPE DIAMETER(INCH) = 12.00  NUMBER OF PIPES = 1
PIPE-FLOW(CFS) = 2.24
PIPE TRAVEL TIME(MIN.) = 0.22  Tc(MIN.) = 5.83
LONGEST FLOWPATH FROM NODE 117.00 TO NODE 121.00 = 256.00 FEET.

*****
FLOW PROCESS FROM NODE      121.00 TO NODE      121.00 IS CODE = 81
-----
>>>>ADDITION OF SUBAREA TO MAINLINE PEAK FLOW<<<<
=====
  100 YEAR RAINFALL INTENSITY(INCH/HOUR) = 5.944
*USER SPECIFIED(SUBAREA):
USER-SPECIFIED RUNOFF COEFFICIENT = .8500
S.C.S. CURVE NUMBER (AMC II) = 0
AREA-AVERAGE RUNOFF COEFFICIENT = 0.8206
SUBAREA AREA(ACRES) = 0.22  SUBAREA RUNOFF(CFS) = 1.11
TOTAL AREA(ACRES) = 0.7  TOTAL RUNOFF(CFS) = 3.32
TC(MIN.) = 5.83

*****
FLOW PROCESS FROM NODE      121.00 TO NODE      122.00 IS CODE = 31
-----
>>>>COMPUTE PIPE-FLOW TRAVEL TIME THRU SUBAREA<<<<
>>>>USING COMPUTER-ESTIMATED PIPESIZE (NON-PRESSURE FLOW)<<<<
=====
ELEVATION DATA: UPSTREAM(FEET) = 190.82  DOWNSTREAM(FEET) = 190.57
FLOW LENGTH(FEET) = 42.00  MANNING'S N = 0.011
DEPTH OF FLOW IN 15.0 INCH PIPE IS 8.2 INCHES
PIPE-FLOW VELOCITY(FEET/SEC.) = 4.85
ESTIMATED PIPE DIAMETER(INCH) = 15.00  NUMBER OF PIPES = 1
PIPE-FLOW(CFS) = 3.32
PIPE TRAVEL TIME(MIN.) = 0.14  Tc(MIN.) = 5.98
LONGEST FLOWPATH FROM NODE 117.00 TO NODE 122.00 = 298.00 FEET.

*****
FLOW PROCESS FROM NODE      122.00 TO NODE      122.00 IS CODE = 81
-----
>>>>ADDITION OF SUBAREA TO MAINLINE PEAK FLOW<<<<

```

```
=====
 100 YEAR RAINFALL INTENSITY(INCH/HOUR) = 5.878
*USER SPECIFIED(SUBAREA):
USER-SPECIFIED RUNOFF COEFFICIENT = .8500
S.C.S. CURVE NUMBER (AMC II) = 0
AREA-AVERAGE RUNOFF COEFFICIENT = 0.8311
SUBAREA AREA(ACRES) = 0.38 SUBAREA RUNOFF(CFS) = 1.90
TOTAL AREA(ACRES) = 1.1 TOTAL RUNOFF(CFS) = 5.18
TC(MIN.) = 5.98
```

```
*****
FLOW PROCESS FROM NODE 122.00 TO NODE 123.00 IS CODE = 31
```

```
-----
>>>>COMPUTE PIPE-FLOW TRAVEL TIME THRU SUBAREA<<<<
>>>>USING COMPUTER-ESTIMATED PIPESIZE (NON-PRESSURE FLOW)<<<<
```

```
=====
ELEVATION DATA: UPSTREAM(FEET) = 190.57 DOWNSTREAM(FEET) = 189.94
FLOW LENGTH(FEET) = 103.00 MANNING'S N = 0.011
DEPTH OF FLOW IN 15.0 INCH PIPE IS 11.0 INCHES
PIPE-FLOW VELOCITY(FEET/SEC.) = 5.35
ESTIMATED PIPE DIAMETER(INCH) = 15.00 NUMBER OF PIPES = 1
PIPE-FLOW(CFS) = 5.18
PIPE TRAVEL TIME(MIN.) = 0.32 Tc(MIN.) = 6.30
LONGEST FLOWPATH FROM NODE 117.00 TO NODE 123.00 = 401.00 FEET.
```

```
*****
FLOW PROCESS FROM NODE 123.00 TO NODE 123.00 IS CODE = 81
```

```
-----
>>>>ADDITION OF SUBAREA TO MAINLINE PEAK FLOW<<<<
```

```
=====
 100 YEAR RAINFALL INTENSITY(INCH/HOUR) = 5.732
*USER SPECIFIED(SUBAREA):
USER-SPECIFIED RUNOFF COEFFICIENT = .8500
S.C.S. CURVE NUMBER (AMC II) = 0
AREA-AVERAGE RUNOFF COEFFICIENT = 0.8358
SUBAREA AREA(ACRES) = 0.35 SUBAREA RUNOFF(CFS) = 1.71
TOTAL AREA(ACRES) = 1.4 TOTAL RUNOFF(CFS) = 6.76
TC(MIN.) = 6.30
```

```
*****
FLOW PROCESS FROM NODE 123.00 TO NODE 124.00 IS CODE = 31
```

```
-----
>>>>COMPUTE PIPE-FLOW TRAVEL TIME THRU SUBAREA<<<<
>>>>USING COMPUTER-ESTIMATED PIPESIZE (NON-PRESSURE FLOW)<<<<
```

```
=====
ELEVATION DATA: UPSTREAM(FEET) = 189.94 DOWNSTREAM(FEET) = 189.73
FLOW LENGTH(FEET) = 33.00 MANNING'S N = 0.011
DEPTH OF FLOW IN 18.0 INCH PIPE IS 11.1 INCHES
PIPE-FLOW VELOCITY(FEET/SEC.) = 5.91
ESTIMATED PIPE DIAMETER(INCH) = 18.00 NUMBER OF PIPES = 1
PIPE-FLOW(CFS) = 6.76
PIPE TRAVEL TIME(MIN.) = 0.09 Tc(MIN.) = 6.39
LONGEST FLOWPATH FROM NODE 117.00 TO NODE 124.00 = 434.00 FEET.
```

```
*****
FLOW PROCESS FROM NODE 124.00 TO NODE 124.00 IS CODE = 81
```

```
-----
>>>>ADDITION OF SUBAREA TO MAINLINE PEAK FLOW<<<<
```

```
=====
 100 YEAR RAINFALL INTENSITY(INCH/HOUR) = 5.690
*USER SPECIFIED(SUBAREA):
USER-SPECIFIED RUNOFF COEFFICIENT = .8500
S.C.S. CURVE NUMBER (AMC II) = 0
```

AREA-AVERAGE RUNOFF COEFFICIENT = 0.8375
SUBAREA AREA(ACRES) = 0.19 SUBAREA RUNOFF(CFS) = 0.92
TOTAL AREA(ACRES) = 1.6 TOTAL RUNOFF(CFS) = 7.62
TC(MIN.) = 6.39

FLOW PROCESS FROM NODE 124.00 TO NODE 125.00 IS CODE = 31

>>>>COMPUTE PIPE-FLOW TRAVEL TIME THRU SUBAREA<<<<<
>>>>USING COMPUTER-ESTIMATED PIPESIZE (NON-PRESSURE FLOW)<<<<<

=====

ELEVATION DATA: UPSTREAM(FEET) =	1289.73	DOWNSTREAM(FEET) =	189.06
FLOW LENGTH(FEET) =	47.00	MANNING'S N =	0.011
DEPTH OF FLOW IN	6.0 INCH PIPE IS	2.0 INCHES	
PIPE-FLOW VELOCITY(FEET/SEC.) =	131.47		
ESTIMATED PIPE DIAMETER(INCH) =	6.00	NUMBER OF PIPES =	1
PIPE-FLOW(CFS) =	7.62		
PIPE TRAVEL TIME(MIN.) =	0.01	Tc(MIN.) =	6.40
LONGEST FLOWPATH FROM NODE	117.00 TO NODE	125.00 =	481.00 FEET.

FLOW PROCESS FROM NODE 125.00 TO NODE 125.00 IS CODE = 81

>>>>ADDITION OF SUBAREA TO MAINLINE PEAK FLOW<<<<<

=====

100 YEAR RAINFALL INTENSITY(INCH/HOUR) =	5.687
*USER SPECIFIED(SUBAREA):	
USER-SPECIFIED RUNOFF COEFFICIENT =	.8500
S.C.S. CURVE NUMBER (AMC II) =	0
AREA-AVERAGE RUNOFF COEFFICIENT =	0.8383
SUBAREA AREA(ACRES) =	0.11 SUBAREA RUNOFF(CFS) = 0.53
TOTAL AREA(ACRES) =	1.7 TOTAL RUNOFF(CFS) = 8.15
TC(MIN.) =	6.40

FLOW PROCESS FROM NODE 125.00 TO NODE 126.00 IS CODE = 31

>>>>COMPUTE PIPE-FLOW TRAVEL TIME THRU SUBAREA<<<<<
>>>>USING COMPUTER-ESTIMATED PIPESIZE (NON-PRESSURE FLOW)<<<<<

=====

ELEVATION DATA: UPSTREAM(FEET) =	188.73	DOWNSTREAM(FEET) =	188.68
FLOW LENGTH(FEET) =	73.00	MANNING'S N =	0.011
DEPTH OF FLOW IN	27.0 INCH PIPE IS	19.5 INCHES	
PIPE-FLOW VELOCITY(FEET/SEC.) =	2.65		
ESTIMATED PIPE DIAMETER(INCH) =	27.00	NUMBER OF PIPES =	1
PIPE-FLOW(CFS) =	8.15		
PIPE TRAVEL TIME(MIN.) =	0.46	Tc(MIN.) =	6.86
LONGEST FLOWPATH FROM NODE	117.00 TO NODE	126.00 =	554.00 FEET.

FLOW PROCESS FROM NODE 126.00 TO NODE 126.00 IS CODE = 81

>>>>ADDITION OF SUBAREA TO MAINLINE PEAK FLOW<<<<<

=====

100 YEAR RAINFALL INTENSITY(INCH/HOUR) =	5.477
*USER SPECIFIED(SUBAREA):	
USER-SPECIFIED RUNOFF COEFFICIENT =	.8500
S.C.S. CURVE NUMBER (AMC II) =	0
AREA-AVERAGE RUNOFF COEFFICIENT =	0.8393
SUBAREA AREA(ACRES) =	0.16 SUBAREA RUNOFF(CFS) = 0.74
TOTAL AREA(ACRES) =	1.9 TOTAL RUNOFF(CFS) = 8.60
TC(MIN.) =	6.86

```

*****
FLOW PROCESS FROM NODE    126.00 TO NODE    127.00 IS CODE = 31
-----
>>>>COMPUTE PIPE-FLOW TRAVEL TIME THRU SUBAREA<<<<
>>>>USING COMPUTER-ESTIMATED PIPESIZE (NON-PRESSURE FLOW)<<<<
=====
ELEVATION DATA: UPSTREAM(FEET) = 188.68  DOWNSTREAM(FEET) = 188.02
FLOW LENGTH(FEET) = 110.00  MANNING'S N = 0.011
DEPTH OF FLOW IN 18.0 INCH PIPE IS 13.6 INCHES
PIPE-FLOW VELOCITY(FEET/SEC.) = 6.02
ESTIMATED PIPE DIAMETER(INCH) = 18.00  NUMBER OF PIPES = 1
PIPE-FLOW(CFS) = 8.60
PIPE TRAVEL TIME(MIN.) = 0.30  Tc(MIN.) = 7.16
LONGEST FLOWPATH FROM NODE    117.00 TO NODE    127.00 = 664.00 FEET.

*****
FLOW PROCESS FROM NODE    127.00 TO NODE    127.00 IS CODE = 81
-----
>>>>ADDITION OF SUBAREA TO MAINLINE PEAK FLOW<<<<
=====
100 YEAR RAINFALL INTENSITY(INCH/HOUR) = 5.338
*USER SPECIFIED(SUBAREA):
USER-SPECIFIED RUNOFF COEFFICIENT = .8500
S.C.S. CURVE NUMBER (AMC II) = 0
AREA-AVERAGE RUNOFF COEFFICIENT = 0.8401
SUBAREA AREA(ACRES) = 0.16  SUBAREA RUNOFF(CFS) = 0.73
TOTAL AREA(ACRES) = 2.0  TOTAL RUNOFF(CFS) = 9.10
TC(MIN.) = 7.16

*****
FLOW PROCESS FROM NODE    127.00 TO NODE    128.00 IS CODE = 31
-----
>>>>COMPUTE PIPE-FLOW TRAVEL TIME THRU SUBAREA<<<<
>>>>USING COMPUTER-ESTIMATED PIPESIZE (NON-PRESSURE FLOW)<<<<
=====
ELEVATION DATA: UPSTREAM(FEET) = 187.69  DOWNSTREAM(FEET) = 187.44
FLOW LENGTH(FEET) = 42.00  MANNING'S N = 0.011
DEPTH OF FLOW IN 18.0 INCH PIPE IS 14.4 INCHES
PIPE-FLOW VELOCITY(FEET/SEC.) = 6.02
ESTIMATED PIPE DIAMETER(INCH) = 18.00  NUMBER OF PIPES = 1
PIPE-FLOW(CFS) = 9.10
PIPE TRAVEL TIME(MIN.) = 0.12  Tc(MIN.) = 7.28
LONGEST FLOWPATH FROM NODE    117.00 TO NODE    128.00 = 706.00 FEET.

*****
FLOW PROCESS FROM NODE    128.00 TO NODE    128.00 IS CODE = 81
-----
>>>>ADDITION OF SUBAREA TO MAINLINE PEAK FLOW<<<<
=====
100 YEAR RAINFALL INTENSITY(INCH/HOUR) = 5.286
*USER SPECIFIED(SUBAREA):
USER-SPECIFIED RUNOFF COEFFICIENT = .8500
S.C.S. CURVE NUMBER (AMC II) = 0
AREA-AVERAGE RUNOFF COEFFICIENT = 0.8410
SUBAREA AREA(ACRES) = 0.20  SUBAREA RUNOFF(CFS) = 0.90
TOTAL AREA(ACRES) = 2.2  TOTAL RUNOFF(CFS) = 9.91
TC(MIN.) = 7.28

*****
FLOW PROCESS FROM NODE    128.00 TO NODE    129.00 IS CODE = 31
-----
>>>>COMPUTE PIPE-FLOW TRAVEL TIME THRU SUBAREA<<<<
>>>>USING COMPUTER-ESTIMATED PIPESIZE (NON-PRESSURE FLOW)<<<<

```

=====
ELEVATION DATA: UPSTREAM(FEET) = 187.44 DOWNSTREAM(FEET) = 186.51
FLOW LENGTH(FEET) = 155.00 MANNING'S N = 0.011
DEPTH OF FLOW IN 21.0 INCH PIPE IS 13.0 INCHES
PIPE-FLOW VELOCITY(FEET/SEC.) = 6.36
ESTIMATED PIPE DIAMETER(INCH) = 21.00 NUMBER OF PIPES = 1
PIPE-FLOW(CFS) = 9.91
PIPE TRAVEL TIME(MIN.) = 0.41 Tc(MIN.) = 7.68
LONGEST FLOWPATH FROM NODE 117.00 TO NODE 129.00 = 861.00 FEET.

FLOW PROCESS FROM NODE 129.00 TO NODE 129.00 IS CODE = 81

>>>>ADDITION OF SUBAREA TO MAINLINE PEAK FLOW<<<<

=====
100 YEAR RAINFALL INTENSITY(INCH/HOUR) = 5.100
*USER SPECIFIED(SUBAREA):
USER-SPECIFIED RUNOFF COEFFICIENT = .8500
S.C.S. CURVE NUMBER (AMC II) = 0
AREA-AVERAGE RUNOFF COEFFICIENT = 0.8423
SUBAREA AREA(ACRES) = 0.37 SUBAREA RUNOFF(CFS) = 1.60
TOTAL AREA(ACRES) = 2.6 TOTAL RUNOFF(CFS) = 11.17
TC(MIN.) = 7.68

FLOW PROCESS FROM NODE 129.00 TO NODE 130.00 IS CODE = 31

>>>>COMPUTE PIPE-FLOW TRAVEL TIME THRU SUBAREA<<<<
>>>>USING COMPUTER-ESTIMATED PIPESIZE (NON-PRESSURE FLOW)<<<<

=====
ELEVATION DATA: UPSTREAM(FEET) = 186.51 DOWNSTREAM(FEET) = 186.10
FLOW LENGTH(FEET) = 67.00 MANNING'S N = 0.011
DEPTH OF FLOW IN 21.0 INCH PIPE IS 14.0 INCHES
PIPE-FLOW VELOCITY(FEET/SEC.) = 6.57
ESTIMATED PIPE DIAMETER(INCH) = 21.00 NUMBER OF PIPES = 1
PIPE-FLOW(CFS) = 11.17
PIPE TRAVEL TIME(MIN.) = 0.17 Tc(MIN.) = 7.85
LONGEST FLOWPATH FROM NODE 117.00 TO NODE 130.00 = 928.00 FEET.

FLOW PROCESS FROM NODE 130.00 TO NODE 131.00 IS CODE = 31

>>>>COMPUTE PIPE-FLOW TRAVEL TIME THRU SUBAREA<<<<
>>>>USING COMPUTER-ESTIMATED PIPESIZE (NON-PRESSURE FLOW)<<<<

=====
ELEVATION DATA: UPSTREAM(FEET) = 185.77 DOWNSTREAM(FEET) = 185.12
FLOW LENGTH(FEET) = 108.00 MANNING'S N = 0.011
DEPTH OF FLOW IN 21.0 INCH PIPE IS 14.1 INCHES
PIPE-FLOW VELOCITY(FEET/SEC.) = 6.52
ESTIMATED PIPE DIAMETER(INCH) = 21.00 NUMBER OF PIPES = 1
PIPE-FLOW(CFS) = 11.17
PIPE TRAVEL TIME(MIN.) = 0.28 Tc(MIN.) = 8.13
LONGEST FLOWPATH FROM NODE 117.00 TO NODE 131.00 = 1036.00 FEET.

FLOW PROCESS FROM NODE 131.00 TO NODE 131.00 IS CODE = 81

>>>>ADDITION OF SUBAREA TO MAINLINE PEAK FLOW<<<<

=====
100 YEAR RAINFALL INTENSITY(INCH/HOUR) = 4.897
*USER SPECIFIED(SUBAREA):
USER-SPECIFIED RUNOFF COEFFICIENT = .8500
S.C.S. CURVE NUMBER (AMC II) = 0

AREA-AVERAGE RUNOFF COEFFICIENT = 0.8442
SUBAREA AREA(ACRES) = 0.84 SUBAREA RUNOFF(CFS) = 3.50
TOTAL AREA(ACRES) = 3.4 TOTAL RUNOFF(CFS) = 14.22
TC(MIN.) = 8.13

FLOW PROCESS FROM NODE 131.00 TO NODE 116.00 IS CODE = 31

>>>>COMPUTE PIPE-FLOW TRAVEL TIME THRU SUBAREA<<<<<
>>>>USING COMPUTER-ESTIMATED PIPESIZE (NON-PRESSURE FLOW)<<<<<

=====

ELEVATION DATA: UPSTREAM(FEET) =	185.12	DOWNSTREAM(FEET) =	184.49
FLOW LENGTH(FEET) =	105.00	MANNING'S N =	0.011
DEPTH OF FLOW IN	24.0 INCH PIPE IS	14.9	INCHES
PIPE-FLOW VELOCITY(FEET/SEC.) =	6.96		
ESTIMATED PIPE DIAMETER(INCH) =	24.00	NUMBER OF PIPES =	1
PIPE-FLOW(CFS) =	14.22		
PIPE TRAVEL TIME(MIN.) =	0.25	Tc(MIN.) =	8.38
LONGEST FLOWPATH FROM NODE	117.00 TO NODE	116.00 =	1141.00 FEET.

FLOW PROCESS FROM NODE 116.00 TO NODE 116.00 IS CODE = 11

>>>>CONFLUENCE MEMORY BANK # 1 WITH THE MAIN-STREAM MEMORY<<<<<

** MAIN STREAM CONFLUENCE DATA **

STREAM NUMBER	RUNOFF (CFS)	Tc (MIN.)	INTENSITY (INCH/HOUR)	AREA (ACRE)
1	14.22	8.38	4.783	3.44

LONGEST FLOWPATH FROM NODE 117.00 TO NODE 116.00 = 1141.00 FEET.

** MEMORY BANK # 1 CONFLUENCE DATA **

STREAM NUMBER	RUNOFF (CFS)	Tc (MIN.)	INTENSITY (INCH/HOUR)	AREA (ACRE)
1	19.48	8.23	4.850	4.81

LONGEST FLOWPATH FROM NODE 100.00 TO NODE 116.00 = 1158.00 FEET.

** PEAK FLOW RATE TABLE **

STREAM NUMBER	RUNOFF (CFS)	Tc (MIN.)	INTENSITY (INCH/HOUR)
1	33.45	8.23	4.850
2	33.43	8.38	4.783

COMPUTED CONFLUENCE ESTIMATES ARE AS FOLLOWS:

PEAK FLOW RATE(CFS) = 33.45 Tc(MIN.) = 8.23
TOTAL AREA(ACRES) = 8.2

FLOW PROCESS FROM NODE 116.00 TO NODE 132.00 IS CODE = 31

>>>>COMPUTE PIPE-FLOW TRAVEL TIME THRU SUBAREA<<<<<
>>>>USING COMPUTER-ESTIMATED PIPESIZE (NON-PRESSURE FLOW)<<<<<

=====

ELEVATION DATA: UPSTREAM(FEET) =	183.11	DOWNSTREAM(FEET) =	182.75
FLOW LENGTH(FEET) =	19.00	MANNING'S N =	0.011
DEPTH OF FLOW IN	24.0 INCH PIPE IS	18.4	INCHES
PIPE-FLOW VELOCITY(FEET/SEC.) =	12.97		
ESTIMATED PIPE DIAMETER(INCH) =	24.00	NUMBER OF PIPES =	1
PIPE-FLOW(CFS) =	33.45		
PIPE TRAVEL TIME(MIN.) =	0.02	Tc(MIN.) =	8.26
LONGEST FLOWPATH FROM NODE	100.00 TO NODE	132.00 =	1177.00 FEET.

```

*****
FLOW PROCESS FROM NODE    133.00 TO NODE    134.00 IS CODE = 31
-----
>>>>COMPUTE PIPE-FLOW TRAVEL TIME THRU SUBAREA<<<<
>>>>USING COMPUTER-ESTIMATED PIPESIZE (NON-PRESSURE FLOW)<<<<
=====
ELEVATION DATA: UPSTREAM(FEET) = 182.75  DOWNSTREAM(FEET) = 179.95
FLOW LENGTH(FEET) = 28.00  MANNING'S N = 0.011
DEPTH OF FLOW IN 18.0 INCH PIPE IS 13.0 INCHES
PIPE-FLOW VELOCITY(FEET/SEC.) = 24.40
ESTIMATED PIPE DIAMETER(INCH) = 18.00  NUMBER OF PIPES = 1
PIPE-FLOW(CFS) = 33.45
PIPE TRAVEL TIME(MIN.) = 0.02  Tc(MIN.) = 8.28
LONGEST FLOWPATH FROM NODE    100.00 TO NODE    134.00 = 1205.00 FEET.

*****
FLOW PROCESS FROM NODE    134.00 TO NODE    135.00 IS CODE = 31
-----
>>>>COMPUTE PIPE-FLOW TRAVEL TIME THRU SUBAREA<<<<
>>>>USING COMPUTER-ESTIMATED PIPESIZE (NON-PRESSURE FLOW)<<<<
=====
ELEVATION DATA: UPSTREAM(FEET) = 179.62  DOWNSTREAM(FEET) = 178.40
FLOW LENGTH(FEET) = 203.00  MANNING'S N = 0.011
DEPTH OF FLOW IN 30.0 INCH PIPE IS 22.5 INCHES
PIPE-FLOW VELOCITY(FEET/SEC.) = 8.46
ESTIMATED PIPE DIAMETER(INCH) = 30.00  NUMBER OF PIPES = 1
PIPE-FLOW(CFS) = 33.45
PIPE TRAVEL TIME(MIN.) = 0.40  Tc(MIN.) = 8.68
LONGEST FLOWPATH FROM NODE    100.00 TO NODE    135.00 = 1408.00 FEET.

*****
FLOW PROCESS FROM NODE    135.00 TO NODE    136.00 IS CODE = 31
-----
>>>>COMPUTE PIPE-FLOW TRAVEL TIME THRU SUBAREA<<<<
>>>>USING COMPUTER-ESTIMATED PIPESIZE (NON-PRESSURE FLOW)<<<<
=====
ELEVATION DATA: UPSTREAM(FEET) = 144.80  DOWNSTREAM(FEET) = 143.67
FLOW LENGTH(FEET) = 76.00  MANNING'S N = 0.011
DEPTH OF FLOW IN 27.0 INCH PIPE IS 17.8 INCHES
PIPE-FLOW VELOCITY(FEET/SEC.) = 12.06
ESTIMATED PIPE DIAMETER(INCH) = 27.00  NUMBER OF PIPES = 1
PIPE-FLOW(CFS) = 33.45
PIPE TRAVEL TIME(MIN.) = 0.11  Tc(MIN.) = 8.78
LONGEST FLOWPATH FROM NODE    100.00 TO NODE    136.00 = 1484.00 FEET.

*****
FLOW PROCESS FROM NODE    136.00 TO NODE    136.00 IS CODE = 81
-----
>>>>ADDITION OF SUBAREA TO MAINLINE PEAK FLOW<<<<
=====
100 YEAR RAINFALL INTENSITY(INCH/HOUR) = 4.600
*USER SPECIFIED(SUBAREA):
USER-SPECIFIED RUNOFF COEFFICIENT = .6000
S.C.S. CURVE NUMBER (AMC II) = 0
AREA-AVERAGE RUNOFF COEFFICIENT = 0.8288
SUBAREA AREA(ACRES) = 0.25  SUBAREA RUNOFF(CFS) = 0.69
TOTAL AREA(ACRES) = 8.5  TOTAL RUNOFF(CFS) = 33.45
TC(MIN.) = 8.78
NOTE: PEAK FLOW RATE DEFAULTED TO UPSTREAM VALUE

*****
FLOW PROCESS FROM NODE    200.00 TO NODE    201.00 IS CODE = 21
-----

```

>>>>RATIONAL METHOD INITIAL SUBAREA ANALYSIS<<<<<

=====

*USER SPECIFIED(SUBAREA):

USER-SPECIFIED RUNOFF COEFFICIENT = .8500
S.C.S. CURVE NUMBER (AMC II) = 0
INITIAL SUBAREA FLOW-LENGTH(FEET) = 100.00
UPSTREAM ELEVATION(FEET) = 196.50
DOWNSTREAM ELEVATION(FEET) = 192.61
ELEVATION DIFFERENCE(FEET) = 3.89
URBAN SUBAREA OVERLAND TIME OF FLOW(MIN.) = 2.861
100 YEAR RAINFALL INTENSITY(INCH/HOUR) = 6.323
NOTE: RAINFALL INTENSITY IS BASED ON Tc = 5-MINUTE.
SUBAREA RUNOFF(CFS) = 0.86
TOTAL AREA(ACRES) = 0.16 TOTAL RUNOFF(CFS) = 0.86

FLOW PROCESS FROM NODE 201.00 TO NODE 202.00 IS CODE = 61

>>>>COMPUTE STREET FLOW TRAVEL TIME THRU SUBAREA<<<<<

>>>>(STANDARD CURB SECTION USED)<<<<<

=====

UPSTREAM ELEVATION(FEET) = 192.61 DOWNSTREAM ELEVATION(FEET) = 149.11
STREET LENGTH(FEET) = 718.00 CURB HEIGHT(INCHES) = 6.0
STREET HALFWIDTH(FEET) = 36.00

DISTANCE FROM CROWN TO CROSSFALL GRADEBREAK(FEET) = 1.00
INSIDE STREET CROSSFALL(DECIMAL) = 0.015
OUTSIDE STREET CROSSFALL(DECIMAL) = 0.015

SPECIFIED NUMBER OF HALFSTREETS CARRYING RUNOFF = 1
STREET PARKWAY CROSSFALL(DECIMAL) = 0.015
Manning's FRICTION FACTOR for Streetflow Section(curbs-to-curbs) = 0.0150
Manning's FRICTION FACTOR for Back-of-Walk Flow Section = 0.0200

**TRAVEL TIME COMPUTED USING ESTIMATED FLOW(CFS) = 3.35
STREETFLOW MODEL RESULTS USING ESTIMATED FLOW:
STREET FLOW DEPTH(FEET) = 0.27
HALFSTREET FLOOD WIDTH(FEET) = 9.16
AVERAGE FLOW VELOCITY(FEET/SEC.) = 4.45
PRODUCT OF DEPTH&VELOCITY(FT*FT/SEC.) = 1.21
STREET FLOW TRAVEL TIME(MIN.) = 2.69 Tc(MIN.) = 5.55
100 YEAR RAINFALL INTENSITY(INCH/HOUR) = 6.071

*USER SPECIFIED(SUBAREA):

USER-SPECIFIED RUNOFF COEFFICIENT = .7900
S.C.S. CURVE NUMBER (AMC II) = 0
AREA-AVERAGE RUNOFF COEFFICIENT = 0.798
SUBAREA AREA(ACRES) = 1.03 SUBAREA RUNOFF(CFS) = 4.94
TOTAL AREA(ACRES) = 1.2 PEAK FLOW RATE(CFS) = 5.77

END OF SUBAREA STREET FLOW HYDRAULICS:

DEPTH(FEET) = 0.31 HALFSTREET FLOOD WIDTH(FEET) = 11.64
FLOW VELOCITY(FEET/SEC.) = 5.06 DEPTH*VELOCITY(FT*FT/SEC.) = 1.56
LONGEST FLOWPATH FROM NODE 200.00 TO NODE 202.00 = 818.00 FEET.

=====

END OF STUDY SUMMARY:

TOTAL AREA(ACRES) = 1.2 TC(MIN.) = 5.55
PEAK FLOW RATE(CFS) = 5.77

=====

END OF RATIONAL METHOD ANALYSIS

100-YEAR POST-PROJECT CONDITION - DETAINED

RATIONAL METHOD HYDROLOGY COMPUTER PROGRAM PACKAGE
Reference: SAN DIEGO COUNTY FLOOD CONTROL DISTRICT
2003,1985,1981 HYDROLOGY MANUAL
(c) Copyright 1982-2016 Advanced Engineering Software (aes)
Ver. 23.0 Release Date: 07/01/2016 License ID 1452

Analysis prepared by:

FILE NAME: 3690D100.DAT
TIME/DATE OF STUDY: 09:19 05/20/2022

USER SPECIFIED HYDROLOGY AND HYDRAULIC MODEL INFORMATION:

USER SPECIFIED STORM EVENT(YEAR) = 100.00
SPECIFIED MINIMUM PIPE SIZE(INCH) = 4.00
SPECIFIED PERCENT OF GRADIENTS(DECIMAL) TO USE FOR FRICTION SLOPE = 0.95
RAINFALL-INTENSITY ADJUSTMENT FACTOR = 1.000

*USER SPECIFIED:

NUMBER OF [TIME,INTENSITY] DATA PAIRS = 9

1) 5.000; 6.323
2) 10.000; 4.044
3) 15.000; 3.113
4) 20.000; 2.586
5) 25.000; 2.239
6) 30.000; 1.991
7) 40.000; 1.654
8) 50.000; 1.432
9) 60.000; 1.273

SAN DIEGO HYDROLOGY MANUAL "C"-VALUES USED FOR RATIONAL METHOD

NOTE: ONLY PEAK CONFLUENCE VALUES CONSIDERED

USER-DEFINED STREET-SECTIONS FOR COUPLED PIPEFLOW AND STREETFLOW MODEL

NO.	HALF- WIDTH (FT)	CROWN TO CROSSFALL (FT)	STREET-CROSSFALL: IN- / OUT-/ SIDE / SIDE/ WAY	CURB HEIGHT (FT)	GUTTER-GEOMETRIES: WIDTH (FT)	LIP (FT)	HIKE (FT)	MANNING FACTOR (n)
1	30.0	20.0	0.018/0.018/0.020	0.67	2.00	0.0312	0.167	0.0150

GLOBAL STREET FLOW-DEPTH CONSTRAINTS:

1. Relative Flow-Depth = 0.00 FEET
as (Maximum Allowable Street Flow Depth) - (Top-of-Curb)
2. (Depth)*(Velocity) Constraint = 6.0 (FT*FT/S)

*SIZE PIPE WITH A FLOW CAPACITY GREATER THAN
OR EQUAL TO THE UPSTREAM TRIBUTARY PIPE.*

FLOW PROCESS FROM NODE 100.00 TO NODE 101.00 IS CODE = 21

>>>>RATIONAL METHOD INITIAL SUBAREA ANALYSIS<<<<<

*USER SPECIFIED(SUBAREA):

USER-SPECIFIED RUNOFF COEFFICIENT = .8500
S.C.S. CURVE NUMBER (AMC II) = 0
INITIAL SUBAREA FLOW-LENGTH(FEET) = 50.00
UPSTREAM ELEVATION(FEET) = 194.20

DOWNSTREAM ELEVATION(FEET) = 193.70
ELEVATION DIFFERENCE(FEET) = 0.50
URBAN SUBAREA OVERLAND TIME OF FLOW(MIN.) = 3.182
100 YEAR RAINFALL INTENSITY(INCH/HOUR) = 6.323
NOTE: RAINFALL INTENSITY IS BASED ON Tc = 5-MINUTE.
SUBAREA RUNOFF(CFS) = 0.21
TOTAL AREA(ACRES) = 0.04 TOTAL RUNOFF(CFS) = 0.21

FLOW PROCESS FROM NODE 101.00 TO NODE 102.00 IS CODE = 51

>>>>COMPUTE TRAPEZOIDAL CHANNEL FLOW<<<<<
>>>>TRAVELTIME THRU SUBAREA (EXISTING ELEMENT)<<<<<

=====

ELEVATION DATA: UPSTREAM(FEET) = 193.70 DOWNSTREAM(FEET) = 192.50
CHANNEL LENGTH THRU SUBAREA(FEET) = 118.00 CHANNEL SLOPE = 0.0102
CHANNEL BASE(FEET) = 50.00 "Z" FACTOR = 50.000
MANNING'S FACTOR = 0.015 MAXIMUM DEPTH(FEET) = 1.00
100 YEAR RAINFALL INTENSITY(INCH/HOUR) = 6.072
*USER SPECIFIED(SUBAREA):
USER-SPECIFIED RUNOFF COEFFICIENT = .8500
S.C.S. CURVE NUMBER (AMC II) = 0
TRAVEL TIME COMPUTED USING ESTIMATED FLOW(CFS) = 1.10
TRAVEL TIME THRU SUBAREA BASED ON VELOCITY(FEET/SEC.) = 0.83
AVERAGE FLOW DEPTH(FEET) = 0.03 TRAVEL TIME(MIN.) = 2.37
Tc(MIN.) = 5.55
SUBAREA AREA(ACRES) = 0.34 SUBAREA RUNOFF(CFS) = 1.75
AREA-AVERAGE RUNOFF COEFFICIENT = 0.850
TOTAL AREA(ACRES) = 0.4 PEAK FLOW RATE(CFS) = 1.96

END OF SUBAREA CHANNEL FLOW HYDRAULICS:
DEPTH(FEET) = 0.04 FLOW VELOCITY(FEET/SEC.) = 1.07
LONGEST FLOWPATH FROM NODE 100.00 TO NODE 102.00 = 168.00 FEET.

FLOW PROCESS FROM NODE 102.00 TO NODE 103.00 IS CODE = 31

>>>>COMPUTE PIPE-FLOW TRAVEL TIME THRU SUBAREA<<<<<
>>>>USING COMPUTER-ESTIMATED PIPESIZE (NON-PRESSURE FLOW)<<<<<

=====

ELEVATION DATA: UPSTREAM(FEET) = 192.50 DOWNSTREAM(FEET) = 191.30
FLOW LENGTH(FEET) = 29.00 MANNING'S N = 0.011
DEPTH OF FLOW IN 9.0 INCH PIPE IS 4.5 INCHES
PIPE-FLOW VELOCITY(FEET/SEC.) = 8.79
ESTIMATED PIPE DIAMETER(INCH) = 9.00 NUMBER OF PIPES = 1
PIPE-FLOW(CFS) = 1.96
PIPE TRAVEL TIME(MIN.) = 0.05 Tc(MIN.) = 5.60
LONGEST FLOWPATH FROM NODE 100.00 TO NODE 103.00 = 197.00 FEET.

FLOW PROCESS FROM NODE 103.00 TO NODE 103.00 IS CODE = 81

>>>>ADDITION OF SUBAREA TO MAINLINE PEAK FLOW<<<<<

=====

100 YEAR RAINFALL INTENSITY(INCH/HOUR) = 6.047
*USER SPECIFIED(SUBAREA):
USER-SPECIFIED RUNOFF COEFFICIENT = .8500
S.C.S. CURVE NUMBER (AMC II) = 0
AREA-AVERAGE RUNOFF COEFFICIENT = 0.8500
SUBAREA AREA(ACRES) = 0.20 SUBAREA RUNOFF(CFS) = 1.03
TOTAL AREA(ACRES) = 0.6 TOTAL RUNOFF(CFS) = 2.98
TC(MIN.) = 5.60

```

*****
FLOW PROCESS FROM NODE    103.00 TO NODE    104.00 IS CODE = 31
-----
>>>>COMPUTE PIPE-FLOW TRAVEL TIME THRU SUBAREA<<<<
>>>>USING COMPUTER-ESTIMATED PIPESIZE (NON-PRESSURE FLOW)<<<<
=====
ELEVATION DATA: UPSTREAM(FEET) = 190.97  DOWNSTREAM(FEET) = 190.35
FLOW LENGTH(FEET) = 103.00  MANNING'S N = 0.011
DEPTH OF FLOW IN 12.0 INCH PIPE IS 9.2 INCHES
PIPE-FLOW VELOCITY(FEET/SEC.) = 4.61
ESTIMATED PIPE DIAMETER(INCH) = 12.00  NUMBER OF PIPES = 1
PIPE-FLOW(CFS) = 2.98
PIPE TRAVEL TIME(MIN.) = 0.37  Tc(MIN.) = 5.98
LONGEST FLOWPATH FROM NODE    100.00 TO NODE    104.00 = 300.00 FEET.

*****
FLOW PROCESS FROM NODE    104.00 TO NODE    104.00 IS CODE = 81
-----
>>>>ADDITION OF SUBAREA TO MAINLINE PEAK FLOW<<<<
=====
100 YEAR RAINFALL INTENSITY(INCH/HOUR) = 5.877
*USER SPECIFIED(SUBAREA):
USER-SPECIFIED RUNOFF COEFFICIENT = .8500
S.C.S. CURVE NUMBER (AMC II) = 0
AREA-AVERAGE RUNOFF COEFFICIENT = 0.8500
SUBAREA AREA(ACRES) = 0.38  SUBAREA RUNOFF(CFS) = 1.90
TOTAL AREA(ACRES) = 1.0  TOTAL RUNOFF(CFS) = 4.80
TC(MIN.) = 5.98

*****
FLOW PROCESS FROM NODE    104.00 TO NODE    105.00 IS CODE = 31
-----
>>>>COMPUTE PIPE-FLOW TRAVEL TIME THRU SUBAREA<<<<
>>>>USING COMPUTER-ESTIMATED PIPESIZE (NON-PRESSURE FLOW)<<<<
=====
ELEVATION DATA: UPSTREAM(FEET) = 190.35  DOWNSTREAM(FEET) = 190.05
FLOW LENGTH(FEET) = 50.00  MANNING'S N = 0.011
DEPTH OF FLOW IN 15.0 INCH PIPE IS 10.4 INCHES
PIPE-FLOW VELOCITY(FEET/SEC.) = 5.26
ESTIMATED PIPE DIAMETER(INCH) = 15.00  NUMBER OF PIPES = 1
PIPE-FLOW(CFS) = 4.80
PIPE TRAVEL TIME(MIN.) = 0.16  Tc(MIN.) = 6.14
LONGEST FLOWPATH FROM NODE    100.00 TO NODE    105.00 = 350.00 FEET.

*****
FLOW PROCESS FROM NODE    105.00 TO NODE    105.00 IS CODE = 81
-----
>>>>ADDITION OF SUBAREA TO MAINLINE PEAK FLOW<<<<
=====
100 YEAR RAINFALL INTENSITY(INCH/HOUR) = 5.805
*USER SPECIFIED(SUBAREA):
USER-SPECIFIED RUNOFF COEFFICIENT = .8500
S.C.S. CURVE NUMBER (AMC II) = 0
AREA-AVERAGE RUNOFF COEFFICIENT = 0.8500
SUBAREA AREA(ACRES) = 0.20  SUBAREA RUNOFF(CFS) = 0.99
TOTAL AREA(ACRES) = 1.2  TOTAL RUNOFF(CFS) = 5.72
TC(MIN.) = 6.14

*****
FLOW PROCESS FROM NODE    105.00 TO NODE    106.00 IS CODE = 31
-----
>>>>COMPUTE PIPE-FLOW TRAVEL TIME THRU SUBAREA<<<<
>>>>USING COMPUTER-ESTIMATED PIPESIZE (NON-PRESSURE FLOW)<<<<

```

=====
ELEVATION DATA: UPSTREAM(FEET) = 190.05 DOWNSTREAM(FEET) = 189.72
FLOW LENGTH(FEET) = 54.00 MANNING'S N = 0.011
DEPTH OF FLOW IN 15.0 INCH PIPE IS 12.1 INCHES
PIPE-FLOW VELOCITY(FEET/SEC.) = 5.40
ESTIMATED PIPE DIAMETER(INCH) = 15.00 NUMBER OF PIPES = 1
PIPE-FLOW(CFS) = 5.72
PIPE TRAVEL TIME(MIN.) = 0.17 Tc(MIN.) = 6.30
LONGEST FLOWPATH FROM NODE 100.00 TO NODE 106.00 = 404.00 FEET.

FLOW PROCESS FROM NODE 106.00 TO NODE 106.00 IS CODE = 81

>>>>ADDITION OF SUBAREA TO MAINLINE PEAK FLOW<<<<

=====
100 YEAR RAINFALL INTENSITY(INCH/HOUR) = 5.729
*USER SPECIFIED(SUBAREA):
USER-SPECIFIED RUNOFF COEFFICIENT = .8500
S.C.S. CURVE NUMBER (AMC II) = 0
AREA-AVERAGE RUNOFF COEFFICIENT = 0.8500
SUBAREA AREA(ACRES) = 0.41 SUBAREA RUNOFF(CFS) = 2.00
TOTAL AREA(ACRES) = 1.6 TOTAL RUNOFF(CFS) = 7.65
TC(MIN.) = 6.30

FLOW PROCESS FROM NODE 106.00 TO NODE 107.00 IS CODE = 31

>>>>COMPUTE PIPE-FLOW TRAVEL TIME THRU SUBAREA<<<<
>>>>USING COMPUTER-ESTIMATED PIPESIZE (NON-PRESSURE FLOW)<<<<

=====
ELEVATION DATA: UPSTREAM(FEET) = 189.72 DOWNSTREAM(FEET) = 189.30
FLOW LENGTH(FEET) = 70.00 MANNING'S N = 0.011
DEPTH OF FLOW IN 18.0 INCH PIPE IS 12.4 INCHES
PIPE-FLOW VELOCITY(FEET/SEC.) = 5.91
ESTIMATED PIPE DIAMETER(INCH) = 18.00 NUMBER OF PIPES = 1
PIPE-FLOW(CFS) = 7.65
PIPE TRAVEL TIME(MIN.) = 0.20 Tc(MIN.) = 6.50
LONGEST FLOWPATH FROM NODE 100.00 TO NODE 107.00 = 474.00 FEET.

FLOW PROCESS FROM NODE 107.00 TO NODE 107.00 IS CODE = 81

>>>>ADDITION OF SUBAREA TO MAINLINE PEAK FLOW<<<<

=====
100 YEAR RAINFALL INTENSITY(INCH/HOUR) = 5.639
*USER SPECIFIED(SUBAREA):
USER-SPECIFIED RUNOFF COEFFICIENT = .8500
S.C.S. CURVE NUMBER (AMC II) = 0
AREA-AVERAGE RUNOFF COEFFICIENT = 0.8500
SUBAREA AREA(ACRES) = 0.14 SUBAREA RUNOFF(CFS) = 0.67
TOTAL AREA(ACRES) = 1.7 TOTAL RUNOFF(CFS) = 8.20
TC(MIN.) = 6.50

FLOW PROCESS FROM NODE 107.00 TO NODE 107.00 IS CODE = 81

>>>>ADDITION OF SUBAREA TO MAINLINE PEAK FLOW<<<<

=====
100 YEAR RAINFALL INTENSITY(INCH/HOUR) = 5.639
*USER SPECIFIED(SUBAREA):
USER-SPECIFIED RUNOFF COEFFICIENT = .6000
S.C.S. CURVE NUMBER (AMC II) = 0
AREA-AVERAGE RUNOFF COEFFICIENT = 0.8036

SUBAREA AREA(ACRES) = 0.39 SUBAREA RUNOFF(CFS) = 1.32
TOTAL AREA(ACRES) = 2.1 TOTAL RUNOFF(CFS) = 9.52
TC(MIN.) = 6.50

FLOW PROCESS FROM NODE 107.00 TO NODE 108.00 IS CODE = 31

>>>>COMPUTE PIPE-FLOW TRAVEL TIME THRU SUBAREA<<<<<
>>>>USING COMPUTER-ESTIMATED PIPESIZE (NON-PRESSURE FLOW)<<<<<

=====

ELEVATION DATA: UPSTREAM(FEET) =	188.97	DOWNSTREAM(FEET) =	188.35
FLOW LENGTH(FEET) =	102.00	MANNING'S N =	0.011
DEPTH OF FLOW IN 21.0 INCH PIPE IS	12.6 INCHES		
PIPE-FLOW VELOCITY(FEET/SEC.) =	6.34		
ESTIMATED PIPE DIAMETER(INCH) =	21.00	NUMBER OF PIPES =	1
PIPE-FLOW(CFS) =	9.52		
PIPE TRAVEL TIME(MIN.) =	0.27	Tc(MIN.) =	6.77
LONGEST FLOWPATH FROM NODE 100.00 TO NODE 108.00 =	576.00 FEET.		

FLOW PROCESS FROM NODE 108.00 TO NODE 108.00 IS CODE = 81

>>>>ADDITION OF SUBAREA TO MAINLINE PEAK FLOW<<<<<

=====

100 YEAR RAINFALL INTENSITY(INCH/HOUR) =	5.517		
*USER SPECIFIED(SUBAREA):			
USER-SPECIFIED RUNOFF COEFFICIENT =	.8500		
S.C.S. CURVE NUMBER (AMC II) =	0		
AREA-AVERAGE RUNOFF COEFFICIENT =	0.8061		
SUBAREA AREA(ACRES) =	0.12	SUBAREA RUNOFF(CFS) =	0.56
TOTAL AREA(ACRES) =	2.2	TOTAL RUNOFF(CFS) =	9.87
TC(MIN.) =	6.77		

FLOW PROCESS FROM NODE 108.00 TO NODE 109.00 IS CODE = 31

>>>>COMPUTE PIPE-FLOW TRAVEL TIME THRU SUBAREA<<<<<
>>>>USING COMPUTER-ESTIMATED PIPESIZE (NON-PRESSURE FLOW)<<<<<

=====

ELEVATION DATA: UPSTREAM(FEET) =	188.02	DOWNSTREAM(FEET) =	187.46
FLOW LENGTH(FEET) =	94.00	MANNING'S N =	0.011
DEPTH OF FLOW IN 21.0 INCH PIPE IS	13.0 INCHES		
PIPE-FLOW VELOCITY(FEET/SEC.) =	6.34		
ESTIMATED PIPE DIAMETER(INCH) =	21.00	NUMBER OF PIPES =	1
PIPE-FLOW(CFS) =	9.87		
PIPE TRAVEL TIME(MIN.) =	0.25	Tc(MIN.) =	7.02
LONGEST FLOWPATH FROM NODE 100.00 TO NODE 109.00 =	670.00 FEET.		

FLOW PROCESS FROM NODE 109.00 TO NODE 109.00 IS CODE = 81

>>>>ADDITION OF SUBAREA TO MAINLINE PEAK FLOW<<<<<

=====

100 YEAR RAINFALL INTENSITY(INCH/HOUR) =	5.404		
*USER SPECIFIED(SUBAREA):			
USER-SPECIFIED RUNOFF COEFFICIENT =	.8500		
S.C.S. CURVE NUMBER (AMC II) =	0		
AREA-AVERAGE RUNOFF COEFFICIENT =	0.8083		
SUBAREA AREA(ACRES) =	0.12	SUBAREA RUNOFF(CFS) =	0.55
TOTAL AREA(ACRES) =	2.3	TOTAL RUNOFF(CFS) =	10.22
TC(MIN.) =	7.02		

FLOW PROCESS FROM NODE 109.00 TO NODE 110.00 IS CODE = 31

>>>>COMPUTE PIPE-FLOW TRAVEL TIME THRU SUBAREA<<<<<
>>>>USING COMPUTER-ESTIMATED PIPESIZE (NON-PRESSURE FLOW)<<<<<
=====

ELEVATION DATA: UPSTREAM(FEET) =	187.13	DOWNSTREAM(FEET) =	186.57
FLOW LENGTH(FEET) =	94.00	MANNING'S N =	0.011
DEPTH OF FLOW IN 21.0 INCH PIPE IS	13.3	INCHES	
PIPE-FLOW VELOCITY(FEET/SEC.) =	6.38		
ESTIMATED PIPE DIAMETER(INCH) =	21.00	NUMBER OF PIPES =	1
PIPE-FLOW(CFS) =	10.22		
PIPE TRAVEL TIME(MIN.) =	0.25	Tc(MIN.) =	7.26
LONGEST FLOWPATH FROM NODE	100.00	TO NODE	110.00 =
			764.00 FEET.

FLOW PROCESS FROM NODE 110.00 TO NODE 110.00 IS CODE = 81

>>>>ADDITION OF SUBAREA TO MAINLINE PEAK FLOW<<<<<
=====

100 YEAR RAINFALL INTENSITY(INCH/HOUR) =	5.293		
*USER SPECIFIED(SUBAREA):			
USER-SPECIFIED RUNOFF COEFFICIENT =	.8500		
S.C.S. CURVE NUMBER (AMC II) =	0		
AREA-AVERAGE RUNOFF COEFFICIENT =	0.8102		
SUBAREA AREA(ACRES) =	0.11	SUBAREA RUNOFF(CFS) =	0.49
TOTAL AREA(ACRES) =	2.4	TOTAL RUNOFF(CFS) =	10.51
TC(MIN.) =	7.26		

FLOW PROCESS FROM NODE 110.00 TO NODE 111.00 IS CODE = 31

>>>>COMPUTE PIPE-FLOW TRAVEL TIME THRU SUBAREA<<<<<
>>>>USING COMPUTER-ESTIMATED PIPESIZE (NON-PRESSURE FLOW)<<<<<
=====

ELEVATION DATA: UPSTREAM(FEET) =	186.24	DOWNSTREAM(FEET) =	185.50
FLOW LENGTH(FEET) =	106.00	MANNING'S N =	0.011
DEPTH OF FLOW IN 21.0 INCH PIPE IS	12.8	INCHES	
PIPE-FLOW VELOCITY(FEET/SEC.) =	6.83		
ESTIMATED PIPE DIAMETER(INCH) =	21.00	NUMBER OF PIPES =	1
PIPE-FLOW(CFS) =	10.51		
PIPE TRAVEL TIME(MIN.) =	0.26	Tc(MIN.) =	7.52
LONGEST FLOWPATH FROM NODE	100.00	TO NODE	111.00 =
			870.00 FEET.

FLOW PROCESS FROM NODE 111.00 TO NODE 111.00 IS CODE = 81

>>>>ADDITION OF SUBAREA TO MAINLINE PEAK FLOW<<<<<
=====

100 YEAR RAINFALL INTENSITY(INCH/HOUR) =	5.175		
*USER SPECIFIED(SUBAREA):			
USER-SPECIFIED RUNOFF COEFFICIENT =	.8500		
S.C.S. CURVE NUMBER (AMC II) =	0		
AREA-AVERAGE RUNOFF COEFFICIENT =	0.8112		
SUBAREA AREA(ACRES) =	0.06	SUBAREA RUNOFF(CFS) =	0.26
TOTAL AREA(ACRES) =	2.5	TOTAL RUNOFF(CFS) =	10.54
TC(MIN.) =	7.52		

FLOW PROCESS FROM NODE 111.00 TO NODE 112.00 IS CODE = 31

>>>>COMPUTE PIPE-FLOW TRAVEL TIME THRU SUBAREA<<<<<
>>>>USING COMPUTER-ESTIMATED PIPESIZE (NON-PRESSURE FLOW)<<<<<
=====

ELEVATION DATA: UPSTREAM(FEET) = 185.17 DOWNSTREAM(FEET) = 184.87
FLOW LENGTH(FEET) = 49.00 MANNING'S N = 0.011
DEPTH OF FLOW IN 21.0 INCH PIPE IS 13.4 INCHES
PIPE-FLOW VELOCITY(FEET/SEC.) = 6.50
ESTIMATED PIPE DIAMETER(INCH) = 21.00 NUMBER OF PIPES = 1
PIPE-FLOW(CFS) = 10.54
PIPE TRAVEL TIME(MIN.) = 0.13 Tc(MIN.) = 7.64
LONGEST FLOWPATH FROM NODE 100.00 TO NODE 112.00 = 919.00 FEET.

FLOW PROCESS FROM NODE 112.00 TO NODE 112.00 IS CODE = 81

>>>>ADDITION OF SUBAREA TO MAINLINE PEAK FLOW<<<<<

=====

100 YEAR RAINFALL INTENSITY(INCH/HOUR) = 5.117
*USER SPECIFIED(SUBAREA):
USER-SPECIFIED RUNOFF COEFFICIENT = .8500
S.C.S. CURVE NUMBER (AMC II) = 0
AREA-AVERAGE RUNOFF COEFFICIENT = 0.8152
SUBAREA AREA(ACRES) = 0.29 SUBAREA RUNOFF(CFS) = 1.26
TOTAL AREA(ACRES) = 2.8 TOTAL RUNOFF(CFS) = 11.68
TC(MIN.) = 7.64

FLOW PROCESS FROM NODE 112.00 TO NODE 113.00 IS CODE = 31

>>>>COMPUTE PIPE-FLOW TRAVEL TIME THRU SUBAREA<<<<<
>>>>USING COMPUTER-ESTIMATED PIPESIZE (NON-PRESSURE FLOW)<<<<<

=====

ELEVATION DATA: UPSTREAM(FEET) = 184.87 DOWNSTREAM(FEET) = 184.25
FLOW LENGTH(FEET) = 104.00 MANNING'S N = 0.011
DEPTH OF FLOW IN 21.0 INCH PIPE IS 14.6 INCHES
PIPE-FLOW VELOCITY(FEET/SEC.) = 6.55
ESTIMATED PIPE DIAMETER(INCH) = 21.00 NUMBER OF PIPES = 1
PIPE-FLOW(CFS) = 11.68
PIPE TRAVEL TIME(MIN.) = 0.26 Tc(MIN.) = 7.91
LONGEST FLOWPATH FROM NODE 100.00 TO NODE 113.00 = 1023.00 FEET.

FLOW PROCESS FROM NODE 113.00 TO NODE 113.00 IS CODE = 81

>>>>ADDITION OF SUBAREA TO MAINLINE PEAK FLOW<<<<<

=====

100 YEAR RAINFALL INTENSITY(INCH/HOUR) = 4.997
*USER SPECIFIED(SUBAREA):
USER-SPECIFIED RUNOFF COEFFICIENT = .8500
S.C.S. CURVE NUMBER (AMC II) = 0
AREA-AVERAGE RUNOFF COEFFICIENT = 0.8182
SUBAREA AREA(ACRES) = 0.27 SUBAREA RUNOFF(CFS) = 1.15
TOTAL AREA(ACRES) = 3.1 TOTAL RUNOFF(CFS) = 12.55
TC(MIN.) = 7.91

FLOW PROCESS FROM NODE 113.00 TO NODE 114.00 IS CODE = 31

>>>>COMPUTE PIPE-FLOW TRAVEL TIME THRU SUBAREA<<<<<
>>>>USING COMPUTER-ESTIMATED PIPESIZE (NON-PRESSURE FLOW)<<<<<

=====

ELEVATION DATA: UPSTREAM(FEET) = 184.25 DOWNSTREAM(FEET) = 183.93
FLOW LENGTH(FEET) = 53.00 MANNING'S N = 0.011
DEPTH OF FLOW IN 21.0 INCH PIPE IS 15.4 INCHES
PIPE-FLOW VELOCITY(FEET/SEC.) = 6.66
ESTIMATED PIPE DIAMETER(INCH) = 21.00 NUMBER OF PIPES = 1

```

PIPE-FLOW(CFS) = 12.55
PIPE TRAVEL TIME(MIN.) = 0.13 Tc(MIN.) = 8.04
LONGEST FLOWPATH FROM NODE 100.00 TO NODE 114.00 = 1076.00 FEET.
*****
FLOW PROCESS FROM NODE 114.00 TO NODE 114.00 IS CODE = 81
-----
>>>>ADDITION OF SUBAREA TO MAINLINE PEAK FLOW<<<<
=====
100 YEAR RAINFALL INTENSITY(INCH/HOUR) = 4.936
*USER SPECIFIED(SUBAREA):
USER-SPECIFIED RUNOFF COEFFICIENT = .8500
S.C.S. CURVE NUMBER (AMC II) = 0
AREA-AVERAGE RUNOFF COEFFICIENT = 0.8257
SUBAREA AREA(ACRES) = 0.94 SUBAREA RUNOFF(CFS) = 3.94
TOTAL AREA(ACRES) = 4.0 TOTAL RUNOFF(CFS) = 16.34
TC(MIN.) = 8.04
*****
FLOW PROCESS FROM NODE 114.00 TO NODE 115.00 IS CODE = 31
-----
>>>>COMPUTE PIPE-FLOW TRAVEL TIME THRU SUBAREA<<<<
>>>>USING COMPUTER-ESTIMATED PIPESIZE (NON-PRESSURE FLOW)<<<<
=====
ELEVATION DATA: UPSTREAM(FEET) = 183.93 DOWNSTREAM(FEET) = 183.63
FLOW LENGTH(FEET) = 51.00 MANNING'S N = 0.011
DEPTH OF FLOW IN 24.0 INCH PIPE IS 16.5 INCHES
PIPE-FLOW VELOCITY(FEET/SEC.) = 7.09
ESTIMATED PIPE DIAMETER(INCH) = 24.00 NUMBER OF PIPES = 1
PIPE-FLOW(CFS) = 16.34
PIPE TRAVEL TIME(MIN.) = 0.12 Tc(MIN.) = 8.16
LONGEST FLOWPATH FROM NODE 100.00 TO NODE 115.00 = 1127.00 FEET.
*****
FLOW PROCESS FROM NODE 115.00 TO NODE 115.00 IS CODE = 81
-----
>>>>ADDITION OF SUBAREA TO MAINLINE PEAK FLOW<<<<
=====
100 YEAR RAINFALL INTENSITY(INCH/HOUR) = 4.882
*USER SPECIFIED(SUBAREA):
USER-SPECIFIED RUNOFF COEFFICIENT = .8500
S.C.S. CURVE NUMBER (AMC II) = 0
AREA-AVERAGE RUNOFF COEFFICIENT = 0.8297
SUBAREA AREA(ACRES) = 0.80 SUBAREA RUNOFF(CFS) = 3.32
TOTAL AREA(ACRES) = 4.8 TOTAL RUNOFF(CFS) = 19.48
TC(MIN.) = 8.16
*****
FLOW PROCESS FROM NODE 115.00 TO NODE 116.00 IS CODE = 31
-----
>>>>COMPUTE PIPE-FLOW TRAVEL TIME THRU SUBAREA<<<<
>>>>USING COMPUTER-ESTIMATED PIPESIZE (NON-PRESSURE FLOW)<<<<
=====
ELEVATION DATA: UPSTREAM(FEET) = 183.63 DOWNSTREAM(FEET) = 183.44
FLOW LENGTH(FEET) = 31.00 MANNING'S N = 0.011
DEPTH OF FLOW IN 24.0 INCH PIPE IS 18.8 INCHES
PIPE-FLOW VELOCITY(FEET/SEC.) = 7.39
ESTIMATED PIPE DIAMETER(INCH) = 24.00 NUMBER OF PIPES = 1
PIPE-FLOW(CFS) = 19.48
PIPE TRAVEL TIME(MIN.) = 0.07 Tc(MIN.) = 8.23
LONGEST FLOWPATH FROM NODE 100.00 TO NODE 116.00 = 1158.00 FEET.
*****

```

```

FLOW PROCESS FROM NODE      116.00 TO NODE      116.00 IS CODE = 10
-----
>>>>MAIN-STREAM MEMORY COPIED ONTO MEMORY BANK # 1 <<<<<
=====
*****
FLOW PROCESS FROM NODE      117.00 TO NODE      118.00 IS CODE = 21
-----
>>>>RATIONAL METHOD INITIAL SUBAREA ANALYSIS<<<<<
=====
*USER SPECIFIED(SUBAREA):
USER-SPECIFIED RUNOFF COEFFICIENT = .8500
S.C.S. CURVE NUMBER (AMC II) = 0
INITIAL SUBAREA FLOW-LENGTH(FEET) = 50.00
UPSTREAM ELEVATION(FEET) = 194.20
DOWNSTREAM ELEVATION(FEET) = 193.70
ELEVATION DIFFERENCE(FEET) = 0.50
URBAN SUBAREA OVERLAND TIME OF FLOW(MIN.) = 3.182
100 YEAR RAINFALL INTENSITY(INCH/HOUR) = 6.323
NOTE: RAINFALL INTENSITY IS BASED ON Tc = 5-MINUTE.
SUBAREA RUNOFF(CFS) = 0.21
TOTAL AREA(ACRES) = 0.04 TOTAL RUNOFF(CFS) = 0.21
*****
FLOW PROCESS FROM NODE      118.00 TO NODE      119.00 IS CODE = 51
-----
>>>>COMPUTE TRAPEZOIDAL CHANNEL FLOW<<<<<
>>>>TRAVELTIME THRU SUBAREA (EXISTING ELEMENT)<<<<<
=====
ELEVATION DATA: UPSTREAM(FEET) = 193.70 DOWNSTREAM(FEET) = 192.50
CHANNEL LENGTH THRU SUBAREA(FEET) = 118.00 CHANNEL SLOPE = 0.0102
CHANNEL BASE(FEET) = 50.00 "Z" FACTOR = 50.000
MANNING'S FACTOR = 0.015 MAXIMUM DEPTH(FEET) = 1.00
100 YEAR RAINFALL INTENSITY(INCH/HOUR) = 6.072
*USER SPECIFIED(SUBAREA):
USER-SPECIFIED RUNOFF COEFFICIENT = .8500
S.C.S. CURVE NUMBER (AMC II) = 0
TRAVEL TIME COMPUTED USING ESTIMATED FLOW(CFS) = 1.10
TRAVEL TIME THRU SUBAREA BASED ON VELOCITY(FEET/SEC.) = 0.83
AVERAGE FLOW DEPTH(FEET) = 0.03 TRAVEL TIME(MIN.) = 2.37
Tc(MIN.) = 5.55
SUBAREA AREA(ACRES) = 0.34 SUBAREA RUNOFF(CFS) = 1.75
AREA-AVERAGE RUNOFF COEFFICIENT = 0.850
TOTAL AREA(ACRES) = 0.4 PEAK FLOW RATE(CFS) = 1.96

END OF SUBAREA CHANNEL FLOW HYDRAULICS:
DEPTH(FEET) = 0.04 FLOW VELOCITY(FEET/SEC.) = 1.07
LONGEST FLOWPATH FROM NODE 117.00 TO NODE 119.00 = 168.00 FEET.
*****
FLOW PROCESS FROM NODE      119.00 TO NODE      120.00 IS CODE = 31
-----
>>>>COMPUTE PIPE-FLOW TRAVEL TIME THRU SUBAREA<<<<<
>>>>USING COMPUTER-ESTIMATED PIPESIZE (NON-PRESSURE FLOW)<<<<<
=====
ELEVATION DATA: UPSTREAM(FEET) = 192.50 DOWNSTREAM(FEET) = 191.51
FLOW LENGTH(FEET) = 29.00 MANNING'S N = 0.011
DEPTH OF FLOW IN 9.0 INCH PIPE IS 4.8 INCHES
PIPE-FLOW VELOCITY(FEET/SEC.) = 8.20
ESTIMATED PIPE DIAMETER(INCH) = 9.00 NUMBER OF PIPES = 1
PIPE-FLOW(CFS) = 1.96
PIPE TRAVEL TIME(MIN.) = 0.06 Tc(MIN.) = 5.61
LONGEST FLOWPATH FROM NODE 117.00 TO NODE 120.00 = 197.00 FEET.

```

```

*****
FLOW PROCESS FROM NODE      120.00 TO NODE      120.00 IS CODE = 81
-----
>>>>ADDITION OF SUBAREA TO MAINLINE PEAK FLOW<<<<
=====
  100 YEAR RAINFALL INTENSITY(INCH/HOUR) = 6.045
*USER SPECIFIED(SUBAREA):
USER-SPECIFIED RUNOFF COEFFICIENT = .6000
S.C.S. CURVE NUMBER (AMC II) = 0
AREA-AVERAGE RUNOFF COEFFICIENT = 0.8065
SUBAREA AREA(ACRES) = 0.08 SUBAREA RUNOFF(CFS) = 0.29
TOTAL AREA(ACRES) = 0.5 TOTAL RUNOFF(CFS) = 2.24
TC(MIN.) = 5.61

*****
FLOW PROCESS FROM NODE      120.00 TO NODE      121.00 IS CODE = 31
-----
>>>>COMPUTE PIPE-FLOW TRAVEL TIME THRU SUBAREA<<<<
>>>>USING COMPUTER-ESTIMATED PIPESIZE (NON-PRESSURE FLOW)<<<<
=====
ELEVATION DATA: UPSTREAM(FEET) = 191.18 DOWNSTREAM(FEET) = 190.82
FLOW LENGTH(FEET) = 59.00 MANNING'S N = 0.011
DEPTH OF FLOW IN 12.0 INCH PIPE IS 7.4 INCHES
PIPE-FLOW VELOCITY(FEET/SEC.) = 4.42
ESTIMATED PIPE DIAMETER(INCH) = 12.00 NUMBER OF PIPES = 1
PIPE-FLOW(CFS) = 2.24
PIPE TRAVEL TIME(MIN.) = 0.22 Tc(MIN.) = 5.83
LONGEST FLOWPATH FROM NODE 117.00 TO NODE 121.00 = 256.00 FEET.

*****
FLOW PROCESS FROM NODE      121.00 TO NODE      121.00 IS CODE = 81
-----
>>>>ADDITION OF SUBAREA TO MAINLINE PEAK FLOW<<<<
=====
  100 YEAR RAINFALL INTENSITY(INCH/HOUR) = 5.944
*USER SPECIFIED(SUBAREA):
USER-SPECIFIED RUNOFF COEFFICIENT = .8500
S.C.S. CURVE NUMBER (AMC II) = 0
AREA-AVERAGE RUNOFF COEFFICIENT = 0.8206
SUBAREA AREA(ACRES) = 0.22 SUBAREA RUNOFF(CFS) = 1.11
TOTAL AREA(ACRES) = 0.7 TOTAL RUNOFF(CFS) = 3.32
TC(MIN.) = 5.83

*****
FLOW PROCESS FROM NODE      121.00 TO NODE      122.00 IS CODE = 31
-----
>>>>COMPUTE PIPE-FLOW TRAVEL TIME THRU SUBAREA<<<<
>>>>USING COMPUTER-ESTIMATED PIPESIZE (NON-PRESSURE FLOW)<<<<
=====
ELEVATION DATA: UPSTREAM(FEET) = 190.82 DOWNSTREAM(FEET) = 190.57
FLOW LENGTH(FEET) = 42.00 MANNING'S N = 0.011
DEPTH OF FLOW IN 15.0 INCH PIPE IS 8.2 INCHES
PIPE-FLOW VELOCITY(FEET/SEC.) = 4.85
ESTIMATED PIPE DIAMETER(INCH) = 15.00 NUMBER OF PIPES = 1
PIPE-FLOW(CFS) = 3.32
PIPE TRAVEL TIME(MIN.) = 0.14 Tc(MIN.) = 5.98
LONGEST FLOWPATH FROM NODE 117.00 TO NODE 122.00 = 298.00 FEET.

*****
FLOW PROCESS FROM NODE      122.00 TO NODE      122.00 IS CODE = 81
-----
>>>>ADDITION OF SUBAREA TO MAINLINE PEAK FLOW<<<<

```

```
=====
 100 YEAR RAINFALL INTENSITY(INCH/HOUR) = 5.878
*USER SPECIFIED(SUBAREA):
USER-SPECIFIED RUNOFF COEFFICIENT = .8500
S.C.S. CURVE NUMBER (AMC II) = 0
AREA-AVERAGE RUNOFF COEFFICIENT = 0.8311
SUBAREA AREA(ACRES) = 0.38 SUBAREA RUNOFF(CFS) = 1.90
TOTAL AREA(ACRES) = 1.1 TOTAL RUNOFF(CFS) = 5.18
TC(MIN.) = 5.98
```

```
*****
FLOW PROCESS FROM NODE 122.00 TO NODE 123.00 IS CODE = 31
```

```
-----
>>>>COMPUTE PIPE-FLOW TRAVEL TIME THRU SUBAREA<<<<
>>>>USING COMPUTER-ESTIMATED PIPESIZE (NON-PRESSURE FLOW)<<<<
```

```
=====
ELEVATION DATA: UPSTREAM(FEET) = 190.57 DOWNSTREAM(FEET) = 189.94
FLOW LENGTH(FEET) = 103.00 MANNING'S N = 0.011
DEPTH OF FLOW IN 15.0 INCH PIPE IS 11.0 INCHES
PIPE-FLOW VELOCITY(FEET/SEC.) = 5.35
ESTIMATED PIPE DIAMETER(INCH) = 15.00 NUMBER OF PIPES = 1
PIPE-FLOW(CFS) = 5.18
PIPE TRAVEL TIME(MIN.) = 0.32 Tc(MIN.) = 6.30
LONGEST FLOWPATH FROM NODE 117.00 TO NODE 123.00 = 401.00 FEET.
```

```
*****
FLOW PROCESS FROM NODE 123.00 TO NODE 123.00 IS CODE = 81
```

```
-----
>>>>ADDITION OF SUBAREA TO MAINLINE PEAK FLOW<<<<
```

```
=====
 100 YEAR RAINFALL INTENSITY(INCH/HOUR) = 5.732
*USER SPECIFIED(SUBAREA):
USER-SPECIFIED RUNOFF COEFFICIENT = .8500
S.C.S. CURVE NUMBER (AMC II) = 0
AREA-AVERAGE RUNOFF COEFFICIENT = 0.8358
SUBAREA AREA(ACRES) = 0.35 SUBAREA RUNOFF(CFS) = 1.71
TOTAL AREA(ACRES) = 1.4 TOTAL RUNOFF(CFS) = 6.76
TC(MIN.) = 6.30
```

```
*****
FLOW PROCESS FROM NODE 123.00 TO NODE 124.00 IS CODE = 31
```

```
-----
>>>>COMPUTE PIPE-FLOW TRAVEL TIME THRU SUBAREA<<<<
>>>>USING COMPUTER-ESTIMATED PIPESIZE (NON-PRESSURE FLOW)<<<<
```

```
=====
ELEVATION DATA: UPSTREAM(FEET) = 189.94 DOWNSTREAM(FEET) = 189.73
FLOW LENGTH(FEET) = 33.00 MANNING'S N = 0.011
DEPTH OF FLOW IN 18.0 INCH PIPE IS 11.1 INCHES
PIPE-FLOW VELOCITY(FEET/SEC.) = 5.91
ESTIMATED PIPE DIAMETER(INCH) = 18.00 NUMBER OF PIPES = 1
PIPE-FLOW(CFS) = 6.76
PIPE TRAVEL TIME(MIN.) = 0.09 Tc(MIN.) = 6.39
LONGEST FLOWPATH FROM NODE 117.00 TO NODE 124.00 = 434.00 FEET.
```

```
*****
FLOW PROCESS FROM NODE 124.00 TO NODE 124.00 IS CODE = 81
```

```
-----
>>>>ADDITION OF SUBAREA TO MAINLINE PEAK FLOW<<<<
```

```
=====
 100 YEAR RAINFALL INTENSITY(INCH/HOUR) = 5.690
*USER SPECIFIED(SUBAREA):
USER-SPECIFIED RUNOFF COEFFICIENT = .8500
S.C.S. CURVE NUMBER (AMC II) = 0
```

AREA-AVERAGE RUNOFF COEFFICIENT = 0.8375
SUBAREA AREA(ACRES) = 0.19 SUBAREA RUNOFF(CFS) = 0.92
TOTAL AREA(ACRES) = 1.6 TOTAL RUNOFF(CFS) = 7.62
TC(MIN.) = 6.39

FLOW PROCESS FROM NODE 124.00 TO NODE 125.00 IS CODE = 31

>>>>COMPUTE PIPE-FLOW TRAVEL TIME THRU SUBAREA<<<<<
>>>>USING COMPUTER-ESTIMATED PIPESIZE (NON-PRESSURE FLOW)<<<<<

=====

ELEVATION DATA: UPSTREAM(FEET) =	1289.73	DOWNSTREAM(FEET) =	189.06
FLOW LENGTH(FEET) =	47.00	MANNING'S N =	0.011
DEPTH OF FLOW IN	6.0 INCH PIPE IS	2.0 INCHES	
PIPE-FLOW VELOCITY(FEET/SEC.) =	131.47		
ESTIMATED PIPE DIAMETER(INCH) =	6.00	NUMBER OF PIPES =	1
PIPE-FLOW(CFS) =	7.62		
PIPE TRAVEL TIME(MIN.) =	0.01	Tc(MIN.) =	6.40
LONGEST FLOWPATH FROM NODE	117.00 TO NODE	125.00 =	481.00 FEET.

FLOW PROCESS FROM NODE 125.00 TO NODE 125.00 IS CODE = 81

>>>>ADDITION OF SUBAREA TO MAINLINE PEAK FLOW<<<<<

=====

100 YEAR RAINFALL INTENSITY(INCH/HOUR) =	5.687
*USER SPECIFIED(SUBAREA):	
USER-SPECIFIED RUNOFF COEFFICIENT =	.8500
S.C.S. CURVE NUMBER (AMC II) =	0
AREA-AVERAGE RUNOFF COEFFICIENT =	0.8383
SUBAREA AREA(ACRES) =	0.11 SUBAREA RUNOFF(CFS) = 0.53
TOTAL AREA(ACRES) =	1.7 TOTAL RUNOFF(CFS) = 8.15
TC(MIN.) =	6.40

FLOW PROCESS FROM NODE 125.00 TO NODE 126.00 IS CODE = 31

>>>>COMPUTE PIPE-FLOW TRAVEL TIME THRU SUBAREA<<<<<
>>>>USING COMPUTER-ESTIMATED PIPESIZE (NON-PRESSURE FLOW)<<<<<

=====

ELEVATION DATA: UPSTREAM(FEET) =	188.73	DOWNSTREAM(FEET) =	188.68
FLOW LENGTH(FEET) =	73.00	MANNING'S N =	0.011
DEPTH OF FLOW IN	27.0 INCH PIPE IS	19.5 INCHES	
PIPE-FLOW VELOCITY(FEET/SEC.) =	2.65		
ESTIMATED PIPE DIAMETER(INCH) =	27.00	NUMBER OF PIPES =	1
PIPE-FLOW(CFS) =	8.15		
PIPE TRAVEL TIME(MIN.) =	0.46	Tc(MIN.) =	6.86
LONGEST FLOWPATH FROM NODE	117.00 TO NODE	126.00 =	554.00 FEET.

FLOW PROCESS FROM NODE 126.00 TO NODE 126.00 IS CODE = 81

>>>>ADDITION OF SUBAREA TO MAINLINE PEAK FLOW<<<<<

=====

100 YEAR RAINFALL INTENSITY(INCH/HOUR) =	5.477
*USER SPECIFIED(SUBAREA):	
USER-SPECIFIED RUNOFF COEFFICIENT =	.8500
S.C.S. CURVE NUMBER (AMC II) =	0
AREA-AVERAGE RUNOFF COEFFICIENT =	0.8393
SUBAREA AREA(ACRES) =	0.16 SUBAREA RUNOFF(CFS) = 0.74
TOTAL AREA(ACRES) =	1.9 TOTAL RUNOFF(CFS) = 8.60
TC(MIN.) =	6.86

```

*****
FLOW PROCESS FROM NODE    126.00 TO NODE    127.00 IS CODE = 31
-----
>>>>COMPUTE PIPE-FLOW TRAVEL TIME THRU SUBAREA<<<<
>>>>USING COMPUTER-ESTIMATED PIPESIZE (NON-PRESSURE FLOW)<<<<
=====
ELEVATION DATA: UPSTREAM(FEET) = 188.68  DOWNSTREAM(FEET) = 188.02
FLOW LENGTH(FEET) = 110.00  MANNING'S N = 0.011
DEPTH OF FLOW IN 18.0 INCH PIPE IS 13.6 INCHES
PIPE-FLOW VELOCITY(FEET/SEC.) = 6.02
ESTIMATED PIPE DIAMETER(INCH) = 18.00  NUMBER OF PIPES = 1
PIPE-FLOW(CFS) = 8.60
PIPE TRAVEL TIME(MIN.) = 0.30  Tc(MIN.) = 7.16
LONGEST FLOWPATH FROM NODE    117.00 TO NODE    127.00 = 664.00 FEET.

*****
FLOW PROCESS FROM NODE    127.00 TO NODE    127.00 IS CODE = 81
-----
>>>>ADDITION OF SUBAREA TO MAINLINE PEAK FLOW<<<<
=====
100 YEAR RAINFALL INTENSITY(INCH/HOUR) = 5.338
*USER SPECIFIED(SUBAREA):
USER-SPECIFIED RUNOFF COEFFICIENT = .8500
S.C.S. CURVE NUMBER (AMC II) = 0
AREA-AVERAGE RUNOFF COEFFICIENT = 0.8401
SUBAREA AREA(ACRES) = 0.16  SUBAREA RUNOFF(CFS) = 0.73
TOTAL AREA(ACRES) = 2.0  TOTAL RUNOFF(CFS) = 9.10
TC(MIN.) = 7.16

*****
FLOW PROCESS FROM NODE    127.00 TO NODE    128.00 IS CODE = 31
-----
>>>>COMPUTE PIPE-FLOW TRAVEL TIME THRU SUBAREA<<<<
>>>>USING COMPUTER-ESTIMATED PIPESIZE (NON-PRESSURE FLOW)<<<<
=====
ELEVATION DATA: UPSTREAM(FEET) = 187.69  DOWNSTREAM(FEET) = 187.44
FLOW LENGTH(FEET) = 42.00  MANNING'S N = 0.011
DEPTH OF FLOW IN 18.0 INCH PIPE IS 14.4 INCHES
PIPE-FLOW VELOCITY(FEET/SEC.) = 6.02
ESTIMATED PIPE DIAMETER(INCH) = 18.00  NUMBER OF PIPES = 1
PIPE-FLOW(CFS) = 9.10
PIPE TRAVEL TIME(MIN.) = 0.12  Tc(MIN.) = 7.28
LONGEST FLOWPATH FROM NODE    117.00 TO NODE    128.00 = 706.00 FEET.

*****
FLOW PROCESS FROM NODE    128.00 TO NODE    128.00 IS CODE = 81
-----
>>>>ADDITION OF SUBAREA TO MAINLINE PEAK FLOW<<<<
=====
100 YEAR RAINFALL INTENSITY(INCH/HOUR) = 5.286
*USER SPECIFIED(SUBAREA):
USER-SPECIFIED RUNOFF COEFFICIENT = .8500
S.C.S. CURVE NUMBER (AMC II) = 0
AREA-AVERAGE RUNOFF COEFFICIENT = 0.8410
SUBAREA AREA(ACRES) = 0.20  SUBAREA RUNOFF(CFS) = 0.90
TOTAL AREA(ACRES) = 2.2  TOTAL RUNOFF(CFS) = 9.91
TC(MIN.) = 7.28

*****
FLOW PROCESS FROM NODE    128.00 TO NODE    129.00 IS CODE = 31
-----
>>>>COMPUTE PIPE-FLOW TRAVEL TIME THRU SUBAREA<<<<
>>>>USING COMPUTER-ESTIMATED PIPESIZE (NON-PRESSURE FLOW)<<<<

```

=====
ELEVATION DATA: UPSTREAM(FEET) = 187.44 DOWNSTREAM(FEET) = 186.51
FLOW LENGTH(FEET) = 155.00 MANNING'S N = 0.011
DEPTH OF FLOW IN 21.0 INCH PIPE IS 13.0 INCHES
PIPE-FLOW VELOCITY(FEET/SEC.) = 6.36
ESTIMATED PIPE DIAMETER(INCH) = 21.00 NUMBER OF PIPES = 1
PIPE-FLOW(CFS) = 9.91
PIPE TRAVEL TIME(MIN.) = 0.41 Tc(MIN.) = 7.68
LONGEST FLOWPATH FROM NODE 117.00 TO NODE 129.00 = 861.00 FEET.

FLOW PROCESS FROM NODE 129.00 TO NODE 129.00 IS CODE = 81

>>>>ADDITION OF SUBAREA TO MAINLINE PEAK FLOW<<<<

=====
100 YEAR RAINFALL INTENSITY(INCH/HOUR) = 5.100
*USER SPECIFIED(SUBAREA):
USER-SPECIFIED RUNOFF COEFFICIENT = .8500
S.C.S. CURVE NUMBER (AMC II) = 0
AREA-AVERAGE RUNOFF COEFFICIENT = 0.8423
SUBAREA AREA(ACRES) = 0.37 SUBAREA RUNOFF(CFS) = 1.60
TOTAL AREA(ACRES) = 2.6 TOTAL RUNOFF(CFS) = 11.17
TC(MIN.) = 7.68

FLOW PROCESS FROM NODE 129.00 TO NODE 130.00 IS CODE = 31

>>>>COMPUTE PIPE-FLOW TRAVEL TIME THRU SUBAREA<<<<
>>>>USING COMPUTER-ESTIMATED PIPESIZE (NON-PRESSURE FLOW)<<<<

=====
ELEVATION DATA: UPSTREAM(FEET) = 186.51 DOWNSTREAM(FEET) = 186.10
FLOW LENGTH(FEET) = 67.00 MANNING'S N = 0.011
DEPTH OF FLOW IN 21.0 INCH PIPE IS 14.0 INCHES
PIPE-FLOW VELOCITY(FEET/SEC.) = 6.57
ESTIMATED PIPE DIAMETER(INCH) = 21.00 NUMBER OF PIPES = 1
PIPE-FLOW(CFS) = 11.17
PIPE TRAVEL TIME(MIN.) = 0.17 Tc(MIN.) = 7.85
LONGEST FLOWPATH FROM NODE 117.00 TO NODE 130.00 = 928.00 FEET.

FLOW PROCESS FROM NODE 130.00 TO NODE 131.00 IS CODE = 31

>>>>COMPUTE PIPE-FLOW TRAVEL TIME THRU SUBAREA<<<<
>>>>USING COMPUTER-ESTIMATED PIPESIZE (NON-PRESSURE FLOW)<<<<

=====
ELEVATION DATA: UPSTREAM(FEET) = 185.77 DOWNSTREAM(FEET) = 185.12
FLOW LENGTH(FEET) = 108.00 MANNING'S N = 0.011
DEPTH OF FLOW IN 21.0 INCH PIPE IS 14.1 INCHES
PIPE-FLOW VELOCITY(FEET/SEC.) = 6.52
ESTIMATED PIPE DIAMETER(INCH) = 21.00 NUMBER OF PIPES = 1
PIPE-FLOW(CFS) = 11.17
PIPE TRAVEL TIME(MIN.) = 0.28 Tc(MIN.) = 8.13
LONGEST FLOWPATH FROM NODE 117.00 TO NODE 131.00 = 1036.00 FEET.

FLOW PROCESS FROM NODE 131.00 TO NODE 131.00 IS CODE = 81

>>>>ADDITION OF SUBAREA TO MAINLINE PEAK FLOW<<<<

=====
100 YEAR RAINFALL INTENSITY(INCH/HOUR) = 4.897
*USER SPECIFIED(SUBAREA):
USER-SPECIFIED RUNOFF COEFFICIENT = .8500
S.C.S. CURVE NUMBER (AMC II) = 0

AREA-AVERAGE RUNOFF COEFFICIENT = 0.8442
SUBAREA AREA(ACRES) = 0.84 SUBAREA RUNOFF(CFS) = 3.50
TOTAL AREA(ACRES) = 3.4 TOTAL RUNOFF(CFS) = 14.22
TC(MIN.) = 8.13

FLOW PROCESS FROM NODE 131.00 TO NODE 116.00 IS CODE = 31

>>>>COMPUTE PIPE-FLOW TRAVEL TIME THRU SUBAREA<<<<<
>>>>USING COMPUTER-ESTIMATED PIPESIZE (NON-PRESSURE FLOW)<<<<<

=====

ELEVATION DATA: UPSTREAM(FEET) =	185.12	DOWNSTREAM(FEET) =	184.49
FLOW LENGTH(FEET) =	105.00	MANNING'S N =	0.011
DEPTH OF FLOW IN	24.0 INCH PIPE IS	14.9	INCHES
PIPE-FLOW VELOCITY(FEET/SEC.) =	6.96		
ESTIMATED PIPE DIAMETER(INCH) =	24.00	NUMBER OF PIPES =	1
PIPE-FLOW(CFS) =	14.22		
PIPE TRAVEL TIME(MIN.) =	0.25	Tc(MIN.) =	8.38
LONGEST FLOWPATH FROM NODE	117.00 TO NODE	116.00 =	1141.00 FEET.

FLOW PROCESS FROM NODE 116.00 TO NODE 116.00 IS CODE = 11

>>>>CONFLUENCE MEMORY BANK # 1 WITH THE MAIN-STREAM MEMORY<<<<<

** MAIN STREAM CONFLUENCE DATA **

STREAM NUMBER	RUNOFF (CFS)	Tc (MIN.)	INTENSITY (INCH/HOUR)	AREA (ACRE)
1	14.22	8.38	4.783	3.44

LONGEST FLOWPATH FROM NODE 117.00 TO NODE 116.00 = 1141.00 FEET.

** MEMORY BANK # 1 CONFLUENCE DATA **

STREAM NUMBER	RUNOFF (CFS)	Tc (MIN.)	INTENSITY (INCH/HOUR)	AREA (ACRE)
1	19.48	8.23	4.850	4.81

LONGEST FLOWPATH FROM NODE 100.00 TO NODE 116.00 = 1158.00 FEET.

** PEAK FLOW RATE TABLE **

STREAM NUMBER	RUNOFF (CFS)	Tc (MIN.)	INTENSITY (INCH/HOUR)
1	33.45	8.23	4.850
2	33.43	8.38	4.783

COMPUTED CONFLUENCE ESTIMATES ARE AS FOLLOWS:
PEAK FLOW RATE(CFS) = 33.45 Tc(MIN.) = 8.23
TOTAL AREA(ACRES) = 8.2

FLOW PROCESS FROM NODE 116.00 TO NODE 132.00 IS CODE = 31

>>>>COMPUTE PIPE-FLOW TRAVEL TIME THRU SUBAREA<<<<<
>>>>USING COMPUTER-ESTIMATED PIPESIZE (NON-PRESSURE FLOW)<<<<<

=====

ELEVATION DATA: UPSTREAM(FEET) =	183.11	DOWNSTREAM(FEET) =	182.75
FLOW LENGTH(FEET) =	19.00	MANNING'S N =	0.011
DEPTH OF FLOW IN	24.0 INCH PIPE IS	18.4	INCHES
PIPE-FLOW VELOCITY(FEET/SEC.) =	12.97		
ESTIMATED PIPE DIAMETER(INCH) =	24.00	NUMBER OF PIPES =	1
PIPE-FLOW(CFS) =	33.45		
PIPE TRAVEL TIME(MIN.) =	0.02	Tc(MIN.) =	8.26
LONGEST FLOWPATH FROM NODE	100.00 TO NODE	132.00 =	1177.00 FEET.

```

*****
FLOW PROCESS FROM NODE    133.00 TO NODE    133.00 IS CODE =    7
-----
>>>>USER SPECIFIED HYDROLOGY INFORMATION AT NODE<<<<
=====
USER-SPECIFIED VALUES ARE AS FOLLOWS:
TC(MIN) = 19.00    RAIN INTENSITY(INCH/HOUR) = 2.69
TOTAL AREA(ACRES) = 8.27    TOTAL RUNOFF(CFS) = 6.99
*****
FLOW PROCESS FROM NODE    133.00 TO NODE    134.00 IS CODE = 31
-----
>>>>COMPUTE PIPE-FLOW TRAVEL TIME THRU SUBAREA<<<<
>>>>USING COMPUTER-ESTIMATED PIPESIZE (NON-PRESSURE FLOW)<<<<
=====
ELEVATION DATA: UPSTREAM(FEET) = 182.75    DOWNSTREAM(FEET) = 179.95
FLOW LENGTH(FEET) = 28.00    MANNING'S N = 0.011
DEPTH OF FLOW IN 12.0 INCH PIPE IS 6.3 INCHES
PIPE-FLOW VELOCITY(FEET/SEC.) = 16.82
ESTIMATED PIPE DIAMETER(INCH) = 12.00    NUMBER OF PIPES = 1
PIPE-FLOW(CFS) = 6.99
PIPE TRAVEL TIME(MIN.) = 0.03    Tc(MIN.) = 19.03
LONGEST FLOWPATH FROM NODE 100.00 TO NODE 134.00 = 1205.00 FEET.
*****
FLOW PROCESS FROM NODE    134.00 TO NODE    135.00 IS CODE = 31
-----
>>>>COMPUTE PIPE-FLOW TRAVEL TIME THRU SUBAREA<<<<
>>>>USING COMPUTER-ESTIMATED PIPESIZE (NON-PRESSURE FLOW)<<<<
=====
ELEVATION DATA: UPSTREAM(FEET) = 179.62    DOWNSTREAM(FEET) = 178.40
FLOW LENGTH(FEET) = 203.00    MANNING'S N = 0.011
DEPTH OF FLOW IN 18.0 INCH PIPE IS 11.6 INCHES
PIPE-FLOW VELOCITY(FEET/SEC.) = 5.82
ESTIMATED PIPE DIAMETER(INCH) = 18.00    NUMBER OF PIPES = 1
PIPE-FLOW(CFS) = 6.99
PIPE TRAVEL TIME(MIN.) = 0.58    Tc(MIN.) = 19.61
LONGEST FLOWPATH FROM NODE 100.00 TO NODE 135.00 = 1408.00 FEET.
*****
FLOW PROCESS FROM NODE    135.00 TO NODE    136.00 IS CODE = 31
-----
>>>>COMPUTE PIPE-FLOW TRAVEL TIME THRU SUBAREA<<<<
>>>>USING COMPUTER-ESTIMATED PIPESIZE (NON-PRESSURE FLOW)<<<<
=====
ELEVATION DATA: UPSTREAM(FEET) = 144.80    DOWNSTREAM(FEET) = 143.67
FLOW LENGTH(FEET) = 76.00    MANNING'S N = 0.011
DEPTH OF FLOW IN 15.0 INCH PIPE IS 9.9 INCHES
PIPE-FLOW VELOCITY(FEET/SEC.) = 8.16
ESTIMATED PIPE DIAMETER(INCH) = 15.00    NUMBER OF PIPES = 1
PIPE-FLOW(CFS) = 6.99
PIPE TRAVEL TIME(MIN.) = 0.16    Tc(MIN.) = 19.76
LONGEST FLOWPATH FROM NODE 100.00 TO NODE 136.00 = 1484.00 FEET.
*****
FLOW PROCESS FROM NODE    136.00 TO NODE    136.00 IS CODE = 81
-----
>>>>ADDITION OF SUBAREA TO MAINLINE PEAK FLOW<<<<
=====
100 YEAR RAINFALL INTENSITY(INCH/HOUR) = 2.611
*USER SPECIFIED(SUBAREA):
USER-SPECIFIED RUNOFF COEFFICIENT = .6000
S.C.S. CURVE NUMBER (AMC II) = 0

```

AREA-AVERAGE RUNOFF COEFFICIENT = 0.3224
SUBAREA AREA(ACRES) = 0.25 SUBAREA RUNOFF(CFS) = 0.39
TOTAL AREA(ACRES) = 8.5 TOTAL RUNOFF(CFS) = 7.17
TC(MIN.) = 19.76

FLOW PROCESS FROM NODE 200.00 TO NODE 201.00 IS CODE = 21

>>>>RATIONAL METHOD INITIAL SUBAREA ANALYSIS<<<<<

=====

*USER SPECIFIED(SUBAREA):

USER-SPECIFIED RUNOFF COEFFICIENT = .8500
S.C.S. CURVE NUMBER (AMC II) = 0
INITIAL SUBAREA FLOW-LENGTH(FEET) = 100.00
UPSTREAM ELEVATION(FEET) = 196.50
DOWNSTREAM ELEVATION(FEET) = 192.61
ELEVATION DIFFERENCE(FEET) = 3.89
URBAN SUBAREA OVERLAND TIME OF FLOW(MIN.) = 2.861
100 YEAR RAINFALL INTENSITY(INCH/HOUR) = 6.323
NOTE: RAINFALL INTENSITY IS BASED ON Tc = 5-MINUTE.
SUBAREA RUNOFF(CFS) = 0.86
TOTAL AREA(ACRES) = 0.16 TOTAL RUNOFF(CFS) = 0.86

FLOW PROCESS FROM NODE 201.00 TO NODE 202.00 IS CODE = 61

>>>>COMPUTE STREET FLOW TRAVEL TIME THRU SUBAREA<<<<<

>>>>(STANDARD CURB SECTION USED)<<<<<

=====

UPSTREAM ELEVATION(FEET) = 192.61 DOWNSTREAM ELEVATION(FEET) = 149.11
STREET LENGTH(FEET) = 718.00 CURB HEIGHT(INCHES) = 6.0
STREET HALFWIDTH(FEET) = 36.00

DISTANCE FROM CROWN TO CROSSFALL GRADEBREAK(FEET) = 1.00
INSIDE STREET CROSSFALL(DECIMAL) = 0.015
OUTSIDE STREET CROSSFALL(DECIMAL) = 0.015

SPECIFIED NUMBER OF HALFSTREETS CARRYING RUNOFF = 1
STREET PARKWAY CROSSFALL(DECIMAL) = 0.015
Manning's FRICTION FACTOR for Streetflow Section(curbs-to-curbs) = 0.0150
Manning's FRICTION FACTOR for Back-of-Walk Flow Section = 0.0200

**TRAVEL TIME COMPUTED USING ESTIMATED FLOW(CFS) = 3.35
STREETFLOW MODEL RESULTS USING ESTIMATED FLOW:
STREET FLOW DEPTH(FEET) = 0.27
HALFSTREET FLOOD WIDTH(FEET) = 9.16
AVERAGE FLOW VELOCITY(FEET/SEC.) = 4.45
PRODUCT OF DEPTH&VELOCITY(FT*FT/SEC.) = 1.21
STREET FLOW TRAVEL TIME(MIN.) = 2.69 Tc(MIN.) = 5.55
100 YEAR RAINFALL INTENSITY(INCH/HOUR) = 6.071

*USER SPECIFIED(SUBAREA):

USER-SPECIFIED RUNOFF COEFFICIENT = .7900
S.C.S. CURVE NUMBER (AMC II) = 0
AREA-AVERAGE RUNOFF COEFFICIENT = 0.798
SUBAREA AREA(ACRES) = 1.03 SUBAREA RUNOFF(CFS) = 4.94
TOTAL AREA(ACRES) = 1.2 PEAK FLOW RATE(CFS) = 5.77

END OF SUBAREA STREET FLOW HYDRAULICS:

DEPTH(FEET) = 0.31 HALFSTREET FLOOD WIDTH(FEET) = 11.64
FLOW VELOCITY(FEET/SEC.) = 5.06 DEPTH*VELOCITY(FT*FT/SEC.) = 1.56
LONGEST FLOWPATH FROM NODE 200.00 TO NODE 202.00 = 818.00 FEET.

=====

END OF STUDY SUMMARY:

TOTAL AREA(ACRES) = 1.2 TC(MIN.) = 5.55
PEAK FLOW RATE(CFS) = 5.77

=====

END OF RATIONAL METHOD ANALYSIS

Appendix 5

Modified-Puls Detention Routing

RUN DATE 5/20/2022
HYDROGRAPH FILE NAME Text1
TIME OF CONCENTRATION 10 MIN.
6 HOUR RAINFALL 2.4 INCHES
BASIN AREA 8.27 ACRES
RUNOFF COEFFICIENT 0.85
PEAK DISCHARGE 33.45 CFS

TIME (MIN) = 0	DISCHARGE (CFS) = 0
TIME (MIN) = 10	DISCHARGE (CFS) = 1
TIME (MIN) = 20	DISCHARGE (CFS) = 1
TIME (MIN) = 30	DISCHARGE (CFS) = 1.1
TIME (MIN) = 40	DISCHARGE (CFS) = 1.1
TIME (MIN) = 50	DISCHARGE (CFS) = 1.1
TIME (MIN) = 60	DISCHARGE (CFS) = 1.2
TIME (MIN) = 70	DISCHARGE (CFS) = 1.2
TIME (MIN) = 80	DISCHARGE (CFS) = 1.2
TIME (MIN) = 90	DISCHARGE (CFS) = 1.3
TIME (MIN) = 100	DISCHARGE (CFS) = 1.4
TIME (MIN) = 110	DISCHARGE (CFS) = 1.4
TIME (MIN) = 120	DISCHARGE (CFS) = 1.5
TIME (MIN) = 130	DISCHARGE (CFS) = 1.6
TIME (MIN) = 140	DISCHARGE (CFS) = 1.7
TIME (MIN) = 150	DISCHARGE (CFS) = 1.8
TIME (MIN) = 160	DISCHARGE (CFS) = 1.9
TIME (MIN) = 170	DISCHARGE (CFS) = 2.1
TIME (MIN) = 180	DISCHARGE (CFS) = 2.2
TIME (MIN) = 190	DISCHARGE (CFS) = 2.5
TIME (MIN) = 200	DISCHARGE (CFS) = 2.8
TIME (MIN) = 210	DISCHARGE (CFS) = 3.4
TIME (MIN) = 220	DISCHARGE (CFS) = 3.8
TIME (MIN) = 230	DISCHARGE (CFS) = 5.6
TIME (MIN) = 240	DISCHARGE (CFS) = 2.9
TIME (MIN) = 250	DISCHARGE (CFS) = 33.45
TIME (MIN) = 260	DISCHARGE (CFS) = 4.5
TIME (MIN) = 270	DISCHARGE (CFS) = 3
TIME (MIN) = 280	DISCHARGE (CFS) = 2.4
TIME (MIN) = 290	DISCHARGE (CFS) = 2
TIME (MIN) = 300	DISCHARGE (CFS) = 1.7
TIME (MIN) = 310	DISCHARGE (CFS) = 1.5
TIME (MIN) = 320	DISCHARGE (CFS) = 1.4
TIME (MIN) = 330	DISCHARGE (CFS) = 1.3
TIME (MIN) = 340	DISCHARGE (CFS) = 1.2
TIME (MIN) = 350	DISCHARGE (CFS) = 1.1
TIME (MIN) = 360	DISCHARGE (CFS) = 1
TIME (MIN) = 370	DISCHARGE (CFS) = 0

Outlet Structure for Discharge of BMP-1

Discharge vs. Elevation Table

<u>Low-flow orifice</u>		<u>Slot orifice</u>		<u>Emergency Overflow</u>	
No.:	1	No.:	1	Invert:	5.5 ft
Invert:	0 ft	Invert:	2.00 ft	L:	14 ft
Dia:	4 in	Length:	2.75 ft	C _w :	3.1
Dia:	0.33 ft	Height:	0.25 ft	<u>Tank Dimensions</u>	
A:	0.087 sq.ft.	A:	0.69 sq.ft	Area:	5,971 sq.ft.
C _o :	0.6	C _o :	0.6	Height:	6 ft
				Total Vol:	35,824 cu.ft.

***Note: h = head above the invert of the lowest surface discharge opening.**

Elev (ft)	h* (ft)	Volume (ac-ft)	Q _{orifice-low} (cfs)	Q _{slot-mid} (cfs)	Q _{emerg} (cfs)	Q _{total} (cfs)
182.75	0.00	0.0000	0.0000	0.000	0.000	0.0000
183.00	0.25	0.0343	0.1292	0.000	0.000	0.1292
183.25	0.50	0.0685	0.2712	0.000	0.000	0.2712
183.50	0.75	0.1028	0.3431	0.000	0.000	0.3431
183.75	1.00	0.1371	0.4023	0.000	0.000	0.4023
184.00	1.25	0.1713	0.4539	0.000	0.000	0.4539
184.25	1.50	0.2056	0.5001	0.000	0.000	0.5001
184.50	1.75	0.2399	0.5425	0.000	0.000	0.5425
184.75	2.00	0.2741	0.5817	0.000	0.000	0.5817
185.00	2.25	0.3084	0.6185	1.433	0.000	2.0519
185.25	2.50	0.3427	0.6532	2.190	0.000	2.8428
185.50	2.75	0.3769	0.6862	2.745	0.000	3.4309
185.75	3.00	0.4112	0.7176	3.205	0.000	3.9228
186.00	3.25	0.4455	0.7477	3.607	0.000	4.3550
186.25	3.50	0.4797	0.7767	3.969	0.000	4.7456
186.50	3.75	0.5140	0.8046	4.300	0.000	5.1048
186.75	4.00	0.5483	0.8316	4.608	0.000	5.4393
187.00	4.25	0.5825	0.8577	4.896	0.000	5.7537
187.25	4.50	0.6168	0.8831	5.168	0.000	6.0513
187.50	4.75	0.6511	0.9077	5.427	0.000	6.3345
187.75	5.00	0.6853	0.9317	5.674	0.000	6.6053
188.00	5.25	0.7196	0.9551	5.910	0.000	6.8652
188.25	5.50	0.7539	0.9779	6.137	0.000	7.1154
188.50	5.75	0.7881	1.0002	6.357	5.425	12.7820
188.75	6.00	0.8224	1.0221	6.569	15.344	22.9350

Note:

1. Weir equation, $Q=C_w L_e (h)^{3/2}$
2. Orifice equation, $Q=C_o A_e (2gh)^{1/2}$
3. Slot orifice acts as a weir when $h^* < h_{slot}$; slot orifice acts as an orifice when $h^* \geq h_{slot}$

HEC-HMS Detention Routing Summary
Project Shinohara



DMA.A



BMP-1



Summary Results for Reservoir "BMP-1"

Project: Shinohara Simulation Run: Q100
Reservoir: BMP-1

Start of Run: 01Jan2000, 00:00 Basin Model: Post_Dev
End of Run: 01Jan2000, 06:05 Meteorologic Model: Met 1
Compute Time: DATA CHANGED, RECOMPUTE Control Specifications: Control 1

Volume Units: IN ACRE-FT

Computed Results

Peak Inflow:	33.45 (CFS)	Date/Time of Peak Inflow:	01Jan2000, 04:10
Peak Discharge:	6.99 (CFS)	Date/Time of Peak Discharge:	01Jan2000, 04:19
Inflow Volume:	n/a	Peak Storage:	0.74 (ACRE-FT)
Discharge Volume:	n/a	Peak Elevation:	5.37 (FT)

Observed Flow Gage BMP 1

Peak Discharge:	33.45 (CFS)	Date/Time of Peak Discharge:	01Jan2000, 04:10
Volume:	n/a		
RMSE Std Dev:	0.93	Nash-Sutcliffe:	0.126
Percent Bias:	-22.43 %		

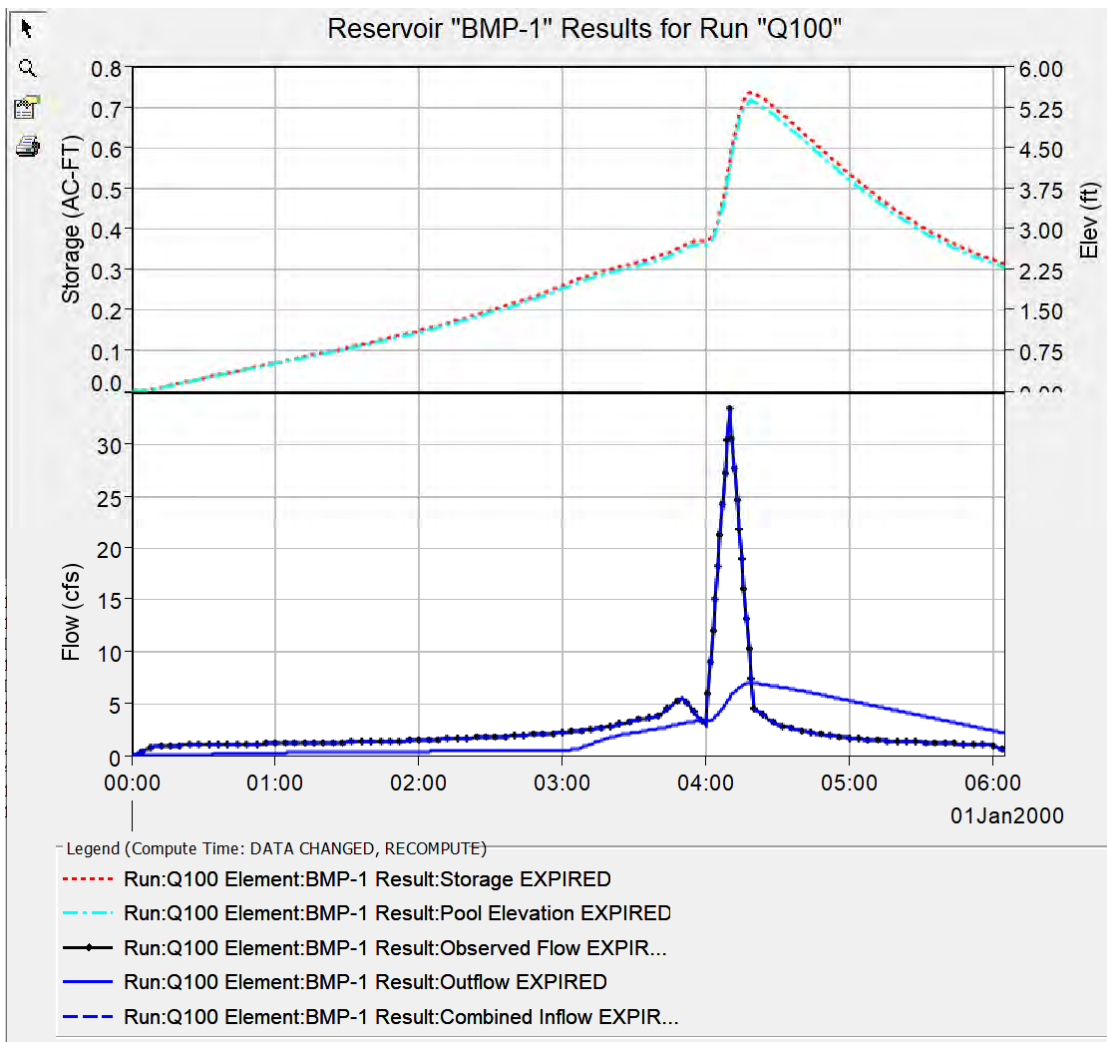

Project Name/_____

ATTACHMENT 6

Project's Geotechnical and Groundwater Investigation Report

Attach project's geotechnical and groundwater investigation report. Refer to Appendix C.4 to determine the reporting requirements.

GEOTECHNICAL INVESTIGATION

**SHINOHARA INDUSTRIAL BUILDING
517 SHINOHARA LANE
INDUSTRIAL BUILDING
CHULA VISTA, CALIFORNIA**



GEOCON
INCORPORATED

GEOTECHNICAL
ENVIRONMENTAL
MATERIALS

PREPARED FOR

**ONPOINT DEVELOPMENT
LA JOLLA, CALIFORNIA**

**JULY 28, 2021
PROJECT NO. G2762-42-01**



Project No. G2762-42-01
July 28, 2021

OnPoint Development
7514 Girard Street, Suite 1515
La Jolla, California 92037

Attention: Mr. Todd Dwyer

Subject: GEOTECHNICAL INVESTIGATION
SHINOHARA INDUSTRIAL BUILDING
517 SHINOHARA LANE
CHULA VISTA, CALIFORNIA

Dear Mr. Dwyer:

In accordance with your request, we have prepared this geotechnical investigation report for the proposed industrial building at the subject site. The site is underlain by Tertiary age San Diego Formation mantled by Very Old Paralic Deposits, alluvium, and topsoil. Undocumented fill berms are present on the property.

This report is based on our observations made during our field investigation performed between June 30 and July 7, 2021, and laboratory testing. Based on the results of this study, we opine that the subject site is suitable for construction of the proposed industrial building. The accompanying report includes the results of our study and conclusions and recommendations regarding geotechnical aspects of site development.

Should you have questions regarding this investigation, or if we may be of further service, please contact the undersigned at your convenience.

Very truly yours,

GEOCON INCORPORATED

Rodney C. Mikesell
GE 2533

RCM:RSA:arm

(e-mail) Addressee



Rupert S. Adams
CEG 2561



TABLE OF CONTENTS

1.	PURPOSE AND SCOPE	1
2.	SITE AND PROJECT DESCRIPTION.....	2
3.	SOIL AND GEOLOGIC CONDITIONS	2
3.1	Undocumented Fill (Qudf)	3
3.2	Previously Placed Fill (Qpf)	3
3.3	Topsoil (Unmapped).....	3
3.4	Alluvium (Qal)	3
3.5	Terrace Deposits (Qt)	3
3.6	Very Old Paralic Deposits (Qvop).....	4
3.7	San Diego Formation (Tsd)	4
4.	GROUNDWATER	4
5.	GEOLOGIC HAZARDS	4
5.1	Faulting and Seismicity	4
5.2	Ground Rupture	6
5.3	Storm Surge, Tsunamis, and Seiches.....	6
5.4	Flooding.....	7
5.5	Liquefaction.....	7
5.6	Landslides.....	7
6.	CONCLUSIONS AND RECOMMENDATIONS.....	8
6.1	General.....	8
6.2	Soil and Excavation Characteristics	9
6.3	Grading Recommendations	11
6.4	Slopes.....	13
6.5	Earthwork Grading Factors.....	15
6.6	Subdrains	15
6.7	Settlement Monitoring.....	15
6.8	Seismic Design Criteria.....	17
6.9	Shallow Foundations	19
6.10	Conventional Retaining Wall Recommendations.....	21
6.11	Lateral Loading.....	24
6.12	Mechanically Stabilized Earth (MSE) Retaining Walls	25
6.13	Soil Nail Walls.....	27
6.14	Preliminary Pavement Recommendations.....	29
6.15	Exterior Concrete Flatwork	32
6.16	Slope Maintenance.....	33
6.17	Storm Water Management.....	34
6.18	Site Drainage and Moisture Protection.....	34
6.19	Grading and Foundation Plan Review	35

MAPS AND ILLUSTRATIONS

Figure 1, Geologic Map

Figure 2, Geologic Cross Section A-A'

TABLE OF CONTENTS (Concluded)

APPENDIX A

FIELD INVESTIGATION

Figure A-1, Log of Small Diameter Boring

Figures A-2 and A-3, Logs of Large Diameter Boring

Figures A-4 to A-23, Logs of Exploratory Test Pits

APPENDIX B

LABORATORY TESTING

Summary of Laboratory Maximum Dry Density and Optimum Moisture Content Test Results

Summary of Laboratory Expansion Index Test Results

Summary of Laboratory Water-Soluble Sulfate Test Results

Summary of Laboratory Chloride Ion Content Test Results

Summary of Laboratory pH and Resistivity Test Results

Summary of Laboratory Atterberg Test Results

APPENDIX C

RECOMMENDED GRADING SPECIFICATIONS

LIST OF REFERENCES

GEOTECHNICAL INVESTIGATION

1. PURPOSE AND SCOPE

This report contains the results of our geotechnical investigation for a proposed industrial building located at the terminus of Shinohara Lane, in Chula Vista, California (see Vicinity Map).



Vicinity Map

The purpose of our investigation was to evaluate subsurface soil and geologic conditions at the site, and provide conclusions and recommendations pertaining to geotechnical aspects of developing the property as proposed.

The scope of our investigation included a site reconnaissance, excavating and logging 20 backhoe test pits, 2 large diameter borings, 1 small diameter boring, and reviewing published and unpublished geologic literature and reports (see List of References). Appendix A presents a discussion of our field investigation. We performed laboratory tests on soil samples obtained from the exploratory test pits to evaluate pertinent physical properties for engineering analyses. The results of laboratory testing are presented in Appendix B.

Site geologic conditions are depicted on Figure 1 (Geologic Map). A CAD file of the preliminary grading plan prepared by Pasco Laret Suiter & Associates was utilized as a base map to plot geologic

contacts and exploratory excavation locations. It is our understanding the site plan has not yet been finalized and building configuration and location might be adjusted from what is shown on our geologic map. An updated geologic map can be provided once final site configuration is known.

The conclusions and recommendations presented herein are based on our analysis of the data obtained during the investigation, and our experience with similar soil and geologic conditions on this and adjacent properties.

2. SITE AND PROJECT DESCRIPTION

The property consists of a rectangular parcel located west of the terminus of Shinohara Lane, north of Main Street and west of Brandywine Avenue, in Chula Vista, California (see Vicinity Map). The approximately 10-acre parcel is currently undeveloped except for minor surface drainage improvements. The property is fenced with gated access via Shinohara Lane at the southeast corner. Based on review of historical aerial photographs, the site was partially graded circa 1992 when it was used as a borrow site. Except for the graded area in the north-central area of the property, the site slopes moderately to steeply from north to south. Site elevations range from approximately 250 feet mean sea level (MSL) at the north end to 145 feet MSL at the south end. The site is boarded by residential developments to the north and west, and commercial/industrial buildings to the south and east.

The current proposed improvements consist of a single-story approximately 190,000 square-foot industrial warehouse building with associated improvements including utilities, paving, storm water management devices, and landscape improvements. Proposed cuts and fills are estimated to be up to 50 feet, with new slopes being up to approximately 10 feet in height. Retaining walls will be required along the perimeter of the site to reach pad grades. We understand the walls will likely be soil nail walls and mechanically stabilized earth (MSE) walls. Paved parking lots and driveways are planned along the perimeter of the site.

The locations and descriptions of the site and proposed development are based on our site reconnaissance and recent field investigations, and our understanding of site development as shown on the preliminary grading study plans prepared Pasco Laret Suiter & Associates. If project details vary significantly from those described, Geocon Incorporated should be contacted to review the changes and provide additional analyses and/or revisions to this report, if warranted.

3. SOIL AND GEOLOGIC CONDITIONS

Based on the results of the field investigation, the site is underlain by Tertiary San Diego Formation capped with Very Old Paralic Deposits, terrace deposits, alluvium, topsoil, previously placed fill and undocumented fill, which are described below in order of increasing age. Mapped geologic conditions

are depicted on the *Geologic Map* (Figure 1), and on the *Geologic Cross Section* (Figure 2). Exploratory test pit and boring logs are presented in Appendix A.

3.1 Undocumented Fill (Qudf)

The southeast and central portions of the site have soil berms that appear to have been constructed during previous grading to control surface water runoff. The undocumented soil generally consists of loose to medium dense, dry to damp, clayey sand with cobble. Several small trash piles are also present at the site. The undocumented fill and trash are unsuitable for support of structural fill or other improvements in their present condition. Undocumented fill should be removed and replaced as compacted fill. Trash should be hauled offsite prior to grading. Soil berms can be incorporated into fill areas during grading, provided they are free of trash and/or hazardous substances.

3.2 Previously Placed Fill (Qpf)

Previously placed compacted fill (by others) associated with a sewer easement adjacent to the northwest corner of the site extends on to the site. We did not evaluate the condition of this fill during our subsurface exploration. However, it is located behind the proposed soil nail wall and will likely not be encountered during grading operations. It might be encountered when drilling soil nails.

3.3 Topsoil (Unmapped)

Topsoil mantles the site, typically consisting of loose/soft to stiff, dry to damp, silty and clayey sand and sandy silt and clay with gravel. Topsoil ranges from one to three feet thick across the site. Remedial grading in the form of removal and recompaction will be required in areas receiving improvements. Portions of the topsoils are highly expansive.

3.4 Alluvium (Qal)

Alluvium is present in the shallow drainages along the east and west sides of the site, and across most of the southern portion of the site. The alluvium ranges in thickness from 2 feet to greater than 20 feet. The alluvium generally consist of medium dense to dense, silty to clayey sand with minor amounts of gravel and cobble. The upper five feet of the alluvium is unsuitable for the support of foundations or structural fills and will require removal during remedial grading operations. Deeper removals may be required if pockets of loose/soft alluvium extend below the recommended remedial depth.

3.5 Terrace Deposits (Qt)

Pleistocene-age Terrace Deposits are present in limited area the site, consisting of loose to medium dense, damp, sand with gravel and cobble up to 10-inches in diameter. The Terrace Deposits are considered suitable for support or structural loads but may require some remedial grading in the upper

five feet. Remedial grading depths in Terrace Deposits should be verified by a Geocon representative during grading operations.

3.6 Very Old Paralic Deposits (Qvop)

Quaternary-age Very Old Paralic Deposits caps the San Diego Formation in the northwest portion of the site. The Very Old Paralic Deposits were up to approximately 8 feet thick in the areas explored and consisted of dense to very dense, medium to coarse grained sandstone with cobble. We expect grading will remove the majority of the Very Old Paralic Deposits within the building pad area. Vertical wall cuts may expose Very Old Paralic Deposits in the northwest corner of the site.

3.7 San Diego Formation (Tsd)

Tertiary-age San Diego Formation underlies the Very Old Paralic Deposits and surficial deposits, is exposed at grade in the central and northern portions of the site, and was identified in most of test pits in the southern portion of the site. The San Diego Formation generally consists of weakly to moderately cemented, massive to laminated/cross-bedded, micaceous, damp to moist, fine- to medium-grained sandstone and silty sandstone, with occasional gravel and cobble beds. The San Diego Formation possesses a “very low” to “low” expansion potential (expansion index of 50 or less). The San Diego Formation is considered suitable for support of structural loads.

Bedding attitudes measured in Test Pit No. 11 and in both large diameter borings (Appendix A) range from approximately N10E to N30W, with dips between 9 and 20 degrees to the west. Measured bedding attitudes were similar to those reported on regional geologic maps of the area.

4. GROUNDWATER

We did not encounter groundwater or seepage during our site investigation. However, it is not uncommon for shallow seepage conditions to develop where none previously existed when sites are irrigated or infiltration is implemented. Seepage is dependent on seasonal precipitation, irrigation, land use, among other factors, and varies as a result. Proper surface drainage will be important to future performance of the project.

5. GEOLOGIC HAZARDS

5.1 Faulting and Seismicity

A review of the referenced geologic materials and our knowledge of the general area indicates that the site is not underlain by active, potentially active, or inactive faults. However, a strand of the potentially active La Nacion Fault is mapped approximately 400 feet east of the site. An active fault is defined by the California Geological Survey (CGS) as a fault showing evidence for activity within the

last 11,700 years. The closest active fault is Newport Inglewood-Rose Canyon Fault zone, located approximately eight miles west of the site. The site is not located within a State of California Earthquake Fault Zone.

The United States Geological Survey (USGS) has developed a program to evaluate the approximate location of faulting in the area of properties. The following figure shows the location of the existing faulting in the San Diego County and Southern California region. The faults are shown as solid, dashed and dotted traces representing well constrained, moderately constrained and inferred faults, respectively. The fault line colors represent faults with ages less than 150 years (red), 15,000 years (orange), 130,000 years (green), 750,000 years (blue) and 1.6 million years (black).



Faults in the San Diego Area

The San Diego County and Southern California region is seismically active. The following figure presents the occurrence of earthquakes with a magnitude greater than 2.5 from the period of 1900 through 2015 according to the Bay Area Earthquake Alliance website.

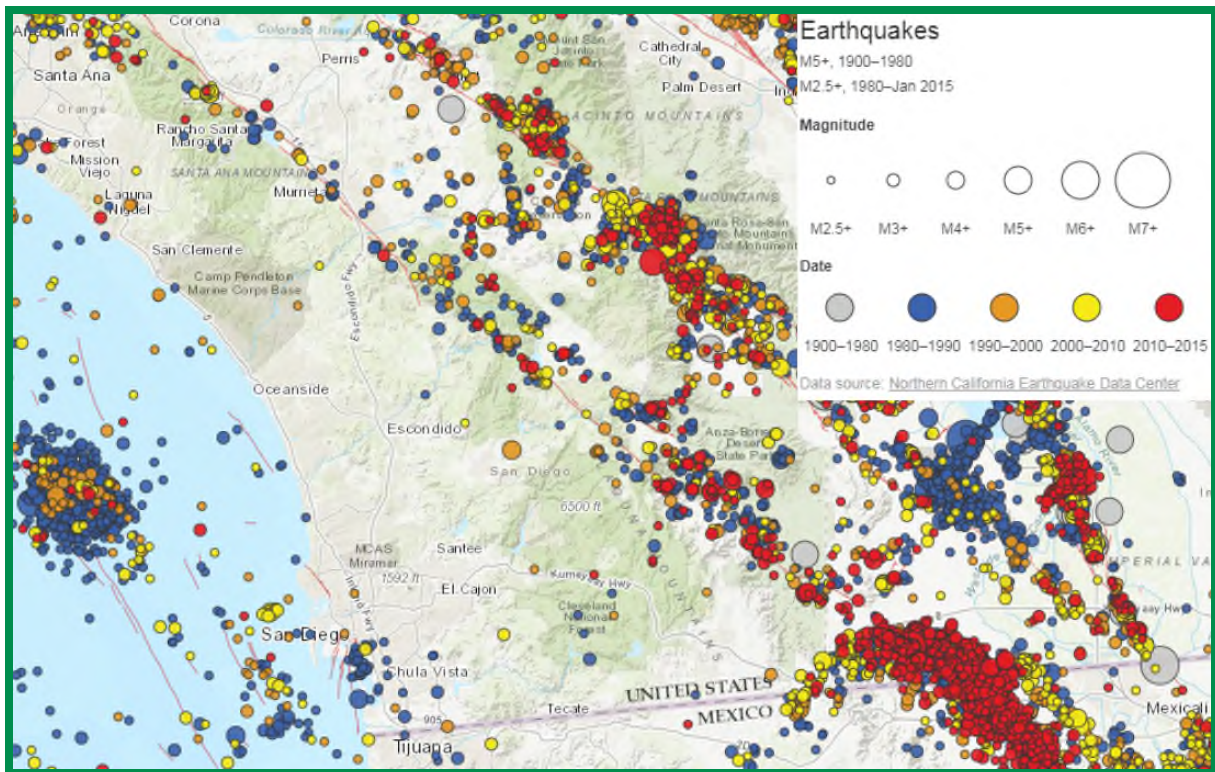

Earthquakes in Southern California

Considerations important in seismic design include the frequency and duration of motion and the soil conditions underlying the site. Seismic design of structures should be evaluated in accordance with the California Building Code (CBC) guidelines currently adopted by the local agency.

5.2 Ground Rupture

The risk associated with ground rupture hazard is very low due to the absence of active faults at the subject site.

5.3 Storm Surge, Tsunamis, and Seiches

Storm surges are large ocean waves that sweep across coastal areas when storms make landfall. Storm surges can cause inundation, severe erosion and backwater flooding along the waterfront. The site is located over six miles from the Pacific Ocean and is at an elevation of about 145 feet or greater above Mean Sea Level (MSL). Therefore, the potential of storm surges affecting the site is considered low.

A tsunami is a series of long period waves generated in the ocean by a sudden displacement of large volumes of water. Causes of tsunamis include underwater earthquakes, volcanic eruptions, or offshore slope failures. The potential for the site to be affected by a tsunami is negligible due to the distance from the Pacific Ocean and the site elevation.

A seiche is a run-up of water within a lake or embayment triggered by fault- or landslide-induced ground displacement. The site is not located in the vicinity of or downstream from such bodies of water. Therefore, the risk of seiches affecting the site is negligible.

5.4 Flooding

According to maps produced by the Federal Emergency Management Agency (FEMA), the site is zoned as “Zone X – Minimal Flood Hazard.” Based on our review of FEMA flood maps, the risk of site flooding is considered low.

5.5 Liquefaction

Liquefaction typically occurs when a site is located in a zone with seismic activity, onsite soils are cohesionless or silt/clay with low plasticity, groundwater is encountered within 50 feet of the surface and soil densities are less than about 70 percent of the maximum dry densities. If the four previous criteria are met, a seismic event could result in a rapid pore water pressure increase from the earthquake-generated ground accelerations. Due to the lack of a permanent, near-surface groundwater table and the dense nature of the underlying geologic units on the property, liquefaction potential for the site is considered very low.

5.6 Landslides

We did not observe evidence of previous or incipient slope instability at the site during our study. Published geologic mapping indicates landslides are not present on or immediately adjacent to the site. Therefore, the risk of landsliding at the site is considered low.

6. CONCLUSIONS AND RECOMMENDATIONS

6.1 General

- 6.1.1 No soil or geologic conditions were observed that would preclude the development of the property as presently proposed provided that the recommendations of this report are followed.
- 6.1.2 The site is underlain by compressible surficial deposits consisting of undocumented fill, topsoil and alluvium, overlying Quaternary-age Terrace Deposits, Very Old Paralic Deposits, and Tertiary-age San Diego Formation. The undocumented fill and topsoil range from approximately one to 4 feet thick. The alluvium extends to depths greater than 20 feet thick in the southeast corner of the site, but may be thicker in unexplored areas of the site. Additionally, minor amounts of trash and construction debris have been placed at the site.
- 6.1.3 Undocumented fill, topsoil, and the upper five feet of alluvium and Terrace Deposits are unsuitable in their present condition to receive additional fill or settlement-sensitive structures and will require removal and recompaction. Portions of the topsoil are highly expansive. To reduce the potential for soil heave impacting foundations and site improvements, we recommend burial of clayey topsoil at least five feet below design pad grade and outside of the foundation, reinforced, and retained zones of MSE walls.
- 6.1.4 We did not encounter groundwater during our subsurface exploration, and groundwater should not be a constraint to project development. However, seepage within surficial soils and formational materials may be encountered during the grading operations, especially during the rainy seasons.
- 6.1.5 Except for possible strong seismic shaking, no significant geologic hazards were observed or are known to exist on the site that would adversely affect the site. No special seismic design considerations, other than those recommended herein, are required.
- 6.1.6 Proper drainage should be maintained in order to preserve the engineering properties of the fill in both the building pads and slope areas. Recommendations for site drainage are provided herein.
- 6.1.7 We did not perform infiltration testing as part of this study as preliminary design plans were not available. Due to the proposed MSE walls and deep fills required in the south (down-gradient) portion of the site needed to create a level building pad, infiltration of storm water is not recommended on this site.

- 6.1.8 Provided the recommendations of this report are followed, it is our opinion that the proposed development will not destabilize or result in settlement of adjacent properties and City right-of-way.
- 6.1.9 Subsurface conditions observed may be extrapolated to reflect general soil/geologic conditions; however, some variations in subsurface conditions between trench locations should be anticipated.

6.2 Soil and Excavation Characteristics

- 6.2.1 The recommendations included herein are provided for stable excavations. It is the responsibility of the contractor and their competent person to ensure all excavations, temporary slopes and trenches are properly constructed and maintained in accordance with applicable OSHA guidelines in order to maintain safety and the stability of the excavations and adjacent improvements. These excavations should not be allowed to become saturated or to dry out. Surcharge loads should not be permitted to a distance equal to the height of the excavation from the top of the excavation. The top of the excavation should be a minimum of 15 feet from the edge of existing improvements. Excavations steeper than those recommended or closer than 15 feet from an existing surface improvement should be shored in accordance with applicable OSHA codes and regulations.
- 6.2.2 The stability of the excavations is dependent on the design and construction of the shoring system and site conditions. Therefore, Geocon Incorporated cannot be responsible for site safety and the stability of the proposed excavations.
- 6.2.3 Excavation of existing undocumented fill and surficial deposits should be possible with moderate to heavy effort using conventional heavy-duty equipment. We expect excavation of the Terrace Deposits, Very Old Paralic Deposits, and the San Diego Formation will require moderate to very heavy effort. Weakly to moderately cemented gravel and/or cobble and zones may be encountered requiring very heavy effort to excavate.
- 6.2.4 The soil encountered in the field investigation is considered to be both “non-expansive” (expansion index [EI] of 20 and less) and “expansive” (EI greater than 20) as defined by 2019 California Building Code (CBC) Section 1803.5.3. Table 6.2.1 presents soil classifications based on the expansion index. We expect the majority of the soils that will be encountered in remedial grading and cut areas will have a “low” expansion potential. Portions of the topsoil possess a “medium” to “high” expansion potential (EI of 51 or greater).

**TABLE 6.2.1
EXPANSION CLASSIFICATION BASED ON EXPANSION INDEX**

Expansion Index (EI)	ASTM D 4829 Expansion Classification	2019 CBC Expansion Classification
0 – 20	Very Low	Non-Expansive
21 – 50	Low	Expansive
51 – 90	Medium	
91 – 130	High	
Greater Than 130	Very High	

6.2.5 We performed laboratory tests on samples of the site materials to evaluate the percentage of water-soluble sulfate content. Appendix B presents results of the laboratory water-soluble sulfate content tests. The test results indicate the on-site materials at the locations tested possess “S0” sulfate exposure to concrete structures as defined by 2019 CBC Section 1904 and ACI 318-14 Chapter 19. Table 6.2.2 presents a summary of concrete requirements set forth by 2019 CBC Section 1904 and ACI 318. The presence of water-soluble sulfates is not a visually discernible characteristic; therefore, other soil samples from the site could yield different concentrations. Additionally, over time landscaping activities (i.e., addition of fertilizers and other soil nutrients) may affect the concentration.

**TABLE 6.2.2
REQUIREMENTS FOR CONCRETE EXPOSED TO
SULFATE-CONTAINING SOLUTIONS**

Exposure Class	Water-Soluble Sulfate (SO ₄) Percent by Weight	Cement Type (ASTM C 150)	Maximum Water to Cement Ratio by Weight ¹	Minimum Compressive Strength (psi)
S0	SO ₄ <0.10	No Type Restriction	n/a	2,500
S1	0.10≤SO ₄ <0.20	II	0.50	4,000
S2	0.20≤SO ₄ ≤2.00	V	0.45	4,500
S3	SO ₄ >2.00	V+Pozzolan or Slag	0.45	4,500

6.2.6 We tested samples for potential of hydrogen (pH) and resistivity and chloride to aid in evaluating the corrosion potential. Appendix B presents the laboratory test results.

6.2.7 Geocon Incorporated does not practice in the field of corrosion engineering. Therefore, further evaluation by a corrosion engineer may be needed if improvements susceptible to corrosion are planned.

6.3 Grading Recommendations

- 6.3.1 Grading should be performed in accordance with the recommendations provided in this report, the Recommended Grading Specifications contained in Appendix C and the City of Chula Vista's Grading Ordinance. Where the recommendations of this section conflict with those of Appendix C, **the recommendations of this section take precedence**. Geocon Incorporated should observe the grading operations on a full-time basis and provide testing during the fill placement.
- 6.3.2 Prior to commencing grading, a preconstruction conference should be held at the site with the City inspector, developer, grading and underground contractors, civil engineer, and geotechnical engineer in attendance. Special soil handling and/or the grading plans can be discussed at that time.
- 6.3.3 Site preparation should begin with the removal of deleterious material, trash and debris, and vegetation. The depth of vegetation removal should be such that material exposed in cut areas or soil to be used as fill is relatively free of organic matter. Material generated during stripping and/or site demolition should be exported from the site. Asphalt and concrete (if encountered) should not be mixed with the fill soil unless approved by the Geotechnical Engineer.
- 6.3.4 Abandoned foundations and buried utilities (if encountered) should be removed and the resultant depressions and/or trenches should be backfilled with properly compacted material as part of the remedial grading.
- 6.3.5 We recommend undocumented fill, topsoil, and the upper five feet of alluvium and Terrace Deposits be removed and replaced as compacted fill throughout the site. Trash and debris may be encountered in the undocumented fill. Trash and debris, if encountered, should be removed from the fill and exported.
- 6.3.6 Estimated remedial removal depths are shown on the Geologic Map (Figure 1). The actual depth of remedial removals should be determined in the field during grading by a representative of Geocon Incorporated prior to placement and compaction of fill.
- 6.3.7 Based on the existing site conditions, we expect grading will result in cuts and fills from existing grade up to approximately 50 feet to create a level building pad. A cut-to-fill transition will be created in the proposed building pad resulting in San Diego Formation at grade in the north portion of the site and compacted fills up to 50 feet deep in the south portion of the site. Undercutting of the north side of the building pad will be required as shown in Table 6.3.1 below.

- 6.3.8 Expansive soils found in the upper three to four feet below existing site grades should be buried in deep fills and outside of the foundation, reinforced and retained zones of MSE walls, and at least five feet below pad grade or three feet below the deepest foundation element, whichever is deeper.
- 6.3.9. Removals at the toes of proposed fill slopes and in front of retaining walls should extend horizontally beyond the edge of the slope toe or wall a distance equal to the depth of removal. A typical detail of remedial grading beyond slope toes is presented below.

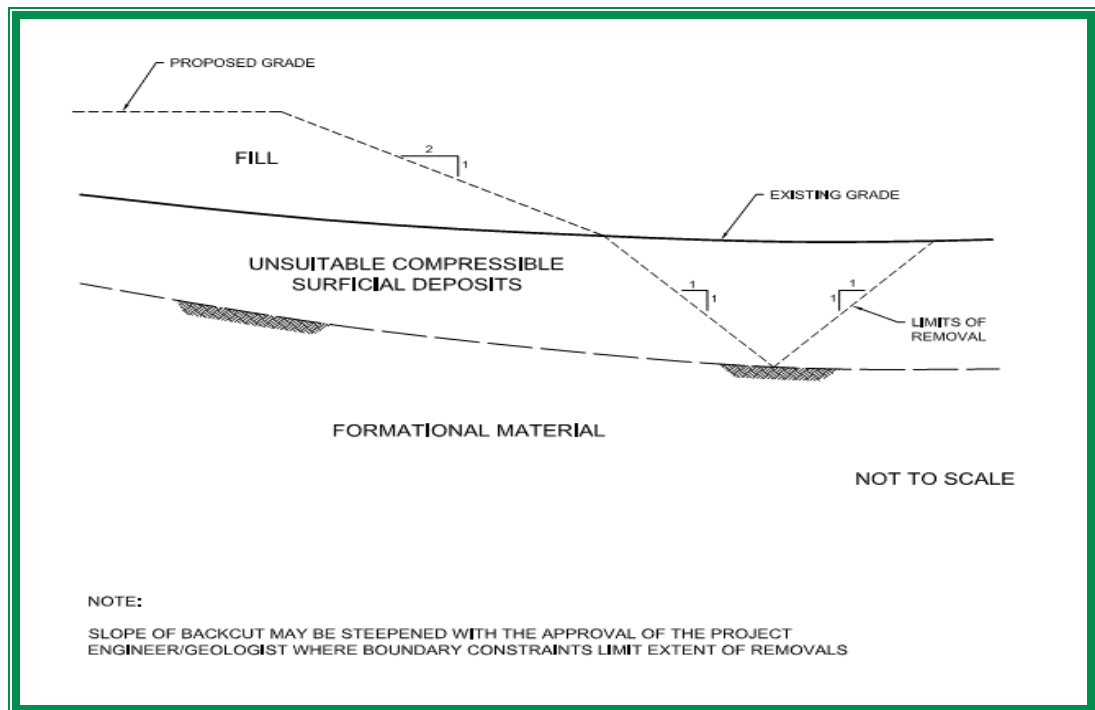

**TABLE 6.3.1
SUMMARY OF GRADING RECOMMENDATIONS**

Area	Removal Requirements
All Structural Improvement Areas	All undocumented fill and topsoil and the Upper 5 feet of Alluvium and Terrace Deposits
Building Pad (North Side [Cut])	Undercut building pad 5 feet below bottom of building footings to remove cut to fill transition
Fill Areas	Expansive Soil Buried at Least 5 Feet Below Pad Grade or at Least 3 Feet Below Bottom of Footings
Remedial Grading Limits	<ul style="list-style-type: none"> • 10 Feet Outside of Building Pads; • 2 Feet Outside of Improvement Areas; • Beyond toe of slopes and retaining walls a distance equal to the depth of the remedial excavation, where possible
Exposed Bottoms of Remedial Grading	Scarify Upper 12 Inches

- 6.3.10 Along the south side of the site an existing retaining wall adjacent to the property margin may impact remedial grading limits. Deepened wall footings may be required so as to not impact the existing retaining wall.
- 6.3.11 Excavation bottoms should be sloped 1 percent to the adjacent street or deepest fill. Prior to fill soil being placed, the existing ground surface should be scarified, moisture conditioned as necessary, and compacted to a depth of at least 12 inches. Deeper removals may be required if saturated or loose fill soil is encountered. A representative of Geocon should be on-site during removals to evaluate the limits of the remedial grading.
- 6.3.12 The site should then be brought to final subgrade elevations with fill compacted in layers. In general, soil native to the site is suitable for use from a geotechnical engineering standpoint as fill if relatively free from vegetation, debris and other deleterious material. Layers of fill should be no thicker than will allow for adequate bonding and compaction. Fill, including backfill and scarified ground surfaces, should be compacted to a dry density of at least 90 percent of the laboratory maximum dry density near to slightly above optimum moisture content in accordance with ASTM Test Procedure D 1557. Fill materials placed below optimum moisture content may require additional moisture conditioning prior to placing additional fill.
- 6.3.13 Imported fill (if necessary) should consist of the characteristics presented in Table 6.3.2. Geocon Incorporated should be notified of the import soil source and should perform laboratory testing of import soil prior to its arrival at the site to determine its suitability as fill material.

**TABLE 6.3.2
SUMMARY OF IMPORT FILL RECOMMENDATIONS**

Soil Characteristic	Values
Expansion Potential	“Very Low” to “Low” (Expansion Index of 50 or less)
Particle Size	Maximum Dimension Less Than 3 Inches
	Generally Free of Debris

6.4 Slopes

- 6.4.1 Slope stability analyses were performed for proposed cut and fill slopes up to 10 feet high (2:1 gradient). The stability analyses were performed using simplified Janbu analysis. Our analyses utilized average drained direct shear strength parameters based on laboratory tests performed for this project and our experience with similar soils. The analyses indicate planned cut and fill slopes, and the existing native perimeter slope will have a calculated factors of safety in excess of 1.5 under static conditions for both deep-seated failure and shallow sloughing conditions. Table 6.4.1 presents the slope stability analysis. Slope

stability analysis for MSE walls should be performed once the wall design is complete and grid locations and lengths are known.

**TABLE 6.4.1
SLOPE STABILITY EVALUATION**

Parameter	Value
Slope Height, H	20 Feet
Slope Inclination, I (Horizontal to Vertical)	2:1
Total Soil Unit Weight, γ	125 pcf
Friction Angle, ϕ	30 Degrees
Cohesion, C	200 psf
Slope Factor $\lambda_{C\phi} = (\gamma H \tan \phi) / C$	7.2
NCf (From Chart)	25
Factor of Safety = $(N_C C) / (\gamma H)$	2.0

6.4.2 Table 6.4.2 presents the surficial slope stability analysis for the proposed sloping conditions.

**TABLE 6.4.2
SURFICIAL SLOPE STABILITY EVALUATION**

Parameter	Value
Slope Height, H	∞
Vertical Depth of Saturation, Z	3 Feet
Slope Inclination, I (Horizontal to Vertical)	2:1 (26.6 Degrees)
Total Soil Unit Weight, γ	125 pcf
Water Unit Weight, γ_w	62.4 pcf
Friction Angle, ϕ	30 Degrees
Cohesion, C	200 psf
Factor of Safety = $(C + (\gamma + \gamma_w) Z \cos^2 I \tan \phi) / (\gamma Z \sin I \cos I)$	1.9

6.4.3 All cut slope excavations should be observed during grading by an engineering geologist to verify that soil and geologic conditions do not differ significantly from those anticipated.

6.4.4 The outer 15 feet (or a distance equal to the height of the slope, whichever is less) of fill slopes should be composed of properly compacted granular *soil* fill to reduce the potential for surficial sloughing. Granular “soil” fill is defined as a well-graded soil mix with less than 20 percent fines (silt and clay particles). Poorly graded soils with less than 5 percent fines should not be used in the slope zone due to high erosion potential. All slopes should be compacted by backrolling with a loaded sheepsfoot roller at vertical intervals not to exceed 4 feet and should

be track-walked at the completion of each slope such that the fill soils are uniformly compacted to at least 90 percent relative compaction to the face of the finished sloped.

- 6.4.5 All slopes should be landscaped with drought-tolerant vegetation, having variable root depths and requiring minimal landscape irrigation. In addition, all slopes should be drained and properly maintained to reduce erosion.

6.5 Earthwork Grading Factors

- 6.5.1 Estimates of shrink-swell factors are based on comparing laboratory compaction tests with the density of the material in its natural state and experience with similar soil types. Variations in natural soil density and compacted fill render shrinkage value estimates very approximate. As an example, the contractor can compact fill to a density of 90 percent or higher of the laboratory maximum dry density. Thus, the contractor has at least a 10 percent range of control over the fill volume. Based on the work performed to date and considering the discussion herein, the earthwork factors in Table 6.5 may be used as a basis for estimating how much the on-site soils may shrink or swell when removed from their natural state and placed as compacted fill.

**TABLE 6.5
SHRINKAGE AND BULK FACTORS**

Soil Unit	Shrink/Bulk Factor
Undocumented Fill (Qudf)	10-15% Shrink
Previously Placed Fill (Qpf)	0-3% Shrink
Topsoil (unmapped)	5-10% Shrink
Alluvium (Qal)	4-8% Shrink
Terrace Deposits (Qt)	0-5% Bulk
Very Old Paralic Deposits (Qvop)	3-5% Bulk
San Diego Formation (Tsd)	3-5% Bulk

6.6 Subdrains

- 6.6.1 With the exception of retaining wall drains, we do not expect subdrains will be required. We should be contacted to provide recommendations for subdrains if field conditions differ from those described herein.

6.7 Settlement Monitoring

- 6.7.1 At the completion of grading, the south side of the site will be underlain by up to 50 feet of compacted fill behind MSE walls. Post-grading settlement (hydro-compression) of properly compacted new fill with a maximum thickness of 50 feet could be up to about 2.5 inches.

We expect the settlement could occur over 20+ years depending on the influx of rain and irrigation water into the fill mass. This settlement will likely be linear from the time the fill is placed to the end of the settlement period. We do not expect the settlement will impact proposed utilities with proposed gradients of 1 percent or greater. The building foundation design should be designed to account for potential hydro-compression settlement. It has been our experience that developments/improvements, such as proposed, can be constructed with the planned fill depths and proposed settlements.

6.7.2 We expect settlement in the fill as a result of self-weight compression could take up to 3 to 9 months. If building foundations will be constructed shortly after completion of the fill mass, building foundations will need to be designed to accommodate differential settlement as a result of self-weight compression. If the planned structures cannot tolerate the expected movement, a construction waiting period should be implemented until settlement monitoring indicates self-weight compression has essentially ceased.

6.7.3 At the south end of the property where fills are the greatest, we recommend settlement monuments be installed subsequent to the wall construction. A typical settlement monument is shown below.

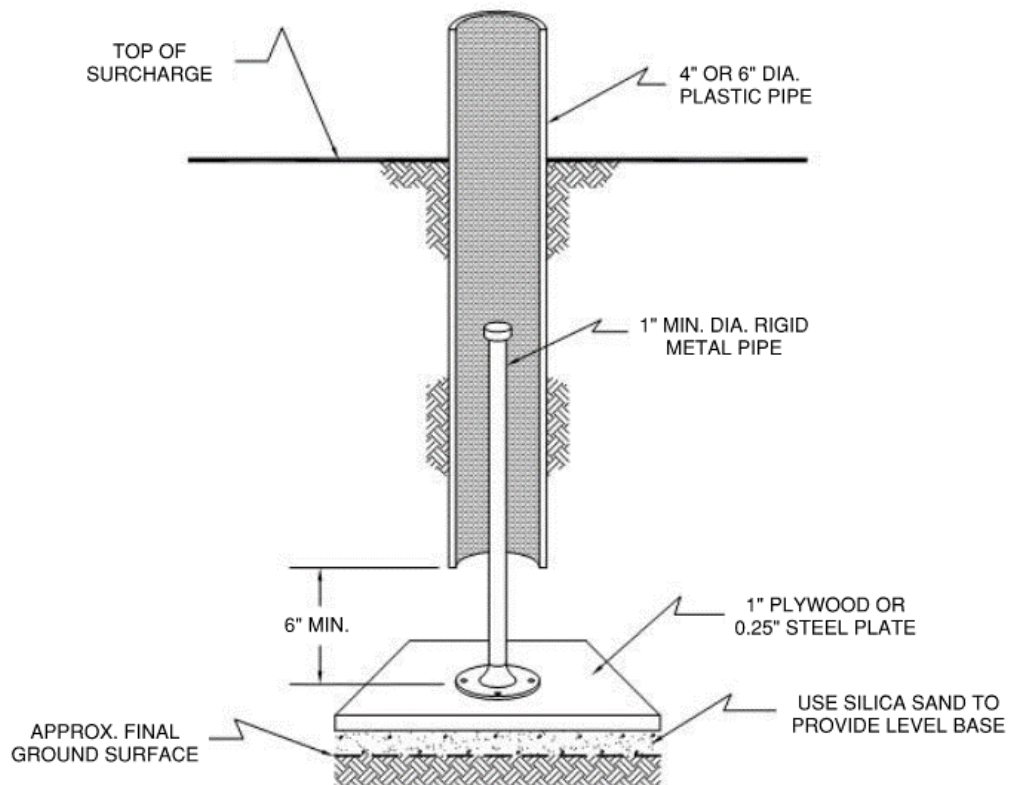

Settlement Plate Detail

6.7.4 Surveying of the surface monument should be performed by the project civil engineer every two weeks for at least three months with the results provided to Geocon for review. Settlement due to primary consolidation will be considered to have ceased when survey readings show a relatively level plateau of settlement data over 4 consecutive readings.

6.8 Seismic Design Criteria

6.8.1 Table 6.8.1 summarizes site-specific design criteria obtained from the 2019 California Building Code (CBC; Based on the 2018 International Building Code [IBC] and ASCE 7-16), Chapter 16 Structural Design, Section 1613 Earthquake Loads. We used the computer program *Seismic Design Maps*, provided by the Structural Engineers Association (SEA) to calculate the seismic design parameters. The short spectral response uses a period of 0.2 second. We evaluated the Site Class based on the discussion in Section 1613.2.2 of the 2019 CBC and Table 20.3-1 of ASCE 7-16. The values presented herein are for the risk-targeted maximum considered earthquake (MCE_R) for Site Classes C and D. The southern portion of the building will be underlain by compacted fill in excess of 40 feet. A Site Class D is appropriate for this condition. The northern portion of the building pad will be underlain by shallow compacted fills. Site Class C is appropriate for this condition.

**TABLE 6.8.1
2019 CBC SEISMIC DESIGN PARAMETERS**

Parameter	Value		2019 CBC Reference
	C	D	
Site Class	C	D	Section 1613.2.2
MCE_R Ground Motion Spectral Response Acceleration – Class B (short), S_S	0.896g	0.896g	Figure 1613.2.1(1)
MCE_R Ground Motion Spectral Response Acceleration – Class B (1 sec), S_1	0.313g	0.313g	Figure 1613.2.1(2)
Site Coefficient, F_A	1.2	1.142	Table 1613.2.3(1)
Site Coefficient, F_V	1.5	1.987*	Table 1613.2.3(2)
Site Class Modified MCE_R Spectral Response Acceleration (short), S_{MS}	1.075g	1.023g	Section 1613.2.3 (Eqn 16-36)
Site Class Modified MCE_R Spectral Response Acceleration – (1 sec), S_{M1}	0.47g	0.622g*	Section 1613.2.3 (Eqn 16-37)
5% Damped Design Spectral Response Acceleration (short), S_{DS}	0.717g	0.682g	Section 1613.2.4 (Eqn 16-38)
5% Damped Design Spectral Response Acceleration (1 sec), S_{D1}	0.313g	0.415g*	Section 1613.2.4 (Eqn 16-39)

*Using the code-based values presented in this table, in lieu of a performing a ground motion hazard analysis, requires the exceptions outlined in ASCE 7-16 Section 11.4.8 be followed by the project structural engineer. Per Section 11.4.8 of ASCE/SEI 7-16, a ground motion hazard analysis should be performed for projects for Site Class “E” sites with S_S greater than or equal to 1.0g and for Site Class “D” and “E” sites with S_1 greater than 0.2g. Section 11.4.8 also provides exceptions which indicates that the ground motion hazard analysis may be waived provided the exceptions are followed.

6.8.2 Table 6.8.2 presents the mapped maximum considered geometric mean (MCE_G) seismic design parameters for projects located in Seismic Design Categories of D through F in accordance with ASCE 7-16.

**TABLE 6.8.2
ASCE 7-16 PEAK GROUND ACCELERATION**

Parameter	Value		ASCE 7-16 Reference
	C	D	
Site Class	C	D	Section 1613.2.2 (2019 CBC)
Mapped MCE_G Peak Ground Acceleration, PGA	0.394g	0.394g	Figure 22-7
Site Coefficient, F_{PGA}	1.2	1.206	Table 11.8-1
Site Class Modified MCE_G Peak Ground Acceleration, PGA_M	0.473g	0.475g	Section 11.8.3 (Eqn 11.8-1)

6.8.3 Conformance to the criteria in Tables 6.8.1 and 6.8.2 for seismic design does not constitute any kind of guarantee or assurance that significant structural damage or ground failure will not occur if a large earthquake occurs. The primary goal of seismic design is to protect life, not to avoid all damage, since such design may be economically prohibitive.

6.8.4 The project structural engineer and architect should evaluate the appropriate Risk Category and Seismic Design Category for the planned structures. The values presented herein assume a Risk Category of II and resulting in a Seismic Design Category D. Table 6.8.3 presents a summary of the risk categories.

**TABLE 6.8.3
ASCE 7-16 RISK CATEGORIES**

Risk Category	Building Use	Examples
I	Low risk to Human Life at Failure	Barn, Storage Shelter
II	Nominal Risk to Human Life at Failure (Buildings Not Designated as I, III or IV)	Residential, Commercial and Industrial Buildings
III	Substantial Risk to Human Life at Failure	Theaters, Lecture Halls, Dining Halls, Schools, Prisons, Small Healthcare Facilities, Infrastructure Plants, Storage for Explosives/Toxins
IV	Essential Facilities	Hazardous Material Facilities, Hospitals, Fire and Rescue, Emergency Shelters, Police Stations, Power Stations, Aviation Control Facilities, National Defense, Water Storage

6.9 Shallow Foundations

6.9.1 The proposed structure can be supported on a shallow foundation system founded in compacted fill provided the grading recommendations provided in Section 6.3 are followed. Foundations for the structure should consist of continuous strip footings and/or isolated spread footings. Table 6.9.1 provides a summary of the foundation design recommendations.

**TABLE 6.9.1
SUMMARY OF FOUNDATION RECOMMENDATIONS**

Parameter	Value
Minimum Continuous Foundation Width	12 inches
Minimum Isolated Foundation Width	24 inches
Minimum Foundation Depth	24 Inches Below Lowest Adjacent Grade
Minimum Steel Reinforcement	4 No. 5 Bars, 2 at the Top and 2 at the Bottom
Allowable Bearing Capacity	2,500 psf
Bearing Capacity Increase	500 psf per Foot of Depth
	300 psf per Foot of Width
Maximum Allowable Bearing Capacity	4,000 psf
Estimated Total Settlement	1 Inch
Estimated Differential Settlement	½ Inch in 40 Feet
Footing Size Used for Settlement	9-Foot Square
Design Expansion Index	50 or less

6.9.2 Additional settlement as a result of self-weight compression and hydro-compression could occur over the life of the structure. We estimate approximately 0.4 percent of the total fill thickness underlying the building pad. Self-weight compression is expected to occur over 3 to 9 months. Hydro-compression is expected to occur over a 20 year or more duration. The estimated fill thickness and total settlement as a result of self-weight compression and hydro-compression is shown on Table 6.9.2 and is in addition to the static settlement indicated on Table 6.9.1. An estimate of total and differential fill settlement, including settlement contours thickness and final foundation recommendations to be used in design can be provided, if desired.

**TABLE 6.9.2
ESTIMATED FILL THICKNESS AND TOTAL AND DIFFERENTIAL FILL SETTLEMENT
AS A RESULT OF SELF-WEIGHT AND HYDRO-COMPRESSION**

Estimated Compacted Fill Thickness (after grading) (feet)	Estimated Total Fill Settlement (Self-Weight and Hydro-Compression) (inches)	Estimated Differential Fill Settlement (Self-Weight and Hydro-Compression) (inches)
0 to 50	0 to 2.5	2.5 inches over a span of 200 feet (angular distortion of 1/960)

6.9.3 The foundations should be embedded in accordance with the recommendations herein and the Wall/Column Footing Dimension Detail. The embedment depths should be measured from the lowest adjacent pad grade for both interior and exterior footings. Footings should be deepened such that the bottom outside edge of the footing is at least 7 feet horizontally from the face of the slope (unless designed with a post-tensioned foundation system as discussed herein).

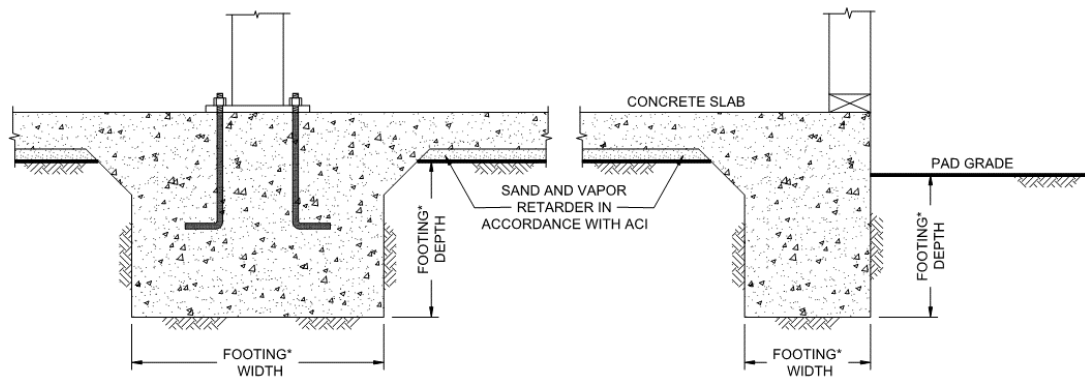

Wall/Column Footing Dimension Detail

6.9.4 The bearing capacity values presented herein are for dead plus live loads and may be increased by one-third when considering transient loads due to wind or seismic forces.

6.9.5 Where buildings or other improvements are planned near the top of a slope steeper than 3:1 (horizontal:vertical), special foundations and/or design considerations are recommended due to the tendency for lateral soil movement to occur.

- For fill slopes less than 20 feet high or cut slopes regardless of height, footings should be deepened such that the bottom outside edge of the footing is at least 7 feet horizontally from the face of the slope.

- When located next to a descending 3:1 (horizontal:vertical) fill slope or steeper, the foundations should be extended to a depth where the minimum horizontal distance is equal to H/3 (where H equals the vertical distance from the top of the fill slope to the base of the fill soil) with a minimum of 7 feet but need not exceed 40 feet. The horizontal distance is measured from the outer, deepest edge of the footing to the face of the slope. A post-tensioned slab and foundation system or mat foundation system can be used to reduce the potential for distress in the structures associated with strain softening and lateral fill extension. Specific design parameters or recommendations for either of these alternatives can be provided once the building location and fill slope geometry have been determined.
- Although other improvements, which are relatively rigid or brittle, such as concrete flatwork or masonry walls, may experience some distress if located near the top of a slope, it is generally not economical to mitigate this potential. It may be possible, however, to incorporate design measures that would permit some lateral soil movement without causing extensive distress. Geocon Incorporated should be consulted for specific recommendations.

6.9.6 We should observe the foundation excavations prior to the placement of reinforcing steel and concrete to check that the exposed soil conditions are similar to those expected and that they have been extended to the appropriate bearing strata. Foundation modifications may be required if unexpected soil conditions are encountered.

6.9.7 Geocon Incorporated should be consulted to provide additional design parameters as required by the structural engineer.

6.10 Conventional Retaining Wall Recommendations

6.10.1 Retaining walls should be designed using the values presented in Table 6.10.1. Soil with an expansion index (EI) of greater than 50 should not be used as backfill soil behind retaining walls.

**TABLE 6.10.1
RETAINING WALL DESIGN RECOMMENDATIONS**

Parameter	Value
Active Soil Pressure, A (Fluid Density, Level Backfill)	35 pcf
Active Soil Pressure, A (Fluid Density, 2:1 Sloping Backfill)	50 pcf
Seismic Pressure, S	18H psf
At-Rest/Restrained Walls Additional Uniform Pressure (0 to 8 Feet High)	7H psf
At-Rest/Restrained Walls Additional Uniform Pressure (8+ Feet High)	13H psf
Expected Expansion Index for the Subject Property	$EI \leq 50$

H equals the height of the retaining portion of the wall

6.10.2 The project retaining walls should be designed as shown in the Retaining Wall Loading Diagram.

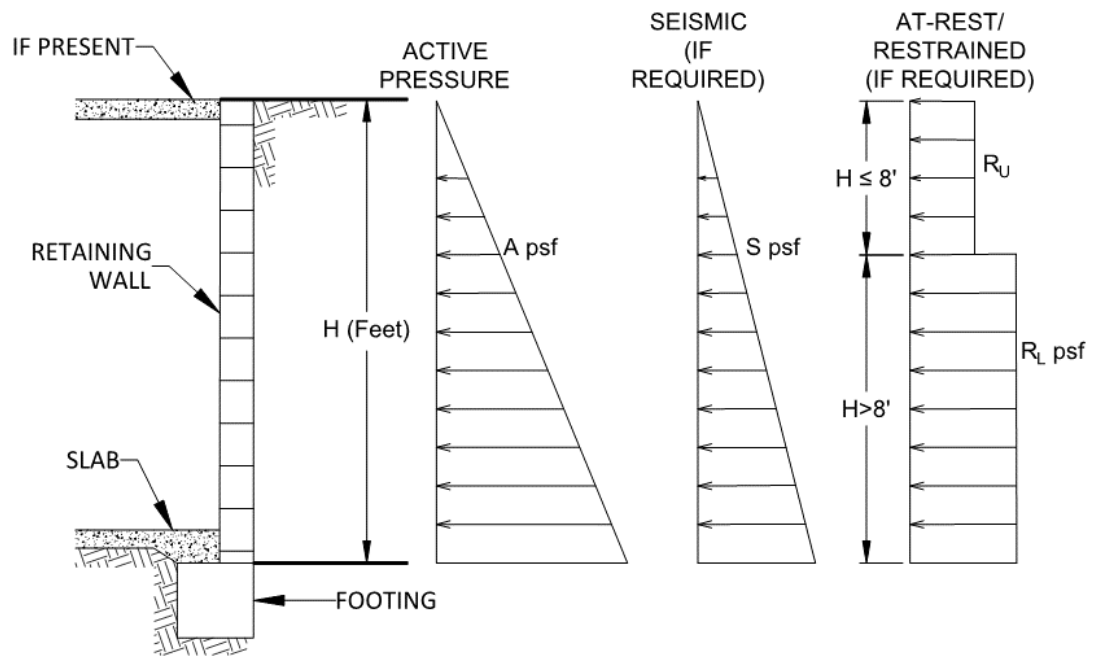

Retaining Wall Loading Diagram

6.10.3 Unrestrained walls are those that are allowed to rotate more than $0.001H$ (where H equals the height of the retaining portion of the wall) at the top of the wall. Where walls are restrained from movement at the top (at-rest condition), an additional uniform pressure should be applied to the wall. For retaining walls subject to vehicular loads within a horizontal distance equal to two-thirds the wall height, a surcharge equivalent to 2 feet of fill soil should be added.

6.10.4 The structural engineer should determine the Seismic Design Category for the project in accordance with Section 1613.2.5 of the 2019 CBC or Section 11.6 of ASCE 7-16. For structures assigned to Seismic Design Category of D, E, or F, retaining walls that support more than 6 feet of backfill should be designed with seismic lateral pressure in accordance with Section 1803.5.12 of the 2019 CBC. The seismic load is dependent on the retained height where H is the height of the wall, in feet, and the calculated loads result in pounds per square foot (psf) exerted at the base of the wall and zero at the top of the wall.

6.10.5 Retaining walls should be designed to ensure stability against overturning sliding, and excessive foundation pressure. Where a keyway is extended below the wall base with the intent to engage passive pressure and enhance sliding stability, it is not necessary to consider active pressure on the keyway.

6.10.6 Drainage openings through the base of the wall (weep holes) should not be used where the seepage could be a nuisance or otherwise adversely affect the property adjacent to the base of the wall. The recommendations herein assume a properly compacted granular (EI of 50 or less) free-draining backfill material with no hydrostatic forces or imposed surcharge load. The retaining wall should be properly drained as shown in the Typical Retaining Wall Drainage Detail. If conditions different than those described are expected, or if specific drainage details are desired, Geocon Incorporated should be contacted for additional recommendations.

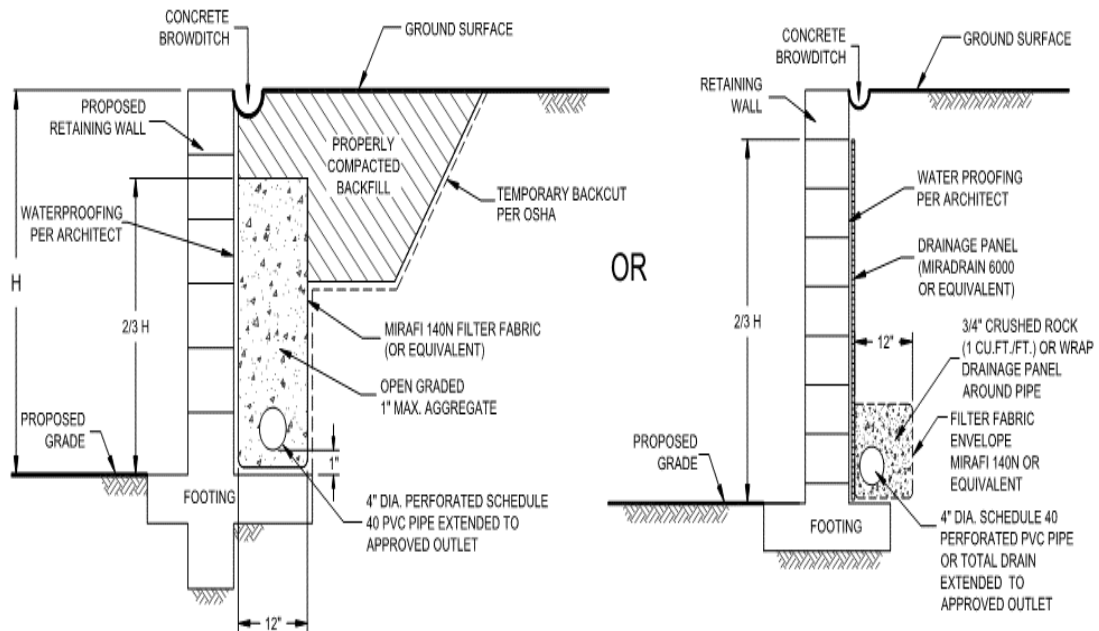

Typical Retaining Wall Drainage Detail

6.10.7 The retaining walls may be designed using either the active and restrained (at-rest) loading condition or the active and seismic loading condition as suggested by the structural engineer. Typically, it appears the design of the restrained condition for retaining wall loading may be adequate for the seismic design of the retaining walls. However, the active earth pressure combined with the seismic design load should be reviewed and also considered in the design of the retaining walls.

6.10.8 In general, wall foundations having should be designed in accordance with Table 6.10.2. The proximity of the foundation to the top of a slope steeper than 3:1 could impact the allowable soil bearing pressure. Therefore, retaining wall foundations should be deepened such that the bottom outside edge of the footing is at least 7 feet horizontally from the face of the slope.

**TABLE 6.10.2
SUMMARY OF RETAINING WALL FOUNDATION RECOMMENDATIONS**

Parameter	Value
Minimum Retaining Wall Foundation Width	12 inches
Minimum Retaining Wall Foundation Depth	12 Inches
Minimum Steel Reinforcement	Per Structural Engineer
Bearing Capacity	2,500 psf
Bearing Capacity Increase	500 psf per additional foot of footing depth
	300 psf per additional foot of footing width
Maximum Bearing Capacity	4,000 psf
Estimated Total Settlement	1 Inch
Estimated Differential Settlement	½ Inch in 40 Feet

- 6.10.9 The recommendations presented herein are generally applicable to the design of rigid concrete or masonry retaining walls. Additional recommendations for MSE walls and soil nail walls are provided in Sections 6.12 and 6.13.
- 6.10.10 Unrestrained walls will move laterally when backfilled and loading is applied. The amount of lateral deflection is dependent on the wall height, the type of soil used for backfill, and loads acting on the wall. The retaining walls and improvements above the retaining walls should be designed to incorporate an appropriate amount of lateral deflection as determined by the structural engineer.
- 6.10.11 Soil contemplated for use as retaining wall backfill, including import materials, should be identified in the field prior to backfill. At that time, Geocon Incorporated should obtain samples for laboratory testing to evaluate its suitability. Modified lateral earth pressures may be necessary if the backfill soil does not meet the required expansion index or shear strength. City or regional standard wall designs, if used, are based on a specific active lateral earth pressure and/or soil friction angle. In this regard, on-site soil to be used as backfill may or may not meet the values for standard wall designs. Geocon Incorporated should be consulted to assess the suitability of the on-site soil for use as wall backfill if standard wall designs will be used.

6.11 Lateral Loading

- 6.11.1 Table 6.11 should be used to help design the proposed structures and improvements to resist lateral loads for the design of footings or shear keys. The allowable passive pressure assumes a horizontal surface extending at least 5 feet, or three times the surface generating the passive pressure, whichever is greater. The upper 12 inches of material in areas not

protected by floor slabs or pavement should not be included in design for passive resistance. Where walls are planned adjacent to and/or on descending slopes, a passive pressure of 150 pcf should be used in design.

**TABLE 6.11
SUMMARY OF LATERAL LOAD DESIGN RECOMMENDATIONS**

Parameter	Value
Passive Pressure Fluid Density	350 pcf
Passive Pressure Fluid Density Adjacent to and/or on Descending Slopes	150 pcf
Coefficient of Friction (Concrete and Soil)	0.35
Coefficient of Friction (Along Vapor Barrier)	0.2 to 0.25*

*Per manufacturer's recommendations.

- 6.11.2 The passive and frictional resistant loads can be combined for design purposes. The lateral passive pressures may be increased by one-third when considering transient loads due to wind or seismic forces.

6.12 Mechanically Stabilized Earth (MSE) Retaining Walls

- 6.12.1 Mechanized stabilized earth (MSE) retaining walls are planned for the project. MSE retaining walls are alternative walls that consist of modular block facing units with geogrid reinforced earth behind the block. The reinforcement grid attaches to the block units and is typically placed at specified vertical intervals and embedment lengths. The grid length and spacing will be determined by the wall designer.
- 6.12.2 The geotechnical parameters listed in Table 6.12.1 can be used for preliminary design of the MSE walls. Once actual soil to be used as backfill has been determined and stockpiled, laboratory testing should be performed to check that the soil meets the parameters used in the design of the MSE walls.

**TABLE 6.12.1
GEOTECHNICAL PARAMETERS FOR MSE WALLS**

Parameter	Reinforced Zone	Retained Zone	Foundation Zone
Angle of Internal Friction	30 degrees	30 degrees	30 degrees
Cohesion	100 psf	100 psf	100 psf
Wet Unit Density	125 pcf	125 pcf	125 pcf

- 6.12.3 The soil parameters presented in Table 6.12.1 are based on our experience and direct shear-strength tests performed during the geotechnical investigation and represent some of the on-site materials. The wet unit density values presented in Table 6.12.1 can be used for design but actual in-place densities may range from approximately 110 to 130 pounds per cubic foot. Geocon has no way of knowing which materials will actually be used as backfill behind the wall during construction. It is up to the wall designers to use their judgment in selection of the design parameters. As such, once backfill materials have been selected and/or stockpiled, sufficient shear tests should be conducted on samples of the proposed backfill materials to check that they conform to actual design values. Results should be provided to the designer to re-evaluate stability of the walls. Dependent upon test results, the designer may require modifications to the original wall design (e.g., longer reinforcement embedment lengths and/or steel reinforcement).
- 6.12.4 Wall foundations should be designed in accordance with Table 6.12.2 The walls should be deepened such that the bottom outside edge of the footing is at least 7 feet horizontally from the face of the slope.

**TABLE 6.12.2
SUMMARY OF MSE RETAINING WALL FOUNDATION RECOMMENDATIONS**

Parameter	Value
Minimum Retaining Wall Foundation Width	12 inches
Minimum Retaining Wall Foundation Depth	12 Inches
Bearing Capacity	2,000 psf
Bearing Capacity Increase	500 psf per Foot of Depth
	300 psf per Foot of Width
Maximum Bearing Capacity	4,000 psf
Estimated Total Settlement	1 Inch
Estimated Differential Settlement	½ Inch in 40 Feet

- 6.12.5 Backfill materials within the reinforced zone should be compacted to a dry density of at least 90 percent of the laboratory maximum dry density near to slightly above optimum moisture content in accordance with ASTM D 1557. This is applicable to the entire embedment width of the reinforcement. Typically, wall designers specify no heavy compaction equipment within 3 feet of the face of the wall. However, smaller equipment (e.g., walk-behind, self-driven compactors or hand whackers) can be used to compact the materials without causing deformation of the wall. If the designer specifies no compactive effort for this zone, the materials are essentially not properly compacted and the reinforcement grid within the uncompacted zone should not be relied upon for

reinforcement, and overall embedment lengths will have to be increased to account for the difference.

- 6.12.6 The wall should be provided with a drainage system sufficient to prevent excessive seepage through the wall and the base of the wall, thus preventing hydrostatic pressures behind the wall.
- 6.12.7 Geosynthetic reinforcement must elongate to develop full tensile resistance. This elongation generally results in movement at the top of the wall. The amount of movement is dependent on the height of the wall (e.g., higher walls rotate more) and the type of reinforcing grid used. In addition, over time the reinforcement grid has been known to exhibit creep (sometimes as much as 5 percent) and can undergo additional movement. Given this condition, the owner should be aware that structures and pavement placed within the reinforced and retained zones of the wall may undergo movement.
- 6.12.8 The MSE wall contractor should provide the estimated deformation of wall and adjacent ground in associated with wall construction. The calculated horizontal and vertical deformations should be determined by the wall designer. Where buildings are located adjacent to the walls, the estimated movements should be provided to the project structural engineer to evaluate if the building foundation can tolerate the expected movements. With respect to improvements adjacent to the wall, cracking and/or movement should be expected.
- 6.12.9 The MSE wall designer/contractor should review this report, including the slope stability requirements, and incorporate our recommendations as presented herein. We should be provided the plans for the MSE walls to check if they are in conformance with our recommendations prior to issuance of a permit and construction.

6.13 Soil Nail Walls

- 6.13.1 We understand soil nail walls are planned for the project. Soil nail walls consist of installing closely spaced steel bars (nails) into a slope or excavation in a top-down construction sequence. Following installation of a horizontal row of nails, drains, waterproofing and wall reinforcing steel are placed and shotcrete applied to create a final wall. The wall should be designed by an engineer familiar with the design of soil nail walls.
- 6.13.2 In general, ground conditions are moderately suited to soil nail wall construction techniques. However, localized gravel, cobble and oversized material could be encountered in the existing materials that could be difficult to drill. Additionally, relatively clean sands may be

encountered that may result in some raveling of the unsupported excavation. Casing or specialized drilling techniques should be planned where raveling exists (e.g. casing).

- 6.13.3 Testing of the soil nails should be performed in accordance with the guidelines of the Federal Highway Administration or similar guidelines. At least two verification tests should be performed to confirm design assumptions for each soil/rock type encountered. Verification tests nails should be sacrificial and should not be used to support the proposed wall. The bond length should be adjusted to allow for pullout testing of the verification nails to evaluate the ultimate bond stress. A minimum of 5 percent of the production nails should also be proof tested and a minimum of 4 sacrificial nails should be tested at the discretion of Geocon Incorporated. Consideration should be given to testing sacrificial nails with an adjusted bond length rather than testing production nails. Geocon Incorporated should observe the nail installation and perform the nail testing.
- 6.13.4 The soil strength parameters listed in Table 6.13 can be used in design of the soil nails. The bond stress is dependent on drilling method, diameter, and construction method. Therefore, the designer should evaluate the bond stress based on soil conditions and the construction method.

**TABLE 6.13
SOIL STRENGTH PARAMETERS FOR SOIL NAIL WALLS**

Description	Cohesion (psf)	Friction Angle (degrees)	Estimated Ultimate Bond Stress (psi)*
Previously Placed Fill	100	28	10
Alluvium	100	28	10
Very Old Paralic Deposits	200	33	20
San Diego Formation	200	33	20

*Assuming gravity fed, open hole drilling techniques.

- 6.13.5 A wall drain system should be incorporated into the design of the soil nail wall as shown herein. Corrosion protection should be provided for the nails.

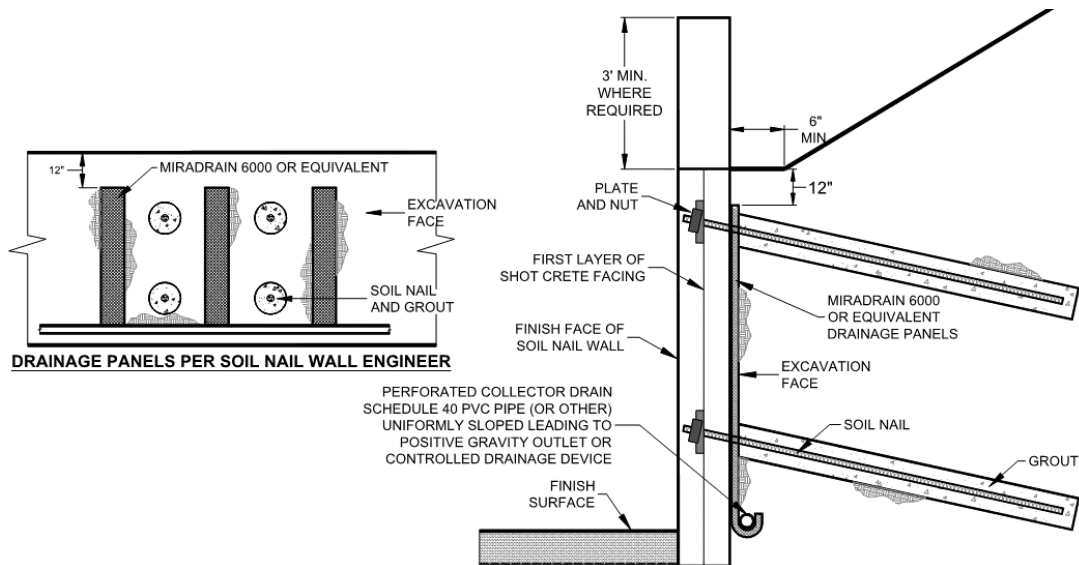

Soil Nail Wall Drainage Detail

6.14 Preliminary Pavement Recommendations

6.14.1 Preliminary pavement recommendations for the driveways and parking areas are provided below. The final pavement sections should be based on the R-Value of the subgrade soil encountered at final subgrade elevation. For preliminary design, we used a laboratory R-Value of 15. We calculated the preliminary flexible pavement sections for asphalt concrete using varying traffic indices (TIs) in general conformance with the *Caltrans Method of Flexible Pavement Design* (Highway Design Manual, Section 608.4). The project civil engineer or traffic engineer should determine the appropriate Traffic Index (TI) or traffic loading expected on the project for the various pavement areas that will be constructed. Recommended preliminary asphalt concrete pavement sections are provided on Table 6.14.1.

**TABLE 16.14.1
PRELIMINARY ASPHALT CONCRETE PAVEMENT SECTIONS**

Traffic Index	Asphalt Concrete (inches)	Class 2 Base (inches)
4.5	3	6
5	3	8
5.5	3	10
6	3.5	10.5
6.5	3.5	12.5
7	4	13
7.5	4.5	15
8	5	15

- 6.14.2 Asphalt concrete should conform to Section 203-6 of the *Standard Specifications for Public Works Construction* (Green Book). Class 2 aggregate base materials should conform to Section 26-1.02B of the *Standard Specifications of the State of California, Department of Transportation* (Caltrans).
- 6.14.3 Prior to placing base material, the subgrade should be scarified, moisture conditioned and recompacted to a minimum of 95 percent relative compaction. The depth of compaction should be at least 12 inches. The base material should be compacted to at least 95 percent relative compaction. Asphalt concrete should be compacted to a density of at least 95 percent of the laboratory Hveem density in accordance with ASTM D 2726.
- 6.14.4 A rigid Portland Cement concrete (PCC) pavement section can also be used. We calculated the rigid pavement section in general conformance with the procedure recommended by the American Concrete Institute report ACI 330R-08 Guide for Design and Construction of Concrete Parking Lots using the parameters presented in Table 6.14.2.

**TABLE 6.14.2
PRELIMINARY RIGID PAVEMENT DESIGN PARAMETERS**

Design Parameter	Design Value
Modulus of subgrade reaction, k	100 pci
Modulus of rupture for concrete, M_R	500 psi
Concrete Compressive Strength	3,000 psi
Traffic Category, TC	A and C
Average daily truck traffic, ADTT	10 and 300

- 6.14.5 Based on the criteria presented herein, the PCC pavement sections should have a minimum thickness as presented in Table 6.14.3.

**TABLE 6.14.3
RIGID VEHICULAR PAVEMENT RECOMMENDATIONS**

Location	Portland Cement Concrete (inches)
Automobile Parking Stalls (TC=A, ADTT=10)	5.5
Driveways (TC=C, ADTT=100)	7.5

- 6.14.6 The PCC vehicular pavement should be placed over subgrade soil that is compacted to a dry density of at least 95 percent of the laboratory maximum dry density near to slightly above optimum moisture content.
- 6.14.7 The rigid pavement should also be designed and constructed incorporating the parameters presented in Table 6.14.4.

**TABLE 6.14.4
ADDITIONAL RIGID PAVEMENT RECOMMENDATIONS**

Subject	Value
Thickened Edge	1.2 Times Slab Thickness
	Minimum Increase of 2 Inches
	4 Feet Wide
Crack Control Joint Spacing	30 Times Slab Thickness
	Max. Spacing of 12 feet for 5.5-Inch-Thick
	Max. Spacing of 15 Feet for Slabs 6 Inches and Thicker
Crack Control Joint Depth	Per ACI 330R-08
	1 Inch Using Early-Entry Saws on Slabs Less Than 9 Inches Thick
Crack Control Joint Width	¼-Inch for Sealed Joints
	⅜-Inch is Common for Sealed Joints
	1/10- to 1/8-Inch is Common for Unsealed Joints

- 6.14.8 Reinforcing steel will not be necessary within the concrete for geotechnical purposes with the possible exception of dowels at construction joints as discussed herein.
- 6.14.9 To control the location and spread of concrete shrinkage cracks, crack-control joints (weakened plane joints) should be included in the design of the concrete pavement slab. Crack-control joints should be sealed with an appropriate sealant to prevent the migration of water through the control joint to the subgrade materials. The depth of the crack-control joints should be determined by the referenced ACI report.
- 6.14.10 To provide load transfer between adjacent pavement slab sections, a butt-type construction joint should be constructed. The butt-type joint should be thickened by at least 20 percent at the edge and taper back at least 4 feet from the face of the slab. As an alternative to the butt-type construction joint, dowelling can be used between construction joints for pavements of 7 inches or thicker. As discussed in the referenced ACI guide, dowels should consist of

smooth, 1-inch-diameter reinforcing steel 14 inches long embedded a minimum of 6 inches into the slab on either side of the construction joint. Dowels should be located at the midpoint of the slab, spaced at 12 inches on center and lubricated to allow joint movement while still transferring loads. In addition, tie bars should be installed as recommended in Section 3.8.3 of the referenced ACI guide. The structural engineer should provide other alternative recommendations for load transfer.

- 6.14.11 Concrete curb/gutter should be placed on soil subgrade compacted to a dry density of at least 90 percent of the laboratory maximum dry density near to slightly above optimum moisture content. Cross-gutters that receives vehicular should be placed on subgrade soil compacted to a dry density of at least 95 percent of the laboratory maximum dry density near to slightly above optimum moisture content. Base materials should not be placed below the curb/gutter, or cross-gutters so water is not able to migrate from the adjacent parkways to the pavement sections. Where flatwork is located directly adjacent to the curb/gutter, the concrete flatwork should be structurally connected to the curbs to help reduce the potential for offsets between the curbs and the flatwork.

6.15 Exterior Concrete Flatwork

- 6.15.1 Exterior concrete flatwork not subject to vehicular traffic should be constructed in accordance with the recommendations presented in Table 6.15. The recommended steel reinforcement would help reduce the potential for cracking.

**TABLE 6.15
MINIMUM CONCRETE FLATWORK RECOMMENDATIONS**

Expansion Index, EI	Minimum Steel Reinforcement* Options	Minimum Thickness
EI ≤ 90	6x6-W2.9/W2.9 (6x6-6/6) welded wire mesh	4 Inches
	No. 3 Bars 18 inches on center, Both Directions	
EI ≤ 130	4x4-W4.0/W4.0 (4x4-4/4) welded wire mesh	
	No. 4 Bars 12 inches on center, Both Directions	

*In excess of 8 feet square.

- 6.15.2 Even with the incorporation of the recommendations of this report, the exterior concrete flatwork has a potential to experience some uplift due to expansive soil beneath grade. The steel reinforcement should overlap continuously in flatwork to reduce the potential for vertical offsets within flatwork. Additionally, flatwork should be structurally connected to the curbs, where possible, to reduce the potential for offsets between the curbs and the flatwork.

- 6.15.3 Concrete flatwork should be provided with crack control joints to reduce and/or control shrinkage cracking. Crack control spacing should be determined by the project structural engineer based upon the slab thickness and intended usage. Criteria of the American Concrete Institute (ACI) should be taken into consideration when establishing crack control spacing. Subgrade soil for exterior slabs not subjected to vehicle loads should be compacted in accordance with criteria presented in the grading section prior to concrete placement. Subgrade soil should be properly compacted, and the moisture content of subgrade soil should be verified prior to placing concrete. Base materials will not be required below concrete improvements.
- 6.15.4 Where exterior flatwork abuts the structure at entrant or exit points, the exterior slab should be dowelled into the structure's foundation stemwall. This recommendation is intended to reduce the potential for differential elevations that could result from differential settlement or minor heave of the flatwork. Dowelling details should be designed by the project structural engineer.
- 6.15.5 The recommendations presented herein are intended to reduce the potential for cracking of exterior slabs as a result of differential movement. However, even with the incorporation of the recommendations presented herein, slabs-on-grade will still crack. The occurrence of concrete shrinkage cracks is independent of the soil supporting characteristics. Their occurrence may be reduced and/or controlled by limiting the slump of the concrete, the use of crack control joints and proper concrete placement and curing. Crack control joints should be spaced at intervals no greater than 12 feet. Literature provided by the Portland Concrete Association (PCA) and American Concrete Institute (ACI) present recommendations for proper concrete mix, construction, and curing practices, and should be incorporated into project construction.

6.16 Slope Maintenance

- 6.16.1 Slopes that are steeper than 3:1 (horizontal:vertical) may, under conditions which are both difficult to prevent and predict, be susceptible to near surface (surficial) slope instability. The instability is typically limited to the outer three feet of a portion of the slope and usually does not directly impact the improvements on the pad areas above or below the slope. The occurrence of surficial instability is more prevalent on fill slopes and is generally preceded by a period of heavy rainfall, excessive irrigation, or the migration of subsurface seepage. The disturbance and/or loosening of the surficial soils, as might result from root growth, soil expansion, or excavation for irrigation lines and slope planting, may also be a significant contributing factor to surficial instability. It is, therefore, recommended that, to the maximum extent practical: (a) disturbed/loosened surficial soils be either removed or properly recompacted, (b) irrigation systems be periodically inspected and maintained to

eliminate leaks and excessive irrigation, and (c) surface drains on and adjacent to slopes be periodically maintained to preclude ponding or erosion. Although the incorporation of the above recommendations should reduce the potential for surficial slope instability, it will not eliminate the possibility, and, therefore, it may be necessary to rebuild or repair a portion of the project's slopes in the future.

6.17 Storm Water Management

- 6.17.1 If storm water management devices are not properly designed and constructed, there is a risk for distress to improvements and property located hydrologically down gradient or adjacent to these devices. Factors such as the amount of water being detained, its residence time, and soil permeability have an important effect on seepage transmission and the potential adverse impacts that may occur if the storm water management features are not properly designed and constructed. We have not performed a hydrogeological study at the site. If infiltration of storm water runoff into the subsurface occurs, downstream improvements may be subjected to seeps, springs, slope instability, raised groundwater, movement of foundations and slabs, or other undesirable impacts as a result of water infiltration.
- 6.17.2 We did not perform an infiltration study on the property. However, based on predicted site conditions at the completion of grading, full and partial infiltration is considered infeasible due to the presence of deep fills surrounded by MSE walls at the down-gradient end of the site. Basins or other storm water devices should utilize a liner to prevent infiltration from causing adverse settlement and heave, and migrating to utilities, and foundations.

6.18 Site Drainage and Moisture Protection

- 6.18.1 Adequate site drainage is critical to reduce the potential for differential soil movement, erosion and subsurface seepage. Under no circumstances should water be allowed to pond adjacent to footings. The site should be graded and maintained such that surface drainage is directed away from structures in accordance with 2019 CBC 1803.3 or other applicable standards. In addition, surface drainage should be directed away from the top of slopes into swales or other controlled drainage devices. Roof and pavement drainage should be directed into conduits that carry runoff away from the proposed structure.
- 6.18.2 In the case of basement walls or building walls retaining landscaping areas, a water-proofing system should be used on the wall and joints, and a Miradrain drainage panel (or similar) should be placed over the waterproofing. The project architect or civil engineer should provide detailed specifications on the plans for all waterproofing and drainage.

- 6.18.3 Underground utilities should be leak free. Utility and irrigation lines should be checked periodically for leaks, and detected leaks should be repaired promptly. Detrimental soil movement could occur if water is allowed to infiltrate the soil for prolonged periods of time.
- 6.18.4 Landscaping planters adjacent to paved areas are not recommended due to the potential for surface or irrigation water to infiltrate the pavement's subgrade and base course. We recommend that subdrains to collect excess irrigation water and transmit it to drainage structures, or impervious above-grade planter boxes be used. In addition, where landscaping is planned adjacent to the pavement, we recommend construction of a cutoff wall along the edge of the pavement that extends at least 6 inches below the bottom of the base material.

6.19 Grading and Foundation Plan Review

- 6.19.1 Geocon Incorporated should review the grading plans and foundation plans for the project prior to final design submittal to evaluate whether additional analyses and/or recommendations are required.

LIMITATIONS AND UNIFORMITY OF CONDITIONS

1. The firm that performed the geotechnical investigation for the project should be retained to provide testing and observation services during construction to provide continuity of geotechnical interpretation and to check that the recommendations presented for geotechnical aspects of site development are incorporated during site grading, construction of improvements, and excavation of foundations. If another geotechnical firm is selected to perform the testing and observation services during construction operations, that firm should prepare a letter indicating their intent to assume the responsibilities of project geotechnical engineer of record. A copy of the letter should be provided to the regulatory agency for their records. In addition, that firm should provide revised recommendations concerning the geotechnical aspects of the proposed development, or a written acknowledgement of their concurrence with the recommendations presented in our report. They should also perform additional analyses deemed necessary to assume the role of Geotechnical Engineer of Record.
2. The recommendations of this report pertain only to the site investigated and are based upon the assumption that the soil conditions do not deviate from those disclosed in the investigation. If any variations or undesirable conditions are encountered during construction, or if the proposed construction will differ from that anticipated herein, Geocon Incorporated should be notified so that supplemental recommendations can be given. The evaluation or identification of the potential presence of hazardous or corrosive materials was not part of the scope of services provided by Geocon Incorporated.
3. This report is issued with the understanding that it is the responsibility of the owner or his representative to ensure that the information and recommendations contained herein are brought to the attention of the architect and engineer for the project and incorporated into the plans, and the necessary steps are taken to see that the contractor and subcontractors carry out such recommendations in the field.
4. The findings of this report are valid as of the present date. However, changes in the conditions of a property can occur with the passage of time, whether they be due to natural processes or the works of man on this or adjacent properties. In addition, changes in applicable or appropriate standards may occur, whether they result from legislation or the broadening of knowledge. Accordingly, the findings of this report may be invalidated wholly or partially by changes outside our control. Therefore, this report is subject to review and should not be relied upon after a period of three years.

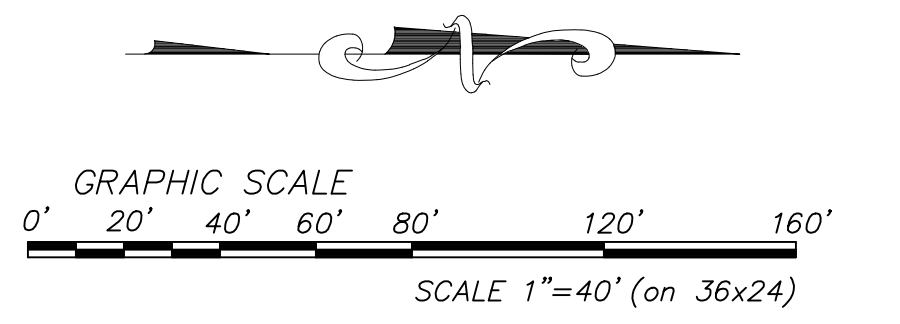
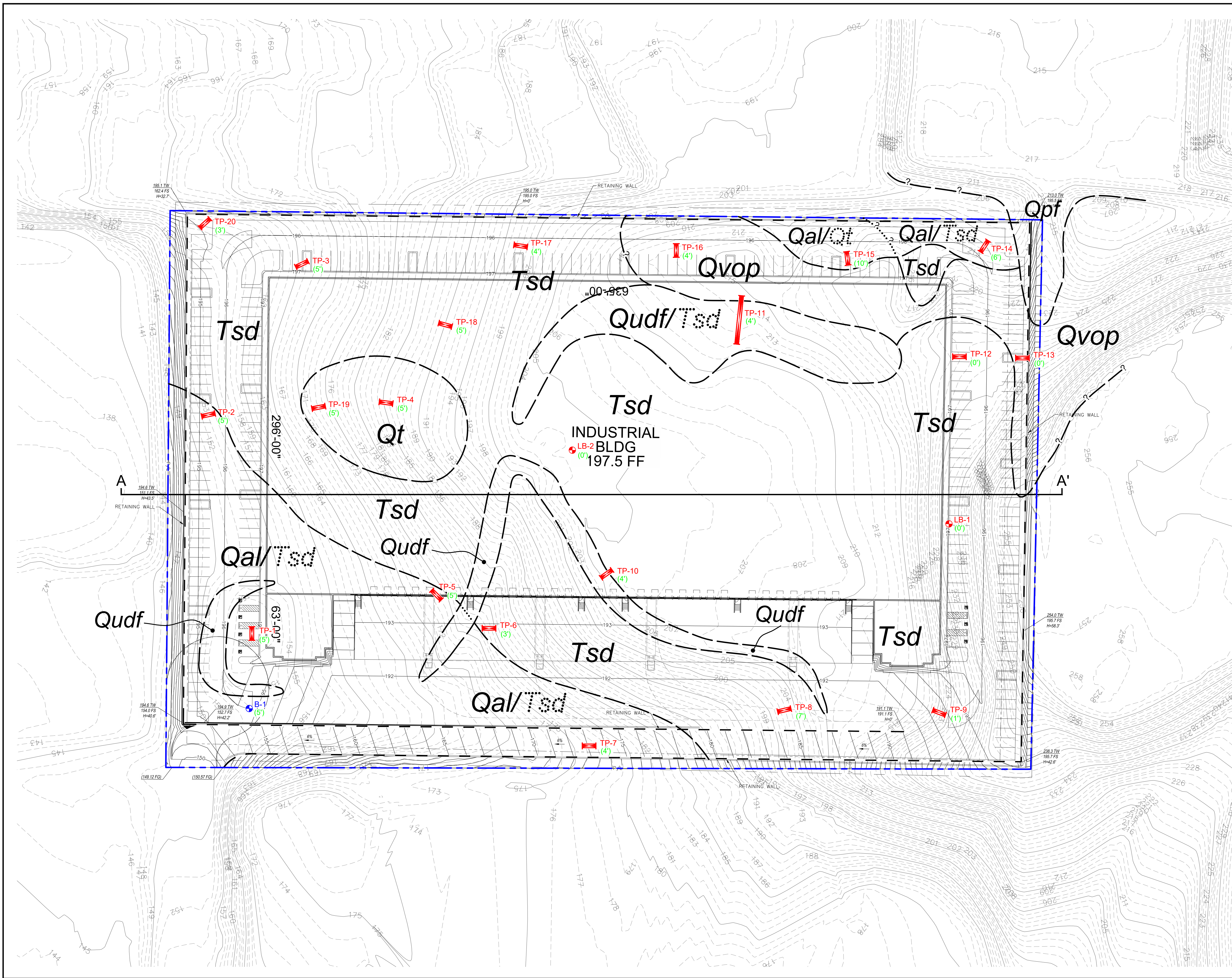

GEOCON LEGEND

- Qudf**.....UNDOCUMENTED FILL
- Qpf**.....PREVIOUSLY PLACED FILL
- Qal**.....ALLUVIUM
- Qvop**.....VERY OLD PARALIC DEPOSITS
- Qt**.....TERRACE DEPOSITS
(Dotted Where Buried)
- Tsd**.....SAN DIEGO FORMATION
(Dotted Where Buried)
-APPROX. LOCATION OF GEOLOGIC CONTACT
(Dotted Where Buried, Queried Where Uncertain)
- B-1**.....APPROX. LOCATION OF BORING
- LB-2**.....APPROX. LOCATION OF LARGE DIAMETER BORING
- TP-20**.....APPROX. LOCATION OF TRENCH
- (5)**.....APPROX. DEPTH OF REMEDIAL GRADING (In Feet)
- A-A'**.....APPROX. LOCATION OF GEOLOGIC CROSS SECTION

GEOLOGIC MAP
SHINOHARA INDUSTRIAL BUILDING
517 SHINOHARA LANE
SAN DIEGO, CALIFORNIA

GEOCON INCORPORATED GEO TECHNICAL ■ ENVIRONMENTAL ■ MATERIALS 6940 FLANDERS DRIVE ■ SAN DIEGO, CALIFORNIA 92121-2974 PHONE 619.538.6900 ■ FAX 619.538.6159	 PROJECT NO. G2762 - 42 - 01 SHEET 1 OF 1	SCALE 1" = 40' DATE 07 - 28 - 2021 FIGURE 1
-------------------------------------------------------------------------------------------------------------------------------------------------------------------------------	-------------------------------------------------	---------------------------------------------------

Printed 07/27/2021 9:20AM | By ALVIN LADRILLON | File Location: Y:\PROJECTS\G2762-42-01 (Shinohara Lane)\SHEETS\G2762-42-01 Geo Map.dwg

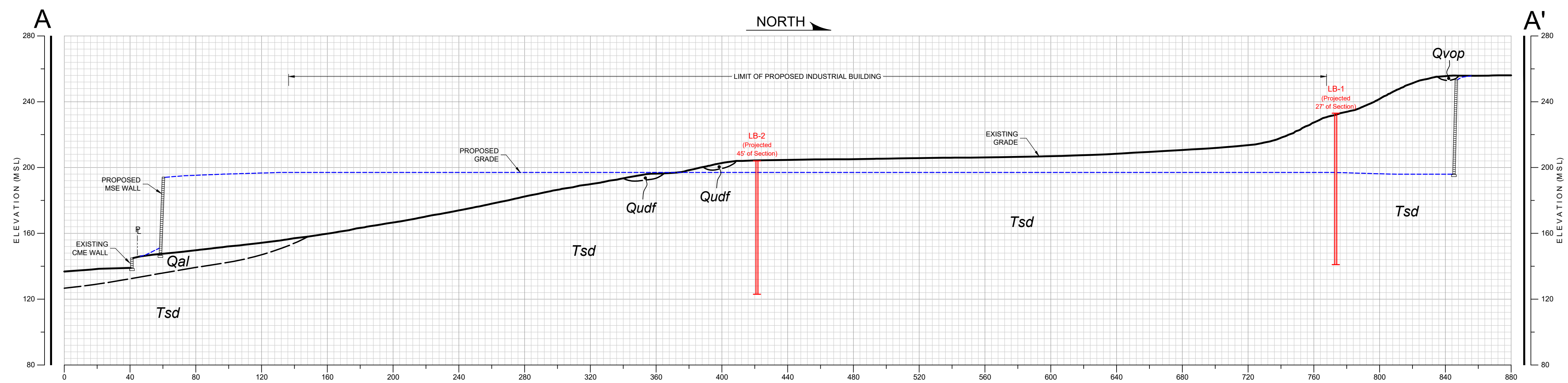

GEOCON LEGEND

<i>Qudf</i> UNDOCUMENTED FILL
<i>Qal</i> ALLUVIUM
<i>Qvop</i> VERY OLD PARALIC DEPOSITS
<i>Tsd</i> SAN DIEGO FORMATION
~ APPROX. LOCATION OF GEOLOGIC CONTACT
LB-1 APPROX. LOCATION OF LARGE DIAMETER BORING

GEOLOGIC CROSS SECTION
 SHINOHARA INDUSTRIAL BUILDING
 517 SHINOHARA LANE
 SAN DIEGO, CALIFORNIA

 <small>GEOCON INCORPORATED GEOTECHNICAL ■ ENVIRONMENTAL ■ MATERIALS 6960 FLANDERS DRIVE - SAN DIEGO, CALIFORNIA 92121 - 2974 PHONE 619-558-6900 - FAX 619-558-6159</small>	SCALE 1" = 40'	DATE 07 - 28 - 2021
	PROJECT NO. G2762 - 42 - 01	FIGURE 2
SHEET 1 OF 1		

Plotted 07/27/2021 9:07AM | By ALVIN LADRILLON | File Location: Y:\PROJECTS\G2762-42-01\517 Shinohara Lane\SHEETS\G2762-42-01.XSection.dwg

APPENDIX

A

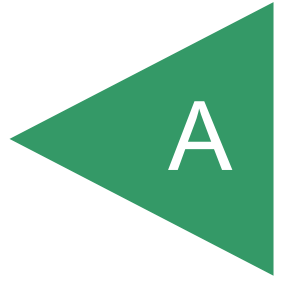

APPENDIX A

FIELD INVESTIGATION

We performed our field investigation between June 30 and July 7, 2021. Our investigation consisted of a site reconnaissance, logging of 20 exploratory test pits, two large diameter borings and one small diameter boring. The exploratory test pits were excavated to depths between 2- and 16-feet using a rubber-tire Caterpillar 430F backhoe. Exploratory borings were drilled to depths between 20- and 92-feet using truck mounted hollow stem and bucket auger drill rigs. The approximate locations of the exploratory test pits borings tests are shown on Figure 1.

The soil conditions encountered in the trenches were visually examined, classified, and logged in general conformance with the American Society for Testing and Materials (ASTM) Practice for Description and Identification of Soils (Visual-Manual Procedure D 2488). Exploratory boring logs are presented in Figures A-1 through A-3, and test pit logs are presented on Figures A-4 through A-23. The logs depict the various soil types encountered and indicate the depths at which samples were obtained.













DEPTH IN FEET	SAMPLE NO.	LITHOLOGY	GROUNDWATER	SOIL CLASS (USCS)	BORING B 1		PENETRATION RESISTANCE (BLOWS/FT.)	DRY DENSITY (P.C.F.)	MOISTURE CONTENT (%)
					ELEV. (MSL.) <u>153'</u>	DATE COMPLETED <u>07-07-2021</u>			
					EQUIPMENT <u>IR A-300</u>		BY: <u>B. KUNA</u>		
MATERIAL DESCRIPTION									
0				SC	ALLUVIUM (Qal) Medium dense, moist, reddish-brown, Clayey, fine to medium SAND; little silt				
2	B1-1						37		
4	B1-2						67		
6					-At 5.5 feet: becomes dense				
8	B1-3						78	120.0	8.3
10	B1-4						91/11.5"	117.7	8.1
12					-At 10.5 feet: becomes very dense				
14									
16	B1-5						50/6"	120.0	9.5
18	B1-6						78/10"		
20					BORING TERMINATED AT 20 FEET Groundwater not encountered Backfilled with drill cuttings on 07-07-2021				

Figure A-1,
Log of Boring B 1, Page 1 of 1

G2762-42-01.GPJ







SAMPLE SYMBOLS	 ... SAMPLING UNSUCCESSFUL	 ... STANDARD PENETRATION TEST	 ... DRIVE SAMPLE (UNDISTURBED)
	 ... DISTURBED OR BAG SAMPLE	 ... CHUNK SAMPLE	 ... WATER TABLE OR  ... SEEPAGE

NOTE: THE LOG OF SUBSURFACE CONDITIONS SHOWN HEREON APPLIES ONLY AT THE SPECIFIC BORING OR TRENCH LOCATION AND AT THE DATE INDICATED. IT IS NOT WARRANTED TO BE REPRESENTATIVE OF SUBSURFACE CONDITIONS AT OTHER LOCATIONS AND TIMES.

DEPTH IN FEET	SAMPLE NO.	LITHOLOGY	GROUNDWATER	SOIL CLASS (USCS)	BORING LB 1		PENETRATION RESISTANCE (BLOWS/FT.)	DRY DENSITY (P.C.F.)	MOISTURE CONTENT (%)
					ELEV. (MSL.) <u>233'</u>	DATE COMPLETED <u>07-05-2021</u>			
					EQUIPMENT <u>EZ BORE</u>		BY: <u>R. ADAMS</u>		
MATERIAL DESCRIPTION									
0				SM	SAN DIEGO FORMATION (Tsd) Dense, damp, pale yellowish-brown to grayish-brown, Silty, very fine grained SANDSTONE; massive, powdery texture, micaceous				
2									
4									
6									
8				SM	-At 7.5 feet: 1-inch thick orangish-brown sand bed; Bedding: N28W/14°SW Dense, damp, pale yellowish-brown to orangish-brown, Silty, fine to medium SANDSTONE; trace gravel (subrounded) up to 4-inch diameter; trace clay, few closed fractures <1/16" thick				
10	LB1-1			SM	Dense, damp, grayish-white, Silty, very fine grained SANDSTONE; massive, highly micaceous		3	104.7	12.8
12									
14									
16									
18				SP	Dense, damp, white to blackish-brown, medium to coarse SANDSTONE; laminated, low cohesion, trace fine gravel; Bedding: N25W/9°SW				
20	LB1-2						5	97.8	4.3
22					-At 21 feet: band of orangish-brown, coarse sand; cross-bedded with subangular gravel lenses, very low cohesion				
24									
26				SP	Dense, dry to damp, orange to dark reddish-brown, medium coarse SANDSTONE; laminated and cross bedded, micaceous, low cohesion, basal contact N30W/20°SW				
28				SM	Dense, damp, grayish-white, Silty, very fine grained SANDSTONE; micaceous				

Figure A-2,
Log of Boring LB 1, Page 1 of 4

G2762-42-01.GPJ

SAMPLE SYMBOLS	 ... SAMPLING UNSUCCESSFUL	 ... STANDARD PENETRATION TEST	 ... DRIVE SAMPLE (UNDISTURBED)
	 ... DISTURBED OR BAG SAMPLE	 ... CHUNK SAMPLE	 ... WATER TABLE OR  ... SEEPAGE

NOTE: THE LOG OF SUBSURFACE CONDITIONS SHOWN HEREON APPLIES ONLY AT THE SPECIFIC BORING OR TRENCH LOCATION AND AT THE DATE INDICATED. IT IS NOT WARRANTED TO BE REPRESENTATIVE OF SUBSURFACE CONDITIONS AT OTHER LOCATIONS AND TIMES.

DEPTH IN FEET	SAMPLE NO.	LITHOLOGY	GROUNDWATER	SOIL CLASS (USCS)	BORING LB 1		PENETRATION RESISTANCE (BLOWS/FT.)	DRY DENSITY (P.C.F.)	MOISTURE CONTENT (%)
					ELEV. (MSL.) <u>233'</u>	DATE COMPLETED <u>07-05-2021</u>			
					EQUIPMENT <u>EZ BORE</u> BY: <u>R. ADAMS</u>				
MATERIAL DESCRIPTION									
30	LB1-3			SP	Dense to very dense, damp, dark reddish-brown to orangish-brown, fine to medium SANDSTONE; massive to weakly laminated, bottom contact N11W/17°W		7		
32									
34					SM	Dense, damp, whitish-gray, Silty, very fine grained SANDSTONE; laminated, highly micaceous with pockets of 100% biotite/muscovite mica			
36						-At 36 feet: 2-inch thick fine gravel bed; <1/2" subrounded to subangular gravel			
38									
40	LB1-4				-At 40 feet: becomes weakly cemented with moderate cohesion		8	87.3	5.7
42									
44						-At 44 feet: trace subrounded gravel			
46						-At 46 feet: multiple krotovina			
48									
50	LB1-5				-At 48 to 50 feet: few dark reddish-brown to orangish-brown, fine sandstone interbeds, laminated, soft sediment load structures present; Bedding: N30W/7°SW		8		
52					SM	Dense to very dense, damp, grayish-white, Silty, very fine grained SANDSTONE; massive, micaceous, small irregular pockets of yellowish white, silt present white some oxidation staining, trace subangular fine gravel			
54									
56									
58									

Figure A-2,
Log of Boring LB 1, Page 2 of 4

G2762-42-01.GPJ

SAMPLE SYMBOLS	... SAMPLING UNSUCCESSFUL	... STANDARD PENETRATION TEST	... DRIVE SAMPLE (UNDISTURBED)
	... DISTURBED OR BAG SAMPLE	... CHUNK SAMPLE	... WATER TABLE OR ... SEEPAGE

NOTE: THE LOG OF SUBSURFACE CONDITIONS SHOWN HEREON APPLIES ONLY AT THE SPECIFIC BORING OR TRENCH LOCATION AND AT THE DATE INDICATED. IT IS NOT WARRANTED TO BE REPRESENTATIVE OF SUBSURFACE CONDITIONS AT OTHER LOCATIONS AND TIMES.

DEPTH IN FEET	SAMPLE NO.	LITHOLOGY	GROUNDWATER	SOIL CLASS (USCS)	BORING LB 1		PENETRATION RESISTANCE (BLOWS/FT.)	DRY DENSITY (P.C.F.)	MOISTURE CONTENT (%)
					ELEV. (MSL.) <u>233'</u>	DATE COMPLETED <u>07-05-2021</u>			
					EQUIPMENT <u>EZ BORE</u> BY: <u>R. ADAMS</u>				
MATERIAL DESCRIPTION									
60				SM					
62									
64									
66					SM	Very dense, damp, orange-brown to reddish-brown, Silty, fine to medium SANDSTONE; several coarse sand interbeds, massive, micaceous			
68									
70	LB1-6					-At 71 to 72 feet: 1-foot thick yellowish-orange, siltstone bed; Bedding: N20W/14°SW		15	
72									
74					SM	Dense, damp, grayish-white, Silty, very fine grained SANDSTONE; massive, micaceous, low cohesion; Bedding: N10W/21°W			
76									
78									
80									
82									
84					-At 84 to 88 feet: few thin subrounded gravel beds				
86									
88									

Figure A-2,
Log of Boring LB 1, Page 3 of 4

G2762-42-01.GPJ







SAMPLE SYMBOLS	... SAMPLING UNSUCCESSFUL	... STANDARD PENETRATION TEST	... DRIVE SAMPLE (UNDISTURBED)
	... DISTURBED OR BAG SAMPLE	... CHUNK SAMPLE	... WATER TABLE OR ... SEEPAGE

NOTE: THE LOG OF SUBSURFACE CONDITIONS SHOWN HEREON APPLIES ONLY AT THE SPECIFIC BORING OR TRENCH LOCATION AND AT THE DATE INDICATED. IT IS NOT WARRANTED TO BE REPRESENTATIVE OF SUBSURFACE CONDITIONS AT OTHER LOCATIONS AND TIMES.

DEPTH IN FEET	SAMPLE NO.	LITHOLOGY	GROUNDWATER	SOIL CLASS (USCS)	BORING LB 1 ELEV. (MSL.) <u>233'</u> DATE COMPLETED <u>07-05-2021</u> EQUIPMENT <u>EZ BORE</u> BY: <u>R. ADAMS</u>	PENETRATION RESISTANCE (BLOWS/FT.)	DRY DENSITY (P.C.F.)	MOISTURE CONTENT (%)
90	LB1-7			SM	MATERIAL DESCRIPTION	20		
92					BORING TERMINATED AT 92 FEET Groundwater not encountered Backfilled on 07-05-2021			

**Figure A-2,
Log of Boring LB 1, Page 4 of 4**

G2762-42-01.GPJ







SAMPLE SYMBOLS	 ... SAMPLING UNSUCCESSFUL	 ... STANDARD PENETRATION TEST	 ... DRIVE SAMPLE (UNDISTURBED)
	 ... DISTURBED OR BAG SAMPLE	 ... CHUNK SAMPLE	 ... WATER TABLE OR  ... SEEPAGE

NOTE: THE LOG OF SUBSURFACE CONDITIONS SHOWN HEREON APPLIES ONLY AT THE SPECIFIC BORING OR TRENCH LOCATION AND AT THE DATE INDICATED. IT IS NOT WARRANTED TO BE REPRESENTATIVE OF SUBSURFACE CONDITIONS AT OTHER LOCATIONS AND TIMES.

DEPTH IN FEET	SAMPLE NO.	LITHOLOGY	GROUNDWATER	SOIL CLASS (USCS)	BORING LB 2		PENETRATION RESISTANCE (BLOWS/FT.)	DRY DENSITY (P.C.F.)	MOISTURE CONTENT (%)
					ELEV. (MSL.) 204'	DATE COMPLETED 07-06-2021			
					EQUIPMENT EZ BORE	BY: R. ADAMS			
MATERIAL DESCRIPTION									
0				SM	SAN DIEGO FORMATION (Tsd) Dense, dry to damp, orange-brown to reddish-brown, Silty, fine to medium SANDSTONE; laminated, slightly bioturbated with pockets of biotite/muscovite mica; Bedding: N30W/14°SW				
2									
4									
6				SP	Dense, dry to damp, orange-brown, Silty, medium coarse SANDSTONE; some subrounded gravel, laminated, low cohesion				
8				SM	Dense to very dense, damp, grayish-white to pale yellowish-white, silty, fine SANDSTONE; highly micaceous, cross-bedded				
10	LB2-1				-At 9 feet: becomes orange-brown to reddish-brown -At 10 feet: 2-inch thick subrounded/subangular gravel bed		5		
12				SM	Dense, damp, whitish-gray, Silty, very fine grained SANDSTONE; highly micaceous, powdery texture, moderate cohesion, pocket of biotite/muscovite, mica throughout, trace 1/4"-1/5" subrounded gravel				
14									
16									
18									
20	LB2-2						4		
22					-At 22 feet: medium to coarse, reddish-brown sandstone bed; Bedding: N5E/11°W				
24					-At 24 to 26 feet: some bioturbation				
26									
28					-At 27 feet: becomes massive				

Figure A-3,
Log of Boring LB 2, Page 1 of 3

G2762-42-01.GPJ

SAMPLE SYMBOLS	 ... SAMPLING UNSUCCESSFUL	 ... STANDARD PENETRATION TEST	 ... DRIVE SAMPLE (UNDISTURBED)
	 ... DISTURBED OR BAG SAMPLE	 ... CHUNK SAMPLE	 ... WATER TABLE OR  ... SEEPAGE

NOTE: THE LOG OF SUBSURFACE CONDITIONS SHOWN HEREON APPLIES ONLY AT THE SPECIFIC BORING OR TRENCH LOCATION AND AT THE DATE INDICATED. IT IS NOT WARRANTED TO BE REPRESENTATIVE OF SUBSURFACE CONDITIONS AT OTHER LOCATIONS AND TIMES.

DEPTH IN FEET	SAMPLE NO.	LITHOLOGY	GROUNDWATER	SOIL CLASS (USCS)	BORING LB 2		PENETRATION RESISTANCE (BLOWS/FT.)	DRY DENSITY (P.C.F.)	MOISTURE CONTENT (%)
					ELEV. (MSL.) <u>204'</u>	DATE COMPLETED <u>07-06-2021</u>			
					EQUIPMENT <u>EZ BORE</u>		BY: <u>R. ADAMS</u>		
MATERIAL DESCRIPTION									
30				SM					
32									
34									
36									
38					SM	Dense, damp, bluish-gray, Silty, fine to medium SANDSTONE; some subrounded cobble up to 8-inch diameter, moderately lubricated; Bedding: N10E/15°W			
40	LB2-3				SM	Dense, damp, whitish-gray, Silty, very fine grained SANDSTONE; massive to weakly laminated, minor bioturbation	10		
42				SM	Very dense, damp, pale yellowish-brown, Silty, fine to medium SANDSTONE; few coarse grained laminate				
44									
46				SP	Dense, dry to damp, orange-brown to grayish-brown, medium to coarse SANDSTONE; cross-bedded, low cohesion, few subrounded and imbricated clay rip clasts 1/2"-3" long; Bedding: NS/10°W				
48									
50				SM	Very dense, damp, orange-brown, Silty, very fine grained SANDSTONE; massive -At 49 feet: contact is offset 4-inch along high angle closed fracture; Fracture: N310E/Vertical, Bedding: N10W/11°W				
52									
54									
56									
58									
					-At 59 to 60 feet: trace subrounded cobble up to 4-inch diameter				

Figure A-3,
Log of Boring LB 2, Page 2 of 3

G2762-42-01.GPJ

SAMPLE SYMBOLS	... SAMPLING UNSUCCESSFUL	... STANDARD PENETRATION TEST	... DRIVE SAMPLE (UNDISTURBED)
	... DISTURBED OR BAG SAMPLE	... CHUNK SAMPLE	... WATER TABLE OR ... SEEPAGE

NOTE: THE LOG OF SUBSURFACE CONDITIONS SHOWN HEREON APPLIES ONLY AT THE SPECIFIC BORING OR TRENCH LOCATION AND AT THE DATE INDICATED. IT IS NOT WARRANTED TO BE REPRESENTATIVE OF SUBSURFACE CONDITIONS AT OTHER LOCATIONS AND TIMES.

DEPTH IN FEET	SAMPLE NO.	LITHOLOGY	GROUNDWATER	SOIL CLASS (USCS)	BORING LB 2 ELEV. (MSL.) <u>204'</u> DATE COMPLETED <u>07-06-2021</u> EQUIPMENT <u>EZ BORE</u> BY: <u>R. ADAMS</u>	PENETRATION RESISTANCE (BLOWS/FT.)	DRY DENSITY (P.C.F.)	MOISTURE CONTENT (%)
MATERIAL DESCRIPTION								
60	LB2-4			SM		18		
62								
64					-At 64 feet: becomes bluish-gray to whitish-gray, Silty, very fine grained SANDSTONE; Bedding: N10W/12°W			
66								
68				SM	Very dense, damp, grayish-brown to bluish-gray, Silty, fine to medium SANDSTONE; massive, oxidation mottling in bioturbated areas			
70								
72								
74								
76								
78								
80	LB2-5					20		
BORING TERMINATED AT 81 FEET Groundwater not encountered Backfilled on 07-06-2021								

Figure A-3,
Log of Boring LB 2, Page 3 of 3

G2762-42-01.GPJ







SAMPLE SYMBOLS	... SAMPLING UNSUCCESSFUL	... STANDARD PENETRATION TEST	... DRIVE SAMPLE (UNDISTURBED)
	... DISTURBED OR BAG SAMPLE	... CHUNK SAMPLE	... WATER TABLE OR ... SEEPAGE

NOTE: THE LOG OF SUBSURFACE CONDITIONS SHOWN HEREON APPLIES ONLY AT THE SPECIFIC BORING OR TRENCH LOCATION AND AT THE DATE INDICATED. IT IS NOT WARRANTED TO BE REPRESENTATIVE OF SUBSURFACE CONDITIONS AT OTHER LOCATIONS AND TIMES.

DEPTH IN FEET	SAMPLE NO.	LITHOLOGY	GROUNDWATER	SOIL CLASS (USCS)	TEST PIT TP 1		PENETRATION RESISTANCE (BLOWS/FT.)	DRY DENSITY (P.C.F.)	MOISTURE CONTENT (%)
					ELEV. (MSL.) <u>152'</u>	DATE COMPLETED <u>06-30-2021</u>			
					EQUIPMENT <u>BACKHOE CAT 430F</u>		BY: <u>R. ADAMS</u>		
MATERIAL DESCRIPTION									
0				SC	ALLUVIUM (Qal) Medium dense, dry to damp, reddish-brown, Clayey, fine to medium SAND; abundant caliche, some silt, blocky, slightly porous.				
2	TP1-1				-At 2 feet: becomes moist				
4					-At 3 feet: clay films and manganese films on parting surface pockets/lenses of sandy clay present				
6					-At 6 feet: occasional subrounded gravel				
8					-At 9 feet: pin-hole porosity and manganese films present with blocky structure and trace subrounded gravel, no caliche				
10	TP1-2			SM	Dense, damp, yellowish-brown, Silty, fine to medium SAND; trace clay, trace subrounded gravel				
12					-At 11 feet: becomes weakly cemented, cobble up to 6-inch diameter				
14				SM	SAN DIEGO FORMATION (Tsd) Dense, damp, pale yellowish-brown to whitish-brown, Silty, fine SANDSTONE; massive, weakly bioturbated, trace angular gravel				
16					TRENCH TERMINATED AT 16 FEET Groundwater not encountered Backfilled on 06-30-2021				

Figure A-4,
Log of Test Pit TP 1, Page 1 of 1

G2762-42-01.GPJ

SAMPLE SYMBOLS	 ... SAMPLING UNSUCCESSFUL	 ... STANDARD PENETRATION TEST	 ... DRIVE SAMPLE (UNDISTURBED)
	 ... DISTURBED OR BAG SAMPLE	 ... CHUNK SAMPLE	 ... WATER TABLE OR  ... SEEPAGE

NOTE: THE LOG OF SUBSURFACE CONDITIONS SHOWN HEREON APPLIES ONLY AT THE SPECIFIC BORING OR TRENCH LOCATION AND AT THE DATE INDICATED. IT IS NOT WARRANTED TO BE REPRESENTATIVE OF SUBSURFACE CONDITIONS AT OTHER LOCATIONS AND TIMES.

NOTE: THE LOG OF SUBSURFACE CONDITIONS SHOWN HEREON APPLIES ONLY AT THE SPECIFIC BORING OR TRENCH LOCATION AND AT THE DATE INDICATED. IT IS NOT WARRANTED TO BE REPRESENTATIVE OF SUBSURFACE CONDITIONS AT OTHER LOCATIONS AND TIMES.

SAMPLE SYMBOLS	
	... SAMPLING UNSUCCESSFUL
	... DISTURBED OR BAG SAMPLE
	... CHUNK SAMPLE
	... STANDARD PENETRATION TEST
	... DRIVE SAMPLE (UNDISTURBED)
	... WATER TABLE OR ... SEEPAGE

Figure A-5,
Log of Test Pit TP 2, Page 1 of 1

G2762-42-01.GPJ

DEPTH IN FEET	SAMPLE NO.	LITHOLOGY	GROUNDWATER	SOIL CLASS (USCS)	MATERIAL DESCRIPTION	TEST PIT TP 2
0				ML	TOPSOIL Firm, dry, pale brown, fine Sandy SILT; trace gravel and cobble	ELEV. (MSL.) 153' DATE COMPLETED 06-30-2021 BY: R. ADAMS EQUIPMENT BACKHOE CAT 430F
2				SM	ALLUVIUM (Qal) Dense, dry to damp, yellowish-brown, Silty, fine SAND; trace subrounded to subangular gravel, some porosity	
4	TP2-1			SM		
8				SM		
10	TP2-2			SM	SAN DIEGO FORMATION (Tsd) Very dense, damp, yellowish-brown, Silty, very fine grained SAND; trace porosity, few clay lined burrows and abundant oxidant mottling	
12					TRENCH TERMINATED AT 12 FEET Groundwater not encountered Backfilled on 06-30-2021	
						MOISTURE CONTENT (%)
						DRY DENSITY (P.C.F.)
						PENETRATION RESISTANCE (BLOWS/FT.)







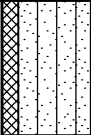
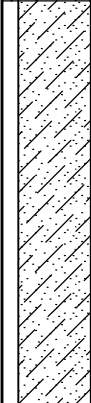
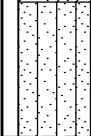
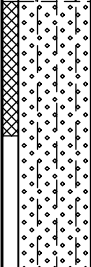

DEPTH IN FEET	SAMPLE NO.	LITHOLOGY	GROUNDWATER	SOIL CLASS (USCS)	TEST PIT TP 3		PENETRATION RESISTANCE (BLOWS/FT.)	DRY DENSITY (P.C.F.)	MOISTURE CONTENT (%)
					ELEV. (MSL.) <u>165'</u>	DATE COMPLETED <u>06-30-2021</u>			
					EQUIPMENT <u>BACKHOE CAT 430F</u>		BY: <u>R. ADAMS</u>		
MATERIAL DESCRIPTION									
0	TP3-1			ML	TOPSOIL Firm dry, pale pinkish-brown to grayish brown, fine to medium Sandy SILT; porous				
2				SC	ALLUVIUM (Qal) Medium dense, moist, dark brown to reddish-brown, Clayey, fine to coarse SAND; trace subrounded gravel -At 4 feet: subrounded gravel/cobble up to 4-inch in diameter -At 4 feet: abundant pin-hole porosity -At 6 feet: becomes dense, blocky texture with clay films on parting surfaces				
8				ML	SAN DIEGO FORMATION (Tsd) Dense to very dense, damp, orangish-brown to pale yellowish-brown, very fine Sandy SILT; some pinhole porosity				
10	TP3-2			SM	Dense, damp, whitish-gray, Silty, fine fine grained SANDSTONE; powdery texture when excavated; micaceous				
14					TRENCH TERMINATED AT 14 FEET Groundwater not encountered Backfilled on 06-30-2021				

Figure A-6,
Log of Test Pit TP 3, Page 1 of 1

G2762-42-01.GPJ

SAMPLE SYMBOLS		... SAMPLING UNSUCCESSFUL		... STANDARD PENETRATION TEST		... DRIVE SAMPLE (UNDISTURBED)
		... DISTURBED OR BAG SAMPLE		... CHUNK SAMPLE		... WATER TABLE OR  ... SEEPAGE

NOTE: THE LOG OF SUBSURFACE CONDITIONS SHOWN HEREON APPLIES ONLY AT THE SPECIFIC BORING OR TRENCH LOCATION AND AT THE DATE INDICATED. IT IS NOT WARRANTED TO BE REPRESENTATIVE OF SUBSURFACE CONDITIONS AT OTHER LOCATIONS AND TIMES.

DEPTH IN FEET	SAMPLE NO.	LITHOLOGY	GROUNDWATER	SOIL CLASS (USCS)	TEST PIT TP 4		PENETRATION RESISTANCE (BLOWS/FT.)	DRY DENSITY (P.C.F.)	MOISTURE CONTENT (%)
					ELEV. (MSL.) <u>185'</u>	DATE COMPLETED <u>06-30-2021</u>			
					EQUIPMENT <u>BACKHOE CAT 430F</u>		BY: <u>R. ADAMS</u>		
MATERIAL DESCRIPTION									
0				GM	TOPSOIL Loose, dry, pale brown, Silty GRAVEL; rounded to subrounded gravel up to 6-inch diameter				
2	TP4-1			GP	TERRACE DEPOSITS (Qt) Dense, dry to damp, pale yellowish-brown, fine to medium Sandy GRAVEL; subrounded gravel and cobble up to 10-inch diameter				
4									
6									
8				SM	SAN DIEGO FORMATION (Tsd) Dense, damp, light gray to pale yellowish-gray, Silty, very fine grained SANDSTONE; micaceous, powdery texture, some gravel and cobble up to 6-inch diameter (subrounded)				
10					TRENCH TERMINATED AT 10 FEET Groundwater not encountered Backfilled on 06-30-2021				

Figure A-7,
Log of Test Pit TP 4, Page 1 of 1

G2762-42-01.GPJ

SAMPLE SYMBOLS	... SAMPLING UNSUCCESSFUL	... STANDARD PENETRATION TEST	... DRIVE SAMPLE (UNDISTURBED)
	... DISTURBED OR BAG SAMPLE	... CHUNK SAMPLE	... WATER TABLE OR ... SEEPAGE

NOTE: THE LOG OF SUBSURFACE CONDITIONS SHOWN HEREON APPLIES ONLY AT THE SPECIFIC BORING OR TRENCH LOCATION AND AT THE DATE INDICATED. IT IS NOT WARRANTED TO BE REPRESENTATIVE OF SUBSURFACE CONDITIONS AT OTHER LOCATIONS AND TIMES.

DEPTH IN FEET	SAMPLE NO.	LITHOLOGY	GROUNDWATER	SOIL CLASS (USCS)	MATERIAL DESCRIPTION	TEST PIT TP 5	MOISTURE CONTENT (%)
0				ML	TOPSOIL Soft to firm, dry, pale pinkish-brown to brown, Sandy SILT; porous, abundant rootlets	ELEV. (MSL.) 173' DATE COMPLETED 06-30-2021 BY: R. ADAMS	
2				SC	ALLUVIUM (Qal) Loose to medium dense, dry to damp, Clayey, fine to medium SAND; blocky, clay/manganese films on parting surfaces		
4				SM	-At 4 feet: cobble layer, subrounded up to 12-inch diameter		
6				SM	SAN DIEGO FORMATION (Tsd) Dense, dry to damp, orangish brown to yellowish gray, Silty, fine to medium SAND; weakly cemented, bioturbated with few 1/8-inch open burrows, trace caliche, oxidation, mottling, no gravel or cobble		
7					-At 7 feet: becomes yellowish orange, very dense		
10	TP5-1				-At 10 feet: shell fragments observed		
12					TRENCH TERMINATED AT 12 FEET Groundwater not encountered Backfilled on 06-30-2021		

Figure A-8,
Log of Test Pit TP 5, Page 1 of 1

G2762-42-01.GPJ

SAMPLE SYMBOLS

- ☐ ... SAMPLING UNSUCCESSFUL
- ☒ ... DISTURBED OR BAG SAMPLE
- ◼ ... CHUNK SAMPLE
- ◼ ... STANDARD PENETRATION TEST
- ◼ ... DRIVE SAMPLE (UNDISTURBED)
- ▲ ... WATER TABLE OR SEEPAGE

NOTE: THE LOG OF SUBSURFACE CONDITIONS SHOWN HEREON APPLIES ONLY AT THE SPECIFIC BORING OR TRENCH LOCATION AND AT THE DATE INDICATED. IT IS NOT WARRANTED TO BE REPRESENTATIVE OF SUBSURFACE CONDITIONS AT OTHER LOCATIONS AND TIMES.

NOTE: THE LOG OF SUBSURFACE CONDITIONS SHOWN HEREON APPLIES ONLY AT THE SPECIFIC BORING OR TRENCH LOCATION AND AT THE DATE INDICATED. IT IS NOT WARRANTED TO BE REPRESENTATIVE OF SUBSURFACE CONDITIONS AT OTHER LOCATIONS AND TIMES.

<p>... SAMPLING UNSUCCESSFUL</p> <p>... STANDARD PENETRATION TEST</p> <p>... DRIVE SAMPLE (UNDISTURBED)</p>	<p>... DISTURBED OR BAG SAMPLE</p> <p>... CHUNK SAMPLE</p> <p>... WATER TABLE OR ... SEEPAGE</p>
-------------------------------------------------------------------------------------------------------------	--------------------------------------------------------------------------------------------------

Figure A-9,
Log of Test Pit TP 6, Page 1 of 1

G2762-42-01.GPJ

DEPTH IN FEET	SAMPLE NO.	LITHOLOGY	GROUNDWATER	SOIL CLASS (USCS)	MATERIAL DESCRIPTION	TEST PIT TP 6
0				SM	TOPSOIL Firm to stiff, dry, brown to grayish-brown, Silty SAND; strong blocky structure, good ped development	<p>ELEV. (MSL.) 178' DATE COMPLETED 06-30-2021</p> <p>EQUIPMENT BACKHOE CAT 430F BY: R. ADAMS</p>
2			SM	SAN DIEGO FORMATION (Tsd) Dense, dry, very pale yellowish-brown to whitish-gray, Silty, very fine grained SAND; powdery texture in places, massive, weakly, bioturbated, some oxidation mottling		
4					TRENCH TERMINATED AT 5 FEET Groundwater not encountered Backfilled on 06-30-2021	
						<p>PENETRATION RESISTANCE (BLOWS/FT.)</p> <p>DRY DENSITY (P.C.F.)</p> <p>MOISTURE CONTENT (%)</p>

NOTE: THE LOG OF SUBSURFACE CONDITIONS SHOWN HEREON APPLIES ONLY AT THE SPECIFIC BORING OR TRENCH LOCATION AND AT THE DATE INDICATED. IT IS NOT WARRANTED TO BE REPRESENTATIVE OF SUBSURFACE CONDITIONS AT OTHER LOCATIONS AND TIMES.

SAMPLE SYMBOLS	
☐ ... SAMPLING UNSUCCESSFUL	☐ ... STANDARD PENETRATION TEST
☒ ... DISTURBED OR BAG SAMPLE	▣ ... CHUNK SAMPLE
☐ ... WATER TABLE OR ... SEEPAGE	▣ ... DRIVE SAMPLE (UNDISTURBED)

Figure A-11,
Log of Test Pit TP 8, Page 1 of 1

G2762-42-01.GPJ

DEPTH IN FEET	SAMPLE NO.	LITHOLOGY	GROUNDWATER	SOIL CLASS (USCS)	MATERIAL DESCRIPTION	TEST PIT TP 8	MOISTURE CONTENT (%)
0	TP8-1			CL	TOPSOIL Soft to stiff, dry to moist, grayish-brown to dark reddish brown, Sandy CLAY; trace gravel	ELEV. (MSL.) 204' DATE COMPLETED 06-30-2021 BY: R. ADAMS EQUIPMENT BACKHOE CAT 430F	
2							
4				SC	ALLUVIUM (Qal) Medium dense, damp to moist, reddish-brown to orangish-brown, Clayey, fine to coarse SAND and Sandy CLAY; weathered		
6				SM	SAN DIEGO FORMATION (Tsd) Dense to very dense, damp, whitish-gray, Silty, very fine grained SAND; powder texture, micaceous		
8							
					TRENCH TERMINATED AT 9 FEET Groundwater not encountered Backfilled on 06-30-2021		

DEPTH IN FEET	SAMPLE NO.	LITHOLOGY	GROUNDWATER	SOIL CLASS (USCS)	TEST PIT TP 9		PENETRATION RESISTANCE (BLOWS/FT.)	DRY DENSITY (P.C.F.)	MOISTURE CONTENT (%)
					ELEV. (MSL.) <u>223'</u>	DATE COMPLETED <u>06-30-2021</u>			
					EQUIPMENT <u>BACKHOE CAT 430F</u>		BY: <u>R. ADAMS</u>		
MATERIAL DESCRIPTION									
0				SM	SAN DIEGO FORMATION (Tsd) Very dense, dry to damp, pale yellowish-brown to gray, Silty, fine fine grained SANDSTONE; massive				
2					-At 2 feet: subrounded gravel layer, 4-inch thick				
4					-At 5-7 feet: thin subvertical 1/4-inch, clay filled fractures				
6				-At 6.5 feet: subrounded pods of caliche					
					TRENCH TERMINATED AT 7 FEET Groundwater not encountered Backfilled on 06-30-2021				

Figure A-12,
Log of Test Pit TP 9, Page 1 of 1

G2762-42-01.GPJ

SAMPLE SYMBOLS	... SAMPLING UNSUCCESSFUL	... STANDARD PENETRATION TEST	... DRIVE SAMPLE (UNDISTURBED)
	... DISTURBED OR BAG SAMPLE	... CHUNK SAMPLE	... WATER TABLE OR ... SEEPAGE

NOTE: THE LOG OF SUBSURFACE CONDITIONS SHOWN HEREON APPLIES ONLY AT THE SPECIFIC BORING OR TRENCH LOCATION AND AT THE DATE INDICATED. IT IS NOT WARRANTED TO BE REPRESENTATIVE OF SUBSURFACE CONDITIONS AT OTHER LOCATIONS AND TIMES.









DEPTH IN FEET	SAMPLE NO.	LITHOLOGY	GROUNDWATER	SOIL CLASS (USCS)	TEST PIT TP 10		PENETRATION RESISTANCE (BLOWS/FT.)	DRY DENSITY (P.C.F.)	MOISTURE CONTENT (%)
					ELEV. (MSL.) <u>205'</u>	DATE COMPLETED <u>06-30-2021</u>			
					EQUIPMENT <u>BACKHOE CAT 430F</u>		BY: <u>R. ADAMS</u>		
MATERIAL DESCRIPTION									
0				SC	UNDOCUMENTED FILL (Qudf) Loose to medium dense, dry to damp, brown to grayish-brown, Clayey, fine to medium SAND; abundant cobble, fill place for perimeter berm				
2									
4				SM	SAN DIEGO FORMATION (Tsd) Very dense, damp, pale yellowish-brown to grayish-brown, Silty, very fine grained SANDSTONE; trace gravel, massive, oxidation mottling throughout				
6									
8					TRENCH TERMINATED AT 8 FEET Groundwater not encountered Backfilled on 06-30-2021				

Figure A-13,
Log of Test Pit TP 10, Page 1 of 1

G2762-42-01.GPJ

SAMPLE SYMBOLS	 ... SAMPLING UNSUCCESSFUL	 ... STANDARD PENETRATION TEST	 ... DRIVE SAMPLE (UNDISTURBED)
	 ... DISTURBED OR BAG SAMPLE	 ... CHUNK SAMPLE	 ... WATER TABLE OR  ... SEEPAGE

NOTE: THE LOG OF SUBSURFACE CONDITIONS SHOWN HEREON APPLIES ONLY AT THE SPECIFIC BORING OR TRENCH LOCATION AND AT THE DATE INDICATED. IT IS NOT WARRANTED TO BE REPRESENTATIVE OF SUBSURFACE CONDITIONS AT OTHER LOCATIONS AND TIMES.









DEPTH IN FEET	SAMPLE NO.	LITHOLOGY	GROUNDWATER	SOIL CLASS (USCS)	TEST PIT TP 11		PENETRATION RESISTANCE (BLOWS/FT.)	DRY DENSITY (P.C.F.)	MOISTURE CONTENT (%)
					ELEV. (MSL.) <u>213'</u>	DATE COMPLETED <u>06-30-2021</u>			
					EQUIPMENT <u>BACKHOE CAT 430F</u>		BY: <u>R. ADAMS</u>		
MATERIAL DESCRIPTION									
0				ML	UNDOCUMENTED FILL (Qudf) Loose, dry, pale reddish-brown, fine Sandy SILT; abundant, cobbles and chunks of the brownish black sandy clay topsoil				
2									
4				SM	SAN DIEGO FORMATION (Tsd) Very dense, damp, whitish-gray to yellowish-gray, Silty, very fine grained SANDSTONE; massive -At 4.5 feet: 4-inch thick coarse grained, orangish-black sand bed; Bedding: N20W/6°W				
6						TRENCH TERMINATED AT 6 FEET Groundwater not encountered Backfilled on 06-30-2021			

Figure A-14,
Log of Test Pit TP 11, Page 1 of 1

G2762-42-01.GPJ

SAMPLE SYMBOLS	 ... SAMPLING UNSUCCESSFUL	 ... STANDARD PENETRATION TEST	 ... DRIVE SAMPLE (UNDISTURBED)
	 ... DISTURBED OR BAG SAMPLE	 ... CHUNK SAMPLE	 ... WATER TABLE OR  ... SEEPAGE

NOTE: THE LOG OF SUBSURFACE CONDITIONS SHOWN HEREON APPLIES ONLY AT THE SPECIFIC BORING OR TRENCH LOCATION AND AT THE DATE INDICATED. IT IS NOT WARRANTED TO BE REPRESENTATIVE OF SUBSURFACE CONDITIONS AT OTHER LOCATIONS AND TIMES.









DEPTH IN FEET	SAMPLE NO.	LITHOLOGY	GROUNDWATER	SOIL CLASS (USCS)	TEST PIT TP 12		PENETRATION RESISTANCE (BLOWS/FT.)	DRY DENSITY (P.C.F.)	MOISTURE CONTENT (%)
					ELEV. (MSL.) <u>227'</u>	DATE COMPLETED <u>06-30-2021</u>			
					EQUIPMENT <u>BACKHOE CAT 430F</u>		BY: <u>R. ADAMS</u>		
MATERIAL DESCRIPTION									
0				SM	SAN DIEGO FORMATION (Tsd) Very dense, dry to damp, pale yellowish-brown, Silty, very fine grained SANDSTONE				
2					TRENCH TERMINATED AT 2 FEET Groundwater not encountered Backfilled on 06-30-2021				

Figure A-15,
Log of Test Pit TP 12, Page 1 of 1

G2762-42-01.GPJ

SAMPLE SYMBOLS		... SAMPLING UNSUCCESSFUL		... STANDARD PENETRATION TEST		... DRIVE SAMPLE (UNDISTURBED)	
		... DISTURBED OR BAG SAMPLE		... CHUNK SAMPLE		... WATER TABLE OR	

NOTE: THE LOG OF SUBSURFACE CONDITIONS SHOWN HEREON APPLIES ONLY AT THE SPECIFIC BORING OR TRENCH LOCATION AND AT THE DATE INDICATED. IT IS NOT WARRANTED TO BE REPRESENTATIVE OF SUBSURFACE CONDITIONS AT OTHER LOCATIONS AND TIMES.

DEPTH IN FEET	SAMPLE NO.	LITHOLOGY	GROUNDWATER	SOIL CLASS (USCS)	TEST PIT TP 13			PENETRATION RESISTANCE (BLOWS/FT.)	DRY DENSITY (P.C.F.)	MOISTURE CONTENT (%)
					ELEV. (MSL.) <u>231'</u>	DATE COMPLETED <u>06-30-2021</u>	EQUIPMENT <u>BACKHOE CAT 430F</u> BY: <u>R. ADAMS</u>			
MATERIAL DESCRIPTION										
0	TP13-1			GP	VERY OLD PARALIC DEPOSITS (Qvop) Dense, dry to damp, brown to grayish-brown, medium coarse SAND with cobble; cobble +/-30%, subrounded up to 10-inch diameter					
2										
4										
6										
8										
10				SM	SAN DIEGO FORMATION (Tsd) Dense, damp to moist, yellowish-brown, Silty, fine to medium SANDSTONE					
TRENCH TERMINATED AT 10 FEET Groundwater not encountered Backfilled on 06-30-2021										

Figure A-16,
Log of Test Pit TP 13, Page 1 of 1

G2762-42-01.GPJ

SAMPLE SYMBOLS		... SAMPLING UNSUCCESSFUL		... STANDARD PENETRATION TEST		... DRIVE SAMPLE (UNDISTURBED)
		... DISTURBED OR BAG SAMPLE		... CHUNK SAMPLE		... WATER TABLE OR ... SEEPAGE

NOTE: THE LOG OF SUBSURFACE CONDITIONS SHOWN HEREON APPLIES ONLY AT THE SPECIFIC BORING OR TRENCH LOCATION AND AT THE DATE INDICATED. IT IS NOT WARRANTED TO BE REPRESENTATIVE OF SUBSURFACE CONDITIONS AT OTHER LOCATIONS AND TIMES.

DEPTH IN FEET	SAMPLE NO.	LITHOLOGY	GROUNDWATER	SOIL CLASS (USCS)	TEST PIT TP 14		PENETRATION RESISTANCE (BLOWS/FT.)	DRY DENSITY (P.C.F.)	MOISTURE CONTENT (%)
					ELEV. (MSL.) <u>212'</u>	DATE COMPLETED <u>06-30-2021</u>			
					EQUIPMENT <u>BACKHOE CAT 430F</u>		BY: <u>R. ADAMS</u>		
MATERIAL DESCRIPTION									
0				SC	TOPSOIL Soft, dry, light brown, Clayey SAND; trace cobble				
				CL	Stiff, moist, blackish-brown, Sandy CLAY; some gravel and cobble				
2				SC	ALLUVIUM (Qal) Loose to medium dense, moist, brownish-black, Clayey SAND; some gravel and cobble, pin-hole porosity throughout				
4				SC	SAN DIEGO FORMATION (Tsd) Medium dense, moist, pinkish-brown to yellowish brown, Clayey, fine to medium SANDSTONE, mottled, weathered, manganese films on parting surfaces				
6				SM	Dense, moist, pale yellowish-brown to yellowish-gray, Silty, very fine grained SANDSTONE; massive, friable				
8									
TRENCH TERMINATED AT 9 FEET Groundwater not encountered Backfilled on 06-30-2021									

Figure A-17,
Log of Test Pit TP 14, Page 1 of 1

G2762-42-01.GPJ

SAMPLE SYMBOLS		... SAMPLING UNSUCCESSFUL		... STANDARD PENETRATION TEST		... DRIVE SAMPLE (UNDISTURBED)
		... DISTURBED OR BAG SAMPLE		... CHUNK SAMPLE		... WATER TABLE OR ... SEEPAGE

NOTE: THE LOG OF SUBSURFACE CONDITIONS SHOWN HEREON APPLIES ONLY AT THE SPECIFIC BORING OR TRENCH LOCATION AND AT THE DATE INDICATED. IT IS NOT WARRANTED TO BE REPRESENTATIVE OF SUBSURFACE CONDITIONS AT OTHER LOCATIONS AND TIMES.

DEPTH IN FEET	SAMPLE NO.	LITHOLOGY	GROUNDWATER	SOIL CLASS (USCS)	TEST PIT TP 15		PENETRATION RESISTANCE (BLOWS/FT.)	DRY DENSITY (P.C.F.)	MOISTURE CONTENT (%)
					ELEV. (MSL.) <u>215'</u>	DATE COMPLETED <u>06-30-2021</u>			
					EQUIPMENT <u>BACKHOE CAT 430F</u>		BY: <u>R. ADAMS</u>		
MATERIAL DESCRIPTION									
0	TP15-1			SM	TOPSOIL Loose, dry to damp, brown, Silty, fine SAND; some cobble				
2				CL	ALLUVIUM (Qal) Stiff, moist, grayish-brown, Sandy CLAY; trace gravel and cobble; pinhole porosity				
4									
6				GP	VERY OLD PARALIC DEPOSITS (Qvop) Dense, damp, reddish-brown to brown, medium to coarse SAND with gravel; trace silt				
8									
10									
12									
14									
16				SM	SAN DIEGO FORMATION (Tsd) Dense, damp, yellow to pale yellowish-gray, Silty, fine to medium SANDSTONE				
					TRENCH TERMINATED AT 16 FEET Groundwater not encountered Backfilled on 06-30-2021				

Figure A-18,
Log of Test Pit TP 15, Page 1 of 1

G2762-42-01.GPJ

SAMPLE SYMBOLS	... SAMPLING UNSUCCESSFUL	... STANDARD PENETRATION TEST	... DRIVE SAMPLE (UNDISTURBED)
	... DISTURBED OR BAG SAMPLE	... CHUNK SAMPLE	... WATER TABLE OR ... SEEPAGE

NOTE: THE LOG OF SUBSURFACE CONDITIONS SHOWN HEREON APPLIES ONLY AT THE SPECIFIC BORING OR TRENCH LOCATION AND AT THE DATE INDICATED. IT IS NOT WARRANTED TO BE REPRESENTATIVE OF SUBSURFACE CONDITIONS AT OTHER LOCATIONS AND TIMES.











DEPTH IN FEET	SAMPLE NO.	LITHOLOGY	GROUNDWATER	SOIL CLASS (USCS)	TEST PIT TP 16		PENETRATION RESISTANCE (BLOWS/FT.)	DRY DENSITY (P.C.F.)	MOISTURE CONTENT (%)
					ELEV. (MSL.) <u>213'</u>	DATE COMPLETED <u>06-30-2021</u>			
					EQUIPMENT <u>BACKHOE CAT 430F</u>		BY: <u>R. ADAMS</u>		
MATERIAL DESCRIPTION									
0				CL	TOPSOIL Soft to firm, dry to damp, brown, Sandy CLAY; some gravel and cobble				
2									
4				SW	VERY OLD PARALIC DEPOSITS (Qvop) Dense, damp, orange brown, SAND with cobble; cobble subrounded up to 12-inch diameter				
6									
8				SM	SAN DIEGO FORMATION (Tsd) Dense, damp, pale, yellowish-brown to grayish brown, Silty, fine SANDSTONE; massive, micaceous				
TRENCH TERMINATED AT 9 FEET Groundwater not encountered Backfilled on 06-30-2021									

Figure A-19,
Log of Test Pit TP 16, Page 1 of 1

G2762-42-01.GPJ

SAMPLE SYMBOLS	 ... SAMPLING UNSUCCESSFUL	 ... STANDARD PENETRATION TEST	 ... DRIVE SAMPLE (UNDISTURBED)
	 ... DISTURBED OR BAG SAMPLE	 ... CHUNK SAMPLE	 ... WATER TABLE OR  ... SEEPAGE

NOTE: THE LOG OF SUBSURFACE CONDITIONS SHOWN HEREON APPLIES ONLY AT THE SPECIFIC BORING OR TRENCH LOCATION AND AT THE DATE INDICATED. IT IS NOT WARRANTED TO BE REPRESENTATIVE OF SUBSURFACE CONDITIONS AT OTHER LOCATIONS AND TIMES.

DEPTH IN FEET	SAMPLE NO.	LITHOLOGY	GROUNDWATER	SOIL CLASS (USCS)	TEST PIT TP 17		PENETRATION RESISTANCE (BLOWS/FT.)	DRY DENSITY (P.C.F.)	MOISTURE CONTENT (%)
					ELEV. (MSL.) <u>198'</u>	DATE COMPLETED <u>06-30-2021</u>			
					EQUIPMENT <u>BACKHOE CAT 430F</u>		BY: <u>R. ADAMS</u>		
MATERIAL DESCRIPTION									
0				ML	TOPSOIL Loose, dry to damp, brown to pale reddish brown, fine to medium Sandy SILT; trace gravel				
2									
4				SM	SAN DIEGO FORMATION (Tsd) Dense, damp, pale yellowish-brown to yellowish-orange, Silty, very fine grained SANDSTONE; massive, mottled, weathered in upper 3 feet, trace gravel, micaceous				
6									
8									
					TRENCH TERMINATED AT 8 FEET Groundwater not encountered Backfilled on 06-30-2021				

Figure A-20,
Log of Test Pit TP 17, Page 1 of 1

G2762-42-01.GPJ

SAMPLE SYMBOLS		... SAMPLING UNSUCCESSFUL		... STANDARD PENETRATION TEST		... DRIVE SAMPLE (UNDISTURBED)
		... DISTURBED OR BAG SAMPLE		... CHUNK SAMPLE		... WATER TABLE OR ... SEEPAGE

NOTE: THE LOG OF SUBSURFACE CONDITIONS SHOWN HEREON APPLIES ONLY AT THE SPECIFIC BORING OR TRENCH LOCATION AND AT THE DATE INDICATED. IT IS NOT WARRANTED TO BE REPRESENTATIVE OF SUBSURFACE CONDITIONS AT OTHER LOCATIONS AND TIMES.









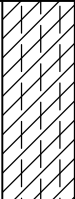

DEPTH IN FEET	SAMPLE NO.	LITHOLOGY	GROUNDWATER	SOIL CLASS (USCS)	TEST PIT TP 18		PENETRATION RESISTANCE (BLOWS/FT.)	DRY DENSITY (P.C.F.)	MOISTURE CONTENT (%)
					ELEV. (MSL.) <u>190'</u>	DATE COMPLETED <u>06-30-2021</u>			
					EQUIPMENT <u>BACKHOE CAT 430F</u>		BY: <u>R. ADAMS</u>		
MATERIAL DESCRIPTION									
0				CL	TOPSOIL Soft to stiff, dry to moist, light brown to reddish-brown, Silty CLAY; trace sand, manganese coatings on parting surfaces				
2									
4				SC	ALLUVIUM (Qal) Medium dense to dense, moist, orange brown, Clayey, medium to coarse SAND; few gravel and cobble				
6				SM	SAN DIEGO FORMATION (Tsd) Dense, damp to moist, pale yellowish-brown to yellowish-gray, Silty, fine to medium SANDSTONE; micaceous, mottled				
8					TRENCH TERMINATED AT 8 FEET Groundwater not encountered Backfilled on 06-30-2021				

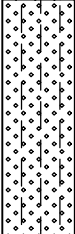
Figure A-21,
Log of Test Pit TP 18, Page 1 of 1

G2762-42-01.GPJ

SAMPLE SYMBOLS	 ... SAMPLING UNSUCCESSFUL	 ... STANDARD PENETRATION TEST	 ... DRIVE SAMPLE (UNDISTURBED)
	 ... DISTURBED OR BAG SAMPLE	 ... CHUNK SAMPLE	 ... WATER TABLE OR  ... SEEPAGE

NOTE: THE LOG OF SUBSURFACE CONDITIONS SHOWN HEREON APPLIES ONLY AT THE SPECIFIC BORING OR TRENCH LOCATION AND AT THE DATE INDICATED. IT IS NOT WARRANTED TO BE REPRESENTATIVE OF SUBSURFACE CONDITIONS AT OTHER LOCATIONS AND TIMES.







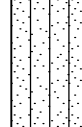
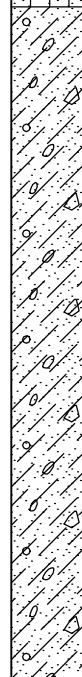

DEPTH IN FEET	SAMPLE NO.	LITHOLOGY	GROUNDWATER	SOIL CLASS (USCS)	TEST PIT TP 19		PENETRATION RESISTANCE (BLOWS/FT.)	DRY DENSITY (P.C.F.)	MOISTURE CONTENT (%)
					ELEV. (MSL.) <u>173'</u>	DATE COMPLETED <u>06-30-2021</u>			
					EQUIPMENT <u>BACKHOE CAT 430F</u>		BY: <u>R. ADAMS</u>		
MATERIAL DESCRIPTION									
0				ML	TOPSOIL Soft, dry, pale reddish-brown, Sandy SILT; trace gravel				
2				SC	TERRACE DEPOSITS (Qt) Dense, moist, yellow to yellowish-brown, Clayey, fine to medium SAND with cobble; caliche stringers common, cobble is subrounded up to 10-inch diameter				
4									
6									
8									
10									
12					TRENCH TERMINATED AT 12 FEET Groundwater not encountered Backfilled on 06-30-2021				

Figure A-22,
Log of Test Pit TP 19, Page 1 of 1

G2762-42-01.GPJ

SAMPLE SYMBOLS	 ... SAMPLING UNSUCCESSFUL	 ... STANDARD PENETRATION TEST	 ... DRIVE SAMPLE (UNDISTURBED)
	 ... DISTURBED OR BAG SAMPLE	 ... CHUNK SAMPLE	 ... WATER TABLE OR  ... SEEPAGE

NOTE: THE LOG OF SUBSURFACE CONDITIONS SHOWN HEREON APPLIES ONLY AT THE SPECIFIC BORING OR TRENCH LOCATION AND AT THE DATE INDICATED. IT IS NOT WARRANTED TO BE REPRESENTATIVE OF SUBSURFACE CONDITIONS AT OTHER LOCATIONS AND TIMES.









DEPTH IN FEET	SAMPLE NO.	LITHOLOGY	GROUNDWATER	SOIL CLASS (USCS)	TEST PIT TP 20		PENETRATION RESISTANCE (BLOWS/FT.)	DRY DENSITY (P.C.F.)	MOISTURE CONTENT (%)
					ELEV. (MSL.) <u>160'</u>	DATE COMPLETED <u>06-30-2021</u>			
					EQUIPMENT <u>BACKHOE CAT 430F</u>		BY: <u>R. ADAMS</u>		
MATERIAL DESCRIPTION									
0				SM	TOPSOIL Loose, dry, olive brown, Silty, very fine grained SAND; trace subrounded gravel				
2				SM	SAN DIEGO FORMATION (Tsd) Dense, damp, orangish-brown to whitish-gray, Silty, very fine grained SANDSTONE; highly micaceous				
4									
6									
					TRENCH TERMINATED AT 7 FEET Groundwater not encountered Backfilled on 06-30-2021				

Figure A-23,
Log of Test Pit TP 20, Page 1 of 1

G2762-42-01.GPJ

SAMPLE SYMBOLS		... SAMPLING UNSUCCESSFUL		... STANDARD PENETRATION TEST		... DRIVE SAMPLE (UNDISTURBED)	
		... DISTURBED OR BAG SAMPLE		... CHUNK SAMPLE		... WATER TABLE OR	

NOTE: THE LOG OF SUBSURFACE CONDITIONS SHOWN HEREON APPLIES ONLY AT THE SPECIFIC BORING OR TRENCH LOCATION AND AT THE DATE INDICATED. IT IS NOT WARRANTED TO BE REPRESENTATIVE OF SUBSURFACE CONDITIONS AT OTHER LOCATIONS AND TIMES.

APPENDIX

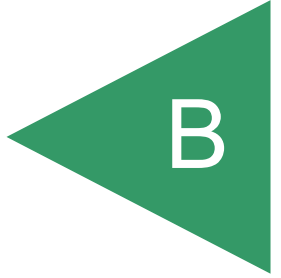

APPENDIX B

LABORATORY TESTING

Laboratory tests were performed in accordance with generally accepted test methods of the American Society for Testing and Materials (ASTM) or other suggested procedures. Selected samples were tested for *in-situ* dry density and moisture content, maximum dry density and optimum moisture content, expansion potential, consolidation potential, gradation, soluble sulfate content, chloride content, p.H. and resistivity, and shear strength. The results of these tests are summarized on the following tables and figures. The in-place dry density and moisture content of the samples tested are presented on the boring logs in Appendix A.

SUMMARY OF LABORATORY MAXIMUM DRY DENSITY AND OPTIMUM MOISTURE CONTENT TEST RESULTS ASTM D 1557-02

Sample No.	Description	Maximum Dry Density (pcf)	Optimum Moisture Content (% dry wt.)
T1-1	Brown clayey fine to medium SAND	123.3	12.1
T1-2	Brown silty SAND with gravel	121.3	12.7
T3-2	Dark yellow Silty fine SAND	103.2	16.5

SUMMARY OF LABORATORY EXPANSION INDEX TEST RESULTS ASTM D 4829-03

Sample No.	Moisture Content		Dry Density (pcf)	Expansion Index
	Before Test (%)	After Test (%)		
T1-1	10.9	22.0	107.3	46
T1-2	10.8	18.0	107.3	16
T3-1	8.3	13.8	116.8	0
T3-2	14.4	26.7	94.1	0
T8-1	11.7	28.0	103.8	99

**SUMMARY OF LABORATORY WATER-SOLUBLE SULFATE TEST RESULTS
CALIFORNIA TEST NO. 417**

Sample No.	Water-Soluble Sulfate (%)	Sulfate Exposure
T1-1	0.020	S0
T3-2	0.001	S0

**SUMMARY OF LABORATORY WATER-SOLUBLE CHLORIDE ION CONTENT TEST RESULTS
AASHTO TEST NO. T 291**

Sample No.	Chloride Ion Content ppm (%)
T1-1	380 (0.038)
T3-2	71 (0.007)

**SUMMARY OF LABORATORY POTENTIAL OF HYDROGEN (PH) AND
RESISTIVITY TEST RESULTS
CALIFORNIA TEST METHOD 643**

Sample No.	Geologic Unit	pH	Minimum Resistivity (ohm-centimeters)
T1-1	Qal	8.92	700

**SUMMARY OF LABORATORY ATTERBERG LIMITS TEST RESULTS
ASTM D 4318**

Sample No.	Liquid Limit (%)	Plastic Limit (%)	Plasticity Index
T1-1	42	20	22
T1-2	30	22	8
T3-2	Non Plastic	Non Plastic	Non Plastic

TEST RESULTS					
SAMPLE NO.	GEOLOGIC UNIT	LIQUID LIMIT	PLASTIC LIMIT	PLASTICITY INDEX	SOIL TYPE
T1-1	Qal	42	20	22	CL

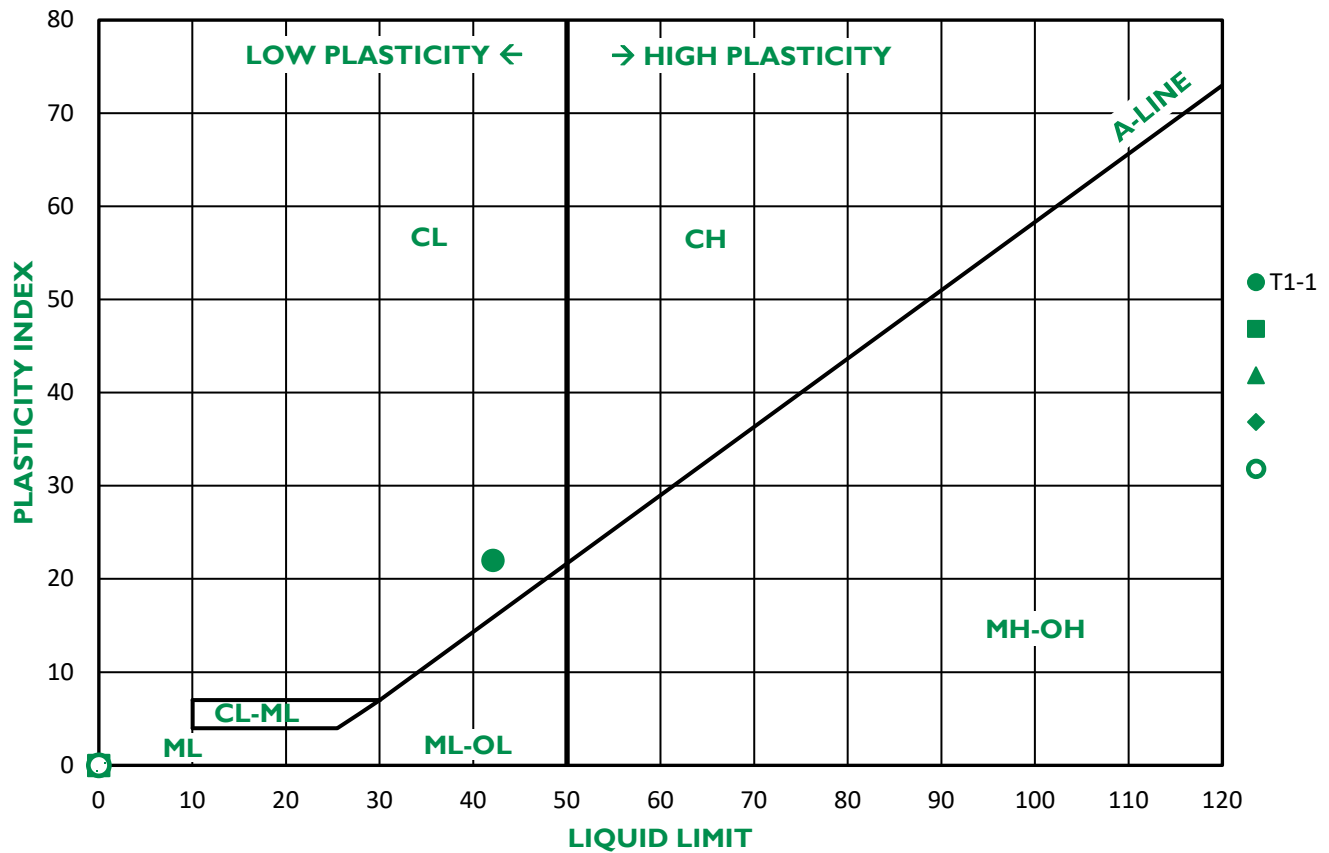

SOIL TYPE DESCRIPTION	
CH	High-Plasticity Clay
CL	Low-Plasticity Clay
ML	Low-Plasticity Silt
CL-ML	Low-Plasticity Clay to Low-Plasticity Silt
MH-OH	High-Plasticity Silt to High-Plasticity, Organic Silt
ML-OL	Low-Plasticity Silt to Low-Plasticity, Organic Silt

GEOCON
INCORPORATED

GEOTECHNICAL CONSULTANTS
6960 FLANDERS DRIVE - SAN DIEGO, CALIFORNIA 92121 - 2974
PHONE 858 558-6900 - FAX 858 558-6159



PLASTICITY INDEX - ASTM D 4318

SHINOHARA
PROJECT NO.: G2762-42-01

TEST RESULTS					
SAMPLE NO.	GEOLOGIC UNIT	LIQUID LIMIT	PLASTIC LIMIT	PLASTICITY INDEX	SOIL TYPE
T1-2	Qal	30	22	8	CL

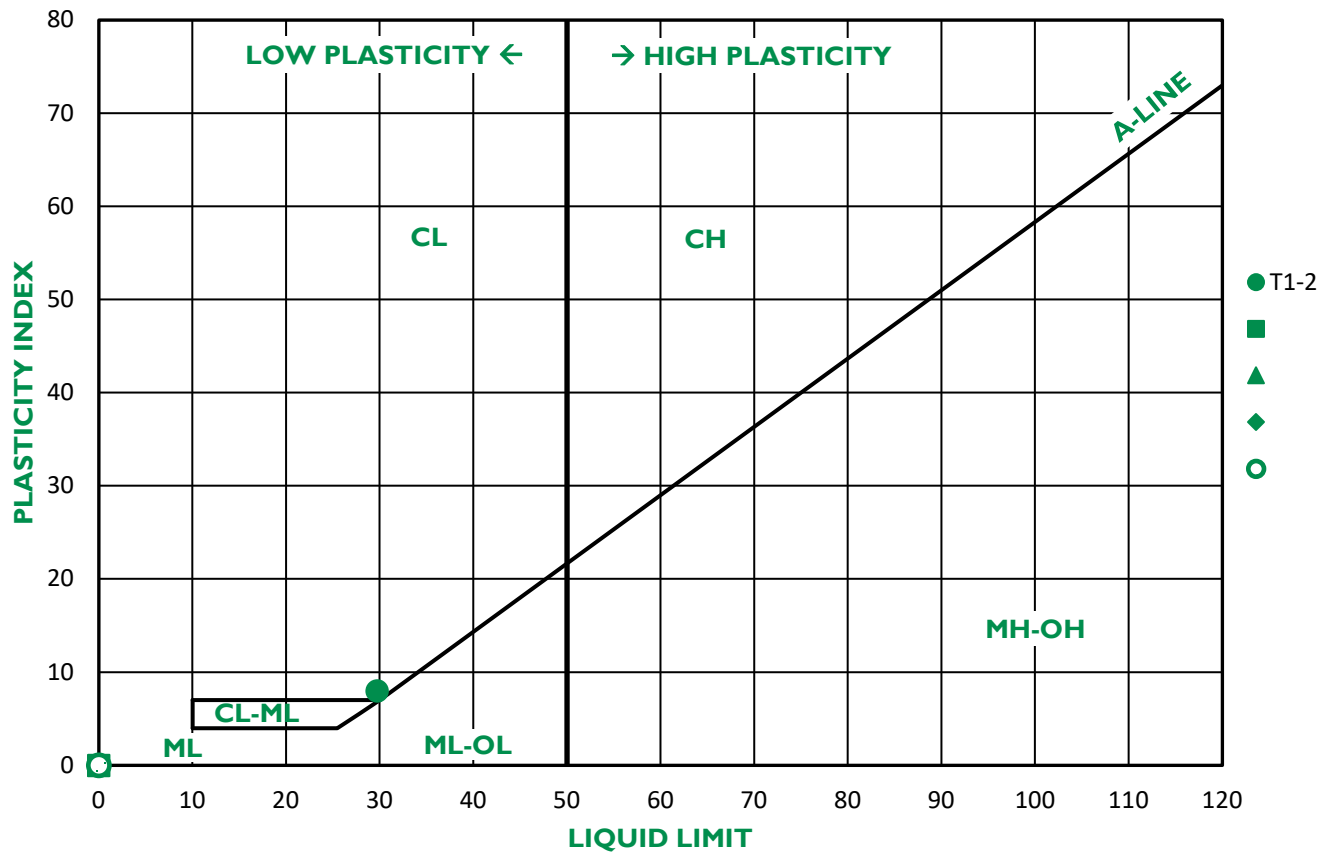

SOIL TYPE DESCRIPTION	
CH	High-Plasticity Clay
CL	Low-Plasticity Clay
ML	Low-Plasticity Silt
CL-ML	Low-Plasticity Clay to Low-Plasticity Silt
MH-OH	High-Plasticity Silt to High-Plasticity, Organic Silt
ML-OL	Low-Plasticity Silt to Low-Plasticity, Organic Silt

GEOCON
INCORPORATED

GEOTECHNICAL CONSULTANTS
6960 FLANDERS DRIVE - SAN DIEGO, CALIFORNIA 92121 - 2974
PHONE 858 558-6900 - FAX 858 558-6159



PLASTICITY INDEX - ASTM D 4318

SHINOHARA
PROJECT NO.: G2762-42-01

SAMPLE NO.: TI-1
 SAMPLE DEPTH (FT.): 2'-4'

GEOLOGIC UNIT: Qal

GRAVEL		SAND			SILT OR CLAY
COARSE	FINE	COARSE	MEDIUM	FINE	

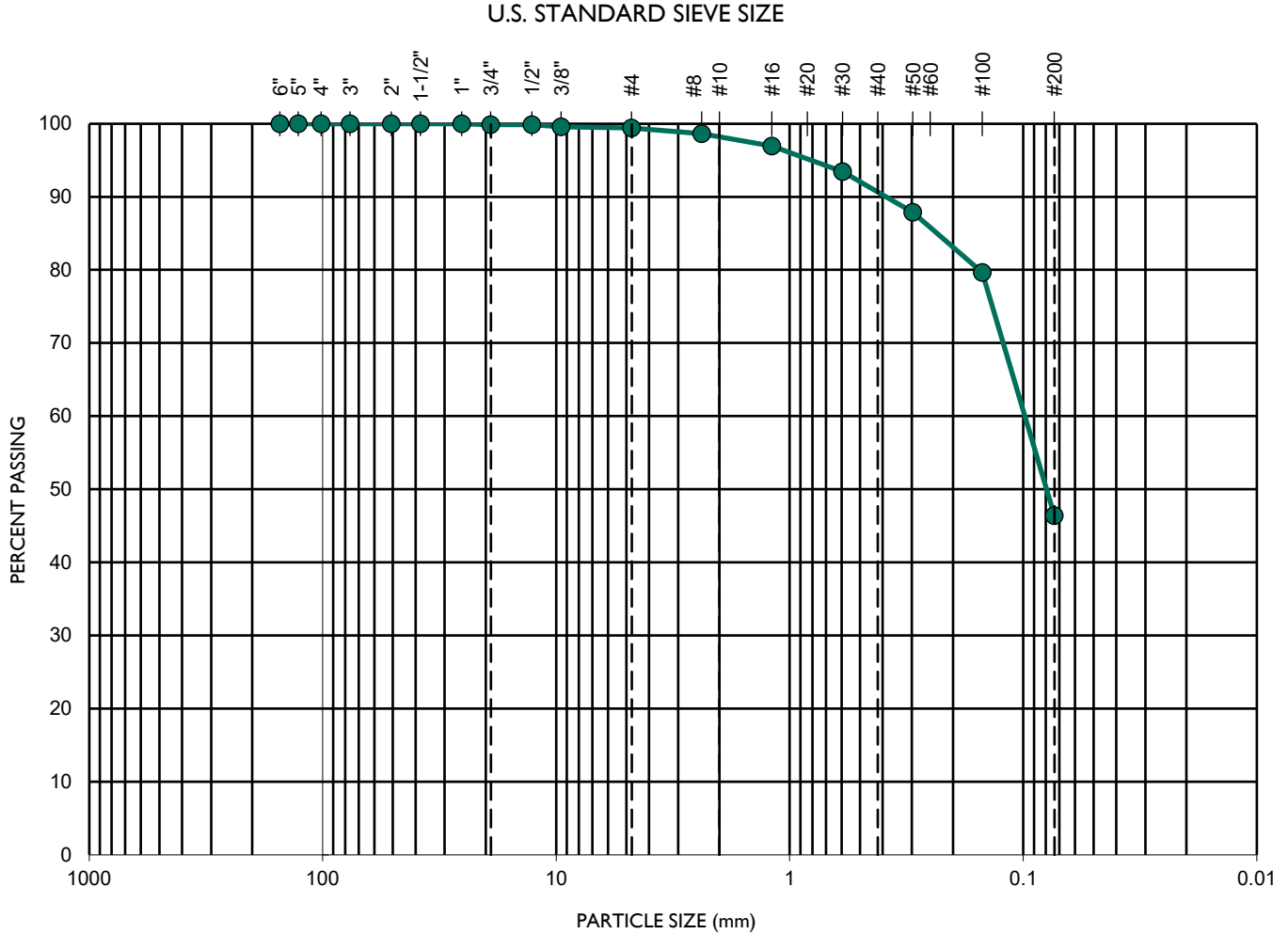

TEST DATA					SOIL DESCRIPTION
D ₁₀ (mm)	D ₃₀ (mm)	D ₆₀ (mm)	C _c	C _u	
0.016	0.048	0.105	1.4	6.6	SC - Clayey SAND

GEOCON
INCORPORATED



GEOTECHNICAL CONSULTANTS
 6960 FLANDERS DRIVE - SAN DIEGO, CALIFORNIA 92121 - 2974
 PHONE 858 558-6900 - FAX 858 558-6159

SIEVE ANALYSES - ASTM D 135

SHINOHARA

PROJECT NO.: G2762-42-01

SAMPLE NO.: TI-2
 SAMPLE DEPTH (FT.): 10'-12'

GEOLOGIC UNIT: Qal

GRAVEL		SAND			SILT OR CLAY
COARSE	FINE	COARSE	MEDIUM	FINE	

U.S. STANDARD SIEVE SIZE

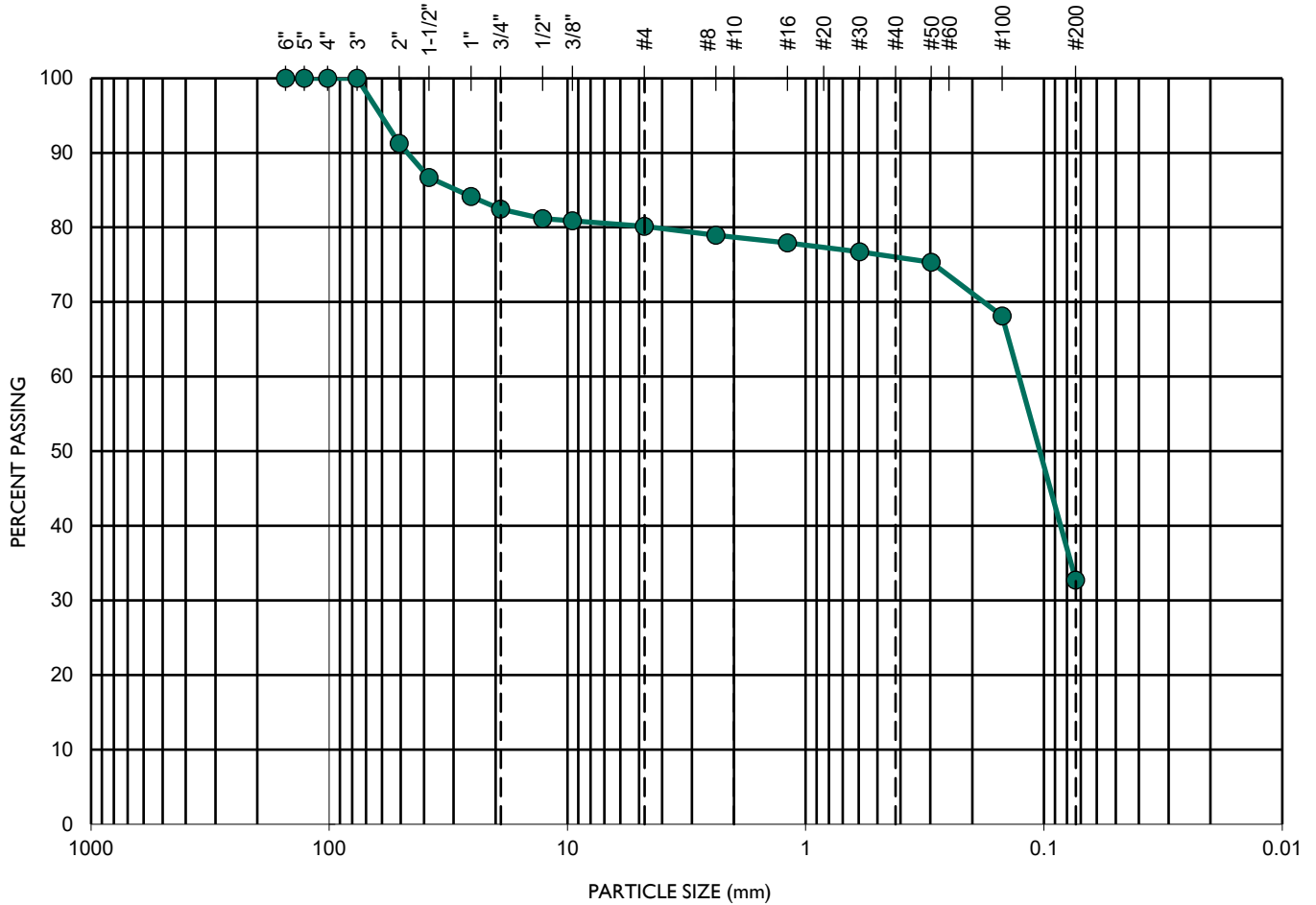

TEST DATA					
D ₁₀ (mm)	D ₃₀ (mm)	D ₆₀ (mm)	C _c	C _u	SOIL DESCRIPTION
0.023	0.068	0.132	1.5	5.9	SM - Silty SAND with gravel

GEOCON
INCORPORATED



GEOTECHNICAL CONSULTANTS
 6960 FLANDERS DRIVE - SAN DIEGO, CALIFORNIA 92121 - 2974
 PHONE 858 558-6900 - FAX 858 558-6159

SIEVE ANALYSES - ASTM D 135

SHINOHARA

PROJECT NO.: G2762-42-01

SAMPLE NO.: **T3-2**
 SAMPLE DEPTH (FT.): **10'-12'**

GEOLOGIC UNIT: **Tsd**

GRAVEL		SAND			SILT OR CLAY
COARSE	FINE	COARSE	MEDIUM	FINE	

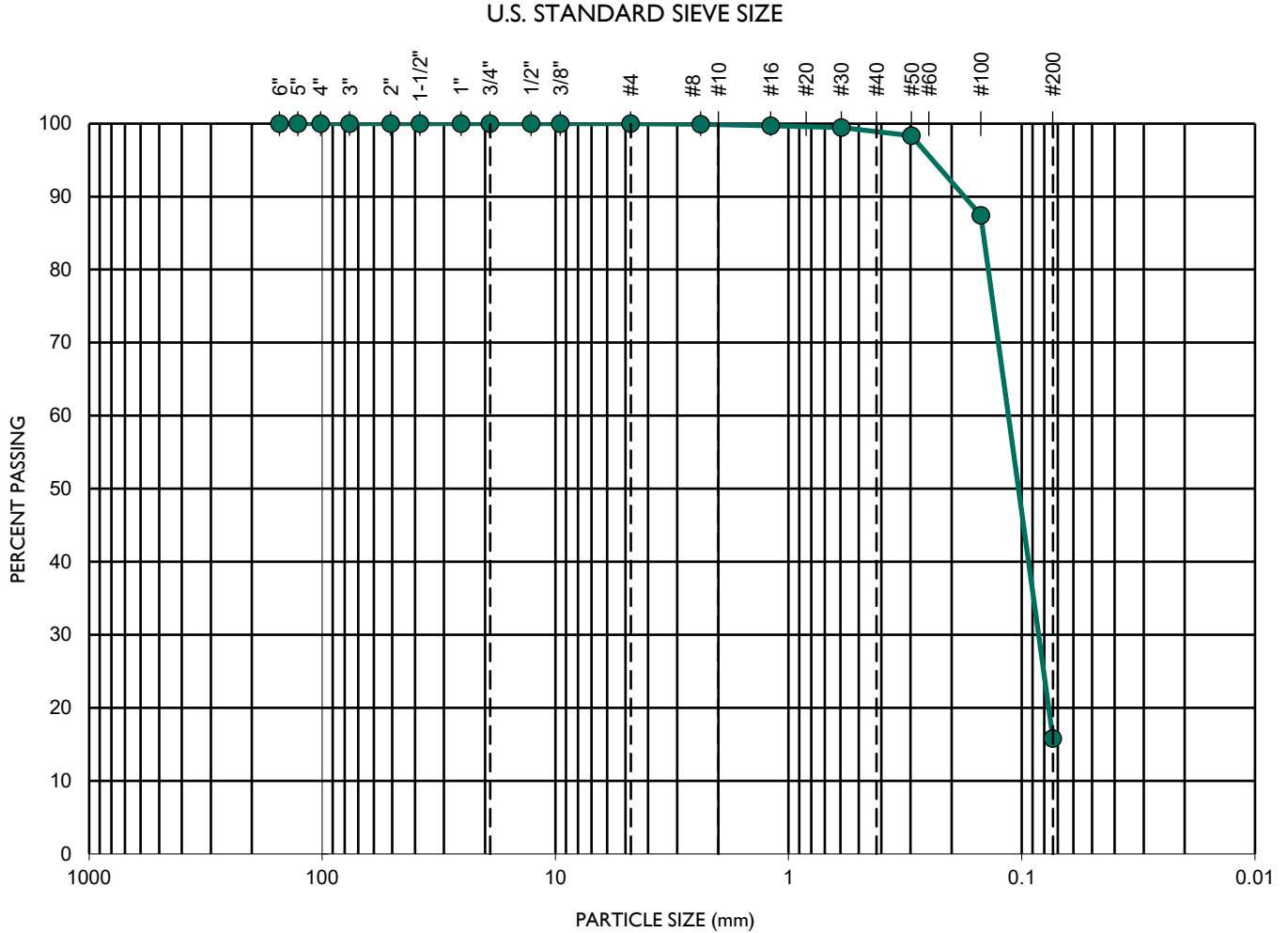

TEST DATA					SOIL DESCRIPTION
D ₁₀ (mm)	D ₃₀ (mm)	D ₆₀ (mm)	C _c	C _u	
0.047	0.089	0.121	1.4	2.6	SM - Silty SAND

GEOCON
INCORPORATED



GEOTECHNICAL CONSULTANTS
 6960 FLANDERS DRIVE - SAN DIEGO, CALIFORNIA 92121 - 2974
 PHONE 858 558-6900 - FAX 858 558-6159

SIEVE ANALYSES - ASTM D 135

SHINOHARA

PROJECT NO.: G2762-42-01

SAMPLE NO.: LBI-1 GEOLOGIC UNIT: Tsd
 SAMPLE DEPTH (FT): 10'-11' NATURAL/REMOLDED: N

INITIAL CONDITIONS				
NORMAL STRESS TEST LOAD	1 K	2 K	4 K	AVERAGE
ACTUAL NORMAL STRESS (PSF):	1000	2000	4000	--
WATER CONTENT (%):	13.0	13.2	12.2	12.8
DRY DENSITY (PCF):	100.7	108.8	104.5	104.7

AFTER TEST CONDITIONS				
NORMAL STRESS TEST LOAD	1 K	2 K	4 K	AVERAGE
WATER CONTENT (%):	28.7	25.9	26.1	26.9
PEAK SHEAR STRESS (PSF):	1125	1599	3046	--
ULT.-E.O.T. SHEAR STRESS (PSF):	1004	1602	3046	--

RESULTS		
PEAK	COHESION, C (PSF)	400
	FRICTION ANGLE (DEGREES)	33
ULTIMATE	COHESION, C (PSF)	280
	FRICTION ANGLE (DEGREES)	34

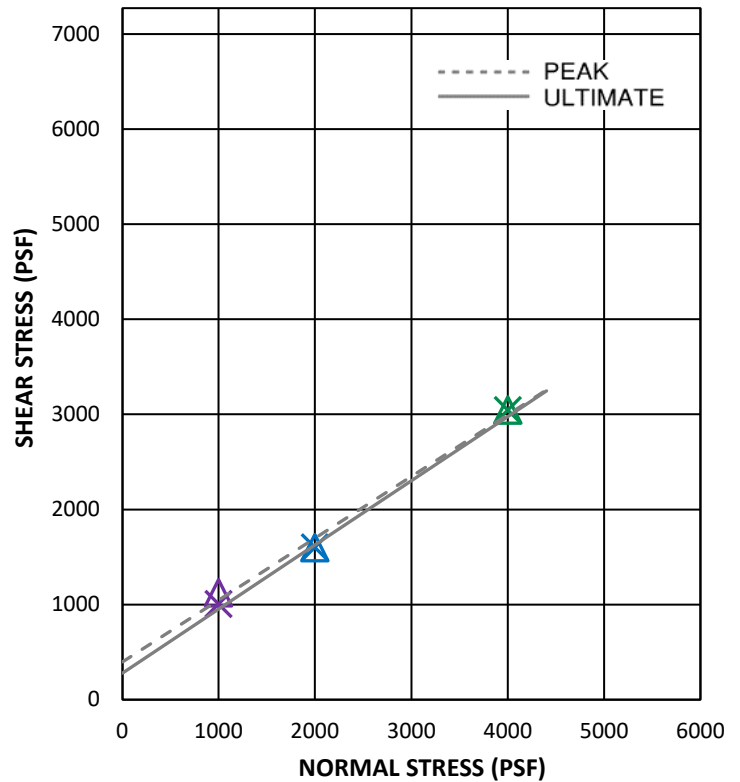
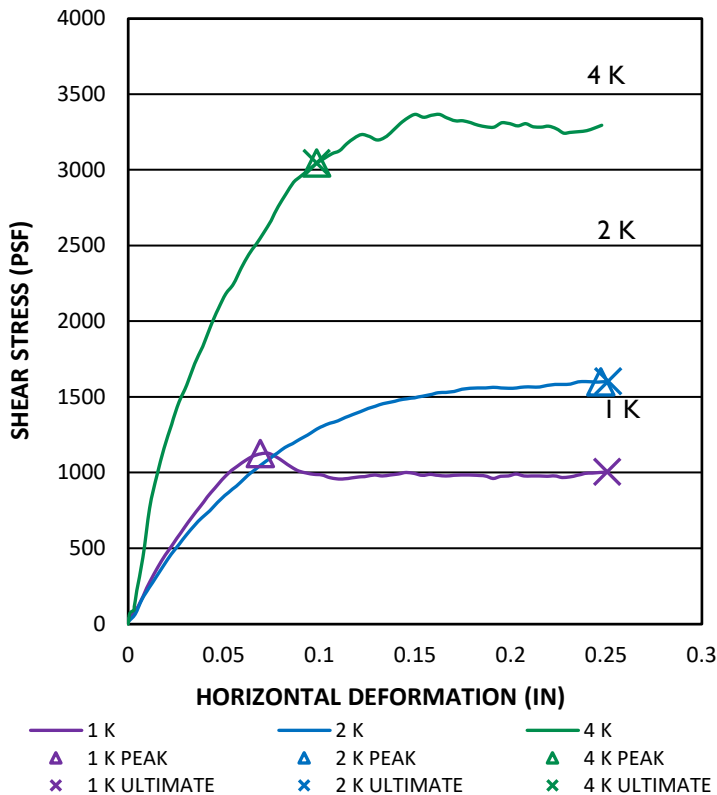

DIRECT SHEAR - ASTM D 3080

GEOCON
INCORPORATED



GEOTECHNICAL CONSULTANTS
 6960 FLANDERS DRIVE - SAN DIEGO, CALIFORNIA 92121-2974
 PHONE 858 558-6900 - FAX 858 558-6159

517 SHINOHARA

PROJECT NO.: G2762-42-01

SAMPLE NO.: LB I-2 GEOLOGIC UNIT: Tsd
 SAMPLE DEPTH (FT): 20' NATURAL/REMOLDED: N

INITIAL CONDITIONS				
NORMAL STRESS TEST LOAD	1 K	2 K	4 K	AVERAGE
ACTUAL NORMAL STRESS (PSF):	1000	2000	4000	--
WATER CONTENT (%):	4.0	4.8	4.1	4.3
DRY DENSITY (PCF):	95.3	97.4	100.8	97.8

AFTER TEST CONDITIONS				
NORMAL STRESS TEST LOAD	1 K	2 K	4 K	AVERAGE
WATER CONTENT (%):	23.1	21.5	19.5	21.4
PEAK SHEAR STRESS (PSF):	1118	1687	3348	--
ULT.-E.O.T. SHEAR STRESS (PSF):	1112	1693	3046	--

RESULTS		
PEAK	COHESION, C (PSF)	290
	FRICTION ANGLE (DEGREES)	37
ULTIMATE	COHESION, C (PSF)	440
	FRICTION ANGLE (DEGREES)	33

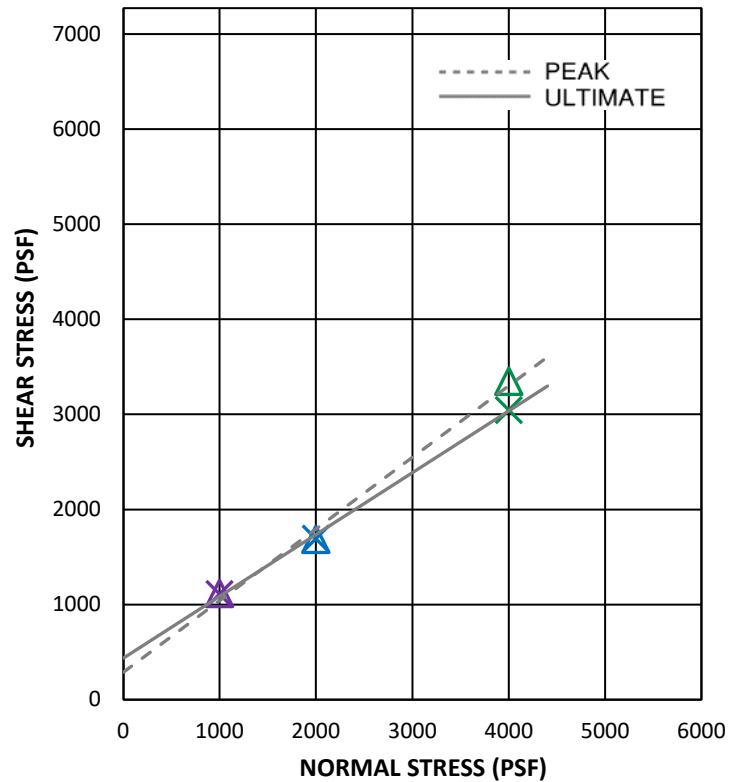
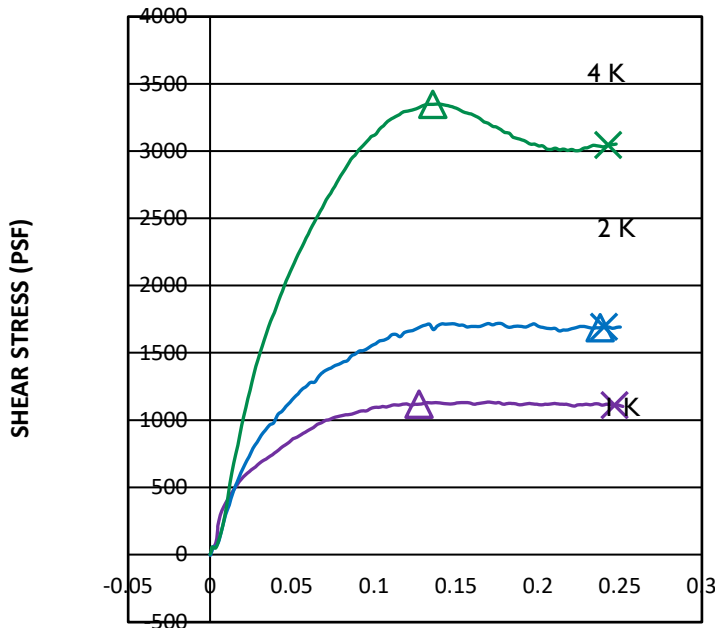

HORIZONTAL DEFORMATION (IN)

— 1 K — 2 K — 4 K
 ▲ 1 K PEAK ▲ 2 K PEAK ▲ 4 K PEAK
 × 1 K ULTIMATE × 2 K ULTIMATE × 4 K ULTIMATE

GEOCON
INCORPORATED



GEOTECHNICAL CONSULTANTS
 6960 FLANDERS DRIVE - SAN DIEGO, CALIFORNIA 92121-2974
 PHONE 858 558-6900 - FAX 858 558-6159

DIRECT SHEAR - ASTM D 3080

SHINOHARA

PROJECT NO.: G2762-42-01

SAMPLE NO.: **LB I-4** GEOLOGIC UNIT: **Tsd**
 SAMPLE DEPTH (FT): **40'** NATURAL/REMOLDED: **N**

INITIAL CONDITIONS				
NORMAL STRESS TEST LOAD	1 K	2 K	4 K	AVERAGE
ACTUAL NORMAL STRESS (PSF):	1000	2000	4000	--
WATER CONTENT (%):	5.2	5.4	6.4	5.7
DRY DENSITY (PCF):	94.5	81.3	86.3	87.3

AFTER TEST CONDITIONS				
NORMAL STRESS TEST LOAD	1 K	2 K	4 K	AVERAGE
WATER CONTENT (%):	28.3	37.5	35.1	33.6
PEAK SHEAR STRESS (PSF):	1086	1586	3338	--
ULT.-E.O.T. SHEAR STRESS (PSF):	793	1563	3361	--

RESULTS		
PEAK	COHESION, C (PSF)	210
	FRICTION ANGLE (DEGREES)	37
ULTIMATE	COHESION, C (PSF)	0
	FRICTION ANGLE (DEGREES)	39

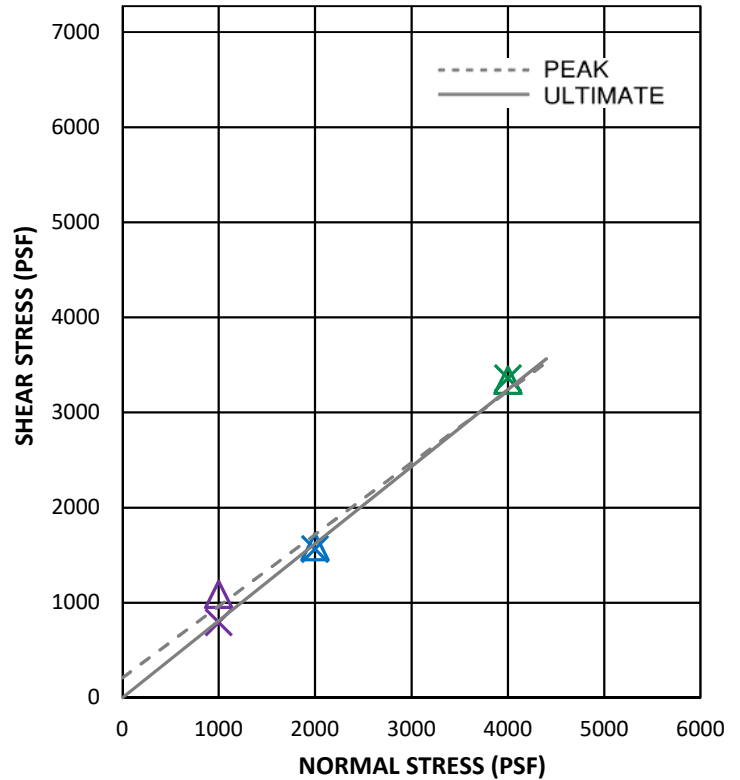
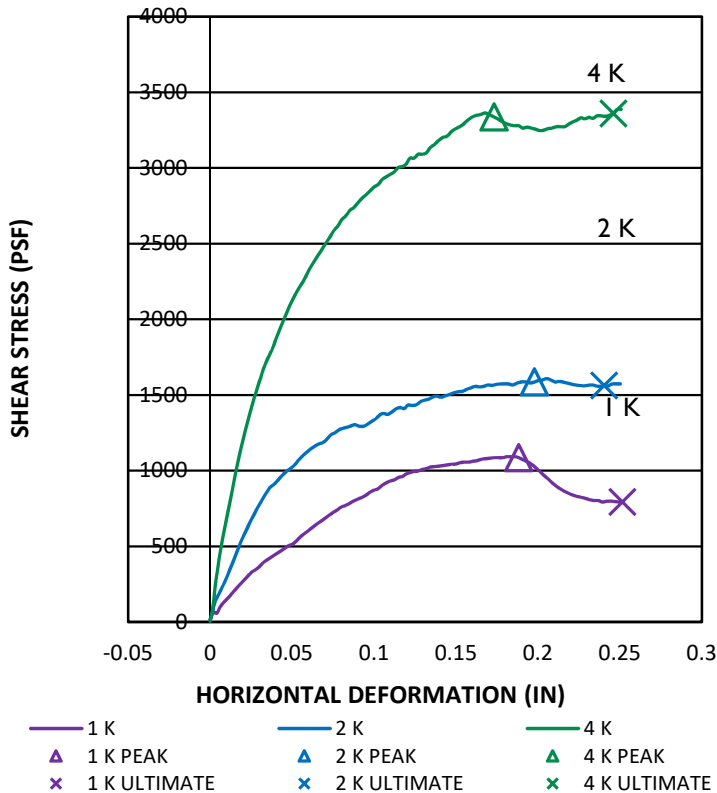

DIRECT SHEAR - ASTM D 3080

GEOCON
 INCORPORATED



GEOTECHNICAL CONSULTANTS
 6960 FLANDERS DRIVE - SAN DIEGO, CALIFORNIA 92121-2974
 PHONE 858 558-6900 - FAX 858 558-6159

517 SHINOHARA

PROJECT NO.: G2762-42-01

SAMPLE NO.: TI-1 GEOLOGIC UNIT: Qal
 SAMPLE DEPTH (FT): 2'-4' NATURAL/REMOVED: R

INITIAL CONDITIONS				
NORMAL STRESS TEST LOAD	1 K	2 K	4 K	AVERAGE
ACTUAL NORMAL STRESS (PSF):	890	2030	4300	--
WATER CONTENT (%):	13.1	10.7	11.5	11.8
DRY DENSITY (PCF):	109.6	113.3	112.6	111.8

AFTER TEST CONDITIONS				
NORMAL STRESS TEST LOAD	1 K	2 K	4 K	AVERAGE
WATER CONTENT (%):	19.0	16.8	18.0	17.9
PEAK SHEAR STRESS (PSF):	1141	1904	2866	--
ULT.-E.O.T. SHEAR STRESS (PSF):	1103	1904	2866	--

RESULTS		
PEAK	COHESION, C (PSF)	780
	FRICTION ANGLE (DEGREES)	26
ULTIMATE	COHESION, C (PSF)	750
	FRICTION ANGLE (DEGREES)	27

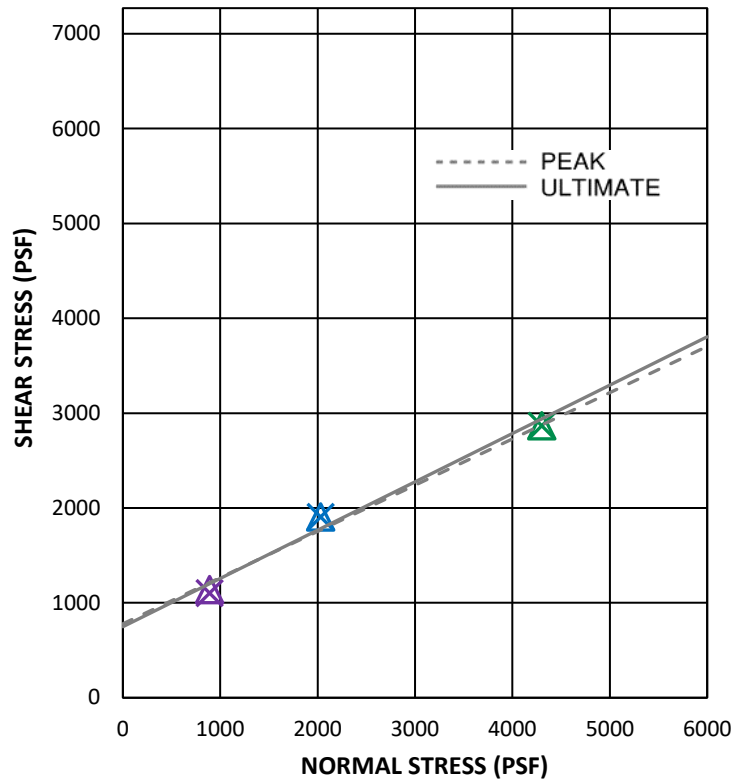
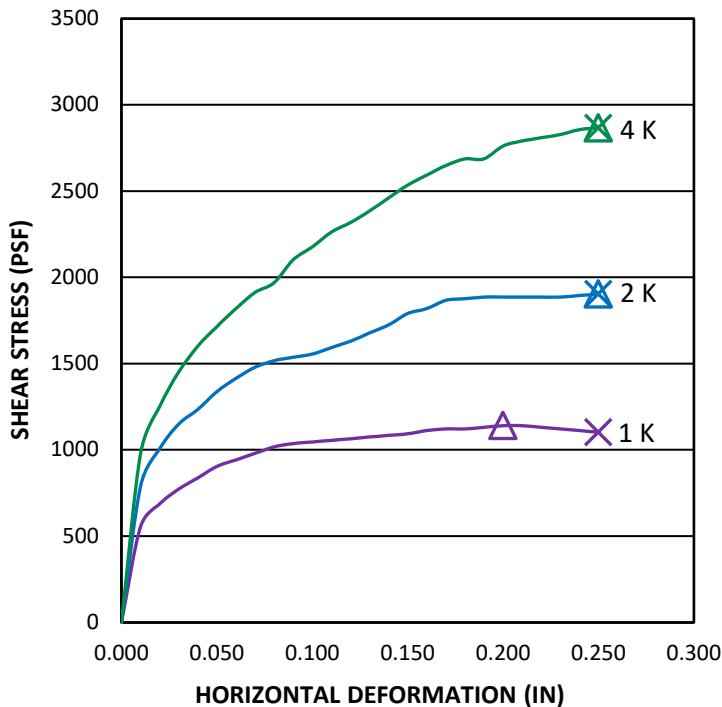

DIRECT SHEAR - ASTM D 3080

GEOCON
 INCORPORATED



GEOTECHNICAL CONSULTANTS
 6960 FLANDERS DRIVE - SAN DIEGO, CALIFORNIA 92121-2974
 PHONE 858 558-6900 - FAX 858 558-6159

SHINOHARA

PROJECT NO.: G2762-42-01

SAMPLE NO.: T1-2 GEOLOGIC UNIT: Qal
 SAMPLE DEPTH (FT): 10'-12' NATURAL/REMOVED: R

INITIAL CONDITIONS				
NORMAL STRESS TEST LOAD	1 K	2 K	4 K	AVERAGE
ACTUAL NORMAL STRESS (PSF):	1000	2000	4000	--
WATER CONTENT (%):	13.6	12.8	13.3	13.2
DRY DENSITY (PCF):	109.0	109.3	109.2	109.2

AFTER TEST CONDITIONS				
NORMAL STRESS TEST LOAD	1 K	2 K	4 K	AVERAGE
WATER CONTENT (%):	17.5	16.9	21.6	18.7
PEAK SHEAR STRESS (PSF):	1219	2012	3530	--
ULT.-E.O.T. SHEAR STRESS (PSF):	1160	2012	3530	--

RESULTS		
PEAK	COHESION, C (PSF)	460
	FRICTION ANGLE (DEGREES)	38
ULTIMATE	COHESION, C (PSF)	400
	FRICTION ANGLE (DEGREES)	38

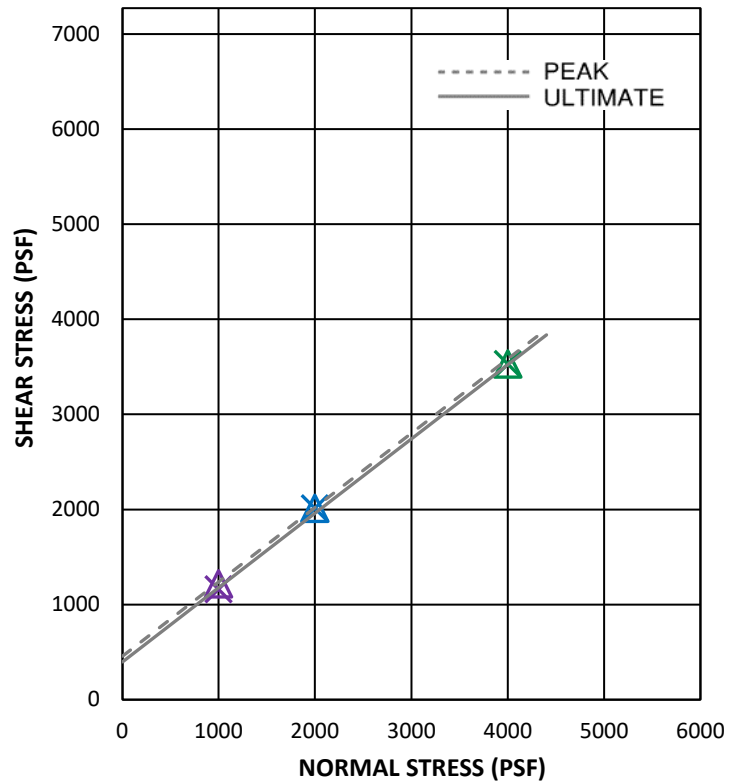
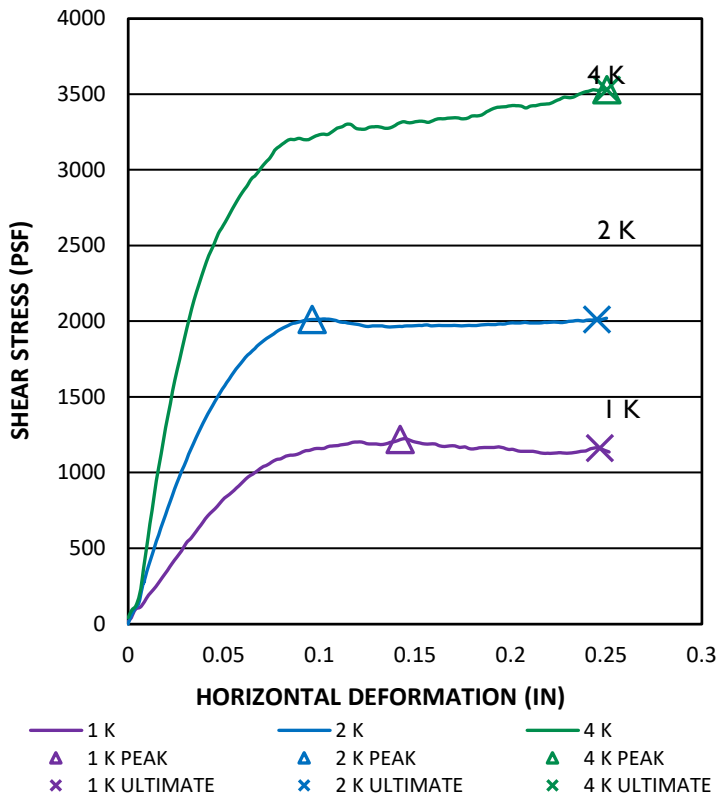

GEOCON
 INCORPORATED



GEOTECHNICAL CONSULTANTS
 6960 FLANDERS DRIVE - SAN DIEGO, CALIFORNIA 92121-2974
 PHONE 858 558-6900 - FAX 858 558-6159

DIRECT SHEAR - ASTM D 3080

SHINOHARA

PROJECT NO.: G2762-42-01

SAMPLE NO.: T3-2 GEOLOGIC UNIT: Tsd
 SAMPLE DEPTH (FT): 10'-12' NATURAL/REMOVED: R

INITIAL CONDITIONS				
NORMAL STRESS TEST LOAD	1 K	2 K	4 K	AVERAGE
ACTUAL NORMAL STRESS (PSF):	890	2030	4300	--
WATER CONTENT (%):	18.5	16.8	18.3	17.9
DRY DENSITY (PCF):	90.9	92.8	91.2	91.6

AFTER TEST CONDITIONS				
NORMAL STRESS TEST LOAD	1 K	2 K	4 K	AVERAGE
WATER CONTENT (%):	32.7	29.7	31.1	31.2
PEAK SHEAR STRESS (PSF):	886	1518	2904	--
ULT.-E.O.T. SHEAR STRESS (PSF):	886	1461	2866	--

RESULTS		
PEAK	COHESION, C (PSF)	340
	FRICTION ANGLE (DEGREES)	31
ULTIMATE	COHESION, C (PSF)	330
	FRICTION ANGLE (DEGREES)	30

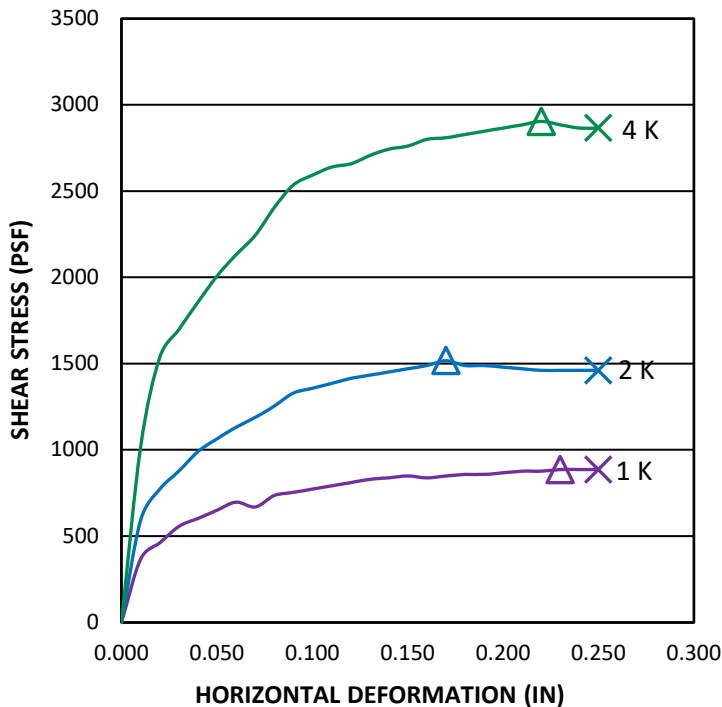

1 K 2 K 4 K
 ▲ 1 K PEAK ▲ 2 K PEAK ▲ 4 K PEAK
 × 1 K ULTIMATE × 2 K ULTIMATE × 4 K ULTIMATE

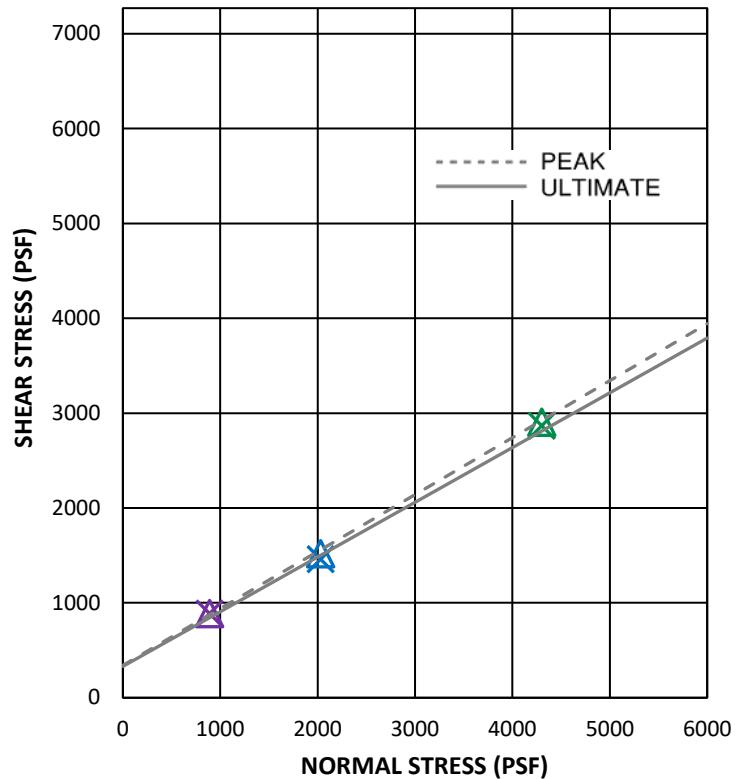

DIRECT SHEAR - ASTM D 3080

GEOCON
 INCORPORATED



GEOTECHNICAL CONSULTANTS
 6960 FLANDERS DRIVE - SAN DIEGO, CALIFORNIA 92121-2974
 PHONE 858 558-6900 - FAX 858 558-6159

SHINOHARA

PROJECT NO.: G2762-42-01

SAMPLE NO.: **B1-3**
 SAMPLE DEPTH (FT): **7.5'**

GEOLOGIC UNIT: **Qal**

TEST INFORMATION	
INITIAL DRY DENSITY (PCF):	120.0
INITIAL WATER CONTENT (%):	8.3%
SAMPLE SATURATED AT (KSF):	4.0
INITIAL SATURATION (%):	57.4%

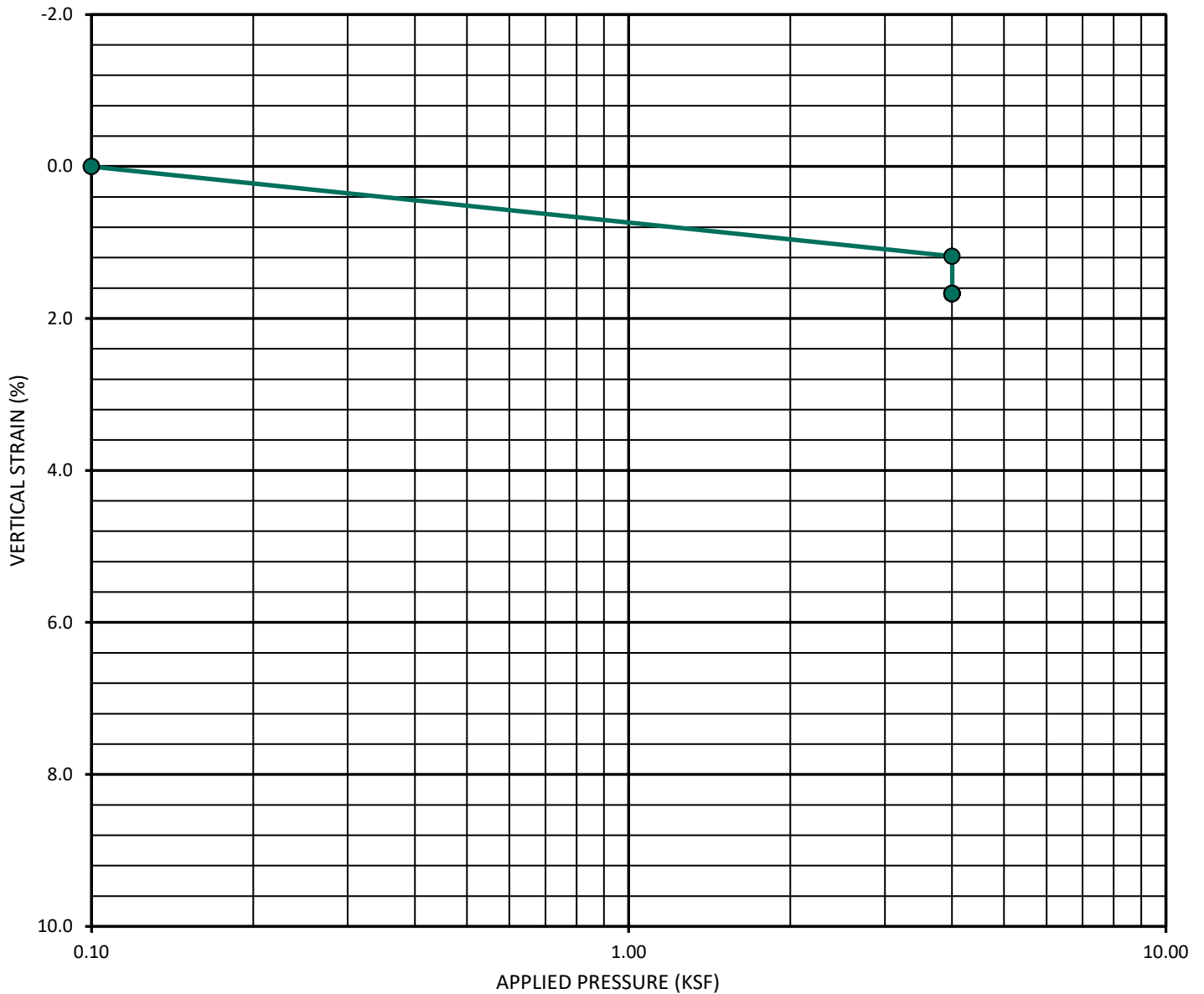

CONSOLIDATION CURVE - ASTM D 2435

GEOCON
 INCORPORATED



GEOTECHNICAL CONSULTANTS
 6960 FLANDERS DRIVE - SAN DIEGO, CALIFORNIA 92121 - 2974
 PHONE 858 558-6900 - FAX 858 558-6159

SHINOHARA

PROJECT NO.: G2762-42-01

SAMPLE NO.: **B1-4**
 SAMPLE DEPTH (FT): **10'**

GEOLOGIC UNIT: **Qal**

TEST INFORMATION	
INITIAL DRY DENSITY (PCF):	117.7
INITIAL WATER CONTENT (%):	8.1%
SAMPLE SATURATED AT (KSF):	4.0
INITIAL SATURATION (%):	52.7%

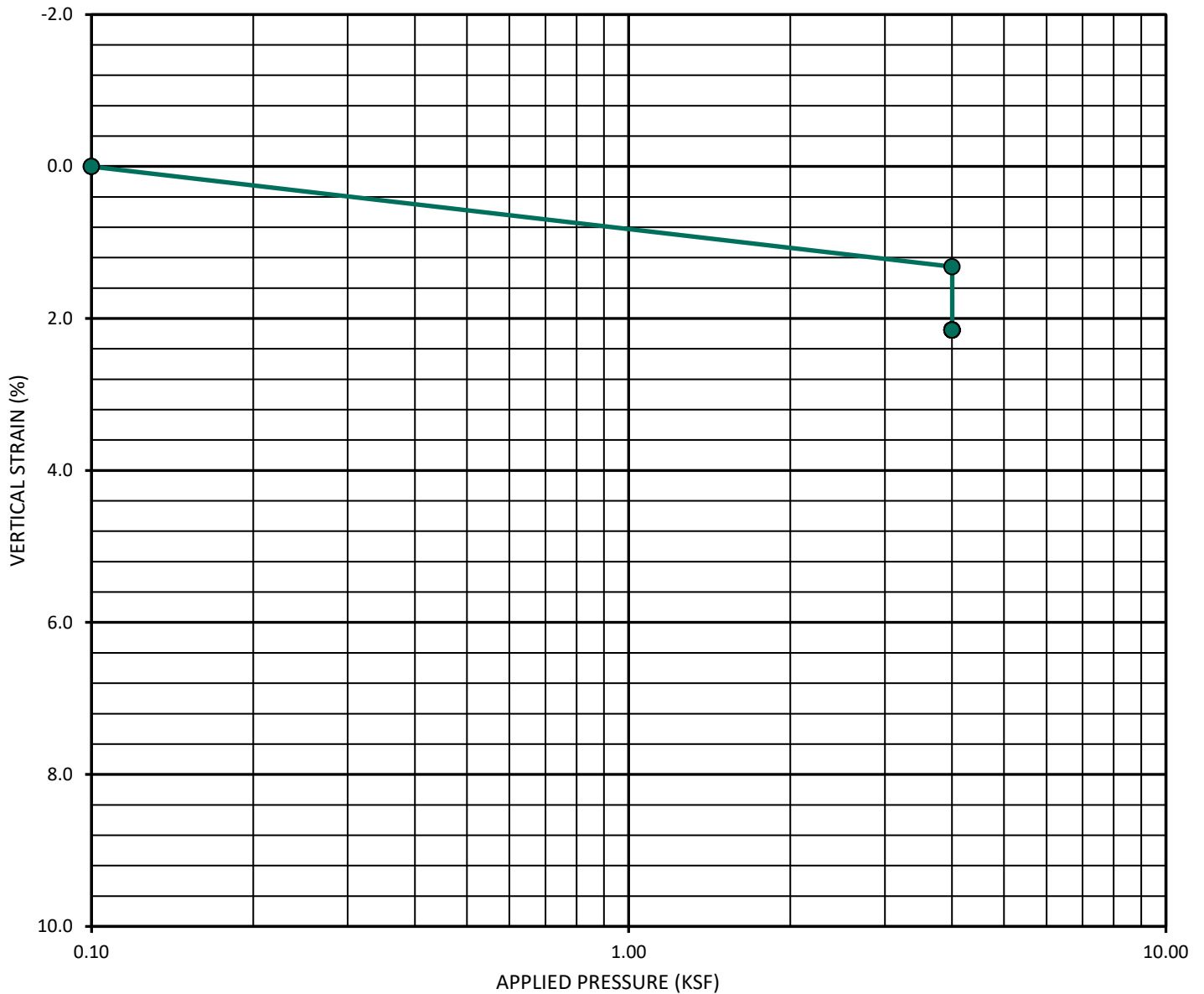

CONSOLIDATION CURVE - ASTM D 2435

GEOCON
 INCORPORATED



GEOTECHNICAL CONSULTANTS
 6960 FLANDERS DRIVE - SAN DIEGO, CALIFORNIA 92121 - 2974
 PHONE 858 558-6900 - FAX 858 558-6159

SHINOHARA

PROJECT NO.: G2762-42-01

SAMPLE NO.: **B1-5**
SAMPLE DEPTH (FT): **15'**

GEOLOGIC UNIT: **Qal**

TEST INFORMATION	
INITIAL DRY DENSITY (PCF):	120.0
INITIAL WATER CONTENT (%):	9.5%
SAMPLE SATURATED AT (KSF):	4.0
INITIAL SATURATION (%):	65.9%

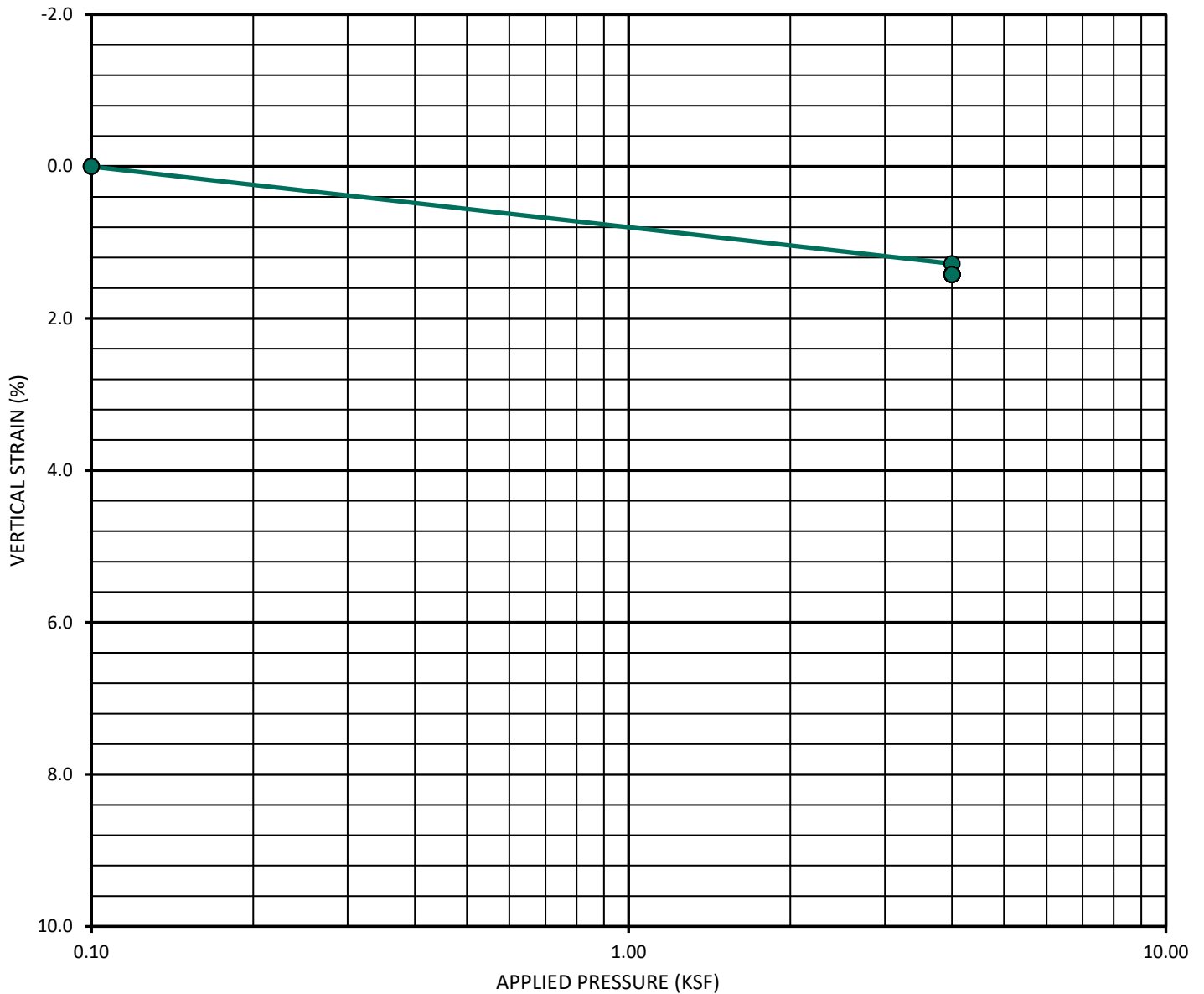

CONSOLIDATION CURVE - ASTM D 2435

GEOCON
INCORPORATED



GEOTECHNICAL CONSULTANTS
6960 FLANDERS DRIVE - SAN DIEGO, CALIFORNIA 92121 - 2974
PHONE 858 558-6900 - FAX 858 558-6159

SHINOHARA

PROJECT NO.: G2762-42-01

APPENDIX

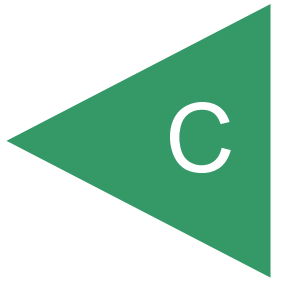

APPENDIX C

RECOMMENDED GRADING SPECIFICATIONS

FOR

**517 SHINOHARA LANE
INDUSTRIAL BUILDING
SAN DIEGO, CALIFORNIA**

PROJECT NO. G2762-42-01

RECOMMENDED GRADING SPECIFICATIONS

1. GENERAL

- 1.1 These Recommended Grading Specifications shall be used in conjunction with the Geotechnical Report for the project prepared by Geocon. The recommendations contained in the text of the Geotechnical Report are a part of the earthwork and grading specifications and shall supersede the provisions contained hereinafter in the case of conflict.
- 1.2 Prior to the commencement of grading, a geotechnical consultant (Consultant) shall be employed for the purpose of observing earthwork procedures and testing the fills for substantial conformance with the recommendations of the Geotechnical Report and these specifications. The Consultant should provide adequate testing and observation services so that they may assess whether, in their opinion, the work was performed in substantial conformance with these specifications. It shall be the responsibility of the Contractor to assist the Consultant and keep them apprised of work schedules and changes so that personnel may be scheduled accordingly.
- 1.3 It shall be the sole responsibility of the Contractor to provide adequate equipment and methods to accomplish the work in accordance with applicable grading codes or agency ordinances, these specifications and the approved grading plans. If, in the opinion of the Consultant, unsatisfactory conditions such as questionable soil materials, poor moisture condition, inadequate compaction, and/or adverse weather result in a quality of work not in conformance with these specifications, the Consultant will be empowered to reject the work and recommend to the Owner that grading be stopped until the unacceptable conditions are corrected.

2. DEFINITIONS

- 2.1 **Owner** shall refer to the owner of the property or the entity on whose behalf the grading work is being performed and who has contracted with the Contractor to have grading performed.
- 2.2 **Contractor** shall refer to the Contractor performing the site grading work.
- 2.3 **Civil Engineer** or **Engineer of Work** shall refer to the California licensed Civil Engineer or consulting firm responsible for preparation of the grading plans, surveying and verifying as-graded topography.
- 2.4 **Consultant** shall refer to the soil engineering and engineering geology consulting firm retained to provide geotechnical services for the project.

- 2.5 **Soil Engineer** shall refer to a California licensed Civil Engineer retained by the Owner, who is experienced in the practice of geotechnical engineering. The Soil Engineer shall be responsible for having qualified representatives on-site to observe and test the Contractor's work for conformance with these specifications.
- 2.6 **Engineering Geologist** shall refer to a California licensed Engineering Geologist retained by the Owner to provide geologic observations and recommendations during the site grading.
- 2.7 **Geotechnical Report** shall refer to a soil report (including all addenda) which may include a geologic reconnaissance or geologic investigation that was prepared specifically for the development of the project for which these Recommended Grading Specifications are intended to apply.

3. MATERIALS

- 3.1 Materials for compacted fill shall consist of any soil excavated from the cut areas or imported to the site that, in the opinion of the Consultant, is suitable for use in construction of fills. In general, fill materials can be classified as *soil* fills, *soil-rock* fills or *rock* fills, as defined below.
- 3.1.1 **Soil fills** are defined as fills containing no rocks or hard lumps greater than 12 inches in maximum dimension and containing at least 40 percent by weight of material smaller than $\frac{3}{4}$ inch in size.
- 3.1.2 **Soil-rock fills** are defined as fills containing no rocks or hard lumps larger than 4 feet in maximum dimension and containing a sufficient matrix of soil fill to allow for proper compaction of soil fill around the rock fragments or hard lumps as specified in Paragraph 6.2. **Oversize rock** is defined as material greater than 12 inches.
- 3.1.3 **Rock fills** are defined as fills containing no rocks or hard lumps larger than 3 feet in maximum dimension and containing little or no fines. Fines are defined as material smaller than $\frac{3}{4}$ inch in maximum dimension. The quantity of fines shall be less than approximately 20 percent of the rock fill quantity.
- 3.2 Material of a perishable, spongy, or otherwise unsuitable nature as determined by the Consultant shall not be used in fills.
- 3.3 Materials used for fill, either imported or on-site, shall not contain hazardous materials as defined by the California Code of Regulations, Title 22, Division 4, Chapter 30, Articles 9

and 10; 40CFR; and any other applicable local, state or federal laws. The Consultant shall not be responsible for the identification or analysis of the potential presence of hazardous materials. However, if observations, odors or soil discoloration cause Consultant to suspect the presence of hazardous materials, the Consultant may request from the Owner the termination of grading operations within the affected area. Prior to resuming grading operations, the Owner shall provide a written report to the Consultant indicating that the suspected materials are not hazardous as defined by applicable laws and regulations.

- 3.4 The outer 15 feet of *soil-rock* fill slopes, measured horizontally, should be composed of properly compacted *soil* fill materials approved by the Consultant. *Rock* fill may extend to the slope face, provided that the slope is not steeper than 2:1 (horizontal:vertical) and a soil layer no thicker than 12 inches is track-walked onto the face for landscaping purposes. This procedure may be utilized provided it is acceptable to the governing agency, Owner and Consultant.
- 3.5 Samples of soil materials to be used for fill should be tested in the laboratory by the Consultant to determine the maximum density, optimum moisture content, and, where appropriate, shear strength, expansion, and gradation characteristics of the soil.
- 3.6 During grading, soil or groundwater conditions other than those identified in the Geotechnical Report may be encountered by the Contractor. The Consultant shall be notified immediately to evaluate the significance of the unanticipated condition.

4. CLEARING AND PREPARING AREAS TO BE FILLED

- 4.1 Areas to be excavated and filled shall be cleared and grubbed. Clearing shall consist of complete removal above the ground surface of trees, stumps, brush, vegetation, man-made structures, and similar debris. Grubbing shall consist of removal of stumps, roots, buried logs and other unsuitable material and shall be performed in areas to be graded. Roots and other projections exceeding 1½ inches in diameter shall be removed to a depth of 3 feet below the surface of the ground. Borrow areas shall be grubbed to the extent necessary to provide suitable fill materials.
- 4.2 Asphalt pavement material removed during clearing operations should be properly disposed at an approved off-site facility or in an acceptable area of the project evaluated by Geocon and the property owner. Concrete fragments that are free of reinforcing steel may be placed in fills, provided they are placed in accordance with Section 6.2 or 6.3 of this document.

- 4.3 After clearing and grubbing of organic matter and other unsuitable material, loose or porous soils shall be removed to the depth recommended in the Geotechnical Report. The depth of removal and compaction should be observed and approved by a representative of the Consultant. The exposed surface shall then be plowed or scarified to a minimum depth of 6 inches and until the surface is free from uneven features that would tend to prevent uniform compaction by the equipment to be used.
- 4.4 Where the slope ratio of the original ground is steeper than 5:1 (horizontal:vertical), or where recommended by the Consultant, the original ground should be benched in accordance with the following illustration.

TYPICAL BENCHING DETAIL

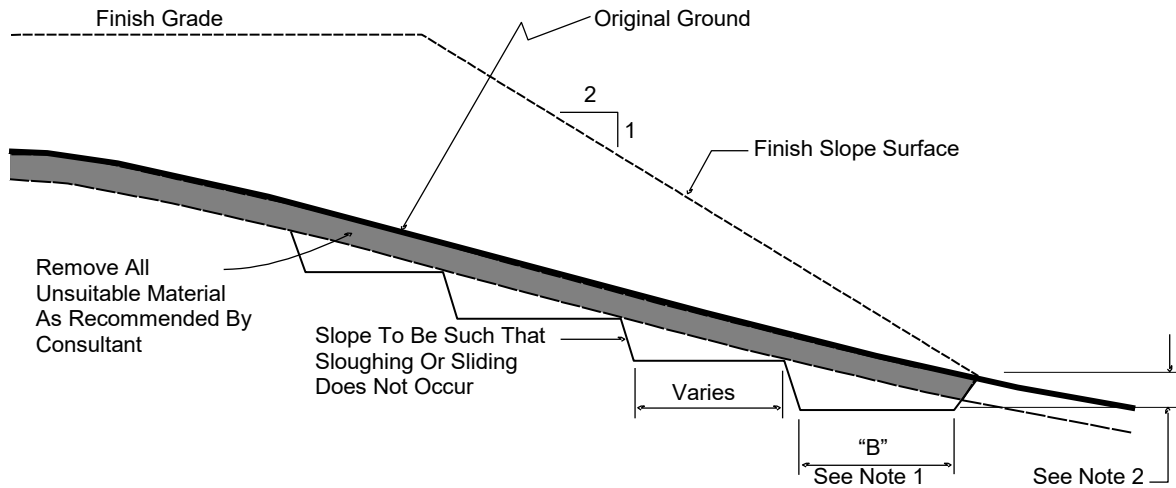

No Scale

- DETAIL NOTES: (1) Key width "B" should be a minimum of 10 feet, or sufficiently wide to permit complete coverage with the compaction equipment used. The base of the key should be graded horizontal, or inclined slightly into the natural slope.
- (2) The outside of the key should be below the topsoil or unsuitable surficial material and at least 2 feet into dense formational material. Where hard rock is exposed in the bottom of the key, the depth and configuration of the key may be modified as approved by the Consultant.

- 4.5 After areas to receive fill have been cleared and scarified, the surface should be moisture conditioned to achieve the proper moisture content, and compacted as recommended in Section 6 of these specifications.

5. COMPACTION EQUIPMENT

- 5.1 Compaction of *soil* or *soil-rock* fill shall be accomplished by sheepsfoot or segmented-steel wheeled rollers, vibratory rollers, multiple-wheel pneumatic-tired rollers, or other types of acceptable compaction equipment. Equipment shall be of such a design that it will be capable of compacting the *soil* or *soil-rock* fill to the specified relative compaction at the specified moisture content.
- 5.2 Compaction of *rock* fills shall be performed in accordance with Section 6.3.

6. PLACING, SPREADING AND COMPACTION OF FILL MATERIAL

- 6.1 *Soil* fill, as defined in Paragraph 3.1.1, shall be placed by the Contractor in accordance with the following recommendations:
- 6.1.1 *Soil* fill shall be placed by the Contractor in layers that, when compacted, should generally not exceed 8 inches. Each layer shall be spread evenly and shall be thoroughly mixed during spreading to obtain uniformity of material and moisture in each layer. The entire fill shall be constructed as a unit in nearly level lifts. Rock materials greater than 12 inches in maximum dimension shall be placed in accordance with Section 6.2 or 6.3 of these specifications.
- 6.1.2 In general, the *soil* fill shall be compacted at a moisture content at or above the optimum moisture content as determined by ASTM D 1557.
- 6.1.3 When the moisture content of *soil* fill is below that specified by the Consultant, water shall be added by the Contractor until the moisture content is in the range specified.
- 6.1.4 When the moisture content of the *soil* fill is above the range specified by the Consultant or too wet to achieve proper compaction, the *soil* fill shall be aerated by the Contractor by blading/mixing, or other satisfactory methods until the moisture content is within the range specified.
- 6.1.5 After each layer has been placed, mixed, and spread evenly, it shall be thoroughly compacted by the Contractor to a relative compaction of at least 90 percent. Relative compaction is defined as the ratio (expressed in percent) of the in-place dry density of the compacted fill to the maximum laboratory dry density as determined in accordance with ASTM D 1557. Compaction shall be continuous over the entire area, and compaction equipment shall make sufficient passes so that the specified minimum relative compaction has been achieved throughout the entire fill.

- 6.1.6 Where practical, soils having an Expansion Index greater than 50 should be placed at least 3 feet below finish pad grade and should be compacted at a moisture content generally 2 to 4 percent greater than the optimum moisture content for the material.
 - 6.1.7 Properly compacted *soil* fill shall extend to the design surface of fill slopes. To achieve proper compaction, it is recommended that fill slopes be over-built by at least 3 feet and then cut to the design grade. This procedure is considered preferable to track-walking of slopes, as described in the following paragraph.
 - 6.1.8 As an alternative to over-building of slopes, slope faces may be back-rolled with a heavy-duty loaded sheepsfoot or vibratory roller at maximum 4-foot fill height intervals. Upon completion, slopes should then be track-walked with a D-8 dozer or similar equipment, such that a dozer track covers all slope surfaces at least twice.
- 6.2 *Soil-rock* fill, as defined in Paragraph 3.1.2, shall be placed by the Contractor in accordance with the following recommendations:
- 6.2.1 Rocks larger than 12 inches but less than 4 feet in maximum dimension may be incorporated into the compacted *soil* fill, but shall be limited to the area measured 15 feet minimum horizontally from the slope face and 5 feet below finish grade or 3 feet below the deepest utility, whichever is deeper.
 - 6.2.2 Rocks or rock fragments up to 4 feet in maximum dimension may either be individually placed or placed in windrows. Under certain conditions, rocks or rock fragments up to 10 feet in maximum dimension may be placed using similar methods. The acceptability of placing rock materials greater than 4 feet in maximum dimension shall be evaluated during grading as specific cases arise and shall be approved by the Consultant prior to placement.
 - 6.2.3 For individual placement, sufficient space shall be provided between rocks to allow for passage of compaction equipment.
 - 6.2.4 For windrow placement, the rocks should be placed in trenches excavated in properly compacted *soil* fill. Trenches should be approximately 5 feet wide and 4 feet deep in maximum dimension. The voids around and beneath rocks should be filled with approved granular soil having a Sand Equivalent of 30 or greater and should be compacted by flooding. Windrows may also be placed utilizing an "open-face" method in lieu of the trench procedure, however, this method should first be approved by the Consultant.

- 6.2.5 Windrows should generally be parallel to each other and may be placed either parallel to or perpendicular to the face of the slope depending on the site geometry. The minimum horizontal spacing for windrows shall be 12 feet center-to-center with a 5-foot stagger or offset from lower courses to next overlying course. The minimum vertical spacing between windrow courses shall be 2 feet from the top of a lower windrow to the bottom of the next higher windrow.
- 6.2.6 Rock placement, fill placement and flooding of approved granular soil in the windrows should be continuously observed by the Consultant.
- 6.3 *Rock* fills, as defined in Section 3.1.3, shall be placed by the Contractor in accordance with the following recommendations:
- 6.3.1 The base of the *rock* fill shall be placed on a sloping surface (minimum slope of 2 percent). The surface shall slope toward suitable subdrainage outlet facilities. The *rock* fills shall be provided with subdrains during construction so that a hydrostatic pressure buildup does not develop. The subdrains shall be permanently connected to controlled drainage facilities to control post-construction infiltration of water.
- 6.3.2 *Rock* fills shall be placed in lifts not exceeding 3 feet. Placement shall be by rock trucks traversing previously placed lifts and dumping at the edge of the currently placed lift. Spreading of the *rock* fill shall be by dozer to facilitate *seating* of the rock. The *rock* fill shall be watered heavily during placement. Watering shall consist of water trucks traversing in front of the current rock lift face and spraying water continuously during rock placement. Compaction equipment with compactive energy comparable to or greater than that of a 20-ton steel vibratory roller or other compaction equipment providing suitable energy to achieve the required compaction or deflection as recommended in Paragraph 6.3.3 shall be utilized. The number of passes to be made should be determined as described in Paragraph 6.3.3. Once a *rock* fill lift has been covered with *soil* fill, no additional *rock* fill lifts will be permitted over the *soil* fill.
- 6.3.3 Plate bearing tests, in accordance with ASTM D 1196, may be performed in both the compacted *soil* fill and in the *rock* fill to aid in determining the required minimum number of passes of the compaction equipment. If performed, a minimum of three plate bearing tests should be performed in the properly compacted *soil* fill (minimum relative compaction of 90 percent). Plate bearing tests shall then be performed on areas of *rock* fill having two passes, four passes and six passes of the compaction equipment, respectively. The number of passes required for the *rock* fill shall be determined by comparing the results of the plate bearing tests for the *soil* fill and the *rock* fill and by evaluating the deflection

variation with number of passes. The required number of passes of the compaction equipment will be performed as necessary until the plate bearing deflections are equal to or less than that determined for the properly compacted *soil* fill. In no case will the required number of passes be less than two.

- 6.3.4 A representative of the Consultant should be present during *rock* fill operations to observe that the minimum number of “passes” have been obtained, that water is being properly applied and that specified procedures are being followed. The actual number of plate bearing tests will be determined by the Consultant during grading.
- 6.3.5 Test pits shall be excavated by the Contractor so that the Consultant can state that, in their opinion, sufficient water is present and that voids between large rocks are properly filled with smaller rock material. In-place density testing will not be required in the *rock* fills.
- 6.3.6 To reduce the potential for “piping” of fines into the *rock* fill from overlying *soil* fill material, a 2-foot layer of graded filter material shall be placed above the uppermost lift of *rock* fill. The need to place graded filter material below the *rock* should be determined by the Consultant prior to commencing grading. The gradation of the graded filter material will be determined at the time the *rock* fill is being excavated. Materials typical of the *rock* fill should be submitted to the Consultant in a timely manner, to allow design of the graded filter prior to the commencement of *rock* fill placement.
- 6.3.7 *Rock* fill placement should be continuously observed during placement by the Consultant.

7. SUBDRAINS

- 7.1 The geologic units on the site may have permeability characteristics and/or fracture systems that could be susceptible under certain conditions to seepage. The use of canyon subdrains may be necessary to mitigate the potential for adverse impacts associated with seepage conditions. Canyon subdrains with lengths in excess of 500 feet or extensions of existing offsite subdrains should use 8-inch-diameter pipes. Canyon subdrains less than 500 feet in length should use 6-inch-diameter pipes.

TYPICAL CANYON DRAIN DETAIL

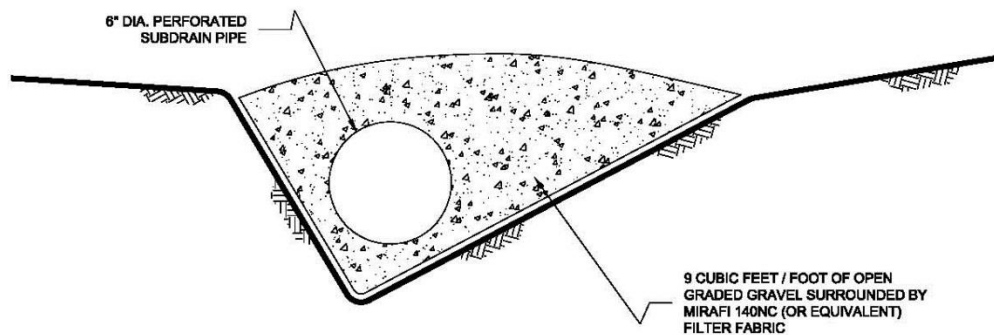
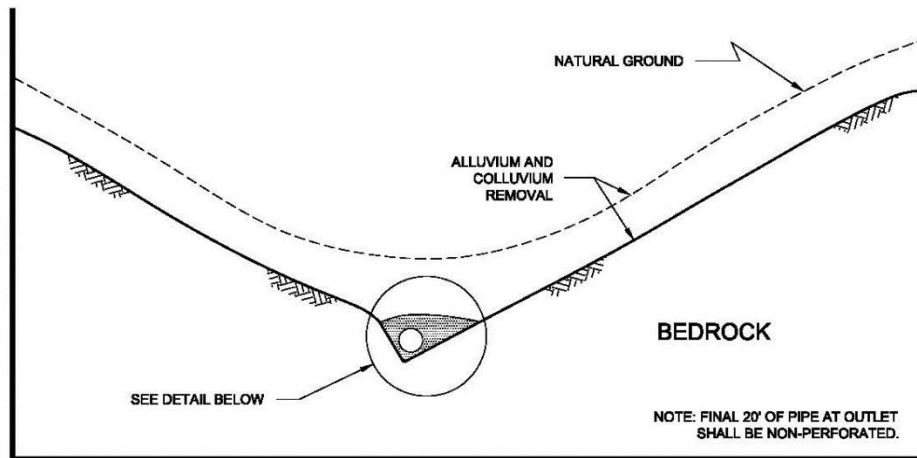

NOTES:

- 1.....8-INCH DIAMETER, SCHEDULE 80 PVC PERFORATED PIPE FOR FILLS IN EXCESS OF 100-FEET IN DEPTH OR A PIPE LENGTH OF LONGER THAN 500 FEET.
- 2.....6-INCH DIAMETER, SCHEDULE 40 PVC PERFORATED PIPE FOR FILLS LESS THAN 100-FEET IN DEPTH OR A PIPE LENGTH SHORTER THAN 500 FEET.

NO SCALE

7.2 Slope drains within stability fill keyways should use 4-inch-diameter (or larger) pipes.

TYPICAL STABILITY FILL DETAIL

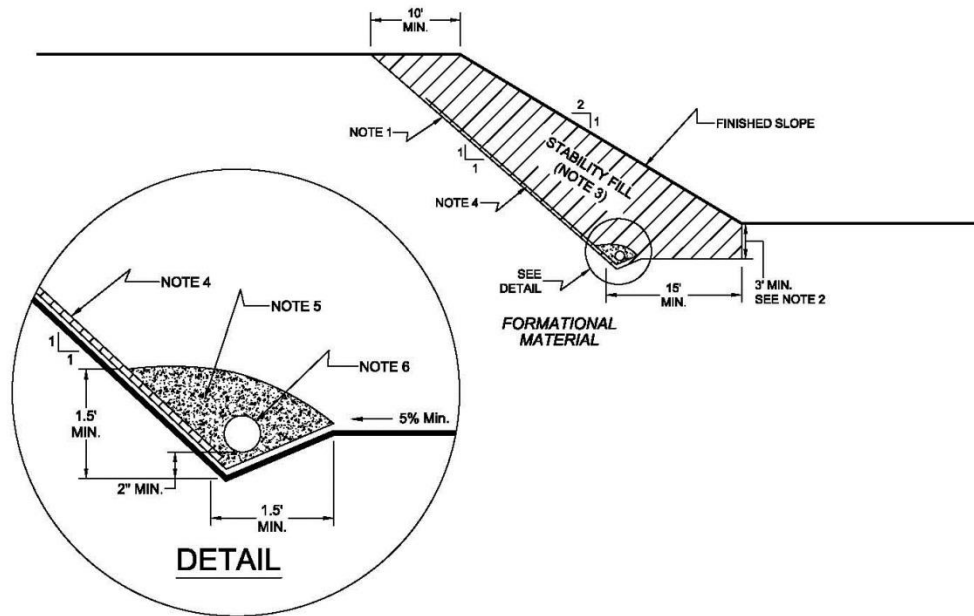

NOTES:

- 1.....EXCAVATE BACKCUT AT 1:1 INCLINATION (UNLESS OTHERWISE NOTED).
- 2.....BASE OF STABILITY FILL TO BE 3 FEET INTO FORMATIONAL MATERIAL, SLOPING A MINIMUM 5% INTO SLOPE.
- 3.....STABILITY FILL TO BE COMPOSED OF PROPERLY COMPACTED GRANULAR SOIL.
- 4.....CHIMNEY DRAINS TO BE APPROVED PREFABRICATED CHIMNEY DRAIN PANELS (MIRADRAIN G200N OR EQUIVALENT) SPACED APPROXIMATELY 20 FEET CENTER TO CENTER AND 4 FEET WIDE. CLOSER SPACING MAY BE REQUIRED IF SEEPAGE IS ENCOUNTERED.
- 5.....FILTER MATERIAL TO BE 3/4-INCH, OPEN-GRADED CRUSHED ROCK ENCLOSED IN APPROVED FILTER FABRIC (MIRAFI 140NC).
- 6.....COLLECTOR PIPE TO BE 4-INCH MINIMUM DIAMETER, PERFORATED, THICK-WALLED PVC SCHEDULE 40 OR EQUIVALENT, AND SLOPED TO DRAIN AT 1 PERCENT MINIMUM TO APPROVED OUTLET.

NO SCALE

7.3 The actual subdrain locations will be evaluated in the field during the remedial grading operations. Additional drains may be necessary depending on the conditions observed and the requirements of the local regulatory agencies. Appropriate subdrain outlets should be evaluated prior to finalizing 40-scale grading plans.

7.4 *Rock fill* or *soil-rock fill* areas may require subdrains along their down-slope perimeters to mitigate the potential for buildup of water from construction or landscape irrigation. The subdrains should be at least 6-inch-diameter pipes encapsulated in gravel and filter fabric. *Rock fill* drains should be constructed using the same requirements as canyon subdrains.

7.5 Prior to outletting, the final 20-foot segment of a subdrain that will not be extended during future development should consist of non-perforated drainpipe. At the non-perforated/perforated interface, a seepage cutoff wall should be constructed on the downslope side of the pipe.

TYPICAL CUT OFF WALL DETAIL

FRONT VIEW

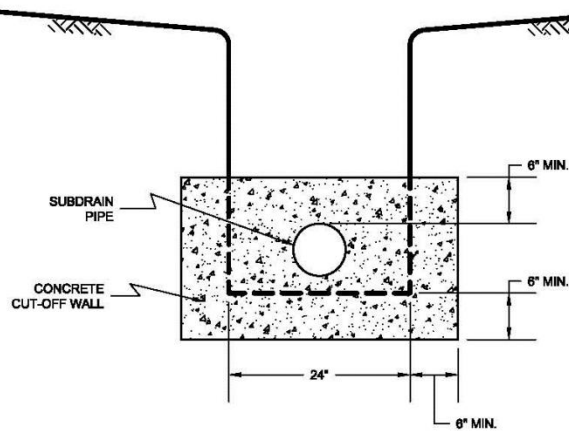

NO SCALE

SIDE VIEW

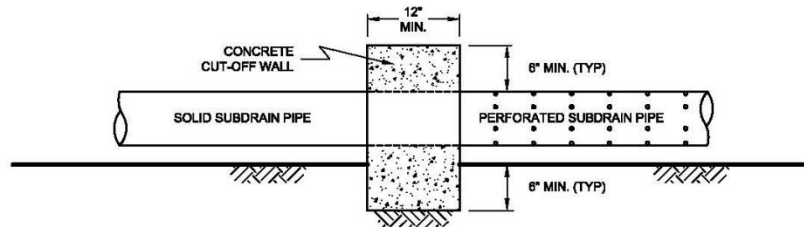

NO SCALE

7.6 Subdrains that discharge into a natural drainage course or open space area should be provided with a permanent headwall structure.

TYPICAL HEADWALL DETAIL

FRONT VIEW

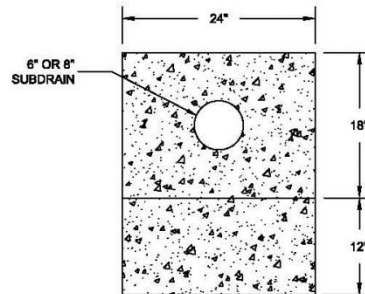

NO SCALE

SIDE VIEW

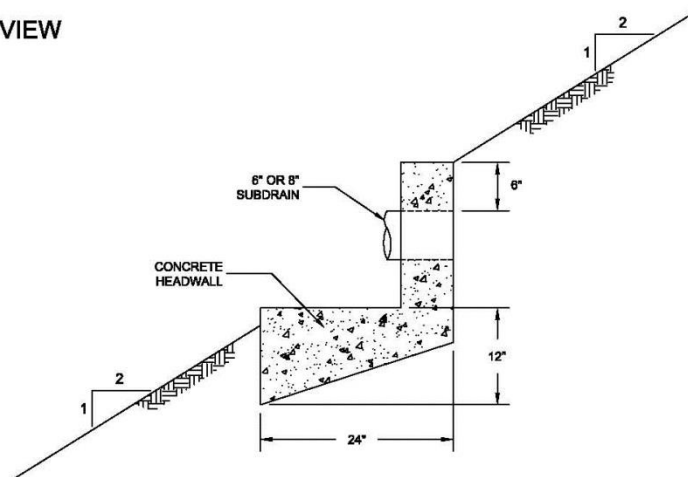

NOTE: HEADWALL SHOULD OUTLET AT TOE OF FILL SLOPE
OR INTO CONTROLLED SURFACE DRAINAGE

NO SCALE

- 7.7 The final grading plans should show the location of the proposed subdrains. After completion of remedial excavations and subdrain installation, the project civil engineer should survey the drain locations and prepare an “as-built” map showing the drain locations. The final outlet and connection locations should be determined during grading operations. Subdrains that will be extended on adjacent projects after grading can be placed on formational material and a vertical riser should be placed at the end of the subdrain. The grading contractor should consider videoing the subdrains shortly after burial to check proper installation and functionality. The contractor is responsible for the performance of the drains.

8. OBSERVATION AND TESTING

- 8.1 The Consultant shall be the Owner's representative to observe and perform tests during clearing, grubbing, filling, and compaction operations. In general, no more than 2 feet in vertical elevation of *soil* or *soil-rock* fill should be placed without at least one field density test being performed within that interval. In addition, a minimum of one field density test should be performed for every 2,000 cubic yards of *soil* or *soil-rock* fill placed and compacted.
- 8.2 The Consultant should perform a sufficient distribution of field density tests of the compacted *soil* or *soil-rock* fill to provide a basis for expressing an opinion whether the fill material is compacted as specified. Density tests shall be performed in the compacted materials below any disturbed surface. When these tests indicate that the density of any layer of fill or portion thereof is below that specified, the particular layer or areas represented by the test shall be reworked until the specified density has been achieved.
- 8.3 During placement of *rock* fill, the Consultant should observe that the minimum number of passes have been obtained per the criteria discussed in Section 6.3.3. The Consultant should request the excavation of observation pits and may perform plate bearing tests on the placed *rock* fills. The observation pits will be excavated to provide a basis for expressing an opinion as to whether the *rock* fill is properly seated and sufficient moisture has been applied to the material. When observations indicate that a layer of *rock* fill or any portion thereof is below that specified, the affected layer or area shall be reworked until the *rock* fill has been adequately seated and sufficient moisture applied.
- 8.4 A settlement monitoring program designed by the Consultant may be conducted in areas of *rock* fill placement. The specific design of the monitoring program shall be as recommended in the Conclusions and Recommendations section of the project Geotechnical Report or in the final report of testing and observation services performed during grading.
- 8.5 We should observe the placement of subdrains, to check that the drainage devices have been placed and constructed in substantial conformance with project specifications.
- 8.6 Testing procedures shall conform to the following Standards as appropriate:

8.6.1 Soil and Soil-Rock Fills:

- 8.6.1.1 Field Density Test, ASTM D 1556, *Density of Soil In-Place By the Sand-Cone Method.*

- 8.6.1.2 Field Density Test, Nuclear Method, ASTM D 6938, *Density of Soil and Soil-Aggregate In-Place by Nuclear Methods (Shallow Depth)*.
- 8.6.1.3 Laboratory Compaction Test, ASTM D 1557, *Moisture-Density Relations of Soils and Soil-Aggregate Mixtures Using 10-Pound Hammer and 18-Inch Drop*.
- 8.6.1.4 Expansion Index Test, ASTM D 4829, *Expansion Index Test*.

9. PROTECTION OF WORK

- 9.1 During construction, the Contractor shall properly grade all excavated surfaces to provide positive drainage and prevent ponding of water. Drainage of surface water shall be controlled to avoid damage to adjoining properties or to finished work on the site. The Contractor shall take remedial measures to prevent erosion of freshly graded areas until such time as permanent drainage and erosion control features have been installed. Areas subjected to erosion or sedimentation shall be properly prepared in accordance with the Specifications prior to placing additional fill or structures.
- 9.2 After completion of grading as observed and tested by the Consultant, no further excavation or filling shall be conducted except in conjunction with the services of the Consultant.

10. CERTIFICATIONS AND FINAL REPORTS

- 10.1 Upon completion of the work, Contractor shall furnish Owner a certification by the Civil Engineer stating that the lots and/or building pads are graded to within 0.1 foot vertically of elevations shown on the grading plan and that all tops and toes of slopes are within 0.5 foot horizontally of the positions shown on the grading plans. After installation of a section of subdrain, the project Civil Engineer should survey its location and prepare an *as-built* plan of the subdrain location. The project Civil Engineer should verify the proper outlet for the subdrains and the Contractor should ensure that the drain system is free of obstructions.
- 10.2 The Owner is responsible for furnishing a final as-graded soil and geologic report satisfactory to the appropriate governing or accepting agencies. The as-graded report should be prepared and signed by a California licensed Civil Engineer experienced in geotechnical engineering and by a California Certified Engineering Geologist, indicating that the geotechnical aspects of the grading were performed in substantial conformance with the Specifications or approved changes to the Specifications.

LIST OF REFERENCES

1. FEMA (2012), *Flood Map Service Center*, FEMA website, <https://msc.fema.gov/portal/home>, flood map numbers 06073C2156G and 06073C2157G, effective May 16, 2012, accessed July 16, 2021;
2. Kennedy, M. P., and S. S. Tan, 2007, *Geologic Map of the Oceanside 30'x60' Quadrangle, California*, USGS Regional Map Series Map No. 1, Scale 1:100,000.
3. SEAOC (2019), *OSHPD Seismic Design Maps*: Structural Engineers Association of California website, <http://seismicmaps.org/>, accessed July 19, 2021;
4. USGS (2019), *Quaternary Fault and Fold Database of the United States*: U.S. Geological Survey website, <https://www.usgs.gov/natural-hazards/earthquake-hazards/faults>, accessed July 19, 2021;
5. Unpublished reports and maps on file with Geocon Incorporated.