

Memorandum

Date: September 9, 2022
To: Rob Natoli
WSC Inc.
cc: South Tahoe Public Utility District
From: Julia Beals, Environmental Scientist
RE: **South Tahoe Public Utility District's Bijou Pump Station Rehabilitation Project – Permitting Recommendations**

5390 Kietzke Lane
Suite 103
Reno, NV 89511
USA

Phone 775 335 2396

www.cardno.com
www.stantec.com

1 Purpose

The South Tahoe Public Utility District (District) is proposing the Bijou Pump Station Rehabilitation Project (Project) at the existing Bijou Pump Station located on Lake Tahoe Boulevard in South Lake Tahoe. The purpose of this memorandum is to provide Project background, a constraints analysis, and permitting recommendations (summarized in Attachment A) for the Project based on the design memo provided by Water Systems Consulting, Inc. (WSC, Inc.) (Attachment B).

2 Background

As described in **Attachment B**, the District owns and operates a sewer collection system that extends throughout the City of South Lake Tahoe (City). The collection system includes approximately 40 pump stations. The Bijou Pump Station is one of the District's "Big 5 Pump Stations" that pumps sewage from the gravity collection system to the District's Wastewater Treatment Plant (WWTP). The Bijou Pump Station was built in 1955 and is the District's oldest pump station. The station receives wastewater from the tourist corridor in the City from Ski Run Boulevard to the California-Nevada state line. Raw sewage is conveyed by the station into 12-inch and 16-inch force mains that extend to the WWTP.

A condition assessment of Bijou Pump Station (Station) was performed in 2018, which identified the following areas of concern:

- > Outdated electrical and controls equipment;
- > Wet well and dry pit air quality concerns from poor ventilation;
- > Weekly need for wet well cleaning;
- > Pump 3 premature failure of bearings and running at high temperatures; and

Corrosion and coating damages to the building from high hydrogen sulfide gas levels resulting in safety hazards during operation, maintenance and wet well access. Upon reviewing these concerns, the District has set forth the following goals for the Project:

- > Improve the structural integrity/seismic resistance of the existing structure;
- > Reduce operational health and safety risks;
- > Reduce operation and maintenance requirements at the station;
- > Improve pump station reliability and redundancy;

- > Provide adequate clearances for new electrical equipment; and
- > Provide remote monitoring and operation capabilities through the SCADA (Supervisory Control and Data Acquisition) system.

3 Project Location

The Station is located at 3705 Lake Tahoe Boulevard in South Lake Tahoe, El Dorado County, California (38.949989°, -119.955753°). The Station is approximately 850 feet southeast of the shoreline of Lake Tahoe at approximately 6,250 feet Lake Tahoe Datum (LTD). The District-owned 2,519 square foot parcel upon which the Station is located (APN 027-690-003) is encircled by the privately-owned parcel of a McDonalds restaurant (APN 027-690-002). A photo of the existing Station is shown in **Figure 1**. The Project vicinity is shown in **Figure 2**.

Per the Lake Tahoe Parcel Tracker, neither parcels have recorded Land Capability Verifications (TRPA 2022a; TRPA 2022b). The parcels likely do not have verifications associated with the APNs because the area was part of a large redevelopment project during the 1990s. However, based on a review of the Bailey Land Capability GIS data, the parcel is located within Land Capability District (LCD 1B), indicating the potential presence of a stream environment zone (SEZ) (Tahoe Open Data 2022).

The parking lot surrounding the pump station is predominantly paved, with the exception of planters vegetated by grasses and ornamental trees/shrubs. Drainage within the parking lot is predominantly flat. Two storm drain inlets are located to the northwest of the District parcel, within the McDonald's parcel (APN 027-690-002). From these storm drains, stormwater is conveyed north via stormwater pipe to the City's Wildwood Basins 3 & 4 and associated drainage ditch, which are adjacent to the northern proximity of the McDonalds parcel (CSLT 2018). The Station is not located within a 100-year special flood hazard zone (TRPA 2022d). Per the Flood Insurance Rate Map (FIRM) for El Dorado County, the Project is located within Zone X/D, which are areas in which flood hazards are undetermined, but possible (FEMA 20120).

The District parcel contains an existing cement block pump station building and standby generator building, which are both surrounded by a concrete masonry unit (CMU) security wall. **Figure 3** shows a site plan based on survey data included in the 30% design plans presented in **Attachment B**.



Figure 1 Existing Station. View is to the north.

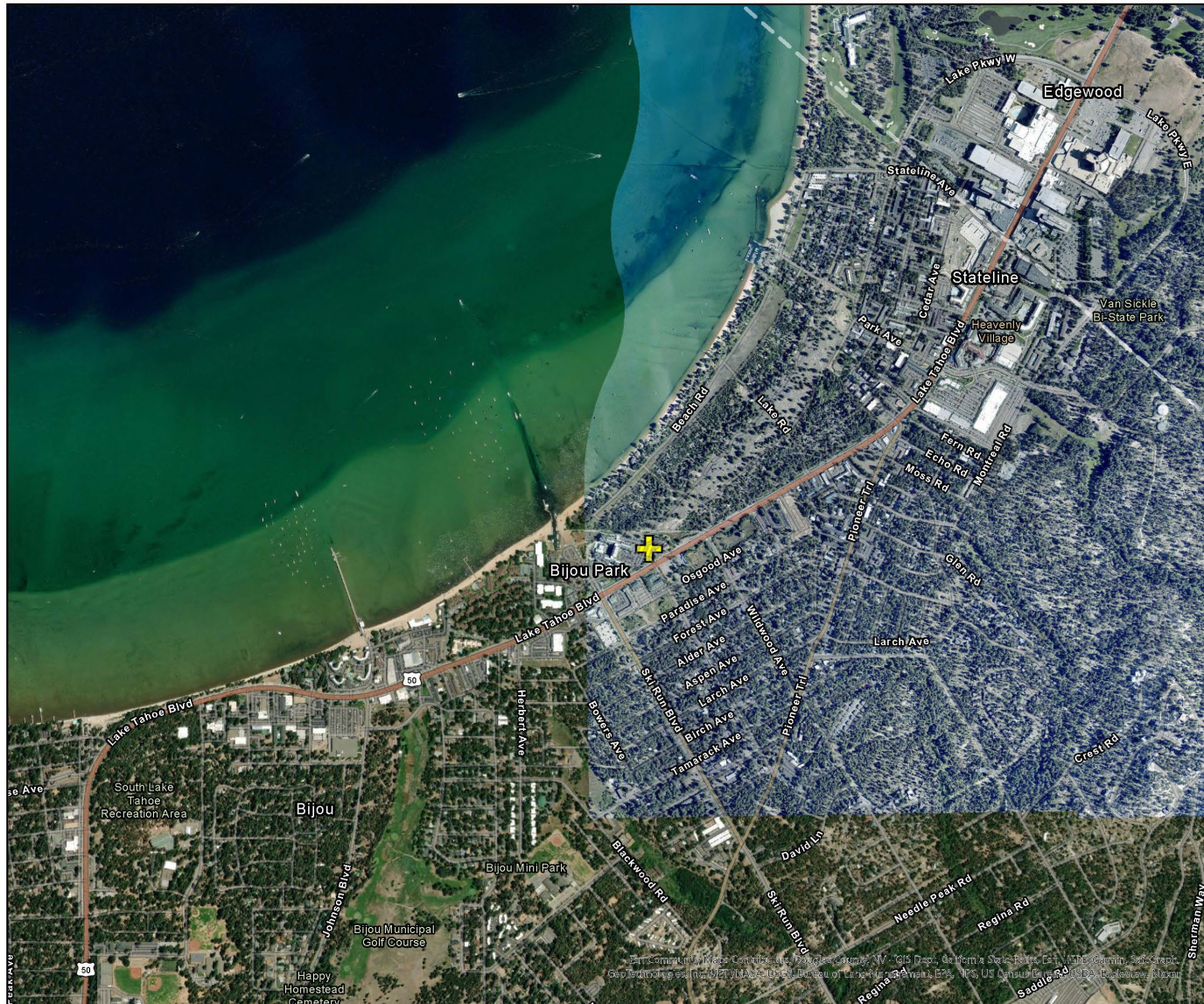

STPUD Bijou Pump Station Rehabilitation

PROJECT VICINITY

Legend

- Project Location

FIGURE 2



Map Produced by Julia Beals
Date: 2022/09/04 | Project: 1300-01 - Phase 01
Coordinate System:
Map: M:\Project1.sprx.01

September 9, 2022
South Tahoe Public Utility District's Bijou Pump Station Rehabilitation Project – Permitting Recommendations

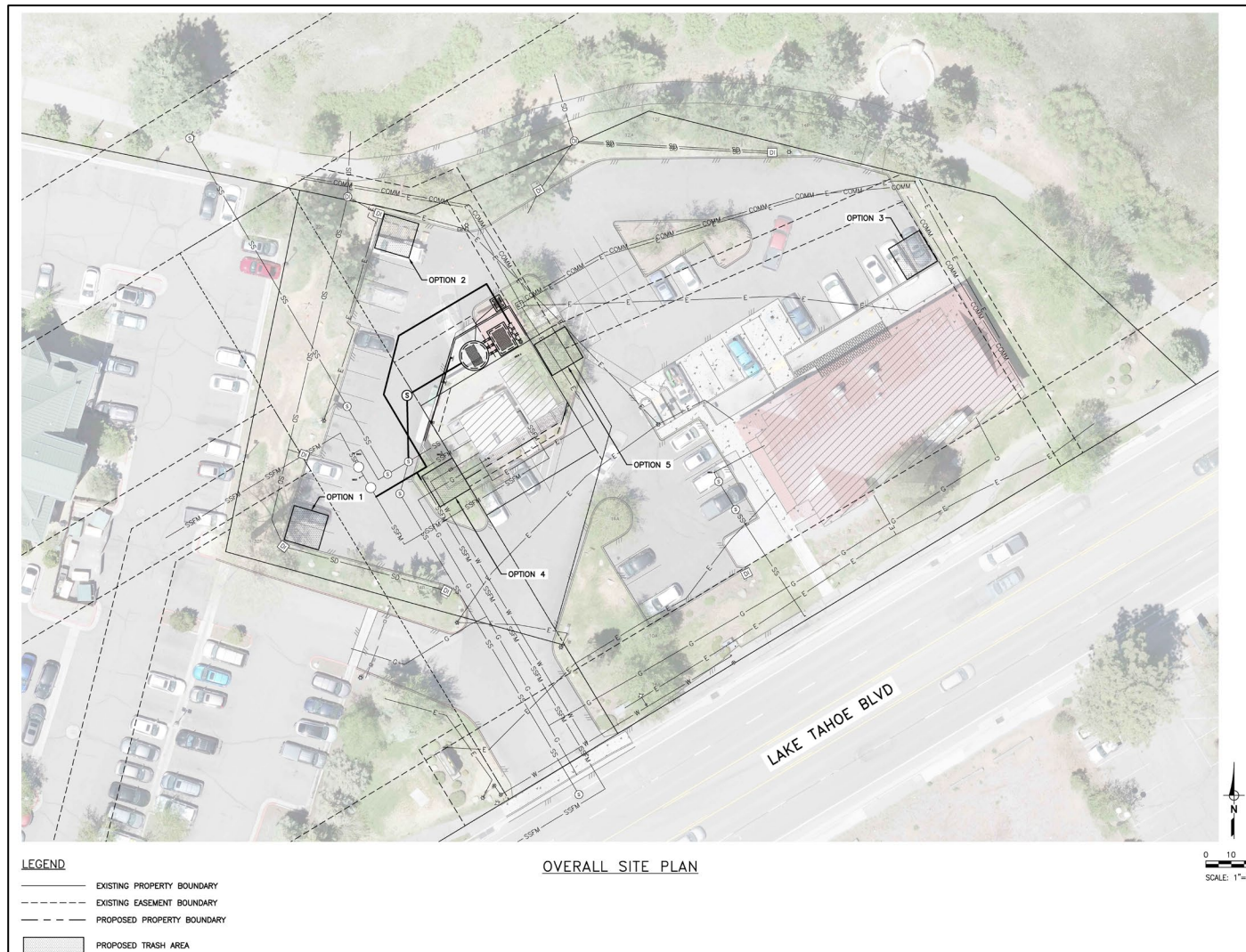

Figure 3 Existing Bijou Pump Station Site

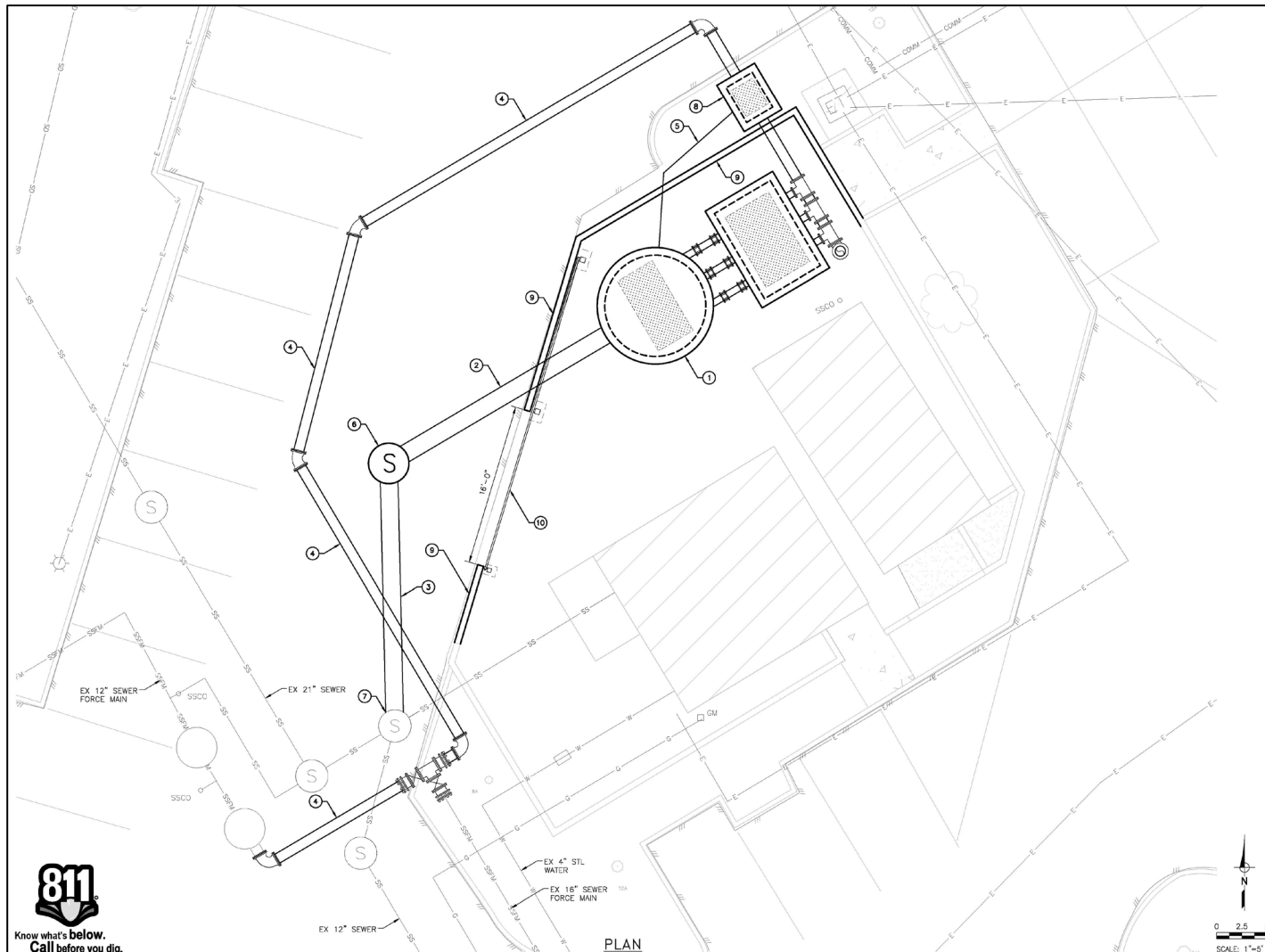

Figure 4 30% Design Plans for New Northwest Well Construction (Refer to Attachment B for Sheet Key Notes)

September 9, 2022

South Tahoe Public Utility District's Bijou Pump Station Rehabilitation Project – Permitting Recommendations



4 Project Description

On July 27, 2022, Alternative 2, New Submersible Pump Station Behind Building, was selected for implementation. As described in **Attachment B**, Alternative 2 abandons the existing wet well and dry pit and constructs a new submersible wet well and valve vault to the northwest of the existing pump station (i.e., behind the existing pump station building). Alternative 2 includes the installation of a new 10-foot (internal) diameter wet well, valve vault, flow meter vault, and reconfiguration of the existing pump station building into a new electrical room. Installation of the wet well will require a shored excavation and 6-feet of wall to wall spacing between the new wet well exterior walls and the existing pump station walls unless caisson drilling is found to be feasible for the existing site conditions. The space requirements for this alternative will result in the need to acquire additional property since the existing parcel is not large enough to accommodate the improvements. The existing perimeter CMU wall will be extended to encompass the new wet well and valve vault.

The top level of the existing pump station building will be reconfigured for new electrical equipment. This electrical room may be expanded to comprise the whole upper level, as access to the wet well will no longer be required. The 30% design plans from **Attachment B** showing the proposed placement of the new wet well and vaults are shown in **Figure 4** above. The building will require some improvements, including: HVAC (Heating Ventilation and Cooling) system and louver replacement; façade repair; concrete fill and crack repair; and filling of the existing dry/wet well controlled low-strength material (CLSM).

The construction of the wet well and valve vault will impact access to the McDonalds dumpster and will require a realignment of the wall on the backside of the existing pump station building to keep the wet well and valve vault within the walled area of the pump station. Relocation of the dumpster, or a change to the dumpster access is required to implement this alternative and will require negotiations for a utility easement or lease agreement with the McDonalds parcel's property owner. The extension of the perimeter wall will encroach into the existing parking lot, which could impede driving access and parking clearances behind the building.

New wet well construction will allow the existing pump station to operate during most of the construction and will only require bypass during the last phase of construction. The District will need to setup their bypass equipment onsite or setup the system to bypass flows to Ski Run Boulevard.

5 California Environmental Quality Act

State permits require confirmation of CEQA compliance. The Project meets the criteria and conditions for a Class 1 Categorical Exemption, Existing Facilities (CEQA Guidelines Section 15301) because Project activities consist of the operation, repair, maintenance, permitting, leasing, licensing, and/or minor alteration of an existing public structure, and no expansion of use beyond that existing will occur. The District will be required to submit a General Development Application to City. Project activities will not affect the State right-of-way of US Highway 50 (HWY 50), and therefore, no encroachment permit will be required from California Department of Transportation (Caltrans). All work will be performed either on existing District property or within a utility easement, lease agreement or land purchase negotiated with the owners of the McDonalds parcel.

6 Tahoe Regional Planning Agency

To streamline the permitting process, TRPA entered into agreements with other agencies and utility companies throughout the basin via Memoranda of Understanding (MOUs). TRPA and the District entered into an MOU for Public Works Providers on March 23, 2012 (TRPA 2012). The activities included in Attachment B of the MOU are identified as either Exempt or Qualified Exempt from TRPA review and approval. Exempt Activities do not require TRPA approval, nor do they require notification to TRPA. Qualified Exempt Activities do not require TRPA approval, but they do require TRPA notification at least 3 days prior to commencement of Project activities. The MOU also states that the MOU Partner "shall certify that a Qualified Exempt Activity allowed under this MOU shall not have a

negative impact on the environment by completing a TRPA Initial Environmental Checklist (IEC) for the activity” (TRPA 2012). The proposed Project activities fall under either Activity 9 or 10 of Attachment B of the MOU, which are described in **Table 1** below.

Table 1 Public Works Providers MOU Activities Consistent with Proposed Project

Activity No.	Activity Level	Activity Description
9	Exempt	Structural maintenance, repair, in-kind replacement of facilities , provided excavation is limited to areas under existing pavement, road shoulder, or compacted soil; no new land coverage is created, and relocated land coverage or permanent land disturbance is limited to 120 square feet in low capability land (Classes 1a, 1b, 1c, 2, and 3) and 500 square feet in high capability land (Classes 4, 5, 6 and 7).
10	Qualified Exempt	Modifications to existing facilities provided the modifications do not result in any increases in water or sewer treatment capacity or growth inducing activity, and any new or relocated land coverage or permanent land disturbance is limited to 240 square feet in low capability land (Classes 1a, 1b, 1c, 2 or 3) and 1,000 square feet in high capability land (Classes 4, 5, 6 and 7).

The proposed Project meets Activity 9’s description of “in-kind replacement of facilities” per the definition provided in the Public Works MOU Presentation, which states “‘in-kind’ replacement means no increase in capacity except where required for standards or safety” (TRPA n.d.). In order for a project to meet Activity 9 criteria, excavation must also be limited to areas under existing pavement, road shoulder, or compacted soil. The Project, as currently proposed, does not involve excavation in areas of uncompacted soil, nor would any land coverage be relocated, which would allow the Project to move forward under Activity 9 as an Exempt activity. However, if ground disturbance within uncompacted soil (e.g., planters within the parking lot) is required, the Project would meet Activity 10 criteria and be classified as a Qualified Exempt activity and would require completion of a TRPA IEC.

6.1 Land Use Designation and Zoning

The Project is located within the Tourist Core, which is centered along US Highway 50 and Ski Run Boulevard from Fairway Avenue to the California-Nevada state line; this area is governed by the Tourist Core Area Plan (TCAP). The TCAP provides more detailed direction than the City’s General Plan and TRPA’s 2012 Regional Plan. Appendix C of the TCAP states that Local Public Health and Safety Facilities are an allowed use for the entirety of the Tourist Core Area, so long as it is not in a Source Water Protection Zone. On August 11, 2022, City staff confirmed that the Station is not located within 600 feet of any wells. Therefore, a Special Use Permit is not required.

6.2 Scenic Resources

The Project is located on along and visible from TRPA-designated Roadway Travel Unit 33 (The Strip), which is currently designated “non-attainment” but trending upward per the TRPA 2011 Threshold Evaluation Report (TRPA 2011; Chapter 9 – Scenic Resources). The Threshold Evaluation Report assesses changes in scenic conditions relative to TRPA Threshold Standards in accordance with TRPA Resolutions 82-11. The following six aspects are considered and rated according to their effect on scenic quality and should be considered towards subsequent engineering designs:

1. Man-made features along the roadway and shoreline
2. Physical distractions to driving along the roadways
3. Roadway characteristics
4. View of the Lake from the roadways
5. General landscape views from the roadways and shoreline
6. Variety of scenery from the roadways and shoreline.

September 9, 2022

South Tahoe Public Utility District's Bijou Pump Station Rehabilitation Project – Permitting Recommendations



Projects in scenic resource areas may require additional review and/or mitigation measures, particularly if the scenic resource area is designated as non-attainment. However, Section 2.3 of the TRPA Code of Ordinances states that exempt activities, which includes qualified exemptions, “are not subject to review and approval by TRPA, provided they do not result in the creation of additional land coverage or relocation of land coverage, comply with Sections 36.6 (Building Design Standards), 36.9 (Water Conservation Standards), 65.1 (Air Quality Control), and meet all restrictions set forth [as defined in Section 2.3]” (TRPA 2022e). Because the Project is not subject to review and approval by TRPA, additional review and/or mitigation measures will not be required. However, the design must still comply with the following requirements as defined by Section 36.6:

- > **Screening Elements:** *The architectural design of a project shall include elements that screen from public view all external mechanical equipment, including refuse enclosures, electrical transformer pads and vaults, satellite receiving disks, communication equipment, and utility hardware on roofs, buildings, or the ground.*
- > **Roof Finishes and Colors:** *Roofs, including mechanical equipment and skylights, shall be constructed of nonglare finishes and earthtone colors that minimize reflectivity. For this subparagraph, non-glare earthtone colors are defined as Munsell® Colors set forth in Appendix G, TRPA Approved Earthtone Colors, of the Design Review Guidelines, that have a value and chroma of 0-4 or other color systems that are equivalent to the adopted hues, values, and chromas of Appendix G. Vegetated roof materials complying with applicable fire defensible space requirements meet the intent of this subparagraph and are encouraged.*
- > **Alternative Energy Production:** *Solar panels or other alternative energy equipment may be exempted from the requirements of 36.6.1.A and B if a project level assessment demonstrates that scenic threshold standards will not be adversely impacted.*
- > **Color of Structures:**
 - *For all structures visible from the Scenic Threshold Travel Routes and from Public Recreation Area and Bicycle Trails identified in the 1993 Lake Tahoe Basin Scenic Resource Evaluation, subdued colors of earthtone ranges shall be used for the primary color of structures.*
 - *Colors shall be within a range of natural colors that blend, rather than contrast, with the existing backdrop vegetation and soils color.*
 - *For this subparagraph, earthtone colors shall be medium to dark and shall meet the Munsell® Colors set forth in Appendix G, TRPA Approved Earthtone Colors, of the Design Review Guidelines or other color systems that are equivalent to the adopted hues, values, and chromas of Appendix G.*
 - *TRPA may grant exceptions to this provision pursuant to Section 67.7, for scenic roadway corridors designated as urban, for unique situations such as site characteristics, or as set forth in subparagraph 83.11.1. Structures in the shoreland that were constructed prior to January 1, 1950, may maintain their historic colors when doing exempt maintenance and repair.*
- > **Building Heights:** *See Chapter 37: Height, for building height standards.*

In addition to Section 36.6 of the TRPA Code of Ordinances, the Project design will also be required to adhere to the design standards set forth in the TCAP.

6.3 Traffic and Circulation

Per Section 22.7 of the TRPA Code of Ordinances, temporary activities that include the closure of a traffic lane or intersection of a state or federal highway for more than one hour requires submittal of a traffic control plan. Assuming the Project does not require closure of US 50 for longer than one hour, no traffic control plan will be required for the Project. However, staging areas located within the McDonald's parking lot may impact access and circulation to the restaurant, which may require negotiations between the District and the McDonald's business owner.

7 Biological Resources

Biological resources within a 0.5-mile buffer of the Project area were evaluated in order to identify any potential effects to special-status species associated with Project implementation. Species assessed include United States Forest Service (USFS) Forest Service Sensitive (FSS) species, USFWS-designated endangered, threatened, candidate, and proposed threatened or endangered species. Also assessed are species listed, or proposed for listing, under the California Endangered Species Act (CESA) and/or California Department of Fish and Wildlife (CDFW)–designated species (i.e., fully protected, species of special concern [SSC], and plants with a California Rare Plant Rank [CRPR] of 1B and 2B).

7.1 Methodology

The following literature and database queries were conducted as part of this biological resource review.

- > California Natural Diversity Database (CNDDDB) Rarefind 5: 0.5-mile query of the Project area (CDFW 2022);
- > California Native Plant Society (CNPS) Online Inventory: query of the three quadrangle maps surrounding the Project area (CNPS 2022);
- > US Fish & Wildlife Service (USFWS) Threatened & Endangered Species Active Critical Habitat Report (USFWS 2022b); and
- > Aerial photos of the Project area (Google Earth 2022).

Refer to **Figure 5** for special-status plants and wildlife occurrences within a 0.5-mile buffer of the Project area. Refer to **Table 2** for special-status plant and wildlife species identified in the CNDDDB query and potential impacts to species within the Project area. The following acronyms are used in **Table 2**:

- > FP: Fully Protected
- > FSS: Forest Service Sensitive
- > SSC: Species of Special Concern
- > WL: Watch List
- > 1B.1: Seriously threatened in California and elsewhere (over 80% of occurrences threatened/high degree and immediacy of threat)
- > 1B.2: Moderately threatened in California and elsewhere (20-80% occurrences threatened/moderate degree and immediacy of threat)
- > 2B.2: Moderately threatened in California but more common elsewhere (20-80% occurrences threatened/moderate degree and immediacy of threat)
- > In addition to querying the CNDDDB database, an IPaC species list was generated on August 4, 2022 (**Attachment C**). Per the IPaC report, the Project area is outside of any USFWS-designated critical habitat (USFWS 2022b). Six species were identified for the Project area, which are listed in **Table 3**. Species listed are not necessarily located within the geographic area of the Project.

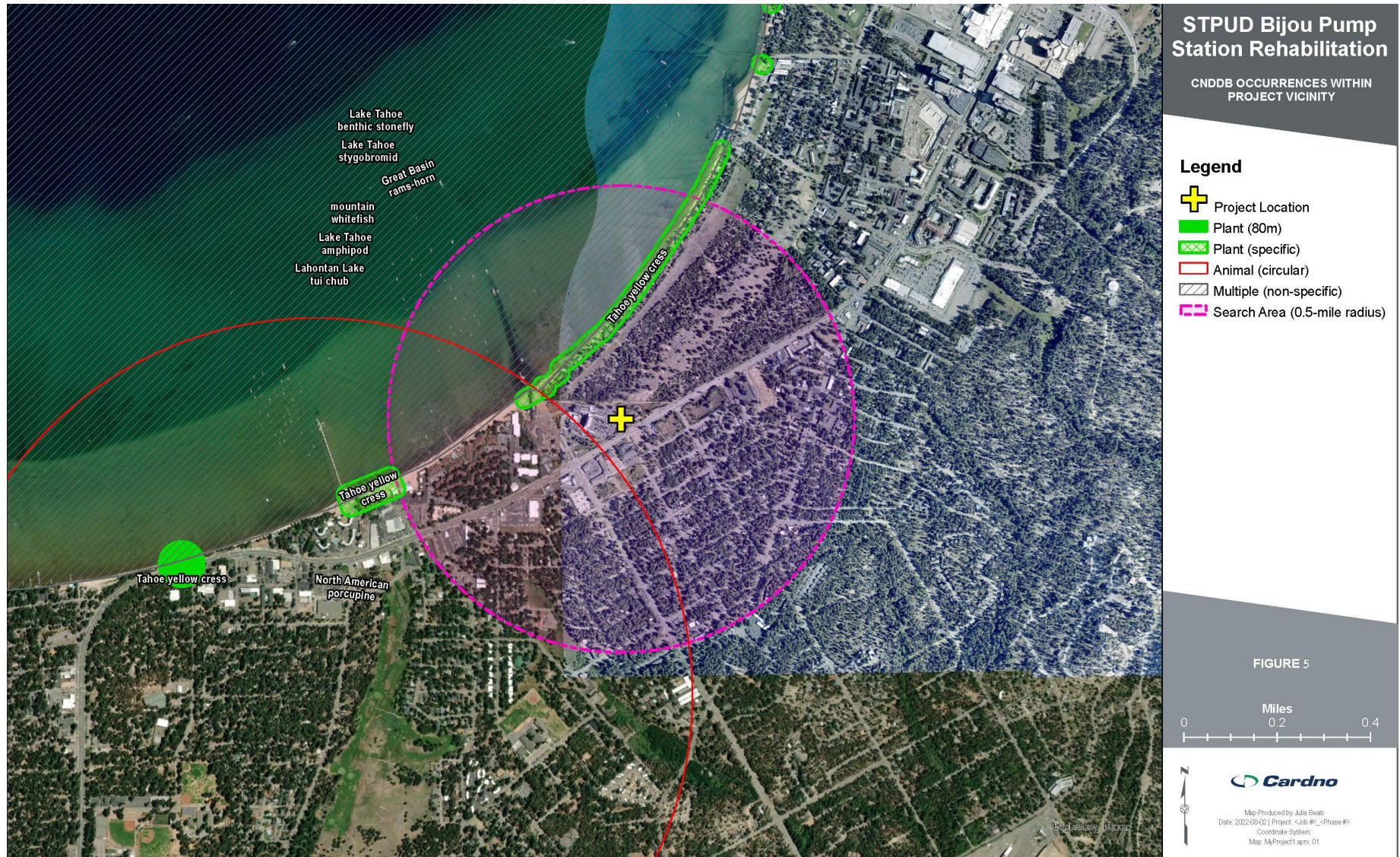

Table 2. Special-status Plants and Wildlife Species Occurrences within 0.5-mile Range

Scientific Name	Common Name	Taxonomic Group	Federal Status	State Status	Rare Plant Rank	CDFW Status	FSS species?	Habitat	Potential impact to species within the Project area
<i>Helisoma newberryi newberryi</i>	Great Basin rams-horn snail	Mollusks	None	None			Yes	Aquatic, freshwater snail	Great Basin rams-horn is found in the Lake Tahoe Basin and in Lake Tahoe. Because the Project is limited to a project area above 6229 and will not have immediately adjacent to , the Project will not impact Great Basin rams-horn or its habitat.
<i>Siphateles bicolor pectinifer</i>	Lahontan Lake tui chub	Fish	None	None		SSC		Aquatic, Great Basin standing waters	Lahontan tui chub is found in Lake Tahoe. However, the Project is limited to upland areas outside of the shorezone of Lake Tahoe and will not impact Lahontan tui chub or its habitat.
<i>Stygobromus laticolus</i>	Lake Tahoe amphipod	Crustaceans	None	None				Aquatic	Lake Tahoe amphipod is found in Lake Tahoe. However, the Project is limited to upland outside of the shorezone of Lake Tahoe and will not impact Lake Tahoe amphipod or its habitat.
<i>Capnia lacustra</i>	Lake Tahoe benthic stonefly	Insects	None	None				Aquatic, Great Basin standing waters	Lake Tahoe benthic stonefly is found in Lake Tahoe. However, the species is associated with deep-water plant beds ranging from 60-110 m deep. The Project is located in upland areas outside of the shorezone of Lake Tahoe and will not impact the Lake Tahoe benthic stonefly or its habitat.
<i>Stygobromus tahoensis</i>	Lake Tahoe stygobromid	Crustaceans	None	None				Aquatic	Lake Tahoe stygobromid is found in Lake Tahoe. However, the Project is limited to upland areas outside of the shorezone of Lake Tahoe and will not impact Lake Tahoe stygobromid or its habitat.
<i>Prosopium williamsoni</i>	mountain whitefish	Fish	None	None		SSC		Aquatic	Mountain whitefish is found in Lake Tahoe. However, the Project is limited to upland areas outside of the shorezone of Lake Tahoe and will not impact mountain whitefish or its habitat.
<i>Erethizon dorsatum</i>	North American porcupine	Mammal	None	None				Forested habitats in the Sierra Nevada	The most recent CNDDB occurrences of North American porcupine within the vicinity of the Project was in 1929, prior to the urbanization of the City of South Lake Tahoe. Because North American porcupine are limited to forested habitat which does not exist within the vicinity of the Project, no impacts will occur.

Source: CDFW 2022

Table 3. Species Included on IPaC Official Species List

Scientific Name	Common Name	Taxonomic Group	Federal Status	Potential impact to species within the Project area
<i>Gulo gulo luscus</i>	North American wolverine	Mammals	Proposed threatened	Wolverines require areas that are cold and receive enough winter precipitation to reliably maintain deep persistent snow late into the warm season, which is not found in the highly-urbanized areas surrounding the Project vicinity. Because no suitable habitat exists within the Project vicinity, no impacts will occur.
<i>Vulpes vulpes necator</i>	Sierra Nevada red fox	Mammals	Endangered	The current known range of Sierra Nevada red fox is outside of the Lake Tahoe Basin. Because no suitable habitat exists within the Project vicinity, no impacts will occur.
<i>Rana sierrae</i>	Sierra Nevada yellow-legged frog	Amphibians	Endangered	Sierra Nevada yellow-legged frog habitat consists of ponds, tarns, lakes, and streams at moderate to high elevation. Because no suitable habitat exists within the Project vicinity, no impacts will occur.
<i>Oncorhynchus clarkii henshawi</i>	Lahontan cutthroat trout	Fish	Threatened	Lahontan cutthroat trout are found in Lake Tahoe. However, the Project is limited to upland areas outside of the shorezone of Lake Tahoe and will not impact Lahontan cutthroat trout or its habitat.
<i>Danaus plexippus</i>	Monarch butterfly	Insects	Candidate	Breeding habitat for the Monarch butterfly requires the presence of milkweed. No impacts to plants are anticipated as part of the Proposed project, therefore no impacts to breeding habitat will occur.
<i>Pinus albicaulis</i>	whitebark pine	Conifers and Cycads	Proposed threatened	Whitebark pine is not present within the Project vicinity. No impacts will occur.

7.2 Permitting Recommendations for Biological Resources

The biological resources review performed for the Project determined that the proposed Project activities would have “no effect” to special-status species. Therefore, permits pertaining to special-status species from CDFW and/or USFWS will not be required for this Project. TRPA requires a tree removal permit for removal of live trees less than 14 inches at diameter breast height; however, no tree removal is proposed for the Project.

8 Aquatic Resources

As discussed previously, the Project area is located approximately 850 feet southeast of Lake Tahoe on land mapped as LCD 1b, which is defined as “stream channels (Stream Environment Zones), marshes, flood plains, and meadows. [LCD 1b] lands are naturally wet and poorly drained and are critical areas for management and protection of water resources” (TRPA 2016). The nearest mapped SEZ is Ski Run Meadows, which is a historic meadow that has been heavily developed but replaced nearby with constructed wetlands. The extent of Ski Run Meadows does not overlap with the McDonald’s parcel, meaning no impacts to this SEZ will occur. Based upon a review of the National Wetlands Inventory (NWI), riverine wetland habitat is present along the northern perimeter of the McDonald’s parcel (USFWS 2022a). In addition, 0.49-acres of freshwater emergent wetland habitat is located east of the mapped riverine habitat. No work is proposed in these locations. Mapped aquatic resources in the Project vicinity are shown in **Figure 6**. Please note that the parcel lines are approximate boundaries.

September 9, 2022

South Tahoe Public Utility District's Bijou Pump Station Rehabilitation Project – Permitting Recommendations



8.1 Permitting Recommendations for Aquatic Resources

Due to the absence of aquatic resources and riparian habitat (i.e., SEZ) within the Project work area, a Clean Water Act Section 404 authorization permitting and the coupled Clean Water Act Section 401 Water Quality Certification will not be required. Similarly, a Lake and Streambed Alteration Agreement through CDFW will not be required.

Geotechnical investigation to determine the depth to groundwater has not been completed at this time; however, the Project's vicinity to Lake Tahoe and other aquatic resources indicates that depth to groundwater may be relatively shallow. Dewatering groundwater, which is a water of the state, requires a permit from the Lahontan Regional Water Quality Control Board (RWQCB). Discharge from dewatering activities to surface waters is considered a limited threat discharge if the groundwater does not contain significant quantities of pollutants. Limited threat discharges are covered by the RWQCB Revised Waste Discharge Requirements and National Pollutant Discharge Elimination System (NPDES) General Permit for Limited Threat Discharges to Surface Waters (Order No. R6T-2003-0034) (Limited Threat Discharges WDR). In order to apply for coverage under the Limited Threat Discharges WDR, the applicant must submit a Notice of Intent and a Best Management Practices (BMP) Plan.

Enrollment under the Construction Storm Water NPDES Permit for the Tahoe Basin (Order No. R6T-2016-0010; Construction General Permit [CGP]) will be required should 1-acre or more of ground disturbance occur during Project construction. The total ground disturbance anticipated for the Project is approximately 5,000 square feet, or 0.12 acres, which does not meet the 1-acre size threshold for CGP enrollment.



9 Cultural and Tribal Cultural Resources

A cultural review was completed on September 9, 2022, to determine whether cultural resources are located within or immediately adjacent to the Project location. Detailed photographs of the site were used in order to conduct a desktop review of the Project area, meaning a survey of the Project site was not required to perform the assessment. Cardno now Stantec performed a background and literature search to identify previously conducted cultural resource inventories and recorded cultural resources within a 0.25-mi (0.4 km) study area surrounding the Area of Potential Effects (APE). This review included a records search of the Northeast Information Center (NEIC); a review of General Land Office (GLO) cadastral survey and USGS topographic quadrangle maps; and a review of secondary sources to determine the extent of previous inventories, previously recorded cultural resources, and historic-period activity in or near the APE.

9.1 Archaeological Sensitivity

Professional staff at the CHRIS North Central Information Center (NCIC) performed a formal records search of the Project area and a 0.25-mile buffer around the Project area on September 7, 2022 (NCIC Reference Number ELD-22-98). Three studies were identified within the project area (See **Table 4**); additionally, eight studies were identified within 0.25 mile of the Project.

Table 4 Archaeological Studies within the Project Area

Author	Year	Title
Chavez, David and Sally B. Woodbridge	1988	Cultural Resources Evaluations for the South Lake Tahoe Redevelopment Plan EIR. (S-002864)
Davis, Herschel	1997	Lands Department Urban Lot Management Project. (S-007578)
Susan Lindstrom	2016	South Tahoe Public Utility District Water Meter Installations Project Cultural Resource Inventory

No known sites were identified within the Project area during the records search. Three resources were identified within 0.25 mile of the Project area (see **Table 5**).

Table 5 Cultural Resources within 0.25-Mile of the Project Area

Primary Number	Resource Name	Description	Location	Eligibility
P-09-5091	Tahoe Meadows (N1632)	Historic District	0.25-mile buffer	2: Determined eligible for the California Register.
P-09-5822	Knight's Inn	Building	0.25-mile buffer	Unknown (7: Not evaluated). Additional details are not currently available.
P-09-5933	3820 Lake Tahoe Boulevard	Building	0.25-mile buffer	Unknown (7: Not Evaluated). Additional details are not currently available.

The resources identified within the 0.25-mile research buffer are historical in nature and consist of two buildings, and the Tahoe Meadows Historic District. The eligibility status of these resources for the National Register of Historic Places (NRHP) is not currently available; however, the Tahoe Meadows have been determined eligible for the California Register of Historical Resources (CRHR). Nonetheless, the resources are located outside of the

September 9, 2022

South Tahoe Public Utility District's Bijou Pump Station Rehabilitation Project – Permitting Recommendations



Project area and would not be directly impacted by Project activities. The Project area itself has not been previously surveyed for cultural resources.

9.1.1 Geoarchaeology

Stantec conducted a desktop geoarchaeological sensitivity assessment of the prospect site, which indicates that the Project is located on Pleistocene alluvial deposits. Alluvial Pleistocene soils generally have the potential to contain buried prehistoric archaeological sites. Therefore, the Project site may be considered moderately sensitive based on the age and nature of the soils present. Additionally, Lake Tahoe is located approximately 830 feet north of the Project area, which are also typically considered highly sensitive.

9.1.2 Tribal Sensitivity

The Project area is in a tribal territory broadly associated with the Washoe. It's anticipated that the following tribes and individuals may be interested in information about the Project.

- > Bridgeport Paiute Indian Colony
- > Susanville Indian Rancheria
- > Washoe Tribe of Nevada and California

9.1.3 Architectural History

Stantec conducted a desktop review of the Project area to determine whether built environment resources are located within or immediately adjacent to the Project location. As the purpose of the project is to rehabilitate the Bijou Pump Station, it was the primary focus of the built environment review. As previously noted in this report, the Bijou Pump Station was built in 1955 and is the District's oldest pump station. It has never been evaluated for inclusion in the NRHP or CRHR. There do not appear to be any other buildings or structures over 50 years old in the Project area.

9.2 Potential Project Effects on Cultural Resources

Based on the Project's location and the lack of known archaeological resources, the prospect site is in a moderately sensitive area for cultural resources. However, the prospect site has been subject to development, and therefore, the potential for encountering prehistoric or historic-period resources in the Project area is considered low. The primary development that the site has been subject to is that of the Bijou Pump Station, which is over 50 years old and has the potential to be adversely impacted by the proposed project.

9.3 Implications and Recommended Next Steps

- > The Project is likely not subject to discretionary approval. In accordance with the Tahoe Regional Planning Agency (TRPA) Memoranda of Understanding (MOA), the Project activities are identified as either Exempt or Qualified Exempt from TRPA review and approval.
 - Activity No. 9: Structural maintenance, repair, in-kind replacement of facilities, provided excavation is limited to areas under existing pavement, road shoulder, or compacted soil; no new land coverage is created, and relocated land coverage or permanent land disturbance is limited to 120 square feet in low capability land (Classes 1a, 1b, 1c, 2, and 3) and 500 square feet in high capability land (Classes 4, 5, 6 and 7).
 - Activity No. 10: Modifications to existing facilities provided the modifications do not result in any increases in water or sewer treatment capacity or growth inducing activity, and any new or relocated land coverage or

September 9, 2022

South Tahoe Public Utility District's Bijou Pump Station Rehabilitation Project – Permitting Recommendations



permanent land disturbance is limited to 240 square feet in low capability land (Classes 1a, 1b, 1c, 2 or 3) and 1,000 square feet in high capability land (Classes 4, 5, 6 and 7).

- > Stantec does not recommend any further studies for the Project due to the low potential for buried archaeological deposits, and the previously disturbed nature of APE (namely modern development). Although the pump station is over 50 years old and meets the criteria for evaluation as a historic resource under CEQA, a significance evaluation, impact assessment, and mitigation are not required as the project is categorically exempt from CEQA per Section 15302. It is recommended that the Project be allowed to continue with standard archaeological measures. If archaeological resources (prehistoric or historic), fossils, or human remains are encountered, work shall be stopped until the appropriate and qualified expert (archaeologist, SHPO or THPO, historian, coroner, etc.) can assess the findings.
- > Projects subject to CEQA are required to comply with Assembly Bill (AB) 52. Under AB 52, a Lead Agency must provide notification to California Native American tribes that have requested to be informed by the CEQA Lead Agency in their geographic area. The Lead Agency must provide a description of the Project and the location. The tribes must respond to the Lead Agency within 30 days of notification to request or dismiss consultation. The prospect site is in an area where tribes may request AB 52 consultation.

10 References

- California Department of Fish and Wildlife (CDFW). 2022. California Natural Diversity Database (CNDDDB) Observations, RareFind 5. Available at: <http://wildlife.ca.gov/Data/CNDDDB>. Accessed July 2022.
- California Native Plant Society (CNPS). 2022. Inventory of Rare and Endangered Plants of California (online edition, v8-03 0.39). Rare Plant Program. Available at: <http://www.rareplants.cnps.org>. Accessed July 2022.
- City of South Lake Tahoe (CSLT). 2018. Stormwater Infrastructure - Public Map. Available at: <https://cslt.maps.arcgis.com/apps/webappviewer/index.html?id=829bb700863c4c04b43af412b6e2fe4a>. Accessed August 3, 2022.
- Federal Emergency Management Agency (FEMA). 2012. Flood Insurance Rate Map – El Dorado County, California and Incorporated Areas.
- Google Earth. 2021. Accessed October 2022.
- Tahoe Regional Planning Agency (TRPA). 2012. Memorandum of Understanding for Public Works Providers. Available at: <https://www.trpa.gov/where-to-apply-for-a-permit/>. Accessed March 18, 2022.
- TRPA. 2016. TRPA Land Coverage 101. Available at: https://www.trpa.gov/wp-content/uploads/documents/archive/TRPA-Land-Coverage-101_Final.pdf. Accessed March 18, 2022.
- TRPA. 2022a. Parcel Tracker – APN: 027-690-002. Available at: <https://parcels.laketahoeinfo.org/Parcel/Detail/027-690-002>. Accessed August 3, 2022.
- TRPA. 2022b. Parcel Tracker – APN: 027-690-003. Available at: <https://parcels.laketahoeinfo.org/Parcel/Detail/027-690-003>. Accessed August 3, 2022.
- TRPA. 2022c. Scenic Protection Program. Available at: <https://www.trpa.gov/scenic-protection-program/>. Accessed August 3, 2022.
- TRPA. 2022d. Tahoe Open Data. Available at: <https://data-trpa.opendata.arcgis.com/>. Accessed August 3, 2022.
- TRPA 2022d. TRPA Code of Ordinances. Available at: <https://www.trpa.gov/wp-content/uploads/TRPA-Code-of-Ordinances.pdf>. Accessed August 9, 2022.
- TRPA. n.d. Public Works MOU Presentation. Available at: https://www.trpa.gov/wp-content/uploads/documents/archive/Public_Works_MOU_Presentation.pdf. Accessed March 18, 2022.
- US Fish & Wildlife Service (USFWS). 2022a. National Wetlands Inventory. Available at: <https://www.fws.gov/program/national-wetlands-inventory>. Accessed August 3, 2022.
- USFWS. 2022b. USFWS Threatened & Endangered Species Active Critical Habitat Report. Available at: <https://ecos.fws.gov/ecp/report/table/critical-habitat.html>. Accessed August 3, 2022.



now



September 9, 2022
South Tahoe Public Utility District's Bijou Pump Station Rehabilitation Project – Permitting Recommendations

Attachment A

Summary of Permitting Recommendations

Agency	Name of Permit or Approval	Permit Application Submittal Materials / Requirements	Summary of why this permit is required (what triggers the permit).
Tahoe Regional Planning Agency (TRPA)			
TRPA	Public Works Providers MOU Exemption	No notification to TRPA is required.	The Project is Exempt if activities are consistent with Activity 9, as defined above.
TRPA	Public Works Providers MOU Qualified Exemption	While the Project will not require a permit from TRPA, Qualified Exempt Activities under the Public Works Provider MOU require notification to TRPA at least 3 business days prior to commencement of Project activities.	A Qualified Exempt Activities form will need to be submitted to TRPA if the Project falls under Activity 10, as defined above.
TRPA	Initial Environmental Checklist (IEC). This is comparable to the a CEQA IS/ND or NEPA EA.	IEC	An Initial Environmental Checklist (IEC) is required if the Project falls under Qualified Exempt Activity 10 of the Public Works Providers MOU.
State			
Lahontan Regional Water Quality Control Board	Revised Waste Discharge Requirements and National Pollutant Discharge Elimination System General Permit for Limited Threat Discharges to Surface Waters (Order No. R6T-2003-0034)	Notice of Intent BMP Plan	Required for limited threat discharges (e.g. construction dewatering.)
Local			
City	General Development Permit – Minor Review	General Development Application	Required for development projects within the City.
District	CEQA Compliance. The Project qualifies for a Class 1 Categorical Exemption, Existing Facilities (CEQA Guidelines Section 15301).	Notice of Exemption	State permits require confirmation of CEQA compliance. The Project is categorically exempt from the requirement for the preparation of an environmental document.



now



September 9, 2022
South Tahoe Public Utility District's Bijou Pump Station Rehabilitation Project – Permitting Recommendations

Attachment B

Technical Memorandum



Date: 9/23/2022

To: Adrian Combes
South Lake Tahoe Public Utility District

Phone: (530) 543-6258

Prepared by: Kendall Stahl P.E.

Reviewed by: Rob Natoli P.E., Jeff Lawrence P.E.

Project: Bijou Pump Station Rehabilitation Project

SUBJECT: BASIS OF DESIGN

1 Project Description

Existing Facilities

The existing Bijou Pump Station was built in 1955 and is the South Tahoe Public Utility District's (District) oldest pump station. Bijou pump station is located in a McDonalds parking lot on Lake Tahoe Blvd and receives wastewater from the tourist corridor in South Lake Tahoe from Ski Run Blvd to the Stateline. The pump station conveys raw sewage into 12-inch and 16-inch force mains that extend to the District's WWTP. The dual forcemains also receive flow from two other lift stations (Johnson and Ski Run). The existing lift station has a design capacity of 2,400 gpm and consists of 3 pumps manufactured by Vaughan Chopper (2) and Cornell (1). The existing pumps are housed in the original concrete building with the dry pit and wet well on the lower level and the electrical equipment on the upper level.

Proposed Facilities

The District is replacing the existing dry pit pump station with a new submersible wet well and valve vault. The new wet well and valve vault will be located north of the existing pump station building as shown in the 30% drawings on Sheet C-1 in Appendix A. A new manhole will be design and located within the McDonalds parking lot to route sewer flows from the two main station gravity sewer lines. The pump station will have a new buried precast polymer concrete well designed for the installation of three (3) submersible sewage pumps and a precast valve vault. Complete replacement of the electrical equipment includes a new Automatic Transfer Switch (ATS), Motor Control Center (MCC), Variable Frequency Drives (VFD) and Control Panel. Replacement of controls, flow and level measurements and communication equipment is also included. The existing generator onsite will be used for backup power for the new pump station.

The District's surrounding property does not provide enough space to construct a new wet well, therefore a permanent easement or lot line adjustment on the north boundary of the property is required to accommodate the new wet well and vault. The District is currently working with McDonalds Property owner to secure a small portion of the property for the new wet well. The extension of the District's facilities north of the perimeter CMU block wall will block access to McDonalds dumpster enclosure. To mitigate the access issue, the District will be relocating the dumpster from the current location as part of the project and will provide McDonalds uninterrupted access to the dumpster during and after construction.

The existing pump station generator buildings will be rehabilitated to extend the life of the structures. For the pump station building, the lower level will be filled with a lightweight flowable fill. The top level will be configured to add space and improve access to the electrical equipment. Structural improvements for the building modifications will add a new beam to support roof loads where the center wall of the pump station is removed. Architectural improvements include rehabilitation or replacement of stucco on the buildings and exterior screening wall.

2 Design Parameters

The District’s Bijou Pump Station is currently designed for a firm capacity of 2,400 gpm and pumps into dual influent forcemains that are shared by Johnson and Ski Run pump stations. The peak wet weather flows (PWWF) at the Bijou pump station were evaluated using the sewer collection system model and are summarized in the Table 1. These flows are based on a December 2019 rain on snow flow event. Because the Bijou station has the capacity to meet current peak and future buildout flows are minimal, the existing firm capacity of 2,400 gpm will be maintained for new pump station design¹.

Table 1 – Peak Flow Capacity Results

Pump Station	Peak Discharge Flow (gpm) ¹	Total Dynamic Head (ft) ²
Johnson PS	2,930	95.7
Bijou PS	1,950	108.1
Ski Run PS	855	112.5

Notes:

- (1) Peak flow based on 25-year design storm.
- (2) Based on all three pump stations discharging simultaneously to both the 12-inch and 16-inch force mains at the same time.
- (3) Information from Carollo Bijou Pump Station Peak Flow Analysis TM dated September 6th, 2022.

3 Wet Well Design

The proposed new wet well will consist of three submersible pumps operated by variable frequency drives (VFDs) in a circular, polymer concrete wet well. The wet well configuration is shown on sheet M-1 in the 30% drawings included as Appendix A and designed in accordance with the Hydraulic Institute (HI) 9.8-2018 standards and pump manufacturer recommendations. A summary of the preliminary wet well design is provided in Table 2 below.

¹ For the project, a 2,400 gpm firm capacity may require upsizing of the electrical service to the pump station. For additional details on pump station hydraulic design a subsequent TM will be provided after model analysis and forcemain testing is complete.

Table 2 – Proposed Wet Well Design

Item	Description	Wet Well Design
1	Pumps	Three (3) VFD-driven pumps supplied by one manufacturer (Vaughan Chopper or Flygt)
2	Size	10-ft Inside Diameter (pending final pump selections)
3	Type	Precast Reinforced Polymer Concrete (by Armorock or approved equal)
4	Hatch	48-inch by 96-inch, H-20 rated and spring loaded hatch; Doors will open towards the east to allow access from the west and site entrance gate
5	Bottom Elevation	6213-ft
6	Top Elevation	6238-ft
7	Gravity Line Invert Elevation	6218-ft (5-ft above bottom)
8	Instruments	One (1) Submersible level transducer, level floats for backup
9	Grouting	Slope walls in accordance with HI Standards
10	Pipe Penetrations	Three (3) 8-inch for pump discharge pipelines; two (2) 4-inch drain lines from valve vault and FM; one (1) 21-inch for the gravity sewer pipeline

4 Pump Selection

As mentioned previously, the new pump station will be designed to the current capacity of the existing pumps of 2,400 gpm. The new pumps will connect to the existing 12-inch and 16-inch dual forcemains shared by Johnson and Ski Run pump stations. Sizing the new pumps is dependent on confirming the minimum flow to the Bijou Pump Station from the collection system hydraulic model and verifying pump curves from the other two pump stations. A summary of the submersible pump design is shown in Table 3. The pump selection will be updated once the hydraulic analysis is completed.

Table 3 – Pump Design Criteria

Item	Description	Submersible Pump Design
1	Number of Pumps	3
2	Pump Station Design Firm Capacity	2,400 gpm
3	Design Flow per Pump ¹	1,200 gpm (preliminary)
4	Total Dynamic Head for Design Flow ¹	Pending -
5	Horsepower (HP) ¹	Pending
6	Drive	VFD
7	Pump Manufacturers	Vaughan Chopper or Flygt
	Pump Type	Submersible Non-Clog (Flygt N-Impeller) or Submersible Chopper Style (Vaughan)
8	Discharge Piping	8-inch Ductile Iron
9	Appurtenances	One (1) magnetic flow meter; Each pump discharge will have a pressure transmitter and indicator, 1-inch combination air release valve, swing check valve, and plug valve for isolation

¹Pump hydraulic design will be updated after model data and flow testing data are received.

There are two pump sizing criteria options for the District to review and consider. This decision will impact pump sizing and potentially require replacement of the electrical service to the pump station.

1. Design the pump station to have a firm capacity of 1,950 gpm (peak storm event flow met with two pumps running) and have a total capacity of 2,400 gpm with three pumps running.
2. Design the pump station to have a firm capacity of 2,400 gpm with two pumps running.

5 Valve Vaults Design

There will be two (2) valve vaults downstream of the wet well for access to the pump discharge piping valves and flowmeter. The first valve vault will be located adjacent to the wet well and include the discharge air release, check and plug valves as shown on sheet M-1 as part of the 30% drawings in Appendix A. Due to site constraints, the pump station flow meter will be in the second vault and located in the McDonalds parking lot upstream of the tie-in locations to the existing 12-inch and 16-inch forcemains. Table 4 provides a summary of the valve vault design criteria.

Table 4 – Valve Vault Design

Item	Description	Valve Vault Design	Flowmeter Vault Design
1	Size	6'-5" x 9'-9" (inside dimensions)	3'-0" x 4'-0" (inside dimensions)
2	Type	Precast polymer concrete	Precast polymer concrete
3	Hatch	H-20 traffic rated Spring-loaded double leaf hatch; Size 5'-0" x 8'-0"	H-20 traffic rated Spring-loaded hatch; Size 3'-0" x 2'-6"
4	Drains	4" drain pipe back to the wet well	4" drain pipe back to the wet well

6 Facility Piping

Table 5 provides the piping materials that will be used in the design.

Table 5. Facility Piping Design Criteria

Application/Condition	Pipe material	Additional comments
Sewer Forcemain, Exposed or Above Grade	Ductile Iron	Epoxy lined and coated
Sewer Forcemain, Below Grade	Ductile Iron or PVC	
Forcemain Drain from Vault	Ductile Iron	
Vault Drains	SDR 35 PVC	
Gravity Sewer Pipeline	PVC PS75 for 18-inch and larger; PVC SDR 26 for 15-inch and smaller	
Pressure Sensing Line	316 Stainless Steel	

Pipeline Design

Each pump will have an 8-inch discharge that ties into a new 10-inch buried manifold. The maximum velocity in the piping will be 10 feet per second (fps). The 10-inch forcemain will head northwest on the site and into the McDonalds parking lot. The flow meter and vault will be located on the 10-inch pipeline before the pipeline splits to connect to the existing 12-inch and 16-inch forcemains. Exposed forcemain

pipng will have flanged fittings and buried connections will be restrained with mechanical joints. A new gravity sewer pipeline will be installed between the wet well, new manhole and to the existing influent manhole. A summary of the pipeline sizes is presented in Table 6.

Table 6 – Pipeline Size

Item	Description	Nominal Diameter
1	Piping Inside Wet Well	8-inch
2	Wet Well to Vaults	8-inch & 12-inch
3	Meter Vault to 12-inch & 16-inch Connections	12-inch
4	Gravity Pipeline to new Wet Well	21-inch

7 Project Site Layout

The site will include improvements to the existing pump building and construction of the new wet well and vaults, gravity sewer piping and a manhole for the cutover from the old station, and a new sanitary forcemain with connections to the existing 12” and 16” forcemains to the WWTP. Construction of a new relocated garbage enclosure, and realignment of a portion of the CMU block wall surrounding the site on the northwest side is also required. As mentioned previously, the site is constrained by the available space within the property lines and the District and McDonalds are working on negotiations to adjust the property line to compensate for the new wet well. Table 7 summarizes the general site design criteria. The relocation of the garbage enclosure will also need to be coordinated with the refuse company.

Table 7 - Site Design Criteria

Item	Description	Project Facility Design
1	Fencing/Gate	CMU Block building; demolish portion northwest of site for construction of new pump station and rebuild to match existing. Install new sliding gate along newly installed wall for vehicle access.
2	Security System	Intrusion alarms on building exterior doors connected to the SCADA system; Security system to match the District’s standard
3	Access	Existing AC paved access through the west side gate from the McDonalds parking lot
4	Drivable Surface	AC paving outside of CMU block wall; inside wall will be concrete surface
5	Landscaping	None
6	Site Drainage	To match existing and sheet flow away from buildings towards existing storm drain inlets
7	Generator	Connect to existing generator with new automatic transfer switch
8	Site Water	Water service currently in existing pump station building
9	Utilities	Site storm drains, Liberty Electric, Southwest Gas, Charter Communications, and water from City of South Lake Tahoe

Garbage Enclosure Relocation

The new location of the wet well and valve vault will extend beyond the existing block wall and will significantly limit access to the McDonalds garbage enclosure. The District has decided to build a new garbage enclosure in a different location onsite that will not be impacted by the new construction. The architecture of the new garbage enclosure will match the existing structure. The preliminary location options for the garbage enclosure are provided in the 30% drawings on sheet G-4 in Appendix A. The final location will be based on McDonalds and Trash Company preferences.

Building Improvements

The District has a 100 year standard for expected useful life of structures within their system. This standard applies to the existing pump station and generator buildings and will be incorporated into the structural and architectural improvements of the buildings. Based on the 1955 construction date, improvements to the structures will be designed to provide a service life until 2055 (33 years).

Structural Design

Although a new wet well is being constructed, the existing pump station building will need structural improvements to house the new electrical equipment. The lower level of the building where the existing pumps and wet well are located will be abandoned and backfilled with a lightweight concrete flowable fill. In the upper level, the interior wall will be demolished to expand the size of the room that will house the new electrical equipment, slab extension to cover the existing wet well, and beam support that spans across the building to replace the load bearing wall. The structural condition assessment completed in 2018 identified roof and wall connections will also be incorporated into the design. The building will require a seismic retrofit as part of the rehabilitation in accordance with ASCE 41-17. The seismic retrofit performance level should be 2-A, which is Damage Control for structural elements and Operational for non-structural elements, for a BSE-1N/2N level earthquake. It is anticipated that additional vertical force resisting elements will be required to compensate for the removal of the interior wall. The existing lateral elements to remain, e.g., the perimeter walls, may require augmentation for these elements to function as part of the lateral-force-resisting system. The new elements will be designed and detailed in accordance with the 2019 California Building Code.

As part of the new construction, there will be a new precast wet well, valve vault and manhole which will interfere with the existing CMU site wall. Therefore, a portion of the CMU wall will be demolished and extended to incorporate the new infrastructure.

Architectural Design

The project includes architectural improvements to the existing pump station building, generator building and new garbage enclosure. The new garbage enclosure will match the architectural design of the existing enclosure and any rehabilitation improvements will do the same. Based on the site visit, a summary of the architectural elements planned for improvement was prepared and is listed below:

Pump Station Building

1. Building is concrete with stucco paint; walls are sound based on visual inspection but require repainting. Paint will require complete removal and testing for lead and asbestos. There is a possibility that the existing paint is lead based and would require testing and possibly a more involved removal process.
2. Exterior access doors are functionally in working condition but show significant wear and tear and will be replaced.
3. Interior walls have missing/broken glass blocks that require replacement.
4. Roof is 90# mineral impregnated cap sheet type and is in excellent condition. Not recommended for replacement.

Generator Building

1. Wood-framed building with three coats of stucco. Stucco has deteriorated and cracked, with the worst of the cracking on the west facing side of the building between the generator and pump buildings. Repair is required.
2. Generator building exterior front access door is functionally in working condition but shows significant wear and tear and will be replaced.
3. Exterior back access door is not in good condition and requires replacement.
4. Roof is 90# mineral impregnated cap sheet type and is in excellent condition. Not recommended for replacement.

Exterior Improvements

1. The wood lattice pergola is close to the end of its useful life span and will be replaced. Recommend replacing with either powder coated steel, aluminum framed, or synthetic wood. Note that replacement with a synthetic wood option would require periodic paint maintenance.
2. Majority (75%) of the exterior wall requires stucco repair. Because a portion of the exterior wall will be removed and replaced, it is recommended the wall, in its entirety, get new stucco and is painted with anti-graffiti paint.

8 Electrical Design

The new pump station replacement will require complete replacement of the existing electrical equipment. The existing upper level of the pump station will be expanded to encompass the entire floor of the existing building. The new electrical equipment includes the following:

- New VFDs with bypass
- New metering switchboard
- New motor control center (MCC)
- New automatic transfer switch (ATS)

Based on pump selection there is a possibility that the service will need to be upgraded. The existing 400A service will be able to support three (3) 75 HP pumps running or two (2) 85 HP pumps running. If three (3) 85 HP pumps are selected, the existing service will not support the load required to run all three. The electrical service should be revisited once pump selection has been further defined.

9 Control Functionality

During normal operation, two pumps will operate in a lead/lag control where only the lead pump will typically operate. After each pumping cycle, the pumps will alternate lead and lag status on a weekly basis. The third pump will provide backup in case one of the duty pumps is taken offline for maintenance. The water level in the wet well will be measured by the submersible level transducer with level floats as backup. The lead pump will ramp up and down in speed based on water level in the wet well. There will be level setpoints that will turn on the lag pump if flows into the pump station continue to increase beyond one pump capacity. Depending on the preferred pump sizing criteria, there will be two (2) pumps in operation to meet the PWWF of 1,950 gpm and design capacity of 2,400 gpm with high level setpoints programmed into the station.

Because the high and low flows in South Tahoe can largely depend on the influx of tourism, the pump station may experience periods of very low flows in relation to their PWWF. During periods of low flow, WSC recommends programming the pumps to operate ON/OFF at low level setpoints vs continuous operation of one pump at very low speeds. This will allow the pumps to operate at higher efficiencies during periods of low flows. There is the potential for low flows in the forcemains during normal operations which could cause buildup in the pipes and reduce forcemain capacity. Programming scheduled station flushes where the wet well (and possibly some of the collection system) is allowed to fill and allowing pumps to turn on at a high flow to scour the forcemains for a short duration. Scheduling flushing every 24 hours will help keep the forcemains clear, provide a wet well cleaning benefit, and allow pumps to operate at their optimum capacity.

10 Construction Considerations

One of the primary considerations when constructing the pump station replacement is maintaining the existing sewer service using a cost-effective, risk managed method. The best option is to keep the existing pump station operational and minimize shut-downs to perform system tie-overs. Because the design replaces the existing lift station, the wet well and large portions of the piping can be installed with the existing pump station remaining online. Shutdowns will be required for replacement of the electrical equipment and improvements to the existing pump station building.

The District has multiple avenues for managing sewer flows during the scheduled shutdowns. The first option includes diverting all Bijou flows to the Ski Run Pump Station. The District has a bypass interconnection that can send flows to Ski Run. However, bypassing to Ski Run is limited by the capacity of the station since it does not have a significantly lower overall capacity than Bijou and would not be a viable option during higher flows. Setting up a temporary bypass system will also be required. The District also owns and operates bypass pumping equipment that could be set up at Bijou or potentially at Ski Run to pump into the dual forcemains.

Dewatering will be a critical component for the excavation and installation of the new wet well. Results from the geotechnical investigation have not yet been formalized in a report, but shallow groundwater was present when drilling the borehole. The District recently encountered similar shallow depths of groundwater at Tahoe Keys Pump Station (approximately 4 ft below ground surface). There are a few anticipated methods for dewatering, including traditional sump pump dewatering, periphery well dewatering, and cutoff walls by sheet pile driving, injecting grout curtail or ground freezing. The most desirable option would be applying one of the cutoff methods to avoid having to pump large volumes of groundwater from the excavation. The dewatering approach will be further defined after the completion of the Geotechnical Report.

11 Cost Estimate

A summary of the estimated construction costs is provided in Table 8. The detailed 30% construction cost estimate is included as Appendix B. The estimate includes escalation for construction in the summer of 2025.

Table 8 – Cost Estimate

Item Description	Total Cost
Contractor Overhead subtotal	\$438,000
Site Construction Subtotal	\$860,400
Concrete Subtotal	\$355,500
Masonry Subtotal	\$36,000
Metals Subtotal	\$7,500
Thermal and Moisture Subtotal	\$33,000
Doors and Windows Subtotal	\$50,500
Finishes Subtotal	\$15,000
Equipment Subtotal	\$375,000
Mechanical Subtotal	\$141,100
Electrical and Controls Subtotal	\$444,300
Construction Subtotal	\$2,692,000
Contingency (25%)	\$690,000
Escalation (13.2%)	\$364,000
Total Project Cost	\$3,811,000

12 Design Elements for Discussion

The following items require further discussion to finalize the basis of design for the rehabilitation of the Bijou Pump Station.

1. Confirm odor control system will be added to the new wet well and confirm any manufacturer preferences.
2. Confirm the new floor elevation of the electrical building. The floor elevation currently is approximately 4-ft below exterior grades with a landing and stairway entrance. Because the electrical room will be expanded to encompass the wet well side of the building, the floor will be raised to eliminate the stair entrance.
3. Finalize the new dumpster location based on discussions with McDonalds and South Tahoe Refuse.
4. Confirm pump station operational preferences indicated in Section 4 above. This will dictate pump selection and potential electrical service needs. Forcemain flow and pressure data from the upcoming testing will also be considered in the pump selections.

Appendix A

30% Drawings

SOUTH TAHOE PUBLIC UTILITY DISTRICT



CONSTRUCTION PLANS FOR BIJOU PUMP STATION REHABILITATION PROJECT SEPTEMBER 2022 30% DESIGN

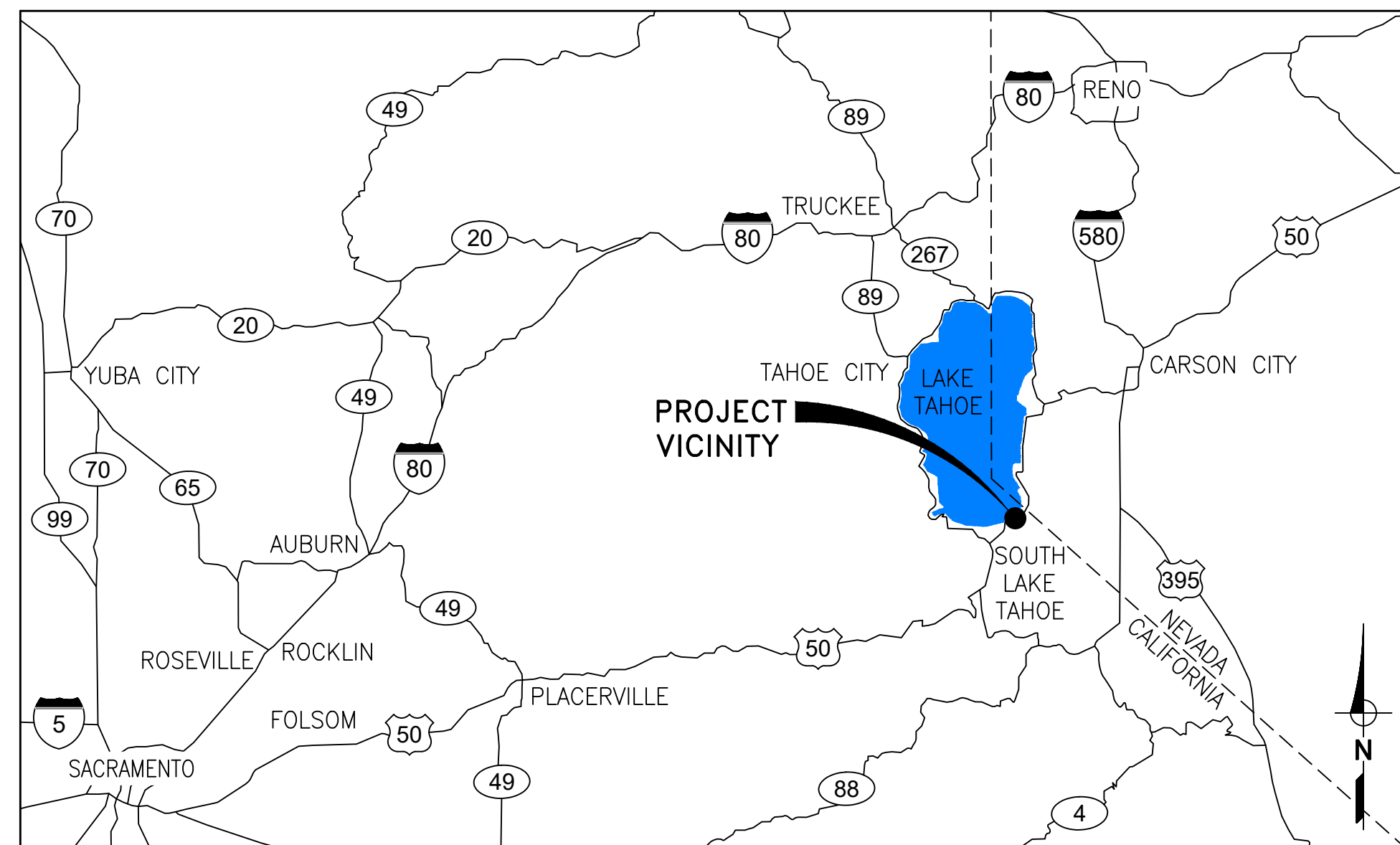

VICINITY MAP
N.T.S.

CONTACT LIST:

TITLE: _____ NUMBER: _____ CONTACT: _____

SITE ADDRESS

A.P.N. 027-690-003-000
3705 LAKE TAHOE BLVD.
EL DORADO COUNTY, CALIFORNIA

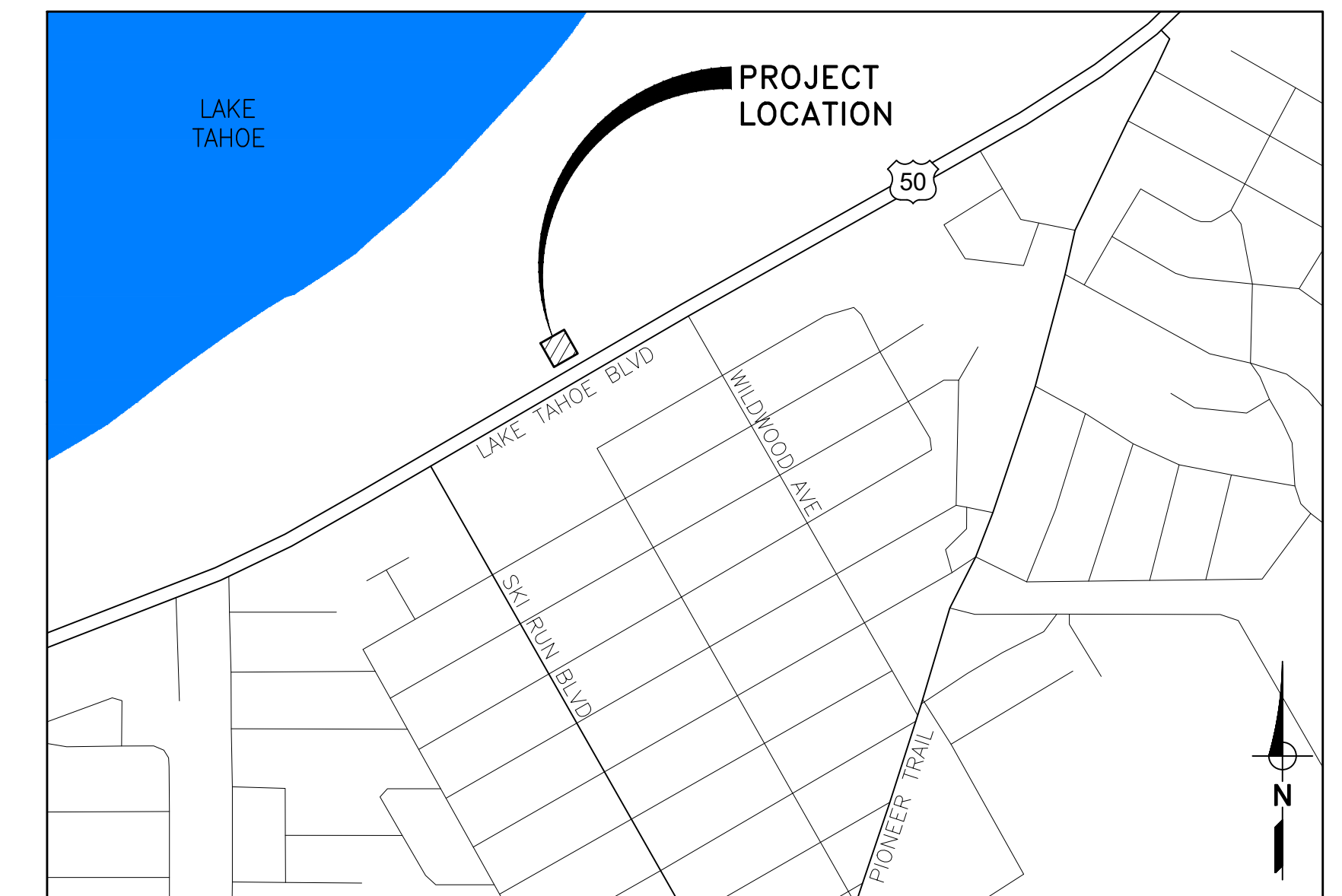

LOCATION MAP
N.T.S.

DRAFT - NOT FOR CONSTRUCTION

Path: W:\3.0 Clients\South Tahoe Public Utility District\1263\11026 Bijou Pump Station Rehabilitation\6.0 Working Files\06 CAD Filename: STPJUD-BIJOU-PS.dwg Plot Date: September 19, 2022 - 8:13 PM CADD User: Chris Durbin

REV	DATE	BY	DESCRIPTION

WARNING
0 1/2 1
IF THIS BAR DOES NOT MEASURE 1" THEN DRAWING IS NOT TO SCALE.

DESIGNED ###
DRAWN ###
CHECKED ###
SCALE AS NOTED

PREPARED BY:
ROB NATOLI
RCE No.: 78271
DATE



2330 EAST BIDWELL STREET, SUITE 110 FOLSOM, CA 95630
PHONE: (916) 778-4288 FAX: (805) 888-2764

SOUTH TAHOE PUBLIC UTILITY DISTRICT
1275 MEADOW CREST DRIVE
SOUTH LAKE TAHOE, CA 96150
APPROVED: _____ POSITION _____ XX/XX/XX

BIJOU PUMP STATION REHABILITATION PROJECT
TITLE SHEET, VICINITY AND LOCATION MAPS

DRAWING
G-1
SHEET 1 OF XX
PROJECT #

Path: W:\3.0 Clients\South Tahoe Public Utility District\1263\11026 Bijou Pump Station Rehabilitation\6.0 Working Files\06 CAD File: STPUD-BIJOU-PS.dwg Plot Date: September 19, 2022 8:13 PM CADD User: Chris Durbin

LEGEND:

EXISTING	CONSTRUCT	
		SURVEY MONUMENT
		CENTERLINE
		EASEMENT LINE
		PROPERTY LINE
		RIGHT OF WAY
		STORM DRAIN
		WATERLINE
		SANITARY SEWER
		RECYCLED WATER
		TELEPHONE
		FIBER OPTIC
		GAS
		OVERHEAD UTILITIES
		ELECTRICAL
		CABLE TV
		EDGE OF PAVEMENT
		FENCE
		HANDRAIL
		GAS VALVE OR HAND HOLE
		FIRE HYDRANT ASSEMBLY
		WATER VALVE
		WATER SERVICE
		FIRE SERVICE
		SEWER CLEANOUT
		STORM DRAIN INLET
		TELEPHONE MANHOLE
		ELECTRIC MANHOLE
		SEWER MANHOLE
		BYPASS VAULT
		GAS METER
		CAP OR PLUG
		REDUCER
		COUPLING
		THRUST BLOCK
		UTILITY PULL BOX
		ELECTRICAL TRANSFORMER
		LIGHT POST
		SIGN
		TREE
		BUSH/TREES/BRUSH
		CONCRETE TILT-UP WALL
		CONCRETE
		PAVERS

MECHANICAL PIPE AND FITTING SYMBOLS

DOUBLE LINE	SINGLE LINE	
		HUB & SPIGOT JOINT (RUBBER GASKET)
		WELD JOINT
		FLANGED JOINT
		FLEXIBLE COUPLING
		GROOVED END COUPLING
		ELBOW UP
		ELBOW DOWN
		TEE UP
		TEE DOWN
		LATERAL UP
		LATERAL DOWN
		CONCENTRIC REDUCER
		ECCENTRIC REDUCER
		UNION
		ELBOW, 90 DEGREE
		CROSS
		TEE
		ELBOW, 45 DEGREE
		LATERAL

VALVES

	BALL VALVE
	BUTTERFLY VALVE
	SILENT CHECK VALVE
	GATE VALVE
	PLUG VALVE
	SWING CHECK VALVE
	STRAINER
	PRESSURE REDUCING/SUSTAINING VALVE (ELEVATION VIEW)
	MAGNETIC FLOW METER
	PRESSURE REDUCING/SUSTAINING VALVE (PLAN VIEW)

ABBREVIATIONS:

~ or ±	APPROXIMATELY	N&T	NAIL AND TIN
ABAND.	ABANDONED	NC	NORMALLY CLOSED
AC/ACP	ASBESTOS CEMENT PIPE	PC350	PRESSURE CLASS 350
CTV/CATV	CABLE TELEVISION	PCC	PORTLAND CEMENT CONCRETE
CL	CENTER LINE	PE	POLYETHYLENE
CLR	CLEARANCE	PL	PROPERTY LINE
CLSM	CONTROLLED LOW-STRENGTH MATERIAL	PP	POWER POLE
CMP	CORRUGATED METAL PIPE	PSI	POUNDS PER SQUARE INCH
CML&C	CEMENT MORTAR LINED AND COATED	PVC	POLYVINYL CHLORIDE
CVR	COVER	R	RADIUS
DI	DUCTILE IRON	RC	RELATIVE COMPACTION
DIP	DUCTILE IRON PIPE	RCE	REGISTERED CIVIL ENGINEER
DN	DOWN	RCP	REINFORCED CONCRETE PIPE
DWG	DRIVEWAY	R/W	RIGHT OF WAY
ELEC	ELECTRIC	RT	RIGHT
EP	EDGE OF PAVEMENT	RW	RECYCLED WATER
EX or EXIST	EXISTING	SFT	SURVEY FEET (DECIMAL FEET)
FCA	FLANGE COUPLING ADAPTER	SD	STORM DRAIN
FD	FOUND	SDMH	STORM DRAIN MANHOLE
FLG	FLANGED	SL	STREET LIGHT
FL	FLOW LINE	SS	SEWER
FH	FIRE HYDRANT	SSFM	SEWER FORCE MAIN
G	GAS	SSMH	SANITARY SEWER MANHOLE
GB	GRADE BREAK	STA	STATION
GV	GATE VALVE	STD	STANDARD
HMA	HOT MIX ASPHALT	STL	STEEL
HPI	HORIZONTAL POINT OF INFLECTION	STPUD	SOUTH TAHOE PUBLIC UTILITY DISTRICT
INV	INVERT	SVC	SERVICE
IP	IRON PIPE	TC	TOP OF CURB
IRR	IRRIGATION	TEL	TELEPHONE
LF	LINEAR FEET	TEMP	TEMPORARY
LS	LAND SURVEYOR	TOP	TOP OF PIPE
LT	LEFT	VAR	VARIES
MAX	MAXIMUM	VCP	VITRIFIED CLAY PIPE
MIN	MINIMUM	VERT	VERTICAL
MJ	MECHANICAL JOINT	VPI	VERTICAL POINT OF INFLECTION
		W	WATER
		WM	WATER METER
		WT	WEIGHT

SECTIONS AND DETAIL NUMBERING SYSTEM

SECTION CUT ON PLAN

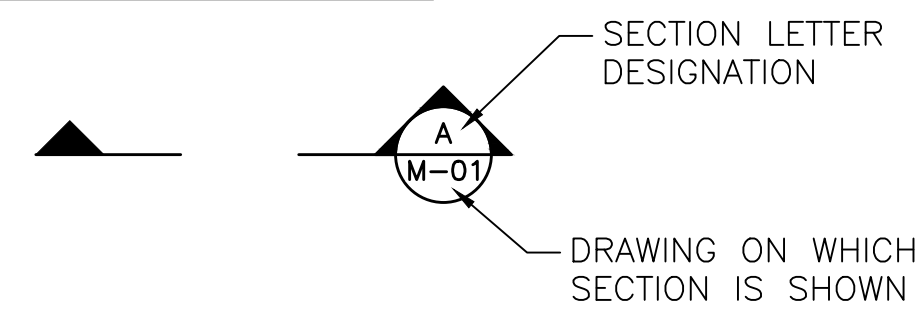

DETAIL NUMBERING SYSTEM

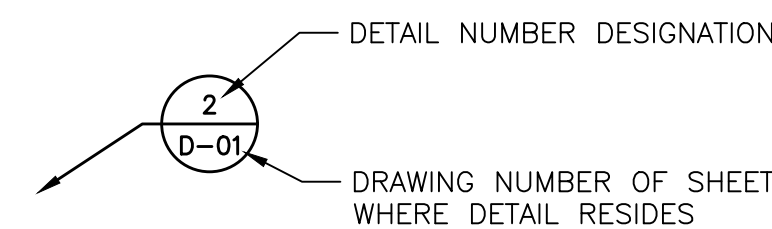

SECTION SHOWN

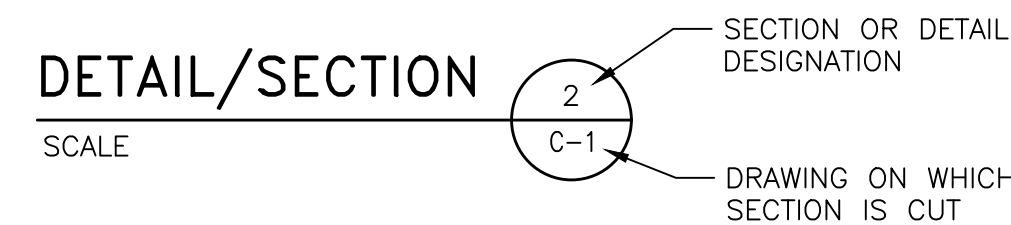

NOTES

- "-" IN DRAWING AREA INDICATES THAT SECTION OR DETAIL IS SHOWN ON THE SAME DRAWING THAT IT IS CUT FROM OR REFERRED TO.

DRAFT - NOT FOR CONSTRUCTION

<table border="1" style="width: 100%; border-collapse: collapse;"> <thead> <tr> <th>REV</th> <th>DATE</th> <th>BY</th> <th>DESCRIPTION</th> </tr> </thead> <tbody> <tr><td> </td><td> </td><td> </td><td> </td></tr> <tr><td> </td><td> </td><td> </td><td> </td></tr> <tr><td> </td><td> </td><td> </td><td> </td></tr> </tbody> </table>	REV	DATE	BY	DESCRIPTION													<p>WARNING</p> <p>IF THIS BAR DOES NOT MEASURE 1" THEN DRAWING IS NOT TO SCALE.</p>	<p>DESIGNED: ###</p> <p>DRAWN: ###</p> <p>CHECKED: ###</p> <p>SCALE: NO SCALE</p>	<p>PREPARED BY:</p> <p>ROB NATOLI RCE No.: 78271</p> <p>DATE: _____</p>		<p>2330 EAST BIDWELL STREET, SUITE 110 FOLSOM, CA 95630 PHONE: (916) 778-4288 FAX: (805) 888-2764</p>	<p>SOUTH TAHOE PUBLIC UTILITY DISTRICT 1275 MEADOW CREST DRIVE SOUTH LAKE TAHOE, CA 96150</p> <p>APPROVED: _____</p> <p>POSITION: _____</p>	<p>BIJOU PUMP STATION REHABILITATION PROJECT</p> <p>G-3</p> <p>LEGENDS AND ABBREVIATIONS</p>	<p>DRAWING</p> <p>G-3</p> <p>SHEET 3 OF XX</p> <p>PROJECT # _____</p>
REV	DATE	BY	DESCRIPTION																					

Path: W:\3.0 Clients\South Tahoe Public Utility District\1263\11026 Bijou Pump Station Rehabilitation\6.0 Working Files\06 CAD File: STPUD-BIJOU-PS.dwg Plot Date: September 19, 2022 8:13 PM CADD User: Chris Durbin

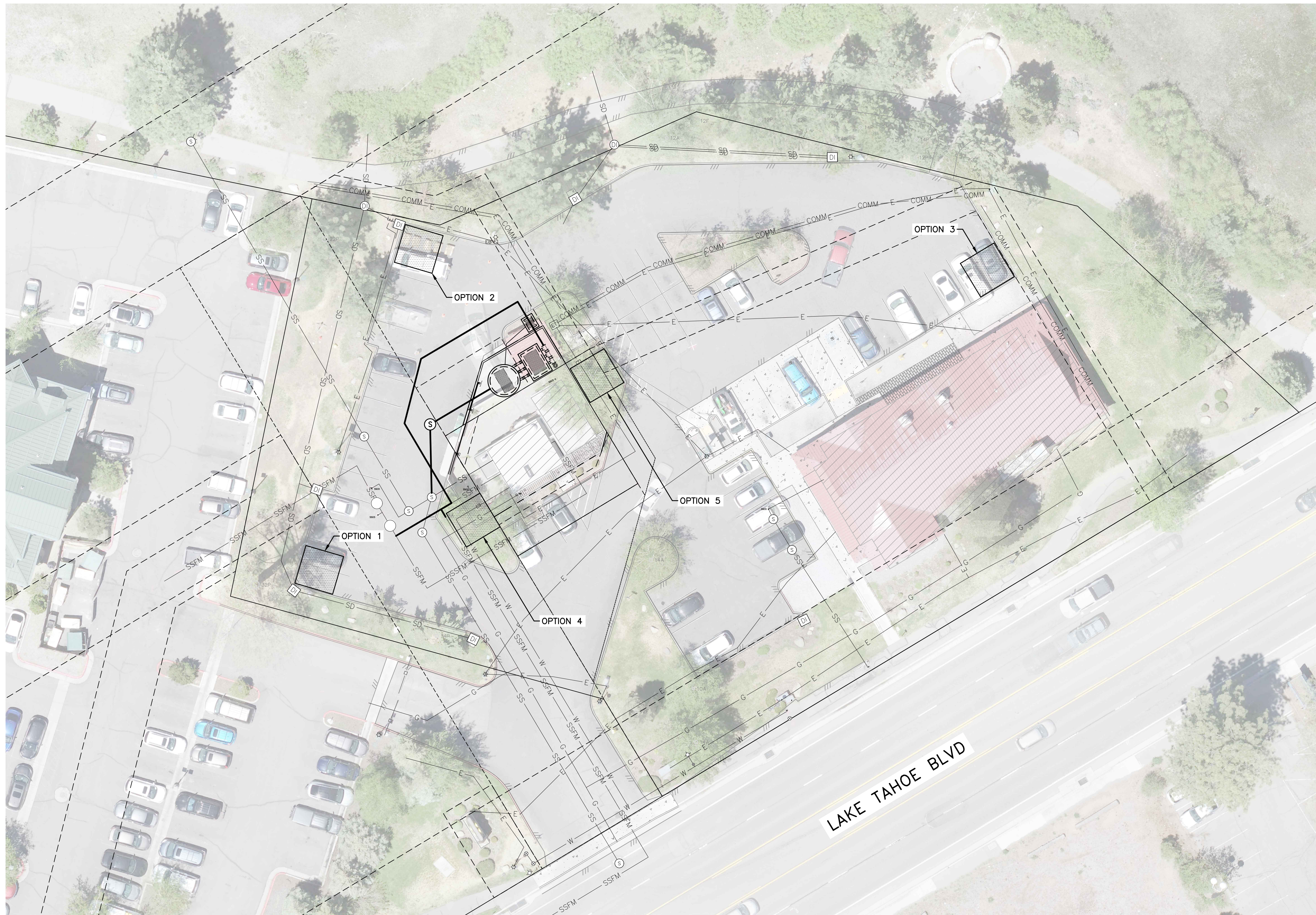

OVERALL SITE PLAN

LEGEND

	EXISTING PROPERTY BOUNDARY
	EXISTING EASEMENT BOUNDARY
	PROPOSED PROPERTY BOUNDARY
	PROPOSED TRASH AREA

SURVEY DATA

BASIS OF BEARINGS

THE BASIS OF BEARINGS FOR THIS SURVEY IS CALIFORNIA STATE PLANE COORDINATE SYSTEM, ZONE II NAD83 (2011) EPOCH 2010.00; SAID BEARINGS ARE BASED LOCALLY UPON NGS-OPUS DERIVED TIES BETWEEN NGS STATIONS "SIGNAL PEAK" AND "INDIAN CREEK".

DISTANCES SHOWN HEREON ARE GROUND DISTANCES USING A COMBINED SCALE FACTOR OF 1.00037683195.

RECORD BEARINGS FROM (R1) HAVE BEEN ROTATED COUNTER CLOCKWISE 1°14'19".

BASIS OF ELEVATIONS

DATUM: NAVD 88
PROJECT BENCHMARK = LUMOS NO. 500 - "CHEVYS"
HAVING AN ELEVATION OF 6238.97

REFERENCES

- R1) FINAL PARCEL MAP, RECORDED IN BOOK 45, PAGE 115, ON MAY 1, 1996, OFFICIAL RECORDS OF EL DORADO COUNTY, STATE OF CALIFORNIA.
- R2) FINAL PARCEL MAP, RECORDED IN BOOK 45, PAGE 44, ON APRIL 14, 1995, OFFICIAL RECORDS OF EL DORADO COUNTY, STATE OF CALIFORNIA.
- R3) GRANT OF EASEMENT, RECORDED IN BOOK 3325, PAGE 704, ON APRIL 5, 1990, OFFICIAL RECORDS OF EL DORADO COUNTY, STATE OF CALIFORNIA.
- R4) GRANT OF EASEMENT, RECORDED IN BOOK 3325, PAGE 707, ON APRIL 5, 1990, OFFICIAL RECORDS OF EL DORADO COUNTY, STATE OF CALIFORNIA.

NOTES

- 1. FIELD WORK WAS PERFORMED ON 6/13/2022.
- 2. EASEMENTS MAY EXIST THAT ARE NOT SHOWN HEREON
- 3. THIS IS NOT A BOUNDARY SURVEY. BOUNDARY SHOWN BY RECORD INFORMATION.
- 4. ONLY TREES 8" DBH (DIAMETER AT BREAST HEIGHT) AND LARGER ARE SHOWN.
- 5. UTILITIES SHOWN ARE BASED ON UTILITY LOCATE MARKS & SURFACE EVIDENCE.

SITE INFORMATION

A.P.N. 027-690-003-000
3705 LAKE TAHOE BLVD.
EL DORADO COUNTY, CALIFORNIA
PARCEL 3 PER (R1)
2,500 SQ.FT.

DRAFT - NOT FOR CONSTRUCTION

REV	DATE	BY	DESCRIPTION

WARNING

IF THIS BAR DOES NOT MEASURE 1" THEN DRAWING IS NOT TO SCALE.

DESIGNED	###
DRAWN	###
CHECKED	###
SCALE	AS NOTED

PREPARED BY:
ROB NATOLI
RCE No.: 78271

DATE



2330 EAST BIDWELL STREET, SUITE 110 FOLSOM, CA 95630
PHONE: (916) 778-4288 FAX: (805) 888-2764

SOUTH TAHOE PUBLIC UTILITY DISTRICT
1275 MEADOW CREST DRIVE
SOUTH LAKE TAHOE, CA 96150

APPROVED: _____ POSITION _____ XX/XX/XX

BIJOU PUMP STATION REHABILITATION PROJECT

OVERALL SITE PLAN

DRAWING
G-4
SHEET 4 OF XX
PROJECT #

Path: W:\3.0 Clients\South Tahoe Public Utility District\1263\11026 Bijou Pump Station Rehabilitation\6.0 Working Files\06 CAD Filename: STPUD-BIJOU-PS.dwg Plot Date: September 19, 2022 8:13 PM CADD User: Chris Durbin

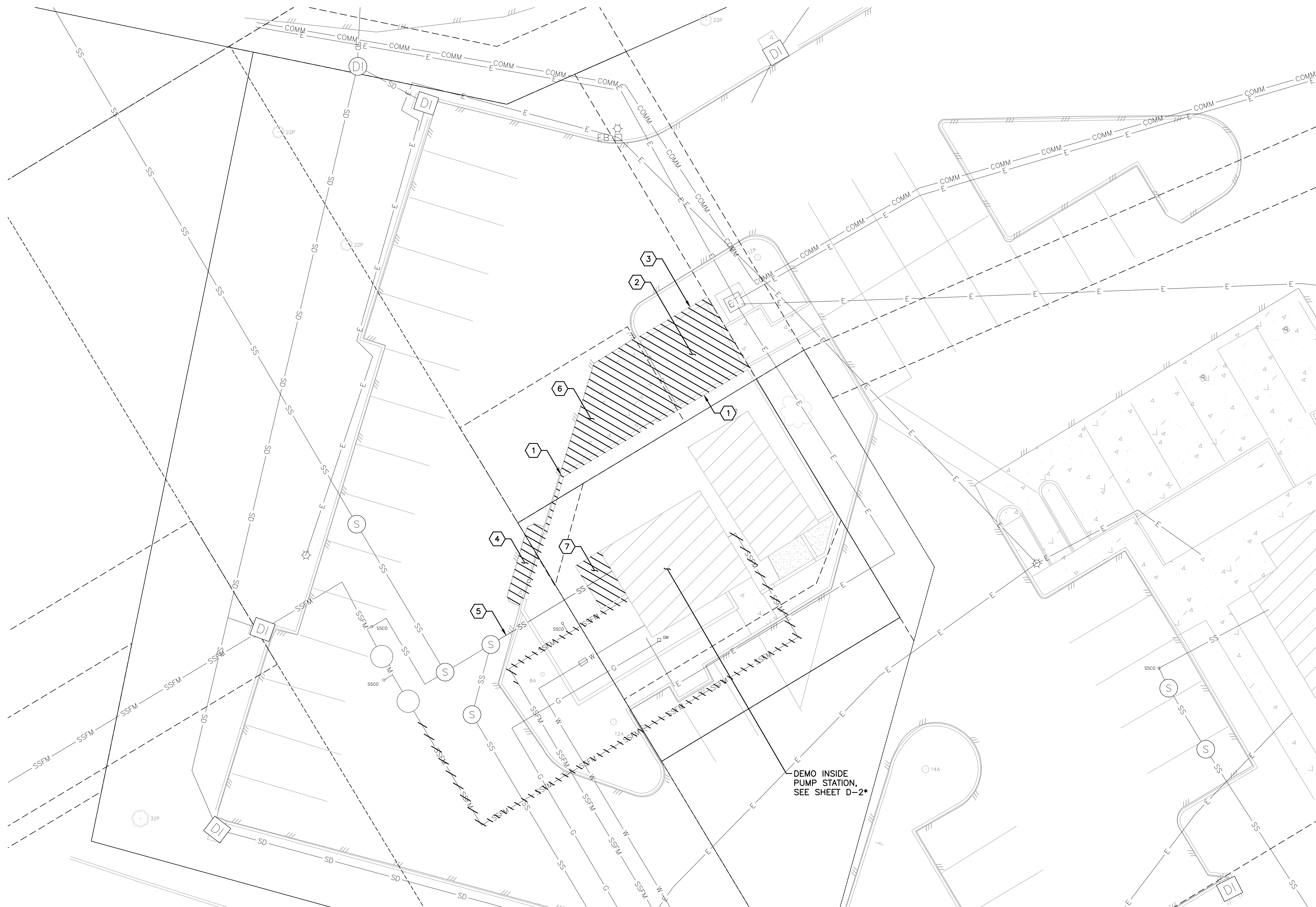

- DEMOLITION KEY NOTES**
- ① DEMOLISH EXISTING WALL AND GATE
 - ② PROTECT EXISTING TRASH RECEPTACLE AND RELOCATE PER DWG G-4
 - ③ DEMOLISH EXISTING WALL AND ROOF OVER EXISTING TRASH RECEPTACLE AREA
 - ④ DEMOLISH EXISTING CONCRETE RAMP
 - ⑤ FILL 21" SS INTO PUMP STATION WITH CLSM
 - ⑥ DEMOLISH CONCRETE APRON
 - ⑦ DEMOLISH SHED AND ODOR CONTROL EQUIPMENT

*SHEET D-2 TO BE PROVIDED AT 60% DESIGN LEVEL
 ALL EQUIPMENT, PIPING, PUMPS, AND MOTORS TO BE DEMOLISHED FROM EXISTING PUMP STATION

EXISTING SITE PLAN



Know what's below.
 Call before you dig.

DRAFT - NOT FOR CONSTRUCTION

REV	DATE	BY	DESCRIPTION

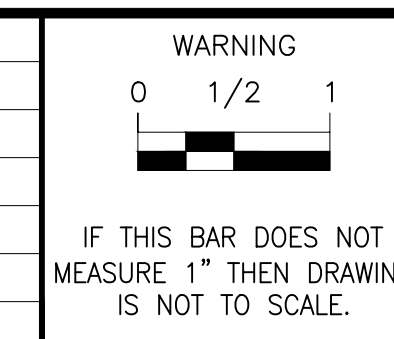

DESIGNED ###
 DRAWN ###
 CHECKED ###
 SCALE AS NOTED

PREPARED BY:
 ROB NATOLI
 RCE No.: 78271

DATE

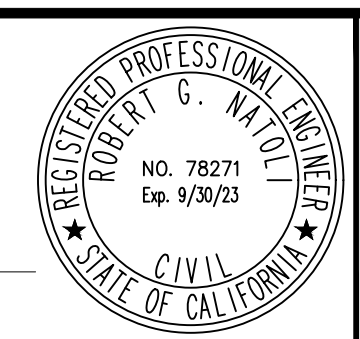

2330 EAST BIDWELL STREET, SUITE 110 FOLSOM, CA 95630
 PHONE: (916) 778-4288 FAX: (805) 888-2764

SOUTH TAHOE PUBLIC UTILITY DISTRICT
 1275 MEADOW CREST DRIVE
 SOUTH LAKE TAHOE, CA 96150

APPROVED: _____ POSITION _____

BIJOU PUMP STATION REHABILITATION PROJECT

DEMOLITION SITE PLAN

DRAWING
D-1
 SHEET 5 OF XX
 PROJECT #

Path: W:\3.0 Clients\South Tahoe Public Utility District\1263\11026 Bijou Pump Station Rehabilitation\6.0 Working Files\06 CAD Filename: STPLUD-BIJOU-PS.dwg Plot Date: September 19, 2022 - 8:13 PM CADD User: Chris Durbin

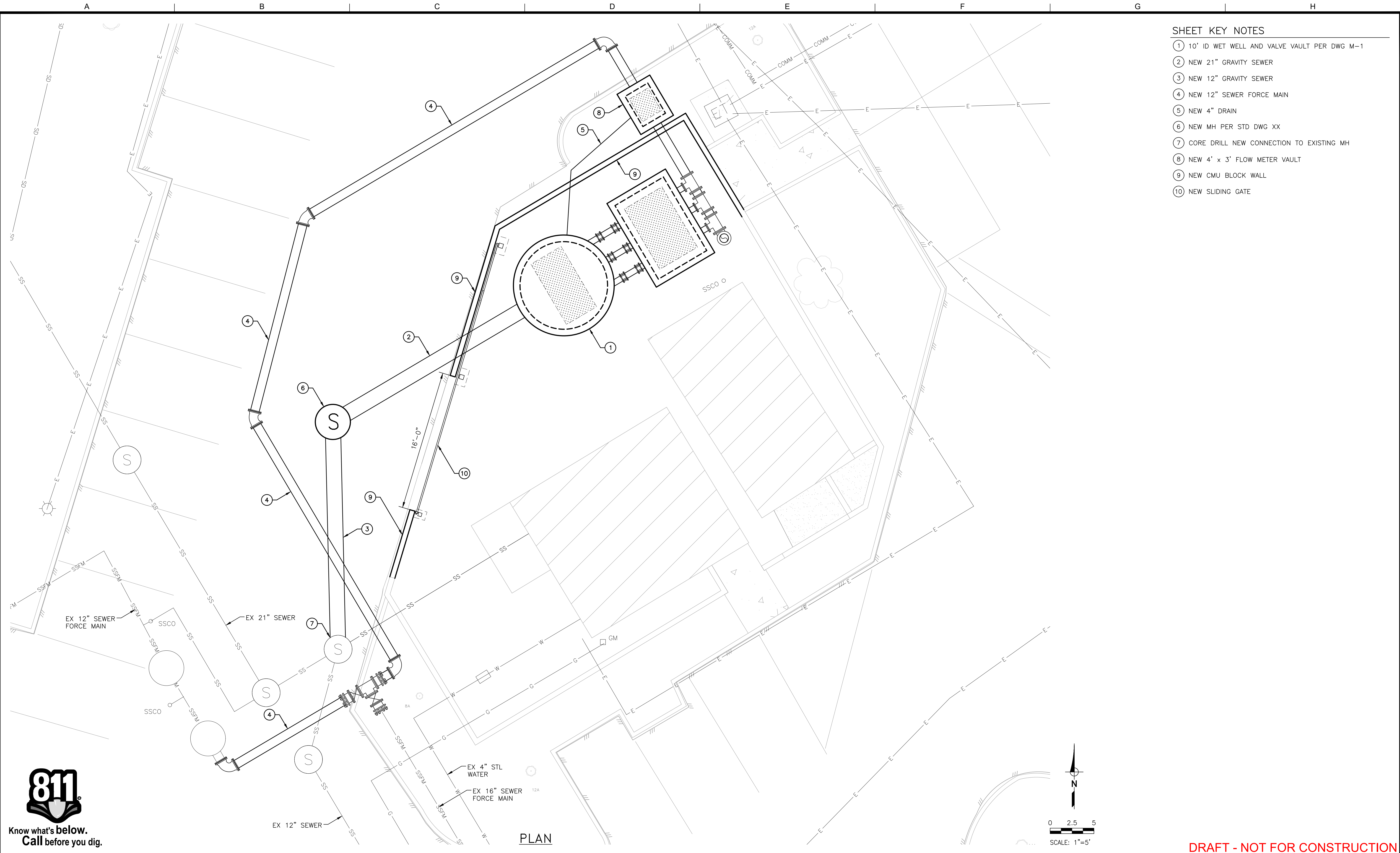

- SHEET KEY NOTES**
- ① 10' ID WET WELL AND VALVE VAULT PER DWG M-1
 - ② NEW 21" GRAVITY SEWER
 - ③ NEW 12" GRAVITY SEWER
 - ④ NEW 12" SEWER FORCE MAIN
 - ⑤ NEW 4" DRAIN
 - ⑥ NEW MH PER STD DWG XX
 - ⑦ CORE DRILL NEW CONNECTION TO EXISTING MH
 - ⑧ NEW 4' x 3' FLOW METER VAULT
 - ⑨ NEW CMU BLOCK WALL
 - ⑩ NEW SLIDING GATE



PLAN

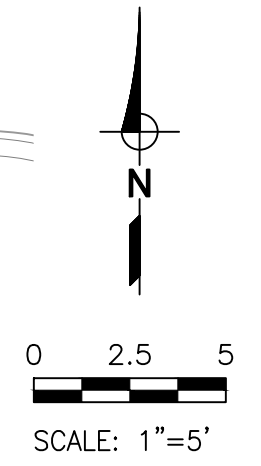

DRAFT - NOT FOR CONSTRUCTION

REV	DATE	BY	DESCRIPTION

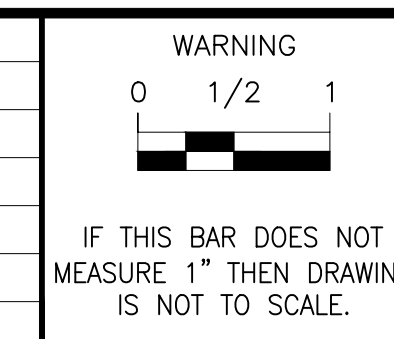

DESIGNED ###
 DRAWN ###
 CHECKED ###
 SCALE AS NOTED

PREPARED BY:
 ROB NATOLI
 RCE No.: 78271

DATE



SOUTH TAHOE PUBLIC UTILITY DISTRICT
 1275 MEADOW CREST DRIVE
 SOUTH LAKE TAHOE, CA 96150

APPROVED: _____ POSITION _____

BIJOU PUMP STATION REHABILITATION PROJECT

PUMP STATION SITE PLAN

DRAWING
C-1
 SHEET 11 OF XX
 PROJECT #

Path: W:\3.0 Clients\South Tahoe Public Utility District\1263\11026 Bijou Pump Station Rehabilitation\6.0 Working Files\06 CAD Filename: STPJUD-BIJOU-PS.dwg Plot Date: September 19, 2022 8:13 PM CADD User: Chris Durbin

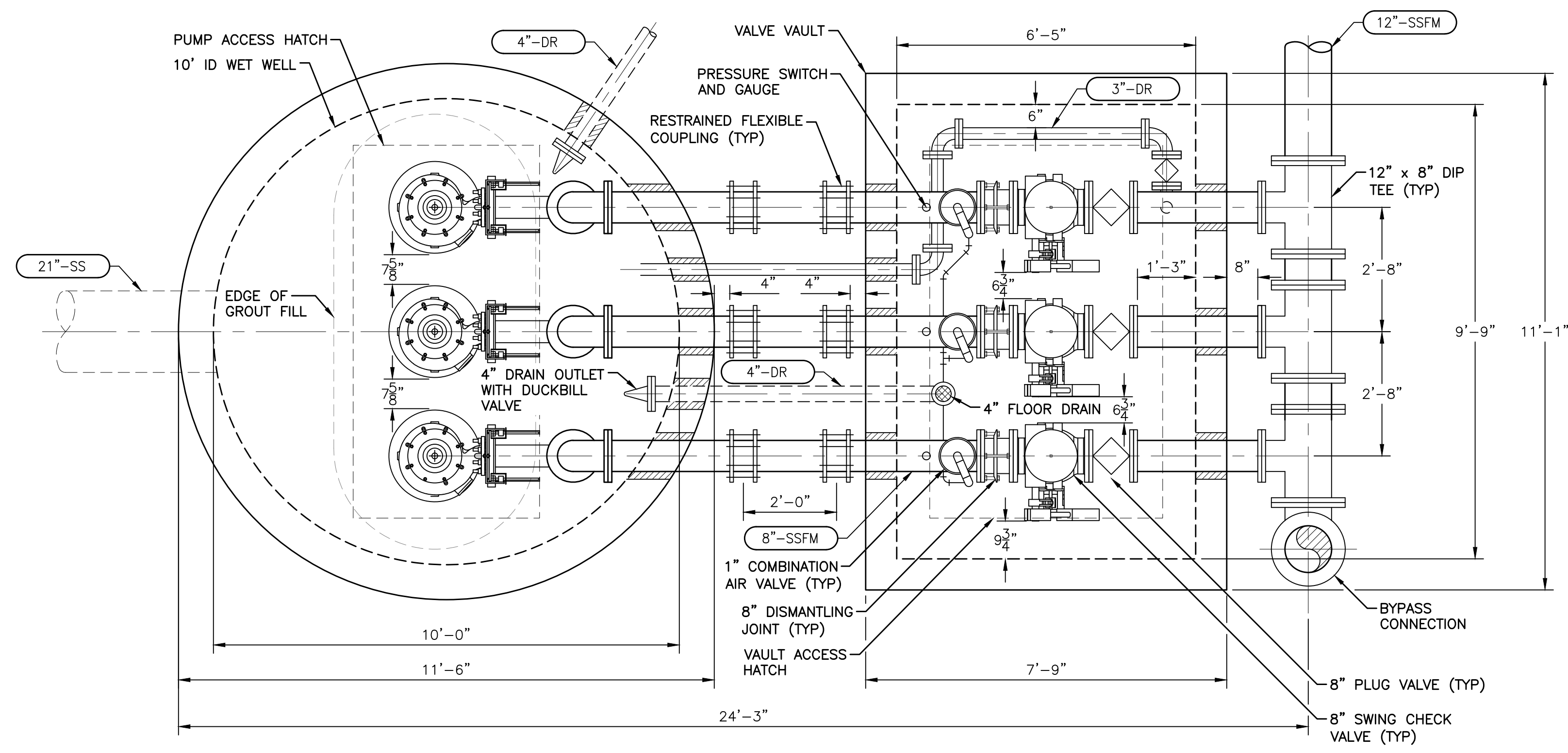

MECHANICAL PLAN
SCALE: 1/2"=1'-0"

DRAFT - NOT FOR CONSTRUCTION

REV	DATE	BY	DESCRIPTION

WARNING
0 1/2 1
IF THIS BAR DOES NOT MEASURE 1" THEN DRAWING IS NOT TO SCALE.

DESIGNED: ###
DRAWN: ###
CHECKED: ###
SCALE: AS SHOWN

PREPARED BY:
ROB NATOLI
RCE No.: 78271
DATE: _____

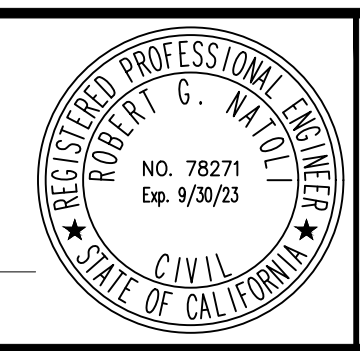

2330 EAST BIDWELL STREET, SUITE 110 FOLSOM, CA 95630
PHONE: (916) 778-4288 FAX: (805) 888-2764

SOUTH TAHOE PUBLIC UTILITY DISTRICT
1275 MEADOW CREST DRIVE
SOUTH LAKE TAHOE, CA 96150

APPROVED: _____
POSITION: _____

BIJOU PUMP STATION REHABILITATION PROJECT

PUMP STATION MECHANICAL PLAN

DRAWING
M-1
SHEET 28 OF XX
PROJECT # _____

Path: C:\Dropbox (TJCAA)\W Drive - CADD From Sharepoint\2022 Projects\122027 - WSC, South Tahoe Bijou PS\122027 - Elec File: 6E-01.dwg Plot Date: August 9, 2022 2:51 PM CADD User: Bee Vee

Table with 3 columns: ONE LINE OR CONTROL DIAGRAM, PLAN, DESCRIPTION. Contains symbols for equipment identifiers, conduit, valves, generators, motors, meters, circuit breakers, surge protection, starters, transformers, switches, and arrestors.

Table with 3 columns: ONE LINE OR CONTROL DIAGRAM, PLAN, DESCRIPTION. Contains symbols for interlocks, electrical interlocks, terminal connections, network terminations, control stations, pushbuttons, selector switches, pilot lights, time delay relays, and various types of switches.

Table with 2 columns: PLAN, DESCRIPTION. Contains symbols for NEMA areas, exposed and concealed conduits, underground duct banks, homeruns, flexible metal conduit, and lighting fixtures.

ABBREVIATIONS table listing symbols for electrical components like AMP, ac, AF, AFF, AL, AIC, AT, ATS, AUTO, AUX, AWG, BCG, BLDG, C, CB, CKT, CL, CMU, CP, CPT, CT, CU, CWS, dc, DIA, DWG, (E), EA, ELEC, EL, ENCL, EQUIP, ETM, (F), FO, FT, FU, G, GRD, GALV, GEN, GFI, GRS, HID, HH, hp, HVAC, Hz, kcmil, kVA, kW, LES, LGT, LP, LV, MAX, MCC, MCP, MFR, MH, MIN, ML, MV, N, N/A, NC, NCL, NIC, NO, NO., NTS, OL, POLE, PB, PC, PH, PNL, PT, PVC, RECEPT, REQD, SEC, SHT, SS, SW, SWBD, SWGR, TC, TEL, TD, TM, TO, TSP, TYP, UG, UON, UPS, V, VA, VAR, VARIOUS, VFD, W, W/., WP, XFMR, etc.

- NOTES: 1. THIS IS A STANDARD LEGEND SHEET... 2. DETAILS REPRESENT TYPICAL INSTALLATION REQUIREMENTS... 3. PLANS DO NOT SHOW ROUTES OR SIZING OF RACEWAYS... 4. IF NOT SHOWN, PROVIDE MINIMUM CONDUIT... 5. WHERE LUMINAIRE MOUNTING HEIGHTS ARE SHOWN...

CONTROL SYSTEM INPUT/OUTPUT DEVICES table showing symbols for digital and analog inputs/outputs, pulse inputs, and momentary outputs.

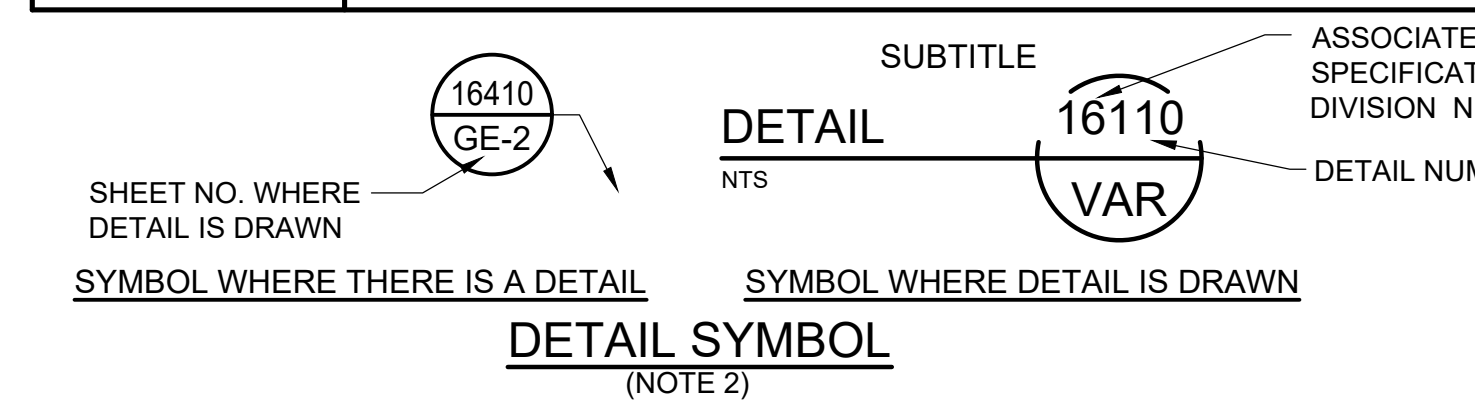

Revision table with columns: REV, DATE, BY, DESCRIPTION.

WARNING: IF THIS BAR DOES NOT MEASURE 1" THEN DRAWING IS NOT TO SCALE. Includes a scale bar showing 0, 1/2, and 1 inch.

DESIGNED BY: BFY, DRAWN: ADP, CHECKED: EAN, SCALE: NTS. PREPARED BY: ROBERT G. NATOLI, RCE No.: 78271, DATE: _____

NOT FOR CONSTRUCTION. WSC logo. 32395 CLINTON KEITH ROAD, #A-206 WILDOMAR, CA 92595. PHONE: (951) 678-0006 FAX: (909) 354-3482

SOUTH TAHOE PUBLIC UTILITY DISTRICT. 1275 MEADOW CREST DRIVE, SOUTH LAKE TAHOE, CA, 96150. APPROVED: _____ POSITION: _____ DATE: _____

BIJOU PUMP STATION REHABILITATION PROJECT. DRAWING: GE-1. ELECTRICAL SYMBOLS AND ABBREVIATIONS. SHEET ## OF PROJECT # -

DRAFT 30% DWGS - NOT FOR CONSTRUCTION

Path: C:\Dropbox (TJCAA)\W Drive - CADD From Sharepoint\2022 Projects\122027 - WSC, South Tahoe Bijou PS\122027 - Elec CADD User: Bee Vue Plot Date: August 9, 2022 - 2:51 PM Filename: E-01.dwg

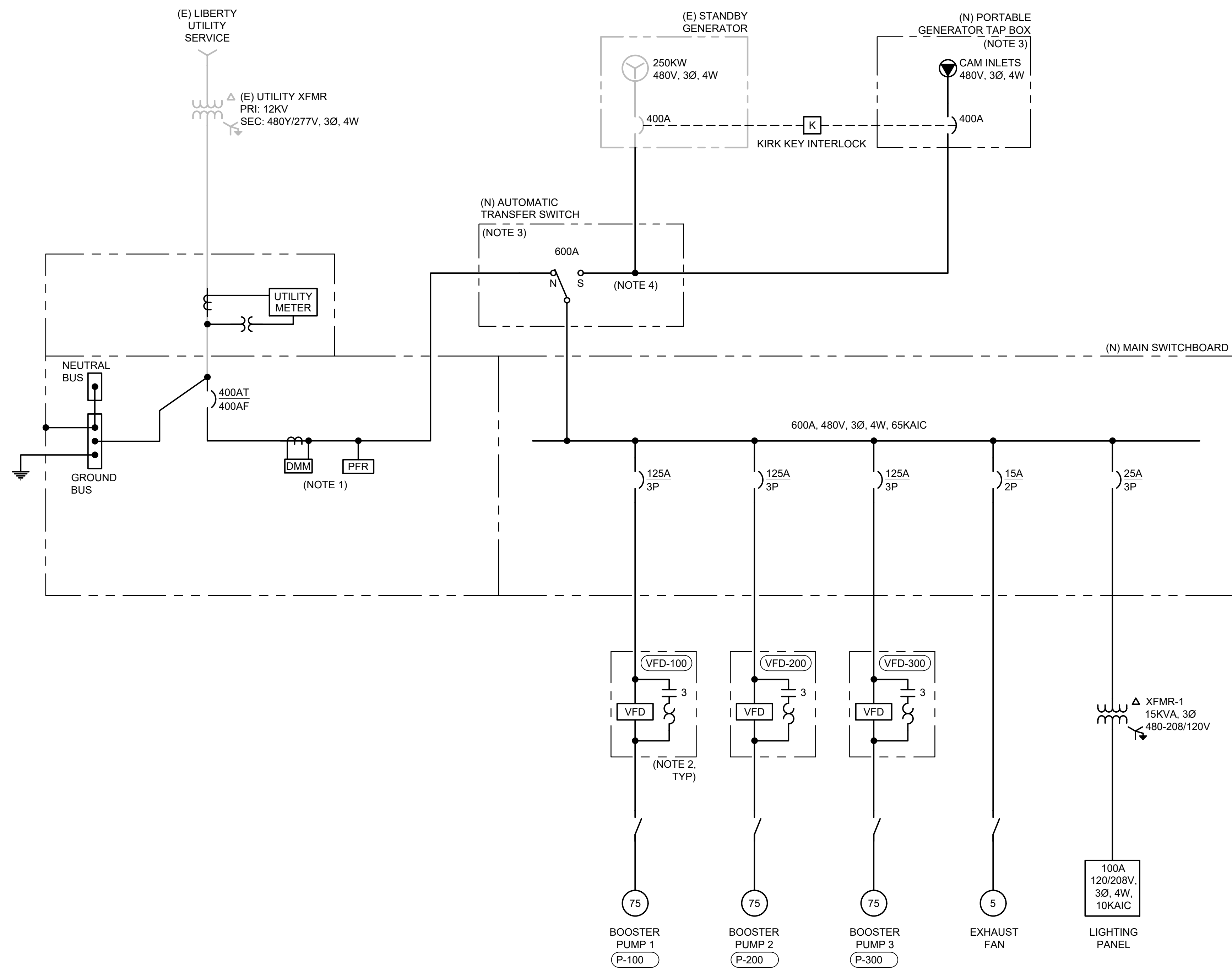

SINGLE LINE DIAGRAM
SCALE: NTS

- NOTES:**
1. PROVIDE POWER MONITORING AND POWER FAILURE RELAY. CONNECT POWER FAILURE RELAY TO PLC FOR STATUS MONITORING.
 2. PROVIDE ALLEN BRADLEY VFD WITH HARMONIC MITIGATION AND MAINTENANCE BYPASS.
 3. INSTALL ATS INSIDE GENERATOR ROOM. INSTALL TAP BOX FOR TEMPORARY GENERATOR ADJACENT TO ATS.
 4. ATS STANDBY BUS LUGS TO ACCOMMODATE BOTH STANDBY AND PORTABLE GENERATOR FEEDER TERMINATIONS.

DRAFT 30% DWGS - NOT FOR CONSTRUCTION



REV	DATE	BY	DESCRIPTION

WARNING
0 1/2 1
IF THIS BAR DOES NOT MEASURE 1" THEN DRAWING IS NOT TO SCALE.

DESIGNED BY BFY
DRAWN ADP
CHECKED EAN
SCALE NTS

PREPARED BY:
ROBERT G. NATOLI
RCE No.: 78271

DATE

NOT FOR CONSTRUCTION

32395 CLINTON KEITH ROAD, #A-206 WILDOMAR, CA 92595
PHONE: (951) 678-0006 FAX: (909) 354-3482

SOUTH TAHOE PUBLIC UTILITY DISTRICT
1275 MEADOW CREST DRIVE,
SOUTH LAKE TAHOE, CA, 96150

APPROVED: _____ POSITION _____ DATE _____

BIJOU PUMP STATION REHABILITATION PROJECT

ELECTRICAL SINGLE LINE DIAGRAM

DRAWING E-1
SHEET ## OF PROJECT #

Path: C:\Dropbox (TJCAA)\W Drive - CADD From Sharepoint\2022 Projects\122027 - WSC, South Tahoe Bijou PS\122027 - Inst. Filename: I-01.dwg Plot Date: September 12, 2022 - 9:23 AM CADD User: Bee Vue

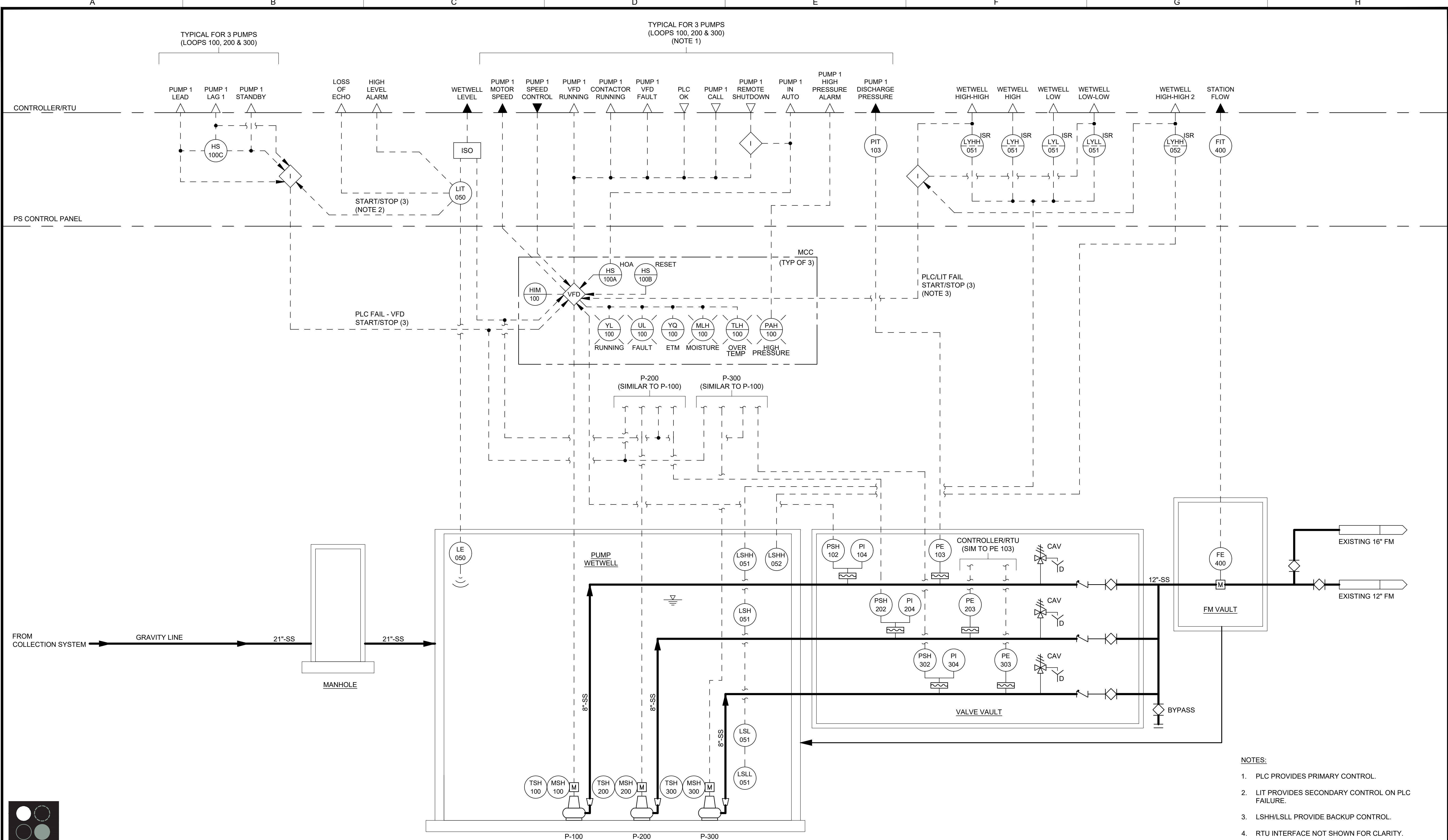

- NOTES:**
1. PLC PROVIDES PRIMARY CONTROL.
 2. LIT PROVIDES SECONDARY CONTROL ON PLC FAILURE.
 3. LSHH/LSLL PROVIDE BACKUP CONTROL.
 4. RTU INTERFACE NOT SHOWN FOR CLARITY.

DRAFT 30% DWGS - NOT FOR CONSTRUCTION

REV	DATE	BY	DESCRIPTION

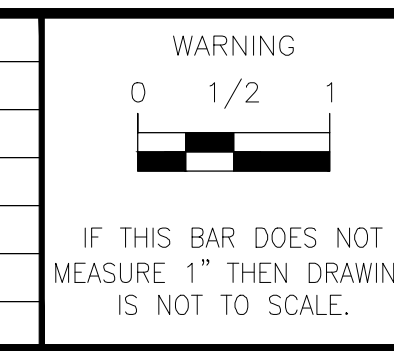

DESIGNED: ADR
 DRAWN: ADP
 CHECKED: MJE
 SCALE: NTS

PREPARED BY: MICHAEL J. ERWIN
 REE No.: 14767
 DATE: _____

32395 CLINTON KEITH ROAD, #A-206 WILDOMAR, CA 92595
 PHONE: (951) 678-0006 FAX: (909) 354-3482

SOUTH TAHOE PUBLIC UTILITY DISTRICT
 1275 MEADOW CREST DRIVE,
 SOUTH LAKE TAHOE, CA, 96150

APPROVED: _____ POSITION _____ DATE _____

BIJOU PUMP STATION REHABILITATION PROJECT

**PROCESS AND INSTRUMENTATION DIAGRAM
 PUMP STATION**

DRAWING 1-1
 SHEET ## OF PROJECT #

Appendix B

30% Construction Cost Estimate



Preliminary Design Opinion of Probable Cost Computation

Project: Bijou Pump Station Rehabilitation	By: AP, KS
Alternative: 30% Design	Reviewed by: RN, JL
Task: AACE Class 4 Cost Estimate	Date: 9/23/2022

DESCRIPTION	QUANTITY	UNITS	UNIT COST	TOTAL COST
Division 01 - General Requirements				
Mobilization/Demobilization	1	LS	7.00%	\$174,600
Bonds and Insurance	1	LS	2.00%	\$47,400
General Conditions	1	LS	3.00%	\$71,800
Shop Drawings and O&M Manuals	1	LS	3.00%	\$71,800
Testing and Startup	1	LS	3.00%	\$71,800
Contractor Overhead subtotal				\$438,000
Division 02 - Site Construction				
Site Work				
Demolish & offhaul portion of existing perimeter wall	65	LF	\$200	\$13,000
Demolish & offhaul paving (AC and concrete)	20	CY	\$40	\$800
Concrete paving inside perimeter wall	760	SF	\$25	\$19,000
AC paving outside perimeter wall	460	SF	\$25	\$11,500
CLSM Fill and abandon 16" FM	25	LF	\$70	\$1,800
CLSM fill dnd abandon 12" FM	90	LF	\$70	\$6,300
Building Rehabilitation				
Demolish shed and odor control equipment	1	LS	\$10,000	\$10,000
Demolish existing concrete ramp and apron	1	LS	\$8,000	\$8,000
Demolish stairs, railing, existing slab	1	LS	\$25,000	\$25,000
Demolish Electrical Equipment	1	LS	\$20,000	\$20,000
Remove pump/metals/equipment from wet well/dry pit	1	LS	\$10,000	\$10,000
Demolish interior pump station wall	1	LS	\$15,000	\$15,000
AC paving outside perimeter wall	460	SF	\$25	\$11,500
Bypassing to Ski-Run or WWTP set up and modifications	1	LS	\$20,000	\$20,000
New Submersible Wet Well and Valve Vault				
Hauling export material	700	CY	\$40	\$28,000
Sheet pile shoring, 25' deep for wet well	2,000	SF	\$70	\$140,000
Sheet pile shoring, 25' deep for manhole	1,000	SF	\$70	\$70,000
Shoring for 21" SS Construction	1,500	SF	\$70	\$105,000
Excavation	900	CY	\$120	\$108,000
Bedding material	20	CY	\$50	\$1,000
Backfill	200	CY	\$80	\$16,000
Realign curb outside wall	1	LS	\$7,500	\$7,500
Dewatering	1	LS	\$120,000	\$120,000
Trash Building Relocation				
Demolish existing trash building	1	LS	\$10,000	\$10,000
Trash building	1	LS	\$83,000	\$83,000
Site Construction Subtotal				\$860,400
Division 03 - Concrete				
Building Rehabilitation				
Extend main room slab	15	CY	\$3,200	\$47,500
Concrete beam support where wall removed	6	CY	\$2,500	\$15,000
Fill dry pit and wet well with low density CLSM	170	CY	\$300	\$51,000
New Submersible Wet Well and Valve Vault				
Precast wet well, 21' deep, 10' ID (polymer conc.)	1	EA	\$140,000	\$140,000
Precast vault, 10' x 8' x 5' (polymer conc.)	1	EA	\$40,000	\$40,000
Precast flow meter vault, 6' x 4' x 5' (polymer conc.)	1	EA	\$20,000	\$20,000
Manhole, 20' deep +/- (polymer conc.)	1	EA	\$35,000	\$35,000
Trash Building Relocation				
Concrete slab on grade	6	CY	\$1,100	\$7,000
Concrete Subtotal				\$355,500
Division 04 - Masonry				
Site Work				
Install CMU new site wall	80	LF	\$450	\$36,000
Masonry Subtotal				\$36,000
Division 05 - Metals				
Miscellaneous metals	1	LS	\$7,500	\$7,500
Metals Subtotal				\$7,500
Division 06 - Wood and Plastic				
Not used				
Wood and Plastic Subtotal				\$0
Division 07 - Thermal and Moisture Protection				
Building Rehabilitation				
Replace wood pergola	1	LS	\$15,000	\$15,000
Rehabilitate Generator building façade (stucco)	1	LS	\$8,000	\$8,000
Rehabilitate pump station building façade (stucco painted)	1	LS	\$10,000	\$10,000
Thermal and Moisture Subtotal				\$33,000
Division 08 - Doors and Windows				
Site Work				
Install 16' slide gate in site wall	1	EA	\$12,000	\$12,000
Building Rehabilitation				
Replace pump station building exterior access doors	2	EA	\$2,500	\$5,000

Replace generator building exterior front access door	1	EA	\$2,500	\$2,500
Replace generator building back access door	1	EA	\$2,500	\$2,500
Replace missing glass blocks	1	LS	\$2,000	\$2,000
Add louvers for ventilation	1	LS	\$10,000	\$10,000
New Submersible Wet Well and Valve Vault				
H-20 traffic rated spring -loaded double leaf hatch, 5' x 8'	1	EA	\$12,696	\$12,700
H-20 traffic rated spring -loaded double leaf hatch, 2' x 2'	1	EA	\$3,726	\$3,800
Doors and Windows Subtotal				\$50,500
Division 09 - Finishes				
Painting and protective coatings (incl building painting)	1	LS	\$15,000	\$15,000
Finishes Subtotal				\$15,000
Division 10 - Specialties				
Not used				
Specialties Subtotal				\$0
Division 11 - Equipment				
New Submersible Wet Well and Valve Vault				
Submersible pumps, 80 HP	3	EA	\$125,000	\$375,000
Equipment Subtotal				\$375,000
Division 12 - Furnishings				
Not used				
Furnishings Subtotal				\$0
Division 13 - Special Construction				
Not used				
Special Construction Subtotal				\$0
Division 14 - Conveying Systems				
Not used				
Conveying Systems Subtotal				\$0
Division 15 - Mechanical				
Building Rehabilitation				
HVAC rehabilitation	1	LS	\$15,000	\$15,000
New Submersible Wet Well and Valve Vault				
3" drain, SDR 35 PVC	15	LF	\$30	\$500
4" drain, SDR 35 PVC	12	LF	\$30	\$400
8" SS, DIP	26	LF	\$120	\$3,100
12" FM, DIP	22	LF	\$180	\$4,000
12" FM, C900 PVC	100	LF	\$100	\$10,000
21" SS, RCP, buried	120	LF	\$180	\$21,600
Duckbill valve, 4", SDR 35 PVC	1	EA	\$500	\$500
Restrained flexible coupling, 8"	6	EA	\$1,000	\$6,000
1" Combination air valve for 8" DIP	3	EA	\$2,000	\$6,000
Dismantling joint, 8", DIP	3	EA	\$2,000	\$6,000
Swing check valve, 8", DIP	3	EA	\$6,400	\$19,200
Plug valve, 8", DIP	3	EA	\$5,000	\$15,000
Tee fitting, 12" x 8", DIP	3	EA	\$4,700	\$14,100
90-degree bend, 12", PVC	1	EA	\$1,000	\$1,000
45-degree bend, 12", PVC	2	EA	\$600	\$1,200
Pipe supports	1	LS	\$7,500	\$7,500
Miscellaneous fittings	1	LS	\$10,000	\$10,000
Mechanical Subtotal				\$141,100
Division 16 - Electrical & Controls				
Security system	1	LS	\$10,000	\$10,000
ATS; 400A, 480V	1	EA	\$20,900	\$20,900
MCC; 400A, 480V	1	EA	\$70,800	\$70,800
VFD; 80 HP	3	EA	\$72,500	\$217,500
Conduit & Wire	1	LS	\$14,500	\$14,500
Flowmeter	3	EA	\$7,000	\$21,000
Float Switches	3	EA	\$1,400	\$4,200
Ultrasonic level transmitter	1	EA	\$3,600	\$3,600
Control Panel	1	LS	\$29,000	\$29,000
Pilot Devices	8	EA	\$800	\$6,400
SCADA Hardware	1	LS	\$7,300	\$7,300
SCADA Software	1	LS	\$7,300	\$7,300
PLC/HMI Programming	1	LS	\$23,200	\$23,200
Telemetry Equipment	1	LS	\$4,300	\$4,300
Antenna Mounting Pole	1	LS	\$4,300	\$4,300
Electrical and Controls Subtotal				\$444,300
Construction Costs Subtotal				\$2,319,000
Constructor Overhead Costs Subtotal				\$438,000
Construction Subtotal				\$2,757,000
Contingency for unknown conditions	25%	PERCENT		\$690,000
Escalation	13.2%	PERCENT		\$364,000
Total Project Cost				\$3,811,000



now



September 9, 2022
South Tahoe Public Utility District's Bijou Pump Station Rehabilitation Project – Permitting Recommendations

Attachment C



United States Department of the Interior



FISH AND WILDLIFE SERVICE
Reno Fish And Wildlife Office
1340 Financial Boulevard, Suite 234
Reno, NV 89502-7147
Phone: (775) 861-6300 Fax: (775) 861-6301

In Reply Refer To:
Project Code: 2022-0071628
Project Name: Bijou Pump Station Rehabilitation Project

August 04, 2022

Subject: List of threatened and endangered species that may occur in your proposed project location or may be affected by your proposed project

To Whom It May Concern:

The enclosed species list identifies threatened, endangered, proposed and candidate species, as well as proposed and final designated critical habitat, that may occur within the boundary of your proposed project and/or may be affected by your proposed project. The species list fulfills the requirements of the U.S. Fish and Wildlife Service (Service) under section 7(c) of the Endangered Species Act (Act) of 1973, as amended (16 U.S.C. 1531 *et seq.*).

New information based on updated surveys, changes in the abundance and distribution of species, changed habitat conditions, or other factors could change this list. Please feel free to contact us if you need more current information or assistance regarding the potential impacts to federally proposed, listed, and candidate species and federally designated and proposed critical habitat. Please note that under 50 CFR 402.12(e) of the regulations implementing section 7 of the Act, the accuracy of this species list should be verified after 90 days. This verification can be completed formally or informally as desired. The Service recommends that verification be completed by visiting the ECOS-IPaC website at regular intervals during project planning and implementation for updates to species lists and information. An updated list may be requested through the ECOS-IPaC system by completing the same process used to receive the enclosed list.

The purpose of the Act is to provide a means whereby threatened and endangered species and the ecosystems upon which they depend may be conserved. Under sections 7(a)(1) and 7(a)(2) of the Act and its implementing regulations (50 CFR 402 *et seq.*), Federal agencies are required to utilize their authorities to carry out programs for the conservation of threatened and endangered species and to determine whether projects may affect threatened and endangered species and/or designated critical habitat.

A Biological Assessment is required for construction projects (or other undertakings having similar physical impacts) that are major Federal actions significantly affecting the quality of the human environment as defined in the National Environmental Policy Act (42 U.S.C. 4332(2)(c)). For projects other than major construction activities, the Service suggests that a biological

evaluation similar to a Biological Assessment be prepared to determine whether the project may affect listed or proposed species and/or designated or proposed critical habitat. Recommended contents of a Biological Assessment are described at 50 CFR 402.12.

If a Federal agency determines, based on the Biological Assessment or biological evaluation, that listed species and/or designated critical habitat may be affected by the proposed project, the agency is required to consult with the Service pursuant to 50 CFR 402. In addition, the Service recommends that candidate species, proposed species and proposed critical habitat be addressed within the consultation. More information on the regulations and procedures for section 7 consultation, including the role of permit or license applicants, can be found in the "Endangered Species Consultation Handbook" at:

<http://www.fws.gov/endangered/esa-library/pdf/TOC-GLOS.PDF>

Migratory Birds: In addition to responsibilities to protect threatened and endangered species under the Endangered Species Act (ESA), there are additional responsibilities under the Migratory Bird Treaty Act (MBTA) and the Bald and Golden Eagle Protection Act (BGEPA) to protect native birds from project-related impacts. Any activity, intentional or unintentional, resulting in take of migratory birds, including eagles, is prohibited unless otherwise permitted by the U.S. Fish and Wildlife Service (50 C.F.R. Sec. 10.12 and 16 U.S.C. Sec. 668(a)). For more information regarding these Acts see <https://www.fws.gov/birds/policies-and-regulations.php>.

The MBTA has no provision for allowing take of migratory birds that may be unintentionally killed or injured by otherwise lawful activities. It is the responsibility of the project proponent to comply with these Acts by identifying potential impacts to migratory birds and eagles within applicable NEPA documents (when there is a federal nexus) or a Bird/Eagle Conservation Plan (when there is no federal nexus). Proponents should implement conservation measures to avoid or minimize the production of project-related stressors or minimize the exposure of birds and their resources to the project-related stressors. For more information on avian stressors and recommended conservation measures see <https://www.fws.gov/birds/bird-enthusiasts/threats-to-birds.php>.

In addition to MBTA and BGEPA, Executive Order 13186: *Responsibilities of Federal Agencies to Protect Migratory Birds*, obligates all Federal agencies that engage in or authorize activities that might affect migratory birds, to minimize those effects and encourage conservation measures that will improve bird populations. Executive Order 13186 provides for the protection of both migratory birds and migratory bird habitat. For information regarding the implementation of Executive Order 13186, please visit <https://www.fws.gov/birds/policies-and-regulations/executive-orders/e0-13186.php>.

We appreciate your concern for threatened and endangered species. The Service encourages Federal agencies to include conservation of threatened and endangered species into their project planning to further the purposes of the Act. Please include the Consultation Code in the header of this letter with any request for consultation or correspondence about your project that you submit to our office.

Attachment(s):

- Official Species List
 - USFWS National Wildlife Refuges and Fish Hatcheries
 - Migratory Birds
 - Wetlands
-

Official Species List

This list is provided pursuant to Section 7 of the Endangered Species Act, and fulfills the requirement for Federal agencies to "request of the Secretary of the Interior information whether any species which is listed or proposed to be listed may be present in the area of a proposed action".

This species list is provided by:

Reno Fish And Wildlife Office

1340 Financial Boulevard, Suite 234

Reno, NV 89502-7147

(775) 861-6300

Project Summary

Project Code: 2022-0071628

Project Name: Bijou Pump Station Rehabilitation Project

Project Type: Utility Infrastructure Maintenance

Project Description: The project involves rehabilitating an existing STPUD pump station in order to address concerns regarding health and safety, structural integrity, and station reliability. No increase in capacity will occur.

Project Location:

Approximate location of the project can be viewed in Google Maps: <https://www.google.com/maps/@38.950014350000004,-119.95569752563888,14z>



Counties: El Dorado County, California

Endangered Species Act Species

There is a total of 6 threatened, endangered, or candidate species on this species list.

Species on this list should be considered in an effects analysis for your project and could include species that exist in another geographic area. For example, certain fish may appear on the species list because a project could affect downstream species.

IPaC does not display listed species or critical habitats under the sole jurisdiction of NOAA Fisheries¹, as USFWS does not have the authority to speak on behalf of NOAA and the Department of Commerce.

See the "Critical habitats" section below for those critical habitats that lie wholly or partially within your project area under this office's jurisdiction. Please contact the designated FWS office if you have questions.

1. [NOAA Fisheries](#), also known as the National Marine Fisheries Service (NMFS), is an office of the National Oceanic and Atmospheric Administration within the Department of Commerce.

Mammals

NAME	STATUS
North American Wolverine <i>Gulo gulo luscus</i> No critical habitat has been designated for this species. Species profile: https://ecos.fws.gov/ecp/species/5123	Proposed Threatened
Sierra Nevada Red Fox <i>Vulpes vulpes necator</i> Population: No critical habitat has been designated for this species. Species profile: https://ecos.fws.gov/ecp/species/4252	Endangered

Amphibians

NAME	STATUS
Sierra Nevada Yellow-legged Frog <i>Rana sierrae</i> There is final critical habitat for this species. The location of the critical habitat is not available. Species profile: https://ecos.fws.gov/ecp/species/9529	Endangered

Fishes

NAME	STATUS
Lahontan Cutthroat Trout <i>Oncorhynchus clarkii henshawi</i> No critical habitat has been designated for this species. Species profile: https://ecos.fws.gov/ecp/species/3964	Threatened

Insects

NAME	STATUS
Monarch Butterfly <i>Danaus plexippus</i> No critical habitat has been designated for this species. Species profile: https://ecos.fws.gov/ecp/species/9743	Candidate

Conifers and Cycads

NAME	STATUS
Whitebark Pine <i>Pinus albicaulis</i> No critical habitat has been designated for this species. Species profile: https://ecos.fws.gov/ecp/species/1748	Proposed Threatened

Critical habitats

THERE ARE NO CRITICAL HABITATS WITHIN YOUR PROJECT AREA UNDER THIS OFFICE'S JURISDICTION.

USFWS National Wildlife Refuge Lands And Fish Hatcheries

Any activity proposed on lands managed by the [National Wildlife Refuge](#) system must undergo a 'Compatibility Determination' conducted by the Refuge. Please contact the individual Refuges to discuss any questions or concerns.

THERE ARE NO REFUGE LANDS OR FISH HATCHERIES WITHIN YOUR PROJECT AREA.

Migratory Birds

Certain birds are protected under the Migratory Bird Treaty Act¹ and the Bald and Golden Eagle Protection Act².

Any person or organization who plans or conducts activities that may result in impacts to migratory birds, eagles, and their habitats should follow appropriate regulations and consider implementing appropriate conservation measures, as described [below](#).

-
1. The [Migratory Birds Treaty Act](#) of 1918.
 2. The [Bald and Golden Eagle Protection Act](#) of 1940.
 3. 50 C.F.R. Sec. 10.12 and 16 U.S.C. Sec. 668(a)

The birds listed below are birds of particular concern either because they occur on the [USFWS Birds of Conservation Concern \(BCC\)](#) list or warrant special attention in your project location. To learn more about the levels of concern for birds on your list and how this list is generated, see the FAQ [below](#). This is not a list of every bird you may find in this location, nor a guarantee that every bird on this list will be found in your project area. To see exact locations of where birders and the general public have sighted birds in and around your project area, visit the [E-bird data mapping tool](#) (Tip: enter your location, desired date range and a species on your list). For projects that occur off the Atlantic Coast, additional maps and models detailing the relative occurrence and abundance of bird species on your list are available. Links to additional information about Atlantic Coast birds, and other important information about your migratory bird list, including how to properly interpret and use your migratory bird report, can be found [below](#).

For guidance on when to schedule activities or implement avoidance and minimization measures to reduce impacts to migratory birds on your list, click on the PROBABILITY OF PRESENCE SUMMARY at the top of your list to see when these birds are most likely to be present and breeding in your project area.

NAME	BREEDING SEASON
Bald Eagle <i>Haliaeetus leucocephalus</i> This is not a Bird of Conservation Concern (BCC) in this area, but warrants attention because of the Eagle Act or for potential susceptibilities in offshore areas from certain types of development or activities. https://ecos.fws.gov/ecp/species/1626	Breeds Jan 1 to Aug 31
Black-throated Gray Warbler <i>Dendroica nigrescens</i> This is a Bird of Conservation Concern (BCC) only in particular Bird Conservation Regions (BCRs) in the continental USA	Breeds May 1 to Jul 20

NAME	BREEDING SEASON
<p>Cassin's Finch <i>Carpodacus cassinii</i> This is a Bird of Conservation Concern (BCC) throughout its range in the continental USA and Alaska. https://ecos.fws.gov/ecp/species/9462</p>	Breeds May 15 to Jul 15
<p>Clark's Grebe <i>Aechmophorus clarkii</i> This is a Bird of Conservation Concern (BCC) throughout its range in the continental USA and Alaska.</p>	Breeds Jun 1 to Aug 31
<p>Evening Grosbeak <i>Coccothraustes vespertinus</i> This is a Bird of Conservation Concern (BCC) throughout its range in the continental USA and Alaska.</p>	Breeds May 15 to Aug 10
<p>Golden Eagle <i>Aquila chrysaetos</i> This is not a Bird of Conservation Concern (BCC) in this area, but warrants attention because of the Eagle Act or for potential susceptibilities in offshore areas from certain types of development or activities. https://ecos.fws.gov/ecp/species/1680</p>	Breeds Dec 1 to Aug 31
<p>Lawrence's Goldfinch <i>Carduelis lawrencei</i> This is a Bird of Conservation Concern (BCC) throughout its range in the continental USA and Alaska. https://ecos.fws.gov/ecp/species/9464</p>	Breeds Mar 20 to Sep 20
<p>Lewis's Woodpecker <i>Melanerpes lewis</i> This is a Bird of Conservation Concern (BCC) throughout its range in the continental USA and Alaska. https://ecos.fws.gov/ecp/species/9408</p>	Breeds Apr 20 to Sep 30
<p>Long-eared Owl <i>asio otus</i> This is a Bird of Conservation Concern (BCC) throughout its range in the continental USA and Alaska. https://ecos.fws.gov/ecp/species/3631</p>	Breeds Mar 1 to Jul 15
<p>Olive-sided Flycatcher <i>Contopus cooperi</i> This is a Bird of Conservation Concern (BCC) throughout its range in the continental USA and Alaska. https://ecos.fws.gov/ecp/species/3914</p>	Breeds May 20 to Aug 31
<p>Western Grebe <i>aechmophorus occidentalis</i> This is a Bird of Conservation Concern (BCC) throughout its range in the continental USA and Alaska. https://ecos.fws.gov/ecp/species/6743</p>	Breeds Jun 1 to Aug 31
<p>Willet <i>Tringa semipalmata</i> This is a Bird of Conservation Concern (BCC) throughout its range in the continental USA and Alaska.</p>	Breeds Apr 20 to Aug 5

Probability Of Presence Summary

The graphs below provide our best understanding of when birds of concern are most likely to be present in your project area. This information can be used to tailor and schedule your project activities to avoid or minimize impacts to birds. Please make sure you read and understand the FAQ "Proper Interpretation and Use of Your Migratory Bird Report" before using or attempting to interpret this report.

Probability of Presence (■)

Each green bar represents the bird's relative probability of presence in the 10km grid cell(s) your project overlaps during a particular week of the year. (A year is represented as 12 4-week months.) A taller bar indicates a higher probability of species presence. The survey effort (see below) can be used to establish a level of confidence in the presence score. One can have higher confidence in the presence score if the corresponding survey effort is also high.

How is the probability of presence score calculated? The calculation is done in three steps:

1. The probability of presence for each week is calculated as the number of survey events in the week where the species was detected divided by the total number of survey events for that week. For example, if in week 12 there were 20 survey events and the Spotted Towhee was found in 5 of them, the probability of presence of the Spotted Towhee in week 12 is 0.25.
2. To properly present the pattern of presence across the year, the relative probability of presence is calculated. This is the probability of presence divided by the maximum probability of presence across all weeks. For example, imagine the probability of presence in week 20 for the Spotted Towhee is 0.05, and that the probability of presence at week 12 (0.25) is the maximum of any week of the year. The relative probability of presence on week 12 is $0.25/0.25 = 1$; at week 20 it is $0.05/0.25 = 0.2$.
3. The relative probability of presence calculated in the previous step undergoes a statistical conversion so that all possible values fall between 0 and 10, inclusive. This is the probability of presence score.

Breeding Season (■)

Yellow bars denote a very liberal estimate of the time-frame inside which the bird breeds across its entire range. If there are no yellow bars shown for a bird, it does not breed in your project area.

Survey Effort (|)

Vertical black lines superimposed on probability of presence bars indicate the number of surveys performed for that species in the 10km grid cell(s) your project area overlaps. The number of surveys is expressed as a range, for example, 33 to 64 surveys.

No Data (-)

A week is marked as having no data if there were no survey events for that week.

Survey Timeframe

Additional information can be found using the following links:

- Birds of Conservation Concern <https://www.fws.gov/program/migratory-birds/species>
- Measures for avoiding and minimizing impacts to birds <https://www.fws.gov/library/collections/avoiding-and-minimizing-incident-take-migratory-birds>
- Nationwide conservation measures for birds <https://www.fws.gov/sites/default/files/documents/nationwide-standard-conservation-measures.pdf>

Migratory Birds FAQ

Tell me more about conservation measures I can implement to avoid or minimize impacts to migratory birds.

[Nationwide Conservation Measures](#) describes measures that can help avoid and minimize impacts to all birds at any location year round. Implementation of these measures is particularly important when birds are most likely to occur in the project area. When birds may be breeding in the area, identifying the locations of any active nests and avoiding their destruction is a very helpful impact minimization measure. To see when birds are most likely to occur and be breeding in your project area, view the Probability of Presence Summary. [Additional measures](#) or [permits](#) may be advisable depending on the type of activity you are conducting and the type of infrastructure or bird species present on your project site.

What does IPaC use to generate the list of migratory birds that potentially occur in my specified location?

The Migratory Bird Resource List is comprised of USFWS [Birds of Conservation Concern \(BCC\)](#) and other species that may warrant special attention in your project location.

The migratory bird list generated for your project is derived from data provided by the [Avian Knowledge Network \(AKN\)](#). The AKN data is based on a growing collection of [survey, banding, and citizen science datasets](#) and is queried and filtered to return a list of those birds reported as occurring in the 10km grid cell(s) which your project intersects, and that have been identified as warranting special attention because they are a BCC species in that area, an eagle ([Eagle Act](#) requirements may apply), or a species that has a particular vulnerability to offshore activities or development.

Again, the Migratory Bird Resource list includes only a subset of birds that may occur in your project area. It is not representative of all birds that may occur in your project area. To get a list of all birds potentially present in your project area, please visit the [Rapid Avian Information Locator \(RAIL\) Tool](#).

What does IPaC use to generate the probability of presence graphs for the migratory birds potentially occurring in my specified location?

The probability of presence graphs associated with your migratory bird list are based on data provided by the [Avian Knowledge Network \(AKN\)](#). This data is derived from a growing collection of [survey, banding, and citizen science datasets](#).

Probability of presence data is continuously being updated as new and better information becomes available. To learn more about how the probability of presence graphs are produced and

how to interpret them, go the Probability of Presence Summary and then click on the "Tell me about these graphs" link.

How do I know if a bird is breeding, wintering or migrating in my area?

To see what part of a particular bird's range your project area falls within (i.e. breeding, wintering, migrating or year-round), you may query your location using the [RAIL Tool](#) and look at the range maps provided for birds in your area at the bottom of the profiles provided for each bird in your results. If a bird on your migratory bird species list has a breeding season associated with it, if that bird does occur in your project area, there may be nests present at some point within the timeframe specified. If "Breeds elsewhere" is indicated, then the bird likely does not breed in your project area.

What are the levels of concern for migratory birds?

Migratory birds delivered through IPaC fall into the following distinct categories of concern:

1. "BCC Rangewide" birds are [Birds of Conservation Concern](#) (BCC) that are of concern throughout their range anywhere within the USA (including Hawaii, the Pacific Islands, Puerto Rico, and the Virgin Islands);
2. "BCC - BCR" birds are BCCs that are of concern only in particular Bird Conservation Regions (BCRs) in the continental USA; and
3. "Non-BCC - Vulnerable" birds are not BCC species in your project area, but appear on your list either because of the [Eagle Act](#) requirements (for eagles) or (for non-eagles) potential susceptibilities in offshore areas from certain types of development or activities (e.g. offshore energy development or longline fishing).

Although it is important to try to avoid and minimize impacts to all birds, efforts should be made, in particular, to avoid and minimize impacts to the birds on this list, especially eagles and BCC species of rangewide concern. For more information on conservation measures you can implement to help avoid and minimize migratory bird impacts and requirements for eagles, please see the FAQs for these topics.

Details about birds that are potentially affected by offshore projects

For additional details about the relative occurrence and abundance of both individual bird species and groups of bird species within your project area off the Atlantic Coast, please visit the [Northeast Ocean Data Portal](#). The Portal also offers data and information about other taxa besides birds that may be helpful to you in your project review. Alternately, you may download the bird model results files underlying the portal maps through the [NOAA NCCOS Integrative Statistical Modeling and Predictive Mapping of Marine Bird Distributions and Abundance on the Atlantic Outer Continental Shelf](#) project webpage.

Bird tracking data can also provide additional details about occurrence and habitat use throughout the year, including migration. Models relying on survey data may not include this information. For additional information on marine bird tracking data, see the [Diving Bird Study](#) and the [nanotag studies](#) or contact [Caleb Spiegel](#) or [Pam Loring](#).

What if I have eagles on my list?

If your project has the potential to disturb or kill eagles, you may need to [obtain a permit](#) to avoid violating the Eagle Act should such impacts occur.

Proper Interpretation and Use of Your Migratory Bird Report

The migratory bird list generated is not a list of all birds in your project area, only a subset of birds of priority concern. To learn more about how your list is generated, and see options for identifying what other birds may be in your project area, please see the FAQ "What does IPaC use to generate the migratory birds potentially occurring in my specified location". Please be aware this report provides the "probability of presence" of birds within the 10 km grid cell(s) that overlap your project; not your exact project footprint. On the graphs provided, please also look carefully at the survey effort (indicated by the black vertical bar) and for the existence of the "no data" indicator (a red horizontal bar). A high survey effort is the key component. If the survey effort is high, then the probability of presence score can be viewed as more dependable. In contrast, a low survey effort bar or no data bar means a lack of data and, therefore, a lack of certainty about presence of the species. This list is not perfect; it is simply a starting point for identifying what birds of concern have the potential to be in your project area, when they might be there, and if they might be breeding (which means nests might be present). The list helps you know what to look for to confirm presence, and helps guide you in knowing when to implement conservation measures to avoid or minimize potential impacts from your project activities, should presence be confirmed. To learn more about conservation measures, visit the FAQ "Tell me about conservation measures I can implement to avoid or minimize impacts to migratory birds" at the bottom of your migratory bird trust resources page.

Wetlands

Impacts to [NWI wetlands](#) and other aquatic habitats may be subject to regulation under Section 404 of the Clean Water Act, or other State/Federal statutes.

For more information please contact the Regulatory Program of the local [U.S. Army Corps of Engineers District](#).

Please note that the NWI data being shown may be out of date. We are currently working to update our NWI data set. We recommend you verify these results with a site visit to determine the actual extent of wetlands on site.

THERE ARE NO WETLANDS WITHIN YOUR PROJECT AREA.

IPaC User Contact Information

Agency: Cardno now Stantec

Name: Julia Beals

Address: 5496 Reno Corporate Drive

City: Reno

State: NV

Zip: 89511

Email: juliabeals93@gmail.com

Phone: 8587758008
