

# Appendix D

---

Geotechnical Assessments

May 5, 2012

W.O. 430412-01

Mr. and Mrs. Shen  
26810 Fond du Lac Road  
Rancho Palos Verdes, CA 90275

Subject: Preliminary Geologic Investigation of Proposed  
Residence at #77 Portuguese Bend Road, Rolling  
Hills, California

Mr. and Mrs. Shen:

Pursuant to your request, a preliminary geologic investigation has been performed at the subject site. The purposes of the investigation were to determine the general geologic characteristics of the near surface earth materials and to provide geologic opinion on the suitability of the parcel for the proposed site improvements.

The opinions and recommendations contained in this report are based upon our understanding of the proposed project and analyses of the geologic data obtained from our field program, area reconnaissance, and review of available geologic reports and maps.

This report completes our scope of geologic engineering services outlined in our proposal dated October 29, 2011.

### **PROPOSED DEVELOPMENT**

Our understanding of the project is that the parcel will be developed with a single family residence, hardscape, and landscape. Minimal grading is anticipated to provide an improved access drive and a building pad. Specific site plans and architectural plans have not yet been prepared.

The intent of the client is and this report is to obtain approval in concept only.

### **WORK SCOPE**

Our work scope for the project included the following:

- Review of available previous site geologic reports.
- Reconnaissance of site and area.
- Logging of exploratory borings.
- Preparation of this report.

### **SITE DESCRIPTION**

The project site is identified as #77 Portuguese Bend Road in the City of Rolling Hills, California and is shown on the Site Vicinity Map, Figure 1. The APN for the property is 7567-013-005.

The parcel is composed of about twenty acres of unimproved land found west of Crest Road at the southern terminus of Portuguese Bend Road. The site is roughly bounded by Burma Road to the east, developed residential parcels to the north, a canyon to the west, and open space to the south.

The parcel is accessed off the southern terminus of Portuguese Bend Road via an unpaved semi improved access drive that is between #73 and #74 Portuguese Bend Road. The access drive continues onto and through the property and is labeled offsite as Burma Road. Within the property various dirt roads and paths transect the property.

The parcel generally slopes downward to the southwest with moderate to gentle gradients, with localized steepened slopes along adjacent canyon walls, as access drive cuts, and within landslide head scarps.

The site shows moderate to heavy growth of brush and grasses.

## REPORT REVIEW

Records were requested at the County of Los Angeles for the subject site and those nearby. Records were requested for 65, 67, 69, 71, 73, 74, and 77 Portuguese Bend Road, 1, 3, 4, and 6 and Running Brand, and County reports for Flying Triangle Landslide or Flying Triangle Annex on February 5, 2012. The County located records for 71 and 73 Portuguese Bend Road and for 1, 3 and 6 Running Brand. A look through these files did not find geologic information considered useful for preparation of this report.

Readers of this report are advised that a record research is not an exact science; it is limited by time and resource constraints, incomplete records, ability of custodian of records to locate files, and where records are located is only a limited interpretation of other consultant's work. Readers of this report should perform their own review of County records to arrive at their own interpretations and conclusions.

Records reviewed in house were as follows;

*Geologic and Soil Investigation, Flying Triangle Extension, Rolling Hills, by Converse Consultants, dated November 10, 1978.* This report addressed the subdivision of the subject lot. This report found the proposed project feasible within the contents of the report. Several landslides were identified within the report with mitigation recommended to achieve buildable conditions. Boring logs and test pit logs from the Converse report are included in Appendix A of this report and are located on our appended geologic map, Figure 3.

*Potion of a County report prepared on the Flying Triangle Landslide and the accompanying geologic map.* The report appears to have been generated to address active Flying Triangle Landslide movement that started to occur in early 1980. The report asserts that active landslide movement occurred within an ancient landslide but not along the same plane. The geologic map prepared by the County for this report has been utilized as the base map for our report and is appended as Figure 3. We were unable to locate any geologic sections shown on the map.

Other records reviewed consisted of Survey Monitoring Reports conducted by the City of Rancho Palos Verdes attached in Appendix B. Along section A-A' just outside the property line is RPV survey point FT08. This survey point and others are shown in relationship to the subject site on a map in Appendix B, along with survey data. This date indicates that survey point FT08 has no movement, which suggests the area has been stable.

## REGIONAL GEOLOGY

Rolling Hills is located within a geographic area known as the Palos Verdes Peninsula. The peninsula's regional geology is a series of sub-parallel synclinal and anticlinal folds and minor faults formed by uplift and deformation south of the Palos Verdes Fault. As uplift progressed, changes in sea level caused wave eroded benches to be cut into the peninsula flanks. As uplift continued geomorphic processes occurred resulting in present day landforms.

A regional geology map, by Thomas Dibblee, is presented on Figure 2. The regional geology map by Dibblee does indicate portions of the subject site to be within the active Flying Triangle Landslide.

A portion of the Landslide Inventory Map for the Palos Verdes Peninsula is attached as Figure 2.1. This map shows landslide masses similar to Dibblee's; although, differences in landslide geometry do occur between the two maps and the Landslide Inventory Map shows a small dormant landslide between the two lower lobes of the Flying Triangle Landslide.

## EXPLORATION

Site exploration locations were determined based on regional geology, historic movement of the Flying Triangle Landslide, and the client's wish to build only one house, with exploration performed in areas of the property which were considered buildable.

Potential buildable portions of the site were explored by placement of five exploratory borings placed by a truck mounted drill rig or a track mounted drill rig at the approximate locations shown on Figure 3. A certified engineering geologist logged the borings.

The borings were drilled to the limits of the rig's capabilities or to a depth where refusal was met.

## SITE LITHOLOGY

Our understanding of the site lithology was developed through review of previous area work, site reconnaissance and logging of the exploratory borings. The site is underlain by unmapped artificial fill and colluvium, terrace deposits, bedrock, and landslide materials.

Artificial fill (Af) is found onsite as side cast fills along paths, drives, and roads. The fills are anticipated to consist of locally derived earth materials and to be unacceptable for support of future structures or additional fills.

Recent landslide materials (Ql) are anticipated to consist of disoriented blocks of Monterey formation in a clayey matrix and some basalt, and to be unacceptable for support of structure or fill.

Colluvium (Qc) encountered consisted of dark gray to black silty clay, diatomaceous, with small to cobble sized bedrock fragments, firm to stiff and damp to moist, surficially porous and desiccated. The material covers most of the site and is unmapped.

Terrace deposits (Qt) were encountered in some borings and consisted of tan brown silty sand, clay, stiff with abundant angular to rounded small rock fragments.

Monterey bedrocks (Tm) observed in the exploratory borings consisted of layered buff, tan, white, grey, diatomaceous siltstone, clayey siltstone, and claystone, thin to thick bedded, slightly firm to hard, moist to very moist; black gray to red brown silty sandstone, firm to hard, and well spaced beds of siliceous siltstone. Some bedrock zones exhibited strong fracturing. Zones of secondary crystallization and gypsum along beds and as inclusions were observed. Some seams of white yellow clay with black inclusions were observed.

Basalt bedrocks (Tb) encountered consisted of brown to oxidized brown medium to coarse grained intrusive rock, weathered to fresh, with occasional gypsum vein.

Offsite exposures of bedrock consisted of Monterey formation with similar lithology as that exposed in the borings, and intrusive basalts. The basalts were observed in the canyon side wall, and become more predominate toward Burma Road.

Exploratory logs by Coast Geotechnical, Inc. are presented on Plates A through E. Future excavations, at other locations, could expose different subsurface conditions than those interpreted and shown within this report.

## **GROUNDWATER**

Groundwater was not observed in the borings logged or observed on the nearby canyon sidewalls.

## **GEOLOGIC DISCUSSION**

### **Structure**

Site geology is presented on Figure 3. The base map utilized is from the County report on the Flying Triangle Landslide and shows a compilation of geologic data from their files and site work. Their interpretation of geologic units and boundaries is still representative for the intent of our report. The base map has been modified with inclusion of our site exploration and geologic sections. Critical geologic cross section A-A', B-B', and C-C' are presented on Figures 4.1 and 4.2. The orientation and location of the geologic sections was chosen based on slope conditions, geologic structure, and opinioned favorable buildable conditions. The site geology map and geologic cross sections are general representations of geologic conditions based on available maps, our site observations, and limited site exploration. These figures shall not be taken as dimensioned surveys. Actual field conditions encountered during construction could differ.

Bedrock structure exposed in the site explorations and within offsite bedrock outcrops shows a regional northwest-southeast strike with a southwesterly dip. This regional dip is locally altered with synclinal and anticlinal folding which is prevalent along the ridge in line with section A-A', and depicted in Section C-C'.

Bedrock bedding shows variable orientations to the canyon wall southeast of BH1, BH2 and BH3 with some out of slope bedding component. This is shown in Section C-C'.

Within Boring 5 a clay seam was identified at twenty feet that could be the contact of the dormant landslide identified on Figure 2.1. landslide. Based on geologic structure this plane would not daylight down slope.

Offsite to the southwest is located the historically active Portuguese Bend Landslide which continues to the beach below.

The soils engineer's stability analysis will need to address these geologic conditions.

Based on the geologic structure interpreted from our site work the ridge line along section A-A' is the most geologically favorable for construction of a residence.

### Landslides

Based on review of available data our opinion is that portions of the subject site have been affected by global ancient and recent land movement and other portions do not show any recent movement.

Active landslides have been shown on Figure 3 as Qls. These landslides have recorded historic movement, are visibly identifiable, and are well documented. These areas will most likely continue to experience some magnitude of movement and, as such, development is not proposed in these areas.

The area around BH5 is opionioned to be a dormant ancient landslide that has no recorded movement and shows no visible characteristics of recent movement. This area could probably be built on but would require addition exploration to address geologic stability.

Converse Consultants within their report showed the ridge along Section A-A' to be a landslide. Our opinion is that they misinterpreted subsurface and surface conditions, and that the area is not a landslide, but rather wave cut terraces and terrace deposits. Our opinion is supported by our logging of subsurface conditions, regional maps not showing the area as landslide, the area not showing as landslide on the County map prepared for the area, and the stable RPV survey point.

A portion of the access drive is within the Flying Triangle Landslide. This portion of the drive, which appears to be predominantly offsite, will be subject to unknown movement and future distress. The issue of accessing a building site across a landslide can be significant and is largely dependent on County approval. This issue should be addressed by the client or his agent at the earliest planning stage. Utilities through this section should be above ground and constructed in a manner similar to other areas within the landslide.

### **SEISMICITY**

Southern California is located in an active seismic region. Moderate to strong earthquakes can occur on numerous local faults. The United States Geological Survey, California Division of Mines and Geology, private consultants, and universities have been studying earthquakes in Southern California for several decades. Early studies were directed toward earthquake prediction and estimation of the effects of strong ground shaking. Studies indicate that earthquake prediction is not practical and not sufficiently accurate to benefit the general public. Governmental agencies are shifting their focus to earthquake resistant structures as opposed to prediction. The purpose of the code seismic design parameters is to prevent collapse during strong ground shaking. Cosmetic damage should be expected.

Within the past 37 years, Southern California and vicinity have experienced an increase in seismic activity beginning with the San Fernando earthquake in 1971. In 1987, a moderate earthquake struck the Whittier area and was located on a previously unknown fault. Ground shaking from this event caused substantial damage to the City of Whittier and surrounding cities. The January 17, 1994, Northridge

earthquake was initiated along a previously unrecognized fault below the San Fernando Valley. The energy released by the earthquake propagated to the southeast, northwest, and northeast in the form of shear and compression waves, which caused the strong ground shaking in portions of the San Fernando Valley, Santa Monica Mountains, Simi Valley, City of Santa Clarita, and City of Santa Monica.

Southern California faults are classified as: active, potentially active, or inactive. Faults from past geologic periods of mountain building that do not display any evidence of recent offset, are considered "inactive or potentially active". Faults that have historically produced earthquakes or show evidence of movement within the past 11,000 years are known as "active faults". The site is not within an Alquist Priolo Zone as shown on DMG CD 2000-03

The Palos Verdes fault is located northeast of the subject site and is generally described in terms of three individual segments, namely the San Pedro Bay, the on-shore, and the Santa Monica Bay segments (Ziony, 1985). All segments are believed to possess a reverse or reverse right oblique sense of motion. References reviewed as part of this report indicate that sedimentary materials; however, evidence for Holocene activity along the on-shore and Santa Monica Bay segments is currently in dispute. Nonetheless, in light of the increased amount of seismicity that has been attributed to the Santa Monica Bay segment, the Palos Verdes Hills fault has been classified as active.

The principal seismic hazard to the subject property and proposed project is strong ground shaking from earthquakes produced by local faults. It is likely that future earthquakes produced in Southern California will shake the subject property. Secondary effects such as surface rupture, liquefaction, or seismic induced flooding are not considered likely.

## SEISMIC HAZARDS

Based on the Seismic Hazard Zone Map published by the State of California, San Pedro Quadrangles, appended as Figure 5, the site is not mapped as being subject to potential seismic induced hazards.

During earthquakes, major destruction of various types of structures has occurred due to the creation of fissures, abnormal and/or unequal movement, and loss of strength or stiffness of the ground. The loss of strength or stiffness of ground may result in the settlement of buildings, failure of earth dams, landslides and other hazards. The process by which loss of strength in soil occurs is called liquefaction. The phenomenon of soil liquefaction is primarily associated with medium to fine grained, saturated, cohesionless soils (sand and silts). The site is underlain by cohesive soils and near surface bedrock and is judged to have a negligible potential for liquefaction-induced hazards.

Earthquake-induced landslide zones were delineated by the State of California using criteria adopted by the California State Mining and Geology Board. Under those criteria, earthquake-induced landslide zones are areas meeting one or more of the following:

1. Areas known to have experienced earthquake-induced slope failure during historic earthquakes.
2. Areas identified as having past landslide movement, including both landslide deposits and source areas.
3. Areas where CDMG's analyses of geologic and geotechnical data indicate that the geologic materials are susceptible to earthquake-induced slope failure.

The soils engineer shall consider these factors, and those presented within this report, in his stability analysis of the site and offsite slope.

## **DRAINAGE**

Existing drainage is uncontrolled. The civil engineer shall devise a drainage plan to comply with local and state guidelines for control and disposal of site surface waters and to minimize adverse effects to site and offsite property. Site waters shall not be allowed to drain over the top of slope or onto the slope.

## **CONCLUSIONS AND RECOMMENDATIONS**

The following conclusions and recommendations are based on our current understanding of the project and are subject to change or modification as the project evolves and/or additional data is obtained.

Based on our geologic assessment of the property the most suitable location for the proposed residence is the ridge along section A-A'. This assessment is tentative subject to review of future grading and site development plans. The client and design consultants are advised that this area is best suited for a small residence with minimal grading. Any variance from this could affect the area in a negative manner.

The proposed development is not anticipated to have an adverse affect, from a geologic perspective, on adjacent sites and vice versa provided our and other design consultant's guidelines, building codes, and construction standards are followed.

Recommendations for the project follow.

## **EARTHWORK**

Potential earthwork may consist of cuts and fills, foundation excavations, removal and recompaction for slab support, possible grading for foundation support, and preparation of hardscape subgrade.

Assumed earthwork is feasible from a geologic viewpoint with the following comments.

- Excavations may encounter hard bedrock which may require heavy equipment to remove or coring to penetrate.
- Existing fills and native earth materials, which are to provide support for foundations, hardscape, interior slabs, or additional fills shall be reworked to the satisfaction of the soils engineer.
- Foundations may derive support from competent bedrock or terrace deposits as determined by the soils engineer. Where foundations are supported by bedrocks the project geologist shall observe the excavations to verify adequate conditions.
- Site soils are expansive in nature and shall be evaluated by the soils engineer for potential impact on site improvements.



## **SLOPE CONSTRUCTION**

The site should be designed to minimize and or avoid any slope construction. Where slope construction is approved by the soils engineer as not affecting site stability the following guidelines shall be followed.

Fill slope construction will require a keyway dimensioned per the recommendations of the soils engineer. At a minimum the keyway shall have at least two feet of embedment into competent bedrock at the toe. The project geologist shall field determine competent bedrock at the time of grading. The keyway shall be sloped back toward the heel. The keyway excavation requires the approval of the project geologist, soils engineer, and County grading inspector prior to placement of fill.

As the fill slope is constructed the fills shall be benched into competent bedrock.

Proper keyway subdrains, back drains, and outlets shall be installed per the direction of the soils engineer and grading plan.

Any cut slopes shall be rebuilt as fill slopes utilizing the previous guidelines. The rebuilt slopes may be constructed as skin fills or stabilization fills depending on analysis of the soils engineer.

## **FOUNDATIONS**

The soils engineer shall determine the bearing material for proposed foundations.

Where foundations are placed into bedrock or drilled caissons utilized the project geologist shall log the excavations and incorporate the geologic information into the final as built geologic map for the project.

## **EXPANSIVE EARTH MATERIALS**

Site earth materials are expansive in nature. These earth materials will experience changes in volume as wetting and drying cycles occur. While proper design and construction can reduce the effects of these wetting and drying cycles on brittle building materials, cracking will occur and should be expected. The soils engineer shall provide recommendations to minimize the effects of expansive soils on site improvements.

## **CREEP FORCE**

The soils engineer shall evaluate site slopes for creep force and provide appropriate recommendations.

## **FOUNDATION SETBACKS**

Foundations shall maintain a horizontal setback as measured from the outside footing edge horizontally to a competent slope surface, of  $H/3$ , where H is the slope height. Minimum setback shall be five feet. Maximum setback shall be forty feet. Based on slope heights exceeding 120 feet, the horizontal setback shall be forty feet.

Additional setbacks could be dictated by the soils engineer based on stability analysis of the site slope. The soil engineer shall specify any needed setbacks from a theoretical 1.5 factor of safety line.

## **CONSTRUCTION EXCAVATIONS**

Guidelines for safe construction cuts shall be provided by the soils engineer. The general contractor is responsible for complying with geotechnical guidelines, OSHA requirements, industry standards, and providing a safe work place.

Construction cuts that expose bedrock must be observed by the project geologist. If the project geologist observes weak bedding planes in any of the cuts, the areas shall be modified in the field as directed by the project geologist and or soils engineer.

## **RETAINING WALLS**

While site specific plans have not yet been prepared, it is not unusual for hillside projects to incorporate retaining walls into the project. It is not known if potential walls would retain bedrock or fill. Where bedrocks are retained the potential for adverse bedding conditions exist. This condition can be mitigated during construction by removing the adverse bedrock to the angle of dip as directed by the project geologist and a lateral distance as directed by the soils engineer.

## **DRAINAGE**

The site shall be designed by the civil engineer for positive drainage away from the structures in compliance with the 2010 CBC. Roof drainage and site drainage shall be collected and dispersed in a non-erosive manner. Irrigation and landscape shall be minimized near structures and along top of slope areas. All site waters shall be directed away from the top of slope area.

## **LANDSCAPING**

We recommend that the project incorporate low water use landscaping.

## **SEISMIC DESIGN**

The soils engineer shall provide the seismic design criteria based on current code.

## **SEPTIC SYSTEM**

The residence will dispose of effluent into a private onsite septic system. The systems in the area typically consist of an advanced treatment tank and seepage pit(s); however, to minimize infiltration of waste waters into subsurface bedrocks we are recommending that the site be restricted to the use of a leach field system. While the project has not yet advanced to the stage where physical testing can be performed; the parcel is opinioned to have adequate room for a leach field.

The use of a leach field disposal system will not affect the geologic stability of the site provided the system is properly located, constructed and maintained.

## **CONSTRUCTION SERVICES**

During construction of the project, it is the responsibility of the client, or their agent to request the project geologist, to provide observation and evaluation of exposed geologic conditions. Typical observations are

made of keyways, benches, foundation excavations, construction cuts, caissons, cut slopes, and other stages as deemed needed. These services are performed on an hourly basis.

### PLAN REVIEW

Plans shall be reviewed by the project geologist for compliance with project recommendations. All recommendations and conclusions are subject to change based on review of project plans.

### SECTION 111 COMPLIANCE STATEMENT

It is the opinion of the undersigned, a duly certified engineering geologist, based upon our work as outlined in the referenced report and in those referenced by it, that if the proposed improvements as we understand them are constructed in accordance with our and other design consultants recommendations, applicable codes, standard care of the industry, and with proper geotechnical and geologic observations (1) the proposed structure(s) will be safe against hazard from local landslide or slippage, and that (2) the proposed building or grading construction will have no adverse effect on the geologic stability of property outside of the building site. The nature and extent of tests conducted for purposes of this declaration are, in the opinion of the undersigned, in conformance with generally accepted practice in the area. Test findings and statements of professional opinion do not constitute a guarantee or warranty, expressed or implied.

### AGENCY REVIEW

All geologic and structural aspects of the proposed development are subject to the review and approval of the governing agency(s). It should be recognized that the governing agency(s) could dictate the manner in which the project proceeds. They could approve or deny any aspect of the proposed improvements and/or could dictate which foundation and grading options are acceptable. Supplemental geologic consulting in response to agency requests for additional information could be required. Responses to these reviews/requests are performed under separate contract, and costs from that incurred for the initial geologic investigation.

### LIMITATIONS

This report presents recommendations pertaining to the subject site based on the assumption that the subsurface conditions do not deviate appreciably from those disclosed by the exploratory excavations. Our recommendations are based on the technical information, our understanding of the proposed construction, and our experience in the geologic field. We do not guarantee the performance of the project, only that our engineering work and judgments meet the standard of care of our profession at this time.

The subsurface conditions, excavation characteristics, and geologic structure described herein and shown on the enclosed cross sections have been projected from excavations on the site as indicated and should in no way be construed to reflect any variations that may occur between these excavations or that may result from changes in subsurface conditions.

In view of the general conditions in the area, the possibility of different local bedrock or soil conditions may exist. Any deviation or unexpected condition observed during construction should be brought to the attention of the Engineering Geologist. In this way, any supplemental recommendations can be made with a minimum of delay necessary to the project.

If the proposed construction will differ from our present understanding of the project, the existing information and possibly new factors may have to be evaluated. Any design changes and the finished plans should be reviewed by the Engineering Geologist. Of particular importance would be extending development to new areas, changes in grading conditions, postponed development for more than a year, or changes in ownership.

This report is issued with the understanding that it is the responsibility of the owner, or of his representative, to ensure that the information and recommendations contained herein are called to the attention of the Architects and Engineers for the project, and incorporated into the plans and that the necessary steps are taken to see that the contractors and subcontractors carry out such recommendations in the field.

This report is subject to review by the controlling authorities for this project.

We appreciate this opportunity to be of service to you.

Respectfully Submitted:  
COAST GEOTECHNICAL, INC

*Todd D. Houseal*  
Todd D. Houseal  
CEG 1914 Exp 4/14

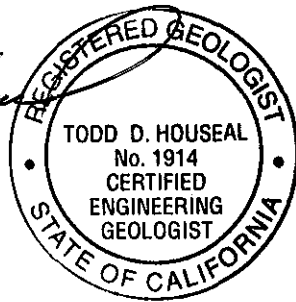

# SITE VICINITY MAP

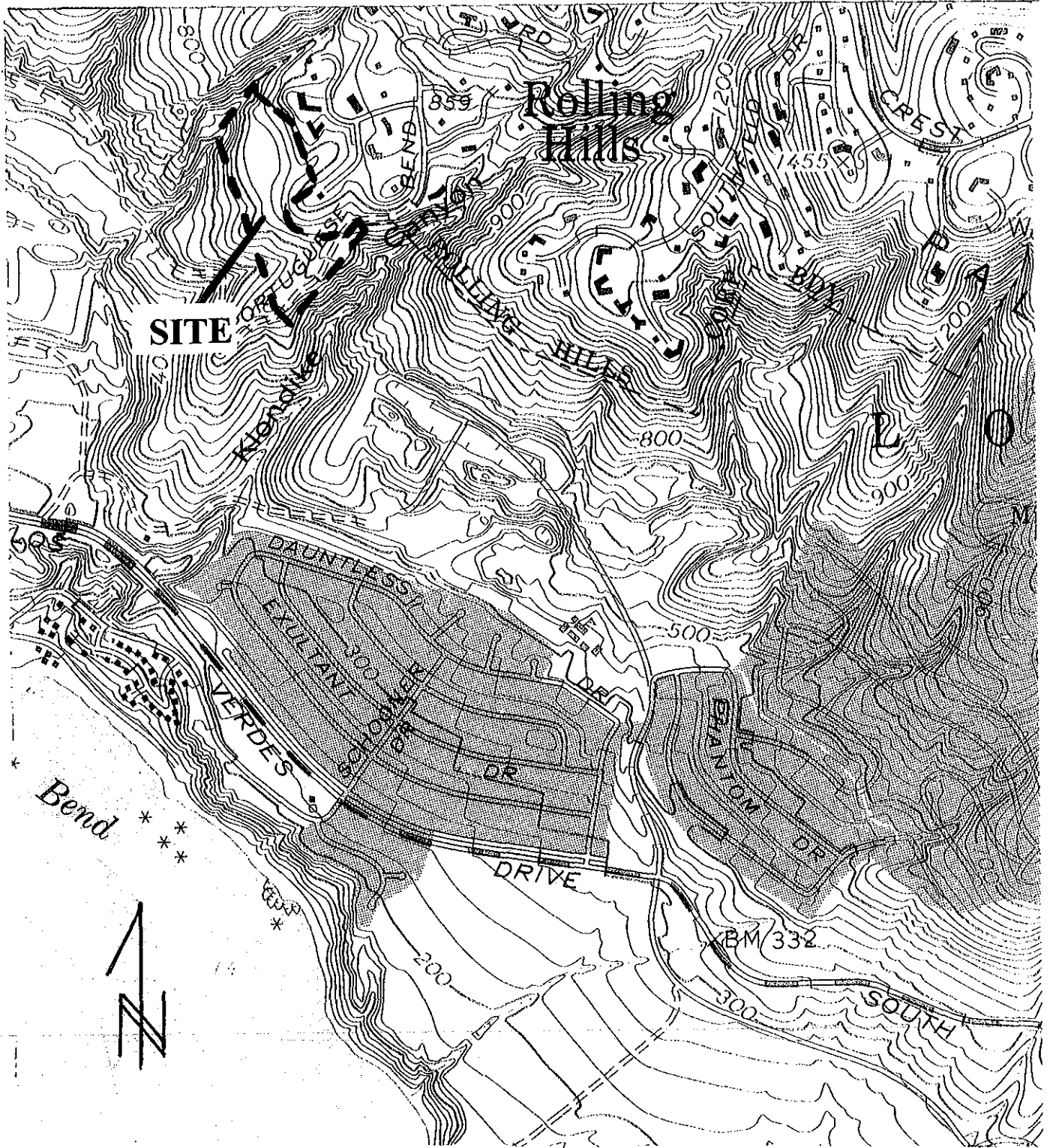

San Pedro USGS Topographic Map

COAST GEOTECHNICAL, INC.

W.O. 430412

Figure 1

# REGIONAL GEOLOGY MAP

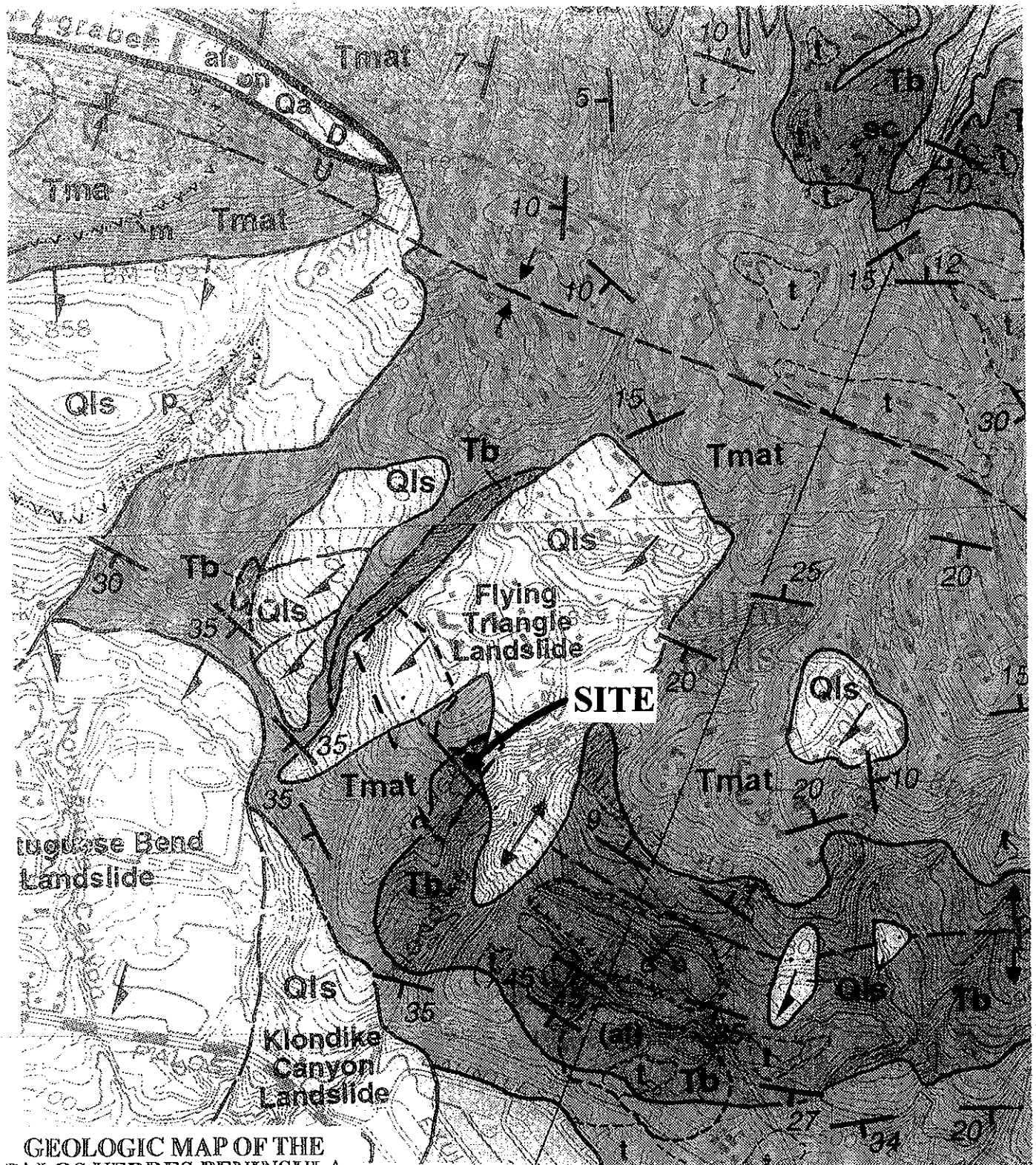

**GEOLOGIC MAP OF THE  
PALOS VERDES PENINSULA  
AND VICINITY**  
Redondo Beach, Torrance,  
and San Pedro Quadrangles  
Los Angeles County, California  
By **THOMAS W. DIBBLEE, JR.**, 1999

Edited by Helmut F. Ehrenspeck  
with Perry L. Billig and Wendy Lou Bartlett



**COAST GEOTECHNICAL, INC.**

W.O. 430412

Figure 2

# REGIONAL GEOLOGY MAP

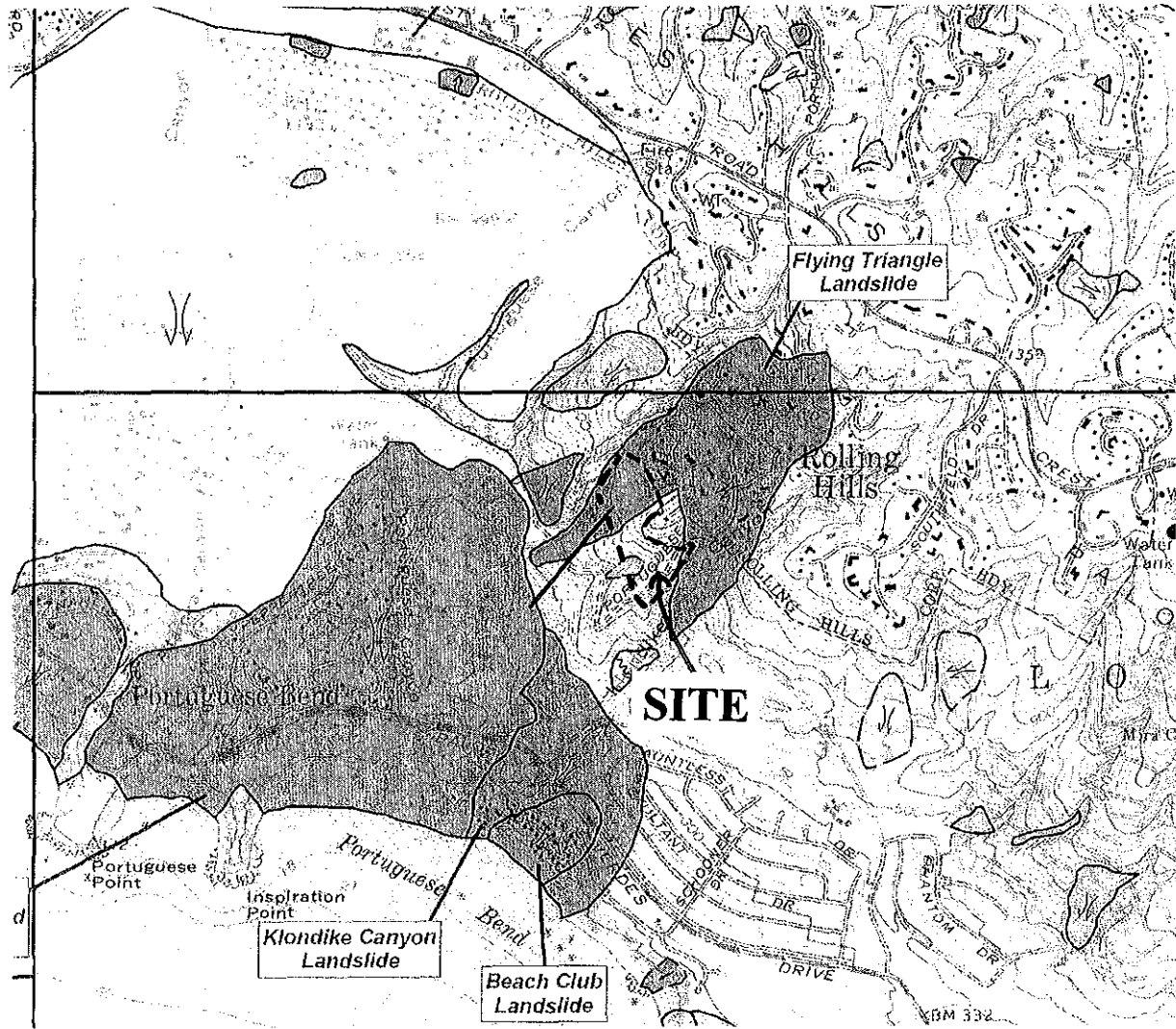

State of California Palos Verdes Landslide Inventory Map



COAST GEOTECHNICAL, INC.

W.O. 430412

Figure 2.1

# REGIONAL GEOLOGY MAP



County of Los Angeles

Geologic Map of the Flying Triangle Landslide

Circa 1981

COAST GEOTECHNICAL, INC.

W.O. 430412

Figure 2.2



**SITE GEOLOGY MAP**

**SEE MAP POCKET**

**COAST GEOTECHNICAL, INC.**

**W.O. 430412      *Figure 3***

GEOLOGIC SECTION A-A'

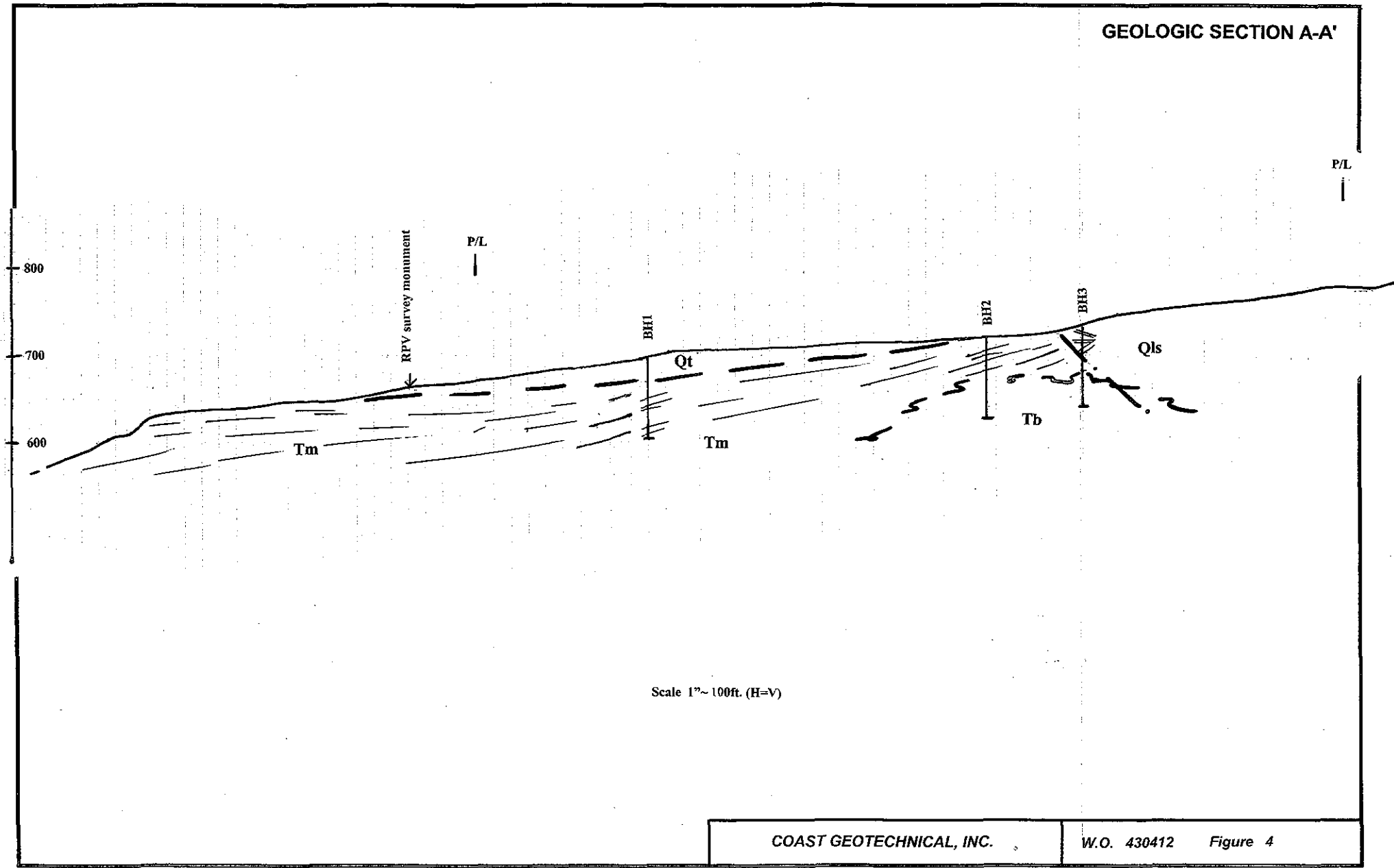

Scale 1" ~ 100ft. (H=V)

COAST GEOTECHNICAL, INC.

W.O. 430412 Figure 4

GEOLOGIC SECTION B-B'

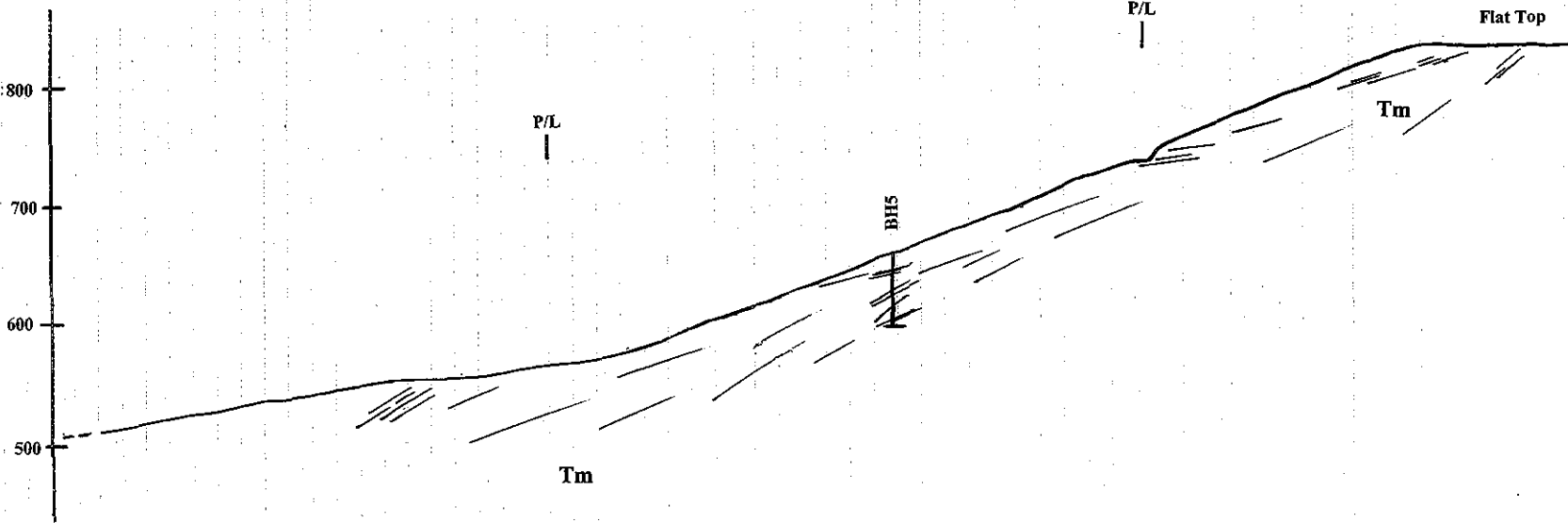

Scale 1" ~ 100ft. (H=V)

# GEOLOGIC SECTION C-C'

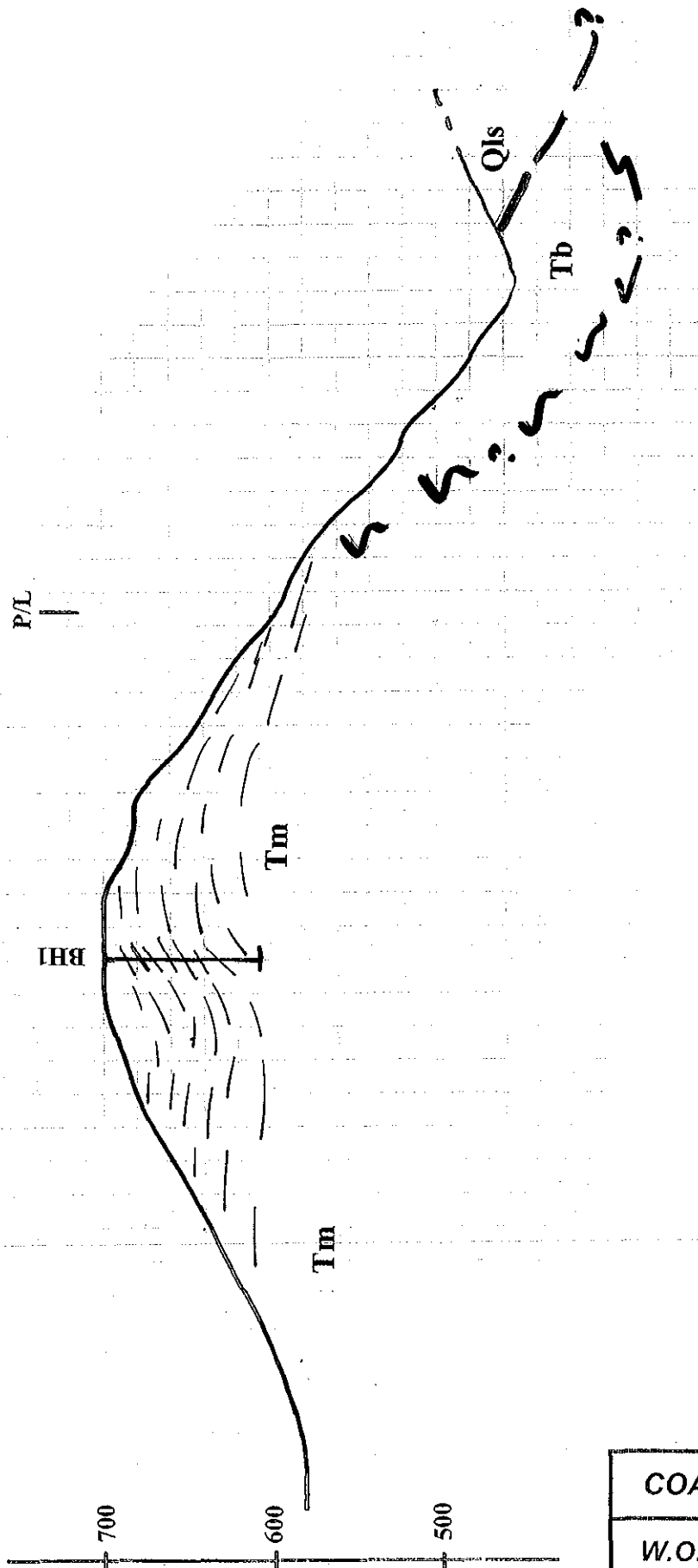

Scale 1" = 100ft. (H=V)

COAST GEOTECHNICAL, INC.

W.O. 430412

Figure 4.2

# SEISMIC HAZARD MAP

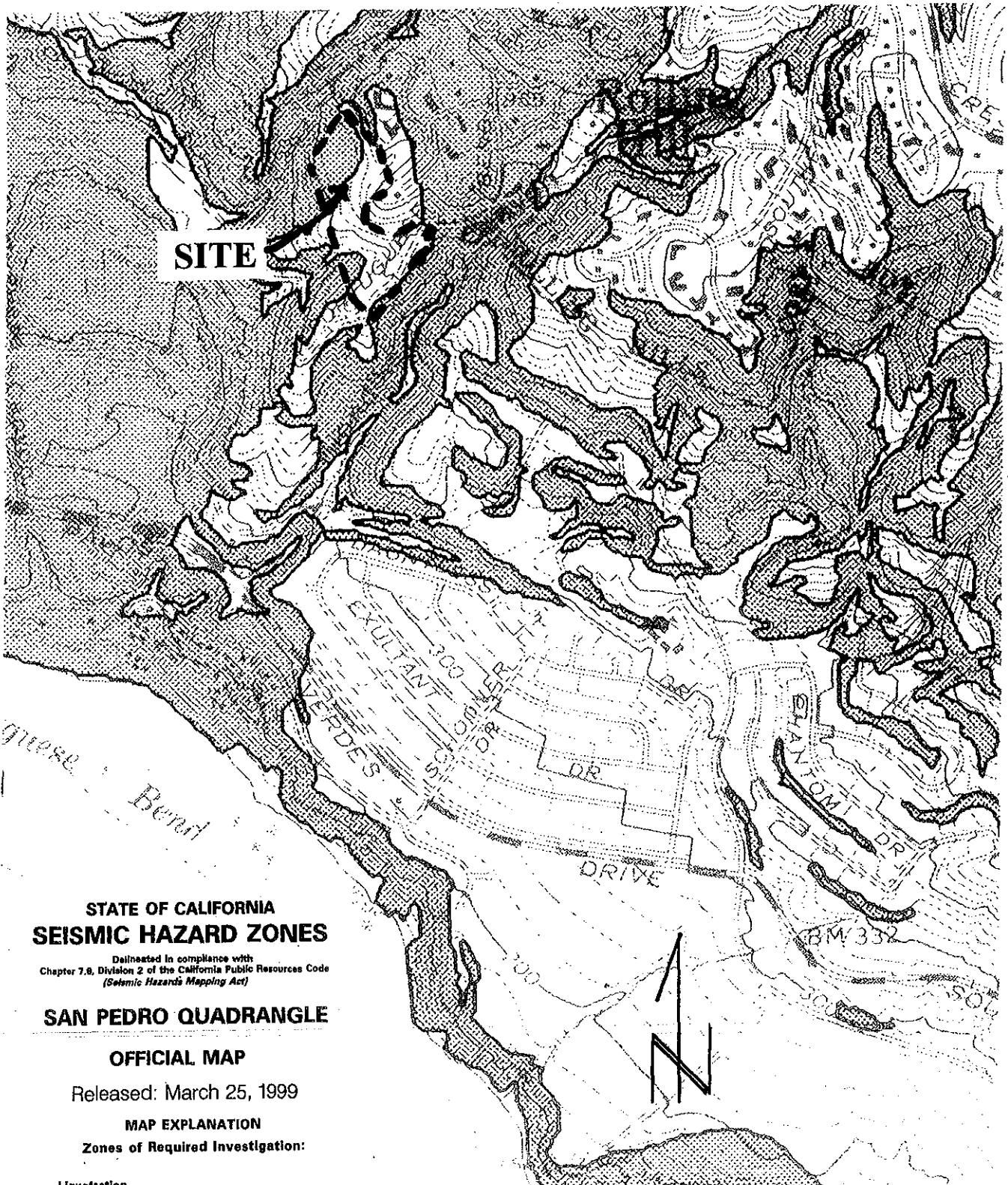

## STATE OF CALIFORNIA SEISMIC HAZARD ZONES

Delimited in compliance with  
Chapter 7.6, Division 2 of the California Public Resources Code  
(Seismic Hazards Mapping Act)

### SAN PEDRO QUADRANGLE

#### OFFICIAL MAP

Released: March 25, 1999

#### MAP EXPLANATION

##### Zones of Required Investigation:

##### Liquefaction

Areas where historic occurrence of liquefaction, or local geological, geotechnical and groundwater conditions indicate a potential for permanent ground displacements such that mitigation as defined in Public Resources Code Section 2693(c) would be required.



##### Earthquake-Induced Landslides

Areas where previous occurrence of landslide movement, or local topographic, geological, geotechnical and subsurface water conditions indicate a potential for permanent ground displacements such that mitigation as defined in Public Resources Code Section 2693(c) would be required.



COAST GEOTECHNICAL, INC.

W.O. 430412

Figure 5

# FIELD LOG OF BORING NO. 1

Project Name: *SHEN*

W.O. *430412*

Log by: *TOH*

Method: *24" BUCKET*

Start:                      Finish:

Date: *2/17/12*

Wt. Of Kelly Bar:

Drop

Samples			Blows			Depth (FT)	DESCRIPTION
Type	No.	Depth	6"	6"	6"		
						10	<i>TAN BROWN SILTY SAND, CLAY, VERY STIFF, ABUNDANT SMALL ROCK FRAGMENTS, ANGULAR TO ROUNDED</i>
							<i>(QC)</i>
						20	
						30	<i>CONTACT WITH BEDROCK FLAT AND CLEAN</i>
<i>033'</i>	<i>N30E</i>	<i>/30W</i>					<i>TAN BROWN SILTSTONE, OXIDIZED ON BEDDING, WELL BEDDED, DIATOMICELLS TO SILICEOUS, COMP, FIRM TO HARD</i>
							<i>(TM)</i>
<i>040'</i>	<i>B - N15E</i>	<i>/48W</i>				40	<i>MINOR GYRIUM SEAMS ALONG BEDROCK</i>
<i>045'</i>	<i>B - N15E</i>	<i>/34W</i>					<i>TIN BEDDED SILTSTONE AND SANDSTONE, MINOR OXIDATION FIRM TO HARD</i>
<i>050'</i>	<i>B N20E</i>	<i>/38W</i>				50	

## FIELD LOG OF BORING NO. 1

 Project Name: *SHEN*

 W.O. *430412*

 Log by: *TDH*

Method:

Start:

Finish:

 Date: *2/17/12*

Wt. Of Kelly Bar:

Drop

Samples			Blows			Depth (FT)	DESCRIPTION
Type	No.	Depth	6"	6"	6"		
		<i>@55'</i>	<i>B - N10°E / 42°N</i>				
		<i>@60'</i>	<i>B - N25E / 35°W</i>			60	
		<i>@64'</i>	<i>B N15E / 44°W</i>				<i>FRACTURED WITH HEAVY OXIDATION AT 65-66', SOUNDS OF CHERT, GYPSUM INFILL</i>
		<i>@70'</i>	<i>B NS / 35°W</i>			70	
		<i>@75'</i>	<i>B N15E / 28°W</i>				<i>THIN BEDDED SILTSTONE AND SANDSTONES, WELL BEDDED, SOME OXIDATION, HARD, DARK</i>
							<i>(Tm)</i>
		<i>@81'</i>	<i>B N20°E / 40°W</i>			80	
		<i>@83'</i>	<i>B N10E / 35°W</i>				
		<i>@85'</i>	<i>B S10W / 49°W</i>			90	
							<i>EDGE 95'- NO H<sub>2</sub>O - NO CLAY</i>

# FIELD LOG OF BORING NO. 2

Project Name: SHEN W.O. 430412 Log by: TOH

Method: 24" Bucket Start: \_\_\_\_\_ Finish: \_\_\_\_\_ Date: 2/20/16

Wt. Of Kelly Bar: \_\_\_\_\_ Drop \_\_\_\_\_

Samples			Blows			Depth (FT)	DESCRIPTION
Type	No.	Depth	6"	6"	6"		
							TOPSOIL
c6	B	EW/29°S					WHITE TAN SANDSTONE, FRACTURED, HARD, THICKLY BEDDED TO INDISTINCT BEDDING, SOME FRACTURES
e10'	B	STE/45°S				10	1/4" OPEN, GYPSUM INFILL, SOME OXIDATION
e24'	B	STOE/18°S				20	4" SEAM OF BROWN CLAY, OXIDIZED, STIFF, MOIST
e31'	B	N70W/24S				30	HARD SILICEOUS SANDSTONE, FRACTURED, GYPSUM SEAM ON BEDDING AND FRACTURES, OXIDATION TO BLACK STAINING
e37'	B	N60W/27°S F NS/75°E				40	
e45'	B	N80°W/8°S				50	BROWN TO OXIDIZED BROWN COARSE GRAINED BASALT, MASSIVE, WEATHERED TO HARD, MINOR GYPSUM INFILL OF FRACTURES

(TV)





# FIELD LOG OF BORING NO. 3

Project Name: *SMEN*

W.O. *430412*

Log by: *TDH*

Method: *24" BUCKET*

Start:

Finish:

Date: *2/22/12*

Wt. Of Kelly Bar:

Drop

Samples			Blows			Depth (FT)	DESCRIPTION
Type	No.	Depth	6"	6"	6"		
							<i>BLACK BROWN DIATOMACEOUS CLAY, LOOSE, ROOTS, SAND (Qc)</i> <i>ROCK?</i>
						10	<i>OXIDIZED BROWN CLAYE GRAYED BASALT, GYPSUM SEAMS AND VEINS, WEATHERED TO HARD</i> <span style="float: right;"><i>(Qls)</i></span>
							<i>@19 B S60E/28E</i>
						20	<i>THIN 1/4 SEAM WHITE CLAY, VERY MOIST, SOFT</i>  <i>VERY FRACTURED SILICEOUS SILTSTONE, GYPSUM SEAM</i> <span style="float: right;"><i>(Qls)</i></span>
						30	<i>BROWN TO OXIDIZED BROWN SILTSTONE, HARD, WELL BEADED, GYPSUM SEAMS ALONG BEDDING + FRACTURES</i>
							<i>@35' BROWN BLACK SEAM OF SILTY CLAY, STIFF, MOIST</i>
						40	<i>YELLOW TAN BUFF SILTSTONE, DIATOMACEOUS TO SILICEOUS FIRM TO HARD</i> <span style="float: right;"><i>(Tm)</i></span>
							<i>@48' B N40W/21W</i>
						50	<i>BROWN VERY FINE SANDY SILTSTONE, HARD, FRACTURED GYPSUM INFILL</i>

# FIELD LOG OF BORING NO. 3

Project Name: SITON W.O. 430412 Log by: TDH

Method: 24" Bucket Start: \_\_\_\_\_ Finish: \_\_\_\_\_ Date: 2/22/12

Wt. Of Kelly Bar: \_\_\_\_\_ Drop \_\_\_\_\_

Samples			Blows			Depth (FT)	DESCRIPTION
Type	No.	Depth	6"	6"	6"		
							<u>0-51' ALTERED MONTEREY WITH BLACK BROWN CLAY</u>
							<u>MINOR GYPSUM</u>
							<u>BROWN TO OXIDIZED BROWN MEDIUM TO COARSE</u>
						60	<u>GRAINED SAND, GYPSUM VEINS, HARD TO WEATHERED</u>
						70	<u>(T6)</u>
						80	
						90	
							<u>END @ 95' - NO H<sub>2</sub>O - NO GRAVEL</u>

# FIELD LOG OF BORING NO. 4

Project Name: SHCN W.O. 430412 Log by: TOH

Method: 24" Bucket - Limited Access Start: \_\_\_\_\_ Finish: \_\_\_\_\_ Date: 2/21/12

Wt. Of Kelly Bar: \_\_\_\_\_ Drop \_\_\_\_\_

Samples			Blows			Depth (FT)	DESCRIPTION
Type	No.	Depth	6"	6"	6"		
							BLACK BROWN CLAY, LOOSE, DRY, ROOTS (Dc)
e5'	B-N75W	/48°S					YELLOW PHOSPHATIC CLAY, WITH OXIDATION, BLACK INCLUSIONS, STIFF, MOIST
						10	
Be15'	EW	/14°S					BLACK BROWN SILICEOUS SANDY SILTSTONE, VERY FRACTURED, MINOR GYPSUM, VERY CLAYEY AT 16-17'
						20	TAN WHITE DIATOMACEOUS SILTSTONE, WELL BEDDED, TIGHT, FIRM TO HARD, VERY TIGHT FOLDING, SOME BASALT SEAMS
e21'	B S50E	/15°S					
						30	GRAY OXIDIZED BROWN CHERTY SILTSTONE, FRACTURED, HARD (Tm)
e28'	B N50°W	/23°S					
e33'	B N75°W	/41°S					
e36'	B N60°W	/20°S					SEAM OF WHITE YELLOW PHOSPHATIC CLAY, STIFF, BLACK INCLUSION
						40	WELL BEDDED GRAY SILTSTONE, SANDY SILTSTONE; GRAY CLAYSTONE WITH SEAM OF WHITE YELLOW CLAY, SLIGHTLY SHEARED AND POLISHED, MINOR GYPSUM
e42'	N50°W	/26°S					
e46'	N65°W	/26°S					
						50	OXIDIZED BROWN SILICEOUS SILTSTONE, HARD
e49'	B N70°W	/20°S					
							EDB @ 56' - NO H <sub>2</sub> O - NO CAVING

# FIELD LOG OF BORING NO. 5

Project Name: SHEN W.O. 430402 Log by: TRH  
 Method: 24" Bucket - Limited Access Start: \_\_\_\_\_ Finish: \_\_\_\_\_ Date: 2/20/12  
 Wt. Of Kelly Bar: \_\_\_\_\_ Drop: \_\_\_\_\_

Samples			Blows			Depth (FT)	DESCRIPTION
Type	No.	Depth	6"	6"	6"		
							<u>BLACK GRAY CLAY, STIFF, MAND</u> (Qd)
<u>e6'</u>	<u>B N80°W/14°W</u>						<u>TAN BROWN SILTY CLAY, SAND, ROCK FRAGMENTS, STIFF, MAND</u> (Qd)
<u>e10'</u>	<u>B N65°W/12°W</u>					10	<u>TAN BROWN TO BUFF SILTSTONE BEDDED WITH SANDSTONE, OXIDIZED, WELL BEDDED, OCCASIONAL BANNET SEAM ALONG BEDDING, ROCK RUBBLE @ 13',</u> (Qd?)
<u>e13'</u>	<u>B S50°E/12°W</u>						
<u>e16'</u>	<u>B S65°E/21°W</u>						
<u>e20'</u>	<u>B S70°E/24°SW</u>					20	<u>OXIDIZED BROWN SANDSTONE WITH TAN SILTSTONE BEDS, SHEARED CLAY AT 18' ABOUT 4" THICK</u>
<u>e24'</u>	<u>B S65°E/28°SW</u>						<u>THIN SEAM OF GRAY BLACK CLAYSTONE, SOFT TO FIRM</u>
<u>e29'</u>	<u>B EW/30°S</u>					30	<u>ABUNDANT GYPSUM SEAMS AND VETIN</u> (Tm)
<u>e34'</u>	<u>B EW/38°S</u>						<u>WELL BEDDED SANDSTONE AND SILTSTONE, FIRM TO HARD, ABUNDANT GYPSUM</u>
<u>e44'</u>	<u>B EW/38°S</u>					40	
<u>e47'</u>	<u>B S80°E/45°S</u>						
<u>e54'</u>	<u>B EW/20°S</u>					50	
							<u>ROPE 60' No Ho No GUNN</u>

# **APPENDIX A**

**Boring logs and test pit logs by  
Converse Consultants**

**SUMMARY  
BORING NO. 1**

DATE DRILLED May 3, 1977

THIS SUMMARY APPLIES ONLY AT THE LOCATION OF THIS BORING AND AT THE TIME OF DRILLING. SUBSURFACE CONDITIONS MAY DIFFER AT OTHER LOCATIONS AND MAY CHANGE AT THIS LOCATION WITH THE PASSAGE OF TIME. THE DATA PRESENTED IS A SIMPLIFICATION OF ACTUAL CONDITIONS ENCOUNTERED.

DRIVE ENERGY  
FT KIPS/FT  
FIELD MOISTURE  
% DRY WEIGHT  
DRY DENSITY  
LB./CU FT.  
SHEAR  
RESISTANCE  
KIPS/SQ FT.

DEPTH  
IN  
FEET

SAMPLES  
SYMBOL

ELEVATION: 730'±

DEPTH IN FEET	SAMPLES SYMBOL	slightly moist	firm to stiff	dark brown		DRIVE ENERGY FT KIPS/FT	FIELD MOISTURE % DRY WEIGHT	DRY DENSITY LB./CU FT.	SHEAR RESISTANCE KIPS/SQ FT.
0					SLOPEWASH SILTY CLAY, with trace to little rock fragments, highly organic				
1	1					7.6	18.4	77	2.49 2.55* 3.00* 3.90* 0.65**
2						6.5	21.1	87	1.91
5						9.4	20.7	97	3.38
4					with trace rock fragments, organic	7.6	23.9	94	2.90
5						9.4	23.8	95	2.72
6	2	dry to	medium hard	light brown	BEDROCKS SHALE, intensely to mod. fractured with gypsum along fractures, stained along fractures, moderately weathered	11	19.6		
7						9.4	14.0	96	
15	8					13	15.5		
		No ground water encountered, End of Boring at 16.0'							
20									

2 Indicates number and range of bulk sample.

\* Bulk sample remolded to 90% max. density before shearing at 1/2, 1, 2, & 1 ksf. (\*\* +sat. & drained).

FLYING TRIANGLE  
City of Rolling Hills, California  
for: Mr. Lowell Wooden

Project No.  
78-2312-03

Drawing No.



**ConverseWardDavisDixon**

Geotechnical Consultants

**SUMMARY  
BORING NO. 2**

DATE DRILLED May 3, 1977

THIS SUMMARY APPLIES ONLY AT THE LOCATION OF THIS BORING AND AT THE TIME OF DRILLING. SUBSURFACE CONDITIONS MAY DIFFER AT OTHER LOCATIONS AND MAY CHANGE AT THIS LOCATION WITH THE PASSAGE OF TIME. THE DATA PRESENTED IS A SIMPLIFICATION OF ACTUAL CONDITIONS ENCOUNTERED.

DRIVE ENERGY  
FT. KIIPS/FT.  
FIELD MOISTURE  
%, DRY WEIGHT  
DRY DENSITY  
LB /CU FT.  
SHEAR  
RESISTANCE  
KIIPS/SQ FT.

DEPTH  
IN  
FEET

SAMPLES  
SYMBOL

ELEVATION: 713'±

DEPTH IN FEET	SAMPLES SYMBOL	dry to slightly moist	mod. hard to hard	light brown	LANDSLIDE DEBRIS	DRIVE ENERGY FT. KIIPS/FT.	FIELD MOISTURE %, DRY WEIGHT	DRY DENSITY LB /CU FT.	SHEAR RESISTANCE KIIPS/SQ FT.
0					very to moderately weathered & disturbed siltstone & shale very fractured				
1					disoriented bedding	13	12.2	100	
2	1				v. fractured to mod. fractured, mod. weathered				0.47* 0.65* 1.02*
10					indistinct bedding	11	13.7	87	
15					siliceous shale bed at 13'	22	14.9	100	
					slide plane				
20	4	slightly moist	hard	light brown	BEDROCKS, SILTSTONE, with interbedded silty sandstone and lenses of chert	17	12.3		

1 Indicates number and range of bulk sample

(Continued) \* Bulk sample remolded to 90% max. density, sat. & drained before shearing at 1/2, 1, & 2 ksf.

FLYING TRIANGLE  
City of Rolling Hills, California  
for: Mr. Lowell Wooden

Project No.  
78-2312-03

Drawing No.



**ConverseWardDavisDixon**

Geotechnical Consultants

FORM NO. 03/77 Approved for publication by



**SUMMARY — BORING N . 2 (Continued)**

DATE DRILLED. May 3, 1977

THIS SUMMARY APPLIES ONLY AT THE LOCATION OF THIS BORING AND AT THE TIME OF DRILLING. SUBSURFACE CONDITIONS MAY DIFFER AT OTHER LOCATIONS AND MAY CHANGE AT THIS LOCATION WITH THE PASSAGE OF TIME. THE DATA PRESENTED IS A SIMPLIFICATION OF ACTUAL CONDITIONS ENCOUNTERED.

DRIVE ENERGY  
FT. KIPS/FT.  
FIELD MOISTURE  
% DRY WEIGHT  
DRY MOISTURE  
LB./CU. FT.  
DRY DENSITY  
KIPS/SQ. FT.  
SHEAR  
RESISTANCE  
KIPS/SQ. FT.

DEPTH  
IN  
FEET

SAMPLES  
SYMBOL

20		slightly moist	hard	light brown	BEDROCKS SILTSTONE & SHALE w/interbedded laminations to thinly bedded sandstone + occasional lenses of chert, sl. weathered, v. to mod. fractured				
25	5					32	22.8	99	6.88
30		No ground water encountered. End of Boring at 25.0'			Attitudes: N 30° W/ 23° W at 20' N 45° W/ 28° W at 25'				
35									
40									

2 Indicates number and range of bulk sample.

FLYING TRIANGLE  
City of Rolling Hills, California  
for: Mr. Lowell Wooden

Project No.  
78-2312-03

Drawing No.



**ConverseWardDavisDixon**

Geotechnical Consultants

FORM NO. D3/77 Approved for publication by

# SUMMARY — BORING NO. 3

DATE DRILLED May 3, 1977

THIS SUMMARY APPLIES ONLY AT THE LOCATION OF THIS BORING AND AT THE TIME OF DRILLING. SUBSURFACE CONDITIONS MAY DIFFER AT OTHER LOCATIONS AND MAY CHANGE AT THIS LOCATION WITH THE PASSAGE OF TIME. THE DATA PRESENTED IS A SIMPLIFICATION OF ACTUAL CONDITIONS ENCOUNTERED.

DEPTH  
IN  
FEET

SAMPLES  
SYMBOL

ELEVATION: 660' ±

DRIVE ENERGY  
FT. KIPS/FT.  
 FIELD MOISTURE  
% DRY WEIGHT  
 DRY DENSITY  
LB./CU. FT.  
 RESISTANCE  
KIPS/50. FT.  
 SHEAR  
KIPS/50. FT.

DEPTH IN FEET	SAMPLES SYMBOL	slightly moist	firm to stiff	dark brown to black	SLOPEWASH SILTY CLAY, with multi-colored coarse sand and gravel-size rock throughout moderately porous	13	20.1	102	6.35
0									
5	1								
	CL				stiffer material less porous				
10	2					16	19.4	102	4.31
15	3					14	18.0	101	4.69
20	4					14	17.7	105	7.19
	5	dry to slightly moist		light brown	BEDROCKS CLAYEY SILTSTONE mod. weathered very fractured indistinctly bedded	11	14.2	89	4.78
20	6					9.4	21.2	89.4	6.66

No groundwater encountered, End of Boring at 20.0'

FLYING TRIANGLE  
City of Rolling Hills, California  
for: Mr. Lowell Wooden

Project No.  
78-2312-03



**Converse Ward Davis Dixon** Geotechnical Consultants

Drawing No.

8

FORM NO. 038/78 Approved for publication by

**SUMMARY — BORING N . 4**

DATE DRILLED. May 3, 1977

THIS SUMMARY APPLIES ONLY AT THE LOCATION OF THIS BORING AND AT THE TIME OF DRILLING. SUBSURFACE CONDITIONS MAY DIFFER AT OTHER LOCATIONS AND MAY CHANGE AT THIS LOCATION WITH THE PASSAGE OF TIME. THE DATA PRESENTED IS A SIMPLIFICATION OF ACTUAL CONDITIONS ENCOUNTERED.

DEPTH IN FEET

SAMPLES SYMBOL

ELEVATION. 634' ±

DRIVE ENERGY  
FT. KIPS/FT.  
FIELD MOISTURE  
% DRY WEIGHT  
DRY DENSITY  
LB./CU. FT.  
RESISTANCE  
KIPS/SQ. FT.  
SHEAR  
RESISTANCE  
KIPS/SQ. FT.

DEPTH IN FEET	SAMPLES SYMBOL	slightly moist	firm to stiff	dark brown to black	DESCRIPTION	DRIVE ENERGY FT. KIPS/FT.	FIELD MOISTURE % DRY WEIGHT	DRY DENSITY LB./CU. FT.	RESISTANCE KIPS/SQ. FT.	SHEAR RESISTANCE KIPS/SQ. FT.
0	1	CL	slightly moist	firm to stiff	dark brown to black	9.2	29.4	91	2.70	
5			SLOPEWASH SILTY CLAY, with little to some multi-colored coarse sand & fine gravel-size rock fragments							
5	2		hard	light brown	BEDROCKS SILTY CLAYSTONE, v. weathered	11	15.1	93	-	
10			slightly weathered							
10	No ground water encountered. End of Boring at 10.0'		Attitude: N 42° W/ 46° W at 10'							
15										
20										

FLYING TRIANGLE  
City of Rolling Hills, California  
for: Mr. Lowell Wooden

Project No.  
78-2312-03

Drawing No.



**ConverseWardDavisDixon**

Geotechnical Consultants

FORM NO. D55/78 Approved for publication by

**SUMMARY — BORING N° 5**

DATE DRILLED: May 3, 1977

THIS SUMMARY APPLIES ONLY AT THE LOCATION OF THIS BORING AND AT THE TIME OF DRILLING. SUBSURFACE CONDITIONS MAY DIFFER AT OTHER LOCATIONS AND MAY CHANGE AT THIS LOCATION WITH THE PASSAGE OF TIME. THE DATA PRESENTED IS A SIMPLIFICATION OF ACTUAL CONDITIONS ENCOUNTERED.

DEPTH IN FEET

SAMPLES SYMBOL

ELEVATION: 725' ±

DRIVE ENERGY  
FT. KIPS/FT.  
FIELD MOISTURE  
% DRY WEIGHT  
DRY DENSITY  
LB./CU. FT.  
SHEAR  
RESISTANCE  
KIPS/SG. FT.

DEPTH IN FEET	SAMPLES SYMBOL	MOISTURE	CONSISTENCY	COLOR	DESCRIPTION	DRIVE ENERGY (FT. KIPS/FT.)	FIELD MOISTURE (% DRY WEIGHT)	DRY DENSITY (LB./CU. FT.)	SHEAR RESISTANCE (KIPS/SG. FT.)
0	CL	dry to slightly moist	firm to stiff	dark brown to black	SLOPEWASH SILTY CLAY, with trace sand & little to some gravel, highly organic				
5	1	slightly moist	soft to mod. hard	light brown	LANDSLIDE DEBRIS SILTSTONE, very weathered & very disturbed	4.4	19.0	71.3	0.83
		dry			moderately to slightly weathered				
10	2 (1)					7.5	27.7	67	
			mod. hard		intermittent areas of hard siliceous shale & limestone beds (5-10" thick)				
			hard						
15	3		mod. hard		siltstone, shale and cherty shale, laminated to very thinly bedded	5.5	20.5	-	-
20	4			light gray		8.2	27.6	78	0.57* 1.63* 1.57*

(1)

Indicates number and range of bulk sample.

(Continued)

\* Sample saturated and drained before shearing at 1/2, 1, & 2 ksf.

FLYING TRIANGLE  
City of Rolling Hills, California  
for: Mr. Lowell Wooden

Project No.  
78-2312-03



**ConverseWardDavisDixon**

Geotechnical Consultants

Drawing No.  
10

FORM NO. D557/78 Approved for publication by

**SUMMARY — BORING N 5 (Continued)**

DATE DRILLED: May 3, 1977

THIS SUMMARY APPLIES ONLY AT THE LOCATION OF THIS BORING AND AT THE TIME OF DRILLING. SUBSURFACE CONDITIONS MAY DIFFER AT OTHER LOCATIONS AND MAY CHANGE AT THIS LOCATION WITH THE PASSAGE OF TIME. THE DATA PRESENTED IS A SIMPLIFICATION OF ACTUAL CONDITIONS ENCOUNTERED.

DEPTH IN FEET

SAMPLES SYMBOL

DRIVE ENERGY  
FT. KIPS/FT.  
FIELD MOISTURE  
% DRY WEIGHT  
DRY DENSITY  
LB./CU. FT.  
SHEAR  
RESISTANCE  
KIPS/SQ. FT.

DEPTH IN FEET	SAMPLES SYMBOL	DRY DENSITY (LB./CU. FT.)	FIELD MOISTURE (% DRY WEIGHT)	DRIVE ENERGY (FT. KIPS/FT.)	SHEAR RESISTANCE (KIPS/SQ. FT.)
20					
25	5		17.1	5.5	3.94
30	6 (2)		25.4	8.5	78
35					
40					

dry

hard

light gray to light brown

LANDSLIDE DEBRIS  
CLAYEY SILTSTONE  
mod. weathered w/intermittent areas of hard beds

slightly porous

hard to very hard

hard

very weathered & very disturbed

bedding in many directions

mod. hard

light brown

well bedded

slide plane

hard

BEDROCKS  
CLAYEY SILTSTONE  
mod. weathered w/lenses of sl. weath. siltstone

(2) Indicates number and range of bulk sample.

(Continued)

FLYING TRIANGLE  
City of Rolling Hills, California  
for: Mr. Lowell Wooden

Project No.  
78-2312-03

Drawing No.



FORM NO. D55/78 Approved for publication by

**SUMMARY — BORING N . 5 (Continued)**

DATE DRILLED: May 4, 1977

THIS SUMMARY APPLIES ONLY AT THE LOCATION OF THIS BORING AND AT THE TIME OF DRILLING. SUBSURFACE CONDITIONS MAY DIFFER AT OTHER LOCATIONS AND MAY CHANGE AT THIS LOCATION WITH THE PASSAGE OF TIME. THE DATA PRESENTED IS A SIMPLIFICATION OF ACTUAL CONDITIONS ENCOUNTERED.

DRIVE ENERGY  
FT. KIPS/FT.  
FIELD MOISTURE  
% DRY WEIGHT  
DRY DENSITY  
LB./CU. FT.  
RESISTANCE  
KIPS/SQ. FT.  
SHEAR  
KIPS/SQ. FT.

DEPTH  
IN  
FEET

SAMPLES  
SYMBOL

DEPTH IN FEET	SAMPLES SYMBOL				DRIVE ENERGY FT. KIPS/FT.	FIELD MOISTURE % DRY WEIGHT	DRY DENSITY LB./CU. FT.	RESISTANCE KIPS/SQ. FT.	SHEAR KIPS/SQ. FT.
		slightly moist	medium hard	light brown					
40	7	slightly moist	medium hard	light brown	34	17.9	-	-	
		dry to sl. moist	very hard	black					CLAYEY SILTSTONE very to mod. fractured
					mod. weathered BASALT	moderately fractured			
45		No ground water encountered. End of Boring at 42.5'							
50									
55									
60									

FLYING TRIANGLE  
City of Rolling Hills, California  
for: Mr. Lowell Wooden

Project No.  
78-2312-03

Drawing No.



**ConverseWardDavisDixon** Geotechnical Consultants

12

Approved for publication by \_\_\_\_\_ FORM NO. D-55/78

SUMMARY — BORING N. 6

DATE DRILLED May 4, 1977

THIS SUMMARY APPLIES ONLY AT THE LOCATION OF THIS BORING AND AT THE TIME OF DRILLING. SUBSURFACE CONDITIONS MAY DIFFER AT OTHER LOCATIONS AND MAY CHANGE AT THIS LOCATION WITH THE PASSAGE OF TIME. THE DATA PRESENTED IS A SIMPLIFICATION OF ACTUAL CONDITIONS ENCOUNTERED.

DEPTH IN FEET

SAMPLES SYMBOL

ELEVATION:

DRIVE ENERGY  
FT. KIPS/FT.  
FIELD MOISTURE  
% DRY WEIGHT  
DRY DENSITY  
LB./CU. FT.  
RESISTANCE  
KIPS/50 FT.  
SHEAR  
RESISTANCE  
KIPS/50 FT.

DEPTH IN FEET	SAMPLES SYMBOL	ELEVATION:				DRIVE ENERGY FT. KIPS/FT.	FIELD MOISTURE % DRY WEIGHT	DRY DENSITY LB./CU. FT.	RESISTANCE KIPS/50 FT.	SHEAR RESISTANCE KIPS/50 FT.
0	CL	dry to slightly moist	firm to stiff	dark brown to black	SLOPEWASH SILTY CLAY, highly organic					
5	1		hard to very hard	light brown	LANDSLIDE DEBRIS CLAYEY SILTSTONE sl. to mod. weathered intensely to moderately fractured	13	27.8	72		
					intermittent zones of very weathered rocks					
10	2				indistinctly bedded	14	20.1	83		
15		No ground water encountered. Refusal at 13.0' (End of Boring)			Attitude: N 42° E / 27° W at 5'					
20										

FLYING TRIANGLE  
City of Rolling Hills, California  
for: Mr. Lowell Wooden

Project No.  
78-2312-03

Drawing No.  
13

Approved for publication by \_\_\_\_\_ FORM NO. 255/78

**SUMMARY  
BORING NO. 7**

DATE DRILLED 10-12-78

THIS SUMMARY APPLIES ONLY AT THE LOCATION OF THIS BORING AND AT THE TIME OF DRILLING. SUBSURFACE CONDITIONS MAY DIFFER AT OTHER LOCATIONS AND MAY CHANGE AT THIS LOCATION WITH THE PASSAGE OF TIME. THE DATA PRESENTED IS A SIMPLIFICATION OF ACTUAL CONDITIONS ENCOUNTERED.

DEPTH  
IN  
FEET

SAMPLES  
SYMBOL

ELEVATION 699.5'

DRIVE ENERGY  
FT. KIPS/FT.  
FIELD MOISTURE  
% DRY WEIGHT  
DRY DENSITY  
LB./CU. FT.  
RESISTANCE  
KIPS/50 FT.  
SHEAR  
RESISTANCE  
KIPS/50 FT.

DEPTH IN FEET	SAMPLES SYMBOL	MOISTURE	CONSISTENCY	COLOR	DESCRIPTION	DRIVE ENERGY (FT. KIPS/FT.)	FIELD MOISTURE (% DRY WEIGHT)	DRY DENSITY (LB./CU. FT.)	RESISTANCE (KIPS/50 FT.)	SHEAR RESISTANCE (KIPS/50 FT.)
0		dry	stiff	brown	LANDSLIDE DEBRIS SILTY CLAY trace fine sand, some shale frag- ments caliche streaks at 3'					
		slightly moist	stiff/firm	yellow brown						
5	1 CL/CH	moist	stiff/very stiff				14			
				brown	more rock and siliceous shale fragments					
10	2 1	very moist	firm/stiff	dark brown	slide plane	22				0.56* 1.02*
15	3	slightly moist	hard	light brown yellow	BEDROCKS abundant siliceous shale and siltstone, occasional sandstone very weathered					
20	4			white yellow	CLAYEY SILTSTONE siliceous shale, little sandstone (fine) slightly weathered, laminated					
20				or. yel.						

1 Indicates number and range of bulk sample

(Continued)

\* Sample saturated & sheared at 1, & 2 ksf.

FLYING TRIANGLE  
City of Rolling Hills, California  
for: Mr. Lowell Wooden

Project No.  
78-2312-03

Drawing No.

FORM NO. D3/77 Approved for publication by



**SUMMARY  
BORING NO. 7 (Continued)**

DATE DRILLED 10-12-78

THIS SUMMARY APPLIES ONLY AT THE LOCATION OF THIS BORING AND AT THE TIME OF DRILLING. SUBSURFACE CONDITIONS MAY DIFFER AT OTHER LOCATIONS AND MAY CHANGE AT THIS LOCATION WITH THE PASSAGE OF TIME. THE DATA PRESENTED IS A SIMPLIFICATION OF ACTUAL CONDITIONS ENCOUNTERED.

DEPTH  
IN  
FEET

SAMPLES  
SYMBOL

DRIVE ENERGY  
FT. KIPI/SFT.  
FIELD MOISTURE  
% DRY WEIGHT  
DRY DENSITY  
LB /CU FT  
RESISTANCE  
KIPS/50 FT  
SHEAR  
KIPS/50 FT

DEPTH IN FEET	SAMPLES SYMBOL	slightly moist	hard/very hard	orange yellow	DESCRIPTION	DRIVE ENERGY FT. KIPI/SFT.	FIELD MOISTURE % DRY WEIGHT	DRY DENSITY LB /CU FT	RESISTANCE KIPS/50 FT	SHEAR KIPS/50 FT
20	5				BEDROCKS CLAYEY SILTSTONE siliceous shale occasional sand stone, laminated slightly weathered	20				
25	6					29				
25					End of Boring at 25' No ground water encountered.  Attitudes: N 45° W/ 40° SW N 65° W/ 35° SW at 25'					
30										

FLYING TRIANGLE  
City of Rolling Hills, California  
for: Mr. Lowell Wooden

Project No.  
78-2312-03

Drawing No

15



**ConverseWardDavisDixon**

Geotechnical Consultants

FORM NO. 03/77 Approved for publication by

**SUMMARY  
BORING NO. 8**

DATE DRILLED 10-12-78

THIS SUMMARY APPLIES ONLY AT THE LOCATION OF THIS BORING AND AT THE TIME OF DRILLING. SUBSURFACE CONDITIONS MAY DIFFER AT OTHER LOCATIONS AND MAY CHANGE AT THIS LOCATION WITH THE PASSAGE OF TIME. THE DATA PRESENTED IS A SIMPLIFICATION OF ACTUAL CONDITIONS ENCOUNTERED.

DEPTH  
IN  
FEET

SAMPLES  
SYMBOL

ELEVATION: 728.5'

DRIVE ENERGY  
FT. KIPI/FT.  
FIELD MOISTURE  
% DRY WEIGHT  
DRY DENSITY  
LB / CU FT.  
RESISTANCE  
KIPI/50 FT.  
SHEAR  
RESISTANCE  
KIPI/50 FT.

0		dry	loose	brown	SLOPEWASH SILTY CLAY trace fine sand shale fragments disturbed material at 4' abundance of sandstone and shale and siltstone fragments			
		moist	firm/ stiff					
5	1	CH	slightly moist	yellow brown/ yellow white	LANDSLIDE DEBRIS CLAYEY SILT abundance of shale and sand- stone fragments very disturbed zone	7.2		
10								
15	2					9.0		0.98*
			mod. hard	yellow orange/ yellow white	CLAYEY SILTSTONE SILTY CLAYSTONE trace sand, (fine) moderately weathered in joints, very fractured	18		3.81*
	3							2.56*
20	4					16		

(Continued)

\* Sample saturated & sheared at 1, 2, & 3 ksf.

FLYING TRIANGLE  
City of Rolling Hills, California  
for: Mr. Lowell Wooden

Project No.  
78-2312-03

Drawing No.



FORM NO. 03/77 Approved for publication by \_\_\_\_\_

DATE DRILLED 10-12-78

SUMMARY BORING NO. 8 (Continued)

THIS SUMMARY APPLIES ONLY AT THE LOCATION OF THIS BORING AND AT THE TIME OF DRILLING. SUBSURFACE CONDITIONS MAY DIFFER AT OTHER LOCATIONS AND MAY CHANGE AT THIS LOCATION WITH THE PASSAGE OF TIME. THE DATA PRESENTED IS A SIMPLIFICATION OF ACTUAL CONDITIONS ENCOUNTERED.

DEPTH IN FEET

SAMPLES SYMBOL

DRIVE ENERGY  
FT KIPS/FT  
FIELD MOISTURE  
% DRY WEIGHT  
DRY DENSITY  
LB /CU FT  
RESISTANCE  
KIPS/SQ FT  
SHEAR  
RESISTANCE  
KIPS/SQ FT

20

slightly moist

mod. hard

yellow orange

CLAYEY SILTSTONE

very hard

SILICEOUS SILTSTONE  
fr-sl. weathered, v. thinly bedded

Refusal at 22', no ground water encountered

25

FORM NO. D3/77 Approved for publication by

FLYING TRIANGLE  
City of Rolling Hills, California  
for: Mr. Lowell Wooden

Project No.  
78-2312-03



ConverseWardDavisDixon

Geotechnical Consultants

Drawing No.

17

**SUMMARY  
BORING NO. 9**

DATE DRILLED 10-13-78

THIS SUMMARY APPLIES ONLY AT THE LOCATION OF THIS BORING AND AT THE TIME OF DRILLING. SUBSURFACE CONDITIONS MAY DIFFER AT OTHER LOCATIONS AND MAY CHANGE AT THIS LOCATION WITH THE PASSAGE OF TIME. THE DATA PRESENTED IS A SIMPLIFICATION OF ACTUAL CONDITIONS ENCOUNTERED.

DRIVE ENERGY  
FT. KIPS/FT.  
FIELD MOISTURE  
% DRY WEIGHT  
DRY DENSITY  
LB./CU. FT.  
SHEAR  
RESISTANCE  
KIPS/50 FT.

DEPTH  
IN  
FEET

SAMPLES  
SYMBOL

ELEVATION 730'

DEPTH IN FEET	SAMPLES SYMBOL	dry	soft	brown	FILL	DRIVE ENERGY FT. KIPS/FT.	FIELD MOISTURE % DRY WEIGHT	DRY DENSITY LB./CU. FT.	SHEAR RESISTANCE KIPS/50 FT.
0	CH/CL	dry	soft	brown	FILL SILTY CLAY, with shale fragments and siliceous shale				
		slightly moist	firm						
5	1	moist	firm/stiff	yellow orange	LANDSLIDE DEBRIS SILTY CLAY/CLAYEY SILT, slightly porous abundance of siliceous shale, shale, and diatomaceous shale fragments, trace fine sand	11	18.8	98	
		slightly moist/moist							
10	2		stiff	yellow brown					0.67* 1.74* 2.82*
			very stiff			14	14.5	88	
15	3	slightly moist		light gray	CLAYEY SILTSTONE bedding slightly weathered, slide plane	68	11.7	112	
			mod. hard/hard	gray yellow orange	"BEDROCKS" SILTSTONE/SHALE laminated slightly weathered, very fractured	31	18.5	87	
20	4	ML							

(Continued)

\* Sample saturated & sheared at 1, 2, & 3 ksf.

FLYING TRIANGLE  
City of Rolling Hills, California  
for: Mr. Lowell Wooden

Project No.  
78-2312-03

Drawing No.



FORM NO. D3/77 Approved for publication by \_\_\_\_\_

**SUMMARY  
BORING NO. 9 (Continued)**

DATE DRILLED 10-13-78

THIS SUMMARY APPLIES ONLY AT THE LOCATION OF THIS BORING AND AT THE TIME OF DRILLING. SUBSURFACE CONDITIONS MAY DIFFER AT OTHER LOCATIONS AND MAY CHANGE AT THIS LOCATION WITH THE PASSAGE OF TIME. THE DATA PRESENTED IS A SIMPLIFICATION OF ACTUAL CONDITIONS ENCOUNTERED.

DEPTH  
IN  
FEET

SAMPLES  
SYMBOL

DRIVE ENERGY  
FT. KIPS/FT.  
FIELD MOISTURE  
% DRY WEIGHT  
DRY DENSITY  
LB /CU FT  
RESISTANCE  
KIPS/SQ FT  
SHEAR  
RESISTANCE  
KIPS/SQ FT

DEPTH IN FEET	SAMPLES SYMBOL	DESCRIPTION	DRIVE ENERGY FT. KIPS/FT.	FIELD MOISTURE % DRY WEIGHT	DRY DENSITY LB /CU FT	RESISTANCE KIPS/SQ FT	SHEAR RESISTANCE KIPS/SQ FT
20	5	slightly moist hard/very yellow orange "BEDROCKS" SILTSTONE/SILICEOUS SHALE, laminated, sl. weathered, very fractured	27	14.3	76		
25							
30	6	mod. hard possible slide plane, disturbed material, silty clay shale fragments	56	21.5	89		
30	7	very hard BEDROCKS SILICEOUS SHALE, lam. sl. weathered	65	25.8	89		
		End of Boring at 31.5' no water encountered Attitude: E-W/50° S at 20'					

FLYING TRIANGLE  
City of Rolling Hills, California  
for: Mr. Lowell Wooden

Project No.  
78-2312-03

Drawing No.

19



**ConverseWardDavisDixon**

Geotechnical Consultants

FORM NO. D3/77 Approved for publication by

**SUMMARY  
BORING NO. 10**

DATE DRILLED 10-16-78

THIS SUMMARY APPLIES ONLY AT THE LOCATION OF THIS BORING AND AT THE TIME OF DRILLING. SUBSURFACE CONDITIONS MAY DIFFER AT OTHER LOCATIONS AND MAY CHANGE AT THIS LOCATION WITH THE PASSAGE OF TIME. THE DATA PRESENTED IS A SIMPLIFICATION OF ACTUAL CONDITIONS ENCOUNTERED.

DRIVE ENERGY  
FT. KIPS/FT  
FIELD MOISTURE  
% DRY WEIGHT  
DRY DENSITY  
LB /CU FT  
SHEAR  
RESISTANCE  
KIPS/50 FT

DEPTH  
IN  
FEET

SAMPLES  
SYMBOL

ELEVATION 581.0'

DEPTH IN FEET	SAMPLES SYMBOL	moist	soft	firm/stiff	hard	color	DESCRIPTION	DRIVE ENERGY FT. KIPS/FT	FIELD MOISTURE % DRY WEIGHT	DRY DENSITY LB /CU FT	SHEAR RESISTANCE KIPS/50 FT
0	1 CH	moist	soft			brown	FILL SILTY CLAY trace fine sand, trace small shale fragments				
5				firm/stiff			SLOPEWASH more shale frag- ments				
10	ML/CL										
15	1 2	slightly moist	stiff			yellow orange	LANDSLIDE DEBRIS CLAYEY SILT/SILTY CLAY, porous, trace sand (fine) abundance of shale fragments	8.1			
20	2			hard		white gray	siliceous shale	7.2			

2 Indicates number and range of bulk sample

(Continued)

FLYING TRIANGLE  
City of Rolling Hills, California  
for: Mr. Lowell Wooden

Project No.  
78-2312-03

Drawing No.



**ConverseWardDavisDixon** Geotechnical Consultants

FORM NO. 03/77 Approved for publication by

**SUMMARY  
BORING NO. 10 (Continued)**

DATE DRILLED 10-13-78

THIS SUMMARY APPLIES ONLY AT THE LOCATION OF THIS BORING AND AT THE TIME OF DRILLING. SUBSURFACE CONDITIONS MAY DIFFER AT OTHER LOCATIONS AND MAY CHANGE AT THIS LOCATION WITH THE PASSAGE OF TIME. THE DATA PRESENTED IS A SIMPLIFICATION OF ACTUAL CONDITIONS ENCOUNTERED.

DRIVE ENERGY  
FT KIPS/FT  
FIELD DRY WEIGHT  
%  
DRY MOISTURE  
LB / CU FT  
DRY DENSITY  
LB / CU FT  
RESISTANCE  
KIPS/50 FT  
SHEAR  
RESISTANCE  
KIPS/50 FT

DEPTH  
IN  
FEET

SAMPLES  
SYMBOL

ELEVATION

20

slightly moist    very hard    yellow brown

LANDSLIDE DEBRIS  
SILICEOUS SHALE

End of Boring at 21'  
No water encountered  
(Refusal at 21')

25

FORM NO. D3/77 Approved for publication by

FLYING TRIANGLE  
City of Rolling Hills, California  
for: Mr. Lowell Wooden

Project No.  
78-2312-03



**ConverseWardDavisDixon** Geotechnical Consultants

Drawing No.

21

**SUMMARY  
BORING NO. 11**

DATE DRILLED 10-16-78

THIS SUMMARY APPLIES ONLY AT THE LOCATION OF THIS BORING AND AT THE TIME OF DRILLING. SUBSURFACE CONDITIONS MAY DIFFER AT OTHER LOCATIONS AND MAY CHANGE AT THIS LOCATION WITH THE PASSAGE OF TIME. THE DATA PRESENTED IS A SIMPLIFICATION OF ACTUAL CONDITIONS ENCOUNTERED.

DEPTH  
IN  
FEET

SAMPLES  
SYMBOL

ELEVATION 729.0'

DRIVE ENERGY  
FT KIPS/FT  
FIELD MOISTURE  
% DRY WEIGHT  
DRY DENSITY  
LB / CU FT  
RESISTANCE  
KIPS/50 FT  
SHEAR  
RESISTANCE  
KIPS/50 FT

DEPTH IN FEET	SAMPLES SYMBOL	MOISTURE	CONSISTENCY	COLOR	DESCRIPTION	DRIVE ENERGY (FT KIPS/FT)	FIELD MOISTURE (% DRY WEIGHT)	DRY DENSITY (LB / CU FT)	RESISTANCE (KIPS/50 FT)	SHEAR RESISTANCE (KIPS/50 FT)
0	CL / CH	slightly moist	stiff	brown	SLOPEWASH SILTY CLAY, trace fine sand, slightly porous shale fragments					
		moist	firm/stiff							
5					more shale and siltstone fragment					
1		very moist	soft	white yellow white	LANDSLIDE DEBRIS CLAY, (bentonitic?) disturbed, very weathered	3.6				
2						8.1				0.84*
10		moist	firm/stiff	light yellow brown	clayey siltstone and shale, mod. weathered, very fractured					
			stiff	yellow orange						
15	3	slightly moist		white yellow						
	4			yellow orange		9.9				
			hard	orange		9.0				
20										

(Continued)

\* Sample saturated & sheared at 1, 2, & 3 ksf.

FLYING TRIANGLE  
City of Rolling Hills, California  
for: Mr. Lowell Wooden

Project No.  
78-2312-03

Drawing No.



**ConverseWardDavisDixon**

Geotechnical Consultants



# SUMMARY BORING NO. 11 (Continued)

DATE DRILLED 10-16-78

THIS SUMMARY APPLIES ONLY AT THE LOCATION OF THIS BORING AND AT THE TIME OF DRILLING. SUBSURFACE CONDITIONS MAY DIFFER AT OTHER LOCATIONS AND MAY CHANGE AT THIS LOCATION WITH THE PASSAGE OF TIME. THE DATA PRESENTED IS A SIMPLIFICATION OF ACTUAL CONDITIONS ENCOUNTERED.

DEPTH  
IN  
FEET

SAMPLES  
SYMBOL

DRIVE ENERGY  
FT. KIPS/FT

FIELD MOISTURE  
% DRY WEIGHT

DRY DENSITY  
LB /CU FT

RESISTANCE  
KIPS/SQ FT

SHEAR  
RESISTANCE  
KIPS/SQ FT

20		slightly moist	very hard	orange	LANDSLIDE DEBRIS, (BLOCK) SILICEOUS SHALE & LIMESTONE				
5			hard	white gray		29			
25					Refusal at 24' No ground water encountered.				

FLYING TRIANGLE  
City of Rolling Hills, California  
for: Mr. Lowell Wooden

Project No.  
78-2312-03

Drawing No.



**ConverseWardDavisDixon**

Geotechnical Consultants

# SUMMARY BORING NO. 12

DATE DRILLED 10-16-78

THIS SUMMARY APPLIES ONLY AT THE LOCATION OF THIS BORING AND AT THE TIME OF DRILLING. SUBSURFACE CONDITIONS MAY DIFFER AT OTHER LOCATIONS AND MAY CHANGE AT THIS LOCATION WITH THE PASSAGE OF TIME. THE DATA PRESENTED IS A SIMPLIFICATION OF ACTUAL CONDITIONS ENCOUNTERED.

DRIVE ENERGY  
FT. KIPS/FT.  
 FIELD MOISTURE  
% DRY WEIGHT  
 DRY DENSITY  
LB /CU FT  
 SHEAR  
RESISTANCE  
KIPS/50 FT

DEPTH  
IN  
FEET

SAMPLES  
SYMBOL

ELEVATION 756.0'

DEPTH IN FEET	SAMPLES SYMBOL	MOISTURE	CONSISTENCY	COLOR	DESCRIPTION	DRIVE ENERGY (FT. KIPS/FT.)	FIELD MOISTURE (% DRY WEIGHT)	DRY DENSITY (LB /CU FT)	SHEAR RESISTANCE (KIPS/50 FT)
0		slightly moist	firm	brown	FILL SILTY CLAY, with trace of fine sand, some rock				
5	1 CL/CH	moist	firm/stiff		SLOPEWASH SILTY CLAY, with abundance of small shale fragments and some gypsum streaks				3.6
10	2 ML	slightly moist	mod. hard to hard	yellow brown	LANDSLIDE DEBRIS very weathered basalt				9.0
15	3			orange brown					9.0
20	4 ML/CL	moist		yellow white	SILTY CLAY, probable slide plane				9.0
20			very hard		BEDROCK CHERTY SHALE, SILICEOUS SHALE, & SILTSTONE				

Refusal at 20', no groundwater encountered

FLYING TRIANGLE  
City of Rolling Hills, California  
for: Mr. Lowell Wooden

Project No.  
78-2312-03

Drawing No.



**ConverseWardDavisDixon**

Geotechnical Consultants

24

FORM NO. D3/77 Approved for publication by

LOG OF EXPLORATORY TRENCHES

Trench No.	Approx. Depth in Feet		Soil/Bedrock Description
	From	To	
1	0.0	10.0	<u>SLOPEWASH</u> - SILTY CLAY and CLAYEY SILT; medium brown, slightly moist, firm to stiff, slightly porous to porous, with angular rock fragments to 3 inches, probably landslide debris.
2	0.0	5.5	<u>SLOPEWASH</u> - SILTY CLAY; medium brown, moist, firm, slightly porous to porous; with angular rock fragments to 2 inches, from 4.5 feet to 5.5 feet angular to sub-angular rock fragments to 14 inches of siliceous shale, cherty shale, limestone and andesite tuff.
	5.5	8.0	<u>BEDROCK</u> - BASALT; dark gray, very weathered, moderately fractured, hard to very hard, dry.
3	0.0	10.0	<u>LANDSLIDE DEBRIS</u> - SHALE and SILTSTONE; very weathered, dry, soft to moderately hard, contorted bedding below 6 feet, laminated to very thinly bedded.
4	0.0	9.5	<u>LANDSLIDE DEBRIS</u> - SILTSTONE and SHALE; disoriented rock fragments, very weathered, dry, soft to hard, slightly porous to porous.
5	0.0	7.0	<u>LANDSLIDE DEBRIS</u> - SILTSTONE and SHALE; disoriented rock fragments, very weathered, dry, soft to hard, slightly porous to porous.
6	0.0	6.0	<u>SLOPEWASH</u> - SILTY CLAY; dark gray - brown, slightly porous, slightly moist, firm to stiff, with angular rock fragments to 4 inches.
	6.0	10.0	<u>LANDSLIDE DEBRIS</u> - SHALE and SILTSTONE; intensely weathered, dry to slightly moist, soft to moderately hard, intensely fractured with disoriented rock fragments to 12 inches.
7	0.0	8.0	<u>SLOPEWASH</u> - SILTY CLAY; dark gray-brown; slightly porous, slightly moist, firm to stiff, with angular rock fragments to 4 inches.
	8.0	10.0	<u>LANDSLIDE DEBRIS</u> - SHALE and SILTSTONE; intensely weathered, dry to slightly moist, soft to moderately hard, intensely fractured with black cherty shale fragments to 6 inches.

LOG OF EXPLORATORY TRENCHES

Trench No.	Approx. Depth in Feet		Soil/Bedrock Description
	From	To	
8	0.0	3.0	<u>SLOPEWASH</u> - SILTY CLAY and CLAYEY SILT; medium brown, porous, firm, dry.
	3.0	6.0	<u>LANDSLIDE DEBRIS</u> - SILTSTONE and SHALE; disoriented, frock fragments, very weathered, dry soft to hard, slightly porous to porous.
9	0.0	2.5	<u>SLOPEWASH</u> - CLAYEY SILT; medium brown, dry, porous, firm, with angular and sub-angular rock fragments to 8 inches.
	2.5	5.5	<u>LANDSLIDE DEBRIS</u> - SILTSTONE and SHALE; clayey siltstone and siliceous shale, light gray-brown, and black cherty shale, moderately hard to very hard, disoriented fragments throughout.
10	0.0	8.0	<u>TOPSOIL/SLOPEWASH</u> - SANDY and CLAYEY SILT; medium brown, soft to firm, very porous in upper four feet, porous to 8 feet, slightly moist, alkali stains below 6 feet, rock fragments to 2 inches throughout.
11	0.0	1.5	<u>TOPSOIL/SLOPEWASH</u> - SANDY SILT; medium brown, firm, dry, porous rock fragments to 2 inches.
	1.5	3.0	<u>BEDROCKS</u> - BASALT; red-brown, moderately hard, intensely weathered, intensely fractured.
	3.0	6.0	<u>BEDROCKS</u> - BASALT; dark brown, moderately hard to hard, very weathered, very fractured.
12	0.0	4.0	<u>LANDSLIDE DEBRIS</u> - SILTSTONE and SHALE; disoriented rock fragments and slabs to 18 inches, below road cut in landslide.
	4.0	5.0	<u>BEDROCKS?</u> - BASALT; very weathered, dark gray-brown, very fractured, probably is not in-place rock.
13	0.0	4.5	<u>TOPSOIL/SLOPEWASH</u> - CLAYEY and SANDY SILT; medium brown, firm to stiff, porous, rock fragments to 3 inches throughout.
	4.5	5.5	<u>BEDROCKS</u> - SILICEOUS SHALE; gray to medium brown, very hard, very to moderately fractured, slightly weathered to moderately weathered.
14	0.0	1.0	<u>TOPSOIL/SLOPEWASH</u> - SANDY SILT; dry, medium gray, porous, soft to firm, rock to 6 inches.
	1.0	4.0	<u>BEDROCKS</u> - SILICEOUS SHALE, SILTSTONE (slightly DIATOMACEOUS) and THIN TUFF BEDS; brown to light gray, very thinly bedded, very fractured, slightly weathered.

LOG OF EXPLORATORY TRENCHES

Trench No.	Approx. Depth in Feet		Soil/Bedrock Description
	From	To	
15	0.0	0.5	<u>TOPSOIL/SLOPEWASH</u> - SANDY SILT; dry, medium gray, porous, soft to firm, rock to 6 inches.
	0.5	6.5	<u>BEDROCKS</u> - SILICEOUS SHALE and SILTSTONE and DIATOMACEOUS SHALE; moderately weathered, very fractured, laminated to thinly bedded.
16	0.0	4.0	<u>BEDROCKS</u> - SILICEOUS SHALE and DIATOMACEOUS SHALE and SILTSTONE; white-gray to red-brown, laminated to very thinly bedded, very fractured to moderately fractured, slightly weathered.
17	0.0	1.5	<u>TOPSOIL/SLOPEWASH</u> - SANDY and CLAYEY SILT; light to medium gray-brown, dry, porous, soft to firm, rock fragments to 10 inches.
	1.5	5.5	<u>BEDROCKS</u> - SILICEOUS SHALE and CLAYEY (BENTONITIC) SILTSTONE; red-brown to gray to gray-green, very fractured to intensely fractured, moderately hard and moderately weathered to very hard and slightly weathered, very thinly bedded to thinly bedded.
18	0.0	7.5	<u>TOPSOIL/SLOPEWASH</u> - CLAYEY SILT and SILTY CLAY; medium to dark brown, moist, soft to firm, some sand, porous to slightly porous, rock fragments throughout to 4 inches.
19	0.0	7.0	<u>TOPSOIL/SLOPEWASH</u> - SANDY and SLIGHTLY CLAYEY SILT; dark brown, slightly moist, very porous, soft to stiff, rock fragments to 2 inches throughout; appears to be large percentage of larger rock - disoriented landslide debris at bottom of trench (color change to light brown).
20	0.0	2.5	<u>TOPSOIL/SLOPEWASH</u> - CLAYEY SILT; dark brown, moist to slightly moist, porous, firm, small to large rock fragments throughout.
	2.5	6.5	<u>TERRACE DEPOSITS</u> - Nonmarine, angular to subangular disoriented rock, typically ¼ inch to 8 inches, moderately hard to stiff/dense, only slightly porous throughout, no bedrocks in-place.
21	0.0	2.0	<u>TOPSOIL/SLOPEWASH</u> - CLAYEY SILT; dark brown, moist to slightly moist, porous, firm, small to large rock fragments to 5 inches.
	2.0	7.0	<u>BEDROCKS</u> - SILICEOUS SHALE, CLAYEY SILTSTONE and DIATOMACEOUS SHALE; light gray to red-brown to gray-brown, laminated to very thinly bedded, moderately weathered, very fractured to intensely fractured, moderately hard to hard.
22	0.0	8.0	<u>TOPSOIL/SLOPEWASH</u> - SILTY CLAY and CLAYEY SILT, some SAND; medium to dark gray-brown, moist, porous to slightly porous, firm to stiff, rock fragments ¼ inch to 6 inches (apparently very weathered bedrocks at bottom).

# **APPENDIX B**

**October 2010 Survey Report**

**Monitoring and Control Survey**

**Rancho Palos Verdes Portuguese Bend Landslide**



FULL DATA POSTING as of Dec. 2008

Document Date: 12/08/10

Notes:

# Indicates stable points, not moving

\* Indicates no movement detected

2 = Hit by mower sometime between 09/07 and 12/08 with an estimated displacement S14E 0.29', the original position is adjusted here to be relative to monitored position used presently, resulting in correct Overall Movements, see Rpt

Table with columns: Point, NAD83 8PC Zone 5 (FT), NAD88, Overall Movements (US Feet), Periodic (14.5 months) Movements (US Feet), North (ft), East (ft), Elev (ft), North, East, Height, Azim., Dist., Note, North, East, Height, Azimuth, Distance, 95% Error, Note.



F10P











# **SWN SOILTECH CONSULTANTS, INC.**

**Geotechnical Engineering**

**3140 West Main Street, Alhambra, California 91801**

**Office: (626) 282-6838 Fax: (626) 270-4142**

**swnsoiltech@gmail.com**

Project Ref. 4868-12

May 10, 2012

Wei-Min and Ying Sai Shen  
26810 Fond Du Lac Road  
Rancho Palos Verdes, CA 90275

Subject: Report of Preliminary Soils Engineering Investigation  
Proposed Residential Development  
77 Portuguese Bend Road  
Rolling Hills, California

Dear Mr. and Mrs. Shen:

In accordance with your request, we are pleased to submit this report of a soils engineering investigation for the proposed residential development of the above referenced site.

The accompanying report has been substantiated by surface and subsurface exploration and mathematical analysis made in accordance with generally accepted engineering practice, including those field and laboratory tests considered necessary in the circumstances.

This report has been prepared for you and your design consultants to be used for evaluation of the subsurface soil conditions for the proposed construction at the subject site. This report has not been prepared for the use by other parties or for other purposes, and may not contain sufficient information for other than the intended use.

Services performed by this facility at the subject site were conducted in a manner consistent with that level of care and skill ordinarily exercised by members of the profession currently practicing in the same locality under similar conditions. No other warranties are expressed nor implied.

It is the professional opinion of the undersigned that this report presents fairly the information requested by you.

Respectfully submitted,

**SWN Soiltech Consultants, Inc.**

  
Stephen W. Ng  
GE 637



# **REPORT**

## **PRELIMINARY SOILS ENGINEERING INVESTIGATION**

PROPOSED RESIDENTIAL DEVELOPMENT  
77 PORTUGUESE BEND ROAD  
ROLLING HILLS, CALIFORNIA

For

Wei-Min and Ying Sai Shen

Project Ref. 4868-12

May 10, 2012

# TABLE OF CONTENTS

	PAGE
INTRODUCTION .....	1
PROPOSED CONSTRUCTION .....	1
SCOPE OF WORK .....	1
SITE CONDITIONS .....	2
SOIL CONDITIONS .....	3
Fill .....	3
Soil/colluvium .....	3
Slide Debris .....	3
Terrace Deposits .....	3
Bedrock .....	3
CONCLUSIONS .....	4
STATEMENT OF COMPLIANCE WITH BUILDING CODE SECTION 111 .....	5
RECOMMENDATIONS .....	6
Site Preparation .....	6
Graded Slopes .....	6
Seismic Design Parameters .....	7
Corrosivity .....	7
Foundations .....	8
Allowable Bearing Capacity .....	8
Settlement .....	8
Lateral Design .....	9
Concrete Slabs .....	9
Preventive Slope Maintenance .....	10
Drainage Control .....	11
Construction Site Maintenance .....	11
Excavation .....	12
Soils Engineering Approval .....	13
REMARKS .....	14
APPENDIX I - FIELD INVESTIGATION .....	15
APPENDIX II - LABORATORY TESTING .....	16
Direct Shear Test Plot, Plates C-1 - C-17	
Consolidation Test Plot, Plates D-1 – D-5	
Corrosivity Test Results, Plate E-1	
APPENDIX III - GRADING GUIDELINES .....	20
APPENDIX IV - SLOPE STABILITY ANALYSIS .....	22
Plates IV-1 – IV-6	
APPENDIX V - SLOPE SURFACE STABILITY ANALYSIS .....	23
Plate V-1	
APPENDIX VI - SEISMIC DESIGN PARAMETERS .....	24
Plate VI-1	

---

## **INTRODUCTION**

This report presents the results of a soils engineering investigation for the proposed development of the subject site located at 77 Portuguese Bend Road, in the City of Rolling Hills, California. The purpose of this investigation was to obtain information on the subsurface soils conditions at the areas of the proposed development at the subject site and to provide recommendations pertinent to grading, foundation design, temporary excavations and other relevant parameters for the design and construction of the proposed development.

Our soils engineering investigation has been conducted in conjunction with an engineering geologic investigation by Coast Geotechnical, whose report (W.O. 430412-01) dated May 5, 2012 should be reviewed in conjunction with this report.

## **PROPOSED CONSTRUCTION**

Development plans are not available at the time of this report. We understand that the proposed development will consist of a new single-family residence. The proposed residence will likely be located at the ridge shown along Section A-A' of the Coast Geotechnical report. Proposed improvement could include creation of a level pad for the proposed residence and an access driveway from Portuguese Bend Road to the residence.

Specific construction plans have not been prepared and await the conclusions and recommendations of this report. Specific construction plans shall be reviewed by this facility, when available, so as to determine the need for further soils engineering study and revised recommendations pertinent to the proposed development. Further geotechnical study may include additional field exploration, laboratory testing and engineering analysis.

## **SCOPE OF WORK**

Our scope of work for this report included the following:

1. Review of available geotechnical data;
2. Subsurface exploration by means of 5 test borings excavated with truck-mounted drill rig and a crawler-mounted drill rig;
3. Logging and sampling of the soils encountered in the exploratory test borings;



- 
4. Laboratory testing of the acquired samples to determine the pertinent soils engineering properties of the subsurface soils;
  5. Soils engineering analysis; and
  6. Preparation of this report that summarizes the field and laboratory findings and provides recommendations pertinent to the design and construction of the project.

The following attached Appendices complete this report:

Appendix I - Procedures and findings of field exploration

Appendix II - Procedures and findings of laboratory testing

Appendix III - Grading guidelines

Appendix IV - Stability analysis of existing slope

Appendix V - Stability analysis of existing slope surface

Appendix VI - Results of search for seismic design parameters from  
National Seismic Hazard Mapping Project Web Site

## **SITE CONDITIONS**

The subject site is comprised of about 20 acres of unimproved land located southwesterly of the southern terminus of Portuguese Bend Road, and at a short distance southwest of Crest Road, in the City of Rolling Hills. The location and topographic features of the subject site are shown on the Geologic Maps and Cross Sections included in the Coast Geotechnical report.

The subject site is accessed from the southern terminus of Portuguese Bend Road. Unpaved access roads and paths provide access to parts of the site. The site includes relatively gentle slopes descending to the southwest. Steeper slopes are present adjacent to drainage ravines and landslide head scarps, as well as cuts for the access roads.

No ground water was encountered in the exploratory test borings to the depths explored and none is anticipated to be within depths pertinent to the proposed development. It should be noted that fluctuations in the level of ground water might occur due to variations in rainfall, temperature and other factors at the time observations are made.

---

## **SOIL CONDITIONS**

Subsurface exploration for this phase of the investigation consisted of 5 test borings. The approximate locations of the exploratory test borings are shown on the geology map included in the Coast Geotechnical report. No significant amount of soil caving was observed in the test borings. No ground water was encountered in the exploratory test borings to the depths explored.

### **Fill**

No significant amount of fill soils was found in the exploratory test borings. Minor amount of fill soils are present along the edges of the existing access roads and paths. These fill soils consist of loose mixtures of locally derived soils and rocks. It should be noted that fill soils of unknown depths may be present at other locations of the site.

### **Soil/Colluvium**

The subject site is generally mantled with a layer of soil/colluvium. Approximately one to 6 feet of soil/colluvium were encountered in the exploratory test borings. Where encountered, the soil/colluvium consists generally of dark-colored, slightly moist to moist, soft to medium stiff, sandy to silty clay with varying amount of rock fragments and roots.

### **Slide Debris**

Landslides are present at parts of the subject site. The limits of the landslides are shown on the geology map included in the Coast Geotechnical report. Approximately 35 feet of slide debris were encountered in the Boring 3. Approximately 18 feet of possible slide debris were encountered in the Boring 5. Where encountered, the slide debris consists generally of light to medium-colored, moist to very moist, stiff to hard, siltstone and basalt. Clay seams are reportedly present within the slide debris.

### **Terrace Deposits**

Up to approximately 30 feet of terrace deposits were found in Boring 1. The terrace deposits consist generally of light to medium-colored, moist to very moist, dense, silty to clayey sand with abundant rock fragments.

### **Bedrock**

Bedrock underlying the subject site consists predominantly of siltstone and basalt, with minor amount of sandstone and claystone. The bedrock is generally light to medium-colored, moist to very moist, and stiff to very hard.

---

## CONCLUSIONS

The geologic investigation by Coast Geotechnical has found favorable geologic conditions at the area of the proposed construction at the subject site. Gross failure of the on-site soils and bedrock is unlikely under normal circumstances. The potential for gross instability that may affect the proposed development is considered to be low if the site is improved and maintained in accordance with our recommendations.

The following should be noted:

1. The existing fill soils, natural soil/colluvium and slide debris are subject to local soil movement. These materials should not be used to support any structure or structural fill soils. It should be noted that the thicknesses of the existing fill soils, natural soil/colluvium and slide debris might vary significantly at different locations of the subject site.
2. The terrace deposits and bedrock underlying the site are suitable for structural support. The proposed residence shall be supported in the terrace deposits or bedrock.
3. New structural fill soils should be placed on terrace deposits or bedrock.
4. Samples of the on-site soils exhibit low to medium potentials for expansion. These materials could swell significantly in the presence of moisture and shrink when dried. Foundations and slabs supported on these soils should be designed for expansive soil conditions. The subgrade soils shall be further tested for expansion potential during construction to determine if revised slab design would be necessary.
5. The existing fill soils, natural soil/colluvium and slide debris have potential for caving in steep cuts. Temporary excavations may need to be supported or trimmed back. Foundation excavations may need to be formed.
6. A representative sample of the soils obtained from the subject site was delivered to Anaheim Test Laboratory to determine the corrosivity potential of the soils. Results are attached in Appendix II.
  - A pH of 6.6 is considered to be within “normal” limits.
  - A sulfate concentration of 1,235 ppm is considered to be moderately corrosive.
  - A chloride concentration of 374 ppm is considered to be moderately corrosive.
  - A resistivity of 600 ohm-cm is considered to be severely corrosive.

- 
7. Slabs and pavements supported by the existing fill soils, natural soil/colluvium or slide debris will be subject to movements resulting in distress. Distress to the slabs and pavements may be reduced by supporting the slabs on terrace deposits or bedrock, or compacted fill placed on the terrace deposits or bedrock. Alternatively the slabs may be structurally supported by foundations embedded in terrace deposits or bedrock.
  8. Typically, cracking of reinforced concrete can occur and is a common process. Reinforcement and crack control joints are intended to minimize this risk. In addition, irregularities of new slabs are common. A completed slab is generally not perfectly level and not free of some type of cracking.
  9. Soil sloughing on the steep portions of the slopes is anticipated. The amount of soil sloughing may be reduced by proper planting and drainage control.
  10. Excavation may be difficult due to the presence of cobbles in the terrace deposits and hardness of some of the bedrock.
  11. There are certain hazards connected with owning a hillside property in Southern California. Property damage may result from flooding, debris flows, slope erosion, brush fires and earthquakes of major magnitude.

#### **STATEMENT OF COMPLIANCE WITH BUILDING CODE SECTION 111**

It is our opinion, based upon tests conducted as described in this report, copies of test results being available for review, that the proposed residence at the subject site will not be affected by hazards from landslide, settlement, or slippage, and that the proposed development will have no adverse effect on the geologic stability of properties outside of the subject site, provided it is constructed and maintained in accordance with recommendations presented in this report.

The nature and extent of tests conducted for purposes of this declaration are, in our opinion, in conformance with generally accepted practice in the area. Test findings and statements of professional opinion do not constitute a guarantee or warranty, expressed or implied.

---

## RECOMMENDATIONS

### Site Preparation

Vegetation and debris encountered during construction shall be removed from the area of the proposed construction. Existing fill soils, natural soil/colluvium and slide debris exposed at the proposed grade of slabs on-grade, or any area to receive fill soils, shall be removed to terrace deposits or bedrock and wasted off-site or replaced as compacted fill.

The excavated soils may be reused in the compacted fill, provided they are cleaned of vegetation and debris. Fill placement shall be in accordance with **Grading Guidelines** given in Appendix III of this report.

The exploratory test borings were backfilled upon completion of the field exploration using the excavated soils. Backfilling was performed to the extent possible with the equipment on hand. However, the backfill was not compacted to the requirements of "structural fill." Structures, concrete flatwork, pavement, utilities or other improvements placed in the vicinity of the test borings shall be designed to span over the test borings.

### Graded Slopes

Extensive grading that would result in high or steep cut or fill slopes is not recommended. The stability of any fill or cut slope and its effect on the stability of the site shall be evaluated during grading.

Fill slopes shall be made no steeper than 2:1 (Horizontal to Vertical). The toe of fill slopes shall be provided with a keyway of no less than 12 feet wide and extending at least 2 feet into terrace deposits or bedrock, measured from the downslope side of the keyway. The fill soils shall be benched into terrace deposits or bedrock as filling progresses.

Fill placement shall be in accordance with **Grading Guidelines** given in Appendix III.

The need for subdrain behind any fill slope should be determined when grading plans are available for review.

We recommend that any cut slopes be made no steeper than 2:1 (Horizontal to Vertical). The Engineering Geologist shall evaluate any proposed cut slopes to determine if any adverse conditions may be created by such cuts.

---

### Seismic Design Parameters

In accordance with Chapter 16 of the 2010 California Building Code, the following seismic parameter values can be utilized in the design of the proposed structures:

Site Class: D for stiff soil profile

Mapped Acceleration Parameters:  $S_s = 1.609 > 1.25$   
 $S_1 = 0.650 > 0.50$

Site Coefficient:  $F_a = 1.0$   
 $F_v = 1.5$

Maximum Spectral Response Acceleration:  $S_{MS} = 1.609$   
 $S_{M1} = 0.976$

Design Spectral Response Acceleration:  $S_{DS} = 1.073$   
 $S_{D1} = 0.650$

Site Seismic Design Category: D

The mapped acceleration parameters were obtained from the National Seismic Hazard Mapping Project Web Site. Results are presented in Appendix VI.

### Corrosivity

The on-site soils have severe corrosive potential. We recommend the following:

1. Type II cement should be used.
2. Buried metal pipes and utilities should be sleeved inside schedule 40 PVC pipes, encased in at least 3 inches of concrete, wrapped with protective tape system or coated with cathodic protection system.
3. Where metal pipes penetrate concrete slabs, plastic sleeves, rubber seals, or other dielectric material should be used to prevent pipes from contacting concrete and reinforcing steel.
4. In accordance with Section 1904.3 of the 2010 California Building Code, concrete shall comply with the maximum water-cementitious materials ratios and/or minimum specified compressive strength and be made with the appropriate type of cement in accordance with the provisions of ACI 318, Section 4.3.

---

## Foundations

The proposed residence shall be supported by foundations embedded into terrace deposits or bedrock.

Spread footings shall be embedded at least 18 inches into terrace deposits or bedrock, measured from the lowest adjacent finished grade of the terrace deposits or bedrock. Caissons, if necessary, shall be embedded at least 3 feet into firm terrace deposits or bedrock.

All foundations shall be continuous or tied with grade beams. At least two #4 bars shall be placed near the top and two #4 bars near the bottom of continuous footings.

Continuous footings shall be at least 12 inches wide. Square footings shall be at least 24 inches wide. Caissons shall be at least 24 inches in diameter.

## Allowable Bearing Capacity

For preliminary design purposes, the allowable bearing value for foundations placed as recommended may be calculated from the following. The allowable bearing value should not exceed 4,000 pounds per square foot for the terrace deposits or bedrock.

<b>Terrace Deposits or Bedrock</b>	Continuous Footings:	$q = 800 + 800d + 400b$
	Square Footings:	$q = 900 + 800d + 300b$
	Caissons:	$q = 900 + 800d + 200b$

where:

q = allowable soil bearing value, in pounds per square foot.

d = depth of foundation into the terrace deposits or bedrock, in feet.

b = smallest width of footing, or diameter of caissons, in feet.

The recommended values are for dead load plus frequently applied live load and may be increased by one-third when considering total loads including short duration of wind or seismic forces.

## Settlement

Total and differential settlements of the proposed foundations, embedded in terrace deposits or bedrock as recommended, are anticipated to be within tolerable limits.

Total settlement of each foundation is expected to be less than ½ inch, accompanied by differential settlement of less than ¼ inch.

---

## Lateral Design

Lateral loads may be resisted by passive earth pressure and friction.

	<b>Allowable Lateral Bearing</b>	<b>Maximum Lateral Bearing</b>	<b>Coefficient of Friction</b>
<b>Terrace Deposits or Bedrock</b>	400 psf/ft.	4,000 psf	0.40

The allowable bearing values may be used provided there is positive contact between the bearing surface and the terrace deposits or bedrock.

If the frictional and lateral bearing resistances are combined, the lateral bearing resistance should be reduced by one-third. The above values may be increased by one-third for short duration of seismic and wind forces.

## Concrete Slabs

Concrete slabs may be constructed with one of the following methods. It should be noted that slabs not structurally supported in terrace deposits or bedrock might still be subject to some distress. Some periodic maintenance may be required.

1. The slabs may be structurally supported by foundations embedded in the terrace deposits or bedrock.
2. The slabs may be post-tensioned.
3. The slabs may be supported on terrace deposits or bedrock or compacted fill placed on the terrace deposits or bedrock. The existing fill soils, natural soil/colluvium or slide debris should be removed and recompacted.

The fill soils shall be compacted to a minimum of 90% relative compaction in accordance with ASTM D 1557 method of compaction. Fill placement shall be in accordance with **Grading Guidelines** given in Appendix III. Presoaking of 24 inches of subgrade soils is recommended

It is recommended that slabs placed on grade be supported by a minimum of 4 inches of base. These slabs shall be at least 5 inches thick and be reinforced with at least No. 4 bars at 18 inches, both ways. A moisture barrier, such as 6-mil visqueen, shall be placed beneath the slabs where upward capillary of moisture is undesirable. The visqueen should be covered with one inch of sand to prevent puncture.



---

The concrete slabs placed on-grade shall be structurally separate from the surrounding footings. Exterior slabs should be provided with proper crack control joints. Typical concrete shrinkage can result in cracks and gaps along the crack control joints and where the slab connects to structures. The gaps will require periodic caulking to limit infiltration of moisture.

Exterior slabs planned adjacent to descending slopes should be provided with a thickened edge. The thickened edge should be at least 12 inches wide, 24 inches deep, and reinforced with four #4 bars, two placed near the top and two near the bottom.

### **Preventive Slope Maintenance**

We recommend that the homeowner maintain an adequate debris, erosion and fire control program to protect the property.

Sloughing and slumping of the surface of any slope may be anticipated if the slope is left unprotected over a period of time, especially during rainy seasons. It should be noted that excessive landscape watering, rodent burrows and uncontrolled surface runoff might cause instability of the slope surface. The following recommendations are provided so as to minimize the potential for erosion of slopes at the subject site.

1. The slopes shall be planted and maintained with a suitable deep-rooted ground cover as soon as possible. Additional protection may be provided by the use of jute mesh or suitable geofabrics. If adequate ground cover is not established before the rainy season, sloughing and slumping of the surficial soils may occur. It is imperative that landscape watering be kept to the minimum required for normal plant growth.
2. Any paved drainage swale and downdrain on the slopes and drain inlet should be kept free of soils and debris.
3. Adequate site drainage shall be provided. All roof and surface drainage shall be conducted away from foundation and slope areas via engineered non-erosive devices to existing stormdrain facilities on the street or down the slopes in a controlled manner. In no case shall water be allowed to pond within the site, drain towards structures or flow in a concentrated and uncontrolled manner down the slopes.

---

## **Drainage Control**

Drainage control is imperative for continued site stability. The risk of unusual settlement or stability of structures can be reduced by proper drainage control and maintenance of yards. It is the responsibility of the owner to maintain the drainage facilities and correct any deficiency found during occupancy of the property.

1. Roof gutters and area drains with proper gradient of the surrounding soils should be provided. Pad and roof drainage should be positively collected and transferred to the street or other approved disposal locations via non-erosive drainage devices.
2. Water should not be allowed to pond on the pad, flow towards any foundation or wall, or sheet-flow over any descending slopes.
3. Drainage from the street, ascending slopes and offsite properties should not be permitted to flow onto the site, unless such runoff can be directed to the street or other approved disposal locations via non-erosive drainage devices.
4. Any crack in paved surfaces should be sealed to limit infiltration of surface water.
5. Slopes and yards should be provided with low maintenance, erosion control vegetation. Care should be taken not to over-irrigate the site. Landscape watering shall be kept to the minimum necessary for normal plant growth.
6. Planting around structures should be minimized. Planters located adjacent to the structures should be sealed and properly drained. The feasibility of utilizing contained planters should be considered.
7. Water and sewer lines within the subject site shall be checked for leakage periodically and repaired if necessary.

## **Construction Site Maintenance**

It is the responsibility of the Contractor to maintain a safe construction site.

1. When excavations exist on a site, the area should be fenced and warning signs posted.
2. All deep excavations must be properly covered and secured.
3. Workers should not be allowed to enter any unshored trench excavations over five feet deep.

- 
4. Earth materials generated from foundation and subgrade excavations should be either removed from the site or properly compacted.
  5. Fill temporarily stockpiled on the site should be placed in a stable area, away from slopes, excavations and improvements. Earth materials must not be spilled over any descending slope.
  6. Temporary erosion control measures and protection of excavation from drainage and erosion during the rainy season is required.

### **Excavation**

Sequence of construction and method shall be determined by the Contractor.

1. Although no significant amount of soil caving was encountered in the exploratory test borings, other excavations may experience caving. Construction methods shall meet the requirements of the California Occupational Safety and Health Association (CAL-OSHA), and other public agencies having jurisdiction.
2. We recommend that the cut slopes be inspected during excavation by personnel of this facility, so that necessary modifications can be made.
3. Where necessary construction space is available, temporary unsurcharged excavations may be considered to the depths and slope ratios tabulated below:

	<b>Maximum Depth of cut (Feet)</b>	<b>Maximum Slope Ratio (Horizontal to Vertical)</b>
<b>Fill/Soil/Slide Debris</b>	0 - 4	Vertical
	4+	1:1
<b>Terrace Deposits/Bedrock</b>	0 - 5	Vertical
	5 - 10	¾:1
	10+	1:1

4. Soils exposed in the cuts should be kept moist but not saturated, to reduce the tendency for raveling and sloughing during construction.
5. The top of the cut slopes should be barricaded to keep vehicles and heavy storage loads at least five feet away from the top of the slopes.
6. During the rainy season, berms should be constructed and maintained along the top of the slopes and plastic sheets should be placed over the slopes to prevent runoff water from eroding the slope faces.

- 
7. Where construction space is not available, the cuts shall be shored or made in slots.
  8. The shoring system shall be designed for an equivalent fluid pressure of no less than 30 pounds per square foot per foot.

### **Soils Engineering Approval**

A set of construction plans should be submitted to this office for review and approval prior to initiation of construction.

As a necessary requisite to the use of this report, the following shall be observed by personnel of this facility:

1. Temporary excavations and bracing.
2. Removal of unsuitable soils in areas of proposed slabs.
3. Bottom of excavation prior to placement of compacted fill.
4. Backfill placement and compaction.
5. Surface and subsurface drainage systems.
6. Foundation excavations.

It is advised that the client contact **SWN Soiltech Consultants, Inc.**, at least 1 week in advance of commencing construction to allow for contractual agreements for geotechnical services during the construction phases of your project.

Please advise this office at least 48 hours prior to any required verification.

Representatives of **SWN Soiltech Consultants, Inc.** will observe work in progress, perform tests on soils, and observe excavations and trenches. It should be understood that the contractor or others shall supervise and direct the work and they shall be solely responsible for all construction means, methods, techniques, sequences and procedures, and shall be solely and completely responsible for the conditions of the job site, including safety of all persons and property during the performance of the work.

Periodic observation by **SWN Soiltech Consultants, Inc.** is not intended to include verification of dimensions or review of the adequacy of the contractor's safety measures in, on, or near the construction site.

---

## REMARKS

This report was prepared by **SWN Soiltech Consultants, Inc.** on the basis of our understanding of the proposed development. In the event of any change in the design or location of any structure, as outlined in this report, the conclusions and recommendations contained herein may not be considered valid unless the changes are reviewed by us and our conclusions and recommendations are modified or reaffirmed after such review.

This report is intended to reduce risk associated with the proposed construction project. The professional opinions and geotechnical advice presented in this report are not intended to imply total performance of the project or guarantee that unusual conditions will not be discovered during or after construction.

The conclusions and recommendations contained herein are based on the surface examination and the findings and observations at the exploratory locations. It is assumed that soil conditions at other locations of the subject site do not deviate significantly from those disclosed at the exploratory locations. Conditions may be concealed by earth materials or existing improvements. If conditions are encountered during construction which appear to be different from those disclosed by the exploratory work, we should be notified so as to consider the need for modifications.

This report has been compiled for the exclusive use of **Wei-Min and Ying Sai Shen** and their authorized representatives. It shall not be transferred to, or used by, a third party, to another project or applied to any other project on this site, other than described herein, without consent and/or thorough review by this facility.

Should the project be delayed beyond the point of **one-year** after the date of this report, the site should be observed and the report reviewed to consider possible changed conditions.

This report is issued with the understanding that it is the responsibility of the owner, or his representative, to assure that the information and recommendations contained herein are called to the attention of the designers and builders for the project.

This report is subject to review by controlling public agencies having jurisdiction. It should be noted that the agencies could dictate the manner in which the project proceeds. No guarantee that the agencies will approve the project is intended, expressed or implied. The agencies may ask questions regarding the information presented in this report and may require additional fieldwork and/or additional evaluations.

---

## **APPENDIX I**

### **FIELD INVESTIGATION**

Field investigation was performed using a truck-mounted drill rig and a crawler-mounted drill rig. Five exploratory test borings were excavated to depths of approximately 56 to 95 feet below the existing ground surface. The approximate locations of the exploratory test borings are shown on the geology map included in the Coast Geotechnical report.

Representative undisturbed and bulk samples of the subsurface soils encountered in the test borings were obtained. The samples were returned to the laboratory for subsequent testing.

---

## APPENDIX II

### LABORATORY TESTING

Laboratory testing was performed after review of the field data and in consideration of the soils engineering conditions of the area of the proposed development to be evaluated. Laboratory testing included determinations of moisture content, density, shear strength, consolidation characteristics, maximum density, optimum moisture content and expansion potential of representative samples of the on-site soils.

#### Moisture Density

The moisture-density information provides a summary of soil consistency for each stratum. The dry unit weight and field moisture content were determined from undisturbed samples, and the results are shown below:

<b>Sample Location</b>	<b>Soil Description</b>	<b>In Situ Dry Density</b>	<b>In Situ Moisture Content</b>
B.1 @ 5'	Terrace – silty-clayey sand	95.4 pcf	17.6%
B.1 @ 15'	Terrace – silty-clayey sand	91.2 pcf	24.5%
B.1 @ 20'	Terrace – silty-clayey sand	93.7 pcf	25.0%
B.1 @ 25'	Terrace – silty-clayey sand	97.2 pcf	14.6%
B.1 @ 35'	Bedrock – siltstone	93.3 pcf	17.7%
B.1 @ 45'	Bedrock – siltstone	91.3 pcf	20.1%
B.1 @ 55'	Bedrock – siltstone	82.4 pcf	26.1%
B.1 @ 75'	Bedrock – siltstone	80.3 pcf	26.4%
B.1 @ 88'	Bedrock – siltstone	86.0 pcf	20.7%
B.2 @ 2'	Bedrock – sandstone	105.1 pcf	15.5%
B.2 @ 8'	Bedrock – sandstone	105.6 pcf	11.1%
B.2 @ 14'	Bedrock – sandstone	114.0 pcf	9.9%
B.2 @ 20'	Bedrock – sandstone	123.2 pcf	8.4%
B.2 @ 30'	Bedrock – sandstone	116.8 pcf	9.6%
B.2 @ 40'	Bedrock – sandstone	104.1 pcf	18.0%
B.2 @ 50'	Bedrock – basalt	103.2 pcf	20.2%
B.2 @ 60'	Bedrock – basalt	112.5 pcf	15.7%
B.2 @ 80'	Bedrock – basalt	99.3 pcf	19.9%
B.2 @ 90'	Bedrock – basalt	113.7 pcf	10.5%

---

**LABORATORY TESTING** (Continued)

**Moisture Density** (Continued)

<b>Sample Location</b>	<b>Soil Description</b>	<b>In Situ Dry Density</b>	<b>In Situ Moisture Content</b>
B.3 @ 3'	Colluvium – sandy-silty clay	94.7 pcf	15.9%
B.3 @ 9'	Slide debris - basalt	113.6 pcf	14.6%
B.3 @ 15'	Slide debris - basalt	103.0 pcf	17.3%
B.3 @ 22'	Slide debris - siltstone	100.2 pcf	16.3%
B.3 @ 32'	Slide debris - siltstone	90.0 pcf	26.2%
B.3 @ 42'	Bedrock - siltstone	104.6 pcf	17.5%
B.3 @ 52'	Bedrock - siltstone	108.9 pcf	15.9%
B.3 @ 62'	Bedrock - basalt	105.0 pcf	15.9%
B.3 @ 72'	Bedrock - basalt	114.5 pcf	14.7%
B.3 @ 95'	Bedrock - basalt	110.8 pcf	7.4%
B.4 @ 5'	Bedrock - clay	78.4 pcf	27.2%
B.4 @ 10'	Bedrock - siltstone	82.9 pcf	23.8%
B.4 @ 16'	Bedrock - siltstone	95.6 pcf	12.4%
B.4 @ 21'	Bedrock - siltstone	97.3 pcf	23.5%
B.4 @ 38'	Bedrock - clay	74.4 pcf	29.5%
B.5 @ 5'	Terrace – silty-clayey sand	92.5 pcf	17.6%
B.5 @ 10'	Bedrock - siltstone	87.7 pcf	27.0%
B.5 @ 15'	Bedrock - siltstone	82.8 pcf	29.2%
B.5 @ 20'	Bedrock - siltstone	93.3 pcf	20.8%
B.5 @ 25'	Bedrock - claystone	75.9 pcf	29.3%
B.5 @ 30'	Bedrock - siltstone	100.4 pcf	22.9%
B.5 @ 35'	Bedrock - siltstone	107.1 pcf	6.9%



---

## **LABORATORY TESTING** (Continued)

### **Shear**

Shear tests were made with a direct shear machine at a constant rate of strain. The machine is designed to test the soils without completely removing the samples from the brass rings. A normal load was applied vertically on each sample and the soil shear strength was determined at this load. Samples were also tested at higher and/or lower normal loads in order to determine the cohesion and angle of internal friction.

The test results are plotted on "Direct Shear Test Plot," Plates C-1 to C-17.

### **Consolidation**

The apparatus used for the consolidation test is designed to test the soils without removing the sample from the brass ring. Loads were applied to the sample in several increments, and the resulting deformations were recorded at selected time intervals. Porous stones were placed in contact with the top and bottom of the sample to permit the ready addition or release of water. The sample was tested at the field and increased moisture contents.

The test results for this investigation are plotted on "Consolidation Test Plot," Plates D-1 to D-5.

### **Maximum Density - Optimum Moisture Content**

A representative bulk sample of the on-site soils was tested in the laboratory to determine the maximum dry density and optimum moisture content using the ASTM D 1557 compaction test method. This test procedure uses 25 blows of a 10-pound hammer, falling a height of 18 inches on each of five layers into a 1/30 cubic foot cylinder. The results of the tests are presented below:

<b>Sample Location</b>	<b>Soil Description</b>	<b>Maximum Dry Density</b>	<b>Optimum Moisture Content (% Dry Wt.)</b>
B.1 @ 2'	Sand, silty-clayey	115.0 pcf	15.0%

---

## **LABORATORY TESTING** (Continued)

### **Expansion Potential**

To determine the expansion potential of the on-site soils, representative samples were remolded at near 50% saturation and then allowed to absorb moisture under a surcharge of 144 psf in accordance with UBC Standard No. 18-1. The results are shown below:

<b>Sample Location</b>	<b>Soil Description</b>	<b>Expansion Index</b>	<b>Potential Expansion</b>
B.2 @ 2'	Sand, silty-clayey	37	Low
B.3 @ 2'	Clay, sandy-silty	53	Medium

### **Corrosivity Test**

A representative sample of the on-site soils was delivered to Anaheim Test Laboratory to determine the corrosivity potential of the soils.

Results are attached on Plate E-1.

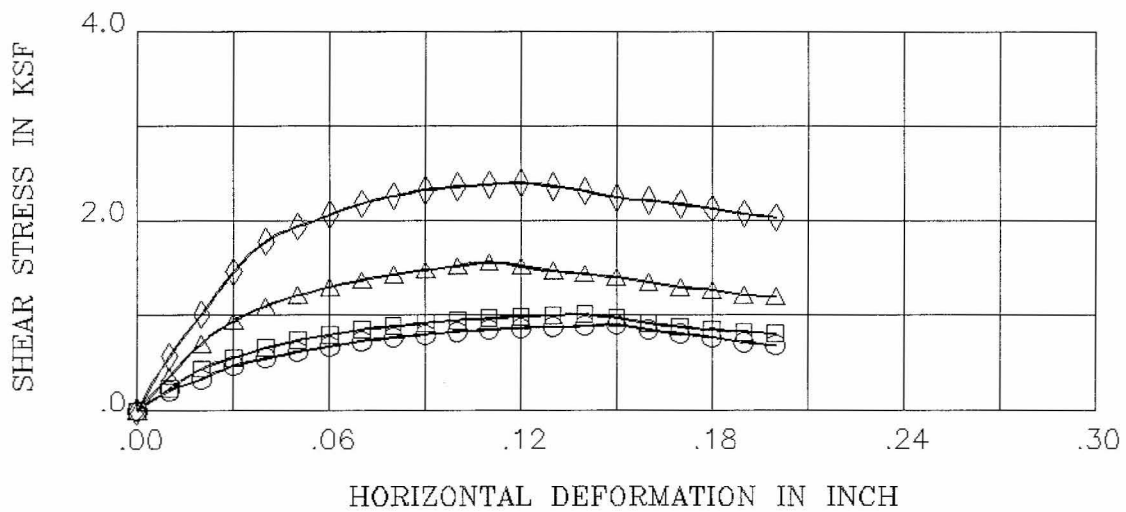
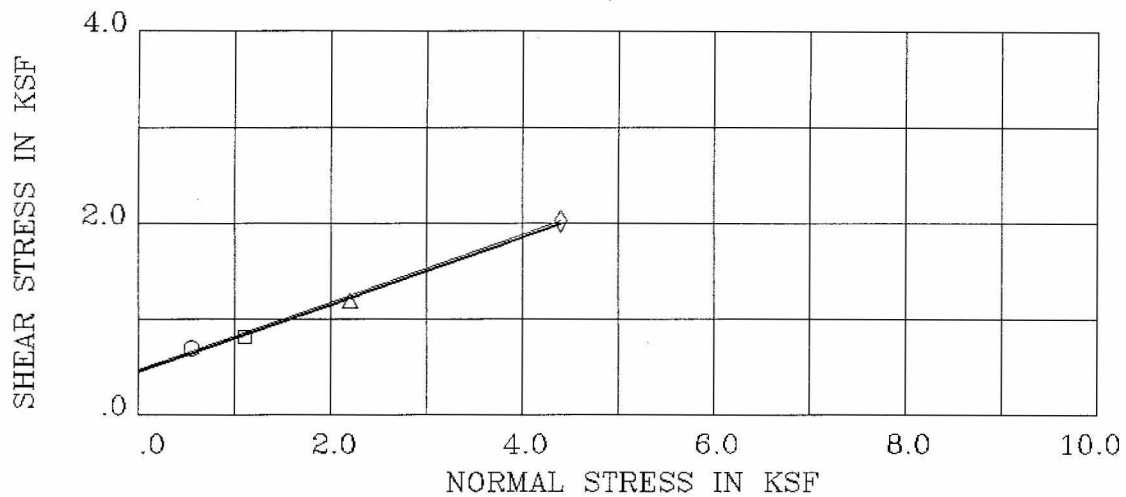

BORING/SAMPLE : B.3/S.1                      DEPTH (ft) : 3  
 DESCRIPTION : Colluvium - sand-silty clay  
 STRENGTH INTERCEPT (C) : .453 KSF  
 FRICTION ANGLE (PHI) : 19.5 DEG                      (RESIDUAL STRENGTH)

SYMBOL	MOISTURE CONTENT (%)	DRY DENSITY (pcf)	VOID RATIO	NORMAL STRESS (ksf)	PEAK SHEAR (ksf)	RESIDUAL SHEAR (ksf)
○	28.9	94.7	.811	.55	.90	.69
□	28.9	94.7	.811	1.10	1.01	.81
△	28.9	94.7	.811	2.20	1.55	1.20
◇	28.9	94.7	.811	4.40	2.39	2.03

Remark : Undisturbed samples, soaked

Project 4868-12	Shen - Portuguese Bend Road	
SWN Soiltech Consultants	DIRECT SHEAR TEST	Plate No. C-1

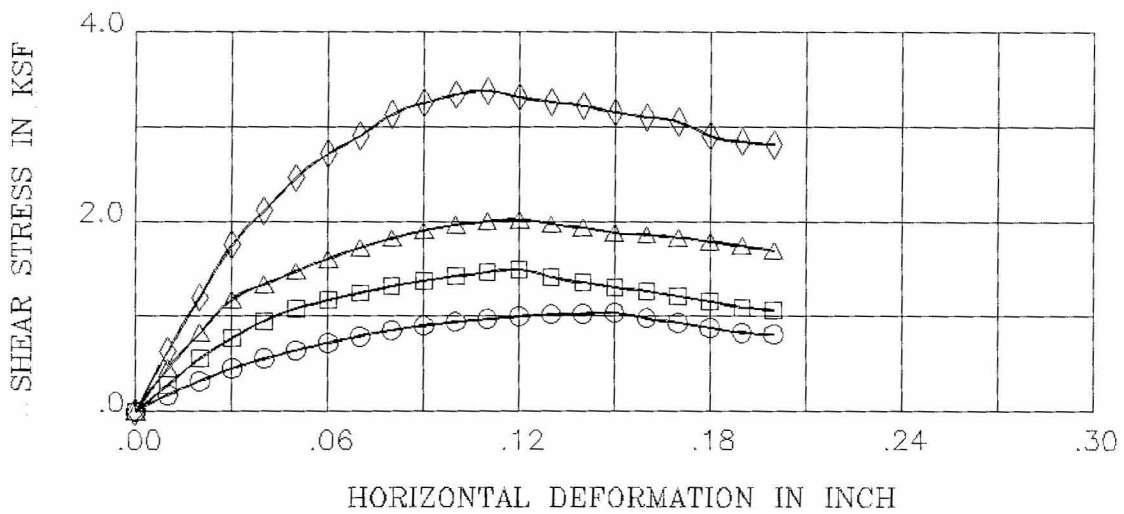
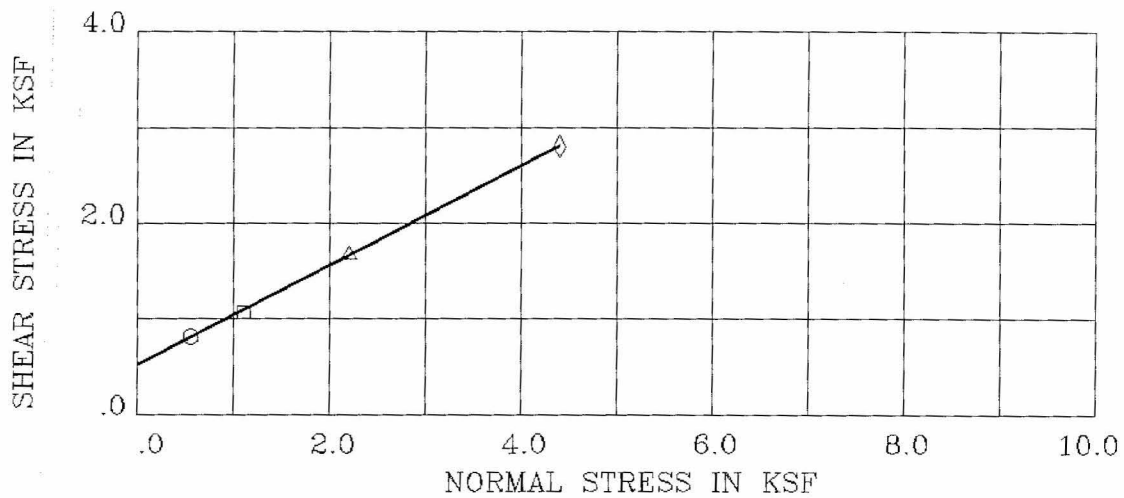

BORING/SAMPLE : B.1/S.1                      DEPTH (ft) : 5  
 DESCRIPTION : Terrace - silty-clayey sand  
 STRENGTH INTERCEPT (C) : .518 KSF  
 FRICTION ANGLE (PHI) : 27.6 DEG                      (RESIDUAL STRENGTH)

SYMBOL	MOISTURE CONTENT (%)	DRY DENSITY (pcf)	VOID RATIO	NORMAL STRESS (ksf)	PEAK SHEAR (ksf)	RESIDUAL SHEAR (ksf)
○	28.6	95.4	.799	.55	1.04	.81
□	28.6	95.4	.799	1.10	1.50	1.07
△	28.6	95.4	.799	2.20	2.02	1.69
◇	28.6	95.4	.799	4.40	3.37	2.81

Remark : Undisturbed samples, soaked

Project 4868-12	Shen - Portuguese Bend Road	
SWN Soiltech Consultants	DIRECT SHEAR TEST	Plate No. C-2

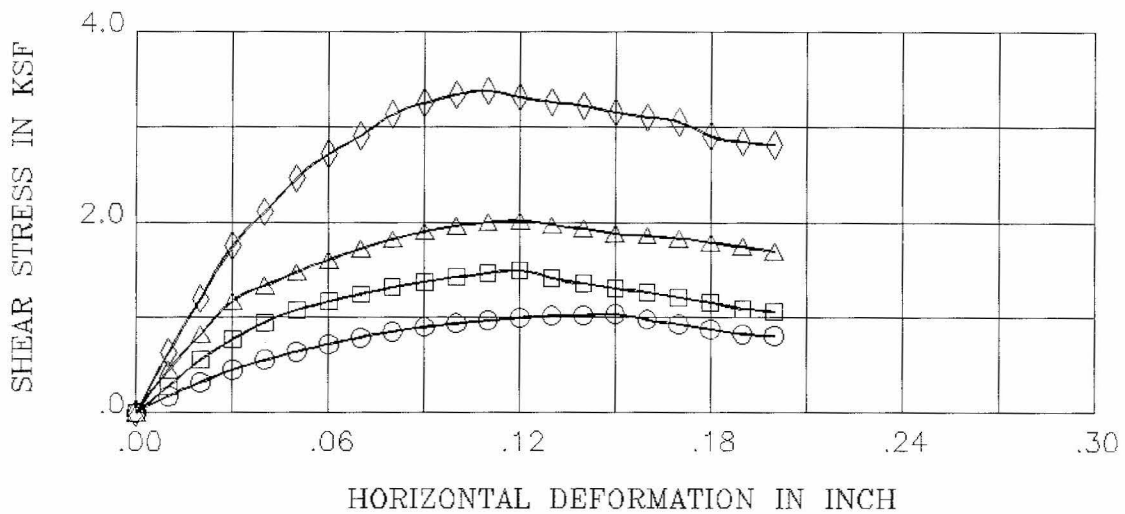
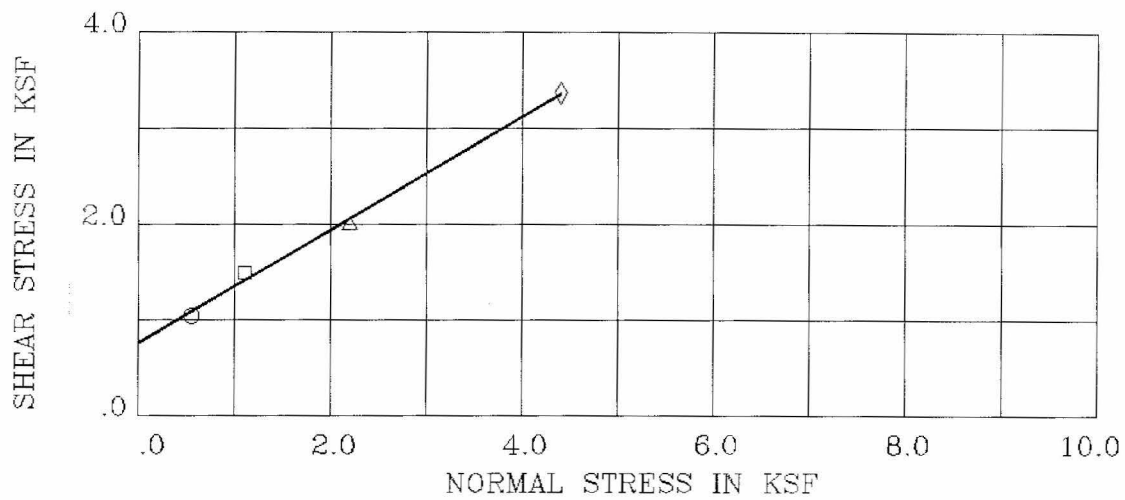

BORING/SAMPLE : B.1/S.1                      DEPTH (ft) : 5  
 DESCRIPTION : Terrace - silty-clayey sand  
 STRENGTH INTERCEPT (C) : .761 KSF  
 FRICTION ANGLE (PHI) : 30.6 DEG                      (PEAK STRENGTH)

SYMBOL	MOISTURE CONTENT (%)	DRY DENSITY (pcf)	VOID RATIO	NORMAL STRESS (ksf)	PEAK SHEAR (ksf)	RESIDUAL SHEAR (ksf)
○	28.6	95.4	.799	.55	1.04	.81
□	28.6	95.4	.799	1.10	1.50	1.07
△	28.6	95.4	.799	2.20	2.02	1.69
◇	28.6	95.4	.799	4.40	3.37	2.81

Remark : Undisturbed samples, soaked

Project 4868-12

Shen - Portuguese Bend Road

SWN  
 Soiltech  
 Consultants

DIRECT SHEAR TEST

Plate No. C-3

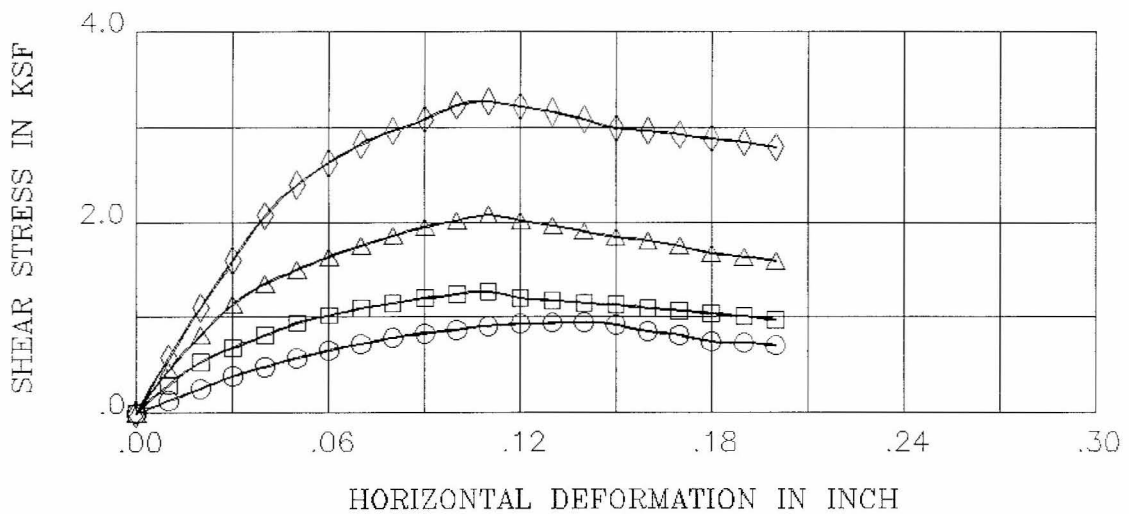
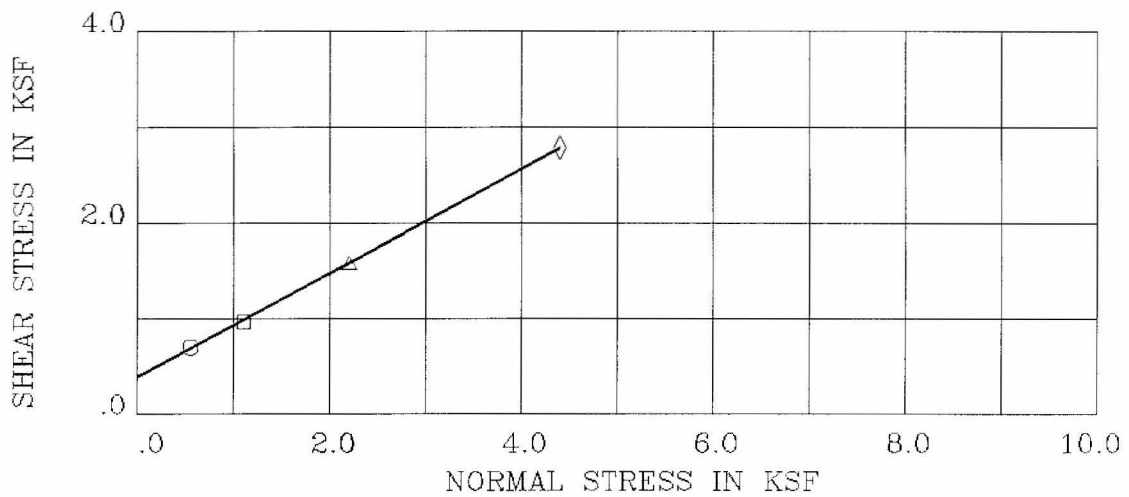

BORING/SAMPLE : B.1/S.3                      DEPTH (ft) : 20  
 DESCRIPTION : Terrace - silty-clayey sand  
 STRENGTH INTERCEPT (C) : .388      KSF  
 FRICTION ANGLE (PHI) : 28.6      DEG                      (RESIDUAL STRENGTH)

SYMBOL	MOISTURE CONTENT (%)	DRY DENSITY (pcf)	VOID RATIO	NORMAL STRESS (ksf)	PEAK SHEAR (ksf)	RESIDUAL SHEAR (ksf)
○	29.2	93.7	.831	.55	.95	.70
□	29.2	93.7	.831	1.10	1.27	.97
△	29.2	93.7	.831	2.20	2.08	1.59
◇	29.2	93.7	.831	4.40	3.27	2.79

Remark : Undisturbed samples, soaked

Project 4868-12	Shen - Portuguese Bend Road
SWN Soiltech Consultants	<b>DIRECT SHEAR TEST</b> Plate No. C-4

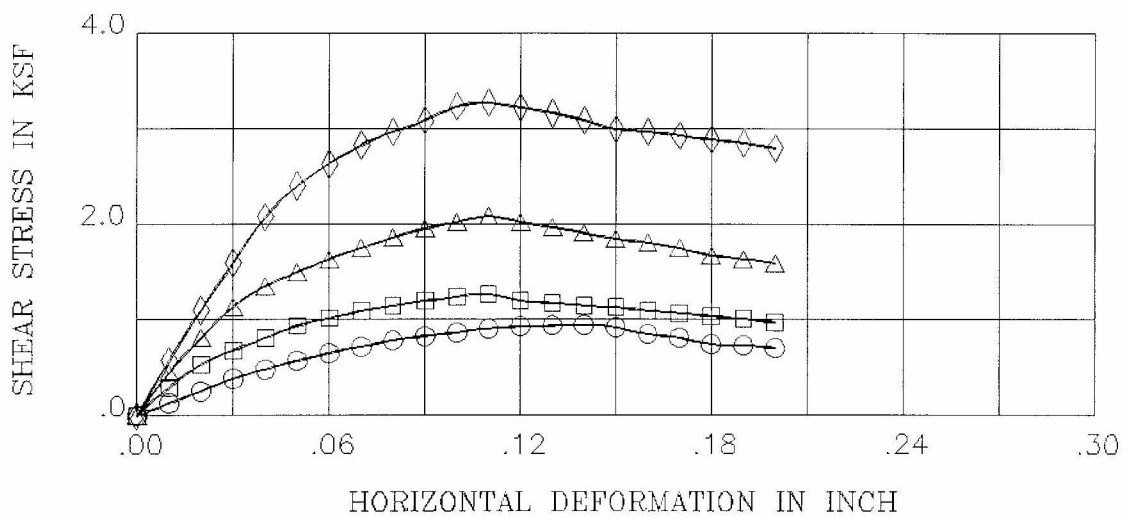
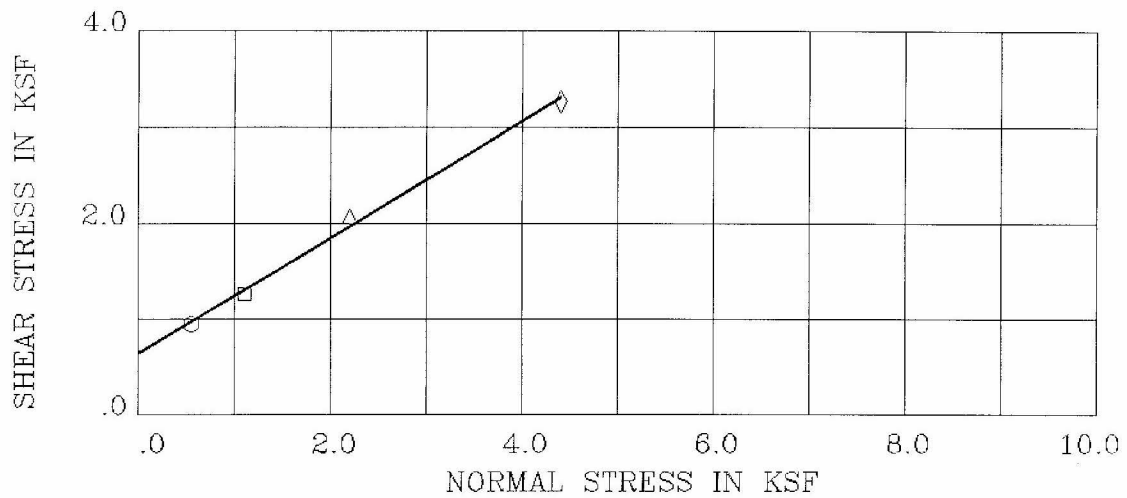

BORING/SAMPLE : B.1/S.3                      DEPTH (ft) : 20  
 DESCRIPTION : Terrace - silty-clayey sand  
 STRENGTH INTERCEPT (C) : .642 KSF  
 FRICTION ANGLE (PHI) : 31.2 DEG                      (PEAK STRENGTH)

SYMBOL	MOISTURE CONTENT (%)	DRY DENSITY (pcf)	VOID RATIO	NORMAL STRESS (ksf)	PEAK SHEAR (ksf)	RESIDUAL SHEAR (ksf)
○	29.2	93.7	.831	.55	.95	.70
□	29.2	93.7	.831	1.10	1.27	.97
△	29.2	93.7	.831	2.20	2.08	1.59
◇	29.2	93.7	.831	4.40	3.27	2.79

Remark : Undisturbed samples, soaked

Project 4868-12	Shen - Portuguese Bend Road
SWN Soiltech Consultants	<b>DIRECT SHEAR TEST</b> Plate No. C-5

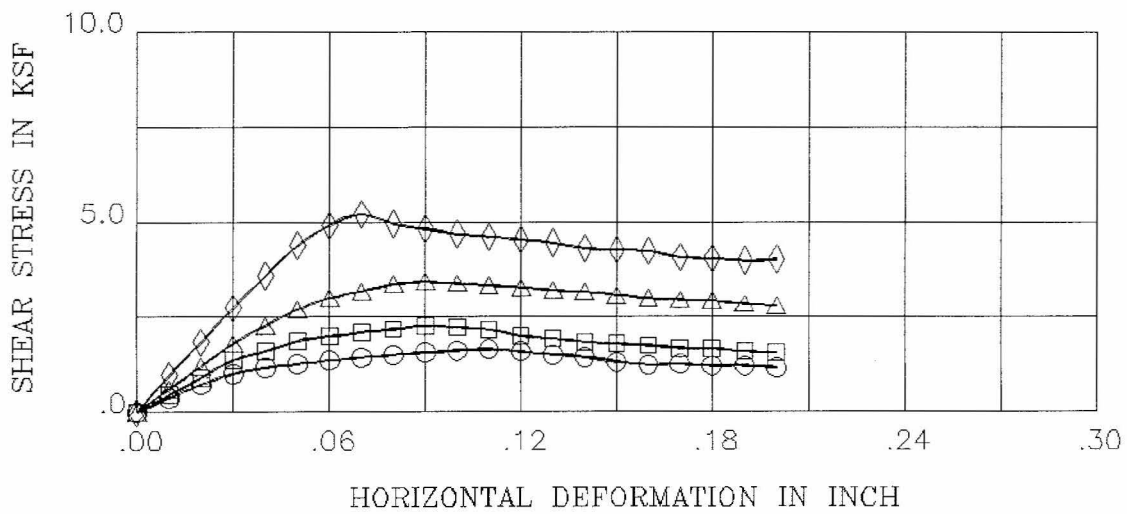
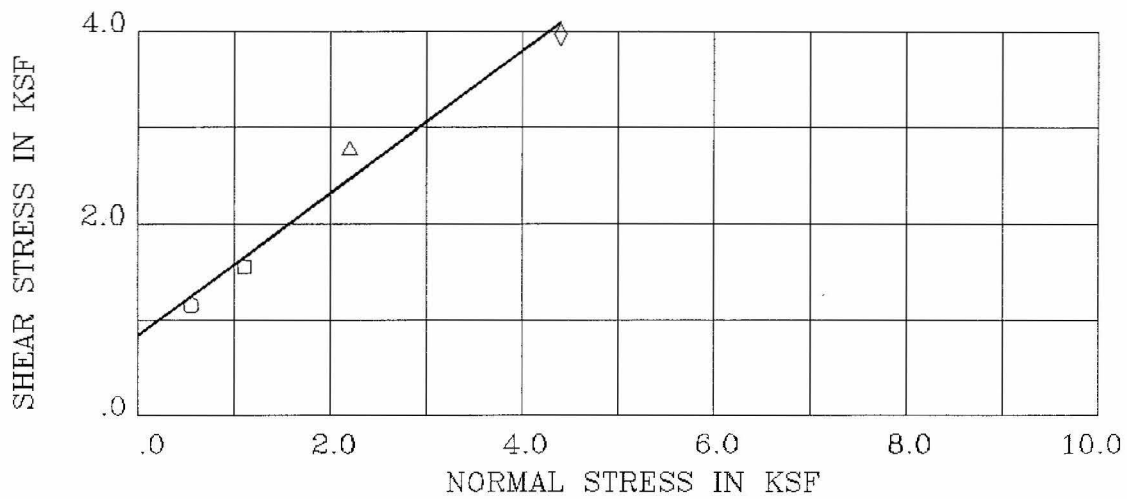

BORING/SAMPLE : B.1/S.8                      DEPTH (ft) : 75  
 DESCRIPTION : Bedrock - siltstone  
 STRENGTH INTERCEPT (C) : .849      KSF  
 FRICTION ANGLE (PHI) : 36.4      DEG                      (RESIDUAL STRENGTH)

SYMBOL	MOISTURE CONTENT (%)	DRY DENSITY (pcf)	VOID RATIO	NORMAL STRESS (ksf)	PEAK SHEAR (ksf)	RESIDUAL SHEAR (ksf)
○	40.6	80.3	1.138	.55	1.65	1.16
□	40.6	80.3	1.138	1.10	2.27	1.56
△	40.6	80.3	1.138	2.20	3.42	2.79
◇	40.6	80.3	1.138	4.40	5.20	3.98

Remark : Undisturbed samples, soaked

Project 4868-12	Shen - Portuguese Bend Road	
SWN Soiltech Consultants	DIRECT SHEAR TEST	Plate No. C-6



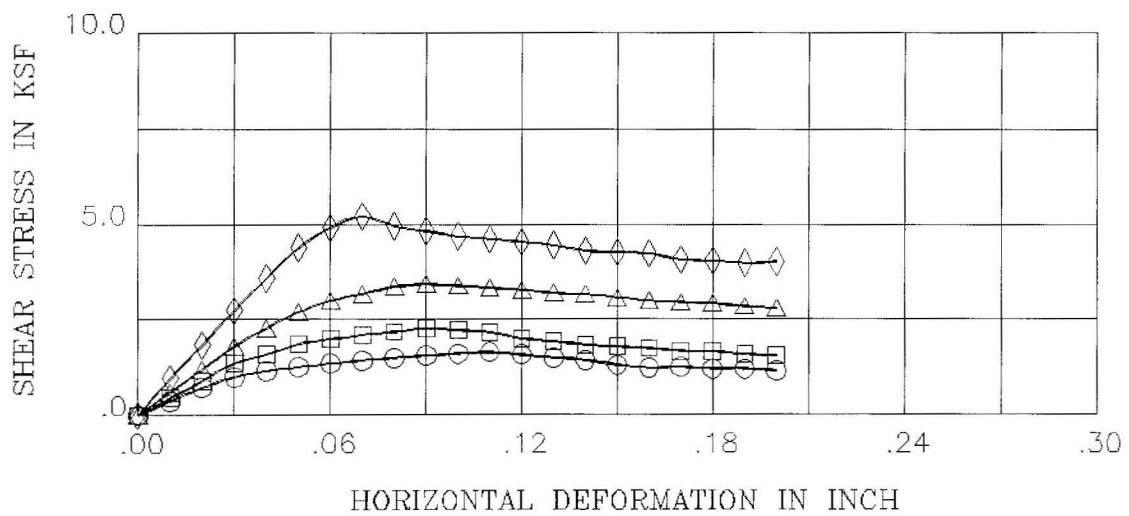
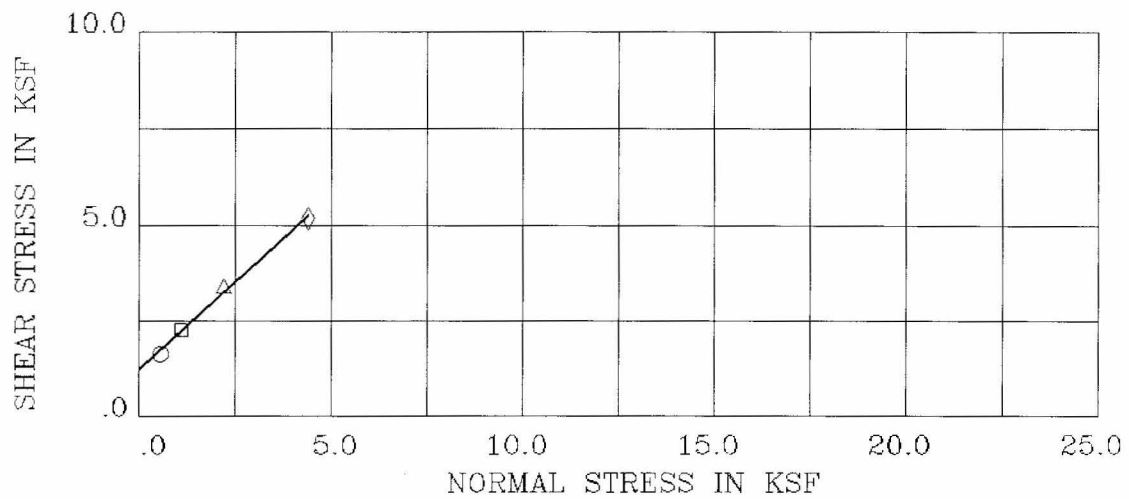

BORING/SAMPLE : B.1/S.8                      DEPTH (ft) : 75  
 DESCRIPTION : Bedrock - siltstone  
 STRENGTH INTERCEPT (C) : 1.250      KSF  
 FRICTION ANGLE (PHI) : 42.5      DEG                      (PEAK STRENGTH)

SYMBOL	MOISTURE CONTENT (%)	DRY DENSITY (pcf)	VOID RATIO	NORMAL STRESS (ksf)	PEAK SHEAR (ksf)	RESIDUAL SHEAR (ksf)
○	40.6	80.3	1.138	.55	1.65	1.16
□	40.6	80.3	1.138	1.10	2.27	1.56
△	40.6	80.3	1.138	2.20	3.42	2.79
◇	40.6	80.3	1.138	4.40	5.20	3.98

Remark : Undisturbed samples, soaked

Project 4868-12	Shen - Portuguese Bend Road	
SWN Soiltech Consultants	DIRECT SHEAR TEST	Plate No. C-7

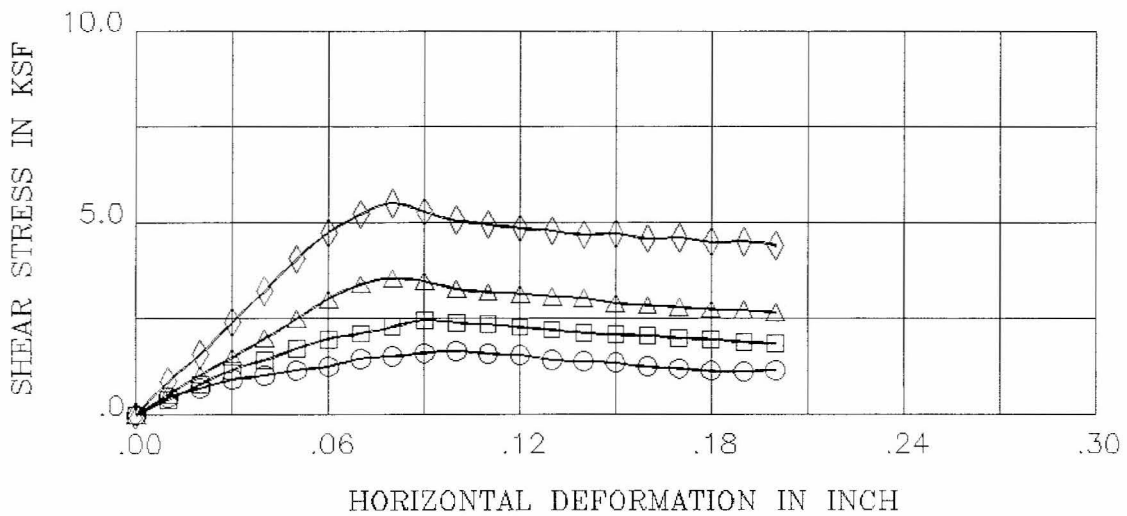
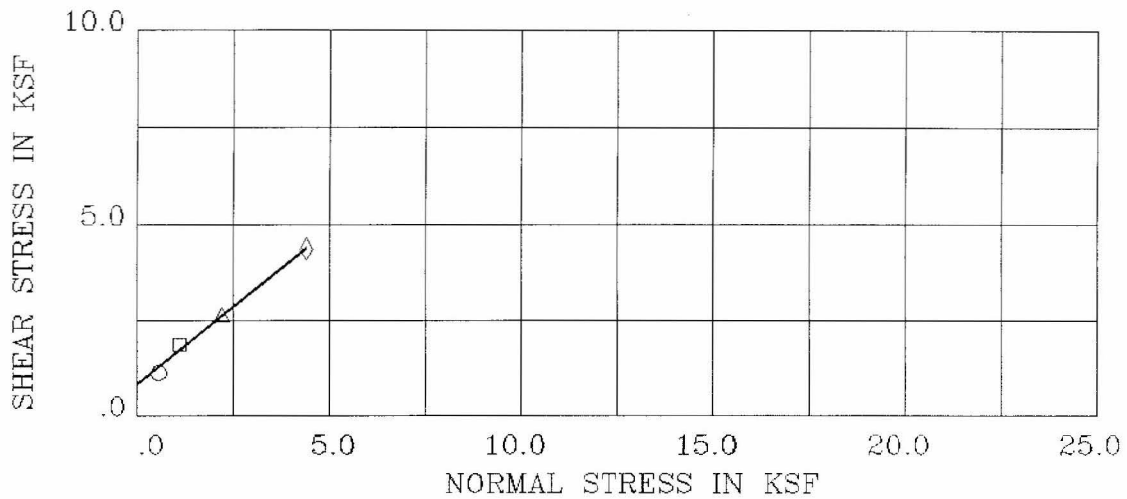

BORING/SAMPLE : B.4/S.4                      DEPTH (ft) : 21  
 DESCRIPTION : Bedrock - siltstone  
 STRENGTH INTERCEPT (C) : .830      KSF                      (RESIDUAL STRENGTH)  
 FRICTION ANGLE (PHI) : 39.2      DEG

SYMBOL	MOISTURE CONTENT (%)	DRY DENSITY (pcf)	VOID RATIO	NORMAL STRESS (ksf)	PEAK SHEAR (ksf)	RESIDUAL SHEAR (ksf)
○	26.6	97.3	.763	.55	1.67	1.13
□	26.6	97.3	.763	1.10	2.46	1.87
△	26.6	97.3	.763	2.20	3.54	2.66
◇	26.6	97.3	.763	4.40	5.49	4.38

Remark : Undisturbed samples, soaked

Project 4868-12	Shen - Portuguese Bend Road	
SWN Soiltech Consultants	DIRECT SHEAR TEST	Plate No. C-8

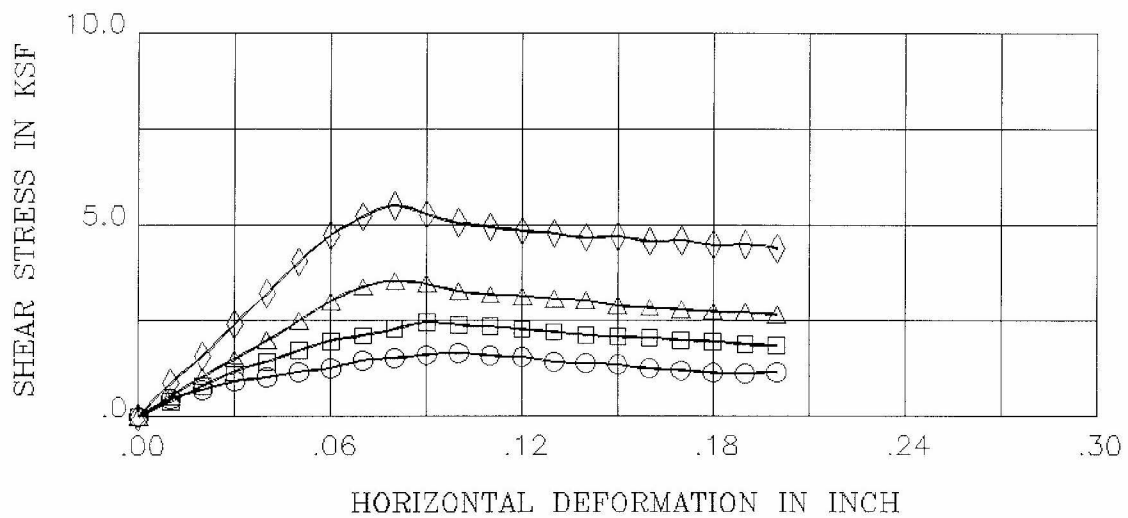
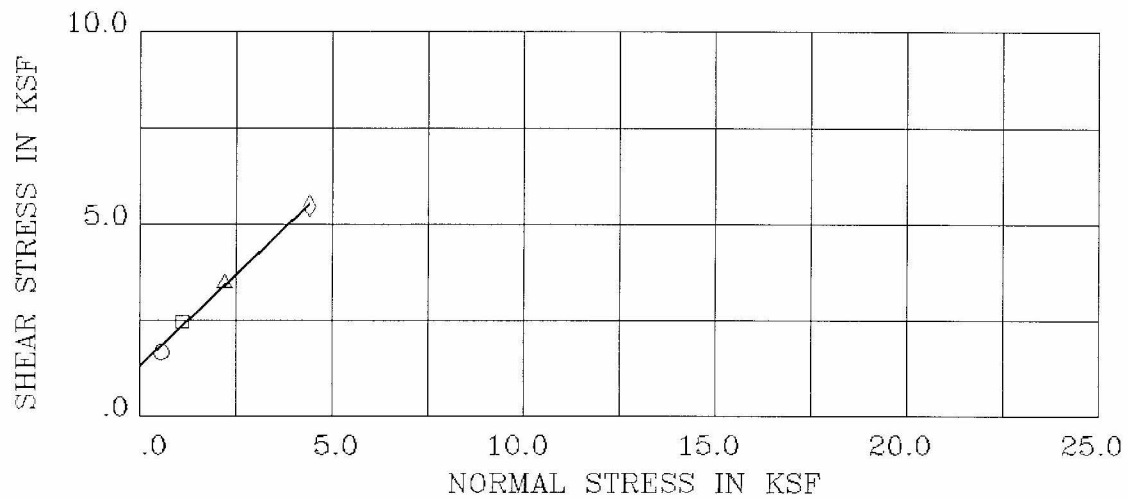

BORING/SAMPLE : B.4/S.4                      DEPTH (ft) : 21  
 DESCRIPTION : Bedrock - siltstone  
 STRENGTH INTERCEPT (C) : 1.295      KSF  
 FRICTION ANGLE (PHI) : 44.1      DEG                      (PEAK STRENGTH)

SYMBOL	MOISTURE CONTENT (%)	DRY DENSITY (pcf)	VOID RATIO	NORMAL STRESS (ksf)	PEAK SHEAR (ksf)	RESIDUAL SHEAR (ksf)
○	26.6	97.3	.763	.55	1.67	1.13
□	26.6	97.3	.763	1.10	2.46	1.87
△	26.6	97.3	.763	2.20	3.54	2.66
◇	26.6	97.3	.763	4.40	5.49	4.38

Remark : Undisturbed samples, soaked

Project 4868-12	Shen - Portuguese Bend Road	
SWN Soiltech Consultants	DIRECT SHEAR TEST	Plate No. C-9

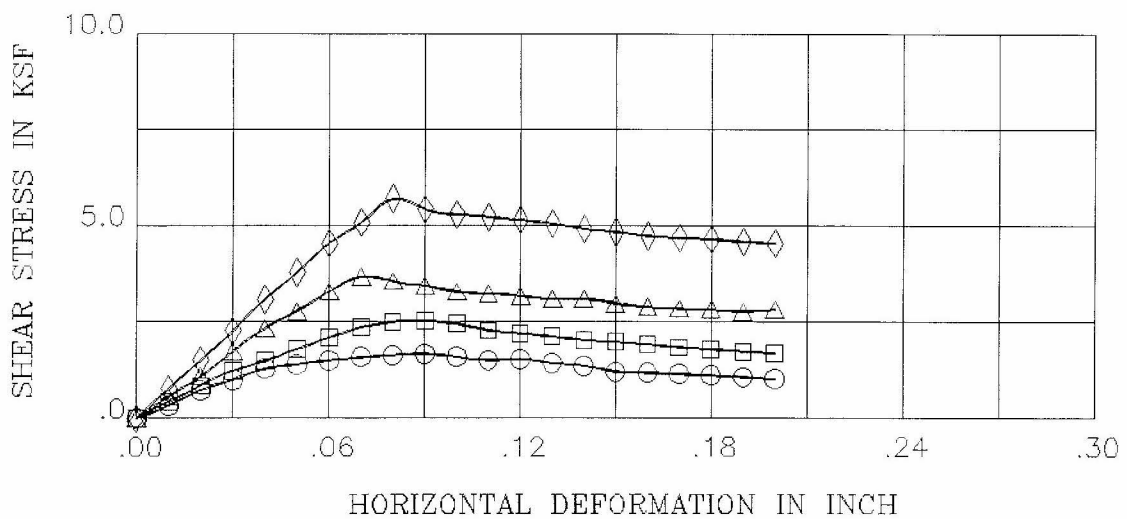
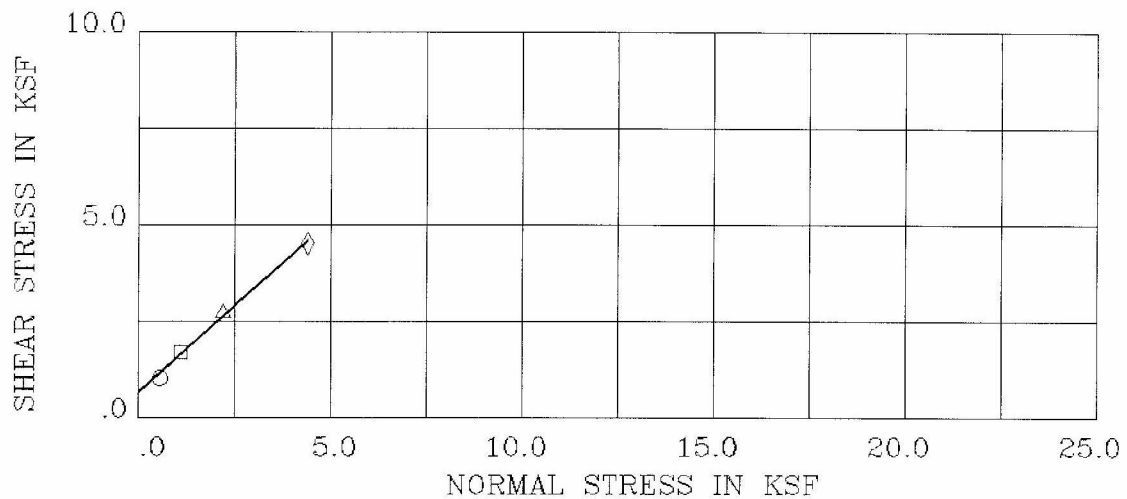

BORING/SAMPLE : B.2/S.7                      DEPTH (ft) : 50  
 DESCRIPTION : Bedrock - basalt  
 STRENGTH INTERCEPT (C) : .666      KSF  
 FRICTION ANGLE (PHI) : 41.8      DEG                      (RESIDUAL STRENGTH)

SYMBOL	MOISTURE CONTENT (%)	DRY DENSITY (pcf)	VOID RATIO	NORMAL STRESS (ksf)	PEAK SHEAR (ksf)	RESIDUAL SHEAR (ksf)
○	23.4	103.2	.663	.55	1.68	1.03
□	23.4	103.2	.663	1.10	2.54	1.70
△	23.4	103.2	.663	2.20	3.68	2.78
◇	23.4	103.2	.663	4.40	5.68	4.53

Remark : Undisturbed samples, soaked

Project 4868-12	Shen - Portuguese Bend Road	
SWN Soiltech Consultants	DIRECT SHEAR TEST	Plate No. C-10

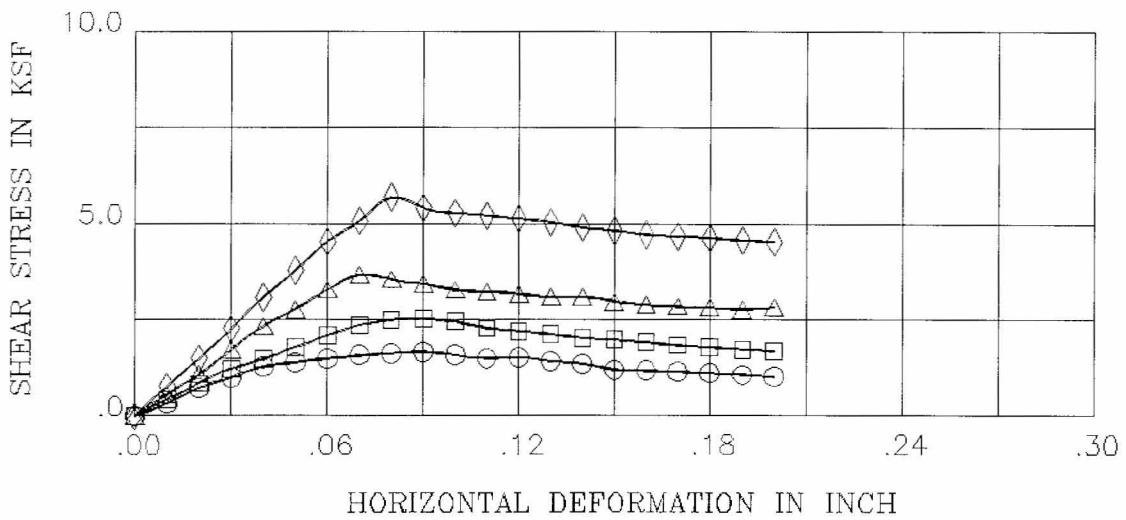
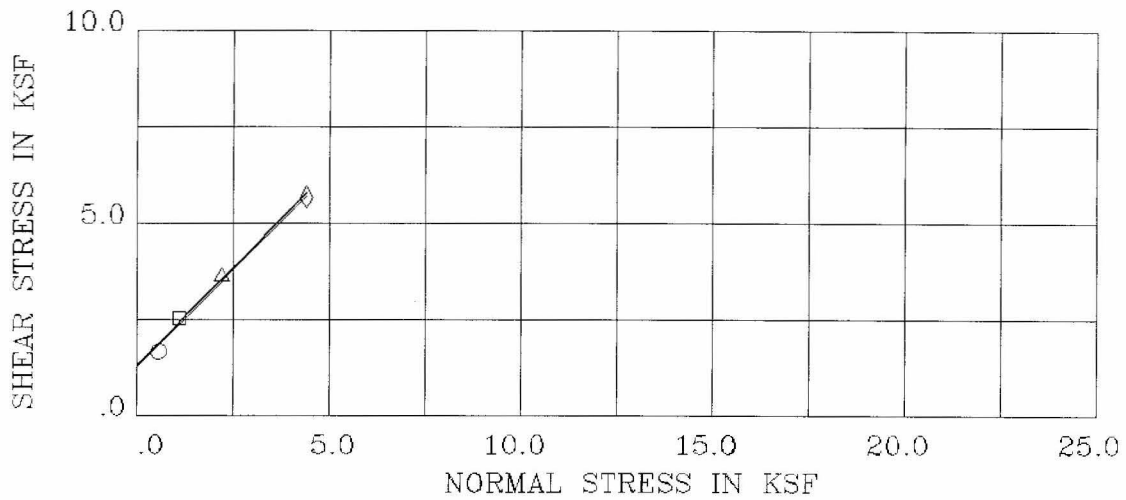

BORING/SAMPLE : B.2/S.7                      DEPTH (ft) : 50  
 DESCRIPTION : Bedrock - basalt  
 STRENGTH INTERCEPT (C) : 1.307      KSF                      (PEAK STRENGTH)  
 FRICTION ANGLE (PHI) : 45.3              DEG

SYMBOL	MOISTURE CONTENT (%)	DRY DENSITY (pcf)	VOID RATIO	NORMAL STRESS (ksf)	PEAK SHEAR (ksf)	RESIDUAL SHEAR (ksf)
O	23.4	103.2	.663	.55	1.68	1.03
□	23.4	103.2	.663	1.10	2.54	1.70
△	23.4	103.2	.663	2.20	3.68	2.78
◇	23.4	103.2	.663	4.40	5.68	4.53

Remark : Undisturbed samples, soaked

Project 4868-12	Shen - Portuguese Bend Road	
SWN Soiltech Consultants	DIRECT SHEAR TEST	Plate No. C-11

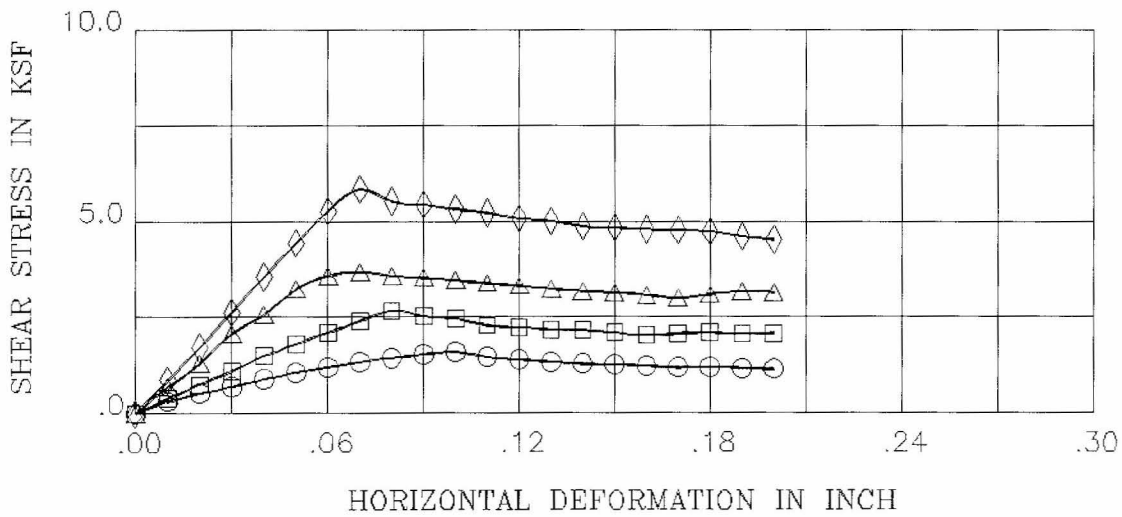
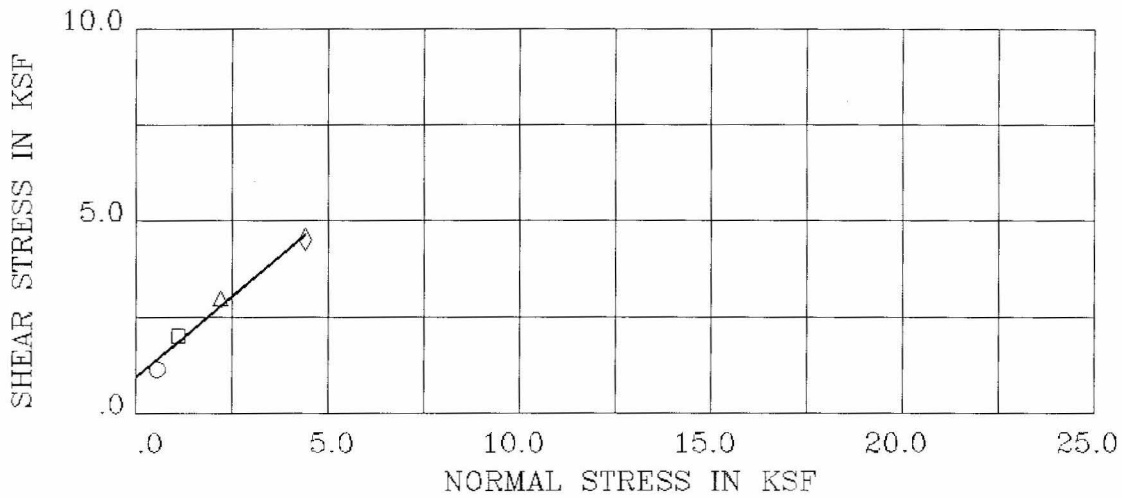

BORING/SAMPLE : B.3/S.10      DEPTH (ft) : 95  
 DESCRIPTION : Bedrock - basalt  
 STRENGTH INTERCEPT (C) : .937      KSF  
 FRICTION ANGLE (PHI) : 40.0      DEG      (RESIDUAL STRENGTH)

SYMBOL	MOISTURE CONTENT (%)	DRY DENSITY (pcf)	VOID RATIO	NORMAL STRESS (ksf)	PEAK SHEAR (ksf)	RESIDUAL SHEAR (ksf)
○	19.4	110.8	.549	.55	1.59	1.15
□	19.4	110.8	.549	1.10	2.66	2.02
△	19.4	110.8	.549	2.20	3.68	2.99
◇	19.4	110.8	.549	4.40	5.83	4.52

Remark : Undisturbed samples, soaked

Project 4868-12	Shen - Portuguese Bend Road	
SWN Soiltech Consultants	DIRECT SHEAR TEST	Plate No. C-12

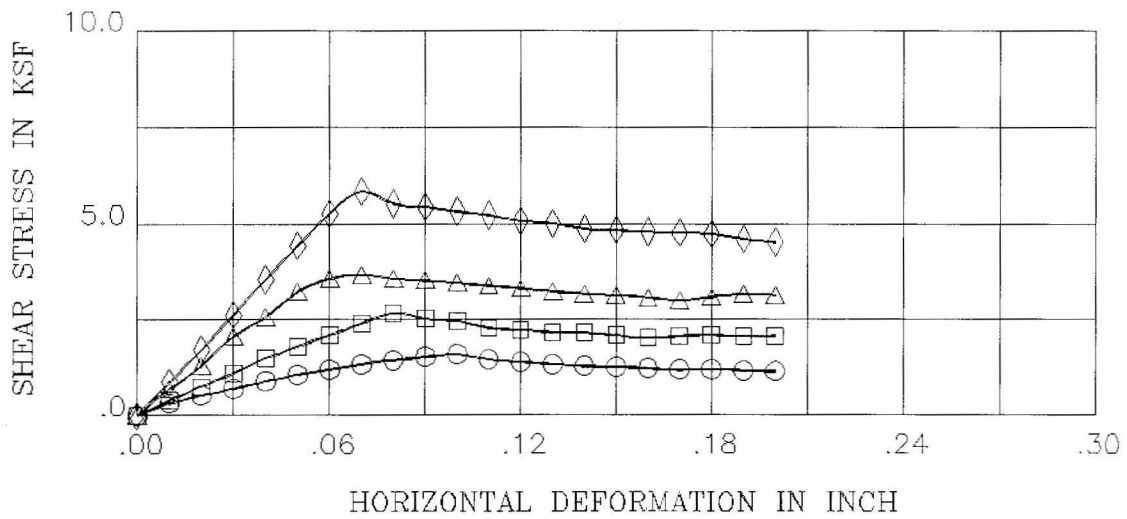
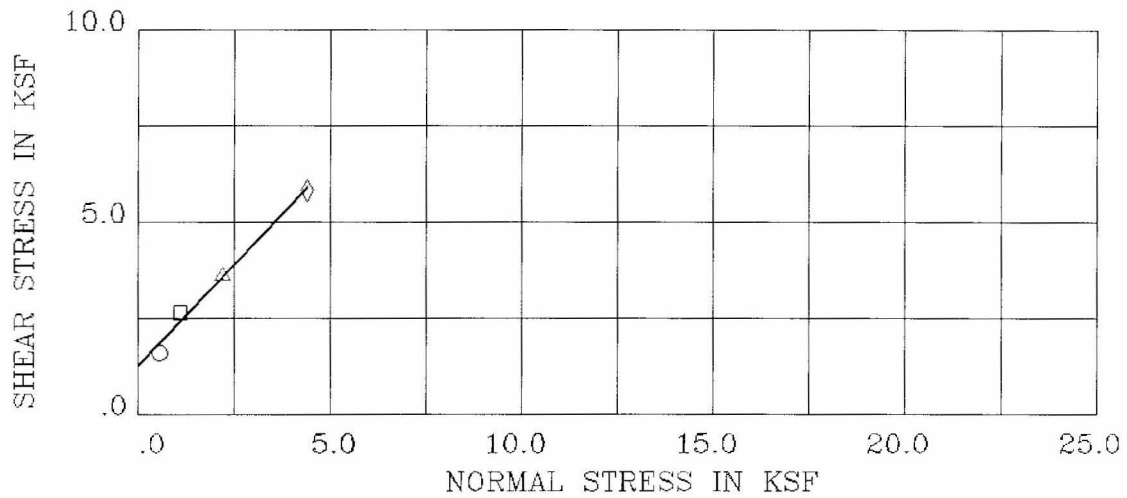

BORING/SAMPLE : B.3/S.10      DEPTH (ft) : 95  
 DESCRIPTION : Bedrock - basalt  
 STRENGTH INTERCEPT (C) : 1.269      KSF      (PEAK STRENGTH)  
 FRICTION ANGLE (PHI) : 46.5      DEG

SYMBOL	MOISTURE CONTENT (%)	DRY DENSITY (pcf)	VOID RATIO	NORMAL STRESS (ksf)	PEAK SHEAR (ksf)	RESIDUAL SHEAR (ksf)
○	19.4	110.8	.549	.55	1.59	1.15
□	19.4	110.8	.549	1.10	2.66	2.02
△	19.4	110.8	.549	2.20	3.68	2.99
◇	19.4	110.8	.549	4.40	5.83	4.52

Remark : Undisturbed samples, soaked

Project 4868-12	Shen - Portuguese Bend Road
SWN Soiltech Consultants	<b>DIRECT SHEAR TEST</b> Plate No. C-13

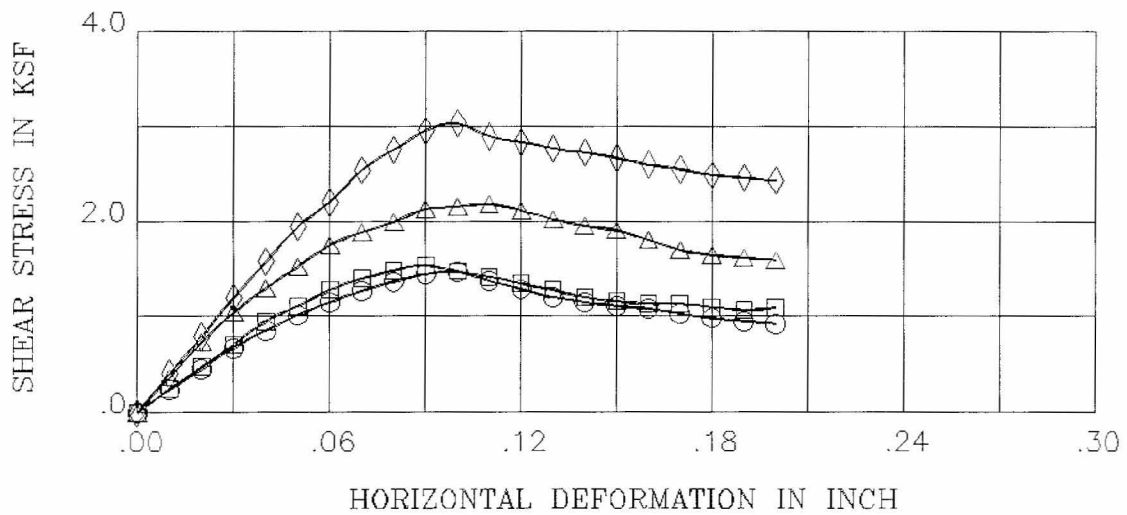
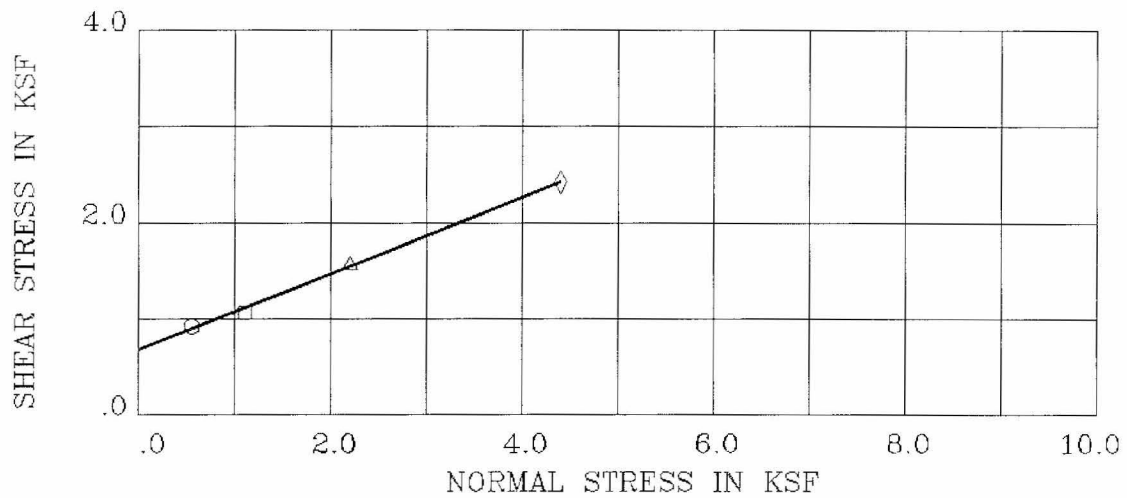

BORING/SAMPLE : B.4/S.1                      DEPTH (ft) : 5  
 DESCRIPTION : Bedrock - clay  
 STRENGTH INTERCEPT (C) : .680      KSF  
 FRICTION ANGLE (PHI) : 21.7      DEG                      (RESIDUAL STRENGTH)

SYMBOL	MOISTURE CONTENT (%)	DRY DENSITY (pcf)	VOID RATIO	NORMAL STRESS (ksf)	PEAK SHEAR (ksf)	RESIDUAL SHEAR (ksf)
○	42.3	78.4	1.190	.55	1.47	.92
□	42.3	78.4	1.190	1.10	1.53	1.07
△	42.3	78.4	1.190	2.20	2.18	1.59
◇	42.3	78.4	1.190	4.40	3.03	2.42

Remark : Undisturbed samples, soaked

Project 4868-12	Shen - Portuguese Bend Road	
SWN Soiltech Consultants	DIRECT SHEAR TEST	Plate No. C-14



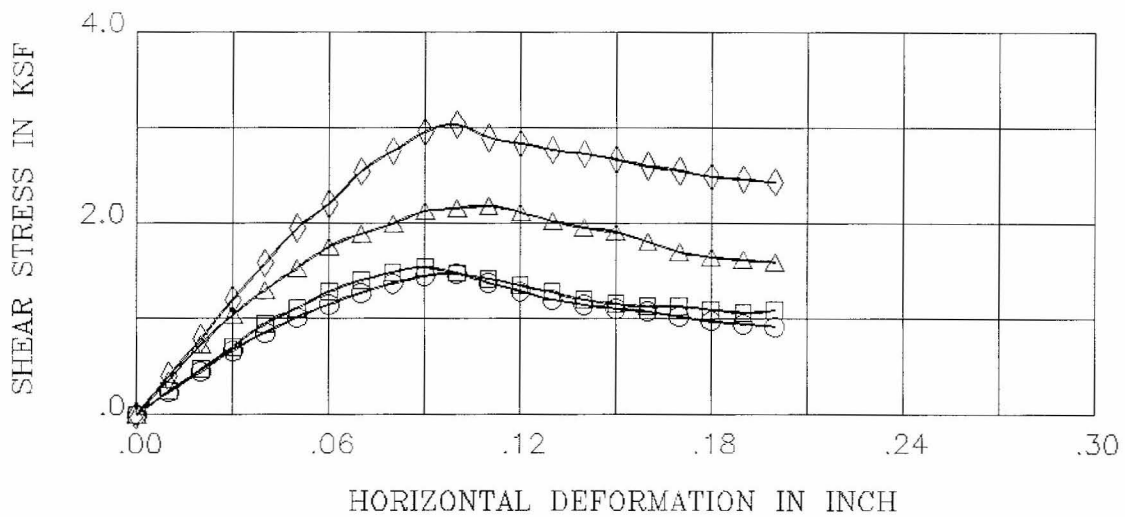
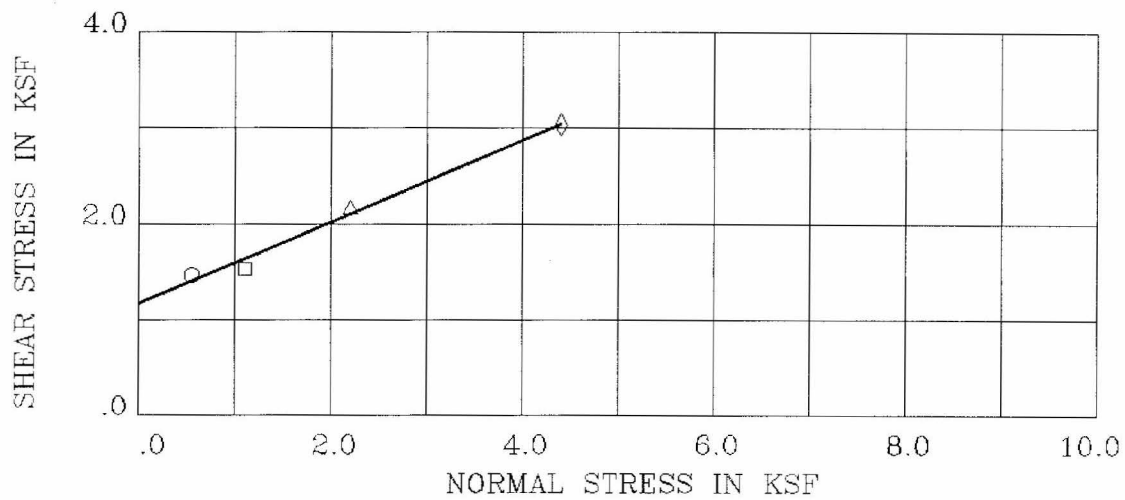

BORING/SAMPLE : B.4/S.1                      DEPTH (ft) : 5  
 DESCRIPTION : Bedrock - clay  
 STRENGTH INTERCEPT (C) : 1.179      KSF  
 FRICTION ANGLE (PHI) : 23.0      DEG                      (PEAK STRENGTH)

SYMBOL	MOISTURE CONTENT (%)	DRY DENSITY (pcf)	VOID RATIO	NORMAL STRESS (ksf)	PEAK SHEAR (ksf)	RESIDUAL SHEAR (ksf)
○	42.3	78.4	1.190	.55	1.47	.92
□	42.3	78.4	1.190	1.10	1.53	1.07
△	42.3	78.4	1.190	2.20	2.18	1.59
◇	42.3	78.4	1.190	4.40	3.03	2.42

Remark : Undisturbed samples, soaked

Project 4868-12	Shen - Portuguese Bend Road
SWN Soiltech Consultants	<b>DIRECT SHEAR TEST</b> Plate No. C-15

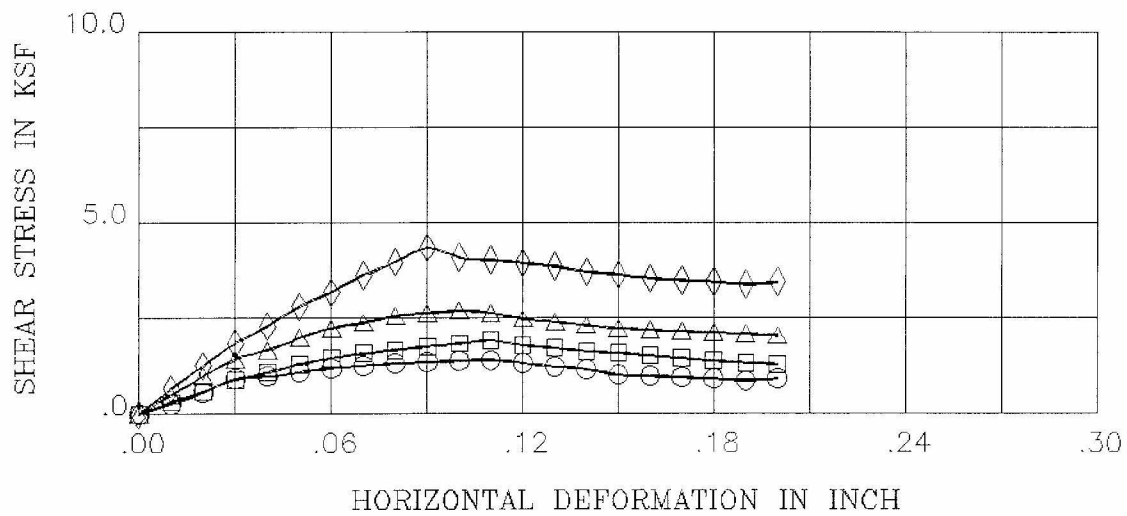
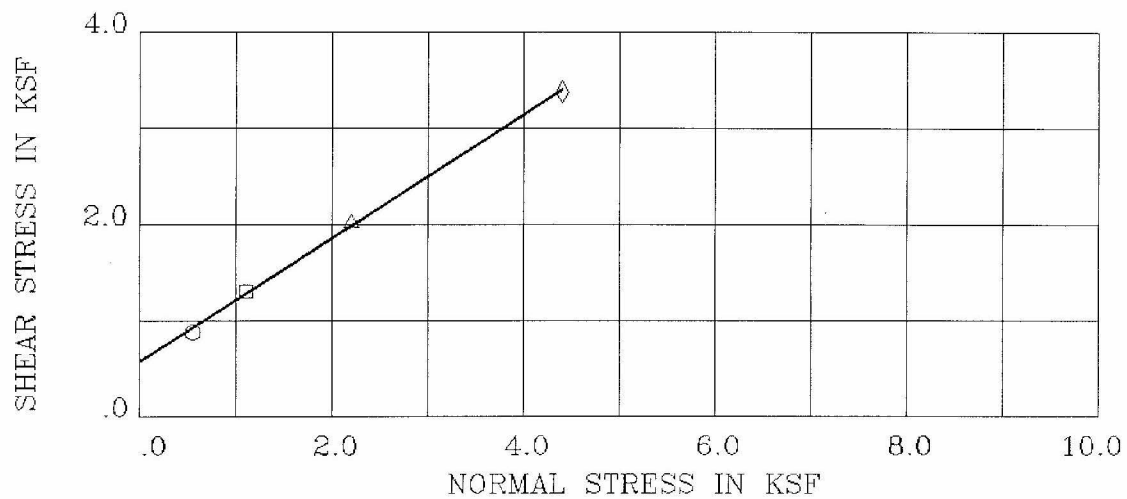

BORING/SAMPLE : B.3/S.5                      DEPTH (ft) : 32  
 DESCRIPTION : Slide Debris - siltstone  
 STRENGTH INTERCEPT (C) : .576 KSF  
 FRICTION ANGLE (PHI) : 32.8 DEG                      (RESIDUAL STRENGTH)

SYMBOL	MOISTURE CONTENT (%)	DRY DENSITY (pcf)	VOID RATIO	NORMAL STRESS (ksf)	PEAK SHEAR (ksf)	RESIDUAL SHEAR (ksf)
○	31.8	90.0	.907	.55	1.42	.88
□	31.8	90.0	.907	1.10	1.92	1.31
△	31.8	90.0	.907	2.20	2.69	2.05
◇	31.8	90.0	.907	4.40	4.32	3.38

Remark : Undisturbed samples, soaked

Project 4868-12	Shen - Portuguese Bend Road
SWN Soiltech Consultants	<b>DIRECT SHEAR TEST</b> Plate No. C-16

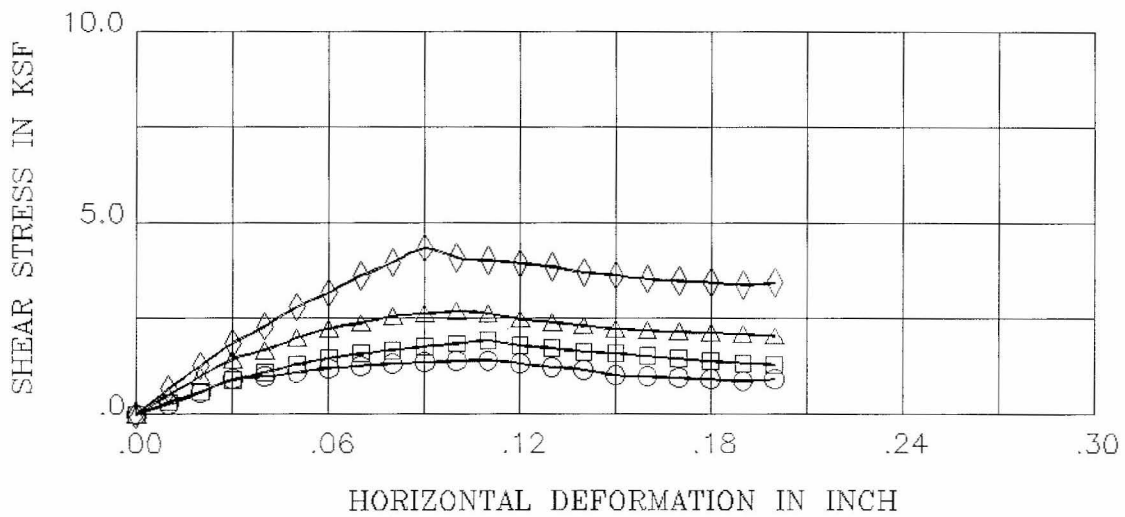
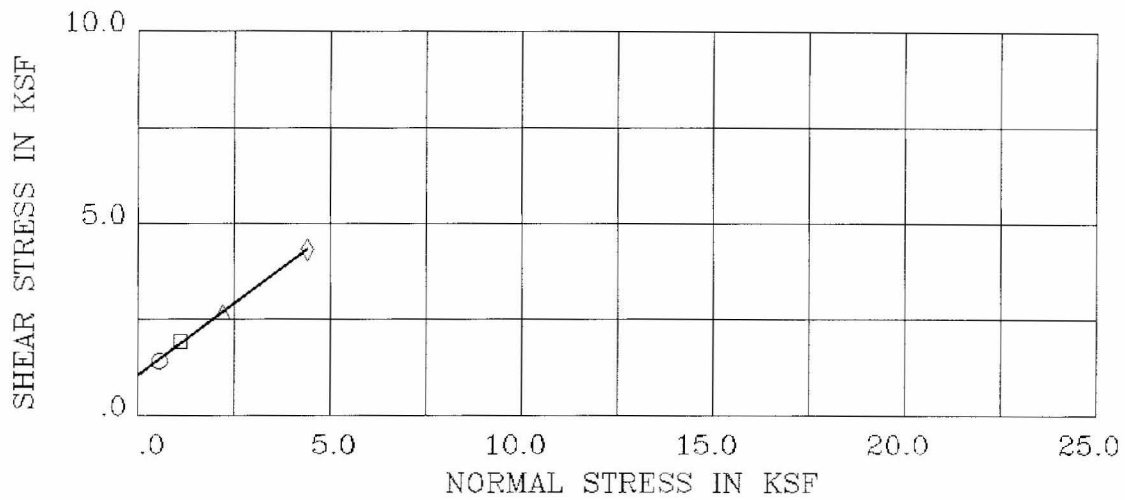

BORING/SAMPLE : B.3/S.5                      DEPTH (ft) : 32  
 DESCRIPTION : Slide Debris - siltstone  
 STRENGTH INTERCEPT (C) : 1.050 KSF  
 FRICTION ANGLE (PHI) : 36.7 DEG                      (PEAK STRENGTH)

SYMBOL	MOISTURE CONTENT (%)	DRY DENSITY (pcf)	VOID RATIO	NORMAL STRESS (ksf)	PEAK SHEAR (ksf)	RESIDUAL SHEAR (ksf)
○	31.8	90.0	.907	.55	1.42	.88
□	31.8	90.0	.907	1.10	1.92	1.31
△	31.8	90.0	.907	2.20	2.69	2.05
◇	31.8	90.0	.907	4.40	4.32	3.38

Remark : Undisturbed samples, soaked

Project 4868-12	Shen - Portuguese Bend Road	
SWN Soiltech Consultants	DIRECT SHEAR TEST	Plate No. C-17

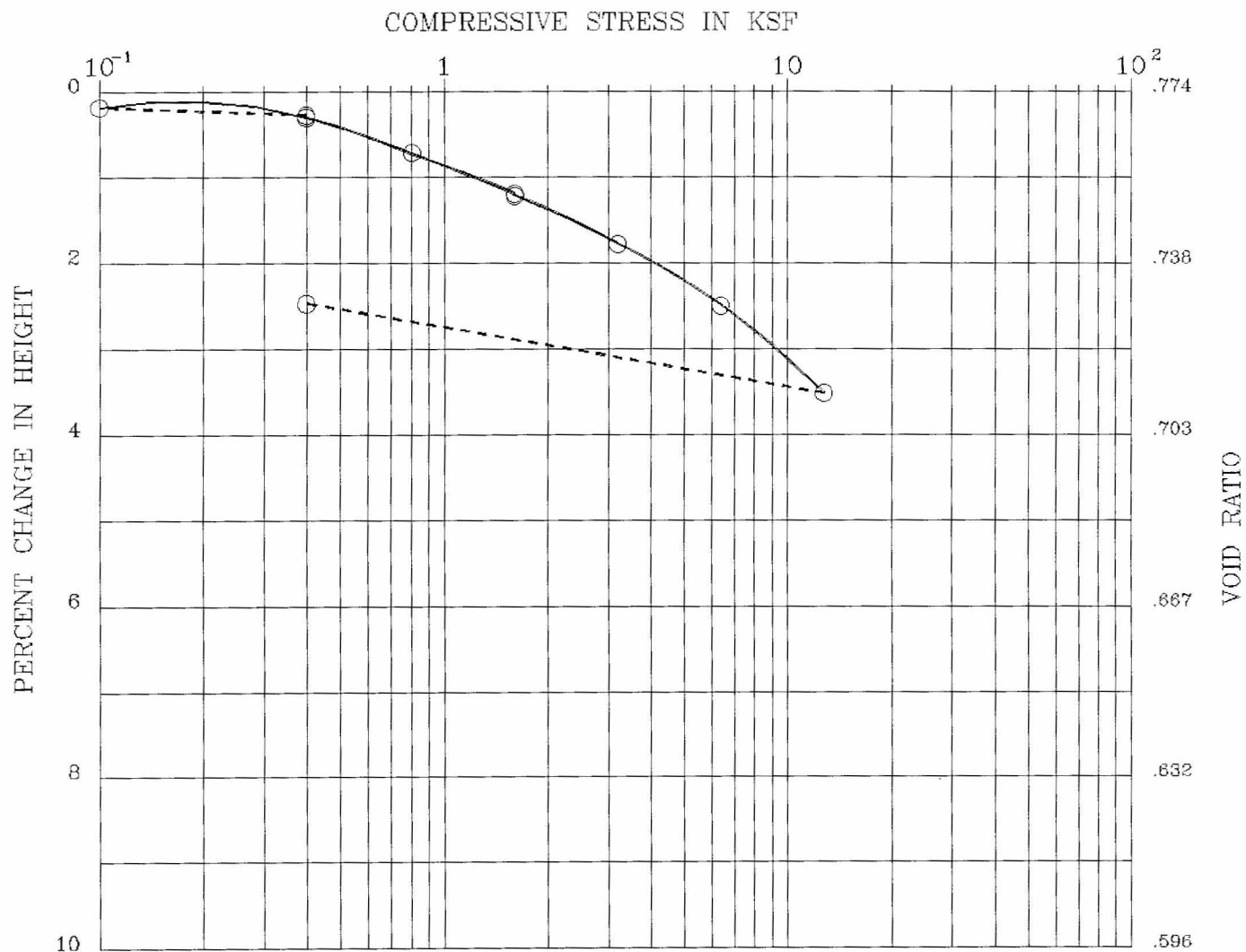

BORING : B.1/S.1                      DESCRIPTION : Terrace - silty-clayey sand  
 DEPTH (ft) : 5                              LIQUID LIMIT :  
 SPEC. GRAVITY : 2.71                      PLASTIC LIMIT :

	MOISTURE CONTENT (%)	DRY DENSITY (pcf)	PERCENT SATURATION	VOID RATIO
INITIAL	17.6	95.4	62	.774
FINAL	27.2	97.3	100	.738

Remark : Undisturbed sample, water added at 1.60 ksf

Project 4868-12	Shen - Portuguese Bend Road	
SWN Soiltech Consultants	CONSOLIDATION TEST	Plate No. D-1

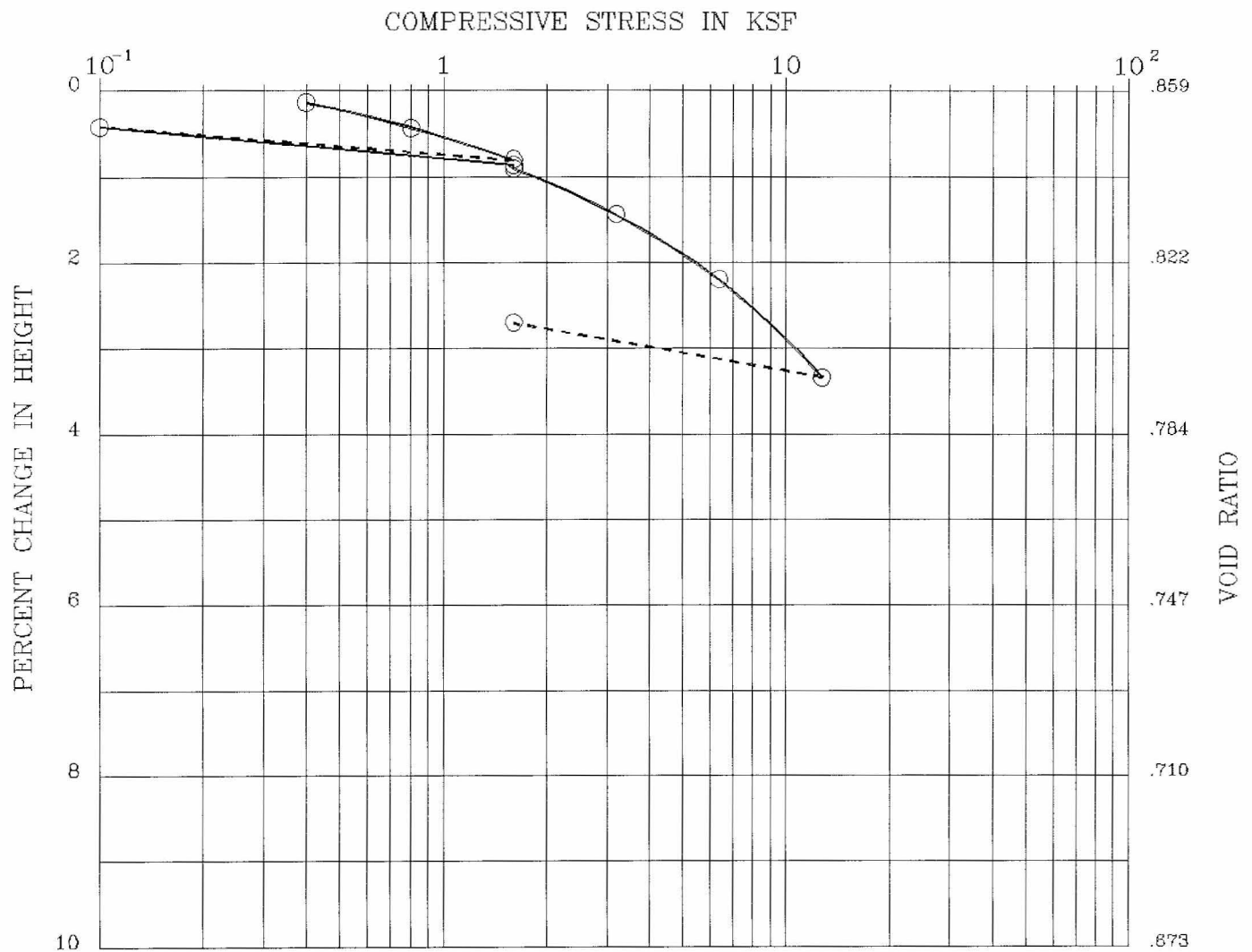

BORING : B.1/S.2                      DESCRIPTION : Terrace - silty-clayey sand  
 DEPTH (ft) : 15                        LIQUID LIMIT :  
 SPEC. GRAVITY : 2.71                    PLASTIC LIMIT :

	<u>MOISTURE CONTENT (%)</u>	<u>DRY DENSITY (pcf)</u>	<u>PERCENT SATURATION</u>	<u>VOID RATIO</u>
INITIAL	24.5	91.2	78	.859
FINAL	29.5	94.0	100	.803

Remark : Undisturbed sample, water added at 1.60 ksf

Project 4868-12	Shen - Portuguese Bend Road	
SWN Soiltech Consultants	CONSOLIDATION TEST	Plate No. D-2

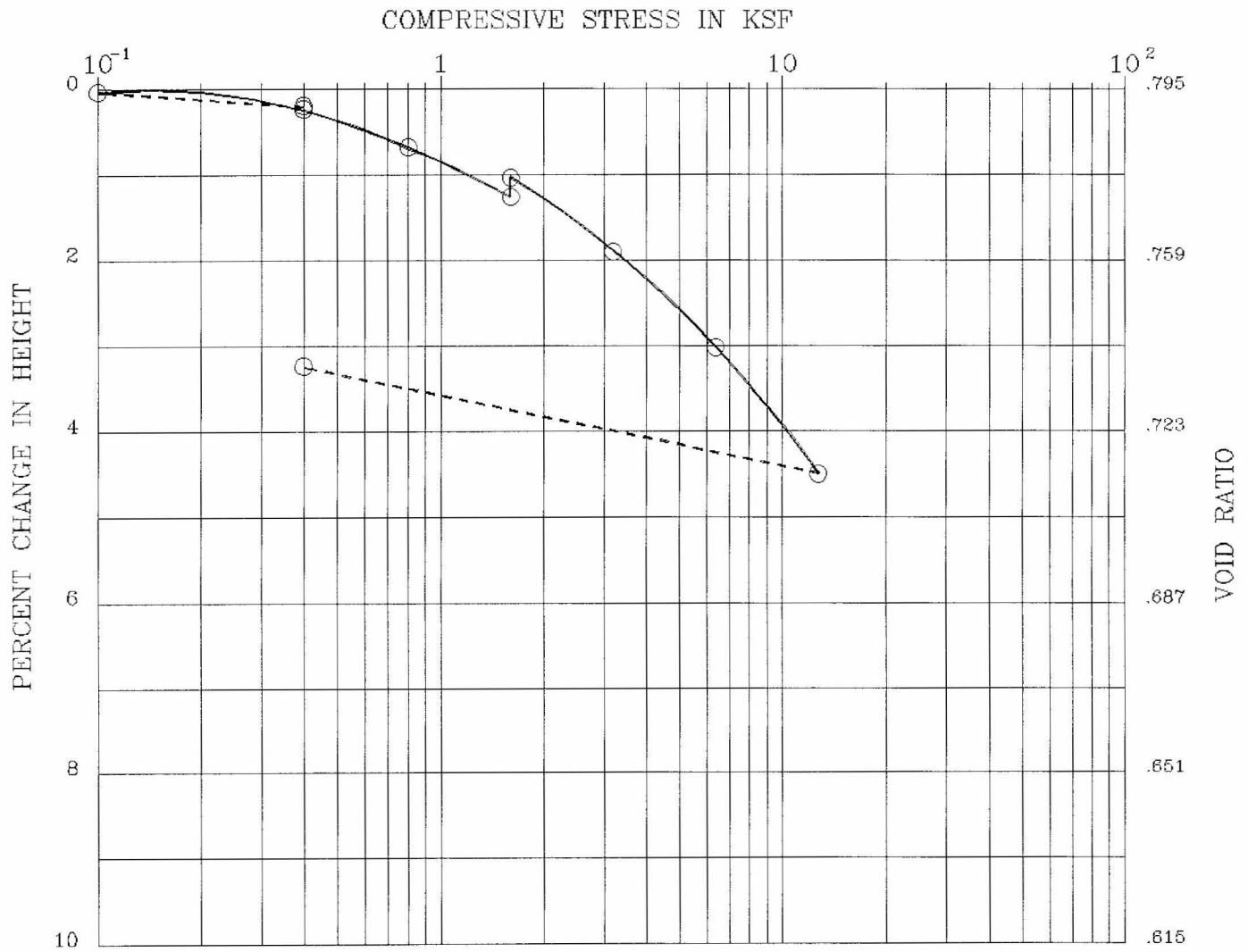

BORING : B.3/S.1                      DESCRIPTION : Colluvium - sandy-silty clay  
 DEPTH (ft) : 3                              LIQUID LIMIT :  
 SPEC. GRAVITY : 2.72                      PLASTIC LIMIT :

	MOISTURE CONTENT (%)	DRY DENSITY (pcf)	PERCENT SATURATION	VOID RATIO
INITIAL	15.9	94.7	55	.795
FINAL	26.5	98.7	100	.723

Remark : Undisturbed sample, water added at 1.60 ksf

Project 4868-12

Shen - Portuguese Bend Road

SWN  
Soiltech  
Consultants

CONSOLIDATION TEST

Plate No. D-3

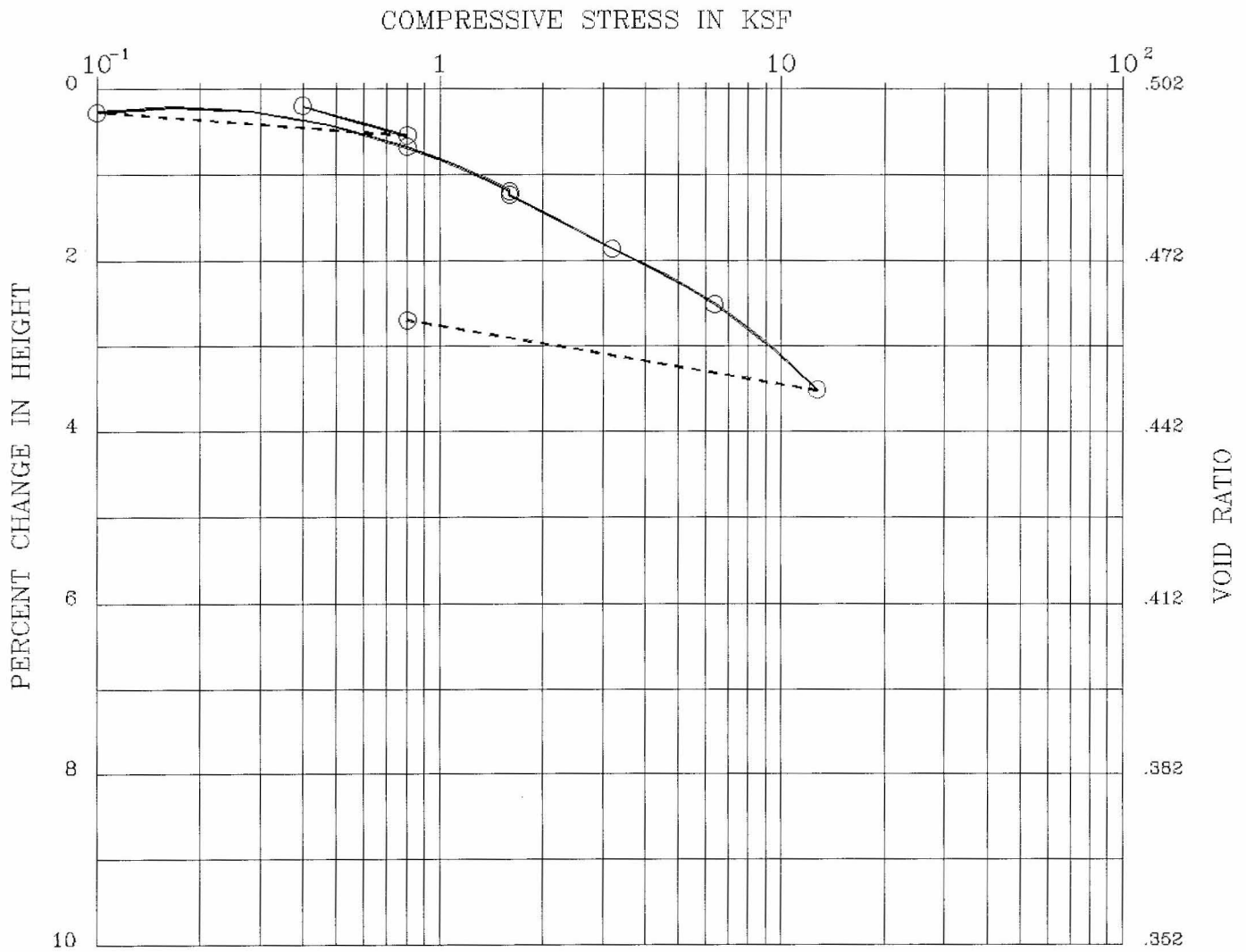

BORING	: B.3/S.2	DESCRIPTION	: Slide debris - basalt
DEPTH (ft)	: 9	LIQUID LIMIT	:
SPEC. GRAVITY	: 2.73	PLASTIC LIMIT	:

	MOISTURE CONTENT (%)	DRY DENSITY (pcf)	PERCENT SATURATION	VOID RATIO
INITIAL	14.6	113.6	80	.502
FINAL	16.7	117.1	100	.457

Remark : Undisturbed sample, water added at 1.60 ksf

Project 4868-12	Shen - Portuguese Bend Road	
SWN Soiltech Consultants	CONSOLIDATION TEST	Plate No. D-4

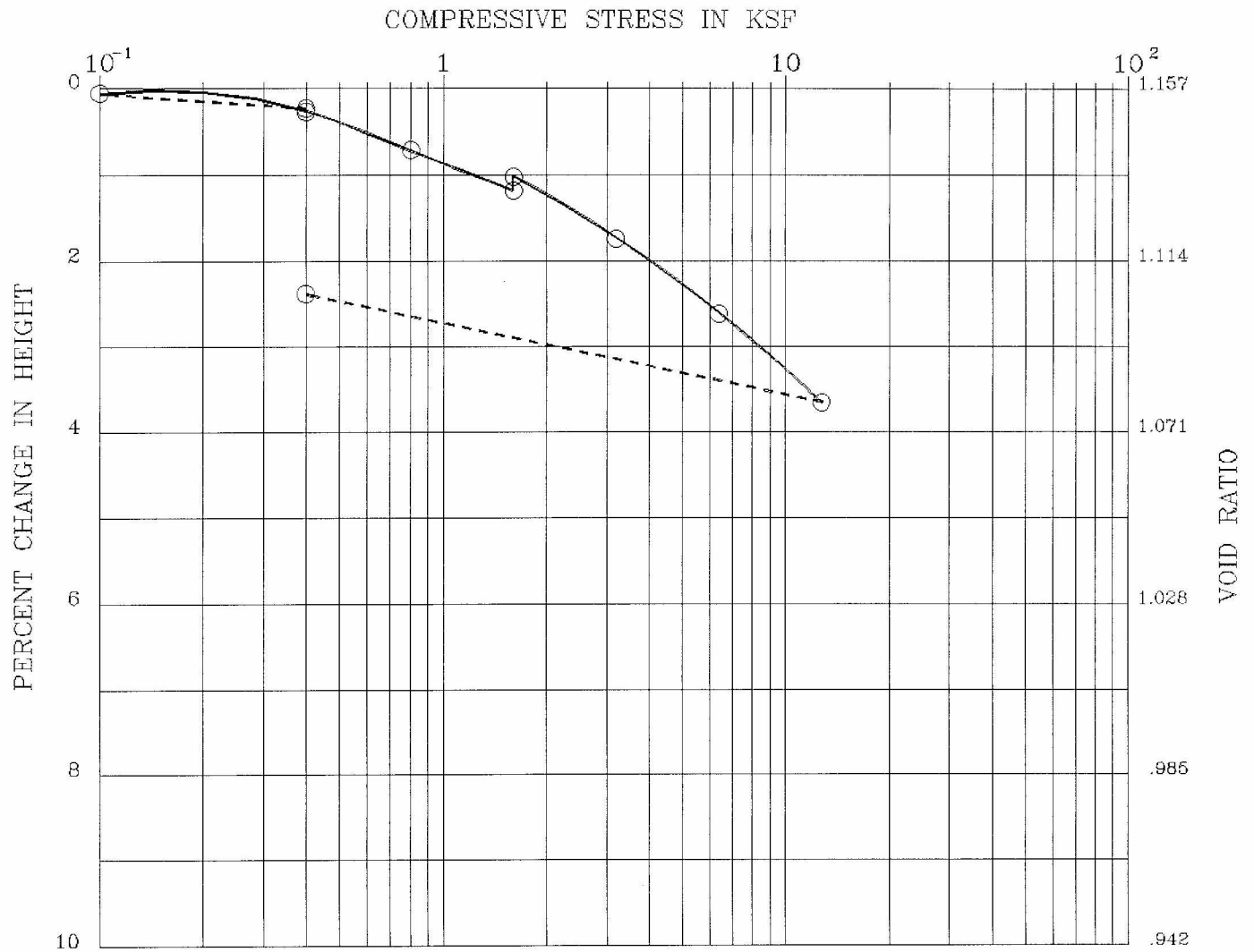

BORING : B.4/S.1                      DESCRIPTION : Bedrock - clay  
 DEPTH (ft) : 5                              LIQUID LIMIT :  
 SPEC. GRAVITY : 2.71                      PLASTIC LIMIT :

	MOISTURE CONTENT (%)	DRY DENSITY (pcf)	PERCENT SATURATION	VOID RATIO
INITIAL	27.2	78.4	64	1.157
FINAL	40.3	80.8	100	1.093

Remark : Undisturbed sample, water added at 1.60 ksf

Project 4868-12	Shen - Portuguese Bend Road	
SWN Soiltech Consultants	CONSOLIDATION TEST	Plate No. D-5



# ANAHEIM TEST LABORATORY

3008 S. ORANGE AVENUE  
SANTA ANA, CALIFORNIA 92707  
PHONE (714) 549-7267

TO:

SWN SOILTECH CONSULTANTS, INC.  
3140 WEST MAIN STREET  
ALHAMBRA, CA 91801

DATE: 3/8/12

P.O. NO.: TRANSMITTAL

LAB NO.: B-5534

SPECIFICATION: CA-417/422/643

PROJECT# 4860-11

MATERIAL: Soil

Shen  
77 Portuguese Bend Road  
Rolling Hills, CA 90274

## ANALYTICAL REPORT

### CORROSION SERIES SUMMARY OF DATA

	PH	SOLUBLE SULFATES per CA. 417 ppm	SOLUBLE CHLORIDES per CA. 422 ppm	MIN. RESISTIVITY per CA. 643 ohm-cm
Terrace deposits B-1 @ 10'-15'	6.6	1,235	374	600 MAX

RESPECTFULLY SUBMITTED

  
WES BRIDGER CHEMIST

---

## APPENDIX III

### GRADING GUIDELINES

1. The grading specifications should be part of the project specifications. The Soils Engineer shall review the grading plan prior to grading.
2. Prior to placement of compacted fill, the site shall be cleared of all vegetation, existing fill, loose topsoil, debris, and any other deleterious materials.
3. Import soils shall be tested and approved by the Soils Engineer prior to import.
4. Surfaces receiving fill soils shall be scarified, aerated, or moistened to moisture content acceptable to the soils engineer, then compacted to a compaction of not less than 90% of the maximum density. Granular soils such as gravels and sand having less than 15 percent finer than 0.005 millimeters shall be compacted to a minimum of 95% of the maximum density.
5. If the moisture content of the fill soils is below the limits specified by the Soils Engineer, water shall be added until the moisture content is as required.
6. If the moisture content of the fill soils is above the limits specified by the Soils Engineer, the fill soils shall be aerated by blading or other satisfactory methods until the moisture content is as required. If drying of soils is not desired, the wet soils shall be mixed with drier materials to achieve an acceptable moisture content.
7. The fill soils shall be placed in lifts of no more than eight (8) inches in thickness and compacted until field density tests indicate that a compaction of not less than 90% of the maximum density as determined by ASTM D 1557 has been obtained. Granular soils such as gravels and sand having less than 15 percent finer than 0.005 millimeters shall be compacted to a minimum of 95% of the maximum density.
8. Compaction shall be accomplished by sheep's-foot roller or other types of acceptable compaction equipment of such design that they would be able to compact the fill materials to the specified density.

---

**GRADING GUIDELINES** (Continued)

9. The final surface of the areas to receive slabs-on-grade should be rolled to a dense smooth surface.
10. Rocks less than 6 inches in greatest dimension may be placed in the fill, provided:
  - a. They are not placed in concentrated pockets; and
  - b. The fine-grained materials surrounding the rocks are sufficiently compacted.
11. Field density tests shall be made in accordance with ASTM D 1556. Field density tests shall be made every 2-foot intervals and not less than one test per 500 cubic yards of fill placed.
12. Rocks larger than 6 inches in greatest dimension shall be removed from the site or placed in accordance with specific recommendations of the Soils Engineer.
13. No fill soils shall be placed during unfavorable weather conditions. When work is interrupted by rains, fill operations shall not be resumed until the field tests by the Soils Engineer indicate that the moisture content and density of the fill are as previously specified.
14. Planting and irrigation of slopes and installation of erosion control and drainage devices shall comply with the requirements of the Grading Codes of controlling agencies.

---

## APPENDIX IV

### SLOPE STABILITY ANALYSIS

Stability of the existing slope below the area of the proposed residence, as shown along Section C-C' of the Coast Geotechnical report, has been analyzed by Bishop's Simplified Method. Searches have been made to determine the most critical failure surfaces.

Both static and seismic loading conditions have been considered. In the seismic analysis, the seismic force is represented by a pseudostatic horizontal inertial force equal to 0.15 times the total weight of the potential sliding mass acting out of the slope.

The shear strength parameters adopted in the analyses are based on direct shear tests on representative undisturbed samples of the terrace deposits and bedrock under soaked conditions. The residual shear strengths of the samples of the terrace deposits and bedrock have been used in the static loading conditions, while the peak shear strengths have been used in the seismic loading conditions. It is our professional opinion that the peak shear strengths of the terrace deposits and bedrock are likely to be available during an earthquake.

		Density	Cohesion	Friction Angle	Plate
Terrace Deposits,	Static	125 pcf	450 psf	28 degrees	C-2,4
	Seismic	125 pcf	700 psf	30 degrees	C-3,5
Bedrock - Basalt,	Static	125 pcf	800 psf	41 degrees	C-10,12
	Seismic	125 pcf	990 psf	46 degrees	C-11,13
Bedrock - Siltstone,	Static	125 pcf	840 psf	38 degrees	C-6,8
	Seismic	125 pcf	990 psf	43 degrees	C-7,9

Calculations are included on Plates IV-1 through IV-6. Factors-of-safety in excess of 1.50 and 1.10 have been obtained for static and seismic loading conditions, respectively.

# Slope stability Analysis

## Section C-C'

Scale: 1" = 100'

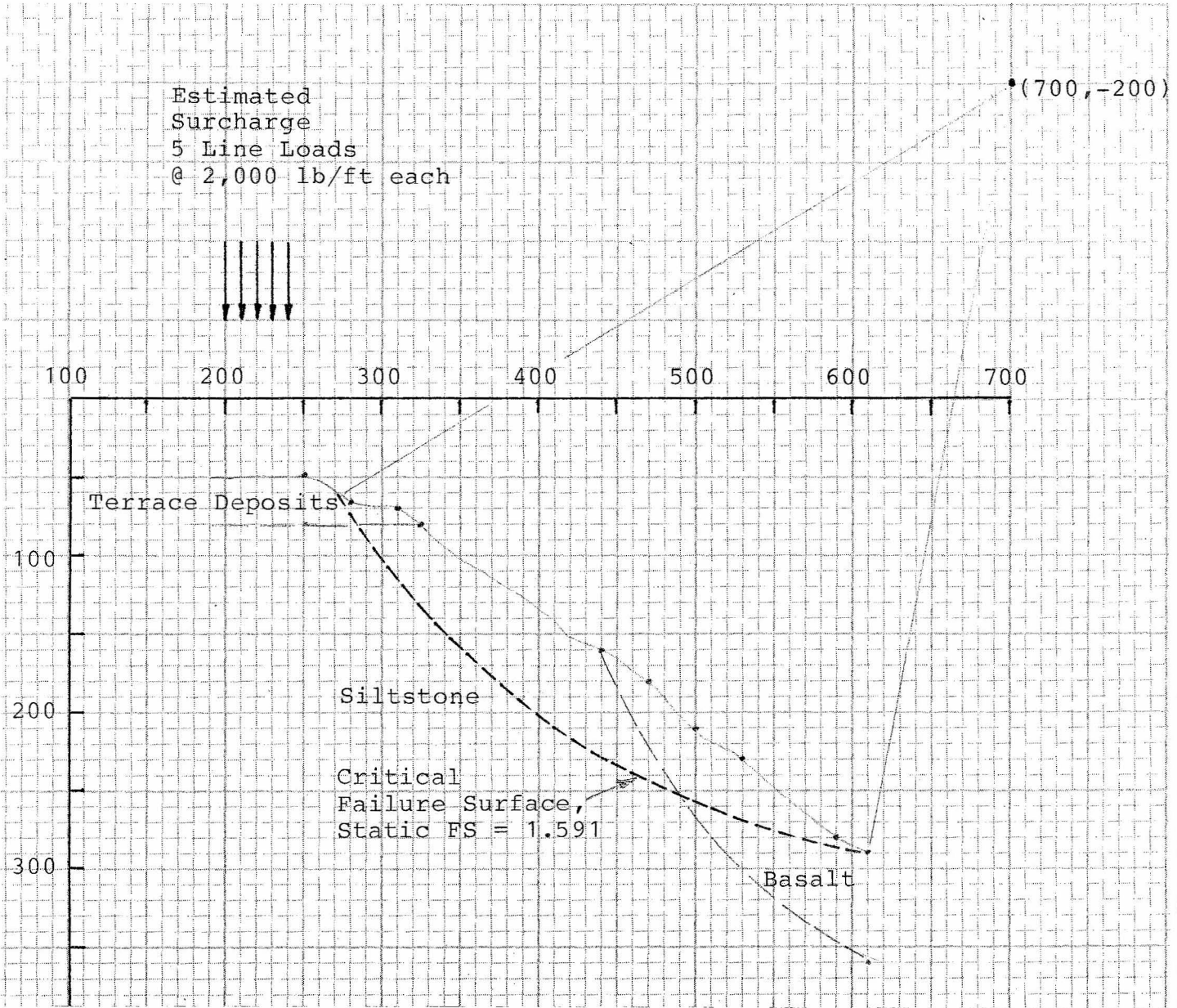

Project: Shen - 77 Portuguese Bend Road  
Project Ref. 4868-12

By: SN  
Date: 5/10/12

Sheet 1 of 6  
Plate IV-1

SWN Soiltech Consultants, Inc.



SEARCH STARTS AT CENTER ( 700.0,-200.0),WITH FINAL GRID OF 10.0

ALL CIRCLES PASS THROUGH THE POINT ( 610.0, 290.0)

GEOMETRY

SECTIONS	.00	250.00	280.00	310.00	325.00	420.00	440.00	470.00
T. CRACKS	50.00	50.00	65.00	70.00	80.00	150.00	160.00	180.00
W IN CRACK	50.00	50.00	65.00	70.00	80.00	150.00	160.00	180.00
BOUNDARY 1	50.00	50.00	65.00	70.00	80.00	150.00	160.00	180.00
BOUNDARY 2	80.00	80.00	80.00	80.00	80.00	150.00	160.00	180.00
BOUNDARY 3	80.00	80.00	80.00	80.00	80.00	150.00	160.00	220.00
BOUNDARY 4	400.00	400.00	400.00	400.00	400.00	400.00	400.00	400.00

SECTIONS	500.00	530.00	590.00	610.00	1500.00
T. CRACKS	210.00	230.00	280.00	290.00	290.00
W IN CRACK	210.00	230.00	280.00	290.00	290.00
BOUNDARY 1	210.00	230.00	280.00	290.00	290.00
BOUNDARY 2	210.00	230.00	280.00	290.00	290.00
BOUNDARY 3	270.00	300.00	345.00	360.00	360.00
BOUNDARY 4	400.00	400.00	400.00	400.00	400.00

SOIL PROPERTIES

LAYER	DENSITY	COHESION	FRICTION ANGLE	DELTA PHI
1	125.00	450.00	28.00	.00
2	125.00	800.00	41.00	.00
3	125.00	840.00	38.00	.00

BOUNDARY FORCES AND PRESSURES

LINE LOADS

X COORDINATE	MAGNITUDE	INCLINATION WITH VERT - DEG
200.00	2000.000	.00
210.00	2000.000	.00
220.00	2000.000	.00
230.00	2000.000	.00
240.00	2000.000	.00

<b>Project:</b> Shen - 77 Portuguese Bend Road	<b>By:</b> SN	<b>Sheet</b> 3 of 6
<b>Project Ref.</b> 4868-12	<b>Date:</b> 5/10/12	<b>Plate</b> IV-3

**SWN Soiltech Consultants, Inc.**

\*\*\*\*\*  
 RESULTS  
 \*\*\*\*\*

NUMBER	TANGENT	RADIUS	(X) CENTER	(Y) CENTER	F.S.
1	298.2	498.2	700.0	-200.0	1.591
2	295.0	495.0	680.0	-200.0	1.596
3	297.9	517.9	700.0	-220.0	1.591
4	302.2	502.2	720.0	-200.0	1.607
5	298.5	478.5	700.0	-180.0	1.597
6	296.5	496.5	690.0	-200.0	1.592
7	298.0	508.0	700.0	-210.0	1.591
8	300.1	500.1	710.0	-200.0	1.595
9	298.4	488.4	700.0	-190.0	1.592
10	296.4	506.4	690.0	-210.0	1.593
11	299.9	509.9	710.0	-210.0	1.591
12	300.3	490.3	710.0	-190.0	1.601
13	296.6	486.6	690.0	-190.0	1.592

F.S. MINIMUM= 1.591 FOR THE CIRCLE OF CENTER ( 700.0,-200.0)



\*\*\*\*\*  
 Shen - Portuguese Bend Rd (4868), Section C-C', Seismic  
 \*\*\*\*\*

\*\*\*\*\*  
 ANALYSIS BY BISHOP'S SIMPLIFIED METHOD  
 \*\*\*\*\*

\*\*\*\*\*  
 INPUT DATA  
 \*\*\*\*\*

CONTROL DATA,  
 AUTOMATIC SEARCH FOR CRITICAL CIRCLE  
 NUMBER OF DEPTH LIMITING TANGENTS 0  
 NUMBER OF VERTICAL SECTIONS 13  
 NUMBER OF SOIL LAYER BOUNDARIES 4  
 NUMBER OF POINTS DEFINING COHESION PROFILE 0  
 NUMBER OF CURVES DEFINING COHESION ANISOTROPY 0  
 NUMBER OF BOUNDARY LINE LOADS 5  
 NUMBER OF BOUNDARY PRESSURE LOADS 0  
  
 SEISMIC COEFFICIENT = .150  
 ATMOSPHERIC PRESSURE = .000  
 UNIT WEIGHT OF WATER = 62.400  
 UNIT WEIGHT OF WATER IN TENSION CRACK = 62.400

SEARCH STARTS AT CENTER ( 720.0,-280.0),WITH FINAL GRID OF 10.0

ALL CIRCLES PASS THROUGH THE POINT ( 610.0, 290.0)

GEOMETRY

SECTIONS	.00	250.00	280.00	310.00	325.00	420.00	440.00	470.00
T. CRACKS	50.00	50.00	65.00	70.00	80.00	150.00	160.00	180.00
W IN CRACK	50.00	50.00	65.00	70.00	80.00	150.00	160.00	180.00
BOUNDARY 1	50.00	50.00	65.00	70.00	80.00	150.00	160.00	180.00
BOUNDARY 2	80.00	80.00	80.00	80.00	80.00	150.00	160.00	180.00
BOUNDARY 3	80.00	80.00	80.00	80.00	80.00	150.00	160.00	220.00
BOUNDARY 4	400.00	400.00	400.00	400.00	400.00	400.00	400.00	400.00
SECTIONS	500.00	530.00	590.00	610.00	1500.00			
T. CRACKS	210.00	230.00	280.00	290.00	290.00			
W IN CRACK	210.00	230.00	280.00	290.00	290.00			
BOUNDARY 1	210.00	230.00	280.00	290.00	290.00			
BOUNDARY 2	210.00	230.00	280.00	290.00	290.00			
BOUNDARY 3	270.00	300.00	345.00	360.00	360.00			
BOUNDARY 4	400.00	400.00	400.00	400.00	400.00			

SOIL PROPERTIES

LAYER	DENSITY	COHESION	FRICTION ANGLE	DELTA PHI
1	125.00	700.00	30.00	.00
2	125.00	990.00	46.00	.00
3	125.00	990.00	43.00	.00

BOUNDARY FORCES AND PRESSURES

LINE LOADS

X COORDINATE	MAGNITUDE	INCLINATION WITH VERT - DEG
200.00	2000.000	.00
210.00	2000.000	.00
220.00	2000.000	.00
230.00	2000.000	.00
240.00	2000.000	.00

\*\*\*\*\*  
 RESULTS  
 \*\*\*\*\*

NUMBER	TANGENT	RADIUS	(X) CENTER	(Y) CENTER	F.S.
1	300.5	580.5	720.0	-280.0	1.455
2	297.1	577.1	700.0	-280.0	1.462
3	300.2	600.2	720.0	-300.0	1.455
4	304.6	584.6	740.0	-280.0	1.463
5	300.9	560.9	720.0	-260.0	1.459
6	298.4	598.4	710.0	-300.0	1.461
7	300.0	610.0	720.0	-310.0	1.456
8	302.1	602.1	730.0	-300.0	1.454
9	300.3	590.3	720.0	-290.0	1.454
10	298.6	588.6	710.0	-290.0	1.457
11	302.3	592.3	730.0	-290.0	1.455
12	300.5	580.5	720.0	-280.0	1.455
13	298.4	598.4	710.0	-300.0	1.461
14	302.1	602.1	730.0	-300.0	1.454
15	302.5	582.5	730.0	-280.0	1.458
16	298.7	578.7	710.0	-280.0	1.456

F.S. MINIMUM= 1.454 FOR THE CIRCLE OF CENTER ( 720.0,-290.0)

<b>Project:</b> Shen - 77 Portuguese Bend Road	<b>By:</b> SN	<b>Sheet 6 of 6</b>
<b>Project Ref.</b> 4868-12	<b>Date:</b> 5/10/12	<b>Plate IV-6</b>

**SWN Soiltech Consultants, Inc.**

---

## APPENDIX V

### SLOPE SURFACE STABILITY ANALYSIS

Stability of the surface of the existing slope below the area of the proposed residence, as shown along Section C-C' of the Coast Geotechnical report, has been analyzed. The existing natural slope is as steep as 1½:1 (Horizontal to Vertical) and exposes soil/colluvium.

The shear strength parameters adopted in the analysis of the existing natural slope are based on direct shear tests on representative undisturbed samples of the colluvium under soaked conditions. The residual shear strength has been used.

	<b>Density</b>	<b>Cohesion</b>	<b>Friction Angle</b>	<b>Plate</b>
Colluvium	125 pcf	450 psf	19 degrees	C-1

Calculations are included on Plate V-1. A factor-of-safety in excess of 1.50 has been obtained for a 1½:1 slope that has colluvium within 4 feet of the slope surface.

## Slope Surface Stability Analysis

Existing Natural Slope

1½:1 (34°)

Calculate the surficial stability of the soil/colluvium using the Infinite Slope Analysis with parallel seepage.

This method was recommended by the A.S.C.E. and the Building and Safety Advisory Committee (8/16/78).

Soil properties (all saturated) reference: Plate C-1

Cohesion	450	psf
Phi angle	19	degrees
Saturated density	125	pcf
Slope angle	34	degrees
Water density	62.4	pcf
Depth of saturation	4	feet

$$\text{Factor of Safety} = \frac{450 + (125 - 62.4)4(\cos 34^\circ)^2 \tan 19^\circ}{125 (4) \cos 34^\circ \sin 34^\circ}$$

The calculated Factor of Safety is 2.20

### Conclusions:

Calculations indicate the natural slope has a Factor of Safety of 2.20 and is considered surficially stable.

Project: Shen - 77 Portuguese Bend Road  
Project Ref. 4868-12

By: SN                      Sheet 1 of 1  
Date: 5/10/12          Plate V-1

**SWN Soiltech Consultants, Inc.**

---

## **APPENDIX VI**

### **SEISMIC DESIGN PARAMETERS**

The seismic design parameters for the proposed structures were determined in accordance with Chapter 16 of the 2010 California Building Code.

The mapped acceleration parameters were obtained from the National Seismic Hazard Mapping Project Web Site (<http://eqhazmaps.usgs.gov/>). The output for the subject site is included in the attached Plate VI-1.

## Seismic Factors

From: National Seismic Hazard Mapping Project Web Site  
(<http://eqhazmaps.usgs.gov/>)

Conterminous 48 States  
2005 ASCE 7 Standard  
Latitude = 33.74573  
Longitude = -118.35570000000001  
Spectral Response Accelerations Ss and S1  
Ss and S1 = Mapped Spectral Acceleration Values  
Site Class B -  $F_a = 1.0$ ,  $F_v = 1.0$   
Data are based on a 0.01 deg grid spacing

Period	Sa
(sec)	(g)
0.2	1.609 (Ss, Site Class B)
1.0	0.650 (S1, Site Class B)

Conterminous 48 States  
2005 ASCE 7 Standard  
Latitude = 33.74573  
Longitude = -118.35570000000001  
Spectral Response Accelerations SMs and SM1  
 $SMs = F_a \times Ss$  and  $SM1 = F_v \times S1$   
Site Class D -  $F_a = 1.0$ ,  $F_v = 1.5$

Period	Sa
(sec)	(g)
0.2	1.609 (SMs, Site Class D)
1.0	0.976 (SM1, Site Class D)

Conterminous 48 States  
2005 ASCE 7 Standard  
Latitude = 33.74573  
Longitude = -118.35570000000001  
Design Spectral Response Accelerations SDs and SD1  
 $SDs = 2/3 \times SMs$  and  $SD1 = 2/3 \times SM1$   
Site Class D -  $F_a = 1.0$ ,  $F_v = 1.5$

Period	Sa
(sec)	(g)
0.2	1.073 (SDs, Site Class D)
1.0	0.650 (SD1, Site Class D)

**Project:** Shen – 77 Portuguese Bend Road, Rolling Hills  
**Project Ref.** 4868-12

**Date:** 3/15/12  
**Plate:** VI-1

**SWN Soiltech Consultants, Inc.**

# COAST GEOTECHNICAL, INC.

1200 W. Commonwealth Avenue, Fullerton, CA 92833 Ph: (714) 870-1211 Fax: (714) 870-1222 E-mail: [coastgeotec@sbcglobal.net](mailto:coastgeotec@sbcglobal.net)

October 31, 2013

W.O. 430412-03

Mr. and Mrs. Shen  
26810 Fond du Lac Road  
Rancho Palos Verdes, CA 90275

Subject: Report of Percolation Feasibility for New Residence, 77  
Portuguese Bend Road, Rolling Hills, County of Los  
Angeles, California

Mr. Shen:

Submitted herewith is the percolation feasibility study performed for 77 Portuguese Bend Road found in the City of Rolling Hills. This report completes our work scope for the project outlined in our proposal dated June 18, 2013.

## **PURPOSE**

The purpose of the percolation study is to determine if the subject site has sufficient area with suitable percolation, physiographic and geologic characteristics for construction of a leach field onsite absorption system, in general accordance with County of Los Angeles guidelines.

The proposed system is to service a new residence.

## **WORK SCOPE**

The project work scope consisted of the following:

1. Location and excavation of six exploratory test pits and boring.
2. Geologic logging of the pits and boring.
3. Pre-saturation and percolation testing for a leach field.
4. Analysis of data.
5. Preparation of this report.

To facilitate compliance with the County of Los Angeles Guidelines, each County requirement is stated below followed by our statement.

### **Item 1**

Item 1 requests the location of the property including the legal description.

# COAST GEOTECHNICAL, INC

- The site is identified as 77 Portuguese Bend Road in the City of Rolling Hills, County of Los Angeles, California. The APN for the property is 7567-013-005.
- The site is shown on a Vicinity Map appended as Figure 1.

## Item 2

Item 2 request the owner's name, address, and phone number.

- The owners' name is Mr. and Mrs. Shen with the mailing address as shown on the cover page of this report.
- A phone number for the owner is 310-373-3833(H) or 310-923-0474(C).

## Item 3

Item 3 requests the type of proposed sewage system.

- Based on our understanding of the project the proposed disposal system will service a new residence. The primary and secondary systems will consist of a septic tank with leach lines. The system will service a residence with three true bedrooms and one bedroom equivalent (detached office/studio) for a bedroom count of four.
- The proposed septic tank and leach trenches will be located west of the proposed studio/office in a landscape area. The area is a ridgeline with general level topography in north-south direction and a gentle downward gradient to the west.

## Item 4

Item 4 requests description of the on-site materials.

- Earth material at the location of the leach trenches is composed of native sandy to silty clays and silty clayey sands. Percolation waters will be disposed of into native soils and terrace materials. Geologic logs of the exploratory pits are presented on Plates A through F. A geologic log of a nearby deep boring, excavated for site geologic work, is presented on Plate G. The pit locations and boring location are presented on Figure 2. A geologic section, A-A', is presented on Figure 3.

## Item 5

Item 5 requests a scaled grading plan.

- a. Figure 2 is a site/grading plan that shows the property lines and proposed site improvements at a reduced scale of 1"= 40ft. An enlarged portion of the plan for the leach field area is attached as Figure 2.1
- b. Figure 2 includes topography that indicates slopes in the area.



# COAST GEOTECHNICAL, INC

- c. No hydrophytic plants or oak trees were observed in the vicinity of the leach field.
- d. No wells, abandoned wells, or springs are present on the site. Drinking waters will be from metered City service.
- e. The pit and boring locations are indicated on Figure 2 and 2.1.
- f. Rock outcrops were not observed in the vicinity of the leach field.
- g. The proposed residence and appurtenances are shown on Figure 2.
- h. The dimensions of the proposed septic tank and leach field are shown on Figure 2.1. Section A-A', Figure 3, is a geologic cross-section that indicates typical leach field construction. Typical leach trench construction is depicted on Figure 6.
- i. The proposed septic tank will be located west of the office/studio as shown on Figure 2 and 2.1. The residence shows three true bedrooms and one bedroom equivalent (office/studio) for a bedroom count of four. Based on a bedroom count of four and table K2 a septic tank size of 1200 gallons shall be utilized. The determined percolation rate does not exceed 5 minutes 20 seconds, as such; a conventional septic tank such as a Jenson JS-1200 or equivalent may be utilized.
- j. A cross-section view of the septic tank, risers and system dimensions is attached as Figure 5.
- k. The primary and expansion leach trenches are shown on Figure 2.1. Each system shall consist of three leach lines each 45 feet in length, by three feet in width with two feet of gravel beneath the pipe. A distribution box will be needed for the system.
- l. The project contractor shall provide documentation of washing of any filler material (if used) by the supplier.
- m. Pertinent setback distances are indicated on Figure 2.1. Setbacks from property lines, buildings, leach lines and septic tanks are per Table K-1.

## Item 6

Item 6 requests a copy of the approved grading plan.

- Figure 2 is a copy of the site/grading plan.

## Item 7

Item 7 requests a historic high groundwater level determination.

- There are no historic water level readings for this area. Consequently, a test boring was advanced to a minimum depth of ten feet below the bottom of the proposed leach line. No waters were encountered.

## Item 8

Item 8 requests a floor plan of the building.

# COAST GEOTECHNICAL, INC

- The proposed house floor plan showing room use is shown on Figure 4. Our interpretation of the proposed residence shows a true bedroom count of three with one bedroom equivalent (office/studio) for a total bedroom count of four.

## Item 9

Item 9 requests a final county geologic review sheet required by Building and Safety.

- Project geologic reports prepared by Coast Geotechnical, Inc. found acceptable conditions for construction of the proposed site improvements. The reports were processed through an outside reviewer for the City of Rolling Hills. To our knowledge the report has been approved.

## Item 10

Item 10 requests percolation test data

- a. Todd Houseal, a Certified Engineering Geologist, performed the percolation testing.
- b. The test pits had a one-foot square pit excavated at the bottom in which to perform the Ryon test. These pits were presoaked in accordance with County guidelines on August 13 2013 between 7:45am and 7:51am.
- c. Percolation testing was performed on August 14, 2013. The test holes were observed to be free of standing water prior to percolation testing.

Testing was performed by filling each test hole with clear waters from a water barrel. Waters were allowed to stabilize then timed readings were taken for each water drop of one inch. The timed drop between the fifth and sixth inch was utilized in determining the needed length of leach field.

Field data and calculations for each test hole are presented on Plates H through M.

Our field data and calculations show favorable conditions for an onsite effluent system. The calculated percolation rates for each test hole exceeds the County of Los Angeles Department of Health minimum rate of 63.5 minutes needed to issue a permit for a leach field private sewage disposal system. An advanced treatment system for effluent will not be required due to percolation rates being slower than the County limit of 5 minutes 20 seconds.

Design of the leach field system is based on the slowest percolation rate obtained from the testing performed. Based on the results obtained from test pit 6 the leach field must be 134 feet in length and utilize two feet of gravels beneath the leach pipe. To accommodate this length of line and to comply with the requirements that individual lines must be of equal length and be on near level ground we recommend that three individual lines each 45 feet in length be used. for a total of length of 135 feet.

## Item 11

# COAST GEOTECHNICAL, INC

Item 11 requests a conclusion on the suitability of the site for the proposed system.

- Information obtained from the percolation testing indicates that the proposed on-site sewage disposal system is suitable from a geologic standpoint.
- Effluent will migrate through structure of the native soils. Effluents will not daylight.

## Item 12

Item 12 requests a signed statement that this report presents an accurate and complete disclosure of all facts known relating to the proposed on-site sewage disposal system.

- It is our opinion that this report presents an accurate and complete disclosure of all facts that are known and relate to the proposed on-site sewage disposal system.
- The client is advised that an onsite sewage disposal system is considered temporary only with eventual failure and requirement for replacement with a new system. Life expectancy of a system varies widely dependent on usage, construction and maintenance. Coast Geotechnical, Inc. makes no warranty or guarantee of the system or length of effectiveness.
- COAST GEOTECHNICAL, INC. shall be consulted if the system loads change from those anticipated; if the trench locations change significantly; if an alternate advanced treatment system is utilized and during construction so the trenches may be observed.

We appreciate this opportunity to be of service to you.

Respectfully submitted:

COAST GEOTECHNICAL, INC.

Todd D. Houseal

CEG 1914 Exp 4/14

# SITE VICINITY MAP

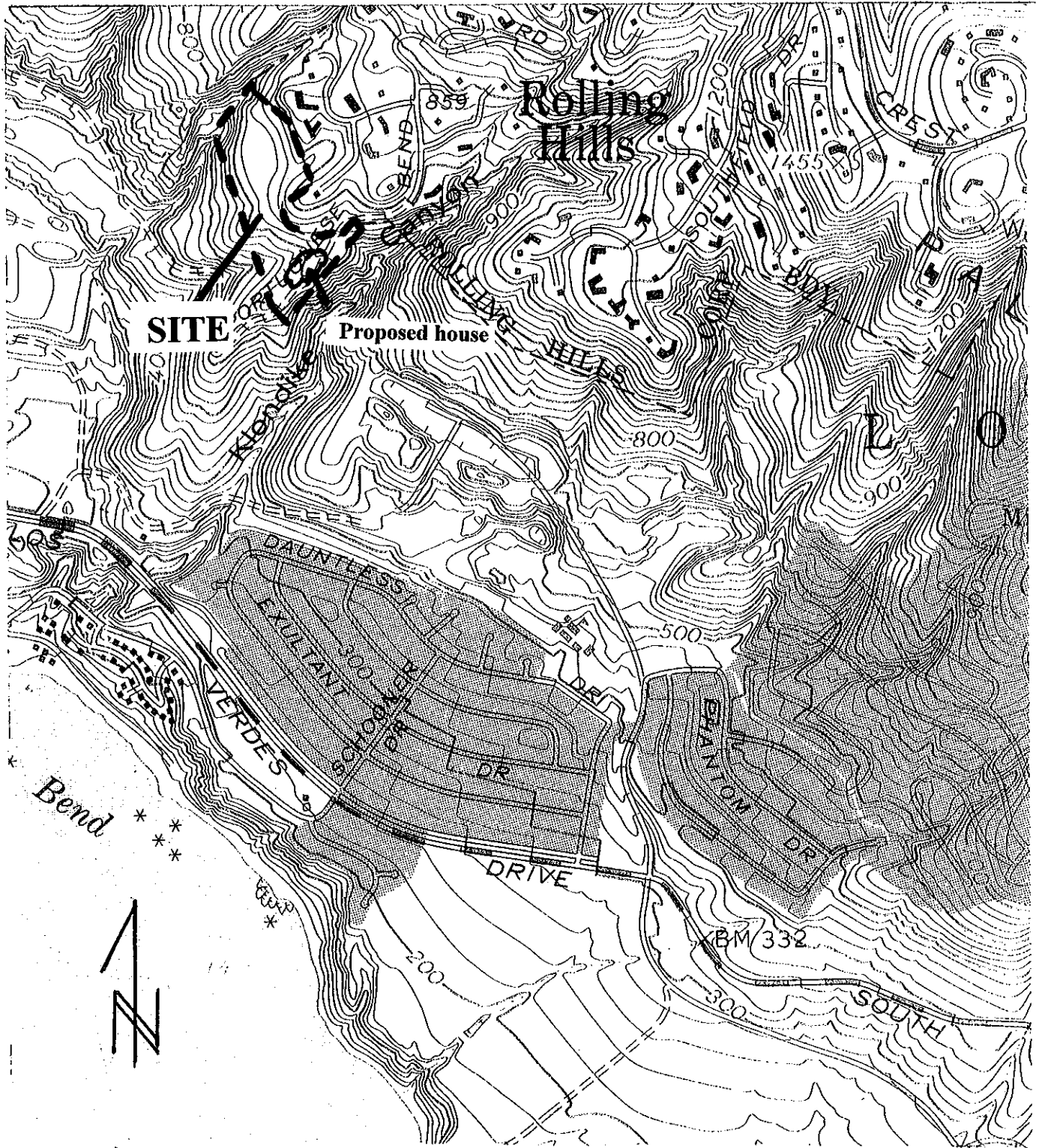

San Pedro USGS Topographic Map

COAST GEOTECHNICAL, INC.

W.O. 430412

Figure 1

**SITE DEVELOPMENT PLAN**

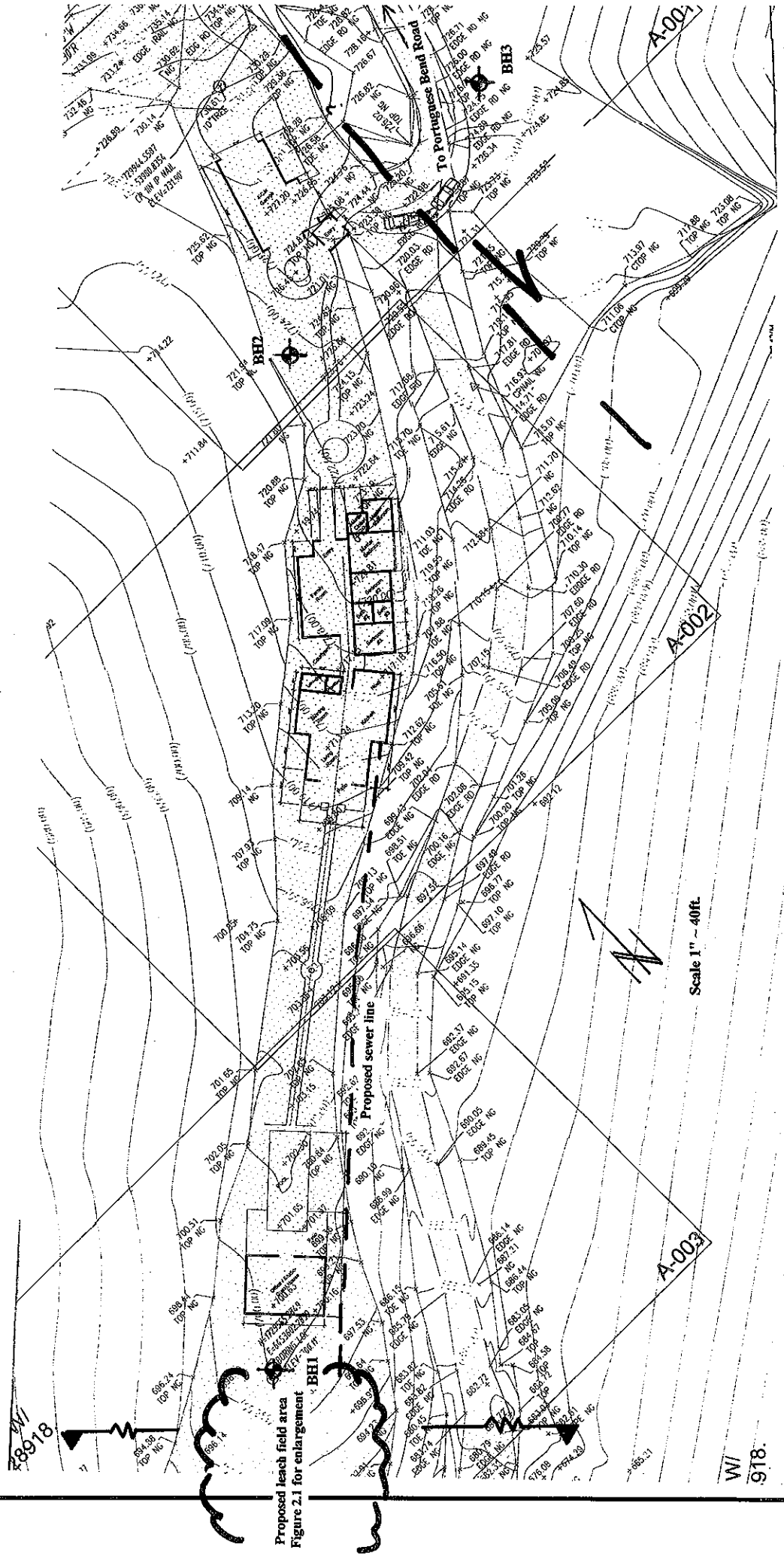

Proposed leach field area  
Figure 2.1 for enlargement

Scale 1" = 40ft.

**LEACH FIELD DESIGN**

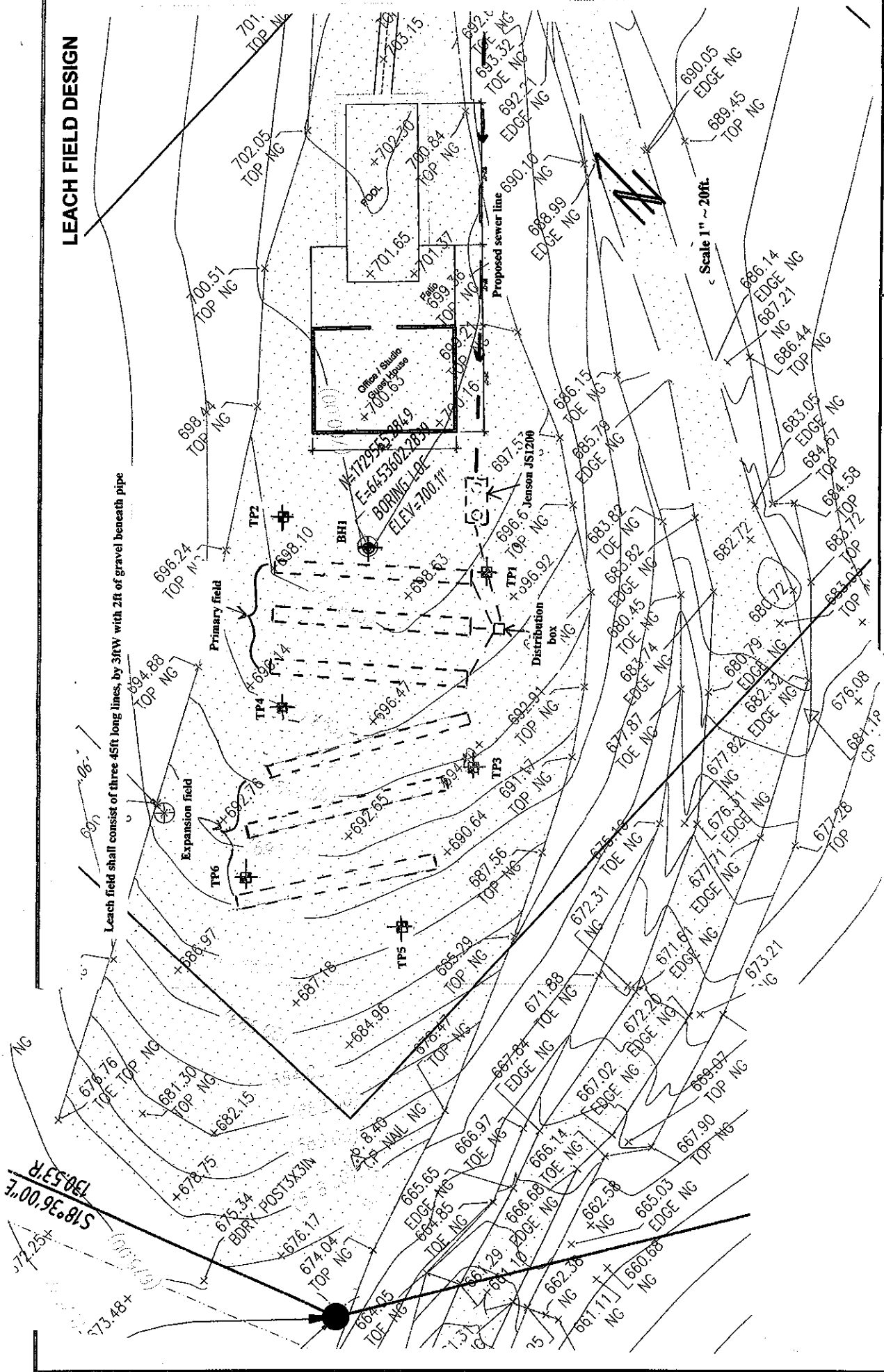

# GEOLOGIC CROSS SECTION

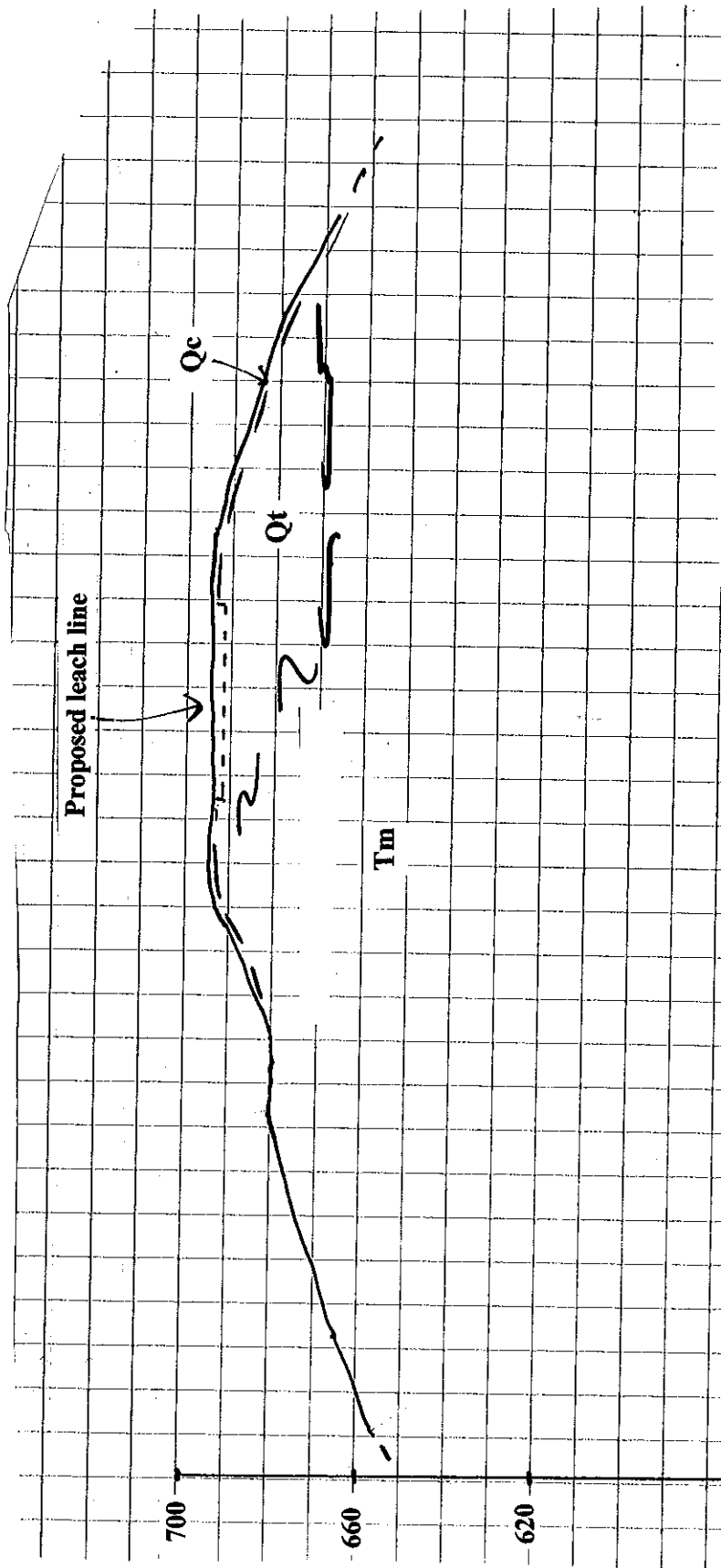

Scale 1" ~ 40ft (H=V)

COAST GEOTECHNICAL, INC.

W.O. 430412 Figure 3

# FLOOR PLAN

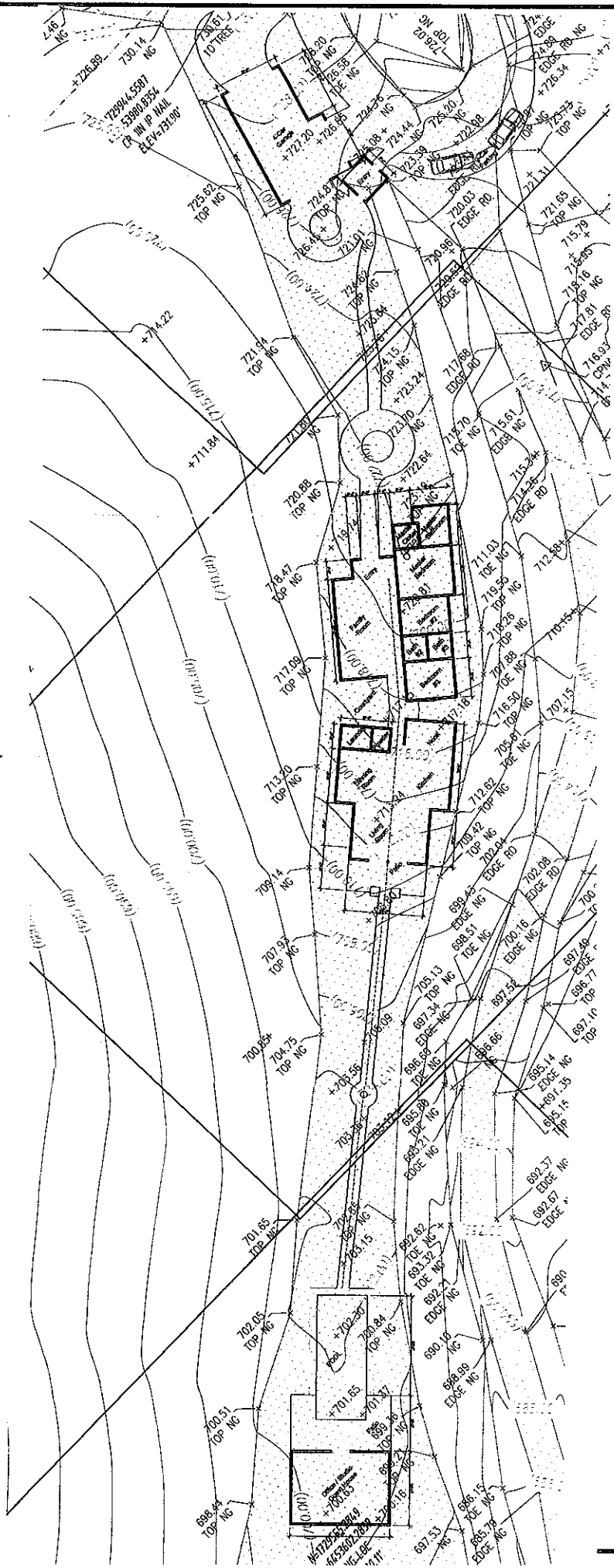

COAST GEOTECHNICAL, INC.

W.O. 430412

Figure 4



# SEPTIC TANK SECTION

## 1200 GALLON RESIDENTIAL SEPTIC TANK

MODEL JS1200

NON-TRAFFIC ACCEPTED BY UPC<sub>®</sub>

**SIDE VIEW  
CUTAWAY**

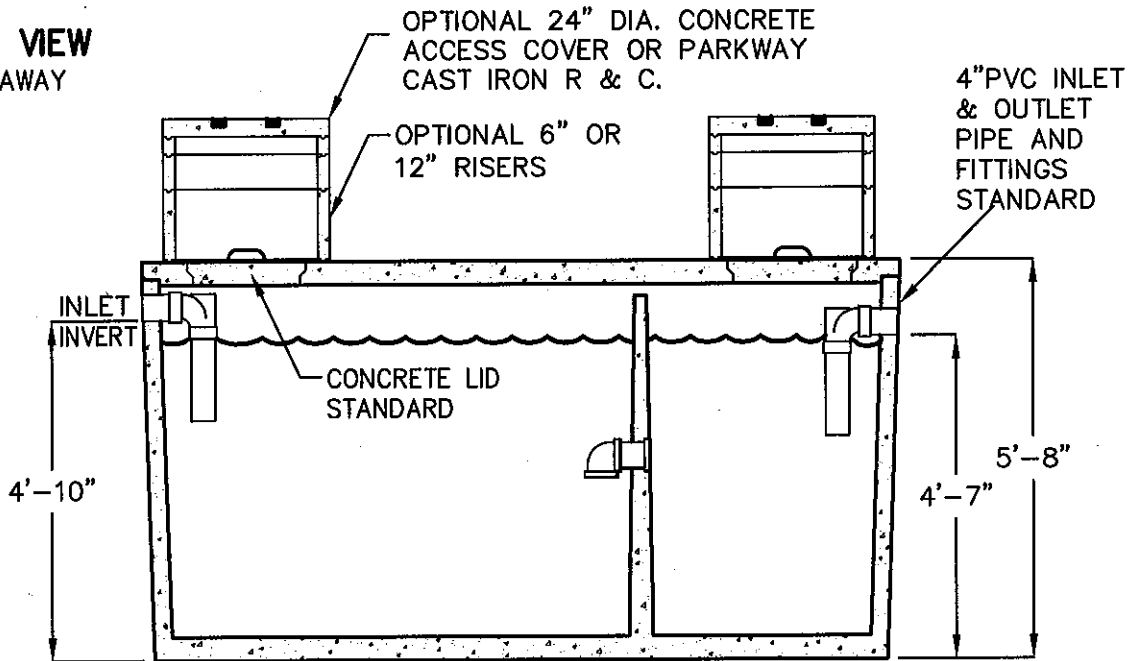

**TOP VIEW**

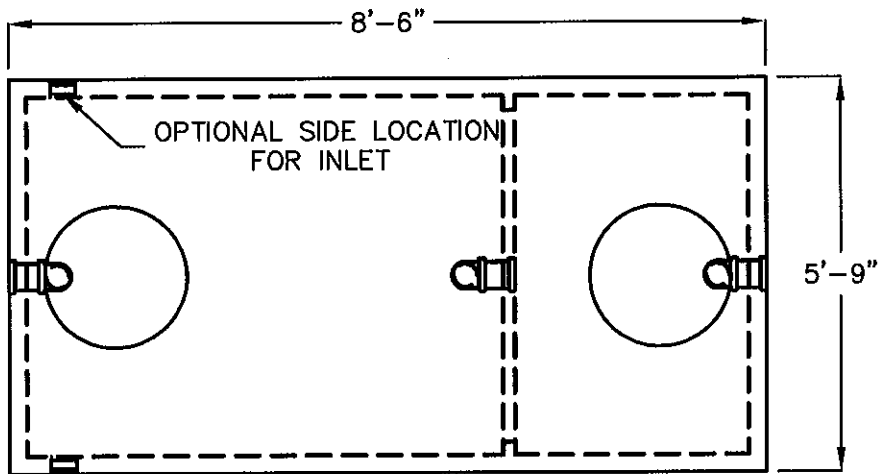

- LIQUID CAPACITY: 1200 GALLONS  
TANK DESIGNED FOR NON-TRAFFIC USE WITH A MAXIMUM LOAD OF 500 PSF AND DRY SOIL CONDITIONS (WATER TABLE BELOW TANK). EARTH COVER OVER TANK NOT TO EXCEED 3'.
- THE PRECAST CONCRETE TANK SHALL BE PLACED ON LEVEL, UNDISTURBED SOIL OR APPROVED COMPACTED FILL.
- EFFLUENT FILTERS ARE AVAILABLE UPON REQUEST.
- FOR COMPLETE DESIGN AND PRODUCT INFORMATION CONTACT JENSEN PRECAST.

**COAST GEOTECHNICAL, INC.**

W.O. 430412

Figure 5

# TYPICAL LEACH LINE TRENCH

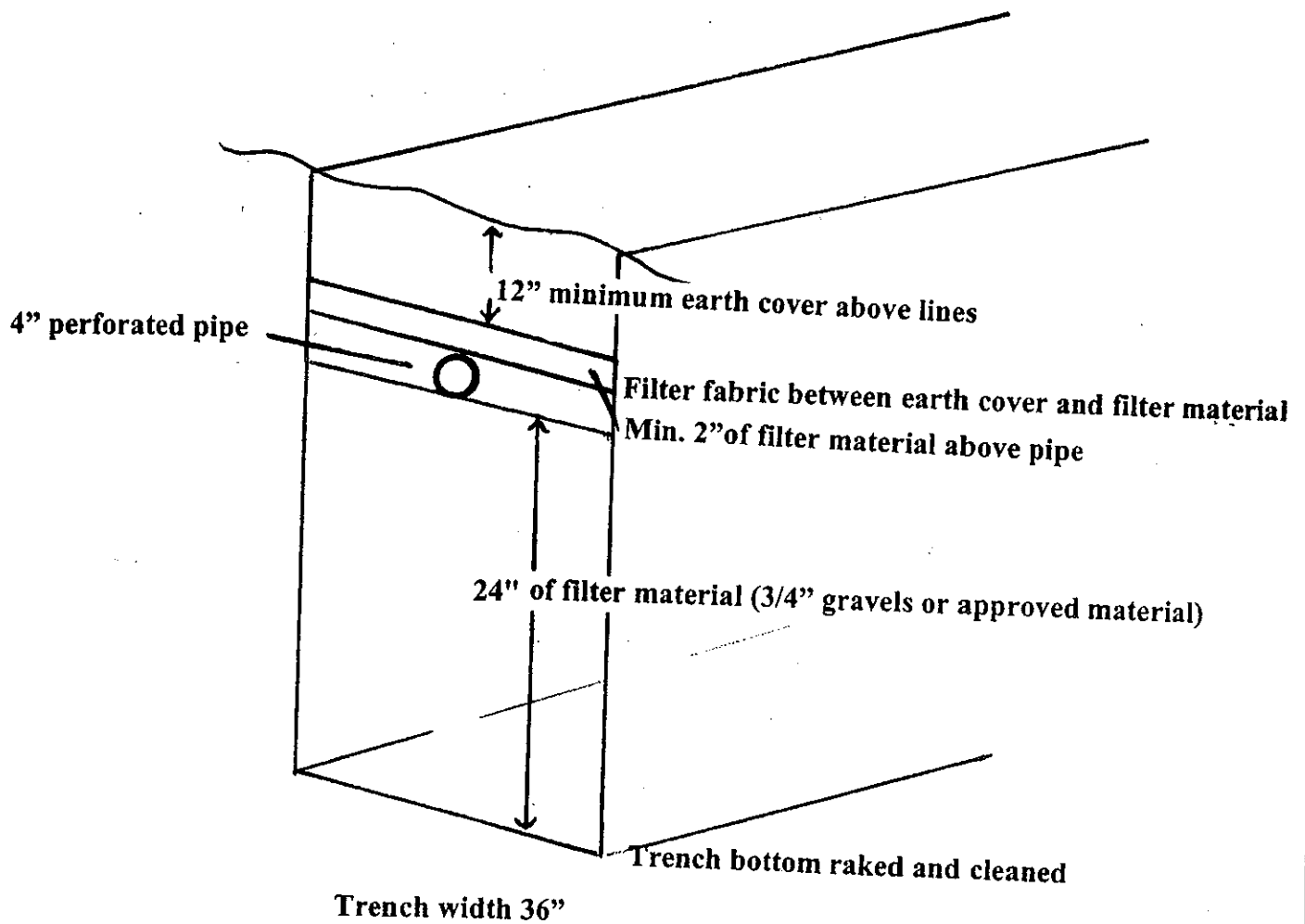

COAST GEOTECHNICAL, INC.

W.O. 430412 Figure 6

# SUMMARY OF TEST PIT NO. 1

Date: 8/13/2013

Dry Density (Pcf)	Moisture (% Dry Wt.)	Samples C B	Depth (Ft.)	Description
			1	BLACK SILTY CLAY, REDDUS, DRY, ROOTS, ROCKS (Qc)
			2	TAU BUFF SILTSTONE WITH ZONES OF SANDSTONE, VERY FRACTURED WEATHERED, HARD Tm
			3	EOPC 3.0' - No H <sub>2</sub> O
			4	
			5	

## CROSS SECTION SKETCH

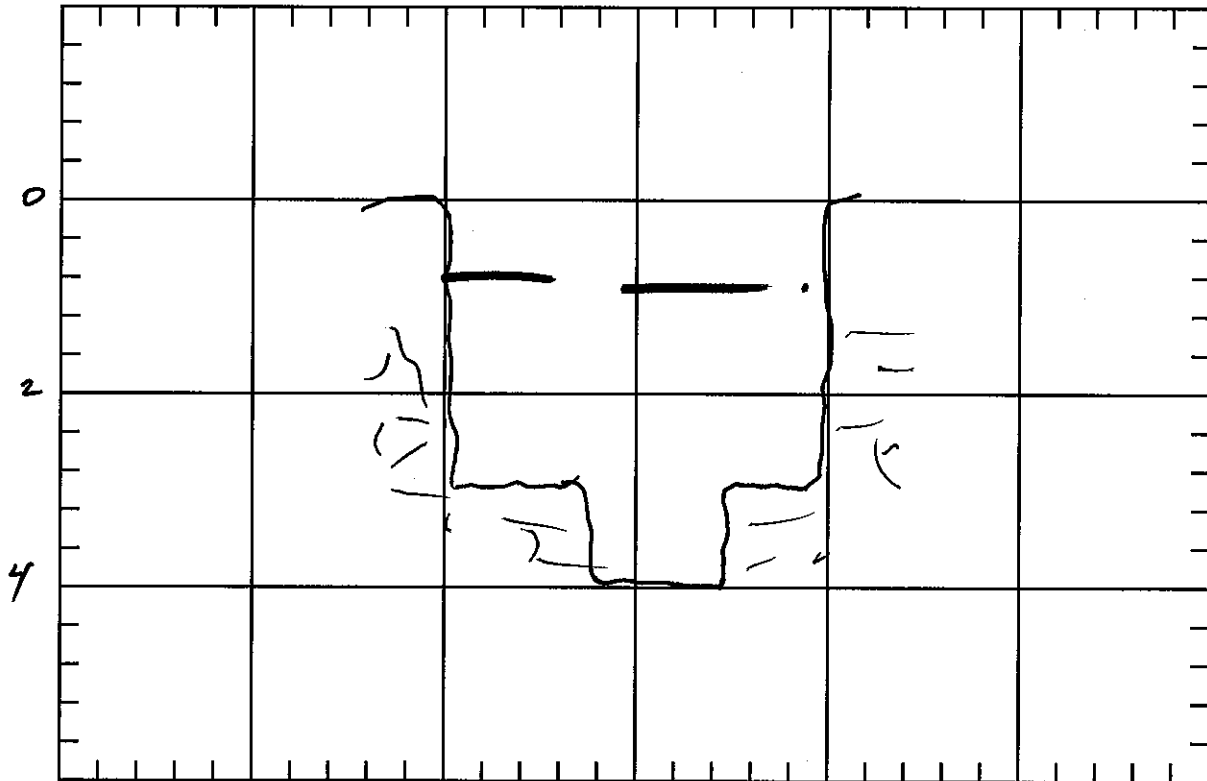

Percolation Study  
77 Portuguese Bend Road  
Rolling Hills, CA

Work Order 430412

Plate No. A

## COAST GEOTECHNICAL, INC.

# SUMMARY OF TEST PIT NO. 2

Date: 8/13/2013

Dry Density (Pcf)	Moisture (% Dry Wt.)	Samples C B	Depth (Ft.)	Description
			1	<p>GRAY BLACK SILTY CLAY. STIFF ROOTS, POORLY, FIRM</p> <p style="text-align: right;">(Qc)</p>
			2	
			3	<p>YELLOW BROWN SILTY SAND, DAMP</p> <p style="text-align: right;">(Qc)</p>
			4	

### CROSS SECTION SKETCH

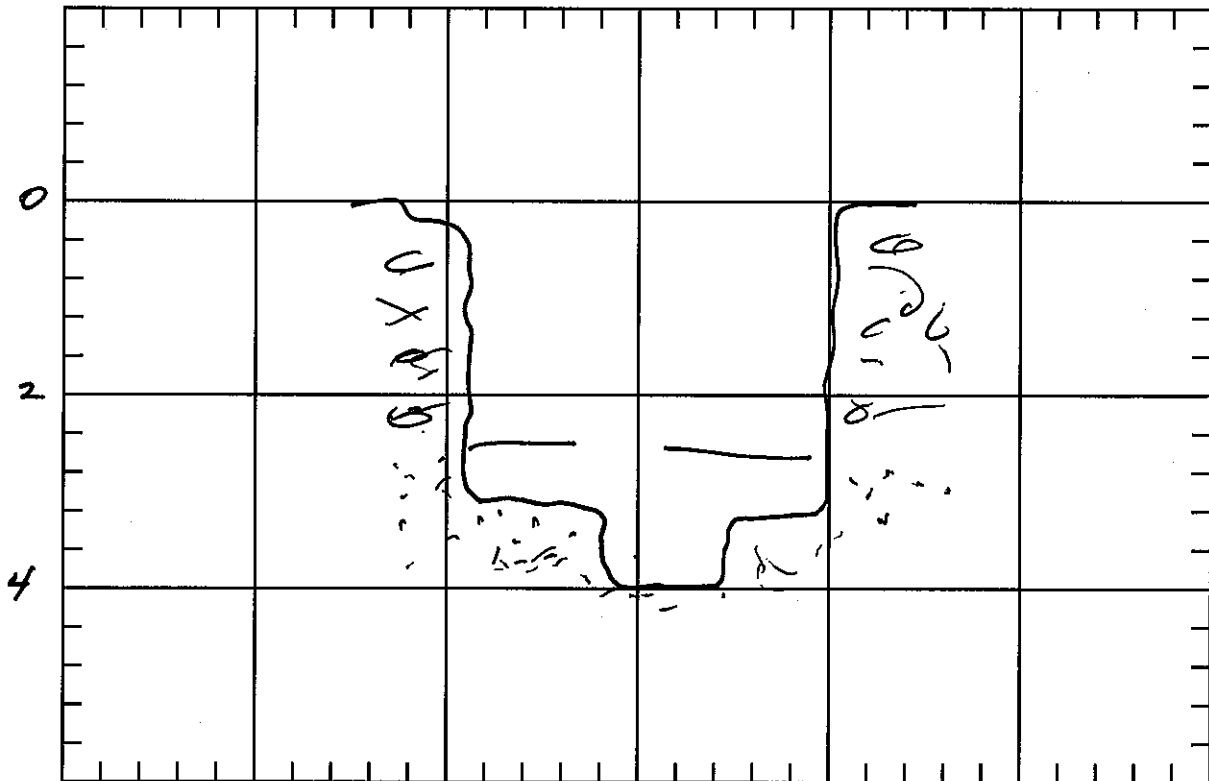

Percolation Study  
77 Portuguese Bend Road  
Rolling Hills, CA

Work Order 430412

Plate No. B

## COAST GEOTECHNICAL, INC.

# SUMMARY OF TEST PIT NO. 3

Date: 8/13/2013

Dry Density (Pcf)	Moisture (% Dry Wt.)	U B	Samples	Depth (Ft.)	Description
				1	BLACK GREY SILTY CLAY, ROCKY, POROUS, DRY, SOFT <span style="float: right;">(Qc)</span>
				2	BUFF TAN SILTY SAND WITH SMALL SUBROUND ROCKS, DRY, FIRM <span style="float: right;">(Qc)</span>
				3	ROPE 3' - No H <sub>2</sub> O <span style="float: right;">(Qc)</span>
				4	
				5	

### CROSS SECTION SKETCH

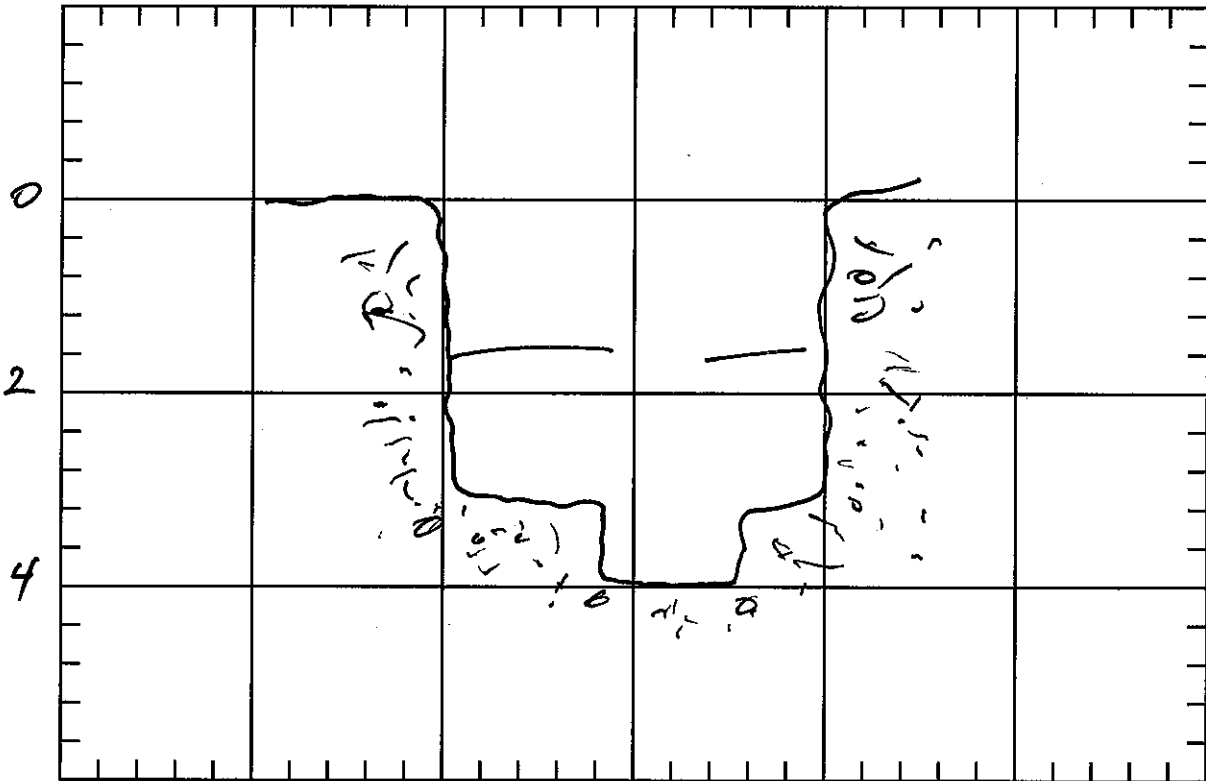

Percolation Study  
77 Portuguese Bend Road  
Rolling Hills, CA

Work Order 430412

Plate No. C

## COAST GEOTECHNICAL, INC.

# SUMMARY OF TEST PIT NO. 4

Date: 8/13/2013

Dry Density (Pcf)	Moisture (% Dry Wt.)	Samples U B	Depth (Ft.)	Description
			1	<p>GRAY BLACK SILTY CLAY, FIRM, ROOTS</p> <p style="text-align: right;">(Rc)</p>
			2	_____
			3	<p>YELLOW BROWN SILTY SAND, ROCK FRAGMENTS, MEDIUM DENSE, DAMP</p>
			4	<p>FOPC 3' - NO H<sub>2</sub>O</p> <p style="text-align: right;">(Rc)</p>

### CROSS SECTION SKETCH

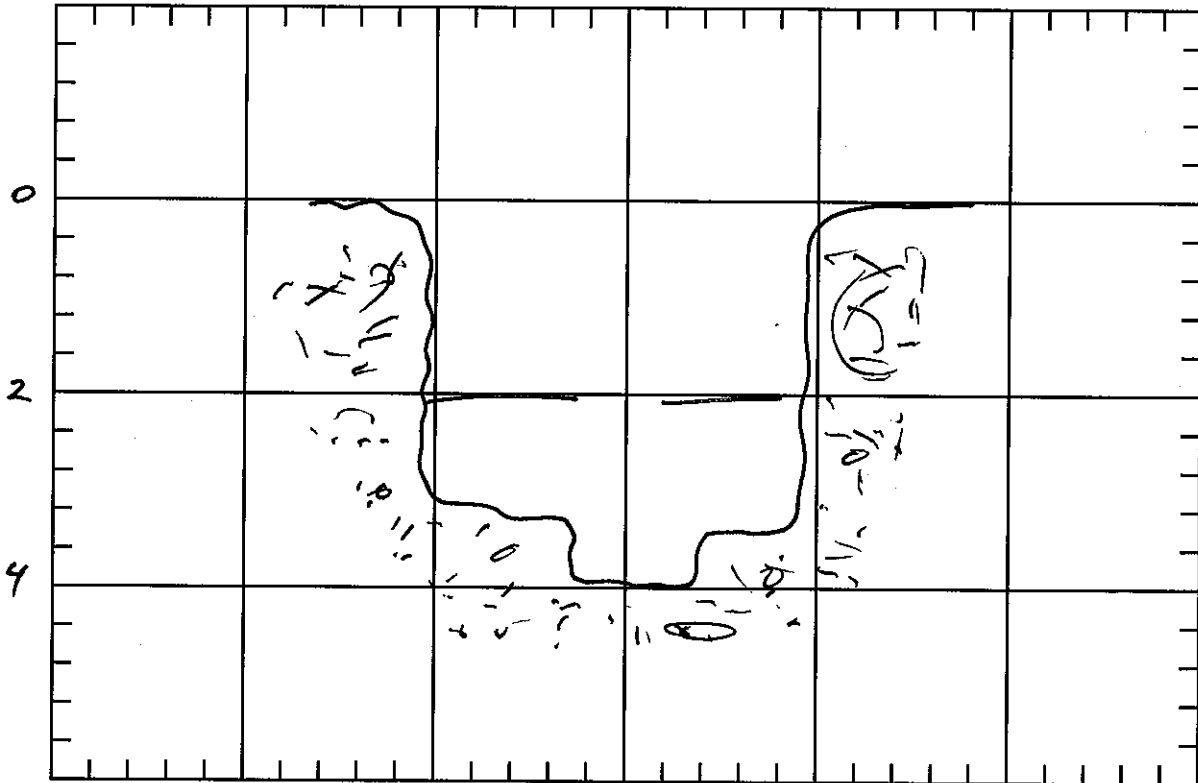

Percolation Study  
77 Portuguese Bend Road  
Rolling Hills, CA

Work Order 430412

Plate No. D

## COAST GEOTECHNICAL, INC.

# SUMMARY OF TEST PIT NO. 5

Date: 8/13/2013

Dry Density (Pcf)	Moisture (% Dry Wt.)	U B Samples	Depth (Ft.)	Description
			1	BLACK GRAY SILTY CLAY, LOOSE, ROCKS, DAMP, ROOTS
			2	(Qc)
			3	YELLOW TAN, BUFF SILTY SAND, ROUNDED ROCK FRAGMENTS, FIRM DAMP
			4	FOPE 3' - No H <sub>2</sub> O
			5	

### CROSS SECTION SKETCH

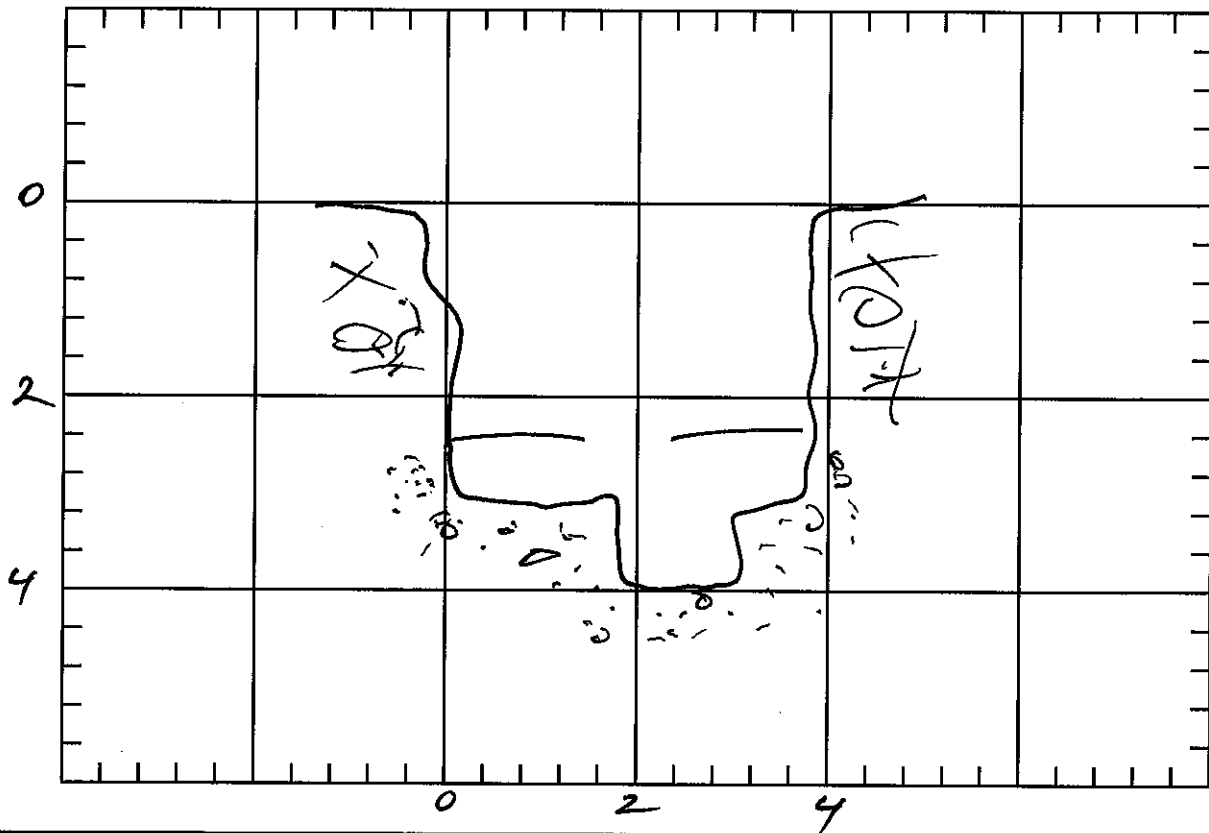

Percolation Study  
77 Portuguese Bend Road  
Rolling Hills, CA

Work Order 430412

Plate No. E

## COAST GEOTECHNICAL, INC.

# SUMMARY OF TEST PIT NO. 6

Date: 8/13/2013

Dry Density (Pcf)	Moisture (% Dry Wt.)	Samples U B	Depth (Ft.)	Description
			1	GRAY BLACK SILTY CLAY, LOOSE, DAMP, ROOTS <span style="float: right;">(Qc)</span>
			2	
			3	YELLOW BROWN TO BUFF SILTY SAND, ABUNDANT ROCKS, FIRM, DAMP <span style="float: right;">(Qd)</span>
			4	EDGE 3' - NO HLL - NO GRAVEL
			5	

**CROSS SECTION SKETCH**

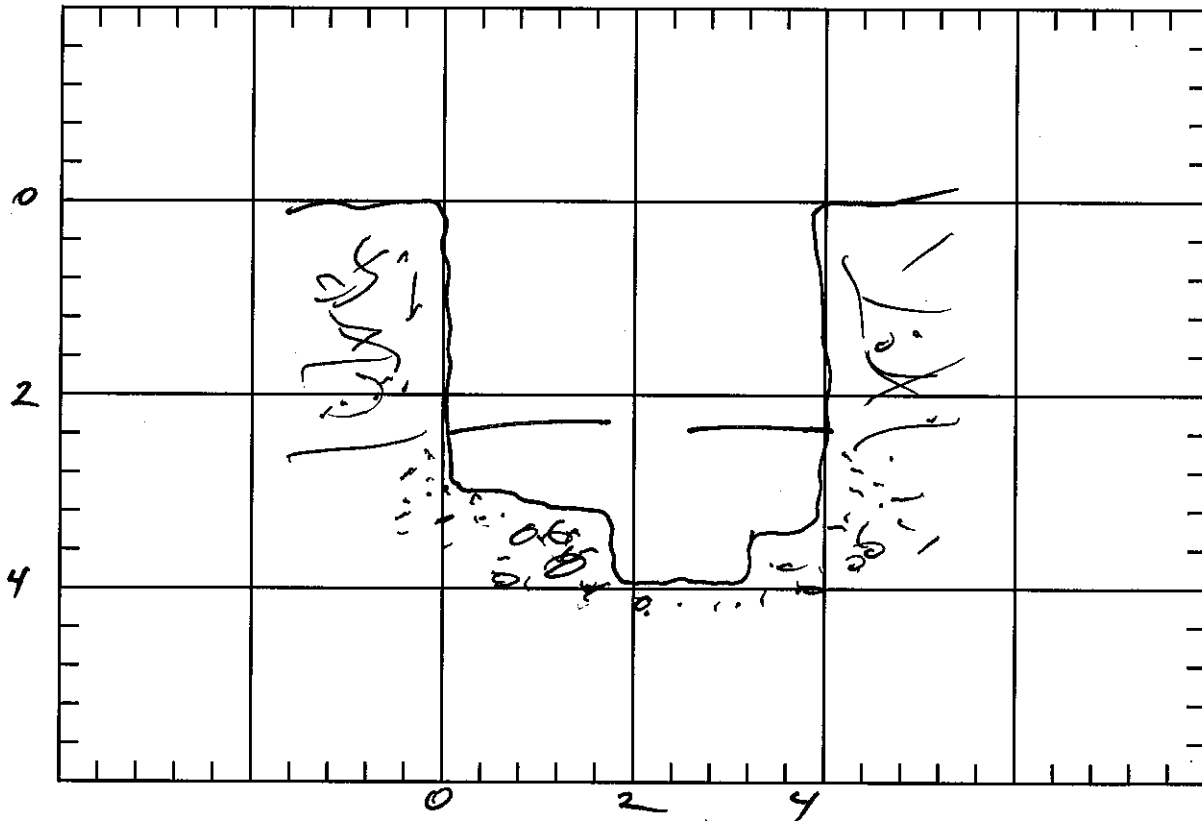

Percolation Study  
77 Portuguese Bend Road  
Rolling Hills, CA

Work Order 430412

Plate No. F

**COAST GEOTECHNICAL, INC.**



# FIELD LOG OF BORING NO. 1

Project Name: SMEN W.O. 430412 Log by: TON

Method: 24" BUCKET Start: \_\_\_\_\_ Finish: \_\_\_\_\_ Date: 2/17/12

Wt. Of Kelly Bar: \_\_\_\_\_ Drop \_\_\_\_\_

Samples			Blows			Depth (FT)	DESCRIPTION
Type	No.	Depth	6"	6"	6"		
						10	<u>TAN BROWN SILTY SAND, CLAY, VERY STIFF, ABUNDANT SMALL ROCK FRAGMENTS, ANGULAR TO ROUNDED</u>
							<u>(OC)</u>
						20	
						30	<u>CONTACT WITH BEDROCK FLAT AND CLEAN</u>
<u>@33'</u>	<u>N30E</u>	<u>/30W</u>					<u>TAN BROWN SILTSTONE, OXIDIZED ON BEDDING, WELL BEDDED, PLATY TO SLICELY, COMP. FIRM TO HARD</u>
							<u>(TM)</u>
<u>@40'</u>	<u>B-N15E</u>	<u>/43W</u>				40	<u>MINOR GYPSUM SEAMS ALONG BEDDING</u>
<u>@45'</u>	<u>B-N15E</u>	<u>/34W</u>					<u>THIN BEDDED SILTSTONE AND SANDSTONE, MINOR OXIDATION FIRM TO HARD</u>
<u>@50'</u>	<u>B-N20E</u>	<u>/38W</u>				50	



# PERCOLATION TEST PIT 1

## PRESOAK

Date – August 13, 2013

Time – 7:45am

## TESTING

Date – August 14, 2013

Each test hole was observed to be free of water prior to testing

Interval (inch drop)	Clock Time	Minutes
0-1	7:45-7:54	9
1-2	7:54-8:07	13
2-3	8:07-8:21	14
3-4	8:21-8:39	18
4-5	8:39-8:57	18
5-6	8:57-9:16	19

## CALCULATION FOR 1200gal TANK

Ryon formula:  $A = (T + 6.24 / 29) \times (C / 2)$

A = Square feet of three foot wide trench

T = Time in minutes for the sixth inch of water to drain – 19 minutes

C = Proposed septic tank capacity – 1200gallons

$$A = (19 + 6.24) / 29 \times (1200 / 2)$$

$$= 522$$

The value (A) is divided by five for lineal feet of trench, for two feet of rock beneath the perforated pipe

$$522/5 = \underline{\underline{105 \text{ feet of trench}}}$$

**COAST GEOTECHNICAL, INC.**

**W.O. 430412      Plate H**

# PERCOLATION TEST PIT 2

## PRESOAK

Date – August 13, 2013

Time – 7:47am

## TESTING

Date – August 14, 2013

Each test hole was observed to be free of water prior to testing

Interval (inch drop)	Clock Time	Minutes
0-1	7:52-7:53	1
1-2	7:53-7:55	2
2-3	7:55-7:58	3
3-4	7:58-8:04	6
4-5	8:04-8:14	10
5-6	8:14-8:24	10

## CALCULATION FOR 1200gal TANK

Ryon formula:  $A = (T + 6.24 / 29) \times (C / 2)$

A = Square feet of three foot wide trench

T = Time in minutes for the sixth inch of water to drain – 10 minutes

C = Proposed septic tank capacity – 1200gallons

$$A = (10 + 6.24) / 29 \times (1200 / 2)$$

$$= 336$$

The value (A) is divided by five for lineal feet of trench, for two feet of rock beneath the perforated pipe

$$336/5 = \underline{\underline{68 \text{ feet of trench}}}$$

**COAST GEOTECHNICAL, INC.**

**W.O. 430412 Plate 1**

# PERCOLATION TEST PIT 3

## PRESOAK

Date – August 13, 2013

Time – 7:47am

## TESTING

Date – August 14, 2013

Each test hole was observed to be free of water prior to testing

Interval (inch drop)	Clock Time	Minutes
0-1	8:02-8:04	2
1-2	8:04-8:20	16
2-3	8:20-8:38	18
3-4	8:38-8:58	20
4-5	8:58-9:18	20
5-6	9:18-9:40	20

## CALCULATION FOR 1200gal TANK

Ryon formula:  $A = (T + 6.24 / 29) \times (C / 2)$

A = Square feet of three foot wide trench

T = Time in minutes for the sixth inch of water to drain – 20 minutes

C = Proposed septic tank capacity – 1200gallons

$$A = (20 + 6.24) / 29 \times (1200 / 2)$$

$$= 543$$

The value (A) is divided by five for lineal feet of trench, for two feet of rock beneath the perforated pipe

$$543/5 = \underline{109 \text{ feet of trench}}$$

**COAST GEOTECHNICAL, INC.**

**W.O. 430412      Plate J**

# PERCOLATION TEST PIT 4

## PRESOAK

Date – August 13, 2013

Time – 7:47am

## TESTING

Date – August 14, 2013

Each test hole was observed to be free of water prior to testing

Interval (inch drop)	Clock Time	Minutes
0-1	8:04-8:07	3
1-2	8:07-8:12	5
2-3	8:12-8:19	7
3-4	8:19-8:27	8
4-5	8:27-8:39	12
5-6	8:39-8:54	15

## CALCULATION FOR 1200gal TANK

Ryon formula:  $A = (T + 6.24 / 29) \times (C / 2)$

A = Square feet of three foot wide trench

T = Time in minutes for the sixth inch of water to drain – 15 minutes

C = Proposed septic tank capacity – 1200gallons

$$A = (15 + 6.24) / 29 \times (1200 / 2)$$

$$= 440$$

The value (A) is divided by five for lineal feet of trench, for two feet of rock beneath the perforated pipe

$$440/5 = \underline{\underline{88 \text{ feet of trench}}}$$

**COAST GEOTECHNICAL, INC.**

**W.O. 430412 Plate K**

# PERCOLATION TEST PIT 5

## PRESOAK

Date – August 13, 2013

Time – 7:50am

## TESTING

Date – August 14, 2013

Each test hole was observed to be free of water prior to testing

Interval (inch drop)	Clock Time	Minutes
0-1	8:21-8:25	4
1-2	8:25-8:33	8
2-3	8:33-8:40	7
3-4	8:40-8:52	8
4-5	8:52-9:04	12
5-6	9:04-9:20	16

## CALCULATION FOR 1200gal TANK

Ryon formula:  $A = (T + 6.24 / 29) \times (C / 2)$

A = Square feet of three foot wide trench

T = Time in minutes for the sixth inch of water to drain – 16 minutes

C = Proposed septic tank capacity – 1200gallons

$$A = (16 + 6.24) / 29 \times (1200 / 2)$$

$$= 461$$

The value (A) is divided by five for lineal feet of trench, for two feet of rock beneath the perforated pipe

$$461/5 = \underline{\underline{93 \text{ feet of trench}}}$$

**COAST GEOTECHNICAL, INC.**

**W.O. 430412 Plate L**

# PERCOLATION TEST PIT 6

## PRESOAK

Date – August 13, 2013

Time – 7:51am

## TESTING

Date – August 14, 2013

Each test hole was observed to be free of water prior to testing

Interval (inch drop)	Clock Time	Minutes
0-1	7:35-7:45	10
1-2	7:45-8:04	19
2-3	8:04-8:23	19
3-4	8:23-8:43	20
4-5	8:43-9:01	20
5-6	9:01-9:29	26

## CALCULATION FOR 1200gal TANK

Ryon formula:  $A = (T + 6.24 / 29) \times (C / 2)$

A = Square feet of three foot wide trench

T = Time in minutes for the sixth inch of water to drain – 26 minutes

C = Proposed septic tank capacity – 1200gallons

$$A = (26 + 6.24) / 29 \times (1200 / 2)$$

$$= 667$$

The value (A) is divided by five for lineal feet of trench, for two feet of rock beneath the perforated pipe

$$667/5 = \underline{134 \text{ feet of trench}}$$

**COAST GEOTECHNICAL, INC.**

**W.O. 430412 Plate M**



# COAST GEOTECHNICAL, INC.

1200 W. Commonwealth Avenue, Fullerton, CA 92833 Ph: (714) 870-1211 Fax: (714) 870-1222 E-mail: [coastgeotec@sbcglobal.net](mailto:coastgeotec@sbcglobal.net)

March 10, 2015

W.O. 430412-04

Mr. and Mrs. Shen  
26810 Fond du Lac Road  
Rancho Palos Verdes, CA 90275

Subject: Addendum Report to Percolation Feasibility for New Residence, 77 Portuguese Bend Road, Rolling Hills, County of Los Angeles, California

## References:

1. Report of Percolation Feasibility for New Residence at 77 Portuguese Bend Road, Rolling Hills, California; by Coast Geotechnical, Inc., W.O. 430412-03, dated October 31, 2013.

Mr. Shen:

Submitted herewith is an update to a percolation feasibility study performed for 77 Portuguese Bend Road in the City of Rolling Hills in 2013. This update report was prepared to address changes to design of the proposed onsite waste water disposal system due to changes in the project design.

## PROJECT CHANGES

Since issuance of the referenced percolation feasibility report the project has gone through several design changes. A revised site grading plan showing the revised changes is attached as Figure 1.

The size of the proposed residence and its location has changed resulting in a larger septic tank and a redesigned leach field.

The following are updated sections of the referenced report.

- Based on our understanding of the project the proposed disposal system will service a new residence and guesthouse. The primary and secondary systems will consist of a septic tank with leach lines. The system will service a residence with four true bedrooms and a guesthouse with one true bedroom and one bedroom equivalent (den) one bedroom equivalent for a bedroom count of six. Floor plans are attached as Figure 3.
- The proposed septic tank and leach trenches will be located west of the proposed guesthouse in a landscape area. The area is a ridgeline with general level topography in north-south direction and a gentle downward gradient to the west.
- Figure 1 is a site/grading plan that shows the property lines and proposed site improvements at a reduced scale of 1" = 50ft. An enlarged portion of the plan for the leach field area is attached as Figure 2 at a scale of 1" ~ 20ft.
- The proposed septic tank will be located west of the guesthouse as shown on Figures 1 and 2. The residence and guesthouse show a bedroom count of six. Based on a bedroom count of six and table K2 a septic tank size of 1500 gallons shall be utilized. The determined percolation rate does not

# COAST GEOTECHNICAL, INC

Mr. Shen  
Update Report of Percolation Feasibility

2

W.O. 430412-04  
March 10, 2015

exceed 5 minutes 20 seconds, as such; a conventional septic tank such as a Jenson JS-1500 or equivalent may be utilized.

- A cross-section view of the septic tank, risers and system dimensions is attached as Figure 4.
- The primary and expansion leach trenches are shown on Figure 2. Each system shall consist of four leach lines each 42 feet in length, by three feet in width with two feet of gravel beneath the pipe. A distribution box will be needed for the system.
- The project contractor shall provide documentation of washing of any filler material (if used) by the supplier.
- Pertinent setback distances are indicated on Figure 2. Setbacks from property lines, buildings, leach lines and septic tanks are per Table K-1.
- Figure 2 is a copy of the site/grading plan.
- Attached Plates H-M shows percolation test results and calculations based on the Ryon formula and a 1500 gallon septic tank. Design of the leach field system is based on the slowest percolation rate obtained from the testing performed. Based on the results obtained from test pit 6 the leach field must be 168 feet in length and utilize two feet of gravels beneath the leach pipe. To accommodate this length of line and to comply with the requirements that individual lines must be of equal length and be on near level ground we recommend that four individual lines each 42 feet in length be used for a total of length of 168 feet. This is shown on Figure 2.

We appreciate this opportunity to be of service to you.

Respectfully submitted:

COAST GEOTECHNICAL, INC.

  
Todd D. Houseal

CEG 1914 Exp 4/14

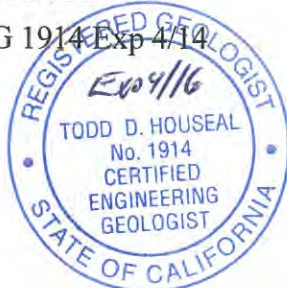

SET NAIL W/  
FEATHER

# SITE PLAN

SET 2'0"  
TAG RCE

SET 2'0" I.P. W/  
TAG RCE 28915

MATCHLINE - SEE SHEET C1.02

*Todd Houseal*  
3/11/15



Location of proposed leach field

ET 2'0" I.P. W/  
AG RCE 28918

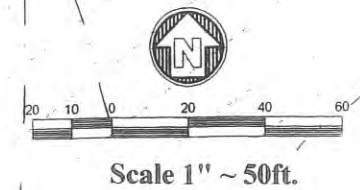
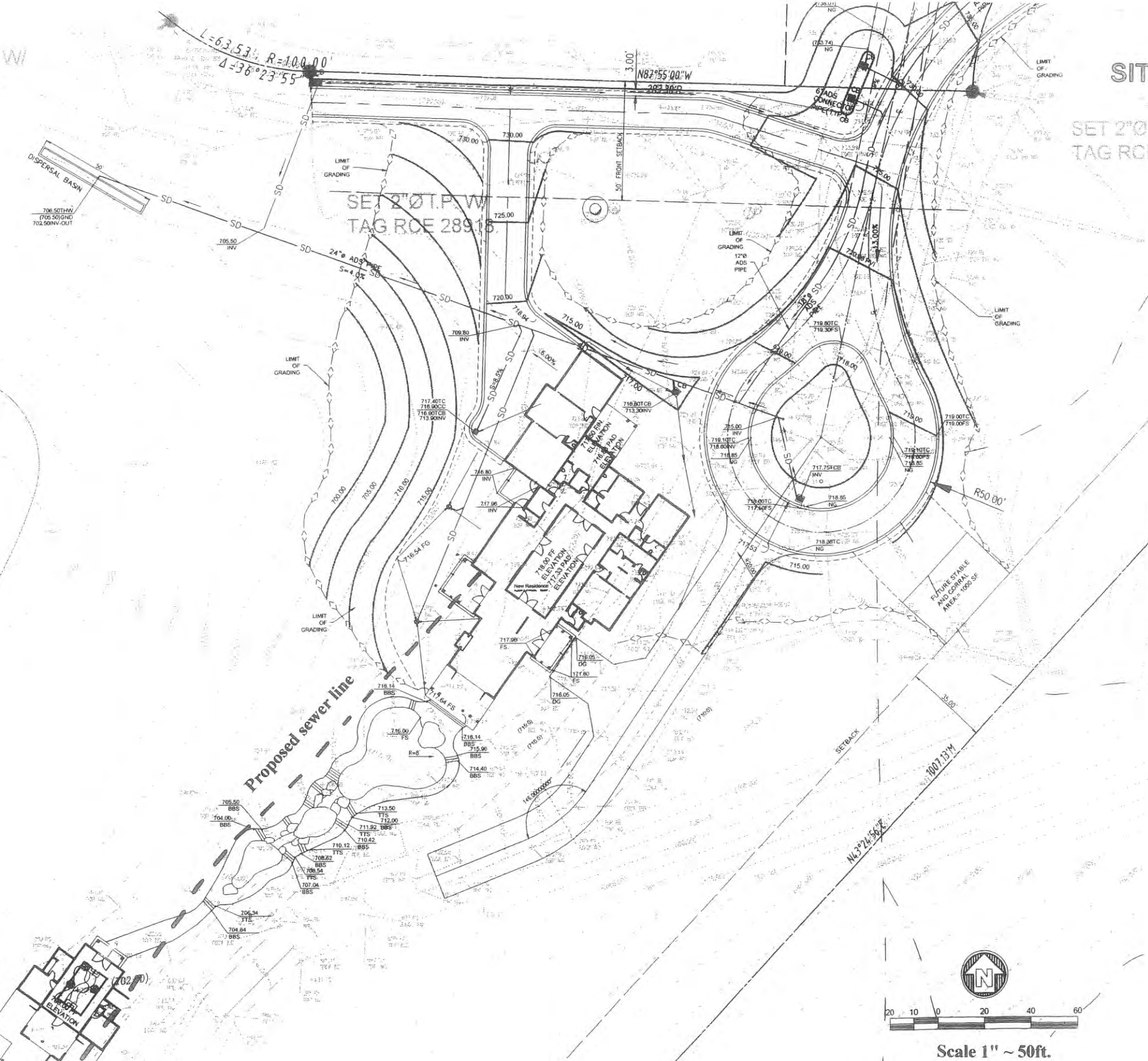
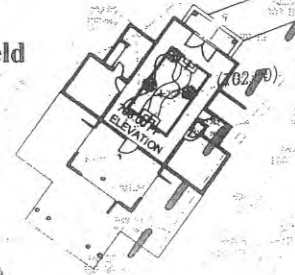

Scale 1" ~ 50ft.

OWNER  
WEI-MEN SHEN, PHD.  
CLIENT  
77 PORTUGUESE BEND ROAD  
ROLLING HILLS, CA 90274

PROJECT  
GRADING AND  
DRAINAGE PLAN  
77 PORTUGUESE BEND ROAD  
ROLLING HILLS, CA 90274



DATE 12/20/14  
SCALE AS SHOWN  
DRAWN R.J.A.  
CHECKED P.A.A.  
FOR NO. 48113-00218  
PROJECT  
P.A. ARCAT  
ENGINEERING, INC.  
500 LANTANA BLVD, SUITE 200, GARDEN GROVE, CA 92640  
TEL: (714) 761-8800  
WWW.PAARCAT.COM

DATE 12/20/14  
SCALE AS SHOWN  
DRAWN R.J.A.  
CHECKED P.A.A.  
FOR NO. 48113-00218  
PROJECT  
P.A. ARCAT  
ENGINEERING, INC.  
500 LANTANA BLVD, SUITE 200, GARDEN GROVE, CA 92640  
TEL: (714) 761-8800  
WWW.PAARCAT.COM  
**C1.03**  
SHEET 4 OF 4 SHEETS

COAST GEOTECHNICAL, INC.

W.O. 430412 Figure 1

SYSTEM DESIGN PLAN

Leach field shall consist of four 42ft. long lines by 3ft wide with 2ft of gravel beneath the pipe

*Todd D. Houseal*  
REGISTERED PROFESSIONAL ENGINEER  
No. 1914  
CERTIFIED ENGINEERING GEOLOGIST  
STATE OF CALIFORNIA  
3/11/15

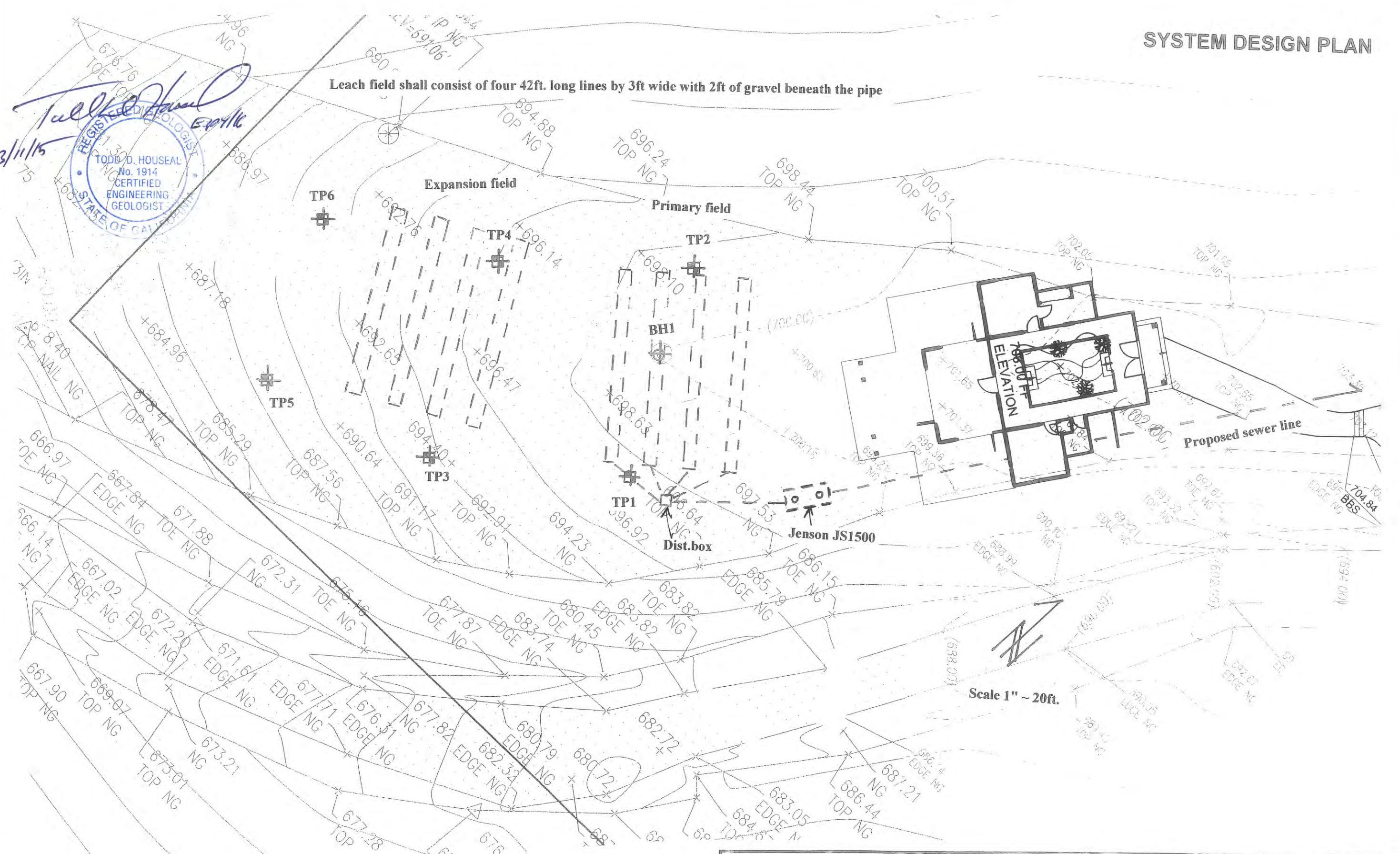

FLOOR PLAN

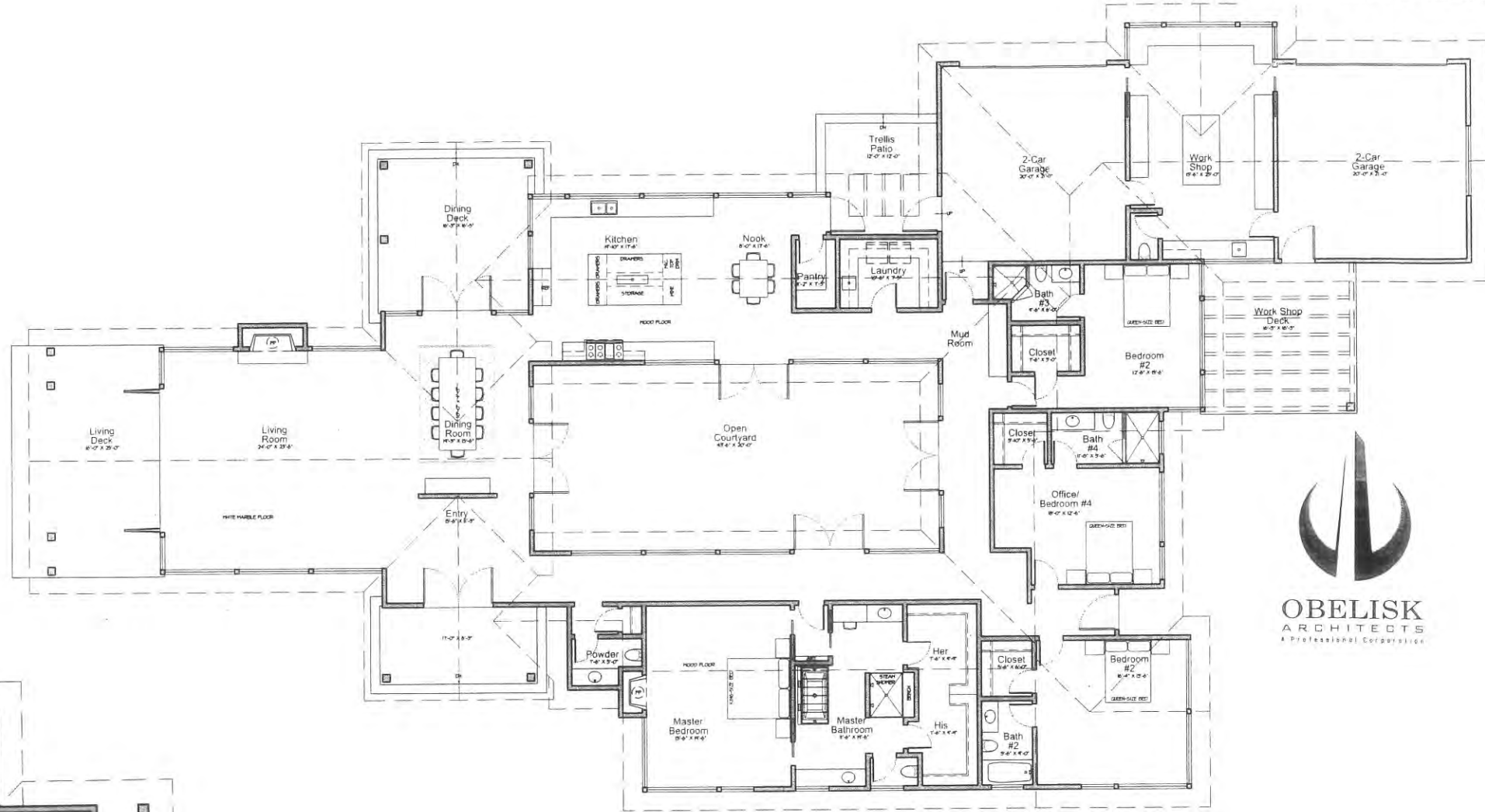

First Floor Plan

SCALE: 1/8" = 1'-0" 4,331.4 sq. ft. (1,351 sq. ft. Garage)



3800 PACIFIC COAST HIGHWAY  
 TORRANCE, CALIFORNIA 90505  
 obeliskarchitects.com  
 310.373.0810 fax  
 310.373.3568 tel

PROJECT  
**Shen  
 Residence**

77 Portuguese Bend Road  
 Rolling Hills  
 CA 90274

REVISIONS

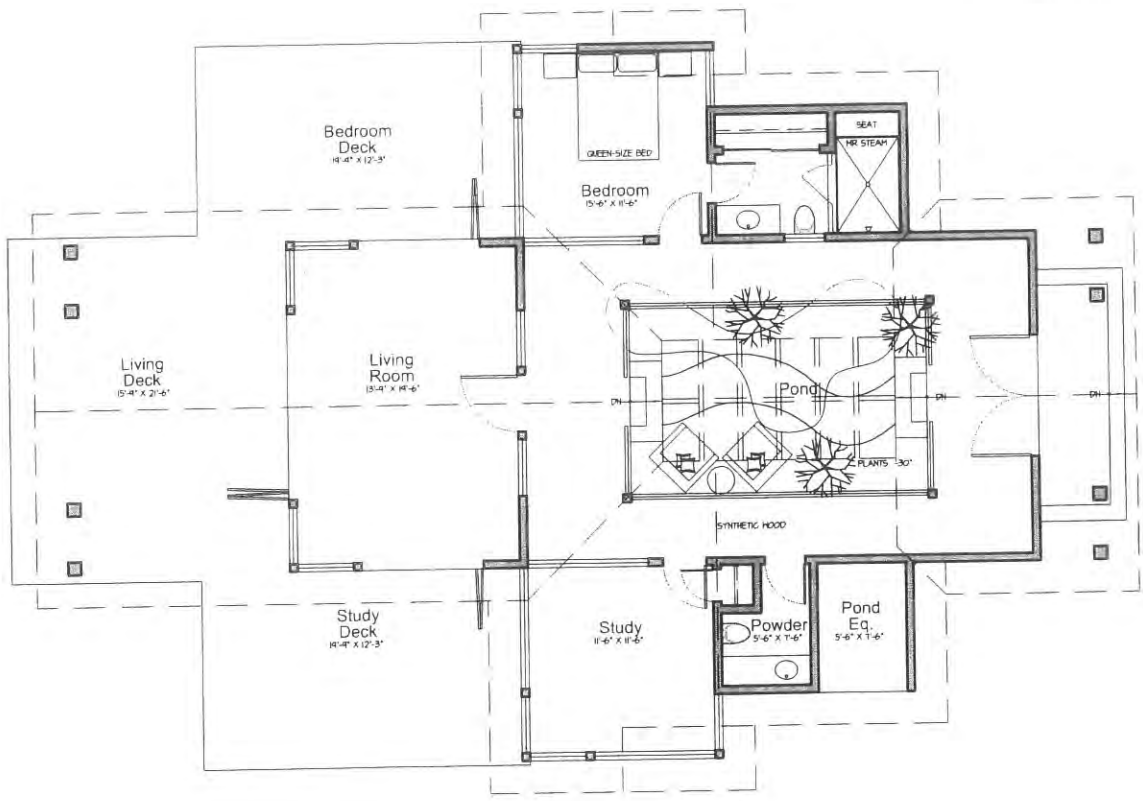

Guest Suite Floor Plan

SCALE: 1/8" = 1'-0"

798.7 sq. ft.



COAST GEOTECHNICAL, INC.

W.O. 430412 Figure 3

# SEPTIC TANK SECTION

## 1500 GALLON RESIDENTIAL SEPTIC TANK MODEL JS1500

NON-TRAFFIC ACCEPTED BY UPC®

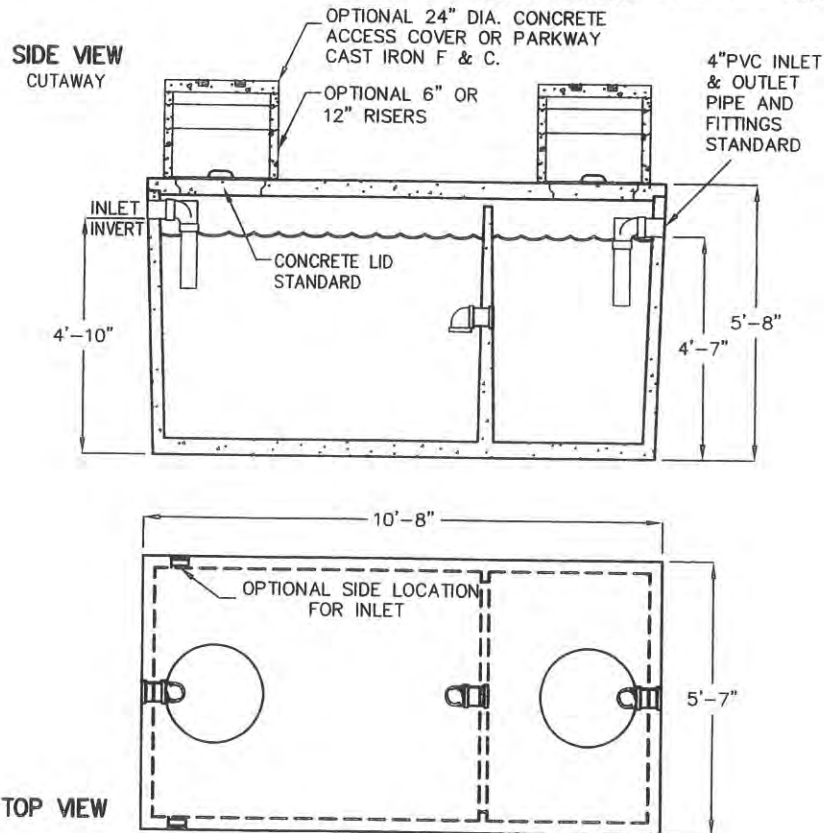

- ▣ LIQUID CAPACITY: 1500 GALLONS  
TANK DESIGNED FOR NON-TRAFFIC USE WITH A MAXIMUM LOAD OF 500 PSF AND DRY SOIL CONDITIONS (WATER TABLE BELOW TANK). EARTH COVER OVER TANK NOT TO EXCEED 3'.
- ▣ THE PRECAST CONCRETE TANK SHALL BE PLACED ON LEVEL, UNDISTURBED SOIL OR APPROVED COMPACTED FILL.
- ▣ EFFLUENT FILTERS ARE AVAILABLE UPON REQUEST.
- ▣ FOR COMPLETE DESIGN AND PRODUCT INFORMATION CONTACT JENSEN PRECAST.

MINIMUM EXCAVATION SIZE:  
6'-7" X 11'-8" X DEPTH REQ'D.

10-01-03  
JS1500\_W.dwg  
© 2003 Jensen Precast

THE DESIGN AND DETAIL OF THIS DRAWING ARE THE PROPERTY OF JENSEN PRECAST AND NOT TO BE USED EXCEPT IN CONNECTION WITH ITS OWN WORK. DESIGN AND INVENTION RIGHTS ARE RESERVED.

**JENSEN**  
PRECAST.

**COAST GEOTECHNICAL, INC.**

**W.O. 430412 Figure 4**

# PERCOLATION TEST PIT 1

## PRESOAK

Date – August 13, 2013

Time – 7:45am

## TESTING

Date – August 14, 2013

Each test hole was observed to be free of water prior to testing

Interval (inch drop)	Clock Time	Minutes
0-1	7:45-7:54	9
1-2	7:54-8:07	13
2-3	8:07-8:21	14
3-4	8:21-8:39	18
4-5	8:39-8:57	18
5-6	8:57-9:16	19

## CALCULATION

Ryon formula:  $A = (T + 6.24 / 29) \times (C / 2)$

A = Square feet of three foot wide trench

T = Time in minutes for the sixth inch of water to drain – 15 minutes

C = Proposed septic tank capacity – 1500gallons

$$A = (19 + 6.24) / 29 \times (1500 / 2)$$

$$= 653$$

The value (A) is divided by five for lineal feet of trench, for two feet of rock beneath the perforated pipe

$$653/5 = 131 \text{ feet of trench}$$

**COAST GEOTECHNICAL, INC.**

**W.O. 430412      Plate H**

# PERCOLATION TEST PIT 2

## PRESOAK

Date – August 13, 2013

Time – 7:47am

## TESTING

Date – August 14, 2013

Each test hole was observed to be free of water prior to testing

Interval (inch drop)	Clock Time	Minutes
0-1	7:52-7:53	1
1-2	7:53-7:55	2
2-3	7:55-7:58	3
3-4	7:58-8:04	6
4-5	8:04-8:14	10
5-6	8:14-8:24	10

## CALCULATION

Ryon formula:  $A = (T + 6.24 / 29) \times (C / 2)$

A = Square feet of three foot wide trench

T = Time in minutes for the sixth inch of water to drain – 10 minutes

C = Proposed septic tank capacity – 1500gallons

$$A = (10 + 6.24) / 29 \times (1500 / 2)$$

$$= 420$$

The value (A) is divided by five for lineal feet of trench, for two feet of rock beneath the perforated pipe

$$420/5 = 84 \text{ feet of trench}$$

**COAST GEOTECHNICAL, INC.**

**W.O. 430412 Plate 1**



# PERCOLATION TEST PIT 3

## PRESOAK

Date – August 13, 2013

Time – 7:47am

## TESTING

Date – August 14, 2013

Each test hole was observed to be free of water prior to testing

Interval (inch drop)	Clock Time	Minutes
0-1	8:02-8:04	2
1-2	8:04-8:20	16
2-3	8:20-8:38	18
3-4	8:38-8:58	20
4-5	8:58-9:18	20
5-6	9:18-9:40	20

## CALCULATION

Ryon formula:  $A = (T + 6.24 / 29) \times (C / 2)$

A = Square feet of three foot wide trench

T = Time in minutes for the sixth inch of water to drain – 20 minutes

C = Proposed septic tank capacity – 1500gallons

$$A = (20 + 6.24) / 29 \times (1500 / 2)$$

$$= 677$$

The value (A) is divided by five for lineal feet of trench, for two feet of rock beneath the perforated pipe

$$677/5 = 136 \text{ feet of trench}$$

**COAST GEOTECHNICAL, INC.**

**W.O. 430412 Plate J**

# PERCOLATION TEST PIT 4

## PRESOAK

Date – August 13, 2013

Time – 7:47am

## TESTING

Date – August 14, 2013

Each test hole was observed to be free of water prior to testing

Interval (inch drop)	Clock Time	Minutes
0-1	8:04-8:07	3
1-2	8:07-8:12	5
2-3	8:12-8:19	7
3-4	8:19-8:27	8
4-5	8:27-8:39	12
5-6	8:39-8:54	15

## CALCULATION

Ryon formula:  $A = (T + 6.24 / 29) \times (C / 2)$

A = Square feet of three foot wide trench

T = Time in minutes for the sixth inch of water to drain – 15 minutes

C = Proposed septic tank capacity – 1500gallons

$$A = (15 + 6.24) / 29 \times (1500 / 2)$$

$$= 550$$

The value (A) is divided by five for lineal feet of trench, for two feet of rock beneath the perforated pipe

$$550/5 = 110 \text{ feet of trench}$$

**COAST GEOTECHNICAL, INC.**

**W.O. 430412      Plate K**

# PERCOLATION TEST PIT 5

## PRESOAK

Date – August 13, 2013

Time – 7:50am

## TESTING

Date – August 14, 2013

Each test hole was observed to be free of water prior to testing

Interval (inch drop)	Clock Time	Minutes
0-1	8:21-8:25	4
1-2	8:25-8:33	8
2-3	8:33-8:40	7
3-4	8:40-8:52	8
4-5	8:52-9:04	12
5-6	9:04-9:20	16

## CALCULATION

Ryon formula:  $A = (T + 6.24 / 29) \times (C / 2)$

A = Square feet of three foot wide trench

T = Time in minutes for the sixth inch of water to drain – 16 minutes

C = Proposed septic tank capacity – 1500gallons

$$A = (16 + 6.24) / 29 \times (1500 / 2)$$

$$= 575$$

The value (A) is divided by five for lineal feet of trench, for two feet of rock beneath the perforated pipe

$$575/5 = 115 \text{ feet of trench}$$

**COAST GEOTECHNICAL, INC.**

**W.O. 430412 Plate L**

# PERCOLATION TEST PIT 6

## PRESOAK

Date – August 13, 2013

Time – 7:51am

## TESTING

Date – August 14, 2013

Each test hole was observed to be free of water prior to testing

Interval (inch drop)	Clock Time	Minutes
0-1	7:35-7:45	10
1-2	7:45-8:04	19
2-3	8:04-8:23	19
3-4	8:23-8:43	20
4-5	8:43-9:01	20
5-6	9:01-9:29	26

## CALCULATION

Ryon formula:  $A = (T + 6.24 / 29) \times (C / 2)$

A = Square feet of three foot wide trench

T = Time in minutes for the sixth inch of water to drain – 26 minutes

C = Proposed septic tank capacity – 1500gallons

$$A = (26 + 6.24) / 29 \times (1500 / 2)$$
$$= 834$$

The value (A) is divided by five for lineal feet of trench, for two feet of rock beneath the perforated pipe

$$834/5 = 168 \text{ feet of trench}$$

**COAST GEOTECHNICAL, INC.**

**W.O. 430412 Plate M**

**SYSTEM DESIGN PLAN**

77 PORTUGUESE BEND RD.  
 ADDRESS: ROLLING HILLS, CA 90214

NEW  REMODEL  BURN-OUT  
 STORM DAMAGED

SYSTEM FAILURE / ADDITION  
 NO. BEDROOMS / F.U. SIX BEDROOMS  
 SEPTIC TANK SIZE: 1500 GALLONS  
 PRESENT: 4 LEACH LINES 42" X 3" WIDE 1/2' OF GRAVEL UNDER PIPE  
 FUTURE: 100% EXPANSION APPROVED

SYSTEM ADDITION:  
 PERC. RATE/SOIL CAT. 2.6 MINUTES / INCH

SPECIAL NOTES/REQUIREMENTS:

Any deviation of this sewage disposal plot plan and/or the floor plan on the reverse without prior Health Dept approval shall nullify and void this approval.

3/23/2015  
 Date

METHOD OF SEWAGE DISPOSAL APPROVED  
 THIS APPROVAL RELATES ONLY TO THE  
 MINIMUM REQUIREMENTS OF THE PLUMBING  
 CODE AND DOES NOT INCLUDE AN  
 EVALUATION OF GEOLOGICAL PROBLEMS

W. Scott C. Baranada  
 COUNTY OF LOS ANGELES  
 DEPARTMENT OF PUBLIC HEALTH

APPROVAL VALID FOR ONE YEAR

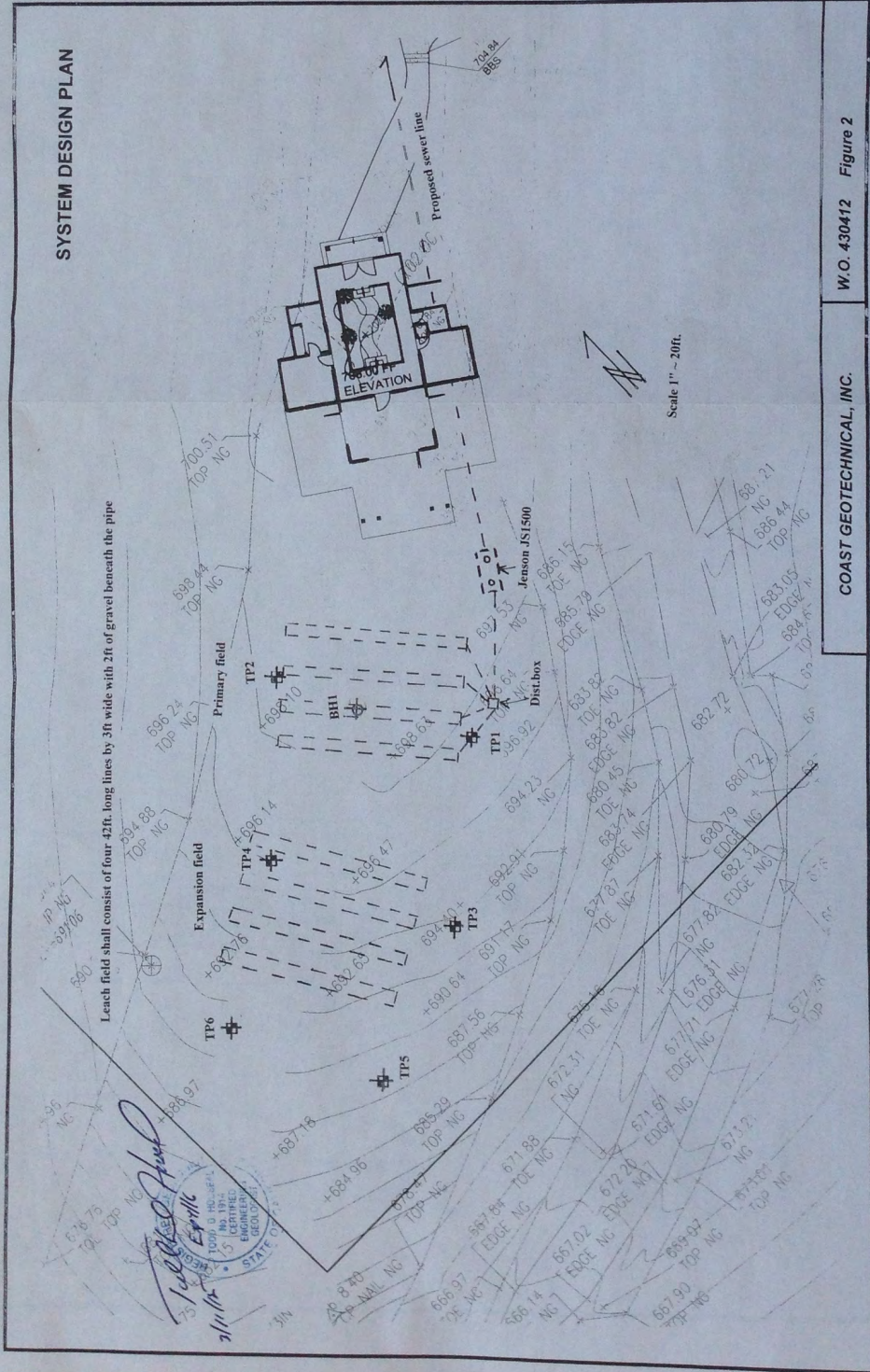

W.O. 430412 Figure 2

COAST GEOTECHNICAL, INC.

**FLOOR PLAN**



**OBELISK**  
ARCHITECTS  
P.A. 10000 UNIVERSITY AVENUE  
SUITE 1000  
DUBLIN, CA 94568  
TEL: 925.835.8100  
WWW.OBELISKARCHITECTS.COM

1800 PACIFIC COAST HIGHWAY  
TORRANCE CALIFORNIA 90505  
OBELISK ARCHITECTS  
TEL: 310.373.0810 FAX:  
310.373.3558 (e)  
PROJECT

**Shen  
Residence**

77 Portuguese Bend Road  
Rolling Hills  
CA 90274

4/10/2010

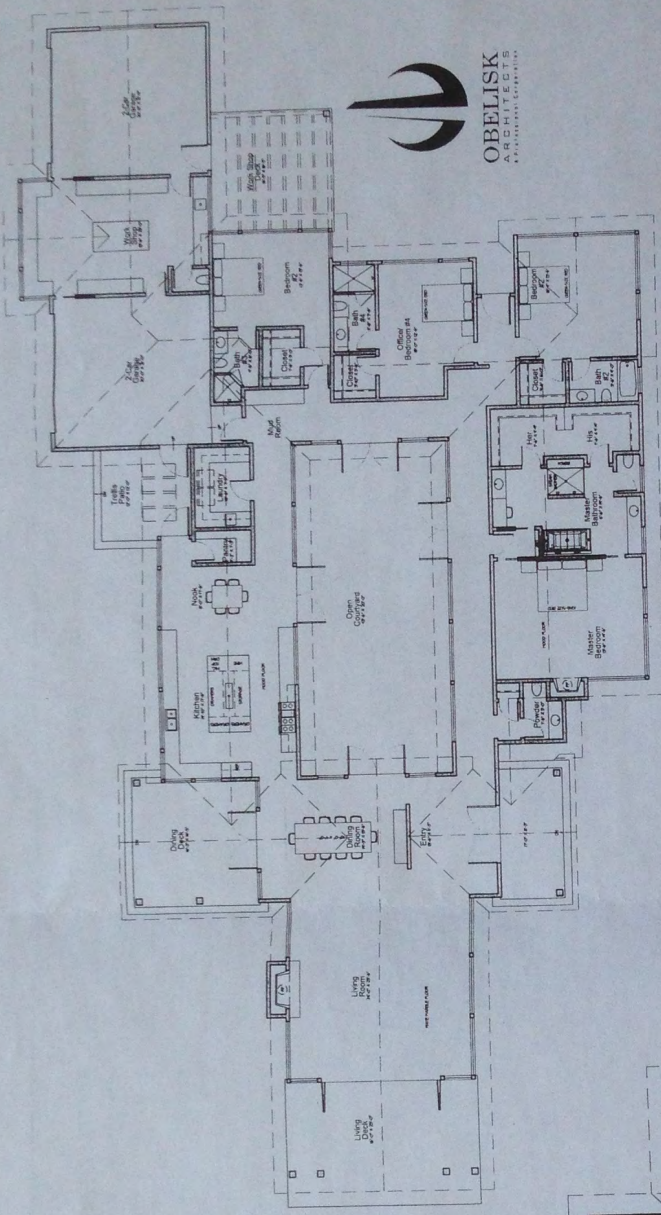

**First Floor Plan**  
SCALE: 1/8" = 1'-0"  
4,231.4 sq. ft. (1,279 sq. ft. Garage)

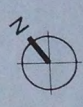
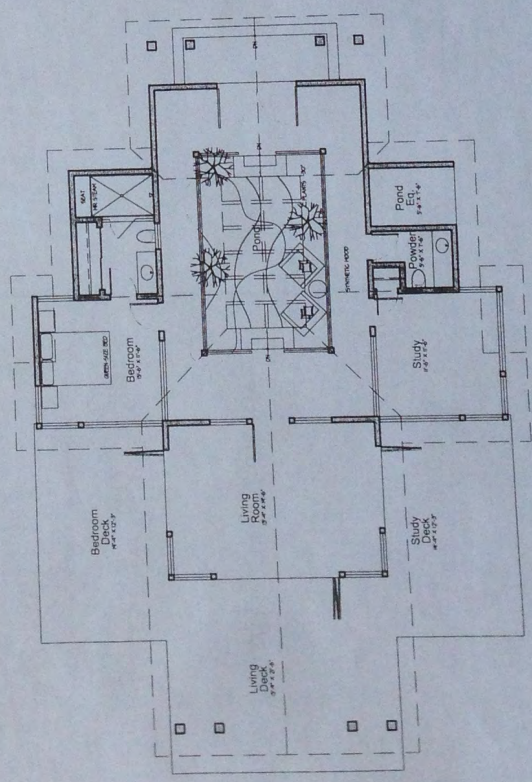

**Guest Suite Floor Plan**  
SCALE: 1/8" = 1'-0"  
1,160.1 sq. ft.

W.O. 430412 Figure 3

COAST GEOTECHNICAL, INC.

# COAST GEOTECHNICAL, INC.

1200 West Commonwealth, Fullerton, CA 92833 • Ph: (714) 870-1211 • Fax: (714) 870-1222 • email: coastgeotec@sbcglobal.net

June 10, 2015

W.O. 430412-05

Mr. and Mrs. Shen  
26810 Fond du Lac Road  
Rancho Palos Verdes, CA 90274

Subject: Geotechnical Review of Proposed Grading Plan  
and Acceptance of Geotechnical Responsibility  
for 77 Portuguese Bend Road, Rolling Hills,  
California

## References:

1. Preliminary Geologic Investigation of Proposed Residence, 77 Portuguese Bend Road, Rolling Hills, California; by COAST GEOTECHNICAL, Inc., W.O. 430412-01, dated May 5, 2012
2. Geologic Response to Geotechnical Review for 77 Portuguese Bend Road, Rolling Hills, California; by COAST GEOTECHNICAL, Inc., W.O. 430412-02, dated February 28, 2013.

Dear Mr. Shen:

This geotechnical review of the proposed grading plan has been prepared at your request. The proposed grading plan is appended. Superimposed on the grading plan is the general geology of the building area. Our understanding of construction is as follows:

- The plan indicates a single family single story residence, a detached office, swimming pool, fire truck hammerhead, hardscape and landscape.
- The habitable buildings will have foundations placed into bedrock or terrace deposits per project reports. Interior floors will be raised wood.
- Minor retaining walls may be required in some areas to accommodate needed topographic changes.
- Across the building pad minimal cut and fills are proposed to achieve designed pad grades.
- A fill slope is planned along the western side of the residence.

## ACCEPTANCE OF RESPONSIBILITY

The soils engineer of record, Mr. Steve Ng, of SWN Soiltech has retired. Coast Geotechnical has agreed to assume this responsibility.

COAST GEOTECHNICAL, Inc. has reviewed the report issued by SWN Soiltech dated May 10, 2012 for the project and is in substantial agreement with the findings and conclusion of the referenced reports and accepts geotechnical responsibility for information therein, unless modified herein.

# COAST GEOTECHNICAL, INC.

---

Mr. Shen  
Grading Plan Review

2

W.O. 430412-05  
June 10, 2015

---

**Findings and conclusions presented by COAST GEOTECHNICAL, Inc. in this report shall supersede all previous project recommendations.**

Based on our understanding of construction the referenced reports are still applicable with the following added comments.

- The proposed fill slope will require a keyway and benching in accordance with the referenced report by SWN Soiltech. A keyway and midslope subdrain will be required. This is depicted on appended cross section A-A' , Figure 2. Outlet pipes shall be placed every 50 feet.
- Pad drainage shall be in accordance with applicable codes. Site waters shall not be allowed to flow off the graded pad onto descending slopes.
- The proposed driveway will be graded to direct drainage to the inside edge of the driveway, where surface drainage is to be collected and directed to a disposal area via non erodible design.
- Along the toe of existing oversteepened driveway cuts a three foot high slough wall shall be constructed to protect the driveway from potential isolated rock falls and slumps.
- Portions of the driveway are within or are near the margin of an active landslide and will require periodic maintenance to retain usability.
- It is recommended that utilities that service the residence and are within an active landslide area, be constructed above grade and with some flexibility to accommodate future land movements. Water and gas utilities should be outfitted with some type of automatic shutoff if breakage occurs.
- The proposed pool/spa shall be designed as free standing and shall be supported by bedrock or terrace. Pool walls shall be designed to support the water, having a density of 62.4 pounds per cubic foot without bearing from adjacent soil. The walls should be able to support the adjacent soil when the pool is empty. The earth pressure may be calculated as an equivalent fluid pressure of 100 pounds per cubic foot for level backfill, plus the lateral pressure due to any superimposed surcharge when the pool is empty. Expansion joints shall be placed between the pool and deck. All pool utility lines shall be backfilled with soils compacted to a minimum of 90% relative compaction. Where pool lines are sensitive to the use of compaction equipment the trenches shall be backfilled with one sack slurry. COAST GEOTECHNICAL, Inc. shall verify the backfill of all trenches. Pool decking shall be cast free of the swimming pool structure and access openings. The free space shall be filled with flexible water stop materials. The client is advised that due to the expansive nature of site soils that some horizontal and vertical movement between the pool and pool decking will occur over time. The pool foundation excavation shall be observed and approved by COAST GEOTECHNICAL, Inc. prior to the placement of reinforcement. These recommendations are subject to change based on the review of pool plans.
- Reinforcement of foundations shall be with four #5 bars two top and two bottom.
- Foundations shall have a minimum embedment of 24 inches below lowest adjacent grade and a minimum of 18 inches of embedment into competent terrace or bedrock, whichever is deeper.



- All proposed foundations and the pool shall comply with a setback of  $H/3$ , where  $H$  is the slope height. The setback is measured from the bottom outside footing edge horizontally to the slope face. Deepened foundations should be anticipated for portions of the project.
- Based on the current CBC the following seismic design parameters are provided. These seismic design values were determined utilizing latitude 33.74498 and longitude -118.355000 for the site, and calculations from the USGS seismic tool application. A printout from the USGS site is appended. A conservative site class D was assigned to site earth materials.
  - Site Class = D
  - Mapped 0.2 Second Spectral Response Acceleration,  $S_s = 1.445g$
  - Mapped One Second Spectral Response Acceleration  $S_1 = 0.546g$
  - Site Coefficient from Table 1613A5.3(1),  $F_a = 1.0$
  - Site Coefficient from Table 1613A5.3(2),  $F_v = 1.5$
  - Maximum Design Spectral Response Acceleration for short period,  $S_{M_s} = 1.445g$
  - Maximum Design Spectral Response Acceleration for one-second period,  $S_{M_1} = 0.819g$
  - 5% Design Spectral Response Acceleration for short period,  $S_{D_s} = 0.963g$
  - 5% Design Spectral Response Acceleration for one-second period,  $S_{D_1} = 0.546g$
- A chemical analysis of typical sub-surface earth material showed a sulfate content of 1,258ppm. Based on the CBC and Table 4.3.1 of ACI 318-05 this is a moderate exposure to sulfate corrosion. Type II 4,000 psi concrete with a maximum water cement ratio of 0.50 shall be utilized for the foundation system. Structural requirements may dictate a higher concrete strength.
- Where a slab on grade is proposed the slab shall be a minimum of five inches actual thickness with #4 bars 12 inches on center each way. Structural design may require additional reinforcement and slab thickness or use of alternate foundation and slab systems.

If the soils at grade become disturbed during construction, they shall be brought to 3-4% over optimum moisture content and compacted to a minimum of 90% relative compaction prior to placing concrete. COAST GEOTECHNICAL, Inc. will need to verify adequate mitigation.

A capillary break shall underlie all slab on grades, shall comply with the requirements of the local jurisdiction, and shall be a minimum of four inches in thickness. Geotechnically coarse clean sand is acceptable; however, some localities require the use of ½-inch or larger clean aggregate gravel. If gravels are used a heavy filter fabric shall be placed over the gravels prior to placement of the vapor barrier to minimize puncturing of the vapor barrier. The gravel shall be compacted with a vibratory plate to consolidated and level condition.

Between the capillary break and bottom of slab a vapor barrier consisting of a plastic film (minimum 15 mil polyvinyl chloride or equivalent) should be used. The vapor barrier should be properly lapped and sealed in accordance with code. The vapor barrier shall be in contact with the slab bottom. The vapor barrier shall underlay all slab on grades.

Prior to placement of the capillary break or vapor barrier, COAST GEOTECHNICAL, Inc., shall test the slab subgrade soils for moisture content.

- Hardscape slab subgrade areas shall exhibit a minimum of 90% relative compaction and a moisture content of 3-4% over optimum, to a depth of at least two feet. Deeper removal, moisture conditioning and compaction may be required if unacceptable conditions are encountered. These areas require testing just prior to placing concrete.

Exterior hardscape slabs will be subject to stress from volume changes in subgrade soils, which may lead to cracking. The followings recommendations will minimize cracking and offsets, but will not eliminate concrete cracks.

Minimum recommendations for exterior concrete slabs are four inches actual thickness with #4 bars at 12-inches on center each way. The proposed driveway shall be six inches actual thickness with #4 bars at 12-inches on center each way. These recommendations supersede any provided on Plate A.

Doweling slabs to perimeter footings can mitigate movement of slabs adjacent to structures and should consist of No. 4 bars bent around exterior slabs. Doweling should be spaced no farther than 36 inches on centers. As an option to doweling, an architectural separation could be provided between the main structure and abutting appurtenance improvements. Presaturation of exterior slab areas is also desirable. At exterior edges of patios and other flatwork, a cut-off wall to the same depth and containing the same reinforcement as exterior footings is highly recommended. If no significant load is associated with the edge of the slab, the width of the cut-off wall may be limited to eight inches. Reinforcement adopted for the main structure may be applied to the appurtenances. Proper control joints, jointing, expansion joints, saw cutting and other measures shall be utilized to control cracking of hardscape.

As an alternative to rigid hardscape or brickwork, flexible pavers may be utilized.

- All utility line, area drains, and other trench backfills shall be compacted to a minimum of 90% relative compaction and shall require testing at a minimum of two-foot vertical intervals.

Utility lines shall be located outside a 45° degree line projected downward from a foundation's bottom edge.

Where below grade utility lines enter a building footprint, a significant section of the trench shall contain a compacted cohesive fill or slurry backfill plug to mitigate the migration of waters through permeable backfill soils into interior building areas.

- Creep loads may impact proposed site improvements. Proposed foundations and site improvements located within twenty feet of a top of slope or located on a slope shall incorporate a creep value of 1,000 pounds per foot of depth for the upper three feet of earth material. Where creep forces are found passive pressure shall be ignored to the depth of the creep zone.
- Regardless of the current condition of site the client is advised that there is an undefined inherent risk of some type of slope failure with all hillside property. Placing a level on this risk is not possible due to influences beyond the control of this consultant and individual property owners, and the lack of offsite subsurface knowledge. Some influences that can affect future slope stability are rainfall, neighbor and site irrigation practices, runoff waters, seismic activity, improper grading activities, improper building activities, poor site drainage, leakage of underground utilities, poor landscaping practices, failure to clear out terrace drains and inlets of debris, uncontrolled rodent burrowing, and other factors. To assist the client in controlling some of these influences Slope Maintenances Guidelines are appended.
- All project recommendations are subject to change based on field conditions encountered.

**SECTION 111 COMPLIANCE STATEMENT**

It is the opinion of the undersigned, a duly certified engineering geologist and soils engineer, based upon our work as outlined in the referenced reports and in those referenced by it, that if the proposed improvements as we understand them are constructed in accordance with our and other design consultants recommendations, applicable codes, standard care of the industry, and with proper geotechnical and geologic observations (1) the proposed structure(s) will be safe against hazard from local landslide or slippage, and that (2) the proposed building or grading construction will have no adverse effect on the geologic stability of property outside of the building site. The nature and extent of tests conducted for purposes of this declaration are, in the opinion of the undersigned, in conformance with generally accepted practice in the area. Test findings and statements of professional opinion do not constitute a guarantee or warranty, expressed or implied

We appreciate this opportunity to be of service to you.

Respectfully submitted:

COAST GEOTECHNICAL, Inc.

Ming-Tarng Chen  
RCE 54011

Todd D. Houseal  
CEG 1914, Exp 04/16

## **Maintenance of Hillside Home Sites Recommendations**

During the wet weather season, homeowners become concerned about the stability of their building sites. In general, modern design and construction practice minimizes the probability of serious slope failure. The grading codes of the local jurisdiction (cities and counties) in California concerning filled land, excavation, terracing and slope construction are among the most stringent in the country and if followed, are adequate to meet most natural occurrences. Therefore, the concern of the homeowner should be directed toward maintaining slopes, drainage provisions and facilities so that they will perform as designed.

The following discussion, general recommendations and simple precautions are presented herein to help the homeowner maintain his hillside-building site.

The general public often regards the natural terrain as stable - "terra firma". This, of course, is an erroneous concept. Nature is always at work altering the landscape. Hills and mountains are worn down by mass wasting (erosion, sliding, creeping) and the valleys and lowlands collect these products. Thus the natural process is toward leveling the terrain. Periodically (over tens of millions of years) major land movements build mountains and erosion tends to level the terrain. In some areas these processes are very slow and in others they are more rapid.

Development of hillsides for residential use is carried out, in as far as possible, to enhance the natural stability of the site and to minimize the probability of instability resulting from the grading necessary to provide home sites, streets, and yards. This has been done by the developers and designers on the basis of geologic and soil mechanics investigations. In order to reduce the risk of slope failures, the slope and drainage provisions and facilities must be maintained by the homeowner.

Homeowners are accustomed to maintaining their homes. They expect to paint their houses periodically, replace wiring, clean out clogged plumbing, repair roofs, etc. Maintenance of the home site, particularly on hillsides should be considered on an even more serious basis. In most cases lot and site maintenance can be taken care of along with landscaping and can be carried out less expensively to the homeowner than repair after neglect.

Most hillside lot problems are associated with water. Uncontrolled water from poor drainage, over irrigation, a broken pipe, cesspool or wet weather causes most damage. Wet weather is the largest cause of slope problems, particularly in California where rain is intermittent, but may be torrential. Therefore, drainage and erosion control are the most important aspects of home site stability. These provisions must not be altered without competent professional advice and maintenance must be carried out to assure their continued operations.

We offer these procedures as a checklist to homeowners:

1. Check roof drains, gutters and down spouts to be sure they are clear. Depending on your location, if you do not have roof gutters and down spouts, you may wish to install them. Without gutters or other adequate drainage, water falls from the roof eaves and collects against foundation and basement walls, which can be undesirable.
2. Clear surface and terrace drainage ditches and check them frequently during the rainy season, with a shovel, if necessary. Ask your neighbors to do likewise.

# COAST GEOTECHNICAL, INC.

---

3. Be sure that all drainage ditches and sub-drains have outlet drains that are open. This should be tested during dry weather. Usually this can be done simply with a hose. If blockage is evident, you may have to clear the drain mechanically.
4. Check all drains at the top of slopes to be sure that they are clear and that water will not overflow the slope itself, causing erosion.
5. Keep subsurface drain openings (weep-holes) clear of debris and other material, which could block them in a storm.
6. Check for loose fill above and below your property if you live on a slope or terrace.
7. Watch hoses and sprinklers. During the rainy season, little, if any, irrigation is required. Over-saturation of the ground is not only unnecessary and expensive, but can cause subsurface damage.
8. Watch for water backup of drains inside the house and toilets during a rainy season since this may indicate drain or sewage blockage.
9. Exercise ordinary precaution. Your house and building site was constructed to meet certain standards, which should protect against any natural occurrence, if you do your part in maintaining them.
10. Care and maintenance of hillside homes includes being sure that terrace drains and brow ditches on slopes or at the top of cuts, or fill slopes are not blocked. They are designed to carry away runoff to a place where it can be safely distributed. Generally, a little shovel work will remove any accumulation of dirt and other debris, which may clog the drain. If several homes are located on the same terrace, it is a good idea to check with your neighbors. Water backed up on their properties may eventually reach yours. Water backed up in surface drains will tend to overflow and seep into the terraces, creating less stable slopes.
11. Water should not be permitted to collect or pond on your home site. Pondered water will tend to either seep into the ground loosening fill or natural ground, or will overflow onto the slope and cause erosion. Once erosion is started, it is difficult to control and severe damage may result rather quickly.
12. Roof drains and gutters or down spouts should not be connected to subsurface drains. Rather, arrange them so that water either flows off your property in a specially designed pipe or it flows out onto a paved driveway or the street. The water then may be dissipated over a wide surface or preferably be carried away in a paved gutter or storm drain. Subdrains are constructed to take care of ordinary subsurface water and cannot handle the overload from roofs during a heavy rain.
13. Water should not be allowed to spill over slopes, even where this may seem to be a good way to prevent ponding. This tends to cause erosion and, in the case of fill slopes, can cut away carefully designed and constructed sites.
14. Loose soil or debris should not be left on or tossed over slopes. Loose soil soaks up water more rapidly than compacted fill. In addition, it is not compacted to the same strength as the slope itself and will tend to slide when laden with water and may even affect the soil beneath it. The sliding may clog terrace drains below or may cause additional damage in weakening the slope. If you live below a slope, try to be sure that loose fill is not dumped above your property.

# COAST GEOTECHNICAL, INC.

---

15. Water should not be discharged into subsurface blanket drains close to slopes. French drains are sometimes used to get rid of excess water when other ways of disposing of water are not readily available. Overloading these drains saturates the ground and, if located close to slopes, may cause slope failure.
16. Surface water should not be discharged into septic tanks or leaching fields. Not only are septic tanks constructed for a different purpose, but they will tend, because of their construction, to accumulate additional water naturally from the ground during a heavy rain. Overloading them artificially during the rainy season is bad for the same reason as subsurface subdrains, and is doubly dangerous since their overflow can pose a serious health hazard. In many areas the use of septic tanks should be discontinued as soon as sewers can be made available.
17. Slopes should not be over-irrigated. In some areas ice plant and other heavy ground cover can cause surface sloughing when saturated due to the increase in weight and weakening of the near surface soil. Planted slopes should be located, where possible, in areas where they will be adequately irrigated by rainfall. A landscape architect familiar with hillside work should design slope planting.
18. Water should not be allowed to gather against foundation, retaining walls and basement walls. These walls are built to withstand the ordinary moisture in the ground and are, where necessary, accompanied by subdrains to carry off the excess moisture. If water is permitted to pond against them, it may seep through the wall causing dampness and leakage inside the basement. It also may cause the soil adjacent to the foundation to swell resulting in structural damage to walls and footings.
19. New fill placed behind walls or in trenches should not be compacted by flooding with water. Not only is flooding the least efficient way of compacting fine grained soil, but could damage the wall foundation.
20. Hoses and sprinklers should not be left running on or near a slope, particularly during the rainy season. This will enhance ground saturation, which may cause damage.
21. Ditches that have been graded around your house or the lot pad should not be blocked. These shallow ditches have been put there for the purpose of quickly removing water toward the driveway, street or other positive outlet. By all means, do not let water become ponded above slopes by blocked ditches.
22. Rodent activity should be controlled to mitigate burrowing and or loosening of surficial soils. Rodent burrows should be filled with compacted cohesive soils to mitigate infiltration of waters that could cause slope instability.

WEB IMAGES VIDEOS MAPS NEWS MORE

bing 77 Portuguese Bend Rd, Rolling Hills, California, United States

Sign in | Settings

Directions My places

77 Portuguese Bend Rd, Rolling Hills, CA 90274

Directions · Email · More  
Not what you wanted?  
Report a problem

Map interface showing a route through Rolling Hills, CA. Roads labeled include Running Brand Rd, Burma Rd, and Puerto Rd. A location pin is placed on Burma Rd with a pop-up menu.

Map navigation controls: Road, Bird's eye, Traffic, Fullscreen, Print, Share, Zoom in (+), Zoom out (-), North arrow.

Location breadcrumb: World • United States • CA • Los Angeles Co. • Rolling Hills • Silver Spur

Pop-up menu for Burma Rd, Palos Verdes Peninsula, CA 90274:

- Add a pushpin
- Directions from here
- Directions to here
- Zoom to region level
- Zoom to city level
- Center map here

Scale bar: 250 feet, 50 m

# USGS Design Maps Summary Report

## User-Specified Input

**Report Title** 77 Portuguese Bend Road, Rolling Hills  
Wed June 10, 2015 14:25:30 UTC

**Building Code Reference Document** ASCE 7-10 Standard  
(which utilizes USGS hazard data a

**Site Coordinates** 33.74498°N, 118.355°W

**Site Soil Classification** Site Class D - "Stiff Soil"

**Risk Category** I/II/III

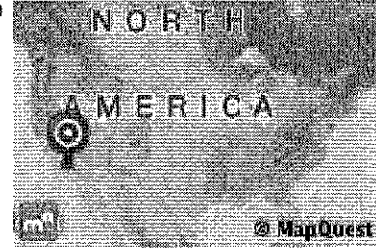

## USGS-Provided Output

$S_s = 1.445 \text{ g}$	$S_{MS} = 1.445 \text{ g}$	$S_{DS} = 0.963 \text{ g}$
$S_1 = 0.546 \text{ g}$	$S_{M1} = 0.819 \text{ g}$	$S_{D1} = 0.546 \text{ g}$

For information on how the  $S_s$  and  $S_1$  values above have been calculated from probabilistic (risk-targeted) and deterministic ground motions in the direction of maximum horizontal response, please return to the application and select the "2009 NEHRP" building code reference document.

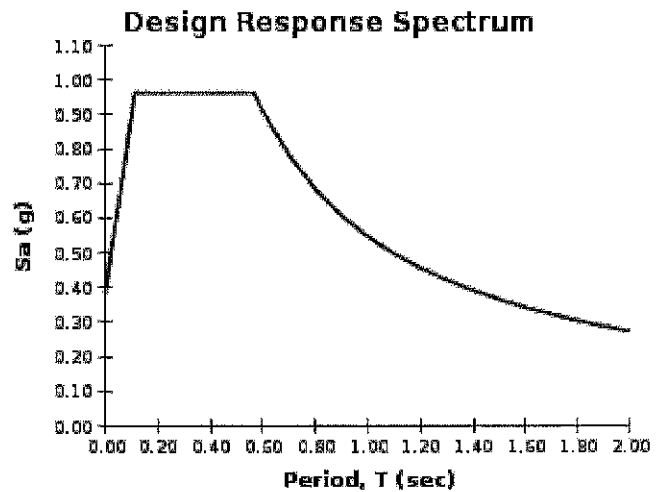
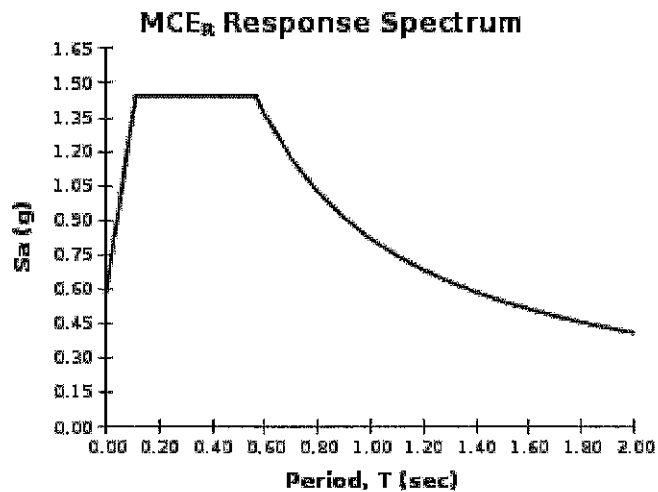

For  $PGA_M$ ,  $T_L$ ,  $C_{RSF}$  and  $C_{RI}$  values, please [view the detailed report](#).

Although this information is a product of the U.S. Geological Survey, we provide no warranty, expressed or implied, as to the accuracy of the data contained therein. This tool is not a substitute for technical subject-matter knowledge.



**Design Maps Detailed Report**

ASCE 7-10 Standard (33.74498°N, 118.355°W)

Site Class D – “Stiff Soil”, Risk Category I/II/III

**Section 11.4.1 — Mapped Acceleration Parameters**

Note: Ground motion values provided below are for the direction of maximum horizontal spectral response acceleration. They have been converted from corresponding geometric mean ground motions computed by the USGS by applying factors of 1.1 (to obtain  $S_s$ ) and 1.3 (to obtain  $S_1$ ). Maps in the 2010 ASCE-7 Standard are provided for Site Class B. Adjustments for other Site Classes are made, as needed, in Section 11.4.3.

**From Figure 22-1** <sup>[1]</sup>

$S_s = 1.445 \text{ g}$

**From Figure 22-2** <sup>[2]</sup>

$S_1 = 0.546 \text{ g}$

**Section 11.4.2 — Site Class**

The authority having jurisdiction (not the USGS), site-specific geotechnical data, and/or the default has classified the site as Site Class D, based on the site soil properties in accordance with Chapter 20.

Table 20.3–1 Site Classification

Site Class	$\bar{v}_s$	$\bar{N}$ or $\bar{N}_{ch}$	$\bar{s}_u$
A. Hard Rock	>5,000 ft/s	N/A	N/A
B. Rock	2,500 to 5,000 ft/s	N/A	N/A
C. Very dense soil and soft rock	1,200 to 2,500 ft/s	>50	>2,000 psf
D. Stiff Soil	600 to 1,200 ft/s	15 to 50	1,000 to 2,000 psf
E. Soft clay soil	<600 ft/s	<15	<1,000 psf
Any profile with more than 10 ft of soil having the characteristics:			
<ul style="list-style-type: none"> <li>• Plasticity index <math>PI &gt; 20</math>,</li> <li>• Moisture content <math>w \geq 40\%</math>, and</li> <li>• Undrained shear strength <math>\bar{s}_u &lt; 500 \text{ psf}</math></li> </ul>			
F. Soils requiring site response analysis in accordance with Section 21.1	See Section 20.3.1		

For SI:  $1\text{ft/s} = 0.3048 \text{ m/s}$   $1\text{lb/ft}^2 = 0.0479 \text{ kN/m}^2$

### Section 11.4.3 — Site Coefficients and Risk-Targeted Maximum Considered Earthquake (MCE<sub>R</sub>) Spectral Response Acceleration Parameters

Table 11.4-1: Site Coefficient  $F_a$ 

Site Class	Mapped MCE <sub>R</sub> Spectral Response Acceleration Parameter at Short Period				
	$S_s \leq 0.25$	$S_s = 0.50$	$S_s = 0.75$	$S_s = 1.00$	$S_s \geq 1.25$
A	0.8	0.8	0.8	0.8	0.8
B	1.0	1.0	1.0	1.0	1.0
C	1.2	1.2	1.1	1.0	1.0
D	1.6	1.4	1.2	1.1	1.0
E	2.5	1.7	1.2	0.9	0.9
F	See Section 11.4.7 of ASCE 7				

Note: Use straight-line interpolation for intermediate values of  $S_s$

**For Site Class = D and  $S_s = 1.445$  g,  $F_a = 1.000$**

Table 11.4-2: Site Coefficient  $F_v$ 

Site Class	Mapped MCE <sub>R</sub> Spectral Response Acceleration Parameter at 1-s Period				
	$S_1 \leq 0.10$	$S_1 = 0.20$	$S_1 = 0.30$	$S_1 = 0.40$	$S_1 \geq 0.50$
A	0.8	0.8	0.8	0.8	0.8
B	1.0	1.0	1.0	1.0	1.0
C	1.7	1.6	1.5	1.4	1.3
D	2.4	2.0	1.8	1.6	1.5
E	3.5	3.2	2.8	2.4	2.4
F	See Section 11.4.7 of ASCE 7				

Note: Use straight-line interpolation for intermediate values of  $S_1$

**For Site Class = D and  $S_1 = 0.546$  g,  $F_v = 1.500$**

**Equation (11.4-1):**  $S_{MS} = F_a S_s = 1.000 \times 1.445 = 1.445 \text{ g}$

**Equation (11.4-2):**  $S_{M1} = F_v S_1 = 1.500 \times 0.546 = 0.819 \text{ g}$

Section 11.4.4 — Design Spectral Acceleration Parameters

**Equation (11.4-3):**  $S_{DS} = \frac{2}{3} S_{MS} = \frac{2}{3} \times 1.445 = 0.963 \text{ g}$

**Equation (11.4-4):**  $S_{D1} = \frac{2}{3} S_{M1} = \frac{2}{3} \times 0.819 = 0.546 \text{ g}$

Section 11.4.5 — Design Response Spectrum

From **Figure 22-12** <sup>[3]</sup>  $T_L = 8 \text{ seconds}$

Figure 11.4-1: Design Response Spectrum

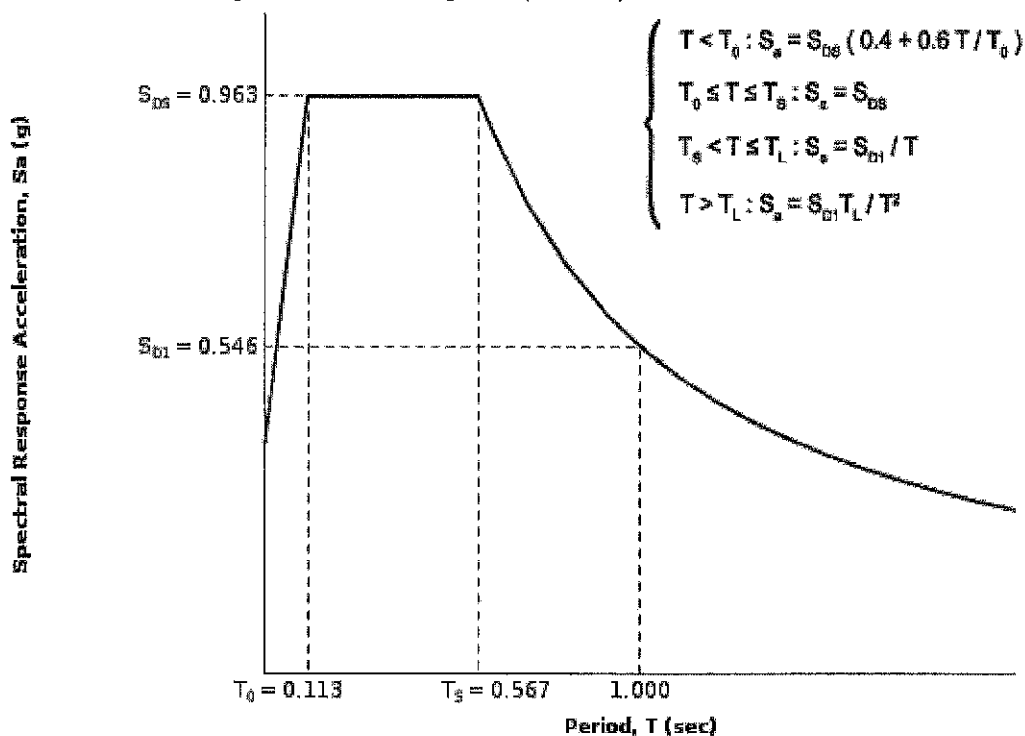

### Section 11.4.6 — Risk-Targeted Maximum Considered Earthquake (MCE<sub>R</sub>) Response Spectrum

The MCE<sub>R</sub> Response Spectrum is determined by multiplying the design response spectrum above by 1.5.

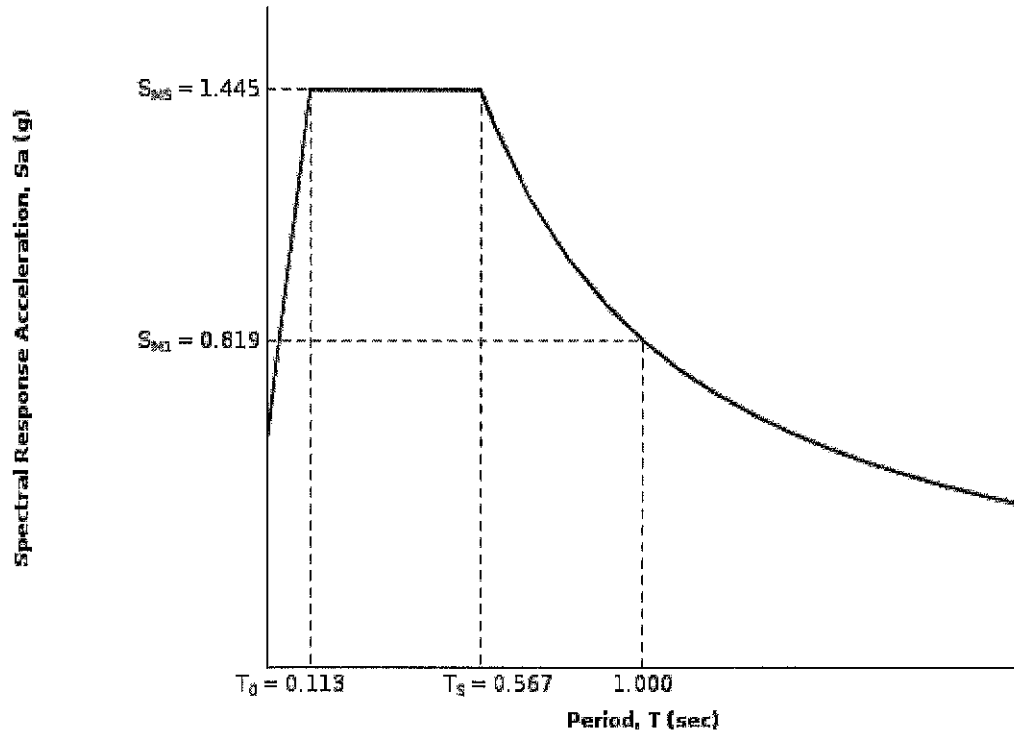

Section 11.8.3 — Additional Geotechnical Investigation Report Requirements for Seismic Design Categories D through F

From **Figure 22-7** <sup>[4]</sup>

PGA = 0.573

**Equation (11.8-1):**

$$PGA_M = F_{PGA}PGA = 1.000 \times 0.573 = 0.573 \text{ g}$$

Table 11.8-1: Site Coefficient  $F_{PGA}$

Site Class	Mapped MCE Geometric Mean Peak Ground Acceleration, PGA				
	PGA ≤ 0.10	PGA = 0.20	PGA = 0.30	PGA = 0.40	PGA ≥ 0.50
A	0.8	0.8	0.8	0.8	0.8
B	1.0	1.0	1.0	1.0	1.0
C	1.2	1.2	1.1	1.0	1.0
D	1.6	1.4	1.2	1.1	1.0
E	2.5	1.7	1.2	0.9	0.9
F	See Section 11.4.7 of ASCE 7				

Note: Use straight-line interpolation for intermediate values of PGA

**For Site Class = D and PGA = 0.573 g,  $F_{PGA} = 1.000$**

Section 21.2.1.1 — Method 1 (from Chapter 21 – Site-Specific Ground Motion Procedures for Seismic Design)

From **Figure 22-17** <sup>[5]</sup>

$C_{RS} = 0.936$

From **Figure 22-18** <sup>[6]</sup>

$C_{R1} = 0.961$

## Section 11.6 — Seismic Design Category

Table 11.6-1 Seismic Design Category Based on Short Period Response Acceleration Parameter

VALUE OF $S_{DS}$	RISK CATEGORY		
	I or II	III	IV
$S_{DS} < 0.167g$	A	A	A
$0.167g \leq S_{DS} < 0.33g$	B	B	C
$0.33g \leq S_{DS} < 0.50g$	C	C	D
$0.50g \leq S_{DS}$	D	D	D

For Risk Category = I and  $S_{DS} = 0.963 g$ , Seismic Design Category = D

Table 11.6-2 Seismic Design Category Based on 1-S Period Response Acceleration Parameter

VALUE OF $S_{D1}$	RISK CATEGORY		
	I or II	III	IV
$S_{D1} < 0.067g$	A	A	A
$0.067g \leq S_{D1} < 0.133g$	B	B	C
$0.133g \leq S_{D1} < 0.20g$	C	C	D
$0.20g \leq S_{D1}$	D	D	D

For Risk Category = I and  $S_{D1} = 0.546 g$ , Seismic Design Category = D

Note: When  $S_1$  is greater than or equal to 0.75g, the Seismic Design Category is **E** for buildings in Risk Categories I, II, and III, and **F** for those in Risk Category IV, irrespective of the above.

Seismic Design Category  $\equiv$  "the more severe design category in accordance with Table 11.6-1 or 11.6-2" = D

Note: See Section 11.6 for alternative approaches to calculating Seismic Design Category.

## References

1. Figure 22-1: [http://earthquake.usgs.gov/hazards/designmaps/downloads/pdfs/2010\\_ASCE-7\\_Figure\\_22-1.pdf](http://earthquake.usgs.gov/hazards/designmaps/downloads/pdfs/2010_ASCE-7_Figure_22-1.pdf)
2. Figure 22-2: [http://earthquake.usgs.gov/hazards/designmaps/downloads/pdfs/2010\\_ASCE-7\\_Figure\\_22-2.pdf](http://earthquake.usgs.gov/hazards/designmaps/downloads/pdfs/2010_ASCE-7_Figure_22-2.pdf)
3. Figure 22-12: [http://earthquake.usgs.gov/hazards/designmaps/downloads/pdfs/2010\\_ASCE-7\\_Figure\\_22-12.pdf](http://earthquake.usgs.gov/hazards/designmaps/downloads/pdfs/2010_ASCE-7_Figure_22-12.pdf)
4. Figure 22-7: [http://earthquake.usgs.gov/hazards/designmaps/downloads/pdfs/2010\\_ASCE-7\\_Figure\\_22-7.pdf](http://earthquake.usgs.gov/hazards/designmaps/downloads/pdfs/2010_ASCE-7_Figure_22-7.pdf)
5. Figure 22-17: [http://earthquake.usgs.gov/hazards/designmaps/downloads/pdfs/2010\\_ASCE-7\\_Figure\\_22-17.pdf](http://earthquake.usgs.gov/hazards/designmaps/downloads/pdfs/2010_ASCE-7_Figure_22-17.pdf)
6. Figure 22-18: [http://earthquake.usgs.gov/hazards/designmaps/downloads/pdfs/2010\\_ASCE-7\\_Figure\\_22-18.pdf](http://earthquake.usgs.gov/hazards/designmaps/downloads/pdfs/2010_ASCE-7_Figure_22-18.pdf)

Qsl (Flying Triangle)

Edge of Flying Triangle Landslide

D4

Tm

Edge of Flying Triangle Landslide

SET 2" GRADE TAG RICE

Qls(Tu)

Qsl (Flying Triangle)

Qls(Tu)

Qls(Dormant)

Tm

Qls(Tu)

Qls(talus)

Qls

Qls(Tu)

Scale 1" = 60ft.

GRADING PLAN

LEGEND

- Qls Landslide
- Qls (Tu) Landslide - basalt bedrock
- Qls (Tu) Landslide - Monterey bedrock
- Tu Basalt
- Tm Monterey formation
- Geologic contact
- Bedding attitude
- Boring location
- Geologic section

COAST GEOTECHNICAL, INC.

W.O. 430412 Figure 1

STAMP



REGISTERED PROFESSIONAL ENGINEER  
 CIVIL  
 STATE OF CALIFORNIA  
 No. 1084  
 Exp. 12-31-04

**PANARRIC ENGINEERING, INC.**  
 200 EAST LANSBURY/100 CORNER AVENUE 201, CARPENTERS VALLEY, CA 94501  
 TEL: (916) 768-3828 WWW.PANARRICENGINEERING.COM FAX: (916) 765-8317

DATE \_\_\_\_\_

PERFECTO A. ARCA RICE P 2018

GEOLOGIC SECTION A-A'

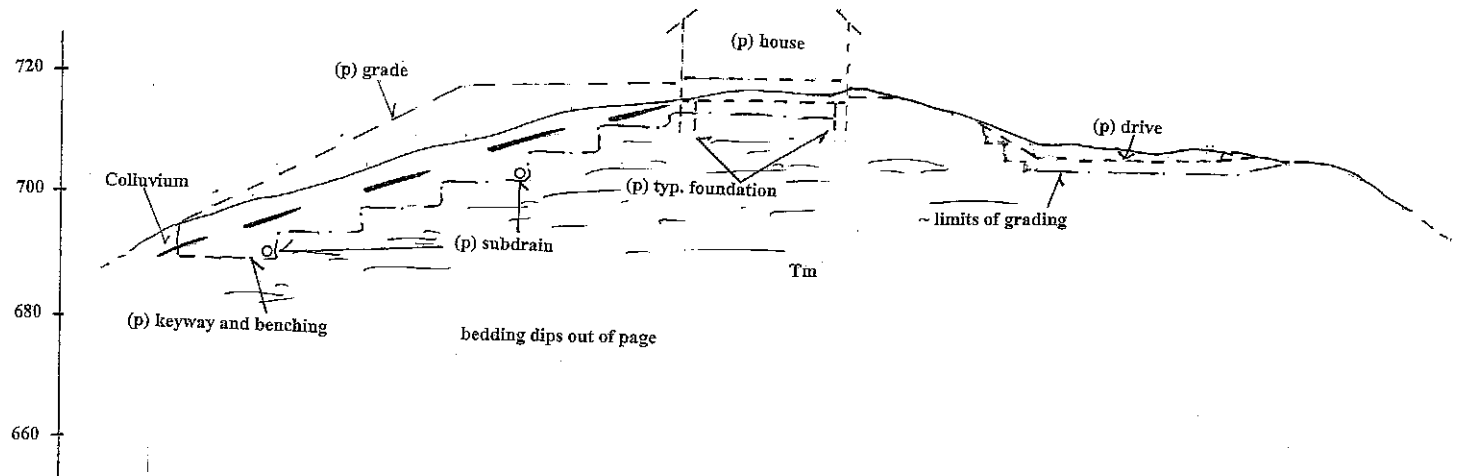

Scale 1' ~ 20ft. (H=V)

COAST GEOTECHNICAL, INC.

W.O. 430412 Figure 2



# FILL SLOPE DETAIL

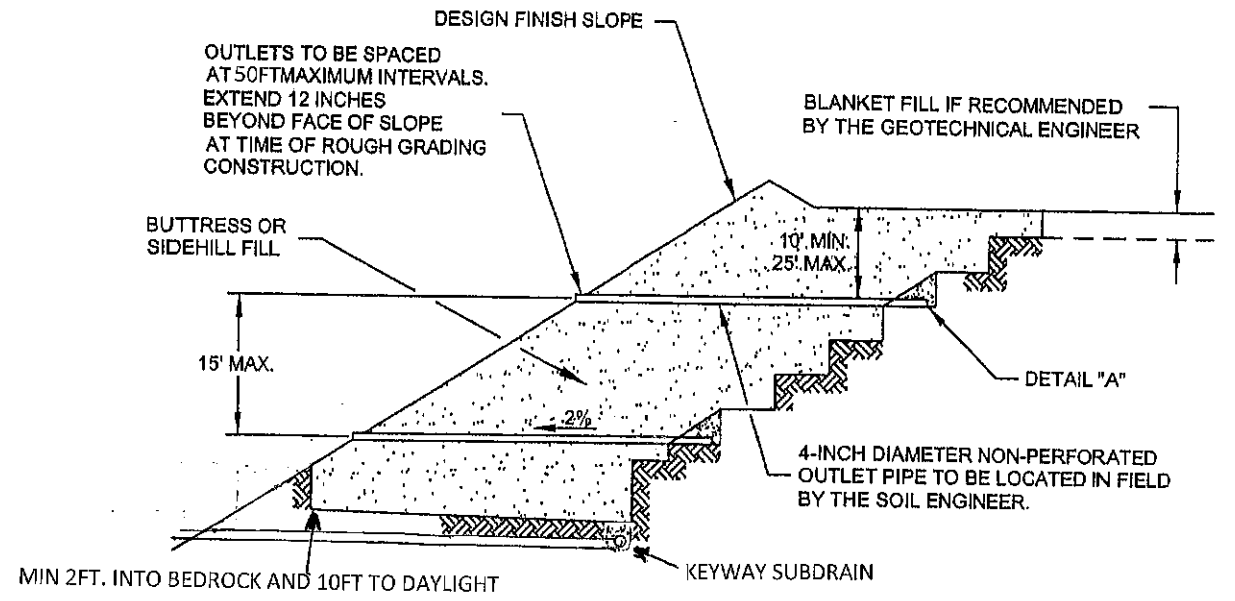

"FILTER MATERIAL" TO MEET FOLLOWING SPECIFICATION OR APPROVED EQUIVALENT: (CONFORMS TO EMA STD. PLAN 323)

"GRAVEL" TO MEET FOLLOWING SPECIFICATION OR APPROVED EQUIVALENT:

SIEVE SIZE	PERCENTAGE PASSING
1"	100
3/4"	90-100
3/8"	40-100
NO. 4	25-40
NO. 8	18-33
NO. 30	5-15
NO. 50	0-7
NO. 200	0-3

SIEVE SIZE	MAXIMUM PERCENTAGE PASSING
1 1/2"	100
NO. 4	50
NO. 200	8
SAND EQUIVALENT = MINIMUM OF 50	

OUTLET PIPE TO BE CONNECTED TO SUBDRAIN PIPE WITH TEE OR ELBOW

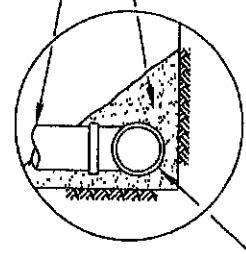

DETAIL "A"

FILTER MATERIAL - MINIMUM OF ONE CUBIC FEET PER FOOT OF PIPE. SEE ABOVE FOR FILTER MATERIAL SPECIFICATION.

ALTERNATIVE: IN LIEU OF FILTER MATERIAL ONE CUBIC FEET OF GRAVEL PER FOOT OF PIPE MAY BE ENCASED IN FILTER FABRIC. SEE ABOVE FOR GRAVEL SPECIFICATION.

FILTER FABRIC SHALL BE MIRAFI 140 OR EQUIVALENT. FILTER FABRIC SHALL BE LAPPED A MINIMUM OF 12 INCHES ON ALL JOINTS.

MINIMUM 4-INCH DIAMETER PVC SCH 40 OR ABS CLASS SDR 35 WITH A CRUSHING STRENGTH OF AT LEAST 1,000 POUNDS, WITH A MINIMUM OF 8 UNIFORMLY SPACED PERFORATIONS PER FOOT OF PIPE INSTALLED WITH PERFORATIONS ON BOTTOM OF PIPE. PROVIDE CAP AT UPSTREAM END OF PIPE. SLOPE AT 2 PERCENT TO OUTLET PIPE.

- NOTES:  
 1. TRENCH FOR OUTLET PIPES TO BE BACKFILLED WITH ON-SITE SOIL.

# COAST GEOTECHNICAL, INC.

1200 West Commonwealth, Fullerton, CA 92833 • Ph: (714) 870-1211 • Fax: (714) 870-1222 • email: coastgeotec@sbcglobal.net

---

December 31, 2016

W.O. 430412-06

Mr. and Mrs. Shen  
26810 Fond du Lac Road  
Rancho Palos Verdes, CA 90275

Subject: Geologic Assessment of Proposed Private  
Offsite Access Drive for #77 Portuguese  
Bend Road, Rolling Hills, California

Mr. and Mrs. Shen:

The following geologic assessment of the proposed private offsite drive to your property has been prepared based on the review of available work, published reports and maps, and professional opinion.

The work provided is intended to be as comprehensive as feasible without in depth detailed discussions of the complex nature of geologic conditions of the area, but should be useful for the purpose of addressing the geology and soils section of the access drive EIR.

## **PROPOSED DEVELOPMENT**

Our understanding of the project is that the property will be developed with a single family residence, hardscape, landscape, pool, and private sewage disposal system. To access the property a private drive must be constructed from the terminus of Portuguese Bend road to the property. Our understanding is that the offsite private access drive will be constructed within an existing easement as depicted on attached plans by P.A. ARCA, Figure 3.

## **SITE DESCRIPTION**

The project site is identified as #77 Portuguese Bend Road in the City of Rolling Hills, California and is shown on the Site Vicinity Map, Figure 1.

The parcel is composed of about twenty acres of unimproved land found west of Crest Road at the southern terminus of Portuguese Bend Road. Burma Road to the east, developed residential parcels to the north, a canyon to the west, and open space to the south bind the property.

The parcel is accessed off the southern terminus of Portuguese Bend Road via an unpaved semi-improved road. The road continues onto and through the property and is labeled offsite as Burma Road. Within the property various dirt roads and paths transect the property.

The parcel generally slopes downward to the southwest with moderate to gentle gradients, with localized steepened slopes along adjacent canyon walls, as road cuts, and within landslide head scarps.

The site shows moderate to heavy growth of brush and grasses.

## RECORD REVIEW

Records were requested at the County of Los Angeles for the subject site and those nearby. Records were requested for 65, 67, 69, 71, 73, 74, and 77 Portuguese Bend Road, 1, 3, 4, and 6 Running Brand, and County reports for the Flying Triangle Landslide or Flying Triangle Annex on February 5, 2012. The County located records for 71 and 73 Portuguese Bend Road and for 1, 3 and 6 Running Brand. A look through these files did not find geologic information considered useful for preparation of this report.

Readers of this report are advised that a record research is not an exact science; it is limited by time and resource constraints, incomplete records, ability of custodian of records to locate files, and where records are located is only a limited interpretation of other consultant's work. Readers of this report should perform their own review of County records to arrive at their own interpretations and conclusions.

Records reviewed in house were as follows;

- *Geologic and Soil Investigation, Flying Triangle Extension, Rolling Hills, by Converse Consultants, dated November 10, 1978.* This report addressed the subdivision of the subject lot. This report found the proposed project feasible within the contents of the report. Several landslides were identified within the report with mitigation recommended to achieve buildable conditions.
- *Potion of a County report prepared on the Flying Triangle Landslide and the accompanying geologic map.* The report appears to have been generated to address active Flying Triangle Landslide movement that started to occur in early 1980. The report asserts that active landslide movement occurred within an ancient landslide but not along the same plane. The geologic map prepared by the County for this report has been utilized as the base map for our report and is appended as Figure 3.
- *Preliminary Geologic Investigation of Proposed Residence, 77 Portuguese Bend Road, Rolling Hills, California; by COAST GEOTECHNICAL, Inc., W.O. 430412-01, dated May 5, 2012.* This report addressed the geologic feasibility of the construction of a single family residence and found conditions to be acceptable.

Other records reviewed consisted of Survey Monitoring Reports conducted by the City of Rancho Palos Verdes attached in Appendix B. Along section A-A' just outside the property line is RPV survey point FT08. This survey point and others are shown in relationship to the subject site on a map in Appendix B, along with survey data. This date indicates that survey point FT08 has no movement, which suggests the area has been stable.

## REGIONAL GEOLOGY

Rolling Hills is located within a geographic area known as the Palos Verdes Peninsula. The peninsula's regional geology is a series of sub-parallel synclinal and anticlinal folds and minor faults formed by uplift and deformation south of the Palos Verdes Fault. As uplift progressed,

changes in sea level caused wave eroded benches to be cut into the peninsula flanks. As uplift continued geomorphic processes occurred resulting in present day landforms.

A regional geology map, by Thomas Dibblee, is presented on Figure 2. The regional geology map by Dibblee does indicate the proposed offsite access drive to be within the Flying Triangle Landslide.

A portion of the Landslide Inventory Map for the Palos Verdes Peninsula is attached as Figure 2.1. This map shows landslide masses similar to Dibblee's; although, differences in landslide geometry do occur between the two maps, and the Landslide Inventory Map shows a small dormant landslide between the two lower lobes of the Flying Triangle Landslide. This map also indicates the proposed offsite access drive to be within the Flying Triangle Landslide.

## **GEOLOGIC UNITS**

Our understanding of the geologic units within the proposed offsite private access drive was developed through review of previous area work and site reconnaissance. The site is underlain by unmapped artificial fill, colluvium, bedrock, and landslide materials.

Artificial fill (Af) is inferred onsite as side cast fills along paths, drives, and roads. The fills are anticipated to consist of locally derived earth materials placed during past earthwork activity. Where present within the proposed offsite private drive, the fills will be mitigated by grading.

Colluvium (Qc) is present at the ground surface in areas unaffected by past grading activities and is composed of dark gray to black silty clay, diatomaceous, with small to cobble sized bedrock fragments, firm to stiff and damp to moist, surficially porous and desiccated.

Monterey bedrocks (Tm) observed as cuts along the upslope side of the existing road consisted of layered buff, tan, white, grey, diatomaceous siltstone, clayey siltstone, and claystone, thin to thick bedded, slightly firm to hard, moist to very moist; black gray to red brown silty sandstone, firm to hard, and well spaced beds of siliceous siltstone. Some bedrock zones exhibited strong fracturing. Zones of secondary crystallization and gypsum along beds and as inclusions were observed.

Basalt bedrocks (Tb) are found at depth and are composed of brown to oxidized brown medium to coarse grained intrusive rock, weathered to fresh, with occasional gypsum vein.

Landslide materials (Qls) are present and range from disoriented blocks of Monterey formation in a clayey matrix and some basalt, to intact blocks of Monterey formation and basalt.

## **GROUNDWATER**

Groundwater was not observed in the borings logged or observed on the nearby canyon sidewalls during performance of site exploration or fieldwork for preparation of the geologic investigation of the property.

## **LANDSLIDES**

Based on review of available data our opinion is that some portions of the general area has been affected by global ancient and recent land movement, while other portions do not show any recent movement.

Active landslides have been shown on Figure 2.2 as Q1s. These landslides have recorded historic movement, are visibly identifiable, and are well documented. These areas will most likely continue to experience some magnitude of movement and, as such, new habitable development is not generally allowed these areas; however, development with infrastructure such as private drives and roads is commonly allowed under a lower standard for uninhabitable development.

The proposed private offsite access drive is within a portion of the Flying Triangle Landslide and will be subject to distress similar to that visible in other developed areas of the landslide complex. Paved roads and drives typically remain usable but require higher maintenance where movement is reflected as cracks and offsets in the pavement.

## **SEISMICITY**

Southern California is located in an active seismic region. Moderate to strong earthquakes can occur on numerous local faults. The United States Geological Survey, California Division of Mines and Geology, private consultants, and universities have been studying earthquakes in Southern California for several decades. Early studies were directed toward earthquake prediction and estimation of the effects of strong ground shaking. Studies indicate that earthquake prediction is not practical and not sufficiently accurate to benefit the general public. Governmental agencies are shifting their focus to earthquake resistant structures as opposed to prediction. The purpose of the code seismic design parameters is to prevent collapse during strong ground shaking. Cosmetic damage should be expected.

Southern California and vicinity has experienced an increase in seismic activity beginning with the San Fernando earthquake in 1971. In 1987, a moderate earthquake struck the Whittier area and was located on a previously unknown fault. Ground shaking from this event caused substantial damage to the City of Whittier and surrounding cities. The January 17, 1994, Northridge earthquake was initiated along a previously unrecognized fault below the San Fernando Valley. The energy released by the earthquake propagated to the southeast, northwest, and northeast in the form of shear and compression waves, which caused the strong ground shaking in portions of the San Fernando Valley, Santa Monica Mountains, Simi Valley, City of Santa Clarita, and City of Santa Monica.

Southern California faults are classified as: active, potentially active, or inactive. Faults from past geologic periods of mountain building that do not display any evidence of recent offset, are considered "inactive or potentially active". Faults that have historically produced earthquakes or

show evidence of movement within the past 11,000 years are known as “active faults”. The site is not within an Alquist Priolo Zone as shown on DMG CD 2000-03

The Palos Verdes fault is located northeast of the subject site and is generally described in terms of three individual segments, namely the San Pedro Bay, the on-shore, and the Santa Monica Bay segments (Ziony, 1985). All segments are believed to have a reverse or reverse right oblique sense of motion. References reviewed as part of this report indicate that sedimentary materials; however, which may show evidence for Holocene activity along the on-shore and Santa Monica Bay segments is currently in dispute. Nonetheless, in light of the increased amount of seismicity that has been attributed to the Santa Monica Bay segment, the Palos Verdes Hills fault could be classified as active, by the State, in the future.

## **SEISMIC HAZARDS**

The potential hazards to be evaluated with regard to seismic conditions include fault rupture, landslides triggered by ground shaking, soil liquefaction, earthquake-induced vertical and lateral displacements, earthquake-induced flooding due to the failure of water containment structures, seiches, and tsunamis.

### **Fault rupture**

The private offsite access drive is not located within a currently designated Alquist-Priolo Earthquake Zone (Bryant and Hart, 2007). No known active faults are mapped on the site. Based on this consideration, the potential for surface fault rupture at the site is considered to be remote.

### **Ground Shaking**

The private offsite access drive is located in a seismically active area that has historically been affected by moderate to occasionally high levels of ground motion, and the project lies in relatively close proximity to several active faults; therefore, during the life of the proposed private access drive, the property will probably experience moderate to occasionally high ground shaking from these fault zones, as well as some background shaking from other seismically active areas of the Southern California region. Design of improvements is typically to maintain structural integrity, not to prevent damage. Earthquake insurance is available where the damage risk is not acceptable to the client.

### **Seismic induced landslide**

Earthquake-induced landslide zones were delineated by the State of California using criteria adopted by the California State Mining and Geology Board. Under those criteria, earthquake-induced landslide zones are areas meeting one or more of the following:

1. Areas known to have experienced earthquake-induced slope failure during historic earthquakes.
2. Areas identified as having past landslide movement, including both landslide deposits and source areas.

3. Areas where CDMG's analyses of geologic and geotechnical data indicate that the geologic materials are susceptible to earthquake-induced slope failure.

Based on the Seismic Hazard Zone Map published by the State of California, San Pedro Quadrangle the private access drive is mapped as being subject to potential seismic induced landslides. This is depicted on the appended printout from a County of Los Angeles GIS system, Figure 4. This system utilizes data from the State maps and places it onto their County map at a more readable scale.

### **Seismic induced liquefaction**

Liquefaction is a seismic phenomenon in which loose, saturated, non-cohesive granular soils exhibit severe reduction in strength and stability when subjected to high-intensity ground shaking. The mechanism by which liquefaction occurs is the progressive increase in excess pore pressure generated by the shaking associated with the seismic event and the tendency for loose non-cohesive soils to consolidate. As the excess pore fluid pressure approaches the in-situ overburden pressure, the soils exhibit behavior similar to a dense fluid with a corresponding significant decrease in shear strength and increase in compressibility. Liquefaction occurs when three general conditions exist: 1) shallow groundwater; 2) low density, non-cohesive sandy soils; and 3) high-intensity ground motion.

Based on the Seismic Hazard Zone Map published by the State of California, San Pedro Quadrangle, appended as Figure 5, the area is not mapped as being subject to potential seismic induced liquefaction.

A liquefaction potential is deemed not present.

### **Lateral spreading**

The occurrence of liquefaction may cause lateral spreading. Lateral spreading is a phenomenon in which lateral displacement can occur on the ground surface due to movement of non-liquefied soils along zones of liquefied soils. For lateral spreading to occur, the liquefiable zone must be continuous, unconstrained laterally, and free to move along sloping ground toward an unconfined area.

The site does not exhibit characteristics common to areas subject to seismic induced lateral spread. Our opinion is that the site is not subject to seismic induced lateral spread.

### **Earthquake-induced settlements**

Strong ground shaking can cause settlement by allowing sediment particles to become more tightly packed, thereby reducing pore space. Unconsolidated, loosely packed alluvium, beach/lake deposits are especially susceptible to this phenomenon. Poorly compacted artificial fills may also experience seismically induced settlement.

Site improvements will be supported by foundations placed into intact landslide materials; seismic induced settlement will be negligible.

### **Earthquake-Induced Flooding**

The failure of dams or other water-retaining structures as a result of earthquakes and strong ground shaking could result in the inundation of adjacent areas. Due to the lack of a major dam or water-retaining structure located near the site, the potential of earthquake-induced flooding affecting the site is considered not to be present.

### **Seiches**

Seiches are large waves generated in enclosed bodies of water in response to ground shaking. Based on the lack of nearby enclosed bodies of water the risk from a seiche event is not present.

### **Tsunamis**

Tsunamis are waves generated in large bodies of water as a result of change of seafloor topography caused by tectonic displacement. Based on the elevation of the site the project has no potential to be affected by a tsunami.

### **DRAINAGE**

Existing drainage is poor. The proposed offsite private access drive will improve the area with designed drainage decreasing the risk of erosion and reducing the infiltration of waters into subsurface earth materials.

### **GEOTECHNICAL HAZARDS**

*Expansive Soils* - Site earth materials are expansive in nature. These earth materials will experience changes in volume as wetting and drying cycles occur. The proposed private access drive will be designed to accommodate anticipated expansive soils and or the condition mitigated through minor grading of the upper dry earth materials

*Hydroconsolidation, subsidence, or settlement* - Through site earthwork and or design any significant effects from potential hydroconsolidation, subsidence, or settlement will be mitigated

*Slope stability* - The standard practice in the industry is to achieve a factor of safety in which the resisting forces are 1.5 times greater than the driving forces (factor of safety of 1.5). Based on recorded historic movement of the Flying Triangle Landslide, the global FOS is probably near 1.0, meaning resisting and driving forces are near equal.

On a local scale, the ascending slope that is affected by construction of the offsite private access drive probably has an existing factor of safety that exceeds 1.0. Through design and engineering the local stability of this slope should be brought into compliance with current building codes.



The primary factors that can determine an areas stability are complex but are generally attributed to geologic structure, earth material strengths, groundwater, and topography. Secondary factors such as redistribution of landmass, erosion, uncontrolled surface waters, overwatering, excessive infiltration of waters , and others, can also have an effect on slope stability.

The proposed private offsite access drive is opinioned not to have a significant impact on the existing global stability of the area, since the private offsite access drive will not increase mass to the slide, will decrease erosion through design, and will improve area drainage and infiltration. Local stability will be improved though support of existing steepened slope conditions with engineered retaining walls and improved drainage.

**INITIAL ENVIRONMENTAL EFFECTS/ STUDY CHECKLIST**

The level of geotechnical information presented in this report and those referenced by it, is opinioned adequate to assess the potential effects of the proposed offsite private access drive on earth resources and or landforms; however, as the project goes through review and permitting design refinement may be required which is consistent with mitigation identified in this report and or other project related documents.

The following Initial Study Checklist follows closely with the City's CEQA Threshold Guide and other sources to screen and focus upon potential environmental impacts resulting from the project.

---

	Potentially Significant Impact	Less Than Significant with Mitigation	Less Than Significant Impact	No Impact
a) Expose people or structures to potential substantial adverse effects, including the risk of loss, injury, or death involving:				
i) Rupture of a known earthquake fault, as delineated on the most recent Alquist-Priolo Earthquake Fault Zoning Map issued by the State Geologist for the area or based on other substantial evidence of a known fault? Refer to Division of Mines and Geology Special Publication 42?	<input type="checkbox"/>	<input type="checkbox"/>	<input type="checkbox"/>	<input checked="" type="checkbox"/>
<i>Comment: The project is not located within a state designated Alquist-Priolo Zone.</i>				
ii) Strong seismic ground shaking?	<input type="checkbox"/>	<input checked="" type="checkbox"/>	<input type="checkbox"/>	<input type="checkbox"/>
<i>Comment: The project is subject to strong ground shaking and will comply with building codes intended to protect people from hazard associated with strong ground shaking.</i>				

# COAST GEOTECHNICAL, INC.

Mr. Shen  
Proposed Assessment of Offsite Private Drive

9

W.O. 430412-06  
December 31, 2016

(iii) Seismic-related ground failure, including liquefaction?

*Comment: The project is not mapped as being within a State designated zone with a potential for liquefaction or seismic induced ground failure.*

iv) Landslides?

*Comment: The project is within the Flying Triangle Landslide which shows recent movements in some areas. The proposed access drive is subject to similar distress as seen in other paved areas of the landslide; however, the proposed access drive is not anticipated to aggravate the stability of the landslide provided the project does not increase the slide mass and utilizes controlled drainage to minimize infiltration and surface runoff of surface waters. As with other areas of the landslide continued maintenance will be needed to maintain usability.*

b) Result in substantial soil erosion or the loss of topsoil?

*Comment: Loose top soil will be mitigated through grading and soil erosion will be mitigated through designed drainage.*

c) Be located on a geologic unit or soil that is unstable, or that would become unstable as a result of the project, and potentially result in on- or off-site landslide, lateral spreading, subsidence, liquefaction or collapse?

*Comment: The project is within the Flying Triangle Landslide which shows recent movements in some areas. The proposed access drive is subject to similar distress as seen in other paved areas of the landslide; however, the proposed access drive is not anticipated to aggravate the stability of the landslide provided the project does not increase the slide mass and utilizes controlled drainage to minimize infiltration and surface runoff of surface waters. As with other areas of the landslide continued maintenance will be needed to maintain usability.*

d) Be located on expansive soil, as defined in Table 18-1-B of the Uniform Building Code (1994), creating substantial risks to life or property?

*Comment: The project will be within an area with expansive soils. This condition will be mitigated to industry standards through site grading and design.*

e) Have soils incapable of adequately supporting the use of septic tanks or alternative waste water disposal systems where sewers are not available for the disposal of waste water?

*Comment: The proposed access drive will not require a septic system.*

**CONCLUSIONS**

The proposed private offsite access drive is not anticipated to increase the activity of the existing landslide, or on a local scale significantly affect adjacent properties and vice versa provided our and other design consultant's guidelines, building codes, and construction standards are followed. Our opinion is that the current design of the private access drive provides sufficient mitigation of geologic concerns.

The private offsite access drive will however be subject to movements typical to similar improvements in the area, and will require continued maintenance to maintain usability. The risk of this movement, and associated cost of repair, is assumed by the property owner and is inherent to the area.

We appreciate this opportunity to be of service to you.

Respectfully submitted:  
COAST GEOTECHNICAL, Inc.

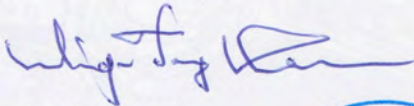

Ming-Tarng Chen  
RCE 54011

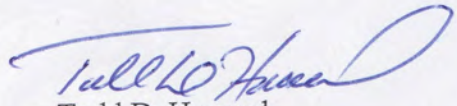

Todd D. Houseal  
CEG 1914, Exp. 04/18

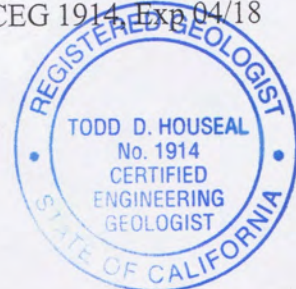

# SITE VICINITY MAP

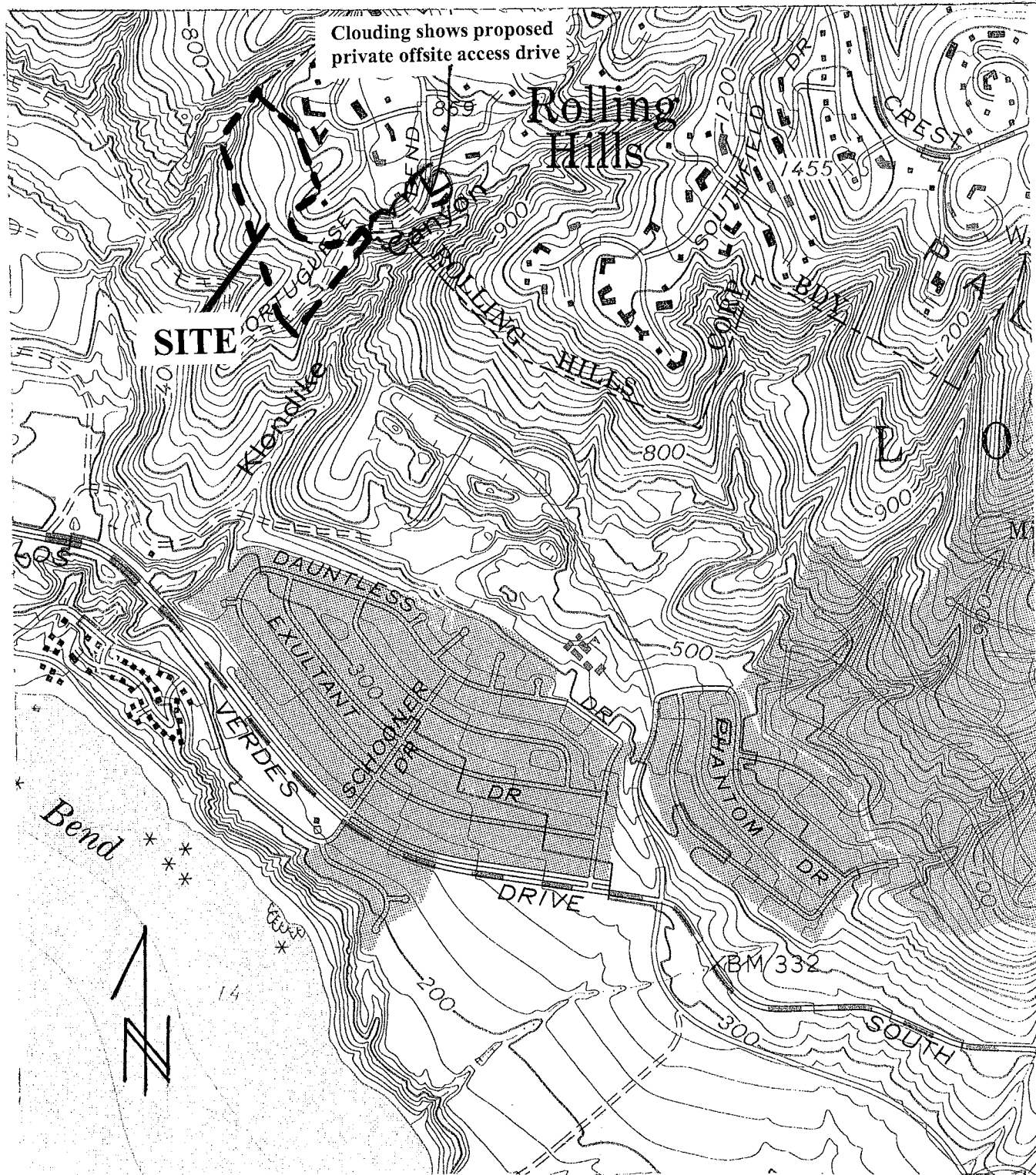

San Pedro USGS Topographic Map

COAST GEOTECHNICAL, INC.

W.O. 430412

Figure 1

# REGIONAL GEOLOGY MAP

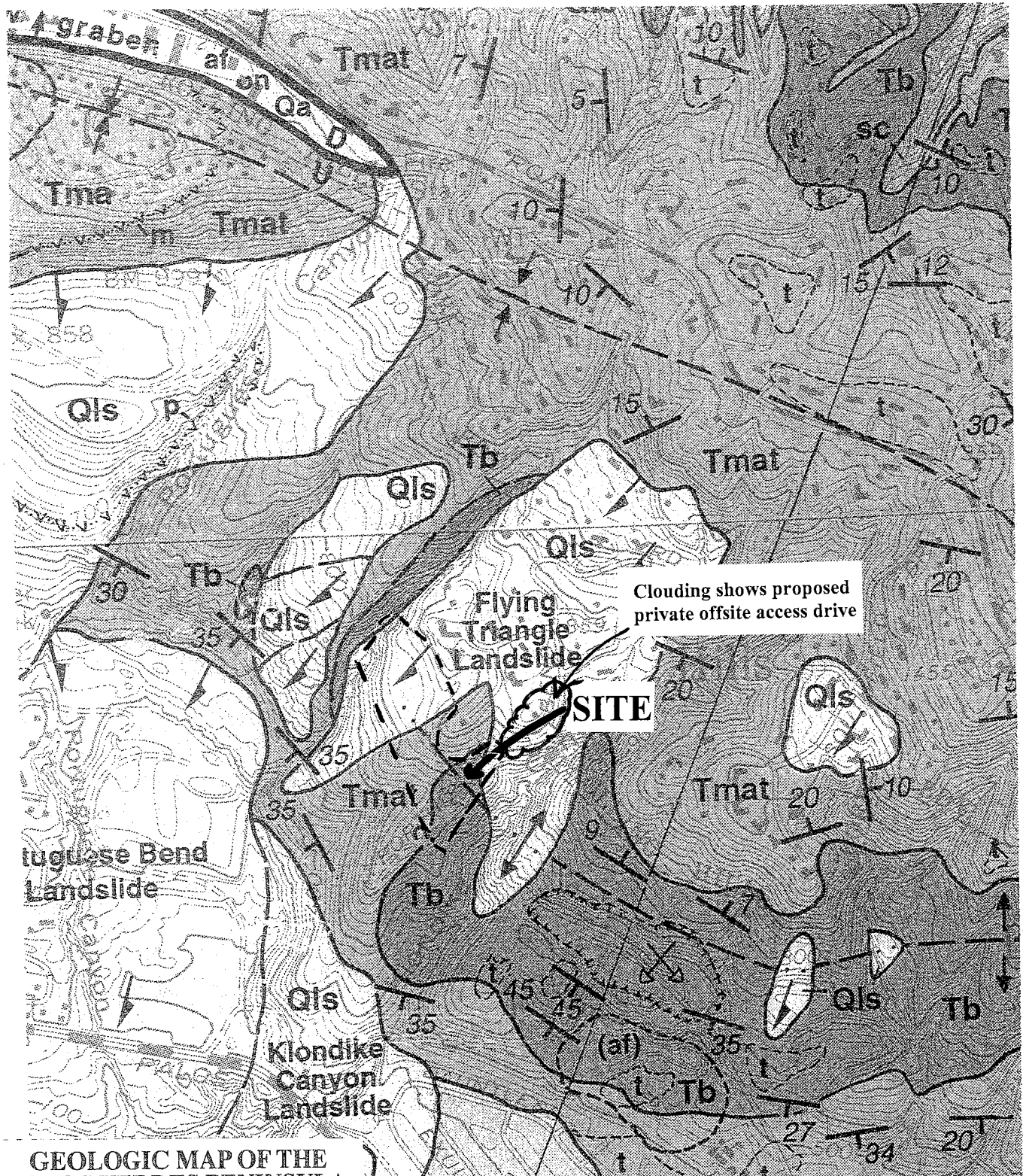

**GEOLOGIC MAP OF THE  
PALOS VERDES PENINSULA  
AND VICINITY**

Redondo Beach, Torrance,  
and San Pedro Quadrangles

Los Angeles County, California

By **THOMAS W. DIBBLEE, JR.**, 1999

Edited by Helmut E. Ehrenspeck  
with Percy L. Ehlig and Wendy Lou Bartlett



**COAST GEOTECHNICAL, INC.**

W.O. 430412

Figure 2

# REGIONAL GEOLOGY MAP

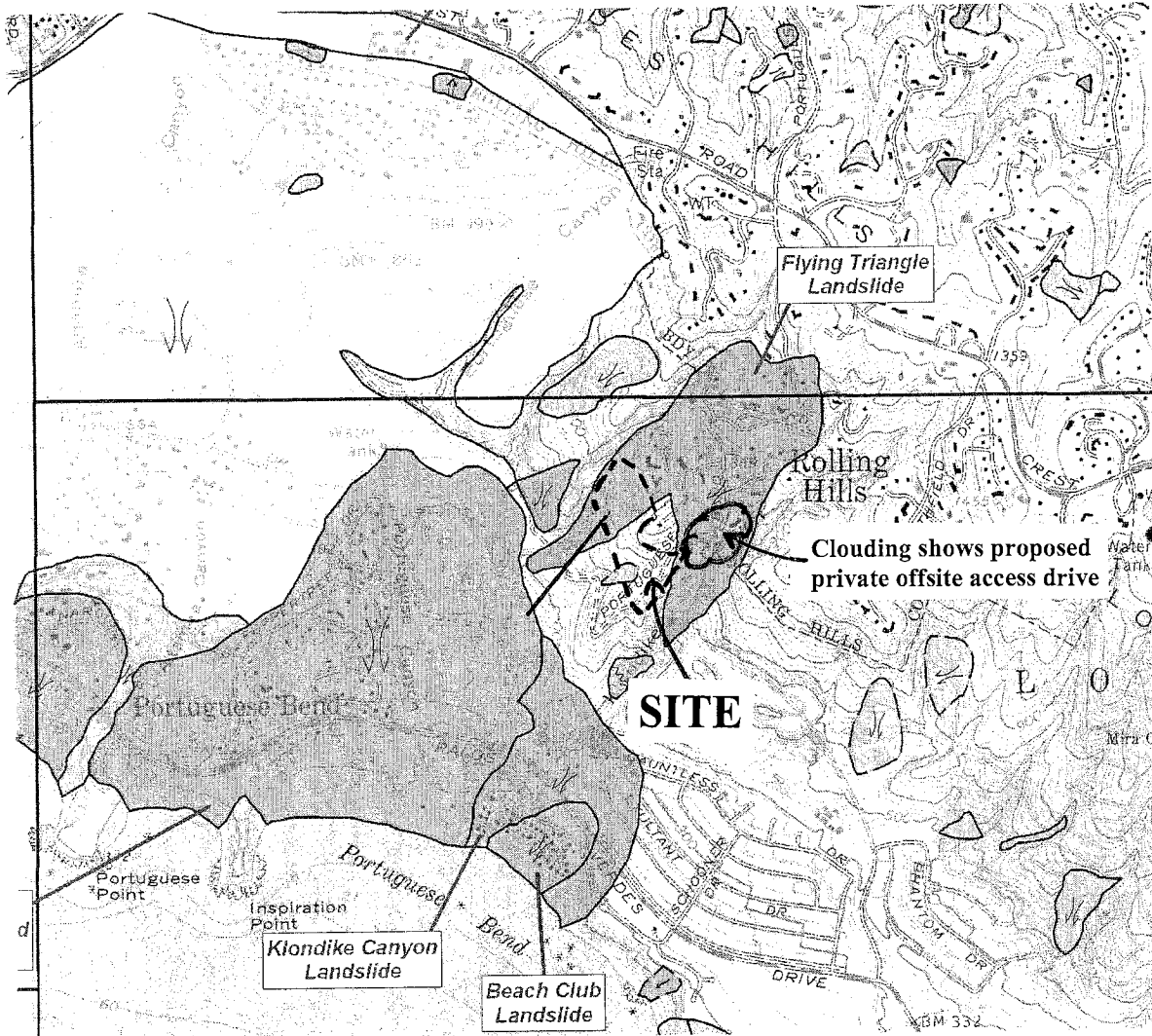

State of California Palos Verdes Landslide Inventory Map



COAST GEOTECHNICAL, INC.

W.O. 430412

Figure 2.1

# REGIONAL GEOLOGY MAP

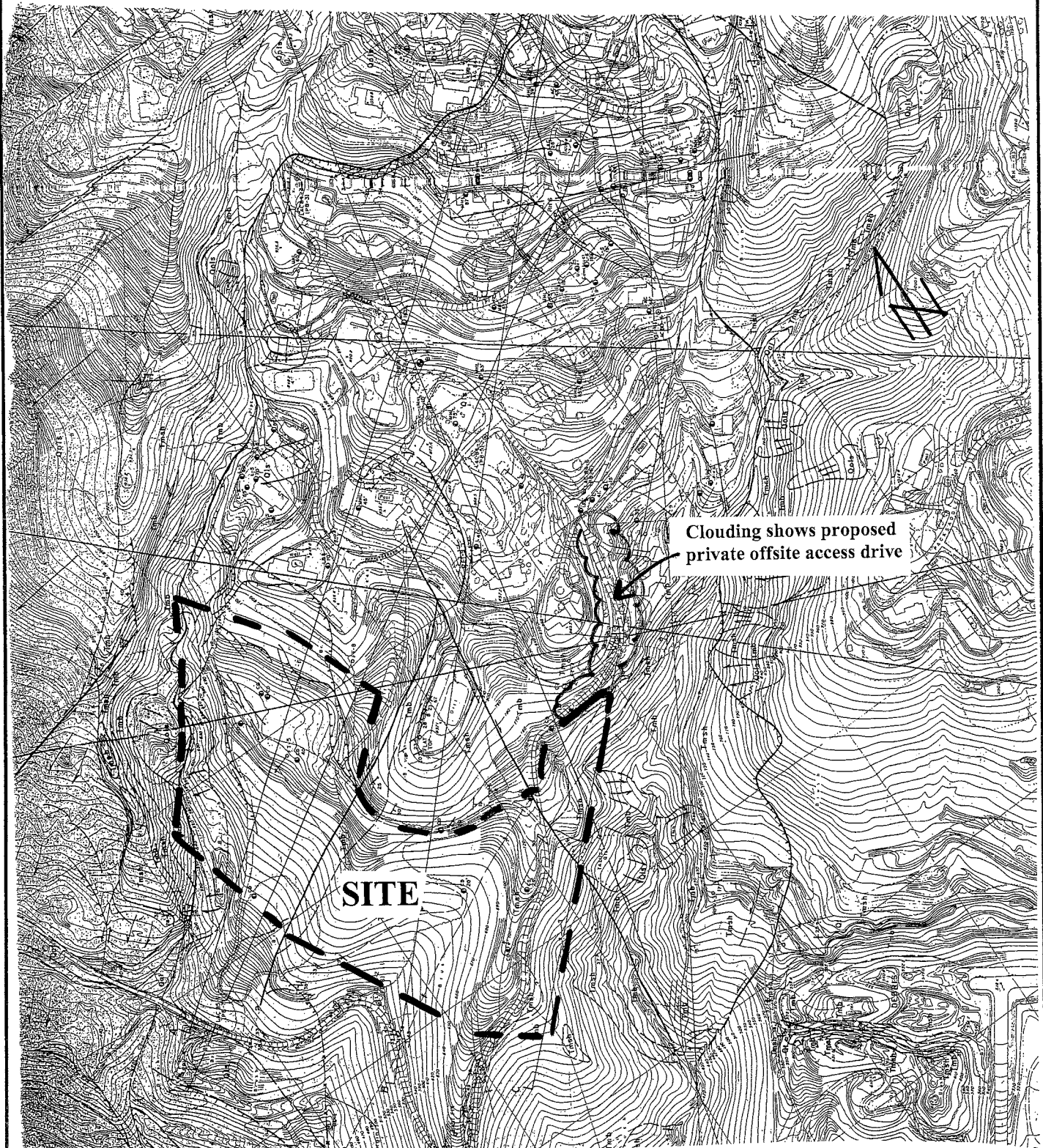

Clouding shows proposed private offsite access drive

**SITE**

County of Los Angeles

Geologic Map of the Flying Triangle Landslide

Circa 1981

COAST GEOTECHNICAL, INC.

W.O. 430412

Figure 2.2

**CONSTRUCTION NOTES:**

- 1 CONSTRUCT ASPHALT CONCRETE BARRIER PER DETAIL 1 (C0.02)
- 2 CONSTRUCT CATCH BASIN WITH FILTER PER DETAIL 5 (C0.02) 6 (C0.02)
- 3 CONSTRUCT JUNCTION STRUCTURE PER DETAIL 5 (C0.04)
- 4 CONSTRUCT ASPHALT CONCRETE PAVEMENT.
- 5 CONSTRUCT STONE PAVERS PER ARCHITECTURAL PLAN SET.
- 6 CONSTRUCT PERVIOUS PAVEMENT TO DG PAVEMENT TRANSITION PER DETAIL 9 (C0.02)
- 7 CONSTRUCT TUFFTRACK GRASS PAVER FIRE LANE PER DETAIL 4 (C0.05)
- 8 PROVIDE AND INSTALL 6" PVC SDR 35 STORM DRAIN LINE
- 9 PROVIDE AND INSTALL 15" PVC SDR 35 STORM DRAIN LINE
- 10 PROVIDE 24" WIDE CURB CUTOUT FOR OVERFLOW PURPOSES PER DETAIL 2 (C0.02)
- 11 CONSTRUCT GRAVITY WALL PER DETAIL 5 (C0.05)
- 12 EXISTING FENCE.
- 13 EXISTING TREE TO BE REMOVED.
- 14 EXISTING TREE TO REMAIN. PROTECT IN PLACE.
- 15 CONSTRUCT L.I.D. BIOFILTRATION AREA PER DETAIL 1 (C0.04)
- 16 CONSTRUCT L.I.D. PLANTER AREA PER DETAIL 3 (C0.04)
- 17 CONSTRUCT LEVEL SPREADER PER DETAIL 2 (C0.04)
- 18 PROVIDE AND INSTALL HARDSCAPE CLEANOUT PER DETAIL 7 (C0.02)
- 19 PROVIDE AND INSTALL LANDSCAPE CLEANOUT PER DETAIL 8 (C0.02)
- 20 PROVIDE AND INSTALL HARDSCAPE AREA DRAIN WITH ROUND GRATE PER DETAIL 10 (C0.02)
- 21 PROVIDE AND INSTALL LANDSCAPE AREA DRAIN WITH ATRIUM GRATE PER DETAIL 11 (C0.02)
- 22 PROVIDE AND INSTALL SMARTDITCH 12" TRAPEZOIDAL GUTTER PER DETAILS 1 (C0.03)
- 23 PROVIDE AND INSTALL SMARTDITCH 12" TRAPEZOIDAL UPSTREAM/DOWNSTREAM FLARED END FITTING PER DETAILS 2 (C0.03) 3 (C0.03)
- 24 CONSTRUCT HEADWALL TO SMARTDITCH TRANSITION PER DETAIL 12 (C0.02)
- 25 CONSTRUCT 2' TALL "TYPICAL FENCE" PER DETAIL 4 (C0.05)
- 26 INSTALL SEPTIC TANK. TO BE DESIGNED BY OTHERS.
- 27 CONSTRUCT CONCRETE EDGING PER DETAIL 4 (C0.05)
- 28 CONSTRUCT ASPHALT ROLLED CURB PER DETAIL 2 (C0.05)
- 29 PROVIDE AND INSTALL POOL GRATE. SEE ARCHITECTURAL PLANS.
- 30 CONSTRUCT REINFORCED CONCRETE CRIB WALL PER SPPWC STANDARD PLAN NO. 619-2.
- 31 CONSTRUCT VEGETATED SWALE.
- 32 INSTALL GRAVEL RIPRAP.
- 33 CONSTRUCT VERTICAL RETAINING WALL PER SPPWC STANDARD PLAN NO. 618-3.

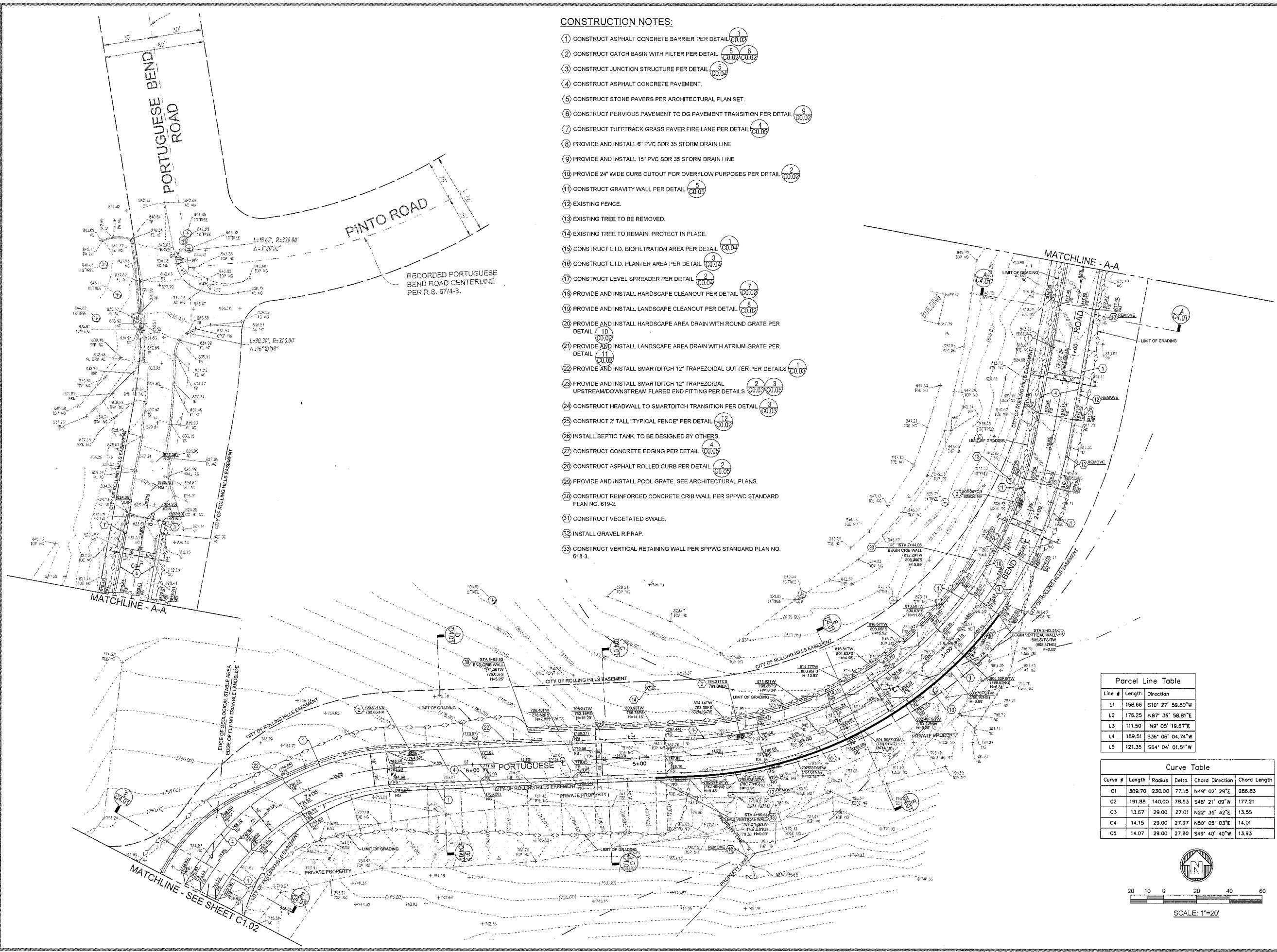

**Parcel Line Table**

Line #	Length	Direction
L1	156.66	S10° 27' 59.80"W
L2	176.25	N87° 36' 58.81"E
L3	111.50	N9° 05' 19.57"E
L4	189.51	S38° 06' 04.74"W
L5	121.35	S64° 04' 01.51"W

**Curve Table**

Curve #	Length	Radius	Delta	Chord Direction	Chord Length
C1	309.70	230.00	77.15	N49° 02' 29"E	286.83
C2	191.88	140.00	78.53	S48° 21' 09"W	177.21
C3	13.67	29.00	27.01	N22° 35' 42"E	13.55
C4	14.15	29.00	27.97	N50° 05' 03"E	14.01
C5	14.07	29.00	27.80	S49° 40' 40"W	13.93

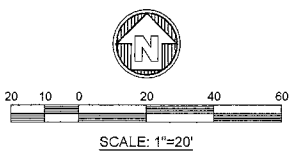
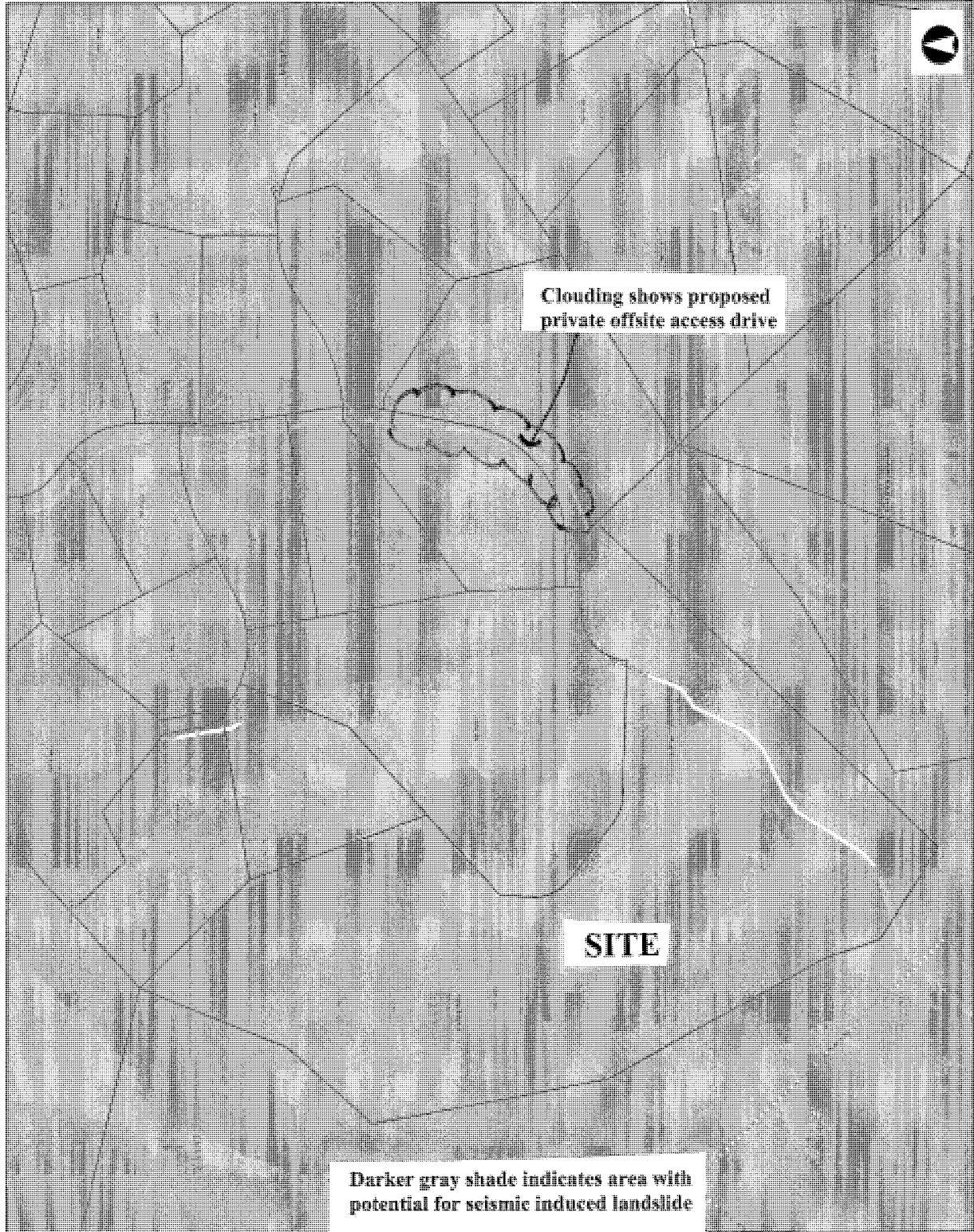

Figure 3



# Los Angeles County GIS Viewer



Darker gray shade indicates area with potential for seismic induced landslide

Clouding shows proposed private offsite access drive

SITE



County of Los Angeles

## Legend

- Landslide zones
- Parcels
- Cities and Communities

## Notes

This map is for reference only and should not be used for legal decisions. While the County of Los Angeles makes its best effort to ensure data is accurate, the County makes no representation or warranty of any kind.

Figure 4

# SEISMIC HAZARD MAP

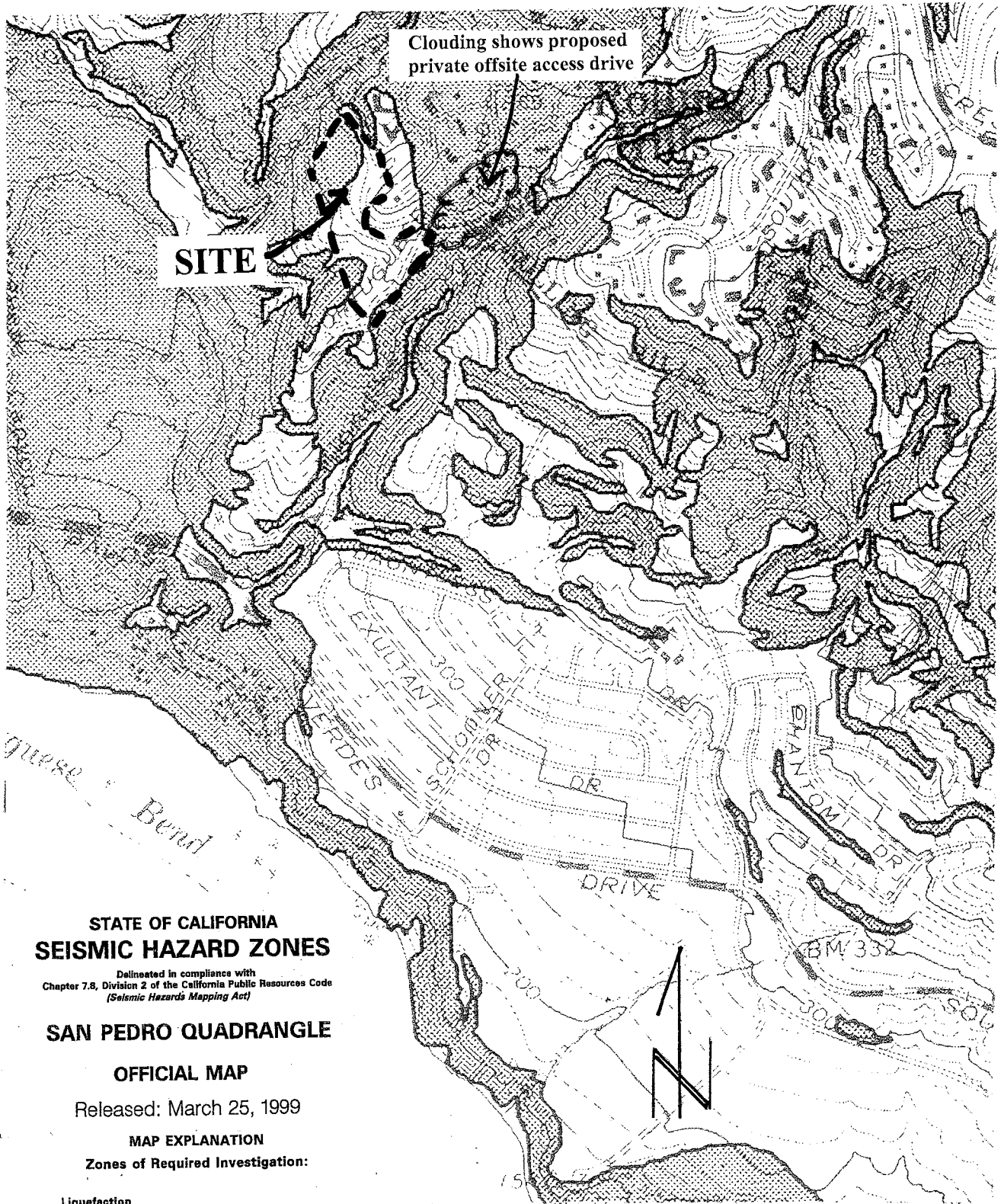

## STATE OF CALIFORNIA SEISMIC HAZARD ZONES

Delineated in compliance with  
Chapter 7.8, Division 2 of the California Public Resources Code  
(Seismic Hazards Mapping Act)

## SAN PEDRO QUADRANGLE

### OFFICIAL MAP

Released: March 25, 1999

#### MAP EXPLANATION

##### Zones of Required Investigation:

##### Liquefaction

Areas where historic occurrence of liquefaction, or local geological, geotechnical and groundwater conditions indicate a potential for permanent ground displacements such that mitigation as defined in Public Resources Code Section 2693(c) would be required.

##### Earthquake-Induced Landslides

Areas where previous occurrence of landslide movement, or local topographic, geological, geotechnical and subsurface water conditions indicate a potential for permanent ground displacements such that mitigation as defined in Public Resources Code Section 2693(c) would be required.

COAST GEOTECHNICAL, INC.

W.O. 430412

Figure 5

# COAST GEOTECHNICAL, INC.

1200 West Commonwealth, Fullerton, CA 92833 • Ph: (714) 870-1211 • Fax: (714) 870-1222 • email: coastgeotec@sbcglobal.net

October 20, 2017

W.O. 430412-07

Mr. and Mrs. Shen  
26810 Fond du Lac Road  
Rancho Palos Verdes, CA 90274

Subject: Response to Geotechnical Comments  
Concerning Proposed Offsite Driveway  
Construction at 77 Portuguese Bend Road,  
Rolling Hills, California

## References:

1. Preliminary Geologic Investigation of Proposed Residence, 77 Portuguese Bend Road, Rolling Hills, California; by COAST GEOTECHNICAL, Inc., W.O. 430412-01, dated May 5, 2012.
2. Geologic Response to Geotechnical Review for 77 Portuguese Bend Road, Rolling Hills, California; by COAST GEOTECHNICAL, Inc., W.O. 430412-02, dated February 28, 2013.
3. Report of Percolation Feasibility for New Residence, 77 Portuguese Bend Road, Rolling Hills, County of Los Angeles, California; by COAST GEOTECHNICAL, Inc., W.O. 430412-03, October 31, 2013.
4. Addendum Report to Percolation Feasibility for New Residence, 77 Portuguese Bend Road, Rolling Hills, County of Los Angeles, California; by COAST GEOTECHNICAL, Inc., W.O. 430412-04, dated March 10, 2015.
5. Geotechnical Review of Proposed Grading Plan and Acceptance of Geotechnical Responsibility for 77 Portuguese Bend Road, Rolling Hills, California; by COAST GEOTECHNICAL, Inc., W.O. 430412-05, dated June 10, 2015.
6. Geologic Assessment of Proposed Private Offsite Access Drive for #77 Portuguese Bend Road, Rolling Hills, California; by COAST GEOTECHNICAL, Inc., W.O. 430412-06, dated December 31, 2016.

Dear Mr. Shen:

This response report has been prepared to address geotechnical comments contained in a June 7, 2017 memorandum authored by Willdan Engineering. The memorandum is attached and our response to geotechnical comments are as follows:

### Item 1c

The proposed grading is for the construction of the private offsite driveway only and is intended to improve drainage, improve conditions of the driveway subgrade, and provide required grades. The grading proposed is not intended to provide stabilization of the regional Flying Triangle Landslide.

# COAST GEOTECHNICAL, INC.

Mr. Shen  
Response report

2

W.O. 430412-06  
October 20, 2017

## Item 3

Geotechnical assessment of the proposed offsite driveway and proposed cribwall to date has been limited to professional opinion. Specific geotechnical design recommendations will be provided at a future date when conceptual approval of the proposed plan has been obtained from the City.

The intent of the cribwall will be to support the construction cut required for the proposed offsite driveway construction. Future analysis of the proposed construction cut will determine the lateral loads that the cribwall must be designed to resist. These loads are typically the active pressure and any loads required to raise the local stability of the slope to a 1.5 factor of safety.

There is no direct intent from the proposed construction to mitigate the effect the regional Flying Triangle Landslide may have on the long term usability of the proposed offsite driveway or to improve the stability of the regional slide; however, the proposed driveway construction will improve local conditions such as drainage and surface runoff which left uncontrolled are typically detrimental to the global and or local stability of slopes.

We appreciate this opportunity to be of service to you.

Respectfully submitted:

COAST GEOTECHNICAL, Inc.

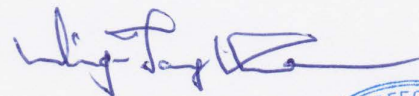

Ming-Tarng Chen  
RCE 54011

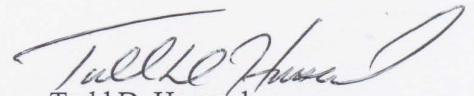

Todd D. Houseal  
CEG 1914, Exp 04/18

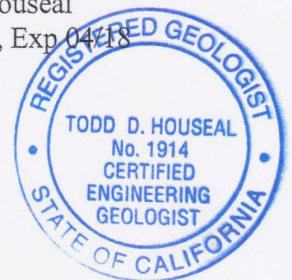

To: Martin Hsieh, Perfecto Arca, Yolanta Schwartz  
From: Elroy Kiepke, Public Works Plan Reviewer  
Date: June 7, 2017  
Subject: Proposed Home at 77 Portuguese Bend Road

I must state first that this should not be considered by any one as a Plan Review. It is merely a review to determine if the applicant has submitted enough information to allow the City Planning Commission to render a reasonable review of the application.

Based on the following plans submitted for review:

Site grading plan consisting of plans sheets G-001, G-004, A-001 thru A.006, A-101, A-102, A-103, A-104, A-201, A-202, A-203, and A-301 all dated December 20, 2016. Along with Civil Drawings C0.01 thru C0.06, C1.01 thru C1.04, C2.01, C3.01 thru C3.03, and C4.01 thru C4.02 all dated November 25, 2016.

My comments are as follows;

1. The earthwork quantities shown on C3.03 are in correct for the following reasons:
  - ARCA a. The Crib Wall is shown as a fill, while this is technically correct, to get to the point of filling the crib the contractor must first cut the material above the proposed grade of the roadway to the back cut for the wall.
  - ARCA b. The grading quantities are limited to On-site work. In review the plan I believe that portions of the cut and fill occurs off-site.
  - ARCA & TODD c. The grading does not appear to include any grading that the Geotechnical Engineer would require for stabilization of portions of the flying Triangle landslide as work cross the landslide proper or crosses the margins of the landslide.
2. The Engineer of record refers to standard details contained within the "Green book" for retaining walls, both the Crib Wall and the vertical Retaining wall. For private development projects, within a Landslide area, the Engineer of record must design and take responsibility for the retaining wall designs. That does not mean that he cannot use the Green book wall for this project, it just means that he must review the design of the wall and accept the design assumptions used for the wall. However, a review of APWA standard 618-3 shows that the maximum wall height shown for this wall is six feet and will not meet the requirements for 80% of the wall.
3. After reading the Geotechnical report submitted for this effort, there appears to be a requirement for the crib wall to stabilize the slope above the proposed road to the normal 1.5 factor of safety, but that is not clear. Since the off-site work is within the Landslide area, it is unclear how a factor of safety of 1.5 might be obtained. First, the Geotechnical Engineer should verify the Factor of safety he expects for the off-site road through the landslide area. Second the Geotechnical Engineer and the Civil Engineer should submit the work that shows that that factor of safety has been provided.
- ARCA 4. The paving plan shows "Stove Pavers" as pavement for the final reach of the driveway. In looking up Stove Paver up on the internet I seem to find bricks that are intended to be place under a wood burning stove to prevent wood drying and spontaneous combustion. I am sure that something else is meant but can find no other product. Provide details of what is intended for Stove Paving for the driveway.
- ARCA 5. On the grading plan for the driveway on and off-site there appear to be a series of catch basins but I can find no plan that shows a storm drain pipe and the outlet. Pease clarify where the storm drain is located and where it is intended to outlet.
- ARCA & OBELISK 6. The original contours are shown on the plans, but they are barely visible and after a week or two in the sun they will likely disappear entirely. Make the contour bolder by lessoning the shading that is currently being used.
- ARCA 7. For the Planning Commission's review of this project, elevation plans would be appropriate to show what the neighbors are going to be looking at with a 13-foot-high vertical retaining wall with a 13-foot crib wall separated by a 20-foot roadway.
- ARCA 8. Crib walls come in all shapes and sizes. Provide an indication for the type of stretcher and header member you plan to use for the Crib Wall.

July 18, 2018

Chris Kelley  
WILLDAN  
13191 Crossroads Parkway North, Suite 405  
Industry, California 91746-3497

**Subject: GEOTECHNICAL REVIEW**  
Proposed Offsite Driveway Construction, Planning Review Stage, Residential  
Development, 77 Portuguese Bend Road, Rolling Hills, California  
Willdan Project No. 101749

**References:**

- 1) "Response to Geotechnical Comments Concerning Proposed Offsite Driveway Construction at 77 Portuguese Bend Road, Rolling Hills, California", Prepared by Coast Geotechnical, Inc., Dated October 20, 2017, Work Order 430412-07
- 2) "Preliminary Planning Set, 77 Portuguese Bend Road, Rolling Hills, CA 90274" Prepared by P.A.

This letter presents our review of the above reports submitted for the proposed access road project. The purpose of this review was to evaluate the documents for adequacy with respect to geotechnical conditions that could affect the proposed development.

The report **IS APPROVED** from a geotechnical viewpoint for Planning Purposes **subject to following conditions.**

**Conditions of Approval:**

The limits of the landslide must be shown on the grading plans at the vicinity of the proposed access road and submitted for review and filling.

This review was performed in accordance with generally accepted professional geotechnical engineering principles and practice in Southern California at this time. We make no other warranty, either express or implied. Comments presented herein are based on review of work by others. No field exploration or laboratory testing was performed. Please contact us if you have questions or need additional services.

Respectfully Submitted

**WILLDAN GEOTECHNICAL**



Ross Khiabani, GE 2202  
Principal Engineer

Distribution: Addressee (via e-mail)



December 13, 2019

Madonna Marcelo  
**MICHAEL BAKER INTERNATIONAL**  
3760 Kilroy Airport Way, Suite 270  
Long Beach, CA 90806

GMU Project 19-224-00

**Subject:** Geotechnical Peer Review, 77 Portuguese Bend Road, City of Rolling Hills, California

**References:** “Shen Residence, Initial Study, Mitigated Negative Declaration (Draft),” prepared by Rincon Consultants, Inc., March 2019, Section 7 and Appendix D.

Dear Ms. Marcelo:

We have performed a planning level geotechnical peer review of the referenced documents, including Appendix D of the draft Initial Study, which includes multiple geotechnical reports and letters. Based on our review, we recommend the geotechnical consultant provide additional information, as detailed below, prior to approval.

1. Please provide an additional geologic x-sec to evaluate keyway dimensions on the proposed fill slope northwest of the planned residence. It appears the geologic structure changes between Section A-A’ (June, 2015 report) and boring B-1. The additional section should be parallel to A-A’ and between the planned residence and guest house. Slope stability analyses should be performed to provide adequate keyway dimensions and to show adequate safety factors in this area.
2. Discuss the “dispersal basins” shown on the plans northwest and southeast of the proposed residence – purpose, potential impact to stability and offsite property. Please confirm the biofiltration and storm drain systems as designed will not adversely impact the planned development or adjacent properties, including the Flying Triangle landslide.
3. Detailed slope stability analyses that models a well-supported geologic interpretation should be performed for Cross Section C-C’. The following specific issues should be addressed.
  - a. Geologic Interpretation - Cross Section C-C’:
    - i. The geology east and west of BH-1 is not supported by sufficient data. Please provide sufficient geologic information that supports the structural interpretation and clearly shows whether bedrock is adverse on section C-C’ both to the east and west.
    - ii. Additional mapping, shallow, or deep exploration may be required to justify the structural interpretation east and west of BH-1.

- b. Shear Strengths:
    - i. The shear strengths contained in the SWN report dated May 10, 2012 indicate that “residual strengths” were obtained. However, the shear strength tests do not appear to be re-shear tests where residual strength is demonstrated. Please provide residual strengths on critical materials that will be used to model any along bedding conditions that are present on Section C-C’.
    - ii. It is not clear that the shear strengths were obtained on the critical materials found in the boring logs. Please explicate and justify.
    - iii. Stark correlations for residual strengths based on PI and Clay fraction should be presented to support the direct shear testing of critical materials.
    - iv. Several of the borings encountered clay seams underlying the proposed development. Please address the potential for any clay seams to be present under the proposed structures, whether these seams may be continuous, and whether these clay seams may impact the stability of the development.
    - v. Please provide a detailed calculation, graph, or other detail that shows how the residual shear strength was determined.
  - c. Water Infiltration/Percolation:
    - i. The percolation reports indicate that some of the planned percolation trenches will discharge effluent water into the bedrock on the east side of section C-C’. Please address how this will impact slope stability. Provide either mitigation or include groundwater in the slope stability analyses.
    - ii. Please address the impact of surface water infiltration on slope stability. All conclusions and opinions should be justified with data, analyses, plans, etc.
4. The entry road is planned to traverse across the existing Flying Triangle landslide. Please address how movement rates of the existing landslide will be accommodated at the landslide boundary. Estimated maintenance and re-construction requirements should be directly addressed.
  5. The plans show a proposed retaining wall along the driveway that exceeds 13 feet in height. Discuss potential design impacts or limitations given the underlying landslide.
  6. The following should be provided for all proposed cut slopes along the entry road:
    - a. Geologic cross sections should be developed with a geologic interpretation that is supported by adequate subsurface data.
    - b. Representative shear strengths that model the geologic conditions (i.e., residual shear strengths for out-of-slope along bedding conditions) should be utilized.
    - c. Mitigation measure options should be presented as necessary.
    - d. Recommendations should be provided for monitoring where existing structures could be impacted.



Ms. Madonna Marcelo, **MICHAEL BAKER INTERNATIONAL**  
*Geotechnical Peer Review, 77 Portuguese Bend Road, Rolling Hills*

- 7. Several of the geotechnical documents provided in Appendix D are not signed/stamped by the consultant. Signed and stamped copies of all documents shall be included in the final Study.
- 8. Significant additional geotechnical evaluation, analyses and recommendations are required for the proposed development shown on the grading plans. In addition to the specific items above the following needs to be addressed prior to grading permit approval: 1) proposed crib wall, 2) proposed vertical roadway wall, and 3) pavement recommendations. This item may be a Condition of Approval at the Planning level.

Should there be any questions regarding the contents of this letter, please feel free to contact us.



Respectfully submitted,

Lisa L. Bates, PG, CEG 2293  
Associate Engineering Geologist



Gregory Silver, M.Sc., PE, GE 2336  
President, Principal Geotechnical Engineer

# COAST GEOTECHNICAL, INC.

1200 West Commonwealth, Fullerton, CA 92833 • Ph: (714) 870-1211 • Fax: (714)870-1222 • email: coastgeotec@sbcglobal.net

---

August 6, 2020

W.O. 430412-08

Mr. and Mrs. Shen  
26810 Fond du Lac Road  
Rancho Palos Verdes, CA 90274

Subject: Response to Geotechnical Peer Review, 77  
Portuguese Bend Road, Rolling Hills, California

## References:

1. Preliminary Geologic Investigation of Proposed Residence, 77 Portuguese Bend Road, Rolling Hills, California; by COAST GEOTECHNICAL, Inc., W.O. 430412-01, dated May 5, 2012.
2. Geologic Response to Geotechnical Review for 77 Portuguese Bend Road, Rolling Hills, California; by COAST GEOTECHNICAL, Inc., W.O. 430412-02, dated February 28, 2013.
3. Report of Percolation Feasibility for New Residence, 77 Portuguese Bend Road, Rolling Hills, County of Los Angeles, California; by COAST GEOTECHNICAL, Inc., W.O. 430412-03, October 31, 2013.
4. Addendum Report to Percolation Feasibility for New Residence, 77 Portuguese Bend Road, Rolling Hills, County of Los Angeles, California; by COAST GEOTECHNICAL, Inc., W.O. 430412-04, dated March 10, 2015.
5. Geotechnical Review of Proposed Grading Plan and Acceptance of Geotechnical Responsibility for 77 Portuguese Bend Road, Rolling Hills, California; by COAST GEOTECHNICAL, Inc., W.O. 430412-05, dated June 10, 2015.
6. Geologic Assessment of Proposed Private Offsite Access Drive for #77 Portuguese Bend Road, Rolling Hills, California; by COAST GEOTECHNICAL, Inc., W.O. 430412-06, dated December 31, 2016.
7. Response to Geotechnical Comments Concerning Proposed Offsite Driveway Construction at 77 Portuguese Bend Road, Rolling Hills, California; by COAST GEOTECHNICAL, Inc., W.O. 430412-07, dated October 20, 2017.

Dear Mr. Shen:

This response report has been prepared to address peer review comments issued on December 13, 2019 by GMU, their Project 19-224-00. The peer review comments are attached and our responses follow.

## Item 1

The proposed fill slope location as shown on the attached grading plan with geology dated July 2020 is slightly different from that shown on Figure 1 of our June 10, 2015 report. The current slope does not extend as far southwest as the slope shown previously. The current proposed fill slope is located westerly of the residence and is shown as a maximum twenty feet in height constructed at about a 2.3:1 (H:V) gradient.

We have utilized the July 2020 grading plan as a base map and plotted our site geologic data and interpretations onto the base map. This new plan is attached as Figure 1R.

# COAST GEOTECHNICAL, INC.

---

Mr. Shen  
Response report

2

W.O. 430412-08  
August 6, 2020

This new plan shows additional geologic data that was contained in Reference 1, but not shown on Figure 1 of the June 2015 report. This data fills in the area between our boring BH1 and the residence. Additional exploration is opinioned not needed at this time.

A new section D-D' was drafted and is presented on attached Figure 2R.

Based on the geologic structure opinioned, the gradient of the existing and proposed slope, and the proposed slope height, the requested analysis is not generally needed under County guidelines.

A typical keyway for the slope proposed is 15-20 feet in width with a minimum embedment of two feet into competent bedrock at the toe, with the approved toe having minimum ten foot daylight to the slope face. We anticipate a keyway depth of 6-8 feet at the toe, with final depth determined in the field at the time of grading.

## **Item 2**

Design of a WQMP plan for a low impact development provides multiple methods of compliance. Due to the geologic sensitivity of the area the use of dispersal basins was opinioned to have the lowest potential impact on the development and offsite areas.

The location of the dispersal basins is still subject to future geotechnical approval. Conceptually the basin northwest of the residence is acceptable; however, those found southeast of the residence may need to be moved to a less sensitive area and or have more separation between them.

Provided the final location of the dispersal basins is in an area geotechnically approved, the basins should have minimal impact on the development and area.

The biofiltration system shown as Detail 1 on C0-04 is a self contained design with an impermeable liner. Provided the biofiltration system is properly constructed and maintained it is opinioned not to have a negative effect on the development or adjacent properties.

## **Item 3**

### *Geologic interpretation-Section C-C'*

The reviewer has postulated concerns that are common to many hillside projects. While published guidelines and industry standards guide professionals within the discipline of geotechnical engineering with respect to project content and analysis, there is still a significant degree of professional opinion involved in hillside development, especially with respect to site exploration and shear strength values.

Our opinion is that sufficient geologic data is presented to support our interpretation of geologic structure presented on Section C-C' (May 5, 2012 report).

East of BH1 supporting geologic data consists of two bedding attitudes from the base map for Figure 3 (May 5, 2012 report), which oriented to the section shows almost neutral to slightly out of slope bedding. Additionally while not depicted in project reports, but shown in the Converse (1978) report are area bedding attitudes that show a more conservative into slope dip.

West of BH1 supporting geologic data consists of data from borings BH5 and CD7, and mapping of bedrock structure along Burma Road, which oriented to the section that generally shows almost neutral to slightly out of slope bedding.

### *Shear strengths*

Shear strength values utilized by SWN Soiltech appear appropriate for the general cross bedding conditions present.

While not specifically stated in the SWN report, industry standards are to use the most critical earth material found in the boring in stability analysis.

If through technical review of project reports the reviewing agency has issue with shear strength values additional data will be obtained and presented as needed.

The presence of clay seams is common in area bedrocks, and it is possible that they are found beneath areas of development. The area proposed for the residence is opinioned to be on a stable ridgeline that did not show clay seams at depth that were found to be continuous or detrimental to development of the residence. The proposed driveway; however, does transect the active Flying Triangle Landslide and it is probable that future movement, along unknown clay seams, could impact stability of the driveway.

### *Water infiltration/percolation*

The proposed leach lines will dispose of effluent into terrace deposits not bedrock. Bedrock in the area of the leach field is not expected to be impacted by the leach field effluent due to vertical and lateral separation from the leach field, nor will the stability of the development be affected by effluent discharge.

Unless the project civil engineer is allowed to discharge site waters into available storm drain systems and or canyon bottoms site surface waters will need to be disposed of onsite, and that onsite disposal of site waters has inherent risk due to the project being in a hillside area.

The disposal system proposed by the civil engineer is usage of dispersion basins, which decant water over an edge onto natural ground at a rate that is non-erosive and allows dispersion of moisture through the upper soil zone, minimizing the risk of surface soils reaching a saturation level. Regardless of the system design there will always be a risk of localized surface failures down slope of these features, the dispersal basins are however, not expected to affect global stability.

The location of the dispersal basins was addressed in Item 2 of this report.

### **Item 4**

If adverse movement of the driveway area occurs at the landslide boundary, or within the landslide, the client will need to do needed repairs and maintenance to correct the area to a usable condition. This is generally done on an as needed basis as movement rates are not uniform over time.

## **Item 5**

The intent of the cribwall will be to support the construction cut required for the proposed offsite driveway construction. Future analysis of the proposed construction cut will determine the lateral loads that the cribwall must be designed to resist. These loads are typically the active pressure and any loads required to raise the local stability of the slope to a 1.5 factor of safety.

The proposed wall has the ability to accommodate some movement from landslide activity, as do nearby homes; however, there is a risk that if movement becomes severe the wall would need deconstruction followed with reconstruction.

The proposed cribwall is not anticipated to affect the global stability of the underlying landslide as the cribwall construction does not significantly alter the geometry or loading of the landslide.

## **Item 6**

The comments by the reviewer are acknowledged as pertinent and would be part of future reports addressing geotechnical aspects of the driveway design. The future reports would address geologic structure with respect to any needed cut slopes, construction cuts, and retaining wall design.

## **Item 7**

The only reports that should be utilized are wet signed hard copies, or those provided directly to the reviewer in a signed pdf format.

The client has been provided with five wet signed hard copies of all project reports prepared by Coast Geotechnical. It is the responsibility of the client to comply with the review comment.

## **Item 8**

The review comment is acknowledged. The client is advised that additional geotechnical input will be required as the project goes through planning and permitting, and changes to project analyses and recommendations could occur.

We appreciate this opportunity to be of service to you.

Respectfully submitted:

COAST GEOTECHNICAL, Inc.

Ming-Tarng Chen  
RCE 54011

Todd D. Houseal  
CEG 1914, Exp 04/22

# GRADING PLAN WITH GEOLOGY

- CONSTRUCTION NOTES:**
- 1 CONSTRUCT CONCRETE BARRIER PER DETAIL (C01.02)
  - 2 CONSTRUCT FILTER PER DETAIL (C01.02)
  - 3 CONSTRUCT PERVIOUS PAVEMENT PER DETAIL (C01.02)
  - 4 CONSTRUCT STONE PAVEMENT PER DETAIL (C01.02)
  - 5 CONSTRUCT STONE PAVEMENT PER DETAIL (C01.02)
  - 6 CONSTRUCT PERVIOUS PAVEMENT PER DETAIL (C01.02)
  - 7 CONSTRUCT TUFFTRACK GRASS PAVER FIRE LANE PER DETAIL (C01.02)
  - 8 PROVIDE AND INSTALL 6" PVC SDR 35 STORM DRAIN LINE UNLESS NOTED OTHERWISE.
  - 9 PROVIDE AND INSTALL 15" PVC SDR 35 STORM DRAIN LINE UNLESS NOTED OTHERWISE.
  - 10 PROVIDE 24" WIDE CURB CUTOUT FOR OVERFLOW PURPOSES PER DETAIL (C01.02)
  - 11 CONSTRUCT GRAVITY WALL PER DETAIL (C01.02)
  - 12 EXISTING FENCE.
  - 13 EXISTING TREE TO BE REMOVED.
  - 14 EXISTING TREE TO REMAIN. PROTECT IN PLACE.
  - 15 CONSTRUCT L.I.D. STORMWATER PLANTER (VEG-2) PER DETAIL (C01.02) USE E PLAN FOR SIZE.
  - 16 CONSTRUCT PERFORATED 6" Ø SLOTTED PVC SDR 26 AS SHOWN ON PLAN.
  - 17 CONSTRUCT LEVEL SPREADER PER DETAIL (C01.02)
  - 18 PROVIDE AND INSTALL HARDSCAPE CLEANOUT PER DETAIL (C01.02)
  - 19 PROVIDE AND INSTALL LANDSCAPE CLEANOUT PER DETAIL (C01.02)
  - 20 PROVIDE AND INSTALL HARDSCAPE AREA DRAIN WITH ROUND GRATE PER DETAIL (C01.02)
  - 21 PROVIDE AND INSTALL LANDSCAPE AREA DRAIN WITH TRIUM GRATE PER DETAIL (C01.02)
  - 22 PROVIDE AND INSTALL SMARTDITCH 12" TRAPEZOIDAL GUTTER PER DETAILS (C01.02)
  - 23 PROVIDE AND INSTALL SMARTDITCH 12" TRAPEZOIDAL UPSTREAM/DOWNSTREAM FLARED END FITTING PER DETAILS (C01.02)
  - 24 CONSTRUCT HEADWALL TO SMARTDITCH TRANSITION PER DETAIL (C01.02)
  - 25 CONSTRUCT 2' TALL "TYPICAL FENCE" PER DETAIL (C01.02)
  - 26 INSTALL SEPTIC TANK TO BE DESIGNED BY OTHERS.
  - 27 CONSTRUCT CONCRETE EDGING PER DETAIL (C01.02)
  - 28 CONSTRUCT ASPHALT ROLLED CURB PER DETAIL (C01.02)
  - 29 PROVIDE AND INSTALL POOL GRATE. SEE ARCHITECTURAL PLANS.
  - 30 CONSTRUCT REINFORCED CONCRETE CRIB WALL PER SPPWC STANDARD PLAN NO. 619-2.
  - 31 CONSTRUCT VEGETATED SWALE.
  - 32 INSTALL GRAVEL RIPRAP.
  - 33 CONSTRUCT VERTICAL RETAINING WALL PER SPPWC STANDARD PLAN NO. 616-3.
  - 34 PROVIDE AND INSTALL TRENCH DRAIN & FILTER PER DETAIL (C01.02)

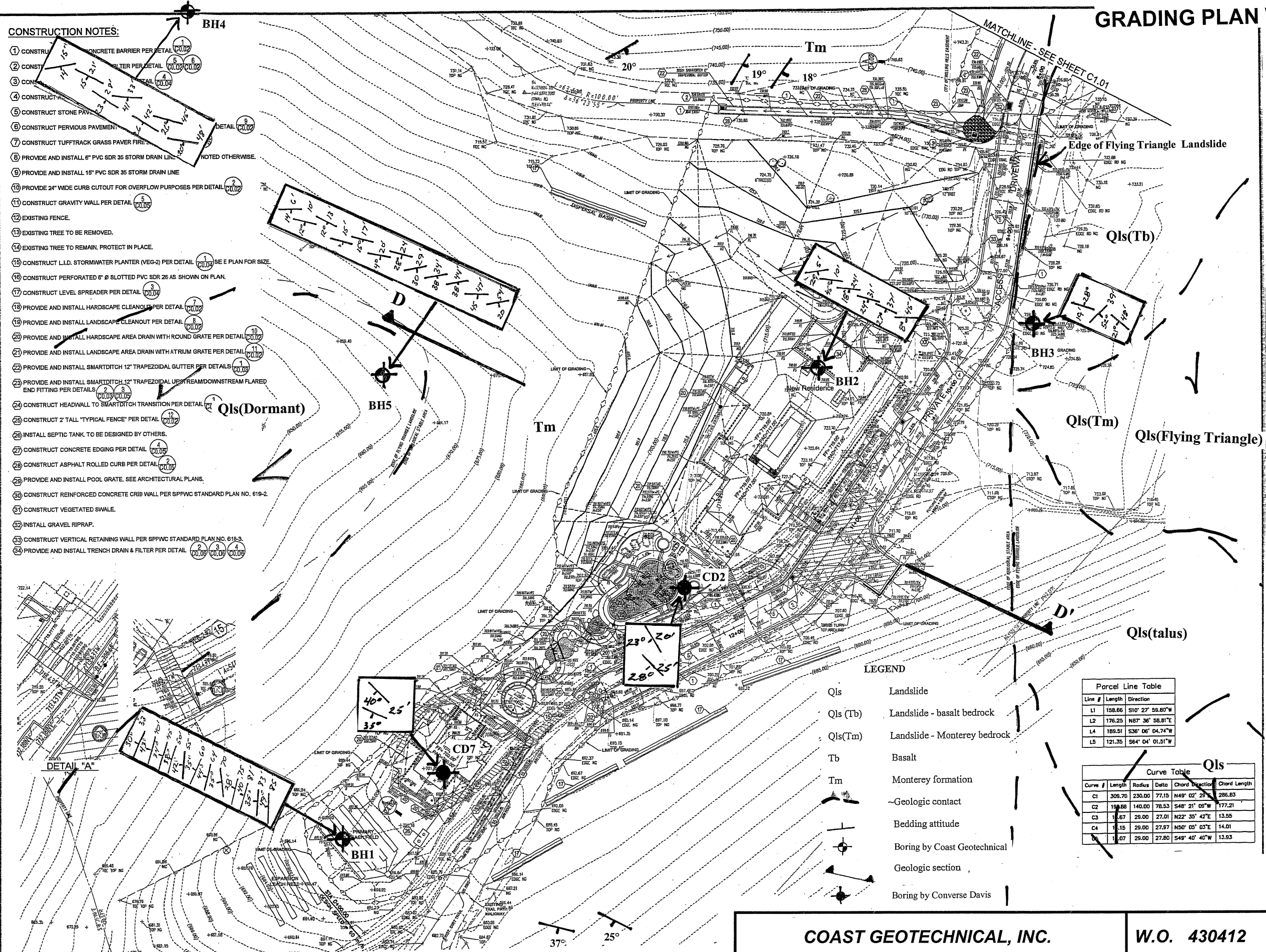

- LEGEND**
- Qls Landslide
  - Qls (Tb) Landslide - basalt bedrock
  - Qls(Tm) Landslide - Monterey bedrock
  - Tb Basalt
  - Tm Monterey formation
  - ~ Geologic contact
  - Bedding attitude
  - Boring by Coast Geotechnical
  - Geologic section
  - Boring by Converse Davis

**Parcel Line Table**

Line #	Length	Direction
L1	156.66	S10° 27' 59.80"W
L2	176.25	N87° 36' 58.81"E
L4	189.51	S36° 06' 04.74"W
L5	121.35	S64° 04' 01.51"W

**Curve Table Qls**

Curve #	Length	Radius	Delta	Chord Direction	Chord Length
C1	309.70	230.00	77.15	N49° 02' 29"	286.63
C2	198.68	140.00	78.53	S46° 21' 09"W	177.21
C3	18.67	28.00	27.01	N22° 35' 42"E	13.55
C4	1.15	29.00	27.97	N50° 05' 03"E	14.01
C5	1.07	29.00	27.80	S49° 40' 40"W	13.93

WELMEN SHEN  
YING SAI  
77 PORTUGUESE BEND ROAD  
ROLLING HILLS, CA 90274

(PRELIMINARY PLANNING SET)  
GRADING PLAN  
77 PORTUGUESE BEND ROAD  
ROLLING HILLS, CA 90274



**P.A. ARCA**  
ENGINEERING, INC.  
REGISTERED PROFESSIONAL ENGINEER  
NO. 10000  
STATE OF CALIFORNIA  
DATE: 07/22/2020

**C1.02**  
SHEET 8 OF 19 SHEETS

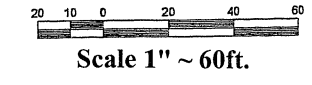

COAST GEOTECHNICAL, INC.

W.O. 430412

Figure 1R





December 13, 2019

Madonna Marcelo  
**MICHAEL BAKER INTERNATIONAL**  
3760 Kilroy Airport Way, Suite 270  
Long Beach, CA 90806

GMU Project 19-224-00

Subject: Geotechnical Peer Review, 77 Portuguese Bend Road, City of Rolling Hills, California

References: "Shen Residence, Initial Study, Mitigated Negative Declaration (Draft)," prepared by Rincon Consultants, Inc., March 2019, Section 7 and Appendix D.

Dear Ms. Marcelo:

We have performed a planning level geotechnical peer review of the referenced documents, including Appendix D of the draft Initial Study, which includes multiple geotechnical reports and letters. Based on our review, we recommend the geotechnical consultant provide additional information, as detailed below, prior to approval.

1. Please provide an additional geologic x-sec to evaluate keyway dimensions on the proposed fill slope northwest of the planned residence. It appears the geologic structure changes between Section A-A' (June, 2015 report) and boring B-1. The additional section should be parallel to A-A' and between the planned residence and guest house. Slope stability analyses should be performed to provide adequate keyway dimensions and to show adequate safety factors in this area.
2. Discuss the "dispersal basins" shown on the plans northwest and southeast of the proposed residence – purpose, potential impact to stability and offsite property. Please confirm the biofiltration and storm drain systems as designed will not adversely impact the planned development or adjacent properties, including the Flying Triangle landslide.
3. Detailed slope stability analyses that models a well-supported geologic interpretation should be performed for Cross Section C-C'. The following specific issues should be addressed.
  - a. Geologic Interpretation - Cross Section C-C':
    - i. The geology east and west of BH-1 is not supported by sufficient data. Please provide sufficient geologic information that supports the structural interpretation and clearly shows whether bedrock is adverse on section C-C' both to the east and west.
    - ii. Additional mapping, shallow, or deep exploration may be required to justify the structural interpretation east and west of BH-1.



- b. Shear Strengths:
    - i. The shear strengths contained in the SWN report dated May 10, 2012 indicate that “residual strengths” were obtained. However, the shear strength tests do not appear to be re-shear tests where residual strength is demonstrated. Please provide residual strengths on critical materials that will be used to model any along bedding conditions that are present on Section C-C’.
    - ii. It is not clear that the shear strengths were obtained on the critical materials found in the boring logs. Please explicate and justify.
    - iii. Stark correlations for residual strengths based on PI and Clay fraction should be presented to support the direct shear testing of critical materials.
    - iv. Several of the borings encountered clay seams underlying the proposed development. Please address the potential for any clay seams to be present under the proposed structures, whether these seams may be continuous, and whether these clay seams may impact the stability of the development.
    - v. Please provide a detailed calculation, graph, or other detail that shows how the residual shear strength was determined.
  - c. Water Infiltration/Percolation:
    - i. The percolation reports indicate that some of the planned percolation trenches will discharge effluent water into the bedrock on the east side of section C-C’. Please address how this will impact slope stability. Provide either mitigation or include groundwater in the slope stability analyses.
    - ii. Please address the impact of surface water infiltration on slope stability. All conclusions and opinions should be justified with data, analyses, plans, etc.
4. The entry road is planned to traverse across the existing Flying Triangle landslide. Please address how movement rates of the existing landslide will be accommodated at the landslide boundary. Estimated maintenance and re-construction requirements should be directly addressed.
5. The plans show a proposed retaining wall along the driveway that exceeds 13 feet in height. Discuss potential design impacts or limitations given the underlying landslide.
6. The following should be provided for all proposed cut slopes along the entry road:
- a. Geologic cross sections should be developed with a geologic interpretation that is supported by adequate subsurface data.
  - b. Representative shear strengths that model the geologic conditions (i.e., residual shear strengths for out-of-slope along bedding conditions) should be utilized.
  - c. Mitigation measure options should be presented as necessary.
  - d. Recommendations should be provided for monitoring where existing structures could be impacted.

Ms. Madonna Marcelo, **MICHAEL BAKER INTERNATIONAL**  
*Geotechnical Peer Review, 77 Portuguese Bend Road, Rolling Hills*

7. Several of the geotechnical documents provided in Appendix D are not signed/stamped by the consultant. Signed and stamped copies of all documents shall be included in the final Study.
8. Significant additional geotechnical evaluation, analyses and recommendations are required for the proposed development shown on the grading plans. In addition to the specific items above the following needs to be addressed prior to grading permit approval: 1) proposed crib wall, 2) proposed vertical roadway wall, and 3) pavement recommendations. This item may be a Condition of Approval at the Planning level.

Should there be any questions regarding the contents of this letter, please feel free to contact us.

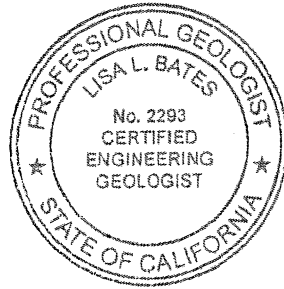

Respectfully submitted,

A handwritten signature in black ink, appearing to be "Lisa L. Bates".

Lisa L. Bates, PG, CEG 2293  
Associate Engineering Geologist

A handwritten signature in black ink, appearing to be "Gregory P. Silver".

Gregory Silver, M.Sc., PE, GE 2336  
President, Principal Geotechnical Engineer

# COAST GEOTECHNICAL, INC.

1200 West Commonwealth, Fullerton, CA 92833 • Ph: (714) 870-1211 • Fax: (714)870-1222 • email: coastgeotec@sbcglobal.net

---

March 31, 2021

W.O. 430412-09

Mr. and Mrs. Shen  
26810 Fond du Lac Road  
Rancho Palos Verdes, CA 90274

Subject: Request for Additional Information from Outside  
Reviewer for 77 Portuguese Bend Road, Rolling  
Hills, California

## References:

1. Preliminary Geologic Investigation of Proposed Residence, 77 Portuguese Bend Road, Rolling Hills, California; by COAST GEOTECHNICAL, Inc., W.O. 430412-01, dated May 5, 2012.
2. Geologic Response to Geotechnical Review for 77 Portuguese Bend Road, Rolling Hills, California; by COAST GEOTECHNICAL, Inc., W.O. 430412-02, dated February 28, 2013.
3. Report of Percolation Feasibility for New Residence, 77 Portuguese Bend Road, Rolling Hills, County of Los Angeles, California; by COAST GEOTECHNICAL, Inc., W.O. 430412-03, October 31, 2013.
4. Addendum Report to Percolation Feasibility for New Residence, 77 Portuguese Bend Road, Rolling Hills, County of Los Angeles, California; by COAST GEOTECHNICAL, Inc., W.O. 430412-04, dated March 10, 2015.
5. Geotechnical Review of Proposed Grading Plan and Acceptance of Geotechnical Responsibility for 77 Portuguese Bend Road, Rolling Hills, California; by COAST GEOTECHNICAL, Inc., W.O. 430412-05, dated June 10, 2015.
6. Geologic Assessment of Proposed Private Offsite Access Drive for #77 Portuguese Bend Road, Rolling Hills, California; by COAST GEOTECHNICAL, Inc., W.O. 430412-06, dated December 31, 2016.
7. Response to Geotechnical Comments Concerning Proposed Offsite Driveway Construction at 77 Portuguese Bend Road, Rolling Hills, California; by COAST GEOTECHNICAL, Inc., W.O. 430412-07, dated October 20, 2017.
8. Response to Geotechnical Peer Review, 77 Portuguese Bend Road, Rolling Hills, California; by COAST GEOTECHNICAL, Inc., W.O. 430412-08, dated August 6, 2020.

Dear Mr. Shen:

This report has been prepared in response to a request by the outside reviewer, GMU, to provide a revised geologic map based on the most recent grading plan that depicts geologic sections from previous project reports.

Our understanding is that the base map for Figure 1R, in Reference 8, is the most recent grading plan.

Previous geologic sections from our June 10, 2012 and June 10, 2015 reports have been depicted on the attached revised Figure 1R. These sections are for location reference only and were not redrafted based on the development shown on revised Figure 1R.

# COAST GEOTECHNICAL, INC.

---

Mr. Shen  
Request for Additional Information

2

W.O. 430412-09  
March 31, 2021

---

This report is subject to review by the controlling authorities for this project.

We appreciate this opportunity to be of service to you.

Respectfully submitted:

COAST GEOTECHNICAL, Inc.



Ming-Tarng Chen  
RCE 54011

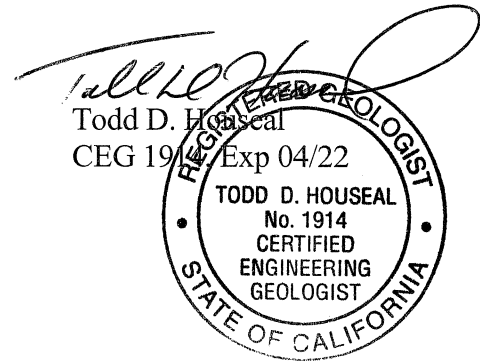

Todd D. Houseal  
CEG 1914

# GRADING PLAN WITH GEOLOGY

- CONSTRUCTION NOTES:**
- 1 CONSTRUCT CONCRETE BARRIER PER DETAIL
  - 2 CONSTRUCT FILTER PER DETAIL
  - 3 CONSTRUCT
  - 4 CONSTRUCT
  - 5 CONSTRUCT STONE PAVEMENT PER DETAIL
  - 6 CONSTRUCT PERVIOUS PAVEMENT
  - 7 CONSTRUCT TUFFTRACK GRASS PAVEMENT
  - 8 PROVIDE AND INSTALL 6" PVC SDR 35 STORM DRAIN LINE NOTED OTHERWISE.
  - 9 PROVIDE AND INSTALL 15" PVC SDR 35 STORM DRAIN LINE
  - 10 PROVIDE 24" WIDE CURB CUTOUT FOR OVERFLOW PURPOSES PER DETAIL
  - 11 CONSTRUCT GRAVITY WALL PER DETAIL
  - 12 EXISTING FENCE.
  - 13 EXISTING TREE TO BE REMOVED.
  - 14 EXISTING TREE TO REMAIN. PROTECT IN PLACE.
  - 15 CONSTRUCT L.I.D. STORMWATER PLANTER (VEG-2) PER DETAIL USE E PLAN FOR SIZE.
  - 16 CONSTRUCT PERFORATED 6" Ø SLOTTED PVC SDR 26 AS SHOWN ON PLAN.
  - 17 CONSTRUCT LEVEL SPREADER PER DETAIL
  - 18 PROVIDE AND INSTALL HARDSCAPE CLEANOUT PER DETAIL
  - 19 PROVIDE AND INSTALL LANDSCAPE CLEANOUT PER DETAIL
  - 20 PROVIDE AND INSTALL HARDSCAPE AREA DRAIN WITH ROUND GRAPE PER DETAIL
  - 21 PROVIDE AND INSTALL LANDSCAPE AREA DRAIN WITH ATRIUM GRATE PER DETAIL
  - 22 PROVIDE AND INSTALL SMARTDITCH 12" TRAPEZOIDAL GUTTER PER DETAILS
  - 23 PROVIDE AND INSTALL SMARTDITCH 12" TRAPEZOIDAL UPSTREAM/DOWNSTREAM FLARED END FITTING PER DETAILS
  - 24 CONSTRUCT HEADWALL TO SMARTDITCH TRANSITION PER DETAIL
  - 25 CONSTRUCT 2' TALL "TYPICAL FENCE" PER DETAIL
  - 26 INSTALL SEPTIC TANK TO BE DESIGNED BY OTHERS.
  - 27 CONSTRUCT CONCRETE EDGING PER DETAIL
  - 28 CONSTRUCT ASPHALT ROLLED CURB PER DETAIL
  - 29 PROVIDE AND INSTALL POOL GRATE. SEE ARCHITECTURAL PLANS.
  - 30 CONSTRUCT REINFORCED CONCRETE CRIB WALL PER SPPWC STANDARD PLAN NO. 619-2.
  - 31 CONSTRUCT VEGETATED SWALE.
  - 32 INSTALL GRAVEL RIPRAP.
  - 33 CONSTRUCT VERTICAL RETAINING WALL PER SPPWC STANDARD PLAN NO. 618-3.
  - 34 PROVIDE AND INSTALL TRENCH DRAIN & FILTER PER DETAIL

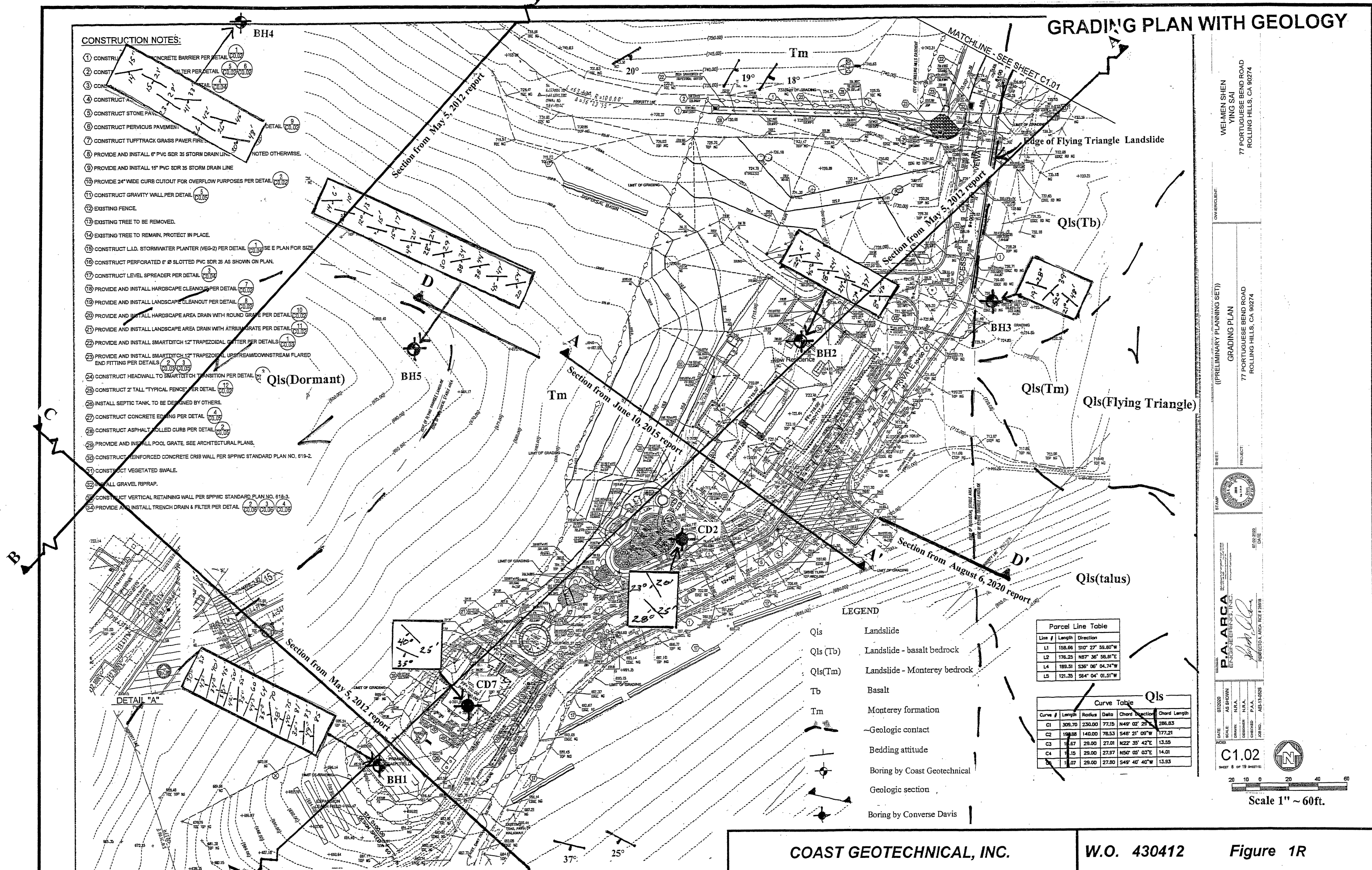

- LEGEND**
- Qls Landslide
  - Qls (Tb) Landslide - basalt bedrock
  - Qls(Tm) Landslide - Monterey bedrock
  - Tb Basalt
  - Tm Monterey formation
  - Geologic contact
  - Bedding attitude
  - Boring by Coast Geotechnical
  - Geologic section
  - Boring by Converse Davis

**Parcel Line Table**

Line #	Length	Direction
L1	158.66	S10° 27' 59.80"W
L2	176.25	N87° 36' 58.81"E
L4	189.51	S36° 06' 04.74"W
L5	121.35	S64° 04' 01.51"W

**Curve Table Qls**

Curve #	Length	Radius	Delta	Chord Direction	Chord Length
C1	309.70	230.00	77.15	N49° 02' 29"	286.83
C2	198.88	140.00	78.53	S48° 21' 09"W	177.21
C3	16.67	29.00	27.01	N22° 35' 42"E	13.55
C4	16.15	29.00	27.97	N50° 05' 03"E	14.01
C5	16.07	29.00	27.80	S49° 40' 40"W	13.93

WEI-MEN SHEN  
YING SAI  
77 PORTUGUESE BEND ROAD  
ROLLING HILLS, CA 90274

GRADING PLAN  
(PRELIMINARY PLANNING SET)  
77 PORTUGUESE BEND ROAD  
ROLLING HILLS, CA 90274



P.A. ARCA  
ENGINEERING, INC.  
DATE: 07/22/2020  
SCALE: AS SHOWN  
DRAWN: N.Y.A.  
CHECKED: P.A.A.  
JOB NO.: AE113025

**C1.02**  
SHEET 8 OF 19 SHEETS

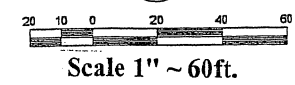

# COAST GEOTECHNICAL, INC.

1200 West Commonwealth, Fullerton, CA 92833 • Ph: (714) 870-1211 • Fax: (714)870-1222 • email: coastgeotec@sbcglobal.net

---

November 18, 2021

W.O. 430412-10

Mr. and Mrs. Shen  
26810 Fond du Lac Road  
Rancho Palos Verdes, CA 90274

Subject: Second Request for Additional Information from  
Outside Reviewer for 77 Portuguese Bend Road,  
Rolling Hills, California

Dear Mr. and Mrs. Shen:

This supplemental report has been prepared in response to a request by the outside reviewer, GMU, to provide new sections, revise a portion of the report to correspond with their review bullet points, and to provide more detail on the use of an onsite waste water disposal system.

*Provide new sections*

On the attached Figure 1R from Reference 8, we have plotted the location of a new Geologic Sections E-E', attached as Figure 2, and Geologic Section F-F' attached as Figure 3.

Geologic Section E-E' was located as requested by the reviewer.

Geologic Section F-F' was located through the proposed leach field to show the relationship of the leach filed with area topography and underling earth materials.

*Revise the response to review comment 3b to correspond to the bullet points i through v.*

b. Shear Strengths

- i. Shear strength values provided by SWN Soiltech appear appropriate for the general cross bedding conditions present.
- ii. While not specifically stated in the SWN report, industry standards are to use the most critical earth material found in the boring in stability analysis. If through technical review of project reports the reviewing agency has issued with shear strength values additional data will be obtained and presented as needed.
- iii. If through technical review of project reports the reviewing agency has need for PI and clay fraction the additional data will be obtained and presented as needed.
- iv. The presence of clay seams is common in area bedrocks, and it is possible that they are found beneath areas of development. The area proposed for the residence is opined to be on a stable ridgeline that did not show clay seams at depth that were found to be continuous or detrimental to development of the residence. The proposed driveway; however, does transect the active Flying Triangle Landslide and it is probable that future movement, along unknown clay seams, could impact stability of the driveway.

# COAST GEOTECHNICAL, INC.

Mr. and Mrs. Shen  
Second Request for Additional Information

2

W.O. 430412-10  
November 18, 2021

- v. We are uncertain how the previous consultant arrived at his residual shear strength plots. If through technical review of project reports the reviewing agency has issued with the residual shear strength values additional data will be obtained and presented as needed.

*Enlarge and detail proposed percolation leach fields on appropriate portion of Section A-A', and address effluent migration*

Attached on Figure 3 is Geologic Section F-F' showing the proposed leach line, subsurface conditions, and a postulated zone of saturation. The section was drafted using Figure 1R and an enlarged portion of the grading plan attached as Figure 3.1.

Additionally, attached on Figure 4 is a portion of Section A-A' showing the proposed leach lines, subsurface conditions, and a postulated zone of saturation. The section was drafted using Figure 1R and Section A-A' from our May 5, 2012 report.

Disposal of effluent in the area has typically been with seepage pits which discharge effluent into earth materials at depth (bedrock) with the use of seepage pits identified as a potential cause of land movement in publications addressing land movement in the area. To mitigate this risk the property will utilize shallow leach fields which dispose of effluent into earth material at a shallow depth. At shallow depth, the zone of saturation from effluent disposal will be well above any bedrock zones. Our opinion is that a leach field system poses very little risk to the gross geologic stability of the site or area.

We appreciate this opportunity to be of service to you.

Respectfully submitted:

COAST GEOTECHNICAL, Inc.

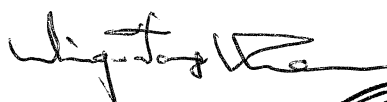

Ming-Tarng Chen  
RCE 54011

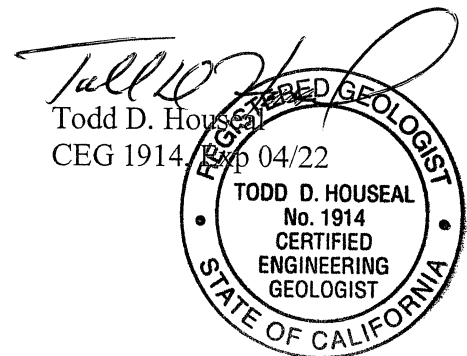

## References

1. Preliminary Geologic Investigation of Proposed Residence, 77 Portuguese Bend Road, Rolling Hills, California; by COAST GEOTECHNICAL, Inc., W.O. 430412-01, dated May 5, 2012.
2. Geologic Response to Geotechnical Review for 77 Portuguese Bend Road, Rolling Hills, California; by COAST GEOTECHNICAL, Inc., W.O. 430412-02, dated February 28, 2013.
3. Report of Percolation Feasibility for New Residence, 77 Portuguese Bend Road, Rolling Hills, County of Los Angeles, California; by COAST GEOTECHNICAL, Inc., W.O. 430412-03, October 31, 2013.
4. Addendum Report to Percolation Feasibility for New Residence, 77 Portuguese Bend Road, Rolling Hills, County of Los Angeles, California; by COAST GEOTECHNICAL, Inc., W.O. 430412-04, dated March 10, 2015.
5. Geotechnical Review of Proposed Grading Plan and Acceptance of Geotechnical Responsibility for 77 Portuguese Bend Road, Rolling Hills, California; by COAST GEOTECHNICAL, Inc., W.O. 430412-05, dated June 10, 2015.
6. Geologic Assessment of Proposed Private Offsite Access Drive for #77 Portuguese Bend Road, Rolling Hills, California; by COAST GEOTECHNICAL, Inc., W.O. 430412-06, dated December 31, 2016.
7. Response to Geotechnical Comments Concerning Proposed Offsite Driveway Construction at 77 Portuguese Bend Road, Rolling Hills, California; by COAST GEOTECHNICAL, Inc., W.O. 430412-07, dated October 20, 2017.
8. Response to Geotechnical Peer Review, 77 Portuguese Bend Road, Rolling Hills, California; by COAST GEOTECHNICAL, Inc., W.O. 430412-08, dated August 6, 2020.
9. Request for Additional Information from Outside Reviewer for 77 Portuguese Bend Road, Rolling Hills, California; by COAST GEOTECHNICAL, Inc., W.O. 430412-09, dated March 31, 2021.



# GRADING PLAN WITH GEOLOGY

Revised 11/13/21 to show Sections E-E' and F-F'

- CONSTRUCTION NOTES:**
- 1 CONSTRUCT CONCRETE BARRIER PER DETAIL C0.02
  - 2 CONSTRUCT CONCRETE CURB PER DETAIL C0.02
  - 3 CONSTRUCT STONE PAVEMENT PER DETAIL C0.04
  - 4 CONSTRUCT PERVIOUS PAVEMENT PER DETAIL C0.04
  - 5 CONSTRUCT STONE PAVEMENT PER DETAIL C0.04
  - 6 CONSTRUCT PERVIOUS PAVEMENT PER DETAIL C0.04
  - 7 CONSTRUCT TUFFTRACK GRASS PAVEMENT PER DETAIL C0.04
  - 8 PROVIDE AND INSTALL 6" PVC SDR 35 STORM DRAIN LINE NOTED OTHERWISE.
  - 9 PROVIDE AND INSTALL 15" PVC SDR 35 STORM DRAIN LINE
  - 10 PROVIDE 24" WIDE CURB CUTOUT FOR OVERFLOW PURPOSES PER DETAIL C0.02
  - 11 CONSTRUCT GRAVITY WALL PER DETAIL C0.05
  - 12 EXISTING FENCE.
  - 13 EXISTING TREE TO BE REMOVED.
  - 14 EXISTING TREE TO REMAIN, PROTECT IN PLACE.
  - 15 CONSTRUCT L.L.D. STORMWATER PLANTER (VEG-2) PER DETAIL C0.04 USE E PLAN FOR SIZE
  - 16 CONSTRUCT PERFORATED 6" Ø SLOTTED PVC SDR 26 AS SHOWN ON PLAN.
  - 17 CONSTRUCT LEVEL SPREADER PER DETAIL C0.04
  - 18 PROVIDE AND INSTALL HARDSCAPE CLEANOUT PER DETAIL C0.02
  - 19 PROVIDE AND INSTALL LANDSCAPE CLEANOUT PER DETAIL C0.02
  - 20 PROVIDE AND INSTALL HARDSCAPE AREA DRAIN WITH ROUND GRAPE PER DETAIL C0.02
  - 21 PROVIDE AND INSTALL LANDSCAPE AREA DRAIN WITH ATRIUM GRATE PER DETAIL C0.02
  - 22 PROVIDE AND INSTALL SMARTDITCH 12" TRAPEZOIDAL GUTTER PER DETAILS C0.01, C0.02
  - 23 PROVIDE AND INSTALL SMARTDITCH 12" TRAPEZOIDAL UPSTREAM/DOWNSTREAM FLARED END FITTING PER DETAILS C0.01, C0.02
  - 24 CONSTRUCT HEADWALL TO SMARTDITCH TRANSITION PER DETAIL C0.02
  - 25 CONSTRUCT 2' TALL TYPICAL FENCE PER DETAIL C0.02
  - 26 INSTALL SEPTIC TANK TO BE DESIGNED BY OTHERS.
  - 27 CONSTRUCT CONCRETE EDGING PER DETAIL C0.05
  - 28 CONSTRUCT ASPHALT ROLLED CURB PER DETAIL C0.05
  - 29 PROVIDE AND INSTALL POOL GRATE. SEE ARCHITECTURAL PLANS.
  - 30 CONSTRUCT REINFORCED CONCRETE CRIB WALL PER SPPWC STANDARD PLAN NO. 619-2.
  - 31 CONSTRUCT VEGETATED SWALE.
  - 32 INSTALL GRAVEL RIPRAP.
  - 33 CONSTRUCT VERTICAL RETAINING WALL PER SPPWC STANDARD PLAN NO. 618-3.
  - 34 PROVIDE AND INSTALL TRENCH DRAIN & FILTER PER DETAIL C0.06, C0.07, C0.08

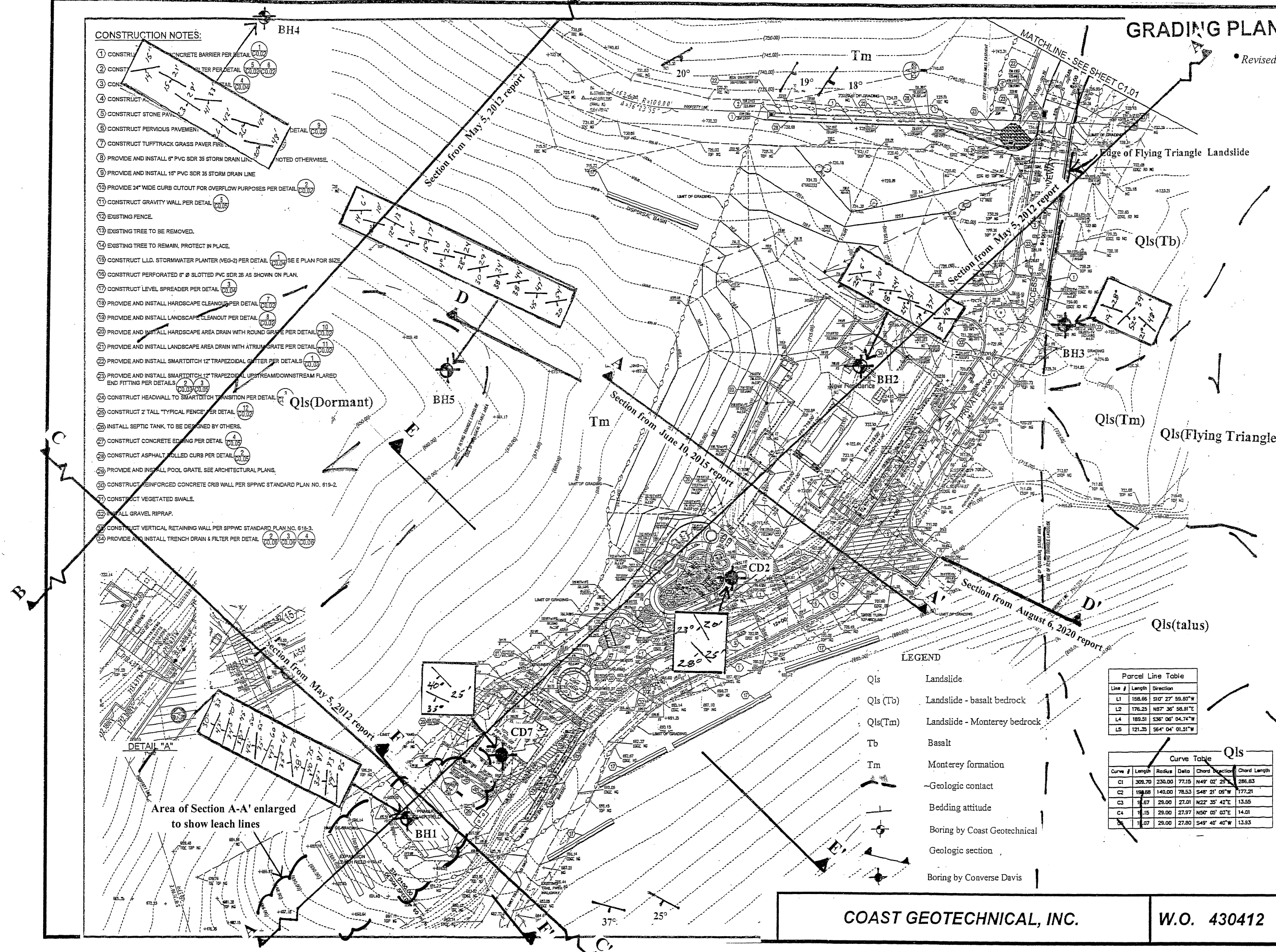

Area of Section A-A' enlarged to show leach lines

**LEGEND**

- Qls Landslide
- Qls (Tb) Landslide - basalt bedrock
- Qls (Tm) Landslide - Monterey bedrock
- Tb Basalt
- Tm Monterey formation
- ~ Geologic contact
- Bedding attitude
- Boring by Coast Geotechnical
- Geologic section
- Boring by Converse Davis

**Parcel Line Table**

Line #	Length	Direction
L1	158.66	S10° 27' 59.80" W
L2	176.25	N87° 36' 58.81" E
L4	189.51	S36° 06' 04.74" W
L5	121.35	S64° 04' 01.51" W

**Curve Table Qls**

Curve #	Length	Radius	Delta	Chord Direction	Chord Length
C1	309.70	230.00	77.15	N49° 02' 25" W	286.63
C2	199.68	140.00	78.53	S46° 21' 09" W	177.21
C3	16.67	25.00	27.01	N22° 25' 42" E	13.55
C4	1.15	25.00	27.97	N50° 05' 03" E	14.01
C5	1.07	25.00	27.80	S49° 40' 40" W	13.93

WEI-MEN SHEN  
YING SAI  
77 PORTUGUESE BEND ROAD  
ROLLING HILLS, CA 90274

PAARCA  
77 PORTUGUESE BEND ROAD  
ROLLING HILLS, CA 90274



PAARCA  
77 PORTUGUESE BEND ROAD  
ROLLING HILLS, CA 90274

C1.02



Scale 1" ~ 60ft.

COAST GEOTECHNICAL, INC.

W.O. 430412

Figure 1R

GEOLOGIC SECTION E-E'

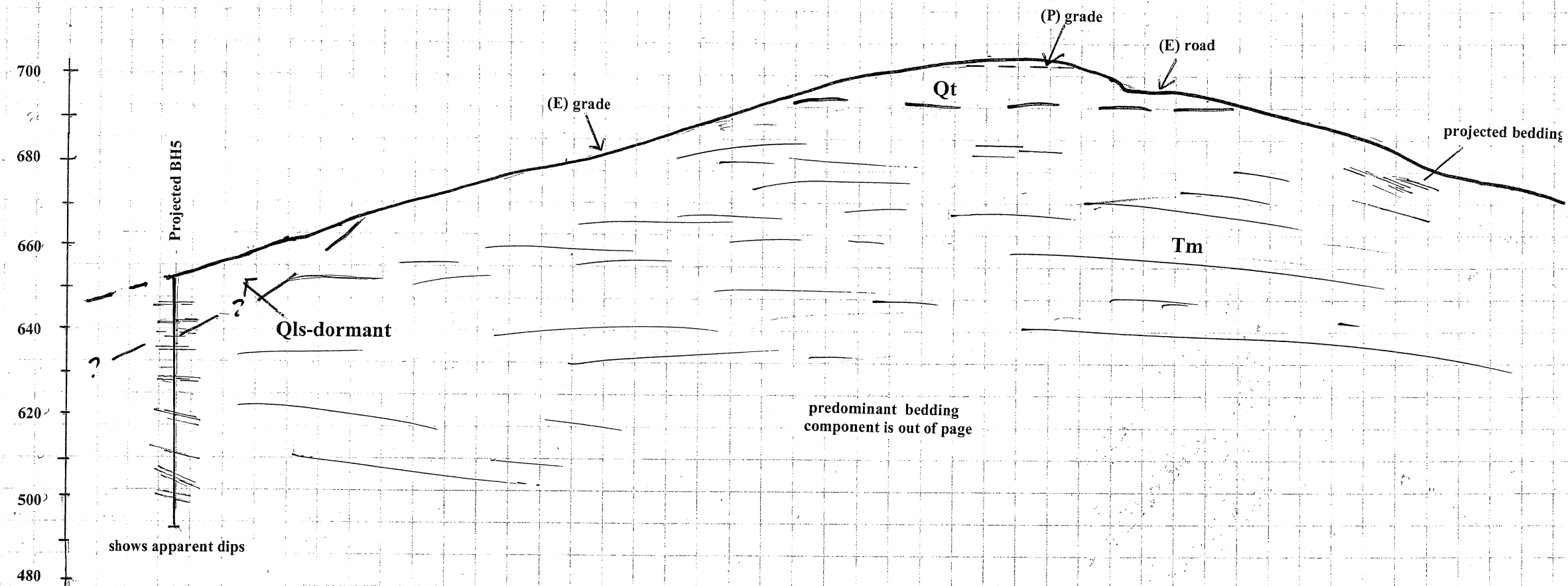

Scale 1" ~ 30ft.(H=V)

# GEOLOGIC SECTION F-F'

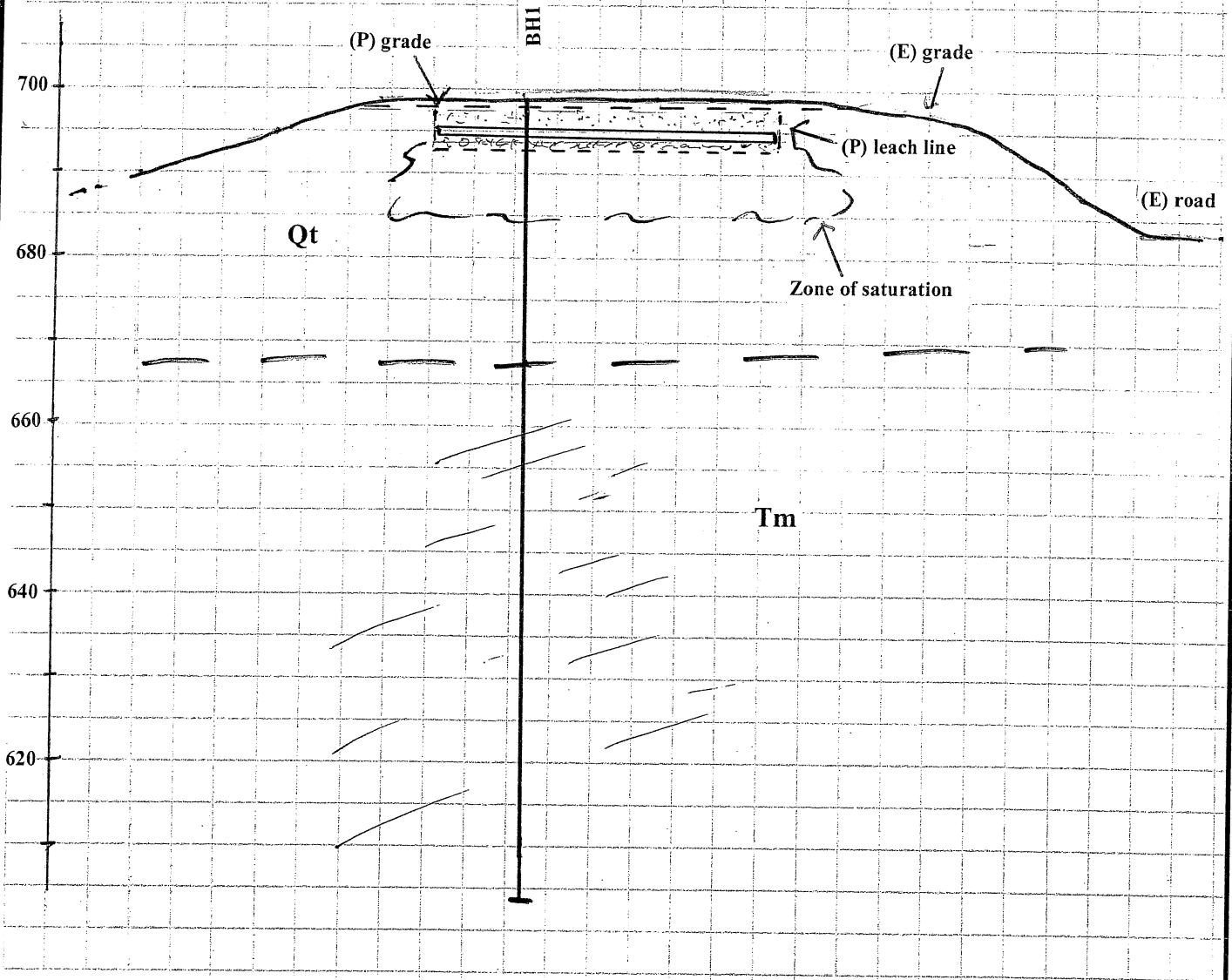

Scale 1" ~ 20ft.(H=V)

**COAST GEOTECHNICAL, INC.**

W.O. 430412      Figure 3



# ENLARGED PORTION SECTION A-A' SHOWING LEACH LINES

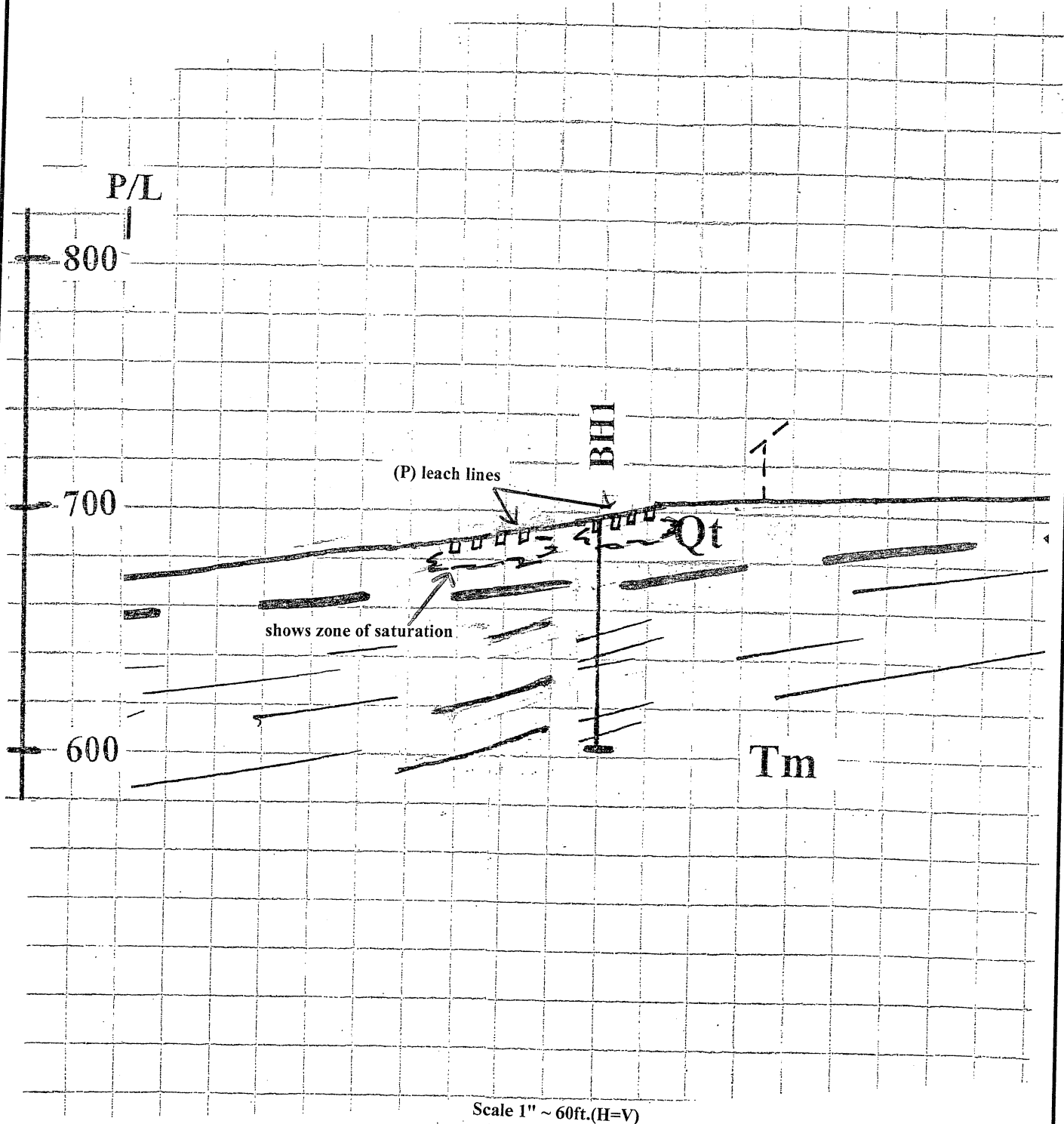

COAST GEOTECHNICAL, INC.

W.O. 430412

Figure 4