

**Appendix K Sewer Area Study, City of Torrance, Del
Amo Circle Dr. Apartments**

Appendices

This page intentionally left blank.



SEWER AREA STUDY

City of Torrance

DEL AMO CIRCLE DR. APARTMENTS

Torrance, California 90503

Prepared For:
Legacy Partners
5141 California Avenue
Suite 100
Irvine, CA 92617

Prepared By:
Fusco Engineering, Inc.
600 Wilshire Blvd, Ste 1470
Los Angeles, California 90017
213.988.8802
www.fusco.com



Project Manager:
Brittany Knott, P.E.
Date Prepared: April 13, 2022
Date Revised: December 13, 2022

Fusco Job Number – 424-026-02

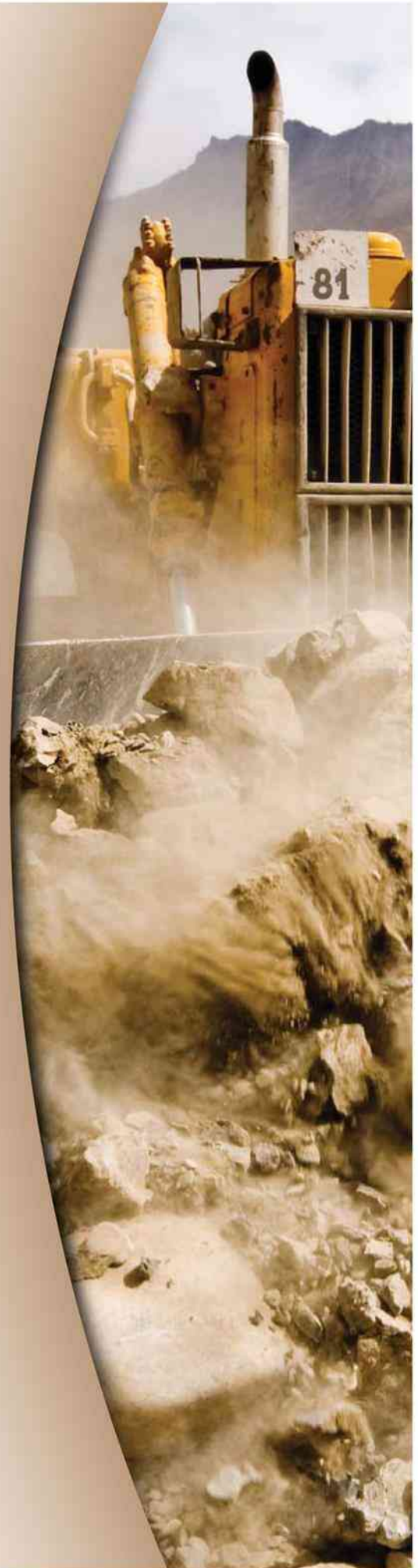

Table of Contents

Section	Page
I. Introduction.....	1
1.1 Purpose of the Study.....	1
1.2 Site Description.....	1
1.3 Proposed Development	1
1.4 Vicinity Map	2
II. List of References	2
III. Methodology.....	2
IV. Existing & Proposed Sewer System	5
V. Conclusion.....	6
VI. List of Appendices.....	7
Appendix 1 – A.L.T.A	
Appendix 2 – City of Torrance As-built plans	
Appendix 3 – County of Los Angeles Proposed Sewer Generation Factors	
Appendix 4 – County of Los Angeles policies for managing available sewer capacity.	
Appendix 5 – Conceptual Utility plan	
Appendix 6 – Bryant Palmer Soto Inc. Sewer Study	
Appendix 7 – Proposed Sewer Study Calculation Summary	
Appendix 8 – Flowmaster Calculations and Cross sections	

I. Introduction

1.1 Purpose of the Study

The objective of this analysis is to calculate and compare the sanitary sewer flows for the existing and proposed conditions for the Del Amo Circle Drive Apartments project that will construct 200 apartments, a 440-space multi-level parking structure, and open space in the City of Torrance, California. The project is being developed by Legacy Partners.

1.2 Site Description

The proposed “Del Amo Circle Apts.” project is located at the northeast intersection of Del Amo Circle and Carson Street in Torrance, CA. The total (gross) project area for the site is approximately 3.0 acres.

The existing project site is currently developed as a surface parking lot with landscaping. The site is bounded by Carson Street to the south, Del Amo Circle to the west, and existing commercial developments to the north and east. (See Vicinity Map –Page 2)

For A.L.T.A. – See Appendix 1.

1.3 Proposed Development

The proposed project will include a 5-story, 200-unit apartment building and a 440-space multi-level parking garage with a roof top pool and amenity deck.

1.4 Vicinity Map

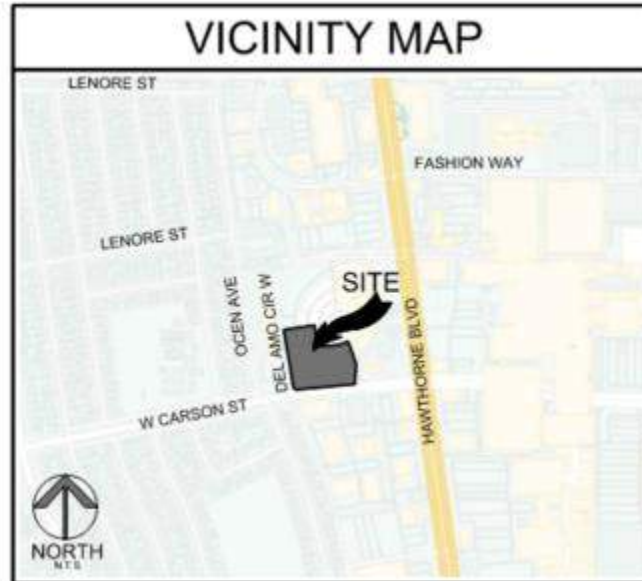

Figure 1

II. List of References

The following is the list of references used for this study:

1. City of Torrance As-Built Plans
2. County of Los Angeles Generation Factors
3. A.L.T.A.
4. Sewer study prepared by Bryant Palmer Soto Inc. dated December 16, 2016.

III. Methodology

This study includes all the tributary flows in the sewer system from upstream of the proposed development, to downstream of the proposed development. The existing tributary flows are based on previous sewer studies prepared for this area, provided in *Appendix 6* of this report.

The tributary sewer flow rates (Q) for the studied sewer lines are analyzed based on LA County sewer generation factor methodology. (See *Appendix 3*)

By using Sewer Generation Factors based on occupancy for the apartments – the “average” estimated flows are determined by the product of the summation of

occupancies by its corresponding daily flows. The daily “PEAK” flows are obtained by the following formula:

$$2.65 \times Q_{ave}^{.906}$$

The proposed building consists of 35 studio apartments, 66 one-bedroom apartments, 30 one-bedroom apartments with a den, 69 two-bedroom apartments, and 2,690 square feet of commercial/leasing space along with 1,932 square feet of clubhouse/bathroom/open. See **Table 1** for the calculated GPD totals for the proposed development.

Table 1

Use	Quantity	Unit	Avg Daily Flow (gal/DU)	Unit	Flow (GPD)	Flow (CFS)	Peak Flow (CFS)
Studio	35	ea	150	gal/DU	5,250	0.008	0.033
1 Bdrm	66	ea	200	gal/DU	13,200	0.020	0.078
1Bdrm+den	30	ea	200	gal/DU	6,000	0.009	0.037
2 Bdrm	69	ea	250	gal/DU	17,250	0.027	0.099
Commercial/Leasing	2,690	sf	100	gal/1,000sf	269	0.0004	0.002
Clubhouse/Bathrooms/open shower	1,932	sf	100	gal/1,000sf	193	0.0003	0.002
Total					42,162	0.0648	0.252

The previous sewer area study prepared by Bryant Palmer Soto Inc. dated December 16, 2016 (see *Appendix 6*) was reviewed and referenced as part of this report. The previous report studied the existing flows attributed to the 12” main in Hawthorne Blvd running south from Carson Street to the County Sanitation District trunk sewer in Sepulveda (SS-142) along with parcels A, B, C, and D of a future proposed development. A summation of the flows as previously calculated for Parcels A through D are shown in **Table 2**.

Table 2

Use	Flow (GPD)	Flow (CFS)	Peak Flow (CFS)
Parcel A	29,640	0.04586	0.162
Parcel B	25	0.00004	0.000
Parcel C	8,750	0.01354	0.054
Parcel D	15,600	0.02414	0.091
Total	54,015	0.0836	0.307

The new proposed Del Amo Circle Apartments project will encompass parcels C and D. The previous study explained that Parcels C and D of the Del Amo site accounted for 0.144 CFS of additional peak sewer flow from existing conditions. The new Del Amo Circle Apartments project generates 0.252 CFS, which is a net increase of 0.108 CFS from the previous study, see **Table 3** below.

Table 3

Use	Flow (GPD)	Flow (CFS)	Peak Flow (CFS)
Parcel A	29,640	0.04586	0.162
Parcel B	25	0.00004	0.000
Parcel C & D - Del Amo Apts.	42,162	0.06480	0.252
Total	71,827	0.1107	0.415

The Bryant Palmer Soto study did not include an analysis of the existing 10" sewer main within Carson Street, upstream from the proposed development. To ensure all tributary flows were accurately represented, the flows from the existing office park on the south

side of Carson Street, which are tributary to that 10" main, were calculated and are shown in **Table 4**.

Table 4

Use	Area	Unit	Avg Daily Flow (CFS/Ac)	Unit	Flow (CFS)	Peak Flow (CFS)
Commercial Office Park	8.12	Ac	0.015	CFS/Ac	0.122	0.393
Total					0.122	0.393

The City of Torrance determines if the existing sewer infrastructure has deficiencies based on analyzing the depth of flow to the diameter of the pipe ratio (d/D). For existing sewers, the criteria are based on LA County parameters and is as follows:

- d/D < 0.50 for existing lines less than to 15" in diameter
- d/D < 0.75 for existing lines greater than or equal 15" in diameter

Based on this criterion, if the existing pipes were to surpass these limits, they would be considered deficient. The Kutter’s Flow depth program, developed by LACDPW, is used to calculate the sewer flow depths for the sewer pipes. A Manning friction factor “n” of 0.013 was used for the existing Torrance VCP sewer pipes.

IV. Existing & Proposed Sewer System

The proposed apartment project is adjacent to Del Amo Circle on the western side of the site and Carson Street to the South. Carson Street has an existing 10" VCP sewer main, flowing easterly along the northerly side of the street. The 10" VCP line connects to a 12" VCP main in Hawthorne Blvd which flows south to a 15" line in Sepulveda Blvd to the south. As-built plans of the applicable sewer systems have been obtained from the City of Torrance Utilities Department. *For Sewer As-Built Plans- See Appendix 2.*

The proposed sewer flows from the project will be collected via an on-site private sewer system before connecting to the existing manhole within Carson Street to the south of the project. Further coordination with the project team shall be completed to determine the size and slope of the proposed sewer laterals.

For the Conceptual Utility Plan - See Appendix 5.

V. Conclusion

The results of this Sewer Area Study were used to determine the flow-depth status of the existing and proposed condition flows. The total proposed peak sewer flow from the proposed residential project is approximately 0.252 cfs (using County of Los Angeles Sewer Unit Flow Factors and the peaking formula explained above). For the purposes of this study, it was assumed no sewer flow credits would be applied for the proposed development.

As indicated in Section III, the City of Torrance determines if the existing sewer infrastructure has deficiencies based on analyzing the depth of flow to the diameter of the pipe ratio (d/D). **Table 5** is an updated version of the existing pipe analysis presented in the Bryan Palmer Soto study, which incorporates the additional peak demands for the proposed apartment project and the existing commercial office park.

Table 5

Pipe	Dia. (in)	Slope (%)	Mall SS Study Measured 2013		Addendum 1 Mall Increase		Del Amo Circle Apts. and Existing Office Park (SS-3025)		Total Peak Flow (Addendum 1 Mall Increase, Del Amo, and Existing Office Park)	
			Peak Flow	% Full	Peak Flow	% Full	Peak Flow	% Full	Peak Flow	% Full
HAWT01	12	0.24	0.6839	43.48	0.8409	48.92	0.807	49.3	1.648	79.9
HAWT03	12	0.24	0.6561	42.48	0.8131	47.97	0.807	49.3	1.620	78.6

Based on the findings of our analyses, the downstream sewer system does not have sufficient capacity to accommodate the proposed development, which is consistent with the results of the Bryant Palmer Soto analysis, and therefore those mitigations outlined in the previous sewer study shown in Appendix 6 will have to be completed.

The mitigation measures previously presented described upsizing the sewer main to a 12" line down to Sepulveda Blvd via various routes. Based on the additional flow from the Del Amo Apartments, as well as the tributary flows from the existing office park, it has been concluded that the existing main will need to be upsized to a minimum 15" pipe at the existing slopes to meet the d/D capacity requirements outlined by the County of Los Angeles. Refer to Appendix 8 - Flowmaster Calculations and Cross sections

VI. List of Appendices

- Appendix 1 – A.L.T.A
- Appendix 2 – City of Torrance As-built plans
- Appendix 3 – County of Los Angeles Proposed Sewer Generation Factors
- Appendix 4 – County of Los Angeles policies for managing available sewer capacity
- Appendix 5 – Conceptual Utility plan
- Appendix 6 – Bryant Palmer Soto Inc. Sewer Study
- Appendix 7 – Proposed Sewer Study Calculation Summary
- Appendix 8 – Flowmaster Calculations and Cross sections

Appendix 1

A.L.T.A.

TITLE INFORMATION

THE TITLE INFORMATION SHOWN HEREON IS PER PRELIMINARY REPORT FOR TITLE INSURANCE NO. 00094011-021-PS4-JC DATED OCTOBER 1, 2018 AS PREPARED BY CHICAGO TITLE INSURANCE COMPANY, LOS ANGELES, CA [TITLE OFFICER: JORDAN CUIRTEL, TELEPHONE: (213)488-4371] NO RESPONSIBILITY OF CONTENT, COMPLETENESS OR ACCURACY OF SAID COMMITMENT IS ASSUMED BY THIS MAP OR THE SURVEYOR.

RECORD OWNER

DEL AMO S, LLC, A DELAWARE LIMITED LIABILITY COMPANY

LEGAL DESCRIPTION

THE LAND REFERRED TO HEREIN BELOW IS SITUATED IN THE COUNTY OF LOS ANGELES, STATE OF CALIFORNIA, AND IS DESCRIBED AS FOLLOWS:

PARCELS 1, 2 AND 3 OF PARCEL MAP NO. 74853 IN THE CITY OF TORRANCE, COUNTY OF LOS ANGELES, STATE OF CALIFORNIA, AS PER MAP RECORDED IN BOOK NO. 399 PAGES 45 THROUGH 49 OF PARCEL MAPS, IN THE OFFICE OF THE COUNTY RECORDER OF SAID COUNTY.

ALSO EXCEPT THEREFROM ALL (100 PERCENT) OF THE OIL, GAS, PETROLEUM AND OTHER HYDROCARBON SUBSTANCES WHICH LIE BELOW A PLANE PARALLEL TO AND 500 FEET BELOW THE NATURAL SURFACE OF SAID LAND WITHOUT, HOWEVER, ANY RIGHT TO ENTER UPON THE SURFACE OF SAID LAND TO EXPLORE FOR, DEVELOP OR REMOVE SAID SUBSTANCES, BUT WITH FULL RIGHT TO EXPLORE FOR, DEVELOP AND REMOVE THE SAME BY MEANS OF WELLS AND EQUIPMENT HAVING SURFACE LOCATIONS OUTSIDE THE OUTER BOUNDARIES OF SAID LAND, IN AND UNDER OR RECOVERABLE FROM SAID LAND, BUT WITHOUT ANY RIGHT OF ENTRY WITHIN THE UPPER 500 FEET MEASURED VERTICALLY FROM THE NATURAL SURFACE OF SAID LAND, AS EXCEPTED IN THE DEED FROM DEL AMO ESTATE COMPANY, A CORPORATION, RECORDED FEBRUARY 18, 1964 AS INSTRUMENT 1035 IN BOOK D-2362, PAGE 545, OFFICIAL RECORDS.

ALSO EXCEPT THEREFROM ALL OIL WELL PUMPS, OIL WELL PUMPING EQUIPMENT, DRILLING EQUIPMENT, TANKS, PIPELINES, AND ALL STRUCTURES, EQUIPMENT AND FACILITIES (WHETHER OR NOT AFFIXED TO THE REAL PROPERTY) OWNED BY GRANTOR AND LOCATED UPON, OVER, UNDER AND WITHIN ANY OF SAID WELL SITES NOS. 45 AND 51, AS GRANTED TO PETROLEUM LAKES GLAZER COMPANY, A PARTNERSHIP, BY DEED RECORDED MAY 1, 1964 AS INSTRUMENT NO. 2196 IN BOOK D-2455, PAGE 975, OFFICIAL RECORDS, TOGETHER WITH ALL PIPE AND PIPELINE FACILITIES AND UTILITY LINES AND UTILITY LINE FACILITIES UPON, OVER OR UNDER SAID LAND WITHIN ANY OF THE EASEMENTS DESCRIBED IN SAID DEED.

ALSO EXCEPT THEREFROM ALL (100 PERCENT) OF THE OIL, GAS, PETROLEUM AND OTHER HYDROCARBON SUBSTANCES WHICH LIE BELOW A PLANE PARALLEL TO AND 500 FEET BELOW THE NATURAL SURFACE OF SAID LAND WITHOUT, HOWEVER, ANY RIGHT TO ENTER UPON THE SURFACE OF SAID LAND TO EXPLORE FOR, DEVELOP OR REMOVE SAID SUBSTANCES, BUT WITH FULL RIGHT TO EXPLORE FOR, DEVELOP AND REMOVE THE SAME BY MEANS OF WELLS AND EQUIPMENT HAVING SURFACE LOCATIONS OUTSIDE THE OUTER BOUNDARIES OF SAID LAND, IN AND UNDER OR RECOVERABLE FROM SAID LAND, BUT WITHOUT ANY RIGHT OF ENTRY WITHIN THE UPPER 500 FEET MEASURED VERTICALLY FROM THE NATURAL SURFACE OF SAID LAND, AS EXCEPTED IN THE DEED FROM DEL AMO ESTATE COMPANY, A CORPORATION, RECORDED FEBRUARY 18, 1964 AS INSTRUMENT 1035 IN BOOK D-2362, PAGE 545, OFFICIAL RECORDS.

ALSO EXCEPT THEREFROM ALL OIL WELL PUMPS, OIL WELL PUMPING EQUIPMENT, DRILLING EQUIPMENT, TANKS, PIPELINES, AND ALL STRUCTURES, EQUIPMENT AND FACILITIES (WHETHER OR NOT AFFIXED TO THE REAL PROPERTY) OWNED BY GRANTOR AND LOCATED UPON, OVER, UNDER AND WITHIN ANY OF SAID WELL SITES NOS. 45 AND 51, AS GRANTED TO PETROLEUM LAKES GLAZER COMPANY, A PARTNERSHIP, BY DEED RECORDED MAY 1, 1964 AS INSTRUMENT NO. 2196 IN BOOK D-2455, PAGE 975, OFFICIAL RECORDS, TOGETHER WITH ALL PIPE AND PIPELINE FACILITIES AND UTILITY LINES AND UTILITY LINE FACILITIES UPON, OVER OR UNDER SAID LAND WITHIN ANY OF THE EASEMENTS DESCRIBED IN SAID DEED.

TITLE EXCEPTIONS AND EASEMENTS

A-B TAXES.

1 WATER RIGHTS, CLAIMS OR TITLE TO WATER, WHETHER OR NOT DISCLOSED BY THE PUBLIC RECORDS.
2 AN EASEMENT IN FAVOR OF DOMINGUEZ WATER COMPANY FOR CONSTRUCTING AND MAINTAINING A WATER PIPELINE AND DISTRIBUTION SYSTEM BY DOCUMENT RECORDED NOVEMBER 9, 1922 AS INSTRUMENT NO. 1030 IN BOOK 1515, PAGE 265, OF OFFICIAL RECORDS.

(DOCUMENT AFFECTS - BLANKET IN NATURE - SEE DOCUMENT FOR FULL PARTICULARS)

3 A WAIVER IN FAVOR OF THE STATE OF CALIFORNIA OF ANY CLAIMS FOR DAMAGE TO SAID LAND BY REASON OF THE LOCATION, CONSTRUCTION, LANDSCAPING AND MAINTENANCE OF A DIVIDED HIGHWAY CONTIGUOUS THERETO AS CONTAINED IN THE DEED FROM DEL AMO ESTATE COMPANY, A CORPORATION, RECORDED JULY 23, 1954 AS INSTRUMENT NO. 3354, IN BOOK 45144, PAGE 203, AND RECORDED JULY 26, 1954 AS INSTRUMENT NO. 2927 IN BOOK 45151, PAGE 419, BOTH OF OFFICIAL RECORDS.

(DOCUMENTS AFFECT - BLANKET IN NATURE - SEE DOCUMENT FOR FULL PARTICULARS)

4 AN EASEMENT IN FAVOR OF DEL AMO ESTATE COMPANY, A CORPORATION, FOR SANITARY SEWER BY DOCUMENT RECORDED FEBRUARY 18, 1964 AS INSTRUMENT NO. 1035 IN BOOK D2362, PAGE 545, OF OFFICIAL RECORDS.

(DOCUMENT AFFECTS - PORTIONS OF SAID DOCUMENT ARE ILLEGIBLE - LEGIBLE PORTIONS OF SAID DOCUMENT ARE PLOTTED HEREON AS [D])

5 A DOCUMENT ENTITLED "GRANT OF EASEMENTS AND DECLARATION OF RESTRICTIONS" RECORDED JANUARY 26, 1967 IN BOOK D-3541, PAGE 845.

(DOCUMENT AFFECTS - BLANKET IN NATURE - SEE DOCUMENT FOR FULL PARTICULARS)

6 AN EASEMENT IN FAVOR OF SOUTHERN CALIFORNIA EDISON COMPANY FOR UNDERGROUND CONDUITS, DUCTS, VAULTS, MANHOLES, PULLBOXES, MARKERS AND CONCRETE PADS, AS PER DOCUMENT RECORDED DECEMBER 18, 1967 AS INSTRUMENT NO. 2237 IN BOOK D3861, PAGE 586, OF OFFICIAL RECORDS.

(DOCUMENT AFFECTS - PLOTTED HEREON AS [E])

7 A DOCUMENT ENTITLED "ASSUMPTION AGREEMENT RE GRANT OF EASEMENTS AND DECLARATION OF RESTRICTIONS" RECORDED NOVEMBER 5, 1971 AS INSTRUMENT NO. 2792 AND RECORDED NOVEMBER 5, 1971 AS INSTRUMENT NO. 2797, BOTH OF OFFICIAL RECORDS.

(DOCUMENTS AFFECT - BLANKET IN NATURE - SEE DOCUMENTS FOR FULL PARTICULARS)

8 AN EASEMENT IN FAVOR OF THE CITY OF TORRANCE, A MUNICIPAL CORPORATION, FOR SANITARY SEWER BY DOCUMENT RECORDED APRIL 30, 1974, AS INSTRUMENT NO. 3287, OF OFFICIAL RECORDS.

(DOCUMENT AFFECTS - PLOTTED HEREON AS [F])

9 AN EASEMENT IN FAVOR OF SOUTHERN CALIFORNIA EDISON COMPANY FOR UNDERGROUND ELECTRIC UTILITIES BY DOCUMENT RECORDED JANUARY 2, 1975 AS INSTRUMENT NO. 1738, OF OFFICIAL RECORDS.

(DOCUMENT AFFECTS - PLOTTED HEREON AS [G])

10 A PERPETUAL NON-EXCLUSIVE EASEMENT FOR INGRESS AND EGRESS, PUBLIC UTILITIES, SEWER LINES, STORM DRAIN FACILITIES, TRAFFIC CONTROL, TRAFFIC SIGNALS, LIGHTING, AND INCIDENTAL PURPOSES, BY DOCUMENT ENTITLED "GRANT OF EASEMENTS AND OPERATING AGREEMENTS", RECORDED JUNE 19, 1981 AS INSTRUMENT NO. 81-611575, OF OFFICIAL RECORDS.

(DOCUMENT AFFECTS - BLANKET IN NATURE - SEE DOCUMENT FOR FULL PARTICULARS)

11 COVENANTS, CONDITIONS AND RESTRICTIONS AS SET FORTH IN THE DOCUMENT REFERRED TO IN THE NUMBERED ITEM LAST ABOVE SHOWN.

(DOCUMENT AFFECTS - BLANKET IN NATURE - SEE DOCUMENT FOR FULL PARTICULARS)

12 A DOCUMENT ENTITLED "DEED RESTRICTION", RECORDED APRIL 24, 2008 AS INSTRUMENT NO. 08-719991, OF OFFICIAL RECORDS.

(DOCUMENT AFFECTS - BLANKET IN NATURE - SEE DOCUMENT FOR FULL PARTICULARS)

13 A DOCUMENT ENTITLED "MEMORANDUM OF PARKING RIGHTS", RECORDED APRIL 24, 2008 AS INSTRUMENT NO. 08-719992, OF OFFICIAL RECORDS.

(DOCUMENT AFFECTS - BLANKET IN NATURE - SEE DOCUMENT FOR FULL PARTICULARS)

14 A DOCUMENT ENTITLED "ASSIGNMENT AND ASSUMPTION OF CONTRACT RIGHTS AGREEMENT", RECORDED JUNE 23, 2015 AS INSTRUMENT NO. 2015-0743787, OF OFFICIAL RECORDS.

(DOCUMENT AFFECTS - NOTHING TO PLOT)

TITLE EXCEPTIONS AND EASEMENTS (CONTINUED)

15 TITLE COMPANY STATEMENT.

16 TITLE COMPANY STATEMENT.

17 TITLE COMPANY STATEMENT.

18 TITLE COMPANY STATEMENT.

19 EASEMENTS IN FAVOR OF THE CITY OF TORRANCE FOR STORM DRAIN, SEWER LANDSCAPING, UTILITY PURPOSES, INCLUDING THE RIGHTS TO MAKE CONNECTIONS THERETO AND RIGHTS INCIDENTAL THERETO AS DELINEATED OR AS OFFERED FOR DEDICATION ON PARCEL MAP NO. 74853 FILED IN PARCEL MAP BOOK 399, PAGES 45 THROUGH 49.

(DOCUMENT AFFECTS - STORM DRAIN EASEMENT PLOTTED HEREON AS [B])

(DOCUMENT AFFECTS - SEWER EASEMENT PLOTTED HEREON AS [C])

(DOCUMENT AFFECTS - LANDSCAPING AND UTILITY EASEMENT PLOTTED HEREON AS [A])

20 EASEMENTS FOR THE PURPOSES OF VARIABLE WIDTH DRIVEWAY, FIRE LANE AND RIGHTS THERETO AS DELINEATED OR AS OFFERED FOR DEDICATION ON PARCEL MAP NO. 74853 FILED IN PARCEL MAP BOOK 399, PAGES 45 THROUGH 49.

(DOCUMENT AFFECTS - PLOTTED HEREON AS [H])

ALTA/NSPS TABLE A ITEM NOTES

ITEM 2 NO ADDRESSES WERE OBSERVED WHILE CONDUCTING THE SURVEY.

ITEM 3 THE LAND SHOWN ON THIS SURVEY LIES ENTIRELY WITHIN FLOOD ZONE "X" (SHADED), BEING DESCRIBED AS "AREAS OF 0.2% ANNUAL CHANCE FLOOD; AREAS OF 1% ANNUAL CHANCE FLOOD WITH AVERAGE DEPTHS OF LESS THAN 1 FOOT OR WITH DRAINAGE AREAS LESS THAN 1 SQUARE MILE; AND AREAS PROTECTED BY LEVEES FROM 1% ANNUAL CHANCE FLOOD" PER FLOOD INSURANCE RATE MAP (FIRM) - COMMUNITY PANEL NUMBER 06037C129F, DATED SEPTEMBER 26, 2008.

ITEM 4 THE GROSS LAND AREA IS: 228,773 SF / 5.252 ACRES

ITEM 6(a) THE CURRENT ZONING CLASSIFICATION IS _____ PER THE CITY OF ...

ITEM 6(b) SEE THE SURVEY PLAT FOR THE LOCATION OF SETBACK LINES.

ITEM 7(a) THERE ARE NO BUILDINGS ON THE SUBJECT PROPERTY.

ITEM 7(b)(1) THERE ARE NO BUILDINGS ON THE SUBJECT PROPERTY.

ITEM 7(c) THERE ARE NO BUILDINGS ON THE SUBJECT PROPERTY.

ITEM 8 SEE THE SURVEY PLAT FOR ANY SUBSTANTIAL FEATURES OBSERVED IN THE PROCESS OF CONDUCTING THE SURVEY.

ITEM 9 SEE THE SURVEY PLAT FOR ANY PARKING STRIPING AND TYPE OF PARKING SPACE. THE PARKING COUNT IS AS FOLLOWS:

REGULAR SPACES	295
HANDICAP SPACES	2
TOTAL SPACES	302

ITEM 13 SEE THE SURVEY PLAT FOR THE NAMES OF ADJOINING OWNERS.

ITEM 14 SEE THE SURVEY PLAT FOR THE DISTANCE TO THE NEAREST INTERSECTING STREET.

BASIS OF BEARINGS

THE BEARINGS SHOWN HEREON ARE BASED ON THE CENTERLINE OF HAWTHORNE BOULEVARD AS SHOWN ON TRACT NO. 26425, FILED IN MAP BOOK 757, PAGES 69-71, BEING NORTH 74°21' WEST.

MONUMENT & ESTABLISHMENT NOTES

● INDICATES FOUND MONUMENT AS NOTED BELOW.

- (A) 2" IRON PIPE TAGGED "LS 9303" TO BE SET, FLUSH.
- (B) LEAD & TAG STAMPED "LS 9303" TO BE SET.
- (C) SPIKE AND WASHER STAMPED "LS 9303" TO BE SET.
- (1) FOUND SPIKE, NO WASHER, FLUSH. ACCEPTED AS SPIKE & WASHER PER R1.
- (2) FOUND BRASS DISK IN WELL. ACCEPTED AS STATE HIGHWAY R/W MONUMENT PER R1.
- (3) FOUND BOD NAIL, NO REFERENCE. ACCEPTED AS CENTERLINE INTERSECTION OF DEL AMO CIRCLE WAY AND HAWTHORNE BOULEVARD, DOWN 0.2 FEET.
- (4) FOUND LEAD, TACK AND TAG STAMPED "RCE9553" PER CITY THE BOOK T-50, PAGE 295, FLUSH.
- (5) FOUND SPIKE & TIN PER CITY THE BOOK T-50, PAGE 295, FLUSH.
- (6) FOUND SPIKE & TIN PER CITY THE BOOK T-50, PAGE 293, FLUSH.
- (7) FOUND SPIKE, FLUSH. ACCEPTED AS SPIKE & TIN PER CITY THE BOOK T-50, PAGE 293.
- (8) FOUND SPIKE & TIN PER CITY THE BOOK T-50, PAGE 290, FLUSH.
- (9) FOUND SPIKE, FLUSH. ACCEPTED AS S&T PER CITY THE BOOK T-50, PAGE 289. ACCEPTED AS CENTERLINE BC OF DEL AMO CIRCLE WAY.
- (10) FOUND SPIKE, FLUSH. ACCEPTED AS S&T PER R1. HELD FOR LINE ONLY FOR CENTERLINE OF DEL AMO CIRCLE WAY. SAID MONUMENT IS SOUTH 08°23'59" EAST, 0.09' FROM ESTABLISHED POSITION.
- (11) FOUND 1.5" IRON PIPE, NO REFERENCE. ACCEPTED AS CENTERLINE BC OF CARSON STREET, DOWN 0.2 FEET.
- (12) FOUND SPIKE SHANK, DOWN 0.2 FEET. ACCEPTED AS S&T PER R1.
- (13) FOUND SPIKE PER CITY THE BOOK T-50, PAGE 299, FLUSH.
- (14) FOUND L&T STAMPED "RCE 9553", PER CITY THE BOOK T-50, PAGE 283. ACCEPTED AS SW CORNER OF LOT 8 OF R1, FLUSH.
- (15) FOUND LEAD, TACK AND TAG STAMPED "RCE 9553", FLUSH. ACCEPTED AS L&T IN WALK STAMPED "R.E. 9553" PER CITY THE BOOK T-50, PAGE 291.
- (16) FOUND SPIKE, DOWN 0.10 FEET, SOUTH 08°23'59" EAST, 0.23 FEET FROM CENTERLINE B.C., NO REFERENCE.
- (17) WESTERLY LINE OF LOT 9 OF R1 ESTABLISHED BY RECORD ANGLES PER SAID R1, ACCEPTED AS BOUNDARY LINE OF D1.
- (18) SEARCHED, FOUND NOTHING. ESTABLISHED BY INTERSECTION OF SURVEY CENTERLINE OF HAWTHORNE BOULEVARD AND THE WESTERLY PROLONGATION OF THE CENTERLINE OF CARSON STREET FROM (1).
- (19) SEARCHED, FOUND NOTHING. ESTABLISHED BY TIES PER CITY THE BOOK T-61, PAGE 122.
- (20) WESTERLY LINE OF LOT 8 PER R1. ESTABLISHED BY RECORD RADIUS (54.19') AND RECORD ANGLE PER SAID R1. ACCEPTED AS BOUNDARY LINES OF D1.
- (21) WESTERLY LINE OF LOT 8 OF R1 ESTABLISHED BY RECORD RADIUS (215.00') AND RECORD ANGLE FROM SOUTHWEST CORNER OF SAID LOT 8 PER SAID R1. ACCEPTED AS BOUNDARY LINE OF D1.
- (22) WESTERLY LINE OF LOT 8 OF R1 ESTABLISHED BY RECORD ANGLES AND RECORD DISTANCE (78.31') PER SAID R1. ACCEPTED AS BOUNDARY LINE OF D1.
- (23) WESTERLY LINE OF LOTS 8 AND 9 OF R1 ESTABLISHED BY RECORD ANGLES AND RECORD DISTANCE (111.39') PER SAID R1. ACCEPTED AS BOUNDARY LINE OF D1.
- (24) ESTABLISHED BY RECORD ANGLE AND RECORD DISTANCE PER R1.
- (25) BOUNDARY LINE OF THAT PORTION AS DESCRIBED IN D1 ESTABLISHED BY HOLDING RECORD ANGLES AND RECORD DISTANCES PER D1.
- (26) EASTERLY LINE OF D1 ESTABLISHED PER D1.

REFERENCES

D1 INDICATES DOCUMENT RECORDED APRIL 24, 2008 AS INSTRUMENT NO. 20080719997, OF OFFICIAL RECORDS.

R1 TRACT NO. 26425 AS PER MAP FILED IN BOOK 757, PAGES 69-71, OF MAPS.

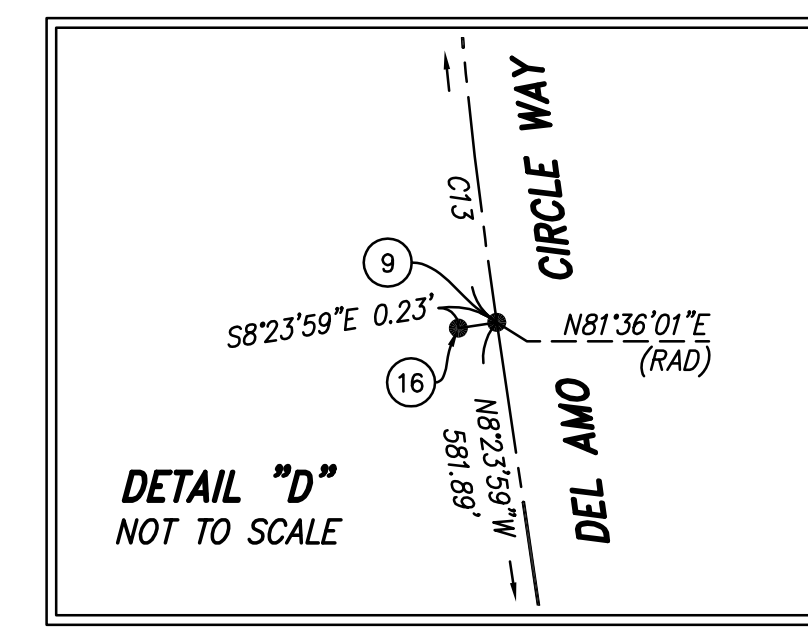
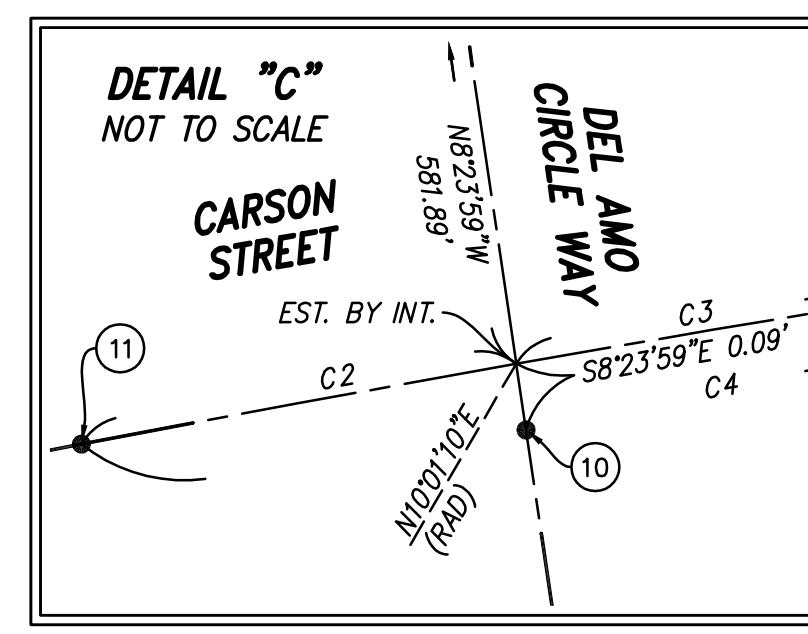
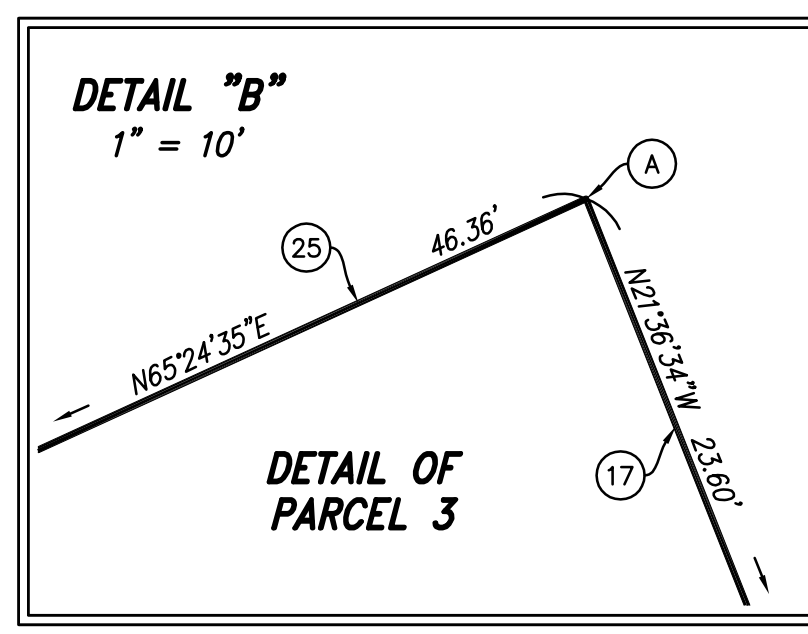
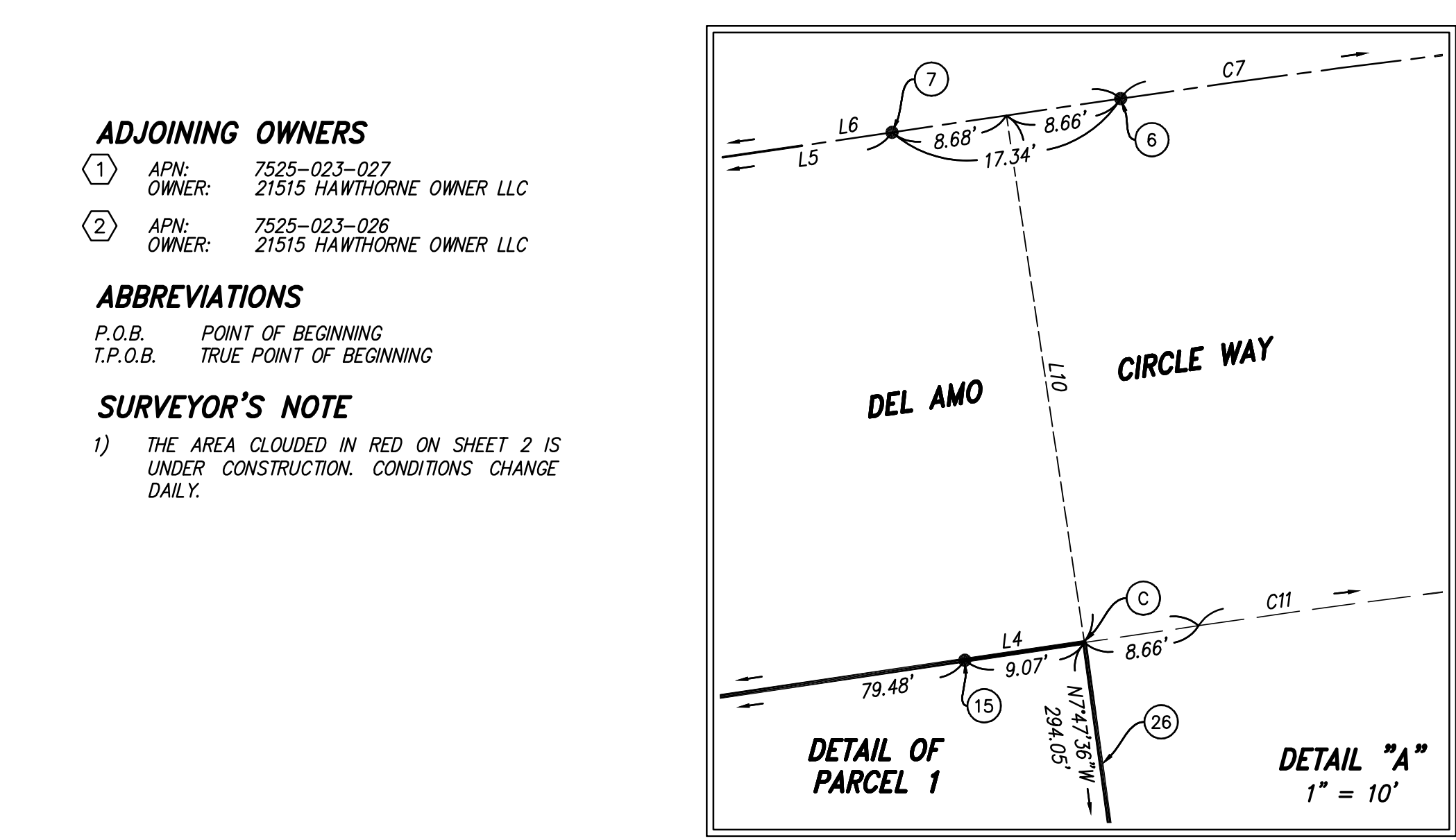
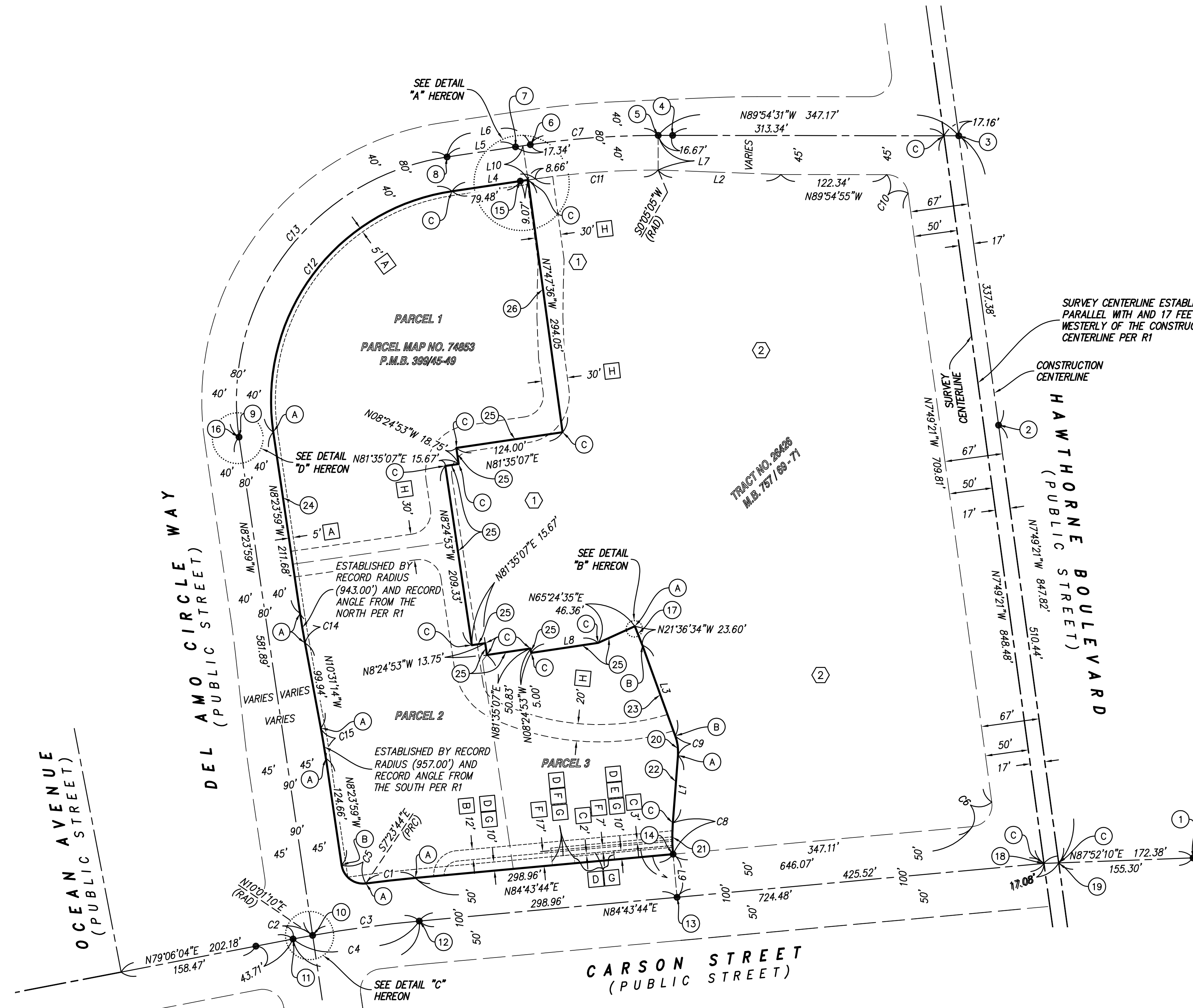

LINE	BEARING	DISTANCE
L1	N04°20'28"E	78.31'
L2	N87°53'38"W	141.75'
L3	N19°58'42"W	111.39'
L4	N81°35'38"E	97.21'
L5	N81°35'38"E	79.87'
L6	N81°35'38"E	97.21'
L7	N00°05'05"E	40.00'
L8	N81°35'07"E	78.41'
L9	N05°16'16"W	50.00'
L10	N08°24'22"W	40.00'

CURVE	DELTA	RADIUS	LENGTH
C1	2°07'28"	1550.00'	57.47'
C2	0°52'46"	1500.00'	23.03'
C3	4°44'54"	1500.00'	124.31'
C4	5°37'40"	1500.00'	147.34'
C5	88°59'45"	25.00'	38.83'
C6	92°33'05"	25.00'	40.38'
C7	8°29'27"	1000.00'	148.19'
C8	9°36'44"	215.00'	36.07'
C9	24°19'10"	54.19'	23.00'
C10	82°05'34"	25.00'	35.82'
C11	8°29'27"	960.00'	142.26'
C12	89°59'38"	245.00'	384.82'
C13	89°59'38"	285.00'	447.65'
C14	2°07'16"	943.00'	34.91'
C15	2°07'16"	957.00'	35.43'

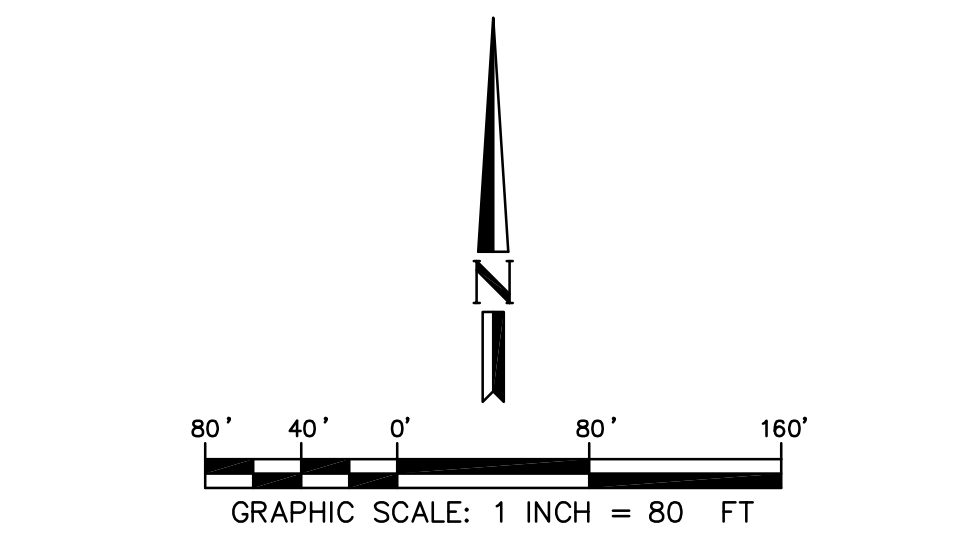

LINE LEGEND	PROPERTY LINE
---	CENTER LINE
---	EASEMENT
---	EXISTING LOT LINE/ RIGHT-OF-WAY LINE
---	PTP PARCEL LINE

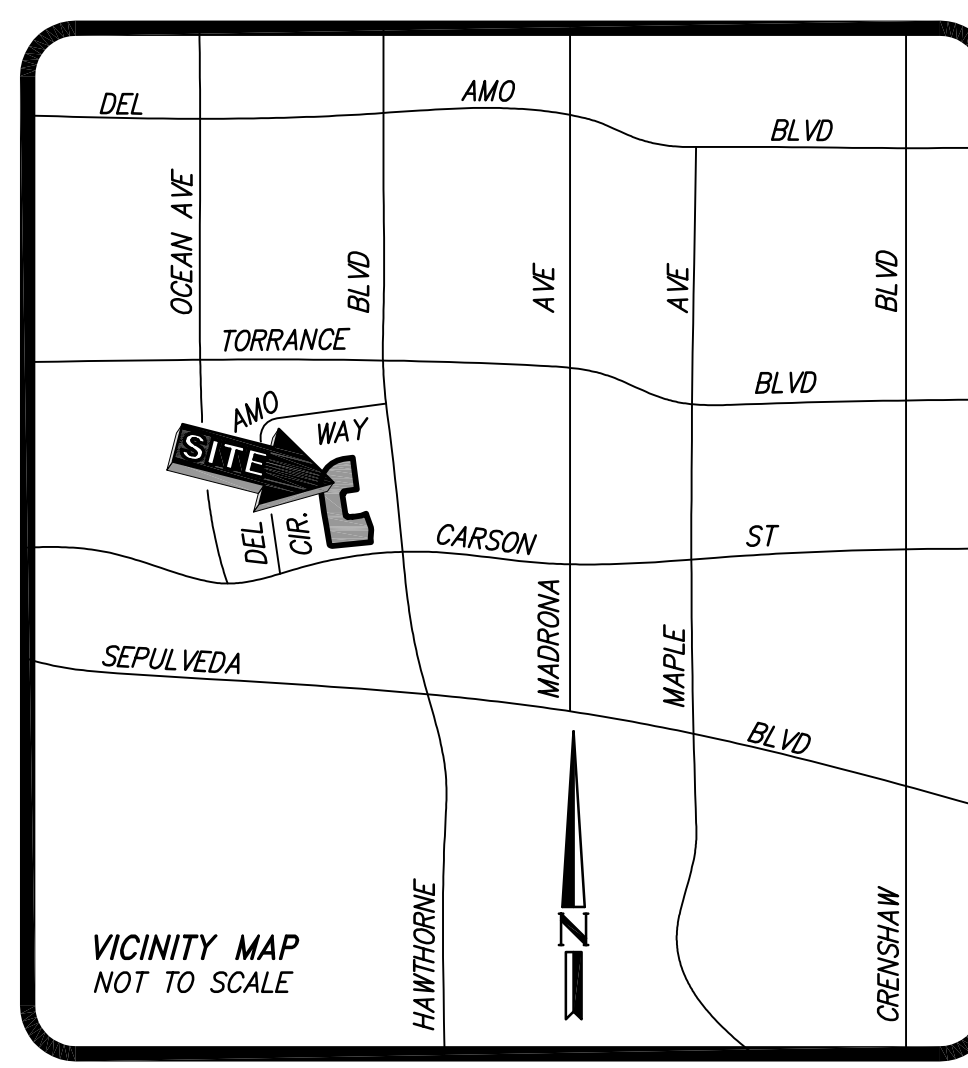

ALTA/NSPS LAND TITLE SURVEY
NE CORNER OF DEL AMO CIRCLE WAY AND CARSON STREET
TORRANCE, CALIFORNIA

TITLE & BOUNDARY INFORMATION

SURVEYOR'S CERTIFICATE
TO: DEL AMO S, LLC, A DELAWARE LIMITED LIABILITY COMPANY; AND CHICAGO TITLE INSURANCE COMPANY

THIS IS TO CERTIFY THAT THIS MAP OR PLAT AND THE SURVEY ON WHICH IT IS BASED WERE MADE IN ACCORDANCE WITH THE 2016 MINIMUM STANDARD DETAIL REQUIREMENTS FOR ALTA/NSPS LAND TITLE SURVEYS, JOINTLY ESTABLISHED AND ADOPTED BY ALTA AND NSPS, AND INCLUDES ITEMS 2, 3, 4, 6(a), 6(b), 7(a), 7(b)(1), 7(c), 8, 9, 13, AND 14 OF TABLE "A" THEREOF. THE FIELD WORK WAS COMPLETED ON NOVEMBER 06, 2017.

PRELIMINARY

JAKE W. LAPPERT
P.L.S. 9303
EMAIL: jlappert@rc-eng.com

DATE: 10/23/2018

NO.	REVISION:	DATE:	ISSUE:
			PRELIMINARY
		10/23/2018	CHECKED: JWL DRAWN: JWL
			DRAWING FILE: 17-52701a101
			PROJECT NO: 17-527
			SHEET NUMBER: 1
			OF 2 SHEETS
			SCALE: 1" = 80'

JWRC Engineering, Inc.
Civil Engineering/Land Surveying/Land Planning

160 S. Old Spring Road, Ste. 210
Anaheim Hills, California 92808
(714) 685-6860

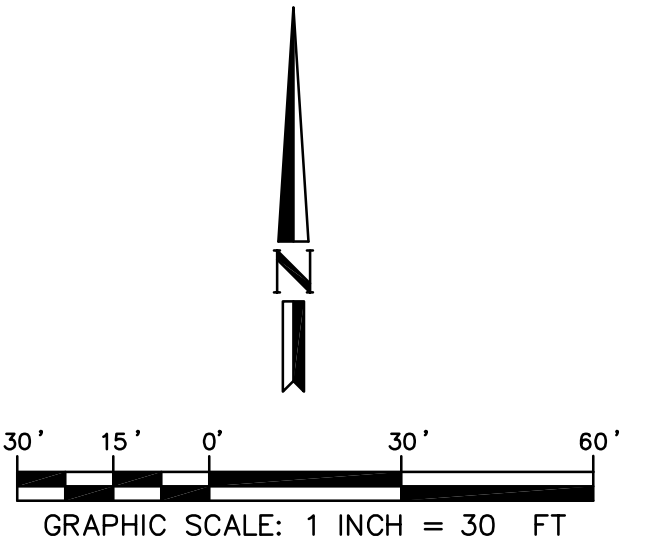

LINE LEGEND

- PROPERTY LINE
- CENTER LINE
- EASEMENT
- EXISTING LOT LINE/ RIGHT-OF-WAY LINE
- PTR PARCEL LINE
- FENCE
- BLOCK WALL

SYMBOL LEGEND

- FIRE HYDRANT
- GATE
- LIGHT POLE
- SIGN
- STREET LIGHT
- TREE
- MANHOLES**
 - SEWER
 - STORM DRAIN
 - TELEPHONE
- VALVES**
 - BACKFLOW PREVENTER
 - IRRIGATION CONTROL VALVE
 - AIR VACUUM
 - WATER

ABBREVIATIONS

- BFP BACKFLOW PREVENTER
- CONC CONCRETE
- ELEC ELECTRICAL
- EPBX ELECTRICAL PULLBOX
- ICV IRRIGATION CONTROL VALVE
- NE NORTHEAST
- NW NORTHWEST
- PBX PULLBOX
- PL PROPERTY LINE
- SDMH STORM DRAIN MANHOLE
- SE SOUTHEAST
- SW SOUTHWEST
- TELE TELEPHONE
- VAC VACUUM
- VLT VAULT
- UNKN UNKNOWN

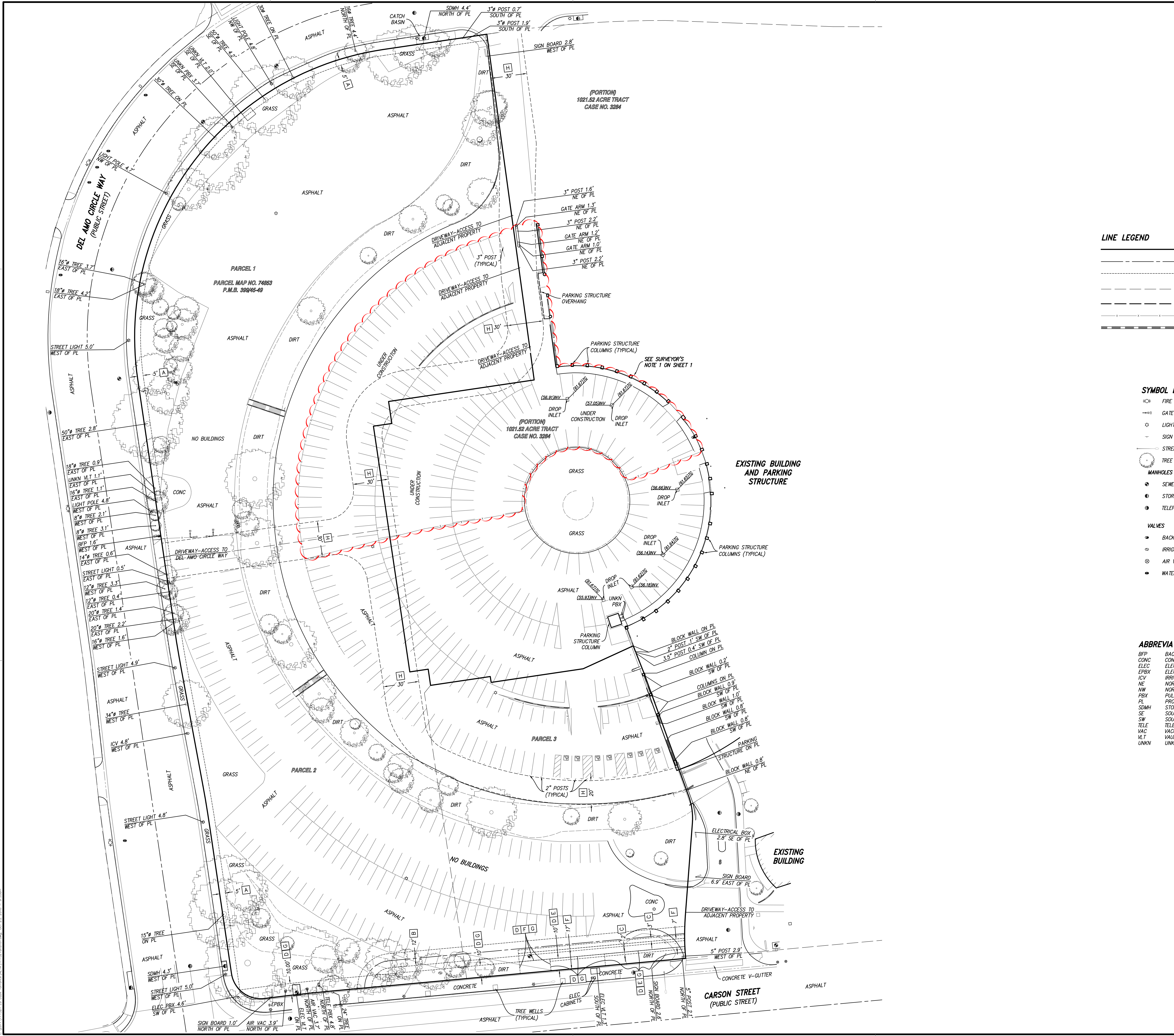

ALTA/NSPS LAND TITLE SURVEY			
NE CORNER OF DEL AMO CIRCLE WAY AND CARSON STREET			
TORRANCE, CALIFORNIA			
TOPOGRAPHIC INFORMATION			
NO. REVISION:	DATE:	ISSUE: PRELIMINARY	DATE: 10/23/2018
		CHECKED: JWL DRAWN: JWL	DRAWING FILE: 17-527a101
		PROJECT NO.: 17-527	
		SHEET NUMBER: 2	
		OF 2 SHEETS	
		SCALE: 1" = 30'	

160 S. Old Springs Road, Ste. 210
 Anaheim Hills, California 92808
 (714) 685-6860

17-527a101.dwg, 10/23/2018, 9:25am, JWL

Appendix 2

City of Torrance As-Built Plans



CITY OF TORRANCE

SANITARY SEWERS
 DRAWN: TT DATE: June 8, 2015
 CHECKED: NA, SY REV:

LEGEND
 8" SEWER UNLESS INDICATED
 STA. DEPTH
 0+00 (8.6)
 CHIMNEY
 LIFT STATION M.H.
 COUNTY SEWER
 PRIVATE SEWER
 ABAND. SEWER & MH
 STREET CENTER LINE
 SEWER EASEMENT



61	62	63
68	69	70
76	77	78

SHEET NO. 69

Appendix 3

County of Los Angeles Proposed Sewer Generation Factors

Estimated Average Daily Sewage Flows for Various Occupancies

Occupancy	Abbreviation	*Average daily flow
Apartment Buildings:		
Bachelor or Single dwelling units	Apt	150 gal/D.U.
1 bedroom dwelling units	Apt	200 gal/D.U.
2 bedroom dwelling units	Apt	250 gal/D.U.
3 bedroom or more dwelling units	Apt	300 gal/D.U.
Auditoriums, churches, etc.	Aud	5 gal/seat
Automobile parking	P	25 gal/1000 sq ft gross floor area
Bars, cocktails lounges, etc.	Bar	20 gal/seat
Commercial Shops & Stores	CS	100 gal/1000 sq ft gross floor area
Hospitals (surgical)	HS	500 gal/bed
Hospitals (convalescent)	HC	85 gal/bed
Hotels	H	150 gal/room
Medical Buildings	MB	300 gal/1000 sq ft gross floor area
Motels	MB	150 gal/unit
Office Buildings	Off	200 gal/1000 sq ft gross floor area
Restaurants, cafeterias, etc.	R	50 gal/seat
Schools:		
Elementary or Jr. High	S	10 gal/student
High Schools	HS	15 gal/student
Universities or Colleges	U	20 gal/student
College Dormitories	CD	85 gal/student

*Multiply the average daily flow by 2.5 to obtain the peak flow

Zoning Coefficients

Zone	Coefficient (cfs/Acre)
Agriculture -----	0.001
Residential*:	
R-1 -----	0.004
R-2 -----	0.008
R-3 -----	0.012
R-4 -----	0.016*
Commercial:	
C-1 through C-4 -----	0.015*
Heavy Industrial:	
M-1 through M-4 -----	0.021*

* Individual building, commercial or industrial plant capacities shall be the determining factor when they exceed the coefficients shown

* Use 0.001 (cfs/unit) for condominiums only

Appendix 4

County of Los Angeles Policies for Managing Available Sewer Capacity

October 12, 2005

Steve Boyce

Dean D. Efstathiou
Approved

TO: Dean Efstathiou

FROM: Dennis Hunter *DH*
Land Development Division

**POLICIES FOR MANAGING AVAILABLE SEWER CAPACITY
AND SEWAGE DISCHARGE IN EXCESS OF DESIGN CAPACITY**

The following will set forth Public Works' policies related to managing sewer infrastructure capacity. Design capacity of the sewer mainline is defined as follows:

< 15" diameter	½ full = 100% capacity (d/D)
≥ 15" diameter	¾ full = 100% capacity (d/D)

When Public Works determines there is available capacity in a mainline sewer for infill and redevelopment projects, the remaining available capacity shall be allocated on a first come – first serve basis.

Sewer Advisory Committee

A Sewer Advisory Committee (SAC) will be formed for the purpose of recommending courses of action to address proposed development connecting to existing sewers that will cause them to be operating beyond their design capacity. The SAC will make their recommendations to Dean Efstathiou, Assistant Director. The SAC will be chaired by Waterworks and Sewer Maintenance Division and will have representatives from Design and Land Development Divisions. Each Division will appoint a Principal Engineer or Senior Civil Engineer as a representative to the SAC and will convene whenever sewer decisions are required to address developmental impacts. Sewer Maintenance will maintain records of SAC meetings and will prepare recommendations to Administration for approval. The SAC may require other Division representatives to participate on a case-by-case basis when necessary, such as Building and Safety and Programs Development.

Divisional Responsibilities

Design Division

1. Support activities of the SAC.
2. Prepare sewer area studies when required.

3. Maintain records/archive of all approved sewer area studies and flow measurements.

Land Development Division

1. Support activities of the SAC.
2. Impose sewer area study requirements for private developments if necessary and review/approve all submittals.
3. Refer cases to SAC when both sewer area studies and flow measurements indicate that a potential overload situation exists or will exist based on criteria described below.
4. Provide copies of all approved sewer area studies and flow measurements to Design Division for archiving.

Waterworks and Sewer Maintenance Division

1. Chair the SAC, maintain meeting records and prepare position papers to Administration.
2. Advise the SAC when an overload condition is observed during maintenance activities.
3. Initiate effort to track and map all overload areas within the Consolidated Maintenance District.
4. Keep database of all flow measurement results.

Design Criteria

1. Capacity of sewer mainlines less than 15" in diameter are considered full (100 percent) when the ratio of the depth of flow (d) over the pipe diameter (D) is equal to 0.5, expressed as $d/D = 0.5$.
2. Capacity of sewer mainlines equal to or greater than 15" in diameter are considered full (100 percent) when the ratio of the depth of flow (d) over the pipe diameter (D) is equal to 0.75, expressed as $d/D = 0.75$.

Dean Efstathiou
August 25, 2005
Page 3

3. When an area study indicates that flow conditions based on calculated discharges is between 101 percent to 150 percent of capacity, no flow measurements and no mitigation will be required. If maintenance records warrant, a flow test may be required.
4. When an area study for a development that proposes to increase the density or change the zoning indicates that flow conditions are between 151 to 200 percent of capacity, flow measurements shall be required. If the flow test indicates that the actual flow condition is below 151 percent, no mitigation will be required. If the flow test results indicate the actual flow is above 151 percent, the case shall be referred to the SAC to evaluate options and make recommendations to Administration for approval. These options may include, but are not limited to: requiring full mitigation from the development, assessing pro-rata shares, creation of a reimbursement district, or establishing a County Improvement (CI) district.

AHN:ca

P:\LD\SUB\SUBPCHECK\SEWER\MISCELLANEOUS\SEWER INFRASTRUCTURE MANAGEMENT

cc: Administration (Kelly)
Building and Safety (Patel)
Design (Kumar)
Land Development (D'Antonio, Burger, ~~Ruiz~~ Chong, Wittler, Narag)
Programs Development (Afshari)
Waterworks and Sewer Maintenance (Del Real, Lehto)

Appendix 5

Conceptual Utility Plans

LEGEND AND ABBREVIATIONS

---	PROPERTY LINE/RIGHT-OF-WAY
---	CENTERLINE
---	EXISTING CURB
---	EXISTING WATER LINE
---	EXISTING SANITARY SEWER LINE
---	EXISTING STORM DRAIN
---	PROPOSED FACE OF CURB
---	PROPOSED BACK OF CURB
---	PROPOSED DOMESTIC WATER LINE
---	PROPOSED FIRE WATER LINE
---	PROPOSED IRRIGATION WATER LINE
---	PROPOSED STORM DRAIN
---	PROPOSED SANITARY SEWER LINE
---	CENTERLINE
---	EXISTING
---	FLOWLINE
---	FINISHED SURFACE
---	PROPERTY LINE
---	PROPOSED
---	RIGHT-OF-WAY
---	STORM DRAIN
---	SANITARY SEWER
---	TOP OF CURB
---	TYPICAL

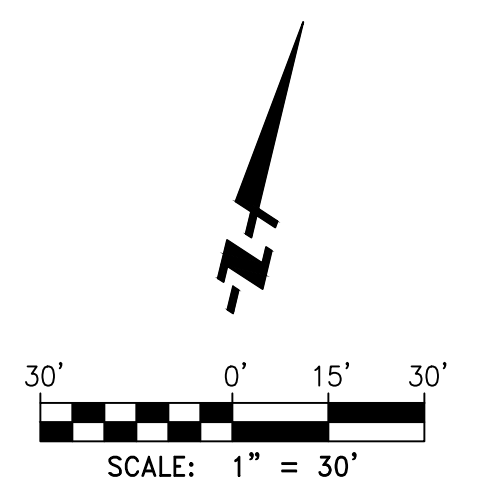
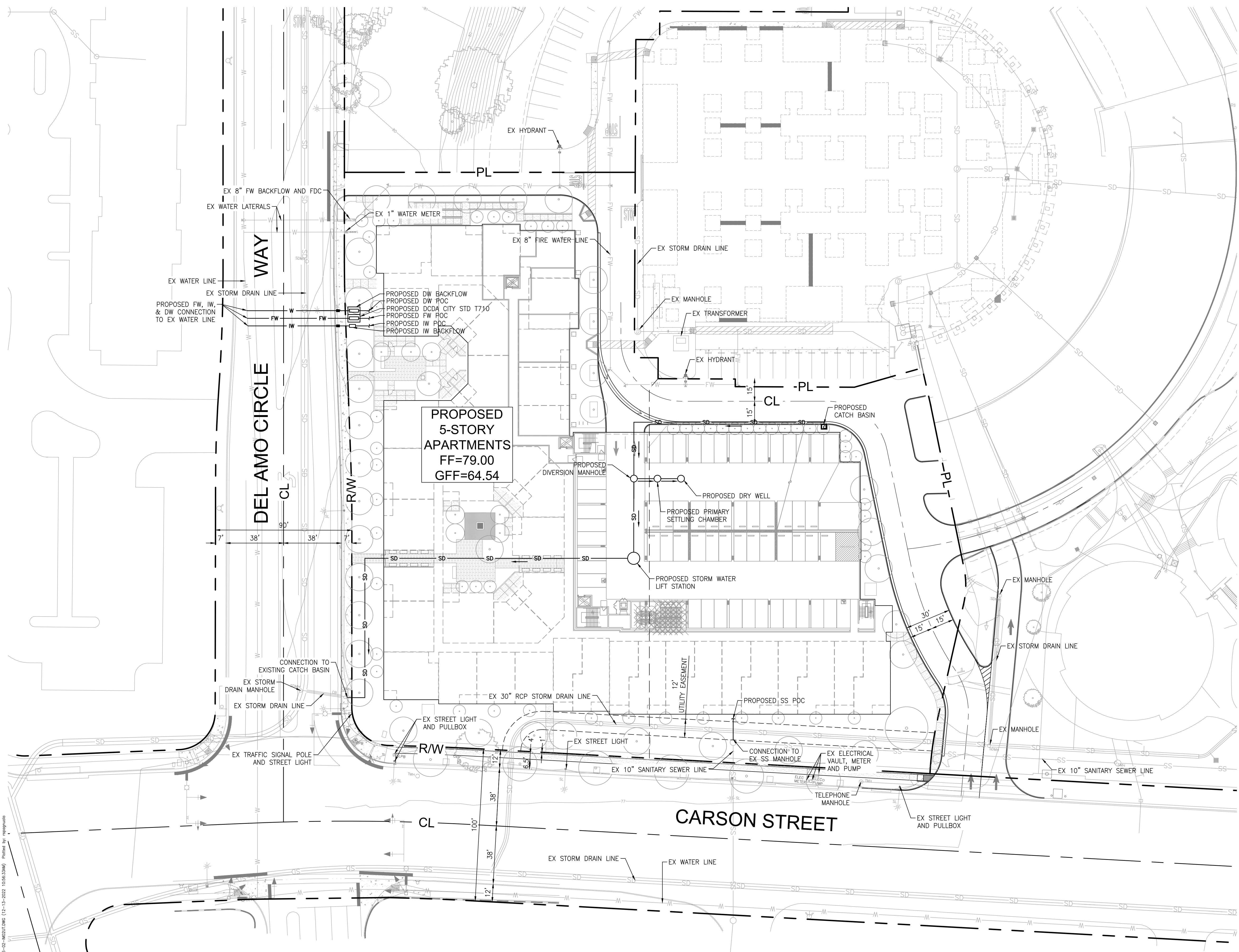

DEL AMO CIRCLE DR. APARTMENTS TORRANCE, CA

LEGACY PARTNERS 5141 CALIFORNIA AVENUE SUITE 100
IRVINE, CA 92617
(949) 930-7712

CONCEPTUAL UTILITY PLAN
DATE: 08-25-22
JOB NO.: 424-026

AO ARCHITECTS
144 NORTH ORANGE ST., ORANGE, CA 92866
(714) 639-9860

C2.00



P:\PROJECTS\CA\22\424\AO_ARCHITECTS\424-026-00-00-000000.dwg (12-13-2022 10:58:33AM) Plotted by: mgagnano

Appendix 6

Bryant Palmer Soto Inc. Sewer Study

SEWER AREA STUDY

Project location:

Northeast Corner of Carson Street and Del Amo Circle
Assessor Parcel 7525-023-024

Prepared for:

Del Amo 5
2601 Airport Drive, Suite 300, Torrance Ca 90505

Prepared By:

Bryant Palmer Soto Inc
2601 Airport Drive, Suite 310, Torrance, Ca 90505
Project Manager Richard Niemeyer ,310-326-9111 ext 114

Date 4-15-2016

Revised 10-25-2016

Revised 11-21-2016

Revised 12-16-2016



Sewer Area Study Narrative

Del Amo 5

Introduction

The following area study has been prepared by Bryant Palmer Soto Inc to determine:

- a) The existing flows and the capacity of the existing 12” sewer built per SS-142 in Hawthorne Boulevard running south from Carson Street to the County Sanitation District trunk sewer in Sepulveda Boulevard.
- b) The new peak flows based on the proposed projects for proposed Parcel A,B,C and D. Parcel B is a proposed parking structure on adjacent ownership(Muller Company).

Note :The South Torrance Trunk Sewer is owned by the County Of Los Angeles Sanitation District. Per Email from * Adriana Raza Sanitation Districts of Los Angeles County, 1955 Workman Mill Road, Whittier, CA 90601, Tel (562) 908-4288 ext. 2717 the “The Districts’ 15 inch diameter South Torrance Trunk Sewer, located in Sepulveda Boulevard at Hawthorne Boulevard, has a capacity of 2.7 million gallons per day (mgd) and conveyed a peak flow of 0.5 mgd when last measured in 2011.”

*Copy of Email from County Sanitation District enclosed at end of this report.

Site Description

The project is located at the Northeast corner of Carson Street and Del Amo Circle Drive and shown on (APN 7525-023-024). The site is adjacent to and west of the Del Amo Financial Center on Hawthorne Boulevard. The site is within the City of Torrance and also in the Hawthorne Boulevard Corridor Specific Plan. The property is 5.2 acres in size. The overall site is bounded by Del Amo Financial Center to the east, Carson Street to the south and Del Amo Circle to the west and north. To the East on the adjacent ownership (Muller Company) are several existing buildings to remain. Muller Company plan is to build a new restaurant and fitness center at the northeast corner of their site (separate development than Del Amo 5). The Del Amo 5 site is currently paved for onsite-site parking but is planned to be developed into Del Amo 5.

Sewer Area Study Narrative

Del Amo 5

Project Description

The Del Amo 5 proposed project will create 3 new parcels:

Parcel A will be developed with 4 story 190 Senior Housing units.

Parcel C will be developed with a 70 unit extended stay Hotel.

Parcel D will be developed a 3 story 100 Senior Housing units.

Parcel B is an existing property owned by Muller Company and on a larger adjacent property and will add a 6 story parking structure (with 714 parking spaces) The new parking structure that will be built within the Muller Company ownership and is not part of Del Amo 5 ownership.

Methodology

The methodology for the sewer capacity is based on:

Existing conditions

- A. Use Del Amo Mall Sewer Study & Addendum # 1 to determine sewer flow conditions and measured maximum flow rate (MGD or CFS)
- B. Calculate maximum depth from measured maximum flow using manning's equation.
- C. Divide the calculated maximum depth by the diameter of sewer pipe to determine the percent full.
- D. Cross check measured flows with flows determined in the City of Torrance Sewer Master Plan dated 1992 (see appendix A).

Proposed Conditions

- E. Calculate total additional daily flow to be produced by proposed development using average daily flow of buildings defined by "Ordinance Prescribing the connection fee rate and mean loadings per unit of usage for the County Sanitation District No. 5 of Los Angeles County "(See appendix B)
- F. Apply peaking factor to proposed additional daily flow.
- G. Add proposed peak flow to baseline existing peak flow.
- H. Calculate maximum depth from total proposed peak flow using Manning's equation.
- I. Divide the calculated maximum depth by the diameter of sewer pipe to determine the percent full.

Assumptions

- J. A Manning's' roughness coefficient of $n=0,013$ for vitrified clay pipe was used in the Manning's equation. This same roughness coefficient was used in the previously approved sewer studies.
- K. The sanitary sewer lines proposed are less than 12" in size and therefore are typically designed to run at a maximum of 50% capacity.

Existing Sewer Pipe Flows and Capacity Analysis

City of Torrance supplied a copy of the Sewer Study done for the Del Amo Fashion Center (dated June, 2013) and the Addendum 1 dated Sept 10, 2014 and Addendum 2 dated Sept 9, 2015, the report was prepared by Tait and Associates. The flows of the 12" sewer in Hawthorne Boulevard were measured as listed on page 2 of the report, over a 14 day period from May 18, 2013 to May 31, 2013 with monitoring devices recording flows in 5 minute intervals.

The result per page 5 of the report (dated June, 2013) shows the existing flows measured for each of the 3 manholes as:

- 1) 10" sewer pipe "CAR04" located at the Carson/Hawthorne Intersection flowing westward at 36.34 percent full.
- 2) 12 sewer pipe " HAWT01" south of Carson/Hawthorne intersection flowing south at 43.48 percent full.
- 3) 12 sewer pipe HAWT03 North of Sepulveda/Hawthorne intersection flowing south at 42.48 percent full.

Addendum #2 was not used in analysis because it anticipates a possible additional restaurant to be added to the mall but the added flows would be diverted to a future sewer main in Fashion Way. The amount of the flow from Mall to sewer in Hawthorne would be approx the same as in Addendum #1.

Per the addendum #1 dated Sept 10, 2014 the proposed Del Amo Fashion Center project will increase the flows at the 3 manholes to:

- 1) 10" sewer pipe "CAR04" located at the Carson/Hawthorne Intersection flowing westward at 43.37 percent full.
- 2) 12 sewer pipe " HAWT01" south of Carson/Hawthorne intersection flowing south at 48.92 percent full.
- 3) 12 sewer pipe HAWT03 North of Sepulveda/Hawthorne intersection flowing south at 47.97 percent full.

Proposed Additional Sewer Flows Analysis

The proposed project sewer contributions were determined using the County of Los Angeles Sanitation District Loading Table 1 "Loadings for Each Class of Land Use" see appendix for Table 1. The proposed sewer flows were then converted from gallons per day to cubic feet per second.

The Del Amo 5 proposed project will create 3 new parcels and the following average flows:

Parcel A will be 4 story 190 Senior Housing units x 156 gpd = 29,640 gpd

Parcel C will be a 70 unit extended stay Hotel x 125 gpd = 8,750 gpd

Parcel D will be a 3 story 100 Senior Housing unit x 156 gpd = 15,600 gpd.

On a portion of existing Parcel B will be a 6 story parking structure with the only connection to the sewer being a floor drain in the elevator pit @ 25 gpd.

PEAK Flow by Parcel is obtained from the formula $2.65 * [(Average Flow)^{0.906}]$

Parcel A :

29,640 gpd x .13368090 x .00000115740 = 0.0458 cfs

then $2.65 * [(0.0458)^{0.906}] = 0.162$ cfs Peak flow Parcel A

Existing Parcel B Parking Structure :

25 gpd x .13368090 x .00000115740 = 0.00000003.86695 cfs

then $2.65 * [(0.00000003.86695)^{0.906}] = 0.0003306$ cfs Peak flow Parking structure

Parcel C

8,750 gpd x .13368090 x .00000115740 = 0.01353 cfs

then $2.65 * [(0.01353)^{0.906}] = 0.053$ cfs Peak flow Parcel C

Parcel D:

15,600 gpd. x .13368090 x .00000115740 = 0.02413 cfs

then $2.65 * [(0.02413)^{0.906}] = 0.09077$ cfs Peak flow Parcel A

Total peak flow

53,990 gpd. x .13368090 x .00000115740 = 0.08353 cfs

then $2.65 * [(0.08353)^{0.906}] = 0.27944$ cfs Peak flow

A separate development (by separate developer) is proposed for the northeast corner of the site which will include a new restaurant and fitness center. The added flows from this project will be .1746 cfs peak flow. This flow may be stored / retained on-site and

discharged off peak or may be discharged real time to the public sewer in Hawthorne Blvd.

			Mall SS Study		Adendum #1			
Pipe	Size Dia	Slope %	Measured 2013		Mall Increase		Del Amo 5	
			Peak Flow	%Full	Peak Flow	%Full	Peak Flow	%Full *
HAWT01	12"	0.24	0.6839	43.48	0.8409	48.92	0.2794	58.22
HAWT03	12"	0.24	0.6561	42.48	0.8131	47.97	0.2794	57.33

*See appendix for printout of calculations using manning's equations for pipe capacities obtain in table.

Note: the planned development (by other developer the Muller Company) on the adjacent property to the east will include a new restaurant and fitness center the added peak flows will be .1746 cfs which will increase the % full flows shown in the table above if flows are discharged real time. The Muller Co project is currently proceeding with design of storage tank to detain flows on site and discharge off-peak.

Findings

The proposed first floor of the units for Parcel A,C and D will be above the sidewalk of the public streets at elevation of 81.00, and will allow for the gravity flow of sewer lines from the proposed 1st floor of the buildings to the invert of the public sewer lines in Del Amo Circle and Carson Street at elevation 75.53. There is sufficient fall from the farthest and lowest points of the proposed project to the existing sewer lines per SS-185.

The existing 12" sewer line in Hawthorne Boulevard from Carson Street to Sepulveda Boulevard will be at 58.22 percent full with the proposed increase by the Del Amo 5 project. Typical design standards call for a 12" sewer pipe to be at 50 percent maximum full for normal peak operations.

Since the existing public sewer main in Hawthorne Blvd will be over 50% full with the addition of this project as proposed and the project on the adjacent property (By other developers), the recommended options are:

1. Construct a new 12" sewer main from Carson Street & Del Amo Circle Drive to Ocean Avenue and then south on Ocean Avenue to Sepulveda Blvd and tie into County Trunk sewer at Ocean & Sepulveda Blvd. The proposed 12 " sewer vertical alignment will need to be verified to confirmed that the existing storm drains in Carson Street are not in conflict for this option.

2. Construct a new 12” sewer main parallel to the existing main in Hawthorne Blvd from Carson Street to Sepulveda Blvd, This options requires Caltrans encroachment permits and extensive traffic control measures or.
3. Construct a 12” public sewer main within a proposed public sewer easement on private property west of Hawthorne Blvd if rights are obtainable from Carson Street to Sepulveda Blvd, (or alternate public right of way as applicable) or
4. Up size existing public sewer in place from Carson Street to Sepulveda Blvd. or
5. Alternate (onsite) stored / retained on –site and discharged off peak flows.

Options 1 -4 would be in lieu of City of Torrance Standard Sewer Development Fees

Option 2 would provide for a new 12” sewer line from Carson Street to Sepulveda Blvd that would have slope of 0.24 percent. The proposed sewer capacity for option 2, under various demand conditions is shown in table below.

Table 1- Impact on proposed Size of Added Sewer Main Option 2

Pipe	Size Dia	Slope %	Del Amo 5	
			Peak Flow	%Full
Del Amo 5	8	0.24	0.2794	48.34
Muller	8	0.24	0.1746	37.21
Combine	8	0.24	0.454	65.63
Del Amo 5	10	0.24	0.2794	34.81
Muller	10	0.24	0.1746	27.27
Combine	10	0.24	0.1746	45.393

APPENDIX “1”

Calculations for Del Amo 5 Sewer Area Study

Calculation Appendix

Del Amo 5

12" sewer pipe running south in Hawthorne blvd from Carson Street to Sepulveda blvd.

Manhole HAW01 at Hawthorne blvd and Carson Street with Del Amo 5 flows added to base flows

Manning Pipe Calculator

Given Input Data:

Shape Circular
Solving for Depth of Flow
Diameter 12.0000 in
Flowrate 1.1194 cfs
Slope 0.0024 ft/ft
Manning's n 0.0130

Computed Results:

Depth 6.9870 in
Area 0.7854 ft²
Wetted Area 0.4746 ft²
Wetted Perimeter 20.8326 in
Perimeter 37.6991 in
Velocity 2.3587 fps
Hydraulic Radius 3.2804 in
Percent Full 58.2251 %
Full flow Flowrate 1.7454 cfs
Full flow velocity 2.2223 fps

12" sewer pipe running south in Hawthorne blvd from Carson Street to Sepulveda blvd.

Manhole HAW03 at Hawthorne blvd and Sepulveda blvd with Del Amo 5 flows added to base flows

Manning Pipe Calculator

Given Input Data:

Shape Circular
Solving for Depth of Flow
Diameter 12.0000 in
Flowrate 1.0925 cfs
Slope 0.0024 ft/ft
Manning's n 0.0130

Computed Results:

Depth 6.8797 in
Area 0.7854 ft²
Wetted Area 0.4657 ft²
Wetted Perimeter 20.6153 in
Perimeter 37.6991 in
Velocity 2.3457 fps
Hydraulic Radius 3.2533 in
Percent Full 57.3309 %
Full flow Flowrate 1.7454 cfs
Full flow velocity 2.2223 fps

Proposed 10" sewer pipe running south in Hawthorne blvd from Carson Street to Sepulveda blvd.

with Del Amo 5 flows only.

Manning Pipe Calculator

Given Input Data:

Shape Circular
Solving for Depth of Flow
Diameter 10.0000 in
Flowrate 0.2794 cfs
Slope 0.0024 ft/ft
Manning's n 0.0130

Computed Results:

Depth 3.4813 in
Area 0.5454 ft²
Wetted Area 0.1689 ft²
Wetted Perimeter 12.6219 in
Perimeter 31.4159 in
Velocity 1.6543 fps
Hydraulic Radius 1.9268 in
Percent Full 34.8134 %
Full flow Flowrate 1.0734 cfs
Full flow velocity 1.9680 fps

Proposed 10" sewer pipe running south in Hawthorne blvd from Carson Street to Sepulveda blvd.

with Muller Company proposed flows only.

Manning Pipe Calculator

Given Input Data:

Shape Circular
Solving for Depth of Flow
Diameter 10.0000 in
Flowrate 0.1746 cfs
Slope 0.0024 ft/ft
Manning's n 0.0130

Computed Results:

Depth 2.7276 in
Area 0.5454 ft²
Wetted Area 0.1205 ft²
Wetted Perimeter 10.9901 in
Perimeter 31.4159 in
Velocity 1.4488 fps
Hydraulic Radius 1.5791 in
Percent Full 27.2759 %
Full flow Flowrate 1.0734 cfs
Full flow velocity 1.9680 fps

**Proposed 10" sewer pipe running south in Hawthorne blvd from Carson Street to Sepulveda blvd.
with Del Amo 5 flows and Muller Company proposed flows**

Manning Pipe Calculator

Given Input Data:

Shape Circular
Solving for Depth of Flow
Diameter 10.0000 in
Flowrate 0.4540 cfs
Slope 0.0024 ft/ft
Manning's n 0.0130

Computed Results:

Depth 4.5393 in
Area 0.5454 ft²
Wetted Area 0.2408 ft²
Wetted Perimeter 14.7852 in
Perimeter 31.4159 in
Velocity 1.8857 fps
Hydraulic Radius 2.3449 in
Percent Full 45.3930 %
Full flow Flowrate 1.0734 cfs
Full flow velocity 1.9680 fps

APPENDIX “A”

City of Torrance Sewer Master Plan

Appendix “A”

City of Torrance Master Plan Discussion

The measurements shown in the City of Torrance Sewer Plan dated 1991 and shown in Appendix “A” are similar to the mall’s measurements shown in the 2013 Sewer Study (before the mall redevelopment) shown in Appendix “C”



CITY OF TORRANCE

SANITARY SEWERS
 DRAWN: TT DATE: May 31, 2016
 CHECKED: NA, SY REV: _____

LEGEND

- 1" - 0" 6" SEWER UNLESS INDICATED
- 0" - 0" 8" ABAND. SEWER & MH
- 0" - 0" 10" STREET CENTER LINE
- 0" - 0" 12" SEWER EASEMENT
- CHIMNEY
- LIFT STATION M.N.
- SS-100 PLAN NO.



54	55	56
61	62	63
66	69	70

SHEET NO. 62



CITY OF TORRANCE

SANITARY SEWERS
 DRAWN: TT DATE: June 8, 2015
 CHECKED: NA, SY REV:

LEGEND
 1" = 100'
 H.C. TO P.C.
 8" SEWER UNLESS INDICATED
 STA. DEPTH
 0.00 (R.B.)
 CHIMNEY
 LIFT STATION M.H.
 COUNTY SEWER
 PRIVATE SEWER
 ABAND. SEWER & MH
 STREET CENTER LINE
 SEWER EASEMENT

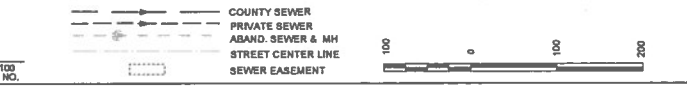

61	62	63
68	69	70
76	77	78

SHEET NO. 69

City of Torrance Sewer Master Plan

INTERFLO Steady State Sewer Flow Model
 Analysis for File: C:\INTERFLO\TORRANCE\MODELS\TORMOD24.DAT

Page: 1
 09-17-91
 1:20 pm

MODEL INPUT

Project Location : City of Torrance Project ID : Model Line #24
 Report Date : 09-10-91 Prepared By: ALR
 Selected Basin : MOD24 Design Capacity: (Specified by Design File)

Basin ID	Upstream Node	Downstream Node	L/S Invert & Lid Elev.	D/S Invert & Lid Elev.	Pipe Length (ft.)	Pipe Diameter (in.)	Slope	Manning Street & n. Comments
S003E	055-5-01	055-5-02	88.20 96.85	83.91 93.75	322.5	8.0	.01330	.013 HAWTHORNE BLVD
S003E	055-5-02	062-2-01	83.80 93.75	79.66 91.05	322.5	8.0	.01284	.013 HAWTHORNE BLVD
S003E	062-2-01	062-2-02	79.66 91.05	75.58 88.55	322.5	8.0	.01265	.013 HAWTHORNE BLVD
S003E	062-2-02	062-2-07	75.48 88.55	71.65 82.00	302.5	8.0	.01266	.013 HAWTHORNE BLVD
S003F	062-2-04	062-2-05	70.77 81.40	70.67 81.75	33.3	12.0	.00300	.013 HAWTHORNE BLVD
S003E	062-2-05	062-5-01	73.62 81.75	69.90 80.95	330.0	12.0	.00218	.013 HAWTHORNE BLVD
S003E	062-2-06	062-2-04	71.16 84.25	70.82 81.40	78.0	10.0	.00436	.013 HAWTHORNE BLVD
S003E	062-2-07	062-2-06	71.60 82.00	71.45 84.25	70.0	10.0	.00214	.013 HAWTHORNE BLVD
S003F	062-5-01	062-5-02	69.84 80.95	69.22 81.45	310.0	12.0	.00200	.013 HAWTHORNE BLVD
S003F	062-5-02	062-5-03	69.10 81.45	68.54 81.85	310.0	12.0	.00181	.013 HAWTHORNE BLVD
S003F	062-5-03	069-2-01	68.35 81.85	67.85 82.65	310.0	12.0	.00161	.013 HAWTHORNE BLVD
S003F	069-2-01	069-2-02	67.61 82.45	66.86 84.03	310.0	12.0	.00242	.013 SEPULVEDA BLVD
S003F	069-2-02	069-2-03	66.86 84.03	66.12 84.55	310.0	12.0	.00239	.013 SEPULVEDA BLVD
S003F	069-2-03	069-5-01	66.12 84.55	65.80 83.50	312.3	12.0	.00102	.013 SEPULVEDA BLVD

PIPE IMPROVEMENTS REPORT

Project Location : City of Torrance Project ID : Model Line #24
 Report Date : 09-10-91 Prepared By: ALR
 Selected Basin : MOD24 Design Capacity: (Specified by Design File)

HAWT01

Upstream Downstream Node	Length, ft. Slope	Diam., in. Manning n	Routed	Routed	Routed	Open	Capacity Used (%)	Required Improvement	Replacement Velocity (fps)	Flow Split (%)
			Flow Depth (in.)	Flow Velocity (fps)	Flow Capacity (GPD)	Channel Capacity (GPD)		Pipe Diameters (in.) Parallel Replacement		
055-5-01	322.5	8.0	1.0	1.834	29,498	900,350	3			
055-5-02	.01330	.013								
055-5-02	322.5	8.0	1.2	2.044	44,247	884,469	5			
062-2-01	.01284	.013								
062-2-01	322.5	8.0	1.4	2.215	58,996	878,037	7			
062-2-02	.01265	.013								
062-2-02	302.5	8.0	1.6	2.366	73,745	878,383	8			
062-2-07	.01266	.013								
062-2-04	33.3	12.0	2.9	1.715	163,608	1,261,252	13			
062-2-05	.00300	.013								
062-2-05	330.0	12.0	3.8	1.701	237,335	1,075,062	22			
062-5-01	.00218	.013								
062-2-06	78.0	10.0	1.9	1.582	73,745	934,472	8			
062-2-04	.00436	.013								
062-2-07	70.0	10.0	2.3	1.231	73,745	655,195	11			
062-2-06	.00214	.013								
062-5-01	310.0	12.0	4.0	1.674	250,889	1,029,293	24			
062-5-02	.00200	.013								
062-5-02	310.0	12.0	4.3	1.638	264,443	978,222	27			
062-5-03	.00181	.013								
062-5-03	310.0	12.0	4.5	1.594	277,998	924,333	30			
069-2-01	.00161	.013								
069-2-01	310.0	12.0	4.2	1.870	291,552	1,132,072	26			
069-2-02	.00242	.013								
069-2-02	310.0	12.0	4.3	1.885	305,106	1,124,499	27			
069-2-03	.00239	.013								
069-2-03	312.3	12.0	5.5	1.400	318,761	736,738	43			
069-5-01	.00102	.013								

HAWT03

FLOW SUMMARY

Project Location : City of Torrance Project ID : Model Line #24
 Report Date : 09-10-91 Prepared By: ALR
 Selected Basin : M0024 Design Capacity: (Specified by Design File)

Basin	(GPD)	Average Flow	Peak Flow	Linear Footage

5003E			Factor: 1.00	1,418
Point Sources		73,745	73,745	
		-----	-----	
		73,745	73,745	

5003F			Factor: 1.00	2,226
Measured Flow		97,311	97,311	
Point Sources		147,705	147,705	
		-----	-----	
		245,016	245,016	

			318,761	3,644

HYDRAULIC GRADELINE REPORT

Project Location : City of Torrance Project ID : Model Line #24
 Report Date : 09-10-91 Prepared By: ALR
 Selected Basin : M0024 Design Capacity: (Specified by Design File)

Node ID	Routed Flow (GPD)	Calculated HGL (ft.)	Lid Elevation (ft.)	Warning
055-5-01	29,498	88.28	96.85	
055-5-02	44,247	83.90	93.75	
062-2-01	58,996	79.78	91.05	
062-2-02	73,745	75.61	88.55	
062-2-04	163,608	71.01	81.40	
062-2-05	237,335	70.94	81.75	
062-2-06	73,745	71.32	84.25	
062-2-07	73,745	71.79	82.00	
062-5-01	250,889	70.18	80.95	
062-5-02	264,443	69.46	81.45	
062-5-03	277,998	68.73	81.85	
069-2-01	291,552	67.96	82.65	
069-2-02	305,106	67.22	84.03	
069-2-03	318,761	66.58	84.55	
069-5-01	318,761	66.09	83.50	

POINT SOURCE FLOWS

Project Location : City of Torrance Project ID : Model Line #24
Report Date : 09-10-91 Prepared By: ALR
Selected Basin : M0024 Design Capacity: (Specified by Design File)

Node ID	Description	Average Flow (GPD)	Peak Flow (GPD)
055-5-01	30% S003E	29,498	29,498.00
055-5-02	15% S003E	14,749	14,749.00
062-2-01	15% S003E	14,749	14,749.00
062-2-02	15% S003E	14,749	14,749.00
062-2-04	S003a	88,407	88,407.00
062-2-05	S003A	59,298	59,298.00

APPENDIX “B”

**ORDINANCE PRESCRIBING THE CONNECTION FEE RATE AND
MEAN LOADINGS PER UNIT OF USAGE FOR THE COUNTY
SANITATION DISTRICT NO. 5 OF LOS ANGELES COUNTY**

TABLE 1
LOADINGS FOR EACH CLASS OF LAND USE

<u>DESCRIPTION</u>	<u>UNIT OF MEASURE</u>	<u>FLOW (Gallons Per Day)</u>	<u>COD (Pounds Per Day)</u>	<u>SUSPENDED SOLIDS (Pounds Per Day)</u>
RESIDENTIAL				
Single Family Home	Parcel	260	1.22	0.59
Duplex	Parcel	312	1.46	0.70
Triplex	Parcel	468	2.19	1.05
Fourplex	Parcel	624	2.92	1.40
Condominiums	Parcel	195	0.92	0.44
Single Family Home (reduced rate)	Parcel	156	0.73	0.35
Five Units or More	No. of Dwlg. Units	156	0.73	0.35
Mobile Home Parks	No. of Spaces	156	0.73	0.35
COMMERCIAL				
Hotel/Motel/Rooming House	Room	125	0.54	0.28
Store	1000 ft ²	100	0.43	0.23
Supermarket	1000 ft ²	150	2.00	1.00
Shopping Center	1000 ft ²	325	3.00	1.17
Regional Mall	1000 ft ²	150	2.10	0.77
Office Building	1000 ft ²	200	0.86	0.45
Professional Building	1000 ft ²	300	1.29	0.68
Restaurant	1000 ft ²	1,000	16.68	5.00
Indoor Theatre	1000 ft ²	125	0.54	0.28
Car Wash				
Tunnel - No Recycling	1000 ft ²	3,700	15.86	8.33
Tunnel - Recycling	1000 ft ²	2,700	11.74	6.16
Wand	1000 ft ²	700	3.00	1.58
Financial Institution	1000 ft ²	100	0.43	0.23
Service Shop	1000 ft ²	100	0.43	0.23
Animal Kennels	1000 ft ²	100	0.43	0.23
Service Station	1000 ft ²	100	0.43	0.23
Auto Sales/Repair	1000 ft ²	100	0.43	0.23
Wholesale Outlet	1000 ft ²	100	0.43	0.23
Nursery/Greenhouse	1000 ft ²	25	0.11	0.06
Manufacturing	1000 ft ²	200	1.86	0.70
Dry Manufacturing	1000 ft ²	25	0.23	0.09
Lumber Yard	1000 ft ²	25	0.23	0.09
Warehousing	1000 ft ²	25	0.23	0.09
Open Storage	1000 ft ²	25	0.23	0.09
Drive-in Theatre	1000 ft ²	20	0.09	0.05

TABLE 1
(continued)
LOADINGS FOR EACH CLASS OF LAND USE

<u>DESCRIPTION</u>	<u>UNIT OF MEASURE</u>	<u>FLOW (Gallons Per Day)</u>	<u>COD (Pounds Per Day)</u>	<u>SUSPENDED SOLIDS (Pounds Per Day)</u>
COMMERCIAL				
Night Club	1000 ft ²	350	1.50	0.79
Bowling/Skating	1000 ft ²	150	1.76	0.55
Club	1000 ft ²	125	0.54	0.27
Auditorium, Amusement	1000 ft ²	350	1.50	0.79
Golf Course, Camp, and Park (Structures and Improvements	1000 ft ²	100	0.43	0.23
Recreational Vehicle Park	No. of Spaces	55	0.34	0.14
Convalescent Home	Bed	125	0.54	0.28
Laundry	1000 ft ²	3,825	16.40	8.61
Mortuary/Cemetery	1000 ft ²	100	1.33	0.67
Health Spa, Gymnasium				
With Showers	1000 ft ²	600	2.58	1.35
Without Showers	1000 ft ²	300	1.29	0.68
Convention Center, Fairground, Racetrack, Sports Stadium/Arena	Average Daily Attendance	10	0.04	0.02
INSTITUTIONAL				
College/University	Student	20	0.09	0.05
Private School	1000 ft ²	200	0.86	0.45
Church	1000 ft ²	50	0.21	0.11

APPENDIX "C"

Del Amo Fashion Center
Sewer Study

Dated March 17, 2014

And

Addendum # 1 dated 9-10-2014



Addendum #1

September 10, 2014

Mr. Ted Symons
 City of Torrance
 3031 Torrance Blvd.
 Torrance, CA 90503

OT
Ted Symons
9/25/14

Re: Del Amo Fashion Center – Sewer Study Addendum

Dear Mr. Symons:

This letter is to serve as an Addendum to the previously submitted Sewer Study prepared by our office, last revised March, 17, 2014. The potential has been discussed for two (2) future restaurant pads to be constructed on the west side of the proposed mall expansion (see updated Figure 2, which is revised from the Figure 2 previously provided in the March sewer study).

The additional square footages from this revised site plan will result in an increase of 15,300 square feet of restaurant use. The restaurant square footage contributing to the Hawthorne Boulevard sewer in the March sewer study was 26,547 square feet; adding the new restaurant area to the previously proposed restaurant area results in 41,847 square feet, with all other areas remaining unchanged.

The proposed additional flow for the improvements was obtained by calculating the flow from the proposed building portion and reducing it by a credit for the existing building portion to be demolished. The proposed improvements were calculated to add 0.157 cfs peak flow.

The total flows under these alternate proposed conditions are summarized below:

Flow Monitoring Study Designation	Location	Pipe Diameter (Inches)	Slope (%)	Base Peak Flow (cfs)	Proposed Peak Flow (Base Peak Plus Additional Peak) (cfs)	Calculated Maximum Depth from Proposed Peak Flow (inches)	Velocity (ft/sec)	Percent Full (%)
CARS04	Carson/Hawthorne Intersection (measuring westward flow)	10	0.44	0.4100	0.5670 <i>.41 + .157 = .5670</i>	4.34	2.50	43.37
HAWT01	South of Carson/Hawthorne Intersection (measuring southward flow)	12	0.24	0.6839	0.8409 <i>.68 + .157 = .84</i>	5.87	2.20	48.92
HAWT03	North of Sepulveda/Hawthorne Intersection (measuring southward flow)	12	0.24	0.6561	0.8131 <i>.65 + .157 = .81</i>	5.76	2.18	47.97

Similar to the original proposed condition, the proposed flow for this alternate proposed condition still increases the capacity to less than 50% for all three locations; therefore it does not warrant an increase in pipe size.

We trust that the enclosed information is sufficient for your review and approval. Please let us know if you need any additional information.

Thank you for your continued assistance on this project.

Sincerely,
TAIT & ASSOCIATES, INC.

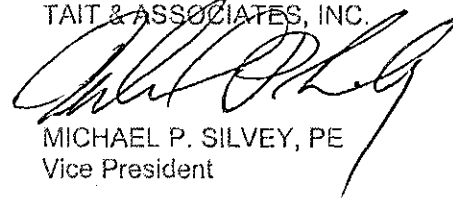

MICHAEL P. SILVEY, PE
Vice President

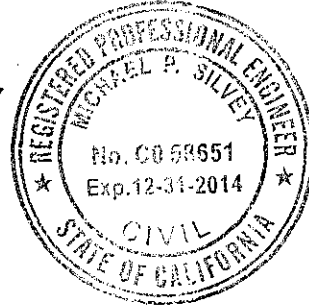

Existing Flows from Site to Hawthorne Boulevard (unchanged from March 17, 2014 study)

Building	Use/Type	Unit	Average Daily Flow (gpd/unit)	Total Daily Flow (gpd)
Medical Office	Medical Buildings	57,775 SF	300 /1000 Gross SF	17,333
Mall Retail	Commercial Shops & Stores	60,037 SF	100 /1000 Gross SF	6,004
Mall Restaurant	Restaurant	17,048 SF	1000 /1000 Gross SF	17,048
Total				40,384

Proposed Flows from Site to Hawthorne Boulevard (including additional restaurant pads)

Building	Use/Type	Unit	Average Daily Flow (gpd/unit)	Total Daily Flow (gpd)
Mall Retail	Commercial Shops & Stores	271,690 SF	100 /1000 Gross SF	27,169
Mall Restaurant	Restaurant	41,847 SF	1000 /1000 Gross SF	41,847
Total				69,016

Ave Flow

Hawthorne Added Sewer Flow (with additional restaurant pads)

Building	Total Daily Flow (gpd)	Average Flow (cfs)	Peak Flow (cfs) 2.65*[(Avg Flow) ^{0.906}]
Proposed Minus Existing Flows	28,632	0.044	0.157

$69,016 - 40,384 = 28,632 \text{ gpd} \Rightarrow 0.044 \text{ cfs}$

proposed peak flows to be added on top of measured peak flows

PROPOSED CONDITIONS MANNING PIPE CALCULATIONS - HAWTHORNE

CARS04 Location, Proposed Conditions, PEAK

Manning Pipe Calculator

Given Input Data:

Shape Circular
Solving for Depth of Flow
Diameter 10.0000 in
Flowrate 0.5670 cfs
Slope 0.0044 ft/ft
Manning's n 0.0130

mean = .41 cfs
+ proposed add'l = .157 cfs

Computed Results:

Depth 4.3373 in
Area 0.5454 ft2
Wetted Area 0.2268 ft2
Wetted Perimeter 14.3786 in
Perimeter 31.4159 in
Velocity 2.4998 fps
Hydraulic Radius 2.2716 in
Percent Full 43.3729 %
Full flow Flowrate 1.4533 cfs
Full flow velocity 2.6647 fps

HAWT01 Location, Proposed Conditions, PEAK

Manning Pipe Calculator

Given Input Data:

Shape Circular
Solving for Depth of Flow
Diameter 12.0000 in
Flowrate 0.8409 cfs
Slope 0.0024 ft/ft
Manning's n 0.0130

mean = .6839 cfs
+ proposed add'l = .157 cfs

Computed Results:

Depth 5.8708 in
Area 0.7854 ft2
Wetted Area 0.3819 ft2
Wetted Perimeter 18.5911 in
Perimeter 37.6991 in
Velocity 2.2017 fps
Hydraulic Radius 2.9583 in
Percent Full 48.9234 %
Full flow Flowrate 1.7454 cfs
Full flow velocity 2.2223 fps

HAWT03 Location, Proposed Conditions, PEAK

Manning Pipe Calculator

Given Input Data:

Shape	Circular
Solving for	Depth of Flow
Diameter	12.0000 in
Flowrate	0.8131 cfs
Slope	0.0024 ft/ft
Manning's n	0.0130

meas = .6561
+ proposed add'l = .157

Computed Results:

Depth	5.7572 in
Area	0.7854 ft2
Wetted Area	0.3725 ft2
Wetted Perimeter	18.3638 in
Perimeter	37.6991 in
Velocity	2.1830 fps
Hydraulic Radius	2.9207 in
Percent Full	47.9764 %
Full flow Flowrate	1.7454 cfs
Full flow velocity	2.2223 fps



Hawthorne Blvd. Sewer Flow Study

Torrance, CA

May 18, 2013 - May 31, 2013

Prepared for:

Michael Silvey, PE
Vice President
Tait & Associates, Inc.
701 N. Parkcenter Drive
Santa Ana, CA 92705

Prepared by:

ADS, LLC
15205 Springdale Street
Huntington Beach, CA 92649

Letter of Transmittal



A Division of ADS LLC

15205 Springdale Street
Huntington Beach, CA 92649-1156

www.adsenv.com

June 17, 2013

Michael Silvey, PE
Tait & Associates, Inc.
701 N. Parkcenter Drive
Santa Ana, CA 92705

Dear Mr. Silvey,

ADS is pleased to submit the Hawthorne Blvd. Sewer Flow Study conducted in the City of Torrance, CA on behalf of Tait & Associates, Inc. Metering was performed at three (3) locations for the period of May 18, 2013 through May 31, 2013 . Included in the report are depth, velocity and quantity hourly averaged hydrographs as well as daily long tables for the metering period in PDF format. An excel file containing Depth, Quantity, and Velocity entities for the flow monitoring location in 5-minute format is also provided.

In addition, we would be happy to further explain any details about the report that may seem unclear. Should you have any questions or comments, I can be reached at (256) 759-2575. You may also contact the Project Manager, Paul Mitchell at (714) 379-9778 ext 223.

Thank you for choosing ADS products and services to meet your flow monitoring needs.

Sincerely,
ADS ENVIRONMENTAL SERVICES

KaTonya Sledge
Sr. Data Analyst

Methodology

Introduction

Background

Tait & Associates, Inc. entered into agreement with ADS Environmental Services to conduct flow monitoring at (3) three locations in the City of Torrance, CA. The study was scheduled for a 14-day period. The objective of this study was to confirm flow to aid in determining future development capacity.

Project Scope

The scope of this study involved using temporary flow monitors to quantify wastewater flows at the designated locations. Specifically, the study included the following key components.

- Investigate the proposed flow-monitoring sites for adequate hydraulic conditions.
- Flow monitor installations.
- Flow monitor confirmations and data collections.
- Flow data analysis.

Equipment installation was completed by May 17, 2013. The 14-day study period began on Saturday, May 18, 2013 and concluded on Friday, May 31, 2013 .

Equipment and Methodology

Flow Quantification Methods

There are two main equations used to measure open channel flow: the Continuity Equation and the Manning Equation. The Continuity Equation, which is considered the most accurate, can be used if both depth of flow and velocity are available. In cases where velocity measurements are not available or not practical to obtain, the Manning Equation can be used to estimate velocity from the depth data based on certain physical characteristics of the pipe (i.e. the slope and roughness of the pipe being measured). However, the Manning equation assumes uniform, steady flow hydraulic conditions with non-varying roughness, which are typically invalid assumptions in most sanitary sewers. The Continuity Equation was used exclusively for this study.

Continuity Equation

The Continuity Equation states that the flow quantity (Q) is equal to the wetted area (A) multiplied by the average velocity (V) of the flow.

$$Q = A * V$$

This equation is applicable in a variety of conditions including backwater, surcharge, and reverse flow. Most modern flow monitoring equipment, including the ADS Models, measure both depth and velocity and therefore use the Continuity Equation to calculate

flow quantities.

Flow Monitoring Equipment

The monitor selected for this project was the ADS Model 3600-flow monitor. This flow monitor is an area flow monitor that uses both the Continuity and Manning's equations to measure flow.

The ADS Model 3600-flow monitor consists of data acquisition sensors and a battery-powered microcomputer. The microcomputer includes a processor unit, data storage, and an on-board clock to control and synchronize the sensor recordings. The monitor was programmed to acquire and store depth of flow and velocity readings at 5-minute intervals.

Three types of data acquisition sensors are available for the Model 3600-flow monitor. The primary depth measurement device is the ADS quad-redundant ultrasonic level sensor. This sensor uses four independent ultrasonic transceivers in pairs to measure the distance from the face of the transceiver housing to the water surface (air range) with up to four transceiver pairs, of the available ones, active at one time. The elapsed time between transmitting and receiving the ultrasonic waves is used to calculate the air range between the sensor and flow surface based on the speed of sound in air. Sensors in the transceiver housing measure temperature, which is used to compensate the ultrasonic signal travel time. The speed of sound will vary with temperature. Since the ultrasonic level sensor is mounted out of the flow, it creates no disturbance to normal flow patterns and does not affect site hydraulics.

Redundant flow depth data can be provided by a pressure depth sensor, and is independent from the ultrasonic level sensor. This sensor uses a piezo-resistive crystal to determine the difference between hydrostatic and atmospheric pressure. The pressure sensor is temperature compensated and vented to the atmosphere through a desiccant filled breather tube. Pressure depth sensors are typically used in large size channels and applications where surcharging is anticipated. Its streamlined shape minimizes flow distortion.

Velocity is measured using the ADS V-3 digital Doppler velocity sensor. This sensor measures velocity in the cross-sectional area of flow. An ultrasonic carrier is transmitted upstream into the flow, and is reflected by suspended particles, air bubbles, or organic matter with a frequency shift proportional to the velocity of the reflecting objects. The reflected signal is received by the sensor and processed using digital spectrum analysis to determine the peak flow velocity. Collected peak velocity information is filtered and processed using field confirmation information and proprietary software to determine the average velocity, which is used to calculate flow quantities. The sensor's small profile, measuring 1.5 inches by 1.15 inches by 0.50 inches thick, minimizes the affects on flow patterns and site hydraulics.

Installation

Installation of flow monitoring equipment typically proceeds in four steps. First, the site is investigated for safety and to determine physical and hydraulic suitability for the flow monitoring equipment. Second, the equipment is physically installed at the selected location. Third, the monitor is tested to assure proper operation of the velocity and depth of flow sensors and verify that the monitor clock is operational and synchronized to the

master computer clock. Fourth, the depth and velocity sensors are confirmed and line confirmations are performed. A typical flow monitor installation is shown in Figure 2.1.

The installations depicted in Figures 2.1 are typical for circular or oval pipes up to approximately 104-inches in diameter or height. In installations into pipes 42-inches or less in diameter, depth and velocity sensors are mounted on an expandable stainless steel ring and installed one to two pipe diameters upstream of the pipe/manhole connection in the incoming sewer pipe. This reduces the affects of turbulence and backwater caused by the connection. In pipes larger than 42 inches in diameter, a special installation is made using two sections of the ring installed one to two feet upstream of the pipe/manhole connection; one bolted to the crown of the pipe for the depth sensor, and the other bolted to the bottom of the pipe (bolts are usually placed just above the water line) to hold the velocity sensor.

Figure 2.1 Typical Installation

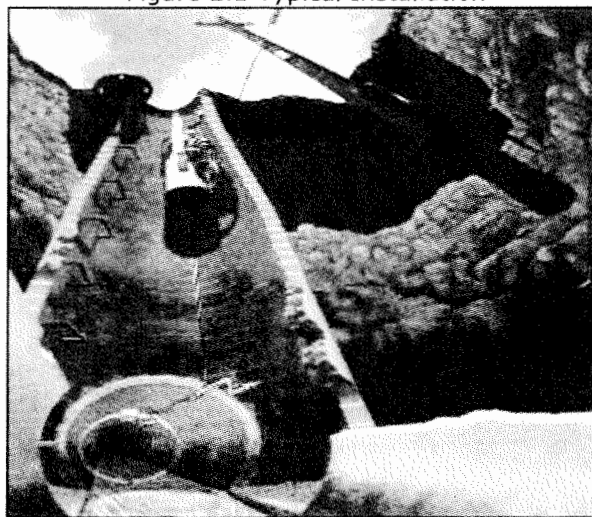

Large Pipe (> 42" Diameter)



Small Pipe (8" to 42" Diameter)

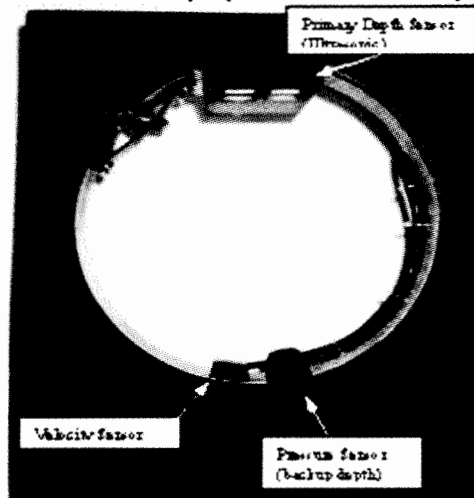

Data Collection, Confirmation, and Quality Assurance

During the monitoring period, field crews visit each monitoring location to retrieve data, verify proper monitor operation, and document field conditions. The following quality assurance steps are taken to assure the integrity of the data collected:

- **Measure Power Supply:** The monitor is powered by a dry cell battery pack. Power levels are recorded and battery packs replaced, if necessary. A separate battery provides back-up power to memory, which allows the primary battery to be replaced without the loss of data.
- **Perform Pipe Line Confirmations and Confirm Depth and Velocity:** Once equipment and sensor installation is accomplished, a member of the field crew descends into the manhole to perform a field measurement of flow rate, depth and velocity to confirm they are in agreement with the monitor. Since the ADS V-3 velocity sensor measures peak velocity in the wetted cross-sectional area of flow, velocity profiles are also taken to develop a relationship between peak and average velocity in lines that meet the hydraulic criteria.
- **Measure Silt Level:** During site confirmation, a member of the field crew descends into the manhole and measures and records the depth of silt at the bottom of the pipe. This data is used to compute the true area of flow.
- **Confirm Monitor Synchronization:** The field crew checks the flow monitor's clock for accuracy.
- **Upload and Review Data:** Data collected by the monitor is uploaded and reviewed for comparison with previous data. All readings are checked for consistency and screened for deviations in the flow patterns, which indicate system anomalies or equipment failure.

Data Analysis and Presentation

Data Analysis

A flow monitor is typically programmed to collect data at either 15-minute or 5-minute intervals throughout the monitoring period. The monitor stores raw data consisting of (1) the air range (distance from sensor to top of flow) for each active ultrasonic depth sensor pair and (2) the peak velocity. If the monitor is equipped with a pressure sensor, then a depth reading from this sensor may also be stored. When the field personnel collects the data, the air range is converted to depth data based on the pipe height and physical offset (distance from the top of the pipe to the surface of the ultrasonic sensor). The data is imported into ADS's proprietary software and is examined by a data analyst to verify its integrity. The data analyst also reviews the daily field reports and site visit records to identify conditions that would affect the collected data.

Velocity profiles and the line confirmation data developed by the field personnel are reviewed by the data analyst to identify inconsistencies and verify data integrity. Velocity profiles are reviewed and an average to peak velocity ratio is calculated for the site. This ratio is used in converting the peak velocity measured by the sensor to the average velocity used in the Continuity equation. The data analyst selects which ultrasonic pairs and/or depth sensor entity will be used to calculate the final depth information. Silt levels present at each site visit are reviewed and representative silt levels established.

Selections for the above parameters can be constant or can change during the monitoring period. While the data analysis process is described in a linear manner, it

often requires an iterative approach to accurately complete.

Data Presentation

This type of flow monitoring project generates a large volume of data. To facilitate review of the data, results have been provided in graphical and tabular formats. The flow data is presented graphically in the form of scattergraphs and hydrographs. The data depicted on the hydrograph is based on hourly averaged data. Tables are provided in daily average format. These tables show the flow rate for each day, along with the daily minimum and maximums, the times they were observed, the total daily flow, and total flow for the month (or monitoring period). The summary tables in the report show minimum and maximum data based on 5-minute data intervals recorded. The following explanation of terms may aid in interpretation of the tables and hydrographs. These entities are based on 5-minute interval data.

DEPTH - Final calculated depth measurement (in inches)

QUANTITY - Final calculated flow rate (in MGD)

VELOCITY - Final calculated flow velocity (in feet per second)

REPORT TOTAL - Total volume of flow recorded for the indicated time period (in MGD).

MINIMUM DEPTH - Lowest depth of flow recorded during the study period (in inches).

MAXIMUM DEPTH - Highest depth of flow recorded during the study period (in inches).

MINIMUM VELOCITY - Lowest flow velocity recorded during the study period (in feet per second).

MAXIMUM VELOCITY - Highest flow velocity reported during the study period (in feet per second).

MINIMUM QUANTITY - Lowest quantity of flow reported during the study period (in MGD).

MAXIMUM QUANTITY - Highest quantity of flow recorded during the study period (in MGD)

Site Commentary

Site Information

CARS04	
Pipe Dimensions	10 "
Silt Level	0.00"

Overview

Site CARS04 functioned under normal conditions during the period Saturday, May 18, 2013 to Friday, May 31, 2013 . No surcharge conditions were experienced at this location. Review of the scattergraph shows that flow in this line remained free-flowing throughout the study period.

Flow depth and velocity measurements recorded by the flow monitor are consistent with field confirmations conducted to date and support the relative accuracy of the flow monitor at this location.

Observations

Average flow depth, velocity, and quantity data observed during Saturday, May 18, 2013 to Friday, May 31, 2013 , along with observed minimum and maximum data, are provided in the following table. In regards to depth, this site flows at 32.7% full at its recorded hourly peak at 3.27 inches and approximately 24.3% full during the typical hourly average depth of 2.43 inches.

Observed Flow Conditions			
Item	Depth (in)	Velocity (ft/s)	Quantity (MGD)
Average	2.43	1.18	0.083
Minimum	1.25	0.48	0.012
Maximum	3.62	1.74	0.196
Time of Minimum	5/21/2013 2:25 AM	5/21/2013 2:25 AM	5/21/2013 2:25 AM
Time of Maximum	5/28/2013 2:15 PM	5/24/2013 9:50 PM	5/28/2013 2:15 PM

Data Quality

Data uptime observed during the Saturday, May 18, 2013 to the Friday, May 31, 2013 monitoring period is provided in the table below. Based upon the quality and consistency of the observed flow depth and velocity data, the Continuity equation was used to calculate flow rate and quantities during the monitoring period.

Percent Uptime	
Depth (in)	100
Velocity (ft/s)	100
Quantity (MGD)	100

Project Name: Torrance Tail 2013		City: Torrance, CA		Agency: Torrance		FM Initials: SK	
Site Name: CARS04		Install Date: 5/17/13		Monitor Type		Peak Doppler	
Address/Location: Hawthorne Blvd and W Carson St.				Monitor Model		3600	
				Data Acquisition		Manual Collect	
				Manhole ID		N/A	
Access: Drive		Type of System:		Pipe Height:		10.00 "	
		Sanitary <input checked="" type="checkbox"/>		Storm <input type="checkbox"/>		Pipe Width:	
		Combined <input type="checkbox"/>					



Investigation Information: **Manhole Information:**

Date/Time of Investigation:		5/17/13		Manhole Depth:		14'	
Site Hydraulics:		Good straight through flow		Manhole Material / Condition		Brick/OK	
Upstream Input: (L/S, P/S)		DNI		Pipe Material / Condition: VCP/Good			
Upstream Manhole:		DNI		Land Use:		Residential <input checked="" type="checkbox"/> Commercial <input type="checkbox"/> Industrial <input type="checkbox"/> Trunk <input type="checkbox"/>	
Downstream Manhole:		DNI		Oxygen: 20.9		H2S: 0 LEL: 0 CO: 0	
Depth of Flow:		2.63 " +/- 0.13"		Safety Notes: 2 man crew required.			
Range (Air DOF):		+/-					
Peak Velocity:		1.43 fps					
Silt:		0.00 Inches					

Other Information:

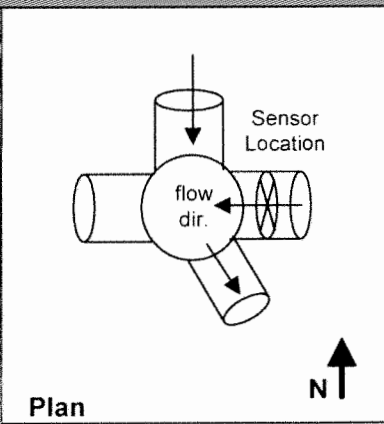
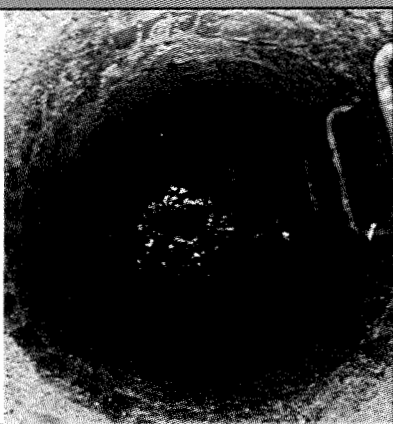
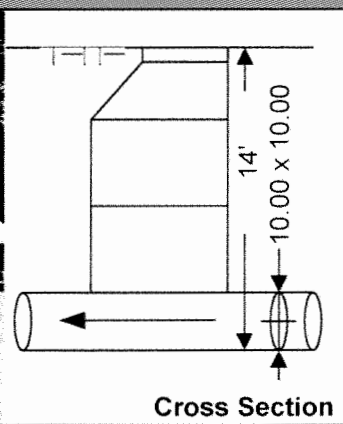

Installation Information		Backup			Distance
		Yes	No	?	
Installation Type:	Ring	<input type="checkbox"/>	<input checked="" type="checkbox"/>	<input type="checkbox"/>	
Sensors Devices:	Ultrasonic / Pressure/ Velocity	<input type="checkbox"/>	<input checked="" type="checkbox"/>	<input type="checkbox"/>	
Surcharge Height:	0	<input type="checkbox"/>	<input checked="" type="checkbox"/>	<input type="checkbox"/>	
Gauge Zone:		<input type="checkbox"/>	<input checked="" type="checkbox"/>	<input type="checkbox"/>	

Additional Site Information / Comments:

Standard Traffic Control with No Safety Concerns

SCATTERGRAPH REPORT

CARS04

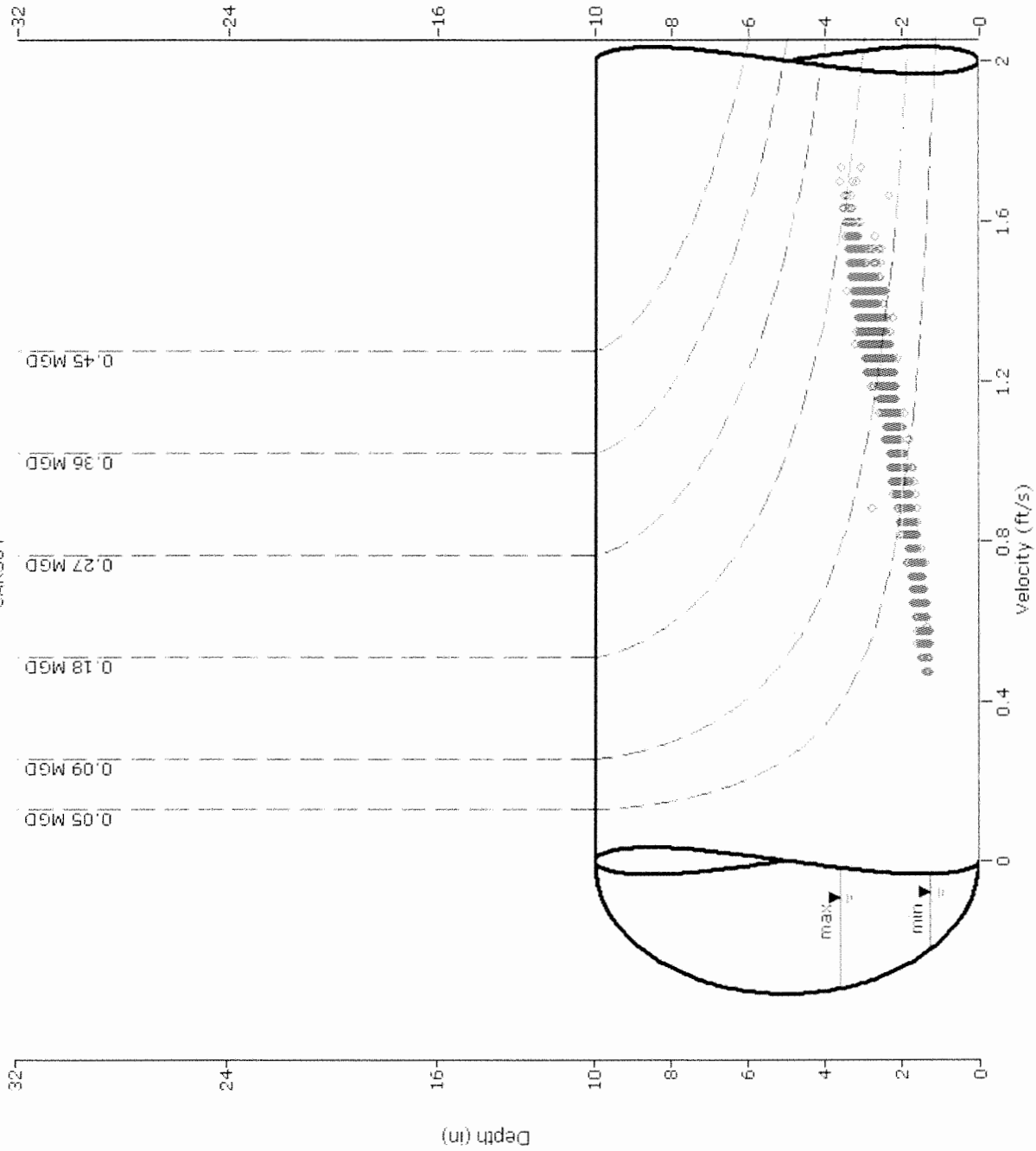

Flow Monitor
CARS04

Pipe Height
10.00 in

Report Period
5/18/2013
To
5/31/2013

Legend

- Depth - Velocity
- - - Iso-QTM
- - - Silt
- ▼ Min-Max Depth



HYDROGRAPH REPORT

CARS04

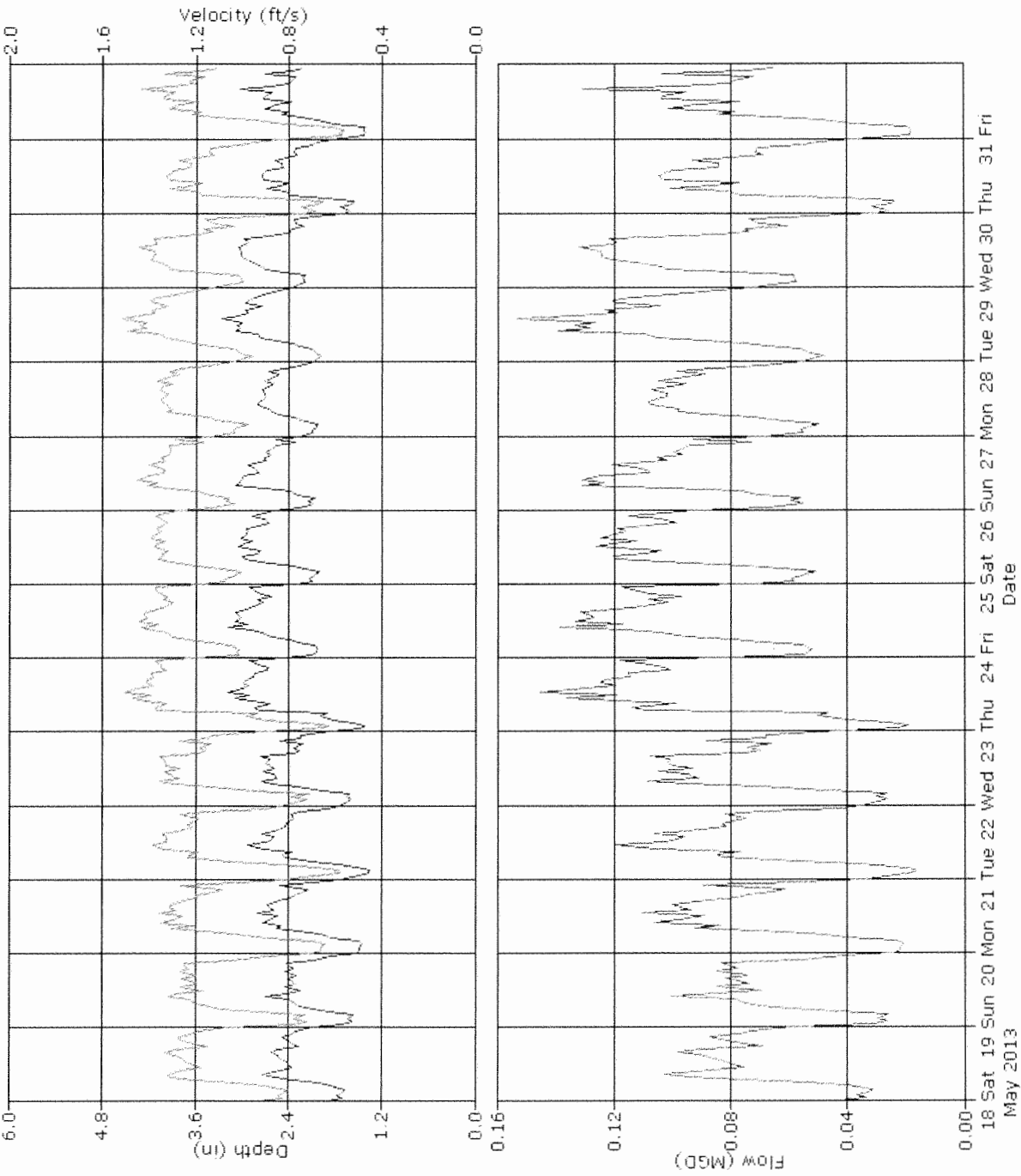

Flow Monitor
CARS04

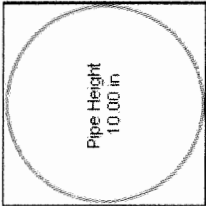

Report Period
5/18/2013
To
5/31/2013

Legend

- Depth
- - - Velocity
- ... Quantity



CARS04, Pipe Height: 10 in

Daily Tabular Report

Date	Depth (in)				Velocity (ft/s)				Quantity (MGD - Total MG)				Rain (in)				
	Time	Min	Time	Max	Avg	Time	Min	Time	Max	Avg	Time	Min		Time	Max	Avg	Total
5/18/2013	01:35	1.48	09:05	3.13	2.26	02:45	0.61	08:30	1.53	1.14	02:45	0.021	09:05	0.144	0.071	0.071	
5/19/2013	04:30	1.44	13:20	2.89	2.18	02:25	0.61	19:55	1.53	1.10	02:25	0.019	13:20	0.121	0.065	0.065	
5/20/2013	02:00	1.28	13:10	3.38	2.21	03:40	0.51	13:10	1.60	1.09	04:15	0.014	13:10	0.168	0.068	0.068	
5/21/2013	02:25	1.25	11:15	3.35	2.23	02:25	0.48	21:50	1.67	1.10	02:25	0.012	10:40	0.158	0.070	0.070	
5/22/2013	04:20	1.47	13:05	3.28	2.30	04:10	0.51	08:15	1.60	1.14	04:10	0.017	13:05	0.154	0.074	0.074	
5/23/2013	02:35	1.30	16:00	3.48	2.54	02:35	0.51	13:25	1.70	1.23	02:35	0.014	16:00	0.178	0.094	0.094	
5/24/2013	03:20	1.90	21:50	3.56	2.68	01:55	0.88	21:50	1.74	1.29	01:55	0.042	21:50	0.196	0.101	0.101	
5/25/2013	04:55	1.94	12:50	3.41	2.66	05:10	0.82	12:45	1.57	1.27	05:10	0.042	09:10	0.161	0.098	0.098	
5/26/2013	04:35	1.99	10:40	3.37	2.62	03:45	0.95	10:35	1.60	1.28	04:05	0.048	10:40	0.167	0.096	0.096	
5/27/2013	04:15	1.96	11:45	3.10	2.49	04:50	0.85	08:00	1.53	1.24	04:50	0.043	07:50	0.138	0.086	0.086	
5/28/2013	02:25	1.93	14:15	3.62	2.67	02:10	0.85	21:50	1.74	1.28	02:15	0.042	14:15	0.196	0.100	0.100	
5/29/2013	23:40	1.94	11:40	3.37	2.59	04:55	0.88	09:55	1.60	1.22	23:40	0.043	11:40	0.160	0.091	0.091	
5/30/2013	03:25	1.41	13:55	3.25	2.27	03:25	0.51	11:50	1.50	1.08	03:25	0.016	13:55	0.149	0.070	0.070	
5/31/2013	01:40	1.27	16:25	3.38	2.26	01:30	0.48	16:25	1.63	1.09	01:40	0.012	16:25	0.171	0.071	0.071	

Report Summary For The Period 5/18/2013 - 5/31/2013

	Depth (in)	Velocity (ft/s)	Quantity (MGD - Total MG)
Total			1.155
Avg	2.43	1.18	0.083

Site Commentary

Site Information

HAWT01	
Pipe Dimensions	12 "
Silt Level	0.00"

Overview

Site HAWT01 functioned under normal conditions during the period Saturday, May 18, 2013 to Friday, May 31, 2013 . No surcharge conditions were experienced at this location. Review of the scattergraph shows that flow in this line remained free-flowing throughout the study period.

Flow depth and velocity measurements recorded by the flow monitor are consistent with field confirmations conducted to date and support the relative accuracy of the flow monitor at this location.

Flow monitoring site CARS04 was located upstream of this location. Flow balances well with the upstream site.

Observations

Average flow depth, velocity, and quantity data observed during Saturday, May 18, 2013 to Friday, May 31, 2013 , along with observed minimum and maximum data, are provided in the following table. In regards to depth, this site flows at 36.6% full at its recorded hourly peak at 4.40 inches and approximately 28.6% full during the typical hourly average depth of 3.43 inches.

Observed Flow Conditions			
Item	Depth (in)	Velocity (ft/s)	Quantity (MGD)
Average	3.43	1.69	0.214
Minimum	1.80	0.74	0.039
Maximum	5.04	2.45	0.442
Time of Minimum	5/21/2013 2:30 AM	5/19/2013 2:30 AM	5/21/2013 2:30 AM
Time of Maximum	5/20/2013 9:10 AM	5/21/2013 11:25 AM	5/20/2013 9:10 AM

Data Quality

Data uptime observed during the Saturday, May 18, 2013 to the Friday, May 31, 2013 monitoring period is provided in the table below. Based upon the quality and consistency of the observed flow depth and velocity data, the Continuity equation was used to calculate flow rate and quantities during the monitoring period.

Percent Uptime	
Depth (in)	100
Velocity (ft/s)	100
Quantity (MGD)	100

Project Name: Torrence Tail		City: Torrance, CA		Agency: Torrance		FM Initials: SK	
Site Name: HAWT01		Install Date: 5/17/13		Monitor Type: Peak Doppler			
Address/Location: Hawthorne Blvd and W Carson St.		Monitor Model: 3600		Data Acquisition: Manual Collect			
Access: Drive		Type of System: Sanitary <input checked="" type="checkbox"/> Storm <input type="checkbox"/> Combined <input type="checkbox"/>		Manhole ID: N/A			
				Pipe Height: 12.00 "			
				Pipe Width: 12.00 "			

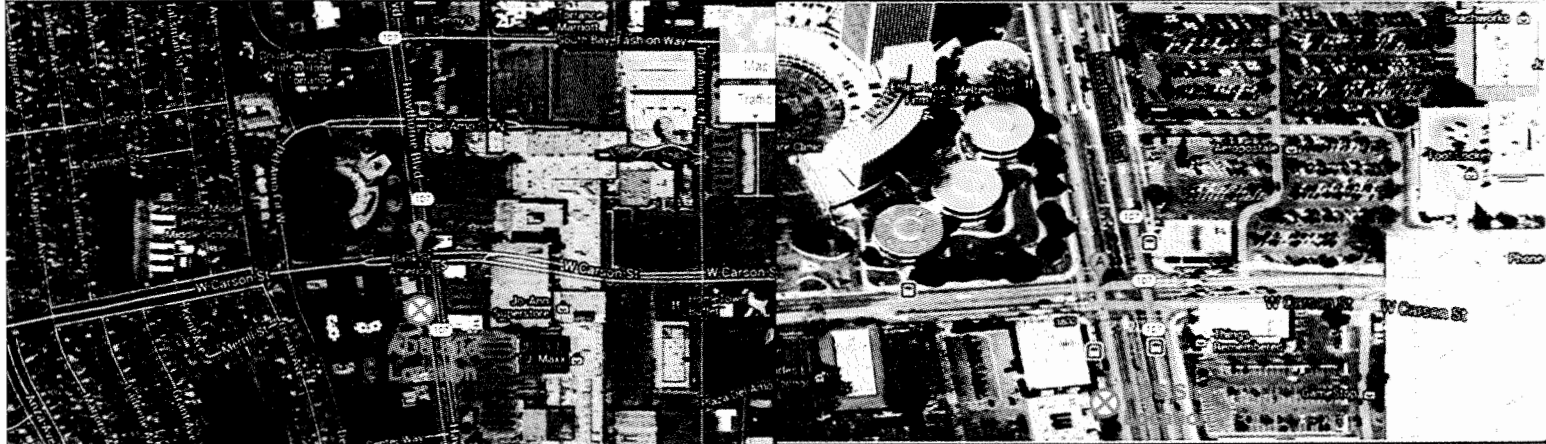

Investigation Information:				Manhole Information:			
Date/Time of Investigation:		5/17/13		Manhole Depth:		12'	
Site Hydraulics:		Good straight through flow		Manhole Material / Condition:		Precast/OK	
Upstream Input: (L/S, P/S)		DNI		Pipe Material / Condition: VCP/Good			
Upstream Manhole:		DNI		Land Use: Residential <input checked="" type="checkbox"/> Commercial <input type="checkbox"/> Industrial <input type="checkbox"/> Trunk <input type="checkbox"/>			
Downstream Manhole:		DNI		Oxygen: 20.9 H2S: 0 LEL: 0 CO: 0			
Depth of Flow:		3.88 " +/- 0.13"		Safety Notes: 2 man crew required.			
Range (Air DOF):		+/-					
Peak Velocity:		2.39 fps					
Silt:		0.00 Inches					

Other Information:

Cross Section

Plan

Installation Information		Backup			Distance
Yes	No	?			
Installation Type: Ring	Trunk	<input type="checkbox"/>	<input checked="" type="checkbox"/>	<input type="checkbox"/>	
Sensors Devices: Ultrasonic / Pressure/ Velocity	Lift / Pump Station	<input type="checkbox"/>	<input checked="" type="checkbox"/>	<input type="checkbox"/>	
Surcharge Height: 0	WWTP	<input type="checkbox"/>	<input checked="" type="checkbox"/>	<input type="checkbox"/>	
Gauge Zone:	Other	<input type="checkbox"/>	<input checked="" type="checkbox"/>	<input type="checkbox"/>	

Additional Site Information / Comments:

Standard Traffic Control with No Safety Concerns

SCATTERGRAPH REPORT

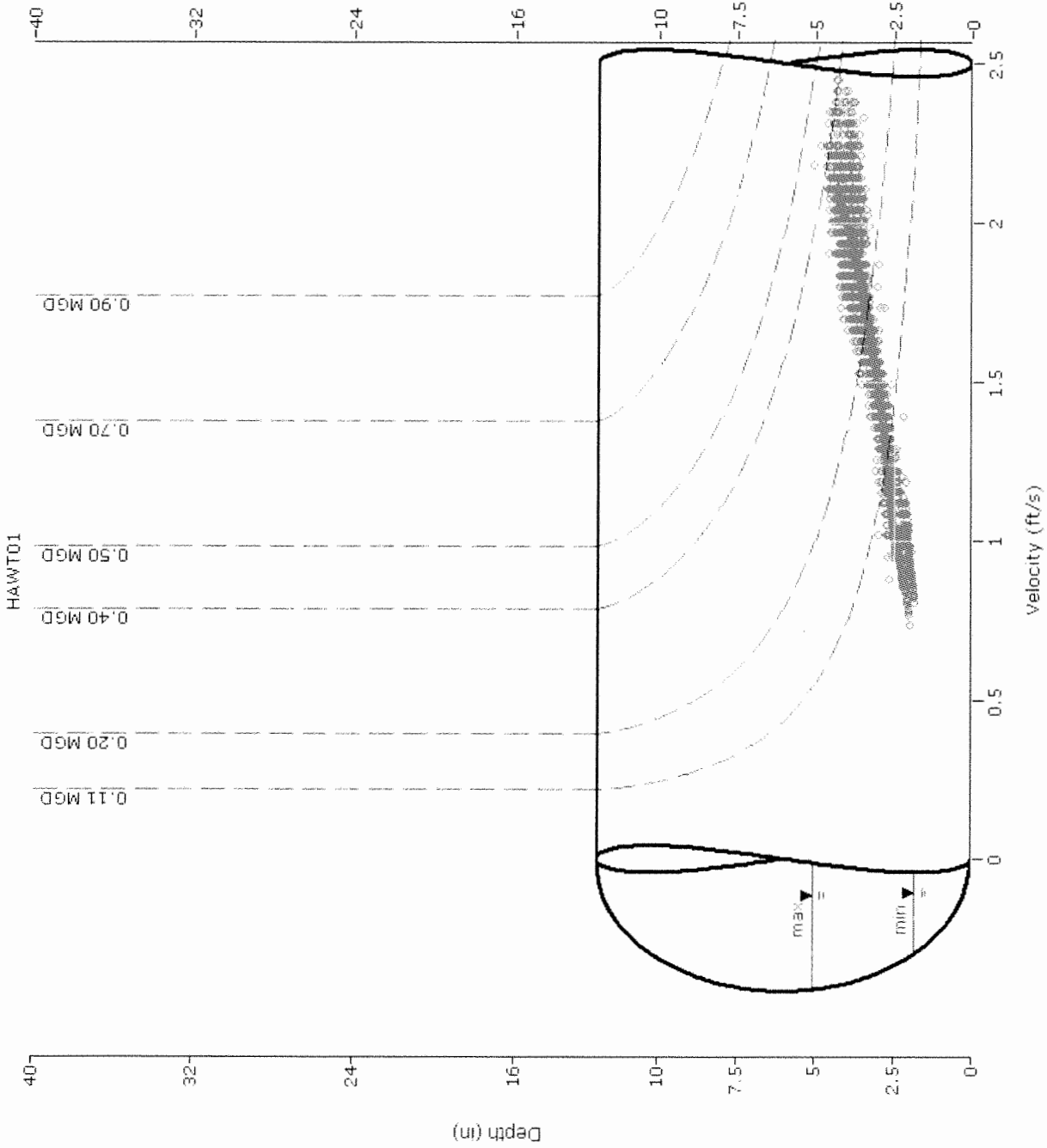

HYDROGRAPH REPORT

HAWT01

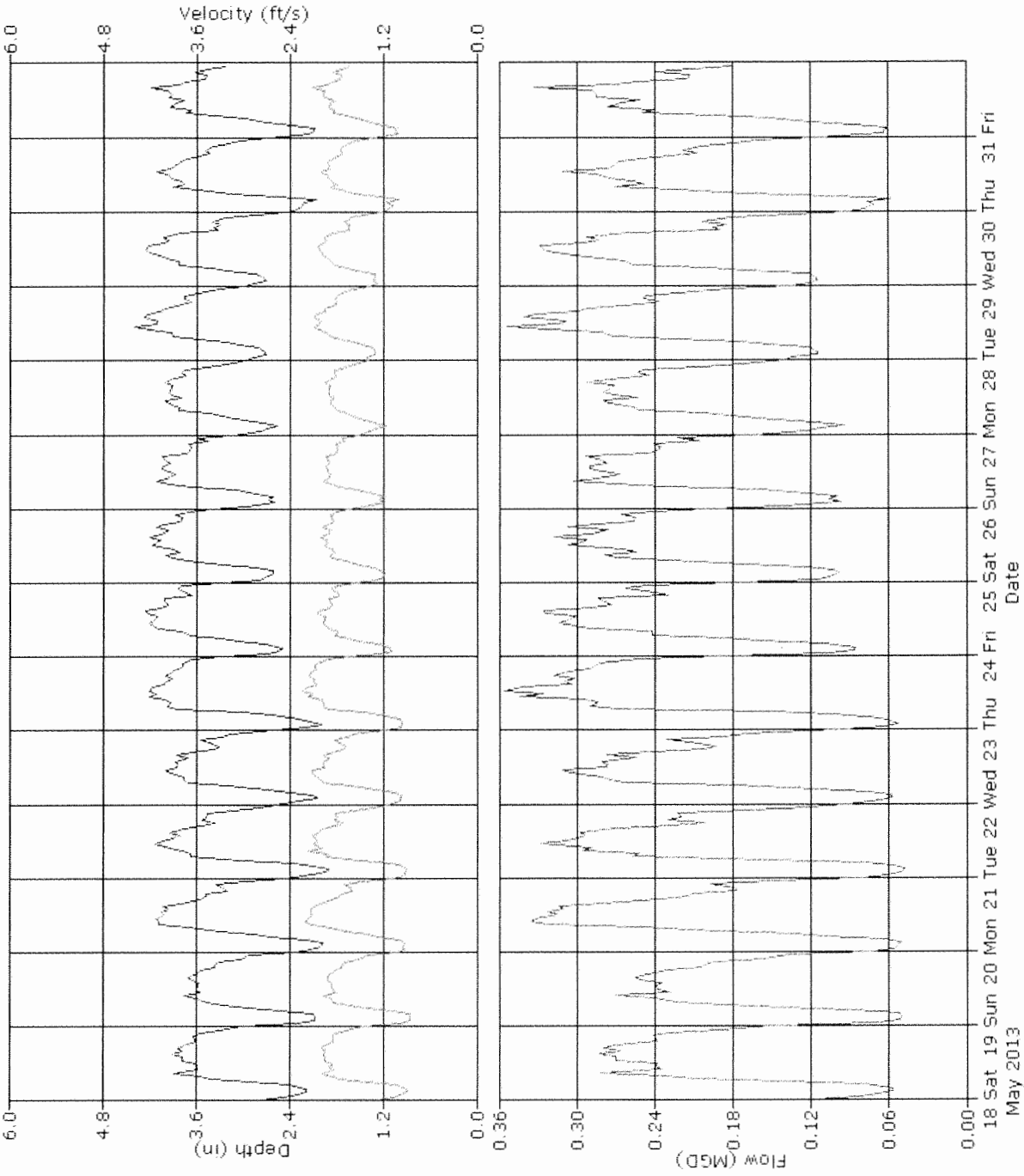

Flow Monitor
HAWT01

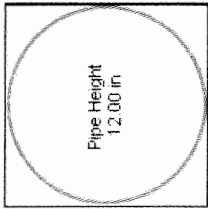

Report Period
5/18/2013
To
5/31/2013

Legend

- Depth
- - - Velocity
- ... Quantity



HAWT01, Pipe Height: 12 in

Daily Tabular Report

Date	Depth (in)				Velocity (ft/s)				Quantity (MGD - Total MG)				Rain (in)				
	Time	Min	Time	Max	Avg	Time	Min	Time	Max	Avg	Time	Min	Time	Max	Avg	Total	Total
5/18/2013	02:50	2.04	15:05	4.29	3.30	02:50	0.82	18:30	2.21	1.65	02:50	0.047	15:05	0.345	0.200	0.200	
5/19/2013	02:30	1.94	09:15	4.02	3.16	02:30	0.74	16:55	2.18	1.58	02:30	0.039	10:05	0.306	0.180	0.180	
5/20/2013	03:55	1.85	09:10	5.04	3.27	03:55	0.85	10:30	2.38	1.66	03:55	0.042	09:10	0.442	0.203	0.203	
5/21/2013	02:30	1.80	10:45	4.39	3.24	02:30	0.81	11:25	2.45	1.65	02:30	0.039	11:25	0.401	0.200	0.200	
5/22/2013	02:40	1.95	12:50	4.39	3.30	03:15	0.87	10:00	2.38	1.67	02:40	0.049	10:30	0.363	0.203	0.203	
5/23/2013	02:40	1.89	11:50	4.61	3.51	01:30	0.87	13:45	2.45	1.79	02:40	0.045	11:45	0.400	0.239	0.239	
5/24/2013	03:20	2.37	15:50	4.63	3.65	02:45	0.95	14:45	2.21	1.73	02:45	0.069	15:50	0.394	0.236	0.236	
5/25/2013	03:35	2.52	18:15	4.63	3.64	04:50	0.95	12:50	2.25	1.72	04:50	0.080	18:15	0.405	0.232	0.232	
5/26/2013	02:40	2.43	17:05	4.59	3.57	02:50	0.88	16:55	2.21	1.72	02:50	0.073	17:05	0.395	0.224	0.224	
5/27/2013	04:15	2.46	14:15	4.23	3.53	03:35	0.95	14:00	2.08	1.70	03:35	0.075	14:10	0.331	0.219	0.219	
5/28/2013	02:20	2.53	11:45	4.55	3.63	00:55	1.02	13:05	2.31	1.76	02:55	0.080	15:25	0.396	0.236	0.236	
5/29/2013	02:30	2.60	13:00	4.60	3.52	01:35	1.02	10:10	2.35	1.70	04:05	0.089	10:10	0.415	0.219	0.219	
5/30/2013	04:55	1.92	13:55	4.45	3.32	04:10	0.83	13:55	2.28	1.64	04:10	0.048	13:55	0.391	0.199	0.199	
5/31/2013	01:55	1.95	16:30	4.42	3.34	01:50	0.77	16:50	2.35	1.66	01:50	0.042	16:50	0.391	0.204	0.204	

Report Summary For The Period 5/18/2013 - 5/31/2013

	Depth (in)	Velocity (ft/s)	Quantity (MGD - Total MG)
Total			2.996
Avg	3.43	1.69	0.214

Site Commentary

Site Information

HAWT03	
Pipe Dimensions	12 "
Silt Level	0.00"

Overview

Site HAWT03 functioned under normal conditions during the period Saturday, May 18, 2013 to Friday, May 31, 2013 . No surcharge conditions were experienced at this location. Review of the scattergraph shows that flow in this line remained free-flowing throughout the study period.

Flow depth and velocity measurements recorded by the flow monitor are consistent with field confirmations conducted to date and support the relative accuracy of the flow monitor at this location.

Flow monitoring site HAWT01 was located immediately upstream of this location. Flow balances well with the upstream site.

Observations

Average flow depth, velocity, and quantity data observed during Saturday, May 18, 2013 to Friday, May 31, 2013 , along with observed minimum and maximum data, are provided in the following table. In regards to depth, this site flows at 37.6% full at its recorded hourly peak at 4.51 inches and approximately 30.3% full during the typical hourly average depth of 3.64 inches.

Observed Flow Conditions			
Item	Depth (in)	Velocity (ft/s)	Quantity (MGD)
Average	3.64	1.71	0.231
Minimum	1.97	0.77	0.045
Maximum	4.90	2.57	0.424
Time of Minimum	5/20/2013 4:10 AM	5/20/2013 4:00 AM	5/20/2013 4:00 AM
Time of Maximum	5/23/2013 12:00 PM	5/27/2013 11:50 AM	5/28/2013 11:25 AM

Data Quality

Data uptime observed during the Saturday, May 18, 2013 to the Friday, May 31, 2013 monitoring period is provided in the table below. Based upon the quality and consistency of the observed flow depth and velocity data, the Continuity equation was used to calculate flow rate and quantities during the monitoring period.

Percent Uptime	
Depth (in)	100
Velocity (ft/s)	100
Quantity (MGD)	100

Project Name: Torrance Tail		City: Torrance, CA		Agency: Torrance		FM Initials: SK	
Site Name: HAWT03		Install Date: 5/17/13		Monitor Type: Peak Doppler		Monitor Model: 3600	
Address/Location: Hawthorne Blvd and W Sepulveda Blvd				Data Acquisition: Manual Collect		Manhole ID: N/A	
Access: Drive		Type of System: Sanitary <input checked="" type="checkbox"/> Storm <input type="checkbox"/> Combined <input type="checkbox"/>		Pipe Height: 12.00 "		Pipe Width: 12.00 "	

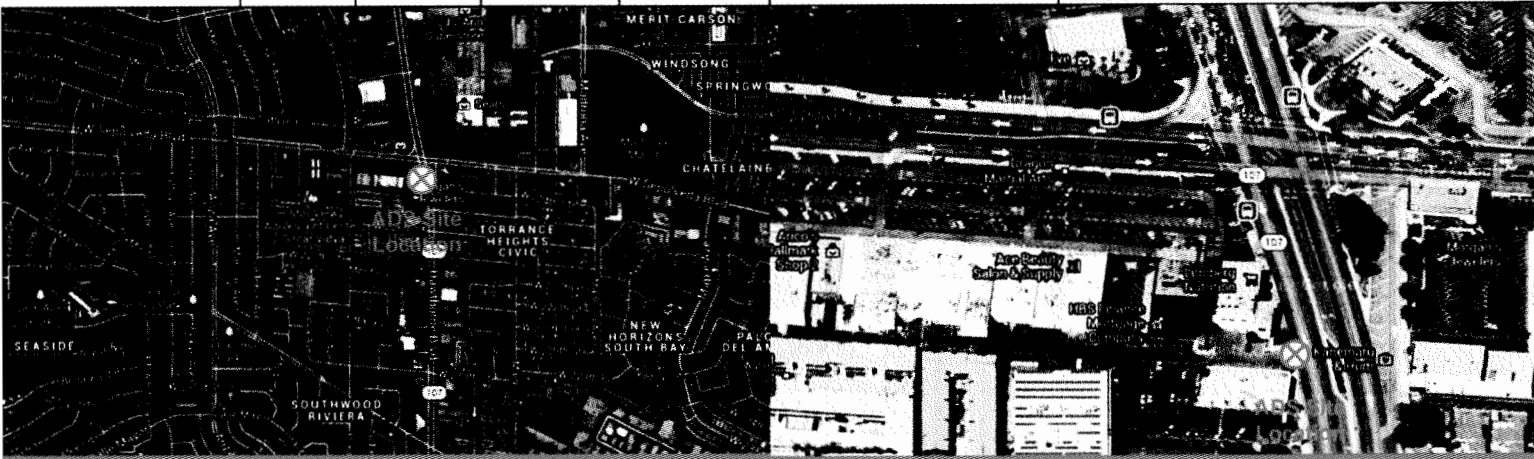

Investigation Information: Manhole Information:

Date/Time of Investigation: 5/17/13		Manhole Depth: 18'	
Site Hydraulics: Good straight through flow		Manhole Material / Condition: Precast/OK	
Upstream Input: (L/S, P/S) DNI		Pipe Material / Condition: VCP/Good	
Upstream Manhole: DNI		Land Use: Residential <input checked="" type="checkbox"/> Commercial <input type="checkbox"/> Industrial <input type="checkbox"/> Trunk <input type="checkbox"/>	
Downstream Manhole: DNI		Oxygen: 20.9 H2S: 0 LEL: 0 CO: 0	
Depth of Flow: 4.00 " +/- 0.13"		Safety Notes: 2 man crew required.	
Range (Air DOF): +/-			
Peak Velocity: 2.58 fps			
Silt: 0.00 Inches			

Other Information:

Cross Section

Plan

Installation Information		Backup			Distance
Installation Type:	Ring	Yes	No	?	
Sensors Devices:	Ultrasonic / Pressure/ Velocity	<input type="checkbox"/>	<input checked="" type="checkbox"/>	<input type="checkbox"/>	
Surcharge Height:	0	<input type="checkbox"/>	<input checked="" type="checkbox"/>	<input type="checkbox"/>	
Gauge Zone:		<input type="checkbox"/>	<input checked="" type="checkbox"/>	<input type="checkbox"/>	

Additional Site Information / Comments:

Standard Traffic Control with No Safety Concerns

SCATTERGRAPH REPORT

HAWT03

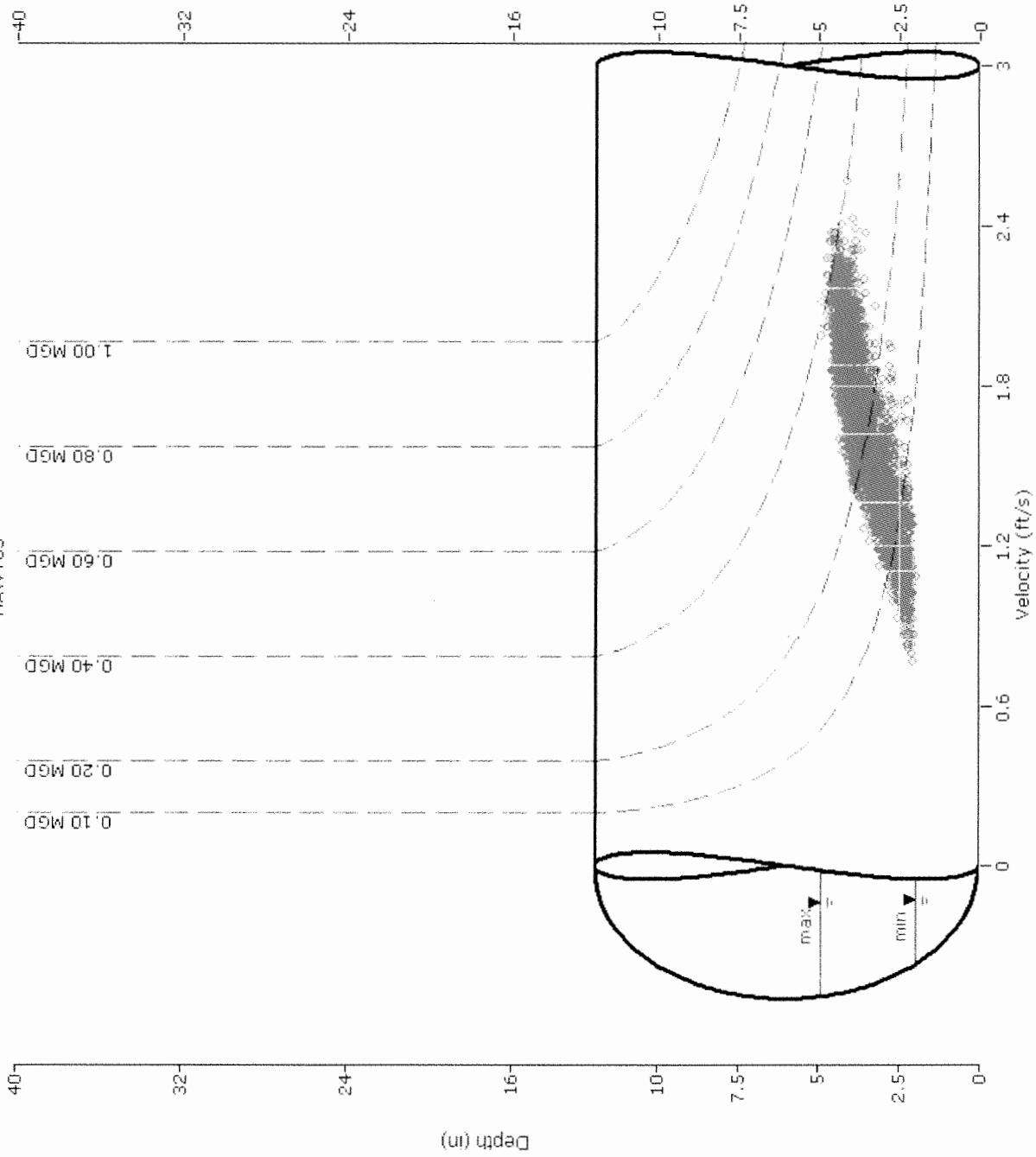

Flow Monitor

HAWT03

Pipe Height
12.00 in

Report Period

5/18/2013
to
5/31/2013

Legend

- Depth - Velocity
- - - Iso-Q***
- - - Silt
- ▼ Min-Max Depth



HYDROGRAPH REPORT

HAWT03

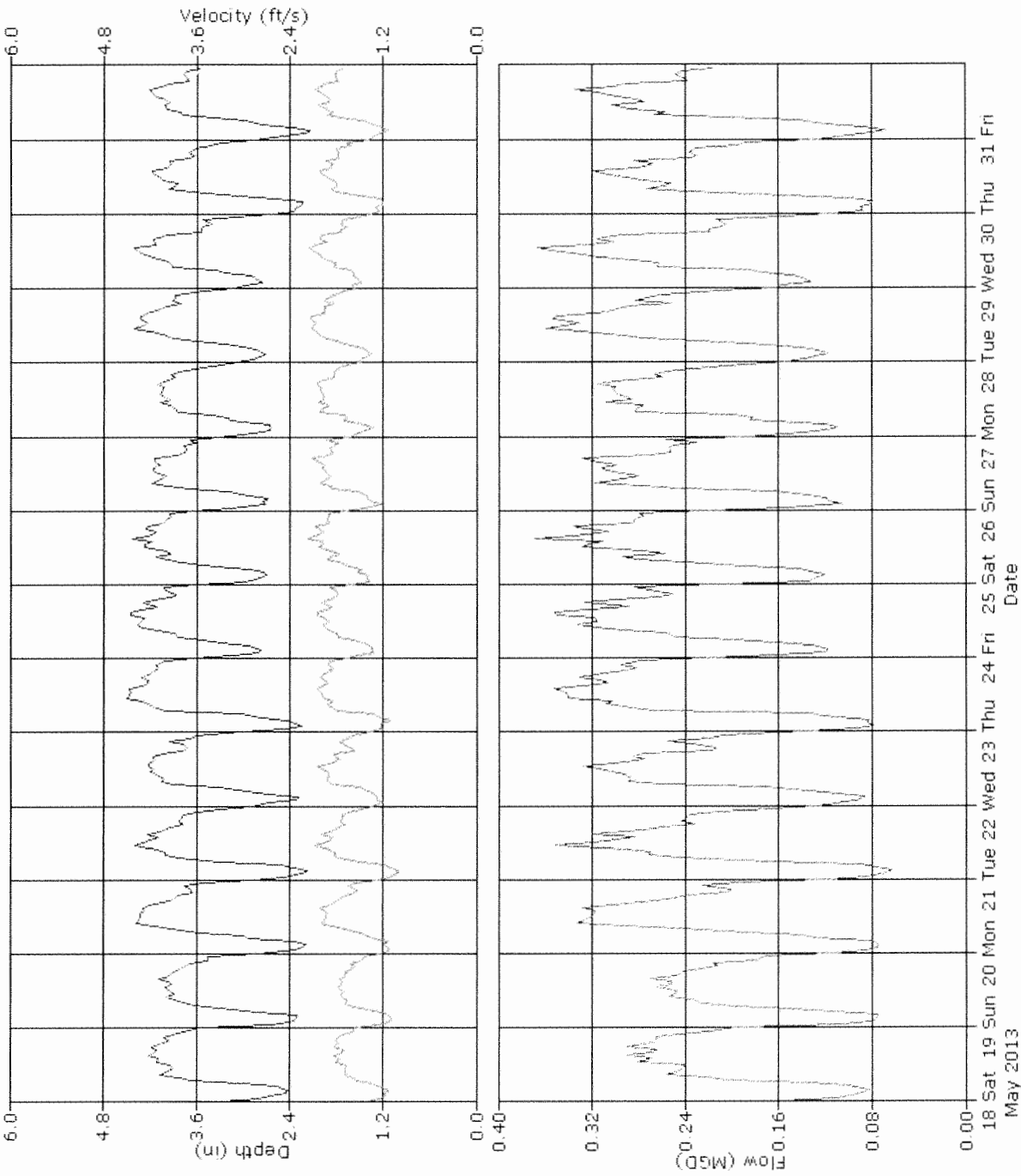

Flow Monitor
HAWT03

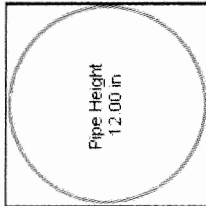

Report Period
5/18/2013
To
5/31/2013

Legend

- Depth
- - - Velocity
- ... Quantity



Daily Tabular Report For The Period 5/18/2013 - 5/31/2013

HAWT03, Pipe Height: 12 in

Daily Tabular Report

Date	Depth (in)			Velocity (ft/s)			Quantity (MGD - Total MG)			Rain (in)						
	Time	Min	Time	Max	Avg	Time	Min	Time	Max	Avg	Time	Max	Avg	Total	Total	
5/18/2013	04:55	2.28	15:45	4.52	3.63	04:40	0.96	14:10	2.12	1.58	04:55	0.067	19:15	0.353	0.213	0.213
5/19/2013	02:45	2.13	16:10	4.37	3.50	02:40	0.87	17:35	2.19	1.54	02:40	0.056	16:10	0.349	0.197	0.197
5/20/2013	04:10	1.97	09:25	4.78	3.58	04:00	0.77	09:20	2.38	1.61	04:00	0.045	09:20	0.413	0.218	0.218
5/21/2013	02:45	2.07	15:35	4.59	3.55	02:35	0.84	11:10	2.22	1.61	03:45	0.049	11:15	0.387	0.216	0.216
5/22/2013	03:55	2.17	12:05	4.60	3.62	03:55	0.84	13:00	2.25	1.66	03:55	0.052	12:05	0.386	0.224	0.224
5/23/2013	03:00	2.10	12:00	4.90	3.78	04:00	0.88	14:25	2.28	1.72	04:00	0.058	11:50	0.415	0.250	0.250
5/24/2013	03:35	2.56	16:00	4.72	3.87	04:20	1.09	12:05	2.28	1.77	04:20	0.096	16:00	0.424	0.258	0.258
5/25/2013	05:00	2.54	16:05	4.62	3.79	04:25	1.06	19:10	2.38	1.81	04:25	0.091	19:10	0.411	0.257	0.257
5/26/2013	02:50	2.56	17:15	4.47	3.68	04:20	1.01	07:30	2.38	1.78	04:20	0.081	17:15	0.377	0.242	0.242
5/27/2013	03:45	2.47	16:55	4.25	3.61	04:00	1.00	11:50	2.57	1.80	04:00	0.076	11:50	0.393	0.238	0.238
5/28/2013	02:55	2.47	11:25	4.63	3.72	03:05	1.19	14:15	2.41	1.82	03:05	0.095	11:25	0.424	0.253	0.253
5/29/2013	02:45	2.61	13:10	4.58	3.64	02:30	1.11	13:10	2.38	1.78	02:30	0.093	13:10	0.424	0.238	0.238
5/30/2013	03:40	2.10	14:05	4.55	3.44	04:30	0.90	17:50	2.27	1.67	04:30	0.055	14:05	0.391	0.211	0.211
5/31/2013	04:05	2.04	16:40	4.59	3.49	03:55	0.93	17:55	2.43	1.71	04:05	0.053	16:40	0.420	0.222	0.222

Report Summary For The Period 5/18/2013 - 5/31/2013

	Depth (in)	Velocity (ft/s)	Quantity (MGD - Total MG)
Total			3.236
Avg	3.64	1.71	0.231

APPENDIX “D”

Copy of Sanitation District
Capacity Letter for Del Amo 5

- Copy of Sanitation District Email

From: Raza, Adriana [araza@lacsds.org]
Sent: Wednesday, March 30, 2016 10:40 AM
To: 'Richard'
Subject: RE: DEI Amo 5 project request Torrance Truck Sewer Capacity Info

Thank you Richard. The following is the information requested:

The Districts' 15 inch diameter South Torrance Trunk Sewer, located in Sepulveda Boulevard at Hawthorne Boulevard, has a capacity of 2.7 million gallons per day (mgd) and conveyed a peak flow of 0.5 mgd when last measured in 2011.

If you have any questions, please email me or contact me at the information below. Have a great day.

Regards,
Adriana Raza
Will Serve Program
Sanitation Districts of Los Angeles County
1955 Workman Mill Road
Whittier, CA 90601
Tel (562) 908-4288 ext. 2717
Fax (562) 695-1874

Appendix 7

Proposed Sewer Study Calculation Summary

Proposed Del Amo Project Unit Summary

Use	Quantity	Unit	Avg Daily Flow (gal/DU)	Unit	Flow (GPD)	Flow (CFS)	Peak Flow (CFS)
Studio	35	ea	150	gal/DU	5,250	0.008	0.033
1 Bdrm	66	ea	200	gal/DU	13,200	0.020	0.078
1Bdrm+den	30	ea	200	gal/DU	6,000	0.009	0.037
2 Bdrm	69	ea	250	gal/DU	17,250	0.027	0.099
Co-work/Leasing	2,690	sf	100	gal/1000sf	269	0.0004	0.002
Clubhouse/Bathrooms/open shower	1,932	sf	100	gal/1000sf	193	0.0003	0.002
Total					42,162	0.0648	0.252

Existing Office Park on South Side of Carson (SS-3025)

Use	Area	Unit	Avg Daily Flow (CFS/Ac)	Unit	Flow (CFS)	Peak Flow (CFS)
Commercial Office Park (SS-3025)	8.12	Ac	0.015	CFS/Ac	0.122	0.393
Total					0.1218	0.393

Proposed CFS increase from 12/16/16 Report **0.645**
 Total Peak Flow from Original 2016 report Parcel A & B 0.162
Total CFS proposed by parcels A-D and the Existing Office Park **0.807**

Page 6 of the 2016 report explains that the existing flow (CFS) downstream of our site is 0.8409

Final proposed flow downstream of Del Amo 5 within Hawthorne Blvd (CFS) 1.65

Revised Table on sheet 6 of the Bryant Palmer Soto Sewer Area Study (Appendix 6)

Pipe	Diameter (inches)	Slope (%)	Mall SS Study Measured 2013		Addendum 1 Mall Increase		Del Amo Circle Apts. and Existing Office Park (SS-3025)		Total Peak Flow (Addendum 1 Mall Increase, Del Amo, and Existing Office Park)	
			Peak Flow	% Full	Peak Flow	% Full	Peak Flow	% Full	Peak Flow	% Full
HAWT01	12	0.24	0.6839	43.48	0.8409	48.92	0.807	49.3	1.648	79.9
HAWT03	12	0.24	0.6561	42.48	0.8131	47.97	0.807	49.3	1.620	78.6

If the mitigation measures provided in the Bryant Palmer Soto report prove to be infeasible, an additional solution is outlined below.

Option A - 15" pipe at 0.24% slope (existing slope)

Pipe	Diameter (inches)	Slope (%)	Total Peak Flow (Addendum 1, Mall Increase, Del Amo, and Existing Office Park)	
			Peak Flow	% Full
HAWT01	15	0.24	1.648	52.1
HAWT03	15	0.24	1.620	51.6

Appendix 8

Flowmaster Calculations and Cross Sections

Cross Section for 12" Sewer pipe @ 0.24% slope

Project Description	
Friction Method	Kutter Formula
Solve For	Normal Depth

Input Data	
Roughness Coefficient	0.013
Channel Slope	0.0024 ft/ft
Normal Depth	9.59 in
Diameter	12.0 in
Discharge	1.65 cfs

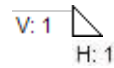
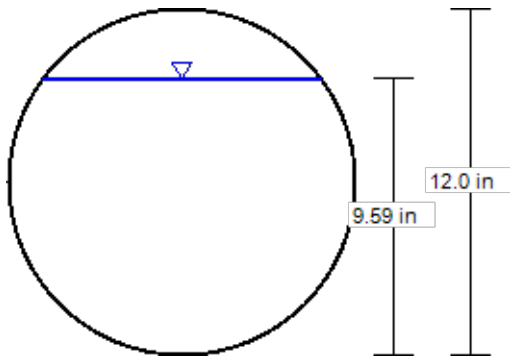

Worksheet for 12" Sewer pipe @ 0.24% slope

Project Description	
Friction Method	Kutter Formula
Solve For	Normal Depth
Input Data	
Roughness Coefficient	0.013
Channel Slope	0.0024 ft/ft
Diameter	12.0 in
Discharge	1.65 cfs
Results	
Normal Depth	9.59 in
Flow Area	0.7 ft ²
Wetted Perimeter	2.2 ft
Hydraulic Radius	3.65 in
Top Width	0.80 ft
Critical Depth	6.55 in
Percent Full	79.9 %
Critical Slope	0.0069 ft/ft
Velocity	2.45 ft/s
Velocity Head	0.09 ft
Specific Energy	0.89 ft
Froude Number	0.471
Maximum Discharge	1.81 cfs
Discharge Full	1.66 cfs
Slope Full	0.0024 ft/ft
Flow Type	Subcritical
GVF Input Data	
Downstream Depth	0.00 in
Length	0.0 ft
Number Of Steps	0
GVF Output Data	
Upstream Depth	0.00 in
Profile Description	N/A
Profile Headloss	0.00 ft
Average End Depth Over Rise	0.0 %
Normal Depth Over Rise	40.5 %
Downstream Velocity	Infinity ft/s
Upstream Velocity	Infinity ft/s
Normal Depth	9.59 in
Critical Depth	6.55 in
Channel Slope	0.0024 ft/ft
Critical Slope	0.0069 ft/ft

Cross Section for 15" Sewer pipe @ 0.24% slope

Project Description	
Friction Method	Kutter Formula
Solve For	Normal Depth

Input Data	
Roughness Coefficient	0.013
Channel Slope	0.0024 ft/ft
Normal Depth	7.82 in
Diameter	15.0 in
Discharge	1.65 cfs

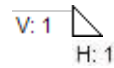
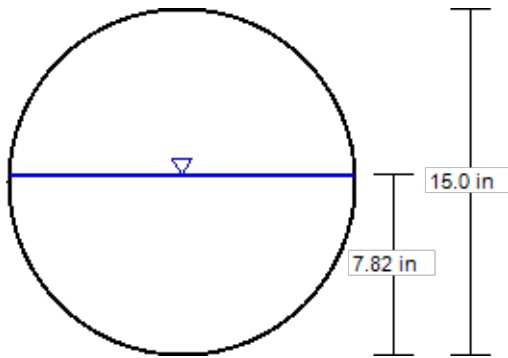

Worksheet for 15" Sewer pipe @ 0.24% slope

Project Description	
Friction Method	Kutter Formula
Solve For	Normal Depth
Input Data	
Roughness Coefficient	0.013
Channel Slope	0.0024 ft/ft
Diameter	15.0 in
Discharge	1.65 cfs
Results	
Normal Depth	7.82 in
Flow Area	0.6 ft ²
Wetted Perimeter	2.0 ft
Hydraulic Radius	3.85 in
Top Width	1.25 ft
Critical Depth	6.11 in
Percent Full	52.1 %
Critical Slope	0.0058 ft/ft
Velocity	2.55 ft/s
Velocity Head	0.10 ft
Specific Energy	0.75 ft
Froude Number	0.624
Maximum Discharge	3.34 cfs
Discharge Full	3.07 cfs
Slope Full	0.0007 ft/ft
Flow Type	Subcritical
GVF Input Data	
Downstream Depth	0.00 in
Length	0.0 ft
Number Of Steps	0
GVF Output Data	
Upstream Depth	0.00 in
Profile Description	N/A
Profile Headloss	0.00 ft
Average End Depth Over Rise	0.0 %
Normal Depth Over Rise	34.6 %
Downstream Velocity	Infinity ft/s
Upstream Velocity	Infinity ft/s
Normal Depth	7.82 in
Critical Depth	6.11 in
Channel Slope	0.0024 ft/ft
Critical Slope	0.0058 ft/ft