

PRELIMINARY
DRAINAGE STUDY
&
HYDRAULIC CALCULATIONS

DRNTY-2022-00005

PREPARED FOR:

MOUNTAIN AVENUE BEES
LYTLE CREEK ROAD
FONTANA, CA 92335
APN 0239-311-03

PREPARED BY:

LAND ENGINEERING CONSULTANTS, INC.
P.O. BOX 541, 650 AVENUE K
CALIMESA, CA. 92320
PH: (909) 795-8882



STEVEN H. RITCHEY

R.C.E. 51129

November 29, 2022
DATE

DISCUSSION

INTRODUCTION

This proposed site is located on the west side of Lytle Creek Road approximately 6,300 feet north of Interstate 15 in the unincorporated area of Fontana within San Bernardino County. The proposed development area sheet flows to the southeast at an approximate average gradient of five percent.

The purpose of this study is to determine the rate of storm water runoff for the design of related drainage facilities for this project, to mitigate increased runoff generated from the proposed development and to address water quality conditions of concern.

The project site encompasses an area of 5.17 acres, and there is a total of 11.01 acres of tributary area that currently drains through this project site. In the proposed condition, the offsite flows will be conveyed around the project through an adequately sized drainage swale.

The project site is located within a studied FEMA Zone X designation area, moderate to low risk, as indicated on Panel 7905 of 9400. The area was studied in Case No. 08-09-0702P, effective October 30, 2008 and has been restudied in Case No. 20-09-1006P, effective December 12, 2022. The project area lies nearby the perimeter of the study area and the offsite flows from the west are in FEMA Zone D designation area, which is an undetermined flood hazard area.

The project site does lie within a Department of Water Resources (DWR) Awareness area from the upstream Grapevine Canyon watershed. This watershed crosses Lytle Creek Road at a culvert bridge crossing just north of the project site then confluences with the Lytle Creek watershed. The DWR Awareness studies are no longer being updated; therefore, at the County's request, the Grapevine Canyon watershed has been analyzed as relates to potential flooding of the project site. The analysis of this watershed shows that the entire flow is easily carried within the existing earthen channel and the existing culvert is adequately sized to carry the flow without the headwater overtopping the bank.

EXISTING WATERSHED DESCRIPTION

The project site currently contains a house, storage building, asphalt drive lane, and a water-well structure and the remaining area is vacant. The entire site sheet flows across the project area to the southeast where it exits the project area and continues in this direction until it joins the drainage swales along Lytle Creek Road. The total runoff generated from the project site during a 100-year 24-hour storm using 25-year rainfall data was determined to be 29.18 cfs in its existing condition.

METHODOLOGY

Rational Method Hydrology

The following scenarios were modeled:

Existing Condition: 100-year for the 1-hour storm

Developed Condition: 100-year for the 1-hour storm

Rainfall depth was derived from precipitation frequency Atlas, NOAA Atlas 14.

Rational method computations were performed using Civilcadd/Civildesign Engineering Software, ver. 7.1, based on the Hydrology Manual. Intensity, runoff coefficients, and discharge were calculated

at each node by the software, based on user input of rainfall, soil type, acreage, and land use parameters.

Printouts of the rational method calculations, as well as, applicable plates from the Manual are included in this report.

Synthetic Hydrograph for Detention Facilities Routing

The following scenario was modeled for peak flows and volume routed through proposed detention facilities:

Existing Condition: 100-year, 25-year, 10-year & 2-year for the 24-hour storms

Development Condition: 100-year, 25-year, 10-year & 2-year for the 24-hour storms

Basin Outflow: 100-year, 25-year, 10-year & 2-year for the 24-hour storms

Rainfall depth was derived from the precipitation frequency Atlas, NOAA Atlas 14.

Synthetic Unit Hydrograph computations were performed using Hydrology Studio 2022 v 3.0.0.26, with data from the San Bernardino County Hydrology Manual methodology.

PROPOSED WATERSHED DESCRIPTION

The project proposes to develop two concrete tilt-up single-story industrial buildings with concrete driveways and parking areas. The offsite flows entering the project area from the north and west will be collected by a drainage swale and conveyed around the project area to bypass the proposed development.

The flows within the project area and generated by the development will be directed around the proposed buildings through swales in the drive lane areas toward a catch basin located in the southeast portion of the drive lane area. The catch basin will then carry the flow to the proposed detention basin (southeast of this location) through an 18-inch PVC pipe. The basin and outlet are designed to detain the increased run-off and outlet it at a rate that is appropriate to mitigate the increase caused by the development of this site. Once the detention basin has completely filled, water may exit through a proposed outlet riser and continue to downstream in its historical course. The total runoff generated from the project during a 100-year 24-hour storm was determined to be 44.65 cfs in its proposed condition.

RESULTS

The detention facilities routing analysis was utilized to design the detention basin and outlet structure facilities to adequately reduce the developed condition peak flow rates to be less than the target peak flow rates as required in accordance with Detention Basin Design Criteria for San Bernardino County and San Bernardino County Detention Basin Design Criteria Memo File 1(FC)-53. The proposed design provides a 4-foot-deep detention basin sized to a total volume of 60,594 cubic feet and an additional 1 foot of freeboard. From full capacity the basin will drawdown in approximately 10 hours. The maximum water surface elevation during a 100-year 24-hour storm is 2183.29 (4.29 feet of depth). During a 100-year 24-hour storm event 44.65 cfs will flow into the basin and 9.49 cfs will outflow, which is less than the target outlet peak flow rate of 26.26 cfs. Tables 1 and 2 below are included as a comparison of the studied flow events target peak flow rates versus the post-basin routed peak flow rates. For each storm event the target flow rates have been met.

Table 1 - Existing Condition and Target Discharge Rates

24-hour Storm Event	Existing Condition Peak Flow Rates	Target Peak Flow Rates (90%)
2-year	11.88	10.69
10-year (using 5-year rainfall)	17.75	15.98
25-year (using 10-year rainfall)	22.59	20.33
100-year (using 25-year rainfall)	29.18	26.26

Table 2 - Developed Condition and Mitigated Discharge Rates

24-hour Storm Event	Developed Condition Peak Flow Rates	Developed Condition Mitigated Peak Flow Rates
2-year	15.21	0.00
10-year	26.84	2.06
25-year	33.86	3.96
100-year	44.65	9.49

Below in Table 3 is a comparison of the rational method 100-year 1-hr results, the peak developed condition 1-hour flow rates were utilized for the hydraulic analysis and design of pipes, swales, catch basins, and culverts.

Table 3 - Rational Method Comparison

Rational Method Results							
Existing Condition				Developed Condition			
Drainage Area	Area (ac)	T_c (min)	Q 100-yr 1-hr (cfs)	Drainage Area	Area (ac)	T_c (min)	Q 100-yr 1-hr (cfs)
100 (offsite)	7.38	13.37	42.76	100 (offsite)	7.38	13.42	42.66
200 (offsite)	3.63	12.45	22.13	200 (offsite)	3.63	12.45	22.13
300 (onsite)	5.12	13.84	28.99	300 & 400 (onsite)	5.12	7.95	42.02
Total	16.13		93.88		16.13		106.81

CONCLUSIONS

This drainage study and the calculations presented herein demonstrate that the onsite flows are collected and carried through the project in a controlled manner within drainage structures adequately sized. All on-site flows are directed toward the detention basin located southeast of the project area to detain the increase run-off generated by the development of this site. This increase has been mitigated by the use of the detention basin and is also sized to retain and mitigate the water quality concerns as outlined in the Water Quality Management Plan.

DRAINAGE AREA MAPS

MOUNTAIN AVENUE BEES - LYTLE CREEK

EXISTING CONDITION DRAINAGE MAP

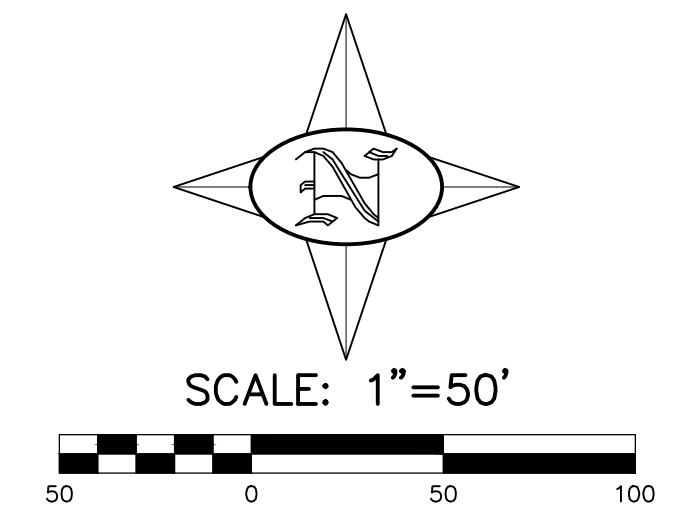

LEGEND:

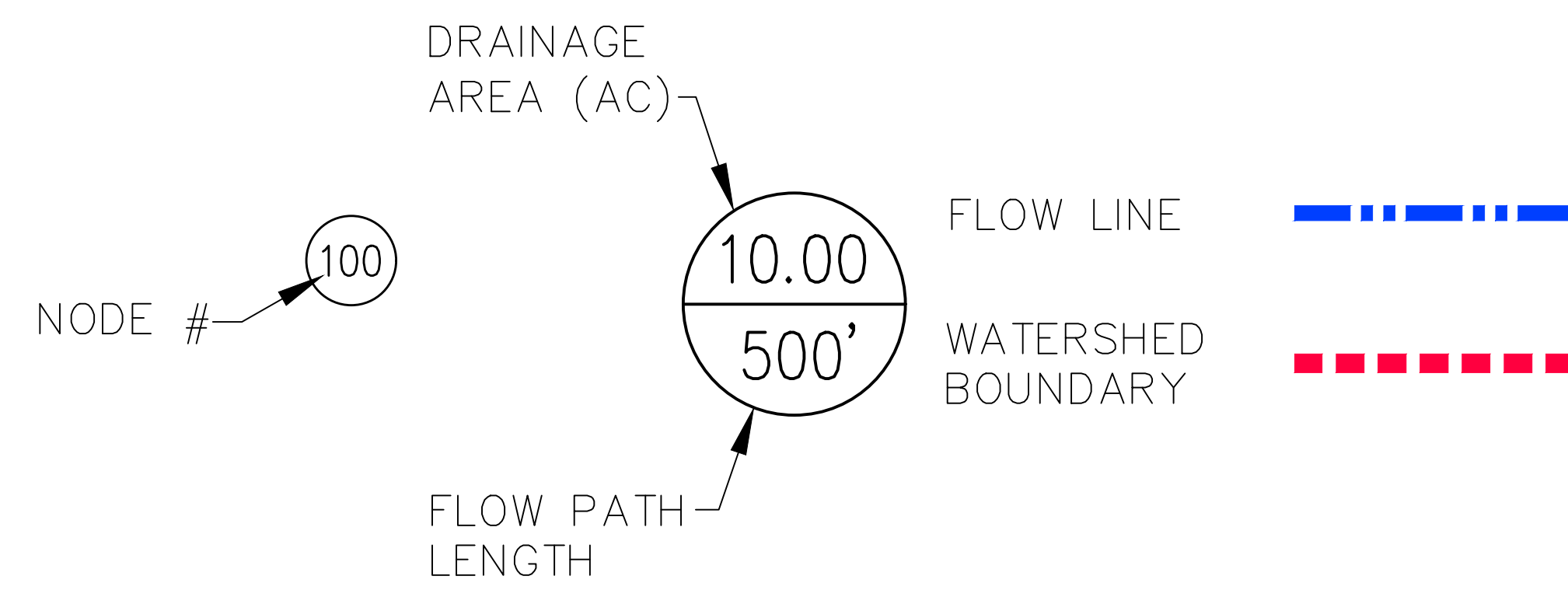

FLOW PROCESS CHART:

FROM NODE	TO NODE	FROM ELEV	TO ELEV	Q (CFS) 100-YR
100	110	2216	2187	26.50
110	120	2216	2187	42.76
200	210	2216	2187	22.13
300	310	2216	2180	28.99

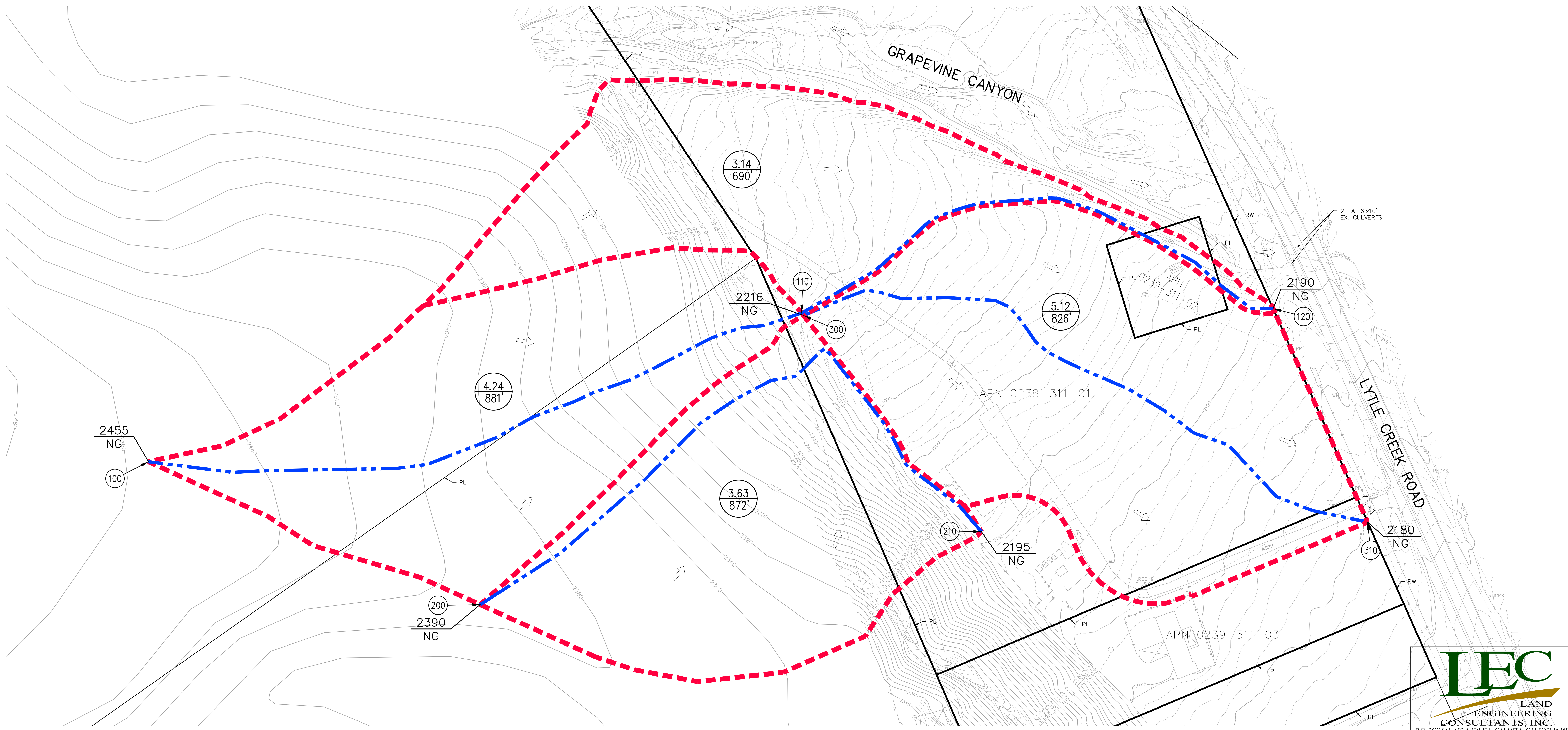

MOUNTAIN AVENUE BEES - LYTLE CREEK

DEVELOPED CONDITION DRAINAGE MAP

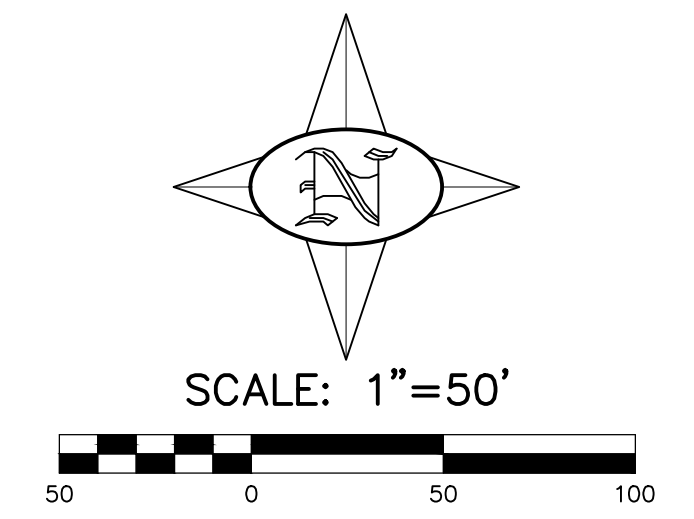

LEGEND:

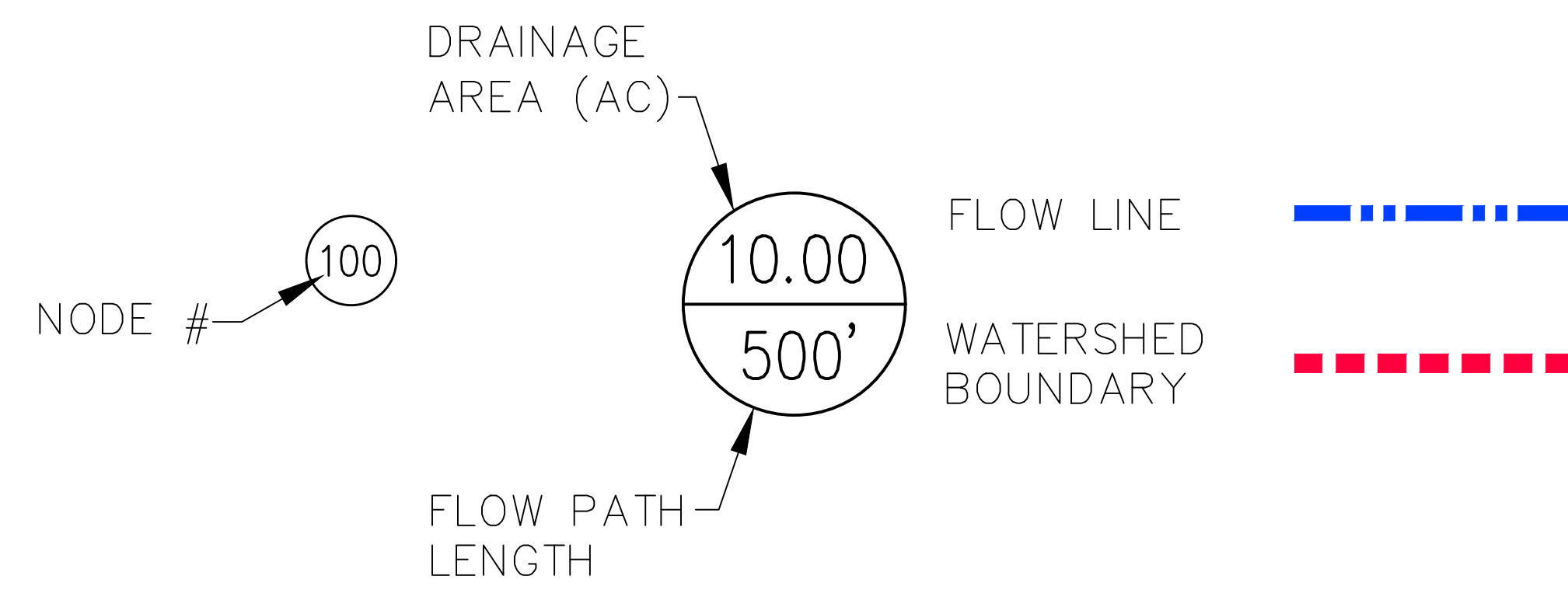

FLOW PROCESS CHART:

FROM NODE	TO NODE	FROM ELEV	TO ELEV	Q (CFS) 100-YR
100	110	2455	2216	26.50
110	120	2214	2190	42.66
200	210	2390	2195	22.13
300	320	2216	2197	16.11
310	320	2205	2197	7.35
320	320	2197	2197	23.13
320	330	2190	2179	23.13
330	330	2179	2179	38.17
400	410	2200	2179	4.11
330	410	2179	2179	42.02

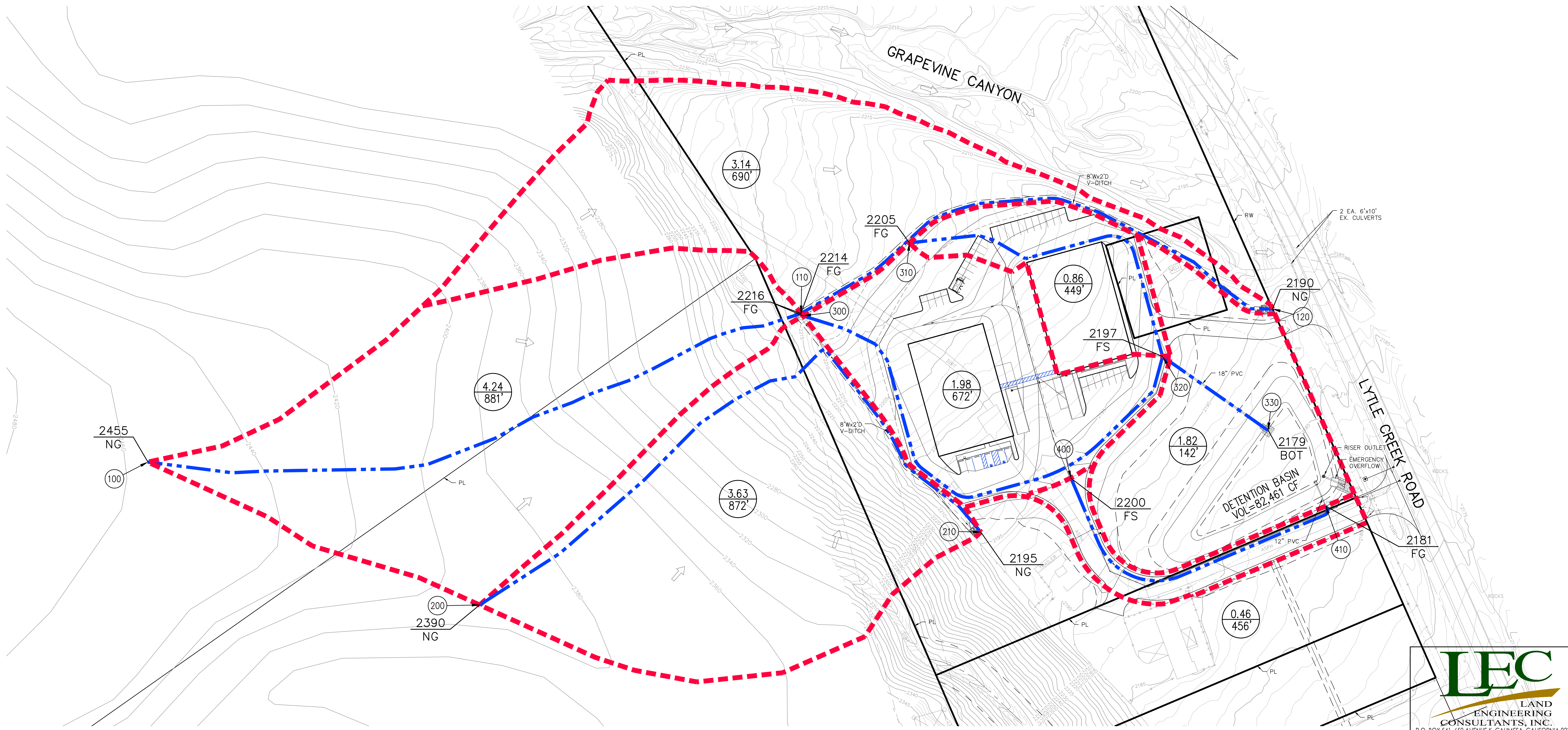

**RATIONAL METHOD HYDROLOGY
DEVELOPED CONDITION**

San Bernardino County Rational Hydrology Program

(Hydrology Manual Date - August 1986)

CIVILCADD/CIVILDESIGN Engineering Software, (c) 1989-2005 Version 7.1
Rational Hydrology Study Date: 11/18/22

MOUNTAIN AVENUE BEES
100 YEAR 1 HOUR STORM
DEVELOPED CONDITION

Program License Serial Number 6165

***** Hydrology Study Control Information *****

Rational hydrology study storm event year is 100.0
Computed rainfall intensity:
Storm year = 100.00 1 hour rainfall = 2.300 (In.)
Slope used for rainfall intensity curve b = 0.7000
Soil antecedent moisture condition (AMC) = 3

+++++
Process from Point/Station 100.000 to Point/Station 110.000
**** INITIAL AREA EVALUATION ****

Soil classification AP and SCS values input by user
USER INPUT of soil data for subarea
SCS curve number for soil(AMC 2) = 78.00
Adjusted SCS curve number for AMC 3 = 92.80
Pervious ratio(Ap) = 1.0000 Max loss rate(Fm)= 0.140(In/Hr)
Initial subarea data:
Initial area flow distance = 881.000(Ft.)
Top (of initial area) elevation = 2455.000(Ft.)
Bottom (of initial area) elevation = 2216.000(Ft.)
Difference in elevation = 239.000(Ft.)
Slope = 0.27128 s(%)= 27.13
TC = k(0.615)*[(length^3)/(elevation change)]^0.2
Initial area time of concentration = 12.028 min.
Rainfall intensity = 7.084(In/Hr) for a 100.0 year storm
Effective runoff coefficient used for area (Q=KCIA) is C = 0.882
Subarea runoff = 26.500(CFS)
Total initial stream area = 4.240(Ac.)
Pervious area fraction = 1.000
Initial area Fm value = 0.140(In/Hr)

+++++
Process from Point/Station 110.000 to Point/Station 120.000
**** IMPROVED CHANNEL TRAVEL TIME ****

Upstream point elevation = 2214.000(Ft.)
 Downstream point elevation = 2190.000(Ft.)
 Channel length thru subarea = 690.000(Ft.)
 Channel base width = 0.000(Ft.)
 Slope or 'Z' of left channel bank = 2.000
 Slope or 'Z' of right channel bank = 2.000
 Estimated mean flow rate at midpoint of channel = 34.609(CFS)
 Manning's 'N' = 0.025
 Maximum depth of channel = 2.000(Ft.)
 Flow(q) thru subarea = 34.609(CFS)
 Depth of flow = 1.445(Ft.), Average velocity = 8.286(Ft/s)
 Channel flow top width = 5.780(Ft.)
 Flow Velocity = 8.29(Ft/s)
 Travel time = 1.39 min.
 Time of concentration = 13.42 min.
 Critical depth = 1.797(Ft.)
 Adding area flow to channel
 Soil classification AP and SCS values input by user
 USER INPUT of soil data for subarea
 SCS curve number for soil(AMC 2) = 78.00
 Adjusted SCS curve number for AMC 3 = 92.80
 Pervious ratio(Ap) = 1.0000 Max loss rate(Fm)= 0.140(In/Hr)
 Rainfall intensity = 6.563(In/Hr) for a 100.0 year storm
 Effective runoff coefficient used for area,(total area with modified
 rational method)(Q=KCIA) is C = 0.881
 Subarea runoff = 16.162(CFS) for 3.140(Ac.)
 Total runoff = 42.662(CFS)
 Effective area this stream = 7.38(Ac.)
 Total Study Area (Main Stream No. 1) = 7.38(Ac.)
 Area averaged Fm value = 0.140(In/Hr)
 Depth of flow = 1.563(Ft.), Average velocity = 8.731(Ft/s)
 Critical depth = 1.953(Ft.)

++++++
 Process from Point/Station 200.000 to Point/Station 210.000
 **** INITIAL AREA EVALUATION ****

Soil classification AP and SCS values input by user
 USER INPUT of soil data for subarea
 SCS curve number for soil(AMC 2) = 78.00
 Adjusted SCS curve number for AMC 3 = 92.80
 Pervious ratio(Ap) = 1.0000 Max loss rate(Fm)= 0.140(In/Hr)
 Initial subarea data:
 Initial area flow distance = 872.000(Ft.)
 Top (of initial area) elevation = 2390.000(Ft.)
 Bottom (of initial area) elevation = 2195.000(Ft.)
 Difference in elevation = 195.000(Ft.)
 Slope = 0.22362 s(%)= 22.36
 $TC = k(0.615)*[(length^3)/(elevation\ change)]^{0.2}$
 Initial area time of concentration = 12.451 min.
 Rainfall intensity = 6.915(In/Hr) for a 100.0 year storm
 Effective runoff coefficient used for area (Q=KCIA) is C = 0.882
 Subarea runoff = 22.134(CFS)
 Total initial stream area = 3.630(Ac.)
 Pervious area fraction = 1.000
 Initial area Fm value = 0.140(In/Hr)

+++++
Process from Point/Station 300.000 to Point/Station 320.000
**** INITIAL AREA EVALUATION ****

COMMERCIAL subarea type
Decimal fraction soil group A = 1.000
Decimal fraction soil group B = 0.000
Decimal fraction soil group C = 0.000
Decimal fraction soil group D = 0.000
SCS curve number for soil(AMC 2) = 32.00
Adjusted SCS curve number for AMC 3 = 52.00
Pervious ratio(Ap) = 0.1000 Max loss rate(Fm)= 0.079(In/Hr)
Initial subarea data:
Initial area flow distance = 672.000(Ft.)
Top (of initial area) elevation = 2216.000(Ft.)
Bottom (of initial area) elevation = 2197.000(Ft.)
Difference in elevation = 19.000(Ft.)
Slope = 0.02827 s(%)= 2.83
TC = k(0.304)*[(length^3)/(elevation change)]^0.2
Initial area time of concentration = 8.386 min.
Rainfall intensity = 9.119(In/Hr) for a 100.0 year storm
Effective runoff coefficient used for area (Q=KCIA) is C = 0.892
Subarea runoff = 16.110(CFS)
Total initial stream area = 1.980(Ac.)
Pervious area fraction = 0.100
Initial area Fm value = 0.079(In/Hr)

+++++
Process from Point/Station 300.000 to Point/Station 320.000
**** CONFLUENCE OF MAIN STREAMS ****

The following data inside Main Stream is listed:

In Main Stream number: 1
Stream flow area = 1.980(Ac.)
Runoff from this stream = 16.110(CFS)
Time of concentration = 8.39 min.
Rainfall intensity = 9.119(In/Hr)
Area averaged loss rate (Fm) = 0.0785(In/Hr)
Area averaged Pervious ratio (Ap) = 0.1000
Program is now starting with Main Stream No. 2

+++++
Process from Point/Station 310.000 to Point/Station 320.000
**** INITIAL AREA EVALUATION ****

COMMERCIAL subarea type
Decimal fraction soil group A = 1.000
Decimal fraction soil group B = 0.000
Decimal fraction soil group C = 0.000
Decimal fraction soil group D = 0.000
SCS curve number for soil(AMC 2) = 32.00
Adjusted SCS curve number for AMC 3 = 52.00
Pervious ratio(Ap) = 0.1000 Max loss rate(Fm)= 0.079(In/Hr)

Initial subarea data:
 Initial area flow distance = 449.000(Ft.)
 Top (of initial area) elevation = 2205.000(Ft.)
 Bottom (of initial area) elevation = 2197.000(Ft.)
 Difference in elevation = 8.000(Ft.)
 Slope = 0.01782 s(%)= 1.78
 $TC = k(0.304)*[(length^3)/(elevation\ change)]^{0.2}$
 Initial area time of concentration = 7.827 min.
 Rainfall intensity = 9.570(In/Hr) for a 100.0 year storm
 Effective runoff coefficient used for area (Q=KCIA) is C = 0.893
 Subarea runoff = 7.346(CFS)
 Total initial stream area = 0.860(Ac.)
 Pervious area fraction = 0.100
 Initial area Fm value = 0.079(In/Hr)

+++++
 Process from Point/Station 310.000 to Point/Station 320.000
 **** CONFLUENCE OF MAIN STREAMS ****

The following data inside Main Stream is listed:

In Main Stream number: 2
 Stream flow area = 0.860(Ac.)
 Runoff from this stream = 7.346(CFS)
 Time of concentration = 7.83 min.
 Rainfall intensity = 9.570(In/Hr)
 Area averaged loss rate (Fm) = 0.0785(In/Hr)
 Area averaged Pervious ratio (Ap) = 0.1000
 Summary of stream data:

Stream No.	Flow rate (CFS)	Area (Ac.)	TC (min)	Fm (In/Hr)	Rainfall Intensity (In/Hr)
------------	-----------------	------------	----------	------------	----------------------------

1	16.11	1.980	8.39	0.079	9.119
2	7.35	0.860	7.83	0.079	9.570

Qmax(1) =
 1.000 * 1.000 * 16.110) +
 0.952 * 1.000 * 7.346) + = 23.108

Qmax(2) =
 1.050 * 0.933 * 16.110) +
 1.000 * 1.000 * 7.346) + = 23.133

Total of 2 main streams to confluence:
 Flow rates before confluence point:
 17.110 8.346
 Maximum flow rates at confluence using above data:
 23.108 23.133
 Area of streams before confluence:
 1.980 0.860
 Effective area values after confluence:
 2.840 2.708

Results of confluence:
 Total flow rate = 23.133(CFS)
 Time of concentration = 7.827 min.

Effective stream area after confluence = 2.708(Ac.)
Study area average Pervious fraction(Ap) = 0.100
Study area average soil loss rate(Fm) = 0.079(In/Hr)
Study area total = 2.84(Ac.)

+++++
Process from Point/Station 320.000 to Point/Station 330.000
**** PIPEFLOW TRAVEL TIME (User specified size) ****

Upstream point/station elevation = 2190.000(Ft.)
Downstream point/station elevation = 2179.000(Ft.)
Pipe length = 142.00(Ft.) Manning's N = 0.012
No. of pipes = 1 Required pipe flow = 23.133(CFS)
Given pipe size = 18.00(In.)
Calculated individual pipe flow = 23.133(CFS)
Normal flow depth in pipe = 11.41(In.)
Flow top width inside pipe = 17.34(In.)
Critical depth could not be calculated.
Pipe flow velocity = 19.56(Ft/s)
Travel time through pipe = 0.12 min.
Time of concentration (TC) = 7.95 min.

+++++
Process from Point/Station 320.000 to Point/Station 330.000
**** SUBAREA FLOW ADDITION ****

Soil classification AP and SCS values input by user
USER INPUT of soil data for subarea
SCS curve number for soil(AMC 2) = 78.00
Adjusted SCS curve number for AMC 3 = 92.80
Pervious ratio(Ap) = 0.9600 Max loss rate(Fm)= 0.134(In/Hr)
Time of concentration = 7.95 min.
Rainfall intensity = 9.468(In/Hr) for a 100.0 year storm
Effective runoff coefficient used for area,(total area with modified
rational method)(Q=KCIA) is C = 0.890
Subarea runoff = 15.039(CFS) for 1.820(Ac.)
Total runoff = 38.172(CFS)
Effective area this stream = 4.53(Ac.)
Total Study Area (Main Stream No. 1) = 15.67(Ac.)
Area averaged Fm value = 0.101(In/Hr)

+++++
Process from Point/Station 320.000 to Point/Station 330.000
**** CONFLUENCE OF MAIN STREAMS ****

The following data inside Main Stream is listed:
In Main Stream number: 1
Stream flow area = 4.528(Ac.)
Runoff from this stream = 38.172(CFS)
Time of concentration = 7.95 min.
Rainfall intensity = 9.468(In/Hr)
Area averaged loss rate (Fm) = 0.1010(In/Hr)
Area averaged Pervious ratio (Ap) = 0.4457
Program is now starting with Main Stream No. 2

```

+++++
Process from Point/Station      400.000 to Point/Station      410.000
**** INITIAL AREA EVALUATION ****

```

```

Soil classification AP and SCS values input by user
USER INPUT of soil data for subarea
SCS curve number for soil(AMC 2) = 32.00
Adjusted SCS curve number for AMC 3 = 52.00
Pervious ratio(Ap) = 0.2300      Max loss rate(Fm)=      0.181(In/Hr)
Initial subarea data:
Initial area flow distance = 456.000(Ft.)
Top (of initial area) elevation = 2200.000(Ft.)
Bottom (of initial area) elevation = 2181.000(Ft.)
Difference in elevation = 19.000(Ft.)
Slope = 0.04167 s(%)= 4.17
TC = k(0.331)*[(length^3)/(elevation change)]^0.2
Initial area time of concentration = 7.240 min.
Rainfall intensity = 10.107(In/Hr) for a 100.0 year storm
Effective runoff coefficient used for area (Q=KCIA) is C = 0.884
Subarea runoff = 4.109(CFS)
Total initial stream area = 0.460(Ac.)
Pervious area fraction = 0.230
Initial area Fm value = 0.181(In/Hr)

```

```

+++++
Process from Point/Station      400.000 to Point/Station      410.000
**** CONFLUENCE OF MAIN STREAMS ****

```

The following data inside Main Stream is listed:

```

In Main Stream number: 2
Stream flow area = 0.460(Ac.)
Runoff from this stream = 4.109(CFS)
Time of concentration = 7.24 min.
Rainfall intensity = 10.107(In/Hr)
Area averaged loss rate (Fm) = 0.1806(In/Hr)
Area averaged Pervious ratio (Ap) = 0.2300
Summary of stream data:

```

Stream No.	Flow rate (CFS)	Area (Ac.)	TC (min)	Fm (In/Hr)	Rainfall Intensity (In/Hr)
1	38.17	4.528	7.95	0.101	9.468
2	4.11	0.460	7.24	0.181	10.107
Qmax(1) =					
	1.000 *	1.000 *	38.172) +		
	0.936 *	1.000 *	4.109) + =		42.017
Qmax(2) =					
	1.068 *	0.911 *	38.172) +		
	1.000 *	1.000 *	4.109) + =		41.253

```

Total of 2 main streams to confluence:
Flow rates before confluence point:
    39.172      5.109

```

Maximum flow rates at confluence using above data:

42.017 41.253

Area of streams before confluence:

4.528 0.460

Effective area values after confluence:

4.988 4.585

Results of confluence:

Total flow rate = 42.017(CFS)

Time of concentration = 7.948 min.

Effective stream area after confluence = 4.988(Ac.)

Study area average Pervious fraction(A_p) = 0.426

Study area average soil loss rate(F_m) = 0.108(In/Hr)

Study area total = 4.99(Ac.)

End of computations, Total Study Area = 16.13 (Ac.)

The following figures may

be used for a unit hydrograph study of the same area.

Note: These figures do not consider reduced effective area effects caused by confluences in the rational equation.

Area averaged pervious area fraction(A_p) = 0.815

Area averaged SCS curve number = 68.6

**RATIONAL METHOD HYDROLOGY
EXISTING CONDITION**

San Bernardino County Rational Hydrology Program

(Hydrology Manual Date - August 1986)

CIVILCADD/CIVILDESIGN Engineering Software, (c) 1989-2005 Version 7.1
Rational Hydrology Study Date: 11/18/22

MOUNTAIN AVENUE BEES
100 YEAR 1 HOUR STORM
EXISTING CONDITION

Program License Serial Number 6165

***** Hydrology Study Control Information *****

Rational hydrology study storm event year is 100.0
Computed rainfall intensity:
Storm year = 100.00 1 hour rainfall = 2.300 (In.)
Slope used for rainfall intensity curve b = 0.7000
Soil antecedent moisture condition (AMC) = 3

+++++
Process from Point/Station 100.000 to Point/Station 110.000
**** INITIAL AREA EVALUATION ****

Soil classification AP and SCS values input by user
USER INPUT of soil data for subarea
SCS curve number for soil(AMC 2) = 78.00
Adjusted SCS curve number for AMC 3 = 92.80
Pervious ratio(Ap) = 1.0000 Max loss rate(Fm)= 0.140(In/Hr)
Initial subarea data:
Initial area flow distance = 881.000(Ft.)
Top (of initial area) elevation = 2455.000(Ft.)
Bottom (of initial area) elevation = 2216.000(Ft.)
Difference in elevation = 239.000(Ft.)
Slope = 0.27128 s(%)= 27.13
TC = k(0.615)*[(length^3)/(elevation change)]^0.2
Initial area time of concentration = 12.028 min.
Rainfall intensity = 7.084(In/Hr) for a 100.0 year storm
Effective runoff coefficient used for area (Q=KCIA) is C = 0.882
Subarea runoff = 26.500(CFS)
Total initial stream area = 4.240(Ac.)
Pervious area fraction = 1.000
Initial area Fm value = 0.140(In/Hr)

+++++
Process from Point/Station 110.000 to Point/Station 120.000
**** IMPROVED CHANNEL TRAVEL TIME ****

Upstream point elevation = 2216.000(Ft.)
 Downstream point elevation = 2190.000(Ft.)
 Channel length thru subarea = 690.000(Ft.)
 Channel base width = 0.000(Ft.)
 Slope or 'Z' of left channel bank = 2.000
 Slope or 'Z' of right channel bank = 2.000
 Estimated mean flow rate at midpoint of channel = 34.656(CFS)
 Manning's 'N' = 0.025
 Maximum depth of channel = 2.000(Ft.)
 Flow(q) thru subarea = 34.656(CFS)
 Depth of flow = 1.424(Ft.), Average velocity = 8.542(Ft/s)
 Channel flow top width = 5.697(Ft.)
 Flow Velocity = 8.54(Ft/s)
 Travel time = 1.35 min.
 Time of concentration = 13.37 min.
 Critical depth = 1.797(Ft.)
 Adding area flow to channel
 Soil classification AP and SCS values input by user
 USER INPUT of soil data for subarea
 SCS curve number for soil(AMC 2) = 78.00
 Adjusted SCS curve number for AMC 3 = 92.80
 Pervious ratio(Ap) = 1.0000 Max loss rate(Fm)= 0.140(In/Hr)
 Rainfall intensity = 6.577(In/Hr) for a 100.0 year storm
 Effective runoff coefficient used for area,(total area with modified
 rational method)(Q=KCIA) is C = 0.881
 Subarea runoff = 16.257(CFS) for 3.140(Ac.)
 Total runoff = 42.756(CFS)
 Effective area this stream = 7.38(Ac.)
 Total Study Area (Main Stream No. 1) = 7.38(Ac.)
 Area averaged Fm value = 0.140(In/Hr)
 Depth of flow = 1.541(Ft.), Average velocity = 9.002(Ft/s)
 Critical depth = 1.953(Ft.)

++++++
 Process from Point/Station 200.000 to Point/Station 210.000
 **** INITIAL AREA EVALUATION ****

Soil classification AP and SCS values input by user
 USER INPUT of soil data for subarea
 SCS curve number for soil(AMC 2) = 78.00
 Adjusted SCS curve number for AMC 3 = 92.80
 Pervious ratio(Ap) = 1.0000 Max loss rate(Fm)= 0.140(In/Hr)
 Initial subarea data:
 Initial area flow distance = 872.000(Ft.)
 Top (of initial area) elevation = 2390.000(Ft.)
 Bottom (of initial area) elevation = 2195.000(Ft.)
 Difference in elevation = 195.000(Ft.)
 Slope = 0.22362 s(%)= 22.36
 $TC = k(0.615)*[(length^3)/(elevation\ change)]^{0.2}$
 Initial area time of concentration = 12.451 min.
 Rainfall intensity = 6.915(In/Hr) for a 100.0 year storm
 Effective runoff coefficient used for area (Q=KCIA) is C = 0.882
 Subarea runoff = 22.134(CFS)
 Total initial stream area = 3.630(Ac.)
 Pervious area fraction = 1.000
 Initial area Fm value = 0.140(In/Hr)

+++++
Process from Point/Station 300.000 to Point/Station 310.000
**** INITIAL AREA EVALUATION ****

Soil classification AP and SCS values input by user
USER INPUT of soil data for subarea
SCS curve number for soil(AMC 2) = 78.00
Adjusted SCS curve number for AMC 3 = 92.80
Pervious ratio(Ap) = 0.9300 Max loss rate(Fm)= 0.130(In/Hr)
Initial subarea data:
Initial area flow distance = 826.000(Ft.)
Top (of initial area) elevation = 2216.000(Ft.)
Bottom (of initial area) elevation = 2180.000(Ft.)
Difference in elevation = 36.000(Ft.)
Slope = 0.04358 s(%)= 4.36
TC = $k(0.504)*[(length^3)/(elevation\ change)]^{0.2}$
Initial area time of concentration = 13.843 min.
Rainfall intensity = 6.421(In/Hr) for a 100.0 year storm
Effective runoff coefficient used for area (Q=KCIA) is C = 0.882
Subarea runoff = 28.986(CFS)
Total initial stream area = 5.120(Ac.)
Pervious area fraction = 0.930
Initial area Fm value = 0.130(In/Hr)
End of computations, Total Study Area = 16.13 (Ac.)
The following figures may
be used for a unit hydrograph study of the same area.
Note: These figures do not consider reduced effective area
effects caused by confluences in the rational equation.

Area averaged pervious area fraction(Ap) = 0.978
Area averaged SCS curve number = 78.0

INFILTRATION BASIN
HYDROGRAPH ROUTING

Table of Contents

Project Name:

Hydrology Studio v 3.0.0.26

11-29-2022

Basin Model Schematic	1
Hydrograph by Return Period	2
2 - Year	
Hydrograph Summary	3
Hydrograph Reports	
Hydrograph No. 1, NRCS Runoff, EX CONDITION DA 1	4
Hydrograph No. 2, NRCS Runoff, DEV CONDITION DA 1	5
Hydrograph No. 3, Pond Route, BASIN 1	6
Detention Pond Reports - BASIN	7
Design Storm Report - NRCS/SCS - Type I, 24-hr	11
5 - Year	
Hydrograph Summary	12
Hydrograph Reports	
Hydrograph No. 1, NRCS Runoff, EX CONDITION DA 1	13
Hydrograph No. 2, NRCS Runoff, DEV CONDITION DA 1	14
Hydrograph No. 3, Pond Route, BASIN 1	15
Design Storm Report - NRCS/SCS - Type I, 24-hr	16
10 - Year	
Hydrograph Summary	17
Hydrograph Reports	
Hydrograph No. 1, NRCS Runoff, EX CONDITION DA 1	18
Hydrograph No. 2, NRCS Runoff, DEV CONDITION DA 1	19
Hydrograph No. 3, Pond Route, BASIN 1	20
Design Storm Report - NRCS/SCS - Type I, 24-hr	21
25 - Year	
Hydrograph Summary	22
Hydrograph Reports	
Hydrograph No. 1, NRCS Runoff, EX CONDITION DA 1	23
Hydrograph No. 2, NRCS Runoff, DEV CONDITION DA 1	24
Hydrograph No. 3, Pond Route, BASIN 1	25
Design Storm Report - NRCS/SCS - Type I, 24-hr	26
100 - Year	
Hydrograph Summary	27
Hydrograph Reports	
Hydrograph No. 1, NRCS Runoff, EX CONDITION DA 1	28
Hydrograph No. 2, NRCS Runoff, DEV CONDITION DA 1	29

Contents continued...

Hydrograph No. 3, Pond Route, BASIN 1	30
Design Storm Report - NRCS/SCS - Type I, 24-hr	31
IDF Report	32
Precipitation Report	33

Basin Model

Hydrology Studio v 3.0.0.26

Project Name:

11-29-2022

EX CONDITION DA 1



DEV CONDITION DA 1



BASIN 1

Hydrograph by Return Period

Project Name:

Hydrology Studio v 3.0.0.26

11-29-2022

Hyd. No.	Hydrograph Type	Hydrograph Name	Peak Outflow (cfs)							
			1-yr	2-yr	3-yr	5-yr	10-yr	25-yr	50-yr	100-yr
1	NRCS Runoff	EX CONDITION DA 1		11.88		17.75	22.59	29.18		39.37
2	NRCS Runoff	DEV CONDITION DA 1		15.21		21.64	26.84	33.86		44.65
3	Pond Route	BASIN 1		0.000		0.818	2.060	3.955		9.490

Hydrograph 2-yr Summary

Project Name:

Hydrology Studio v 3.0.0.26

11-29-2022

Hyd. No.	Hydrograph Type	Hydrograph Name	Peak Flow (cfs)	Time to Peak (hrs)	Hydrograph Volume (cuft)	Inflow Hyd(s)	Maximum Elevation (ft)	Maximum Storage (cuft)
1	NRCS Runoff	EX CONDITION DA 1	11.88	10.00	61,947	---		
2	NRCS Runoff	DEV CONDITION DA 1	15.21	9.97	70,369	---		
3	Pond Route	BASIN 1	0.000	8.80	0.000	2	2180.89	23,711

Hydrograph Report

Project Name:

Hydrology Studio v 3.0.0.26

11-29-2022

EX CONDITION DA 1

Hyd. No. 1

Hydrograph Type	= NRCS Runoff	Peak Flow	= 11.88 cfs
Storm Frequency	= 2-yr	Time to Peak	= 10.00 hrs
Time Interval	= 2 min	Runoff Volume	= 61,947 cuft
Drainage Area	= 5.12 ac	Curve Number	= 79.41*
Tc Method	= User	Time of Conc. (Tc)	= 12.45 min
Total Rainfall	= 5.45 in	Design Storm	= Type I
Storm Duration	= 24 hrs	Shape Factor	= 484

* Composite CN Worksheet

AREA (ac)	CN	DESCRIPTION
4.76	78	BARREN
0.36	98	IMPERVIOUS
5.12	79	Weighted CN Method Employed

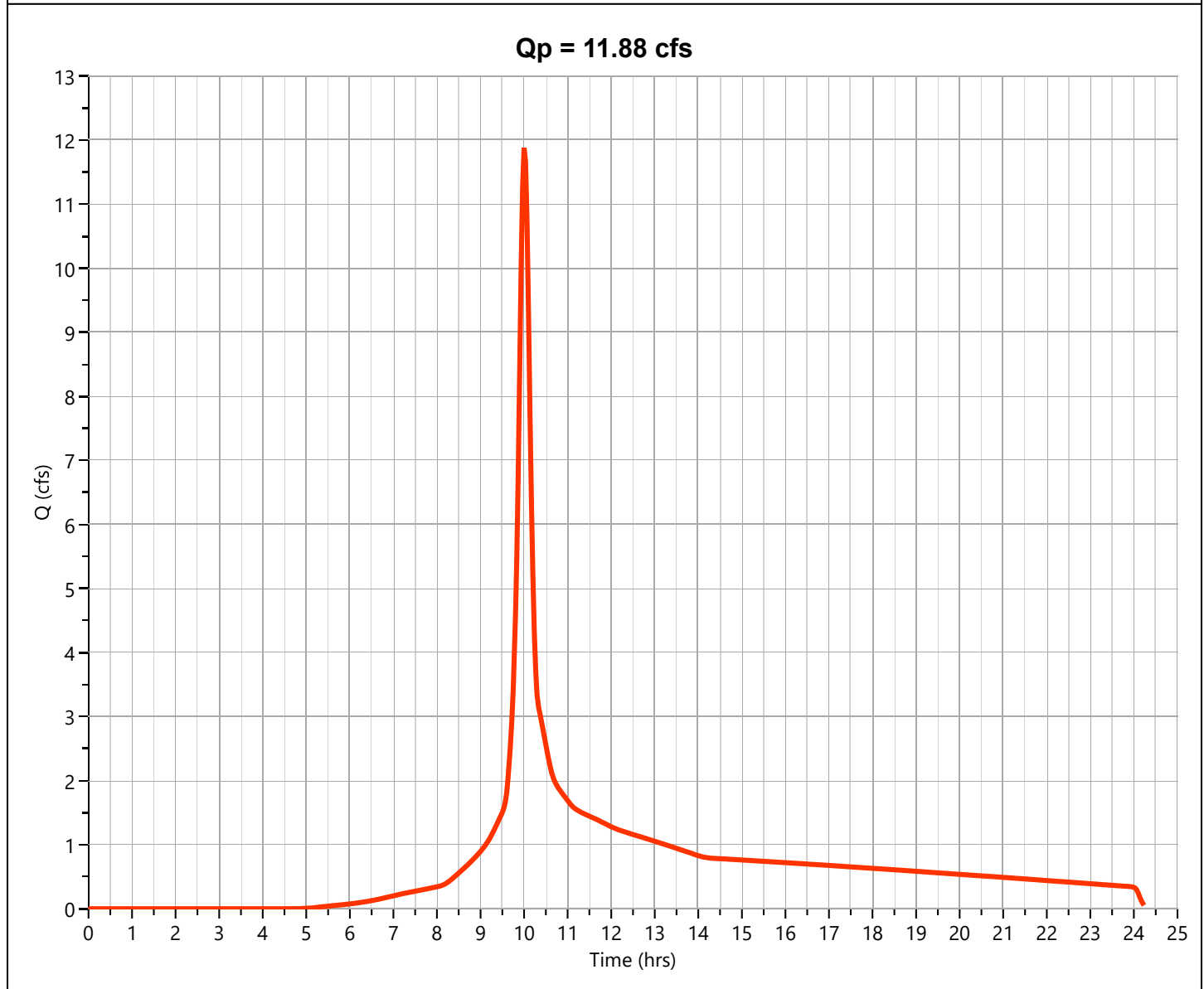

Hydrograph Report

Project Name:

Hydrology Studio v 3.0.0.26

11-29-2022

DEV CONDITION DA 1

Hyd. No. 2

Hydrograph Type	= NRCS Runoff	Peak Flow	= 15.21 cfs
Storm Frequency	= 2-yr	Time to Peak	= 9.97 hrs
Time Interval	= 2 min	Runoff Volume	= 70,369 cuft
Drainage Area	= 5.12 ac	Curve Number	= 85*
Tc Method	= User	Time of Conc. (Tc)	= 7.95 min
Total Rainfall	= 5.45 in	Design Storm	= Type I
Storm Duration	= 24 hrs	Shape Factor	= 484

* Composite CN Worksheet

AREA (ac)	CN	DESCRIPTION
2.61	98	CONC/BLDG
2.15	78	NATURAL
0.36	32	LANDSCAPE
5.12	85	Weighted CN Method Employed

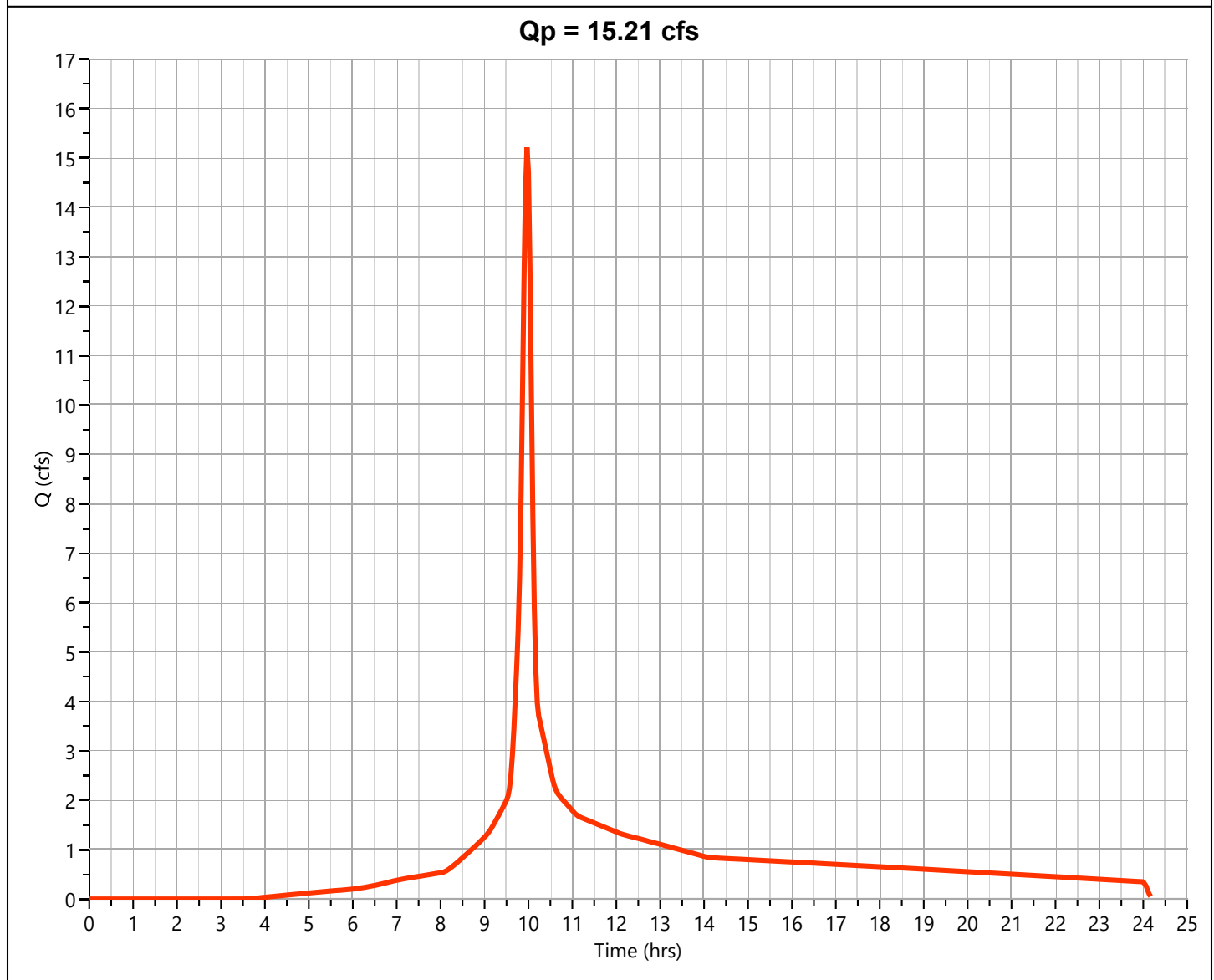

Hydrograph Report

Project Name:

Hydrology Studio v 3.0.0.26

11-29-2022

BASIN 1

Hyd. No. 3

Hydrograph Type	= Pond Route	Peak Flow	= 0.000 cfs
Storm Frequency	= 2-yr	Time to Peak	= 8.80 hrs
Time Interval	= 2 min	Hydrograph Volume	= 0.000 cuft
Inflow Hydrograph	= 2 - DEV CONDITION DA 1	Max. Elevation	= 2180.89 ft
Pond Name	= BASIN	Max. Storage	= 23,711 cuft

Pond Routing by Storage Indication Method

Qp = 0.00 cfs

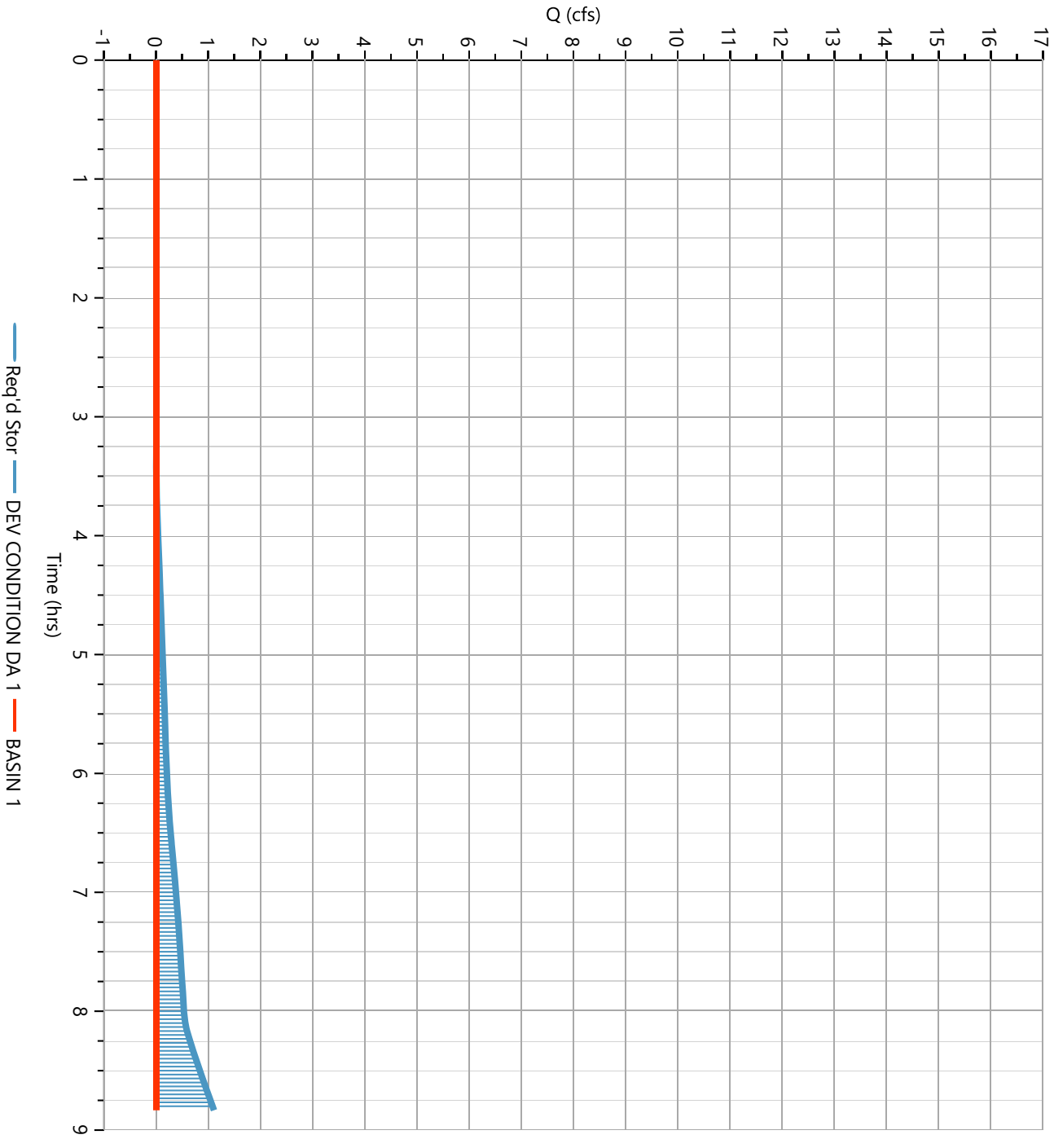

Pond Report

Project Name:

Hydrology Studio v 3.0.0.26

11-29-2022

BASIN

Stage-Storage

User Defined Contours		Stage / Storage Table				
Description	Input	Stage (ft)	Elevation (ft)	Contour Area (sqft)	Incr. Storage (cuft)	Total Storage (cuft)
Bottom Elevation, ft	2179.00	0.00	2179.00	10,356	0.000	0.000
Voids (%)	100.00	1.00	2180.00	12,597	11,477	11,477
Volume Calc	None	2.00	2181.00	15,014	13,806	25,282
		3.00	2182.00	17,611	16,313	41,595
		4.00	2183.00	20,388	19,000	60,594
		5.00	2184.00	23,345	21,867	82,461

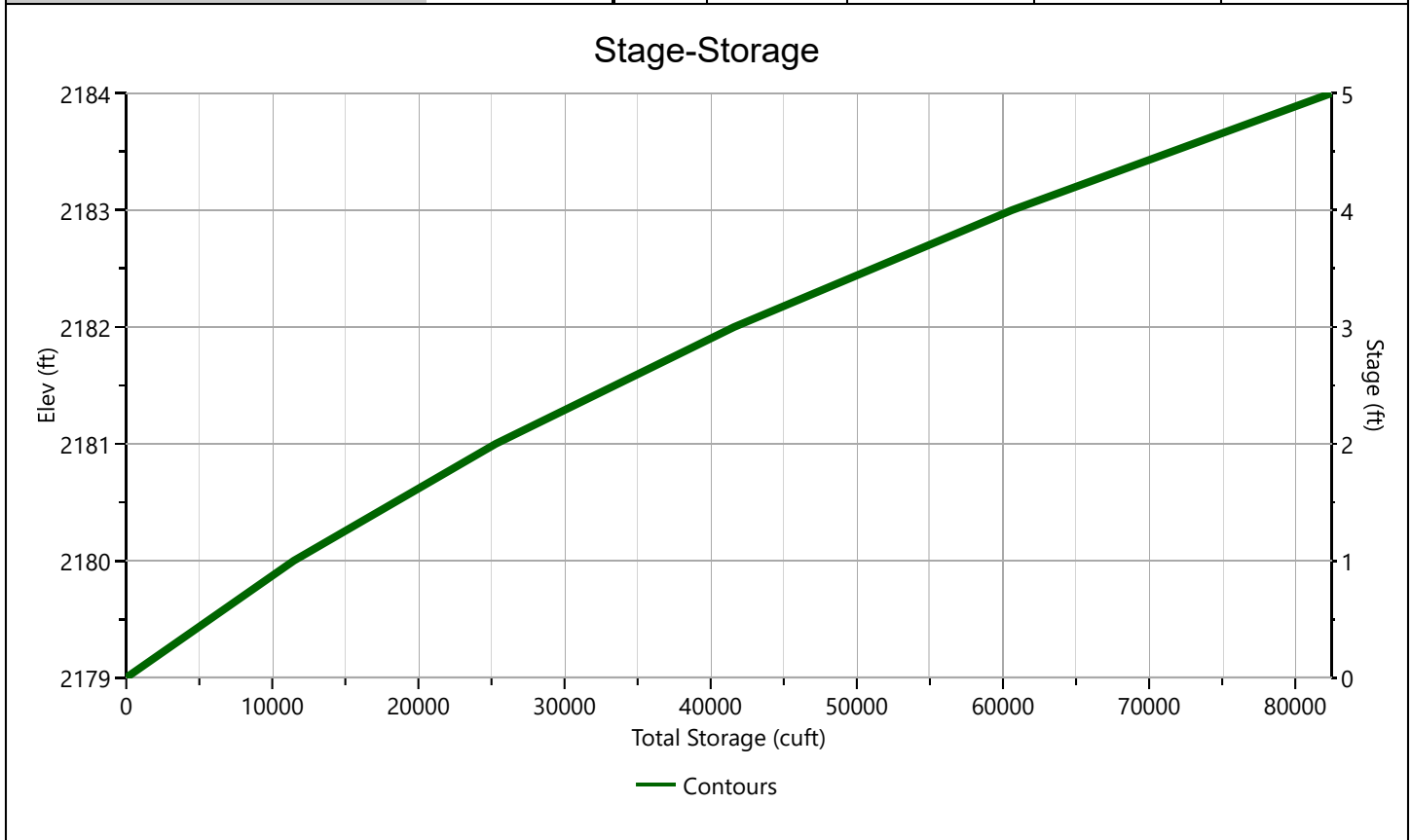

Pond Report

Project Name:

Hydrology Studio v 3.0.0.26

11-29-2022

BASIN

Stage-Discharge

Culvert / Orifices	Culvert	Orifices			Orifice Plate
		1	2	3	
Rise, in	18				Orifice Dia, in
Span, in	18				No. Orifices
No. Barrels	1				Invert Elevation, ft
Invert Elevation, ft	2181.00				Height, ft
Orifice Coefficient, Co	0.60				Orifice Coefficient, Co
Length, ft	20				
Barrel Slope, %	1				
N-Value, n	0.013				
Weirs	Riser*	Weirs			Ancillary
Shape / Type	Circular	1*	2	3	Exfiltration, in/hr
Crest Elevation, ft	2183	Rectangular	Rectangular		3.56**
Crest Length, ft	9.42	2181	2183.5		
Angle, deg		1	10		
Weir Coefficient, Cw	3.3	3.3	2.6		

*Routes through Culvert. **Exfiltration extracted from outflow hydrograph. Rate applied to contours.

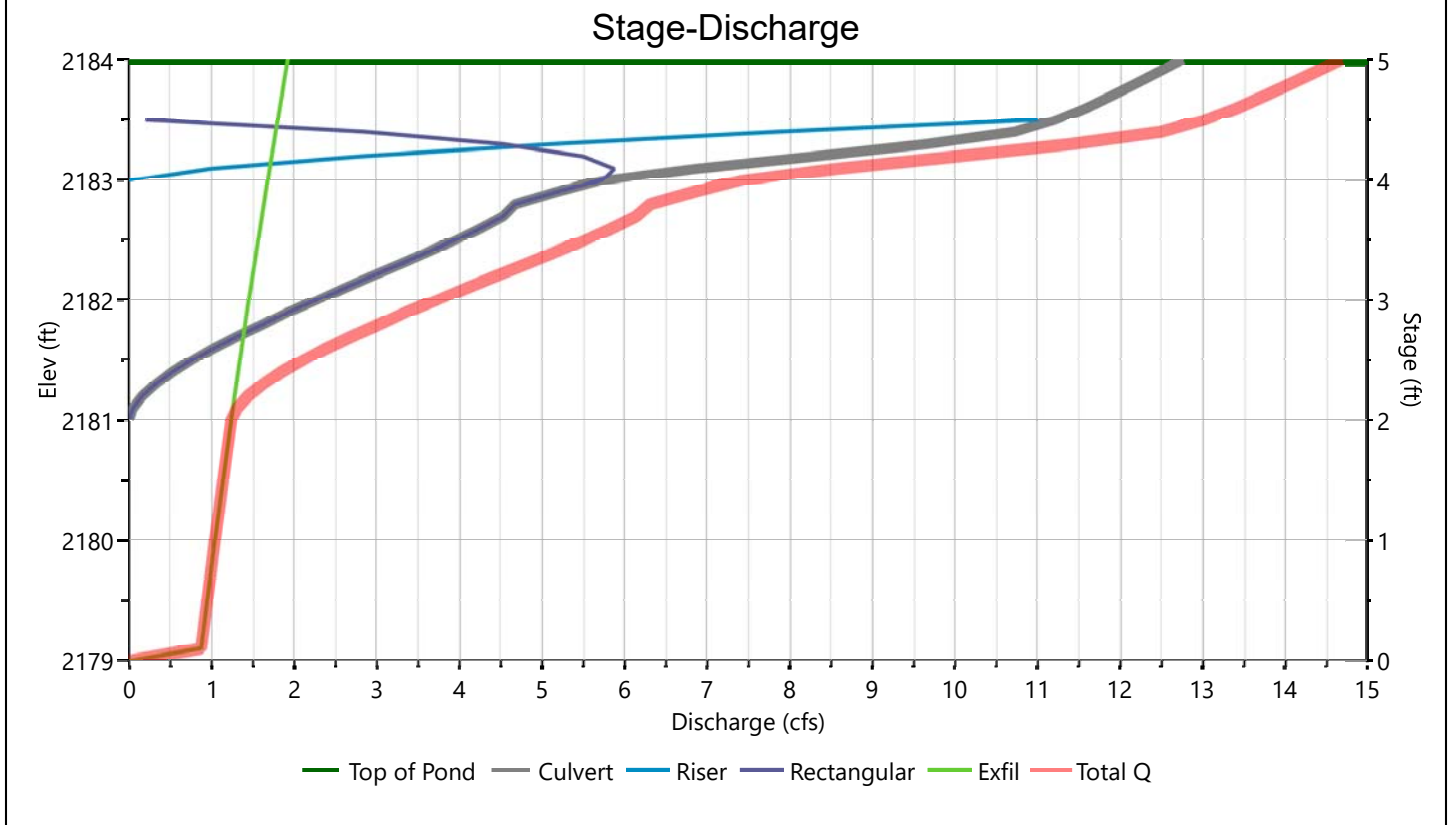

Pond Report

Project Name:

Hydrology Studio v 3.0.0.26

11-29-2022

BASIN

Stage-Storage-Discharge Summary

Stage (ft)	Elev. (ft)	Storage (cuft)	Culvert (cfs)	Orifices, cfs			Riser (cfs)	Weirs, cfs			Pf Riser (cfs)	Exfil (cfs)	User (cfs)	Total (cfs)
				1	2	3		1	2	3				
0.00	2179.00	0.000	0.000				0.000	0.000	0.000			0.000		0.000
1.00	2180.00	11,477	0.000				0.000	0.000	0.000			1.038		1.038
2.00	2181.00	25,282	0.000				0.000	0.000	0.000			1.237		1.237
3.00	2182.00	41,595	2.274 oc				0.000	2.274 s	0.000			1.451		3.726
4.00	2183.00	60,594	5.730 oc				0.000	5.730 s	0.000			1.680		7.411
5.00	2184.00	82,461	12.76 ic				0.000	0.000	0.000			1.924		14.69

Suffix key: ic = inlet control, oc = outlet control, s = submerged weir

BASIN

Pond Drawdown

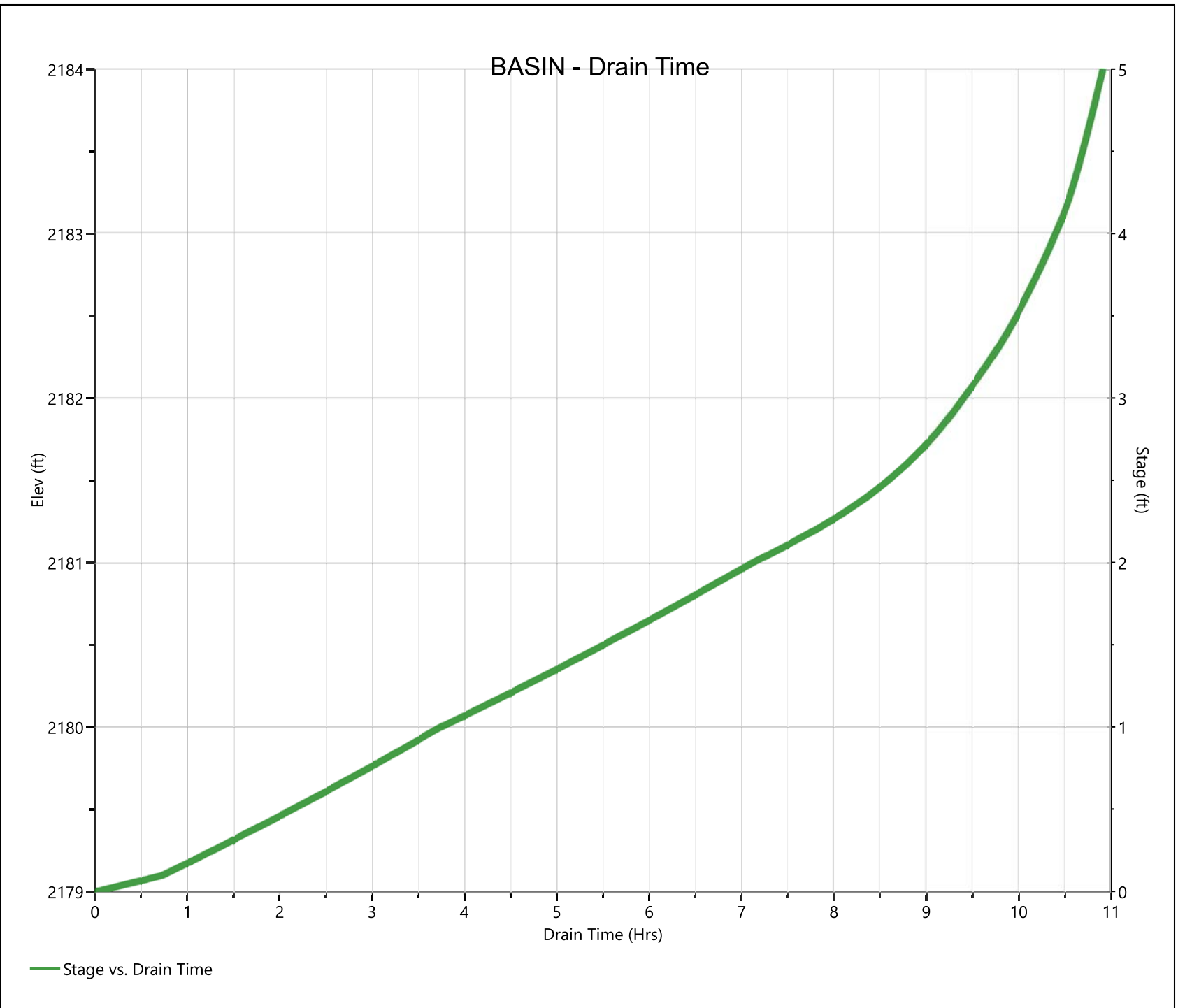

Design Storm Report

Custom Storm filename: TR32850.cds

Hydrology Studio v 3.0.0.26

11-29-2022

Storm Distribution: NRCS/SCS - Type I, 24-hr

Storm Duration	Total Rainfall Volume (in)								
	1-yr	✓ 2-yr	3-yr	5-yr	10-yr	25-yr	50-yr	100-yr	
24 hrs	0.00	5.45	0.00	7.15	8.53	10.40	0.00	13.30	

Incremental Rainfall Distribution, 2-yr									
Time (hrs)	Precip (in)	Time (hrs)	Precip (in)	Time (hrs)	Precip (in)	Time (hrs)	Precip (in)	Time (hrs)	Precip (in)
8.87	0.013414	9.23	0.017358	9.60	0.035631	9.97	0.098613	10.33	0.022527
8.90	0.013647	9.27	0.017803	9.63	0.041425	10.00	0.057753	10.37	0.021437
8.93	0.013879	9.30	0.018249	9.67	0.047219	10.03	0.030672	10.40	0.020347
8.97	0.014112	9.33	0.018695	9.70	0.053013	10.07	0.031247	10.43	0.019257
9.00	0.014344	9.37	0.019140	9.73	0.058807	10.10	0.030157	10.47	0.018167
9.03	0.014685	9.40	0.019586	9.77	0.070967	10.13	0.029067	10.50	0.017077
9.07	0.015129	9.43	0.020032	9.80	0.103109	10.17	0.027977	10.53	0.016402
9.10	0.015575	9.47	0.020478	9.83	0.128850	10.20	0.026887	10.57	0.016132
9.13	0.016021	9.50	0.020923	9.87	0.141271	10.23	0.025797	10.60	0.015865
9.17	0.016466	9.53	0.024040	9.90	0.140372	10.27	0.024707	10.63	0.015599
9.20	0.016912	9.57	0.029837	9.93	0.126153	10.30	0.023617	10.67	0.015333

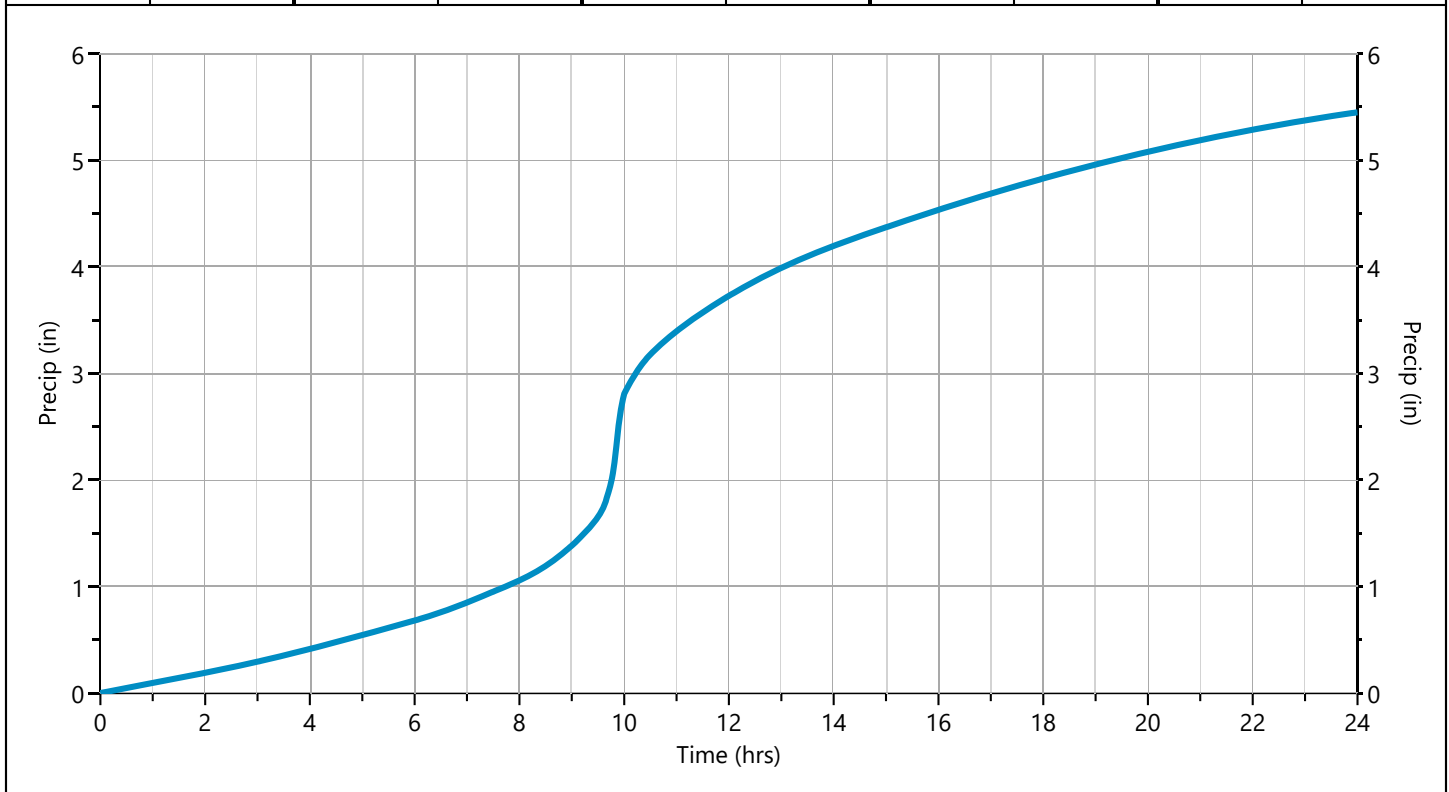

Hydrograph 5-yr Summary

Project Name:

Hydrology Studio v 3.0.0.26

11-29-2022

Hyd. No.	Hydrograph Type	Hydrograph Name	Peak Flow (cfs)	Time to Peak (hrs)	Hydrograph Volume (cuft)	Inflow Hyd(s)	Maximum Elevation (ft)	Maximum Storage (cuft)
1	NRCS Runoff	EX CONDITION DA 1	17.75	10.00	91,374	---		
2	NRCS Runoff	DEV CONDITION DA 1	21.64	9.97	100,290	---		
3	Pond Route	BASIN 1	0.818	11.40	10,615	2	2181.52	33,771

Hydrograph Report

Project Name:

Hydrology Studio v 3.0.0.26

11-29-2022

EX CONDITION DA 1

Hyd. No. 1

Hydrograph Type	= NRCS Runoff	Peak Flow	= 17.75 cfs
Storm Frequency	= 5-yr	Time to Peak	= 10.00 hrs
Time Interval	= 2 min	Runoff Volume	= 91,374 cuft
Drainage Area	= 5.12 ac	Curve Number	= 79.41*
Tc Method	= User	Time of Conc. (Tc)	= 12.45 min
Total Rainfall	= 7.15 in	Design Storm	= Type I
Storm Duration	= 24 hrs	Shape Factor	= 484

* Composite CN Worksheet

AREA (ac)	CN	DESCRIPTION
4.76	78	BARREN
0.36	98	IMPERVIOUS
5.12	79	Weighted CN Method Employed

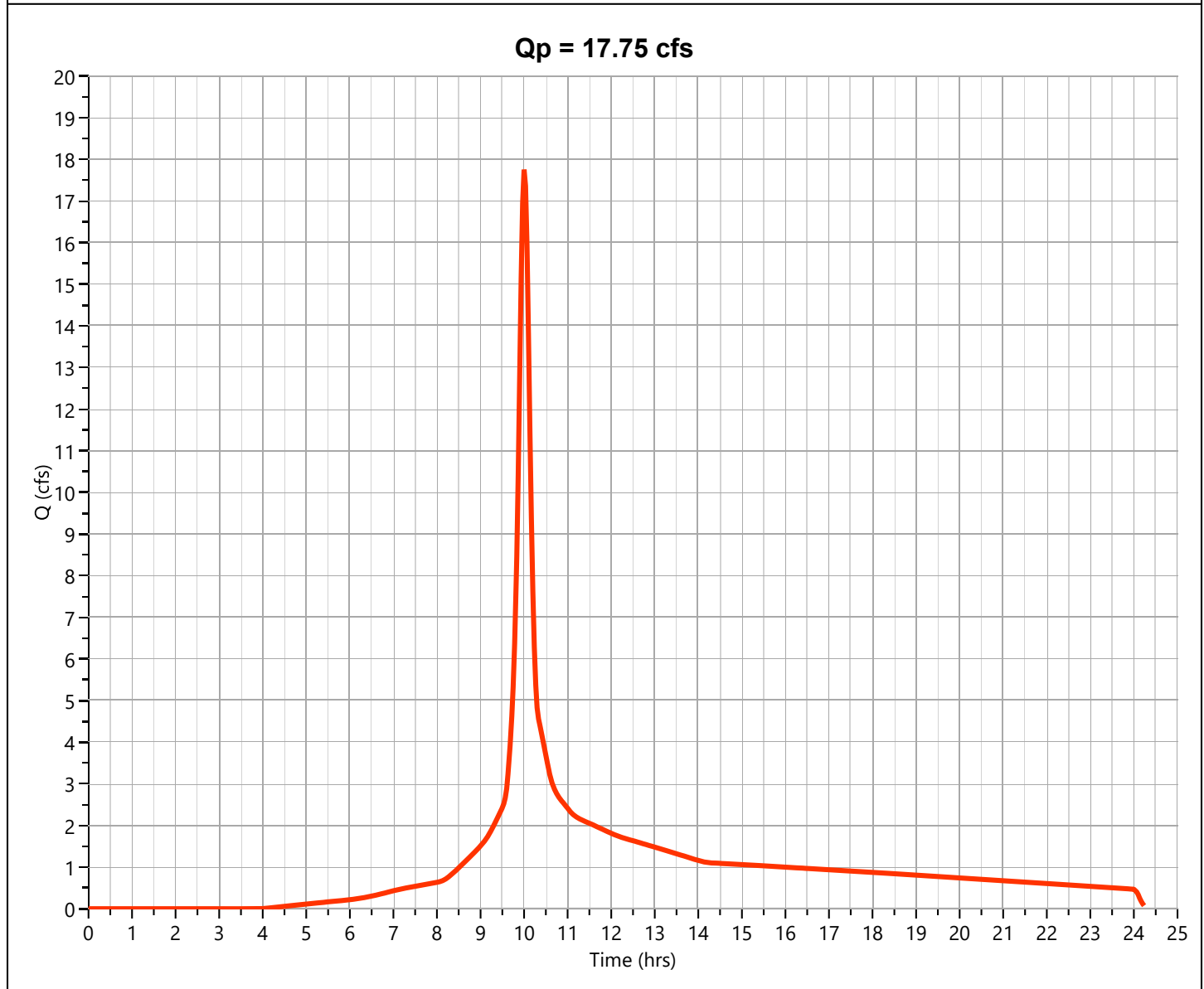

Hydrograph Report

Project Name:

Hydrology Studio v 3.0.0.26

11-29-2022

DEV CONDITION DA 1

Hyd. No. 2

Hydrograph Type	= NRCS Runoff	Peak Flow	= 21.64 cfs
Storm Frequency	= 5-yr	Time to Peak	= 9.97 hrs
Time Interval	= 2 min	Runoff Volume	= 100,290 cuft
Drainage Area	= 5.12 ac	Curve Number	= 85*
Tc Method	= User	Time of Conc. (Tc)	= 7.95 min
Total Rainfall	= 7.15 in	Design Storm	= Type I
Storm Duration	= 24 hrs	Shape Factor	= 484

* Composite CN Worksheet

AREA (ac)	CN	DESCRIPTION
2.61	98	CONC/BLDG
2.15	78	NATURAL
0.36	32	LANDSCAPE
5.12	85	Weighted CN Method Employed

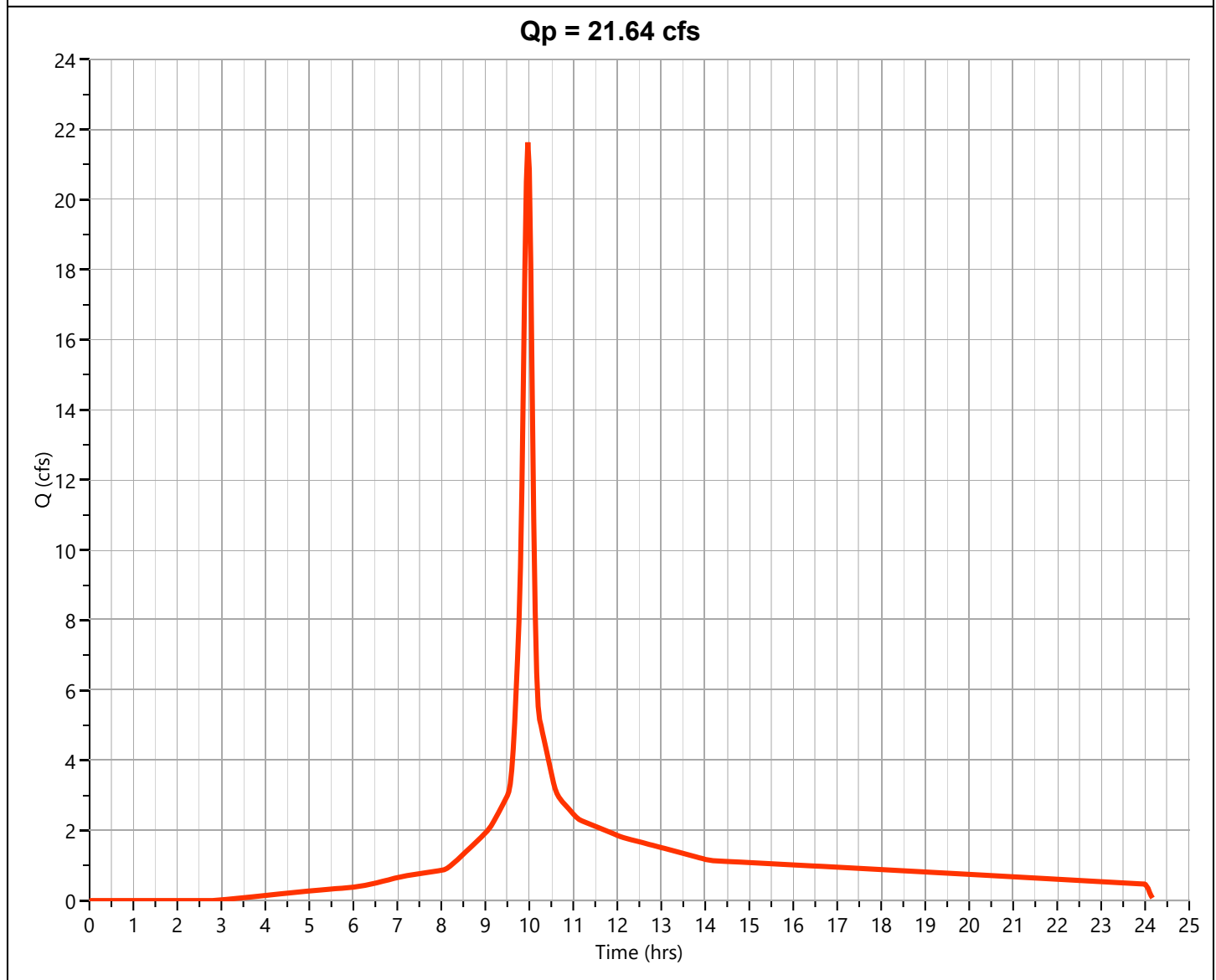

Hydrograph Report

Project Name:

Hydrology Studio v 3.0.0.26

11-29-2022

BASIN 1

Hyd. No. 3

Hydrograph Type	= Pond Route	Peak Flow	= 0.818 cfs
Storm Frequency	= 5-yr	Time to Peak	= 11.40 hrs
Time Interval	= 2 min	Hydrograph Volume	= 10,615 cuft
Inflow Hydrograph	= 2 - DEV CONDITION DA 1	Max. Elevation	= 2181.52 ft
Pond Name	= BASIN	Max. Storage	= 33,771 cuft

Pond Routing by Storage Indication Method

Qp = 0.82 cfs

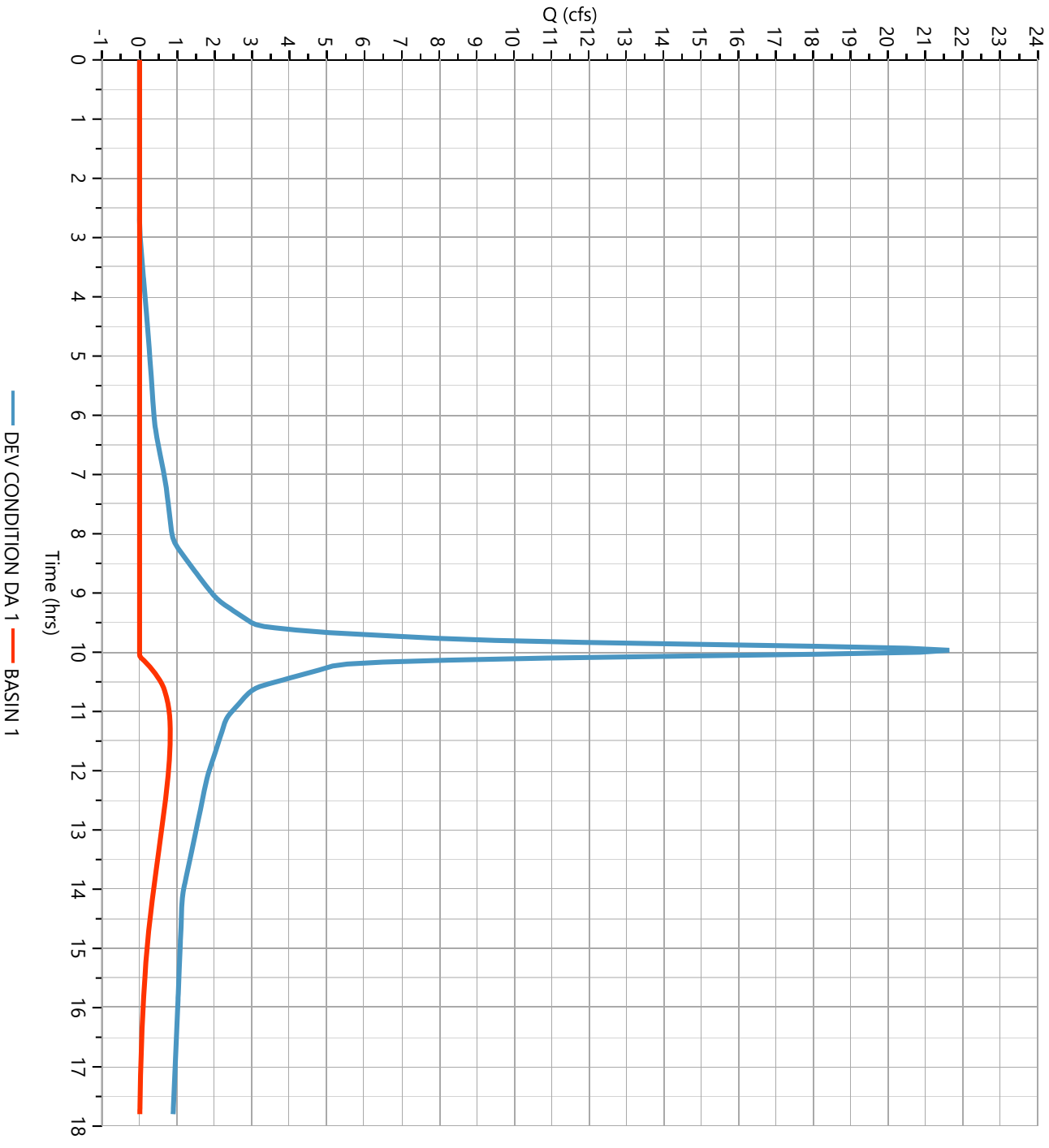

Design Storm Report

Custom Storm filename: TR32850.cds

Hydrology Studio v 3.0.0.26

11-29-2022

Storm Distribution: NRCS/SCS - Type I, 24-hr

Storm Duration	Total Rainfall Volume (in)								
	1-yr	2-yr	3-yr	✓ 5-yr	10-yr	25-yr	50-yr	100-yr	
24 hrs	0.00	5.45	0.00	7.15	8.53	10.40	0.00	13.30	

Incremental Rainfall Distribution, 5-yr									
Time (hrs)	Precip (in)	Time (hrs)	Precip (in)	Time (hrs)	Precip (in)	Time (hrs)	Precip (in)	Time (hrs)	Precip (in)
8.87	0.017599	9.23	0.022772	9.60	0.046745	9.97	0.129373	10.33	0.029553
8.90	0.017904	9.27	0.023357	9.63	0.054346	10.00	0.075768	10.37	0.028123
8.93	0.018209	9.30	0.023941	9.67	0.061948	10.03	0.040239	10.40	0.026693
8.97	0.018514	9.33	0.024526	9.70	0.069549	10.07	0.040993	10.43	0.025263
9.00	0.018819	9.37	0.025111	9.73	0.077150	10.10	0.039563	10.47	0.023833
9.03	0.019265	9.40	0.025696	9.77	0.093103	10.13	0.038133	10.50	0.022403
9.07	0.019848	9.43	0.026280	9.80	0.135271	10.17	0.036703	10.53	0.021518
9.10	0.020433	9.47	0.026865	9.83	0.169042	10.20	0.035273	10.57	0.021164
9.13	0.021018	9.50	0.027450	9.87	0.185338	10.23	0.033843	10.60	0.020814
9.17	0.021603	9.53	0.031538	9.90	0.184158	10.27	0.032413	10.63	0.020465
9.20	0.022187	9.57	0.039144	9.93	0.165503	10.30	0.030983	10.67	0.020115

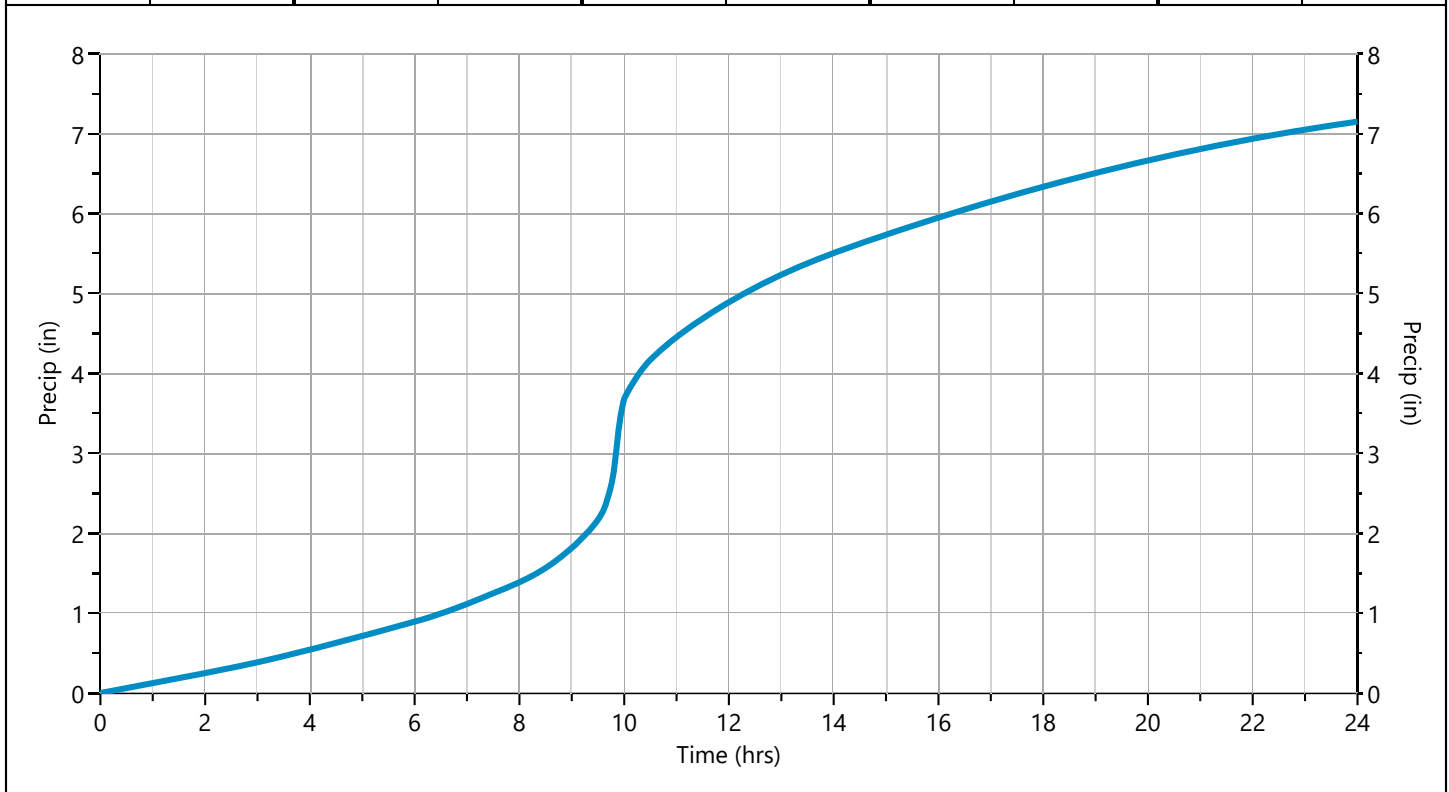

Hydrograph 10-yr Summary

Project Name:

Hydrology Studio v 3.0.0.26

11-29-2022

Hyd. No.	Hydrograph Type	Hydrograph Name	Peak Flow (cfs)	Time to Peak (hrs)	Hydrograph Volume (cuft)	Inflow Hyd(s)	Maximum Elevation (ft)	Maximum Storage (cuft)
1	NRCS Runoff	EX CONDITION DA 1	22.59	10.00	116,005	---		
2	NRCS Runoff	DEV CONDITION DA 1	26.84	9.97	124,999	---		
3	Pond Route	BASIN 1	2.060	10.73	25,944	2	2181.94	40,545

Hydrograph Report

Project Name:

Hydrology Studio v 3.0.0.26

11-29-2022

EX CONDITION DA 1

Hyd. No. 1

Hydrograph Type	= NRCS Runoff	Peak Flow	= 22.59 cfs
Storm Frequency	= 10-yr	Time to Peak	= 10.00 hrs
Time Interval	= 2 min	Runoff Volume	= 116,005 cuft
Drainage Area	= 5.12 ac	Curve Number	= 79.41*
Tc Method	= User	Time of Conc. (Tc)	= 12.45 min
Total Rainfall	= 8.53 in	Design Storm	= Type I
Storm Duration	= 24 hrs	Shape Factor	= 484

* Composite CN Worksheet

AREA (ac)	CN	DESCRIPTION
4.76	78	BARREN
0.36	98	IMPERVIOUS
5.12	79	Weighted CN Method Employed

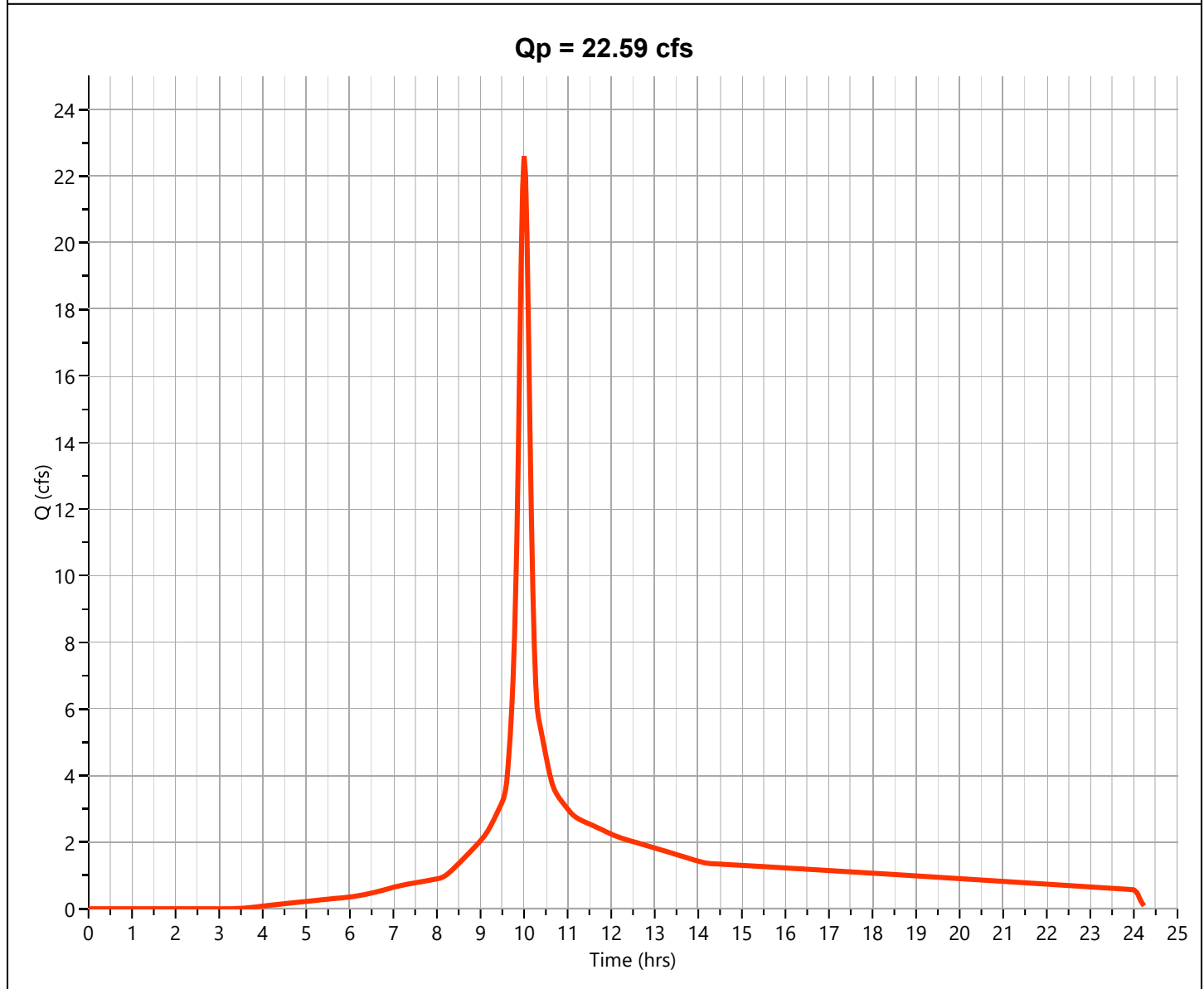

Hydrograph Report

Project Name:

Hydrology Studio v 3.0.0.26

11-29-2022

DEV CONDITION DA 1

Hyd. No. 2

Hydrograph Type	= NRCS Runoff	Peak Flow	= 26.84 cfs
Storm Frequency	= 10-yr	Time to Peak	= 9.97 hrs
Time Interval	= 2 min	Runoff Volume	= 124,999 cuft
Drainage Area	= 5.12 ac	Curve Number	= 85*
Tc Method	= User	Time of Conc. (Tc)	= 7.95 min
Total Rainfall	= 8.53 in	Design Storm	= Type I
Storm Duration	= 24 hrs	Shape Factor	= 484

* Composite CN Worksheet

AREA (ac)	CN	DESCRIPTION
2.61	98	CONC/BLDG
2.15	78	NATURAL
0.36	32	LANDSCAPE
5.12	85	Weighted CN Method Employed

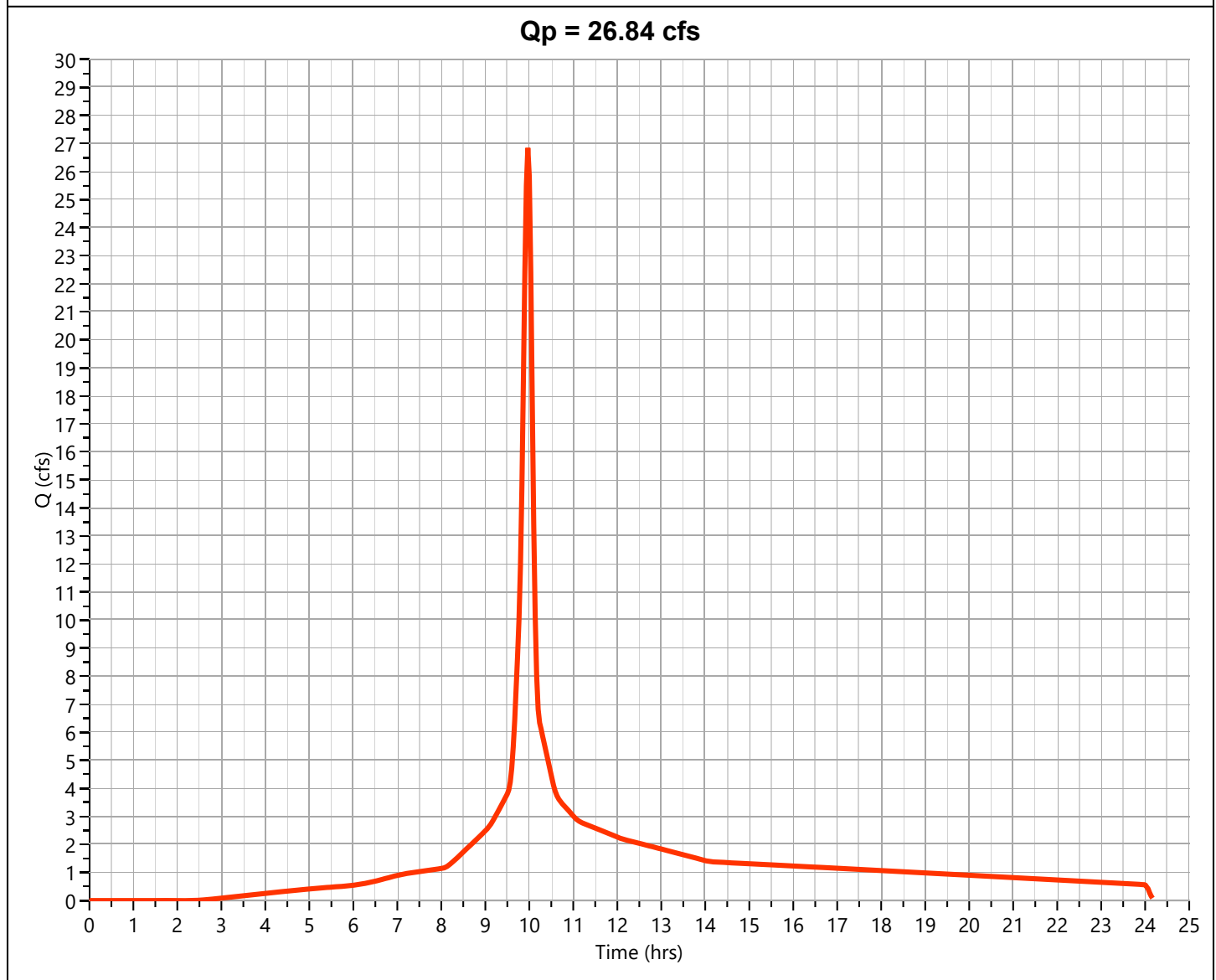

Hydrograph Report

Project Name:

Hydrology Studio v 3.0.0.26

11-29-2022

BASIN 1

Hyd. No. 3

Hydrograph Type	= Pond Route	Peak Flow	= 2.060 cfs
Storm Frequency	= 10-yr	Time to Peak	= 10.73 hrs
Time Interval	= 2 min	Hydrograph Volume	= 25,944 cuft
Inflow Hydrograph	= 2 - DEV CONDITION DA 1	Max. Elevation	= 2181.94 ft
Pond Name	= BASIN	Max. Storage	= 40,545 cuft

Pond Routing by Storage Indication Method

Center of mass detention time = 3 min

Qp = 2.06 cfs

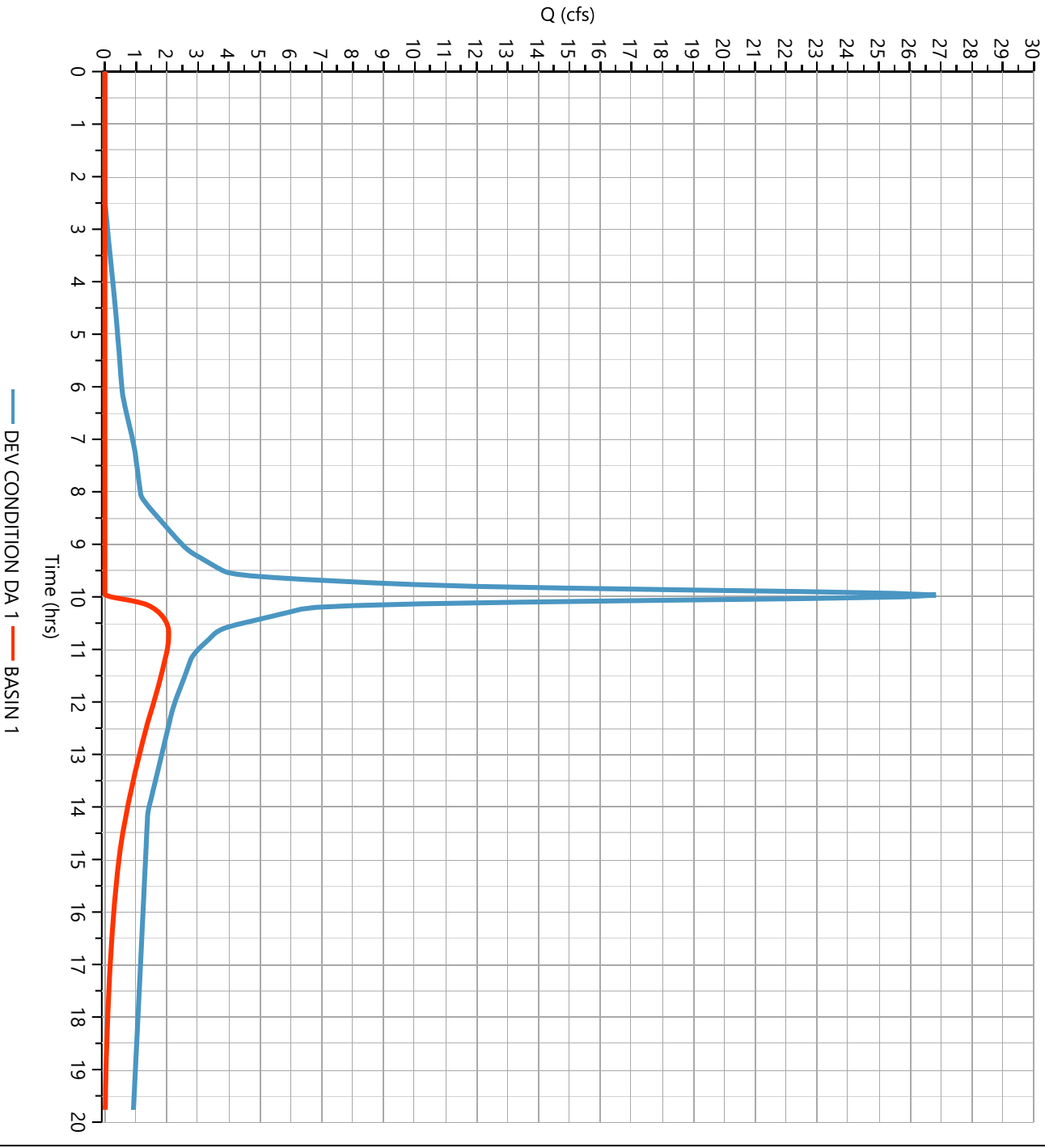

Design Storm Report

Custom Storm filename: TR32850.cds

Hydrology Studio v 3.0.0.26

11-29-2022

Storm Distribution: NRCS/SCS - Type I, 24-hr

Storm Duration	Total Rainfall Volume (in)								
	1-yr	2-yr	3-yr	5-yr	✓ 10-yr	25-yr	50-yr	100-yr	
24 hrs	0.00	5.45	0.00	7.15	8.53	10.40	0.00	13.30	

Incremental Rainfall Distribution, 10-yr									
Time (hrs)	Precip (in)	Time (hrs)	Precip (in)	Time (hrs)	Precip (in)	Time (hrs)	Precip (in)	Time (hrs)	Precip (in)
8.87	0.020995	9.23	0.027167	9.60	0.055767	9.97	0.154343	10.33	0.035257
8.90	0.021359	9.27	0.027865	9.63	0.064836	10.00	0.090392	10.37	0.033551
8.93	0.021723	9.30	0.028562	9.67	0.073904	10.03	0.048005	10.40	0.031845
8.97	0.022087	9.33	0.029260	9.70	0.082972	10.07	0.048905	10.43	0.030139
9.00	0.022451	9.37	0.029957	9.73	0.092041	10.10	0.047199	10.47	0.028433
9.03	0.022984	9.40	0.030655	9.77	0.111073	10.13	0.045493	10.50	0.026727
9.07	0.023679	9.43	0.031353	9.80	0.161379	10.17	0.043787	10.53	0.025671
9.10	0.024377	9.47	0.032050	9.83	0.201668	10.20	0.042081	10.57	0.025249
9.13	0.025074	9.50	0.032748	9.87	0.221109	10.23	0.040375	10.60	0.024832
9.17	0.025772	9.53	0.037625	9.90	0.219702	10.27	0.038669	10.63	0.024415
9.20	0.026470	9.57	0.046699	9.93	0.197446	10.30	0.036963	10.67	0.023998

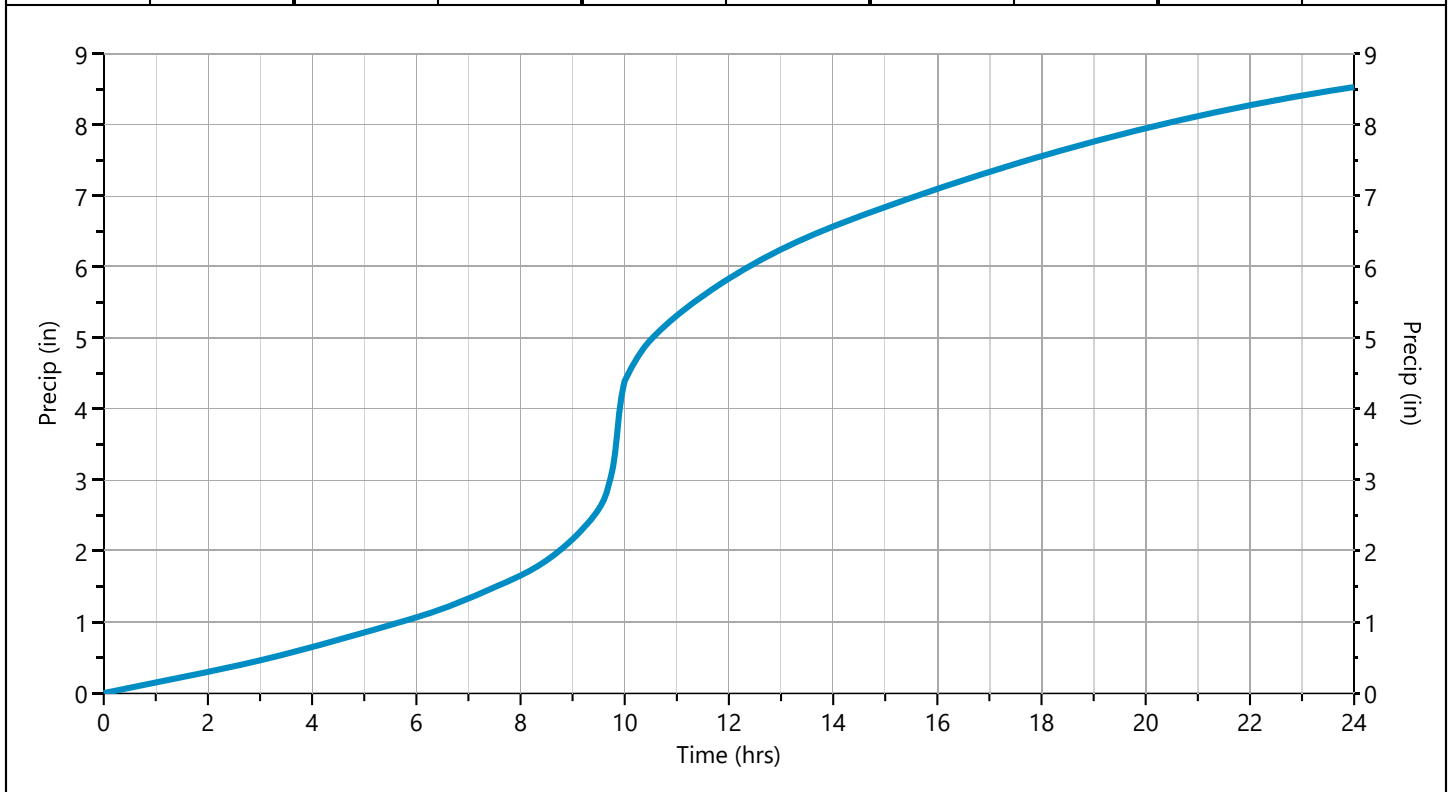

Hydrograph 25-yr Summary

Project Name:

Hydrology Studio v 3.0.0.26

11-29-2022

Hyd. No.	Hydrograph Type	Hydrograph Name	Peak Flow (cfs)	Time to Peak (hrs)	Hydrograph Volume (cuft)	Inflow Hyd(s)	Maximum Elevation (ft)	Maximum Storage (cuft)
1	NRCS Runoff	EX CONDITION DA 1	29.18	10.00	150,025	---		
2	NRCS Runoff	DEV CONDITION DA 1	33.86	9.97	158,833	---		
3	Pond Route	BASIN 1	3.955	10.50	49,905	2	2182.50	51,153

Hydrograph Report

Project Name:

Hydrology Studio v 3.0.0.26

11-29-2022

EX CONDITION DA 1

Hyd. No. 1

Hydrograph Type	= NRCS Runoff	Peak Flow	= 29.18 cfs
Storm Frequency	= 25-yr	Time to Peak	= 10.00 hrs
Time Interval	= 2 min	Runoff Volume	= 150,025 cuft
Drainage Area	= 5.12 ac	Curve Number	= 79.41*
Tc Method	= User	Time of Conc. (Tc)	= 12.45 min
Total Rainfall	= 10.40 in	Design Storm	= Type I
Storm Duration	= 24 hrs	Shape Factor	= 484

* Composite CN Worksheet

AREA (ac)	CN	DESCRIPTION
4.76	78	BARREN
0.36	98	IMPERVIOUS
5.12	79	Weighted CN Method Employed

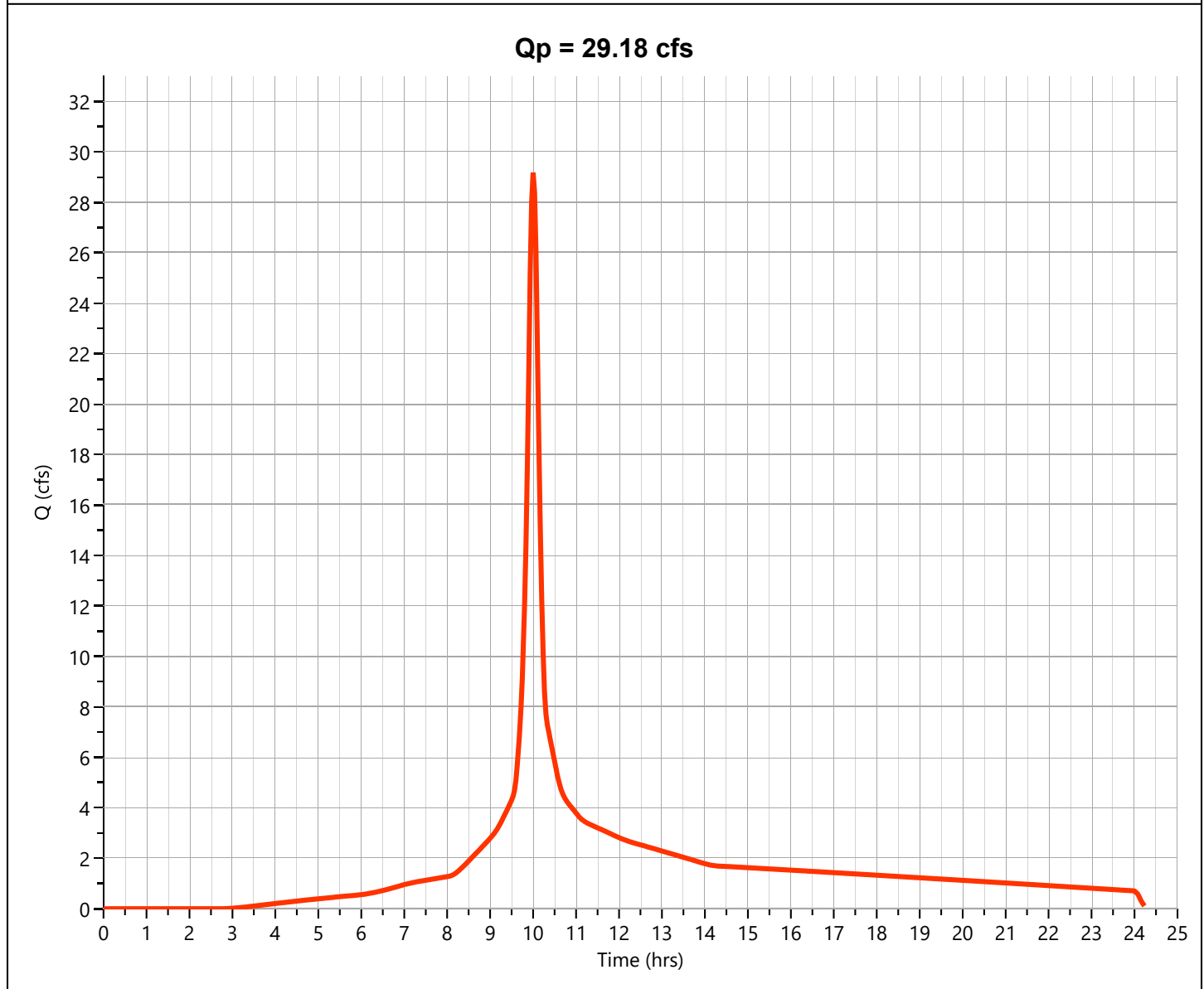

Hydrograph Report

Project Name:

Hydrology Studio v 3.0.0.26

11-29-2022

DEV CONDITION DA 1

Hyd. No. 2

Hydrograph Type	= NRCS Runoff	Peak Flow	= 33.86 cfs
Storm Frequency	= 25-yr	Time to Peak	= 9.97 hrs
Time Interval	= 2 min	Runoff Volume	= 158,833 cuft
Drainage Area	= 5.12 ac	Curve Number	= 85*
Tc Method	= User	Time of Conc. (Tc)	= 7.95 min
Total Rainfall	= 10.40 in	Design Storm	= Type I
Storm Duration	= 24 hrs	Shape Factor	= 484

* Composite CN Worksheet

AREA (ac)	CN	DESCRIPTION
2.61	98	CONC/BLDG
2.15	78	NATURAL
0.36	32	LANDSCAPE
5.12	85	Weighted CN Method Employed

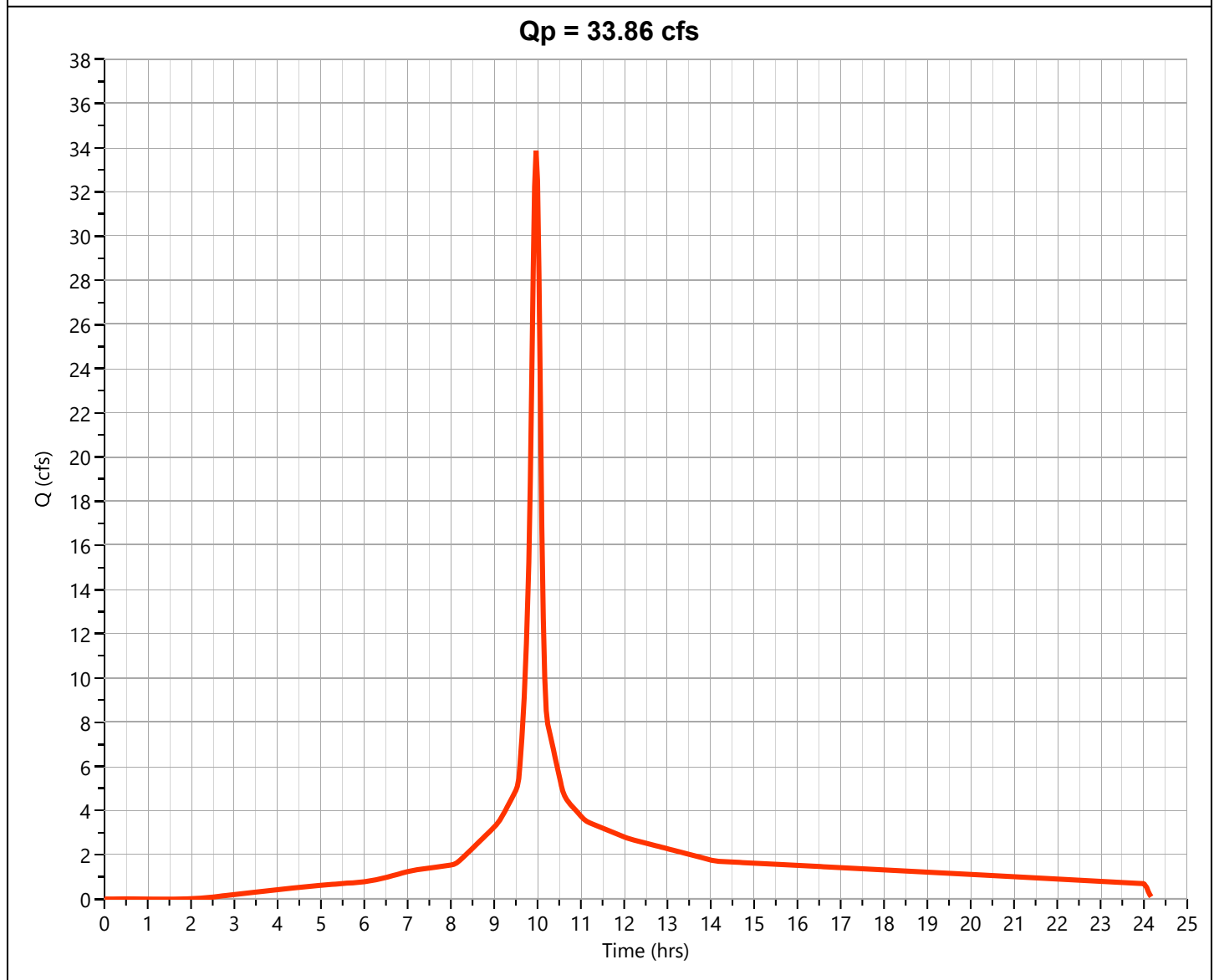

Hydrograph Report

Project Name:

Hydrology Studio v 3.0.0.26

11-29-2022

BASIN 1

Hyd. No. 3

Hydrograph Type	= Pond Route	Peak Flow	= 3.955 cfs
Storm Frequency	= 25-yr	Time to Peak	= 10.50 hrs
Time Interval	= 2 min	Hydrograph Volume	= 49,905 cuft
Inflow Hydrograph	= 2 - DEV CONDITION DA 1	Max. Elevation	= 2182.50 ft
Pond Name	= BASIN	Max. Storage	= 51,153 cuft

Pond Routing by Storage Indication Method

Center of mass detention time = 20 min

Qp = 3.96 cfs

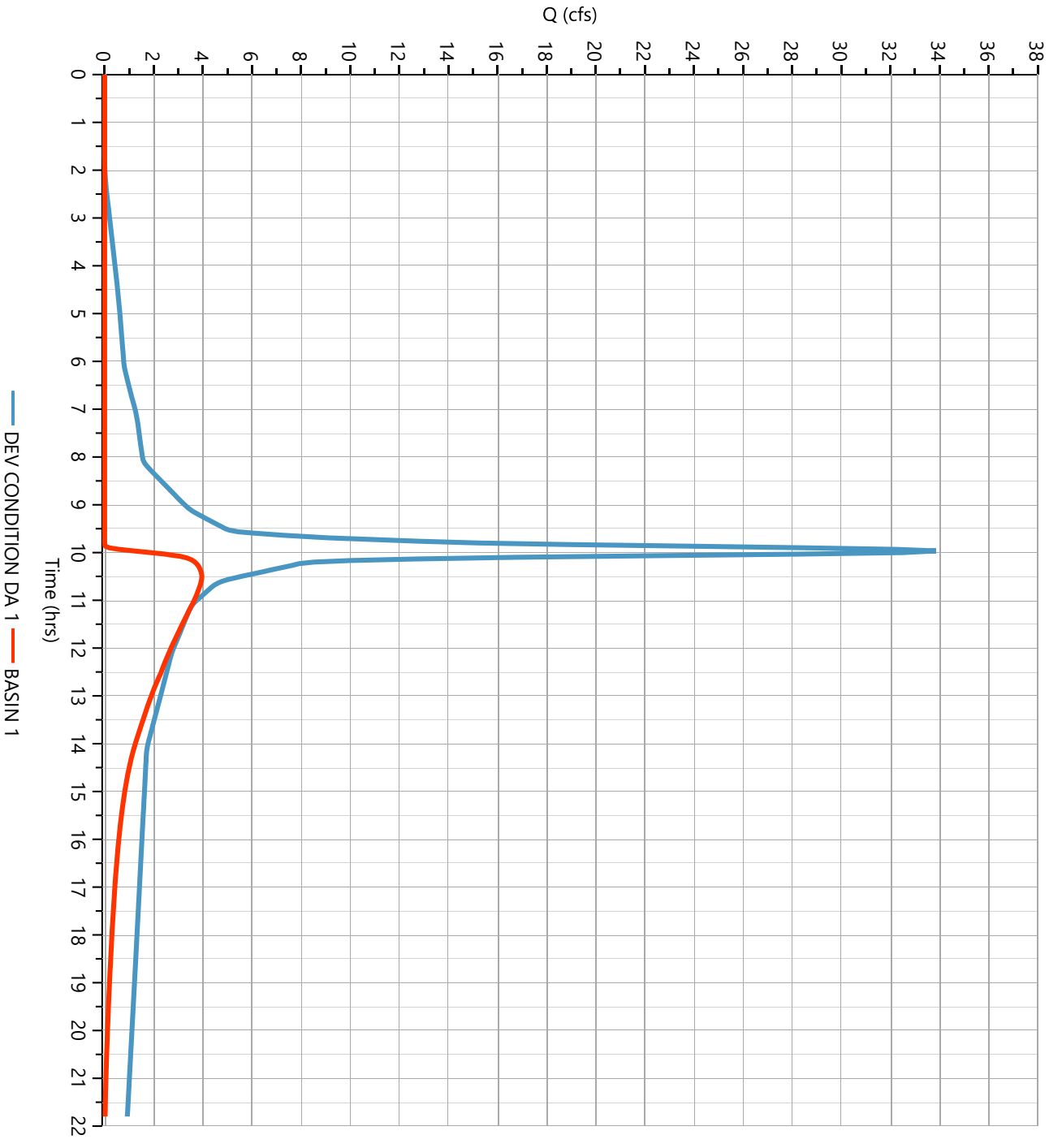

Design Storm Report

Storm Distribution: NRCS/SCS - Type I, 24-hr

Storm Duration	Total Rainfall Volume (in)								
	1-yr	2-yr	3-yr	5-yr	10-yr	✓ 25-yr	50-yr	100-yr	
24 hrs	0.00	5.45	0.00	7.15	8.53	10.40	0.00	13.30	

Incremental Rainfall Distribution, 25-yr									
Time (hrs)	Precip (in)	Time (hrs)	Precip (in)	Time (hrs)	Precip (in)	Time (hrs)	Precip (in)	Time (hrs)	Precip (in)
8.87	0.025598	9.23	0.033123	9.60	0.067993	9.97	0.188179	10.33	0.042987
8.90	0.026042	9.27	0.033973	9.63	0.079049	10.00	0.110208	10.37	0.040906
8.93	0.026485	9.30	0.034824	9.67	0.090106	10.03	0.058529	10.40	0.038827
8.97	0.026929	9.33	0.035674	9.70	0.101162	10.07	0.059627	10.43	0.036747
9.00	0.027373	9.37	0.036525	9.73	0.112218	10.10	0.057547	10.47	0.034667
9.03	0.028022	9.40	0.037375	9.77	0.135423	10.13	0.055467	10.50	0.032587
9.07	0.028871	9.43	0.038226	9.80	0.196758	10.17	0.053387	10.53	0.031300
9.10	0.029721	9.47	0.039076	9.83	0.245879	10.20	0.051306	10.57	0.030784
9.13	0.030571	9.50	0.039927	9.87	0.269582	10.23	0.049227	10.60	0.030276
9.17	0.031422	9.53	0.045874	9.90	0.267866	10.27	0.047147	10.63	0.029767
9.20	0.032272	9.57	0.056937	9.93	0.240732	10.30	0.045066	10.67	0.029259

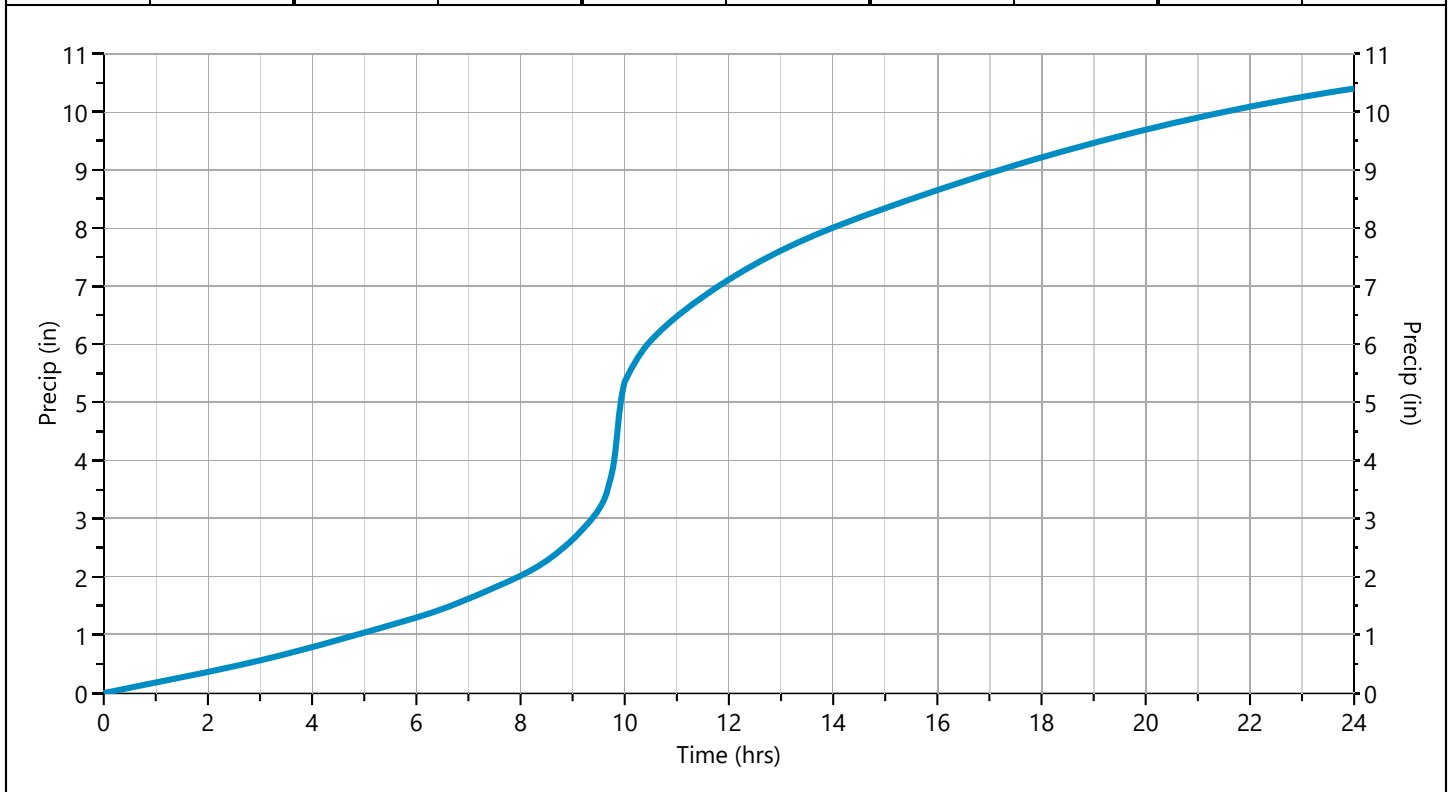

Hydrograph 100-yr Summary

Project Name:

Hydrology Studio v 3.0.0.26

11-29-2022

Hyd. No.	Hydrograph Type	Hydrograph Name	Peak Flow (cfs)	Time to Peak (hrs)	Hydrograph Volume (cuft)	Inflow Hyd(s)	Maximum Elevation (ft)	Maximum Storage (cuft)
1	NRCS Runoff	EX CONDITION DA 1	39.37	10.00	203,659	---		
2	NRCS Runoff	DEV CONDITION DA 1	44.65	9.97	211,765	---		
3	Pond Route	BASIN 1	9.490	10.20	91,619	2	2183.29	66,900

Hydrograph Report

Project Name:

Hydrology Studio v 3.0.0.26

11-29-2022

EX CONDITION DA 1

Hyd. No. 1

Hydrograph Type	= NRCS Runoff	Peak Flow	= 39.37 cfs
Storm Frequency	= 100-yr	Time to Peak	= 10.00 hrs
Time Interval	= 2 min	Runoff Volume	= 203,659 cuft
Drainage Area	= 5.12 ac	Curve Number	= 79.41*
Tc Method	= User	Time of Conc. (Tc)	= 12.45 min
Total Rainfall	= 13.30 in	Design Storm	= Type I
Storm Duration	= 24 hrs	Shape Factor	= 484

* Composite CN Worksheet

AREA (ac)	CN	DESCRIPTION
4.76	78	BARREN
0.36	98	IMPERVIOUS
5.12	79	Weighted CN Method Employed

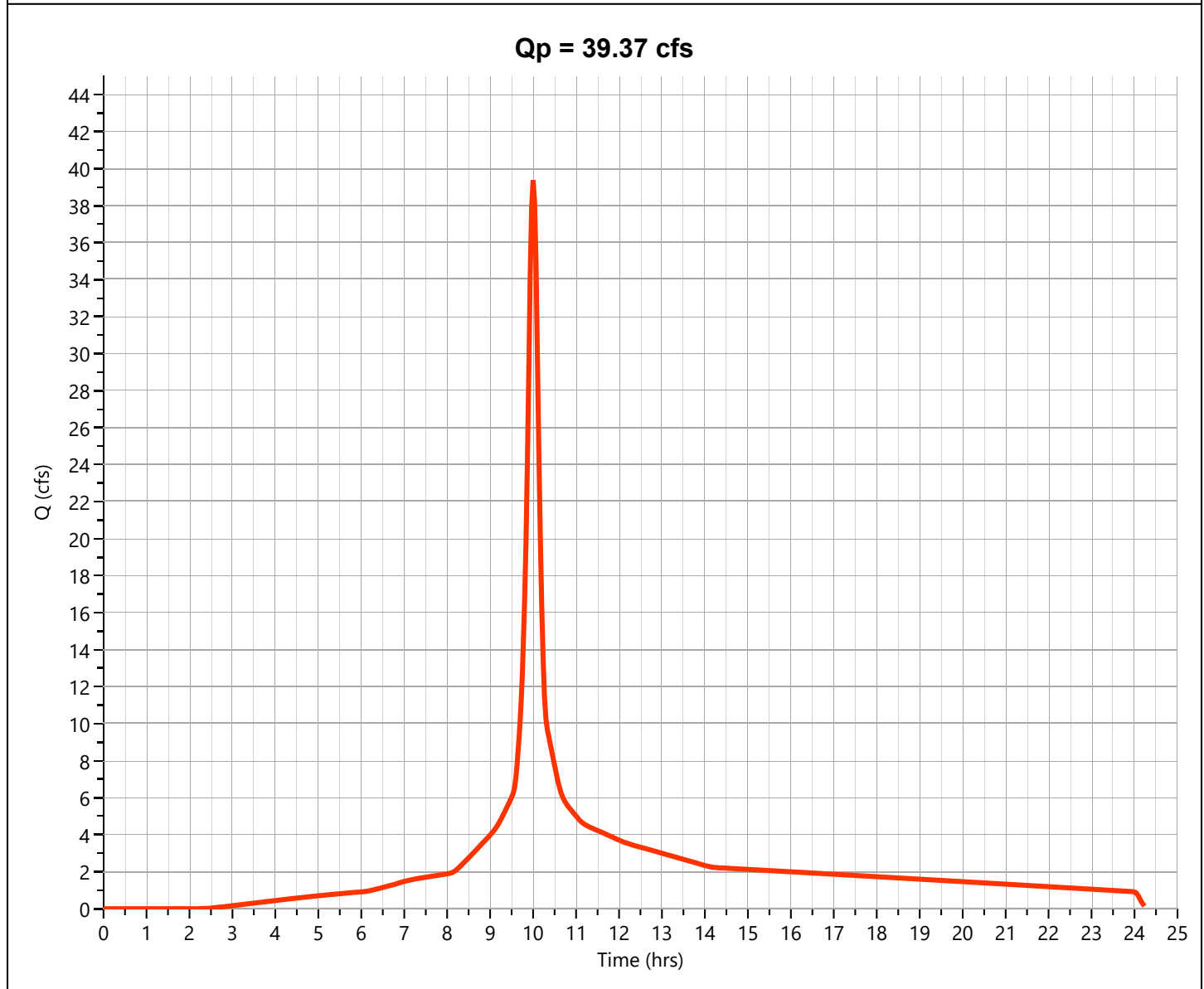

Hydrograph Report

Project Name:

Hydrology Studio v 3.0.0.26

11-29-2022

DEV CONDITION DA 1

Hyd. No. 2

Hydrograph Type	= NRCS Runoff	Peak Flow	= 44.65 cfs
Storm Frequency	= 100-yr	Time to Peak	= 9.97 hrs
Time Interval	= 2 min	Runoff Volume	= 211,765 cuft
Drainage Area	= 5.12 ac	Curve Number	= 85*
Tc Method	= User	Time of Conc. (Tc)	= 7.95 min
Total Rainfall	= 13.30 in	Design Storm	= Type I
Storm Duration	= 24 hrs	Shape Factor	= 484

* Composite CN Worksheet

AREA (ac)	CN	DESCRIPTION
2.61	98	CONC/BLDG
2.15	78	NATURAL
0.36	32	LANDSCAPE
5.12	85	Weighted CN Method Employed

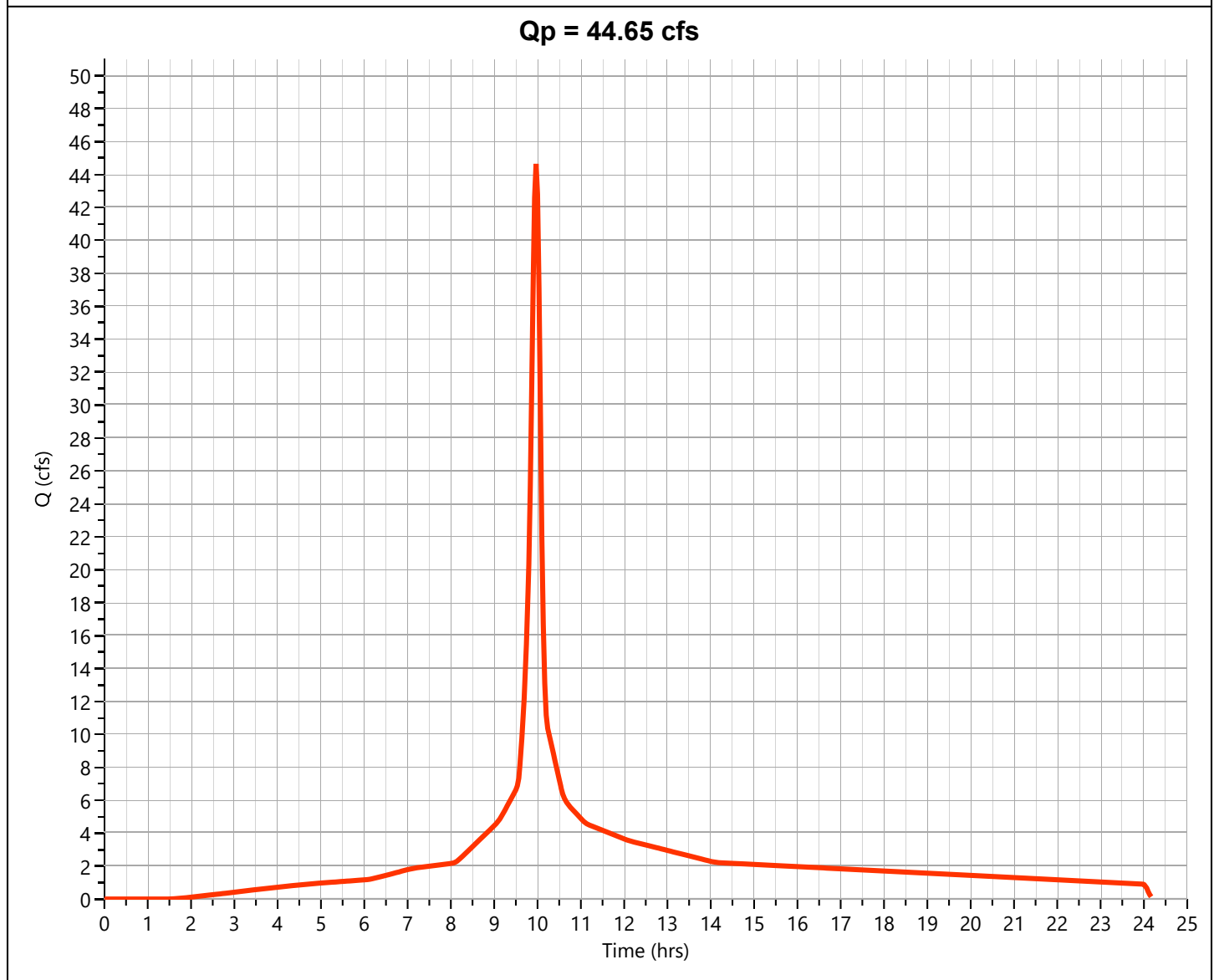

Hydrograph Report

Project Name:

Hydrology Studio v 3.0.0.26

11-29-2022

BASIN 1

Hyd. No. 3

Hydrograph Type	= Pond Route	Peak Flow	= 9.490 cfs
Storm Frequency	= 100-yr	Time to Peak	= 10.20 hrs
Time Interval	= 2 min	Hydrograph Volume	= 91,619 cuft
Inflow Hydrograph	= 2 - DEV CONDITION DA 1	Max. Elevation	= 2183.29 ft
Pond Name	= BASIN	Max. Storage	= 66,900 cuft

Pond Routing by Storage Indication Method

Center of mass detention time = 41 min

Qp = 9.49 cfs

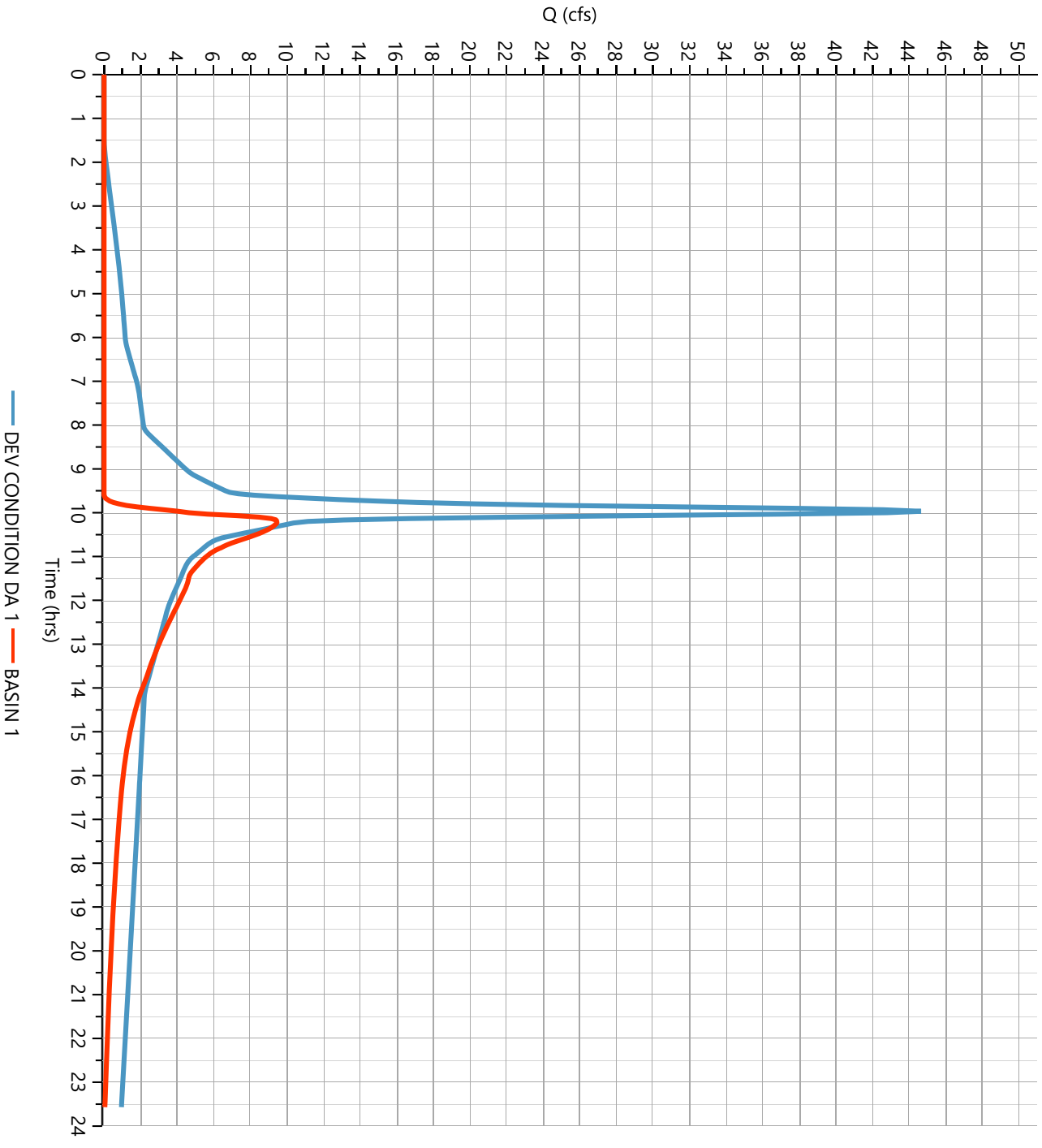

Design Storm Report

Custom Storm filename: TR32850.cds

Hydrology Studio v 3.0.0.26

11-29-2022

Storm Distribution: NRCS/SCS - Type I, 24-hr

Storm Duration	Total Rainfall Volume (in)							
	1-yr	2-yr	3-yr	5-yr	10-yr	25-yr	50-yr	✓ 100-yr
24 hrs	0.00	5.45	0.00	7.15	8.53	10.40	0.00	13.30

Incremental Rainfall Distribution, 100-yr									
Time (hrs)	Precip (in)	Time (hrs)	Precip (in)	Time (hrs)	Precip (in)	Time (hrs)	Precip (in)	Time (hrs)	Precip (in)
8.87	0.032736	9.23	0.042359	9.60	0.086952	9.97	0.240652	10.33	0.054973
8.90	0.033303	9.27	0.043447	9.63	0.101092	10.00	0.140939	10.37	0.052313
8.93	0.033871	9.30	0.044534	9.67	0.115231	10.03	0.074850	10.40	0.049653
8.97	0.034438	9.33	0.045622	9.70	0.129371	10.07	0.076253	10.43	0.046994
9.00	0.035006	9.37	0.046710	9.73	0.143510	10.10	0.073593	10.47	0.044333
9.03	0.035836	9.40	0.047797	9.77	0.173185	10.13	0.070933	10.50	0.041673
9.07	0.036921	9.43	0.048885	9.80	0.251623	10.17	0.068273	10.53	0.040027
9.10	0.038008	9.47	0.049973	9.83	0.314442	10.20	0.065613	10.57	0.039368
9.13	0.039096	9.50	0.051060	9.87	0.344754	10.23	0.062953	10.60	0.038718
9.17	0.040184	9.53	0.058666	9.90	0.342559	10.27	0.060293	10.63	0.038067
9.20	0.041271	9.57	0.072813	9.93	0.307859	10.30	0.057633	10.67	0.037417

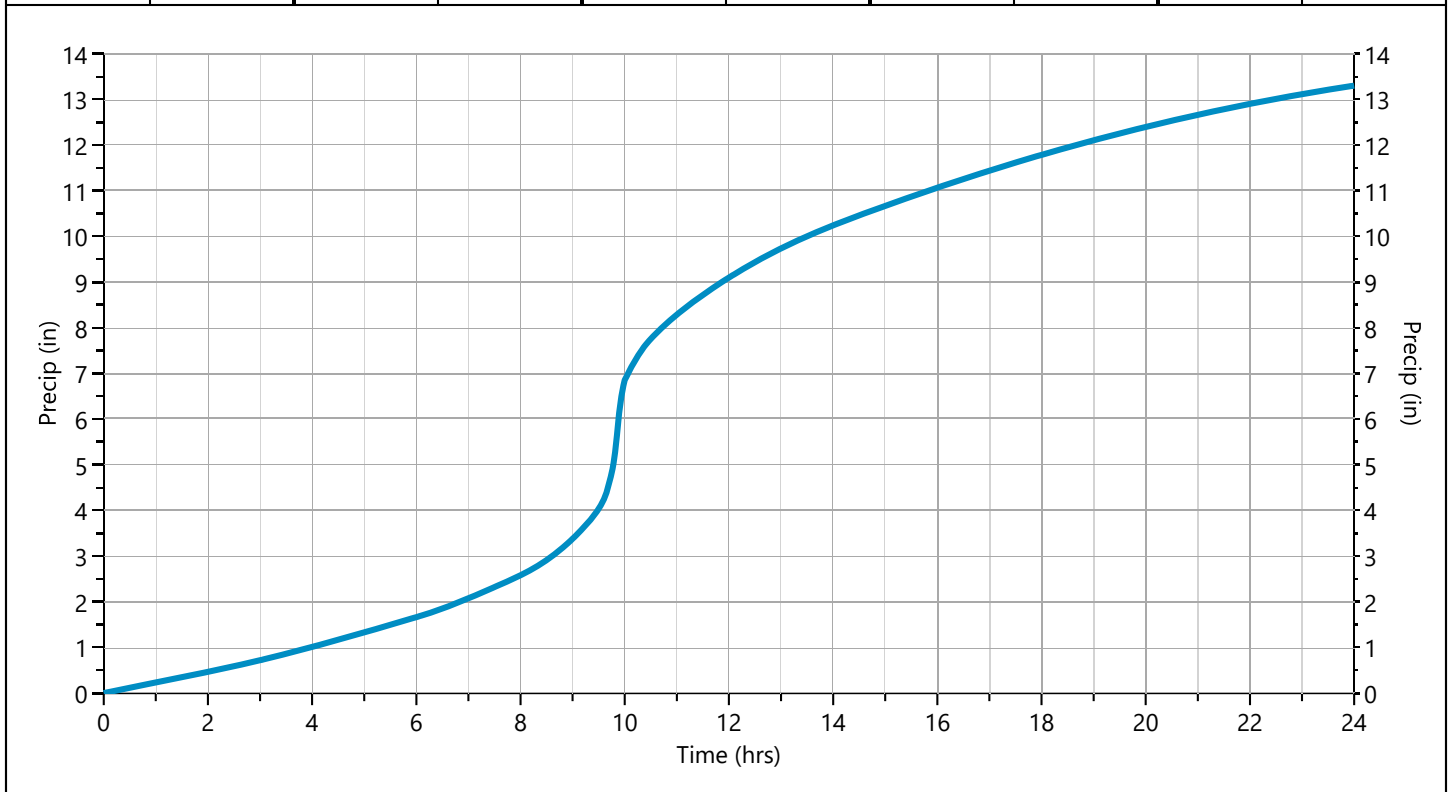

IDF Report

Equation Coefficients	Intensity = B / (Tc + D)/ \sqrt{E} (in/hr)							
	1-yr	2-yr	3-yr	5-yr	10-yr	25-yr	50-yr	100-yr
B	2.2472	2.6658	0.0000	4.3056	4.4944	5.7019	6.6481	7.0705
D	0.2000	0.1000	0.0000	1.0000	0.2000	0.3000	0.3000	0.1000
E	0.4469	0.4237	0.0000	0.4794	0.4469	0.4643	0.4695	0.4477

Minimum Tc = 5 minutes

Tc (min)	Intensity Values (in/hr)								
	1-yr	2-yr	3-yr	5-yr	10-yr	25-yr	50-yr	100-yr	
Cf	1.00	1.00	1.00	1.00	1.00	1.00	1.00	1.00	
5	1.08	1.34	0	1.82	2.15	2.63	3.04	3.41	
10	0.80	1.00	0	1.36	1.59	1.93	2.22	2.51	
15	0.67	0.84	0	1.14	1.33	1.61	1.85	2.10	
20	0.59	0.75	0	1.00	1.17	1.41	1.62	1.85	
25	0.53	0.68	0	0.90	1.06	1.27	1.46	1.67	
30	0.49	0.63	0	0.83	0.98	1.17	1.34	1.54	
35	0.46	0.59	0	0.77	0.92	1.09	1.25	1.44	
40	0.43	0.56	0	0.73	0.86	1.02	1.17	1.35	
45	0.41	0.53	0	0.69	0.82	0.97	1.11	1.29	
50	0.39	0.51	0	0.65	0.78	0.92	1.06	1.23	
55	0.37	0.49	0	0.63	0.75	0.88	1.01	1.17	
60	0.36	0.47	0	0.60	0.72	0.85	0.97	1.13	

Cf = Correction Factor applied to Rational Method runoff coefficient.

Sample IDF Curves

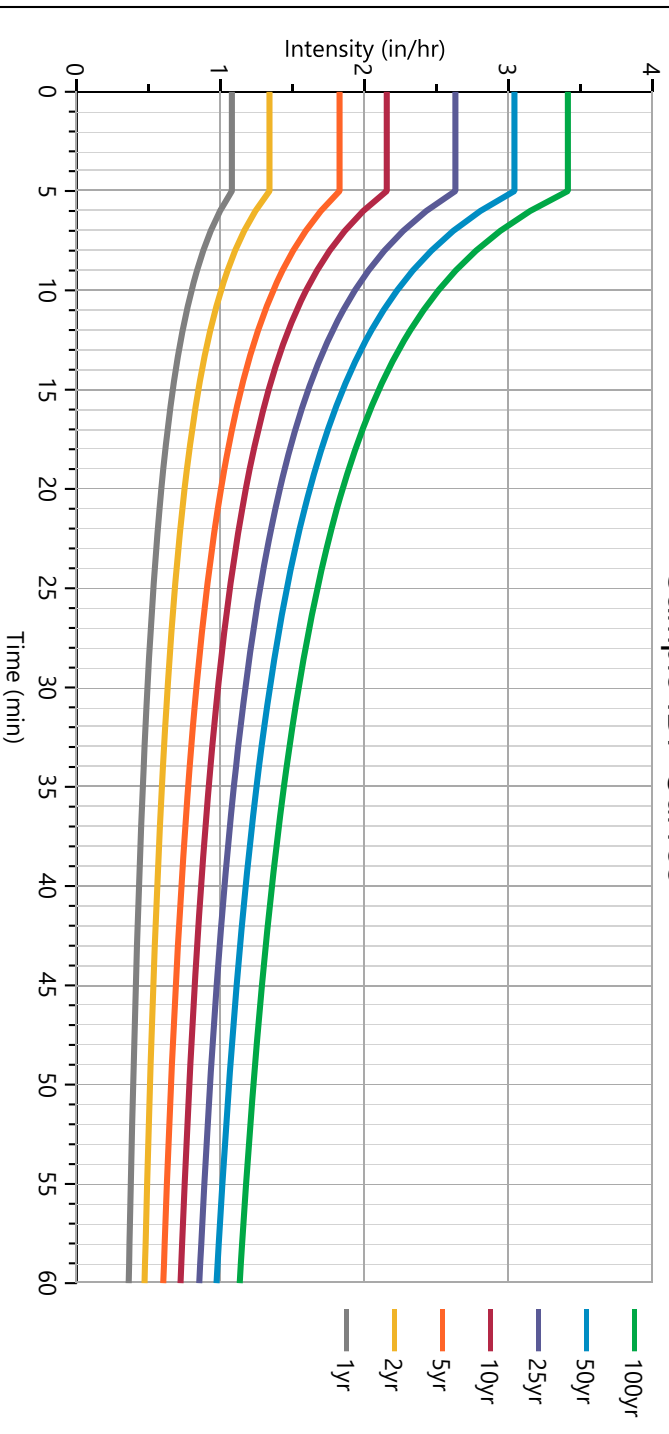

Precipitation Report

	Active	1-yr	2-yr	3-yr	5-yr	10-yr	25-yr	50-yr	100-yr
Active			✓		✓	✓	✓		✓
SCS Storms	> SCS Dimensionless Storms								
SCS 6hr		0	0	0	0	0	0	0	0
Type I, 24-hr	✓	0	5.45	0	7.15	8.53	10.40	0	13.30
Type IA, 24-hr		0	0	0	0	0	0	0	0
Type II, 24-hr		0	0	0	0	0	0	0	0
Type II FL, 24-hr		0	0	0	0	0	0	0	0
Type III, 24-hr		0	0	0	0	0	0	0	0
Synthetic Storms	> IDF-Based Synthetic Storms								
1-hr		0.36	0.47	0	0.60	0.72	0.85	0.97	1.13
2-hr		0.53	0.70	0	0.86	1.06	1.23	1.40	1.66
3-hr		0.66	0.89	0	1.07	1.32	1.53	1.74	2.07
6-hr		0.97	1.32	0	1.54	1.94	2.22	2.51	3.04
12-hr		1.42	1.97	0	2.20	2.85	3.22	3.63	4.46
24-hr		2.09	2.94	0	3.16	4.18	4.67	5.25	6.54
Huff Distribution	> 1st Quartile (0 to 6 hrs)								
1-hr		0	0	0	0	0	0	0	0
2-hr		0	0	0	0	0	0	0	0
3-hr		0	0	0	0	0	0	0	0
6-hr		0	0	0	0	0	0	0	0
Huff Distribution	> 2nd Quartile (>6 to 12 hrs)								
8-hr		0	0	0	0	0	0	0	0
12-hr		0	0	0	0	0	0	0	0
Huff Distribution	> 3rd Quartile (>12 to 24 hrs)								
18-hr		0	0	0	0	0	0	0	0
24-hr		0	0	0	0	0	0	0	0
Custom Storms	> Custom Storm Distributions								
Custom Storm		0	0	0	0	0	0	0	0
My Custom Storm 2		0	0	0	0	0	0	0	0
My Custom Storm 3		0	0	0	0	0	0	0	0
My Custom Storm 4		0	0	0	0	0	0	0	0
My Custom Storm 5		0	0	0	0	0	0	0	0
My Custom Storm 6		0	0	0	0	0	0	0	0
My Custom Storm 7		0	0	0	0	0	0	0	0
My Custom Storm 8		0	0	0	0	0	0	0	0
My Custom Storm 9		0	0	0	0	0	0	0	0
My Custom Storm 10		0	0	0	0	0	0	0	0

Precipitation Report Cont'd

Precipitation filename: MTN AVE BEES.pcp

Rainfall totals in Inches

11-29-2022

	Active	1-yr	2-yr	3-yr	5-yr	10-yr	25-yr	50-yr	100-yr
Active			✓		✓	✓	✓		✓
Huff Indiana	> Indianapolis								
30-min		0.99	1.19	0	1.44	1.63	1.89	2.08	2.28
1-hr		1.21	1.46	0	1.81	2.08	2.45	2.75	3.06
2-hr		1.46	1.77	0	2.22	2.57	3.05	3.44	3.85
3-hr		1.57	1.90	0	2.38	2.76	3.30	3.75	4.21
6-hr		1.92	2.31	0	2.88	3.36	4.01	4.56	5.13
12-hr		0	0	0	0	0	0	0	0
24-hr		0	0	0	0	0	0	0	0
Huff Indiana	> Evansville								
30-min		0.99	1.19	0	1.44	1.63	1.89	2.08	2.28
1-hr		1.21	1.46	0	1.81	2.08	2.45	2.75	3.06
2-hr		1.46	1.77	0	2.22	2.57	3.05	3.44	3.85
3-hr		1.57	1.90	0	2.38	2.76	3.30	3.75	4.21
6-hr		1.92	2.31	0	2.88	3.36	4.01	4.56	5.13
12-hr		0	0	0	0	0	0	0	0
24-hr		0	0	0	0	0	0	0	0
Huff Indiana	> Fort Wayne								
30-min		0.99	1.19	0	1.44	1.63	1.89	2.08	2.28
1-hr		1.21	1.46	0	1.81	2.08	2.45	2.75	3.06
2-hr		1.46	1.77	0	2.22	2.57	3.05	3.44	3.85
3-hr		1.57	1.90	0	2.38	2.76	3.30	3.75	4.21
6-hr		1.92	2.31	0	2.88	3.36	4.01	4.56	5.13
12-hr		0	0	0	0	0	0	0	0
24-hr		0	0	0	0	0	0	0	0
Huff Indiana	> South Bend								
30-min		0.99	1.19	0	1.44	1.63	1.89	2.08	2.28
1-hr		1.21	1.46	0	1.81	2.08	2.45	2.75	3.06
2-hr		1.46	1.77	0	2.22	2.57	3.05	3.44	3.85
3-hr		1.57	1.90	0	2.38	2.76	3.30	3.75	4.21
6-hr		1.92	2.31	0	2.88	3.36	4.01	4.56	5.13
12-hr		0	0	0	0	0	0	0	0
24-hr		0	0	0	0	0	0	0	0

Precipitation Report Cont'd

Precipitation filename: MTN AVE BEES.pcp

Rainfall totals in Inches

11-29-2022

	Active	1-yr	2-yr	3-yr	5-yr	10-yr	25-yr	50-yr	100-yr
Active			✓		✓	✓	✓		✓
NRCS Storms	> NRCS Dimensionless Storms								
NRCS MSE1, 24-hr		2.72	3.27	0	4.07	4.72	5.63	6.37	7.15
NRCS MSE2, 24-hr		2.72	3.27	0	4.07	4.72	5.63	6.37	7.15
NRCS MSE3, 24-hr		2.72	3.27	0	4.07	4.72	5.63	6.37	7.15
NRCS MSE4, 24-hr		2.72	3.27	0	4.07	4.72	5.63	6.37	7.15
NRCS MSE5, 24-hr		2.72	3.27	0	4.07	4.72	5.63	6.37	7.15
NRCS MSE6, 24-hr		2.72	3.27	0	4.07	4.72	5.63	6.37	7.15
NOAA-A, 24-hr		2.72	3.27	0	4.07	4.72	5.63	6.37	7.15
NOAA-B, 24-hr		2.72	3.27	0	4.07	4.72	5.63	6.37	7.15
NOAA-C, 24-hr		2.72	3.27	0	4.07	4.72	5.63	6.37	7.15
NOAA-D, 24-hr		2.72	3.27	0	4.07	4.72	5.63	6.37	7.15
NRCC-A, 24-hr		2.72	3.27	0	4.07	4.72	5.63	6.37	7.15
NRCC-B, 24-hr		2.72	3.27	0	4.07	4.72	5.63	6.37	7.15
NRCC-C, 24-hr		2.72	3.27	0	4.07	4.72	5.63	6.37	7.15
NRCC-D, 24-hr		2.72	3.27	0	4.07	4.72	5.63	6.37	7.15
CA-1, 24-hr		2.72	3.27	0	4.07	4.72	5.63	6.37	7.15
CA-2, 24-hr		2.72	3.27	0	4.07	4.72	5.63	6.37	7.15
CA-3, 24-hr		2.72	3.27	0	4.07	4.72	5.63	6.37	7.15
CA-4, 24-hr		2.72	3.27	0	4.07	4.72	5.63	6.37	7.15
CA-5, 24-hr		2.72	3.27	0	4.07	4.72	5.63	6.37	7.15
CA-6, 24-hr		2.72	3.27	0	4.07	4.72	5.63	6.37	7.15
FDOT Storms	> Florida DOT Storms								
FDOT, 1-hr		0	0	0	0	0	0	0	0
FDOT, 2-hr		0	0	0	0	0	0	0	0
FDOT, 4-hr		0	0	0	0	0	0	0	0
FDOT, 8-hr		0	0	0	0	0	0	0	0
FDOT, 24-hr		0	0	0	0	0	0	0	0
FDOT, 72-hr		0	0	0	0	0	0	0	0
SFWMD, 72-hr		0	0	0	0	0	0	0	0
Austin Storms	> Austin Frequency Storms								
Austin Zone 1, 24-hr		0	0	0	0	0	0	0	0
Austin Zone 2, 24-hr		0	0	0	0	0	0	0	0

HYDRAULIC CALCULATIONS

Channel Report

NODE 200 TO 210: DETERMINE CAPACITY 8' WIDE x 2' DEEP V-DITCH @ 0.7% MIN.

Triangular

Side Slopes (z:1) = 2.00, 2.00

Total Depth (ft) = 2.00

Invert Elev (ft) = 100.00

Slope (%) = 0.70

N-Value = 0.025

Calculations

Compute by: Known Depth

Known Depth (ft) = 2.00

Highlighted

Depth (ft) = 2.00

Q (cfs) = 36.93

Area (sqft) = 8.00

Velocity (ft/s) = 4.62

Wetted Perim (ft) = 8.94

Crit Depth, Yc (ft) = 1.85

Top Width (ft) = 8.00

EGL (ft) = 2.33

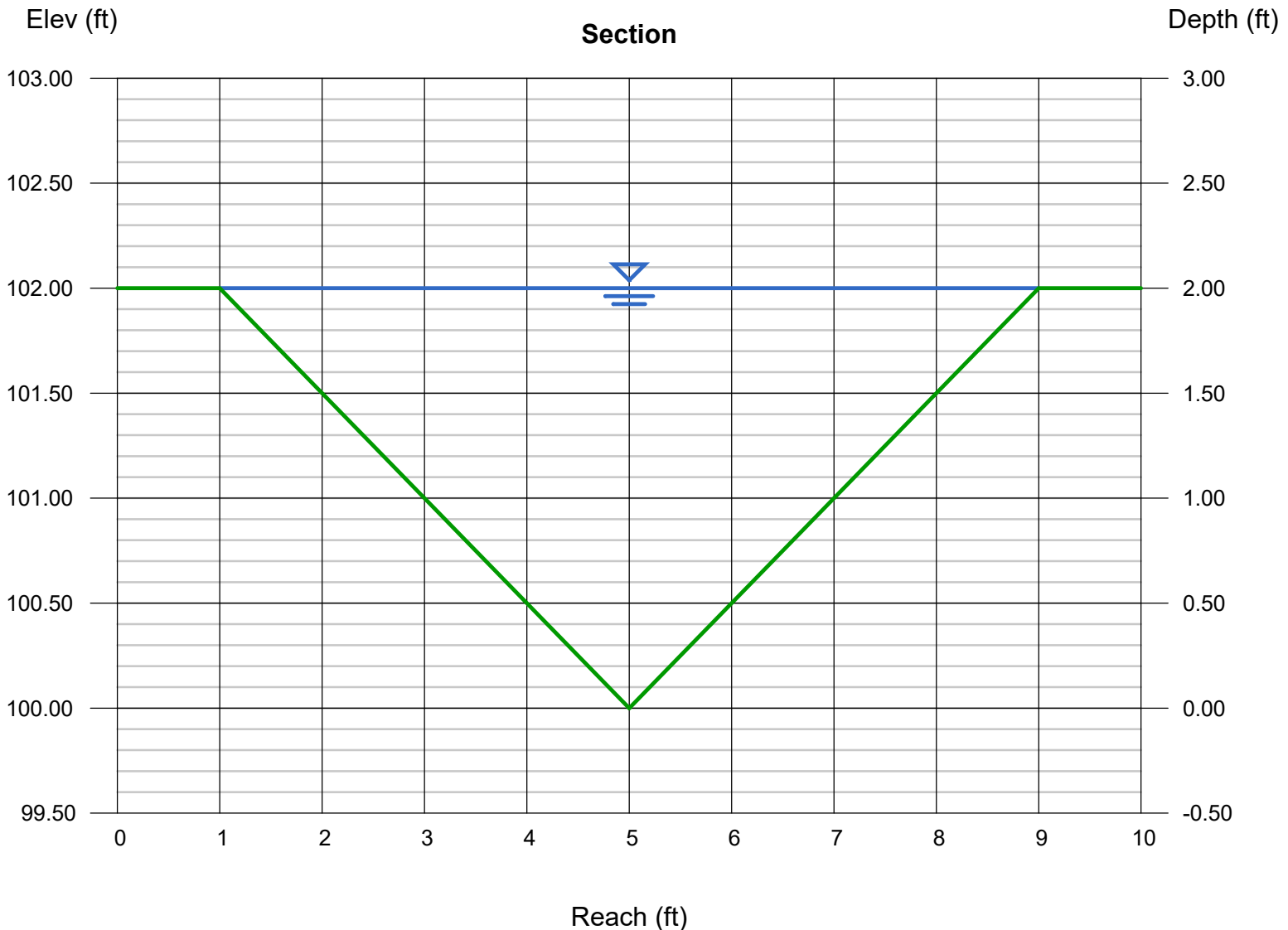

Channel Report

NODE 110 TO 120: DETERMINE CAPACITY OF 8' WIDE x 2' DEEP V-DITCH @ 1.0% MIN.

Triangular

Side Slopes (z:1) = 2.00, 2.00
Total Depth (ft) = 2.00

Invert Elev (ft) = 100.00
Slope (%) = 1.00
N-Value = 0.025

Calculations

Compute by: Known Depth
Known Depth (ft) = 2.00

Highlighted

Depth (ft) = 2.00
Q (cfs) = 44.14
Area (sqft) = 8.00
Velocity (ft/s) = 5.52
Wetted Perim (ft) = 8.94
Crit Depth, Yc (ft) = 1.98
Top Width (ft) = 8.00
EGL (ft) = 2.47

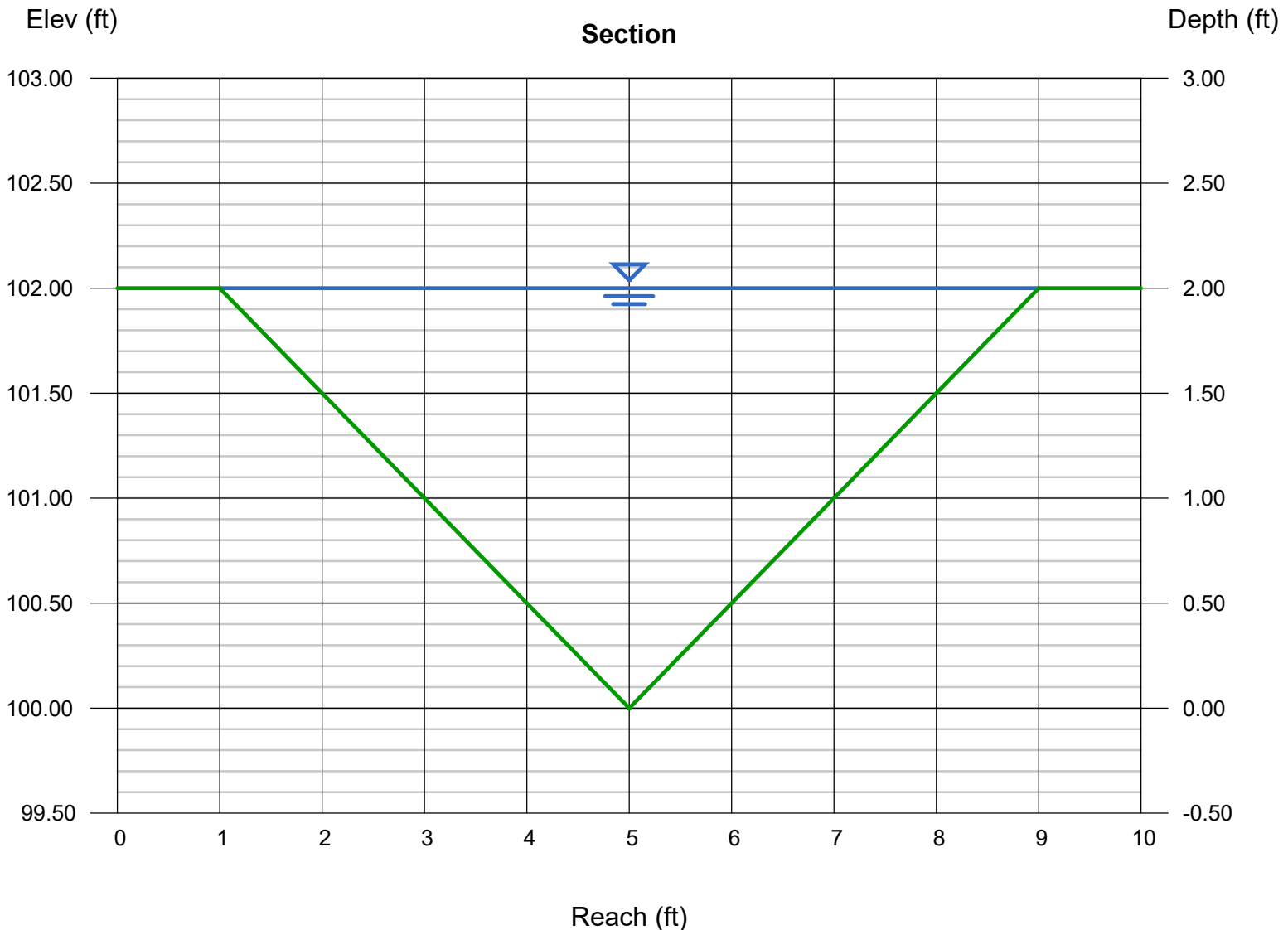

Channel Report

NODE 410 TO 330:DETERMINE CAPACITY 12" PVC @ 5.33%

Circular

Diameter (ft) = 1.00

Invert Elev (ft) = 100.00
Slope (%) = 5.33
N-Value = 0.011

Highlighted

Depth (ft) = 0.46
Q (cfs) = 4.110
Area (sqft) = 0.35
Velocity (ft/s) = 11.58
Wetted Perim (ft) = 1.49
Crit Depth, Yc (ft) = 0.86
Top Width (ft) = 1.00
EGL (ft) = 2.55

Calculations

Compute by: Known Q
Known Q (cfs) = 4.11

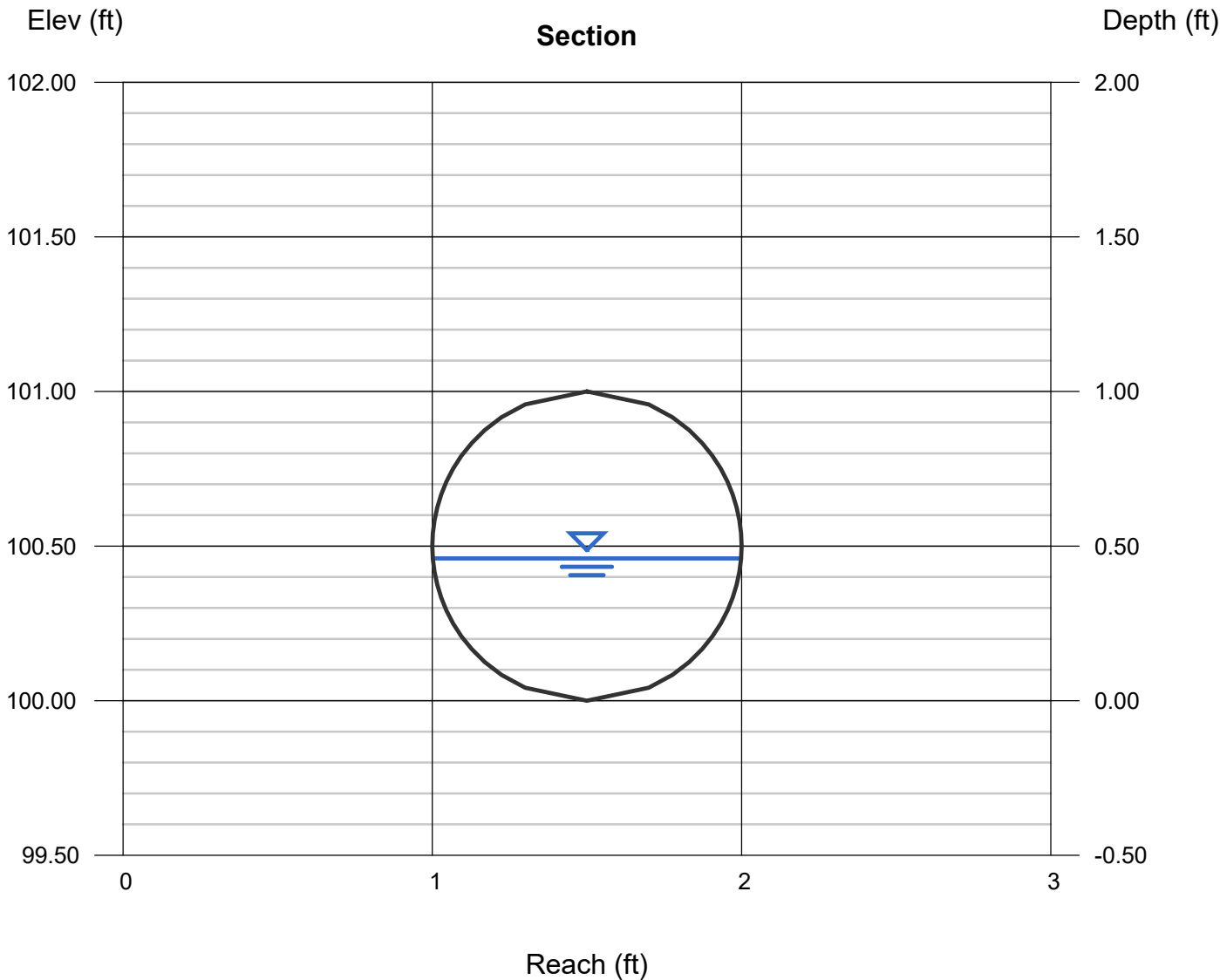

Channel Report

NODE 320 TO 330: DETERMINE CAPACITY 18" PVC @ 10.0%

Circular

Diameter (ft) = 1.50

Invert Elev (ft) = 100.00
Slope (%) = 10.00
N-Value = 0.011

Highlighted

Depth (ft) = 0.83
Q (cfs) = 23.13
Area (sqft) = 1.01
Velocity (ft/s) = 23.15
Wetted Perim (ft) = 2.52
Crit Depth, Yc (ft) = 1.49
Top Width (ft) = 1.49
EGL (ft) = 9.16

Calculations

Compute by: Known Q
Known Q (cfs) = 23.13

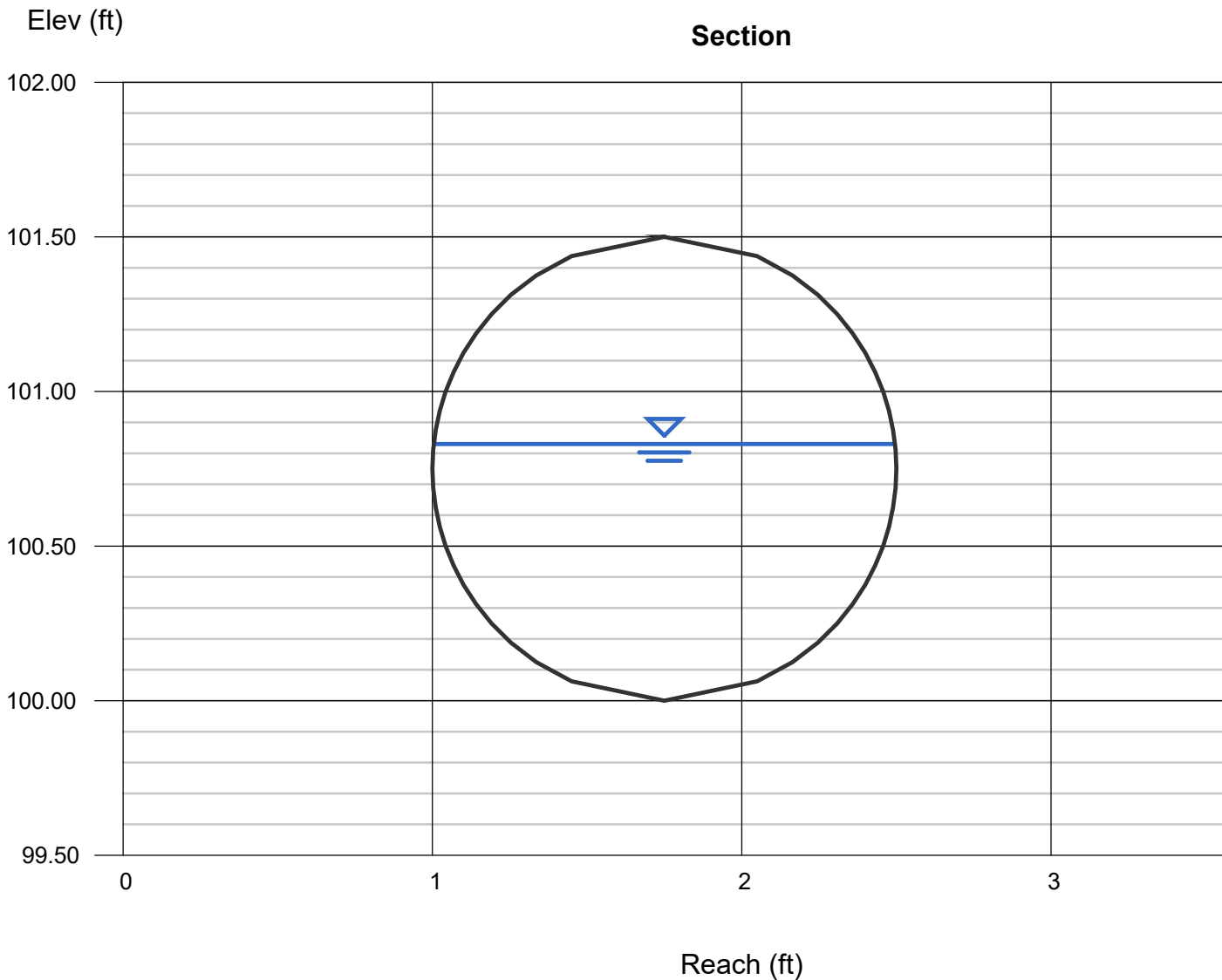

Channel Report

DETERMINE CAPACITY OF 18 INCH RCP AT BASIN OUTLET

Circular

Diameter (ft) = 1.50

Invert Elev (ft) = 2181.00

Slope (%) = 1.00

N-Value = 0.013

Calculations

Compute by: Known Q

Known Q (cfs) = 9.49

Highlighted

Depth (ft) = 1.12

Q (cfs) = 9.490

Area (sqft) = 1.42

Velocity (ft/s) = 6.69

Wetted Perim (ft) = 3.14

Crit Depth, Y_c (ft) = 1.19

Top Width (ft) = 1.30

EGL (ft) = 1.82

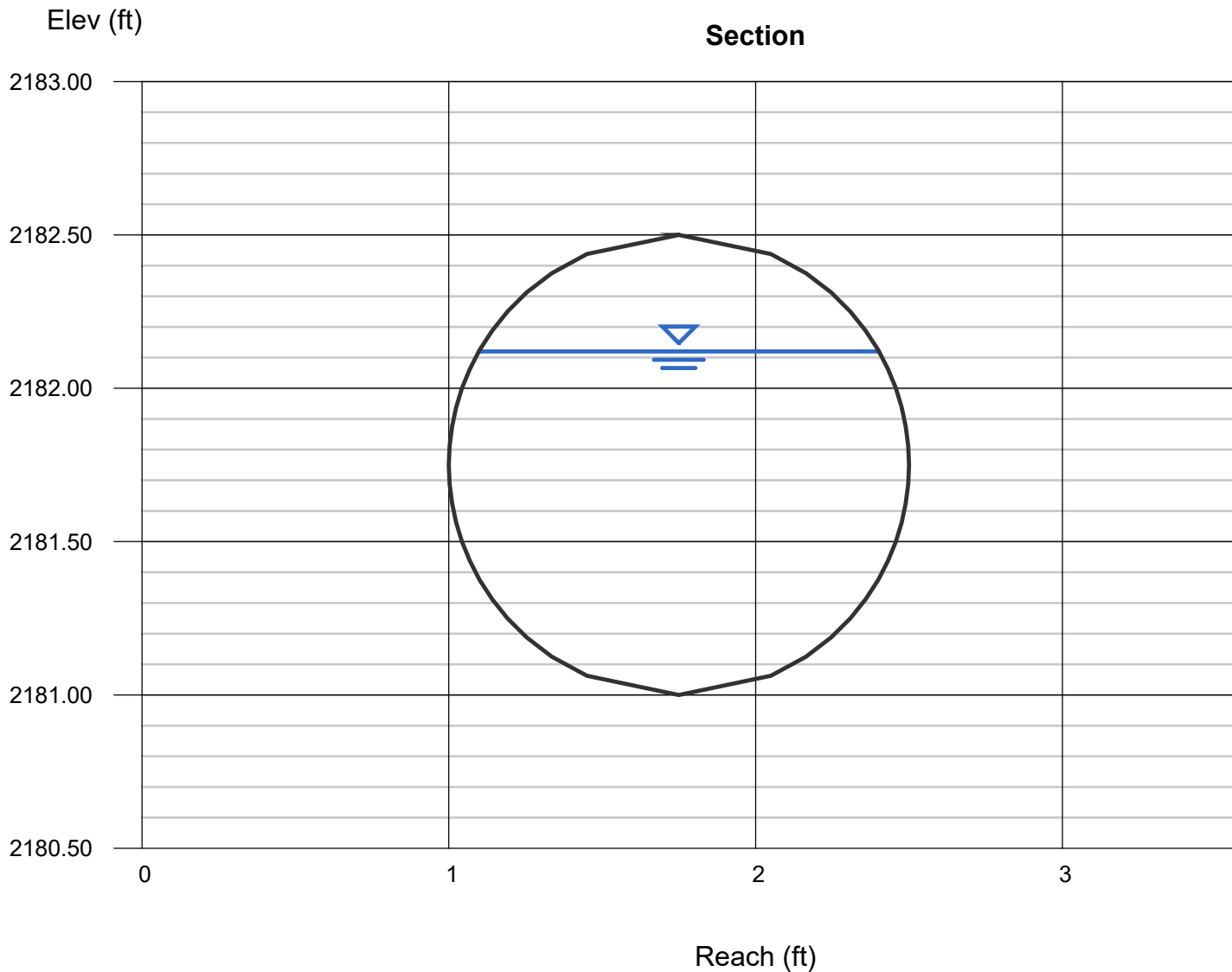

GRAPEVINE CANYON ANALYSIS

LYTLE CREEK - GRAPEVINE CANYON
FOR MOUNTAIN AVENUE BEES, INC.
EXISTING CONDITION DRAINAGE MAP TO CULVERT AT LYTLE CREEK ROAD

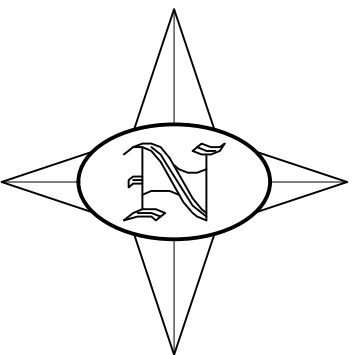

SCALE: 1"=300'

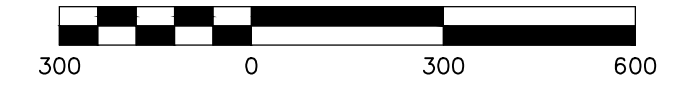

LEGEND:

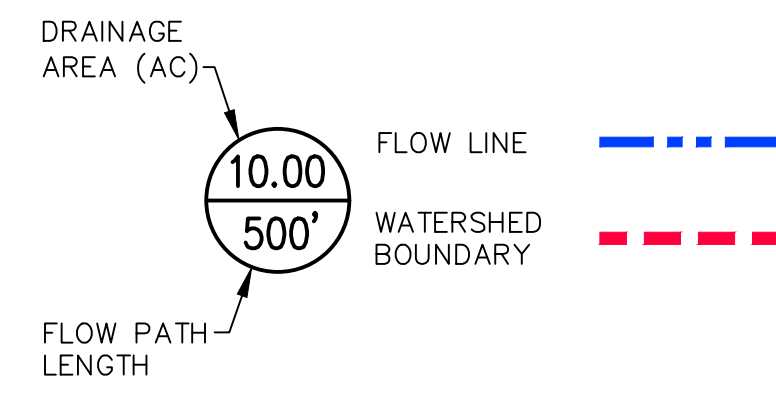

LYTLE CREEK - GRAPEVINE CANYON
 FOR MOUNTAIN AVENUE BEES, INC.
 FLOW DEPTH SECTIONS UPSTREAM OF LYTLE CREEK ROAD

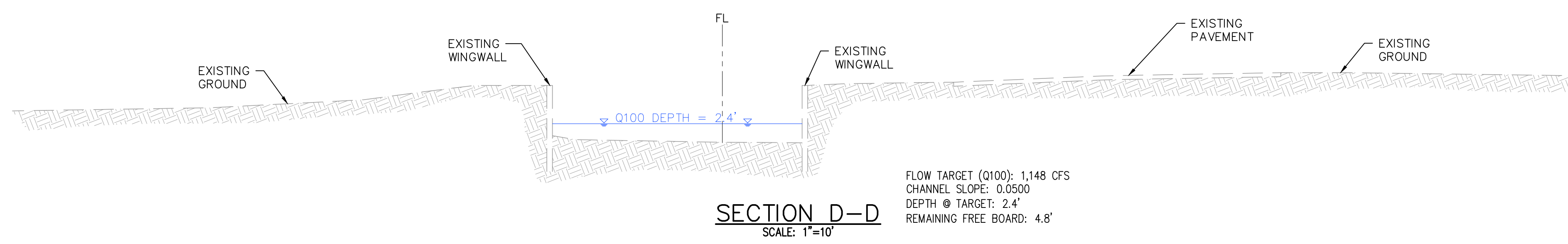
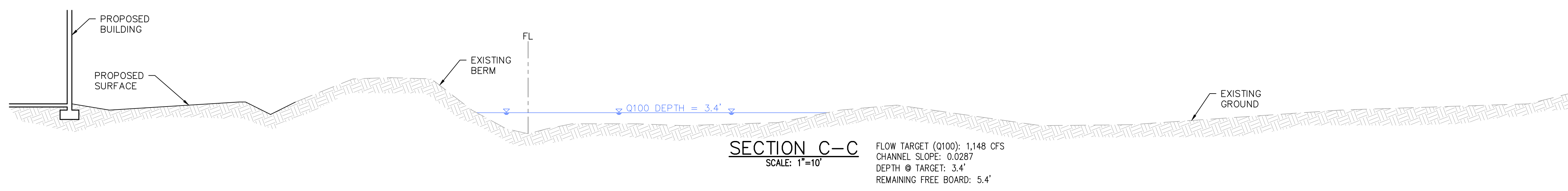
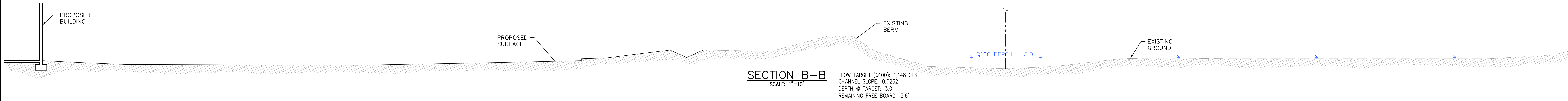
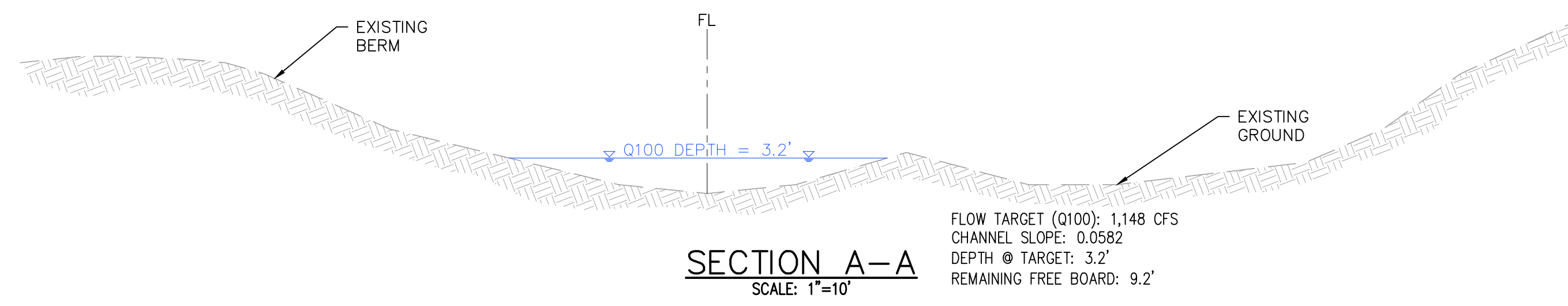
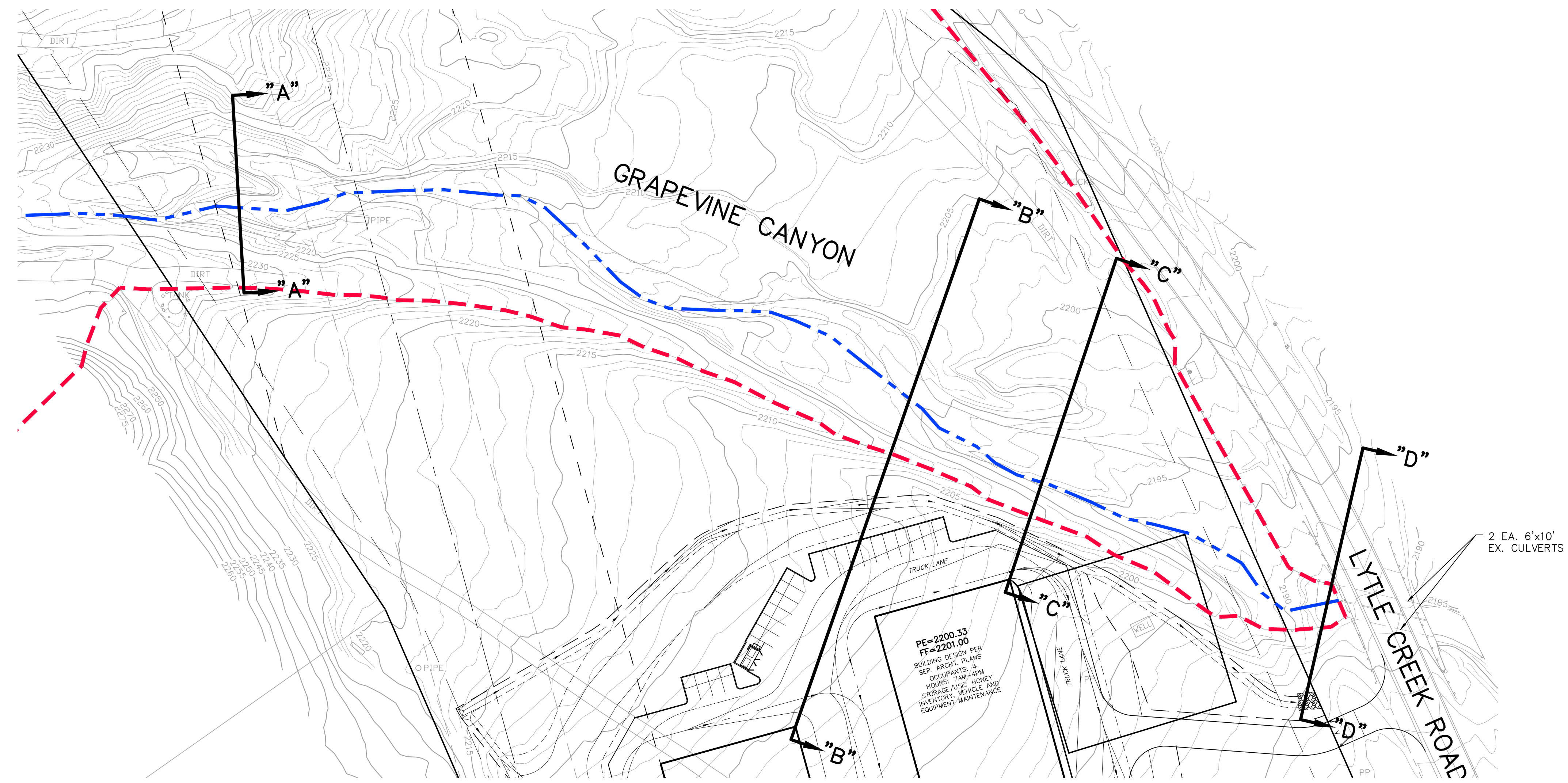
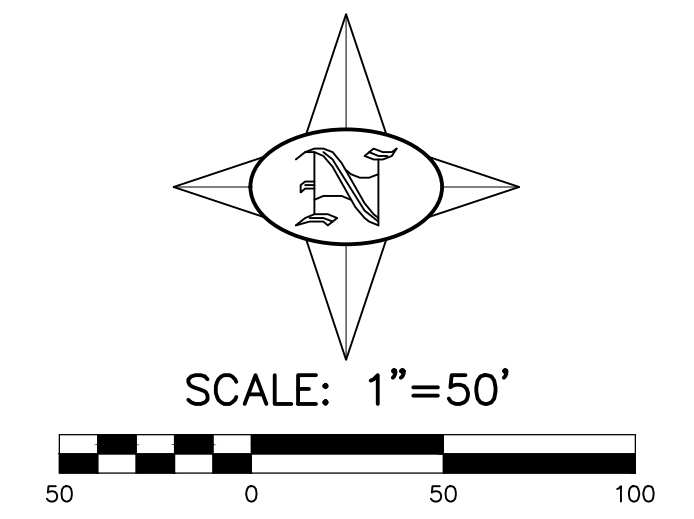

U n i t H y d r o g r a p h A n a l y s i s

Copyright (c) CIVILCADD/CIVILDESIGN, 1989 - 2004, Version 7.0

Study date 09/02/22

+++++

San Bernardino County Synthetic Unit Hydrology Method
Manual date - August 1986

Program License Serial Number 6165

MTN AVES BEES - GRAPEVINE CHANNEL
100-YR 24-HR STORM
EXISTING CONDITION

Storm Event Year = 100

Antecedent Moisture Condition = 3

English (in-lb) Input Units Used

English Rainfall Data (Inches) Input Values Used

English Units used in output format

Area averaged rainfall intensity isohyetal data:

Sub-Area (Ac.)	Duration (hours)	Isohyetal (In)
Rainfall data for year 100		
413.50	1	2.30

Rainfall data for year 100		
413.50	6	6.84

Rainfall data for year 100		
413.50	24	13.30

+++++

***** Area-averaged max loss rate, Fm *****

SCS curve No.(AMCII)	SCS curve NO.(AMC 3)	Area (Ac.)	Area Fraction	Fp(Fig C6) (In/Hr)	Ap (dec.)	Fm (In/Hr)
78.0	92.8	413.50	1.000	0.140	1.000	0.140

Area-averaged adjusted loss rate Fm (In/Hr) = 0.140

***** Area-Averaged low loss rate fraction, Yb *****

Area (Ac.)	Area Fract	SCS CN (AMC2)	SCS CN (AMC3)	S	Pervious Yield Fr
413.50	1.000	78.0	92.8	0.78	0.933

Area-averaged catchment yield fraction, Y = 0.933

Area-averaged low loss fraction, Yb = 0.067

+++++

Watercourse length = 12620.00(Ft.)

Length from concentration point to centroid = 7478.00(Ft.)

Elevation difference along watercourse = 2584.00(Ft.)

Mannings friction factor along watercourse = 0.040

Watershed area = 413.50(Ac.)

Catchment Lag time = 0.405 hours

Unit interval = 5.000 minutes

Unit interval percentage of lag time = 20.5941

Hydrograph baseflow = 0.00(CFS)

Average maximum watershed loss rate(Fm) = 0.140(In/Hr)

Average low loss rate fraction (Yb) = 0.067 (decimal)

FOOTHILL S-Graph Selected

Computed peak 5-minute rainfall = 0.550(In)

Computed peak 30-minute rainfall = 1.480(In)

Specified peak 1-hour rainfall = 2.300(In)

Computed peak 3-hour rainfall = 4.530(In)

Specified peak 6-hour rainfall = 6.840(In)

Specified peak 24-hour rainfall = 13.300(In)

Note: user specified rainfall values used.

Rainfall depth area reduction factors:

Using a total area of 413.50(Ac.) (Ref: fig. E-4)

5-minute factor = 0.981	Adjusted rainfall = 0.539(In)
30-minute factor = 0.981	Adjusted rainfall = 1.451(In)
1-hour factor = 0.981	Adjusted rainfall = 2.255(In)
3-hour factor = 0.998	Adjusted rainfall = 4.519(In)
6-hour factor = 0.999	Adjusted rainfall = 6.831(In)
24-hour factor = 0.999	Adjusted rainfall = 13.293(In)

U n i t H y d r o g r a p h

+++++

Interval Number	'S' Graph Mean values	Unit Hydrograph ((CFS))
-----------------	-----------------------	-------------------------

(K = 5000.77 (CFS))

1	1.352	67.631
2	5.172	191.017
3	11.018	292.321
4	20.487	473.536
5	39.339	942.724
6	58.127	939.574

7	66.843	435.838
8	72.907	303.259
9	77.677	238.526
10	81.564	194.410
11	84.737	158.659
12	87.420	134.168
13	89.708	114.430
14	91.621	95.662
15	93.258	81.875
16	94.621	68.168
17	95.711	54.461
18	96.616	45.274
19	97.362	37.329
20	97.890	26.364
21	98.166	13.833
22	98.413	12.335
23	98.634	11.044
24	98.840	10.299
25	99.024	9.227
26	99.151	6.339
27	99.276	6.268
28	99.431	7.725
29	99.595	8.239
30	99.729	6.696
31	99.812	4.157
32	99.891	3.922
33	99.939	2.385
34	100.000	1.193

Peak Unit Number	Adjusted mass rainfall (In)	Unit rainfall (In)
1	0.5393	0.5393
2	0.7910	0.2516
3	0.9896	0.1986
4	1.1601	0.1705
5	1.3123	0.1522
6	1.4513	0.1391
7	1.6008	0.1495
8	1.7427	0.1419
9	1.8783	0.1356
10	2.0085	0.1302
11	2.1340	0.1255
12	2.2554	0.1214
13	2.3726	0.1171
14	2.4864	0.1139
15	2.5973	0.1109
16	2.7056	0.1082
17	2.8113	0.1058
18	2.9148	0.1035
19	3.0162	0.1014
20	3.1157	0.0995
21	3.2134	0.0977
22	3.3093	0.0960
23	3.4037	0.0944
24	3.4966	0.0929
25	3.5880	0.0915
26	3.6782	0.0901

27	3.7670	0.0889
28	3.8547	0.0877
29	3.9412	0.0865
30	4.0267	0.0854
31	4.1110	0.0844
32	4.1944	0.0834
33	4.2769	0.0824
34	4.3584	0.0815
35	4.4391	0.0807
36	4.5189	0.0798
37	4.5933	0.0744
38	4.6669	0.0736
39	4.7397	0.0728
40	4.8118	0.0721
41	4.8832	0.0714
42	4.9538	0.0707
43	5.0238	0.0700
44	5.0932	0.0693
45	5.1618	0.0687
46	5.2299	0.0681
47	5.2974	0.0675
48	5.3643	0.0669
49	5.4307	0.0663
50	5.4965	0.0658
51	5.5617	0.0653
52	5.6265	0.0648
53	5.6908	0.0643
54	5.7545	0.0638
55	5.8178	0.0633
56	5.8807	0.0628
57	5.9430	0.0624
58	6.0050	0.0619
59	6.0665	0.0615
60	6.1276	0.0611
61	6.1883	0.0607
62	6.2485	0.0603
63	6.3084	0.0599
64	6.3679	0.0595
65	6.4271	0.0591
66	6.4858	0.0588
67	6.5442	0.0584
68	6.6023	0.0581
69	6.6600	0.0577
70	6.7174	0.0574
71	6.7744	0.0570
72	6.8312	0.0567
73	6.8766	0.0454
74	6.9216	0.0451
75	6.9664	0.0448
76	7.0109	0.0445
77	7.0550	0.0442
78	7.0989	0.0439
79	7.1424	0.0436
80	7.1857	0.0433
81	7.2287	0.0430
82	7.2714	0.0427
83	7.3139	0.0425

84	7.3561	0.0422
85	7.3980	0.0419
86	7.4397	0.0417
87	7.4811	0.0414
88	7.5222	0.0412
89	7.5632	0.0409
90	7.6039	0.0407
91	7.6443	0.0405
92	7.6846	0.0402
93	7.7246	0.0400
94	7.7643	0.0398
95	7.8039	0.0396
96	7.8432	0.0393
97	7.8824	0.0391
98	7.9213	0.0389
99	7.9600	0.0387
100	7.9985	0.0385
101	8.0368	0.0383
102	8.0749	0.0381
103	8.1129	0.0379
104	8.1506	0.0377
105	8.1881	0.0375
106	8.2255	0.0374
107	8.2627	0.0372
108	8.2997	0.0370
109	8.3365	0.0368
110	8.3731	0.0366
111	8.4096	0.0365
112	8.4459	0.0363
113	8.4820	0.0361
114	8.5180	0.0360
115	8.5538	0.0358
116	8.5894	0.0356
117	8.6249	0.0355
118	8.6602	0.0353
119	8.6954	0.0352
120	8.7304	0.0350
121	8.7653	0.0349
122	8.8000	0.0347
123	8.8346	0.0346
124	8.8690	0.0344
125	8.9033	0.0343
126	8.9374	0.0341
127	8.9714	0.0340
128	9.0052	0.0339
129	9.0390	0.0337
130	9.0725	0.0336
131	9.1060	0.0334
132	9.1393	0.0333
133	9.1725	0.0332
134	9.2055	0.0331
135	9.2385	0.0329
136	9.2713	0.0328
137	9.3040	0.0327
138	9.3365	0.0326
139	9.3689	0.0324
140	9.4012	0.0323

141	9.4334	0.0322
142	9.4655	0.0321
143	9.4975	0.0320
144	9.5293	0.0318
145	9.5610	0.0317
146	9.5926	0.0316
147	9.6241	0.0315
148	9.6555	0.0314
149	9.6868	0.0313
150	9.7180	0.0312
151	9.7490	0.0311
152	9.7800	0.0310
153	9.8108	0.0308
154	9.8416	0.0307
155	9.8722	0.0306
156	9.9027	0.0305
157	9.9332	0.0304
158	9.9635	0.0303
159	9.9937	0.0302
160	10.0239	0.0301
161	10.0539	0.0300
162	10.0838	0.0299
163	10.1137	0.0298
164	10.1434	0.0298
165	10.1731	0.0297
166	10.2027	0.0296
167	10.2321	0.0295
168	10.2615	0.0294
169	10.2908	0.0293
170	10.3200	0.0292
171	10.3491	0.0291
172	10.3781	0.0290
173	10.4071	0.0289
174	10.4359	0.0288
175	10.4647	0.0288
176	10.4933	0.0287
177	10.5219	0.0286
178	10.5504	0.0285
179	10.5789	0.0284
180	10.6072	0.0283
181	10.6355	0.0283
182	10.6636	0.0282
183	10.6917	0.0281
184	10.7198	0.0280
185	10.7477	0.0279
186	10.7756	0.0279
187	10.8033	0.0278
188	10.8310	0.0277
189	10.8587	0.0276
190	10.8862	0.0276
191	10.9137	0.0275
192	10.9411	0.0274
193	10.9684	0.0273
194	10.9957	0.0273
195	11.0229	0.0272
196	11.0500	0.0271
197	11.0770	0.0270

198	11.1040	0.0270
199	11.1309	0.0269
200	11.1577	0.0268
201	11.1845	0.0268
202	11.2112	0.0267
203	11.2378	0.0266
204	11.2643	0.0266
205	11.2908	0.0265
206	11.3172	0.0264
207	11.3436	0.0264
208	11.3699	0.0263
209	11.3961	0.0262
210	11.4222	0.0262
211	11.4483	0.0261
212	11.4744	0.0260
213	11.5003	0.0260
214	11.5262	0.0259
215	11.5520	0.0258
216	11.5778	0.0258
217	11.6035	0.0257
218	11.6292	0.0256
219	11.6548	0.0256
220	11.6803	0.0255
221	11.7058	0.0255
222	11.7312	0.0254
223	11.7565	0.0253
224	11.7818	0.0253
225	11.8070	0.0252
226	11.8322	0.0252
227	11.8573	0.0251
228	11.8824	0.0251
229	11.9074	0.0250
230	11.9323	0.0249
231	11.9572	0.0249
232	11.9820	0.0248
233	12.0068	0.0248
234	12.0315	0.0247
235	12.0562	0.0247
236	12.0808	0.0246
237	12.1054	0.0246
238	12.1299	0.0245
239	12.1543	0.0244
240	12.1787	0.0244
241	12.2031	0.0243
242	12.2273	0.0243
243	12.2516	0.0242
244	12.2758	0.0242
245	12.2999	0.0241
246	12.3240	0.0241
247	12.3480	0.0240
248	12.3720	0.0240
249	12.3959	0.0239
250	12.4198	0.0239
251	12.4437	0.0238
252	12.4674	0.0238
253	12.4912	0.0237
254	12.5149	0.0237

255	12.5385	0.0236
256	12.5621	0.0236
257	12.5856	0.0235
258	12.6091	0.0235
259	12.6326	0.0234
260	12.6560	0.0234
261	12.6793	0.0234
262	12.7026	0.0233
263	12.7259	0.0233
264	12.7491	0.0232
265	12.7723	0.0232
266	12.7954	0.0231
267	12.8185	0.0231
268	12.8415	0.0230
269	12.8645	0.0230
270	12.8874	0.0229
271	12.9103	0.0229
272	12.9332	0.0229
273	12.9560	0.0228
274	12.9788	0.0228
275	13.0015	0.0227
276	13.0242	0.0227
277	13.0468	0.0226
278	13.0694	0.0226
279	13.0920	0.0226
280	13.1145	0.0225
281	13.1370	0.0225
282	13.1594	0.0224
283	13.1818	0.0224
284	13.2041	0.0223
285	13.2264	0.0223
286	13.2487	0.0223
287	13.2709	0.0222
288	13.2931	0.0222

Unit Period (number)	Unit Rainfall (In)	Unit Soil-Loss (In)	Effective Rainfall (In)
1	0.0222	0.0015	0.0207
2	0.0222	0.0015	0.0207
3	0.0223	0.0015	0.0208
4	0.0223	0.0015	0.0209
5	0.0224	0.0015	0.0209
6	0.0225	0.0015	0.0210
7	0.0226	0.0015	0.0211
8	0.0226	0.0015	0.0211
9	0.0227	0.0015	0.0212
10	0.0227	0.0015	0.0212
11	0.0228	0.0015	0.0213
12	0.0229	0.0015	0.0213
13	0.0229	0.0015	0.0214
14	0.0230	0.0015	0.0215
15	0.0231	0.0015	0.0215
16	0.0231	0.0015	0.0216
17	0.0232	0.0015	0.0217
18	0.0233	0.0016	0.0217

19	0.0234	0.0016	0.0218
20	0.0234	0.0016	0.0218
21	0.0235	0.0016	0.0219
22	0.0235	0.0016	0.0220
23	0.0236	0.0016	0.0221
24	0.0237	0.0016	0.0221
25	0.0238	0.0016	0.0222
26	0.0238	0.0016	0.0222
27	0.0239	0.0016	0.0223
28	0.0240	0.0016	0.0224
29	0.0241	0.0016	0.0225
30	0.0241	0.0016	0.0225
31	0.0242	0.0016	0.0226
32	0.0243	0.0016	0.0227
33	0.0244	0.0016	0.0228
34	0.0244	0.0016	0.0228
35	0.0246	0.0016	0.0229
36	0.0246	0.0016	0.0230
37	0.0247	0.0017	0.0231
38	0.0248	0.0017	0.0231
39	0.0249	0.0017	0.0232
40	0.0249	0.0017	0.0233
41	0.0251	0.0017	0.0234
42	0.0251	0.0017	0.0234
43	0.0252	0.0017	0.0235
44	0.0253	0.0017	0.0236
45	0.0254	0.0017	0.0237
46	0.0255	0.0017	0.0238
47	0.0256	0.0017	0.0239
48	0.0256	0.0017	0.0239
49	0.0258	0.0017	0.0241
50	0.0258	0.0017	0.0241
51	0.0260	0.0017	0.0242
52	0.0260	0.0017	0.0243
53	0.0262	0.0017	0.0244
54	0.0262	0.0018	0.0245
55	0.0264	0.0018	0.0246
56	0.0264	0.0018	0.0247
57	0.0266	0.0018	0.0248
58	0.0266	0.0018	0.0248
59	0.0268	0.0018	0.0250
60	0.0268	0.0018	0.0250
61	0.0270	0.0018	0.0252
62	0.0270	0.0018	0.0252
63	0.0272	0.0018	0.0254
64	0.0273	0.0018	0.0254
65	0.0274	0.0018	0.0256
66	0.0275	0.0018	0.0256
67	0.0276	0.0018	0.0258
68	0.0277	0.0018	0.0259
69	0.0279	0.0019	0.0260
70	0.0279	0.0019	0.0261
71	0.0281	0.0019	0.0262
72	0.0282	0.0019	0.0263
73	0.0283	0.0019	0.0264
74	0.0284	0.0019	0.0265
75	0.0286	0.0019	0.0267

76	0.0287	0.0019	0.0268
77	0.0288	0.0019	0.0269
78	0.0289	0.0019	0.0270
79	0.0291	0.0019	0.0272
80	0.0292	0.0019	0.0272
81	0.0294	0.0020	0.0274
82	0.0295	0.0020	0.0275
83	0.0297	0.0020	0.0277
84	0.0298	0.0020	0.0278
85	0.0299	0.0020	0.0279
86	0.0300	0.0020	0.0280
87	0.0302	0.0020	0.0282
88	0.0303	0.0020	0.0283
89	0.0305	0.0020	0.0285
90	0.0306	0.0020	0.0286
91	0.0308	0.0021	0.0288
92	0.0310	0.0021	0.0289
93	0.0312	0.0021	0.0291
94	0.0313	0.0021	0.0292
95	0.0315	0.0021	0.0294
96	0.0316	0.0021	0.0295
97	0.0318	0.0021	0.0297
98	0.0320	0.0021	0.0298
99	0.0322	0.0021	0.0300
100	0.0323	0.0022	0.0302
101	0.0326	0.0022	0.0304
102	0.0327	0.0022	0.0305
103	0.0329	0.0022	0.0307
104	0.0331	0.0022	0.0308
105	0.0333	0.0022	0.0311
106	0.0334	0.0022	0.0312
107	0.0337	0.0023	0.0315
108	0.0339	0.0023	0.0316
109	0.0341	0.0023	0.0319
110	0.0343	0.0023	0.0320
111	0.0346	0.0023	0.0323
112	0.0347	0.0023	0.0324
113	0.0350	0.0023	0.0327
114	0.0352	0.0023	0.0328
115	0.0355	0.0024	0.0331
116	0.0356	0.0024	0.0333
117	0.0360	0.0024	0.0336
118	0.0361	0.0024	0.0337
119	0.0365	0.0024	0.0340
120	0.0366	0.0024	0.0342
121	0.0370	0.0025	0.0345
122	0.0372	0.0025	0.0347
123	0.0375	0.0025	0.0350
124	0.0377	0.0025	0.0352
125	0.0381	0.0025	0.0356
126	0.0383	0.0026	0.0358
127	0.0387	0.0026	0.0361
128	0.0389	0.0026	0.0363
129	0.0393	0.0026	0.0367
130	0.0396	0.0026	0.0369
131	0.0400	0.0027	0.0373
132	0.0402	0.0027	0.0375

133	0.0407	0.0027	0.0380
134	0.0409	0.0027	0.0382
135	0.0414	0.0028	0.0387
136	0.0417	0.0028	0.0389
137	0.0422	0.0028	0.0394
138	0.0425	0.0028	0.0396
139	0.0430	0.0029	0.0401
140	0.0433	0.0029	0.0404
141	0.0439	0.0029	0.0409
142	0.0442	0.0029	0.0412
143	0.0448	0.0030	0.0418
144	0.0451	0.0030	0.0421
145	0.0567	0.0038	0.0529
146	0.0570	0.0038	0.0532
147	0.0577	0.0039	0.0539
148	0.0581	0.0039	0.0542
149	0.0588	0.0039	0.0548
150	0.0591	0.0039	0.0552
151	0.0599	0.0040	0.0559
152	0.0603	0.0040	0.0563
153	0.0611	0.0041	0.0570
154	0.0615	0.0041	0.0574
155	0.0624	0.0042	0.0582
156	0.0628	0.0042	0.0586
157	0.0638	0.0043	0.0595
158	0.0643	0.0043	0.0600
159	0.0653	0.0044	0.0609
160	0.0658	0.0044	0.0614
161	0.0669	0.0045	0.0624
162	0.0675	0.0045	0.0630
163	0.0687	0.0046	0.0641
164	0.0693	0.0046	0.0647
165	0.0707	0.0047	0.0659
166	0.0714	0.0048	0.0666
167	0.0728	0.0049	0.0680
168	0.0736	0.0049	0.0687
169	0.0798	0.0053	0.0745
170	0.0807	0.0054	0.0753
171	0.0824	0.0055	0.0769
172	0.0834	0.0056	0.0778
173	0.0854	0.0057	0.0797
174	0.0865	0.0058	0.0807
175	0.0889	0.0059	0.0829
176	0.0901	0.0060	0.0841
177	0.0929	0.0062	0.0867
178	0.0944	0.0063	0.0881
179	0.0977	0.0065	0.0911
180	0.0995	0.0066	0.0928
181	0.1035	0.0069	0.0966
182	0.1058	0.0071	0.0987
183	0.1109	0.0074	0.1035
184	0.1139	0.0076	0.1063
185	0.1214	0.0081	0.1133
186	0.1255	0.0084	0.1171
187	0.1356	0.0090	0.1265
188	0.1419	0.0095	0.1324
189	0.1391	0.0093	0.1298

190	0.1522	0.0102	0.1420
191	0.1986	0.0117	0.1869
192	0.2516	0.0117	0.2400
193	0.5393	0.0117	0.5277
194	0.1705	0.0114	0.1591
195	0.1495	0.0100	0.1395
196	0.1302	0.0087	0.1215
197	0.1171	0.0078	0.1093
198	0.1082	0.0072	0.1010
199	0.1014	0.0068	0.0946
200	0.0960	0.0064	0.0896
201	0.0915	0.0061	0.0854
202	0.0877	0.0059	0.0818
203	0.0844	0.0056	0.0788
204	0.0815	0.0054	0.0761
205	0.0744	0.0050	0.0695
206	0.0721	0.0048	0.0673
207	0.0700	0.0047	0.0653
208	0.0681	0.0045	0.0635
209	0.0663	0.0044	0.0619
210	0.0648	0.0043	0.0604
211	0.0633	0.0042	0.0591
212	0.0619	0.0041	0.0578
213	0.0607	0.0041	0.0566
214	0.0595	0.0040	0.0555
215	0.0584	0.0039	0.0545
216	0.0574	0.0038	0.0535
217	0.0454	0.0030	0.0424
218	0.0445	0.0030	0.0415
219	0.0436	0.0029	0.0407
220	0.0427	0.0029	0.0399
221	0.0419	0.0028	0.0391
222	0.0412	0.0027	0.0384
223	0.0405	0.0027	0.0378
224	0.0398	0.0027	0.0371
225	0.0391	0.0026	0.0365
226	0.0385	0.0026	0.0359
227	0.0379	0.0025	0.0354
228	0.0374	0.0025	0.0349
229	0.0368	0.0025	0.0344
230	0.0363	0.0024	0.0339
231	0.0358	0.0024	0.0334
232	0.0353	0.0024	0.0330
233	0.0349	0.0023	0.0325
234	0.0344	0.0023	0.0321
235	0.0340	0.0023	0.0317
236	0.0336	0.0022	0.0313
237	0.0332	0.0022	0.0310
238	0.0328	0.0022	0.0306
239	0.0324	0.0022	0.0303
240	0.0321	0.0021	0.0299
241	0.0317	0.0021	0.0296
242	0.0314	0.0021	0.0293
243	0.0311	0.0021	0.0290
244	0.0307	0.0021	0.0287
245	0.0304	0.0020	0.0284
246	0.0301	0.0020	0.0281

247	0.0298	0.0020	0.0279
248	0.0296	0.0020	0.0276
249	0.0293	0.0020	0.0273
250	0.0290	0.0019	0.0271
251	0.0288	0.0019	0.0268
252	0.0285	0.0019	0.0266
253	0.0283	0.0019	0.0264
254	0.0280	0.0019	0.0261
255	0.0278	0.0019	0.0259
256	0.0276	0.0018	0.0257
257	0.0273	0.0018	0.0255
258	0.0271	0.0018	0.0253
259	0.0269	0.0018	0.0251
260	0.0267	0.0018	0.0249
261	0.0265	0.0018	0.0247
262	0.0263	0.0018	0.0245
263	0.0261	0.0017	0.0243
264	0.0259	0.0017	0.0242
265	0.0257	0.0017	0.0240
266	0.0255	0.0017	0.0238
267	0.0253	0.0017	0.0237
268	0.0252	0.0017	0.0235
269	0.0250	0.0017	0.0233
270	0.0248	0.0017	0.0232
271	0.0247	0.0016	0.0230
272	0.0245	0.0016	0.0229
273	0.0243	0.0016	0.0227
274	0.0242	0.0016	0.0226
275	0.0240	0.0016	0.0224
276	0.0239	0.0016	0.0223
277	0.0237	0.0016	0.0222
278	0.0236	0.0016	0.0220
279	0.0234	0.0016	0.0219
280	0.0233	0.0016	0.0218
281	0.0232	0.0015	0.0216
282	0.0230	0.0015	0.0215
283	0.0229	0.0015	0.0214
284	0.0228	0.0015	0.0212
285	0.0226	0.0015	0.0211
286	0.0225	0.0015	0.0210
287	0.0224	0.0015	0.0209
288	0.0223	0.0015	0.0208

Total soil rain loss = 0.86(In)
Total effective rainfall = 12.44(In)
Peak flow rate in flood hydrograph = 1148.34(CFS)

+++++
24 - H O U R S T O R M
R u n o f f H y d r o g r a p h

Hydrograph in 5 Minute intervals ((CFS))

Time(h+m) Volume Ac.Ft Q(CFS) 0 300.0 600.0 900.0 1200.0

0+ 5	0.0096	1.40	Q
0+10	0.0465	5.36	Q
0+15	0.1252	11.42	Q
0+20	0.2716	21.26	Q
0+25	0.5528	40.83	VQ
0+30	0.9686	60.38	V Q
0+35	1.4477	69.57	V Q
0+40	1.9714	76.03	V Q
0+45	2.5305	81.18	V Q
0+50	3.1188	85.43	V Q
0+55	3.7314	88.95	V Q
1+ 0	4.3648	91.97	V Q
1+ 5	5.0163	94.60	V Q
1+10	5.6833	96.85	V Q
1+15	6.3639	98.82	V Q
1+20	7.0561	100.51	V Q
1+25	7.7580	101.92	V Q
1+30	8.4684	103.15	V Q
1+35	9.1862	104.22	V Q
1+40	9.9098	105.07	V Q
1+45	10.6376	105.66	V Q
1+50	11.3692	106.23	V Q
1+55	12.1045	106.77	V Q
2+ 0	12.8435	107.30	V Q
2+ 5	13.5860	107.81	V Q
2+10	14.3317	108.27	V Q
2+15	15.0804	108.72	V Q
2+20	15.8326	109.21	V Q
2+25	16.5882	109.72	V Q
2+30	17.3472	110.19	V Q
2+35	18.1090	110.62	V Q
2+40	18.8738	111.05	V Q
2+45	19.6413	111.44	V Q
2+50	20.4114	111.82	V Q
2+55	21.1839	112.17	V Q
3+ 0	21.9589	112.53	VQ
3+ 5	22.7363	112.89	VQ
3+10	23.5163	113.25	VQ
3+15	24.2988	113.62	VQ
3+20	25.0838	113.99	VQ
3+25	25.8714	114.36	VQ
3+30	26.6616	114.74	VQ
3+35	27.4545	115.12	VQ
3+40	28.2500	115.51	VQ
3+45	29.0482	115.90	VQ
3+50	29.8491	116.29	VQ
3+55	30.6527	116.69	VQ
4+ 0	31.4591	117.09	VQ
4+ 5	32.2682	117.49	Q
4+10	33.0802	117.90	Q
4+15	33.8950	118.31	Q
4+20	34.7127	118.73	Q
4+25	35.5334	119.15	Q
4+30	36.3569	119.58	Q
4+35	37.1834	120.01	VQ
4+40	38.0129	120.44	VQ
4+45	38.8455	120.88	VQ

4+50	39.6811	121.33	VQ			
4+55	40.5197	121.78	VQ			
5+ 0	41.3616	122.23	VQ			
5+ 5	42.2066	122.69	VQ			
5+10	43.0547	123.16	Q			
5+15	43.9062	123.63	Q			
5+20	44.7609	124.10	Q			
5+25	45.6188	124.58	Q			
5+30	46.4802	125.07	Q			
5+35	47.3449	125.56	Q			
5+40	48.2131	126.06	Q			
5+45	49.0847	126.56	Q			
5+50	49.9598	127.07	Q			
5+55	50.8385	127.58	Q			
6+ 0	51.7207	128.10	Q			
6+ 5	52.6066	128.63	Q			
6+10	53.4961	129.16	Q			
6+15	54.3894	129.70	QV			
6+20	55.2865	130.25	QV			
6+25	56.1873	130.80	QV			
6+30	57.0920	131.37	QV			
6+35	58.0006	131.93	QV			
6+40	58.9132	132.51	QV			
6+45	59.8298	133.09	QV			
6+50	60.7505	133.68	QV			
6+55	61.6752	134.28	QV			
7+ 0	62.6042	134.88	QV			
7+ 5	63.5374	135.49	QV			
7+10	64.4748	136.12	Q V			
7+15	65.4166	136.75	Q V			
7+20	66.3628	137.39	Q V			
7+25	67.3134	138.03	Q V			
7+30	68.2686	138.69	Q V			
7+35	69.2283	139.36	Q V			
7+40	70.1928	140.03	Q V			
7+45	71.1619	140.72	Q V			
7+50	72.1358	141.41	Q V			
7+55	73.1146	142.12	Q V			
8+ 0	74.0983	142.83	Q V			
8+ 5	75.0869	143.56	Q V			
8+10	76.0807	144.30	Q V			
8+15	77.0796	145.04	Q V			
8+20	78.0838	145.80	Q V			
8+25	79.0933	146.57	Q V			
8+30	80.1081	147.36	Q V			
8+35	81.1285	148.15	Q V			
8+40	82.1544	148.96	Q V			
8+45	83.1860	149.78	Q V			
8+50	84.2233	150.62	Q V			
8+55	85.2665	151.47	Q V			
9+ 0	86.3156	152.33	Q V			
9+ 5	87.3707	153.21	Q V			
9+10	88.4321	154.10	Q V			
9+15	89.4996	155.01	Q V			
9+20	90.5736	155.94	Q V			
9+25	91.6540	156.87	Q V			
9+30	92.7410	157.83	Q V			

9+35	93.8347	158.81	Q	V		
9+40	94.9352	159.80	Q	V		
9+45	96.0427	160.81	Q	V		
9+50	97.1573	161.84	Q	V		
9+55	98.2791	162.89	Q	V		
10+ 0	99.4083	163.96	Q	V		
10+ 5	100.5450	165.05	Q	V		
10+10	101.6893	166.16	Q	V		
10+15	102.8415	167.29	Q	V		
10+20	104.0016	168.45	Q	V		
10+25	105.1699	169.63	Q	V		
10+30	106.3464	170.84	Q	V		
10+35	107.5315	172.07	Q	V		
10+40	108.7252	173.33	Q	V		
10+45	109.9277	174.61	Q	V		
10+50	111.1393	175.92	Q	V		
10+55	112.3601	177.26	Q	V		
11+ 0	113.5904	178.64	Q	V		
11+ 5	114.8304	180.04	Q	V		
11+10	116.0803	181.48	Q	V		
11+15	117.3402	182.95	Q	V		
11+20	118.6106	184.46	Q	V		
11+25	119.8916	186.00	Q	V		
11+30	121.1835	187.59	Q	V		
11+35	122.4866	189.21	Q	V		
11+40	123.8012	190.88	Q	V		
11+45	125.1275	192.58	Q	V		
11+50	126.4659	194.34	Q	V		
11+55	127.8167	196.14	Q	V		
12+ 0	129.1803	197.99	Q	V		
12+ 5	130.5618	200.59	Q	V		
12+10	131.9703	204.51	Q	V		
12+15	133.4132	209.52	Q	V		
12+20	134.9039	216.45	Q	V		
12+25	136.4758	228.24	Q	V		
12+30	138.1291	240.06	Q	V		
12+35	139.8285	246.75	Q	V		
12+40	141.5650	252.15	Q	V		
12+45	143.3346	256.94	Q	V		
12+50	145.1345	261.35	Q	V		
12+55	146.9629	265.47	Q	V		
13+ 0	148.8184	269.43	Q	V		
13+ 5	150.7003	273.26	Q	V		
13+10	152.6080	276.99	Q	V		
13+15	154.5410	280.67	Q	V		
13+20	156.4992	284.33	Q	V		
13+25	158.4822	287.94	Q	V		
13+30	160.4903	291.58	Q	V		
13+35	162.5238	295.26	Q	V		
13+40	164.5828	298.96	Q	V		
13+45	166.6673	302.68	Q	V		
13+50	168.7785	306.54	Q	V		
13+55	170.9172	310.54	Q	V		
14+ 0	173.0847	314.73	Q	V		
14+ 5	175.2843	319.37	Q	V		
14+10	177.5207	324.74	Q	V		
14+15	179.7985	330.74	Q	V		

14+20	182.1248	337.77	Q	V					
14+25	184.5150	347.05	Q	V					
14+30	186.9707	356.57	Q	V					
14+35	189.4789	364.19	Q	V					
14+40	192.0381	371.59	Q	V					
14+45	194.6488	379.07	Q	V					
14+50	197.3126	386.80	Q	V					
14+55	200.0318	394.82	Q	V					
15+ 0	202.8095	403.32	Q	V					
15+ 5	205.6493	412.35	Q	V					
15+10	208.5560	422.04	Q	V					
15+15	211.5348	432.52	Q	V					
15+20	214.5923	443.96	Q	V					
15+25	217.7369	456.58	Q	V					
15+30	220.9787	470.71	Q	V					
15+35	224.3306	486.69	Q	V					
15+40	227.8087	505.03	Q	V					
15+45	231.4275	525.45	Q	V					
15+50	235.2000	547.76	Q	V					
15+55	239.1605	575.07	Q	V					
16+ 0	243.3710	611.36	Q	V					
16+ 5	248.0049	672.84	Q	V					
16+10	253.2313	758.88	Q	V	Q				
16+15	259.1336	857.00	Q	V	V	Q			
16+20	265.9089	983.77	Q	V	V		Q		
16+25	273.8175	1148.34	Q	V	V			Q	
16+30	281.3751	1097.37	Q	V	V			Q	
16+35	287.4108	876.38	Q	V	V	Q			
16+40	292.8097	783.92	Q	V	Q	V			
16+45	297.7553	718.10	Q	V	Q	V			
16+50	302.3366	665.20	Q	V	Q	V			
16+55	306.6086	620.31	Q	V	Q	V			
17+ 0	310.6236	582.97	Q	V	Q	V			
17+ 5	314.4105	549.86	Q	V	Q	V			
17+10	317.9852	519.05	Q	V	Q	V			
17+15	321.3695	491.39	Q	V	Q	V			
17+20	324.5705	464.79	Q	V	Q	V			
17+25	327.5873	438.05	Q	V	Q	V			
17+30	330.4398	414.18	Q	V	Q	V			
17+35	333.1521	393.82	Q	V	Q	V			
17+40	335.7304	374.38	Q	V	Q	V			
17+45	338.1868	356.67	Q	V	Q	V			
17+50	340.5588	344.40	Q	V	Q	V			
17+55	342.8556	333.51	Q	V	Q	V			
18+ 0	345.0853	323.75	Q	V	Q	V			
18+ 5	347.2475	313.95	Q	V	Q	V			
18+10	349.3357	303.21	Q	V	Q	V			
18+15	351.3547	293.17	Q	V	Q	V			
18+20	353.2982	282.19	Q	V	Q	V			
18+25	355.1322	266.30	Q	V	Q	V			
18+30	356.8541	250.02	Q	V	Q	V			
18+35	358.4999	238.97	Q	V	Q	V			
18+40	360.0863	230.34	Q	V	Q	V			
18+45	361.6172	222.29	Q	V	Q	V			
18+50	363.0989	215.14	Q	V	Q	V			
18+55	364.5366	208.76	Q	V	Q	V			
19+ 0	365.9370	203.33	Q	V	Q	V			

19+ 5	367.3032	198.38	Q	V
19+10	368.6384	193.87	Q	V
19+15	369.9448	189.69	Q	V
19+20	371.2245	185.82	Q	V
19+25	372.4797	182.25	Q	V
19+30	373.7119	178.92	Q	V
19+35	374.9227	175.81	Q	V
19+40	376.1138	172.94	Q	V
19+45	377.2868	170.32	Q	V
19+50	378.4426	167.82	Q	V
19+55	379.5820	165.44	Q	V
20+ 0	380.7057	163.16	Q	V
20+ 5	381.8143	160.97	Q	V
20+10	382.9085	158.89	Q	V
20+15	383.9889	156.88	Q	V
20+20	385.0559	154.93	Q	V
20+25	386.1099	153.03	Q	V
20+30	387.1513	151.22	Q	V
20+35	388.1809	149.49	Q	V
20+40	389.1989	147.81	Q	V
20+45	390.2058	146.21	Q	V
20+50	391.2021	144.66	Q	V
20+55	392.1882	143.18	Q	V
21+ 0	393.1644	141.74	Q	V
21+ 5	394.1309	140.34	Q	V
21+10	395.0880	138.98	Q	V
21+15	396.0361	137.66	Q	V
21+20	396.9753	136.37	Q	V
21+25	397.9059	135.12	Q	V
21+30	398.8282	133.91	Q	V
21+35	399.7422	132.72	Q	V
21+40	400.6484	131.57	Q	V
21+45	401.5468	130.45	Q	V
21+50	402.4376	129.35	Q	V
21+55	403.3211	128.28	Q	V
22+ 0	404.1973	127.23	Q	V
22+ 5	405.0666	126.21	Q	V
22+10	405.9290	125.22	Q	V
22+15	406.7846	124.25	Q	V
22+20	407.6338	123.29	Q	V
22+25	408.4765	122.36	Q	V
22+30	409.3130	121.45	Q	V
22+35	410.1433	120.56	Q	V
22+40	410.9676	119.69	Q	V
22+45	411.7861	118.84	Q	V
22+50	412.5988	118.00	Q	V
22+55	413.4059	117.19	Q	V
23+ 0	414.2074	116.38	Q	V
23+ 5	415.0035	115.60	Q	V
23+10	415.7944	114.83	Q	V
23+15	416.5800	114.07	Q	V
23+20	417.3605	113.33	Q	V
23+25	418.1360	112.60	Q	V
23+30	418.9066	111.89	Q	V
23+35	419.6724	111.19	Q	V
23+40	420.4334	110.50	Q	V
23+45	421.1898	109.83	Q	V

23+50	421.9416	109.16	Q			V
23+55	422.6889	108.51	Q			V
24+ 0	423.4318	107.87	Q			V
24+ 5	424.1608	105.84	Q			V
24+10	424.8583	101.28	Q			V
24+15	425.5103	94.66	Q			V
24+20	426.0911	84.34	Q			V
24+25	426.5344	64.38	Q			V
24+30	426.8416	44.59	Q			V
24+35	427.0849	35.33	Q			V
24+40	427.2836	28.86	Q			V
24+45	427.4473	23.77	Q			V
24+50	427.5824	19.61	Q			V
24+55	427.6941	16.22	Q			V
25+ 0	427.7861	13.36	Q			V
25+ 5	427.8613	10.92	Q			V
25+10	427.9224	8.88	Q			V
25+15	427.9715	7.13	Q			V
25+20	428.0107	5.68	Q			V
25+25	428.0419	4.53	Q			V
25+30	428.0664	3.56	Q			V
25+35	428.0855	2.77	Q			V
25+40	428.1007	2.21	Q			V
25+45	428.1139	1.91	Q			V
25+50	428.1253	1.65	Q			V
25+55	428.1350	1.41	Q			V
26+ 0	428.1432	1.19	Q			V
26+ 5	428.1500	0.99	Q			V
26+10	428.1559	0.86	Q			V
26+15	428.1609	0.72	Q			V
26+20	428.1647	0.56	Q			V
26+25	428.1673	0.38	Q			V
26+30	428.1690	0.24	Q			V
26+35	428.1701	0.16	Q			V
26+40	428.1706	0.07	Q			V
26+45	428.1708	0.02	Q			V

Culvert Report

HEADWATER DEPTH OF 2 EA. 6'x10' CULVERT @ GRAPEVINE CANYON / LYTLE CREEK

Invert Elev Dn (ft)	=	2182.00
Pipe Length (ft)	=	60.00
Slope (%)	=	5.00
Invert Elev Up (ft)	=	2185.00
Rise (in)	=	72.0
Shape	=	Box
Span (in)	=	120.0
No. Barrels	=	2
n-Value	=	0.014
Culvert Type	=	Flared Wingwalls, Top Edge Bevel
Culvert Entrance	=	18D to 33.7D wingwall flare, d=0.083D
Coeff. K,M,c,Y,k	=	0.486, 0.667, 0.0249, 0.83, 0.2

Calculations	
Qmin (cfs)	= 1148.00
Qmax (cfs)	= 1148.00
Tailwater Elev (ft)	= Normal
Highlighted	
Qtotal (cfs)	= 1148.00
Qpipe (cfs)	= 1148.00
Qovertop (cfs)	= 0.00
Veloc Dn (ft/s)	= 20.43
Veloc Up (ft/s)	= 12.29
HGL Dn (ft)	= 2184.81
HGL Up (ft)	= 2189.67
Hw Elev (ft)	= 2192.24
Hw/D (ft)	= 1.21
Flow Regime	= Inlet Control

Embankment	
Top Elevation (ft)	= 2192.90
Top Width (ft)	= 53.00
Crest Width (ft)	= 20.00

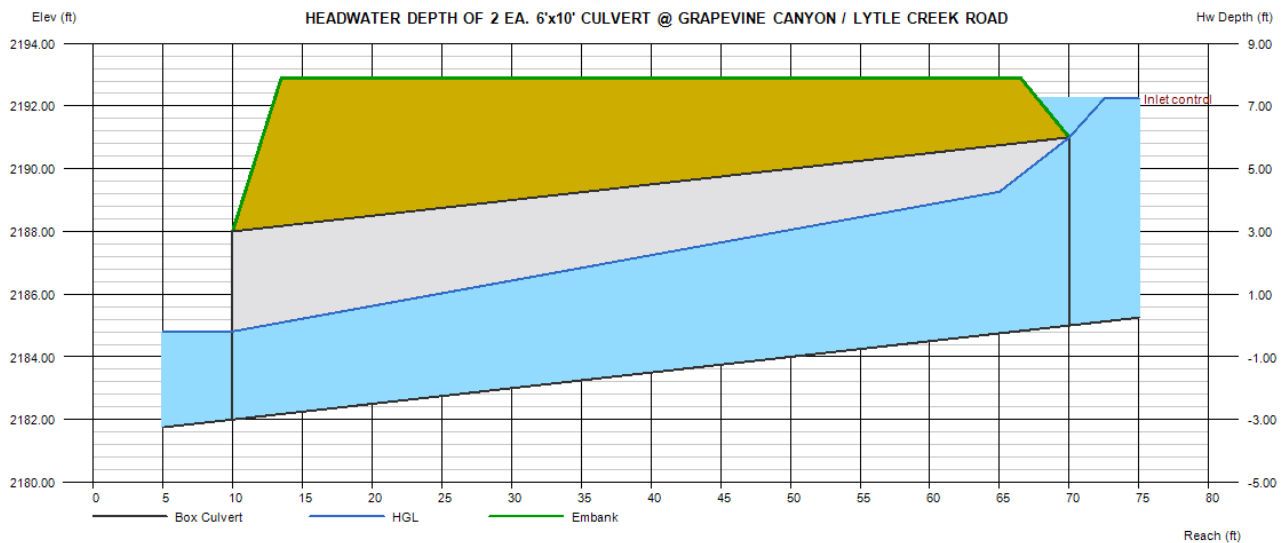

REFERENCE MAPS & CHARTS

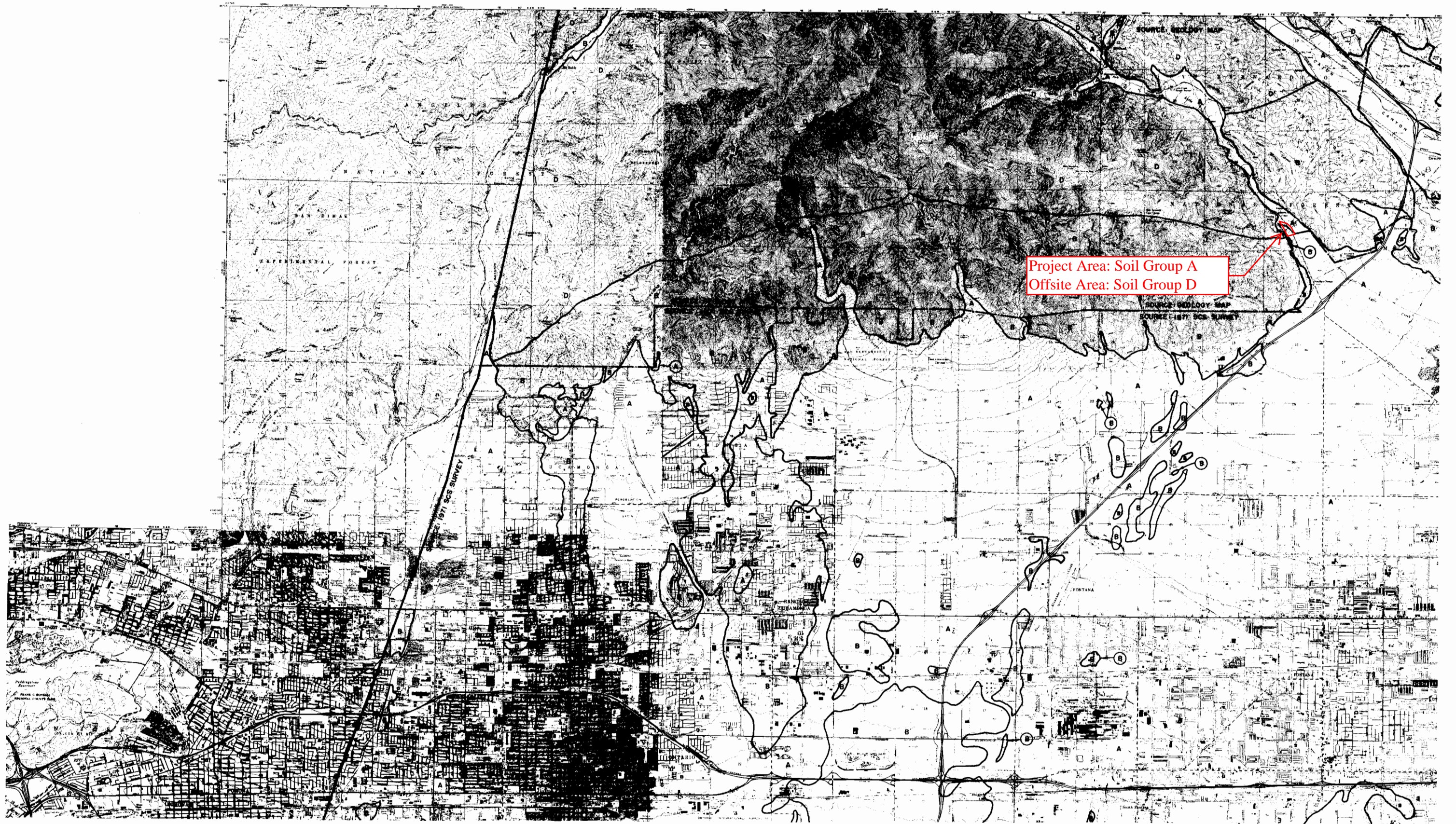

Project Area: Soil Group A
 Offsite Area: Soil Group D

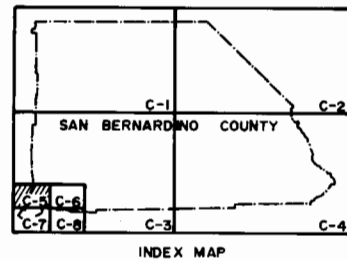

- LEGEND
- SOIL GROUP BOUNDARY
 - A SOIL GROUP DESIGNATION
 - - - BOUNDARY OF INDICATED SOURCE



SCALE REDUCED BY 1/2



NOAA Atlas 14, Volume 6, Version 2
Location name: Fontana, California, USA*
Latitude: 34.1978°, Longitude: -117.4467°
Elevation: 2200.14 ft**



* source: ESRI Maps
 ** source: USGS

POINT PRECIPITATION FREQUENCY ESTIMATES

Sanja Perica, Sarah Dietz, Sarah Heim, Lillian Hiner, Kazungu Maitaria, Deborah Martin, Sandra Pavlovic, Ishani Roy, Carl Tryppaluk, Dale Unruh, Fenglin Yan, Michael Yekta, Tan Zhao, Geoffrey Bonnin, Daniel Brewer, Li-Chuan Chen, Tye Parzybok, John Yarchoan

NOAA, National Weather Service, Silver Spring, Maryland

[PF_tabular](#) | [PF_graphical](#) | [Maps_&_aerials](#)

PF tabular

PDS-based point precipitation frequency estimates with 90% confidence intervals (in inches)¹										
Duration	Average recurrence interval (years)									
	1	2	5	10	25	50	100	200	500	1000
5-min	0.170 (0.142-0.207)	0.222 (0.185-0.271)	0.292 (0.241-0.356)	0.348 (0.286-0.429)	0.427 (0.339-0.543)	0.488 (0.379-0.634)	0.550 (0.417-0.734)	0.616 (0.453-0.845)	0.705 (0.497-1.01)	0.776 (0.528-1.15)
10-min	0.244 (0.203-0.297)	0.319 (0.265-0.388)	0.418 (0.346-0.510)	0.499 (0.410-0.614)	0.612 (0.485-0.779)	0.699 (0.543-0.909)	0.789 (0.597-1.05)	0.882 (0.649-1.21)	1.01 (0.713-1.45)	1.11 (0.757-1.65)
15-min	0.295 (0.245-0.359)	0.386 (0.320-0.469)	0.505 (0.418-0.616)	0.604 (0.496-0.743)	0.740 (0.587-0.942)	0.845 (0.656-1.10)	0.954 (0.722-1.27)	1.07 (0.785-1.46)	1.22 (0.862-1.75)	1.35 (0.916-2.00)
30-min	0.459 (0.382-0.558)	0.600 (0.498-0.730)	0.786 (0.651-0.959)	0.940 (0.771-1.16)	1.15 (0.913-1.47)	1.32 (1.02-1.71)	1.48 (1.12-1.98)	1.66 (1.22-2.28)	1.90 (1.34-2.72)	2.09 (1.43-3.10)
60-min	0.712 (0.592-0.865)	0.930 (0.773-1.13)	1.22 (1.01-1.49)	1.46 (1.20-1.79)	1.79 (1.42-2.27)	2.04 (1.58-2.65)	2.30 (1.74-3.07)	2.58 (1.90-3.53)	2.95 (2.08-4.22)	3.25 (2.21-4.82)
2-hr	1.09 (0.908-1.33)	1.43 (1.18-1.73)	1.87 (1.54-2.28)	2.23 (1.83-2.74)	2.73 (2.16-3.47)	3.12 (2.42-4.05)	3.52 (2.66-4.69)	3.93 (2.89-5.40)	4.50 (3.18-6.45)	4.96 (3.37-7.35)
3-hr	1.41 (1.17-1.71)	1.84 (1.53-2.24)	2.41 (1.99-2.94)	2.88 (2.36-3.54)	3.52 (2.79-4.48)	4.02 (3.12-5.23)	4.53 (3.43-6.04)	5.07 (3.73-6.95)	5.80 (4.09-8.31)	6.38 (4.35-9.47)
6-hr	2.13 (1.77-2.59)	2.78 (2.31-3.39)	3.64 (3.02-4.45)	4.35 (3.57-5.35)	5.32 (4.22-6.77)	6.07 (4.71-7.89)	6.84 (5.18-9.12)	7.63 (5.62-10.5)	8.73 (6.15-12.5)	9.58 (6.53-14.2)
12-hr	2.97 (2.47-3.61)	3.88 (3.22-4.72)	5.07 (4.20-6.19)	6.04 (4.96-7.43)	7.35 (5.84-9.36)	8.36 (6.50-10.9)	9.39 (7.11-12.5)	10.4 (7.69-14.3)	11.9 (8.38-17.0)	13.0 (8.84-19.3)
24-hr	4.14 (3.67-4.77)	5.45 (4.82-6.28)	7.15 (6.31-8.27)	8.53 (7.47-9.95)	10.4 (8.82-12.5)	11.8 (9.83-14.6)	13.3 (10.8-16.8)	14.8 (11.7-19.2)	16.8 (12.7-22.7)	18.4 (13.5-25.7)
2-day	5.22 (4.62-6.01)	7.02 (6.21-8.10)	9.46 (8.34-10.9)	11.5 (10.1-13.4)	14.4 (12.2-17.3)	16.7 (13.8-20.5)	19.0 (15.4-24.0)	21.6 (17.0-27.9)	25.1 (19.0-33.9)	28.0 (20.5-39.1)
3-day	5.72 (5.07-6.59)	7.81 (6.91-9.01)	10.7 (9.45-12.4)	13.2 (11.6-15.4)	16.8 (14.3-20.3)	19.8 (16.4-24.4)	23.0 (18.6-28.9)	26.4 (20.8-34.2)	31.4 (23.8-42.4)	35.5 (26.0-49.6)
4-day	6.13 (5.43-7.06)	8.41 (7.44-9.70)	11.6 (10.3-13.5)	14.4 (12.6-16.8)	18.6 (15.7-22.3)	22.0 (18.2-27.0)	25.6 (20.8-32.3)	29.7 (23.4-38.4)	35.6 (26.9-48.0)	40.5 (29.6-56.5)
7-day	7.00 (6.20-8.07)	9.64 (8.52-11.1)	13.4 (11.8-15.5)	16.6 (14.5-19.4)	21.4 (18.1-25.8)	25.3 (21.0-31.2)	29.6 (24.0-37.3)	34.4 (27.1-44.5)	41.3 (31.2-55.7)	47.0 (34.4-65.6)
10-day	7.64 (6.77-8.80)	10.5 (9.31-12.1)	14.6 (12.9-16.9)	18.1 (15.9-21.2)	23.4 (19.8-28.1)	27.7 (23.0-34.1)	32.4 (26.2-40.8)	37.5 (29.6-48.6)	45.1 (34.1-60.8)	51.4 (37.6-71.7)
20-day	9.15 (8.10-10.5)	12.6 (11.2-14.6)	17.5 (15.5-20.3)	21.8 (19.1-25.5)	28.2 (23.8-33.9)	33.4 (27.7-41.1)	39.1 (31.6-49.2)	45.3 (35.7-58.7)	54.5 (41.2-73.5)	62.1 (45.4-86.7)
30-day	10.5 (9.31-12.1)	14.5 (12.9-16.8)	20.2 (17.8-23.4)	25.2 (22.0-29.3)	32.5 (27.5-39.1)	38.5 (31.9-47.3)	45.1 (36.5-56.8)	52.3 (41.2-67.7)	62.8 (47.5-84.7)	71.7 (52.4-100)
45-day	12.2 (10.8-14.0)	16.9 (14.9-19.4)	23.5 (20.7-27.1)	29.2 (25.6-34.1)	37.7 (31.9-45.4)	44.7 (37.1-55.0)	52.3 (42.4-65.9)	60.7 (47.8-78.5)	72.9 (55.1-98.3)	83.1 (60.7-116)
60-day	14.2 (12.6-16.3)	19.6 (17.3-22.6)	27.3 (24.1-31.5)	34.0 (29.7-39.6)	43.7 (37.1-52.7)	51.9 (43.0-63.8)	60.6 (49.1-76.4)	70.3 (55.4-91.0)	84.4 (63.8-114)	96.2 (70.3-134)

¹ Precipitation frequency (PF) estimates in this table are based on frequency analysis of partial duration series (PDS). Numbers in parenthesis are PF estimates at lower and upper bounds of the 90% confidence interval. The probability that precipitation frequency estimates (for a given duration and average recurrence interval) will be greater than the upper bound (or less than the lower bound) is 5%. Estimates at upper bounds are not checked against probable maximum precipitation (PMP) estimates and may be higher than currently valid PMP values. Please refer to NOAA Atlas 14 document for more information.

[Back to Top](#)

PF graphical

PDS-based depth-duration-frequency (DDF) curves

Latitude: 34.1978°, Longitude: -117.4467°

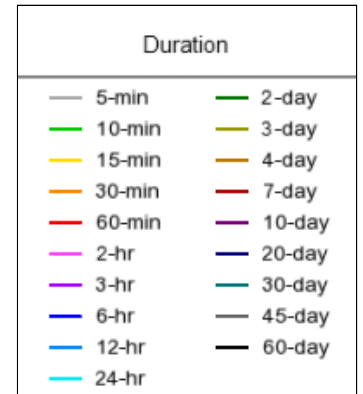
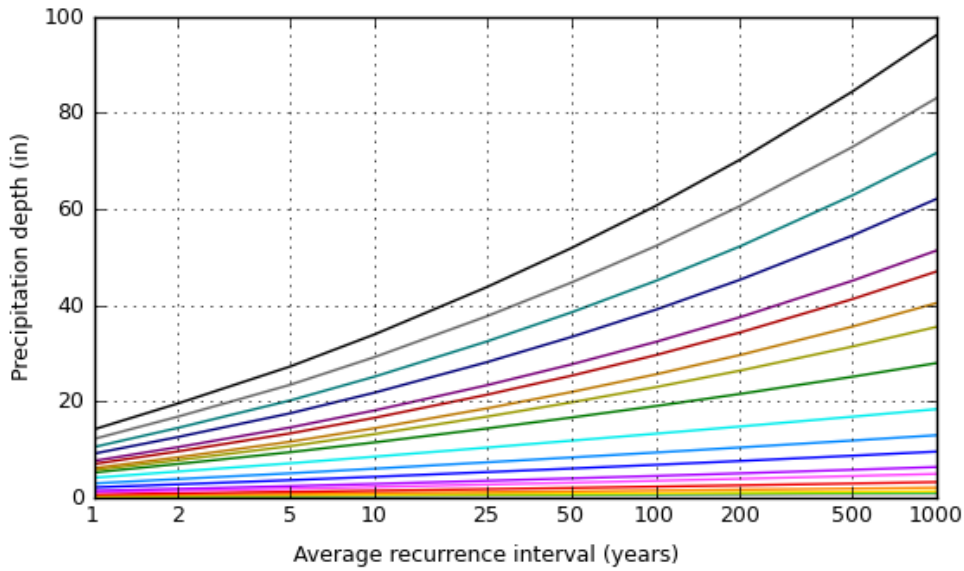
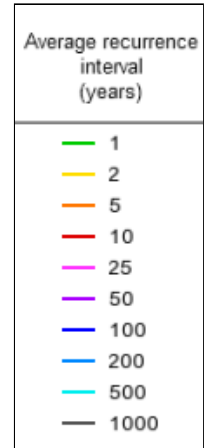
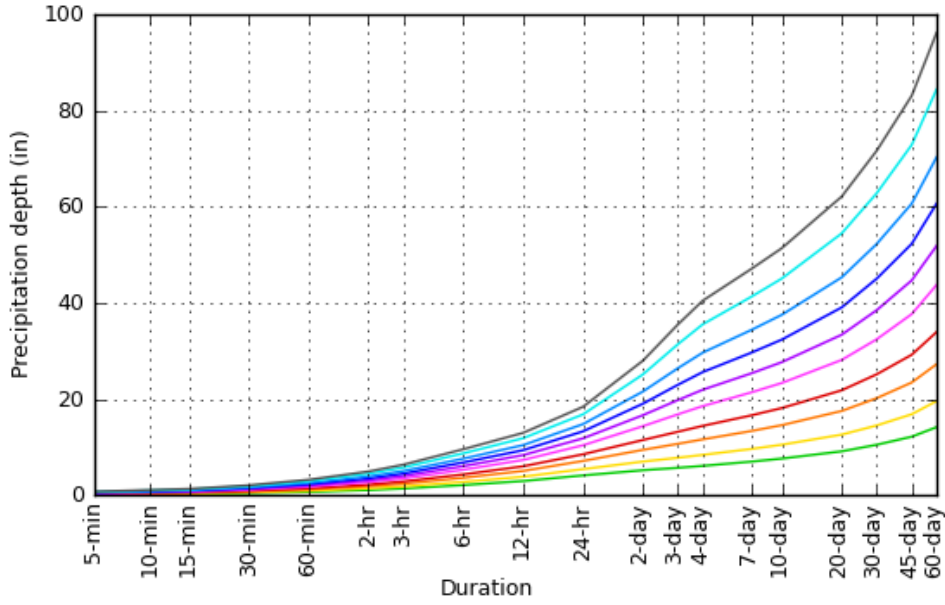

[Back to Top](#)

Maps & arials

Small scale terrain

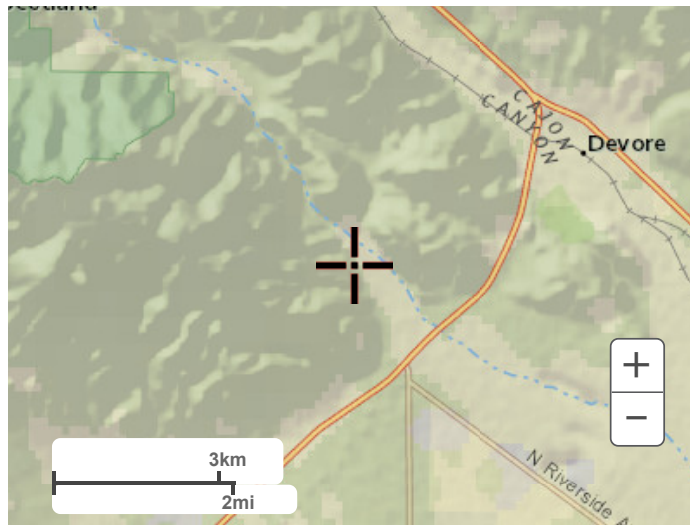

Large scale terrain



Large scale map



Large scale aerial



[Back to Top](#)

[US Department of Commerce](#)
[National Oceanic and Atmospheric Administration](#)
[National Weather Service](#)
[National Water Center](#)
1325 East West Highway
Silver Spring, MD 20910
Questions?: HDSC.Questions@noaa.gov

[Disclaimer](#)