

Coachella Valley Water District

**DRAFT FEASIBILITY STUDY  
FOR STORAGE OF  
COLORADO RIVER WATER**

July 2019

**Submitted by:**  
Dahl Consultants, Inc.



# Table of Contents

---

- 1 Summary and Benefits ..... 1
- 2 Background..... 4
- 3 Project Description..... 6
- 4 Theory of Operations ..... 16
- 5 Construction Sequencing..... 19
- 6 Cost Estimates..... 26

# 1 Summary and Benefits

---

The Mid-Canal Reservoir is proposed as an inline reservoir between Check 11 (Mile Post 54.6) and Check 14 (Mile Post 59.5). The reservoir will be formed by removing the existing embankment between the existing lined canal with the original earthen canal section to form a single wide trapezoidal section. The materials removed will be used to construct more gradual canal side slopes (3:1) and raise the invert (2 feet higher). Existing check structures and siphons will remain in place. Check 11 will serve as the inlet control structure and Check 14 will be the outlet control structure. The newer siphons (11, 12, & 13) will continue to be used to convey flow through the reservoir, with siphons 12 and 13 dividing the reservoir into three cells, see **Figure 1**.

The Mid-canal Reservoir will create direct economic benefits and cost savings. Converting the Coachella Canal to in-line regulatory storage at this location will also greatly enhance water operations. Benefits will include:



- Elimination of Recurring Lining Repairs - Reconstructing canal pools between Check 11 and Check 14 will eliminate recurring problems with damage to the concrete lining in this section of the canal. The heavy clay soils in this area are largely responsible for ongoing lining damage and for restrictions to canal operations. The reservoir will eliminate the concrete canal lining in this segment, which has been the area most prone to expensive repairs. Thus far, repair costs have exceeded \$4M. It will also help prevent similar problems in the lined canal upstream and downstream from the reservoir by smoothing operations and decreasing water level fluctuations that can cause lining damage.
- Normal Operational Benefits
  - Water storage to help manage large, rapid delivery flow changes that affect Coachella Canal operations.
  - Increased amount of operational storage in the project to help compensate for loss of in-channel storage caused by the Coachella Canal Lining Project.
  - Reservoir storage is easier to manage than using in-channel storage in Coachella Canal reaches, especially with limitations to water level fluctuations in the concrete-lined canal.
  - Although Lake Cahuilla will continue to provide storage for mismatches between total canal inflow and total deliveries, canal capacity limits restrict how much excess water can be routed all the way to the tail end.
  - The Mid-canal Reservoir will be able to supply shortages in the middle and lower ends of the Coachella Canal delivery system and will help attenuate large flow changes that might otherwise exceed drawdown criteria or exceed capacity near the canal's downstream end.
- Refinement to Current Operational Procedures - Allows refinement of the current operating rules listed in the Operating Procedures (OP), which should provide CVWD with more flexibility. It is understood that SDCWA wishes to revisit the current OP, unrelated to this project.

- Reduction in Potential for CVWD Water Allocation Losses – At times when significant emergency cuts to CVWD orders are required (such as large rainfall events), valuable water supply can be lost to Mexico or the Brock Reservoir.
- Frost Events – Although difficult to quantify, CVWD’s ability to draw from this new source of stored water could significantly reduce potential crop damage – commonly estimated as a very high potential loss.

The total volume of the new reservoir will be **728 acre-feet** (ac-ft). Based on experience and evaluation of construction costs for numerous existing reservoirs, Dahl Consultants has adopted a budget number of about \$10,000 per acre-ft as a “rule of thumb” cost for an optimally constructed reservoir. With an estimated construction cost of **\$6.4 million**, the ratio of cost to storage volume is about **\$9000/ac-ft**. This cost is lower than typical new reservoir construction, largely because of earthwork savings from using existing embankment material.

The Mid-canal Reservoir Project appears to be technically and economically feasible.



		COACHELLA VALLEY WATER DISTRICT FEASIBILITY STUDY FOR STORAGE OF COLORADO RIVER WATER	DATE MARCH 2019
		SITE MAP	FIGURE NUMBER 1

## 2 Background

---

Coachella Canal operations have always been challenging for several reasons:

- Long distances from source of water to delivery area
- Lengthy delays to get flow changes downstream
- Lack of operating storage
- Coordination with Reclamation and IID for water orders

Loss of in-canal storage as a result of the construction of the Coachella Canal Lining Project created additional difficulties. During 2011, specific operating procedures were developed and documented in a report titled *Coachella Canal Lining Project Operating Procedures*. These operational procedures were developed with the condition that Check 14 would be locked out (in the full-open position) and a weir would be installed at the inlet to Siphon 13. Further, the gate at Check 18 would be operated in a manner to minimize water level depths in the pools between Check 11 and Check 18. These agreed upon operating procedures imposed even greater reductions in usable in-canal storage.

In 2015, a study was conducted and documented in a report titled *Feasibility Study to Investigate Storage Requirements for the Coachella Canal* by Dahl Consultants and Rogers Engineering Hydraulics Inc. evaluated hydraulic operations and water storage possibilities, yielding the following conclusions:

- Water storage is necessary to manage large, rapid delivery flow changes that affect Coachella Canal operations.
- The Coachella Canal Lining Project reduced the amount of useful storage in the project and made existing storage more difficult to use. The reduced canal prism size and the restrictions imposed by drawdown limitations both resulted in significantly less operational storage in middle portion of the canal system.
- A number of sites in the area of North Shore were evaluated but none were found feasible due to construction cost, institutional concerns (DSOD), and operations. An affordable all-gravity system could not be found.
- Alternatives methods of using storage exist, including active management of canal water levels to use in-canal storage and diverting canal water to or from reservoirs near the canal (off-canal storage).
- Lake Cahuilla should continue to be used to provide storage for major imbalances between total canal inflow and total canal outflows. However, the canal's capacity limits how much excess flow can be routed all the way to Lake Cahuilla. Additionally, storage located at the canal's tail end has limited value to supply shortages upstream.
- In-canal storage can help to manage flow-change events, but it is complicated to use in-canal storage effectively and it can require constant operator attention. It is problematic for operators to actively use in-canal storage while they also must manage multiple other daily tasks.

- Additional storage near the middle of the Coachella Canal length would be valuable to spread out large flow changes over several hours and reduce peak flows through the canal. Mid-system storage can attenuate large flow changes that might otherwise exceed drawdown criteria or exceed capacity near the canal’s downstream end (e.g. in the Silver Rock area).

The 2015 study used data provided by CVWD to compute the amount of additional storage that would be required to manage predicted events that cause either an excess or a deficit in water supplied through the canal. **Table 1** shows the amount of flow mismatch and duration of these events, and the resulting amount of storage volume needed for each.

**Table 1 – Major Events that cause Excess or Shortage of Water in Coachella Canal**

Canal Inflow Decrease or Cut			
Excess Water Events	Flow Amount (cfs)	Duration (hours)	Resulting Storage Requirements (AF)
Rain storm: Flood inflows plus delivery shutdowns	150	24	300
Weekend Ramp Down	300	24	600
Canal Inflow Increase			
Deficit Water Events	Flow Amount (cfs)	Duration (hours)	Resulting Storage Requirements (AF)
Frost prevention: unscheduled delivery increase	75	24	150
Sunday into Monday Ramp Up	250	24	500

The previous study in 2015 used a computer model that was developed to study hydraulic operations and water storage for Coachella Canal. Building upon that model, this investigation used similar methods to quantify storage volumes and how these volumes would provide either additional supply or space to contain excess water during those events that create a flow mismatch in the canal system.

### 3 Project Description

---

The Mid-Canal Reservoir is proposed as an inline reservoir between Check 11 (Mile Post 54.6) and Check 14 (Mile Post 59.5), as shown in **Figure 1**. This location was selected for several reasons:

- Well situated in CVWD’s canal delivery system, which will provide valuable regulatory storage that is easily used.
- Readily adaptable existing facilities –
  - Relatively new check structures already in place
  - Large cross section geometry, combining the old canal and the new canal to provide ample storage volume
- Flow regulation using gravity flow both into and out of the reservoir.
- Soils in this reach of the Coachella Canal contain impermeable clay, so the reservoir can be constructed with material excavated from the site without a PVC or concrete liner.
- Retirement of the concrete canal lining – The canal lining constructed as part of the Coachella Canal Lining Project (CCLP) has not performed well due to the heavy clay foundations. Retiring the concrete lining will reduce future potential lining replacement costs for this reach of the canal.
- The project is not jurisdictional under DSOD. This is in contrast to issues that surfaced for other sites considered and evaluated as part of the North Shore sites that were evaluated in our previous study.

The existing lined canal will be combined with the old canal prism to create a wide section that will serve as an inline reservoir between Check 11 and Check 14, see **Figures 2 through 5**. This will create a flow-through reservoir with all canal flow passing through the reservoir. Removing the existing embankment between the two canals provides significant storage volume. Check 11 will control inflow to the reservoir and Check 14 will serve as the reservoir outlet structure. Existing Siphons 11, 12, and 13 will remain in place, with inflow to the reservoir through Check 11 and uncontrolled flow through Siphon 12 and Siphon 13. Siphons 12 and 13 will divide the reservoir into three cells.

Embankments near Check 14 will be raised to maximize the amount of useful storage and to allow for a maximum reservoir level that is 3 feet higher than present canal design water level. Since the new reservoir invert is approximately 2 feet higher than the existing concrete canal invert, the maximum water depth in the reservoir is 12 feet at Check 14. Modifications to Siphons 12 and 13 and Check 14, shown on **Figures 6 and 7**, will be required to accommodate the higher water levels and raised inverts. This configuration creates the storage volumes shown in **Table 2**, with a total volume over 700 acre-feet.



**Table 2 – Reservoir Volume vs. Depth**

Reservoir Depth at Downstream End (Check 14) (feet)	Total Volume (acre-feet)
12	728
11	640
10	556
9	475
8	397
7	323
6	252
5	184
4	120
3	59
2	28
1	9
0	0

Cost to raise embankments is relatively low because much of the canal is in cut and there will be an abundance of material from the removal of the center berm. Raising the water surface 3 feet above the present canal design water elevation at Check 14 creates about 250 acre-feet of additional storage. All of this storage in the upper part of the reservoir is usable as regulatory storage that will provide significant operational benefits.

Because the proposed reservoir is in-line with the canal, water level at the reservoir’s upstream end must remain low enough to convey canal flow into the reservoir through Check 11, and level at the downstream end must be high enough to convey water out of the reservoir through Check 14. Level at the upstream end does not pose a restriction, because it will only start to limit inflow if the reservoir is full while inflow through Check 11 is 1200 cfs or greater. There should never be a need for this much flow into the reservoir when it’s already full.

Level at the reservoir downstream end will pose a restriction. Outflow through Check 14 requires enough head to push the water through Check 14, and this required head is proportional to the square of the flow rate. As the outflow increases, the minimum required reservoir level also increases. **Table 3** shows a range of canal flow rates and the required minimum reservoir depths to convey flow through Check 14. Because the reservoir levels cannot be lowered below the required minimums, storage volume below these minimum levels cannot be used. Therefore, at higher flow rates the amount of usable storage is limited to the upper portion of the reservoir.

Because the reservoir will behave like a large canal when passing flow through its length, water depth will not fall below the normal depth needed to pass a given flow. This doesn’t pose any problems, but it does reduce the amount of effective storage because the volume needed to pass flow doesn’t serve as regulatory storage.

The above limitations determine the useful operating range of water levels in the reservoir and the useful volume of storage at different flow rates. **Table 3** shows these minimum reservoir depths (at the downstream end) and the corresponding usable storage volumes. For each of the flows in **Table 3**, usable storage equals the water volume above the minimum reservoir depth for that flow rate.

**Table 3 – Minimum Reservoir Depth and Usable Storage Volumes**

Canal Flow Rate (cfs)	Minimum Reservoir Depth (feet)	Usable Storage Volume (acre-feet)
25	0.5	728
50	0.8	728
100	1.2	728
200	1.8	718
400	2.8	660
600	4.4	570
800	5.8	490
1000	7.1	395
1200	8.3	305

Topographic survey data was collected to determine the “as-built” distribution of soils made during construction of the CCLP. The collected topo data was used to create a digital terrain model (DTM) for the pools that was then patched into the DTM developed from aerial photomapping during the design of the CCLP. The resulting combined DTM provides a good representation of the existing terrain for the reservoir cells between the siphons. Utilizing the above-described DTM, the proposed canal geometry will minimize/eliminate most hauling or importing of material during construction.

A preliminary geotechnical investigation was conducted to verify the suitability of the existing soils for use in lining the bottoms and sides of the reservoir to form an acceptable seepage barrier. The investigation included collection of soils samples from each of the proposed reservoir cells for laboratory testing including permeability testing. The test results show that the material in the embankment between the existing and old canal can be used to construct the reservoir sides and bottoms without the need to locate and mine an “all clay” source. The material in these embankments came from excavation of the original canal and the new CCLP. The material was sufficiently mixed (clays, silts, and sands) during the previous earthwork operations to become a good source for construction of a relatively homogenous compacted fill for the reservoir. The expected permeability of the fills is less than  $1 \times 10^{-5}$  cm/sec which will be adequate to prevent seepage losses outside allowable ranges.

The preliminary geotechnical evaluation is included as an appendix to this report. Recommendations in the report include providing slope protection on the westerly facing slopes (right side slope when facing downstream) which would be the slope most exposed to wave action from the dominant wind direction.

Currently, the radial gates at Check 14 are locked out in the full-open position. Commercial power is not available at this site. Instead, the site is powered by batteries charged by solar panels. The solar installation has not performed well. Although it is rarely used, the solar system has been maintained. CVWD could consider a redesign of the solar system to bring it to an acceptable reliability or commercial power can be extended from the overhead power line that currently terminates at Check 11. Solar technology, especially related to batteries, has advanced significantly since the initial installation over 10 years ago.

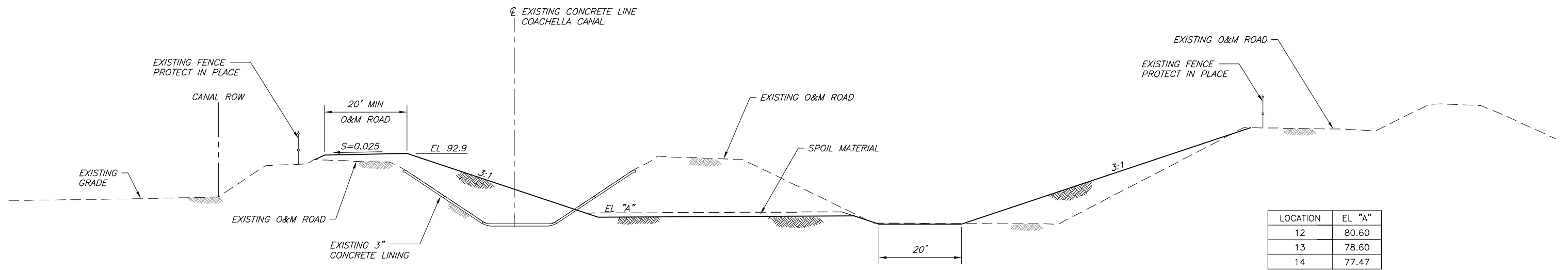

LOCATION	EL "A"
12	80.60
13	78.60
14	77.47

**EXISTING VS. NEW SECTION** (A)  
SCALE: 1" = 1'-0"

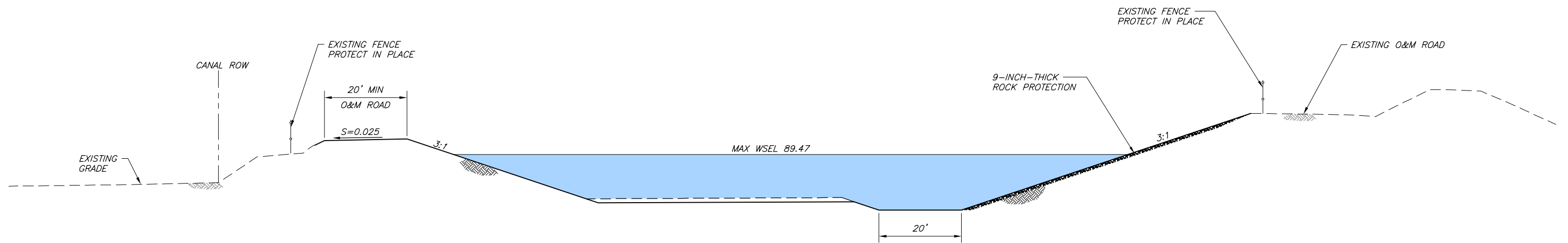

**COMPLETED SECTION** (B)  
SCALE: 1" = 1'-0"

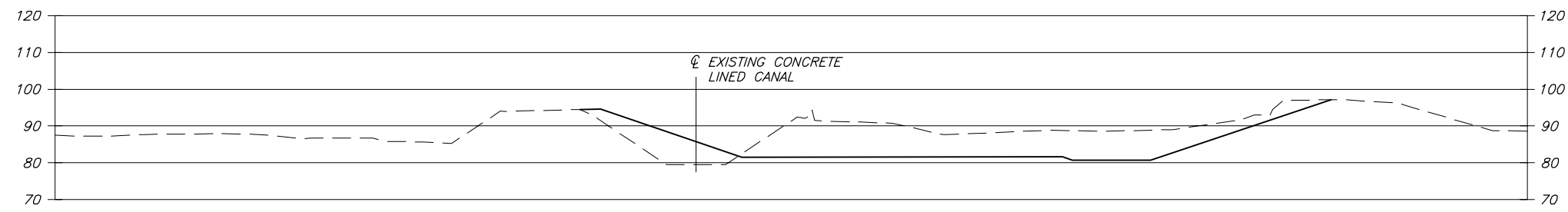

**SECTION AT STA 2807+00** A  
 SCALE: 1" = 20'

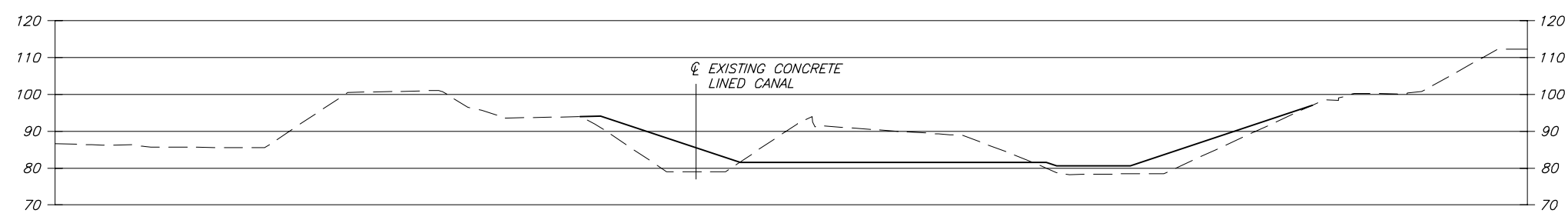

**SECTION AT 2847+00** B  
 SCALE: 1" = 20'

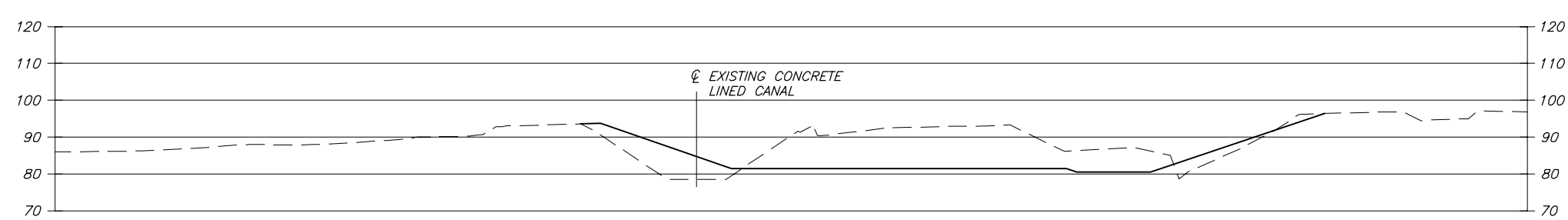

**SECTION AT 2888+00** C  
 SCALE: 1" = 20'

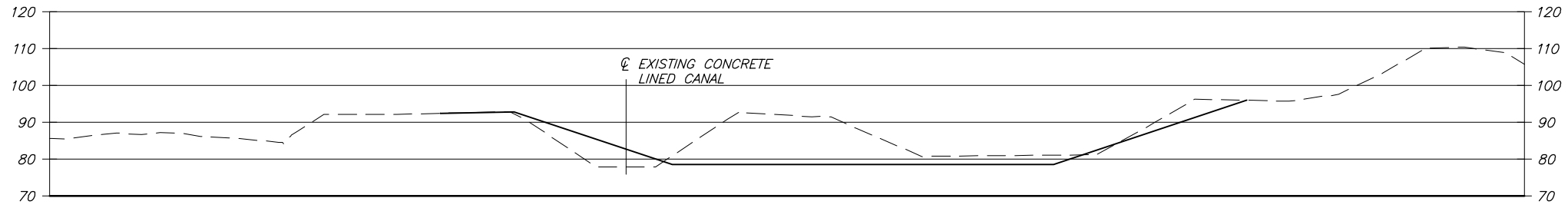

SECTION AT STA 2893+00 (D)  
SCALE: 1" = 20'

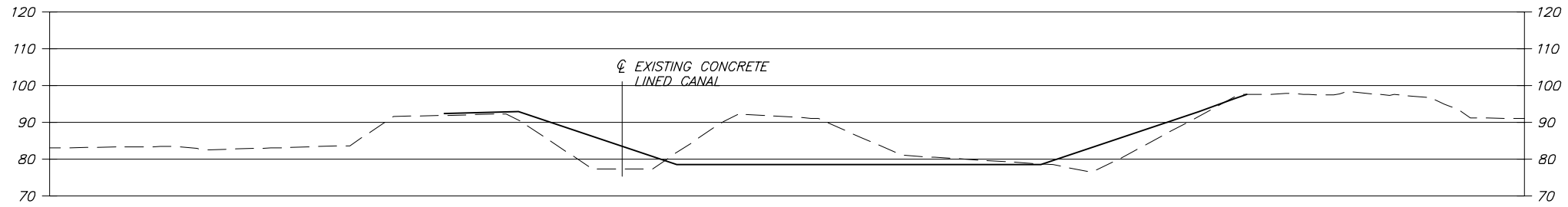

SECTION AT STA 2946+00 (E)  
SCALE: 1" = 20'

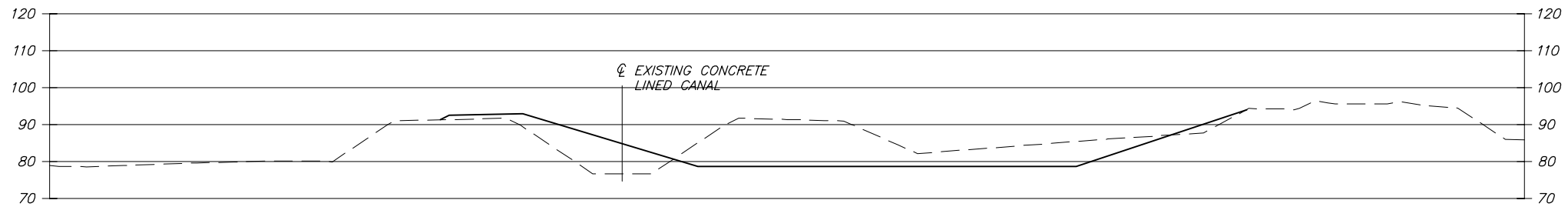

SECTION AT STA 2999+00 (F)  
SCALE: 1" = 20'

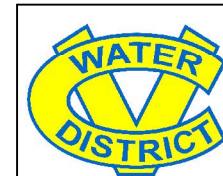

COACHELLA VALLEY WATER DISTRICT  
FEASIBILITY STUDY FOR STORAGE OF COLORADO RIVER WATER

CELL 2 CROSS SECTIONS

DATE  
MARCH 2019

FIGURE NUMBER  
4

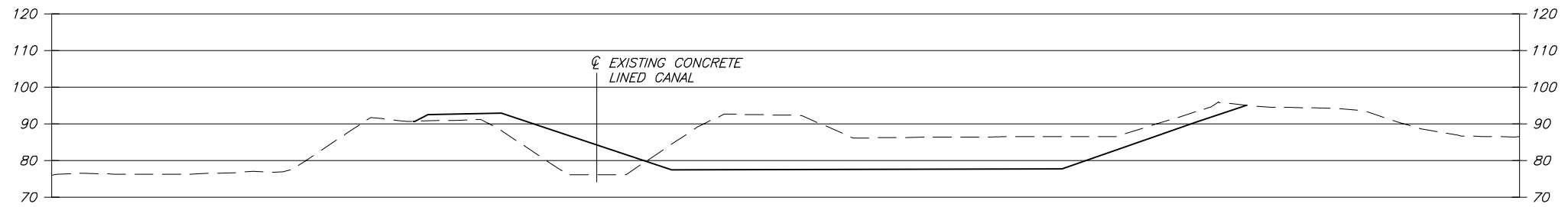

SECTION AT STA 3003+00 G  
SCALE: 1" = 20'

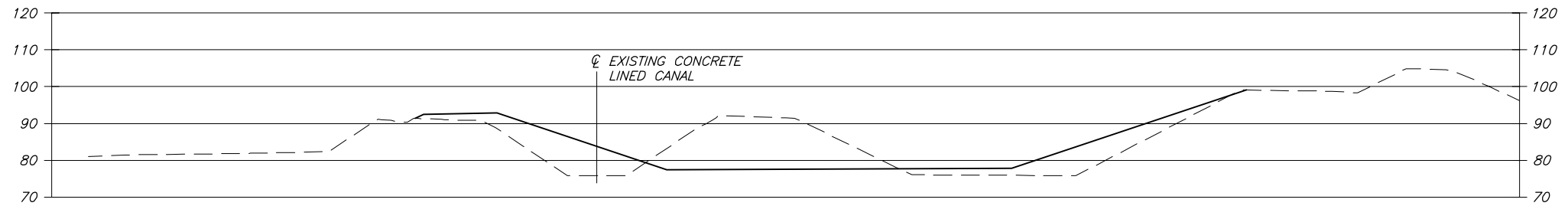

SECTION AT STA 3033+00 H  
SCALE: 1" = 20'

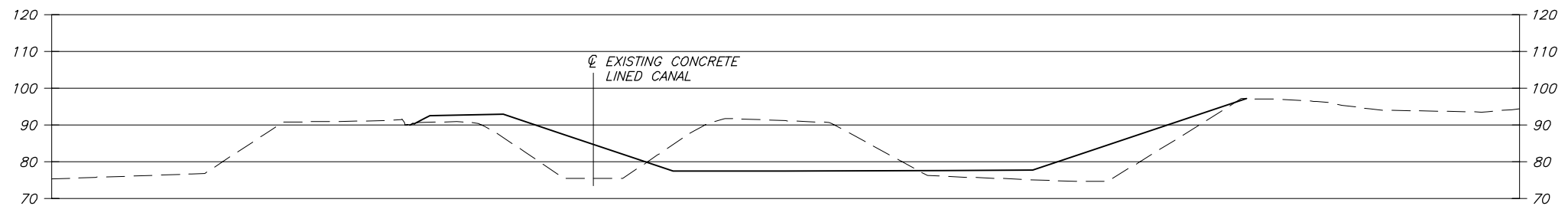

SECTION AT STA 3062+00 J  
SCALE: 1" = 20'

TABLE OF DATA						
SIPHON NO	EL "A"	EL "B"	EL "C"	EL "D"	EL "E"	EL "F"
12 INLET	78.56	74.56	93.56	80.56	N/A	N/A
13 INLET	76.69	72.69	91.69	78.69	91.69	92.19
13 OUTLET	76.16	72.16	91.16	78.16	91.16	91.66

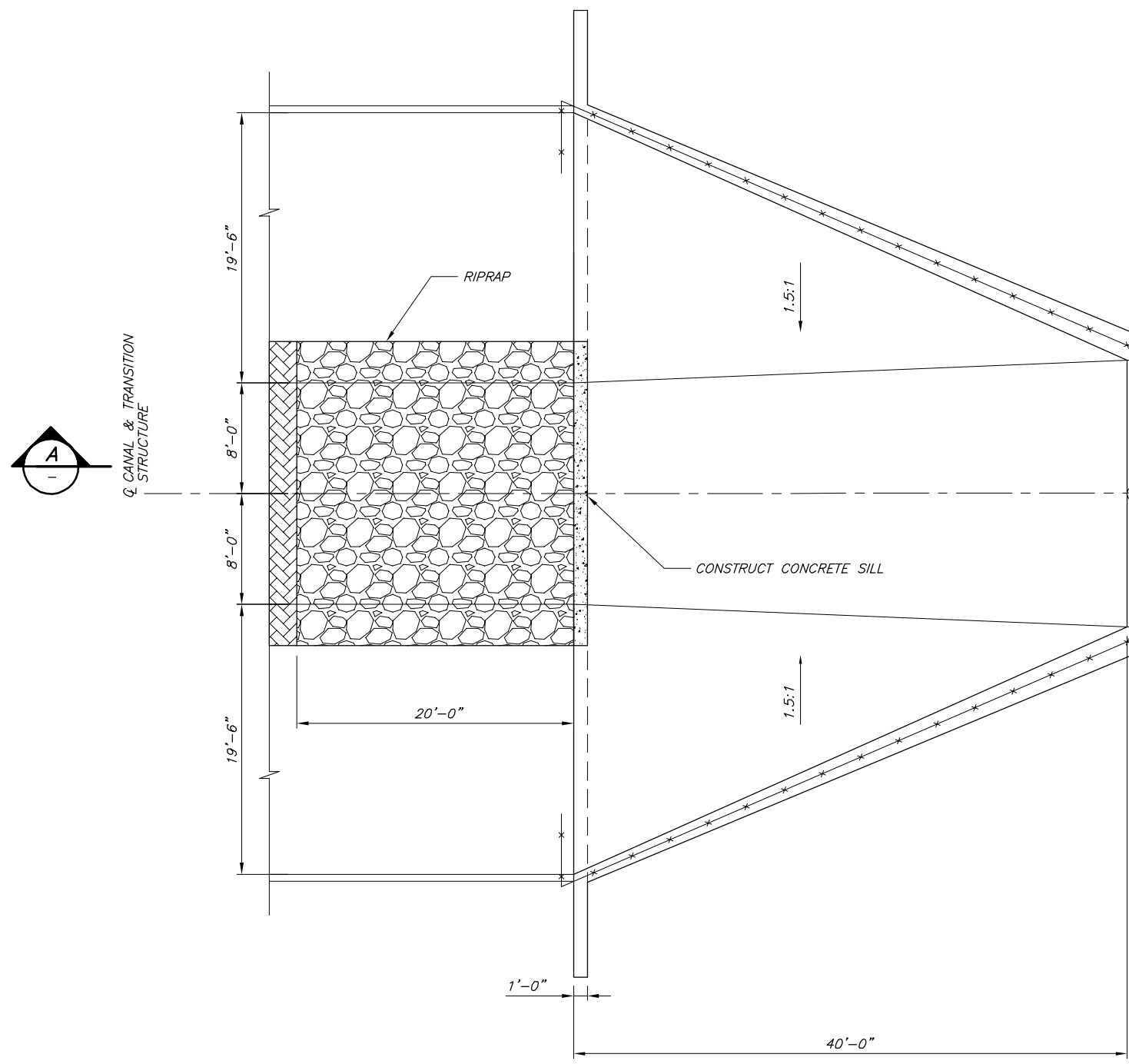

**PLAN**  
SCALE: 3/16" = 1'-0"  
1

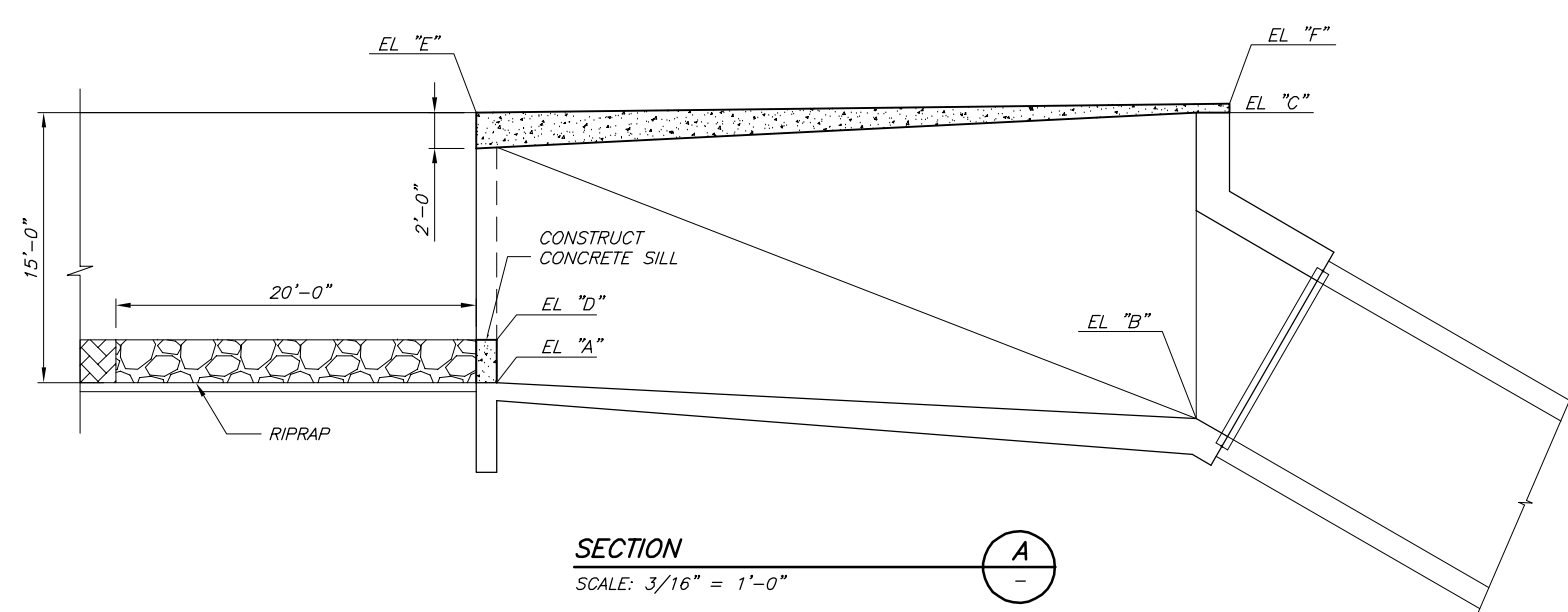

**SECTION**  
SCALE: 3/16" = 1'-0"  
A

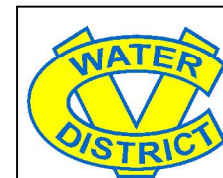

COACHELLA VALLEY WATER DISTRICT  
FEASIBILITY STUDY FOR STORAGE OF COLORADO RIVER WATER

MODIFICATIONS AT SIPHON 12 & 13

DATE  
MARCH 2019

FIGURE NUMBER  
6



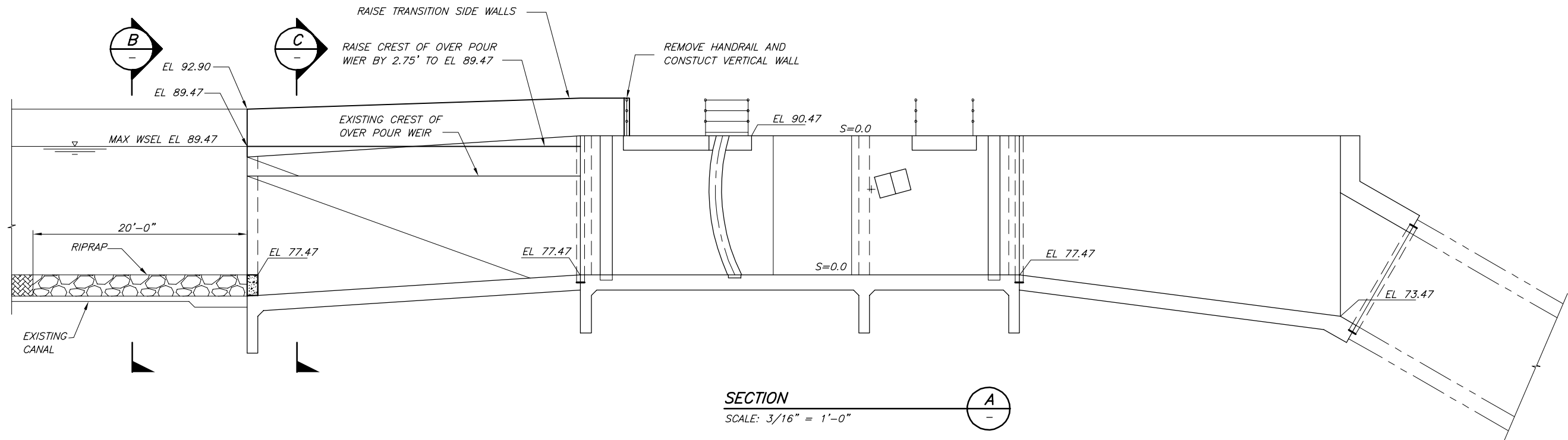

**SECTION A**  
SCALE: 3/16" = 1'-0"

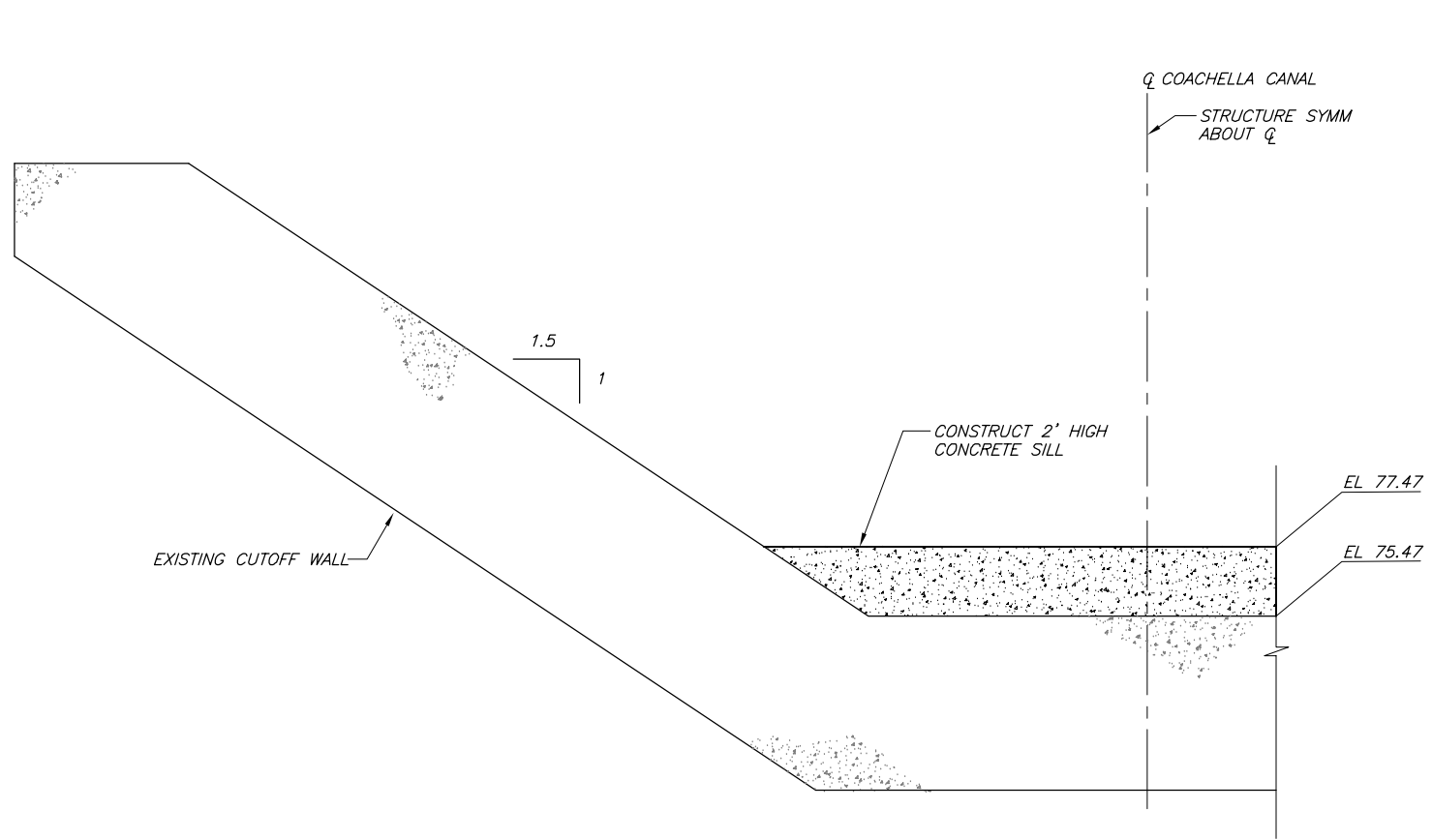

**SECTION B**  
SCALE: 3/8" = 1'-0"

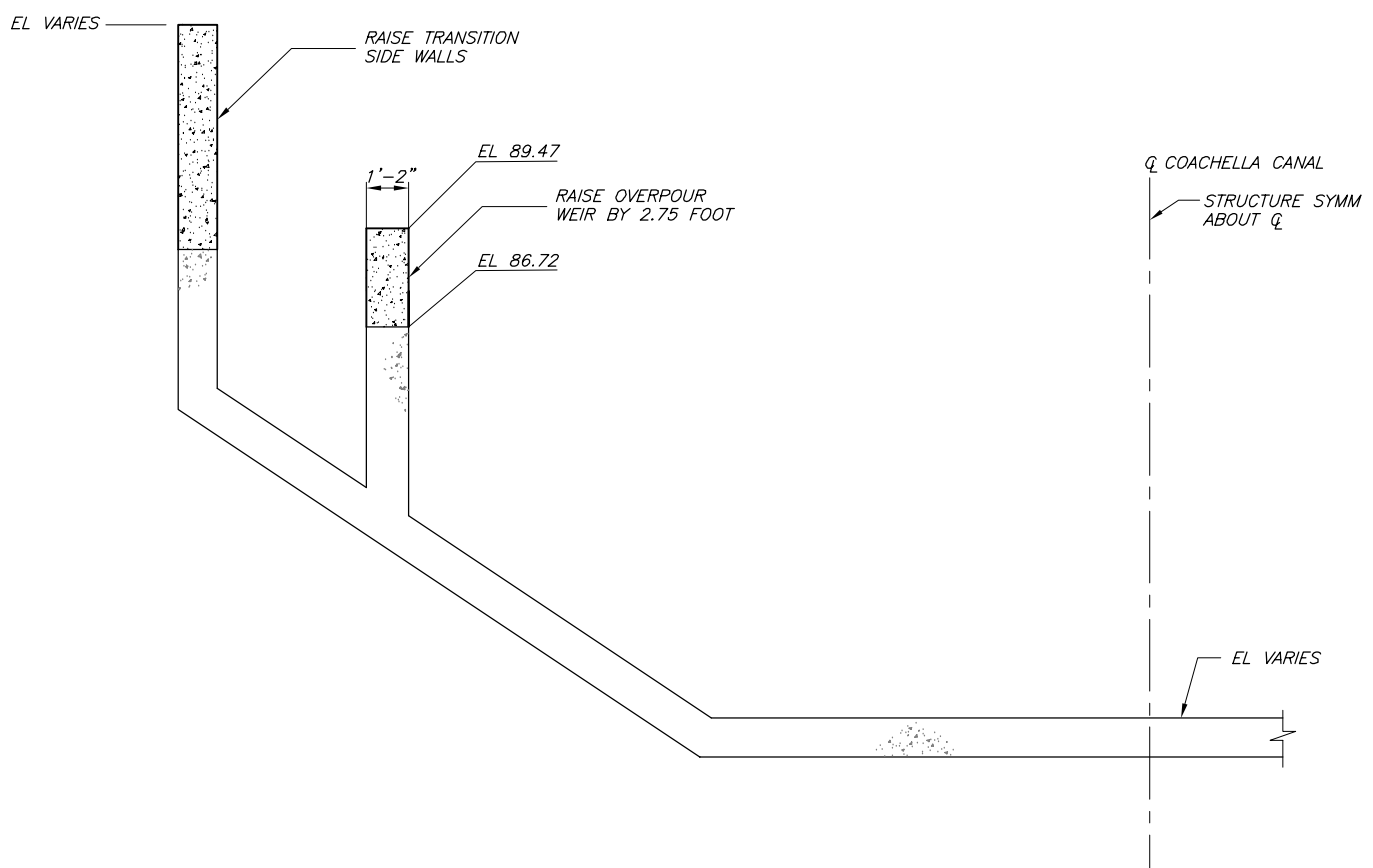

**SECTION C**  
SCALE: 3/8" = 1'-0"

## 4 Theory of Operations

---

The reservoir will have three cells separated by Siphons 12 and 13. With no additional control structures added at these two siphon inlets, the water surface will be almost level and at about the same elevation in all three cells during low-flow conditions (<400 cfs). At higher flow rates, the water surface will step down from upstream cell to downstream cell due to head loss through the siphons. The size of these steps will increase with flow rate, up to about a 6" drop between cells at maximum canal flow. The three-cell reservoir will resemble a wide canal with three pools, except the water surface within each cell will be almost horizontal due to the increased cell width and resulting low flow velocity.

Reservoir water level will be controlled at Check 14, much the same as controlling a checked water surface in the canal. A minimum water depth must be maintained at this point in order to pass flow into canal Pool 15 downstream. This minimum allowable water depth depends on canal flow rate. Most of the time, water level in Pool 15 will be the normal depth for the present flow rate. At low flows, Pool 15 will operate at a relatively low water level. Therefore, the water level upstream of Check 14 can be correspondingly low. At high flows, water depth in Pool 15 will be higher and reservoir water level must be higher also in order to push water through Check 14. This restriction will reduce the amount of available regulatory storage in the reservoir during high flow periods. A high checked water level at Check 18 can also affect the depth in Pool 15 during high-flow conditions, but typical operations at Check 18 will not significantly affect the minimum reservoir depth.

As discussed in Section 4, Table 3 shows the minimum allowable water depth required in the reservoir at varying flow rates for conveyance to Pool 15. Table 3 also shows the resulting amount of available reservoir storage above the minimum reservoir depth. For most normal operating conditions, the minimum reservoir level will be between 3 and 6 feet deep and the amount of usable storage will be from 500 to 700 acre-feet.

The reservoir will provide volume to store excess water or to supply water into the canal when needed. A given volume in the reservoir equates to an inflow or outflow rate for a particular length of time. Tables 4, 5, and 6 show how much time it takes to fill or drain volumes from the reservoir, and therefore how the reservoir level will change over time. Differential volume is shown for 1-foot increments of depth, for the useful operating range in the reservoir. Reservoir level will rise at a rate that is proportional to the net rate of *inflow* into the reservoir, or level will fall at a rate that is proportional to the net *outflow* from the reservoir. (Note: these net inflows or outflows are different than the through-flow in the canal that influences how low the reservoir can drop.)

**Table 4** shows the time, in hours, to fill the reservoir at different net inflow rates. Incremental time is shown for each 1-foot increase of water level. Total time to fill the entire reservoir and average time for a 1-foot level change are shown at the bottom. A depth range from 4 to 12 feet is shown because the bottom 4 feet of the reservoir will be needed for conveyance into Pool 15 except during periods of very

low canal flows (less than 400 cfs). (Note: even when the reservoir is full with a 12-foot depth at the downstream end, up to 1200 cfs could flow into the reservoir with a typical checked water level at Check 11.)

**Table 4 – Time (in hours) to increase reservoir level vs.net inflow rate**

Reservoir Depth (feet)	Differential Volume (acre-feet)	Net flow into reservoir (cfs):					
		50	100	200	400	600	800
		Time (in hours) to increase reservoir level by 1 foot					
12	88	21.3	10.6	5.3	2.7	1.8	1.3
11	84	20.3	10.2	5.1	2.5	1.7	1.3
10	81	19.6	9.8	4.9	2.5	1.6	1.2
9	78	18.9	9.4	4.7	2.4	1.6	1.2
8	74	17.9	9.0	4.5	2.2	1.5	1.1
7	71	17.2	8.6	4.3	2.1	1.4	1.1
6	68	16.5	8.2	4.1	2.1	1.4	1.0
5	64	15.5	7.7	3.9	1.9	1.3	
4	61	14.8	7.4	3.7	1.8	1.2	
<b>Totals:</b>	<b>669 AF</b>	<b>132 hr</b>	<b>88 hr</b>	<b>44 hr</b>	<b>21hr</b>	<b>13 hr</b>	<b>8 hr</b>
<b>Average time for a 1-foot change in level (hrs)</b>		<b>19 hr</b>	<b>9 hr</b>	<b>5 hr</b>	<b>2.4 hr</b>	<b>1.6 hr</b>	<b>1.2 hr</b>

**Table 5** shows the time, in hours, to drain the reservoir at different *net* outflow rates. The table only shows values for conditions that are possible within the outflow limitations caused by higher water levels in Pool 15 as flow through Check 14 increases. When the *net* flow out of the reservoir is 600 or 800 cfs then the outflow going into Pool 15 must be at least that large, so corresponding minimum depths will further limit the usable storage. Values in **Table 3** above should be used to show additional limitations on the useful storage amount based on flow rate in the canal downstream.

**Table 5 – Time (in hours) to decrease reservoir level vs.net outflow rate.**

Reservoir Depth (feet)	Differential Volume (acre-feet)	Net flow out of reservoir (cfs):					
		50	100	200	400	600	800
		Time (in hours) to decrease reservoir level by 1 foot					
12	88	21.3	10.6	5.3	2.7	1.8	1.3
11	84	20.3	10.2	5.1	2.5	1.7	1.3
10	81	19.6	9.8	4.9	2.5	1.6	1.2
9	78	18.9	9.4	4.7	2.4	1.6	1.2
8	74	17.9	9.0	4.5	2.2	1.5	1.1
7	71	17.2	8.6	4.3	2.1	1.4	1.1
6	68	16.5	8.2	4.1	2.1	1.4	1.0
5	64	15.5	7.7	3.9	1.9	1.3	
4	61	14.8	7.4	3.7	1.8		
<b>Totals:</b>	<b>669 AF</b>	<b>132 hr</b>	<b>88 hr</b>	<b>44 hr</b>	<b>21hr</b>	<b>12 hr</b>	<b>8 hr</b>
<b>Average time for a 1-foot change in level (hrs)</b>		<b>19 hr</b>	<b>9 hr</b>	<b>5 hr</b>	<b>2.4 hr</b>	<b>1.6 hr</b>	<b>1.2 hr</b>

As a summary of how the reservoir will provide compensating flows for surplus or deficit events, **Table 6** shows how long it will take to drain or fill reservoir storage. Two examples are shown, a low-flow case with 400 cfs flowing through Siphon 14 and a high-flow case with 1,000 cfs flowing through Siphon 14. The time durations for filling or draining the available storage are shown.

**Table 6 – Summary of storage use vs. time**

When the flow through Siphon 14 is:		400 cfs (low flow)	1000 cfs (high flow)
Usable storage volume is:		660 acre-feet	395 acre-feet
Differential flow (filling or draining)	Average time to change level by 1 foot	Time to drain/fill entire usable volume of 660 acre-feet	Time to drain/fill entire usable volume of 395 acre-feet
50 cfs	18 hr	160 hr	96 hr
100 cfs	9 hr	80 hr	48 hr
200 cfs	5 hr	40 hr	24 hr
400 cfs	2.3 hr	20 hr	12 hr
600 cfs	1.5 hr	13 hr	8 hr
800 cfs	1 hr	10 hr	6 hr

## 5 Construction Sequencing

---

At present, it is anticipated that construction would begin in summer 2020 and be completed by spring 2021. Construction will include two brief shutdowns during low periods in winter 2020/21. Work can be sequenced as shown in **Figures 8 through 10** using the steps below.

### **Step 1 – Earthwork in existing old canal** (completed during summer/fall)

- Clear, scarify, and compact subgrade from Siphon 11 to 14
- Remove portion of existing left embankment
- Construct compacted right embankment using removed material from left embankment
- Work completed for all reaches without disrupting service in existing canal

### **Step 2 – Diversions** (completed during winter low-flow period)

- Coordinate temporary shutdown with CVWD
- Construct temporary plugs in the canal to isolate Siphons 11 (downstream only), 12, 13, and 14 (upstream only)
- Complete structural modifications at Siphons 12 and 13 and Check 14
- Construct temporary transitions to divert flow into the old canal

### **Step 3 – Earthwork in lined canal** (completed during winter low-flow period)

- Dewater existing lined canal pools
- Remove portion of canal-right concrete lining and place on new canal invert
- Remove portion of existing canal right embankment and use it to construct compacted clay liner over the canal left embankment and invert concrete lining

### **Step 4 – Complete final reservoir section** (completed during winter low-flow period)

- Coordinate temporary shutdown with CVWD
- Dewater old canal
- Use remaining embankment between old and new canals to construct finished reservoir left embankment
- Any excess material can be spoiled on reservoir invert
- Construct final transitions (see **Figure 11**)

The temporary shutdowns will require closing the gates at Check 11 and dewatering the canal by gravity through Check 14. **Table 7** shows how the water volume in canal pools 11, 12, and 13 will be depleted, and when water level will be low enough for construction activities to begin.

This example assumes that canal flow rate is 400 cfs prior to shutdown, which will create a normal flow depth of 6 feet in these canal pools. At this flow rate, water level in Pool 14 should be low enough to not restrict reservoir outflow through Siphon 14, and the siphon drops will create starting level in canal pools 11, 12, and 13 that are even a little lower than 6 feet. The table shows that the upstream end of Pool 11 will be almost empty in about 2 hours, and all of Pool 11 should be empty in about 3 hours. The upstream end of Pool 12 should be empty in about 3 hours and all of Pool 12 should be empty in about 4 hours. It will also be possible to construct temporary berms and pump out the remaining water in work areas before these areas are completely empty from gravity flow.

**Table 7 – Volume depletion and depth reductions vs. time (dewatering existing canal)**

Time (hours)	Canal 3-pools combined		Res outflow thru Check 14 Q (cfs)	Pool 13		Pool 12		Pool 11	
	Total Volume (ac-ft)	Percent Volume		d/s Y (ft)	u/s Y (ft)	d/s Y (ft)	u/s Y (ft)	d/s Y (ft)	u/s Y (ft)
0	75	100%	400	5.70	5.70	5.50	5.60	5.30	5.40
0.5	59	79%	368	5.50	5.50	5.30	4.70	3.70	2.80
1	45	61%	316	5.00	5.20	4.20	4.20	2.70	1.70
2	24	32%	220	4.10	3.40	2.90	1.70	1.10	0.20
3	10	14%	136	2.70	2.00	1.50	0.25	0	0
4	3	3%	65	1.50	0.80	0.30	0	0	0
5	1	1%	10	0.30	0	0	0	0	0

**Table 8** shows an example schedule for filling the newly completed reservoir. Inflow to the reservoir through Check 11 should be ramped up gradually at first to avoid high flow velocities on the new reservoir invert. It would be best to increase inflow gradually from zero to 100 cfs over the first few minutes. The filling strategy in the table suggests increasing inflow in 100 cfs increments every 10 minutes for the first half hour, after which time all three reservoir cells should contain some water.

After that time, inflow can be increased as desired to achieve the desired flow for Coachella Canal downstream from the reservoir. It should take about 3 hours to obtain enough reservoir depth (about 3 feet) to pass 400 cfs out of the reservoir into Pool 14, and approximately another hour to achieve enough depth (about 4 ft) to pass 600 cfs out of the reservoir.

**Table 8 – Volume Filling Schedule**

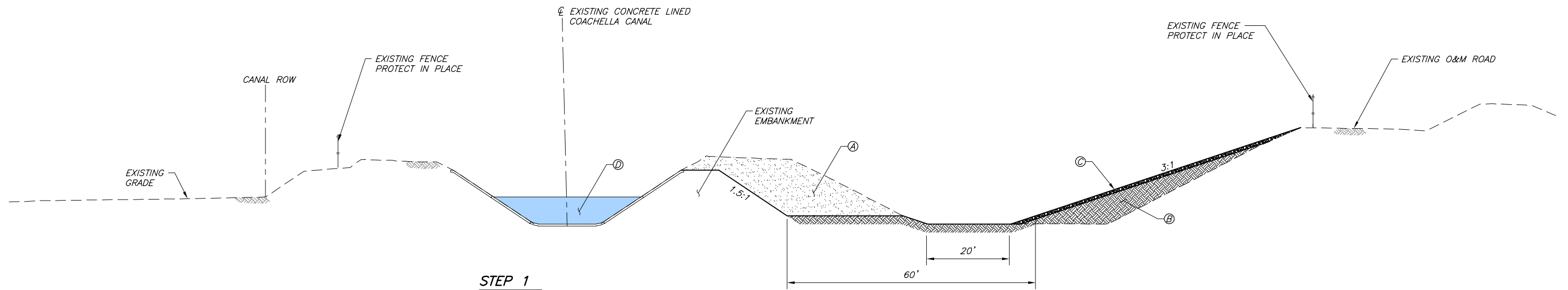

Time	Inflow cfs	Cells being filled	Average Depth feet
0	100	1	0.00
10 min	200	1, 2	0.10
20 min	300	1, 2	0.15
30 min	400	1, 2, 3	0.20
40 min	600	1, 2, 3	0.25
50 min	800	1, 2, 3	0.39
1 hr	1000	1, 2, 3	0.58
2 hr	1000	1, 2, 3	2.00
3 hr	1000	1, 2, 3	3.30
4 hr	1000	1, 2, 3	4.50
5 hr	1000	1, 2, 3	5.60

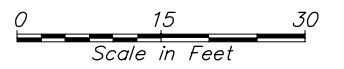

**STEP 1**

- Ⓐ REMOVE PORTION OF EXISTING EMBANKMENT.
- Ⓑ CONSTRUCT COMPACTED EMBANKMENT ALONG OLD CANAL USING THE MATERIAL EXCAVATED FROM THE EXISTING EMBANKMENTS.
- Ⓒ FURNISH AND PLACE 9-INCH-THICK ROCK PROTECTION ALONG WESTERLY SLOPE.
- Ⓓ WORK SHALL BE COMPLETED FOR ALL CELLS WITHOUT DISRUPTING SERVICE TO EXISTING CANAL.



		COACHELLA VALLEY WATER DISTRICT FEASIBILITY STUDY FOR STORAGE OF COLORADO RIVER WATER	DATE MARCH 2019
		<b>SEQUENCING PLAN</b> <b>SHEET 1 OF 3</b>	FIGURE NUMBER <b>8</b>



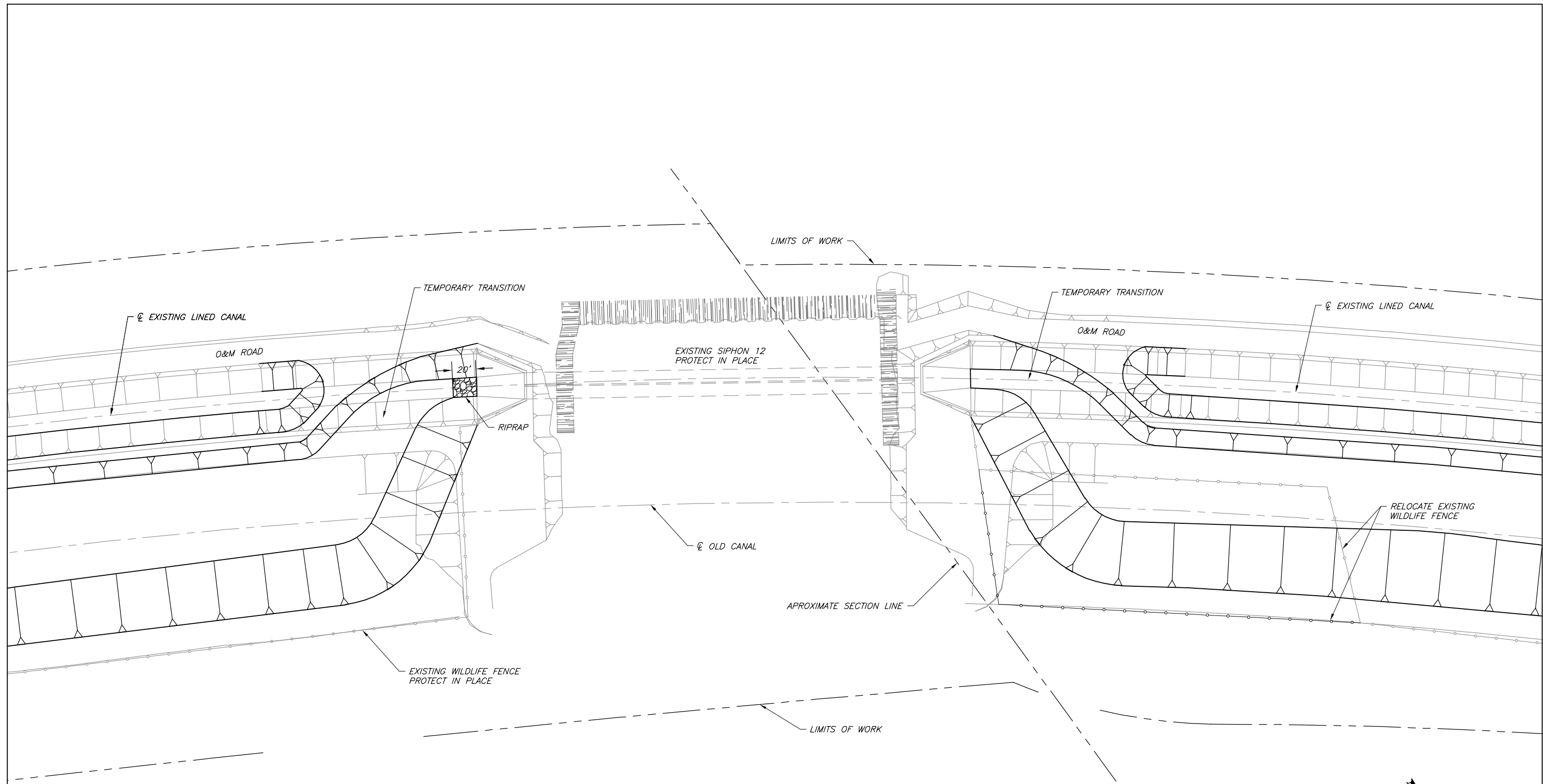

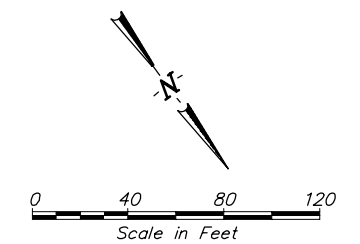

**STEP 2**

Ⓐ COORDINATE TEMPORARY SHUTDOWN WITH CVWD, ISOLATE EXISTING CANAL POOLS FROM WORK AREA, AND CONSTRUCT TEMPORARY TRANSITIONS.



 	COACHELLA VALLEY WATER DISTRICT FEASIBILITY STUDY FOR STORAGE OF COLORADO RIVER WATER	DATE MARCH 2019
	SEQUENCING PLAN SHEET 2 OF 3	FIGURE NUMBER 9

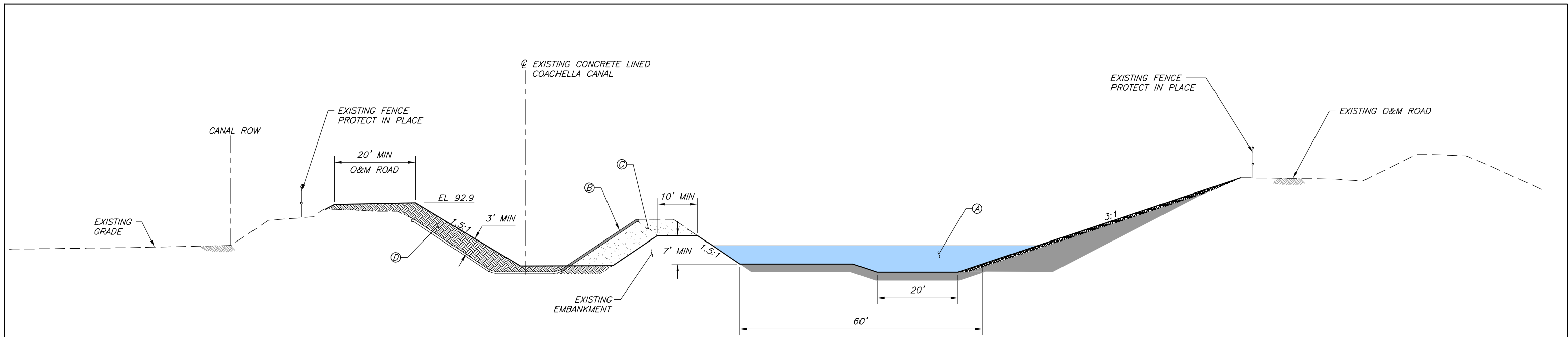

**STEP 3**

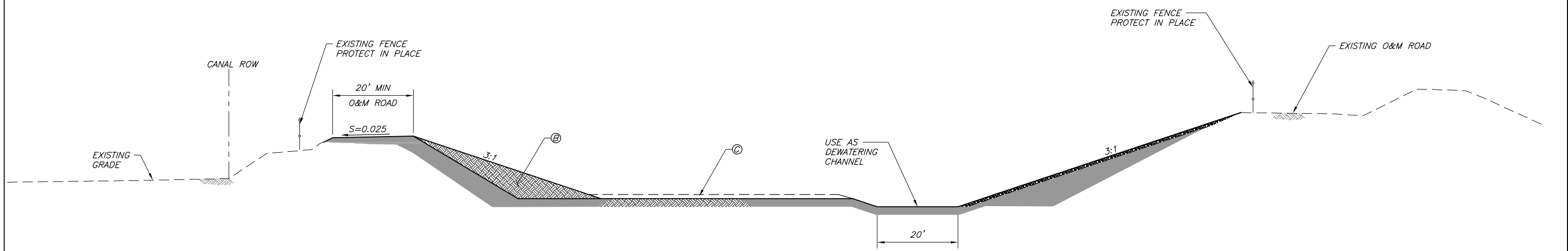

- Ⓐ FLOW DIVERTED TO THE OLD CANAL.
- Ⓑ CUT AND REMOVE EXISTING LINING ON CANAL RIGHT AND PLACE WASTE MATERIAL ALONG COACHELLA CANAL INVERT. WORK SHALL BE COMPLETED WITHOUT DISRUPTING SERVICE IN THE OLD CANAL.
- Ⓒ REMOVE PORTION OF EXISTING EMBANKMENT TO CONSTRUCT CLAY LINER.
- Ⓓ CONSTRUCT 3-FOOT-THICK MINIMUM CLAY LINER.



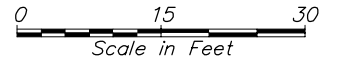

**STEP 4**

- Ⓐ COORDINATE TEMPORARY SHUTDOWN WITH CVWD AND DEWATER OLD CANAL.
- Ⓑ USE REMAINING EMBANKMENT MATERIAL FROM STEP 2 TO CONSTRUCT NEW EMBANKMENT.
- Ⓒ ANY EXCESS MATERIAL SHALL BE SPOILED AS SHOWN.

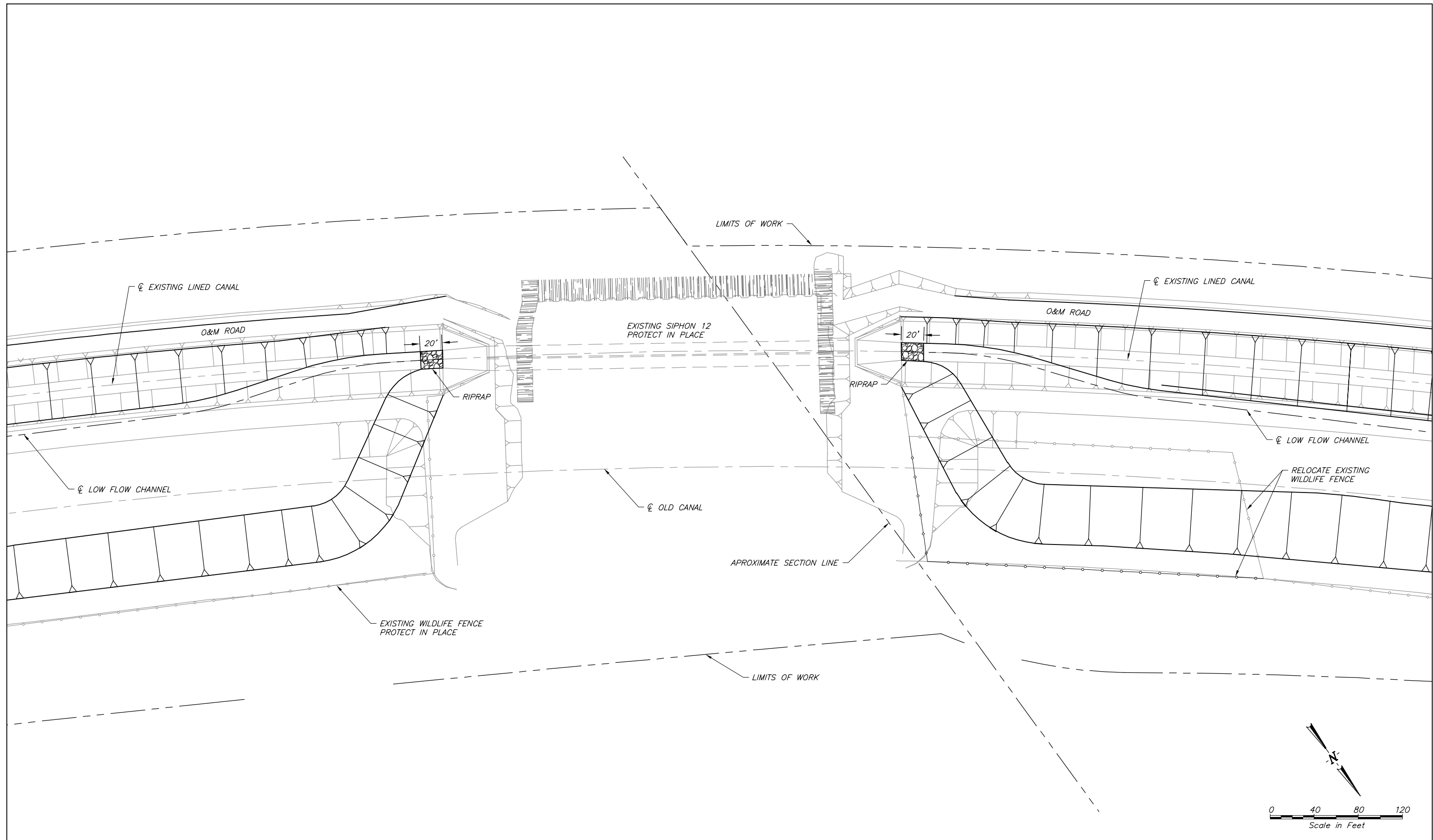

		COACHELLA VALLEY WATER DISTRICT FEASIBILITY STUDY FOR STORAGE OF COLORADO RIVER WATER	DATE MARCH 2019
		<b>SEQUENCING PLAN SHEET 3 OF 3</b>	FIGURE NUMBER <b>10</b>



 	COACHELLA VALLEY WATER DISTRICT FEASIBILITY STUDY FOR STORAGE OF COLORADO RIVER WATER	DATE MARCH 2019
	<b>SIPHON 12 TRANSITION PLAN</b>	FIGURE NUMBER 11

## 6 Cost Estimates

The estimated project costs are considered between a Class 3 and a Class 4 according to the Cost Estimate Classification System. **Table 9** below shows a Cost Estimate Classification Matrix including Accuracy Ranges and Typical Contingencies. Initial construction cost estimates are shown in **Table 10**.

**Table 9 – Cost Estimate Classification Matrix**

Estimate Class	LEVEL OF PROJECT DEFINITION Expressed as % of Complete Project Definition	END USAGE Typical Purpose of Estimate	METHODOLOGY Typical Estimating Techniques	EXPECTED ACCURACY RANGE At 90% Confidence Level	TYPICAL CONTINGENCY To Achieve 50% Probability of Overrun/Underrun
5	<=5%	Preliminary Project Screening Estimate, Capital Budget OOM Estimate, Alternate Schemes Evaluation, Strategic Analysis	Capacity Factored, Parametric Models, Judgment, Analogy, Historical Project Comparison, Cost Unit Cost	Low: -20% to -50% High: +30% to +100%	15% to 40%
4	5% to 20%	Preliminary Project Estimate, Reality Check Estimate, Alternate Schemes Evaluation, Feasibility Study	Equipment Factored Parametric Models, Historical Relationship Factors, Broad Unit Cost Data	Low: -15% to -30% High: +20% to +50%	10% to 25%
3	20% to 60%	Project Funding Estimate, Fair Price Check Estimate, Alternate Schemes Evaluation	Semi-Detailed Unit Costs with Assembly Level Line Items by Trade, Historical Relationship Factors	Low: -10% to -20% High: +10% to +30%	5% to 15%
2	60% to 99%	Project Funding Estimate, Control Estimate, Bid Estimate	Detailed Estimating Data by Trade, with Detailed Takeoff Quantities	Low: -5% to -15% High: +5% to +20%	5% to 15% of unexpected funds
1	90% to 100%	Firm Bid Estimate	Detailed Estimating Data by Trade with Detailed Firm Takeoff Quantities	Low: -3% to -10% High: +3% to +15%	3% to 10% Of unexpected funds

\*Note: Modified ACCE

**Table 10 – Engineer’s Opinion of Probable Construction Costs**

Item No.	Item Description	Quantity	Unit	Unit Price	Amount
1	Mobilization and Demobilization	1	LS	\$ 760,000	\$ 760,000
2	Sheeting, Shoring, and Bracing	1	LS	\$ 10,000	\$ 10,000
3	Storm Water Pollution Prevention Plan (SWPPP)	1	LS	\$ 50,000	\$ 50,000
4	All-Risk Insurance	1	LS	\$ 150,000	\$ 150,000
	<b>Cell 1</b>				
5	Clear, scarify, and compact subgrade	1	LS	\$ 48,100	\$ 48,100
6	Excavation and embankment work	168,714	CY	\$ 2.43	\$ 409,500
7	Repair drain pipe and install riprap	1	LS	\$ 19,000	\$ 19,000
8	Construct diversion	1	LS	\$ 52,700	\$ 52,700
9	Riprap at diversion	200	CY	\$ 126.50	\$ 25,300
10	Structural concrete	9	CY	\$ 2,500	\$ 22,500
11	Slope Protection	5,927	CY	\$ 20	\$ 118,600
	<b>Cell 2</b>				
12	Clear, scarify, and compact subgrade	1	LS	\$ 83,500	\$ 83,500
13	Excavation and embankment work	275,920	CY	\$ 2.56	\$ 706,100
14	Repair drain pipe and install riprap	1	LS	\$ 19,000	\$ 19,000
15	Construct diversion	1	LS	\$ 52,700	\$ 52,700
16	Riprap at diversion	200	CY	\$ 126.50	\$ 25,300
17	Structural concrete	9	CY	\$ 2,500	\$ 22,500
18	Slope Protection	13,002	CY	\$ 20	\$ 260,100
	<b>Cell 3</b>				
19	Clear, scarify, and compact subgrade	1	LS	\$ 66,600	\$ 66,600
20	Excavation and embankment work	207,844	CY	\$ 2.89	\$ 601,500
21	Repair drain pipe and install riprap	1	LS	\$ 19,000	\$ 19,000
22	Construct diversion	1	LS	\$ 52,700	\$ 52,700
23	Riprap at diversion	200	CY	\$ 126.50	\$ 25,300
24	Structural concrete	24	CY	\$ 2,500	\$ 60,000
25	Slope Protection	11,208	CY	\$ 20	\$ 224,200
26	Electrical	1	LS	\$ 1,200,000	\$ 1,200,000
				SUBTOTAL	\$ 5,084,200
				CONTINGENCY (25%)	\$ 1,271,100
				<b>CONSTRUCTION TOTAL</b>	<b>\$ 6,355,300</b>

Based on experience and evaluation of construction costs for numerous existing reservoirs, Dahl Consultants has adopted a budget number of about \$10,000 per acre-ft as a “rule of thumb” cost for an optimally constructed reservoir. Generally, reservoirs that fit this category have a square footprint (equal sided) and good balance of earthwork i.e. excavation matches required fills. The square footprint minimizes the area of the plastic liner and corresponding concrete cover for any given storage capacity.

The North Shore sites that were evaluated in our previous study had costs as high as \$36,000 per acre-ft for the long linear alternatives (in the old canal between Siphons 29 and 32). Other alternatives considered in that study required construction of a new reservoir on the steep terrain adjacent to the canal. That concept required embankments that would have the design water surface elevation at 25 feet or more above the original ground at the downstream toe of embankment. This would have required lengthy and costly approvals from DWR Division of Safety of Dams (DSOD). None of the sites identified in the North Shore area were found to be institutionally and/or economically feasible.

This long and relatively narrow reservoir shape does not match the traditional optimal configuration. However, cost reductions are created by the fact that the reservoir uses a previously excavated canal in a reach of the Coachella Canal that contains significant amounts of impermeable clay. Therefore, the normal costs for excavation, plastic liner, and concrete slope protection are avoided. Based on the preliminary cost estimate and volume of storage, this project can be constructed for less than the target \$10,000 per acre-foot.