

APPENDIX 9b



Ventura Engineering Inland INC
VEI

PRELIMINARY WATER QUALITY MANAGEMENT PLAN

NEW COMMERCIAL / RETAIL WQP21-004

NEC PALM AVENUE & W. 5TH STREET
HIGHLAND, CALIFORNIA 92346
APNs: 1201-331-02, 03, 04, 14, 15 & 19

PREPARED FOR:

EADY TRUST
TRUSTEE JEAN EADY MATLOCK
C/O PAULA HUMBERT
3380 PUNTA ALTA #A
LAGUNA WOODS, CALIFORNIA 92637
(951) 312-2601

PREPARED BY:

WILFREDO VENTURA
VENTURA ENGINEERING INLAND
27393 YNEZ ROAD, SUITE 159
TEMECULA, CALIFORNIA 92591
(951) 252-7632

REVISION 4: May 11, 2022 **REVISION 3:** April 12, 2022 **REVISION 2:** March 8, 2022
REVISION 1: January 11, 2022 **ORIGINAL DATE:** October 29, 2021

I hereby declare that I am the engineer of work for this project, that I have exercised responsible charge over the design of the project as defined in Section 6703 of the Business and Professions code, and that the design is consistent with current standards.



5/11/22

WILFREDO VENTURA
R.C.E. NO. 66532

DATE

Water Quality Management Plan

For:

NEW COMMERCIAL / RETAIL

AGENCY NUMBER – WQP21-004

APNS: 1201-331-02, 03, 05, 14, 15 & 19

Prepared for:

Eady Trust, c/o Paula Humbert
3380 Punta Alta #A
Laguna Woods, California 92637
(951) 312-2601

Prepared by:

Ventura Engineering Inland, Inc.
27393 Ynez Road, Suite 159
Temecula, California 92591
(951) 252-7632

Submittal Date: October 29, 2021

Revision Date: January 11, 2022

Revision Date: March 8, 2022

Revision Date: April 12, 2022

Revision Date: May 11, 2022

Approval Date: _____

Project Owner's Certification

This Water Quality Management Plan (WQMP) has been prepared for the Eady Trust by Ventura Engineering Inland, Inc.. The WQMP is intended to comply with the requirements of the City of Highland and the NPDES Areawide Stormwater Program requiring the preparation of a WQMP. The undersigned, while it owns the subject property, is responsible for the implementation of the provisions of this plan and will ensure that this plan is amended as appropriate to reflect up-to-date conditions on the site consistent with San Bernardino County's Municipal Storm Water Management Program and the intent of the NPDES Permit for San Bernardino County and the incorporated cities of San Bernardino County within the Santa Ana Region. Once the undersigned transfers its interest in the property, its successors in interest and the city/county shall be notified of the transfer. The new owner will be informed of its responsibility under this WQMP. A copy of the approved WQMP shall be available on the subject site in perpetuity.

"I certify under a penalty of law that the provisions (implementation, operation, maintenance, and funding) of the WQMP have been accepted and that the plan will be transferred to future successors."

Project Data			
Permit/Application Number(s):	WQP21-004	Grading Permit Number(s):	
Tract/Parcel Map Number(s):	Lot 8 of Royal Palms Tract 3202 & Vacated Alley to the East	Building Permit Number(s):	
CUP, SUP, and/or APN (Specify Lot Numbers if Portions of Tract):			APNs: 1201-331-02, 03, 05, 14, 15 & 19
Owner's Signature			
Owner Name: Paula Humbert			
Title	Trustee		
Company	Eady Trust		
Address	3380 Punta Alta #A, Laguna Woods, California 92637		
Email	paulaehumbert@aol.com		
Telephone #	(951) 321-2601		
Signature			Date

Preparer's Certification

Project Data			
Permit/Application Number(s):	WQP21-004	Grading Permit Number(s):	
Tract/Parcel Map Number(s):	Lot 8 of Royal Palms Tract 3202 & Vacated Alley to the East	Building Permit Number(s):	
CUP, SUP, and/or APN (Specify Lot Numbers if Portions of Tract):			APNs: 1201-331-02, 03, 05, 14, 15 & 19

“The selection, sizing and design of stormwater treatment and other stormwater quality and quantity control measures in this plan were prepared under my oversight and meet the requirements of Regional Water Quality Control Board Order No. R8-2010-0036.”

Engineer: Wilfredo S.B. Ventura		PE Stamp Below
Title	Owner	
Company	Ventura Engineering Inland, Inc.	
Address	27393 Ynez Road, Suite 159, Temecula, CA 92591	
Email	wilfredo@venturaengineeringinland.com	
Telephone #	(951) 252-7632	
Signature		
Date		

Table of Contents

Section 1	Discretionary Permits	1-1
Section 2	Project Description	2-1
	2.1 Project Information.....	2-1
	2.2 Property Ownership / Management	2-2
	2.3 Potential Stormwater Pollutants	2-3
	2.4 Water Quality Credits	2-4
Section 3	Site and Watershed Description	3-1
Section 4	Best Management Practices	4-1
	4.1 Source Control BMP	4-1
	4.1.1 Pollution Prevention	4-1
	4.1.2 Preventative LID Site Design Practices	4-6
	4.2 Project Performance Criteria.....	4-7
	4.3 Project Conformance Analysis.....	4-12
	4.3.1 Site Design Hydrologic Source Control BMP	4-14
	4.3.2 Infiltration BMP	4-16
	4.3.3 Harvest and Use BMP	4-18
	4.3.4 Biotreatment BMP.....	4-19
	4.3.5 Conformance Summary.....	4-23
	4.3.6 Hydromodification Control BMP	4-24
	4.4 Alternative Compliance Plan (if applicable).....	4-25
Section 5	Inspection & Maintenance Responsibility Post Construction BMPs.....	5-1
Section 6	Site Plan and Drainage Plan.....	6-1
	6.1. Site Plan and Drainage Plan.....	6-1
	6.2 Electronic Data Submittal	6-1

Forms

Form 1-1	Project Information	1-1
Form 2.1-1	Description of Proposed Project	2-1
Form 2.2-1	Property Ownership/Management.....	2-2
Form 2.3-1	Pollutants of Concern	2-3
Form 2.4-1	Water Quality Credits	2-4
Form 3-1	Site Location and Hydrologic Features	3-1
Form 3-2	Hydrologic Characteristics.....	3-2
Form 3-3	Watershed Description.....	3-3
Form 4.1-1	Non-Structural Source Control BMP.....	4-2
Form 4.1-2	Structural Source Control BMP	4-4
Form 4.1-3	Site Design Practices Checklist.....	4-6
Form 4.2-1	LID BMP Performance Criteria for Design Capture Volume	4-7
Form 4.2-2	Summary of HCOG Assessment.....	4-8
Form 4.2-3	HCOG Assessment for Runoff Volume	4-9

Form 4.2-4 HCOC Assessment for Time of Concentration	4-10
Form 4.2-5 HCOC Assessment for Peak Runoff.....	4-11
Form 4.3-1 Infiltration BMP Feasibility	4-13
Form 4.3-2 Site Design Hydrologic Source Control BMP	4-14
Form 4.3-3 Infiltration LID BMP	4-17
Form 4.3-4 Harvest and Use BMP	4-18
Form 4.3-5 Selection and Evaluation of Biotreatment BMP	4-19
Form 4.3-6 Volume Based Biotreatment – Bioretention and Planter Boxes w/Underdrains	4-20
Form 4.3-7 Volume Based Biotreatment- Constructed Wetlands and Extended Detention	4-21
Form 4.3-8 Flow Based Biotreatment	4-22
Form 4.3-9 Conformance Summary and Alternative Compliance Volume Estimate	4-23
Form 4.3-10 Hydromodification Control BMP	4-24
Form 5-1 BMP Inspection and Maintenance	5-1

Attachment 1: WQMP Exhibits

Attachment 2: Reference Plans

Attachment 3: NRCS Soils Report

Attachment 4: Infiltration Report

Attachment 5: Stormwater Facilities Mapping

Attachment 6: Drainage Analysis Reference

Attachment 7: Operations & Maintenance Plan

Section 1 Discretionary Permit(s)

Form 1-1 Project Information					
Project Name		New Commercial / Retail			
Project Owner Contact Name:		Jean Eady Matlock, Trustee of the Eady Trust			
Mailing Address:	3380 Punta Alta #A Laguna Woods, California 92637	E-mail Address:	paulaehumbert@aol.com	Telephone:	(951) 312-2601
Permit/Application Number(s):	WQP21-004	Tract/Parcel Map Number(s):	Lot 8 of Royal Palms Tract 3202 & Vacated Alley to the East		
Additional Information/Comments:	See Below				
Description of Project:	<ol style="list-style-type: none"> 1. THE PROJECT INVOLVES (7) SEVEN PARCELS TOTALING APPROXIMATELY 1.88 NET ACRES. 2. PROPOSED C-STORE, WITH ATTACHED 40 FOOT LONG ROLL OVER CAR WASH. 3. PROPOSED SIX MPD FUELING CANOPY. 4. PROPOSED HIGH SPEED DIESEL CANOPY. 5. PROPOSED 22 PARKING STALLS INCLUDING; 2 VACUUM, 1 ADA, AND 2 ELECTRIC VEHICLE CHARGING STATIONS. 6. ONSITE IMPROVEMENTS CONSIST OF ON-SITE PARKING, WQMP AREAS, SITE CIRCULATION, LANDSCAPING AND SITE LIGHTING. 7. OFFSITE IMPROVEMENTS CONSIST OF NEW UTILITY CONNECTIONS, SIDEWALK /CURB AND GUTTERS, AND DRIVEWAY APPROACHES. 8. PROPOSED ZONE CHANGE TO BUSINESS PARK. 				
Provide summary of Conceptual WQMP conditions (if previously submitted and approved). Attach complete copy.	Project site is divided into 4 DMAs that drain tributary areas into separate infiltration basins. Isolated landscape areas will also be allowed to pond in amended soils.				

Section 2 Project Description

2.1 Project Information

This section of the WQMP should provide the information listed below. The information provided for Conceptual/ Preliminary WQMP should give sufficient detail to identify the major proposed site design and LID BMPs and other anticipated water quality features that impact site planning. Final Project WQMP must specifically identify all BMP incorporated into the final site design and provide other detailed information as described herein.

The purpose of this information is to help determine the applicable development category, pollutants of concern, watershed description, and long-term maintenance responsibilities for the project, and any applicable water quality credits. This information will be used in conjunction with the information in Section 3, Site Description, to establish the performance criteria and to select the LID BMP or other BMP for the project or other alternative programs that the project will participate in, which are described in Section 4.

Form 2.1-1 Description of Proposed Project					
1 Development Category (Select all that apply):					
<input type="checkbox"/> Significant re-development involving the addition or replacement of 5,000 ft ² or more of impervious surface on an already developed site	<input checked="" type="checkbox"/> New development involving the creation of 10,000 ft ² or more of impervious surface collectively over entire site	<input type="checkbox"/> Automotive repair shops with standard industrial classification (SIC) codes 5013, 5014, 5541, 7532- 7534, 7536-7539	<input type="checkbox"/> Restaurants (with SIC code 5812) where the land area of development is 5,000 ft ² or more		
<input type="checkbox"/> Hillside developments of 5,000 ft ² or more which are located on areas with known erosive soil conditions or where the natural slope is 25 percent or more	<input type="checkbox"/> Developments of 2,500 ft ² of impervious surface or more adjacent to (within 200 ft) or discharging directly into environmentally sensitive areas or waterbodies listed on the CWA Section 303(d) list of impaired waters.	<input type="checkbox"/> Parking lots of 5,000 ft ² or more exposed to storm water	<input checked="" type="checkbox"/> Retail gasoline outlets that are either 5,000 ft ² or more, or have a projected average daily traffic of 100 or more vehicles per day		
<input type="checkbox"/> Non-Priority / Non-Category Project <i>May require source control LID BMPs and other LIP requirements. Please consult with local jurisdiction on specific requirements.</i>					
2 Project Area (ft ²):	80,983	3 Number of Dwelling Units:	n/a	4 SIC Code:	5541
5 Is Project going to be phased? Yes <input type="checkbox"/> No <input checked="" type="checkbox"/> <i>If yes, ensure that the WQMP evaluates each phase as a distinct DA, requiring LID BMPs to address runoff at time of completion.</i>					
6 Does Project include roads? Yes <input type="checkbox"/> No <input checked="" type="checkbox"/> <i>If yes, ensure that applicable requirements for transportation projects are addressed (see Appendix A of TGD for WQMP)</i>					

2.2 Property Ownership/Management

Describe the ownership/management of all portions of the project and site. State whether any infrastructure will transfer to public agencies (City, County, Caltrans, etc.) after project completion. State if a homeowners or property owners association will be formed and be responsible for the long-term maintenance of project stormwater facilities. Describe any lot-level stormwater features that will be the responsibility of individual property owners.

Form 2.2-1 Property Ownership/Management

Describe property ownership/management responsible for long-term maintenance of WQMP stormwater facilities:

The property owner is the responsible entity for implementation of WQMP requirements as follows:

BMP Inspection and Monitoring shall be the responsibility of:

Eady Trust
c/o Trustee Paula Humbert
3380 Punta Alta #A
Laguna Woods, California 92637
(951) 696-1490

BMP Operations and Maintenance shall be the responsibility of:

Eady Trust
c/o Trustee Paula Humbert
3380 Punta Alta #A
Laguna Woods, California 92637
(951) 696-1490

Financial responsibility shall be:

Eady Trust
c/o Trustee Paula Humbert
3380 Punta Alta #A
Laguna Woods, California 92637
(951) 696-1490

2.3 Potential Stormwater Pollutants

Determine and describe expected stormwater pollutants of concern based on land uses and site activities (refer to Table 3-3 in the TGD for WQMP).

Form 2.3-1 Pollutants of Concern			
Pollutant	Please check: E=Expected, N=Not Expected		Additional Information and Comments
Pathogens (Bacterial / Virus)	E <input checked="" type="checkbox"/>	N <input type="checkbox"/>	Landscaped Areas
Nutrients - Phosphorous	E <input checked="" type="checkbox"/>	N <input type="checkbox"/>	Landscaped Areas
Nutrients - Nitrogen	E <input checked="" type="checkbox"/>	N <input type="checkbox"/>	Landscaped Areas
Noxious Aquatic Plants	E <input type="checkbox"/>	N <input checked="" type="checkbox"/>	Not Allowed Per Landscape Regulations
Sediment	E <input checked="" type="checkbox"/>	N <input type="checkbox"/>	Landscaped Areas
Metals	E <input checked="" type="checkbox"/>	N <input type="checkbox"/>	O&M will address
Oil and Grease	E <input checked="" type="checkbox"/>	N <input type="checkbox"/>	O&M will address
Trash/Debris	E <input checked="" type="checkbox"/>	N <input type="checkbox"/>	O&M will address
Pesticides / Herbicides	E <input checked="" type="checkbox"/>	N <input type="checkbox"/>	O&M will address
Organic Compounds	E <input checked="" type="checkbox"/>	N <input type="checkbox"/>	Landscaped Areas
Other:	E <input type="checkbox"/>	N <input type="checkbox"/>	
Other:	E <input type="checkbox"/>	N <input type="checkbox"/>	
Other:	E <input type="checkbox"/>	N <input type="checkbox"/>	
Other:	E <input type="checkbox"/>	N <input type="checkbox"/>	
Other:	E <input type="checkbox"/>	N <input type="checkbox"/>	

2.4 Water Quality Credits

A water quality credit program is applicable for certain types of development projects if it is not feasible to meet the requirements for on-site LID. Proponents for eligible projects, as described below, can apply for water quality credits that would reduce project obligations for selecting and sizing other treatment BMP or participating in other alternative compliance programs. Refer to Section 6.2 in the TGD for WQMP to determine if water quality credits are applicable for the project.

Form 2.4-1 Water Quality Credits			
1 Project Types that Qualify for Water Quality Credits: <i>Select all that apply</i>			
<input type="checkbox"/> Redevelopment projects that reduce the overall impervious footprint of the project site. [Credit = % impervious reduced]	Higher density development projects <input type="checkbox"/> Vertical density [20%] <input type="checkbox"/> 7 units/ acre [5%]	<input type="checkbox"/> Mixed use development, (combination of residential, commercial, industrial, office, institutional, or other land uses which incorporate design principles that demonstrate environmental benefits not realized through single use projects) [20%]	<input type="checkbox"/> Brownfield redevelopment (redevelop real property complicated by presence or potential of hazardous contaminants) [25%]
<input type="checkbox"/> Redevelopment projects in established historic district, historic preservation area, or similar significant core city center areas [10%]	<input type="checkbox"/> Transit-oriented developments (mixed use residential or commercial area designed to maximize access to public transportation) [20%]	<input type="checkbox"/> In-fill projects (conversion of empty lots & other underused spaces < 5 acres, substantially surrounded by urban land uses, into more beneficially used spaces, such as residential or commercial areas) [10%]	<input type="checkbox"/> Live-Work developments (variety of developments designed to support residential and vocational needs) [20%]
2 Total Credit % <i>(Total all credit percentages up to a maximum allowable credit of 50 percent)</i>			
Description of Water Quality Credit Eligibility (if applicable)	None Apply At This Time		

Section 3 Site and Watershed Description

Describe the project site conditions that will facilitate the selection of BMP through an analysis of the physical conditions and limitations of the site and its receiving waters. Identify distinct drainage areas (DA) that collect flow from a portion of the site and describe how runoff from each DA (and sub-watershed DMAs) is conveyed to the site outlet(s). Refer to Section 3.2 in the TGD for WQMP. The form below is provided as an example. Then complete Forms 3.2 and 3.3 for each DA on the project site. ***If the project has more than one drainage area for stormwater management, then complete additional versions of these forms for each DA / outlet.***

Form 3-1 Site Location and Hydrologic Features			
Site coordinates take GPS measurement at approximate center of site	Latitude 34° 6' 30.39" N	Longitude -117° 12'; 30.00" W	Thomas Bros Map page Page 577, Grid H7
¹ San Bernardino County climatic region: <input checked="" type="checkbox"/> Valley <input type="checkbox"/> Mountain			
² Does the site have more than one drainage area (DA): Yes <input type="checkbox"/> No <input checked="" type="checkbox"/> <i>If no, proceed to Form 3-2. If yes, then use this form to show a conceptual schematic describing DMAs and hydrologic feature connecting DMAs to the site outlet(s). An example is provided below that can be modified for proposed project or a drawing clearly showing DMA and flow routing may be attached</i>			
Conveyance	Briefly describe on-site drainage features to convey runoff that is not retained within a DMA		
DA1 to Outlet A	All on-site areas drain to tributed infiltration areas. Overflows are tied into the same existing carb basin in Palm at the NEC of W. 5 th Street.		

Form 3-2 Existing Hydrologic Characteristics for Drainage Area 1				
For Drainage Area 1's sub-watershed DMA, provide the following characteristics	DMA A	DMA B	DMA C	DMA D
1 DMA drainage area (ft ²)	84,283			
2 Existing site impervious area (ft ²)	0			
3 Antecedent moisture condition <i>For desert areas, use http://www.sbcounty.gov/dpw/floodcontrol/pdf/20100412_map.pdf</i>	II			
4 Hydrologic soil group <i>Refer to Watershed Mapping Tool – http://permitrack.sbcounty.gov/wap/</i>	A			
5 Longest flow path length (ft)	440			
6 Longest flow path slope (ft/ft)	0.0125			
7 Current land cover type(s) <i>Select from Fig C-3 of Hydrology Manual</i>	Urban			
8 Pre-developed pervious area condition: <i>Based on the extent of wet season vegetated cover good >75%; Fair 50-75%; Poor <50% Attach photos of site to support rating</i>	Fair			

Form 3-2 Existing Hydrologic Characteristics for Drainage Area 1 (use only as needed for additional DMA w/in DA 1)				
For Drainage Area 1's sub-watershed DMA, provide the following characteristics	DMA E	DMA F	DMA G	DMA H
1 DMA drainage area (ft ²)				
2 Existing site impervious area (ft ²)				
3 Antecedent moisture condition <i>For desert areas, use http://www.sbcounty.gov/dpw/floodcontrol/pdf/20100412_map.pdf</i>				
4 Hydrologic soil group <i>Refer to Watershed Mapping Tool – http://permitrack.sbcounty.gov/wap/</i>				
5 Longest flowpath length (ft)				
6 Longest flowpath slope (ft/ft)				
7 Current land cover type(s) <i>Select from Fig C-3 of Hydrology Manual</i>				
8 Pre-developed pervious area condition: <i>Based on the extent of wet season vegetated cover good >75%; Fair 50-75%; Poor <50% Attach photos of site to support rating</i>				

Form 3-3 Watershed Description for Drainage Area	
Receiving waters <i>Refer to Watershed Mapping Tool -</i> http://permitrack.sbcounty.gov/wap/ <i>See "Drainage Facilities" link at this website</i>	* City Creek Channel
Applicable TMDLs <i>Refer to Local Implementation Plan</i>	* Not Listed
303(d) listed impairments <i>Refer to Local Implementation Plan and Watershed Mapping Tool –</i> http://permitrack.sbcounty.gov/wap/ and State Water Resources Control Board website – http://www.waterboards.ca.gov/santaana/water_issues/programs/tmdl/index.shtml	* Not Listed
Environmentally Sensitive Areas (ESA) <i>Refer to Watershed Mapping Tool –</i> http://permitrack.sbcounty.gov/wap/	* Not Listed
Unlined Downstream Water Bodies <i>Refer to Watershed Mapping Tool –</i> http://permitrack.sbcounty.gov/wap/	* Not Listed
Hydrologic Conditions of Concern	<input type="checkbox"/> Yes Complete Hydrologic Conditions of Concern (HCO) Assessment. Include Forms 4.2-2 through Form 4.2-5 and Hydromodification BMP Form 4.3-10 in submittal <input checked="" type="checkbox"/> No
Watershed-based BMP included in a RWQCB approved WAP	<input type="checkbox"/> Yes Attach verification of regional BMP evaluation criteria in WAP <ul style="list-style-type: none"> • More Effective than On-site LID • Remaining Capacity for Project DCV • Upstream of any Water of the US • Operational at Project Completion • Long-Term Maintenance Plan <input checked="" type="checkbox"/> No

** This is the preliminary phase. The Final WQMP will define all reaches to the discharge point at the Pacific Ocean.*

Section 4 Best Management Practices (BMP)

4.1 Source Control BMP

4.1.1 Pollution Prevention

Non-structural and structural source control BMP are required to be incorporated into all new development and significant redevelopment projects. Form 4.1-1 and 4.1-2 are used to describe specific source control BMPs used in the WQMP or to explain why a certain BMP is not applicable. Table 7-3 of the TGD for WQMP provides a list of applicable source control BMP for projects with specific types of potential pollutant sources or activities. The source control BMP in this table must be implemented for projects with these specific types of potential pollutant sources or activities.

The preparers of this WQMP have reviewed the source control BMP requirements for new development and significant redevelopment projects. The preparers have also reviewed the specific BMP required for project as specified in Forms 4.1-1 and 4.1-2. All applicable non-structural and structural source control BMP shall be implemented in the project.

Form 4.1-1-1 Non-Structural Source Control BMPs

Identifier	Name	Check One		Describe BMP Implementation OR, if not applicable, state reason *
		Included	Not Applicable	
N1	Education of Property Owners, Tenants and Occupants on Stormwater BMPs	<input checked="" type="checkbox"/>	<input type="checkbox"/>	O&M Plan will be created
N2	Activity Restrictions	<input type="checkbox"/>	<input checked="" type="checkbox"/>	Not Applicable
N3	Landscape Management BMPs	<input checked="" type="checkbox"/>	<input type="checkbox"/>	Landscape will be maintained per City requirements. Select landscaping areas will also will be allowed to pond 6" over 6" of amended soils.
N4	BMP Maintenance	<input checked="" type="checkbox"/>	<input type="checkbox"/>	O&M Plan will be created
N5	Title 22 CCR Compliance (How development will comply)	<input checked="" type="checkbox"/>	<input type="checkbox"/>	Through Building Department review and approvals
N6	Local Water Quality Ordinances	<input checked="" type="checkbox"/>	<input type="checkbox"/>	Landscape will be maintained per City requirements
N7	Spill Contingency Plan	<input checked="" type="checkbox"/>	<input type="checkbox"/>	Per Retail Gas Station Operations Regulations
N8	Underground Storage Tank Compliance	<input checked="" type="checkbox"/>	<input type="checkbox"/>	Per Retail Gas Station Operations Regulations
N9	Hazardous Materials Disclosure Compliance	<input checked="" type="checkbox"/>	<input type="checkbox"/>	Per Retail Gas Station Operations Regulations

** This is the preliminary phase. The Final WQMP will expand on the description column.*

Form 4.1-1 Non-Structural Source Control BMPs

Identifier	Name	Check One		Describe BMP Implementation OR, if not applicable, state reason *
		Included	Not Applicable	
N10	Uniform Fire Code Implementation	<input checked="" type="checkbox"/>	<input type="checkbox"/>	Through Building Department review and approvals
N11	Litter/Debris Control Program	<input checked="" type="checkbox"/>	<input type="checkbox"/>	Trash enclosure proposed per City requirements
N12	Employee Training	<input checked="" type="checkbox"/>	<input type="checkbox"/>	Per Retail Gas Station Operations Regulations
N13	Housekeeping of Loading Docks	<input type="checkbox"/>	<input checked="" type="checkbox"/>	None proposed
N14	Catch Basin Inspection Program	<input checked="" type="checkbox"/>	<input type="checkbox"/>	O&M Plan will be created
N15	Vacuum Sweeping of Private Streets and Parking Lots	<input checked="" type="checkbox"/>	<input type="checkbox"/>	O&M Plan will be created (parking areas)
N16	Other Non-structural Measures for Public Agency Projects	<input type="checkbox"/>	<input checked="" type="checkbox"/>	None proposed
N17	Comply with all other applicable NPDES permits	<input checked="" type="checkbox"/>	<input type="checkbox"/>	WDID# will be obtained for Construction Disturbance over 1 acre

** This is the preliminary phase. The Final WQMP will expand on the description column.*

Form 4.1-2 Structural Source Control BMPs

Identifier	Name	Check One		Describe BMP Implementation OR, If not applicable, state reason *
		Included	Not Applicable	
S1	Provide storm drain system stencilling and signage (CASQA New Development BMP Handbook SD-13)	<input checked="" type="checkbox"/>	<input type="checkbox"/>	O&M Plan will be created with use of CASQA SD-13.
S2	Design and construct outdoor material storage areas to reduce pollution introduction (CASQA New Development BMP Handbook SD-34)	<input type="checkbox"/>	<input checked="" type="checkbox"/>	None proposed
S3	Design and construct trash and waste storage areas to reduce pollution introduction (CASQA New Development BMP Handbook SD-32)	<input checked="" type="checkbox"/>	<input type="checkbox"/>	Trash enclosure proposed per City requirements and CASQA SD-32
S4	Use efficient irrigation systems & landscape design, water conservation, smart controllers, and source control (Statewide Model Landscape Ordinance; CASQA New Development BMP Handbook SD-12)	<input checked="" type="checkbox"/>	<input type="checkbox"/>	Landscape will be maintained per City requirements and CASQA SD-12
S5	Finish grade of landscaped areas at a minimum of 1-2 inches below top of curb, sidewalk, or pavement	<input checked="" type="checkbox"/>	<input type="checkbox"/>	Per proposed grading plan
S6	Protect slopes and channels and provide energy dissipation (CASQA New Development BMP Handbook SD-10)	<input type="checkbox"/>	<input checked="" type="checkbox"/>	None Proposed
S7	Covered dock areas (CASQA New Development BMP Handbook SD-31)	<input type="checkbox"/>	<input checked="" type="checkbox"/>	None proposed
S8	Covered maintenance bays with spill containment plans (CASQA New Development BMP Handbook SD-31)	<input type="checkbox"/>	<input checked="" type="checkbox"/>	None proposed
S9	Vehicle wash areas with spill containment plans (CASQA New Development BMP Handbook SD-33)	<input checked="" type="checkbox"/>	<input type="checkbox"/>	Enclosed Car Wash per Building Department Approvals. CASQA SD-33 may apply
S10	Covered outdoor processing areas (CASQA New Development BMP Handbook SD-36)	<input type="checkbox"/>	<input checked="" type="checkbox"/>	None Proposed

** This is the preliminary phase. The Final WQMP will expand on the description column.*

Form 4.1-2 Structural Source Control BMPs				
Identifier	Name	Check One		Describe BMP Implementation OR, If not applicable, state reason *
		Included	Not Applicable	
S11	Equipment wash areas with spill containment plans (CASQA New Development BMP Handbook SD-33)	<input type="checkbox"/>	<input checked="" type="checkbox"/>	None proposed
S12	Fueling areas (CASQA New Development BMP Handbook SD-30)	<input checked="" type="checkbox"/>	<input type="checkbox"/>	Per Retail Gas Station Operations Regulations and CASQA SD-30
S13	Hillside landscaping (CASQA New Development BMP Handbook SD-10)	<input type="checkbox"/>	<input checked="" type="checkbox"/>	No hillsides present on site
S14	Wash water control for food preparation areas	<input checked="" type="checkbox"/>	<input type="checkbox"/>	Inside preparation areas only and shall be processed through Building Department review and approvals
S15	Community car wash racks (CASQA New Development BMP Handbook SD-33)	<input type="checkbox"/>	<input checked="" type="checkbox"/>	None proposed

* This is the preliminary phase. The Final WQMP will expand on the description column.

4.1.2 Preventative LID Site Design Practices

Site design practices associated with new LID requirements in the MS4 Permit should be considered in the earliest phases of a project. Preventative site design practices can result in smaller DCV for LID BMP and hydromodification control BMP by reducing runoff generation. Describe site design and drainage plan including:

- A narrative of site design practices utilized or rationale for not using practices
- A narrative of how site plan incorporates preventive site design practices
- Include an attached Site Plan layout which shows how preventative site design practices are included in WQMP

Refer to Section 5.2 of the TGD for WQMP for more details.

Form 4.1-3 Preventative LID Site Design Practices Checklist
<p>Site Design Practices <i>If yes, explain how preventative site design practice is addressed in project site plan. If no, other LID BMPs must be selected to meet targets</i></p>
<p>Minimize impervious areas: Yes <input checked="" type="checkbox"/> No <input type="checkbox"/> Explanation: Additional landscaped areas have been added or expanded on the project site to incorporate infiltration areas and minimize the impervious surfaces required by the project.</p>
<p>Maximize natural infiltration capacity: Yes <input checked="" type="checkbox"/> No <input type="checkbox"/> Explanation: Infiltration areas are being proposed for low impact design.</p>
<p>Preserve existing drainage patterns and time of concentration: Yes <input checked="" type="checkbox"/> No <input type="checkbox"/> Explanation: Project site was previously developed for multiple lots or structures and has been re-developed as a retail gas station with a C-store; however, the same downstream inlet will be the compliance point for hydrologic patterns.</p>
<p>Disconnect impervious areas: Yes <input checked="" type="checkbox"/> No <input type="checkbox"/> Explanation: Roofs drains are discharged to adjacent landscape areas prior to being discharged to the site BMPs. Some isolated landscaping areas will be allowed to pond 6" over 6" amended soils as well.</p>
<p>Protect existing vegetation and sensitive areas: Yes <input type="checkbox"/> No <input checked="" type="checkbox"/> Explanation: None present to preserve. Site was 100% developed in the past.</p>
<p>Re-vegetate disturbed areas: Yes <input type="checkbox"/> No <input checked="" type="checkbox"/> Explanation: Site as previously fully disturbed and the project area is only disturbing what is needed to construct the new buildings and retail gas facility. The remained of the site is low impact design elements, landscaping, or infiltration areas.</p>
<p>Minimize unnecessary compaction in stormwater retention/infiltration basin/trench areas: Yes <input checked="" type="checkbox"/> No <input type="checkbox"/> Explanation: Per geotechnical findings, the most suitable spots for infiltration as being used for the infiltration areas.</p>
<p>Utilize vegetated drainage swales in place of underground piping or imperviously lined swales: Yes <input checked="" type="checkbox"/> No <input type="checkbox"/> Explanation: Vegetated swales are being used where feasible. Storm drain piping is only for overflow elements.</p>
<p>Stake off areas that will be used for landscaping to minimize compaction during construction : Yes <input checked="" type="checkbox"/> No <input type="checkbox"/> Explanation: Landscape areas DAM1-LS1; DMA2-LS thru LS6; DMA3-LS7 thru LS-10; and DMA4-LS11 will be staked out to limit compaction in the designated areas.</p>

4.2 Project Performance Criteria

The purpose of this section of the Project WQMP is to establish targets for post-development hydrology based on performance criteria specified in the MS4 Permit. These targets include runoff volume for water quality control (referred to as LID design capture volume), and runoff volume, time of concentration, and peak runoff for protection of any downstream waterbody segments with a HCOC. ***If the project has more than one outlet for stormwater runoff, then complete additional versions of these forms for each DA / outlet.***

Methods applied in the following forms include:

- For LID BMP Design Capture Volume (DCV), the San Bernardino County Stormwater Program requires use of the P₆ method (MS4 Permit Section XI.D.6a.ii) – Form 4.2-1
- For HCOC pre- and post-development hydrologic calculation, the San Bernardino County Stormwater Program requires the use of the Rational Method (San Bernardino County Hydrology Manual Section D). Forms 4.2-2 through Form 4.2-5 calculate hydrologic variables including runoff volume, time of concentration, and peak runoff from the project site pre- and post-development using the Hydrology Manual Rational Method approach. For projects greater than 640 acres (1.0 mi²), the Rational Method and these forms should not be used. For such projects, the Unit Hydrograph Method (San Bernardino County Hydrology Manual Section E) shall be applied for hydrologic calculations for HCOC performance criteria.

Refer to Section 4 in the TGD for WQMP for detailed guidance and instructions.

Form 4.2-1 LID BMP Performance Criteria for DCV for DA1-DMA1		
1 Project area DA 1 (ft ²): 32,478	2 Imperviousness after applying preventative site design practices (Imp%): 70.5%	3 Runoff Coefficient (Rc): 0.50 $R_c = 0.858(\text{Imp}\%)^{0.3} - 0.78(\text{Imp}\%)^{0.2} + 0.774(\text{Imp}\%) + 0.04$
4 Determine 1-hour rainfall depth for a 2-year return period P _{2yr-1hr} (in): 0.512 http://hdsc.nws.noaa.gov/hdsc/pfds/so/sca_pfds.html		
5 Compute P ₆ , Mean 6-hr Precipitation (inches): 0.758 (Using Valley = 1.4807) <i>P₆ = Item 4 * C₁, where C₁ is a function of site climatic region specified in Form 3-1 Item 1 (Valley = 1.4807; Mountain = 1.909; Desert = 1.2371)</i>		
6 Drawdown Rate Use 48 hours as the default condition. Selection and use of the 24 hour drawdown time condition is subject to approval by the local jurisdiction. The necessary BMP footprint is a function of drawdown time. While shorter drawdown times reduce the performance criteria for LID BMP design capture volume, the depth of water that can be stored is also reduced.		24-hrs <input type="checkbox"/> 48-hrs <input checked="" type="checkbox"/>
7 Compute design capture volume, DCV (ft ³): 2,008 $DCV = 1/12 * [\text{Item 1} * \text{Item 3} * \text{Item 5} * C_2]$, where C ₂ is a function of drawdown rate (24-hr = 1.582; 48-hr = 1.963) Compute separate DCV for each outlet from the project site per schematic drawn in Form 3-1 Item 2		

Form 4.2-1 LID BMP Performance Criteria for for DCV for DA1-DMA2		
1 Project area DA 1 (ft ²): 17,825	2 Imperviousness after applying preventative site design practices (Imp%): 56.5%	3 Runoff Coefficient (Rc): 0.38 $R_c = 0.858(\text{Imp}\%)^{0.3} - 0.78(\text{Imp}\%)^{0.2} + 0.774(\text{Imp}\%) + 0.04$
4 Determine 1-hour rainfall depth for a 2-year return period $P_{2\text{yr-1hr}}$ (in): 0.512 http://hdsc.nws.noaa.gov/hdsc/pfds/sa/sca_pfds.html		
5 Compute P_6 , Mean 6-hr Precipitation (inches): 0.758 (Using Valley = 1.4807) $P_6 = \text{Item 4} * C_1$, where C_1 is a function of site climatic region specified in Form 3-1 Item 1 (Valley = 1.4807; Mountain = 1.909; Desert = 1.2371)		
6 Drawdown Rate <i>Use 48 hours as the default condition. Selection and use of the 24 hour drawdown time condition is subject to approval by the local jurisdiction. The necessary BMP footprint is a function of drawdown time. While shorter drawdown times reduce the performance criteria for LID BMP design capture volume, the depth of water that can be stored is also reduced.</i>		24-hrs <input type="checkbox"/> 48-hrs <input checked="" type="checkbox"/>
7 Compute design capture volume, DCV (ft ³): 847 $DCV = 1/12 * [\text{Item 1} * \text{Item 3} * \text{Item 5} * C_2]$, where C_2 is a function of drawdown rate (24-hr = 1.582; 48-hr = 1.963) Compute separate DCV for each outlet from the project site per schematic drawn in Form 3-1 Item 2		

Form 4.2-1 LID BMP Performance Criteria for for DCV for DA1-DMA3		
1 Project area DA 1 (ft ²): 17,756	2 Imperviousness after applying preventative site design practices (Imp%): 82.8	3 Runoff Coefficient (Rc): 0.63 $R_c = 0.858(\text{Imp}\%)^{0.3} - 0.78(\text{Imp}\%)^{0.2} + 0.774(\text{Imp}\%) + 0.04$
4 Determine 1-hour rainfall depth for a 2-year return period $P_{2\text{yr-1hr}}$ (in): 0.512 http://hdsc.nws.noaa.gov/hdsc/pfds/sa/sca_pfds.html		
5 Compute P_6 , Mean 6-hr Precipitation (inches): 0.758 (Using Valley = 1.4807) $P_6 = \text{Item 4} * C_1$, where C_1 is a function of site climatic region specified in Form 3-1 Item 1 (Valley = 1.4807; Mountain = 1.909; Desert = 1.2371)		
6 Drawdown Rate <i>Use 48 hours as the default condition. Selection and use of the 24 hour drawdown time condition is subject to approval by the local jurisdiction. The necessary BMP footprint is a function of drawdown time. While shorter drawdown times reduce the performance criteria for LID BMP design capture volume, the depth of water that can be stored is also reduced.</i>		24-hrs <input type="checkbox"/> 48-hrs <input checked="" type="checkbox"/>
7 Compute design capture volume, DCV (ft ³): 1,395 $DCV = 1/12 * [\text{Item 1} * \text{Item 3} * \text{Item 5} * C_2]$, where C_2 is a function of drawdown rate (24-hr = 1.582; 48-hr = 1.963) Compute separate DCV for each outlet from the project site per schematic drawn in Form 3-1 Item 2		

Form 4.2-1 LID BMP Performance Criteria for DCV for DA1-DMA4		
1 Project area DA 1 (ft ²): 11,690	2 Imperviousness after applying preventative site design practices (Imp%): 76.1%	3 Runoff Coefficient (Rc): 0.56 $R_c = 0.858(\text{Imp}\%)^{0.3} - 0.78(\text{Imp}\%)^{0.2} + 0.774(\text{Imp}\%) + 0.04$
4 Determine 1-hour rainfall depth for a 2-year return period $P_{2\text{yr-1hr}}$ (in): 0.512 http://hdsc.nws.noaa.gov/hdsc/pfds/sa/sca_pfds.html		
5 Compute P_6 , Mean 6-hr Precipitation (inches): 0.758 (Using Valley = 1.4807) $P_6 = \text{Item 4} * C_1$, where C_1 is a function of site climatic region specified in Form 3-1 Item 1 (Valley = 1.4807; Mountain = 1.909; Desert = 1.2371)		
6 Drawdown Rate Use 48 hours as the default condition. Selection and use of the 24 hour drawdown time condition is subject to approval by the local jurisdiction. The necessary BMP footprint is a function of drawdown time. While shorter drawdown times reduce the performance criteria for LID BMP design capture volume, the depth of water that can be stored is also reduced.		24-hrs <input type="checkbox"/> 48-hrs <input checked="" type="checkbox"/>
7 Compute design capture volume, DCV (ft ³): 805 $DCV = 1/12 * [\text{Item 1} * \text{Item 3} * \text{Item 5} * C_2]$, where C_2 is a function of drawdown rate (24-hr = 1.582; 48-hr = 1.963) Compute separate DCV for each outlet from the project site per schematic drawn in Form 3-1 Item 2		

Form 4.2-2 Summary of HCOC Assessment (DA 1)

Does project have the potential to cause or contribute to an HCOC in a downstream channel: Yes No

Go to: <http://permitrack.sbcounty.gov/wap/>

If "Yes", then complete HCOC assessment of site hydrology for 2yr storm event using Forms 4.2-3 through 4.2-5 and insert results below
 (Forms 4.2-3 through 4.2-5 may be replaced by computer software analysis based on the San Bernardino County Hydrology Manual)

If "No," then proceed to Section 4.3 Project Conformance Analysis

Condition	Runoff Volume (ft ³)	Time of Concentration (min)	Peak Runoff (cfs)
Pre-developed	1 <i>Form 4.2-3 Item 12</i>	2 <i>Form 4.2-4 Item 13</i>	3 <i>Form 4.2-5 Item 10</i>
Post-developed	4 <i>Form 4.2-3 Item 13</i>	5 <i>Form 4.2-4 Item 14</i>	6 <i>Form 4.2-5 Item 14</i>
Difference	7 <i>Item 4 – Item 1</i>	8 <i>Item 2 – Item 5</i>	9 <i>Item 6 – Item 3</i>
Difference (as % of pre-developed)	10 % <i>Item 7 / Item 1</i>	11 % <i>Item 8 / Item 2</i>	12 % <i>Item 9 / Item 3</i>

Form 4.2-3 HCOC Assessment for Runoff Volume (DA 1)

Form 4.2-3 HCOC Assessment for Runoff Volume (DA 1)								
Weighted Curve Number Determination for: Pre-developed DA	DMA A	DMA B	DMA C	DMA D	DMA E	DMA F	DMA G	DMA H
1a Land Cover type								
2a Hydrologic Soil Group (HSG)								
3a DMA Area, ft ² <i>sum of areas of DMA should equal area of DA</i>								
4a Curve Number (CN) <i>use Items 1 and 2 to select the appropriate CN from Appendix C-2 of the TGD for WQMP</i>								
Weighted Curve Number Determination for: Post-developed DA	DMA A	DMA B	DMA C	DMA D	DMA E	DMA F	DMA G	DMA H
1b Land Cover type								
2b Hydrologic Soil Group (HSG)								
3b DMA Area, ft ² <i>sum of areas of DMA should equal area of DA</i>								
4b Curve Number (CN) <i>use Items 5 and 6 to select the appropriate CN from Appendix C-2 of the TGD for WQMP</i>								
5 Pre-Developed area-weighted CN:	7 Pre-developed soil storage capacity, S (in): <i>S = (1000 / Item 5) - 10</i>				9 Initial abstraction, I _a (in): <i>I_a = 0.2 * Item 7</i>			
6 Post-Developed area-weighted CN:	8 Post-developed soil storage capacity, S (in): <i>S = (1000 / Item 6) - 10</i>				10 Initial abstraction, I _a (in): <i>I_a = 0.2 * Item 8</i>			
11 Precipitation for 2 yr, 24 hr storm (in): <i>Go to: http://hdsc.nws.noaa.gov/hdsc/pfds/qa/sca_pfds.html</i>								
12 Pre-developed Volume (ft ³): <i>V_{pre} = (1 / 12) * (Item sum of Item 3) * [(Item 11 - Item 9)^2 / ((Item 11 - Item 9 + Item 7))]</i>								
13 Post-developed Volume (ft ³): <i>V_{pre} = (1 / 12) * (Item sum of Item 3) * [(Item 11 - Item 10)^2 / ((Item 11 - Item 10 + Item 8))]</i>								
14 Volume Reduction needed to meet HCOC Requirement, (ft ³): <i>V_{HCOC} = (Item 13 * 0.95) - Item 12</i>								

Form 4.2-4 HCOC Assessment for Time of Concentration (DA 1)

Compute time of concentration for pre and post developed conditions for each DA (For projects using the Hydrology Manual complete the form below)

Variables	Pre-developed DA1 <i>Use additional forms if there are more than 4 DMA</i>				Post-developed DA1 <i>Use additional forms if there are more than 4 DMA</i>			
	DMA A	DMA B	DMA C	DMA D	DMA A	DMA B	DMA C	DMA D
1 Length of flowpath (ft) <i>Use Form 3-2 Item 5 for pre-developed condition</i>								
2 Change in elevation (ft)								
3 Slope (ft/ft), $S_o = \text{Item 2} / \text{Item 1}$								
4 Land cover								
5 Initial DMA Time of Concentration (min) <i>Appendix C-1 of the TGD for WQMP</i>								
6 Length of conveyance from DMA outlet to project site outlet (ft) <i>May be zero if DMA outlet is at project site outlet</i>								
7 Cross-sectional area of channel (ft ²)								
8 Wetted perimeter of channel (ft)								
9 Manning's roughness of channel (n)								
10 Channel flow velocity (ft/sec) $V_{fps} = (1.49 / \text{Item 9}) * (\text{Item 7} / \text{Item 8})^{0.67} * (\text{Item 3})^{0.5}$								
11 Travel time to outlet (min) $T_t = \text{Item 6} / (\text{Item 10} * 60)$								
12 Total time of concentration (min) $T_c = \text{Item 5} + \text{Item 11}$								
13 Pre-developed time of concentration (min): <i>Minimum of Item 12 pre-developed DMA</i>								
14 Post-developed time of concentration (min): <i>Minimum of Item 12 post-developed DMA</i>								
15 Additional time of concentration needed to meet HCOC requirement (min): $T_{C-HCOC} = (\text{Item 13} * 0.95) - \text{Item 14}$								

Form 4.2-5 HCOC Assessment for Peak Runoff (DA 1)

Compute peak runoff for pre- and post-developed conditions

Variables	Pre-developed DA to Project Outlet <i>(Use additional forms if more than 3 DMA)</i>			Post-developed DA to Project Outlet <i>(Use additional forms if more than 3 DMA)</i>		
	DMA A	DMA B	DMA C	DMA A	DMA B	DMA C
1 Rainfall Intensity for storm duration equal to time of concentration <i>$I_{peak} = 10^{(LOG Form 4.2-1 Item 4 - 0.6 LOG Form 4.2-4 Item 5 / 60)}$</i>						
2 Drainage Area of each DMA (Acres) <i>For DMA with outlet at project site outlet, include upstream DMA (Using example schematic in Form 3-1, DMA A will include drainage from DMA C)</i>						
3 Ratio of pervious area to total area <i>For DMA with outlet at project site outlet, include upstream DMA (Using example schematic in Form 3-1, DMA A will include drainage from DMA C)</i>						
4 Pervious area infiltration rate (in/hr) <i>Use pervious area CN and antecedent moisture condition with Appendix C-3 of the TGD for WQMP</i>						
5 Maximum loss rate (in/hr) <i>$F_m = Item 3 * Item 4$ Use area-weighted F_m from DMA with outlet at project site outlet, include upstream DMA (Using example schematic in Form 3-1, DMA A will include drainage from DMA C)</i>						
6 Peak Flow from DMA (cfs) <i>$Q_p = Item 2 * 0.9 * (Item 1 - Item 5)$</i>						
7 Time of concentration adjustment factor for other DMA to site discharge point <i>Form 4.2-4 Item 12 DMA / Other DMA upstream of site discharge point (If ratio is greater than 1.0, then use maximum value of 1.0)</i>	DMA A	<i>n/a</i>		<i>n/a</i>		
	DMA B		<i>n/a</i>		<i>n/a</i>	
	DMA C		<i>n/a</i>			<i>n/a</i>
8 Pre-developed Q_p at T_c for DMA A: <i>$Q_p = Item 6_{DMAA} + [Item 6_{DMAB} * (Item 1_{DMAA} - Item 5_{DMAB}) / (Item 1_{DMAB} - Item 5_{DMAB}) * Item 7_{DMAA/2}] + [Item 6_{DMAC} * (Item 1_{DMAA} - Item 5_{DMAC}) / (Item 1_{DMAC} - Item 5_{DMAC}) * Item 7_{DMAA/3}]$</i>	9 Pre-developed Q_p at T_c for DMA B: <i>$Q_p = Item 6_{DMAB} + [Item 6_{DMAA} * (Item 1_{DMAB} - Item 5_{DMAA}) / (Item 1_{DMAA} - Item 5_{DMAA}) * Item 7_{DMAB/1}] + [Item 6_{DMAC} * (Item 1_{DMAB} - Item 5_{DMAC}) / (Item 1_{DMAC} - Item 5_{DMAC}) * Item 7_{DMAB/3}]$</i>		10 Pre-developed Q_p at T_c for DMA C: <i>$Q_p = Item 6_{DMAC} + [Item 6_{DMAA} * (Item 1_{DMAC} - Item 5_{DMAA}) / (Item 1_{DMAA} - Item 5_{DMAA}) * Item 7_{DMAC/1}] + [Item 6_{DMAB} * (Item 1_{DMAC} - Item 5_{DMAB}) / (Item 1_{DMAB} - Item 5_{DMAB}) * Item 7_{DMAC/2}]$</i>			
10 Peak runoff from pre-developed condition confluence analysis (cfs): <i>Maximum of Item 8, 9, and 10 (including additional forms as needed)</i>						
11 Post-developed Q_p at T_c for DMA A: <i>Same as Item 8 for post-developed values</i>	12 Post-developed Q_p at T_c for DMA B: <i>Same as Item 9 for post-developed values</i>		13 Post-developed Q_p at T_c for DMA C: <i>Same as Item 10 for post-developed values</i>			
14 Peak runoff from post-developed condition confluence analysis (cfs): <i>Maximum of Item 11, 12, and 13 (including additional forms as needed)</i>						
15 Peak runoff reduction needed to meet HCOC Requirement (cfs): $Q_{p-HCOC} = (Item 14 * 0.95) - Item 10$						

4.3 Project Conformance Analysis

Complete the following forms for each project site DA to document that the proposed LID BMPs conform to the project DCV developed to meet performance criteria specified in the MS₄ Permit (WQMP Template Section 4.2). For the LID DCV, the forms are ordered according to hierarchy of BMP selection as required by the MS₄ Permit (see Section 5.3.1 in the TGD for WQMP). The forms compute the following for on-site LID BMP:

- Site Design and Hydrologic Source Controls (Form 4.3-2)
- Retention and Infiltration (Form 4.3-3)
- Harvested and Use (Form 4.3-4) or
- Biotreatment (Form 4.3-5).

At the end of each form, additional fields facilitate the determination of the extent of mitigation provided by the specific BMP category, allowing for use of the next category of BMP in the hierarchy, if necessary.

The first step in the analysis, using Section 5.3.2.1 of the TGD for WQMP, is to complete Forms 4.3-1 and 4.3-3) to determine if retention and infiltration BMPs are infeasible for the project. For each feasibility criterion in Form 4.3-1, if the answer is “Yes,” provide all study findings that includes relevant calculations, maps, data sources, etc. used to make the determination of infeasibility.

Next, complete Forms 4.3-2 and 4.3-4 to determine the feasibility of applicable HSC and harvest and use BMPs, and, if their implementation is feasible, the extent of mitigation of the DCV.

If no site constraints exist that would limit the type of BMP to be implemented in a DA, evaluate the use of combinations of LID BMPs, including all applicable HSC BMPs to maximize on-site retention of the DCV. If no combination of BMP can mitigate the entire DCV, implement the single BMP type, or combination of BMP types, that maximizes on-site retention of the DCV within the minimum effective area.

If the combination of LID HSC, retention and infiltration, and harvest and use BMPs are unable to mitigate the entire DCV, then biotreatment BMPs may be implemented by the project proponent. If biotreatment BMPs are used, then they must be sized to provide sufficient capacity for effective treatment of the remainder of the volume-based performance criteria that cannot be achieved with LID BMPs (TGD for WQMP Section 5.4.4.2).

Under no circumstances shall any portion of the DCV be released from the site without effective mitigation and/or treatment.

Form 4.3-1 Infiltration BMP Feasibility (DA 1)

Feasibility Criterion – Complete evaluation for each DA on the Project Site

¹ Would infiltration BMP pose significant risk for groundwater related concerns? Yes No
Refer to Section 5.3.2.1 of the TGD for WQMP

If Yes, Provide basis: (attach)

² Would installation of infiltration BMP significantly increase the risk of geotechnical hazards? Yes No
 (Yes, if the answer to any of the following questions is yes, as established by a geotechnical expert):

- The location is less than 50 feet away from slopes steeper than 15 percent
- The location is less than eight feet from building foundations or an alternative setback.
- A study certified by a geotechnical professional or an available watershed study determines that stormwater infiltration would result in significantly increased risks of geotechnical hazards.

If Yes, Provide basis: (attach)

³ Would infiltration of runoff on a Project site violate downstream water rights? Yes No

If Yes, Provide basis: (attach)

⁴ Is proposed infiltration facility located on hydrologic soil group (HSG) D soils or does the site geotechnical investigation indicate presence of soil characteristics, which support categorization as D soils? Yes No

If Yes, Provide basis: (attach)

⁵ Is the design infiltration rate, after accounting for safety factor of 2.0, below proposed facility less than 0.3 in/hr (accounting for soil amendments)? Yes No

If Yes, Provide basis: (attach)

⁶ Would on-site infiltration or reduction of runoff over pre-developed conditions be partially or fully inconsistent with watershed management strategies as defined in the WAP, or impair beneficial uses? Yes No

See Section 3.5 of the TGD for WQMP and WAP

If Yes, Provide basis: (attach)

⁷ Any answer from Item 1 through Item 3 is “Yes”: Yes No
If yes, infiltration of any volume is not feasible onsite. Proceed to Form 4.3-4, Harvest and Use BMP. If no, then proceed to Item 8 below.

⁸ Any answer from Item 4 through Item 6 is “Yes”: Yes No
If yes, infiltration is permissible but is not required to be considered. Proceed to Form 4.3-2, Hydrologic Source Control BMP. If no, then proceed to Item 9, below.

⁹ All answers to Item 1 through Item 6 are “No”:
Infiltration of the full DCV is potentially feasible, LID infiltration BMP must be designed to infiltrate the full DCV to the MEP. Proceed to Form 4.3-2, Hydrologic Source Control BMP.

4.3.1 Site Design Hydrologic Source Control BMP

Section XI.E. of the Permit emphasizes the use of LID preventative measures; and the use of LID HSC BMPs reduces the portion of the DCV that must be addressed in downstream BMPs. Therefore, all applicable HSC shall be provided except where they are mutually exclusive with each other, or with other BMPs. Mutual exclusivity may result from overlapping BMP footprints such that either would be potentially feasible by itself, but both could not be implemented. Please note that while there are no numeric standards regarding the use of HSC, if a project cannot feasibly meet BMP sizing requirements or cannot fully address HCOCs, feasibility of all applicable HSC must be part of demonstrating that the BMP system has been designed to retain the maximum feasible portion of the DCV. Complete Form 4.3-2 to identify and calculate estimated retention volume from implementing site design HSC BMP. Refer to Section 5.4.1 in the TGD for more detailed guidance.

Form 4.3-2 Site Design Hydrologic Source Control BMPs (DA 1)			
1 Implementation of Impervious Area Dispersion BMP (i.e. routing runoff from impervious to pervious areas), excluding impervious areas planned for routing to on-lot infiltration BMP: Yes <input type="checkbox"/> No <input checked="" type="checkbox"/> <i>If yes, complete Items 2-5; If no, proceed to Item 6</i>	DA DMA BMP Type	DA DMA BMP Type	DA DMA BMP Type
2 Total impervious area draining to pervious area (ft ²)			
3 Ratio of pervious area receiving runoff to impervious area			
4 Retention volume achieved from impervious area dispersion (ft ³) $V = \text{Item 2} * \text{Item 3} * (0.5/12)$, assuming retention of 0.5 inches of runoff			
5 Sum of retention volume achieved from impervious area dispersion (ft ³): 0 $V_{\text{retention}} = \text{Sum of Item 4 for all BMPs}$			
6 Implementation of Localized On-lot Infiltration BMPs (e.g. on-lot rain gardens): Yes <input type="checkbox"/> No <input checked="" type="checkbox"/> <i>If yes, complete Items 7-13 for aggregate of all on-lot infiltration BMP in each DA; if no, proceed to Item 14</i>	Landscaped Areas Not Being Dispersed To 6" Deep Amended Soils, 6" Ponding DMA1 (None) / DMA2 (LS2) / DMA3 (None) / DMA4 (None)		
7 Ponding surface area (ft ²)	n/a / 3668 / n/a / n/a		
8 Ponding depth (ft)	n/a / 0.5 / n/a / n/a		
9 Surface area of amended soil/gravel (ft ²)	n/a / 3668 / n/a / n/a		
10 Average depth of amended soil/gravel (ft)	n/a / 0.5 / n/a / n/a		
11 Average porosity of amended soil/gravel	n/a / 30% / n/a / n/a		
12 Retention volume achieved from on-lot infiltration (ft ³) $V_{\text{retention}} = (\text{Item 7} * \text{Item 8}) + (\text{Item 9} * \text{Item 10} * \text{Item 11})$	n/a / 2384 / n/a / n/a		
13 Runoff volume retention from on-lot infiltration (ft ³): 0 / 2,384 / 0 / 0 $V_{\text{retention}} = \text{Sum of Item 12 for all BMPs}$			

Form 4.3-2 Site Design Hydrologic Source Control BMPs (DA 1)			
14 Implementation of evapotranspiration BMP (green, brown, or blue roofs): Yes <input type="checkbox"/> No <input checked="" type="checkbox"/> <i>If yes, complete Items 15-20. If no, proceed to Item 21</i>	DA DMA BMP Type	DA DMA BMP Type	DA DMA BMP Type
15 Rooftop area planned for ET BMP (ft ²)			
16 Average wet season ET demand (in/day) <i>Use local values, typical ~ 0.1</i>			
17 Daily ET demand (ft ³ /day) <i>Item 15 * (Item 16 / 12)</i>			
18 Drawdown time (hrs) <i>Copy Item 6 in Form 4.2-1</i>			
19 Retention Volume (ft ³) <i>V_{retention} = Item 17 * (Item 18 / 24)</i>			
20 Runoff volume retention from evapotranspiration BMPs (ft ³): 0 <i>V_{retention} = Sum of Item 19 for all BMPs</i>			
21 Implementation of Street Trees: Yes <input type="checkbox"/> No <input checked="" type="checkbox"/> <i>If yes, complete Items 22-25. If no, proceed to Item 26</i>	DA DMA BMP Type	DA DMA BMP Type	DA DMA BMP Type
22 Number of Street Trees			
23 Average canopy cover over impervious area (ft ²)			
24 Runoff volume retention from street trees (ft ³) <i>V_{retention} = Item 22 * Item 23 * (0.05/12) assume runoff retention of 0.05 inches</i>			
25 Runoff volume retention from street tree BMPs (ft ³): 0 <i>V_{retention} = Sum of Item 24 for all BMPs</i>			
26 Implementation of residential rain barrel/cisterns: Yes <input type="checkbox"/> No <input checked="" type="checkbox"/> <i>If yes, complete Items 27-29; If no, proceed to Item 30</i>	DA DMA BMP Type	DA DMA BMP Type	DA DMA BMP Type
27 Number of rain barrels/cisterns			
28 Runoff volume retention from rain barrels/cisterns (ft ³) <i>V_{retention} = Item 27 * 3</i>			
29 Runoff volume retention from residential rain barrels/Cisterns (ft ³): 0 <i>V_{retention} = Sum of Item 28 for all BMPs</i>			
30 Total Retention Volume from Site Design Hydrologic Source Control BMPs: 0 / 2,384 / 0 / 0 <i>Sum of Items 5, 13, 20, 25 and 29</i>			

4.3.2 Infiltration BMPs

Use Form 4.3-3 to compute on-site retention of runoff from proposed retention and infiltration BMPs. Volume retention estimates are sensitive to the percolation rate used, which determines the amount of runoff that can be infiltrated within the specified drawdown time. The infiltration safety factor reduces field measured percolation to account for potential inaccuracy associated with field measurements, declining BMP performance over time, and compaction during construction. Appendix D of the TGD for WQMP provides guidance on estimating an appropriate safety factor to use in Form 4.3-3.

If site constraints limit the use of BMPs to a single type and implementation of retention and infiltration BMPs mitigate no more than 40% of the DCV, then they are considered infeasible and the Project Proponent may evaluate the effectiveness of BMPs lower in the LID hierarchy of use (Section 5.5.1 of the TGD for WQMP)

If implementation of infiltrations BMPs is feasible as determined using Form 4.3-1, then LID infiltration BMPs shall be implemented to the MEP (section 4.1 of the TGD for WQMP).

Form 4.3-3 Infiltration LID BMP - including underground BMPs (DA 1)

1 Remaining LID DCV not met by site design HSC BMP (ft ³): 2,008 / 0 / 1,395 / 805 $V_{unmet} = \text{Form 4.2-1 Item 7} - \text{Form 4.3-2 Item 30}$	
BMP Type Use columns to the right to compute runoff volume retention from proposed infiltration BMP (select BMP from Table 5-4 in TGD for WQMP) - Use additional forms for more BMPs	DA1 -DMA1 / DA1 -DMA2 / DA1 -DMA3 / DA1 -DMA4 BMP Type Infiltration
2 Infiltration rate of underlying soils (in/hr) See Section 5.4.2 and Appendix D of the TGD for WQMP for minimum requirements for assessment methods	6.48 / 6.48 / 6.48 / 6.48
3 Infiltration safety factor See TGD Section 5.4.2 and Appendix D	3 / 3 / 3 / 3
4 Design percolation rate (in/hr) $P_{design} = \text{Item 2} / \text{Item 3}$	2.16 / 2.16 / 2.16 / 2.16
5 Poned water drawdown time (hr) Copy Item 6 in Form 4.2-1	48 / 48 / 48 / 48
6 Maximum ponding depth (ft) BMP specific, see Table 5-4 of the TGD for WQMP for BMP design details	0.5 / 0.5 / 0.5 / 0.5
7 Ponding Depth (ft) $d_{BMP} = \text{Minimum of } (1/12 * \text{Item 4} * \text{Item 5}) \text{ or Item 6}$	0.5 / 0.5 / 0.5 / 0.5
8 Infiltrating surface area, SA_{BMP} (ft ²) the lesser of the area needed for infiltration of full DCV or minimum space requirements from Table 5.7 of the TGD for WQMP	6,568 / 649 / 1,106 / 805
9 Amended soil depth, d_{media} (ft) Only included in certain BMP types, see Table 5-4 in the TGD for WQMP for reference to BMP design details	0 / 0 / 0 / 0
10 Amended soil porosity	0 / 0 / 0 / 0
11 Gravel depth, d_{media} (ft) Only included in certain BMP types, see Table 5-4 of the TGD for WQMP for BMP design details	1 / 1 / 1 / 2
12 Gravel porosity	40% / 40% / 40% / 40%
13 Duration of storm as basin is filling (hrs) Typical ~ 3hrs	3 / 3 / 3 / 3
14 Above Ground Retention Volume (ft ³) $V_{retention} = \text{Item 8} * [\text{Item 7} + (\text{Item 9} * \text{Item 10}) + (\text{Item 11} * \text{Item 12}) + (\text{Item 13} * (\text{Item 4} / 12))]$	3,778 / 934 / 1,593 / 1,047
15 Underground Retention Volume (ft ³) Volume determined using manufacturer's specifications and calculations	0 / 0 / 0 / 0
16 Total Retention Volume from LID Infiltration BMPs: 3,778 / 934 / 1,593 / 1,047 (Sum of Items 14 and 15 for all infiltration BMP)	
17 Fraction of DCV achieved with infiltration BMP: 188% / 110% / 114% / 130% $\text{Retention\%} = \text{Item 16} / \text{Form 4.2-1 Item 7}$	
18 Is full LID DCV retained onsite with combination of hydrologic source control and LID retention/infiltration BMPs? Yes <input checked="" type="checkbox"/> No <input type="checkbox"/> If yes, demonstrate conformance using Form 4.3-10; If no, then reduce Item 3, Factor of Safety to 2.0 and increase Item 8, Infiltrating Surface Area, such that the portion of the site area used for retention and infiltration BMPs equals or exceeds the minimum effective area thresholds (Table 5-7 of the TGD for WQMP) for the applicable category of development and repeat all above calculations.	

4.3.3 Harvest and Use BMP

Harvest and use BMP may be considered if the full LID DCV cannot be met by maximizing infiltration BMPs. Use Form 4.3-4 to compute on-site retention of runoff from proposed harvest and use BMPs.

Volume retention estimates for harvest and use BMPs are sensitive to the on-site demand for captured stormwater. Since irrigation water demand is low in the wet season, when most rainfall events occur in San Bernardino County, the volume of water that can be used within a specified drawdown period is relatively low. The bottom portion of Form 4.3-4 facilitates the necessary computations to show infeasibility if a minimum incremental benefit of 40 percent of the LID DCV would not be achievable with MEP implementation of on-site harvest and use of stormwater (Section 5.5.4 of the TGD for WQMP).

Form 4.3-4 Harvest and Use BMPs (DA 1)			
1 Remaining LID DCV not met by site design HSC or infiltration BMP (ft ³): 0 <i>V_{unmet} = Form 4.2-1 Item 7 - Form 4.3-2 Item 30 - Form 4.3-3 Item 16</i>			
BMP Type(s) <i>Compute runoff volume retention from proposed harvest and use BMP (Select BMPs from Table 5-4 of the TGD for WQMP) - Use additional forms for more BMPs</i>	DA DMA BMP Type	DA DMA BMP Type	DA DMA BMP Type
2 Describe cistern or runoff detention facility			
3 Storage volume for proposed detention type (ft ³) <i>Volume of cistern</i>			
4 Landscaped area planned for use of harvested stormwater (ft ²)			
5 Average wet season daily irrigation demand (in/day) <i>Use local values, typical ~ 0.1 in/day</i>			
6 Daily water demand (ft ³ /day) <i>Item 4 * (Item 5 / 12)</i>			
7 Drawdown time (hrs) <i>Copy Item 6 from Form 4.2-1</i>			
8 Retention Volume (ft ³) <i>V_{retention} = Minimum of (Item 3) or (Item 6 * (Item 7 / 24))</i>			
9 Total Retention Volume (ft ³) from Harvest and Use BMP <i>Sum of Item 8 for all harvest and use BMP included in plan</i>			
10 Is the full DCV retained with a combination of LID HSC, retention and infiltration, and harvest & use BMPs? Yes <input checked="" type="checkbox"/> No <input type="checkbox"/> <i>If yes, demonstrate conformance using Form 4.3-10. If no, then re-evaluate combinations of all LID BMP and optimize their implementation such that the maximum portion of the DCV is retained on-site (using a single BMP type or combination of BMP types). If the full DCV cannot be mitigated after this optimization process, proceed to Section 4.3.4.</i>			

4.3.4 Biotreatment BMP

Biotreatment BMPs may be considered if the full LID DCV cannot be met by maximizing retention and infiltration, and harvest and use BMPs. A key consideration when using biotreatment BMP is the effectiveness of the proposed BMP in addressing the pollutants of concern for the project (see Table 5-5 of the TGD for WQMP).

Use Form 4.3-5 to summarize the potential for volume based and/or flow based biotreatment options to biotreat the remaining unmet LID DCV w. Biotreatment computations are included as follows:

- Use Form 4.3-6 to compute biotreatment in small volume based biotreatment BMP (e.g. bioretention w/underdrains);
- Use Form 4.3-7 to compute biotreatment in large volume based biotreatment BMP (e.g. constructed wetlands);
- Use Form 4.3-8 to compute sizing criteria for flow-based biotreatment BMP (e.g. bioswales)

Form 4.3-5 Selection and Evaluation of Biotreatment BMP (DA 1)		
1 Remaining LID DCV not met by site design HSC, infiltration, or harvest and use BMP for potential biotreatment (ft ³): <i>Form 4.2-1 Item 7 - Form 4.3-2 Item 30 – Form 4.3-3 Item 16- Form 4.3-4 Item 9</i>	List pollutants of concern <i>Copy from Form 2.3-1.</i>	
2 Biotreatment BMP Selected <i>(Select biotreatment BMP(s) necessary to ensure all pollutants of concern are addressed through Unit Operations and Processes, described in Table 5-5 of the TGD for WQMP)</i>	Volume-based biotreatment <i>Use Forms 4.3-6 and 4.3-7 to compute treated volume</i> <input type="checkbox"/> Bioretention with underdrain <input type="checkbox"/> Planter box with underdrain <input type="checkbox"/> Constructed wetlands <input type="checkbox"/> Wet extended detention <input type="checkbox"/> Dry extended detention	Flow-based biotreatment <i>Use Form 4.3-8 to compute treated volume</i> <input type="checkbox"/> Vegetated swale <input type="checkbox"/> Vegetated filter strip <input type="checkbox"/> Proprietary biotreatment
3 Volume biotreated in volume based biotreatment BMP (ft ³): <i>Form 4.3-6 Item 15 + Form 4.3-7 Item 13</i>	4 Compute remaining LID DCV with implementation of volume based biotreatment BMP (ft ³): <i>Item 1 – Item 3</i>	5 Remaining fraction of LID DCV for sizing flow based biotreatment BMP: % <i>Item 4 / Item 1</i>
6 Flow-based biotreatment BMP capacity provided (cfs): <i>Use Figure 5-2 of the TGD for WQMP to determine flow capacity required to provide biotreatment of remaining percentage of unmet LID DCV (Item 5), for the project’s precipitation zone (Form 3-1 Item 1)</i>		
7 Metrics for MEP determination: <ul style="list-style-type: none"> • Provided a WQMP with the portion of site area used for suite of LID BMP equal to minimum thresholds in Table 5-7 of the TGD for WQMP for the proposed category of development: <input type="checkbox"/> <i>If maximized on-site retention BMPs is feasible for partial capture, then LID BMP implementation must be optimized to retain and infiltrate the maximum portion of the DCV possible within the prescribed minimum effective area. The remaining portion of the DCV shall then be mitigated using biotreatment BMP.</i> 		

Form 4.3-6 Volume Based Biotreatment (DA 1) – Bioretention and Planter Boxes with Underdrains

Biotreatment BMP Type <i>(Bioretention w/underdrain, planter box w/underdrain, other comparable BMP)</i>	DA DMA BMP Type	DA DMA BMP Type	DA DMA BMP Type
1 Pollutants addressed with BMP <i>List all pollutant of concern that will be effectively reduced through specific Unit Operations and Processes described in Table 5-5 of the TGD for WQMP</i>			
2 Amended soil infiltration rate <i>Typical ~ 5.0</i>			
3 Amended soil infiltration safety factor <i>Typical ~ 2.0</i>			
4 Amended soil design percolation rate (in/hr) $P_{design} = \text{Item 2} / \text{Item 3}$			
5 Poned water drawdown time (hr) <i>Copy Item 6 from Form 4.2-1</i>			
6 Maximum ponding depth (ft) <i>see Table 5-6 of the TGD for WQMP for reference to BMP design details</i>			
7 Ponding Depth (ft) $d_{BMP} = \text{Minimum of } (1/12 * \text{Item 4} * \text{Item 5}) \text{ or Item 6}$			
8 Amended soil surface area (ft ²)			
9 Amended soil depth (ft) <i>see Table 5-6 of the TGD for WQMP for reference to BMP design details</i>			
10 Amended soil porosity, n			
11 Gravel depth (ft) <i>see Table 5-6 of the TGD for WQMP for reference to BMP design details</i>			
12 Gravel porosity, n			
13 Duration of storm as basin is filling (hrs) <i>Typical ~ 3hrs</i>			
14 Biotreated Volume (ft ³) $V_{biotreated} = \text{Item 8} * [(\text{Item 7}/2) + (\text{Item 9} * \text{Item 10}) + (\text{Item 11} * \text{Item 12}) + (\text{Item 13} * (\text{Item 4} / 12))]$			
15 Total biotreated volume from bioretention and/or planter box with underdrains BMP: <i>Sum of Item 14 for all volume-based BMPs included in this form</i>			

Form 4.3-7 Volume Based Biotreatment (DA 1) – Constructed Wetlands and Extended Detention

Biotreatment BMP Type <i>Constructed wetlands, extended wet detention, extended dry detention, or other comparable proprietary BMP. If BMP includes multiple modules (e.g. forebay and main basin), provide separate estimates for storage and pollutants treated in each module.</i>	DA DMA BMP Type		DA DMA BMP Type	
	Forebay	Basin	Forebay	Basin
1 Pollutants addressed with BMP forebay and basin <i>List all pollutant of concern that will be effectively reduced through specific Unit Operations and Processes described in Table 5-5 of the TGD for WQMP</i>				
2 Bottom width (ft)				
3 Bottom length (ft)				
4 Bottom area (ft ²) $A_{bottom} = \text{Item 2} * \text{Item 3}$				
5 Side slope (ft/ft)				
6 Depth of storage (ft)				
7 Water surface area (ft ²) $A_{surface} = (\text{Item 2} + (2 * \text{Item 5} * \text{Item 6})) * (\text{Item 3} + (2 * \text{Item 5} * \text{Item 6}))$				
8 Storage volume (ft ³) <i>For BMP with a forebay, ensure fraction of total storage is within ranges specified in BMP specific fact sheets, see Table 5-6 of the TGD for WQMP for reference to BMP design details</i> $V = \text{Item 6} / 3 * [\text{Item 4} + \text{Item 7} + (\text{Item 4} * \text{Item 7})^{0.5}]$				
9 Drawdown Time (hrs) <i>Copy Item 6 from Form 2.1</i>				
10 Outflow rate (cfs) $Q_{BMP} = (\text{Item 8}_{forebay} + \text{Item 8}_{basin}) / (\text{Item 9} * 3600)$				
11 Duration of design storm event (hrs)				
12 Biotreated Volume (ft ³) $V_{biotreated} = (\text{Item 8}_{forebay} + \text{Item 8}_{basin}) + (\text{Item 10} * \text{Item 11} * 3600)$				
13 Total biotreated volume from constructed wetlands, extended dry detention, or extended wet detention : <i>(Sum of Item 12 for all BMP included in plan)</i>				

Form 4.3-8 Flow Based Biotreatment (DA 1)			
Biotreatment BMP Type <i>Vegetated swale, vegetated filter strip, or other comparable proprietary BMP</i>	DA DMA BMP Type	DA DMA BMP Type	DA DMA BMP Type
1 Pollutants addressed with BMP <i>List all pollutant of concern that will be effectively reduced through specific Unit Operations and Processes described in TGD Table 5-5</i>			
2 Flow depth for water quality treatment (ft) <i>BMP specific, see Table 5-6 of the TGD for WQMP for reference to BMP design details</i>			
3 Bed slope (ft/ft) <i>BMP specific, see Table 5-6 of the TGD for WQMP for reference to BMP design details</i>			
4 Manning's roughness coefficient			
5 Bottom width (ft) <i>$b_w = (\text{Form 4.3-5 Item 6} * \text{Item 4}) / (1.49 * \text{Item 2}^{1.67} * \text{Item 3}^{0.5})$</i>			
6 Side Slope (ft/ft) <i>BMP specific, see Table 5-6 of the TGD for WQMP for reference to BMP design details</i>			
7 Cross sectional area (ft ²) <i>$A = (\text{Item 5} * \text{Item 2}) + (\text{Item 6} * \text{Item 2}^2)$</i>			
8 Water quality flow velocity (ft/sec) <i>$V = \text{Form 4.3-5 Item 6} / \text{Item 7}$</i>			
9 Hydraulic residence time (min) <i>Pollutant specific, see Table 5-6 of the TGD for WQMP for reference to BMP design details</i>			
10 Length of flow based BMP (ft) <i>$L = \text{Item 8} * \text{Item 9} * 60$</i>			
11 Water surface area at water quality flow depth (ft ²) <i>$SA_{top} = (\text{Item 5} + (2 * \text{Item 2} * \text{Item 6})) * \text{Item 10}$</i>			

4.3.5 Conformance Summary

Complete Form 4.3-9 to demonstrate how on-site LID DCV is met with proposed site design hydrologic source control, infiltration, harvest and use, and/or biotreatment BMP. The bottom line of the form is used to describe the basis for infeasibility determination for on-site LID BMP to achieve full LID DCV, and provides methods for computing remaining volume to be addressed in an alternative compliance plan. If the project has more than one outlet, then complete additional versions of this form for each outlet.

Form 4.3-9 Conformance Summary and Alternative Compliance Volume Estimate (DA 1)	
1	Total LID DCV for the Project DA-1 (ft ³): 2,008 / 847 / 1,395 / 805 [5,055 Total] <i>Copy Item 7 in Form 4.2-1</i>
2	On-site retention with site design hydrologic source control LID BMP (ft ³): 0 / 2,384 / 0 / 0 [2,384 Total] <i>Copy Item 30 in Form 4.3-2</i>
3	On-site retention with LID infiltration BMP (ft ³): 3,778 / 934 / 1,593 / 1,047 [7,352 Total] <i>Copy Item 16 in Form 4.3-3</i>
4	On-site retention with LID harvest and use BMP (ft ³): 0 <i>Copy Item 9 in Form 4.3-4</i>
5	On-site biotreatment with volume based biotreatment BMP (ft ³): 0 <i>Copy Item 3 in Form 4.3-5</i>
6	Flow capacity provided by flow based biotreatment BMP (cfs): 0 <i>Copy Item 6 in Form 4.3-5</i>
7	LID BMP performance criteria are achieved if answer to any of the following is "Yes": <ul style="list-style-type: none"> • Full retention of LID DCV with site design HSC, infiltration, or harvest and use BMP: Yes <input checked="" type="checkbox"/> No <input type="checkbox"/> <i>If yes, sum of Items 2, 3, and 4 is greater than Item 1</i> • Combination of on-site retention BMPs for a portion of the LID DCV and volume-based biotreatment BMP that address all pollutants of concern for the remaining LID DCV: Yes <input type="checkbox"/> No <input type="checkbox"/> <i>If yes, a) sum of Items 2, 3, 4, and 5 is greater than Item 1, and Items 2, 3 and 4 are maximized; or b) Item 6 is greater than Form 4.3-5 Item 6 and Items 2, 3 and 4 are maximized</i> ▪ On-site retention and infiltration is determined to be infeasible and biotreatment BMP provide biotreatment for all pollutants of concern for full LID DCV: Yes <input type="checkbox"/> No <input type="checkbox"/> <i>If yes, Form 4.3-1 Items 7 and 8 were both checked yes</i>
8	If the LID DCV is not achieved by any of these means, then the project may be allowed to develop an alternative compliance plan. Check box that describes the scenario which caused the need for alternative compliance: <ul style="list-style-type: none"> • Combination of HSC, retention and infiltration, harvest and use, and biotreatment BMPs provide less than full LID DCV capture: <input type="checkbox"/> <i>Checked yes for Form 4.3-5 Item 7, Item 6 is zero, and sum of Items 2, 3, 4, and 5 is less than Item 1. If so, apply water quality credits and calculate volume for alternative compliance, $V_{alt} = (Item\ 1 - Item\ 2 - Item\ 3 - Item\ 4 - Item\ 5) * (100 - Form\ 2.4-1\ Item\ 2)\%$</i> • An approved Watershed Action Plan (WAP) demonstrates that water quality and hydrologic impacts of urbanization are more effective when managed in at an off-site facility: <input type="checkbox"/> <i>Attach appropriate WAP section, including technical documentation, showing effectiveness comparisons for the project site and regional watershed</i>

4.3.6 Hydromodification Control BMP

Use Form 4.3-10 to compute the remaining runoff volume retention, after LID BMP are implemented, needed to address HCOC, and the increase in time of concentration and decrease in peak runoff necessary to meet targets for protection of waterbodies with a potential HCOC. Describe hydromodification control BMP that address HCOC, which may include off-site BMP and/or in-stream controls. Section 5.6 of the TGD for WQMP provides additional details on selection and evaluation of hydromodification control BMP.

Form 4.3-10 Hydromodification Control BMPs (DA 1)	
<p>1 Volume reduction needed for HCOC performance criteria (ft³): N/A (Form 4.2-2 Item 4 * 0.95) – Form 4.2-2 Item 1</p>	<p>2 On-site retention with site design hydrologic source control, infiltration, and harvest and use LID BMP (ft³): 12,055 <i>Sum of Form 4.3-9 Items 2, 3, and 4 Evaluate option to increase implementation of on-site retention in Forms 4.3-2, 4.3-3, and 4.3-4 in excess of LID DCV toward achieving HCOC volume reduction</i></p>
<p>3 Remaining volume for HCOC volume capture (ft³): N/A <i>Item 1 – Item 2</i></p>	<p>4 Volume capture provided by incorporating additional on-site or off-site retention BMPs (ft³): N/A <i>Existing downstream BMP may be used to demonstrate additional volume capture (if so, attach to this WQMP a hydrologic analysis showing how the additional volume would be retained during a 2-yr storm event for the regional watershed)</i></p>
<p>5 If Item 4 is less than Item 3, incorporate in-stream controls on downstream waterbody segment to prevent impacts due to hydromodification <input type="checkbox"/> <i>Attach in-stream control BMP selection and evaluation to this WQMP</i></p>	
<p>6 Is Form 4.2-2 Item 11 less than or equal to 5%: Yes <input type="checkbox"/> No <input type="checkbox"/> <i>If yes, HCOC performance criteria is achieved. If no, select one or more mitigation options below:</i></p> <ul style="list-style-type: none"> • Demonstrate increase in time of concentration achieved by proposed LID site design, LID BMP, and additional on-site or off-site retention BMP <input type="checkbox"/> <i>BMP upstream of a waterbody segment with a potential HCOC may be used to demonstrate increased time of concentration through hydrograph attenuation (if so, show that the hydraulic residence time provided in BMP for a 2-year storm event is equal or greater than the addition time of concentration requirement in Form 4.2-4 Item 15)</i> • Increase time of concentration by preserving pre-developed flow path and/or increase travel time by reducing slope and increasing cross-sectional area and roughness for proposed on-site conveyance facilities <input type="checkbox"/> • Incorporate appropriate in-stream controls for downstream waterbody segment to prevent impacts due to hydromodification, in a plan approved and signed by a licensed engineer in the State of California <input type="checkbox"/> 	
<p>7 Form 4.2-2 Item 12 less than or equal to 5%: Yes <input type="checkbox"/> No <input type="checkbox"/> <i>If yes, HCOC performance criteria is achieved. If no, select one or more mitigation options below:</i></p> <ul style="list-style-type: none"> • Demonstrate reduction in peak runoff achieved by proposed LID site design, LID BMPs, and additional on-site or off-site retention BMPs <input type="checkbox"/> <i>BMPs upstream of a waterbody segment with a potential HCOC may be used to demonstrate additional peak runoff reduction through hydrograph attenuation (if so, attach to this WQMP, a hydrograph analysis showing how the peak runoff would be reduced during a 2-yr storm event)</i> • Incorporate appropriate in-stream controls for downstream waterbody segment to prevent impacts due to hydromodification, in a plan approved and signed by a licensed engineer in the State of California <input type="checkbox"/> 	

4.4 Alternative Compliance Plan (if applicable)

Describe an alternative compliance plan (if applicable) for projects not fully able to infiltrate, harvest and use, or biotreat the DCV via on-site LID practices. A project proponent must develop an alternative compliance plan to address the remainder of the LID DCV. Depending on project type some projects may qualify for water quality credits that can be applied to reduce the DCV that must be treated prior to development of an alternative compliance plan (see Form 2.4-1, Water Quality Credits). Form 4.3-9 Item 8 includes instructions on how to apply water quality credits when computing the DCV that must be met through alternative compliance. Alternative compliance plans may include one or more of the following elements:

- On-site structural treatment control BMP - All treatment control BMP should be located as close to possible to the pollutant sources and should not be located within receiving waters;
- Off-site structural treatment control BMP - Pollutant removal should occur prior to discharge of runoff to receiving waters;
- Urban runoff fund or In-lieu program, if available

Depending upon the proposed alternative compliance plan, approval by the executive officer may or may not be required (see Section 6 of the TGD for WQMP).

Section 5 Inspection and Maintenance Responsibility for Post Construction BMP

All BMP included as part of the project WQMP are required to be maintained through regular scheduled inspection and maintenance (refer to Section 8, Post Construction BMP Requirements, in the TGD for WQMP). Fully complete Form 5-1 summarizing all BMP included in the WQMP. Attach additional forms as needed. The WQMP shall also include a detailed Operation and Maintenance Plan for all BMP and may require a Maintenance Agreement (consult the jurisdiction's LIP). If a Maintenance Agreement is required, it must also be attached to the WQMP.

Form 5-1 BMP Inspection and Maintenance (use additional forms as necessary)			
BMP	Responsible Party(s)	Inspection/ Maintenance Activities Required	Minimum Frequency of Activities
Source Control BMPs	Property Owner	See O&M Plan In Attachment 7 (to be completed with Final Engineering)	See O&M Plan In Attachment 7 (to be completed with Final Engineering)
DA1 -BMP1	Property Owner	See O&M Plan In Attachment 7 (to be completed with Final Engineering)	See O&M Plan In Attachment 7 (to be completed with Final Engineering)
DA1 -BMP2	Property Owner	See O&M Plan In Attachment 7 (to be completed with Final Engineering)	See O&M Plan In Attachment 7 (to be completed with Final Engineering)
DA1 -BMP3	Property Owner	See O&M Plan In Attachment 7 (to be completed with Final Engineering)	See O&M Plan In Attachment 7 (to be completed with Final Engineering)
DA1 -BMP4	Property Owner	See O&M Plan In Attachment 7 (to be completed with Final Engineering)	See O&M Plan In Attachment 7 (to be completed with Final Engineering)

Section 6 WQMP Attachments

6.1. Site Plan and Drainage Plan

Include a site plan and drainage plan sheet set containing the following minimum information:

- Project location
- Site boundary
- Land uses and land covers, as applicable
- Suitability/feasibility constraints
- Structural Source Control BMP locations
- Site Design Hydrologic Source Control BMP locations
- LID BMP details
- Drainage delineations and flow information
- Drainage connections

6.2 Electronic Data Submittal

Minimum requirements include submittal of PDF exhibits in addition to hard copies. Format must not require specialized software to open. If the local jurisdiction requires specialized electronic document formats (as described in their local Local Implementation Plan), this section will describe the contents (e.g., layering, nomenclature, geo-referencing, etc.) of these documents so that they may be interpreted efficiently and accurately.

6.3 Post Construction

Attach all O&M Plans and Maintenance Agreements for BMP to the WQMP.

6.4 Other Supporting Documentation

- BMP Educational Materials
- Activity Restriction – C, C&R's & Lease Agreements

Attachment 1: WQMP Exhibits

Please refer to the attached exhibits.

CITY OF HIGHLAND

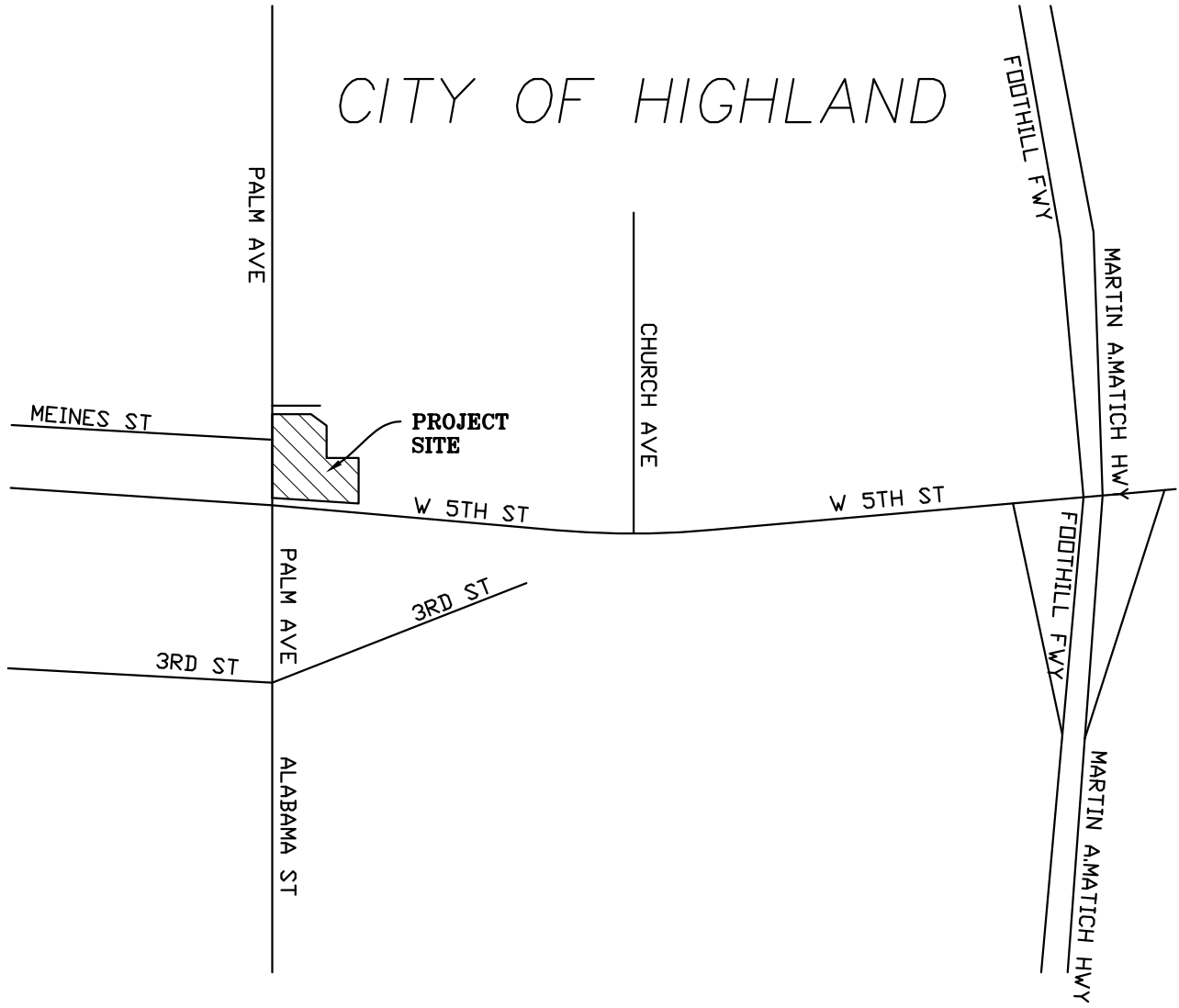

VICINITY MAP

N.T.S.

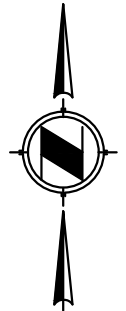

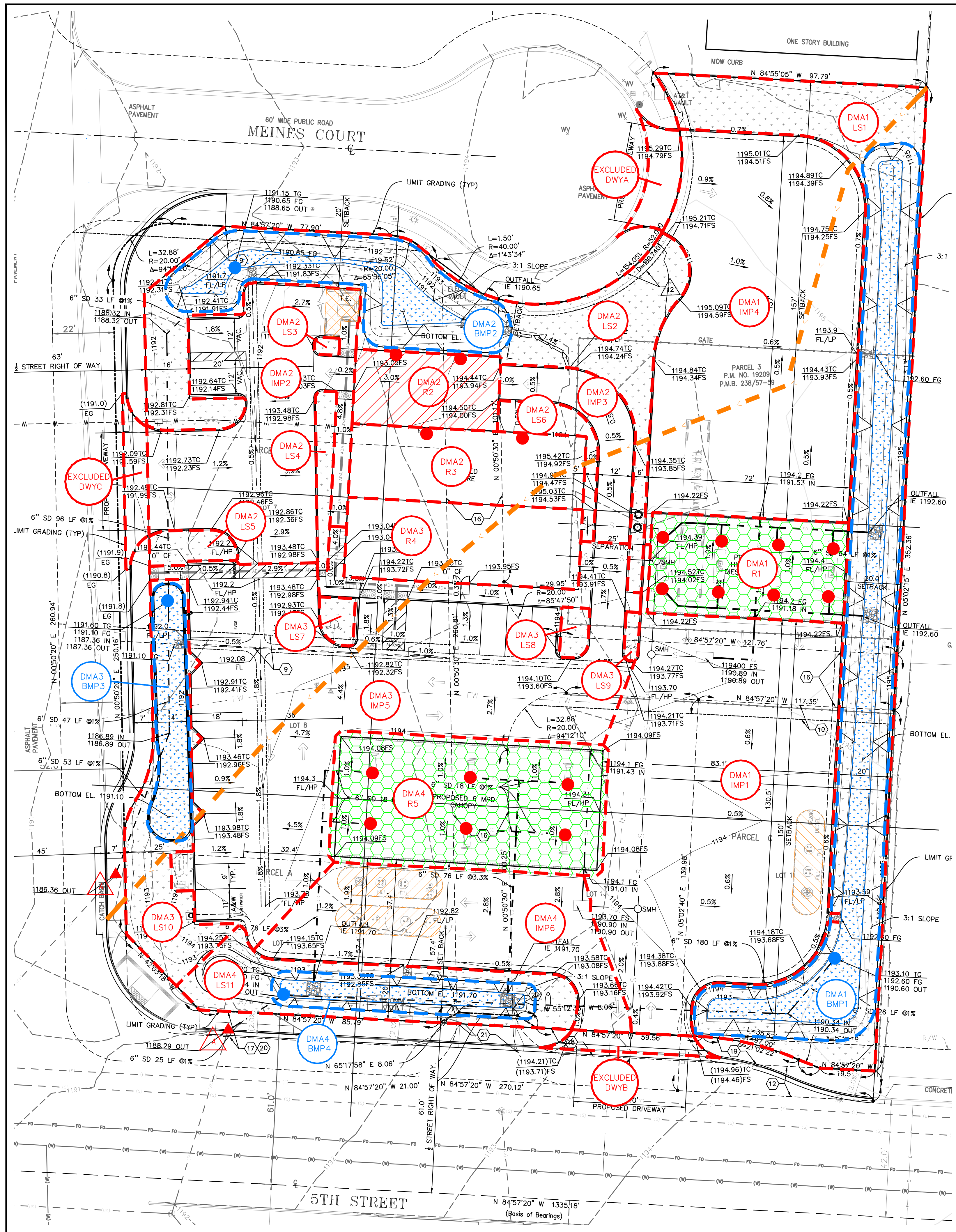

DA1 AREA SUMMARY					
SUBAREA ID	COVER TYPE	SUB-AREA (SQ-FT)	DCV (CU-FT)	SITE DESIGN VOLUME (CU-FT)	INFILTRATION VOLUME (CU-FT)
DA1-DMA1-R1 DA1-DMA1-IMP1 DA1-DMA1-IMP4 DA1-DMA1-LS1 DA1-DMA1-BMP1	ROOF IMPERVIOUS PAVING IMPERVIOUS PAVING LANDSCAPE INFILTRATION AREA	2,538 10,890 9,469 3,022 6,68	2,008	0	3,778
DA1-DMA2-R2 DA1-DMA2-R3 DA1-DMA2-IMP2 DA1-DMA2-IMP3 DA1-DMA2-LS2 DA1-DMA2-LS3 DA1-DMA2-LS4 DA1-DMA2-LS5 DA1-DMA2-LS6 DA1-DMA2-BMP2	ROOF ROOF IMPERVIOUS PAVING IMPERVIOUS PAVING LANDSCAPE LANDSCAPE LANDSCAPE LANDSCAPE LANDSCAPE INFILTRATION AREA	1,388 2,211 5,270 1,205 3,668 53 362 343 512 2,814	847	2,384	934
DA1-DMA3-R4 DA1-DMA3-IMP5 DA1-DMA3-LS7 DA1-DMA3-LS8 DA1-DMA3-LS9 DA1-DMA3-LS10 DA1-DMA3-BMP3	ROOF IMPERVIOUS PAVING LANDSCAPE LANDSCAPE LANDSCAPE LANDSCAPE INFILTRATION AREA	2,406 12,298 192 173 85 1,496 1,106	1,395	0	1,593
DA1-DMA4-R4 DA1-DMA4-IMP6 DA1-DMA4-LS11 DA1-DMA4-BMP3	ROOF IMPERVIOUS PAVING LANDSCAPE INFILTRATION AREA	4,598 4,297 1,230 1,565	805	0	805
EXCLUDED AREAS	DWYA DWYB DWYC	456 354 415	N/A	N/A	N/A
TOTAL PROJECT AREA		80,983	5,055	2,384	7,352

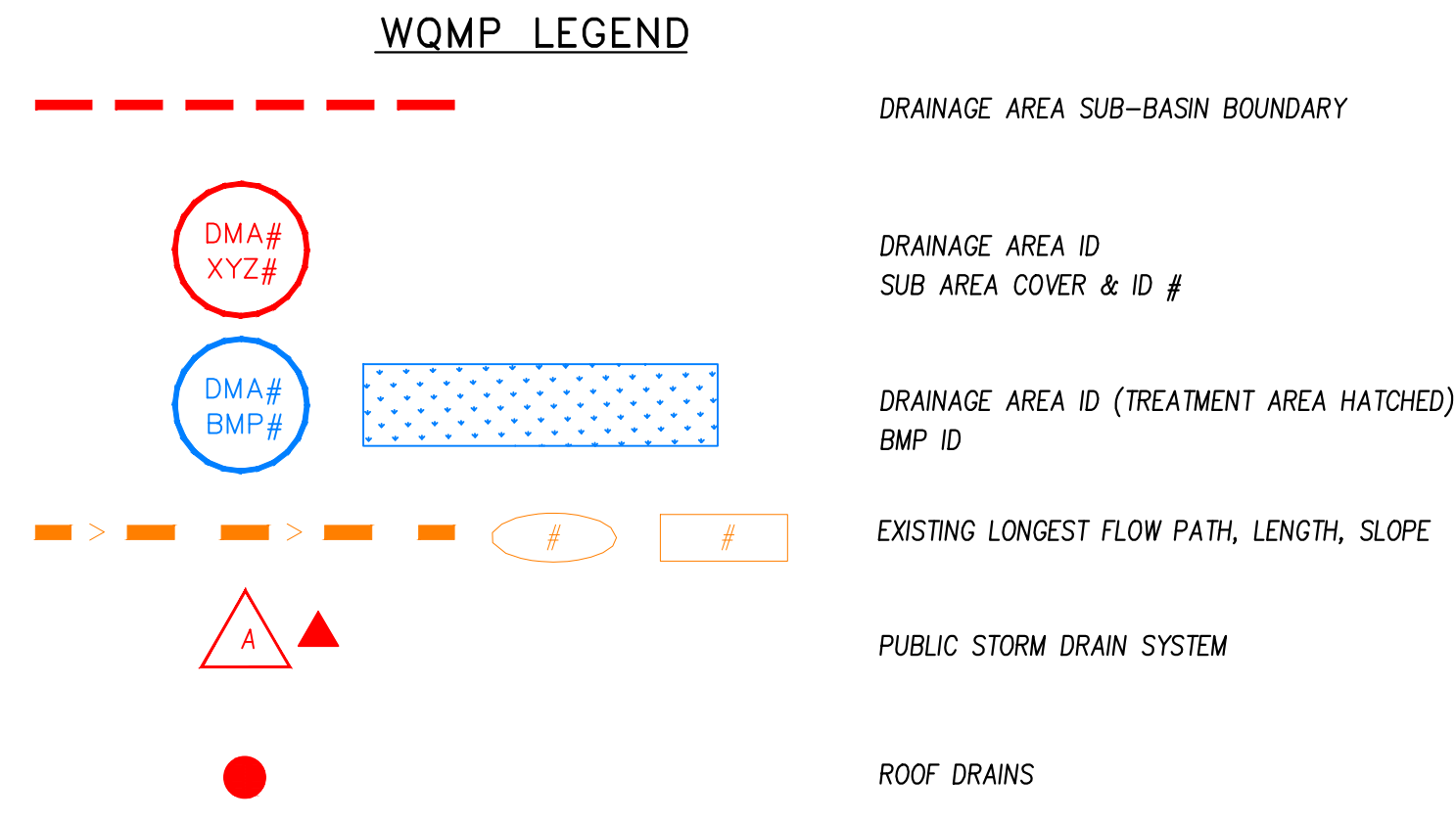

FORM 4.1-1 NON-STRUCTURAL SOURCE CONTROL BMP LEGEND

- N1 EDUCATIONAL MATERIALS NO SYMBOL
- N3 LANDSCAPE MANAGEMENT BMPS
- N4 BMP MAINTENANCE NO SYMBOL
- N5 TITLE 22 CCR NO SYMBOL
- N6 LOCAL WATER QUALITY ORDINANCE
- N7 SPILL CONTINGENCY PLAN NO SYMBOL
- N8 UNDERGROUND STORAGE TANK COMPLIANCE
- N9 HAZARDOUS MATERIAL DISCLOSURE COMPLIANCE NO SYMBOL
- N10 UNIFORM FIRE CODE IMPLEMENTATION NO SYMBOL
- N11 LITTER/DEBRIS CONTROL PROGRAM
- N12 EMPLOYEE TRAINING NO SYMBOL
- N14 CATCH BASIN INSPECTION PROGRAM

FORM 4.1-2 STRUCTURAL SOURCE CONTROL BMP LEGEND

- S1 STORM DRAIN STENCILING
- S3 TRASH ENCLOSURE
- S4 USE EFFICIENT IRRIGATION
- S5 FINISHED GRADE HEIGHT NO SYMBOL
- S9 VEHICLE WASH AREAS
- S12 FUELING AREAS
- S14 FOOD WASHING NO SYMBOL

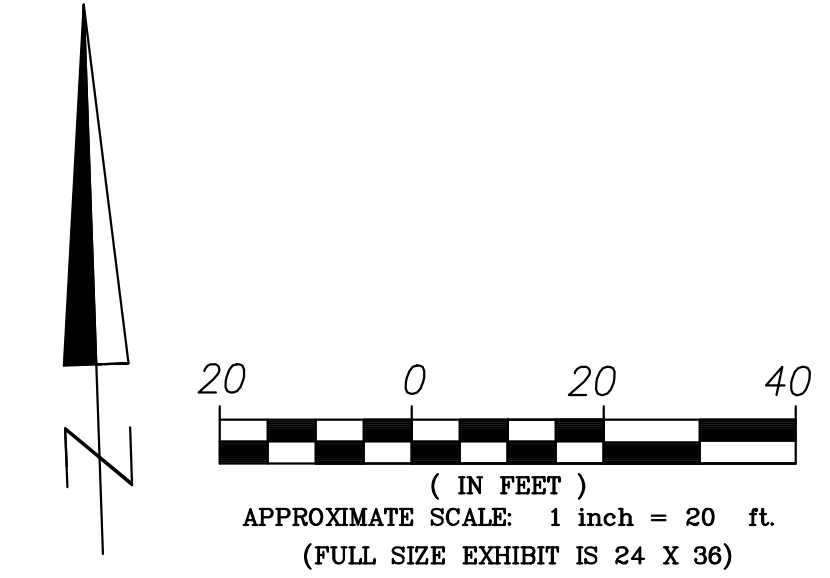
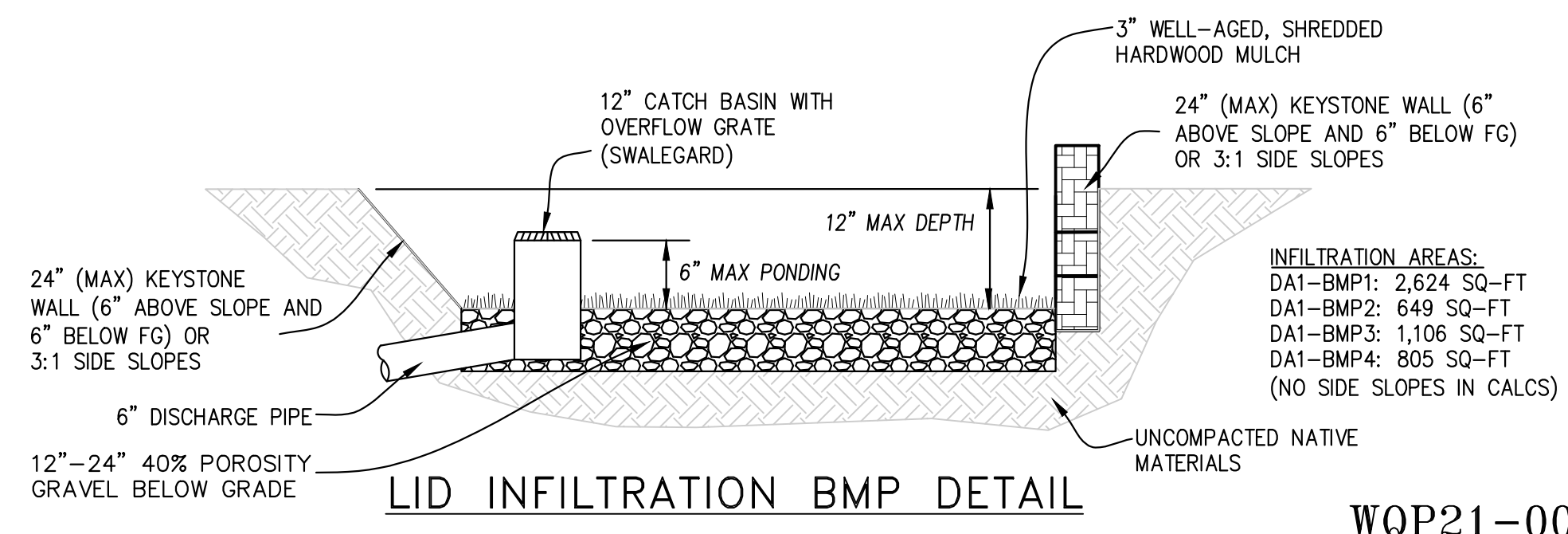

VENTURA ENGINEERING, LLC
27393 YNEZ ROAD, SUITE 159 TEMECULA, CALIFORNIA 92591
PHONE (951) 252-7632
FAX (951) 346-5726

CITY OF HIGHLAND
NEW COMMERCIAL / RETAIL
NEC PALM AVENUE & N. 5TH STREET
HIGHLAND, CALIFORNIA 92637
APNS: 1201-311-02, 03, 05, 14, 15 & 19
WQMP EXHIBIT

WQP21-004

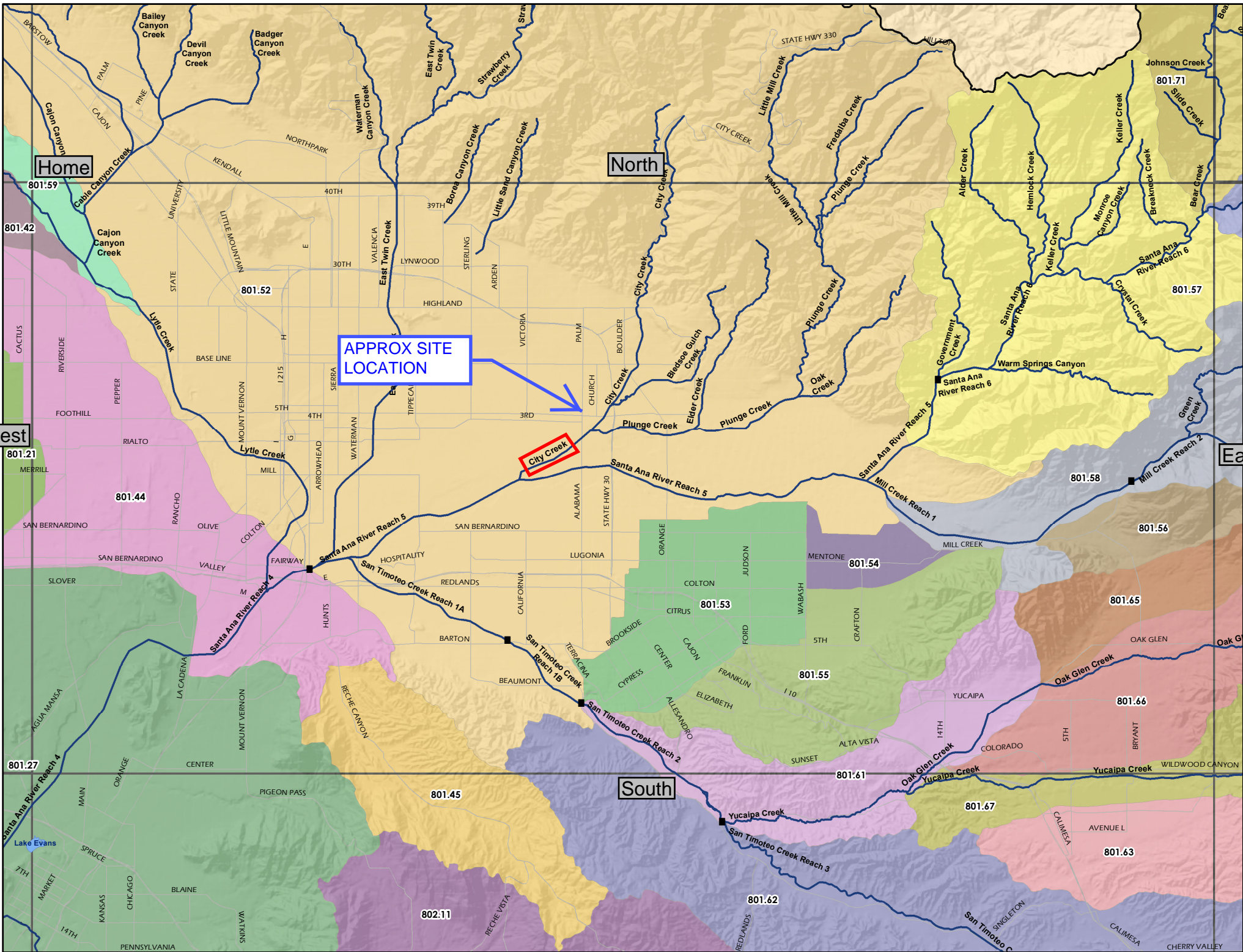

Home

North

APPROX SITE
LOCATION

City Creek

East

South

West

Attachment 2: Reference Plans

Please refer to the attached references.

CONCEPTUAL GRADING PLAN FOR PROPOSED GAS STATION AND C-STORE NEC PALM AVENUE & W. 5TH STREET CITY OF HIGHLAND, CALIFORNIA 92346

APN: 1201-311-02, 03, 05 AND 1201-301-14, 15, 19

SITE ADDRESS:

NEC PALM AVENUE & W.5TH STREET
HIGHLAND, CALIFORNIA 92346

SHEET INDEX:

- TITLE SHEET
- CONCEPTUAL GRADING PLAN
- SECTIONS
- DETAILS

OWNER:

JEAN EDY MATLOCK
TRUSTEE OF EADY TRUST, C/O
PAUKA HUMBERT
3380 PUNTA ALTA, #A,
LAGUNA WOODS, CALIFORNIA 92637

LOT SIZE:

1.89 ACRES.

EARTHWORK QUANTITIES:

RAW CUT - 1,093 C.Y.
RAW FILL - 854 C.Y.
NET - 239 C.Y.

QUANTITIES ARE FOR ESTIMATING PURPOSES ONLY.
CONTRACTOR TO VERIFY QUANTITIES PRIOR TO CONSTRUCTION.

AREA OF DISTURBANCE:

AREA OF DISTURBANCE = 80,195 S.F. (1.84 ACRES)

24-HOUR EMERGENCY CONTACT: OWNER

TOPOGRAPHIC SOURCE:

ALTA AND LAND TITLE SURVEY PERFORMED BY RAY R. ZEOLLARI
LS 8346, EXPIRATION DATE 12/31/21

FIELD SURVEY DATED 9/8/21

TOTAL IMPERVIOUS AREA:

TOTAL PROPOSED IMPERVIOUS AREA = 57,673 SF.

UTILITY NOTE:

UNI: THE LOCATION OF UTILITIES SHOWN HEREON ARE FROM OBSERVED EVIDENCE OF ABOVE GROUND APPURTENANCES ONLY. THE SURVEYOR WAS NOT PROVIDED WITH UNDERGROUND PLANS OR SURFACE GROUND MARKINGS TO DETERMINE THE LOCATION OF ANY SUBTERRANEAN USES.
UN2: FROM OBSERVED ABOVE GROUND APPURTENANCES ONLY AS SHOWN HEREON, GAS, ELECTRIC, STORM SEWER, SANITARY SEWER, TELEPHONE AND WATER LINES AND/OR SERVICE IS AVAILABLE FOR THE SUBJECT PROPERTY WITHIN THE PUBLIC RIGHT OF WAY OF MEINES COURT, PALM AVENUE AND 5TH STREET.

BASIS OF BEARINGS:

BASIS OF BEARINGS FOR THIS SURVEY WAS THE CENTER LINE OF 5TH STREET AS SHOWN ON PARCEL MAP NO. 19209 FILED IN BOOK 238 PAGE 57-59 OF PARCEL MAPS, RIVERSIDE COUNTY, CALIFORNIA SAID BEARING BEING NORTH 84°57'20" WEST.

FLOOD NOTE:

BY GRAPHIC PLOTTING ONLY. THIS PROPERTY IS IN ZONE AE OF THE FLOOD INSURANCE RATE MAP, MAP NO. 06071C8702H WHICH BEARS AN EFFECTIVE DATE OF 08/28/2008 AND IS NOT IN A SPECIAL FLOOD HAZARD AREA AS SHOWN ON FEMA WEBSITE (FEMA.GOV) BY FIRMETTE CREATED ON 09/06/2021. WE HAVE LEARNED THIS COMMUNITY DOES CURRENTLY PARTICIPATE IN THE PROGRAM. NO FIELD SURVEYING WAS PERFORMED TO DETERMINE THIS ZONE.

SOURCE BENCHMARK:

SOURCE BENCHMARK: COUNTY OF SAN BERNARDINO FB 4018 PAGE 1778-1793 TOP OF 1" IP 0.2 DOWN AT THE INTERSECTION OF PALM AND 5TH STREET EL=1190.57 (NAVD29)

NOTES:

- THE ENGINEER WHO PREPARED THE GRADING PLAN HAS VERIFIED THE CONSISTENCY BETWEEN ON-SITE GRADING INFORMATION AND THE WORK THE WITHIN R/W APPROVED BY THE TRANSPORTATION DEPARTMENT.
- THE ENGINEER OF RECORD HAS EVALUATED THE DRAINAGE AND HAS DETERMINED THAT THE PROJECT PERPETUATES NATURAL DRAINAGE PATTERNS, AND WILL NOT ADVERSELY AFFECT ADJACENT PROPERTIES.
- EXCEPT FOR THE RETAINING WALLS IN CONJUNCTION WITH THIS GRADING, ALL INFORMATION ASSOCIATED WITH BUILDINGS (INCLUDING SETBACKS AND FINISH FLOOR ELEVATIONS) IS FOR REFERENCE ONLY AND THE APPROVAL OF THIS GRADING PLAN DOES NOT INCLUDE ANY PROVISIONS ASSOCIATED WITH BUILDINGS.
- CUT AREA UNDER BUILDING SHOULD BE OVER-EXCAVATED (2 FEET BELOW FOOTING AND 5 FEET BEYOND THE BUILDING LINE OR AS RECOMMENDED BY THE SOILS ENGINEER) AND RECOMPACTED WHEN A BUILDING CROSSES CUT-FILL TRANSITION.

RECORD DESCRIPTION:

THE LAND REFERRED TO HEREIN BELOW IS SITUATED IN THE CITY OF HIGHLAND, COUNTY OF SAN BERNARDINO, STATE OF CALIFORNIA, AND IS DESCRIBED AS FOLLOWS:

PARCEL 3, AS SHOWN ON THAT CERTAIN PARCEL MAP NO. 19209, FILED IN THE OFFICE OF THE RECORDER OF THE COUNTY OF SAN BERNARDINO, STATE OF CALIFORNIA RECORDED ON MAY 09, 2011 IN BOOK 238 OF PARCEL MAPS, AT PAGES 57, 58 AND 59.

PARCEL A: LOTS 8 AND 9, TRACT NO. 3202, IN THE COUNTY OF SAN BERNARDINO, STATE OF CALIFORNIA, AS PER MAP RECORDED IN BOOK 43, PAGES 38 AND 39, OF MAPS, IN THE OFFICE OF THE COUNTY RECORDER OF SAID COUNTY.

TOGETHER WITH THAT PORTION OF AN ALLEY AS VACATED AND DESCRIBED BY RESOLUTION OF THE CITY COUNCIL OF THE CITY OF HIGHLAND, CALIFORNIA, ORDERING THE SUMMERY VACATION OF PUBLIC RIGHT-OF-WAY (CITY ALLEY) THAT WOULD PASS BY OPERATION OF LAW, ADOPTED JULY 27, 2010, A CERTIFIED COPY OF SAID RESOLUTION RECORDED JULY 29, 2010 AS INSTRUMENT NO. 2010-0304441 OF OFFICIAL RECORDS OF THE COUNTY OF SAN BERNARDINO.

ALSO TOGETHER WITH THAT PORTION OF AN ALLEY AS VACATED AND DESCRIBED BY RESOLUTION OF THE CITY COUNCIL OF THE CITY OF HIGHLAND, CALIFORNIA, ORDERING THE SUMMERY VACATION OF PUBLIC RIGHT-OF-WAY (CITY ALLEY) THAT WOULD PASS BY OPERATION OF LAW, ADOPTED DECEMBER 12, 2017, A CERTIFIED COPY OF SAID RESOLUTION RECORDED DECEMBER 21, 2017 AS INSTRUMENT NO. 2017-0542568 OF OFFICIAL RECORDS OF THE COUNTY OF SAN BERNARDINO.

EXCEPTING THEREFROM THOSE PORTIONS OF LOTS 8 AND 9, ROYAL PALMS TRACT NO. 3202, UNIT NO. 1, AS PER MAP RECORDED IN BOOK 43, OF MAPS, PAGES 38 AND 39, RECORDS OF SAID COUNTY, DESCRIBED AS FOLLOWS:

PARCEL NO. 1 (PALM AVENUE)
THE WEST 22.00 FEET OF SAID LOTS 8 AND 9.

PARCEL NO. 2 (FIFTH STREET)
THE SOUTHERLY 10.75 FEET OF SAID LOT 9, MEASURED AT RIGHT ANGLES TO THE CENTERLINE OF EAST FIFTH STREET AS SHOWN ON SAID MAP OF TRACT NO. 3202.

PARCEL NO. 3
A TRIANGULAR-SHAPED PARCEL OF LAND, BOUNDED AS FOLLOWS:
ON THE SOUTH BY THE NORTH LINE OF SAID PARCEL NO. 2; ON THE WEST BY THE EAST LINE OF SAID PARCEL NO. 1; AND ON THE NORTHEAST BY THE ARC OF A CURVE CONCAVE TO THE NORTHEAST AND HAVING A RADIUS OF 20.00 FEET, SAID CURVE BEING TANGENT TO THE NORTH LINE OF SAID PARCEL NO. 2 AND TANGENT TO THE EAST LINE OF SAID PARCEL NO. 1.

PARCEL NO. 4
A TRIANGULAR-SHAPED PARCEL OF LAND BOUNDED AS FOLLOWS:
ON THE SOUTH BY THE NORTH LINE OF SAID PARCEL NO. 2; ON THE EAST BY THE EAST LINE OF SAID LOT 9; AND ON THE NORTHWEST BY THE ARC OF A CURVE CONCAVE TO THE NORTHWEST AND HAVING A RADIUS OF 20.00 FEET, SAID CURVE BEING TANGENT TO THE NORTH LINE OF SAID PARCEL NO. 2, AND TANGENT TO THE EAST LINE OF SAID LOT 9.

PARCEL B:
LOTS 6 AND 7, TRACT NO. 3202, ROYAL PALMS TRACT NO. 1, AS PER MAP RECORDED IN BOOK 43, PAGES 38 AND 39.
TOGETHER WITH THAT PORTION OF AN ALLEY AS VACATED AND DESCRIBED BY RESOLUTION OF THE CITY COUNCIL OF THE CITY OF HIGHLAND, CALIFORNIA, ORDERING THE SUMMERY VACATION OF PUBLIC RIGHT-OF-WAY (CITY ALLEY) THAT WOULD PASS BY OPERATION OF LAW, ADOPTED JULY 27, 2010, A CERTIFIED COPY OF SAID RESOLUTION RECORDED JULY 29, 2010 AS INSTRUMENT NO. 2010-0304441 OF OFFICIAL RECORDS OF THE COUNTY OF SAN BERNARDINO.

EXCEPT FOR THOSE PORTIONS GRANTED TO THE COUNTY OF SAN BERNARDINO IN DEED RECORDED FEBRUARY 7, 1980 AS INSTRUMENT NO. 80-32744, OFFICIAL RECORDS.

PARCEL C:
LOTS 10 AND 11, ROYAL PALMS TRACT, UNIT NO. 1, TRACT NO. 3202, AS PER MAP ON FILE IN BOOK 43 OF MAPS, PAGES 38 AND 39, SAN BERNARDINO COUNTY RECORDS.

TOGETHER WITH THAT PORTION OF AN ALLEY AS VACATED AND DESCRIBED BY RESOLUTION OF THE CITY COUNCIL OF THE CITY OF HIGHLAND, CALIFORNIA, ORDERING THE SUMMERY VACATION OF PUBLIC RIGHT-OF-WAY (CITY ALLEY) THAT WOULD PASS BY OPERATION OF LAW, ADOPTED JULY 27, 2010, A CERTIFIED COPY OF SAID RESOLUTION RECORDED JULY 29, 2010 AS INSTRUMENT NO. 2010-0304441 OF OFFICIAL RECORDS OF THE COUNTY OF SAN BERNARDINO.

ALSO TOGETHER WITH THAT PORTION OF AN ALLEY AS VACATED AND DESCRIBED BY RESOLUTION OF THE CITY COUNCIL OF THE CITY OF HIGHLAND, CALIFORNIA, ORDERING THE SUMMERY VACATION OF PUBLIC RIGHT-OF-WAY (CITY ALLEY) THAT WOULD PASS BY OPERATION OF LAW, ADOPTED DECEMBER 12, 2017, A CERTIFIED COPY OF SAID RESOLUTION RECORDED DECEMBER 21, 2017 AS INSTRUMENT NO. 2017-0542567 OF OFFICIAL RECORDS OF THE COUNTY OF SAN BERNARDINO.

FOR CONVEYANCING PURPOSES ONLY:

- APN 1201-301-19-0-000
- APN 1201-311-02-0-000 (AFFECTS LOT 8 AND PORTION OF ALLEY OF PARCEL A)
- 1201-311-03-0-000 (AFFECTS LOT 9 AND PORTION OF ALLEY OF PARCEL A)
- 1201-311-04-0-000 (AFFECTS LOT 10 AND PORTION OF ALLEY OF PARCEL C)
- 1201-311-05-0-000 (AFFECTS LOT 11 AND PORTION OF ALLEY OF PARCEL C)
- 1201-301-14-0-000 (AFFECTS LOT 6 AND PORTION OF ALLEY OF PARCEL B)
- 1201-301-15-0-000 (AFFECTS LOT 7 AND PORTION OF ALLEY OF PARCEL B)

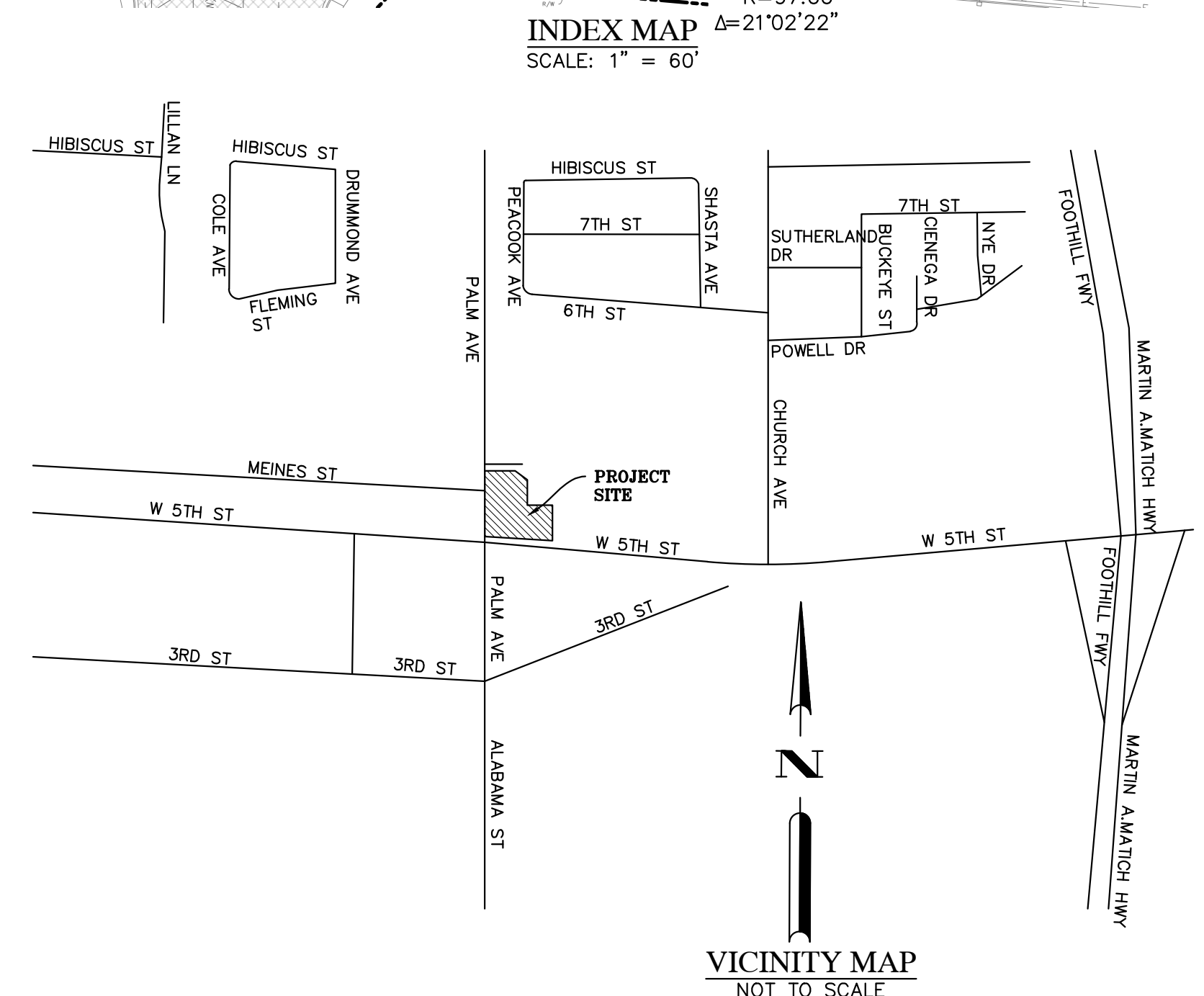
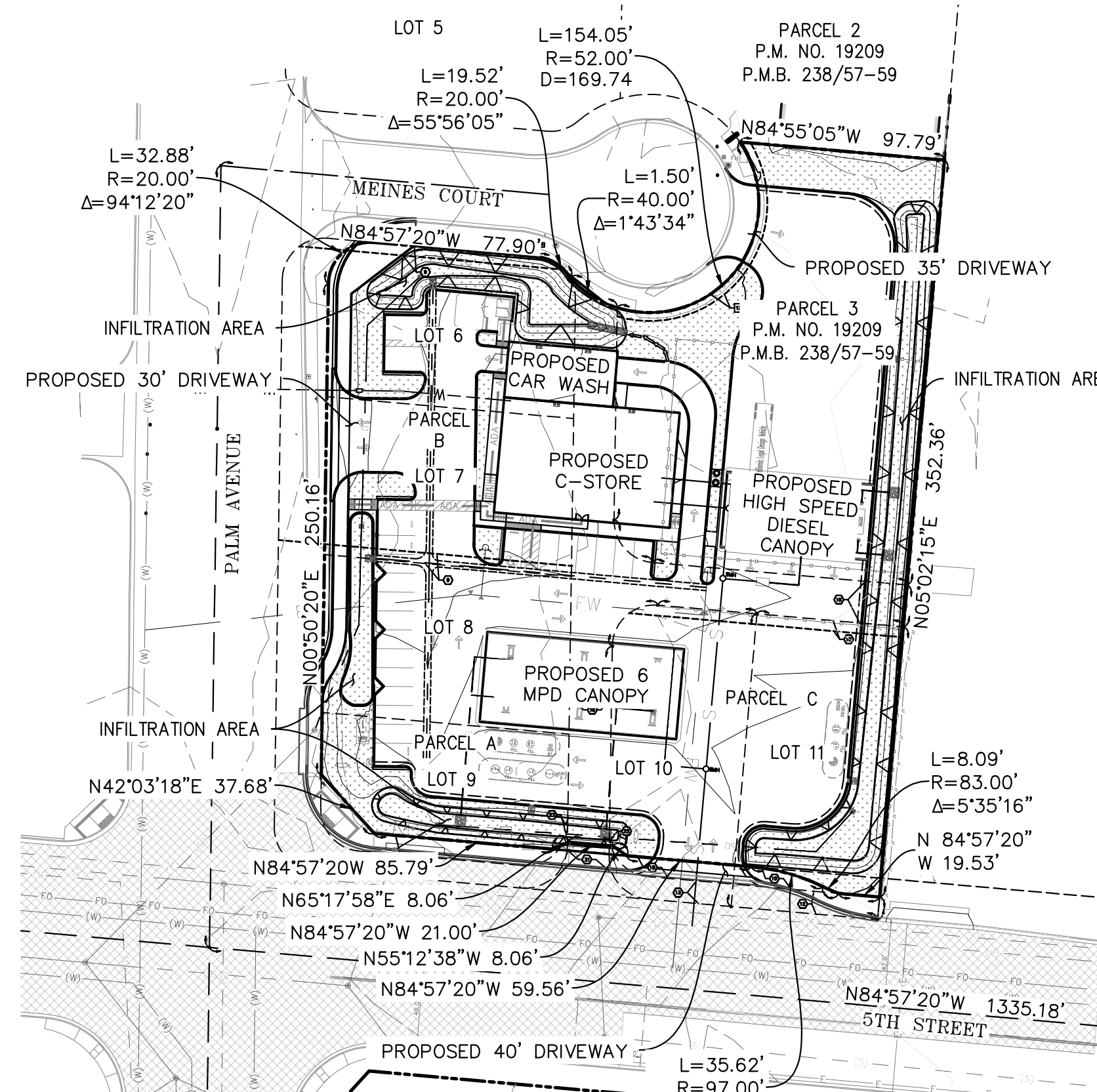

LEGEND:

---	PROPERTY LINE	
---	LIMIT OF DISTURBANCE	
---	PROPOSED ELEVATION	
---	EXISTING ELEVATION	
---	EXISTING MAIN SEWER	
---	EXISTING MAIN WATER	
---	PROPOSED 8" SEWER	299 LF.
---	PROPOSED 2" PVC WATER LATERAL	165 LF.
---	PROPOSED 6" PVC FIRE WATER LATERAL	481 LF.
---	PROPOSED 6" STORM DRAIN	1017 LF.
---	ADA PATH OF TRAVEL	
---	PROPOSED LANDSCAPING	2,498 SF.
---	PROPOSED 6" CURB PER CITY OF HIGHLAND STD. NO.201	1,080 LF.
---	PROPOSED 6" CURB & GUTTER PER CITY OF HIGHLAND STD. NO.202	566 LF.
---	PROPOSED 3" RIBBON GUTTER	375 LF.
---	PROPOSED 3" VEGETATED SWALE	26 LF.
---	RIPRAP (SIZES PER PLAN)	11 EA.
---	9"X9" CATCH BASIN	4 EA.
---	GREASE INTERCEPTOR	2 EA.
---	SEWER MANHOLE	3 EA.
---	EXISTING MANHOLE	3 EA.
---	PROPOSED FIRE HYDRANT	2 EA.
---	PROPOSED 8" TRENCH DRAIN WITH GRATE	328 LF.
---	PROPOSED 8" SHALLOW SIDE OUTLET	4 EA.
---	PROPOSED ROOF DOWNSPOUT	18 EA.

ABBREVIATIONS:

C/F	CUT/FILL LIMIT	IE	INVERT ELEVATION
DWY	DRIVEWAY	PAD EL.	PAD ELEVATION
FF EL.	FINISHED FLOOR ELEVATION	TG	TOP OF GRADE
FL	FLOW LINE	TYP	TYPICAL
FG	FINISHED GRADE	BOT	BOTTOM
FS	FINISHED SURFACE		
HP	HIGH POINT		

QUANTITIES:

REVIEWED BY:	DATE:	PLANS PREPARED BY: Ventura Engineering Inland, INC 27393 Ynez Road, Suite 159 Temecula, CA 92591 Phone: (951)252-7632 wilfredo@venturaengineeringinland.com 	PLANS PREPARED UNDER THE SUPERVISION OF:	REVISIONS:	CITY OF HIGHLAND		CONCEPTUAL GRADING PLAN	
APPROVED BY:	DATE:		APPROVED BY: _____ APPROVED BY: _____	DATE: _____ DATE: _____	MARK: _____ DESCRIPTION: _____ APPR.: _____ DATE: _____	PLANNING: _____ BUILDING AND SAFETY: _____	APN: 1201-311-02, 3&5 AND 1201-301-14, 15&19 PROPOSED GAS STATION AND C-STORE NEC PALM AVENUE & W.5TH STREET HIGHLAND, CALIFORNIA 92346 TITLE SHEET	DRAWER NO.: _____ SHEET 1 OF 4

PRELIMINARY CONSTRUCTION NOTES:

- 1 PROPOSED INFILTRATION AREA DETAIL 1 SEE SHEET 4.
- 2 PROPOSED SWALEGRAD 9"x9" GRATE INLET CATCH BASIN PER DETAIL 2 SEE SHEET 4.
- 3 PROPOSED 8" PVC CLEAN OUT.
- 4 PROPOSED 6" PVC (SDR 35) STORMDRAIN PIPE.
- 5 PROPOSED 6" CURB & GUTTER PER CITY OF HIGHLAND STD. NO. 202.
- 6 PROPOSED 6" CURB PER CITY OF HIGHLAND STD. NO. 201.
- 7 PROPOSED 3" RIBBON GUTTER PER DETAIL 3 SEE SHEET 4.
- 8 PROPOSED 3" CUT CURB AND APRON PER DETAIL 2 SEE SHEET 4.
- 9 PROPOSED CONCRETE DRIVEWAY PER CITY OF HIGHLAND STANDARD NO. 213.
- 10 PROPOSED TRASH ENCLOSURE PER CITY OF HIGHLAND STANDARD.
- 11 PROPOSED TRUNCATED DOMES PER ADA STANDARD.
- 12 PROPOSED 4" PCC SIDEWALK PER CITY HIGHLAND STD. NO. 208 TYPE B.
- 13 PROPOSED LANDSCAPE.
- 14 FUTURE IMPROVEMENTS IN THE RIGHT-OF-WAY WILL BE PERFORMED BY THE CITY IN SPRING 2022 PER SIP-12A. CURB LINE SHALL BE MOVED BY THAT PLAN PER CITY TO THE LOCATION SHOWN ON THIS PLAN AS PROVIDED BY SIP-12A.
- 15 PROPOSED ADA PATH OF TRAVEL.
- 16 CATCH BASIN TO BE INSTALLED IF CONSTRUCTION STARTS BEFORE THE CIP PROJECT.
- 17 PCC DRIVEWAY APPROACH TO BE INSTALLED IF CONSTRUCTION STARTS BEFORE THE CIP PROJECT.
- 18 PCC SIDEWALK TO BE INSTALLED IF CONSTRUCTION STARTS BEFORE THE CIP PROJECT.
- 19 PROPOSED RAMP RUN.
- 20 PROPOSED LANDING.
- 21 PROPOSED ROOF DOWNSPOUT PER ARCHITECTURAL PLANS.
- 22 PROPOSED 8" TRENCH DRAIN WITH GRATE PER DETAIL 5 AND 6 SEE SHEET 4.
- 23 PROPOSED OIL WATER SEPARATOR PER DETAIL 8 SEE SHEET 4.
- 24 PROPOSED 6" SEWER LATERAL FROM THE SEPARATOR TO THE 8" SEWER LATERAL.
- 25 PROPOSED 8" SHALLOW SIDE OUTLET PER DETAIL 7 SEE SHEET 4.
- 26 PROPOSED RIPRAP WITH NO. 2 BACKING ROCK PER DETAIL 4 SEE SHEET 4.
- 27 PROPOSED LOCATION OF EV CHARGING STATION WITH 2 CHARGING PORTS.
- 28 PROPOSED 3" VEGETATED SWALE PER DETAIL 9 SEE SHEET 4.
- 29 PROPOSED 18" BMP WALL PER DETAIL 1 SEE SHEET 4.

PRELIMINARY UTILITY NOTES:

- 15 EXISTING WATER MAIN.
- 16 EXISTING SEWER MAIN.
- 17 PROPOSED 8" SEWER LATERAL.
- 18 PROPOSED 2" WATER LATERAL.
- 19 PROPOSED 6" FIRE WATER LATERAL.
- 20 PROPOSED FIRE HYDRANT.
- 21 PROPOSED THRUST BLOCK.
- 22 PROPOSED BLOCK TEE.
- 23 PROPOSED BLOCK 11.5" BEND.
- 24 PROPOSED WATER 2" METER.
- 25 PROPOSED BACK FLOW PREVENTION DEVICE.
- 26 PROPOSED GREASE INTERCEPTOR.
- 27 PROPOSED 12" SEWER MANHOLE.
- 28 PROPOSED SEWER CLEAN OUT.
- 29 PROPOSED WATER TAP AT EXISTING MAIN.

EASEMENT NOTES:

- 12 AN EASEMENT SHOWN OR DEDICATED ON THE MAP OF PARCEL MAP NO. 19209 RECORDED MAY 09, 2011 ON FILE IN BOOK 238, PAGES 57, 58 AND 59, OF PARCEL MAPS. -SHOWN HEREIN.
- 9 AN EASEMENT FOR EITHER OR BOTH POLE LINES, CONDUITS AND INCIDENTAL PURPOSES, RECORDED APRIL 08, 1948 AS BOOK 2209, PAGE 123 OF OFFICIAL RECORDS. -SHOWN HEREIN.
- 10 AN EASEMENT FOR THE CONSTRUCTION, MAINTENANCE AND OPERATION OF ELECTRIC LINES AND TELEPHONE LINES AND CABLES AND INCIDENTAL PURPOSES, RECORDED JANUARY 28, 1948 AS BOOK 2114, PAGE 328 OF OFFICIAL RECORDS. -SHOWN HEREIN.
- 12 AN EASEMENT FOR ROADS AND DRAINAGE AND PUBLIC UTILITY AND INCIDENTAL PURPOSES, RECORDED FEBRUARY 03, 2003 AS INSTRUMENT NO. 2003-0069669 OF OFFICIAL RECORDS. -SHOWN HEREIN.
- 13 AN EASEMENT FOR ROADS AND DRAINAGE AND PUBLIC UTILITY AND INCIDENTAL PURPOSES, RECORDED FEBRUARY 03, 2003 AS INSTRUMENT NO. 2003-0069670 OF OFFICIAL RECORDS. -SHOWN HEREIN.
- 16 THE RIGHTS, IF ANY, OF A CITY, PUBLIC UTILITY OR SPECIAL DISTRICT TO PRESERVE A PUBLIC EASEMENT IN ALLEY AS THE SAME WAS VACATED BY THE DOCUMENT RECORDED JULY 29, 2010 AS INSTRUMENT NO. 2010-0304441 OF OFFICIAL RECORDS. -SHOWN HEREIN.
- 17 AN EASEMENT FOR ROADS, DRAINAGE, AND PUBLIC UTILITY AND INCIDENTAL PURPOSES, RECORDED NOVEMBER 03, 2016 AS INSTRUMENT NO. 2016-0463405 OF OFFICIAL RECORDS. -SHOWN HEREIN.
- 18 AN EASEMENT FOR ROADS, DRAINAGE, AND PUBLIC UTILITY AND INCIDENTAL PURPOSES, RECORDED NOVEMBER 03, 2016 AS INSTRUMENT NO. 2016-0463406 OF OFFICIAL RECORDS. -SHOWN HEREIN.
- 19 AN EASEMENT FOR ROADS, DRAINAGE, PUBLIC UTILITY AND INCIDENTAL PURPOSES, RECORDED DECEMBER 21, 2017 AS INSTRUMENT NO. 2017-0542564 OF OFFICIAL RECORDS. -SHOWN HEREIN.
- 20 AN EASEMENT FOR ROADS, DRAINAGE, PUBLIC UTILITY AND INCIDENTAL PURPOSES, RECORDED DECEMBER 21, 2017 AS INSTRUMENT NO. 2017-0542565 OF OFFICIAL RECORDS. -SHOWN HEREIN.
- 21 AN EASEMENT FOR ROADS, DRAINAGE, PUBLIC UTILITY AND INCIDENTAL PURPOSES, RECORDED DECEMBER 21, 2017 AS INSTRUMENT NO. 2017-0542566 OF OFFICIAL RECORDS. -SHOWN HEREIN.
- 22 THE RIGHTS, IF ANY, OF A CITY, PUBLIC UTILITY OR SPECIAL DISTRICT TO PRESERVE A PUBLIC EASEMENT IN ALLEY AS THE SAME WAS VACATED BY THE DOCUMENT RECORDED DECEMBER 21, 2017 AS INSTRUMENT NO. 2017-0542567 OF OFFICIAL RECORDS. -SHOWN HEREIN.
- 23 THE RIGHTS, IF ANY, OF A CITY, PUBLIC UTILITY OR SPECIAL DISTRICT TO PRESERVE A PUBLIC EASEMENT IN ALLEY AS THE SAME WAS VACATED BY THE DOCUMENT RECORDED DECEMBER 21, 2017 AS INSTRUMENT NO. 2017-0542568 OF OFFICIAL RECORDS. -SHOWN HEREIN.

UTILITY AS BUILT DATA:

ALL EXISTING UTILITY DATA TO BE FIELD VERIFIED.

SECTION NOTE:

SEE SHEET 3 FOR SECTIONS.

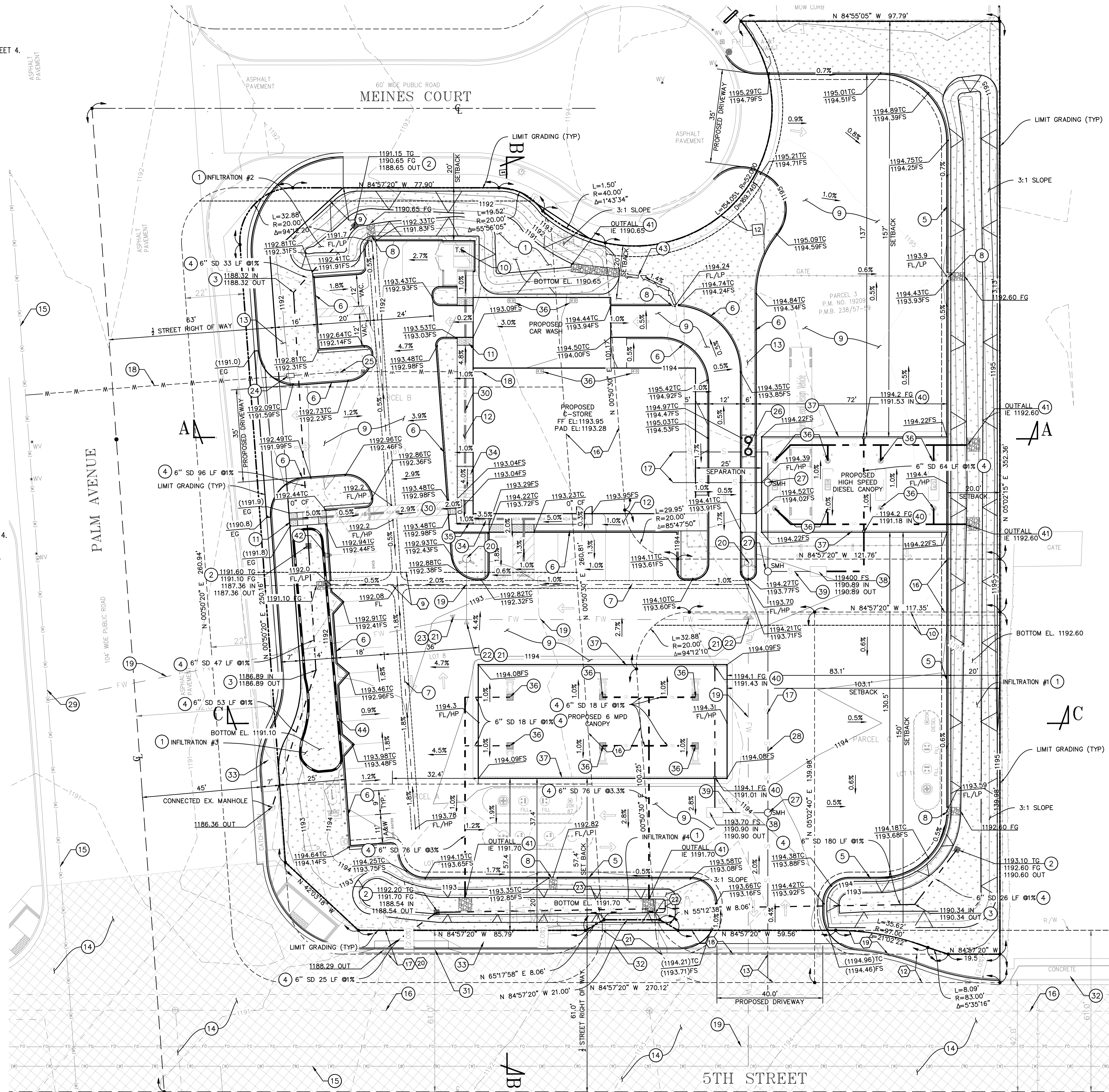

DIG ALERT
CALL BEFORE YOU DIG
811

REVIEWED BY:	DATE
APPROVED BY:	DATE
JOE BARRAGAN—DIRECTOR OF PUBLIC WORKS	

PLANS PREPARED BY:
Ventura Engineering Inland, INC
27393 Ynez Road, Suite 159
Temecula, CA 92591
Phone: (951)252-7632
wilfredo@venturaengineeringinland.com

WILFREDO S.D. VENTURA
RCE 66532 EXP. 06/30/24

5/11/22
DATE

PLANS PREPARED UNDER THE SUPERVISION OF:

DATE: _____

MARK	DESCRIPTION	APPR.	DATE

CITY OF HIGHLAND	
APPROVED BY	APPROVED BY
PLANNING	BUILDING AND SAFETY

CONCEPTUAL GRADING PLAN

APN: 1201-311-02, 3&5 AND 1201-301-14, 15&19
PROPOSED GAS STATION AND C-STORE
NEC PALM AVENUE & W.5TH STREET
HIGHLAND, CALIFORNIA 92346
CONCEPTUAL GRADING PLAN

DRAWER NO.
SHEET 2 OF 4

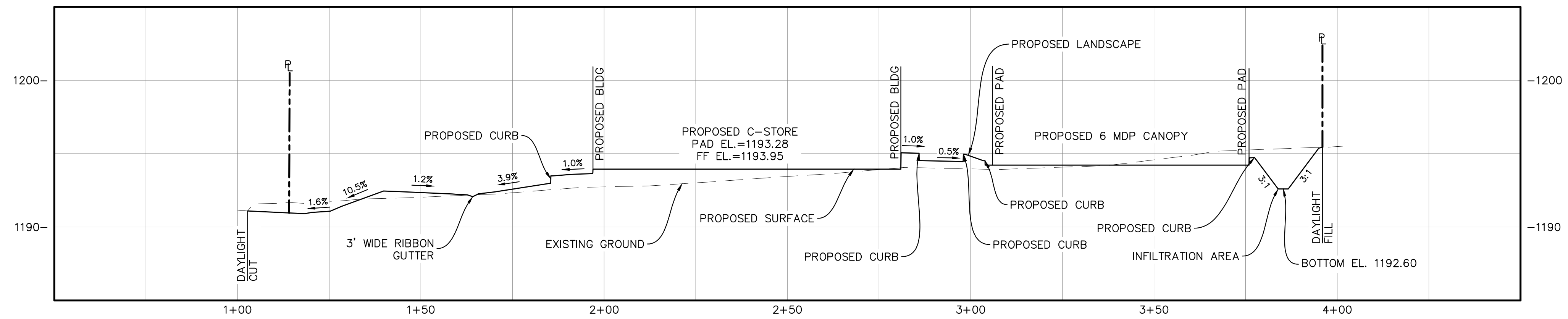

SECTION A-A
HORIZONTAL SCALE: 1"=20'
VERTICAL SCALE: 1"=5'

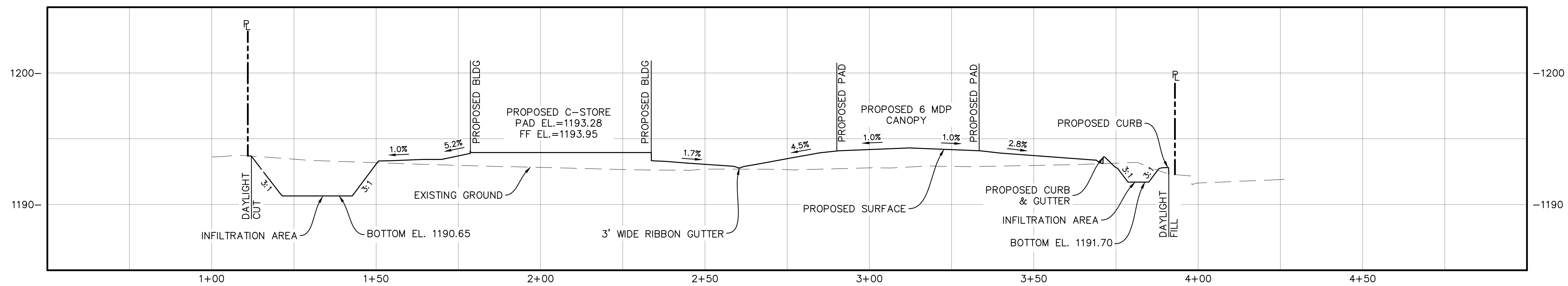

SECTION B-B
HORIZONTAL SCALE: 1"=20'
VERTICAL SCALE: 1"=5'

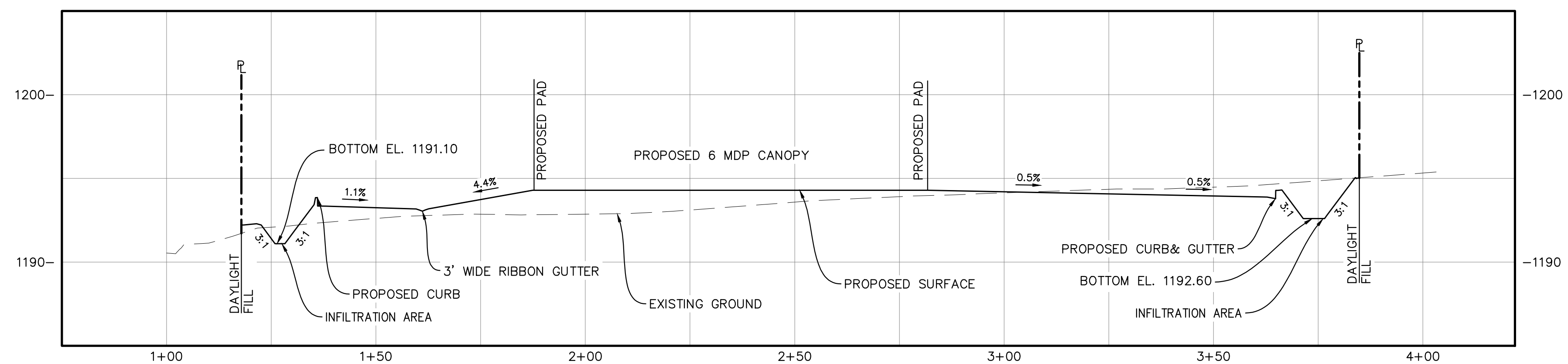

SECTION C-C
HORIZONTAL SCALE: 1"=20'
VERTICAL SCALE: 1"=5'

REVIEWED BY:	DATE
APPROVED BY:	DATE
JOE BARRAGAN—DIRECTOR OF PUBLIC WORKS	

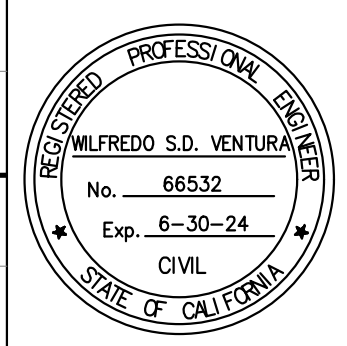

PLANS PREPARED BY:
Ventura Engineering Inland, INC
27393 Ynez Road, Suite 159
Temecula, CA 92591
Phone: (951)252-7632
wilfredo@venturaengineeringinland.com

5/11/22
DATE

WILFREDO S.D. VENTURA
RCE 66532 EXP. 06/30/24

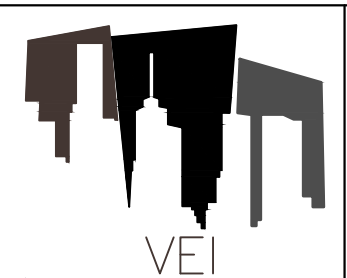

PLANS PREPARED UNDER THE SUPERVISION OF:	DATE:

MARK	DESCRIPTION	APPR.	DATE

CITY OF HIGHLAND	
APPROVED BY	APPROVED BY
PLANNING	BUILDING AND SAFETY

CONCEPTUAL GRADING PLAN	
APN: 1201-311-02, 3&5 AND 1201-301-14, 15&19	
PROPOSED GAS STATION AND C-STORE NEC PALM AVENUE & W.5TH STREET HIGHLAND, CALIFORNIA 92346	
SECTIONS	
DRAWER NO.	SHEET 3 OF 4

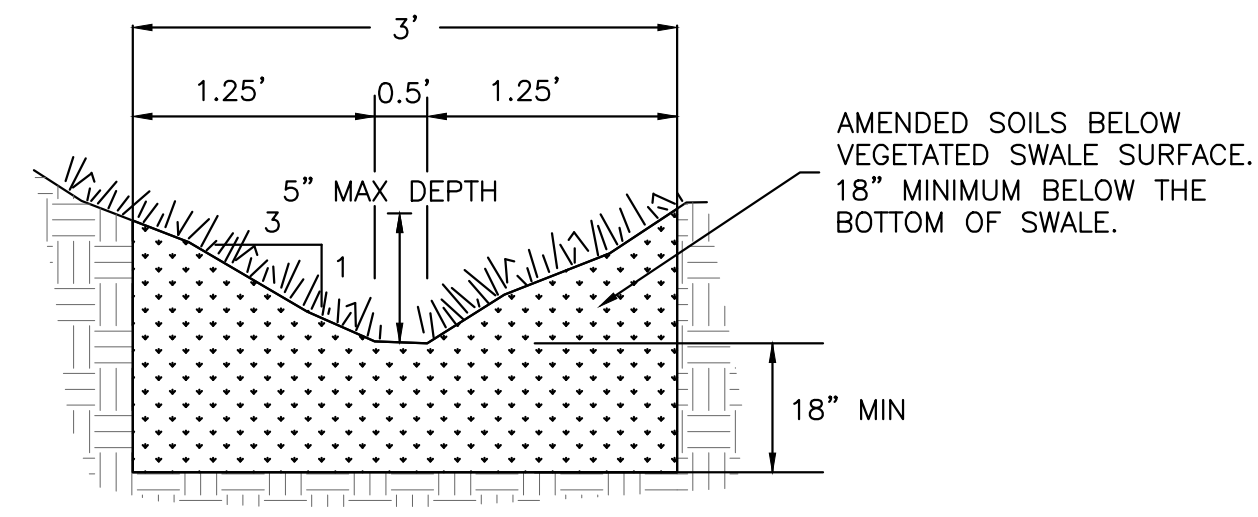

9 PROPOSED CONDITIONS VEGETATED SWALE DETAIL:
NOT TO SCALE

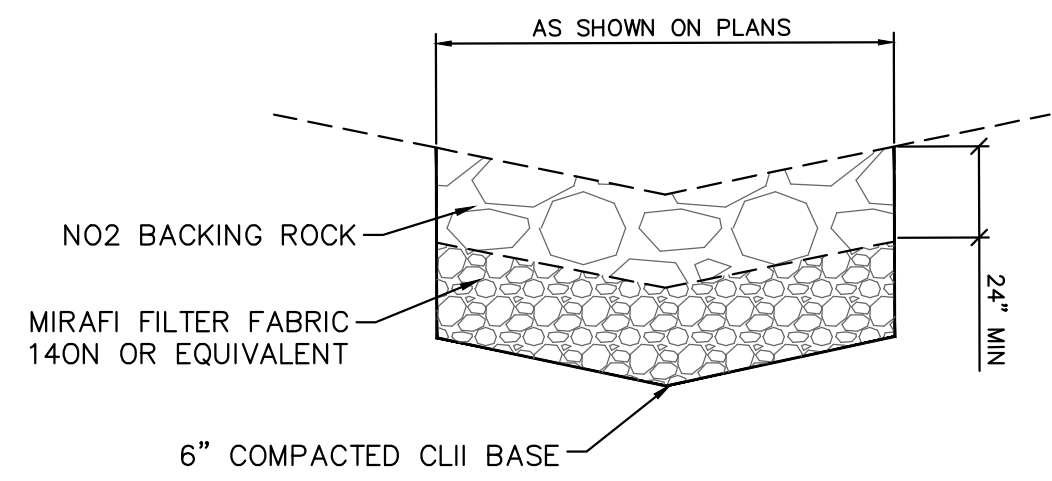

4 PROPOSED RIPRAP WITH NO. 2 BACKING ROCK DETAIL:
NOT TO SCALE

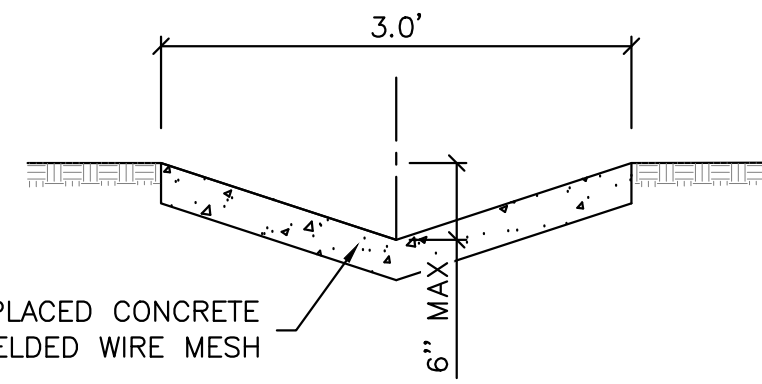

3 GUTTER DETAIL:
NOT TO SCALE

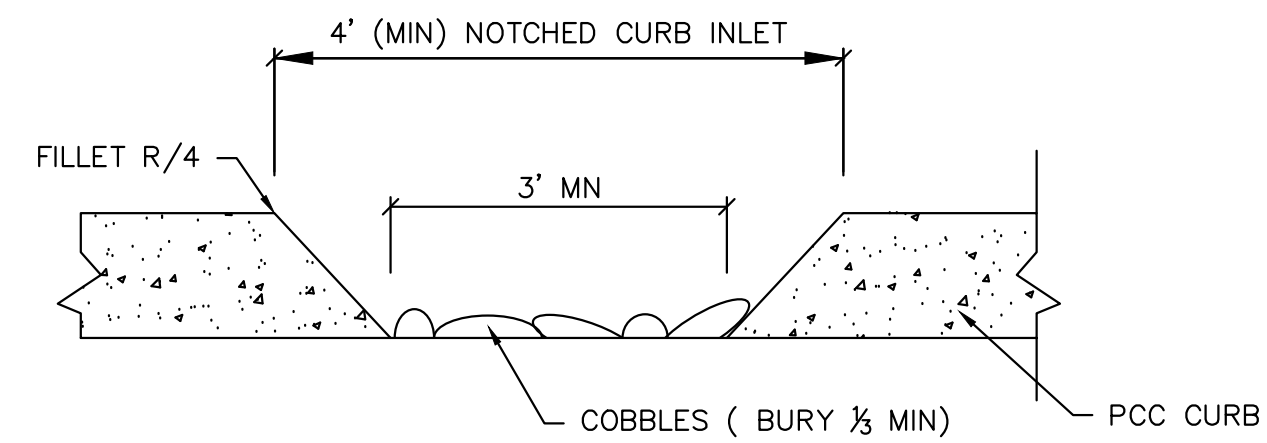

2 CURB CUT DETAIL:
NOT TO SCALE

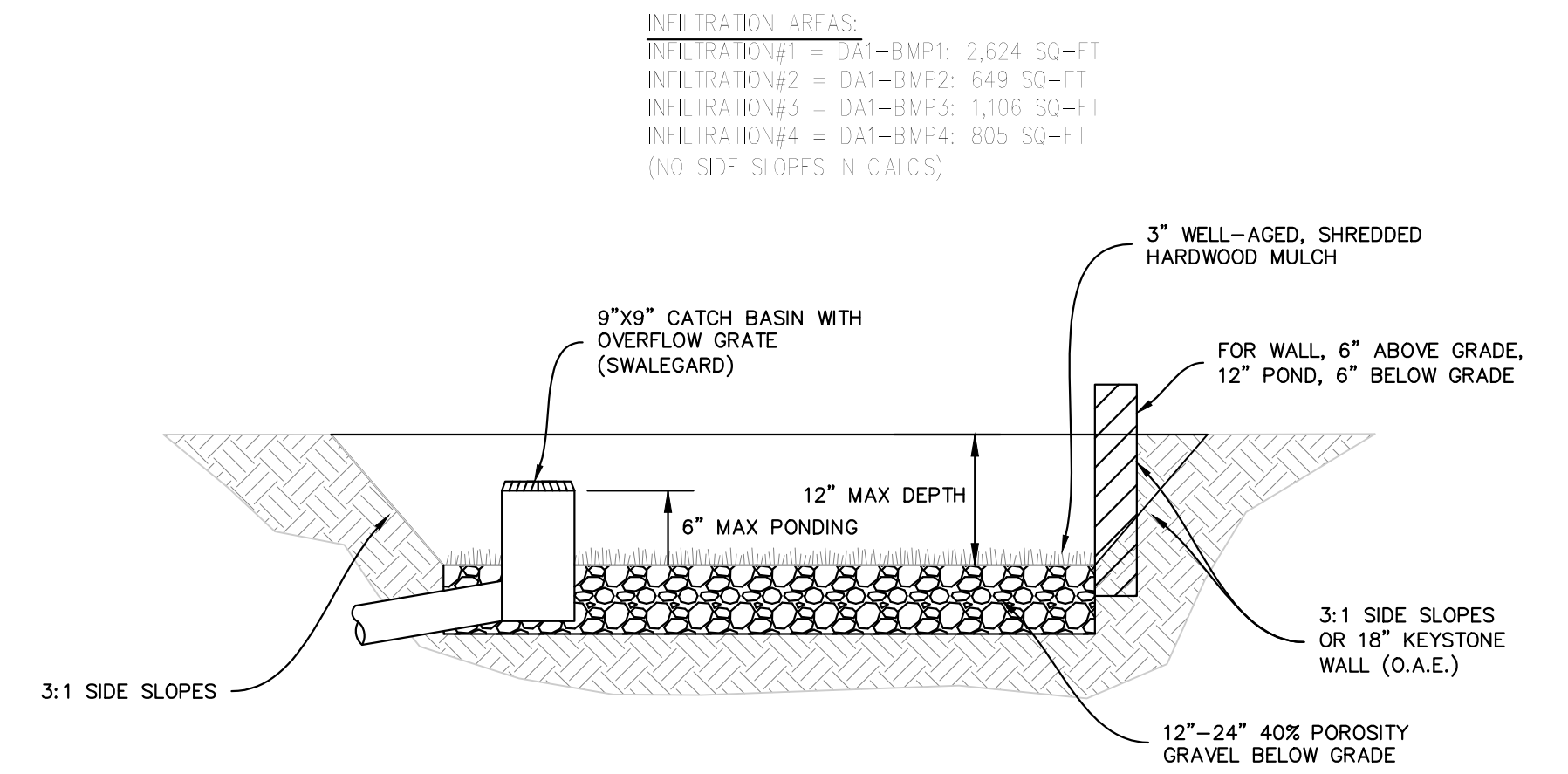

1 LID INFILTRATION BMP DETAIL:
NOT TO SCALE

INFILTRATION AREAS:
INFILTRATION#1 = DA1-BMP1: 2,624 SQ-FT
INFILTRATION#2 = DA1-BMP2: 649 SQ-FT
INFILTRATION#3 = DA1-BMP3: 1,106 SQ-FT
INFILTRATION#4 = DA1-BMP4: 805 SQ-FT
(NO SIDE SLOPES IN CALC'S)

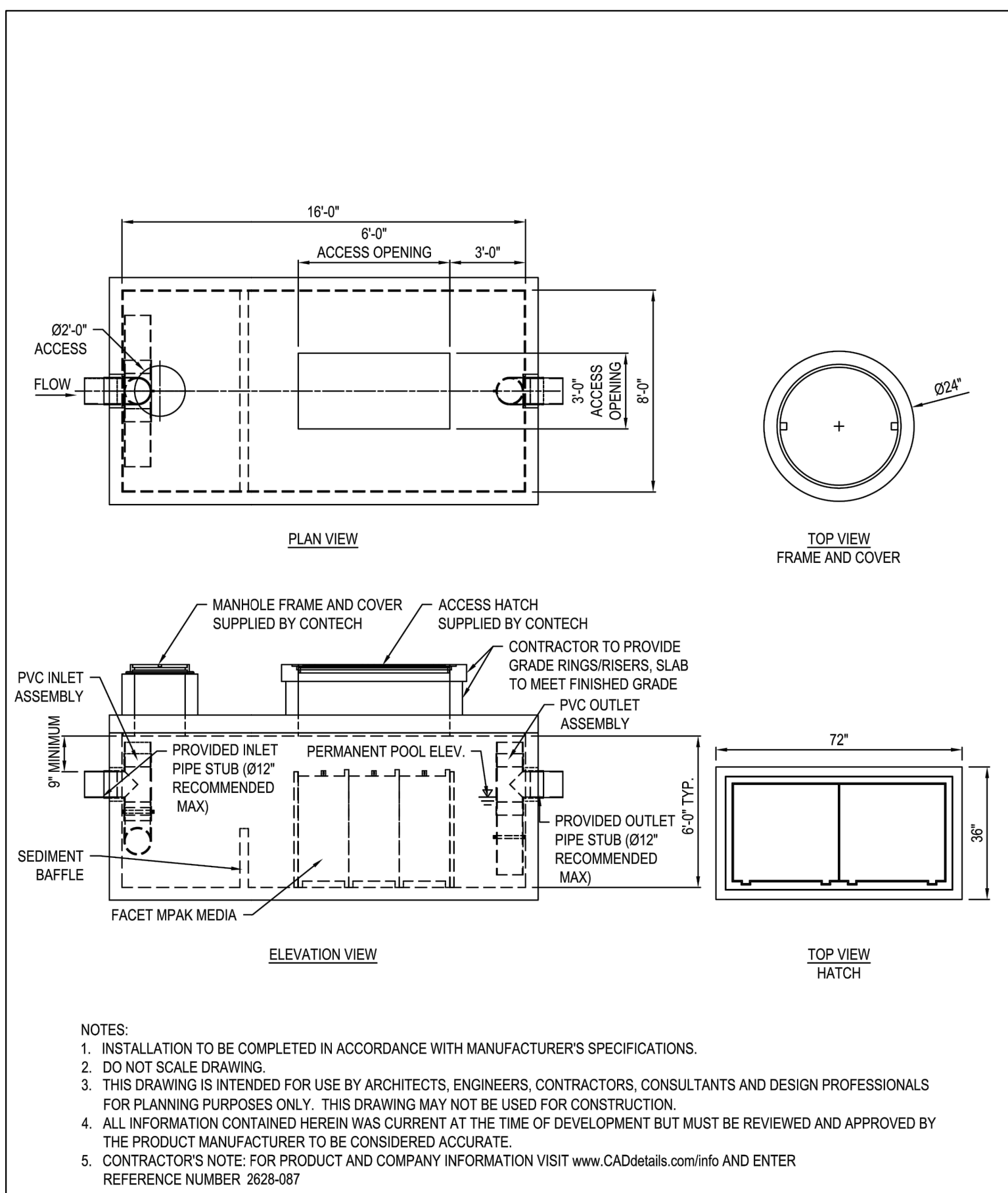

8 PROPOSED OIL WATER SEPARATOR:
NOT TO SCALE

NDS TECHNICAL SPECIFICATIONS
WE PUT WATER IN ITS PLACE

8" PRO SERIES SHALLOW PROFILE SIDE OUTLET

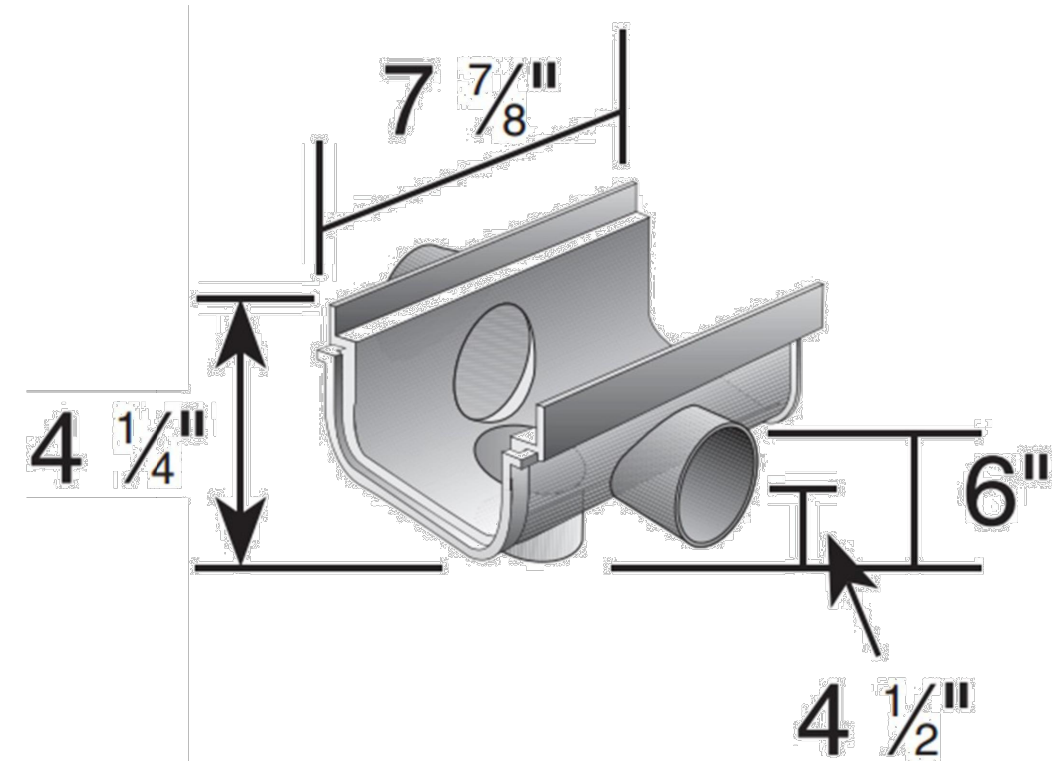

Material: UV Protected High Impact PVC
Colors: Gray (832)
Weight: 1.38 lbs each
Use with 8" Shallow Profile Pro Series Channels
Fits: Bottom: 3" & 4" Sewer and Drain fittings, 3" SDR-32.5 Class 125, & SDR-41 Class 100 pipe,
Sides: 1-1/2" SCH-40 pipe

7 PROPOSED 8" SHALLOW SIDE OUTLET:
NOT TO SCALE

NDS TECHNICAL SPECIFICATIONS
WE PUT WATER IN ITS PLACE

8" Pro Series Grate

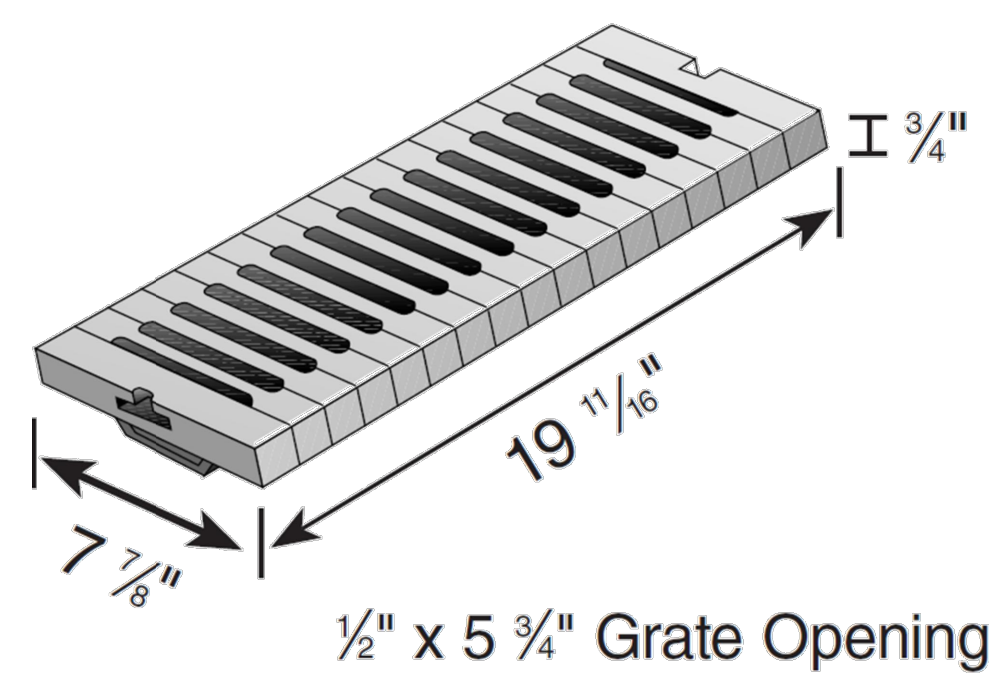

Part #: 838
Material: High Impact Glass Reinforced Nylon
Color: Light Gray
Use for 8" Pro Series Channel Grate Opening: 1/2" x 5-3/4"
Open Surface Area: 30.85 Sq. Inches Per Foot.
Head Pressure / Flow rate:
1" = 133.47 GPM per Foot
0.5" = 94.37 GPM per Foot
Weight Per Each: 3.89 lbs.
UV inhibitor

Class C
• Loads of 176-325 psi.
• Recommended for heavy-duty pneumatic tire forklifts and tractor trailers at speeds less than 20 m.p.h., H-20 rated.

ADA Compliant

6 PROPOSED 8" GRATE:
NOT TO SCALE

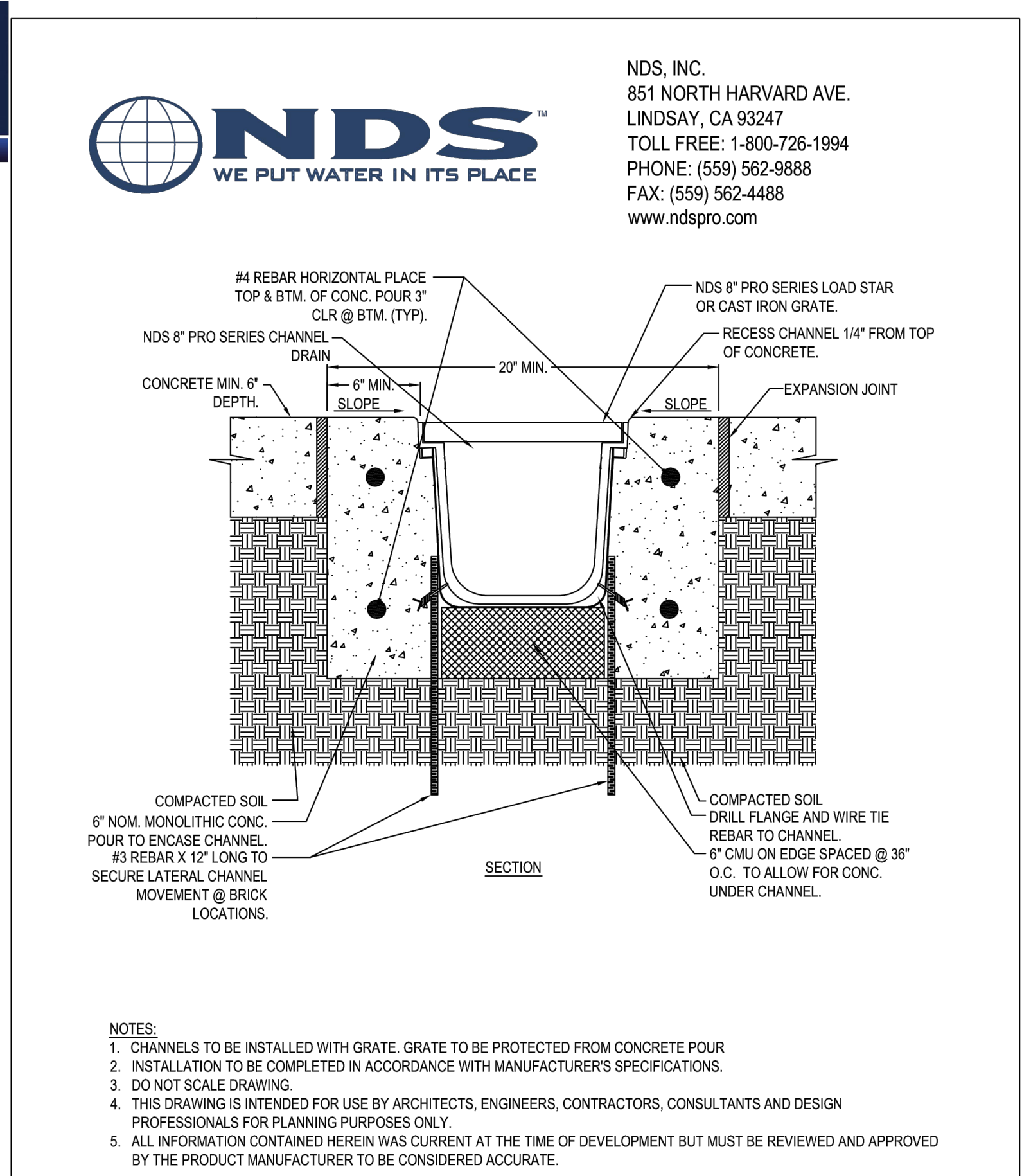

5 PROPOSED 8" TRENCH DRAIN:
NOT TO SCALE

Attachment 3: NRCS Soils Report

Please refer to the attached references.

Custom Soil Resource Report for San Bernardino County Southwestern Part, California

Highland Gas Station

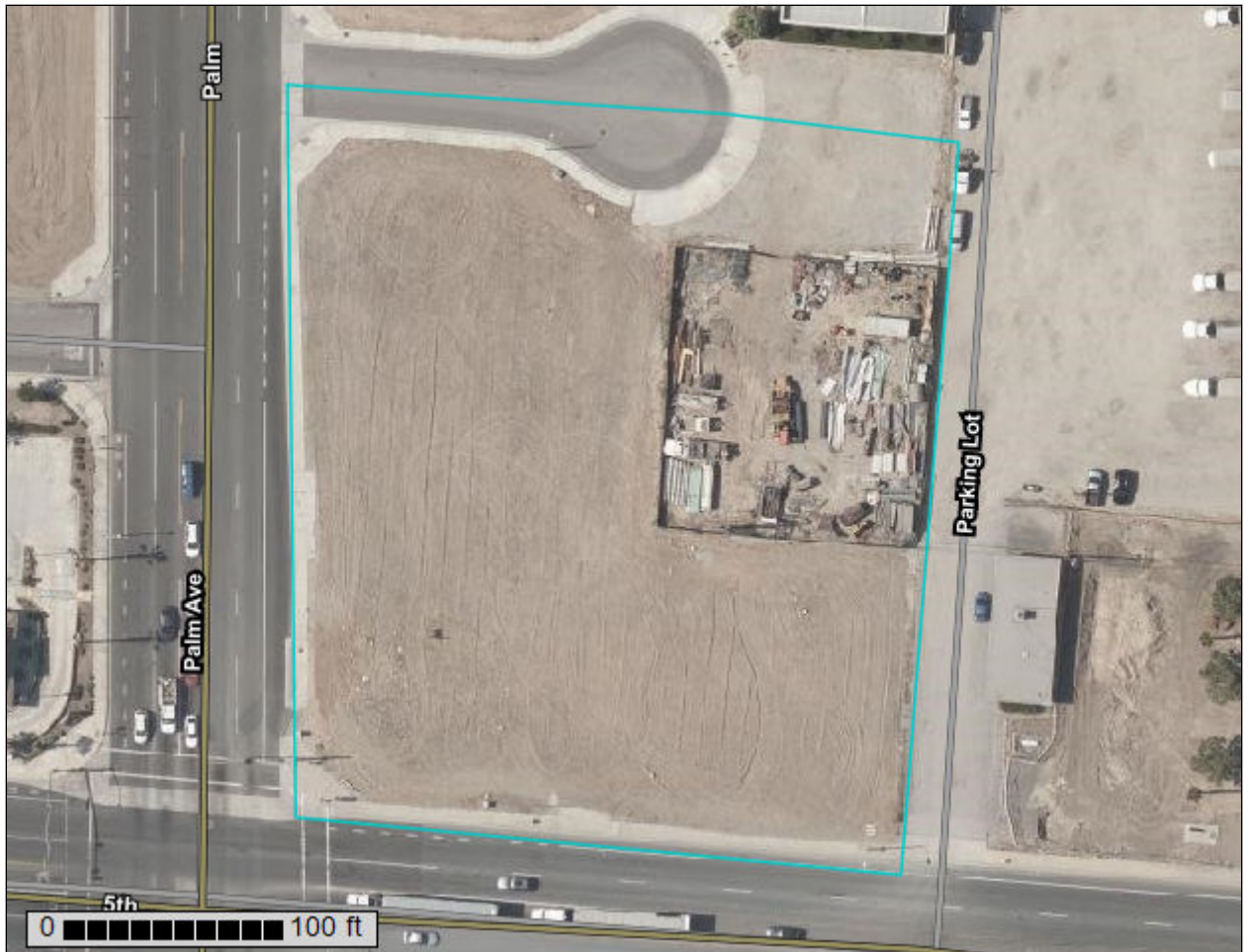

Preface

Soil surveys contain information that affects land use planning in survey areas. They highlight soil limitations that affect various land uses and provide information about the properties of the soils in the survey areas. Soil surveys are designed for many different users, including farmers, ranchers, foresters, agronomists, urban planners, community officials, engineers, developers, builders, and home buyers. Also, conservationists, teachers, students, and specialists in recreation, waste disposal, and pollution control can use the surveys to help them understand, protect, or enhance the environment.

Various land use regulations of Federal, State, and local governments may impose special restrictions on land use or land treatment. Soil surveys identify soil properties that are used in making various land use or land treatment decisions. The information is intended to help the land users identify and reduce the effects of soil limitations on various land uses. The landowner or user is responsible for identifying and complying with existing laws and regulations.

Although soil survey information can be used for general farm, local, and wider area planning, onsite investigation is needed to supplement this information in some cases. Examples include soil quality assessments (<http://www.nrcs.usda.gov/wps/portal/nrcs/main/soils/health/>) and certain conservation and engineering applications. For more detailed information, contact your local USDA Service Center (<https://offices.sc.egov.usda.gov/locator/app?agency=nrcs>) or your NRCS State Soil Scientist (http://www.nrcs.usda.gov/wps/portal/nrcs/detail/soils/contactus/?cid=nrcs142p2_053951).

Great differences in soil properties can occur within short distances. Some soils are seasonally wet or subject to flooding. Some are too unstable to be used as a foundation for buildings or roads. Clayey or wet soils are poorly suited to use as septic tank absorption fields. A high water table makes a soil poorly suited to basements or underground installations.

The National Cooperative Soil Survey is a joint effort of the United States Department of Agriculture and other Federal agencies, State agencies including the Agricultural Experiment Stations, and local agencies. The Natural Resources Conservation Service (NRCS) has leadership for the Federal part of the National Cooperative Soil Survey.

Information about soils is updated periodically. Updated information is available through the NRCS Web Soil Survey, the site for official soil survey information.

The U.S. Department of Agriculture (USDA) prohibits discrimination in all its programs and activities on the basis of race, color, national origin, age, disability, and where applicable, sex, marital status, familial status, parental status, religion, sexual orientation, genetic information, political beliefs, reprisal, or because all or a part of an individual's income is derived from any public assistance program. (Not all prohibited bases apply to all programs.) Persons with disabilities who require

alternative means for communication of program information (Braille, large print, audiotape, etc.) should contact USDA's TARGET Center at (202) 720-2600 (voice and TDD). To file a complaint of discrimination, write to USDA, Director, Office of Civil Rights, 1400 Independence Avenue, S.W., Washington, D.C. 20250-9410 or call (800) 795-3272 (voice) or (202) 720-6382 (TDD). USDA is an equal opportunity provider and employer.

Contents

Preface	2
How Soil Surveys Are Made	5
Soil Map	8
Soil Map.....	9
Legend.....	10
Map Unit Legend.....	12
Map Unit Descriptions.....	12
San Bernardino County Southwestern Part, California.....	14
TvC—Tujunga gravelly loamy sand, 0 to 9 percent slopes.....	14
References	16

How Soil Surveys Are Made

Soil surveys are made to provide information about the soils and miscellaneous areas in a specific area. They include a description of the soils and miscellaneous areas and their location on the landscape and tables that show soil properties and limitations affecting various uses. Soil scientists observed the steepness, length, and shape of the slopes; the general pattern of drainage; the kinds of crops and native plants; and the kinds of bedrock. They observed and described many soil profiles. A soil profile is the sequence of natural layers, or horizons, in a soil. The profile extends from the surface down into the unconsolidated material in which the soil formed or from the surface down to bedrock. The unconsolidated material is devoid of roots and other living organisms and has not been changed by other biological activity.

Currently, soils are mapped according to the boundaries of major land resource areas (MLRAs). MLRAs are geographically associated land resource units that share common characteristics related to physiography, geology, climate, water resources, soils, biological resources, and land uses (USDA, 2006). Soil survey areas typically consist of parts of one or more MLRA.

The soils and miscellaneous areas in a survey area occur in an orderly pattern that is related to the geology, landforms, relief, climate, and natural vegetation of the area. Each kind of soil and miscellaneous area is associated with a particular kind of landform or with a segment of the landform. By observing the soils and miscellaneous areas in the survey area and relating their position to specific segments of the landform, a soil scientist develops a concept, or model, of how they were formed. Thus, during mapping, this model enables the soil scientist to predict with a considerable degree of accuracy the kind of soil or miscellaneous area at a specific location on the landscape.

Commonly, individual soils on the landscape merge into one another as their characteristics gradually change. To construct an accurate soil map, however, soil scientists must determine the boundaries between the soils. They can observe only a limited number of soil profiles. Nevertheless, these observations, supplemented by an understanding of the soil-vegetation-landscape relationship, are sufficient to verify predictions of the kinds of soil in an area and to determine the boundaries.

Soil scientists recorded the characteristics of the soil profiles that they studied. They noted soil color, texture, size and shape of soil aggregates, kind and amount of rock fragments, distribution of plant roots, reaction, and other features that enable them to identify soils. After describing the soils in the survey area and determining their properties, the soil scientists assigned the soils to taxonomic classes (units). Taxonomic classes are concepts. Each taxonomic class has a set of soil characteristics with precisely defined limits. The classes are used as a basis for comparison to classify soils systematically. Soil taxonomy, the system of taxonomic classification used in the United States, is based mainly on the kind and character of soil properties and the arrangement of horizons within the profile. After the soil

Custom Soil Resource Report

scientists classified and named the soils in the survey area, they compared the individual soils with similar soils in the same taxonomic class in other areas so that they could confirm data and assemble additional data based on experience and research.

The objective of soil mapping is not to delineate pure map unit components; the objective is to separate the landscape into landforms or landform segments that have similar use and management requirements. Each map unit is defined by a unique combination of soil components and/or miscellaneous areas in predictable proportions. Some components may be highly contrasting to the other components of the map unit. The presence of minor components in a map unit in no way diminishes the usefulness or accuracy of the data. The delineation of such landforms and landform segments on the map provides sufficient information for the development of resource plans. If intensive use of small areas is planned, onsite investigation is needed to define and locate the soils and miscellaneous areas.

Soil scientists make many field observations in the process of producing a soil map. The frequency of observation is dependent upon several factors, including scale of mapping, intensity of mapping, design of map units, complexity of the landscape, and experience of the soil scientist. Observations are made to test and refine the soil-landscape model and predictions and to verify the classification of the soils at specific locations. Once the soil-landscape model is refined, a significantly smaller number of measurements of individual soil properties are made and recorded. These measurements may include field measurements, such as those for color, depth to bedrock, and texture, and laboratory measurements, such as those for content of sand, silt, clay, salt, and other components. Properties of each soil typically vary from one point to another across the landscape.

Observations for map unit components are aggregated to develop ranges of characteristics for the components. The aggregated values are presented. Direct measurements do not exist for every property presented for every map unit component. Values for some properties are estimated from combinations of other properties.

While a soil survey is in progress, samples of some of the soils in the area generally are collected for laboratory analyses and for engineering tests. Soil scientists interpret the data from these analyses and tests as well as the field-observed characteristics and the soil properties to determine the expected behavior of the soils under different uses. Interpretations for all of the soils are field tested through observation of the soils in different uses and under different levels of management. Some interpretations are modified to fit local conditions, and some new interpretations are developed to meet local needs. Data are assembled from other sources, such as research information, production records, and field experience of specialists. For example, data on crop yields under defined levels of management are assembled from farm records and from field or plot experiments on the same kinds of soil.

Predictions about soil behavior are based not only on soil properties but also on such variables as climate and biological activity. Soil conditions are predictable over long periods of time, but they are not predictable from year to year. For example, soil scientists can predict with a fairly high degree of accuracy that a given soil will have a high water table within certain depths in most years, but they cannot predict that a high water table will always be at a specific level in the soil on a specific date.

After soil scientists located and identified the significant natural bodies of soil in the survey area, they drew the boundaries of these bodies on aerial photographs and

Custom Soil Resource Report

identified each as a specific map unit. Aerial photographs show trees, buildings, fields, roads, and rivers, all of which help in locating boundaries accurately.

Soil Map

The soil map section includes the soil map for the defined area of interest, a list of soil map units on the map and extent of each map unit, and cartographic symbols displayed on the map. Also presented are various metadata about data used to produce the map, and a description of each soil map unit.

Custom Soil Resource Report Soil Map

































Map Scale: 1:721 if printed on A portrait (8.5" x 11") sheet.



Map projection: Web Mercator Corner coordinates: WGS84 Edge tics: UTM Zone 11N WGS84

MAP LEGEND

- Area of Interest (AOI)**
 -  Area of Interest (AOI)
- Soils**
 -  Soil Map Unit Polygons
 -  Soil Map Unit Lines
 -  Soil Map Unit Points
- Special Point Features**
 -  Blowout
 -  Borrow Pit
 -  Clay Spot
 -  Closed Depression
 -  Gravel Pit
 -  Gravelly Spot
 -  Landfill
 -  Lava Flow
 -  Marsh or swamp
 -  Mine or Quarry
 -  Miscellaneous Water
 -  Perennial Water
 -  Rock Outcrop
 -  Saline Spot
 -  Sandy Spot
 -  Severely Eroded Spot
 -  Sinkhole
 -  Slide or Slip
 -  Sodic Spot
- Water Features**
 -  Streams and Canals
- Transportation**
 -  Rails
 -  Interstate Highways
 -  US Routes
 -  Major Roads
 -  Local Roads
- Background**
 -  Aerial Photography

MAP INFORMATION

The soil surveys that comprise your AOI were mapped at 1:24,000.

Warning: Soil Map may not be valid at this scale.

Enlargement of maps beyond the scale of mapping can cause misunderstanding of the detail of mapping and accuracy of soil line placement. The maps do not show the small areas of contrasting soils that could have been shown at a more detailed scale.

Please rely on the bar scale on each map sheet for map measurements.

Source of Map: Natural Resources Conservation Service
 Web Soil Survey URL:
 Coordinate System: Web Mercator (EPSG:3857)

Maps from the Web Soil Survey are based on the Web Mercator projection, which preserves direction and shape but distorts distance and area. A projection that preserves area, such as the Albers equal-area conic projection, should be used if more accurate calculations of distance or area are required.

This product is generated from the USDA-NRCS certified data as of the version date(s) listed below.

Soil Survey Area: San Bernardino County Southwestern Part, California
 Survey Area Data: Version 13, Sep 13, 2021

Soil map units are labeled (as space allows) for map scales 1:50,000 or larger.

Date(s) aerial images were photographed: Apr 1, 2018—Jun 30, 2018

The orthophoto or other base map on which the soil lines were compiled and digitized probably differs from the background

MAP LEGEND

MAP INFORMATION

imagery displayed on these maps. As a result, some minor shifting of map unit boundaries may be evident.

Map Unit Legend

Map Unit Symbol	Map Unit Name	Acres in AOI	Percent of AOI
TvC	Tujunga gravelly loamy sand, 0 to 9 percent slopes	2.2	100.0%
Totals for Area of Interest		2.2	100.0%

Map Unit Descriptions

The map units delineated on the detailed soil maps in a soil survey represent the soils or miscellaneous areas in the survey area. The map unit descriptions, along with the maps, can be used to determine the composition and properties of a unit.

A map unit delineation on a soil map represents an area dominated by one or more major kinds of soil or miscellaneous areas. A map unit is identified and named according to the taxonomic classification of the dominant soils. Within a taxonomic class there are precisely defined limits for the properties of the soils. On the landscape, however, the soils are natural phenomena, and they have the characteristic variability of all natural phenomena. Thus, the range of some observed properties may extend beyond the limits defined for a taxonomic class. Areas of soils of a single taxonomic class rarely, if ever, can be mapped without including areas of other taxonomic classes. Consequently, every map unit is made up of the soils or miscellaneous areas for which it is named and some minor components that belong to taxonomic classes other than those of the major soils.

Most minor soils have properties similar to those of the dominant soil or soils in the map unit, and thus they do not affect use and management. These are called noncontrasting, or similar, components. They may or may not be mentioned in a particular map unit description. Other minor components, however, have properties and behavioral characteristics divergent enough to affect use or to require different management. These are called contrasting, or dissimilar, components. They generally are in small areas and could not be mapped separately because of the scale used. Some small areas of strongly contrasting soils or miscellaneous areas are identified by a special symbol on the maps. If included in the database for a given area, the contrasting minor components are identified in the map unit descriptions along with some characteristics of each. A few areas of minor components may not have been observed, and consequently they are not mentioned in the descriptions, especially where the pattern was so complex that it was impractical to make enough observations to identify all the soils and miscellaneous areas on the landscape.

The presence of minor components in a map unit in no way diminishes the usefulness or accuracy of the data. The objective of mapping is not to delineate pure taxonomic classes but rather to separate the landscape into landforms or landform segments that have similar use and management requirements. The delineation of such segments on the map provides sufficient information for the development of resource plans. If intensive use of small areas is planned, however, onsite investigation is needed to define and locate the soils and miscellaneous areas.

Custom Soil Resource Report

An identifying symbol precedes the map unit name in the map unit descriptions. Each description includes general facts about the unit and gives important soil properties and qualities.

Soils that have profiles that are almost alike make up a *soil series*. Except for differences in texture of the surface layer, all the soils of a series have major horizons that are similar in composition, thickness, and arrangement.

Soils of one series can differ in texture of the surface layer, slope, stoniness, salinity, degree of erosion, and other characteristics that affect their use. On the basis of such differences, a soil series is divided into *soil phases*. Most of the areas shown on the detailed soil maps are phases of soil series. The name of a soil phase commonly indicates a feature that affects use or management. For example, Alpha silt loam, 0 to 2 percent slopes, is a phase of the Alpha series.

Some map units are made up of two or more major soils or miscellaneous areas. These map units are complexes, associations, or undifferentiated groups.

A *complex* consists of two or more soils or miscellaneous areas in such an intricate pattern or in such small areas that they cannot be shown separately on the maps. The pattern and proportion of the soils or miscellaneous areas are somewhat similar in all areas. Alpha-Beta complex, 0 to 6 percent slopes, is an example.

An *association* is made up of two or more geographically associated soils or miscellaneous areas that are shown as one unit on the maps. Because of present or anticipated uses of the map units in the survey area, it was not considered practical or necessary to map the soils or miscellaneous areas separately. The pattern and relative proportion of the soils or miscellaneous areas are somewhat similar. Alpha-Beta association, 0 to 2 percent slopes, is an example.

An *undifferentiated group* is made up of two or more soils or miscellaneous areas that could be mapped individually but are mapped as one unit because similar interpretations can be made for use and management. The pattern and proportion of the soils or miscellaneous areas in a mapped area are not uniform. An area can be made up of only one of the major soils or miscellaneous areas, or it can be made up of all of them. Alpha and Beta soils, 0 to 2 percent slopes, is an example.

Some surveys include *miscellaneous areas*. Such areas have little or no soil material and support little or no vegetation. Rock outcrop is an example.

San Bernardino County Southwestern Part, California

TvC—Tujunga gravelly loamy sand, 0 to 9 percent slopes

Map Unit Setting

National map unit symbol: hcl2
Elevation: 10 to 1,500 feet
Mean annual precipitation: 10 to 25 inches
Mean annual air temperature: 59 to 64 degrees F
Frost-free period: 250 to 350 days
Farmland classification: Not prime farmland

Map Unit Composition

Tujunga and similar soils: 85 percent
Minor components: 15 percent
Estimates are based on observations, descriptions, and transects of the mapunit.

Description of Tujunga

Setting

Landform: Alluvial fans
Landform position (two-dimensional): Backslope
Landform position (three-dimensional): Tread
Down-slope shape: Linear
Across-slope shape: Linear
Parent material: Alluvium derived from granite

Typical profile

H1 - 0 to 36 inches: gravelly loamy sand
H2 - 36 to 60 inches: gravelly sand

Properties and qualities

Slope: 0 to 9 percent
Depth to restrictive feature: More than 80 inches
Drainage class: Somewhat excessively drained
Runoff class: Very low
Capacity of the most limiting layer to transmit water (Ksat): High to very high (5.95 to 19.98 in/hr)
Depth to water table: More than 80 inches
Frequency of flooding: Rare
Frequency of ponding: None
Available water supply, 0 to 60 inches: Low (about 3.8 inches)

Interpretive groups

Land capability classification (irrigated): 4s
Land capability classification (nonirrigated): 4e
Hydrologic Soil Group: A
Ecological site: R019XG912CA - Sandy Fan
Hydric soil rating: No

Minor Components

Unnamed

Percent of map unit: 5 percent
Landform: Drainageways
Hydric soil rating: Yes

Custom Soil Resource Report

Soboba, gravelly loamy sand

Percent of map unit: 5 percent

Hydric soil rating: No

Delhi, fine sand

Percent of map unit: 5 percent

Hydric soil rating: No

References

- American Association of State Highway and Transportation Officials (AASHTO). 2004. Standard specifications for transportation materials and methods of sampling and testing. 24th edition.
- American Society for Testing and Materials (ASTM). 2005. Standard classification of soils for engineering purposes. ASTM Standard D2487-00.
- Cowardin, L.M., V. Carter, F.C. Golet, and E.T. LaRoe. 1979. Classification of wetlands and deep-water habitats of the United States. U.S. Fish and Wildlife Service FWS/OBS-79/31.
- Federal Register. July 13, 1994. Changes in hydric soils of the United States.
- Federal Register. September 18, 2002. Hydric soils of the United States.
- Hurt, G.W., and L.M. Vasilas, editors. Version 6.0, 2006. Field indicators of hydric soils in the United States.
- National Research Council. 1995. Wetlands: Characteristics and boundaries.
- Soil Survey Division Staff. 1993. Soil survey manual. Soil Conservation Service. U.S. Department of Agriculture Handbook 18. http://www.nrcs.usda.gov/wps/portal/nrcs/detail/national/soils/?cid=nrcs142p2_054262
- Soil Survey Staff. 1999. Soil taxonomy: A basic system of soil classification for making and interpreting soil surveys. 2nd edition. Natural Resources Conservation Service, U.S. Department of Agriculture Handbook 436. http://www.nrcs.usda.gov/wps/portal/nrcs/detail/national/soils/?cid=nrcs142p2_053577
- Soil Survey Staff. 2010. Keys to soil taxonomy. 11th edition. U.S. Department of Agriculture, Natural Resources Conservation Service. http://www.nrcs.usda.gov/wps/portal/nrcs/detail/national/soils/?cid=nrcs142p2_053580
- Tiner, R.W., Jr. 1985. Wetlands of Delaware. U.S. Fish and Wildlife Service and Delaware Department of Natural Resources and Environmental Control, Wetlands Section.
- United States Army Corps of Engineers, Environmental Laboratory. 1987. Corps of Engineers wetlands delineation manual. Waterways Experiment Station Technical Report Y-87-1.
- United States Department of Agriculture, Natural Resources Conservation Service. National forestry manual. http://www.nrcs.usda.gov/wps/portal/nrcs/detail/soils/home/?cid=nrcs142p2_053374
- United States Department of Agriculture, Natural Resources Conservation Service. National range and pasture handbook. <http://www.nrcs.usda.gov/wps/portal/nrcs/detail/national/landuse/rangepasture/?cid=stelprdb1043084>

Custom Soil Resource Report

United States Department of Agriculture, Natural Resources Conservation Service. National soil survey handbook, title 430-VI. http://www.nrcs.usda.gov/wps/portal/nrcs/detail/soils/scientists/?cid=nrcs142p2_054242

United States Department of Agriculture, Natural Resources Conservation Service. 2006. Land resource regions and major land resource areas of the United States, the Caribbean, and the Pacific Basin. U.S. Department of Agriculture Handbook 296. http://www.nrcs.usda.gov/wps/portal/nrcs/detail/national/soils/?cid=nrcs142p2_053624

United States Department of Agriculture, Soil Conservation Service. 1961. Land capability classification. U.S. Department of Agriculture Handbook 210. http://www.nrcs.usda.gov/Internet/FSE_DOCUMENTS/nrcs142p2_052290.pdf

Attachment 4: Infiltration Report

Please refer to the attached site-specific geotechnical infiltration report.

October 25, 2021

Project No. 213955-12A

Mr. Viraj Patel
c/o Alex Hann
511 North Main Street
Lake Elsinore, CA 92530

Subject: Infiltration Testing for Water Quality Treatment Areas, Proposed Commercial Development, Assessor Parcel Numbers 1201-311-02, 1201-311-03, 1201-311-04, 1201-311-05, 1201-301-14, 1201-301-15, and 1201-301-19, Located at the Southeast Corner of Palm Avenue and Meines Street, City of Highland, San Bernardino County, California

INTRODUCTION

Earth Strata Geotechnical Services is pleased to present this infiltration feasibility report for the proposed commercial development, located on at the southeast corner of Palm Avenue and Meines Street, Assessor Parcel Numbers 1201-311-02 through 05, 1201-301-14, 1201-301-15, and 1201-301-19, in the City of Highland, San Bernardino County, California. The purpose of our study was to determine the infiltration rates and physical characteristics of the subsurface earth materials at the approximate depth of the proposed WQMP area within the proposed development. This feasibility report provides the infiltration rates to be used for the design and the development of the water quality management plan, where applicable.

PROPERTY DESCRIPTION

The subject property is located at the southeast corner of Palm Avenue and Meines Street in the City of Highland, San Bernardino County, California. The approximate location of the site is shown on the Vicinity Map, Figure 1.

The subject property is comprised of approximately 1.87 acres of previously developed land. The site has not been graded. Topographic relief at the subject property is relatively low with the terrain being generally flat. Elevations at the site range from approximately 1,190 to 1,193 feet above mean sea level (msl), for a difference of about 3± feet across the entire site. Drainage within the subject property generally flows to the southwest.

The site is currently bordered by commercial development to the north and east, as well as Palm Avenue to the west, and West 5th Street to the south. Most of the vegetation on the site consists of light amounts of annual weeds/grasses.

PROPOSED CONSTRUCTION

Based on the conceptual site plan provided by Empire Design Group, the proposed development as illustrated on the conceptual grading plans will consist of a commercial development complete with interior streets, utilities, parking and an onsite water quality treatment basin.

SUBSURFACE EXPLORATION

Subsurface Exploration

Subsurface exploration within the subject site was performed on October 13, 2021, for the exploratory excavations. A truck mounted hollow-stem-auger drill rig was utilized to drill six (6) borings throughout the site to a maximum depth of 10 feet. The exploratory holes were excavated for geotechnical evaluation purposes with respect to the proposed developments and to interpret whether groundwater or impermeable soil layers were present. An underground utilities clearance was obtained from Underground Service Alert of Southern California, prior to the subsurface exploration. The approximate locations of the exploratory excavations are shown on the attached Infiltration Location Map, Plate 1 and descriptive logs are presented in Appendix A.

Earth materials encountered during exploration were classified and logged in general accordance with the Standard Practice for Description and Identification of Soils (Visual-Manual Procedure) of ASTM D 2488. Upon completion of laboratory testing, exploratory logs and sample descriptions may have been reconciled to reflect laboratory test results with regard to ASTM D 2487.

Earth Materials

A general description of the earth materials observed on site is provided below.

Quaternary Gravel (Qg): Quaternary Gravel was encountered directly from the surface to a maximum depth of 15 feet. This bedrock unit consists predominately of interbedded gray to medium brown, fine to medium grained silty sand, fine to coarse grained sandstone, with occasional siltstone and claystone layers.

INFILTRATION TESTING

The double ring infiltrometer test method was utilized to perform a total of two (2) infiltration tests on October 22, 2021 to evaluate near surface infiltration rates in order to estimate the amount of storm water runoff that can infiltrate into the onsite water quality treatment plan areas. The infiltration tests were performed in general accordance with the requirements of double ring infiltration testing, ASTM D3385 and the guidelines of the San Bernardino County Local Agency Management Program (LAMP).

The infiltration tests were performed using double ring infiltrometer and Mariotte tubes at a depth of 3 feet below existing grades. The locations of the infiltration tests are indicated on the attached infiltration Location Map, Plate 1. The double ring infiltrometer tests were located by property boundary measurement on the site plan and by using geographic features. Infiltration test data recorded in the field are summarized in the following table and is included within Appendix B including the graph of Infiltration Rate versus Elapsed Time.

Infiltration Test Summary

TEST NUMBER	INFILTRATION HOLE DEPTH (ft.)	INFILTRATION RATE (in/hr)	DESCRIPTION
DR-1	5	6.48	Poorly Graded SAND
DR-2	5	-*	Poorly Graded SAND

* Reliable testing data was unable to be obtained as water infiltrated at too fast a rate to measure

The infiltration test rate was 6.48 inches per hour (in/hr).

CONCLUSIONS AND RECOMMENDATIONS

General

From geotechnical and engineering geologic points of view, the proposed WQMP areas, where tested, is considered suitable for infiltration for the proposed development, provided the following conclusions and recommendations are incorporated into the plans and are implemented during construction.

Groundwater

Groundwater was not observed during our subsurface exploration to a total depth of 10 feet. Potential groundwater impact is considered very low. Local well data indicates regional groundwater highs approximately 50 feet below existing surface, which meets the minimum separation of >10 feet from the bottom of infiltration facility to the groundwater mark.

Geologic/ Geotechnical Screening

The proposed WQMP areas (see Plate 1) are located at a lower elevation than the proposed structures in competent native earth materials.

The proposed structures will be supported by compacted fill and competent earth materials, with groundwater at a depth of approximately 50 feet. According to the County of San Bernardino reports, the subject site is located in an area where liquefaction potential is considered low. As such, the potential for earthquake induced liquefaction and lateral spreading beneath the proposed structures is considered low due to the recommended compacted fill, relatively low groundwater level, and the dense nature of the deeper onsite earth materials.

Preliminary laboratory test results indicate onsite earth materials exhibit an expansion potential of **VERY LOW** as classified in accordance with 2019 CBC Section 1803.5.3 and ASTM D4829.

Therefore, infiltration within the proposed WQMP areas will not encroach on any proposed structures and will not increase the risk of geologic hazards.

Recommended Factor of Safety

The recommended factor of safety for the infiltration design is 3.

Based on the data presented in this report and the recommendations set forth herein, it is the opinion of Earth Strata Geotechnical Services that the WQMP area can be designed for an infiltration rate of 2.16 inches per hour in the vicinity of DR-1 and DR-2.

GRADING PLAN REVIEW AND CONSTRUCTION SERVICES

This report has been prepared for the exclusive use of **Mr. Viraj Patel** and their authorized representative. It likely does not contain sufficient information for other parties or other uses. Earth Strata should be engaged to review the final design plans and specifications prior to construction. This is to verify that the recommendations contained in this report have been properly incorporated into the project plans and specifications. Should Earth Strata not be accorded the opportunity to review the project plans and specifications, we are not responsible for misinterpretation of our recommendations.

Earth Strata should be retained to provide observations during construction to validate this report. In order to allow for design changes in the event that the subsurface conditions differ from those anticipated prior to construction.

Earth Strata should review any changes in the project and modify and approve in writing the conclusions and recommendations of this report. This report and the drawings contained within are intended for design input purposes only and are not intended to act as construction drawings or specifications. In the event that conditions encountered during grading or construction operations appear to be different than those indicated in this report, this office should be notified immediately, as revisions may be required.

REPORT LIMITATIONS

Our services were performed using the degree of care and skill ordinarily exercised, under similar circumstances, by reputable soils engineers and geologists, practicing at the time and location this report was prepared. No other warranty, expressed or implied, is made as to the conclusions and professional advice included in this report.

Earth materials vary in type, strength, and other geotechnical properties between points of observation and exploration. Groundwater and moisture conditions can also vary due to natural processes or the works of man on this or adjacent properties. As a result, we do not and cannot have complete knowledge of the subsurface conditions beneath the subject property. No practical study can completely eliminate uncertainty with regard to the anticipated geotechnical conditions in connection with a subject property.

The conclusions and recommendations within this report are based upon the findings at the points of observation and are subject to confirmation by Earth Strata during construction. This report is considered valid for a period of one year from the time the report was issued.

This report was prepared with the understanding that it is the responsibility of the owner or their representative, to ensure that the conclusions and recommendations contained herein are brought to the attention of the other project consultants and are incorporated into the plans and specifications. The owners' contractor should properly implement the conclusions and recommendations during grading and construction, and notify the owner if they consider any of the recommendations presented herein to be unsafe or unsuitable.

Respectfully submitted,

EARTH STRATA GEOTECHNICAL SERVICES

Stephen M. Poole, PE 40219
President
Principal Engineer

SMP/jmr

Distribution: (1) Addressee

Attachments: Figure 1 – Vicinity Map (*Rear of Text*)
Appendix A – Exploratory Logs (*Rear of Text*)
Appendix B – Infiltration Test Sheets (*Rear of Text*)
Appendix C – Historic Groundwater Data (*Rear of Text*)
Plate 1 – Infiltration Location Map (*Rear of Text*)

FIGURE 1
VICINITY MAP

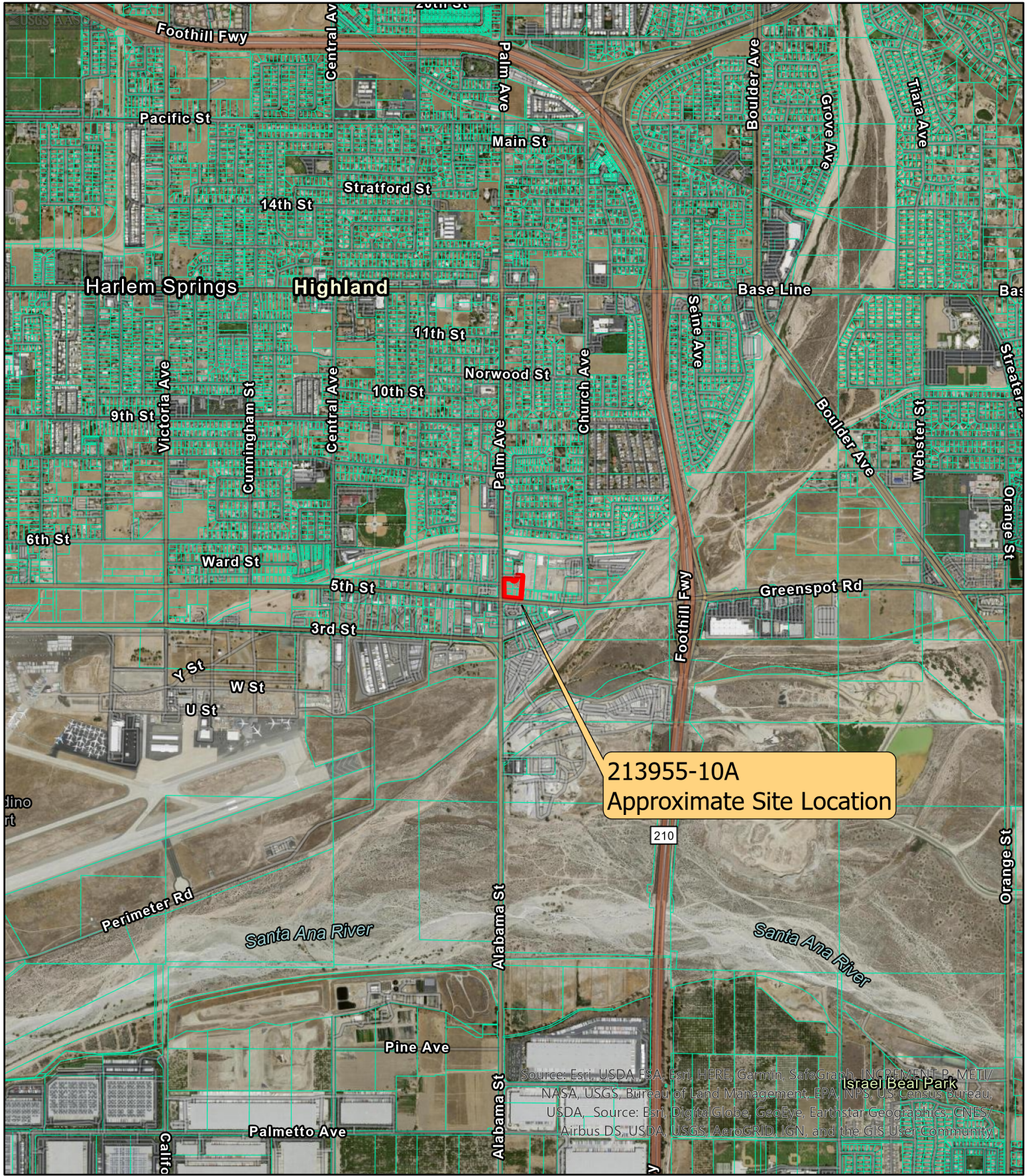

213955-10A
Approximate Site Location

Source: Esri, USDA FSA, Esri, HERE, Garmin, SafeGraph, INCREMENT P, METI/
NASA, USGS, Bureau of Land Management, EPA, NPS, US Census Bureau,
USDA, Source: Esri, DigitalGlobe, GeoEye, Earthstar Geographics, CNES/
Airbus DS, USDA, USGS, AeroGRID, IGN, and the GIS User Community

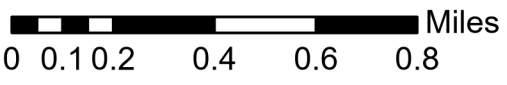

Earth Strata Geotechnical Services, Inc.
Geotechnical, Environmental and Materials Testing Consultants
www.ESGSINC.com (951) 397-8315

APPENDIX A
EXPLORATORY LOGS

Geotechnical Boring Log B-1

Date: October 13, 2021	Project Name: Palm Avenue, Highland	Page: 1 of 1
Project Number: 213955-10B	Logged By: JMR	
Drilling Company: Drilling It	Type of Rig: B-61	
Drive Weight (lbs): 140	Drop (in): 30	Hole Diameter (in): 8
Top of Hole Elevation (ft): See Map	Hole Location: See Geotechnical Map	

Depth (ft)	Blow Count Per Foot	Sample Depth	Dry Density (pcf)	Moisture (%)	Classification Symbol	MATERIAL DESCRIPTION
0						<u>Topsoil</u>
					SM	Silty SAND; light brown, dry, loose, fine to coarse sand
	19	2.5'	106.1	1.3		<u>Quaternary Alluvial Sand and Clay of Valley Areas (Qa)</u>
					SP-SM	Poorly-Graded SAND with Silt; light to dark brown, dry, medium dense, medium to co
5						Dense 5 to 7 feet
	48	5'	97.7	2.1		
	50/4"	7.5'	121.6	1.4		Becomes very dense, gravel and cobbles below 7 feet
10						
	50/6"	10'	-	4.5		Practical Refusal at 10.5 feet
						Total Depth: 10.5 feet
						No Groundwater
15						
20						
25						
30						

42184 Remington Avenue, Temecula, CA 92590

Earth Strata Geotechnical Services, Inc.

Geotechnical, Environmental and Materials Testing Consultants

www.ESGSINC.com (951) 397-8315

Geotechnical Boring Log B-2

Date: October 13, 2021	Project Name: Palm Avenue, Highland	Page: 1 of 1
Project Number: 213955-10B	Logged By: JMR	
Drilling Company: Drilling It	Type of Rig: B-61	
Drive Weight (lbs): 140	Drop (in): 30	Hole Diameter (in): 8
Top of Hole Elevation (ft): See Map	Hole Location: See Geotechnical Map	

Depth (ft)	Blow Count Per Foot	Sample Depth	Dry Density (pcf)	Moisture (%)	Classification Symbol	MATERIAL DESCRIPTION
0						<u>Topsoil</u>
					SM	Silty SAND; light brown, dry, loose, fine to coarse sand
	30	2.5'	110.0	1.5		<u>Quaternary Alluvial Sand and Clay of Valley Areas (Qa)</u>
					SM	Silty SAND; dark brown, dry, medium dense, medium to coarse sand
5					SP	Poorly-Graded SAND; light to dark brown, dry, very dense, coarse sand with gravel
	68/11"	5'	101.4	2.3		
		5-10'				
	50/4"	7.5'	-	1.3		
10						Practical Refusal at 10 feet
						Total Depth: 10 feet
						No Groundwater
15						
20						
25						
30						

Geotechnical Boring Log B-3

Date: October 13, 2021	Project Name: Palm Avenue, Highland	Page: 1 of 1
Project Number: 213955-10B	Logged By: JMR	
Drilling Company: Drilling It	Type of Rig: B-61	
Drive Weight (lbs): 140	Drop (in): 30	Hole Diameter (in): 8
Top of Hole Elevation (ft): See Map	Hole Location: See Geotechnical Map	

Depth (ft)	Blow Count Per Foot	Sample Depth	Dry Density (pcf)	Moisture (%)	Classification Symbol	MATERIAL DESCRIPTION
0						<u>Topsoil</u>
					SM	Silty SAND; light brown, dry, loose, fine to coarse sand
	28	2.5'	-	1.1		<u>Quaternary Alluvial Sand and Clay of Valley Areas (Qa)</u>
					SM	Silty SAND; light to dark brown, dry, medium dense, medium to coarse sand
5					SP-SM	Poorly-Graded SAND with Silt; light brown, dry, very dense, coarse sand with gravel and
	65/8"	5'	-	1.3		
						Total Depth: 7 feet
						No Groundwater
10						
15						
20						
25						
30						

42184 Remington Avenue, Temecula, CA 92590

Earth Strata Geotechnical Services, Inc.

Geotechnical, Environmental and Materials Testing Consultants

www.ESGSINC.com (951) 397-8315

Geotechnical Boring Log B-4

Date: October 13, 2021	Project Name: Palm Avenue, Highland	Page: 1 of 1
Project Number: 213955-10B	Logged By: JMR	
Drilling Company: Drilling It	Type of Rig: B-61	
Drive Weight (lbs): 140	Drop (in): 30	Hole Diameter (in): 8
Top of Hole Elevation (ft): See Map	Hole Location: See Geotechnical Map	

Depth (ft)	Blow Count Per Foot	Sample Depth	Dry Density (pcf)	Moisture (%)	Classification Symbol	MATERIAL DESCRIPTION
0						<u>Topsoil</u>
					SM	Silty SAND; light brown, dry, loose, fine to coarse sand
	10	2.5'	-	1.2		<u>Quaternary Alluvial Sand and Clay of Valley Areas (Qa)</u>
					SM	Silty SAND; dark brown, dry, loose, medium to coarse sand
5					SP-SM	Poorly-Graded SAND with Silt; light brown, dry, very dense, coarse sand with gravel and
	58/11"	5'	-	-		No Recovery at 5 feet
	50/4"	7.5'	-	1.5		Practical Refusal at 8 feet
						Total Depth: 8 feet
10						No Groundwater
15						
20						
25						
30						

42184 Remington Avenue, Temecula, CA 92590

Earth Strata Geotechnical Services, Inc.
 Geotechnical, Environmental and Materials Testing Consultants
www.ESGSINC.com (951) 397-8315

Geotechnical Boring Log B-5

Date: October 13, 2021	Project Name: Palm Avenue, Highland	Page: 1 of 1
Project Number: 213955-10B	Logged By: JMR	
Drilling Company: Drilling It	Type of Rig: B-61	
Drive Weight (lbs): 140	Drop (in): 30	Hole Diameter (in): 8
Top of Hole Elevation (ft): See Map	Hole Location: See Geotechnical Map	

Depth (ft)	Blow Count Per Foot	Sample Depth	Dry Density (pcf)	Moisture (%)	Classification Symbol	MATERIAL DESCRIPTION
0						<u>Topsoil</u>
					SM	Silty SAND; light brown, dry, loose, fine to coarse sand
	14	2.5'	-	1.5		<u>Quaternary Alluvial Sand and Clay of Valley Areas (Qa)</u>
					SM	Silty SAND; dark brown, dry, loose, medium to coarse sand
5					SP-SM	Poorly-Graded SAND with Silt; light brown, dry, dense, coarse sand with gravel and co
	34	5'	108.4	1.5		
						Becomes very dense at 7 feet
	50/4"	7.5'	-	0.9		Practical Refusal at 8 feet
						Total Depth: 8 feet
10						No Groundwater
15						
20						
25						
30						

Geotechnical Boring Log B-6

Date: October 13, 2021	Project Name: Palm Avenue, Highland	Page: 1 of 1
Project Number: 213955-10B	Logged By: JMR	
Drilling Company: Drilling It	Type of Rig: B-61	
Drive Weight (lbs): 140	Drop (in): 30	Hole Diameter (in): 8
Top of Hole Elevation (ft): See Map	Hole Location: See Geotechnical Map	

Depth (ft)	Blow Count Per Foot	Sample Depth	Dry Density (pcf)	Moisture (%)	Classification Symbol	MATERIAL DESCRIPTION
0		0-5'				<u>Topsoil</u>
					SM	Silty SAND; light brown, dry, loose, fine to coarse sand
	50/6"	2.5'	-	-		<u>Quaternary Alluvial Sand and Clay of Valley Areas (Qa)</u>
					SM	Silty SAND; reddish brown, dry, very dense, medium to coarse sand
						No Recovery at 2.5 feet
5	50/4"	5'	108.6	0.9		Practical Refusal at 5.5 feet
						Total Depth: 5.5 feet
						No Groundwater
10						
15						
20						
25						
30						

42184 Remington Avenue, Temecula, CA 92590

Earth Strata Geotechnical Services, Inc.

Geotechnical, Environmental and Materials Testing Consultants

www.ESGSINC.com (951) 397-8315

APPENDIX B
INFILTRATION TEST SHEETS

Turf-Tec International - Record Chart for IN10-W - (12 & 24 Inch Infiltration Rings)

Test No. DR-1 **Location** See Map

Project Identification: Palm and Meines - Highland		Constants		Depth of Liquid Container		Mariotte Tube Volume	
Test Location: DR-1		Inner Ring	Annular Ring	Inner Infiltration Rate cm/h	Annular Infiltration Rate cm/h	Inner Infiltration Rate in/h	Annular Infiltration Rate in/h
Liquid Used: TAP WATER	pH: 8.0						
Tested By: JMR	Date: 10/22/2021	Liquid level maintained (X) Flow Valve () Floate Valve () Mariotte Tubes		Area cm²		Depth of Liquid (cm)	
Depth to water table:		Penetration Depth of Outer Ring:		9 cm		Other	
	Depth of Test	3					

Earth Strata Geotechnical Services, Inc.
 Geotechnical, Environmental and Materials Testing Consultants
 www.ESGSINC.com (951) 397-8315

Trial #	Start / End	Date MM/DD/YY	Time HR:MIN	Time Increment (Total)	Elapsed Time (Min)	Flow Readings				Infiltration Rates			Ground Temperature		Remarks	
						Inner Ring Reading cm	Inner Mariotte Tube Flow (ml)	Annular Space Reading cm	Annular Space Mariotte Tube Flow (ml)	Inner Infiltration Rate cm/h	Inner Infiltration Rate in/h	Annular Infiltration Rate cm/h	Annular Infiltration Rate in/h	Ground Temp Depth (cm)		Temp at Depth (c)
	Start Test	10/22/2021	9:55	0:10												
1	End Test	10/22/2021	10:05	0:10	10	5.00	3000	6.00	16,500	24.69	9.72	45.23	17.81			
	Start Test	10/22/2021	10:05	0:10												
2	End Test	10/22/2021	10:15	0:20	20	6.00	2,000	6.00	18,700	16.46	6.48	51.26	20.18			
	Start Test	10/22/2021	10:15	0:10												
3	End Test	10/22/2021	10:25	0:30	30	6.00	2,000	6.00	18,200	16.46	6.48	49.89	19.64			
	Start Test	10/22/2021	10:25	0:10												
4	End Test	10/22/2021	10:35	0:40	40	6.00	2,100	6.00	38,100	17.28	6.80	104.43	41.11			
	Start Test	10/22/2021	10:35	0:10												
5	End Test	10/22/2021	10:45	0:50	50	6.00	2,000	6.00	20,800	16.46	6.48	57.01	22.45			
	Start Test	10/22/2021	10:45	0:10												
6	End Test	10/22/2021	10:55	1:00	60	6.00	2,000	6.00	19,600	16.46	6.48	53.72	21.15			
	Start Test	10/22/2021	10:55	0:10												
7	End Test	10/22/2021	11:05	1:10	70	6.00	2,000	6.00	19,600	16.46	6.48	53.72	21.15			
	Start Test	10/22/2021	11:05	0:10												
8	End Test	10/22/2021	11:15	1:20	80	6.00	2,000	6.00	19,600	16.46	6.48	53.72	21.15			
	Start Test	10/22/2021	11:15	0:10												
9	End Test	10/22/2021	11:25	1:30	90	6.00	2,000	6.00	19,600	16.46	6.48	53.72	21.15			
	Start Test	10/22/2021	11:25	0:10												
10	End Test	10/22/2021	11:35	1:40	100	6.00	2,000	6.00	19,600	16.46	6.48	53.72	21.15			
	Start Test	10/22/2021	11:35	0:10												
11	End Test	10/22/2021	11:45	1:50	110	6.00	2,100	6.00	19,500	17.28	6.80	53.45	21.04			
	Start Test	10/22/2021	11:45	0:10												
12	End Test	10/22/2021	11:55	2:00	120	6.00	2,000	6.00	19,500	16.46	6.48	53.45	21.04			
	Start Test															
	End Test															
	Start Test															
	End Test															
	Start Test															
	End Test															
	Start Test															
	End Test															
	Start Test															
	End Test															
	Start Test															
	End Test															
	Start Test															
	End Test															



Project Identification:	Palm and Meines - Highland	
Test Location:	DR-1	
Liquid Used:	TAP WATER	pH: 8.0
Tested By:	JMR	
Depth to water table:	0	



ELAPSED TIME VS. INFILTRATION RATE

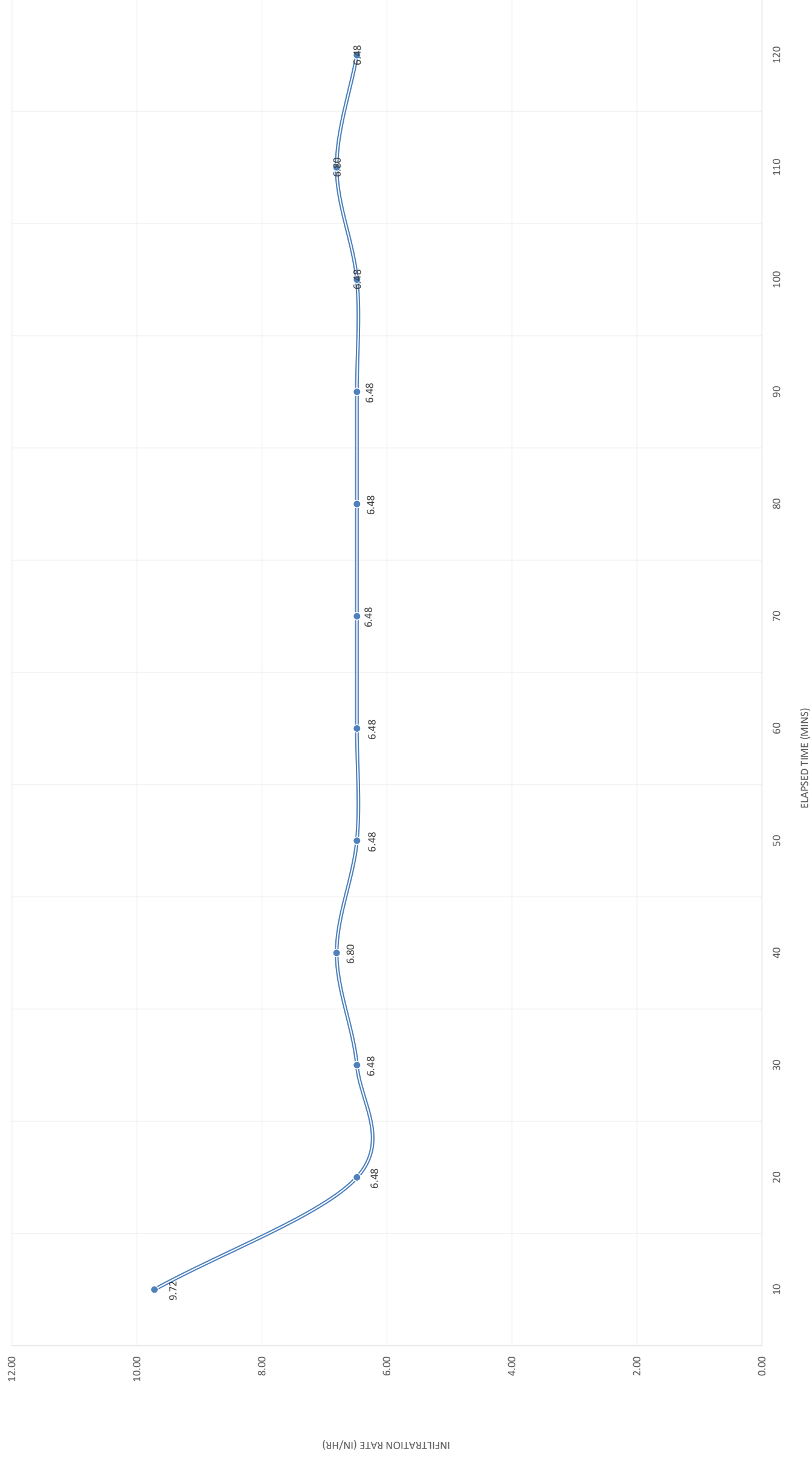

Turf-Tec International - Record Chart for IN10-W - (12 & 24 Inch Infiltration Rings)

Project Identification: Palm and Meines - Highland
Test Location: DR-2
Liquid Used: TAP WATER
Tested By: JMR

Constants
 Inner Ring
 Annular Ring

Area cm2
 729
 2189

Depth of Liquid Container
 Number
 1
 2

Mariotte Tube Volume
 3000
 10000

Earth Strata Geotechnical Services, Inc.
 Geotechnical, Environmental and Materials Testing Consultants
 www.ESGSIINC.com (951) 397-8315

Liquid level maintained (X) Flow Valve () Mariotte Tubes
 Penetration Depth of Outer Ring: 9 cm Other

Test No.	DR-2	Location	See Map	Date MM/DD/YY	Time HR:MIN	Time Increment / (Total)	Elapsed Time (Min)	Flow Readings			Infiltration Rates			Ground Temperature		Remarks				
								Inner Ring Reading cm	Inner Mariotte Tube Flow (ml)	Annular Space Reading cm	Annular Space Mariotte Tube Flow (ml)	Liquid Temp of	Inner Infiltration Rate cm/h	Inner Infiltration Rate in/h	Annular Infiltration Rate cm/h		Annular Infiltration Rate in/h	Ground Temp Depth (cm)	Temp at Depth (c)	
1	Start Test	10/22/2021	12:20	0:10	0:10	10	6.00	16200	6.00	23,100										
																	End Test	10/22/2021	12:30	0:10
2	Start Test	10/22/2021	12:40	0:20	20	6.00	13,000	6.00	21,000											
																	End Test	10/22/2021	13:15	0:10
3	Start Test	10/22/2021	13:25	0:30	30	6.00	12,500	6.00	21,000											
																	End Test	10/22/2021	13:25	0:10
4	Start Test	10/22/2021	13:35	0:40	40	6.00	12,000	6.00	21,000											
																	End Test	10/22/2021	13:35	0:40
	Start Test																			
	End Test																			



Project Identification:	Palm and Meines - Highland	
Test Location:	DR-2	
Liquid Used:	TAP WATER	pH: 8.0
Tested By:	JMR	
Depth to water table:	> 30 Feet	

ELAPSED TIME VS. INFILTRATION RATE

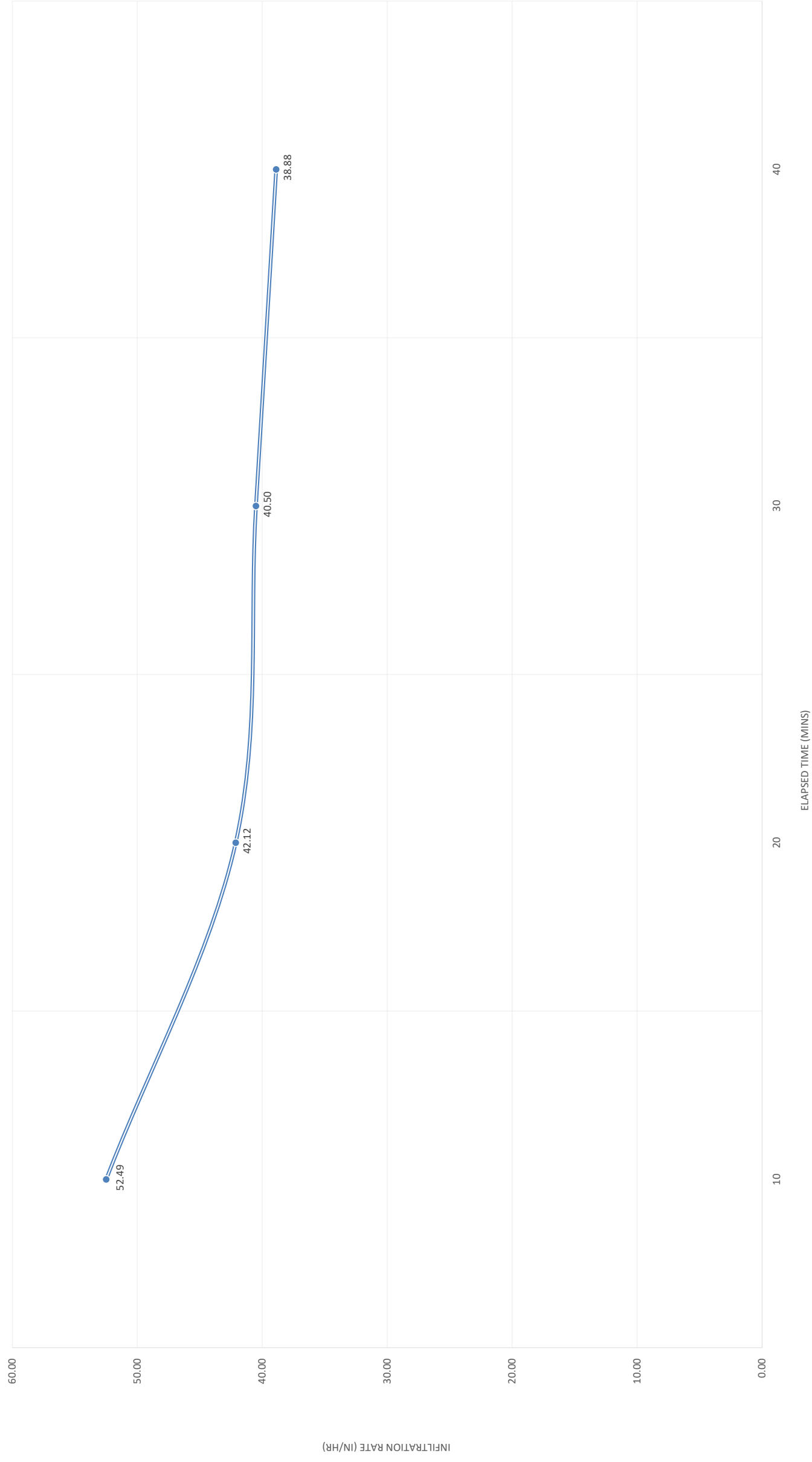

APPENDIX C
HISTORIC GROUNDWATER
DATA



Groundwater Level Report

Station 341070N1172268W001

Station Data Groundwater Level Data

State Well Number:	01S03W05N006S
Local Well Name:	
Site Code:	341070N1172268W001
Latitude (NAD83):	34.107
Longitude (NAD83):	-117.2268
Basin Subbasin Name (Code):	San Bernardino (8-002.06)
Well Use Type:	Unknown
Well Status:	Active
WCR Number:	
Reference Point Elevation (NAVD88 ft):	1145.500
Ground Surface Elevation (NAVD88 ft):	1145.500
Well Depth (feet bgs):	
Perforated Interval Depths (feet bgs):	

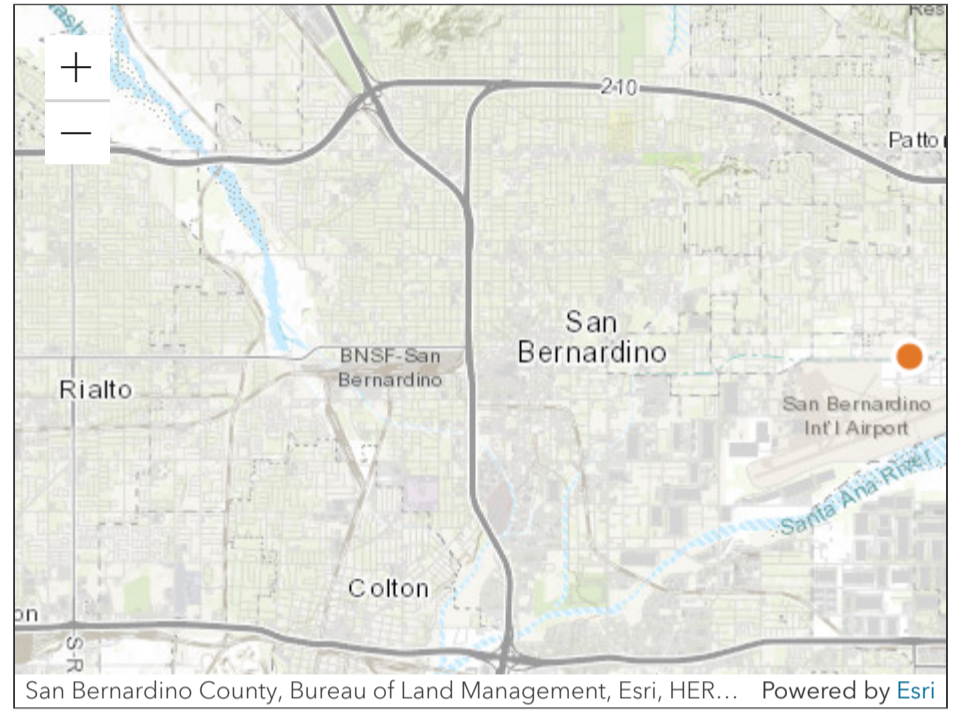



[Back to Search](#)

Groundwater Level Report

Station 341070N1172268W001

Station Data **Groundwater Level Data**

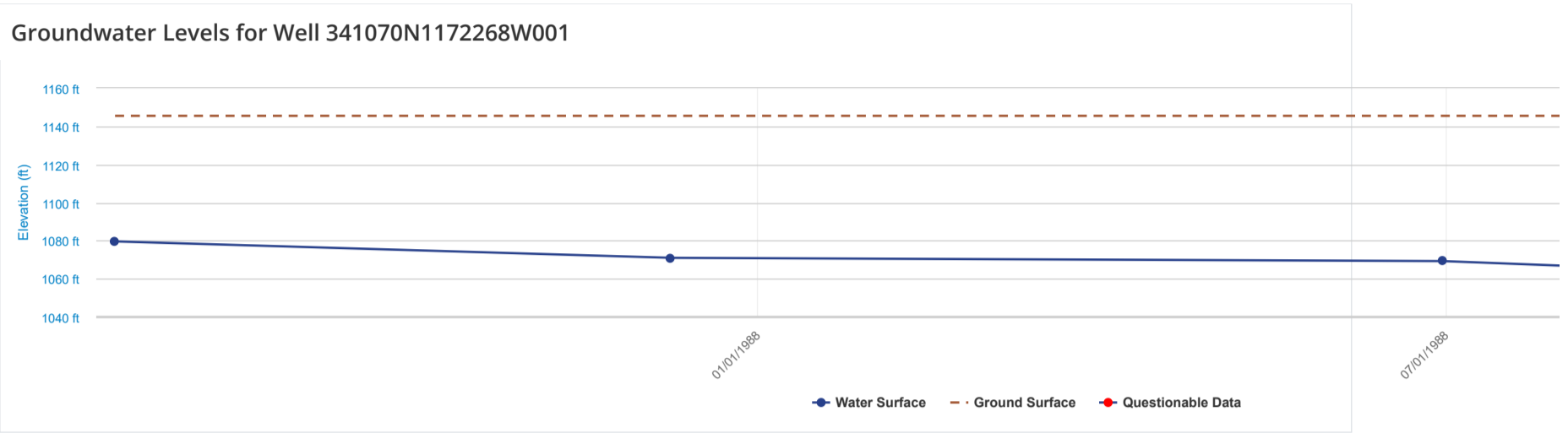



[Download Data](#)

Measurement Date (PST)	Reference Point Elevation	Ground Surface Elevation	Distance from RP to WS	Groundwater Elevation	Ground Surface to Water Surface	Measurement Issue	Collecting Agency	Water Level Measurement Comments
07/15/1987 00:00:00	1145.500	1145.500	65.9	1079.6	65.9		Department of Water Resou...	
12/09/1987 00:00:00	1145.500	1145.500	74.51	1070.99	74.51		Department of Water Resou...	
06/30/1988 00:00:00	1145.500	1145.500	76.23	1069.27	76.23		Department of Water Resou...	
11/23/1988 00:00:00	1145.500	1145.500	87.3	1058.2	87.3		Department of Water Resou...	
4 records								

LEGEND
Locations are Approximate

Symbols

-  - Limits of Report
-  - Double Ring Test Location

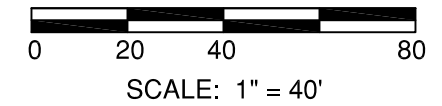

INFILTRATION MAP

LOCATED ON THE SOUTHWEST CORNER OF PALM AVENUE AND MEINES STREET
CITY OF HIGHLAND, SAN BERNARDINO COUNTY, CALIFORNIA
APN 1201-311-02, 1201-311-03, 1201-311-04, 1201-311-05, 1201-301-14, 1201-301-15, & 1201-301-19

PROJECT	PROPOSED COMMERCIAL DEVELOPMENT		
CLIENT	MR. JEAN EDY MATLOCK		
PROJECT NO.	213955-12A		
DATE	OCTOBER 2021		
SCALE	1" = 40'		
DWG XREFS			
REVISION			
DRAWN BY	JDG	PLATE	1 OF 1

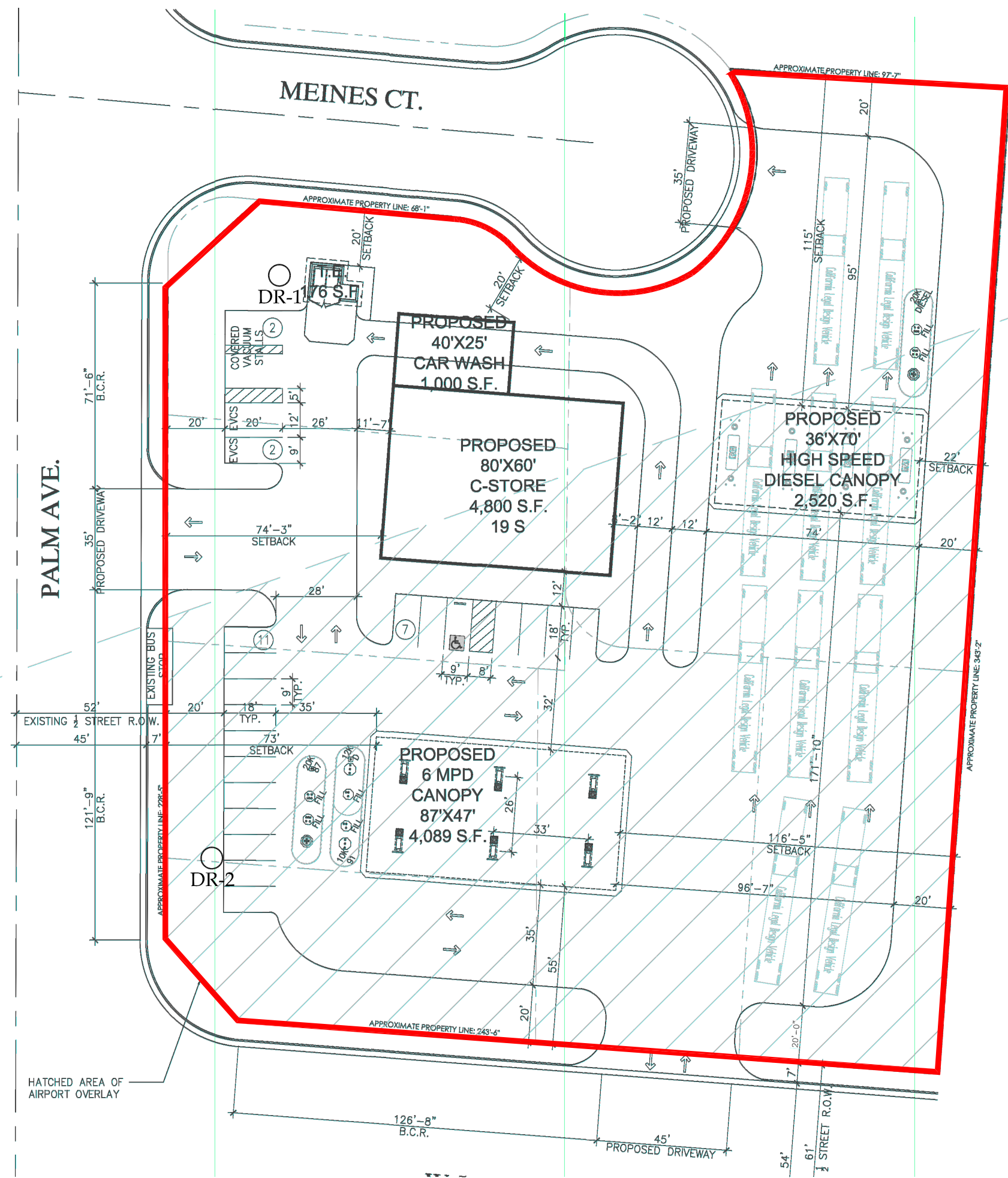

Attachment 5: Stormwater Facilities Mapping

Please refer to the attached references.



WQMP Project Report

County of San Bernardino Stormwater Program

Santa Ana River Watershed Geodatabase

Friday, October 29, 2021

Note: The information provided in this report and on the Stormwater Geodatabase for the County of San Bernardino Stormwater Program is intended to provide basic guidance in the preparation of the applicant's Water Quality Management Plan (WQMP) and should not be relied upon without independent verification.

Project Site Parcel Number(s):	120130116, 120130116, 120130119, 120131103, 120130114, 120130115, 120131102, 120131104, 120131105
Project Site Acreage:	4.782
HCOC Exempt Area:	Yes. Verify that the project is completely within the HCOC exemption area.
Closest Receiving Waters: <small>(Applicant to verify based on local drainage facilities and topography.)</small>	System Number - 603 Facility Name - City Creek Channel Owner - SBCFCD
Closest channel segment's susceptibility to Hydromodification:	EHM
Highest downstream hydromodification susceptibility:	High
Is this drainage segment subject to TMDLs?	No
Are there downstream drainage segments subject to TMDLs?	No
Is this drainage segment a 303d listed stream?	No
Are there 303d listed streams downstream?	Yes
Are there unlined downstream waterbodies?	No
Project Site Onsite Soil Group(s):	A
Environmentally Sensitive Areas within 200':	None
Groundwater Depth (FT):	-234
Parcels with potential septic tanks within 1000':	No
Known Groundwater Contamination Plumes within 1000':	No
Studies and Reports Related to Project Site:	CSDP #6 Existing Facilities and Capacities CSDP No. 6 Volume II CSDP No. 6 Deficiency Analysis CSDP No. 6 Deficiency Analysis CSDP No. 6 Existing Facilities CSDP No. 6 Proposed Master Planned Facilities CSDP No. 6 Volume I CSDP No. 7 Storm Drain Systems CSDP No. 7 Storm Drain Systems CSDP No. 7 Storm Drain Systems CSDP No. 7 Storm Drain Hydraulic Design Data SBVMWD High Groundwater / Pressure Zone Area

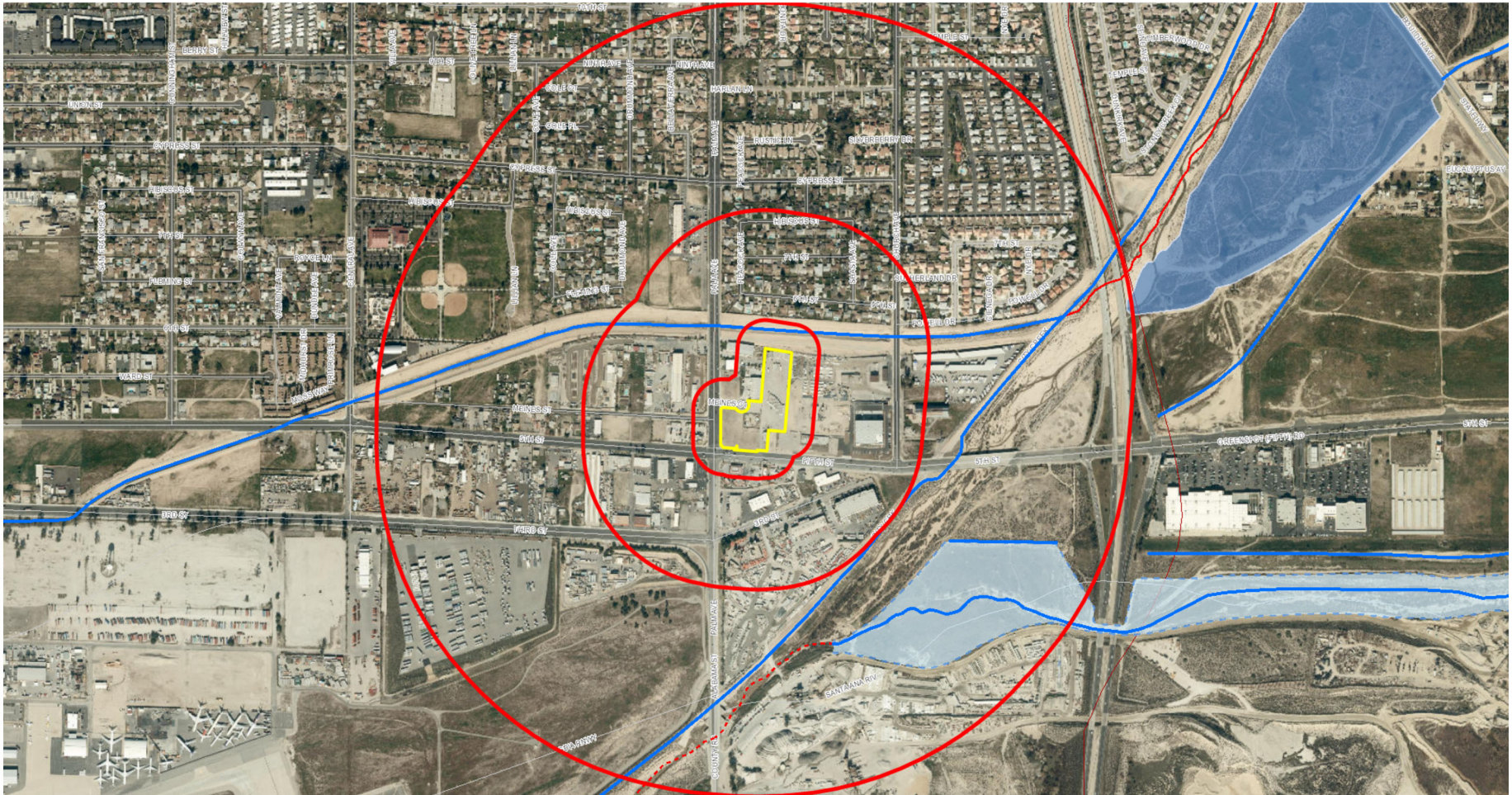

0.2 Miles



Site Address: permitrack.sbcounty.gov/wap

County of San Bernardino
Stormwater Facility Mapping
Stormwater Map

Figure F-1

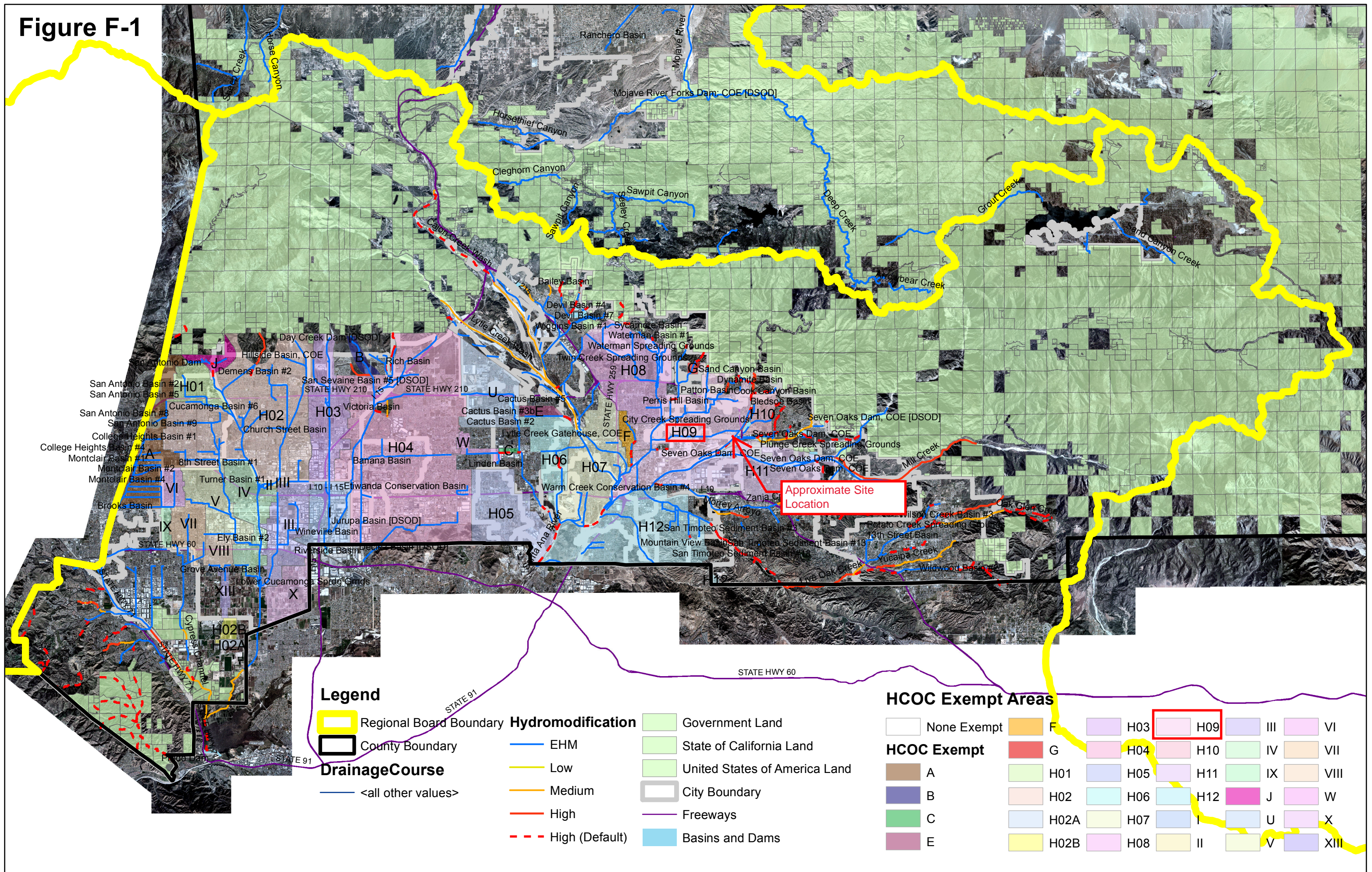

Legend

- Regional Board Boundary
- County Boundary
- Drainage Course**
- <all other values>

Hydromodification

- EHM
- Low
- Medium
- High
- High (Default)

- Government Land
- State of California Land
- United States of America Land
- City Boundary
- Freeways
- Basins and Dams

HCOC Exempt Areas

- | | | | | | | | | | | | | | | | | | | | | | | | | |
|---|---|---|---|---|---|---|---|---|---|---|---|---|--|---|--|---|--|---|--|--|---|--|---|--|
| None Exempt | F | H03 | H04 | H05 | H06 | H07 | H08 | H09 | H10 | H11 | H12 | I | II | III | IV | V | VI | VII | VIII | IX | X | XI | XII | XIII |
|---|---|---|---|---|---|---|---|---|---|---|---|---|--|---|--|---|--|---|--|--|---|--|---|--|

Hydromodification

A.1 Hydrologic Conditions of Concern (HCOC) Analysis

HCOC Exemption:

1. **Sump Condition:** All downstream conveyance channel to an adequate sump (for example, Prado Dam, Santa Ana River, or other Lake, Reservoir or naturally erosion resistant feature) that will receive runoff from the project are engineered and regularly maintained to ensure design flow capacity; no sensitive stream habitat areas will be adversely affected; or are not identified on the Co-Permittees Hydromodification Sensitivity Maps.
2. **Pre = Post:** The runoff flow rate, volume and velocity for the post-development condition of the Priority Development Project do not exceed the pre-development (i.e, naturally occurring condition for the 2-year, 24-hour rainfall event utilizing latest San Bernardino County Hydrology Manual.
 - a. Submit a substantiated hydrologic analysis to justify your request.
3. **Diversion to Storage Area:** The drainage areas that divert to water storage areas which are considered as control/release point and utilized for water conservation.
 - a. See Appendix F for the HCOC Exemption Map and the on-line Watershed Geodatabase (<http://sbcounty.permitrack.com/wap>) for reference.
4. **Less than One Acre:** The Priority Development Project disturbs less than one acre. The Co-permittee has the discretion to require a Project Specific WQMP to address HCOCs on projects less than one acre on a case by case basis. The project disturbs less than one acre and is not part of a common plan of development.
5. **Built Out Area:** The contributing watershed area to which the project discharges has a developed area percentage greater than 90 percent.
 - a. See Appendix F for the HCOC Exemption Map and the on-line Watershed Geodatabase (<http://sbcounty.permitrack.com/wap>) for reference.

Summary of HCOC Exempted Area

	HCOC Exemption reasoning				
	1	2	3	4	5
Area					
A			X		X
B			X		
C					X
E			X		
F					X
G			X		X
H01	X		X		
H02	X		X		
H02A	X		X		
H02B			X		
H03			X		
H04	X		X		
H05	X				
H06			X		
H07	X				
H08	X		X		
H09	X				
H10	X		X		
H11	X		X		
H12	X				
J			X		
U			X		
W			X		
I			X		
II			X		
III					X
IV			X		X
V			X*		
VI					X
VII					X
VIII			X		
IX					X
X			X		
XIII			X		

*Detention/Conservation Basin

Attachment 6: Drainage Analysis References

Please refer to the attached references.



POINT PRECIPITATION FREQUENCY ESTIMATES

Sanja Perica, Sarah Dietz, Sarah Heim, Lillian Hiner, Kazungu Maitaria, Deborah Martin, Sandra Pavlovic, Ishani Roy, Carl Trypaluk, Dale Unruh, Fenglin Yan, Michael Yekta, Tan Zhao, Geoffrey Bonnin, Daniel Brewer, Li-Chuan Chen, Tye Parzybok, John Yarchoan

NOAA, National Weather Service, Silver Spring, Maryland

[PF_tabular](#) | [PF_graphical](#) | [Maps_&_aerials](#)

PF tabular

PDS-based point precipitation frequency estimates with 90% confidence intervals (in inches) ¹										
Duration	Average recurrence interval (years)									
	1	2	5	10	25	50	100	200	500	1000
5-min	0.103 (0.086-0.125)	0.135 (0.112-0.164)	0.178 (0.148-0.217)	0.214 (0.176-0.264)	0.266 (0.211-0.338)	0.307 (0.239-0.399)	0.351 (0.266-0.467)	0.397 (0.292-0.545)	0.463 (0.327-0.663)	0.517 (0.352-0.766)
10-min	0.148 (0.123-0.179)	0.193 (0.161-0.235)	0.255 (0.211-0.311)	0.307 (0.253-0.378)	0.381 (0.303-0.485)	0.440 (0.342-0.572)	0.503 (0.381-0.670)	0.569 (0.419-0.781)	0.664 (0.469-0.950)	0.741 (0.505-1.10)
15-min	0.179 (0.149-0.217)	0.234 (0.194-0.284)	0.309 (0.256-0.376)	0.372 (0.305-0.457)	0.461 (0.366-0.587)	0.532 (0.414-0.692)	0.608 (0.461-0.810)	0.688 (0.507-0.944)	0.803 (0.567-1.15)	0.896 (0.610-1.33)
30-min	0.268 (0.223-0.326)	0.351 (0.291-0.426)	0.463 (0.384-0.565)	0.558 (0.458-0.686)	0.691 (0.549-0.880)	0.799 (0.621-1.04)	0.912 (0.691-1.22)	1.03 (0.760-1.42)	1.20 (0.850-1.72)	1.34 (0.916-1.99)
60-min	0.391 (0.325-0.475)	0.512 (0.425-0.622)	0.676 (0.560-0.824)	0.814 (0.668-1.00)	1.01 (0.801-1.28)	1.17 (0.905-1.52)	1.33 (1.01-1.77)	1.51 (1.11-2.07)	1.76 (1.24-2.52)	1.96 (1.34-2.91)
2-hr	0.561 (0.467-0.682)	0.721 (0.599-0.877)	0.936 (0.775-1.14)	1.11 (0.915-1.37)	1.36 (1.08-1.73)	1.56 (1.21-2.02)	1.76 (1.33-2.34)	1.97 (1.45-2.70)	2.26 (1.60-3.23)	2.49 (1.70-3.69)
3-hr	0.690 (0.574-0.838)	0.881 (0.732-1.07)	1.13 (0.939-1.38)	1.34 (1.10-1.65)	1.63 (1.30-2.08)	1.86 (1.44-2.42)	2.09 (1.58-2.79)	2.33 (1.72-3.20)	2.66 (1.88-3.81)	2.92 (1.99-4.33)
6-hr	0.965 (0.802-1.17)	1.23 (1.02-1.49)	1.57 (1.30-1.92)	1.85 (1.52-2.28)	2.24 (1.78-2.85)	2.54 (1.97-3.30)	2.84 (2.15-3.79)	3.15 (2.32-4.33)	3.58 (2.53-5.13)	3.91 (2.67-5.80)
12-hr	1.28 (1.06-1.55)	1.64 (1.36-2.00)	2.12 (1.75-2.58)	2.50 (2.05-3.07)	3.02 (2.40-3.84)	3.42 (2.66-4.44)	3.82 (2.90-5.10)	4.24 (3.12-5.81)	4.80 (3.39-6.86)	5.23 (3.56-7.75)
24-hr	1.72 (1.53-1.99)	2.24 (1.99-2.59)	2.92 (2.58-3.38)	3.47 (3.04-4.05)	4.22 (3.57-5.08)	4.78 (3.97-5.88)	5.36 (4.34-6.75)	5.94 (4.69-7.70)	6.74 (5.10-9.08)	7.35 (5.38-10.2)
2-day	2.12 (1.88-2.44)	2.80 (2.47-3.23)	3.69 (3.25-4.26)	4.42 (3.86-5.15)	5.41 (4.58-6.51)	6.17 (5.12-7.59)	6.95 (5.63-8.75)	7.76 (6.11-10.0)	8.85 (6.70-11.9)	9.70 (7.10-13.5)
3-day	2.30 (2.04-2.65)	3.06 (2.71-3.53)	4.08 (3.60-4.72)	4.92 (4.30-5.73)	6.07 (5.14-7.31)	6.96 (5.78-8.56)	7.89 (6.39-9.93)	8.84 (6.97-11.4)	10.2 (7.69-13.7)	11.2 (8.19-15.6)
4-day	2.47 (2.19-2.85)	3.32 (2.93-3.83)	4.45 (3.92-5.15)	5.38 (4.71-6.28)	6.68 (5.66-8.05)	7.69 (6.38-9.46)	8.74 (7.08-11.0)	9.83 (7.75-12.7)	11.3 (8.58-15.3)	12.5 (9.17-17.5)
7-day	2.83 (2.51-3.26)	3.85 (3.40-4.44)	5.22 (4.60-6.04)	6.36 (5.56-7.41)	7.94 (6.72-9.56)	9.18 (7.62-11.3)	10.5 (8.48-13.2)	11.8 (9.31-15.3)	13.7 (10.4-18.4)	15.2 (11.1-21.1)
10-day	3.06 (2.71-3.53)	4.20 (3.72-4.85)	5.74 (5.06-6.64)	7.02 (6.14-8.18)	8.80 (7.45-10.6)	10.2 (8.46-12.5)	11.7 (9.44-14.7)	13.2 (10.4-17.1)	15.3 (11.6-20.6)	17.0 (12.4-23.7)
20-day	3.77 (3.34-4.34)	5.23 (4.63-6.04)	7.21 (6.36-8.34)	8.87 (7.76-10.3)	11.2 (9.48-13.5)	13.0 (10.8-16.0)	15.0 (12.1-18.8)	17.0 (13.4-22.0)	19.8 (15.0-26.7)	22.0 (16.1-30.7)
30-day	4.44 (3.93-5.12)	6.17 (5.46-7.12)	8.51 (7.51-9.85)	10.5 (9.17-12.2)	13.2 (11.2-16.0)	15.4 (12.8-19.0)	17.7 (14.4-22.3)	20.2 (15.9-26.1)	23.5 (17.8-31.7)	26.3 (19.2-36.6)
45-day	5.33 (4.72-6.15)	7.35 (6.50-8.48)	10.1 (8.90-11.7)	12.4 (10.9-14.5)	15.7 (13.3-18.9)	18.3 (15.2-22.5)	21.0 (17.0-26.4)	23.9 (18.8-30.9)	27.9 (21.1-37.6)	31.1 (22.8-43.4)
60-day	6.27 (5.55-7.22)	8.53 (7.55-9.85)	11.6 (10.3-13.5)	14.2 (12.5-16.6)	17.9 (15.2-21.6)	20.9 (17.3-25.7)	24.0 (19.4-30.2)	27.2 (21.5-35.2)	31.8 (24.1-42.9)	35.5 (26.0-49.5)

¹ Precipitation frequency (PF) estimates in this table are based on frequency analysis of partial duration series (PDS). Numbers in parenthesis are PF estimates at lower and upper bounds of the 90% confidence interval. The probability that precipitation frequency estimates (for a given duration and average recurrence interval) will be greater than the upper bound (or less than the lower bound) is 5%. Estimates at upper bounds are not checked against probable maximum precipitation (PMP) estimates and may be higher than currently valid PMP values. Please refer to NOAA Atlas 14 document for more information.

[Back to Top](#)

PF graphical

PDS-based depth-duration-frequency (DDF) curves
 Latitude: 34.1083°, Longitude: -117.2085°

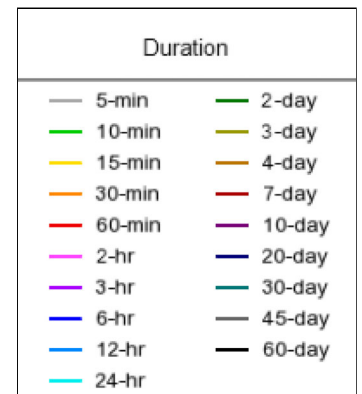
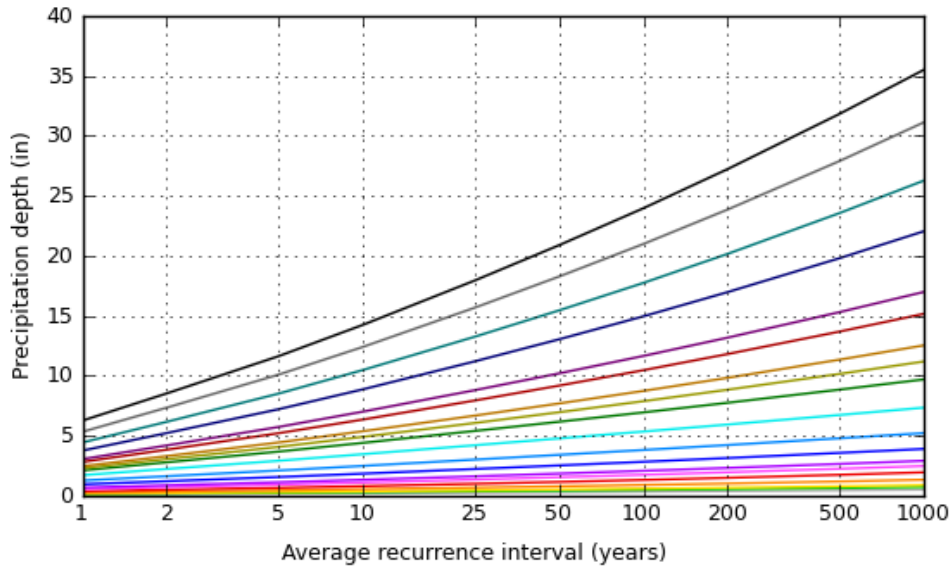
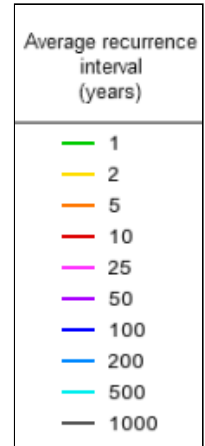
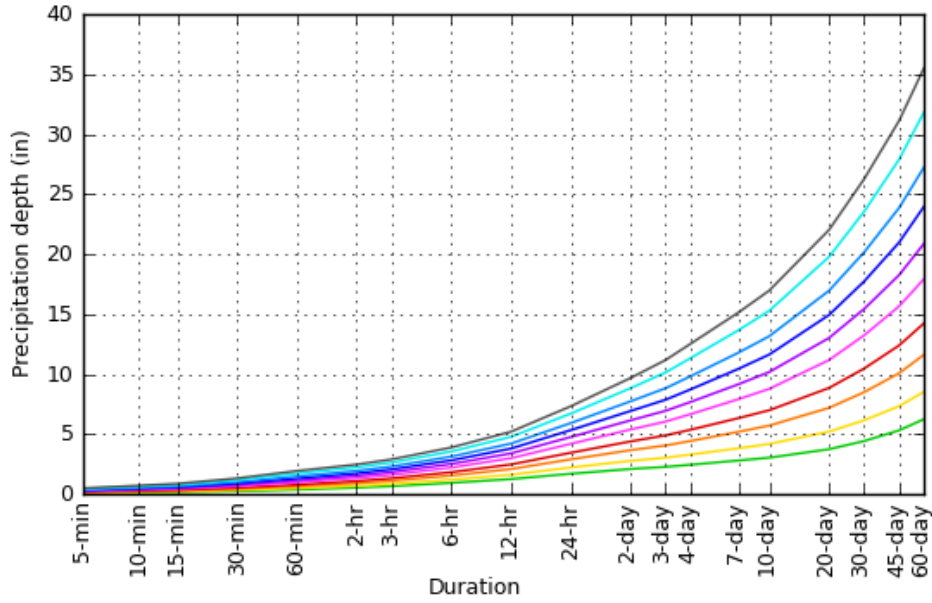

[Back to Top](#)

Maps & aerials

Small scale terrain



Large scale terrain



Large scale map



Large scale aerial

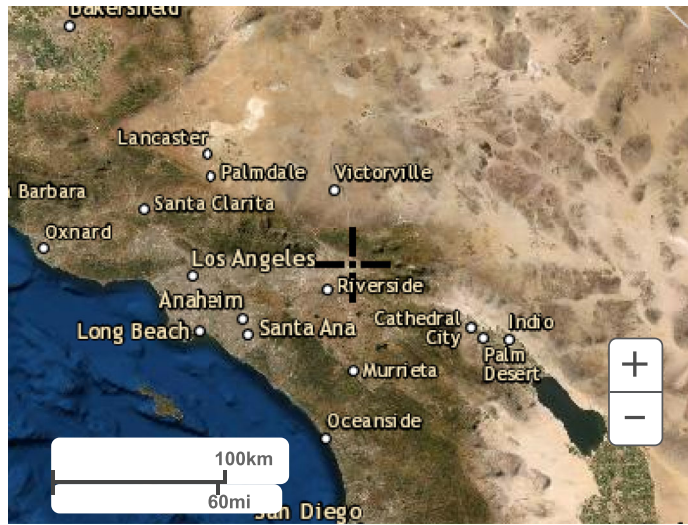

[Back to Top](#)

[US Department of Commerce](#)
[National Oceanic and Atmospheric Administration](#)
[National Weather Service](#)
[National Water Center](#)
1325 East West Highway
Silver Spring, MD 20910
Questions?: HDSC.Questions@noaa.gov

[Disclaimer](#)

LIMITATIONS:

1. Maximum length = 1000 Feet
2. Maximum area = 10 Acres

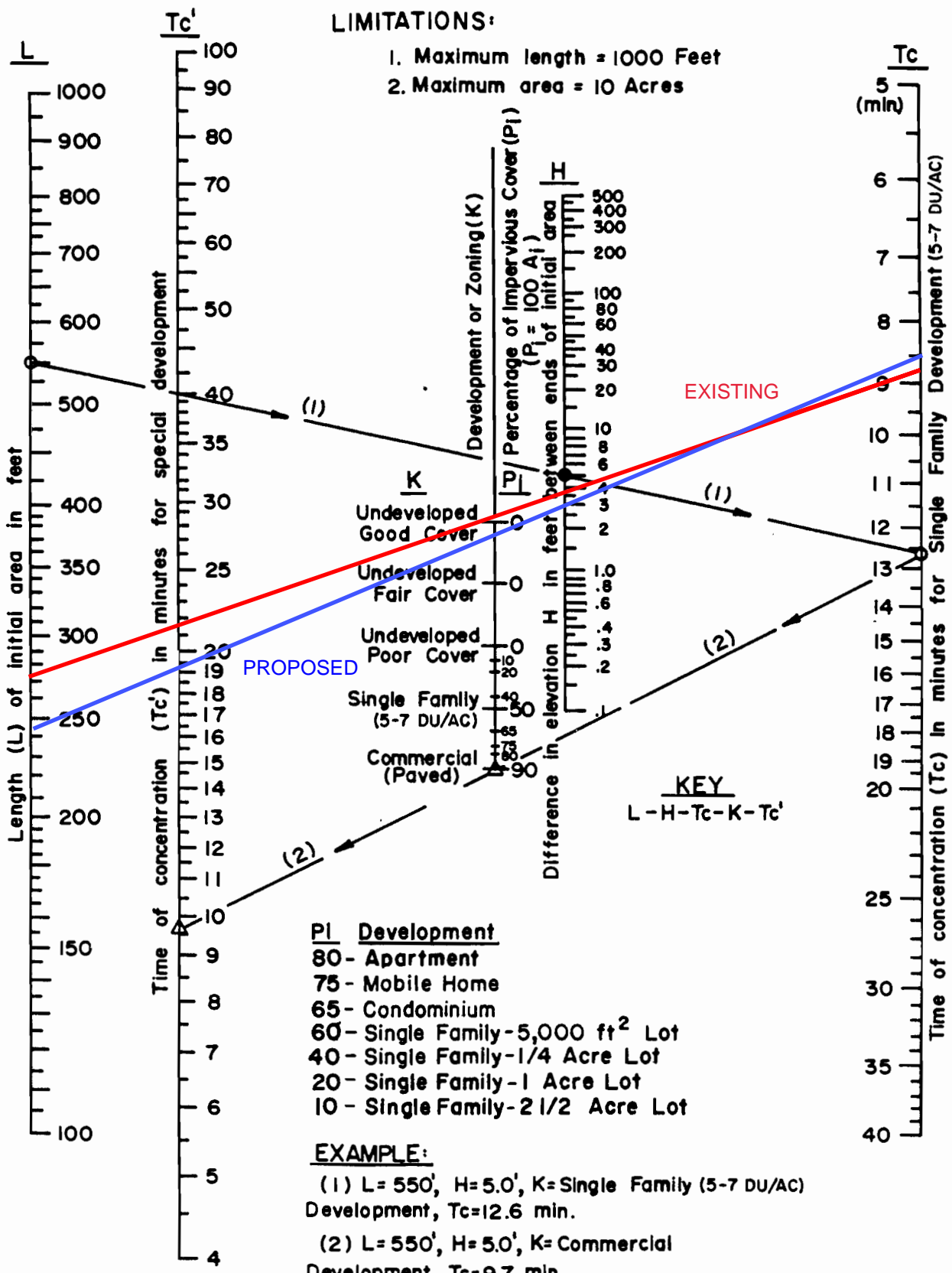

SAN BERNARDINO COUNTY
HYDROLOGY MANUAL

TIME OF CONCENTRATION
NOMOGRAPH
FOR INITIAL SUBAREA

Curve (I) Numbers of Hydrologic Soil-Cover Complexes For Pervious Areas-AMC II

Cover Type (3)	Quality of Cover (2)	Soil Group			
		A	B	C	D
<u>NATURAL COVERS -</u>					
Barren (Rockland, eroded and graded land)		78	86	91	93
Chaparral, Broadleaf (Manzonita, ceanothus and scrub oak)	Poor	53	70	80	85
	Fair	40	63	75	81
	Good	31	57	71	78
Chaparral, Narrowleaf (Chamise and redshank)	Poor	71	82	88	91
	Fair	55	72	81	86
Grass, Annual or Perennial	Poor	67	78	86	89
	Fair	50	69	79	84
	Good	38	61	74	80
Meadows or Cienegas (Areas with seasonally high water table, principal vegetation is sod forming grass)	Poor	63	77	85	88
	Fair	51	70	80	84
	Good	30	58	71	78
Open Brush (Soft wood shrubs - buckwheat, sage, etc.)	Poor	62	76	84	88
	Fair	46	66	77	83
	Good	41	63	75	81
Woodland (Coniferous or broadleaf trees predominate. Canopy density is at least 50 percent.)	Poor	45	66	77	83
	Fair	36	60	73	79
	Good	25	55	70	77
Woodland, Grass (Coniferous or broadleaf trees with canopy density from 20 to 50 percent)	Poor	57	73	82	86
	Fair	44	65	77	82
	Good	33	58	72	79
<u>URBAN COVERS -</u>					
Residential or Commercial Landscaping (Lawn, shrubs, etc.)	Good	32	56	69	75
Turf (Irrigated and mowed grass)	Poor	58	74	83	87
	Fair	44	65	77	82
	Good	33	58	72	79
<u>AGRICULTURAL COVERS -</u>					
Fallow (Land plowed but not tilled or seeded)		77	86	91	94

SAN BERNARDINO COUNTY
HYDROLOGY MANUAL

**CURVE NUMBERS
FOR
PERVIOUS AREAS**

Curve (I) Numbers of Hydrologic Soil-Cover Complexes For Pervious Areas-AMC II

Cover Type (3)	Quality of Cover (2)	Soil Group			
		A	B	C	D
AGRICULTURAL COVERS (Continued)					
Legumes, Close Seeded (Alfalfa, sweetclover, timothy, etc.)	Poor	66	77	85	89
	Good	58	72	81	85
Orchards, Evergreen (Citrus, avocados, etc.)	Poor	57	73	82	86
	Fair	44	65	77	82
	Good	33	58	72	79
Pasture, Dryland (Annual grasses)	Poor	68	79	86	89
	Fair	49	69	79	84
	Good	39	61	74	80
Pasture, Irrigated (Legumes and perennial grass)	Poor	58	74	83	87
	Fair	44	65	77	82
	Good	33	58	72	79
Row Crops (Field crops - tomatoes, sugar beets, etc.)	Poor	72	81	88	91
	Good	67	78	85	89
Small grain (Wheat, oats, barley, etc.)	Poor	65	76	84	88
	Good	63	75	83	87

Notes:

- All curve numbers are for Antecedent Moisture Condition (AMC) II.
- Quality of cover definitions:

Poor-Heavily grazed, regularly burned areas, or areas of high burn potential. Less than 50 percent of the ground surface is protected by plant cover or brush and tree canopy.

Fair-Moderate cover with 50 percent to 75 percent of the ground surface protected.

Good-Heavy or dense cover with more than 75 percent of the ground surface protected.
- See Figure C-2 for definition of cover types.

SAN BERNARDINO COUNTY
HYDROLOGY MANUAL

CURVE NUMBERS
FOR
PERVIOUS AREAS

ACTUAL IMPERVIOUS COVER

Land Use (1)	Range-Percent	Recommended Value For Average Conditions-Percent (2)
Natural or Agriculture	0 - 0	0
Public Park	10 - 25	15
School	30 - 50	40
Single Family Residential: (3)		
2.5 acre lots	5 - 15	10
1 acre lots	10 - 25	20
2 dwellings/acre	20 - 40	30
3-4 dwellings/acre	30 - 50	40
5-7 dwellings/acre	35 - 55	50
8-10 dwellings/acre	50 - 70	60
More than 10 dwellings/acre	65 - 90	80
Multiple Family Residential:		
Condominiums	45 - 70	65
Apartments	65 - 90	80
Mobile Home Park	60 - 85	75
Commercial, Downtown Business or Industrial	80 - 100	90

Notes:

1. Land use should be based on ultimate development of the watershed. Long range master plans for the County and incorporated cities should be reviewed to insure reasonable land use assumptions.
2. Recommended values are based on average conditions which may not apply to a particular study area. The percentage impervious may vary greatly even on comparable sized lots due to differences in dwelling size, improvements, etc. Landscape practices should also be considered as it is common in some areas to use ornamental gravels underlain by impervious plastic materials in place of lawns and shrubs. A field investigation of a study area shall always be made, and a review of aerial photos, where available, may assist in estimating the percentage of impervious cover in developed areas.
3. For typical equestrian subdivisions increase impervious area 5 percent over the values recommended in the table above.

**SAN BERNARDINO COUNTY
HYDROLOGY MANUAL**

**ACTUAL IMPERVIOUS COVER
FOR
DEVELOPED AREAS**

Attachment 7: Operations & Maintenance Plan

Please refer to the attached references.

The operations maintenance program and associated documents will be added during the next round of corrections, once BMPs approved tentatively for use.