

MARTIN BACKUP GENERATING FACILITY

Draft Environmental Impact Report

SCH # 2023020422



CALIFORNIA
ENERGY
COMMISSION
Gavin Newsom,
Governor

March 2024
CEC-700-2024-001-D

DOCKET NUMBER 22-SPPE-03

DRAFT ENVIRONMENTAL IMPACT REPORT

Martin Backup Generating Facility

(22-SPPE-03)

Lead Agency

California Energy Commission



March 2024

Table of Contents

1	Summary	1-1
2	Introduction	2-1
3	Project Description	3-1
4	Environmental Setting and Environmental Impacts	
4.1	Aesthetics	4.1-1
4.2	Agriculture and Forestry Resources	4.2-1
4.3	Air Quality	4.3-1
4.4	Biological Resources	4.4-1
4.5	Cultural and Tribal Cultural Resources	4.5-1
4.6	Energy and Energy Resources	4.6-1
4.7	Geology and Soils	4.7-1
4.8	Greenhouse Gas Emissions	4.8-1
4.9	Hazards and Hazardous Materials	4.9-1
4.10	Hydrology and Water Quality	4.10-1
4.11	Land Use and Planning	4.11-1
4.12	Mineral Resources	4.12-1
4.13	Noise	4.13-1
4.14	Population and Housing	4.14-1
4.15	Public Services	4.15-1
4.16	Recreation	4.16-1
4.17	Transportation	4.17-1
4.18	Utilities and Service Systems	4.18-1
4.19	Wildfire	4.19-1
4.20	Mandatory Findings of Significance	4.20-1
4.21	Environmental Justice	4.21-1
5	Alternatives	5-1
6	Authors and Reviewers	6-1
7	Mitigation Monitoring and Reporting Program	7-1

Appendix A: Project’s Jurisdictional and Generating Capacity Analysis

Appendix B: Silicon Valley Power’s Transmission System, Related Pacific Gas

and Electric Company's Transmission System and Emergency Operation
Appendix C: Mailing List

Section 1

Summary

1 Summary

This environmental impact report (EIR) has been prepared by the California Energy Commission (CEC) to evaluate the potential environmental effects of the Martin Backup Generating Facility (22-SPPE-03), in compliance with the California Environmental Quality Act (CEQA), the CEQA Guidelines, the Warren-Alquist Act, and California Code of Regulations, Title 20, Division 2, Article 5– Small Power Plant Exemptions. The Martin Backup Generating Facility (MBGF) includes diesel-fired generators to provide emergency backup power to the Martin Data Center (MDC). The MBGF, the MDC, and related utility infrastructure, together constitute the “project” under the CEQA.

The CEC has the exclusive authority to certify all thermal power plants (50 megawatts [MW] and greater) and related facilities proposed for construction in California. The Small Power Plant Exemption (SPPE) process allows applicants with facilities not exceeding 100 MW to obtain an exemption from the CEC’s jurisdiction and proceed with local permitting rather than requiring the CEC’s certification. The CEC can grant an exemption if it finds that the proposed facility would not create a substantial adverse impact on the environment or energy resources. Public Resources Code section 25519(c) designates the CEC as the lead agency, in accordance with CEQA, for all facilities seeking an SPPE.

1.1 Project Summary

Martin Avenue Properties, LLC (Martin Properties or applicant) filed an application with the CEC seeking an exemption from the CEC’s jurisdiction for the MBGF. The proposed project would be located at 651 Martin Avenue in Santa Clara, California. The project site is approximately 7.17 acres, and the property (Assessor’s Parcel Number 224-04-071) is zoned MH-Heavy Industrial.

The project would include a four-story, data center building (approximately 468,175 square-feet), a 96-MW emergency backup generating facility, a new electrical switching station, a new electrical substation, switchgear and distribution cabling to interconnect the generators to their respective portion of the building, surface parking, landscaping, and utility pipeline connections.

To provide reliable operation of the data center, the project includes 44 2.75-MW Tier 4 compliant renewable diesel-fired emergency backup generators to provide electrical power to support the data center in case of a loss of utility power, and, additionally, to support redundant critical cooling equipment and other general building and life safety services. The project also includes a new onsite switching station constructed to Silicon Valley Power (SVP) specifications and an onsite 100 (mega volt-ampere) MVA substation. The substation is to provide 60 kilovolt (kV) service to the site and be part of the SVP60 kV loop system. The proposed switching station will be located along Martin Ave and cut into the existing 60 kV line passing nearby. The station will be configured as a loop with two radial taps to the MDC substation. Reliability is maintained such that, if there is a

fault along any section of the loop, electric service is still supplied from the receiving station at the other of the 60 kV loop.

There may be up to three new transmission poles anticipated to be utilized as tie-in. All three would be located on the project site.

Utility interconnections for domestic water, recycled water, fire water, irrigation water, storm drain, sanitary sewer, and fiber connections would be made to existing City of Santa Clara (City) infrastructure along Martin Avenue. A 12-inch diameter domestic potable water line operated by the City in Martin Avenue that is located along the frontage of the property would serve as the primary source for potable and fire supply to the project. The project would require an offsite linear for a 100-foot offsite recycled water pipeline extension.

1.2 Summary of Environmental Impacts and Mitigation Measures

In accordance with section 25519(c) of the Public Resources Code and CEQA, CEC serves as the lead agency to review an SPPE application and perform any required environmental analyses. Upon granting of an exemption, the local permitting authorities— in this case the City of Santa Clara and Bay Area Air Quality Management District (BAAQMD)—would perform any follow-up CEQA analysis and impose mitigation, as necessary, for granting approval of the project.

The mitigation measures would be enforced by the appropriate responsible agency under CEQA.

Below is an overview of the analysis included in **Section 4 Environmental Setting, Environmental Impacts and Mitigation**. Impacts are categorized by the type of impact as follows:

1. No Impact. The scenario in which no adverse physical changes to (or impacts on) the environment would be expected.
2. Less Than Significant Impact. An impact that would not exceed the defined significance criteria or would be eliminated or reduced to a less than significant level through implementation of the applicant's project measures or compliance with existing federal, state, and local laws and regulations.
3. Less Than Significant with Mitigation Incorporated. An impact that would be reduced to a less than significant level through implementation of the identified mitigation measure(s).
4. Significant and Unavoidable Impact. An adverse effect that meets the significance criteria, but there appears to be no feasible mitigation available that would reduce the impact to a less than significant level. In some cases, mitigation may be available to lessen a given impact, but the residual effects of that impact would continue to be significant even after implementation of the mitigation measure(s).

Staff concludes that with the implementation of the mitigation measures presented below, the potentially significant impacts identified in this EIR would be avoided or reduced to less than significant levels. Staff concluded that impacts in the areas of Air Quality, Biological Resources, Cultural and Tribal Cultural Resources, Geology and Soils (paleontology), Greenhouse Gas Emissions, Hazards and Hazardous Materials, and Transportation would be potentially significant, but with mitigation measures would be reduced to less than significant. Aesthetics, Energy and Energy Resources, Hydrology and Water Quality, Land Use, Noise, Population and Housing, Recreation, and Utilities and Service Systems would have less than significant impacts from the project. Agriculture and Forestry Resources, Mineral Resources, Public Services, and Wildfire would have no impact from the project. If exempted, the mitigation measures identified in this EIR would be enforced by the City of Santa Clara. The following summarizes the potential impacts and mitigation as required.

Air Quality

Less Than Significant with Mitigation Incorporated. Staff's overall conclusion is that, with the implementation of mitigation measure **AQ-1** the project would not have a significant impact on air quality. To reach this conclusion, this section assesses the impacts of two primary types of air emissions: (1) criteria pollutants, which have health-based ambient air quality standards (AAQS); and (2) toxic air contaminants (TACs), which are identified as potentially harmful even at low levels and have no established safe levels or health-based AAQS.

These two primary types of emissions can potentially result from multiple phases of the project, and through a variety of activities. To summarize, project demolition, grading, excavation, and construction would occur across two phases. The first phase (Phase I) would include demolition of the four existing buildings and infrastructure that cannot be reused; grading of the entire site; installation of utility services including interim power and construction of the on-site utility substation; and construction of the shell of the building and some of the interior rooms, as necessary for tenants (DayZenLLC 2022a, pg. 2-17). The Phase II activities would primarily involve fitting out the remainder of the interior rooms with no potential for notable emissions (DayZenLLC 2023a; Response to Data Request 4). The existing four buildings at 651 Martin Avenue would be demolished to allow for construction of the new MDC building. Demolition and construction activities are estimated to last approximately 14 months to the initial occupancy of the building. Construction activities are estimated to last an additional 11 months indoors to bring the building to full occupancy (DayZenLLC 2022a, pg. 2-17).

The project would not conflict with or obstruct implementation of the applicable air quality plan. The project would not expose sensitive receptors to substantial pollutant concentrations. The project would not result in other emissions (such as those leading to odors) adversely affecting a substantial number of people. Air quality impacts during project construction would be reduced with implementation of mitigation measure **AQ-1**. This measure requires incorporation of the BAAQMD's best management practices to

control fugitive dust. This measure also incorporates exhaust control measures to reduce emissions from construction equipment. During readiness testing and maintenance operation of the engines, the oxides of nitrogen (NOx [as an ozone precursor]) emissions of the standby generators would be fully offset through the permitting process with the BAAQMD, if required. With implementation of these measures during construction and NOx offsets for operations through BAAQMD's permitting requirements, the project would not cause a cumulatively considerable net increase of any criteria pollutant, and impacts would be reduced to a less than significant level.

Biological Resources

Less Than Significant with Mitigation Incorporated. Staff concluded that the proposed project would have less than significant impacts on biological resources with mitigation incorporated. To reach this determination, staff reviewed the information provided by the applicant in addition to conducting a standard 9 Quad search of the California Natural Diversity Database maintained by the California Department of Fish and Wildlife (CDFW), and inquiring with experts from the United States Fish and Wildlife Service (USFWS), CDFW, and the Santa Clara Valley Habitat Agency. Staff also considered the potential of nitrogen deposition impacts from the project and through applying a qualitative assessment using CEC staff nitrogen deposition modeling performed for other similar backup generator projects. Staff found that there would be no significant impacts from nitrogen deposition on any sensitive habitats or special-status species. Following this analysis, staff has identified the following mitigation measures as necessary to reduce impacts to biological resources to less than significant.

- **BIO-1** requires development and use of a worker environmental awareness program (WEAP) to actively train on-site personnel in identifying and avoiding special-status species, specifically burrowing owls as well as nesting migratory birds.
- **BIO-2** includes measures to prevent and reduce impacts on burrowing owls to less-than-significant levels, including pre-construction surveys, establishing buffer zones during the breeding and non-breeding season, monitoring, discouraging re-colonization, and passive relocation.
- **BIO-3** includes requirements to conduct tree removal outside the migratory bird nesting period if possible, to conduct nesting bird surveys prior to the initiation of any construction activities during the nesting period, to establish buffers to avoid the disturbance of nesting birds if active nests are detected, and to conduct monitoring of active bird nests.
- **BIO-4** creates a detailed reporting structure for bird surveys, avian protection measures by compiling these reports and measures within an Avian Protection Plan.
- **BIO-5** requires bat clearance surveys be conducted prior to removal of existing buildings or trees, development of a Bat Mitigation and Monitoring Plan (Plan), and outlines other protection measures as needed. With all of these mitigation measures incorporated the project would not have any significant impacts on biological resources or adversely affect any species identified as candidate, sensitive, or special-

status species in local or regional plans, policies, regulations, or by the CDFW or USFWS.

Cultural and Tribal Cultural Resources

Less Than Significant with Mitigation Incorporated. The project would not impact any known resources that could meet CEQA's criteria for historical resources, unique archaeological resources, or tribal cultural resources. However, previous cultural resources studies in the project area indicate that buried archaeological or ethnographic resources could be encountered during ground disturbing activities at the project site. Staff recommends a series of mitigation measures, **CUL-1** through **CUL-9**, to address the inadvertent discovery of previously unknown buried cultural resources, including human remains.

- **CUL-1** requires that a qualified archaeologist prepare a Cultural Resources Identification, Monitoring and Treatment Plan in consultation with the Tamien Nation and a qualified Native American monitor, to ensure that potential impacts to any as-yet unidentified cultural resources are reduced to a less-than-significant level.
- **CUL-2** requires qualified specialists and Native American monitors to prepare a workforce environmental awareness program, or WEAP, to instruct construction workers on the obligation to protect and preserve buried archaeological and Native American resources that could be encountered during construction. It includes instructions regarding the need to halt work in the vicinity of potential archaeological and Native American resources that could be encountered. Mitigation measure
- **CUL-3** requires that a preliminary field investigation be conducted by a qualified archaeologist and Native American monitor to determine if cultural deposits are present once pavement is removed and soils are accessible for inspection.
- **CUL-4** requires that all ground disturbing activities be completed under the observation of a qualified archaeologist and Native American monitor and provides for the cultural resources monitors to have the authority to temporarily halt construction activities within a 50-foot radius of finds.
- **CUL-5** specifies the procedures for documenting and evaluating cultural resources finds made during the preliminary field investigation, grading, or other construction activities. Further, CUL-5 requires that a qualified archaeologist make recommendations to the Santa Clara Director of Community Development regarding data recovery, curation, or other appropriate mitigation.
- **CUL-6** specifies procedures for the event that human remains are discovered.
- **CUL-7** affords for the installation of security fencing onsite, to avoid destruction or theft of cultural resources, at the discretion of the City of Santa Clara's Director of Community Development and requires the qualified archaeologist and Native American monitor to advise the Director of Community Development on security measures to be taken to ensure the safety of any cultural resources.

- **CUL-8** requires that the project owner or its representative prepare a closing cultural resources report summarizing the results of the field investigations, data recovery activities and results, and compliance with the Cultural Resources Identification, Monitoring, and Treatment Plan once all analyses and studies required have been completed.
- **CUL-9** requires that all archaeological cultural resources recovered and not identified as tribal cultural resources be transferred to a long-term curation facility, and all Native American/tribal cultural resources and artifacts be reburied onsite, if feasible and if requested by the Native American representative. With implementation of these mitigation measures, potential impacts on cultural and tribal cultural resources would be reduced to a less than significant level.

Geology and Soils (paleontology)

Less Than Significant with Mitigation Incorporated. Staff concluded that the proposed project would not have any significant impacts on geological and soil resources. However, staff also concluded that mitigation measures would be necessary to reduce impacts to paleontological resources to a less than significant level. To reach these determinations, staff reviewed the information provided by the applicant in addition to publicly available literature, maps, air photos, and documents related to geological, soil, and paleontological resources. The geologic map review of the project area included maps published by the U.S. Geological Survey. A paleontological record search of the University of California Museum of Paleontology, Berkeley online paleontological database was conducted by the applicant for the project area, including a 10-mile buffer zone surrounding the project.

Staff concluded that ground-disturbing activities including earthwork and trenching to depths greater than ten feet below the ground surface have the potential to impact undiscovered paleontological resources. According to the applicant, the project would require excavation trenching of depths of up to 15 feet below the existing grade for the construction of the recycled water line along Martin Avenue. Building foundations would incorporate augured piles, anticipated to depths of 30 feet below the existing grade. Following this analysis, staff has identified mitigation measure **GEO-1** to reduce impacts to paleontological resources to a less than significant level. Staff proposes **GEO-1**, to train construction personnel and guide recovery and processing of any significant paleontological finds. Impacts related to geological and soil resources would either have no impact or have a less than significant impact.

Greenhouse Gas Emissions

Less Than Significant with Mitigation Incorporated. With the incorporation of the project features and mitigation measures **GHG-1** and **GHG-2**, greenhouse gas (GHG) emissions related to the project would be consistent with the applicable plans and policies adopted to reduce GHG emissions and would comply with all regulations or requirements adopted to implement a statewide, regional, or local plan for the reduction or mitigation of GHG

emissions. The potential for the project to conflict with an applicable plan, policy, or regulation for GHG emissions reductions would be less than significant.

With the use of renewable diesel for 100 percent of total energy use by the emergency standby generators and ultra-low sulfur diesel as a secondary fuel in the event of supply challenges or disruption in obtaining renewable diesel as required by **GHG-2**, the GHG emissions from the facility's stationary sources would not exceed the 10,000 metric tons of carbon dioxide equivalent per year (MTCO₂e/yr) BAAQMD bright-line threshold of significance for GHG emissions from stationary sources.

The project would comply with the requirements of the City of Santa Clara's 2022 Climate Action Plan with the proposed design measures and implementation of **GHG-1**, which would require the project owner to participate in Silicon Valley Power's (SVP) Large Customer Renewable Energy Program (LCRE) (i.e., 100 percent carbon-free electricity) for electricity accounts associated with the project, or participate in other renewable energy programs that achieves the same goals as SVP's LCRE program of 100 percent carbon-free electricity, or purchase renewable energy credits or similar instruments that accomplish the same goals of 100 percent carbon-free electricity.

Hazards and Hazardous Materials

Less Than Significant with Mitigation Incorporated. During demolition activities, there is the potential that lead-based paint could be present and released. Additionally, ground disturbing activities associated with demolition and construction of the project would have the potential to encounter remnant or unknown contaminated soil or groundwater. Staff concludes that with implementation of **HAZ-1**, **HAZ-2**, and **HAZ-3**, impacts to the public or the environment due to lead-based paint or contaminated soils or groundwater would be reduced to a less than significant level.

- **HAZ-1** requires the testing and removal of lead-based paint contaminated materials prior to issuance of demolition permits.
- **HAZ-2** requires a Site Management Plan to establish proper procedures to be taken when contaminated soil or groundwater is found, and a Health and Safety Plan to protect and educate workers in the event contaminated soil or groundwater is encountered.
- **HAZ-3** requires testing of soil and groundwater for contamination per plans and protocols established in the Site Management Plan.

Transportation

Less Than Significant with Mitigation Incorporated. Project-generated vehicle miles traveled (VMT) per employee would exceed the City's industrial threshold of 14.37 VMT per employee. Staff proposes **TRANS-1**, which would require the project owner to implement multi-modal infrastructure improvements and Transportation Demand Management (TDM) measures, to reduce the project VMT to a less than significant level. Staff concludes that with implementation of **TRANS-1** to lower project generated VMT

to a level below the city's industrial VMT threshold, impacts to VMT would be reduced to a less than significant level.

1.3 Summary of Alternatives to the Proposed Project

CEQA requires that an EIR consider and discuss alternatives to the proposed project. Section 15126.6 of the CEQA Guidelines provides that an EIR must describe and compare the merits of a "reasonable range of potentially feasible alternatives," focusing on those that "would feasibly attain most of the basic objectives of the project but would avoid or substantially lessen any of the significant environmental effects of the project".

A full analysis of project alternatives is provided in **Section 5 Alternatives**, along with a description of alternatives initially considered and not evaluated further, primarily due to feasibility and reliability issues. In addition to the No Project/No Build Alternative (Alternative 1), staff carried forward the Natural Gas Internal Combustion Engine Alternative (Alternative 2) for analysis and comparison to the proposed project.

1.3.1 Alternative 1: No Project/No Build Alternative

Staff evaluated a No Project/No Build scenario in which no new development of the project site would occur, and current conditions would continue at the site for an unknown period. Although a different project could be proposed at the site in the future, no development plan exists to allow a comparison with the proposed project, and it would be speculative to assume the characteristics of such an alternative. The No Project/No Build Alternative would avoid the proposed project's potentially significant impacts identified in this EIR (no impact compared to the proposed project). Therefore, Alternative 1 is the environmentally superior alternative. However, if the project is not constructed, the applicant's project objectives would not be attained.

1.3.2 Alternative 2: Natural Gas Internal Combustion Engine (ICE) Alternative

An alternative that would meet the project objectives is the use of natural gas internal combustion engines (ICEs) for the emergency backup generators (gensets). (Under the proposed project, the gensets would use renewable diesel as the primary fuel with ultra-low sulfur, or conventional, diesel as the secondary fuel.)

Under Alternative 2, the footprint of the natural gas ICEs might not be the same as for the proposed project's diesel-fueled gensets. The number of engines and associated equipment, height, fuel delivery, and onsite fuel storage would be different. However, it is assumed that the massing and locations of the data center buildings would be essentially the same as for the proposed project. Under this alternative, engine startup times would be fast enough that a redesign of the proposed project's uninterruptible power supply (UPS) system would not be needed.

Fuel for the natural gas ICEs could be supplied by the Pacific Gas and Electric (PG&E) underground transmission system. The two closest locations for independent natural gas

pipeline connections are approximately 0.15 mile north of the project site on Walsh Avenue and approximately 0.2 mile west of the project site on Lafayette Street. Access to both pipelines would most likely ensure the same level of reliability for ICEs as renewable diesel-fired gensets.

Staff compared criteria air pollutant and greenhouse gas emissions of natural gas ICEs to the proposed project's diesel-fueled engines. Under Alternative 2, criteria air pollutant emissions and air quality impacts would be much less than those identified under the proposed project. Air toxics emissions would likely be less due to the reductions in volatile organic compounds (VOCs) and particulate matter (PM); therefore, public health impacts using natural gas ICEs would likely be less than under the proposed project. The greenhouse gas (GHG) impacts are likely to be similar to those of the proposed project, but only if renewable natural gas is used for this alternative. Staff considers Alternative 2 to be environmentally superior to the proposed project due to its deep reductions in criteria air pollutants.

1.4 Known Areas of Controversy

The CEC issued a Notice of Preparation (NOP) on February 17, 2023, seeking input from responsible and trustee agencies and the public regarding the scope and context of environmental areas in the EIR for a 30-day comment period that ended on March 17, 2023. In total, two comment letters were received¹. Issues of concern reflected in these letters include, but are not limited to, the following excerpts:

Water Resources:

Data centers can use significant amounts of water. Impacts related to water use and an analysis of water supply, including recycled water, should be conducted as part of the EIR.

According to the Federal Emergency Management Agency (FEMA) Flood Insurance Rate Map 06085C0227H, effective May 18, 2009, a portion of the site is located in Zone AO, a special flood hazard area with a flood depth of one foot, and the remainder of the site is located in Zone X, an area with reduced flood risk due to levee.

According to the Inundation Map for the Hypothetical Fair Weather Failure of Both Austrian Dam and Leniham Dam published by Valley Water in November 2019, the project site is located within the Lexington (Lenihan) Reservoir dam failure inundation area.

Valley Water records indicate that 1 active well is located on the subject property. If the well will continue to be used following permitted activity, it must be protected so that it does not become lost or damaged during completion of permitted activity. If the well will not be used following permitted activity, it must be properly destroyed under permit from Valley Water. While Valley Water has records for most wells located in the County, it is

¹ Comment letters were received from the Native American Heritage Commission and the Santa Clara Valley Water District.

always possible that a well exists that is not in Valley Water's records. If previously unknown wells are found on the subject property during development, they must be properly destroyed under permit from Valley Water or registered with Valley Water and protected from damage.

Valley Water does not have any right of way or facilities within the project limits; therefore, in accordance with Valley Water's Water Resources Protection Ordinance, a Valley Water encroachment permit is not required for the proposed project.

Tribal Cultural Resources:

Ensure that the CEC complies with Assembly Bill 52 (Gatto, Chapter 532, Statutes of 2014) (includes tribal consultation requirements) in its review of the proposed project. Additional comments and concerns include recommended actions to adequately assess the existence and significance of tribal cultural resources and plan for avoidance, preservation in place, or barring both, mitigation of project-related impacts to tribal cultural resources.

Staff has reviewed and considered the comments received and addressed them as appropriate in the applicable section.

1.5 Issues to be Resolved

Staff concluded that all potentially significant impacts can be mitigated to a less than significant level. There are no remaining issues to be resolved.

Section 2

Introduction

2 Introduction

Project Title

Martin Backup Generating Facility (22-SPPE-03)

SCH#: #2023020422

Lead Agency Name and Address

California Energy Commission
715 P Street
Sacramento, California 95814-6400

Lead Agency Contact Person and Phone Number

John Heiser, Project Manager
Siting, Transmission and Environmental Protection Division
California Energy Commission
(916) 628-5566

2.1 Energy Commission Jurisdiction and the Small Power Plant Exemption Process

The California Energy Commission (CEC) is the state agency authorized by statute to issue a license for all thermal electric power plants, 50 megawatts (MW) and greater, proposed for construction in California. Chapter 6 of Division 15 of the Public Resources Code establishes the power plant site certification process through which the CEC exercises this role. Within this authority, Public Resources Code Section 25541, permits the CEC to exempt projects between 50 and 100 MW from its jurisdiction, which allows such projects to proceed with local permitting rather than requiring a CEC license. CEC can grant an exemption if it finds that the proposed project would not create a substantial adverse impact on the environment or energy resources. The CEC has adopted the Small Power Plant Exemption (SPPE) process to review applications for the exemption and determine whether the statutory requirements have been met (California Code of Regulations, title 20, section 1936 and sections 1940-1942).

2.2 CEQA Lead Agency

In accordance with Public Resources Code, section 25519(c) and the California Environmental Quality Act (CEQA), CEC serves as the lead agency to review an SPPE application and perform any required environmental analyses. After CEC grants an exemption, the local permitting authorities—in this case the City of Santa Clara and the Bay Area Air Quality Management District—would perform any follow-up CEQA analysis and impose mitigation, as necessary, for granting approval of the project. If the CEC grants a small power plant exemption for the project, the city of Santa Clara's Project

Clearance Committee (PCC) would then be responsible for completing its review of a Master Plan submitted by Martin Properties, and final approval or denial of the project. In addition, the project would seek approval from the city Zoning Administrator for a conditional use permit to allow the use under the MH zoning, and for a minor modification for the exceedance of the maximum building height, to be within the allowable 25 percent limit. The Bay Area Air Quality Management District would need to grant approval for an Authority to Construct permit and a Permit to Operate.

2.3 Purpose of the Environmental Impact Report

The purpose of this environmental impact report (EIR) is to provide agency decision makers and the public with objective information regarding the project's significant effects on the environment and energy resources, identify possible ways to minimize the significant effects, and describe reasonable alternatives to the project. This information will be used by the CEC Commissioners in considering the applicant's request to exempt the project from CEC's power plant licensing jurisdiction, and by the local jurisdictions in deciding whether to issue permits and approve the project.

Unlike most development project approval processes, the discretionary decision being considered by the CEC is not approval of the applicant's project, but whether the statutory requirements for exemption from CEC's jurisdiction have been met. While the CEC's environmental analysis assesses the applicant's project to support the CEC's jurisdictional decision and uses the term "project" to reference the data center and backup generators, it is important to remember that the CEC's discretionary decision is limited to determining the appropriate permitting authority and not approval of the project. Upon exempting the project, the CEC would have no permitting authority over the project and would not be responsible for any mitigation or permit conditions imposed by the City of Santa Clara or other local agencies.

2.4 Environmental Review Process

2.4.1 Tribal Consultation

Pursuant to Public Resources Code, section 21080.3.1, the CEC's Tribal Liaison mailed letters (dated January 17, 2023) to representatives of the Tamien Nation and the Wuksachi Indian Tribe/Eshom Valley Band inviting consultation, as both tribes are traditionally and culturally affiliated with the geographic area the project is located in, and have previously requested formal notification of any projects within this area (CEC 2023). Consistent with the CEC's tribal consultation policy (CEC 2021), CEC staff also mailed letters inviting consultation with eight additional tribes identified by the Native American Heritage Commission that might be interested in the proposed project (CEC 2023, Campagne 2022b). The Tamien Nation was the only tribe to respond requesting consultation for the project. Consultation meetings were held between the CEC and the Tamien Nation on February 1, 2023 and June 22, 2023, where information was exchanged and the Tribe made specific requests regarding the proposed mitigation measures relating to cultural and tribal cultural resources. CEC staff has incorporated the requests from the

Tamien Nation into the staff-proposed Mitigation Measures **CUL-1** through **CUL-9** contained in this EIR. See **Section 4.5 Cultural and Tribal Cultural Resources** for full details on consultation efforts.

2.4.2 Notice of Preparation of an EIR

In accordance with the CEQA Guidelines, a Notice of Preparation (NOP) of the EIR was circulated to the public and public agencies, including responsible and trustee agencies, for a 30-day comment period from February 17, 2023, to March 16, 2023 (State Clearinghouse #2023020422). The NOP was issued via the project's docket, to the GovDelivery system for those signed up for the project's subscription list, the State Clearinghouse, and via email with delivery notification. The issuance of the NOP satisfied the agency notification requirement specified in section 15082 of the CEQA Guidelines (California Code of Regulations, Title 14, Chapter 3). Staff reviewed and considered the comments received during the NOP comment period. Staff has addressed the comments as appropriate in the applicable technical section. The mailing list used to engage with stakeholder agencies can be found in **Appendix C**.

2.4.3 Draft EIR

The environmental analysis of this SPPE application takes the form of an EIR, which is prepared to conform to the requirements of CEQA, the CEQA Guidelines (California Code of Regulations, Title 14, section 15000 et. seq.), and the CEC's regulations and policies. The EIR is based on information from the applicant's SPPE application and associated submittals, site visits, data requests and responses, and additional staff research, including consultation with other agencies, such as responsible and trustee agencies, and relevant information received during any public meetings.

The process for public notification of the Draft EIR is set forth in section 15087 of the CEQA Guidelines (California Code of Regulations, Title 14, Chapter 3) and requires at least one of the following procedures:

- (1) Publication at least one time in a newspaper of general circulation in the area affected by the proposed project.
- (2) Posting of notice by the lead agency on and off site in the area where the project is to be located.
- (3) Direct mailing to the owners and occupants of property contiguous to the parcel or parcels on which the project is located. Owners of such property shall be identified as shown on the latest equalized assessment roll.

Staff mailed notification of the Draft EIR to all owners and occupants contiguous (adjacent) to the project site and linears. In addition, staff mailed notification of the Draft EIR to local public libraries and to interested persons who requested notification. Staff posted the Draft EIR to the project's CEC docket, which resulted in an automated email notification of the Draft EIR via the GovDelivery system to those signed up to the project's subscription list.

For public agency notice, the Draft EIR was submitted to the State Clearinghouse for circulation to state agencies and mailed directly by the CEC to federal, state, regional, and local agencies. See **Appendix C** for the mailing list.

2.4.4 Final EIR and Decision on the Small Power Plant Exemption

Substantive comments received on the Draft EIR will be formally addressed in the Final EIR. The Final EIR will be sent to responsible agencies and commentors on the Draft EIR and posted to the project's docket and subscription list.

Following publication of the Final EIR, the CEC's executive director (or designee) will file a recommendation with the CEC whether the application meets the requirements of Public Resources Code section 25541 for an SPPE (that is, the proposed project would not create a substantial adverse impact on the environment or energy resources). As part of its decision on the SPPE, the CEC must certify that it has reviewed and considered the information in the Final EIR and that the EIR has been completed in conformity with the requirements of CEQA.

2.5 Organization of this EIR

This EIR is organized into five sections, as described below:

- Section 1 Summary. This section provides a concise overview of the proposed project and the necessary approvals; the environmental impacts that would result from the proposed project; mitigation measures identified to reduce or eliminate these impacts; project alternatives; nature of comments received on the NOP; and areas of known controversy and issues to be resolved.
- Section 2 Introduction. This section describes the type, purpose, and function of the EIR; the environmental review process; and the organization of the EIR.
- Section 3 Project Description. This section summarizes the proposed project, including the location of the site and project boundaries, characteristics of the proposed project, and objectives sought by the proposed project.
- Section 4 Environmental Setting, Environmental Impacts and Mitigation. This section includes the environmental setting; regulatory background; approach to analysis; project-specific and cumulative impacts; and mitigation measures, when appropriate. Staff evaluates the potential environmental impacts that might reasonably be anticipated to result from construction and operation of the proposed project. Staff's analysis is broken down into the following environmental resource topics derived from CEQA Appendix G:
 - Aesthetics
 - Agricultural and Forestry Resources
 - Air Quality
 - Biological Resources
 - Land Use and Planning
 - Mineral Resources
 - Noise
 - Population and Housing

- | | |
|-----------------------------------|--------------------------------------|
| - Cultural and Tribal Resources | - Public Services |
| - Energy | - Recreation |
| - Geology and Soils | - Transportation |
| - Greenhouse Gases | - Utilities and Service Systems |
| - Hazards and Hazardous Materials | - Wildfire |
| - Hydrology and Water Quality | - Mandatory Findings of Significance |

In addition, the document includes an analysis of how the project would potentially impact an Environmental Justice¹.

For each subject area, the analysis includes a description of the existing conditions and setting related to the subject area, an analysis of the proposed project's potential environmental impacts, and a discussion of mitigation measures, if necessary, to reduce potentially significant impacts to less than significant levels.

- Section 5 Alternatives. This section includes a discussion of a reasonable range of alternatives to the proposed project, or to the location of the project, which could feasibly attain most of the basic objectives of the project but would avoid or substantially lessen any of the significant effects of the project, and an evaluation of the comparative merits of the alternatives. This section also includes an evaluation of the no project alternative.

¹ An environmental justice population is based on race and ethnicity or low-income status. See Section 4.21 Environmental Justice for more information.

Section 3

Project Description

3 Project Description

Martin Avenue Properties, LLC filed an application with the California Energy Commission (CEC) seeking a small power plant exemption (SPPE) from the CEC’s licensing jurisdiction for the proposed Martin Backup Generating Facility in the city of Santa Clara. The Martin Backup Generating Facility (MBGF) would be used exclusively to provide up to 96 megawatts (MW) of backup power to the proposed Martin Data Center (MDC) in the event of a disruption in electric service to the MDC. The proposed project (collectively the MBGF and MDC) is subject to the CEC’s review under the California Environmental Quality Act (CEQA).

3.1 Project Location

The proposed project would be located at 651 Martin Avenue in Santa Clara, California. The project site is approximately 7.17 acres, and the property (Assessor’s Parcel Number 224-04-071) is zoned MH-Heavy Industrial. **Figure 3-1** shows the regional location and **Figure 3-2** identifies the project location, including boundaries.

3.2 Project Objectives

The applicant’s goal is for the MDC to be a state-of-the-art data center that provides greater than 99.999 percent reliability (five nines of reliability). The MDC’s purpose is to provide a wide variety of organizations with with space to house and support their mission-critical servers, including space conditioning and a steady stream of high-quality power supply.

The MDC’s Project Objectives, as stated by the applicant, are as follows:

- Develop a state-of-the-art data center large enough to meeet projected growth;
- Develop the Data Center on land that has been zoned for data center use at a location acceptable to the city of Santa Clara;
- Develop a Data Center that can be constructed in two phases which can be timed to match projected growth;
- To incorporate the most reliable and flexible form of backup electric generating technology into the MBGF considering the following evaluation criteria:

Reliability. The selected technology must be extremely reliable in the case of an emergency loss of electricity from the utility.

- The MBGF must provide a higher reliability than 99.999 percent inorder for the MDC to achieve an overall reliability of equal to or greater than 99.999 percent reliability.
- The MBGF must provide reliability to the greatest extent feasible during natural disasters including earthquakes.

- The selected backup electric generation technology must have a proven built-in resilience so if any of the backup units fails due to external or internal failure, the system would have redundancy to continue to operate without interruption.
- The MDC must have on-site means to sustain power for 24-hours minimum in failure mode, inclusive of utility outage.

Commercial Availability and Feasibility. The selected backup electric generation technology must be extremely reliable in the case of an emergency loss of electricity from the utility.

Technical Feasibility. The selected backup electric generation technology must utilize systems that are compatible with one another. (DayZenLLC 2020a)

3.3 Project Overview

Four existing structures and a parking lot on the project site would be demolished to construct a new data center building, electrical switching station (to be owned and operated by Silicon Valley Power), substation (project owned), generator equipment yard, surface parking and landscaping, and a recycled water pipeline. More specifically, the project would consist of two main components: a four-level data center suite component and the generator yard component. The four-story, 468,175 square foot MDC building would consist of suites housing client servers, and corresponding electrical/uninterruptible power supply (UPS) rooms consisting of the system and batteries sized to handle up to five minutes of back-up power as well as the administrative facilities, including support facilities such as the building lobby, restrooms, conference rooms, landlord office space, customer office space, loading dock and storage.

3.3.1 Data Center

The proposed MDC building would be in the center of the site and would be set back at a minimum of 149 feet from the front yard to the south (Martin Avenue), and a minimum of 46 feet from the side yard to the west (adjacent to a non-residential zone). The building would be a minimum of 141 feet from the side yard to the east (adjacent to railroad tracks), and a minimum of 50 feet from the rear yard to the north (adjacent to a non-residential zone). The building would be 87.5 feet tall. A sound attenuating screen topping off at 102.25 feet fully encloses roof mounted equipment, with the ultimate height at the top of the elevator parapet of 119.66 feet. An Architectural Site Plan is provided in **Figure 3-3**.

The MDC would be supplied electricity by Silicon Valley Power (SVP) through a new distribution substation to be constructed on the site as part of the project. The 100 mega volt-ampere (MVA) two-bay substation along the southern boundary of the site would be owned and operated by SVP. The design allows for one of the two 100 MVA 60 kilovolt (kV) 34.5 step-down transformers to be taken out of service, effectively providing 100 MVA of total power (a 2-to-make-1 design).

3.3.2 Backup Generating Facility

Generator Configuration. The project's generating facility would include 44 diesel-fired standby backup generators (Caterpillar Model 3516E) to provide up to 96 MW of emergency generating capacity (total load) to the data center in the event of a loss of electric service from SVP. Of this, 64 MW would be for critical information technology (IT) equipment load, mechanical equipment to cool the IT equipment, lighting, and data center monitoring equipment. The maximum peak generating capacity of each generator is 2.75 MW for standby applications (short-duration operations). The generators are equipped with selective catalytic reduction equipment and diesel particulate filters to comply with Tier 4 emission standards.

The emergency backup generators would be stacked vertically in twenty-two groups of two. Forty generators would be used to serve the 16 data center suites, and four house generators would serve the non-suite energy needs of the facility. Each emergency generator is a fully independent package system with dedicated diesel fuel tank and urea storage providing more than 24-hours of emergency generation at full output. The gensets are arranged in a "5 to make 4" setup serving 16 data center suites, providing a dedicated backup genset in case of a failure or maintenance, hence the "5 to make 4".

The generator enclosures would be approximately 10 feet wide, 30 feet long, and 29 feet high. The generators would have a stack height between approximately 25 and 55 feet. Each pair of generators would be spaced approximately five feet apart horizontally. The west end of the generator yard would be partially enclosed with a 70-foot-high perforated metal screen to obscure views of the gensets from Martin Avenue.

Fuel System. The gensets will use renewable diesel as the primary fuel when feasible and ultra-low sulfur diesel as fuel (<15 parts per million sulfur by weight) when renewable diesel is not readily available. Each of the 44 generators would have an approximately 5,400-gallon diesel fuel storage tank with high fuel level of approximately 5,100 gallons. Approximately 4,700 gallons are required per generator for 24-hours of operation.

Cooling System. Each generator would be air cooled independently as part of its integrated package and therefore there is no common cooling system for the MBGF.

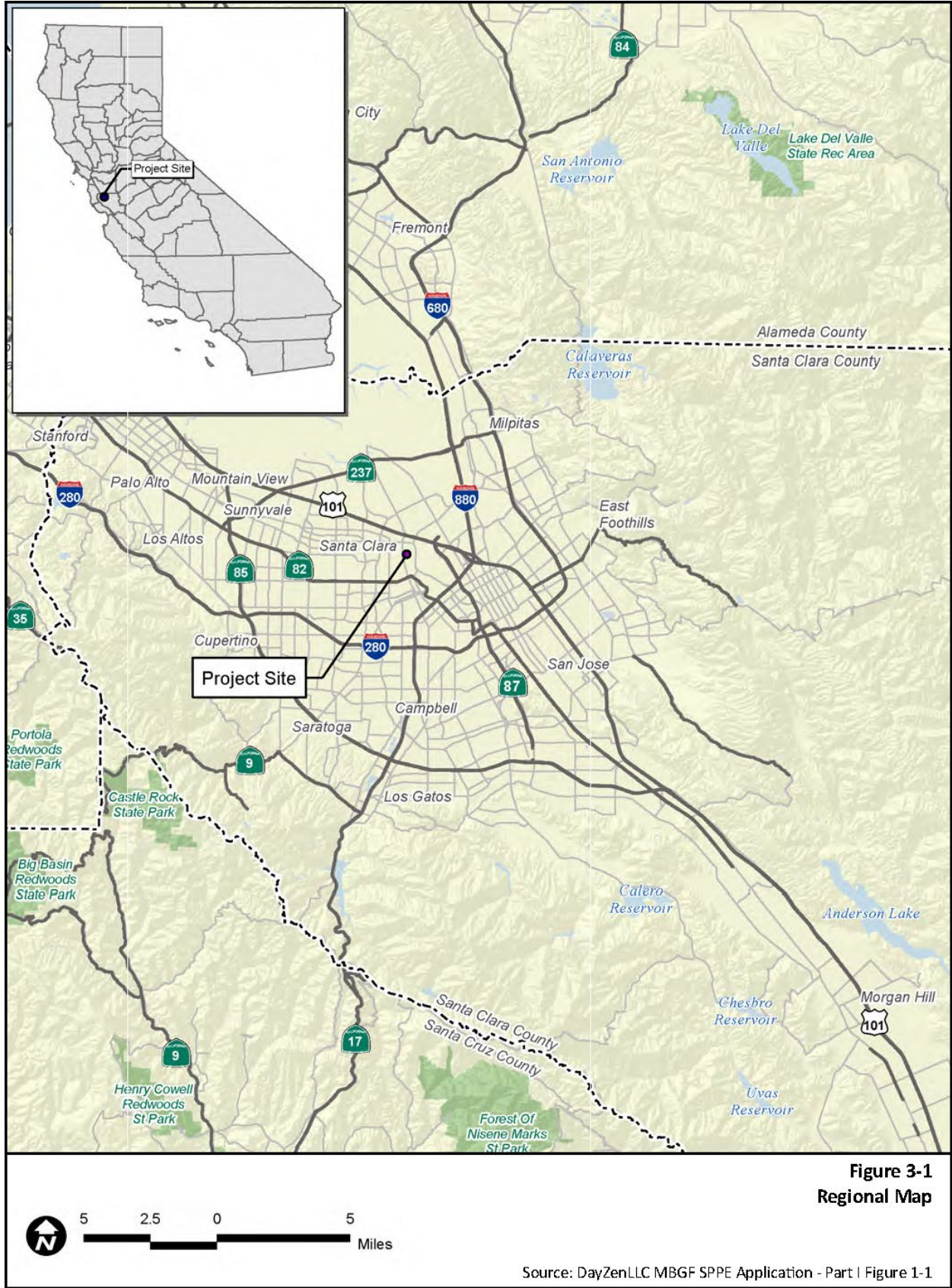
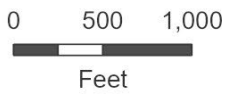
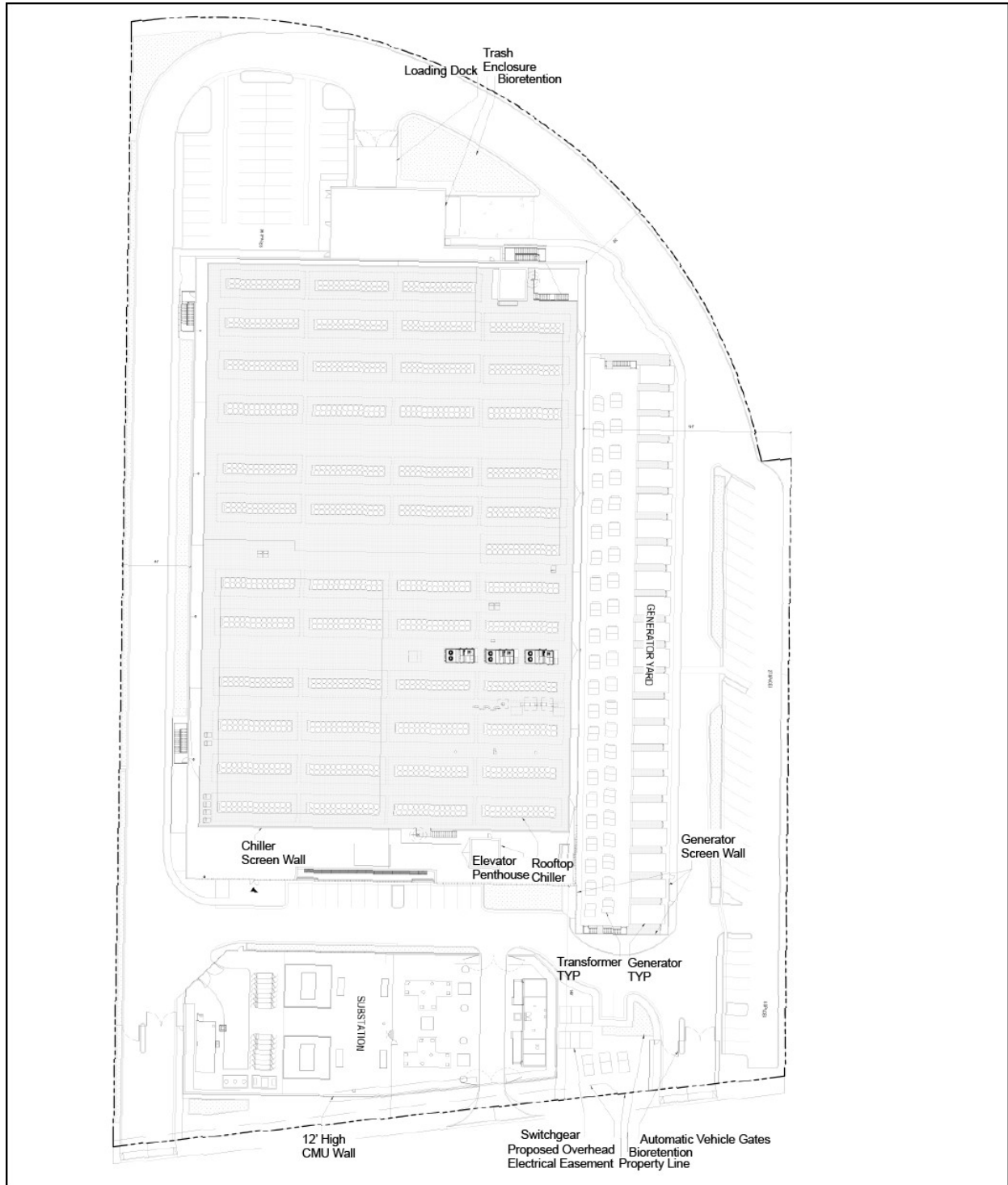



Figure 3-2
Project Location



Source: DayZen LLC MBGF SPPE Application
Part I Figure 1-2



**Figure 3-3
Site Plan**

Source: DayZenLLC MBGF SPPE Application
Part I Figure A0.0

3.3.3 Onsite Substation and Switching Station

The proposed on-site substation would only be capable of delivering electricity to the MDC from the proposed SVP on-site switching station. The proposed on-site switching station would be along Martin Avenue and would be connected to an existing, adjacent 60 kV transmission line. The switching station would be configured as a loop with two radial taps to the MDC substation. Reliability is maintained such that, if there is a fault along any section of the loop, electric service is still supplied from the other end of the 60 kV loop. (DayZenLLC 2022a).

The new conductor that would interconnect the new substation to the bulk electric system will be an ACCR Type, size 715 double bundle with a carrying capacity of 310 MVA. SVP's general practice is to use tubular steel transmission poles structures to loop in and out of an SVP switching station. Tie in would occur by intercepting and routing the line through the switching station. There may be up to three new on-site transmission poles to accomplish the tie-in.

3.3.4 Water Supply and Water Use

For site grading and construction, the applicant estimates using 1.75 acre-feet of water over the 24-month, project construction period. During operation, at full buildout, the project is expected to use approximately 2.0-acre feet of water per year (AFY). In addition, the project could be expected to use approximately 1.0 AFY for landscape purposes and personal hygienic purposes.

The MDC could require water when outside air temperatures approach design limits to augment its adiabatic cooling system. The MDC would be designed to use up to 0.8 AFY of recycled water supply for cooling when it is available. For potable water, the project site is within the jurisdiction and service territory of the city of Santa Clara Department of Water and Sewer Utilities. Water is provided via the San Francisco Public Utilities Commission, the Santa Clara Valley Water District, and 26 groundwater wells operated by the city's Water and Sewer Utility (see additional discussion of both potable and recycled water below).

3.3.5 Utility Connections

Other than the proposed electrical connections described above, the project would not require new connections to utilities and service systems. The project would use the pre-existing connections to the city's stormwater, telecommunications, fiber, and waste systems where possible.

Storm Drainage

The city of Santa Clara owns and maintains the municipal storm drainage system that currently serves the developed site and would continue to serve the proposed project. Existing stormwater runoff exits the site via an on-site catch basin or drains as sheet flow towards the storm drainage system on Lafayette Street. The runoff eventually empties into the Guadalupe River and ultimately into the San Francisco Bay. (DayZenLLC 2022a).

Domestic (Potable) Water

Water services to the site are provided by the city of Santa Clara Department of Water and Sewer Utilities. Approximately 70 percent of the city's potable water is provided by an extensive underground aquifer (accessed by the city's wells). The remaining roughly 30 percent is provided by two wholesale water importers: the Santa Clara Valley Water District (imported from the Sacramento-San Joaquin Delta) and the San Francisco Hetch Hetchy Regional Water System (imported from the Sierra Nevada). The water system consists of more than 335 miles of water mains, 27 active water wells, and seven storage tanks with 28.8 million gallons of water storage capacity.

Recycled Water

Tertiary treated (or "recycled") water comprises approximately 16 percent of the overall water supplied by the city. Recycled water is supplied from South Bay Recycled Water which provides advanced tertiary treated water from the San Jose-Santa Clara Regional Wastewater Facility (RWF), formerly known as the San Jose/Santa Clara Water Pollution Control Plant. The city's recycled water program delivers recycled water throughout the city in addition to existing potable water supplies. Recycled water is used for landscaping, parks, public services, and businesses. The project plans to use recycled water for landscaping needs. An existing recycled water line is on the east side of the Union Pacific Railroad tracks, approximately 100 feet east of the subject property. The project intends to extend the recycled water line as a secondary source of water. A potable water connection would be provided as a back-up source to the recycled water system in the interim period. (DayZenLLC 2022a)

Fire Water

The project would use existing city infrastructure systems located along Martin Avenue, including fire water service.

Wastewater (Sanitary Sewer)

Wastewater from the city of Santa Clara is treated at the RWF. Wastewater from the pre-existing buildings on-site discharges to either a 12-inch or 15-inch sanitary sewer line, and eventually to the RWF. Sanitary sewer lines that serve the project site are, and would continue to be, maintained by the city of Santa Clara Water and Sewer Utilities.

The RWF is owned jointly by the two cities and operated by the city of San Jose's Department of Environmental Services. The facility is one of the largest advanced wastewater treatment facilities in California and serves over 1,400,000 people in Santa Clara and the surrounding region. The RWF provides primary, secondary, and tertiary treatment of wastewater and has the capacity to treat 167 million gallons of wastewater a day. Approximately 10 percent of the RWF's effluent is recycled for non-potable uses and the remainder flows into San Francisco Bay. The National Pollutant Discharge Elimination System (NPDES) permit for RWF includes wastewater discharge requirements.

3.3.6 Landscaping

Along with demolishing the existing structure and ancillary improvements, the project would remove all 33 existing on-site trees and other miscellaneous vegetation that may be presently associated with the existing commercial enterprise. Trees would be replaced according to the city of Santa Clara landscape ordinance standards (a 2:1 replacement with 24-inch box trees, or a 1:1 replacement with 36-inch trees). The project proposes to mitigate for the loss of trees through a combination of 24-inch box size and 36-inch box size replacements.

New landscaping consisting of trees, large and medium shrubs, and groundcovers would be installed along the property boundaries, building perimeters, stormwater treatment facilities, and landscape beds distributed throughout the parking facilities. Trees would be planted five feet away from new or existing water mains or utility lines.

New landscape plantings would include drought tolerant native and non-native trees, shrubs, and ground covers. The landscape design would meet state and city water efficient landscape ordinance (WELO) requirements for water use. It is estimated that the new planting would be approximately 40-45 percent under the landscape maximum water use for the site as calculated with the WELO formulas. (DayZenLLC 2022a).

3.3.7 Stormwater Management

The San Francisco Bay Regional Water Quality Control Board (RWQCB) has issued a Municipal Regional Stormwater NPDES Permit (MRP) to regulate stormwater discharges from municipalities and local agencies. Under Provision C.3 of the MRP, new and redevelopment projects that create or replace 10,000 square feet or more of impervious surface area are required to implement site design, source control, and Low-Impact Development (LID)-based stormwater treatment controls to treat post-construction stormwater runoff.

3.3.8 Waste Management (Solid Waste)

The project would not create any waste material other than minor amounts of solid waste created during construction and maintenance activities. Solid waste and recycling collection in the city of Santa Clara is provided by Mission Trail Waste System through a contract with the city. The city has an arrangement with the owners of Newby Island Sanitary Landfill (NISL), located in San Jose to provide disposal capacity for the city of Santa Clara through 2024. Recycling services are provided through Stevens Creek Disposal and Recycling (DayzenLLC2022a).

3.3.9 Hazardous Materials Management

The project applicant would prepare a Spill Prevention, Control, and Countermeasure Plan (SPCC) to address the storage, use, and delivery of diesel fuel for the gensets. Regarding storage, each genset and its integrated fuel tanks would be designed with double walls. The interstitial space between the walls of each tank would be continuously monitored

electronically for the existence of liquids. This monitoring system would be electronically linked to an alarm system in the engineering office that alerts personnel if a leak is detected. Additionally, the gensets would be housed within a self-sheltering enclosure that prevents the intrusion of stormwater.

Regarding delivery, diesel fuel would be delivered on an as-needed basis in a compartmentalized tanker truck with a maximum capacity of 8,500 gallons. The tanker truck would park on the access road to the south of the generator yard and extend the fuel fill hose through one of multiple hinged openings in the precast screen wall surrounding the generator equipment yard. There would be no loading/unloading racks or containment for re-fueling events; however, a spill catch basin would be located at each fill port for the gensets. To prevent a release from entering the storm drain system, drains would be blocked off by the truck driver and/or facility staff during fueling events. Rubber pads or similar devices would be kept in the generation yard to allow for the quick blockage of the storm sewer drains during fueling events. To further minimize the potential for diesel fuel to come into contact with stormwater, to the extent feasible, fueling operations would be scheduled at times when storm events are improbable. Warning signs and/or wheel chocks would be used in the loading and/or unloading areas to prevent vehicles from departing before the complete disconnection of flexible or fixed transfer lines. An emergency pump shut-off would be used if a pump hose breaks while fueling the tanks. Tanker truck loading and unloading procedures would be posted at the loading and unloading areas.

Regarding usage, urea or diesel exhaust fluid would be used as part of the diesel engine combustion process to meet the emissions requirements. Urea is stored in 2.55-gallon drums within the generator enclosure. These drums can be filled in place from other drums, totes, or bulk tanker truck at the tank top or swapped out for new using quick connection fittings at the tank top.

3.3.10 Energy and Water Efficiency Measures

Due to the heat generated by the data center equipment, cooling is one of the main uses of electricity in data center operations. To reduce GHG emissions and reduce the use of energy related to building operations, the MDC proposes to implement the following energy (and water) efficiency measures:

- LEED lighting fixtures and occupancy sensors
- Daylight penetration to offices
- Reflective roof surface
- Meet or exceed Title 24 requirements
- Electric vehicle (EV) parking
- Low flow plumbing fixtures
- Use a low GHG emission refrigerant in the project chillers

- Landscaping would meet City of Santa Clara requirements for low water use

The data center industry uses a factor called the Power Utilization Efficiency Factor (PUE), or in the case of Martin Properties, Power Usage Effectiveness, to estimate the efficiency of its data centers. It is defined as the ratio of total facility energy draw, including the facility's mechanical and electrical loads to IT server electrical power draw ($PUE = \frac{\text{total facility source energy [including the Critical IT source energy]}}{\text{critical IT source energy}}$). The PUE is calculated by dividing the total demand of the data center by the Critical IT load. The theoretical peak PUE for the Worst Day Calculation would be 1.45 (Total 92.8 MW demand of Building on Worst Case Day divided by 64.0 MW Total Critical IT Load). The annual PUE would be 1.26 (Total 80.7 MW demand of Building average conditions divided by 64.0 MW Design Critical IT Load). These PUE estimates are based on design assumptions and represent worst case (DayZen 2020a).

As described above, the expected PUE is much lower because the client leases are rarely fully utilized. The actual PUE would be closer to 1.25. While the PUE is always greater than 1, the closer it is to 1, the greater the portion of the power drawn by the facility that goes to the critical IT server equipment. The PUE has been used as a guideline for assessing and comparing energy and power efficiencies associated with data centers since 2007. According to the Uptime Institute 2019 Annual Data Center Survey Results, the current industry average PUE is 1.67. (DayZenLLC 2021e and DayZenLLC 2022a.)

3.4 Project Construction

Site preparation activities for the project would include the ground preparation and grading of the entire site. The applicant estimates that up to 12,000 cubic yards of soil will be imported to raise the site to acceptable elevation per Federal Emergency Management Agency flood zone information (Zone AO). Grading of the site is not expected to require the export of any soil or undocumented fill material. Construction would include concrete slabs, fencing, installation of underground and above ground conduit and electrical cabling to interconnect to the MDC building switchgear, and placing and securing the gensets. The gensets themselves would be assembled offsite, delivered to site by truck, and placed within the generation yard by crane. Construction of the generation yard and placement of the gensets is expected to take six months and is included in the overall Phase I construction schedule.

Project construction is anticipated to begin in 2024. Phase I, involving demolition, grading, installation of utility services, including interim power and construction of the on-site substation; and construction of the building shell and some tenant improvements, is expected to last 14 months. Phase II construction would begin as soon as commercially feasible and take approximately 11 months to complete for commercial operation of the remaining interior rooms by the end of 2025.

3.5 Workforce

The Phase I construction workforce will reach a peak number of approximately 190 workers and an average of approximately 100 per month. The Phase II construction workforce is estimated to peak at approximately 100 workers per month, with an average of approximately 60 per month. These estimates of construction workers include the construction worker estimates of 10 to 15 for the MBGF, and one crane operator.

Daily operations personnel, including both tenants and project operations staff is estimated to be 33-35 persons per typical workday. Operations staff typically includes security guards, a janitor, and possibly visitors. (DayZenLLC 2022a)

3.6 References

DayZenLLC 2022a – DayZenLLC (DayZenLLC). (TN 247325). MBGF SPPE Application – Part I – Main App and Appendix A, dated November 7, 2022. Available online at:<https://efiling.energy.ca.gov/Lists/DocketLog.aspx?docketnumber=22-SPPE-03>

DayZenLLC2021e – DayZenLLC (DayZenLLC). (TN 237423). VDC CA3BGF SPPE Application Part II, dated April 12, 2021. Available online at:
<https://efiling.energy.ca.gov/Lists/DocketLog.aspx?docketnumber=21-SPPE-01>

Section 4

Environmental Setting and Environmental Impacts

4.1 Aesthetics

This section describes the environmental setting and regulatory background and discusses impacts pertaining to aesthetics associated with the construction and operation of the project in the existing landscape.¹

AESTHETICS	Potentially Significant Impact	Less Than Significant with Mitigation Incorporated	Less Than Significant Impact	No Impact
Except as provided in Public Resources Code section 21099 ² , would the project:				
a. Have a substantial adverse effect on a scenic vista?	<input type="checkbox"/>	<input type="checkbox"/>	<input checked="" type="checkbox"/>	<input type="checkbox"/>
b. Substantially damage scenic resources, including, but not limited to, trees, rock outcroppings, and historic buildings within a state scenic highway?	<input type="checkbox"/>	<input type="checkbox"/>	<input checked="" type="checkbox"/>	<input type="checkbox"/>
c. In non-urbanized areas, substantially degrade the existing visual character or quality of public views of the site and its surroundings? (Public views are those that are experienced from publicly accessible vantage point). If the project is in an urbanized area, would the project conflict with applicable zoning and other regulations governing scenic quality?	<input type="checkbox"/>	<input type="checkbox"/>	<input checked="" type="checkbox"/>	<input type="checkbox"/>
d. Create a new source of substantial light or glare which would adversely affect day or nighttime views in the area?	<input type="checkbox"/>	<input type="checkbox"/>	<input checked="" type="checkbox"/>	<input type="checkbox"/>

Environmental checklist established by CEQA Guidelines, Appendix G.

4.1.1 Environmental Setting

The proposed project would be constructed on relatively flat land in a highly developed urban area in the eastern portion of the city of Santa Clara, California. United States Highway 101 (U.S. 101) is a little more than a ½-mile to the north, Norman Y. Mineta San José International Airport a little more than ¼-mile to the east.

1 Landscape is defined as, "The outdoor environment, natural or built, which can be directly perceived by a person visiting and using that environment. A scene is the subset of a landscape which is viewed from one location (vantage point) looking in one direction." (Hull and Revell 1989) "The term landscape clearly focuses upon the visual properties or characteristics of the environment, these include natural and man-made elements and physical and biological resources which could be identified visually; thus non-visual biological functions, cultural/historical values, wildlife and endangered species, wilderness value, opportunities for recreation activities and a large array of tastes, smells and feelings are not included." (Daniel and Vining 1983; Amir and Gidalizon 1990)

2 Public Resources Code section 21099 asks is the proposed project an "employment center project" on an "infill site" within a "transit priority area" as defined in this section. Public Resources Code section 21099(d)(1) states, "Aesthetic and parking impacts of a residential, mixed-use residential, or employment center project on an infill site within a transit priority area shall not be considered significant impacts on the environment."

Land uses in the vicinity of the project site are primarily intensive commercial and heavy industrial.

The project site is a little more than seven acres. It has four existing one-story buildings (approximately 3,500 square feet [sq. ft.], 27,200 sq. ft., 5,000 sq. ft., 41,300 sq. ft.) and improvements, trees and landscaping that are to be removed from the site.

The project's major publicly visible building and structures would include a four-story data center (approximately 467,200 square feet) and improvements, 44 diesel-fired backup generators (gensets), and a substation. Three new transmission poles are anticipated to be on the project site. Refer to **Section 3 Project Description** for details regarding the project.

Regulatory Background

Federal

No federal regulations related to aesthetics apply to the project.

State

California Scenic Highway Program. The California Scenic Highway Program was established by the Legislature as Article 2.5 (commencing with section 260) of the Streets and Highways Code. Its purpose is to protect and enhance the natural scenic beauty of California highways and adjacent corridors, through special conservation treatment.

Section 263 of the Streets and Highways Code, the "State Scenic Highway System List" provides a list of highways that have been either officially designated or are eligible for designation as a state scenic highway. Review of the list shows the project site is not along a designated state scenic highway.

Local

City of Santa Clara 2010-2035 General Plan. The City of Santa Clara 2010-2035 General Plan (General Plan) identifies the General Plan designations, and land use goals and policies of real property within the city of Santa Clara. The General Plan shows the project site land use designation is Heavy Industrial.

"This classification allows primary manufacturing, refining and similar activities. It also accommodates warehousing and distribution, as well as data centers. Supporting ancillary office space, excluding medical facilities, or retail associated with the primary use, may be up to a maximum of ten percent of the building area. No stand-alone retail uses are allowed. Because uses in the designation may be noxious or include hazardous materials, places of assembly, such as religious institutions and schools, and uses catering predominately to sensitive receptors, such as children and the elderly, as well as entertainment uses such as clubs, theaters and sports venues south of U.S. Highway 101, are also prohibited. The maximum FAR is 0.45." (Santa Clara 2010, Chapter 5, section 5.2.2)

Santa Clara City Code. The City of Santa Clara zoning map shows the project site within the Heavy Industrial (MH) zoning district.

“This district is intended to encourage sound heavy industrial development in the city by providing and protecting an environment exclusively for such development, subject to regulations necessary to ensure the purity of the air and the waters in the bay area, and the protection of nearby uses of the land from hazards, noise, or other radiated disturbances.” (Santa Clara 2023a, section 18.50.010)

CEC staff (staff) reviewed the following zoning requirements that have some relation to aesthetics specific to governing scenic quality in accordance with Public Resources Code section 21071 applicable to the project. Public Resources section 21071, zoning and other regulations are discussed under subsection “4.1.2 Environmental Impacts.”

- The MH zoning maximum permitted building height is 70 feet. (Santa Clara 2022a, section 18.50.050)
- Open landscaped area. The following yards and areas shall be developed into and permanently maintained as open landscaped areas containing ground cover, trees, and shrubs. (Santa Clara 2023a, section 18.50.120)
 - (a) A minimum of ten feet of the required front and street side yards, exclusive of City-permitted driveway cuts, shall be developed into and permanently maintained as open landscaped areas subject to the approval of the Director of Planning and Inspection.
 - (b) A minimum area equal to at least 10 percent of the required parking area to be evenly distributed throughout the parking area and adjacent to buildings.
 - (c) An alternative proposal, equal to or exceeding the open landscaped area provisions provided herein, may be used subject to approval by the Director of Community Development in accordance with the provisions of Chapter 18.76 Santa Clara City Code.
- Additional development standards. (Santa Clara 2023a, section 18.50.140)
 - (a) Outdoor storage areas shall be screened from the street by a minimum six-foot-high solid fence located behind required frontage landscaping.
 - (c) Lighting. Lighting shall be directed away from residential areas and public streets.
 - (d) Trash Disposal. Each property shall provide adequate and accessible trash disposal areas. Said disposal area shall be screened from public view by a masonry enclosure, with solid wood gates, at least six feet in height.
 - (f) Outdoor Storage and Exposed Mechanical Equipment. Subject to the applicable development standards, outdoor storage and exposed mechanical equipment shall not exceed six feet in height within the first six feet immediately adjacent to the front or street side yard setback line, or any interior side or rear lot line. Beyond this point, storage may extend an additional one foot in height for each one foot of setback but shall not exceed the maximum building height of ten (10) feet.

Height of mechanical equipment and any accompanying screening shall be subject to Director of Community Development approval.

4.1.2 Environmental Impacts

a. Would the project have a substantial adverse effect on a scenic vista?

Neither CEQA nor the CEQA Guidelines provide a clear-cut definition of what constitutes a scenic vista. Lead agencies may look to local planning thresholds for guidance when defining the visual impact standard for the purposes of CEQA.³ A general plan, specific plan, zoning, or other planning document may provide guidance.

Construction and Operation

Less Than Significant Impact. The construction and operation of the project would not have a substantial adverse effect on a scenic vista.

The General Plan does not identify a distinct scenic vista or a specific related policy.

The California Energy Commission has used the following definition of "scenic vista" in a number of its decisions concerning thermal power plant projects: "a distant view of high pictorial quality perceived through and along a corridor or opening."⁴ Staff reviewed aerial and street view imagery (Google Earth, Google Maps), site photographs, and concluded the project would be located on a relatively unenclosed plain, the Santa Clara Valley floor, and not within a scenic vista as defined.

b. Would the project substantially damage scenic resources, including, but not limited to, trees, rock outcroppings, and historic buildings within a state scenic highway?

Neither CEQA nor the CEQA Guidelines provide a clear-cut definition of what constitutes a scenic resource. A scenic resource as presented in the above question may be explained as a widely recognized natural or man-made feature tangible in the landscape (e.g., a scenic resource designated in an adopted federal, state, or local government document, plan, or regulation, a landmark, or a cultural resource [historic values however differ from

3 Mira Mar Mobile Community v. City of Oceanside (2004) 119 Cal. App. 4th 477.

4 California Energy Commission Final Decision for GWF Tracy Combined Cycle Power Plant Project Docket Number 08-AFC-7, Visual Resources, pg. 321; California Energy Commission Decision for Mariposa Energy Project Docket Number 09-AFC-3, Visual Resources, pg. 5; California Energy Commission Decision for Blythe Solar Power Project Docket Number 09-AFC-6, Visual Resources, pg. 514; California Energy Commission Decision for Genesis Solar Energy Project Docket Number 09-AFC-8, Visual Resources, pg. 7-8; California Energy Commission Decision for Pio Pico Energy Center Docket Number 11-AFC-01, Visual Resources, pg. 8.5-4.

aesthetic or scenic values]). Staff evaluated if the project would substantially damage—eliminate or obstruct—the public view⁵ of a scenic resource.

Construction and Operation

Less Than Significant Impact. The construction and operation of the project would not substantially damage a scenic resource.

Review of the General Plan, and aerial and street view imagery concluded there is no recognized scenic resource on the site or in the vicinity that would have a public view of the project. A three-mile⁶ distance zone surrounding the project was used in the identification and evaluation of scenic resources. In this urban area there are existing aboveground buildings, structures, earthworks, equipment, trees, and vegetation that would block or limit the public view of the project.

c. Would the project, in non-urbanized areas, substantially degrade the existing visual character or quality of public views of the site and its surroundings? (Public views are those that are experienced from publicly accessible vantage point). If the project is in an urbanized area, would the project conflict with applicable zoning and other regulations governing scenic quality?

Public Resources Code section 21071 defines an “urbanized area.”⁷ The city of Santa Clara is an incorporated city with a population greater than 100,000 which constitutes an urbanized area. Information from the U.S. Census Bureau shows the city of Santa Clara population 127,151 (Census 2020). As a result, the project was reviewed for conformance with zoning and other regulations governing scenic quality.

Staff review of Public Resource Code section 21099 concluded the proposed project is not an employment center project located within a transit priority area.

Construction and Operation

Less Than Significant Impact. The construction and operation of the project would not conflict with applicable zoning and other regulations governing scenic quality.

5 A public view can be defined as the visible area from a location where the public has a legal and physical right of access to real property (e.g., city sidewalk, public park, town square, state highway). CEQA Guidelines Appendix G Environmental Checklist Form, I. Aesthetics, c. states “Public views are those that are experienced from publicly accessible vantage point.”

6 “Based on the curve of the Earth: Standing on a flat surface with your eyes about 5 feet off the ground, the farthest edge that you can see is about 3 miles away.” (Health Line 2019)

7 An “urbanized area” includes “(a) An incorporated city that meets either of the following criteria: (1) Has a population of at least 100,000 persons. (2) Has a population of less than 100,000 persons if the population of that city and not more than two contiguous incorporated cities combined equals at least 100,000 persons.” (Public Resources Code section 21071)

The project site is in the MH zoning district. "This district is intended to encourage sound heavy industrial development in the city ..." (Santa Clara 2023a, section 18.50.020)

- The MH zoning has a maximum building height of 70 feet. (Santa Clara 2023a, section 18.50.070)

The data center building would be approximately 87.5 feet in height to the top of parapet. If the City approves the applicant's minor modification to the building height, the proposed data center height of 87.5 feet would be permitted on the site. (DayZenLLC 2022a, p. 4-118) A mechanical equipment screen on the roof the data center building would extend to a height of 102.25 feet.

In accordance with the city code "the height limitations ... do not apply to spires, belfries, cupolas, antennas, water tanks, ventilators, chimneys, or other mechanical appurtenances usually required to be placed above the roof level and not intended for human occupancy or to be used for any commercial or advertising purposes." (Santa Clara 2022a, section 18.64.010)

A few purposes of a height limit include to preserve a scenic vista, protect the public view of a scenic resource (e.g., architectural structure, a landmark, natural feature), and to maintain the character of a site and surrounding area (e.g., residential or commercial area). As previously discussed, review of aerial and street imagery shows the project's buildings and structures are not within a scenic vista, would not block the public view of a scenic resource, and elevations submitted show the project's building and structure heights would be similar to the heights of buildings and structures on adjacent properties and in the surrounding area.

- Open landscaped area shall be developed into and permanently maintained as open landscaped areas containing ground cover, trees, and shrubs. (Santa Clara 2023a, section 18.30.130)

New landscaping consisting of trees, large and medium shrubs, and groundcovers would be installed along the property boundaries, building perimeters, stormwater treatment facilities, and landscape beds distributed throughout the parking facilities. Trees would be planted five feet away from new or existing water mains or utility lines. The new landscape would include drought tolerant native and non-native trees, shrubs, and ground covers. New planting would also be tolerant of recycled water. The landscape design would meet State and City Water Efficient Landscape Ordinance (WELO) requirements for water use. (DayZenLLC 2022a, p. 4-36).

- Lighting. Lighting shall be directed away from residential areas and public streets. (Santa Clara 2022a, section 18.50.140)

"[O]utdoor lighting would be angled downward and would include light visors and light hoods." (DayZenLLC 2022a, p. 4-8) The closest residential area is approximately 1,500 feet to the southwest.

- **Trash Disposal.** Each property shall provide adequate and accessible trash disposal areas. The trash disposal is to be screened from public view by a masonry enclosure, with solid wood gates, at least six (6) feet in height. (Santa Clara 2022a, section 18.50.140)

As shown on the project's site plan (Figure C) and the full building exterior elevations (Figure A3.0), a trash enclosure would be sited near the project site's most northern property line along the east side of a parking area (rear of the property) behind an 8-foot-tall masonry wall. The trash enclosure would not be in the public view. (DayZenLLC 2022a, DayZenLLC 2022b)

- **Outdoor Storage and Exposed Mechanical Equipment.** Subject to the applicable development standards, outdoor storage and exposed mechanical equipment shall not exceed six (6) feet in height within the first six (6) feet immediately adjacent to the front or street side yard setback line or any interior side or rear lot line. Beyond this point, storage may extend to a maximum height of ten (10) feet. Height of mechanical equipment and any accompanying screening shall be subject to Director of Community Development approval. (Santa Clara 2023a, section 18.50.140)

The applicant's architectural site plan (Figure A0.0) and site plan (Figure C2) show the 44 diesel-fired backup gensets would be in an enclosed generator yard on the east side of the project site. The generator yard would not be within the first six feet immediately adjacent to the front or street side yard setback line or any interior side or rear lot line. (DayZenLLC 2022a, DayZenLLC 2022b)

Staff concludes that the project would be consistent with policies in the General Plan and conform with zoning listed in the Regulatory Background subsection.

The project would have 44 Caterpillar diesel gensets to provide backup generation in case of an interruption in electrical supply from Silicon Valley Power. Manufacturer and performance data shows the generator exhaust stack flow temperature at 100 percent load standby would be 897 degrees Fahrenheit for a Caterpillar Model 3516E. This extremely high temperature (greater than 212 degrees Fahrenheit heating steam) would eliminate the necessary saturated moisture (vapor) rising from the generator exhaust stack that could condense in the atmosphere forming a publicly visible water vapor plume (visible plume). The operation of the gensets would not result in visible plumes because there is no water content in the generator's exhaust stack flow (dry air mass flow).

d. Would the project create a new source of substantial light or glare which would adversely affect day or nighttime views in the area?

Light pollution is the "inappropriate or excessive use of artificial light...." (IDA 2021) Light pollution "occurs when outdoor lighting is misdirected, misplaced, unshielded, excessive or unnecessary. As a result, light spills unnecessarily upward and outward, causing glare, light trespass, and a nighttime urban 'sky glow' overhead, indicating wasted energy and obscuring the stars overhead." (DSS 2017)

The International Dark-Sky Association (IDA) is the authority on light pollution. IDA recognizes to minimize the harmful effects of light pollution, lighting should: only be on when needed; only light the area that needs it; be no brighter than necessary; minimize blue light emissions;⁸ and be fully shielded.

Reflectance is the proportion of perpendicularly incident light reflected from the surface or body of a material.⁹ All surfaces reflect light. Materials and coatings that diffuse illumination or collection, reflectance and scattering are of utmost importance. Material with a non-shiny, textured or matt/powder finish are preferable to glossy or shiny finishes. A few examples of materials and surfaces that should be avoided if possible: any material with a reflectance greater than 35 percent; any shiny, highly reflective materials even for small surfaces; large smooth surfaces; and large expanses of glass. "An ideal coating is non-specular (to decrease geometrical effects) durable, high in reflectance and spectrally flat over a wide wavelength range to give a flat spectral response in input or output." (Labsphere 2020)

Construction and Operation

Less Than Significant Impact. The construction and operation of the project would not create a new source of substantial light, glare, or reflectance adversely affecting day or nighttime views in the area.

- Lighting shall be directed away from residential areas and public streets. (Santa Clara 2022a, section 18.50.140c)

The nearest residential area is approximately 1,500 feet south of the project site with no adjacency.

The project includes outdoor lighting for driveways, entrances, walkways, parking areas, and security purposes. LED lighting fixtures would be installed throughout the project site. Outdoor lighting would be angled downward onsite and include light visors, light hoods, and utilize lighting controls to reduce energy usage.

Exterior surfaces of the project would consist primarily of colored precast concrete panels, glass curtain walls, pre-manufactured colored EIFS (Exterior Insulation and Finish System) layers, and metal panels that would significantly reduce reflectance offsite.

The construction laydown and staging areas may have nighttime lighting for security purposes. Outdoor construction-related lighting would be directed onsite and away from surrounding properties.

⁸ Studies show exposure to blue light can cause eye strain, fatigue, headaches, and sleeplessness.

⁹ Electrical4U, "What is Reflectance?" October 11, 2020. Accessed on: December 19, 2022. Available online at: <https://www.electrical4u.com/-what-is-reflectance/>

4.1.3 Mitigation Measures

None required.

4.1.4 References

- Amir and Gidalizon 1990 – S. Amir and E. Gidalizon (Amir and Gidalizon). "Expert-based method for the evaluation of visual absorption capacity of the landscape." *Journal of Environmental Management*, Vol. 30, No. 3, April 1990, cited by *The James Hutton Institute*, August 12, 2014. Accessed on: March 29, 2023. Available online at: <https://macaulay.webarchive.hutton.ac.uk/ccw/task-two/evaluate.html>
- BLM 1986 – Bureau of Land Management (BLM). United States Department of Interior Bureau of Land Management Manual H-8410-1 Visual Resources Inventory, January 17, 1986. Accessed on: March 29, 2023. Available online at: <http://blmwyomingvisual.anl.gov/documents/>
- Census 2020 – United States Census Bureau (Census). P1: TOTAL POPULATION - Universe: Total population, 2020 Census Summary File 1. Available online at: <https://data.census.gov/cedsci/>
- Daniel and Vining 1983 – Terry C. Daniel and Joanne Vining, *Behaviour and the Natural Environment*, Plenum Press, New York, 1983, "Methodological Issues in the Assessment of Landscape Quality," cited by *The James Hutton Institute*, August 12, 2014. Accessed on: March 29, 2023. Available online at: <https://macaulay.webarchive.hutton.ac.uk/ccw/task-two/evaluate.html>
- DayZenLLC 2022a – DayZenLLC (DayZenLLC). (TN 247325). Martin Backup Generating Facility Application for SPPE dated November 2022. Available online at: <https://efiling.energy.ca.gov/Lists/DocketLog.aspx?docketnumber=22-SPPE-03>
- DayZenLLC 2022b – DayZenLLC (DayZenLLC). (TN 247326). MGBF SPPE Application – Part V, Appendices F, G and H docketed date November 8, 2022. Available online at: <https://efiling.energy.ca.gov/Lists/DocketLog.aspx?docketnumber=22-SPPE-03>
- DSS 2017 – Dark Sky Society (DSS). Accessed on: March 29, 2023. Available online at: <https://www.darkskysociety.org/>
- Electrical 4U 2020 – Electrical4U (Electrical 4U). "What is Reflectance?" October 22, 2020. Accessed on: March 29, 2023. Available online at: <https://www.electrical4u.com/what-is-reflectance/>
- Health Line 2019 – health line (health line), "How Far Can We See and Why?" May 23, 2019. Accessed on: March 29, 2023. Available online at: <https://www.healthline.com/health/how-far-can-the-human-eye-see>
- Hull and Revell 1989 – R. Bruce Hull and Grant R.B. Revell (Hull and Revell). "Issues in sampling landscapes for visual quality assessments," *Landscape and Urban Planning*, Vol. 17, No. 4, August 1989, pgs. 323-330 cited by The James Hutton

Institute, August 12, 2014. Accessed on: March 29, 2023. Available online at:
<https://macaulay.webarchive.hutton.ac.uk/ccw/task-two/evaluate.html>

IDA 2021 – International Dark-Sky Association (IDA). Accessed on: March 29, 2023.
Available online at: <https://www.darksky.org/light-pollution/>

Labsphere 2020 – Labsphere, Inc. (Labshpere). "Technical Guide: Reflectance Materials
and Coatings." n.d. Accessed on: March 29, 2023. Available online at:
[https://www.labsphere.com/wp-content/uploads/2023/01/Reflectance-Coatings-
and-Materials.pdf](https://www.labsphere.com/wp-content/uploads/2023/01/Reflectance-Coatings-and-Materials.pdf)

Santa Clara 2010 – City of Santa Clara (Santa Clara). City of Santa Clara 2010-2035
General Plan (General Plan) adopted November 16, 2010. Accessed on: March
29, 2023. Available online at: [https://www.santaclaraca.gov/our-
city/departments-a-f/community-development/planning-division/general-plan](https://www.santaclaraca.gov/our-city/departments-a-f/community-development/planning-division/general-plan)

Santa Clara 2022a – City of Santa Clara (Santa Clara). Santa Clara City Code. February
23, 2021. Accessed on: March 29, 2023. Available online at:
<https://www.codepublishing.com/CA/SantaClara/#!/SantaClaraNT.html>

4.2 Agriculture and Forestry Resources

This section describes the environmental setting and regulatory background and discusses impacts associated with the construction and operation of the project with respect to agriculture and forestry resources.

AGRICULTURE AND FORESTRY RESOURCES In determining whether impacts to agricultural resources are significant environmental effects, lead agencies may refer to the California Agricultural Land Evaluation and Site Assessment Model (1997) prepared by the California Department of Conservation as an optional model to use in assessing impacts on agriculture and farmland. In determining whether impacts to forest resources, including timberland, are significant environmental effects, lead agencies may refer to information compiled by the California Department of Forestry and Fire Protection regarding the state's inventory of forest land, including the Forest and Range Assessment Project and the Forest Legacy Assessment Project; and forest carbon measurement methodology provided in Forest Protocols adopted by the California Air Resources Board.	Potentially Significant Impact	Less Than Significant with Mitigation Incorporated	Less Than Significant Impact	No Impact
a. Convert Prime Farmland, Unique Farmland, or Farmland of Statewide Importance (Farmland), as shown on the maps prepared pursuant to the Farmland Mapping and Monitoring Program of the California Resources Agency, to non-agricultural use?	<input type="checkbox"/>	<input type="checkbox"/>	<input type="checkbox"/>	<input checked="" type="checkbox"/>
b. Conflict with existing zoning for agricultural use, or a Williamson Act contract?	<input type="checkbox"/>	<input type="checkbox"/>	<input type="checkbox"/>	<input checked="" type="checkbox"/>
c. Conflict with existing zoning for, or cause rezoning of, forest land (as defined in Public Resources Code section 12220(g)), timberland (as defined by Public Resources Code section 4526), or timberland zoned Timberland Production (as defined by Government Code section 51104(g))?	<input type="checkbox"/>	<input type="checkbox"/>	<input type="checkbox"/>	<input checked="" type="checkbox"/>
d. Result in the loss of forest land or conversion of forest land to non-forest use?	<input type="checkbox"/>	<input type="checkbox"/>	<input type="checkbox"/>	<input checked="" type="checkbox"/>
e. Involve other changes in the existing environment which, due to their location or nature, could result in conversion of Farmland to non-agricultural use or conversion of forest land to non-forest use?	<input type="checkbox"/>	<input type="checkbox"/>	<input type="checkbox"/>	<input checked="" type="checkbox"/>

Environmental checklist established by CEQA Guidelines, Appendix G.

4.2.1 Environmental Setting

Historical information shows that the project site was in agricultural uses from at least 1939 through the mid-1950s (TRC 2021). The first industrial and manufacturing uses were developed on the site between approximately 1950 and 1956. Similar uses were developed in the surrounding area during the same period. Structures currently on the site include industrial buildings and paved surface parking.

Regulatory Background

Federal

No federal regulations relating to agriculture and forestry resources apply to the project.

State

Farmland Mapping and Monitoring Program. The California Department of Conservation (CDOC) established the Farmland Mapping and Monitoring Program (FMMP) in 1982 to assess the location, quantity, and quality of agricultural lands and conversion of those lands to other uses. The FMMP identifies and maps agricultural lands as Prime Farmland, Farmland of Statewide Importance, Unique Farmland, Farmland of Local Importance, and Grazing Land. The project site does not include agricultural land.

The Santa Clara County Important Farmland Map shows that the project site and surrounding area is classified as Urban and Built-Up Land (CDOC 2021). This is one of two categories used for reporting changes in land use as required for the FMMP biennial farmland conversion report (CDOC 2019). The Urban and Built-up Land category indicates land “occupied by structures with a building density of at least one unit to 1.5 acres, or approximately six structures to a 10-acre parcel.”

Williamson Act. The California Land Conservation Act of 1965, or Williamson Act, is the principal method for encouraging the preservation of agricultural lands in California (Gov. Code, § 51200 et seq.). It enables local governments to enter in contracts with private landowners who agree to maintain specified parcels of land in agricultural or related open space use in exchange for tax benefits.

Local

City of Santa Clara General Plan and Zoning Ordinance. The project site is in an area of contiguous properties designated Heavy Industrial, as shown on the Land Use Diagram in the *City of Santa Clara 2010–2035 General Plan*. This classification “allows primary manufacturing, refining and similar activities. It also accommodates warehousing and distribution, as well as data centers” (Santa Clara 2010). The project site is in the MH, Heavy Industrial zoning district; permitted uses include “manufacturing, processing, assembling, research, wholesale, or storage uses...” (Santa Clara 2022, § 18.50.030, subd. (b)).

4.2.2 Environmental Impacts

- a. Would the project convert Prime Farmland, Unique Farmland, or Farmland of Statewide Importance (Farmland), as shown on the maps prepared pursuant to the Farmland Mapping and Monitoring Program of the California Resources Agency, to non-agricultural use?**

Construction and Operation

No Impact. The project site is within a large, intensively urbanized region of the county. As shown on the Santa Clara County Important Farmland Map, the predominant classification in the region is Urban and Built-up Land (CDOC 2021). There is no Farmland located in the project area or the region surrounding the site. Therefore, the project would not convert Farmland to a non-agricultural use. Project construction and operation would cause no impact on Farmland.

- b. Would the project conflict with existing zoning for agricultural use, or a Williamson Act contract?**

Construction and Operation

No Impact. The project site is zoned MH, Heavy Industrial, which is a non-agricultural zoning district. The Santa Clara County Important Farmland Map shows that the site and surrounding urbanized region is classified as Urban and Built-up Land (CDOC 2021). No properties with this classification are in agricultural uses, and none would be subject to Williamson Act contracts. Therefore, project construction and operation would not conflict with existing zoning for agricultural use or a Williamson Act contract, and no impact would occur.

- c. Would the project conflict with existing zoning for, or cause rezoning of, forest land (as defined in Public Resources Code section 12220(g)), timberland (as defined by Public Resources Code section 4526), or timberland zoned Timberland Production (as defined by Government Code section 51104(g))?**

Construction and Operation

No Impact. The project site is in the MH, Heavy Industrial zoning district. Development in the project area primarily includes industrial uses. No land in the area is zoned for forest land, timberland, or timberland production. Therefore, project construction and operation would cause no impact on such lands or uses.

d. Would the project result in the loss of forest land or conversion of forest land to non-forest use?

Construction and Operation

No Impact. The project site does not contain forest land and is not in a region where forest land is present. Therefore, project construction and operation would cause no loss of forest land, and no impact would occur.

e. Would the project involve other changes in the existing environment which, due to their location or nature, could result in conversion of Farmland to non-agricultural use or conversion of forest land to non-forest use?

Construction and Operation

No Impact. Starting in the 1950s, the project site and other properties in the area have been developed with manufacturing and other industrial uses. The proposed project would be consistent with these and other similar uses in the project area. Construction and operation activities would cause no changes in the existing environment that could cause conversion of Farmland to a non-agricultural use or forest land to a non-forest use. Therefore, no impact would occur.

4.2.3 Mitigation Measures

None required.

4.2.4 References

CDOC 2019 – California Department of Conservation. Division of Land Resource Protection, Farmland Mapping and Monitoring Program. Important Farmland Categories. Accessed on: February 6, 2023. Available online at: <https://www.conservation.ca.gov/dlrp/fmmp/Pages/Important-Farmland-Categories.aspx>

CDOC 2021 – California Department of Conservation. Division of Land Resource Protection, Farmland Mapping and Monitoring Program. *Santa Clara County Important Farmland 2018*. Map published June 2021. Accessed on: February 6, 2023. Available online at: <https://www.conservation.ca.gov/dlrp/fmmp/Pages/SantaClara.aspx>

Santa Clara 2010 – City of Santa Clara. Community Development Department, Planning Division. *City of Santa Clara 2010–2035 General Plan*. Chapter 5 Goals and Policies. Section 5.2.2 Land Use Classifications and Diagram. Land Use Diagram Phase III, revised April 23, 2021. Accessed on: February 6, 2023. Available online at: <https://www.santaclaraca.gov/our-city/departments-a-f/community-development/planning-division/general-plan>

Santa Clara 2022 – City of Santa Clara. Santa Clara City Code. Title 18 Zoning. Chapter 18.50 Regulations for MH – Heavy Industrial Zoning District. Current through Ordinance 2054, passed November 1, 2022. Accessed on: February 6, 2023. Available online at: <https://www.codepublishing.com/CA/SantaClara/>

TRC 2021 – TRC Solutions, Inc. (TN 247328). Phase I Environmental Site Assessment, 651 Martin Avenue, Santa Clara, CA 95050. July 29, 2021. Appendix E to the Martin Backup Generating Facility Small Power Plant Exemption Application. Submitted to the CEC in November 2022 by Martin Avenue Properties LLC. Section 4.1 Historic Use Information, and aerial photograph package. Available online at: <https://efiling.energy.ca.gov/Lists/DocketLog.aspx?docketnumber=22-SPPE-03>

4.3 Air Quality

This section describes the environmental setting and regulatory background and discusses impacts specific to air quality associated with the demolition/construction, routine operation, and the potential for emergency operation of the Martin Data Center (MDC) and the associated Martin Backup Generating Facility (MBGF), known together as the “project”.

Under the proposed project, the emergency backup generators, or gensets, would use renewable diesel as the primary fuel with ultra-low sulfur (conventional) diesel as the secondary backup fuel if renewable diesel is unavailable, as required by mitigation measure **GHG-2** (DayZenLLC 2022a). However, the applicant estimated the emissions and air quality impacts based on the emission factors of conventional diesel (DayZenLLC 2022b). According to the currently available data (CARB 2021), the air quality and public health impacts using renewable diesel during project operations would likely be similar to those that would occur with the use of conventional diesel. Therefore, for the proposed project, staff expects that the impacts during project operations from the use of renewable diesel would be similar to those estimated based on the use of conventional diesel. Other emission-relevant facts arising out of this project are typical of those in commercial construction in developed urban areas, and operation of data centers, as described.

The analysis follows the recommended determinations as set forth in the environmental checklist established by the CEQA Guidelines, Appendix G:

AIR QUALITY Where available, the significance criteria established by the applicable air quality management district or air pollution control district may be relied upon to make the following determinations.	Potentially Significant Impact	Less Than Significant with Mitigation Incorporated	Less Than Significant Impact	No Impact
Would the project:				
a. Conflict with or obstruct implementation of the applicable air quality plan?	<input type="checkbox"/>	<input type="checkbox"/>	<input checked="" type="checkbox"/>	<input type="checkbox"/>
b. Result in a cumulatively considerable net increase of any criteria pollutant for which the project region is non-attainment under an applicable federal or state ambient air quality standard?	<input type="checkbox"/>	<input checked="" type="checkbox"/>	<input type="checkbox"/>	<input type="checkbox"/>
c. Expose sensitive receptors to substantial pollutant concentrations?	<input type="checkbox"/>	<input checked="" type="checkbox"/>	<input type="checkbox"/>	<input type="checkbox"/>
d. Result in other emissions (such as those leading to odors) adversely affecting a substantial number of people?	<input type="checkbox"/>	<input type="checkbox"/>	<input checked="" type="checkbox"/>	<input type="checkbox"/>

Environmental checklist established by CEQA Guidelines, Appendix G.

4.3.1 Summary

CEC staff's (staff) overall conclusion is that, with the implementation of mitigation measure **AQ-1** the project would not have a significant impact on air quality. To reach this conclusion, this section assesses the impacts of two primary types of air emissions: (1) criteria pollutants, which have health-based ambient air quality standards (AAQS); and (2) toxic air contaminants (TACs), which are identified as potentially harmful even at low levels and have no established safe levels or health-based AAQS.

These two primary types of emissions can potentially result from multiple phases of the project, and through a variety of activities. To summarize the pertinent portions of the project description, project demolition, grading, excavation, and construction would occur across two phases. The first phase (Phase I) would include demolition of the four existing buildings and infrastructure that cannot be reused; grading of the entire site; installation of utility services including interim power and construction of the on-site utility substation; and construction of the shell of the building and some of the interior rooms, as necessary for tenants (DayZenLLC 2022a, pg. 2-17). The Phase II activities would primarily involve fitting out the remainder of the interior rooms with no potential for notable emissions (DayZenLLC 2023a; Response to Data Request 4). The existing four buildings at 651 Martin Avenue would be demolished to allow for construction of the new MDC building. Demolition and construction activities are estimated to last approximately 14 months to the initial occupancy of the building. Construction activities are estimated to last an additional 11 months indoors to bring the building to full occupancy (DayZenLLC 2022a, pg. 2-17).

4.3.1.1 Significance Criteria

This air quality evaluation analyzes the degree to which the project would potentially cause a significant impact according to the California Environmental Quality Act (CEQA) guidelines. Various standards and thresholds apply to various phases of the project. By way of background, the Bay Area Air Quality Management District (BAAQMD) is the local air district responsible for the attainment and maintenance of the federal and state AAQS and associated program requirements at the project location. In April of 2023, BAAQMD made new guidelines available (BAAQMD 2023b). To determine the significance of the potential air quality emissions and impacts, this analysis applies the air quality project-level thresholds of significance that were adopted by the BAAQMD's Board of Directors on June 2, 2010, as recommended by the updated guidelines released by BAAQMD in April 2023 (BAAQMD 2023b). This analysis includes qualitative determinations and the quantification of whether project construction or operation would exceed numeric emissions and health risk thresholds as set forth by BAAQMD and other applicable significance thresholds.

As will be described in greater detail below, BAAQMD CEQA Guidelines project-level thresholds of significance ("BAAQMD significance thresholds") for criteria pollutants and precursor pollutants and the health risks of TACs that apply during construction and

operation are shown in **Table 4.3-1**. If a project exceeds the identified significance thresholds, its emissions would be cumulatively considerable, resulting in significant adverse air quality impacts to the Bay Area region’s existing air quality conditions. Staff evaluates project emissions against the BAAQMD significance thresholds under environmental checklist criterion “b.”

TABLE 4.3-1 BAAQMD THRESHOLDS OF SIGNIFICANCE

Pollutant	Construction	Operation	
	Average Daily Emissions (lbs/day)	Average Daily Emissions (lbs/day)	Maximum Annual Emissions (tpy)
ROG	54	54	10
NOx	54	54	10
PM10	82 (exhaust)	82	15
PM2.5	54 (exhaust)	54	10
PM10/PM2.5 (fugitive dust)	Best Management Practices	None	
Local CO	None	9.0 ppm (8-hour average), 20.0 ppm (1-hour average)	
Risk and Hazards for New Sources and Receptors (Individual Project)	Same as Operation Threshold	Compliance with Qualified Community Risk Reduction Plan OR Increased cancer risk of >10.0 in one million Increased non-cancer risk of > 1.0 Hazard Index (Chronic or Acute) Ambient PM2.5 increase: > 0.3 µg/m ³ annual average	
Risk and Hazards for New Sources and Receptors (Cumulative Threshold)	Same as Operation Threshold	Compliance with Qualified Community Risk Reduction Plan OR Cancer: > 100 in one million (from all local sources) Non-cancer: > 10.0 Hazard Index (from all local sources) (Chronic) PM2.5: > 0.8 µg/m ³ annual average (from all local sources)	

Source: BAAQMD 2023b.

Note: The air quality project-level thresholds of significance were adopted by the Air District’s Board of Directors on June 2, 2010.

Next, for fugitive dust emissions during construction periods, the BAAQMD CEQA Guidelines do not have a significance threshold. Rather, BAAQMD recommends using a current Best Management Practices (BMPs) approach, which has been a pragmatic and effective approach to the control of fugitive dust emissions.

Also, the project’s potential to expose sensitive receptors to substantial pollutant concentrations are evaluated following environmental checklist criterion “c.” Staff addresses both the ambient air quality impacts of criteria pollutants, which have health-based standards, and the impacts of TACs, which are identified as potentially harmful

even at low levels and have no established safe levels or health-based ambient air quality standards.

To provide thorough assessment of all such impacts from the project, this section includes ambient air quality impact modeling for the demolition/construction and operation phases, which also includes readiness testing and maintenance of the proposed renewable diesel-fueled gensets to estimate the air quality impacts caused by the emissions. The State and federal AAQS, shown in **Table 4.3-2**, are health protective values, so staff uses these health-based regulatory standards to help define what is considered a substantial pollutant concentration for criteria pollutants.¹ Staff's analysis determines whether the project would be likely to exceed any AAQS or contribute substantially to an existing or projected air quality violation. If necessary, the analysis proposes mitigation to reduce or eliminate these pollutant exceedances or substantial contributions.

For this analysis, staff also uses the U.S. EPA Significant Impact Levels (SILs) as well as the BAAQMD CEQA Guidelines significance threshold to determine project impact significance of particulate matter concentrations. Regulatory agencies have traditionally applied SILs as a de minimis value, which represents the off-site concentration predicted to result from a source's emissions that does not warrant additional analysis or mitigation. If a source's modeled impacts at any off-site location do not exceed relevant SILs, the source owner would typically not need to assess multi-source or cumulative air quality modeling to Ambient Air Quality Standard (NAAQS) or California Ambient Air Quality Standard (CAAQS).

In the project area, data in **Table 4.3-4** shows that the background levels of particulate matter of 10 micrometers or less in diameter (PM₁₀) and particulate matter of 2.5 micrometers and smaller in diameter (PM_{2.5}) exceed the most-stringent standards in the baseline conditions. Staff compares the project's contribution to local criteria pollutant concentrations to SILs to determine whether the project's emissions would contribute significantly to those exceedances.

To determine if the project could contribute substantially to the existing PM₁₀ exceedances, this analysis relies on the United States Environmental Protection Agency (U.S. EPA) PM₁₀ SILs established in federal regulations for non-attainment areas (40 CFR 51.165(b)(2)) for 24-hour impacts (5 µg/m³) and for annual impacts (1 µg/m³). The same federal regulation (40 CFR 51.165(b)(2)) also established the U.S. EPA PM_{2.5} SILs concentrations for 24-hour impacts (1.2 µg/m³) and for annual impacts (0.3 µg/m³). BAAQMD does not have applicable alternative criteria.

¹ This approach provides a complete analysis that describes the foreseeable effects of the project in relation to all potential air quality related health impacts, including impacts of criteria pollutants to sensitive receptors; and therefore, addresses the California Supreme Court December 2018 *Sierra Club v. County of Fresno* opinion (<https://www.courts.ca.gov/opinions/archive/S219783A.PDF>).

The BAAQMD has a significance threshold for a project-level increase in annual PM2.5 concentrations which is also 0.3 micrograms per cubic meter ($\mu\text{g}/\text{m}^3$), as shown in **Table 4.3-1**. However, in April 2018, the U.S. EPA issued *Guidance on Significant Impact Levels for Ozone and Fine Particles in the Prevention of Significant Deterioration Permitting Program* (U.S. EPA 2018a), which recommends PM2.5 SILs levels for 24-hour impacts to be 1.2 $\mu\text{g}/\text{m}^3$ (as in [40 CFR 51.165(b)(2)]) and for annual impacts to be 0.2 $\mu\text{g}/\text{m}^3$ (lower than 0.3 $\mu\text{g}/\text{m}^3$). Note that the U.S. EPA SILs values are all based on the forms of the applicable NAAQS. For example, the 24-hour PM2.5 SILs of 1.2 $\mu\text{g}/\text{m}^3$ is based on the 98th percentile 24-hour concentrations averaged over three years. The annual PM2.5 SILs of 0.2 $\mu\text{g}/\text{m}^3$ is based on a three-year average of annual average concentrations.

For TACs, the standards used to measure the significance of an impact are based on the levels of a TAC that cause harm to human health. There are two kinds of thresholds for TACs: cancer risk and non-cancer risk. Cancer risk is expressed as excess cancer cases per one million exposed individuals, typically over a lifetime of exposure. Acute and chronic exposure to non-carcinogens is expressed as a hazard index (HI), which is the ratio of expected exposure levels to acceptable reference exposure levels (REL) for each of the TACs with acute and chronic health effects. The significance thresholds for TACs and PM2.5 are listed in **Table 4.3-1**.

In addition to the TAC impacts created by project emissions, the analysis must also evaluate whether the TAC emissions of a project would have a cumulative significant impact, combined with past, present, and foreseeable future TAC sources (BAAQMD 2023b).

CEQA requires staff to consider: "*whether the cumulative impact is significant and whether the effects of the project are cumulatively considerable,*" and CEQA allows that "*The mere existence of significant cumulative impacts caused by other projects alone shall not constitute substantial evidence that the proposed project's incremental effects are cumulatively considerable.*" [CEQA Guidelines § 15064(h)(1) and (4).] The following paragraphs show the two sets of thresholds used by staff in the assessment of: (1) whether the effects of the project are cumulatively considerable; and (2) the significance of the cumulative impact for public health.

The BAAQMD project-level threshold addresses the potential for an individual project to significantly elevate existing risks or hazards. A project would have a cumulatively considerable impact if it resulted in (BAAQMD 2023b):

- An excess lifetime cancer risk level of more than 10.0 in one million.
- A non-cancer chronic HI greater than 1.0.
- A non-cancer acute HI greater than 1.0.
- An incremental increase in the annual average PM2.5 concentration of greater than 0.3 $\mu\text{g}/\text{m}^3$.

The BAAQMD significance thresholds for cumulative impacts are also summarized below for local community risks and hazards (BAAQMD 2023b). The cumulative threshold addresses the potential that a project would have a cumulative significant impact if the aggregate total of all past, present, and foreseeable future sources within a 1,000-foot radius (or greater where appropriate) results in (BAAQMD 2023b, Chapter 5):

- An excess lifetime cancer risk level of more than 100 in one million.
- A non-cancer chronic HI greater than 10.0.
- An annual average PM_{2.5} concentration of greater than 0.8 µg/m³.

Finally, the CEQA environmental checklist criterion “a” (page 4.3-1) requires this air quality analysis address the consistency of the project with BAAQMD’s Bay Area 2017 Clean Air Plan. Under that Plan, if a project would not exceed the BAAQMD significance thresholds discussed above, then a project would also be consistent with and not have any impact on BAAQMD’s Bay Area 2017 Clean Air Plan. This plan provides a regional strategy to protect public health and the climate, and it defines an integrated, multipollutant control strategy to reduce emissions of particulate matter, TACs, ozone and key ozone precursors, and greenhouse gases (GHG).

4.3.1.2 Criteria Pollutants (including Fugitive Dust)

Construction

To complete the analysis described in CEQA environmental checklist criterion “b,” staff evaluates construction-phase emissions that are a result of construction equipment, material movement, paving activities, and on-site and off-site vehicle trips, such as material haul trucks, worker commutes, and delivery vehicles and determines whether these emissions are cumulatively considerable.

As shown in **Table 4.3-5** on page 4.3-30, the project’s average daily criteria pollutant emissions during construction would be lower than the relevant numeric BAAQMD significance thresholds. There is no numerical threshold for fugitive dust generated during construction. The BAAQMD CEQA Guidelines recommend the control of fugitive dust through BMPs which will render impacts from fugitive dust emissions less than significant (BAAQMD 2023b). Staff recommends mitigation measure **AQ-1**, which incorporates the project applicant’s proposed measures that would include BAAQMD’s recommended construction BMPs and exhaust emissions controls. With the implementation of mitigation measure **AQ-1**, the fugitive dust impacts from construction would be less than significant.

To evaluate whether the project would expose sensitive receptors to substantial pollutant concentrations under the CEQA environmental checklist criterion “c”, regarding the localized impacts of construction criteria pollutant emissions, staff compares them to the AAQS. Construction is considered short-term, and construction impacts would be further reduced with the implementation of mitigation measure **AQ-1**, which includes BAAQMD’s recommended construction BMPs and exhaust emissions mitigation measures.

With the implementation of mitigation measure **AQ-1**, criteria pollutant and fugitive dust emissions from project construction would not exceed any BAAQMD CEQA Guidelines significance threshold, cause a cumulatively considerable net increase of any criteria pollutant, conflict with or obstruct any applicable regional or local air quality plan, or expose sensitive receptors to substantial criteria pollutant concentrations. The air quality impacts of construction would thus be less than significant.

Operation

Staff evaluates criteria pollutant emissions from operation and maintenance in two sections: (A) "routine operation" emissions including, among other things, emissions from readiness testing and maintenance of the 44 gensets; and (B) "emergency operation" emissions from using the gensets to support the electricity demand of the project.

(A) Routine Operation

Under CEQA environmental checklist criterion "b," staff concludes that cumulatively considerable criteria pollutant emissions from the project's routine operation would be less than significant. Routine operation of the project would generate criteria pollutant emissions from readiness testing and maintenance of the 44 gensets, off-site vehicle trips for worker commutes and material deliveries, and facility upkeep, such as architectural coatings, consumer product use, landscaping, water use, waste generation, natural gas use for comfort heating, and electricity use.

As shown in **Table 4.3-6**, staff finds that the project's total net annual and average daily emissions would not exceed any of the BAAQMD significance thresholds.

The project would also emit ammonia from the urea used in the selective catalytic reduction (SCR) system for the gensets. There is no BAAQMD threshold for ammonia, which is not a criteria pollutant but instead a precursor to particulate matter. Because the project's primary emissions of particulate matter are well below the BAAQMD CEQA Guidelines significance thresholds, secondary particulate matter impacts from the project's ammonia emissions of 0.29 tons per year (tpy) would be less than significant and not require additional mitigation or offsets.

Under environmental checklist criterion "c," staff also analyzes the localized impacts of the project's criteria pollutant emissions during readiness testing and maintenance of the gensets. Staff finds that the project would not expose sensitive receptors to substantial criteria pollutant concentrations.

Staff concludes that criteria pollutant emissions from routine operation of the project would not exceed any BAAQMD CEQA Guidelines significance threshold, cause a cumulatively considerable net increase of any criteria pollutant, or conflict with or obstruct any applicable regional or local air quality plan. Additionally, the project would not expose sensitive receptors to substantial criteria pollutant concentrations. The air quality impacts of routine operation would thus be less than significant.

(B) Emergency Operation

The emergency use of the gensets could occur in the event of a power outage or other disruption, upset, or instability that triggers a need for the project to use emergency backup power. Such emergency operations would be infrequent and for unplanned circumstances, which are beyond the control of the project owner. Emergency operations and the impacts of air pollutants during emergencies are generally exempt from air district offsetting and modeling requirements. Emissions from emergency operations are not regular, expected, or easily quantifiable such that they cannot be modeled or predicted with certainty.

(1) Criteria Pollutant Emissions from Emergency Operation

As discussed under CEQA environmental checklist criterion "b," the BAAQMD 2019 policy, *Calculating Potential to Emit for Emergency Backup Power Generators*, requires a facility's potential to emit (PTE) to be calculated based on emissions proportional to emergency operation for 100 hours per year per genset, in addition to the permitted limits for readiness testing and maintenance (BAAQMD 2019). However, after comparing the PTE calculated to determine the account eligibility threshold, the applicant would only be required to offset permitted emissions from readiness testing and maintenance and not the emissions from emergency operation. BAAQMD requires the use of offsets to counterbalance increases in regular and predictable emissions, not increases in emissions occurring infrequently when emergency conditions arise.

Emissions during routine operation are conservatively estimated with the assumption of 35 hours of readiness testing and maintenance per year per engine. This level of routine operation is likely conservatively high because other data center project applicants previously have stated that routine testing and maintenance would rarely exceed 12 hours per year.

(2) Criteria Pollutant Impacts from Emergency Operation

As discussed in detail under the subsection, "Emergency Operations Impacts for Criteria Pollutants" under CEQA environmental checklist criterion "c," the air quality impacts of genset operation during emergencies are not quantified below because the impacts of emergency operations are typically not evaluated during facility permitting and local air districts do not normally conduct an air quality impact assessment of such impacts. Staff assessed the likelihood of emergency events but finds that assessing the air quality impacts of emergency operations would require a host of unvalidated, unverifiable, and speculative assumptions about when and under what circumstances such a hypothetical emergency would occur. Such a speculative analysis is not required under CEQA (CEQA Guidelines §§ 15064(d)(3) and 15145), and, most importantly, would not provide meaningful information by which to determine project impacts. If emergency operation becomes a more frequent occurrence and more data is gathered regarding when and how these facilities operate during emergency situations, this conclusion might change.

The use of diesel engines for “non-testing/non-maintenance” purposes may only be triggered by emergency events, and these types of events are infrequent, irregular, and unlikely. The resulting emissions are not easily predictable or quantifiable. See more detailed discussion under the subsection “Emergency Operations Impacts for Criteria Pollutants” under CEQA environmental checklist criterion “c.”

Cumulative Impacts

Staff concludes that the project’s criteria pollutant emissions would not be cumulatively considerable. BAAQMD CEQA Guidelines state that if a project’s daily average or annual emissions of operational-related criteria pollutants or precursors do not exceed any BAAQMD threshold of significance, as listed in **Table 4.3-1** above, the project would not result in a cumulatively significant impact. As explained above, staff finds that criteria pollutant emissions from routine operation would be below the BAAQMD CEQA Guidelines thresholds of significance.

In addition, under CEQA environmental checklist criterion “c,” staff performed a cumulative impacts analysis for annual PM_{2.5} impacts as part of a consideration of local community risks and hazards. Staff concludes that the project’s contribution to the annual PM_{2.5} concentrations would not have a cumulatively considerable impact.

4.3.1.3 Toxic Air Contaminants (TACs)

Under environmental checklist criterion “c,” staff analyzes the potential impacts of the project’s TAC emissions separately for construction and routine operation. Staff also analyzes the cumulative effects of the project’s TAC emissions together with the impacts of other sources within 1,000 feet. Staff concludes that the individual and cumulative impacts from the project’s TAC emissions would be less than significant.

Staff finds the health risks at all sensitive receptor locations would be less than the BAAQMD CEQA Guidelines significance thresholds shown in **Table 4.3-1**. Staff concludes that the health risks from project construction and routine operation would not cause a cumulatively considerable contribution to local community risk and hazard impacts, and the construction impact would be further reduced with the implementation of mitigation measure **AQ-1**.

Staff finds that significant cumulative health risks would not occur at sensitive receptor locations, and the project’s contribution is not cumulatively considerable because the project effects would be less than the BAAQMD CEQA Guidelines significance thresholds shown in **Table 4.3-1**. Staff concludes that the effect of cumulative TAC emissions would be less than significant.

4.3.1.4 Background on Air Quality Evaluation

Criteria Pollutant Evaluation

California Air Resources Board (CARB) and U.S. EPA have each established federal and state AAQS for criteria pollutants. While both NAAQS and CAAQS apply to every location in California, typically the state standards are lower (i.e., more stringent) than federal standards. Air districts adopt rules and attainment and maintenance plans aimed at protecting public health and reducing emissions. (Health and Safety Code, §40001). Air districts incorporate these requirements into the State Implementation Plan (SIP), which CARB submits for approval to the U.S. EPA as the state's overall plan to come into attainment for federal NAAQS. (Health and Safety Code, §39602) Once a SIP is approved by the U.S. EPA and published in the Federal Register, the requirements in the SIP become federally enforceable. Consistency of the project with the applicable air quality management plan, i.e. Bay Area 2017 Clean Air Plan (BAAQMD 2017a), is evaluated here because CEQA environmental checklist criterion "a" requires substantial evidence to support staff's conclusions of whether the project will conflict with or obstruct implementation of the applicable air quality plan.

Generally, state law designates local air districts as having primary responsibility for the control of air pollution from all sources other than mobile sources while the control of vehicular air sources is the responsibility of CARB. (Health and Safety Code, §39002) Additionally, CARB is charged with coordinating efforts to attain and maintain CAAQS and NAAQS. (Health and Safety Code, §39003) Areas that meet the CAAQS or NAAQS, based upon air monitoring measurements made by either the local air district or CARB, are classified as "attainment areas," and areas that have monitoring data that exceed AAQS are classified as "nonattainment areas." (Health and Safety Code, §39608) Additionally, any given area can be classified as "attainment" for some pollutants and "nonattainment" for others. Even for the same pollutant, an area can be attainment for one averaging time and nonattainment for another.

Air monitoring stations, usually operated by local air districts or CARB, measure the ambient air to determine an area's attainment status for NAAQS and CAAQS. Depending on the pollutant, the time over which these pollutants are measured varies from 1-hour, to 3-hours, to 8-hours, to 24-hours and to annual averages. Most criteria pollutants have ambient standards with more than one averaging time. Pollutant concentrations are expressed in terms of mass of pollution per unit volume of air, typically using micrograms for the mass portion of the expression and cubic meters of air for the volume, or "micrograms per cubic meter of air, expressed as $\mu\text{g}/\text{m}^3$." The concentration can also be expressed as parts of pollution per million parts of air or "ppm." AAQS appear in Section 4.3.2 of this analysis.

Some forms of air pollution are primary air pollutants, which are gases and particles directly emitted from stationary and mobile sources. Other forms of air pollution are secondary air pollutants that result from complex interactions between primary pollutants,

background atmospheric constituents, and other secondary pollutants. Some pollutants can be a combination of both primary and secondary formation, such as PM_{2.5}. In this case, the primary pollutant component of PM_{2.5} is directly emitted from the stack of diesel-fueled engines and the secondary pollutant component of PM_{2.5} is formed in the air by the transformation of gaseous NO_x and sulfur oxides (SO_x) into particles. In this case, the NO_x and SO_x emissions are precursors to the formation of the secondary aerosol pollutant. Emissions of NO_x include nitric oxide (NO) and nitrogen dioxide (NO₂).

In the case of stack emissions from diesel-fueled engines, approximately 90 percent of the NO_x is in the form of NO while the remainder is directly emitted NO₂. The ambient standards are expressly for NO₂, not NO. Once these gases exit the stack, chemical reactions in the region downwind of the facility, meteorological conditions, and sunlight interact to convert the NO into NO₂, ozone, and particulates. Most ozone in the ambient air is not directly emitted. Rather, it is formed in the air when the NO to NO₂ reaction occurs, followed by a set of complex reactions including interactions with volatile organic compounds (VOC). BAAQMD also uses the term precursor organic compounds (POC) instead of VOC.

The local air district's New Source Review (NSR) program does the following: (1) defines the facility's potential-to-emit; (2) determines whether the sources would achieve minimum performance standards; (3) assesses whether the sources would achieve the Best Available Control Technology (BACT) requirements; and (4) determines whether the project would trigger offset requirements. These issues are addressed as part of CEQA environmental checklist criterion "b" in this air quality analysis.

Non-Criteria Pollutant Evaluation

Non-criteria pollutants that are typically evaluated are airborne toxic pollutants identified to have potential harmful human health impacts. Evaluations assess the potential risks from TACs and hazardous air pollutants (HAPs). TACs include toxic air pollutants identified by CARB, and HAPs include toxic air pollutants identified at the federal level. Most toxic air pollutants do not have AAQS; however, AAQS have been established for a few pollutants. Since TACs have no AAQS that specify health-based levels considered safe for everyone, a health risk assessment (HRA) is used to determine if people might be exposed to those types of pollutants at unhealthy levels.

The health risks from the project's TACs emissions are compared with the BAAQMD significance thresholds for a single source. If risks to the maximally exposed sensitive receptors are below significance thresholds, then impacts to other receptors would also be below significance thresholds. Cumulative HRA results are also compared with the BAAQMD significance thresholds for cumulative risk and hazards.

TACs are separated into "carcinogens" and "non-carcinogens" based on the nature of the physiological effects associated with exposure to the pollutant. Therefore, there are two types of thresholds for TACs: cancer risk and non-cancer risk. Cancer risk is expressed as

excess cancer cases per one million exposed individuals, typically over a lifetime of exposure. Acute and chronic exposure to non-carcinogens is expressed as a HI, which is the ratio of expected exposure levels to acceptable REL for each of the TACs associated with acute and chronic health effects.

The impact evaluation of toxic pollutants focuses on the project's incremental impact due to diesel particulate matter (DPM) exhaust from construction equipment and from the stacks of the diesel-fueled gensets. That is because DPM is the primary TAC of concern. This issue is addressed as part of CEQA environmental checklist criterion "c" in this air quality analysis.

Odor Impact Evaluation

Aside from criteria pollutants and TACs, impacts may arise from other emissions, notably related to odor. This issue is addressed as part of CEQA environmental checklist criterion "d" in this air quality analysis.

4.3.2 Environmental Setting

The proposed project site encompasses approximately 7.17 acres at 651 Martin Avenue in Santa Clara, California (APN 224-04-071). The project area consists primarily of commercial and industrial land uses. To the north and west of the site are existing warehouse and office buildings, and to the east is an existing railroad line operated by Union Pacific Railroad (UPRR). The boundary of the Norman Y. Mineta San José International Airport is located approximately 0.3 miles east of the site. Martin Avenue is south of the site. Refer to the **Section 3 Project Description** for further details regarding the project.

Overall air quality in the San Francisco Bay Area Air Basin (SFBAAB) is better than most other developed areas in California, including the South Coast, San Joaquin Valley, and Sacramento air basin regions. This is due to a more favorable climate with cooler temperatures and regional air flow patterns that transport pollutants emitted in the air basin out of the air basin. Although air quality improvements have occurred, violations and exceedances of the state ozone and PM standards continue to persist in the SFBAAB, and still pose challenges to CARB and local air districts (CARB 2013). The project area's proximity to both the Pacific Ocean and the San Francisco Bay has a moderating influence on the climate. This portion of the Santa Clara Valley is bounded by the San Francisco Bay to the north, the Santa Cruz Mountains to the southwest and west, and the Diablo Range to the northeast. The surrounding terrain greatly influences winds in the valley, resulting in a prevailing wind that flows along the Santa Clara Valley's northwest-southeast axis. As described in more detail below, the SFBAAB is classified as attainment/unclassifiable for CO, NO₂, and SO₂ standards, but nonattainment for ozone, PM₁₀, and PM_{2.5} standards.

Pollutants in the air can cause health problems, especially for children, the elderly, and people with heart or lung problems. Healthy adults may experience symptoms during

periods of intense exercise. Pollutants can also cause damage to vegetation, animals, and property.

Criteria Pollutants

The U.S. EPA and the CARB have established AAQS for several pollutants based on their adverse health effects. The U.S. EPA has set NAAQS for ozone (O₃), carbon monoxide (CO), NO₂, PM₁₀, PM_{2.5}, sulfur dioxide (SO₂), and lead (Pb). Primary standards were set to protect public health; secondary standards were set to protect public welfare against visibility impairment, damage to animals, crops, vegetation, and buildings. In addition, CARB has established CAAQS for these pollutants, as well as for sulfate (SO₄), visibility reducing particles, hydrogen sulfide (H₂S), and vinyl chloride. CAAQS are generally stricter than NAAQS. The standards currently in effect in California and relevant to the project are shown in **Table 4.3-2**.

TABLE 4.3-2 NATIONAL AND CALIFORNIA AMBIENT AIR QUALITY STANDARDS

Pollutant	Averaging Time	California Standards ^a	National Standards ^b	
			Primary	Secondary
O ₃	1-hour	0.09 ppm (180 µg/m ³)	—	Same as Primary Standard
	8-hour	0.070 ppm (137 µg/m ³)	0.070 ppm (137 µg/m ³)	
PM ₁₀	24-hour	50 µg/m ³	150 µg/m ³	Same as Primary Standard
	Annual Mean	20 µg/m ³	—	
PM _{2.5}	24-hour	—	35 µg/m ³	Same as Primary Standard
	Annual Mean	12 µg/m ³	12 µg/m ³	15 µg/m ³
CO	1-hour	20 ppm (23 mg/m ³)	35 ppm (40 mg/m ³)	—
	8-hour	9.0 ppm (10 mg/m ³)	9 ppm (10 mg/m ³)	—
NO ₂	1-hour	0.18 ppm (339 µg/m ³)	0.100 ppm (188 µg/m ³) ^c	—
	Annual Mean	0.030 ppm (57 µg/m ³)	0.053 ppm (100 µg/m ³)	Same as Primary Standard
SO ₂ ^d	1-hour	0.25 ppm (655 µg/m ³)	75 ppb (196 µg/m ³)	—
	3-hour	—	—	0.5 ppm (1,300 µg/m ³)
	24-hour	0.04 ppm (105 µg/m ³)	0.14 ppm (for certain areas) ^d	—
	Annual Mean	—	0.030 ppm (for certain areas) ^d	—

Notes: ppm=parts per million; ppb = parts per billion; µg/m³ = micrograms per cubic meter; mg/m³ = milligrams per cubic meter; “—” = no standard

^a California standards for O₃, CO (except 8-hour Lake Tahoe), SO₂ (1 and 24 hour), NO₂, and particulate matter (PM₁₀, PM_{2.5}, and visibility reducing particles), are values that are not to be exceeded. All others are not to be equaled or exceeded.

^b National standards (other than O₃, PM, NO₂ [see note c below], and those based on annual arithmetic mean) are not to be exceeded more than once a year. The 8-hour O₃ standard is attained when the fourth highest 8-hour concentration measured at each site in a year, averaged over three years, is equal to or less than the standard. The 24 hour PM₁₀ standard of 150 µg/m³ is not to be exceeded more than once per year on average over a 3-year period. The 24-hour PM_{2.5} standard is attained when the 3-year average of 98th percentile concentration is less than or equal to 35 µg/m³.

^c To attain the 1-hour national standard, the 3-year average of the annual 98th percentile of the 1-hour daily maximum concentrations at each site must not exceed 0.100 ppm.

^d On June 2, 2010, a new 1-hour SO₂ standard was established and the existing 24-hour and annual primary standards were revoked. To attain the 1-hour national standard, the 3-year average of the annual 99th percentile of the 1-hour daily maximum concentrations at each site must not exceed 75 ppb. The previous SO₂ standards (24-hour and annual) will additionally remain in effect in certain areas: (1) any area for which it is not yet 1 year since the effective date of designation under the current (2010) standards, and (2) any area for which an implementation plan providing for attainment of the current (2010) standard has not been submitted and approved and which is designated nonattainment under the previous SO₂ standards or is not meeting the requirements of a SIP call under the previous SO₂ standards (40 CFR 50.4(3)). A SIP call is a U.S. EPA action requiring a state to resubmit all or part of its State Implementation Plan to demonstrate attainment of the required NAAQS.

Sources: BAAQMD 2023a, U.S. EPA 2023a

Attainment Status and Air Quality Plans

The proposed project would be in Santa Clara County in the SFBAAB, under the jurisdiction of BAAQMD. **Table 4.3-3** summarizes attainment status for the relevant criteria pollutants in the SFBAAB with both NAAQS and CAAQS.

Pollutant	Averaging Time	State Designation	Federal Designation
O ₃	1-hour	Nonattainment	—
	8-hour	Nonattainment	Nonattainment
PM ₁₀	24-hour	Nonattainment	Unclassified
	Annual	Nonattainment	—
PM _{2.5}	24-hour	—	Nonattainment ^a
	Annual	Nonattainment	Unclassifiable/attainment ^b
CO	1-hour	Attainment	Attainment
	8-hour	Attainment	Attainment
NO ₂	1-hour	Attainment	Unclassifiable/Attainment
	Annual	Attainment	Attainment
SO ₂	1-hour	Attainment	Attainment/Unclassifiable ^c
	24-hour	Attainment	— ^d
	Annual	—	— ^d

Notes:

^a On January 9, 2013, U.S. EPA issued a final rule to determine that the Bay Area attains the 24-hour PM_{2.5} national standard (U.S. EPA 2013). This U.S. EPA rule suspends key SIP requirements as long as monitoring data continues to show that the Bay Area attains the standard. Despite this U.S. EPA action, the Bay Area will continue to be designated as “non-attainment” for the national 24-hour PM_{2.5} standard until such time as the BAAQMD submits a “redesignation request” and a “maintenance plan” to U.S. EPA, and U.S. EPA approves the proposed redesignation.

^b In December 2012, U.S. EPA strengthened the annual PM_{2.5} NAAQS from 15.0 to 12.0 µg/m³. In December 2014, U.S. EPA issued final area designations for the 2012 primary annual PM_{2.5} NAAQS (U.S. EPA 2014). Areas designated “unclassifiable/attainment” must continue to take steps to prevent their air quality from deteriorating to unhealthy levels. The effective date of this standard is April 15, 2015.

^c On January 9, 2018, U.S. EPA issued a final rule to establish the initial air quality designations for certain areas in the U.S. for the 2010 SO₂ primary NAAQS (U.S. EPA 2018b). This final rule designated the SFBAAB as attainment/unclassifiable for the 2010 SO₂ primary NAAQS.

^d See note d under **Table 4.3-2**.

Sources: CARB 2023a, BAAQMD 2023a, U.S. EPA 2013, U.S. EPA 2014, U.S. EPA 2018b

Existing Ambient Air Quality

The nearest background ambient air quality monitoring station to the project is the San Jose-Jackson Street station, which is about 3 miles southeast of the project site. **Table 4.3-4** presents the air quality monitoring data from the San Jose-Jackson Street monitoring station from 2017 to 2021, the most recent years for which data are available. Data in this table that are marked in **bold** indicate that the most-stringent current standard was exceeded during that period.

TABLE 4.3-4 AMBIENT AIR QUALITY MONITORING DATA

Pollutant	Averaging Time	2017	2018	2019	2020	2021
O ₃ (ppm)	1-hour	0.121	0.078	0.095	0.106	0.098
	8-hour	0.098	0.061	0.081	0.085	0.084
PM10 (µg/m ³)	24-hour	70	121.8	77.1	137.1	45.1
	Annual	21.3	23.1	19.1	24.8	20.1
PM2.5 (µg/m ³)	24-hour (98th percentile)	34.3	73.4	20.6	56.1	23.3
	Annual	9.5	12.9	9.1	11.5	8.9
NO ₂ (ppb)	1-hour (maximum)	67.5	86.1	59.8	51.9	47.8
	1-hour (98th percentile)	50	59	52	45	39.2
	Annual	12.24	12.04	10.63	9	8.73
CO (ppm)	1-hour	2.1	2.5	1.7	1.9	1.7
	8-hour	1.8	2.1	1.3	1.5	1.5
SO ₂ (ppb)	1-hour (maximum)	3.6	6.9	14.5	2.9	1.8
	1-hour (99th percentile)	3	3	2	2	2
	24-hour	1.1	1.1	1.5	0.8	0.7

Notes: All data from San Jose-Jackson Street monitoring station.

Concentrations in **bold** type are those that exceed the limiting ambient air quality standard.

Sources: CARB 2023b, U.S. EPA 2023b

The maximum concentration values listed in **Table 4.3-4** have not been screened to remove values that are designated as exceptional events. Violations that are the result of exceptional events, such as wildfires, are normally excluded from consideration as AAQS violations (U.S. EPA 2023b). Exceptional events undoubtedly affected many of the maximum concentration values in recent years, especially between September to mid-November during wildfire activity. The ozone, PM10, and PM2.5 in 2020 illustrate the effect of events like the extensive northern California wildland fires.² Even though fires tended to be far from the monitoring stations, the blanket of smoke and adverse air quality most likely affected air monitoring stations in the urban areas surrounding the project. This analysis uses the background ambient air quality concentrations from 2019 to 2021 to represent the baseline conditions at the project site.

Health Effects of Criteria Pollutants

Below are descriptions of the health effects of criteria pollutants that are a concern in the regional study area. The California Health and Safety Code Section 39606 requires CARB to adopt ambient air quality standards at levels that adequately protect the health of the public, including infants and children, with an adequate margin of safety. Ambient air quality standards define clean air (CARB 2023c).

Ozone. Ozone is a respiratory irritant and an oxidant that increases susceptibility to respiratory infections and that can cause substantial damage to vegetation and other

² Wildfires also emit substantial amounts of volatile and semi-volatile organic materials and nitrogen oxides that form ozone and organic particulate matter (NOAA 2019).

materials. Ozone is not emitted directly into the atmosphere but is a secondary air pollutant produced in the atmosphere through a complex series of photochemical reactions involving reactive organic gases (ROG) and NO_x, including NO₂. ROG and NO_x are known as precursor compounds for ozone. Significant ozone production generally requires ozone precursors to be present in a stable atmosphere with strong sunlight.

Ozone can cause the muscles in the airways to constrict, trapping air in the alveoli, potentially leading to wheezing and shortness of breath. Ozone can make it more difficult to breathe deeply and vigorously; cause shortness of breath and pain when taking a deep breath; cause coughing and sore or scratchy throat; inflame and damage the airways; aggravate lung diseases such as asthma, emphysema, and chronic bronchitis; increase the frequency of asthma attacks; make the lungs more susceptible to infection; continue to damage the lungs even when the symptoms have disappeared; and cause chronic obstructive pulmonary disease. Long-term exposure to ozone is linked to aggravation of asthma and may be one of many causes of asthma development. Long-term exposures to higher concentrations of ozone may also be linked to permanent lung damage, such as abnormal lung development in children. The inhalation of ozone causes inflammation and irritation of the tissues lining human airways, causing and worsening a variety of symptoms, and exposure to ozone can reduce the volume of air that the lungs breathe in and cause shortness of breath.

People most at risk for adverse health effects from breathing air containing ozone include people with asthma, children, older adults, and people who are active outdoors, especially outdoor workers. Children are at greatest risk from exposure to ozone because their lungs are still developing and they are more likely to be active outdoors when ozone levels are high, which increases their exposure. Studies show that children are no more or less likely to suffer harmful effects than adults; however, children and teens may be more susceptible to ozone and other pollutants because they spend nearly twice as much time outdoors and engaged in vigorous activities compared to adults. Children breathe more rapidly than adults and inhale more pollution per pound of their body weight than adults and are less likely than adults to notice their own symptoms and avoid harmful exposures.

Particulate Matter. PM₁₀ and PM_{2.5} represent size fractions of particulate matter that can be inhaled into air passages and the lungs and can cause adverse health effects. Very small particles of certain substances (e.g., sulfates and nitrates) can cause lung damage directly, or can contain absorbed gases (e.g., chlorides or ammonium) that may be injurious to health. The health effects of particulate matter may include cardiovascular effects, such as cardiac arrhythmias and heart attacks, and respiratory effects, such as asthma attacks and bronchitis. Particulates can also reduce visibility.

Nitrogen Dioxide. Breathing air with a high concentration of NO₂ can irritate airways in the human respiratory system. Such exposures over short periods (as represented by the 1-hour standards) can aggravate respiratory diseases, particularly asthma, leading to respiratory symptoms (such as coughing, wheezing or difficulty breathing), hospital admissions and visits to emergency rooms. Longer exposures to elevated concentrations

of NO₂ (as represented by the annual standards) may contribute to the development of asthma and potentially increase susceptibility to respiratory infections. People with asthma, as well as children and the elderly are generally at greater risk for the health effects of NO₂. NO_x (includes NO₂ and NO) reacts with other chemicals in the air and sunlight to form both particulate matter and ozone.

Carbon Monoxide. CO is a pollutant that is a product of incomplete combustion and is mostly associated with motor vehicle traffic. High CO concentrations develop primarily during winter when periods of light winds combine with the formation of ground level temperature inversions (typically from the evening through early morning). These conditions result in reduced dispersion of vehicle emissions. Motor vehicles also exhibit increased CO emission rates at low air temperatures. When inhaled at high concentrations, CO combines with hemoglobin in the blood and reduces the oxygen-carrying capacity of the blood. This results in reduced oxygen reaching the brain, heart, and other body tissues. This condition is especially critical for people with cardiovascular diseases, chronic lung disease, or anemia.

Sulfur Dioxide. SO₂ is produced through the combustion of sulfur or sulfur-containing fuels such as coal. SO₂ is also a precursor to the formation of atmospheric sulfate and particulate matter (PM₁₀ and PM_{2.5}) and contributes to potential atmospheric sulfuric acid formation that could precipitate downwind as acid rain.

Lead. Lead has a range of adverse neurotoxin health effects and was predominately released into the atmosphere primarily via the combustion of leaded gasoline. The phase-out of leaded gasoline has resulted in decreasing levels of atmospheric lead.

Toxic Air Contaminants

California Health and Safety Code, section 39655, defines a toxic air contaminant (TAC) as "an air pollutant which may cause or contribute to an increase in mortality or an increase in serious illness, or which may pose a present or potential hazard to human health." In addition, substances which have been listed as HAPs pursuant to 42 U.S.C. section 7412 are included as TACs under the state law pursuant to Health and Safety Code, section 39657 (b). CARB formally identified HAPs in California Code of Regulations, Title 17, section 93001 (OEHHA 2023).

TACs, or air toxics, are different from criteria pollutants such as ground-level ozone, particulate matter, carbon monoxide, nitrogen dioxide, sulfur dioxide, and lead. Criteria air pollutants are regulated using NAAQS and CAAQS, as noted above. However, there are no ambient standards for most TACs³, therefore, site-specific HRAs are conducted to evaluate whether risks of exposure to TACs create an adverse impact. Specific TACs have known acute, chronic, and cancer health impacts. CARB has identified TACs in California Code of Regulations, Title 17, sections 93000 and 93001. The nearly 200 regulated TACs

³ Ambient air quality standards for TACs exist for lead (federal and state standards), hydrogen sulfide (state standard), and vinyl chloride (state standard).

include asbestos, organic, and inorganic chemical compounds and compound categories, diesel exhaust, and certain metals. The requirements of the Air Toxic "Hot Spots" Information and Assessment Act of 1987 (Health and Saf. Code, §44300 et seq.) apply to facilities that emit these listed TACs above regulated threshold quantities.

Health Effects of TACs

The health effects associated with TACs are quite diverse and generally are assessed locally, rather than regionally. Exposure to TACs can cause serious health effects, including cancer and birth defects. Other adverse health effects can include damage to the immune system, neurological, reproductive (reduced fertility), development, and respiratory problems (BAAQMD 2023b). Numerous other health effects also have been linked to exposure to TACs, including heart disease, Sudden Infant Death Syndrome, respiratory infections in children, lung cancer, and breast cancer (OEHHA 2015).

The primary on-site TAC emission sources for the MBGF would be diesel engines, including engines in vehicles and equipment used during construction and stationary genset engines during readiness testing and maintenance. Diesel exhaust is a complex mixture of thousands of gases and fine particles and contains over 40 substances listed by the U.S. EPA as HAPs and by CARB as TACs. The solid material in diesel exhaust is known as DPM (CARB 2023d).

DPM has been the accepted surrogate for whole diesel exhaust since the late 1990's. CARB identified DPM as the surrogate compound for whole diesel exhaust in its Proposed Identification of Diesel Exhaust as a Toxic Air Contaminant staff report in April 1998 (Appendix III, Part A, Exposure Assessment) (CARB 1998). DPM is primarily composed of aggregates of spherical carbon particles coated with organic and inorganic substances. Diesel exhaust deserves attention mainly because of its ability to induce serious noncancerous effects and its status as a likely human carcinogen. Diesel exhaust is also characterized by ARB as "particulate matter from diesel-fueled engines." The impacts from human exposure would include both short- and long-term health effects. Short-term effects can include increased coughing, labored breathing, chest tightness, wheezing, and eye and nasal irritation. Effects from long-term exposure can include increased coughing, chronic bronchitis, reductions in lung function, and inflammation of the lung. Epidemiological studies strongly suggest a causal relationship between occupational diesel exhaust exposure and lung cancer. Diesel exhaust is listed by the U.S. EPA as "likely to be carcinogenic to humans" (U.S. EPA 2002).

Sensitive Receptors

A valid CEQA analysis will take into consideration a project's impacts on health of people. (See CEQA Appendix G, environmental checklist criterion "c.") People vary in their relative sensitivity to pollutants. Sensitive receptors are defined as groups of individuals that may be more susceptible to health risks due to chemical exposure. Sensitive individuals, such as infants, the aged, and people with specific illnesses or diseases, are the subpopulations that are more sensitive to the effects of toxic substance exposure. Examples of sensitive

receptors include residences, schools and school yards, parks and playgrounds, daycare centers, nursing homes, and medical facilities. Residences could include houses, apartments, and senior living complexes. Medical facilities could include hospitals, convalescent homes, and health clinics. Acute receptor locations may include areas of intermittent public exposure, for example, at playgrounds, sports fields, dog walking areas, outdoor event pavilions (BAAQMD 2023b, Appendix E). The potential sensitive receptor locations evaluated in the HRA for the project include (DayZenLLC 2022b, pg. 19):

- Residential dwellings, including apartments, houses, and condominiums.
- Schools, colleges, and universities.
- Daycare centers.
- Hospitals and health clinics.
- Senior-care facilities.

Sensitive Receptors Near the Project

BAAQMD CEQA Guidelines recommends that any proposed project, including the siting of a new TAC emissions source, assess associated community risks and hazards impacts within 1,000 feet of the proposed project and take into account both individual and nearby cumulative sources (that is, proposed project plus existing and foreseeable future projects). Cumulative sources represent the combined total risk values of each individual source within the 1,000-foot evaluation zone. A lead agency should enlarge the 1,000-foot radius on a case-by-case basis if an unusually large source or sources of risk or hazard emissions that may affect a proposed project is beyond the recommended radius (BAAQMD 2023b, Appendix E).

Staff previously used a six-mile radius for cumulative impacts analyses of power plant projects that were substantially different than the proposed project. Based on staff's modeling experience, beyond six miles there is no statistically significant concentration overlap for nonreactive pollutant concentration between two stationary emission sources. The six-mile radius is more appropriate to be used for the turbines with tall stacks and more buoyant plumes. But the diesel proposed genset engines would result in more localized impacts due to shorter stacks and less buoyant plumes. The worst-case impacts of the diesel genset engines would occur at or near the fence line and decrease rapidly with distance from the fence line. Therefore, staff believes that the BAAQMD CEQA Guidelines-recommended 1,000 feet is reasonable for the cumulative HRA of the project.

The proposed MDC project site encompasses approximately 7.17 acres (DayZenLLC 2022a, pg. 2-6). No sensitive receptors are within 1,000 feet of the project site. The nearest sensitive receptors include several residences approximately 1,400 feet to the southwest of the project site, on property zoned for heavy industrial uses (DayZenLLC 2022b, pg. ES-1). The applicant also identified a daycare/school facility located over 4,920 feet (1,500 meters) northwest of the Project site and a daycare facility located

4,800 feet (1,470 meters) south of the Project site as sensitive receptors (DayZenLLC 2022b, pg. 14). **Figure 4.3-1** shows the map of sensitive receptors near the project.

CARE Community

One goal of BAAQMD's Community Air Risk Evaluation Program (CARE Program) is to identify areas where air pollution contributes most to health impacts and where populations are most vulnerable to air pollution.⁴ The proposed MDC project is located in the 2013 Cumulative Impact Area as established by the CARE Program. According to the current version of the California Communities Environmental Health Screening Tool (CalEnviroScreen), released by California Office of Environmental Health Hazard Assessment (OEHHA) in 2021, the census tract of the project site has an overall CalEnviroScreen 4.0 percentile score of 60. The proposed project site is not in or within 1,000 feet of an Overburdened Community, as defined in BAAQMD Regulation 2-1-243.⁵

4 <https://www.baaqmd.gov/community-health/community-health-protection-program/community-air-risk-evaluation-care-program>

5 Overburdened Community: An area located (i) within a census tract identified by the California Communities Environmental Health Screening Tool (CalEnviroScreen), Version 4.0, as having an overall CalEnviroScreen score at or above the 70th percentile, or (ii) within 1,000 feet of any such census tract (BAAQMD Regulation 2-1-243).

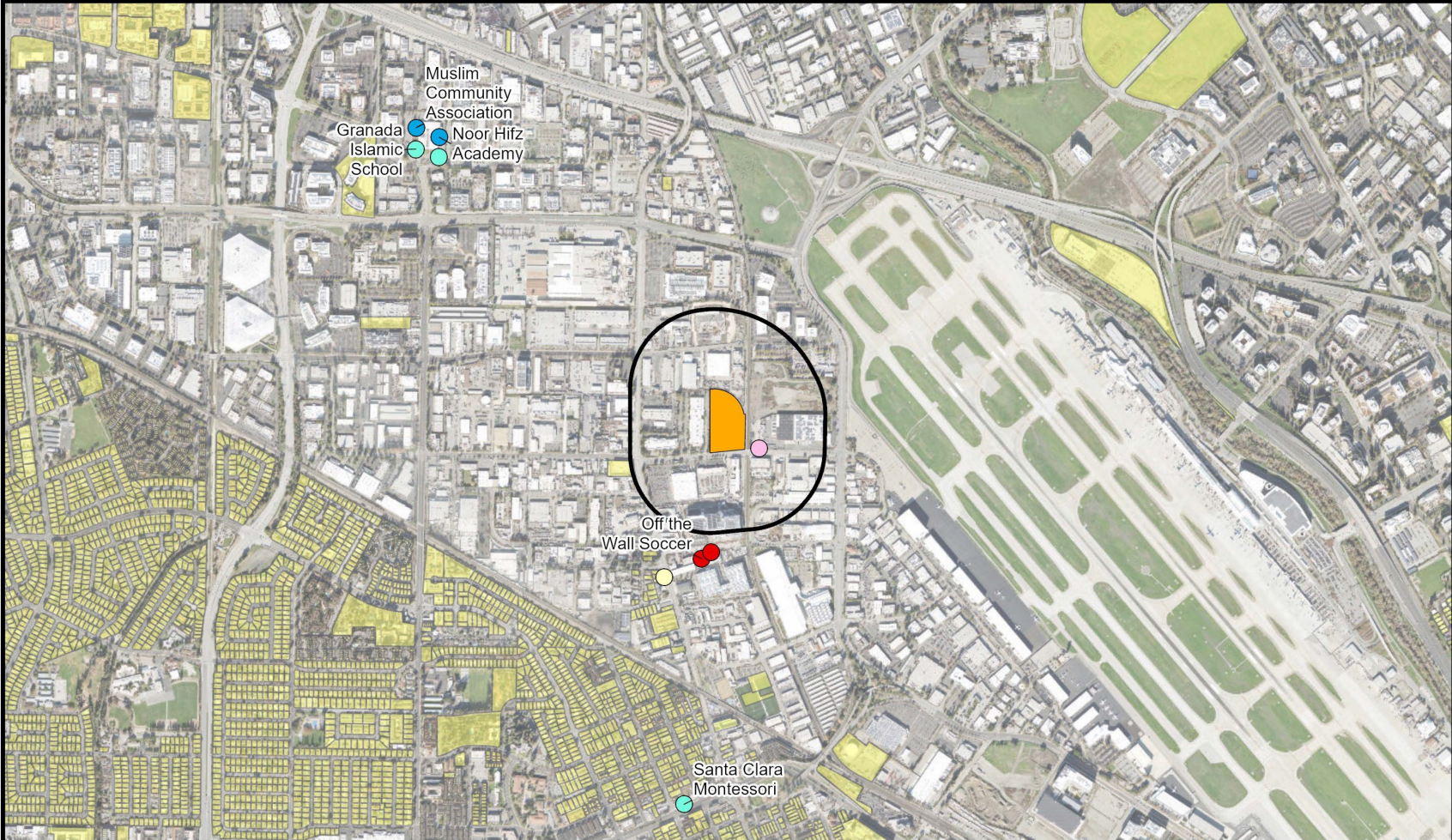

Martin Backup Generating Facility

- Project Footprint
- 1,000 Ft Influence Zone
- Residential Community

Sensitive Receptors

- Daycare/School
- Recreational
- Residential
- School
- Worker

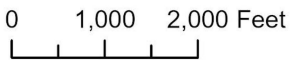

Figure 4.3-1
1,000 Foot Influence Zone

Sources: California Energy Commission, HIFLD, USGS, CDPH, ORNL, Esri

Regulatory Background

Federal, state, and regional agencies share responsibility for managing and regulating air quality in the SFBAAB.

Federal

Federal Clean Air Act. The federal Clean Air Act (CAA) (42 U.S.C., § 7401 et seq.) establishes the statutory framework for regulation of air quality in the United States. Under the CAA, the U.S. EPA oversees the implementation of federal programs for permitting new and modified stationary sources, controlling TACs, and reducing emissions from motor vehicles and other mobile sources.

Title I (Air Pollution Prevention and Control) of CAA requires establishment of NAAQS, air quality designations, and plan requirements for nonattainment areas. States are required to submit a SIP to the U.S. EPA for areas in nonattainment with NAAQS. The SIP must demonstrate how state and local regulatory agencies will institute rules, regulations, and other programs to attain NAAQS. Once approved by the U.S. EPA and published in the Federal Register, the local air district rules contained in the SIP are federally enforceable.

Prevention of Significant Deterioration (PSD) is a federal program for federal attainment areas. The purpose of the federal PSD program is to ensure that attainment areas remain in attainment of NAAQS based upon a proposed facility's annual PTE. If the annual emissions of a proposed project are less than prescribed amounts, a PSD review is not required. The low annual emissions expected for this project indicate that the project is not expected to be subject to PSD, with a final determination made by BAAQMD at the time of permitting subsequent to the CEC determination.

New Source Performance Standard (NSPS) Subpart IIII—Standards of Performance for Stationary Compression Ignition Internal Combustion Engines. Clean Air Act section 111 (42 U.S.C., § 7411) authorizes the U.S. EPA to develop technology-based standards for specific categories of sources. Manufacturers of emergency stationary internal combustion engines (ICE) using diesel fuel must certify that new engines comply with these emission standards (40 C.F.R., § 60.4205). Under NSPS Subpart IIII, owners and operators of emergency engines must limit operation to a maximum of 100 hours per year for maintenance and testing, which allows for some use if necessary, to protect grid reliability; there is no time limit on the use of an emergency stationary ICE in emergency situations (40 C.F.R., § 60.4211(f)). The project's Tier 4 diesel-fired gensets would be subject to and likely to comply with the requirements in NSPS Subpart IIII.

National Emission Standard for Hazardous Air Pollutants. The CAA, section 112 (42 U.S.C., § 7412) addresses emissions of HAPs. CAA defines HAPs as a variety of substances that pose serious health risks. Direct exposure to HAPs has been shown to cause cancer, reproductive effects or birth defects, damage to the brain and nervous system, and respiratory disorders. Categories of sources that cause HAP emissions are

controlled through separate standards under CAA Section 112: National Emission Standards for Hazardous Air Pollutants (NESHAP). These standards are specifically designed to reduce the potency, persistence, or potential bioaccumulation of HAPs. New sources that emit more than 10 tpy of any specified HAP or more than 25 tpy of any combination of HAPs are required to apply Maximum Achievable Control Technology.

Asbestos is a HAP regulated under the NESHAP. The asbestos NESHAP is intended to provide protection from the release of asbestos fibers during activities involving the handling of asbestos. CAA air toxics regulations specify work practices for asbestos to be followed during demolitions and renovations. The regulations require a thorough inspection of the area where the demolition or renovation would occur and advance notification of the appropriate delegated entity. Work practice standards that control asbestos emissions must be implemented, such as removing all asbestos-containing materials (ACM), adequately wetting all regulated ACM, and sealing ACM in leak-tight containers and disposing of the asbestos-containing waste material as expediently as practicable.

State

Generally, state law designates local air districts as having primary responsibility for the control of air pollution from all sources other than mobile sources while the control of vehicular air sources is the responsibility of CARB. (Health and Saf. Code, §39002) CARB is also responsible for the state's overall air quality management, including, among other things, establishing CAAQS for criteria pollutants identifying TACs of statewide concern and adopting measures to reduce the emissions of those TACs through airborne toxic control measures (ATCM), and regulating emissions of GHGs.

Air Toxic "Hot Spots" Information and Assessment Act of 1987. The Air Toxic "Hot Spots" Information and Assessment Act of 1987 (Assembly Bill 2588 (Connelly, Statutes of 1987), and codified as Health and Safety Code, § 44300 and the following), identifies TAC hot spots where emissions from specific stationary sources may expose individuals to an elevated risk of adverse health effects, particularly cancer or reproductive harm. Many TACs are also classified as HAPs. AB 2588 requires that a business or other establishment identified as a significant stationary source of toxic emissions provide the affected population with information about the health risks posed by their emissions.

Airborne Toxic Control Measure (ATCM) for Stationary Compression Ignition Engines, Emergency Standby Diesel-Fueled Compression Ignition Engines. Statewide regulations govern the use of and emissions performance standards for emergency standby diesel-fueled engines, including those of the project. As defined in regulation (Cal. Code Regs., tit. 17, §93115.4(a)(29)), an emergency standby engine is, among other possible use, one that provides electrical power during an emergency use and is not the source of primary power at the facility and is not operated to supply power to the electric grid. The corresponding ATCM (Cal. Code Regs., tit. 17, CCR §93115.6) restricts each emergency standby engine to operate no more than 50 hours per year for

maintenance and testing purposes. The ATCM establishes no limit on engine operation for emergency use or for emission testing to show compliance with the ATCM's standards.

Asbestos Airborne Toxic Control Measure for Construction, Grading, Quarrying, and Surface Mining Operations. CARB has adopted the Asbestos ATCM for Construction, Grading, Quarrying, and Surface Mining Operations to minimize the generation of asbestos from earth disturbance or construction activities (Cal. Code Regs., tit.17 § 93105). The Asbestos ATCM applies to any project that would include sites to be disturbed in a geographic ultramafic rock unit area or an area where naturally occurring asbestos, serpentine, or ultramafic rocks are determined to be present. Based upon review of the US Geological Survey map detailing natural occurrence of asbestos in California, naturally occurring asbestos is not expected to be present at the project site (Van Gosen and Clinkenbeard 2011).

Regional

Bay Area 2017 Clean Air Plan. The BAAQMD adopted the Bay Area 2017 Clean Air Plan on April 19, 2017 (BAAQMD 2017a). The 2017 Clean Air Plan provides a regional strategy to protect public health and protect the climate. The 2017 Clean Air Plan updates the most recent Bay Area ozone plan, the 2010 Clean Air Plan, pursuant to air quality planning requirements defined in state law. The 2017 Clean Air Plan defines an integrated, multi-pollutant control strategy to reduce emissions of particulate matter, TACs, ozone and key ozone precursors, and greenhouse gas emissions.

BAAQMD California Environmental Quality Act Guidelines. The BAAQMD publishes CEQA Air Quality Guidelines to assist lead agencies in evaluating a project's potential impacts on air quality. The BAAQMD published an updated version of its CEQA Air Quality Guidelines in April 2023 (BAAQMD 2023b) that apply to this project.

BAAQMD Regulation 2, Rule 2: New Source Review (NSR). This rule applies to all new or modified sources requiring an Authority to Construct permit and/or Permit to Operate. The NSR process requires the applicant to use the Best Available Control Technology (BACT) to control emissions if the source will have the PTE a BAAQMD BACT pollutant in an amount of 10 or more pounds per day (lbs/day). The NSR process also establishes the requirements to offset emissions increases and to protect the NAAQS.

To prevent sources from worsening regional nonattainment conditions, the NSR rule requires offsets at a 1:1 ratio if more than 10 tpy of NO_x or precursor organic compounds (POC), or more than 100 tpy of PM_{2.5}, PM₁₀, or SO₂, are emitted. If the PTE for NO_x or POC is more than 10 tpy but less than 35 tpy, BAAQMD needs to provide any required offsets at 1:1 ratio from the Small Facility Banking Account in BAAQMD's Emissions Bank. If the PTE for NO_x or POC is 35 tpy or more, the offset ratio increases to 1.15:1, and offsets can no longer be obtained through the Small Facility Banking Account.

On June 3, 2019, the BAAQMD staff issued a policy to protect the Small Facility Banking Account from over-withdrawal by new emergency backup generator sources. The policy

provides procedures, applicable to the determination of access to the Small Facility Banking Account only, for calculating a facility's PTE to determine eligibility for emission reduction credits (ERCs) from the Small Facility Banking Account for emergency backup generators (BAAQMD 2019). When determining the PTE for a facility with emergency backup generators, the PTE shall include as a proxy, emissions proportional to emergency operation for 100 hours per year per standby generator, in addition to the permitted limits for readiness testing and maintenance (generally 50 hours/year or less per standby or backup engine). BAAQMD would not allow an owner/operator to accept a permit condition to limit emergency operation to less than 100 hours per year to reduce the source's PTE for purposes of qualifying for the Small Facility Banking Account.

After comparing the PTE calculated to determine the account eligibility threshold, the amount of offsets required would be determined only upon the permitted emissions from readiness testing and maintenance and not the emissions from emergency operation. Emissions offsets represent ongoing emission reductions that continue every year, year after year, in perpetuity. BAAQMD requires the use of offsets to counterbalance increases in regular and predictable emissions, not increases in emissions occurring infrequently when emergency conditions arise. An owner/operator may reduce the hours of readiness testing and maintenance or install emissions controls to achieve a PTE of less than 35 tons per year (BAAQMD 2019).

BAAQMD Regulation 2, Rule 5: New Source Review of Toxic Air Contaminants.

This rule provides for the review of new and modified sources of TAC emissions to evaluate potential public exposure and health risk. Under this rule, a project would be denied an Authority to Construct permit if it exceeds any of the specified risk limits, which are consistent with BAAQMD's recommended significance thresholds. Best Available Control Technology for Toxics (TBACT) would also be required for any new or modified source of TACs where the source has a cancer risk greater than 1.0 in 1 million or a chronic hazard index (HI) greater than 0.20. The specific toxicity values of each TAC for use in an HRA, as identified by California Office of Environmental Health Hazard Assessment (OEHHA), are listed in Table 2-5-1 of BAAQMD Rule 2-5.

BAAQMD Regulation 9, Rule 8: Nitrogen Oxides and Carbon Monoxide from Stationary Internal Combustion Engines.

This rule limits NO_x and CO emissions from stationary internal combustion engines with an output rated by the manufacturer at more than 50 brake horsepower. This regulation (Rule 9-8-231) defines emergency use as "the use of an emergency standby or low usage engine during any of the following:"

- In the event of unforeseeable loss of regular natural gas supply;
- In the event of unforeseeable failure of regular electric power supply;
- Mitigation or prevention of an imminent flood;
- Mitigation of or prevention of an imminent overflow of sewage or waste water;
- Fire or prevention of an imminent fire;

- Failure or imminent failure of a primary motor or source of power, but only for such time as needed to repair or replace the primary motor or source of power; or
- Prevention of the imminent release of hazardous material.

Local

The City of Santa Clara (City) 2010-2035 General Plan (General Plan) includes goals and policies to reduce exposure of the city's sensitive population to the exposure of air pollution and TACs. The following goals, policies, and actions are applicable to the project:

Air Quality Goals

- 5.10.2-G1: Improved air quality in Santa Clara and the region.
- 5.10.2-G2: Reduced greenhouse gas (GHG) emissions that meet the State and regional goals and requirements to combat climate change.

Air Quality Policies

- 5.10.2-P1: Support alternative transportation modes and efficient parking mechanisms to improve air quality.
- 5.10.2-P2: Encourage development patterns that reduce vehicle miles traveled and air pollution.
- 5.10.2-P3: Encourage implementation of technological advances that minimize public health hazards and reduce the generation of air pollutants.
- 5.10.2-P4: Encourage measures to reduce GHG emissions to reach 30 percent below 1990 levels by 2020.
- 5.10.2-P5: Promote regional air pollution prevention plans for local industry and businesses.
- 5.10.2-P6: Require "Best Management Practices" for construction dust abatement.

4.3.3 Environmental Impacts

CEQA Guidelines Appendix G directs that, where available, the significance criteria established by the applicable air quality management district or air pollution control district may be relied upon to make the following determinations.

a. Would the project conflict with or obstruct implementation of the applicable air quality plan?

This section considers the project's consistency with the applicable air quality plan (AQP). This is a qualitative determination that considers the combined effects of project construction and operation.

Construction and Operations

Less Than Significant Impact. The applicable AQP is the Bay Area 2017 Clean Air Plan (BAAQMD 2017a). A project would be consistent with the AQP if that project (BAAQMD 2023b, Chapter 5):

- 1) Supports the primary goals of the AQP.

The determination for this criterion, can be met through consistency with the BAAQMD significance thresholds. As explained in the discussions under environmental checklist criteria “b” and “c” of this air quality analysis, starting from page 4.3-29 and page 4.3-36 respectively, the project would have less than significant impacts related to the BAAQMD significance thresholds. Since the project emissions comply with the significance thresholds, the project would have a less than significant impact related to the primary goals of the AQP.

- 2) Includes applicable control measures from the AQP.

The project would include the implementation of applicable control measures from the AQP. The project-level applicable control measures set forth in the Bay Area 2017 Clean Air Plan include: Decarbonize Electricity Generation (EN1), Green Buildings (BL1), and Bicycle and Pedestrian Access and Facilities (TR9). The project would comply with these control measures through compliance with the City’s General Plan and the City’s Climate Action Plan, as demonstrated in more detail in **Section 4.8 Greenhouse Gas Emissions**.

- 3) Does not disrupt or hinder implementation of any AQP control measures.

Examples of disrupting or hindering implementation of an AQP would be proposing excessive parking or precluding the extension of public transit or bike paths. The project design as proposed is not known to hinder the implementation of any AQP control measure.

Implementation of AQP control measures in the Bay Area 2017 Clean Air Plan depends on successful management of new or modified stationary sources through the permitting process, including the NSR program. Staff expects the project to satisfy all applicable air quality requirements, including the provisions of the NSR program, as follows. If BAAQMD determines that NO_x emissions need to be offset, the NO_x emissions of the gensets during readiness testing and maintenance would be fully offset through the permitting process with BAAQMD. Final details regarding the calculation of the facility’s PTE and the ultimate NSR permitting requirements under BAAQMD’s Regulation 2, Rule 2, would be determined through the permitting process with BAAQMD.

For emergency-use diesel engines with output over 1,000 brake horsepower, BAAQMD updated the definition of BACT in December 2020 to reflect the use of engines achieving Tier 4 exhaust standards (BAAQMD 2020); this requires Tier 4-compliant engines, that may include Tier 2 engines abated by catalyzed diesel particulate filter (DPF) and selective catalytic reduction (SCR). Each of the 44 diesel back-up emergency generators proposed

for this project would be equipped with SCR equipment and DPF to achieve compliance with Tier 4 emission standards. Staff expects the proposed generators would meet the current BAAQMD BACT requirements. However, BAAQMD would make the final determination of BACT during the permitting process.

For these reasons, the project would be consistent with the Bay Area 2017 Clean Air Plan and would have a less than significant impact related to implementation of the applicable AQP.

b. Would the project result in a cumulatively considerable net increase of any criteria pollutant for which the project region is non-attainment under an applicable federal or state ambient air quality standard?

This section quantifies the project's nonattainment criteria pollutant emissions and other criteria pollutant emissions to determine whether the net emissions increase would exceed any of the BAAQMD emissions thresholds for criteria pollutants.

Construction

Less Than Significant with Mitigation Incorporated. Project demolition, grading, excavation and construction would occur across two phases. Construction emissions would primarily occur during the initial 14 months of the first phase. The first phase (Phase I) would include demolition of the four existing buildings and infrastructure that cannot be reused; grading of the entire site; installation of utility services including interim power and construction of the on-site utility substation; and construction of the shell of the building and some of the interior rooms, as necessary for tenants (DayZenLLC 2022a, pg. 2-17). The Phase II activities would primarily involve fitting out the remainder of the interior rooms with no potential for notable emissions (DayZenLLC 2023a; Response to Data Request 4).

The site is currently developed with four separate single-story structures that would be demolished. The structures were used as commercial/warehouse and include associated paved surface parking and loading dock. The total area of the existing office buildings is approximately 77,220 square feet.

Project construction emissions include onsite and offsite emissions. Onsite construction emissions from project construction will result from demolition activities, site preparation and grading activities, building erection, parking lot construction activities, "finish" construction activities, and the use of onsite construction equipment. Offsite construction emissions will be derived primarily from material transport to and from the site, and worker travel (DayZenLLC 2022b, pg. 8, Table 19). Emissions from the Phase I construction period were estimated using the California Emissions Estimator Model

(CalEEMod) program (version 2022.1).⁶ The estimated criteria pollutant construction-phase emissions are summarized in **Table 4.3-5**.

TABLE 4.3-5 CRITERIA POLLUTANT EMISSIONS FROM PROJECT DEMOLITION/CONSTRUCTION

Pollutant	Average Daily Emissions (lbs/day) ^a	Overall Construction Emissions (tons)	BAAQMD Significance Thresholds for Construction-related Average Daily Emissions (lbs/day) ^c	Threshold Exceeded?
ROG/VOC	16	2.5	54	No
CO	16	3.3	None	N/A
NOx	5.7	0.92	54	No
SO ₂	0.03	0.01	None	N/A
PM10 ^b	0.12 (exhaust) 1.98 (fugitive)	< 0.1 (exhaust) 0.4 (fugitive)	82	No
PM2.5 ^b	0.12 (exhaust) 0.56 (fugitive)	< 0.1 (exhaust) 0.1 (fugitive)	54	No

Notes:

^a BAAQMD's thresholds are average daily thresholds for construction. Accordingly, the average daily emissions are the total estimated construction emissions averaged over total workdays.

^b The average daily PM10 and PM2.5 exhaust emissions are compared to BAAQMD's significance thresholds for exhaust emissions. Fugitive emissions will be controlled with best management practices (BMPs), in accordance with the significance threshold.

^c BAAQMD 2023b.

Source: DayZenLLC 2022b, Table 7 and CalEEMod results (mitigated).

The average daily emissions shown in **Table 4.3-5** indicate that construction emissions would be lower than the applicable BAAQMD significance thresholds for all criteria pollutants.

BAAQMD has no numerical threshold for fugitive dust generated during construction and instead recommends the control of fugitive dust through BMPs to conclude that impacts from fugitive dust emissions are less than significant (BAAQMD 2023b). The applicant proposed measures which include BAAQMD's recommended construction BMPs and exhaust emissions reduction measures. Staff generally concurs with the applicant's proposed measures and recommends mitigation measure **AQ-1**. Mitigation measure **AQ-1** would ensure that PM10 and PM2.5 emissions are reduced to a level that would not result in a considerable increase of these pollutants. This impact would be reduced to less than significant with mitigation measure **AQ-1**.

⁶ CalEEMod was developed by the California Air Pollution Control Officers Association in collaboration with California Air Districts. This model is a construction and emissions estimating computer model that estimates direct criteria pollutant and direct and indirect greenhouse gas emissions for a variety of land use projects. The model calculates maximum daily and annual emissions. The model also identifies mitigation measures to reduce criteria pollutant and GHG emissions along with calculating the benefits achieved from measures.

Operation

Less Than Significant Impact. Operation emissions would result from diesel fuel combustion from the gensets, off-site vehicle trips for worker commutes and material deliveries, and facility upkeep, such as architectural coatings, consumer product use, landscaping, water use, waste generation, fuel storage and electricity use.

Operational emissions are quantified with the same methods as used by the applicant (DayZenLLC 2022b, Table 15). Electricity from the grid would provide the energy for onsite building heating and cooling, lighting, appliances and electronics; no natural gas use would occur (DayZenLLC 2022b, Table 15). The primary stationary sources are 44 individual gensets; the engines would be fueled on diesel from 44 individual storage tanks for a combined onsite diesel fuel storage capacity of approximately 237,600 gallons (DayZenLLC 2023a, Response to Data Request 14). Each of these emission sources is described in more detail below.

Stationary Sources – Generator Emissions. The project would include 44 gensets powered by 2.75-MW Caterpillar 3516E engines (DayZenLLC 2022a, pg.1-1. DayZenLLC 2022b, p.1). Each engine would be equipped with SCR and diesel DPF to achieve compliance with Tier 4 emission standards.

All gensets would be operated for routine maintenance and readiness testing to ensure they would function during an emergency event. During routine readiness testing, criteria pollutants and TACs would be emitted directly from the gensets. Criteria pollutant emissions from generator testing were quantified using information provided by the manufacturer. In estimating the annual emissions, the applicant assumed that testing would occur for no more than 35 hours per year. The Airborne Toxic Control Measure for Stationary Compression Ignition Engines (Cal. Code Regs., tit.17, § 93115) limits testing to 50 hours per year per engine. However, it is the applicant's experience that each engine would be operated for considerably less than 35 hours a year. Maintenance and readiness testing usually occurs at loads ranging from 25 to 100 percent load (DayZenLLC 2023a, Response to Data Request 9). When filing this application, emissions estimates were provided for engines operating at 100 percent load and settings at 75, 50, 25, and 10 percent (DayZenLLC 2022b, Tables 24 to 29. DayZenLLC 202a, Response to Data Request 8).

The applicant proposes to limit readiness and maintenance testing to two different scenarios. Three or fewer gensets would run at a time for the "monthly testing" scenario. Single-engine runs of gradually increasing load would involve one genset at a time for "annual testing" to be conducted pursuant to manufacturer specifications (DayZenLLC 2023a, Responses to Data Requests 16 to 18). Genset operation for emergency use and emission testing for compliance purposes is not limited. The emission calculations are based on the genset horsepower, hours of operation, and emission factors provided by Petersen Power Systems for the ECOcube engine configuration (DayZenLLC 2023a, Response to Data Request 5).

The emission factors for sulfur dioxide (SO₂) are calculated with the assumption that the proposed genset will use ultra-low sulfur diesel fuel which contains 0.0015% sulfur as defined under 40 CFR 80, Subpart I. Per this assumption, the SO₂ emission rate uses load-specific fuel consumption and assumes 15 ppm fuel sulfur content (DayZenLLC 2022b).

Staff requested clarifications from the applicant on the anticipated monthly and annual testing scenarios, and the applicant agreed to request the BAAQMD to require certain operating limits that would be made enforceable by the air permitting process.

Staff and the applicant assume that maintenance and readiness testing would occur with the following limitations: (1) during monthly generator testing, up to three engines will be operated concurrently at loads no greater than 10 percent, for up to 15 minutes with all emissions uncontrolled; (2) during annual generator testing, each single-engine run will begin with 15 minutes of operation at loads no greater than 25 percent to allow sufficient warm up of the SCR; (3) each engine would operate a maximum of 35 hours per year; (4) testing would be confined to within the 10-hour period of 7:00 am and 5:00 pm, daily (DayZenLLC 2022b; DayZenLLC 2023a, Responses to Data Requests 16 to 18).

Emergency Operations. Emissions that could occur in the event of a power outage or other disruption, upset, or instability that triggers emergency operations would not occur on a regular or predictable basis. However, the BAAQMD 2019 policy, *Calculating Potential to Emit for Emergency Backup Power Generators*, requires a facility's PTE to be calculated based on emissions proportional to emergency operation for 100 hours per year per engine, in addition to the permitted limits for readiness testing and maintenance (BAAQMD 2019). However, after comparing the PTE calculated to determine the account eligibility threshold, the applicant would only be required to offset permitted emissions from readiness testing and maintenance and not the emissions from emergency operation. BAAQMD requires the use of offsets to counterbalance increases in regular and predictable emissions, not increases in emissions occurring infrequently when emergency conditions arise. The potential ambient air quality impacts of emissions during emergency operations are analyzed qualitatively under CEQA environmental checklist criterion "c" starting from page 4.3-36.

Stationary Sources – Diesel Fuel Storage Tanks. Each of the 44 generator units would have an approximately 5,400-gallon diesel fuel storage tank. Approximately 4,700 gallons could be required for 24-hour use of an engine (DayZenLLC 2022a, pg. 2-12). The applicant estimated the VOC emissions from the 44 diesel storage tanks using US EPA's recommended methodology for liquid storage tanks. To estimate the annual fuel throughput of each tank, the applicant multiplied the hourly fuel usage rate for the generators at 100 percent load (194.1 gallons per hour) times the proposed maximum annual hours of operation for the generators (35 hours annually). This assumption would overestimate the annual fuel usage because the applicant anticipates the engines to operate at full load for only a fraction of their use in a given year (DayZenLLC 2023a, Response to Data Request 14).

Miscellaneous Operational Emissions. Miscellaneous operational emissions would occur from operational activities, such as worker travel, deliveries, energy and fuel use for facility electrical, heating and cooling needs, periodic use of architectural coatings, and landscaping, etc. The mobile source emissions include each vehicle trip generated by employees and visitors, for approximately 463 daily vehicle trips (DayZenLLC 2022a, Table 4.17-2). Each generator would be air cooled (DayZenLLC 2022a, pg. 2-12). Temperatures in the interior space of the MDC would be managed using water and evaporative cooling in an adiabatic cooling system (DayZenLLC 2022a, pg. 2-19).

Table 4.3-6 provides the annual criteria pollutant emission estimates for project readiness testing and maintenance using the emissions source assumptions noted above.

TABLE 4.3-6 CRITERIA POLLUTANT ANNUAL EMISSIONS FROM PROJECT READINESS TESTING AND MAINTENANCE (TPY)

Source Type	ROG/ VOC	CO	NOx	SO2	PM10	PM2.5
Architectural Coating	0.24	--	--	--	--	--
Consumer Products	1.8	--	--	--	--	--
Landscaping	0.29	1.77	0.01	< 0.01	0.005	0.005
Building Energy	--	--	--	--	--	--
Mobile Emissions	0.27	2.16	0.24	0.01	0.2	0.04
Diesel Storage Tanks	0.027	--	--	--	--	--
Standby Generators (Testing Only)	0.41	4.39	3.43	0.03	0.14	0.14
Total Net Emissions (excludes Emergency Use)	3.04	4.39	3.68	0.03	0.34	0.18
BAAQMD Annual Significance Thresholds	10	--	10	--	15	10
Threshold Exceeded?	No	N/A	No	N/A	No	No

Source: DayZenLLC 2022b, Table 10 and 11 (annual); DayZenLLC 2023a, Response to Data Request 14, Table 2 (3/22/2023); and CEC staff analysis.

Notes:

- The annual non-emergency use of the standby generators, for readiness testing and maintenance would be limited to 35 hours per year per engine.
- Per BAAQMD 2019 policy, the assumption of 100 hours per year of annual emergency use of the standby generators determines the applicability of BAAQMD offset banking account eligibility. This assumption is not used to determine the quantity of emission offsets required.
- Annual emissions from standby generators reflect 100 percent load and proposed abatement (warmed up) to achieve Tier 4 emissions standards.

Table 4.3-7 provides the daily criteria pollutant emission estimates for project readiness testing and maintenance using the emissions source assumptions noted above.

TABLE 4.3-7 CRITERIA POLLUTANT AVERAGE DAILY EMISSIONS FROM PROJECT READINESS TESTING AND MAINTENANCE (LBS/DAY)

Source Type	ROG/ VOC	CO	NOx	SO ₂	PM10	PM2.5
Architectural Coating	1.3	--	--	--	--	--
Consumer Products	9.7	--	--	--	--	--
Landscaping	1.6	9.7	0.08	< 0.1	0.03	0.03
Building Energy	--	--	--	--	--	--
Mobile Emissions	1.5	11.9	1.3	< 0.1	1.1	0.22
Diesel Storage Tanks	0.15	--	--	--	--	--
Standby Generators (Testing Only)	2.4	24	18.8	< 0.2	0.75	0.75
Total Net Emissions (excludes Emergency Use)	16.65	45.6	20.18	< 0.3	1.88	1.00
BAAQMD Daily Significance Thresholds	54	--	54	--	82	54
Threshold Exceeded?	No	N/A	No	N/A	No	No

Source: DayZenLLC 2022b, Table 9 (average daily); DayZenLLC 2023a, Response to Data Request 14, Table 2 (3/22/2023); CEC staff analysis.

Notes:

a. The average daily emissions from standby generators reflect 100 percent load and proposed abatement (warmed up) to achieve Tier 4 emissions standards.

Table 4.3-6 and **Table 4.3-7** show that with NOx emissions from the readiness testing and maintenance of the gensets at less than 54 lbs/day and 10 tpy, the project would not exceed any of the BAAQMD emissions significance thresholds.

The annual rate of NOx emissions from the gensets assume use of the gensets at 100 percent load, using Tier 4 emission factors. Emissions during readiness testing and maintenance would be lower when running on lower actual loads, although the control systems would normally require approximately 15 minutes for the SCR to warm up.

The applicant evaluated the potential obligations for emission offsets by assuming 35 hours of operation for testing and maintenance purposes, plus an additional 100 hours of emergency operation (DayZenLLC 2022b, Table 11). For the 100 hours of emergency operations (considering the BAAQMD 2019 policy [BAAQMD 2019]), the applicant estimated the annual NOx PTE as 13 tpy, which is greater than 10 tpy and less than 35 tpy (DayZenLLC 2022b, Table 11). Therefore, if offsets are required, the offset ratio would be 1:1 with the inclusion of emergency operation and the BAAQMD policy-required 100 hours. The exact amount and the source of the NOx offsets would be confirmed through the permitting process with BAAQMD.

Annual and average daily rates of NOx emissions shown in **Table 4.3-6** and **Table 4.3-7** were calculated using full load and fully controlled emission factors. During the BAAQMD's review, different scenarios of emissions calculations may be used assuming partial control to Tier 2 standards or assuming a warmup period before achieving full control to Tier 4 standards. The result could modify the offset requirement accordingly.

Nonetheless, the NO_x emissions of the gensets during readiness testing and maintenance would be fully offset through the permitting process with BAAQMD, if BAAQMD determines that offsets are required.

In addition to the criteria air pollutant emissions shown above, ammonia would also be emitted from the urea used in the SCR system. Ammonia is considered a particulate precursor but not a criteria pollutant. Reactive with sulfur and nitrogen compounds, ammonia is common in the atmosphere primarily from natural sources or as a byproduct of tailpipe controls on motor vehicles. Currently, there are no BAAQMD-recommended models or procedures for estimating secondary particulate nitrate or sulfate formation from individual sources, such as the proposed project. BAAQMD CEQA Guidelines do not include a significance threshold for ammonia emissions. The applicant conservatively estimated the ammonia emissions of the project to be 0.29 tpy assuming the SCR is effective for a total of 35 hours per year per engine (DayZenLLC 2023a, Response to Data Request 13). However, it would take time for the SCR to warm up, especially during low-load readiness testing and maintenance, and, therefore, actual ammonia emissions would be less than applicant's estimates. The primary emissions of particulate matter from this project are well below the BAAQMD significance threshold and do not require additional mitigation or trigger the need for offsets. Therefore, staff expects the secondary particulate matter impacts from ammonia emissions would be less than significant and would not require additional mitigation or offsets.

The project's operations would not result in a cumulatively considerable net increase of any criteria pollutant, and therefore the impact of these very low levels of criteria pollutants would be less than significant.

Cumulative Impacts of Criteria Pollutant Emissions

According to the BAAQMD CEQA Guidelines (BAAQMD 2023b, Chapter 5.2.1), in developing thresholds of significance for air pollutants (as shown in **Table 4.3-1**), BAAQMD considered the emission levels for which a project's individual emissions would be cumulatively considerable. If a project exceeds the identified significance thresholds, its emissions would be cumulatively considerable, resulting in significant adverse air quality impacts to the region's existing air quality conditions.

Table 4.3-6 and **Table 4.3-7** show that with NO_x emissions from the readiness testing and maintenance of the gensets fully offset through the permitting process with BAAQMD, the project would not exceed any of the BAAQMD emissions significance thresholds. The BAAQMD CEQA Guidelines state that, if the project's daily average or annual emissions of operational-related criteria pollutants or precursors do not exceed the identified project-level thresholds of significance, its emissions would not make a cumulatively considerable contribution to the cumulative impact of nonattainment (BAAQMD 2023b, Chapter 5). Therefore, **Table 4.3-6** and **Table 4.3-7** show that the project would not be expected to result in a cumulatively considerable net increase of criteria pollutants during the lifetime of the project, including the readiness testing and maintenance of the gensets.

As discussed above, NOx offsets required through the BAAQMD permitting process for readiness testing and maintenance, and the project emissions would not exceed the BAAQMD significance thresholds. Therefore, the project would not result in a cumulatively considerable net increase of any criteria pollutant. Construction impacts would be less than significant with mitigation incorporated, and operational related impacts would be less than significant.

c. Would the project expose sensitive receptors to substantial pollutant concentrations?

This section quantifies the ambient air quality pollutant concentrations caused by the project and identifies sensitive receptors potentially impacted by project construction and operations.

This section is comprised of separate discussions addressing impacts from criteria pollutants in staff's Air Quality Impact Analysis (AQIA) and impacts from TACs in staff's HRA. Staff's AQIA discusses criteria pollutant impacts from construction and operation. The AQIA section also discusses issues associated with potential emergency operations. Staff's HRA discusses the results of TACs for both construction and operation (readiness testing and maintenance) and cumulative sources.

Air Quality Impact Analysis for Criteria Pollutants

Staff considers any new AAQS exceedance and substantial contribution to any existing AAQS exceedance caused by the project's emissions to be substantial evidence of potentially significant impacts that would require the evaluation of potential mitigation measures. In this case, the SFBAAB is classified as nonattainment for ozone, PM10, and PM2.5.

Construction Criteria Pollutants

Less Than Significant Impact with Mitigation Incorporated. Construction emissions of criteria pollutants are shown in **Table 4.3-5** under criterion "b" of the CEQA environmental checklist. Emissions during project construction would not exceed significance thresholds for construction activities, as established in the BAAQMD CEQA Guidelines. With the implementation of the mitigation measure **AQ-1** to control fugitive dust and exhaust emissions (Section 4.3.4, Mitigation Measures), construction emissions would not exceed the BAAQMD significance thresholds. Although project construction emissions would fall below the emissions thresholds, this section of the staff analysis explores the ambient air quality impacts of criteria pollutant emissions during construction to evaluate whether substantial pollutant concentrations could occur.

Table 4.3-8 shows the impacts of the project during the construction period. The project impact column shows the worst-case impacts of the project from modeling. The background column shows the highest concentrations from the prior three years (2019-2021) from the Jackson Street station. The background PM10 and PM2.5 are shown in **bold** because these exceed the corresponding limiting standards. The total impact

column shows the sum of the existing background condition plus the maximum modeled impact predicted by the modeling analysis for construction. The limiting standard column combines CAAQS or NAAQS, whichever is more stringent.

TABLE 4.3-8 MBGF MAXIMUM IMPACTS DURING DEMOLITION AND CONSTRUCTION ($\mu\text{g}/\text{m}^3$)

Pollutant	Averaging Time	Project Impact	Background	Total Impact	Limiting Standard	Percent of Standard
PM10	24-hour	15.70	134	150	50	299%
	Annual	0.47	25	25	20	127%
PM2.5	24-hour	5.60	56	62	35	176%
	Annual	0.19	11.5	12	12	97%
CO	1-hour	318	2,129	2,447	23,000	11%
	8-hour	107	1,718	1,825	10,000	18%
NO ₂	State 1-hour	67	113	180	339	53%
	Federal 1-hour	67	98	165	188	88%
	Annual	0.94	20	21	57	37%
SO ₂	State 1-hour	2.05	38	40	655	6%
	Federal 1-hour	2.1	5.2	7	196	4%
	24-hour	0.23	3.9	4	105	4%

Notes: Concentrations in **bold** type are those that exceed the limiting ambient air quality standard.
Source: DayZenLLC 2022b (TN 247329) and DayZenLLC 2023b (TN 250687) for PM10/PM2.5.

Table 4.3-8 shows that the impacts during demolition and construction would be below the limiting standards for CO, NO₂, and SO₂. **Table 4.3-8** also shows that the existing 24-hour and annual PM10 background concentrations are already above the CAAQS. The project would therefore contribute to existing exceedances of the 24-hour and annual PM10 CAAQS. The modeled 24-hour PM10 concentration of 15.7 $\mu\text{g}/\text{m}^3$ from project construction would exceed the US EPA PM10 SILs of 5 $\mu\text{g}/\text{m}^3$ for 24-hour impacts. Because this impact is driven by fugitive dust sources, the maximum modeled PM10 impacts during construction would occur at or near the project fence line and would decrease rapidly with increasing distance from the fence line. The 24-hour PM10 impacts would be below the U.S. EPA PM10 SIL of 5 $\mu\text{g}/\text{m}^3$ for all locations 300 feet beyond the fence line (DayZenLLC 2023b, Response to Data Request 1). The maximum modeled annual PM10 concentration of 0.47 $\mu\text{g}/\text{m}^3$ would not exceed the PM10 SILs of 1 $\mu\text{g}/\text{m}^3$ for annual impacts. With implementation of the mitigation measure **AQ-1** to control fugitive dust, the PM10 impacts of the project during construction would be less than significant.

Table 4.3-8 also shows that the existing 24-hour PM2.5 background concentrations are already above the limiting standard. The project would therefore contribute to existing exceedances of the 24-hour PM2.5 standards. The maximum 24-hour PM2.5 impacts of 5.6 $\mu\text{g}/\text{m}^3$ would exceed the 24-hour PM2.5 SIL of 1.2 $\mu\text{g}/\text{m}^3$. Because this impact is driven by fugitive dust sources, it would be confined to areas close to the project fence line. The 24-hour PM2.5 impacts would be below the U.S. EPA PM2.5 SIL of 1.2 $\mu\text{g}/\text{m}^3$ for all locations 700 feet beyond the fence line (DayZenLLC 2023b, Response to Data Request 1). The maximum modeled annual PM2.5 impact of 0.19 $\mu\text{g}/\text{m}^3$ would be lower

than the BAAQMD CEQA Guidelines significance threshold of $0.3 \mu\text{g}/\text{m}^3$ and U.S. EPA annual PM_{2.5} SILs level of $0.2 \mu\text{g}/\text{m}^3$. The PM_{2.5} impacts of the project during construction would be less than significant.

Project construction would not expose sensitive receptors to substantial criteria pollutant concentrations, and this impact would be less than significant.

Readiness Testing and Maintenance Criteria Pollutants

Less Than Significant Impact. The applicant provided an ambient air quality impact analysis to compare worst-case ground-level impacts resulting from the project's readiness testing and maintenance with established state and federal ambient air quality standards. The applicant used the American Meteorological Society/Environmental Protection Agency Regulatory Model (AERMOD [Version 22112]) with regulatory default options, as recommended in US EPA's Guideline on Air Quality Models (US EPA 2017).

The applicant's modeling analysis, described in more detail below, included the standby generator engines, but did not include other minor on-site emissions sources that emit at much lower levels. The applicant's modeling analysis included an impact analysis for readiness testing and maintenance.

Meteorological Data. The applicant used a customized 5-year (2017-2021) record of meteorological data, collected at the San Jose International Airport surface station. The monitoring station is located approximately 2 kilometers east of the proposed project site and best represents the meteorology at the project site. The concurrent daily upper air sounding data from the Oakland International Airport station were also included. The BAAQMD preprocessed the data with AERMET (Version 18081) for direct use in AERMOD.

Modeling Assumptions for Readiness Testing and Maintenance

At full buildout of the MBGF there will be a single row of backup emergency generators in a double-stacked arrangement with 22 generators on each level. The exhaust stacks for both levels of generators would be routed away from the building horizontally, penetrate an adjacent screening wall, and discharge at a 45-degree angle. The release height for the upper generators would be 55.25 feet (16.84 meters) and a release height of 27.9 feet (8.5 meters) for the lower generators. Due to the 45-degree discharge point, only the vertical component of the exit velocity was included in the modeling. The stacks of the engines would be 24 inches in diameter (DayZenLLC 2022b).

All engines could be tested or used at any load condition. The applicant's analysis modeled all engines at five different load conditions representing 10, 25, 50, 75, and 100 percent load settings to determine the worst-case concentrations. Additionally, the modeling also presumes that routine readiness testing would be limited to occur within certain hours of the day. The applicant proposes to accept a permit condition from BAAQMD for limiting readiness testing to only be allowed during a 10-hour period between 7:00 a.m. and 5:00 p.m. daily (DayZenLLC 2023a, Response to Data Request 20).

The annual average concentrations assume up to 35 hours per generator per year for readiness testing and maintenance purposes (DayZenLLC 2023a, Response to Data Request 19).

The short-term (i.e., 1-hour, 8-hour, and 24-hour) and long-term (annual) impacts of readiness testing were all analyzed according to the averaging period of each standard for each hour, each day, and each year of the meteorological dataset.

Refined Analysis for 1-Hour NO₂ standards. The modeling considers the use of the diesel-fired gensets in all proposed readiness testing and maintenance scenarios. Refined modeling for all 1-hour averaging periods considers the possibility of any single generator operating at any of five different load conditions. The 1-hour scenarios also include 18 different two- or three-engine groups for the monthly testing under 10 percent load.

For the monthly testing scenario, where groups of engines were evaluated as operating simultaneously, the applicant followed a third-tier approach using the Ozone Limiting Method (OLM) Group option for comparison to the 1-hour NO₂ NAAQS and CAAQS. For the annual testing scenario, where single-source runs occur, a third-tier Plume Volume Molar Ratio Method (PVMRM) was used to demonstrate compliance with the 1-hour NO₂ NAAQS and CAAQS. As part of the Appendix W updates of US EPA's Guideline on Air Quality Models (U.S. EPA 2017), U.S. EPA incorporated the PVMRM as a regulatory default method for NO₂ modelling.

In both cases, the applicant used a NO₂/NO_x in-stack ratio of 0.10 for the proposed backup emergency generators. This value was selected based on data from onsite generators of the same make and model as the proposed generators, and from USEPA's In-Stack Ratio Database for diesel/kerosene-fired reciprocating internal combustion engines (RICE).

For analysis relative to the state one-hour NO₂ standard, the modeled NO₂ results from PVMRM or OLM are added to the maximum 1-hour background NO₂ value. For the 1-hour NO₂ NAAQS analysis, the modeled NO₂ results from PVMRM or OLM are added to the seasonal, hour-of-day background values, input into the model (DayZenLLC 2022b; DayZen2023a, Response to Data Request 6). For the 1-hour NO₂ CAAQS, the applicant uses maximum single-hour NO₂ background concentration from the hours of the day in which the generators would be tested (DayZenLLC 2022b, footnote to Table 33). The applicant also uses hour-by-hour ozone data (2017-2021) from San Jose in the analysis of NO₂ formation (DayZenLLC 2022b).

Table 4.3-9 shows that the impacts from standby generator engine testing during operation would not cause exceedances of the PM₁₀, PM_{2.5}, CO, NO₂, or SO₂ standards. The existing PM₁₀ and PM_{2.5} background concentrations are above the limiting standards in the background conditions. The project would therefore contribute to existing exceedances of the PM₁₀ and PM_{2.5} standards. Modeling shows that the individual project impact would be limited. The modeled PM₁₀ concentrations from project standby

generator engine testing are below the PM10 SILs of 5 µg/m³ for 24-hour impacts and 1 µg/m³ for annual impacts. The modeled PM2.5 concentrations are below the 24-hour PM2.5 SIL of 1.2 µg/m³.

TABLE 4.3-9 MBGF MAXIMUM IMPACTS DURING READINESS TESTING AND MAINTENANCE (µg/m³)

Pollutant	Averaging Time	Project Impact	Background	Total Impact	Limiting Standard	Percent of Standard
PM10	24-hour	0.131	134	134	50	268%
	Annual	0.033	25	25	20	125%
PM2.5	24-hour	0.131	56	56	35	160%
	Annual	0.033	11.5	11.53	12	96%
CO	1-hour	181	2,129	2,310	23,000	10%
	8-hour	122	1,718	1,840	10,000	18%
NO ₂ ^{a, b}	State 1-hour	323		323	339	95%
	Federal 1-hour	155		155	188	82%
	Annual	6	20	26	57	46%
SO ₂	State 1-hour	1.11	38	39	655	6%
	Federal 1-hour	1.11	5.2	6	196	3%
	24-hour	0.026	3.9	4	105	4%

Notes:

Concentrations in **bold** type are those that exceed the limiting ambient air quality standard.

^a. The NO₂ impacts are evaluated using either the U.S. EPA Ozone Limiting Method (OLM) and Plume Volume Molar Ratio Method (PVMRM) options in AERMOD, depending on scenario.

^b. For CAAQS 1-hour NO₂ impacts, this is the highest 1-hour project impact and maximum background. For NAAQS 1-hour NO₂ impacts, this is the project impact plus seasonal hour of day background for source "EG42" using the maximum 8th-highest daily 1-hour result as averaged over five years to relate to the yearly 98th percentile.

Source: DayZenLLC 2022b, Tables 32, 33 and 36.

The results provided in **Table 4.3-9** are the maximum impacts determined at any point at the project fence line or beyond. The impacts for sensitive receptors would be lower than these values because they are located further away from the stacks. The criteria pollutant concentrations in **Table 4.3-9** show that impacts during routine operation with readiness testing and maintenance would be below the limiting standards. Accordingly, standby generator engine testing would not expose sensitive receptors to substantial pollutant concentrations, and this impact would be less than significant.

Localized CO Concentrations. Engine exhaust may elevate localized CO concentrations, resulting in "hot spots." Receptors exposed to these CO hot spots may have a greater likelihood of developing adverse health effects. CO hot spots are typically observed at heavily congested intersections where a substantial number of vehicles idle for prolonged durations throughout the day. BAAQMD screening guidance indicates that a project would not exceed the CO significance threshold if projections indicate traffic levels would not increase at any affected intersection to more than 44,000 vehicles per hour, or at any affected intersections to more than 24,000 vehicles per hour where vertical and/or horizontal mixing is substantially limited (BAAQMD 2023b, Chapter 4.2).

The proposed project would generate vehicle trips to the site. These trips would include workers and material and equipment deliveries. It is unlikely that the addition of vehicle trips from the project on any roadway in the vicinity of the project site would result in an exceedance of the BAAQMD screening threshold. As a result, the additional vehicle trips associated with the project would result in a negligible effect on CO concentrations in the vicinity of the project site.

Table 4.3-8 and **Table 4.3-9** show the maximum CO concentrations resulting from the project's construction and operation and modeling results confirm that impacts would be well below the limiting standards and BAAQMD CEQA Guidelines significance thresholds of 20.0 ppm (23,000 $\mu\text{g}/\text{m}^3$) for 1-hour average concentrations and 9.0 ppm (10,000 $\mu\text{g}/\text{m}^3$) for 8-hour average concentrations.

Localized CO impacts during construction and operation would not expose sensitive receptors to substantial pollutant concentrations, and this impact would be less than significant.

Emergency Operations Impacts for Criteria Pollutants

This section addresses the potential for emergency situations that could trigger the unplanned operation of the project's diesel-fired gensets. Emergency use of the gensets could occur in the event of a power outage or other disruption, upset, or instability that triggers a need for emergency backup power at MDC.

The air quality impacts of genset operation during emergencies are not quantified below because the impacts of emergency operations are typically not evaluated during facility permitting and local air districts do not normally conduct an air quality impact assessment of such impacts. CEC staff assessed the likelihood of emergency events but finds that modeling the air quality impacts of emergency operations would require a host of unvalidated, unverifiable, and speculative assumptions about when and under what circumstances such a hypothetical emergency would occur. Such a speculative analysis is not required under CEQA (CEQA Guidelines §§ 15064(d)(3), 15145), and, most importantly, would not provide meaningful information by which to determine project impacts.

Emissions that occur during the emergency use of the gensets would not occur on a regular or predictable basis (see **Appendix B** for more information). During the permitting process, BAAQMD policy requires facilities to presume that each of their generators will experience 100 hours per year of emergency operation when calculating their PTE for determining the applicability of certain permitting regulations (BAAQMD 2019).

Although normally excluded from ambient air quality impact analysis during permit review, the BAAQMD CEQA Air Quality Guidelines recommend that lead agencies include non-testing and non-maintenance (emergency) operations hours in addition to the permitted testing and maintenance hours for purposes of calculating emissions (BAAQMD

2023b, Chapter 5.2.4). Scoping comments on a previous similar project (the CA3 Data Center project) from BAAQMD provided a review of data centers that initiated operation of diesel engines for “non-testing/non-maintenance” purposes, for the purpose of informing staff’s consideration of scenarios of backup power generation operations beyond routine testing and maintenance (BAAQMD 2021).

Staff reviewed the use of diesel engines for “non-testing/non-maintenance” purposes and confirmed that these types of events are infrequent, irregular, and unlikely and the resulting emissions are not easily predictable or quantifiable (see **Appendix B** for more information). Extended durations of standby generator engines use occurred for “non-testing/non-maintenance” purposes, mostly due to extreme events within the 13-month record of the data. The 13-month period of BAAQMD’s review (September 1, 2019, to September 30, 2020) included the implementation of Pacific Gas and Electric’s Public Safety Power Shutoff (PSPS), severe wildfires, several California Independent System Operator (CAISO)-declared emergencies, and winter storms.

Including usage during the extreme events, 1,877 engine-hours of diesel engine use occurred at 20 data centers for “non-testing/non-maintenance” purposes (less than half of the 45 facilities included in the review, and less than a third of such facilities under BAAQMD’s jurisdiction at the time of data collection) during the surveyed 13-month period. BAAQMD’s review covered 288 individual diesel engines that operated over a 13-month record. Because the backup generator engines were collectively available for over 2.74 million engine-hours during the 13-month period (288 engines * 9,504 hours in the 13-month record), and they were used for “non-testing/non-maintenance” purposes for 1,877 engine-hours, at those facilities where operation occurred, the engines entered into emergency operations during 0.07 percent of their available time (1,877 / 2.74 million). Staff’s analysis of BAAQMD’s information found that the average runtime for each diesel backup generator engine per event in BAAQMD’s review was approximately 5.0 hours. Based on this data, staff determined that the emergency use of the standby generator engines was infrequent and of short duration.

Due to the number of factors that need to be considered, using an air quality model to evaluate ambient air quality impacts during emergency operations would require substantial and inappropriate speculation and would render the results of any such exercise too speculative to be meaningful. This remains especially true when neither the CEC nor any other agency known to CEC has established or used in practice a threshold of significance by which to interpret air quality modeling results from emergency operations. Emergency operation would be very infrequent, and emergency operations would not occur routinely during the lifetime of the facility. Accordingly, the potential for any adverse impacts to ambient air quality concentrations would be a very-low probability event.

Thus, staff concludes that assessing the impacts of emergency operation of the gensets would be speculative due to the infrequent, irregular, and unplanned nature of emergency

events. Emissions and impacts during emergency operation are not objectively predictable or quantifiable.

Because of the infrequent nature of emergency conditions and the reliability of the grid as detailed in **Appendix B**, the project's emergency operation would be unlikely to expose sensitive receptors to substantial concentrations of criteria air pollutants.

Cumulative Impacts for Criteria Pollutants

The conclusion for cumulative impacts to criteria air pollutant concentrations relies on the quantified emissions and the modeled concentrations presented above. Under CEQA environmental checklist criterion "b" above, staff concludes that the project emissions would not exceed the BAAQMD significance thresholds. Additionally, impacts to the general population and sensitive populations during construction would be reduced with the implementation of mitigation measure **AQ-1**. The project's NOx emissions would be fully offset for readiness testing and maintenance. Therefore, the project would not result in a cumulatively considerable net increase of any criteria pollutant, and the project's potential to contribute to the cumulative impact of criteria pollutant concentrations would be less than significant with mitigation incorporated.

Health Risk Assessment for Toxic Air Contaminants

The HRA provides three separate analyses, based on substantial evidence as described, that supports the conclusion that the project would not expose sensitive receptors to substantial pollutant concentrations of TACs. An analysis was conducted for (1) the period of project demolition/construction, (2) for the period of operation, which consists of readiness testing and maintenance, and (3) the cumulative risk and hazards for the project including the project's impact with the impacts of existing sources in the area.

The HRA estimated risks of excess lifetime cancer risk, chronic non-cancer HI, acute non-cancer HI, and annual PM2.5 concentration at the maximally exposed individual resident (MEIR), maximally exposed individual worker (MEIW), maximally exposed school/daycare receptor (MESR/MEDR), and maximally exposed recreational receptor (MERR) (DayZenLLC 2022b, pg. 19):

- Point of maximum impact (PMI) – this receptor represents the highest concentration and risk point on the receptor grid for the analysis under consideration.
- Maximum exposed individual residential receptor (MEIR) – this receptor represents the maximum impacted actual residential location on the grid for the analysis under consideration; for this project, the MEIR is along Lafayette Street approximately 1,400 feet southwest of the MBGF site.
- Maximum exposed individual worker receptor (MEIW) – this receptor represents the maximum impacted actual worker location on the grid for the analysis under consideration; for this project, the MEIW is the same as the PMI, located along Martin Avenue approximately 100 feet east of the MBGF site.

- Maximally exposed school/daycare receptor (MESR/MEDR) – this receptor represents the maximum impacted location on the grid for a non-residential sensitive receptor, i.e., school, hospital, daycare center, convalescent home, etc. For this project the MESR/MEDR is over 4,800 feet northwest of the MBGF site.
- Maximally exposed recreational receptor (MERR) – this receptor represents the maximum impacted location on the grid for a recreational, non-residential receptor; for this project, the MERR is an indoor soccer facility at 700 Mathew Street, approximately 1,300 feet south of the MBGF site.

As required by the 2015 OEHHA Guidance, sensitive receptor (including residential) cancer risks were estimated assuming exposure beginning in the third trimester of pregnancy, and worker cancer risk was estimated assuming an 8-hour-per-day, 250 day-per-year exposure, beginning at the age of 16 (OEHHA 2015).

Air would be the dominant pathway for public exposure to chemical substances released by the project. Emissions to the air would consist primarily of combustion by-products produced by the diesel-fired emergency standby engines. Direct inhalation is considered the most likely exposure pathway. The HRA was conducted in accordance with guidance established by the OEHHA (OEHHA 2015).

Cancer Risk

Cancer risk is the probability or chance of developing cancer over a period of exposure normally defined as either 30 or 70-years depending on the project type and agency risk procedures. Carcinogens are not assumed to have a threshold below which there would be no human health impact. In other words, any exposure to a carcinogen is assumed to have some probability of getting cancer. Various state and local regulations use an excess cancer risk greater than 10-in-1 million as a level deemed unacceptable on a project basis (BAAQMD 2023b, Appendix A and Appendix E).

Health risks potentially associated with concentrations of carcinogenic pollutants in air were calculated as estimated excess lifetime cancer risks. The excess lifetime cancer risk for a pollutant can be estimated as the product of the concentration in air and a unit risk factor. The unit risk factor is a cancer potency factor, developed by assuming constant exposure to an ambient concentration of 1 $\mu\text{g}/\text{m}^3$ of a given substance. In other words, it represents the increased cancer risk associated with continuous exposure to a concentration in air over a pre-defined exposure period, i.e., usually a 30 or 70-year lifetime (OEHHA 2015).

Non-Cancer Risk

Non-cancer health effects can be either chronic or acute. Assessing non-cancer hazards assumes that there is a dose of the chemical of concern below which there would be no impact on human health. The air concentration corresponding to this dose is called the Reference Exposure Level (REL). The REL is an airborne concentration level at or below which no adverse non-cancer health effects are anticipated. Non-cancer health risks are

measured in terms of a hazard quotient (HQ), which is the calculated exposure of each contaminant divided by its REL. Hazard quotients for pollutants affecting the same target organ are typically summed with the resulting totals expressed as hazard indices (HIs) for each organ system (OEHHA 2015). A HI of less than 1.0 is considered to result in non-cancer chronic and acute health impacts that are less than significant (BAAQMD 2023b, Appendix A).

Evaluation of potential non-cancer health effects from exposure to short-term and long-term concentrations in air was performed by comparing modeled concentrations in air with the RELs. RELs are based on the most sensitive adverse effects reported in the medical and toxicological literature. Chronic toxicity is defined as adverse health effects from prolonged chemical exposure, caused by chemicals accumulating in the body. The chronic hazard index was calculated using the hazard quotients calculated with annual concentrations. Acute toxicity is defined as adverse health effects caused by a brief chemical exposure of no more than 24 hours. One-hour average concentrations are divided by acute RELs to obtain a hazard index for health effects caused by relatively high, short-term exposure to air toxics.

Review of Applicant's HRA

Staff reviewed the applicant's modeling files and agreed with the inputs used by the applicant, and this analysis summarizes the results provided by the applicant from the model for carcinogenic and non-cancer health risks. The applicant's HRA used unitized emissions rates (1 gram per second) in AERMOD (version 22112) and scaled the results to arrive at concentrations for individual TACs (DayZenLLC 2022b, pg 13), then derived the potential health impacts from TAC exposure through the inhalation pathway (DayZenLLC 2022b, pg 15). The applicant's risk characterization methods for all off-site receptors follows assumptions for inhalation rates, exposure durations, and age-sensitivity factors that are consistent with OEHHA (2015) guidelines (DayZenLLC 2022b, Table 40). The project's HRA uses cancer potency factors and RELs published in the Consolidated Table of OEHHA / CARB Approved Risk Assessment Health Values from May 2022 (DayZenLLC 2022b, Table 42). The applicant's HRA found that the maximum cancer risk impact, chronic HI, acute HI and PM2.5 concentrations at all receptors would be below the BAAQMD thresholds of significance (DayZenLLC 2022b, pg. 19). These results are described in greater detail below.

Construction HRA

Less Than Significant Impact. Onsite construction emissions from the construction of the MDC would result from demolition activities, site preparation and grading activities, building erection, parking lot construction activities, "finish" construction activities, and use of onsite construction equipment. Offsite construction emissions would be derived primarily from materials transport to and from the site, and worker travel (DayZenLLC 2022b, Table 19). Emissions from the 15-month construction period were estimated using the CalEEMod program (DayZenLLC 2022b, pp.ES-2).

Emissions of toxic pollutants during construction of the facility would be dominated by the effects of particulate matter from the onsite and offsite diesel-fueled engines. Construction health risk impacts include the effects of exhaust emissions from onsite construction and from the offsite on-road mobile sources up to 1,000 feet from the Project boundary, assuming a fifteen-month construction period (DayZenLLC 2022b, page 9). DPM is the surrogate compound for construction equipment diesel exhaust (DayZenLLC 2022b, page 13). Construction health risk impacts are based solely on DPM emissions (DayZenLLC 2022b, Table 38). There are no acute non-cancer health risks analyzed for construction HRA because there is no acute inhalation REL for DPM, indicating that DPM is not known to result in acute health hazards.

The results of the HRA for construction activities are presented in **Table 4.3-10** (DayZenLLC 2022b, Table 43). It shows that the maximum cancer risk impact and chronic HIs at the MEIR, MEIW, MESR/MEDR, and MERR would be less than BAAQMD’s significance thresholds. Annual average concentrations of PM2.5 are presented for these locations excluding fugitive dust and the result would be less than 0.3 µg/m³ and would not exceed BAAQMD’s significance threshold for local risk. Therefore, staff concluded that the health risks of the project construction period would cause a less than significant impact.

Note that the risk values shown in **Table 4.3-10** are the highest of those modeled for each type of sensitive receptors. The risk values at other locations for each type of sensitive receptors would be lower than those shown in **Table 4.3-10**. Health risks at all sensitive receptors would be below the significance thresholds. The health risks from project construction would be less than significant, and no mitigation would be necessary. The health risks from project construction would be further reduced with the implementation of mitigation measure **AQ-1**.

TABLE 4.3-10 CONSTRUCTION – MODELED RECEPTOR MAXIMUM HEALTH RISK

Receptor Type	Cancer Risk Impact (in one million)	Chronic Non-Cancer Hazard Index (HI)	Acute Non-Cancer Hazard Index (HI)	PM2.5 Concentration (µg/m ³)
Residential, MEIR ¹	0.011	0.000012	-	0.000059
Worker, MEIW ²	0.34	0.0050	-	0.025
School/Daycare, MESR/MEDR ³	0.040	0.000014	-	0.000071
Recreational, MERR ⁴	0.00076	0.000053	-	0.00027
BAAQMD Threshold	10	1	1	0.3

Notes:

¹ Maximally Exposed Individual Resident (MEIR): along Lafayette Street approximately 1,400 feet southwest of the MBGF site.

² Maximally Exposed Individual Worker (MEIW): along Martin Avenue approximately 100 feet east of the MBGF site; this is the same location as the PMI.

³ Maximally Exposed School/Daycare Receptor (MESR/MEDR): over 4,800 feet northwest of the MBGF site.

⁴ Maximally Exposed Recreational Receptor (MERR): indoor soccer facility at 700 Mathew Street, approximately 1,300 feet south of the MBGF site.

Source: DayZenLLC 2022b, Table 43.

Operation HRA

Less Than Significant Impact. Primary operation emissions would result from the 44 standby diesel generators. The only on-site emissions included in the applicant's HRA are the TAC emissions from testing and maintenance of the diesel-fueled emergency standby engines. Other on-site sources, including diesel storage tanks would be minor in comparison with the stationary sources and unlikely to pose substantial risks. Offsite vehicle trips for worker commutes and material deliveries were not included in HRA.

DPM is the approved surrogate compound for the mixture of substances in diesel fuel combustion emissions for purposes of health risk assessment. There would also be some VOC emissions (n-Hexane) from the ultra-low sulfur diesel (ULSD) day tanks. Since the emissions of this VOC HAP from diesel storage tank losses would be much lower than the significance threshold of BAAQMD Rule 2-5, Table 2-5-1 (Toxics NSR), it indicates their impacts would be insignificant. Therefore, they were not included in the operations HRA analysis (DayZenLLC 2023a, Response to Data Request 15).

Each of the proposed diesel engines would be equipped with SCR and DPF to meet the Tier 4 standards (DayZenLLC 2022a, pp. 2-11). DPM emissions resulting from diesel stationary combustion were assumed equal to PM10/2.5 emissions (DayZenLLC 2022b, pg. 4, Tables 8 through 11). Overall, testing in either the monthly or annual scenarios would occur for no more than 35 hours per year. The Airborne Toxic Control Measures (ATCM) for Stationary Toxic Compression Ignition Engines (Title 17, Section 93115, CCR) limits each engine to no more than 50 hours annually for reliability purposes (i.e., testing and maintenance). The applicant proposes a more-stringent limit to use each generator a maximum of 35 hours per year for non-emergency operations (testing and maintenance).

Emissions of toxic pollutants potentially associated with the facility were estimated using emission factors provided by Peterson Power Systems for the ecoCUBE engine configuration based on inlet and outlet emission performance, with the controlled emission factors accounting for the presence of DPF and SCR control devices (DayZenLLC 2022b, page 5, Table 8). In addition, manufacturer specification sheets for the Caterpillar gensets are included (DayZenLLC 2022b, Appendix B, and DayZenLLC 2023a, Response to Data Request 5).

Maintenance and readiness testing usually occurs at loads ranging from 10 to 100% load. For purposes of this application, average daily and maximum annual emissions were assumed to occur at 100% load (DayZenLLC 2022b, pg. 5). Annual emissions of TAC (DPM) for each engine are based on each engine in use up to 35 hours per year, at 100% load, with Safety Power ecoCUBE controls with minimum NOx control efficiency of 90% and minimum DPM control efficiency of 70% (ATCM limit) (DayZenLLC 2022b, Table 10).

The results of the applicant’s HRA for facility wide MBGF operation are presented in **Table 4.3-11** (DayZenLLC 2022b, pg. 19, Table 44) and show that the maximum cancer risk impact, chronic hazard index, acute hazard index, and PM2.5 concentrations at the PMI, MEIR, MEIW, MESR/MEDR, and MERR during the operation of the project would be less than the BAAQMD’s significance thresholds. Staff concluded that the health risks of the project operation would be a less-than-significant impact.

TABLE 4.3-11 OPERATION – MODELED RECEPTOR MAXIMUM HEALTH RISK

Receptor Type	Cancer Risk Impact (in one million)	Chronic Non-Cancer Hazard Index (HI)	Acute Non-Cancer Hazard Index (HI)	PM2.5 Concentration (µg/m ³)
Residential, MEIR ¹	0.28	0.000073	0.075	0.00037
Worker, MEIW ²	6.8	0.0053	0.37	0.026
School/Daycare, MESR/MEDR ³	0.79	0.000077	0.053	0.00039
Recreational, MERR ⁴	0.028	0.00017	0.072	0.00085
BAAQMD Threshold	10	1	1	0.3

Notes:

¹ Maximally Exposed Individual Resident (MEIR): along Lafayette Street approximately 1,400 feet southwest of the MBGF site.

² Maximally Exposed Individual Worker (MEIW): along Martin Avenue approximately 100 feet east of the MBGF site; this is the same location as the PMI.

³ Maximally Exposed School/Daycare Receptor (MESR/MEDR): over 4,800 feet northwest of the MBGF site.

⁴ Maximally Exposed Recreational Receptor (MERR): indoor soccer facility at 700 Mathew Street, approximately 1,300 feet south of the MBGF site.

Source: DayZenLLC 2022b, pg. 19, Table 44.

The proposed MDC project would not be located inside the boundaries of or within 1,000 feet of an Overburdened Community, as defined in BAAQMD Regulation 2-1-243; therefore, it is not subject to the cancer risk limit of BAAQMD Regulation 2, Rule 5 as amended in 2021 (i.e., 6 in one million if within an area defined as an Overburdened Community). The proposed MDC project is within the 2013 Cumulative Impact Area, as designated by BAAQMD’s CARE Program.

It should be noted that the risk values shown in **Table 4.3-11** are the highest of those modeled for each type of sensitive receptors. The risk values at other locations for each type of sensitive receptors would be lower than those shown in **Table 4.3-11**. Because health risks at all sensitive receptors would be below the significance thresholds, the health risks from the project’s operation would be less than significant, and no mitigation would be necessary.

In conclusion, staff finds the health risks at sensitive receptor locations would be less than the BAAQMD CEQA Guidelines significance thresholds shown in **Table 4.3-1**. The health risks from the project’s construction would not exceed the significance thresholds and would be further reduced with the implementation of mitigation measure **AQ-1**. For routine operation, staff concludes that the project’s health risks and potential to expose

sensitive receptors to substantial pollutant concentrations of TACs would be less than significant.

Emergency Operations HRA

The HRA for genset operation includes the maximum allowed runtime of 35 hours per year per engine. Different scenarios of using the gensets during emergencies are not quantified for reasons discussed in the previous subsection “Emergency Operations Impacts for Criteria Pollutants.”

Cumulative HRA

Less Than Significant Impact. This discussion addresses the impacts from cumulative sources in comparison to the BAAQMD significance thresholds for risk and hazards from cumulative sources (BAAQMD 2023b). The cumulative HRA is an assessment of the project’s impact summed with the impacts of other sources within 1,000 feet of the project. The results of this cumulative HRA are compared to the BAAQMD’s cumulative thresholds for new sources. As mentioned above, the cumulative local community risk and hazard impact is significant if the aggregate total of all past, present, and foreseeable future sources within a 1,000-foot distance from the fence line of a source and the contribution from the project, exceeds the following:

- An excess lifetime cancer risk level of more than 100 in one million.
- A non-cancer chronic HI greater than 10.0.
- An annual average PM_{2.5} concentration of greater than 0.8 µg/m³

The applicant provided a cumulative HRA and compared results with the BAAQMD thresholds for cumulative risk and hazards (DayZenLLC 2022b, Table 45 and Appendix D; updated in DayZenLLC 2023a, Responses to Data Requests 23 and 24). The applicant identified the existing, background stationary sources available from the BAAQMD’s Permitted Stationary Source Risks and Hazards Screening Tool by querying the data for sources within 1,000 feet of each receptor of concern (DayZenLLC 2022b, Table 45 and Appendix D). Data on potential health impacts from existing, background railroad and major roadway sources are also from BAAQMD’s screening tools, which were updated during the preparation of this analysis. Information on the cumulative health risk impacts at the MEIR, MEIW, MESR/MEDR, and MERR are provided separately for each receptor type (DayZenLLC 2022b, Appendix D; updated in DayZenLLC 2023a, Responses to Data Requests 23 and 24).

Staff independently reviewed the applicant’s cumulative HRA. This analysis presents the results of individual effects of the proposed project’s impact when summed with the impacts of existing and foreseeable sources within 1,000 feet of the maximally exposed receptors. During staff’s review, consideration was given to the effects of four local projects that are presently approved, under development, or pending development:

- Sequoia Data Center (2600 De La Cruz Blvd.)

- Walsh Data Center (651 Walsh Ave.)
- Lafayette Data Center (2825 Lafayette Dr.)
- 1200 Memorex Drive Data Center (1200 Memorex Dr.)

Staff also added consideration of health impacts from portions of the San Jose International Airport, where located within 2,000 feet of the MEIW. For other maximally exposed receptor types, airport-related sources would be beyond 2,000 feet, which is a distance that precludes the possibility the sources would combine to produce a cumulative impact.

The maximum cumulative cancer risk for any receptor type was found to be 61.3 in a million, lower than the threshold of 100 in a million. The maximum cumulative non-cancer chronic HI would be 0.18, which below the threshold of 10. The maximum cumulative PM2.5 concentration would exceed the threshold of 0.8 µg/m³ at certain sensitive receptors due to the effects of existing, background stationary and mobile sources in the region (DayZenLLC 2022b, Appendix D, and DayZenLLC 2023a, Responses to Data Requests 23 and 24).

The cumulative HRA in this analysis includes the proposed MBGF project with the following sources: (1) existing or background stationary sources; (2) background surrounding highways, main streets, and railways; (3) the approved Sequoia Data Center at 2600 De La Cruz Blvd.; (4) the approved Walsh Data Center at 651 Walsh Ave.; (5) the proposed Lafayette Data Center at 2825 Lafayette Dr.; and (6) the approved 1200 Memorex Drive Data Center. This analysis also includes portions of the San Jose International Airport for the MEIW as previously analyzed by staff for the MEIW in the Commission Final Decision for the Sequoia Data Center (in Docket 19-SPPE-03, TN 238706: 7/6/2021).

The results of staff’s cumulative HRA are compared to the BAAQMD CEQA cumulative thresholds of significance (BAAQMD 2023b) in **Table 4.3-12**, **Table 4.3-13**, **Table 4.3-14** and **Table 4.3-15**.

TABLE 4.3-12 CUMULATIVE RISKS AND HAZARDS – RESIDENTIAL, MEIR

Contribution of Cumulative Sources	Cancer Risk Impact (in one million)	Chronic Non-Cancer Hazard Index (HI)	Acute Non-Cancer Hazard Index (HI)	PM2.5 Concentration (µg/m³)
MBGF Project at MEIR	0.28	0.000073	0.075	0.00037
Background Stationary Sources	3.17	0.01337	0	3.670
Sequoia Data Center	0.19	0.00005	0.1	0.0003
Walsh Data Center	0.04	0.00001	---	---
Lafayette Data Center	6.10	0.00141	---	---
1200 Memorex Drive Data Center	4.27	0.00098	---	0.005
Background Mobile Sources	47.26	0.07264	0	0.602

TABLE 4.3-12 CUMULATIVE RISKS AND HAZARDS – RESIDENTIAL, MEIR

Contribution of Cumulative Sources	Cancer Risk Impact (in one million)	Chronic Non-Cancer Hazard Index (HI)	Acute Non-Cancer Hazard Index (HI)	PM2.5 Concentration (µg/m³)
Cumulative Impact at MEIR	61.31	0.0885	0.175	4.278
BAAQMD Threshold	100	10.0	No threshold	0.8

Notes:

Background Stationary and Mobile Sources from BAAQMD raster files as processed by the applicant (DayZenLLC 2023a, Response to Data Request 23).

Sequoia Data Center risks are as presented in the Commission Final Decision for that project (TN 238706) not adjusted for distance.

Walsh Data Center risks are as presented in the Commission Final Decision for that project (TN 234408) not adjusted for distance.

Lafayette Data Center risks are as presented in the Draft EIR for that project (TN 249557) not adjusted for distance.

1200 Memorex Drive risks are as presented from the March 2021 Air Quality and Greenhouse Gas Emissions Assessment and Draft EIR for that project, summarized by the applicant (DayZenLLC 2023a).

Source: DayZenLLC 2023a, Response to Data Request 23 and 24, Table D1.

TABLE 4.3-13 CUMULATIVE RISKS AND HAZARDS – WORKER, MEIW

Contribution of Cumulative Sources	Cancer Risk Impact (in one million)	Chronic Non-Cancer Hazard Index (HI)	Acute Non-Cancer Hazard Index (HI)	PM2.5 Concentration (µg/m³)
MBGF Project at MEIW	6.8	0.0053	0.37	0.026
Background Stationary Sources	0.14	0.0011	0	0.000
Sequoia Data Center	2.20	0.0070	0.54	0.040
Walsh Data Center	4.64	0.0036	---	---
Lafayette Data Center	1.83	0.0019	---	---
San Jose International Airport	7.97	0.1500	---	0.058
Background Mobile Sources	27.04	0.0147	---	0.333
Cumulative Impact at MEIW	50.62	0.1836	0.91	0.458
BAAQMD Threshold	100	10.0	No threshold	0.8

Notes:

Background Stationary and Mobile Sources from BAAQMD raster files as processed by the applicant (DayZenLLC 2023a, Response to Data Request 23).

Sequoia Data Center risks are as presented in the Commission Final Decision for that project (TN 238706) not adjusted for distance.

Walsh Data Center risks are as presented in the Commission Final Decision for that project (TN 234408) not adjusted for distance.

Lafayette Data Center risks are as presented in the Draft EIR for that project (TN 249557) not adjusted for distance.

San Jose International Airport risks, added by staff, as presented for the MEIW in the Commission Final Decision for the Sequoia Data Center project (TN 238706).

Source: DayZenLLC 2023a, Response to Data Request 23 and 24, Table 45.

TABLE 4.3-14 CUMULATIVE RISKS AND HAZARDS – SCHOOL/DAYCARE, MESR/MEDR

Contribution of Cumulative Sources	Cancer Risk Impact (in one million)	Chronic Non-Cancer Hazard Index (HI)	Acute Non-Cancer Hazard Index (HI)	PM2.5 Concentration (µg/m³)
MBGF Project at MESR/MEDR	0.79	0.00008	0.053	0.00039
Background Stationary Sources	19.38	0.04005	0	0.066
Sequoia Data Center	0.50	0.00003	0.06	0.00016
Walsh Data Center	0.04	0.00001	---	---
Lafayette Data Center	0.15	0.00003	---	---
Background Mobile Sources	35.04	0.04518	0	0.764
Cumulative Impact at MESR/MEDR	55.90	0.0854	0.113	0.831
BAAQMD Threshold	100	10.0	No threshold	0.8

Notes:

Background Stationary and Mobile Sources from BAAQMD raster files as processed by the applicant (DayZenLLC 2023a, Response to Data Request 23).

Sequoia Data Center risks are as presented in the Commission Final Decision for that project (TN 238706) not adjusted for distance.

Walsh Data Center risks are as presented in the Commission Final Decision for that project (TN 234408) not adjusted for distance.

Lafayette Data Center risks are as presented in the Draft EIR for that project (TN 249557) not adjusted for distance.

Source: DayZenLLC 2023a, Response to Data Request 23 and 24, Table D2.

TABLE 4.3-15 CUMULATIVE RISKS AND HAZARDS – RECREATIONAL, MERR

Contribution of Cumulative Sources	Cancer Risk Impact (in one million)	Chronic Non-Cancer Hazard Index (HI)	Acute Non-Cancer Hazard Index (HI)	PM2.5 Concentration (µg/m³)
MBGF Project at MERR	0.028	0.00017	0.072	0.00085
Background Stationary Sources	7.06	0.03283	0	9.763
Sequoia Data Center	0.002	0.00006	0.11	0.00031
Background Mobile Sources	28.15	0.02000	0	0.348
Cumulative Impact at MERR	35.24	0.0531	0.182	10.112
BAAQMD Threshold	100	10.0	No threshold	0.8

Notes:

Background Stationary and Mobile Sources from BAAQMD raster files as processed by the applicant (DayZenLLC 2023a, Response to Data Request 23).

Sequoia Data Center risks are as presented in the Commission Final Decision for the “soccer child receptor” in that project (TN 238706).

Source: DayZenLLC 2023a, Response to Data Request 23 and 24, Table D3.

Table 4.3-12, Table 4.3-13, Table 4.3-14, and Table 4.3-15 summarize the results of the staff cumulative HRA and compares them to the BAAQMD significance thresholds for cumulative risk and hazards. The cancer risk, non-cancer HI, and PM2.5 concentration impacts of local data center projects were drawn from prior analyses and added to the proposed project effects using the maximum value for the sensitive receptors as well as

at the nearest residences of those cumulative projects, without adjusting for the distance between the proposed project receptor and the cumulative projects' receptors.

The cumulative impact at each receptor shows that the project would not cause a cumulatively considerable contribution along with existing and foreseeable projects to cancer risk or non-cancer HI. For cancer risk and non-cancer hazards, staff finds that cumulative impacts at all sensitive receptor locations would be less than the BAAQMD significance thresholds shown in **Table 4.3-1**.

The local cumulative PM_{2.5} concentrations are dominated by the effects of existing, background stationary and mobile sources and would exceed the cumulative threshold for some receptors. Because the overall cumulative impact to PM_{2.5} exceeds the significance level determined, the proposed project would contribute to a significant cumulative impact. Based on the PM_{2.5} impact of the proposed project being well below the PM_{2.5} threshold of 0.3 µg/m³ for an individual project, the project's incremental contribution to the cumulative impact would not be cumulatively considerable. Staff concludes that the project's contribution to the cumulative health risk impacts would be less than significant.

Required Mitigation Measures: None.

d. Result in other emissions (such as those leading to odors) adversely affecting a substantial number of people?

This section considers impacts that may arise from emissions other than criteria air pollutants and TACs, such as emissions that may lead to odors.

BAAQMD states that, while offensive odors rarely cause direct health impacts or any physical harm, they still can be very unpleasant and lead to considerable distress among the public, often generating citizen complaints to local governments and BAAQMD (BAAQMD 2023b). Any project with the potential to frequently expose members of the public to objectionable odors would be deemed to have a significant impact. Odor impacts on residential areas and other sensitive receptors warrant the closest scrutiny, but consideration should also be given to other land uses where people may congregate, such as recreational facilities, worksites, and commercial areas.

BAAQMD CEQA Guidelines recommend a two-step process for determining the significance of potential odor impacts. First, determine whether the project would result in an odor source affecting receptors within the distances indicated in **Table 4.3-16**. Second, if the proposed project would result in an odor source and receptors within the screening level distances indicated in **Table 4.3-16**, a more detailed analysis should be conducted (BAAQMD 2023b).

TABLE 4.3-16 PROJECT SCREENING TRIGGER LEVELS FOR POTENTIAL ODOR SOURCES

Land Use/Type of Operation	Project Screening Distance
Wastewater Treatment Plant	2 miles
Wastewater Pumping Facilities	1 mile
Sanitary Landfill	2 miles
Transfer Station	1 mile
Composting Facility	1 mile
Petroleum Refinery	2 miles
Asphalt Batch Plant	2 miles
Chemical Manufacturing	2 miles
Fiberglass Manufacturing	1 mile
Painting/Coating Operations	1 mile
Rendering Plant	2 miles
Coffee Roaster	1 mile
Food Processing Facility	1 mile
Confined Animal Facility/Feed Lot/Dairy	1 mile
Green Waste and Recycling Operations	1 mile
Metal Smelting Plants	2 miles

Source: BAAQMD 2023b, Table 5-4.

The project is not a type of operation that is classified as a typical odor source by BAAQMD, as shown in **Table 4.3-16**. The diesel engine generators would not be stationary sources of a type that are typically known to cause significant odor impacts.

Construction

Less Than Significant Impact. Minor odor sources during construction activities include diesel exhaust from heavy-duty equipment. Odors from construction activities near existing receptors would be temporary in nature and dissipate as a function of distance. Accordingly, the construction of the project is not expected to result in substantial emissions that may lead to odor impacts or impacts of emissions other than those of criteria pollutants and TACs identified elsewhere in this analysis.

Fugitive dust emissions can also create a nuisance that can cause adverse effects. The project is proposing to comply with the BAAQMD construction fugitive dust control BMPs and so should not have substantial fugitive dust emissions during construction that could adversely affect a substantial number of people.

Therefore, the construction of the project would not result in other emissions, such as those leading to odors, that could adversely affect a substantial number of people, and construction activities would have a less than significant impact.

Operation

Less Than Significant Impact. Potential odor sources from project readiness testing and maintenance along with emergency operation would include diesel exhaust from genset

readiness testing and maintenance, trash pick-up and other heavy-duty delivery vehicles, and the occasional use of architectural coatings during routine maintenance. When compared to existing odor sources near the project site, which include heavy and light industrial uses, odor impacts from project readiness testing and maintenance along with emergency operations would be similar.

Once built and operating, the project would have no notable emissions other than those of criteria pollutants and TACs identified elsewhere in this analysis. Therefore, nuisance impacts would not be likely to occur during operation, including readiness testing and maintenance or emergency operation. During readiness testing and maintenance and during emergency operation, the project would not result in odors or other emissions that could adversely affect a substantial number of people and would have a less than significant impact related to odors. In conclusion, staff finds that the project would not likely create objectionable odors affecting a substantial number of people, and operation would have a less than significant impact.

4.3.4 Mitigation Measures

AQ-1: To ensure that fugitive dust impacts are less than significant, the project will implement the Bay Area Air Quality Management District (BAAQMD) recommended Best Management Practices (BMPs) during the construction phase, the project owner shall implement a construction emissions control plan that has been reviewed and approved by the Director or Director's designee of the City of Santa Clara Community Development prior to the issuance of any grading or building permits, whichever occurs earliest. These BMPs are incorporated into the design of the project and will include:

- Water all exposed areas (e.g., parking areas, graded areas, unpaved access roads) twice a day.
- Maintain a minimum soil moisture of 12% in exposed areas by maintaining proper watering frequency.
- Cover all haul trucks carrying sand, soil, or other loose material.
- Suspend excavation, grading, and/or demolition activities when average wind speed exceeds 20 miles per hour.
- Pave all roadways, driveways, and sidewalks as soon as possible. Lay building pads as soon as grading is completed, unless seeding or soil binders are used.
- Install wind breaks (e.g., trees, fences) on the windward side(s) of actively disturbed areas of construction with a maximum 50 percent air porosity.
- Use wet power vacuum street sweepers at least once per day to sweep and remove any mud or dirt-track next to public streets if visible soil material is carried onto the streets. The use of dry power sweeping is prohibited.
- Limit vehicle speeds on unpaved roads to 15 miles per hour (mph).

- Minimize idling time for all engines by shutting engines when not in use or limiting idling time to a maximum of five minutes. Provide clear signage for construction workers at all access points.
- Properly tune and maintain construction equipment in accordance with manufacturer's specifications. All equipment shall be checked by a certified mechanic and determined to be running in proper condition prior to operation.
- Post a publicly visible sign with the telephone number and person to contact regarding dust complaints and the BAAQMD General Air Pollution Complaints telephone number. The contact person shall implement corrective measures, as needed, within 48 hours, and the BAAQMD shall be informed of any legitimate complaints received to verify compliance with applicable regulations. Limit simultaneous occurrence of excavation, grading, and ground-disturbing construction activities.
- As a condition of contract, require all on-road heavy-duty trucks to be zero emissions or meet the most stringent emissions standard, such as model year (MY) 2024 to 2026, as available. Use grid power for construction activities whenever possible; if grid power is not available, use alternative power such as battery storage, hydrogen fuel cells, or renewable fuels. If no other options are available, use diesel generators compliant with Tier 4 Final standards.
- Install vegetative ground cover in disturbed areas as soon as possible and water appropriately until vegetation is established.
- Limit simultaneous occurrence of excavation, grading, and ground-disturbing construction activities.
- Install water washers to wash all trucks and equipment, including their tires, prior to leaving site.
- Treat site access to 100 feet from the paved road with a 6- to 12-inch compacted layer of wood chip, mulch, or gravel.
- Install sandbag or other erosion control measures to prevent silt runoff to public roadways from sites with a slope greater than one percent.
- Minimize idling time of diesel-powered construction vehicles to two minutes.
- All off-road equipment greater than 25 horsepower (hp) shall have engines that meet or exceed Tier 4 Final off-road emission standards. Use of zero-emission and hybrid-powered equipment is encouraged.
- All on-road trucks used for material delivery or hauling shall have engines that meet or exceed 2014 CARB emissions standards.
- Where grid power is available, portable diesel engines should be prohibited.
- Use low VOC (i.e., ROG) coatings beyond the local requirements (i.e., Regulation 8, Rule 3: Architectural Coatings).

- All construction equipment, diesel trucks, and generators be equipped with Best Available Control Technology for emission reductions of NO_x and PM.
- All contractors use equipment that meets CARB's most recent certification standard for off-road heavy-duty diesel engines.
- Unpaved roads providing access to sites located 100 feet or further from a paved road shall be treated with a 6- to 12-inch layer of compacted layer of wood chips, mulch, or gravel.
- Minimize the amount of excavated material or waste materials stored at the site.
- Hydroseed or apply non-toxic soil stabilizers to construction areas, including previously graded areas, that are inactive for at least 10 calendar days.

4.3.5 References

BAAQMD 2017a – Bay Area Air Quality Management District (BAAQMD). Final 2017 Clean Air Plan, Adopted April 19, 2017. Accessed January 2020. Available online at: http://www.baaqmd.gov/~media/files/planning-and-research/plans/2017-clean-air-plan/attachment-a_-proposed-final-cap-vol-1-pdf.pdf

BAAQMD 2017b – Bay Area Air Quality Management District (BAAQMD). California Environmental Quality Act, Air Quality Guidelines. Updated May 2017. Accessed March 2020. Available online at: http://www.baaqmd.gov/~media/files/planning-and-research/ceqa/ceqa_guidelines_may2017-pdf.pdf?la=en

BAAQMD 2019 – Bay Area Air Quality Management District (BAAQMD). Calculating Potential to Emit for Emergency Backup Power Generators. Dated June 3, 2019. Available online at: http://www.baaqmd.gov/~media/files/engineering/policy_and_procedures/banking-and-offsets/calculating-pte-for-emergency-generators-06032019-pdf

BAAQMD 2020 – Bay Area Air Quality Management District (BAAQMD). BAAQMD Letter Re: BACT Determination for Diesel Back-up Engines Greater Than or Equal to 1,000 Brake Horsepower: Great Oaks South Backup Generating Facility (TN 236091), December 2020. Accessed April 2023. Available online at: <https://efiling.energy.ca.gov/Lists/DocketLog.aspx?docketnumber=20-SPPE-01>

BAAQMD 2021 – Bay Area Air Quality Management District Comments (BAAQMD). (TN 239805). Letter for CA3 Data Center NOP, dated September 21, 2021. Available online at: <https://efiling.energy.ca.gov/Lists/DocketLog.aspx?docketnumber=21-SPPE-01>

BAAQMD 2023a – Bay Area Air Quality Management District (BAAQMD). Air Quality Standards and Attainment Status. Accessed April 2023. Available online at: <https://www.baaqmd.gov/about-air-quality/research-and-data/air-quality-standards-and-attainment-status>

- BAAQMD 2023b – Bay Area Air Quality Management District (BAAQMD). California Environmental Quality Act Air Quality Guidelines, Updated April 2023. Available online at: <https://www.baaqmd.gov/plans-and-climate/california-environmental-quality-act-ceqa/updated-ceqa-guidelines>
- CARB 1998 – California Air Resources Board (ARB). 1998. Proposed Identification of Diesel Exhaust as a Toxic Air Contaminant. Appendix III, Part A, Exposure Assessment. June 1998. Accessed March, 2020. Available online at: https://ww3.arb.ca.gov/toxics/dieseltac/part_a.pdf
- CARB 2013 – California Air Resources Board (ARB). The California Almanac of Emissions and Air Quality -2013 Edition. Accessed January 2020. Available online at: <https://www.arb.ca.gov/aqd/almanac/almanac13/almanac13.htm>
- CARB 2021 – California Air Resources Board. Low Emission Diesel (LED) Study: Biodiesel and Renewable Diesel Emissions in Legacy and New Technology Diesel Engines, Final Report – November 2021. Accessed May 2023. Available Online at: <https://ww2.arb.ca.gov/resources/documents/low-emission-diesel-led-study-biodiesel-and-renewable-diesel-emissions-legacy>
- CARB 2023a – California Air Resources Board (CARB). Maps of State and Federal Area Designations. Accessed April 2023. Available online at: <https://www.arb.ca.gov/desig/adm/adm.htm>
- CARB 2023b – California Air Resources Board (CARB). Air Quality Data Statistics Top 4 Summary. Accessed April 2023. Available online at: <https://www.arb.ca.gov/adam/topfour/topfour1.php>
- CARB 2023c – California Air Resources Board (CARB). California Ambient Air Quality Standards. Accessed April 2023. Available online at: <https://ww2.arb.ca.gov/resources/california-ambient-air-quality-standards>
- CARB 2023d – California Air Resources Board (CARB). Accessed April 2023. Overview: Diesel Exhaust & Health. Available online at: <https://ww2.arb.ca.gov/resources/overview-diesel-exhaust-and-health>
- DayZenLLC 2022a – Martin Backup Generating Facility. (TN# 247325). MBGF SPPE Application - Part 1- Main App and Appendix A. Dated November 8, 2022. Available online at: <https://efiling.energy.ca.gov/Lists/DocketLog.aspx?docketnumber=22-SPPE-03>
- DayZenLLC 2022b – Martin Backup Generating Facility. (TN# 247329). MBGF SPPE Application - Part 2 - App B-D. Dated November 8, 2022. Available online at: <https://efiling.energy.ca.gov/Lists/DocketLog.aspx?docketnumber=22-SPPE-03>
- DayZenLLC 2023a – Martin Backup Generating Facility. (TN# 249350). Martin Properties Responses to Data Request Set 1 – MBGF. Dated March 17, 2023. Available online at: <https://efiling.energy.ca.gov/Lists/DocketLog.aspx?docketnumber=22-SPPE-03>

- DayZenLLC 2023b – Martin Backup Generating Facility. (TN# 250687). Martin Properties Responses to Data Requests Set 2 – MBGF. Dated June 20, 2023. Available online at:
<https://efiling.energy.ca.gov/Lists/DocketLog.aspx?docketnumber=22-SPPE-03>
- NOAA 2019 – National Oceanic and Atmospheric Administration (NOAA). The Impact of Wildfires on Climate and Air Quality, An emerging focus of the NOAA ESRL Chemical Sciences Division. Accessed January 2020. Available online at:
<https://www.esrl.noaa.gov/csd/factsheets/csdWildfiresFIREX.pdf>
- OEHHA 2015 – Office of Environmental Health Hazard Assessment (OEHHA). Air Toxics Hot Spots Program Risk Assessment Guidelines. Guidance Manual for Preparation of Health Risk Assessments, March 6, 2015. Available online at:
<https://oehha.ca.gov/media/downloads/crn/2015guidancemanual.pdf>
- OEHHA 2023 – Office of Environmental Health Hazard Assessment (OEHHA). Toxic Air Contaminants. Accessed April 2023. Available online at:
<https://oehha.ca.gov/air/toxic-air-contaminants>
- U.S. EPA 2002 – United States Environmental Protection Agency (U.S. EPA). Health Assessment Document For Diesel Engine Exhaust. May 2002. Accessed April 2023. Available online at:
https://cfpub.epa.gov/si/si_public_file_download.cfm?p_download_id=36319&Lab=NCEA
- U.S. EPA 2013 – United States Environmental Protection Agency (U.S. EPA). Determination of Attainment for the San Francisco Bay Area Nonattainment Area for the 2006 Fine Particle Standard; California; Determination Regarding Applicability of Clean Air Act Requirements. Accessed April 2023. Available online at: <https://www.federalregister.gov/documents/2013/01/09/2013-00170/determination-of-attainment-for-the-san-francisco-bay-area-nonattainment-area-for-the-2006-fine>
- U.S. EPA 2014 – United States Environmental Protection Agency (U.S. EPA). EPA Finalizes Initial Area Designations for the 2012 National Air Quality Standard for Fine Particles - Dec 2014. Accessed April 2023. Available online at:
<https://www.epa.gov/particle-pollution-designations/epa-finalizes-initial-area-designations-2012-national-air-quality>
- U.S. EPA 2017 – United States Environmental Protection Agency (US EPA). 2017. Guideline on Air Quality Models. 40 Code of Federal Regulations (CFR) Part 51, Appendix W. January. Accessed January 2020. Available online at:
https://www3.epa.gov/ttn/scram/appendix_w-2016.htm
- U.S. EPA 2018a – United States Environmental Protection Agency (U.S. EPA). Guidance on Significant Impact Levels for Ozone and Fine Particles in the Prevention of Significant Deterioration Permitting Program. Accessed April 2023. Available online at: https://www.epa.gov/sites/production/files/2018-04/documents/sils_policy_guidance_document_final_signed_4-17-18.pdf

- U.S. EPA 2018b – United States Environmental Protection Agency (U.S. EPA). Air Quality Designations for the 2010 Sulfur Dioxide (SO₂) Primary National Ambient Air Quality Standard—Round 3. Accessed April 2023. Available online at: <https://www.govinfo.gov/content/pkg/FR-2018-01-09/pdf/2017-28423.pdf>
- U.S. EPA 2023a – United States Environmental Protection Agency (U.S. EPA). NAAQS Table. Accessed April 2023. Available online at: <https://www.epa.gov/criteria-air-pollutants/naaqs-table>
- U.S. EPA 2023b – United States Environmental Protection Agency (U.S. EPA). Outdoor Air Quality Data, Monitor Values Report. Accessed April 2023. Available online at: <https://www.epa.gov/outdoor-air-quality-data/monitor-values-report>
- Van Gosen and Clinkenbeard 2011 – Van Gosen, B.S., and Clinkenbeard, J.P. (Van Gosen and Clinkenbeard). Reported Historic Asbestos Mines, Historic Asbestos Prospects, and Other Natural Occurrences of Asbestos in California: U.S. Geological Survey Open-File Report 2011-1188. Accessed May 2022. Available online at: <http://pubs.usgs.gov/of/2011/1188/>

4.4 Biological Resources

This section describes the environmental setting and regulatory background, and discusses impacts associated with the construction and operation of the project with respect to biological resources that occur in the project area.

BIOLOGICAL RESOURCES	Potentially Significant Impact	Less Than Significant with Mitigation Incorporated	Less Than Significant Impact	No Impact
Except as provided in Public Resources Code Section 21099, would the project:				
a. Have a substantial adverse effect, either directly or through habitat modifications, on any species identified as a candidate, sensitive, or special-status species in local or regional plans, policies, or regulations, or by the California Department of Fish and Wildlife or U.S. Fish and Wildlife Service?	<input type="checkbox"/>	<input checked="" type="checkbox"/>	<input type="checkbox"/>	<input type="checkbox"/>
b. Have a substantial adverse effect on any riparian habitat or other sensitive natural community identified in local or regional plans, policies, regulations or by the California Department of Fish and Wildlife or U.S. Fish and Wildlife Service?	<input type="checkbox"/>	<input type="checkbox"/>	<input checked="" type="checkbox"/>	<input type="checkbox"/>
c. Have a substantial adverse effect on state or federally protected wetlands (including, but not limited to, marsh, vernal pool, coastal, etc.) through direct removal, filling, hydrological interruption, or other means?	<input type="checkbox"/>	<input type="checkbox"/>	<input checked="" type="checkbox"/>	<input type="checkbox"/>
d. Interfere substantially with the movement of any native resident or migratory fish or wildlife species or with established native resident or migratory wildlife corridors, or impede the use of native wildlife nursery sites?	<input type="checkbox"/>	<input type="checkbox"/>	<input type="checkbox"/>	<input checked="" type="checkbox"/>
e. Conflict with any local policies or ordinances protecting biological resources, such as a tree preservation policy or ordinance?	<input type="checkbox"/>	<input type="checkbox"/>	<input checked="" type="checkbox"/>	<input type="checkbox"/>
f. Conflict with the provisions of an adopted Habitat Conservation Plan, Natural Community Conservation Plan, or other approved local, regional, or State habitat conservation plan?	<input type="checkbox"/>	<input type="checkbox"/>	<input type="checkbox"/>	<input checked="" type="checkbox"/>

Environmental checklist established by CEQA Guidelines, Appendix G.

4.4.1 Environmental Setting

Due to the developed nature of the project site and the immediate surrounding areas, as well as on-going disturbance typical of a city area, as described in the Project Description (DayZenLLC 2022a, pages 2-6 and 2-7), the site does not provide habitat capable of supporting special-status plant and wildlife species. There are a mix of ornamental native and non-native trees and shrubs typical of developed properties that exist sporadically along the north, east, and south boundary lines, including trees lining the western

boundary that are part of the adjacent property. Thirty-three trees and several ornamental shrubs onsite would be removed to allow for construction of the project. The railroad corridor to the east of the property has non-native invasive shrubs and ruderal vegetation. Ruderal vegetation also exists along the eastern boundary. Two street entrances from Martin Ave are located along the developed southern boundary, which is comprised of ornamental landscaping, concrete driveways and pavement.

The minimal habitat onsite accommodates non special-status wildlife common in an urban setting and provides for nesting and foraging birds. Reconnaissance-level surveys for biological resources were conducted for the proposed project by a FirstCarbon Solutions Senior Biologist on October 25, 2022 (DayZen 2022b). No special-status animal species were observed, and the only wildlife activity was limited to avian species: Say's phoebe (*Sayornis saya*), house finch (*Haemorhous mexicanus*), American crow (*Corvus brachyrhynchos*), rock pigeon (*Columba livia*), and house sparrow (*Passer domesticus*). In addition to low wildlife activity there were also no other signs, for instance scat, of other animal species. Common wildlife, such as racoons, opossums, and rats are still assumed to be present onsite. No special-status plants or presence of sensitive habitat was observed.

Although no sensitive habitat communities exist onsite there are sensitive habitats nearby. The closest bodies of water and wetland habitat lie less than half a mile northeast within the northern boundary of the SJC airport, and consist of two freshwater wetlands, one 7 acres and the other 18 acres, that are flooded year-round due to human design. Between them lies approximately two acres of freshwater emergent wetland habitat (NWI 2023). Less than a mile to the east of the project boundary lies approximately 24 acres of Freshwater Forested/Shrub Wetland (classified PSSC) within the Guadalupe River Corridor. The Guadalupe River flows into both the Guadalupe and Alviso sloughs emptying into San Francisco Bay approximately 4.6 miles northwest of the project site. The land bordering and adjacent to the San Francisco Bay comprises the nearest lands that sustain wildlife communities including: The Don Edwards San Francisco Bay National Wildlife Refuge, Baylands Park, and Alviso Park, approximately 4.5, 4, and 3.75 miles northwest of the project site respectively. The Sierra Vista Open Space Preserve and Alum Rock Park are other wildlife communities of note further away, approximately 6 miles slightly northeast of the project site. These protected natural wildlife preserves and parks offer a variety of habitats, such as salt marsh, wetlands, oak woodlands, and grasslands, that support hundreds of species, including federal and state threatened and endangered species. The San Francisco Bay alone is home to over 500 terrestrial and aquatic wildlife species, 20 of which are threatened or endangered species. During annual migrations, millions of bird species could be transients and fly over San Francisco Bay and the surrounding area as they follow the Pacific Flyway migration path (USEPA 2023).

The proximity of these nearby habitats, which support special status animal species, allow for the possibility that special-status species might occur onsite as foragers, transients and possible residents. Based on a CNDDDB search, California Energy Commission (CEC) staff considered this potential by identifying special-status plant and wildlife species that

may occur within a 9 quad search parameter from the project site. This search yielded more than 700 records of special-status plant and animal species. Staff focused on special-status species that are present within the same quad, San Jose West, as the project site. More in-depth discussions of special-status species with potential to occur onsite and that could be affected by the project are included below under each potential impact category. Nitrogen deposition impacts may extend beyond a typical 9-quad topographic search; therefore, staff also conducted a broader 6-mile radius search for special-status species and habitat.

Regulatory Background

Federal

Endangered Species Act (16 U.S.C., § 1530 et seq., and 50 C.F.R., part 17.1 et seq.). The Endangered Species Act (ESA) designates and provides for protection of threatened and endangered plant and animal species, and their critical habitat. Its purpose is to protect and recover imperiled species and the ecosystems for which they depend. It is administered by the United States Fish and Wildlife Service (USFWS) and the National Marine Fisheries Service (NMFS). The USFWS is responsible for terrestrial and freshwater organisms while NMFS is responsible for marine wildlife such as whales and anadromous fish (such as salmon). Species may be listed as endangered or threatened. All species of plants and animals, except pest insects, are eligible for listing. Species are defined to include subspecies, varieties, and for vertebrates, distinct population segments. The ESA protects endangered and threatened species and their habitats by prohibiting the “take” of listed animals and the interstate or international trade in listed plants and animals, including their parts and products, except under federal permit. Take of federally listed species as defined in the ESA is prohibited without incidental take authorization, which may be obtained through Section 7 consultation (between federal agencies) or a Section 10 Habitat Conservation Plan.

The Bald and Golden Eagle Protection Act (16 U.S.C. 668-668c). This Act—enforced through regulations written by the USFWS—prohibits the “taking” of bald and golden eagles, including their parts, nests, or eggs. To take is defined as to “pursue, shoot, shoot at, poison, wound, kill, capture, trap, collect, destroy, molest, or disturb” any bald or golden eagle, whether “alive or dead...unless authorized by permit”.

Migratory Bird Treaty Act (16 U.S.C., §§ 703-711). The Migratory Bird Treaty Act (MBTA) makes it illegal to take, possess, import, export, transport, sell, purchase, barter, or offer for sale, purchase, or barter, any migratory bird, or the parts, nests, or eggs of such a bird except under the terms of a valid federal permit. The USFWS has authority and responsibility for enforcing the MBTA.

Clean Water Act Sections 401 and 404. The Clean Water Act (CWA) (33 U.S.C., §§ 1251–1376) requires the permitting and monitoring of all discharges to surface water bodies. Section 404 (33 U.S.C., § 1344) requires a permit from the United States Army Corps of Engineers (USACE) for a discharge from dredged or fill materials into a water of

the United States, including wetlands. Section 401 (33 U.S.C., § 1341) requires a permit from the regional water quality control board for the discharge of pollutants. By federal law, every applicant for a federal permit or license for an activity that may result in a discharge into a California water body, including wetlands, must request state certification that the proposed activity will not violate state and federal water quality standards.

State

California Fish and Game Code Section 1600-1605. Fish and Game Code section 1600, *et seq.* does not specifically contain provisions regulating activities that would impact wetlands, isolated areas containing riparian vegetation, or wetland hydrology. The California Fish and Game Commission policy regarding wetlands resources, updated in August 2005, states that "it is the policy of the Fish and Game Commission to seek to provide for the protection, preservation, restoration, enhancement and expansion of wetland habitat in California" and to "strongly discourage development in or conversion of wetlands." As a result, although the Fish and Game Commission has no independent statutory permitting authority related to wetlands, the policy underscores that the Commission does not support wetland development proposals unless "project mitigation assures there will be 'no net loss' of either wetland habitat values or acreage" and "prefers mitigation which would achieve expansion of wetland acreage and enhancement of wetland habitat values." Section 2785(e) of the Fish and Game Code further states, "Riparian means lands which contain habitat which grows close to and which depends on soil moisture from a nearby freshwater source." The 1993 Executive order W-59-93 establishes the "no net loss" policy to also protect California's wetlands. The California Department of Fish and Wildlife (CDFW) implements this Executive Order.

Native Plant Protection (Fish and Game Code, § 1900 et seq.). The Native Plant Protection Act was enacted in 1977 and designates state rare and endangered plants and provides specific protection measures for identified populations. Those laws prohibit the take of endangered or rare native plants but include some exceptions for agricultural and nursery operations; for emergencies; after properly notifying CDFW, for vegetation removal, from canals, roads, and other sites; due to changes in land use; and in certain other situations. The administering agency is CDFW.

California Endangered Species Act (Fish and G. Code, §§ 2050-2098). The California Endangered Species Act (CESA) of 1984 states that all native species of fish, amphibians, reptiles, birds, mammals, invertebrates, and plants, and their habitats, threatened with extinction and those experiencing a significant decline which, if not halted, would lead to a threatened or endangered designation, will be protected and preserved. CESA prohibits the take of any species of wildlife designated by the California Fish and Game Commission as endangered, threatened, or candidate species. The CDFW may authorize the take of any such species if certain conditions are met. These criteria are listed in Title 14 of the California Code of Regulations, section 783.4 subdivisions (a) and (b). For purposes of CESA "take" means to hunt, pursue, catch, capture, or kill, or attempt to hunt, pursue, catch, capture, or kill these species (Fish and G. Code, § 86).

California Fish and Game Code Section 3503. This section makes it unlawful to take, possess, or needlessly destroy the nest or eggs of any bird, except as otherwise provided by this code or any regulation made pursuant thereto.

California Fish and Game Code Section 3503.5. This section makes it unlawful to take, possess, or destroy any birds in the orders Falconiformes and Strigiformes or to take, possess, or destroy the nest or eggs of any such bird.

California Fish and Game Code Section 3513. This section protects California's migratory birds by making it unlawful to take or possess any migratory nongame bird as designated in the Migratory Bird Treaty Act or any part of such migratory nongame birds.

California Fish and Game Code Section 3800. All birds occurring naturally in California that are not resident game birds, migratory game birds, or fully protected birds are nongame birds. It is unlawful to take any nongame bird except as provided in this code or in accordance with regulations of the commission or, when relating to mining operations, a mitigation plan approved by the department.

California Fish and Game Code Sections 3511, 4700, 5050, and 5515. These sections designate certain species as fully protected and prohibit the take of such species or their habitat unless for scientific purposes (see also Cal. Code Regs., tit. 14, § 670.7). Incidental take of fully protected species may also be authorized in a Natural Community Conservation Plan (NCCP) (Fish and G. Code, § 2835).

The administering agency for the Fish and Game Code sections discussed above is CDFW.

Porter-Cologne Water Quality Control Act. The State Water Resources Control Board (SWRCB) and the nine Regional Water Quality Control Boards (RWQCBs) have jurisdiction over all surface water and groundwater in California, including wetlands, headwaters, and riparian areas. The SWRCB or applicable RWQCB must issue waste discharge requirements for any activity that discharges waste that could affect the quality of waters of the state.

Local

City of Santa Clara 2010 – 2035 General Plan. The General Plan (adopted November 16, 2010) goals and policies specific to the City of Santa Clara to protect and preserve the city's natural habitat and wildlife are described in Chapter 5 Goals and Policies, Section 10 Environmental Quality (Santa Clara 2010). The administering agency is the Planning Division of the city of Santa Clara. General Plan goals and policies applicable to the proposed project are as follows:

- 5.3.1-P10 Provide opportunities for increased landscaping and trees in the community, including requirements for new development to provide street trees and a minimum 2:1 on- or off-site replacement for trees removed as part of the proposal to help increase the urban forest and minimize the heat island effect.

- 5.10.1-G1 Protect fish, wildlife, and their habitats, including rare and endangered species.
- 5.10.1-P1 Require environmental review prior to approval of any development with the potential to degrade the habitat of any threatened or endangered species.
- 5.10.1-P3 Require preservation of all City-designated heritage trees listed in the Heritage Tree Appendix 8.10 of the General Plan.
- 5.10.1-P4 Protect all healthy cedars, redwoods, oaks, olives, bay laurel and pepper trees of any size, and all other trees over 36 inches in circumference measured from 48 inches above-grade on private and public property as well as in the public right-of-way.
- 5.10.1-P12 Encourage property owners and landscapers to use native plants and wildlife-compatible nonnative plants, when feasible.

Santa Clara City Code, Chapter 12.35 Trees and Shrubs, Sections .010 – .100.

These sections of the Santa Clara City Code specify how to proceed with certain tree and shrub issues, such as removal, alteration, maintenance of trees and if trees become hazardous to public safety. Here is a synopsis of sections that are most applicable to proposed project:

- 12.35.050 City Trees Planting, Maintenance and Removal. The city has jurisdiction over the planting, maintenance, removal determination, relocation, etc. of city trees. Property owners are responsible for maintenance of city trees on property owned by them. This includes notifying the city if there is a tree that becomes a nuisance or is possibly dangerous to the public; the city has the authority to require the pruning or removal of a tree under these circumstances at the owner's expense (the city might do this work or issue a permit that the owner must execute within 30 days or pay a fine).
- 12.35.70 Private Trees and Plants. Property owners are responsible for maintenance of private trees on property owned by them. If the city determines that a tree on private property has become a public nuisance or is possibly dangerous to the public the city has the authority to require the pruning or removal of a tree under these circumstances at the owner's expense (the city might do this work or issue a permit that the owner must execute within 30 days or pay a fine).
- 12.35.080 – 12.35.100. Restricts the removal, alteration, or damage of healthy trees on private property without a permit, including trees with a diameter of 38 inches or more measured at 54 inches above natural grade, and all trees with a diameter of 12 inches or more when measured at 54 inches above natural grade of the following species: California buckeye (*Aesculus californica*), big leaf maple (*Acer macrophyllum*), deodar cedar (*Cedrus deodara*), blue Atlas cedar (*Cedrus atlantica* "Glauca"), camphor tree (*Cinnamomum camphora*), western sycamore (*Platanus racemosa*), native oak trees (*Quercus spp.*), coast redwood, and California bay laurel (*Umbellularia californica*). The City's Community Design Guidelines require that mature trees removed or proposed for removal be replaced onsite, at a minimum,

with a 24- or 36-inch box. Other standards may apply in cases where particular planting requirements must be met. All work shall be done in accordance with ANSI A300 standards, developed as voluntary industry consensus standards by the Tree Care Industry Association, and follow all tree care best management practices published by International Society of Arboriculture (ISA) necessary to protect the vitality of the tree.

City Code, section 12.35.090 details the requirements of the tree removal application and process including tree replacement ratios. When site development/redevelopment is occurring, a tree survey conducted by an arborist who has been certified by ISA shall be submitted as part of the required application materials. The report shall explain why the tree(s) cannot be relocated.

The City's Department of Community Development shall have the ability to require the reasonable alteration of a proposed building in order to retain trees, to require relocation (on or off site) of protected trees which the applicant proposes to remove. Replanting of trees shall be included as part of the landscaping plan for the proposed project. Replacement trees are required to be planted at replacement ratios specified in City Code, section 12.35.090(c)(7). The plan shall include tree protection measures that will occur during and after construction, and specifically identify the tree protection zone. City trees and protected trees shall be protected by use of best management practices (BMPs), design conditions, and measures listed in City Code, section 12.35.100 (d-f).

Architectural Committee Policies - Community Design Guidelines. The City's Architectural Committee maintains a Community Design Guideline used for architectural review in order to "provide a manual of consistent development standards in the interest of continued maintenance and enhancement of the high-quality living and working environment of the City of Santa Clara." The manual includes the following guidelines relevant to the project:

Landscaping & Minimum Planting Sizes

The following minimum plant sizes shall apply when landscaping is required as a condition of approval or in any planting area within the public right-of-way. Other standards may apply in cases where particular planting requirements must be met.

Trees:

- Minimum fifteen (15) gallon on private property
- Minimum fifteen (15) gallon street tree
- Minimum twenty-four (24) or thirty-six (36) inch box to replace a mature tree which has been or is proposed to be removed.

4.4.2 Environmental Impacts

- a. Would the project have a substantial adverse effect, either directly or through habitat modifications, on any species identified as a candidate, sensitive, or special status species in local or regional plans, policies, or regulations, or by the California Department of Fish and Wildlife or U.S. Fish and Wildlife Service?**

Construction

Less Than Significant with Mitigation Incorporated. Special-status plant and animal species may be present in the study area and are protected by existing federal, state, and local laws, policies, and regulations as previously described above. In addition to the information provided by the applicant, CEC staff conducted a standard 9 Quad CNDDDB search and made inquiries via email to experts from the USFWS, CDFW, and the Santa Clara Valley Habitat Agency (SCVHA). Staff did not receive any emails back expressing concerns regarding special-status species. Staff has selected the following species to discuss below based on recent occurrences recorded in CNDDDB of each species, as well as each species' presence within the quad containing the project and/or each species' known occurrence within a two-mile radius of the project's immediate location.

Wildlife and Plant Species

Out of all the CNDDDB records that resulted in the search and the special-status species that are known to occur in the vicinity of the project site, there are only a few special-status species that staff considers having potential to occur within the project site, and that potential is low, including Western burrowing owl. Staff considered the possibility of the rest of the special-status species briefly discussed below but considers it highly unlikely for these species to be found at all on the site for the reasons mentioned in the analysis.

Four special-status plant species are recorded occurring in the San Jose West quad. Two additional species have been recorded when a two-mile radius was considered. However, all of them are considered either extirpated or possibly extirpated from the area (CNDDDB 2023). Out of these results, Robust spineflower (*Chorizanthe robusta var. robusta*) is the only listed plant species that is currently listed as federally endangered. CEC staff agrees with the applicant's analysis, which concluded the site would not support native plant life based on no special-status plant species being found during the site visit on October 25, 2022, and research. Due to the developed nature of the site and lack of suitable habitat (the main habitat for Robust spineflower is coastal scrub and coastal dunes (CNPS 2023)) special-status plant species are not expected to grow or exist onsite.

Similarly, multiple special-status animal species may have both historic and, for some, more recent records occurring within this area of Santa Clara, but are not expected onsite due to a lack of suitable habitat and the highly urbanized conditions of the site and surrounding area. These species include: yellow rail (*Coturnicops noveboracensis*),

western pond turtle (*Emys marmorata*), steelhead - central California coast DPS (*Oncorhynchus mykiss irideus pop. 8*), California tiger salamander (*Ambystoma californiense pop. 1*), San Francisco dusky-footed woodrat (*Neotoma fuscipes annectens*), crotch bumble bee (*Bombus crotchii*), western bumble bee (*Bombus occidentalis*), and obscure bumble bee (*Bombus caliginosus*). While most special-status species in the area are not expected to occur, and burrowing owl and bats have low potential to occur, the project site is near several natural wildlife preserves and parks as mentioned previously in the "Environmental Setting" subsection above. Being so close to important wildlife preserves, like Don Edwards National Wildlife Refuge, and 4.5 miles southeast of San Francisco Bay, means that flyover and transient special-status bird species are possible, especially during annual migrations and nesting bird season. Existing mature trees on and near the project site provide potential habitat and food sources for these migratory birds, including raptors and other bird species, which are protected by MBTA and sections 3503 and 3503.5 of the Fish and Game Code. In addition, bat species, discussed more below, may occur occasionally onsite and utilize existing landscape trees and buildings for roosting. Thus, since it is possible for special-status species and nesting birds to occur onsite, it is important that a worker environmental awareness program (WEAP) is developed, and onsite construction personnel are trained to recognize and avoid biological resources. The WEAP will help protect and prevent harm to biological species during construction and ensure that impacts to all biological resources are less than significant. Therefore, staff proposes mitigation measure **BIO-1** to develop and implement a WEAP.

Special Status Species – Western Burrowing Owl

Western burrowing owls (*Athene cunicularia*), a California species of special concern, are known to occur less than a quarter mile away within the fields surrounding the runways on the outer edges of the San José International Airport (SJC). Their presence has been consistent in the last decade, and they have recently been spotted the last several years as recorded in the Santa Clara Valley Audubon Society annual bird list count. Even though the project site does not fall within the conservation zone or expanded study area for burrowing owl identified in the Santa Clara Valley Habitat Plan Figure 5-11 and Figure 5-10, and is not a covered project by the plan, these figures do demonstrate how close the project is to breeding and overwintering habitats in the Santa Clara area. The SJC just west of the project site is one of two largest known occupied breeding habitats in the area; the second is located about 3.30 miles directly north at the San José-Santa Clara Regional Wastewater Facility Bufferlands. A recent study showed that while tagged burrowing owl have been known to travel up to 7.5 miles between breeding sites, most owls will stay within a 1-to-4-mile distance between a breeding and over-wintering site (CDFW 2018). In addition, there are multiple known burrowing owl over-wintering sites nearby, again the closest occurring less than a quarter mile west of the project site according to the SCVHP Figure 5-11.

CEC staff used the SCVHA's Geobrowser to check the SCVHP's applicable boundaries, to use it to clarify the above distances and to examine the surrounding area of the project site. Satellite imagery shows that beyond the railroad that lies adjacent to the project boundary to the east, there is what appears to be a storage yard (just behind Enterprise

Rent-A-Car) with ruderal vegetation and trees. Continuing east on the other side of the storage yard, De La Cruz Boulevard lies between the yard and the airport. Given that burrowing owls are capable of traveling miles, it is a reasonable possibility that a burrowing owl might cross De La Cruz Boulevard to get to the storage yard and beyond to the project site. Based on staff's personal experience and knowledge gained while evaluating environmental impacts of CEC-licensed projects, including Alamitos Energy Center (13-AFC-01) and Huntington Beach Energy Project (12-AFC-02C), burrowing owl may move onsite during construction to inhabit the most meager of habitat available, such as a pipe culvert. Besides staff's personal experience, various literature concurs that when there is a lack of burrows abandoned by other animals they sometimes will burrow in human-made structures like water drainage ducts, PVC pipe, or other opportunistic places that provide a den-like coverage (CLO 2022). Furthermore, the presence of burrowing owls appearing onsite during construction on the projects mentioned above, and the presence of the breeding colony at the airport, are prime examples of the species' adaptability to human activity and noise.

Although the project site lacks the natural habitat, grasslands, and ruderal habitat with abandoned ground squirrel burrows that burrowing owls prefer, staff has taken all the facts mentioned above into account and considers there to be a low potential for burrowing owl to occur onsite. If burrowing owls occurred onsite and the correct procedures were not adhered to, a significant impact to this species might occur. Therefore, consistent with mitigation measures adopted for similar SPPE projects in the area, and the CDFW's Staff Report on Burrowing Owl Mitigation (2012), staff formulated and proposes **BIO-2**. This mitigation measure would reduce impacts to burrowing owls to less than significant levels. Pre-construction surveys would reduce the impacts to burrowing owl during the construction phase during breeding and non-breeding season. **BIO-2** also accounts for different buffer zones between these seasons, monitoring, discouraging re-colonization, and passive relocation. The implementation of **BIO-2** would ensure that any impacts to burrowing owl are avoided and rendered less than significant.

Special Status Species – Nesting Birds

If construction occurs during the nesting bird season from February through August, it is possible for construction activities to affect nesting and migratory birds that are attracted to the urban vegetated areas on and near the project site. This includes the 33 trees onsite that would be removed during construction and the trees adjacent to any construction areas. Many avian species nest within trees, while some species are known to nest on the ground and other opportune places. In addition to migratory birds, the project site could also attract raptors. Mature trees could provide potential foraging habitat for Cooper's hawk (*Accipiter cooperii*; WL). The potential for nesting on the site is low due to the lack of dense forests or nearby streams. Other special-status raptors are not likely to occur based on lack of specific habitat requirements, such as Swainson's hawk (*Buteo swainsoni*; ST), which require more open habitats and grasslands often near agricultural areas for foraging, or American peregrine falcon (*Falco peregrinus anatum*; FP), which often utilize high-rise buildings, bridges, or cliffs for nesting. Staff thinks that the presence of Golden eagle (*Aquila chrysaetos*) is not likely for the same reason.

However, while the chance is low it is still possible for them to occur as transients, and golden eagles have been known to nest in man-made structures like electrical towers.

Construction activity near nesting birds is disruptive and sometimes can cause nest abandonment and thus mortality of hatched chicks and eggs. Destruction of active bird nests, nest abandonment, and/or loss of reproductive effort caused by disturbance are considered "take" by the CDFW, and therefore would be a significant impact. The applicant's proposed design measure PDM BIO-1 incorporated into the project to avoid and reduce impacts to nesting birds, lacks the level of detail and scope necessary to ensure potential project impacts on birds protected by the Migratory Bird Treaty Act (MBTA) and Fish and Game codes would be avoided or reduced to less than significant levels. Although PDM BIO-1 discusses the need for pre-construction surveys of nesting birds during the nesting bird season, staff has determined that certain aspects of the measure are insufficient. Specifically, the language refers to "surveys" but does not specify how many days apart they will be conducted. The buffer zones need to be defined in feet and applied to the "construction" zone, which should be defined as the project site and all related facilities. Besides describing the surveys, PDM BIO-1 also discusses the monitoring of nests if they are found. The key provision omitted from this measure is a requirement that the designated biologist has the authority to stop construction work if it is determined that a nesting bird is in distress. Lastly, the reporting requirements related to the timing of submitting the report conflict with the timing of the surveys, and there is no requirement to update nesting maps.

To ensure impacts to nesting birds are avoided and minimized to less than significant, staff is proposing mitigation measures **BIO-3** and **BIO-4**, which would replace PDM BIO-1. These measures would clarify all required details discussed above. With adherence to **BIO-3** and **BIO-4**, project impacts to nesting birds covered by federal and state laws would be less than significant.

Special Status Species – Bats

Demolition of the existing buildings and tree removal associated with project implementation could result in direct destruction of active roosts of protected or common bats, if present. Although not detected during the site visit conducted by FirstCarbon Solutions on the applicant's behalf, the Applicant's Biological Assessment states it is possible for pallid bat (*Antrozous pallidus* / SSC) to be a transient onsite because this species will forage for miles surrounding a maternal colony (TN 247329). CEC staff agrees that while no signs of bats were seen during a past site visit, it is still possible that bat species might use the existing trees and buildings onsite, as they provide marginal roosting habitat for bat species. In addition to the pallid bat, these bat species include Townsend's big-eared bat (*Corynorhinus townsendii* / SSC) and hoary bat (*Lasiurus cinereus*). Pallid bats and Townsend's big-eared bats are both considered special-status species by CDFW and listed as Species of Special Concern. Destruction of active special-status bat roosts and direct impacts on individual bats including injury and mortality would be a significant impact.

Although the applicant provided PDM BIO-2 as a measure to reduce impacts to bats, the language used to describe when the surveys would take place, i.e. “[i]f suitable roosting habitat...will be affected,” improperly conditions the performance of surveys on a determination that suitable habitat exists. CEC staff and the applicant agree it is possible for bat species to be present onsite, so the measure should unconditionally state that surveys are required.

Therefore, CEC staff proposes mitigation measure **BIO-5** requiring bat clearance surveys be conducted prior to demolition of the existing buildings or removal of trees and development of a Bat Mitigation and Monitoring Plan (Plan). The Plan would provide information on the methods to detect and exclude bats, roost removal procedures, and compensatory mitigation methods (i.e., the placement of bat boxes) should permanent impacts to roosts be required. The Plan also makes clear that the City of Santa Clara would review and approve a Bat Mitigation and Monitoring Plan if one was required. The Plan would be submitted to the City’s Community Development Department for approval. With implementation of **BIO-5**, impacts to bat species resulting from the proposed project would be less than significant.

Implementation of mitigation measures **BIO-1, BIO-2, BIO-3, BIO-4** and **BIO-5** would reduce potential impacts to protected wildlife species, including raptors and other migratory birds as well as bats, resulting from the construction phase of the proposed project to less than significant. Therefore, the construction phase of the project would not have a substantial adverse effect on special-status species and impacts would be less than significant.

Operation

Less Than Significant. Direct impacts from operation and maintenance activities, which includes operations of the data center equipment, employee traffic and parking, regular mechanical testing of the backup generating units, and site maintenance such as landscape, irrigation and building maintenance, are expected to result in the same level of human presence and disturbance as current activities on the property. These are not expected to negatively affect biological resources. However, indirect impacts resulting from project-related nitrogen deposition on nitrogen-sensitive habitats resulting from emergency testing and sporadic (undefined) emergency operation of the diesel backup generators could potentially affect biological resources.

Nitrogen deposition is defined as the input of nitrogen oxide (NO_x) and ammonia (NH₃) derived pollutants, primarily nitric acid (HNO₃), from the atmosphere to the biosphere. Nitrogen deposition sources are primarily vehicular, agricultural, and industrial emissions (including power plants). The proposed project will result in over a thousand less vehicular trips than current conditions (DayZenLLC 2022a, page 4-149), and therefore vehicular emissions would not contribute to nitrogen deposition. Existing nitrogen deposition levels in the area would be contributed to by the operation of the project’s 44, 2.75-megawatt, emergency backup diesel generators. Although the generators would run only during an emergency, the units undergo monthly testing and maintenance to assure they are

working properly, resulting in some emissions of nitrogen oxides (NO_x). This contribution to nitrogen deposition can lead to impacts on sensitive species including changes in species composition among native plants and the enhancement of invasive species such as grasses (Fenn et al. 2003, Weiss 2006, and CEC 2006). The increased dominance and growth of invasive annual non-native species is especially prevalent in low biomass vegetation communities that are naturally nitrogen-limited (e.g., serpentine soils). Nitrogen deposition artificially fertilizes the soil, creating conditions for non-native species to persist and ultimately displace native species, resulting in conversion of one habitat type to another. Increased nitrogen deposition in nitrogen poor soils allows for the proliferation of non-native species that can crowd out native species. Special status animal species that depend on these sensitive habitats may in turn be disrupted.

Using CNDDDB Rarefind and BIOS, and the SCVHA Geobrowser, CEC staff identified two areas of protected habitat sensitive to nitrogen deposition within a 6 mile radius of the project (the typical deposition zone for NO_x with reliable modeling results). These include northern coastal salt marsh located in the Guadalupe Slough near the San Francisco Bay Trail, approximately 5 miles northwest of the proposed project site, and serpentine soil located right inside the 6 mile search radius northeast of the project site where serpentine bedrock is mapped. CEC staff used nitrogen deposition modeling, as described below, to assess possible impacts from the Martin project.

Staff uses the “critical load” metric to measure impacts from nitrogen deposition. Critical load is defined as the concentration level of a pollutant below which no detrimental ecological effects have been documented to occur over long-term studies. Staff also considers the contribution of other projects in the six-mile radius of the project, which is referred to as the background levels of nitrogen deposition.

Staff performed a qualitative assessment of the project’s contribution of atmospheric nitrogen, based on experience reviewing highly similar backup generating facilities in the vicinity with comparable generating capacity and utilizing the same Tier 4 engine emissions technology. CEC staff used GIS shapefiles modeled from the Community Multiscale Air Quality (CMAQ 2012) modeling-predicted values of annual total deposition for the similar facilities to interpolate anticipated nitrogen emissions from the project. While the data from CMAQ (2012) is dated, it is the most current known data available, and is considered to be conservative in values reported.

Staff’s interpolation of emissions used data derived from the American Meteorological Society/Environmental Protection Agency Regulatory Model (AERMOD) for the similar projects, consistent with past practice.

Northern Coastal Salt Marsh

Less Than Significant Impact. Northern coastal salt marsh is considered a sensitive natural community by CNDDDB and several special-status species known to occur in this area of northern coastal salt marsh habitat include California Ridgway’s rail (*Rallus obsoletus*; FE, SE, FP), Alameda song sparrow (*Melospiza melodia pusillula*; BCC, SSC), and salt marsh

harvest mouse (*Reithrodontomys raviventris*; FE, SE) (CNDDDB 2023). Based on nitrogen deposition modeling for the similar facilities, staff finds that the contribution at a 2 mile radius from the proposed project was between 0.02 and 0.20 kilograms of nitrogen per hectare per year (kg N/ha/yr). CEC air quality staff found the 2-mile radius is appropriate because dispersion of the plume decreases in concentration over time and distance. Staff then calculated that this value added to the baseline nitrogen deposition value (11.4 kg N/ha/yr) for northern coastal salt marsh would be substantially below the critical load (30-40 kg N/ha/yr) for this habitat type. Thus, the project would have a less than significant impact from nitrogen deposition on northern coastal salt marsh and associated species.

Serpentine Soils

No Impact. Associated plants such as the federally-endangered Metcalf Canyon jewelflower (*Streptanthus albidus ssp. albidus*) and Santa Clara Valley dudleya (*Dudleya abramsii ssp. setchellii*), and wildlife species such as federally-threatened Bay checkerspot butterfly (*Euphydryas editha bayensis*) are designated nitrogen-sensitive pursuant to the SCVHP (SCVHP 2012; Figure 3-4). These species all occur within the San Jose East quad where serpentine soils are mapped according to SCVHP. Staff concludes, based on professional knowledge of modeling performed for similar projects in the same vicinity, that even if the proposed project was several miles closer to the serpentine soil habitat, and the highest values of nitrogen emissions were used to model the worst case scenarios, Martin's contribution to nitrogen deposition where serpentine habitat is located would be approximately zero. Therefore, Staff concludes that the proposed project would have no impacts from nitrogen deposition on serpentine soil habitat or special status species that rely on this habitat.

b. Would the project have a substantial adverse effect on any riparian habitat or other sensitive natural community identified in local or regional plans, policies, and regulations or by the California Department of Fish and Wildlife or U.S. Fish and Wildlife Service?

Construction

No Impact. The project site is fully developed, urbanized land surrounded by commercial and industrial development. There are no riparian habitats or other sensitive natural communities identified in local or regional plans, policies, and regulations or by CDFW or USFWS within the project site. Therefore, there would be no direct impacts. Also, while under construction the proposed project would not contribute to nitrogen deposition through nitrogen emissions from the use of generators nor through increased vehicle trips. Therefore, no indirect impacts would occur on riparian or sensitive habitats located within a 6 mile radius of the proposed project during the construction phase.

Operation

Less Than Significant Impact. No direct impacts would occur to riparian habitat or other identified sensitive natural community during operation of the project because no such

habitats or communities exist at the project site. However, CEC staff also considered indirect impacts from nitrogen deposition resulting from operation of the proposed project as a potential impact on sensitive natural communities. Northern coastal salt marsh and serpentine soils are the only sensitive natural communities known to occur within 6 miles of the proposed project.

Staff's analysis above concluded the proposed project's contribution to nitrogen deposition for northern coastal salt marsh would not result in a substantial adverse effect and would not exceed vegetation-specific critical loads at any location for either sensitive habitat. Therefore, this would be a less than significant impact.

c. Would the project have a substantial adverse effect on state or federally protected wetlands (including, but not limited to, marsh, vernal pool, coastal, etc.) through direct removal, filling, hydrological interruption, or other means?

There are no waters of the United States, including any protected wetlands, as defined by Section 401 and 404 of the Clean Water Act, nor waters of the state as defined by section 1600 of the CA Fish and Game Code, on the project site. Guadalupe River is the nearest body of water (except for the man-made wetlands within SJC airport), and is approximately one mile to the east from the project site. The Guadalupe River flows into the San Francisco Bay approximately 4.6 miles northwest of the project site. The nearest estuarine and marine wetlands are found within the Guadalupe River corridor (NWI 2023).

Construction and Operation

Less Than Significant Impact. Although there are no waters of the United States near the project site, construction activities, especially excavation of soil, would potentially produce sediments in surface water runoff. On-site adherence to discharge requirements for the control of solids and pollutants leaving the construction area, as required in the local National Pollution Discharge Elimination System (NPDES) authorization, as well as a Stormwater Pollution Prevention Plan (SWPPP) written to be consistent with the NPDES would ensure that impacts to natural waterways would be avoided. The applicant acknowledged these requirements in the application and has specified that The San Francisco Bay Regional Water Quality Control Board has already issued a Municipal Regional Stormwater NPDES Permit for the project. Impacts from operation and maintenance of the project would be similar to those anticipated during construction. These measures of the local NPDES, and a project specific SWPPP, would ensure impacts to any natural waterways during construction are less than significant.

d. Would the project interfere substantially with the movement of any native resident or migratory fish or wildlife species or with

established native resident or migratory wildlife corridors, or impede the use of wildlife nursery sites?

Construction and Operation

No Impact. There are no established wildlife corridors in the immediate project vicinity. Any wildlife in the surrounding area, including any possible native residents, have already adjusted to the developed conditions and any activities associated with urbanization. The site and adjacent properties do not support wildlife species or provide natural areas that could serve as corridors for the movement of wildlife. The Guadalupe River corridor, approximately one mile to the east of the proposed project, is the closest area where movement or land migration of native wildlife species would occur. Since the project site isn't near or within an established wildlife corridor it would have no impact on any established wildlife corridor. As previously mentioned above it is approximately .25 miles west of the SJC airport, which is the location of breeding burrowing owl and overwintering colonies. Even though the project is within an area identified as occupied burrowing owl nesting habitat within Figure 5-11 (SCVHA 2012) the project would not negatively affect the use of the established breeding and overwintering colonies. It is possible for burrowing owls to travel within the proposed project site (most likely to rest/forage/overwinter, much less likely to breed when the SJC colony is so close) in addition to other migratory and nearby resident birds or potentially other wildlife living in the area (except for migratory fish as there are no rivers, creeks, or streams on or near the project area). The construction and ongoing operation of the project would not impede the movements of these visiting species. However, some wildlife species more sensitive to urban activity, especially construction, would be discouraged from attempting to use the project area as a resting, foraging, or breeding site. These species that are more sensitive to urbanization are already discouraged from other current businesses and other industrial operations in the area surrounding the proposed project. However, this would not be considered a "significant impact," and it is not a result specific to this project. Thus, the existence of the project would have no impact on the movement of any wildlife species or prevention of wildlife nurseries in the area.

e. Would the project conflict with any local policies or ordinances protecting biological resources, such as a tree preservation policy or ordinance?

The proposal entails development of an industrial data center on a designated Urban/Developed, Heavy Industrial (MH) zoned property. As mentioned previously in the Environmental Setting subsection above, the site is completely developed with four existing buildings, pavement and parking lots. There is no naturally occurring vegetation existing on the project site as trees surrounding the site are part of the existing ornamental landscape, along with a strip of mostly shrubs and a few ornamental trees lining the southern boundary that borders Martin Avenue. There are no other resources on the site that would be subject to local ordinances protecting biological resources. Due to the lack of natural vegetation and habitat, the project would not conflict with any conservation land use goals or policies protecting natural habitats as mentioned in the

City of Santa Clara General Plan. However, there are sections of the Santa Clara's general plan that protect trees along with sections of the city code.

Construction

Less Than Significant. The arborist report contained in Appendix C of the SPPE application surveyed 33 trees, all of which are proposed for removal during construction including two olive trees (*Oliva europa*; Trees #14 and #28) and a Peruvian pepper tree (*Schinus molle*; Tree #26). These three trees, #14, #28, and #26, are protected. No other protected trees, including heritage trees listed in the Heritage Tree Appendix 8.10 of the General Plan, are present onsite. Although these olive trees are non-native, the City of Santa Clara General Plan specifies (Policy 5.10.1-P4) that all olive trees must be protected whether on public or private land (Santa Clara 2010). This policy also applies to the Peruvian pepper tree, and Santa Clara City Code section 12.35.080 also protects it as it is larger than the 38" diameter specified in the code. These trees, including all of the trees scheduled for removal, are part of the city's urban forest and new development is responsible for providing a minimum 2:1 tree replacement ratio on or off site for trees removed (Policy 5.3.1-P10). Private property owners should also plant native or non-native wildlife friendly plants and trees (Policy 5.10.1-P12).

In PDM BIO-3 and PDM BIO-4 the applicant proposes how to mitigate for the trees being removed and to protect any trees remaining. The applicant proposes to mitigate for the loss of the 33 trees by planting a combination of 24" box size and 36" box size trees. The final number of trees required by the City to be planted on site would be determined upon approval of the project's Landscape Plan by the City's Director of Community Development during Architectural Review. The applicant has also committed to following the protection measures for any remaining trees as specified during the Architectural Review. Staff reviewed the applicant's measures; however, the recommended measures included in the Certified Arborist Report, prepared by HMM and included in the SPPE Application, are more robust and comprehensive to protect existing trees. For example, the Certified Arborist Report included the required establishment of Tree Protection Zones (TPZs), measures to avoid impacts during grading and trenching near tree roots, measures to avoid impacts during grading near trees, measures to take prior to cutting any tree limbs or roots, and measures for maintenance of trees onsite. The measures in the Certified Arborist Report are typically incorporated into the landscape plan with the addition of the City's Arborist Notes, as required by local General Plan policies and City Code (Santa Clara 2010 and 2022). All required tree protection measures would be included in the project's Landscape Plan to be adopted during final Architectural Review, as part of the permit approval process by the City.

Since the applicant committed to following the tree permit and the final requirements from the Architectural Review as part of the project, which would include the protection measures specified in the Certified Arborist Report, CEC staff concludes that construction and operation of the project would not conflict with local policies or ordinances protecting biological resources, ensuring that impacts under this criterion would be less than significant.

Operation and Maintenance

No Impact. Once constructed, there is no indication that operation and maintenance of the project would require the removal of additional trees. However, if removal of trees becomes necessary in the future, the site owner would be required to comply with local policies and ordinances regarding the protection/replacement of trees. Operating the data center and maintaining the buildings, on-site ornamental landscaping, and maintenance of the transmission line would involve levels of intrusion and disturbance similar to or less than that at similar office and industrial uses in the vicinity. Thus, operation of the project would not conflict with local policies and ordinances protecting biological resources.

f. Would the project conflict with the provisions of an adopted Habitat Conservation Plan, Natural Communities Conservation Plan, or other approved local, regional, or State habitat conservation plan?

Construction and Operation

No Impact. There are no approved habitat conservation plans, natural community conservation plans, or other adopted plans that would apply to the proposed project. There is the Santa Clara Valley Habitat Plan (SCVHP), which was adopted in 2012 for the protection and recovery of resources over a 519,000-acre study area encompassing the majority of land in Santa Clara County (SCVHA 2023). However, as mentioned above CEC staff carefully checked the Santa Clara Valley Habitat Agency Geobrowser, and confirmed that the project site is not within the adopted SCVHP permitting area. Therefore, the proposed project would have no impact with respect to this subject of analysis.

4.4.3 Mitigation Measures

BIO-1: Worker Environmental Awareness Program (WEAP)

A worker environmental awareness program biological resources module will be conducted for onsite construction personnel prior to the start of construction activities. The module will explain all the measures developed to prevent impacts on special-status species, including Western burrowing owl and golden eagle, and nesting birds. The module will also include a description of special-status species and their habitat needs, as well as an explanation of the status of these species and their protection under Endangered Species Act, California Endangered Species Act, and other statutes. A brochure will be provided with color photos of sensitive species, as well as a discussion of any permit measures. A copy of this WEAP program and brochure shall be provided for review and approval to Director or Director's designee with the City of San Jose Department of Planning, Building and Code Enforcement at least 30 days prior to the start of construction. This includes the following measures:

- **Environmental Inspector:** A qualified Environmental Inspector shall verify implementation and compliance with all mitigation measures. The Environmental Inspector shall have the authority to stop work or determine alternative work practices

where safe to do so, as appropriate, if construction activities are likely to affect sensitive biological resources.

- Litter and Trash Management: Food scraps, wrappers, food containers, cans, bottles, and other trash from the project area shall be deposited into closed trash containers. Trash containers shall be removed from the project work areas at the end of each working day unless located in an existing substation, potential staging area, or the switching station site.
- Parking: Vehicles and equipment shall be parked on pavement, existing roads, and previously disturbed or developed areas, or work areas as identified in this document.
- Work Areas, Staging Areas: Work, staging, vehicle parking, and equipment parking areas shall be contained within the final areas that are negotiated with the relevant property owners, or as noted above.
- Pets and Firearms: No pets or firearms shall be permitted at the project site.

BIO-2: Burrowing Owl Surveys, Monitoring, Prevention and Relocation

Surveys for burrowing owl shall be conducted by a qualified biologist, with a bachelor's degree or above in a biological science field and demonstrated field expertise in ornithology, and in particular, nesting behavior. Surveys of suitable habitat areas as determined by a qualified biologist, shall be conducted within 300 feet of the proposed project construction including staging, grading, site excavation and improvements, and the transmission line extension, or as directed by the City of Santa Clara. Surveys shall be conducted in accordance with the most recent California Department of Fish and Wildlife (CDFW) guidance (current guidance: CDFW 2012). Any habitat areas adjacent to the project site but not publicly accessible will be surveyed with binoculars. Surveys, avoidance and mitigation shall be conducted according to the parameters and limitations listed below, depending on the time of year:

- 1) Breeding Season (February 1 through August 31): Pre-construction surveys for burrowing owls shall be performed at least 14 days prior and again 24 hours prior to initial ground disturbance activities, or as directed by the City of Santa Clara.
 - a) Any occupied burrows shall not be disturbed and shall be provided with a 250-foot protective buffer on areas controlled by the Project Owner until and unless modified by the local permitting agency (City of Santa Clara) in consultation with CDFW, or unless a qualified biologist approved by the local permitting agency verifies through non-invasive means that either: (1) the birds have not begun egg laying, or (2) juveniles from the occupied burrows are foraging independently and are capable of independent survival.
 - b) Once the fledglings in an active burrow are capable of independent survival, a Burrowing Owl Exclusion Plan (BOEP) is developed and approved by the local permitting agency, and habitat is mitigated in accordance with the California Department of Fish and Wildlife (CDFW) staff report guidance (CDFW 2012), then the burrow may be destroyed. Pre-construction surveys following destruction of

burrows and prior to initial construction activities are required (24 hours prior) to ensure owls do not re-colonize the project.

- c) If project activities are delayed or suspended for more than 15 days during the breeding season, surveys shall be repeated.
- 2) Non-breeding Season (September 1 through January 31): Pre-construction surveys following the staff report on burrowing owls (CDFW 2012) shall be performed prior (at least 14 days prior and again 24 hours prior) to initial ground disturbance activities, or as directed by the City of Santa Clara. Burrowing owls may be evicted via passive exclusion after a BOEP is developed and approved by the local permitting agency, and habitat is mitigated in accordance with the CDFW staff report (CDFW 2012).
- a) Pre-construction surveys following destruction of burrows are required 24 hours prior to initial construction activities to ensure owls do not re-colonize the project. If owls are found within 160 feet of the project, it is recommended that visual screens or other measures be implemented to limit disturbance of the owls without evicting them from the occupied burrows.

If no burrowing owls are detected, no further measures are required. If burrowing owls are detected, no construction activities will occur within 250 feet of occupied burrows during the breeding season or within 160 feet of occupied burrows during the non-breeding season. The size of any avoidance buffer may be increased or decreased as determined by the qualified biologist based on the planned construction activities and the sensitivity of the burrowing owls. Additionally, burrowing owls shall be monitored by a qualified biologist during construction to assess the sensitivity of the burrowing owls to the construction activities. During the non-breeding season passive relocation may be conducted in accord with an approved BOEP.

If a burrowing owl is observed at the project at any time during construction, then a buffer area shall be established in accord with the above seasonal criteria (consistent with CDFW 2012 guidance or current guidance) until the animal can be passively relocated out of the construction area.

BIO-3: Nesting Bird Avoidance and Minimization Measures

The project applicant shall schedule demolition and construction activities to avoid the nesting season. The nesting season for most birds, including most raptors in the San Francisco Bay area, extends from February 1st through August 31st (inclusive).

If any construction or demolition activities, including tree or vegetation removal or ground disturbance, occurs during the nesting season (February 1 through August 31, for most birds, including most raptors in the San Francisco Bay area), the project applicant shall adhere to the following guidelines:

- The project applicant shall submit the resume of an ornithologist or other qualified biologist (with at least a bachelor's degree in a biological science field and demonstrated field expertise in avian species) for approval by the City of Santa Clara.

- The pre-approved ornithologist or other qualified biologist (Designated Biologist, DB) shall conduct at least two pre-construction nest survey(s). The two pre-construction surveys shall be separated by a minimum 11-day interval and conducted no more than 14 days prior to initiation of any construction activity. One survey shall be conducted within the 3-day period preceding initiation of construction activity. Additional follow-up surveys may be required if periods of construction inactivity exceed two weeks in any given area, an interval during which birds may establish a nesting territory and initiate egg laying and incubation.
- Surveys shall cover all potential nesting habitat and substrate within the project site and any offsite facilities (i.e., electrical transmission line, staging area, employee parking) and publicly accessible areas within 500 feet of the project boundary. Any habitat areas adjacent to the project site but not publicly accessible shall be surveyed with binoculars. These surveys shall include the orders Falconiformes and Strigiformes (raptors and owls). Surveys shall be conducted at appropriate nesting times and concentrate on potential roosting or perch sites.
- If active nests are detected during on-site surveys, a no-disturbance buffer zone (protected area surrounding the nest) shall be established around each nest with fencing, flagging and/or signage, as appropriate. Initially each nest will have the following buffer zone: 150 feet for any migratory bird nests, 250 feet for any raptor and owl nests (including burrowing owl), and 500 feet for any special status species. Ultimately, the size of each buffer zone shall be determined by the Designated Biologist in consultation with the California Department of Fish and Wildlife (CDFW) and approved by the City of Santa Clara. Collaboration to determine the appropriate buffer size for each nest found should be based upon the species, topography, behavior of the nesting birds, and type of activity that would occur in the vicinity of the nest. Once the buffer zone is established, other than the DB adjusting the buffer zone, it shall remain undisturbed and no construction activities, as defined above, shall occur within the buffer zone the DB and City of Santa Clara verifies that the nest(s) are no longer active.
- If active nests are detected during the surveys, the DB shall monitor the nest weekly (at least once a week for special status species) until the DB determines that nestlings have fledged and dispersed, or the nest is no longer active. This applies to both onsite and offsite nests. If signs of disturbance or distress are observed, the DB shall immediately implement adaptive measures to reduce disturbance. These measures may include, but are not limited to, increasing buffer size, halting disruptive construction activities in the vicinity of the nest until fledging is confirmed, or placement of visual screens or sound-dampening structures between the nest and construction activity, where possible. The DB shall have sole authority not only to order the cessation of nearby project activities, but also when to resume project activities based upon the observed behavior of the nesting pairs and whether the nesting pairs continue to exhibit signs of distress.
- If active nests of special-status species are detected during pre-construction surveys or during project construction, the Director or their designee for the City of San Jose's

Department of Planning, Building and Code Enforcement shall be notified within 24 hours. A letter through email may be used initially and shall state how impacts of any nesting birds will be avoided by citing the appropriate information from this mitigation measure. The final notification shall include all the reporting elements as described below. This guideline shall also apply to any new nests discovered during project construction. All other guidelines above shall be followed.

BIO-4: Nesting Bird Reporting and the Avian Protection Plan

The DB shall be responsible for preparing the pre-construction nest survey reports (including the burrowing owl survey report per BIO-2). The report(s) shall include the time, date, methods, and duration of the surveys; identity and qualifications of the surveyor(s); and a list of species observed. If active nests are detected during the surveys, the reports shall also include a map made using GPS technology or aerial photo identifying the location of the nest(s), species, and a depiction of the boundary of the no-disturbance buffer zone around the nest(s). As new nests are discovered during construction, or buffer zones are adjusted, this map of bird nests should be updated. Inactive nests should be indicated by color in order to more visually comprehend where active nests are located.

A compilation shall be made of the pre-construction nest survey reports, including a summary of all the guidelines contained in BIO-2 and BIO-3. This compilation, known as the Avian Protection Plan, shall be submitted to the Director or their designee for the City of San Jose's Department of Planning, Building and Code Enforcement prior to any construction activities for review and approval.

BIO-5: Bat Species Avoidance and Impact Minimization

- Before the removal of buildings, trees, or other suitable roosting habitat for special-status bats will be affected by project construction, a qualified wildlife biologist shall conduct surveys for special-status bats during the appropriate time of day to maximize detectability to determine if bat species are roosting near the work area. This shall occur no less than 7 days and no more than 14 days prior to beginning tree removal and/or demolition or ground disturbance. Survey methodology may include visual surveys of bats (e.g., observation of bats during foraging period), inspection for suitable habitat, bat sign (e.g., guano), or use of ultrasonic detectors (e.g., Anabat, etc.). Visual surveys shall include trees and structures within 50-feet of construction activities. The type of survey will depend on the condition of the potential roosting habitat. If no bat roosts are found, then no further study and no further mitigation is required.
- If evidence of bat use is observed, the number and species of bats using the roost shall be determined. Bat detectors may be used to supplement survey efforts.
- If roosts or a maternity colony are determined to be present and must be removed, the bats shall be excluded from the roosting site before the tree or structure is removed. Exclusion methods may include use of one-way doors at roost entrances (bats may leave, but not reenter) or sealing roost entrances when the site can be

confirmed to contain no bats. Exclusion efforts may be restricted during periods of sensitive activity (e.g., during hibernation or while females in maternity colonies are nursing young).

- If roosts cannot be avoided or it is determined that construction activities may cause roost abandonment, such activities shall not commence until permanent, elevated bat houses have been installed outside of, but near, the construction area. Placement and height will be determined by a qualified wildlife biologist, but the height of bat house shall be at least 15 feet. Bat houses shall be multi-chambered and be purchased or constructed in accordance with California Department of Fish and Wildlife (CDFW) standards. The number of bat houses required shall be dependent upon the size and number of colonies found, but at least one bat house shall be installed for each pair of bats (if occurring individually) or of a sufficient number to accommodate each colony of bats to be relocated.
- If bat roosts are detected, then a Bat Mitigation and Monitoring Plan (Plan) shall be prepared and implemented to mitigate for the loss of roosting habitat. The Plan shall include information pertaining to the species of bat and location of the roost, exclusion methods and roost removal procedures, compensatory mitigation for permanent impacts (including specific mitigation ratios and location of proposed mitigation as described in the above bullet) and monitoring to assess bat use of mitigation areas. This Plan shall be submitted to the City of Santa Clara and CDFW for review and approval prior to project activities that would disturb roosting bats.

4.4.4 References

- CDFW 2012 – California Department of Fish and Wildlife (CDFW). Staff Report on Burrowing Owl Mitigation. Accessed on November 29, 2022. Available online at: <https://nrm.dfg.ca.gov/FileHandler.ashx?DocumentID=83843&inline=true>
- CEC 2006 – California Energy Commission (CEC). Impacts of Nitrogen Deposition on California Ecosystems and Biodiversity. Prepared by the University of California, Santa Barbara and Creekside Center for Earth Observation. Public Interest Energy Research Program Publication. CEC-500-2005-165
- CLO 2022 – Cornell University, The Cornell University Lab of Ornithology (CLO). All About Birds. Last accessed on December 14, 2022. Available online at: <https://www.allaboutbirds.org/news/>
- CNDDDB 2023 – California Natural Diversity Database (CNDDDB). BIOS and Rarefind 5 (Government Version) 9 quad, 2mile and 6mile search around the proposed project. Accessed June 15, 2023
- CNPS 2023 – California Native Plant Society (CNPS), Rare Plant Program – Inventory of Rare and Endangered Plants of California (online edition, v8-03 0 39). Accessed July 5, 2023. Available online at <http://www.rareplants.cnps.org>
- DayZen 2022a – MBGF SPPE Application- Part I- Main App and Appendix A (TN247325). November 2022. Available online at: <https://efiling.energy.ca.gov/Lists/DocketLog.aspx?docketnumber=22-SPPE-03>

- DayZen 2022b – MBGF SPPE Application- Part II- Appendices B C and D (TN247329). November 2022. Available online at:
<https://efiling.energy.ca.gov/Lists/DocketLog.aspx?docketnumber=22-SPPE-03>
- DayZen 2023a – Martin Properties Responses to CEC Data Request Set 1 - MBGF (TN249350). March 17, 2023. Available online at: <https://efiling.energy.ca.gov/Lists/DocketLog.aspx?docketnumber=22-SPPE-03>
- Fenn et al. 2003 – Fenn, M.E., Baron, J.S., Allen, E.B., Rueth, H.M., Nydick, K.R., Geiser, L., Bowman, W.D., Sickman, J.O., Meixner, T., Johnson, D.W., P. Neitlich (Fenn et al.). 2003. Ecological effects of nitrogen deposition in the western United States. *Bioscience* 53(4): 404-420
- NWI 2023 – National Wetlands Inventory: Surface Waters and Wetlands. Accessed on: April 27, 2023. Available online at:
<https://fwsprimary.wim.usgs.gov/wetlands/apps/wetlands-mapper/>
- Santa Clara 2010 – City of Santa Clara (Santa Clara). City of Santa Clara 2010-2035 General Plan. November 16, 2010. Last accessed on: July 5, 2023. Available online at: <https://www.santaclaraca.gov/our-city/departments-a-f/community-development/planning-division/general-plan>
- Santa Clara 2022 – City of Santa Clara (Santa Clara). Santa Clara City Code, Chapter 12.35: Trees and Shrubs. Version: November 15, 2022. Accessed: July 2023. Available online at:
<https://www.codepublishing.com/CA/SantaClara/#!/SantaClara12/SantaClara1235.html#12.35>
- SCVHP 2012 – Santa Clara Valley Habitat Plan (SCVHP). Final Santa Clara Valley Habitat Plan. August 2012. Available online at: <https://scv-habitatagency.org/178/Santa-Clara-Valley-Habitat-Plan>
- SCVHA 2023 – Santa Clara Valley Habitat Agency Geobrowser. Last accessed on 05/06/2023. Available online: <http://www.hcpmaps.com/habitat/>
- Weiss 2006 – Weiss. Impacts of Nitrogen Deposition on California Ecosystems and Biodiversity. California Energy Commission, PIER Energy-Related Environmental Research. CEC-500-2005-165

4.5 Cultural and Tribal Cultural Resources

This section describes the environmental and regulatory setting and discusses the impacts associated with the construction and operation of the project with respect to cultural and tribal cultural resources.

CULTURAL RESOURCES	Potentially Significant Impact	Less Than Significant with Mitigation Incorporated	Less Than Significant Impact	No Impact
Would the project:				
a. Cause a substantial adverse change in the significance of a historical resource pursuant to §15064.5?	<input type="checkbox"/>	<input checked="" type="checkbox"/>	<input type="checkbox"/>	<input type="checkbox"/>
b. Cause a substantial adverse change in the significance of a unique archaeological resource pursuant to §15064.5?	<input type="checkbox"/>	<input checked="" type="checkbox"/>	<input type="checkbox"/>	<input type="checkbox"/>
c. Disturb any human remains, including those interred outside of dedicated cemeteries?	<input type="checkbox"/>	<input checked="" type="checkbox"/>	<input type="checkbox"/>	<input type="checkbox"/>

TRIBAL CULTURAL RESOURCES	Potentially Significant Impact	Less Than Significant with Mitigation Incorporated	Less Than Significant Impact	No Impact
Would the project cause a substantial adverse change in the significance of a tribal cultural resource, defined in Public Resources Code section 21074 as either a site, feature, place, cultural landscape that is geographically defined in terms of the size and scope of the landscape, sacred place, or object with cultural value to a California Native American tribe, and that is:				
a. Listed or eligible for listing in the California Register of Historical Resources, or in a local register of historical resources as defined in Public Resources Code section 5020.1(k), or	<input type="checkbox"/>	<input type="checkbox"/>	<input type="checkbox"/>	<input checked="" type="checkbox"/>
b. A resource determined by the lead agency, in its discretion and supported by substantial evidence, to be significant pursuant to criteria set forth in subdivision (c) of Public Resources Code Section 5024.1. In applying the criteria set forth in subdivision (c) of Public Resource Code Section 5024.1, the lead agency shall consider the significance of the resource to a California Native American tribe.	<input type="checkbox"/>	<input checked="" type="checkbox"/>	<input type="checkbox"/>	<input type="checkbox"/>

Environmental checklist established by CEQA Guidelines, Appendix G.

4.5.1 Environmental Setting

This section assesses the potential impacts on cultural and tribal cultural resources, of the proposed Martin Backup Generating Facility (MBGF), which provides power for the Martin Data Center. Together, the two are referred to as “the project”. The section considers four broad classes of cultural resources: prehistoric, ethnographic, historic-period, and tribal cultural resources. The next four paragraphs briefly describe these

classes of resources. Afterward, the Cultural and Tribal Cultural Resources section presents the environmental setting pertinent to these resources:

- *Native American archaeological, ethnographic, and historic contexts*—generally describes who lived in the project vicinity, the timing of their occupation, and what uses they made of the area
- *Methods of analysis*—establishes what kinds of physical traces (cultural and tribal cultural resources) past peoples might have left in the project area, given the project vicinity’s archaeological, ethnographic, and historic contexts
- *Results* following from those methods—identifies the specific resources present or expectable in the project area
- *Regulatory setting*—presents the criteria for identifying significant cultural and tribal cultural resources under the California Environmental Quality Act (CEQA) and other applicable authorities, as well as criteria for identifying significant impacts on these resources
- *Impacts*—identifies any impacts on cultural and tribal cultural resources, along with the severity of any such impacts
- *Mitigation measures*—proposes measures to avoid, minimize, rectify, reduce or eliminate, or compensate for identified impacts

Native American archaeological resources are those materials relating to Native American occupation and use of a particular environment. These resources may include sites and deposits, structures, artifacts, rock art, trails, and other traces of Native American activity. In California, exclusive Native American residence began more than 12,000 years ago and extended through the eighteenth century until A.D. 1769, when Europeans first settled in California.

Ethnographic resources are those materials important to the heritage of a particular ethnic or cultural group, such as Native Americans or African, European, or Asian immigrants. They may include traditional resource collecting areas, ceremonial sites, topographic features, value-imbued landscapes, cemeteries, shrines, or neighborhoods and structures. Ethnographic resources are variations of natural resources and standard cultural resource types. They are subsistence and ceremonial locales and sites, structures, objects, and rural and urban landscapes assigned cultural significance by traditional users. The decision to call resources “ethnographic” depends on whether associated peoples perceive them as traditionally meaningful to their identity as a group and the survival of their lifeways.

Historic-period resources are those materials, archaeological and architectural, usually but not necessarily associated with Euro-American exploration and settlement of an area and the beginning of a written historical record. They may include archaeological deposits, sites, structures, trail and road corridors, artifacts, or other evidence of historic human activity. Under federal and state requirements, historic period cultural resources

must be 50 years or older to be considered of potential historic importance. A resource less than 50 years of age may be historically significant if the resource is of exceptional importance. The Office of Historic Preservation (OHP 1995, page 2) endorses recording and evaluating resources 45 years or older to accommodate a five-year lag in the planning process.

Tribal cultural resources are a category of historical resources recently introduced into CEQA by Assembly Bill 52 (Stats. 2014). Tribal cultural resources are resources that are any of the following: sites, features, places, cultural landscapes, sacred places, or objects that are included in or determined eligible to the California Register of Historical Resources (CRHR), or that are included on a local register of historical resources as defined in Public Resources Code, section 5020.1(k). Tribal cultural resources can be archaeological (Native American), ethnographic, or historic (built environment or archaeological).

California Native American Archaeological Context

The city of Santa Clara is within the valley created by the Santa Cruz and Gavilan mountains on the west and the Diablo Range on the east. The Santa Clara Valley is a structural valley (that is, the uplifting mountains formed the valley, as opposed to erosional forces) (NPS 2018).

The proposed project would be in the western Santa Clara Valley, within the watersheds created by the Guadalupe River and creeks emanating from the western mountains. Historically, the Guadalupe River was about 0.75 mile east of the proposed project site, and an unnamed slough was about 2,350 feet east of the proposed project site (USGS 1889). An analysis of historic maps and field notes identifies the area of the proposed project as having historically been a habitat of wet meadows that covered broad portions of the Santa Clara Valley. These wet meadows are characterized by poor draining clay soils and nearly flat topography subject to cyclical flooding and seasonal inundation. Dominant plant species within these wetlands consisted of rhizomatous ryegrasses (*Elymus* spp.) with other wetland plant species such as wire rush (*Juncus balticus*), irisleaf rush (*Juncus xiphioides*), California buttercup (*Ranunculus californicus*), blue-eyed grass (*Sisyrinchium bellum*), Hoover's button-celery (*Eryngium aristulatum* var. *hooveri*), California wild rose (*Rosa californica*), wild nettles, and blackberries. (SFEI 2010.) The proposed project site is located at an elevation of approximately 40 feet above sea level on a broad alluvial plain comprised of unconsolidated soils about 500 feet thick that consist of estuarine and younger alluvial deposits that gradually descends to the shore of the San Francisco Bay 6 miles to the northeast (Heller-Leib et al. 2023, Pages 1, 12–13; DayZen 2022e, Appendix D, page 2).

The proposed project site is located north of downtown Santa Clara, in an industrial area at 651 Martin Avenue. Land use in the area is primarily industrial and commercial, with railroad tracks east of the site, commercial-industrial property and Central Expressway to

the north, commercial-industrial properties and Lafayette Street to the west, and commercial-industrial properties to the south.

The archaeological record in the Santa Clara Valley began about 9000 years before present (B.P., or before 1950) with the Metcalf Creek Aspect, the local expression of the Millingstone cultural pattern. Archaeological deposits dating to this period are characterized by milling slabs and handstones, and large wide-stemmed and leaf-shaped projectile points. Native people during this period were mobile foragers and burials were typically flexed and placed beneath millingstone cairns (Milliken et al. 2007, page 114).

This Early Holocene culture extended until the beginning of the Early Period (circa (ca.)) 5500 B.P., which exhibits developments in groundstone technology (i.e., replacing millingstones with the mortar and pestle), less movement of entire communities, regional symbolic integration between cultural groups, and increased trade. Also referred to locally as the Sandhill Bluff Aspect, this pattern lasted until ca. 2500 B.P., when the Lower Middle Period began with a "major disruption in symbolic integration systems." (Milliken et al. 2007, page 115.) Archaeological assemblages from the Lower Middle Period include more saucer-shaped beads made from the shell of the olive sea snail and circular abalone ornaments (and a disappearance of the rectangular shell beads), and bone tools and whistles.

The Upper Middle Period began ca. 1520 B.P. with a disruption of the olive sea snail-shell bead trade network, abandonment of some village sites, and changes in shell bead manufacture. Some South Bay burials from this period were extended instead of flexed, and grave goods were lacking. (Milliken et al. 2007, page 116.)

The Late Period began ca. 900 B.P. with groups increasing the intensity of the creation of wealth objects as seen in burials. Smaller projectile points for use in the bow and arrow emerged during this period and some of the mortuary evidence suggests the introduction of cremation, at least among the wealthiest of individuals. (Milliken et al. 2007, page 117.)

Archaeological research in the project vicinity reveals a rich and lengthy archaeological record. Archaeologists have found numerous buried Native American sites throughout the lower Santa Clara Valley. Rapid development of the valley covered numerous archaeological sites in pavement or with structures (Bertagnole 2022; Busby et al. 1996a, pages 2–4; Hylkema 1994, page 252; Parsons and KEMCO 1983, pages 18 and 35). Below even the archaeological sites capped by the veneer of recent building, the Guadalupe River and smaller streams (Saratoga and San Tomas Aquino creeks) buried generations of Native American sites under layers of silt and clay. As a result, the surface archaeological record of the Santa Clara Valley represents only the last 2,000 years of human occupation. The remaining 7,000 years of native archaeological record lay anywhere from near surface up to 30 feet below the modern ground surface. (Busby et al. 1996a, pages 2–4; Busby et al. 1996b, page 2; Jones et al. 2007, page 130; Parsons and KEMCO 1983, pages 16, 25–26, 33; Ruby et al. 1992:9, 12, 17–19.)

Ethnographic Context

The Costanoans are the Native Americans who inhabited the Bay Area since time immemorial. The Costanoan designation refers to those who spoke one of eight separate, but related, languages. The Costanoan languages are similar to Miwok and are part of the Yok-Utian language family of the Penutian stock (Golla 2007, pages 75–76). Costanoan and Miwokan are both part of the Utian language family within the Penutian stock. Tamyen (Santa Clara Costanoan) was spoken around the southern end of San Francisco Bay and the lower Santa Clara Valley (and was spoken by those in the project vicinity). (Milliken et al. 2007, Figure 8.1; Shipley 1978, pages 84 and 89.)

Each village was a separate and politically autonomous tribelet, with about 200 people living within each. Tribelets were the basic unit of political organization, with chiefs, either women or men, descended from their patrilineal relative. In the late 1700s, there were two tribelets near the proposed project site, San Jose Cupertino and Santa Clara; both were presumably Tamyen speakers. (Levy 1978, Figure 1.) Kroeber (1976, Figure 42) indicates that two other settlements may have been within a few miles of the project site on the Guadalupe River, *Tamie-n* near Santa Clara, and *Ulis-tak* farther north near the San Francisco Bay.

Like most other Native Americans in California, acorns were the staple food of the Costanoan people in the Santa Clara region. Other nuts such as buckeye, California laurel, and hazelnuts were also eaten. The Costanoans set controlled fires to promote the growth of the nuts, seeds, and plants upon which they relied. The primary mammals taken by the Costanoan included the black-tailed deer, elk, antelope, grizzly bear, mountain lion, sea lion, and whale. Waterfowl, salmon, steelhead, and lampreys were also important components of the Costanoan diet. (Levy 1978, page 491.)

Thatched, domed houses were the most common type of structure for the Costanoans. Sweathouses along the banks of rivers were also constructed, in addition to larger dance enclosures and assembly houses. (Levy 1978, page 492.)

Bodies were either buried or cremated on the day of death. The Chalon and Rumsen groups likely practiced inhumation, while the Chochenyo and Ramaytush usually cremated their dead. Cremations also entailed burning the deceased's property. (Kroeber 1976, page 469; Levy 1978, page 490.)

Trade was important for the Costanoan groups, and their primary partners in trade were the Plains Miwok, Sierra Miwok, and Yokuts. The Costanoan provided coastal resources such as mussels, abalone shell, dried abalone, and salt to the Yokuts in exchange for pinon pine nuts. The Miwok obtained Olivella sea snail shells from the Costanoans. Conflict, in the form of warfare, occurred between Costanoan tribelets as well with the Costanoans and the Esselen, Salinan, and Northern Valley Yokuts. (Davis 1961, page 19; Levy 1978, page 488.)

A common archaeological manifestation of a Costanoan village site is the shell mound deposits (Kroeber 1976, page 466). Mussels are the primary shells that constitute these mounds, in addition to other household wastes.

The Spanish established seven missions in Costanoan territory between 1770 and 1797. By 1810, the last Costanoan village was subsumed within the mission system. Missions in the Bay Area brought together various language and cultural groups including the Esselen, Foothill Yokuts, Plains Miwok, Saclan Miwok, Lake Miwok, Coast Miwok, and Patwin. The mission closest to the proposed project area was Santa Clara de Asís, built in 1777. The mission is no longer extant, but the area is still rich in archaeological manifestations from the mission period and before. (Levy 1978, page 486.)

Mission Santa Clara de Asís occupied two different sites prior to its establishment in its current location. The original mission location was where Norman Y. Mineta San Jose International Airport taxiways now exist. The second location was where Memorial Cross Park has been established at the northeast corner of De La Cruz Boulevard and Martin Avenue (Perzel et al. 2019, page 15). All three locations of the mission reflect the confluence of Native American and European American lives in the project area.

Historic Context

To inform an understanding of the potential significance of built environment resources near the proposed project, a review of the major historical timeline markers for the project area provides context. This subsection offers a brief look at those events and trends in the history of the Santa Clara Valley region that provide that context for the project site:

- Spanish Mission Period
- Mexican Period
- American Period
 - Transportation and Railroads
 - Agriculture and Fruit Industry
 - Post-World War II (WWII) and Silicon Valley
 - Project Site History

Spanish/Mission Period (1769 to 1821)

The Spanish Period was characterized by several important developments, such as the establishment of Spanish Colonial military outposts (presidios), pueblos, and missions throughout Alta California. Nearest to the proposed project were the Santa Clara de Asís Mission (1777), El Pueblo de San Jose de Guadalupe (1777) and Mission (1797), and Santa Cruz Mission (1791). The Spanish government also awarded land grants to soldiers and others and thus began the tradition of large land grants used for agriculture and livestock. Little remains of the cultural landscape that existed during this time aside from

some roads that follow the same early transportation routes. (Santa Clara 2012, pages 22–26.)

Mexican Period (1821 to 1848)

Following Mexican independence from Spain in 1821, Mexican Governor Pio Pico granted lands to Mexican settlers, including the former lands of the missions, whose connection to the government was lost in the Decree of Secularization in 1834. The Mexican governor granted 43 ranchos in the Santa Clara Valley between 1802 and 1845. Local planning agencies lack detailed information on the location and integrity of these early California sites (Santa Clara 2012, pages 30–32). The project site does not appear to be located within the boundaries of the historic Spanish-Mexican Ranchos. On maps drawn in 1876, to the south of the project site is the city grid of Santa Clara, to the east is El Potrero de Santa Clara, to the north is Rancho Ulistac, and to the west is Saratoga Creek and the Enright Tract (Rambo 1968). Santa Clara’s historic context statement laments that most traces of original haciendas, adobes, and other rancho structures are not discernible in the landscape today and few records of them exist (Santa Clara 2012, page 32).

American Period (1848 to Present)

California became the thirty-first state in the union in 1850. In 1851, Santa Clara College, now Santa Clara University, was founded on the site of the Santa Clara de Asís Mission. The incorporation of the City of Santa Clara followed in 1852. In 1866, the city officially established a grid street system to accommodate anticipated growth. Today, this area is known as the Old Quad neighborhood. Early industries in the city included wheat production and flour milling, seed and fruit packing, and manufacturing. Leather tanning and wood products were two key industries of the city well into the twentieth century. Similarly, seed growing and fruit farming and packing (especially pears, cherries, apricots, and prunes) were mainstays, contributing to the city’s exports (City of Santa Clara 2010, page 3-2).

Transportation and Railroads

In 1869, the Western Pacific Railroad completed a rail line from San Jose to Niles, California, effectively connecting San Jose with the Transcontinental Railroad. This opened new markets for the agricultural and manufactured products of the entire Santa Clara Valley. In 1982, Western Pacific merged with Union Pacific Railroad (Santa Clara 2012, page 44).

Senator James Fair, a multi-millionaire, envisioned a route from the east side of San Francisco Bay, south to San Jose, then on to Los Gatos and through the mountains to Felton, ultimately connecting to Santa Cruz. Senator Fair incorporated the South Pacific Coast Railroad in 1876 and immediately began building the segment from Dumbarton in the East Bay to Los Gatos, by way of Santa Clara and San Jose. Following that segment, the rail line passed through the Santa Cruz Mountains to connect with the narrow-gauge railroad at Felton. The Southern Pacific acquired these rail lines in 1887 and eventually converted the narrow-gauge lines to standard gauge (Lehmann 2000, pages 31–33).

The Santa Cruz Division of the Southern Pacific Railroad passed adjacent to the eastern edge of the downtown grid of Santa Clara and adjacent to the current project site (City of Santa Clara 2017; USGS 1899). A 1915 topographic map shows the route of the entire Santa Cruz division from San Jose through the Santa Cruz Mountains to Santa Cruz (USGS 1915).

The first San Jose Airport was completed in 1949. Attracted by the increasing job market, the population of the Santa Clara Valley experienced phenomenal growth after 1950 (Santa Clara 2012, page 46). A modern airport terminal, known as Terminal C, opened in 1965. Designed by a local architect, Hollis Logue Jr., it was described by the San Jose Mercury News as a “palace of glass, concrete and steel” (SJMN 1965). It was certainly a design of its time, with Googie-inspired (mid-century roadside architecture style) design elements at the cornice line, concrete columns, and glass walls. The San Jose Airport Terminal C was demolished and replaced by the current Norman Y. Mineta San Jose International Airport in 2010, known as Terminal B.

Santa Clara Valley Agriculture and Fruit Industry

Fruit orchards and vegetable farms dominated the Santa Clara Valley from the 1890s to the 1940s. Wheat and flour milling were the first major agricultural activities. In support of the fruit and vegetable industry, canning operations flourished in the northeastern portion of the county. Fruit packing companies were common in Santa Clara Valley in the first third of the twentieth century. Nearly half of the world’s supply of fresh, dried, and canned fruit through the end of WWII originated and shipped from the valley. The agricultural base economy and its support operations were gradually displaced by expanding suburban development, light industrial and high-tech research-and-development operations by the 1970s (Fike 2016, page 2).

Post WWII and Silicon Valley

Industrial growth expanded in Santa Clara significantly after WWII. The Owens Corning plant on Lafayette Street was one of the first new industrial businesses to settle in the Santa Clara Valley and represents the shift toward industrial uses in the valley after WWII. A 1948 aerial photograph shows the plant under construction along Lafayette Street with agricultural uses surrounding it (Santa Clara City Library 2019). The plant remains in that location today. Throughout the valley, post-war residential home developments slowly replaced the orchards and agricultural fields. Due to the increased pressure from housing, the City of Santa Clara grew from 6,500 residents in 1940 to 86,000 residents by 1970 (Fike 2016, page 2). Thus, the landscape was forever transformed.

From 1960 to 1980, much of the industrial growth was in the electronics research and manufacturing sectors. The City of Santa Clara is home to Intel, Applied Materials, Sun Microsystems, Nvidia, National Semiconductor, and other high technology companies (City of Santa Clara 2010, pages 3-3 through 3-6). More recently, Santa Clara has become home to numerous data centers supporting the operations of the high technology companies of the Silicon Valley. At least a dozen existing or proposed data centers are

within one mile of the proposed Martin Data Center. This represents yet another contextual shift in the history of the Santa Clara/Silicon Valley.

Project Site 651 Martin Avenue

The vicinity of the project site consists of commercial and industrial uses dating from the late 1940s to the 1950s and has continued more recently with the development of data centers. The surrounding commercial and industrial operations are indicative of the shift that took place after WWII from agricultural-based businesses to light industrial and ultimately high-tech research and development facilities. The project site is a parcel with four buildings consisting of three warehouses, a light industrial building, and a shed which were constructed in the 1950s and 1960s. The buildings were initially used for metal ladder fabrication, and later used as an auto shop. The parcel is primarily rectangular in shape with a curved northern end and is approximately 7.17 acres. The project proposes to demolish the four existing buildings and shed at 651 Martin Avenue and replace them with a four-story 483,363 square foot data center, substation, and Silicon Valley Power junction (switching yard) to service the data center (Heller-Leib et al. 2023, pages i, 34–45, and Appendix C).

Methods

Project Area of Analysis

The project area of analysis (PAA) defines the geographic area in which the proposed project has the potential to affect cultural or tribal cultural resources. Effects may be immediate, further removed in time, or cumulative. They may be physical, visual, audible, or olfactory in character. A PAA may or may not be one uninterrupted expanse. It could include the site of the proposed project (project site), the routes of requisite transmission lines and water and natural gas pipelines, and other offsite ancillary facilities, in addition to one or several discontinuous areas where the project could arguably affect cultural or tribal cultural resources.

The California Energy Commission (CEC) staff defines the PAA as comprising the proposed project site, immediately adjacent parcels, and all appurtenant, proposed improvements. The PAA has archaeological, ethnographic, and historic built environment components, as described in the following paragraphs.

The CEC staff defines the archaeological component of the PAA consists of all areas where the applicant proposes ground disturbance to construct, operate, and decommission the proposed project. This includes the proposed building site, demolition of various facilities, areas slated for concrete and hardscape removal, removal and replacement of landscaping vegetation (including 33 trees from the project site), landscaping, surface parking, areas to be graded, on-site staging and laydown areas, storm water controls, and a new electrical distribution subsystem. Demolition, grading and construction will disturb soils at variable depths across the project area. Recommendations in the project geotechnical investigation recommends deep foundations such as auger-cast piles up to

30 feet deep for the data center, a reinforced mat foundation or drilled piers at least 10 feet deep for the proposed substation, and the mitigation of undocumented fill soils up to 2.5 feet below surface across the proposed project site (DayZen 2022e, Appendix D, pages 10–25). The applicant proposes demolition and excavation to variable depths, to a maximum of 5 feet below current grade for underground utilities and storm water treatment, and 10 feet for interconnection between the generating yards and the data center building (DayZen 2022a, pages 4-64, 4-65; DayZen 2022a, Appendix A, sheets C3, C4). The applicant proposes to import 12,000 cubic yards of fill to the project site. (DayZen 2022a, page 2-17).

For tribal cultural resources, the PAA takes into account sacred sites, ethnographic resources, traditional cultural properties (places), and larger areas such as ethnographic landscapes that can be vast and encompassing, including view sheds that contribute to the historical significance of such resources. The Native American Heritage Commission (NAHC) assists project-specific cultural resources consultants and agency staff in identifying these resources, and consultation with Native Americans and other ethnic or community groups may contribute to defining the PAA. In the case of the proposed project, the immediate environs consist largely of office parks, industrial structures, and the San Jose International Airport. CEC staff therefore treats the ethnographic component of the PAA as coterminous with the archaeological component.

The proposed project site consists primarily of a warehouse complex, pavement, and modest landscape elements, much of which dates to the 1950s and 1960s. The historic built environment PAA for this project includes properties within a one-parcel buffer from the project site and the recycled water line extension.

Literature Review

The literature review for this analysis consisted of a records search at the California Historical Resources Information System (CHRIS), review of the application for small power plant exemption (SPPE), and examination of pertinent literature concerning cultural resources in the northern Santa Clara Valley.

The Northwest Information Center (NWIC) of the CHRIS is the State of California’s official repository of cultural resource records, previous cultural resources studies, and historical information concerning cultural resources for 18 counties, including Santa Clara County. The applicant’s consultant submitted a records search request at the NWIC on July 29, 2022 (Heller-Leib et al. 2023, page 25). The records search area included the project site and a 0.5-mile radius surrounding it to identify previously recorded cultural resources and previous cultural resource studies in the vicinity of the project site.

CEC staff also examined historic maps and aerial photographs of the PAA and vicinity to identify cultural resources (DayZen 2022c, Appendix C; DayZen 2022d, Appendix C; GLO 1866). These sources depict the historic appearance of the PAA each decade from 1866 through 2012 (excepting the 1870s, and 1900s through the 1920s). The historic maps studied date to 1866, 1898, 1897, 1899, 1953, 1961, 1968, 1973, 1980, and 2012, and

include the following USGS quadrangles: San Jose (15-minute series), Milpitas, and San Jose West (7.5-minute series). The historic aerial images studied are: 1939, 1948, 1950, 1956, 1963, 1968, 1974, 1982, 1993, 1998, 2006, 2009, 2012, and 2016.

In addition, the CEC staff consulted:

- City of Santa Clara's General Plan 2010–2035 (General Plan), including its Historic Preservation and Resource Inventory (City of Santa Clara 2010)
- County of Santa Clara Historic Context Statement (SCC 2012)
- MAP Santa Clara tool (Santa Clara 2023).

CEC staff also consulted the National Register of Historic Places (NRHP), CRHR, Historic American Building Survey, Historic American Engineering Record, Historic American Landscape Survey, and internal CEC files.

Tribal Consultation

Applicant's Correspondence

On July 29, 2022, an archaeologist retained by the applicant contacted the California Native American Heritage Commission (NAHC) on the behalf of the applicant to request a search of the Sacred Lands File and to determine if the NAHC had any knowledge of Native American cultural resources in the vicinity of the project area. The NAHC responded on August 30, 2022, reporting that the results of the Sacred Lands File search were negative, and provided contact information for 11 representatives of California Native American tribes. These individuals represent:

- Amah Mutsun Tribal Band
- Amah Mutsun Tribal Band of Mission San Juan Bautista
- Indian Canyon Mutsun Band of Costanoan
- Muwekma Ohlone Indian Tribe of the San Francisco Bay Area
- North Valley Yokuts Tribe
- The Ohlone Indian Tribe
- Wuksachi Indian Tribe/Eshom Valley Band
- Tamien Nation (Campagne 2022a.)

The applicant did not contact the individuals identified in the contacts list in their identification efforts (Heller-Leib et al. 2023, page 29).

CEC Consultation

The California Environmental Quality Act (CEQA) requires lead agencies to consult with all California Native American tribes that have traditional and cultural affiliation with the geographic area of a project, and that have previously requested consultation. To invoke

an agency's requirement to consult under CEQA, a tribe must first send the lead agency a written request for formal notification of any projects within the geographic area with which they are traditionally and culturally affiliated. (Pub. Resources Code, § 21080.3.1(b).) The CEC has requests for formal notification on file from the Tamien Nation and the Wuksachi Indian Tribe/Eshom Valley Band, both California Native American tribes that have traditional and cultural affiliation with the geographic area of the proposed project (Geary 2021; Woodrow 2016). Accordingly, the CEC's Tribal Liaison mailed a letter (dated January 17, 2023) to the Tamien Nation's chairperson and Tribal Historic Preservation Officer, and to the Wuksachi Indian Tribe/Eshom Valley Band's chairperson inviting consultation pursuant to Public Resources Code, section 21080.3.1, and providing general information concerning the proposed project and its location (CEC 2023). Consistent with the CEC's tribal consultation policy (CEC 2021), CEC staff contacted the NAHC on November 9, 2022, to request a search of the Sacred Lands File and a list of California Native American tribes that might be interested in the proposed project. The NAHC responded on December 5, 2022, and provided a list of eight California Native American tribes to contact (Campagne 2022b). In addition to the Tamien Nation and Wuksachi Indian Tribe/Eshom Valley Band, CEC staff mailed initial consultation letters to the Amah Mutsun Tribal Band, Amah Mutsun Tribal Band of Mission San Juan Bautista, Indian Canyon Mutsun Band of Costanoan, Muwekma Ohlone Indian Tribe of the San Francisco Bay Area, North Valley Yokuts Tribe, and Ohlone Indian Tribe on January 17, 2023 (CEC 2023). CEC staff provided electronic copies of the initial consultation letters inviting consultation via email to the individuals identified on the NAHC contact list on February 2, 2023. See the following subsection, "Results," for tribal responses and lead agency follow-up.

Archaeological Survey

An Archaeologist retained by the applicant conducted a field investigation and pedestrian survey of the project area on August 22, 2022. The investigators reported that the entire project area was developed and covered with structures or pavement. (Heller-Leib et al. 2023, pages 30–31, 34.)

Historic Architectural Survey

An archaeologist under direct supervision of a historian retained by the applicant visited the property on August 22, 2022 to evaluate and document the project site property. An archaeologist under direct supervision of a historian retained by the applicant revisited the site on September 28, 2022 to evaluate and document three parcels adjacent to the project site containing historic built environment resources (650 Walsh Avenue, 590 Martin Avenue, and 630 Martin Avenue). A historian retained by the applicant conducted an architectural survey of the railroad segment (P-43-000928) adjacent to the project site on April 5, 2023. Combined, these surveys covered all built environment resources over 45 years of age on or within one parcel of the project site, the recycled waterline, and adjacent parcels. CEC cultural resources staff conducted an architectural investigation inclusive of the project site and a one-parcel buffer from the proposed project boundaries on February 1, 2023. Buildings or structures 45 years or older, or considered significant,

were identified as part of this effort. Any building or facility constructed in 1977 or earlier, or potentially eligible for the CRHR or local register, was surveyed and evaluated by the applicant’s consultant for potential significance (Heller-Leib et al. 2023, pages 30–31).

Results

Literature Review Results

The NWIC records search indicated that no previous investigations had been conducted within the proposed project area. However, four previous cultural resources studies were identified as having been conducted directly south of the project area (Cartier et al. 1992; Nelson et al. 2000; Holson et al. 2002; Sikes et al. 2006). Ninety-one additional prior investigations were identified as having been conducted within the 0.5-mile search area surrounding the project area.

The NWIC has no records of previously recorded cultural resources within the project area, however six previously recorded resources were identified within the 0.5-mile records search area (Heller-Leib et al. 2023, pages 28–29). Three of the previously recorded resources identified in NWIC records search are archaeological resources and three are built environment resources (Cultural Resources Table 1).

An inhouse review of project files conducted by CEC staff resulted in the identification of two additional previously recorded archaeological resources (CA-SCL-000762/P-43-000649 and CA-SCL-000828/P-43-001163) located within one mile of the project site.

TABLE 4.5-1 PREVIOUSLY RECORDED CULTURAL RESOURCES WITHIN 0.5 MILE OF THE PROJECT

Primary Number	Resource Name	Description	Eligibility
P-43-000433	Old Mission Site	Multicomponent; Pre-contact lithic scatter	Unknown
P-43-001080	Waste Management Site	Pre-contact burial site with lithic scatter	Unknown
P-43-001731	Paragon Building	Industrial building	Unknown
P-43-003529	Santa Clara Public Works Building Maintenance Facility	Industrial building, public utility building	Unknown
P-43-004159	CA-SCL-001070/H	Multicomponent; Native American burials, thermal features, and artifacts; Historic residential artifacts, commercial and Industrial features	Unknown
P-43-000928	Peninsula Commute Service	Multicomponent	Ineligible

CA-SCL-000430 (P-43-000433), the location of the early Santa Clara Mission, is located east of the proposed project site on the grounds of the San Jose Municipal Airport and is recorded as a multicomponent archaeological resource, though only Native American cultural items have been observed on the surface of the site. Constituents documented

at the site include obsidian and chert projectile points, lithic fragments, fire-altered rock (FAR), and ground stone fragments. (Cartier 1980; Psota 2019, page 2.)

CA-SCL-000702 (P-43-001080) is a Native American cultural deposit located north of the proposed project area and contained 10 flexed burials with associated grave goods (i.e., two grinding slabs, one handstone, and pieces of Franciscan and Monterey chert). The deposit was in the upper portion of alluvial sediments, ranging from 160 to 185 centimeters (63 to 73 inches) below the preconstruction ground surface. (Leventhal et al. 1990.)

CA-SCL-000762 (P-43-000649) is a Native American shell midden deposit located on both sides of the Guadalupe River channel. (Voss et al. 1993.)

CA-SCL-000828 (P-43-001163) is a small buried Native American cultural deposit situated on a terrace of the Guadalupe River. Cultural materials observed in the deposit consist of shells, shell fragments, Fire Affected Rock (FAR), and a deer antler. (White and Thomas 1999.)

CA-SCL-001070/H (P-43-004159) is a multicomponent archaeological site discovered in 2020 during cultural resources monitoring of construction activities 550 feet from the proposed project. This archaeological site consists of historic-era deposits and older Native American cultural deposits observed buried at a depth of 150 to 250 centimeters (59 to 98 inches) below the preconstruction ground surface. The archaeological deposits are overlaid with disturbed soils and commercial and industrial development. Historic-era constituents at the site consist of a combination of residential, industrial, and structural materials, and include a large buried brick-lined feature, a refuse pit, and a horse skeleton. The Native American cultural component represents "a significant prehistoric site" that has yielded 39 burial features and isolated fragments of human remains representing 41 individuals, two thermal features, and numerous isolated artifacts (Bertagnole 2022, page 2). The Archaeological Site Record indicates that the boundary definition of the site was limited by development and that the site may extend beyond the parcel on which it is recorded. Archaeologists also note that the site has yielded numerous paleontological fossils representing bison, camel, and elk from a deposit within a prehistoric stream channel.

Three previously recorded built environment resources are within 0.5 mile of the project site. Only one is within the project area of analysis (P-43-000928) (see Cultural Resources Table 1).

Tribal Consultation Results

The December 5, 2022, search of the Sacred Lands File did not identify Native American cultural resources in the search area (Campagne 2022b).

The Wuksachi Indian Tribe/Eshom Valley Band has not responded to the CEC's invitation to consult under Public Resources Code, Section 21080.3.1.

In response to the CEC Tribal Liaison’s letters inviting consultation under Public Resources Code, section 21080.3.1, Chairwoman Geary of the Tamien Nation requested consultation for the Martin Backup Generating Facility project during a virtual meeting with CEC staff on February 1, 2023. At this time the Chairwoman also requested any cultural resource assessments that have been completed on all or part of the PAA, as well as the results of records searches conducted at the NWIC related to the project. At the meeting the Tamien Nation expressed the need for archaeological and Native American monitoring of the construction of the project due to the relative sensitivity of the project area and the potential for encountering buried cultural deposits and Native American ancestral remains. The requested project information and documents were provided electronically to the Tamien Nation on February 2, 2023. Another meeting between the CEC and the Tamien Nation was held on June 22, 2023, where the Tamien Nation requested that they be consulted in the development and review of any monitoring and treatment plans for the project, that the Tribe have an opportunity to provide tribal cultural resources sensitivity training in conjunction with any Worker Environmental Awareness Program training, that the members of the Tamien Nation be selected as the Native American monitors for the project, and that consultation with the CEC include review of the Cultural and Tribal Resources section of the draft environmental impact report.

Consultation between the CEC and Tamien Nation is ongoing as of the time of this writing; CEC staff will update this results discussion in the final environmental impact report (FEIR) after consultation concludes.

No other responses to the CEC’s tribal consultation efforts were received.

Historic Architectural Survey

The built environment PAA used for this project includes properties within a one-parcel buffer from the project site. Five properties have been identified with structures 45 years or older within this study area, including the project site. These resources have been surveyed and evaluated by the applicant’s consultants. The resources comprise four commercial warehouse facilities and the Union Pacific/Southern Pacific Santa Cruz Division railroad tracks (Heller-Leib et al. 2023). These are identified in Cultural Resources Table 2 and described below in the Architectural Survey Results.

Address	APN	Description	Year Built
651 Martin Avenue (project site)	224-04-071	Warehouses	1952, 1956, 1960, 1961, 1968
650 Walsh	224-04-077	Warehouse	1956/1959
590 Martin Avenue	230-03-069	Warehouse	1955
630 Martin Avenue	224-35-014	Warehouse	1954/1956
(P-43-000928) Union Pacific/Southern Pacific Railroad-Santa Cruz Division	Not Applicable	Railroad tracks	1870s

The records search conducted at the NWIC indicates that neither the subject property nor the parcels within the one-parcel PAA have been previously recorded or evaluated. The applicant and CEC staff investigated the four properties adjacent to the project site with extant structures that are 45 years or older. Methods employed included review of online permit information (City of Santa Clara 2022), topographic and aerial images, and literature and historical accounts. Based on this research, CEC staff recommends that the five properties do not constitute historical resources under CEQA, individually or as contributors to a district, per the criteria of the CRHR. These buildings embody the common vernacular of post-war industrial and warehouse buildings that do not pertain to any significant regional or statewide historical movement or event (Criterion 1), are not associated with any person of significance regionally or statewide (Criterion 2), and are not the work of a master nor an example of a known and recognizable architectural style (Criterion 3). Additionally, the properties do not have the potential to yield important information related to prehistory or history unavailable in another form (Criterion 4).

CEC staff also evaluated the five properties for their potential eligibility for the City of Santa Clara's Historic Preservation and Resource Inventory using the Criterion for Historical or Cultural Significance, Criterion for Architectural Significance, and Criterion for Geographical Significance (see below). The project site and the adjacent properties do not meet the criteria and staff recommends they are not eligible for local listing.

651 Martin Avenue

There are four buildings and a shed located at 651 Martin Avenue. Building 1, the southernmost building on the property, is a three-bay warehouse with a folded plate roof. It has corrugated metal and fiber cement stucco siding. The entrance is located on the east side of the building and is made up of three large roll-up doors. The southern roll-up door is covered by an awning. There are two roll-up doors on the west side of the building. The south side of the building faces Martin Avenue and has four roll-up doors and a roll-up door under an awning. Building 2 is a corrugated metal warehouse with a shallowly pitched front-facing gable roof. There is a wing on the southwest corner that projects towards Building 1 and a metal roll-up door north of the southern wing. Building 3 is on the eastern property line. It has metal corrugated siding and a shed roof. There is a wing on the northwest corner of the building projecting toward Building 4. The roof extends over this wing to provide shade. There are two metal roll-up doors on the wing and a metal roll-up door south of the wing on the west side. Building 4 is a five-bay warehouse with a folded plate roof and corrugated metal siding. The northern three bays are not as wide as the southern two bays. There is a shed behind the first shorter bay to the west. The two north bays are not enclosed while the other bays have metal walls on the east side of the building. There is also a shed between buildings 1 and 4. (Heller-Leib et al. 2023, pages 34–39, 42–45 and Appendix C.)

The first record of buildings or structures at this location was a building permit for a 14-by 20-foot storage shed issued in 1952 and the buildings and the buildings were constructed later in the 1950s and 1960s and were initially used for metal ladder

fabrication, and later as an auto shop. These buildings are broadly associated with the post-WWII industrial growth in Santa Clara; however, the association is not significant. Many other nearby industrial properties were developed during this same period and there is no specific significant association between these buildings and the regions' industrial growth. Therefore, these buildings are not significant under Criterion 1 of the CRHR. These buildings do not appear to be associated with any significant individuals, or groups of people, therefore they are ineligible under Criterion 2 of the CRHR. These buildings are ineligible for Criterion 3 because they are not a significant example of their architectural style and do not display a significant design or represent the work of a master. These buildings do not appear to contain the potential to reveal new information that is not already recorded; therefore, these buildings are ineligible for Criterion 4 of the CRHR. (Heller-Leib et al. 2023, pages 34–39, 42–45 and Appendix C.) This lack of historical or architectural significance makes it ineligible for listing under the CRHR or City of Santa Clara's significance criteria. Thus, the resource does not qualify as a historical resource under CEQA.

590 Martin Avenue

590 Martin Avenue is a rectangular, single-story, utilitarian warehouse at the northwest corner of a square parcel with a surface parking lot in the rear. The warehouse has a flat, parapeted roof, and stucco clad exterior walls. The north side of the building is the primary façade. The building entrance is in the rear facing the parking lot under a small cloth awning. The storefront consists of an aluminum and glass door with a transom light and large side lights on either side. There is an additional aluminum and glass door with transom lights and one side light to the east. The east side of the building has a pedestrian door atop an aluminum staircase. There is a loading door on the southern end of the western exterior wall. There is surface parking on the lot on the north side of the building and a larger surface parking lot south of the building. There are three planters on the northern side of the building in the parking lot, and five planters within the southern surface parking lot. (Heller-Leib et al. 2023, pages 50–55 and Appendix C.)

The warehouse at 590 Martin Avenue was constructed in 1955. Prior to this, the subject property appears to have been an undeveloped agricultural property. This building is broadly associated with the post-WWII industrial growth in Santa Clara; however, the association is not significant. Many other nearby industrial properties were developed during this same period and there is no specific significant association between this building and the region's industrial growth. Therefore, these buildings are not significant under Criterion 1 of the CRHR. These buildings do not appear to be associated with any significant individuals, or groups of people, therefore it is ineligible under Criterion 2 of the CRHR. This building is ineligible for Criterion 3 because they are not a significant example of its architectural style and do not display a significant design or represent the work of a master. This building does not appear to contain the potential to reveal new information that is not already recorded; therefore, these buildings are ineligible for Criterion 4 of the CRHR. (Heller-Leib et al. 2023, pages 50–55 and Appendix C.) This lack of historical or architectural significance makes it ineligible for listing under the CRHR or

City of Santa Clara's significance criteria. Thus, the resource does not qualify as a historical resource under CEQA.

630 Martin Avenue

630 Martin Avenue is a long narrow property with a long, narrow, irregular warehouse with multiple additions roughly central to the property. The roof has both flat and gabled sections, and the exterior walls have corrugated metal siding. The primary façade is on the east side and has four bays. Each bay has a three-pane clerestory window over an awning. The central eastern bay has one window and a door, accessed by concrete steps and a concrete landing with metal railing. The western exterior wall has two awnings; the northern awning covers a sliding window and door accessed by concrete steps, and the southern awning covers two metal sliding windows. There is a projecting entranceway that has a tiered roof, a metal roll-up door under an awning, two metal French doors (both accessed by wooden stairways), and two fixed clerestory windows. To the south are two additions constructed in the 1980s with metal and glass doors and industrial windows. The change in siding is clearly visible on the east side of the building. There are five metal sliding windows under canopies on the north half of the building. The rest of the property is covered with paved surface parking. There are trees along the western property line and a railroad next to the eastern property line. (Heller-Leib et al. 2023, pages 55–59 and Appendix C.)

The warehouse at 630 Martin Avenue was constructed in 1956. Prior to this the subject property appears to have been an undeveloped agricultural property. Originally the property was a woodworking and plywood manufacturing plant for the Tristate Plywood Company. By 1987, the Sanspray Corporation, an aggregate panel manufacturer, occupied the property. Currently, Alliance Roofing occupies the property. This building is broadly associated with the post-WWII industrial growth of Santa Clara; however, the association is not significant. Many other nearby industrial properties were developed during this same period and there is no specific significant association between this building and the region's industrial growth. Therefore, these buildings are not significant under Criterion 1 of the CRHR. These buildings do not appear to be associated with any significant individuals, or groups of people, therefore it is ineligible under Criterion 2 of the CRHR. This building is ineligible for Criterion 3 because they are not a significant example of its architectural style and do not display a significant design or represent the work of a master. This building does not appear to contain the potential to reveal new information that is not already recorded; therefore, these buildings are ineligible for Criterion 4 of the CRHR. (Heller-Leib et al. 2023, pages 55–59 and Appendix C.) This lack of historical or architectural significance makes it ineligible for listing under the CRHR or City of Santa Clara's significance criteria. Thus, the resource does not qualify as a historical resource under CEQA.

Southern Pacific Commute Service Track (P-43-000928)

This resource is a double-track segment of the existing Caltrain Commuter rail service line. The right-of-way segment is approximately 2,526 feet long, comprised of two sets

of track set atop a central bed of ballast, flanked by an unpaved, gravel-covered right-of-way on either side of the tracks. The segment of railroad track adjacent to 651 Martin Avenue began in 1864 as part of the Peninsula Commute Service as a single track. In the early 1900s, a second track was added. The original rails were replaced in the late 1950s, and several spur lines were built to connect several warehouses built along the track between 1943 and 1953. The spur lines were used until at least 1980 but have since fallen out of use. California Department of Transportation electrification equipment was added to the right of way within the last decade. (Heller-Leib et al. 2023, pages 39–41, 59–63, and Appendix C.)

When it was constructed in 1864 the Peninsula Commute Service was the only railroad connecting San Francisco and San Jose, allowing people to easily travel between either side of the Peninsula for the first time in California’s history. Towns like San Carlos and Atherton were created around stops along the rail line and grew along the railroad. However, the railroad no longer retains integrity since the track itself has been significantly altered both to accommodate the transition from steam engines to diesel engines, which have different track requirements, and to add a second track. This track segment was again altered in the 1950s when the tracks were replaced so they could be used for nearby light industrial warehouses. While this railroad segment is associated with the rapid growth of the Santa Clara Valley and the rise of industry in Santa Clara in the twentieth century, it is not directly associated with any significant events in this development and there is no evidence that it was significant during this period (CRHR Criterion 1). Archival research failed to indicate any significant direct association between individuals that are known to be historic figures at the national, state, or local level (CRHR Criterion 2). The resource is a double set of tracks that is ubiquitous and lacks any architectural distinction or significance (CRHR Criterion 3). The resource is unlikely to yield important new information about design, construction methods, materials or engineering that could not be ascertained through literature review or from other existing sources (CRHR Criterion 4). (Heller-Leib et al. 2023, pages 39–41, 59–63, and Appendix C.) This lack of historical or architectural significance makes it ineligible for listing under the CRHR or City of Santa Clara’s significance criteria. Thus, the resource does not qualify as a historical resource under CEQA.

650 Walsh Avenue

650 Walsh Avenue is an irregularly shaped lot developed with a simple, square, single-story warehouse. The warehouse has four-bays with a low-pitched folded plate roof. The four bays are on the north façade. Each bay has a central metal roll-up loading door, and the east two bays have pedestrian doors. A fixed window in an aluminum frame is located on the second to the east bay. There is an additional metal roll-up loading door in the center of the western exterior wall. There is a planter long the north property line. The rest of the property consists of surface parking. (Heller-Leib et al. 2023, pages 45–50 and Appendix C.)

The warehouse along 650 Walsh Avenue was constructed in 1956 by the Pole Frame Construction Co. Prior to this, the subject property appears to have been an agricultural property. This building is broadly associated with the post-WWII industrial growth in Santa Clara; however, the association is not significant. Many other nearby industrial properties were developed during this same period and there is no specific significant association between this building and the region’s industrial growth. Therefore, these buildings are not significant under Criterion 1 of the CRHR. These buildings do not appear to be associated with any significant individuals, or groups of people, therefore it is ineligible under Criterion 2 of the CRHR. This building is ineligible for Criterion 3 because they are not a significant example of its architectural style and do not display a significant design or represent the work of a master. This building does not appear to contain the potential to reveal new information that is not already recorded; therefore, these buildings are ineligible for Criterion 4 of the CRHR (Heller-Leib et al. 2023, pages 45–50 and Appendix C.) This lack of historical or architectural significance makes it ineligible for listing under the CRHR or City of Santa Clara’s significance criteria. Thus, the resource does not qualify as a historical resource under CEQA.

Archaeological Sensitivity

The application and staff’s literature review indicate that the potential for buried archaeological resources to occur in the project vicinity mirrors the high frequency of buried archaeological deposits throughout the Santa Clara Valley (see Byrd et al. 2017, page 4-2; Cartier and Detlefs 1980, page 4; Hylkema 1998, page 20; Mission College 2019, pages 92–93). Researchers have identified at least 16 buried Native American archaeological sites in the Santa Clara Valley (Byrd et al. 2017, page 4-3; Rehor and Kubal 2014, page 55, Table 8). CEC staff’s literature review identified four buried Native American archaeological resources within 1 mile of the archaeological PAA (Cultural Resources Table 3) with cultural deposits observed buried 4.9–12.4 feet below the modern ground surface. Archaeologists working independently of the present analysis have estimated the PAA’s likelihood to contain buried Native American archaeological resources as moderate (Byrd at al. 2017, Figure 17). However, considering the recently discovered buried archaeological deposit (CA-SCL-001070/H, containing 39 burial features and numerous artifacts), its close proximity to the project site, and the likelihood that cultural deposits might extend beyond what’s currently documented, CEC staff concludes that the PAA is likely to contain buried archaeological resources.

TABLE 4.5-3 PREVIOUSLY RECORDED ARCHAEOLOGICAL RESOURCES WITHIN 1 MILE OF THE PROJECT

Site Number	Primary Number	Cultural Components	Depth	Description
CA-SCL-000430/H	P-43-000433	Multicomponent	Surface	Surface lithic scatter
CA-SCL-000702	P-43-001080	Native American	160–185 cmbs (63–73 in)	Buried deposit containing 11 Native American burials and funerary items

TABLE 4.5-3 PREVIOUSLY RECORDED ARCHAEOLOGICAL RESOURCES WITHIN 1 MILE OF THE PROJECT

Site Number	Primary Number	Cultural Components	Depth	Description
CA-SCL-001070/H	P-43-004159	Multicomponent	150–250 cmbs (59–98 in)	Buried deposit containing 39 Native American burials, features, and artifacts, and historic features and artifacts
CA-SCL-000762	P-43-000649	Native American	Unknown; Exposed Cut Bank	Shell midden visible in cut banks on both sides of an incised channel of the Guadalupe River
CA-SCL-000828	P-43-001163	Native American	240–380 cmbs (94–149 in)	Site covered by historic fill, buried deposit containing whole and fragmentary sea snail shells, fire affected rock, and a deer antler fragment

Regulatory Background

Federal

No federal regulations related to cultural or tribal cultural resources apply to the project.

State

California Environmental Quality Act. CEQA requires the lead agency to evaluate cultural and tribal cultural resources by determining whether they meet several sets of specified criteria that make such resources eligible to the CRHR. Those cultural or tribal cultural resources eligible to the CRHR are historical resources. The evaluation then influences the analysis of potential impacts to such historical resources and the mitigation(s) that may be required to ameliorate any such impacts.

CEQA and the CEQA Guidelines define significant cultural resources under two regulatory definitions: historical resources and unique archaeological resources. A historical resource is defined as a “resource listed in, or determined to be eligible by the State Historical Resources Commission, for listing in the CRHR”, or “a resource listed in a local register of historical resources or identified as significant in a historical resource survey meeting the requirements of Section 5024.1(g) of the Public Resources Code,” or “any object, building, structure, site, area, place, record, or manuscript which a lead agency determines to be historically significant or significant in the architectural, engineering, scientific, economic, agricultural, educational, social, political, military, or cultural annals of California, provided the agency’s determination is supported by substantial evidence in light of the whole record.” (Cal. Code Regs., tit. 14, 15064.5(a).) Historical resources that are automatically listed in the CRHR include California historical resources listed in or formally determined

eligible for the NRHP and California Registered Historical Landmarks from No. 770 onward (Pub. Resources Code, § 5024.1(d)).

CEQA generally considers a resource historically significant if it meets the criteria for listing in the CRHR. In addition to being at least 50 years old, a resource must meet one or more of the following four criteria (Pub. Resources Code, § 5024.1):

- Criterion 1, is associated with events that have made a significant contribution to the broad patterns of our history;
- Criterion 2, is associated with the lives of persons significant in our past;
- Criterion 3, embodies the distinctive characteristics of a type, period, or method of construction, or represents the work of an important creative individual, or possesses high artistic values; or
- Criterion 4, has yielded, or may be likely to yield, information important to history or prehistory.

In addition, historical resources must also possess integrity of location, design, setting, materials, workmanship, feeling, and association (Cal. Code Regs., tit. 14, § 4852(c)).

Even if a resource is not listed or determined to be eligible for listing in the CRHR, CEQA requires the lead agency to make a determination as to whether the resource is a historical resource as defined in Public Resources Code, sections 5020.1(j) or 5024.1.

In addition to historical resources, archaeological artifacts, objects, or sites can meet CEQA's definition of a unique archaeological resource, even if the resource does not qualify as a historical resource (Cal. Code Regs., tit. 14, § 15064.5(c)(3)). Archaeological artifacts, objects, or sites can qualify as unique archaeological resources if it is clearly demonstrable that, without merely adding to the current body of knowledge, there is a high probability that the resource meets any of the following criteria:

1. Contains information needed to answer important scientific research questions and that there is a demonstrable public interest in that information.
2. Has a special and particular quality such as being the oldest of its type or the best available example of its type.
3. Is directly associated with a scientifically recognized important prehistoric or historic event or person." (Pub. Resources Code, § 21083.2(g)).

To determine whether a proposed project may have a significant effect on the environment (CEQA defines historical resources to be a part of the environment), staff analyzes the project's potential to cause a substantial adverse change in the significance of historical or unique archaeological resources. The magnitude of an impact depends on:

- the historical resource(s) affected;
- the specific historic significances of any potentially impacted historical resource(s);

- how the historical resource(s) significance is manifested physically and perceptually;
- appraisals of those aspects of any historical resource's integrity that figure importantly in the manifestation of the resource's historical significance; and
- how much the impact will change historical resource integrity appraisals.

Title 14, California Code of Regulations, section 15064.5(b) defines a substantial adverse change as "physical demolition, destruction, relocation or alteration of the resource or its immediate surroundings such that the significance of an historical resource would be materially impaired."

California Native American Tribes, Lead Agency Tribal Consultation Responsibilities, and Tribal Cultural Resources. CEQA provides definitions for California Native American tribes, lead agency responsibilities to consult with California Native American tribes, and tribal cultural resources. A "California Native American tribe" is a "Native American tribe located in California that is on the contact list maintained by the Native American Heritage Commission (NAHC) for the purposes of Chapter 905 of the Statutes of 2004" (Pub. Resources Code, § 21073). Lead agencies implementing CEQA are responsible for consultation with California Native American tribes about tribal cultural resources within specific timeframes, observant of tribal confidentiality, and—if tribal cultural resources could be impacted by a CEQA project—are to exhaust the consultation to points of agreement or termination.

Tribal cultural resources are either of the following:

1. Sites, features, places, cultural landscapes, sacred places, and objects with cultural value to a California Native American tribe that are either of the following:
 - a. Included or determined to be eligible for inclusion in the CRHR
 - b. Included in a local register of historical resources as defined in the Public Resources Code, section 5020.1(k).
2. A resource determined by the lead agency, in its discretion and supported by substantial evidence, to be significant pursuant to criteria set forth in the Public Resources Code, section 5024.1(c). In applying these criteria, the lead agency shall consider the significance of the resource to a California Native American tribe. (Pub. Resources Code, § 21074(a).)

A cultural landscape that meets the criteria of Public Resources Code, section 21074(a), is a tribal cultural resource to the extent that the landscape is geographically defined in terms of its size and scope (Pub. Resources Code, § 21074(b)). Historical resources, unique archaeological resources, and non-unique archaeological resources, as defined at Public Resources Code, sections 21084.1, 21083.2(g), and 21083.2(h), may also be tribal cultural resources if they conform to the criteria of Public Resources Code, section 21074(a).

CEQA also states that a project with an impact that may cause a substantial adverse change in the significance of a tribal cultural resource is a project that may have a significant effect on the environment (Pub. Resources Code, § 21084.2).

Local

City of Santa Clara General Plan

Section 5.6.3 of the City of Santa Clara's General Plan outlines the goals and policies related to archaeological and cultural resources. The applicable goals in this section of the General Plan encourage the protection and preservation of cultural resources, including archaeological and paleontological sites, and encourage appropriate mitigation in the event of discovery during construction.

Relevant policies require protecting historic resources through avoidance or reduction of potential impacts, using the Secretary of the Interior's Standards for the Treatment of Historic Properties, and using the city's established historic preservation program for ensuring resource evaluation, protection, and integrity (City of Santa Clara 2010).

Appendix 8.9 of the General Plan, the Historic Preservation and Resource Inventory, established criteria for local significance and included a list of recorded historic properties (City of Santa Clara 2010). In addition, the city has embedded in its Municipal Code a section on Historic Preservation (Title 18 Zoning, Chapter 18.106, Historic Preservation). The purpose of Chapter 18.106 is "to promote the identification, protection, enhancement and perpetuation of buildings, structures and properties within the City that reflect special elements of the City's social, economical, historical, architectural, engineering, archaeological, cultural, natural, or aesthetic heritage" (Santa Clara 2018). The chapter requires maintenance of a Historic Resource Inventory.

Appendix 8.9 of the General Plan also identifies significance criteria for local listings. The City of Santa Clara's City Council adopted the Criteria for Local Significance on April 20, 2004 and incorporated the criteria into the General Plan Appendix 8.9. Any building, site, or property in the city that is 50 years old or older and meets certain criteria of architectural, cultural, historical, geographical, or archaeological significance is potentially eligible. The Criteria for Local Significance established in General Plan Appendix 8.9 (City of Santa Clara 2010) are as follows:

Criterion for Historic or Cultural Significance - To be historically or culturally significant, a property must meet at least one of the following criteria:

1. The site, building or property has character, interest, integrity and reflects the heritage and cultural development of the city, region, state, or nation.
2. The property is associated with a historical event.
3. The property is associated with an important individual or group who contributed in a significant way to the political, social and/or cultural life of the community.

4. The property is associated with a significant industrial, institutional, commercial, agricultural, or transportation activity.
5. A building's direct association with broad patterns of local area history, including development and settlement patterns, early or important transportation routes or social, political, or economic trends and activities. Included is the recognition of urban street pattern and infrastructure.
6. A notable historical relationship between a site, building, or property's site and its immediate environment, including original native trees, topographical features, outbuildings or agricultural setting.

Criterion for Architectural Significance - To be architecturally significant, a property must meet at least one of the following criteria:

1. The property characterizes an architectural style associated with a particular era and/or ethnic group.
2. The property is identified with a particular architect, master builder, or craftsman.
3. The property is architecturally unique or innovative.
4. The property has a strong or unique relationship to other areas potentially eligible for preservation because of architectural significance.
5. The property has a visual symbolic meaning or appeal for the community.
6. A building's unique or uncommon building materials or its historically early or innovative method of construction or assembly.
7. A building's notable or special attributes of an aesthetic or functional nature. These may include massing, proportion, materials, details, fenestration, ornamentation, artwork, or functional layout.

Criterion for Geographical Significance - To be geographically significant, a property must meet at least one of the following criteria:

1. A neighborhood, group, or unique area directly associated with broad patterns of local area history.
2. A building's continuity and compatibility with adjacent buildings and/or visual contribution to a group of similar buildings.
3. An intact, historical landscape or landscape features associated with an existing building.
4. A notable use of landscaping design in conjunction with an existing building.

Criterion for Archaeological Significance - For the purposes of CEQA, an "important archaeological resource" is one which:

1. Is associated with an event or person of
 - a. Recognized significance in California or American history, or

- b. Recognized scientific importance in prehistory.
2. Can provide information, which is both of demonstrable public interest, and useful in addressing scientifically consequential and reasonable or archaeological research questions;
3. Has a special or particular quality such as oldest, best example, largest, or last surviving example of its kind;
4. Is at least 100 years old and possesses substantial stratigraphic integrity; or
5. Involves important research questions that historical research has shown can be answered only with archaeological methods.

4.5.2 Environmental Impacts

Cultural Resources CEQA Checklist Questions

a. Would the project cause a substantial adverse change in the significance of a historical resource as defined in §15064.5?

Construction

Less Than Significant Impact with Mitigation Incorporated. No historic built environment resources meeting CEQA's criteria for historical resources are located on site or within the PAA. No archaeological or ethnographic resources meeting CEQA's criteria for historical resources occupy the surface of the PAA. Previous studies in the project vicinity, however, indicate that the PAA could harbor buried archaeological or ethnographic resources. The project site is located 550 feet of CA-001070/H, a large multicomponent buried archaeological site with cultural deposits likely to extend beyond its currently documented boundaries. Based on the available information, the project site is highly likely to contain buried cultural deposits.

The ground disturbance required to build the proposed project would extend into native soils up to 30 feet below grade. Known buried archaeological sites in Santa Clara Valley are located at depths of 1.0–10.5 feet below grade (Rehor and Kubal 2014, Table 4-1). If such resources were to be damaged during construction, it would be considered a significant impact, particularly since virtually all archaeological sites 5,000 years or older occur only in buried contexts.

To reduce the significance of impacts on unidentified historical resources that may exist within the project area, the applicant proposed PDM CUL-1 and PDM CUL-2 (DayZen 2020a, pages 4-42 through 4-45). The applicant proposed mitigation package was found insufficient to fully address potential impacts. The applicant-proposed measures were incorporated into the staff proposed mitigation measures contained in this EIR; notable differences between the two are discussed below.

PDM CUL-1 requires that a treatment plan be developed in consultation with the qualified Native American monitor. Staff evaluated this measure in the context of potential impacts and in consideration of requests from the Tamien Nation during consultation with the CEC staff and determined it was mostly sufficient to reduce impacts. In response to this request, staff incorporated the concerns expressed by the Tamien Nation (Tamien Nation is the only California Native American tribe to have consulted with the CEC on this project). The applicant did not include the identification of potential reburial locations on site as a component of the proposed monitoring and treatment plan, should tribal cultural resources be discovered. Staff proposes mitigation measure **CUL-1** requiring the development of a monitoring and treatment plan that includes the identification of potential reburial locations for tribal cultural resources and requires consultation with the Native American Monitor on the development of the Plan. As discussed below, staff proposed measure **CUL-4** gives preference to members of the Tamien Nation to be selected as a Native American monitor.

In PDM CUL-1, the applicant proposed Cultural Sensitivity Training prior to construction in conjunction with Archaeological Monitoring Contractor Awareness Training facilitated by the project archaeologist. Through consultation with the Tamien Nation, the tribe requested that Tribal Cultural Resources Sensitivity Training (a separate component of the training that provides the tribal perspective and complements the archaeologist's training material) be conducted by a Native American Monitor who is a member of the Tamien Nation, therefore staff incorporated the request of the Tamien Nation. Staff proposes mitigation measure **CUL-2**, requiring Worker Environmental Awareness Training facilitated by the project archaeologist be held in conjunction with Tribal Cultural Resources Sensitivity Training conducted by the Native American monitor with a preference for the Tamien Nation in the selection of Native American monitors.

The applicant's measure, PDM-CUL 1 also proposes preliminary field investigations of the surface and subsurface soils in the project area after removal of pavement and prior to issuance of grading and building permits. Representatives from the Tamien Nation expressed concern that testing itself could impact tribal cultural resources if they are present in the project area. The Tamien Nation requested that subsurface testing not be included in the preliminary field investigation strategy but expressed a willingness to compromise if testing locations were limited to soils to be disturbed by construction activities. In response to this request, staff has recommended in mitigation measure **CUL-1** that the Tamien Nation be consulted in the development of the preliminary field investigation plan. Staff proposes mitigation measure **CUL-3**, requiring preliminary field investigations be conducted.

The applicant's measures contained within PDM CUL-1 propose monitoring of all ground-disturbing activities by a qualified archaeologist and a qualified Native American monitor. Representatives from the Tamien Nation requested that its members be granted preference for selection as qualified Native American Monitors for the proposed project. Staff proposes mitigation measure **CUL-4**, requiring monitoring for all ground-disturbing

activities and providing preference to members of the Tamien Nation in the selection of Native American monitors.

The applicant proposes measures within PDM CUL-1, relating to the evaluation and recovery of cultural materials. Staff determined that additional measures, including reporting and documentation protocols and recording finds on appropriate forms, would be needed to reduce impacts. Staff proposes mitigation measure **CUL-5**, requiring specific reporting and documentation protocols be followed, including recording finds using California Department of Parks and Recreation 523 series forms, and evaluation of finds by a qualified archaeologist.

No human remains or cemeteries are known to exist with the project site, however human remains have been discovered near the project site and it is possible that construction activities associated with the proposed project could damage or destroy previously undiscovered human remains. PDM CUL-2 proposes to follow the provisions of California Health and Safety Code section 7050.5 and Public Resources Code sections 5097.9 through 5097.99, if human remains are found during the field investigation, grading or construction activities. Staff evaluated this measure in the context of impacts and determined it is sufficient to reduce impacts. Staff proposes mitigation measure **CUL-6** requiring compliance with section 7050.05 of the Health and Safety Code and sections 5097.9 through 5097.99 of the Public Resources Code, if human remains are discovered at any point during the project.

Not included in the project design measures proposed by the applicant are provisions relating to on-site security, the production of a Closing Cultural Resources Report summarizing the results of investigations, data recovery activities, and compliance with the treatment plan, and requirements relating to the curation and reburial of archaeological and tribal cultural resources. Therefore, to reduce potential impacts staff proposes:

- Mitigation Measure **CUL-7**, providing for on-site security measures,
- Mitigation Measure **CUL-8**, requiring a Closing Cultural Resources Report be prepared and submitted to the City of Santa Clara's Director of Community Development prior to issuance of any certificates of occupancy, and
- Mitigation Measure **CUL-9**, requiring curation or reburial of archaeological materials or tribal cultural resources upon completion of the Closing Cultural Resources Report and prior to issuance of any certificates of occupancy.

To reduce the significance of impacts on unidentified historical resources that may exist with the project area staff proposes mitigation measures **CUL-1** through **CUL-9** contained in this DEIR. The proposed mitigation program addresses the practical limitations of conducting a cultural resources investigation within a project area that is fully developed, where soil visibility was nonexistent, and the area has high potential for harboring archaeological deposits. These measures would reduce impacts to any

discovered historical resources as defined in CEQA Guidelines section 15064.5, to a less-than-significant level.

Operation

No Impact. Operation and maintenance of the proposed project would not require excavation or other ground-disturbance. Therefore, there would be no impact to historical resources as defined in CEQA Guidelines Section 15064.5.

b. Would the project cause a substantial adverse change in the significance of a unique archaeological resource pursuant to §15064.5?

Construction

Less Than Significant Impact with Mitigation Incorporated. As discussed in CEQA environmental criterion "a" above for construction, implementation of mitigation measures **CUL-1** through **CUL-9** would reduce impacts to unique archaeological resources to a less-than-significant level.

Operation

No Impact. Operation and maintenance of the proposed project would not require excavation or other ground-disturbance. Therefore, there would be no impact to unique archaeological resources, as defined in CEQA Guidelines section 15064.5.

c. Would the project disturb any human remains, including those interred outside of formal cemeteries?

Construction

Less Than Significant Impact with Mitigation Incorporated. As discussed in CEQA Environmental Checklist criteria "a" and "b" above for construction, implementation of mitigation measures **CUL-1** through **CUL-9** would reduce impacts to human remains to a less than significant level. In particular, mitigation measure **CUL-1** requires a treatment plan that includes the identification of potential reburial locations, mitigation measure **CUL-2** requires cultural sensitivity training, and through mitigation measures **CUL-5** and **CUL-6**, establishes a protocol to minimize or avoid impacts on inadvertently discovered human remains.

Operation

No Impact. Operation and maintenance of the proposed project would not require excavation or other ground-disturbance. Therefore, there would be no impact to human remains during operation and maintenance of the proposed project.

Tribal Cultural Resources CEQA Checklist Questions

Would the project cause a substantial adverse change in the significance of a tribal cultural resource, defined in Public Resources Code, section 21074, as either a site, feature, place, cultural landscape that is geographically defined in terms of the size and scope of the landscape, sacred place, or object with cultural value to a California Native American tribe, and that is:

- a. Listed or eligible for listing in the California Register of Historical Resources or in a local register of historical resources, as defined in Public Resources Code, section 5020.1(k)?**

Construction

No Impact. There are no tribal cultural resources listed or eligible for listing in the CRHR or other state registers, NRHP, or local register of historical resources in the PAA, and, therefore, no impacts would occur during construction.

Operation

No Impact. Ground-disturbing activities are not part of the operational or maintenance profile of the proposed project. Impacts on tribal cultural resources listed or eligible for listing in the CRHR or other state registers, NRHP, or local register of historical resources would, therefore, not occur during operation or maintenance.

- b. A resource determined by the lead agency, in its discretion and supported by substantial evidence, to be significant pursuant to criteria set forth in Public Resources Code, section 5024.1 (c). In applying the criteria set forth in Public Resources Code, section 5024.1 (c), the lead agency shall consider the significance of the resource to a California Native American tribe?**

Construction

Less Than Significant Impact with Mitigation Incorporated. Although there are no known tribal cultural resources on or directly adjacent to the proposed site, ground disturbance associated with the proposed project could result in the exposure and destruction of buried, as-yet unknown California Native American archaeological resources that could qualify as tribal cultural resources. If these resources were to be exposed or destroyed, it would be a significant impact. Implementation of mitigation measures **CUL-1** through **CUL-9** would reduce impacts on buried, tribal cultural resources to a less than significant level (see CEQA environmental Checklist criterion "a" and "b" above).

Operation

No Impact. Ground-disturbing activities are not part of the operational or maintenance profile of the proposed project. Impacts on tribal cultural resources listed or eligible for listing in the CRHR or other state registers, NRHP, or local registers of historical resources would, therefore, not occur during operation and maintenance.

4.5.3 Mitigation Measures

CUL-1: Cultural Resources Identification, Monitoring, and Treatment Plan. Prior to the issuance of any grading permit, a project-specific Cultural Resources Identification, Monitoring, and Treatment Plan (Plan) shall be prepared. The Plan shall be prepared by a Secretary of the Interior-qualified archaeologist, in consultation with the Tamien Nation and a qualified Native American monitor registered with the Native American Heritage Commission (NAHC) with an interest in the city of Santa Clara and that is traditionally and culturally affiliated with the geographic area. The Plan shall reflect permit-level detail pertaining to depths and locations of all ground disturbing activities. The Plan shall be prepared and submitted to the City of Santa Clara's Director of Community Development prior to approval of any grading permit. The Plan shall contain, at a minimum:

- Identification of the scope of work and range of subsurface effects (including location map and development plan), including requirements for preliminary field investigation and construction monitoring
- Description of the environmental setting (past and present) and the historic, California Native American archaeological, and ethnographic background of the parcel (potential range of what might be found)
- Development of research questions and goals to be addressed by the investigation (what is significant vs. what is redundant information)
- Detailed field strategy (including the preliminary field investigation) used to identify cultural deposits, record, recover, or avoid the finds and address research goals
- Analytical methods
- Handling and preservation of cultural materials
- Report structure of the closing cultural resources report including a confidential technical report and layperson's report and an outline of document contents in one year of completion of construction (provide a draft for review before a final report)
- Disposition of the artifacts, including identification of potential reburial location(s) on site
- Appendices: all site records, correspondence, and consultation with Native Americans, etc.

CUL-2: Worker Environmental Awareness Program Training. Prior to issuance of the grading permit by the City of Santa Clara Community Development Department, and for the duration of ground disturbance, the project shall be required to submit evidence

that Worker Environmental Awareness Program (WEAP) training was held for all existing and any new employees. The training shall be facilitated by the project archaeologist in coordination with a Native American representative registered with the Native American Heritage Commission for the city of Santa Clara and that is traditionally and culturally affiliated with the geographic area as described in Public Resources Code, section 21080.3. This training should include: a discussion of applicable laws and penalties under the laws; samples or visual aids of artifacts that could be encountered in the project vicinity, including what those artifacts may look like partially buried, or wholly buried and freshly exposed, and instructions to halt work in the vicinity of any potential cultural resource discovery, and notify the city-approved archaeologist and Native American cultural resources monitor. The Native American monitor shall provide a Tribal Cultural Resources Sensitivity Training in conjunction with the WEAP.

CUL-3: Preliminary Field Investigations. After removal of pavement at the project site and prior to grading, a Secretary of the Interior-qualified archaeologist and qualified Native American monitor shall conduct a pedestrian survey over the exposed soils to determine if any surface archaeological manifestations are present. Prior to issuance of any grading or demolition permits, the project applicant shall complete a preliminary field investigation program in conformance with the project-specific Cultural Resources Identification, Monitoring, and Treatment Plan required under Mitigation Measure **CUL-1**. Results of the investigation shall be provided to the City of Santa Clara's Director of Community Development prior to issuance of any grading permit. If any finds were discovered during the preliminary field investigation, the project archaeologist shall implement Mitigation Measure **CUL-5** for evaluation and recovery methodologies. The results of the preliminary field investigation shall be submitted to the Director of Community Development for review and approval prior to issuance of any grading permit. The California Department of Parks and Recreation 523 series forms shall be submitted along with the report for any cultural resources encountered over 50 years old.

CUL-4: Construction Monitoring and Protection Measures. All ground-disturbing activities (e.g., grading and excavation) shall be completed under the observation of a Secretary of the Interior-qualified archaeologist and a qualified Native American monitor, registered with the Native American Heritage Commission (NAHC) with an interest in the city of Santa Clara. Preference in selecting Native American monitors shall be given to members of the Tamien Nation and Native Americans with:

- Traditional ties to the area being monitored
- Knowledge of local Native American village sites and habitation patterns
- Knowledge and understanding of Health and Safety Code, section 7050.5 and Public Resources Code, section 5097.9 et seq.
- Ability to effectively communicate the requirements of Health and Safety Code, section 7050.5 and Public Resources Code, section 5097.9 et seq.

- Ability to work with law enforcement officials and the Native American Heritage Commission to ensure the return of all associated grave goods taken from a Native American grave during excavation
- Ability to travel to project sites within traditional tribal territory
- Knowledge and understanding of Title 14, California Code of Regulations, section 15064.5
- Ability to advocate for the preservation in place of Native American cultural features through knowledge and understanding California Environmental Quality Act (CEQA) mitigation provisions
- Ability to read a topographical map and be able to locate site and reburial locations for future inclusion in the NAHC's Sacred Lands Inventory
- Knowledge and understanding of archaeological practices, including the phases of archaeological investigation

The qualified archaeologist or a qualified Native American monitor, shall have authority to halt construction activities temporarily within a 50-foot radius of any cultural resources finds.

If the archaeologist and Native American monitor believe that a reduction in monitoring activities is prudent, then a letter report detailing the rationale for making such a reduction and summarizing the monitoring results shall be provided to the Director of Community Development. If, for any reasons, the qualified archaeologist or a qualified Native American monitor is not present, but construction crews encounter a cultural resource, all work shall stop temporarily within 50 feet of the find until a qualified archaeologist in consultation with a qualified Native American monitor has been contacted to determine the proper course of action. The Director of Community Development shall be notified of any finds during the grading or other construction activities. Any human remains encountered during construction shall be treated according to the protocol identified in Mitigation Measure **CUL-6**.

CUL-5: Evaluation and Data Recovery. The City of Santa Clara's Director of Community Development shall be notified of any finds during the preliminary field investigation, grading, or other construction activities. Any historic or Native American cultural material identified in the project area during the preliminary field investigation and during grading or other construction activities shall be evaluated for eligibility for listing as a Candidate City Landmark or a historical resource (per CEQA) by a Secretary of the Interior-qualified archaeologist.

If Native American cultural materials or historic resources are encountered, all activity within a 50-foot radius of the find shall be stopped, the Director of Community Development shall be notified, and a Secretary of the Interior-qualified archaeologist shall examine the find and record the site, including field notes, measurements, and photography, and document the find using the California Department of Parks and

Recreation 523 series forms. The archaeologist shall make recommendations regarding eligibility as a Candidate City Landmark and/or a CEQA historical resource, data recovery, curation, or other appropriate mitigation. Ground disturbance within the 50-foot radius can resume once these steps are taken and the Director of Community Development has concurred with the recommendations.

Data recovery methods may include, but are not limited to, backhoe trenching, shovel test units, hand auguring, and hand-excavation. The techniques used for data recovery shall follow the protocols identified in the project-specific Cultural Resources Identification, Monitoring, and Treatment Plan. Data recovery shall include excavation and exposure of features, field documentation, and recordation.

CUL-6: Human Remains. If human remains are discovered during the preliminary field investigation, excavation and/or grading, building, or other construction activities at the site, all activity within a 50-foot radius of the find will be stopped. The Santa Clara County Coroner will be notified and shall determine whether the remains are of Native American origin or whether an investigation into the cause of death is required. If the remains are determined to be Native American, the coroner will notify the Native American Heritage Commission (NAHC) immediately. Once the NAHC identifies the most likely descendants, the descendants will make recommendations regarding treatment and disposition with appropriate dignity proper burial, which will be implemented in accordance with section 15064.5(e) of the California Environmental Quality Act Guidelines. All actions taken under this mitigation measure shall comply with Health and Human Safety Code, section 7050.5(b).

CUL-7: Site Security. At the discretion of the City of Santa Clara's Director of Community Development, site fencing shall be installed on-site during the preliminary field investigation, grading, building, or other construction activities to avoid destruction and/or theft of potential cultural resources. The responsible qualified archaeologist, in consultation with a qualified Native American monitor, registered with the Native American Heritage Commission (NAHC) with an interest in the city of Santa Clara and that is traditionally and culturally affiliated with the geographic area, shall advise the Santa Clara Director of Community Development as to the necessity for a security guard. The purpose of the security guard shall be to ensure the safety of any potential cultural resources (including human remains) that are left exposed overnight. The Director of Community Development shall have the final discretion to authorize the use of a security guard at the project site.

CUL-8: Closing Cultural Resources Report. Once all analyses and studies required by the project-specific Cultural Resources Identification, Monitoring, and Treatment Plan (Plan) have been completed, the project applicant, or representative, shall prepare a closing cultural resources report summarizing the results of the preliminary field investigation, data recovery activities and results, and compliance with the Plan during all demolition, grading, building, and other construction activities. The report shall document the results of field and laboratory investigations and shall meet the Secretary

of the Interior's Standards for Archaeological Documentation. The contents of the report shall be consistent with the protocol included in the project-specific Cultural Resources Treatment Plan. The report shall be submitted to the City of Santa Clara's Director of Community Development for review and approval prior to issuance of any certificates of occupancy (temporary or final). Once approved, the final documentation shall be submitted to the Northwest Information Center at Sonoma State University, as appropriate.

CUL-9: Curation. Upon completion of the closing cultural resources report required by Mitigation Measure **CUL-8**, all recovered archaeological materials not identified as tribal cultural resources by the Native American monitor, shall be transferred to a long-term curation facility. Any curation facility used shall meet the standards outlined in the National Park Services' Curation of Federally Owned and Administered Archaeological Collections (36 CFR 79). The project owner shall notify the City of Santa Clara's Director of Community Development of the selected curation facility prior to the issuance of any certificates of occupancy (temporary or final). To the extent feasible, and in consultation with the Native American representative, all recovered Native American/tribal cultural resources and artifacts shall be reburied on-site in an area that is unlikely to be disturbed again. Treatment of materials to be curated shall be consistent with the protocols included in the project-specific Cultural Resources Identification, Monitoring, and Treatment Plan. All archaeological materials recovered during the data recovery efforts shall be cleaned, sorted, catalogued, and analyzed following standard archaeological procedures, and shall be documented in a report submitted to the City of Santa Clara's Director of Community Development and the Northwest Information Center (NWIC).

4.5.4 References

- Bertagnole 2022 – Stephanie Bertagnole, California Department of Parks and Recreation Archaeological Site Record for CA-SCL-001070/H (P-43-004159). Confidential document on file, Northwest Information Center, Rohnert Park, CA. Prepared by Klienfelder, Inc., March 31, 2022
- Busby et al. 1996b – Colin I. Busby, Donna M. Garaventa, Melody E. Tannam, and Stuart A. Guedon, *Supplemental Report: Historic Properties Affected or Potentially Affected by the South Bay Water Recycling Program*. Prepared for Parsons Engineering Science, Alameda, CA. Confidential report on file, Northwest Information Center, California Historical Resources Information System, Rohnert Park. Study S-019072a. June 1996
- Byrd et al. 2017 – Brian F. Byrd, Adrian R. Whitaker, Patricia J. Mikkelsen, and Jeffrey S. Rosenthal, *San Francisco Bay-Delta Regional Context and Research Design for Native American Archaeological Resources, Caltrans District 4*. Confidential report on file, Northwest Information Center, California Historical Resources Information System, Rohnert Park. Study S-049780. Prepared for Office of Cultural Resources Studies, District 4, California Department of Transportation, Oakland, June 2017

- Campagne 2022a – Cody Campagne, Letter Regarding 651 Martin Avenue Survey Project, Santa Clara County. Addressed to Katherine Sinsky, PaleoWest Archaeology, Walnut Creek, CA. Prepared by California Native American Heritage Commission, West Sacramento, CA. August 30, 2022
- Campagne 2022b – Cody Campagne, Letter Regarding Martin Backup Generating Facility Project, Santa Clara County. Addressed to Cameron Travis, California Energy Commission, Sacramento, CA. Prepared by California Native American Heritage Commission, West Sacramento, CA. December 5, 2022
- Cartier 1980 – R. Cartier, Archaeological Site Record for CA-SCL-430/H (P-43-433). Confidential record on file, Northwest Information Center, California Historical Resources Information System, Rohnert Park. February 1980
- Cartier and Detlefs 1980 – Robert Cartier and Charlene Detlefs, *Archaeological Evaluation of the San Jose Municipal Airport*. Prepared for the City of San Jose, San Jose, CA. Confidential report on file, Northwest Information Center, California Historical Resources Information System, Rohnert Parks. March 1980
- Cartier et al. 1992 – Robert Cartier, Allika Ruby, Jason Bass, and Mike Kelley, *Evaluation of Archaeological Resources for the San Jose/Santa Clara Nonpotable Water Reclamation Project*. Prepared for Engineering Science, Inc., Alameda, CA. Confidential report on file, Northwest Information Center, California Historical Resources Information System, Rohnert Park. Study S-014230. May 11, 1992
- CEC 2021 – California Energy Commission, *Tribal Consultation Policy*. Revised. November 2021. Sacramento, CA. CEC-700-2022-001. Accessed June 2, 2023. Electronic document, <https://www.energy.ca.gov/sites/default/files/2022-02/CEC-700-2022-001.pdf>
- CEC 2023 – California Energy Commission, (TN 252562). Initial Tribal Consultation Letters, Dated January 17, 2023. Available online at: [<https://efiling.energy.ca.gov/GetDocument.aspx?tn=252562&DocumentContentId=87649>]
- City of Santa Clara 2010 – City of Santa Clara, *City of Santa Clara General Plan 2010-2035*. November 16, 2010 <https://www.santaclaraca.gov/our-city/departments-a-f/community-development/planning-division/general-plan>. Accessed December 17, 2019
- City of Santa Clara 2017 – City of Santa Clara, *Initial Study, McLaren Data Center Project*. February 2017
- City of Santa Clara 2018 – City of Santa Clara, City Code, Title 18 Zoning, Chapter 18.106 Historic Preservation. Accessed: October 2022. Available online at: <http://codepublishing.com/CA/SantaClara/#!/santaclaral8/SantaClara18106.html#18.106.030>

- Davis 1961 – James T. Davis, *Trade Routes and Economic Exchange among the Indians of California*. University of California Archaeological Survey, No. 54. March 31, 1961
- DayZen 2022a – DayZen LLC (TN 247325). Martin Backup Generating Facility Application for Small Power Plant Exemption, Dated November 2022. Available online at: <https://efiling.energy.ca.gov/Lists/DocketLog.aspx?docketnumber=22-SPPE-03>
- DayZenLLC 2022c – DayZenLLC (DayZenLLC). (TN 247327). MBGF SPPE Application – Part IV – Appendix E, Part 2, dated November 7, 2022. Available online at: <https://efiling.energy.ca.gov/Lists/DocketLog.aspx?docketnumber=22-SPPE-03>
- DayZenLLC 2022d – DayZenLLC (DayZenLLC). (TN 247328). MBGF SPPE Application – Part III – Appendix E, Part 1, dated November 7, 2022. Available online at: <https://efiling.energy.ca.gov/Lists/DocketLog.aspx?docketnumber=22-SPPE-03>
- DayZenLLC 2022e – DayZenLLC (DayZenLLC). (TN 247329). MBGF SPPE Application – Part II – Appendices B, C and D, dated November 7, 2022. Available online at: <https://efiling.energy.ca.gov/Lists/DocketLog.aspx?docketnumber=22-SPPE-03>
- Fike 2016 – Aisha Fike, California Department of Recreation Primary Record Form for 651 Mathew Street. ICF International. Prepared for the City of Santa Clara. October 25, 2016
- Geary 2021 – Quirina Geary, Letter Regarding California Environmental Quality Act Public Resources Code section 21080.3, subd. (b) Request for Formal Notification of Proposed Projects Within the Tamien Nation’s Geographic Area of Traditional and Cultural Affiliation. Submitted to California Energy Commission, Sacramento. Prepared by Tamien Nation, San Jose CA. September 17, 2021
- GLO 1866 – General Land Office, Map of Township No. 6 South, Range No. 1 West, Mount Diablo Meridian. Surveyed 1851, 1853, 1857–1862, 1865, 1866. San Francisco, May 12, 1866.
- Golla 2007 – Victor Golla, Linguistic Prehistory. Chapter 6 in *California Prehistory: Colonization, Culture, and Complexity*, edited by Terry L. Jones and Kathryn A. Klar, pp. 71–82. Lanham, MD: AltaMira, 2007
- Heller-Leib et al. 2023 – Abby Heller-Leib, Andrew Bursan, and John Eddy, *Cultural Resources Assessment for the 651 Martin Avenue Project, City and County of Santa Clara, California*. Report prepared for Martin Avenue Properties, LLC. Prepared by Paleowest, Walnut Creek, CA. June 20, 2023
- Holson et al. 2002 – John Holson, Cordelia Sutch, and Stephanie Pau, *Cultural Resources Report for San Jose Local Loops, Level 3 Fiber Optics Project in Santa Clara and Alameda Counties, California*. Confidential report on file, Northwest Information Center, California Historical Resources Information System, Rohnert Park. Study S-025173. Prepared for Fluor Global Services, Inc., Aliso Viejo, CA. Prepared by Pacific Legacy, Albany, CA. May 2002

- Hylkema 1994 – Mark G. Hylkema, Tamien Station Archaeological Project. In *The Ohlone Past and Present: Native Americans of the San Francisco Bay Region*, compiled and edited by Lowell J. Bean, pp. 249–270. Anthropological Papers No. 42. Menlo Park, CA: Ballena Press, 1994
- Hylkema 1998 – Mark G. Hylkema, *Extended Phase I Archaeological Survey Report: Subsurface Presence/Absence Testing at the Woolen Mills Chinatown Site (CA-SCL-807/H) and Three Storm Water Detention Basins, for the Route 87 Guadalupe Corridor Freeway Project, City of San Jose, Santa Clara County, California*. Confidential report on file, Northwest Information Center, California Historical Resources Information System, Rohnert Park. Study S-020327. Office of Environmental Planning, South, District 4, California Department of Transportation, Oakland. May 8, 1998
- Kroeber 1976 – A. L. Kroeber, *Handbook of the Indians of California*. Originally published in 1925, Bulletin No. 78, Bureau of American Ethnology, Smithsonian Institution, Washington, D.C. Reprinted. New York: Dover Publications, 1976
- Lehmann 2000 – Susan Lehmann. Economic Development of the City of Santa Cruz, 1850-1950. From: Fully Developed Context Statement for the City of Santa Cruz. Prepared for City of Santa Cruz Planning and Development Department. Chapter 3, Context I: Economic Development of the City of Santa Cruz 1850-1950, pages 25-27. October 20, 2000. Electronic document, <https://history.santacruzpl.org/omeka/items/show/134510#?c=0&m=0&s=0&cv=0>. Accessed December 19, 2019
- Leventhal et al. 1990 – Alan Leventhal, Rosemary Cambra, and Andrew Galvan, Archeological Site Record for P-43-001080 (CA-SCL-702, Waste Management Site). Confidential record on file, Northwest Information Center, California Historical Resources Information System, Rohnert Park. Prepared by Ohlone Families Consulting Service, San Jose, CA. August 3, 1990
- Levy 1978 – Richard Levy, Costanoan. In *Handbook of North American Indians*, Vol. 8, *California*. Robert F. Heizer, ed., pages 485–495. Washington, D.C.: Smithsonian Institute, 1978
- Milliken et al. 2007 – Randall Milliken, Richard T. Fitzgerald, Mark G. Hylkema, Randy Groza, Tom Origer, David G. Bieling, Alan Leventhal, Randy S. Wiberg, Andrew Gottsfield, Donna Gillette, Viviana Bellifemine, Eric Strother, Robert Cartier, and David A. Fredrickson, Punctuated Culture Change in the San Francisco Bay Area. In *California Prehistory: Colonization, Culture, and Complexity*. Terry L. Jones and Kathryn A. Klar, eds., pages 99–124. Lanham, MD: AltaMira Press, 2007
- Mission College 2019 – Mission College. (TN 230848), Application for Small Power Plant Exemption: Mission College Data Center, dated November 2019. Available online at: <https://efiling.energy.ca.gov/Lists/DocketLog.aspx?docketnumber=19-SPPE-05>

- Nelson et al. 2000 – Wendy J. Nelson, Maureen Carpenter, and Julia G. Costello, *Cultural Resources Survey for the Level (3) Communications Long Haul Fiber Optics Project, Segment WS05: San Jose to San Luis Obispo*. Confidential report on file, Northwest Information Center, California Historical Resources Information System, Rohnert Park. Study S-022819. Prepared for Parson Brinckerhoff Network Services, Pleasanton, CA. Prepared by Far Western Anthropological Research Group, Inc., Davis, CA. June 30, 2000
- NPS 2018 – National Park Service. Early History. <https://www.nps.gov/articles/early-history.htm>. Accessed January 15, 2020
- OHP 1995 – Office of Historic Preservation, *Instructions for Recording Historical Resources*. Sacramento, CA: Office of Historic Preservation, March 1995
- Parsons and KEMCO 1983 – Parsons Brinckerhoff Quade & Douglas and Kobori Environmental Management Corp. *Data Recovery Plan for the Guadalupe Corridor Transportation Project, Santa Clara County, California*. Prepared for Santa Clara County Transportation Agency. Confidential report on file, Northwest Information Center, California Historical Resources Information System, Rohnert Park. Study S-006066. February 1983
- Perzel et al. 2019 – Rachel Perzel, Mark Strother, Hannah Haas, and Steven Treffers, *Cultural Resources Technical Report- CyrusOne Santa Clara 1 Data Center Project -2600 De La Cruz Boulevard, City and County of Santa Clara, California*. Confidential. Prepared for Circlepoint, San Jose, CA. Submitted to California Energy Commission, Sacramento. Rincon Consultants Project No. 19-06692. Oakland, CA, September 2019
- Psota 2019 – Sunshine Psota, Letter Regarding Results of a CEQA Archaeological Literature Search for Lafayette Street Data Center, 2825 Lafayette Street, City and County of Santa Clara. Confidential. Prepared for David J. Powers & Associates, San Jose, CA. Prepared by Holman & Associates, San Francisco, CA. November 9, 2019
- Rambo 1968 – Ralph Rambo, *Map of Santa Clara Ranchos. A Delineation of Spanish-Mexican Government Ranchos Land Grants or Ranchos and Pueblo Sites in Early Santa Clara Valley*. San Jose, CA: Harlan-Young Press, 1968
- SCC 2012 – County of Santa Clara Department of Planning and Development, Planning Office (SCC) County of Santa Clara Historic Context Statement. December 2004, Revised February 2012
- Santa Clara 2012 – County of Santa Clara, *County of Santa Clara Historic Context Statement*. Department of Planning and Development Planning Office. December 2004, revised February 2012
- Santa Clara 2023 – City of Santa Clara (Santa Clara). Map Santa Clara tool. Accessed March 20, 2023. Available online at: <https://www.santaclaraca.gov/our-city/about-santa-clara/maps>

- Santa Clara City Library 2019 – Santa Clara City Library, Owens Corning Fiberglas Plant in Santa Clara, CA under Construction, 1948. Santa Clara City Library Silicon Valley History Online Collection. November 6, 2019.
<https://calisphere.org/item/ark:/13030/kt3c6017tm/>
- SFEI 2010 – San Francisco Estuary Institute, *Historical Vegetation and Drainage Patterns of Western Santa Clara Valley: A Technical Memorandum Describing Landscape Ecology in Lower Peninsula, West Valley, and Guadalupe Watershed Management Areas*. Historical Ecology Program, Contribution No. 622
- Sikes et al. 2006 – Nancy Sikes, Cindy Arrington, Bryon Bass, Chris Corey, Kevin Hunt, Steve O’Neil, and Catherine T. Pruet, *Cultural Resources Final Report of Monitoring and Findings for the Qwest Network Construction Project, State of California*. Prepared for Qwest Communications, Denver, CO. Confidential report on file, Northwest Information Center, California Historical Resources Information System, Rohnert Park. S-033061. Prepared by SWCA Environmental Consultants, Sacramento, CA. December 2006
- SJMN 1965 – San Jose Mercury News, “Terminal Issues in New Era,” San Jose Mercury News, September 12, 1965, page 41
- USGS 1889 – United States Geological Survey, San Jose Quadrangle. 1889
- USGS 1899 – United States Geological Survey, San Jose Quadrangle. 1899
- USGS 1915 – United States Geological Survey, Geologic and Topographic Map of the Coast Route. 1915
- USGS 1980 – United States Geological Survey, San Jose West, California, Quadrangle. 7.5-minute Topographic Series. Photorevised version of 1961 edition. Denver, 1980
- Voss et al. 1993 – Barb Voss, Leigh Martin, and Nina Ilic, Archaeological Site Record for P-43-000649 (CA-SCL-762). Confidential record on file, Northwest Information Center, California Historical Resources Information System, Rohnert Park. Prepared by Woodward-Clyde Consultants, Oakland. May 7, 1993
- White and Thomas 1999 – G. White and D. Thomas, California Department of Parks and Recreation 523 Forms for P-43-001163 (CA-SCL-828, Fuel Farm Site). Confidential record on file, Northwest Information Center, California Historical Resources Information System, Rohnert Park. Prepared by Archaeological Research Program, California State University, Chico. October 8, 1999
- Woodrow 2016 – Kenneth Woodrow, Letter Regarding California Environmental Quality Act Public Resources Code Section 21080.3, subd. (b) Request for Formal Notification of Proposed Projects within the Tribe’s Geographic Area of Traditional and Cultural Affiliation. Submitted to California Energy Commission, Sacramento. Prepared by Wucksachi Indian Tribe, Salinas, CA. December 8, 2016

4.6 Energy and Energy Resources

This section describes the environmental and regulatory setting and discusses impacts associated with the construction and operation of the project specific to energy and energy resources¹.

ENERGY	Potentially Significant Impact	Less Than Significant with Mitigation Incorporated	Less Than Significant Impact	No Impact
Would the project:				
a. Result in potentially significant environmental impact due to wasteful, inefficient, or unnecessary consumption of energy resources during project construction or operation?	<input type="checkbox"/>	<input type="checkbox"/>	<input checked="" type="checkbox"/>	<input type="checkbox"/>
b. Conflict with or obstruct a state or local plan for renewable energy or energy efficiency?	<input type="checkbox"/>	<input type="checkbox"/>	<input type="checkbox"/>	<input checked="" type="checkbox"/>

Environmental checklist established by CEQA Guidelines, Appendix G.

4.6.1 Environmental Setting

The project would consist of a four-story building, utility substation, exterior generator equipment yard, surface parking and landscaping, and recycled water pipeline. The generator yard would house forty-four 2.75-megawatt (MW) diesel-fueled backup generators (gensets). Forty gensets, of which eight gensets would be redundant, would provide backup power to support an uninterruptible power supply exclusively for the project and its data center. The remaining four gensets (life safety gensets), of which two gensets would be redundant, would provide backup power to support critical cooling equipment, other general building (administration) and life safety services. The gensets would be used to provide backup power only during emergency outages when electric service provided by Silicon Valley Power (SVP), via Pacific Gas & Electric Company (PG&E) transmission lines is interrupted. The backup gensets would be electrically isolated from the PG&E electrical transmission grid with no means to deliver electricity offsite.

The gensets would each be a Caterpillar Model 3516E (Tier 4 compliant) with a peak rated output capacity of 2.75 MW and a continuous, steady-state output capacity of 2.2 MW, and fuel consumption rate of 192 gallons per hour (gal/hr) at full load (DayZenLLC 2022a, Section 4.6.3). CEC staff (staff) has verified the output capacity and rate of fuel consumption of these gensets from their product sheets (Caterpillar 2023). The maximum electrical load requirement of the data center would be 96.8 MW, which includes the electrical power load of the Information Technology (IT) servers, the cooling load of the data center buildings, as well as the facility's ancillary loads. See **Section 3.0 Project Description** for further information. For the purposes of testing and maintenance, only one genset would run at any given time.

¹ This section includes staff's analysis of the project's potential impact on Energy Resources, as required by Public Resources Code section 25541 when considering a Small Power Plant Exemption

Regulatory Background

Federal

Energy Star and Fuel Efficiency. At the federal level, energy standards set by the United States Environmental Protection Agency (EPA) apply to numerous consumer products and appliances. The EPA also sets fuel efficiency standards for automobiles and other modes of transportation.

State

California 2022 Energy Efficiency Standards for Residential and Nonresidential Buildings—Green Building Standards Code, California Code of Regulations, Title 24. The California Green Building Standards Code (California Code of Regulations, Title 24, Part 11) applies to the planning, design, operation, construction, use, and occupancy of newly constructed buildings and requires the installation of energy- and water-efficient indoor infrastructure. **Senate Bill 100—The 100 Percent Clean Energy Act of 2018.** Senate Bill (SB) 100 (Chapter 312, Statutes of 2018) requires that retail sellers and local publicly owned electric utilities procure a minimum quantity of electricity products from eligible renewable energy resources so that the total kilowatt-hours of those products sold to their retail end-use customers achieve 44 percent of retail sales by December 31, 2024, 52 percent by December 31, 2027, and 60 percent by December 31, 2030. This requirement applies to SVP, the primary provider of energy for the project. The bill also requires the Public Utilities Commission, California Energy Commission, and State Air Resources Board to utilize programs authorized under existing statutes to meet the state policy goal of 100 percent of total retail sales of electricity in California provided by eligible renewable energy resources and zero-carbon resources by December 31, 2045.

Local

City of Santa Clara Climate Action Plan. The city's Climate Action Plan (CAP) was adopted on December 3, 2013 and updated in June 7, 2022. It specifies strategies and measures to be taken for several focus areas, one of which is energy efficiency. To achieve the goals set in the CAP, the city adopted some policies in the City of Santa Clara 2010-2035 General Plan (General Plan) as discussed below.

City of Santa Clara General Plan 2010-2035. The General Plan was adopted by the Santa Clara City Council in November 2010. Applicable General Plan Policies and Actions regarding energy are detailed in Chapter 5.10.3 – Energy Goals and Policies and are summarized below:

- Policy 5.10.3-P1: Promote the use of renewable energy resources, conservation and recycling programs.
- Policy 5.10.3-P4: Encourage new development to incorporate sustainable building design, site planning and construction, including encouraging solar opportunities.

- Policy 5.10.3-P5: Reduce energy consumption through sustainable construction practices, materials, and recycling.
- Policy 5.10.3-P6: Promote sustainable buildings and land planning for all new development, including programs that reduce energy and water consumption in new development.
- Policy 5.10.3-P8: Provide incentives for LEED certified or equivalent development.

The project would be required to comply with the applicable provisions in the city's General Plan and zoning ordinance, as verified by the city's design review process.

4.6.2 Environmental Impacts

a. Result in potentially significant environmental impact due to wasteful, inefficient, or unnecessary consumption of energy resources, during project construction or operation?

Construction

Less Than Significant Impact. Construction vehicles and equipment would consume nonrenewable energy resources, primarily fossil fuels (oil, gasoline, and diesel). It is anticipated that these nonrenewable energy resources would be used efficiently during construction activities and would not result in significant long-term depletion of these energy resources or permanently increase the project's reliance on them.

The project would implement measures to minimize the idling of construction equipment and would require all such equipment to be maintained and properly tuned (see **Section 4.3 Air Quality** for more discussion). This would ensure that fuel consumed during construction would not be wasted through unnecessary idling or the operation of poorly maintained equipment, and not add to unnecessary air emissions. Additionally, as a requirement by the city's construction and/or demolition permit, the project would participate in the Construction & Demolition Debris Recycling Program by recycling or diverting at least 65 percent of materials generated for discard by the project to reduce the amount of demolition and construction waste going to the landfill. Diversion saves energy by reusing and recycling materials for other uses (instead of landfilling materials and using additional nonrenewable resources).

Therefore, the construction phase of the project would create a less-than-significant impact on local and regional energy supplies and a less-than-significant environmental impact due to wasteful, inefficient, or unnecessary consumption of energy resources.

Operation

Less Than Significant Impact. The total number of hours of operation for reliability purposes (i.e., readiness testing and maintenance) for the gensets would be limited by the data center to no more than 50 hours per genset annually (DayZenLLC 2022a, Section 2.2.12). The primary fuel for the gensets would be renewable diesel (to the maximum

extent feasible), with ultra-low sulfur diesel (ULSD or conventional) as backup fuel (DayZennLLC 2022a, Section 4.6.3.1). Renewable diesel is a direct replacement alternative to conventional diesel fuel for the project's gensets. It is not a fossil fuel and is made of nonpetroleum renewable resources (vegetable oil or other biomass feedstock such as wood, agricultural waste, garbage, etc.). Renewable diesel is produced through various thermochemical processes, such as hydrotreating, gasification, and pyrolysis. Please note that renewable diesel is not the same as biodiesel and has different fuel properties than biodiesel. Biodiesel is produced through transesterification, which is a chemical process that converts fats and oils into fatty acid methyl esters. (See **Section 5 Alternatives** for further discussion).

The total quantities of renewable diesel or ULSD diesel fuel used for all the gensets operating at full load would approximate 10,000 barrels per year (bbl/yr).² California has a renewable diesel and ULSD fuel supply of approximately 6,300,000 bbl/yr³ and 310,000,000 bbl/yr⁴, respectively. The project's use of fuel constitutes a small fraction of the renewable diesel and ULSD's available resources (less than 0.15 and 0.003 percent, respectively)—the supply from the combination of these two resources is more than sufficient to meet the project's necessary demand. Moreover, the current supply of renewable diesel does not account for more refineries that are coming online, and any import supply. Future and import supply would bolster renewable diesel's available resource.

Since the project would use renewable diesel, with ULSD as backup supply, the project's use of fuel on energy resources would be less than significant.

It is important to note that maintenance and readiness testing of the gensets are crucial to the project's viability. The most important data center criterion is reliability. Crucial public services, such as the 911, Offices of Emergency Management, and utility infrastructure, are increasingly using data centers for their operation. The reliability and data security requirements of a data center would be compromised by limiting or reducing fuel consumption for maintenance and readiness testing. This includes both the primary and redundant gensets. Even though the redundant gensets are purposed to provide backup service to the primary gensets, their operational reliability is equally important, and they are designed to start up at the same time as the primary gensets during emergency operations, with each genset running at 80 percent capacity (DayZenLLC 2022a, Section 2.2.5). If any of the primary gensets fails to operate, a redundant one must be immediately ready to run to take up the lost load. So, it is crucial that the redundant gensets be regularly tested and maintained according to the same testing and

2 Calculated as: (192 gal/hr x 50 hours per year x 44 generators) = 422,400 gallons per year = 10,057 bbl/yr.

3 This is the annual production of 265,000,000 gallons obtained from the U.S. Energy Information Administration's U.S. Renewable Diesel Fuel and Other Biofuels Plant Production Capacity

4 This is the sum of the annual production of 108,657,000 bbl and available stocks of 202,075,000 bbl obtained from the Energy Commission's Weekly Fuels Watch Report for 2022 (latest annual report available).

maintenance requirements as the primary ones and as prescribed by the manufacturer's warranty conditions. The use of diesel fuel for the gensets for readiness testing and maintenance would not be wasteful, inefficient, or unnecessary.

The gensets would use diesel and lubricating oils. However, the use of the standby gensets for emergency purposes would be limited to times when there is an interruption of SVP's delivery of electric service or other rare emergencies that would require the facility to switch to genset use. Under emergency conditions, defined as the loss of electrical power to the data center, which are infrequent and short-duration events, the gensets could operate and use diesel fuel, as necessary, to maintain data center operations. Data centers, such as this one, could voluntarily participate in CPUC's Emergency Load Reduction Program, in which case, they would disconnect from the grid and use their on-site generators to supply their own electricity in the event of an energy shortage emergency. However, based on data between 2001 and 2020, energy shortages are rare events. Such events have not impacted SVP customers directly and staff expects their effects to decrease over time; see **Appendix B** for more discussion.

The Caterpillar generator models selected for this project have an efficiency rating comparable to other Tier 4 commercially available diesel-fueled generators of similar generating capacity.

Power Usage Effectiveness (PUE) is a metric used to compare the energy efficiency of facilities that house computer servers. It is a common metric for determining how effectively a data center's infrastructure systems can deliver power to the computer systems it houses. PUE was published in 2016 as a global standard under the International Organization for Standardization, the International Electrotechnical Commission, as well as the European Standards (ISO 20160, European Standards 2016). It is defined as the ratio of total facility energy draw (including the facility's mechanical and electrical loads) to IT server electrical power draw ($PUE = \text{total facility source energy [including the IT source energy]} / \text{IT source energy}$). This approach to calculating a data center's energy efficiency is similar to the American Society of Heating, Refrigerating, and Air-conditioning Engineers (ASHRAE) Energy Standard for Data Centers (ASHRAE 90.4). However, there is a notable difference: ASHRAE 90.4, which intends to tackle and regulate poorer performers, calculates energy efficiency by providing an alternative path that allows tradeoffs between mechanical and electrical loads, particularly within existing, older data centers, while the PUE is a more appropriate path to determining a new data center's energy efficiency.

A PUE of 2 means that the data center must draw two watts of electricity for each watt of power consumed by the IT server equipment. While the PUE is always greater than 1, the closer it is to 1, the greater the portion of the power drawn by the facility that goes to the IT server equipment.

The PUE has been used as a guideline for assessing and comparing energy and power efficiencies associated with data centers since 2007 (ASHRAE 2016). It must be noted that the PUE metric was designed to compare facilities of similar size and within similar

climatic conditions. PUE factors started around 2.0, but values have since been migrating down to 1.25 or lower, demonstrating a significant improvement in efficient energy usage over the years. A facility with a PUE of 1.5-2.0 is considered “efficient” while one with a PUE of 1.2-1.5 is considered “very efficient.”

The peak PUE for the project would be 1.45, and its annual average PUE would be 1.26 (DayZenLLC 2022a, Section 2.2.3.2). The project’s peak operation PUE estimate is based on design assumptions and represents the worst case; that is, the hottest day with all server bays occupied and all servers operating at 100 percent capacity.

The project would be constructed in accordance with the 2022 California Green Building Standards Code and would include green building measures to reduce energy consumption. Examples of these measures include:

- Utilizing lighting control to reduce energy usage; and
- Air economization⁵ integrated into the central air handling system for building cooling.

The project’s consumption of energy resources during operation would not be wasteful, inefficient, or unnecessary. Thus, project operation would have a less-than-significant adverse effect on local or regional energy supplies and resources.

b. Conflict with or obstruct a state or local plan for renewable energy or energy efficiency?

Construction and Operation

No Impact. During operation, the project would use energy resources in SVP’s portfolio of resources. SVP’s 2018 Integrated Resource Plan identifies that it expects to exceed 50 percent of eligible renewable resources by 2030 (SVP 2018). SVP’s 2021 non-residential power mix was composed of approximately 27 percent eligible renewable, 6.7 percent large hydroelectric, 34.3 percent nonrenewable, and 32 percent unspecified sources of power (SVP 2023). In addition, SVP offers customers 100 percent carbon-free renewable electricity through the Green Power Standard (SVP 2023).

In accordance with the city’s CAP (B-1-7), the project would participate in SVP’s Green Power Standard operating on 100 percent carbon-free energy (DayZennLLC 2023a, Section 4.8.3.2). Therefore, the project will not obstruct SVP’s compliance with a state plan for renewable energy.

In addition, the project’s use of ULSD as a backup fuel for the gensets’ primary fuel would not obstruct or inhibit the state from achieving its energy-related goals. As previously mentioned, the gensets would operate only during routine testing and maintenance (limited to 50 hours per genset), and in the rare case of emergencies to serve the project

⁵ An air economizer is a ducting arrangement, including dampers, linkages, and an automatic control system that allows a cooling supply fan system to supply outside air to reduce or eliminate the need for mechanical cooling.

and not the wider electric grid. See **Sections 4.3 Air Quality and 4.8 Greenhouse Gas** for more discussion.

The project, through energy-efficient design, use of renewable diesel fuel, and renewable electricity use from SVP, its primary electricity source, would neither conflict with nor obstruct state or local plans for renewable energy or energy efficiency, and, therefore, would have no impact on those plans.

4.6.3 Mitigation Measures

None required.

4.6.4 References

- ASHRAE 2016 – American Society of Heating, Refrigerating, and Air-conditioning Engineers ASHRAE Journal (ASHRAE). Article: Supercomputers, Super Efficiency, pp. 38-39. Published in January 2016. Available online at: <https://technologyportal.ashrae.org/journal/articledetail/1670>
- CEC 2021 – California Energy Commission (CEC). (TN 230953). Review of Silicon Valley Power’s 2018 Integrated Resource Plan, dated December 2, 2019. Available online at: <https://efiling.energy.ca.gov/GetDocument.aspx?tn=230953&DocumentContentId=62579>
- CEC 2022b – California Energy Commission (CEC). (TN 241242). Report of Conversation – City of Santa Clara Silicon Valley Power, dated January 12-13, 2022. Available online at: <https://efiling.energy.ca.gov/Lists/DocketLog.aspx?docketnumber=21-SPPE-01>
- Caterpillar 2022 – Caterpillar. Diesel Generator Sets. Accessed: April 5, 2022. Available online at: https://www.cat.com/en_US/products/new/power-systems/electric-power/diesel-generator-sets/1000033111.html
- DayZenLLC 2022a – DayZenLLC (DayZenLLC). (TN 247325). MBGF SPPE Application – Part I – Main App and Appendix A, dated November 7, 2022. Available online at: <https://efiling.energy.ca.gov/Lists/DocketLog.aspx?docketnumber=22-SPPE-03>
- European Standards 2016 – European Standards. CSN EN 50600-4-2 Information technology – Data centre facilities and infrastructures – Part 4-1: Power Usage Effectiveness. Released 2016. Available online at: <https://www.en-standard.eu/csn-en-50600-4-2-information-technology-data-centre-facilities-and-infrastructures-part-4-2-power-usage-effectiveness/>
- ISO 2016 – ISO. ISO/IEC 30134-2:2016, Information technology – Data centres – key performance indicators – Part 2: Power usage effectiveness (PUE). Published April 2016. Available online at: <https://www.iso.org/standard/63451.html>

SVP 2018 – Silicon Valley Power (SVP). 2018 Integrated Resource Plan for Silicon Valley Power. November 12, 2018. Available online at:
<https://www.siliconvalleypower.com/home/showdocument?id=62481>

SVP 2023 – Silicon Valley Power (SVP). 2021 Power Content Label. Available online at:
<https://www.siliconvalleypower.com/svp-and-community/about-svp/power-content-label>

4.7 Geology and Soils

This section describes the environmental setting and regulatory background and discusses impacts, associated with the construction and operation of the project with respect to geology and soils.

GEOLOGY AND SOILS	Potentially Significant Impact	Less Than Significant with Mitigation Incorporated	Less Than Significant Impact	No Impact
Would the project:				
a. Directly or indirectly cause potential substantial adverse effects, including the risk of loss, injury, or death involving:				
i. Rupture of a known earthquake fault, as delineated on the most recent Alquist-Priolo Earthquake Fault Zoning Map issued by the State Geologist for the area or based on other substantial evidence of a known fault? Refer to Division of Mines and Geology Special Publication 42.	<input type="checkbox"/>	<input type="checkbox"/>	<input checked="" type="checkbox"/>	<input type="checkbox"/>
ii. Strong seismic ground shaking?	<input type="checkbox"/>	<input type="checkbox"/>	<input checked="" type="checkbox"/>	<input type="checkbox"/>
iii. Seismic-related ground failure, including liquefaction?	<input type="checkbox"/>	<input type="checkbox"/>	<input checked="" type="checkbox"/>	<input type="checkbox"/>
iv. Landslides?	<input type="checkbox"/>	<input type="checkbox"/>	<input checked="" type="checkbox"/>	<input type="checkbox"/>
b. Result in substantial soil erosion or the loss of topsoil?	<input type="checkbox"/>	<input type="checkbox"/>	<input checked="" type="checkbox"/>	<input type="checkbox"/>
c. Be located on geologic units or soil that is unstable, or that would become unstable as a result of the project, and potentially result in on- or off-site landslide, lateral spreading, subsidence, liquefaction, or collapse?	<input type="checkbox"/>	<input type="checkbox"/>	<input checked="" type="checkbox"/>	<input type="checkbox"/>
d. Be located on expansive soil, as defined in Section 1803.5.3 of the California Building Code, creating substantial direct or indirect risks to life or property?*	<input type="checkbox"/>	<input type="checkbox"/>	<input checked="" type="checkbox"/>	<input type="checkbox"/>
e. Have soils incapable of adequately supporting the use of septic tanks or alternative wastewater disposal systems where sewers are not available for the disposal of waste water?	<input type="checkbox"/>	<input type="checkbox"/>	<input type="checkbox"/>	<input checked="" type="checkbox"/>
f. Directly or indirectly destroy a unique paleontological resource or site or unique geologic feature?	<input type="checkbox"/>	<input checked="" type="checkbox"/>	<input type="checkbox"/>	<input type="checkbox"/>

*Geology and Soils question (d) reflects the current 2022 California Building Code (CBC), effective January 1, 2023, which is based on the International Building Code (2021).
Environmental checklist established by CEQA Guidelines, Appendix G.

4.7.1 Environmental Setting

Analysis of existing data included reviews of publicly available literature, maps, air photos, and documents. The geologic map review of the project area included maps published

by the U.S. Geological Survey (Helley and Wesling 1989 and Helley et al. 1994). A paleontological record search of the University of California Museum of Paleontology, Berkeley online paleontological database was conducted for the project area, including a 10-mile buffer zone surrounding the project site (UCMP 2022).

Paleontological Sensitivity

Paleontological resources are the fossilized remains of organisms from prehistoric environments found in geologic strata, ranging from mammoth and dinosaur bones to impressions of ancient animals and plants, trace remains, and microfossils. These are valued for their information about the history of the earth and its past ecological settings. The California Public Resources Code (Section 5097.5) specifies that unauthorized removal of a paleontological resource is a misdemeanor.

Regional Geologic Setting

The proposed project is situated in the Coast Ranges geomorphic province southern ranges section (**Figure 4.7-1**). The northern and southern ranges are separated by a depression containing the San Francisco Bay. The Coast Ranges contain many elongate ridges and narrow valleys that are approximately parallel to the coast, although the coast trends slightly northward more than the ridges and valleys (Norris and Webb 1990). The differences between the two ranges occur because the northern ranges lie east of the San Andreas Fault zone, whereas the southern ranges predominantly lie to the west (Norris and Webb 1990). The northern ranges and portions of the southern ranges east of the San Andreas Fault zone are generally underlain by strongly deformed Franciscan subduction complex rocks, and the areas west of the San Andreas Fault zone, in both the northern and southern ranges, are generally underlain by a strongly deformed granitic-metamorphic complex known as the Salinian block. The basement rock beneath the project site, which lies east of the San Andreas Fault zone consists of Franciscan Complex rocks (Norris and Webb 1990).



**Figure 4.7-1
Geomorphic Provinces**

- City/Town/Populated Place
- E-Eureka F-Fresno N-Needles
- R-Redding B-Bakersfield K-Kelso
- S-Sacramento SB-Santa Barbara SD-San Diego
- SF-San Francisco LA-Los Angeles
- M-Monterey PS-Palm Springs

Sources: California Department of Conservation,
California Geological Survey, 2002

Local Geology

Figure 4.7-2 depicts the surficial geology in the vicinity of the project. The project site is in the Santa Clara Valley, a relatively broad alluvial basin, bounded by the San Francisco Bay to the north, the Santa Cruz Mountains to the west and southwest, and the Diablo Mountain Range to the east and southeast. The Santa Clara Valley basin contains alluvial deposits derived from the Diablo Range and the Santa Cruz Mountains. The valley sediments were deposited as a series of coalescing alluvial fans by streams that drain the adjacent mountains. Interbedded bay and lacustrine (lake) deposits are mapped near the San Francisco Bay. The alluvial soil thickness in the area of the site is mapped to be greater than 500 feet thick (DayZenLLC 2022e) and include the groundwater aquifers of the area (Norris and Webb 1990).

The project site is mapped in the San Jose West 7½ Quadrangle, Santa Clara County (USGS 1980) and is underlain by Holocene age (less than 11,000 years old) flood plain deposits (Qhb) (**Figures 4.7-2**) (Helley et al. 1994). The deposits are generally described as organic-rich clay to very fine silty-clay deposits occupying the lowest topographic positions between Holocene age natural stream levee deposits. In the San Jose West quadrangle these deposits are found west of the Guadalupe River and border the natural levees of San Tomas Aquinas and Saratoga Creeks at the northern edge of the quadrangle.

There are no unique geologic features on or adjacent to the project site. According to the United States Geological Survey, 7.5-Minute Topographic Map for San Jose West (USGS 1980), the site is located approximately 1 mile southwest of the Guadalupe River. The site elevation is approximately 47 feet above mean sea level, and local topography slopes generally north. Erosion hazards are limited and there are no landslide hazards.

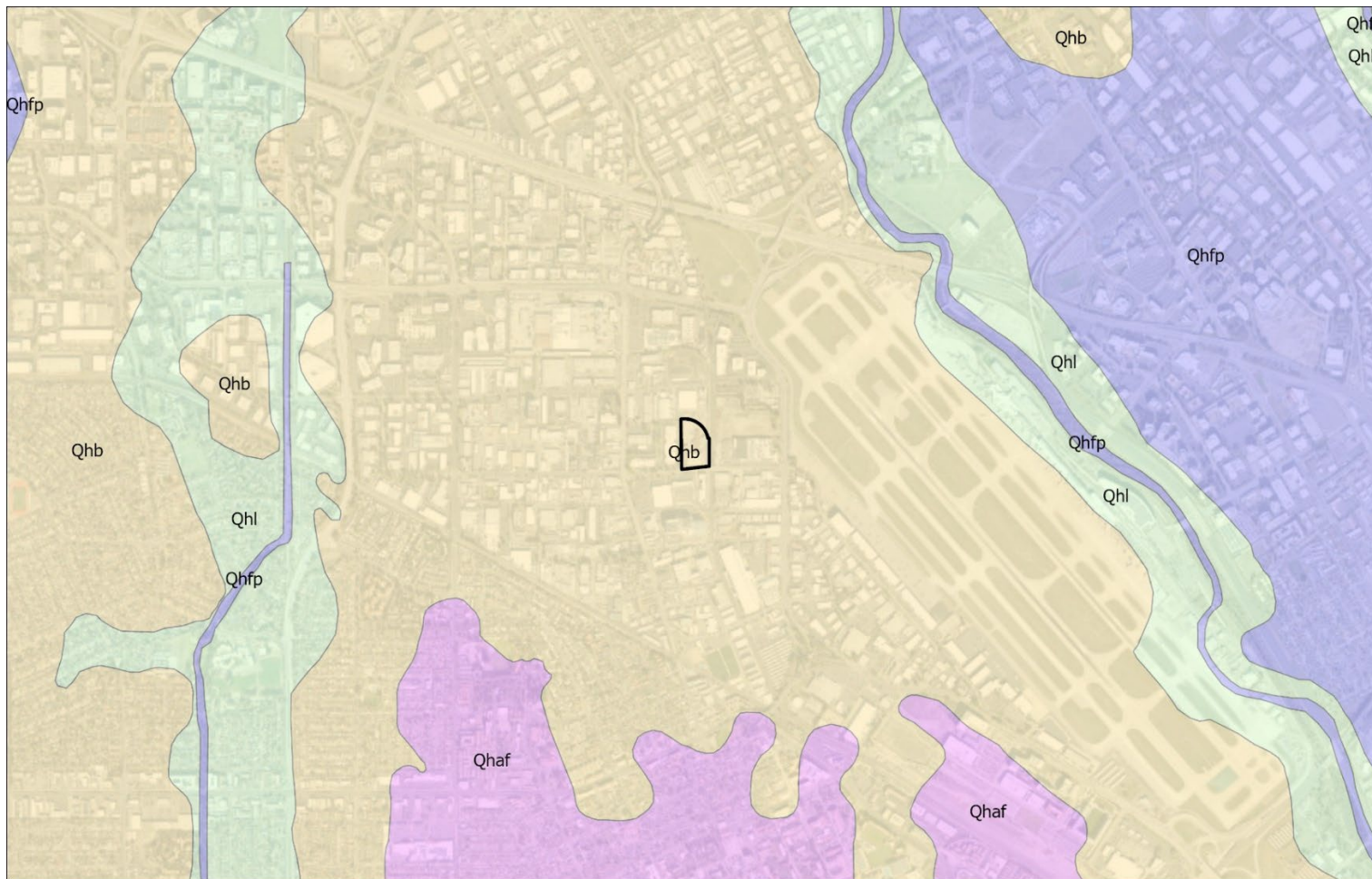

- Project Site
- Qhaf: Holocene Natural Alluvial Fan
- Qhb: Holocene Floodbasin Deposits
- Qhfp: Holocene Floodplain Deposits
- Qhl: Holocene Natural Levee Deposits

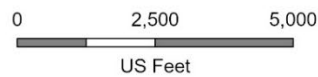

Figure 4.7-2
Surficial Geology

Source: USGS
OFR Report 94-231

REF: Digitized from (<https://pubs.usgs.gov/of/1994/of94-231/sccomap.pdf>)

Groundwater

Groundwater in the project area has been historically high. Cornerstone prepared a geotechnical investigation for the site (DayZenLLC 2022e) and encountered groundwater in their exploratory borings at depths ranging from about 10½ to 15 feet below current grades. Cornerstone also inferred groundwater at depths ranging from approximately 10½ to 11 feet below existing grades in their CPTs based on pore pressure dissipation tests. The Hazard Zones Map for the San Jose West Quadrangle, Report 058, maps groundwater at depths of less than 10 feet below the current grades in the vicinity of the site (CGS 2002).

Cornerstone also reviewed groundwater data available online from the State Water Resources Control Board website GeoTracker. Nearby monitoring well data indicates that groundwater has been measured at depths of approximately 6.9 to 8.8 feet at wells located approximately ⅓ mile east at 2495 De La Cruz Boulevard between May 2002 and January 2009 (Geotracker 2023). Based on this, Cornerstone used a design groundwater depth of 6 feet below the ground surface in their analyses.

Fluctuations in the level of the groundwater may occur due to variations in rainfall, underground drainage patterns, and other factors not evident at the time measurements were made.

The city of Santa Clara relies on groundwater from the Santa Clara groundwater basin for about 59 percent of its water supply. Imported water from the Santa Clara Valley Water District (SCVWD, Valley Water) and the San Francisco Public Utilities Commission (SFPUC) Hetch-Hetchy system make up the sum of the city's needs. Based on mapping provided by the City of Santa Clara Water Utility, the project area is serviced by both well water and water from the SFPUC Hetch-Hetchy system (Santa Clara 2021).

Further discussion regarding water use can be found in **Section 4.10 Hydrology and Water Quality** as well as in **Section 4.19 Utilities and Service Systems**.

Seismicity and Seismic Hazards

The San Francisco Bay Area is one of the most seismically active areas in the United States. The significant earthquakes that occur in the Bay Area are generally associated with crustal movement along well-defined active fault zones of the San Andreas Fault system (Figure 4.7-3), which regionally trend in a northwesterly direction (CGS 2010). Higher levels of shaking and damage would be expected from earthquakes occurring along faults at closer distances to the project site.

While seismologists cannot predict earthquake events, geologists from the United States Geological Survey have recently updated estimates from their 2014 Uniform California Earthquake Rupture Forecast (Version 3; UCERF3) publication. The estimated probability of one or more magnitude 6.7 earthquakes (the size of the destructive 1994 Northridge earthquake) expected to occur somewhere in the San Francisco Bay Area has been

increased to 72 percent for the period from 2014 to 2043. The faults in the region with the highest estimated probability of generating earthquakes of magnitude 6.7 or larger are the Hayward (33%), Calaveras (26%), and San Andreas Faults (22%). The faults considered capable of generating significant earthquakes are generally associated with well-defined areas of crustal movement, which trend northwesterly (DayZenLLC 2022e).

The table below presents the State-considered active faults within 25 kilometers (15½ miles) of the site.

Fault Name	Distance	
	(miles)	(kilometers)
Hayward (Southeast Extension)	6.3	10.1
Monte Vista-Shannon	7.6	12.3
Hayward (Total Length)	8.9	14.3
Calaveras	9.4	15.2
San Andreas (1906)	11.4	18.4

The site is not located within an Earthquake Fault Zone as defined by the State of California Alquist-Priolo Earthquake Fault Zoning Act and there are no known active or potentially active faults crossing the project site. However, because of the proximity of the site to major active faults, ground shaking, ground failure, or liquefaction due to an earthquake could cause damage to the structures.

Structural design of facilities in California are required to incorporate design features to ensure public safety if a seismic event generates sufficient ground motion to impact the structural integrity of the facility in accordance with the CBC (CBC 2022).

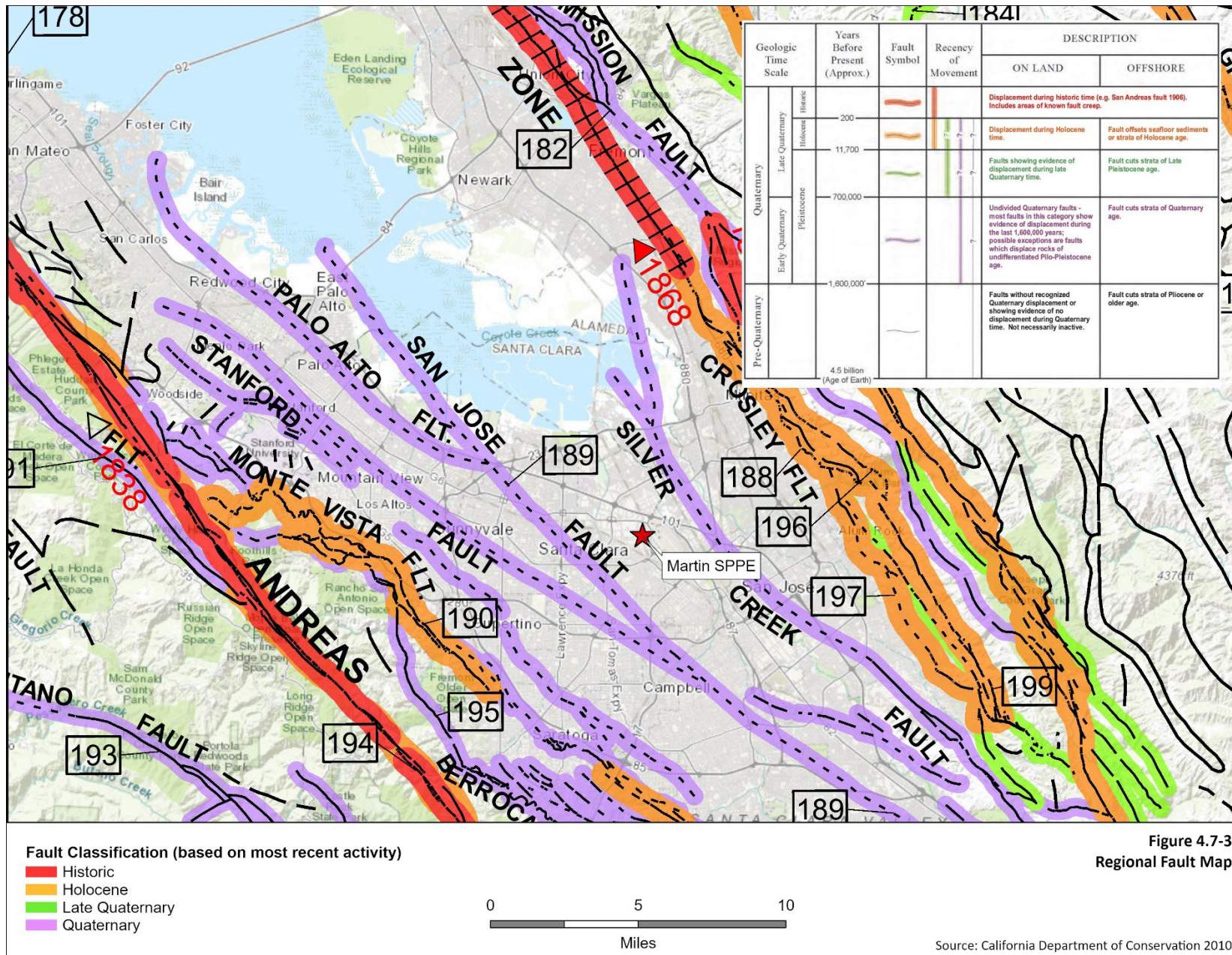

Figure 4.7-3
Regional Fault Map

Source: California Department of Conservation 2010

Soils

Figure 4.7-2 depicts the surficial soil units at and near the project site. The surface soils at the site and vicinity are mapped as Holocene age floodplain deposits (Qhb) (Helley 1994). The deposits are generally described as organic-rich clay to very fine silty-clay deposits occupying the lowest topographic positions between Holocene natural levee deposits of existing and past stream channels.

Based on the borings conducted at the project site (DayZenLLC 2022e), the site is underlain by approximately 1¼ to 2½ feet of undocumented fill underlain by native alluvial soil to the maximum depths explored of approximately 81 feet below the ground surface. The undocumented fills were identified as highly variable and generally consisted of very stiff sandy lean clay, very stiff to hard fat clay with sand, and medium dense clayey sand with gravel.

Below the undocumented fills, the borings generally encountered native alluvial soils consisting of stiff to very stiff fat clay to a depth of about 6 to 9 feet below existing grades. Below the upper fat clay layer, Borings EB-1 to EB-3, EB-5, and EB-7 to EB-8 generally encountered stiff to very stiff lean clay to a depth of about 18 to 26 feet underlain by interbedded layers of medium dense to very dense sands with variable amounts of silt and clay to the terminal boring depths of about 30 to 81 feet. Below the upper fat clay layer, Borings EB-4 and EB-6 generally encountered medium dense to dense sands with variable amounts of silt and clay to a depth of about 21 to 26 feet below existing grades underlain by stiff to very stiff lean clay with interbedded layers of medium dense to dense sands with variable amounts clay to the terminal boring depths of about 60 feet below existing grades. Borings EB-6 and EB-7 also encountered a layer of stiff to very stiff sandy silt between about 42 to 47 feet below existing grades.

Beneath the terminal boring depth of 81 feet, CPTs performed at the site generally interpreted the underlying soils as interbedded layers of very stiff to hard clays with varying amounts of sand and silt and dense to very dense sands with varying amounts of clay and silt fines to the maximum depth explored of 120 feet.

The site is generally blanketed by very highly expansive surficial soils. Expansive soils can undergo significant volume change with changes in moisture content, shrinking and hardening when dried and expanding and softening when wetted. To reduce the potential for damage to the planned structures, slabs-on-grade should have sufficient reinforcement and be supported on a layer of non-expansive fill; footings should extend below the zone of seasonal moisture fluctuation. In addition, it is important to limit moisture changes in the surficial soils by using positive drainage away from buildings as well as limiting landscaping watering. Evaluation of potential import sources for the site should consider the acceptable range of plasticity as recommended by Cornerstone (DayZenLLC 2022e).

Liquefaction

During strong ground shaking, loose, saturated, cohesionless soils can experience a temporary loss of shear strength and act as a fluid, a phenomenon known as liquefaction. Liquefaction depends on the depth to water, grain size distribution, relative soil density, degree of saturation, and intensity and duration of the earthquake. Soils most susceptible to liquefaction are loose, uniformly graded, saturated, fine-grained sands that lie close to the ground surface (Youd et al. 2001).

According to the State of California Official Seismic Hazard Zones Map for the San Jose West Quadrangle (CGS 2002), the site is mapped in an area where historical occurrences of liquefaction, or local geological, geotechnical and groundwater conditions indicate a potential for permanent ground displacements such that mitigation as defined in Public Resources Code Section 2693(c) would be required. The site is in an area considered to have a moderate susceptibility to earthquake-induced liquefaction, according to the Association of Bay Area Governments (ABAG) Earthquake Liquefaction Susceptibility Map (Knudsen et al., 2000).

Cornerstone performed liquefaction analysis on select borings and CPTs and determined that several layers could potentially experience liquefaction that could result in post-liquefaction total settlement of up to about 1.0 inch at the ground surface of up to about 1 inch based on the Yoshimine (2006) method. Cornerstone estimated differential settlements are anticipated to be on the order of $\frac{2}{3}$ -inch or less over a horizontal distance of 30 to 40 feet.

Lateral Spreading

Lateral spreading typically occurs as a form of horizontal displacement of relatively flat-lying alluvial material toward an open or "free" face such as an open body of water, channel, or excavation. In soils, this movement is generally due to failure along a weak plane and may often be associated with liquefaction. As cracks develop within the weakened material, blocks of soil displace laterally towards the open face. Cracking and lateral movement may gradually propagate away from the face as blocks continue to break free. Lateral spreading is generally the most pervasive and damaging type of liquefaction-induced ground failure induced by earthquakes. However, failure in this mode is analytically unpredictable because it is difficult to evaluate where the first tension crack would occur. The project site is relatively flat, there is no open-face slope, and there are no stream channels on or adjacent to the site; therefore, the project site would not be subject to lateral spreading.

Regulatory Background

The project would be required to comply with all applicable federal, state, and local laws and regulations and would need to obtain building permits that would be issued by the city of Santa Clara. The issuance of the building permits and oversight provided by the city would confirm that the project complies with the applicable regulatory framework.

Federal

As described in **Section 4.10 Hydrology and Water Quality** and noted further below, erosion control is regulated by the Federal Clean Water Act, State of California Porter Cologne Water Quality Act, the National Pollutant Discharge Elimination System (NPDES), and city General Plan policies 6-29 and 8-14.

Federal Clean Water Act and State Porter-Cologne Water Quality Control Act – Construction Site Discharges. Under the federal Clean Water Act, discharge of storm water from construction sites must comply with the conditions of a NPDES permit. The State Water Resources Control Board (SWRCB) has adopted a statewide General Permit for Storm Water Discharges Associated with Construction and Land Disturbance Activities (Construction General Permit) that applies to projects resulting in one or more acres of soil disturbance., A construction Storm Water Pollution Prevention Plan (SWPPP) is required for projects disturbing more than one acre of soil, specifying site management activities to be implemented during site development. These management activities include construction storm water best management practices (BMPs); erosion and sedimentation controls; dewatering; runoff controls; and construction equipment maintenance. The SWRCB requires a Notice of Intent (NOI) to be filed prior to any storm water discharge from construction activities, and that the SWPPP be implemented and maintained onsite.

Paleontological Resources Preservation Act. The Paleontological Resources Preservation Act of 2009 (PRPA) (16 U.S.C. § 470aaa 1-11) was enacted on March 30, 2009, within the Omnibus Public Land Management Act of 2009, to provide guidance related to the management, collection, and curation of paleontological resources from federal lands.

In 2020, to clarify and ensure uniform implementation of the PRPA, the Department of the Interior (DOI) provided additional guidance to the PRPA under rule 43 of the Code of Federal Regulations (CFR) by adding a new part 49 entitled "Paleontological Resources Preservation." In accordance with 16 U.S.C. 470aaa-1, the rule outlines how the four bureaus (Bureau of Reclamation, Bureau of Land Management, the U.S. Fish and Wildlife Service, and the National Park Service) manage, protect, and preserve paleontological resources on Federal land using scientific principles and expertise.

Together PRPA and the regulations at Part 49 require the bureaus to:

- Manage paleontological resources using scientific principles and expertise.
- Maintain program of inventory and monitoring of paleontological resources.
- Establish an education program to increase public awareness about paleontological resources.

The regulations also:

- Implement a program of permitting for the collection of paleontological resources.

- Require bureaus to preserve paleontological objects for the public in approved museum collections.
- Provide for casual collection of common non-vertebrate fossils by the public without a permit (BLM and Reclamation lands only).

State

Alquist-Priolo Earthquake Fault Zoning Act. The Alquist-Priolo Earthquake Fault Zoning Act was passed following the 1971 San Fernando earthquake. The act regulates development in California near known active faults due to hazards associated with surface fault ruptures. Alquist-Priolo maps are distributed to affected cities, counties, and state agencies for their use in planning and controlling new construction. Areas within an Alquist-Priolo Earthquake Fault Zone require special studies to evaluate the potential for surface rupture to ensure that no structures intended for human occupancy are constructed across an active fault.

Seismic Hazards Mapping Act. The Seismic Hazards Mapping Act (SHMA) was passed in 1990 following the 1989 Loma Prieta earthquake. The SHMA directs the California Geological Survey (CGS) to identify and map areas prone to liquefaction, earthquake-induced landslides, and amplified ground shaking. CGS has completed seismic hazard mapping for the portions of California most susceptible to liquefaction, landslides, and ground shaking, including the central San Francisco Bay Area. The SHMA requires that agencies only approve projects in seismic hazard zones following site-specific geotechnical investigations to determine if the seismic hazard is present and identify measures to reduce earthquake-related hazards.

California Building Code. The California Building Code (CBC) prescribes standards for constructing safer buildings. The CBC contains provisions for earthquake safety based on factors including occupancy type, soil and rock profile, ground strength, and distance to seismic sources. The CBC requires that a site-specific geotechnical investigation report be prepared for most development projects to evaluate seismic and geologic conditions, such as surface fault ruptures, ground shaking, liquefaction, differential settlement, lateral spreading, expansive soils, and slope stability. The CBC is updated every three years, with the 2022 CBC effective on January 1, 2023.

California Division of Occupational Safety and Health Regulations. Excavation, shoring, and trenching activities during construction are subject to occupational safety standards for stabilization by the California Division of Occupational Safety and Health (Cal/OSHA) under Title 8 of the California Code of Regulations and Excavation Rules. These regulations minimize the potential for instability and collapse that could injure construction workers on the site.

State Paleontological Laws, Ordinances, Regulations, and Standards. The California Public Resources Code (Section 5097.5) specifies that unauthorized removal of a paleontological resource is a misdemeanor. Under the California Environmental Quality

Act (CEQA) Guidelines, a project would have a significant impact on paleontological resources if it would disturb or destroy a unique paleontological resource or site or unique geologic feature.

CEQA encourages the protection of all aspects of the environment by requiring state and local agencies to prepare multidisciplinary analyses of the environmental impacts of a project and to make decisions based on the findings of those analyses. CEQA includes in its definition of historical resources, any object or site that “has yielded, or may be likely to yield, information important in prehistory” (California Code Regulations, title 14, § 15064.5(a)(3)(D)), which is typically interpreted by professional scientists as including fossil materials and other paleontological resources. More specifically, destruction of a “unique paleontological resource or site or unique geologic feature” may be a significant impact under CEQA (CEQA Guidelines Appendix G.VII (f)).

Local

Santa Clara General Plan. Staff reviewed the City of Santa Clara General Plan (Santa Clara 2010) for provisions relevant to geology and soils applicable to the project. Section 5.6.3 of the general plan identifies the protection of paleontological resources as a goal of the city and policies 5.6.3-P1 through P6 outline how the protection of paleontological resources would be achieved. Section 5.10.5 identifies policies related to geotechnical engineering.

- 5.6.3-G1 Protection and preservation of cultural resources, as well as archaeological and paleontological sites.
- 5.6.3-G2 Appropriate mitigation if human remains, archaeological resources or paleontological resources are discovered during construction activities.
- 5.6.3-P1 Require that new development avoid or reduce potential impacts to archaeological, paleontological, and cultural resources.
- 5.6.3-P2 Encourage salvage and preservation of scientifically valuable paleontological or archaeological materials.
- 5.6.3-P3 Consult with California Native American tribes prior to considering amendments to the city’s general plan.
- 5.6.3-P4 Require that a qualified paleontologist/archaeologist monitor all grading and/or excavation if there is a potential to affect archeological or paleontological resources, including sites within 500 feet of natural water courses and in the Old Quad neighborhood.
- 5.6.3-P5 In the event that archaeological/paleontological resources are discovered, require that work be suspended until the significance of the find and recommended actions are determined by a qualified archaeologist/paleontologist.
- 5.6.3-P6 In the event that human remains are discovered, work with the appropriate Native American representative and follow the procedures set forth in State law.

- 5.10.5-P5: Regulate development, including remodeling or structural rehabilitation, to ensure adequate mitigation of safety hazards, including flooding, seismic, erosion, liquefaction, and subsidence dangers.
- 5.10.5-P6: Require that new development is designed to meet current safety standards and implement appropriate building codes to reduce risks associated with geologic conditions.
- 5.10.5-P7: Implement all recommendations and design solutions identified in project soils reports to reduce potential adverse effects associated with unstable soils or seismic hazards.

Santa Clara City Code. Title 15 of the Santa Clara City Code includes the city's adopted Building and Construction Code. These regulations are based on the CBC and include requirements for building foundations, walls, and seismic resistant design. Requirements for grading and excavation permits and erosion control are included in Chapter 15.15 Building Code. Requirements for building safety and earthquake reduction hazard are addressed in Chapter 15.55 Seismic Hazard Identification. Title 15 of the Santa Clara City Code includes the city's adopted Building and Construction Code. These regulations are based on the CBC and include requirements for building foundations, walls, and seismic resistant design. Requirements for grading and excavation permits and erosion control are included in Chapter 15.15 Building Code. Requirements for building safety and earthquake reduction hazard are addressed in Chapter 15.55 Seismic Hazard Identification.

4.7.2 Environmental Impacts

- a. Would the project directly or indirectly cause potential substantial adverse effects, including the risk of loss, injury, or death involving:**
 - i. Rupture of a known earthquake fault, as delineated on the most recent Alquist-Priolo Earthquake Fault Zoning Map issued by the State Geologist for the area or based on other substantial evidence of a known fault? Refer to Division of Mines and Geology Special Publication 42.**

Construction

Less Than Significant Impact. The probability that construction of the proposed project would have an impact on the risk of loss, injury, or death involving rupture of an earthquake fault during construction is remote. The project site is within the seismically active San Francisco Bay region with nearby historically active faults including the Hayward (southeast extension) fault zone, approximately 6.3 miles to the east and the Monte Vista-Shannon fault zone, approximately 7.6 miles to the southwest (**Figure 4.7-3**). No active or potentially active faults are known to pass directly beneath the site. The development of the project would not expose people or buildings to known risks of fault

rupture because of the site's distance from faults and the absence of known faults within or near the site. Given this, the impact would be less than significant.

Operation

Less Than Significant Impact. The probability that the operation or maintenance of the proposed project would have an impact on the risk of loss, injury, or death involving rupture of an earthquake fault during operation is remote. Since there are no mapped Alquist-Priolo Special Studies Zones for active faults crossing the project site (**Figure 4.7-3**) and the zone of damage related to a fault surface rupture are limited to a relatively narrow area along either side of the fault during rupture, the impact would be less than significant.

ii. Strong seismic ground shaking?

Construction

Less Than Significant Impact. Earthquakes along several nearby active faults in the region could cause strong ground shaking at the site (DayZenLLC 2022e). The intensity of ground motion and the damage done by ground shaking would depend on the characteristics of the generating fault, distance to the fault and rupture zone, earthquake magnitude, earthquake duration, and site-specific geologic conditions. The design of the project would include an assessment of the potential impacts of strong seismic ground shaking from a site-specific design-level seismic event. Conformance to the applicable seismic design criteria of the CBC (CBC 2022) would minimize seismic hazards, to the extent feasible. Furthermore, recommendations for ground improvement to further reduce, to the extent feasible, the ground settlement hazard at the site would be provided in a site-specific design-level geotechnical investigation report and incorporated into the project design (DayZenLLC 2022e).

A project-specific geotechnical engineering report would be provided to the city building official for review and approval prior to the issuance of a building permit. The project construction plans would be developed by the design engineer and would include the recommendations provided by the geotechnical engineer in the geotechnical engineering report. With the implementation of seismic design criteria per the current CBC (CBC 2022) and the issuance of a building permit by the city building official, the project would not expose people or property, directly or indirectly, to significant impacts associated with geologic or seismic ground shaking.

Operation

Less Than Significant Impact. The proposed project could be subject to strong seismic ground shaking (DayZenLLC 2022e) during operation and maintenance. However, with the implementation of the seismic design guidelines per the current CBC (CBC 2022) and the issuance of a building permit by the city building official the project would not expose people or property, directly or indirectly, to significant impacts associated with geologic or seismic ground shaking. Therefore, the impacts of the project on the safety of people

or structures from strong seismic ground-shaking would continue to be less than significant.

iii. Seismic-related ground failure, including liquefaction?

Construction

Less than Significant Impact. The site is located within a state-designated liquefaction hazard zone, and there is potential for soil layers at the site to liquefy during a seismic event. Analyses indicate that several soil layers could potentially experience liquefaction triggering that could result in post-liquefaction total settlement at the ground surface up to about 1.0 inch and differential settlement on the order of $\frac{2}{3}$ -inch or less over a horizontal distance of 30 to 40 feet. The proposed structures would be designed and constructed in accordance with applicable provisions of the CBC (CBC 2022) that are designed to address liquefaction concerns to the extent feasible.

In addition, as discussed under CEQA criterion "a", a project-specific design would be included within a geotechnical engineering report and provided to the city building department for review and approval prior to the issuance of a building permit. Therefore, with the implementation of the seismic design criteria for ground failure and the anticipated project-specific recommendations in the final geotechnical engineering report and the issuance of a building permit by the city building official, the project would not expose people or property to any significant direct or indirect impacts associated with geologic or seismic conditions onsite, including liquefaction.

Operation

Less Than Significant Impact. During the operation and maintenance of the proposed project the project facility could be subject to strong seismic ground shaking (DayZenLLC 2022e). However, by implementing the seismic design guidelines per the current CBC (CBC 2022) and the issuance of a building permit by the city building official, the project would not expose people or property, directly or indirectly, to significant impacts associated with the effects of seismic ground shaking, such as ground failure, liquefaction, or subsidence. Therefore, risks to people or structures from strong seismic ground-shaking would continue to be less than significant.

iv. Landslides?

Construction

Less Than Significant Impact. As the project site is relatively flat with no open faces or slopes near the site, there is low potential for landslides and, therefore, no direct or indirect significant impacts associated with landslides are expected.

Operation

Less Than Significant Impact. As the project site is relatively flat with no open faces or slopes near the site, there is low potential for landslides. Construction, operation, and

maintenance of the project would not change the general surface morphology of the site. Therefore, no direct or indirect significant impacts associated with landslides are expected.

b. Would the project result in substantial soil erosion or the loss of topsoil?

Construction

Less Than Significant Impact. Construction activities associated with the project (including excavation, trenching, and grading) would temporarily increase sedimentation and erosion by exposing soils to wind and runoff until construction is complete and new vegetation is established. As discussed in **Section 4.10 Hydrology and Water Quality**, the project would be subject to construction-related storm water permit requirements. Prior to any ground-disturbing construction activity, the project must comply with the Construction General Permit, which includes filing a NOI with the SWRCB, coordinating with the city, and preparing and implementing a SWPPP. The SWPPP would include best management practices (BMPs) for storm water quality control, including soil stabilization practices, sediment control practices, and wind erosion control practices. When construction is complete, the project would be required to file a Notice of Termination with the San Francisco Bay RWQCB and the city, documenting that all elements of the SWPPP have been implemented.

By complying with existing permits and other applicable laws and regulations, substantial soil erosion or loss of topsoil would not occur; and runoff from the project site would not violate the applicable waste discharge requirements or otherwise contribute to the degradation of storm water runoff quality. Therefore, impacts related to erosion and loss of topsoil would be less than significant and no mitigation is required.

Operation

Less Than Significant Impact. Erosion and sedimentation BMPs implemented to comply with the NPDES permit would ensure the site would not include areas of exposed topsoil subject to erosion. Surface water runoff from the facility would not be expected to impact soil erosion or cause the loss of topsoil during project operation. Any occasional minor surface disturbance required during maintenance activities would be temporary and small. Operation and maintenance work would not require surface disturbance and thereby would not result in increased erosion or topsoil loss. Therefore, no significant impact associated with erosion or loss of topsoil would occur.

c. Would the project be located on geologic units or soil that is unstable, or that would become unstable as a result of the project, and potentially result in on- or off-site landslide, lateral spreading, subsidence, liquefaction, or collapse?

Construction

Less Than Significant Impact. The project site and immediate surrounding area are not subject to landslides or lateral spreading. The project site is in a mapped liquefaction hazard zone. The project would not be located on a geologic unit or soil that is unstable, or that would become unstable as a result of the project, and potentially result in on-site or off-site landslide, lateral spreading, subsidence, liquefaction, or collapse. By implementing the seismic design guidelines per the current CBC (CBC 2022) and the issuance of a building permit by the city building official, the project impacts associated with construction on geologic units or soil that could become unstable would have a less than significant impact.

Operation

Less Than Significant Impact. Operation and maintenance activities would not change the surface runoff or geotechnical characteristics of the material beneath the project facilities. Thus, operation and maintenance activities would not introduce new soil stability hazards. Occasional minor surface disturbance required during maintenance activities may continue but such disturbance would be temporary and likely small. The project would not expose people or property, directly or indirectly, to unstable geologic or soil units. Therefore, operation and maintenance activities would have a less than significant impact.

d. Would the project be located on expansive soil, as defined in Section 1803.5.3 of the California Building Code (2022), creating substantial direct or indirect risks to life or property?

Construction and Operation

Less Than Significant Impact. Expansive soil behavior is a condition where clay soils react to changes in moisture content by expanding or contracting. Poorly drained soils have greater shrink-swell potential. Potential causes of moisture fluctuations include drying during construction, and subsequent wetting from rain, capillary rise, landscape irrigation, and type of plant selection. If untreated, expansive soils could damage future buildings and pavements on the project site.

The project site is located on expansive soil as defined in Section 1803.5.3 of the CBC. The project would be required to adhere to the CBC, which would reduce impacts related to expansive soils to a less than significant level. The policies of the City of Santa Clara 2010-2035 General Plan have been adopted for the purpose of avoiding or mitigating environmental effects resulting from planned development within the city. Santa Clara General Plan Policy 5.10.5-P6 requires that new development be designed to meet current safety standards and implement appropriate building codes to reduce risks associated with geologic conditions (Santa Clara 2010). Therefore, risks to people or structures from expansive soil would be less than significant with mitigation incorporated into the project design.

e. Would the project have soils incapable of adequately supporting the use of septic tanks or alternative wastewater disposal systems where sewers are not available for the disposal of wastewater?

Construction and Operation

No Impact. The project would connect to an existing city-provided sanitary sewer connection, so the project site would not need to support septic tanks or alternative wastewater disposal systems. Therefore, there would be no impact to soils because of sanitary waste disposal from the project during construction or operation.

f. Directly or indirectly destroy a unique paleontological resource or site or unique geologic feature?

Construction and Operation

Less Than Significant with Mitigation Incorporated. There are no known paleontological resources within the project site. A search of the University of California Museum of Paleontology database failed to identify any paleontological resources in the vicinity of the site (UCMP 2022). However, ground-disturbing activities of ten feet or more have the potential to impact undiscovered paleontological resources. The project would require excavation trenching of depths of up to 15 feet below the existing grade. Foundations would be augured piles, likely to exceed depths of 30 feet below the existing grade. Although unlikely, paleontological resources could be encountered during construction of the project.

The applicant has proposed a measure to reduce impacts to unique paleontological resources. The measure includes protocols for training, identification of paleontological resources, and preparing a salvage plan, including treatment and reporting. Staff considers the measure sufficient to reduce impacts to paleontological resources, and proposes **GEO-1** to address the potential for the discovery of paleontological resources during excavation in native materials.

Although the project site would be graded and any excavation for deep foundations would be completed prior to installation of the Martin Backup Generating Facility (MBGF), construction of the MBGF would include trenching to install underground cabling for the electrical interconnection between each generator yard and the building it serves. This trenching is most likely to occur in previously disturbed soils shallower than 10 feet below the existing grade. It is unlikely that trenching activities would encounter potential paleontological resources. However, trenching for the construction of the recycled water line along Martin Avenue could require trenching of depths greater than 10 feet below the existing grade and any potential impacts from these trenching activities would be reduced to less than significant levels with the implementation of **GEO-1**.

There is no potential to disturb paleontological resources during operations because there would be no earth-moving activities required for operations. Occasional minor surface

disturbance may continue to be required during maintenance activities, but such disturbance would be temporary, small, and most likely limited to the disturbance of fill.

With the implementation of **GEO-1**, impacts to paleontological resources would be reduced to a less than significant level.

There are no unique geologic features within the site footprint.

4.7.3 Mitigation Measures

GEO-1:

- Prior to the start of any subsurface excavations that would extend beyond previously disturbed soils, all construction forepersons and field supervisors shall receive training by a qualified professional paleontologist, as defined by the Society of Vertebrate Paleontology, who is experienced in teaching non-specialists, to ensure they can recognize fossil materials and shall follow proper notification procedures in the event any are uncovered during construction. Procedures to be conveyed to workers are halting construction within 50 feet of any potential fossil find and notifying a qualified paleontologist, who shall evaluate its significance.
- If a fossil is found and determined by the qualified paleontologist to be significant and avoidance is not feasible, the paleontologist shall develop and implement an excavation and salvage plan in accordance with Society of Vertebrate Paleontology standards. Construction work in these areas shall be halted or diverted to allow the preparation of the plan and recovery of fossil remains in a timely manner. Fossil remains collected during the monitoring and salvage portion of the mitigation program shall be cleaned, repaired, sorted, and cataloged. Prepared fossils, along with copies of all pertinent field notes, photos, and maps, shall then be deposited in a scientific institution with paleontological collections. A final Paleontological Mitigation Plan Report that outlines the results of the mitigation program shall be prepared and submitted to the Director or Director's designee with the City of Santa Clara Community Development Department at the conclusion of construction. The Director or Director's Designee with the City of Santa Clara shall be responsible for ensuring that the paleontologist's recommendations regarding treatment and reporting are implemented.

4.7.4 References

CBC 2022 – California Building Code (CBC). California Building Standard Commission.

Accessed on: November 18, 2022. Available online at:

<http://www.bsc.ca.gov/Codes.aspx>

CGS 2002 State of California Official Seismic Hazard Zones Map for the San Jose West Quadrangle, Report 058. Accessed on: November 18, 2022. Available online at:

<https://maps.conservation.ca.gov/cgs/informationwarehouse/regulatorymaps/>

- CGS 2010 – California Geological Survey (CGS), California Department of Conservation. Fault Activity Map of California. Accessed on: November 18, 2022. Available online at: <http://maps.conservation.ca.gov/cgs/fam/>
- DayZenLLC 2022a – DayZenLLC (DayZenLLC). (TN 247325). MBGF SPPE Application – Part I – Main App and Appendix A, dated November 7, 2022. Available online at: <https://efiling.energy.ca.gov/Lists/DocketLog.aspx?docketnumber=22-SPPE-03>
- DayZenLLC 2022e – DayZenLLC (DayZenLLC). (TN 247329). MBGF SPPE Application – Part II – Appendices B, C and D, dated November 7, 2022. Available online at: <https://efiling.energy.ca.gov/Lists/DocketLog.aspx?docketnumber=22-SPPE-03>
- GeoTracker 2023. State Water Resource Control Board. State of California. Accessed on: November 18, 2022. Available online at: <https://geotracker.waterboards.ca.gov/>.
- Helley et al. 1994 – E. J. Helley, R.W. Graymer, G.A. Phelps, P.K. Showalter, and C.M. Wentworth. Preliminary Quaternary geologic maps of Santa Clara Valley, Santa Clara, Alameda, and San Mateo Counties, California: A Digital Database, USGS Open-File Report 94.231, 1994. Accessed on: January 13, 2023. Available online at: <https://pubs.usgs.gov/of/1994/0231/report.pdf>
- Wesling and Helley 1989 – J.R. Wesling and E.J. Helley, Quaternary Geologic Map of the San Jose West Quadrangle, Santa Clara County, California, U.S. Geological Survey Open-File Report 89-672, 1989. Accessed on: November 18, 2022. Available online at: <https://pubs.usgs.gov/of/1989/0672/>.
- Knudsen et al. 2000 – Knudsen, K.L., Sowers, J.M., Wentworth, C.M., Witter, R.C., Helley, E.J., Nicholson, R.S., Wright, H.M. and Brown, K.H., Association of Bay Area Governments (ABAG) Earthquake Liquefaction Susceptibility Map. Last Updated March 2020. Accessed on: November 18, 2022. Available online at: <https://abag.ca.gov/our-work/resilience/data-research/hazard-viewer>
- Norris and Webb 1990 – Robert M. Norris and Robert W. Webb, 1990, Geology of California, Second Edition, John Wiley and Sons. ISBN-13: 978-0471509806. Accessed on: November 18, 2022
- Santa Clara 2010 – City of Santa Clara (Santa Clara). 2010-2035 General Plan. Approved November 16, 2010. Accessed on: November 18, 2022. Available online at: <https://www.santaclaraca.gov/our-city/departments-a-f/community-development/planning-division/general-plan>
- Santa Clara 2012 – City of Santa Clara (Santa Clara Water Utility). Accessed on: November 18, 2022. Available online at: <https://www.santaclaraca.gov/home/showpublisheddocument/8618/635713044859030000>.
- Santa Clara 2021 – City of Santa Clara (Santa Clara Water Utility). 2020 Urban Water Management Plan. November 18, 2022. Available online at:

<https://www.santaclaraca.gov/home/showpublisheddocument/74073/637606452907100000>. Accessed on: January 27, 2023

UCMP 2022 – University of California Museum of Paleontology (UCMP) 2021. *UCMP database*. Accessed on: November 17, 2022. Available online at: <http://ucmpdb.berkeley.edu/>

USGS 1980 – United States Geologic Survey (USGS). San Jose West Quadrangle, 7.5 Minutes Series (Topographic), Santa Clara County, California. Accessed on: November 17, 2022. Available online at: <https://livingatlas.arcgis.com/topoexplorer/index.html>

Wentworth, Carl M. et al. 1999. Preliminary geologic map of the San Jose 30 x 60-minute quadrangle, California, U.S. Geological Survey Open-File Report 98-795. Accessed on: November 18, 2022. Available online at: <https://doi.org/10.3133/ofr98795>

Youd et al. 2001 – T. L. Youd, I. M. Idriss, Ronald D. Andrus, Ignacio Arango, Gonzalo Castro, John T. Christian, Richardo Dobry, W. D. Liam Finn, Leslie F. Harder, Mary Ellen Hynes, Kenji Ishihara, Joseph P. Koester, Sam S.C. Liao, William F. Marcuson, Geoffrey R. Martin, James K. Mitchell, Yoshiharu Moriwaki, Maurice S. Power, Peter K. Robertson, Raymond B. Seed, and Kenneth H Stokoe "Liquefaction Resistance of Soils: Summary Report from the 1996 NCEER and 1998 NCEER/NSF Workshops on Evaluation of Liquefaction Resistance of Soils." *ASCE Journal of Geotechnical and Geoenvironmental Engineering*, Vol 127, No. 10. October. Accessed on: November 18, 2022. Available online at: <http://www.ce.memphis.edu/7137/PDFs/Reference2/Youd%20ad%20Idriss.pdf>

4.8 Greenhouse Gas Emissions

This section describes the environmental and regulatory setting and discusses greenhouse gas (GHG) emissions impacts associated with the demolition/construction, direct “stationary source” emissions from emergency backup generators (gensets), and indirect and “non-stationary source” emissions from the operation of the project.

GREENHOUSE GAS EMISSIONS	Potentially Significant Impact	Less Than Significant with Mitigation Incorporated	Less Than Significant Impact	No Impact
Would the project:				
a. Generate greenhouse gas emissions, either directly or indirectly, that may have a significant impact on the environment?	<input type="checkbox"/>	<input checked="" type="checkbox"/>	<input type="checkbox"/>	<input type="checkbox"/>
b. Conflict with an applicable plan, policy or regulation adopted for the purpose of reducing the emissions of greenhouse gases?	<input type="checkbox"/>	<input checked="" type="checkbox"/>	<input type="checkbox"/>	<input type="checkbox"/>

Environmental checklist established CEQA Guidelines, Appendix G.

4.8.1 Summary

The Martin Data Center (MDC), and the associated Martin Backup Generating Facility (MBGF), are collectively called “the project” in the analysis that follows. In this analysis, CEC staff (staff) concludes that, with the implementation of mitigation measures **GHG-1** and **GHG-2**, the project’s potential GHG emissions impacts would be less than significant.

This section includes both quantitative and qualitative analyses of the project’s three categories of GHG emissions: (1) emissions related to the construction/demolition phase of the project; (2) direct “stationary source” emissions from the operation of the emergency backup generators; and (3) indirect and “non-stationary source” emissions from the operation of the project, the vast majority of which are indirect emissions from the electricity consumed by the project.

For each category of GHG emissions, this section describes and calculates the emissions, identifies the threshold of significance that applies to the project’s emissions source, and applies the applicable methodology or threshold of significance to determine if the project’s GHG emissions impacts are less than significant.

Significance Criteria

California Environmental Quality Act (CEQA) Guidelines for GHG Emissions.

With the enactment of Senate Bill 97 (Dutton, Chapter 185, Statutes of 2007), the Governor’s Office of Planning and Research was required by July 1, 2009, to prepare, develop, and transmit to the Natural Resources Agency guidelines for the feasible mitigation of GHG emissions or the effects of GHG emissions. Those amendments to the

CEQA guidelines became effective March 18, 2010, and were subsequently updated in December 2018 to further address the analysis of GHG emissions, including the following:

- Lead agencies must analyze the GHG emissions of proposed projects. (See CEQA Guidelines, § 15064.4, subd. (a))
- The focus of the lead agency's analysis should be on the project's effect on climate change, rather than simply focusing on the quantity of emissions and how that quantity of emissions compares to statewide or global emissions. (See CEQA Guidelines, § 15064.4, subd. (b))
- The impacts analysis of GHG emissions is global in nature and thus should be considered in a broader context. A project's incremental contribution may be cumulatively considerable even if it appears relatively small compared to statewide, national, or global emissions. (See CEQA Guidelines, § 15064.4, subd. (b))
- Lead agencies should consider a timeframe for the analysis that is appropriate for the project. (See CEQA Guidelines, § 15064.4, subd. (b))
- A lead agency's analysis must reasonably reflect evolving scientific knowledge and state regulatory schemes. (See CEQA Guidelines, § 15064.4, subd. (b).)
- Lead agencies may rely on an adopted statewide, regional, or local plan in evaluating a project's GHG emissions. (See CEQA Guidelines, § 15064.4, subd. (b)(3))
- Lead agencies may analyze and mitigate the significant impact of GHG emissions as part of a larger plan for the reduction of greenhouse gases. (See CEQA Guidelines, §15183.5, sub. (a))
- A project's incremental contribution to a cumulative GHG emissions effect may be determined not to be significant and the effects of the project to not be cumulatively considerable if the project complies with the requirements of the GHG emissions reduction strategy. (See CEQA Guidelines, §§ 15064, sub. (h)(3); 15130, sub. (d); 15183, sub. (b))
- In determining the significance of a project's impacts, the lead agency may consider a project's consistency with the state's long-term climate goals or strategies, provided that substantial evidence supports the agency's analysis of how those goals or strategies address the project's incremental contribution to climate change and its conclusion that the project's incremental contribution is consistent with those plans, goals, or strategies. (See CEQA Guidelines, § 15064.4, subd. (b)(3))
- The lead agency has discretion to select the model or methodology it considers most appropriate to enable decision makers to intelligently account for the project's incremental contribution to climate change. (See CEQA Guidelines, § 15064.4, subd. (c).)

The Bay Area Air Quality Management District (BAAQMD) CEQA Guidelines include recommended thresholds of significance for determining whether projects would have significant adverse GHG impacts.

Construction/Demolition Emissions. For construction-related GHG emissions, the BAAQMD CEQA Guidelines do not identify a numerical GHG emissions threshold of significance, but instead recommend that those emissions should be quantified and disclosed using available data and tools, to determine the amount, types, and sources of GHG emissions resulting from the project. In addition, the BAAQMD CEQA Guidelines state that projects should incorporate of best management practices (BMPs) to reduce GHG emissions during construction.

Direct Stationary Sources Emissions. For stationary sources, BAAQMD adopted a numeric threshold of significance of 10,000 metric tons of carbon dioxide equivalent per year (MTCO₂e/yr) for projects that require permits from BAAQMD (BAAQMD 2023, Section 6.4).

In this analysis, approximately 3,287 MTCO₂e/yr would be emitted by the stationary sources. This level falls below the BAAQMD CEQA Guidelines bright-line threshold of significance of 10,000 MTCO₂e/yr, and on this basis, the GHG impacts from the project's emergency backup generators would be considered to have a less-than-significant impact. Staff recommends implementing additional mitigation that would reduce the level of GHG emissions from the emergency backup generators by requiring use of renewable diesel fuel.

Indirect and Non-Stationary Source Emissions. Other project-related emissions from mobile sources, area sources, energy use, and water use would not be included for comparison to the threshold of significance for stationary sources of GHG, based on guidance in the BAAQMD CEQA Guidelines (BAAQMD 2023, Section 6.4).

Instead, in April 2022, the BAAQMD adopted updated thresholds of significance with the publication of *Justification Report: CEQA Thresholds for Evaluating the Significance of Climate Impacts From Land Use Projects and Plans* (BAAQMD 2022) to assist lead agencies when evaluating the indirect and "non-stationary" source emissions of land use development projects. Under the BAAQMD's 2022 CEQA thresholds of significance for land use projects, a CEQA lead agency can conclude that a project will not make a cumulatively considerable contribution to global climate change if the project is designed and built to be consistent with the requirements of either Option A or Option B of the BAAQMD thresholds (BAAQMD 2023). In Option A, projects must include, at a minimum, the project design elements of buildings and transportation. In Option B, projects must be consistent with a local GHG reduction strategy that meets the criteria under CEQA Guidelines Section 15183.5(b) (BAAQMD 2022, p.2). The proposed project would meet the new BAAQMD GHG Land Use Project standards by demonstrating compliance with the 2022 CAP and therefore consistent with "a local GHG reduction strategy that meets the criteria under State CEQA Guidelines Section 15183.5(b)"; and therefore, complying with Option B of the standards.

The City of Santa Clara Climate Action Plan 2022 (2022 CAP) is the latest update to the City of Santa Clara's (City) Climate Action Plan and is designed to meet the statewide

GHG reduction targets for 2030 set by SB 32, and to achieve net carbon neutrality no later than 2045 by EO B-55-18 targets.

As a qualified Climate Action Plan, the 2022 CAP allows for tiering and streamlining of GHG analyses under CEQA. The 2022 CAP identifies existing City policies and regulations as well as new measures to be implemented by development projects in the areas of building/energy use, transportation & land use, materials & consumption, natural resources & water resources, and community resilience & wellbeing. Projects that comply with the policies and strategies outlined in the 2022 CAP and that are consistent with the General Plan land use designation on the project site would have a less than significant GHG impact (DayZen 2022a, p. 4-76).

Construction/Demolition Emissions

As discussed in more detail under CEQA environmental checklist criterion "a," the applicant estimated that the maximum annual GHG emissions from construction sources would be approximately 806 MTCO₂e during the estimated 20 months of construction, including demolition, site preparation, grading, and on-and-off-site construction (DayZen 2022a). Therefore, the project's short-term construction-related GHG emissions have been quantified and disclosed. In addition, the project would implement certain best management practices (BMPs), as specified in mitigation measure **AQ-1**, that would have the effect of reducing construction-related GHG emissions. The project would also participate in the City's Construction & Demolition Debris Recycling Program to further reduce GHG emissions (DayZen 2022a, Table 4.8-3 and Table 4.8-4). Staff concludes that the project's construction-related GHG emissions impacts would be less than significant.

Direct Stationary Source Emissions (Emergency Backup Generators)

The project's emergency backup generators would be stationary sources of direct GHG emissions from project operation. The emergency backup generators would emit GHG emissions mostly during readiness testing and maintenance and infrequently during short durations of emergency operation. The GHG emissions from the emergency backup generators are subject to the BAAQMD CEQA Guidelines GHG bright-line threshold of significance for stationary sources (BAAQMD 2023, Section 6.4). Staff evaluated the GHG impacts of the emergency backup generators with the consideration of the GHG bright-line threshold of significance of 10,000 MTCO₂e/yr.

To compare project GHG emissions against the stationary source threshold, staff performed a quantitative estimation of the GHG emissions from readiness testing and maintenance of the gensets and estimates these emissions at 3,287 MTCO₂e/yr, which is lower than the BAAQMD CEQA Guidelines' GHG bright-line threshold of significance of 10,000 MTCO₂e/yr. As well, GHG emissions from the project would not exceed CARB's regulatory threshold level for required inclusion in and compliance with the cap-and-trade program, which is 25,000 MTCO₂e/yr.

The project's likelihood of operating the emergency backup generators for unplanned circumstances or emergency purposes is low and, if such operation did occur, it would be infrequent and of short duration (See **Appendix B**). Staff concludes that an estimate of 35 hours of emergency backup generator operation per year per engine adequately accounts for both readiness testing and maintenance, and emergency operation, for any given year, even if ultra-low sulfur diesel is used during short emergency operation durations in the event of supply challenges or disruption in obtaining renewable diesel.

Staff concludes that with the implementation of mitigation measure **GHG-2**, the GHG emissions from the project's stationary sources would be less than significant. In addition, with the implementation of **GHG-2**, the project's stationary sources would not conflict with plans, policies, or regulations adopted to achieve long-term GHG emissions reduction goals.

Indirect and Non-Stationary Source Emissions

The operation of the project would generate GHG emissions beyond those from the operation of the emergency backup generators, including offsite vehicle trips for worker commutes and material deliveries, and facility upkeep, including architectural coatings, consumer product use, landscaping, water use, waste generation, and electricity use. The GHG emissions from indirect and non-stationary sources are shown in **Table 4.8-4** under environmental checklist criterion "a."

The GHG impacts from the indirect and non-stationary sources would be considered to have a less-than-significant impact if the project is consistent with the CAP and applicable regulatory programs and policies adopted by CARB or other California agencies. Under environmental checklist criterion "b," staff identifies the requirements specified in the City's 2022 CAP and regulatory programs and policies that apply to the project.

Indirect Emissions from Electricity Use. Staff conservatively assumes the project could consume up to 840,960 megawatt hours (MWh) of electricity per year after full build-out, but actual electricity demand would be lower. With the carbon intensity of 222 lbs CO₂/MWh for 2023 based on Silicon Valley Power's (SVP) prediction and CalEEMod default methane (CH₄) and nitrous oxide (N₂O) intensity factors (0.033 lbs/MWh and 0.004 lbs/MWh, respectively), the worst-case GHG emissions due to electricity use during full build-out operation would be 85,344 MTCO₂e/yr¹.

Electricity to the project would be provided by SVP, a utility that is on track to meet their 2030 GHG emissions reductions target. SVP is subject to CARB's cap-and-trade program requirements and the Renewables Portfolio Standard (RPS) requirements.

¹ Annual electricity use: 96 MW x 8,760 hours/year = 840,960 MWh/year.

Carbon intensity of CO₂e: 224 lbs CO₂/MWh.

GHG emission due to electricity use = 224 lbs CO₂/MWh x 840,960 MWh/year = 85,344 MT CO₂e/year

Actual GHG emissions associated with electricity use at the project will be much less than 85,344 MTCO₂e/yr since actual electricity use will be less than the maximum use and the SVP annual average emission factor will be tracking downward towards “zero net” with the implementation of state and local measures to reduce GHG emissions associated with electricity production and California’s fuels.

In addition, the City adopted the 2022 CAP Update on June 7, 2022. The 2022 CAP Update includes Action B-1-7, “Carbon neutral data centers: requiring all new data centers to operate on 100 percent carbon neutral energy, with offsets as needed.”

As discussed in detail under CEQA environmental checklist criterion “b,” the project would implement a variety of energy efficiency measures. The project would comply with all applicable city and state green building standards code measures. The project would comply with Energy and Climate Measure (ECM)-1 – Energy Efficiency in BAAQMD’s 2017 Bay Area Clean Air Plan. Additionally, the applicant proposed to enter into contracts for a supply of 100 percent carbon-free electricity to avoid GHG emissions from electricity use; this would be achieved with mitigation measure **GHG-1**. Therefore, for these and the reasons discussed above, and with implementation of **GHG-1**, the project would not conflict with plans, policies, or regulations adopted to achieve long-term GHG emissions reduction goals.

Other Indirect and Non-Stationary Source Emissions. The project’s other indirect and non-stationary sources include mobile sources, landscaping, water use, waste, and refrigerant use as shown in **Table 4.8-4**. The project’s compliance with the 2022 CAP and applicable regulatory programs and policies adopted by CARB and other California agencies would ensure the project’s GHG emissions from these sources would not have a significant impact. For example, staff analyzed the project’s compliance and consistency with policies related to transportation (5.8.5-P1 in the General Plan, Measure 6.1 and Measure 6.3 in the 2022 CAP, Action T-3-1 and Action T-1-5 in the 2022 CAP Update), water (5.10.3-P6, 5.10.4-P6, 5.10.4-P7 in the General Plan, Measure 3.1 in the 2013 CAP, Action N-3-4 and Action N-3-6 in the 2022 CAP Update), and waste (Measure 4.2 in the 2022 CAP, Action M-3-1 in the 2022 CAP Update). Staff concludes that these indirect and non-stationary sources would comply with local and regional plans and strategies adopted to reduce GHG emissions and the project’s GHG impacts from these sources would be less than significant.

With the implementation of mitigation measure **GHG-1** and other project design features, GHG emissions related to the project from indirect and non-stationary sources would be consistent with the applicable plans and policies adopted to reduce GHG emissions and would comply with all regulations or requirements adopted to implement a statewide, regional, or local plan for the reduction or mitigation of GHG emissions. The potential for the project to conflict with an applicable plan, policy, or regulation for GHG reductions would be less than significant.

4.8.2 Environmental Setting

Unlike emissions of criteria and toxic air pollutants, which have local or regional impacts, emissions of GHGs have a much broader, global impact. Global warming associated with the "greenhouse effect" is a process whereby GHGs accumulating in the atmosphere contribute to an increase in the temperature of the Earth's atmosphere. The principal GHGs that contribute to global warming and climate change include carbon dioxide (CO₂), methane (CH₄), nitrous oxide (N₂O), black carbon, and fluorinated gases (F-gases) (hydrofluorocarbons [HFCs], perfluorocarbons [PFCs], and sulfur hexafluoride [SF₆])². Emissions of GHGs contributing to global climate change are attributable in large part to human activities associated with the transportation, industrial/manufacturing, utility, residential, commercial, and agricultural sectors³.

Each GHG has its own potency and effect upon the Earth's energy balance, expressed in terms of a global warming potential (GWP), with CO₂ being assigned a value of 1. Specifically, the GWP is a measure of how much energy the emissions of 1 ton of a gas will absorb over a given time relative to the emissions of 1 ton of CO₂. The larger the GWP, the more that a given gas warms the Earth compared to CO₂ over that time. The time usually used for GWPs is 100 years⁴.

For example, CH₄ has a GWP of 28 over 100 years from the Fifth Assessment Report (AR5)⁵ of the Intergovernmental Panel on Climate Change (IPCC 2013), which means that it has a global warming effect 28 times greater than CO₂ on an equal-mass basis. The F-gases are sometimes called high-GWP gases because, for a given amount of mass, they trap substantially more heat than CO₂. The GWPs for these gases can be in the thousands or tens of thousands. The carbon dioxide equivalent (CO₂e) for a source is obtained by multiplying each quantity of GHG by its GWP and then adding the results together to obtain a single, combined emission rate representing all GHGs in terms of CO₂e.

Regulatory Background

Federal

The project would not be subject to any federal requirements for GHGs.

2 US. EPA. Overview of Greenhouse Gases, which is available online at: <https://www.epa.gov/ghgemissions/overview-greenhouse-gases>

3 US. EPA. Sources of Greenhouse Gas Emissions, which is available online at <https://www.epa.gov/ghgemissions/sources-greenhouse-gas-emissions>

4 US. EPA. Understanding Global Warming Potentials, which is available online at <https://www.epa.gov/ghgemissions/understanding-global-warming-potentials>

5 The GWP values have been refined in the 2021 IPCC Sixth Assessment Report (AR6). Available online at: <https://www.ipcc.ch/report/ar6/wg1/>. The GWP for CH₄ has been updated to 29.8 from fossil fuel sources and 27.0 from non-fossil sources.

State

California Global Warming Solutions Act of 2006. In 2006, the state Legislature passed the California Global Warming Solutions Act of 2006 (Assembly Bill 32, Núñez, Chapter 488, Statutes of 2006), codified as Health and Safety Code, section 38500 and the following, which provided the initial framework for regulating GHG emissions in California. This law required CARB to design and implement GHG emissions limits, regulations, and other measures such that statewide GHG emissions are reduced in a technologically feasible and cost-effective manner to 1990 levels by 2020. AB 32 also required CARB to implement a mandatory GHG emissions reporting program for major sources, which includes electricity generators, industrial facilities, fuel suppliers, and electricity importers.

CARB Scoping Plan. Part of the Legislature's direction to CARB under AB 32 was to develop a scoping plan that serves as a statewide planning document to coordinate the main strategies California will use to reduce GHG emissions that cause climate change. CARB approved the AB 32 Climate Change Scoping Plan (scoping plan) in 2008 and released updates in 2014, 2017, and 2022. The scoping plan includes a range of GHG emissions reduction actions, which include direct regulations, alternative compliance mechanisms, monetary and non-monetary incentives, voluntary actions, and market-based compliance mechanisms, such as the cap-and-trade program. In December 2007, CARB set the statewide 2020 emissions limit, defined as reducing emissions to 1990 levels, at 427 million metric tons of CO₂e (MMTCO₂e). The 2014 scoping plan adjusted the 1990 emissions estimate and the statewide 2020 emissions limit goal to 431 MMTCO₂e (CARB 2014). The 2017 scoping plan (CARB 2017a) demonstrates the approach necessary to achieve California's 2030 target, which is to reduce GHG emissions 40 percent below 1990 levels to 260 MMTCO₂e. On November 16, 2022, CARB published the 2022 Scoping Plan for Achieving Carbon Neutrality (CARB 2022b), which lays out a path to achieve targets for carbon neutrality by 2045.

Mandatory Reporting of Greenhouse Gas Emissions. AB 32 also required CARB to adopt regulations to require the reporting and verification of statewide greenhouse gas emissions (Health and Safety Code, section 38530). CARB's Regulation for the Mandatory Reporting of Greenhouse Gas Emissions (Cal. Code Regs., tit. 17 §§95100 to 95163), which took effect January 2009, requires annual GHG emissions reporting from electric power entities, fuel suppliers, CO₂ suppliers, petroleum and natural gas system operators, and industrial facilities that emit at least 10,000 MTCO₂e/yr from stationary combustion and/or process sources. The project would not be impacted by this regulation because stationary source testing and maintenance combustion GHG emissions are expected to be below the reporting threshold of 10,000 MTCO₂e/yr, as shown in **Table 4.8-3**.

Cap-and-Trade Program. CARB's cap-and-trade program (Health and Saf. Code, § 38562; 17 Cal. Code Regs., §§95801 to 96022) took effect January 1, 2012. The cap-and-trade program establishes a declining limit on major sources of GHG emissions by sector throughout California, and it creates economic incentives for sources to invest in

cleaner, more efficient technologies. The current version of the regulation, effective April 2019, established the increasingly stringent compliance obligations for years 2021 to 2030. The cap-and-trade program applies to covered entities that fall within certain source categories, including first deliverers of electricity (such as fossil fuel power plants) and electrical distribution utilities; in this case, the project would obtain electrical service from SVP. Covered entities in the cap-and-trade program, including SVP, must hold compliance instruments sufficient to cover their actual GHG emissions, as set and verified through the CARB's Mandatory Reporting regulation. For the electricity supplied to the project from the grid, SVP bears the GHG emissions compliance obligation under the cap-and-trade program for delivering electricity to the grid from its power plants and for making deliveries to end-users, such as the project, unless the project is otherwise a covered entity in the cap-and-trade program.

Executive Order B-30-15. On April 29, 2015, former Governor Brown issued Executive Order B-30-15, directing state agencies to implement measures to reduce GHG emissions 40 percent below their 1990 levels by 2030 and to make it possible to achieve the previously stated goal of an 80 percent GHG emissions reduction below 1990 GHG emissions by 2050 (CARB 2017a).

Statewide 2030 GHG Emissions Limit. On September 8, 2016, SB 32, codified as Health and Safety Code, section 38566, extended California's commitment to reduce GHG emissions by requiring the state to reduce statewide GHG emissions by 40 percent below 1990 levels by 2030 (CARB 2017a).

Renewable Energy Programs. In 2002, California initially established the RPS with the goal of increasing the percentage of renewable energy in the state's electricity mix to 20 percent by 2017. State energy agencies recommended accelerating that goal, and former Governor Schwarzenegger's Executive Order S-14-08 (November 2008) required California utilities to reach the 33 percent renewable electricity goal by 2020, consistent with the CARB's 2008 scoping plan. In April 2011, Senate Bill X1-2 (Simitian, Chapter 1, Statutes of 2011) of the First Extraordinary Session was signed into law. SB X1-2 expressly applied the 33 percent RPS by December 31, 2020, to all retail sellers of electricity and established renewable energy standards for interim years prior to 2020.

- **Clean Energy and Pollution Reduction Act (Senate Bill 350, De León, Chapter 547, Statutes of 2015):** Beginning in 2016, SB 350 took effect declaring it the intent of the Legislature to acknowledge Governor Brown's clean energy, clean air and greenhouse gas emissions reduction goals for 2030 and beyond. SB 350 increases California's renewable electricity procurement goal from 33 percent by 2020 to 50 percent by 2030.
- **The 100 Percent Clean Energy Act of 2018 (Senate Bill 100, De León, Chapter 312, Statutes of 2018):** Beginning in 2019, the RPS deadlines advanced to 50 percent renewable resources by December 31, 2026, and 60 percent by December 31, 2030. In addition, SB 100 establishes policy that renewable energy

resources and zero-carbon resources supply 100 percent of all retail sales of electricity by December 31, 2045.

- **Clean Energy, Jobs, and Affordability Act of 2022 (Senate Bill 1020, Laird, Chapter 361, Statutes of 2022):** Accelerates the timelines set forth in SB 100 to provide that eligible renewable energy resources and zero-carbon resources supply 90 percent of all retail sales of electricity to California end-use customers by December 31, 2035, 95 percent of all retail sales of electricity to California end-use customers by December 31, 2040, 100 percent of all retail sales of electricity to California end-use customers by December 31, 2045, and 100 percent of electricity procured to serve all state agencies by December 31, 2035, as specified.

Short-Lived Climate Pollutant Strategy. To best support the reduction of GHG emissions consistent with AB 32, CARB released the Short-Lived Climate Pollutant (SLCP) Strategy, under Health and Safety Code, section 39730, in March 2017. Health and Safety Code, section 39730, defined SLCPs as having lifetimes in the atmosphere ranging from “a few days to a few decades.” Then beginning in 2017 under Health and Safety Code, section 39730.5, CARB was directed to set targets to reduce SLCP emissions 40 percent below 2013 levels by 2030 for CH₄ and HFCs and 50 percent below 2013 levels by 2030 for anthropogenic black carbon (CARB 2017b). The SLCP Strategy was integrated into the 2017 update to CARB’s scoping plan. To help meet the HFC reduction goal, California adopted HFC prohibitions and consolidated the California HFC prohibition regulation (previously Cal. Code Regs., tit. 17, §§ 95371-95377) and the statute (Senate Bill 1013 [Lara, Chapter 375, Statutes of 2018], Health and Saf. Code § 39734) into one place. The California Code of Regulations title, 17, section 95375(c)(1) states that no person shall sell, lease, rent, install, use, or otherwise enter into commerce in the State of California any end-use equipment or product manufactured after the effective date that does not comply with Table 3 (which includes chillers) of section 95374(c) of the sub-article, with exceptions stated under California Code of Regulations, title, 17, section 95375(c)(2). In addition, on September 30, 2022, the Governor approved Senate Bill 1206 (Skinner, Chapter 884, Statutes of 2022), which would prohibit a person from offering for sale or distribution, or otherwise entering into commerce in the state, bulk HFCs or bulk blends containing HFCs that exceed a specified GWP limit beginning January 1, 2025, and lower GWP limits beginning January 1, 2030, and January 1, 2033. The bill does not restrict the authority of CARB to establish regulations lowering the maximum allowable GWP limits below the limits established by the bill.

Executive Order B-55-18. On September 10, 2018, the same day he signed SB 100 into law, former Governor Brown issued Executive Order B-55-18 to achieve carbon neutrality, stating the governor’s intention “to achieve carbon neutrality as soon as possible, and no later than 2045, and achieve and maintain net negative emissions thereafter. This goal is in addition to the existing statewide targets of reducing greenhouse gas emissions.” From the 2020 GHG limit of 431 MMTCO_{2e}, California will need to reduce statewide emissions another 170 million tons to meet its 2030 statutory target of 260 million tons per year (40 percent below 1990 levels). The state would need

to cut annual emissions by a further 175 million tons to meet its 2050 goal (set by executive order) of 85 million tons per year (80 percent below 1990 levels).

Reducing SF₆ Emissions from Gas Insulated Switchgear. In early 2011, CARB adopted a regulation (17 CCR §§95350 to 95359) to reduce SF₆ emissions in gas insulated switchgear (GIS) used in the electricity sector's transmission and distribution system as an early action measure pursuant to AB 32. SF₆ is an extremely powerful and long-lived GHG. The 100-year GWP of SF₆ is 22,800 (from IPCC Fourth Assessment Report), making it the most potent of the six main GHGs, according to the U.S. EPA. Because of its extremely high GWP, small reductions in SF₆ emissions can have a large impact on reducing GHG emissions, which are the main drivers of climate change. The regulation requires GIS owners to report SF₆ emissions annually and requires reductions of SF₆ emissions from GIS over time, setting an annual emission rate limit for each GIS owner. The maximum allowable emission rate started at 10 percent in 2011 and has decreased one percent per year since then. The limit reached one percent in 2020 and remained at that level going forward. However, data show that statewide SF₆ capacity is growing by one to five percent per year, which would increase the expected SF₆ emissions. In response to emerging technologies using lower or zero GWP insulators, CARB amended the regulation (Cal. Code Regs., tit. 17, §§ 95350-95359.1) in 2021 to further reduce GHG emissions from gas-insulated equipment (GIE [changed from GIS to include more devices beyond switchgear]). Key provisions of the amended regulation include a phase-out schedule in stages between 2025 and 2033 for new SF₆ GIE, coverage of other GHG beyond SF₆ used in GIE, and other changes that enhance accuracy of emissions accounting and reporting.

The California Climate Crisis Act (Assembly Bill 1279). Assembly Bill 1279 (Muratsuchi, Chapter 337, Statutes of 2022) establishes the policy of the state to achieve carbon neutrality as soon as possible, but no later than 2045; to maintain net negative GHG emissions thereafter; and to ensure that by 2045 statewide anthropogenic GHG emissions are reduced at least 85 percent below 1990 levels. The bill requires CARB to ensure that Scoping Plan updates identify and recommend measures to achieve carbon neutrality, and to identify and implement policies and strategies that enable CO₂ removal solutions and carbon capture, utilization, and storage (CCUS) technologies. The CARB 2022 Scoping Plan for Achieving Carbon Neutrality (CARB 2022c) plans for the 2045 target set forth by AB 1279 and Executive Order B-55-18.

Regional

2017 Bay Area Clean Air Plan. BAAQMD adopted the 2017 Bay Area Clean Air Plan on April 19, 2017 (BAAQMD 2017a). It provides a regional strategy to protect public health and protect the climate. To protect public health, the plan describes how BAAQMD will continue its progress toward attaining all state and federal ambient air quality standards and eliminating health risk disparities from exposure to air pollution among Bay Area communities. To protect the climate, the plan defines a vision for transitioning the region to a post-carbon economy needed to achieve ambitious GHG emissions reduction targets

for 2030 and 2050 and provides a regional climate protection strategy that will put the Bay Area on a pathway to achieving those GHG emissions reduction targets.

BAAQMD CEQA Guidelines. The purpose of the BAAQMD CEQA Guidelines is to assist lead agencies in evaluating a project's air quality and climate impacts (BAAQMD 2023). This document describes the criteria that BAAQMD uses when reviewing and commenting on the adequacy of environmental documents. It recommends thresholds of significance for determining whether a project would have significant adverse environmental impacts, identifies methodologies for predicting project emissions and impacts, and identifies measures that can be used to avoid or reduce air quality impacts. The BAAQMD CEQA Guidelines include methodologies for estimating GHG emissions.

The BAAQMD CEQA Guidelines include the project-level and plan level thresholds for climate impacts that were adopted in April 2022. The guidelines also include a bright-line threshold of significance of 10,000 MTCO₂e/yr for stationary sources (BAAQMD 2023, Section 6.4). The stationary source GHG threshold was first adopted by the BAAQMD Board of Directors on June 2, 2010. The BAAQMD staff indicates that it will reevaluate the stationary source threshold of significance as necessary to reflect substantive changes to assumptions, underlying data, analytical methodologies, state and local policies and programs, and court decisions regarding GHG emissions since June 2010 (BAAQMD 2023, Section 2.2.5 of Appendix A).

Diesel Free by '33. In 2018, BAAQMD established a program intended to reduce GHG and criteria pollutant emissions by eliminating petroleum use by the end of 2033. Local Bay Area agencies are encouraged to voluntarily adopt the Statement of Purpose of this initiative. Entities signing the Statement of Purpose pledge to develop their own individual strategies to achieve the goal of reaching zero diesel emissions in their communities. Signatories to this agreement express their intent to:

1. Collaborate and coordinate on ordinances, policies, and procurement practices that will reduce diesel emissions to zero within their jurisdictions, communities, or companies;
2. Share and promote effective financing mechanisms domestically and internationally to the extent feasible that allow for the purchase of zero emissions equipment;
3. Share information and assessments regarding zero emissions technology;
4. Build capacity for action and technology adaptation through technology transfer and sharing expertise;
5. Use policies and incentives that assist the private sector as it moves to diesel-free fleets and buildings; and
6. Periodic reporting to all signers of progress towards the zero- diesel emissions goal.

Plan Bay Area 2040. Under the requirements of The Sustainable Communities and Climate Protection Act of 2008 (Senate Bill 375, Steinberg, Chapter 728, Statutes of 2008), all metropolitan regions in California must complete a Sustainable Communities

Strategy (SCS) as part of their Regional Transportation Plan. In the Bay Area, the Metropolitan Transportation Commission (MTC) and Association of Bay Area Governments (ABAG) are jointly responsible for developing and adopting an SCS that integrates transportation, land use, and housing to meet GHG emissions reduction targets set by CARB. In July 2017, the MTC and ABAG approved Plan Bay Area 2040, which is a strategic update to the previous plan approved in July 2013. The Bay Area GHG emissions reduction targets established by CARB in September 2010 include a seven percent reduction in GHG emissions per capita from passenger vehicles by 2020 compared to 2005 emissions. Similarly, Plan Bay Area 2040 includes a target to reduce GHG emissions per capita from passenger vehicles 15 percent by 2035 compared to 2005 emissions (MTC & ABAG 2017).

Local

City of Santa Clara 2010-2035 General Plan. The City of Santa Clara 2010-2035 General Plan (General Plan) includes policies that address the reduction of GHG emissions during the planning horizon of the General Plan. Goals and policies that address sustainability (see Appendix 8.13: Sustainability Goals and Policies Matrix) in the General Plan are aimed at reducing the city's contribution to GHG emissions. As described below, the development of a comprehensive GHG emissions reduction strategy for the city is also included in the General Plan.

City of Santa Clara Climate Action Plan. The City has a comprehensive GHG emissions reduction strategy, referred to as the City's 2022 Climate Action Plan (CAP) Update (Santa Clara 2022). The 2022 CAP includes a plan for implementing the plan and monitoring and evaluating progress through the implementation phases. The 2022 CAP is designed to meet the statewide GHG reduction targets of 40% reduction in emissions for 2030 set by SB 32, 80% reduction in emissions for 2035 by the City's interim target, and net carbon neutrality by no later than 2045 by EO B-55-18 target (Santa Clara 2022, p.4).

The 2022 CAP identifies existing City policies and regulations as well as new measures to be implemented by development projects in the areas of building/energy use, transportation and land use, materials and consumption, natural resources and water resources, and community resilience and wellbeing. Projects that comply with the policies and strategies outlined in the 2022 CAP and that are consistent with the General Plan land use designation on the project site would have a less than significant GHG impact (DayZen 2022a, p. 4-71).

The 2022 CAP identified the city's approach to achieve its share of statewide emissions reductions for the near-term (2023-2026), mid-term (2027-2030), and long-term (after 2030) phase timeframes established by Health and Safety Code, section 38550. The City's original CAP, adopted on December 3, 2013, specified the strategies and measures to be taken for a number of focus areas city-wide to achieve the overall emissions reduction target. The 2022 CAP also includes oversight and accountability, including a creation of a City Sustainability & Climate Action Team to coordinate implementation and regular public updates and reporting on CAP progress through a Community Dashboard. This

update also includes monitoring and evaluations, including annual progress reports and frequent updates of the City's GHG emissions inventory.

The 2022 CAP Update reflects the 2030 GHG emissions limit requirements and progress toward meeting the long-term targets of Executive Order B-55-18. In addition to these targets, the City aspires to reduce emissions more aggressively in the near-term: achieve an 80 percent reduction in per-service population emissions by 2035. The 2022 CAP Update identifies strategies and actions in these main areas: building and energy, transportation and land use, materials and consumption, natural systems and water resources, and community resilience and well-being. To achieve the interim target of an 80 percent reduction in per-service population emissions by 2035, the city will take additional actions including achieve 100 percent carbon neutral electricity by 2035 and require all new construction to be all-electric (with minor exemptions). Actions specifically related to data centers for achieving GHG emissions reductions include:

- B-1-7, Carbon neutral data centers:
Require all new data centers to operate on 100% carbon neutral energy, with offsets as needed.
- B-3-6, Alternative fuel backup generators:
Provide information and technical assistance to data centers and other large commercial users to transition from diesel to lower-carbon backup generators (e.g., renewable diesel).
- B-3-7, Renewable electricity for new data centers:
Support convening of a data center working group to identify and implement renewable electricity purchasing options for commercial customers.

The CEQA Guidelines allow a lead agency to use a Qualified GHG Reduction Strategy to determine the degree to which a proposed project would cause a significant adverse impact. Compliance with appropriate measures in the CAP would ensure an individual project is not cumulatively significant under CEQA.

Silicon Valley Power's Integrated Resource Plan and Other Programs. The City adopted an Integrated Resource Plan (IRP) for SVP dated November 12, 2018 (SVP 2018). The IRP was developed as required by SB 350 and must be updated at least every five years. The IRPs provide a framework to evaluate how utilities have chosen to align with greenhouse gas emissions reduction targets as well as energy and other policy goals outlined in SB 350. The most challenging goals in the IRP call for the city to: (1) increase procurement of energy from renewable electricity sources to 60 percent by 2030, and (2) double energy efficiency savings in electricity and natural gas end uses by 2030.

CEC staff in the Supply Analysis Office of the Energy Assessments Division have reviewed SVP's 2018 IRP (CEC 2019) and found that, among other things, by the year 2030 SVP:

(1) achieves a 40 percent GHG emissions reduction from 1990 levels, and (2) meets the RPS goals of SB 350 to use 50 percent renewables.

In addition to carrying out activities related to their IRP, SVP has also created a Large Customer Renewable Energy (LCRE) program to allow its large customers to sign up for 100 percent renewable energy. In November 2021, the city approved SVP's LCRE program, which became effective January 1, 2022 (SVP 2021). The program is a voluntary green program for large customers to purchase additional renewable energy above the amount of renewable energy already included in SVP's energy delivery portfolio to accelerate customers' higher corporate renewable and sustainability goals. Customers have two options to participate in the program: (1) SVP procures supplemental renewable energy for customers for a one-year term, and (2) customers provide their own supplemental renewable energy resource under a five-year or 10-year term customer agreement with SVP. The program is available for the project applicant to use.

Existing Conditions

California is a contributor to global GHG emissions. The total gross California GHG emissions in 2019 were 404.5 MMTCO₂e (CARB 2022a). The largest category of GHG emissions in California is transportation, followed by industrial activities and electricity generation in state and out of state (CARB 2022a). In 2020, the total gross California GHG emissions were 369.2 MMTCO₂e (CARB 2022a).

In 2019, the total gross U.S. greenhouse gas emissions were 6,571.7 MMTCO₂e, or 5,841.2 MMTCO₂e after accounting for sequestration from the land sector (U.S. EPA 2022). While in 2020, total gross U.S. greenhouse gas emissions were 5,981.4 MMTCO₂e, or 5,222.4 MMTCO₂e after accounting for sequestration from the land sector (U.S. EPA 2022). The sharp decline of GHG emissions in 2020 compared to 2019 was largely due to the impacts of the coronavirus (COVID-19) pandemic on travel and economic activity (CARB 2022a, U.S. EPA 2022).

The City prepares an annual report to assess progress towards meeting the GHG emissions reduction targets established in the CAP and recommend next steps to help the City meet its targets. The City tracks changes in communitywide GHG emissions since 2008, which is the City's jurisdictional baseline year for the GHG emissions inventory. The CAP 2018 Annual Report provides the City's GHG emissions inventory in 2016, which is the most recent GHG emissions inventory for Santa Clara. **Table 4.8-1** presents the City's 2016 GHG emissions inventory (Santa Clara 2018).

TABLE 4.8-1 CITY OF SANTA CLARA 2016 GHG EMISSIONS INVENTORY

Sector	Carbon dioxide equivalent emissions (MTCO₂e)
Commercial Energy	1,080,261
Residential Energy	132,912
Transportation & Mobile Sources	505,989
Solid Waste	25,724
Water & Wastewater	24,292
Total Emissions	1,769,178

Source: Santa Clara 2018.

As stated in their 2018 IRP (SVP 2018), SVP follows the state’s preferred loading order in procuring new energy resources. First, the current load (customer) is encouraged to participate in energy efficiency programs to reduce their usage, thus freeing up existing resources (and any related emissions) for new load (electricity demand). In addition, both the City and SVP encourage the use of renewable resources and clean distributed generation, and the local area has seen a significant increase in the use of large and small rooftop photovoltaics. Demand displaced by customer-based renewable projects is also available to meet new loads.

SVP seeks to meet its RPS milestones through the addition of new renewable resources. In January 2018, SVP began providing 100 percent carbon-free power to all residential customers. This is reflected in the Power Content Label through separate products for the residential and non-residential mix (SVP 2023). A comparison of SVP’s and the statewide power mix for 2021 is shown in **Table 4.8-2**. SVP is in various stages of clean energy procurement for the future, negotiating contracts for over 700 Megawatts of energy, totaling over 2,200,000 MWh annually. This is equivalent to powering 366,000 homes. These resources will be constructed and brought online over the next five years (SVP 2023). As with all load-serving entities in California, the carbon intensity factor will continue to change as the power mix gradually increases the use of renewable resources to achieve California’s GHG and renewable energy goals.

TABLE 4.8-2 COMPARISON OF SVP AND STATEWIDE POWER MIX – 2021

Energy Resources	SVP Residential Mix	SVP Non-Residential Mix	SVP Green Power Standard Mix	Green Power National Mix	2021 CA Power Mix
Eligible Renewable	35.9%	27.0%	100%	27.0%	33.6%
Biomass & Biowaste	0%	2.1%	0%	2.1%	2.3%
Geothermal	0%	7.1%	0%	7.1%	4.8%
Eligible Hydroelectric	0%	5.9%	0%	5.9%	1.0%
Solar	14.7%	4.1%	100%	4.1%	14.2%
Wind	21.2%	7.8%	0%	7.8%	11.4%
Coal	0%	0%	0%	0%	3.0%
Large Hydroelectric	64.1%	6.7%	0%	6.7%	9.2%

TABLE 4.8-2 COMPARISON OF SVP AND STATEWIDE POWER MIX – 2021

Energy Resources	SVP Residential Mix	SVP Non-Residential Mix	SVP Green Power Standard Mix	Green Power National Mix	2021 CA Power Mix
Natural Gas	0%	34.3%	0%	34.3%	37.9%
Nuclear	0%	0%	0%	0%	9.3%
Other	0%	0%	0%	0%	0.2%
Unspecified sources of power	0%	32.0%	0%	32.0%	6.8%
TOTAL	100%	100%	100%	100%	100%

Source: SVP 2023

4.8.3 Environmental Impacts

Methodology

The applicant estimated GHG emissions for demolition/construction from the demolition/construction equipment, vendor and hauling truck trips, and worker vehicle trips.

GHG emissions from the project operation are a result of diesel fuel combustion from the readiness testing and maintenance of the emergency backup generators, offsite vehicle trips for worker commutes and material deliveries, and facility upkeep (such as architectural coatings, consumer product use, landscaping, water use, waste generation, and electricity use).

a. Would the project generate greenhouse gas emissions, either directly or indirectly, that may have a significant impact on the environment?

Construction

Less Than Significant Impact. Construction of the project would result in GHG emissions generated by the on-site operation of construction equipment, vendor and hauling truck trips, and worker trips. The applicant estimated that these sources would generate a total of approximately 806 MTCO₂e during the estimated 20 months of construction, including demolition, site preparation, grading, and on-and-off-site construction (DayZen 2022a, p. 2-17).

Because construction emissions would cease once construction is complete, these emissions are considered short term. The BAAQMD CEQA Guidelines do not identify a GHG emissions threshold for construction-related emissions. Instead, BAAQMD recommends that GHG emissions from construction be quantified and disclosed using available data and tools, to determine the amount, types, and sources of GHG emissions resulting from the project. In addition, the BAAQMD CEQA Guidelines states that projects should incorporate BMPs to reduce GHG emissions during construction. BMPs may include the use of alternative-fueled (for example, renewable diesel or electric) construction

vehicles and equipment for at least 15 percent of the fleet, use of at least 20 percent of locally sourced or recycled building materials, and recycling or reusing at least 50 percent of construction waste (BAAQMD 2023, Table 6-1). The project would implement mitigation measure **AQ-1**, which would require, among other things, that the construction equipment be tuned and maintained in accordance with manufacturer's specifications and that construction equipment idling time be limited to five minutes to reduce GHG emissions from fuel consumed from unnecessary idling or the operation of poorly maintained equipment. The project would also participate in the City's Construction & Demolition Debris Recycling Program by recycling or diverting at least 65 percent of materials generated for discards by the project to reduce the amount of demolition and construction waste going to the landfill (DayZen 2022a, p. 4-52 and 4-78). The quantity of construction-related GHG emissions would be limited to the construction phase, which would ensure GHG impacts are less than significant.

Operation

Less Than Significant with Mitigation Incorporated. GHG emissions from project operation and maintenance would consist of direct "stationary source" emissions from routine readiness testing and maintenance of the emergency backup generators and indirect and "non-stationary source" emissions from offsite vehicle trips for worker commutes and material deliveries, and facility upkeep, including architectural coatings, consumer product use, landscaping, water use, waste generation, and electricity use.

i. Direct Project Stationary Combustion Sources

The applicant proposed to use renewable diesel instead of conventional diesel fuel for a gradually increasing fraction of the total energy use per the schedule specified in the applicant's measure **GHG-2** with ultra-low sulfur diesel (<15 parts per million sulfur by weight) being used only as secondary backup fuel for the gensets (DayZenLLC 2022a, pg. 2-29). As discussed in more detail in **Section 4.6 Energy and Energy Resources**, the current supply for both renewable diesel and ultra-low sulfur diesel is more than sufficient to meet the project's necessary demand. The available resource of renewable diesel would increase with more refineries coming online and more import supply. Staff expects that most likely the readiness testing and maintenance would be done with renewable diesel because such refueling can be scheduled. However, during emergency operations, the applicant might need to use ultra-low sulfur diesel in the event of supply challenges or disruption in obtaining renewable diesel (CEC 2022).

BAAQMD CEQA Guidelines recommend using renewable diesel fuel in off-road construction equipment (BAAQMD 2023, Table 6-1), and staff believes that the project can feasibly use renewable diesel in the emergency backup generators. Accordingly, with the use of 100 percent renewable diesel, the fuel-cycle GHG emissions would be reduced, and staff concludes that the GHG emissions from the gensets for routine readiness testing and maintenance would be less than significant.

Table 4.8-3 shows the annual GHG emissions for the gensets routine readiness testing and maintenance. The emissions are conservatively estimated based on 35 hours of annual testing and maintenance at 100 percent load per engine.

TABLE 4.8-3 GREENHOUSE GAS EMISSIONS FROM GENSETS TESTING AND MAINTENANCE	
Source	Maximum Annual Emissions (MTCO₂e/yr)
Gensets – Testing and Maintenance	3,287
BAAQMD Threshold for Stationary Sources of GHG	10,000
Exceeds Threshold?	No

Source: (DayZen 2022b, Table 4.8-2).

GHG emissions from the project’s stationary sources (i.e. the emergency backup generators) for routine readiness testing and maintenance are well below the BAAQMD CEQA Guidelines GHG emissions significance bright-line threshold of 10,000 MTCO₂e/yr for stationary sources and would not exceed the threshold level for inclusion in CARB’s cap-and-trade program, which is 25,000 MTCO₂e/yr.

The project’s likelihood of operating the emergency backup generators for unplanned circumstances or emergency purposes is low and, if such operation did occur, it would be infrequent and of short duration. As discussed in more detail in **Appendix B**, the analysis of BAAQMD’s review of diesel engine use shows that the overall number of hours of operation for the facilities in the review that did run (which was less than half of them) was 0.07 percent of the available time over the 13-month period, which included the rare heat storm events in 2020 and is the only period for which data are available to staff. The average runtime for each event in BAAQMD’s review was approximately 5.0 hours. Staff concludes the GHG emissions of the emergency backup generators during unplanned circumstances or emergency purposes would not add significantly to the GHG emissions estimated for readiness testing and maintenance. As discussed in more detail in **Appendix B**, the analysis of BAAQMD’s review of diesel engine use shows that average engine ran no more than 36.5 hours over the 13-month period, which included the rare heat storm events in 2020. Staff expects diesel engine use during normal years would be much less than 36.5 hours. Thus, 35 hours of emergency backup generator operation per year is an appropriate estimate of operational time to accommodate both readiness testing and maintenance and emergency operation for any given year, even if ultra-low sulfur diesel is used during short emergency operation durations in the event of supply challenges or disruption in obtaining renewable diesel.

The applicant proposed a measure (**GHG-2**) which committed to use renewable diesel as primary fuel or ultra-low sulfur diesel as secondary fuel for the gensets. Staff agrees that this would be beneficial because the use of renewable diesel would reduce carbon dioxide emissions when compared with petroleum diesel. Staff proposes mitigation measure **GHG-2** to require the applicant to use renewable diesel for 100 percent of total energy use by the emergency backup generators, and only use ultra-low sulfur diesel as a secondary fuel in the event of supply challenges or disruption in obtaining renewable

diesel. The project owner shall perform any source test of the emergency backup generators using renewable diesel if required by the BAAQMD.

With the implementation of **GHG-2**, the environmental impact of GHG emissions from the project's stationary sources would be less than significant. In addition, as discussed below, with the implementation of **GHG-2**, the project's stationary sources would not conflict with plans, policies, or regulations adopted to achieve long-term GHG emissions reduction goals.

ii. Indirect and Non-Stationary Sources Emissions

Maximum GHG emissions from indirect and non-stationary sources (i.e., energy use, mobile sources and building operation) are provided in **Table 4.8-4**.

Project Electricity Usage. **Table 4.8-4** shows the indirect GHG emissions attributed to electricity use. It also shows the worst-case GHG emissions due to electricity use, which would be during full build-out operation. The primary function of the project is to house computer servers, which require electricity and cooling 24 hours a day to operate. Annual GHG emissions associated with electricity usage are the product of the maximum estimated annual electricity usage and the utility-specific carbon intensity factor, which depends on the utility's portfolio of power generation sources. The projected maximum demand for the project is 96 MW but will be built in phases. After full build-out, staff estimates that the worst-case energy use from the project's activities would be up to 840,960 MWh/year (= 96 MW × 8,760 hours/year). Actual electricity usage in any year would be lower than this level.

Electricity for the project would be provided by SVP, a utility that is on track to meet their 2030 GHG emissions reductions target. SVP is subject to CARB's cap-and-trade program requirements and the Renewables Portfolio Standard (RPS) requirements. Even as SVP improves its fuel mix to meet 2030 and other GHG emissions reduction goals, the project would indirectly emit a significant amount of GHGs as a result of its electricity use. As with all load serving entities in California, the carbon intensity factor would continue to change as the power mix gradually increases the use of renewable resources to achieve California's GHG and renewable energy goals.

Actual GHG emissions associated with electricity use at the project would be much less than the indirect GHG emissions shown in **Table 4.8-4** since actual electricity use would be less than the maximum and the SVP annual average emission factor would be tracking downward towards "zero net" with the implementation of state and local measures to reduce GHG emissions associated with electricity production and California's fuels.

In addition, the City adopted the 2022 CAP Update on June 7, 2022. The 2022 CAP Update includes Action B-1-7, "Carbon neutral data centers: requiring all new data centers to operate on 100 percent carbon neutral energy, with offsets as needed." The proposed project is subject to Action B-1-7. The applicant proposed a measure to comply with Action B-1-7 by contracting with SVP for a supply of 100 percent carbon-free electricity

(mitigation measure **GHG-1**) (DayZen 2022a, pg. 2-29). Staff evaluated the applicant's measure in the context of the project's compliance with Action B-1-7 and potential impacts associated with carbon use and concludes that the mitigation measure is sufficient. Staff concludes that without this mitigation the project could result in a significant, adverse impact as a result of its indirect GHG emissions. Therefore, staff proposes mitigation measure **GHG-1** to require the applicant to participate in SVP's Large Customer Renewable Energy (LCRE) program or other renewable energy program that accomplishes the same objective as SVP's LCRE program for 100 percent carbon-free electricity or purchase renewable energy credits or similar instruments that accomplish the same goals of 100 percent carbon-free electricity. With implementation of **GHG-1** the project would be consistent with Action B-1-7 and potential impacts associated with electricity use would be reduced to less than significant.

Project Mobile Emissions Sources. Table 4.8-4 shows the applicant's estimated annual GHG emissions from mobile emissions sources. Trip rates for land use types are default values obtained from CalEEMod, and the project land uses would generate up to 463 trips per day during operations (DayZen 2022b, p. 5 and Table 13). The emissions estimate did not account for the net change in trips at the site associated with the existing land use. However, the applicant conservatively estimated the GHG emissions based on 463 trips per day for the project.

Project Water Consumption and Waste Generation. Table 4.8-4 shows the estimated annual GHG emissions from water consumption and waste generation. Water consumption results in indirect emissions from electricity usage for water conveyance and wastewater treatment. Daily operations at the project would also generate solid waste, which results in fugitive GHG emissions during waste decomposition at the landfill.

Refrigerant Use. The project would use refrigerants in forty-eight (48) rooftop air-cooled chillers (DayZen 2022a). The refrigerant used in the air-cooled chillers proposed would be R-513a. The applicant estimates a 0.5 percent annual refrigerant loss a year. Each chiller unit is charged with 756.2 lbs of R-513a. The applicant estimated a total of 181 lbs of refrigerant would be lost in a year for all (48) of the chiller units for the whole project. Since R-513a has a GWP of 629.76, the project would create about 52 MTCO_{2e} into the atmosphere annually due to refrigerant loss (DayZen 2022a, p. 4-87).

Sulfur Hexafluoride Leakage. SF₆ would be used in the proposed breakers. Each breaker would contain approximately 25 lbs of SF₆, for a total of 50 lbs. The applicant estimated that the emissions of SF₆ due to leakage would be 0.075 lbs/yr at most assuming only one of the two breakers would leak with a leakage rate of 0.3% (DayZen 2023a, p. 13-14). Staff used a GWP of 23,900 to estimate the CO₂-equivalent of 0.075 lbs/yr of SF₆ to be about 0.8 MTCO_{2e}/yr (Table 4.8-4).

TABLE 4.8-4. MAXIMUM GHG EMISSIONS FROM ENERGY USE, MOBILE SOURCES, AND BUILDING OPERATION DURING PROJECT OPERATION

Source	Annual Emissions (MTCO ₂ e/yr)
Energy Use ^a	85,344
Mobile Sources ^b	497
Area Sources ^c	6.6
Water Use ^d	2
Waste Generation ^e	170
Cooling System R-513a Leakage ^f	52
Sulfur Hexafluoride (SF ₆) Leakage	0.8
Total	86,072

Sources: DayZen 2022b, DayZen 2023a, CEC staff analysis.

Notes:

^a Based on SVP carbon intensity factor of 222 lbs of CO₂ per MWh provided by SVP for the online year of 2025.

^b Trip rates for land use types are default values obtained from CalEEMod.

^c Operational emissions estimated using CalEEMod.

^d Annual GHG emissions associated with water usage were based on an estimated annual water usage of 911,000 gallons per year as provided by Martin LLC.

^e Annual GHG emissions associated with solid waste generation estimated using CalEEMod.

^f The applicant estimated GHG emissions from refrigerant leakage based on the leakage rate of 0.5 percent per year (CEC 2023) and a GWP of 629.76 for R-513a.

Summary of Indirect and Non-stationary GHG Emissions. As shown in **Table 4.8-4**, operation of the project is estimated to generate 85,344 MTCO₂e/yr from maximum possible electricity use and other non-stationary sources. However, this does not include efficiency measures that would be pursued as part of the project, nor does it reflect implementation of state and local measures to reduce GHG emissions associated with electricity production and California’s fuels. For example, programs to implement SB 350 and SB 100 would continue to promote renewable resources in the power mix and ensure the ongoing substantial reductions in GHG emissions from electricity generation. In addition, with the implementation of mitigation measure **GHG-1**, the project would use 100 percent carbon-free electricity by contracting with SVP at the 2020 Green Power Standard or participating in other renewable energy programs that accomplishes the same objective such as SVP’s Large Customer Renewable Energy (LCRE) Program for 100 percent carbon-free electricity. Therefore, with the implementation of mitigation measure **GHG-1**, the GHG impacts from the project’s electricity use would be less than significant.

Conclusion

Less Than Significant with Mitigation Incorporated. The mitigation elements contained in **GHG-1** and **GHG-2** ensure the total emission profile of the project remains less than significant.

With the use of 100 percent renewable diesel, the project’s stationary source GHG emissions from readiness testing and maintenance of the gensets would be reduced to the extent feasible, and stationary source emissions would be below the BAAQMD CEQA Guidelines threshold of significance of 10,000 MTCO₂e/yr.

Staff proposes mitigation measure **GHG-2** which ensures the applicant would use renewable diesel for 100 percent of total energy use by the gensets, and only use ultra-low sulfur diesel as a secondary fuel in the event of supply challenges or disruption in obtaining renewable diesel. The City of Santa Clara's Community Development Department (CDD) may grant temporary relief from the 100 percent renewable diesel requirement if the applicant can demonstrate a good faith effort to comply with the requirement and that compliance is not practical. With this measure, the project's direct GHG emissions from stationary sources would not have a significant direct or indirect impact on the environment. With **GHG-2**, the operation of the gensets would not hinder California's efforts to achieve the statewide 2045 GHG emissions reduction goal.

As discussed below, with the implementation of **GHG-1** and other proposed design measures, the GHG emissions from the project's energy usage, mobile sources, and building operation would occur in a manner consistent with the City's CAP and the policies reflected in Executive Order B-55-18, CARB's scoping plan, and later programs to implement SB 350 and SB 100 to achieve the statewide 2030 and other future GHG emissions reduction targets. These categories of GHG emissions would not result in a "cumulatively considerable" contribution under CEQA because they would conform with all applicable plans, policies, and regulations adopted for the purpose of GHG emissions reductions, as discussed further in "b" below. In addition, under the BAAQMD's 2022 CEQA thresholds of significance for land use projects "option B", GHG impacts from indirect and non-stationary emissions sources of the project would be considered to have a less-than-significant impact since the project is consistent with the City's CAP. Therefore, the maximum potential rate of GHG emissions from the project's energy usage, mobile sources, and building operation are determined to have less-than-significant GHG impacts.

The majority of the project's operational GHG emissions would occur from electricity use or during the readiness testing and maintenance of the gensets. The project's likelihood of operating for unplanned circumstances or emergency purposes is low and if such operation did occur it would be infrequent and of short duration. Staff concludes that 35 hours of operation per year per engine reasonably accommodates both readiness testing and maintenance and emergency operation for any given year. Staff, therefore, concludes that GHG emissions during emergency operation would be less than significant.

b. Would the project conflict with an applicable plan, policy or regulation adopted for the purpose of reducing the emissions of greenhouse gases?

Construction

Less Than Significant. The project's short-term demolition and construction GHG emissions would not interfere with the state's ability to achieve long-term GHG emissions reduction goals. As mentioned above, the project would implement BMPs, as specified in mitigation measure **AQ-1**, that would reduce construction-related GHG emissions. The

project would also participate in the City's Construction & Demolition Debris Recycling Program to further reduce GHG emissions. The City could also make the use of alternative fuels a condition of approval for new developments during pre-construction review meetings. The vehicles and fuel supplies used during demolition and construction of the project are required to comply with the applicable GHG reduction programs for mobile sources and suppliers of transportation fuels. The project would conform to relevant programs and recommended actions detailed in CARB's scoping plan. Similarly, the project components would not conflict with regulations adopted to achieve the goals of CARB's scoping plan. The project would be consistent with General Plan Energy Policies 5.10.3-P1 (promote the use of renewable energy resources, conservation, and recycling programs), 5.10.3-P4 (encourage new development to incorporate sustainable building design, site planning and construction, including encouraging solar opportunities), and 5.10.3-P5 (reduce energy consumption through sustainable construction practices, materials, and recycling) (DayZen 2022a, pg. 4-83). The project would also comply with the City's construction debris diversion ordinance and state waste diversion requirements to reduce the amount of waste in landfills (DayZen 2022a, Table 4.8-3).

Operation and Maintenance

Less Than Significant with Mitigation Incorporated. The project's GHG emissions related to operation and maintenance would be caused by the combustion of diesel fuel in the emergency backup generator engines and other routine operational activities (including energy use, mobile sources, and building operation).

i. Direct Project Stationary Combustion Sources

The direct project stationary combustion sources are the emergency backup generator engines.

State Plans, Policies, and Regulations

As discussed under Regulatory Background above, California has set ambitious 2030, 2045, and 2050 GHG emissions reduction goals. Because of these goals, staff concludes that the identified methods of carbon reduction contained in **GHG-1** and **GHG-2** would be necessary to ensure the project's GHG emissions are less than significant.

SB 100 established a landmark policy requiring renewable energy and zero-carbon resources supply 100 percent of electric retail sales to end-use customers by 2045. While the project is not directly required to comply with the SB 100 provisions, it is technically a generator of electricity and, therefore, it is reasonable to apply the GHG emissions reduction goal to the project. Mitigation measure **GHG-2** would ensure the applicant uses renewable diesel for 100 percent of total energy use by the gensets, and only use ultra-low sulfur diesel as a secondary fuel in the event of supply challenges or disruption in obtaining renewable diesel. The City's CDD may grant temporary relief from the 100 percent renewable diesel requirement if the applicant can demonstrate a good faith effort to comply with the requirement and that compliance is not practical. The mitigation would also require annually reporting the status of procuring and using renewable diesel. With

implementation of mitigation measure **GHG-2**, the project's stationary sources would use renewable diesel to ensure that the operation of the gensets would not hinder California's efforts to achieve the statewide 2045 GHG emissions reduction goal.

Regional Plans, Policies, and Regulations

Bay Area 2017 Clean Air Plan. With **GHG-2**, the direct project stationary combustion sources (i.e. emergency backup generator engines) would also be consistent with BAAQMD's Bay Area 2017 Clean Air Plan measure to Decarbonize Electricity Generation (EN1).

Diesel Free by '33. In 2018, the Mayor of Santa Clara personally became a signatory to the BAAQMD's Diesel Free by '33 initiative. However, the CEC has concluded that Diesel Free by '33 is not an applicable GHG emissions reduction strategy, program, or law that facilities must comply with. Nevertheless, it is a regional goal to reduce petroleum-based diesel fuel emissions in communities.

Renewable diesel is currently used mostly as a transportation fuel. There are both federal (CEC 2020a) and state incentives that offset the increased cost of renewable diesel compared to petroleum-based diesel when used in transportation applications. However, staff is unaware of any incentives that would apply to stationary sources, including the project. Staff proposes mitigation measure **GHG-2** to require the applicant to use renewable diesel for 100 percent of total energy use by the gensets, and only use ultra-low sulfur diesel as a secondary fuel in the event of supply challenges or disruption in obtaining renewable diesel.

Local Plans, Policies, and Regulations

City of Santa Clara General Plan. Air quality policy 5.10.2-P3 encourages the implementation of technological advances that minimize public health hazards and reduce the generation of air pollutants. The project proposes to use emergency backup generators with advanced air pollution controls. The project would be consistent with the Air Quality policy 5.10.2-P3 of the City's General Plan.

2022 CAP Update. The 2022 CAP Update includes Action B-3-6 Alternative fuel backup generators, which would require the City to provide information and technical assistance to data centers and other large commercial users to transition from petroleum-based diesel to lower-carbon backup generators (e.g., renewable diesel) by 2030. Mitigation measure **GHG-2** would require the applicant to use renewable diesel for 100 percent of total energy use by the gensets, and only use ultra-low sulfur diesel as a secondary fuel in the event of supply challenges or disruption in obtaining renewable diesel. The project would be consistent with the Action B-3-6 Alternative fuel backup generators in the 2022 CAP Update.

ii. Indirect and Non-Stationary Sources Emissions

The project's indirect and non-stationary sources emissions include those from energy use, mobile sources and building operation.

State Plans, Policies, and Regulations

The project's GHG emissions are predominantly from electricity usage. Multiple measures contained in CARB's scoping plan address GHG emissions from energy use. For example, CARB's cap-and-trade program, through the regulation of upstream electricity producers, would account for GHG emissions in the project's power mix and requires these emissions to be reduced by the amount needed to achieve the statewide 2030 GHG emissions reduction goal. Electricity sources and suppliers used by the project must comply with the RPS and cap-and-trade program requirements. This, however, is not to say that new large consumers of electricity should not also be responsible for the GHG emissions resulting from their electricity use.

While SVP itself is compliant with SB 100, staff concludes that because the project would present such a large, single potential increase in load (up to 96 MW at full build out), it is not sufficient to point to SVP's compliance to conclude the project's indirect emissions from electricity use are less than significant. The more electricity demand added to the grid, the harder it becomes to meet long-term GHG emissions reduction goals. Transmission resources are not infinite, and renewable imports are increasingly being taken as other states establish their own GHG emissions reduction goals. Adding renewable generation, while obviously preferable to fossil-fueled generation, is not without its own potential environmental impacts, and asking all customers of a load serving entity to share in the costs of greening additional demand brought on by large commercial customers raises equity concerns. Numerous data centers, many with just under 100 MW loads, are being proposed in SVP territory, with several already under construction or about to start. Without a requirement that these data center facilities bear responsibility for ensuring that their electricity use would not impede the attainment of the state's GHG emissions reduction goals, including SB 100, it is unclear how the state is going to make the increasingly steep reductions needed to avert the most catastrophic climate change scenarios. The applicant proposes to contract with SVP at the 2020 Green Power Standard (i.e., 100 percent carbon-free electricity) or participate in a program such as SVP's LCRE program to purchase 100 percent renewable electricity. Staff has confirmed with SVP that the applicant can participate in SVP's LCRE program to purchase 100 percent renewable electricity. Therefore, to conclude the project would not impede the attainment of the state's GHG emissions reduction goals, staff recommends the implementation of mitigation measure **GHG-1**, which requires the project applicant to participate in SVP's LCRE program or other renewable energy program that accomplishes the same objective as SVP's LCRE program for 100 percent carbon-free electricity or purchase renewable energy credits or similar instruments that accomplish the same goals of 100 percent carbon-free electricity.

Other project activities, such as mobile sources and building operation, would be similar to those of other commercial or industrial projects subject to development review by the City. The project would comply with all applicable city and state green building standards measures, including California Code of Regulations, Title 24, Part 6, baseline standard requirements for energy efficiency, based on the 2019 Energy Efficiency Standards requirements, and the 2019 California Green Building Standards Code, commonly referred to as CALGreen (California Code of Regulations, Title 24, Part 11).

The applicant would use a low GWP refrigerant, R-513a, in the air-cooled chillers (DayZen 2022a, p.4-87). The use of the proposed low GWP refrigerant would be allowed under the HFC prohibition regulation and the HFC sale and distribution prohibition (SB 1206).

With implementation of mitigation measure **GHG-1**, the operation of the project would not conflict with regulations adopted to achieve the goals of the scoping plan. Accordingly, the project's operational activities would not interfere with the state's ability to achieve long-term GHG emissions reduction goals.

Regional Plans, Policies, and Regulations

Bay Area 2017 Clean Air Plan. BAAQMD's Bay Area 2017 Clean Air Plan (BAAQMD 2017a) includes Energy and Climate Measure (ECM)-1 – Energy Efficiency, and due to the relatively high project electrical demand, energy efficiency measures are included in the design and operation of the onsite electrical and mechanical systems, consistent with this measure. Mitigation measure **GHG-1** requires the project applicant to participate in SVP's LCRE program or other renewable energy program that accomplishes the same objective as SVP's LCRE program for 100 percent carbon-free electricity or purchase renewable energy credits or similar instruments that accomplish the same goals of 100 percent carbon-free electricity. These features would be consistent with BAAQMD's Bay Area 2017 Clean Air Plan measure to Decarbonize Electricity Generation (EN1).

BAAQMD CEQA Thresholds of Significance. Under the BAAQMD's 2022 CEQA thresholds of significance for land use projects, a CEQA lead agency can conclude that a project would not make a cumulatively considerable contribution to global climate change if the project is designed and built to be consistent with the requirements of either Option A or Option B of the BAAQMD thresholds (BAAQMD 2022, p.2). In Option A, projects must include, at a minimum, the project design elements of buildings and transportation. In Option B, projects must be consistent with a local GHG reduction strategy that meets the criteria under CEQA Guidelines Section 15183.5(b) (BAAQMD 2022, pg. 2).

The proposed project would meet the new BAAQMD GHG Land Use Project standards by demonstrating compliance with the 2022 CAP and therefore consistent with "a local GHG reduction strategy that meets the criteria under State CEQA Guidelines Section 15183.5(b)"; and therefore, complying with Item B of the standards. (DayZen 2022a, p. 4-73). Discussions of the project's consistency with BAAQMD thresholds for land use projects are provided below in **Table 4.8-5**.

TABLE 4.8-5 CONSISTENCY WITH BAAQMD THRESHOLDS FOR LAND USE PROJECTS

BAAQMD Threshold Project Consistency	BAAQMD Threshold Project Consistency
Buildings	
a. The project will not include natural gas appliances or natural gas plumbing (in both residential and nonresidential development).	Consistent. The project would not include natural gas appliances or natural gas plumbing.
b. The project will not result in any wasteful, inefficient, or unnecessary energy usage as determined by the analysis required under CEQA Section 21100(b)(3) and Section 15126.2(b) of the State CEQA Guidelines.	Consistent. As described in further detail in Section 4.6 Energy, the project would not result in any wasteful, inefficient, or unnecessary energy usage.
Transportation	
a. Achieve a reduction in project-generated vehicle miles traveled (VMT) below the regional average consistent with the current version of the California Climate Change Scoping Plan (currently 15 percent) or meet a locally adopted Senate Bill 743 VMT target, reflecting the recommendations provided in the Governor’s Office of Planning and Research’s Technical Advisory on Evaluating Transportation Impacts in CEQA: i. Residential projects: 15 percent below the existing VMT per capita ii. Office projects: 15 percent below the existing VMT per employee iii. Retail projects: no net increase in existing VMT	Consistent. As described in further detail in Section 4.17 Transportation, project generated VMT would be 15 percent below the countywide average with implementation of Transportation Demand Management (TDM) measures included in the project.
b. Achieve compliance with off-street electric vehicle requirements in the most recently adopted version of CALGreen Tier 2.	Consistent. The applicant is working with the City to include the necessary electric vehicle parking spaces to comply with the requirements of CALGreen Tier 2.

Source: DayZen 2022a, Table 4.8-1

Plan Bay Area 2040/SB 375. MTC and ABAG developed an SCS with the adopted Plan Bay Area 2040 to achieve the Bay Area’s regional GHG emissions reduction target. Plan Bay Area 2040 sets a 15 percent GHG emissions reduction per capita target from passenger vehicles by 2035 when compared to the project 2005 emissions. However, these emission reduction targets are intended for land use and transportation strategies only. Mitigation measure **TRANS-1** would require the applicant implement a Transportation Demand Management (TDM) program to reduce vehicle trips and vehicle miles travelled (VMT) and thus would not contribute to a substantial increase in passenger vehicle travel within the region (see **Section 4.17 Transportation** for more information).

Local Plans, Policies, and Regulations

City of Santa Clara General Plan. The City adopted the General Plan to accommodate planned housing and employment growth through 2035. As part of the City’s General Plan Update in 2011, new policies were adopted that address the reduction of GHG emissions during the planning horizon of the General Plan. In addition to the reduction

measures in the CAP, the General Plan includes goals and policies to address sustainability aimed at reducing the city’s contribution to GHG emissions. For the project, the implementation of policies that increase energy efficiency or reduce energy use would effectively reduce indirect GHG emissions associated with energy consumption. The consistency of the project with the applicable land use, air quality, energy, and water policies in the General Plan is analyzed in **Table 4.8-6** below. As shown, the project would be consistent with the applicable sustainability policies in the General Plan.

TABLE 4.8-6 PROJECT CONSISTENCY WITH GENERAL PLAN SUSTAINABILITY POLICIES RELATED TO INDIRECT AND NON-STATIONARY SOURCES EMISSIONS

Emission Reduction Policies	Project Consistency
<i>Air Quality Policies</i>	
5.10.2-P4 Encourage measures to reduce greenhouse gas emissions to reach 30 percent below 1990 levels by 2020.	Water conservation and energy efficiency measures included in the project would reduce GHG emissions associated with the generation of electricity.
<i>Energy Policies</i>	
5.10.3-P1 Promote the use of renewable energy resources, conservation, and recycling programs.	The project would divert at least 65 percent of construction waste.
5.10.3-P4 Encourage new development to incorporate sustainable building design, site planning, and construction, including encouraging solar opportunities.	The project would utilize lighting control to reduce energy usage for new exterior lighting and air economization for building cooling. Water efficient landscaping and ultra-low flow plumbing fixtures in the building would be installed to limit water consumption.
5.10.3-P5 Reduce energy consumption through sustainable construction practices, materials, and recycling.	
5.10.3-P6 Promote sustainable buildings and land planning for all new development, including programs that reduce energy and water consumption in new development.	
5.10.3-P8 Provide incentives for LEED certified, or equivalent development.	Not applicable. With implementation of mitigation measure GHG-1 , the project owner will participate in the SVP’s LCRE program for 100 percent carbon-free electricity or purchase carbon offsets or similar instruments that accomplish the same goals of 100 percent carbon-free electricity associated with the project. Besides, with implementation of mitigation measure GHG-2 , the applicant would use renewable diesel for 100 percent of total energy use by the gensets, and only use ultra-low sulfur diesel as a secondary fuel in the event of supply challenges or disruption in obtaining renewable diesel. As a result, onsite renewable energy generation is not needed to offset the project’s emissions.
<i>Water Use Policies</i>	
5.10.4-P6 Maximize the use of recycled water for construction, maintenance, irrigation, and other appropriate applications.	The project would use recycled water for mechanical cooling and for landscaping.
5.10.4-P7 Require installation of native and low-water consumption plant species in new	The project would use water efficient landscaping with low-water usage plant material to minimize irrigation requirements.

TABLE 4.8-6 PROJECT CONSISTENCY WITH GENERAL PLAN SUSTAINABILITY POLICIES RELATED TO INDIRECT AND NON-STATIONARY SOURCES EMISSIONS

Emission Reduction Policies	Project Consistency
development and public spaces to reduce water usage.	

Source: DayZen 2022a, Table 3.8-4, pg. 4-83.

City of Santa Clara Climate Action Plan. Discussion of the project’s conformance with the applicable reduction measures for new development in 2022 CAP Update are provided below in **Table 4.8-7**:

TABLE 4.8-7: SUMMARY OF APPLICABLE CLIMATE ACTION PLAN MEASURES AND PROJECT CONSISTENCY

Applicable Climate Action Plan Measures		Project Compliance
Water Conservation		
N-3-3	Water-Efficient landscaping requirements: Expand requirements for water-efficient landscaping practices, including requirements for cooling (trees, green roofs) and drought-tolerant native plants.	The project proposes to integrate water conservation practices, such as efficient landscapes and high-efficiency irrigation systems.
N-3-5	Recycled Water Connection Requirements: Require the use of recycled water for all non-potable uses where recycled water is available, per City Code 13	There is an existing recycled water pipeline located on the east side of the UPRR tracks, approximately 100 feet to the east of the subject property. The project would extend the recycled water line as a primary source of water for landscaping. The data center would be designed to use up to 1.0 AFY of recycled water provided by the City of Santa Clara.
Materials and Consumption – Increase Waste Diversion		
M-1-1	Compliance with State Solid Waste Ordinance: Comply with state solid waste laws, including AB 1826, AB 341, and SB 1383. These bills require that businesses, public entities, and communities expand recycling and composting infrastructure to meet the state’s ambitious landfill waste reduction targets. AB 1826 requires commercial businesses that generate a certain level of organic waste arrange for recycling services for that waste. AB 341 similarly requires that commercial businesses and public entities that generate a certain level of weekly waste have a recycling program in place. SB 1383 requires that California reduce waste to landfills by 75% by 2025 and rescue 20% of surplus edible food in phases beginning in 2022.	The proposed project would include recycling services and participate in the City’s Construction and Demolition Debris Recycling Program.
Transportation and Land Use		
T-1-2	EV Charging for all New Construction: Implement EV charging requirements as specified in the adopted 2021 Reach Codes.	The project would provide at least four electric vehicle charging stations, 17 EV capable

TABLE 4.8-7: SUMMARY OF APPLICABLE CLIMATE ACTION PLAN MEASURES AND PROJECT CONSISTENCY

Applicable Climate Action Plan Measures		Project Compliance
		spaces (of which one is EV van accessible), and six clean air vehicle parking spaces.
Natural Systems and Water Resources – Increase Tree Canopy Cover		
N-1-3	Urban Forest Partnership: Promote healthy, well-managed urban forests by participating in the County’s Urban Forest Alliance partnership.	The MDC proposes to mitigate for the loss 33 trees by planting trees in accordance with the City’s General Plan (Policy 5.3.1-P10).
Community Resilience and Well-Being: Prepare for Climate Change		
C-2-3	High-Albedo Parking Lots: As part of conditions of approval, require new parking lots to be surfaced with more sustainable pavement materials (e.g., high-albedo permeable pavement, e-pavement, etc.) to reduce heat gain during extreme heat events, reduce energy consumption related to cooling, and reduce stormwater runoff.	Per City requirements, the proposed surface parking would be paved with sustainable pavement, such as high-albedo permeable pavement or e-pavement.
Electric Fuels to Achieve Net-Zero Carbon Buildings		
B-1-5	Reach Codes for New Construction: Implement all-electric codes, with exceptions. The All-electric building electrification with electric vehicle charging reach code ordinance would apply to all new building permit applications per City Ordinance 2034.	The project would comply with the City’s Reach Codes and would not use natural gas. The project would provide four electric vehicle charging stations.
B-1-7	Carbon-Neutral Data Centers: Require all new data centers to operate on 100% carbon neutral energy, with offsets as needed. This requirement does not apply to data centers with planning application approval within six months of the CAP adoption date. Use offsets as needed to help ease the transition to carbon neutral energy but ensure that reducing emissions remains the main priority.	Per mitigation measure GHG-1 , the project would contract with SVP at the Green Power Standard (i.e., 100% carbon-free electricity) for electricity accounts associated with the project or participate in a clean energy program that accomplishes the same goals of 100 percent carbon-free electricity as the SVP 2020 Green Power Standard.
Maximize Renewable Energy Generation and Storage Capacity		
B-3-6	Alternative Backup Generators: Provide information and technical assistance to data centers and other large commercial users to transition from diesel to lower-carbon backup generators (e.g., renewable diesel). Consider promoting the use of non-diesel alternatives as alternative back-up power source for data centers when SVP service is unavailable.	As discussed in Section 5, Martin Properties evaluated and determined that alternative backup generation technologies could not feasibly attain the primary reliability objective of the project’s backup generation. The project will use renewable diesel fuel as its primary fuel as described in Project Design Measure PDM GHG-2 .

Source: DayZen 2022a, Table 4.8-3

Conclusion

Less Than Significant with Mitigation Incorporated. With the incorporation of the project features and mitigation measures **GHG-1** and **GHG-2**, GHG emissions related to the project would be consistent with the applicable plans and policies adopted to reduce GHG emissions and would comply with all regulations or requirements adopted to implement a statewide, regional, or local plan for the reduction or mitigation of GHG emissions. The potential for the project to conflict with an applicable plan, policy, or regulation for GHG emissions reductions would be less than significant.

4.8.4 Mitigation Measures

GHG-1: The project owner shall participate in SVP's Large Customer Renewable Energy (LCRE) Program or other renewable energy program that accomplishes the same objective as SVP's LCRE Program for 100 percent carbon-free electricity, or (2) purchase renewable energy credits or similar instruments that accomplish the same goals of 100 percent carbon-free electricity.

During Operation, the project owner shall provide documentation to the director, or director's designee, of the city of Santa Clara Electric Utility Department of initial enrollment and shall submit annual reporting to the director, or director's designee, of the city of Santa Clara Electric Utility Department documenting either continued participation in SVP's LCRE Program or documentation that alternative measures continue to provide 100 percent carbon-free electricity as verified by an independent third-party auditor specializing in greenhouse gas emissions.

GHG-2: The project owner shall use renewable diesel for 100 percent of total energy use by the gensets, and only use ultra-low sulfur diesel (ULSD) as a secondary fuel in the event of supply challenges or disruption in obtaining renewable diesel. The City of Santa Clara Community Development Department (CDD) may grant temporary relief from the 100 percent renewable diesel requirement if the project owner can demonstrate a good faith effort to comply with the requirement and that compliance is not practicable. The project owner shall provide an annual report of the status of procuring and using renewable diesel to the director, or director's designee, of the City of Santa Clara CDD demonstrating compliance with the mitigation measure.

4.8.5 References

BAAQMD 2017a – Bay Area Air Quality Management District (BAAQMD). Final 2017 Clean Air Plan, Adopted April 19, 2017. Accessed August 2021. Available online at: http://www.baaqmd.gov/~media/files/planning-and-research/plans/2017-clean-air-plan/attachment-a_-proposed-final-cap-vol-1-pdf.pdf

BAAQMD 2022 – Bay Area Air Quality Management District (BAAQMD). Justification Report: CEQA Thresholds for Evaluating the Significance of Climate Impacts From Land Use Projects and Plans, dated April 2022. Accessed June 2023.

- Available online at: <https://www.baaqmd.gov/~/media/files/planning-and-research/ceqa/ceqa-thresholds-2022/justification-report-pdf.pdf?la=en>
- BAAQMD 2023 – Bay Area Air Quality Management District (BAAQMD). California Environmental Quality Act Air Quality Guidelines, Updated April 2023. Accessed August 2023. Available online at: <https://www.baaqmd.gov/plans-and-climate/california-environmental-quality-act-ceqa/updated-ceqa-guidelines>
- CARB 2014 – California Air Resources Board (CARB). First Update to the Climate Change Scoping Plan, dated May 2014. Accessed August 2021. Available online at: https://ww3.arb.ca.gov/cc/scopingplan/2013_update/first_update_climate_change_scoping_plan.pdf
- CARB 2017a – California Air Resources Board (CARB). 2017 Climate Change Scoping Plan Update: The Strategy for Achieving California’s 2030 GHG Target, November 2017. Accessed August 2021. Available online at: https://ww3.arb.ca.gov/cc/scopingplan/scoping_plan_2017.pdf
- CARB 2017b – California Air Resources Board (CARB). Short-Lived Climate Pollutant Reduction Strategy, March 2017. Accessed August 2021. Available online at: https://ww2.arb.ca.gov/sites/default/files/2020-07/final_SLCP_strategy.pdf
- CARB 2022a – California Air Resources Board (CARB). California Greenhouse Gas Emissions for 2000 to 2020 Trends of Emissions and Other Indicators. Date of Release: October 26, 2022. Accessed February 2023. Available online at: https://ww2.arb.ca.gov/sites/default/files/classic/cc/inventory/2000-2020_ghg_inventory_trends.pdf
- CARB 2022b – California Air Resources Board (CARB). Low Carbon Fuel Standard Reporting Tool Quarterly Summaries, Quarterly Data Summary and Spreadsheet, dated October 31, 2022. Accessed February 2023. Available online at: https://ww2.arb.ca.gov/sites/default/files/2022-10/quarterlysummary_103122_1.xlsx
- CARB 2022c – California Air Resources Board (CARB). 2022 Scoping Plan for Achieving Carbon Neutrality, November 16, 2022. Accessed February 2023. Available online at: <https://ww2.arb.ca.gov/our-work/programs/ab-32-climate-change-scoping-plan/2022-scoping-plan-documents>
- CEC 2019 – California Energy Commission (CEC). September 23, 2019 California Energy Commission Letter to Ms Kathleen Hughes – Silicon Valley Power (TN 229814). Accessed May 2022. Available online at: <https://efiling.energy.ca.gov/GetDocument.aspx?tn=229814&DocumentContentId=61260>
- CEC 2020a – California Energy Commission (CEC). ROC with US EPA and CEC staff G. Bemis - Supersedes TN 234348 (TN 234353), August 2020. Accessed May 2022. Available online at: <https://efiling.energy.ca.gov/Lists/DocketLog.aspx?docketnumber=20-SPPE-01>

CEC 2022 – California Energy Commission (CEC). (TN 247764). Report of Conversation re: STACK Trade Zone Park Renewable Diesel Use, dated November 29, 2022. Available online at:

<https://efiling.energy.ca.gov/Lists/DocketLog.aspx?docketnumber=21-SPPE-02>

DayZen 2022a – MBGF SPPE Application- Part I- Main App and Appendix A (TN247325). November 2022. Available online at:

<https://efiling.energy.ca.gov/Lists/DocketLog.aspx?docketnumber=22-SPPE-03>

DayZen 2022b – MBGF SPPE Application- Part II- Appendices B C and D (TN247329). November 2022. Available online at:

<https://efiling.energy.ca.gov/Lists/DocketLog.aspx?docketnumber=22-SPPE-03>

DayZen 2023a – Martin Properties Responses to CEC Data Request Set 1 - MBGF (TN 249350). March 17, 2023. Available online at:

<https://efiling.energy.ca.gov/Lists/DocketLog.aspx?docketnumber=22-SPPE-03>

IPCC 2013 – Intergovernmental Panel on Climate Change (IPCC). Climate Change 2013: The Physical Science Basis. Contribution of Working Group I to the Fifth Assessment Report of the Intergovernmental Panel on Climate Change [Stocker, T.F., D. Qin, G.-K. Plattner, M. Tignor, S.K. Allen, J. Boschung, A. Nauels, Y. Xia, V. Bex and P.M. Midgley (eds.)]. Cambridge University Press, Cambridge, United Kingdom and New York, NY, USA, 1535 pp, doi:10.1017/CBO9781107415324. Accessed August 2021. Available online at: <https://www.ipcc.ch/report/ar5/wg1/>

MTC & ABAG 2017 – Metropolitan Transportation Commission and Association of Bay Area Governments (MTC & ABAG). Plan Bay Area 2040. Adopted July 26, 2017. Accessed August 2021. Available online at: <https://mtc.ca.gov/our-work/plans-projects/plan-bay-area-2040>

Santa Clara 2018 – City of Santa Clara (Santa Clara). City of Santa Clara Climate Action Plan Annual Report. July 2018. Accessed August 2021. Available online at: <http://santaclaraca.gov/home/showdocument?id=62433>

Santa Clara 2022 – City of Santa Clara (Santa Clara). Santa Clara Climate Action Plan. June 2022. Accessed March 2023. Available online at: <http://santaclara.gov/home/showpublisheddocument/78208/6379701300988700> (santaclaraca.gov)

SVP 2018 – Silicon Valley Power (SVP). Final 2018 Integrated Resource Plan dated 12 November 2018. Accessed August 2021. Available online at: <https://www.siliconvalleypower.com/svp-and-community/about-svp/integrated-resource-plan>

SVP 2021 – Silicon Valley Power (SVP). Action on a Resolution Establishing Silicon Valley Power (SVP) Large Customer Renewable Energy (LCRE) Program – A Voluntary Program for Large Customers to Purchase Additional Renewable Energy Above the Amount of Renewable Energy Already Required in SVP's Energy Delivery Portfolio. November 2021. Available online at: <https://santaclara.legistar.com/LegislationDetail.aspx?ID=5215843&GUID=1BAC>

DF6A-915D-48D4-981F-
949273F4EEA1&Options=ID%7CText%7C&Search=Green+Energy

SVP 2023 – Silicon Valley Power (SVP). 2021 Power Content Label. Accessed May 2023.
Available online at: <https://www.siliconvalleypower.com/svp-and-community/about-svp/power-content-label>

U.S. EPA 2022 – United States Environmental Protection Agency (U.S. EPA). Inventory of U.S. Greenhouse Gas Emissions and Sinks. Accessed November 2022.
Available online at: <https://www.epa.gov/ghgemissions/inventory-us-greenhouse-gas-emissions-and-sinks>

4.9 Hazards and Hazardous Materials

This section describes the environmental setting and regulatory background and discusses impacts associated with the construction and operation of the project with respect to hazards and hazardous materials.

HAZARDS AND HAZARDOUS MATERIALS	Potentially Significant Impact	Less Than Significant with Mitigation Incorporated	Less Than Significant Impact	No Impact
Would the project:				
a. Create a significant hazard to the public or the environment through the routine transport, use, or disposal of hazardous materials?	<input type="checkbox"/>	<input checked="" type="checkbox"/>	<input type="checkbox"/>	<input type="checkbox"/>
b. Create a significant hazard to the public or the environment through reasonably foreseeable upset and accident conditions involving the release of hazardous materials into the environment?	<input type="checkbox"/>	<input type="checkbox"/>	<input checked="" type="checkbox"/>	<input type="checkbox"/>
c. Emit hazardous emissions or handle hazardous or acutely hazardous materials, substances, or waste within one-quarter mile of an existing or proposed school?	<input type="checkbox"/>	<input type="checkbox"/>	<input type="checkbox"/>	<input checked="" type="checkbox"/>
d. Be located on a site which is included on a list of hazardous materials sites compiled pursuant to Government Code Section 65962.5 and, as a result, would it create a significant hazard to the public or the environment?	<input type="checkbox"/>	<input checked="" type="checkbox"/>	<input type="checkbox"/>	<input type="checkbox"/>
e. For a project located within an airport land use plan or, where such a plan has not been adopted, within two miles of a public airport or public use airport, would the project result in a safety hazard or excessive noise for people residing or working in the project area?	<input type="checkbox"/>	<input type="checkbox"/>	<input checked="" type="checkbox"/>	<input type="checkbox"/>
f. Impair implementation of or physically interfere with an adopted emergency response plan or emergency evacuation plan?	<input type="checkbox"/>	<input type="checkbox"/>	<input type="checkbox"/>	<input checked="" type="checkbox"/>
g. Expose people or structures, either directly or indirectly, to a significant risk of loss, injury or death involving wildland fires?	<input type="checkbox"/>	<input type="checkbox"/>	<input type="checkbox"/>	<input checked="" type="checkbox"/>

Environmental checklist established by CEQA Guidelines, Appendix G.

4.9.1 Environmental Setting

Hazardous Materials

Demolition and Construction. The proposed project would include demolition of four existing buildings and all infrastructure at 651 Martin Avenue, Santa Clara, with no reuse for the proposed project. Due to the pre-1970 construction date of the existing buildings, there is potential for asbestos containing material (ACM) and lead based paint (LBP) on and within components of the buildings.

In addition, the proposed project would involve limited transport, storage, use, and disposal of hazardous materials during demolition and construction activities. Known and anticipated hazardous materials handling during demolition and construction would include the transport of fuels, lubricating fluids, and solvents associated with construction equipment, as well as the transport of potentially contaminated soils excavated from the project site. All hazardous materials would be stored, handled, and used in accordance with applicable regulations. Spills and leaks of hazardous materials during construction activities would be likely to involve small quantities and be contained to the site.

Operation. During operation, the facility would store a large quantity of diesel fuel, totaling approximately 237,600 gallons for all the emergency backup generators (gensets), in integrated diesel fuel storage tanks within each genset package to provide 24 hours of uninterrupted emergency generation. Diesel fuel would be delivered via a compartmentalized tanker truck with maximum capacity of 8,500 gallons. Each genset enclosure would also include a 250-gallon tank of Diesel Exhaust Fluid (DEF) (diluted urea); DEF is used as part of the diesel engine combustion process to meet the Tier 4 emissions requirements. The project applicant states it will prepare a State and federally compliant Spill Prevention, Control and Countermeasure Plan (SPCC) to address the storage, use and delivery of diesel fuel for the gensets (DayZenLLC 2022a).

Hazardous Waste and Substances Sites

Existing and past land use activities can indicate the prior release of hazardous materials that may remain on the site.

The project site is in an area with properties of varying commercial and industrial land uses, and of former industrial and agricultural land uses. Further information can be found in **Section 3 Project Description**.

The project owner hired TRC Solutions, Inc. (TRC) to conduct a Phase 1 Environmental Site Assessment (ESA) to determine the location of existing hazardous wastes and hazardous material release sites within 0.25 mile of the project. The analysis provided by TRC within the Phase 1 ESA included a search through Environmental Data Resources, Inc., a proprietary database related to generation, storage, handling, transportation, treatment of wastes, and the remediation of contaminated soil and groundwater sites. TRC also included searches of the State Water Resources Control Board's (SWRCB) Geotracker database, and the California Department of Toxic Substance Control's (DTSC) EnviroStor database.

Based on the TRC Phase I ESA conducted in July 2021, the project site has a history of agricultural use from approximately 1939 to 1956 and of industrial use from 1956 to the present. The Phase I ESA identified several environmental conditions associated with the site's former agricultural use and the former presence of two underground storage tanks (USTs). The site's former agricultural use may result in heavy metal or pesticide impacts to shallow soil in the project area. TRC identified through the Geotracker database, the former presence of two USTs on the site: a 500-gallon gasoline tank and an 880-gallon

Debur waste tank related to formed aluminum manufacturing operations in the southern parcel. The two USTs were removed in 2001 and in 1989, respectively. The project site is in an area with known volatile organic compound (VOC) impacts to groundwater and in soil resulting from former USTs. The Phase I ESA also identified environmental conditions associated with a former paperboard manufacturing facility located approximately 150 feet east of the project site at 2600 De La Cruz Boulevard. Limited subsurface investigation at 2600 De La Cruz Boulevard performed in 2018 identified petroleum hydrocarbons and fuel-related VOCs in groundwater; and fuel-related VOCs, chlorinated solvents, and several other VOCs in soil gas samples (DayZenLLC 2022c).

In addition to the Phase I ESA, TRC completed a Phase II ESA in September 2021 to evaluate the presence of potential contaminants in soil and soil vapor from past uses at the project site. TRC conducted a limited subsurface investigation that included twelve soil samples and eight soil vapor samples to evaluate the current subsurface conditions. Metal concentrations of arsenic and nickel detected in the soil samples collected were above respective environmental screening levels (ESLs) established by the Regional Water Quality Control Board (RWQCB) for construction workers and commercial users. In the soil vapor samples collected, VOC concentrations of benzene in one sample were detected above respective ESLs (DayZenLLC 2022d).

Airports

The Norman Y. Mineta San José International Airport, a public airport, is approximately one quarter mile east of the proposed project site. The project site is inside the Traffic Pattern Zone, and partially within the Turning Safety Zone (TSZ), according to the Santa Clara County Airport Land Use Commission Plans. The TSZ represents the approach and departure areas that have the third highest level of exposure to potential aircraft accidents. The project's Federal Aviation Regulations (FAR) Part 77 obstruction surface is 212 feet above mean sea level (AMSL), as identified in Figure 6 of the Comprehensive Land Use Plan (CLUP) for the Norman Y. Mineta San José International Airport (SCCALUC 2016).

Schools

There are no schools or daycares within one quarter mile of the project site. The closest school to the project site is the Scotts Lane Elementary School, which is approximately 0.8 miles southwest of the project site.

Emergency Evacuation Routes

The county of Santa Clara Operational Area Hazard Mitigation Plan and city of Santa Clara Emergency Operations Plan identify hazards and provide a risk assessment for the potential natural hazards, such as a flood, wildfire, or earthquake, that could impact the county. The plan does not identify any designated evacuation routes near the project site (Santa Clara County 2017, City of Santa Clara 2017).

Wildfire Hazards

The California Department of Forestry and Fire Protection (Cal Fire) identifies and maps areas of significant fire hazards based on fuels, terrain, and other relevant factors. The maps identify this information as a series of Fire Hazard Severity Zones, which are progressively ranked in severity as un-zoned, moderate, high, and very high. State responsibility areas (SRAs) are locations where the State of California is responsible for wildland fire protection. Local responsibility areas (LRAs) are locations where the responding agency is the county or city. The project site would be within Santa Clara County.

The Cal Fire maps for Santa Clara County indicate that the project site is in an LRA (CalFire 2022). Within the LRA, the project site falls within an un-zoned Fire Hazard Severity Zone that indicates that the project site has a less than moderate susceptibility to wildland fires. For more information on wildfire hazards, see **Section 4.19 Wildfire**.

Regulatory Background

Federal

Resource Conservation and Recovery Act (RCRA). The RCRA, adopted in 1976 established a program administered by the United States Environmental Protection Agency (U.S. EPA) for the regulation of the generation, transportation, treatment, storage, and disposal of hazardous waste. RCRA was amended in 1984 by the Hazardous and Solid Waste Act, which affirmed and extended the “cradle to grave” system of regulating hazardous wastes. The use of certain techniques for the disposal of some hazardous wastes was specifically prohibited by the Hazardous and Solid Waste Act.

Comprehensive Environmental Response, Compensation, and Liability Act (CERCLA). Congress enacted the federal CERCLA, including the Superfund program, on December 11, 1980. This law provided broad federal authority to respond directly to releases or threatened releases of hazardous substances that may endanger public health or the environment. CERCLA established requirements concerning closed and abandoned hazardous waste sites; provided for liability of persons responsible for releases of hazardous waste at these sites; and established a trust fund to provide for cleanup when no responsible party could be identified. CERCLA also enabled the revision of the National Contingency Plan. The National Contingency Plan provided the guidelines and procedures needed to respond to releases and threatened releases of hazardous substances, pollutants, and/or contaminants. The National Contingency Plan also established the National Priorities List. CERCLA was amended by the Superfund Amendments and Reauthorization Act on October 17, 1986.

Clean Water Act (CWA). The CWA is the principal federal statute protecting navigable waters and adjoining shorelines from pollution. The law was enacted with the intent of restoring and maintaining the chemical, physical, and biological integrity of the waters of the United States. Since its enactment, the CWA has formed the foundation for regulations detailing specific requirements for pollution prevention and response

measures. The U.S. EPA implements provisions of the CWA through a variety of regulations, including the National Contingency Plan, as described above, and the Oil Pollution and Prevention Regulations. Implementation of the CWA is the responsibility of each state.

As part of the CWA, the U.S. EPA oversees and enforces the Oil Pollution Prevention regulation (Title 40, Code of Federal Regulations (CFR), Part 112), which is often referred to as the "SPCC rule" because the regulations describe the requirements for facilities to prepare, amend, and implement SPCC Plans. A facility is subject to SPCC regulations if the total above ground oil storage capacity exceeds 1,320 gallons, or the underground oil storage capacity exceeds 42,000 gallons, and if, due to its location, the facility could reasonably be expected to discharge oil into or upon the "navigable waters" of the United States. The rule specifies that proactive, and not passive, measures be used to respond to oil discharges.

National Pollutant Discharge Elimination System (NPDES). The NPDES permit program, created in 1972 by the CWA, helps address water pollution by regulating point sources that discharge pollutants to waters of the United States. The permit provides two levels of control: technology-based limits and water quality-based limits (if technology-based limits are not sufficient to provide protection of the water body). Under the CWA, the U.S. EPA may authorize state, tribal, and territorial governments to administer the NPDES permit program, enabling them to perform many of the permitting, administrative, and enforcement aspects of the NPDES program. In states authorized to implement CWA programs, the U.S. EPA retains oversight responsibilities. Within the state of California, the SWRCB issues both general permits and individual permits under the NPDES permit program.

Department of Transportation (DOT). The United States DOT is the primary federal agency responsible for regulating the proper handling and storage of hazardous materials during transportation (49 CFR §§ 171-177 and 350-399).

Toxic Substance Control Act (TSCA). The TSCA of 1976 authorizes the U.S. EPA to regulate and screen all chemicals produced or imported into the United States to prevent unreasonable risks to health and the environment. The TSCA provides the U.S. EPA with the authority to require reporting, record-keeping and testing requirements, and restrictions relating to chemical substances and/or mixtures. Certain substances are generally excluded from TSCA, including, among others, food, drugs, cosmetics and pesticides. The TSCA addresses the production, importation, use, and disposal of specific chemicals.

Federal Aviation Administration (FAA). Title 14, Part 77.9 of the Code of Federal Regulations requires FAA notification for any construction or alteration of navigable airspace exceeding 200 feet above ground level (AGL). It also requires notification for construction or alterations within 20,000 feet of an airport with a runway more than 3,200 feet in length if the height of the construction or alteration exceeds a slope of 100 to 1

extending outward and upward from the nearest point of the nearest runway of the airport.

If a project's height exceeds 200 feet or exceeds the 100:1 surface, the project applicant must submit a copy of FAA Form 7460-1, Notice of Proposed Construction or Alteration, to the FAA.

State

California Environmental Protection Agency (CalEPA). CalEPA created in 1991, unified California's environmental authority in a single cabinet-level agency and brought the California Air Resources Board (CARB), State Water Resources Control Board (SWRCB), Regional Water Quality Control Boards (RWQCBs), Integrated Waste Management Board, Department of Toxic Substance Control (DTSC), Office of Environmental Health Hazard Assessment, and Department of Pesticide Regulation under one agency. These agencies under the CalEPA "umbrella" provide protection of human health and the environment and ensure the coordinated deployment of state resources. Their mission is to restore, protect and enhance the environment, to ensure public health, environmental quality, and economic vitality.

The California Hazardous Waste Control Law. CalEPA administers the California Hazardous Waste Control Law to regulate hazardous wastes. The Hazardous Waste Control Law lists 791 chemicals and about 300 common materials that may be hazardous, establishes criteria for identifying, packaging and labeling hazardous wastes, prescribes management controls, establishes permit requirements for treatment, storage, disposal and transportation, and identifies some wastes that cannot be disposed of in landfills.

Department of Toxic Substances Control (DTSC). DTSC is the primary agency in California that regulates hazardous waste, cleans up existing contamination, and looks for ways to reduce the hazardous waste produced in California. DTSC regulates hazardous waste in California primarily under the authority of RCRA and the California Health and Safety Code. Other laws that affect hazardous waste are specific to handling, storage, transportation, disposal, treatment, reduction, cleanup, and emergency planning.

California Occupational Safety and Health Administration (Cal OSHA). California Occupational Safety and Health Administration (Cal OSHA) is the primary agency responsible for worker safety related to the handling and use of chemicals in the workplace. Cal OSHA standards are generally more stringent than federal regulations. Employers are required to monitor worker exposure to listed hazardous substances and notify workers of exposure (Title 8, Cal. Code Regs., §§ 337 340). The regulations specify requirements for employee training, availability of safety equipment, accident-prevention programs, and hazardous substance exposure warnings.

California Department of Public Health (CDPH). Under Title 17, Public Health, Division 1, State Department of Health Services, Chapter 8 - Accreditation, Certification and Work Practices for Lead-Based Paint and Lead Hazards, the CDPH oversees the Lead

Related Contractor (LRC) program certification requirements and work practice standards. LRC certification means that CDPH has evaluated and approved a person's qualifications, through the issuance of five different certificates, to perform lead-related construction work in residential and public buildings. CDPH evaluates applicants to make sure they have completed state-approved training and have relevant experience and education. The certifications are for Lead Inspector/Assessor, Lead Project Monitor, Lead Sampling Technician, Lead Supervisor, and Lead Worker. Certificates are granted to individuals, not to companies or businesses. The CDPH also provides guidelines and forms for required safe work practices related to lead hazards.

Porter-Cologne Water Quality Act. This state law provides a comprehensive water quality management system for the protection of California waters. The act designates the SWRCB as the ultimate authority over State water rights and water quality policy and also established nine RWQCBs to oversee water quality on a day-to-day basis at the local and regional level. The RWQCBs have the responsibility of granting NPDES permits and setting waste discharge requirements for stormwater runoff from construction sites. The proposed project's NPDES permits in California would be under the jurisdiction of the San Francisco Bay RWQCB.

Department of California Highway Patrol. Department of California Highway Patrol is the primary agency responsible for enforcing the regulations related to the transport of hazardous materials on California roads and highways (Title 13, Cal. Code Regs., §§ 1160-1167).

The Aboveground Petroleum Storage Act Program. The aboveground program requires tank facilities storing greater than 1,320 gallons of petroleum that stores any amount of petroleum, to develop and implement the SPCC Plan requirements under CFR Part 112. A tank facility is any tank or tanks that are aboveground, including connected piping, that contain petroleum and are used by an owner or operator at a single location or site, is in secondary containment, and it is used to hold oil. The Certified Unified Program Agency (CUPA) regulates businesses storing petroleum in aboveground containers or tanks (California Health & Safety Code, Chapter 6.67, Sections 25270-25270.13). The Santa Clara Fire Department Community Risk Reduction Division is the CUPA for the city of Santa Clara.

Local

San Francisco Bay Region Municipal Regional Stormwater NPDES Permit (MRP) Order No. R2-2015-0049. The SWRCB has found that there is a reasonable potential that municipal stormwater discharges in the San Francisco Bay Region cause or may cause or contribute to the following pollutants exceeding water quality standards; mercury, polychlorinated biphenyls (PCBs), furans, dieldrin, chlordane, DDT, selenium; pesticide associated toxicity, and trash. Therefore, pollutant control actions and further pollutant impact assessments by permittees of the San Francisco Bay Region MRP are required as set forth in the MRP. The San Francisco Bay Region MRP also requires that permittees develop an assessment methodology for applicable structures planned for

demolition to ensure PCBs do not enter municipal storm drain systems per Provision C.12.f. Buildings constructed between 1950 and 1980 proposed for demolition must be screened for the presence of PCBs prior to the issuance of a demolition permit.

Santa Clara County Operational Area Hazard Mitigation Plan. The plan includes a risk assessment that identifies the natural hazards and risks that can impact a community based on historical experience, estimates the potential frequency and magnitude of disasters, and assesses potential losses to life and property. The plan also includes developed mitigation goals and objectives as part of a strategy for mitigating hazard-related losses (Santa Clara County 2017).

City of Santa Clara Emergency Operations Plan. The plan establishes the foundational policies and procedures that define how the city of Santa Clara will prepare for, respond to, recover from, and mitigate against natural or human-caused disasters. It provides a description of the emergency management organization and how it is activated (City of Santa Clara 2017).

Santa Clara Fire Department, Community Risk Reduction Division. Senate Bill 1082 (Health and Safety Code Chapter 6.11) established the Unified Program (a unified hazardous waste and hazardous materials management regulatory program). The Unified Program is implemented at the local level by local government agencies certified by Cal EPA, known as the Certified Unified Program Agency (CUPA). CUPA agencies implement all the Unified Program elements and serve as a local contact for area businesses. The CUPA for the project area is the Santa Clara Fire Department Community Risk Reduction Division (City of Santa Clara 2021). As CUPA for the city of Santa Clara, the Santa Clara Fire Department administers the following California programs:

- Hazardous Materials Business Plan (HMBP) - Facilities that store any hazardous material at or above the State-defined thresholds, generally 55 gallons of a liquid, 200 cubic feet of a gas, and 500 pounds of a solid, are subject to a HMBP. The Santa Clara Fire Department oversees the preparation and submittal of the HMBP.
- Aboveground Storage Tank SPCC Plan - The Santa Clara Fire Department inspects facilities that store petroleum products in aboveground tanks for compliance with the Aboveground Petroleum Storage Act and referenced sections of the federal SPCC rule.
- California Accidental Release Prevention Program (CalARP) - Businesses that handle more than the State threshold quantity of a regulated substance must develop a Risk Management Plan (RMP); an RMP is a detailed engineering analysis of the potential accident factors present at a business and the mitigation measures that can be implemented to reduce this accident potential. The Santa Clara Fire Department implements the CalARP within the city of Santa Clara.
- Hazardous Waste Generator Program - Businesses that generate hazardous waste are required to submit a "Hazardous Waste Generator Permit Application" when they move into the city or begin generating hazardous waste. The Santa Clara Fire Department maintains records and conducts inspections of hazardous waste

generators within the city of Santa Clara. The Santa Clara Fire Department issues hazardous waste generator permits.

- Onsite Treatment of Hazardous Wastes - The Santa Clara Fire Department maintains records and conducts inspections of hazardous waste generators who treat wastes on-site in a Fixed Treatment Unit under Permit by Rule, Conditional Authorization, and Conditional Exemption.
- Underground Storage Tank (UST) - The Santa Clara Fire Department maintains records of and inspects underground storage tanks. All underground storage tanks are required to meet current state regulations. The Santa Clara Fire Department issues UST permits.

Santa Clara County Department of Environmental Health (SCDEH) Hazardous Materials Compliance Division (HMCD). The HMCD administers the Site Mitigation Program which oversees the Local Oversight Program and the Site Cleanup Program. The Local Oversight Program oversees the cleanup of sites contaminated by petroleum from UST releases throughout Santa Clara County. The Site Cleanup Program oversees the cleanup of properties contaminated by hazardous materials not exclusively associated with petroleum USTs. California Health and Safety Code, sections 101480 through 101490 state that a responsible party for a contaminated site may request local agency oversight of site assessment and remediation activities. In addition, the HMCD administers the Hazardous Materials Storage Ordinance (County Ordinance No. NS-517.31) and the Toxic Gas Ordinance (County Ordinance No. NS-517.44)

City of Santa Clara General Plan. The City of Santa Clara 2010-2035 General Plan includes policies applicable to all development projects in the city of Santa Clara (City of Santa Clara 2010). The following are applicable to the proposed project:

- 5.10.5-P22: Regulate development on sites with known or suspected contamination of soil and/or groundwater to ensure that construction workers, the public, future occupants and the environment are adequately protected from hazards associated with contamination, in accordance with applicable regulations.
- 5.10.5-P23 Require appropriate clean-up and remediation of contaminated sites.
- 5.10.5-P24 Protect City residents from the risks inherent in the transport, distribution, use and storage of hazardous materials.
- 5.10.5-P25 Use Best Management Practices to control the transport of hazardous substances and to identify appropriate haul routes to minimize community exposure to potential hazards.
- 5.10.5-P26 Survey pre-1980 buildings and abate any lead-based paint and asbestos prior to structural renovation and demolition, in compliance with all applicable regulations.
- 5.10.5-P27 Locate hazardous waste management facilities in areas designated as Heavy Industrial on the Land Use Diagram if compatible with surrounding uses and consistent with the County Hazardous Waste Management Plan.

- 5.10.5-P28 Continue to require all new development and subdivisions to meet or exceed the City's adopted Fire Code provisions.
- 5.10.5-P29 Continue to refer proposed projects located within the Airport Influence Area to the Airport Land Use Commission.
- 5.10.5-P30 Review the location and design of development within Airport Land Use Commission jurisdiction for compatibility with the Airport Land Use Compatibility Plan.
- 5.10.5-P31 Discourage schools, hospitals, sensitive uses and critical infrastructure, such as power plants, electric substations and communications facilities, from locating within specified safety zones for the Airport as designated in the Airport Comprehensive Land Use Plan.
- 5.10.5-P32 Encourage all new projects within the Airport Influence Area to dedicate an aviation easement.
- 5.10.5-P33 Limit the height of structures in accordance with the Federal Aviation Administration Federal Aviation Regulations, FAR Part 77 criteria.
- 5.10.5-P34 Implement minimum setbacks of 500 feet from roadways with average daily trips of 100,000 or more and 100 feet from railroad tracks for new residential or other uses with sensitive receptors, unless a project-specific study identifies measures, such as site design, tiered landscaping, air filtration systems, and window design, to reduce exposure, demonstrating that the potential risks can be reduced to acceptable levels.
- 5.10.5-P35 Establish minimum buffers between odor sources and new residential or other uses with sensitive receptors, consistent with Bay Area Air Quality Management District (BAAQMD) guidelines, unless a project-specific study demonstrates that these risks can be reduced to acceptable levels.

Airport Comprehensive Land Use Plan. The Santa Clara County Airport Land Use Commission (ALUC) adopted the Comprehensive Land Use Plan (CLUP) for the Norman Y. Mineta San José International Airport in 2011; the ALUC approved minor amendments to the CLUP in 2016. The CLUP's objective of safety compatibility is to minimize the risks associated with potential aircraft accidents (SCCALUC 2016). Safety impacts are evaluated according to the Airport Safety Zones shown in Figure 7 of the CLUP. Safety compatibility includes a policy concerning fuel and hazardous materials storage:

- Policy S-4 – Storage of fuel or other hazardous materials shall be prohibited in the Runway Protection Zone. Above ground storage of fuel or other hazardous materials shall be prohibited in the Inner Safety Zone and Turning Safety Zone. In the Sideline Safety Zones and Outer Safety Zones, storage of fuel or other hazardous materials not associated with aircraft use should be discouraged.

4.9.2 Environmental Impacts

a. Create a significant hazard to the public or the environment through the routine transport, use, or disposal of hazardous materials?

Construction

Less Than Significant Impact with Mitigation Incorporated. During the construction phase of the project, the only hazardous materials used would be paints, cleaners, solvents, gasoline, motor oil, welding gases, and lubricants. Any hazardous material would be stored in designated construction staging areas in compliance with local, state, and federal requirements, when not in use. Any impacts resulting from spills or other accidental releases of these materials would be limited to the site and easily cleaned up due to the small quantities involved and their infrequent use, hence reduced chances of worker exposure or environmental contamination. Temporary containment berms would also be used to help contain any spills during the construction of the project.

There is a potential that ACM and LBP could be present and released by demolition activities, since the pre-existing structures were built prior to 1970. Permits for demolition would be required from the BAAQMD that require an asbestos survey prior to commencement of demolition activities. Any ACM discovered would be remediated in accordance with applicable BAAQMD regulations and any other applicable local and state regulations. Although the BAAQMD demolition permit requires ACM testing, it does not require LBP testing be conducted nor does it regulate demolition of LBP contaminated structures. Existing regulations from Cal EPA, Cal OSHA, and CDPH regulate the handling and disposal of lead and LBP. However, there are no existing regulations that require testing for LBP in commercial buildings. Since the building has the potential for LBP, but testing is not required, staff recommends mitigation measure **HAZ-1** for testing and removal of LBP contaminated materials prior to building demolition. LBP contaminated materials shall be handled, transported, and disposed of per applicable local, state, and federal regulations. Therefore, the routine transport, use or disposal of hazardous materials during project demolition and construction would have a less than significant impact to the public or the environment through compliance with regulations and implementation of mitigation measure **HAZ-1**.

During construction, all 44 2.75 MW diesel gensets fuel tanks would have to be filled, requiring many tanker truck trips. Diesel fuel has a long history of being routinely transported and used as a common motor fuel. It is appropriate to rely upon the extensive regulatory framework that applies to the shipment of hazardous materials on California highways and roads to ensure safe handling in general transportation (see Federal Hazardous Materials Transportation Law 49 USC § 5101 et seq., DOT regulations 49 CFR subpart H, §§ 172–700, and California Department of Motor Vehicles regulations on hazardous cargo). Therefore, the transportation of diesel fuel would pose a less than significant risk to the surrounding public.

Operation

Less Than Significant Impact. Diesel fuel would be used during routine testing and maintenance, and emergency operation of the 44 2.75 MW gensets. BAAQMD's enforceable permit conditions limit each engine to no more than 35 hours operation annually for readiness and maintenance testing. Each genset would be run once a month for up to 15 minutes with no load on the engine for monthly maintenance testing purposes. Each genset would also be required to run for no more than 2 hours per year for annual testing purposes. During the annual test, each genset would be cycled through a sequence of loads: 25% load for 15 minutes to warm up, 75% load for 15 minutes, 100% load for 1 hour, and 25% load for 15 minutes to cool down. At 100% load, the average fuel consumption for each genset would be approximately 191.7 gallons per hour of diesel fuel (DayZenLLC 2023f).

The project would use standard practice for fuel quality and maintenance of stored diesel fuel. Standard practice includes that each engine would have a fuel filtration system that would filter the fuel contents daily. The fuel filtration system would be inspected quarterly, and a fuel sample would be collected for testing. The fuel filters would be replaced as needed or annually which would reduce any effects of fuel degradation on engine components and operation. Commercial diesel fuels also contain biocides that prevent microbial growth and additives that help to stabilize the fuel for several months.

To comply with Tier 4 emissions standards, the diesel gensets would use selective catalytic reduction (SCR) that injects a liquid-reductant through a special catalyst into the exhaust stream of the diesel engine. The reductant source would be diesel exhaust fluid (DEF) which is a non-hazardous urea solution of 67.5 percent water and 32.5 percent automotive grade urea. Each genset enclosure is equipped with 250-gallons of DEF. The DEF consumption would vary depending upon the environment, operation, and duty cycle of equipment. On average, DEF consumption would be 3 percent to 5 percent of diesel fuel consumption or approximately 9.3 gallons per hour of DEF. The estimated shelf life of the DEF based on ambient temperatures for the Santa Clara area is approximately 12 to 18 months. The project applicant does not anticipate the need for replacement of degraded DEF based on the testing and maintenance schedule. The DEF fluid levels would be monitored. These tanks can be filled in place inside the genset enclosure. The replacement strategy is to contract with a commercial supplier to either replenish the DEF supply by adding DEF from a bulk tanker truck or bulk tank to the DEF tank inside the genset enclosure (DayZenLLC 2023f).

During operation, a large quantity of diesel fuel, totaling approximately 237,600 gallons for all the gensets, would be stored in integrated diesel fuel storage tanks within each genset package. The genset package would be constructed with a pair of genset enclosures in a stacked configuration. The bottom genset enclosure would be placed on a concrete slab and the upper genset enclosure would be supported on a raised structural steel platform. Each genset enclosure would contain dedicated diesel fuel tank and DEF storage located on a skid below the genset.

Although diesel fuel would be stored on-site, it would be stored in dedicated 5,400-gallon diesel fuel storage tanks for each genset. Each genset unit and its integrated fuel tanks would be of double-walled high integrity design. The interstitial space between the walls of each tank would be continuously monitored electronically for the existence of liquids or for the presence of leaks. The above design features would ensure that the diesel fuel gensets meet the secondary containment requirements of the California Health and Safety Code for the Above Ground Petroleum Storage Act (APSA).

The monthly no load test would require the tanks to be refilled to 95 percent capacity approximately every three to five months. Additionally, diesel fuel would be scheduled and delivered via a compartmentalized tanker truck with maximum capacity of 8,500 gallons. Diesel fuel transport would comply with all appropriate regulations regarding transport of hazardous materials on California roads and highways.

Hazardous materials storage at the project site would be regulated under local, state, and federal regulations. For example, the project would be subject to the APSA due to the volume of fuel that would be stored in aboveground tanks. Tank facilities under the APSA must comply with all requirements and prepare and implement a SPCC plan, which the applicant has committed to preparing. The spill prevention measures described above would be incorporated into the plan. Additionally, an HMBP would be required and completed for the safe storage and use of chemicals and would incorporate all relevant regulations. Transport of diesel fuel would comply with regulations that apply to the shipment of hazardous materials on California roads and highways to ensure safe handling in general transportation. Conformance with relevant laws and regulations would minimize the likelihood of hazardous material releases from the project.

With the above listed safety features and precautions, the off-site risk to the public or environment through the routine transport, use, or disposal of hazardous materials would have a less than significant impact.

b. Create a significant hazard to the public or the environment through reasonably foreseeable upset and accident conditions involving the release of hazardous materials into the environment?

Construction

Less Than Significant Impact. Hazardous materials would be stored, handled, and used in accordance with applicable regulations. Pursuant to these statutory and regulatory requirements, personnel would be required to follow instructions on health and safety precautions and procedures to follow in the event of a release of hazardous materials. Also under existing requirements, all equipment and materials storage would be routinely inspected for leaks. As well, records would be maintained for documenting compliance with the storage and handling of hazardous materials. Although construction related use of paints, cleaners, solvents, gasoline, motor oil, welding gasses, lubricants and the like would occur, for the above reasons, the project impacts would be less than significant.

Operation

Less Than Significant Impact. The project would not create a significant hazard to the public or environment due to an accidental release of a hazardous material. As described above in criterion "a" the project would include the use and storage of diesel fuel for the emergency operation, testing and maintenance of the backup gensets. Additionally, minor amounts of hazardous materials would be stored and used for maintenance of on-site equipment. All hazardous materials would be used and stored in accordance with federal, State, and local regulations. A HMBP and a SPCC plan would be completed for the safe storage and use of chemicals. The SPCC would include the listed spill prevention measures outlined in criterion "a". The conformance with relevant laws and regulations would minimize the likelihood of hazardous material releases from the project.

With the above listed safety features and precautions, the risk to the off-site public or environment through reasonably foreseeable upset and accident conditions involving the release of hazardous materials would have a less than significant impact.

c. Emit hazardous emissions or handle hazardous or acutely hazardous materials, substances, or waste within one-quarter mile of an existing or proposed school?

Construction

No Impact. There are no schools located or proposed within 0.25 mile of the project site. In addition, no acutely hazardous materials would be used during project demolition or construction activities, and there are no hazardous materials that would be emitted from the site at rates capable of creating offsite impacts. Therefore, there would be no impact.

Operation

No Impact. There are no schools located or proposed within 0.25 mile of the project site, and no acutely hazardous material would be used during project operation. Therefore, no impact from routine maintenance or operation would occur.

d. Be located on a site which is included on a list of hazardous materials sites compiled pursuant to Government Code Section 65962.5 and, as a result, would it create a significant hazard to the public or the environment?

Construction

Less Than Significant Impact with Mitigation Incorporated. According to a review of the DTSC Envirostor and SWRCB GeoTracker databases, the project site does not have any known, open cases on the lists of hazardous materials sites compiled pursuant to Government Code section 65962.5 (DTSC 2023, SWRCB 2023a). One open remediation site is located about a quarter mile away at 651 Walsh Avenue according to the SWRCB GeoTracker database and is associated with the demolition and construction of the Walsh Data Center at that site (SWRCB 2023b). Potential contaminants of concern at the Walsh

site include benzene, DDD/DDE/DDT, ethylbenzene, lead, mercury (elemental), tetrachloroethylene (PCE), trichloroethylene (TCE), and zinc. TRC's Phase I ESA for the project site identified historical recognized environmental conditions (HRECs) from the 2600 De La Cruz Boulevard site located approximately 150 feet east of the project site. Limited subsurface investigation at 2600 De La Cruz Boulevard performed in 2018 identified VOCs in groundwater and soil gas samples, but the extents of the VOC impacts are unknown to TRC. Therefore, there exists a potential for contaminated soil or groundwater to migrate from adjacent sites to other locations within the project site. In addition, the site is in an area with known VOC impacts to groundwater and in soil resulting from former USTs.

At the project site, TRC's Phase I ESA identified HRECs from the former presence of two USTs that were removed in 2001. It is unclear whether the impacted soil was removed as part of UST removal. TRC's limited subsurface investigation conducted during a Phase II ESA found the presence of arsenic and nickel above respective ESLs in soil samples, and benzene above respective ESLs in soil vapor samples.

Demolition activities for the project would include ground disturbing activities for removal of below ground structures such as utilities and building structure foundations. Ground disturbing activities associated with construction would include site grading, construction of concrete foundations and structural steel framing, fencing, installation of underground utilities, including conduit and electrical cabling to interconnect the gensets to the buildings, and placement and securing of the gensets. Demolition and ground disturbing activities would have the potential to encounter impacted groundwater and/or soil. The contaminated soils could contain organochlorine pesticides, heavy metals, and VOCs. Sites with known contamination are required per Cal OSHA regulations to notify, educate, and give instructions to employees regarding the hazards. However, Cal OSHA regulations do not require the above actions for potentially contaminated sites, nor does it specify how this information on potential hazards would be transmitted to workers.

Staff reviewed the applicant's proposed design measure, PDM HAZ-1, for reducing potentially significant soil and groundwater impacts to construction workers to a less than significant level. Applicant's PDM HAZ-1 requires shallow soil sampling including an approved soil sampling plan and report of the findings prior to issuance of grading permits. Staff finds that PDM HAZ-1 is insufficient as it only requires sampling of shallow soils. Applicant's PDM HAZ-1 also requires disposal of soils in accordance with state and federal requirements if concentrations are found above applicable ESLs or hazardous waste limits. PDM HAZ-1 is lacking detail about the notification of local agencies as well as the appropriate regulatory oversight agency. Additionally, PDM HAZ-1 requires preparation of a Site Management Plan (SMP) and Health and Safety Plan (HSP). CEC staff finds that PDM HAZ-1 is insufficient, lacking the detailed information that should be included in the SMP and HSP to meet industry standards.

Therefore, staff recommends mitigation measures **HAZ-2** and **HAZ-3**. Mitigation measure **HAZ-2** specifies preparation of a SMP and HSP and identifies the minimum information to be included in each plan. The information to be included in the SMP would

include protocols for testing any remnant or unknown soil and/or groundwater contamination via sampling and testing prior to issuance of demolition permits and would identify procedures to follow if unknown or remnant contamination is encountered during project activities. If contamination is identified through the sampling and testing, the appropriate local, state, and federal regulations would be followed, and local and state agencies would be coordinated with regarding handling and disposal of the contaminated soil or groundwater. Mitigation measure **HAZ-3** specifies testing of soil and/or groundwater per the plan and protocols developed in the SMP to fully identify potential soil or groundwater contamination at the project site. Any contaminated soils identified by testing would be removed and disposed of according to the appropriate local, state, and federal regulations under the oversight of the agency taking lead jurisdiction.

With implementation of mitigation measures **HAZ-2** and **HAZ-3** and compliance with all applicable local, state, and federal regulations, there would be a less than significant impact to people or the environment from hazardous materials at an environmentally contaminated site.

Operation

No Impact. Operation and maintenance activities would not involve excavation activities and would therefore have no impact.

e. For a project located within an airport land use plan or, where such a plan has not been adopted, within two miles of a public airport or public use airport, would the project result in a safety hazard or excessive noise for people residing or working in the project area?

Construction

Less Than Significant Impact. The Norman Y. Mineta San José International Airport, a public airport, is located approximately one quarter mile east of the proposed project site. The FAA establishes a FAR Part 77 obstruction surface of 212 feet above mean sea level (AMSL) at the project site, as identified in Figure 6 of the airport's Comprehensive Land Use Plan (CLUP) (SCCALUC 2016). The project site surface is at approximately 46 feet AMSL. Therefore, according to Figure 6 of the CLUP, any structure greater than 166 feet in height AGL would be an obstruction to air navigation. The highest point of the proposed project structure, the top of the freight elevator parapet, would be approximately 119.66 feet above ground level (AGL) (DayZenLLC 2022a). Based on this peak height, the project would not exceed the FAR Part 77 obstruction surface of 212 feet AMSL, or 166 feet AGL at the project site, shown in the CLUP for the Norman Y. Mineta San José International Airport. Further discussion can be found in **Section 4.17 Transportation**.

The project site is still subject to Title 14, Part 77.9 of the Code of Federal Regulations, Construction or Alteration Requiring Notice, which requires FAA notification for construction or alterations within 20,000 feet of an airport with a runway more than 3,200 feet in length if the height of the construction or alteration exceeds a slope of 100 to 1 extending outward and upward from the nearest point of the nearest runway of the

airport. With a maximum project height of 119.66 feet AGL, the project would exceed the FAA notification 100:1 surface threshold of 21.6 feet at the project site. As a result, the project applicant would need to submit Form 7460-1, Notice of Proposed Construction or Alteration, to the FAA. Staff anticipates the FAA issuing a Determination of No Hazard for the project applicant. The city of Santa Clara, as the permitting agency for the project, would be responsible to ensure consistency with this requirement and compliance with any of the FAA's conditions. Compliance with this federal requirement, and with FAA determinations, would reduce any potential aviation hazard impacts to less than significant. Further discussion can be found in **Section 4.17 Transportation**.

The project is in the Turning Safety Zone (TSZ) of the Norman Y. Mineta José International Airport according to the most recent CLUP amended in 2016, by the Santa Clara County Airport Land Use Commission (ALUC) (SCCALUC 2016). The project proposes above-ground fuel storage tanks, which are prohibited in the TSZ by CLUP Policy S-4. However, the portion of the TSZ which traverses the site is based on the use of Runway 11-29, which was temporarily closed in 2009 and designated for permanent closure in 2020 (San Jose 2020a). The most recent Airport Master Plan as amended through April 2020 lists airfield project A-26 for the conversion of Runway 11-29 to a taxiway (San Jose 2020a). The most recent FAA approved airport layout plan shows the area of Runway 11-29 as a future taxiway (San Jose 2020b). County of Santa Clara Department of Planning and Development staff recently submitted proposed amendments to the CLUP reflecting this and other changes at the ALUC's May 24, 2023, meeting. The draft amended CLUP, dated May 4, 2023, shows in Figure 7 "Safety Zones" and Figure 8 "Airport Influence Area" that the TSZ is proposed for removal above the project site (DayZenLLC 2023g).

With the ALUC's approval of Santa Clara County Planning and Development staff's proposed amendments to the CLUP, which are currently under review, the project would be consistent with CLUP Policy S-4, and the project's proposed above-ground fuel storage tanks would no longer be in the TSZ or any other safety zone where such tanks are prohibited. The city of Santa Clara would ensure during their permit review process that the project complies with all applicable CLUP policies. Staff anticipates for the reasons listed above that the project would comply with the Santa Clara CLUP. Compliance with the CLUP, and with ALUC determinations, would reduce any potential aviation safety zone impacts to less than significant. Further discussion can be found in **Section 4.11 Land Use**, and **Section 4.17 Transportation**.

Project construction would not result in excessive noise impacts for people residing or working in the project area, as described in a more detailed analysis in **Section 4.13 Noise**. Therefore, the project would not result in excessive noise and would have a less than significant impact.

Operation

Less Than Significant Impact. Operation and maintenance activities for the project site would be similar to those for a similarly sized industrial building and would not have an

impact on people working or residing in the area. The proposed project structures would be similar to existing surrounding buildings. As described above, the project applicant must comply with federal FAA requirements and the Santa Clara County ALUC CLUP. In addition, the thermal plume generated by the project would not pose a safety hazard to any aircraft near the Norman Y. Mineta San Jose International Airport, as described in a more detailed analysis in **Section 4.17 Transportation**. Therefore, there would be a less than significant impact for people residing or working in the project area due to a safety hazard or excessive noise.

f. Impair implementation of or physically interfere with an adopted emergency response plan or emergency evacuation plan?

Construction

No Impact. A review of the county of Santa Clara County Operational Area Hazard Mitigation Plan and the city of Santa Clara Emergency Operations Plan for the project revealed no specific mapping or delineation of emergency evacuation or access routes. The plans identified that the area police, fire, and other emergency services would implement their emergency response or evacuation plans according to their communications protocols and hazard mitigation programs. The proposed project site is not identified on any emergency evacuation or access routes. In addition, the construction would not require any road closures since the work would all be done onsite. During project construction, there would be no impact to an adopted response plan or emergency evacuation plan.

Operation

No Impact. After construction, no lane closures would be needed, and no impact to a response plan or emergency evacuation plan would occur.

g. Expose people or structures, either directly or indirectly, to a significant risk of loss, injury or death involving wildland fires?

Construction

No Impact. The proposed project site is in an urban part of Santa Clara County. It is within an un-zoned Fire Hazard Severity Zone, within a local responsibility area (LRA), indicating that the project site has a less than moderate susceptibility to wildland fires. The project site is not adjacent to wildlands. The project site is currently developed with four existing commercial buildings. The project area consists primarily of commercial and industrial land uses to the north, east, south, and west. Although equipment and vehicles used during construction, as well as welding activities, have the potential to ignite dry vegetation, the project is within an urban area surrounded by industrial and commercial zones that have irrigated landscaping and very limited dry vegetation. In the event of construction triggered fire at the project site, it would be served by the city of Santa Clara Fire Department. The closest fire station is Fire Station #2 located at 1900 Walsh Avenue

in the city of Santa Clara. Therefore, there would be no impact from wildland fires resulting from construction activities related to the project.

Operation

No Impact. The project site is located within a LRA that is not located within or near any wildlands. The project site would be served by the city of Santa Clara Fire Department in the event of project related or other local fires. The closest fire station is Fire Station #2 located at 1900 Walsh Avenue in the city of Santa Clara. As discussed for construction, there would be no impact from wildland fires.

4.9.3 Mitigation Measures

HAZ-1: Prior to issuance of demolition permits, a lead-based paint (LBP) visual inspection and pre-demolition survey, including sampling and testing of suspect materials, shall be conducted of on-site buildings to determine the presence of LBP. The survey shall be conducted by a contractor with California Department of Public Health (CDPH) Lead Related Construction (LRC) certified personnel as required by CDPH regulations. The findings of the LBP survey shall be submitted to the Santa Clara City Fire Department Community Risk Reduction Division for review.

HAZ-2: Prior to issuance of demolition or grading permits, the project applicant shall prepare a Site Management Plan (SMP) to guide activities during demolition, exaction, and initial construction to ensure that potentially contaminated soils are identified, characterized, removed, and disposed of properly. The purpose of the SMP is to establish appropriate management practices for handling impacted soil or other materials that may be encountered during construction activities. The SMP shall be reviewed and approved by the Santa Clara County Environmental Services Department and the Santa Clara Fire Department Community Risk Reduction Division prior to any work on the site, including prior to soil and groundwater sampling.

The SMP shall be implemented during project demolition and construction and shall include, but shall not be limited to, the following components:

- A detailed discussion of the site background.
- Prior to any onsite work, Health and Safety Plans (HSP) for the project shall be prepared by all contractors and subcontractors that will be working at the project site and incorporated in the SMP. The HSPs shall be prepared by an industrial hygienist. The HSPs shall be specific to each of the contractors' or subcontractors' scopes of work and based upon the known environmental conditions for the site prior to project construction. The HSPs shall be updated as needed if site conditions change significantly, such as the discovery of contaminated soil or groundwater. The HSPs shall be approved by the Director or Director's designee with the Santa Clara County Environmental Services Department and the Santa Clara Fire Department Community Risk Reduction Division, implemented under the direction of a Site Safety and Health Officer. Copies of the approved HSPs shall be kept at the project site.

- Description of soil and groundwater testing, which shall include (but not be limited to) the collection of soil samples and groundwater samples and analyses for volatile organic compounds (VOCs) and any other contaminants identified in previous environmental studies in the soil and groundwater and lead and organochlorine pesticides in the soil to verify presence or absence of remnant or unknown soil or groundwater contamination. This soil and groundwater characterization shall be performed prior to initiation of project construction.
- Protocols for sampling at the site to verify or rule out a vapor encroachment conditions at the site and within the buildings to be demolished and, if verified, for remediation of vapor encroachment conditions within the existing building prior to demolition and to prevent it in the proposed structures.
- Protocols for sampling of soil and groundwater to facilitate the profiling of the soil and groundwater for appropriate off-site disposal or reuse, and for construction worker safety, dust mitigation during demolition and construction and potential exposure of contaminated soil or groundwater to future users of the site prior to project construction.
- Procedures to be undertaken if contamination is identified above action levels or previously unknown contamination is discovered prior to or during project demolition or construction.
- Notification procedures if previously undiscovered significantly impacted soil or groundwater, or free fuel product is encountered during demolition or construction.
- Sampling and laboratory analyses of excess soil requiring disposal at an appropriate off-site waste disposal facility.
- Procedures and protocols for the safe storage, stockpiling, and disposal of contaminated soils.
- Protocols to manage groundwater, including segregation or treatment of contaminated groundwater, if necessary, that may be encountered during trenching or subsurface excavation activities.

If there are no contaminants identified on the project site that exceed applicable environmental screening levels (ESLs) for construction workers and residential users published by the Regional Water Quality Control Board (RWQCB), California Department of Toxic Substances Control (DTSC), or California Environmental Protection Agency, the SMP does not need to be submitted to an oversight agency and instead only needs to be submitted to the Santa Clara County Environmental Health Department and the Santa Clara Fire Department Community Risk Reduction Division for approval prior to issuance of a grading permit and prior to conducting any demolition activities.

If contaminants are identified at concentrations exceeding applicable ESLs, the project applicant shall obtain regulatory oversight from the agency with jurisdictional authority. The type and extent of contamination on the project site will govern which of the following regulatory agencies will supervise the remediation: Santa Clara Fire Department

Community Risk Reduction Division (CUPA), DTSC under a Site Cleanup Program, State Water Resources Control Board (SWRCB), or the Santa Clara County Department of Environmental Health. The SMP and planned remedial measures shall be reviewed and approved by the oversight agency. A copy of the SMP shall be submitted to the Director or Director's designee with the Santa Clara County Environmental Services Department and, the Santa Clara Fire Department Community Risk Reduction Division. Copies of the approved SMP shall be kept at the project site.

HAZ-3: Prior to the issuance of grading permits, soil and/or groundwater samples shall be taken in areas where disturbance is anticipated to determine if contaminated soils or groundwater with concentrations above ESLs for construction workers and residential users may be present due to historical agricultural use and from historical leaks and spills. Sampling shall be conducted per the protocols outlined in the approved project SMP. Once the soil sampling analysis is complete, a report of the findings shall be submitted to the appropriate agencies per the requirements of the SMP.

Any contaminated soils identified by testing conducted in compliance with the SMP and found in concentrations above ESLs shall either be removed and disposed of according to California Hazardous Waste Regulations or the contaminated portions of the site shall be capped beneath the planned development under the regulatory oversight of the agency taking lead jurisdiction. Contaminated soil excavated from the site shall be hauled off-site and disposed of at a licensed hazardous materials disposal site.

4.9.4 References

- CalFire 2022 – California Department of Forestry and Fire Protection (CalFire). 2022 Santa Clara County – State Responsibility Area Fire Hazard Severity Zones. Accessed on: February 2023. Available online at: <https://osfm.fire.ca.gov/divisions/wildfire-planning-engineering/wildland-hazards-building-codes/fire-hazard-severity-zones-maps/>
- CEC 2023 – California Energy Commission (CEC). (TN 248751). Data Requests Set 1 for Martin Avenue Properties, LLC/c/o Scott Galati, dated February 10, 2023. Available online at: <https://efiling.energy.ca.gov/GetDocument.aspx?tn=248751&DocumentContentId=83271>
- City of Santa Clara 2010 – City of Santa Clara 2010-2035 General Plan. Adopted November 16, 2010. Accessed on: February 2023. Available online at: <https://www.santaclaraca.gov/our-city/departments-a-f/community-development/planning-division/general-plan>
- City of Santa Clara 2017 – City of Santa Clara Emergency Operations Plan, Annex L Hazard Mitigation Plan Volumes 1&2. Accessed on: March 2023. Available online at: <https://www.santaclaraca.gov/services/emergency-services/emergency-preparedness>

- City of Santa Clara 2021 – Santa Clara Fire Department Community Risk Reduction Division. Accessed on: July 2023. Available online at:
<https://www.santaclaraca.gov/our-city/departments-a-f/fire-department/divisions/community-risk-reduction-division>
- DayZenLLC 2022a – MBGF SPPE Application - Part I - Main App and Appendix A, dated November 8, 2022. (TN 247325). Available online at:
<https://efiling.energy.ca.gov/GetDocument.aspx?tn=247325&DocumentContentId=81710>
- DayZenLLC 2022b – MBGF SPPE Application - Part II - Appendices B C and D, dated November 8, 2022. (TN 247329). Available online at:
<https://efiling.energy.ca.gov/GetDocument.aspx?tn=247329&DocumentContentId=81711>
- DayZenLLC 2022c – MBGF SPPE Application - Part III, Appendix E, Part 1, dated November 8, 2022. (TN 247328). Available online at:
<https://efiling.energy.ca.gov/GetDocument.aspx?tn=247328&DocumentContentId=81712>
- DayZenLLC 2022d – MBGF SPPE Application - Part IV, Appendix E, Part 2, dated November 8, 2022. (TN 247327). Available online at:
<https://efiling.energy.ca.gov/GetDocument.aspx?tn=247327&DocumentContentId=81713>
- DayZenLLC 2022e – MBGF SPPE Application - Part V, Appendices F G and H, dated November 8, 2022. (TN 247326). Available online at:
<https://efiling.energy.ca.gov/GetDocument.aspx?tn=247326&DocumentContentId=81714>
- DayZenLLC 2023f – Martin Properties Responses to CEC Data Request Set 1 - MBGF, dated March 17, 2023. (TN 249350). Available online at:
<https://efiling.energy.ca.gov/GetDocument.aspx?tn=249350&DocumentContentId=83900>
- DayZenLLC 2023g – Martin Properties Supplemental Responses to Data Requests 34, 35, and 36 - MBGF, dated June 29, 2023. (TN 250811). Available online at:
<https://efiling.energy.ca.gov/GetDocument.aspx?tn=250811&DocumentContentId=85708>
- DTSC 2023 – Department of Toxic Substances Control (DTSC). Envirostor Database. Accessed on: April 2023. Available online at:
<http://www.envirostor.dtsc.ca.gov/public/>
- San Jose 2020a – City of San Jose Airport Department. Airport Master Plan for Norman Y. Mineta San Jose International Airport as Amended Through April 2020. Accessed on: July 2023. Available online at:
<https://www.flysanjose.com/sites/default/files/rsheelen/MP-ExecSum2020.pdf>

San Jose 2020b – Norman Y. Mineta San Jose International Airport Future Airport Layout Plan. Accessed on: July 2023. Available online at:
https://www.flysanjose.com/sites/default/files/rsheelen/SJC.FUT_.ALP_.pdf

Santa Clara County 2017 – County of Santa Clara Emergency Management. October 15, 2017. Santa Clara County Operational Area Hazard Mitigation Plan Volumes 1&2. Accessed on: July 19, 2023. Available online at:
<https://emergencymanagement.sccgov.org/multi-jurisdictional-hazard-mitigation-plan-mjhmp>

SCCALUC 2016 – Santa Clara County Airport Land Use Commission (SCCALUC). 2016. Mineta San José International Airport Comprehensive Land Use Plan for Santa Clara County. Accessed on: February 2023. Available online at:
https://stgenpln.blob.core.windows.net/document/ALUC_SJC_CLUP.pdf

SWRCBa 2023 – State Water Resources Control Board (SWRCB). GeoTracker Database. Accessed on: April 2023. Available online at:
<http://geotracker.waterboards.ca.gov>

SWRCBb 2023 – State Water Resources Control Board (SWRCB). GeoTracker Database. 651 Walsh Partners LLC (T10000012412). Accessed on: July 2023. Available online at:
https://geotracker.waterboards.ca.gov/profile_report.asp?global_id=T10000012412

4.10 Hydrology and Water Quality

This section describes the environmental setting and regulatory background and discusses impacts associated with the construction and operation of the project with respect to hydrology and water quality.

HYDROLOGY AND WATER QUALITY	Potentially Significant Impact	Less Than Significant with Mitigation Incorporated	Less Than Significant Impact	No Impact
Would the project:				
a. Violate water quality standards or waste discharge requirements or otherwise substantially degrade surface or ground water quality?	<input type="checkbox"/>	<input type="checkbox"/>	<input checked="" type="checkbox"/>	<input type="checkbox"/>
b. Substantially decrease groundwater supplies or interfere substantially with groundwater recharge such that the project may impede sustainable groundwater management of the basin?	<input type="checkbox"/>	<input type="checkbox"/>	<input checked="" type="checkbox"/>	<input type="checkbox"/>
c. Substantially alter the existing drainage pattern of the site or area, including through the alteration of the course of a stream or river, or through the addition of impervious surfaces in a manner which would:				
i. result in substantial erosion or siltation, on- or offsite;	<input type="checkbox"/>	<input type="checkbox"/>	<input checked="" type="checkbox"/>	<input type="checkbox"/>
ii. substantially increase the rate or amount of surface runoff in a manner which would result in flooding on- or offsite;	<input type="checkbox"/>	<input type="checkbox"/>	<input checked="" type="checkbox"/>	<input type="checkbox"/>
iii. create or contribute runoff water which would exceed the capacity of existing or planned stormwater drainage systems or provide substantial additional sources of polluted runoff; or	<input type="checkbox"/>	<input type="checkbox"/>	<input checked="" type="checkbox"/>	<input type="checkbox"/>
iv. impede or redirect flood flows?	<input type="checkbox"/>	<input type="checkbox"/>	<input checked="" type="checkbox"/>	<input type="checkbox"/>
d. In flood hazard, tsunami, or seiche zones, risk release of pollutants due to project inundation?	<input type="checkbox"/>	<input type="checkbox"/>	<input checked="" type="checkbox"/>	<input type="checkbox"/>
e. Conflict with or obstruct implementation of a water quality control plan or sustainable groundwater management plan?	<input type="checkbox"/>	<input type="checkbox"/>	<input checked="" type="checkbox"/>	<input type="checkbox"/>

Environmental checklist established by CEQA Guidelines, Appendix G

4.10.1 Environmental Setting

The proposed Martin Backup Generating Facility (MBGF) would provide 96 MWs of backup emergency power generation for the proposed Martin Data Center (MDC). Both the MBGF and the MDC would be at 651 Martin Avenue in Santa Clara, California. Prior to the mid-1950s the site was utilized for agriculture but has been used for industrial purposes since then. This analysis primarily pertains to the MBGF but also considers the impacts of the MDC.

Storm Drainage and Water Quality

The project would be constructed in the city of Santa Clara, within the Guadalupe River watershed. The Guadalupe River watershed drains to San Francisco Bay, about 5 miles north of the proposed project site. The project site is west of the Guadalupe River and east of San Tomas Aquino Creek. Stormwater from the project site drains into the city of Santa Clara's storm drain system along Martin Avenue, which in turn discharges to the Guadalupe River and ultimately to the San Francisco Bay. The water quality of Guadalupe River is influenced by pollutants contained in stormwater runoff from the site and nearby industrial properties. Stormwater runoff from urban areas typically contains conventional pollutants such as sediment, metals, pesticides, herbicides, oil, grease, asbestos, lead, and animal wastes.

It should be noted that the applicant misidentified the project watershed as the San Tomas Aquino.

Groundwater

The Santa Clara Valley groundwater basin is divided into four interconnected subbasins that border the southern San Francisco Bay. The proposed project would be in the Santa Clara Subbasin, which extends across the Santa Clara Valley in the region south of San Francisco Bay. Fluctuations in rainfall, changing drainage patterns, and other hydrologic factors can influence groundwater levels. Based on the *Santa Clara County Depth to First Groundwater* online map (SCVWD 2017), the historic shallowest observed depth to groundwater in the general site area was about 5 to 10 feet below ground surface (bgs).

In 1983, a 550-gallon gasoline underground storage tank (UST) was removed from the southern portion of the site. In 1989, sampling conducted at the site indicated moderate concentrations of petroleum compounds were present in the soil and groundwater. Later that same year, an 880-gallon waste oil UST was removed. In September 2001 following additional groundwater sampling, the site was closed due to the lack of petroleum compounds detected (SWCRB 2022).

Flooding

The elevation of the existing project site is between 42 and 44 feet above the 1988 North American Vertical Datum (NAVD88) (USGS 2022). According to the Federal Emergency Management Agency's (FEMA) Flood Insurance Rate Map (FIRM), the proposed project site is in Zones AO and X. Zone AO is defined as areas with a one percent chance of annual flood (100-yr flood) with depths of 1 to 3 feet (usually sheet flow on sloping terrain). Zone X is defined as areas of 0.2 percent annual chance of flood (or a 500-year flood); areas of one percent chance of annual flood (100-yr flood) with average depths of less than one foot or with drainage areas less than one square mile; and areas protected by levees from one percent annual chance of flood (FEMA 2009).

The project site is identified as within the inundation zone for the failure of the Lenihan dam with an estimated 1 to 2 feet of inundation (SCVWD 2019). According to the National Oceanic and Atmospheric Administration's (NOAA's) *Digital Coast, Sea Level Rise Viewer* (NOAA 2022), the project site is not within an area mapped as low-lying with respect to sea level rise and is outside an area to be affected by a projected 3-meter rise in sea level. Neither is the project site located near a large body of water, the ocean, or steep slopes, and lies outside of a tsunami hazard zone (CGS 2021).

Regulatory Background

Federal

Clean Water Act and California's Porter-Cologne Water Quality Control Act.

The State Water Resources Control Board (SWRCB) and its nine affiliated Regional Water Quality Control Boards (RWQCBs) are responsible for the regulation and enforcement of the water quality protection requirements of the federal Clean Water Act (CWA) and the State's Porter-Cologne Water Quality Control Act (Porter-Cologne). The National Pollutant Discharge Elimination System (NPDES) is the permitting program that allows point source dischargers to comply with the CWA and Porter-Cologne laws. This regulatory framework protects the beneficial uses of the state's surface and groundwater resources for public benefit and environmental protection. Protection of water quality could be achieved by ensuring the proposed project complies with applicable NPDES permits from the SWRCB or the San Francisco Bay RWQCB.

Under Section 303(d) of the CWA, States are required to identify impaired surface water bodies and develop total maximum daily loads (TMDLs) for contaminants of concern. TMDL is the quantity of a pollutant that can be assimilated by a water body without violating water quality standards.

The United States Environmental Protection Agency (EPA) lists the project site within the Guadalupe River watershed included in the Section 303(d) List of Impaired Waters for California as affected by mercury, pesticides, and trash (EPA 2022). Listing of a water body as impaired does not necessarily suggest that the water body cannot support beneficial uses; rather, the intent is to identify the water body as requiring future development of a TMDL to maintain water quality and reduce the potential for future water quality degradation.

The San Francisco Bay RWQCB issued a Municipal Regional Stormwater NPDES Permit (Permit Number CAS612008) that requires co-permittees to implement a stormwater quality protection program. This regional permit applies to 77 Bay Area municipalities, including the city of Santa Clara. Under the provisions of the Municipal NPDES Permit, redevelopment projects that disturb more than 10,000 square feet are required to design and construct stormwater treatment controls to treat post-construction stormwater runoff. The permit requires the post-construction runoff from qualifying projects to be treated by using low-impact development treatment controls, such as biotreatment facilities.

The Santa Clara Valley Urban Runoff Pollution Prevention Program (SCVURPPP) assists co-permittees, such as the city of Santa Clara, in the implementation of the provisions of the Municipal NPDES Permit. In addition to water quality controls, the Municipal NPDES Permit requires all new and redevelopment projects that create or replace one acre or more of impervious surface to manage development-related increases in peak runoff, where such hydromodification is likely to cause impacts to beneficial uses of local streams. Projects may be deemed exempt from the permit requirements under one of the following three conditions (SCVURPPP 2005):

1. The project will not increase the potential for erosion or other non-beneficial impacts,
2. The project drains into a hardened channel or tidally influenced area, and
3. The project lies within a watershed that is over 90% developed or with greater than 65 percent impervious surface.

According to the SCVURPPP *Classification of Subwatersheds and Catchment Areas for Determining Applicability of Hydromodification Management (HM) Requirements* map, the project site is within an area of greater than 65 percent impervious surface (SCVURPPP 2010); thus, the project site is not subject to the SCVURPPP hydromodification requirements.

It should be noted that the applicant misidentified the project location as within an area of the SCVURPPP 2010 map designated as Catchments Draining to Hardened Channel and/or Tidal Areas, although this does not alter the assessment regarding hydromodification requirements.

Federal Emergency Management Agency Flood Insurance Program.

The national standard of flood magnitude used for floodplain management is a flood having a one percent probability of occurrence for any given year, otherwise known as the 100-year flood, or base flood. FIRM, the official map created and distributed by FEMA for the National Flood Insurance Program shows areas subject to inundation by the base flood for participating communities. FIRMs contain flood risk information based on historic, meteorologic, hydrologic, and hydraulic data, as well as open-space conditions, flood control works, and development. As stated above, the proposed project site is in both Zones AO and X, which are subject to inundation by a one-percent or less annual chance of shallow flooding with average depths of less than one foot, and/or flood depths of 1 to 3 feet.

State

State Sustainable Groundwater Management Act. The 2014 Sustainable Groundwater Management Act (SGMA) requires local public agencies and Groundwater Sustainability Agencies (GSAs) in high- and medium-priority basins to develop and implement Groundwater Sustainability Plans (GSPs) or alternatives to GSPs. GSPs are

detailed road maps for how groundwater basins will be managed to reach long-term sustainability.

The Santa Clara Valley Water District (SCVWD) is the exclusive GSA for the Santa Clara Valley groundwater Subbasin, which contains the proposed project. SCVWD developed a groundwater management plan for the Santa Clara and Llagas Subbasins that is intended to be functionally equivalent to a GSP.

Local

City of Santa Clara Code (Discharge into the Storm Drain Prohibited). Section of 13.20.030 of the Santa Clara City Code prohibits the discharge of various hazardous materials and contaminants into the city storm drain system.

Prevention of Flood Damage. Chapter 15.45 of the Santa Clara City Code requires that buildings' lowest floor be constructed at least as high as the base flood elevation.

4.10.2 Environmental Impacts

Environmental impacts evaluated in this section include the construction and operation elements of the proposed project.

a. Would the project violate water quality standards or waste discharge requirements or otherwise substantially degrade surface or groundwater quality?

Less Than Significant Impact. The proposed project would disturb about 6.5 acres of land and be subject to construction-related stormwater permit requirements of California's NPDES General Permit for Stormwater Discharges Associated with Construction and Land Disturbance Activities (Construction General Permit) administered by the SWRCB. Prior to any ground-disturbing construction activity, the applicant must comply with the Construction General Permit, which includes the preparation of a construction Stormwater Pollution Prevention Plan (SWPPP). By implementing the construction SWPPP, redevelopment of the site would not cause substantial degradation in the quality, or an increase in the rate or volume of stormwater runoff from the site during construction.

In addition, the Municipal NPDES permit, as well as the SCVURPPP, requires that redevelopment not result in a substantial net increase in stormwater flow exiting the project site during operation. As a result, runoff from the project site would not be expected to exceed the capacity of the local drainage system or to significantly contribute to the degradation of stormwater runoff quality.

The project could potentially result in soil excavation to a maximum depth of 15 feet below grade. It is therefore possible the project would encounter groundwater during excavation activities and dewatering would be necessary during construction. If dewatering is necessary, and the discharge is found to be uncontaminated, the project

owner would be allowed to discharge dewatering water to waters of the US, within the San Francisco RWQCB's jurisdiction, under the Construction General Permit. However, if the discharged groundwater is found to be contaminated, a special permit would be necessary depending on the nature of the contamination. This would require the applicant to treat the groundwater before discharge or haul away the untreated water by a permitted service provider. This is further addressed by a mitigation measure proposed by the applicant and analyzed further in **Section 4.9 Hazards and Hazardous Materials**.

The applicant proposed a mitigation measure to reduce potential impacts to water quality (PD HYD-1.1). The applicant's measure proposes best management practices that would typically be included in the SWPPP; therefore, the project would not be expected to violate water quality standards or waste discharge requirements during construction and operation, and impacts would be less than significant.

b. Would the project substantially decrease groundwater supplies or interfere substantially with groundwater recharge such that the project may impede sustainable groundwater management of the basin?

Less Than Significant Impact. The project as proposed would rely on Santa Clara municipal water and does not propose installing any groundwater extraction wells. The city's 2020 UWMP indicates the project site lies within an area serviced by both imported surface water from the San Francisco Public Utilities Commission (SFPUC) and groundwater, and that the City has sufficient supply to meet the project's demand of 2 AFY of potable water in normal and single dry year scenarios (Santa Clara 2021). However, the UWMP shows that the city would have a deficit in a multiple dry-year scenario that assumes supply from SFPUC would be interrupted. Under this scenario, the city's supply from SFPUC might be interrupted if certain conditions specified in the interruptible contract between the city and SFPUC are met (Santa Clara 2021). The city would have to replace the demand using groundwater or water supplied by SCVWD if the supply from SFPUC is interrupted.

The groundwater basin has been managed, successfully preventing overdraft conditions, according to the UWMP. In case of a water supply shortage, the city has adopted water conservation policies to reduce consumption such that available supplies are sufficient to meet demand. In addition, the project site does not lie within a recharge area (Santa Clara 2021).

The project's impact on groundwater supplies or recharge during construction and operation would therefore be less than significant.

c. Would the project substantially alter the existing drainage pattern of the site or area, including through the alteration of the course of a stream or river, or through the addition of impervious surfaces in a manner which would:

i. Result in substantial erosion or siltation on- or off-site;

Less Than Significant Impact. During construction, the SWPPP would be implemented incorporating source control and treatment BMPs. These BMPs would reduce the overall runoff into the city's stormwater collection system, also reducing erosion and sedimentation impacts.

The proposed operational stormwater design includes approximately 11,000 square feet of Low Impact Development (LID) stormwater treatment controls consisting of bioretention areas, at-grade flow-through planters, and subsurface infiltration systems that will maximize the opportunity for infiltration and evapotranspiration. Implementation of construction SWPPP and the project stormwater design would ensure the project would not result in a substantial net increase in stormwater flow exiting the project site or alter local runoff drainage patterns during project construction and operation. Therefore, impacts would be less than significant.

ii. Substantially increase the rate or amount of surface runoff in a manner that would result in flooding on- or off-site;

Less Than Significant Impact. Surface runoff from the proposed project would be controlled as described in criterion "a" and "c (i)" above. Therefore, impacts would be less than significant.

iii. Create or contribute runoff water that would exceed the capacity of existing or planned stormwater drainage systems or provide substantial additional sources of polluted runoff; or

Less Than Significant Impact. The proposed project would include a new stormwater collection system that includes drainage swales to reduce the overall runoff into the city's collection system. The discharge of polluted runoff would be expected to be similarly reduced. Therefore, impacts would be less than significant.

iv. Impede or redirect flood flows?

Less Than Significant Impact. Though the site is between San Tomas Aquino Creek and the Guadalupe River, these waterways pose a low flood risk. According to the FEMA Flood Insurance Rate Map for the area, the project site is within Zones AO and X. As described above, while Zone AO may be vulnerable to a 100-year flood, Zone X is expected to be protected from the 100-year flood. The project site is also not within an area mapped as vulnerable to sea level rise in the NOAA's *Digital Coast, Sea Level Rise Viewer* (NOAA 2020). The proposed project would have structures similar to those at the existing site and would not add significantly to the existing potential of the site to impede flood flows.

Therefore, no net change in obstruction would be expected from the proposed project and the impacts would be less than significant.

d. Would the project, in flood hazard, tsunami, or seiche zones, risk release of pollutants due to project inundation?

Less Than Significant Impact. As described above in criterion "c (iv)" the project site is within FEMA flood Zones AO and X and subject to low or no inundation by the 100-year flood. The project is therefore not expected to be a source of pollution from flooding. The project site is not within an area mapped as vulnerable to sea level rise in the NOAA's *Digital Coast, Sea Level Rise Viewer* (NOAA 2022). Neither is the project located near a large body of water, the ocean, or steep slopes, and lies outside of a tsunami hazard zone (CGS 2021).

Lexington Reservoir and the associated James J. Lenihan Dam are located on Los Gatos Creek approximately 15 miles upstream. The Lenihan Dam Flood Inundation Map shows that dam failure would result in flooding at the project site. The California Division of Safety of Dams is responsible for inspecting dams on an annual basis to ensure the dams are safe, performing as intended and not prone to developing problems. As part of its comprehensive dam safety program, the SCVWD routinely monitors and studies the condition of each of its ten dams, including Lenihan Dam. In the unlikely event of a flood, the release of on-site pollutants would be prevented by the SWPPP, a Hazardous Materials Business Plan, and an emergency spill response program. All of these measures would work together to help keep potential pollutants properly contained. Therefore, the impacts would be less than significant.

e. Would the project conflict with or obstruct the implementation of a water quality control plan or sustainable groundwater management plan?

Less Than Significant Impact. The San Francisco Bay Basin (Basin Plan) developed by the RWQCB is the local water quality control plan. The project would comply with the Basin Plan by implementing the requirements of the Construction General Permit as described in section (a) above, which includes the preparation of a construction SWPPP. The project would not be expected to obstruct the implementation of the Basin Plan and this impact would be less than significant.

SCVWD developed a groundwater management plan for the Santa Clara and Llagas Subbasins that is intended to be functionally equivalent to a GSP. The information contained in the SCVWD groundwater management plan is used to inform the city of Santa Clara's UWMP about groundwater supplies. Therefore, it is reasonable to rely on the UWMP to evaluate how a proposed project would impact the implementation of the sustainable groundwater management plan. As discussed above in criterion (b), the city's 2020 UWMP estimates that it has sufficient supply to meet the project's potable water demand under normal conditions but may have to resort to water conservation measures

and replacing SFPUC water supply with SCVWD provided groundwater or surface water during dry-year scenarios. The proposed project would therefore not be expected to impede the implementation of the SCVWD's groundwater management plan. This impact would be less than significant.

4.10.3 Mitigation Measures

None required.

4.10.4 References

CGS 2021 – California Geological Survey (CGS). Tsunami Hazard Area Map, County of Santa Clara. July 8, 2021. Accessed on November 23, 2022. Available online at: https://www.conservation.ca.gov/cgs/Documents/SHP/Tsunami/HazardArea/Maps/Tsunami_Hazard_Area_Map_Santa_Clara_County_a11y.pdf

FEMA 2009 – Federal Emergency Management Agency (FEMA). FEMA's National Flood Hazard Layer (NFHL) Viewer, Panel No. 06085C0227H effective May 18, 2009. Accessed on: November 23, 2022. Available online at: <https://hazards-fema.maps.arcgis.com/apps/webappviewer/index.html?id=8b0adb51996444d4879338b5529aa9cd&extent=-121.9026729380225,37.39865747819159,-121.88739507547326,37.40718029041653>

NOAA 2022 – National Oceanic and Atmospheric Administration (NOAA). Digital Coast, Sea Level Rise Viewer. Accessed on: November 23, 2022. Available online at: <https://coast.noaa.gov/slr/#/layer/slr/-10/13575013.261277929/4495037.001196679/15/satellite/none/0.8/2050/interHigh/midAccretion>

Santa Clara 2021 – City of Santa Clara (Santa Clara) 2020 Urban Water Management Plan. Prepared by the City of Santa Clara Water and Sewer Utilities. Figure 6.1. Adopted June 22, 2021. Accessed: November 30, 2022. Available online at: <https://www.santaclaraca.gov/home/showpublisheddocument/74073/637606452907100000>

SCVURPPP 2005 – Santa Clara Valley Urban Runoff Pollution Prevention Program (SCVURPPP). Hydromodification Management Plan. Prepared by the SCVURPPP Management Committee. April 21, 2005. Accessed on November 28, 2022. Available online at: https://scvurppp.org/wp-content/uploads/2021/08/hmp_complete_032905.pdf

SCVURPPP 2010 – Santa Clara Valley Urban Runoff Pollution Prevention Program (SCVURPPP). Classification of Subwatersheds and Catchment Areas for Determining Applicability of Hydromodification Management (HM) Requirements. Revised November 2010. From: Appendix E-2 of C.3 Stormwater Handbook. June 2016. Accessed on November 28, 2022. Available online at: <https://scvurppp.org/2016/06/20/c-3-stormwater-handbook-june-2016/>

SCVWD 2017 – Santa Clara Valley Water District (SCVWD). Santa Clara County Depth to First Groundwater. Information updated on January 24, 2017. Accessed on November 23, 2022. Available online at: <https://data-valleywater.opendata.arcgis.com/datasets/santa-clara-county-depth-to-first-groundwater/explore?location=37.404923%2C-121.893811%2C16.00>

SCVWD 2019 – Santa Clara Valley Water District (SCVWD). Inundation Map for the Hypothetical Fair Weather Failure of Lenihan Dam, Federal Dam ID: CA00294, State Dam ID: 72-008. Sheet 13 of 19. November 2019. Assessed on November 23, 2022. Available online at: https://fmds.water.ca.gov/webgis/?appid=dam_prototype_v2

SWCRB 2022 – State Water Resources Control Board (SWCRB). GeoTracker website. Accessed on November 23, 2022. Available online at: https://geotracker.waterboards.ca.gov/profile_report.asp?global_id=T0608500660

USEPA 2022 – United States Environmental Protection Agency (USEPA). How's My Waterway? EPA website. Assessed on November 28, 2022. Available online at: <https://mywaterway.epa.gov/state/CA/water-quality-overview>

USGS 2022 – United States Geological Survey (USGS). TopoView website. Accessed November 23, 2022. Available online at: <https://ngmdb.usgs.gov/topoview/viewer/#15/37.3792/-121.9331>

4.11 Land Use and Planning

This section describes the environmental setting, regulatory background, and impacts associated with construction and operation of the proposed project with respect to land use and planning.

LAND USE AND PLANNING	Potentially Significant Impact	Less Than Significant with Mitigation Incorporated	Less Than Significant Impact	No Impact
Would the project:				
a. Physically divide an established community?	<input type="checkbox"/>	<input type="checkbox"/>	<input type="checkbox"/>	<input checked="" type="checkbox"/>
b. Cause a significant environmental impact due to a conflict with any land use plan, policy, or regulation adopted for the purpose of avoiding or mitigating an environmental effect?	<input type="checkbox"/>	<input type="checkbox"/>	<input checked="" type="checkbox"/>	<input type="checkbox"/>

Environmental checklist established by CEQA Guidelines, Appendix G.

4.11.1 Environmental Setting

The Martin Data Center (MDC) is proposed for location at 651 Martin Avenue in the city of Santa Clara. The approximately 7.17-acre site (APN 224-04-071) is currently developed with four single-story structures for commercial and warehouse uses totaling approximately 77,220 square feet. As part of the project, these existing structures would be demolished, and a new approximately 468,175square-foot data center with back-up generators (gensets), a switching station, and a substation would be constructed (DayZenLLC 2022a, DayZenLLC 2023b).The project site is zoned Heavy Industrial (MH) (Santa Clara 2021) and surrounded mainly by commercial and industrial land uses, including a Union Pacific railroad line running in a north-south direction adjacent to the eastern portion of the property. The San José Mineta International Airport is located approximately 0.26 miles east of the site.

Regulatory Background

Federal

Code of Federal Regulations, Title 14, Section 77.9(b). These regulations provide requirements for when an applicant must notify the Federal Aviation Administration (FAA) of new structures near an airport. This section addresses these regulations under the discussions of the City of Santa Clara 2010-2035 General Plan and the Comprehensive Land Use Plan (CLUP) for the San José Mineta International Airport, as both these plans have policies based on Section 77.9(b) of the Code of Federal Regulations.

State

No state regulations relating to land use and planning apply to the proposed project.

Local

City of Santa Clara 2010-2035 General Plan. The City of Santa Clara 2010-2035 General Plan (General Plan) shows that the proposed project site is within an area designated as Heavy Industrial during all three phases of General Plan implementation (Santa Clara 2014, Figures 5.2-1, 5.2-2, and 5.2-3). The General Plan also includes land use policies pertaining to the proposed project, discussed later in this section.

City of Santa Clara Zoning Code. The project site is in the Heavy Industrial (MH) zoning district (Santa Clara 2021). The City of Santa Clara Zoning Code (Zoning Code) includes development standards for parcels in the MH zoning district, including minimum side, front, and rear setbacks, maximum height, and maximum lot coverage, discussed later in this section (Santa Clara 2023).

Comprehensive Land Use Plan, San José Mineta International Airport. The Santa Clara County Airport Land Use Commission (ALUC) adopted the Comprehensive Land Use Plan (CLUP) for the San José Mineta International Airport in 2011; the ALUC approved minor amendments to the CLUP in 2016. The purpose of the CLUP is to safeguard the welfare of the inhabitants in the airport vicinity and ensure that new land uses do not affect airport operations. The project site is within the Airport Influence Area, which is a “composite of the areas surrounding the Airport that are affected by noise, height, and safety considerations” (Santa Clara County 2016). Therefore, the CLUP policies regarding land use and planning apply to the project. The project is also located within the CLUP’s Turning Safety Zone (TSZ) for the San José Mineta International Airport, which means that additional policies apply to the project, as discussed later in this section (Santa Clara County 2016).

4.11.2 Environmental Impacts

a. Would the project physically divide an established community?

Construction and Operation

No Impact. All construction, except for construction of linears, would take place on the project site, which was previously developed and does not serve as a link between communities. If any lane closures would be required during construction of linears, the city of Santa Clara would ensure adequate access to neighborhood properties with traffic control measures. Roadways, sidewalks, or bikeways would not be permanently obstructed, and operation and maintenance of the project would occur fully on site. Therefore, project construction and operation would not prevent pedestrian, bike, or vehicular movement between different areas of the community, and no impact would occur.

b. Would the project cause a significant environmental impact due to a conflict with any land use plan, policy, or regulation adopted for the purpose of avoiding or mitigating an environmental effect?

Construction and Operation

Less Than Significant Impact. As discussed in the subsections that follow, construction and operation of the project would not conflict with applicable land use plans or policies such that significant environmental impacts would occur. Impacts would be less than significant.

City of Santa Clara General Plan. Adopting a general plan avoids or mitigates environmental impacts. Consistency with General plan policies help to minimize environmental impacts.

The City of Santa Clara's General Plan land use designation for the project site is Heavy Industrial. The proposed project is consistent with the uses allowed under the Heavy Industrial land use designation. According to the General Plan, the Heavy Industrial land use designation "...allows primary manufacturing, refining, and similar activities. It also accommodates warehousing and distribution, as well as data centers" (Santa Clara 2014).

General Plan land use policies pertaining to the project are listed below (Santa Clara 2014), along with a discussion of project conformance:

- *5.3.5-P7: Require building heights to conform to the requirements of the Federal Aviation Administration, where applicable.*

This policy is based in part on Code of Federal Regulations, Title 14, Section 77.9(b), noted in the "Regulatory Background" discussion earlier in this Land Use section. According to these regulations, the FAA notification height for the project site, given its proximity to the airport, is approximately 21.6 feet. The project's structures, and some of the equipment needed for project construction, would exceed this notification height, requiring the applicant to submit Form 7460-1, Notice of Proposed Construction or Alteration, to the FAA. The FAA would then provide a review of the proposed project and determine whether the project height is a hazard to aviation. The city of Santa Clara, as the permitting agency for the project, would ensure consistency with this requirement and compliance with any of the FAA's conditions. Therefore, the project would be consistent with this General Plan policy. (See **Section 4.17 Transportation** for more information about FAA notification.)

- *5.3.5-P12: Promote development, such as manufacturing, auto services and data centers, in Light and Heavy Industrial classifications to complement employment areas and retail uses.*

The proposed project would locate a data center within the Heavy Industrial land use designation to complement nearby employment areas and retail uses. Therefore, the proposed project would be consistent with this policy.

- *5.3.5-P13: Prohibit development on Heavy Industrial designated properties from exceeding the intensity or including uses beyond those defined in the land use classification.*

The General Plan lists data centers as an allowed use in the Heavy Industrial land use designation. The project would not include uses beyond those allowed in the land use designation; however, the project would exceed the intensity allowed in the Heavy Industrial land use designation.

The General Plan allows a maximum floor-area-ratio (FAR) of 0.45 for properties designated as Heavy Industrial. FAR is calculated as the ratio of the total building square footage (not including any building area used for parking) to the gross square footage of the building site (Santa Clara 2014). FAR is a tool for local governments to predict and limit the intensity of land uses and their resulting environmental impacts, based on the number of people expected to occupy a building. A project with a higher than allowed FAR could cause environmental impacts related to increased vehicle miles travelled (VMT), or to aesthetics, such as area views. The FAR of the proposed project is calculated by dividing 468,175 square feet (the floor area of the data center) by 312,237 square feet (the gross site area). The result is a FAR of approximately 1.5, which exceeds the maximum of 0.45 given in the General Plan for the Heavy Industrial land use designation (DayZenLLC 2022a). However, the project's impacts to VMT and aesthetics would be less than significant, so the project's inconsistency with the General Plan's FAR maximum for the site would not result in significant environmental impacts. (See **Section 4.17 Transportation** for an analysis of the project's potential impacts on transportation using the VMT metric and **Section 4.1 Aesthetics** for an analysis of the project's visual impacts.)

- *5.3.5-P19: Restrict the use and storage of hazardous materials for industrial uses within 500 feet of existing residential uses.*

The nearest residential uses are approximately 1,400 feet to the southwest of the project site on land zoned Heavy Industrial. Therefore, any hazardous substances at the project site, such as diesel fuel, would not be located within 500 feet of residential uses.

- *5.9.2-P9: Prohibit new public and quasi-public facilities on land designated for Light or Heavy Industrial uses on the Land Use Diagram, excluding public utility facilities.*

The applicant proposes construction of a new onsite substation owned and operated by Silicon Valley Power that would provide power to the proposed project. As a public utility facility, the substation would not conflict with the site's Heavy Industrial land use designation.

For these reasons, the project would be consistent with the General Plan.

City of Santa Clara Zoning Code. Part of the purpose of adopting a Zoning Code is to avoid or mitigate environmental impacts. Project consistency with the Zoning Code can help ensure that environmental impacts are minimized.

- Zoning Designation – As discussed earlier, the proposed project site’s zoning designation is Heavy Industrial (Santa Clara 2021). According to the City of Santa Clara Zoning Code, the Heavy Industrial zoning district allows any use permitted in the Planned Industrial or Light Industrial districts, including: a variety of office, laboratory, and manufacturing uses; commercial storage and wholesale distribution warehouses; plants and facilities associated with industrial processes and repair; incidental retail sales of industrial products or products manufactured on-site, under certain conditions; incidental and accessory buildings; and emergency shelters (Santa Clara 2023, Sections 18.46.030, 18.48.030, and 18.50.030).

The Heavy Industrial Zoning District also allows its own additional uses, including: railroad and trucking related uses; public utility related uses and public service uses; and incidental and accessory buildings and uses on the same lot with and necessary for the operation of any permitted use (Santa Clara 2023, Section 18.50.030). The district also allows any manufacturing, processing, assembling, research, wholesale, or storage uses that, in the opinion of the Planning Commission, shall not be objectionable by reason of the production of offensive noise, smoke, odor, dust, noxious gases, vibrations, glare, heat, fire hazards, industrial wastes, or handling of explosives or dangerous materials (Santa Clara 2022, Section 18.50.030).

The project’s substation is included on the list of permitted uses in the Heavy Industrial zoning district by the category “public utility related uses and public service uses”. However, the list of permitted uses does not include data centers (Santa Clara 2023, Sections 18.46.030, 18.48.030, and 18.50.030). Section 18.48.050(d)(2) of the Santa Clara Zoning Code provides that City approval of a conditional use permit may allow “other uses not normally permitted but that are... appropriate for an industrial area, such as lodges and bingo halls” (Santa Clara 2023). The City of Santa Clara has permitted data centers in industrial zoning districts in the past, and the General Plan land use designation of Heavy Industrial lists data centers as an allowed use. Therefore, a data center could be allowed on the project site with the City’s issuance of a conditional use permit.

Regarding the conditional use permit process, the Zoning Code further states: “Such use permits shall not be granted if the proposed use or structure would be objectionable or detrimental to adjacent properties or to the industrial area in general by reason of traffic, parking, noise, inappropriate design, or signs” (Santa Clara 2023, Section 18.50.040). The proposed project would not cause objectionable or detrimental environmental impacts affecting nearby properties. (See **Sections 4.1 Aesthetics, 4.3 Air Quality, 4.9 Hazards and Hazardous Materials, 4.13 Noise, and 4.17 Transportation** of this environmental impact report for more information.)

- Setbacks and Lot Coverage – The Heavy Industrial zoning district requires a front building setback of 15 feet from the street. Requirements for side and rear setbacks for buildings and structures not abutting streets is zero if the property does not abut a residential district, as is the case for the project site. The Heavy Industrial zoning district has no maximum lot coverage (Santa Clara 2023, Chapter 18.50). The proposed project meets all setback requirements, with a front yard setback of

approximately 149 feet, exceeding the 15-foot requirement, and at least 46 feet for the side and rear setbacks, although there are no required side and rear setbacks for this project (DayZenLLC 2022a).

- Height –The maximum permitted height in the Heavy Industrial zoning district is 70 feet (Santa Clara 2023, Section 18.50.070). The height of the proposed data center building would be 87.5 feet to the highest point of the roof parapet¹ (DayZenLLC 2022a). While this height exceeds the maximum permitted height of 70 feet within the Heavy Industrial zoning district, the City Zoning Administrator has the authority to grant a minor modification to the permitted height provided that the height does not exceed 25% of the zoning requirement, which would be 87.5 feet within the Heavy Industrial zone (Santa Clara 2023, Section 18.90.020). With issuance of a minor modification from the city, the project would not conflict with the height restrictions in the Heavy Industrial zone.
- Parking – Section 18.74.020 of the Santa Clara City Code establishes the number of vehicular parking spaces required for data centers as one space per 4,000 square feet of gross floor area (Santa Clara 2023). The floor area of the proposed data center is 468,175 square feet (DayZenLLC 2022a), meaning that 117 parking spaces are required. The project would provide 84 parking spaces onsite, including one accessible parking space and one van accessible parking space (DayZenLLC 2023b). Although the number of parking spaces does not meet the minimum required by the Santa Clara City Code, the number of parking spaces would be sufficient for the needs of the data center. The applicant anticipates that on an average day, there would be approximately 33 to 35 people total at the data center, with 17 to 30 people there at the same time (DayZenLLC 2023b). Because the proposed project would provide sufficient parking for the anticipated number of users, the project would not cause people to drive longer distances to find parking, resulting in potential air quality impacts, or cause users to park off-site, resulting in potential roadway hazards (Downey Brand 2021). For these reasons, the provision of less parking than required by City Code would not result in an environmental impact. During the permitting process, the city will review the project’s parking plan and ensure that the provided parking is adequate.

Comprehensive Land Use Plan (CLUP), San José Mineta International Airport. As discussed earlier, the project site is within the Airport Influence Area, meaning that

¹Section 18.06.010(h)(1) defines “height of buildings” as “a vertical distance from the ‘grade’ to the highest point of the coping of a flat roof...” (Santa Clara 2022). Using this definition, 87.5 feet (height from the top of the grade to the top of the data center parapet) is the “height of buildings” for this project.

There are technically higher parts of the project which are excluded from the definition of “height of buildings”, and therefore do not need to meet the Zoning Code’s height limitation. These include a rooftop dunnage platform for mechanical equipment (at 94.25 feet), a sound attenuating screen enclosing the platform (at 102.25 feet), and a freight elevator parapet (at 119.66 feet). Section 18.64.010(a) of the City of Santa Clara Zoning Code states that height limitations “... do not apply to spires, belfries, cupolas, antennas, water tanks, ventilators, chimneys, or other mechanical appurtenances usually required to be placed above the roof level and not intended for human occupancy or to be used for any commercial or advertising purposes” (Santa Clara 2022).

CLUP policies regarding land use and planning apply to the project. According to the CLUP, the project is also located within the TSZ of the San José Mineta International Airport (Santa Clara County 2016). The applicable CLUP policies for the project and the project's conformance are discussed below:

- *Policy G-5: Where legally allowed, dedication of an avigation easement to the City of San José shall be required to be offered as a condition of approval on all projects located within an Airport Influence Area, other than reconstruction projects as defined in paragraph 4.3.7. All such easements shall be similar to that shown as Exhibit 1 in Appendix A.*

The City of Santa Clara will ensure through its project permitting process that the applicant dedicates an avigation easement to the City of San José if necessary.

- *Policy G-6: Any proposed uses that may cause a hazard to aircraft in flight are not permitted within the AIA. Such uses include electrical interference, high intensity lighting, attraction of birds (certain agricultural uses, sanitary landfills), and activities that may produce smoke, dust, or glare. This policy requires the height at maturity of newly planted trees to be considered to avoid future penetration of the FAA FAR Part 77 Surfaces.*

The proposed project would not involve the use of any unlicensed high current, high frequency electrical systems capable of interfering with flight operations, or include any features which could attract birds, such as retention ponds. The proposed project would not create smoke, dust or glare. (See **Section 4.1 Aesthetics** for more details.) The project's chillers and emergency diesel-fired generators would emit thermal plumes, but not at vertical velocities that would be expected to cause hazards to aircraft in flight, as discussed in **Section 4.17 Transportation**. The City's permitting process would also ensure that any trees proposed for the site would be an appropriate height at maturity; given the height of the data center, it would be highly unlikely that any trees considered for the site would exceed the height of the data center. For these reasons, the proposed project would not create hazardous conditions for aircraft in flight, and the project would be consistent with Policy G-6.

- *Policy G-7: All new exterior lighting or large video displays within the AIA shall be designed to create no interference with aircraft operations. Such lighting shall be constructed and located so that only the intended area is illuminated, and off-site glare is fully controlled. The lighting shall be arrayed in such a manner that it cannot be mistaken for airport approach or runway lights by pilots.*

As discussed in section **4.1 Aesthetics**, outdoor lighting would be directed or shielded to ensure the project would not create a new source of substantial light or glare. Therefore, the project would conform to Policy G-7.

- *Policy H-1: Any structure or object that penetrates the Federal Aviation Regulations Part 77, Objects Affecting Navigable Airspace, (FAR Part 77) surfaces as illustrated in Figure 6, is presumed to be a hazard to air navigation and will be considered an incompatible land use, except in the following circumstance. If the structure or object*

is above the FAR Part 77 surface, the proponent may submit the project data to the FAA for evaluation and air navigation hazard determination, in which case the FAA's determination shall prevail.

The project structures do not penetrate the surface shown in Figure 6. Therefore, the project would conform to Policy H-1. (However, the project does require FAA notification under Section 77.9(b) of the Code of Federal Regulations.) See **Section 4.17 Transportation** for details.

- *H-2: Any project that may exceed a FAR Part 77 surface must notify the Federal Aviation Administration (FAA) as required by FAR Part 77, Subpart B on FAA Form 7460-1, Notice of Proposed Construction or Alteration. (Notification to the FAA under FAR Part 77, Subpart B, is required even for certain proposed construction that does not exceed the height limits allowed by Subpart C of the FARs).*

As stated above, the project structures do not penetrate the FAR Part 77 surface shown in Figure 6. Therefore, the project would conform to Policy H-2. (However, the project does require FAA notification under Section 77.9(b) of the Code of Federal Regulations.) See **Section 4.17 Transportation** for details.

- *Policy S-4: Storage of fuel or other hazardous materials shall be prohibited in the Runway Protection Zone. Above ground storage of fuel or other hazardous materials shall be prohibited in the Inner Safety Zone and Turning Safety Zone. In the Sideline Safety Zones and Outer Safety Zones, storage of fuel or other hazardous materials not associated with aircraft use should be discouraged.*

This policy prohibits above-ground fuel storage tanks in the TSZ of the San José Mineta International Airport. As discussed earlier, according to Figure 7 "Safety Zones" in the CLUP, the project, which proposes above-ground fuel storage tanks, is located within the TSZ (Santa Clara County 2016). However, the portion of the TSZ which traverses the site is based on the use of Runway 11-29, which was temporarily closed in 2009 and designated for permanent closure in 2020 (San José 2020a). The most recent Airport Master Plan, as amended through April 2020, lists airfield project A-26 as the conversion of Runway 11-29 to a taxiway (San José 2020a). Consistent with this, the most recent Airport Layout Plan for the airport (conditionally approved by the FAA) also shows Runway 11-29 as a future taxiway (San José 2020b). County of Santa Clara Department of Planning and Development staff recently submitted proposed amendments to the CLUP reflecting revised safety zones in accordance with the retirement of Runway 11-29 at the ALUC's May 24, 2023 meeting. The draft amended CLUP, dated May 4, 2023, shows in Figure 7 "Safety Zones" and Figure 8 "Airport Influence Area" that the TSZ is proposed for removal above the project site (DayZenLLC 2023d).

With the ALUC's approval of Santa Clara County Planning and Development staff's proposed amendments to the CLUP, which are currently under review, the proposed project would be consistent with CLUP Policy S-4. The project's proposed above-ground fuel storage tanks would no longer be located within the TSZ or any other safety zone

where these tanks are prohibited. The City of Santa Clara would ensure during the permit review process that the project would comply with all applicable CLUP policies.

- *Policy S-7: The following uses shall be prohibited in all Airport Safety Zones:*
 - *Any use which would direct a steady light or flashing light of red, white, green, or amber colors associated with airport operations toward an aircraft engaged in an initial straight climb following takeoff or toward an aircraft engaged in a straight final approach toward a landing at an airport, other than an FAA-approved navigational signal light or visual approach slope indicator.*
 - *Any use that would cause sunlight to be reflected towards an aircraft engaged in an initial straight climb following takeoff or towards an aircraft engaged in a straight final approach towards a landing at an airport.*
 - *Any use which would generate smoke or water vapor, or which would attract large concentrations of birds, or which may otherwise negatively affect safe air navigation within the area.*
 - *Any use which would generate electrical interference that may be detrimental to the operation of aircraft and/or aircraft instrumentation, communication or navigation equipment.*

The project would not direct inappropriate lighting or glare at departing or landing aircraft, and it would not generate smoke or water vapor. (See **Section 4.1 Aesthetics** for details.) It also would not involve the use of any unlicensed high current, high frequency electrical systems capable of interfering with flight operations.

Furthermore, this policy likely would not apply to the project because the TSZ traversing the site is expected to be removed by the ALUC. As discussed earlier with regard to CLUP Policy S-4, the portion of the TSZ which traverses the site is based on the use of Runway 11-29, which is not in use and is proposed for conversion to a taxiway in the most recent Airport Master Plan (San José 2020a). County of Santa Clara Department of Planning and Development staff submitted proposed amendments to the CLUP reflecting this and other changes at the ALUC's May 24, 2023 meeting.

For all these reasons, the proposed project would be consistent with Policy S-7.

- *Policy O-1: All new projects within the AIA that are subject to discretionary review and approval shall be required to dedicate in compliance with state law, an avigation easement to the City of San José. The avigation easement shall be similar to that shown as Exhibit 1 in Appendix A. (In September of 2002 Assembly Bill AB2776 was signed into law and became effective on January 1, 2004. This statute requires that as part of the real estate transfer process, the residential property purchaser be informed if the property is in an Airport Influence Area and be informed of the potential impacts resulting from the associated airport.)*

As discussed earlier, the City of Santa Clara would ensure through its project permitting process that the applicant dedicates an aviation easement to the City of San José as necessary.

With City of Santa Clara approval of a conditional use permit for the data center use, City of Santa Clara approval of a minor modification for the project height to exceed the maximum allowed in the Heavy Industrial zone, and the applicant and City abiding by any FAA determination conditions resulting from FAA notification, the proposed project would be consistent with the General Plan and Zoning Code. This consistency specifically includes the uses, policies, and development standards associated with the Heavy Industrial General Plan land use designation and zoning district. Runway 11-29, which is associated with the TSZ at the project site, is no longer in use. With ALUC approval of the proposed amendment to the CLUP, the project would be consistent with CLUP policies, as the TSZ prohibiting above-ground fuel storage tanks would be removed from the project site. For these reasons, the proposed project would not cause a significant environmental impact due to a conflict with any land use plan, policy, or regulation adopted for the purpose of avoiding or mitigating an environmental effect.

4.11.3 Mitigation Measures

None required.

4.11.4 References

DayZenLLC 2022a – DayZenLLC (DayZenLLC). (TN 247325). MBGF SPPE Application – Part I – Main App and Appendix A, dated November 7, 2022. Available online at: <https://efiling.energy.ca.gov/Lists/DocketLog.aspx?docketnumber=22-SPPE-03>

DayZenLLC 2023b – DayZenLLC (DayZenLLC). (TN 250687). Martin Properties Responses to Data Request Set 2 – MBGF, dated June 20, 2023. Available online at: <https://efiling.energy.ca.gov/Lists/DocketLog.aspx?docketnumber=22-SPPE-03>

DayZenLLC 2023d – DayZenLLC (DayZenLLC). (TN 250811). Martin Properties Supplemental Responses to Data Requests 34, 35, and 36 – MBGF, dated June 29, 2023. Available online at: <https://efiling.energy.ca.gov/Lists/DocketLog.aspx?docketnumber=22-SPPE-03>

Downey Brand 2021 – *Are Reductions in Parking a CEQA Impact – Second District Finds Context is Key*. By Breana M. Inoshita, Christian L. Marsh, and Hina Gupta. Downey Brand CEQA Chronicles, October 22, 2021. Accessed July 2023. Available online at: <https://www.ceqachronicles.com/2021/10/are-reductions-in-parking-a-ceqa-impact-second-district-finds-context-is-key/>

San José 2020a – City of San José Airport Department. Airport Master Plan for Norman Y. Mineta San José International Airport. Amended April 2020. Accessed July 2023. Available online at: <https://www.flysanjose.com/sites/default/files/rsheelen/MP-ExecSum2020.pdf>

- San José 2020b – Norman Y. Mineta San José International Airport Future Airport Layout Plan. Accessed on: July 18, 2023. Available online at:
https://www.flysanjose.com/sites/default/files/rsheelen/SJC.FUT_.ALP_.pdf
- Santa Clara 2021 – City of Santa Clara (Santa Clara). Zoning (Interactive). Updated July 14, 2021. Accessed on: July 2023. Available online at:
<https://www.santaclaraca.gov/our-city/departments-a-f/community-development/planning-division/zoning>
- Santa Clara 2023 – City of Santa Clara (Santa Clara). Santa Clara City Code. Current through Ordinance 2059, passed March 21, 2023. Accessed July 2023. Available online at: <https://www.santaclaraca.gov/our-city/departments-a-f/community-development/planning-division/city-code>
- Santa Clara 2014 – City of Santa Clara. City of Santa Clara 2010-2035 General Plan. Amended December 9, 2014. Accessed May 2023. Available online at:
<https://www.santaclaraca.gov/our-city/departments-a-f/community-development/planning-division/general-plan>
- Santa Clara County 2016 – Santa Clara County Airport Land Use Commission (Santa Clara County). Comprehensive Land Use Plan, Santa Clara County, Norman Y. Mineta San José International Airport. Amended November 16, 2016. Accessed May 2023. Available online at:
https://stgenpln.blob.core.windows.net/document/ALUC_SJC_CLUP.pdf

4.12 Mineral Resources

This section describes the environmental setting and regulatory background and discusses impacts associated with the construction and operation of the project with respect to mineral resources.

MINERAL RESOURCES	Potentially Significant Impact	Less Than Significant with Mitigation Incorporated	Less Than Significant Impact	No Impact
Would the project:				
a. Result in the loss of availability of a known mineral resource that would be of value to the region and the residents of the State?	<input type="checkbox"/>	<input type="checkbox"/>	<input type="checkbox"/>	<input checked="" type="checkbox"/>
b. Result in the loss of availability of a locally important mineral resource recovery site delineated on a local general plan, specific plan, or other land use plan?	<input type="checkbox"/>	<input type="checkbox"/>	<input type="checkbox"/>	<input checked="" type="checkbox"/>

Environmental checklist established by CEQA Guidelines, Appendix G.

4.12.1 Environmental Setting

Information on mineral resources was compiled from published literature, maps, and review of aerial photographs.

Impacts to mineral resources from project construction and operational activities were evaluated qualitatively based on the project location, site conditions, expected construction practices and materials to be used, and construction duration and operational activities.

The project site is in the city of Santa Clara within Santa Clara County in an area identified as Mineral Resource Zone 1 (MRZ-1) for aggregate materials by the State of California (DOC 2022). MRZ-1 is described as “areas where available information indicates that no significant mineral deposits are present, or where it is judged that little likelihood for their presence” exists (DOC 2022). The project site and surrounding area are not known to support significant mineral resources of any type and no mineral resources are currently being extracted in the city (Santa Clara 2011).

The Department of Conservation, Division of Mine Reclamation’s list of mines (as of November 16, 2022), referred to as the Assembly Bill (AB) 3098 List and regulated under the Surface Mining and Reclamation Act (SMARA), identifies the following facilities in Santa Clara County (DOC 2016):

- Curtner Quarry – Located approximately 7½ miles northeast.
- Hanson Permanente Cement Quarry – Located approximately 9½ miles southwest.
- Lexington Quarry – Located approximately 11½ miles south.

- Stevens Creek Quarry Plant 1 - Located approximately 9 miles southwest.

The Division of Mine Reclamation maps two additional sites that are not listed on the current AB 3098 list. These quarries are identified as the Azevedo Quarry located at Communications Hill, about 8 miles southeast of the site and the Serpa Pit located about 7 miles northeast of the site (DOC 2016).

Regulatory Background

Federal

No federal regulations related to mineral resources apply to the project.

State

Surface Mining and Reclamation Act. The California legislature enacted SMARA in 1975. This act provides for the reclamation of mined lands and directs the State Geologist to identify and map the non-fuel mineral resources of the state to show where economically significant mineral deposits occur and where they are likely to occur based upon the best available scientific data. The California Geological Survey (CGS), through the Mineral Resources Program, is responsible for inventorying the non-fuel mineral resources of the state (SMARA Mineral Land Classification).

CGS classifies the South San Francisco Bay P-C Region (project vicinity) according to the presence or absence of significant concrete grade aggregate deposits, according to Mineral Resource Zones (MRZs). The Department of Conservation Special Publication 51, Guidelines for Classification and Designation of Mineral Lands (DOC 1983) defines the four major MRZ divisions, MRZ-1, MRZ-2, MRZ-3, and MRZ-4. MRZ-2 and MRZ-3 are further subdivided into categories MRZ-2a, MRZ-2b, MRZ-3a, and MRZ-3b.

Assembly Bills 3098 and 3257. Assembly Bill 3098 (AB 3098) was passed in 1992 to promote compliance with state mining laws by establishing the State's preference of buying mined materials from operations that met certain minimum legal requirements. The Division of Mine Reclamation was tasked with creating and maintaining a list of mining operations that established a reclamation plan and financial assurances (the List). Public Contracts Code section 10295.5 restricts the purchase of sand, gravel, aggregate, and other mined materials by State agencies to only those surface mining operations on the List. The Division of Mine Reclamation provides updates to the Department of General Services, the agency responsible for enforcing the provisions of the Public Contracts Code section 10295.5, to identify those operations that meet the listing requirements of Public Resources Code section 2717. Additionally, Public Contracts Code section 20676 prohibits contractors and surface mining operators from selling mined materials to local governments if they are not identified on the List.

Assembly Bill 3257 was signed into law in 2018 to clarify the criteria to be used by the Division of Mine Reclamation to generate and maintain the AB 3098 List. AB 3257 clarifies that to be eligible for the List, an operation must report its status to the Division of Mine

Reclamation as either newly permitted, active, or idle. Operations reported as closed with no intent to resume will no longer appear on the List. AB 3257 also revised the criteria used by the Division of Mine Reclamation to determine List eligibility.

Local

No local regulations related to mineral resources apply to the project.

4.12.2 Environmental Impacts

a. Would the project result in the loss of availability of a known mineral resource that would be of value to the region and the residents of the State?

Construction and Operation

No Impact. The project site is in an area that does not contain any significant mineral deposits or where the likelihood for their presence is little. Therefore, the project would not result in the loss of availability of a known mineral resource.

b. Would the project result in the loss of availability of a locally important mineral resource recovery site delineated on a local general plan, specific plan, or other land use plan?

Construction and Operation

No Impact. The project site has not been delineated in the city of Santa Clara General Plan, or other land use plans, as an important mineral resource recovery site. Also, the project site is in an MRZ-1 area described as not containing any significant mineral deposits, or that the likelihood for their presence is little. Therefore, the project would not result in the loss of availability of a locally important mineral resource.

4.12.3 Mitigation Measures

None required.

4.12.4 References

DOC 1983 – California Department of Conservation (DOC). California Surface Mining and Reclamation Policies and Procedures, Guidelines for Classification and Designation of Mineral Lands. Special Publication 51. 1983. Accessed on: December 14, 2022. Available online at:
<https://www.conservation.ca.gov/smgb/Guidelines/Documents/ClassDesig.pdf>

DOC 2022 – California Department of Conservation (DOC). Surface Mining and Reclamation Act (SMARA) Mineral Lands Classification (MLC) data portal. Mineral Land Classification:
Update of Mineral Land Classification: Aggregate Minerals in the South San

Francisco Bay Production-Consumption Region. Author: Susan Kohler-Antablin (1996) DMG Open File Report 96-03, Plate 1. Accessed on: November 16, 2022.

Available online at:

<https://maps.conservation.ca.gov/cgs/informationwarehouse/index.html?map=mlc>

DOC 2016 – California Department of Conservation (DOC). AB 3098 List. This list is updated daily. Accessed on: November 16, 2022. Available online at:

<https://www.conservation.ca.gov/dmr>

Santa Clara 2011 – City of Santa Clara (Santa Clara). Integrated Final Environmental Impact Report, Draft 2010-2035 General Plan, Volume I, EIR text. Accessed on: November 16, 2022. Available online at:

<https://www.santaclaraca.gov/home/showpublisheddocument/12900/635713044859030000>

4.13 Noise and Vibration

This section describes the environmental and regulatory setting and discusses impacts associated with the construction and operation of the project related to noise and vibration.

NOISE	Potentially Significant Impact	Less Than Significant with Mitigation Incorporated	Less Than Significant Impact	No Impact
Would the project result in:				
a. Generation of a substantial temporary or permanent increase in ambient noise levels in the vicinity of the project in excess of standards established in the local general plan or noise ordinance, or applicable standards of other agencies?	<input type="checkbox"/>	<input type="checkbox"/>	<input checked="" type="checkbox"/>	<input type="checkbox"/>
b. Generation of excessive groundborne vibration or groundborne noise levels?	<input type="checkbox"/>	<input type="checkbox"/>	<input checked="" type="checkbox"/>	<input type="checkbox"/>
c. For a project located within the vicinity of a private airstrip or an airport land use plan or, where such a plan has not been adopted, within two miles of a public airport or public use airport, would the project expose people residing or working in the project area to excessive noise levels?	<input type="checkbox"/>	<input type="checkbox"/>	<input checked="" type="checkbox"/>	<input type="checkbox"/>

Environmental checklist established by CEQA Guidelines, Appendix G.

4.13.1 Environmental Setting

The Martin Data Center (MDC or project) project area consists primarily of heavy industrial (MH) land uses. The proposed data center would be located on an approximately 7-acre site bounded by Martin Avenue to the south, freight train tracks to the east, and industrial properties to the north and west. The San Jose Mineta International Airport is approximately 1,400 feet east of the project site (DayZenLLC 2022b). The nearest residences are located on a property zoned for light industrial uses (ML), approximately 1,400 feet to the southwest of the project site (DayZenLLC 2022a). The predominant ambient noise sources are attributed to the automobile traffic on Martin Avenue, trains passing by, surrounding industrial uses, and aircraft arriving to and departing from the airport (DayZenLLC 2022a).

A long-term ambient noise monitoring survey was conducted in the areas surrounding the project site from September 28 through September 30, 2022 (DayZenLLC 2022b).

The applicant surveyed two monitoring locations—LT-1 located on the south side of the project site adjacent to Martin Avenue, and LT-2 located on the north side of the project site adjacent to an industrial property. The ambient sound level measured at LT-1 and LT-2 were approximately 69 and 62 decibels on the A-weighted scale (dBA) L_{eq}^1 , respectively.

Regulatory Background

Thresholds of Significance

The California Environmental Quality Act (CEQA) Guidelines state that a project would normally be considered to have a significant impact if noise levels conflict with adopted environmental standards or plans, or if noise levels generated by the project would substantially increase existing noise levels at noise-sensitive receivers on a permanent or temporary basis. CEQA does not define what noise level increase would be substantial. Generally, an increase of 3 dBA is noticeable and an increase of 5 dBA is distinct.

Other factors, such as the frequency of occurrence of the noise and time of day/night it occurs are also commonly considered in determining if such an increase is clearly significant or not.

There are no adopted thresholds for an increase in dBA level to be considered a significant impact for construction activities. Noise due to construction activities are considered to be less than significant if the construction activity is temporary and the use of heavy equipment and noisy activities are limited to daytime hours. However, an increase of 10 dBA or more during the day can be perceived as noisy (triggering a community reaction) and warrant additional measures to address the noise levels. An increase of 10 dBA corresponds to a doubling of loudness or dBA level and is generally considered to be the starting point at which significant noise impacts may occur (triggering a community reaction). It is very difficult to identify the exact level of noise resulting from construction because it fluctuates based on many factors over the course of a week, day, or even hour. It also depends on other factors, such as intervening structures, land topography and land cover. For example, intervening structures block or impede sound waves, and undulating topography and land roughness would play a role in attenuating the propagation of noise waves. Therefore, performance standards (i.e., a complaint and redress process) are ultimately used as a backstop measure to address any impacts that are perceived by the community.

In September 2013, the California Department of Transportation (Caltrans) released the Transportation and Construction Vibration Guidance Manual, which includes the Federal Transit Administration's (FTA) methods and findings. The Caltrans manual states that for construction activities that generate vibration, the threshold of human response begins

¹ L_{eq} is a measurement of average energy level intensity of noise over a given period of time.

at a peak particle velocity (PPV) of 0.16 inch per second (in/sec). This is characterized by Caltrans as a "distinctly perceptible" event with an incident range of transient to continuous (Caltrans 2013). A level of 0.20 in/sec has been found to be annoying to people in buildings and can pose a risk of architectural damage to buildings.

Local

City of Santa Clara 2010-2035 General Plan. The City of Santa Clara 2010-2035 (General Plan) describes the levels of exterior noise considered compatible for various land uses to guide land use planning decisions. The Santa Clara City Code, discussed below, establishes more specific sound limits (Santa Clara 2022). The General Plan also includes several policies that aim to keep noise levels within acceptable levels and avoid nuisance to residents. The following are General Plan policies applicable to the project:

Policy 5.10.6-P1: Review all land use and development proposals for consistency with the General Plan compatibility standards and acceptable noise exposure levels defined on Table 5.10-1.

Policy 5.10.6-P3: New development should include noise control techniques to reduce noise to acceptable levels, including site layout (setbacks, separation and shielding), building treatments (mechanical ventilation system, sound-rated windows, solid core doors and baffling) and structural measures (earthen berms and sound walls).

Policy 5.10.6-P4: Encourage the control of noise at the source through site design, building design, landscaping, hours of operation and other techniques.

Policy 5.10.6-P5: Require noise-generating uses near residential neighborhoods to include solid walls and heavy landscaping along common property lines, and to place compressors and mechanical equipment in sound-proof enclosures.

City of Santa Clara Zoning Code (City Code). Chapter 9.10 (noise ordinance) of the City Code applies to the regulation of noise and vibration for this project. Section 9.10.040 specifies the exterior noise limits that apply to land use zones within the city. The city of Santa Clara's (city) exterior noise limit is 75 dBA (anytime) for MH land use zones, 70 dBA (anytime) for ML land use zones, 65 dBA daytime and 60 dBA nighttime for commercial land use zones, and 55 dBA daytime and 50 dBA nighttime for residential land use zones. The city's noise limits for stationary noise sources are not applicable to emergency work, including the operation of emergency backup generators (gensets) during an emergency (Section 9.10.070). It should also be noted that based on historical data, such emergency operation has occurred infrequently, and this project is not expected to be different. However, the intermittent testing of emergency gensets is subject to the local noise regulations previously discussed in the City Code (Section 9.10.040).

4.13.2 Environmental Impacts and Mitigation Measures

a. **Would the project result in generation of a substantial temporary or permanent increase in ambient noise levels in the vicinity of the project in excess of standards established in the local general plan or noise ordinance, or applicable standards of other agencies?**

Construction

Less Than Significant Impact. The City Code (Section 9.10.070) does not establish construction noise sources in its prescribed noise level limits (Santa Clara 2022). The city limits construction and demolition activities at the project site within 300 feet of any residentially zoned property except within the hours of 7:00 A.M. to 6:00 P.M. following on weekdays other than holidays, Monday through Friday, inclusive; and within the hours of 9:00 A.M. to 6:00 P.M. following, inclusive, on any Saturday which is not a holiday (Section 9.10.230). There are no residences within 300 feet from the project site boundary.

Demolition and construction activities for the project would occur in six phases and take approximately 15 months to complete. Demolition of four separate single-story structures would occur prior to construction of the project (DayZenLLC 2022a). Demolition and construction activities would likely utilize equipment that could generate noise levels that exceed ambient noise, such as bulldozers and jackhammers. Typical equipment used for the construction and demolition of similar projects produces noise levels between 82 and 91 dBA at 50 feet.

The project's site preparation and building construction phase would generate the highest noise level of 90 dBA at 50 feet (DayZenLLC 2022b). Noise levels due to these construction phases would be 73 dBA at the adjacent MH property west of the project site (DayZenLLC 2022b, Figure 3). At this location, the ambient noise level (66 dBA) would increase by up to 7 dBA. This is less than 10 dBA, and therefore, construction noise levels at the adjacent MH property would be less-than-significant. Moreover, the loudest construction activities would be infrequent and of short duration.

The nearest residences (land use designation ML) are located approximately 1,400 feet to the southwest of the project site (DayZenLLC 2022b, Figure 3). Noise at this location due to the loudest construction phases would be 57 dBA and would not exceed the ambient noise level. The ambient noise level at this location is 58 dBA L_{eq} (Santa Clara 2014, section 5.10.6, Figure 5.10-4). Therefore, noise due to the loudest phases of construction would have a less-than-significant impact on these residences.

Nevertheless, the city would require a series of performance standards, as part of their condition of approval for construction (Santa Clara 2023). These performance standards are ultimately used as a backstop measure to address any noise impacts that might be

perceived by the community. These standards are quite effective and are summarized below.

- Submit a noise control plan to the city for approval.
- Limit construction work to daytime hours and away from sensitive receptors as much as practicable.
- Use quiet construction equipment when possible.
- Locate staging and parking areas away from noise-sensitive receptors.
- Establish speed limits for construction vehicles.
- Establish a redress and complaint process.

Noise impact from project construction would not exceed adopted environmental standards or plans. Furthermore, noise impacts from project construction would be less than significant.

Operation

Less Than Significant Impact. The proposed emergency backup generators (gensets) would provide backup power to the data center building in the event of an equipment failure or other conditions resulting in an interruption of the electricity delivered from Silicon Valley Power (SVP) via Pacific Gas and Electric Company (PG&E) utility lines. Sources of operational noise for the project would include the 44 backup gensets and 48 air-cooled chillers. The gensets would be stacked vertically on the east side of the building in twenty-two groups of two. The project's 48 air-cooled chillers are spaced around the building's rooftop to provide cooling for the data center. The basis of design for the chillers is the York YVFA0459 which are located on the roof of 85 feet tall building, with the top of the chillers approximately 19 feet above the rooftop.

The City's General Plan along with the City Code (Section 9.10.040) establish mitigation and noise level performance standards to control noise within the city. The General Plan policy includes goals to minimize operational noise impacts from existing and new industrial and commercial development to protect sensitive land uses from noise intrusions. As described above, the nearest residences, 1,400 feet away, are in a ML land use designation. Therefore, the maximum sound level allowance applicable to this location in accordance with the City Code is 70 dBA anytime. Also in accordance with this code, the maximum noise level allowance at the adjacent MH land use properties is 75 dBA anytime (Section 9.10.040).

The noise levels during operation would include two modes: 1) normal, which assumes day-to-day operating conditions including operation of all chillers at full load, without any of the gensets operating, and 2) testing, which includes testing of three gensets concurrently with operation of all chillers at full load.

Noise levels during "normal" mode would not increase the daytime and nighttime ambient noise levels at the nearest residences 1,400 feet southwest of the project. At these residential receptors the noise level would be 54 dBA L_{eq} , while the daytime and nighttime ambient noise levels are 65 and 55 dBA L_{eq} , respectively. This noise level would also be below the City's noise level limit. The noise level at the closest heavy industrial zone property east of the project site would be 69 dBA L_{eq} . The operational noise level would be below the daytime ambient noise level, as well as the City's noise level limits at the adjacent heavy industrial land uses.

Genset testing would not occur at night. Noise levels during "testing" mode would not increase the ambient noise levels at the nearest residences and at the adjacent industrial property east of the project (nearest to the gensets). During testing, the noise level at these residences would be 54 dBA L_{eq} , while the daytime ambient noise level is 65 dBA. The noise level at the industrial property would be 69 dBA L_{eq} , while the daytime ambient noise level at this location is 75 dBA. In addition, noise levels during testing at the adjacent industrial property would be below the City's noise level limits.

Humming noise, or white noise, from the operation of an industrial facility, such as a data center, is usually associated with either equipment imbalance that can occur in older or poorly designed equipment, or due to the lack of noise-control features. The project, on the other hand, would be a new, state-of-the-art facility, incorporating low-noise equipment and noise-control features. The project is not expected to generate a humming noise or any other tonal noise discernable at the adjacent properties.

Noise impacts from project operation would not exceed adopted environmental standards or plans and would be less than significant.

b. Would the project result in generation of excessive groundborne vibration or groundborne noise levels?

Construction

Less Than Significant Impact. The equipment with the highest potential to generate significant vibration during project construction is the vibratory roller, which could be used adjacent to the property line. This analysis relies on the vibration thresholds identified by Caltrans to determine the significance of vibration impacts related to adverse human reactions. While the city does not specify a numerical threshold for vibration, the City Code (section 9.10.050) prohibits activities that generate vibration levels above the vibration perception threshold of an individual at the closest property line point to the vibration source. The threshold of human response begins at a PPV of 0.16 in/sec. Caltrans characterizes this as a "distinctly perceptible" event (Caltrans 2013). A level of 0.20 in/sec has been found to be annoying to people in buildings and can pose a risk of architectural damage to buildings.

Jackhammers can cause a groundborne vibration rate of 0.035 in/sec at 25 feet (less than the threshold of human response), and vibratory rollers can cause a groundborne vibration of 0.21 in/sec at 25 feet (Caltrans 2013). However, vibration rates dissipate rapidly with distance, and the vibration rate generated by a vibratory roller drops from 0.210 in/sec to 0.055 in/sec at a distance of 85 feet from the source. The closest structure is an industrial building 85 feet west of the project site boundary. At this location, the vibration rate due to the use of a vibratory roller would be below the Caltrans PPV limit of 0.08 in/sec. Therefore, temporary vibration impacts from construction equipment are expected to be less than significant.

Operation

Less Than Significant Impact. Sources of groundborne vibration associated with project operation would include the gensets and rooftop equipment. These pieces of equipment would be well-balanced, as they are designed to produce very low vibration levels (less than the threshold of human response) throughout the life of a project. In most cases, even when there is an imbalance, they could contribute to ground vibration levels only in the vicinity of the equipment and would be dampened within a short distance. Furthermore, the gensets would be equipped with specifications that ensure sufficient exhaust silencing to reduce vibration. Therefore, vibration impacts due to project operation would be less than significant.

c. For a project located within the vicinity of a private airstrip or an airport land use plan or, where such a plan has not been adopted, within two miles of a public airport or public use airport, would the project expose people residing or working in the project area to excessive noise levels?

Construction and Operation

Less Than Significant Impact. The nearest airport to the project site is the San Jose Mineta International Airport, located approximately 1,400 feet to the east. The project site is located inside the Airport Noise Zone (the 65 to 70 dB CNEL contour, as set forth by state law) as defined in the Comprehensive Land Use Plan for the airport. Aircraft-related noise is occasionally audible at the project site. The project's operational noise levels would not exceed the 24-hour ambient noise levels at the nearest residential receptors. The project site is surrounded by mostly industrial uses, and the closest residence is about 1,400 feet away from the project site and 2,700 feet away from the airport. Thus, the project would not combine with the airport to expose people to excessive noise levels.

4.13.3 Mitigation Measures

None required.

4.13.4 References

- Caltrans 2013 – California Department of Transportation (Caltrans). Technical Noise Supplement to the Caltrans Traffic Noise Analysis Protocol, A Guide for Measuring, Modeling, and Abating Highway Operation and Construction Noise Impacts, Division of Environmental Analysis, Environmental Engineering, September 2013. Report No. CT-HWANP-RT-13069.25.3. Accessed on May 19, 2023. Available online at: <https://dot.ca.gov/-/media/dot-media/programs/environmental-analysis/documents/env/traffic-noise-protocol-april-2020-a11y.pdf>
- DayZenLLC 2022a – DayZenLLC (DayZenLLC). (TN 247325). MBGF SPPE Application – Part I – Main App and Appendix A, dated November 7, 2022. Accessed on May 19, 2023. Available online at: <https://efiling.energy.ca.gov/Lists/DocketLog.aspx?docketnumber=22-SPPE-03>
- DayZenLLC 2022b – DayZenLLC (DayZenLLC). (TN 247326). MBGF SPPE Application – Part V – Appendices F, G, and H, dated November 7, 2022. Accessed on May 19, 2023. Available online at: <https://efiling.energy.ca.gov/Lists/DocketLog.aspx?docketnumber=22-SPPE-03>
- Santa Clara 2014 – City of Santa Clara (Santa Clara). City of Santa Clara 2010-2035 General Plan. Approved by City Council November 16, 2010 and updated December 9, 2014. Accessed on: May 19, 2023. Available online at: <https://www.santaclaraca.gov/our-city/departments-a-f/community-development/planning-division/general-plan>
- Santa Clara 2022 – City of Santa Clara (Santa Clara). City of Santa Clara City Code, Chapter 9.0: Regulation of Noise and Vibration. Accessed on May 19, 2023. Available online at: <https://www.codepublishing.com/CA/SantaClara/#!/SantaClara09/SantaClara0910.html#9.10>
- Santa Clara 2023 – City of Santa Clara (Santa Clara). (TN 249467). Record of Conversation with City of Santa Clara staff re City of Santa Clara Permitting Conditions, dated March 28, 2023. Accessed on: May 19, 2023. Available online at: <https://efiling.energy.ca.gov/Lists/DocketLog.aspx?docketnumber=22-SPPE-01>

4.14 Population and Housing

This section describes the environmental and regulatory setting and discusses the impacts specific to population and housing associated with the construction and operation of the project.

POPULATION AND HOUSING	Potentially Significant Impact	Less Than Significant with Mitigation Incorporated	Less Than Significant Impact	No Impact
Would the project:				
a. Induce substantial unplanned population growth in an area, either directly (for example, by proposing new homes and businesses) or indirectly (for example, through extension of roads or other infrastructure)?	<input type="checkbox"/>	<input type="checkbox"/>	<input checked="" type="checkbox"/>	<input type="checkbox"/>
b. Displace substantial numbers of existing people or housing, necessitating the construction of replacement housing elsewhere?	<input type="checkbox"/>	<input type="checkbox"/>	<input type="checkbox"/>	<input checked="" type="checkbox"/>

Environmental checklist established by CEQA Guidelines, Appendix G.

4.14.1 Environmental Setting

The project is proposed in the city of Santa Clara in Santa Clara County. Nearby cities include the cities of Campbell, Cupertino, Milpitas, San Jose, and Sunnyvale. The applicant estimates the construction and operations workers would come from the greater Bay Area. CEC staff (staff) considers that the local workers¹ from the greater Bay Area are not likely to temporarily (during construction) or permanently (during operations) move closer to the project. Staff considers the city of Santa Clara as the study area for population and housing-related impacts and the San Jose-Sunnyvale-Santa Clara Metropolitan Statistical Area (MSA), which covers San Benito and Santa Clara counties, as the setting for labor supply for the project.

Population Growth

The city of Santa Clara has an estimated land area of 18.4 square miles. The Housing Element of the Comprehensive General Plan for the City of Santa Clara (adopted December 2014) forecasts population and housing estimates in three phases, reflecting the near (2010-2015), mid (2015-2023), and long term (2023-2035) horizons. By 2035, the general plan would allow for an additional 32,400 residents (Santa Clara 2014, pg. 2-4). The 2020 population for the city was 127,647 people (US Census 2020).

Association of Bay Area Governments (ABAG) data is used in **Table 4.14-1** to show household growth projections between 2015 and 2050. ABAG divides the Bay Area counties into sub-county areas, called super districts. The super districts are combinations

¹ Workers with a greater commute would be considered non-local and would tend to seek lodging closer to the project site (temporarily during construction or permanently during operations).

of cities, towns, and unincorporated areas that represent a more localized pattern of growth within the Bay Area (ABAG 2021a, page 122). The historical and projected households for the super districts within proximity of the project site, plus Santa Clara County is shown in **Table 4.14-1**. The household projections between 2015 and 2050 show a growth ranging from 42 to 199 percent or 1.2 and 5.7 percent per year in super districts throughout a 6-mile radius of the project site.

TABLE 4.14-1 HISTORICAL AND PROJECTED HOUSEHOLDS

Super District	Area	2015	2050	Projected Household Change 2015-2050 Number	Projected Household Change 2015-2050 Percent (%)	Projected Household Change 2015-2050 Percent per Year (%)
North Santa Clara County	Sunnyvale, Santa Clara (partial), Mountain View (partial), Milpitas (partial), San Jose (partial), Palo Alto (partial)	107,000	320,000	212,000	199%	5.7%
West Santa Clara County	Los Gatos, Monte Sereno, Saratoga, Cupertino, Campbell (partial), Santa Clara (partial)	121,000	172,000	51,000	42%	1.2%
Central Santa Clara County	Campbell (partial), San Jose (partial)	105,000	168,000	63,000	60%	1.7%
East Santa Clara County	Milpitas (partial), San Jose (partial)	108,000	180,000	453,000	67%	1.9%
Santa Clara County		623,000	1,075,000	602,061	73%	2.1%

Source: ABAG 2021b

Housing

Table 4.14-2 presents housing supply data for the project area. Year 2023 housing estimates indicated 3,411 vacant housing units within the city of Santa Clara. The vacancy rate for the cities within and around a six-mile radius of the project site ranges from 3.0 percent to 6.4 percent (CA DOF 2023).

TABLE 4.14-2 HOUSING SUPPLY ESTIMATES IN THE PROJECT AREA

Housing Supply	2023 Total Number	2023 Vacant Number	2023 Vacant Percent
Campbell	18,451	926	5.0
Cupertino	21,787	1,108	5.1
Milpitas	25,769	765	3.0
San Jose	345,798	15,114	4.4
Santa Clara	53,370	3,411	6.4
Sunnyvale	63,111	2,966	4.7
Santa Clara County	701,539	34,781	5.0

Source: CA DOF 2023

By 2035, the general plan would allow for an additional 32,400 residents in 13,312 new housing units, and 25,040 new jobs in 24,253,600 square feet of new non-residential development. This development would occur in addition to “in progress” development taking place under the general plan, for a total population of 154,990 and a total employment base of 152,860 by 2035 (Santa Clara 2014, pg. 2-4). The Santa Clara County regional housing needs assessment allocation projects a county need of 129,577 new housing units by 2031. Of the 129,577 new housing units, 11,632 new housing units would be needed in the city of San Clara (ABAG 2021c, page 28).

Labor Supply

According to the California Employment Development Department 2018-2028 Occupational Employment Projections for the San Jose-Sunnyvale-Santa Clara MSA, the 2028 projected employment for the construction trade workers is 41,380, which is a 0.8 percent annual average percent change from 2018 estimated employment levels (38,350) as shown in **Table 4.14-3**. In addition, the projected employment for computer and information system managers is 15,760, which is a 1.2 percent annual average percent change from 2018 estimated employment levels (14,110) (CA EDD 2021).

TABLE 4.14-3 PROJECTED EMPLOYMENT GROWTH

	Year 2018	Year 2028	Annual Average Percent Change
San Jose-Sunnyvale-Santa Clara MSA			
Construction Trade Workers	38,350	41,380	0.8%
Computer and Information System Managers	14,110	15,760	1.2%

Source: CA EDD 2021

Regulatory Background

No regulations related to population and housing apply to the project.

4.14.2 Environmental Impacts

- a. Would the project induce substantial unplanned population growth in an area, either directly (for example, by proposing new homes and businesses) or indirectly (for example, through extension of roads or other infrastructure)?**

Construction

Less Than Significant Impact. The project would not directly or indirectly induce substantial unplanned growth in the city of Santa Clara. The project does not propose new housing or land use designation changes and would not facilitate growth by extending growth inducing infrastructure such as roads, water supply pipelines, or other growth inducing infrastructure. While the project includes 44 backup generators, the electricity produced would directly serve the project if utility power interruptions occurred and would not be an extension of infrastructure that would result in indirect population growth.

Construction activities would take place in two phases. Phase I would last approximately 14 months and include demolition of the existing buildings and infrastructure, grading, installation of interim utility services, and construction of the shell building. Phase II would last approximately 11 months and include construction of the remainder of the building interior rooms and components. Phase I construction would employ an average of 100 workers per month and reach a peak workforce of 190 workers per month. Construction during Phase II would employ an average of 60 workers per month and reach a peak workforce of 100 workers per month. (DayZenLLC 2022a, pg. 2-17).

The applicant anticipates the construction workforce for the project would be sourced locally from the greater Bay Area (DayZenLLC 2022a). As shown in the "Setting" subsection of this analysis, there is a sufficient local construction workforce in the San Jose-Sunnyvale-Santa Clara MSA to accommodate the project; thus, the construction workforce would not likely seek temporary lodging closer to the project site. Therefore, the project's construction workforce would not directly or indirectly induce substantial population growth in the project area. The impact would be less than significant.

Operation

Less Than Significant Impact. The project would require 19 to 21 operations workers with approximately 10 to 14 tenant employees and visitors on a daily basis. Operational workers would work a 4 day-40hour work schedule. The applicant anticipates the operations workforce would be sourced from the greater Bay Area (DayZenLLC 2022a). Based on the proximity of the supply of operations workers, they are not likely to relocate closer to the project. As shown in the "Setting" subsection of this analysis, there is a sufficient local operations workforce in the San Jose-Sunnyvale-Santa Clara MSA. If some operations workers were to relocate, housing data shows a vacancy rate of 6.4 percent in the city of Santa Clara. A 5-percent vacancy is a largely industry-accepted minimum

benchmark for a sufficient amount of housing available for occupancy (Virginia Tech 2006). There is a sufficient supply of available housing units if operations workers seek housing closer to the project. In addition, the city's general plan has accounted for population growth in the city of Santa Clara. Therefore, the project's operations workforce would not directly or indirectly induce a substantial unplanned population growth in the project area. The impact would be less than significant.

b. Would the project displace substantial numbers of existing people or housing, necessitating the construction of replacement housing elsewhere?

Construction and Operation

No Impact. The project would occur on a parcel currently occupied by four single-story commercial/warehouse buildings. There are no residents or housing units on the project site. Therefore, the project would not displace any people or housing. Construction of replacement housing elsewhere would not be necessary and thus, no impact would occur.

4.14.3 Mitigation Measures

None required.

4.14.4 References

- ABAG 2021a – Association of Bay Area Governments (ABAG). Plan Bay Area 2050. October 1, 2021. Available online at:
https://www.planbayarea.org/sites/default/files/documents/Plan_Bay_Area_2050_October_2021_rev.pdf
- ABAG 2021b – Association of Bay Area Governments (ABAG). Plan Bay Area 2050 Growth Pattern. January 21, 2021. Available online at:
https://www.planbayarea.org/sites/default/files/FinalBlueprintRelease_December_2020_GrowthPattern_Jan2021Update.pdf
- ABAG 2021c – Association of Bay Area Governments (ABAG). Final Regional Housing Need Allocation (RHNA) Plan: San Francisco Bay Area 2023-2031, Adopted December 2021. Updated March 2022. Available online at:
https://abag.ca.gov/sites/default/files/documents/2022-04/Final_RHNA_Methodology_Report_2023-2031_March2022_Update.pdf
- CA DOF 2023 – California Department of Finance (CA DOF). E-5 Population and Housing Estimates for Cities, Counties and the State — January 1, 2021-2023, with 2020 Benchmark, May 2023. Available online at:
<https://dof.ca.gov/Forecasting/Demographics/Estimates/e-5-population-and-housing-estimates-for-cities-counties-and-the-state-2020-2023/>
- CA EDD 2022 – Employment Development Department, State of California (CA EDD). Labor Market Information Division, 2018-2028 Occupational Employment

Projections, San Jose-Sunnyvale-Santa Clara Metropolitan Statistical Area, (San Benito and Santa Clara Counties), data last update April 2021. Available online at:

<https://view.officeapps.live.com/op/view.aspx?src=https%3A%2F%2Flabormarketinginfo.edd.ca.gov%2Ffile%2Foccproj%2Fsjos%24occproj.xlsx&wdOrigin=BROWSLINK>

DayZenLLC 2022a – DayZenLLC (DayZenLLC). (TN 247325). MBGF SPPE Application – Part I – Main App and Appendix A, dated November 7, 2022. Available online at: <https://efiling.energy.ca.gov/Lists/DocketLog.aspx?docketnumber=22-SPPE-03>

Santa Clara 2014 – City of Santa Clara (Santa Clara). General Plan Land Use Component and Housing Element Updates, EIR Addendum. Prepared by ESA, November 2014. Adopted December 9, 2014. Available online at: <https://www.santaclaraca.gov/home/showdocument?id=46446>

US Census 2020 – United States Census Bureau (US Census). P1: TOTAL POPULATION - Universe: Total population, 2020 Census Summary File 1. Available online at: <https://data.census.gov/cedsci/>

4.15 Public Services

This section describes the environmental and regulatory setting and discusses impacts specific to public services associated with the construction and operation of the project.

PUBLIC SERVICES				
Would the project result in substantial adverse physical impacts associated with the provision of new or physically altered governmental facilities, need for new or physically altered governmental facilities, the construction of which could cause significant environmental impacts, in order to maintain acceptable service ratios, response times, or other performance objectives for any of the public services:				
	Potentially Significant Impact	Less Than Significant with Mitigation Incorporated	Less Than Significant Impact	No Impact
a. Fire protection?	<input type="checkbox"/>	<input type="checkbox"/>	<input type="checkbox"/>	<input checked="" type="checkbox"/>
b. Police protection?	<input type="checkbox"/>	<input type="checkbox"/>	<input type="checkbox"/>	<input checked="" type="checkbox"/>
c. Schools?	<input type="checkbox"/>	<input type="checkbox"/>	<input type="checkbox"/>	<input checked="" type="checkbox"/>
d. Parks?	<input type="checkbox"/>	<input type="checkbox"/>	<input type="checkbox"/>	<input checked="" type="checkbox"/>
e. Other public facilities?	<input type="checkbox"/>	<input type="checkbox"/>	<input type="checkbox"/>	<input checked="" type="checkbox"/>

Environmental checklist established by CEQA Guidelines, Appendix G.

4.15.1 Environmental Setting

The project is proposed in the city of Santa Clara in Santa Clara County in accordance with current building and fire codes. Fire and police protection services are provided from departments within the city of Santa Clara. Recreation facilities and other public facilities like libraries are within the city of Santa Clara. The project site is within the Santa Clara Unified School District. The study area for public services-related impacts is the city of Santa Clara. Site preparation activities include ground preparation and site grading. The project would construct a four-story approximately 467,000 square foot data center building, generator equipment yard, surface parking, and landscaping. A substation owned and operated by Silicon Valley Power would also be constructed on the project site.

Fire Protection

The project would be located within the jurisdiction of the Santa Clara Fire Department (SCFD). The SCFD responds to emergency incidents and provides emergency medical services, fire prevention, and hazardous materials services to the city of Santa Clara (Santa Clara 2023a). There are 9 fire station districts in the city of Santa Clara; the project site is in District 2 at 1900 Walsh Avenue, approximately 0.7 mile west of the project site (Santa Clara 2023b).

SCFD has approximately 155 fire service personnel supplemented by 11 Reserve Firefighters. In 2022, SCFD had a total call volume of 10,698 calls. Approximately 73.1 percent of the calls were for emergency medical service, 9.1 percent were for alarm

activation, 7.6 percent were for service, 6.6 percent for good intent/special incidents, 2.6 percent were for fire, 1.0 percent were for hazardous materials, and 0.1 percent were for technical rescue (Santa Clara 2022a). Based on the city's 2021 estimated population and the department's current fire personnel roster, the department's staffing ratio is 1.2 fire personnel for every 1,000 residents.

Police Protection

Police protection would be provided by the Santa Clara Police Department (SCPD). SCPD has two police stations. The police headquarters, located approximately one mile south, is the closest station to the project site.

The SCPD's standard for the response time for high priority calls is three minutes or less (Santa Clara 2010, section 5.9.3). Response times to the proposed project would approximate three minutes since it is located within an existing service area. In 2021, there were 61,421 calls for service and the department's average response time for priority 1 calls was approximately 2.59 minutes (from dispatch to first officer arrival). Police staff includes 153 sworn officers and 79 civilian professionals. As of 2021, there were 1.1 officers for every 1,000 residents. (Santa Clara 2022b)

Schools

The project would be located within the Santa Clara Unified School District. The district covers a 56 square mile area and serves neighborhoods in the cities of Santa Clara, Sunnyvale, San Jose, and Cupertino (SCUSD 2023a). The Santa Clara Unified School District had an enrollment of 14,028 students in the 2021/2022 school year (CDE 2022). Santa Clara Unified School District facilities include: two alternative schools, one community day school, four high schools, four middle schools, 17 elementary schools, and one K-8 school (SCUSD 2023b). The nearest schools to the project site are the Granada Islamic (private), approximately one mile northwest of the project and the Scott Lane Elementary (public), approximately 0.8 miles southwest of the project.

Parks

The city of Santa Clara has 350 total park acres, made up of improved and unimproved acreage. Included in the park and recreation areas are community parks, mini/pocket parks, neighborhood parks, public open space, recreation facilities, recreational trails, and joint use facilities (Santa Clara 2019). The city of Santa Clara has a parkland dedication/in lieu standard based on the city's existing ratio of developed park acreage per 1,000 residents (Santa Clara 2019). The service population used to estimate the existing service standard for parks in the current development impact fee update study (August 2019) is 126,408 residents (Santa Clara 2019). With a combined total of 328 acres¹, Santa Clara has approximately 2.6 acres per 1,000 residents and meets its park standards (Santa Clara 2019, pg. 19).

¹ Total acres of improved and unimproved parkland that meets the Mitigation Fee Act Standard

The closest parks are Rotary Park located 0.8 miles southwest of the project site and Larry J Marsalli Park located 0.9 miles south of the project site. Rotary Park has a small children's tot lot with a picnic area. Larry J Marsalli Park is a seven-acre park with a picnic area, restrooms, softball field, and play area. The parks are maintained by the City of Santa Clara (Santa Clara 2023c).

Other Public Facilities

The Santa Clara City Library has three branches to serve the city of Santa Clara. The closest library to the project site is the Northside Branch Library, which is approximately 2 miles to the north (Santa Clara 2023d).

Regulatory Background

No regulations related to public services apply to the project.

4.15.2 Environmental Impacts

Would the project result in substantial adverse physical impacts associated with the provision of new or physically altered governmental facilities, need for new or physically altered governmental facilities, the construction of which could cause significant environmental impacts, in order to maintain acceptable service ratios, response times, or other performance objectives for any of the public services:

a. Fire protection?

Construction

No Impact. The project site is currently developed with four single-story office buildings and is already serviced by fire protection services. The project site is in an industrial area surrounded by commercial and industrial land uses.

Project construction activities that could pose a risk for fire or the need for fire protection response due to heated exhaust or sparks, include the use of cranes, excavation equipment, vehicles, and bulldozers. Other construction activities with a potential fire risk due to heat sources or open flames could include the use of torches or welding equipment.

The standard for response to structure fire calls for the first unit to arrive is under 6 minutes from dispatch of alarm, 90 percent of the time. Current data show the SCFD arrived in 4 minutes and 50 seconds or less, 90 percent of the time. The SCFD standard for an effective firefighting force (17 personnel) on scene is less than 10 minutes from dispatch of alarm, 90 percent of the time for structure fire calls. SCFD arrived in 9 minutes and 14 seconds, 90 percent of the time, according to current data. For emergency medical calls, the standard for an advanced life support fire company is to arrive in under eight

minutes from dispatch of the alarm, 90 percent of the time. Current data shows that SCFD arrived in six minutes and seven seconds or less, 90 percent of the time (Santa Clara 2022a).

Emergency response time to the project would be consistent with approximately six minutes, since it is located within an existing service area. While there may be a slight increased need for fire protection response during project construction, these effects would not be sufficient to induce the construction of new or physically altered governmental facilities that could result in significant environmental impacts; therefore, there would be no impact.

Operation

No Impact. The project would employ 19 to 21 operations workers and have 10 to 14 daily tenants or visitors. The applicant estimates the workers would be hired locally from the greater Bay Area (DayZenLLC 2022a). Based on the proximity of the supply of operations workers, they are not likely to relocate closer to the project. The few operations employees that may move into the city and within the service area would have a negligible effect on the ability of the fire stations that serve the project site to meet their emergency service and response standards.

Each of the 44 generator units backing up the data center activities would have a diesel fuel storage tank, equipped with double-walled diesel tanks incorporating leak detection systems (DayZenLLC 2022a, pg. 2-14). The project would complete a Hazardous Materials Business Plan for the safe storage and use of chemicals onsite (see **Section 4.9 Hazards and Hazardous Materials**). A compartmentalized truck would deliver diesel fuel on as-needed basis. An emergency pump shut-off is activated in the event a pump hose breaks during refueling (DayZenLLC 2022a, pg. 2-13). SCFD would review the project plans to ensure appropriate safety features are incorporated to reduce fire hazards (DayZenLLC 2022a, pg. 4-141). With all the above safe storage and handling elements, there would be no impact to the fire protection services.

b. Police Protection?

Construction

No Impact. The construction workforce is not expected to relocate closer to the project site and would not increase the demand for emergency response services, including police protection. Construction of the project would include concrete wall and chain link fence for the substation (DayZenLLC 2022a, pg. 2-16), and outdoor security lighting would be installed along the data center building and driveway entrances (DayZenLLC 2022a, pg. 4-8). As noted in the "Setting" subsection above, SCPD meets their response goals. The response goals for the police department would not be significantly affected by the project nor would the project induce construction of new or physically altered governmental facilities, such as police stations that could result in significant environmental impacts; therefore, there would be impact.

Operation

No Impact. Operation of the project would have a negligible effect on the emergency response times of the stations that serve the project site and vicinity. The project site is currently developed with four pre-existing buildings that are already served by the SCPD. As described in the construction analysis above, the project would employ outdoor security lighting along the Martin Data Center building and driveway entrances and fencing to deter criminal activity during operation as protection for the substation. (DayZenLLC 2022, pg. 2-16, 4-8). Additionally, SCPD would review the final site design during local agency approval of the project, including proposed landscaping, access, and lighting, to ensure the project provides adequate safety and security measures (DayZenLLC 2022a, pg. 4-141). The project would not result in substantial adverse physical environmental impacts associated with the provision of new or physically altered police service facilities to maintain acceptable service ratios, response times, or other performance objectives; therefore, there would be no impact.

c. Schools?

Construction and Operation

No Impact. The project would be in the Santa Clara Unified School District. District Board Policy (BP 7211 Facilities: Developer Fees) allows the Board of Trustees to establish, levy, and collect developer fees on residential, commercial, and industrial construction within the district. Government Code section 65995 expressly provides that “[t]he payment or satisfaction of a fee, charge, or other requirement levied or imposed pursuant to Section 17620 of the Education Code in the amount specified in Section 65995... are hereby deemed to be full and complete mitigation of the impacts of any legislative or adjudicative act, or both, involving but not limited to, the planning, use, or development of real property, or any change in governmental organization... on the provision of adequate school facilities.” The current school impact fee for the district is \$0.78 per square foot of covered, enclosed commercial/industrial space (SCUSD 2022). Based on the proposed size of the building (467,200 square feet), an estimated \$364,416 would be assessed. These fees would be collected at the time the applicant applies for building permits from the city of Santa Clara; therefore, there would be no impact.

d. Parks?

Construction

No Impact. As identified in the “Setting” subsection, the city is currently meeting its park standards with a ratio of 2.6 acres per 1,000 residents. Construction of the project would require an average of 100 workers and a peak of 190 workers during Phase I. During Phase II, the project would require an average of 60 workers and a peak of 100 workers (DayZenLLC 2022a). The construction workforce would be drawn from the greater Bay Area, which would not require an influx of new workers (see **Section 4.14 Population and Housing**). Construction workers may visit park facilities before, during, or after the workday but this use would be temporary and cease at the end of project construction.

Construction of the project would not affect park standards or increase the demand for park facilities. The project construction would have no impact on parks or park facilities.

Operation

No Impact. The project would employ 19 to 21 operations workers. Like the project construction workforce, operations employees would be drawn from the greater Bay Area and are not likely to relocate closer to the project. If some operations workers were to visit local parks it would have a negligible increase on the usage of or demand for parks or other recreational facilities. Therefore, the project would not result in substantial adverse physical environmental impacts associated with the provision of new or physically altered park facilities to maintain acceptable service ratios or other performance objectives and there would be no impact.

e. Other Public Facilities?

Construction

No Impact. The project construction workforce would be drawn from the greater Bay Area and workers would not likely relocate closer to the project site. If construction workers were to visit public facilities in the vicinity of the project, the use would be temporary and cease at the end of construction. Therefore, there would be no impact on public facilities during project construction.

Operation

No Impact. The project's 19 to 21 operations employees would be drawn from the greater Bay Area and are not expected to relocate closer to the project site. If employees were to visit local public facilities, it would have a negligible increase in the usage of or demand for the surrounding libraries or public facilities. Therefore, the project's operations no impact on public facilities.

4.15.3 Mitigation Measures

None required.

4.15.4 References

CDE 2022 – California Department of Education (CDE). California Department of Education Educational Demographics Unit, Data Quest, Select District Level Data for the year 2021 - 2022, Enrollment by Ethnicity and Grade, Santa Clara Unified Report (43-69674). Available online at:
<https://dq.cde.ca.gov/dataquest/dqcensus/EnrEthGrd.aspx?cds=4369674&agglevel=district&year=2021-22>

DayZenLLC 2022a – DayZenLLC (DayZenLLC). (TN 247325). MBGF SPPE Application – Part I – Main App and Appendix A, dated November 7, 2022. Available online at:
<https://efiling.energy.ca.gov/Lists/DocketLog.aspx?docketnumber=22-SPPE-03>

- Santa Clara 2010 – City of Santa Clara (Santa Clara). City of Santa Clara General Plan Celebrating Our Past, Present and Future. Adopted November 16, 2010. Available online at:
<https://www.santaclaraca.gov/home/showpublisheddocument/56139/636619791319700000>
- Santa Clara 2019 – City of Santa Clara (Santa Clara). City of Santa Clara Park and Recreation Facilities Development Impact Fee Update Study. Approved August 27, 2019. Prepared by: Willdan Financial Services. Available online at:
<https://www.santaclaraca.gov/home/showpublisheddocument/72443/637523451515170000>
- Santa Clara 2022a – City of Santa Clara (Santa Clara). City of Santa Clara Fire Department Annual Report 2022. Accessed on: February 2023. Available online at:
<https://www.santaclaraca.gov/home/showpublisheddocument/79529/638122459641170000>
- Santa Clara 2022b – City of Santa Clara (Santa Clara). Santa Clara Police Department Website – Fact Sheet. February 14, 2022. Accessed on: January 2023. Available online at: <https://www.santaclaraca.gov/our-city/departments-g-z/police-department/about-us/fact-sheet>
- Santa Clara 2023a – City of Santa Clara (Santa Clara). Santa Clara Fire Department Website – About Us. Accessed on: January 2023. Available online at:
<https://www.santaclaraca.gov/our-city/departments-a-f/fire-department/about-us>
- Santa Clara 2023b – City of Santa Clara (Santa Clara). Santa Clara Fire Department Website - City of Santa Clara: Public Safety. Accessed on: January 2023. Available online at:
<http://missioncity.maps.arcgis.com/apps/MapTour/index.html?appid=15779cefd9bc463d8bc6229b61d921d5>
- Santa Clara 2023c – City of Santa Clara (Santa Clara). Parks and Recreation Department, Parks. Accessed on: January 2023. Available online at:
<http://missioncity.maps.arcgis.com/apps/MapTour/index.html?appid=4c84d4f8913541cebd8a8ef3fc31a326&>
- Santa Clara 2023d – City of Santa Clara City (Santa Clara). Santa Clara City Library Website- About the Library. Accessed on: January 2023. Available online at:
<https://www.sclibrary.org/about-us/locations-and-hours/northside-branch-library>
- SCUSD 2022 – Santa Clara Unified School District (SCUSD). Santa Clara Unified School District Developer Fee. Approved on April 7, 2022 and effective June 6, 2022. Accessed on: January 2023. Available online at:
<https://www.santaclarausd.org/Page/53>

SCUSD 2023a – Santa Clara Unified School District (SCUSD). Santa Clara Unified School District, About Us. Accessed on: January 2023. Available online at:
<https://www.santaclarausd.org/domain/15>

SCUSD 2023b – Santa Clara Unified School District (SCUSD). Santa Clara Unified School District, School Directory. Accessed on: January 2023. Available online at:
<https://www.santaclarausd.org/site/Default.aspx?PageType=1&SiteID=8&ChannelID=44&DirectoryType=6>

4.16 Recreation

This section describes the environmental and regulatory setting and discusses impacts specific to recreation associated with the construction and operation of the project.

RECREATION	Potentially Significant Impact	Less Than Significant with Mitigation Incorporated	Less Than Significant Impact	No Impact
a. Would the project increase the use of existing neighborhood and regional parks or other recreational facilities such that substantial physical deterioration of the facility would occur or be accelerated?	<input type="checkbox"/>	<input type="checkbox"/>	<input checked="" type="checkbox"/>	<input type="checkbox"/>
b. Does the project include recreational facilities or require the construction or expansion of recreational facilities which might have an adverse physical effect on the environment?	<input type="checkbox"/>	<input type="checkbox"/>	<input checked="" type="checkbox"/>	<input type="checkbox"/>

Environmental checklist established by CEQA Guidelines, Appendix G.

4.16.1 Environmental Setting

The project is proposed in the city of Santa Clara in Santa Clara County. The project would construct a four-story, approximately 467,200 square foot data center building, generator equipment yard, surface parking, and landscaping. A substation owned and operated by Silicon Valley Power would also be constructed on the project site.

While nearby cities include the cities of Campbell, Cupertino, Milpitas, San Jose, and Sunnyvale, staff considers the city of Santa Clara as the project study area for recreation impacts. This is consistent with staff's experience that local workers are not likely to relocate temporarily or permanently closer to the project site (see **Section 4.14 Population and Housing**) and thus, not add new users to the city's recreation facilities.

Recreation Facilities

The city of Santa Clara has 2 community parks, 6 mini parks, 26 neighborhood parks, 3 open space parks, 5 recreational facilities, 4 trail reaches, and 11 joint use facilities for a total of approximately 255 acres of developed parks, not including city golf courses and 98 acres of undeveloped parks (Santa Clara 2019, pages 6-8). The closest recreational resources are Rotary Park located 0.8 miles southwest of the project site and Larry J Marsalli Park located 0.9 miles south of the project site. Rotary Park has a small children's tot lot with a picnic area. Larry J Marsalli Park is a seven-acre park with a picnic area, restrooms, softball field, and play area. The parks are maintained by the city of Santa Clara (Santa Clara 2023).

Regulatory Background

No regulations related to recreation apply to the project.

4.16.2 Environmental Impacts

a. Would the project increase the use of existing neighborhood and regional parks or other recreational facilities such that substantial physical deterioration of the facility would occur or be accelerated?

Construction

No Impact. The project would require an average of 100 workers per month and a maximum of 190 workers per month during the peak construction period of Phase I. During Phase II, the project would require an average of 60 workers per month and a maximum of 100 workers per month during the peak construction period. The applicant estimates that the construction workforce would be recruited from the greater Bay Area and would likely be drawn from the San Jose-Sunnyvale-Santa Clara region¹. Based on the proximity of the available workforce to the project, construction workers from neighboring cities and counties are not likely to temporarily relocate closer to the project site or visit the nearby parks. Thus, the project would not increase the use of or accelerate the physical deterioration of parks or other recreational facilities. Therefore, the project would have no impact on the surrounding parks and recreational facilities.

Operation

Less Than Significant Impact. The project would require 19 to 21 permanent operations employees with approximately 10 to 14 tenant employees or visitors daily. Permanent employees would be drawn from the greater Bay Area (see **Section 4.14 Population and Housing**). Based on the proximity of the supply of permanent employees, they are not likely to relocate closer to the project. Permanent employees may use parks or recreational facilities near the project site before, during, or after the workday but this would not cause or accelerate substantial physical deterioration of the existing parks or facilities. The impact on surrounding parks and recreational facilities would be less than significant.

b. Does the project include recreational facilities or require the construction or expansion of recreational facilities, which might have an adverse physical effect on the environment?

Construction

No Impact. Recreational facilities are not included as part of the project, nor would the project require the construction or expansion of recreational facilities. The construction

¹ Region in this instance is the Metropolitan Statistical Area. A Metropolitan Statistical Area is a geographical region with a relatively high population density at its core and close economic ties throughout the area.

needs of the project would be supplied by the existing workforce from the greater Bay Area and would not require an influx of new workers. If any construction workers were to visit park facilities, this use would be temporary and cease at the end of the project. Therefore, the project would have no impact on recreational facilities.

Operation

Less Than Significant Impact. The project would have a small permanent operational workforce of 19 to 21 employees drawn from the greater Bay Area. This small workforce would not create a demand for recreational facilities that would require the construction or expansion of recreational facilities. Therefore, the project would have a less than significant impact on recreational facilities and would not require the construction or expansion of recreational facilities to accommodate the project.

4.16.3 Mitigation Measure

None required.

4.16.4 References

- Santa Clara 2019 – City of Santa Clara (Santa Clara). City of Santa Clara Park and Recreation. Facilities Development Impact Fee Update Study – Administrative Draft, approved August 27, 2019, prepared by Willdan Financial Services. Available online at:
<https://www.santaclaraca.gov/home/showpublisheddocument/72443/637523451515170000>
- Santa Clara 2023 – City of Santa Clara (Santa Clara). Parks and Recreation Department, Parks. Accessed on: January 2023. Available online at:
<http://missioncity.maps.arcgis.com/apps/MapTour/index.html?appid=4c84d4f8913541cebd8a8ef3fc31a326&>

4.17 Transportation

This section describes the environmental setting, regulatory background, and impacts associated with the construction and operation of the project with respect to transportation.

TRANSPORTATION		Potentially Significant Impact	Less Than Significant with Mitigation Incorporated	Less Than Significant Impact	No Impact
Would the project:					
a. Conflict with a program, plan, ordinance, or policy addressing the circulation system, including transit, roadway, bicycle, and pedestrian facilities?	<input type="checkbox"/>	<input type="checkbox"/>	<input checked="" type="checkbox"/>	<input type="checkbox"/>	<input type="checkbox"/>
b. Conflict or be inconsistent with CEQA Guidelines section 15064.3, subdivision (b)?	<input type="checkbox"/>	<input checked="" type="checkbox"/>	<input type="checkbox"/>	<input type="checkbox"/>	<input type="checkbox"/>
c. Substantially increase hazards due to a geometric design feature (e.g., sharp curves or dangerous intersections) or incompatible uses (e.g., farm equipment)?	<input type="checkbox"/>	<input type="checkbox"/>	<input checked="" type="checkbox"/>	<input type="checkbox"/>	<input type="checkbox"/>
d. Result in inadequate emergency access?	<input type="checkbox"/>	<input type="checkbox"/>	<input checked="" type="checkbox"/>	<input type="checkbox"/>	<input type="checkbox"/>

Environmental checklist established by CEQA Guidelines, Appendix G.

4.17.1 Environmental Setting

The 7.17-acre project site is at 651 Martin Avenue in Santa Clara, California. The project would consist of construction of a four-story, approximately 468,175 square-foot data center building, utility substation, generator equipment yard, surface parking and landscaping, and a recycled water pipeline extension (DayZenLLC 2022a, DayZenLLC 2023b). The data center building would be approximately 87.5 feet in height to the top of the parapet, while the mechanical equipment screen on the roof the building would extend to a height of 102.25 feet, and the elevator parapet to a height of 119.66 feet. The site is currently developed with an approximately 35,800 square-foot single-story airport parking facility, 41,400 square-foot single-story automobile care center, and paved surface parking which would all be demolished as part of the project.

The project would include three driveway entrances from Martin Avenue located (1) at the southwest corner of the site, (2) 250 feet east of the southwest corner, and (3) at the southeast corner of the site. The site currently has two entrances from Martin Avenue in the same general areas as two of the three proposed entrances. The project would provide a total of 84 parking spaces on site including 1 accessible and 1 van accessible parking space (DayZenLLC 2022a, DayZenLLC 2023b).

Numerous freeways, including U.S. Highway 101 (US-101) and Interstates 237, 280, 680 and 880, provide regional access to the Santa Clara area. Local access to the project area

is provided by the Central Expressway, San Tomas Expressway, Lafayette Street, and De La Cruz Boulevard, the latter of which connects directly to US-101 approximately one mile north of the project site. Lafayette Street and De La Cruz Boulevard connect to Martin Avenue, which provides direct access to the project site.

Transportation infrastructure on Martin Avenue between Lafayette Street and De La Cruz Boulevard is limited to two travel lanes in each direction with pedestrian sidewalks on the north side of the street west of the project site, and along the majority of the south side of the street (with some gaps to the east of the project site). Because Martin Avenue is a short collector road serving the various industrial and commercial uses that are located along this segment, there are no designated bicycle lanes (VTA 2020).

Public transit service to the project area includes regional rail (provided by Caltrain) and local light rail and local bus transport (provided by the Santa Clara Valley Transportation Agency [VTA]). The nearest transit hub to the project is the Caltrain Santa Clara Transit Center, located approximately 1.6 miles south of the project site on Railroad Avenue, one block northeast of El Camino Real. The Santa Clara Transit Center is part of the regional Caltrain commuter rail system and is one of 32 stations serving the San Francisco Peninsula. From Santa Clara Transit Center, the Caltrain regional rail connects to the VTA local light rail system at the San Jose Diridon Station, which is in downtown San Jose approximately 3 miles southeast of the Santa Clara Station. The San Jose Diridon Station is served by the VTA Green light rail line, Amtrak, and the ACE Train (VTA 2023).

The Santa Clara Transit Center is served by VTA local Bus Routes 21, 53 and 59, frequent Bus Routes 22 and 60, and rapid Bus Route 522. The VTA Bus Route 59 stops at Scott Street and Martin Avenue, which is the closest bus stop to the project site (VTA 2023). From this stop, the project site is approximately 0.7 miles to the east. Alternate access is provided by bus Route 22 and Route 59 which connect one mile south at Lafayette Street and El Camino Real (VTA 2023). Direct public transit access is not available to the project site.

The Santa Clara Transit Center is also the planned terminus for the VTA's extension of the Bay Area Rapid Transit (BART) system from the Berryessa/North San Jose BART Station. The six-mile-long BART extension, known as BART Silicon Valley Phase II, is due to be completed in 2030 and would enhance regional transit connections to the project area (VTA 2019).

The closest airport to the project site is the San José Mineta International Airport, with the nearest runway located approximately 0.4 miles east of the nearest lot line of the project site.

Regulatory Background

Federal

Code of Federal Regulations (14 CFR §77.9). Under federal law, 14 CFR § 77.9(a), notification is required to be sent to the Federal Aviation Administration (FAA) for any construction or alterations exceeding 200 feet above ground level (AGL) (CFR 2023a). If a project's height, including any temporary equipment (such as cranes used during construction) or any ancillary structures (such as transmission poles or roof spires), exceeds 200 feet AGL, the project applicant must submit a copy of FAA Form 7460-1, Notice of Proposed Construction or Alteration, to the FAA. The FAA then reviews the project to determine any potential hazards to navigable airspace.

The more applicable, and more restrictive, regulation for this project is 14 CFR § 77.9(b). This more restrictive regulation states that where a project is located within a horizontal distance of 20,000 feet from a public or military airport where at least one runway is more than 3,200 feet in length, the FAA must be notified of any construction or alteration of greater height than an imaginary surface extending outward and upward at a slope of 100 to 1 from the nearest point of the nearest runway (CFR 2023a). Because San José Mineta International Airport has a runway, Runway 12/30, exceeding this length, and because the edge of the project site is located approximately 2,160 feet east of the closest part of this runway, 14 CFR § 77.9(b) requires FAA notification for any proposed temporary or permanent features on the project site that exceed 21.6 feet in height AGL.

Code of Federal Regulations (14 CFR § 91.119 et. seq). Under federal law, 14 CFR § 91.119(b), unless necessary for takeoff or landing, no person may operate an aircraft over any congested area of a city, town, or settlement, or over any open-air assembly of persons, below an altitude of 1,000 feet above the highest obstacle within a horizontal radius of 2,000 feet of the aircraft.

State

California Department of Transportation. Project construction activities that require the movement of oversized or excessive load vehicles on state roadways require a transportation permit issued by the California Department of Transportation under Vehicle Code, section 35780 (Caltrans 1992).

Local

City of Santa Clara 2021-2035 General Plan. The City of Santa Clara 2010-2035 General Plan (General Plan) includes policies for the purpose of avoiding or mitigating impacts resulting from planned development projects within the city. While a number of General Plan policies pertain to city efforts to enhance the overall multimodal transportation system, the following policies are specific to new development and are assumed applicable to the proposed project (Santa Clara 2010):

- **Policy 5.8.3-P8:** Require new development to include transit stop amenities, such as pedestrian pathways to stops, benches, traveler information and shelters.

- **Policy 5.8.3-P9:** Require new development to incorporate reduced onsite parking and provide enhanced amenities, such as pedestrian links, benches and lighting, in order to encourage transit use and increase access to transit services.
- **Policy 5.8.3-P10:** Require new development to participate in public/private partnerships to provide new transit options between Santa Clara residences and businesses.
- **Policy 5.8.4-P6:** Require new development to connect individual sites with existing and planned bicycle and pedestrian facilities, as well as with on-site and neighborhood amenities/services, to promote alternate modes of transportation.
- **Policy 5.8.4-P7:** Require new development to provide sidewalks, street trees and lighting on both sides of all streets in accordance with city standards, including new developments in employment areas.
- **Policy 5.8.4-P8:** Require new development and public facilities to provide improvements, such as sidewalks, landscaping and bicycling facilities, to promote pedestrian and bicycle use.
- **Policy 5.8.5-P1:** Require new development and city employees to implement transportation demand management programs that can include site-design measures, including preferred carpool and vanpool parking, enhanced pedestrian access, bicycle storage and recreational facilities.
- **Policy 5.8.5-P2:** Require development to offer on-site services, such as ATMs, dry cleaning, exercise rooms, cafeterias, and concierge services, to reduce daytime trips.
- **Policy 5.8.5-P3:** Encourage all new development to provide on-site bicycle facilities and pedestrian circulation.
- **Policy 5.8.5-P4:** Encourage new development to participate in shuttle programs to access local transit services within the city, including buses, light rail, Bay Area Rapid Transit, Caltrain, Altamont Commuter Express Yellow Shuttle and Lawrence Caltrain Bowers/Walsh Shuttle services.

City of Santa Clara, Bicycle Master Plan Update 2018. The City of Santa Clara adopted an update to its Bicycle Master Plan in June 2019 which establishes a long-term vision for improving bicycling in Santa Clara through policy, program, and project recommendations. This plan includes a series of high-priority recommended facility improvements including the following bikeways in the vicinity of the project site (Santa Clara 2018):

- A Class IV separated bikeway along Martin Avenue, between De La Cruz Boulevard and Lafayette Street.
- A Class IV separated bikeway along De La Cruz Boulevard, between the Central Expressway and Coleman Avenue.
- A Class IV separated bikeway along Lafayette Boulevard, between Laurelwood Road and Warburton Avenue.

Project improvements along the project's Martin Avenue frontage should anticipate and not preclude these planned bikeways.

City of Santa Clara, Transportation Analysis Policy. The City of Santa Clara approved their Transportation Analysis Policy on June 23, 2020. This policy establishes requirements for evaluating transportation impacts under the California Environmental Quality Act (CEQA) using the Vehicle Miles Traveled (VMT) methodology. The policy includes VMT baselines, thresholds, and criteria for exempting certain types of land use projects from VMT analysis. The policy also formalizes Transportation Operational Analysis (TOA) requirements that occur outside of CEQA.

With respect to VMT analyses under CEQA, the Transportation Analysis Policy establishes the following requirements that are applicable to the proposed project (Santa Clara 2020):

- Evaluating VMT. To evaluate whether a project will have a significant impact under CEQA, the City policy states that industrial use projects will have a less than significant impact if they result in a 15 percent VMT reduction compared to the existing Countywide VMT per employee. Additionally, the policy states that per State guidance, small projects (generating 110 daily trips or less) are presumed to have a less than significant impact and do not require a VMT analysis.

Projects that do not meet the above VMT threshold and/or small project requirement are required to evaluate and disclose potential VMT environmental impacts with the established threshold criteria outlined in the City's Transportation Analysis Policy.

Santa Clara County Airport Land Use Commission's Comprehensive Land Use Plan for San José Mineta International Airport. The project site is located within the San Jose Mineta International Airport's Area of Influence, as identified in the Santa Clara County Comprehensive Land Use Plan (CLUP) for the airport (Santa Clara County 2016). Figure 6 of the CLUP identifies the Federal Aviation Regulations (FAR) Part 77 Surfaces for the San José Mineta International Airport (Santa Clara County 2016; CFR 2023b). Any structures exceeding these Part 77 Surfaces could result in the obstruction of airspace and create hazards to aircraft entering or exiting the airport. The Part 77 Surface at the project site is 212 feet above mean sea level (AMSL), meaning that any structures at the project site exceeding 212 feet AMSL could pose a safety hazard (Santa Clara County 2016). The finished floor elevation of the data center building pad would be approximately 46 feet AMSL (DayZenLLC 2022a). Therefore, according to Figure 6 of the CLUP, any structure greater than 166 feet in height AGL may pose a safety hazard.

4.17.2 Environmental Impacts

a. Conflict with a program, plan, ordinance or policy addressing the circulation system, including transit, roadway, bicycle and pedestrian facilities?

Construction

Less Than Significant Impact. Construction of the project would not significantly obstruct any transit, roadway, bicycle, or pedestrian facilities in the area. Construction activities would occur mostly onsite and not in the public right-of-way, with the exception of extending an existing recycled water line from its location on the east side of the Union Pacific Railroad (UPRR) tracks 100 feet east of the project site to the site for secondary water needs. Detailed plans for the temporary construction associated with connecting the project site to the existing buried recycled water line are not yet available, but final design will include a construction plan to comply with local ordinances. While this construction is expected to require temporary lane blockages/closures on Martin Avenue during daytime hours, it would not interfere with a designated bike lane or transit route, as none exist on the affected portion of Martin Avenue. Furthermore, Martin Avenue has two travel lanes in each direction, four total, which could accommodate the closure of two lanes while still maintaining an open lane for eastbound and westbound travel. Project construction would not otherwise temporarily or permanently alter any public roadways or intersections.

The City of Santa Clara, as the permitting agency, would ensure the project applicant obtains the proper encroachment permit to minimize disruption to Walsh Avenue during construction. Furthermore, the city would require the applicant to obtain any required permits from Caltrans for the movement of oversized or excessive load vehicles on state roadways prior to construction to reduce effects on the state transportation network. The permitting process ensures that all applicable requirements are complied with. Therefore, the construction of the project would not conflict with any program, plan, ordinance, or policy addressing the circulation system, including transit, roadway, bicycle, and pedestrian facilities, and would, therefore, have less than significant impacts.

Operation

Less Than Significant Impact. The segment of Martin Avenue onto which the project site directly fronts contains a sidewalk on the south side of the street, but does not contain any other pedestrian, bicycle, or public transit facilities. As noted in subsection 4.17.1 Environmental Setting, however, a future bikeway facility is planned for Martin Avenue. Operation of the project would not obstruct existing pedestrian, bike, or transit facilities or the future planned bikeway.

As noted in subsection 4.17.1, the City of Santa Clara Bicycle Master Plan Update 2018 recommends a Class IV separated bikeway be installed on Martin Avenue, between De La Cruz Boulevard and Lafayette Boulevard (Santa Clara 2018). At this time, a final design

for the bikeway is not available; however, implementation of a Class IV facility would narrow the width along Martin Avenue available for truck turning movements. A revised project site plan and accompanying truck turning movements show that trucks exiting the project site, turning both left (eastbound) and right (westbound), would not encroach on the existing parking lane along the north and south sides of Martin Avenue (DayZenLLC 2023). The revised turning movements would also be compatible with a future planned separated bikeway assuming replacement of the northerly parking lane with a 10-foot-wide separated bikeway (including buffer).

The City of Santa Clara, as the permitting agency, would determine any transportation demand management (TDM) activities or conditions of approval necessary for the project to be consistent with General Plan Policies 5.8.3-P8, 5.8.3-P9, 5.8.3-P10, 5.8.4-P6, 5.8.4-P7, 5.8.4-P8, 5.8.5-P1, 5.8.5-P2, 5.8.5-P3, and 5.8.5-P4 (discussed under the "Regulatory Background" heading of this section). These policies are intended to improve multimodal accessibility between land uses and to facilitate the use of non-vehicular travel. For these reasons, operation of the project would not conflict with any program, plan, ordinance, or policy addressing the circulation system, including transit, roadway, bicycle, and pedestrian facilities, and would, therefore, have less than significant impacts.

b. Conflict or be inconsistent with CEQA Guidelines section 15064.3, subdivision (b)?

CEQA Guidelines section 15064.3, subdivision (b), states that VMT is the most appropriate measure of transportation impacts under CEQA. VMT refers to the amount and distance of automobile travel attributable to a project. Increased VMT exceeding an applicable threshold could constitute a significant impact. If existing models or methods are not available to estimate the VMT for a particular project being considered, a lead agency may analyze the project's VMT qualitatively, evaluating factors such as the availability of transit or proximity to other destinations.

Construction

Less Than Significant Impact. For construction traffic, a qualitative analysis of VMT impacts (instead of a more detailed quantitative analysis) is often appropriate (see CEQA Guidelines section 15064.3, subdivision (b)(3)) (CCR 2023). Project construction would involve a temporary increase in vehicle trips resulting from workers commuting to the project site and the delivery and hauling of project materials.

Demolition, grading, excavation, and construction would take place in two phases. Phase I would include demolition of the existing buildings and infrastructure that cannot be reused, grading of the entire site, installation of utility services including interim power and construction of the on-site substation, and construction of the shell of the building and some of the interior rooms necessary to meet tenant schedules. Phase II activities would include construction of the remaining interior rooms and components of the building as the building is leased to tenants. Phase I is anticipated to begin in May 2024 and take 6 months to complete. Phase II would begin as soon as commercially feasible, anticipated in 2025, and take approximately 11 months to complete.

Phase I would include a construction workforce with a peak number of workers of approximately 190 per day and an average of approximately 100 per day. The Phase II construction workforce is estimated to have a peak number of workers of approximately 100 per day and an average of approximately 60 per day.

Like other recent data center projects, construction workforce daily trip generation was estimated using the daily trip rates for employees at a general light industrial facility. The Institute of Transportation Engineers (ITE) Trip Generation Manual, 11th Edition, provides a trip generation rate for general light industrial land uses (land use code 110) of 3.10 daily one-way trips per employee (ITE 2021).

Phase I project construction is estimated to generate an average of 310 daily one-way construction worker trips and peak of 590 daily one-way construction worker trips. Phase II project construction is estimated to generate an average of 190 daily one-way construction worker trips and peak of 310 daily one-way construction worker trips. Calculations for the project’s construction workforce trip generation estimates are shown in **Table 4.17-1**.

Construction Phase	Anticipated Daily Workforce¹	Rate²	Daily Trips
Phase I, Peak	190	3.10 trips per construction worker	590
Phase I, Average	100		310
Phase II, Peak	100		310
Phase II, Average	60		190

Notes:

1 Anticipated daily workforce numbers based on the MBGF SPPE Application – Part I.

2 ITE Trip Generation land use category (110) Industrial – General Light Industrial, General Urban/Suburban: Daily Trips $T = 3.10 (x)$, where x represents the number of employees.

Source: ITE Trip Generation Manual, 11th Edition; Fehr & Peers, 2023.

Many of the construction worker trips would be expected to occur prior to the morning and evening peak traffic hours in the Santa Clara region, in accordance with typical construction schedules. Truck trips associated with the removal and delivery of equipment and materials would occur throughout the day and would be scheduled for off-peak regional traffic hours whenever possible. Preparation of the site would include grading the entire site. It is possible that up to 12,000 cubic yards of soil would be imported to raise the site. Grading of the site is not expected to require the export of any soil or undocumented fill material. It is estimated that the importation of soil could be transported to the site with an average frequency of about 105 trucks per day (DayZenLLC 2022c). Projects under construction are required to comply with traffic control plan requirements of the City of Santa Clara as noted in the City’s engineering permit specifications (Santa Clara 2023). These plans are designed to minimize disruptions to traffic and conflicts between modes so work in the public right-of-way is done in an expeditious manner and causes as little inconvenience to the traveling public as possible. Further, all public traffic would be permitted to pass through the work areas with the least obstruction and inconvenience and all modes must be allowed to pass at

all times except during an emergency closure. Therefore, construction-related activity would not disrupt existing travel patterns of vehicles, bicyclists, pedestrians, or transit users in a manner that would increase baseline VMT.

Upon the completion of construction, all temporary worker commute trips and truck trips would cease. As such, project-related construction trips would generally be minor and limited to construction equipment and personnel and would not result in long-term trip generation. Further, construction trips would not result in temporary average daily emissions increases that exceed the Bay Area Air Quality Management District (BAAQMD) CEQA threshold or obstruct the implementation of plans and policies related to the reduction of greenhouse gas emissions by reducing VMT. Refer to **Section 4.3 Air Quality** for information related to exhaust emissions during construction. For these reasons, project construction would not conflict or be inconsistent with CEQA Guidelines section 15064.3, subdivision (b).

Operation

Less Than Significant with Mitigation Incorporated. The data center would be operational 24 hours, 7 days a week. **Table 4.17-2** summarizes the anticipated headcount of personnel and visitors that would be on-site throughout a typical day.

TABLE 4.17-2. ANTICIPATED AVERAGE DAILY HEADCOUNT		
Type	Daily Persons	Persons Per Shift
Data Center Operations	14	2-9 ¹
Security	5	2-5 ²
Janitor	2	1-2
Tenant Personnel	10-12	10-12
Visitors	2	2
TOTAL	33-35	17-30

1 Operational staff would work in three shifts: Day Shift (9 employees), Swing Shift (3 employees), and Graveyard Shift (2 employees)

2 There would be 2 security staff stationed at the building and 3 shift rovers that patrol the project building and other nearby Vantage sites.

Source: Kimley-Horn, 2022.

Operation trips would be generated by the 33-35 employees at the building throughout the day, with 17-30 employees in the building at the same time (DayZenLLC 2022c). As previously noted, the project would provide 84 parking spaces which is fewer than the 117 required by City of Santa Clara Municipal Code Section 18.74.020.d.2. The proposed supply would accommodate the parking demand of 17-30 persons per shift, or 33-35 daily persons, by providing a surplus of 54 spaces at times of peak parking usage, conservatively assuming each employee drives alone.

The trip generation was determined based on average rates from the Institute of Transportation Engineers (ITE) Trip Generation Manual, 11th Edition, as shown in **Table 4.17-3**. This manual provides trip rates based on land use. For the project, ITE Land Use 160: Data Center was used, which estimates 0.99 one-way trips would occur for every 1,000 square feet of data center land use. Based on a transportation operational analysis

conducted for the proposed project, it is estimated that the project would generate a total of 464 daily worker one-way trips, including 52 trips occurring in the morning peak hours (7:00–9:00 a.m.) and 42 trips occurring in the afternoon peak hours (4:00–6:00 p.m.). Accounting for trips generated by existing uses, the project is estimated to generate approximately 222 Daily, 17 AM peak period, and 11 PM peak period net new one-way vehicle trips.

Table 4.17-3. PROJECT TRIP GENERATION ESTIMATE

Land Use	Size ¹	Daily ²	AM Peak			PM Peak		
			In	Out	Total	In	Out	Total
Proposed New Uses								
Data Center ³	468.2	464	29	23	52	13	29	42
Existing Uses⁴								
Airport Parking Facility	35.8	242 ⁵	20	15	35	2	29	31
Automobile Care Center	41.4							
Net New Vehicle Trips		222	9	8	17	11	0	11

1. KSF = 1,000 square feet.

2. This Daily total estimate reflects one-way trips.

3. ITE Trip Generation land use category (160) Industrial - Data Center, General Urban/Suburban (Adj Streets, 7-9AM, 4-6PM)

Daily: T = 0.99 (X)

AM Peak Hour: T = 0.11 (X) (55% entering, 45% exiting)

PM Peak Hour: T = 0.09 (X) (30% entering, 70% exiting)

4. Trip generation for existing uses during the AM and PM peak periods are based on actual driveway counts collected at the project site on April 25, 2023, from 8:00-9:00 AM and 5:00-6:00 PM.

5. Daily trips for existing uses were estimated by applying a multiplier to the total PM Peak trips. This multiplier is based on a weighted average (weighted by respective square footage) of each existing use's Daily/PM trip ratio as determined using the ITE Trip Generation Manual.

a. For the Airport Parking Facility we used ITE Trip Generation land use category (110) Industrial - General Light Industrial, General Urban/Suburban (Adj Streets, 7-9AM, 4-6PM)

Daily: T = 4.87 (X)

PM Peak Hour: T = 0.65 (X)

Daily/PM Ratio = 7.57

b. For the Automobile Care Center, ITE does not provide a daily rate for the most applicable land use category: (942) Services - Automotive Care Center. Therefore, the ratio of Daily/PM Peak Hour of Adjacent Street Traffic ratio for a similar land use (943) Services - Automobile Parts and Service Center was used.

Daily: T = 16.6 (X)

PM Peak Hour: T = 2.06 (X)

Daily/PM Ratio = 8.05

Sources: ITE Trip Generation Manual, 11th Edition; Fehr & Peers, 2023.

The VTA in conjunction with Santa Clara County and the cities in the county developed the Santa Clara Countywide VMT Evaluation Tool. This tool allows local government staff, consultants, and new developments to measure VMT for land use projects within Santa Clara County. Based on this tool, the target VMT for the project is 15 percent below the county average, which results in project-related commute trips needing to be no more than 14.1 daily vehicle miles per worker.

Table 4.17-4 shows the VMT analysis conducted for the project. As shown, the project under a normal 5-day workweek schedule would exceed the VMT threshold. However, when the workweek schedule is shifted to a 4-40 (four days a week, 10-hour workdays), the project’s VMT would reduce to below the threshold.

Table 4.17-4. VTA VMT ESTIMATION		
VMT Threshold and Scenario	VMT Per Worker	
Santa Clara County Average VMT	16.6	<i>Exceed 14.1 VMT Threshold?</i>
Project Threshold: 15% Below County Average	14.1	
Estimated Project VMT (5-Day Work Schedule)	15.9	<i>YES</i>
Estimated Project VMT (4-40 Work Schedule)	13.3	<i>NO</i>

Source: Fehr & Peers, 2023.

To meet the target VMT for the project, the applicant has proposed an alternative work schedule for employees reflecting a 4-40 workweek (40 hours in 4 days) so that the project VMT would be below the city’s threshold. This is a Transportation Demand Management (TDM) measure, which is the commitment to a 4-40 work schedule. Staff evaluated the measure in the context of impacts to VMT and concludes that the requirement defined in this TDM measure is sufficient. This TDM measure would reduce the project VMT to 13.3 per employee, causing the project VMT to fall below the city-approved threshold of 14.1. The city requires a TDM annual report, which would allow it to obtain confirmation that the 4-40 work schedule has been complied with. Staff proposes **TRANS-1**, which would require the implementation of a TDM program that incorporates the 4-40 work schedule TDM measure.

Additionally, the City of Santa Clara, as the permitting agency for the project, would ensure project consistency with the General Plan policies related to trip reduction, transit connectivity, and alternative modes of transportation (as provided in Section 4.17.1, Local Regulatory Background). Therefore, with implementation of **TRANS-1**, the project would have a less-than-significant impact on VMT.

c. Substantially increase hazards due to a geometric design feature (e.g., sharp curves or dangerous intersections) or incompatible uses (e.g., farm equipment)?

Construction

Less Than Significant Impact.

Circulation Network: As discussed under question “a” above, project construction would include extending an existing recycled water line from a location 100 feet east of the project site within the UPRR right-of-way to the site for secondary water needs. Detailed plans for this construction activity and related temporary lane blockages or closures on Walsh Avenue are not yet available, but final design will include a construction plan to comply with local ordinances. Project construction would not otherwise temporarily or permanently alter any public roadways or intersections that could result in roadway hazards.

The City of Santa Clara, as the permitting agency, would ensure the project applicant obtains the proper encroachment permit to minimize disruption to Martin Avenue during construction. As part of this permit, the City of Santa Clara may require the applicant to ensure temporary lane closures and traffic control measures occur according to standard guidelines outlined in the Manual on Uniform Traffic Control Devices, the Standard Specifications for Public Works Construction, and the California Joint Utility Traffic Control Manual. Lastly, the City of Santa Clara would require the applicant to obtain any required permits from Caltrans for the movement of oversized or excessive load vehicles on state roadways prior to construction to reduce effects on the state transportation network, as discussed under the "Regulatory Background" heading of this section. These actions would reduce any hazards from construction activities affecting roadways and from transporting materials to and from the site. Therefore, the impact to roadway hazards would be less than significant.

Aviation: As discussed under the "Regulatory Background" heading of this section, under 14 CFR § 77.9, the height threshold for FAA notification is 21.6 feet AGL at the project site (CFR 2023a). Project construction is expected to require equipment that would exceed this height, including the use of a crane for placement of each generator within the generation yard. As a result, the project applicant is required to submit Form 7460-1, Notice of Proposed Construction or Alteration, to the FAA for any construction equipment over 21.6 feet AGL in height. The FAA would then review the project and provide a determination of whether the equipment is a hazard to aviation. (It should be noted that the FAA generally grants a Determination of No Hazard for temporary construction equipment, accompanied by conditions with which the applicant must comply, such as lighting and marking of the equipment for visibility.) The City of Santa Clara, as the permitting agency for the project, would ensure consistency with this requirement and compliance with any of the FAA's conditions. Therefore, project construction would be consistent with 14 CFR § 77.9, ensuring that construction equipment would not result in aviation hazards.

Furthermore, Federal law, 14 CFR § 91.119, states that unless necessary for takeoff or landing, the minimum safe altitude for aircraft is 1,000 feet AGL over congested areas, such as the urban area around the project site (CFR 2023c). Given the northwest-southeast orientation of San José Mineta International Airport runways and minimum safe altitude requirements, aircraft would not be expected to be flying low enough to encounter the project's construction equipment. For this reason and the other reasons discussed above, project construction would result in less than significant hazards to aircraft.

Operation

Less Than Significant Impact.

Circulation Network: The existing curb locations would remain the same as they are currently. The western and eastern driveways on Martin Avenue would remain in approximately the same location though the width of both would increase from 32 feet

and 35 feet, respectively, to 37 feet. An additional 16-foot-wide driveway would be constructed along the project frontage approximately 250 feet east of the western project boundary. Access to the site at all three driveways would be controlled by automatic vehicle gates.

Passenger vehicles may enter or exit the project site via both the west and east driveways; however, security protocols would likely require these vehicles to enter through the security checkpoint located at the east driveway. As these two driveways would be nearly identical to the existing vehicle ingress and egress points of the site, the passenger vehicle turning movements would not increase surface transportation hazards.

Truck turning movements shown on the site plan indicate that trucks needing to access the main Data Hall Building would enter the project site via the west driveway and exit via the east driveway. Meanwhile, use of the middle driveway would be limited to use by trucks entering or exiting the site to serve the SVP substation. Turning movements for trucks exiting the project site, turning both left (eastbound) and right (westbound), indicate these vehicles would clear the existing parking lane along the north and south sides of Martin Avenue as well as the existing railroad crossing gates which are angled slightly toward the roadway. Given the truck turning movement diagrams, it is anticipated that the operation of the project would not increase surface transportation hazards and would be compatible with and not preclude a future planned separated bikeway on Martin Avenue.

Aviation: As discussed earlier, under 14 CFR § 77.9, the height threshold for FAA notification is 21.6 feet AGL at the project site (CFR 2023a). Furthermore, as discussed earlier, Figure 6 of the Santa Clara County Airport Land Use Commission's CLUP for the San José Mineta International Airport indicates that any structure greater than 166 feet AGL may pose a safety hazard at the site, based on 14 CFR § 77.19 (Santa Clara County 2016; CFR 2023b). The highest point of the proposed project structure, the top of the freight elevator parapet, would be approximately 119.66 feet AGL (DayZenLLC 2022a). Based on this peak height, the project would not exceed the FAR Part 77 Surfaces shown in the CLUP for the San José Mineta International Airport. However, the project structures would exceed the FAA's notification threshold of 21.6 feet AGL at the project site, requiring the project applicant to submit Form 7460-1, Notice of Proposed Construction or Alteration, to the FAA. The City of Santa Clara, as the permitting agency for the project, would ensure consistency with this requirement and compliance with any of the FAA's conditions, as discussed previously for the construction equipment. This would ensure that project operation, which includes the permanent structures, would be consistent with FAA requirements and not result in aviation hazards.

The project would include 44 backup emergency diesel generators and 48 roof-mounted air chillers (DayZenLLC 2023c). The project's emergency diesel generators and chillers would discharge thermal plumes, high-velocity columns of hot air, during operation. Thermal plume velocities would be greatest at the discharge points, with plume velocities decreasing with increasing altitude. Plume velocities would also be highest during certain weather conditions, such as cool temperatures and calm winds. High velocity thermal

plumes have the potential to affect aviation safety, and the FAA Aeronautical Information Manual identifies thermal plumes as potential flight hazards (FAA 2022), though it should be noted that while the FAA regulates the height of physical structures, it does not regulate plumes. Aircraft flying through thermal plumes may experience significant air disturbances, such as turbulence and vertical shear. The FAA manual advises that, when able, a pilot should fly upwind of smokestacks and cooling towers to avoid encountering thermal plumes.

CEC staff uses a peak vertical plume velocity of 10.6 meters per second (m/s) (5.3 m/s average plume velocity) as a screening threshold for potential impacts to aviation. Based on a literature search, this velocity generally defines the point at which aircraft begin to experience severe turbulence.

The applicant modeled the plume velocity of the project's backup generators and rooftop chillers to determine whether the project's thermal plumes would exceed 10.6 m/s at altitudes where aircraft would fly. In addition, the applicant provided a supplemental analysis that modeled the San José Mineta International Airport's imaginary surfaces and obstacle clearance surfaces and considered aircraft overflight of the site. The applicant's analysis was independently reviewed and accepted by CEC Air Quality staff. CEC staff calculated that under worst-case weather conditions and calculation methods¹, the vertical velocity of the plumes from the backup generators would not drop below 10.6 m/s until reaching an altitude of 121 feet AGL. The vertical velocity of the plumes from the chillers would not drop below 10.6 m/s until reaching an altitude of 127 feet AGL.

Considering the elevation of the project site is approximately 46 feet AMSL, the chillers would produce a worst-case plume reaching hazardous velocities of 10.6 m/s up to an altitude of 173 feet AMSL over the project site. Therefore, thermal plumes generated by the project would not encroach into the FAA obstruction surface of 212 feet AMSL over the project site (shown in Figure 6 of the CLUP) at a vertical velocity that would have the potential to affect aviation safety.

As noted in the Construction subsection above, 14 CFR § 91.119 states that unless necessary for takeoff or landing, the minimum safe altitude for aircraft is 1,000 feet AGL for congested areas, such as the urban area around the project site (CFR 2023c). Given the northwest-southeast orientation of San José Mineta International Airport runways and minimum safe altitude requirements, aircraft would not be expected to fly so low over the project site as to encounter buildings or operations equipment. The project is also consistent with General Plan policies concerning airport hazards and airspace protection and with CLUP policies, as discussed further in **Sections 5.9 Hazards and Hazardous**

¹ Worst-case weather conditions are based on very calm-wind and neutral atmospheric conditions for the entire vertical extent of the plume, with 100 percent maximum loading, to determine worst-case impacts. It should be noted that the critical vertical velocities identified in the thermal plume analysis are extremely conservative in that these worst-case conditions typically only occur during a few hours each year (DayZen 2023c).

Materials and **5.11 Land Use** of this document. Therefore, the project would result in less than significant hazards to aircraft from operations activity. For this reason and the other reasons discussed above, project operation would result in less than significant hazards to aircraft.

d. Result in inadequate emergency access?

Construction

Less Than Significant Impact. As discussed under Impact 4.17.2a, project construction would include extending an existing recycled water line from 100 feet east of the project site within the UPRR right-of-way to the site for secondary water needs. While this construction is anticipated to require temporary lane blockages or closures on Martin Avenue during daytime hours, as previously noted, final design will include a construction plan to comply with local ordinances. Project construction would not otherwise temporarily or permanently alter any public roadways or intersections that could result in roadway hazards.

The City of Santa Clara, as the permitting agency, would ensure the project applicant obtains the proper encroachment permit to minimize disruption to Martin Avenue during construction. As part of this permit, the City of Santa Clara may require the applicant to ensure temporary lane closures and traffic control measures occur according to standard guidelines outlined in the Manual on Uniform Traffic Control Devices, the Standard Specifications for Public Works Construction, and or the California Joint Utility Traffic Control Manual. This would ensure emergency vehicle travel on Martin Avenue and access to adjacent buildings is not disrupted during the construction of the recycled water line extension. Therefore, the impact would be less than significant.

Operation

Less Than Significant Impact. Emergency access to the site would be provided via the east and west driveways and circulation of the site would be provided via a fire lane around the perimeter of the data center building extending north-south between the data center building and substation. Driveway and drive aisle widths would be equal to or greater than 20-feet-wide which meets the California Fire Code (CFC 2019). According to the fire truck turning movements included in the project site plan, fire trucks would be able to maneuver into and out of the site and circulate throughout the site along the proposed fire lanes.

According to the project application, the Santa Clara Fire Department would review the site development plans to ensure fire protection design features are incorporated and adequate emergency access is provided (DayZenLLC 2022a). The incorporation of changes into the project design requested by the City of Santa Clara Fire Department would ensure proper access and movement of emergency service vehicles throughout the project site (DayZenLLC 2023). Lastly, the City of Santa Clara, as the permitting agency, would ensure the project is consistent with building and zoning code

requirements, ensuring adequate emergency access. Therefore, the impact would be less than significant.

4.17.3 Mitigation Measures

TRANS-1: The project shall implement a Transportation Demand Management (TDM) program sufficient to demonstrate that vehicle miles travelled (VMT) associated with the project would be reduced to 14.1 or less per employee. The TDM program shall include, but is not limited to, the following measure, which has been determined to be a feasible method for achieving the required VMT reduction:

- The operations workforce at the project shall work a 4-40 work schedule (40 hours in 4 days).

Prior to the issuance of an occupancy permit, the TDM program shall be submitted and approved by the Director of Community Development and shall be monitored annually to gauge its effectiveness in meeting the required VMT reduction. The TDM program shall establish an appropriate estimate of initial vehicle trips generated by the occupant of the proposed project and shall include the conducting of driveway traffic counts annually to measure peak-hour entering and exiting vehicle volumes. The volumes shall be compared to trip thresholds established in the TDM program to determine whether the required reduction in vehicle trips is being met. The results of annual vehicle counts shall be reported in writing to the Director of Community Development.

If TDM program monitoring results show that the trip reduction targets are not being met, the TDM program shall be updated to identify replacement and/or additional feasible TDM measures to be implemented. The updated TDM program shall be subject to the same approvals and monitoring requirements listed above.

4.17.4 References

CFR 2023a – Code of Federal Regulations (CFR). Title 14, Section 77.9, Construction or Alteration Requiring Notice. 2023. Accessed on: April 11, 2023. Available online at: <https://ecfr.io/Title-14/Section-77.9>

CFR 2023b – Code of Federal Regulations (CFR). Title 14, Section 77.19, Civil Airport Imaginary Surfaces. 2023. Accessed on July 25, 2023. Available online at: <https://www.ecfr.gov/current/title-14/section-77.19>

CFR 2023c – Code of Federal Regulations (CFR). Title 14, Section 91.119, Minimum Safe Altitudes: General. 2023. Accessed on: May 16, 2023. Available online at: <https://ecfr.io/Title-14/Section-91.119>

Caltrans 1992 – California Vehicle Code (VEH). Division 15, Chapter 5, Article 6, Section 35780, Permits and Agreements. 1992. Accessed on: April 11, 2023. Available online at: https://leginfo.legislature.ca.gov/faces/codes_displaySection.xhtml?lawCode=VEH§ionNum=35780

- CCR 2023 – California Code of Regulations, Title 14, Section 15064.3 - Determining the Significance of Transportation Impacts. 2023. Accessed on April 11, 2023. Available online at:
[https://govt.westlaw.com/calregs/Document/I87B888FD5B4D11EC976B000D3A7C4BC3?viewType=FullText&originationContext=documenttoc&transitionType=CategoryPageItem&contextData=\(sc.Default\)](https://govt.westlaw.com/calregs/Document/I87B888FD5B4D11EC976B000D3A7C4BC3?viewType=FullText&originationContext=documenttoc&transitionType=CategoryPageItem&contextData=(sc.Default))
- CFC 2019 – California Fire Code, Title 24, Part 9, Section 503.2 Fire Apparatus Access Roads - Specification. Accessed on April 13, 2023. Available online at:
<https://codes.iccsafe.org/content/CFC2019P4/chapter-5-fire-service-features>
- DayZenLLC 2022a – DayZenLLC (DayZenLLC). (TN 247325). MBGF SPPE Application - Part I - Main App and Appendix A, dated November 7, 2022. Available online at: <https://efiling.energy.ca.gov/Lists/DocketLog.aspx?docketnumber=22-SPPE-03>
- DayZenLLC 2022b – DayZenLLC (DayZenLLC). (TN 247329). MBGF SPPE Application - Part II – Appendices B D and D, dated November 7, 2022. Available online at: <https://efiling.energy.ca.gov/Lists/DocketLog.aspx?docketnumber=22-SPPE-03>
- DayZenLLC 2022c – DayZenLLC (DayZenLLC). (TN 247326). MBGF SPPE Application - Part V - Appendices F G and H, dated November 7, 2022. Available online at: <https://efiling.energy.ca.gov/Lists/DocketLog.aspx?docketnumber=22-SPPE-03>
- DayZenLLC 2023b – DayZenLLC (DayZenLLC). (TN 250687). Martin Properties Responses to Data Request Set 2 – MBGF, dated June 20, 2023. Available online at: <https://efiling.energy.ca.gov/Lists/DocketLog.aspx?docketnumber=22-SPPE-03>
- DayZenLLC 2023c – DayZenLLC (DayZenLLC). (TN 250723). Martin Properties Supplemental Response to DR 37 – MBGF, dated June 23, 2023. Available online at: <https://efiling.energy.ca.gov/Lists/DocketLog.aspx?docketnumber=22-SPPE-03>
- FAA 2022 – Federal Aviation Administration (FAA). Aeronautical Information Manual, Chapter 7. Safety of Flight, Section 6: Potential Flight Hazards, Subsection 7-6-16: Avoid Flight in the Vicinity of Exhaust Plumes (Smoke Stacks and Cooling Towers), November 3, 2022. Accessed on: December 30, 2022. Available online at:
https://www.faa.gov/air_traffic/publications/atpubs/aim_html/chap7_section_6.html
- ITE 2021 – The Institute of Transportation Engineers. Trip Generation Manual, Eleventh Edition’s trip generation rate. Available for purchase online at:
<https://www.ite.org/technical-resources/topics/trip-and-parking-generation/>
- Santa Clara 2010 – City of Santa Clara. 2010-2035 General Plan, Chapter 5 Goals and Policies. Accessed on April 11, 2023. Available online at:

<https://www.santaclaraca.gov/our-city/departments-a-f/community-development/planning-division/general-plan>

Santa Clara 2018 – City of Santa Clara and Alta Planning + Design. Bicycle Master Plan Update 2018. June 2019. Accessed on April 28, 2023. Available online at: <https://www.santaclaraca.gov/our-city/departments-g-z/public-works/engineering/traffic-engineering/bicycle-master-plan-update-2018>

Santa Clara 2020 – City of Santa Clara. Resolution and Final Transportation Analysis Policy. June 23, 2020. Accessed on April 11, 2023. Available online at: <https://www.santaclaraca.gov/home/showpublisheddocument/71449/637459525139300000>

Santa Clara 2023 – City of Santa Clara. Public Works – Engineering Permits. Accessed on July 20, 2023. Available online at: <https://www.santaclaraca.gov/our-city/departments-g-z/public-works/engineering/permits>

Santa Clara County 2016 – Airport Land Use Commission. Comprehensive Land Use Plan for Norman Y. Mineta San Jose International Airport. November 16, 2016. Accessed on April 11, 2023. Available online at: https://stgenpln.blob.core.windows.net/document/ALUC_SJC_CLUP.pdf

VTA 2019 – Santa Clara Valley Transportation Agency (VTA). VTA's BART Silicon Valley Phase II. 2019. Accessed on May 1, 2023. Available online at: <https://www.vta.org/projects/bart-sv/phase-ii>

VTA 2020 – Santa Clara Valley Transportation Agency (VTA). Bikeways Map. June 2020. Accessed on: April 10, 2023. Available online at: https://www.vta.org/sites/default/files/2023-02/VTA-Bike-Map_5_20-Hi-Res.pdf

VTA 2023 – Santa Clara Valley Transportation Agency (VTA). VTA System Maps, Downtown San Jose Map and Main Map. January 16, 2023. Accessed on April 10, 2023. Available online at: <https://www.vta.org/go/maps>

4.18 Utilities and Service Systems

This section describes the environmental setting and regulatory background and discusses impacts associated with the construction and operation of the project with respect to utilities and service systems.

UTILITIES AND SERVICE SYSTEMS	Potentially Significant Impact	Less Than Significant with Mitigation Incorporated	Less Than Significant Impact	No Impact
Would the project:				
a. Require or result in the relocation or construction of new or expanded water, wastewater treatment or storm water drainage, electric power, natural gas, or telecommunications facilities, the construction or relocation of which could cause significant environmental effects?	<input type="checkbox"/>	<input type="checkbox"/>	<input checked="" type="checkbox"/>	<input type="checkbox"/>
b. Have sufficient water supplies available to serve the project and reasonably foreseeable future development during normal, dry and multiple dry years?	<input type="checkbox"/>	<input type="checkbox"/>	<input checked="" type="checkbox"/>	<input type="checkbox"/>
c. Result in a determination by the wastewater treatment provider which serves or may serve the project that it has inadequate capacity to serve the project's projected demand in addition to the provider's existing commitments?	<input type="checkbox"/>	<input type="checkbox"/>	<input checked="" type="checkbox"/>	<input type="checkbox"/>
d. Generate solid waste in excess of State or local standards, or in excess of the capacity of local infrastructure, or otherwise impair the attainment of solid waste reduction goals?	<input type="checkbox"/>	<input type="checkbox"/>	<input checked="" type="checkbox"/>	<input type="checkbox"/>
e. Comply with federal, state, and local management and reduction statutes and regulations related to solid waste?	<input type="checkbox"/>	<input type="checkbox"/>	<input type="checkbox"/>	<input checked="" type="checkbox"/>

Environmental checklist established by CEQA Guidelines, Appendix G.

4.18.1 Environmental Setting

The proposed Martin Backup Generating Facility (MBGF) would provide 96 MWs of backup emergency power generation for the proposed Martin Data Center (MDC). Both the MBGF and the MDC, the (project) would be at 651 Martin Avenue in Santa Clara, California. Prior to the mid-1950s the site was utilized for agriculture but has been used for industrial purposes since then. This analysis primarily pertains to the MBGF but also considers the potential impacts of the MDC.

Potable Water Supply

Potable water for the proposed project would be provided by the Santa Clara Department of Water and Sewer Utilities which serves over 127,647 customers across an 18.3 square mile area. The City water system consists of more than 335 miles of distribution mains, 26 groundwater wells, and seven storage tanks with approximately 28.8 million gallons

of capacity. Potable water supply for this area is serviced by both imported surface water from the San Francisco Public Utilities Commission (SFPUC) and groundwater locally produced from the Santa Clara Valley Subbasin. The Santa Clara Urban Water Management Plan (UWMP) states that the Santa Clara Valley Subbasin is managed by the Santa Clara Valley Water District (SCVWD), the local Groundwater Sustainability Agency (GSA) (Santa Clara 2021). According to the SCVWD's 2021 Groundwater Management Plan (GWMP), the California Department of Water Resources (DWR) has identified the Santa Clara Valley Subbasin as a medium-priority groundwater basin, and that this subbasin is not in critical overdraft condition (SCVWD 2021).

The applicant proposes to use approximately 1.75 acre-feet (AF) of potable water during two phases of construction over 24 months. Approximately 2 acre-feet per year (AFY) would be used (1 AFY for landscaping) during operations. Potable water use at the site has been 3.2 AFY historically.

According to the UWMP, the city would have a deficit in a multiple dry-year scenario assuming supply from SFPUC would be interrupted. Under this scenario, the city's supply from SFPUC might be suspended if certain conditions specified in the interruptible contract between the city and SFPUC are satisfied (Santa Clara 2021). If the SFPUC water supply is suspended, the city would have to replace the demand using groundwater or water supplied by SCVWD. However, according to the city's UWMP, *Table 7-4A Retail: Multiple Dry Years Supply and Demand Comparison*, Santa Clara would have adequate supplies between 2020 and 2040 during normal, single-dry, and multiple-dry years to serve the proposed project assuming increased groundwater pumping (Santa Clara 2021).

Wastewater Service

The City of Santa Clara Departments of Public Works and Water and Sewer Utilities are responsible for the wastewater collection system. Wastewater is collected by the City's sewer system and is conveyed by pipelines to the San Jose-Santa Clara Regional Wastewater Facility (RWF), formerly known as the San Jose/Santa Clara Water Pollution Control Plant. Located in Alviso, the RWF is owned jointly by San Jose and Santa Clara and is operated by the City of San Jose's Department of Environmental Services. The RWF has the capacity to treat 167 million gallons per day (mgd) of wastewater and currently treats an average of 110 mgd, thus it has 57 mgd or 34 percent of available capacity. RWF's effluent undergoes advanced tertiary treatment to meet Title 22 recycled water standards, after which approximately 20 percent flows to South Bay Water Recycling (SBWR) program adjacent pump station to be distributed to customers in the area. The remaining 80 percent of the tertiary treated water flows into San Francisco Bay (San Jose 2022). The RWF's current Wastewater Discharge Requirements (WDRs) were issued by the San Francisco Regional Water Quality Control Board (RWQCB) in September 2014. Wastewater from the project site enters the city's sanitary system by means of a pipeline along Martin Avenue.

Recycled Water Supply

Recycled water is supplied to the City of Santa Clara through the SBWR program. The SBWR obtains advanced tertiary treated water from the San Jose-Santa Clara RWF. The RWF is located approximately 4.5 miles north of the project site. The State of California Water Code sections 13550 and 13551 include language prohibiting the use of potable water where recycled water can be used, such as cooling, if recycled water is available and economically feasible. A recycled water pipeline is aligned in Martin Avenue approximately 100 feet east of the project site. The applicant proposes to extend the recycled water pipeline to provide service to the project. The project's recycled water demand would be an estimated 0.8 AFY for the adiabatic cooling system on the rooftop air-cooled chillers.

Storm Sewer Service

The project would be constructed in the city of Santa Clara, within the Guadalupe River watershed. The city of Santa Clara owns and maintains the municipal storm drainage system in the vicinity of the project site. The storm drain line serving the project site is a 24-inch storm main along Martin Avenue. Storm water runoff from the project site empties into the city's storm-drain pipeline that discharges into the Guadalupe River which drains to the San Francisco Bay, located approximately 7.8 miles northwest of the proposed project site.

Solid Waste

Solid waste collection in the city of Santa Clara is provided by Mission Trail Waste System (Mission Trail) through a contract with the city. Recycling services are provided by Steven's Creek Disposal and Recycling. All waste is sorted locally at the Newby Island Resource Recovery Park. After sorting, recyclable materials are captured for reuse, diverting them from the landfill, and organic material is taken to a Zero-Waste Energy Development facility, where it is put through an anaerobic digestion process, ultimately producing electricity and compost.

On December 7, 2016, the city of San Jose approved the expansion of the Newby Island Landfill by raising the height of the existing landfill by 95 feet, thereby increasing landfill capacity by 15.12 million cubic yards (San Jose 2016). According to CalRecycle, as of January 31, 2020, Newby Island Landfill is permitted to accept a maximum of 4,000 tons of solid waste per day, has a remaining disposal capacity of 16.4 million cubic yards, and is permitted to operate through 2041 (CalRecycle 2020).

Electric Power, Natural Gas, and Telecommunications

Electricity needed for MDC operation would be provided by Silicon Valley Power (SVP), the City's energy utility. The MDC would include the construction of an on-site switching station to provide 60 kV service built to SVP specifications.

Telecommunication services in the project area are provided by several fiber optics providers, such as CenturyLink, Zayo, AT&T, and others. The applicant anticipates that telecommunication services would be provided to the facility as per industry practice via established rights of way.

PG&E is the owner and provider of natural gas within the city of Santa Clara; however, the proposed project would not utilize natural gas.

Regulatory Background

Federal

Clean Water Act and California's Porter-Cologne Water Quality Control Act.

The State Water Resources Control Board (SWRCB) and its nine RWQCBs are responsible for the regulation and enforcement of the water quality protection requirements of the Federal Clean Water Act (CWA) and the State's Porter-Cologne Water Quality Control Act (Porter-Cologne). The National Pollutant Discharge Elimination System (NPDES) is the permitting program that allows point source dischargers to comply with the CWA and Porter-Cologne laws. This regulatory framework protects the beneficial uses of the state's surface and groundwater resources for public benefit and environmental protection. Protection of water quality could be achieved by the proposed project by complying with applicable NPDES permits from the SWRCB or the San Francisco Bay RWQCB. The RWF complies with the Clean Water Act through its current NPDES WDRs, issued by the San Francisco RWQCB in September 2014.

Under Section 303(d) of the CWA, states are required to identify impaired surface water bodies and develop total maximum daily loads (TMDLs) for contaminants of concern. The TMDL is the quantity of a pollutant that can be assimilated by a water body without violating water quality standards. Listing an impaired water body does not necessarily suggest that the water body cannot support beneficial uses; rather, the intent is to help identify the future development of a TMDL to maintain water quality and reduce the potential for future water quality degradation. The United States Environmental Protection Agency (USEPA) lists the project site as within the Guadalupe River watershed, included on the Section 303(d) List of Impaired Waters for California and is affected by mercury, pesticides, and trash (USEPA 2022).

The San Francisco Bay RWQCB issued a Municipal Regional Storm Water NPDES Permit (Permit Number CAS612008) that requires co-permittees to implement a storm water quality protection program. This regional permit applies to 77 Bay Area municipalities, including the city of Santa Clara. Under the provisions of the Municipal NPDES Permit reissued in May 2022, redevelopment projects that disturb more than 5,000 square feet are required to design and construct storm water treatment controls to treat post-construction storm water runoff. The permit requires the post-construction runoff from qualifying projects to be treated using low-impact development (LID) treatment controls, such as biotreatment facilities.

The Santa Clara Valley Urban Runoff Pollution Prevention Program (SCVURPPP) assists co-permittees, such as the city of Santa Clara, in the implementation of the provisions of the Municipal NPDES Permit. In addition to water quality controls, the Municipal NPDES Permit requires all new and redevelopment projects that create or replace one acre or more of impervious surface to manage development-related increases in peak runoff, where such hydromodification is likely to cause increased impacts to beneficial uses of local streams. Projects may be deemed exempt from the permit requirements under one of the following three conditions (SCVURPPP 2005):

1. The Project will not increase the potential for erosion or other non-beneficial impacts,
2. The Project drains into a hardened channel or tidally influenced area, or
3. The Project lies within a watershed that is over 90% developed or with greater than 65 percent impervious surface.

The project site in an area with greater than 65 percent impervious surface (SCVURPPP 2010); thus, the project site is not subject to the SCVURPPP hydromodification requirements.

State

California Water Code, Sections 10910-10915. California Water Code (Sections 10910-10915) requires water service providers to evaluate stresses to the water supply service system caused by proposed project developments. The code sections require public water systems to prepare water supply assessments (WSA) for certain defined development projects subject to the California Environmental Quality Act (CEQA). According to Section 10912 (a), if a "Project" meets any of seven criteria, then a detailed WSA would be required. A California Department of Water Resources document titled "Guidebook for Implementation of Senate Bill 610 and Senate Bill 221 of 2001" (DWR 2003) provides further guidance for how to interpret the sections of the Water Code. The MDC would be an industrial/manufacturing facility with less than 650,000 square feet, occupying less than 40 acres, expected to have fewer than 1,000 employees, and would have a 2 AFY potable water demand (less than the amount needed for 500 dwelling units). Therefore, the MDC does not meet any of the Section 10912 criteria and does not require preparation of a WSA.

California Energy Efficiency Standards for Residential and Nonresidential Buildings—Green Building Code (2011), Title 24 Update (2014). The California Green Buildings Standards Code requires energy and water-efficient indoor infrastructure applied to the design, construction, operation, and occupancy of newly constructed buildings. The related waste management plan is required to allow for the diversion of 50 percent of the generated waste away from the landfill.

Integrated Waste Management Act. The Integrated Waste Management Act of 1989 established the California Integrated Waste Management Board (CIWMB), revamped the government codes regulating solid waste management, and required cities and counties

to reduce the amount of solid waste disposed of in landfills by 50 percent. To comply with the Integrated Waste Management Act, counties must adopt regulations and policies to fulfill the requirements of the Act.

California Assembly Bill 341 (Reduction of Solid Waste). Enacted on May 7, 2012, AB 341 set a statewide goal of reducing solid waste by 75 percent by 2020. It also established mandatory recycling programs for solid waste generated by businesses, public entities, and multi-family dwellings generated solid waste.

California Senate Bill 1383 (Reduction of Organic Waste). Effective at the beginning of 2022, SB 1383 establishes statewide targets to reduce 2014 organic waste levels to 50 percent by 2020 and to 75 percent by 2025.

California Senate Bill 350 (Renewable Energy Targets). SB 350, the Clean Energy and Pollution Reduction Act of 2015 adopts regulations that increase the procurement of electricity from renewable sources to 50 percent by 2030. SB 350 also required the establishment of annual targets for statewide energy efficiency savings and demand reduction by November 1, 2017. These energy efficiency savings and demand reductions were intended to achieve a cumulative doubling of statewide energy efficiency savings in electricity and natural gas use by January 1, 2030.

California Senate Bill 100 (The 100 Percent Clean Energy Act of 2018). SB 100 increases the targeted procurement of electricity from renewable sources to 60 percent by 2030 from the previous target of 50 percent identified in SB 350. Additionally, SB 100 targets 100 percent of electricity sold in California to come from eligible renewable energy resources and zero-carbon resources by 2045. SB 100 will impact the implementation of electric power facilities through 2045. The SB 100 Joint Agency Report: *Charting a path to a 100 percent Clean Energy Future*, estimates an increased utility-scale capacity of 145 GW by 2045, which includes in-state and out-of-state renewable sources and energy storage (CEC 2021).

Local

City of Santa Clara 2010-2035 General Plan. The City of Santa Clara 2010-2035 General Plan (General Plan) includes policies related to utilities and service systems (Santa Clara 2014). With respect to waste, General Plan Policy 5.10.1-P8 encourages an 80 percent per capita reduction of solid waste tonnage by 2020, or as consistent with the Climate Action Plan (CAP) (Santa Clara 2022).

Santa Clara City Code. According to Santa Clara City Code Section 8.25.285, applicants seeking building or demolition permits for projects greater than 5,000 square feet are required to recycle at least 50 percent of the solid waste generated by the project.

Santa Clara City Reach Code Ordinance 2034. City ordinance 2034 stipulates that all newly constructed buildings will be "All-Electric", with some exemptions.

4.18.2 Environmental Impacts

Environmental impacts evaluated in this section include the construction and operation elements of the proposed project.

a. Would the project require or result in the relocation or construction of new or expanded water, wastewater treatment or storm water drainage, electric power, natural gas, or telecommunications facilities, the construction or relocation of which could cause significant environmental effects?

Less Than Significant Impact. The project would not require any new utility connections and would be connected to the existing utilities, with the exception of extending the recycled water pipeline.

The project's wastewater flow during construction and operation would be treated by the RWF, which is monitored by the San Francisco Bay RWQCB to ensure compliance with the facility's NPDES wastewater discharge permit. The RWF is permitted to treat the industrial and sanitary waste flows that would be generated by the project. The RWF treats an average of 110 mgd of wastewater, which is 57 mgd less than its 167 mgd treatment capacity. Compared to the current conditions, the proposed project would not increase the amount of wastewater discharged to the sanitary sewer (DayZen LLC 2022). Therefore, the project would not cause the RWF to exceed its wastewater treatment requirements of the San Francisco Bay RWQCB for project construction and operation. The impact of the project on wastewater treatment capacity would be less than significant.

The expected load demand of 77 MWs for the MDC (DayZenLLC 2022) would result in an annual use of 674,982 MWh per year. Electricity demand for the proposed MDC would be provided by SVP (DayZenLLC 2022). In 2022, SVP sold approximately 4.41 million MWh to its customers, the vast majority of which was for non-residential (industrial) customers (SVP 2023). As of the end of 2022, SVP owned supplies and guaranteed future deliveries totaling an estimated 4.52 million MWh per year of total energy supplies (SVP 2023). The project's estimated annual energy demand of 674,982 MWh per year would be 14.9 percent of SVP's overall electrical supply creating a significant impact.

However, SVP Chief Operating Officer, Kevin Kolnowski has testified in recent data center proceedings that SVP is taking multiple actions to meet the requirements of SB 100 and that the additional load from data centers is anticipated and accounted for in SVP demand analysis and integrated resource planning process. SVP currently has adequate resources to meet expected demand through 2030. Mr. Kolnowski has testified that SVP already has over 400 MW of renewable power coming online in the next several years, an additional 100 MW of renewable power being investigated as SVP continues to procure renewable energy supply (CEC 2020a, CEC 2022b).

Telecommunication services for the proposed project would be supplied by providers that have been serving the existing businesses in the project area. Those providers have adequate available capacity to accommodate the project needs during construction and operation. The impact of the project on telecommunication services would be less than significant.

PG&E provides natural gas to customers in the general area surrounding the site. However, in accordance with the City of Santa Clara's Reach Code ordinance, no natural gas infrastructure will be installed as part of the project. Therefore, natural gas service would not be an impact.

Based on the previous discussion, the project would have less than significant impacts.

b. Would the project have sufficient water supplies available to serve the project and reasonably foreseeable future development during normal, dry, and multiple dry years?

Less Than Significant Impact. The water system in the project area is operated and maintained by the Santa Clara Department of Water and Sewer Utilities. Potable water supply for this area is serviced by both SFPUC imported surface water and groundwater locally produced from the Santa Clara Valley Subbasin. Potable water is brought to the site by connection to a 12-inch water main along Martin Avenue.

According to the 2020 UWMP, the citywide demand for potable water in 2020 was 18,302 AF. The city also distributed 3,499 AFY of recycled water resulting in a savings of 19 percent of potable water. The UWMP also concludes that the city is expected to meet projected future potable water demands ranging from approximately 21,801 AFY in 2025 to 31,676 AFY in 2045. Demands for recycled water are projected at approximately 4,570 AFY in 2025 and gradually increase to 9,488 AFY in 2045 (Santa Clara 2021).

The project is estimated to use approximately 1.75 AF of potable water during the two phases of construction expected to last about 24 months. That is equivalent to 0.88 AFY, which is less than half the project's estimated annual demand of approximately 2 AFY for operational needs and is less than the historic use of 3.2 AFY by the previous user at the project site (DayZenLLC 2022). The impact of construction water demand would, therefore, be less than significant.

The proposed project would have an operational demand of approximately 2.0 AFY of potable water, 1 AFY of which would be for landscaping purposes. The city's UWMP for 2020 shows that the city has a sufficient supply to meet the project's demand in normal and single dry-year scenarios. However, the UWMP indicates that the city could have a deficit in multiple dry-year scenarios if water supply from SFPUC is interrupted under certain conditions specified in the interruptible contract between the city and SFPUC. If supply from SFPUC is interrupted, the city has conservation plans and other measures in place to manage supply to meet demand. Examples of measures the city would implement to deal with water shortages include increasing groundwater pumping,

encouraging customers to practice voluntarily rationing, or imposing mandatory water supply reductions (Santa Clara 2021).

The proposed project would be constructed on a previously disturbed, fully developed site that was previously used for industrial purposes. Historic annual potable water use of the existing commercial facility has been approximately 3.2 AFY. Thus, the proposed project would result in a slight net reduction in potable water use benefiting local water supplies.

c. Would the project result in a determination by the wastewater treatment provider which serves or may serve the project that it has inadequate capacity to serve the project's projected demand in addition to the provider's existing commitments?

Less Than Significant Impact. As stated above in the Environmental Setting subsection, the RWF treats an average of 110 mgd of wastewater, which is 57 mgd less than its 167 mgd treatment capacity. Compared to the current conditions, the project would not increase the amount of wastewater discharged to the sanitary sewer (DayZen LLC 2022). Implementation of the proposed project would not result in an increase in the RWF's need for wastewater treatment beyond its designed capacity.

Therefore, the impact on wastewater treatment facilities would be less than significant.

d. Would the project generate solid waste in excess of State or local standards, or in excess of the capacity of local infrastructure, or otherwise impair the attainment of solid waste reduction goals?

Less Than Significant Impact. The demolition and construction activities for the project would result in minor amounts of solid waste resulting in a temporary increase. The project would divert construction and demolition waste during project construction to help the city reach its 80 percent waste diversion rate as required by Measure M-1-1 of the CAP (DayZenLLC 2022). Operations would result in the long-term generation of a small amount of solid waste.

Based on estimates using a default solid waste disposal rate (1.42 lbs./ 100 sq. ft. of building area/ day) for a manufacturing warehouse scenario (CalRecycle 2023), the project would generate approximately 6,674 pounds, or 3.3 tons of solid waste per day (DayZenLLC 2022). The solid waste would be disposed of at the Newby Island Landfill in San Jose. On December 7, 2016, the city of San Jose approved the expansion of the Newby Island Landfill by raising the height of the existing landfill by 95 feet, thereby increasing landfill capacity by 15.12 million cubic yards (San Jose 2016). According to CalRecycle, as of January 31, 2020, Newby Island Landfill is permitted to accept a maximum of 4,000 tons of solid waste per day, has a remaining disposal capacity of 16.4 million cubic yards, and is permitted to operate until 2041 (CalRecycle 2020). The estimated solid waste generation rate of 3.3 tons per day constitutes a small fraction (0.08 percent) of the total daily capacity of 4,000 tons per day the landfill is capable of processing.

Therefore, the impact resulting from the construction and operation of the proposed project on landfill capacity would be less than significant.

e. Would the project comply with federal, state, and local management and reduction statutes and regulations related to solid waste?

No Impact. The California Integrated Waste Management Act of 1989 (Assembly Bill 939) requires local jurisdictions in California to reduce, by 50 percent, the amount of solid waste disposed of in landfills by the year 2000 and beyond. Moreover, Assembly Bill 341 of 2011 sets statewide goals of reducing solid waste by 75 percent by 2020 and Senate Bill 1383 of 2016 establishes statewide targets to reduce organic waste levels to 75 percent by 2025.

During construction, the project would collect and haul construction debris off-site for recycling or disposal in local jurisdictions that have programs in place to comply with these state requirements. Typically, data centers do not generate special or unique wastes. Likewise, the project would not generate any special or unique wastes that would make the project not comply with federal, state, and local statutes or solid waste management and reduction regulations. Management of hazardous waste and applicable federal regulations are discussed in **Section 4.9 Hazards and Hazardous Materials**. During operation, the project would comply with federal, state, and local statutes and regulations related to solid waste.

There would be no change in compliance with federal, state, or local statutes and regulations related to solid waste management and reduction. No impact would occur.

4.18.3 Mitigation Measures

None required.

4.18.4 References

CEC 2020a – California Energy Commission (CEC). CEC Walsh Transcript-Walsh Evidentiary Hearing, May 27, 2020, Docket # 19-SPPE-02, TN#233287. Accessed on: January 25, 2023. Available online at: <https://efiling.energy.ca.gov/GetDocument.aspx?tn=233287&DocumentContentId=65774>

CEC 2020b – California Energy Commission (CEC). CEC Mission College Transcript-Mission College Evidentiary Hearing, June 15, 2020, Docket # 19-SPPE-05, TN# 233540. Accessed on: January 25, 2023. Available online at: <https://efiling.energy.ca.gov/GetDocument.aspx?tn=233540&DocumentContentId=66082>

CEC 2021 – California Energy Commission (CEC). California Energy Commission SB 100 Joint Agency Report Achieving 100 Percent Clean Electricity in California: An Initial Assessment. Report. p. 75. TN#237167. Accessed on December 7, 2022.

- Available online at:
<https://efiling.energy.ca.gov/Lists/DocketLog.aspx?docketnumber=19-SB-100>
- CalRecycle 2020 – California Department of Resources Recycling and Recovery (CalRecycle). Newby Island Sanitary Landfill (43-AN-0003), SWIS Facility/Site Summary website. Accessed: December 22, 2022. Available online at:
<https://www2.calrecycle.ca.gov/SolidWaste/Site/Summary/3388>
- CalRecycle 2023 – Department of Resources, Recycling and Recovery (CalRecycle). *Estimated Solid Waste Generation Rates* webpage. Accessed on February 13, 2023. Available online:
<https://www2.calrecycle.ca.gov/WasteCharacterization/General/Rates>
- DayZen LLC 2022 – DayZen LLC (DayZen LLC). (TN 247325). Martin Backup Generating Facility Application for SPPE, dated November 2022. Accessed on: February 13, 2023. Available online at:
<https://efiling.energy.ca.gov/GetDocument.aspx?tn=247325&DocumentContentId=81710>
- DWR 2003 – Department of Water Resources (DWR). Guidebook for Implementation of Senate Bill 610 and Senate Bill 221 of 2001. California Department of Water Resources. October 8, 2003. Accessed on December 7, 2022. Available online at: <https://documents.pub/reader/full/guidebook-for-implementation-of-senate-bill-610-and-for-implementation-of-senate>
- SCVURPPP 2005 – Santa Clara Valley Urban Runoff Pollution Prevention Program (SCVURPPP). Hydromodification Management Plan. Prepared by the SCVURPPP Management Committee. April 21, 2005. Accessed on December 6, 2022. Available online at:
https://scvurppp.org/wpcontent/uploads/2021/08/hmp_complete_032905.pdf
- SCVURPPP 2010 – Santa Clara Valley Urban Runoff Pollution Prevention Program (SCVURPPP). Classification of Subwatersheds and Catchment Areas for Determining Applicability of Hydromodification Management (HM) Requirements. Revised November 2010. From: Appendix E-2 of C.3 Stormwater Handbook. June 2016. Accessed on December 6, 2022. Available online at:
<https://scvurppp.org/2016/06/20/c-3-stormwater-handbook-june-2016/>
- Santa Clara 2014 – City of Santa Clara (Santa Clara). City of Santa Clara 2010-2035 General Plan. Approved by City Council November 16, 2010 and updated December 9, 2014. Accessed on: February 13, 2023. Available online at:
<https://www.santaclaraca.gov/our-city/departments-a-f/community-development/planning-division/general-plan>
- Santa Clara 2021 – City of Santa Clara Water and Sewer Utilities (Santa Clara). 2020 Urban Water Management Plan. Prepared by the City of Santa Clara Water and Sewer Utilities. Adopted June 22, 2021. Accessed: January 18, 2023. Available online at:
<https://www.santaclaraca.gov/home/showpublisheddocument/74073/637606452>

907100000

Santa Clara 2022 – City of Santa Clara (Santa Clara). City of Santa Clara 2010-2035 General Plan. Adopted June 2022. Accessed on: February 13, 2023. Available online at:
<https://www.santaclaraca.gov/home/showpublisheddocument/78208/637970130098870000>

SCVWD 2021 – Santa Clara Valley Water District (SCVWD). 2021 Groundwater Management Plan for the Santa Clara and Llagas Subbasins. November 2021. Accessed on: January 18, 2023. Available online at:
<https://sgma.water.ca.gov/portal/alternative/periodiceval/preview/6>

San Jose 2016 – City of San Jose, Department of Planning, Building, and Code Enforcement (San Jose). Planned Development Permit, File No. PD14-014. Approved December 7, 2016. Accessed on December 22, 2022. Available online at: <https://www.ci.milpitas.ca.gov/wp-content/uploads/2018/08/Memo-to-Council-Odor-Update-and-SBOSG-Memo.pdf>

San Jose 2022 – City of San Jose (San Jose). San Jose-Santa Clara Regional Wastewater Facility website. Accessed on January 18, 2023. Available online at: <https://www.sanjoseca.gov/your-government/environment/water-utilities/regional-wastewater-facility>

SVP 2023 – Silicon Valley Power (SVP). 2022 Utility Fact Sheet. Accessed on May 9, 2023. Available online at: <https://www.siliconvalleypower.com/svp-and-community/about-svp/utility-fact-sheet>

USEPA 2022 – United States Environmental Protection Agency (USEPA). How's My Waterway? EPA website. Assessed on January 18, 2023. Available online at: <https://mywaterway.epa.gov/state/CA/water-quality-overview>

4.19 Wildfire

This section describes the environmental and regulatory setting and discusses impacts associated with the construction and operation of the project with respect to wildfires.

WILDFIRE	Potentially Significant Impact	Less Than Significant with Mitigation Incorporated	Less Than Significant Impact	No Impact
If located in or near state responsibility areas or lands classified as very high fire hazard severity zones, would the project:				
a. Substantially impair an adopted emergency response plan or emergency evacuation plan?	<input type="checkbox"/>	<input type="checkbox"/>	<input type="checkbox"/>	<input checked="" type="checkbox"/>
b. Due to slope, prevailing winds, and other factors, exacerbate wildfire risks, and thereby expose project occupants to, pollutant concentrations from a wildfire or the uncontrolled spread of a wildfire?	<input type="checkbox"/>	<input type="checkbox"/>	<input type="checkbox"/>	<input checked="" type="checkbox"/>
c. Require the installation or maintenance of associated infrastructure (such as roads, fuel breaks, emergency water sources, power lines or other utilities) that may exacerbate fire risk or that may result in temporary or ongoing impacts to the environment?	<input type="checkbox"/>	<input type="checkbox"/>	<input type="checkbox"/>	<input checked="" type="checkbox"/>
d. Expose people or structures to significant risks, including downslope or downstream flooding or landslides, as a result of runoff, post-fire slope instability, or drainage changes?	<input type="checkbox"/>	<input type="checkbox"/>	<input type="checkbox"/>	<input checked="" type="checkbox"/>

Environmental criteria established by CEQA Guidelines, Appendix G.

4.19.1 Environmental Setting

Wildfire Hazards

The Department of Forestry and Fire Protection (Cal Fire) identifies and maps areas of significant fire hazards based on fuels, terrain, and other relevant factors. These maps categorize this information by Fire Hazard Severity Zones (FHSZ), grouped into unzoned, moderate, high, and very high zones. State Responsibility Areas (SRA) are locations where the State of California is responsible for wildfire protection and Local Responsibility Areas (LRA) are locations where the responding agency is the county or city.

The California Public Utilities Commission (CPUC) categorizes fire threat areas as Tier 1, Tier 2, or Tier 3. Tier 1 (or CAL FIRE Zone 1) encompasses High Hazard Zones (HHZ) on the United States Forest Service joint map of Tree Mortality HHZ. This tier represents areas where tree mortality directly coincides with critical infrastructure such as communities, roads, and utility lines, and are a direct threat to public safety. Tier 2 consists of areas where there is an elevated risk (including likelihood and potential impacts on people and property) from wildfires associated with overhead utility power lines or overhead utility power-line facilities also supporting communication facilities. Tier 3 consists of areas where there is an extreme risk (including likelihood and potential

impacts on people and property) from wildfires associated with overhead utility power lines or overhead utility power-line facilities also supporting communication facilities.

The project site is surrounded by industrial development in the city of Santa Clara and is not located in SRA but is located within a LRA (Cal Fire 2022a). The project is not near a moderate, high, or very high FHSZ (Cal Fire 2022b). Neither is the project on land classified as having a fire threat by the CPUC. The city of Santa Clara is not in the vicinity of wildlands.

Regulatory Background

Federal

No federal regulations related to wildfires apply to the project.

State

Fire Hazard Severity Zones (Pub. Resources Code, §§ 4201-4204). The purpose of this code section is to provide for the classification of lands within SRAs in accordance with the severity of fire hazard present, to identify measures to be taken to retard the rate of spreading, and to reduce the potential intensity of uncontrolled fires that threaten to destroy resources, life, or property.

Fire Hazard Severity (Cal. Code Regs, tit. 14, § 1280). FHSZs reflect the degree of severity of fire hazard.

CPUC General Order 95: Rules for Overhead Electric Line Construction. CPUC GO 95, Section 35, covers all aspects of design, construction, operation, and maintenance of overhead electrical lines and management of safety hazards. Application of the code would ensure adequate service and safety to persons engaged in the construction, maintenance, operation or use of overhead lines and to the public in general.

CPUC General Order 166: Standards for Operation, Reliability, and Safety during Emergencies and Disasters. CPUC GO 166 covers the standards which require all electric utilities to be prepared for emergencies and disasters to minimize damage and inconvenience to the public which may occur as a result of electric system failures, major outages, or hazards posed by damage to electric distribution facilities.

Local

Santa Clara County Operational Area Hazard Mitigation Plan. The plan includes risk assessment that identifies the natural hazards and risks that can impact a community based on historical experience, estimate the potential frequency and magnitude of disasters, and assess potential losses to life and property. The plan also includes developed mitigation goals and objectives as part of a strategy for mitigating hazard-related losses.

4.19.2 Environmental Impacts

a. Would the project substantially impair an adopted emergency response plan or emergency evacuation plan?

Construction

No Impact. During project construction, traffic levels would experience a minimal increase that is not expected to degrade traffic performance significantly. Emergency response access during construction would not be significantly impeded. The project would not involve the development of structures that could potentially impair implementation of or physically interfere with an adopted emergency response plan or emergency evacuation plan. No streets would be closed, rerouted, or substantially altered during construction.

Additionally, the project is not located in or near an SRA or a very high FHSZ, or land classified as having a fire threat by the CPUC.

Operation

No Impact. The project does not involve the addition of a large number of people to the local area, as discussed in **Section 4.14 Population and Housing** and thereby would not increase emergency response demand during a potential evacuation. Thus, the project would not interfere with the coordination of the county's emergency operations plan at the emergency operations center or alternate emergency operations center, nor would the project interfere with any statewide emergency response, or evacuation routes or plans. The site and surrounding area would maintain adequate emergency access.

Additionally, the project is not located in or near an SRA or a very high FHSZ, or land classified as having a fire threat by the CPUC.

b. Would the project due to slope, prevailing winds, and other factors, exacerbate wildfire risks, and thereby expose project occupants to, pollutant concentrations from a wildfire or the uncontrolled spread of a wildfire?

Construction and Operation

No Impact. The topography of the project site is flat and the project area is highly developed with minimal open space areas, faces, or slopes. Therefore, project construction would not exacerbate wildfire risk or expose occupants to pollutant concentrations from a wildfire.

Additionally, the project is not located in or near an SRA or a very high FHSZ, or land classified as having a fire threat by the CPUC.

c. Would the project require the installation or maintenance of associated infrastructure (such as roads, fuel breaks, emergency water sources, power lines or other utilities) that may exacerbate fire risk or that may result in temporary or ongoing impacts to the environment?

Construction

No Impact. The project would construct several linear features that include a domestic potable water line, a fire water line, an offsite recycled water line, a sanitary sewer line, an electrical supply line, an irrigation line and a storm water drainage line. The domestic potable water, fire water, storm water, recycled water, irrigation lines and sanitary sewer lines would be underground utilities that connect to the existing utilities in Martin Avenue along the property frontage. The construction of these utilities would not block access to any road or result in traffic congestion.

Installation of the required substation and switching station would not block access to any road or result in traffic congestion. The constructed electrical supply line and other project infrastructure would not constitute a possible ignition source for local vegetation, nor would it block access to any road or result in traffic congestion.

Additionally, the project is not located in or near an SRA or a very high FHSZ, or land classified as having a fire threat by the CPUC.

Operation

No Impact. The project would not require the installation of associated infrastructure that could exacerbate fire risk or result in impacts to the environment. Maintenance of the project and proposed utilities would not physically block any access roads or result in traffic congestion that could significantly compromise timely access to this facility or any other location.

Additionally, the project is not located in or near a SRA or a very high FHSZ, or land classified as having a fire threat by the CPUC.

d. Would the project expose people or structures to significant risks, including downslope or downstream flooding or landslides, as a result of runoff, post-fire slope instability, or drainage changes?

Construction

No Impact. The project would not substantially alter local drainage patterns. Storm water discharge during construction would be managed according to the project's Storm Water Pollution Prevention Plan, and appropriately discharged to the city of Santa Clara's storm drain system. The project would therefore not be expected to contribute to a flooding hazard onsite or offsite. For further discussion of the potential flooding impacts that could

result from the proposed project, please see the discussion in section **4.10 Hydrology and Water Quality**.

As discussed in this section, the topography of the project site and surrounding area is relatively flat and highly developed. Therefore, the project would not be exposed to post-fire slope instability or drainage changes.

Additionally, the project is not located in or near an SRA or a very high FHSZ, or land classified as having a fire threat by the CPUC, so the types of hazards listed as potentially occurring in a post-fire situation are not likely to occur.

Operation

No Impact. Operation of the project would not alter the course of a drainage (stream or river) and would not substantially alter local drainage patterns. The proposed onsite storm drainage system would be designed to meet the city's storm water drainage standards and sized adequately to convey water away from the site and to the city of Santa Clara's storm drain system. The project would therefore not contribute to a flooding hazard onsite or offsite.

As discussed in this section, the topography of the project site and surrounding area is relatively flat and highly developed. Therefore, the project would not be exposed to post-fire slope instability or drainage changes.

Additionally, the project is not located in or near an SRA or a very high FHSZ, or land classified as having a fire threat by the CPUC, so the types of hazards listed as potentially occurring in a post-fire situation are not likely to occur.

4.19.3 Mitigation Measures

None required.

4.19.4 References

Cal Fire 2023a – Department of Forestry and Fire Protection (CalFire). *Santa Clara County Fire Hazard Severity Zones in Local Responsibility Area*. Accessed on: April 17, 2023. Available online at: https://osfm.fire.ca.gov/media/5935/san_jose.pdf

Cal Fire 2023b – Department of Forestry and Fire Protection (CalFire). *Santa Clara County Fire Hazard Severity Zones in State Responsibility Area*. Accessed on: April 17, 2023. Available online at: https://osfm.fire.ca.gov/media/op4oxpaq/fhsz_county_sra_e_2022_santaclara.pdf

4.20 Mandatory Findings of Significance

This section describes impacts specific to mandatory findings of significance associated with the construction and operation of the project.

MANDATORY FINDINGS OF SIGNIFICANCE	Potentially Significant Impact	Less Than Significant with Mitigation Incorporated	Less Than Significant Impact	No Impact
a. Does the project have the potential to substantially degrade the quality of the environment, substantially reduce the habitat of a fish or wildlife species, cause a fish or wildlife population to drop below self-sustaining levels, threaten to eliminate a plant or animal community, substantially reduce the number or restrict the range of a rare or endangered plant or animal or eliminate important examples of the major periods of California history or prehistory?	<input type="checkbox"/>	<input checked="" type="checkbox"/>	<input type="checkbox"/>	<input type="checkbox"/>
b. Does the project have impacts that are individually limited, but cumulatively considerable? ("Cumulatively considerable" means that the incremental effects of an individual project are significant when viewed in connection with the effects of past projects, the effects of other current projects, and the effects of probable future projects)??	<input type="checkbox"/>	<input checked="" type="checkbox"/>	<input type="checkbox"/>	<input type="checkbox"/>
c. Does the project have environmental effects which will cause substantial adverse effects on human beings, either directly or indirectly?	<input type="checkbox"/>	<input type="checkbox"/>	<input checked="" type="checkbox"/>	<input type="checkbox"/>

Environmental checklist established by CEQA Guidelines, Appendix G.

a. Does the project have the potential to substantially degrade the quality of the environment, substantially reduce the habitat of a fish or wildlife species, cause a fish or wildlife population to drop below self-sustaining levels, threaten to eliminate a plant or animal community, substantially reduce the number or restrict the range of a rare or endangered plant or animal or eliminate important examples of the major periods of California history or prehistory?

Less Than Significant with Mitigation Incorporated.

Biological Resources

Less Than Significant with Mitigation Incorporated. With mitigation, the project would not substantially degrade the quality of the environment, reduce the existing habitat of any fish or wildlife species, cause any fish or wildlife population to drop below self-sustaining

levels, threaten to eliminate any plant or animal community, or substantially reduce the number or restrict the range of a rare, threatened, or endangered species.

The project site is zoned MH - Heavy Industrial and designated Urban/Developed. Similarly, the surrounding neighborhood consists of commercial and industrial buildings. Historically, the railroad located on the eastern side of the property has been present since the late 1880s, and much of the area surrounding the site was agricultural farmland until the 1950s, eventually transitioning to its present-day industrial and commercial use. The four existing buildings on the property that were previously used for commercial/warehouse purposes would be demolished as part of the project per a City of Santa Clara demolition permit. Paved parking lots surround the buildings. Along the boundary lines of the property there are a mix of ornamental native, non-native trees, and shrubs typical of developed properties. Thirty-three trees and several ornamental shrubs onsite would be removed to allow for construction of the project. Ruderal vegetation also exists along the eastern boundary and further to the east along the railroad corridor. The minimal habitat onsite is enough to accommodate common wildlife and provide for nesting and foraging birds. Although, the site does not contain any special habitat capable of supporting special-status plant and wildlife species, it is approximately four miles southeast of several important wildlife communities such as the Don Edwards San Francisco Bay National Wildlife Refuge, Baylands Park, and Alviso Park. The nearest bodies of water are freshwater wetland and emergent freshwater wetlands located less than half mile northeast within the northern boundary of the San José Mineta International Airport. Within a mile to the east of the project lies approximately 24 acres of Freshwater Forested/Shrub Wetland within the Guadalupe River Corridor that flows north to the San Francisco Bay. Due to the proximity of these important offsite wildlife preserves, parks, and habitat communities mentioned above it is possible that special-status species might occur onsite as foragers, transients, and possible residents. Staff concluded that in addition to special-status nesting and migratory birds there was a low potential for western burrowing owl and a few special- status species of bats to occur onsite.

Staff has proposed mitigation measures **BIO-1** through **BIO-5** to ensure that no significant impacts to special-status plants or wildlife would occur during construction and operation of the project. **Table 4.20-1** provides a summary table of all the proposed mitigation measures, which are fully reported in **Section 4.4 Biological Resources**.

TABLE 4.20-1: BIOLOGICAL RESOURCES MITIGATION MEASURES	
BIO-1	Worker Environmental Awareness Program (WEAP)
BIO-2	Burrowing Owl Surveys, Monitoring, Prevention and Relocation
BIO-3	Nesting Bird Avoidance and Minimization Measures
BIO-4	Nesting Bird Reporting and the Avian Protection Plan
BIO-5	Bat Species Avoidance and Impact Minimization

With implementation of the above mitigation measures, the project would not substantially degrade the quality of the environment, substantially reduce the habitat of a fish or wildlife species, cause a fish or wildlife population to drop below self-sustaining levels, threaten to eliminate a plant or animal community, substantially reduce the number or restrict the range of a rare or endangered plant or animal.

Additional measures that would ensure ongoing viability of wildlife movement corridors such as the Guadalupe River include control of stormwater or pollutant runoff (discussed further in **Section 4.10 Hydrology and Water Quality**) via a National Pollutant Discharge Elimination System General Permit for Storm Water Discharges Associated with Construction and Land Disturbance Activities (Construction General Permit).

Cultural and Tribal Cultural Resources

Less Than Significant with Mitigation Incorporated. Important examples of the major periods of California history or prehistory represented by historical, unique archaeological, or tribal cultural resources are not known to be present in the project area. Nevertheless, the extent of proposed ground disturbance has the potential to damage unknown, buried archaeological resources in the project area. As described in **Section 4.5 Cultural and Tribal Cultural Resources**, most archaeological resources aged about 5,000 years or older are buried beneath the ground surface. If these resources were to be exposed or destroyed, it would be a significant impact. Implementation of mitigation measures **CUL-1** through **CUL-9**, included in **Section 4.5 Cultural and Tribal Cultural Resources** would reduce the impacts to buried cultural resources to a less-than-significant level. **Table 4.20-2** provides a summary table of all the mitigation measures proposed in **Section 4.5 Cultural and Tribal Cultural Resources**.

TABLE 4.20-2: CULTURAL AND TRIBAL CULTURAL RESOURCES MITIGATION MEASURES

CUL-1	Cultural Resources Identification, Monitoring, and Treatment Plan
CUL-2	Worker Environmental Awareness Program (WEAP)
CUL-3	Preliminary Field Investigations
CUL-4	Construction Monitoring and Protection Measures
CUL-5	Evaluation and Data Recovery
CUL-6	Human Remains
CUL-7	Site Security
CUL-8	Closing Cultural Resources Report
CUL-9	Curation

With implementation of above mitigation measures, the proposed project is unlikely to eliminate important examples of major periods of California history or prehistory and the impact would be less than significant.

Geology and Soils

Less Than Significant with Mitigation Incorporated. There are no known paleontological resources within the project site. A search of the University of California Museum of

Paleontology database failed to identify any paleontological resources in the vicinity of the site (UCMP 2022). However, as described in **Section 4.7 Geology and Soils**, ground-disturbing activities of ten feet or more have the potential to impact undiscovered paleontological resources. The project would require excavation trenching of depths of up to 15 feet below the existing grade. Foundations would be augured piles, likely to exceed depths of 30 feet below the existing grade. Although unlikely, paleontological resources could be encountered during construction of the project. If significant paleontological resources were to be exposed or destroyed, it would be a significant impact. Adherence to the City of Santa Clara General Plan (Santa Clara 2010) policies (5.6.3-G1, 5.6.3-G2, 5.6.3-P1, 5.6.3-P2, 5.6.3-P4, and 5.6.3-P5), and implementation of **GEO-1**, which identifies the mitigation measures required of the project owner in the event of the discovery of paleontological resources during excavation, included in **Section 4.7 Geology and Soils** would reduce the impacts to buried paleontological resources to a less-than-significant level. The proposed project is unlikely to eliminate important examples of paleontological resources that are part of the prehistory of California, therefore, the impact would be less than significant.

b. Does the project have impacts that are individually limited, but cumulatively considerable? (“Cumulatively considerable” means that the incremental effects of an individual project are significant when viewed in connection with the effects of past projects, the effects of other current projects, and the effects of probable future projects)?

Less Than Significant with Mitigation Incorporated. California Environmental Quality Act (CEQA) Guidelines 15130(b) state that an adequate discussion of significant cumulative impacts can employ one of two methods to establish the effects of other past, current, and probable future projects. A lead agency may select a list of projects, including those outside the control of the agency, or, alternatively, a summary of projections. These projections may be from an adopted general plan or related planning document, or from a prior environmental document that has been adopted or certified, and these documents may describe or evaluate the regional or area-wide conditions contributing to the cumulative impact.

General Plan Projection

This section evaluates cumulative impacts using the City of Santa Clara 2010-2035 General Plan Integrated Final Environmental Impact Report (General Plan FEIR) since the project would be consistent with applicable land use plans and policies (Santa Clara 2011). The General Plan FEIR identified that the build out of the General Plan would contribute to five, significant and unavoidable cumulative impacts in the areas of climate change, noise, population and housing, traffic, and solid waste.

General Plan Significant Unavoidable Impacts

The General Plan FEIR identified the following significant unavoidable environmental impacts applicable to the proposed project:

- Climate Change – Contribution to greenhouse gas (GHG) emissions exceeding Santa Clara’s emission reduction target for 2035;
- Noise – Increase in localized traffic noise level on roadway segments throughout Santa Clara;
- Population and Housing – Exacerbation of land use impacts arising from the jobs/housing imbalance;
- Traffic – Degradation of traffic operations on regional roadways and highways within Santa Clara of an unacceptable level of service; and
- Solid Waste – Contribution to solid waste generation beyond available capacity after 2024.

Although the project, in combination with future development in the city of Santa Clara, could conceivably have a significant cumulative impact to these environmental resources, the following discussion demonstrates how the project’s contribution to these impacts would be less than cumulatively considerable.

Greenhouse Gas Emissions

Less Than Significant Impact with Mitigation Incorporated. The Bay Area Air Quality Management District (BAAQMD) CEQA Air Quality Guidelines do not identify a greenhouse gas (GHG) emissions threshold for construction-related emissions. Instead, BAAQMD recommends that GHG emissions from construction be quantified and disclosed. The BAAQMD further recommends incorporation of best management practices to reduce GHG emissions during construction, as feasible and applicable. The project’s construction emissions would be in conformance with state and local GHG emissions reduction goals, so impacts would be less than significant.

For operation, including readiness testing and maintenance-related emissions, the BAAQMD CEQA Air Quality Guidelines states that for stationary-source projects, the threshold to determine the significance of an impact from GHG emissions is 10,000 metric tons per year of carbon dioxide equivalent (MTCO₂e/yr).

Other project-related emissions from mobile sources, area sources, energy use, and water use would not be included for comparison to the threshold of significance for stationary sources of GHG, based on guidance in the BAAQMD CEQA Guidelines (BAAQMD 2023, Section 6.4). Instead, in April 2022, the BAAQMD updated thresholds of significance to assist lead agencies when evaluating the indirect and “non-stationary” source emissions of land use development projects. Under the BAAQMD’s 2022 CEQA thresholds of significance for land use projects, a CEQA lead agency can conclude that a project would not make a cumulatively considerable contribution to global climate change if the project is designed and built to be consistent with the requirements of either Option A or Option B of the BAAQMD thresholds. In Option A, projects must include, at a minimum, the project design elements of buildings and transportation. In Option B, projects must be consistent with a local GHG reduction strategy that meets the criteria under CEQA

Guidelines Section 15183.5(b) (BAAQMD 2022, p.2). The proposed project is consistent with Option B by demonstrating compliance with the City of Santa Clara Climate Action Plan 2022 and therefore consistent with “a local GHG reduction strategy that meets the criteria under State CEQA Guidelines Section 15183.5(b)”.

Staff proposes implementation of mitigation measure **GHG-1** which would require the applicant to use renewable diesel for 100 percent of total energy use by the emergency backup generators, and only use ultra-low sulfur diesel (ULSD) as a secondary fuel in the event of supply challenges or disruption in obtaining renewable diesel. Staff also proposes implementation of **GHG-2** which would require the applicant to participate in Silicon Valley Power’s Large Customer Renewable Energy (LCRE) Program or other renewable energy program that accomplishes the same objective as SVP’s LCRE Program for 100 percent carbon-free electricity or purchase carbon offsets renewable energy credits or similar instruments that accomplish the same goals of 100 percent carbon-free electricity. With the implementation of the mitigation measures described in **Section 4.8 Greenhouse Gas Emissions** of this analysis (**GHG-1** and **GHG-2**), the project would ensure that the project-related emissions would not significantly add to the global problem of climate change, nor would the project hinder California’s ability to reach California’s GHG reduction goals in any significant way, even when considered cumulatively. Additionally, the project would implement efficiency measures to meet California green building standards, and additional voluntary efficiency and use reduction measures. As such, with implementation of **GHG-1** and **GHG-2**, GHG emissions related to the project would not conflict with the City’s Climate Action Plan or other plans, policies, or regulations adopted for the purpose of reducing the emissions of GHGs. Therefore, the project’s GHG emissions would not be considered cumulatively significant.

Noise

Less Than Significant Impact. Construction activities would increase existing noise levels at the adjacent industrial land uses, but they would be temporary and intermittent. In addition, construction activities would not occur on Sundays and holidays, in compliance with the Santa Clara City Code, Section 9.10.230. While construction of the proposed project would temporarily increase noise levels in the immediate neighboring areas of the project site, there are no noise-sensitive land uses in the immediate vicinity of the project (the closest sensitive receptor is about 1,400 feet away). Also, the loudest noise levels from construction and demolition activities are not expected to be higher than the existing ambient noise levels at the closest residential area. Thus, construction activities would result in a less than significant noise impact.

Sources of operational noise for the project would include the backup generators, rooftop mechanical equipment including HVAC and other equipment necessary for project operation. The operational noise levels would comply with the City’s noise limits and would not elevate the existing ambient noise levels at the nearest residences. Furthermore, since the project is not adjacent to, or near a residential land use, no noise reduction measures would be required, and operation of the project would have a less than significant impact and would not be cumulatively considerable.

Population and Housing

Less Than Significant Impact. The General Plan FEIR identified significant impacts from the job growth allowed under the General Plan. The General Plan FEIR concluded that substantial residential development could be required elsewhere in the region to provide adequate housing opportunities to future workers. As described in **Section 4.14 Population and Housing**, the project would not displace any people or housing, or necessitate construction of replacement housing elsewhere. Operation of the project is anticipated to require 19 to 21 operation workers and 10 to 14 tenant employees and visitors daily. The project's construction and operation workforce would not directly or indirectly induce a substantial population growth in the project area. Therefore, the project's contribution to the jobs-housing imbalance would not be cumulatively considerable.

Transportation

Less Than Significant with Mitigation Incorporated. The General Plan FEIR anticipates significant traffic impacts from the build-out of the General Plan. As discussed in **Section 4.17 Transportation**, implementation of **TRANS-1** would reduce the project generated VMT to a level below the City's industrial threshold and reduce the project impact to a less than significant level. **TRANS-1** requires the operations workforce to work a 4-40 schedule (40 hours in 4 days) as part of the project's Transportation Demand Management program for VMT reduction. With implementation of **TRANS-1**, the project's contribution to cumulative transportation impacts during project construction and operation would not be cumulatively considerable.

Solid Waste Impacts (Utilities and Service Systems)

Less Than Significant Impact. As determined in **Section 4.17 Utilities and Service Systems**, adequate water supply, as well as wastewater treatment capacity, are available to serve the project. Likewise, there are adequate electricity and telecommunication services in the vicinity to meet the project's needs. Natural gas resources would not be used on the project as proposed.

The nearby Newby Island Landfill has available landfill capacity through 2041. The current landfill impacts are addressed within an ongoing Santa Clara County Integrated Waste Management Plan to provide waste disposal services. The project would generate minimal operational waste as data centers typically require very little equipment turnover. Additionally, the project does not include a residential component and would not increase the supply and demand of utility services and infrastructure. Therefore, the project's contribution to this cumulative impact would not be considerable.

Other Technical Areas

Although the City's General Plan FEIR did not identify significant effects in the areas of air quality, cultural resources, and geology (paleontology), and did not include an analysis of impacts to tribal cultural resources as the General Plan FEIR was adopted before the passage of AB 52 requiring such analysis, the CEC staff concluded that the project's

impacts in these areas are *less than significant with mitigation*. Thus, staff has considered whether the project would contribute to cumulatively considerable impacts in these areas. Staff has also included an analysis of potential cumulative impacts for the other technical areas where project impacts would be *less than significant*.

Aesthetics

Less Than Significant Impact. The proposed project would be constructed on relatively flat land in a highly developed urban area in the eastern portion of the city of Santa Clara, California. United States Highway 101 (U.S. 101) is a little more than a ½-mile to the north, San José Mineta International Airport a little more than ¼-mile to the east.

As discussed in **Section 4.1 Aesthetics**, review of the General Plan, and aerial and street view imagery concluded the project site is not within a scenic vista, and there is no recognized scenic resource on the site or in the vicinity that the project would block its public view.

The project and new or foreseeable projects are within an “urbanized area” as defined per Public Resources Code section 21071. At this location they would be consistent with policies in the General Plan and conform with applicable zoning and other regulations governing scenic quality.

The project includes outdoor lighting for driveways, entrances, walkways, parking areas, and security purposes. LED lighting fixtures would be installed throughout the project site. Outdoor lighting would be angled downward onsite and include light visors, light hoods, and utilize lighting controls to reduce energy usage.

Exterior surfaces of the project would consist primarily of colored precast concrete panels, glass curtain walls, pre-manufactured colored EIFS (Exterior Insulation and Finish System) layers, and metal panels that would significantly reduce reflectance offsite.

The project site does not border residential uses. The nearest residential area “as the crow flies” is approximately 1,500 feet south of the project site. For these reasons, project impacts to aesthetics would be less than significant and not cumulatively considerable.

Air Quality

Less Than Significant with Mitigation Incorporated. The proposed project would be located in Santa Clara County in the San Francisco Bay Area Air Basin (SFBAAB), under the jurisdiction of the Bay Area Air Quality Management District (BAAQMD). The SFBAAB is designated as a nonattainment area for ozone and particulate matter with a diameter of 2.5 microns or less (called “PM2.5”) under both California Ambient Air Quality Standards (CAAQS) and National Ambient Air Quality Standards (NAAQS). The SFBAAB is also designated as nonattainment for particulate matter with a diameter of 10 microns or less (called “PM10”) under CAAQS, but not NAAQS.

SFBAAB's nonattainment status is attributed to the region's development history. Past, present, and future development projects contribute to the region's adverse air quality impacts on a cumulative basis. In developing thresholds of significance for air pollutants, BAAQMD considers the emission levels for which a project's individual emissions would be cumulatively considerable. If a project exceeds the identified significance thresholds, its emissions would be cumulatively considerable, resulting in significant adverse air quality impacts to the region's existing air quality conditions. CEQA would then require implementation of all feasible mitigation measures.

The demolition and construction emissions of the project would be lower than the thresholds of significance from the BAAQMD CEQA Air Quality Guidelines. There is no numerical threshold for fugitive dust generated during construction in BAAQMD. BAAQMD considers fugitive dust emissions to be potentially significant without incorporation of basic construction mitigation measures, also called best management practices (BMPs). The applicant would be required to incorporate the BAAQMD's recommended BMPs and staff identifies this as mitigation measure **AQ-1**. Therefore, the project's construction emissions would not be cumulatively considerable.

For project operation, including readiness testing and maintenance, NO_x emissions of the standby generators are not estimated to exceed the BAAQMD significance threshold of 10 tons per year. All other pollutants would also have estimated emission rates below BAAQMD significance thresholds. As discussed in **Section 4.3 Air Quality**, the daily average and annual emissions of criteria air pollutants and precursors during total project operation would not exceed any applicable threshold of significance, and the project would not result in a cumulatively significant emissions increase. Therefore, the project emissions during operation, including readiness testing and maintenance would not be cumulatively considerable.

The criteria pollutant air quality impact analysis found that the concentrations from construction and readiness testing and maintenance of the gensets would not cause any exceedance of ambient air quality standards. Therefore, the project's criteria air pollutant impacts from genset readiness testing and maintenance would be less than significant.

The health risk assessment shows that the project's health risk impacts would not exceed BAAQMD significance thresholds during construction or emergency backup generator readiness testing and maintenance. The project would not expose sensitive receptors to substantial toxic air contaminant (TAC) concentrations during construction or emergency backup generator readiness testing and maintenance.

Due to the infrequent nature of emergency conditions and the record of highly reliable electric service available to the project (see **Appendix B**), the project's emergency operations would be unlikely to expose sensitive receptors to substantial concentrations of criteria air pollutants or TACs.

Therefore, the project's air quality impacts would not be cumulatively significant.

Biological Resources

Less Than Significant Impact with Mitigation Incorporated. One operational impact that could potentially affect biological resources, and be cumulatively significant, is an indirect impact resulting from project-related nitrogen deposition on nitrogen-sensitive habitats resulting from emergency testing and sporadic (undefined) emergency operation of the diesel backup generators. Using California Natural Diversity Database Rarefind and BIOS, and the Santa Clara Valley Habitat Agency Geobrowser, CEC staff identified two areas of protected habitat sensitive to nitrogen deposition within a six-mile radius of the project (the typical deposition zone for NO_x with reliable modeling results). These include northern coastal salt marsh located in the Guadalupe Slough near the San Francisco Bay Trail, approximately five miles northwest of the proposed project site, and serpentine soil located inside the six-mile search radius northeast of the project where serpentine bedrock is mapped. CEC staff used nitrogen deposition modeling data from similar SPPE projects with similar distances from these habitats to assess possible impacts from the Martin project. After a thorough analysis, staff concluded that nitrogen deposition would have a less than significant impact on biological resources, and therefore would not result in a significant cumulative impact.

Similarly, another potential cumulatively significant impact would be to the urban forest and heritage trees which are protected under the City of Santa Clara General Plan and sections of the Santa Clara City Code. There are three heritage trees as well as thirty other trees that would be removed, all of them protected under the general plan and city code, which would require a city-issued permit. The applicant has committed to following the tree permit and the final requirements from the Architectural Review as part of the project, which would include the protection measures specified in the Certified Arborist Report (see **Section 4.4 Biological Resources** for more information). This is detailed within mitigation measures **MM BIO-6** and **MM BIO-7**. With adherence to **MM BIO-6** and **MM BIO-7** construction and operation of the project would not have a significant nor a cumulatively significant impact on biological resources.

Cultural and Tribal Cultural Resources

Less Than Significant Impact with Mitigation Incorporated. The General Plan FEIR does not specifically address impacts on tribal cultural resources. Historical resources and unique archaeological resources, as defined by CEQA, share several of the impact vulnerabilities that tribal cultural resources face, especially the effects of ground-disturbing activities. In addition, historical and unique archaeological resources can also qualify as tribal cultural resources. The suite of mitigation measures for cultural resources presented in the General Plan FEIR would reduce the severity of some impacts on tribal cultural resources. No known tribal cultural resources have been found on the project site, although ground disturbance associated with the proposed project could result in the exposure and destruction of buried, as-yet unknown archaeological resources that could qualify as tribal cultural resources. Implementation of mitigation measures **CUL-1** through **CUL-9** would prevent, minimize, or compensate for impacts on buried, tribal

cultural resources. Project impacts to tribal cultural resources therefore would not be cumulatively considerable.

Energy and Energy Resources

Less Than Significant Impact. The project would use 44 Tier 4 renewable diesel-fired gensets for emergency backup generation, and administration and life safety service needs. The total number of hours of operation from the gensets for operational reliability purposes would be limited to no more than 50 hours annually.

At a rate of 50 hours, the total quantities of renewable diesel or ultra-low-sulfur diesel (ULSD) fuel used for all the gensets operating at full load would approximate 10,000 barrels per year (bbl/yr). California has a renewable diesel and ULSD fuel supply of approximately 6,300,000 bbl/yr and 310,000,000 bbl/yr, respectively. The project's use of fuel constitutes a small fraction of the renewable diesel and ULSD's available resources (less than 0.15 and 0.003 percent, respectively)—the supply from the combination of these two resources is more than sufficient to meet the project's necessary demand. For these reasons, the project's use of fuel would be less than significant.

The project's consumption of energy resources during operation would not be inefficient or wasteful, as discussed in **Section 4.6 Energy and Energy Resources**. Project operation would have a less than significant adverse effect on local or regional energy supplies and energy resources and likewise, would not be cumulatively considerable.

Geology and Soils

Less Than Significant with Mitigation Incorporated. The Santa Clara General Plan identified six policies (5.6.3-G1, 5.6.3-G2, 5.6.3-P1, 5.6.3-P2, 5.6.3-P4, and 5.6.3-P5) that specifically address impacts on paleontological resources (Santa Clara 2010). Paleontological resources can be impacted by the effects of ground-disturbing activities. A search of the University of California Museum of Paleontology database failed to identify any paleontological resources at or within the vicinity of the site (UCMP 2022). However, ground-disturbing activities of ten feet or more have the potential to impact undiscovered paleontological resources. The project would require excavation trenching of depths of up to 15 feet below the existing grade. Foundations would be augured piles, likely to exceed depths of 30 feet below the existing grade. Although unlikely, paleontological resources could be encountered during construction of the project.

Adherence to the City of Santa Clara General Plan and implementation of **GEO-1** included in **Section 4.7 Geology and Soils** would reduce the impacts to buried paleontological resources to a less-than-significant level. The proposed project is unlikely to eliminate important examples of paleontological resources that are part of the prehistory of California and project impacts to paleontological resources therefore would not be cumulatively considerable.

Hazards and Hazardous Materials

Less Than Significant with Mitigation Incorporated. As discussed in **Section 4.9 Hazards and Hazardous Materials** the project would use hazardous materials in small quantities as associated with demolition and construction. When not in use, any hazardous material would be stored in designated construction staging areas in compliance with local, state, and federal requirements. Diesel fuel transport would comply with all appropriate regulations regarding transport of hazardous materials on California roads and highways. Although diesel fuel would be stored on-site, it would be stored in dedicated 5,400-gallon diesel fuel storage tanks for each generator. The design features of the storage tanks would ensure that the diesel fuel generators meet the secondary containment requirements of the California Health and Safety Code for the above ground petroleum storage tank program. The risk of a fire on site would be reduced to less than significant through adherence to applicable codes and the use of effective safety management practices. In addition, the project would implement procedures, safety features, and precautions that would reduce the risk of an accidental hazardous materials release. The incorporation of **HAZ-1** would ensure the testing and removal of lead-based paint contaminated materials prior to building demolition. With incorporation of **HAZ-2** and **HAZ-3**, soil and groundwater samples would be taken, and any contaminated soil and groundwater encountered would be handled and disposed of properly. Therefore, the impact from the use, transport, disposal, or accidental release of hazardous materials would not be considered cumulatively significant.

Hydrology and Water Quality

Less Than Significant Impact. The project would be required to comply with the City of Santa Clara Flood Damage Prevention Code (Chapter 15.45), the Construction and Municipal National Pollutant Discharge Elimination System Permits, and the Santa Clara Valley Urban Runoff Pollution Prevention Program. The plans and permits work together to establish specific requirements to reduce storm water pollution from new and redevelopment projects, singularly and cumulatively. If implemented as described in **Section 4.10 Hydrology and Water Quality** of this analysis, these standards would protect the watershed receiving discharge from the project from a cumulatively considerable impact to the basin's hydrology. Similarly, these same plans and permits would be protective of water quality. These standards would be protective of the quality of both surface water and groundwater bodies receiving discharge from the project and impacts would not be cumulatively significant.

Land Use and Planning

Less Than Significant Impact. A land use impact could occur if a project would physically divide an established community. Project construction and operation would occur mostly onsite and would not prevent pedestrian, bike, or vehicular movement between different areas of the community, and therefore the project would not physically divide an established community.

A land use impact could also occur if a project would cause a significant environmental impact due to a conflict with any land use plan, policy, or regulation adopted for the purpose of avoiding or mitigating an environmental effect. Staff assessed consistency of the proposed project with relevant policies and regulatory requirements contained in the City of Santa Clara 2010–2035 General Plan (General Plan), the Santa Clara Zoning Code, and the Comprehensive Land Use Plan (CLUP) for the San José Mineta International Airport. The General Plan land use designation for the site is Heavy Industrial, which accommodates data center land uses, and the project would be consistent with all applicable General Plan policies. The proposed project would also be consistent with the Santa Clara Zoning Code, with City of Santa Clara approval of a conditional use permit for the data center use, and approval of a minor modification for the project height. With these City approvals, the project would be consistent with the uses and standards associated with the site's Heavy Industrial zoning designation. The proposed project would also be consistent with the CLUP after a forthcoming amendment, which considers current and planned future airport operations. The amendment would remove the Turning Safety Zone from the project site, and therefore, the project's proposed above-ground fuel storage tanks would no longer be located within this zone or any other safety zone where these tanks are prohibited. The City of Santa Clara would ensure project compliance with all applicable CLUP policies during the permit review process. For these reasons, project impacts due to conflicts with land use plans, policies, or regulations adopted for the purpose of avoiding or mitigating an environmental effect would be less than significant, and there would be no cumulative impacts from conflicts with land use regulations. See **Section 4.11 Land Use and Planning** for details.

Public Services

Less Than Significant Impact. As discussed in **Section 4.15 Public Services**, the construction and operation of the project would not result in substantial adverse physical environmental impacts associated with the provision of new or physically altered fire and police service facilities to maintain acceptable service ratios, response times, or other performance objectives. The project would be consistent with the planned growth in the general plan. The project plans would be reviewed by the Santa Clara Fire Department to ensure appropriate safety features are incorporated to reduce fire hazards.

In accordance with California Government Code Section 65996, the project would be required to pay the appropriate school impact fees to the Santa Clara Unified School District. Operation of the project is anticipated to require approximately 19 to 21 employees, which the applicant anticipates would be drawn from the great Bay Area. Even if all of the operation workforce would relocate closer to the project site, the additional population would be consistent with growth projections and service ratios in the General Plan and thus the project would not cause significant environmental impacts associated with the provision of new or physically altered park and other public facilities in order to maintain acceptable service ratios or other performance objectives. The project's impacts to the public services would not be cumulatively considerable.

Recreation

Less Than Significant Impact. As discussed in **Section 4.16 Recreation**, the project does not require or propose the construction or expansion of recreation facilities. Operation of the project is anticipated to require 19 to 21 employees. The project's operation workforce would be consistent with growth projections and service ratios in the General Plan and, thus, the project would not increase the use of existing parks or recreational facilities to the extent that substantial physical deterioration of the park or facility would result. The project's impacts to recreation would not be cumulatively considerable.

c. Does the project have environmental effects which will cause substantial adverse effects on human beings, either directly or indirectly?

Less Than Significant Impact. The proposed project would not cause substantial adverse effects on human beings either directly or indirectly. The proposed project would result in less than significant impacts to human health during construction and operation, including changes to air and water quality, and exposure to geologic hazards, noise, and hazardous materials, as well as from greenhouse (GHG) emissions. As discussed in **Section 4.3 Air Quality**, with implementation of **AQ-1**, which includes the BAAQMD's recommended BMPs for fugitive dust and construction equipment emissions, the project would result in a less than significant impact related to human health. As discussed in **Section 4.7 Geology and Soils**, impacts to people or property associated with geologic or seismic conditions onsite would be less than significant. As discussed in **Section 4.8 Greenhouse Gas Emissions**, direct GHG emissions from maintenance and testing of the project gensets would be less than significant with implementation of **GHG-1**, and indirect GHG emissions from the project's energy usage, mobile sources, and building operation (electricity use) would be less than significant with implementation of **GHG-2**. The project would result in temporary noise impacts to humans during construction and intermittently during operation. As discussed in **Section 4.13 Noise**, noise impacts would be less than significant. As discussed in **Section 4.9 Hazards and Hazardous Materials**, hazards impacts would be less than significant with the implementation of **HAZ-1**, **HAZ-2**, and **HAZ-3**. As discussed in **Section 4.10 Hydrology and Water Quality**, water quality impacts would be less than significant. No additional impacts to human beings would occur during construction, operation and maintenance activities.

References

- DayZenLLC 2022a – DayZenLLC (DayZenLLC). (TN 247325). MGBF SPPE Application – Part I – Main App and Appendix A, dated November 7, 2022. Available online at: <https://efiling.energy.ca.gov/Lists/DocketLog.aspx?docketnumber=22-SPPE-03>
- Santa Clara 2010 – City of Santa Clara (Santa Clara). City of Santa Clara 2010–2035 General Plan. Adopted November 16, 2010. Available online at: <https://www.santaclaraca.gov/our-city/departments-a-f/community-development/planning-division/general-plan>

Santa Clara 2011 – City of Santa Clara (Santa Clara). 2010-2035 General Plan Integrated Final Environmental Impact Report. January 2011. Available online at: <http://santaclaraca.gov/home/showdocument?id=12900>

UCMP 2022 – University of California Museum of Paleontology (UCMP) 2021. UCMP database. Accessed on: November 17, 2022. Available online at: <http://ucmpdb.berkeley.edu/>

4.21 Environmental Justice

This section describes the environmental setting and regulatory background and discusses impacts specific to environmental justice associated with the construction and operation of the proposed project.

4.21.1 Environmental Setting and Regulatory Background

The United States Environmental Protection Agency (U.S. EPA) defines environmental justice (EJ) as, “the fair treatment and meaningful involvement of all people regardless of race, color, national origin or income with respect to the development, implementation and enforcement of environmental laws, regulations and policies” (U.S. EPA 2015, pg. 4).

The “Environmental Justice in the Energy Commission Site Certification Process” subsection immediately below describes why EJ is part of the California Energy Commission’s (CEC’s) site certification process, the methodology used to identify an EJ population, and the consideration of data from the California Environmental Protection Agency’s (CalEPA) California Communities Environmental Health Screening Tool (CalEnviroScreen 4.0). Below that, the “Project Outreach” subsection discusses the CEC’s outreach program specifically as it relates to the proposed project. Lastly, the “Environmental Justice Project Screening” subsection presents the demographic data for those people living in a six-mile radius of the project site and a determination on presence or absence of an EJ population. When an EJ population is identified, the analysis in 10 technical areas¹ consider the project’s impacts on this population and whether any impacts would disproportionately affect the EJ population.

Environmental Justice in the CEC Site Certification Process

California law defines EJ as “the fair treatment of people of all races, cultures and income with respect to the development, adoption, implementation, and enforcement of environmental laws, regulations, and policies” (Gov. Code, § 65040.12; Pub. Resources Code, §§ 71110-71118). All departments, boards, commissions, conservancies and special programs of the California Natural Resources Agency must consider EJ in their decision-making process if their actions have an impact on the environment, environmental laws, or policies. Such actions that require EJ consideration may include:

- Adopting regulations;
- Enforcing environmental laws or regulations;
- Making discretionary decisions or taking actions that affect the environment;
- Providing funding for activities affecting the environment; and

¹ The 10 technical areas are Aesthetics, Air Quality, Cultural and Tribal Cultural Resources, Hazards and Hazardous Materials, Hydrology and Water Quality, Land Use and Planning, Noise, Population and Housing, Transportation, and Utilities and Service Systems. Cultural and Tribal Cultural Resources considers impacts to Native American populations.

- Interacting with the public on environmental issues.

The California Natural Resources Agency recognizes that EJ communities are commonly identified as those where residents are predominantly minorities or live below the poverty level; where residents have been excluded from the environmental policy setting or decision-making process; where they are subject to a disproportionate impact from one or more environmental hazards; and where residents experience disparate implementation of environmental regulations, requirements, practices, and activities in their communities. Environmental justice efforts attempt to address the inequities of environmental protection in these communities.

An EJ analysis is composed of the following:

- Identification of areas potentially affected by various emissions or impacts from a proposed project;
- Providing notice in appropriate languages (when possible) of the proposed project and opportunities for participation in public meetings to EJ communities;
- A determination of whether there is a significant population of minority persons, or persons below the poverty level, living in an area potentially affected by the proposed project; and
- A determination of whether there may be a significant adverse impact on a population of minority persons or persons below the poverty level caused by the proposed project alone, or in combination with other existing and/or planned projects in the area.

Bay Area Air Quality Management District Community Health Programs

The project site is located within the Bay Area Air Quality Management District (BAAQMD). BAAQMD has community health programs intended to reduce air pollution disparities in the San Francisco Bay Area. The Community Health Protection Program is BAAQMD's local implementation of the California Air Resources Board's (CARB) Community Air Protection Program, as enacted by Assembly Bill (AB) 617 (C. Garcia, Chapter 136, Statutes of 2017).²

² The statewide Community Air Protection Program requires CARB to develop a new community-focused program to reduce exposure more effectively to air pollution and preserve public health and to take measures to protect communities disproportionately impacted by air pollution. CARB is required to select the highest priority locations in the state for the deployment of community air monitoring systems and select locations around the state for the preparation of community emissions reduction programs. CARB's governing board has selected 17 communities for a community emissions reduction program (CARB 2023). The project site is not located in an AB 617 community.

The Community Air Risk Evaluation (CARE) program was implemented by BAAQMD to identify areas in the Bay Area that experience a disproportionate share of air pollution exposure. One goal of the CARE program is to identify areas where air pollution contributes most to health impacts and where populations are most vulnerable to air pollution (BAAQMD 2023). The proposed project is located in the 2013 Cumulative Impact Area and therefore a CARE community. However, since its overall CalEnviroScreen

CalEnviroScreen - More Information About an EJ Population

CalEnviroScreen is a science-based mapping tool used by CalEPA to identify disadvantaged communities³ pursuant to Health and Safety Code section 39711 as enacted by Senate Bill (SB) 535 (De León, Stats. 2012 Ch. 830). As required by state law, disadvantaged communities are identified based on geographic, socioeconomic, public health, and environmental hazard criteria. CalEnviroScreen identifies impacted communities by taking into consideration pollution exposure and its effects, as well as health and socioeconomic status, at the census-tract level (OEHHA 2021, pg. 8).⁴

Using data from federal and state sources, the tool consists of four components in two broad categories. The Exposure and Environmental Effects components comprise a Pollution Burden category, and the Sensitive Populations and Socioeconomic Factors components comprise a Population Characteristic category. The four components are made up of environmental, health, and socioeconomic data from 21 indicators.

CalEnviroScreen scores presents a relative, rather than an absolute, evaluation of pollution burdens and vulnerabilities in California communities by providing a relative ranking of communities across the state (OEHHA 2021, pg. 8). Calculating the CalEnviroScreen scores begins by assigning percentile scores to the 21 statewide indicators, which fall into two categories of Pollution Burden and Population Characteristics. The percentiles are averaged for the set of indicators in each of the four components (Exposures, Environmental Effects, Sensitive Populations, and Socioeconomic Factors). These four components in turn, are combined to yield an overall CalEnviroScreen score (Cal/EPA 2022a, pg. 5-6). Each category has a maximum score of 10, and, thus, when multiplied the maximum CalEnviroScreen score is 100. Based on these scores, census tracts across California are ranked relative to one another. Values for the various components are shown as percentiles, which indicate the percent of all census tracts with a lower score. A higher percentile indicates a higher potential relative burden. A percentile does not describe the magnitude of the difference between two tracts, but rather it simply tells the percentage of tracts with lower values for that indicator (OEHHA 2021, pg. 20).

4.0 percentile score is 60 (less than 70), the proposed project is not located in an overburdened community (BAAQMD 2021).

3 The California Environmental Protection Agency, for purposes of its Cap-and-Trade Program, defines communities in terms of census tracts and identifies four types of geographic areas as disadvantaged: (1) census tracts receiving the highest 25 percent of overall scores in CalEnviroScreen 4.0; (2) census tracts lacking overall scores in CalEnviroScreen 4.0 due to data gaps, but receiving the highest 5 percent of CalEnviroScreen 4.0 cumulative pollution burden scores; (3) census tracts identified in the 2017 DAC designation as disadvantaged, regardless of their scores in CalEnviroScreen 4.0; (4) and areas under the control of federally recognized Tribes (CalEPA 2022a).

4 Note that CalEnviroScreen is not intended to substitute for a cumulative impact analysis under the California Environmental Quality Act (CEQA); restrict the authority of government agencies in permit and land use decisions; or guide all public policy decisions.

Table 4.21-1 lists the indicators that go into the Pollution Burden score and the Population Characteristics score to form the final CalEnviroScreen score. These indicators are used to measure factors that affect the potential for pollution impacts in communities.

TABLE 4.21-1 COMPONENTS THAT FORM THE CALENVIROSCREEN 4.0 SCORE	
Pollution Burden	
Exposure Indicators	Environmental Effects Indicators
Children’s lead risk from housing	Cleanup sites
Diesel particulate matter (PM) emissions	Groundwater threats
Drinking water contaminants	Hazardous waste
Ozone concentrations	Impaired water bodies
PM 2.5 concentrations	Solid waste sites and facilities
Pesticide use	
Toxic releases from facilities	
Traffic impacts	
Population Characteristics	
Sensitive Populations Indicators	Socioeconomic Factors Indicators
Asthma emergency department	Educational attainment
Cardiovascular disease (emergency department visits for heart attacks)	Housing burdened low-income households
Low birth-weight infants	Linguistic isolation
	Poverty
	Unemployment

Notes: PM= particulate matter. PM 2.5= fine particulate matter 2.5 microns or less. Source: OEHHA 2021

For the technical areas of Air Quality, Hydrology and Water Quality, and Utilities and Service Systems, CEC staff (staff) review the CalEnviroScreen data for the project area as follows:

- For Air Quality, these indicators are asthma, cardiovascular disease, diesel particulate matter (PM) emissions, low birth-weight infants, ozone concentrations, pesticide use, PM with diameters of 2.5 micrometers or smaller (PM2.5) concentrations, toxic releases from facilities, and traffic impacts.
- For Hydrology and Water Quality, these indicators are drinking water contaminants, groundwater threats, and impaired water bodies.
- For Utilities and Service Systems, these indicators are cleanup sites, hazardous waste, and solid waste sites and facilities.

When these technical areas have identified a potential project impact where an EJ population is present, CalEnviroScreen is used to better understand the characteristics of the areas where the impact would occur and ensure that disadvantaged communities in the vicinity of the proposed project have not been missed when screened by race/ethnicity and low income.

Project Outreach

Environmental justice principles are described in California Government Code section 65040.12, and may be incorporated into local land use standards. Under this guidance, one principle of environmental justice is for government decisionmakers to engage in meaningful involvement with potentially impacted communities. Consistent with US EPA policy, meaningful involvement occurs when:

- those whose environment or health would be potentially affected by the decision on the proposed activity have an appropriate opportunity to participate in the decision;
- the population's contribution can influence the decision; and,
- the concerns of all participants involved are considered in the decision-making process.

Furthermore, it is the policy of California Natural Resources Agency that the public, including minority and low-income populations, are informed of opportunities to participate in the development and implementation of all Resources Agency programs, policies and activities, and that they are not discriminated against, treated unfairly, or caused to experience disproportionately high and adverse human health or environmental effects from environmental decisions (CNRA 2023).

The staff docketed and mailed to the project mail list a Notice of Preparation of a draft EIR on February 17, 2023. Translation of the public notice was not necessary because there are no residences within 1,000 feet of the project site.

Environmental Justice Project Screening

Figure 4.21-1 shows 2020 census blocks in a six-mile radius of the project with a minority population greater than or equal to 50 percent (U.S. Census 2020). The population in these census blocks represents an EJ population based on race and ethnicity as defined in the U.S. EPA's *Guidance on Considering Environmental Justice During the Development of Regulatory Actions* (U.S. EPA 2015).

Based on California Department of Education data in **Table 4.21-2** and presented in **Figure 4.21-2**, staff concludes that the percentage of those living in the school districts of Luther Burbank Elementary, Orchard Elementary, San Jose Unified, and Santa Clara school districts (in a six-mile radius of the project site) are enrolled in the free or reduced price meal program is larger than those in the reference geography (Santa Clara County). Thus, the populations in these school districts are considered an EJ population based on a low income population as defined in *Guidance on Considering Environmental Justice During the Development of Regulatory Actions*.

TABLE 4.21-2 LOW INCOME DATA WITHIN THE PROJECT AREA

School Districts in a Six-Mile Radius of the Project Site	Enrollment Used for Meals	Free or Reduced Price Meals	
Berryessa Union Elementary	5,940	1,588	26.7%
Campbell Union Elementary	6,253	2,070	33.1%
Cupertino Union Elementary	13,467	2,153	16.0%
Luther Burbank Elementary	422	350	82.9%
Milpitas Unified	9,967	2,802	28.1%
Moreland Elementary	3,940	1,311	33.3%
Orchard Elementary	763	335	43.9%
Santa Clara Unified	13,919	5,602	40.2%
San Jose Unified	26,479	11,284	42.6%
Sunnyvale Elementary	5,465	1,636	29.9%
Reference Geography			
Santa Clara County	236,428	80,551	34.1%

Note: **Bold** indicates school districts considered having an EJ population based on low income. Source: CDE 2023.

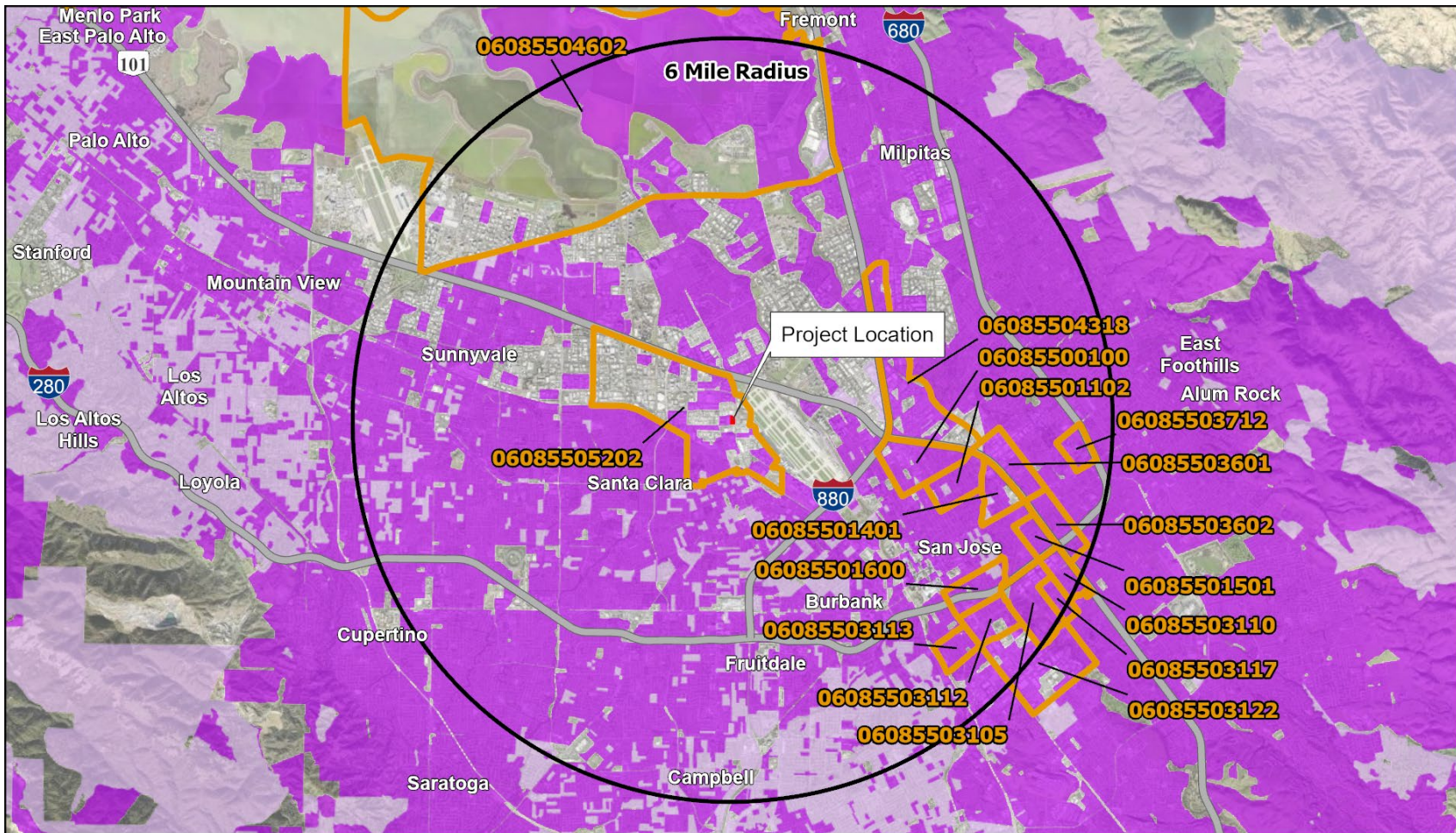

■ Martin Backup Generating Facility (MBGF)

 6 Mile Radius

 Disadvantaged Communities That Intersect the 6 Mile Radius

2020 Census

Percent Minority Population by Census Block

- 0 - 49%
- 50 - 100%

Disadvantaged Communities are Census tracts that: 1. have highest 25 percent of overall scores in CalEnviroScreen 4.0 (CES 4.0); 2. lack overall scores in CES 4.0 due to data gaps, but receive highest 5 percent of CES 4.0 cumulative pollution burden scores; 3. are identified in 2017 DAC designation as disadvantaged, regardless of CES 4.0 scores; and, 4. are under control of federally recognized Tribes (CalEPA 2022).



**Figure 4.21-1
Minority Population and
Disadvantaged Communities**

Census 2020 PL 94-171 Data and SB 535
Disadvantaged Communities, 2022

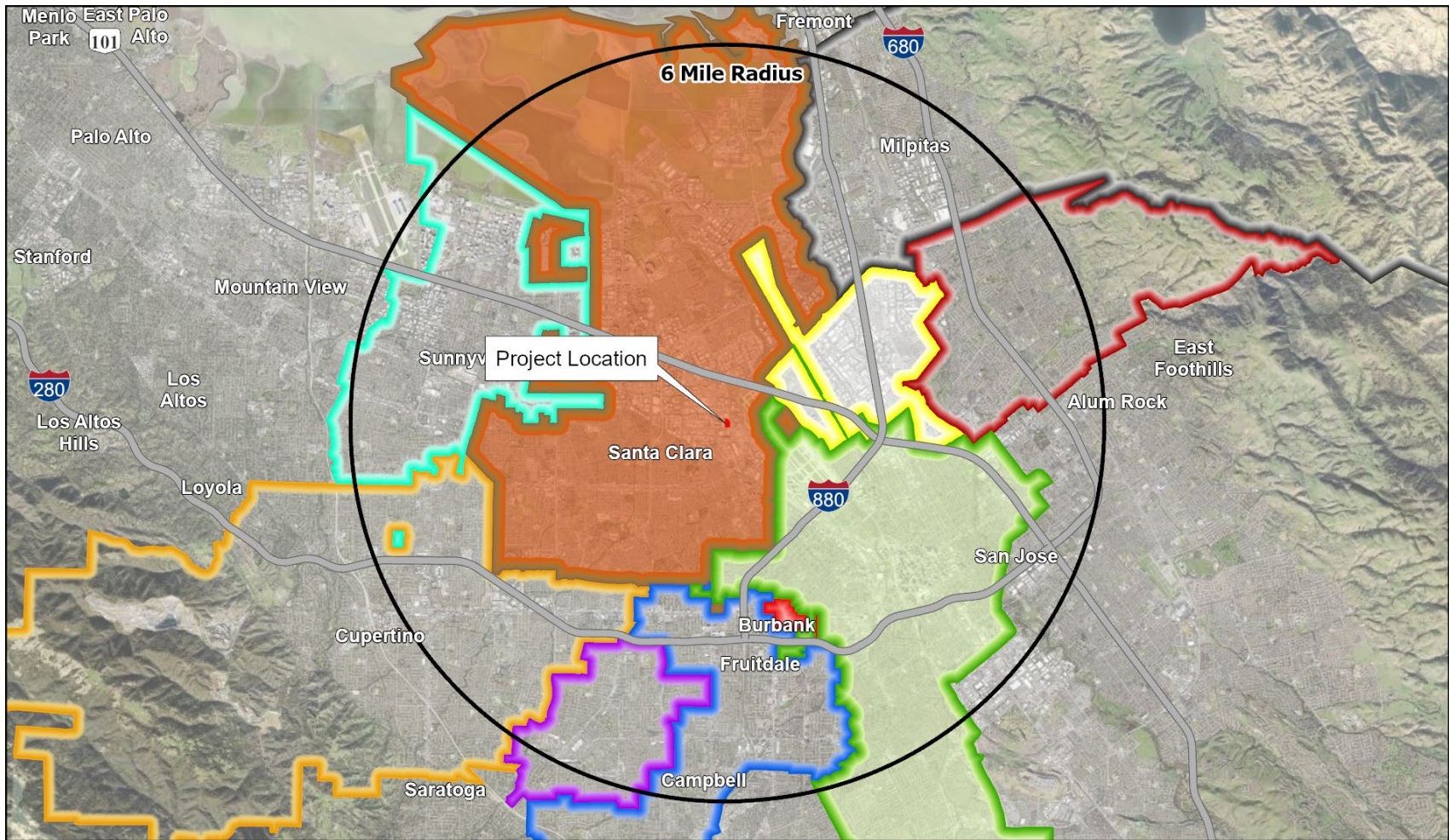

Martin Backup Generating Facility (MBGF)	San Jose Unified
6 Mile Radius	Santa Clara Unified
Campbell Union Elementary	Sunnyvale Elementary
Cupertino Union Elementary	Luther Burbank Elementary
Moreland	Berryessa Union Elementary
Orchard Elementary	Milpitas Unified

**Figure 4.21-2
Low Income Population**

Note: Shaded areas have an EJ population based on low income
Sources: TIGER Data, CDE 2023

Table 4.21-3 presents the CalEnviroScreen overall scores and DAC category for the disadvantaged communities within a six-mile radius of the project site. The location of each of these census tracts is shown on **Figure 4.21-1**. Staff used CalEnviroScreen to identify disadvantaged communities⁵ in the vicinity of the proposed project and better understand the characteristics of the areas where impacts would occur.

TABLE 4.21-3 CALENVIROSCREEN SCORES FOR DISADVANTAGED COMMUNITIES

Census Tract No.	Total Population	CES 4.0 Percentile	Pollution Burden Percentile	Population Characteristics Percentile	DAC Category
06085505202	6,936	59.53	86.86	37.92	CES 3.0 DAC Only
06085501401	3,226	71.72	67.98	66.69	CES 3.0 DAC Only
06085501600	7,716	85.01	77.80	81.48	CES 4.0 top 25%
06085503113	5,052	67.75	62.85	63.46	CES 3.0 DAC Only
06085503112	4,141	77.50	75.68	70.34	CES 4.0 top 25%
06085503105	2,460	78.97	70.19	76.61	CES 4.0 top 25%
06085504318	6,095	80.06	88.82	63.28	CES 4.0 top 25%
06085500100	8,306	71.19	89.77	50.16	CES 3.0 DAC Only
06085501102	4,305	71.32	79.53	57.83	CES 3.0 DAC Only
06085503712	4,484	75.77	40.05	94.52	CES 4.0 top 25%
06085503601	3,383	85.36	84.12	76.94	CES 4.0 top 25%
06085503602	5,602	75.71	49.27	87.28	CES 4.0 top 25%
06085501501	4,623	71.03	49.88	79.37	CES 3.0 DAC Only
06085503110	4,917	77.17	50.57	88.65	CES 4.0 top 25%
06085503117	3,071	59.32	27.54	79.53	CES 3.0 DAC Only
06085503122	3,602	69.25	67.58	62.68	CES 3.0 DAC Only
06085504602	2,355	66.97	82.46	49.76	CES 3.0 DAC Only

Notes: Disadvantaged communities by census tract in the project’s six-mile radius. Shaded row indicates census tract where project is located.

Source: CalEPA 2022b

The CalEnviroScreen indicators are used to measure factors that affect the potential⁶ for pollution impacts in communities. **Table 4.21-4** presents the CalEnviroScreen percentiles for the indicators that make up the pollution burden percentile. **Table 4.21-5** presents

5 The CalEPA, for purposes of its Cap-and-Trade Program, has defines communities in terms of census tracts and identifies four types of geographic areas as disadvantaged: (1) census tracts receiving the highest 25 percent of overall scores in CalEnviroScreen 4.0; (2) census tracts lacking overall scores in CalEnviroScreen 4.0 due to data gaps, but receiving the highest 5 percent of CalEnviroScreen 4.0 cumulative pollution burden scores; (3) census tracts identified in the 2017 DAC designation as disadvantaged, regardless of their scores in CalEnviroScreen 4.0; (4) and areas under the control of federally recognized Tribes. (CalEPA 2022a).

6 It is important to note that CalEnviroScreen is not an expression of health risk and does not provide quantitative information on increases of impacts for specific sites or project. CalEnviroScreen uses the criteria of “proximity” to a hazardous waste site, a leaking underground tank, contaminated soil, an emission stack (industry, power plant, etc.) to determine that a population is “impacted”. It does not address general principles of toxicology: dose/response and exposure pathways. For certain toxic chemicals to pose a risk to the public, offsite migration pathways must exist (through ingestion, inhalation, dermal contact, etc.) and contact to a certain amount – not just any amount – must exist.

the CalEnviroScreen percentiles for the indicators that make up the population characteristics.

TABLE 4.21-4 CALENVIROSCREEN INDICATOR PERCENTILES FOR POLLUTION BURDEN FOR DISADVANTAGED COMMUNITIES

Census Tract No.	Percentiles													
	Pollution Burden	Ozone	PM2.5	Diesel PM	Drinking Water	Lead	Pesticides	Toxic Release	Traffic	Cleanup Sites	Groundwater Threats	Hazardous Waste	Impaired Water Bodies	Solid Waste
06085505202	86.86	17.65	22.50	79.33	50.17	56.66	1.97	37.85	82.46	99.85	98.41	98.37	33.16	95.01
06085501401	67.98	20.85	37.29	78.38	22.74	83.02	0.00	33.03	87.66	62.04	73.75	28.30	33.16	85.22
06085501600	77.80	20.85	37.13	95.13	22.74	83.20	0.79	32.10	79.25	50.56	91.57	65.18	43.78	77.96
06085503113	62.85	20.85	32.20	79.96	22.74	88.75	0.00	32.12	77.06	33.87	92.98	35.98	33.16	70.42
06085503112	75.68	22.19	35.54	89.82	22.74	57.69	0.00	31.56	62.36	72.81	93.52	77.02	43.78	91.04
06085503105	70.19	22.19	38.77	83.48	22.74	24.39	0.00	30.98	91.53	70.42	82.32	75.96	33.16	94.57
06085504318	88.82	20.85	33.71	90.49	22.74	52.73	4.97	39.48	94.31	99.74	96.73	99.85	33.16	99.77
06085500100	89.77	20.85	37.86	89.71	22.74	70.23	3.59	35.00	81.73	98.11	96.26	98.99	43.78	97.87
06085501102	79.53	20.85	36.85	63.71	22.74	91.30	0.41	33.76	68.21	83.85	88.01	86.45	33.16	91.43
06085503712	40.05	20.85	34.18	87.99	22.74	58.49	0.00	31.16	95.96	0.00	43.85	88.48	12.45	0.00
06085503601	84.12	20.85	35.76	91.50	22.74	93.48	0.00	33.02	91.00	81.02	62.49	91.36	33.16	84.74
06085503602	49.27	22.19	41.56	95.30	22.74	75.97	0.00	31.20	94.83	0.00	62.73	78.98	12.45	0.00
06085501501	49.88	20.85	38.97	94.82	22.74	77.82	0.00	31.41	98.70	0.00	66.45	11.08	33.16	44.31
06085503110	50.57	22.19	38.56	96.17	22.74	60.89	0.00	30.83	99.54	0.00	63.71	24.71	33.16	54.85
06085503117	27.54	22.19	37.62	44.54	22.74	52.79	0.00	30.66	58.18	18.70	47.43	16.64	33.16	64.40
06085503122	67.58	22.19	33.20	80.29	22.74	29.12	0.00	30.31	53.55	80.37	94.89	87.65	33.16	98.79
06085504602	82.46	15.05	19.43	29.00	39.04	50.59	0.00	30.32	94.13	99.38	94.17	93.21	91.87	99.95

Notes: Disadvantaged communities by census tract in the project's six-mile radius. Shaded row indicates census tract where project is located.

Source: CalEPA 2022b

TABLE 4.21-5 CALENVIROSCREEN INDICATOR PERCENTILES FOR POPULATION CHARACTERISTICS FOR DISADVANTAGED COMMUNITIES

Census Tract No.	Percentiles								
	Population Characteristics	Asthma	Low Birth Weight	Cardiovascular Disease	Education	Linguistic Isolation	Poverty	Unemployment	Housing Burden
06085505202	37.92	28.61	54.62	47.52	55.80	15.64	35.15	4.89	89.21
06085501401	66.69	60.99	73.33	31.68	79.73	93.80	65.93	29.41	62.42
06085501600	81.48	72.98	91.34	39.71	63.76	67.45	80.28	64.51	94.47
06085503113	63.46	53.23	49.62	17.24	91.09	63.04	82.54	57.25	92.84
06085503112	70.34	54.97	73.76	25.87	75.22	86.13	72.40	66.61	73.41
06085503105	76.61	62.33	55.85	39.46	86.36	99.49	69.35	76.05	81.32
06085504318	63.28	36.05	71.79	28.12	78.63	95.72	59.52	78.97	46.02
06085500100	50.16	66.59	54.12	42.40	66.31	76.64	40.80	17.11	26.17
06085501102	57.83	69.65	61.41	45.03	65.20	67.72	34.70	52.52	37.48
06085503712	94.52	88.43	93.65	71.62	83.23	97.48	64.90	56.19	95.67
06085503601	76.94	73.54	77.05	53.39	79.42	95.03	78.45	21.11	63.26
06085503602	87.28	88.33	44.47	71.54	90.36	96.21	71.42	72.53	83.94
06085501501	79.37	81.90	30.59	59.88	89.52	95.21	69.16	81.69	71.15
06085503110	88.65	79.21	53.85	66.05	96.71	95.99	87.39	69.13	83.94
06085503117	79.53	79.47	33.95	66.44	90.94	98.06	79.55	49.86	77.21
06085503122	62.68	44.14	65.36	16.65	81.70	95.29	87.50	15.84	91.46
06085504602	49.76	37.96	98.85	40.00	73.42	NA	27.85	36.44	23.80

Notes: Disadvantaged communities by census tract in the project's six-mile radius. Shaded row indicates census tract where project is located.

Source: CalEPA 2022b

4.21.2 Environmental Impacts and Mitigation Measures

The following technical areas discuss impacts to EJ populations: Aesthetics, Air Quality⁷ Cultural and Tribal Cultural Resources, Hazards and Hazardous Materials, Hydrology and Water Quality, Land Use and Planning, Noise, Population and Housing, Transportation, and Utilities and Service Systems. As noted on page 4.12-4, the three technical areas that could have project impacts that can overlap with the indicators in CalEnviroScreen are: Air Quality, Hydrology and Water Quality, and Utilities and Service Systems.

Aesthetics

Less Than Significant Impact. A disproportionate impact to an EJ population pertaining to Aesthetics may occur if a project is in proximity to an EJ population and any of the following CEQA Guidelines Aesthetics-related considerations are met:

- The project, if in an “urbanized area” per Public Resources Code section 21071 conflicts with applicable zoning and other regulations governing scenic quality.
- The project, if in a non-urbanized area, substantially degrades the existing visual character or quality of the public view of the site and its surroundings.
- The project creates a new source of substantial light and glare that would adversely affect day or nighttime views in the area.

First, the project is in an urbanized area as defined in Public Resources Code section 21071 and conforms to the applicable city zoning and other regulations governing scenic quality.

Second, since the project is not in a non-urbanized area, the second bulleted consideration above is inapplicable.

Last, staff reviewed current aerial and street imagery (2023 dated Google Earth and Google Maps), other maps, site and vicinity photographs in addition to the EJ figures in the EJ section and concluded the nearest EJ population would have a low daylight visibility in the public view of the project due to the existence of aboveground landscape components (buildings, structures, earthworks, trees, etc.) obstructing or obscuring the public view of the project from an EJ population.

Also, the project includes outdoor lighting for driveways, entrances, walkways, parking areas, and security purposes. Outdoor lighting would be angled downward onsite and include light visors, light hoods, and utilize lighting controls to reduce energy usage. LED lighting fixtures would be installed throughout the project site. As such, the nighttime light would not be visible to an EJ population.

And, exterior surfaces of the project would consist primarily of colored precast concrete panels, glass curtain walls, pre-manufactured colored EIFS (Exterior Insulation and Finish

⁷ Public Health concern discussed under Air Quality

System) layers, and metal panels that would significantly reduce reflectance offsite. Project components would have low reflectance offsite.

The project's aesthetic effect would not have a disproportionate effect on an EJ population. The project would have a less than significant impact on the environment.

Air Quality

Less Than Significant with Mitigation Incorporated. **Table 4.21-4** and **Table 4.21-5** include indicators that relate to both air quality and public health. Criteria pollutants such as ozone and PM_{2.5} are indicators related to air quality. Indicators that are associated with protecting public health are: Diesel PM, Pesticide Use, Toxic Release from Facilities, Traffic Impacts, Asthma, Low Birth Weight Infants, and Cardiovascular Disease. Each of these air quality and public health indicators are summarized under this Air Quality subsection.

Staff identified the potential air quality impacts (i.e., ozone and PM_{2.5}) that could affect the EJ population represented in **Figures 4.21-1** and **4.21-2**. Staff also examined individual contributions of indicators in CalEnviroScreen that are relevant to air quality (see **Table 4.21-4**).

Staff identified the potential public health impacts (i.e., cancer and non-cancer health effects) that could affect the EJ population represented in **Figures 4.21-1** and **4.21-2**. These potential public health risks were evaluated quantitatively based on the most sensitive population, which includes the EJ population, by conducting a health risk assessment (HRA). The results were presented by levels of risk. The potential construction and emergency backup generator (gensets) readiness testing and maintenance risks are associated with exposure to diesel PM.

In **Section 4.3 Air Quality**, staff concludes that, with the implementation of mitigation measure **AQ-1**, the project would not have a significant impact on air quality or public health. Criteria pollutants would not cause or contribute significantly to exceedances of health-based ambient standards and the project's toxic air emissions would not exceed health risk limits. Likewise, the project would not cause disproportionate air quality or public health impacts on sensitive populations, such as the EJ population represented in **Figures 4.21-1** and **4.21-2**.

The text below further explains each of the air quality and public health indicators included in **Tables 4.21-4** and **4.21-5**.

Ozone Impacts

Results for ozone are included in **Table 4.21-4**. Ozone levels in all the census tracts within six-mile radius of the project site are relatively low, with percentiles at or below 22. Another way to look at the data is that approximately 78 percent of all California census tracts have higher ozone levels than these census tracts near the project. For

ozone, the census tracts within a six-mile radius of the proposed project's site are not exposed to high ozone concentrations compared to the rest of the state.

The project would not contribute significantly to regional air quality as it relates to ozone. The project would be required to comply with air quality emission rate significance thresholds for NO_x and VOCs, which are precursor pollutants that create ozone during the construction and testing and maintenance phases. The project would use best management practices (BMPs) during construction, which would reduce NO_x and VOCs. The project's impacts would not cause exceedance of AAQS during readiness testing and maintenance. NO_x emissions resulting from readiness testing and maintenance would need to be fully offset to reduce net impacts to levels below the BAAQMD's CEQA threshold. VOC emissions would be below the BAAQMD's threshold of significance and the applicant would not be required to offset them. Therefore, the project would not contribute significantly to regional ozone concentrations, relative to baseline conditions.

Staff concludes that the project would not expose sensitive receptors to substantial ozone precursor concentrations. The project's ozone and ozone precursor air quality impacts would be less than significant for the local EJ community and the general population. Additionally, as NO_x emissions of the gensets would be fully offset, the project would not result in a cumulatively considerable net increase of secondary pollutants such as ozone in the air basin.

PM_{2.5} Impacts

According to CalEnviroScreen data, census tracts are ordered by PM_{2.5} concentration values, and then are assigned a percentile based on the statewide distribution of values and are shown in **Table 4.21-4**. All of the census tracts within the six-mile radius of the project site range from the lowest of 19.43 percentile for census tract 6085504602 to the highest of 41.56 percentile for census tract 6085503602 in the PM_{2.5} indicator (see **Table 4.21-4**). This indicates that the highest PM concentrations in census tract 6085503602 are higher than 41.56 percent of tracts statewide. This means that these communities are exposed to below average PM_{2.5} concentrations compared to the rest of the state.

As fully evaluated in the Air Quality section of this environmental impact report, the project would not contribute significantly to the regional air quality related to PM_{2.5}. The project would not expose sensitive receptors to substantial pollutant concentrations of PM_{2.5} during construction or readiness testing and maintenance of the gensets. The project would use BMPs during construction, which would reduce PM emissions. The gensets would be equipped with diesel PM filters, which would reduce PM emissions from the engines. Therefore, the project would not contribute significantly to regional PM_{2.5} concentrations, relative to baseline conditions.

The project's PM_{2.5} air quality impacts would be less than significant for the local EJ community and the general population. Additionally, as NO_x emissions of the gensets would be fully offset, the project would not result in cumulatively considerable net increase of secondary pollutants such as PM in the air basin.

Diesel Particulate Matter (Diesel PM)

This indicator represents how much diesel PM is emitted into the air within and near the census tract. The data are from 2016 California Air Resources Board's emission data from on-road vehicles (trucks, buses, and cars) and off-road sources (ships and trains, for example). This is the most recent data available with which to make the necessary comparisons.

Table 4.21-4 shows that among these census tracts, six are higher than the 90th percentile. They are 95.13, 90.49, 91.5, 95.3, 94.82 and 96.17 (in census tracts 06085501600, 06085504318, 06085503601, 06085503602, 06085501501, and 06085503110, respectively), meaning they are higher than 95.13, 90.49, 91.5, 95.3, 94.82 and 96.17 percent of the census tracts in California.

However, according to the results of the HRA conducted for this project in **Section 4.3 Air Quality**, impacts associated with diesel PM from the proposed project construction and operation activities (diesel-fueled equipment) would be less than significant and would not have a significant cumulative contribution to the diesel PM levels in the disadvantaged communities. Therefore, the project's diesel PM impacts would be less than significant for the local EJ community and the general population.

Pesticide Use

Specific pesticides included in the Pesticide Use indicator in CalEnviroScreen were narrowed from the list of all registered pesticides in use in California to focus on a subset of 132 selected active pesticide ingredients that are filtered for hazard and volatility for the years 2017-2019 collected by the California Department of Pesticide Regulation. Only pesticides used on agricultural commodities are included in the indicator.

Table 4.21-4 shows that the highest percentile in the project's six-mile radius is from census tract 6085504318, indicating that pesticide use in this census tract (6085504318) is only higher than 4.97 percent of tracts statewide. This also indicates that pesticide use in these census tracts are below the statewide average and that these communities are not exposed to high pesticide concentrations as compared to the rest of the state. If pesticide-contaminated soil is discovered, it will either be treated on site or removed in accordance with mitigation measure **HAZ-1**. Therefore, the pesticide use would be less than significant for the local EJ community and the general population.

Toxic Releases from Facilities

This indicator represents modeled toxicity-weighted concentrations of chemical releases to air from facility emissions and off-site incineration in and near the census tract. The U.S. EPA provides public information on the amount of chemicals released into the environment from many facilities. The data are from 2017-2019.

Table 4.21-4 shows that the highest percentile in the project's six-mile radius is from census tract 6085504318, indicating that toxic release from facilities threats in this census tract (6085504318) is higher than 39.48 percent of tracts statewide. This also

indicates that these communities are lower than the state average for exposure to toxic releases. This also indicates that these communities are not exposed to high toxic releases from facilities as compared to the rest of the state.

According to the results of the HRA conducted for the project in **Section 4.3 Air Quality**, impacts associated with toxic releases from construction and operation activities (diesel-fueled equipment) would be less than significant. The project would not have a significant cumulative contribution to toxic releases. Therefore, the project's toxics emissions would be less than significant for the local EJ community and the general population.

Traffic Impacts

This indicator represents the sum of traffic volumes adjusted by road segment length. It is calculated as sum of traffic volumes adjusted by road segment length (vehicle-kilometers per hour) divided by total road length (kilometers) within 150 meters of the census tract. The data are from 2017.

Table 4.21-4 shows that among these census tracts, eight are higher than the 90th percentile. The highest percentiles are 99.54 and 98.7 (in census tracts 06085503110 and 06085501501, respectively), meaning these two are higher than 99.54 and 98.7 percent of the census tracts in California. Traffic volume impacts are related to the diesel PM emitted from diesel-fueled vehicles.

The proposed project would generate a small number of vehicle trips to the site during normal operation of the proposed project. These trips include workers, material, and equipment deliveries. It is unlikely that the addition of vehicle trips from the project would result in a significant contribution to the traffic impacts on any roadway in the vicinity of the project site. However, according to the results of the HRA conducted for the project in **Section 4.3 Air Quality**, impacts associated with diesel PM from the proposed project construction and operation activities (diesel-fueled equipment) would be less than significant and would not have a significant cumulative contribution to the diesel PM-related traffic impacts in the disadvantaged communities. Therefore, the project's traffic volume impact would not have a significant cumulative contribution to the traffic density for the local EJ community and the general population.

Asthma

This indicator is a representation of an asthma rate. It measures the number of emergency department (ED) visits for asthma per 10,000 people over the years 2015 to 2017. The information was collected by the California Office of Statewide Health Planning and Development (OSHPD).

Table 4.21-5 shows that none of these census tracts are higher than the 90th percentile in the Asthma indicator. The highest percentile is from census tract 6085503712 (88.43 percent). This indicates the number of emergency department visits for asthma per 10,000 people over the years 2015 to 2017 are higher than 88.43 percent of tracts statewide. Census tract 06085503602 was slightly lower, at the 88.33 percentile. This

indicates that these two communities have the above average numbers of emergency room visits due to asthma compared to the rest of the state.

According to the results of the HRA conducted for the project in **Section 4.3 Air Quality**, impacts associated with emissions from construction and operation activities (diesel-fueled equipment) would be less than significant and would not have a significant cumulative contribution to asthma ER visits. Therefore, the project's emissions would not have a significant cumulative contribution to asthma ER visits for the local EJ community and the general population.

Low Birth Weight Infants

This indicator measures the percentage of babies born weighing less than 2,500 grams (about 5.5 pounds) out of the total number of live births over the years 2009 to 2015. The information was collected by the California Department of Public Health (CDPH).

Table 4.21-5 shows that among these census tracts, three of them are higher than the 90th percentile. They are 98.85, 91.34 and 93.65 (in census tracts 06085504602, 06085501600, and 06085503712, respectively), meaning they are higher than 98.85, 91.34 and 93.65 percent of the census tracts in California. This indicates that these three communities are higher than the state average of low birth weight infants.

The HRA of the project in **Section 4.3 Air Quality** was based on a highly conservative health-protective methodology that accounts for impacts on the most sensitive individuals in a given population. According to the results of the assessment, the risks at the maximally exposed sensitive receptors (i.e., the point of maximum impact [PMI], the maximally exposed individual resident [MEIR], the maximally exposed individual worker [MEIW], maximally exposed daycare/school receptor (MEDR/MESR), and the maximally exposed individual recreational receptor [MERR]) would be below health-based thresholds. Therefore, the toxic emissions from the project would not cause significant health effects for the low birth weight infants in these disadvantaged communities or have a significant cumulative contribution to these disadvantaged communities. The project's emissions would not have a significant cumulative contribution to low birth weight infant births for the local EJ community and the general population.

Cardiovascular Disease

This indicator represents the rate of heart attacks. It measures the number of emergency department (ED) visits for acute myocardial infarction (AMI) (or heart attack) per 10,000 people over the years 2015 to 2017.

Table 4.21-5 shows that none of these census tracts are higher than the 90th percentile in the Cardiovascular Disease indicator. The highest percentile is from census tract 6085503712. It indicates the number of emergency department visits for acute myocardial infarction (or heart attack) per 10,000 people over the years 2015 to 2017 is higher than 71.62 percent of tracts statewide. This also indicates that this community is

about the average number of emergency department visits for acute myocardial infarction (or heart attack) compared to the rest of the state.

According to the results of the HRA conducted for the project in **Section 4.3 Air Quality**, impacts associated with emissions from construction and operation activities (diesel-fueled equipment) would be less than significant and would not have a significant cumulative contribution to cardiovascular disease. The project's emissions would not have a significant cumulative contribution to cardiovascular disease for the local EJ community and the general population.

Cultural and Tribal Cultural Resources

No Impact. Staff considered EJ populations in its analysis of the project. Staff did not identify any Native American EJ populations that either reside within 6 miles of the project or that rely on any subsistence resources that could be impacted by the proposed project.

Hazards and Hazardous Materials

Less Than Significant Impact. EJ populations may experience disproportionate hazards and hazardous materials impacts if the storage and use of hazardous materials within or near EJ communities occur to a greater extent than within the community at large. However, a disproportionate impact upon the EJ population resulting from the planned storage and use of hazardous materials on the site is extremely low. Diesel fuel to run the emergency generators is the hazardous material that the project site would have in greatest quantity. The total quantity would be divided up and stored in many separate double-walled fuel tanks (one for each generator) with proper spill controls. Therefore, the likelihood of a spill of sufficient quantity to impact the surrounding community and EJ population would be very unlikely, thus the impact on the EJ community would be less than significant.

Hydrology and Water Quality

Less Than Significant Impact. A disproportionate hydrologic or water quality impact on an EJ population could occur if the project introduces an additional pollutant burden to a disadvantaged community, such as impairing drinking water sources, exacerbating groundwater contamination threats, or contributing pollutants to impaired water bodies.

Since the overall CalEnviroScreen score reflects the collective impacts of multiple pollutants and factors, staff examined the individual contributions to indicators as they relate to hydrology and water quality. The pollutants of concern in this analysis are those from construction and operational activities. The CalEnviroScreen scores for the disadvantaged community census tracts in a six-mile radius of the project (see **Figure 4.21-1**) are presented in **Table 4.21-4** for each of the following environmental stressors that relate to hydrology and water quality: Drinking Water Contaminants, Groundwater Threat, and Impaired Water Bodies. The percentile for each disadvantaged census tract reflects its relative ranking among all of California's census tracts.

CalEnviroScreen assigns a score to each type of stressor. To assess the impact of a stressor on population within a census tract, the score is assigned a weighting factor that decreases with distance from the census tract. For stationary stressors related to hydrology or water quality, the weighting factor diminishes to zero for distances larger than 1,000 meters (0.6 mile). As **Figure 4.21-1** shows, all but one of the assessed census tracts are more than 1,000 meters away from the project. The only census tract that is within 1,000 meters of the proposed project site is tract 6085505202—the tract in which the project would be located. Therefore, this analysis focuses on that census tract.

Drinking Water Contaminants

Low income and rural communities, particularly those served by small community water systems, can be disproportionately exposed to contaminants in their drinking water. CalEnviroScreen aggregates drinking water quality data from the California Department of Public Health, the U.S. EPA, and the California State Water Resources Control Board (SWRCB). The score provided by the Drinking Water Contaminant metric calculation is intended to rank water supplies relative to their history or likelihood to provide water that exceeds drinking water standards. Census tract 6085505202 scored 50 percent in the Drinking Water Contaminants indicator (see **Table 4.21-4**). This indicates that the drinking water contamination threat in this census tract is moderate, and that this community does not have a significant level of exposure to contaminants through drinking water.

The project would not contribute significantly to drinking water source degradation. The project would be required to comply with the Clean Water Act (CWA) by controlling the discharge of pollutants during its construction and operation phases. The project would implement modern operational phase stormwater and containment controls that would improve upon the site's potential to release contaminants to the environment. The project would therefore provide a long-term drinking water quality benefit relative to baseline conditions. The project's hydrology and water quality impacts would be reduced to less than significant for the census tract of concern and the general population.

Groundwater Threats

Common groundwater pollutants found at leaking underground storage tank and cleanup sites in California include gasoline and diesel fuels, chlorinated solvents and other volatile organic compounds such as benzene, toluene, and methyl tert-butyl ether; heavy metals such as lead, chromium and arsenic; polycyclic aromatic hydrocarbons; persistent organic pollutants like polychlorinated biphenyls; Dichlorodiphenyl-trichloroethane and other insecticides; and perchlorate. CalEnviroScreen aggregates data from the SWRCB's GeoTracker website about groundwater threats. The score provided by the Groundwater Threat metric calculation is intended to rank the relative risk of environmental contamination by groundwater contamination, within each census tract. Census tract 6085505202 scored 98 percent in the Groundwater Threat indicator (see **Table 4.21-4**). This indicates that groundwater contamination threats in this census tract are within the top 10 percent of tracts statewide and that this community is located alongside a relatively high proportion of groundwater threats.

The project would not contribute significantly to groundwater degradation, relative to existing conditions. The project would be required to comply with the CWA by controlling the discharge of pollutants during its construction and operation phases. The project would implement modern operational phase stormwater and containment controls that would improve upon the site's potential to release contaminants to groundwater. The project's hydrology and water quality impacts would be reduced to less than significant for the census tract of concern and the general population.

Impaired Water Bodies

Rivers, lakes, estuaries, and marine waters in California are important for many different uses. Water bodies used for recreation may also be important to the quality of life of nearby residents if subsistence fishing is critical to their livelihood. Water bodies also support abundant flora and fauna. Changes in aquatic environments can affect biological diversity and overall health of ecosystems. Aquatic species important to local economies may be impaired if the habitats where they seek food and reproduce are changed. Additionally, communities of color, low-income communities, and tribes generally depend on the fish, aquatic plants, and wildlife provided by nearby surface waters to a greater extent than the general population. CalEnviroScreen aggregates data from the SWRCB's Final 2012 California Integrated Report (CWA Section 303(d) List / 305(b) Report). The score provided by the Impaired Water Bodies metric calculation is intended to rank the relative risk of impaired water bodies, within each census tract.

Census tract 6085505202 scored 33 percent in the Impaired Water Bodies indicator (see **Table 4.21-4**). This indicates that impaired water bodies in this census tract is below the statewide average in terms of relative abundance and that these communities are not expected to contain a higher amount of impaired water bodies.

The project would not contribute significantly to the impairment of local or regional water bodies. The project would be required to comply with the CWA by controlling the discharge of pollutants during its construction and operation phases. Also, the project would implement modern operational phase stormwater and containment controls that would improve upon the site's potential to release contaminants to the environment. The project would therefore provide a long-term benefit to local and regional water bodies, relative to baseline conditions. The project's hydrology and water quality impacts would be reduced to less than significant for the census tract of concern and the general population.

Land Use and Planning

Less Than Significant Impact. A land use impact could occur if a project would physically divide an established community. Project construction and operation would occur mostly onsite and would not prevent pedestrian, bike, or vehicular movement between different areas of the community, and therefore the project would not physically divide an established community.

A land use impact could also occur if a project would cause a significant environmental impact due to a conflict with any land use plan, policy, or regulation adopted for the purpose of avoiding or mitigating an environmental effect. As discussed in **Section 4.11 Land Use and Planning** of this EIR, the project would be consistent with the relevant land use plans, policies, and regulations with City of Santa Clara approval of a conditional use permit for the data center use, City approval of a minor modification for the project's height, and the forthcoming amendment to the Comprehensive Land Use Plan for the San José Mineta International Airport. For these reasons, project impacts due to conflicts with land use plans, policies, or regulations adopted for the purpose of avoiding or mitigating an environmental effect would be less than significant. See **Section 4.11 Land Use and Planning** for details. Land use impacts from the project would be less than significant, including potential disproportionate impacts on an EJ population.

Noise

Less Than Significant Impact. EJ populations may experience disproportionate noise impacts if the siting of unmitigated industrial facilities occurs within or near EJ communities to a greater extent than within the community at large. As shown in **Figure 4.21-1**, the project site is within a census tract having an EJ population. The area surrounding the site is primarily zoned for heavy industrial uses and the nearest residences are approximately 1,400 feet away from the project site.

Noise at the nearest residences due to the loudest construction phases would not exceed the ambient noise level. However, the loudest construction phase could elevate the existing ambient noise levels at nearby heavy industrial zone by up to 7 dBA. The city would require a series of performance standards, as part of their condition of approval for construction. These performance standards are ultimately used as a backstop measure to address any noise impacts that might be perceived by the community.

Since the project is near a residential land use, noise reduction measures, such as mechanical equipment enclosures and parapet walls, would be required (incorporated in the operational noise modeling). The operational noise levels would comply with the city's noise limits and would not elevate the existing ambient noise levels at the nearest residences.

Thus, the project's construction and operational noise impacts would be less than significant for all the area's population, including the EJ population.

Population and Housing

Less Than Significant Impact. The study area used to analyze the population influx and housing supply impacts includes the towns of Campbell, Cupertino, Milpitas, San Jose, Santa Clara, Sunnyvale, and unincorporated Santa Clara County. CEC staff considered the project's population and housing impacts on the EJ population living in these geographic areas.

The potential for population and housing impacts is predominantly driven by the temporary influx of non-local construction workers seeking lodging closer to a project site. The project's population and housing impact could disproportionately affect an EJ population, if the influx of non-local workers were to displace minority or low income residents from where they live, causing them to find housing elsewhere. For the project, the construction workers would be drawn from the greater Bay Area and thus would not likely seek temporary lodging closer to the project site. The operations workers are also anticipated to be drawn from the greater Bay Area and would not likely seek housing closer to the project site. If some operations workers were to relocate closer to the project site, there would be sufficient housing in the project area. As the project would not displace any residents or remove any housing, there would be no disproportionate impact to EJ populations from this project.

Transportation

Less Than Significant Impact. Generally, reductions in transportation options can significantly impact EJ populations. In particular, an impact to bus transit, pedestrian facilities, or bicycle facilities could cause disproportionate impacts to low-income communities, as low-income residents more often use these modes of transportation. However, as concluded in section **5.17 Transportation**, temporary construction activities associated with the project's extension of the existing recycled water line along Martin Avenue would not interfere with alternative transportation, including pedestrian, bicycle or transit routes, as none exist on the affected portion of Martin Avenue. Impacts would be less than significant, and therefore would cause less than significant impacts to EJ populations. Likewise, transportation impacts would not be disproportionate.

Utilities and System Services

Less Than Significant Impact. A disproportionate utilities and system services impact on an EJ population could occur if the project wastes impact the disadvantaged community such as contributing to or exacerbating the effects of cleanup sites, hazardous waste generators and facilities, and solid waste facilities.

Since the overall CalEnviroScreen score reflects the collective impacts of multiple pollutants and factors, staff examined the individual contributions to indicators as they relate to wastes addressed under utilities and system services. The wastes of concern in this analysis are those from construction and operational activities. The handling and disposal of each type of waste depends on the hazardous ranking of its constituent materials. Existing laws, ordinances, regulations, and standards ensure the desired handling and disposal of waste materials in order to prevent potential public or environmental health impacts. The CalEnviroScreen scores for the disadvantaged community census tracts in a six-mile radius of the project (see **Figure 4.21-1**) are presented in **Table 4.21-4** for each of the following environmental stressors that relate to waste management: cleanup sites, hazardous waste generators and facilities, and solid waste facilities. The percentile for each disadvantaged census tract reflects its relative ranking among all of California's census tracts.

CalEnviroScreen assigns a score to each indicator of stressors. To assess the impact of a stressor on the population within a census tract, the score is assigned a weighting factor that decreases with distance from the census tract. For stationary stressors, the weighting factor diminishes to zero for distances larger than 1,000 meters (0.6 mile). As **Figure 4.21-1** shows, all but one of the assessed census tracts are more than 1,000 meters away from the project. The only tract that is within 1,000 meters of the proposed project site is tract 6085505202—the tract in which the project would be located. Therefore, this analysis focuses on that tract.

Cleanup Sites

This indicator is calculated by considering the number of cleanup sites including Superfund sites on the National Priorities List (NPL), the weight of each site, and the distance to the census tract. Sites undergoing cleanup actions by governmental authorities, or by property owners, have suffered environmental degradation due to the presence of hazardous substances. Of primary concern is the potential for people to come in contact with these substances.

The percentile score in the cleanup sites indicator for the only census tract within 1,000 meters of the project site (tract 6085505202) is 99.85 (see **Table 4.21-4**). The interpretation is that contamination threats due to the presence of cleanup sites in this census tract are among the highest of all tracts statewide. This is an indication that the communities within that tract are located alongside a relatively high proportion of cleanup sites.

If there is any existing contamination at the project site, it would be remediated by the current owner in accordance with regulatory requirements that would ensure there would be no impacts to on- or off-site receptors. In addition, the project owner would have to comply with appropriate laws, ordinances, regulations, and standards that would require additional cleanup of contaminated soils and groundwater that might be encountered during construction and operation activities. Therefore, the project would not contribute significantly to the effects from cleanup sites for the relevant census tract and for the general population.

Hazardous Waste Generators and Facilities

This indicator is calculated by considering the number of permitted treatment, storage, and disposal facilities (TSDFs) or generators of hazardous waste, the weighting factor of each generator or site, and the distance to the census tract. Most hazardous waste must be transported from hazardous waste generators to permitted TSDFs by registered hazardous waste transporters. Most shipments must be accompanied by a hazardous waste manifest. There are widespread concerns for both human health and the environment from sites that serve for the processing and disposal of hazardous waste. Newer facilities are designed to prevent the contamination of air, water, and soil with hazardous material. However, even newer facilities may negatively affect perceptions of surrounding areas in ways that have economic, social, and health impacts.

The percentile score in the hazardous waste generators and facilities indicator for the only census tract within 1,000 meters of the project site is 98.37. The interpretation is that this census tract is among the worst of all tracts statewide in terms of threats related to hazardous waste generation and facilities, meaning that the communities in that tract are located alongside sites with a high relative proportion of hazardous waste generators and facilities.

The project would not contribute significantly to hazardous waste generation or to the number or size of facilities handling hazardous waste processing. Further, the project would be required to comply with appropriate laws, ordinances, regulations, and standards to control storage and disposal of hazardous waste during its construction and operation phases. The project would implement modern operational phase controls to prevent or reduce the generation of hazardous wastes and to dispose of them in a manner that would minimize impacts to the environment both during project construction and operation. The project's impacts related to hazardous waste generation and disposal would be reduced to less than significant for the relevant census tract and the general population.

Solid Waste Facilities

This indicator is calculated by considering the number of solid waste facilities including illegal sites, the weighting factor of each, and the distance to a census tract. Newer solid waste landfills are designed to prevent the contamination of air, water, and soil with hazardous materials. However, older sites that are out of compliance with current standards or illegal solid waste sites may degrade environmental conditions in the surrounding area and pose a risk of exposure. Other types of facilities, such as composting, treatment, and recycling facilities may raise concerns about odors, vermin, and increased traffic.

The percentile score in the solid waste facilities indicator for the only assessed census tract within 1,000 meters is 95 (see **Table 4.21-4**). The interpretation is that the number and type of facilities within or nearby this census tract are in the upper 10 percent of the census tracts in California. This also indicates that environmental deterioration due to the presence of solid waste facilities in this census tract is within the top 10 percent of tracts statewide.

The solid waste generated during the construction and operation of the project would be segregated, where practical for recycling, and disposed where there is adequate capacity for disposal of non-hazardous waste. Also, the project would be required to develop and implement plans that would ensure proper disposal of nonhazardous waste at appropriately licensed facilities. The project owner would use solid waste sites or facilities that are verified to comply with current laws, ordinances, regulations, and standards. In addition, there would be no increase of solid waste generators and facilities in the area due to project construction or operation because there is adequate space for the disposal of waste from the project. Therefore, there would be no impact due to solid waste

facilities that would disproportionately impact an EJ community in the relevant census tract.

4.21.3 References

- Alexis NE et al. 2010 – Alexis NE, Lay JC, Hazucha M, Harris B, Hernandez ML, Bromberg PA, et al. Low-level ozone exposure induces airways inflammation and modifies cell surface phenotypes in healthy humans. *Inhal Toxicol* 22(7):593-600. Available online at: <https://www.ncbi.nlm.nih.gov/pubmed/20384440>
- BAAQMD 2021 – Bay Area Air Quality Management District (BAAQMD). AAQMD Regulation 2-1-243 Overburdened Community. Available online at: https://www.baaqmd.gov/~/media/dotgov/files/rules/reg-2-permits/2021-amendments/documents/20211215_rg0201-pdf.pdf?la=en
- BAAQMD 2023 – Bay Area Air Quality Management District (BAAQMD). Community Air Risk Evaluation Program. Accessed on January 2023. Available online at: <https://www.baaqmd.gov/community-health/community-health-protection-program/community-air-risk-evaluation-care-program>
- Burnett RT et al. 2001 – Burnett RT, Smith-Doiron M, Stieb D, Raizenne ME, Brook JR, et al. Association between Ozone and Hospitalization for Acute Respiratory Diseases in Children Less than 2 Years of Age. *American Journal of Epidemiology* 153(5):444-452. Available online at: <https://academic.oup.com/aje/article/153/5/444/149769>
- CARB 2023 – California Air Resources Board (CARB). Community Air Protection Selection Process. Accessed January 2023. Available online at: <https://ww2.arb.ca.gov/capp-selection>
- CalEPA 2022a – California Environmental Protection Agency (CalEPA). *Final Designation of Disadvantage Communities Pursuant to Senate Bill 535*, May 2022. Available online at: https://calepa.ca.gov/wp-content/uploads/sites/6/2022/05/Updated-Disadvantaged-Communities-Designation-DAC-May-2022-Eng.a.hp_-1.pdf
- CalEPA 2022b – California Environmental Protection Agency (CalEPA). SB 535 Excel Spreadsheet and data dictionary, last updated May 2022. Available online at: <https://oehha.ca.gov/calenviroscreen/sb535>
- CDE 2023 – California Department of Education (CDE). California Department of Education Educational Demographics Unit, Data Quest, Selected District Level Data - 4369674--Santa Clara Unified for the year 2021-2023. Free or Reduced Price Meals. Available online at: <https://www.cde.ca.gov/ds/ad/dataquest.asp>
- CNRA 2023 – California Natural Resources Agency (CNRA). Environmental Justice Policy California Resources Agency. Available online at: <https://www.conservation.ca.gov/Documents/Environmental%20Justice%20Policy%20-%20CNRA.pdf>
- Fann N et al. 2012 – Fann N, Lamson AD, Anenberg SC, Wesson K, Risley D, Hubbell BJ, Estimating the National Public Health Burden Associated with Exposure to

- Ambient PM2.5 and Ozone. Risk Analysis 32(1):81- 95. Available online at: <https://pubmed.ncbi.nlm.nih.gov/21627672/>
- Lin S et al. 2008 – Lin S, Liu X, Le, LH, Hwang, S, Chronic Exposure to Ambient Ozone and Asthma Hospital Admissions among Children. Environ Health Perspect 116(12):1725-1730. Available online at: <https://www.ncbi.nlm.nih.gov/pmc/articles/PMC2599770/>
- Medina-Ramón M, Schwartz J 2008 – Who is more vulnerable to die from ozone air pollution? Epidemiology 19(5):672-9. Available online at: <https://www.ncbi.nlm.nih.gov/pubmed/18480732>
- OEHHA 2021 – California Environmental Protection Agency’s Office of Environmental Health Hazzard and Assessment (OEHHA). CalEnviroScreen 4.0, October 2021. Available online at: <https://oehha.ca.gov/media/downloads/calenviroscreen/report/calenviroscreen40reportf2021.pdf>
- U.S. Census 2020 – United States Census Bureau (U.S. Census). QT-PL-Race, Hispanic or Latino, Age United States Census Bureau (U.S. Census). PL-Race, Hispanic or Latino, Age, and Housing Occupancy: 2020 – DEC Redistricting Data (Public Law 94-171) Summary File, Tables P1, P2, P3, P4, H1. Available online at: <https://www.census.gov/data.html>
- U.S. EPA 2015 – United States Environmental Protection Agency (U.S. EPA). Guidance on Considering Environmental Justice During the Development of Regulatory Actions, May 2015. Available online at: <https://www.epa.gov/environmentaljustice/guidance-considering-environmental-justice-during-development-action>
- Zanobetti A, Schwartz J 2011 – Ozone and survival in four cohorts with potentially predisposing diseases. Am J Respir Crit Care Med 184(7):836-41. Available online at: <https://www.ncbi.nlm.nih.gov/pubmed/21700916>

Section 6

Authors and Reviewers

6 Authors and Reviewers

Lead Agency—California Energy Commission

Technical Staff / Section Authors

Laiping Ng (Appendix B)
Mark Hamblin (Aesthetics)
Andrea Koch (Agriculture/Forestry, Land Use)
Brewster Birdsall (Air Quality and Greenhouse Gas Emissions)
Winston Potts (Air Quality and Greenhouse Gas Emissions)
Tia Taylor (Biological Resources)
Patrick Riordan and Cameron Travis (Cultural and Tribal Cultural Resources)
Kenneth Salyphone (Energy/Energy Resources, Alternatives, Appendix A)
Michael Turner (Geology/Soils and Minerals)
Michele Shi (Hazards/Hazardous Materials)
Karim Abulaban (Hydrology/Water Resources, Wildfire, Utilities/Service Systems)
Ardalan Sofi (Noise and Vibration)
Ellen LeFevre (Population/Housing, Public Services, Recreation, Environmental Justice, Mandatory Findings of Significance)
Andy Kosinski, Molly Riddle (Transportation)
Andrea Koch (Alternatives)

Supervision and Management

Joseph Hughes, Air Quality Unit Supervisor
Steve Kerr, Community Resources Unit Supervisor
Gabriel Roark, Cultural Resources Unit Supervisor/Assistant Tribal Liaison
Shahab Khoshmashrab, Engineering Unit Supervisor/Senior Mechanical Engineer
Brett Fooks, Safety and Reliability Program Manager
Mark Hesters, Transmission Technical Senior (Appendix B)
Eric Knight, Environmental Branch Manager and Acting Biology Unit Supervisor
Elizabeth Huber, Director—Siting, Transmission and Environmental Protection Division

Project Management/Legal

John Heiser, Project Manager
Jared Babula, Kari Anderson and Briana Ziff, Staff Counsel

Project Assistant

Marichka Haws

Section 7

Mitigation Monitoring and Reporting Program

MITIGATION MONITORING AND REPORTING PROGRAM

**Martin Backup Generating Facility
22-SPPE-03
March 2024**

PREFACE

Section 21081.6 of the California Environmental Quality Act (CEQA) requires a Lead Agency to adopt a Mitigation Monitoring and Reporting Program (MMRP) whenever it approves a project for which measures have been required to mitigate or avoid significant effects on the environment. The purpose of the monitoring and reporting program is to ensure compliance with the mitigation measures during project implementation.

While the California Energy Commission (CEC) is the lead agency in assessing the exemption application, the CEC is not the jurisdiction that will be approving the project for construction and operations. Such authority will be with the City of Santa Clara (City). Therefore, the MMRP will be implemented and enforced by the City upon its approval of the project.

The Environmental Impact Report (EIR) prepared for the Martin Backup Generating Facility project concluded that the implementation of the project would not result in significant effects on the environment with the incorporation of mitigation measures. This MMRP addresses those measures in terms of how and when they will be implemented.

This document does *not* discuss those subjects for which the EIR concluded that the impacts from implementation of the project would be less than significant.

I, the applicant, on the behalf of, hereby agree to fully implement the mitigation measures described below which have been developed in conjunction with the preparation of an EIR for my proposed project. I understand that these mitigation measures or substantially similar measures will be adopted as conditions of approval with my development permit request to avoid or significantly reduce potential environmental impacts to a less than significant level.

Project Applicant’s Signature _____

Date _____

MITIGATION	MONITORING AND REPORTING PROGRAM				
	Documentation of Compliance [Project Applicant/Proponent Responsibility]		Documentation of Compliance [Lead Agency Responsibility]		
	Method of Compliance or Mitigation Action	Timing of Compliance	Oversight Responsibility	Actions/Reports	Monitoring Timing or Schedule
AIR QUALITY					
Impact 4.3-b Would the project result in a cumulatively considerable net increase of any criteria pollutant for which the project region is non-attainment under an applicable federal or state ambient air quality standard?					
<p>AQ-1: To ensure that fugitive dust impacts are less than significant, the project will implement the Bay Area Air Quality Management District (BAAQMD) recommended Best Management Practices (BMPs) during the construction phase, the project owner shall implement a construction emissions control plan that has been reviewed and approved by the Director or Director’s designee of the City of Santa Clara Community Development Department prior to the issuance of any grading or building permits, whichever occurs earliest. These BMPs are incorporated into the design of the project and will include:</p> <ul style="list-style-type: none"> • Water all exposed areas (e.g., parking areas, graded areas, unpaved access roads) twice a day. • Maintain a minimum soil moisture of 12% in exposed areas by maintaining proper watering frequency. 	Implement the BAAQMD’s recommended BMPs to control fugitive dust and additional measures to control exhaust emissions	During construction phase	City of Santa Clara Director of Community Development or Director’s designee	Receive and approve the fugitive dust control measures and exhaust control measures during construction	Prior to the issuance of any demolition, grading, and/or building permits (whichever occurs earliest)

MITIGATION	MONITORING AND REPORTING PROGRAM				
	Documentation of Compliance [Project Applicant/Proponent Responsibility]		Documentation of Compliance [Lead Agency Responsibility]		
	Method of Compliance or Mitigation Action	Timing of Compliance	Oversight Responsibility	Actions/Reports	Monitoring Timing or Schedule
AIR QUALITY					
<ul style="list-style-type: none"> • Cover all haul trucks carrying sand, soil, or other loose material. • Suspend excavation, grading, and/or demolition activities when average wind speed exceeds 20 miles per hour. • Pave all roadways, driveways, and sidewalks as soon as possible. Lay building pads as soon as grading is completed, unless seeding or soil binders are used. • Install wind breaks (e.g., trees, fences) on the windward side(s) of actively disturbed areas of construction with a maximum 50 percent air porosity. • Use wet power vacuum street sweepers at least once per day to remove any mud or dirt-track next to public streets if visible soil material is carried onto the streets. The use of dry power sweeping is prohibited. • Limit vehicle speeds on unpaved roads to 15 miles per hour (mph). • Minimize idling time for all engines by shutting engines when not in use 					

MITIGATION	MONITORING AND REPORTING PROGRAM				
	Documentation of Compliance [Project Applicant/Proponent Responsibility]		Documentation of Compliance [Lead Agency Responsibility]		
	Method of Compliance or Mitigation Action	Timing of Compliance	Oversight Responsibility	Actions/Reports	Monitoring Timing or Schedule
AIR QUALITY					
<p>or limiting idling time to a maximum of five minutes. Provide clear signage for construction workers at all access points.</p> <ul style="list-style-type: none"> • Properly tune and maintain construction equipment in accordance with manufacturer's specifications. All equipment shall be checked by a certified mechanic and determined to be running in proper condition prior to operation. • Post a publicly visible sign with the telephone number and name of the person to contact regarding dust complaints and the BAAQMD telephone number. The contact person shall implement corrective measures, as needed, within 48 hours, and the BAAQMD shall be informed of any legitimate complaints received to verify compliance with applicable regulations. Limit simultaneous occurrence of excavation, grading, and ground-disturbing construction activities. 					

MITIGATION	MONITORING AND REPORTING PROGRAM				
	Documentation of Compliance [Project Applicant/Proponent Responsibility]		Documentation of Compliance [Lead Agency Responsibility]		
	Method of Compliance or Mitigation Action	Timing of Compliance	Oversight Responsibility	Actions/Reports	Monitoring Timing or Schedule
AIR QUALITY					
<ul style="list-style-type: none"> Minimize idling time of diesel-powered construction vehicles to two minutes. As a condition of contract, require all on-road heavy-duty trucks to be zero emissions or meet the most stringent emissions standard, such as model year (MY) 2024 to 2026, as available. Use grid power for construction activities whenever possible; if grid power is not available, use alternative power such as battery storage, hydrogen fuel cells, or renewable fuels. If no other options are available, use Final Tier 4 diesel generators. Install vegetative ground cover in disturbed areas as soon as possible and water appropriately until vegetation is established. Limit simultaneous occurrence of excavation, grading, and ground-disturbing construction activities. Install water washers to wash all trucks and equipment, including their tires, prior to leaving site. 					

MITIGATION	MONITORING AND REPORTING PROGRAM				
	Documentation of Compliance [Project Applicant/Proponent Responsibility]		Documentation of Compliance [Lead Agency Responsibility]		
	Method of Compliance or Mitigation Action	Timing of Compliance	Oversight Responsibility	Actions/Reports	Monitoring Timing or Schedule
AIR QUALITY					
<ul style="list-style-type: none"> • Install sandbags or other erosion control measures shall be installed to prevent silt runoff to public roadways from sites with a slope greater than one percent. • All off-road equipment greater than 25 horsepower (hp) shall have engines that meet or exceed Tier 4 final off-road emission standards. Use of zero-emission and hybrid-powered equipment is encouraged. • All on-road trucks used for material delivery or hauling shall have engines that meet or exceed 2014 CARB emissions standards. • Where grid power is available, portable diesel engines should be prohibited. • Use low VOC (i.e., ROG) coatings beyond the local requirements (i.e., Regulation 8, Rule 3: Architectural Coatings). • All construction equipment, diesel trucks, and generators be equipped with Best Available Control Technology for emission reductions of NOx and PM. 					

MITIGATION	MONITORING AND REPORTING PROGRAM				
	Documentation of Compliance [Project Applicant/Proponent Responsibility]		Documentation of Compliance [Lead Agency Responsibility]		
	Method of Compliance or Mitigation Action	Timing of Compliance	Oversight Responsibility	Actions/Reports	Monitoring Timing or Schedule
AIR QUALITY					
<ul style="list-style-type: none"> • All contractors use equipment that meets CARB's most recent certification standard for off-road heavy-duty diesel engines. • Unpaved roads providing access to sites located 100 feet or further from a paved road shall be treated with a 6- to 12-inch layer of compacted layer of wood chips, mulch, or gravel. • Minimize the amount of excavated material or waste materials stored at the site. • Hydroseed or apply non-toxic soil stabilizers to construction areas, including previously graded areas, that are inactive for at least 10 calendar days. 					
Impact 4.3-c Would the project expose sensitive receptors to substantial pollutant concentrations?					
AQ-1 (see Impact 4.3-b for mitigation)					

MITIGATION	MONITORING AND REPORTING PROGRAM				
	Documentation of Compliance [Project Applicant/Proponent Responsibility]		Documentation of Compliance [Lead Agency Responsibility]		
	Method of Compliance or Mitigation Action	Timing of Compliance	Oversight Responsibility	Actions/Reports	Monitoring Timing or Schedule
BIOLOGICAL RESOURCES					
Impact 4.4-a Would the project have a substantial adverse effect, either directly or through habitat modifications, on any species identified as a candidate, sensitive, or special-status species in local or regional plans, policies, or regulations, or by the California Department of Fish and Wildlife or U.S. Fish and Wildlife Service?					
<p>BIO-1: Worker Environmental Awareness Program (WEAP) A worker environmental awareness program biological resources module will be conducted for onsite construction personnel prior to the start of construction activities. The module will explain all the measures developed to prevent impacts on special-status species, including Western burrowing owl and golden eagle, and nesting birds. The module will also include a description of special-status species and their habitat needs, as well as an explanation of the status of these species and their protection under Endangered Species Act, California Endangered Species Act, and other statutes. A brochure will be provided with color photos of sensitive species, as well as a discussion of any permit measures. A copy of this WEAP program and brochure shall be provided for review</p>	<p>A qualified biologist designated to work on the project (i.e., Designated Biologist (DB)) shall prepare a worker environmental awareness program (WEAP) of biological resources</p>	<p>At least 30 days prior to the initiation of any construction or demolition activities.</p>	<p>City of Santa Clara Director of Community Development or Director's designee.</p>	<p>The DB will prepare, approve and oversee the program's content and administering to the onsite construction personnel. The information contained in the program shall explain all the measures developed to prevent impacts on special-status species, including Western burrowing owl and golden eagle, and nesting birds. It will explain special status species protection under Endangered Species Act,</p>	<p>The WEAP will be provided to the City of Santa Clara Director of Community Development or Director's designee and approved before the start of any construction or demolition related activities. All onsite personnel and construction workers must undergo the WEAP training and a written account of this shall be kept on file and submitted to the City if requested.</p>

MITIGATION	MONITORING AND REPORTING PROGRAM				
	Documentation of Compliance [Project Applicant/Proponent Responsibility]		Documentation of Compliance [Lead Agency Responsibility]		
	Method of Compliance or Mitigation Action	Timing of Compliance	Oversight Responsibility	Actions/Reports	Monitoring Timing or Schedule
BIOLOGICAL RESOURCES					
<p>and approval to Director or Director's designee with the City of Santa Clara Community Development at least 30 days prior to the start of construction. This includes the following measures:</p> <ul style="list-style-type: none"> • Environmental Inspector: A qualified Environmental Inspector shall verify implementation and compliance with all mitigation measures. The Environmental Inspector shall have the authority to stop work or determine alternative work practices where safe to do so, as appropriate, if construction activities are likely to affect sensitive biological resources. • Litter and Trash Management: Food scraps, wrappers, food containers, cans, bottles, and other trash from the project area shall be deposited into closed trash containers. Trash containers shall be removed from the project work areas at the end of each working day unless located in an existing substation, potential 				<p>California Endangered Species Act, and other applicable laws. Also, project related measures must be reviewed. A brochure with color photos and all this information shall be provided to workers.</p>	

MITIGATION	MONITORING AND REPORTING PROGRAM				
	Documentation of Compliance [Project Applicant/Proponent Responsibility]		Documentation of Compliance [Lead Agency Responsibility]		
	Method of Compliance or Mitigation Action	Timing of Compliance	Oversight Responsibility	Actions/Reports	Monitoring Timing or Schedule
BIOLOGICAL RESOURCES					
staging area, or the switching station site. <ul style="list-style-type: none"> • Parking: Vehicles and equipment shall be parked on pavement, existing roads, and previously disturbed or developed areas, or work areas as identified in this document. • Work Areas, Staging Areas: Work, staging, vehicle parking, and equipment parking areas shall be contained within the final areas that are negotiated with the relevant property owners, or as noted above. • Pets and Firearms: No pets or firearms shall be permitted at the project site. 					
BIO-2: Burrowing Owl Surveys, Monitoring, Prevention and Relocation Surveys for burrowing owl shall be conducted by a qualified biologist, with a bachelor's degree or above in a biological science field and demonstrated field expertise in ornithology, and in particular, nesting	Conduct preconstruction surveys for burrowing owls by a qualified biologist within 300 feet of proposed project and	First survey at least 14 days prior and the second survey conducted 24 hours prior to initial construction activities (i.e.	City of Santa Clara Director of Community Development Department or Director's designee.	DB will conduct these surveys in accordance with the most recent California Department of Fish and Wildlife (CDFW) guidance (current guidance: CDFW	Survey results should be approved by the city before the start of any construction activities.

MITIGATION	MONITORING AND REPORTING PROGRAM				
	Documentation of Compliance [Project Applicant/Proponent Responsibility]		Documentation of Compliance [Lead Agency Responsibility]		
	Method of Compliance or Mitigation Action	Timing of Compliance	Oversight Responsibility	Actions/Reports	Monitoring Timing or Schedule
BIOLOGICAL RESOURCES					
<p>behavior. Surveys of suitable habitat areas as determined by a qualified biologist, shall be conducted within 300 feet of the proposed project construction including staging, grading, site excavation and improvements, and the transmission line extension, or as directed by the City of Santa Clara. Surveys shall be conducted in accordance with the most recent California Department of Fish and Wildlife (CDFW) guidance (current guidance: CDFW 2012). Any habitat areas adjacent to the project site but not publicly accessible will be surveyed with binoculars. Surveys, avoidance and mitigation shall be conducted according to the parameters and limitations listed below, depending on the time of year:</p> <p>1. <u>Breeding Season (February 1 through August 31)</u>: Pre-construction surveys for burrowing owls shall be performed at least 14 days prior and again 24 hours prior to initial ground disturbance</p>	<p>project components as specified in first column.</p>	<p>vegetation removal, grading, excavation, etc.).</p> <p>Surveys will be repeated as specified in first column based on the guidelines per time of year.</p>		<p>2012). Results will be submitted to City of Santa Clara Director of Planning, Building and Code Enforcement or Director's designee.</p>	
	<p>If burrowing owls are detected, no construction activities will occur within 250 feet of occupied burrows during the breeding season or within 160 feet of occupied burrows during</p>	<p>Buffer zones and monitoring will begin immediately as soon as occupied burrows are found.</p>	<p>City of Santa Clara Director of Community Development Department or Director's designee.</p>	<p>DB will establish the buffer zone; any modifications will be in coordination with the City of Santa Clara and CDFW or DB as specified. Monitoring will be conducted by DB as specified.</p>	<p>Buffer zones and monitoring may be ceased as found in current CDFW guidance, as specified per this COC in first column and DB has decided sufficient</p>

MITIGATION	MONITORING AND REPORTING PROGRAM				
	Documentation of Compliance [Project Applicant/Proponent Responsibility]		Documentation of Compliance [Lead Agency Responsibility]		
	Method of Compliance or Mitigation Action	Timing of Compliance	Oversight Responsibility	Actions/Reports	Monitoring Timing or Schedule
BIOLOGICAL RESOURCES					
<p>activities, or as directed by the City of Santa Clara.</p> <p>(a) Any occupied burrows shall not be disturbed and shall be provided with a 250-foot protective buffer on areas controlled by the Project Owner until and unless modified by the local permitting agency (City of Santa Clara) in consultation with CDFW, or unless a qualified biologist approved by the local permitting agency verifies through non-invasive means that either: (1) the birds have not begun egg laying, or (2) juveniles from the occupied burrows are foraging independently and are capable of independent survival.</p> <p>(b) Once the fledglings in an active burrow are capable of independent survival, a Burrowing Owl Exclusion Plan (BOEP) is developed and approved by the local permitting agency, and habitat is mitigated in accordance with the California Department of Fish and Wildlife (CDFW) staff</p>	<p>the non-breeding season. Additionally, burrowing owls shall be monitored by a qualified biologist during construction to assess the sensitivity of the burrowing owls to the construction activities.</p>				
	<p>A Burrowing Owl Exclusion Plan (BOEP) must be written by the DB before the destruction of burrowing owl burrows or passive relocation of</p>	<p>Determined by breeding season as specified in first column.</p>	<p>City of Santa Clara Director of Community Development Department or Director's designee.</p>	<p>The BOEP is written by the DB and approved by the City of Santa Clara. The BOEP is carried out by the DB and habitat is mitigated in accordance with the current California Department of Fish</p>	<p>As directed by DB and specified in first column.</p>

MITIGATION	MONITORING AND REPORTING PROGRAM				
	Documentation of Compliance [Project Applicant/Proponent Responsibility]		Documentation of Compliance [Lead Agency Responsibility]		
	Method of Compliance or Mitigation Action	Timing of Compliance	Oversight Responsibility	Actions/Reports	Monitoring Timing or Schedule
BIOLOGICAL RESOURCES					
<p>report guidance (CDFW 2012), then the burrow may be destroyed. Pre-construction surveys following destruction of burrows and prior to initial construction activities are required (24 hours prior) to ensure owls do not re-colonize the project.</p> <p>(c) If project activities are delayed or suspended for more than 15 days during the breeding season, surveys shall be repeated.</p> <p>2. <u>Non-breeding Season (September 1 through January 31)</u>: Pre-construction surveys following the staff report on burrowing owls (CDFW 2012) shall be performed prior (at least 14 days prior and again 24 hours prior) to initial ground disturbance activities, or as directed by the City of Santa Clara. Burrowing owls may be evicted via passive exclusion after a BOEP is developed and approved by the local permitting agency, and habitat is mitigated in accordance with the CDFW staff report (CDFW 2012).</p>	owls can take place.			and Wildlife (CDFW) staff report guidance.	

MITIGATION	MONITORING AND REPORTING PROGRAM				
	Documentation of Compliance [Project Applicant/Proponent Responsibility]		Documentation of Compliance [Lead Agency Responsibility]		
	Method of Compliance or Mitigation Action	Timing of Compliance	Oversight Responsibility	Actions/Reports	Monitoring Timing or Schedule
BIOLOGICAL RESOURCES					
<p>(a) Pre-construction surveys following destruction of burrows are required 24 hours prior to initial construction activities to ensure owls do not re-colonize the project. If owls are found within 160 feet of the project, it is recommended that visual screens or other measures be implemented to limit disturbance of the owls without evicting them from the occupied burrows.</p> <p>If no burrowing owls are detected, no further measures are required. If burrowing owls are detected, no construction activities will occur within 250 feet of occupied burrows during the breeding season or within 160 feet of occupied burrows during the non-breeding season. The size of any avoidance buffer may be increased or decreased as determined by the qualified biologist based on the planned construction activities and the sensitivity of the burrowing owls. Additionally, burrowing owls shall be monitored by a qualified biologist</p>					

MITIGATION	MONITORING AND REPORTING PROGRAM				
	Documentation of Compliance [Project Applicant/Proponent Responsibility]		Documentation of Compliance [Lead Agency Responsibility]		
	Method of Compliance or Mitigation Action	Timing of Compliance	Oversight Responsibility	Actions/Reports	Monitoring Timing or Schedule
BIOLOGICAL RESOURCES					
during construction to assess the sensitivity of the burrowing owls to the construction activities. During the non-breeding season passive relocation may be conducted in accord with an approved BOEP. If a burrowing owl is observed at the project at any time during construction, then a buffer area shall be established in accord with the above seasonal criteria (consistent with CDFW 2012 guidance or current guidance) until the animal can be passively relocated out of the construction area.					
BIO-3: Nesting Bird Avoidance and Minimization Measures The project applicant shall schedule demolition and construction activities to avoid the nesting season. The nesting season for most birds, including most raptors in the San Francisco Bay area, extends from February 1st through August 31st (inclusive). If any construction or demolition activities, including tree or vegetation removal or ground disturbance, occurs during the nesting season (February 1	Construction, if at all feasible, shall be avoided during the nesting bird season.	Non-nesting bird season (i.e., September through January)	Project owner	Approval by City of Santa Clara Director of Community Development Department or Director's designee	Schedule construction activities for September through January.
	If any construction or demolition activities occurs during the nesting season, a qualified and	If construction is going to occur during nesting bird season (i.e., February 1	City of Santa Clara Director of Community Development Department or Director's designee.	Submit results of preconstruction surveys by a qualified biologist to City of Santa Clara Director of Community	Submit results of preconstruction survey no more than 14 days prior to issuance of any tree removal, grading,

MITIGATION	MONITORING AND REPORTING PROGRAM				
	Documentation of Compliance [Project Applicant/Proponent Responsibility]		Documentation of Compliance [Lead Agency Responsibility]		
	Method of Compliance or Mitigation Action	Timing of Compliance	Oversight Responsibility	Actions/Reports	Monitoring Timing or Schedule
BIOLOGICAL RESOURCES					
<p>through August 31, for most birds, including most raptors in the San Francisco Bay area), the project applicant shall adhere to the following guidelines:</p> <ul style="list-style-type: none"> The project applicant shall submit the resume of an ornithologist or other qualified biologist (with at least a bachelor's degree in a biological science field and demonstrated field expertise in avian species) for approval by the City of Santa Clara. The pre-approved ornithologist or other qualified biologist (Designated Biologist, DB) shall conduct at least two pre-construction nest survey(s). The two pre-construction surveys shall be separated by a minimum 11-day interval and conducted no more than 14 days prior to initiation of any construction activity. One survey shall be conducted within the 3-day period preceding initiation of construction activity. 	<p>approved biologist shall conduct two pre-construction surveys for nesting migratory birds onsite and offsite facilities and within 500 feet (for raptors) of the project boundary, where accessible.</p>	<p>through August 31). The surveys shall be separated by a minimum 11-day interval and conducted no more than 14 days prior to initiation of any construction activity. One survey shall be conducted within the 3-day period preceding initiation of construction activity.</p>		<p>Development Department or Director's designee.</p>	<p>demolition or building permit issuance</p>
		<p>If a nesting bird is detected, an appropriate construction-</p>	<p>Upon detection of a nesting migratory bird</p>	<p>City of Santa Clara Director of Community Development</p>	<p>California Department of Fish and Wildlife (CDFW) and approved by the City of Santa Clara</p>

MITIGATION	MONITORING AND REPORTING PROGRAM				
	Documentation of Compliance [Project Applicant/Proponent Responsibility]		Documentation of Compliance [Lead Agency Responsibility]		
	Method of Compliance or Mitigation Action	Timing of Compliance	Oversight Responsibility	Actions/Reports	Monitoring Timing or Schedule
BIOLOGICAL RESOURCES					
<p>Additional follow-up surveys may be required if periods of construction inactivity exceed two weeks in any given area, an interval during which birds may establish a nesting territory and initiate egg laying and incubation.</p> <ul style="list-style-type: none"> Surveys shall cover all potential nesting habitat and substrate within the project site and any offsite facilities (i.e., electrical transmission line, staging area, employee parking) and publicly accessible areas within 500 feet of the project boundary. Any habitat areas adjacent to the project site but not publicly accessible shall be surveyed with binoculars. These surveys shall include the orders Falconiformes and Strigiformes (raptors and owls). Surveys shall be conducted at appropriate nesting times and concentrate on potential roosting or perch sites. If active nests are detected during on-site surveys, a no-disturbance buffer zone (protected area 	<p>free buffer shall be established by the DB in consultation with the California Department of Fish and Wildlife (CDFW) and approved by the City of Santa Clara. All other directives on buffer zones shall be adhered to.</p>		<p>Department or Director's designee</p>	<p>Director of Community Development Department or Director's designee</p>	
	<p>Project biologist to monitor the buffer to verify compliance bi-weekly. All other directives on monitoring</p>	<p>Bi-weekly until nestlings have fledged or nests are no longer active.</p>	<p>City of Santa Clara Director of Community Development Department t or Director's designee</p>	<p>Follow all directives on monitoring and document monitoring and nest progress to be approved by City of Santa Clara Director of Community Development</p>	<p>Monitoring shall begin immediately upon establishing an active nest.</p>

MITIGATION	MONITORING AND REPORTING PROGRAM				
	Documentation of Compliance [Project Applicant/Proponent Responsibility]		Documentation of Compliance [Lead Agency Responsibility]		
	Method of Compliance or Mitigation Action	Timing of Compliance	Oversight Responsibility	Actions/Reports	Monitoring Timing or Schedule
BIOLOGICAL RESOURCES					
<p>surrounding the nest) shall be established around each nest with fencing, flagging and/or signage, as appropriate. Initially each nest will have the following buffer zone: 150 feet for any migratory bird nests, 250 feet for any raptor and owl nests (including burrowing owl), and 500 feet for any special status species. Ultimately, the size of each buffer zone shall be determined by the Designated Biologist in consultation with the California Department of Fish and Wildlife (CDFW) and approved by the City of Santa Clara. Collaboration to determine the appropriate buffer size for each nest found should be based upon the species, topography, behavior of the nesting birds, and type of activity that would occur in the vicinity of the nest. Once the buffer zone is established, other than the DB adjusting the buffer zone, it shall remain undisturbed and no construction activities, as defined</p>	shall be adhered to.			Department or Director's designee	
	<p>If active nests of special-status species are detected during pre-construction surveys or during project construction, the Director or their designee for the City of Santa Clara Community Development Department shall be notified within 24 hours. A letter through email may be used initially and shall state how impacts of any</p>	<p>During pre-construction surveys or during project construction.</p>	<p>City of Santa Clara Director of Community Development Department or Director's designee</p>	<p>California Department of Fish and Wildlife (CDFW) and approved by the City of Santa Clara Director of Community Development Department or Director's designee</p>	<p>Notify within 24 hours of discovering active nest of special-status species (or any new nest found after pre-construction survey and during construction.)</p>

MITIGATION	MONITORING AND REPORTING PROGRAM				
	Documentation of Compliance [Project Applicant/Proponent Responsibility]		Documentation of Compliance [Lead Agency Responsibility]		
	Method of Compliance or Mitigation Action	Timing of Compliance	Oversight Responsibility	Actions/Reports	Monitoring Timing or Schedule
BIOLOGICAL RESOURCES					
<p>above, shall occur within the buffer zone until the DB and City of Santa Clara verifies that the nest(s) are no longer active.</p> <ul style="list-style-type: none"> If active nests are detected during the surveys, the DB shall monitor the nest weekly (at least once a week for special status species) until the DB determines that nestlings have fledged and dispersed, or the nest is no longer active. This applies to both onsite and offsite nests. If signs of disturbance or distress are observed, the DB shall immediately implement adaptive measures to reduce disturbance. These measures may include, but are not limited to, increasing buffer size, halting disruptive construction activities in the vicinity of the nest until fledging is confirmed, or placement of visual screens or sound-dampening structures between the nest and construction activity, where possible. The DB shall have sole authority not only to 	<p>nesting birds will be avoided by citing the appropriate information from this mitigation measure. The final notification shall include all the reporting elements as described in BIO-4. This guideline shall also apply to any new nests discovered during project construction. All other guidelines in BIO-3 that are applicable shall be followed.</p>				

MITIGATION	MONITORING AND REPORTING PROGRAM				
	Documentation of Compliance [Project Applicant/Proponent Responsibility]		Documentation of Compliance [Lead Agency Responsibility]		
	Method of Compliance or Mitigation Action	Timing of Compliance	Oversight Responsibility	Actions/Reports	Monitoring Timing or Schedule
BIOLOGICAL RESOURCES					
<p>order the cessation of nearby project activities, but also when to resume project activities based upon the observed behavior of the nesting pairs and whether the nesting pairs continue to exhibit signs of distress.</p> <ul style="list-style-type: none"> If active nests of special-status species are detected during pre-construction surveys or during project construction, the Director or their designee for the City of Santa Clara's Department of Planning, Building and Code Enforcement shall be notified within 24 hours. A letter through email may be used initially and shall state how impacts of any nesting birds will be avoided by citing the appropriate information from this mitigation measure. The final notification shall include all the reporting elements as described below. This guideline shall also apply to any new nests discovered during project construction. All other guidelines above shall be followed. 					

MITIGATION	MONITORING AND REPORTING PROGRAM				
	Documentation of Compliance [Project Applicant/Proponent Responsibility]		Documentation of Compliance [Lead Agency Responsibility]		
	Method of Compliance or Mitigation Action	Timing of Compliance	Oversight Responsibility	Actions/Reports	Monitoring Timing or Schedule
BIOLOGICAL RESOURCES					
<p>BIO-4: Nesting Bird Reporting and the Avian Protection Plan The DB shall be responsible for preparing the pre-construction nest survey reports (including the burrowing owl survey report per BIO-2). The report(s) shall include the time, date, methods, and duration of the surveys; identity and qualifications of the surveyor(s); and a list of species observed. If active nests are detected during the surveys, the reports shall also include a map made using GPS technology or aerial photo identifying the location of the nest(s), species, and a depiction of the boundary of the no-disturbance buffer zone around the nest(s). As new nests are discovered during construction, or buffer zones are adjusted, this map of bird nests should be updated. Inactive nests should be indicated by color in order to more visually comprehend where active nests are located. A compilation shall be made of the pre-construction nest survey reports, including a summary of all the</p>	<p>Designated biologist shall prepare reports summarizing the results of the preconstruction surveys for BIO-2 and BIO-3. Reports shall include survey result details specified. All active nests shall be mapped with GPS technology (as specified) and updated as applicable during construction. The designated biologist will compile BIO-2 and BIO-3</p>	<p>Pre-Construction: Submit no more than 14 days prior to issuance of any tree removal, grading, demolition or building permit issuance And On-going during construction</p>	<p>City of Santa Clara Director of Community Development Department or Director's designee</p>	<p>California Department of Fish and Wildlife (CDFW) and approved by the City of Santa Clara Director of Community Development Department or Director's designee</p>	<p>Submit Avian Protection Plan (i.e., compilation of BIO-2 and BIO-3 reports of preconstruction surveys as well as all other guidelines) no more than 14 days prior to issuance of any tree removal, grading, demolition or building permit issuance</p>

MITIGATION	MONITORING AND REPORTING PROGRAM				
	Documentation of Compliance [Project Applicant/Proponent Responsibility]		Documentation of Compliance [Lead Agency Responsibility]		
	Method of Compliance or Mitigation Action	Timing of Compliance	Oversight Responsibility	Actions/Reports	Monitoring Timing or Schedule
BIOLOGICAL RESOURCES					
guidelines contained in BIO-2 and BIO-3 . This compilation, known as the Avian Protection Plan, shall be submitted to the Director or their designee for the City of Santa Clara's Community Development Department prior to any construction activities for review and approval.	survey result reports with the addition of all other guidelines of these measures and present them as the Avian Protection Plan for approval.				
BIO-5: Avoid and Minimize Impacts to Bat Species <ul style="list-style-type: none"> Before the removal of buildings, trees, or other suitable roosting habitat for special-status bats will be affected by project construction, a qualified wildlife biologist shall conduct surveys for special-status bats during the appropriate time of day to maximize detectability to determine if bat species are roosting near the work area. This shall occur no less than 7 days and no more than 14 days prior to beginning tree removal and/or 	A qualified biologist shall conduct surveys during the appropriate time of day to determine if bats are roosting	No less than 7 days and no more than 14 days prior to beginning tree removal and/or demolition or ground disturbance	City of Santa Clara Director of Community Development or Director's designee.	The type of survey to be used will depend on the condition of the potential roosting habitat. Visual surveys shall include trees and structures within 50 feet of construction activities. A tally of the number and species of bats using the roost shall be documented and submitted in report.	Prior to initiation of any onsite project related tree removal and/or demolition or ground disturbance

MITIGATION	MONITORING AND REPORTING PROGRAM				
	Documentation of Compliance [Project Applicant/Proponent Responsibility]		Documentation of Compliance [Lead Agency Responsibility]		
	Method of Compliance or Mitigation Action	Timing of Compliance	Oversight Responsibility	Actions/Reports	Monitoring Timing or Schedule
BIOLOGICAL RESOURCES					
<p>demolition or ground disturbance. Survey methodology may include visual surveys of bats (e.g., observation of bats during foraging period), inspection for suitable habitat, bat sign (e.g., guano), or use of ultrasonic detectors (e.g., Anabat, etc.). Visual surveys shall include trees and structures within 50-feet of construction activities. The type of survey will depend on the condition of the potential roosting habitat. If no bat roosts are found, then no further study and no further mitigation is required.</p> <ul style="list-style-type: none"> If evidence of bat use is observed, the number and species of bats using the roost shall be determined. Bat detectors may be used to supplement survey efforts. If roosts or a maternity colony are determined to be present and must be removed, the bats shall be excluded from the roosting site before the tree or structure is removed. Exclusion methods may 	<p>A qualified biologist shall exclude bats from any found roosting sites</p>	<p>Prior to initiation of any onsite project related tree removal and/or demolition of structure containing bat roost(s) or ground disturbance near these trees/structures that might disturb the bat colony.</p>	<p>City of Santa Clara Director of Community Development or Director's designee.</p>	<p>Qualified biologist may use exclusion methods mentioned and must determine whether exclusion efforts need to be restricted based on sensitive timing for bat colonies.</p>	<p>Prior to initiation of any onsite project related tree removal and/or demolition of structure containing bat roost(s) or ground disturbance near these trees/structures that might disturb the bat colony.</p>
	<p>If negative impacts to roost can't be avoided or roost abandonment is probable, a qualified biologist shall halt all construction</p>	<p>Prior to initiation of any onsite project related tree removal and/or demolition of structure containing bat roost(s) or ground disturbance</p>	<p>City of Santa Clara Director of Community Development or Director's designee.</p>	<p>A qualified biologist will oversee installation of bat houses, including approval of placement and height. Height of bat house shall be at least 15 feet. Bat houses shall be multi-chambered</p>	<p>Prior to initiation of any onsite project related tree removal and/or demolition of structure containing bat roost(s) or ground disturbance near these trees/structures</p>

MITIGATION	MONITORING AND REPORTING PROGRAM				
	Documentation of Compliance [Project Applicant/Proponent Responsibility]		Documentation of Compliance [Lead Agency Responsibility]		
	Method of Compliance or Mitigation Action	Timing of Compliance	Oversight Responsibility	Actions/Reports	Monitoring Timing or Schedule
BIOLOGICAL RESOURCES					
<p>include use of one-way doors at roost entrances (bats may leave, but not reenter) or sealing roost entrances when the site can be confirmed to contain no bats. Exclusion efforts may be restricted during periods of sensitive activity (e.g., during hibernation or while females in maternity colonies are nursing young).</p> <ul style="list-style-type: none"> If roosts cannot be avoided or it is determined that construction activities may cause roost abandonment, such activities shall not commence until permanent, elevated bat houses have been installed outside of, but near, the construction area. Placement and height will be determined by a qualified wildlife biologist, but the height of bat house shall be at least 15 feet. Bat houses shall be multi-chambered and be purchased or constructed in accordance with California Department of Fish and Wildlife (CDFW) standards. The number of bat houses required 	related activities.	near these trees/structures that might disturb the bat colony.		and be purchased or constructed in accordance with California Department of Fish and Wildlife (CDFW) standards. The number of bat houses required shall based on the size of the colony found, but at least one bat house shall be installed for each pair of bats.	that might disturb the bat colony.
	If bat roosts are detected, a Bat Mitigation and Monitoring Plan shall be prepared and implemented for habitat loss.	Prior to initiation of any onsite project related tree removal and/or demolition of structure containing bat roost(s) or ground disturbance near these	City of Santa Clara Director of Community Development or Director's designee and California Department of Fish and Wildlife.	The Plan shall include species of bat and location of the roost, exclusion methods and roost removal procedures, compensatory mitigation for permanent impacts (including specific mitigation ratios and location of proposed	Prior to initiation of any onsite project related tree removal and/or demolition of structure containing bat roost(s) or ground disturbance near these trees/structures

MITIGATION	MONITORING AND REPORTING PROGRAM				
	Documentation of Compliance [Project Applicant/Proponent Responsibility]		Documentation of Compliance [Lead Agency Responsibility]		
	Method of Compliance or Mitigation Action	Timing of Compliance	Oversight Responsibility	Actions/Reports	Monitoring Timing or Schedule
BIOLOGICAL RESOURCES					
<p>shall be dependent upon the size and number of colonies found, but at least one bat house shall be installed for each pair of bats (if occurring individually) or of a sufficient number to accommodate each colony of bats to be relocated.</p> <ul style="list-style-type: none"> If bat roosts are detected, then a Bat Mitigation and Monitoring Plan (Plan) shall be prepared and implemented to mitigate for the loss of roosting habitat. The Plan shall include information pertaining to the species of bat and location of the roost, exclusion methods and roost removal procedures, compensatory mitigation for permanent impacts (including specific mitigation ratios and location of proposed mitigation as described in the above bullet) and monitoring to assess bat use of mitigation areas. This Plan shall be submitted to the City of Santa Clara and CDFW for review and approval prior to project activities that would disturb roosting bats. 		trees/structures that might disturb the bat colony.		mitigation as described in the above bullet) and monitoring to assess bat use of mitigation areas.	that might disturb the bat colony.

MITIGATION	MONITORING AND REPORTING PROGRAM				
	Documentation of Compliance [Project Applicant/Proponent Responsibility]		Documentation of Compliance [Lead Agency Responsibility]		
	Method of Compliance or Mitigation Action	Timing of Compliance	Oversight Responsibility	Actions/Reports	Monitoring Timing or Schedule
CULTURAL AND TRIBAL CULTURAL RESOURCES					
Impact 4.5-a Would the project cause a substantial adverse change in the significance of a historical resource pursuant to §15064.5?					
CUL-1: Cultural Resources Identification, Monitoring, and Treatment Plan Prior to the issuance of any grading permit, a project-specific Cultural Resources Identification, Monitoring, and Treatment Plan (Plan) shall be prepared. The Plan shall be prepared by a Secretary of the Interior-qualified archaeologist, in consultation with the Tamien Nation and a qualified Native American monitor registered with the Native American Heritage Commission (NAHC) with an interest in the city of Santa Clara and that is traditionally and culturally affiliated with the geographic area. The Plan shall reflect permit-level detail pertaining to depths and locations of all ground disturbing activities. The Plan shall be prepared and submitted to the City of Santa's Clara Director of Community Development prior to approval of any grading permit. The Plan shall contain, at a minimum:	A qualified archaeologist in consultation with the Tamien Nation and a qualified Native American monitor shall prepare a project specific Cultural Resources Identification, Monitoring, and Treatment Plan and submit it to the City of Santa Clara Director of Community Development or Director's designee for review and approval	Prior to issuance of grading permits	City of Santa Clara Director of Community Development or Director's designee	Review and approve the Cultural Resources Identification, Monitoring, and Treatment Plan	Prior to issuance of grading permit

MITIGATION	MONITORING AND REPORTING PROGRAM				
	Documentation of Compliance [Project Applicant/Proponent Responsibility]		Documentation of Compliance [Lead Agency Responsibility]		
	Method of Compliance or Mitigation Action	Timing of Compliance	Oversight Responsibility	Actions/Reports	Monitoring Timing or Schedule
CULTURAL AND TRIBAL CULTURAL RESOURCES					
<ul style="list-style-type: none"> • Identification of the scope of work and range of subsurface effects (including location map and development plan), including requirements for preliminary field investigation and construction monitoring. • Description of the environmental setting (past and present) and the historic, California Native American archaeological, and ethnographic background of the parcel (potential range of what might be found). • Development of research questions and goals to be addressed by the investigation (what is significant vs. what is redundant information). • Detailed field strategy (including the preliminary field investigation) used to identify cultural deposits, record, recover, or avoid the finds and address research goals. • Analytical methods. • Handling and preservation of cultural materials. • Report structure of the closing cultural resources report including a confidential technical report and 					

MITIGATION	MONITORING AND REPORTING PROGRAM				
	Documentation of Compliance [Project Applicant/Proponent Responsibility]		Documentation of Compliance [Lead Agency Responsibility]		
	Method of Compliance or Mitigation Action	Timing of Compliance	Oversight Responsibility	Actions/Reports	Monitoring Timing or Schedule
CULTURAL AND TRIBAL CULTURAL RESOURCES					
layperson's report and an outline of document contents in one year of completion of construction (provide a draft for review before a final report). <ul style="list-style-type: none"> Disposition of the artifacts, including identification of potential reburial location(s) on site. Appendices: all site records, correspondence, and consultation with Native Americans, etc.					
CUL-2: Worker Environmental Awareness Program Training Prior to issuance of the grading permit by the City of Santa Clara's Community Development Department, and for the duration of ground disturbance, the project shall be required to submit evidence that Worker Environmental Awareness Program (WEAP) training was held for all existing and any new employees. The training shall be facilitated by the project archaeologist in coordination with a Native American representative registered with the Native American Heritage Commissions with an interest in the city of Santa Clara and that is traditionally and	The qualified archaeological specialists in consultation with the Native American representative shall prepare a WEAP and submit an electronic copy to the City of Santa Clara Director of Community Development or Director's	Prior to issuance of grading permit	City of Santa Clara Director of Community Development or Director's designee	Review and approve the Workforce Environmental Awareness Program	Prior to issuance of grading permit.

MITIGATION	MONITORING AND REPORTING PROGRAM				
	Documentation of Compliance [Project Applicant/Proponent Responsibility]		Documentation of Compliance [Lead Agency Responsibility]		
	Method of Compliance or Mitigation Action	Timing of Compliance	Oversight Responsibility	Actions/Reports	Monitoring Timing or Schedule
CULTURAL AND TRIBAL CULTURAL RESOURCES					
culturally affiliated with the geographic area as described in Public Resources Code, section 21080.3. This training should include: a discussion of applicable laws and penalties under the laws; samples or visual aids of artifacts that could be encountered in the project vicinity, including what those artifacts may look like partially buried, or wholly buried and freshly exposed, and instructions to halt work in the vicinity of any potential cultural resource discovery, and notify the City-approved archaeologist and Native American cultural resources monitor. The Native American monitor shall provide a Tribal Cultural Resources Sensitivity Training in conjunction with the WEAP.	designee for review and approval.				
	WEAP and Tribal Cultural Resources Sensitivity training shall be provided to all existing and new employees and a monthly report shall be submitted to the City of Santa Clara Director of Community Development or Director's designee quantifying the number of workers who received training the prior month as well as a running total of	Prior to and for the duration of ground disturbing activities	Applicant/Owner; City of Santa Clara Director of Community Development or Director's designee	Review and approve the WEAP training monthly reports	Monthly for the duration of ground disturbing construction activities

MITIGATION	MONITORING AND REPORTING PROGRAM				
	Documentation of Compliance [Project Applicant/Proponent Responsibility]		Documentation of Compliance [Lead Agency Responsibility]		
	Method of Compliance or Mitigation Action	Timing of Compliance	Oversight Responsibility	Actions/Reports	Monitoring Timing or Schedule
CULTURAL AND TRIBAL CULTURAL RESOURCES					
	all workers who have received training over the course of the project				
CUL-3: Preliminary Field Investigations After removal of pavement at the project site and prior to grading, a Secretary of the Interior-qualified archaeologist and qualified Native American monitor shall conduct a pedestrian survey over the exposed soils to determine if any surface archaeological manifestations are present. Prior to issuance of any grading or demolition permits, the project applicant shall complete a preliminary field investigation program in conformance with the project-specific Cultural Resources Identification, Monitoring, and Treatment Plan required under CUL-1 . Results of the investigation shall be provided to the City of Santa Clara's Director of Community Development prior to issuance of any grading permit. If any finds were discovered during the	The qualified archaeologist shall conduct a preliminary field investigation of exposed soils with a Native American monitor present	After demolition of the existing building, removal of pavement, and prior to grading	City of Santa Clara Director of Community Development or Director's designee	Review the results and approve next steps	Prior to grading
	If the preliminary field investigation determines that resources are present and significant, treatment plan will be followed	Prior to grading	City of Santa Clara Director of Community Development or Director's designee	Review the results and approve next steps	Prior to grading

MITIGATION	MONITORING AND REPORTING PROGRAM				
	Documentation of Compliance [Project Applicant/Proponent Responsibility]		Documentation of Compliance [Lead Agency Responsibility]		
	Method of Compliance or Mitigation Action	Timing of Compliance	Oversight Responsibility	Actions/Reports	Monitoring Timing or Schedule
CULTURAL AND TRIBAL CULTURAL RESOURCES					
preliminary field investigation, the project archaeologist shall implement CUL-5 for evaluation and recovery methodologies. The results of the preliminary field investigation shall be submitted to the Director of Community Development for review and approval prior to issuance of any grading permit. The California Department of Parks and Recreation 523 series forms shall be submitted along with the report for any cultural resources encountered over 50 years old.					
CUL-4: Construction Monitoring and Protection Measures All ground-disturbing activities (e.g., grading and excavation) shall be completed under the observation of a Secretary of the Interior-qualified archaeologist and a qualified Native American monitor, registered with the Native American Heritage Commission (NAHC) with an interest in the city of Santa Clara. Preference in selecting Native American monitors shall be given to members of the Tamien Nation and Native Americans with:	Project applicant/owner shall submit the qualifications of archaeological specialists and Native American monitors to the City of Santa Clara Director of Community Development or Director's designee with a	Prior to issuance of a grading permit	City of Santa Clara Director of Community Development or Director's designee	Review and approve the qualifications of archaeologist and Native American monitors	Prior to issuance of a grading permit

MITIGATION	MONITORING AND REPORTING PROGRAM				
	Documentation of Compliance [Project Applicant/Proponent Responsibility]		Documentation of Compliance [Lead Agency Responsibility]		
	Method of Compliance or Mitigation Action	Timing of Compliance	Oversight Responsibility	Actions/Reports	Monitoring Timing or Schedule
CULTURAL AND TRIBAL CULTURAL RESOURCES					
<ul style="list-style-type: none"> Traditional ties to the area being monitored. Knowledge of local Native American village sites and habitation patterns. Knowledge and understanding of Health and Safety Code, section 7050.5 and Public Resources Code, section 5097.9 et seq. Ability to effectively communicate the requirements of Health and Safety Code, section 7050.5 and Public Resources Code, section 5097.9 et seq. Ability to work with law enforcement officials and the Native American Heritage Commission to ensure the return of all associated grave goods taken from a Native American grave during excavation. Ability to travel to project sites within traditional tribal territory. Knowledge and understanding of Title 14, California Code of Regulations, section 15064.5. Ability to advocate for the preservation in place of Native 	signed letter of commitment or agreement to monitor				
	The archaeologist and Native American monitor will monitor full-time all grading and ground disturbing activities and maintain a daily monitoring log	During grading and ground disturbing activities	City of Santa Clara Director of Community Development or Director's designee.	Review monitoring logs as needed	During grading and ground disturbing activities
	Work shall be stopped if cultural resources are encountered within a 50' radius	During ground disturbing activities	City of Santa Clara Director of Community Development or Director's designee; Secretary of the Interior-qualified archaeologist or qualified Native American monitor	Review and approve work stoppage	During grading and ground disturbing activities

MITIGATION	MONITORING AND REPORTING PROGRAM				
	Documentation of Compliance [Project Applicant/Proponent Responsibility]		Documentation of Compliance [Lead Agency Responsibility]		
	Method of Compliance or Mitigation Action	Timing of Compliance	Oversight Responsibility	Actions/Reports	Monitoring Timing or Schedule
CULTURAL AND TRIBAL CULTURAL RESOURCES					
<p>American cultural features through knowledge and understanding California Environmental Quality Act (CEQA) mitigation provisions.</p> <ul style="list-style-type: none"> • Ability to read a topographical map and be able to locate site and reburial locations for future inclusion in the NAHC’s Sacred Lands Inventory. • Knowledge and understanding of archaeological practices, including the phases of archaeological investigation. <p>The qualified archaeologist or a qualified Native American monitor, shall have authority to halt construction activities temporarily within a 50-foot radius of any cultural resources finds. If the archaeologist and Native American monitor believe that a reduction in monitoring activities is prudent, then a letter report detailing the rationale for making such a reduction and summarizing the monitoring results shall be provided to the Director of Community Development. If, for any reasons, the qualified archaeologist or a qualified</p>	<p>If the archaeologist and Native American monitor believe that a reduction in monitoring activities is prudent, they may prepare a report detailing their rationale for the reduction and submit it to the Santa Clara Director of Community Development or Director’s designee</p>	<p>During grading and ground disturbing activities</p>	<p>City of Santa Clara Director of Community Development or Director’s designee</p>	<p>Review and approve request to reduce cultural resources monitoring</p>	<p>During grading and ground disturbing activities</p>

MITIGATION	MONITORING AND REPORTING PROGRAM				
	Documentation of Compliance [Project Applicant/Proponent Responsibility]		Documentation of Compliance [Lead Agency Responsibility]		
	Method of Compliance or Mitigation Action	Timing of Compliance	Oversight Responsibility	Actions/Reports	Monitoring Timing or Schedule
CULTURAL AND TRIBAL CULTURAL RESOURCES					
Native American monitor is not present, but construction crews encounter a cultural resource, all work shall stop temporarily within 50 feet of the find until a qualified archaeologist in consultation with a qualified Native American monitor has been contacted to determine the proper course of action. The Director of Community Development shall be notified of any finds during the grading or other construction activities. Any human remains encountered during construction shall be treated according to the protocol identified in CUL-6 .					
CUL-5: Evaluation and Data Recovery The City of Santa Clara’s Director of Community Development shall be notified of any finds during the preliminary field investigation, grading, or other construction activities. Any historic or Native American cultural material identified in the project area during the preliminary field investigation and during grading or other construction activities shall be evaluated for eligibility for listing as a	All construction activity will stop within 50-feet of an archaeological discovery, the City of Santa Clara Director of Community Development or Director’s designee will be notified, and a	During the preliminary field investigation, grading, and construction phase	City of Santa Clara Director of Community Development or Director’s designee	Review and approve the recommendation(s) of the qualified archaeologist	During the preliminary field investigation, grading, and construction phase.

MITIGATION	MONITORING AND REPORTING PROGRAM				
	Documentation of Compliance [Project Applicant/Proponent Responsibility]		Documentation of Compliance [Lead Agency Responsibility]		
	Method of Compliance or Mitigation Action	Timing of Compliance	Oversight Responsibility	Actions/Reports	Monitoring Timing or Schedule
CULTURAL AND TRIBAL CULTURAL RESOURCES					
<p>Candidate City Landmark or a California Historical Resource by a Secretary of the Interior-qualified archaeologist. If Native American cultural materials or historic resources are encountered, all activity within a 50-foot radius of the find shall be stopped, the Director of Community Development shall be notified, and a Secretary of the Interior-qualified archaeologist shall examine the find and record the site, including field notes, measurements, and photography, and document the find using the California Department of Parks and Recreation 523 series forms. The archaeologist shall make recommendations regarding eligibility as a Candidate City Landmark and/or a California Historical Resource, data recovery, curation, or other appropriate mitigation. Ground disturbance within the 50-foot radius can resume once these steps are taken and the Director of Community Development has concurred with the recommendations. Data recovery methods may include, but are not limited to, backhoe</p>	<p>qualified archaeologist will inspect the find</p> <p>Examination of the find and recordation on DPR 523 Series forms along with a determination of eligibility and recommendation for data recovery or curation</p>	<p>While ground disturbing activities are halted and prior to returning to work</p>	<p>Secretary of the Interior-qualified archaeologist; City of Santa Clara Director of Community Development or Director's designee</p>	<p>Record on DPR 523 Series forms with eligibility and curation recommendations;</p> <p>If the find does meet the definition of a historical, unique archaeological, or tribal cultural resource and cannot be avoided, review and authorize implementation appropriate treatment/mitigation per treatment and mitigation plan and</p>	<p>During grading and ground disturbing activities</p>

MITIGATION	MONITORING AND REPORTING PROGRAM				
	Documentation of Compliance [Project Applicant/Proponent Responsibility]		Documentation of Compliance [Lead Agency Responsibility]		
	Method of Compliance or Mitigation Action	Timing of Compliance	Oversight Responsibility	Actions/Reports	Monitoring Timing or Schedule
CULTURAL AND TRIBAL CULTURAL RESOURCES					
trenching, shovel test units, hand auguring, and hand-excavation. The techniques used for data recovery shall follow the protocols identified in the project-specific Cultural Resources Identification, Monitoring, and Treatment Plan. Data recovery shall include excavation and exposure of features, field documentation, and recordation.				authorize construction to resume in the vicinity of the find after appropriate mitigation is completed; or Authorize construction to resume in the vicinity of the find if the find does not meet the definition of a historical, unique archaeological, or tribal cultural resource.	
CUL-6: Human Remains If human remains are discovered during the preliminary field investigation, excavation and/or grading, building, or other construction activities at the site, all activity within a 50-foot radius of the find will be stopped. The Santa Clara County Coroner will be notified and shall determine whether the remains are of	All construction activity will stop within 50-feet of the discovery of human remains, the Santa Clara County Coroner and City of Santa Clara Director of	Immediately upon discovery of human remains	City of Santa Clara Director of Community Development or Director's designee	The Santa Clara County coroner shall contact the NAHC if human remains are found and believed to the Native American. Authorize implementation of the treatment plan based on the	Upon discovery of human remains

MITIGATION	MONITORING AND REPORTING PROGRAM				
	Documentation of Compliance [Project Applicant/Proponent Responsibility]		Documentation of Compliance [Lead Agency Responsibility]		
	Method of Compliance or Mitigation Action	Timing of Compliance	Oversight Responsibility	Actions/Reports	Monitoring Timing or Schedule
CULTURAL AND TRIBAL CULTURAL RESOURCES					
Native American origin or whether an investigation into the cause of death is required. If the remains are determined to be Native American, the Coroner will notify the Native American Heritage Commission (NAHC) immediately. Once NAHC identifies the most likely descendants, the descendants will make recommendations regarding treatment and disposition with appropriate dignity, which will be implemented in accordance with section 15064.5(e) of the California Environmental Quality Act Guidelines. All actions taken under this mitigation measure shall comply with Health and Human Safety Code, section 7050.5(b).	Community Development or Director's designee will be notified immediately			recommendations of the MLD, if the remains are determined to be of Native American origin. Authorize construction to resume in the vicinity of the find when appropriate treatment is completed.	
CUL-7: Site Security At the discretion of the City of Santa Clara's Director of Community Development, site fencing shall be installed on-site during the preliminary field investigation, grading, building, or other construction activities to avoid destruction and/or theft of potential cultural resources. The responsible qualified archaeologist, in consultation	The qualified archaeologist in consultation with the Native American monitor shall advise the City of Santa Clara Director of Community	During ground disturbing activities	City of Santa Clara Director of Community Development or Director's designee	Review and implement site security advice	During ground disturbing activities

MITIGATION	MONITORING AND REPORTING PROGRAM				
	Documentation of Compliance [Project Applicant/Proponent Responsibility]		Documentation of Compliance [Lead Agency Responsibility]		
	Method of Compliance or Mitigation Action	Timing of Compliance	Oversight Responsibility	Actions/Reports	Monitoring Timing or Schedule
CULTURAL AND TRIBAL CULTURAL RESOURCES					
with a qualified Native American monitor, registered with the Native American Heritage Commission (NAHC) with an interest in the city of Santa Clara and that is traditionally and culturally affiliated with the geographic area, shall advise the Director of Community Development as to the necessity for a security guard. The purpose of the security guard shall be to ensure the safety of any potential cultural resources (including human remains) that are left exposed overnight. The Director of Community Development shall have the final discretion to authorize the use of a security guard at the project site.	Development or Director's designee on the necessity for a security guard				
CUL-8: Closing Cultural Resources Report Once all analyses and studies required by the project-specific Cultural Resources Identification, Monitoring, and Treatment Plan (Plan) have been completed, the project applicant, or representative, shall prepare a closing cultural resources report summarizing the results of the preliminary field investigation, data recovery activities	A closing cultural resources report shall summarize the findings documenting any cultural resources found during construction	Upon completion of monitoring and prior to issuance of any Certificates of Occupancy	City of Santa Clara Director of Community Development or Director's designee; Secretary of Interior-qualified archaeologist	Review and approve closing cultural resources report	Upon completion of cultural resources monitoring and prior to issuance of any Certificates of Occupancy

MITIGATION	MONITORING AND REPORTING PROGRAM				
	Documentation of Compliance [Project Applicant/Proponent Responsibility]		Documentation of Compliance [Lead Agency Responsibility]		
	Method of Compliance or Mitigation Action	Timing of Compliance	Oversight Responsibility	Actions/Reports	Monitoring Timing or Schedule
CULTURAL AND TRIBAL CULTURAL RESOURCES					
and results, and compliance with the Plan during all demolition, grading, building, and other construction activities. The report shall document the results of field and laboratory investigations and shall meet the Secretary of the Interior's Standards for Archaeological Documentation. The contents of the report shall be consistent with the protocol included in the project-specific Cultural Resources Treatment Plan. The report shall be submitted to the City of Santa Clara's Director of Community Development for review and approval prior to issuance of any certificates of occupancy (temporary or final). Once approved, the final documentation shall be submitted to the Northwest Information Center at Sonoma State University, as appropriate.	Submittal of the closing cultural resources report to the NWIC	Upon finalization of the report	City of Santa Clara Director of Community Development or Director's designee	Obtain proof of submittal to NWIC	Upon finalization of the report
CUL-9: Curation Upon completion of the closing cultural resources report required by CUL-8 , all recovered archaeological materials not identified as tribal cultural resources by the Native American monitor, shall be transferred to a long-term curation	All archaeological materials not identified as tribal cultural resources shall be curated at a	Upon completion of the closing cultural resources report	Project Applicant/ Owner	Notification of selection of collections facility submitted to City of Santa Clara Director of Community	Prior to issuing Certification of Occupancy

MITIGATION	MONITORING AND REPORTING PROGRAM				
	Documentation of Compliance [Project Applicant/Proponent Responsibility]		Documentation of Compliance [Lead Agency Responsibility]		
	Method of Compliance or Mitigation Action	Timing of Compliance	Oversight Responsibility	Actions/Reports	Monitoring Timing or Schedule
CULTURAL AND TRIBAL CULTURAL RESOURCES					
facility. Any curation facility used shall meet the standards outlined in the National Park Service Curation of Federally Owned and Administered Archaeological Collections (36 CFR 79). The project owner shall notify the City of Santa Clara’s Director of Community Development of the selected curation facility prior to the issuance of any certificates of occupancy (temporary or final). To the extent feasible, and in consultation with the Native American representative, all recovered Native American/tribal cultural resources and artifacts shall be reburied on-site in an area that is unlikely to be disturbed again. Treatment of materials to be curated shall be consistent with the protocols included in the project-specific Cultural Resources Identification, Monitoring, and Treatment Plan. All archaeological materials recovered during the data recovery efforts shall be cleaned, sorted, catalogued, and analyzed following standard archaeological procedures, and shall be documented in a report submitted to the City of	long-term collections facility			Development or Director’s designee.	
	Native American and tribal cultural resources should be reburied on-site, if feasible	Prior to issuance of Certificate of Occupancy	City of Santa Clara Director of Community Development or Director’s designee	Confirm with Native American monitor and MLD (if applicable)	Prior to issuing Certification of Occupancy

MITIGATION	MONITORING AND REPORTING PROGRAM				
	Documentation of Compliance [Project Applicant/Proponent Responsibility]		Documentation of Compliance [Lead Agency Responsibility]		
	Method of Compliance or Mitigation Action	Timing of Compliance	Oversight Responsibility	Actions/Reports	Monitoring Timing or Schedule
CULTURAL AND TRIBAL CULTURAL RESOURCES					
Santa Clara’s Director of Community Development and the Northwest Information Center (NWIC).					
Impact 4.5-b Would the project cause a substantial adverse change in the significance of a unique archaeological resource pursuant to §15064.5?					
CUL-1 through CUL-9 (See impact 4.5-a for mitigation)					
Impact 4.5-c Would the project disturb any human remains, including those interred outside of formal cemeteries?					
CUL-1 through CUL-9 (See impact 4.5-a for mitigation)					
Impact 4.5-e Would the project cause a substantial adverse change in the significance of a tribal cultural resource, defined in Public Resources Code section 21074 as either a site, feature, place, cultural landscape that is geographically defined in terms of the size and scope of the landscape, sacred place, or object with cultural value to a California Native American tribe, and that is a resource determined by the lead agency, in its discretion and supported by substantial evidence, to be significant pursuant to criteria set forth in subdivision (c) of Public Resources Code Section 5024.1. In applying the criteria set forth in subdivision (c) of Public Resource Code Section 5024.1, the lead agency shall consider the significance of the resource to a California Native American tribe?					
CUL-1 through CUL-9 (See impact 4.5-a for mitigation)					

MITIGATION	MONITORING AND REPORTING PROGRAM				
	Documentation of Compliance [Project Applicant/Proponent Responsibility]		Documentation of Compliance [Lead Agency Responsibility]		
	Method of Compliance or Mitigation Action	Timing of Compliance	Oversight Responsibility	Actions/Reports	Monitoring Timing or Schedule
GEOLOGY AND SOILS (PALEONTOLOGY)					
Impact 4.7-f Would the project directly or indirectly destroy a unique paleontological resource or site or unique geologic feature?					
GEO-1: <ul style="list-style-type: none"> Prior to the start of any subsurface excavations that would extend beyond previously disturbed soils, all construction forepersons and field supervisors shall receive training by a qualified professional paleontologist, as defined by the Society of Vertebrate Paleontology, who is experienced in teaching non-specialists, to ensure they can recognize fossil materials and shall follow proper notification procedures in the event any are uncovered during construction. Procedures to be conveyed to workers are halting construction within 50 feet of any potential fossil find and notifying a qualified paleontologist, who shall evaluate its significance. If a fossil is found and determined by the qualified paleontologist to be significant and avoidance is not feasible, the paleontologist shall 	Secure services of an on-call qualified professional paleontologist, as defined by the Society of Vertebrate Paleontology to train all construction forepersons and field supervisors to recognize fossil materials and follow proper notification procedures in the event any are uncovered during construction. If suspected fossils are	Prior to the start of any subsurface excavations.	City of Santa Clara Director or Director's designee	City of Santa Clara Director or Director's designee to verify that the services of an on-call qualified professional paleontologist have been procured and that training of all construction forepersons and field supervisors has taken place.	Prior to the start of any subsurface excavations.

MITIGATION	MONITORING AND REPORTING PROGRAM				
	Documentation of Compliance [Project Applicant/Proponent Responsibility]		Documentation of Compliance [Lead Agency Responsibility]		
	Method of Compliance or Mitigation Action	Timing of Compliance	Oversight Responsibility	Actions/Reports	Monitoring Timing or Schedule
GEOLOGY AND SOILS (PALEONTOLOGY)					
develop and implement an excavation and salvage plan in accordance with Society of Vertebrate Paleontology standards. Construction work in these areas shall be halted or diverted to allow the preparation of the plan and recovery of fossil remains in a timely manner. Fossil remains collected during the monitoring and salvage portion of the mitigation program shall be cleaned, repaired, sorted, and cataloged. Prepared fossils, along with copies of all pertinent field notes, photos, and maps, shall then be deposited in a scientific institution with paleontological collections. A final Paleontological Mitigation Plan Report that outlines the results of the mitigation program shall be prepared and submitted to the Director or Director's designee with the City of Santa Clara Community Development Department at the conclusion of construction. The Director or Director's Designee	encountered during construction, the construction workers shall halt construction within 50 feet of any potential fossil find and notify the paleontologist, who shall evaluate its significance.				
	If a fossil is found and determined by the qualified paleontologist to be significant and avoidance is not feasible, the paleontologist shall develop and implement an excavation and salvage plan in accordance	Upon discovery of a fossil that has been determined by the qualified paleontologist to be significant and avoidance is not feasible.	City of Santa Clara Director or Director's designee	City of Santa Clara Director or Director's designee to review and approve the fossil excavation and salvage plan.	Upon discovery of a fossil that has been determined by the qualified paleontologist to be significant and avoidance is not feasible.

MITIGATION	MONITORING AND REPORTING PROGRAM				
	Documentation of Compliance [Project Applicant/Proponent Responsibility]		Documentation of Compliance [Lead Agency Responsibility]		
	Method of Compliance or Mitigation Action	Timing of Compliance	Oversight Responsibility	Actions/Reports	Monitoring Timing or Schedule
GEOLOGY AND SOILS (PALEONTOLOGY)					
with the City of Santa Clara shall be responsible for ensuring that the paleontologist's recommendations regarding treatment and reporting are implemented.	with Society of Vertebrate Paleontology standards.				
	A final Paleontological Mitigation Plan Report that outlines the results of the mitigation program shall be prepared and submitted to the Director or Director's designee with the City of Santa Clara at the conclusion of construction.	At the conclusion of construction.	City of Santa Clara Director or Director's designee	The Director or Director's Designee with the City of Santa Clara shall review the final Paleontological Mitigation Plan Report. The Director or Director's Designee with the City of Santa Clara shall be responsible for ensuring that the paleontologist's recommendations regarding treatment and reporting are implemented.	At the conclusion of construction.

MITIGATION	MONITORING AND REPORTING PROGRAM				
	Documentation of Compliance [Project Applicant/Proponent Responsibility]		Documentation of Compliance [Lead Agency Responsibility]		
	Method of Compliance or Mitigation Action	Timing of Compliance	Oversight Responsibility	Actions/Reports	Monitoring Timing or Schedule
GREENHOUSE GAS EMISSIONS					
Impact 4.8-a Would the project generate greenhouse gas emissions, either directly or indirectly, that may have a significant impact on the environment?					
<p>GHG-1: The project owner shall participate in SVP's Large Customer Renewable Energy (LCRE) Program or other renewable energy program that accomplishes the same objective as SVP's LCRE Program for 100 percent carbon-free electricity, or (2) purchase renewable energy credits or similar instruments that accomplish the same goals of 100 percent carbon-free electricity.</p> <p>During Operation, the project owner shall provide documentation to the director, or director's designee, of the city of Santa Clara Electric Utility Department of initial enrollment and shall submit annual reporting to the director, or director's designee, of the city of Santa Clara Electric Utility Department documenting either continued participation in SVP's LCRE Program or documentation that alternative measures continue to provide 100 percent carbon-free electricity as verified by an independent</p>	<p>Use renewable diesel as the primary fuel and ULSD as a secondary fuel in the event of supply challenges or disruptions</p>	<p>Following commencement of project operation then annually for the life of the project</p>	<p>Director of Electric Utility Department or Director's designee</p>	<p>The project owner shall provide an annual report of renewable diesel supply and distribution</p>	<p>Following commencement of project operation then annually for the life of the project</p>

MITIGATION	MONITORING AND REPORTING PROGRAM				
	Documentation of Compliance [Project Applicant/Proponent Responsibility]		Documentation of Compliance [Lead Agency Responsibility]		
	Method of Compliance or Mitigation Action	Timing of Compliance	Oversight Responsibility	Actions/Reports	Monitoring Timing or Schedule
GREENHOUSE GAS EMISSIONS					
third-party auditor specializing in greenhouse gas emissions.					
GHG-2: The project owner shall use renewable diesel for 100 percent of total energy use by the gensets, and only use ultra-low sulfur diesel (ULSD) as a secondary fuel in the event of supply challenges or disruption in obtaining renewable diesel. The City of Santa Clara Community Development Department (CDD) may grant temporary relief from the 100 percent renewable diesel requirement if the project owner can demonstrate a good faith effort to comply with the requirement and that compliance is not practicable. The project owner shall provide an annual report of the status of procuring and using renewable diesel to the director, or director's designee, of the City of Santa Clara CDD demonstrating compliance with the mitigation measure.	Ensure that 100 percent of the renewable electricity purchased is covered by carbon-free resources	Prior to local approval of project entitlements and during the operational phase	Director of Electric Utility Department or Director's designee	The project owner shall provide proof of enrollment in SVP's LCRE or other acceptable instrument and annual report, with verification by a qualified third-party auditor specializing in greenhouse gas emissions	Upon commencing project operation and annually for the life of the project
Impact 4.8-b Would the project conflict with an applicable plan, policy or regulation adopted for the purpose or reducing the emissions of greenhouse gasses?					
GHG-1 and GHG-2 (See impact 4.8-a for mitigation)					

MITIGATION	MONITORING AND REPORTING PROGRAM				
	Documentation of Compliance [Project Applicant/Proponent Responsibility]		Documentation of Compliance [Lead Agency Responsibility]		
	Method of Compliance or Mitigation Action	Timing of Compliance	Oversight Responsibility	Actions/Reports	Monitoring Timing or Schedule
HAZARDS AND HAZARDOUS MATERIALS					
Impact 4.9-d Would the project be located on a site that is included of a list of hazardous materials sites compiled pursuant to Government Code Section 65962.5 and, as a result, would it create a significant hazard to the public or the environment?					
HAZ-1: Prior to issuance of demolition permits, a lead-based paint (LBP) visual inspection and pre-demolition survey, including sampling and testing of suspect materials, shall be conducted of on-site buildings to determine the presence of LBP. The survey shall be conducted by a contractor with California Department of Public Health (CDPH) Lead Related Construction (LRC) certified personnel as required by CDPH regulations. The findings of the LBP survey shall be submitted to the Santa Clara City Fire Department Community Risk Reduction Division for review.	Conduct an LBP visual inspection and a pre-demolition LBP survey of the on-site buildings. Prepare a report of LBP survey findings and submit it to the Santa Clara City Fire Department Community Risk Reduction Division for review.	Prior to issuance of demolition permits, and prior to start of Project construction.	Santa Clara City Fire Department Community Risk Reduction Division	Review submitted documentation/report to verify presence of LBP onsite after pre-demolition survey.	After LBP pre-demolition survey and prior to issuance of demolition permits. Prior to start of Project construction.
HAZ-2: Prior to issuance of demolition or grading permits, the project applicant shall prepare a Site Management Plan (SMP) to guide activities during demolition, exaction, and initial construction to ensure that potentially contaminated soils are identified, characterized, removed, and disposed of properly. The	Prepare and implement a SMP, including HSPs. Submit the HSPs for review and approval to the Santa Clara County Department of Environmental Health and the Santa Clara	Prior to issuance of demolition or grading permits, prior to soil and groundwater sampling, and prior to the	If no soil or groundwater contaminants exceeding applicable ESLs are identified, Santa Clara County Department of	Review and approve submitted SMP and HSPs Review submitted documentation/report of results of soil and groundwater site characterization to	Prior to issuance of any grading, demolition, or building permits, prior to and during handling and removal of any identified contaminated soil

MITIGATION	MONITORING AND REPORTING PROGRAM				
	Documentation of Compliance [Project Applicant/Proponent Responsibility]		Documentation of Compliance [Lead Agency Responsibility]		
	Method of Compliance or Mitigation Action	Timing of Compliance	Oversight Responsibility	Actions/Reports	Monitoring Timing or Schedule
HAZARDS AND HAZARDOUS MATERIALS					
<p>purpose of the SMP is to establish appropriate management practices for handling impacted soil or other materials that may be encountered during construction activities. The SMP shall be reviewed and approved by the Santa Clara County Environmental Services Department and the Santa Clara Fire Department Community Risk Reduction Division prior to any work on the site, including prior to soil and groundwater sampling.</p> <p>The SMP shall be implemented during project demolition and construction and shall include, but shall not be limited to, the following components:</p> <ul style="list-style-type: none"> • A detailed discussion of the site background. • Prior to any onsite work, Health and Safety Plans (HSP) for the project shall be prepared by all contractors and subcontractors that will be working at the project site and incorporated in the SMP. The HSPs shall be prepared by an industrial hygienist. The HSPs 	<p>Fire Department Community Risk Reduction Division.</p> <p>If no soil or groundwater contaminants exceeding applicable ESLs are identified, submit the SMP for review and approval to the Santa Clara County Department of Environmental Health and the Santa Clara Fire Department Community Risk Reduction Division.</p> <p>If soil or groundwater contaminants exceeding applicable ESLs are identified, obtain regulatory oversight from the agency with jurisdictional authority for characterization and remediation</p>	<p>start of and during construction.</p>	<p>Environmental Health and the Santa Clara Fire Department Community Risk Reduction Division.</p> <p>If soil or groundwater contaminants exceeding applicable ESLs are identified, Santa Clara Fire Department Community Risk Reduction Division (CUPA), California Department of Toxic Substances Control under a Site Cleanup Program, State Water Resources</p>	<p>verify presence or absence and levels of contamination.</p> <p>Provide regulatory oversight for site characterization and remediation in the event of identification of contaminated soil or groundwater.</p> <p>Provide verification of regulatory compliance to Santa Clara County Department of Environmental Health and the Santa Clara City Fire Department Community Risk Reduction Division.</p>	<p>or groundwater, and prior to the start of and during construction.</p>

MITIGATION	MONITORING AND REPORTING PROGRAM				
	Documentation of Compliance [Project Applicant/Proponent Responsibility]		Documentation of Compliance [Lead Agency Responsibility]		
	Method of Compliance or Mitigation Action	Timing of Compliance	Oversight Responsibility	Actions/Reports	Monitoring Timing or Schedule
HAZARDS AND HAZARDOUS MATERIALS					
<p>shall be specific to each of the contractors' or subcontractors' scopes of work and based upon the known environmental conditions for the site prior to project construction. The HSPs shall be updated as needed if site conditions change significantly, such as the discovery of contaminated soil or groundwater. The HSPs shall be approved by the Director or Director's designee with the Santa Clara County Environmental Services Department and the Santa Clara Fire Department Community Risk Reduction Division, implemented under the direction of a Site Safety and Health Officer. Copies of the approved HSPs shall be kept at the project site.</p> <ul style="list-style-type: none"> Description of soil and groundwater testing, which shall include (but not be limited to) the collection of soil samples and groundwater samples and analyses for volatile organic compounds (VOCs) and any other 	<p>oversite. Submit the SMP and planned remedial measures for review and approval to the oversight agency. Submit a copy of the SMP to the Santa Clara County Department of Environmental Health and the Santa Clara Fire Department Community Risk Reduction Division.</p>		<p>Control Board (SWRCB), or the Santa Clara County Department of Environmental Health.</p>		

MITIGATION	MONITORING AND REPORTING PROGRAM				
	Documentation of Compliance [Project Applicant/Proponent Responsibility]		Documentation of Compliance [Lead Agency Responsibility]		
	Method of Compliance or Mitigation Action	Timing of Compliance	Oversight Responsibility	Actions/Reports	Monitoring Timing or Schedule
HAZARDS AND HAZARDOUS MATERIALS					
<p>contaminants identified in previous environmental studies in the soil and groundwater and lead and organochlorine pesticides in the soil to verify presence of absence of remnant or unknown soil or groundwater contamination. This soil and groundwater characterization shall be performed prior to initiation of project construction.</p> <ul style="list-style-type: none"> • Protocols for sampling at the site to verify or rule out a vapor encroachment conditions at the site and within the buildings to be demolished and, if verified, for remediation of vapor encroachment conditions within the existing building prior to demolition and to prevent it in the proposed structures. • Protocols for sampling of soil and groundwater to facilitate the profiling of the soil and groundwater for appropriate off-site disposal or reuse, and for construction worker safety, dust mitigation during demolition and construction and potential 					

MITIGATION	MONITORING AND REPORTING PROGRAM				
	Documentation of Compliance [Project Applicant/Proponent Responsibility]		Documentation of Compliance [Lead Agency Responsibility]		
	Method of Compliance or Mitigation Action	Timing of Compliance	Oversight Responsibility	Actions/Reports	Monitoring Timing or Schedule
HAZARDS AND HAZARDOUS MATERIALS					
<p>exposure of contaminated soil or groundwater to future users of the site prior to project construction.</p> <ul style="list-style-type: none"> • Procedures to be undertaken if contamination is identified above action levels or previously unknown contamination is discovered prior to or during project demolition or construction. • Notification procedures if previously undiscovered significantly impacted soil or groundwater, or free fuel product is encountered during demolition or construction. • Sampling and laboratory analyses of excess soil requiring disposal at an appropriate off-site waste disposal facility. • Procedures and protocols for the safe storage, stockpiling, and disposal of contaminated soils. • Protocols to manage groundwater, including segregation or treatment of contaminated groundwater, if necessary, that may be 					

MITIGATION	MONITORING AND REPORTING PROGRAM				
	Documentation of Compliance [Project Applicant/Proponent Responsibility]		Documentation of Compliance [Lead Agency Responsibility]		
	Method of Compliance or Mitigation Action	Timing of Compliance	Oversight Responsibility	Actions/Reports	Monitoring Timing or Schedule
HAZARDS AND HAZARDOUS MATERIALS					
<p>encountered during trenching or subsurface excavation activities.</p> <p>If there are no contaminants identified on the project site that exceed applicable environmental screening levels (ESLs) for construction workers and residential users published by the Regional Water Quality Control Board (RWQCB), California Department of Toxic Substances Control (DTSC), or California Environmental Protection Agency, the SMP does not need to be submitted to an oversight agency and instead only needs to be submitted to the Santa Clara County Environmental Health Department and the Santa Clara Fire Department Community Risk Reduction Division for approval prior to issuance of a grading permit and prior to conducting any demolition activities.</p> <p>If contaminants are identified at concentrations exceeding applicable ESLs, the project applicant shall obtain regulatory oversight from the agency with jurisdictional authority. The type and extent of contamination</p>					

MITIGATION	MONITORING AND REPORTING PROGRAM				
	Documentation of Compliance [Project Applicant/Proponent Responsibility]		Documentation of Compliance [Lead Agency Responsibility]		
	Method of Compliance or Mitigation Action	Timing of Compliance	Oversight Responsibility	Actions/Reports	Monitoring Timing or Schedule
HAZARDS AND HAZARDOUS MATERIALS					
on the project site will govern which of the following regulatory agencies will supervise the remediation: Santa Clara Fire Department Community Risk Reduction Division (CUPA), DTSC under a Site Cleanup Program, State Water Resources Control Board (SWRCB), or the Santa Clara County Department of Environmental Health. The SMP and planned remedial measures shall be reviewed and approved by the oversight agency. A copy of the SMP shall be submitted to the Director or Director's designee with the Santa Clara County Environmental Services Department and, the Santa Clara Fire Department Community Risk Reduction Division. Copies of the approved SMP shall be kept at the project site.					
HAZ-3: Prior to the issuance of grading permits, soil and/or groundwater samples shall be taken in areas where disturbance is anticipated to determine if contaminated soils or groundwater with concentrations above ESLs for construction workers and residential users may be present due to	Conduct soil and groundwater site characterization per the plan and protocols outlined in the SMP. Prepare a report with the results of site characterization and	Prior to issuance of demolition or grading permits and prior to the start of construction.	Santa Clara Fire Department Community Risk Reduction Division, California Department of Toxic Substances	Verify receipt of site characterization report. Provide regulatory oversight for remediation in the event of identification	Prior to issuance of demolition or grading permits and prior to the start of construction.

MITIGATION	MONITORING AND REPORTING PROGRAM				
	Documentation of Compliance [Project Applicant/Proponent Responsibility]		Documentation of Compliance [Lead Agency Responsibility]		
	Method of Compliance or Mitigation Action	Timing of Compliance	Oversight Responsibility	Actions/Reports	Monitoring Timing or Schedule
HAZARDS AND HAZARDOUS MATERIALS					
<p>historical agricultural use and from historical leaks and spills. Sampling shall be conducted per the protocols outlined in the approved project SMP. Once the soil sampling analysis is complete, a report of the findings shall be submitted to the appropriate agencies per the requirements of the SMP.</p> <p>Any contaminated soils identified by testing conducted in compliance with the SMP and found in concentrations above ESLs shall either be removed and disposed of according to California Hazardous Waste Regulations or the contaminated portions of the site shall be capped beneath the planned development under the regulatory oversight of the agency taking lead jurisdiction. Contaminated soil excavated from the site shall be hauled off-site and disposed of at a licensed hazardous materials disposal site.</p>	<p>submit to the appropriate agencies per the requirements of the SMP.</p> <p>Remove or dispose of contaminated soils identified by the site characterization with the regulatory oversight of the agency taking lead jurisdiction.</p>		<p>Control, State Water Resources Control Board, or the Santa Clara County Department of Environmental Health.</p>	<p>of contaminated soil or groundwater.</p>	

MITIGATION	MONITORING AND REPORTING PROGRAM				
	Documentation of Compliance [Project Applicant/Proponent Responsibility]		Documentation of Compliance [Lead Agency Responsibility]		
	Method of Compliance or Mitigation Action	Timing of Compliance	Oversight Responsibility	Actions/Reports	Monitoring Timing or Schedule
TRANSPORTATION					
Impact 4.17-b Would the project conflict or be inconsistent with CEQA Guidelines section 15064.3, subdivision (b)?					
<p>TRANS-1: The project shall implement a Transportation Demand Management (TDM) program sufficient to demonstrate that vehicle miles travelled (VMT) associated with the project would be reduced to 14.1 or less per employee. The TDM program shall include, but is not limited to, the following measure, which has been determined to be a feasible method for achieving the required VMT reduction:</p> <ul style="list-style-type: none"> The operations workforce at the project shall work a 4-40 work schedule (40 hours in 4 days). <p>Prior to the issuance of an occupancy permit, the TDM program shall be submitted and approved by the Director of Community Development and shall be monitored annually to gauge its effectiveness in meeting the required VMT reduction. The TDM program shall establish an appropriate estimate of initial vehicle trips generated by the occupant of</p>	<p>Preparation of a Transportation Demand Management (TDM) program that includes a requirement that at a minimum, the project owner shall require that the operations workforce at the project shall work a 4-40 work schedule.</p>	<p>Prior to the issuance of any City of Santa Clara Public Works occupancy permits.</p>	<p>City of Santa Clara Director of Community Development or Director's designee.</p>	<p>Review and approve Transportation Demand Management program.</p>	<p>Prior to the issuance of any City of Santa Clara Public Works occupancy permits.</p>

MITIGATION	MONITORING AND REPORTING PROGRAM				
	Documentation of Compliance [Project Applicant/Proponent Responsibility]		Documentation of Compliance [Lead Agency Responsibility]		
	Method of Compliance or Mitigation Action	Timing of Compliance	Oversight Responsibility	Actions/Reports	Monitoring Timing or Schedule
TRANSPORTATION					
the proposed project and shall include the conducting of driveway traffic counts annually to measure peak-hour entering and exiting vehicle volumes. The volumes shall be compared to trip thresholds established in the TDM program to determine whether the required reduction in vehicle trips is being met. The results of annual vehicle counts shall be reported in writing to the Director of Community Development. If TDM program monitoring results show that the trip reduction targets are not being met, the TDM program shall be updated to identify replacement and/or additional feasible TDM measures to be implemented. The updated TDM program shall be subject to the same approvals and monitoring requirements listed above.					

Source: California Energy Commission. Draft Environmental Impact Report for the Martin Backup Generating Facility. March 2024.

Appendix A

Project's Jurisdictional and Generating Capacity Analysis

Appendix A: Project’s Jurisdictional and Generating Capacity Analysis

The Martin Backup Generating Facility and Data Center (MDC or project) proposed by Martin Avenue Properties LLC (Martin Properties) would include 44 diesel-fueled standby emergency backup generators (gensets) that would provide emergency backup power supply for the project only during interruptions of electric service delivered by Silicon Valley Power, via Pacific Gas and Electric transmission lines. The gensets would be electrically isolated from the PG&E electrical transmission system with no means to deliver electricity offsite of MDC (the distribution line would only allow power to flow in one direction—from PG&E electrical transmission line to the project).

The 44 gensets would each have a nameplate output capacity of 2.75 megawatts (MW). The maximum total facility load requirements would not exceed 96.8 MW. This includes the critical information technology (IT) load of the servers and server bays, the cooling load of the IT servers and bays, and the facility’s ancillary electrical and telecommunications equipment operating loads to support the data customers and campus. The California Energy Commission (CEC) is responsible for reviewing, and ultimately approving or denying, all applications for thermal electric power plants that are 50 MW and greater being proposed for construction in California. (Pub. Resources Code, § 25500.) The CEC has a regulatory process, referred to as the Small Power Plant Exemption (SPPE) process, that allows applicants with projects between 50 and 100 MW to obtain an exemption from the CEC’s jurisdiction and from obtaining a CEC certificate (license) and instead proceed with local approval if the CEC finds that the proposed project would not create a substantial adverse impact on the environment or energy resources. (Pub. Resources Code, § 25541.)

CEC staff (staff) calculated a net deliverable or useable electricity capacity of more than 50 MW and less than 100 MW from the project’s gensets, qualifying it for a SPPE under the capacity criterion. The factors below support this conclusion, followed by a more detailed discussion:

1. The diesel-fueled reciprocating engine gensets use a thermal energy source.
2. The gensets and the associated project equipment that they would support would all be located on a common property under common ownership sharing common utilities, and the 44 gensets should be aggregated and considered as one thermal power generating facility with a generation capacity of greater than 50 MW.
3. While the project has an apparent installed generation capacity greater than 100 MW (44 gensets, each with 2.75 MW peak capacity), the “extra” MW installed are redundant. In no case would the maximum facility-wide load demand exceed 96.8 MW due to physical constraints built into the project.
4. Jurisdictional analyses are based on the net MWs that can be delivered for “use” (i.e., to a data center facility or the electricity grid), not the gross or nameplate rating.

Unlike a traditional power plant supplying electricity to the grid, for a data center, the maximum load being served is determinative and not the combined net capacity of the installed gensets. Here, the maximum facility wide project load requirement would be 96.8 MW.

5. The gensets would be exclusively connected to the project's buildings and would not be capable of delivering electricity to any off-site user or to the electrical transmission grid. The proposed redundancies built into the design of the facility are to ensure performance reliability, not to generate and supply the facility with more than 96.8 MW of electricity.
6. The restriction on the facility's load demand is hardwired through various control systems. It would be physically impossible for the gensets to generate more electricity than the buildings require. Excess electricity would damage components or at a minimum, isolate the project loads from the gensets.

To make a jurisdictional recommendation, staff assessed the generating capacity of the project, using the following:

1. *MDC is a thermal power plant under the statutory definition.*

The Warren-Alquist State Energy Resources Conservation and Development Act (Public Resources Code, section 25000 et. seq) defines a thermal power plant "as any stationary or floating electrical generating facility using any source of thermal energy, with a generating capacity of 50 megawatts or more, and any facilities appurtenant thereto." (Pub. Resources Code, § 25120.) The project's generation yard would be made up of gensets that use diesel-fueled engines to convert the thermal energy in the renewable diesel fuel¹ into electricity via a rotating generator, and, thus, each genset is an electrical generating device that uses a source of thermal energy. The facility proposes to use 44 such gensets to service MDC.

The project's 44 gensets, and the associated data center that they would support, would all be located on a common property under common ownership sharing common utilities. The gensets would operate to provide backup electricity to the project when its connection to the grid is lost. The genset system configuration includes a 5-to-make-4 arrangement for the data center building meaning that for every four gensets that would support load in the event of a utility failure, there is one redundant genset. The 44 gensets would never operate simultaneously at 100 percent capacity. However, any genset can function either as a primary back-up to the grid or a back-up to the grid back-up gensets, so there is not a functional difference in the type of engine or generator between each genset. All the gensets at the project would share a common trigger for operation during an emergency: the transfer switch isolating the project from the grid. Thus, because the project is stationary, under common ownership sharing common utilities, uses a fuel

1 Renewable diesel fuel is composed of a mixture of hydrocarbons, containing chemical energy. When ignited, this chemical energy is converted to thermal energy.

source to generate thermal energy, and has a generating capacity of 96.8 MW, the project meets the statutory definition of a thermal power plant.

2. California Code of Regulations, Title 20, section 2003 requires the generating capacity to be the net generating capacity.

For the proposed project, the data center would be installed during the initial construction of the project by the project owner, but there is no specific timeline proposed for when data center would need the full capacity of gensets; the exact timing of individual leases that fill server bay space is subject to the market decisions of disparate customers. Therefore, it may be years before the data center is at full load. Nevertheless, for purposes of this analysis, staff assumes full load will eventually be reached.

California Code of Regulations, title 20, section 2003 specifies how the CEC calculates “generating capacity” for jurisdictional determinations, including the 50 MW threshold for the definition of a thermal power plant under Public Resources Code, section 25120. However, section 2003, which uses nameplate capacity in addition to consideration of other factors, only addresses steam and combustion turbines, not diesel-fueled gensets as used in the project, and is, therefore, not controlling here. There are also other reasons to conclude that simply focusing on nameplate capacity here is not appropriate.

For a typical power plant, outside the factors identified in California Code of Regulations, title 20, section 2003, there is almost no limit on what might be generated and provided to the grid, so the approach outlined in that provision identifies the potential maximum generating capacity and is reasonable for those facilities. This is not the case with data centers, where producing electricity more than what the data center requires would be economically wasteful and likely result in damage to the facility.

In traditional turbine-based power plants, parasitic loads (fans, pumps, and heaters) are external to the turbine. Thus, the generating capacity is the total net MWs at the switchyard bus; that is, gross MWs less parasitic loads. If the grid “demands” more, the power plant cannot deliver more electricity unless it burns fuel at a higher rate or reduces parasitic loads. Even then, equipment would have to have the physical capacity to burn more fuel and convert thermal energy into rotational energy, and then operate the generator at a higher output. The calculations assume normal conditions, where generation would be under average operating conditions, and assumes the onsite loads (often called parasitic loads) are also average (e.g., a filter backwash pumping load would not be included if that operation only occurs monthly or annually). Typically, at a traditional power plant, no redundant generating equipment is installed.² Generating capacity at a traditional power plant is determined based on the net capacity of all

² At modern power plants, some equipment design includes 50 to 100 percent redundancy. The redundant equipment is generally limited to certain critical components like transformers, which are often custom items with long lead times for fabrication, or boiler water feed pumps, which are intended to protect the steam boiler components from damage from too much heat if circulating water flow is interrupted.

generators proposed to be installed and connected to the grid because there is almost no limitation on the amount of MWs the grid can “take” from the facility.

Typically, emergency backup generating facilities serving data centers are designed such that they do not deliver power to the electricity grid, and all the electricity generated is consumed by the data center’s load demand, such as the case here. Data centers are designed with precise loads, assuming full build-out, and providing electricity more than these loads is not only economically wasteful (burning fuel for no benefit or reason) but can result in damage to the sensitive components located inside these data centers as well as to the heating, ventilation, air conditioning (HVAC) unit and other systems serving the buildings. Therefore, for purposes of evaluating the capacity of emergency backup generating facilities serving data centers, it is reasonable for staff to consider building loads to be the controlling factor in determining generating capacity.

3. Data centers are analyzed differently than conventional power plant facilities for several reasons.

To determine the net generating capacity of a collection of gensets³ for data centers, the approach is slightly different but consistent with that used on a traditional power plant. The differences are: 1) the end user is the building and data servers, not the grid, and 2) extra gensets or generating capacity are installed to provide electricity not only for building and data server loads but to provide redundancy that achieves a statistical reliability (five nines of reliability) that can be marketed to data customers.

Staff’s approach is consistent with widely practiced standards. For example, ASHRAE’s (American Society of Heating, Refrigerating and Air-Conditioning Engineers) Energy Standards for Data Centers do not use the nameplate or gross capacity but the net generating capacity of data centers, or the actual cooling and IT server loads.⁴ These ASHRAE standards are performance-based as opposed to prescriptive standards, advocating the determination of load requirements be based on project-specific operational characteristics.

Staff’s approach to calculating generating capacity has also been devised based on the International Organization for Standardization (ISO), which sets standards for different industries including the energy industry. The ISO standards are widely accepted by, and used throughout, the energy industry. Consistent with staff’s method, the ISO specifies

³ Backup generators, by definition, generally have the following characteristics: reliable starts, fast starting to full load, cheap to maintain as they sit idle most of the time, use cheap and stable fuel as the fuel sits unused most of the time, and use high-density fuels to limit storage volumes onsite so the project can operate if “islanded.”

⁴ American National Standards Institute (ANSI)/ASHRAE Standard 90.4-2016, www.ashrae.org.

that generating capacity should be the net capacity at average annual ambient conditions.⁵

In the case of the MDC, the load demand acts as a limit to the generation levels from the gensets. The limit would be fixed by the specification and installation of electrical buses and panels, switchyard, and breakers effectively capping the capacity limit. This factor is not present in a capacity generation determination for a typical power plant feeding to the grid because the grid does not act in the same way the "MDC grid" does. If the breakers between the data center building and the gensets were to trip due to excess generation, the data center would be isolated from the gensets, with the servers and building cooling forced to shut down. This subverts the intention of using the gensets to maintain reliable and high-quality electricity. Excess electricity would damage components or, at a minimum, isolate the load from the gensets. If the building cooling load were to increase (e.g., the day gets warmer), the gensets would open the engine fuel throttle to increase generation output and match demand but would still not exceed the combined 96.8 MW IT and building demand.

4. MDC's capacity would not exceed 96.8 MW.

The cooling equipment's maximum demand would also be fixed by the specification and installation of equipment that have an upper physical limit of cooling capacity and would include some redundant cooling equipment. Such redundant equipment could only be operated if a primary component fails and could not be operated in addition to the primary components because that would damage the data center. The data center would be served from the grid or from the gensets with electricity that matches and does not exceed demand for the operations of the data server bays and buildings.

The heat rejected by the IT servers must be removed from each server bay or else the server equipment and data would be damaged. Any attempt to add more servers to a bay would result in direct, immediate, and dire consequences because the building and equipment would have been designed for an upper critical IT load. It is important to note that the maximum combined facility load of 96.8 MW is based on 100 percent critical IT load with maximum cooling on the hottest day. In actuality, the critical IT load and related cooling load would typically be less than this worst-case scenario.

The generation by MDC would be regulated by each building and each bay in that building. MDC would employ physical electronic devices and software technology that limit and monitor the facility's electrical load to ensure that it does not exceed 96.8 MW.

For the maximum generating capacity to increase, the project would have to be redesigned to physically fit more servers in a server bay or add more bays. The project owner would have to address the unplanned increase in electricity demand for normal

5 ISO 3046-1 Reciprocating Internal Combustion Engines – Performance, www.iso.org/standards.

operations because the existing electrical equipment would not be sized for the higher electricity throughput. Additionally, the project owner would have to install additional cooling equipment units to address the increased heat rejected by the server bays and buildings, and install additional redundant cooling equipment, additional uninterruptible power supply (UPS) battery units, and additional gensets to maintain the level of backup and reliability to match the new higher levels of load. This is an unlikely outcome because such changes are not trivial and would result in a cascade of design and physical changes to the facility.

Once the MDC loses connection to the local grid, the transfer switch isolates the MDC from the local electrical transmission grid, and all the gensets assigned to a server bay set initiate startup. As the gensets start, synchronize, and take up load associated with their server bays and building equipment, the UPS system would provide full-load power for up to five minutes⁶ to smoothly transition the MDC customers' data servers from the grid to the gensets. If a genset or two fail to start or synchronize, the remaining genset in the 5-to-make-4 server bay ramps up to higher output levels. The output of the genset assigned to a server bay set match (meet but cannot exceed) the MDC data customers' IT demand in the respective server bay and the server bay's HVAC demand. The combined output of the server bay set is autonomously determined by the electrical equipment in the MDC server bays and building equipment.

Combined output would be limited by sizing the electricity handling equipment to throttle transfer capacity to no more than 96.8 MW, which would prevent damage to IT servers and building equipment. Therefore, it would be physically impossible for the gensets to generate more electricity than what the data center would use, or more than 96.8 MW.

References

DayZenLLC 2022a – DayZenLLC (DayZenLLC). (TN 247325). MBGF SPPE Application – Part I – Main App and Appendix A, dated November 7, 2022. Available online at: <https://efiling.energy.ca.gov/Lists/DocketLog.aspx?docketnumber=22-SPPE-03>

⁶ The gensets are expected to be on and synchronized within a minute or so, but the UPS can supply up to 5 minutes of power at 100 percent full-load UPS to ensure a complete transition from the grid to the gensets.

Appendix B

Silicon Valley Power's Transmission System,
Related Pacific Gas and Electric Company's
Transmission System and Emergency
Operation

Appendix B: Silicon Valley Power's Transmission System, Related Pacific Gas and Electric Company's Transmission System and Emergency Operation

This appendix includes a discussion of the Silicon Valley Power's (SVP) and Pacific Gas and Electric Company's (PG&E) electrical system reliability (including supporting information) and emergency operations.

Electrical System Reliability

Apart from readiness testing and maintenance, the Martin Backup Generating Facility (MBGF) emergency backup generators (gensets) are designed to operate only when the electric system is unable to provide power to the Martin Data Center (MDC). To understand the potential for the gensets to operate during emergencies, one needs to know the conditions under which the electric system is unable to provide power to MDC. There are essentially five conditions that might result in the operation of the gensets:

1. A fault occurs (power supply interruption) or planned maintenance is required on the equipment interconnecting MDC to the SVP 60 kV loop system, and MDC's electricity needs cannot be met.
2. An outage or fault occurs on the utility transmission system, and PG&E is unable to deliver power to SVP system which provides electricity to MDC.
3. A Public Safety Power Shutoff (PSPS) impacts the utility transmission system, and MDC is not able to receive power from SVP.
4. An energy shortage crisis similar to the one in late Summer 2020 where the utility for transmission (e.g. PG&E) is unable to supply electricity to SVP or MDC's operators voluntarily disconnect from the utility and rely on gensets to provide the needed electricity.
5. The gensets could also run when the utility/the California Independent System Operator (CAISO) calls for participants in the Emergency Load Reduction Program (ELRP) or Demand Side Grid Support (DSGS) programs to reduce loads.

The SVP 60 kilovolt (kV) loop systems are designed to provide reliable electric service to customers even under contingency conditions, when one part of the electric network is not functioning. The interconnections for data centers, like MDC, on the SVP 60 kV system are designed with redundant equipment throughout, such that there is no single point of failure. It takes at least two contingencies before customers on the 60 kV system lose power and, in the case of data centers, would instead rely on gensets. According to SVP, double outages on the 60 kV loop systems are extremely rare, and the data supports this.

SVP provided a list of the outages on its 60 kV system over the last 12 years. There were 41 outages, only six of which resulted in customers being without power. This means that in 35 of these outages the redundant design of the system prevented customers from being without power; data centers would not be isolated from the grid and would not

have relied on their gensets.

Only four outages from January 1, 2009, to June 16, 2021, affected data centers in the SVP service territory. One approximately 7.5-hour outage on May 28, 2016, which was the result of two contingencies (a balloon and a breaker failure), affected two data centers. Another 12-minute outage on December 2, 2016, affected four data centers. Two different outages on August 16, 2020 (both outages due to multiple lightning strikes), with one approximately 2.5 hours and the other one approximately 10.5 hours, affected data centers at various locations on the associated loops.

SVP's root-cause analysis of every outage resulted in changes in maintenance procedures to ensure that breakers are reset before power is restored to a portion of the system that was down for maintenance. Outages would be extremely rare, and the consequences or effects on the fleet of data centers almost negligible.

Wildfire policies could impact SVP's ability to supply power to customers if curtailments on the PG&E system interrupt SVP's access to its remote electricity supplies. A PSPS essentially de-energizes power lines to prevent the lines from causing or being damaged by wildfires. The PSPSs to date have been generally limited to high-fire risk zones and only implemented under special conditions. While the SVP service territory and the SVP's primary PG&E bulk transmission line interconnection points are not in high-risk zones, a line de-energization in one of PG&E's high-risk fire zones to reduce the risk of lines causing a wildfire could reduce the SVP electricity transmission access and supply through PG&E lines.

The future impact of PSPSs on the PG&E system are not currently known. Two broadly implemented PSPSs in the PG&E service territory during the fall of 2020 had no impact on SVP and its customers. As the utilities and regulators try to balance the costs and benefits of PSPSs by finetuning and targeting the implementation, the most likely outcome is that future PSPSs will have even fewer potential effects on SVP service territory. SVP has the ability to produce about 200 megawatts (MW) through generators located locally and can adapt to planned outages on the PG&E system just as it has reacted or recovered from unplanned outages in the past to maintain reliable and high-quality electricity supplies to its service territory customers.

Energy shortages, like those that occurred on two occasions in 2020, could prevent a utility from supplying MDC's electricity needs and MDC would then rely on gensets. Recently, the California Public Utilities Commission (CPUC) adopted a new five-year pilot program (D.21-03-056), in effect through 2025, that orders PG&E, Southern California Edison, and San Diego Gas & Electric to administer the Emergency Load Reduction Program (ELRP). Data centers could voluntarily participate in ELRP and, in the event of an energy shortage emergency, these utilities would disconnect from the grid and use their on-site gensets to supply electricity. However, diesel backup generators can only participate in an ELRP event to achieve Incremental Load Reduction if there is an emergency order issued by the Governor and even then only if those BUGS are not located in a disadvantaged community. Additionally, even with an emergency order issued by the Governor, the diesel backup generators would be required to comply with federal permit

requirements. The ELRP provides a mechanism for utilities to measure the load reduction and provide financial compensation to the participants. The ELRP does not affect the likelihood of emergency events. The last time an emergency event occurred, like those in 2020, was 2001. Given the state's efforts to address the causes of past energy emergencies, we expect energy emergencies to continue to be rare events. In addition, in the text below, the California Energy Commission (CEC) staff discussed that MDC would not be online in time to be part of the first phase of the ELRP, and it is less likely that these types of measures will be necessary beyond the immediate future. ELRP has been dispatched multiple times in the summers of 2021 and 2022, lowering electricity demand statewide during critical conditions. Lastly, the United States Environmental Protection Agency (U.S. EPA) does not consider participation in such a program to be an emergency use and, thus, operation in such a program would have to comply with Title 40, Code of Federal Regulations (CFR), Section 60.4211(f). For these reasons staff does not consider the existence of the ELRP to have any effect on the likelihood of the MBGF backup generators operating outside of testing and maintenance.

Like ELRP, the DSGS is another program that offers incentives to electric customers that provide load reduction and backup generation to support the state's electrical grid during extreme events, reducing the risk of blackouts.

Combustion resources may dispatch during an Energy Emergency Alert (EEA) level of EEA 2 or higher if the Governor issues an emergency proclamation. Participants may only dispatch at a lower EEA level (Watch or EEA 1) if explicitly authorized by the Governor Emergency Proclamation. Participation in the program does not waive any air or operation permit requirements and operation in such a program would have to comply with Title 40, Code of Federal Regulations (CFR), Section 60.4211(f).

Still, staff expects the MBGF gensets to be required to supply data center loads only rarely. The gensets would not be used when maintenance is performed on the transmission line or substation. Also, MBGF gensets would not be interconnected to the transmission or distribution grid and would not provide power to the grid.

Emergency Operations

Historical Power Outage Frequency

This section provides information on the likelihood of an interruption of SVP's electrical supply that would trigger the emergency operation of the gensets at the MBGF. More than 12 years of historical data of past outages of data centers in the SVP service territory is available. Staff has used this data to estimate the frequency and duration of reasonably foreseeable, future electrical outages that could trigger emergency operations. Emergency operations would be unplanned and infrequent.

Reliability statistics for all electric customers served by SVP appears within the 2018 Integrated Resource Plan (IRP), and to expand on this information, staff explored specifically how data centers in SVP's territory have been historically affected by outages.

The 2018 IRP states, "SVP's electric system experiences approximately 0.5 to 1.5 hours

of outage time per customer per year. This compares favorably with other utilities in California with reliability factors ranging from 1.0 to 2.5 hours outage per customer per year” (SVP 2018a). The 2018 IRP for SVP reports the Average Service Availability Index (ASAI), defined as the customer-minutes-available divided by the total customer-minutes, expressed as a percentage, and the ASAI has been 99.979% or higher in each recent year, with an average of 99.989 over the past seven years. The System Average Interruption Frequency Index (SAIFI) (interruptions per customer) shows that one or fewer outages have occurred, on average, for all customer types annually (SVP 2018a). This data for all customers is summarized in **Table B-1**.

TABLE B-1 SVP RELIABILITY STATISTICS FOR ALL CUSTOMER TYPES

Year	ASAI (%)	SAIDI (minutes)	SAIFI (interruptions per customer)	Total Outages (number)
2012	99.994	29.34	0.48	67
2013	99.991	47.33	0.49	69
2014	99.989	56.6	0.48	80
2015	99.986	73.96	0.59	123
2016	99.993	36.29	0.5	123
2017	99.979	109.08	1.03	195
2018	99.992	42.61	0.41	132

Notes:

ASAI (%): Average Service Availability Index - (customer minutes available / total customer minutes, as a %).

SAIDI (minutes): System Average Interruption Duration Index - (average minutes interrupted per customer for all customer).

SAIFI (number): System Average Interruption Frequency Index - (number of interruptions per customer for all customers).

Source: SVP 2018a.

The proposed MDC would be a large customer of SVP that would receive better-than-average reliability compared to all SVP customers by including a dedicated onsite substation that would be directly served by SVP’s looped 60 kV system. Staff reviewed the frequency and duration of known data center customers’ outages, as provided by SVP as part of the proceeding from CA3 (DayZenLLC 2021, TN 238416), to discern how redundant features allow SVP’s system to provide greater reliability to data centers when compared with average SVP customers.

Project-specific design factors include the site-specific substation that would connect MDC to the SVP looped 60 kV system, a limited number of commercial customers on the looped 60 kV system, redundant transformers to supply MDC, and MDC’s proposed uninterruptible power supply (UPS) battery system to carry critical loads during short-term electric service disruptions or transients.

As mentioned above, there were 41 outages on the SVP 60 kV system over 12 years (January 1, 2009 to June 16, 2021), only six of which resulted in customers being without power. Of these outages, only four of them affected data centers in the SVP service territory. These customers are all served by a distribution system that includes “looped” lines that can provide alternate flow paths for power flow to data centers. Thus, in

general, it takes more than one 60-kV system path failure to cause a power outage at a data center.

BAAQMD’s Review of Data Center Diesel Genset Engine Operations

Bay Area Air Quality Management District (BAAQMD) provided a review of data centers that initiated the operation of diesel genset engines for “non-testing/non-maintenance” purposes to inform staff’s consideration of scenarios of emergency backup power generation operations beyond routine testing and maintenance (BAAQMD 2021b, TN 239805). BAAQMD’s review covers a recent 13-month period (September 1, 2019, to September 30, 2020) that spans different types of emergency situations across California.

There are 66 data centers under the jurisdiction of BAAQMD with staff at BAAQMD gathering information from 45 of those data center facilities. The review listed 20 facilities that reported some level of “non-testing/non-maintenance” diesel genset engine use in the 13-month period (CEC 2021a).

The scope of BAAQMD’s review can be summarized as follows:

- Period covered: 13 months (9,504 hours)
- Facilities (data centers) under BAAQMD jurisdiction: 66 data centers
- Facilities from which information was collected: 45 data centers
- Facilities responding with some “non-testing/non-maintenance” use: 20 data centers
- Permitted genset engines at the 20 facilities responding: 288 engines
- Installed generating capacity of genset engines at the 20 facilities responding: 686.5 MW
- Information was not provided for the 25 facilities that did not report any non-testing/non-maintenance use or the other 21 facilities under BAAQMD’s jurisdiction that were not surveyed in this data gathering effort.

The BAAQMD normally issues permits for diesel genset engines, and the permit requires each owner or operator to maintain records of the number of operating hours for each “emergency” and the nature of the emergency. The types of events within BAAQMD’s review period include a Governor-proclaimed state of emergency, other outages, power quality events, and human errors. The data shows that 75 percent of all genset engine-hours occurred either during the August 2020 Governor-proclaimed state of emergency or the subsequent heat event in September 2020.

For the 20 data centers listed in BAAQMD’s review, the total permitted and installed generating capacity of these facilities equals 686.5 MW, across 288 individual genset engines. The total amount of “non-testing/non-maintenance” runtime of all these 288 genset engines amounted to approximately 1,877 engine-hours of operation.

Table B-2 summarizes the runtimes found by BAAQMD’s review for each of the 20 data centers. BAAQMD’s review identified one data center facility that ran diesel gensets for approximately 400 hours for non-testing/non-maintenance purposes during this time.

Table B-2 shows that this facility has over 40 individual genset engines permitted at the site for an average runtime of about 10 hours per engine. The different data centers within BAAQMD’s review showed that nine of the 20 facilities responding had fewer than 50 hours of operating one or more diesel genset engines for non-testing/non-maintenance purposes.

TABLE B-2 BAAQMD’S REVIEW OF NON-TESTING/ NON-MAINTENANCE OPERATION (ENGINE-HOURS)

Data Center	# of Permitted Genset Engines	# of Genset Engines with Non-Testing/ Non-Maintenance Operations	Sum of Non-Testing/ Non-Maintenance Operations (Engine-Hours)	Average Hours of Operations per Genset Engine Used
1	10	10	83	8.3
2	5	5	77	15.3
3	6	6	108	18.0
4	44	44	22	0.5
5	3	2	11	5.5
6	6	6	219	36.5
7	24	24	202	8.4
8	26	24	10	0.4
9	5	5	26	5.2
10	41	40	401	10.0
11	14	11	75	6.8
12	11	11	275	25.0
13	5	5	85	17.0
14	22	8	28	3.4
15	8	7	98	14.0
16	17	4	10	2.4
17	2	2	4	2.0
18	8	6	18	3.0
19	6	6	24	4.0
20	25	17	103	6.0
Total	288	243	1,877	Max. 36.5

Sources: BAAQMD 2021b, Energy Commission staff analysis of data from BAAQMD

From the runtimes of all the genset engines at all facilities in BAAQMD’s review, **Table B-2** estimates that the average genset engine ran no more than 36.5 hours over the 13-month period. Staff also found that no single engine within BAAQMD’s review ran for more than 50 hours overall for “non-testing/non-maintenance” purposes.

Staff used the data in BAAQMD’s review (BAAQMD 2021b) and a clarifying email of BAAQMD results (CEC 2021a) to estimate the power production during “non-testing/non-maintenance” diesel genset engine use and found that approximately 1,575 megawatt hours (MWh) were generated during this 13-month (9,504 hour) period. The power generated by these genset engines presumably displaced grid service for the on-site data center facility electrical demand. Based on the installed generating capacity of 686.5 MW partially operating within the 13-month record, the genset engines in BAAQMD’s review that did operate would have an extremely low capacity-factor of 0.024 percent [0.024 percent = 1,575 MWh / (686.5 MW * 9,504 hours)]. This capacity factor is only considering the facilities that had genset engines that ran during this 13-month period. Twenty-five of the 45 facilities reporting had zero hours of engine runtime.

Consideration of Extreme Events. California experienced different types of emergency situations within the 13-month period (September 1, 2019, to September 30, 2020) of BAAQMD’s review. This period included the expansion of PG&E’s PSPS program, severe wildfires, several California Independent System Operator (CAISO) declared emergencies, and winter storms. From August 14, to 19, 2020, California experienced excessive heat. On August 16, 2020, Governor Newsom proclaimed a state of emergency because of the extreme heat wave in California and surrounding western states. This was a one in 30-year weather event that resulted in the first system-wide power outages California had seen in 20 years. In addition to the extreme heat wave in mid-August, high temperatures and high electricity demand occurred over the 2020 Labor Day weekend, especially on Sunday, September 6, and Monday, September 7, 2020 (CAISO 2021). Thus, the data set provided is not necessarily representative of an average 13-month period from which one could extrapolate average genset facility use into the future.

Table B-3 summarizes how these extreme events influenced the runtimes found by BAAQMD’s review for each of the 20 data centers.

Table B-3 shows that most “non-testing/non-maintenance” diesel genset engine use identified by BAAQMD’s review (over 1,400 engine-hours out of 1,877 engine-hours) occurred either during the August 2020 Governor-proclaimed state of emergency or the subsequent heat event in September. Excluding these extreme events results in 473.7 engine-hours of “non-testing/non-maintenance” diesel genset engine use during other dates, or fewer than two hours per engine for all 288 engines in the review. Out of the 20 data centers that ran genset engines for “non-testing/non-maintenance” purposes, the 473.7 engine-hours of runtime outside of extreme events was spread across 10 data centers out of the 45 data centers covered by BAAQMD’s review.

Similarly, staff estimates that over 50 percent of the overall power produced by the genset engines in BAAQMD’s review (at least 843 MWh of 1,575 MWh) occurred during the Governor-proclaimed state of emergency, and another 25 percent of the power produced was attributable to unknown days in the period. Staff’s analysis of actual power produced during each day of the 13-month record appears in **Table B-4**.

TABLE B-3 EXTREME EVENTS: NON-TESTING/NON-MAINTENANCE OPERATION (ENGINE-HOURS)

Data Center	Operations During August 2020 State of Emergency (Engine-Hours)	Operations During September 2020 Heat Event (Engine-Hours)	Other Dates of Operations (Engine-Hours)	Sum of Non- Testing/ Non-Maintenance Operations (Engine-Hours)
1	82.7	—	—	83
2	—	—	76.6	77
3	107.8	—	—	108
4	21.6	—	—	22
5	11.0	—	—	11
6	218.8	—	—	219
7	88.2	81.2	32.5	202
8	—	—	10.3	10

TABLE B-3 EXTREME EVENTS: NON-TESTING/NON-MAINTENANCE OPERATION (ENGINE-HOURS)

Data Center	Operations During August 2020 State of Emergency (Engine-Hours)	Operations During September 2020 Heat Event (Engine-Hours)	Other Dates of Operations (Engine-Hours)	Sum of Non- Testing/ Non-Maintenance Operations (Engine-Hours)
9	26.0	—	—	26
10	259.7	—	141.1	401
11	75.0	—	—	75
12	275.3	—	—	275
13	—	—	85.0	85
14	19.9	—	7.6	28
15	—	—	98.0	98
16	—	—	9.6	10
17	—	—	4.0	4
18	9.0	—	9.0	18
19	24.0	—	—	24
20	88.4	14.3	—	103
Total	1,307.4	95.5	473.7	1,877

Sources: BAAQMD 2021b, Energy Commission staff analysis of data from BAAQMD

Across all events, including the extreme event days within the period, **Table B-4** shows that the average genset engine loading in BAAQMD’s review was below 40 percent. However, the data does not establish a typical type of operation that could be reasonably expected to occur during any emergency or any typical operational characteristics that could be used in representative air quality modeling. For example, some genset engines in the data set ran at no load or with very low loads; one genset engine ran at no load for 41.7 hours while the highest genset engine load in the data set was 70 percent load. The range of genset engine loads and the fact that most genset engines operated at low loads demonstrates the difficulty in predicting the level of facility electrical demands that would need to be served by the genset engines during an emergency. This also demonstrates the difficulty in making an informed prediction of the genset engines’ emission rates, which vary depending on load, in the event of an emergency.

TABLE B-4 EXTREME EVENTS: NON-TESTING/NON-MAINTENANCE OPERATION (ENGINE LOADS)

Date of Event Start	Extreme Heat Wave Event?	Non-Testing/Non-Maintenance Operations - at actual load (MWh - per day)	Average Genset Engine Loading on Event Day
Unknown	—	418.0	45.3%
11/26/2019	—	1.1	13.8%
11/27/2019	—	5.5	17.7%
2/15/2020	—	0.7	7.0%
7/31/2020	—	2.9	17.3%

TABLE B-4 EXTREME EVENTS: NON-TESTING/NON-MAINTENANCE OPERATION (ENGINE LOADS)

Date of Event Start	Extreme Heat Wave Event?	Non-Testing/Non-Maintenance Operations - at actual load (MWh - per day)	Average Genset Engine Loading on Event Day
8/14/2020	—	39.0	48.0%
8/16/2020	—	25.6	38.4%
8/17/2020	Aug 2020 Emergency	843.1	34.5%
8/18/2020	Aug 2020 Emergency	112.0	31.2%
8/19/2020	Aug 2020 Emergency	14.4	40.0%
8/25/2020	—	5.4	30.0%
9/6/2020	Sept 2020 Event	90.0	48.6%
9/7/2020	Sept 2020 Event	16.8	39.2%
Total	—	1,574.7	Average 31.6%

Sources: BAAQMD 2021b, Energy Commission staff analysis of data from BAAQMD

Frequency of Diesel Genset Engine Emergency Use, Discussion: The BAAQMD review illustrates that genset engines were used at data centers for “non-testing/non-maintenance” purposes that could occur more frequently than utility service power outages. In staff’s review of prior data center cases that were proposed within the SVP territory, staff found that the likelihood of an outage on SVP’s looped 60 kV system that forces the emergency operation of a data center’s gensets would be “extremely rare” and a low-probability event. For the prior cases in SVP territory, staff estimated a 1.6 percent probability of any given data center facility experiencing a power outage in a period of a year based on 10 years of data between 2009 and 2019 (e.g. CEC 2020a, p. 5.3-35, and CEC 2020b, p. 5.3-47).

In BAAQMD’s review, including the extreme events, 1,877 engine-hours of diesel genset engine use occurred at 20 data centers for “non-testing/non-maintenance” purposes (less than half of the 45 facilities included in the review, and less than a third of such facilities under BAAQMD’s jurisdiction). These runtimes occurred due to power outages, in response to the heat storm, and also for other unspecified situations categorized by the genset engine operators as “emergencies.” BAAQMD’s review covered 288 individual diesel genset engines that operated over a 13-month record. Data was not provided concerning the number of genset engines at the 25 facilities that did not operate under these circumstances. Because the genset engines were collectively available for over 2.74 million engine-hours during the 13-month period (288 engines * 9,504 hours), and they were used for emergency operations for 1,877 engine-hours, at those facilities where operation occurred, the genset engines entered emergency operations during 0.07 percent of their available time (1,877 / 2.74 million). This confirms that emergency use of the genset engines would be very infrequent. It is important to note that this calculation only takes into consideration those genset engines that BAAQMD found to run during this time period; a more comprehensive review would also include the availability of the 25 facilities that had zero hours of genset engine run time and also conceivably the 21 facilities that were not surveyed at all. If these facilities without

genset engine runs were included, the estimated probability that any given genset engine would be likely to run would be lower.

Duration of Diesel Genset Engine Emergency Use, Discussion: The average runtime for each event in BAAQMD’s review was approximately 5.0 hours. This shows that the duration of diesel genset engine use for “non-testing/non-maintenance” purposes, without excluding the extreme events, could involve longer runtimes than for typical utility service power outages. However, again this calculation does not factor in the larger proportion of facilities that did not run at all. In staff’s review of prior data center cases, staff found an average of 2.6 hours per outage, based on only two transmission line outages that occurred in 10 years (between 2009 and 2019) affecting data centers served by SVP’s 60-KV lines (e.g. CEC 2020a, CEC 2020b).

BAAQMD’s review of diesel genset engine use considers a wider variety of reasons for running the genset engines than solely an electric power service outage. The listed reasons include: state of emergency load shedding, human error event, utility-inflicted disturbance, lightning strikes to transmission line, utility outage, power outage, system-wide power quality event, equipment failure, power bump, power supplier request, power blips, UPS/board repair, utility sag event, mandatory load transfer, and substation transformer power equipment failure. Many of these explanations are simply subcategories under the general category of grid reliability analyzed for prior cases. Others like a human error event, equipment failure, and UPS/board repair appear to be exceedingly rare occurrences unlikely to significantly add to the calculation of when emergency operations might occur. Lastly, the category of emergency load shedding/power supplier request/mandatory load transfer all appear related to the heat storm and Governor-proclaimed state of emergency described above and, given the state’s efforts to address reliability in response to such events, are to re-occur with such frequency. The provision of these categories and sub-categories helps to explain why BAAQMD’s review shows different instances of genset engines running than staff found in prior cases and longer durations of runtimes during emergency situations. Although emergency operations could be triggered for a range of situations, including extreme events like those of August and September 2020, this information confirms that regardless of the triggering event, emergency operations of genset engines would be expected to be infrequent and of short duration.

Summary of Staff’s Analysis of “Non-testing/Non-maintenance” Genset Engine Use: The BAAQMD’s review of “non-testing/non-maintenance” genset engine operations expands our understanding of “when, why, and for how long” diesel genset engine use might occur. BAAQMD’s 13-month period of review included a Governor-proclaimed state of emergency, other outages, power quality events, and human errors. Accordingly, BAAQMD’s review confirms that genset engine use may occur for reasons other than grid outages, though the period is not representative of a typical year due to the rare heat storm events. Many genset engines were used for “non-testing/non-maintenance” purposes in the period reviewed by BAAQMD, but the overall number of hours of operation for the less than half of the facilities in the review that did run was 0.07 percent of the available time. Genset engine loading levels recorded during these times of use were low (average below 40 percent), and the capacity factor of these

genset engines was extremely low (0.024 percent). The BAAQMD review confirms that these types of events remain infrequent, irregular, and unlikely, and the resulting emissions are not easily predictable or quantifiable. The BAAQMD review does not show that these facilities operate significantly more than staff previously analyzed in the grid reliability context in prior cases.

CPUC Decision, D.21-03-056, Directing PG&E, Southern California Edison, and San Diego Gas and Electric to Take Actions to Prepare for Potential Extreme Weather in the Summers of 2021 and 2022

On March 25, 2021, the CPUC adopted decision D.21-03-056, which directed the utilities to take specific actions to decrease peak and net peak demand and increase peak and net peak supply for the summers of 2021 and 2022, to avert the potential need for rotating outages as occurred in summer 2020. On December 2, 2021, the CPUC adopted decision D.21-12-015, which is Phase 2 of the proceeding, and focuses on increasing electric supply and reducing demand for 2022 and 2023 (CPUC 2021b).

Addressed in the decisions are the following scoped issues:

- Flex Alert program authorization and design
- Modifications to and expansion of Critical Peak Pricing (CPP) Program
- The development of an ELRP
- Modifications to existing demand response (DR) programs
- Expedited IRP procurement
- Modifications to the planning reserve margin (PRM)
- Parameters for supply side capacity procurement
- Expanded electric vehicle participation

This menu of options attempts to ensure grid reliability. One of the options, ELRP, allows PG&E, Southern California Edison, San Diego Gas & Electric, and CAISO to access additional load reduction during times of high grid stress and emergencies involving inadequate market resources, with the goal of avoiding rotating outages while minimizing costs to ratepayers.

The CPUC decisions would allow data centers to choose to participate in a program whereby they could be asked to shed load if an extreme heat event similar to the August 2020 event occurs in the summer of 2022 or 2023. The initial duration of the ELRP pilot program will be five years, 2021-2025, with years 2023-2025 subject to review and revision in the Demand Response Applications proceeding that is expected to be initiated May 2022.¹ However, the CPUC decision lays out many options for emergency load reduction to ensure grid reliability that could be utilized before resorting to gensets. The decision explains that the ELRP design aspects that are subject to review and revision as

¹ CPUC Decision 21-12-015 Attachments 1-3. Available Online at:
<https://docs.cpuc.ca.gov/PublishedDocs/Published/G000/M428/K821/428821668.PDF>

part of the pilot program include minimizing the use of diesel gensets where there are safe, cost-effective, and feasible alternatives (CPUC 2021a, Section 5.2, page 19).

However, it is not expected that MDC would be operational until after the summer of 2025, based on these factors: 1) estimated construction schedule of 14 months to the initial occupancy of the building; 2) estimated completion of the CEC exemption proceeding in late 2024; 3) additional time needed for the City of Santa Clara and BAAQMD to permit the project. Thus, MDC would not be online in time to be part of the first phase of ELRP. It is less likely that these types of measures will be necessary beyond the immediate future, as longer-term strategies for grid resilience, such as battery facilities to supplement intermittent renewable generation, come online.

Additionally, the U.S. EPA does not consider participation in such a program to be an emergency use and, thus, there can be no deviations from federal applicable requirements in title V permits or local regulations approved by U.S. EPA in the state implementation plan to participate in such a program. Additionally, the backup generators would have to comply with Title 40, Code of Federal Regulations (CFR), Section 60.4211(f). For these reasons staff does not consider the existence of the ELRP to have any effect on the likelihood of the Martin Backup Generators operating outside of testing and maintenance.

Furthermore, based on the capacity factors and run times for data centers that operated during the 2020 heat events, even if it were necessary to call on data centers to shed load again, it is expected that these facilities would be called on very infrequently and would have very low capacity-factors and run times in any potential future events.

Electrical Reliability Supporting Information

The following questions were directed to SVP regarding data centers connecting to its 60 kV system in the course of staff evaluating impacts of the recently approved CA3 Data Center (CA3DC). The MDC is substantially similar to the CA3 project and presents nearly identical impacts on SVP. SVP has provided answers to the following questions, and this information applies to the MDC project:

17.A. VDC Supplemental Responses to Data Requests 17-20 (TN: 238416)

Please explain whether the additional load associated with CA3DC would cause overloads on the SVP transmission system that would require upgrades to the existing system.

RESPONSE TO DATA REQUEST 17

SVP provided the following response.

From SVP's initial investigations, the additional load associated with CA3DC will be loadramp restricted until projects to reconfigure the Center Loop and Northwest loop and certain PG&E projects being developed to increase the transmission capacity to the SVP system are completed. To fully understand the impacts of this facility, SVP is conducting a System Impact Study funded by CA3DC and that information will be presented to CA3DC. The System Impact Study is underway. Once the System Impact

Study and the SVP and PG&E projects are completed, CA3DC will be allowed to ramp based upon the approved load ramp schedule. Please see attached letter to Vantage from SVP dated 9/24/2020 for additional details related to when load will be able to be served to this facility.

VDC adds that it is proceeding in constructing and operating the CA3DC in phases as described in its SPPE Application pursuant to the 9/24/2020 letter (attached). The SPPE Application has been prepared to accommodate the future load growth and electricity availability but presents the “whole of the action” as required by CEQA for full planned buildout of the CA3DC facility.

18. Please provide for the 60 kV loop on the SVP system that would serve the CA3DC:
- a. A physical description
 - b. The interconnection points to SVP service
 - c. The breakers and isolation devices and use protocols
 - d. A list of other connected loads and type of customers
 - e. A written description of the redundant features that allow the system to provide continuous service during maintenance and fault conditions

RESPONSE TO DATA REQUEST 18

The following response was provided by SVP.

- a. The loop serving CA3DC is an overhead transmission line comprised of mainly wooden transmission poles, bundled 954 AAC Conductor, serving the Central Clara Area.
 - b. Interconnection with the SVP system would be in the 60KV Junction Feeder that serves the customer’s transformer.
 - c. SVP utilizes a breaker and half bus design primarily to isolate any faults within each breakers zone of protection, isolating a fault to the specific location and preventing an extended outage to adjacent transformers within the substation or to an adjacent substation.
 - d. Center Loop serves a mix of General Distribution substations and customer dedicated 60kV Junctions for a total of six substations.
 - e. Loop services are designed to have two sources of power so that in the event of an unplanned outage, the faulted zone is isolated from the remainder of the loop system, isolating the unplanned outage to the affected zone. In the same manner, a planned outage used to perform maintenance on a section of the transmission line can be performed without having to drop load, by planning the isolation locations around the piece of equipment to be maintained.
19. Please describe any outages or service interruptions on the 60 kV systems that would serve the CA3DC:
- a. How many 60 kV lines serve data centers in SVP, and how many data centers are

on each?

- b. What is the frequency of these outages and how would they require the use of backup generators?
- c. How long were outages and what were their causes?
- d. Are there breakers on the 60 kV line or disconnect switch(es) and did they isolate the faults?
- e. What was the response to the outage(s) by the existing data centers (i.e., initiated operation of some or all back up generation equipment, data offshoring, data center planned shutdown, etc.)?

RESPONSE TO DATA REQUEST 19

The following responses were provided by SVP.

- a. SVP currently has five 60 kV loops plus an internal 60 kV loop at the Scott Receiving Station (SRS) and the Kifer Receiving Station (KRS). The number of Data Centers (DC) on each Loop:
 - i. North East Loop—4 DC
 - ii. North West Loop—5 DC
 - iii. East Loop—8 DC
 - iv. Center Loop--18 DC
 - v. South Loop—5 DC
 - vi. SRS Internal Loop – 2 DC
 - vii. KRS Internal Loop – 4 DC

b&c. There were four outages between January 1st, 2009 and June 16, 2021 where SVP lost both 60kV feeds into a substation that affected a data center where back-up generators were required to operate. Over this period, this equates to a system reliability of 99.98%.

The outages occurred on May 28th, 2016 (7 hours 23 minutes), December 2nd, 2016 (12 minutes) and two different outages on August 16th, 2020 (one 2 hours 21 minutes and second 10 hours 22 minutes). This is a total outage time affecting data centers of 20 hours and 18 minutes. Only the data centers at various locations on the associated loops were affected, not all data centers.

Since 2009, 60kV outage data is presented in the below table (over 12 years, 5 months of data). The items highlighted in yellow indicate that there was some kind of fault occurred. The items highlighted in blue is when we had a customer out of power as a result. The non-highlighted items are where an outage was taken to correct an observed situation.

- d. Each loop has breaker/switches and they operated as expected.
- e. SVP does not have knowledge of how each data center reacts to an SVP-caused

outage. SVP only know the times we restored service.

20. Please provide the following regarding PSPS events:

- a. Would historical PSPS events have resulted in the emergency operations of the backup generators at the proposed CA3DC?
- b. Have there been changes to the SVP and PG&E system around the CA3DC that would affect the likelihood that future PSPS events would result in the operation of emergency generators at the proposed CA3DC?

RESPONSE TO DATA REQUEST 20

SVP provided the following responses.

- a. To date, SVP has not had any historical PSPS events. As such there has been no impact to SVP or SVP customers by a PG&E initiated PSPS event in other areas.
- b. SVP has not been notified of any changes related to PG&E’s transmission system that would change the likelihood of future PSPS events.

DATE	LINE (S)	CAUSE	DURATION	CUSTOMERS OUT OF POWER
01/29/21	HOM-BRO	Tree Trimming	1 Hour 38 Min	0
12/29/20	ZEN-URA	Tree Trimming	1 Hour 25 Min	0
09/26/20	HOM-BRO	Tree Trimming	2 Hours 55 Min	0
09/22/20	NAJ-PLM	Tree Trimming	1 Hour 36 Min	0
08/16/20	KRS 60KV BUS AND LAF SUB	Multiple lightning strikes	2 hours 21 Min	1273
08/16/20	WAL-FIB, WAL-URA	Multiple lightning strikes	10 Hours 22 Min	5438
10/24/19	MIS CB62 (NRS-MIS)	Hot spot repair	29 Min	0
10/11/19	WAL-FIB	Balloons close to line	6 Min	0
09/17/16	KRS-PLM	Rotten pole replacement	10 Hours 5 Min	0
08/14/19	SRS CB982-(SRS-CEN)	Faulty JMUX Card	4 Min	0
03/30/19	URA-WAL	Bird @ UW43	1 Hour 46 Min	0
11/22/18	HOM-SER	Pole Fire HS9 (force out)	1 Hour 27 Min	0
07/5/18	SER-HOM	Force out to remove balloons	9 Min	0
05/5/18	SER-HOM	Force out to remove balloons	11 Min	0
09/1/17	AGN-NAJ	Force out to cut trees	1 hour 5 min	0
08/8/17	URA-ZEN	Force out to remove balloons	20 Min	0
05/25/17	SRS-FRV	Tripped during SCADA commissioning	1 Min	0
05/8/17	NWN-ZEN	Force out to remove bird	50 Min	0
04/29/17	SRS-HOM	Force out to remove balloons	2 Hours 22 Min	0
03/20/17	JUL-CEN	Third Party got into 60kv	9 Hours 55 Min	0
01/22/17	SER-BRO	Tree in wires	3 Hours 31 Min	0

DATE	LINE (S)	CAUSE	DURATION	CUSTOMERS OUT OF POWER
01/22/17	NAJ-PLM	A phase contact guy wire when winds pick up	1 Hour 47 Min	0
01/19/17	KRS-PLM	Palm frond between phases	41 Min	0
01/18/17	NAJ-PLM	A phase contact guy wire when winds pick up	1 Hour 44 min	0
12/02/16	RAY T1 & T2	Dropped both transformers during restoration switching due to relay not reset	12 Min	257
09/06/16	SRS-CEN	Bird Contact	40 Min	0
06/30/16	WAL-FIB	Bird nest contact	12 Hours 4 Min	0
05/28/16	SRS-FRV- NWN-ZEN	Balloons in line and breaker fail	7 Hours 23 Min	28
02/17/16	SRS-FRV	Palm tree with fire	7 Hours	0
11/18/15	SER-BRO	Arcing wires forced	2 Hours 59 Min	0
11/16/15	SER-BRO	Rotten pole- forced	22 Hours 32 Min	0
11/09/15	JUL CB32	Possible lightning	53 min	0
10/29/15	SER-BRO	Roller arcing-forced	3 Hours 33 Min	0
08/12/15	BRO-DCJ, BRO T1	Squirrel on CB100	3 Hours 55 Min	2155
06/24/15	CCA CB22	Bad JMUX card	3 Hours 23 Min	0
05/30/15	SER-BRO	No cause found	3 Hours 12 Min	0
03/31/15	BRO-DCJ 12KV BUS 1 & 2	Squirrel across 12kv bus tie	3 Hours 26 Min	2927
01/28/15	Mission CB12	Shorted control cable	6 Hours 29 Min	0
04/24/14	DCJ CB42	Tripped during relay work. BF wired as TT	1 Hour 30 Min	0
10/14/13	URA_WAL	Sheared Hydrant hit 60kV above	2 Hours 26 Min	0
12/06/12	Jul CB 32	Tripped due to cabinet vibration	2 Min	0



September 24, 2020

Vantage Data Centers
Sam Huckaby, Vice President – Construction
2820 Northwestern Parkway
Santa Clara, CA 95051

Subject: New Data Center at 2590 Walsh

Dear Mr. Huckaby,

The City of Santa Clara's Electric Department, Silicon Valley Power, is the electric utility for the City of Santa Clara. Electric service to the subject project will be provided in accordance with the Rules and Regulations for the utility as approved by the Santa Clara City Council. Silicon Valley Power has reviewed the power needs and commitments at all Vantage sites within the City per the property list below:

- 2820 Northwestern
- 2897 Northwestern
- 737 Mathew
- 2590 Walsh (new proposed project not yet approved – request for 90 MVA)

Based on Vantage's existing and future power needs, Silicon Valley Power should be able to provide the following total power combined for all the sites:

- Up to 126.5 MVA from the current date to the end of Second Quarter of 2022
- Up to 192.5 MVA at Third Quarter of 2022 upon completion of the South Loop Project.
 - If there are delays on the South Loop Project, it will affect the timeline to increase from 126.5 to 192.5.
 - 737 Mathew is limited to 33 MW until the South Loop Project is completed.
- Silicon Valley Power is starting the process for additional transmission capacity to the City. The conceptual timeline for completion is Fourth Quarter of 2025. Upon completion of additional transmission, Vantage can increase from 192.5 MVA to 273 MVA.
- If Vantage has a need to exceed 192.5 MVA prior to these timeframes, the City would be interested in partnering on a battery storage project or other generation facility to serve those needs.

The specific details of this service and SVP system modifications required to provide this capacity for 2590 Walsh will be worked out in a Substation Service Agreement at a future date. The City is also in the process of reviewing and updating its load development fee, which will be applicable for any new project (or above 192.5 MVA). It is also important to note that all appropriate fees will need to be paid, and this letter does not supersede any requirements or

881 Martin Avenue • Santa Clara, CA 95050 • 408-615-6600 • Fax 408-249-0217
www.siliconvalleypower.com

agreements for the already approved sites at 2820 Northwestern, 2897 Northwestern, and 737 Mathew.

Questions can be directed to Wendy Stone at (408) 615-5648.

Thank you,

A handwritten signature in blue ink, appearing to read 'MP', with a stylized flourish at the end.

Manuel Pineda
Chief Electric Utility Officer
City of Santa Clara – Silicon Valley Power

cc: Michael Stoner

B. Schematic diagram of the SVP 230 kV, 115 kV and 60 kV transmission system, and SVP System Map

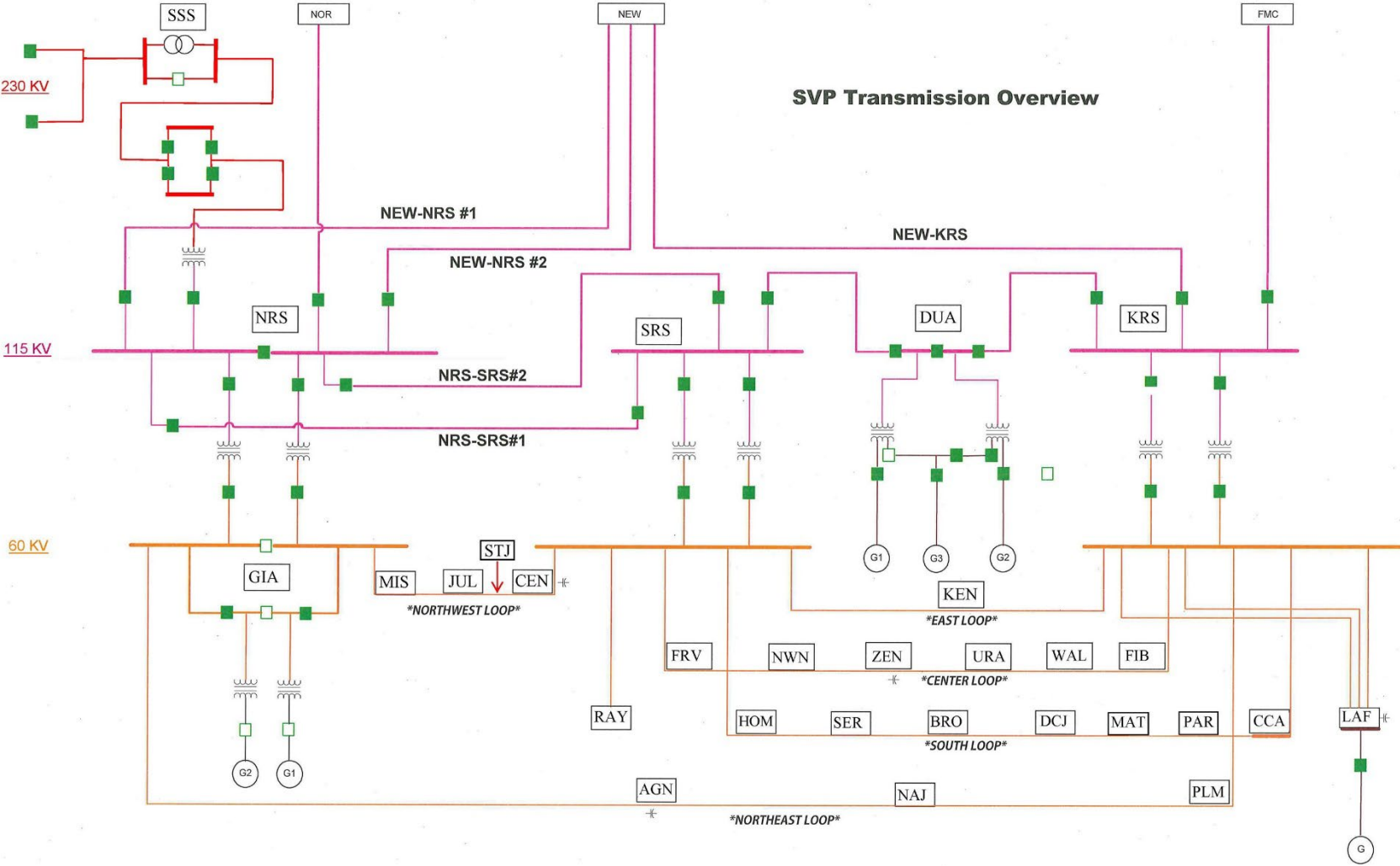

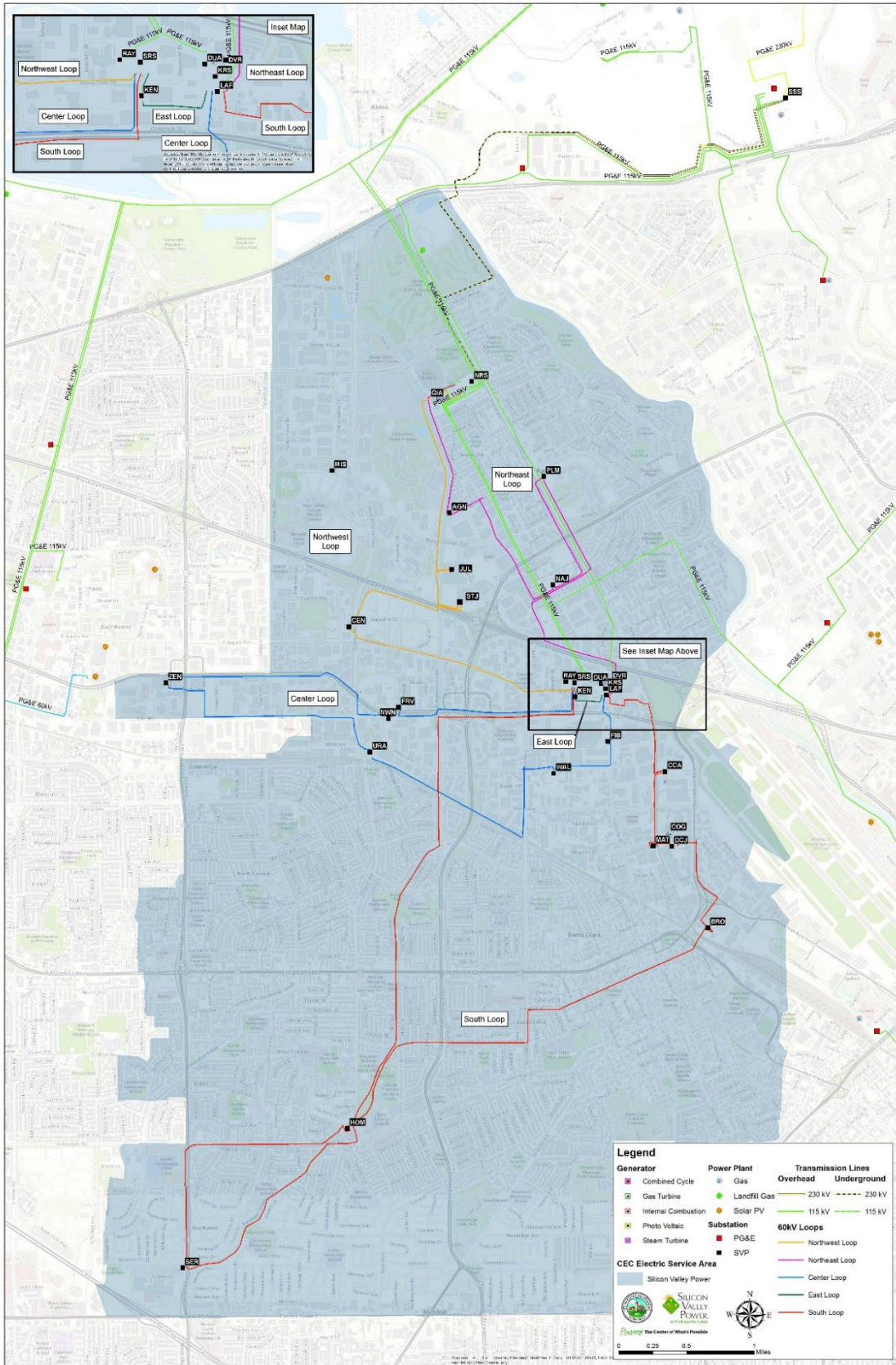

C. A list of the customers connected to each of the five 60 kV loops in the SVP system

SVP Loop Customers and Loading Peak - Substation

Substation	Loop	Customer/Industry	Substation	Loop	Customer/Industry
Fairview	Center	Mfg1	Central	Northwest	Medical2
Fairview	Center	Datacenter1	Central	Northwest	Real Estate2
Fairview	Center	Datacenter2	Central	Northwest	Real Estate3
Fairview	Center	Datacenter3	Central	Northwest	Real Estate4
Fairview	Center	Datacenter4	Central	Northwest	Datacenter24
FIB	Center	Mfg2	Central	Northwest	Datacenter25
Lafayette	Center	Mfg3	Central	Northwest	R&D2
Lafayette	Center	Datacenter5	Central	Northwest	Real Estate5
Lafayette	Center	Mfg4	Central	Northwest	Real Estate6
Lafayette	Center	Mfg5	Central	Northwest	Healthcare equipment
Lafayette	Center	Datacenter6	Central	Northwest	Education13
Lafayette	Center	Mfg6	Central	Northwest	Semiconductor/R&D
NWN	Center	Datacenter7	JUL	Northwest	Datacenter26
Uranium	Center	Datacenter8	Mission	Northwest	Property Management7
Uranium	Center	R&D1	Mission	Northwest	Computer hardware/software 2
Uranium	Center	Property Management1	Mission	Northwest	Real Estate7
Uranium	Center	Datacenter9	Mission	Northwest	Datacenter27
Uranium	Center	Datacenter10	Mission	Northwest	Software1
Uranium	Center	Datacenter11	Mission	Northwest	Computer hardware/software 3
Uranium	Center	Property Management2	Mission	Northwest	Cyber Security 2
Uranium	Center	Education1	Mission	Northwest	Conventions 2
Uranium	Center	Education2	Mission	Northwest	Hotel3
Uranium	Center	Education3	Mission	Northwest	Medical3
Uranium	Center	Education4	Mission	Northwest	Cyber Security 3
Uranium	Center	Semiconductor/ Telecommunications	Mission	Northwest	Education14
Uranium	Center	Gaming/AI/ Semiconductors1	Mission	Northwest	Datacenter28
Uranium	Center	R&D/Mfg	Mission	Northwest	R&D3
Uranium	Center	Mfg7	Mission	Northwest	Semiconductor6
Walsh	Center	Semiconductor1	Mission	Northwest	Storage1
Walsh	Center	Gaming/AI/ Semiconductors2	Mission	Northwest	Entertainment3
Walsh	Center	Mfg8	Mission	Northwest	Property Management8
Walsh	Center	Gaming/AI/ Semiconductors3	Mission	Northwest	Medical4
Walsh	Center	Datacenter12	Mission	Northwest	Telecommunications2
Walsh	Center	Education5	Mission	Northwest	NFL5
Walsh	Center	Government1	Raymond	Northwest	Datacenter29
Walsh	Center	Government2	Raymond	Northwest	Datacenter30
Walsh	Center	Semiconductor2	Raymond	Northwest	Datacenter31
Walsh	Center	Semiconductor/R&D/Mfg	Raymond	Northwest	Datacenter32
Walsh	Center	Mfg9	Raymond	Northwest	Telecommunications3
Walsh	Center	Telecommunications1	Raymond	Northwest	Datacenter33
Walsh	Center	Datacenter13	Raymond	Northwest	Gaming/AI/Semiconductors5
Walsh	Center	Education6	Raymond	Northwest	Datacenter34
Walsh	Center	Datacenter14	Brokaw	South	Government3

SVP Loop Customers and Loading Peak - Substation

Substation	Loop	Customer/Industry	Substation	Loop	Customer/Industry
Zeno	Center	Education7	Brokaw	South	Education15
Zeno	Center	Education8	Brokaw	South	Education16
Zeno	Center	Semiconductor3	Brokaw	South	Education17
Zeno	Center	Datacenter15	Brokaw	South	Real Estate8
Zeno	Center	Bio Tech 1	Brokaw	South	Design1
Zeno	Center	Semiconductor/ Telecommunications	Brokaw	South	Security 2
Zeno	Center	Semiconductor/R&D/Mfg	Brokaw	South	Education18
Agnew	Northeast	Security1	Brokaw	South	Education19
Agnew	Northeast	Property Management3	CCA	South	Mfg12
Agnew	Northeast	Property Management4	DCJ	South	Datacenter35
Agnew	Northeast	Entertainment1	Homestead	South	Education20
Agnew	Northeast	NFL1	Homestead	South	Education21
Agnew	Northeast	Property Management5	Homestead	South	Education22
Agnew	Northeast	Entertainment2	Homestead	South	Education23
Agnew	Northeast	Hotel1	Homestead	South	Education24
Agnew	Northeast	Datacenter18	Homestead	South	Education25
Agnew	Northeast	Medical1	Homestead	South	Education26
Agnew	Northeast	Mfg10	Homestead	South	Healthcare1
Agnew	Northeast	Datacenter19	Homestead	South	Telecommunications4
Agnew	Northeast	Datacenter20	Homestead	South	Education27
Agnew	Northeast	Datacenter21	Homestead	South	Education28
Agnew	Northeast	Datacenter22	MAT	South	Datacenter36
Agnew	Northeast	Cyber Security 1	PRK	South	Datacenter37
Agnew	Northeast	Hotel2	Serra	South	Medical device
Agnew	Northeast	Property Management6	Serra	South	Education29
NAJ	Northeast	Mfg11	Serra	South	Education30
Palm	Northeast	Datacenter/software/ cloud computing	Serra	South	Healthcare2
Palm	Northeast	NFL2	Serra	South	Healthcare3
Palm	Northeast	NFL3	Serra	South	Healthcare4
Palm	Northeast	NFL4	Serra	South	Healthcare5
Palm	Northeast	Education9	Kenneth	East	Datacenter16
Palm	Northeast	Education10	Kenneth	East	Datacenter17
Palm	Northeast	Conventions 1	Kenneth	East	Gaming/AI/Semiconductors4
Palm	Northeast	Education11			
Palm	Northeast	Semiconductor4			
Palm	Northeast	Datacenter23			
Palm	Northeast	Education12			
Palm	Northeast	Real Estate1			
Palm	Northeast	Network hardware1			
Palm	Northeast	Semiconductor5			
Palm	Northeast	Computer hardware/software 1			

SVP Loop Customers and Loading Peak - Loop

Center 141MW	East Loop 15MW	Northeast Loop 28MW	Northwest Loop 112MW	South Loop 65MW
Mfg1	Datacenter16	Security1	Medical2	Government3
Datacenter1	Datacenter17	Property Management3	Real Estate2	Education15
Datacenter2	Gaming/AI/ Semiconductors4	Property Management4	Real Estate3	Education16
Datacenter3		Entertainment1	Real Estate4	Education17
Datacenter4		NFL1	Datacenter24	Real Estate8
Mfg2		Property Management5	Datacenter25	Design1
Mfg3		Entertainment2	R&D2	Security 2
Datacenter5		Hotel1	Real Estate5	Education18
Mfg4		Datacenter18	Real Estate6	Education19
Mfg5		Medical1	Healthcare equipment	Mfg12
Datacenter6		Mfg10	Education13	Datacenter35
Mfg6		Datacenter19	Semiconductor/R&D	Education20
Datacenter7		Datacenter20	Datacenter26	Education21
Datacenter8		Datacenter21	Property Management7	Education22
R&D1		Datacenter22	Computer hardware/software 2	Education23
Property Management1		Cyber Security 1	Real Estate7	Education24
Datacenter9		Hotel2	Datacenter27	Education25
Datacenter10		Property Management6	Software1	Education26
Datacenter11		Mfg11	Computer hardware/software 3	Healthcare1
Property Management2		Datacenter/software/cloud computing	Cyber Security 2	Telecommunications 4
Education1		NFL2	Conventions 2	Education27
Education2		NFL3	Hotel3	Education28
Education3		NFL4	Medical3	Datacenter36
Education4		Education9	Cyber Security 3	Datacenter37
Semiconductor/ Telecommunications		Education10	Education14	Medical device
Gaming/AI/Semiconductors1		Conventions 1	Datacenter28	Education29
R&D/Mfg		Education11	R&D3	Education30
Mfg7		Semiconductor4	Semiconductor6	Healthcare2
Semiconductor1		Datacenter23	Storage1	Healthcare3
Gaming/AI/Semiconductors2		Education12	Entertainment3	Healthcare4
Mfg8		Real Estate1	Property Management8	Healthcare5
Gaming/AI/Semiconductors3		Network hardware1	Medical4	

Center 141MW	East Loop 15MW	Northeast Loop 28MW	Northwest Loop 112MW	South Loop 65MW
Datacenter12		Semiconductor5	Telecommunications2	
Education5		Computer	NFL5	
Government1			Datacenter29	
Government2			Datacenter30	
Semiconductor2			Datacenter31	
Semiconductor/R&D/Mfg			Datacenter32	
Mfg9			Telecommunications3	
Telecommunications1			Datacenter33	
Datacenter13			Gaming/AI/Semiconductors5	
Education6			Datacenter34	
Datacenter14				
Education7				
Education8				
Semiconductor3				
Datacenter15				
Bio Tech 1				
Semiconductor/ Telecommunications				
Semiconductor/R&D/Mfg				

References

- BAAQMD 2021b – Bay Area Air Quality Management District Comments (BAAQMD). (TN 239805). Letter for CA3 Data Center NOP, dated September 21, 2021. Available online at: <https://efiling.energy.ca.gov/Lists/DocketLog.aspx?docketnumber=21-SPPE-01>
- CAISO 2021 – California Independent System Operator (CAISO). Final Root Cause Analysis Mid-August 2020 Extreme Heat Wave, dated January 13, 2021. Accessed November 2021. Available online at: <http://www.caiso.com/Documents/Final-Root-Cause-Analysis-Mid-August-2020-Extreme-Heat-Wave.pdf>
- CEC 2020a – California Energy Commission (CEC). Walsh Data Center Initial Study and Proposed Mitigated Negative Declaration (TN 232078), February 2020. Available online at: <https://efiling.energy.ca.gov/Lists/DocketLog.aspx?docketnumber=19-SPPE-02>
- CEC 2020b – California Energy Commission (CEC). Mission College Data Center Initial Study and Proposed Mitigated Negative Declaration (TN 232798), April 2020. Available online at: <https://efiling.energy.ca.gov/Lists/DocketLog.aspx?docketnumber=19-SPPE-05>
- CEC 2021a – California Energy Commission (CEC). Record of Conversation with J. Zielkiewicz, BAAQMD Staff Regarding Emergency Operations: Great Oaks South Backup Generating Facility (TN 237631), May 2021. Available online at: <https://efiling.energy.ca.gov/Lists/DocketLog.aspx?docketnumber=20-SPPE-01>
- CEC 2021b – California Energy Commission (CEC). 2021 Total System Electric Generation. Available online at: <https://www.energy.ca.gov/data-reports/energy-almanac/california-electricity-data/2021-total-system-electric-generation>
- CEC 2023 – California Energy Commission (CEC). Demand Side Grid Support (DSGS) Program Guidelines, Second Edition - Proposed Draft Program Guidelines. Available online at: <https://efiling.energy.ca.gov/GetDocument.aspx?tn=249847>
- CPUC 2021a – California Public Utilities Commission (CPUC). Decision Directing Pacific Gas and Electric Company, Southern California Edison Company, and San Diego Gas & Electric Company To Take Actions To Prepare For Potential Extreme Weather In The Summers Of 2021 and 2022. Decision 21-03-056 March 25, 2021. Available online at: <https://docs.cpuc.ca.gov/publisheddocs/published/g000/m373/k745/373745051.pdf>
- CPUC 2021b – California Public Utilities Commission (CPUC). Phase 2 Decision Directing Pacific Gas and Electric Company, Southern California Edison Company, and San Diego Gas & Electric Company To Take Actions To Prepare For Potential Extreme Weather In The Summers Of 2022 and 2023. Decision 21-12-015, December 2,

2021. Available online at:
<https://docs.cpuc.ca.gov/PublishedDocs/Published/G000/M428/K821/428821475.PDF>

DayZenLLC 2021 – DayZenLLC (DayZenLLC). (TN 238416). VDC Supplemental Responses to Data Requests 15-20 CA3BGF, dated June 22, 2021. Available online at: <https://efiling.energy.ca.gov/Lists/DocketLog.aspx?docketnumber=21-SPPE-01>

SVP 2018a – Silicon Valley Power (SVP). Final 2018 Integrated Resource Plan for Silicon Valley Power. Adopted by the Santa Clara City Council, November 27, 2018. Available online at: <http://www.siliconvalleypower.com/svp-and-community/about-svp/integrated-resource-plan>

Appendix C

Mailing List

Appendix C: Mailing List

The following is the mailing list for the Martin Backup Generating project.

The following is a list of the State agencies that received State Clearinghouse notices and documents:

- California Air Resources Board (ARB)
- California Department of Transportation, District 4 (DOT)
- California Department of Water Resources (DWR)
- California Energy Commission
- California Natural Resources Agency
- California Public Utilities Commission (CPUC)
- California Regional Water Quality Control Board, San Francisco Bay Region 2 (RWQCB)
- Department of Toxic Substances Control, Office of Historic Preservation
- San Francisco Bay Conservation and Development Commission (BCDC)
- State Water Resources Control Board, Division of Water Quality
- California Native American Heritage Commission (NAHC)
- California Department of Fish and Wildlife, Bay Delta Region 3 (CDFW)

Table C-1 presents the list of occupants and property owners contiguous to the project site.

Table C-2 presents the list of agencies, including responsible and trustee agencies and libraries.

TABLE C-1 OWNERS AND OCCUPANTS OF PROPERTY CONTIGUOUS TO PROJECT SITE

Name	Address	City	State	Zip
OCCUPANT	881 MARTIN AVE	SANTA CLARA	CA	95050
OCCUPANT	801 MARTIN AVE	SANTA CLARA	CA	95050
GAHRAHMAT FAMILY LP II	3476 EDWARD AVE	SANTA CLARA	CA	95054
SOUTHERN PACIFIC TRANSPORTATION CO	65 CAHILL ST	SAN JOSE	CA	95110
PELIO 650 WALSH LLC	14573 BIG BASIN WAY	SARATOGA	CA	95070
OCCUPANT	660 WALSH AVE	SANTA CLARA	CA	95050
OCCUPANT	664 WALSH AVE	SANTA CLARA	CA	95050
OCCUPANT	668 WALSH AVE	SANTA CLARA	CA	95050
OCCUPANT	672 WALSH AVE	SANTA CLARA	CA	95050
OCCUPANT	676 WALSH AVE	SANTA CLARA	CA	95050
OCCUPANT	680 WALSH AVE	SANTA CLARA	CA	95050
OCCUPANT	684 WALSH AVE	SANTA CLARA	CA	95050
OCCUPANT	686 WALSH AVE	SANTA CLARA	CA	95050
OCCUPANT	688 WALSH AVE	SANTA CLARA	CA	95050
OCCUPANT	696 WALSH AVE	SANTA CLARA	CA	95050
OCCUPANT	651 MARTIN AVE	SANTA CLARA	CA	95050
D & R MILLER PROPS LLC	630 MARTIN AVE	SANTA CLARA	CA	95050
PENINSULA BUILDING MATERIALS CO	2490 CHARLESTON RD	MOUNTAIN VIEW	CA	94043
OCCUPANT	680 MARTIN AVE	SANTA CLARA	CA	95050
OCCUPANT	650 MARTIN AVE	SANTA CLARA	CA	95050
OCCUPANT	650 WALSH AVE	SANTA CLARA	CA	95050
MARTIN AVENUE PROPERTIES LLC,	1840 CENTURY PARK E STE 1900	SANTA CLARA	CA	95054

TABLE C-2 AGENCIES AND LIBRARIES							
First Name	Last Name	Title	Agency	Address	City	State	Zip
XUNA	CAI	SUPERVISING AIR QUALITY ENGINEER	BAAQMD, ENGINEERING DIVISION	375 BEALE STREET, SUITE 600	SAN FRANCISCO	CA	94105
PAMELA	LEONG	DIRECTOR, OFFICER	BAAQMD, ENGINEERING DIVISION	375 BEALE STREET, SUITE 600	SAN FRANCISCO	CA	94105
WENDY	GOODFRIEND		BAAQMD, PLANNING AND CLIMATE PROTECTION	375 BEALE STREET, SUITE 600	SAN FRANCISCO	CA	94105
			CALIFORNIA INDEPENDENT SYSTEM OPERATOR	250 OUTCROPPING WAY	FOLSOM	CA	95630
GLORIA	SCIARA	DEVELOPMENT REVIEW OFFICER	CITY OF SANTA CLARA PLANNING DIVISION	1500 WARBURTON AVENUE	SANTA CLARA	CA	95050
FREDERICK	CHUN	ASSISTANT FIRE MARSHALL	CITY OF SANTA CLARA-- FIRE PREVENTION/HAZARDOUS MATERIALS	1675 LINCOLN STREET	SANTA CLARA	CA	95050-4653
BEN	AGHEGNEHU		COUNTY OF SANTA CLARA ROADS AND AIRPORT DEPARTMENT	101 SKYPORT DRIVE	SAN JOSE	CA	95110
			COUNTY OF SANTA CLARA, OFFICE OF THE CLERK RECORDER	70 WEST HEDDING STREET	SAN JOSE	CA	95110
KATHERINE	KENNEDY	AIRPORT PLANNER	FEDERAL AVIATION ADMINISTRATION (FAA)	1000 MARINA BOULEVARD, SUITE 220	BRISBANE	CA	94005
REBECCA	BUSTOS	STAFF LIAISON	HISTORICAL AND LANDMARKS COMMISSION	1500 WARBURTON AVENUE	SANTA CLARA	CA	95050
JAMES	BOOTH	DISTRICT CONSERVATIONIST	NATURAL RESOURCES CONSERVATION SERVICES	2337 TECHNOLOGY PKWY., SUITE C	HOLLISTER	CA	95023-2544
FAIYAZ	ALI	DEPUTY DIRECTOR	SAN JOSÉ MINETA INTERNATIONAL AIRPORT, AVIATION DEPARTMENT	1701 AIRPORT BOULEVARD, SUITE B-1130	SAN JOSE	CA	95110-1206

TABLE C-2 AGENCIES AND LIBRARIES

First Name	Last Name	Title	Agency	Address	City	State	Zip
DANIEL	WELSH	DEPUTY FIELD SUPERVISOR	SAN FRANCISCO BAY-DELTA FISH AND WILDLIFE OFFICE	650 CAPITOL MALL, SUITE 8-300	SACRAMENTO	CA	95814
			COUNTY OF SANTA CLARA ROADS AND AIRPORT DEPARTMENT	101 SKYPORT DRIVE	SAN JOSE	CA	95110
			SANTA CLARA FIRE STATION #2	1900 WALSH AVE	SANTA CLARA	CA	95050
GERRY	HAAS	PROGRAM MANAGER	SANTA CLARA VALLEY HABITAT AGENCY	535 ALKIRE AVENUE	MORGAN HILL	CA	95037
			SANTA CLARA VALLEY TRANSPORTATION AUTHORITY	3331 NORTH FIRST STREET	SAN JOSE	CA	95134-1927
COLLEEN	HAGGERTY		SANTA CLARA VALLEY WATER DISTRICT--COMMUNITY PROJECTS REVIEW UNIT	5750 ALMADEN EXPRESSWAY	SAN JOSE	CA	95118
WENDY	STONE	PROGRAM MANAGER, CUSTOMER DEVELOPMENT	SILICON VALLEY POWER	1500 WARBURTON AVENUE	SANTA CLARA	CA	95050
KEVIN	KEATING	ELECTRIC DIVISION MANAGER	SILICON VALLEY POWER (CITY OF SANTA CLARA)	1500 WARBURTON AVENUE	SANTA CLARA	CA	95050
RYAN	OLAH	DIVISION SUPERVISOR	US FISH & WILDLIFE SERVICE, SACRAMENTO FISH & WILDLIFE OFFICE, COAST BAY DIVISION	2800 COTTAGE WAY RM W-2605	SACRAMENTO	CA	95825
RYAN	SHEELLEN	AIRPORT PLANNER	SAN JOSÉ MINETA INTERNATIONAL AIRPORT, PLANNING & DEVELOPMENT	1701 AIRPORT BLVD STE B-1130	SAN JOSE	CA	95110
CARL	HILBRANTS	SENIOR PLANNER, ALUC COORDINATOR	SANTA CLARA COUNTY PLANNING COMMISSION, DEPARTMENT OF PLANNING AND DEVELOPMENT	70 WEST HEDDING STREET, 7TH FLOOR	SAN JOSE	CA	95110

TABLE C-2 AGENCIES AND LIBRARIES

First Name	Last Name	Title	Agency	Address	City	State	Zip
TIFFANY	VIEN		CITY OF SANTA CLARA COMMUNITY DEVELOPMENT DEPARTMENT	1500 WARBURTON AVENUE	SANTA CLARA	CA	95050
			NORTHSIDE BRANCH LIBRARY	695 MORELAND WAY	SANTA CLARA	CA	95054