

APPENDIX F-2
Stormwater Quality Management Plan

Page intentionally blank

TABLE OF CONTENTS

- Acronym Sheet
- PDP SWQMP Preparer's Certification Page
- PDP SWQMP Project Owner's Certification Page
- Submittal Record
- Project Vicinity Map
- FORM I-1 Applicability of Storm Water BMP Requirements
- FORM I-2 Project Type Determination Checklist (Standard Project or PDP)
- FORM I-3B Site Information Checklist for PDPs
- FORM I-4 Source Control BMP Checklist for All Development Projects
- FORM I-5 Site Design BMP Checklist for All Development Projects
- FORM I-6 Summary of PDP Structural BMPs
- Attachment 1: Backup for PDP Pollutant Control BMPs
 - Attachment 1a: DMA Exhibit
 - Attachment 1b: Tabular Summary of DMAs and Design Capture Volume Calculations
 - Attachment 1c: Harvest and Use Feasibility Screening (when applicable)
 - Attachment 1d: Categorization of Infiltration Feasibility Condition (when applicable)
 - Attachment 1e: Pollutant Control BMP Design Worksheets / Calculations
- Attachment 2: Backup for PDP Hydromodification Control Measures
 - Attachment 2a: Hydromodification Management Exhibit
 - Attachment 2b: Management of Critical Coarse Sediment Yield Areas
 - Attachment 2c: Geomorphic Assessment of Receiving Channels
 - Attachment 2d: Flow Control Facility Design
- Attachment 3: Structural BMP Maintenance Plan
 - Attachment 3a: B Structural BMP Maintenance Thresholds and Actions
 - Attachment 3b: Draft Maintenance Agreement (when applicable)
- Attachment 4: Copy of Plan Sheets Showing Permanent Storm Water BMPs

ACRONYMS

APN	Assessor's Parcel Number
BMP	Best Management Practice
HMP	Hydromodification Management Plan
HSG	Hydrologic Soil Group
MS4	Municipal Separate Storm Sewer System
N/A	Not Applicable
NRCS	Natural Resources Conservation Service
PDP	Priority Development Project
PE	Professional Engineer
SC	Source Control
SD	Site Design
SDRWQCB	San Diego Regional Water Quality Control Board
SIC	Standard Industrial Classification
SWQMP	Storm Water Quality Management Plan

PDP SWQMP PREPARER'S CERTIFICATION PAGE

Project Name: South Pacific
Permit Application Number:

PREPARER'S CERTIFICATION

I hereby declare that I am the Engineer in Responsible Charge of design of storm water best management practices (BMPs) for this project, and that I have exercised responsible charge over the design of the BMPs as defined in Section 6703 of the Business and Professions Code, and that the design is consistent with the PDP requirements of the City of San Marcos BMP Design Manual, which is a design manual for compliance with local City of San Marcos and regional MS4 Permit (California Regional Water Quality Control Board San Diego Region Order No. R9-2015-0100) requirements for storm water management.

I have read and understand that the [City Engineer] has adopted minimum requirements for managing urban runoff, including storm water, from land development activities, as described in the BMP Design Manual. I certify that this PDP SWQMP has been completed to the best of my ability and accurately reflects the project being proposed and the applicable BMPs proposed to minimize the potentially negative impacts of this project's land development activities on water quality. I understand and acknowledge that the plan check review of this PDP SWQMP by the [City Engineer] is confined to a review and does not relieve me, as the Engineer in Responsible Charge of design of storm water BMPs for this project, of my responsibilities for project design.

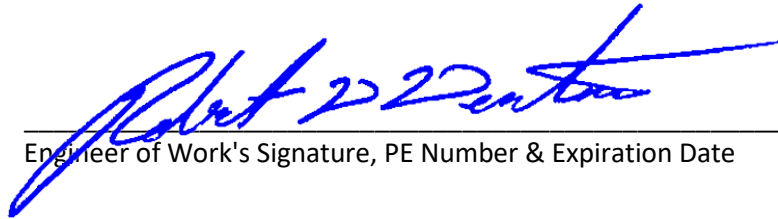

Engineer of Work's Signature, PE Number & Expiration Date

Robert D. Dentino, RCE 45629, 12-31- 22

Print Name

Excel Engineering

Company

11/3/2023

Date

Engineer's Seal:



Page intentionally blank

PDP SWQMP PROJECT OWNER'S CERTIFICATION PAGE

Project Name: South Pacific
Permit Application Number:

PROJECT OWNER'S CERTIFICATION

This PDP SWQMP has been prepared for Hughes Circuits, Inc. by Excel Engineering. The PDP SWQMP is intended to comply with the PDP requirements of the City of San Marcos BMP Design Manual, which is a design manual for compliance with local City of San Marcos and regional MS4 Permit (California Regional Water Quality Control Board San Diego Region Order No. R9-2015-0100) requirements for storm water management.

The undersigned, while it owns the subject property, is responsible for the implementation of the provisions of this plan. Once the undersigned transfers its interests in the property, its successor-in-interest shall bear the aforementioned responsibility to implement the best management practices (BMPs) described within this plan, including ensuring on-going operation and maintenance of structural BMPs. A signed copy of this document shall be available on the subject property into perpetuity.

Project Owner's Signature

Print Name

Hughes Circuits, Inc. _____
Company

Date

Page intentionally blank

SUBMITTAL RECORD

Use this Table to keep a record of submittals of this PDP SWQMP. Each time the PDP SWQMP is re-submitted, provide the date and status of the project. In column 4 summarize the changes that have been made or indicate if response to plancheck comments is included. When applicable, insert response to plancheck comments behind this page.

Submittal Number	Date	Project Status	Summary of Changes
1		<input checked="" type="checkbox"/> Preliminary Design / Planning/ CEQA <input type="checkbox"/> Final Design	Initial Submittal
2		<input type="checkbox"/> Preliminary Design / Planning/ CEQA <input type="checkbox"/> Final Design	
3		<input type="checkbox"/> Preliminary Design / Planning/ CEQA <input type="checkbox"/> Final Design	
4		<input type="checkbox"/> Preliminary Design / Planning/ CEQA <input type="checkbox"/> Final Design	

PROJECT VICINITY MAP

Project Name: South Pacific
Permit Application Number:

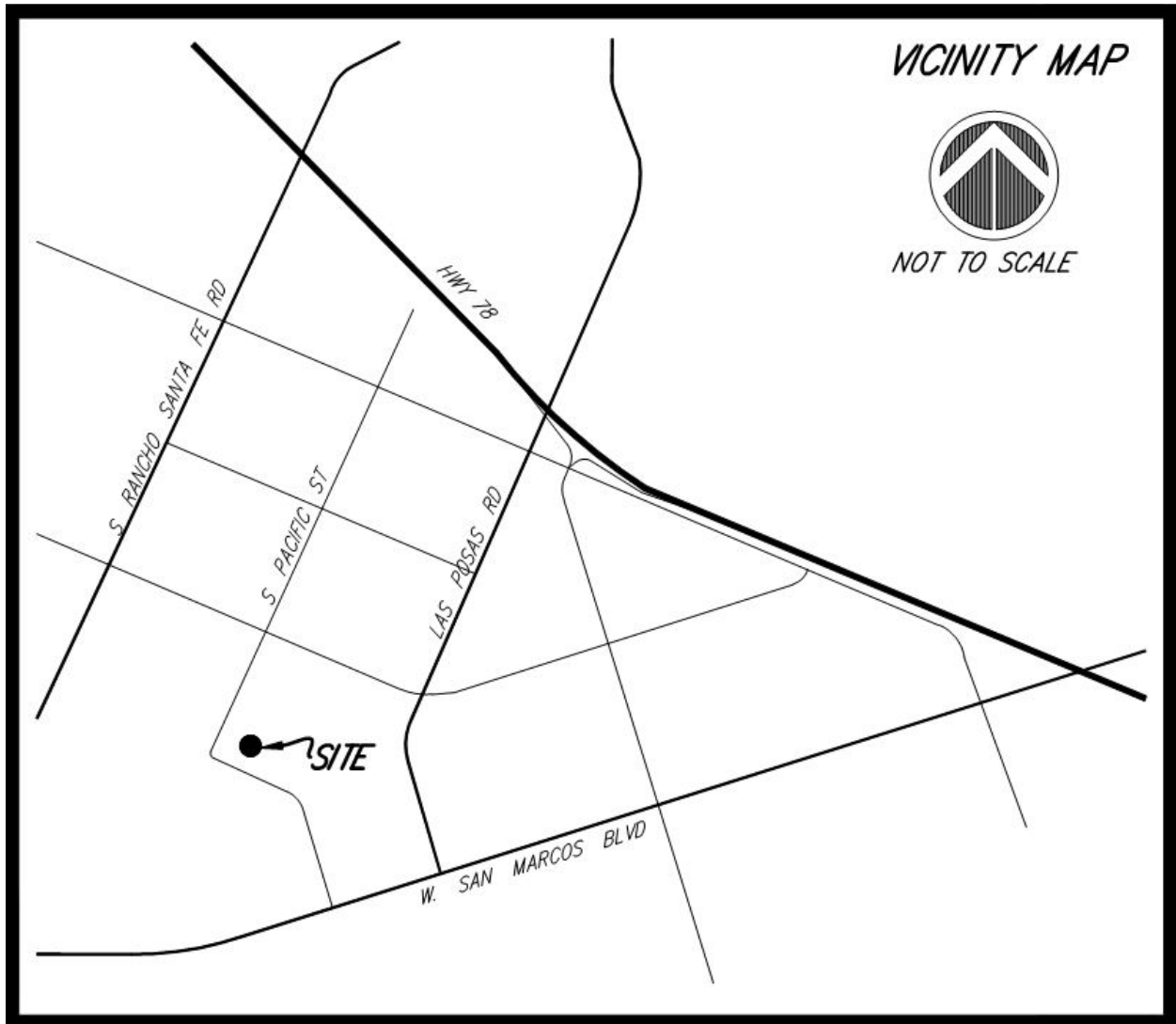

Applicability of Storm Water Best Management Practices (BMP) Requirements

(Storm Water Intake Form for all Development Permit Applications)

For detailed information please visit:

<http://www.san-marcos.net/departments/development-services/stormwater/development-planning>

Form I-1
[March 15, 2016]

Project Identification

Project Name: South Pacific

Description: Proposed project is an industrial project that will include driveways, a single building, structural BMPs, parking and all amenities.

Permit Application Number (if applicable):

Date: 2/24/2022

Project Address: NE Corner of South Pacific Street , San Marcos, CA 92078

Determination of Requirements

This form is required as part of the City's application process. The purpose of this form is to identify potential land development planning storm water requirements that apply to development projects.

Development projects are defined as construction, rehabilitation, redevelopment, or reconstruction of any public or private projects. In addition, the identification of a development project, as it relates to storm water regulations, would truly apply to development and redevelopment activities that have the potential to contact storm water and contribute a source of pollutants, or reduce the natural absorption and infiltration abilities of the land.

To access the BMP Design Manual, Storm Water Quality Management Plan (SWQMP) templates, and other pertinent information related to this program please refer to:

<http://www.san-marcos.net/departments/development-services/stormwater/development-planning>

Please answer each of the following steps below, starting with Step 1 and progressing through each step until reaching "Stop".

Step	Answer	Progression
Step 1: Based on the above, Is the project a "development project" (See definition above)? See Section 1.3 of the BMP Design Manual for further guidance if necessary.	<input checked="" type="checkbox"/> Yes	Go to Step 2.
	<input type="checkbox"/> No	Permanent BMP requirements do not apply. No SWQMP will be required. Provide brief discussion below. STOP.
Discussion / justification if the project is <u>not</u> a "development project" (e.g., the project includes <i>only</i> interior remodels within an existing building):		
Step 2: Is the project a Standard Project, Priority Development Project (PDP), or exception to PDP definitions? To answer this item, complete Form I-2, Project Type Determination. See Section 1.4 of the BMP Design Manual <i>in its entirety</i> for guidance. In addition to Section 1.4, please refer to the City's SWQMP Submittal Requirements form.	<input type="checkbox"/> Standard Project	<u>Only</u> Standard Project requirements apply, including <u>Standard Project SWQMP</u> . STOP.
	<input checked="" type="checkbox"/> PDP	<u>Standard and PDP</u> requirements apply, including <u>PDP SWQMP</u> . Go to Step 3 on the following page.
	<input type="checkbox"/> Exception to PDP definitions	<u>Standard Project</u> requirements apply, <u>and any additional requirements specific to the type of project</u> . Provide discussion and list any additional requirements below. Prepare <u>Standard Project SWQMP</u> . STOP.
Discussion / justification, and additional requirements for exceptions to PDP definitions, if applicable:		

Step 3 (PDPs only). Please answer the list of questions in this section to determine if hydromodification requirements apply to the proposed PDP. Does the project:

Step 3a. Discharge storm water runoff directly to the Pacific Ocean?	<input type="checkbox"/> Yes	STOP. Hydromodification requirements do not apply.
	<input checked="" type="checkbox"/> No	Continue to Step 3b.
Step 3b. Discharge storm water runoff directly to an enclosed embayment, not within protected areas?	<input type="checkbox"/> Yes	STOP. Hydromodification requirements do not apply.
	<input checked="" type="checkbox"/> No	Continue to Step 3c.
Step 3c. Discharge storm water runoff directly to a water storage reservoir or lake, below spillway or normal operating level?	<input type="checkbox"/> Yes	STOP. Hydromodification requirements do not apply.
	<input checked="" type="checkbox"/> No	Continue to Step 3d.
Step 3d. Discharge storm water runoff directly to an area identified in WMAA?	<input type="checkbox"/> Yes	STOP. Hydromodification requirements do not apply.
	<input checked="" type="checkbox"/> No	Hydromodification requirements apply to the project. Go to Step 4.



Discussion / justification if hydromodification control requirements do not apply:

Step 4 (PDPs subject to hydromodification control requirements only). Does protection of critical coarse sediment yield areas apply based on review of WMAA Potential Critical Coarse Sediment Yield Area Map? See Section 6.2 of the BMP Design Manual for guidance.	<input type="checkbox"/> Yes	Management measures required for protection of critical coarse sediment yield areas (Chapter 6.2). Stop.
	<input checked="" type="checkbox"/> No	Management measures not required for protection of critical coarse sediment yield areas. Provide brief discussion below. Stop.

Potential Critical Coarse Sediment

Data From WMAA Map

Legend

-  PCCSYA
-  Proposed Project
-  Proposed Project

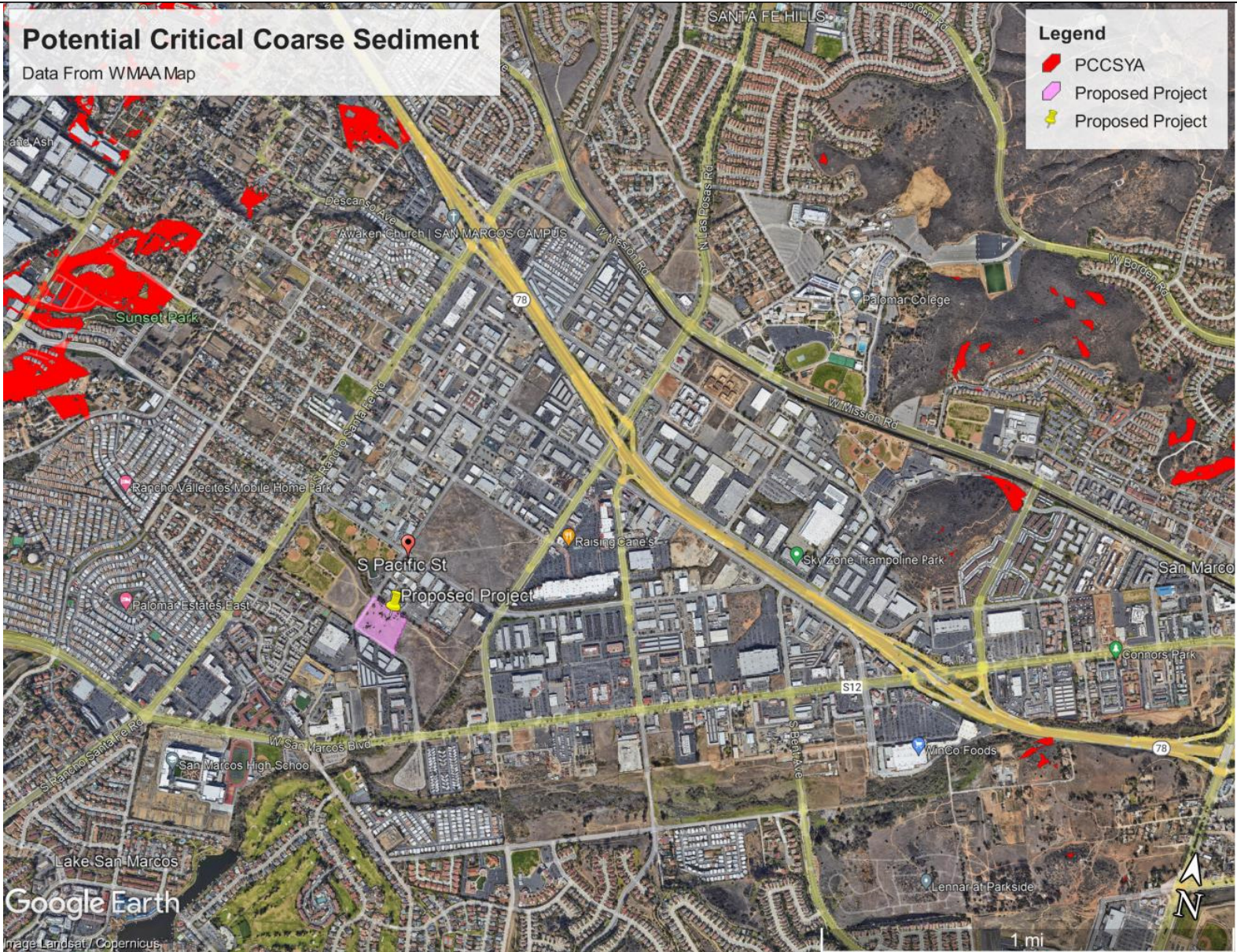

No Potential Critical Coarse Sediment Yield areas nearby that will influence the project.

Project Type Determination Checklist		Form I-2 [March 15, 2016]	
Project Information			
Project Name/Description: South Pacific			
Permit Application Number (if applicable):		Date: 2/24/2022	
Project Address: NE Corner of South Pacific Street , San Marcos, CA 92078			
Project Type Determination: Standard Project or Priority Development Project (PDP)			
The project is (select one): <input checked="" type="checkbox"/> New Development <input type="checkbox"/> Redevelopment			
The total proposed newly created or replaced impervious area is: 106214.09 ft ² (2.44) acres			
Is the project in any of the following categories, (a) through (f)?			
Yes <input checked="" type="checkbox"/>	No <input type="checkbox"/>	(a)	New development projects that create 10,000 square feet or more of impervious surfaces (collectively over the entire project site). This includes commercial, industrial, residential, mixed-use, and public development projects on public or private land.
Yes <input type="checkbox"/>	No <input checked="" type="checkbox"/>	(b)	Redevelopment projects that create and/or replace 5,000 square feet or more of impervious surface (collectively over the entire project site on an existing site of 10,000 square feet or more of impervious surfaces). This includes commercial, industrial, residential, mixed-use, and public development projects on public or private land.
Yes <input checked="" type="checkbox"/>	No <input type="checkbox"/>	(c)	New and redevelopment projects that create and/or replace 5,000 square feet or more of impervious surface (collectively over the entire project site), and support one or more of the following uses: <ul style="list-style-type: none"> (i) Restaurants. This category is defined as a facility that sells prepared foods and drinks for consumption, including stationary lunch counters and refreshment stands selling prepared foods and drinks for immediate consumption (Standard Industrial Classification (SIC) code 5812). (ii) Hillside development projects. This category includes development on any natural slope that is twenty-five percent or greater. (iii) Parking lots. This category is defined as a land area or facility for the temporary parking or storage of motor vehicles used personally, for business, or for commerce. (iv) Streets, roads, highways, freeways, and driveways. This category is defined as any paved impervious surface used for the transportation of automobiles, trucks, motorcycles, and other vehicles.

Yes <input type="checkbox"/>	No <input checked="" type="checkbox"/>	(d)	<p>New or redevelopment projects that create and/or replace 2,500 square feet or more of impervious surface (collectively over the entire project site), and discharging directly to an Environmentally Sensitive Area (ESA). "Discharging directly to" includes flow that is conveyed overland a distance of 200 feet or less from the project to the ESA, or conveyed in a pipe or open channel any distance as an isolated flow from the project to the ESA (i.e. not commingled with flows from adjacent lands).</p> <p><i>Note: ESAs are areas that include but are not limited to all Clean Water Act Section 303(d) impaired water bodies; areas designated as Areas of Special Biological Significance by the State Water Board and San Diego Water Board; State Water Quality Protected Areas; water bodies designated with the RARE beneficial use by the State Water Board and San Diego Water Board; and any other equivalent environmentally sensitive areas which have been identified by the Copermittees. See BMP Design Manual Section 1.4.2 for additional guidance.</i></p>
Yes <input type="checkbox"/>	No <input checked="" type="checkbox"/>	(e)	<p>New development projects, or redevelopment projects that create and/or replace 5,000 square feet or more of impervious surface, that support one or more of the following uses:</p> <ul style="list-style-type: none"> (i) Automotive repair shops. This category is defined as a facility that is categorized in any one of the following SIC codes: 5013, 5014, 5541, 7532-7534, or 7536-7539. (ii) Retail gasoline outlets (RGOs). This category includes RGOs that meet the following criteria: (a) 5,000 square feet or more or (b) a projected Average Daily Traffic (ADT) of 100 or more vehicles per day.
Yes <input checked="" type="checkbox"/>	No <input type="checkbox"/>	(f)	<p>New or redevelopment projects that result in the disturbance of one or more acres of land and are expected to generate pollutants post construction.</p> <p><i>Note: See BMP Design Manual Section 1.4.2 for additional guidance.</i></p>

Does the project meet the definition of one or more of the Priority Development Project categories (a) through (f) listed above?

- No – the project is not a Priority Development Project (Standard Project).
 Yes – the project is a Priority Development Project (PDP).

The following is for redevelopment PDPs only:

The area of existing (pre-project) impervious area at the project site is: _____ ft² (A)
 The total proposed newly created or replaced impervious area is _____ ft² (B)
 Percent impervious surface created or replaced (B/A)*100: _____ %
 The percent impervious surface created or replaced is (select one based on the above calculation):
 less than or equal to fifty percent (50%) – only new impervious areas are considered PDP
 OR
 greater than fifty percent (50%) – the entire project site is a PDP

Site Information Checklist For PDPs		Form I-3B (PDPs) [March 15, 2016]
Project Summary Information		
Project Name	South Pacific	
Project Address	NE Corner of South Pacific Street , San Marcos, CA 92078	
Assessor's Parcel Number(s) (APN(s))	219-223-20&22	
Permit Application Number		
Project Hydrologic Unit	Select One: <input type="checkbox"/> Santa Margarita 902 <input type="checkbox"/> San Luis Rey 903 <input checked="" type="checkbox"/> Carlsbad 904 <input type="checkbox"/> San Dieguito 905 <input type="checkbox"/> Penasquitos 906 <input type="checkbox"/> San Diego 907 <input type="checkbox"/> Pueblo San Diego 908 <input type="checkbox"/> Sweetwater 909 <input type="checkbox"/> Otay 910 <input type="checkbox"/> Tijuana 911	
Project Watershed (Complete Hydrologic Unit, Area, and Subarea Name with Numeric Identifier)	The project is located in the Richland Hydrologic Sub Area of the San Marcos Hydrologic Area of the Carlsbad Hydrologic Unit (904.52).	
Parcel Area (total area of Assessor's Parcel(s) associated with the project)	<u>2.926</u> Acres (<u>127456.56</u> Square Feet)	
Area to be Disturbed by the Project (Project Area)	<u>2.926</u> Acres (<u>127456.56</u> Square Feet)	
Project Proposed Impervious Area (subset of Project Area)	<u>2.44</u> Acres (<u>106214.09</u> Square Feet)	
Project Proposed Pervious Area (subset of Project Area)	<u>0.49</u> Acres (<u>21242.47</u> Square Feet)	
Note: Proposed Impervious Area + Proposed Pervious Area = Area to be Disturbed by the Project. This may be less than the Parcel Area.		

Description of Existing Site Condition

Current Status of the Site (select all that apply):

- Existing development
 Previously graded but not built out
 Demolition completed without new construction
 Agricultural or other non-impervious use
 Vacant, undeveloped/natural

Description / Additional Information:

The existing site condition is undeveloped natural area with soil type D.

Existing Land Cover Includes (select all that apply):

- Vegetative Cover
 Non-Vegetated Pervious Areas
 Impervious Areas

Description / Additional Information:

Underlying Soil belongs to Hydrologic Soil Group (select all that apply):

- NRCS Type A
 NRCS Type B
 NRCS Type C
 NRCS Type D

Approximate Depth to Groundwater (GW):

- GW Depth < 5 feet
 5 feet < GW Depth < 10 feet
 10 feet < GW Depth < 20 feet
 GW Depth > 20 feet

Note: At the upper northwest corner of the project site the GW depth is 4'. At the rest portion of the project site the GW depth is between 6'-10'.

Existing Natural Hydrologic Features (select all that apply):

- Watercourses
 Seeps
 Springs
 Wetlands
 None

Description / Additional Information:

Description of Existing Site Drainage Patterns

How is storm water runoff conveyed from the site? At a minimum, this description should answer:

- (1) whether existing drainage conveyance is natural or urban;
- (2) Is runoff from offsite conveyed through the site? If yes, quantify all offsite drainage areas, design flows, and locations where offsite flows enter the project site, and summarize how such flows are conveyed through the site;
- (3) Provide details regarding existing project site drainage conveyance network, including any existing storm drains, concrete channels, swales, detention facilities, storm water treatment facilities, natural or constructed channels; and
- (4) Identify all discharge locations from the existing project site along with a summary of conveyance system size and capacity for each of the discharge locations. Provide summary of the pre-project drainage areas and design flows to each of the existing runoff discharge locations.

Describe existing site drainage patterns:

The majority of the existing offsite surface slopes generally from the north to the south. When the water reaches South Pacific Street along the west border of the project, it flows into the existing dual 48 inches pipes then flow through vacant property before entry the project area.

The site is currently undeveloped. The existing onsite surface slope is approximately 2% and runs generally from the north to the south. When the water from offsite reaches to the north edge of the project, it flows along the slope until it reaches the project's POC at the south edge of the property. According to the Web Soil Survey, the entire existing site is Soil Type D.

Description of Proposed Site Development

Project Description / Proposed Land Use and/or Activities:

The project is proposing to build a building, parking lots with landscape area, and structural Biofiltration BMPs (BF-2) along with a Modular Wetlands proprietary biofiltration (BF-3).

List/describe proposed impervious features of the project (e.g., buildings, roadways, parking lots, courtyards, athletic courts, other impervious features):

The proposed impervious areas of the project will include a building, the associated parking lot, and the paved road.

List/describe proposed pervious features of the project (e.g., landscape areas):

The proposed pervious areas of the project will include two biofiltration BMPs (BF-2), pervious pavers in the parking stalls, and minor landscaped areas around the building's footprint.

Does the project include grading and changes to site topography?

- Yes
- No

Description / Additional Information:

The current site has a slight upward slope from South Pacific then drops down to a lower elevation that creates an entire channel that conveys waters from the north. The proposed project will raise the site and allow the water to convey through the site through proposed Reinforced Concrete Pipes.

Description of Proposed Site Drainage Patterns

Does the project include changes to site drainage (e.g., installation of new storm water conveyance systems)?

Yes

No

If yes, provide details regarding the proposed project site drainage conveyance network, including storm drains, concrete channels, swales, detention facilities, storm water treatment facilities, natural or constructed channels, and the method for conveying offsite flows through or around the proposed project site. Identify all discharge locations from the proposed project site along with a summary of the conveyance system size and capacity for each of the discharge locations. Provide a summary of pre- and post-project drainage areas and design flows to each of the runoff discharge locations. Reference the drainage study for detailed calculations.

Describe proposed site drainage patterns:

The project proposes to build a building, parking and landscape areas. The proposed parking slopes to the project's biofiltration basin (BMP-A) at 0.5%. To decrease impervious area on the site, the parking stalls will be installed with pervious concrete. The proposed building is approximately 1.298 acres. The 1.024 acres of the building will discharge roof water into BMP-A, another 0.274 acres of the building will discharge roof water into BMP-B. After all stormwater from parking lot and roof get collected and treated in BMP-A and BMP-B, it flows into the 48 inches storage tank, which is located at the north and east edge of the project site. This storage tank is used for detaining post-developed onsite water. At the end of the storage tank, a weir plate with two orifices is used for regulating low flow. Each of the biofiltration basins have an emergency spillway that will ultimately allow water to go to the street. It should be noted this is a last attempt emergency spillway for safety; these spillways should not have water actually going through them.

A 24 inches pipe connect the storage tank with two proposed new 66 inches culverts. These two new 66 inches culverts run from the north to the south and meet with the existing two 66 inches culvert at south pacific street. These two 66 inches culverts route storm water through the site and finally collects into the POC at the South Pacific Street.

At the west and south edge of the project site, there is approximately 0.497 acres which include pervious and landscaped slope that will not flow to the basins. This section drains surface water from the north to the south and collects in an existing 18 inches storm drain pipe which ties to an existing 27 inches storm drain to the POC.

At the south side of the project site, there is BMP-C which is a modular wetland system to convey storm water from north to south. The proposed 18 inches outlet pipe of the modular wetland is connecting with the existing 18 inches RCP pipe where the headwall used to be. Storm water drains southernly to the modular wetland system and get treated, then drains into the existing 18 inches storm drain pipe to the POC.

At the southeast corner of the project site, there is a dispersion area to route surface runoff from impervious street area to the adjacent pervious area. This is to slow surface runoff and reduce discharge by infiltration and evapotranspiration. BMP-D is the dispersion area for DMA-4. 100% of the impervious will be going to the dispersion area.

At the east part of the project site, the parcel APN 219-223-20, water is intercepted at the south easterly corner at a headwall which connects to dual 24 inches pipes. These two new 24 inches pipes goes under BMP-B and connect with the two proposed new 66 inches culverts to route storm water to the POC at the South Pacific Street.

For more information on these flows, see the Drainage Study of this project.

Identify whether any of the following features, activities, and/or pollutant source areas will be present (select all that apply):

- On-site storm drain inlets
- Interior floor drains and elevator shaft sump pumps
- Interior parking garages
- Need for future indoor & structural pest control
- Landscape/Outdoor Pesticide Use
- Pools, spas, ponds, decorative fountains, and other water features
- Food service
- Refuse areas
- Industrial processes
- Outdoor storage of equipment or materials
- Vehicle and Equipment Cleaning
- Vehicle/Equipment Repair and Maintenance
- Fuel Dispensing Areas
- Loading Docks
- Fire Sprinkler Test Water
- Miscellaneous Drain or Wash Water
- Plazas, sidewalks, and parking lots

Description / Additional Information:

Identification and Narrative of Receiving Water and Pollutants of Concern

Describe flow path of storm water from the project site discharge location(s), through urban storm conveyance systems as applicable, to receiving creeks, rivers, and lagoons as applicable, and ultimate discharge to the Pacific Ocean (or bay, lagoon, lake or reservoir, as applicable):

The flow path of storm water from the project site discharge the upper of San Marcos Creek then to the Lake San Marcos and ultimate discharge to the Pacific Ocean.

List any 303(d) impaired water bodies within the path of storm water from the project site to the Pacific Ocean (or bay, lagoon, lake or reservoir, as applicable), identify the pollutant(s)/stressor(s) causing impairment, and identify any TMDLs and/or Highest Priority Pollutants from the WQIP for the impaired water bodies:

303(d) Impaired Water Body	Pollutant(s)/Stressor(s)	TMDLs / WQIP Highest Priority Pollutant
San Marcos Creek	Indicator Bacteria, Phosphorus, Selenium	Nutrients
Lake San Marcos	Ammonia (N), Copper, Nutrients, Phosphorus	
Batiquitos Lagoon	Pathogen	

Identification of Project Site Pollutants*

***Identification of project site pollutants is only required if flow-thru treatment BMPs are implemented onsite in lieu of retention or biofiltration BMPs (note the project must also participate in an alternative compliance program unless prior lawful approval to meet earlier PDP requirements is demonstrated)**

Identify pollutants expected from the project site based on all proposed use(s) of the site (see BMP Design Manual Appendix B.6):

*Pollutant	Not Applicable to the Project Site	Expected from the Project Site	Also a Receiving Water Pollutant of Concern
Sediment		X	
Nutrients	X		
Heavy Metals		X	
Organic Compounds		X	
Trash & Debris		X	
Oxygen Demanding Substances		X	
Oil & Grease		X	
Bacteria & Viruses		X	
Pesticides		X	

*Note: Only Applies to BMP-C (Modular Wetlands Flow Through)

Hydromodification Management Requirements

Do hydromodification management requirements apply (see Section 1.6 of the BMP Design Manual)?

- Yes, hydromodification management flow control structural BMPs required.
- No, the project will discharge runoff directly to existing underground storm drains discharging directly to water storage reservoirs, lakes, enclosed embayments, or the Pacific Ocean.
- No, the project will discharge runoff directly to conveyance channels whose bed and bank are concrete-lined all the way from the point of discharge to water storage reservoirs, lakes, enclosed embayments, or the Pacific Ocean.
- No, the project will discharge runoff directly to an area identified as appropriate for an exemption by the WMAA for the watershed in which the project resides.

Description / Additional Information (to be provided if a 'No' answer has been selected above):

Critical Coarse Sediment Yield Areas*

***This Section only required if hydromodification management requirements apply**

Based on the maps provided within the WMAA, do potential critical coarse sediment yield areas exist within the project drainage boundaries?

Based on the maps provided within the WMAA, do potential critical coarse sediment yield areas exist within the project drainage boundaries?

- Yes
- No, No critical coarse sediment yield areas to be protected based on WMAA maps

If yes, have any of the optional analyses presented in Section 6.2 of the BMP Design Manual been performed?

- 6.2.1 Verification of Geomorphic Landscape Units (GLUs) Onsite
- 6.2.2 Downstream Systems Sensitivity to Coarse Sediment
- 6.2.3 Optional Additional Analysis of Potential Critical Coarse Sediment Yield Areas Onsite
- No optional analyses performed, the project will avoid critical coarse sediment yield areas identified based on WMAA maps

If optional analyses were performed, what is the final result?

- No critical coarse sediment yield areas to be protected based on verification of GLUs onsite
- Critical coarse sediment yield areas exist but additional analysis has determined that protection is not required. Documentation attached in Attachment 2.b of the SWQMP.
- Critical coarse sediment yield areas exist and require protection. The project will implement management measures described in Sections 6.2.4 and 6.2.5 as applicable, and the areas are identified on the SWQMP Exhibit.

Discussion / Additional Information:

Flow Control for Post-Project Runoff*

***This Section only required if hydromodification management requirements apply**

List and describe point(s) of compliance (POCs) for flow control for hydromodification management (see Section 6.3.1). For each POC, provide a POC identification name or number correlating to the project's HMP Exhibit and a receiving channel identification name or number correlating to the project's HMP Exhibit.

There is one POC at the southeast corner of the property. Water flows from biofiltration basins and storage tank to the street at this point.

Has a geomorphic assessment been performed for the receiving channel(s)?

- No, the low flow threshold is 0.1Q2 (default low flow threshold)
- Yes, the result is the low flow threshold is 0.1Q2
- Yes, the result is the low flow threshold is 0.3Q2
- Yes, the result is the low flow threshold is 0.5Q2

If a geomorphic assessment has been performed, provide title, date, and preparer:

San Marcos Creek Specific Plan, Master Water Quality and Hydromodification Management Plan, Final December 15, 2011, City of San Marcos.

Discussion / Additional Information: (optional)

See Attachment 2C for the geomorphic assessment.

Other Site Requirements and Constraints

When applicable, list other site requirements or constraints that will influence storm water management design, such as zoning requirements including setbacks and open space, or local codes governing minimum street width, sidewalk construction, allowable pavement types, and drainage requirements.

There is a section constraint at the street that makes sizing an appropriate biofiltration system work, in this case Modular Wetlands bio clean was chosen.

Optional Additional Information or Continuation of Previous Sections As Needed

This space provided for additional information or continuation of information from previous sections as needed.

Source Control BMP Checklist for All Development Projects (Standard Projects and Priority Development Projects)		Form I-4 [March 15, 2016]	
Project Identification			
Project Name: South Pacific			
Permit Application Number:			
Source Control BMPs			
All development projects must implement source control BMPs SC-1 through SC-6 where applicable and feasible. See Chapter 4 and Appendix E of the Model BMP Design Manual for information to implement source control BMPs shown in this checklist.			
Answer each category below pursuant to the following.			
<ul style="list-style-type: none"> • "Yes" means the project will implement the source control BMP as described in Chapter 4 and/or Appendix E of the Model BMP Design Manual. Discussion / justification is not required. • "No" means the BMP is applicable to the project but it is not feasible to implement. Discussion / justification must be provided. • "N/A" means the BMP is not applicable at the project site because the project does not include the feature that is addressed by the BMP (e.g., the project has no outdoor materials storage areas). Discussion / justification may be provided. 			
Source Control Requirement		Applied?	
SC-1 Prevention of Illicit Discharges into the MS4		<input checked="" type="checkbox"/> Yes	<input type="checkbox"/> No <input type="checkbox"/> N/A
Discussion / justification if SC-1 not implemented:			
SC-2 Storm Drain Stenciling or Signage		<input checked="" type="checkbox"/> Yes	<input type="checkbox"/> No <input type="checkbox"/> N/A
Discussion / justification if SC-2 not implemented:			
SC-3 Protect Outdoor Materials Storage Areas from Rainfall, Run-On, Runoff, and Wind Dispersal		<input type="checkbox"/> Yes	<input type="checkbox"/> No <input checked="" type="checkbox"/> N/A
Discussion / justification if SC-3 not implemented:			
SC-4 Protect Materials Stored in Outdoor Work Areas from Rainfall, Run-On, Runoff, and Wind Dispersal		<input type="checkbox"/> Yes	<input type="checkbox"/> No <input checked="" type="checkbox"/> N/A
Discussion / justification if SC-4 not implemented:			

Source Control Requirement	Applied?		
SC-5 Protect Trash Storage Areas from Rainfall, Run-On, Runoff, and Wind Dispersal	<input checked="" type="checkbox"/> Yes	<input type="checkbox"/> No	<input type="checkbox"/> N/A
Discussion / justification if SC-5 not implemented:			
SC-6 Additional BMPs Based on Potential Sources of Runoff Pollutants (must answer for each source listed below)			
<input checked="" type="checkbox"/> On-site storm drain inlets	<input checked="" type="checkbox"/> Yes	<input type="checkbox"/> No	<input type="checkbox"/> N/A
<input type="checkbox"/> Interior floor drains and elevator shaft sump pumps	<input type="checkbox"/> Yes	<input type="checkbox"/> No	<input checked="" type="checkbox"/> N/A
<input type="checkbox"/> Interior parking garages	<input type="checkbox"/> Yes	<input type="checkbox"/> No	<input checked="" type="checkbox"/> N/A
<input checked="" type="checkbox"/> Need for future indoor & structural pest control	<input checked="" type="checkbox"/> Yes	<input type="checkbox"/> No	<input type="checkbox"/> N/A
<input checked="" type="checkbox"/> Landscape/Outdoor Pesticide Use	<input checked="" type="checkbox"/> Yes	<input type="checkbox"/> No	<input type="checkbox"/> N/A
<input type="checkbox"/> Pools, spas, decorative fountains, and other water features	<input type="checkbox"/> Yes	<input type="checkbox"/> No	<input checked="" type="checkbox"/> N/A
<input type="checkbox"/> Food service	<input type="checkbox"/> Yes	<input type="checkbox"/> No	<input checked="" type="checkbox"/> N/A
<input checked="" type="checkbox"/> Refuse areas	<input checked="" type="checkbox"/> Yes	<input type="checkbox"/> No	<input type="checkbox"/> N/A
<input type="checkbox"/> Industrial processes	<input type="checkbox"/> Yes	<input type="checkbox"/> No	<input checked="" type="checkbox"/> N/A
<input type="checkbox"/> Outdoor storage of equipment or materials	<input type="checkbox"/> Yes	<input type="checkbox"/> No	<input checked="" type="checkbox"/> N/A
<input type="checkbox"/> Vehicle and Equipment Cleaning	<input type="checkbox"/> Yes	<input type="checkbox"/> No	<input checked="" type="checkbox"/> N/A
<input type="checkbox"/> Vehicle/Equipment Repair and Maintenance	<input type="checkbox"/> Yes	<input type="checkbox"/> No	<input checked="" type="checkbox"/> N/A
<input type="checkbox"/> Fuel Dispensing Areas	<input type="checkbox"/> Yes	<input type="checkbox"/> No	<input checked="" type="checkbox"/> N/A
<input type="checkbox"/> Loading Docks	<input type="checkbox"/> Yes	<input type="checkbox"/> No	<input checked="" type="checkbox"/> N/A
<input checked="" type="checkbox"/> Fire Sprinkler Test Water	<input checked="" type="checkbox"/> Yes	<input type="checkbox"/> No	<input type="checkbox"/> N/A
<input type="checkbox"/> Miscellaneous Drain or Wash Water	<input type="checkbox"/> Yes	<input type="checkbox"/> No	<input checked="" type="checkbox"/> N/A
<input checked="" type="checkbox"/> Plazas, sidewalks, and parking lots	<input checked="" type="checkbox"/> Yes	<input type="checkbox"/> No	<input type="checkbox"/> N/A
Discussion / justification if SC-6 not implemented. Clearly identify which sources of runoff pollutants are discussed. Justification must be provided for <u>all</u> "No" answers shown above.			

Site Design BMP Checklist for All Development Projects (Standard Projects and Priority Development Projects)	Form I-5 [March 15, 2016]
---	--------------------------------------

Project Identification

Project Name: South Pacific

Permit Application Number

Site Design BMPs

All development projects must implement site design BMPs SD-1 through SD-8 where applicable and feasible. See Chapter 4 and Appendix E of the Model BMP Design Manual for information to implement site design BMPs shown in this checklist.

Answer each category below pursuant to the following.

- "Yes" means the project will implement the site design BMP as described in Chapter 4 and/or Appendix E of the Model BMP Design Manual. Discussion / justification is not required.
- "No" means the BMP is applicable to the project but it is not feasible to implement. Discussion / justification must be provided.
- "N/A" means the BMP is not applicable at the project site because the project does not include the feature that is addressed by the BMP (e.g., the project site has no existing natural areas to conserve). Discussion / justification may be provided.

Site Design Requirement	Applied?		
SD-1 Maintain Natural Drainage Pathways and Hydrologic Features	<input checked="" type="checkbox"/> Yes	<input type="checkbox"/> No	<input type="checkbox"/> N/A
Discussion / justification if SD-1 not implemented:			
SD-2 Conserve Natural Areas, Soils, and Vegetation	<input checked="" type="checkbox"/> Yes	<input type="checkbox"/> No	<input type="checkbox"/> N/A
Discussion / justification if SD-2 not implemented:			
SD-3 Minimize Impervious Area	<input checked="" type="checkbox"/> Yes	<input type="checkbox"/> No	<input type="checkbox"/> N/A
Discussion / justification if SD-3 not implemented:			
SD-4 Minimize Soil Compaction	<input checked="" type="checkbox"/> Yes	<input type="checkbox"/> No	<input type="checkbox"/> N/A
Discussion / justification if SD-4 not implemented:			
SD-5 Impervious Area Dispersion	<input type="checkbox"/> Yes	<input checked="" type="checkbox"/> No	<input type="checkbox"/> N/A
Discussion / justification if SD-5 not implemented: There are no significant areas of level vegetation to implement this BMP. All impervious areas are directed to a biofiltration pond.			

Site Design Requirement	Applied?		
SD-6 Runoff Collection	<input checked="" type="checkbox"/> Yes	<input type="checkbox"/> No	<input type="checkbox"/> N/A
Discussion / justification if SD-6 not implemented:			
SD-7 Landscaping with Native or Drought Tolerant Species	<input checked="" type="checkbox"/> Yes	<input type="checkbox"/> No	<input type="checkbox"/> N/A
Discussion / justification if SD-7 not implemented:			
SD-8 Harvesting and Using Precipitation	<input type="checkbox"/> Yes	<input type="checkbox"/> No	<input checked="" type="checkbox"/> N/A
Discussion / justification if SD-8 not implemented:			

Summary of PDP Structural BMPs	Form I-6 (PDPs) [March 15, 2016]
Project Identification	
Project Name: South Pacific	
Permit Application Number:	
PDP Structural BMPs	
<p>All PDPs must implement structural BMPs for storm water pollutant control (see Chapter 5 of the BMP Design Manual). Selection of PDP structural BMPs for storm water pollutant control must be based on the selection process described in Chapter 5. PDPs subject to hydromodification management requirements must also implement structural BMPs for flow control for hydromodification management (see Chapter 6 of the BMP Design Manual). Both storm water pollutant control and flow control for hydromodification management can be achieved within the same structural BMP(s).</p>	
<p>PDP structural BMPs must be verified by the local jurisdiction at the completion of construction. This may include requiring the project owner or project owner's representative and engineer of record to certify construction of the structural BMPs (see Section 1.12 of the BMP Design Manual). PDP structural BMPs must be maintained into perpetuity, and the local jurisdiction must confirm the maintenance (see Section 7 of the BMP Design Manual).</p>	
<p>Use this form to provide narrative description of the general strategy for structural BMP implementation at the project site in the box below. Then complete the PDP structural BMP summary information sheet (page 3 of this form) for each structural BMP within the project (copy the BMP summary information page as many times as needed to provide summary information for each individual structural BMP).</p>	
<p>Describe the general strategy for structural BMP implementation at the site. This information must describe how the steps for selecting and designing storm water pollutant control BMPs presented in Section 5.1 of the BMP Design Manual were followed, and the results (type of BMPs selected). For projects requiring hydromodification flow control BMPs, indicate whether pollutant control and flow control BMPs are integrated or separate.</p> <p><i>Step 1, the project was divided up and evaluated at the DMA scale. Each DMA area was classified as Self-Treating, Self-Retaining or Draining to a Best Management Practice (BMP).</i></p> <p><i>Step 2, For the DMAs that drain to BMPs, the appropriate runoff factors were applied to each area and the required Design Capture Volume (DCV) of each sub area calculated. For this project, Harvest and reuse is not considered feasible.</i></p> <p><i>Step 3, due to the impermeability of the underlying soils, (soil type D), infiltration BMPs are not feasible.</i></p> <p><i>Step 3A&B for the no infiltration condition leads to section 5.5.3 which is the Biofiltration BMP category. The various sizing methods included in Appendix B.5 were followed and the entire DCV can be treated within the proposed BMPs.</i></p> <p><i>Step 4, each Biofiltration BMP area is sized in accordance with the fact sheet BF- 2 or Proprietary biofiltration with BF-3 found in appendix E of the BMP design manual. This project requires hydromodification controls, so the Biofiltration units accomplish both storm water treatment and flow control mitigation in an integrated design.</i></p> <p>(Continue on page 2 as necessary.)</p>	

(Page reserved for continuation of description of general strategy for structural BMP implementation at the site)

(Continued from page 1)

DMA 5 and DMA 6 are self mitigating area and drain to natural areas; therefore they not a part of sizing calculations.

Structural BMP Summary Information

(Copy this page as needed to provide information for each individual proposed structural BMP)

Structural BMP ID No. **BMP-A**

Construction Plan Sheet No.

Type of structural BMP:

- Retention by harvest and use (HU-1)
- Retention by infiltration basin (INF-1)
- Retention by bioretention (INF-2)
- Retention by permeable pavement (INF-3)
- Partial retention by biofiltration with partial retention (PR-1)
- Biofiltration (BF-1)
- Biofiltration with Nutrient Sensitive Media Design (BF-2)
- Proprietary Biofiltration (BF-3) meeting all requirements of Appendix F
- Flow-thru treatment control with prior lawful approval to meet earlier PDP requirements (provide BMP type/description in discussion section below)
- Flow-thru treatment control included as pre-treatment/forebay for an onsite retention or biofiltration BMP (provide BMP type/description and indicate which onsite retention or biofiltration BMP it serves in discussion section below)
- Flow-thru treatment control with alternative compliance (provide BMP type/description in discussion section below)
- Detention pond or vault for hydromodification management
- Other (describe in discussion section below)

Purpose:

- Pollutant control only
- Hydromodification control only
- Combined pollutant control and hydromodification control
- Pre-treatment/forebay for another structural BMP
- Other (describe in discussion section below)

Who will certify construction of this BMP? Provide name and contact information for the party responsible to sign BMP verification forms if required by the [City Engineer] (See Section 1.12 of the BMP Design Manual)	The Engineer of Work Robert Dentino Excel Engineering 440 State Place Escondido, CA 92029
Who will be the final owner of this BMP?	Project Owner
Who will maintain this BMP into perpetuity?	Project Owner
What is the funding mechanism for maintenance?	Project Owner

Structural BMP Summary Information
(Copy this page as needed to provide information for each individual proposed structural BMP)

Structural BMP ID No. **BMP-B**

Construction Plan Sheet No.

Type of structural BMP:

- Retention by harvest and use (HU-1)
- Retention by infiltration basin (INF-1)
- Retention by bioretention (INF-2)
- Retention by permeable pavement (INF-3)
- Partial retention by biofiltration with partial retention (PR-1)
- Biofiltration (BF-1)
- Biofiltration with Nutrient Sensitive Media Design (BF-2)
- Proprietary Biofiltration (BF-3) meeting all requirements of Appendix F
- Flow-thru treatment control with prior lawful approval to meet earlier PDP requirements (provide BMP type/description in discussion section below)
- Flow-thru treatment control included as pre-treatment/forebay for an onsite retention or biofiltration BMP (provide BMP type/description and indicate which onsite retention or biofiltration BMP it serves in discussion section below)
- Flow-thru treatment control with alternative compliance (provide BMP type/description in discussion section below)
- Detention pond or vault for hydromodification management
- Other (describe in discussion section below)

Purpose:

- Pollutant control only
- Hydromodification control only
- Combined pollutant control and hydromodification control
- Pre-treatment/forebay for another structural BMP
- Other (describe in discussion section below)

Who will certify construction of this BMP? Provide name and contact information for the party responsible to sign BMP verification forms if required by the [City Engineer] (See Section 1.12 of the BMP Design Manual)	The Engineer of Work Robert Dentino Excel Engineering 440 State Place Escondido, CA 92029
Who will be the final owner of this BMP?	Project Owner
Who will maintain this BMP into perpetuity?	Project Owner
What is the funding mechanism for maintenance?	Project Owner

Structural BMP Summary Information

(Copy this page as needed to provide information for each individual proposed structural BMP)

Structural BMP ID No. **BMP-C (Modular Wetlands)**

Construction Plan Sheet No.

Type of structural BMP:

- Retention by harvest and use (HU-1)
- Retention by infiltration basin (INF-1)
- Retention by bioretention (INF-2)
- Retention by permeable pavement (INF-3)
- Partial retention by biofiltration with partial retention (PR-1)
- Biofiltration (BF-1)
- Biofiltration with Nutrient Sensitive Media Design (BF-2)
- Proprietary Biofiltration (BF-3) meeting all requirements of Appendix F
- Flow-thru treatment control with prior lawful approval to meet earlier PDP requirements (provide BMP type/description in discussion section below)
- Flow-thru treatment control included as pre-treatment/forebay for an onsite retention or biofiltration BMP (provide BMP type/description and indicate which onsite retention or biofiltration BMP it serves in discussion section below)
- Flow-thru treatment control with alternative compliance (provide BMP type/description in discussion section below)
- Detention pond or vault for hydromodification management
- Other (describe in discussion section below)

Purpose:

- Pollutant control only
- Hydromodification control only
- Combined pollutant control and hydromodification control
- Pre-treatment/forebay for another structural BMP
- Other (describe in discussion section below)

Who will certify construction of this BMP? Provide name and contact information for the party responsible to sign BMP verification forms if required by the [City Engineer] (See Section 1.12 of the BMP Design Manual)	The Engineer of Work Robert Dentino Excel Engineering 440 State Place Escondido, CA 92029
Who will be the final owner of this BMP?	Project Owner
Who will maintain this BMP into perpetuity?	Project Owner
What is the funding mechanism for maintenance?	Project Owner

Structural BMP Summary Information

(Copy this page as needed to provide information for each individual proposed structural BMP)

Structural BMP ID No. **BMP-E (Storage Pipe)**

Construction Plan Sheet No.

Type of structural BMP:

- Retention by harvest and use (HU-1)
- Retention by infiltration basin (INF-1)
- Retention by bioretention (INF-2)
- Retention by permeable pavement (INF-3)
- Partial retention by biofiltration with partial retention (PR-1)
- Biofiltration (BF-1)
- Biofiltration with Nutrient Sensitive Media Design (BF-2)
- Proprietary Biofiltration (BF-3) meeting all requirements of Appendix F
- Flow-thru treatment control with prior lawful approval to meet earlier PDP requirements (provide BMP type/description in discussion section below)
- Flow-thru treatment control included as pre-treatment/forebay for an onsite retention or biofiltration BMP (provide BMP type/description and indicate which onsite retention or biofiltration BMP it serves in discussion section below)
- Flow-thru treatment control with alternative compliance (provide BMP type/description in discussion section below)
- Detention pond or vault for hydromodification management
- Other (describe in discussion section below)
Hydromodification and Hydrology Detention

Purpose:

- Pollutant control only
- Hydromodification control only
- Combined pollutant control and hydromodification control
- Pre-treatment/forebay for another structural BMP
- Other (describe in discussion section below)
Hydromodification and Hydrology Detention

Who will certify construction of this BMP? Provide name and contact information for the party responsible to sign BMP verification forms if required by the [City Engineer] (See Section 1.12 of the BMP Design Manual)	The Engineer of Work Robert Dentino Excel Engineering 440 State Place Escondido, CA 92029
Who will be the final owner of this BMP?	Project Owner
Who will maintain this BMP into perpetuity?	Project Owner
What is the funding mechanism for maintenance?	Project Owner

**ATTACHMENT 1
BACKUP FOR PDP POLLUTANT CONTROL BMPS**

This is the cover sheet for Attachment 1.

Indicate which Items are Included behind this cover sheet:

Attachment Sequence	Contents	Checklist
Attachment 1a	DMA Exhibit (Required) See DMA Exhibit Checklist on the back of this Attachment cover sheet.	<input checked="" type="checkbox"/> Included
Attachment 1b	Tabular Summary of DMAs Showing DMA ID matching DMA Exhibit, DMA Area, and DMA Type (Required)* *Provide table in this Attachment OR on DMA Exhibit in Attachment 1a	<input checked="" type="checkbox"/> Included on DMA Exhibit in Attachment 1a <input type="checkbox"/> Included as Attachment 1b, separate from DMA Exhibit
Attachment 1c	Form I-7, Harvest and Use Feasibility Screening Checklist (Required unless the entire project will use infiltration BMPs) Refer to Appendix B.3-1 of the BMP Design Manual to complete Form I-7.	<input checked="" type="checkbox"/> Included <input type="checkbox"/> Not included because the entire project will use infiltration BMPs
Attachment 1d	Form I-8, Categorization of Infiltration Feasibility Condition (Required unless the project will use harvest and use BMPs) Refer to Appendices C and D of the BMP Design Manual to complete Form I-8.	<input checked="" type="checkbox"/> Included <input type="checkbox"/> Not included because the entire project will use harvest and use BMPs
Attachment 1e	Pollutant Control BMP Design Worksheets / Calculations (Required) Refer to Appendices B and E of the BMP Design Manual for structural pollutant control BMP design guidelines	<input checked="" type="checkbox"/> Included

Attachment 1A

DMA Exhibit

Use this checklist to ensure the required information has been included on the DMA Exhibit:

The DMA Exhibit must identify:

- Underlying hydrologic soil group
- Approximate depth to groundwater
- Existing natural hydrologic features (watercourses, seeps, springs, wetlands)
- Critical coarse sediment yield areas to be protected
- Existing topography and impervious areas
- Existing and proposed site drainage network and connections to drainage offsite
- Proposed demolition
- Proposed grading
- Proposed impervious features
- Proposed design features and surface treatments used to minimize imperviousness
- Drainage management area (DMA) boundaries, DMA ID numbers, and DMA areas (square footage or acreage), and DMA type (i.e., drains to BMP, self-retaining, or self-mitigating)
- Potential pollutant source areas and corresponding required source controls (see Chapter 4, Appendix E.1, and Form I-3B)
- Structural BMPs (identify location, type of BMP, and size/detail)

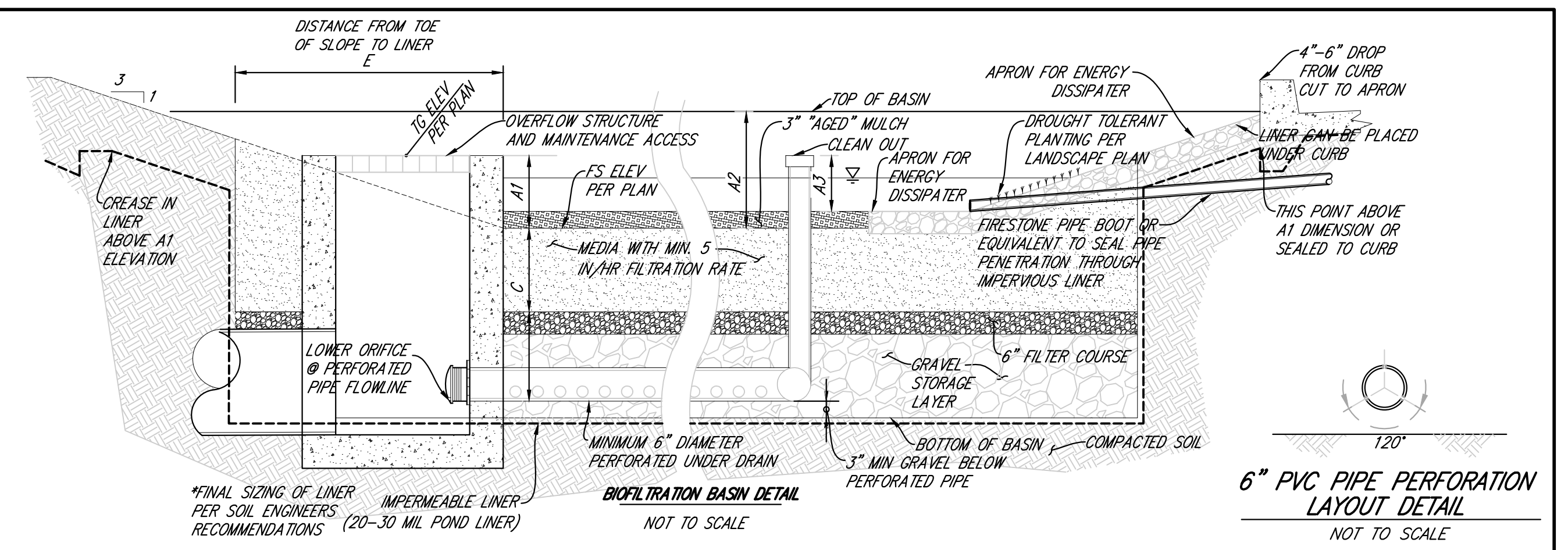
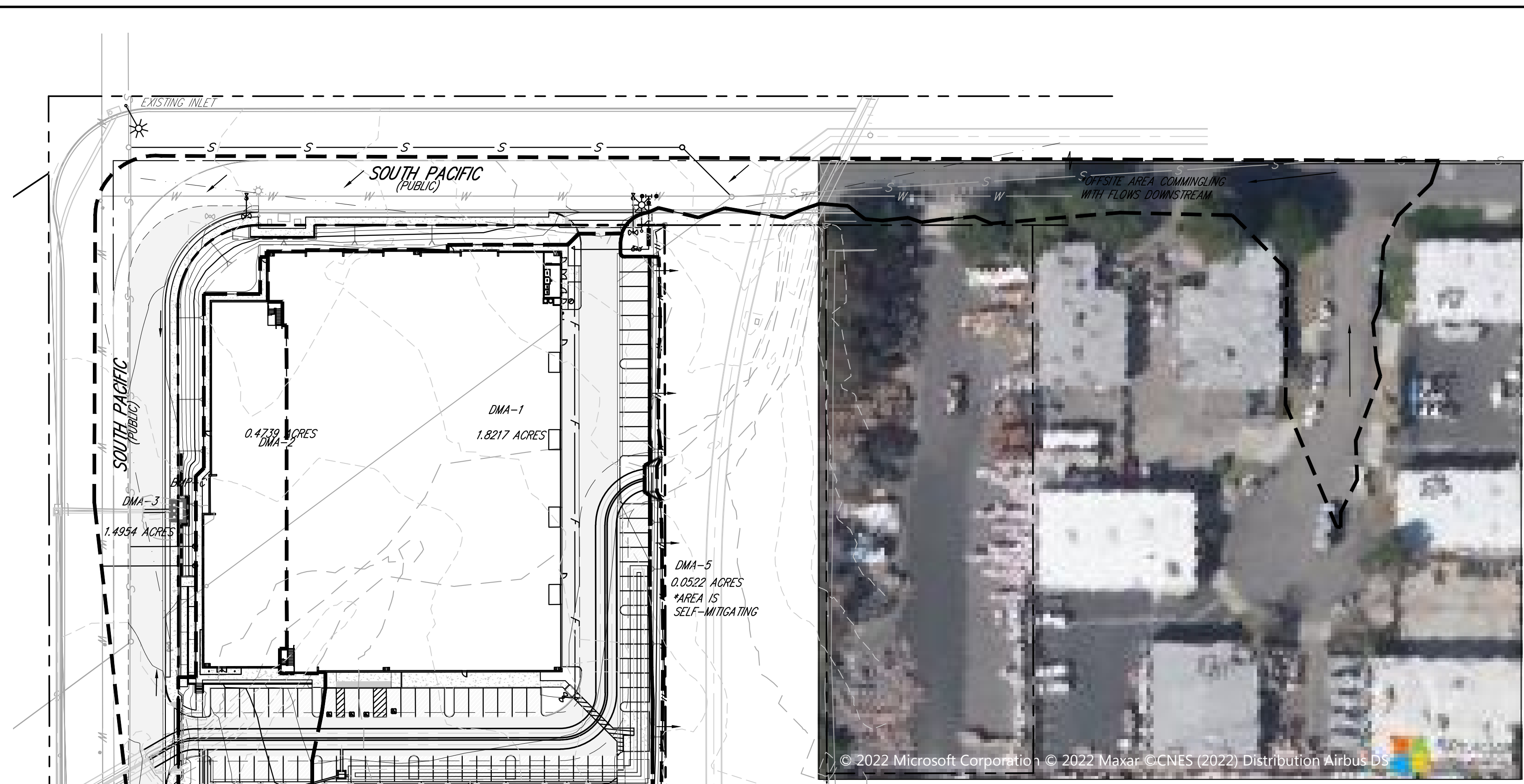

STRUCTURAL BIO-BASIN SUMMARY TABLE

DMA NAME	DMA TYPE	BMP NAME	TYPE OF BMP	EFFECTIVE AREA (SQFT)	A1 (INCH) WATER QUALITY	A2 (INCH) TOP OF BASIN	A3 (INCH) CLEAN OUT	B (INCH) UPPER ORIFICE	C (INCH) MEDIA	D (INCH) GRAVEL	E (INCH) OFFSET	BOX RISER OVERFLOW STRUCTURE SIZE (INCHES)	ORIFICES DIAMETER		IMPERMEABLE LINER ?
													UPPER (INCH)	LOWER (INCH)	
DMA-1	DRAINS TO BMP	BMP-A	BIOFILTRATION	2866	9	12	6	-	18	12	3	24x24	-	1.50	YES
DMA-2	DRAINS TO BMP	BMP-B	BIOFILTRATION	963	9	14	6	-	18	12	3.5	24x24	-	1.8125	YES
DMA-3	DRAINS TO BMP	BMP-C	MODULAR WETLAND	-	-	-	-	-	-	-	-	-	-	-	-
DMA-4	DRAINS TO BMP	BMP-D	DISPERSION AREA	894	-	-	-	-	**14	-	-	-	-	-	-

*NOTE: BMP-C IS NOT BEING USED FOR FLOW CONTROL.
 **NOTE: BMP-D HAS 11 INCHES AMENDED SOIL + 3 INCHES OF MULCH FOR TOTAL OF 14 INCHES OF MEDIA.

HYDROLOGIC SOIL GROUP
 THE HYDROLOGICAL SOIL GROUP FOR THIS SITE IS TYPE D.

EXISTING SITE FEATURES:
 • THE APPROXIMATE DEPTH TO GROUNDWATER IS 4-10 FEET.
 • THERE ARE NO NATURAL HYDROLOGIC FEATURES ON THE SITE.
 • THE SITE PROPOSES TO CONNECT TO THE EXISTING PUBLIC STORM DRAIN SYSTEM LOCATED IN THE SOUTH EDGE OF THE SITE.
 • BASED ON WATERSHED MAPPING OF POTENTIAL CRITICAL COARSE SEDIMENT YIELD AREAS (CCSYA), THERE ARE NO CCSYA LOCATED WITHIN THE PROJECT BOUNDARY OR TRIBUTARY TO THE RUNOFF BYPASSED AROUND THE SITE.

- WATER QUALITY BASIN INSTALLATION NOTES:**
- 3 INCHES OF WELL-AGED, SHREDDED HARDWOOD MULCH.
 - AN UNDERDRAIN CLEANOUT WITH A MINIMUM 6-INCH DIAMETER AND LOCKABLE CAP IS PLACED EVERY 250 TO 300 FEET AS REQUIRED BASED ON UNDERDRAIN LENGTH.
 - VEGETATION USED SHOULD BE SUITABLE FOR THE CLIMATE PER LANDSCAPE PLANS.
 - FILTER COARSE IS A MINIMUM OF 6 INCHES PROVIDED IN TWO SEPARATE 3 INCH LAYERS. THE TOP LAYER SHALL BE MADE OF ASTM C33 CHOKER SAND AND THE BOTTOM LAYER BE OF ASTM NO. 8 AGGREGATE. MARKERS STAKES SHALL BE USED TO ENSURE UNIFORM LIFT THICKNESS.
 - AASHTO NO. 57 STONE OR CLASS 2 PERMEABLE PER CAL TRANS SPECIFICATION 68-1.025 IS RECOMMENDED FOR THE AGGREGATE STORAGE LAYER. WASHED, OPEN-GRADED CRUSHED ROCK MAY BE USED, HOWEVER, A 4 INCH MINIMUM WASHED PEA GRAVEL FILTER COURSE LAYER AT THE TOP OF THE CRUSHED ROCK IS REQUIRED.
 - IMPERMEABLE LINER SHALL BE INSTALLED WHEN THE BIOFILTRATION BASIN IS WITHIN 10 FEET OF RETAINING WALLS OR BUILDING FOUNDATIONS, OR AS RECOMMENDED BY THE SOILS ENGINEER, OR REQUIRED BY THESE PLANS. IMPERMEABLE LINER SHALL BE 30 MIL THICK (PER COUNTY OF SAN DIEGO GREEN STREETS DESIGN STANDARD DRAWING GS-3.00 AND COUNTY GREEN STREETS SUPPLEMENT TO CAL TRANS SPECIFICATIONS 20-11.08B) CONFIGURED TO ENTIRELY ENCOMPASS THE SIDES OF THE WATER QUALITY BASIN.
 - IMPERMEABLE LINER BE CONSTRUCTED IN COMPLIANCE WITH THE COUNTY OF SAN DIEGO GREEN STREETS SUPPLEMENT TO CAL TRANS SPECIFICATIONS 20-11.08B.
 - BIOFILTRATION SOIL MEDIA LAYER (BSM) SHALL CONSIST OF 60% TO 80% BY VOLUME SAND, UP TO 20% BY VOLUME TOPSOIL, AND UP TO 20% BY VOLUME COMPOST (PER COUNTY OF SAN DIEGO BMP DESIGN MANUAL SEPTEMBER 2020 APPENDIX F.2 SECTION 803-2 BLENDED BSM CRITERIA AND TESTING REQUIREMENTS) PLACED IN 6" LIFTS AND COMPACTED WITH WATER PRIOR TO THE NEXT LIFT. INITIAL PERMEABILITY SHALL BE 8" PER HOUR (WITH ASSUMED STABILIZED PERMEABILITY OF 5" PER HOUR).
 - THE AGGREGATE STORAGE LAYER SHALL BE COMPACTED IN ACCORDANCE WITH SOILS ENGINEER'S RECOMMENDATIONS.
 - OVERFLOW STRUCTURE TO HAVE A MINIMUM OF 2 INCHES OF FREEBOARD.
 - ALL LINER INSTALLATIONS, FIELD WELDING OF SEAMS, AND OBSERVATION OF SOIL MIX PLACEMENT SHALL REQUIRE SPECIAL INSPECTION BY THE PROJECT GEOTECHNICAL ENGINEER OR OTHER QUALIFIED PERSON. A LETTER CERTIFYING PROPER INSTALLATION SHALL BE PROVIDED TO THE ENGINEER OF RECORD TO ACCEPTANCE OF THE FACILITIES.
 - SPECIAL INSPECTION SHALL BE REQUIRED FOR CONSTRUCTION OF ALL BIOFILTRATION BASINS. INSPECTION SHALL BE PERFORMED BY A QUALIFIED INDIVIDUAL (SUCH AS: ENGINEER OF RECORD, OSD). INSPECTION SHALL INCLUDE:
 - VERIFICATION OF OVERALL DIMENSIONS PRIOR TO PLACEMENT OF MATERIALS;
 - PLACEMENT OF THE LINER, IF REQUIRED, AND SEAMS OR PENETRATIONS
 - PLACEMENT OF THE GRAVEL, FILTER MATERIALS, AND FILTER MEDIA;
 - ALL INLET AND OUTLET STRUCTURES INCLUDING UNDERDRAINS, IF REQUIRED.
 - CONTRACTOR SHALL TAKE PICTURES AT EACH STAGE OF INSTALLATION AND SUBMITTED TO ENGINEER FOR VERIFICATION OF INSTALL.
 - INSPECTOR SHALL BE GIVEN A MINIMUM OF 48 HOURS PRIOR TO INSPECTION. UPON COMPLETION THE INSPECTOR SHALL PROVIDE A CERTIFICATION TO THE ENGINEER OF WORK.
 - PROPOSED MATERIALS, SUCH AS AGGREGATE, FILTER MATERIAL, AND FILTER MEDIA SHALL BE SUBMITTED TO THE ENGINEER OF WORK FOR APPROVAL.

SITE BMP SUMMARY TABLE

DMA NAME	DMA TYPE	BMP NAME	TYPE OF BMP	EFFECTIVE AREA (SQFT)	AMENDED SOIL DEPTH (INCH)
DMA-4	DRAINS TO BMP	BMP-D	DISPERSION AREA	942	11

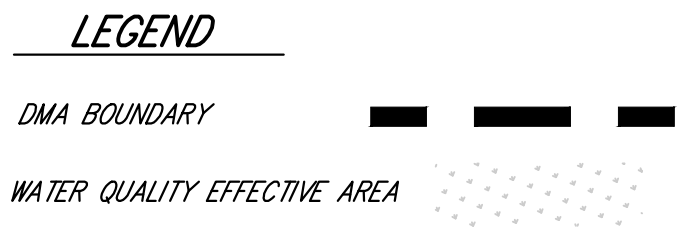

SOURCE CONTROL

SOURCE CONTROL REQUIREMENT	NODE	IMPLEMENTATION
SC-1 PREVENTION OF ILLICIT DISCHARGES	SC-1	EFFECTIVE IRRIGATION WILL BE IMPLEMENTED AND VEHICLE WASHING IS PROHIBITED
SC-2 STORM DRAIN STENCILING OR SIGNAGE	SC-2	STENCIL EVERY INLET WITH PROHIBITIVE WORDS: "NO DUMPING! DRAINS TO WATERWAYS" AND "NO CONTAMINE" IN SPANISH.
SC-5 PROTECT TRASH STORAGE	SC-5	TRASH ENCLOSURE WILL BE PROTECTED BY LID OR BE WALLED WITH ROOF TO AVOID STORMWATER GET CONTAMINATED

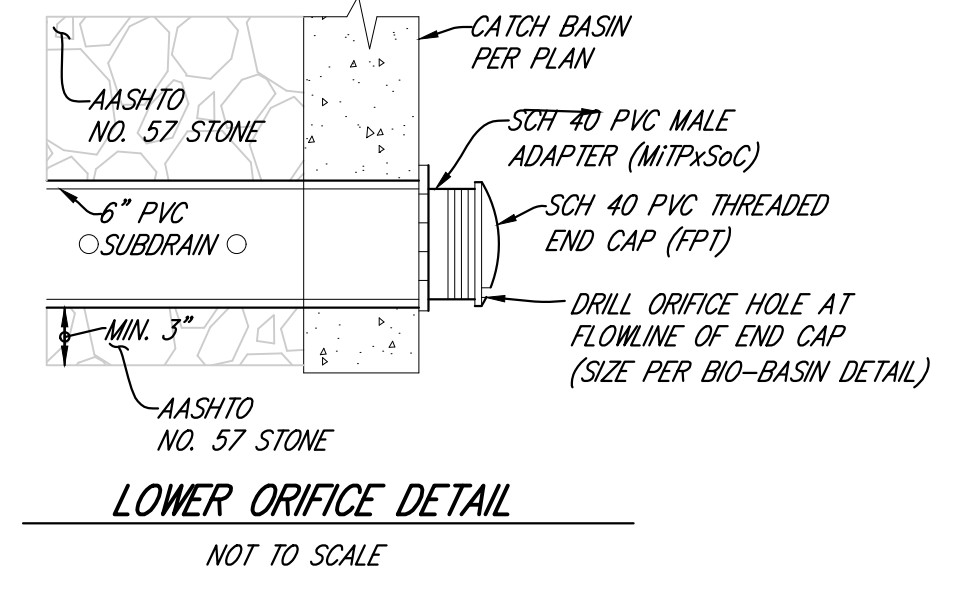
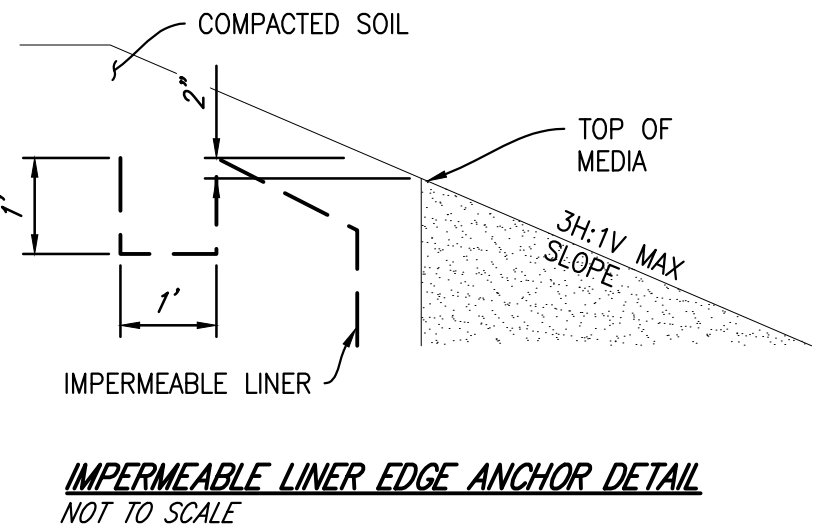
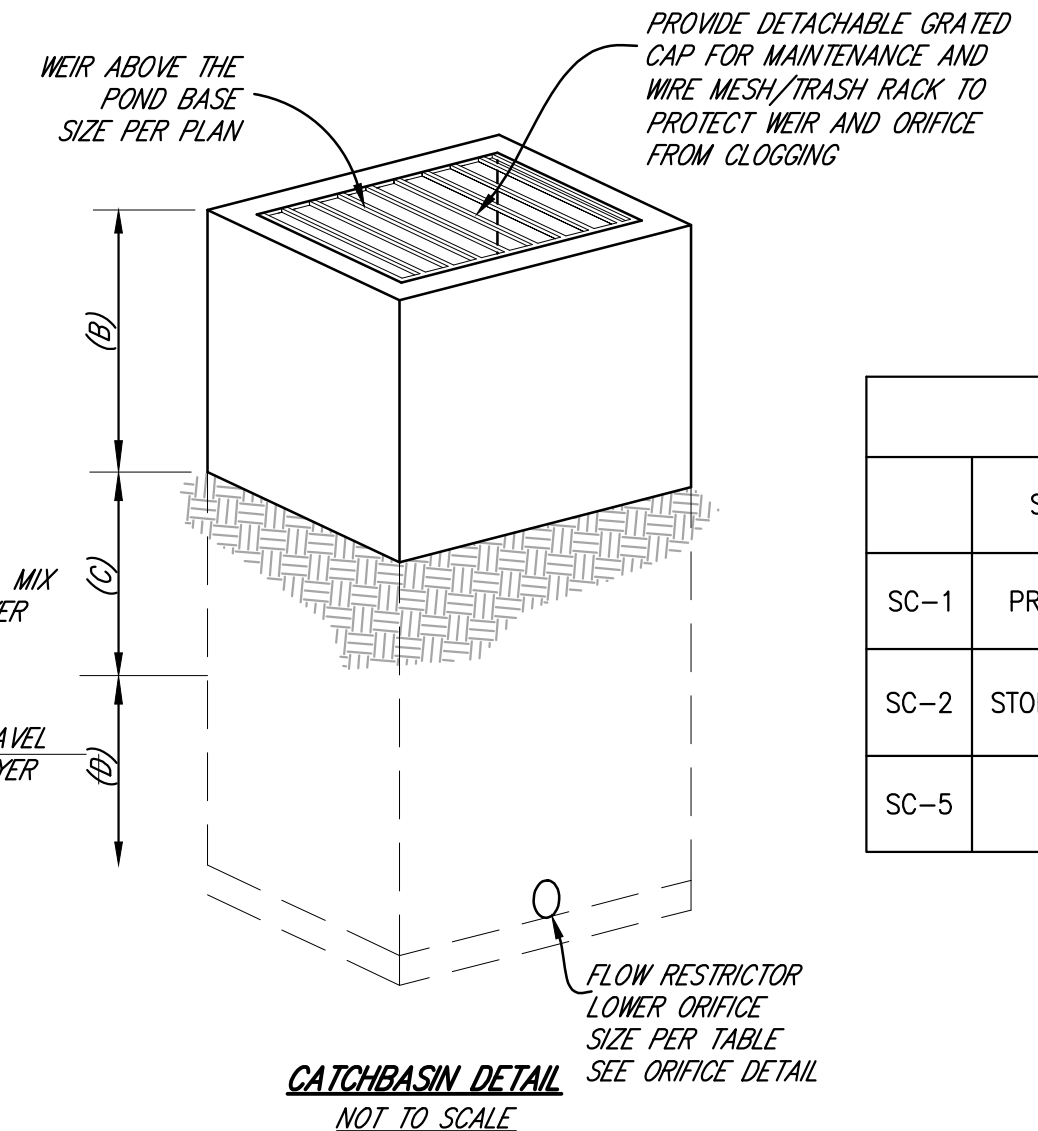
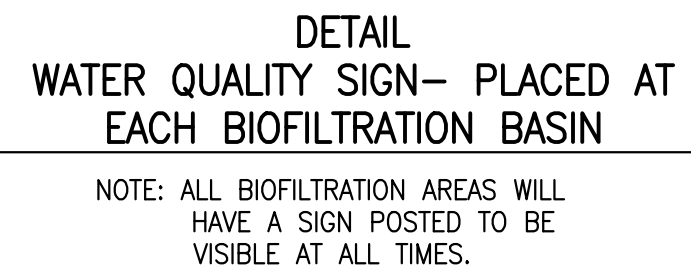
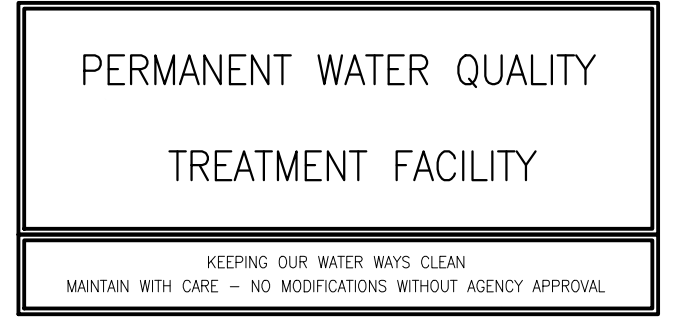

DETAIL "NO DUMPING" AT CATCH BASINS

NOTE: ALL CATCH BASINS WITH GRATES SHALL BE STENCILED WITH CITY REQUIRED ITEM PER ABOVE DETAIL (DAS MANUFACTURING #SDO OR EQUIVALENT).

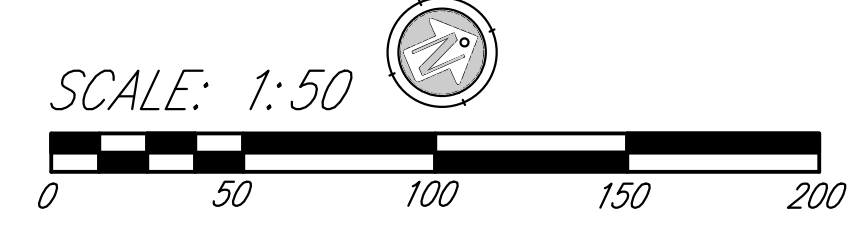

SOUTH PACIFIC STREET DMA EXHIBIT

Attachment 1B

Tabular Summary of DMA's

Design Capture Volume		Worksheet B-2.1				
1	85th percentile 24-hr storm depth from Figure B.1-1	d=	0.67	0.67	0.67	inches
2	Area tributary to BMP (s)	A=	1.82	0.47	0.50	Acres
3	Area weighted runoff factor (estimate using Appendix B.1.1 and B.2.1)	C=	0.77	0.80	0.64	unitless
4	Street trees volume reduction	TCV=				cubic-feet
5	Rain barrels volume reduction	RCV=				cubic-feet
6	Calculate DCV= (3630 x C x d x A) - TCV -RCV	DCV=	3,411.00	922.00	774.00	cubic-feet

Drainage Basin ID or Name	DMA-1	DMA-2	DMA-3	UNITS
85th Percentile 24-hr Storm Depth	0.67	0.67	0.68	INCHES
Impervious Surfaces	66,908	17,980	14,565	SQFT
Engineered Pervious Surfaces	12,444	2,662	7,094	SQFT
Total Tributary Area	79,352	20,643	21,659	SQFT
Total Tributary Area	1.82	0.47	0.50	ACRE

Attachment 1C
Harvest and Use Feasibility
Screening Checklist

Harvest and Use Feasibility Checklist		Form I-7
<p>1. Is there a demand for harvested water (check all that apply) at the project site that is reliably present during the wet season?</p> <p><input checked="" type="checkbox"/> Toilet and urinal flushing</p> <p><input checked="" type="checkbox"/> Landscape irrigation</p> <p><input type="checkbox"/> Other: _____</p>		
<p>2. If there is a demand; estimate the anticipated average wet season demand over a period of 36 hours. Guidance for planning level demand calculations for toilet/urinal flushing and landscape irrigation is provided in Section B.3.2.</p> <p>Flushing: $(72 \text{ employees}) \times (9.3 \text{ gal/emp}) = 669.6 \text{ gallons}$ $(669.6 \text{ gal})(1.5 \text{ days}) / (7.48 \text{ gal/cu. ft.}) = 134.3 \text{ cu. ft.}$</p> <p>Irrigation: 36-hr Mod. Water per Table B.3-3 = $(1,470 \text{ gal days/acre})(0.49 \text{ acres}) / (7.48 \text{ gal/cu feet}) = 96.3 \text{ cu ft.}$</p> <p>Total Demand = 230.6 cu. ft.</p>		
<p>3. Calculate the DCV using worksheet B-2.1.</p> <p>DCV = <u>4333</u> (cubic feet) DCV = 4333 $0.25 \times \text{DCV} = 1083.25$</p>		
<p>3a. Is the 36 hour demand greater than or equal to the DCV?</p> <p><input type="checkbox"/> Yes / <input checked="" type="checkbox"/> No </p> <p style="text-align: center;"></p>	<p>3b. Is the 36 hour demand greater than 0.25DCV but less than the full DCV?</p> <p><input type="checkbox"/> Yes / <input checked="" type="checkbox"/> No </p> <p style="text-align: center;"></p>	<p>3c. Is the 36 hour demand less than 0.25DCV?</p> <p><input checked="" type="checkbox"/> Yes </p>
<p>Harvest and use appears to be feasible. Conduct more detailed evaluation and sizing calculations to confirm that DCV can be used at an adequate rate to meet drawdown criteria.</p>	<p>Harvest and use may be feasible. Conduct more detailed evaluation and sizing calculations to determine feasibility. Harvest and use may only be able to be used for a portion of the site, or (optionally) the storage may need to be upsized to meet long term capture targets while draining in longer than 36 hours.</p>	<p>Harvest and use is considered to be infeasible.</p>
<p>Is harvest and use feasible based on further evaluation?</p> <p><input type="checkbox"/> Yes, refer to Appendix E to select and size harvest and use BMPs.</p> <p><input checked="" type="checkbox"/> No, select alternate BMPs.</p>		

Attachment 1D
Categorization of Infiltration
Feasibility Condition

Worksheet I-8 : Categorization of Infiltration Feasibility Condition

Categorization of Infiltration Feasibility Condition		Worksheet I-8	
Part 1 - Full Infiltration Feasibility Screening Criteria Would infiltration of the full design volume be feasible from a physical perspective without any undesirable consequences that cannot be reasonably mitigated?			
Criteria	Screening Question	Yes	No
1	Is the estimated reliable infiltration rate below proposed facility locations greater than 0.5 inches per hour? The response to this Screening Question shall be based on a comprehensive evaluation of the factors presented in Appendix C.2 and Appendix D.		X
Provide basis: The NRCS soils across the site are all Type D soils. the site soils are consistent with the NRCS mapped soil types based on site explorations and percolation testing. According to soil report, the approximate depth to groundwater is between 4-10 feet, which should have an infiltration rate is 0.			
Summarize findings of studies; provide reference to studies, calculations, maps, data sources, etc. Provide narrative discussion of study/data source applicability.			
2	Can infiltration greater than 0.5 inches per hour be allowed without increasing risk of geotechnical hazards (slope stability, groundwater mounding, utilities, or other factors) that cannot be mitigated to an acceptable level? The response to this Screening Question shall be based on a comprehensive evaluation of the factors presented in Appendix C.2.		X
Provide basis: The NRCS soils across the site are all Type D soils. the site soils are consistent with the NRCS mapped soil types based on site explorations and percolation testing. According to soil report, the approximate depth to groundwater is between 4-10 feet, which should have an infiltration rate is 0.			
Summarize findings of studies; provide reference to studies, calculations, maps, data sources, etc. Provide narrative discussion of study/data source applicability.			

Worksheet I-8 Page 2 of 4

Criteria	Screening Question	Yes	No
3	Can infiltration greater than 0.5 inches per hour be allowed without increasing risk of groundwater contamination (shallow water table, storm water pollutants or other factors) that cannot be mitigated to an acceptable level? The response to this Screening Question shall be based on a comprehensive evaluation of the factors presented in Appendix C.3.		X
<p>Provide basis:</p> <p>The NRCS soils across the site are all Type D soils. the site soils are consistent with the NRCS mapped soil types based on site explorations and percolation testing. According to soil report, the approximate depth to groundwater is between 4-10 feet, which should have an infiltration rate is 0.</p> <p>Summarize findings of studies; provide reference to studies, calculations, maps, data sources, etc. Provide narrative discussion of study/data source applicability.</p>			
4	Can infiltration greater than 0.5 inches per hour be allowed without causing potential water balance issues such as change of seasonality of ephemeral streams or increased discharge of contaminated groundwater to surface waters? The response to this Screening Question shall be based on a comprehensive evaluation of the factors presented in Appendix C.3.		X
<p>Provide basis:</p> <p>The NRCS soils across the site are all Type D soils. the site soils are consistent with the NRCS mapped soil types based on site explorations and percolation testing. According to soil report, the approximate depth to groundwater is between 4-10 feet, which should have an infiltration rate is 0.</p> <p>Summarize findings of studies; provide reference to studies, calculations, maps, data sources, etc. Provide narrative discussion of study/data source applicability.</p>			
Part 1 Result*	<p>If all answers to rows 1 - 4 are “Yes” a full infiltration design is potentially feasible. The feasibility screening category is Full Infiltration</p> <p>If any answer from row 1-4 is “No”, infiltration may be possible to some extent but would not generally be feasible or desirable to achieve a “full infiltration” design. Proceed to Part 2</p>		

*To be completed using gathered site information and best professional judgment considering the definition of MEP in the MS4 Permit. Additional testing and/or studies may be required by City Engineer to substantiate findings.

Worksheet I-8 Page 3 of 4

Part 2 – Partial Infiltration vs. No Infiltration Feasibility Screening Criteria
 Would infiltration of water in any appreciable amount be physically feasible without any negative consequences that cannot be reasonably mitigated?

Criteria	Screening Question	Yes	No
5	Do soil and geologic conditions allow for infiltration in any appreciable rate or volume? The response to this Screening Question shall be based on a comprehensive evaluation of the factors presented in Appendix C.2 and Appendix D.		X
<p>Provide basis: Due to site soils not percolating and the significant amount of clayey soils, it is unlikely that any appreciable volume of water will infiltrate.</p> <p>Summarize findings of studies; provide reference to studies, calculations, maps, data sources, etc. Provide narrative discussion of study/data source applicability and why it was not feasible to mitigate low infiltration rates.</p>			
6	Can Infiltration in any appreciable quantity be allowed without increasing risk of geotechnical hazards (slope stability, groundwater mounding, utilities, or other factors) that cannot be mitigated to an acceptable level? The response to this Screening Question shall be based on a comprehensive evaluation of the factors presented in Appendix C.2.		X
<p>Provide basis:</p> <p>The NRCS soils across the site are all Type D soils. the site soils are consistent with the NRCS mapped soil types based on site explorations and percolation testing. According to soil report, the approximate depth to groundwater is between 4-10 feet, which should have an infiltration rate is 0.</p> <p>Summarize findings of studies; provide reference to studies, calculations, maps, data sources, etc. Provide narrative discussion of study/data source applicability and why it was not feasible to mitigate low infiltration rates.</p>			

Worksheet I-8 Page 4 of 4

Criteria	Screening Question	Yes	No
7	Can Infiltration in any appreciable quantity be allowed without posing significant risk for groundwater related concerns (shallow water table, storm water pollutants or other factors)? The response to this Screening Question shall be based on a comprehensive evaluation of the factors presented in Appendix C.3.		X
<p>Provide basis:</p> <p>The NRCS soils across the site are all Type D soils. the site soils are consistent with the NRCS mapped soil types based on site explorations and percolation testing. According to soil report, the approximate depth to groundwater is between 4-10 feet, which should have an infiltration rate is 0.</p> <p>Summarize findings of studies; provide reference to studies, calculations, maps, data sources, etc. Provide narrative discussion of study/data source applicability and why it was not feasible to mitigate low infiltration rates.</p>			
8	Can infiltration be allowed without violating downstream water rights? The response to this Screening Question shall be based on a comprehensive evaluation of the factors presented in Appendix C.3.		X
<p>Provide basis:</p> <p>The NRCS soils across the site are all Type D soils. the site soils are consistent with the NRCS mapped soil types based on site explorations and percolation testing. According to soil report, the approximate depth to groundwater is between 4-10 feet, which should have an infiltration rate is 0.</p> <p>Summarize findings of studies; provide reference to studies, calculations, maps, data sources, etc. Provide narrative discussion of study/data source applicability and why it was not feasible to mitigate low infiltration rates.</p>			
Part 2 Result*	<p>If all answers from row 1-4 are yes then partial infiltration design is potentially feasible. The feasibility screening category is Partial Infiltration.</p> <p>If any answer from row 5-8 is no, then infiltration of any volume is considered to be infeasible within the drainage area. The feasibility screening category is No Infiltration.</p>		No Inf.

*To be completed using gathered site information and best professional judgment considering the definition of MEP in the MS4 Permit. Additional testing and/or studies may be required by City Engineer to substantiate findings

Attachment 1E
Pollutant Control BMP Design
Worksheets & Calculations

Flow-thru Design Flows		Worksheet B-6.1		
0	BMP-C Sizing for MWS L-8-12-5'6"-C			
1	DCV Start with 0 if no Carry over from Another DMA	DCV	0	cubic-feet
2	DCV retained	DCV _{retained}	0	cubic-feet
3	DCV biofiltered	DCV _{biofiltered}	0	cubic-feet
4	DCV requiring flow-thru (Line 1 — Line 2 — 0.67*Line 3)	DCV _{flow-thru}	0	cubic-feet
5	Adjustment factor (Line 4 / Line 1)	AF=	1	unitless
6	Design rainfall intensity	i=	0.2	in/hr
7	Area tributary to BMP (s)	A=	1.5369	acres
8	Area-weighted runoff factor (estimate using Appendix B.2)	C=	0.800	unitless
9	Calculate Flow Rate = AF x (C x I x A)*1.5	Q=	0.37	cfs

Automated Worksheet B.1: Calculation of Design Capture Volume (V2.0)

Category	#	Description	<i>i</i>	<i>ii</i>	<i>iii</i>	Units
Standard Drainage Basin Inputs	1	Drainage Basin ID or Name	BMP-A	BMP-B	BMP-D	unitless
	2	85th Percentile 24-hr Storm Depth	0.67	0.67	0.67	inches
	3	Impervious Surfaces <u>Not Directed to Dispersion Area</u> (C=0.90)	66,908	17,980		sq-ft
	4	Semi-Pervious Surfaces <u>Not Serving as Dispersion Area</u> (C=0.30)				sq-ft
	5	Engineered Pervious Surfaces <u>Not Serving as Dispersion Area</u> (C=0.10)	12,444	2,662		sq-ft
	6	Natural Type A Soil <u>Not Serving as Dispersion Area</u> (C=0.10)				sq-ft
	7	Natural Type B Soil <u>Not Serving as Dispersion Area</u> (C=0.14)				sq-ft
	8	Natural Type C Soil <u>Not Serving as Dispersion Area</u> (C=0.23)				sq-ft
	9	Natural Type D Soil <u>Not Serving as Dispersion Area</u> (C=0.30)				sq-ft
Dispersion Area, Tree Well & Rain Barrel Inputs (Optional)	10	Does Tributary Incorporate Dispersion, Tree Wells, and/or Rain Barrels?	No	No	Yes	yes/no
	11	Impervious Surfaces Directed to Dispersion Area per SD-B (Ci=0.90)			6,575	sq-ft
	12	Semi-Pervious Surfaces Serving as Dispersion Area per SD-B (Ci=0.30)				sq-ft
	13	Engineered Pervious Surfaces Serving as Dispersion Area per SD-B (Ci=0.10)			4,773	sq-ft
	14	Natural Type A Soil Serving as Dispersion Area per SD-B (Ci=0.10)				sq-ft
	15	Natural Type B Soil Serving as Dispersion Area per SD-B (Ci=0.14)				sq-ft
	16	Natural Type C Soil Serving as Dispersion Area per SD-B (Ci=0.23)				sq-ft
	17	Natural Type D Soil Serving as Dispersion Area per SD-B (Ci=0.30)				sq-ft
	18	Number of Tree Wells Proposed per SD-A				#
	19	Average Mature Tree Canopy Diameter				ft
	20	Number of Rain Barrels Proposed per SD-E				#
21	Average Rain Barrel Size				gal	
Initial Runoff Factor Calculation	22	Total Tributary Area	79,352	20,642	11,348	sq-ft
	23	Initial Runoff Factor for Standard Drainage Areas	0.77	0.80	0.00	unitless
	24	Initial Runoff Factor for Dispersed & Dispersion Areas	0.00	0.00	0.56	unitless
	25	Initial Weighted Runoff Factor	0.77	0.80	0.56	unitless
	26	Initial Design Capture Volume	3,411	922	355	cubic-feet
Dispersion Area Adjustments	27	Total Impervious Area Dispersed to Pervious Surface	0	0	6,575	sq-ft
	28	Total Pervious Dispersion Area	0	0	4,773	sq-ft
	29	Ratio of Dispersed Impervious Area to Pervious Dispersion Area	n/a	n/a	1.40	ratio
	30	Adjustment Factor for Dispersed & Dispersion Areas	1.00	1.00	0.00	ratio
	31	Runoff Factor After Dispersion Techniques	0.77	0.80	0.00	unitless
	32	Design Capture Volume After Dispersion Techniques	3,411	922	0	cubic-feet
Tree & Barrel Adjustments	33	Total Tree Well Volume Reduction	0	0	0	cubic-feet
	34	Total Rain Barrel Volume Reduction	0	0	0	cubic-feet
Results	35	Final Adjusted Runoff Factor	0.77	0.80	0.00	unitless
	36	Final Effective Tributary Area	61,101	16,514	0	sq-ft
	37	Initial Design Capture Volume Retained by Site Design Elements	0	0	355	cubic-feet
	38	Final Design Capture Volume Tributary to BMP	3,411	922	0	cubic-feet
No Warning Messages						

Automated Worksheet B.3: BMP Performance (V2.0)

Category	#	Description	<i>i</i>	<i>ii</i>	Units
BMP Inputs	1	Drainage Basin ID or Name	BMP-A	BMP-B	sq-ft
	2	Design Infiltration Rate Recommended	0.000	0.000	in/hr
	3	Design Capture Volume Tributary to BMP	3,411	922	cubic-feet
	4	Is BMP Vegetated or Unvegetated?	Vegetated	Vegetated	unitless
	5	Is BMP Impermeably Lined or Unlined?	Lined	Lined	unitless
	6	Does BMP Have an Underdrain?	Underdrain	Underdrain	unitless
	7	Does BMP Utilize Standard or Specialized Media?	Standard	Standard	unitless
	8	Provided Surface Area	1,920	759	sq-ft
	9	Provided Surface Ponding Depth	6	6	inches
	10	Provided Soil Media Thickness	18	18	inches
	11	Provided Gravel Thickness (Total Thickness)	15	15	inches
	12	Underdrain Offset	3	3	inches
	13	Diameter of Underdrain or Hydromod Orifice (Select Smallest)	0.50	0.50	inches
	14	Specialized Soil Media Filtration Rate			in/hr
	15	Specialized Soil Media Pore Space for Retention			unitless
	16	Specialized Soil Media Pore Space for Biofiltration			unitless
	17	Specialized Gravel Media Pore Space			unitless
Retention Calculations	18	Volume Infiltrated Over 6 Hour Storm	0	0	cubic-feet
	19	Ponding Pore Space Available for Retention	0.00	0.00	unitless
	20	Soil Media Pore Space Available for Retention	0.05	0.05	unitless
	21	Gravel Pore Space Available for Retention (Above Underdrain)	0.00	0.00	unitless
	22	Gravel Pore Space Available for Retention (Below Underdrain)	0.40	0.40	unitless
	23	Effective Retention Depth	2.10	2.10	inches
	24	Fraction of DCV Retained (Independent of Drawdown Time)	0.10	0.14	ratio
	25	Calculated Retention Storage Drawdown Time	120	120	hours
	26	Efficacy of Retention Processes	0.12	0.16	ratio
	27	Volume Retained by BMP (Considering Drawdown Time)	412	148	cubic-feet
28	Design Capture Volume Remaining for Biofiltration	2,999	774	cubic-feet	
Biofiltration Calculations	29	Max Hydromod Flow Rate through Underdrain	0.0113	0.0113	cfs
	30	Max Soil Filtration Rate Allowed by Underdrain Orifice	0.25	0.64	in/hr
	31	Soil Media Filtration Rate per Specifications	5.00	5.00	in/hr
	32	Soil Media Filtration Rate to be used for Sizing	0.25	0.64	in/hr
	33	Depth Biofiltered Over 6 Hour Storm	1.53	3.87	inches
	34	Ponding Pore Space Available for Biofiltration	1.00	1.00	unitless
	35	Soil Media Pore Space Available for Biofiltration	0.20	0.20	unitless
	36	Gravel Pore Space Available for Biofiltration (Above Underdrain)	0.40	0.40	unitless
	37	Effective Depth of Biofiltration Storage	14.40	14.40	inches
	38	Drawdown Time for Surface Ponding	24	9	hours
	39	Drawdown Time for Effective Biofiltration Depth	56	22	hours
	40	Total Depth Biofiltered	15.93	18.27	inches
	41	Option 1 - Biofilter 1.50 DCV: Target Volume	4,498	1,160	cubic-feet
	42	Option 1 - Provided Biofiltration Volume	2,549	1,156	cubic-feet
	43	Option 2 - Store 0.75 DCV: Target Volume	2,249	580	cubic-feet
	44	Option 2 - Provided Storage Volume	2,249	580	cubic-feet
	45	Portion of Biofiltration Performance Standard Satisfied	1.00	1.00	ratio
Result	46	Do Site Design Elements and BMPs Satisfy Annual Retention Requirements?	Yes	Yes	yes/no
	47	Overall Portion of Performance Standard Satisfied (BMP Efficacy Factor)	1.00	1.00	ratio
	48	Deficit of Effectively Treated Stormwater	0	0	cubic-feet

No Warning Messages

SITE SPECIFIC DATA			
PROJECT NUMBER	15339		
PROJECT NAME	SOUTH PACIFIC STREET		
PROJECT LOCATION	SAN MARCOS, CA		
STRUCTURE ID	BMP-C		
TREATMENT REQUIRED			
VOLUME BASED (CF)	FLOW BASED (CFS)		
N/A	0.3695		
TREATMENT HGL AVAILABLE (FT)	N/K		
PEAK BYPASS REQUIRED (CFS) - IF APPLICABLE	7.0		
PIPE DATA	I.E.	MATERIAL	DIAMETER
INLET PIPE 1	N/A	N/A	N/A
INLET PIPE 2	N/A	N/A	N/A
OUTLET PIPE	521.37	RCP	18"
	PRETREATMENT	BIOFILTRATION	DISCHARGE
RIM ELEVATION	526.95	526.95	526.95
SURFACE LOAD	H-20 DIRECT	N/A	H-20 DIRECT
FRAME & COVER	2EA Ø30"	OPEN PLANTER	Ø30"
WETLAND MEDIA VOLUME (CY)	11.15		
ORIFICE SIZE (DIA. INCHES)	Ø2.90"		
NOTES: PRELIMINARY NOT FOR CONSTRUCTION. ENGINEER TO CONFIRM ELEVATIONS AND PEAK FLOW RATE. ALL MANHOLE CASTINGS TO BE ADA COMPLIANT.			

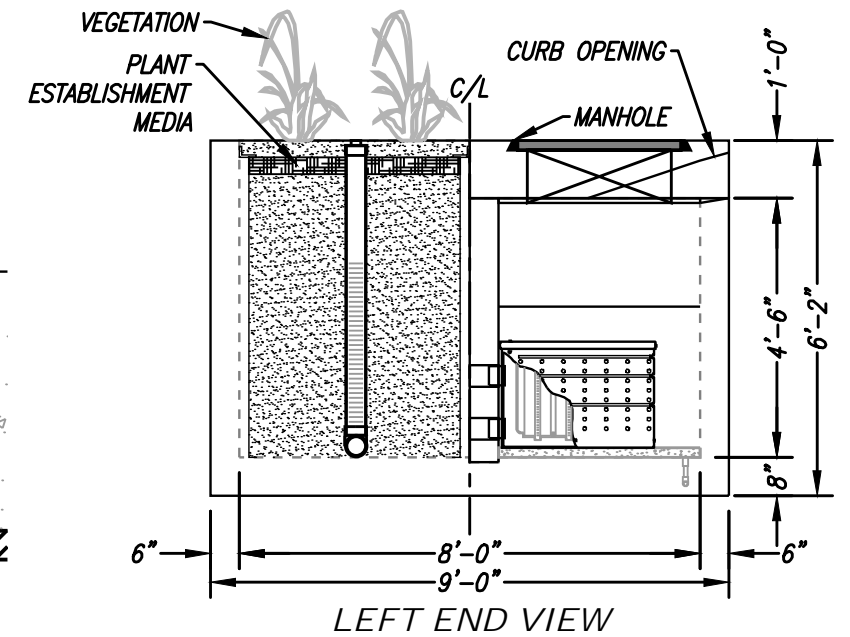
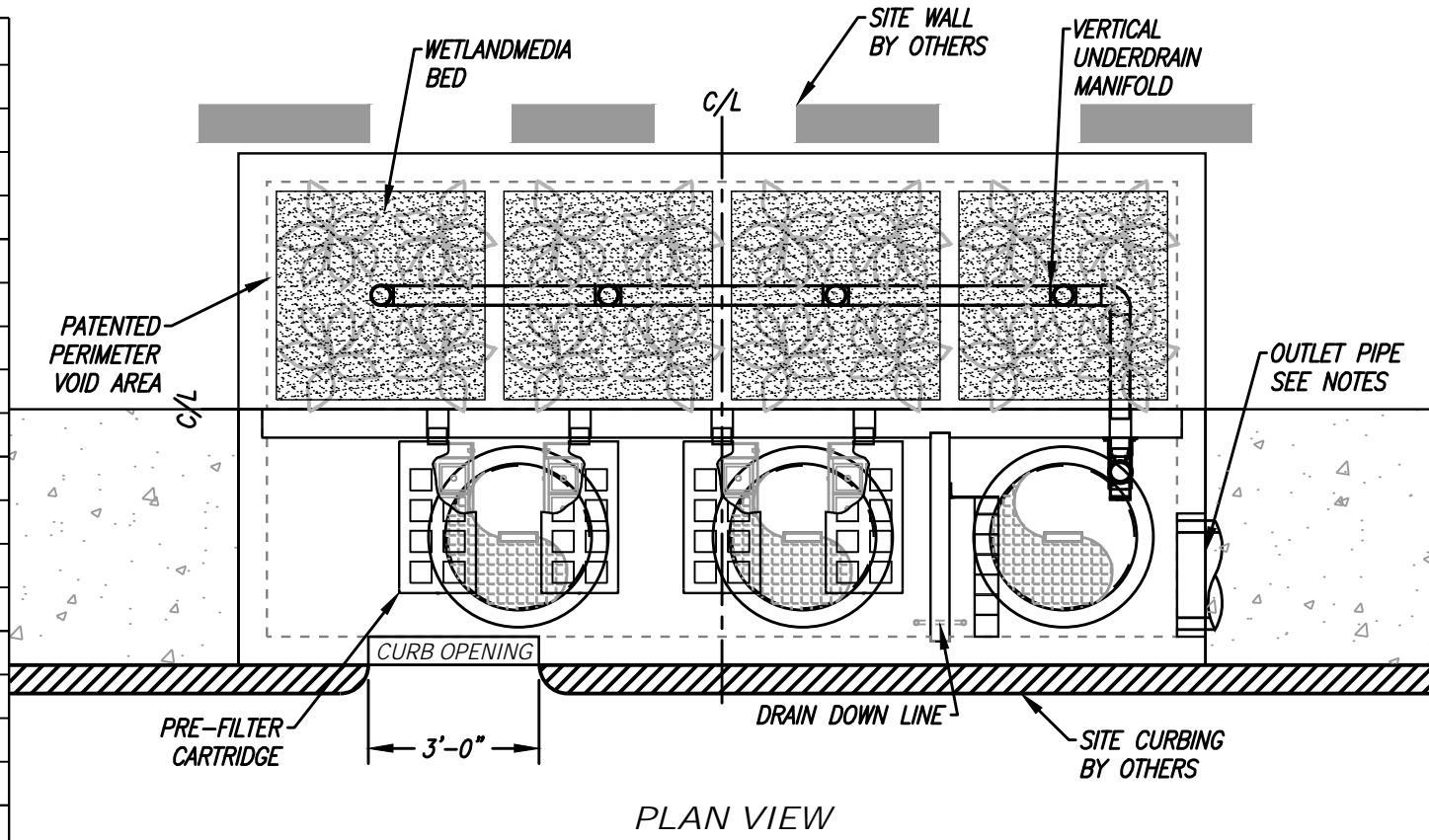

INSTALLATION NOTES

1. CONTRACTOR TO PROVIDE ALL LABOR, EQUIPMENT, MATERIALS AND INCIDENTALS REQUIRED TO OFFLOAD AND INSTALL THE SYSTEM AND APPURTENANCES IN ACCORDANCE WITH THIS DRAWING AND THE MANUFACTURERS' SPECIFICATIONS, UNLESS OTHERWISE STATED IN MANUFACTURER'S CONTRACT.
2. UNIT MUST BE INSTALLED ON LEVEL BASE. MANUFACTURER RECOMMENDS A MINIMUM 6" LEVEL ROCK BASE UNLESS SPECIFIED BY THE PROJECT ENGINEER. CONTRACTOR IS RESPONSIBLE FOR VERIFYING PROJECT ENGINEER'S RECOMMENDED BASE SPECIFICATIONS.
4. CONTRACTOR TO SUPPLY AND INSTALL ALL EXTERNAL CONNECTING PIPES. ALL PIPES MUST BE FLUSH WITH INSIDE SURFACE OF CONCRETE (PIPES CANNOT INTRUDE BEYOND FLUSH). INVERT OF OUTFLOW PIPE MUST BE FLUSH WITH DISCHARGE CHAMBER FLOOR. ALL PIPES SHALL BE SEALED WATERTIGHT PER MANUFACTURER'S STANDARD CONNECTION DETAIL.
5. CONTRACTOR RESPONSIBLE FOR INSTALLATION OF ALL PIPES, RISERS, MANHOLES, AND HATCHES. CONTRACTOR TO USE GROUT AND/OR BRICKS TO MATCH COVERS WITH FINISHED SURFACE UNLESS SPECIFIED OTHERWISE.
6. VEGETATION SUPPLIED AND INSTALLED BY OTHERS. ALL UNITS WITH VEGETATION MUST HAVE DRIP OR SPRAY IRRIGATION SUPPLIED AND INSTALLED BY OTHERS.
7. CONTRACTOR RESPONSIBLE FOR CONTACTING BIO CLEAN FOR ACTIVATION OF UNIT. MANUFACTURER'S WARRANTY IS VOID WITHOUT PROPER ACTIVATION BY A BIO CLEAN REPRESENTATIVE.

GENERAL NOTES

1. MANUFACTURER TO PROVIDE ALL MATERIALS UNLESS OTHERWISE NOTED.
2. ALL DIMENSIONS, ELEVATIONS, SPECIFICATIONS AND CAPACITIES ARE SUBJECT TO CHANGE. FOR PROJECT SPECIFIC DRAWINGS DETAILING EXACT DIMENSIONS, WEIGHTS AND ACCESSORIES PLEASE CONTACT BIO CLEAN.

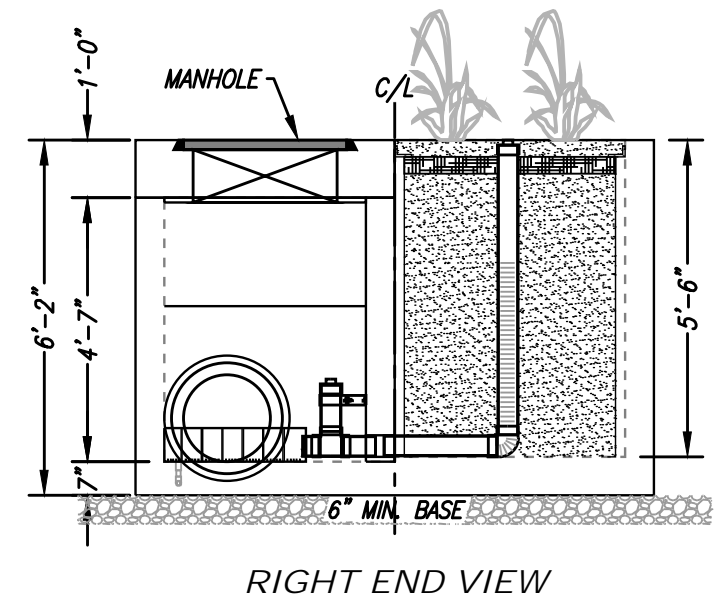
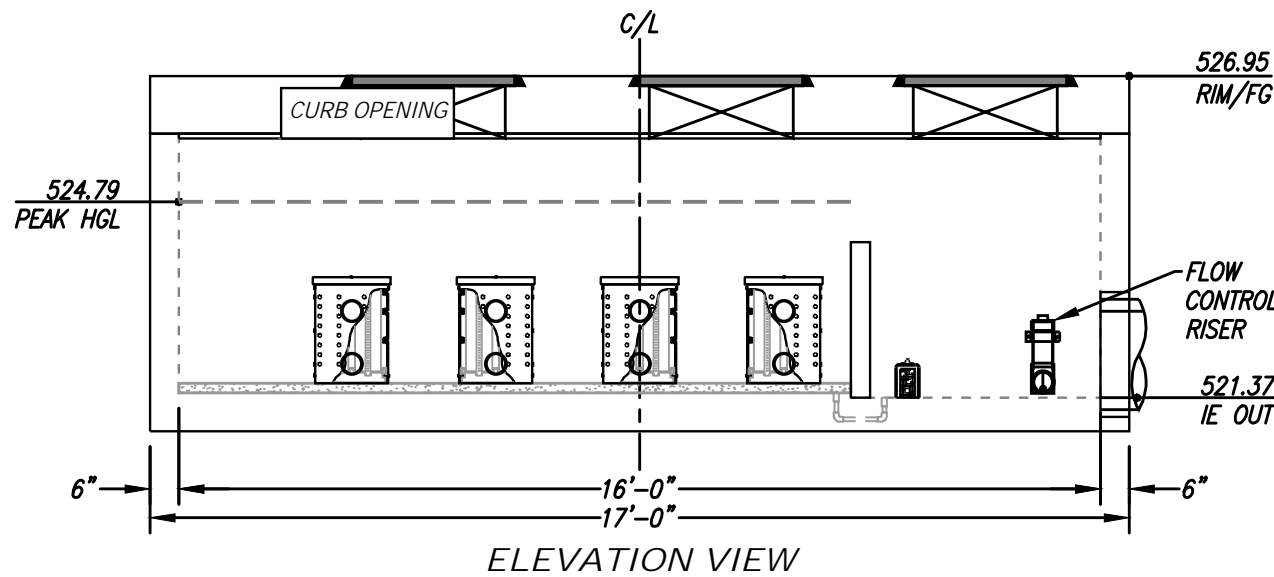

INTERNAL BYPASS DISCLOSURE:

THE DESIGN AND CAPACITY OF THE PEAK CONVEYANCE METHOD TO BE REVIEWED AND APPROVED BY THE ENGINEER OF RECORD. HGL(S) AT PEAK FLOW SHALL BE ASSESSED TO ENSURE NO UPSTREAM FLOODING. PEAK HGL AND BYPASS CAPACITY SHOWN ON DRAWING ARE USED FOR GUIDANCE ONLY.

TREATMENT FLOW (CFS)	0.3695
OPERATING HEAD (FT)	2.7
PRETREATMENT LOADING RATE (GPM/SF)	1.6
WETLAND MEDIA LOADING RATE (GPM/SF)	1.0

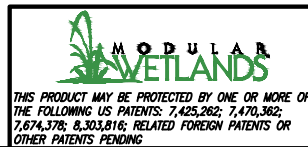

PROPRIETARY AND CONFIDENTIAL:
THE INFORMATION CONTAINED IN THIS DOCUMENT IS THE SOLE PROPERTY OF FORTERRA AND ITS COMPANIES. THIS DOCUMENT, NOR ANY PART THEREOF, MAY BE USED, REPRODUCED OR MODIFIED IN ANY MANNER WITH OUT THE WRITTEN CONSENT OF FORTERRA.



MWS-L-8-16-5'-6"-C
STORMWATER BIOFILTRATION SYSTEM
STANDARD DETAIL

**ATTACHMENT 2
BACKUP FOR PDP HYDROMODIFICATION CONTROL MEASURES**

This is the cover sheet for Attachment 2.

Mark this box if this attachment is empty because the project is exempt from PDP hydromodification management requirements.

Indicate which Items are Included behind this cover sheet:

Attachment Sequence	Contents	Checklist
Attachment 2a	Hydromodification Management Exhibit (Required)	<input checked="" type="checkbox"/> Included See Hydromodification Management Exhibit Checklist on the back of this Attachment cover sheet.
Attachment 2b	Management of Critical Coarse Sediment Yield Areas (WMAA Exhibit is required, additional analyses are optional) See Section 6.2 of the BMP Design Manual.	<input checked="" type="checkbox"/> Exhibit showing project drainage boundaries marked on WMAA Critical Coarse Sediment Yield Area Map (Required) Optional analyses for Critical Coarse Sediment Yield Area Determination <input checked="" type="checkbox"/> 6.2.1 Verification of Geomorphic Landscape Units Onsite <input checked="" type="checkbox"/> 6.2.2 Downstream Systems Sensitivity to Coarse Sediment <input checked="" type="checkbox"/> 6.2.3 Optional Additional Analysis of Potential Critical Coarse Sediment Yield Areas Onsite
Attachment 2c	Geomorphic Assessment of Receiving Channels (Optional) See Section 6.3.4 of the BMP Design Manual.	<input type="checkbox"/> Not performed <input checked="" type="checkbox"/> Included <input type="checkbox"/> Submitted as separate stand-alone document
Attachment 2d	Flow Control Facility Design, including Structural BMP Drawdown Calculations and Overflow Design Summary (Required) See Chapter 6 and Appendix G of the BMP Design Manual	<input checked="" type="checkbox"/> Included <input type="checkbox"/> Submitted as separate stand-alone document
Attachment 2e	Vector Control Plan (Required when structural BMPs will not drain in 96 hours)	<input type="checkbox"/> Included <input checked="" type="checkbox"/> Not required because BMPs will drain in less than 96 hours

Attachment 2A:
Hydromodification Management Exhibit

Use this checklist to ensure the required information has been included on the Hydromodification Management Exhibit:

The Hydromodification Management Exhibit must identify:

- Underlying hydrologic soil group
- Approximate depth to groundwater
- Existing natural hydrologic features (watercourses, seeps, springs, wetlands)
- Critical coarse sediment yield areas to be protected
- Existing topography
- Existing and proposed site drainage network and connections to drainage offsite
- Proposed grading
- Proposed impervious features
- Proposed design features and surface treatments used to minimize imperviousness
- Point(s) of Compliance (POC) for Hydromodification Management
- Existing and proposed drainage boundary and drainage area to each POC (when necessary, create separate exhibits for pre-development and post-project conditions)
- Structural BMPs for hydromodification management (identify location, type of BMP, and size/detail)

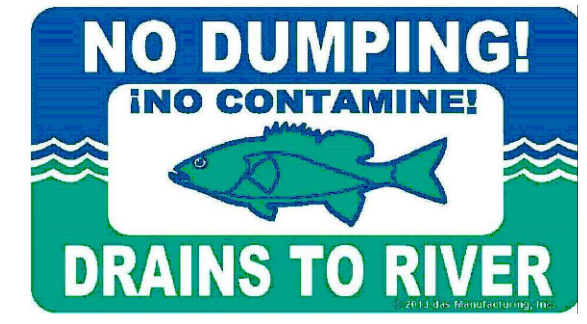
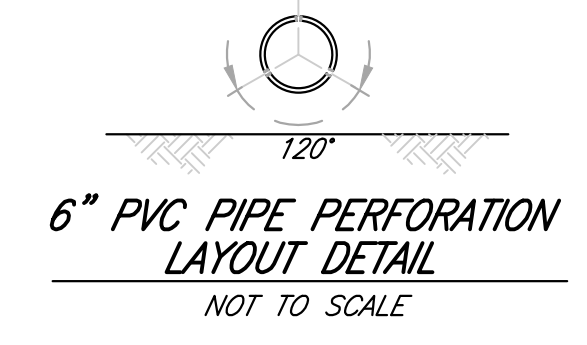
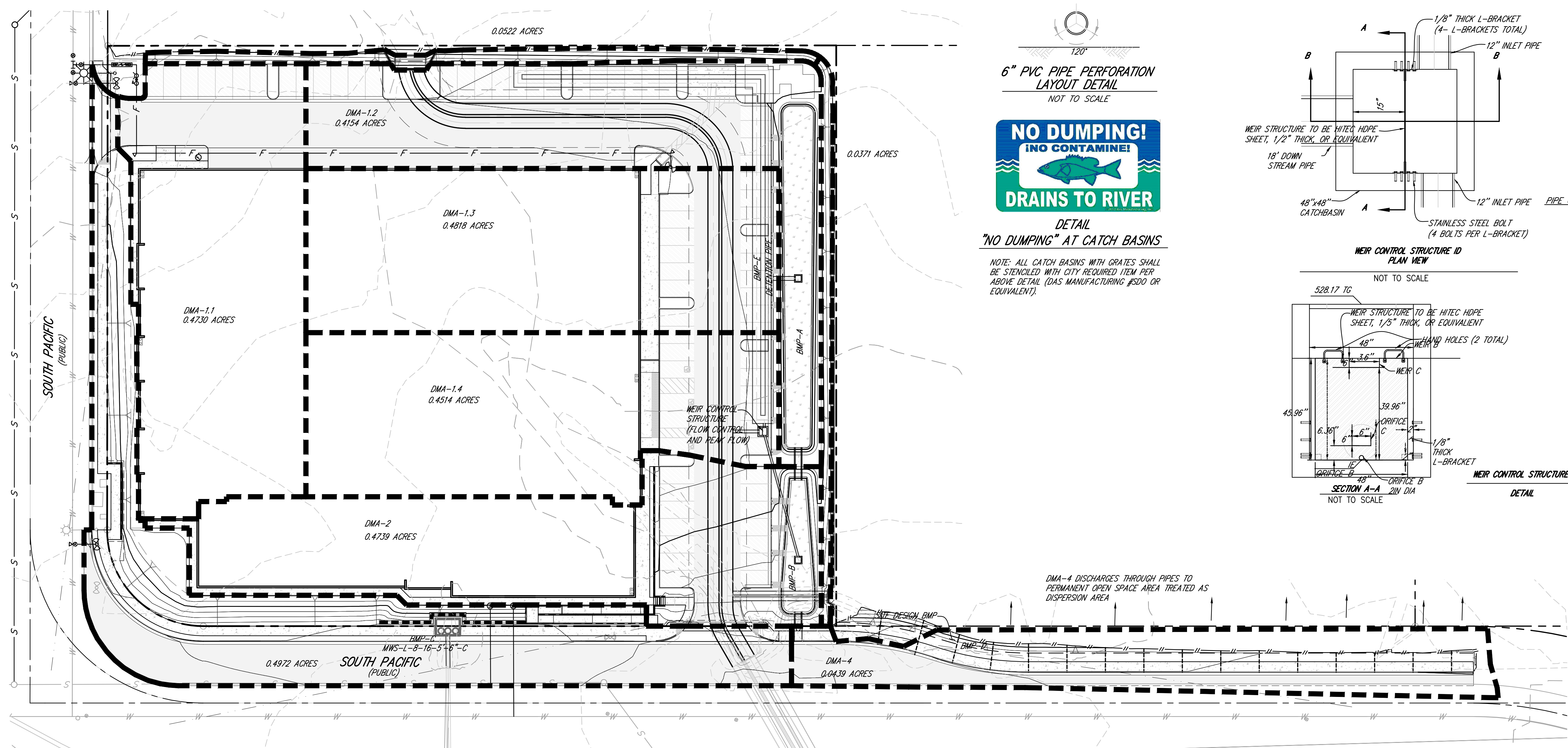

DETAIL
"NO DUMPING" AT CATCH BASINS
 NOTE: ALL CATCH BASINS WITH GRATES SHALL BE STENCILED WITH CITY REQUIRED ITEM PER ABOVE DETAIL (DAS MANUFACTURING #SD0 OR EQUIVALENT).

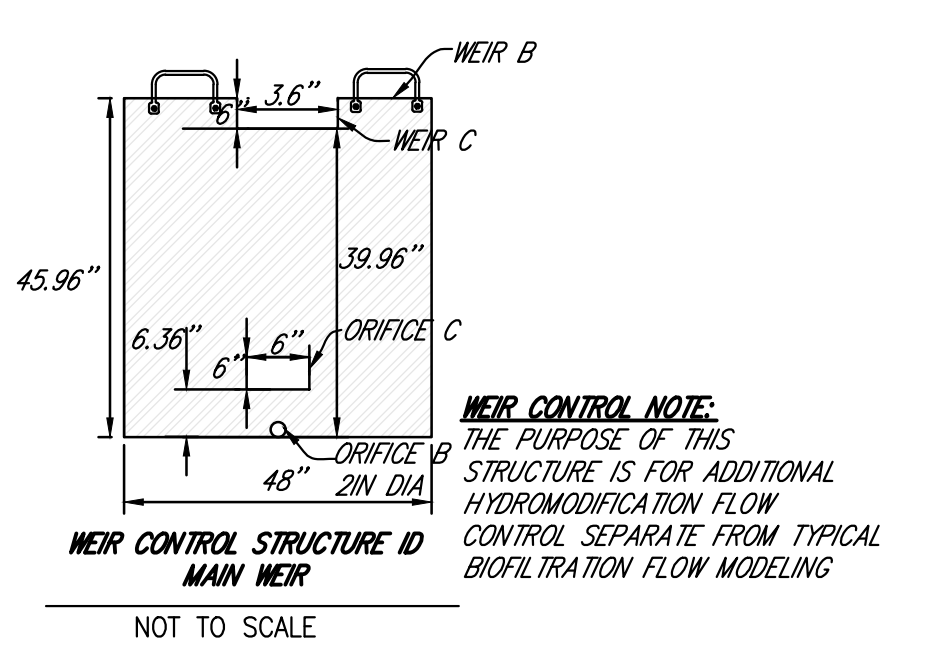
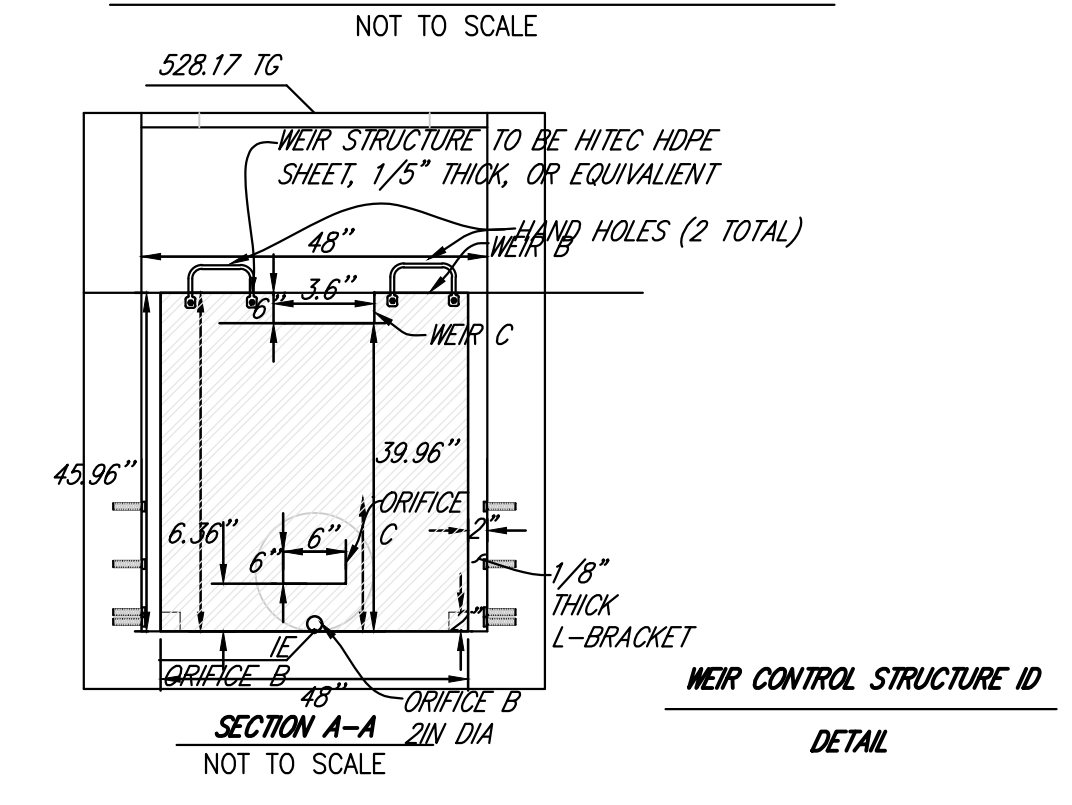
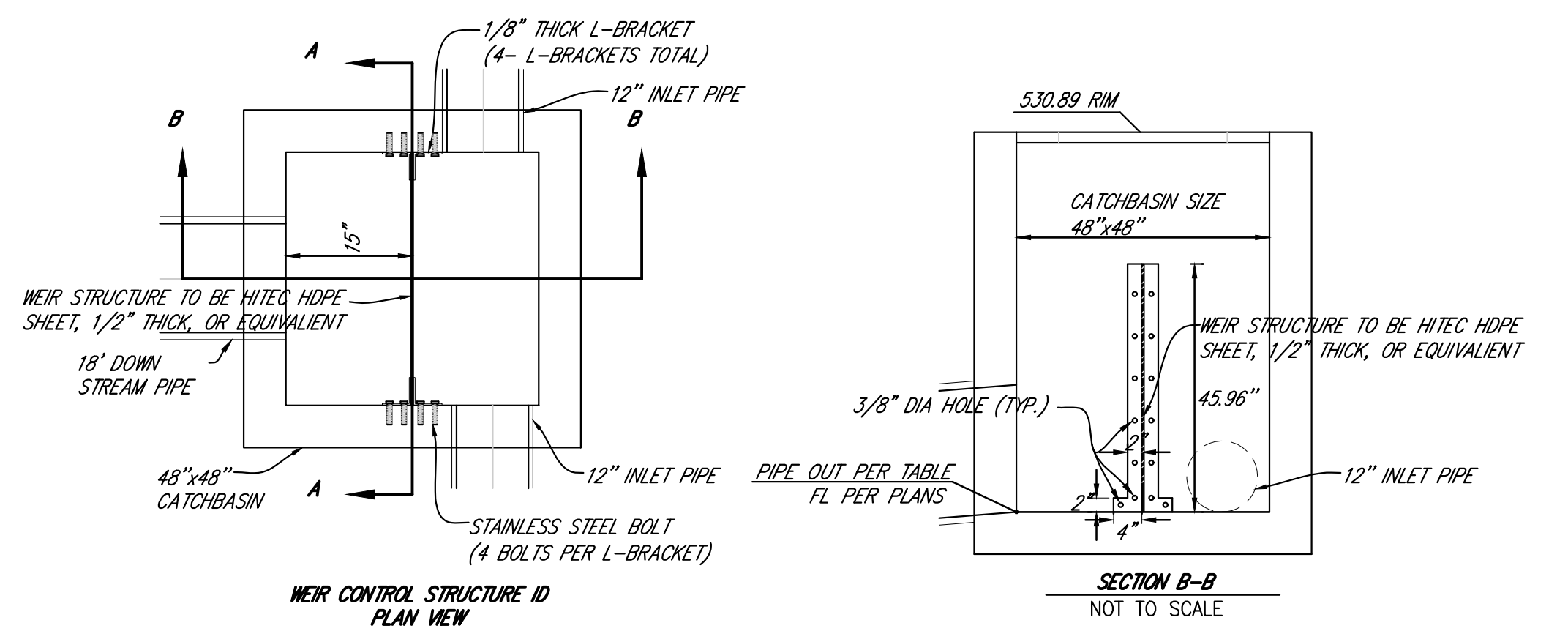

DMA-4 DISCHARGES THROUGH PIPES TO PERMANENT OPEN SPACE AREA TREATED AS DISPERSION AREA

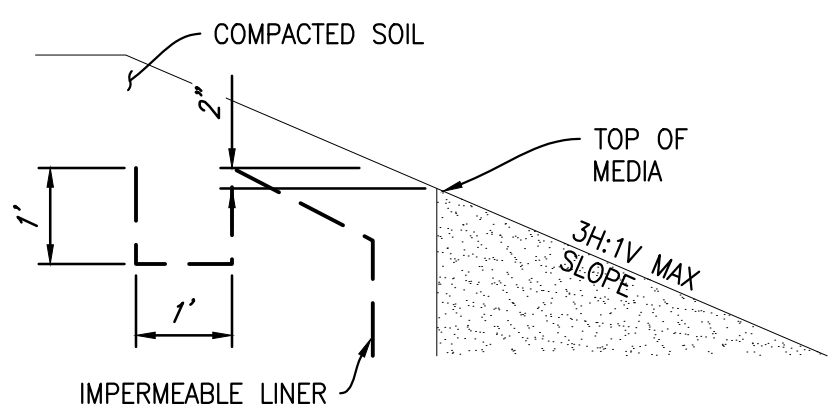
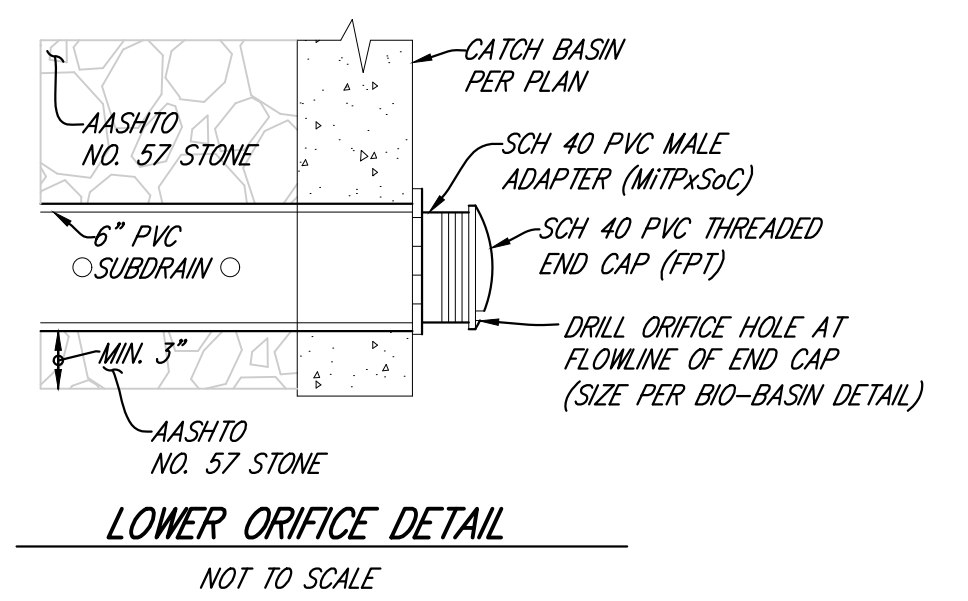
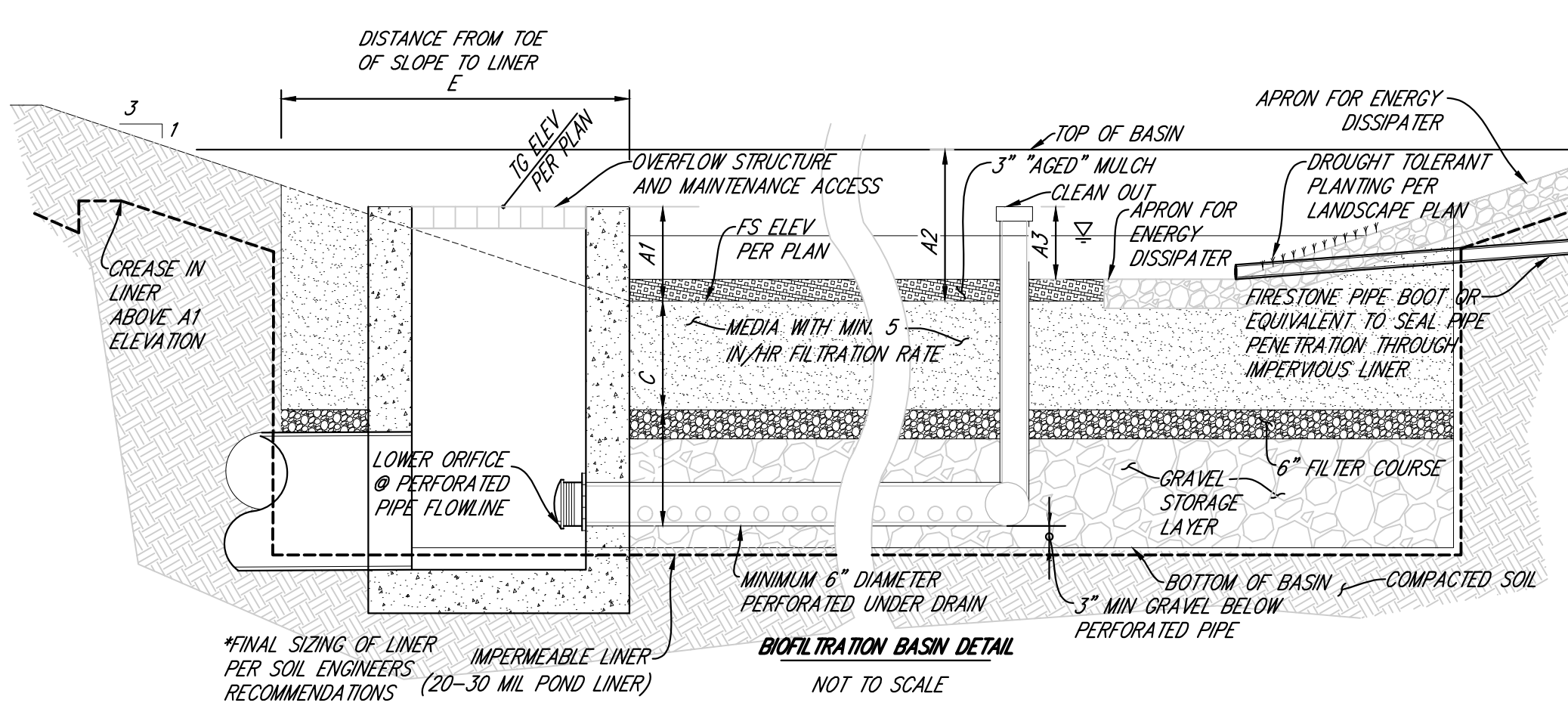

WATER QUALITY BASIN SOIL NOTES

- BIOFILTRATION SOIL MEDIA LAYER (BSM) SHALL CONSIST OF 60% TO 80% BY VOLUME SAND, UP TO 20% BY VOLUME TOPSOIL, AND UP TO 20% BY VOLUME COMPOST (PER COUNTY OF SAN DIEGO BMP DESIGN MANUAL, SEPTEMBER 2020 APPENDIX F.2 SECTION 803-2 BLENDED BSM CRITERIA AND TESTING REQUIREMENTS) PLACED IN 6" LIFTS AND COMPACTED WITH WATER PRIOR TO THE NEXT LIFT. INITIAL PERMEABILITY SHALL BE 8" PER HOUR (WITH ASSUMED STABILIZED PERMEABILITY OF 5" PER HOUR).

IMPERMEABLE LINER EDGE ANCHOR DETAIL
 NOT TO SCALE

HYDROLOGIC SOIL GROUP
 THE HYDROLOGIC SOIL GROUP FOR THIS SITE IS TYPE D.

EXISTING SITE FEATURES:

- THE APPROXIMATE DEPTH TO GROUNDWATER IS 4-10 FEET.
- THERE ARE NO NATURAL HYDROLOGIC FEATURES ON THE SITE.
- THE SITE PROPOSES TO CONNECT TO THE EXISTING PUBLIC STORM DRAIN SYSTEM LOCATED IN THE SOUTH EDGE OF THE SITE.
- BASED ON WATERSHED MAPPING OF POTENTIAL CRITICAL COARSE SEDIMENT YIELD AREAS (CCSYA), THERE ARE NO CCSYA LOCATED WITHIN THE PROJECT BOUNDARY OR TRIBUTARY TO THE RUNOFF BYPASSED AROUND THE SITE.

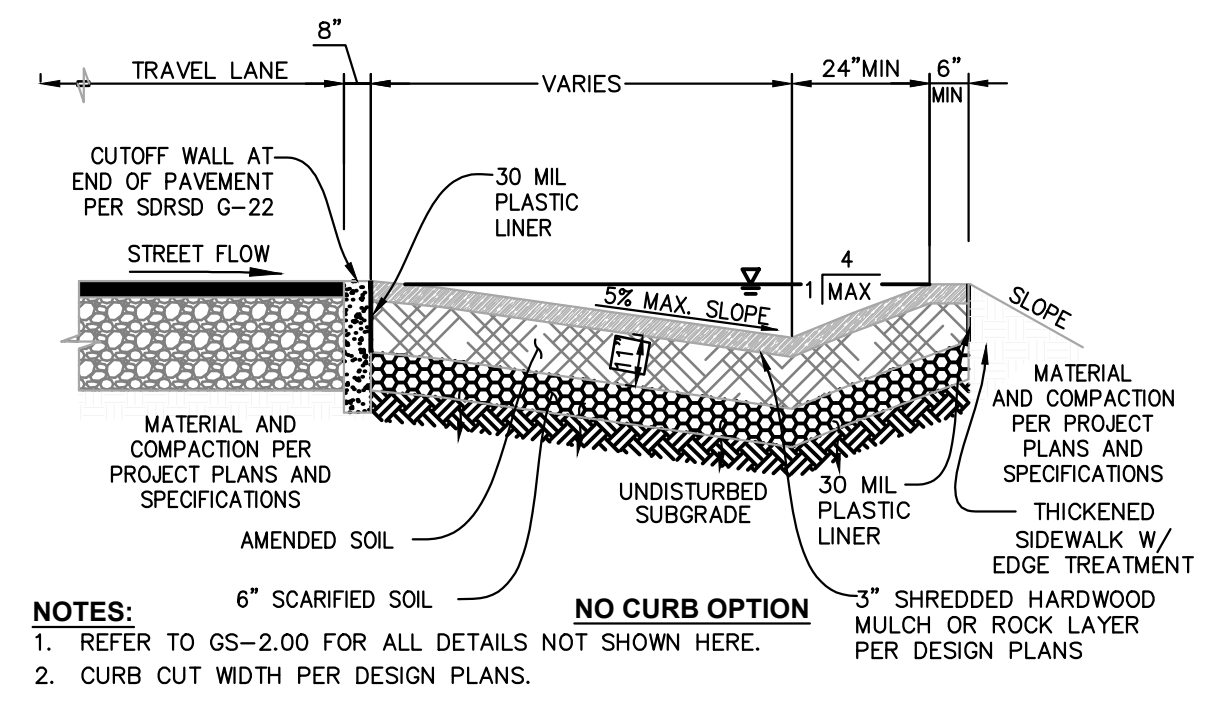

SCALE: 1:30

SOUTH PACIFIC STREET HYDROMODIFICATION MANAGEMENT EXHIBIT

DMA NAME	DMA TYPE	BMP NAME	TYPE OF BMP	EFFECTIVE AREA (SQFT)	A1 (INCH) WATER QUALITY	A2 (INCH) TOP OF BASIN	A3 (INCH) CLEAN OUT	B (INCH) UPPER ORIFICE	C (INCH) MEDIA	D (INCH) GRAVEL	E (INCH) OFFSET	BOX RISER OVERFLOW STRUCTURE SIZE (INCHES)	ORIFICES DIAMETER		IMPERMEABLE LINER ?
													UPPER (INCH)	LOWER (INCH)	
DMA-1	DRAINS TO BMP	BMP-A	BIOFILTRATION	2866	9	12	6	-	18	12	3	24X24	-	1.50	YES
DMA-2	DRAINS TO BMP	BMP-B	BIOFILTRATION	963	9	14	6	-	18	12	3.5	24X24	-	1.8125	YES
DMA-3	DRAINS TO BMP	*BMP-C	MODULAR WETLAND	-	-	-	-	-	-	-	-	-	-	-	-
DMA-4	DRAINS TO BMP	BMP-D	DISPERSION AREA	894	-	-	-	-	**14	-	-	-	-	-	-

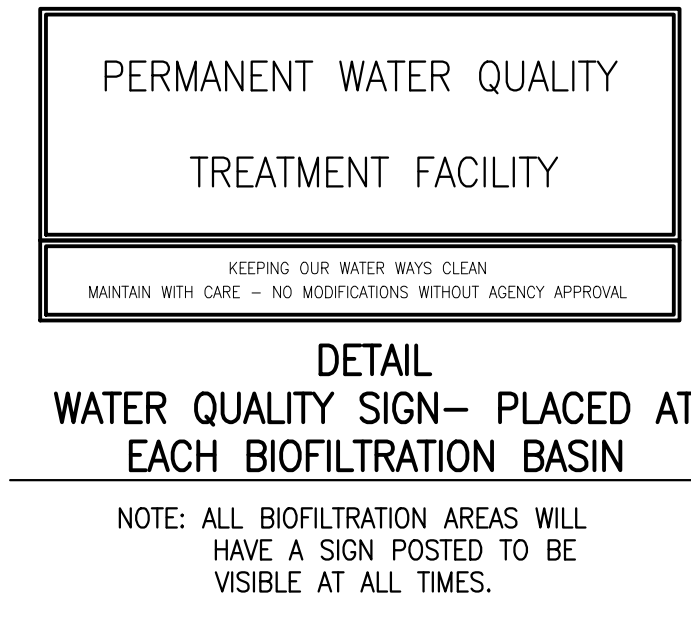



*NOTE: BMP-C IS NOT BEING USED FOR FLOW CONTROL.
 **NOTE: BMP-D HAS 11 INCHES AMENDED SOIL + 3 INCHES OF MULCH FOR TOTAL OF 14 INCHES MEDIA.

Attachment 2B:
Management of Critical Coarse Sediment Yield Areas

Potential Critical Coarse Sediment

Data From WMAA Map

Legend

-  PCCSYA
-  Proposed Project
-  Proposed Project

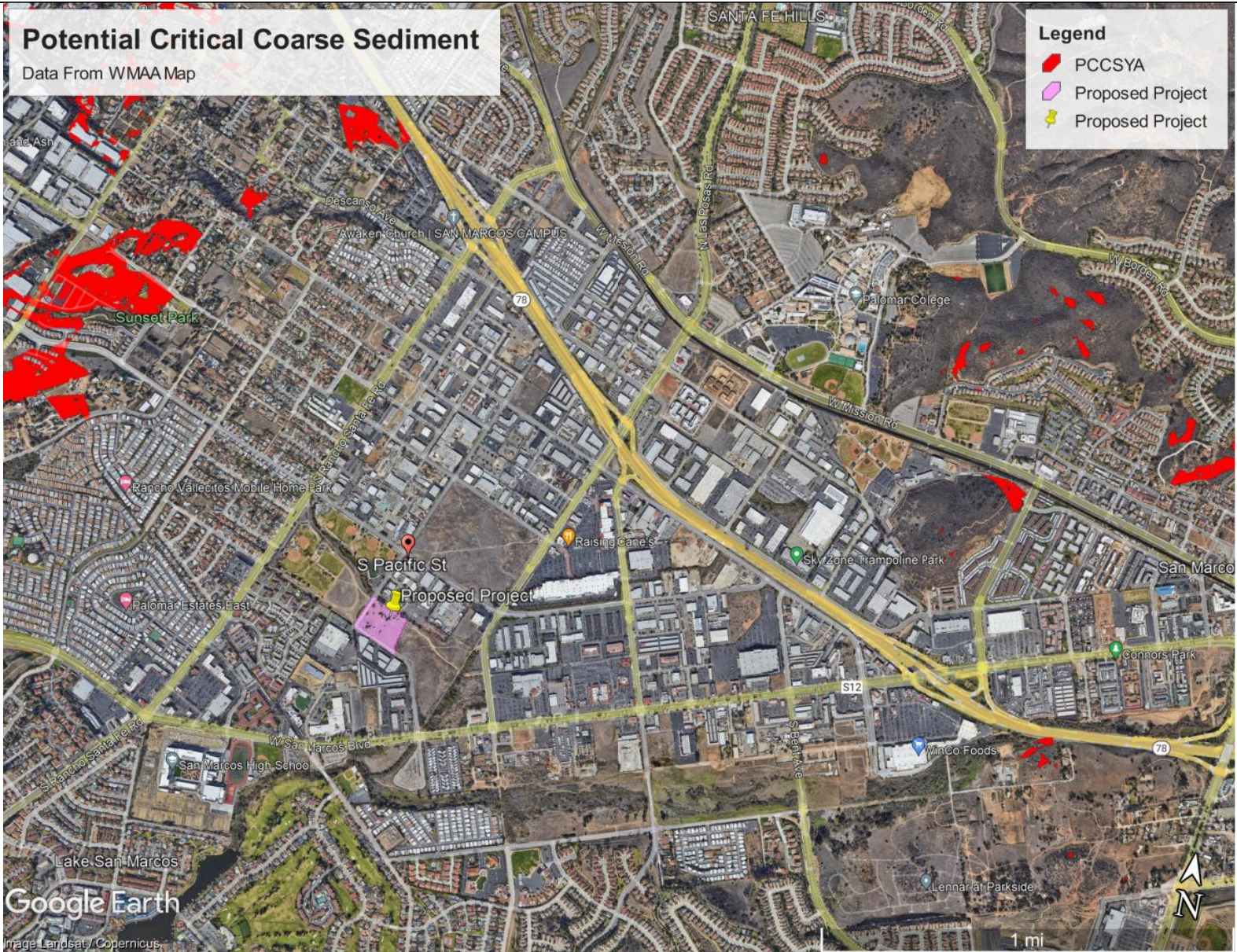

No Potential Critical Coarse Sediment Yield areas nearby that will influence the project.

Attachment 2C:
Geomorphic Assessment of Receiving Channels



CITY OF SAN MARCOS

FINAL December 15, 2011

San Marcos Creek Specific Plan Master Water Quality and Hydromodification Management Plan





FINAL San Marcos Creek Specific Plan Master Water Quality and Hydromodification Management Plan

TABLE OF CONTENTS

	<u>Page</u>
STORMWATER PROGRAM MANAGER APPROVAL OF MASTER WQTR	i-ii
OBJECTIVES OF MASTER WATER QUALITY AND HYDROMODIFICATION MANAGEMENT PLAN (MASTER WQ/HMP MANAGEMENT PLAN	iii
1.0 PROJECT DESCRIPTION & PHASING.....	1-1
1.1 San Marcos Creek Specific Plan	1-1
Figure: San Marcos Creek Project Vicinity	F1-1
1.2 Alternative Assessment For Order R9 2007-0001 Compliance	1-3
1.3 Project Planning	1-3
Figure: San Marcos Creek Project Vicinity Future Land Use.....	F1-2
Figure: San Marcos Creek Project Vicinity Land Use (2009 SANDAG Designations).....	F1-3
Figure: San Marcos Creek Improvements Alternative 7	F1-4
2.0 EXISTING CONDITIONS	2-1
2.1 <u>Watershed</u>	2-1
2.2 303(d) Listings for San Marcos Creek/Lake San Marcos	2-1
Marcos	
Table 2-1 2010 303(d) Listings for San Marcos Creek/ Lake San 2-1	
Table 2-2 Basin Plan Inland Surface Waters Beneficial Uses For San Marcos Creek/Lake San Marcos	2-2
Figure: San Marcos Creek Specific Plan HAS Map.....	F2-1
Figure: Lake San Marcos Area.....	F2-2
2.3 Existing Treatment Controls In Specific Plan Area	2-5
Figure: San Marcos Creek Vicinity Existing MS4 System/Water Quality	



FINAL San Marcos Creek Specific Plan

Master Water Quality and Hydromodification Management Plan

BMP's Marcos	F2-3
Table 2-3 Estimated Existing Land Use Pollutant Concentrations.....	2-7
2.4 SWAMP Assessments in San Marcos Creek	2-8
Table 2-4 Summary of SWAMP 2002/2007 Physical Habitat Assessment for San Marcos Creek in Specific Plan Area	2-8
2.5 Existing Water Quality in Specific Plan Area	2-9
Figure: San Marcos Creek Monitoring Stations	F2-4
3.0 WATER QUALITY / HYDROMODIFICATION COMPLIANCE REQUIREMENTS	3-1
3.1 Drainage Management Areas.....	3-1
Figure 3-1 DMA Areas.....	3-2
3.2 Hydromodification Assessment	3-3
3.3 Hydromodification Criteria Used For Specific Plan Analysis.....	3-4
3.4 San Marcos Creek Channel Susceptability Analysis	3-6
3.5 Summary of Chang and Consultants June 2011 HMP/Water Quality Analysis	3-6
Figure 3-2 Proposed IBI and DMA Locatoins	3-7
3.6 Hydromodification Facility Sizing.....	3-8
Table 3-1 Bioretention Basin Sizing to Treat Public Areas	3-9
Table 3-2 Bioretention Basin Sizing to Treat All Areas (100% of Public and 100% of Private)	3-10
3.7 <u>Conclusion</u>	3-11
4.0 WATER QUALITY POLLUTANT REMOVAL EFFECTIVENESS	4-12
4.1 Study Findings.....	4-12
Table 4-1 Bioretention Pollutant Removal Effectiveness	4-12
Table 4-2 Comparison Between Existing and Proposed Pollutant Concentrations-With Treatment (Bioretention) for Entire Study Area.....	4-13



FINAL San Marcos Creek Specific Plan Master Water Quality and Hydromodification Management Plan

Table 4-3 Percent Difference Between Existing and Proposed Pollutant Concentrations- With Treatment (Bioretention) by Drainage Management Area	4-14
Table 4-4 Comparison Between Existing, Proposed with Treatment, and Literature Pollutant Concentrations For Entire Study Area	4-15
Table 4-5 Comparison Between Existing, Proposed with Treatment, and Literature Pollutant Concentrations by Drainage Management Area.....	4-16
4.2 Larry Walker and Associates Independent Validation	4-16
4.3 Las Posas/San Marcos Creek Restoration Expected Water Quality Benefits	4-17
4.4 Recommended Field Validation.....	4-17
4.5 <u>Conclusions</u>	4-18
5.0 PRIVATE DEVELOPMENT REQUIREMENTS	5-1
5.1 Model Block Development.....	5-1
5.2 Basic Guidelines For Model Block Private Development For Permit Compliance	5-1
5.3 Temporary Water Quality Impacts (Construction/Biological)	5-3

APPENDICES

- A. Preliminary Water Quality Treatment Analysis
- B. Water Quality/HMP Analysis
- C. Water Quality/HMP Calculation Summary
- D. Water Quality Uptake of Restoration Projects
- E. Existing Water Quality Baseline Data

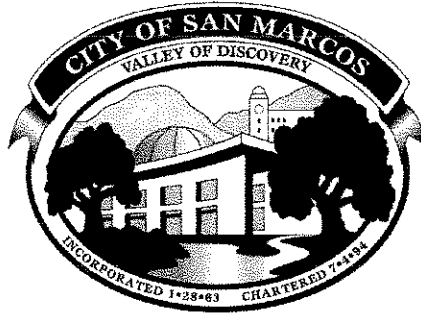

Administration
1 Civic Center Drive
San Marcos, CA 92069-2918

Tel: 760.744.1050
Fax: 760.744.9520
Web: www.San-Marcos.net

December 15, 2011

Mike Porter

San Diego Regional Water Quality Control Board

9174 Sky Park Court, Suite 100
San Diego, CA. 92123-4340

Re: WQTR 401 Permit Condition for City of San Marcos – San Marcos Creek Specific Plan - City of San Marcos Stormwater Program Manager Letter Confirmation of Final Master Water Quality and Hydromodification Management Plan (Final Master WQTR Dated December 15, 2011) Meets Local SUSMP Requirements

Dear Mr. Porter:

This letter serves to confirm to the San Diego Regional Water Quality Control Board in the determination that the subject project will comply with certain 401 Certification conditions requiring priority development projects to confirm that their project design meets local SUSMP requirements.

The adopted San Marcos Creek Specific Plan and the Final Master WQTR dated December 15, 2011 are framework plans for guiding development in a 135-acre specific plan area. A Final Master Water Quality and Hydromodification Management Plan (Master WQTR) has been completed to guide development and ensure that hydromodification (HMP) effects and Water Quality Requirements can be met under Order R9 2007-0001 at a master plan level and project specific level.

The Final Master WQTR has provided a technical assessment of permit compliance for meeting water quality and HMP requirements for 100 percent of the public facilities and a minimum percentage of private development in shared bioretention facilities in the Promenade. Private development will be required to implement LID and other water quality/HMP facilities for any remainder treatment required onsite.

In addition, the Final Master WQTR includes recommendations for monitoring the efficacy of the BMP effectiveness as part of a 401 permit conditions as requested.

The City is attaching the Final Master Water Quality Technical Report (WQTR) to this letter. By way of my signature below and my signature on each individual development project Water Quality Improvement Plans (WQIPs) in the Specific Plan Area, I certify that the both the attached Final Master WQTR and each individual development project in the Specific Plan Area meets the following Local SUSMP Requirements of the City of San Marcos and that the measures being taken are protective of water quality:

- 85th percentile capture of the 24 hour storm;
- LID Requirements;
- Site Design Requirements;
- Source Control Requirements; and
- Hydromodification Requirements

Any revisions made hereafter will continue to comply with the local SUSMP requirements and will not result in any decreases in water quality treatment or capacity. This Final Master WQTR is signed by way of this letter by the City of San Marcos Stormwater Program Manager and provided to the San Diego Water Board to fulfill the condition of the 401 Certification for this project.



Erica Ryan

Stormwater Program Manager

City of San Marcos



FINAL San Marcos Creek Specific Plan Master Water Quality and Hydromodification Management Plan

Objectives of Master Water Quality and Hydromodification Management Plan (Master WQ/HMP Management Plan)

This Master WQ/HMP Management Plan for the San Marcos Creek Specific Plan is intended to:

1. Provide a master management plan for water quality and hydromodification facilities within the specific plan development area;
2. Meet the Municipal Stormwater Permit Requirements for development in the San Diego Regional Water Quality Control Board (SDRWQCB) Order R9 2007-0001 (Permit) for water quality and hydromodification (HMP) development requirements as of January 14, 2011;
3. Implement shared and managed water quality and HMP facilities for each of the eight designated drainage management areas (DMAs);
4. Identify the required surface storage bioretention capacity in each of the eight DMA WQ/HMP facilities to adequately treat urban runoff and retain and release the natural rainfall rate for all public facilities and a designated portion of private development;
5. Identify a framework to be implemented and submitted annually with the 401 permit Mitigation and Monitoring Reporting Program (MMRP) to:
 - a. Ensure achievement of anticipated pollutant removal rates by treatment controls to implement a net reduction of current urban runoff load to water bodies downstream (San Marcos Creek, Lake San Marcos, Batiquitos Lagoon, and the Pacific Ocean);
 - b. Ensure HMP capacity is adequate for each DMA;
 - c. Ensure improving IBI/BMI scores over time; and
 - d. Ensure water quality improvement over time in San Marcos Creek.
 - e. Coordinate with required annual biological MMRP reporting requirements.
 - f. Provide baseline framework for 401 certification compliance.
6. Identify a consistent application of water quality treatment design, review and construction implementation for private development projects;

In addition to ensuring consistency in the application of WQ/HMP within a private development project located in the San Marcos Creek Specific Plan area, the Master WQ/HMP Management Plan also ensures that the Specific Plan area functions within ongoing watershed planning so that each project takes into consideration its



FINAL San Marcos Creek Specific Plan Master Water Quality and Hydromodification Management Plan

role within the Specific Plan area as well as within the SAN MARCOS Creek watershed.



FINAL San Marcos Creek Specific Plan

Master Water Quality and Hydromodification Management Plan

1.0 PROJECT DESCRIPTION AND PHASING

1.1 SAN MARCOS CREEK SPECIFIC PLAN

Figure 1-1 shows the project location in the City of San Marcos. The San Marcos Creek adopted Specific Plan represents an effort to create a managed planning framework for future growth and redevelopment of the approximately 214-acre area along San Marcos Creek in central San Marcos between Discovery Street and SR 78. Approximately 124 acres are proposed for development.

The overall goals of the Specific Plan are to:

1. Create a smart growth downtown area which is currently absent in San Marcos; and
2. Restore San Marcos Creek/Las Posas Creek in the Specific Plan Area.

The Specific Plan provides a comprehensive vision for a creekside district along with goals, policies and development standards to guide future public and private actions relating to the area's development and conservation of open space and natural resources. The Specific Plan also serves as the mechanism for insuring that future development will be coordinated and occur in an orderly and well-planned manner. The vision for the Specific Plan area is a generally more urbanized feel.

The proposed land-use is a smart growth based mixed-use commercial core and "downtown" for San Marcos. The proposed Specific Plan land-uses will balance retail and entertainment uses with a mix of residential, office, and service uses to neighborhoods with both active and passive elements. The proposed land-use within the Specific Plan consists of the following:

- Streets: 42.6 acres
 - Mixed-Use: 75.6 acres
 - Improved Parks: 17.3 acres
- Subtotal Development Area: 135.54 acres**
- Natural Open-Space: 78.5 acres
- Total Area: 214.00 acres**





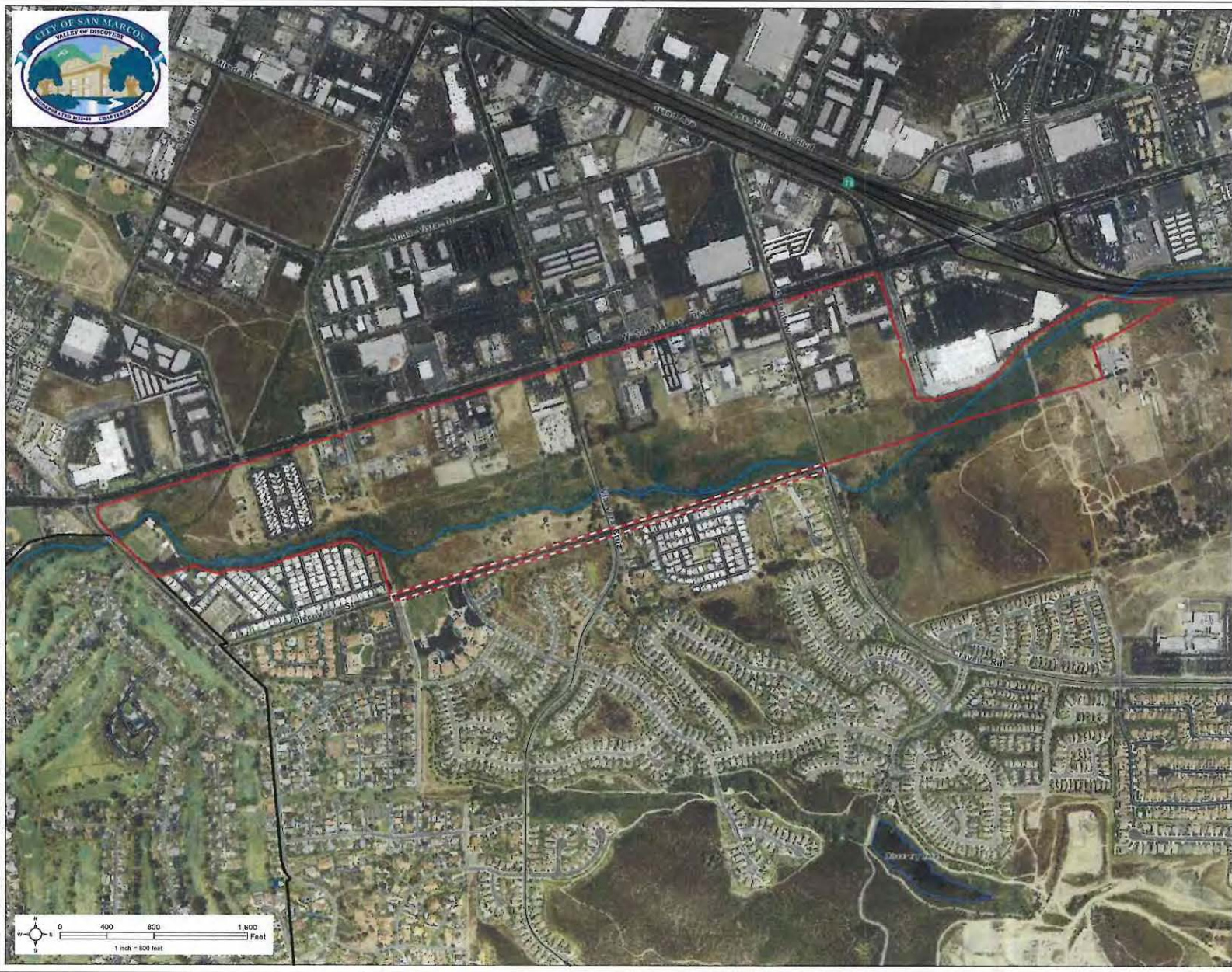

FINAL San Marcos Creek Specific Plan Master Water Quality and Hydromodification Management Plan

Figure 1-1 Vicinity Map



San Marcos Creek Project Vicinity

-  San Marcos Creek
-  Lakes
-  San Marcos Creek Specific Plan Area
-  Discovery Street ROW
(Included in master WQTR analysis)
-  San Marcos City Limits

Source of Data: SanGIS, 07/10 and City of San Marcos, 2/11
 Created By: City of San Marcos GIS

Every effort has been made to assure the accuracy of the maps and data provided; however, some information may not be accurate or current. The City of San Marcos assumes no responsibility arising from use of this information and incorporates by reference its disclaimer regarding the lack of any warranties, whether expressed or implied, concerning the use of the same. For additional information see the Disclaimer on the City's website.

X:\Projects\Stormwater\Projects\SMMCreek_Main\CountyMasterPlan\Mapa\Fig_6_SMMCreek_Vicinity.mxd 8/8/2011



FINAL San Marcos Creek Specific Plan

Master Water Quality and Hydromodification Management Plan

1.2 ALTERNATIVE ASSESSMENT FOR ORDER R9 2007-0001 COMPLIANCE

The proposed project used as the basis for the assessment and development of the Master WQ/HMP Management Plan is the City's preferred Alternative 7 to be consistent with the Army Corps of Engineers 404(b) analysis and the selected LEDPA for the project. Alternative 7 was evaluated for compliance with the January 14, 2011 Order R9 2007-0001 requirements.

Figure 1-2 shows the current Alternative 7 concept plan developed by WRT in September 2011. Figure 1 was used as the basis by Mikhail Ogawa Engineering (MOE) and Wayne Chang Consultants for the Water Quality and HMP Order R9 2007-0001 compliance assessments

Other alternatives developed by the City, including Alternatives 1-6, 8, 8a, and 9, were also assessed for Order R9 2007-0001 water quality and hydromodification compliance. All other alternatives were found to be permit compliant or the development footprints were adjusted to accommodate required bioretention acreages for water quality and hydromodification.

1.3 PROJECT PHASING

The project will be constructed in two primary phases:

- **Phase I - Near Term (by 2014):** By 2014, the City plans to have constructed and placed into operation the promenade, the shared bioretention water quality and hydromodification facilities located in the promenade, restoration of San Marcos Creek and Las Posas Creek, floodwall improvements, primary utility infrastructure, and critical circulation element improvements in the Specific Plan Area.

It is important to note that by 2014 immediate water quality and hydromodification benefits to San Marcos Creek and Lake San Marcos would occur due to:

- The restoration of San Marcos Creek and Las Posas Creek into balanced creek systems within a key location within the subwatershed; and
- The immediate implementation and operation of the shared bioretention facilities in the promenade in advance of any



FINAL San Marcos Creek Specific Plan

Master Water Quality and Hydromodification Management Plan

development anticipated over the estimated long term buildout of the specific plan area.

- **Phase II – Long Term (20 Year Estimated Buildout):** Private development of the specific plan area (predominately mixed use areas) is required by the specific plan to be developed in model blocks to ensure development consistency. It is anticipated that buildout of the remainder of the Specific Plan Area would occur based primarily on economic factors over a 20 year time frame.



FINAL San Marcos Creek Specific Plan Master Water Quality and Hydromodification Management Plan

Figure 1-2 September 2011 Alternative 7, WRT

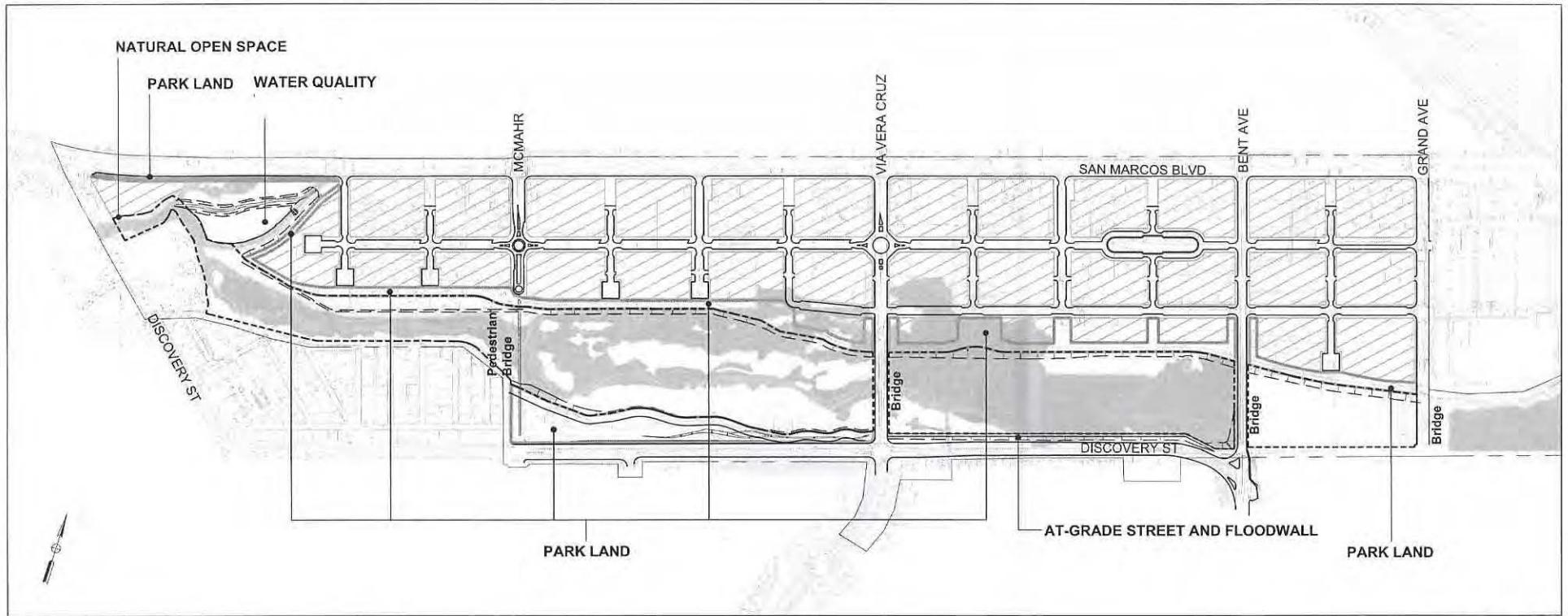

SCALE: 1"=800'

SAN MARCOS CREEK IMPROVEMENTS

ALTERNATIVE 7: REALIGNMENT OF LAS POSAS CREEK, DEVELOPMENT REDUCTION BETWEEN MCMAHR AND VIA VERA CRUZ ,AT-GRADE DISCOVERY STREET WITH FLOODWALL, ELIMINATION OF CHANNEL EXCAVATION WEST OF VIA VERA CRUZ, BRIDGE CROSSING AT BENT AVENUE

LEGEND

- PADS
- ROADWAYS
- PARK LAND
- ARMY CORPS JURISDICTIONAL AREA

LAND USE COMPARISON

	NEW DEVELOPMENT AREA (AC)	RETAIL (SF)	OFFICE (SF)	RESIDENTIAL (UNIT)	PARK (AC)
ADOPTED PLAN	81.30	1,284,703	598,205	2,341	20.64
ALT. 7 PLAN	75.55	1,193,841	555,897	2,175	16.45
DIFFERENCE	-5.75	-90,862	-42,308	-166	-4.19

	AREA (AC)
ROAD	14.76
PARK LAND	16.45
NATURAL OPEN SPACE	60.66
COMMERCIAL/RESIDENTIAL	75.55
TOTAL	167.42

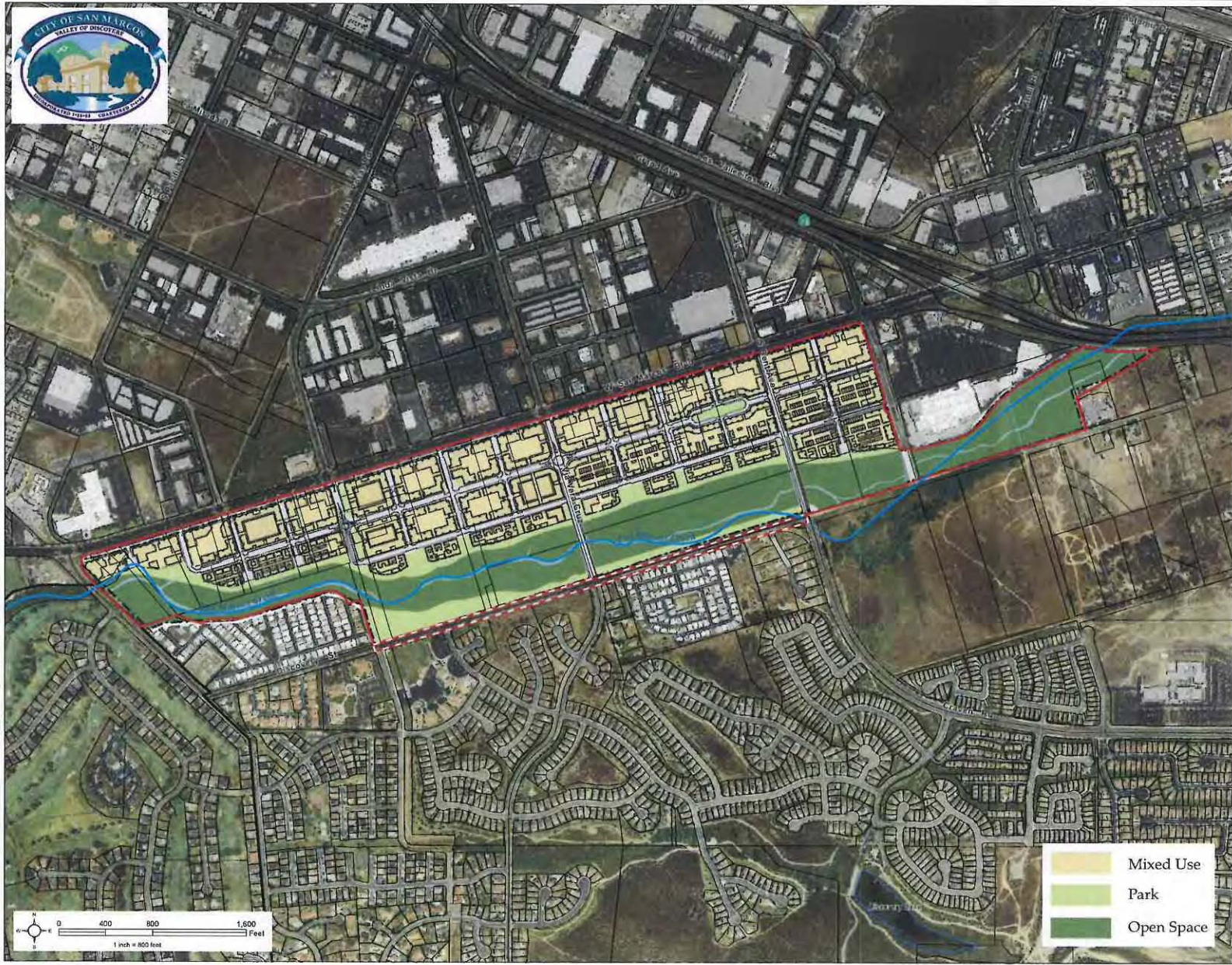

San Marcos Creek Project Vicinity Future Land Use

- San Marcos Creek
- Lakes
- Parcels
- San Marcos Creek Specific Plan Area
- Discovery Street ROW
(Included in master WQTR analysis)
- San Marcos City Limits

- Mixed Use
- Park
- Open Space

Source of Data: WRT, 07/07, SanGIS, 07/11,
and City of San Marcos, 2/11

Created By: City of San Marcos GIS

Every effort has been made to assure the accuracy of the maps and data provided; however, some information may not be accurate or current. The City of San Marcos assumes no responsibility arising from use of this information and incorporates by reference its disclaimer regarding the lack of any warranties, whether expressed or implied, concerning the use of the same. For additional information see the Disclaimer on the City's website.

L:\Projects\Stormwater\Projects\SMCreek_WaterQuality\MasterPlan\Map\Fig4b_SMCreekExisting_LU.mxd 8/10/2011



San Marcos Creek Project Vicinity Land Use (2009 SANDAG Designations)

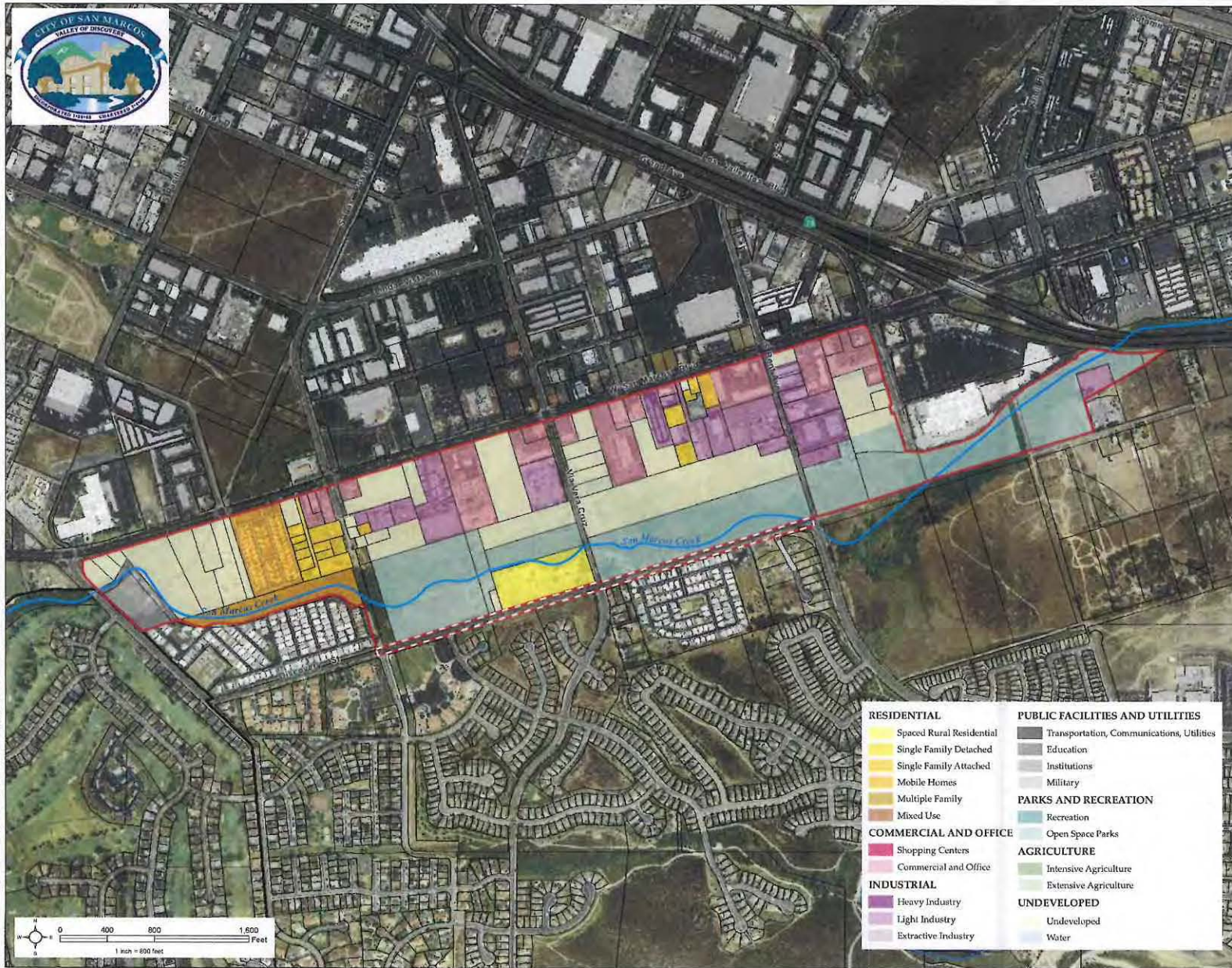

- San Marcos Creek
- Lakes
- Parcels
- San Marcos Creek Specific Plan Area
- Discovery Street ROW
(Included in master WQTR analysis)
- San Marcos City Limits

<p>RESIDENTIAL</p> <ul style="list-style-type: none"> Spaced Rural Residential Single Family Detached Single Family Attached Mobile Homes Multiple Family Mixed Use <p>COMMERCIAL AND OFFICE</p> <ul style="list-style-type: none"> Shopping Centers Commercial and Office <p>INDUSTRIAL</p> <ul style="list-style-type: none"> Heavy Industry Light Industry Extractive Industry 	<p>PUBLIC FACILITIES AND UTILITIES</p> <ul style="list-style-type: none"> Transportation, Communications, Utilities Education Institutions Military <p>PARKS AND RECREATION</p> <ul style="list-style-type: none"> Recreation Open Space Parks <p>AGRICULTURE</p> <ul style="list-style-type: none"> Intensive Agriculture Extensive Agriculture <p>UNDEVELOPED</p> <ul style="list-style-type: none"> Undeveloped Water
--	--

Source of Data: SANDAG, 10/09, SanGIS, 07/11,
and City of San Marcos, 2/11

Created By: City of San Marcos GIS

Every effort has been made to assure the accuracy of the maps and data provided; however, some information may not be accurate or current. The City of San Marcos assumes no responsibility arising from use of this information and incorporates by reference its disclaimer regarding the lack of any warranties, whether expressed or implied, concerning the use of the same. For additional information see the Disclaimer on the City's website.



FINAL San Marcos Creek Specific Plan

Master Water Quality and Hydromodification Management Plan

2.0 EXISTING CONDITIONS

2.1 WATERSHED

Figure 2-1 shows that the San Marcos Creek Specific Plan area is located in the Upper San Marcos Creek (USMC) Watershed of the Carlsbad Hydrographic Unit (HU 904). The USMC Watershed is approximately 29 square miles and is comprised of two sub-watersheds. The primary water bodies in the USMC watershed are Upper San Marcos Creek and Lake San Marcos. The Specific Plan Area discharges into both the San Marcos Creek above Lake San Marcos, Lake San Marcos, and ultimately to the Batiquitos Lagoon and Pacific Ocean.

The Specific Plan Area is located in the Richland HSA (HSA 904.52) which comprises the lower portion of the USMC Watershed, and comprises 69% of the total land area of the USMC Watershed or 12, 863 acres. The proposed development area of the Specific Plan area is approximately 1.0% (135 developed acres) of the total area of the Richland HSA.

2.2 303(D) LISTINGS AND TMDLS

Table 2-1 summarizes current water quality impairments in San Marcos Creek and Lake San Marcos as identified on the current State of California's 303(d) List of Impaired Water Body Segments. **Table 2-2** lists the beneficial uses of San Marcos Creek, Lake San Marcos, and unnamed intermittent streams that are established in the Water Quality Control Plan for the San Diego Basin (Basin Plan).

Table 2-1

2010 303(d) Listings for San Marcos Creek/Lake San Marcos

303(d) Listed Water Body	2010
San Marcos Creek	DDE, phosphorous, selenium, sediment toxicity
Lake San Marcos	Ammonia as N, Nutrients,



FINAL San Marcos Creek Specific Plan Master Water Quality and Hydromodification Management Plan

**Table 2-2
Basin Plan Inland Surface Waters
Beneficial Uses for San Marcos Creek/Lake San Marcos**

Water Body	Beneficial Uses
San Marcos Creek/Lake San Marcos (904.52 - Richland)	MUN (excepted), AGR, REC1, REC2, WARM, WILD

There are two TMDLs in place or underway in the Specific Plan Area. Currently the San Marcos HA is under the Bacteria I TMDL (adopted 2010) with designated load allocations. This TMDL is applicable to the entire San Marcos HA including the Specific Plan area. The City of San Marcos is participating in the Bacteria I TMDL. The Lead Agency for this effort is the City of Encinitas.

The Upper San Marcos Creek is also under a Voluntary Nutrient TMDL which commenced in June 2011. Load allocations have not yet been identified. The City of San Marcos is the lead agency for the Upper San Marcos Voluntary Nutrient TMDL (See **Figure 2-2**). The City of San Marcos is also the designated lead in the USMC Watershed Nutrient Management Plan effort.

The Specific Plan Area is just upstream of Lake San Marcos and must consider as the primary pollutants of concern the reduction of bacteria, phosphorous, nitrogen, selenium and other metals, and sediments into the Creek and Lake. DDE has been in use for decades and is attached to soil particulates. Regulatory bans and phase outs on the use of DDE pesticides over the last several years will take into effect along with increased soil stabilization practices. DDE derivatives are no longer commercially available and the concentrations are anticipated to reduce over time coupled with appropriate best management practices from existing development, proposed development and soil stabilization practices required during construction.

The Specific Plan Area is located in a key point in the USMC watershed. Because the Specific Plan Area is located at the western most part of the USMC where drainage areas from the Richland and Twin Oaks Valley HSA converge, it is poised to provide a significant net positive change to water quality through two primary objectives of the Specific Plan and the this Master WQ/HMP Management Plan:

1. Restoration and Enhancement to a balanced creek system of Las Posas Creek and San Marcos Creek; and
2. Implementation by approximately 2014 of shared hydromodification and water quality bioretention facilities in the promenade.



FINAL San Marcos Creek Specific Plan Master Water Quality and Hydromodification Management Plan

Figure 2-1 Watershed Map

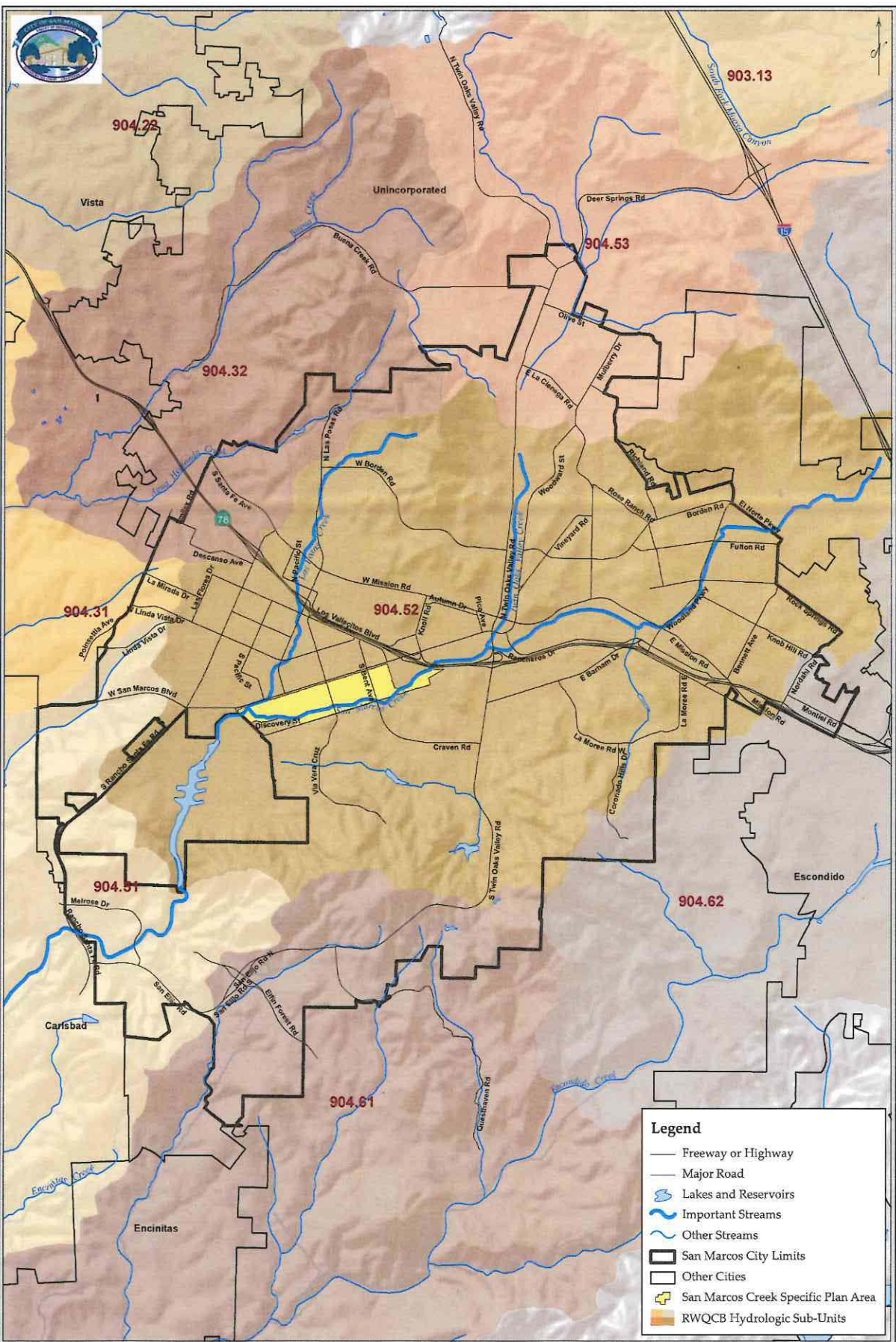

X:\Projects\Stormwater Projects\SMCreek_WaterQuality\MasterPlan\Maps\Fig 1_HSA_Graphical\EW\mxd 6/27/2011

Legend

- Freeway or Highway
- Major Road
- ☪ Lakes and Reservoirs
- ~ Important Streams
- ~ Other Streams
- ▭ San Marcos City Limits
- ▭ Other Cities
- ☒ San Marcos Creek Specific Plan Area
- ▭ RWQCB Hydrologic Sub-Units

Every effort has been made to assure the accuracy of the maps and data provided; however, some information may not be accurate or current. The City of San Marcos assumes no responsibility arising from use of this information and incorporates by reference its disclaimer regarding the lack of any warranties, whether expressed or implied, concerning the use of the same. For additional information see the Disclaimer on the City's website.

San Marcos Creek Specific Plan HSA MAP

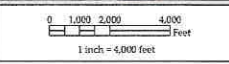

CREATED BY: City of San Marcos GIS
SOURCES OF DATA: SanGIS, 10/09;
City of San Marcos, 2011



FINAL San Marcos Creek Specific Plan Master Water Quality and Hydromodification Management Plan

Figure 2-2 USMC Management Plan and Voluntary Nutrient TMDL Area

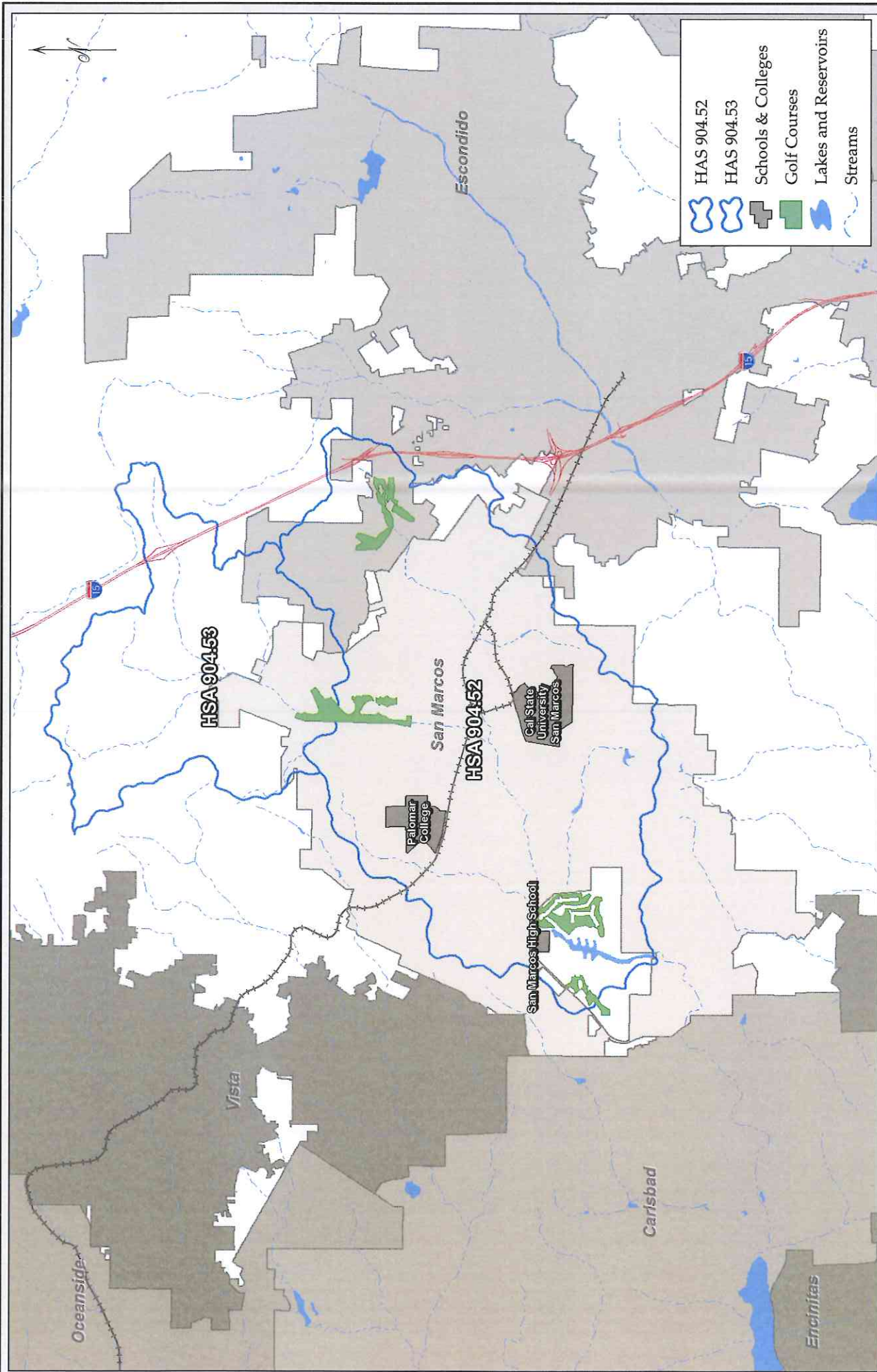

Lake San Marcos Area



2.3 EXISTING TREATMENT CONTROLS IN SPECIFIC PLAN AREA

The Study Area consists of 135.5 acres on the north and south side of Avenue and Discovery Street in the City of San Marcos (See **Figure 1-1**). Existing development is generally located closer to San Marcos Boulevard.

Existing development in the area between Grand Avenue and McMahar Road consists primarily of commercial and legal nonconforming industrial uses, including neighborhood “strip” retail centers, two gas stations, a lumberyard, three storage facilities, a construction material storage yard, auto services, a bowling alley, office uses, and a fast food restaurant (San Marcos Creek Specific Plan, 2007). Additionally, there are several residential uses in the study area.

The existing land-use acreages within the Study Area consist of the following:

- Streets 12.65 ac
- Commercial Acreage: 28.02 ac
- Industrial Acreage: 17.57 ac
- Residential Acreage: 12.66 ac
- Vacant Acreage: 64.4 ac

Figure 2-3 shows that there are **no treatment controls or hydromodification facilities in the specific plan area**. All treatment controls implemented since 2001 are located outside of the Specific Plan Area and consist predominantly of filters installed during the 2001 Municipal Stormwater Permit cycle which have since been established as a last resort treatment control and not as effective as infiltration and/ or bioretention facilities.

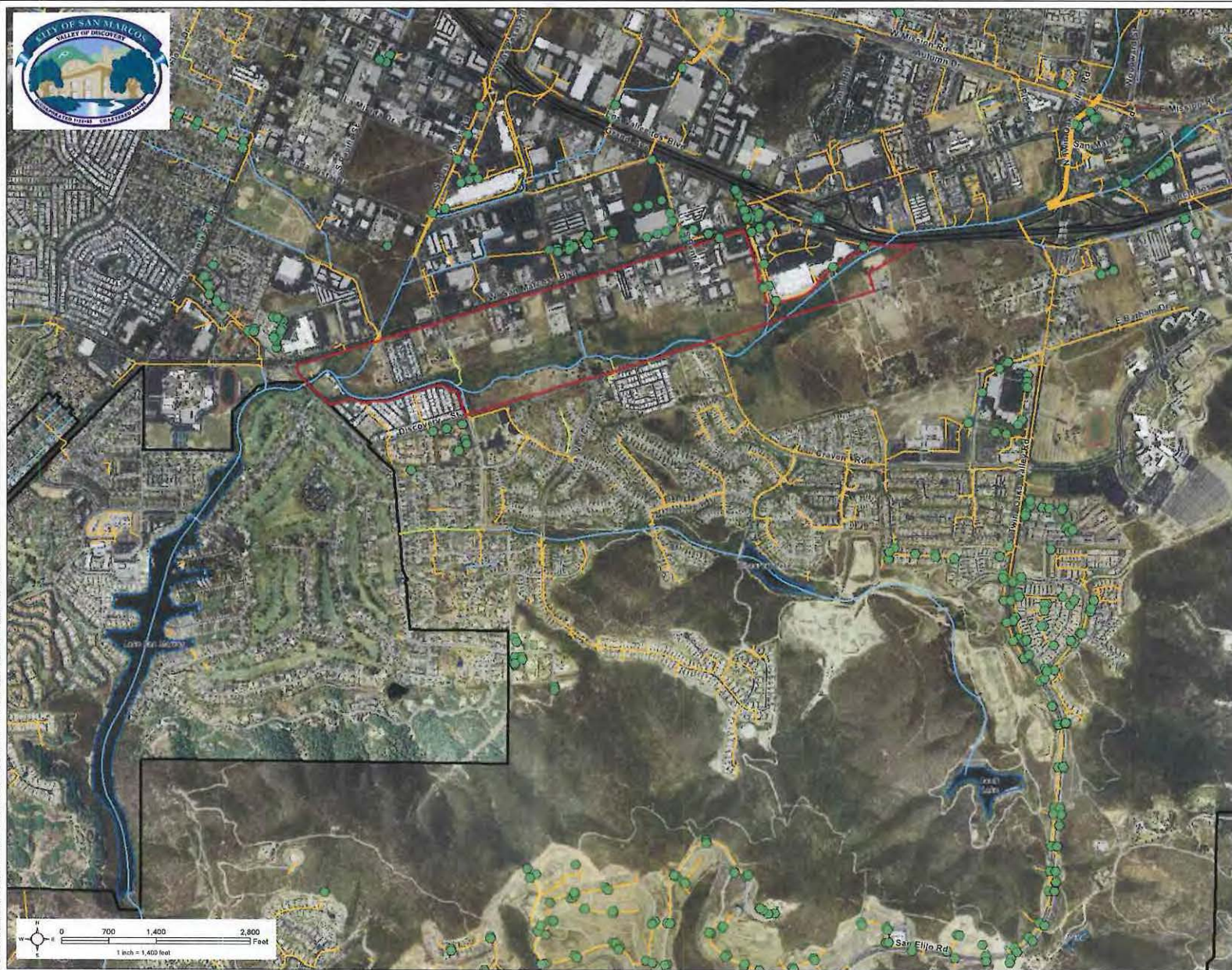

Table 2-3 represents existing water quality conditions within the Specific Plan area under existing land use conditions (See **Appendix A**, MOE 2011). Without water quality treatment in the proposed Specific Plan Area, the pollutant concentrations estimated in **Table 2-3** would continue for 1 - bacteria (fecal coliform), 2-oil and grease, 3-sediment (TSS), 4- nutrients (NH₃, NO₂+NO₃, Nitrogen Total Kjeldahl, phosphorous (Total), and 5 – metals (Cd, Cu, Pb, Ni, Zn).



FINAL San Marcos Creek Specific Plan Master Water Quality and Hydromodification Management Plan

Figure 2-3 Existing Treatment Controls in SP Area



San Marcos Creek Vicinity Existing MS4 System / Water Quality BMPs

- BMP
- Brow Ditch
- Channel wider than 5 ft
- Ditch less than 5 ft wide
- Storm Mains
- Detention Basins
- Lakes
- San Marcos Creek Specific Plan Area
- San Marcos City Limits

Source of Data: SanGIS, 07/10 and City of San Marcos, 2/11

Created By: City of San Marcos GIS

Every effort has been made to assure the accuracy of the maps and data provided; however, some information may not be accurate or current. The City of San Marcos assumes no responsibility arising from use of this information and incorporates by reference its disclaimer regarding the lack of any warranties, whether expressed or implied, concerning the use of the same. For additional information see the Disclaimer on the City's website.



FINAL San Marcos Creek Specific Plan Master Water Quality and Hydromodification Management Plan

**Table 2-3
Estimated Existing Land Use Pollutant Concentrations**



Constituent	Units	Estimated Existing Concentrations of Pollutants in Specific Plan Area
TSS	(mg/L)	90.07
COD	(mg/L)	109.59
Fecal Coliform	(mpn/100 mL)	4,962.7
NH3	(mg/L)	0.73
NO2+NO3	(mg/L)	0.74
Nitrogen, Total Kjeldahl	(mg/L)	1.71
Phosphorous, Total	(mg/L)	0.45
Cd, Total	(ug/L)	0.84
Cu, Total	(ug/L)	21.77
Pb, Total	(ug/L)	29.66
Ni, Total	(ug/L)	7.63
Zn, Total	(ug/L)	190.74
Oil and Grease	(mg/L)	2.57

The estimated existing pollutant concentrations were calculated using land use types from the National Stormwater Quality Database EPA rainfall Zone 6 (see **Appendix A**, MOE Preliminary Water Quality Treatment Analysis, July 2011) .



FINAL San Marcos Creek Specific Plan

Master Water Quality and Hydromodification Management Plan

2.4 2002/2007 SWAMP ASSESSMENTS IN SAN MARCOS CREEK

In 2002 and 2007, the Stormwater Ambient Monitoring Program (SWAMP) conducted a physical habitat assessment in the San Marcos Creek in just south of McMahr (see results for 2002/2007 SWAMP 904CBSAM3). The SWAMP assessment compared physical habitat component ranges for 10 physical habitat components. Numeric ratings from 0 (poor rating - heavily impacted habitat) to 20 (best rating - unimpacted habitat) were given to each component. The ability of a creek to perform natural water quality functions and its susceptibility to hydromodification are inherent in the physical habitat components. In general, the concept is that a balanced physical stream system provides the maximum water quality benefit and resistance to hydromodification. **Table 2-4** summarizes the individual physical habitat ratings for San Marcos Creek in the Specific Plan area and provides a generalized assessment of those features that relate most to water quality and those physical habitat features that relate most to hydromodification. The 2002 SWAMP mean rating for San Marcos Creek was 11.5 based on all components and was rated a moderately altered habitat (greater than 10). Good bank stability is achieved for scores over 15.

Table 2-4

Summary of SWAMP 2002/2007 Physical Habitat Assessment for San Marcos Creek in Specific Plan Area

Physical Habitat Component Description	Score	Generalized WQ or HMP Component of Natural Creek System
Epifaunal Cover	11	WQ
Embeddedness	2	WQ
Velocity Depth Regime	11	HMP/WQ
Sediment Deposition	20	HMP/WQ
Channel Flow	19	HMP/WQ
Channel Alteration	2	WQ
Riffle Frequency	6	WQ
Bank Stability	20	HMP
Vegetation Protection	18	HMP/WQ
Riparian Zone	6	WQ

Source: 2002 and 2007 SWAMP Reports on the Carlsbad Hydrologic Unit

The overall summary rating for San Marcos Creek in the Specific Plan Area was rated poor based on three ecological health indicators. Water Chemistry (High severity of impact; 6+ exceedences of aquatic life), Toxicity (Low severity of Impact; Frequency of toxicity between 0.0 and 0.1) and Bioassessment (High



FINAL San Marcos Creek Specific Plan

Master Water Quality and Hydromodification Management Plan

Severity of impact, IBI score between 0 and 40). This result was also identified for two locations assessed from 1998 through 2002 and included in the SDRWQCB 2002 Biological Assessment Report where site IDs 44 and 46 (one near McMahr and one near Rancho Santa Fe Road) also had poor IBI scores (both between 10 and 45) and BMI (bio assessment metrics and benthic macroinvertebrate) assessments which supported the poor rating.

The San Marcos Creek in the Specific Plan Area, while it has relatively stable banks, is in effect not a balanced stream system and is currently functioning at a substantially diminished capacity to naturally uptake water quality constituents.

DUDEK and associates confirmed during focused biological resource assessments for the Specific Plan proposed corridor of restoration for Las Posas Creek and San Marcos Creek that of the estimated 43.54 acres of existing wetlands, that roughly 35 acres (90%) were disturbed wetlands with inclusions of between 20% to 100% weeds. Undisturbed wetlands (wetlands with less than 20% weeds) comprised only 8.61 acres (10%) of the natural creek systems in the specific plan area.

2.5 EXISTING WATER QUALITY IN SPECIFIC PLAN AREA

Figure 2-4 shows ongoing water quality monitoring stations that are conducted annually in the specific plan area for two purposes:

- MS4 dry weather monitoring; and
- Upper San Marcos Creek Nutrient Management Plan and Voluntary Nutrient TMDL data gathering efforts.

There are currently five monitoring stations in the Specific Plan Area. Like the rest of the Calrsbad Watershed and County-wide, urban runoff for nutrients and bacteria are above the Basin Plan Water Quality Objectives and generally below the Order R9 2007-0001 actionable levels.

Data gathered from these monitoring stations will be used to identify existing baseline water quality for the specific plan area.



FINAL San Marcos Creek Specific Plan Master Water Quality and Hydromodification Management Plan

Figure 2-4 Existing Water Quality Monitoring Stations in Specific Plan Area

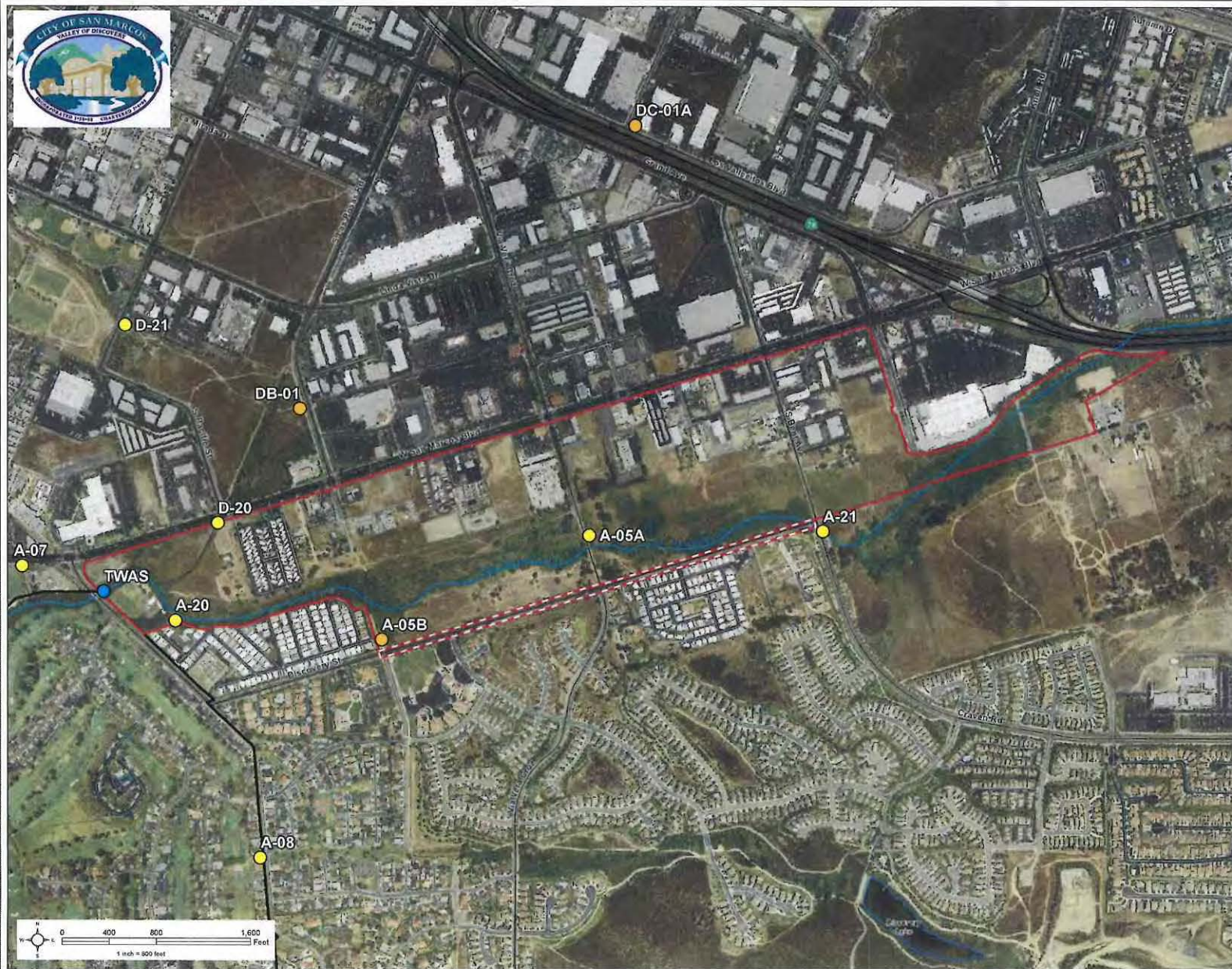

San Marcos Creek Monitoring Stations

- Mass Loading (TWAS) Site
- Dry Weather Sites
- Lake San Marcos Quarterly Monitoring Sites
- ~ San Marcos Creek
- Lakes
- San Marcos Creek Specific Plan Area
- Discovery Street ROW (Included in master WQTR analysis)
- San Marcos City Limits

Source of Data: SanGIS, 07/10 and City of San Marcos, 7/11

Created By: City of San Marcos GIS

Every effort has been made to assure the accuracy of the maps and data provided; however, some information may not be accurate or current. The City of San Marcos assumes no responsibility arising from use of this information and incorporates by reference its disclaimer regarding the lack of any warranties, whether expressed or implied, concerning the use of the same. For additional information see the Disclaimer on the City's website.



FINAL San Marcos Creek Specific Plan Master Water Quality and Hydromodification Management Plan

3.0 WATER QUALITY/HYDROMODIFICATION COMPLIANCE REQUIREMENTS

3.1 DRAINAGE MANAGEMENT AREAS

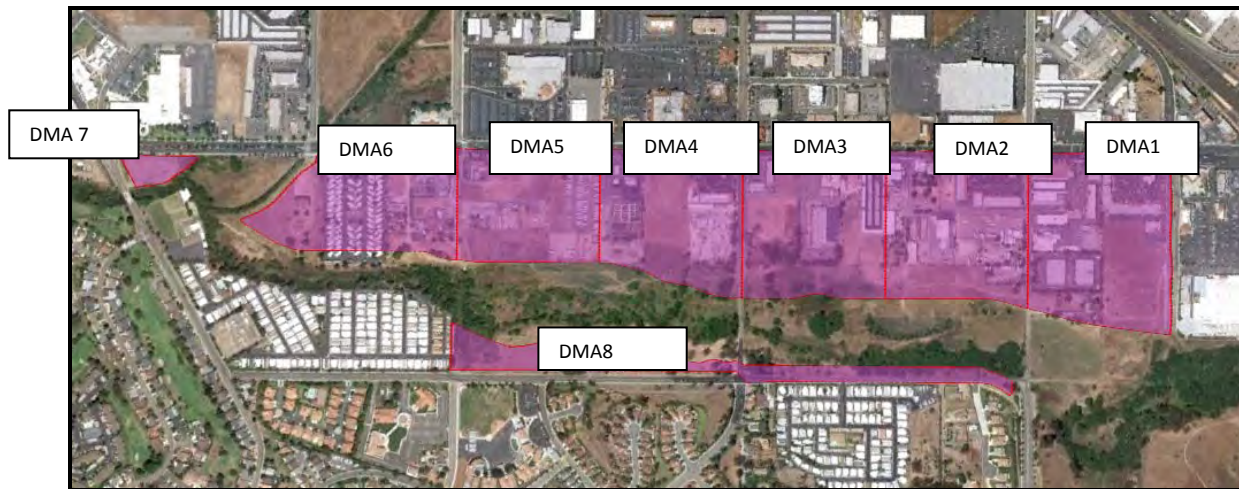

Specific Plan DMA Concept

The Specific Plan area was divided into a total of eight Drainage Management Areas (DMAs) with corresponding discharge points. Each of these eight DMAs was designated to share common hydrology and be constructed with backbone drainage systems in Phase I to correspond to function both individually and collectively in the specific plan area. (See **Figure 3-1**). It is intended that each DMA will have its own distinct water quality treatment and hydromodification facilities to address runoff and pollutants generated by all of the public streets and a designated portion of the private development land uses in each DMA. Each DMA in the Specific Plan area will be constructed with a shared water quality and HMP bioretention facility sized to meet the approved HMP plan adopted by the SDRWQCB and treat the 2-year storm for water quality required under the March 25, 2010 SUSMP requirements. The concept of shared facilities for a master plan area is allowed in the permit and is in fact preferred by the SDRWQCB. The City of San Marcos discussed the DMA approach and shared facility management approach for permit compliance with the SDRWQCB and gained conceptual approval as an acceptable approach to permit compliance.



FINAL San Marcos Creek Specific Plan Master Water Quality and Hydromodification Management Plan

Figure 3-1 DMA areas wayne chang



NOTE:

DMA'S ARE BASED ON THE ALTERNATIVE 7 SITE PLAN.

GRAPHIC SCALE

0 250 500



1 INCH = 500 FEET

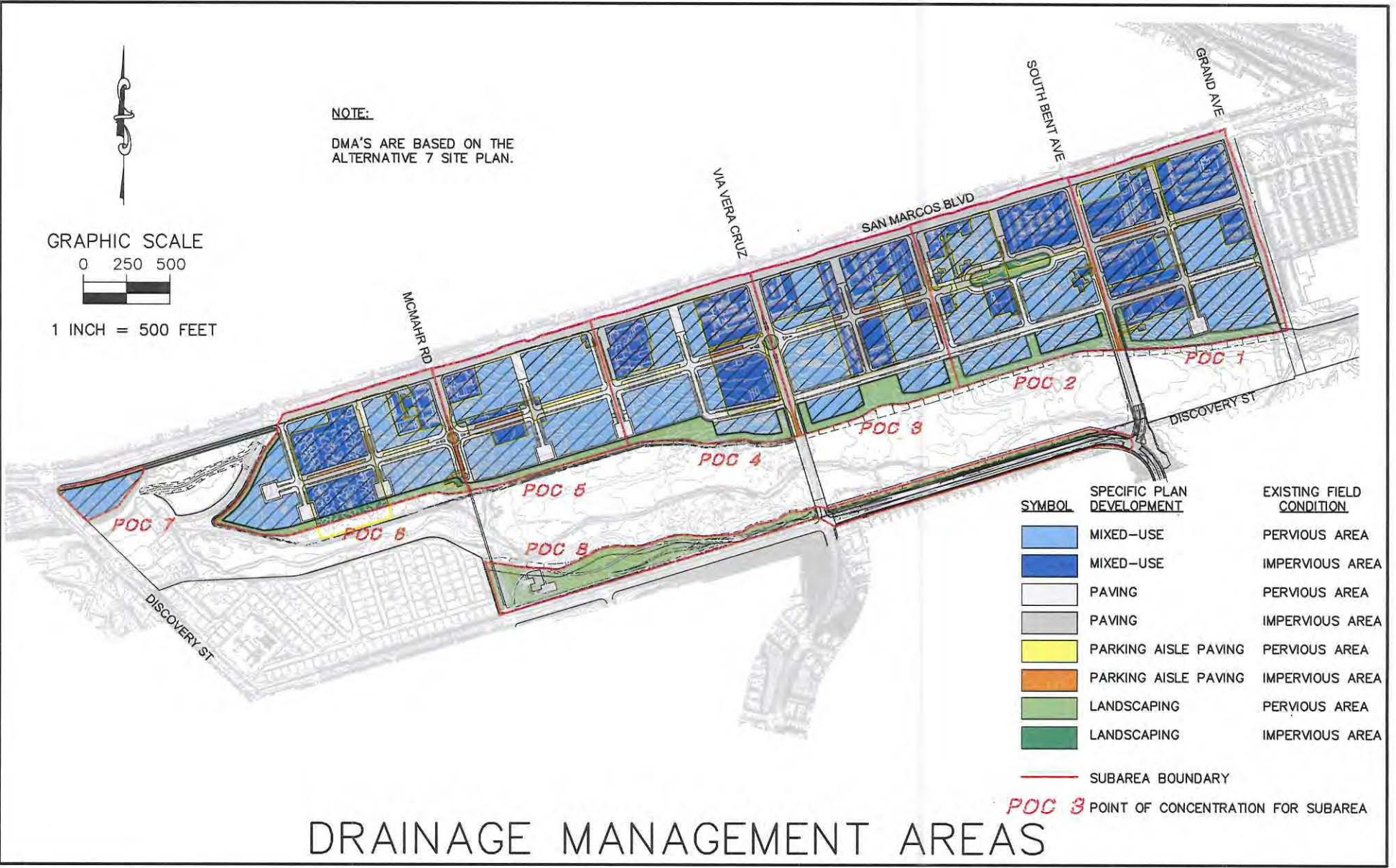

SYMBOL	SPECIFIC PLAN DEVELOPMENT	EXISTING FIELD CONDITION
	MIXED-USE	PERVIOUS AREA
	MIXED-USE	IMPERVIOUS AREA
	PAVING	PERVIOUS AREA
	PAVING	IMPERVIOUS AREA
	PARKING AISLE PAVING	PERVIOUS AREA
	PARKING AISLE PAVING	IMPERVIOUS AREA
	LANDSCAPING	PERVIOUS AREA
	LANDSCAPING	IMPERVIOUS AREA
	SUBAREA BOUNDARY	
	POC 3 POINT OF CONCENTRATION FOR SUBAREA	

DRAINAGE MANAGEMENT AREAS



FINAL San Marcos Creek Specific Plan

Master Water Quality and Hydromodification Management Plan

Shared facilities for public and private development for each of the DMAs ensures that water quality and HMP facilities and requirements are appropriately maintained and met by placing the shared facilities under a City managed community facilities district (CFD). The CFD will include monitoring and maintenance costs that will be required under the 401 permit for this project for water quality.

Compliance with the January 2011 Order R9 2007-0001 permit is based on each of the DMAs meeting the required sizing for water quality treatment and HMP in the promenade. In order to be in compliance with Order R9 2007-0001, each individual DMA must:

1. Meet permit compliance requirements at the designated discharge points for each DMA; and
2. The entire Specific Plan must meet permit compliance requirements in its entirety.



Water Quality/HMP Shared Facility Concept

In short, the DMAs function and meet expected permit compliance requirements independently from each other but also must collectively achieve permit compliance for the entire specific plan area.

3.2 HYDROMODIFICATION ASSESSMENT

Chang Consultants prepared a hydromodification and water quality facility analysis in accordance with the adopted City SUSMP and HMP plan approved by the SDRWQCB. The study identified the required bioretention facilities to meet



FINAL San Marcos Creek Specific Plan

Master Water Quality and Hydromodification Management Plan

HMP and water quality facilities for public and private shared facilities. Bio retention facilities were selected as the permit required treatment control facility for DMAs 1-8 for the following reasons:

- Pollutants of concern must be treated by a medium pollutant efficiency removal rate or better;
- Bioretention facilities provide the appropriate pollutant removal efficiency rate for metals (selenium), nutrients, and bacteria.

The analyses were performed to provide base numerics for permit compliance over the development life of the Specific Plan area to ensure that permit compliance, water quality, and HMP effects were properly mitigated over the life of the project.

The City of San Marcos will construct hydromodification facilities to serve 100 percent of their infrastructure improvements a portion of the facilities will have excess capacity allowing some treatment and HMP capacity for private development projects. In most cases, an individual developer will be required to address their hydromodification needs as part of their project design and in accordance with this document and the current SUSMP requirements. Detailed hydromodification analyses must be prepared for each development project and submitted to the City for review and approval.

In addition, the percent capacity outlined for each DMA will be reported on an annual basis to the SDRWQCB under the 401 permit MMRP process to ensure that permit compliance has been continually met.

The following is a summary of the analysis contained in Appendix A:

3.3 HYDROMODIFICATION CRITERIA USED FOR SPECIFIC PLAN ANALYSIS

Hydromodification must be implemented to ensure that post-development peak flows and durations do not exceed pre-development peak flows and durations. The SUSMP criteria are generally defined as follows (see **Appendix A** for a more detailed description of the criteria):

1. The post-project discharge rates and durations shall not deviate above the pre-project rates and durations by more than 10 percent over and more than 10 percent of the length of the flow duration curve.



FINAL San Marcos Creek Specific Plan Master Water Quality and Hydromodification Management Plan

2. For flow rates ranging from the lower flow threshold to Q_5 , the post-project peak flows shall not exceed pre-project peak flows.
3. Tables 7-1 through 7-5 in the HMP (See **Appendix B**) were used for sizing factors for various preferred facilities including bioretention. The sizing factors will yield similar results as the County of San Diego's BMP Sizing Calculator. Appendix A also has for the overall specific plan area. the results of the BMP sizing calculator
4. The sizing factor selection depends on the applicable lower flow threshold ($0.1Q_2$, $0.3Q_2$, or $0.5Q_2$).
5. SCWWRP's Hydromodification Screening Tool for Southern California was conducted for the San Marcos Creek in the Specific Plan Area (See **Appendix B**) and the analysis resulted in a $0.5Q_2$ lower flow threshold.
6. The HMP analysis used a conservative approach to ensure that the water quality/ HMP bioretention facilities were conservatively sized. Assumptions included:
 - a. Type D soils for the entire Specific Plan area;
 - b. Building setbacks;
 - c. Proximity to the floodwall;
 - d. Backbone underground utility clearances;
 - e. Geotechnical information;
 - f. Groundwater levels in the promenade;
 - g. Specific Plan recreational requirements; and
 - h. Street right of way requirements.

Underground systems were evaluated; however, due to proximity to the floodwall and the high groundwater in the promenade area (5 feet to 10 feet below grade), vault systems were deemed infeasible at the preliminary assessment level. In addition, Order R9 2007-0001 specifies that infiltration methods must be considered first and foremost before going to non-infiltration methods. Therefore, all HMP and water quality facilities in the promenade are bioretention facilities.



FINAL San Marcos Creek Specific Plan

Master Water Quality and Hydromodification Management Plan

3.4 SAN MARCOS CREEK CHANNEL SUSCEPTIBILITY ANALYSIS

A channel screening study has been performed for the project and is included in **Appendix B**. The study determined that the receiving waterbody, San Marcos Creek, has a low susceptibility to erosion. Consequently, the hydromodification analyses are based on a 50 percent lower flow threshold, or .5 Q₂. See **Figure 3-2**.

3.5 SUMMARY OF CHANG AND CONSULTANTS JUNE 2011 HMP/WATER QUALITY ANALYSIS

□ Approach and Factors

The Alternative 7 Specific Plan area was subdivided into eight subareas for independent hydromodification analyses (**see Figure 3-1**). Each subarea has a hydromodification point of compliance at its discharge point into San Marcos Creek. Seven subareas cover the primary Specific Plan development area (mixed-use, streets, Promenade, etc.) north of San Marcos Creek, while the eighth subarea covers the Discovery Street widening and park land south of San Marcos Creek (see **Figure 3-1**).

Subareas 1 through 6 support generally rectangular mixed-use development blocks bounded by north-south and east-west aligned streets. The southerly strip along San Marcos Creek will contain a landscaped Promenade with a multi-use trail. Drainage Management Areas (DMA) were delineated within each subarea. The DMA's define individual areas of mixed-use development, paving, and landscaping.

The proposed mixed-use development was assumed to contain 85 percent impervious surfaces and 15 percent pervious surfaces. The proposed streets consist of standard (asphalt or concrete) paved surfaces in the travel lanes as well as in the diagonal parking areas and in the widened parallel parking aisles.

Figure 3-1 delineates the post-project mixed-use, paving, and landscaping DMA's within each subarea. Under pre-project conditions, development (commercial, retail, industrial, streets, etc.) exists in portions of the Specific Plan area.

The pre-project developed areas were delineated in a general manner using aerial photographs, topographic mapping, and a field investigation. The pre-project developed areas were assumed to contain 90 percent impervious surfaces and 10 percent pervious surfaces based on the document review and field investigation. Each DMA category was further refined to reflect areas supporting pre-project development (90 percent impervious area) or with no pre-project development (pervious area).



FINAL San Marcos Creek Specific Plan Master Water Quality and Hydromodification Management Plan

Figure 3-2 – Proposed IBI and DMA Locations

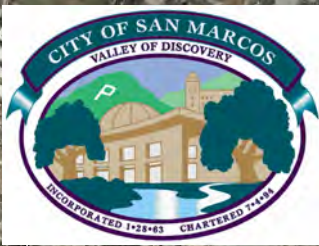

San Marcos Creek Proposed Master WQTR IBI Monitoring Locations and HMP Drainage Management Areas

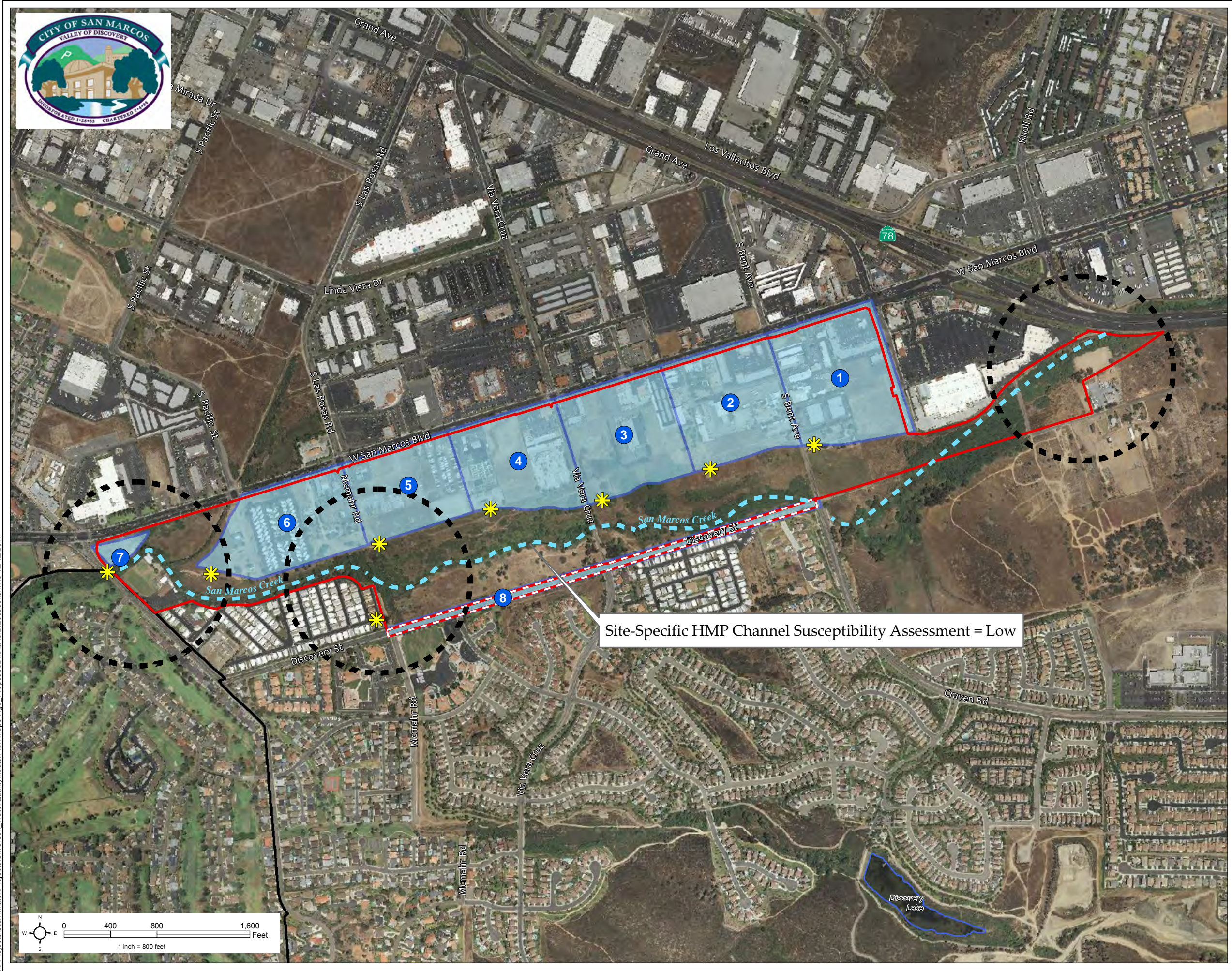

- 1 Drainage Management Areas ID#
- ★ Discharge Points
- ☾ Lakes
- HMP SCWRP Analysis
- Drainage Management Areas (DMA)
- Proposed IBI Monitoring Locations
- San Marcos Creek Specific Plan Area
- Discovery Street ROW
(Included in master WQTR analysis)
- San Marcos City Limits

Site-Specific HMP Channel Susceptibility Assessment = Low

Source of Data: City of San Marcos, 7/2009 & 12/2011
Created By: City of San Marcos GIS

Every effort has been made to assure the accuracy of the maps and data provided; however, some information may not be accurate or current. The City of San Marcos assumes no responsibility arising from use of this information and incorporates by reference its disclaimer regarding the lack of any warranties, whether expressed or implied, concerning the use of the same. For additional information see the Disclaimer on the City's website.

X:\Projects\Stormwater\Projects\SMCreek_WaterQualityMasterPlan\Maps\Fig6_ProposedDMAAndIBILocations.mxd 12/12/2011

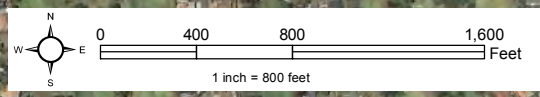



FINAL San Marcos Creek Specific Plan

Master Water Quality and Hydromodification Management Plan

Appendix C contains a spreadsheet summarizing the DMAs tributary to each point of compliance for Subareas 1 through 8. The spreadsheet defines individual DMAs for the post-project mixed-use development, paving, and landscaping categories. During final engineering of any future development projects in the Specific Plan area, these assumptions will need to be verified and adjusted by each project, as appropriate.

3.6 HYDROMODIFICATION FACILITY SIZING

The DMA results are used for hydromodification facility sizing within each of the eight subareas. Each DMA is multiplied by a runoff factor, which provides an area reduction due to infiltration through the DMA surface. (See **Appendix B**, Table 1).

The final step in the hydromodification sizing is to determine the necessary treatment areas and volumes for each DMA. The City of San Marcos intends to include bioretention basins in the Promenade within each subarea DMA.

Spurlock Poirier determined the bioretention area available in the Promenade within each subarea (see **Figure 3-3**). The bioretention basin sizing is calculated by multiplying the total subarea DMA by the appropriate sizing factors from Table 7-1 of the County of San Diego HMP (see **Appendix B**).

The sizing factors in Table 7-1 were chosen based on the following values: lower flow threshold ($0.5Q_2$), soil group (D), existing ground slope (flat), and rain gauge (Oceanside).

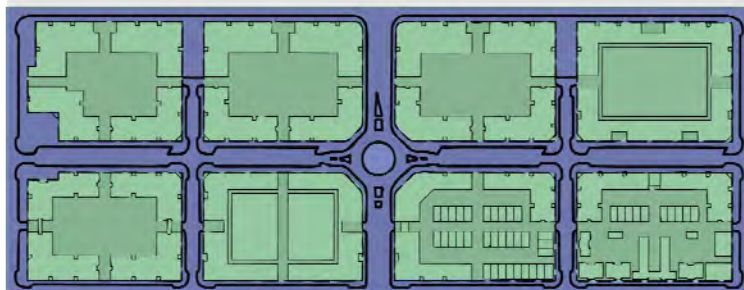

Private
Public

within the public right-of-way and the Promenade).

Therefore, the mixed-use areas were subtracted from the DMAs for the sizing. The bioretention basin results are summarized in **Table 3-1**. The sizing will provide the required flow control and will also satisfy the treatment control needs for the public areas.

For these values, the surface area, surface volume, and subsurface volume sizing factors are 0.065, 0.0542, and 0.0390, respectively. The bioretention basins will treat the public areas (streets and sidewalks



FINAL San Marcos Creek Specific Plan

Master Water Quality and Hydromodification Management Plan

Table 3-1
Bioretention Basin Sizing to Treat Public Areas

DMA	Adjusted DMA, ac	Surface Area, ac	Surface Volume, ac-ft	Subsurface Volume, ac-ft	Bio retention Area Available in Promenade (Alt 7) Surface Area, ac	Permit Compliance Met HMP/WQ
1	2.30	0.15	0.12	0.09	0.18	YES
2	3.92	0.25	0.21	0.15	0.30	YES
3	3.43	0.22	0.19	0.13	0.32	YES
4	3.61	0.23	0.20	0.14	0.31	YES
5	3.39	0.22	0.18	0.13	0.20	YES
6	3.29	0.21	0.18	0.13	0.37	YES
7	0.06	0.0038	0.0032	0.0023	0.0032	YES
8	3.28	0.21	0.18	0.13	0.18	YES

A comparison of the required bioretention basin surface area in Table 3-1 with the available surface area by Spurlock Poirier (See **Figure 3-3**) reveals that the available area is sufficient. Spurlock Poirier did not determine the available bioretention area in Subarea 8, but this is primarily park land, so sufficient area is available.

An additional analysis was performed to determine the bioretention basin sizing assuming each entire subarea is treated (including the mixed use areas). The results are provided in **Table 3-2**.



FINAL San Marcos Creek Specific Plan

Master Water Quality and Hydromodification Management Plan

Table 3-2
Bioretention Basin Sizing to Treat All Areas
(100% Public and 100% Private)

DMA	Adjusted DMA, ac	Surface Area, ac	Surface Volume, ac-ft	Subsurface Volume, ac-ft	% Remainder in Shared Facilities Available for Private Development (see Table 3-1)
1	9.32	0.61	0.51	0.36	7
2	11.15	0.72	0.60	0.43	11
3	10.21	0.66	0.55	0.40	23
4	9.12	0.59	0.49	0.36	22
5	11.10	0.72	0.60	0.43	4
6	8.86	0.58	0.48	0.35	44
7	1.33	0.09	0.07	0.05	0
8	3.28	0.21	0.18	0.13	n/a

The available bioretention area in the Promenade is not sufficient for the entire subarea. The available bioretention area constructed in the promenade would be constructed to provide 100% of the surface area for each DMA from Table 3-1 and for 100% of the public facilities and between 7% to 44% of the private development surface area in **Table 3-2**. Consequently, the private development areas will need to provide supplemental treatment systems on site to make up the difference.



**FINAL San Marcos Creek Specific Plan
Master Water Quality and Hydromodification
Management Plan**

**MASTER WQTR DMA COMPLIANCE POINTS
FOR DEVELOPMENT IN SPECIFIC PLAN AREA**

CREEKSIDE PROMENADE
CONCEPTUAL BIO-INFILTRATION TAKEOFFS
ALTERNATIVE 7

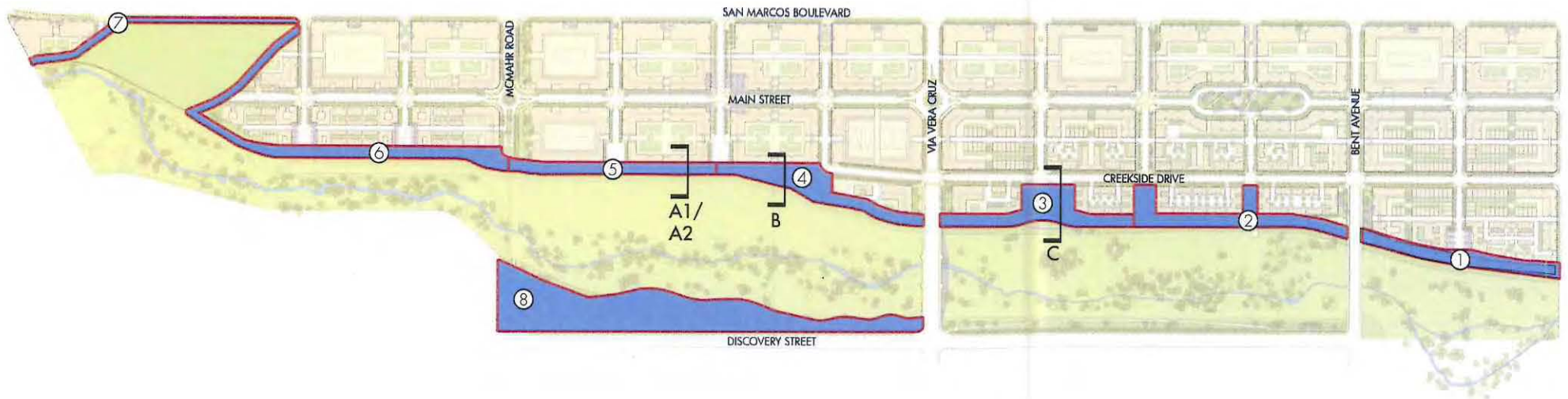

CREEKSIDE PROMENADE
ALTERNATIVE 7
SECTION A1

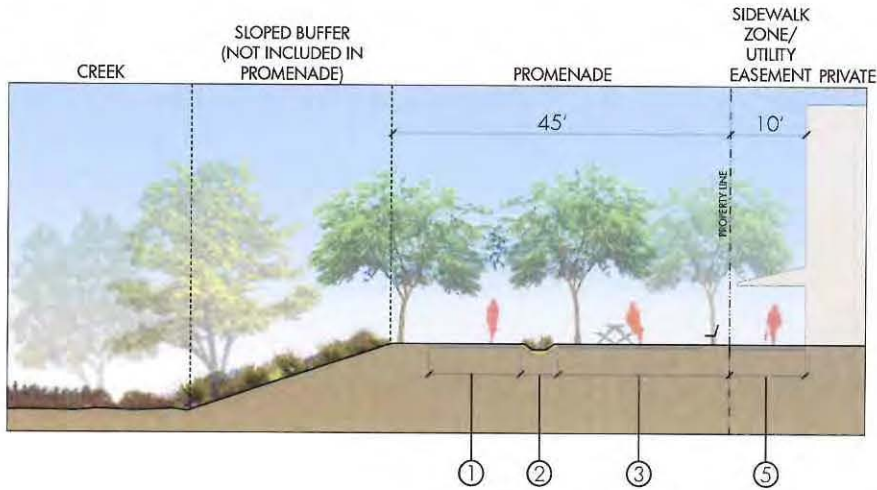

ALTERNATIVE 7
SECTION A2

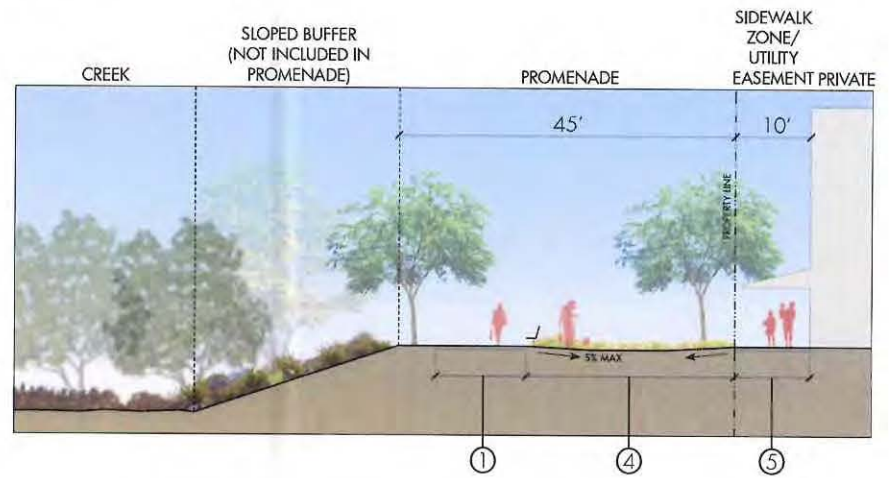

- ① 12' WIDE MULCH TRAIL
- ② INFILTRATION BAND, 10% WIDTH OF PROMENADE (4.5' SWALE AS SHOWN)
- ③ MINOR OPEN SPACE AMENITY AREA (22' AS SHOWN)
- ④ SELF-RETAINING/RECREATIONAL USE AREA (30' AS SHOWN)
- ⑤ SIDEWALK ZONE / UTILITY EASEMENT

CREEKSIDE PROMENADE
 ALTERNATIVE 7
 SECTION B

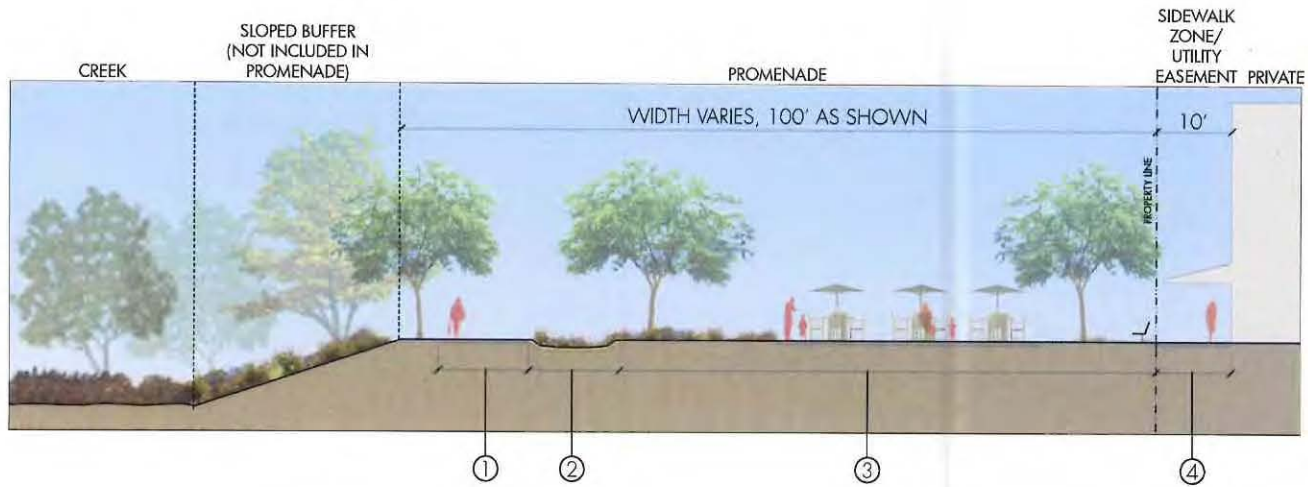

- ① 12' WIDE MULTI-USE TRAIL
- ② INFILTRATION BAND, 10% WIDTH OF PROMENADE (10' SWALE AS SHOWN)
- ③ MAJOR OPEN SPACE AMENITY AREA (70' AS SHOWN)
- ④ SIDEWALK ZONE / UTILITY EASEMENT

CREEKSIDE PROMENADE
ALTERNATIVE 7
SECTION C

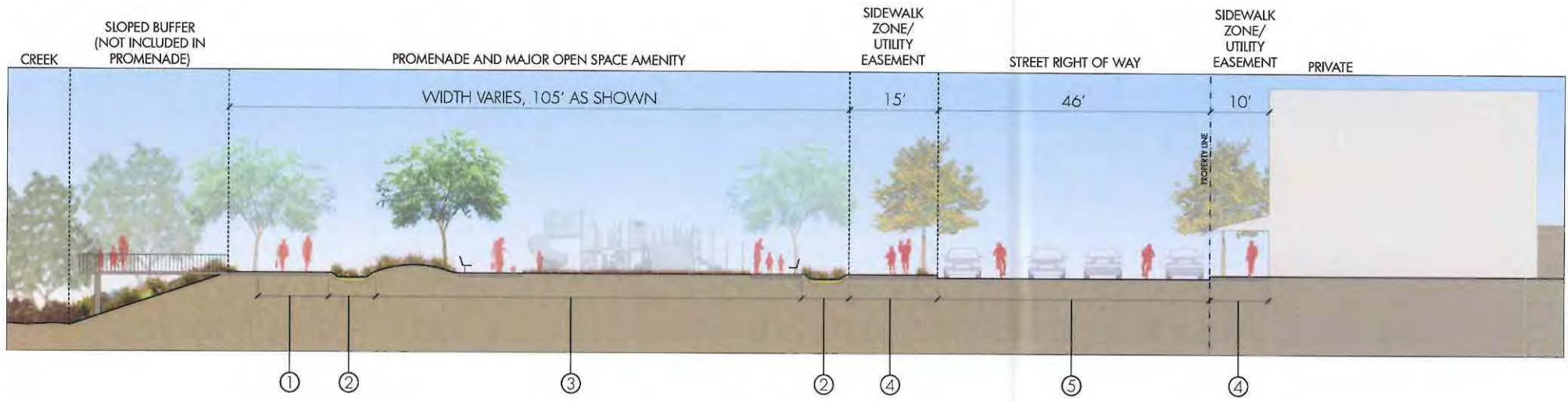

- ① 12' WIDE MULTUSE TRAIL
- ② INFILTRATION BAND, 10% WIDTH OF PROMENADE (TWO 6' SWALES AS SHOWN)
- ③ MAJOR OPEN SPACE AMENITY AREA
- ④ SIDEWALK ZONE / UTILITY EASEMENT
- ⑤ STREET R.O.W. PER SPECIFIC PLAN



FINAL San Marcos Creek Specific Plan Master Water Quality and Hydromodification Management Plan

3.7 CONCLUSION

The hydromodification analyses demonstrate that the Promenade bioretention area for flow and treatment control of run off generated with the required percent provides by the public areas to meet permit compliance. Private development will need to supplement this with LID to maximize infiltration onsite as required by the permit and specific plan (See **Appendix C**). The analyses contained herein are part of the Master Water Quality/HMP Management Plan and intended to provide general guidelines for BMPs in the Specific Plan area. More detailed analyses will be required for each final engineering project in the Specific Plan area. The detailed analyses should include confirmation of the downstream lower flow threshold and conditions in the project area. These conditions should be reassessed on an annual monitoring schedule to ensure accuracy of the results.



FINAL San Marcos Creek Specific Plan

Master Water Quality and Hydromodification Management Plan

4.0 WATER QUALITY POLLUTANT REMOVAL EFFECTIVENESS

4.1 STUDY FINDINGS

MOE made a water quality pollutant removal effectiveness for the overall specific plan area and on a DMA basis to provide a preliminary effectiveness assessment. (See Appendix A). MOE assumed that 20% of the urban runoff from the proposed impervious development (110 ac.) would be treated via engineered Bioretention Units, and the remaining 80% of the site will be treated via other BMPs or combinations of BMPs available. The City intends to implement the most effective BMPs for the uses that are permitted by the Specific Plan to achieve the removal efficiencies required by the current municipal stormwater permit. **Table 4-1** shows the general pollutant removal effectiveness of bioretention units which are listed as water quality treatment objectives for the Specific Plan Area, including flow-through planters, bioswales, and porous pavers.

**Table 4-1
Bioretention Pollutant Removal Effectiveness**

Pollutant	Removal Rate*	Removal Rate for Analysis
Total Suspended Solids	90%	90%
COD	N/A	82%
Bacteria	90%	90%
NH3	N/A	70% - low end of phosphorous
NO2+NO3	N/A	70% - low end of phosphorous
TKN	68% - 80%	74%
Total Phosphorous	70% - 83%	76%
Metals (Cu, Zn, Pb)	93% - 98%	95%
Metals (Cd, Ni)	N/A	93% - low end of metals

*Source: EPA, 1999

The pollutant removal effectiveness of the Bioretention Units has been documented in various locations, e.g., EPA, CASQA, LID manuals, etc. The following table lists the Removal Rates for properly designed and constructed Bioretention Units. For the Specific Plan, a conservative approach to pollutant removal effectiveness is taken. Table 4-1 also includes the % removal rates



FINAL San Marcos Creek Specific Plan

Master Water Quality and Hydromodification Management Plan

applied to the portion of urban runoff that is to be treated by Bioretention Units. Tables 4-2 and 4-3 show that for all pollutants of concern overalls and at each DMA level, a reduction and effective removal rate of medium or better would be achieved for the project.

Table 4-2

Comparison between Existing and Proposed Pollutant Concentrations – With Treatment (Bioretention) for Entire Study Area

Constituent	Units	Existing	Proposed with Treatment	Difference
TSS	(mg/L)	90.07	9.92	-80.14
COD	(mg/L)	109.59	4.13	-105.47
Fecal Coliform	(mpn/100 mL)	4,962.73	296.04	-4666.69
NH3	(mg/L)	0.73	0.54	-0.19
NO2+NO3	(mg/L)	0.84	0.63	-0.21
Nitrogen, Total Kjeldahl	(mg/L)	1.71	0.75	-0.96
Phosphorous, Total	(mg/L)	0.45	0.11	-0.34
Cd, Total	(ug/L)	0.84	0.08	-0.77
Cu, Total	(ug/L)	21.77	3.03	-18.74
Pb, Total	(ug/L)	29.66	2.94	-26.72
Ni, Total	(ug/L)	7.63	0.85	-6.78
Zn, Total	(ug/L)	190.74	19.02	-171.72
Oil and Grease	(mg/L)	2.57	0.10	-2.47



FINAL San Marcos Creek Specific Plan

Master Water Quality and Hydromodification Management Plan

Table 4-3

Percent Difference between Existing and Proposed Pollutant Concentrations – With Treatment (Bioretention) by Drainage Management Area

Pollutant	DMA								Total Project Area
	BMP 1	BMP 2	BMP 3	BMP 4	BMP 5	BMP 6	BMP 7	BMP 8	
TSS	-90.6%	-91.4%	-86.7%	-89.7%	-85.6%	-86.6%	-78.5%	-88.7%	-89.0%
COD	-96.8%	-96.9%	-95.7%	-96.6%	-95.0%	-95.5%	-88.5%	-96.5%	-96.2%
Fecal Coliform	-94.3%	-94.3%	-94.4%	-94.0%	-94.9%	-93.7%	-95.6%	-91.4%	-94.0%
NH3	-34.7%	-11.6%	-31.6%	-37.8%	-12.6%	-14.8%	222.3%	-43.9%	-26.4%
NO2+NO3	-31.1%	-41.1%	-11.6%	-28.1%	-8.7%	-19.9%	41.9%	-26.7%	-25.3%
Nitrogen, Total Kjeldahl	-61.4%	-63.0%	-49.6%	-59.4%	-43.9%	-51.1%	11.6%	-58.5%	-56.1%
Phosphorous, Total	-78.7%	-81.9%	-68.7%	-76.3%	-67.3%	-69.4%	-56.1%	-71.1%	-75.0%
Cd, Total	-92.1%	-93.1%	-88.0%	-91.1%	-87.5%	-89.5%	-78.4%	-90.6%	-90.7%
Cu, Total	-88.0%	-90.3%	-79.6%	-85.9%	-80.4%	-83.4%	-69.1%	-89.8%	-86.1%
Pb, Total	-91.7%	-94.3%	-81.0%	-89.8%	-83.5%	-89.0%	-63.4%	-90.7%	-90.1%
Ni, Total	-91.0%	-92.7%	-82.6%	-89.7%	-81.2%	-87.5%	ND	-86.7%	-88.9%
Zn, Total	-91.8%	-93.3%	-85.2%	-90.6%	-84.4%	-88.5%	-45.5%	-89.4%	-90.0%
Oil and Grease	-96.3%	-96.1%	-95.7%	-96.3%	-95.1%	-95.4%	-91.4%	-96.4%	-95.9%

In order to perform a desktop validation of the results of the study, the proposed pollutant concentrations following bioretention treatment were compared with irreducible pollutant concentrations located in published studies. As the data is limited, some of the concentrations from the literature appear as ranges and not as absolute values. The pollutant concentrations presented in this study using the percent removal method are within reasonable range of the irreducible concentrations proposed by the literature. Tables 4-4 presents the comparison between the existing, proposed, and literature pollutant concentrations. Similarly, Table 4-5, is a summary of the results when analyzed on a DMA level.



FINAL San Marcos Creek Specific Plan

Master Water Quality and Hydromodification Management Plan

Table 4-4

Comparison between Existing, Proposed with Treatment, and Literature Pollutant Concentrations for Entire Study Area

Constituent	Units	Literature*	Existing	Proposed with Treatment
TSS	(mg/L)	TSS=10	90.07	9.92
COD	(mg/L)		109.59	4.13
Fecal Coliform	(mpn/100 mL)		4,962.73	296.04
NH3	(mg/L)		0.73	0.54
NO2+NO3	(mg/L)		0.84	0.63
Nitrogen, Total Kjeldahl	(mg/L)	1.1<[N _T <1.69	1.71	0.75
Phosphorous, Total	(mg/L)	0.048<[P]<1.3 98	0.45	0.11
Cd, Total	(ug/L)		0.84	0.08
Cu, Total	(ug/L)	[Cu]<10	21.77	3.03
Pb, Total	(ug/L)	[Pb]<5	29.66	2.94
Ni, Total	(ug/L)		7.63	0.85
Zn, Total	(ug/L)	[Zn]<50	190.74	19.02
Oil and Grease	(mg/L)		2.57	0.10

Note:

Irreducible concentrations reported for TSS, Cu, Pb, and Zn. Values for NO₃, Total N, and P represented as a range of values reported in same measurement units from literature.

* Barrett and Limonuzin, 2009.



FINAL San Marcos Creek Specific Plan

Master Water Quality and Hydromodification Management Plan

Table 4-5

Comparison between Existing, Proposed with Treatment, and Literature Pollutant Concentrations by Drainage Management Area

Constituent	Units	Literature*	DMA							
			BMP 1	BMP 2	BMP 3	BMP 4	BMP 5	BMP 6	BMP 7	BMP 8
TSS	(mg/L)	TSS=10	10.41	10.01	10.15	10.14	10.32	10.10	10.44	6.76
COD	(mg/L)		4.45	4.17	4.27	4.25	4.37	4.26	4.83	2.03
Fecal Coliform	(mpn/100 mL)		262.5	288.6	280.2	278.6	266.9	286.7	317.4	512.2
NH3	(mg/L)		0.59	0.55	0.56	0.56	0.58	0.56	0.58	0.25
NO2+NO3	(mg/L)		0.66	0.63	0.64	0.63	0.65	0.65	0.84	0.38
Nitrogen, Total Kjeldahl	(mg/L)	1.1<[N _T <1.69	0.80	0.76	0.77	0.77	0.79	0.77	0.83	0.43
Phosphorous, Total	(mg/L)	0.048<[P]<1.398	0.12	0.11	0.11	0.11	0.12	0.12	0.14	0.08
Cd, Total	(ug/L)		0.08	0.08	0.08	0.08	0.08	0.08	0.08	0.05
Cu, Total	(ug/L)	[Cu]<10	3.23	3.07	3.12	3.13	3.20	3.10	3.09	1.77
Pb, Total	(ug/L)	[Pb]<5	3.20	2.97	3.05	3.03	3.13	3.05	3.66	1.22
Ni, Total	(ug/L)		0.94	0.86	0.89	0.88	0.92	0.88	1.00	0.27
Zn, Total	(ug/L)	[Zn]<50	20.67	19.28	19.77	19.69	20.31	19.64	21.81	8.26
Oil and Grease	(mg/L)		0.11	0.11	0.11	0.11	0.11	0.11	0.11	0.06

Note:

Irreducible concentrations reported for TSS, Cu, Pb, and Zn. Values for NO₃, Total N, and P represented as a range of values reported in same measurement units from literature.

* Barrett and Limonuzin, 2009.

4.2 LARRY WALKER AND ASSOCIATES INDEPENDENT VALIDATION

The SDRWQCB requested independent third party validation of the water quality analysis and removal rates. This was conducted by Larry Walker and Associates (LWA) and is included in **Appendix A**.

LWA validated the pollutant removal rates for the project and provided recommendations for monitoring. LWA concluded that:

- The MOE assessment was conservative and therefore protective of water quality;
- The analysis provides a reasonable assessment and would result in a reduction of pollutant loads.



FINAL San Marcos Creek Specific Plan

Master Water Quality and Hydromodification Management Plan

- Representative outfalls are acceptable
- Two stations would be adequate;
- Either flow weighted composites or grab samples
- Continuous flow measures
- Storms greater than .25 inches and 72 hour separation
- 9 storms for statistical variation.

4.3 LAS POSAS/SAN MARCOS CREEK RESTORATION EXPECTED WATER QUALITY BENEFITS

Under the Phase I portion of the project, the Las Posas Creek and San Marcos Creek would be restored, enhanced, or additional wetlands created. Other similar projects were researched to determine what additional benefits could be achieved with the restoration. A literature review of available data sets were conducted by DMAX Engineering and are included in **Appendix D**.

The added water quality benefit of the creek restoration in the specific plan area cannot be used for development water quality and HMP compliance, however, it would provide an added water quality benefit.

Four similar restorations were reviewed, including one locally in San Diego: Forrester Creek. While it is difficult to compare projects, in general, the data suggests that under wet and dry weather conditions that a reduction in key pollutants (nitrogen, phosphorous, and bacteria) creek restorations would occur.

In addition, Forrester Creek showed an improved IBI score from 11 to 28. It is expected that the creek restorations will result in a similar if not better results.

4.4 RECOMMENDED FIELD VALIDATION

Based upon the results presented above, it is anticipated that future monitoring is implemented to validate the results. There are two types of monitoring that are expected:

1. Assess impacts of the specific plan area development on the watershed and;
2. Assess the discharge results from the specific plan area.

To determine the impacts of the SPA on the watershed, it is anticipated that upstream and downstream monitoring locations are utilized. It is important to capture baseline data to support potential changes in habitat, bioassessments



FINAL San Marcos Creek Specific Plan

Master Water Quality and Hydromodification Management Plan

and water quality. **Figure 3-1** shows three potential bioassessment location areas in the specific plan area.

At the discharge level, each DMA and the study area as a whole could be monitored individually to determine the range of effluent concentrations generated from each area or summarized in a study area collective result. It is important to distinguish run-on flow and pollutant concentrations while conducting monitoring of the discharges. The monitoring protocols, frequency, baseline conditions will be specifically addressed through the development of a Quality Assurance Plan that will be required under the 401 Permit and reviewed and approved by the SDRWQCB.

It is also encouraged to implement project (i.e., each development) specific monitoring locations to allow for investigations to occur when discharge runoff concentrations warrant such upstream investigations.

4.5 CONCLUSIONS

The San Marcos Creek Specific Plan calls for many opportunities to use planned surface areas as low impact development site design/treatment control BMPs. There are also opportunities to design and construct bioretention BMPs within the Specific Plan Area that meet the conceptual design of the Specific Plan.

The analyzed treatment systems consider not only the expected pollutant concentrations from the built-out Specific Plan Area, but also the expected treatment runoff quantities based on the regionally accepted treatment requirements (85th percentile rain events for flow and volume based treatment).

This analysis demonstrates an expected decrease in pollutant loading when comparing the existing site conditions to the permit compliant built-out Specific Plan for the Study Area.

It is important to note that the levels of the constituents expected to be generated are below the action levels for municipal permit monitoring activities and, at those levels, are not considered risks to human health or the environment.

Comparison of the proposed pollutant concentrations based on the percent removal with those from performance-based effluents show similar results. The pollutant concentrations from the literature validate the methods and the proposed post-treatment effluent concentrations presented in the study.

The analysis is considered conservative in nature because it does not consider the differences between the existing facilities, with their pollutant-generating activities exposed to rainfall, and the built-out conditions, which will likely be much less outdoor pollutant generating activities. A combination of changes in



FINAL San Marcos Creek Specific Plan Master Water Quality and Hydromodification Management Plan

land use and new design and construction, and relocating pollutant activities indoors, supports this statement. The monitoring program approved by the SDRWQCB will be designed to confirm the preliminary analysis.



FINAL San Marcos Creek Specific Plan

Master Water Quality and Hydromodification Management Plan

5.0 PRIVATE DEVELOPMENT REQUIREMENTS

5.1 MODEL BLOCK DEVELOPMENT

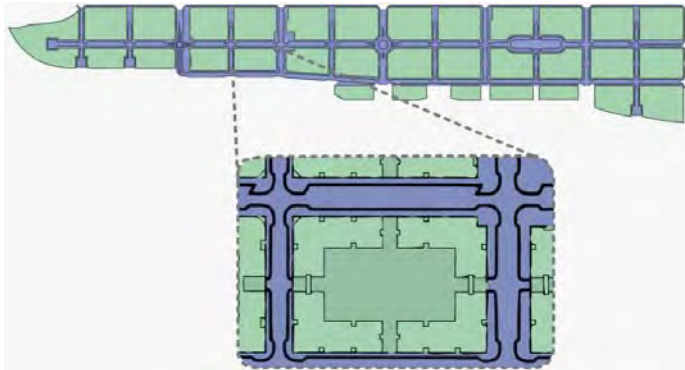

Private development in the specific plan area is required to be developed in model blocks. This assures a managed and cohesive development pattern within each DMA.

It also assures that permit compliance onsite and in the shared WQ/HMP facilities can

be tracked and reported on an annual basis

5.2 BASIC GUIDELINES FOR MODEL BLOCK PRIVATE DEVELOPMENT FOR PERMIT COMPLIANCE

The following are the guiding elements of the Master WQ/HMP Management Plan which a project specific WQTR will be developed for each project in addition to the Current SUSMP/HMP Requirements, project type requirements, and LID, Site Design, and Source Control requirements in Order R9 2007-0001:

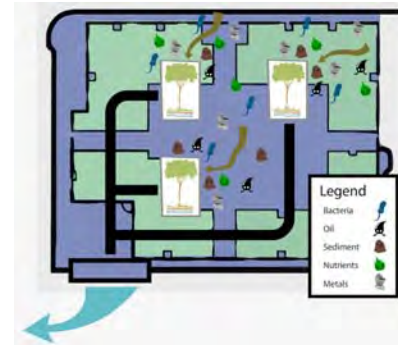

- All projects in the San Marcos Creek Specific Plan Area are categorized as SUSMP Priority projects and must adhere to the source control, site design, and treatment control requirements and criteria of the SUSMP.
- All projects in the Specific Plan Area must follow the City of San Marcos SUSMP in effect January 14, 2011 for WQ/HMP.
- All projects in the Specific Plan Area must show pre-project pollutant load and HMP calculations and post project pollutant load reduction and HMP calculations for all pollutants generated by land uses and potential land uses.



FINAL San Marcos Creek Specific Plan

Master Water Quality and Hydromodification Management Plan

- All projects in the specific plan area must show a pollutant load reduction over existing condition land uses through the selection of appropriate BMPs and design criteria for wet weather conditions and dry weather conditions.
- All projects must assume the worst case land use for the plan view acreage:

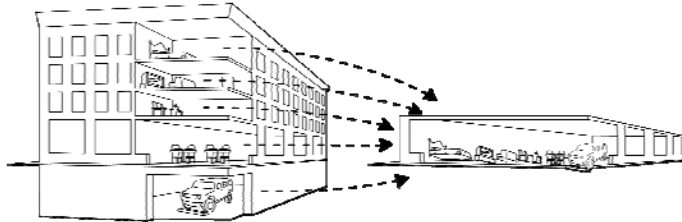

- The primary pollutants of concern are Nutrients, Bacteria (all) , selenium, DDE/DDT, sediment toxicity,
- All private development projects in the Specific Plan Area must develop a preliminary and final WQ/HMP plan for submittal and approval by the City.
- All projects must show and meet all TMDL load allocations on a project specific basis in place at the time the TMDL is in place.
- Projects in the Specific Plan area WILL NOT be granted waivers for site design, source control, LID, or treatment control requirements.
- All connections from the project private storm drain system to the City MS4 must have monitoring manholes installed and labeled;
- Projects must participate in the CFD.
- Projects must demonstrate maximum utilization of LID features: permeable pavement, landscape, flow through planters, and other viable runoff reduction measures allowed by the specific plan or technologically available at the time of development.

REFERENCE DOCUMENTS

Documents intended to be used in the preparation of project specific Water quality improvement plans in the Specific Plan Area include:

- City of San Marcos Current Stormwater Standards Manual and SUSMP
- Current City of San Marcos Water Quality Ordinance 14.15
- CASQA Current Treatment Control BMP Design Requirements



FINAL San Marcos Creek Specific Plan Master Water Quality and Hydromodification Management Plan

- January 2010 Upper San Marcos Creek Nutrient Management Plan
- Bacteria I TMDL (SDRWQCB Region 9)
- Upper San Marcos Creek Nutrient TMDL and Management Plan (SDRWQCB Region 9)
- Final Regional Hydromodification Management Plan
- 2011 San Marcos Creek Specific Plan Area Preliminary Water Quality Treatment Analysis (MOE, 2011)
- 2011 San Marcos Creek Specific Plan HMP Analysis (Wayne Chang & Associates, 2011)

5.3 TEMPORARY WATER QUALITY IMPACTS (CONSTRUCTION/BIOLOGICAL)

For all phases of the project the current General Construction Permit (GCP) requirements will be followed on a project by project basis. Order R9 2008-0002 (Dewatering Permit for construction activities) may also need to be implemented for project specific construction activities.

The GCP requires the preparation of a SWPPP. The City requires that this document and coverage under the GCP is completed prior to the issuance of grading permits. A risk level assessment and BMP sheets based on anticipated pollutants being generated during the construction phase will have pollutant specific BMPs for each of the four stages of construction (Demolition, grading, vertical construction, and landscaping). Permit coverage will be required prior to the start of any work and an effective combination of erosion and sediment controls, rain event action plans, testing of runoff, and enhanced inspections are required. Mobilization of BMPs 48 hours in advance of a predicted rain event is also required.

Biological resources impacts are also addressed during construction and are considered in the impacts on habitat. Anticipated BMPs include biological monitoring and placing visual barriers (i.e. orange fencing) to prevent construction activities in habitat areas will be included and coordinated with the MMRP.



**San Marcos Creek Specific Plan
Master Water Quality and Hydromodification
Management Plan**

APPENDIX A

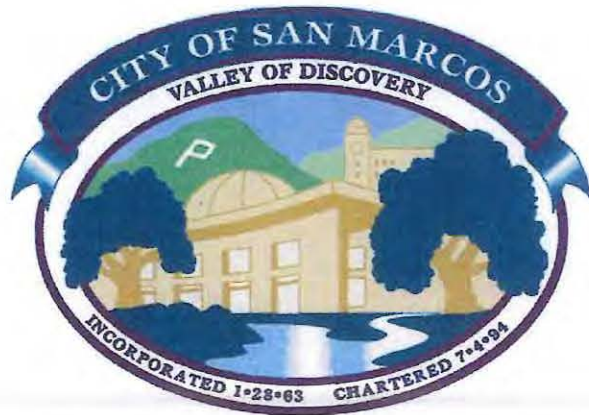

San Marcos Creek Specific Plan Area Preliminary Water Quality Treatment Analysis



Prepared by
Mikhail Ogawa Engineering

Revised July 2011

Study Purpose

The City of San Marcos (City) has prepared a Specific Plan for the San Marcos Creek area. The San Marcos Creek Specific Plan (Specific Plan) represents an effort to create a planning framework for future growth and redevelopment of the approximately 214-acre area along San Marcos Creek in central San Marcos (Figure 1). The Specific Plan has been developed with a thorough analysis of environmental conditions and input from City decision-makers, landowners, neighbors, and the community-at-large. It provides a comprehensive vision for this creekside district along with goals, policies and development standards to guide future public and private actions relating to the Area's development and conservation of open space and natural resources. The Specific Plan also serves as a mechanism for ensuring that future development will be coordinated and well-planned.



Figure1: Not to Scale – Specific Plan and Study Area: red dashed line represents the Specific Plan Area and the blue shaded area is the Study Area (modified from San Marcos Creek Specific Plan, 2007)

During a 401 Certification pre-application meeting with the San Diego Regional Water Quality Control Board (RWQCB), the RWQCB staff requested that a study be conducted to compare pre-project¹ impacts on water quality to post-project¹ impacts to determine how much impact the completed Specific Plan Area would have on water quality and the beneficial uses of the receiving waters. The comparison is between (1) the existing land use with no existing treatment control Best Management Practices (BMPs) and (2) the completed Specific Plan Area with expected treatment control BMPs in place and operating.

Study Area

The Study Area consists of 135.5 acres on the north and south sides of San Marcos Creek between Grand Avenue and Discovery Street in the City of San Marcos (Figure 1). Existing development is generally located near San Marcos Boulevard. Development in the area between Grand Avenue and McMahr Road consists primarily of commercial and legal nonconforming industrial uses, including neighborhood "strip" retail centers, two gas stations, a lumberyard, three storage facilities, a construction material storage yard, auto services, a bowling alley, office uses,

¹ For the purposes of this report discussion, the term "project" refers to the completely built-out Specific Plan area.

and a fast food restaurant (San Marcos Creek Specific Plan, 2007). Additionally, there are several residential uses within the Study Area.

For the purposes of this analysis, existing land use means the current site conditions as they exist. The Vacant land use category is a combination of developable acreage that remains vacant in an undisturbed state and open space that is not developable. The existing land use within the Study Area consists of the following approximate acreages:

Streets:	12.65 ac
Commercial Acreage:	28.02 ac
Industrial Acreage:	17.57 ac
Residential Acreage:	12.66 ac
Vacant Acreage:	64.64 ac

The proposed land use is a mixed-use commercial core and "downtown" for San Marcos. The proposed land use will balance retail and entertainment uses with a mix of residential, office, and service uses to create a new "24-hour" neighborhood with active/passive use.

The proposed land use within the Study Area consists of the following:

Streets	42.6 ac
Mixed-Use ² :	75.6 ac
Improved Park Space ³ :	17.3 ac



Figure 2: Not to Scale – Proposed Land Use for Specific Plan and Study Area (San Marcos Creek Specific Plan, 2007)

As seen in Figures 2 and 4, there are planned pervious surface areas within the mixed use areas (shaded in green) that may be used for low impact development site design/treatment control BMPs. Per the specific plan those areas are described as courtyards, plazas and parks. The intent is to create community gathering spaces that have pervious surfaces.

The Study Area is within the San Marcos Hydrologic Area (904.5) of the Carlsbad Hydrologic Unit as defined by the RWQCB. Downstream of the Specific Plan Area is San Marcos Lake, a man-made lake (by way of a dam) that is surrounded by two golf courses and residential housing.

² For the purposes of the discussion and of this report, the term "mixed-use" includes hardscape, building coverage, and parking typically associated with commercial/residential/parking land uses

³ The Study Area Improved Park Space consists of linear greenways, multi-use trail, and urban parks.

Downstream of the lake, San Marcos Creek meanders through various land use areas and discharges into the Batiquitos Lagoon prior to ultimate discharge to the Pacific Ocean.

The approved State Water Resources Control Board (SWRCB) 2010 303(d) list provides information about waters that are determined to be impaired for certain pollutant types. The following is a list of waterbodies that the SWRCB has determined to be impaired that the San Marcos Creek Specific Plan Area is tributary to:

Table 1 – 2010 Approved 303(d) Listings Related to Specific Plan Area

Water Body Name	Pollutant/Stressor
San Marcos Creek	DDE, Phosphorus, Sediment toxicity, Selenium
San Marcos Lake	Ammonia (as N), Nutrients

Methods and Results

Drainage Management Areas

The proposed project will have a total of eight Drainage Management Areas (DMAs); delineated areas that share common hydrology and drainage systems – see Figure 3 below. It is intended that each DMA will have its own distinct treatment and flow controls to address runoff and pollutants generated within them. The analyses, and results presented below, were conducted on both the DMA level and the entire specific plan area.

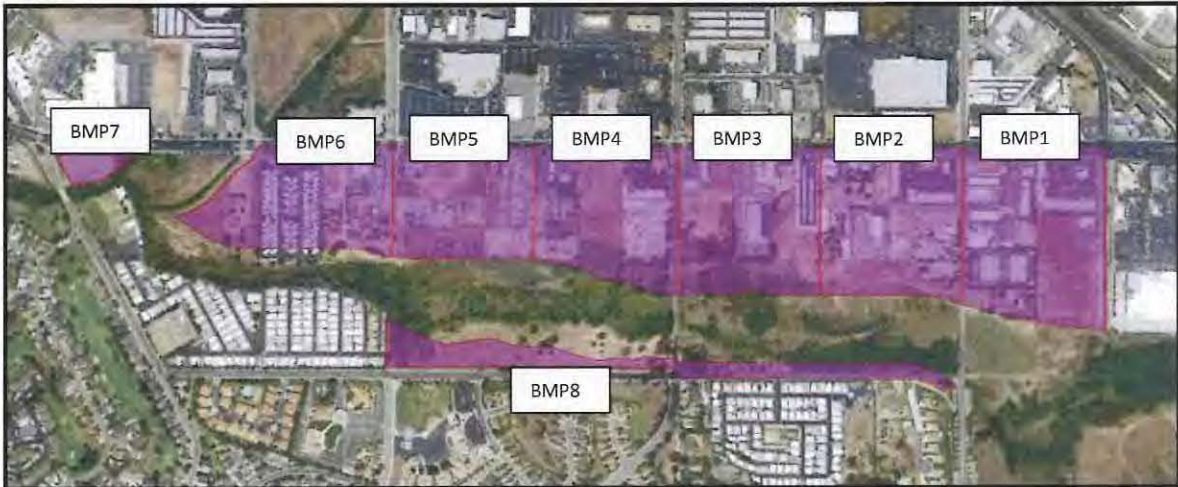

Figure 3: Not to Scale – Proposed Drainage Management Areas

Pollutant Concentrations

This study uses a median concentration approach. Urban runoff contaminant concentrations have substantial variability based on the types of land use. In general, land use defines the imperviousness and types and amounts of pollutants that are present within the area of land use.

The approach estimates the existing concentrations of contaminants based on existing land use. The study uses the concentration values (Table 2) for the land use type from the National Stormwater Quality Database (NSDQ) Version 1.1 (Pitt et al., February 2004). This database represents monitoring data collected from over 3,750 individual storm events over nearly a ten-year period from more than 65 agencies throughout the country. The data characterize the median concentrations from specific land use types including, streets, residential, commercial, industrial and open space. A smaller subset of the data from sites within EPA Rainfall Zone 6 (southwestern US) was extracted from the national database as it better characterizes the study area. Medians were generated from this dataset for all land uses except Vacant, where only 2 events were recorded and the data was insufficient. Vacant concentrations were therefore

characterized from the national database. The NO₂ + NO₃ median concentration for streets land use was also characterized from the national database due to lack of data within Zone 6.

Table 2 – NSDQ Median Concentrations

Constituent	Units	Streets	Residential	Commercial	Industrial	Vacant**
TSS	(mg/L)	99	94.5	111	200	48.5
COD	(mg/L)	110	135	175	235	42.1
Fecal Coliform	(mpn/100 mL)	1700	2450	2700	4500	7200
NH ₃	(mg/L)	1.39	0.865	1.6	0.83	0.18
NO ₂ +NO ₃	(mg/L)	0.3*	1.1	1	1.7	0.59
Nitrogen, Total Kjeldahl	(mg/L)	2	2.25	2.55	3.35	0.74
Phosphorous, Total	(mg/L)	0.2385	0.455	0.47	1.1	0.31
Cd, Total	(ug/L)	1	1.1	1	2	0.38
Cu, Total	(ug/L)	42	25	17.5	55	10
Pb, Total	(ug/L)	24	50	23	102	10
Ni, Total	(ug/L)	8.9	14	11.5	24	ND
Zn, Total	(ug/L)	207.5	300	250	560	40
Oil and Grease	(mg/L)	3.5	3	4	4	1.3

(NSDQ Database, EPA Rainfall Zone 6 – Pitt et al., 2004)

* NO₂ + NO₃ value for Streets land use based on entire NSDQ dataset.

** Vacant land use values based on entire NSDQ dataset.

Based on the NSDQ and the existing land use information, the expected pre-project constituent concentrations are calculated by prorating and combining the NSDQ concentrations based on the representative land use area for each of the four categories (streets, residential, commercial, industrial and open space). The resulting concentrations are shown in the Table 3 below.

Table 3 – Estimated Existing Land use and Pollutant Concentrations for Entire Study Area

Constituent	Area	Streets	Residential	Commercial	Industrial	Vacant	Total
	Acres	12.65	12.66	28.02	17.57	64.64	135.54
	% of Total	9.33%	9.34%	20.67%	12.96%	47.69%	100%
Constituent	Units	Pollutant Concentrations					
TSS	(mg/L)	9.24	8.83	22.95	25.93	23.13	90.07
COD	(mg/L)	10.27	12.61	36.18	30.46	20.08	109.59
Fecal Coliform	(mpn/100 mL)	158.6	228.4	558.2	583.3	3,433.7	4,962.7
NH ₃	(mg/L)	0.13	0.08	0.33	0.11	0.09	0.73
NO ₂ +NO ₃	(mg/L)	0.03	0.10	0.21	0.22	0.28	0.84
Nitrogen, Total Kjeldahl	(mg/L)	0.19	0.21	0.53	0.43	0.35	1.71
Phosphorous, Total	(mg/L)	0.02	0.04	0.10	0.14	0.15	0.45
Cd, Total	(ug/L)	0.09	0.10	0.21	0.26	0.18	0.84
Cu, Total	(ug/L)	3.92	2.34	3.62	7.13	4.77	21.77
Pb, Total	(ug/L)	2.24	4.67	4.75	13.22	4.77	29.66
Ni, Total	(ug/L)	0.83	1.31	2.38	3.11	ND	7.63
Zn, Total	(ug/L)	19.37	28.02	51.68	72.59	19.08	190.74
Oil and Grease	(mg/L)	0.33	0.28	0.83	0.52	0.62	2.57

Using the same method, the proposed contaminant concentrations are calculated based on the proposed land use. Because the planned land use is a mixed-use concept (residential/commercial/parking), the most impactful median concentration values for each constituent are selected from the NSDQ database for the Residential, Commercial, and Parking (i.e. Streets) land use categories. Table 4 represents the median concentration values used to determine the proposed constituent concentrations (Table 5).

Table 4 – Proposed NSDQ Median Concentrations – Worst Case for Mixed Use Category for Entire Study Area

Constituent	Units	Streets	Mixed Use	Improved Park Space
TSS	(mg/L)	99	111	48.5
COD	(mg/L)	110	175	42.1
Fecal Coliform	(mpn/100 mL)	1700	2700	7200
NH3	(mg/L)	1.39	1.6	0.18
NO2+NO3	(mg/L)	0.3	1.1	0.59
Nitrogen, Total Kjeldahl	(mg/L)	2	2.55	0.74
Phosphorous, Total	(mg/L)	0.2385	0.47	0.31
Cd, Total	(ug/L)	1	1.1	0.38
Cu, Total	(ug/L)	42	42	10
Pb, Total	(ug/L)	24	50	10
Ni, Total	(ug/L)	8.9	14	ND
Zn, Total	(ug/L)	207.5	300	40
Oil and Grease	(mg/L)	3.5	4	1.3

(NSDQ Database, EPA Rainfall Zone 6 – Pitt et al., February 2004)

Mixed Use areas composed of Residential, Commercial, and Parking land uses.

Table 5 – Estimated Proposed Land Use and Pollutant Concentrations for Entire Study Area

	Area	Streets	Pervious Streets	Mixed Use	Improved Park Space	Total
	Acres	39.02	3.58	75.62	17.31	135.54
	% of Total	28.79%	2.64%	55.80%	12.77%	100%
Constituent	Units	Pollutant Concentrations				
TSS	(mg/L)	28.50	2.61	61.94	6.19	99.25
COD	(mg/L)	31.67	2.91	97.65	5.38	137.60
Fecal Coliform	(mpn/100 mL)	489.4	44.9	1,506.6	919.5	2,960.4
NH3	(mg/L)	0.40	0.04	0.89	0.02	1.35
NO2+NO3	(mg/L)	0.09	0.01	0.61	0.08	0.78
Nitrogen, Total Kjeldahl	(mg/L)	0.58	0.05	1.42	0.09	2.15
Phosphorous, Total	(mg/L)	0.07	0.01	0.26	0.04	0.38
Cd, Total	(ug/L)	0.29	0.03	0.61	0.05	0.98
Cu, Total	(ug/L)	12.09	1.11	23.44	1.28	37.91
Pb, Total	(ug/L)	6.91	0.63	27.90	1.28	36.72
Ni, Total	(ug/L)	2.56	0.24	7.81	ND	10.61
Zn, Total	(ug/L)	59.74	5.48	167.40	5.11	237.73
Oil and Grease	(mg/L)	1.01	0.09	2.23	0.17	3.50

Mixed Use areas composed of Residential, Commercial, and Parking land uses.

Based on this study approach and available data sets, without treatment for the proposed built-out Specific Plan Area, the pollutant loading for ten of the thirteen constituents would likely increase. Additionally, the reduction in Phosphorous and the sum of Nitrite and Nitrate would be negligible. Table 6 below represents the comparison between existing and proposed conditions.

Table 6 – Comparison Between Existing and Proposed Pollutant Concentrations – No Treatment for Entire Study Area

Constituent	Units	Existing	Proposed No Treatment	Difference
TSS	(mg/L)	90.07	99.25	9.18
COD	(mg/L)	109.59	137.60	28.01
Fecal Coliform	(mpn/100 mL)	4,962.7	2,960.4	-2,002.3
NH3	(mg/L)	0.73	1.35	0.62
NO2+NO3	(mg/L)	0.84	0.78	-0.06
Nitrogen, Total Kjeldahl	(mg/L)	1.71	2.15	0.43
Phosphorous, Total	(mg/L)	0.45	0.38	-0.08
Cd, Total	(ug/L)	0.84	0.98	0.13
Cu, Total	(ug/L)	21.77	37.91	16.14
Pb, Total	(ug/L)	29.66	36.72	7.06
Ni, Total	(ug/L)	7.63	10.61	2.98
Zn, Total	(ug/L)	190.74	237.73	46.99
Oil and Grease	(mg/L)	2.57	3.50	0.93

Treatment Controls Preliminary Design

The overall Specific Plan Area design phase is in a preliminary stage and selection of the final treatment systems has not yet been made. However, for purposes of this analysis, it is assumed that 100% of the urban runoff from the proposed development (118.2 ac.) will be treated via engineered bioretention best management practices (BMPs) including bioretention units, flow through planters, etc. There are many BMPs and combinations available and the City intends to implement or require the implementation of the most effective BMPs for the uses that are permitted by the Specific Plan.

Based on current local practice and guidelines – San Diego County LID Handbook and Model Standard Urban Stormwater Mitigation Plan – the amount of surface area required for the bioretention systems is 4% of the tributary impervious surface area.

The make up of the Specific Plan Area is conducive for meeting the 4% area required for the LID BMPs to be utilized for both the mixed use (highly developed) public right-of-ways and designated open space park areas. This study assumes that the necessary minimum of 4% area will be required through the City's regulatory development requirements.

It is important to note that of the 135.5 ac. within the Study Area, 17.3 acres are expected to be open space parks that will accommodate the use of bioretention BMPs to treat the runoff that is generated from these areas (Figures 2 and 5) and some public impervious surfaces, e.g. some streets and sidewalks.

The pollutant removal effectiveness of bioretention is published in various documents (e.g. EPA, CASQA, LID manuals, etc.). Table 7 lists the removal rates for bioretention BMPs. For this study, a conservative approach to pollutant removal effectiveness is taken, i.e., the lower estimates of available data ranges are used in the approach. The table also includes the percent (%) removal rates applied to the urban runoff that is to be treated by bioretention.

Table 7 – Bioretention Pollutant Removal Effectiveness

Pollutant	Published Removal Rate	Removal Rate for Analysis
TSS	90%*	90%
COD	97%**	97%
Bacteria	90%*	90%
NH3 (ammonia)	60% - 80%***	60%
NO3 (nitrate)	20%****	20%
Nitrogen, Total Kjeldahl	65% - 75%***	65%
Total Phosphorous	70% - 83%*	70%
Metals (Cu, Zn, Pb)	92%***	92%
Metals (Cd, Ni)	N/A	92% - comparable to other heavy metals
Oil and Grease	> 97%****	97%

*EPA, 1999

**Low Impact Development Center

***Davis, et al, 2001

****Hsieh et al., 2003

*****Davis, et al., 2006



Figure 4: Example of system that meet conceptual plans of Specific Plan (WSUD.org)

Applying the treatment control BMPs discussed above, Table 8 below represents the built-out status with treatment controls applied. The negative numbers demonstrate a reduction in pollutant concentrations from existing conditions to proposed built-out conditions with treatment. Similarly, Table 9, is a summary of the results when analyzed on a DMA level. It is important to note, that for several of the pollutant comparisons in the BMP7 DMA area, the comparison in concentrations are shown as a significant increase – this is due to the initial concentrations being completely open space in its existing conditions and having relatively low or no expected pollutant generation.

Additionally, as shown in Figure 6, the Specific Plan calls for plazas, park areas and thus, opportunities for site design and pervious surfaces that can be used as treatment control BMPs.

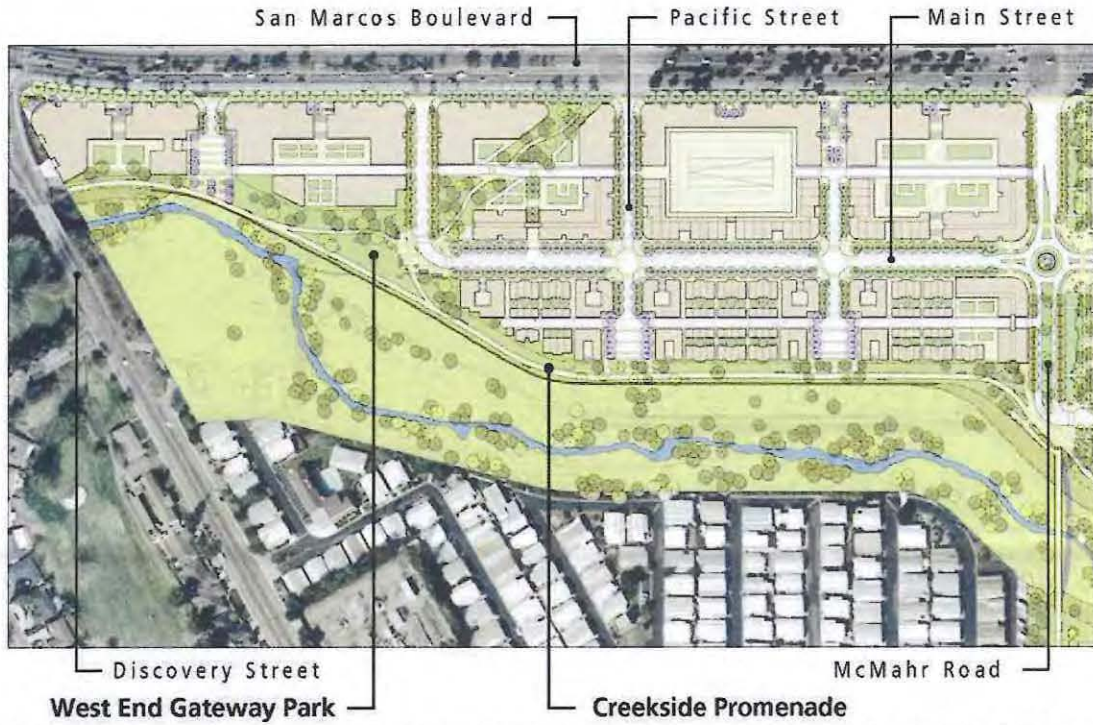

Figure 5: Not to Scale – Figure showing opportunities for alternative pervious surfaces (San Marcos Creek Specific Plan, 2007)



Figure 6: Rendering showing opportunities for alternative pervious surfaces (San Marcos Creek Specific Plan, 2007)

Table 8 – Comparison between Existing and Proposed Pollutant Concentrations – With Treatment (Bioretention) for Entire Study Area

Constituent	Units	Existing	Proposed with Treatment	Difference
TSS	(mg/L)	90.07	9.92	-80.14
COD	(mg/L)	109.59	4.13	-105.47
Fecal Coliform	(mpn/100 mL)	4,962.73	296.04	-4666.69
NH3	(mg/L)	0.73	0.54	-0.19
NO2+NO3	(mg/L)	0.84	0.63	-0.21
Nitrogen, Total Kjeldahl	(mg/L)	1.71	0.75	-0.96
Phosphorous, Total	(mg/L)	0.45	0.11	-0.34
Cd, Total	(ug/L)	0.84	0.08	-0.77
Cu, Total	(ug/L)	21.77	3.03	-18.74
Pb, Total	(ug/L)	29.66	2.94	-26.72
Ni, Total	(ug/L)	7.63	0.85	-6.78
Zn, Total	(ug/L)	190.74	19.02	-171.72
Oil and Grease	(mg/L)	2.57	0.10	-2.47

Table 9 – Percent Difference between Existing and Proposed Pollutant Concentrations – With Treatment (Bioretention) by Drainage Management Area

Pollutant	DMA								Total Project Area
	BMP 1	BMP 2	BMP 3	BMP 4	BMP 5	BMP 6	BMP 7	BMP 8	
TSS	-90.6%	-91.4%	-86.7%	-89.7%	-85.6%	-86.6%	-78.5%	-88.7%	-89.0%
COD	-96.8%	-96.9%	-95.7%	-96.6%	-95.0%	-95.5%	-88.5%	-96.5%	-96.2%
Fecal Coliform	-94.3%	-94.3%	-94.4%	-94.0%	-94.9%	-93.7%	-95.6%	-91.4%	-94.0%
NH3	-34.7%	-11.6%	-31.6%	-37.8%	-12.6%	-14.8%	222.3%	-43.9%	-26.4%
NO2+NO3	-31.1%	-41.1%	-11.6%	-28.1%	-8.7%	-19.9%	41.9%	-26.7%	-25.3%
Nitrogen, Total Kjeldahl	-61.4%	-63.0%	-49.6%	-59.4%	-43.9%	-51.1%	11.6%	-58.5%	-56.1%
Phosphorous, Total	-78.7%	-81.9%	-68.7%	-76.3%	-67.3%	-69.4%	-56.1%	-71.1%	-75.0%
Cd, Total	-92.1%	-93.1%	-88.0%	-91.1%	-87.5%	-89.5%	-78.4%	-90.6%	-90.7%
Cu, Total	-88.0%	-90.3%	-79.6%	-85.9%	-80.4%	-83.4%	-69.1%	-89.8%	-86.1%
Pb, Total	-91.7%	-94.3%	-81.0%	-89.8%	-83.5%	-89.0%	-63.4%	-90.7%	-90.1%
Ni, Total	-91.0%	-92.7%	-82.6%	-89.7%	-81.2%	-87.5%	ND	-86.7%	-88.9%
Zn, Total	-91.8%	-93.3%	-85.2%	-90.6%	-84.4%	-88.5%	-45.5%	-89.4%	-90.0%
Oil and Grease	-96.3%	-96.1%	-95.7%	-96.3%	-95.1%	-95.4%	-91.4%	-96.4%	-95.9%

As an alternative to using median concentrations and percent removal to calculate proposed pollutant concentrations, expected effluent concentrations can be located in published literature for a variety of BMPs. These performance-based effluents have been documented for the some BMPs, although the literature is somewhat limited in respect to bioretention.

In order to perform a desktop validation of the results of the study, the proposed pollutant concentrations following bioretention treatment were compared with irreducible pollutant concentrations located in published studies. As the data is limited, some of the concentrations from the literature appear as ranges and not as absolute values. The pollutant concentrations presented in this study using the percent removal method are within reasonable range of the irreducible concentrations proposed by the literature. Table 10 presents the comparison between the existing, proposed, and literature pollutant concentrations. Similarly, Table 11, is a summary of the results when analyzed on a DMA level.

Table 10 – Comparison between Existing, Proposed with Treatment, and Literature Pollutant Concentrations for Entire Study Area

Constituent	Units	Literature*	Existing	Proposed with Treatment
TSS	(mg/L)	TSS=10	90.07	9.92
COD	(mg/L)		109.59	4.13
Fecal Coliform	(mpn/100 mL)		4,962.73	296.04
NH3	(mg/L)		0.73	0.54
NO2+NO3	(mg/L)		0.84	0.63
Nitrogen, Total Kjeldahl	(mg/L)	1.1<[N _T]<1.69	1.71	0.75
Phosphorous, Total	(mg/L)	0.048<[P]<1.398	0.45	0.11
Cd, Total	(ug/L)		0.84	0.08
Cu, Total	(ug/L)	[Cu]<10	21.77	3.03
Pb, Total	(ug/L)	[Pb]<5	29.66	2.94
Ni, Total	(ug/L)		7.63	0.85
Zn, Total	(ug/L)	[Zn]<50	190.74	19.02
Oil and Grease	(mg/L)		2.57	0.10

Note:

Irreducible concentrations reported for TSS, Cu, Pb, and Zn. Values for NO₃, Total N, and P represented as a range of values reported in same measurement units from literature.

* Barrett and Limonuzin, 2009.

Table 11 – Comparison between Existing, Proposed with Treatment, and Literature Pollutant Concentrations by Drainage Management Area

Constituent	Units	Literature*	DMA							
			BMP 1	BMP 2	BMP 3	BMP 4	BMP 5	BMP 6	BMP 7	BMP 8
TSS	(mg/L)	TSS=10	10.41	10.01	10.15	10.14	10.32	10.10	10.44	6.76
COD	(mg/L)		4.45	4.17	4.27	4.25	4.37	4.26	4.83	2.03
Fecal Coliform	(mpn/100 mL)		262.5	288.6	280.2	278.6	266.9	286.7	317.4	512.2
NH3	(mg/L)		0.59	0.55	0.56	0.56	0.58	0.56	0.58	0.25
NO2+NO3	(mg/L)		0.66	0.63	0.64	0.63	0.65	0.65	0.84	0.38
Nitrogen, Total Kjeldahl	(mg/L)	1.1<[N _T]<1.69	0.80	0.76	0.77	0.77	0.79	0.77	0.83	0.43
Phosphorous, Total	(mg/L)	0.048<[P]<1.398	0.12	0.11	0.11	0.11	0.12	0.12	0.14	0.08
Cd, Total	(ug/L)		0.08	0.08	0.08	0.08	0.08	0.08	0.08	0.05
Cu, Total	(ug/L)	[Cu]<10	3.23	3.07	3.12	3.13	3.20	3.10	3.09	1.77
Pb, Total	(ug/L)	[Pb]<5	3.20	2.97	3.05	3.03	3.13	3.05	3.66	1.22
Ni, Total	(ug/L)		0.94	0.86	0.89	0.88	0.92	0.88	1.00	0.27
Zn, Total	(ug/L)	[Zn]<50	20.67	19.28	19.77	19.69	20.31	19.64	21.81	8.26
Oil and Grease	(mg/L)		0.11	0.11	0.11	0.11	0.11	0.11	0.11	0.06

Note:

Irreducible concentrations reported for TSS, Cu, Pb, and Zn. Values for NO₃, Total N, and P represented as a range of values reported in same measurement units from literature.

* Barrett and Limonuzin, 2009.

Recommended Field Validation

Based upon the results presented above, it is anticipated that future monitoring is implemented to validate the results. There are two types of monitoring that are expected: that to determine impacts of the specific plan area development on the watershed and that to determine the discharge results from the specific plan area.

To determine the impacts of the SPA on the watershed, it is anticipated that upstream and downstream monitoring locations are utilized. It is important to capture baseline data to support potential changes in habitat, bioassessments and water quality. As each new phase is developed within the SPA, monitoring could take place to determine if cumulative changes to the watershed are occurring and to what extent.

At the discharge level, each DMA and the study area as a whole could be monitored individually to determine the range of effluent concentrations generated from each area or summarized in a study area collective result. It is important to distinguish run-on flow and pollutant concentrations while conducting monitoring of the discharges.

It is also encouraged to implement project (i.e., each development) specific monitoring locations to allow for investigations to occur when discharge runoff concentrations warrant such upstream investigations.

Conclusions

The San Marcos Creek Specific Plan calls for many opportunities to use planned surface areas as low impact development site design/treatment control BMPs. There are also opportunities to design and construct bioretention BMPs within the Specific Plan Area that meet the conceptual design of the Specific Plan. Figures 4 and 7 show examples of such BMPs.

The analyzed treatment systems consider not only the expected pollutant concentrations from the built-out Specific Plan Area, but also the expected treatment runoff quantities based on the regionally accepted treatment requirements (85th percentile rain events for flow and volume based treatment).

This analysis demonstrates an expected decrease in pollutant loading when comparing the existing site conditions to the built-out Specific Plan for the Study Area, when implementation of the example treatment control BMPs are included. It is important to note that the levels of the constituents expected to be generated are below the action levels for municipal monitoring activities and, at those levels, are not considered risks to human health or the environment.

Comparison of the proposed pollutant concentrations based on the percent removal with those from performance-based effluents show similar results. The pollutant concentrations from the literature validate the methods and the proposed post-treatment effluent concentrations presented in the study.

The analysis is considered conservative in nature because it does not consider the differences between the existing facilities, with their pollutant-generating activities exposed to rainfall, and the built-out conditions, which will likely be much less outdoor pollutant generating activities. A combination of changes in land use and new design and construction, and relocating pollutant activities indoors, supports this statement.

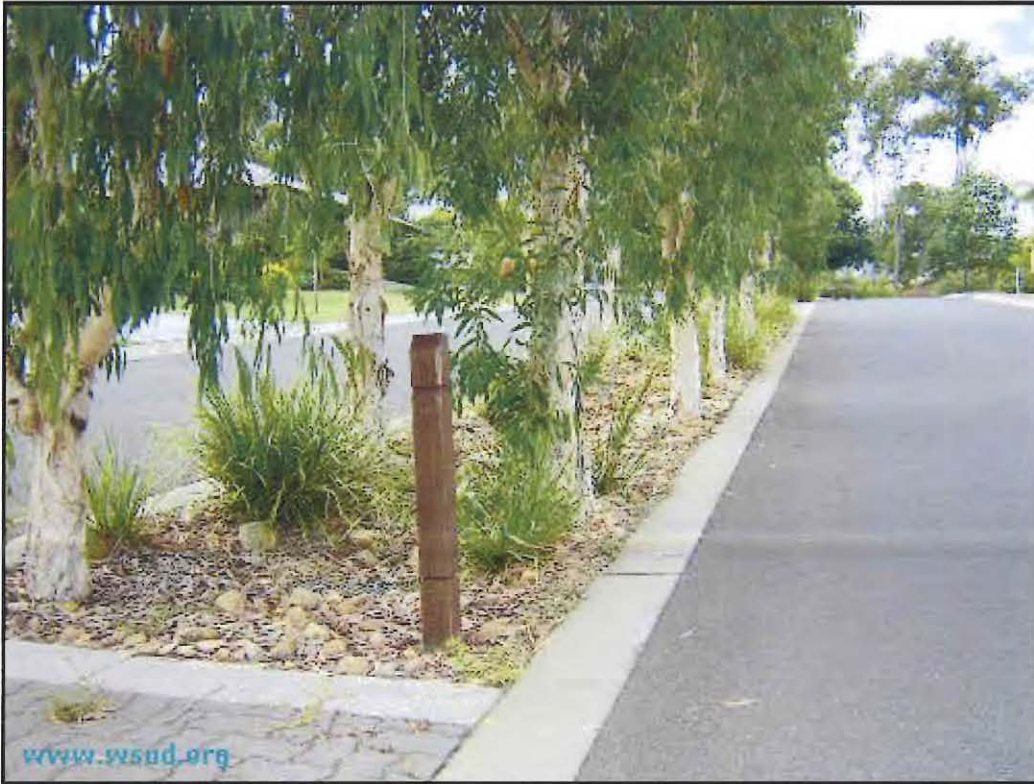

Figure 7: Example of system that meets conceptual plans of Specific Plan (WSUD.org)

References:

1. City of San Marcos, 2007. San Marcos Creek Specific Plan. City of San Marcos, San Marcos, California
2. Dahlenberg, John, 2006. Water Sensitive Urban Design – www.wsud.org Accessed on October 28, 2007
3. Davis, Allen P., Mohammad Shokouhian, Himanshu Sharma, and Christie Minami. 2001. Laboratory study of biological retention (bioretention) for urban storm water management. *Water Environment Research* 73: 5-14.
4. Davis, AP, et al. 2006. Water quality improvement through bioretention media: Nitrogen and phosphorus removal. *Water Environment Research*, 78 (3): 284-293.
5. Hsieh, et al., 2003. Multiple-Event Study of Bioretention for Treatment of Urban Storm Water Runoff. University of Maryland, College Park, Maryland.
6. Pitt, Robert et al., 2004. Findings from the National Stormwater Quality Database. Center for Watershed Protection, Ellicott City, Maryland.
7. United States Environmental Protection Agency, 1999. Storm Water Technology Fact Sheet – Bioretention. Office of Water, Municipal Technology Branch, Washington D.C.
8. Michael Barrett and Maelle Limonuzin, Center for Research in Water Resources, University of Texas, September 2009. Literature Review of Extended Detention and Biofiltration Systems prepared for the City of Austin.



June 1, 2010

To: Mikhail Ogawa, MOE

From: Malcolm Walker, LWA

A handwritten signature in black ink, appearing to be "MW", is written over the printed name "Malcolm Walker, LWA".

Cc: Erica Ryan, City of San Marcos

Subject: Technical Review of San Marcos Creek Specific Plan Area Preliminary Water Quality Treatment Analysis by MOE, April 2010

Consistent with a request from the City of San Marcos I have provided an independent review of the subject report. The objectives of my review were two-fold: (1) to critique the technical assumptions used in the analysis and to provide recommendations, if necessary, for improvements to the analysis and (2) to provide a framework for validating the analysis. This memorandum is organized to respond to each objective.

Technical Review

The City of San Marcos is currently preparing a Specific Plan for the San Marcos Creek. The Specific Plan represents the City's efforts to provide a planning framework for the 214 acre area along San Marcos Creek. The Regional Board, in reviewing the plan and considering 401 certification, requested to City to assess the difference in water quality impacts that would occur. Thus the purpose of the subject analysis was to compare pre-project water quality with post-project water quality. The approach taken in the analysis reflected a spreadsheet analysis using event mean concentrations and land use designation. The fundamental idea was to estimate the runoff quality (based on constituent concentrations) from current development without the use of BMPs versus the runoff quality from future development using BMPs (in this analysis bioretention was the BMP of choice). Such an approach is appropriate and has been used in other environmental analysis including CEQA. Although a more detailed loading model may better characterize water quality conditions, to perform such an analysis would require more site specific data and would be more resource intensive. The analysis described in the MOE report appears conservative (i.e. protective) and adequate for a planning level assessment of water quality impacts. That being said I have provided in the following sections recommendations to corroborate the analysis. My recommendations are not intended to replace the MOE analysis but rather to either validate or not the conclusion by using different assumptions and databases.

In conducting the analysis there are two critical assumptions that were used to assess the pre and post development water quality impacts. These two include:

- Event Mean Concentrations from designated land uses (Table 2)

June 1, 2010

- BMP Pollutant Removal Effectiveness (Table 7)

Each is addressed below.

Event Mean Concentrations

The analysis uses EMCs from the National Stormwater Quality Database (NSQD) Version 1.1 (Pitt, et.al, February 2004). This database reflects a comprehensive compilation of outfall monitoring data for the entire nation. The database presents an accurate picture of runoff quality from a national perspective. As a result the database includes data from areas with considerably more rainfall than what occurs in the San Diego area. A more representative subset of this database that would reflect San Diego is the data from USEPA rainfall region 6. This region includes California, Nevada and Arizona. This same dataset is currently being used by the Regional Board (Los Angeles and San Diego) in developing stormwater action levels and consequently is being considered as representative of drier climates. I would recommend that this subset be used to characterize the runoff quality from development. The dataset is not as large as the National Dataset but it's more relevant and representative of San Marcos.

Another comment that I would like to make regarding the EMCs is the use of a single value. Stormwater quality will vary based on a number of factors – days since last rainfall, rainfall intensity, time of year of the rainfall event, and rainfall amount. The use of the large dataset allows one to capture a range of events and develop a central tendency of the data but the reality is that EMCs will vary and more likely a range of values will provide a more accurate assessment. That being said the use of median EMCs as used in the MOE analysis is reasonable for making a preliminary assessment.

And finally although the analysis is EMC based (i.e. concentration based) one could compare pollutant loadings. The use of bioretention has the additional benefit of reducing the volume of discharge. Thus instead of using storm water concentration to assess effectiveness, one could use loading to assess water quality improvements. As noted previously this type of assessment would be more accurate but also require more site specific data and resources to complete. The use of EMCs is a conservative approach since it does not account for the volume reduction aspect of bioretention BMP.

BMP Pollutant Removal Effectiveness

The analysis in Table 7 provides the expected pollutant removal effectiveness (as a percentage) for bioretention BMPs. The estimate effectiveness is based on a number of different references. Although the use of removal efficiency is a common engineering approach for unit process evaluation, the variability of stormwater (see above discussion) makes the use of removal efficiency limited. In fact the ASCE/EPA BMP Database (<http://www.bmpdatabase.org/>) recommends that percent removal efficiency not be used to assess BMP performance but rather a performance based effluent¹. For most BMPs the

¹Wright Water Engineers and Geosyntec Consultants, 2007. Frequently Asked Questions Fact Sheet for the International Stormwater BMP Database: Why does the International Stormwater BMP

ASCE/EPA database provides a comprehensive review of performance. However, for bioretention the database is inadequate. Bioretention is a subset of the BMP category of biofiltration. Furthermore a closer review of the biofiltration category shows that there are few bioretention BMP performance studies. This issue has been noted and the database in the future will be modified to distinguish the performance of bioretention. In the meantime and in lieu of using the ASCE/EPA database I would recommend that the performance data from a comprehensive literature review conducted by the City of Austin² be used.

Summary

The analysis conducted for the City of San Marcos provides a reasonable preliminary evaluation of the water quality changes that would occur with the implementation of the Specific Plan. Even with the recommendations suggested in this memorandum to corroborate the analysis, the fundamental conclusion that pollutant loads after the implementation of the Specific Plan will be less than the current pollutant loadings will likely not change.

Validation of Assessment

The subject analysis is a reasonable assessment of the changes in water quality impacts from the Specific Plan. However, the assessment could be validated to confirm some of the basic assumptions (e.g. EMCs and/or BMP performance). The validation of the EMC would be a costly effort because of the need to capture a range of storms for the different land uses presented in the Specific Plan. Instead the more reasonable and cost effective validation effort would be to measure the overall effectiveness of bioretention BMPs. Since the BMPs will be applied across the entire area in the Specific Plan the selection of representative outfalls will provide confirmation of the overall effectiveness of the BMPs. With that in mind it is recommended that the following monitoring program be considered to validate the preliminary assessment.

Monitoring Locations. Select outfalls in which the developed area draining to the outfall has implemented bioretention BMPs consistent with City requirements. Care should be provided to ensure that the outfalls do not include runoff from up gradient areas not subject to the BMP requirements.

Number of Stations. 2

Type of monitoring. Optimally a flow weighted composite sampler should be installed to capture representative samples. Alternatively, grab samples could be collected timed to capture the full

Database Project omit percent removal as a measure of BMP performance? (as posted on www.bmpdatabase.org)

² Michael Barrett and Maelle Limonuzin, Center for Research in Water Resources, University of Texas, September 2009. Literature Review of Extended Detention and Biofiltration Systems prepared for the City of Austin.

hydrographs and then composited. It is also recommended that flow be measure, preferably continuously. As previously noted assessing load reductions is relevant for bioretention BMPs and thus the need for measuring flow.

List of Constituents. Obviously the constituent list should include the constituents considered in the Specific Plan assessment. Alternatively only constituents that have been identified as problematic in the watershed such sediment and phosphorus and constituents typically present in stormwater such as metals and specifically copper and zinc.

Storm Criteria. Mobilization for storms can be difficult and expensive. In order to help focus storm collection activities it is suggested the following criteria be used

- Storms greater than 0.25 inches. This value may need to be adjusted to reflect site specific conditions (drainage area, slope, soils) and rainfall conditions. This criterion should be established to allow adequate opportunity to collect at least two storms per year.
- 72 hour separation between storm events

Number of storms. Suggest that at least 9 storms are monitored to allow statistical comparison with BMP performance. Given the variability of storms it is important to have a sufficient number.

And finally by identifying the need to establish monitoring stations early in the planning process, the cost, ease of installation, and effectiveness of the monitoring station can be optimized.



**San Marcos Creek Specific Plan
Master Water Quality and Hydromodification
Management Plan**

APPENDIX B

SAN MARCOS SPECIFIC PLAN

**MASTER WATER QUALITY
TECHNICAL REPORT**

**HYDROMODIFICATION AND CHANNEL
SUSCEPTIBILITY ANALYSIS**

August 12, 2011



A handwritten signature in cursive script, appearing to read "Wayne W. Chang".

Wayne W. Chang, MS, PE

ChangConsultants

Civil Engineering • Hydrology • Hydraulics • Sedimentation

**P.O. Box 9496
Rancho Santa Fe, CA 92067
(858) 692-0760**

Hydromodification Criteria

As of January 14, 2011, the *Standard Urban Stormwater Mitigation Plan* (SUSMP) expands water quality regulations to include hydromodification (flow control). Hydromodification applies to priority development projects and must be implemented to ensure that post-development peak flows and durations do not exceed pre-development peak flows and durations. Hydromodification will cause a project to mitigate potential erosion in downstream receiving waterbodies for a range of lower flow events. The SUSMP criteria are defined as follows:

1. For flow rates ranging from 10, 30, or 50 percent of the pre-project 2-year runoff event ($0.1Q_2$, $0.3Q_2$, or $0.5Q_2$) to the pre-project 10-year runoff event (Q_{10}), the post-project discharge rates and durations shall not deviate above the pre-project rates and durations by more than 10 percent over and more than 10 percent of the length of the flow duration curve. The specific lower flow threshold will depend on results from the Southern California Coastal Water Research Project's (SCCWRP) channel screening study and the critical flow calculator.
2. For flow rates ranging from the lower flow threshold to Q_5 , the post-project peak flows shall not exceed pre-project peak flows. For flow rates from Q_5 to Q_{10} , post-project peak flows may exceed pre-project flows by up to 10 percent for a 1-year frequency interval. For example, post-project flows could exceed pre-project flows by up to 10 percent for the interval from Q_9 to Q_{10} or from $Q_{5.5}$ to $Q_{6.5}$, but not from Q_8 to Q_{10} .

The County of San Diego's January 13, 2011, *Final Hydromodification Management Plan* (HMP), outlines methodology for sizing facilities to meet the SUSMP hydromodification criteria. Tables 7-1 through 7-5 in the HMP contain sizing factors for various preferred facilities including bioretention, bioretention plus cisterns, bioretention plus vaults, flow-through planters, and infiltration. Facility design using these sizing factors will provide surface areas and volumes needed to satisfy hydromodification. The sizing factors will yield similar results as the County of San Diego's BMP Sizing Calculator. The sizing factor selection depends on the applicable lower flow threshold ($0.1Q_2$, $0.3Q_2$, or $0.5Q_2$) mentioned in the first bullet criteria. The lower flow threshold evaluation is described in SCCWRP's "Hydromodification Screening Tool for Southern California" included in Appendix B of the HMP. Alternatively, a threshold of $0.1Q_2$ is selected if a channel screening study is not performed, but will result in the most conservative (greatest) facility sizing.

The San Marcos Creek Specific Plan is a priority development project, so it must meet hydromodification requirements. A channel screening study has been performed for the project and is included in **Appendix A**. The study determined that the receiving waterbody, San Marcos Creek, has a low susceptibility to erosion. Consequently, the hydromodification analyses are based on a 50 percent lower flow threshold. The following sections outline the hydromodification analyses for the Specific Plan project based on this threshold. The analyses were performed to provide guidelines and regulations for future development in the Specific Plan area. The City of San Marcos may construct hydromodification facilities to serve their infrastructure improvements. In some instances, the City's facilities might have excess capacity allowing some treatment for private development projects. In most cases, an individual developer will be required to address their hydromodification needs as part of their project design and in

accordance with this document. Detailed hydromodification analyses must be prepared for each development project and submitted to the City for review and approval.

Specific Plan Hydromodification Analyses

The overall (Alternative 7) Specific Plan area was subdivided into eight subareas for independent hydromodification analyses. Each subarea has a hydromodification point of compliance at its discharge point into San Marcos Creek. Seven subareas cover the primary Specific Plan development area (mixed-use, streets, Promenade, etc.) north of San Marcos Creek, while the eighth subarea covers the Discovery Street widening and park land south of San Marcos Creek (see **Figure 1**). The first subarea is located between Grand Avenue and South Bent Avenue. The second subarea is generally the easterly half of the project between South Bent Avenue and Via Vera Cruz. The third subarea is generally the westerly half of the project between South Bent Avenue and Via Vera Cruz. The fourth subarea is the generally the easterly half of the project between Via Vera Cruz and McMahr Road. The fifth subarea is generally the westerly half of the project between Via Vera Cruz and McMahr Road. The sixth subarea is between McMahr Road and Las Posas Creek. The seventh subarea is between Las Posas Creek and Discovery Street. The eighth subarea is the project area south of San Marcos Creek.

Subareas 1 through 6 support generally rectangular mixed-use development blocks bounded by north-south and east-west aligned streets. The southerly strip along San Marcos Creek will contain a landscaped Promenade with a multi-use trail. Drainage Management Areas (DMA) were delineated within each subarea. The DMA's define individual areas of mixed-use development, paving, and landscaping. The proposed mixed-use development was assumed to contain 85 percent impervious surfaces and 15 percent pervious surfaces. The proposed streets consist of standard (asphalt or concrete) paved surfaces in the travel lanes as well as in the diagonal parking areas and in the widened parallel parking aisles. The landscaping areas include the Promenade, landscape medians, park land, and the 15 percent pervious surfaces within the mixed-use development.

Proposed development in Subareas 7 and 8 varies somewhat from Subareas 1 through 6. Subarea 7 will support a triangular mixed-use area as well as a strip of park land along San Marcos Boulevard. Subarea 8 will include widening of a portion of Discovery Street from South Bent Avenue to Via Vera Cruz and an adjacent floodwall along San Marcos Creek. Subarea 8 will also include park land with trails along the south side of San Marcos Creek between Via Vera Cruz and McMahr Road.

Figure 1 delineates the post-project mixed-use, paving, and landscaping DMA's within each subarea. Under pre-project conditions, development (commercial, retail, industrial, streets, etc.) exists in portions of the Specific Plan area. The pre-project developed areas were delineated in a general manner using aerial photographs, topographic mapping, and a field investigation. The pre-project developed areas were assumed to contain 90 percent impervious surfaces and 10 percent pervious surfaces based on the document review and field investigation. Each DMA category was further refined to reflect areas supporting pre-project development (90 percent impervious area) or with no pre-project development (pervious area).

Appendix B contains a spreadsheet summarizing the DMAs tributary to each point of compliance for Subareas 1 through 8. The spreadsheet defines individual DMAs for the post-project mixed-use development, paving, and landscaping categories. The spreadsheet includes an adjusted area column that accounts for the post-project mixed-use development comprised of 85 percent impervious area and 15 percent pervious (landscaping) area as well as the pre-project developed areas containing 90 percent impervious surfaces and 10 percent pervious surfaces. During final engineering of any future development projects in the Specific Plan area, these assumptions will need to be verified and adjusted by each project, as appropriate.

Hydromodification Facility Sizing

The DMA results are used for hydromodification facility sizing within each of the eight subareas. Each DMA is multiplied by a runoff factor, which provides an area reduction due to infiltration through the DMA surface. Typical runoff factors from the County of San Diego SUSMP are listed in Table 1 for a variety of surface types.

Surface	Runoff Factor
Roofs	1.0
Concrete	1.0
Pervious Concrete	0.1
Porous Asphalt	0.1
Grouted Unit Pavers	1.0
Solid Unit Pavers on Granular Base	0.2
Crushed Aggregate	0.1
Turfblock	0.1
Amended, mulched soil	0.1
Landscape	0.1

Table 1. Typical DMA Runoff Factors

A runoff factor of 1.0 was used for the impervious portion of the mixed-use areas and for the paving. A runoff factor of 0.1 was used for the pervious portion of the mixed-use areas and landscaping. The spreadsheet in **Appendix B** includes the runoff factor-adjusted DMAs.

The final step in the hydromodification sizing is to determine the necessary treatment areas and volumes. The City of San Marcos intends to include bioretention basins in the Promenade within each subarea. Spurlock Poirier determined the bioretention area available in the Promenade within each subarea (see **Figure 2**). The bioretention basin sizing is calculated by multiplying the total subarea DMA by the appropriate sizing factors from Table 7-1 of the County of San Diego HMP. The portion of the DMA’s within the footprint of a pre-project impervious surface are excluded from the overall DMA because these areas are a source of pollutants in the baseline condition. Table 7-1 contains sizing factors for the basin area, surface volume (assuming 10 inches of ponded depth), and subsurface volume (assuming 1.5 feet of growing medium with 40 percent porosity over 2.5 feet of gravel with 40 percent porosity). The sizing factors in Table 7-1

were chosen based on the following values: lower flow threshold ($0.5Q_2$), soil group (D), existing ground slope (flat), and rain gauge (Oceanside). For these values, the surface area, surface volume, and subsurface volume sizing factors are 0.065, 0.0542, and 0.0390, respectively. The bioretention basins will treat the public areas (streets and sidewalks within the public right-of-way and the Promenade). Therefore, the mixed-use areas were subtracted from the DMAs for the sizing. The bioretention basin results are summarized in Table 2. The sizing will provide the required flow control and will also satisfy the treatment control needs for the public areas.

Subarea	Adjusted DMA, ac	Surface Area, ac	Surface Volume, ac-ft	Subsurface Volume, ac-ft
1	2.30	0.15	0.12	0.09
2	3.92	0.25	0.21	0.15
3	3.43	0.22	0.19	0.13
4	3.61	0.23	0.20	0.14
5	3.39	0.22	0.18	0.13
6	3.29	0.21	0.18	0.13
7	0.06	0.0038	0.0032	0.0023
8	3.28	0.21	0.18	0.13

Table 2. Bioretention Basin Sizing to Treat Public Areas

A comparison of the required bioretention basin surface area in Table 2 with the available surface area by Spurlock Poirier reveals that the available area is sufficient. Spurlock Poirier did not determine the available bioretention area in Subarea 8, but this is primarily park land, so sufficient area is available.

An additional analysis was performed to determine the bioretention basin sizing assuming each entire subarea is treated (including the mixed use areas). The results are provided in Table 3.

Subarea	Adjusted DMA, ac	Surface Area, ac	Surface Volume, ac-ft	Subsurface Volume, ac-ft
1	9.32	0.61	0.51	0.36
2	11.15	0.72	0.60	0.43
3	10.21	0.66	0.55	0.40
4	9.12	0.59	0.49	0.36
5	11.10	0.72	0.60	0.43
6	8.86	0.58	0.48	0.35
7	1.33	0.09	0.07	0.05
8	3.28	0.21	0.18	0.13

Table 3. Bioretention Basin Sizing to Treat All Areas

The available bioretention area in the Promenade is not sufficient for the entire subarea. Consequently, the mixed-use areas will need to provide supplemental treatment systems.

Hydromodification Criteria

The hydromodification analyses demonstrate that the Promenade has sufficient bioretention area for flow and treatment control of runoff generated by the public areas. Private development will need to supplement this with additional best management practices. The analyses contained herein are part of the Master Water Quality Management Plan and intended to provide general guidelines for BMPs in the Specific Plan area. More detailed analyses will be required for each final engineering project in the Specific Plan area. The detailed analyses should include confirmation of the downstream lower flow threshold and conditions in the project area. These conditions should be reassessed on a 2-year monitoring schedule to ensure accuracy of the results.



NOTE:

DMA'S ARE BASED ON THE
ALTERNATIVE 7 SITE PLAN.

GRAPHIC SCALE

0 250 500



1 INCH = 500 FEET

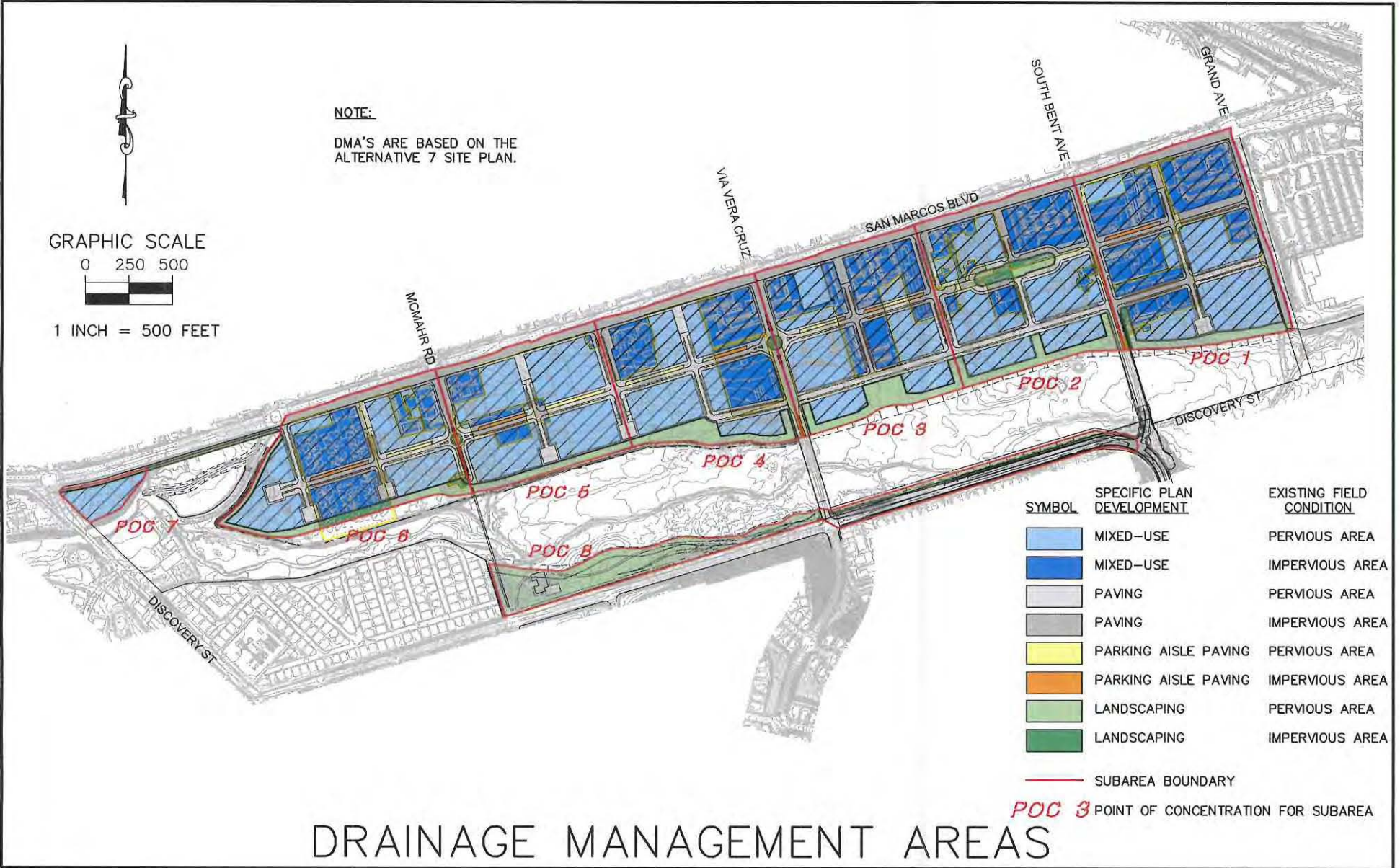

DRAINAGE MANAGEMENT AREAS

Sizing factors have been developed by the consultant team through the use of continuous simulation hydrologic modeling and these factors will be built into the San Diego LID/HMP Sizing Calculator to assist with HMP implementation. Sizing factors are ratios of the required mitigation size (in area or volume) as compared to the contributing developed area. The same concepts used to develop sizing factors in Contra Costa County are being used to develop sizing factors based on conditions in the San Diego area. Tables 7-1 through 7-5 detail sizing factors which have been determined to ensure compliance with peak flow and flow duration criteria as outlined in this HMP.

Table 7-1. Sizing Factors for Bioretention Facilities

Lower Flow Threshold	Soil Group	Slope	Rain Gauge	A	V ₁	V ₂
0.5Q ₂	A	Flat	Lindbergh	0.060	0.0500	N/A
0.5Q ₂	A	Moderate	Lindbergh	0.055	0.0458	N/A
0.5Q ₂	A	Steep	Lindbergh	0.045	0.0375	N/A
0.5Q ₂	B	Flat	Lindbergh	0.093	0.0771	N/A
0.5Q ₂	B	Moderate	Lindbergh	0.085	0.0708	N/A
0.5Q ₂	B	Steep	Lindbergh	0.065	0.0542	N/A
0.5Q ₂	C	Flat	Lindbergh	0.100	0.0833	0.0600
0.5Q ₂	C	Moderate	Lindbergh	0.100	0.0833	0.0600
0.5Q ₂	C	Steep	Lindbergh	0.075	0.0625	0.0450
0.5Q ₂	D	Flat	Lindbergh	0.080	0.0667	0.0480
0.5Q ₂	D	Moderate	Lindbergh	0.080	0.0667	0.0480
0.5Q ₂	D	Steep	Lindbergh	0.060	0.0500	0.0360
0.5Q ₂	A	Flat	Oceanside	0.070	0.0583	N/A
0.5Q ₂	A	Moderate	Oceanside	0.065	0.0542	N/A
0.5Q ₂	A	Steep	Oceanside	0.060	0.0500	N/A
0.5Q ₂	B	Flat	Oceanside	0.098	0.0813	N/A
0.5Q ₂	B	Moderate	Oceanside	0.090	0.0750	N/A
0.5Q ₂	B	Steep	Oceanside	0.075	0.0625	N/A
0.5Q ₂	C	Flat	Oceanside	0.075	0.0625	0.0450
0.5Q ₂	C	Moderate	Oceanside	0.075	0.0625	0.0450
0.5Q ₂	C	Steep	Oceanside	0.060	0.0500	0.0360
0.5Q ₂	D	Flat	Oceanside	0.065	0.0542	0.0390
0.5Q ₂	D	Moderate	Oceanside	0.065	0.0542	0.0390
0.5Q ₂	D	Steep	Oceanside	0.050	0.0417	0.0300
0.5Q ₂	A	Flat	L Wohlford	0.050	0.0417	N/A
0.5Q ₂	A	Moderate	L Wohlford	0.045	0.0375	N/A
0.5Q ₂	A	Steep	L Wohlford	0.040	0.0333	N/A
0.5Q ₂	B	Flat	L Wohlford	0.048	0.0396	N/A
0.5Q ₂	B	Moderate	L Wohlford	0.045	0.0375	N/A
0.5Q ₂	B	Steep	L Wohlford	0.040	0.0333	N/A

Table 7-2. Sizing Factors for Bioretention Plus Cistern Facilities

Lower Flow Threshold	Soil Group	Slope	Rain Gauge	A	V ₁	V ₂
0.1Q ₂	B	Moderate	L Wohlford	0.020	0.4000	N/A
0.1Q ₂	B	Steep	L Wohlford	0.020	0.3200	N/A
0.1Q ₂	C	Flat	L Wohlford	0.020	0.3200	N/A
0.1Q ₂	C	Moderate	L Wohlford	0.020	0.3200	N/A
0.1Q ₂	C	Steep	L Wohlford	0.020	0.2200	N/A
0.1Q ₂	D	Flat	L Wohlford	0.020	0.2400	N/A
0.1Q ₂	D	Moderate	L Wohlford	0.020	0.2400	N/A
0.1Q ₂	D	Steep	L Wohlford	0.020	0.1800	N/A

Q₂ = 2-year pre-project flow rate based upon partial duration analysis of long-term hourly rainfall records

Q₁₀ = 10-year pre-project flow rate based upon partial duration analysis of long-term hourly rainfall records

A = Bioretention surface area sizing factor

V₁ = Cistern volume sizing factor

Table 7-3. Sizing Factors for Bioretention Plus Vault Facilities

Lower Flow Threshold	Soil Group	Slope	Rain Gauge	A	V ₁	V ₂
0.5Q ₂	A	Flat	Lindbergh	N/A	N/A	N/A
0.5Q ₂	A	Moderate	Lindbergh	N/A	N/A	N/A
0.5Q ₂	A	Steep	Lindbergh	N/A	N/A	N/A
0.5Q ₂	B	Flat	Lindbergh	0.040	0.3600	N/A
0.5Q ₂	B	Moderate	Lindbergh	0.040	0.2400	N/A
0.5Q ₂	B	Steep	Lindbergh	0.040	0.1400	N/A
0.5Q ₂	C	Flat	Lindbergh	0.040	0.1600	N/A
0.5Q ₂	C	Moderate	Lindbergh	0.040	0.1600	N/A
0.5Q ₂	C	Steep	Lindbergh	0.040	0.1200	N/A
0.5Q ₂	D	Flat	Lindbergh	0.040	0.1400	N/A
0.5Q ₂	D	Moderate	Lindbergh	0.040	0.1400	N/A
0.5Q ₂	D	Steep	Lindbergh	0.040	0.1000	N/A
0.5Q ₂	A	Flat	Oceanside	N/A	N/A	N/A
0.5Q ₂	A	Moderate	Oceanside	N/A	N/A	N/A
0.5Q ₂	A	Steep	Oceanside	N/A	N/A	N/A
0.5Q ₂	B	Flat	Oceanside	0.040	0.2100	N/A
0.5Q ₂	B	Moderate	Oceanside	0.040	0.1800	N/A
0.5Q ₂	B	Steep	Oceanside	0.040	0.1400	N/A
0.5Q ₂	C	Flat	Oceanside	0.040	0.1400	N/A
0.5Q ₂	C	Moderate	Oceanside	0.040	0.1400	N/A
0.5Q ₂	C	Steep	Oceanside	0.040	0.1200	N/A
0.5Q ₂	D	Flat	Oceanside	0.040	0.1400	N/A
0.5Q ₂	D	Moderate	Oceanside	0.040	0.1400	N/A
0.5Q ₂	D	Steep	Oceanside	0.040	0.1200	N/A
0.5Q ₂	D	Flat	Oceanside	0.040	0.1400	N/A

APPENDIX A

SCCWRP INITIAL DESKTOP ANALYSIS

INTRODUCTION

This report provides hydromodification screening analyses for the San Marcos Specific Plan project. The project has been divided into seven drainage subareas north of the creek and one subarea south of the creek (see Figure 1). Each subarea will contain a flow (and treatment) control facility and be served by a storm drain system that discharges into San Marcos Creek. The flow control facility sizing is dependent on the flow threshold in the receiving waterbody.

The County of San Diego's January 13, 2011, *Final Hydromodification Management Plan* (HMP) outlines low flow thresholds for hydromodification analyses. The thresholds are based on a percentage of the pre-project 2-year flow (Q_2), i.e., $0.1Q_2$ (low), $0.3Q_2$ (medium), or $0.5Q_2$ (high). A threshold of $0.1Q_2$ represents a downstream receiving conveyance system with a high susceptibility to erosion. This is the default value used for hydromodification analyses and will result in the most conservative (greatest) on-site facility sizing. A threshold of $0.3Q_2$ or $0.5Q_2$ represents downstream receiving conveyance systems with a medium or low susceptibility to erosion, respectively. In order to qualify for a medium or low susceptibility threshold, a project must perform a channel screening analysis based on a "hydromodification screening tool" procedure developed by the Southern California Coastal Water Research Project (SCCWRP). The SCCWRP results are compared with the critical shear stress calculator results from the County of San Diego's BMP Sizing Calculator to establish the appropriate susceptibility threshold of low, medium, or high.

The SCCWRP screening tool requires both office and field work to establish the vertical and lateral susceptibility of a downstream receiving channel to erosion. The vertical and lateral assessments are performed independently of each other although the lateral results can be affected by the vertical rating. The screening was performed to assess San Marcos Creek near the Specific Plan project, which extends from Discovery Street on the downstream end to Grand Avenue on the upstream end.

The initial step in performing the SCCWRP screening analysis is to establish the domain of analysis and the study reaches within the domain. This is followed by office and field components of the screening tool along with the associated analyses and results. The following sections cover these procedures in sequence.

DOMAIN OF ANALYSIS

SCCWRP defines an upstream and downstream domain of analysis, which establish the required study area. The County of San Diego's HMP specifies the downstream domain of analysis based on the SCCWRP criteria with some refinements. The HMP indicates that the downstream limit is defined when one of these is reached:

- at least one reach downstream of the first grade control point
- tidal backwater/lentic waterbody
- equal order tributary

- accumulation of 50 percent drainage area for stream systems or 100 percent drainage area for urban conveyance systems (storm drains, hardened channels, etc.)

The upstream limit is defined as:

- proceed upstream for 20 channel top widths or to the first grade control point, whichever comes first. Identify hard points that can check headward migration and evidence of active headcutting.

SCCWRP defines the maximum spatial unit, or reach (a reach is circa 20 channel widths), for assigning a susceptibility rating within the domain of analysis to be 200 meters (656 feet). If the domain of analysis is greater than 200 meters, the study area should be subdivided into smaller reaches for analysis.

Downstream Domain of Analysis

The downstream domain of analysis for the study area has been determined using the bullet items above. The downstream-most discharge location from the project will be just upstream of the Discovery Street crossing of San Marcos Creek. The first permanent grade control below this discharge location is the Lake San Marcos dam, which is approximately 1.6 miles downstream of the Discovery Street crossing. The Lake San Marcos dam is a concrete arch dam, so it will act as a permanent grade control along San Marcos Creek.

The nearest lentic waterbody is Lake San Marcos. The upper (northerly) end of Lake San Marcos begins approximately 1,900 feet downstream of the Discovery Street crossing. Lake San Marcos then extends for another 1.3 miles to the dam.

The equal order tributary or accumulation of 50 percent drainage area will be significantly further downstream than Lake San Marcos or its dam because the watershed area tributary to the study reach covers over 20 square miles (see discussion in Initial Desktop Analysis section below). The urban conveyance system does not apply since San Marcos Creek is primarily a natural conveyance system.

Based on this information, the downstream domain of analysis is defined by the upper end of Lake San Marcos. This lentic waterbody is the closer to the project site than the other downstream domain of analysis locations.

Upstream Domain of Analysis

Echo Lane crosses San Marcos Creek approximately 900 feet upstream of the upstream project limit at Grand Avenue. The roadway is at the elevation of the creek bed and contains a culvert along the thalweg. The culvert can convey low flow, but during moderate to high storm events the creek flow will overtop the roadway. Since Echo Lane is a non-erodible asphalt crossing spanning the entire creek width, it functions as a grade control and is the first grade control point upstream of the project. Echo Lane is further upstream than the 200 meter limit, but was selected as the upstream domain of analysis because it is a well-defined grade control.

Study Reaches within Domain of Analysis

The domain of analysis along San Marcos Creek extends from the upper end of Lake San Marcos to Echo Lane. The domain of analysis was subdivided into four study reaches with similar characteristics (see the Study Area Exhibit in Appendix A). Reach 1 extends from the upper end of Lake San Marcos to the confluence of San Marcos Creek with Las Posas Creek. The reach length along the creek thalweg is approximately 2,550 feet. Reach 2 extends from the Las Posas Creek confluence to a point nearly 2,350 feet upstream along the thalweg. Reach 3 extends from the upper end of Reach 2 approximately 3,890 feet along the creek thalweg to South Bent Avenue. Reach 4 extends approximately 2,130 feet along the thalweg from South Bent Avenue to Echo Lane.

Reaches 1, 2, 3, and 4 are longer than the 656 feet maximum reach length specified by SCCWRP. The four reach locations were selected based on consistency within each reach. Review of topographic mapping, aerial photographs, and field conditions reveals that the physical (channel geometry and slope), vegetative, hydraulic, and soil conditions within each of these reaches is relatively uniform. Subdividing the reaches into smaller subreaches of less than 656 feet will not yield significantly varying results within a reach. Consequently, the screening tool was applied across Reach 1, 2, 3, and 4, and the results will be the same within each reach.

INITIAL DESKTOP ANALYSIS

After the domain of analysis is established, SCCWRP requires an “initial desktop analysis” that involves office work. The initial desktop analysis establishes the watershed area, mean annual precipitation, valley slope, and valley width. These terms are defined in Form 1 included in Appendix A. SCCWRP recommends the use of National Elevation Data (NED) to determine the watershed area, valley slope, and valley width. A review of the NED for San Marcos determined that it is equivalent to USGS quadrangle maps. The topographic resolution on USGS maps is low and typically on a 25-foot contour interval. For this report, recent topographic mapping along San Marcos Creek was used to establish the valley slope and valley width because the topography is at a 1-foot contour interval, which is much greater detail than NED. The 1-foot contour mapping did not cover the area near Lake San Marcos or the south creek bank between South Bent Avenue and Echo Lane. For these areas, the City of San Marcos’ 2-foot contour topographic mapping was used.

The watershed area tributary to San Marcos Creek was established in the March 27, 1991, *San Marcos Creek Flood Control Improvement Project – Design Development Study*, by Willdan Associates. This report contains hydrologic analyses that determined the San Marcos Creek watershed area upstream of the Discovery Street bridge to be 17,003 acres (26.57 square miles). This area was used for Reach 1. The watershed area upstream of the Las Posas Creek confluence was determined to 13,427 acres (20.98 square miles). This area was used for Reach 2 through 4. A summary table from the report identifying the watershed areas is included in Appendix A.

The mean annual precipitation is provided by the County of San Diego’s BMP Sizing Calculator (see Appendix A) and is 13.3 inches. The valley slope of Reach 1 through 4 was determined from the 1-foot contour interval topographic mapping in the Study Area Exhibit in Appendix A. This is the longitudinal slope measured along the thalweg. The valley width was estimated from

the topographic mapping. This is the valley bottom width defined by clear breaks in the surface slope on the topographic mapping. The valley slope and valley width at each reach is summarized in Table 1.

Reach	Valley Slope, m/m	Valley Width, m
1	0.0033	30
2	0.0049	40
3	0.0042	52
4	0.0038	79

Table 1. Summary of Valley Slope and Width

These values were input to a spreadsheet to calculate the simulated peak flow, screening index, and valley width index outlined in Form 1. The input data and results are included in Appendix A. This completes the initial desktop analysis.

FIELD SCREENING

After the initial desktop analysis is done, a field assessment must be performed. The field assessment is used to establish a natural channel’s vertical and lateral susceptibility to erosion. SCCWRP states that although they are admittedly linked, vertical and lateral susceptibility are assessed separately for several reasons. First, vertical and lateral responses are primarily controlled by different types of resistance, which, when assessed separately, may improve ease of use and lead to increased repeatability compared to an integrated, cross-dimensional assessment. Second, the mechanistic differences between vertical and lateral responses point to different modeling tools and potentially different management strategies. Having separate screening ratings may better direct users and managers to the most appropriate tools for subsequent analyses.

The field screening tool uses combinations of decision trees and checklists. Decision trees are typically used when a question can be answered fairly definitively and/or quantitatively (e.g., $d_{50} < 16$ mm). Checklists are used where answers are relatively qualitative (e.g., the condition of a grade control). Low, medium, high, and very high ratings are applied separately to the vertical and lateral analyses. When the vertical and lateral analyses return divergent values, the most conservative value shall be selected as the flow threshold for the hydromodification analyses.

Visual observation reveals that each study reach contains a densely vegetated, natural watercourse (see Figures 2 to 16). The vegetative cover extends across the creek bottoms and sides. The cover was so dense that most areas were difficult to access by foot, and some areas were only possible to access if the vegetation was trimmed. Due to the dense cover and flat valley slopes calculated through Form 1, the vertical and lateral stability was anticipated to have a limited susceptibility to erosion.

Vertical Stability

The purpose of the vertical stability decision tree (Figure 6-4 in the County of San Diego HMP) is to assess the state of the channel bed with a particular focus on the risk of incision (i.e., down cutting). The decision tree is included in Figure 20. The first step is to assess the channel bed resistance. There are three categories defined as follows:

1. Labile Bed – sand-dominated bed, little resistant substrate.
2. Transitional/Intermediate Bed – bed typically characterized by gravel/small cobble, Intermediate level of resistance of the substrate and uncertain potential for armoring.
3. Threshold Bed (Coarse/Armored Bed) – armored with large cobbles or larger bed material or highly-resistant bed substrate (i.e., bedrock).

Channel bed resistance is a function of the bed material and vegetation. Figures 17 through 19 show photographs of the larger bed material in the study reaches. A gravelometer is included in the photographs for reference. Each square on the gravelometer indicates grain size in millimeters (the gravelometer squares range from 2 to 180 millimeters). The larger material in the figures was discovered in some isolated locations and generally ranges from 16 to 32 millimeters (mm). The channel bed material in the reaches is generally of smaller size.

Figures 2 through 16 show dense vegetation throughout Reaches 1 through 4. Vegetation prevents bed incision because its root structure binds soil and because the aboveground vegetative growth can greatly reduce flow velocities. Table 5-13 from the County of San Diego's *Drainage Design Manual* outlines maximum permissible velocities for various channel linings (Table 5-13 is included in Appendix B). Maximum permissible velocity is defined in the manual as the velocity below which a channel section will remain stable. Table 5-13 indicates that a fully-lined channel with unreinforced vegetation has a maximum permissible velocity of 5 feet per second (fps). Due to the dense cover and large vegetation, the permissible velocity is likely greater than 5 fps in most reach areas. Table 5-13 indicates that 5 fps is equivalent to an unvegetated channel containing cobbles (grain size from 64 to 256 mm) and shingles (rounded cobbles). In comparison, coarse gravel (19 to 75 mm) has a maximum permissible velocity of 4 fps. Based on this information, the heavily vegetated San Marcos Creek channel has an equivalent grain size of at least 64 mm.

Vegetation in a watercourse can be dynamic, i.e., the vegetation size and density can change over time. An increase in vegetation will further reduce the potential for vertical incision, while a decrease can allow greater incision. A primary cause for a reduction in vegetation is removal due to hydraulic forces and shear stress during periods of high flow. Detailed hydraulic analyses of San Marcos Creek along Reaches 1 through 4 show that the flow velocities are primarily non-erosive within the range of hydromodification flows. Therefore, the vegetative condition will not be adversely impacted by these flows. A review of historic aerial photos covering nearly the past 20 years indicates that the vegetative growth has tended to increase over time.

Based on the photographs and site investigation, the bed resistance is within the transitional/intermediate bed category. Dr. Eric Stein from SCCWRP, who co-authored the *Hydromodification Screening Tool* in the *Final Hydromodification Management Plan* (HMP),

indicated that a transitional/intermediate bed requires the most rigorous analysis steps and will generate appropriate results for the size range. Transitional/intermediate beds cover a wide susceptibility/potential response range and need to be assessed in greater detail to develop a weight of evidence for the appropriate screening rating. The three primary risk factors used to assess vertical susceptibility for channels with transitional/intermediate bed materials are:

1. Armoring potential – three states (Checklist 1)
2. Grade control – three states (Checklist 2)
3. Proximity to regionally-calibrated incision/braiding threshold (Mobility Index Threshold – Probability Diagram)

These three risk factors are assessed using checklists and a diagram (see Appendix B), and the results of each are combined to provide a final vertical susceptibility rating for the intermediate/transitional bed-material group. Each checklist and diagram contains a Category A, B, or C rating. Category A is the most resistant to vertical changes while Category C is the most susceptible.

Checklist 1 determines armoring potential of the channel bed. The channel bed along each of the four reaches is within category B, which represents intermediate bed material within unknown armoring potential due to a surface veneer and dense vegetation. The soil was probed and penetration was relatively difficult through the underlying layer. Due to the dense vegetative growth, the armoring potential could have been rated higher, but Category B was conservatively (i.e., more potential for channel incision) chosen.

Checklist 2 determines grade control characteristics of the channel bed. Grade controls can be improvements such as the roadway crossings at Via Vera Cruz, South Bent Avenue, and Echo Lane. Each of these crossings consists of a non-erodible surface in a well-maintained condition as well as culverts, which together prevent degradation of the upstream channel bed. This combined with the relatively flat valley slope means that each grade control's influence will extend over a large upstream distance. SCCWRP also states that grade controls can be natural. Examples are vegetation or confluences with a larger waterbody such as Lake San Marcos. As indicated above and verified with photographs, each reach contains dense vegetation (see Figures 2 through 16). The plant roots and fallen tree trunks serve as a natural grade control. The spacing of these is much closer than the 50 meters identified in the checklist. Further evidence of the effectiveness of the natural grade controls is the absence of headcutting, mass wasting (large vertical erosion of a channel bank), or undercutting of existing drainage facilities. Based on this information, each reach is within Category A on Checklist 2.

The Mobility Index Threshold is a probability diagram that depicts the risk of incising or braiding based on the potential stream power of the valley relative to the median particle diameter. The threshold is based on regional data from Dr. Howard Chang of Chang Consultants and others. The probability diagram is based on d_{50} as well as the Screening Index determined in the initial desktop analysis (see Appendix A). d_{50} is derived from field conditions. As discussed above, the gravelometer revealed particles at 16 mm and greater, while the equivalent grain size

for the densely vegetated channel is at least 64 mm. The Screening Index for each reach calculated in Appendix A varies from 0.0089 to 0.0274. The Mobility Index Threshold diagram shows that the 50 percent probability of incising or braiding for a d_{50} of 16 and 64 mm has indexes of 0.049 and 0.101, respectively. Since the Screening Index values for each reach are less than these values, each reach falls well within Category A.

The overall vertical rating is determined from the Checklist 1, Checklist 2, and Mobility Index Threshold results. The scoring is based on the following values:

Category A = -1, Category B = 0, Category C = 1

The vertical rating score is the sum of the armoring potential score, grade control score, and Mobility Index Threshold score ($0 + -1 + -1 = -2$). The combined score of -2 is considered a low threshold for vertical susceptibility.

Lateral Stability

The purpose of the lateral decision tree (Figure 6-5 from County of San Diego HMP included in Figure 21) is to assess the state of the channel banks with a focus on the risk of widening. Channels can widen from either bank failure or through fluvial avulsions such as chute cutoffs and braiding. Widening through fluvial avulsions/active braiding is a relatively straightforward observation. If braiding is not already occurring, the next logical step is to assess the condition of the banks. Banks fail through a variety of mechanisms; however, one of the most important distinctions is whether they fail in mass (as many particles) or by fluvial detachment of individual particles. Although much research is dedicated to the combined effects of weakening, fluvial erosion, and mass failure, SCCWRP found it valuable to segregate bank types based on the inference of the dominant failure mechanism (as the management approach may vary based on the dominant failure mechanism). A decision tree (Form 4 in Appendix B) is used in conducting the lateral susceptibility assessment. Definitions and photographic examples are also provided below for terms used in the lateral susceptibility assessment.

The first step in the decision tree is to determine if lateral adjustments are occurring. The adjustments can take the form of extensive mass wasting (greater than 50 percent of the banks are exhibiting planar, slab, or rotational failures and/or scalloping, undermining, and/or tension cracks). The adjustments can also involve extensive fluvial erosion (significant and frequent bank cuts on over 50 percent of the banks). Neither mass wasting nor extensive fluvial erosion was evident within any of the reaches. The banks are intact in the photographs included in the figures. The dense vegetation supports the absence of large lateral adjustments.

The next step is to assess the consolidation of the bank material. The banks were moderate to well-consolidated. This determination was made because the banks were difficult to penetrate with a probe. In addition, the banks showed limited evidence of crumbling and were composed of tightly-packed particles (see figures).

Form 6 (see Appendix B) is used to assess the probability of mass wasting. Form 6 identifies a 10, 50, and 90 percent probability based on the bank angle and bank height. The 1- and 2-foot contour interval topographic mapping indicates that the maximum bank angle is 2 to 1

(horizontal to vertical) or 26.6 degrees in any of the reaches. The majority of the banks are flatter than this. Form 6 shows that the probability of mass wasting and bank failure has less than 10 percent risk for a 26.6 degree bank angle or less regardless of the bank height.

The final step is based on the braiding risk determined from the Mobility Index Threshold in the vertical rating. The braiding risk for each reach is less than 50 percent per the Vertical Stability analysis above. From this, the lateral susceptibility rating is low (red circles are included on the Form 4 Decision Tree in Appendix B showing the decision path).

CONCLUSION

The SCCWRP channel screening tools were used to assess the downstream channel susceptibility for the San Marcos Creek Specific Plan project. The project will discharge into San Marcos Creek at several locations between Discovery Street and Grand Avenue. The assessment was made for San Marcos Creek from the upper end of Lake San Marcos to Echo Lane. The assessment was performed based on office analyses and field work. The results indicate a low threshold for vertical and lateral susceptibilities in all four reaches.

The HMP requires that these results be compared with the critical stress calculator results incorporated in the County of San Diego's BMP Sizing Calculator. The BMP Sizing Calculator results for a typical creek section returns a low susceptibility. Therefore, the SCCWRP analyses and critical stress calculator demonstrate that the project can be designed assuming a low susceptibility, i.e., $0.5Q_2$.

The SCCWRP results are consistent with the physical condition of San Marcos Creek, which has a low longitudinal slope, supports dense vegetative growth, and contains a series of grade controls. The growth is so dense that travel by foot was very difficult in most areas. None of the four study reaches exhibits signs of extensive, ongoing erosion.

INTRODUCTION

This report provides hydromodification screening analyses for the San Marcos Specific Plan project. The project has been divided into seven drainage subareas north of the creek and one subarea south of the creek (see Figure 1). Each subarea will contain a flow (and treatment) control facility and be served by a storm drain system that discharges into San Marcos Creek. The flow control facility sizing is dependent on the flow threshold in the receiving waterbody.

The County of San Diego's January 13, 2011, *Final Hydromodification Management Plan* (HMP) outlines low flow thresholds for hydromodification analyses. The thresholds are based on a percentage of the pre-project 2-year flow (Q_2), i.e., $0.1Q_2$ (low), $0.3Q_2$ (medium), or $0.5Q_2$ (high). A threshold of $0.1Q_2$ represents a downstream receiving conveyance system with a high susceptibility to erosion. This is the default value used for hydromodification analyses and will result in the most conservative (greatest) on-site facility sizing. A threshold of $0.3Q_2$ or $0.5Q_2$ represents downstream receiving conveyance systems with a medium or low susceptibility to erosion, respectively. In order to qualify for a medium or low susceptibility threshold, a project must perform a channel screening analysis based on a "hydromodification screening tool" procedure developed by the Southern California Coastal Water Research Project (SCCWRP). The SCCWRP results are compared with the critical shear stress calculator results from the County of San Diego's BMP Sizing Calculator to establish the appropriate susceptibility threshold of low, medium, or high.

The SCCWRP screening tool requires both office and field work to establish the vertical and lateral susceptibility of a downstream receiving channel to erosion. The vertical and lateral assessments are performed independently of each other although the lateral results can be affected by the vertical rating. The screening was performed to assess San Marcos Creek near the Specific Plan project, which extends from Discovery Street on the downstream end to Grand Avenue on the upstream end.

The initial step in performing the SCCWRP screening analysis is to establish the domain of analysis and the study reaches within the domain. This is followed by office and field components of the screening tool along with the associated analyses and results. The following sections cover these procedures in sequence.

DOMAIN OF ANALYSIS

SCCWRP defines an upstream and downstream domain of analysis, which establish the required study area. The County of San Diego's HMP specifies the downstream domain of analysis based on the SCCWRP criteria with some refinements. The HMP indicates that the downstream limit is defined when one of these is reached:

- at least one reach downstream of the first grade control point
- tidal backwater/lentic waterbody
- equal order tributary

- accumulation of 50 percent drainage area for stream systems or 100 percent drainage area for urban conveyance systems (storm drains, hardened channels, etc.)

The upstream limit is defined as:

- proceed upstream for 20 channel top widths or to the first grade control point, whichever comes first. Identify hard points that can check headward migration and evidence of active headcutting.

SCCWRP defines the maximum spatial unit, or reach (a reach is circa 20 channel widths), for assigning a susceptibility rating within the domain of analysis to be 200 meters (656 feet). If the domain of analysis is greater than 200 meters, the study area should be subdivided into smaller reaches for analysis.

Downstream Domain of Analysis

The downstream domain of analysis for the study area has been determined using the bullet items above. The downstream-most discharge location from the project will be just upstream of the Discovery Street crossing of San Marcos Creek. The first permanent grade control below this discharge location is the Lake San Marcos dam, which is approximately 1.6 miles downstream of the Discovery Street crossing. The Lake San Marcos dam is a concrete arch dam, so it will act as a permanent grade control along San Marcos Creek.

The nearest lentic waterbody is Lake San Marcos. The upper (northerly) end of Lake San Marcos begins approximately 1,900 feet downstream of the Discovery Street crossing. Lake San Marcos then extends for another 1.3 miles to the dam.

The equal order tributary or accumulation of 50 percent drainage area will be significantly further downstream than Lake San Marcos or its dam because the watershed area tributary to the study reach covers over 20 square miles (see discussion in Initial Desktop Analysis section below). The urban conveyance system does not apply since San Marcos Creek is primarily a natural conveyance system.

Based on this information, the downstream domain of analysis is defined by the upper end of Lake San Marcos. This lentic waterbody is the closer to the project site than the other downstream domain of analysis locations.

Upstream Domain of Analysis

Echo Lane crosses San Marcos Creek approximately 900 feet upstream of the upstream project limit at Grand Avenue. The roadway is at the elevation of the creek bed and contains a culvert along the thalweg. The culvert can convey low flow, but during moderate to high storm events the creek flow will overtop the roadway. Since Echo Lane is a non-erodible asphalt crossing spanning the entire creek width, it functions as a grade control and is the first grade control point upstream of the project. Echo Lane is further upstream than the 200 meter limit, but was selected as the upstream domain of analysis because it is a well-defined grade control.

Study Reaches within Domain of Analysis

The domain of analysis along San Marcos Creek extends from the upper end of Lake San Marcos to Echo Lane. The domain of analysis was subdivided into four study reaches with similar characteristics (see the Study Area Exhibit in [Appendix A](#)). Reach 1 extends from the upper end of Lake San Marcos to the confluence of San Marcos Creek with Las Posas Creek. The reach length along the creek thalweg is approximately 2,550 feet. Reach 2 extends from the Las Posas Creek confluence to a point nearly 2,350 feet upstream along the thalweg. Reach 3 extends from the upper end of Reach 2 approximately 3,890 feet along the creek thalweg to South Bent Avenue. Reach 4 extends approximately 2,130 feet along the thalweg from South Bent Avenue to Echo Lane.

Reaches 1, 2, 3, and 4 are longer than the 656 feet maximum reach length specified by SCCWRP. The four reach locations were selected based on consistency within each reach. Review of topographic mapping, aerial photographs, and field conditions reveals that the physical (channel geometry and slope), vegetative, hydraulic, and soil conditions within each of these reaches is relatively uniform. Subdividing the reaches into smaller subreaches of less than 656 feet will not yield significantly varying results within a reach. Consequently, the screening tool was applied across Reach 1, 2, 3, and 4, and the results will be the same within each reach.

INITIAL DESKTOP ANALYSIS

After the domain of analysis is established, SCCWRP requires an “initial desktop analysis” that involves office work. The initial desktop analysis establishes the watershed area, mean annual precipitation, valley slope, and valley width. These terms are defined in Form 1 included in [Appendix A](#). SCCWRP recommends the use of National Elevation Data (NED) to determine the watershed area, valley slope, and valley width. A review of the NED for San Marcos determined that it is equivalent to USGS quadrangle maps. The topographic resolution on USGS maps is low and typically on a 25-foot contour interval. For this report, recent topographic mapping along San Marcos Creek was used to establish the valley slope and valley width because the topography is at a 1-foot contour interval, which is much greater detail than NED. The 1-foot contour mapping did not cover the area near Lake San Marcos or the south creek bank between South Bent Avenue and Echo Lane. For these areas, the City of San Marcos’ 2-foot contour topographic mapping was used.

The watershed area tributary to San Marcos Creek was established in the March 27, 1991, *San Marcos Creek Flood Control Improvement Project – Design Development Study*, by Willdan Associates. This report contains hydrologic analyses that determined the San Marcos Creek watershed area upstream of the Discovery Street bridge to be 17,003 acres (26.57 square miles). This area was used for Reach 1. The watershed area upstream of the Las Posas Creek confluence was determined to 13,427 acres (20.98 square miles). This area was used for Reach 2 through 4. A summary table from the report identifying the watershed areas is included in [Appendix A](#).

The mean annual precipitation is provided by the County of San Diego’s BMP Sizing Calculator ([see Appendix A](#)) and is 13.3 inches. The valley slope of Reach 1 through 4 was determined from the 1-foot contour interval topographic mapping in the Study Area Exhibit in [Appendix A](#). This is the longitudinal slope measured along the thalweg. The valley width was estimated from

the topographic mapping. This is the valley bottom width defined by clear breaks in the surface slope on the topographic mapping. The valley slope and valley width at each reach is summarized in [Table 1](#).

Reach	Valley Slope, m/m	Valley Width, m
1	0.0033	30
2	0.0049	40
3	0.0042	52
4	0.0038	79

Table 1. Summary of Valley Slope and Width

These values were input to a spreadsheet to calculate the simulated peak flow, screening index, and valley width index outlined in Form 1. The input data and results are included in [Appendix A](#). This completes the initial desktop analysis.

FIELD SCREENING

After the initial desktop analysis is done, a field assessment must be performed. The field assessment is used to establish a natural channel's vertical and lateral susceptibility to erosion. SCCWRP states that although they are admittedly linked, vertical and lateral susceptibility are assessed separately for several reasons. First, vertical and lateral responses are primarily controlled by different types of resistance, which, when assessed separately, may improve ease of use and lead to increased repeatability compared to an integrated, cross-dimensional assessment. Second, the mechanistic differences between vertical and lateral responses point to different modeling tools and potentially different management strategies. Having separate screening ratings may better direct users and managers to the most appropriate tools for subsequent analyses.

The field screening tool uses combinations of decision trees and checklists. Decision trees are typically used when a question can be answered fairly definitively and/or quantitatively (e.g., $d_{50} < 16$ mm). Checklists are used where answers are relatively qualitative (e.g., the condition of a grade control). Low, medium, high, and very high ratings are applied separately to the vertical and lateral analyses. When the vertical and lateral analyses return divergent values, the most conservative value shall be selected as the flow threshold for the hydromodification analyses.

Visual observation reveals that each study reach contains a densely vegetated, natural watercourse (see [Figures 2 to 16](#)). The vegetative cover extends across the creek bottoms and sides. The cover was so dense that most areas were difficult to access by foot, and some areas were only possible to access if the vegetation was trimmed. Due to the dense cover and flat valley slopes calculated through Form 1, the vertical and lateral stability was anticipated to have a limited susceptibility to erosion.

Vertical Stability

The purpose of the vertical stability decision tree (Figure 6-4 in the County of San Diego HMP) is to assess the state of the channel bed with a particular focus on the risk of incision (i.e., down cutting). The decision tree is included in Figure 20. The first step is to assess the channel bed resistance. There are three categories defined as follows:

1. Labile Bed – sand-dominated bed, little resistant substrate.
2. Transitional/Intermediate Bed – bed typically characterized by gravel/small cobble, Intermediate level of resistance of the substrate and uncertain potential for armoring.
3. Threshold Bed (Coarse/Armored Bed) – armored with large cobbles or larger bed material or highly-resistant bed substrate (i.e., bedrock).

Channel bed resistance is a function of the bed material and vegetation. Figures 17 through 19 show photographs of the larger bed material in the study reaches. A gravelometer is included in the photographs for reference. Each square on the gravelometer indicates grain size in millimeters (the gravelometer squares range from 2 to 180 millimeters). The larger material in the figures was discovered in some isolated locations and generally ranges from 16 to 32 millimeters (mm). The channel bed material in the reaches is generally of smaller size.

Figures 2 through 16 show dense vegetation throughout Reaches 1 through 4. Vegetation prevents bed incision because its root structure binds soil and because the aboveground vegetative growth can greatly reduce flow velocities. Table 5-13 from the County of San Diego's *Drainage Design Manual* outlines maximum permissible velocities for various channel linings (Table 5-13 is included in Appendix B). Maximum permissible velocity is defined in the manual as the velocity below which a channel section will remain stable. Table 5-13 indicates that a fully-lined channel with unreinforced vegetation has a maximum permissible velocity of 5 feet per second (fps). Due to the dense cover and large vegetation, the permissible velocity is likely greater than 5 fps in most reach areas. Table 5-13 indicates that 5 fps is equivalent to an unvegetated channel containing cobbles (grain size from 64 to 256 mm) and shingles (rounded cobbles). In comparison, coarse gravel (19 to 75 mm) has a maximum permissible velocity of 4 fps. Based on this information, the heavily vegetated San Marcos Creek channel has an equivalent grain size of at least 64 mm.

Vegetation in a watercourse can be dynamic, i.e., the vegetation size and density can change over time. An increase in vegetation will further reduce the potential for vertical incision, while a decrease can allow greater incision. A primary cause for a reduction in vegetation is removal due to hydraulic forces and shear stress during periods of high flow. Detailed hydraulic analyses of San Marcos Creek along Reaches 1 through 4 show that the flow velocities are primarily non-erosive within the range of hydromodification flows. Therefore, the vegetative condition will not be adversely impacted by these flows. A review of historic aerial photos covering nearly the past 20 years indicates that the vegetative growth has tended to increase over time.

Based on the photographs and site investigation, the bed resistance is within the transitional/intermediate bed category. Dr. Eric Stein from SCCWRP, who co-authored the *Hydromodification Screening Tool* in the *Final Hydromodification Management Plan* (HMP),

indicated that a transitional/intermediate bed requires the most rigorous analysis steps and will generate appropriate results for the size range. Transitional/intermediate beds cover a wide susceptibility/potential response range and need to be assessed in greater detail to develop a weight of evidence for the appropriate screening rating. The three primary risk factors used to assess vertical susceptibility for channels with transitional/intermediate bed materials are:

1. Armoring potential – three states (Checklist 1)
2. Grade control – three states (Checklist 2)
3. Proximity to regionally-calibrated incision/braiding threshold (Mobility Index Threshold – Probability Diagram)

These three risk factors are assessed using checklists and a diagram (see [Appendix B](#)), and the results of each are combined to provide a final vertical susceptibility rating for the intermediate/transitional bed-material group. Each checklist and diagram contains a Category A, B, or C rating. Category A is the most resistant to vertical changes while Category C is the most susceptible.

Checklist 1 determines armoring potential of the channel bed. The channel bed along each of the four reaches is within category B, which represents intermediate bed material within unknown armoring potential due to a surface veneer and dense vegetation. The soil was probed and penetration was relatively difficult through the underlying layer. Due to the dense vegetative growth, the armoring potential could have been rated higher, but Category B was conservatively (i.e., more potential for channel incision) chosen.

Checklist 2 determines grade control characteristics of the channel bed. Grade controls can be improvements such as the roadway crossings at Via Vera Cruz, South Bent Avenue, and Echo Lane. Each of these crossings consists of a non-erodible surface in a well-maintained condition as well as culverts, which together prevent degradation of the upstream channel bed. This combined with the relatively flat valley slope means that each grade control's influence will extend over a large upstream distance. SCCWRP also states that grade controls can be natural. Examples are vegetation or confluences with a larger waterbody such as Lake San Marcos. As indicated above and verified with photographs, each reach contains dense vegetation (see [Figures 2 through 16](#)). The plant roots and fallen tree trunks serve as a natural grade control. The spacing of these is much closer than the 50 meters identified in the checklist. Further evidence of the effectiveness of the natural grade controls is the absence of headcutting, mass wasting (large vertical erosion of a channel bank), or undercutting of existing drainage facilities. Based on this information, each reach is within Category A on Checklist 2.

The Mobility Index Threshold is a probability diagram that depicts the risk of incising or braiding based on the potential stream power of the valley relative to the median particle diameter. The threshold is based on regional data from Dr. Howard Chang of Chang Consultants and others. The probability diagram is based on d_{50} as well as the Screening Index determined in the initial desktop analysis (see [Appendix A](#)). d_{50} is derived from field conditions. As discussed above, the gravelometer revealed particles at 16 mm and greater, while the equivalent grain size

for the densely vegetated channel is at least 64 mm. The Screening Index for each reach calculated in Appendix A varies from 0.0089 to 0.0274. The Mobility Index Threshold diagram shows that the 50 percent probability of incising or braiding for a d_{50} of 16 and 64 mm has indexes of 0.049 and 0.101, respectively. Since the Screening Index values for each reach are less than these values, each reach falls well within Category A.

The overall vertical rating is determined from the Checklist 1, Checklist 2, and Mobility Index Threshold results. The scoring is based on the following values:

Category A = -1, Category B = 0, Category C = 1

The vertical rating score is the sum of the armoring potential score, grade control score, and Mobility Index Threshold score ($0 + -1 + -1 = -2$). The combined score of -2 is considered a low threshold for vertical susceptibility.

Lateral Stability

The purpose of the lateral decision tree (Figure 6-5 from County of San Diego HMP included in Figure 21) is to assess the state of the channel banks with a focus on the risk of widening. Channels can widen from either bank failure or through fluvial avulsions such as chute cutoffs and braiding. Widening through fluvial avulsions/active braiding is a relatively straightforward observation. If braiding is not already occurring, the next logical step is to assess the condition of the banks. Banks fail through a variety of mechanisms; however, one of the most important distinctions is whether they fail in mass (as many particles) or by fluvial detachment of individual particles. Although much research is dedicated to the combined effects of weakening, fluvial erosion, and mass failure, SCCWRP found it valuable to segregate bank types based on the inference of the dominant failure mechanism (as the management approach may vary based on the dominant failure mechanism). A decision tree (Form 4 in Appendix B) is used in conducting the lateral susceptibility assessment. Definitions and photographic examples are also provided below for terms used in the lateral susceptibility assessment.

The first step in the decision tree is to determine if lateral adjustments are occurring. The adjustments can take the form of extensive mass wasting (greater than 50 percent of the banks are exhibiting planar, slab, or rotational failures and/or scalloping, undermining, and/or tension cracks). The adjustments can also involve extensive fluvial erosion (significant and frequent bank cuts on over 50 percent of the banks). Neither mass wasting nor extensive fluvial erosion was evident within any of the reaches. The banks are intact in the photographs included in the figures. The dense vegetation supports the absence of large lateral adjustments.

The next step is to assess the consolidation of the bank material. The banks were moderate to well-consolidated. This determination was made because the banks were difficult to penetrate with a probe. In addition, the banks showed limited evidence of crumbling and were composed of tightly-packed particles (see figures).

Form 6 (see Appendix B) is used to assess the probability of mass wasting. Form 6 identifies a 10, 50, and 90 percent probability based on the bank angle and bank height. The 1- and 2-foot contour interval topographic mapping indicates that the maximum bank angle is 2 to 1

(horizontal to vertical) or 26.6 degrees in any of the reaches. The majority of the banks are flatter than this. Form 6 shows that the probability of mass wasting and bank failure has less than 10 percent risk for a 26.6 degree bank angle or less regardless of the bank height.

The final step is based on the braiding risk determined from the Mobility Index Threshold in the vertical rating. The braiding risk for each reach is less than 50 percent per the Vertical Stability analysis above. From this, the lateral susceptibility rating is low (red circles are included on the Form 4 Decision Tree in Appendix B showing the decision path).

CONCLUSION

The SCCWRP channel screening tools were used to assess the downstream channel susceptibility for the San Marcos Creek Specific Plan project. The project will discharge into San Marcos Creek at several locations between Discovery Street and Grand Avenue. The assessment was made for San Marcos Creek from the upper end of Lake San Marcos to Echo Lane. The assessment was performed based on office analyses and field work. The results indicate a low threshold for vertical and lateral susceptibilities in all four reaches.

The HMP requires that these results be compared with the critical stress calculator results incorporated in the County of San Diego's BMP Sizing Calculator. The BMP Sizing Calculator results for a typical creek section returns a low susceptibility. Therefore, the SCCWRP analyses and critical stress calculator demonstrate that the project can be designed assuming a low susceptibility, i.e., $0.5Q_2$.

The SCCWRP results are consistent with the physical condition of San Marcos Creek, which has a low longitudinal slope, supports dense vegetative growth, and contains a series of grade controls. The growth is so dense that travel by foot was very difficult in most areas. None of the four study reaches exhibits signs of extensive, ongoing erosion.



NOTE:

DMA'S ARE BASED ON THE ALTERNATIVE 7 SITE PLAN.

GRAPHIC SCALE

0 250 500



1 INCH = 500 FEET

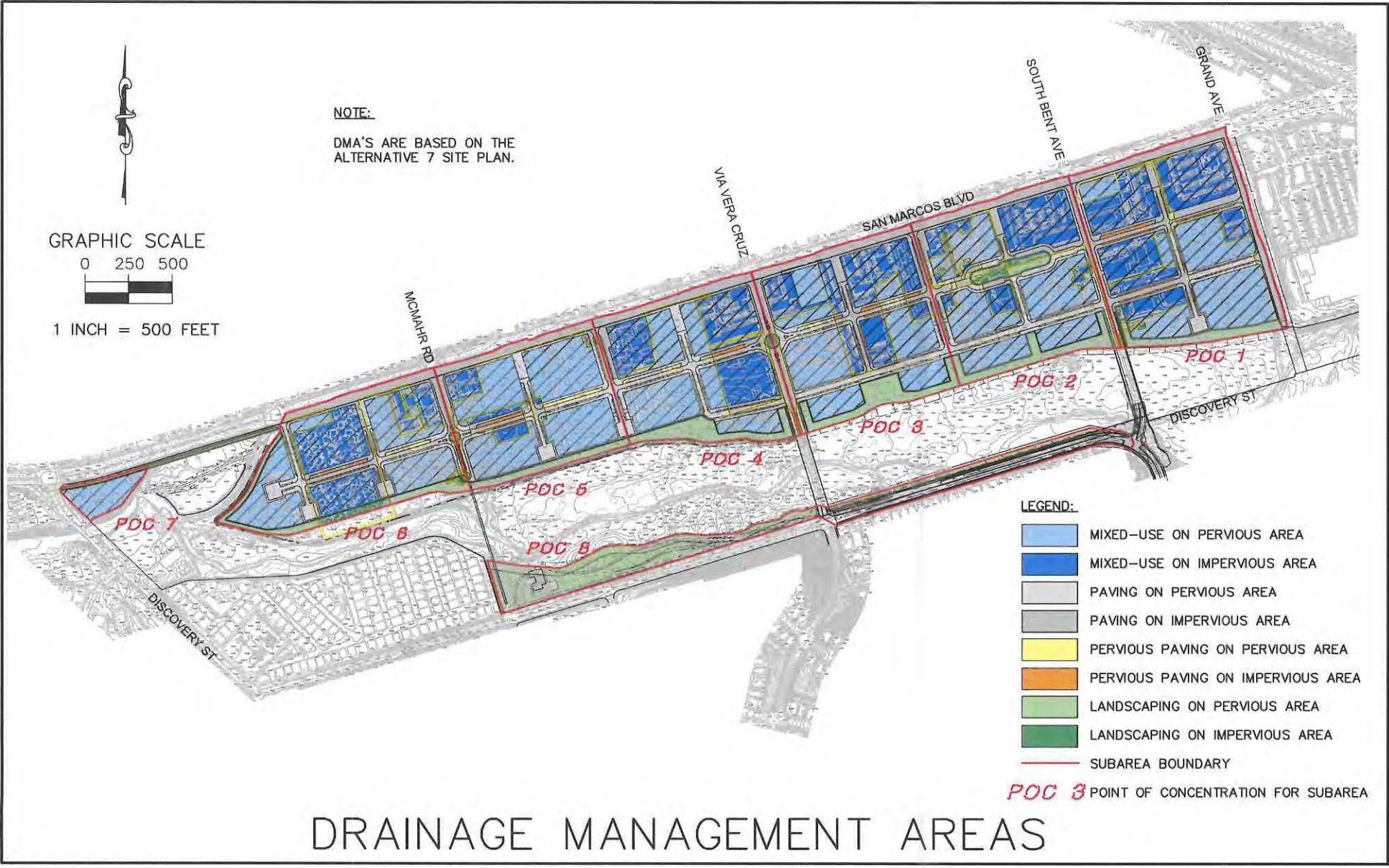

LEGEND:

-  MIXED-USE ON PERVIOUS AREA
-  MIXED-USE ON IMPERVIOUS AREA
-  PAVING ON PERVIOUS AREA
-  PAVING ON IMPERVIOUS AREA
-  PERVIOUS PAVING ON PERVIOUS AREA
-  PERVIOUS PAVING ON IMPERVIOUS AREA
-  LANDSCAPING ON PERVIOUS AREA
-  LANDSCAPING ON IMPERVIOUS AREA
-  SUBAREA BOUNDARY

POC 3 POINT OF CONCENTRATION FOR SUBAREA

DRAINAGE MANAGEMENT AREAS



Figure 2. Looking East towards Discharge of Reach 1 to Lake San Marcos



Figure 3. Looking Upstream at West Edge of Reach 1



Figure 4. Looking Downstream at East Edge of Reach 1



Figure 5. Looking Downstream at Reach 1 from Discovery Street Crossing



Figure 6. Looking Upstream at Reach 1 from Discovery Street Crossing



Figure 7. Looking Upstream along Reach 2 near Las Posas Creek Confluence



Figure 8. Looking Upstream along South Edge of Reach 2



Figure 9. Looking Upstream along North Edge of Reach 2



Figure 10. Looking Downstream at Reach 3 from Via Vera Cruz



Figure 11. Looking Upstream at Reach 3 from Via Vera Cruz



Figure 12. Looking Downstream along South Edge of Reach 3



Figure 13. Looking Downstream towards North Edge of Reach 3



Figure 14. Looking Upstream at Reach 4 from South Bent Avenue



Figure 15. Looking Downstream towards North Edge of Reach 4



Figure 16. Looking towards North Edge of Reach 4 from Echo Lane

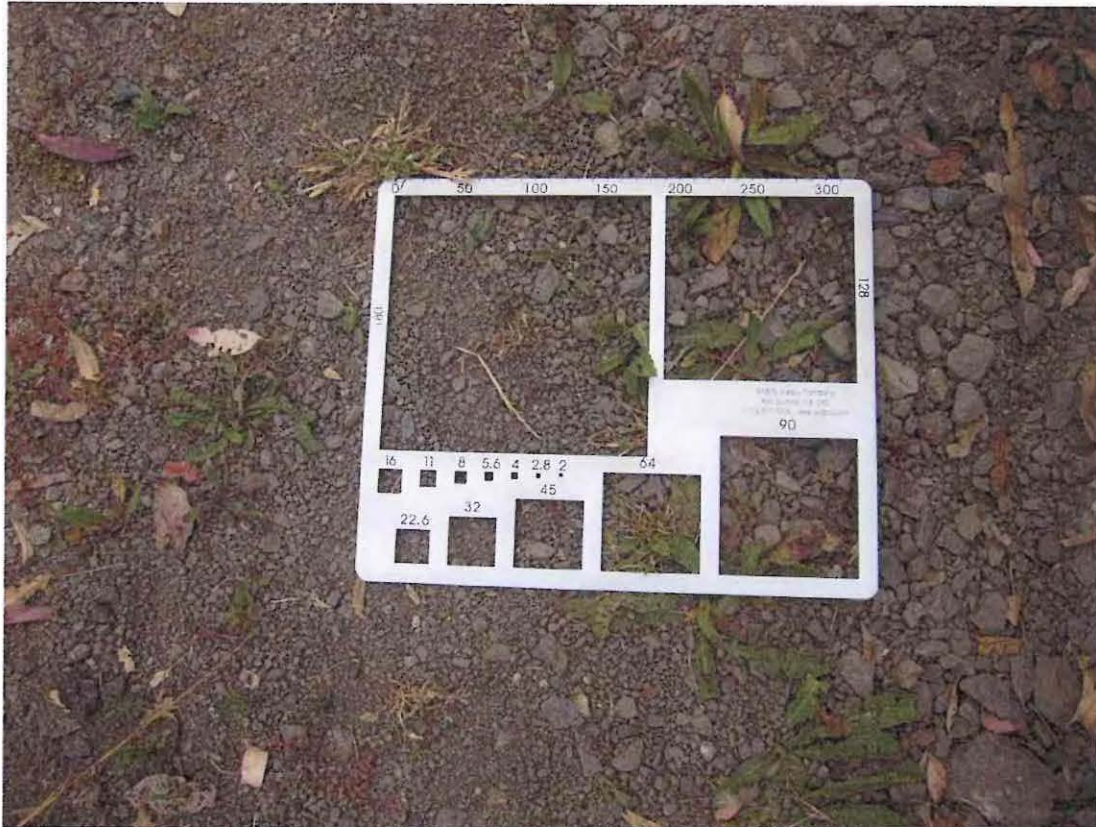

Figure 17. Channel Material near Via Vera Cruz



Figure 18. Channel Material near South Bent Avenue



Figure 19. Channel Material near Echo Lane

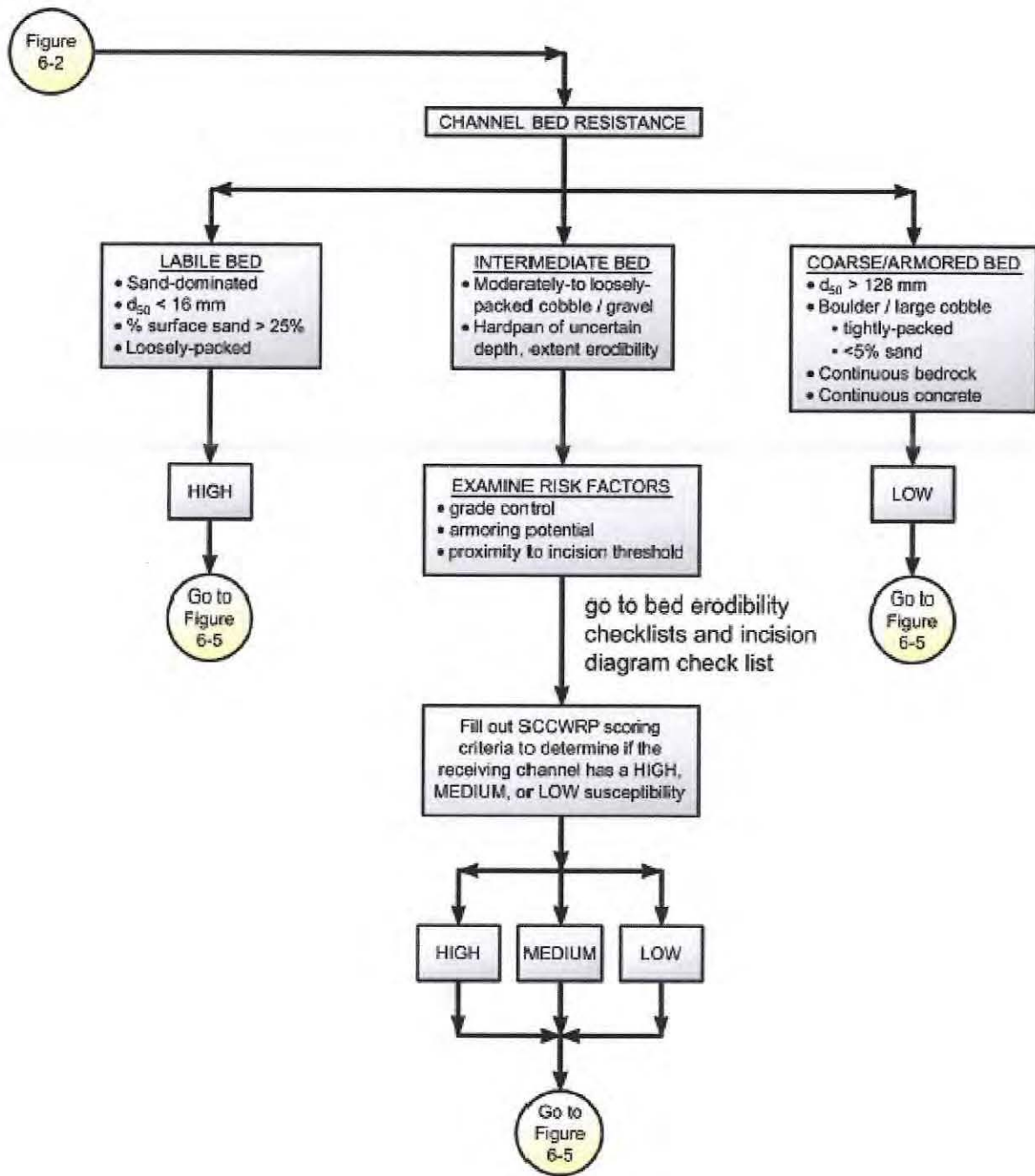

Figure 6-4. SCCWRP Vertical Susceptibility

Figure 20. SCCWRP Vertical Channel Susceptibility Matrix

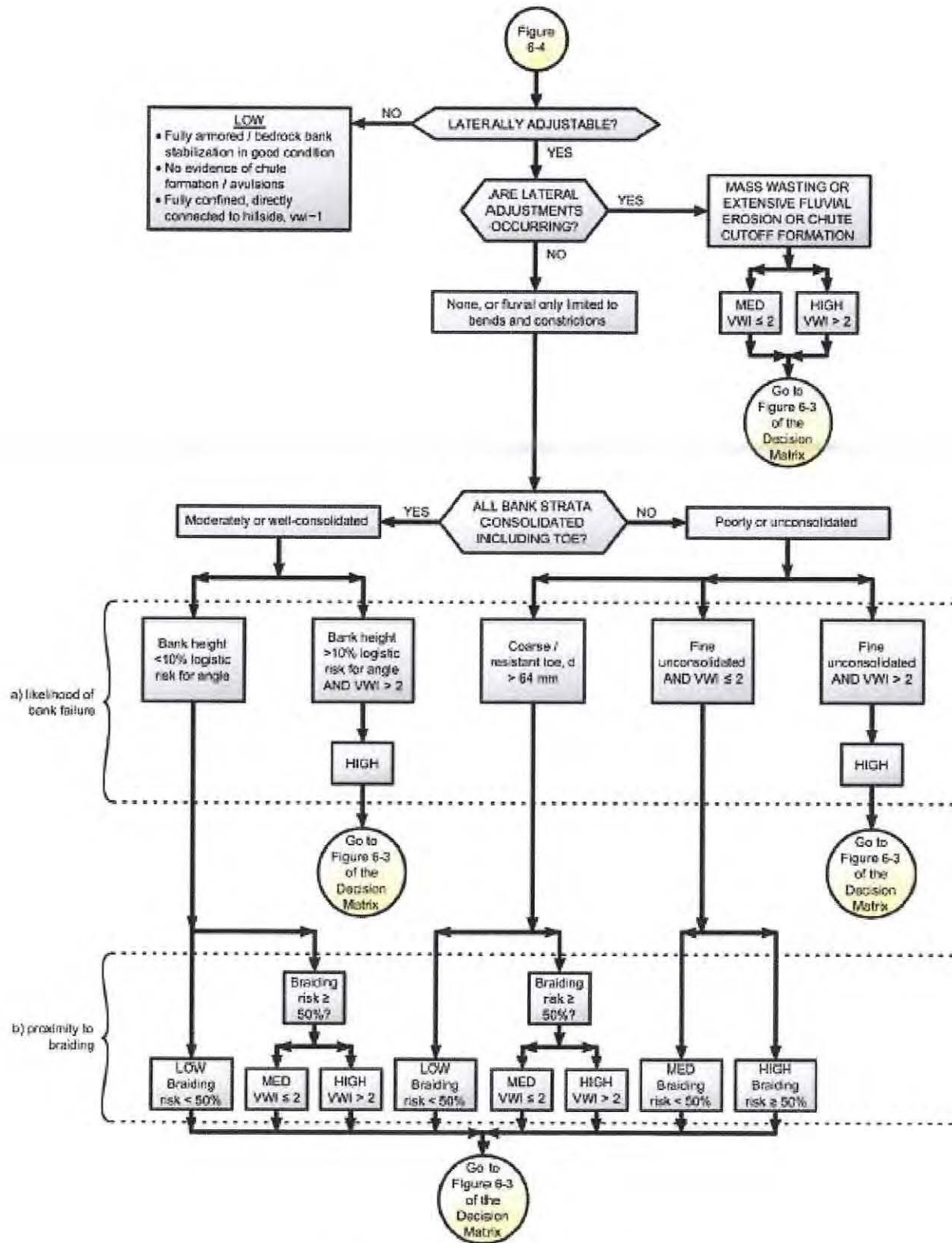

Figure 6-5. Lateral Channel Susceptibility

Figure 21. SCCWRP Lateral Channel Susceptibility Matrix

APPENDIX A

SCCWRP INITIAL DESKTOP ANALYSIS

FORM 1: INITIAL DESKTOP ANALYSIS

IF required at multiple locations, circle one (applicant site, upstream extent, downstream extent)

Location: Latitude: 33.1363 Longitude: -117.1716
 Description (river name, crossing streets, etc.): San Marcos Creek from upper end of Lake San Marcos to Echo Lane

GIS Parameters: US Customary units used for contributing drainage area (A) and mean annual precipitation (P) to apply regional flow equations after the USGS

Table 2.1: Initial desktop analysis in GIS

Symbol	Variable (units)	Value	Description and Source
Watershed properties (English units)	A	Area (mi ²)	contributing drainage area to location via published Hydrologic Unit Codes (HUCs) and/or ≤ 30 m National Elevation Data (NED), USGS seamless server
	P	Mean annual precipitation (in.)	area-averaged annual precipitation via USGS delineated polygons using records from 1900 to 1960 (Natural Resources Conservation Service (NRCS) shape file using records from 1961 to 1990 was less accurate in hydrologic models)
Site properties (SI units)	S_v	Valley slope (m/m)	geomorphically-defined valley slope at site via NED, dictated by watershed configuration, confluences, consistent valley widths, etc., over a distance of up to ~500 m or 10% of the main-channel length from site to drainage divide (whichever is smaller)
	W_v	Valley width (m)	valley bottom width at site from natural valley wall to valley wall, dictated by clear breaks in surface slope on NED raster, irrespective of potential armoring from floodplain encroachment, levees, etc.

Table 2.2: Simplified peak flow (Hawley and Bledsoe, In review), screening index, and valley width index

Symbol	Dependent Variable (units)	Value	Equation	Required units
Q_{10cfs}	10-yr peak flow (ft ³ /s)		$Q_{10cfs} = 18.2 * A^{0.87} * P^{0.77}$	A (mi ²) P (in.)
Q₁₀	10-yr peak flow (m ³ /s)		$Q_{10} = 0.0283 * Q_{10cfs}$	Q _{10cfs} (cfs)
INDEX	10-yr screening index (m ^{1.5} /s ^{0.5})		$INDEX = S_v * Q_{10}^{0.5}$	S _v (m/m) Q ₁₀ (m ³ /s)
W_{ref}	Reference width (m)		$W_{ref} = 6.99 * Q_{10}^{0.438}$	Q ₁₀ (m ³ /s)
VWI	Valley width index (m/m)		$VWI = W_v / W_{ref}$	W _v (m) W _{ref} (m)

Note: Gray highlighting indicates values directly used in field assessments

(Sheet 1 of 1)

SCCWRP FORM 1 ANALYSES

Study Reach	Area A, sq. mi.	Mean Annual Precip. P, inches	Valley Slope Sv, m/m	Valley Width Wv, m	10-Year Flow Q10cfs, cfs	10-Year Flow Q10, cms	10-Year Screening Index INDEX	Reference Width Wref, m	Valley Width Index VWI, m/m
Reach 1	26.57	13.3	0.0033	30	2,315	65.5	0.0267	43.66	0.69
Reach 2	20.98	13.3	0.0049	40	1,885	53.4	0.0358	39.90	1.00
Reach 3	20.98	13.3	0.0042	52	1,885	53.4	0.0307	39.90	1.30
Reach 4	20.98	13.3	0.0038	79	1,885	53.4	0.0278	39.90	1.98

1990 SAN MARCOS CREEK DESIGN DEVELOPMENT STUDY
 ULTIMATE BUILDOUT CONDITION
 WILLDAN ASSOCIATES

	CONC. PT	CONTRIBUTING AREA (Acres)	100 YEAR FREQUENCY						10 YEAR FREQUENCY	
			24 HOUR DURATION			6 HOUR DURATION			24 HOUR	6 HOUR
			AMC 2	(AVERAGE) AMC 2.5	AMC 3	AMC 2	(AVERAGE) AMC 2.5	AMC 3	AMC 2	AMC 2
SMC-U/S Discovery St. Bridge and *** D/S L.P. & Discovery S.D. Confluence	291-2	17,003	13,400	14,775	16,150	13,850	18,050	22,250	7,100	6,650
SMC-U/S Las Posas & Discovery S.D. Confluence	221-0	13,427	10,450	11,625	12,800	11,200	14,875	18,550	5,500	5,200
SMC-U/S Of S.R. 78 Crossing	231-0	12,638	9,850	11,000	12,150	11,150	14,750	18,350	5,300	5,250
SMC-D/S North & East Branch Confluence	241-1	11,775	9,150	10,250	11,350	10,250	13,625	17,000	4,900	4,800
SMC-East Branch-U/S North Branch Confluence	161-0	4,660	4,000	4,400	4,800	5,950	7,500	9,050	2,200	2,950
SMC East Branch - 1700' E/O Valpreda Rd.	-									
SMC East Branch - N/O A.T.&S.F. R.R., 1100' W/O Woodland Prkwy. / Richland	261-0	3,600	3,100	3,400	3,700	5,000	6,150	7,300	1,700	2,600
SMC East Branch - S/O Mission @ Woodland Prkwy/Richland	-	3,010								
SMC East Branch - Rock Springs Rd. @ Knob Hill Rd.	151-0	2,516	2,200	2,400	2,600	3,550	4,350	5,150	1,250	1,850
SMC North Branch - U/S E. Branch Confluence	241-0	7,115	5,350	6,025	6,700	5,050	6,975	8,900	2,800	2,350
SMC North Branch - 1300' U/S Of Mission	181-0	6,975	5,250	5,900	6,550	4,950	6,875	8,800	2,700	2,300
SMC North Branch - 1500' U/S Of Borden Rd.	101-0	6,145	4,600	5,200	5,800	4,550	6,400	8,250	2,400	2,100
SMC North Branch - U/S Of La Cienega Rd.	71-0	4,786	3,500	4,025	4,550	3,650	5,225	6,800	1,800	1,700
SMC North Branch - 1500' U/S Of Olive Dr.	41-0	3,376	2,500	2,875	3,250	2,900	4,000	5,100	1,250	1,300
Las Posas Branch - U/S Of SMC Confluence	-									
Las Posas Branch - U/S Of San Marcos Blvd.	211-0	2,113	2,000	2,075	2,150	3,350	3,725	4,100	1,200	2,050
Las Posas Branch - U/S Of Grand Ave.	-									
Las Posas Branch - Las Posas Rd., 500' N/O Fwy	191-0	936	800	850	900	1,150	1,325	1,500	500	700
Las Posas Branch - @ Proposed Detention Basin	91-0	542	550	575	600	950	1,075	1,200	300	550
Proposed Discovery St. S.D. System ***	291-0	1,464	1,300	1,400	1,500	1,800	2,200	2,600	750	950
East Barham Area S.D. System (Confluence Pt. 1700' E/O T.O. Vly Rd.)	271-0	315	250	300	350	400	525	650	150	200
Vineyard Rd. S.D. System	171-0	377	350	375	400	600	700	800	200	350

NOTES

* TSM 339

** TSM 302

*** No Detention Taken For Proposed Discovery Hills Dev't

Compliance Basin Summary

Basin Name:	San Marcos SP Basin
Receiving Water:	San Marcos Creek
Rainfall Basin	Oceanside
Mean Annual Precipitation (inches)	13.3

**MEAN ANNUAL PRECIPITATION FROM
COUNTY OF SAN DIEGO BMP CALCULATOR**

APPENDIX B

SCCWRP FIELD SCREENING DATA

Table 5-13 Maximum Permissible Velocities for Lined and Unlined Channels

Material or Lining	Maximum Permissible Average Velocity* (ft/sec)
Natural and Improved Unlined Channels	
Fine Sand, Colloidal	1.50
Sandy Loam, Noncolloidal	1.75
Silt Loam, Noncolloidal	2.00
Alluvial Silts, Noncolloidal	2.00
Ordinary Firm Loam	2.50
Volcanic Ash	2.50
Stiff Clay, Very Colloidal	3.75
Alluvial Silts, Colloidal	3.75
Shales And Hardpans	6.00
Fine Gravel	2.50
Graded Loam To Cobbles When Noncolloidal	3.75
Graded Silts To Cobbles When Colloidal	4.00
Coarse Gravel, Noncolloidal	4.00
Cobbles And Shingles	5.00
Sandy Silt	2.00
Silty Clay	2.50
Clay	6.00
Poor Sedimentary Rock	10.0
Fully-Lined Channels	
Unreinforced Vegetation	5.0
Reinforced Turf	10.0
Loose Riprap	per Table 5-2
Grouted Riprap	25.0
Gabions	15.0
Soil Cement	15.0
Concrete	35.0

* Maximum permissible velocity listed here is basic guideline; higher design velocities may be used, provided appropriate technical documentation from manufacturer.

Checklists and diagram for assessing potential bed erodibility – transitional/intermediate bed material:

Checklist 1: Armoring Potential

- A. A mix of coarse gravels and cobbles that are tightly packed with < 5% surface material of diameter < 2 mm
- B. Intermediate to A. and C. or hardpan of unknown resistance, spatial extent (longitudinal and depth), or unknown armoring potential due to surface veneer covering gravel or coarser layer encountered with probe
- C. Gravels/cobbles that are loosely packed and/or > 25% surface material of diameter < 2 mm



Figure 2.3: Armoring potential photographic supplement for assessing intermediate beds ($16 < d_{50} < 128$ mm) in conjunction with Checklist 1

Checklist 2: Grade Control

- A. Grade control is present with spacing < 50 m or every $2/S_v$
- No evidence of failure/ineffectiveness, e.g., no headcutting (> 30 cm), no active mass wasting (analyst cannot say grade control sufficient if mass-wasting checklist indicates presence), no exposed bridge pilings, no culverts/structures undermined
 - Hard points in serviceable condition at decadal time scale, e.g., no apparent undermining, flanking, failing grout
 - If geologic grade control, rock should be resistant igneous and/or metamorphic or if sedimentary/hardpan should be subjected to hammer test/borings before placing in this category (criteria TBD)
- B. Intermediate to A. and C. – artificial or geologic grade control present but spaced $2/S_v$ to $4/S_v$ or potential evidence of failure or hardpan of uncertain resistance
- C. Grade control absent, spaced > 100 m or $> 4/S_v$, or clear evidence of ineffectiveness

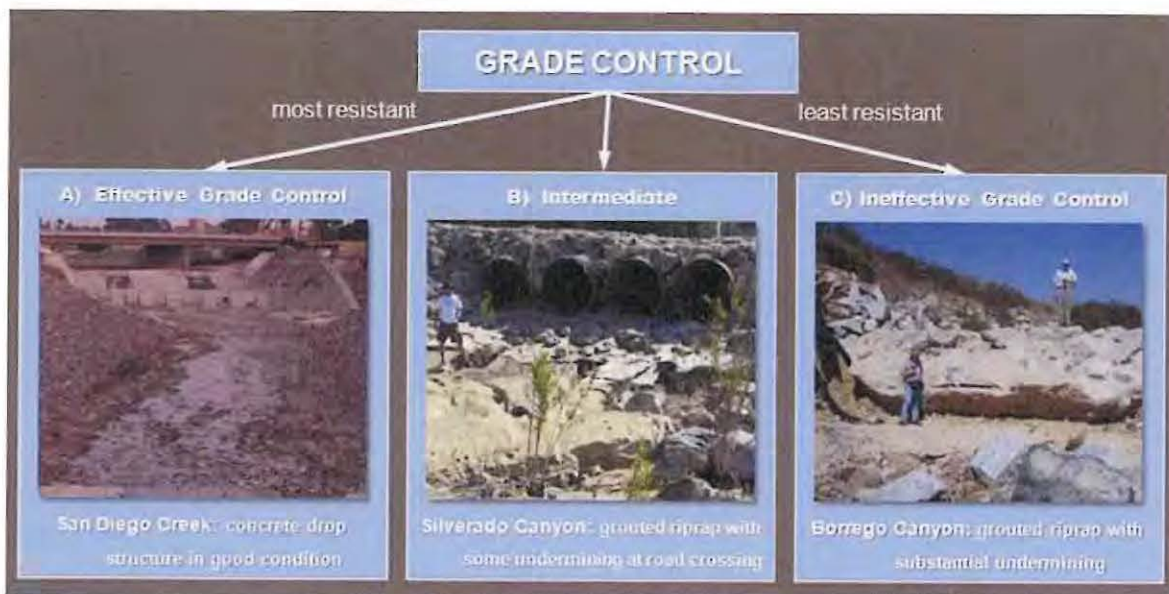

Figure 2.4: Grade-control (condition) photographic supplement for assessing intermediate beds ($16 < d_{50} < 128$ mm) in conjunction with Checklist 2

Diagram – Regionally-calibrated screening index threshold for incising/braiding

For transitional bed channels where the bed material d_{50} is between 16 and 128 mm, use the diagram and table (Figure 2.5 and Table 2.3, respectively) to determine if the risk of incision is $\geq 50\%$.

(Sheet 3 of 5)

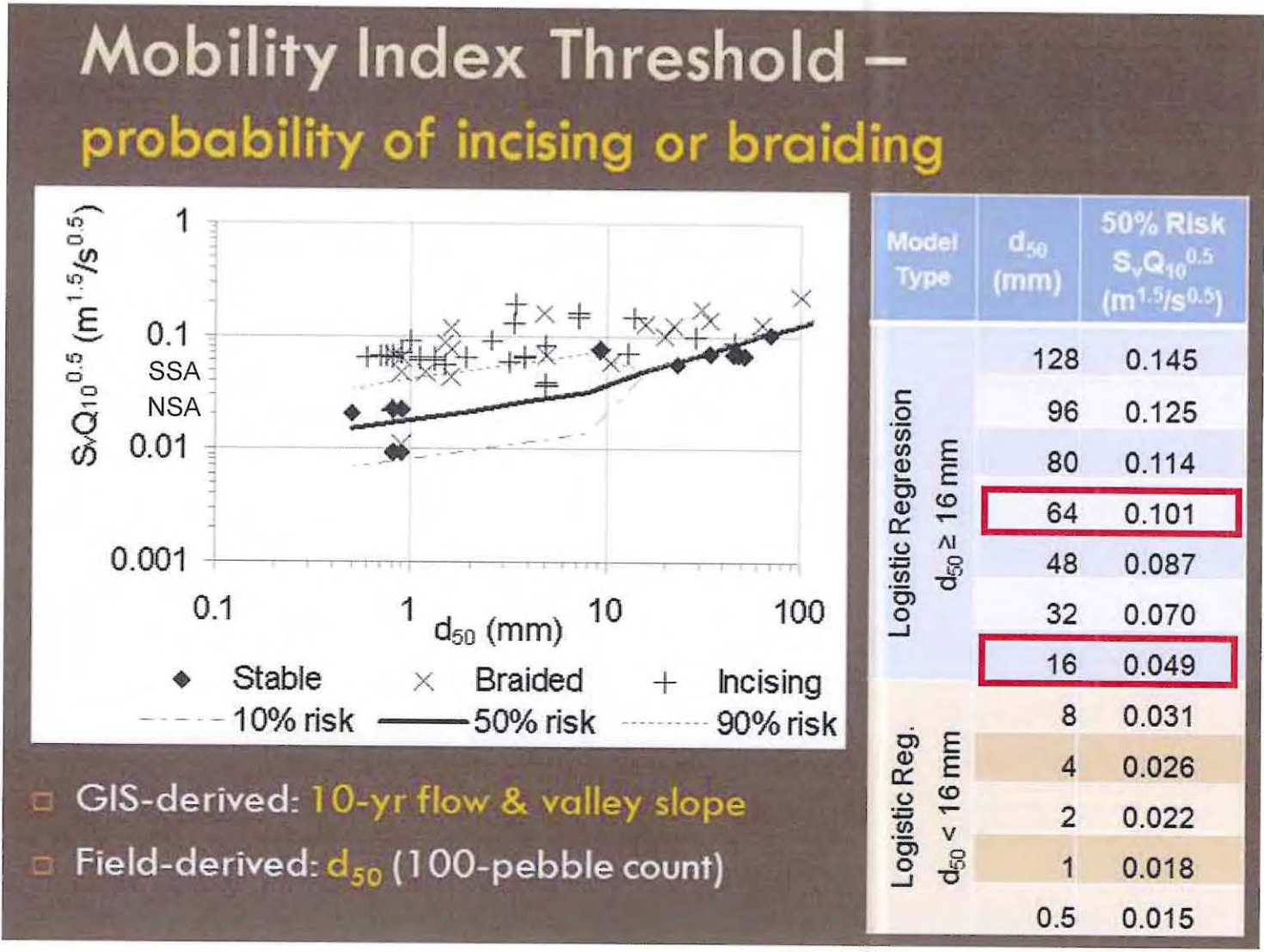

Figure 2.5: Probability of incising/braiding based on logistic regression of Screening Index and d_{50}

FORM 4: LATERAL SUSCEPTIBILITY FIELD SHEET

Circle appropriate nodes/pathway for proposed site or use sequence of questions provided below (Form 5).

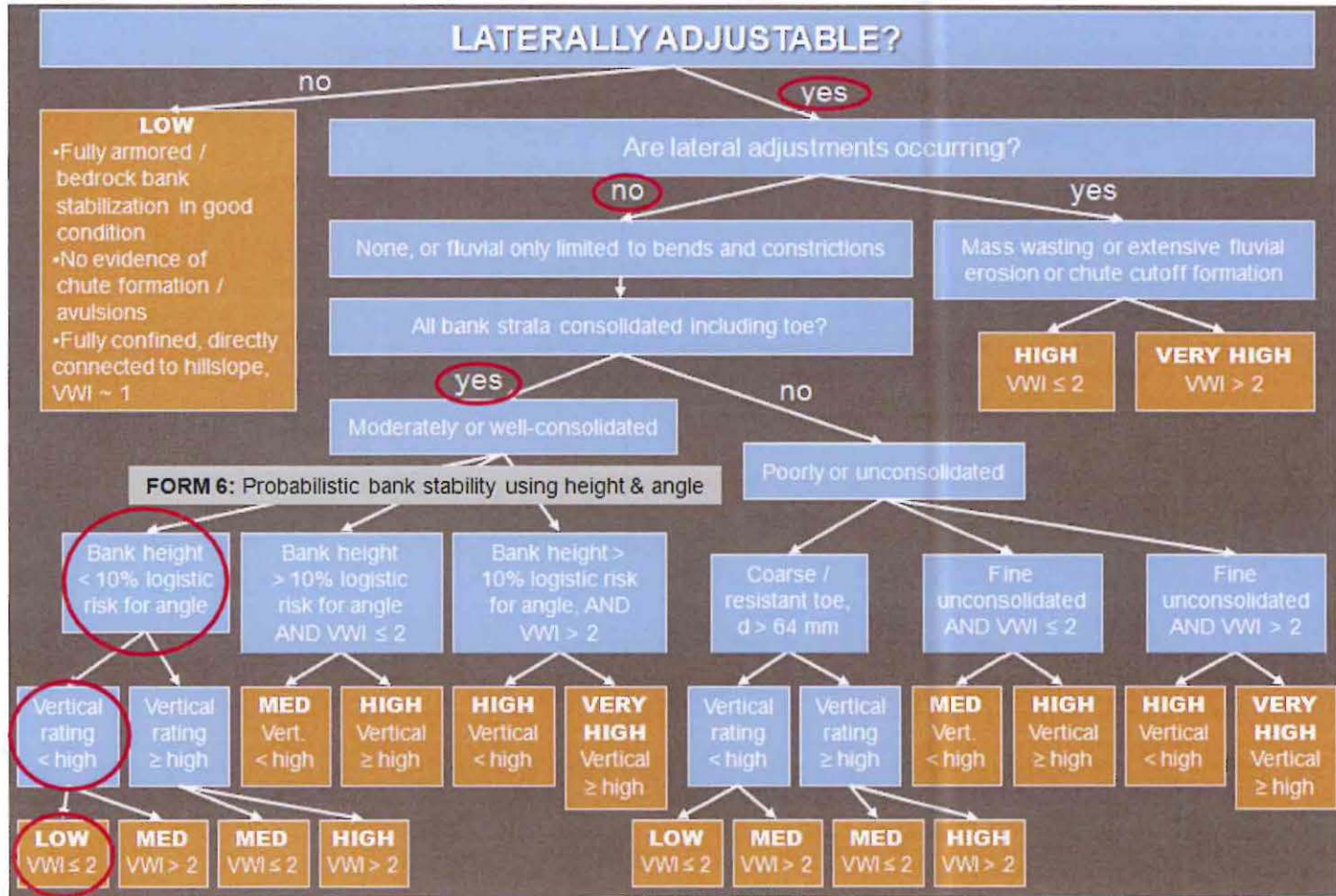

Figure 2.10: Lateral Susceptibility decision tree

(Sheet 1 of 1)

FORM 6: LATERAL SUSCEPTIBILITY

If mass wasting is not currently extensive and the banks are moderately- to well-consolidated, measure bank height and angle **at several locations** (i.e., at least three locations that capture the range of conditions present in the study reach) to estimate representative values for the reach. Use diagram/table below to determine if risk of bank failure is > 10%. Support your results with photographs that include a protractor/rod/tape/person for scale reference.

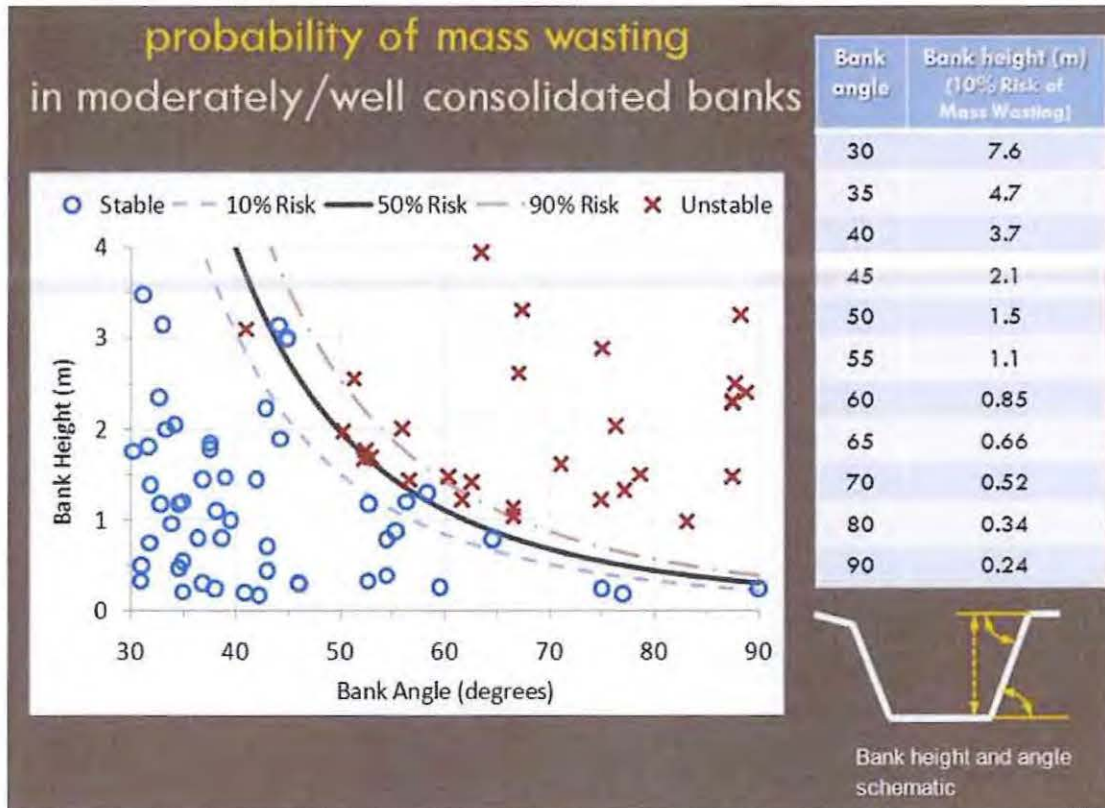

Figure 2.11: Lateral probability of bank-failure diagram

Table 2.6: Applicant-determined values for Lateral probability of bank failure

Bank Angle (degrees) (from Field)	Bank Height (m) (from Field)	Corresponding Bank Height for 10% Risk of Mass Wasting (m) (from Table)	Rating (LOW-VERY HIGH depending on other decision-tree components)
Left Bank			
Right Bank			

(Sheet 1 of 1)

PROBABILITY < 10% FOR BANK ANGLE = 26.6 DEGREES



GRAPHIC SCALE





0 300 600



1 INCH = 600 FEET



LEGEND:

-  REACH 1
-  REACH 2
-  REACH 3
-  REACH 4

STUDY AREA EXHIBIT

SAN MARCOS CREEK SPECIFIC PLAN



**San Marcos Creek Specific Plan
Master Water Quality and Hydromodification
Management Plan**

APPENDIX C

Project Summary

Project Name	San Marcos Creek Specific Plan - Public Areas
Project Applicant	City of San Marcos
Jurisdiction	City of San Marcos
Parcel (APN)	Varies
Hydrologic Unit	Carlsbad

Compliance Basin Summary

Basin Name:	Specif Plan Area North of San Marcos Creek
Receiving Water:	San Marcos Creek
Rainfall Basin	Oceanside
Mean Annual Precipitation (Inches)	13.3
Project Basin Area (acres):	20.01
Watershed Area (acres):	17000.00
SCCWRP Lateral Channel Susceptibility (H, M, L):	Low (Lateral)
SCCWRP Vertical Channel Susceptibility (H, M, L):	Low (Vertical)
Overall Channel Susceptibility (H, M, L):	LOW
Lower Flow Threshold (% of 2-Year Flow):	0.5

Drainage Management Area Summary

ID	Type	BMP ID	Description	Area (ac)	Pre-Project Cover	Post Surface Type	Drainage Soil	Slope
10200	Drains to LID	BMP 1	Paving on Pervious Area	16.86	Pervious (Pre)	Concrete or asphalt	Type D (high runoff - clay soi...	Flat - slope (less ...
10201	Drains to LID	BMP 1	Paving on Impervious Area	2.17	Impervious (Pre)	Concrete or asphalt	Type D (high runoff - clay soi...	Flat - slope (less ...
10202	Drains to LID	BMP 1	Landscaping on Pervious Area	0.93	Pervious (Pre)	Landscaping	Type D (high runoff - clay soi...	Flat - slope (less ...
10203	Drains to LID	BMP 1	Landscaping on Impervious Area	0.05	Impervious (Pre)	Landscaping	Type D (high runoff - clay soi...	Flat - slope (less ...

LID Facility Summary

BMP ID	Type	Description	Plan Area (sqft)	Volume 1(cft)	Volume 2(cft)	Orifice Flow (cfs)	Orifice Size (inch)
BMP 1	Bioretention	Overall Bioretention Area	48002	40026	28801	2.175	8.00

ALT 7 HYDROMODIFICATION ANALYSIS WORKSHEET - DMA DATA (Same as Alt 7 LEDPA v2 but with non-pervious paving in parking aisles in

(see work map for DMA delineations)

Creek North		100% Public & Pvt	Public Area Only	PVT only	Avail in Prom Alt 7	HMP/WQ REQMNT MET- ALL pub + 100%PVT AC	HMP/WQ REQMNT MET pub only AC	%pvt Addl in Prom
P.O.C.1	DMA Name	Bioretention, ac	Bioretention, ac					
	Total	0.61	0.15	0.46	0.18	-0.43	0.03	7%
P.O.C.2	DMA Name	Bioretention, ac	Bioretention, ac					
	Total	0.72	0.25	0.47	0.30	-0.42	0.05	11%
P.O.C.3	DMA Name	Bioretention, ac	Bioretention, ac					
	Total	0.66	0.22	0.44	0.32	-0.34	0.10	23%
P.O.C.4	DMA Name	Bioretention, ac	Bioretention, ac					
	Total	0.59	0.23	0.36	0.31	-0.28	0.08	22%
P.O.C.5	DMA Name	Bioretention, ac	Bioretention, ac					
	Total	0.72	0.22	0.50	0.2	-0.52	-0.02	4%
P.O.C.6	DMA Name	Bioretention, ac	Bioretention, ac					
	Total	0.58	0.21	0.36	0.37	-0.21	0.16	44%
						NO	YES	Yes
West of P.O.C.7	Las Posas CreeK	Bioretention, ac	Bioretention, ac					
	Total	0.09	0.00	0.08	0 n/a	n/a	n/a	n/a
Creek South P.O.C.8	Discovery Street	Bioretention, ac	Bioretention, ac				YES	yes
	Total	0.21	0.21	0.00	2.9	2.69	2.69	n/a
						YES		n/a

Notes:
 Mixed-Use on Pervious Area assumed to be 85% impervious and 15% landscaping. Adjusted Area accounts for 15% adjustment.
 Existing impervious areas assumed to contain 10% pervious. Adjusted Area accounts for 10% adjustment.
 Landscaping includes 15% landscaping from Mixed-Use on Pervious Area
 Calculations based on 0.5Q2, flat slope, Oceanside gage, and type D soil.
 Public areas exclude Mixed-Use

Mixed-Use on Impervious Area	0	0.00	0.00	1.0	0.00													
Paving on Pervious Area	107,426	2.47	2.47	1.0	2.47													
Paving on Impervious Area	67,552	1.55	0.16	1.0	0.16													
Non-Pervious Paving on Pervious Area	0	0.00	0.00	1.0	0.00													
Non-Pervious Paving on Impervious Area	0	0.00	0.00	1.0	0.00													
Landscaping on Pervious Area	287,050	6.59	6.59	0.1	0.66													
Landscaping on Impervious Area	1,101	0.03	0.00	0.1	0.00													
Total	463,128	10.63	9.21		3.28	0.21	0.18	0.13	0.13	0.46	3.28	0.21	0.18	0.13	0.13	0.46		

Notes:
Mixed-Use on Pervious Area assumed to be 85% impervious and 15% landscaping. Adjusted Area accounts for 15% adjustment.
Existing impervious areas assumed to contain 10% pervious. Adjusted Area accounts for 10% adjustment.
Landscaping includes 15% landscaping from Mixed-Use on Pervious Area
Calculations based on 0.5Q2, flat slope, Oceanside gage, and type D soil.
Public areas exclude Mixed-Use

P.O.C.	Actual Area, sf	Area, ac
1	1,096,901.9	25.18
2	946,373.6	21.73
3	943,368.2	21.66
4	842,715.8	19.35
5	720,849.0	16.55
6	816,634.6	18.75
7	73,643.8	1.69
8	463,128.6	10.63
		135.53



**San Marcos Creek Specific Plan
Master Water Quality and Hydromodification
Management Plan**

APPENDIX D

MEMO

Date December 16, 2010
To Erica Ryan, City of San Marcos Storm Water Program Manager
From John Quenzer, D-MAX Engineering, Inc.
Subject Creek Restoration Water Quality Improvement Potential

To evaluate the potential degree of pollutant reduction associated with implementing creek restoration activities associated with the San Marcos Creek Specific Plan, a review of water quality monitoring data from selected creek and wetland restoration projects was done.

Although several creek restoration projects have been completed in Southern California, long-term post-project water quality monitoring to quantify any differences in chemical or biological constituents has not been completed for most studies. Several studies on creek restoration highlight the need for more systematic data collection following restoration projects in order to evaluate the potential water quality benefits. Two creek restoration projects and two linear wetland projects, which are somewhat similar to creeks with restored wetland vegetation, were located for comparison. Forester Creek in Santee is likely the best comparison due to similarities in project area size, climate, and project type. The studies referenced are listed below:

- Study 1: Forester Creek Improvement Project (D-MAX, 2008; D-MAX, 2010; WESTON, 2008)
- Study 2: Wood Canyon Emergent Wetland Project (City of Aliso Viejo, 2007)
- Study 3: Demonstration Urban Stormwater Treatment (DUST) marsh system (Association of Bay Area Governments)
- Study 4: Accotink Creek restoration (Selvakumar, 2007)

Data for dry weather conditions is presented in tables 1 and 2, wet weather data is presented in tables 3 and 4, and benthic macroinvertebrate assessment data is presented in Table 5. Percent reductions are based on comparison of median influent to median effluent values in the post-project condition. Because most data is dry weather data, an anticipated percent reduction for the proposed San Marcos Creek restoration is only shown for ambient conditions (Table 1). Additional information about the characteristics of the sites monitored for the above four studies is provided in Table 6.

The data suggest that potential pollutant reduction impact of creek restoration projects is largely dependent on the degree to which wetland areas are created as part of the project and the baseline pollutant levels within the restoration area. The Forester Creek Improvement Project, which included creation of wetland areas and had relatively high baseline input levels of nitrate nitrogen and fecal coliform, showed significant reductions in those constituents. A statistically significant increase in the benthic macroinvertebrate IBI score was also observed for Forester Creek, raising the assessment rating from poor/very poor to fair. The improved area of Forester Creek is now one of the few urban streams segments in San Diego County in which an unimpaired (fair or better) IBI score has been recorded. Conversely, the restoration of Accotink Creek in Virginia did not involve creation of wetland areas, and no significant change in pollutant levels was observed.

Table 1: Dry Weather (Ambient) Monitoring Results – Percent Reduction

Constituent	Study 1	Study 2	Study 4	Anticipated Reduction
Nitrate Nitrogen (mg/L)	60%	5%	na	30 to 60%
Total Kjeldahl Nitrogen (mg/L)	0%	na	No Change	No Change
Total Nitrogen (mg/L)	46%	na	na	20 to 50%
Orthophosphate Phosphorus (mg/L)	-5%	-34%	na	No Change
Total Phosphorus (mg/L)	6%	na	No Change	No Change
Enterococcus (MPN/100 mL)	-20%*	98%	na	10-80%
Fecal Coliform (MPN/100 mL)	87%**	100%	na	50-90%
pH	5%	na	na	No Change

na = no data available

- percent reduction represents a constituent increase

*Change is based on small sample size and is not statistically significant ($p > 0.05$)

**Change is statistically significant per Wilcoxon Signed-Rank Test ($p < 0.05$)

Table 2: Median Concentration Recorded at Downstream End (Outflow)

Constituent	Study 1	Study 2	Study 4
Nitrate Nitrogen (mg/L)	2.01	3.5	na
Total Kjeldahl Nitrogen (mg/L)	1.45	na	0.29
Total Nitrogen (mg/L)	3.75	na	na
Orthophosphate Phosphorus (mg/L)	0.22	0.59	na
Total Phosphorus (mg/L)	0.29	na	0.02
Enterococcus (MPN/100 mL)	na	300	na
Fecal Coliform (MPN/100 mL)	300	10	na
pH	7.9	na	na

na= no data available

Table 3: Wet Weather (Storm Event) Monitoring Results – Percent Reduction

Constituent	Study 3	Study 4
Nitrate Nitrogen (mg/L)	4%	na
Total Kjeldahl Nitrogen (mg/L)	11%	No Change
Orthophosphate Phosphorus (mg/L)	24%	na
Total Phosphorus (mg/L)	34%	No Change
Fecal Coliform (MPN/100 mL)	21%	na
TSS (mg/L)	45%	na
pH	3%	na

na= no data available

Table 4: Median Concentration Recorded at Downstream End (Outflow)

Constituent	Study 3	Study 4
Nitrate Nitrogen (mg/L)	1.83	na
Total Kjeldahl Nitrogen (mg/L)	1.95	0.65
Orthophosphate Phosphorus (mg/L)	0.07	na
Total Phosphorus (mg/L)	0.22	0.22
Fecal Coliform (MPN/100 mL)	742.2	na
TSS (mg/L)	40.75	na
pH	7.89	na

na= no data available

Table 5: Macroinvertebrate Assessments

Metric	Study 1	Study 4
Change in Assessment Score	180% Improvement*	No Change
Impaired/Unimpaired	Unimpaired	Impaired

*Caution should be exercised in interpreting this result, as it is based on only one post-project monitoring event (IBI score of 28) and two pre-project monitoring events (IBI scores of 9 and 11)

Table 6: Characteristics of Referenced Projects

No.	Study	Location	Length	Wetlands Created	Drainage Area	Year Completed	Description
1	Forester Creek Improvement Project	Santee, CA	4,415 ft	14 acres	25 mi ²	2008	Channel widened to contain 100 year storm. Widened channel bed and banks revegetated with freshwater marsh and southern willow scrub.
2	Wood Canyon Emergent Wetland Project	Aliso Viejo, CA	not reported	Yes	298 acres	2005	Created a wetland habitat using native riparian/wetland plant species within the detention basin, in order to enhance water quality, flood control and channel protection at the beginning of the creek.
3	Demonstration Urban Stormwater Treatment (DUST) Marsh	Fremont, CA	0.5 mi channel in marsh system	21 acres	4.6 mi ²	Data collected in 1985-86	The DUST Marsh at Coyote Hills Regional Park in Fremont, California was designed as a prototype system research facility to study wetland creation for storm water treatment in the San Francisco Bay Area. Runoff water enters the initial Debris Basin and is divided among two parallel flow systems (a lagoon and a pond system). The two systems discharge into a common third system (a marsh system). <i>Only data from the marsh system was evaluated.</i>
4	Accotink Creek Restoration	Fairfax, VA	1,800 ft	None	5.3 mi ²	2006	Efforts focused on methods to control erosion. Coconut fiber mats were placed on sloed areas, imbricated rock boulders were placed in highly eroding areas to stabilize stream banks and eliminate undercutting, and root wads of felled trees during channel reconstruction were used in some portions of the stream bank both to divert flow and add natural habitat to the stream reach.

References

Association of Bay Area Governments. Demonstration Urban Stormwater Treatment Marsh data, accessed at <http://www.bmpdatabase.org>

City of Aliso Viejo. *Wood Canyon Emergent Wetland Restoration Project*. 2007.
http://www.cityofaliso Viejo.com/environmental_care/Wood_Canyon_Wetlands.pdf

D-MAX Engineering, Inc. *City of Santee 2010 Additional Study Rivers and Creeks*. December 2010. Prepared for the City of Santee.

D-MAX Engineering, Inc. *City of Santee Forester Creek Improvement Project Water Quality Monitoring Summary Report*. October 28, 2008. Prepared for the City of Santee.

Selvakumar, A. et al. "Role of Stream Restoration on In-Stream Water Quality in an Urban Watershed: Case Study." *J. of Ecotechnology* 2007(2): pp 23-37.
<http://nr.stpi.org.tw/ejournal/JOE/2007/EJ54-2007-3%282%29-23.pdf>

WESTON Solutions, Inc. *Stream Bioassessment for the Forrester Creek Enhancement Project: June 2008 Survey*. July 2008. Prepared for Nordby Biological Consulting for the City of Santee.

Forester Creek Nutrients Results

Analyte	SampleDate	Units	Upstream	Downstream	Change
Nitrate/Nitrite as N	28-May-08	mg/L	5.16	3.24	-37.21%
Nitrate/Nitrite as N	09-Sep-08	mg/L	3.72	0.99	-73.39%
Nitrate/Nitrite as N	19-May-09	mg/L	4.93	0.65	-86.82%
Nitrate/Nitrite as N	02-Sep-09	mg/L	3.36	1.32	-60.71%
Nitrate/Nitrite as N	17-May-10	mg/L	7.36	4.3	-41.58%
Nitrate/Nitrite as N	15-Sep-10	mg/L	6.28	2.7	-57.01%
Orthophosphate as P	28-May-08	mg/L	0.05	0.11	120.00%
Orthophosphate as P	09-Sep-08	mg/L	0.32	0.32	0.00%
Orthophosphate as P	19-May-09	mg/L	0.33	0.66	100.00%
Orthophosphate as P	02-Sep-09	mg/L	0.05	0.12	140.00%
Orthophosphate as P	17-May-10	mg/L	0.34	0.09	-73.53%
Orthophosphate as P	15-Sep-10	mg/L	0.1	0.36	260.00%
Total Kjeldahl Nitrogen (TKN)	28-May-08	mg/L	2.7	1.9	-29.63%
Total Kjeldahl Nitrogen (TKN)	09-Sep-08	mg/L	2.2	2.1	-4.55%
Total Kjeldahl Nitrogen (TKN)	19-May-09	mg/L	1.1	0.8	-27.27%
Total Kjeldahl Nitrogen (TKN)	02-Sep-09	mg/L	0.6	0.25	-58.33%
Total Kjeldahl Nitrogen (TKN)	17-May-10	mg/L	0.8	1.2	50.00%
Total Kjeldahl Nitrogen (TKN)	15-Sep-10	mg/L	1.8	1.7	-5.56%
Total Nitrogen (sum of TKN, Nitrate as N, and Nitrite as N)	28-May-08	mg/L	7.8	5.2	-33.33%
Total Nitrogen (sum of TKN, Nitrate as N, and Nitrite as N)	09-Sep-08	mg/L	5.9	3.1	-47.46%
Total Nitrogen (sum of TKN, Nitrate as N, and Nitrite as N)	19-May-09	mg/L	6	1.4	-76.67%
Total Nitrogen (sum of TKN, Nitrate as N, and Nitrite as N)	02-Sep-09	mg/L	4	1.6	-60.00%
Total Nitrogen (sum of TKN, Nitrate as N, and Nitrite as N)	17-May-10	mg/L	8.2	5.5	-32.93%
Total Nitrogen (sum of TKN, Nitrate as N, and Nitrite as N)	15-Sep-10	mg/L	8.1	4.4	-45.68%
Total Phosphorus	28-May-08	mg/L	0.06	0.11	83.33%
Total Phosphorus	09-Sep-08	mg/L	0.36	0.33	-8.33%
Total Phosphorus	19-May-09	mg/L	0.34	0.67	97.06%
Total Phosphorus	02-Sep-09	mg/L	0.28	0.25	-10.71%
Total Phosphorus	17-May-10	mg/L	0.35	0.21	-40.00%
Total Phosphorus	15-Sep-10	mg/L	0.12	0.37	208.33%

Note

"nd" values are reported as half the detection limit for statistical analysis purposes

Ratio(D/U)
0.63
0.27
0.13
0.39
0.58
0.43
2.20
1.00
2.00
2.40
0.26
3.60
0.70
0.95
0.73
0.42
1.50
0.94
0.67
0.53
0.23
0.40
0.67
0.54
1.83
0.92
1.97
0.89
0.60
3.08

Forester Creek Nutrients Results

Analyte	SampleDate	Units	Upstream	Downstream	Change	Ratio(D/U)
Nitrate/Nitrite as N	28-May-08	mg/L	5.16	3.24	-37.21%	0.63
Nitrate/Nitrite as N	09-Sep-08	mg/L	3.72	0.99	-73.39%	0.27
Nitrate/Nitrite as N	19-May-09	mg/L	4.93	0.65	-86.82%	0.13
Nitrate/Nitrite as N	02-Sep-09	mg/L	3.36	1.32	-60.71%	0.39
Nitrate/Nitrite as N	17-May-10	mg/L	7.36	4.3	-41.58%	0.58
Nitrate/Nitrite as N	15-Sep-10	mg/L	6.28	2.7	-57.01%	0.43
Orthophosphate as P	28-May-08	mg/L	0.05	0.11	120.00%	2.20
Orthophosphate as P	09-Sep-08	mg/L	0.32	0.32	0.00%	1.00
Orthophosphate as P	19-May-09	mg/L	0.33	0.66	100.00%	2.00
Orthophosphate as P	02-Sep-09	mg/L	0.05	0.12	140.00%	2.40
Orthophosphate as P	17-May-10	mg/L	0.34	0.09	-73.53%	0.26
Orthophosphate as P	15-Sep-10	mg/L	0.1	0.36	260.00%	3.60
Total Kjeldahl Nitrogen (TKN)	28-May-08	mg/L	2.7	1.9	-29.63%	0.70
Total Kjeldahl Nitrogen (TKN)	09-Sep-08	mg/L	2.2	2.1	-4.55%	0.95
Total Kjeldahl Nitrogen (TKN)	19-May-09	mg/L	1.1	0.8	-27.27%	0.73
Total Kjeldahl Nitrogen (TKN)	02-Sep-09	mg/L	0.6	0.25	-58.33%	0.42
Total Kjeldahl Nitrogen (TKN)	17-May-10	mg/L	0.8	1.2	50.00%	1.50
Total Kjeldahl Nitrogen (TKN)	15-Sep-10	mg/L	1.8	1.7	-5.56%	0.94
Total Nitrogen (sum of TKN, Nitrate as N, and Nitrite as N)	28-May-08	mg/L	7.8	5.2	-33.33%	0.67
Total Nitrogen (sum of TKN, Nitrate as N, and Nitrite as N)	09-Sep-08	mg/L	5.9	3.1	-47.46%	0.53
Total Nitrogen (sum of TKN, Nitrate as N, and Nitrite as N)	19-May-09	mg/L	6	1.4	-76.67%	0.23
Total Nitrogen (sum of TKN, Nitrate as N, and Nitrite as N)	02-Sep-09	mg/L	4	1.6	-60.00%	0.40
Total Nitrogen (sum of TKN, Nitrate as N, and Nitrite as N)	17-May-10	mg/L	8.2	5.5	-32.93%	0.67
Total Nitrogen (sum of TKN, Nitrate as N, and Nitrite as N)	15-Sep-10	mg/L	8.1	4.4	-45.68%	0.54
Total Phosphorus	28-May-08	mg/L	0.06	0.11	83.33%	1.83

Total Phosphorus	09-Sep-08	mg/L	0.36	0.33	-8.33%	0.92
Total Phosphorus	19-May-09	mg/L	0.34	0.67	97.06%	1.97
Total Phosphorus	02-Sep-09	mg/L	0.28	0.25	-10.71%	0.89
Total Phosphorus	17-May-10	mg/L	0.35	0.21	-40.00%	0.60
Total Phosphorus	15-Sep-10	mg/L	0.12	0.37	208.33%	3.08

Note

"nd" values are reported as half the detection limit for statistical analysis purposes



**FINAL San Marcos Creek Specific Plan
Master Water Quality and Hydromodification
Management Plan**

APPENDIX E

Available Baseline Water Quality Data for the San Marcos Creek Specific Plan Area

Site No.	Year	Watershed	GIS Coordinates		Physicals											Chemical								Dissolved Metals					Bacteria							
					Drainage Area	Discharge Rate	Mean Discharge (cubic feet per hour)	Total Precip.	Storm Duration	Sample Period	Water Temperature	pH	Conductivity	Turbidity	Total Suspended Solids (TSS)	Chemical Oxygen Demand (COD)	Ammonia as N	Nitrite as N	Nitrate as N	Total Kjeldahl Nitrogen (TKN)	Total Nitrogen	Orthophosphate as PO ₄	Total Phosphorus as P	Cadmium	Copper	Lead	Nickel	Zinc	Total Coliform	Fecal Coliform	Enterococcus					
																																acres	gpm	cfh	inches	hours
Order R9-2007-0001 Dry Weather Monitoring (Sites A-05B and DB-01)																																				
A-05B	2008	904.52	33.12951	-117.19251	nm	20	nm	nm	nm	nm	22.5	7.5	1.72	2.21	nm	nm	0.239	na	1.436	na	na	0.306	na	na	na	na	na	na	na	na	na	na	na	na	na	na
A-05B	2009	904.52	33.12951	-117.19251	nm	0.5	nm	nm	nm	nm	22.8	7.9	1.20	0.67	nm	nm	0.117	na	0.4	na	na	0.542	na	na	na	na	na	na	na	na	na	na	na	na	na	
A-05B	2010	904.52	33.12951	-117.19251	nm	<1	nm	nm	nm	nm	25.4	7.6	0.99	1.64	nm	nm	0.209	na	0.581J	na	na	0.344	na	na	na	na	na	na	na	na	na	na	na	na	na	
A-05B	2011	904.52	33.12951	-117.19251	nm	1	nm	nm	nm	nm	22.6	7.85	0.76	1.49	nm	nm	0.15J	na	0.34J	na	na	0.25	na	na	na	na	na	na	na	na	na	na	na	na	na	
DB-01	1997	904.52	33.13491	-117.19482	nm	nm	nm	nm	nm	nm	nm	nm	1.62	nm	nm	nm	0.11	na	na	na	na	na	na	na	na	na	na	na	na	na	na	na	na	na	na	
DB-01	1998	904.52	33.13491	-117.19482	nm	nm	nm	nm	nm	nm	nm	nm	3.51	nm	nm	nm	nd	na	na	na	na	na	na	na	na	na	na	na	na	na	na	na	na	na	na	
DB-01	1999	904.52	33.13491	-117.19482	nm	nm	nm	nm	nm	nm	nm	nm	2.91	nm	nm	nm	0.4	na	na	na	na	na	na	na	na	na	na	na	na	na	na	na	na	na	na	
DB-01	2000	904.52	33.13491	-117.19482	nm	nm	nm	nm	nm	nm	nm	nm	2.49	nm	nm	nm	0.2	na	na	na	na	na	na	na	na	na	na	na	na	na	na	na	na	na	na	
DB-01	2001	904.52	33.13491	-117.19482	nm	nm	nm	nm	nm	nm	nm	nm	2.72	nm	nm	nm	0.3	na	na	na	na	na	na	na	na	na	na	na	na	na	na	na	na	na	na	
DB-01	2002	904.52	33.13491	-117.19482	nm	1	nm	nm	nm	nm	26	8.5	2.96	12.64	nm	nm	0.5	na	<0.05	na	na	0.07	na	na	na	na	na	na	na	na	na	na	na	na	na	
DB-01	2003	904.52	33.13491	-117.19482	nm	2	nm	nm	nm	nm	30	9.4	3.01	16.8	nm	nm	0.3	na	nd	na	na	0.03	na	na	na	na	na	na	na	na	na	na	na	na	na	
DB-01	2004	904.52	33.13491	-117.19482	nm	2	nm	nm	nm	nm	26	8.8	3.43	15.02	nm	nm	0.3	na	nd	na	na	0.13	na	na	na	na	na	na	na	na	na	na	na	na	na	
DB-01	2005	904.52	33.13491	-117.19482	nm	5	nm	nm	nm	nm	22	8.9	2.00	6.04	nm	nm	0.1	na	1.25	na	na	0.03	na	na	na	na	na	na	na	na	na	na	na	na	na	
DB-01	2006	904.52	33.13491	-117.19482	nm	5	nm	nm	nm	nm	26.2	8.8	2.60	2.98	nm	nm	0.2	na	2.5	na	na	0.03	na	na	na	na	na	na	na	na	na	na	na	na	na	
DB-01	2007	904.52	33.13491	-117.19482	nm	3	nm	nm	nm	nm	23.7	9.5	2.70	3.92	nm	nm	0.2	na	0.02	na	na	nd	na	na	na	na	na	na	na	na	na	na	na	na	na	
DB-01	2008	904.52	33.13491	-117.19482	nm	9	nm	nm	nm	nm	29.5	8.8	3.33	3.41	nm	nm	0.240	na	2.420	na	na	0.023	na	na	na	na	na	na	na	na	na	50,000	1,100	3,000		
DB-01	2009	904.52	33.13491	-117.19482	nm	1	nm	nm	nm	nm	24.8	7.9	3.11	8.13	nm	nm	0.243	na	<1.13	na	na	0.101	na	na	na	na	na	na	na	na	170,000	3,000	5,000			
DB-01	2010	904.52	33.13491	-117.19482	nm	3	nm	nm	nm	nm	31.9	8.4	2.69	3.28	nm	nm	0.391	na	0.537J	na	na	0.047J	na	na	na	na	na	na	na	23,000	300	300	300			
DB-01	2011	904.52	33.13491	-117.19482	nm	2	nm	nm	nm	nm	22.9	7.95	2.80	9.98	nm	nm	0.25	na	0.19J	na	na	0.01J	na	na	na	na	na	na	na	nd	280	7	220			
City of San Marcos Upper San Marcos Creek Bimonthly Dry Weather Monitoring (A-20, A-05A, and A-21)																																				
A-20	5/10/2011	904.52	33.13078	-117.19388	nm	409	nm	nm	nm	nm	17.8	7.8	2.09	8.27	nm	nm	0.1	na	3.25	1.4	4.7	0.12	0.17	na	na	na	na	na	na	na	na	na	na	na	na	
A-20	8/22/2011	904.52	33.13078	-117.19388	nm	484	nm	nm	nm	nm	25	8.1	2	15.09	nm	nm	0.87	na	2.2	0.9	4.1	0.11	0.13	na	na	na	na	na	na	na	na	na	na	na	na	
A-05A	6/10/2011	904.52	33.13200	-117.18678	nm	390	nm	nm	nm	nm	19.2	8.1	1.98	17.01	nm	nm	0.19	na	3.05	2.8	5.9	0.22	0.23	na	na	na	na	na	na	na	na	na	na	na	na	
A-05A	8/23/2011	904.52	33.13200	-117.18678	nm	221	nm	nm	nm	nm	23.5	8.66	2.02	15.44	nm	nm	1.3	na	2.0	1.34	3.4	0.52	0.55	na	na	na	na	na	na	na	na	na	na	na	na	
A-21	5/4/2011	904.52	33.13215	-117.18031	nm	Ponded	nm	nm	nm	nm	20.6	7.8	2.09	6.48	nm	nm	0.25	na	4.17	2.7	4.7	0.12	0.17	na	na	na	na	na	na	na	na	na	na	na	na	
A-21	8/23/2011	904.52	33.13215	-117.18031	nm	<1	nm	nm	nm	nm	20.3	7.66	1.99	18.76	nm	nm	1.15	na	1.8	1.19	3.0	0.58	0.6	na	na	na	na	na	na	na	na	na	na	na	na	
Regional Wet Weather Monitoring (County of San Diego Lake San Marcos FY 10 TWAS for FY 11)																																				
Discovery Street (entire)**	12/7/2009	904.52	33.13044	-117.20064	17,197*	nm	365,967	1.44	11.58	6.7	nm	nm	nm	nm	109.29*	nm	0.335*	0.056*	0.866*	2.012*	2.935*	0.201*	0.227*	na	na	na	na	na	na	na	na	na	na	na	na	
Discovery Street (entire)**	2/5-7/2010	904.52	33.13044	-117.20064	17,197	nm	82,221	1.08	36.5	45.15	nm	nm	nm	nm	4.29	nm	0.006	0.008	0.268	0.109	0.385	0.041	0.058	na	na	na	na	na	na	na	na	na	na	na	na	
Discovery Street (partial)**	12/7/2009	904.52	33.13044	-117.20064	11,123	nm	365,967	1.44	11.58	6.7	nm	nm	nm	nm	70.69	nm	0.217	0.036	0.56	1.302	1.898	0.13	0.147	na	na	na	na	na	na	na	na	na	na	na	na	
Discovery Street (partial)**	2/5-7/2010	904.52	33.13044	-117.20064	11,123	nm	82,221	1.08	36.5	45.15	nm	nm	nm	nm	2.78	nm	0.004	0.005	0.173	0.07	0.249	0.027	0.038	na	na	na	na	na	na	na	na	na	na	na	na	

NOTES:

gpm = gallons per minute

cfh = cubic feet per hour

mS/cm = microseimens per centimeter

NTU = Nephelometric Turbidity Units

mg/L = milligrams per liter

µg/L = micrograms per liter

MPN/100 mL = most probable number (of colony-forming units) per 100 milliliters

J = Detected but below the reporting limit; therefore, result is an estimated concentration.

na = not analyzed

nd = non-detect

nm = not measured

* The result may not be representative of the entire storm event as only 58% of the discharge was sampled; sampling was stopped prematurely due to flooding.

**Drainage Areas in acres and wet weather Constituent Flux in Grams per Acre per Hour (g/acre/hr). Flux for Discovery Street Station has been calculated for the entire drainage area for the partial

Attachment 2D:
Flow Control Facility Design

Table of Contents

INTRODUCTION

Section I	Pre- and Post-Development Model Setup	3
Section II	System Representation	8
Section III	Continuous Simulation Options	13
Section IV	Bio-filtration As LID Control	14
Section V	Running the Simulation	17
Section VI	Result Analysis	18
Section VII	Summary and Conclusion	27

ATTACHEMENTS

Attachment A	SWMM Drainage Management Area Map
Attachment B	SWMM Statistics Analysis, Flow Duration Curve and Pass/Fail Table
Attachment C	SWMM Input Data Summary and Detail

INTRODUCTION

This report provides Hydromodification and Water Quality design based on LID (Low Impact Development) principles for the project Solaris.

The project site is located the northeast corner of south pacific street, San Marcos, CA. The site is currently undeveloped. The existing onsite surface slope is approximately 2% and runs generally from the north to the south. When the water from offsite reaches to the north edge of the project, it flows along the slope until it reaches the project's POC at the south edge of the property.

The project proposes to grade the site into a building with associated streets and utilities serving the respective lots. The project will also construct two biofiltration basins to treat the anticipated pollutants generated by this type of project. The ultimate construction of the individual lots is not part of this project.

The Hydromodification and Water Quality calculations were performed utilizing continuous simulation analysis to size the storm water treatment and control facilities. Storm Water Management Model (SWMM) version 5.1 distributed by USEPA is the basis of all calculations within this report. SWMM generates peak flow recurrence frequencies and flow duration series statistics based on an assigned rain gauge for pre-development, unmitigated post-development flows and post-development mitigated flows to determine compliance with the State Water Resources Control Board Order No.R9-2015-001 and Hydromodification Management Plan (HMP) requirements.

Total Parcel area is 2.96 acres for the project site. There is one point of compliance (POC) for this project in the analysis; POC receives flows from north portion of the site and drains to south edge of the site and flows to two existing 66 inches culvert on the south edge of the site.

The Hydromodification and Water Quality system proposed for this project consists of 2 bio-filtration basins with one point of compliances located on the south edge of the project. This system detains storm water in the basin surface and also in the underdrain reservoir. The bio-filtration system, filters storm water through plant roots and a biologically active soil mix, and then releases it into the existing storm drain system which currently collects the site storm flows. The resulting mitigated outflows are shown to be equal to or less than all continuously simulated storms based on the historical data collected from the Escondido rain gage.

Low Flow Threshold

A downstream channel assessment has been completed for this project and therefore the low flow threshold utilized for the system analysis is 50% of 2-year storm event (0.5Q2). This will be used as the low flow threshold to meet peak flow frequency and flow duration controls.

SECTION I. MODEL SETUP

Pre-development Model Setup

The SWMM model for this project's pre-development site is analyzed using historical rain gauge data. The Escondido Rain gauge is utilized for this project. That data provides continuous precipitation input to a sub-catchment with its outfall based on the contributing basins imperviousness.

The imperviousness parameter in SWMM is the amount of effective or directly connected impervious area. The effective impervious area is the impervious area that drains directly to the Stormwater conveyance system. The pre-development condition Describe existing condition (use same description from HYD -Report).

The pre-development topography is described as natural terrain. The property drains primarily by overland flow to an existing storm drain system located at the south edge of the project site. The site is relatively level with a small 2:1 cut slope. Storm water drains from the north to the south of the project site and travel to POC at the south edge of the site.

At the north edge and the east edge of the project are two small self-mitigating area. This part of storm water discharges in a north southerly direction. All these flows travel by overland flow to the POC at the south edge of the site. All the discharge from the project's POC makes their way via side streets to meet up with an unnamed tributary of the San Marcos Creek.

For this study, the site is assumed to have 0% of impervious surface in the existing condition.

Post-Development Model Setup

The project proposes to build a single industrial building with supporting parking lot, and landscape area. The project proposes to build a parking lot which slopes at 0.5% to onsite biofiltration basins (BMP A and BMP B). The building's roof is directed into two biofiltration basins along the east boundary of the development footprint. The treated flows from that basin are combined with other flows and eventually make their way to South Pacific Street.

The north portion of the proposed building and parking lots drains easterly to BMP-A then to the 48 inches storage tank. The remaining portion of the building and parking lots drains easterly to BMP-B then to the 48 inches storage tank. This storage tank is used for detaining post-developed onsite water. At the end of the storage tank, a weir plate with two orifices is used for regulating low flow.

For the areas of the project that will remain vegetated, such as the cut and fill slopes, the county element for Natural ground cover is used. For the remainder of the site the entire area is considered Industrial as far as ground surface and percent imperviousness.

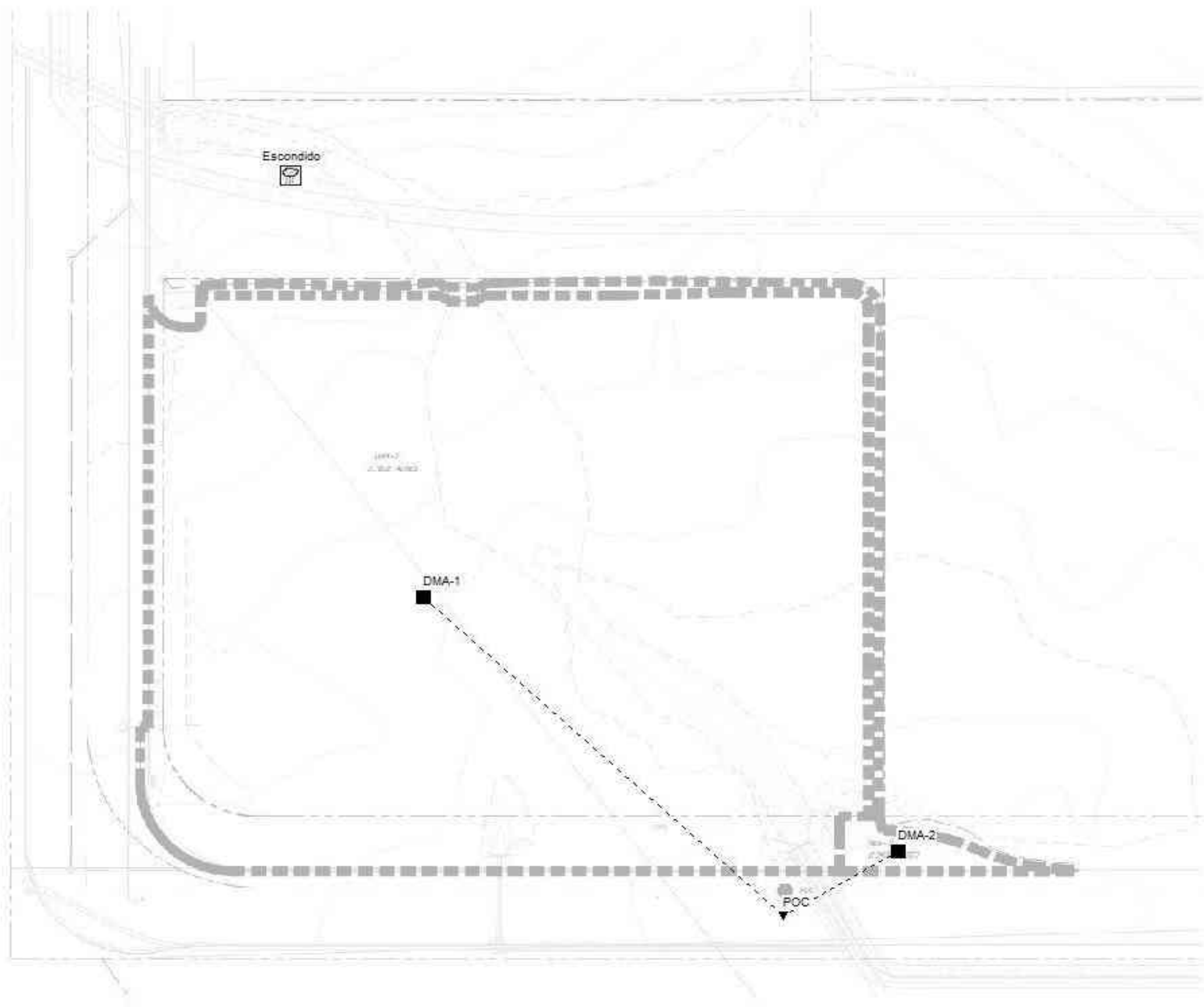

Fig.3 – SWMM Pre-Development Model

Post-Development Drainage Management Areas (DMAs)

The DMAs provide an important framework for feasibility screening, BMP prioritization and storm water management system configuration. **DMAs are defined based on drainage patterns of the site and the BMPs to which they drain.**

Note: Hydromod and Hydrology areas will not equal the same area.

DMA Table for Post-development for South Pacific

HYDROMODIFICATION TABLE				
SOIL	DMA	AREA (ACRE)	% IMPERV.	POC
SOIL D	DMA-1.1	0.47302	93	1
SOIL D	DMA-1.2	0.349647	79	1
SOIL D	DMA-1.3	0.48181	88	1
SOIL D	DMA-1.4	0.451387	92	1
SOIL D	DMA-2	0.451783	84	1
SOIL D	DMA-3	0.497234	67	1
SOIL D	DMA-4	0.078803	73	1
SOIL D	DMA-5	0.05217	0	1
SOIL D	DMA-6	0.037132	0	1

EFFECTIVE AREA TABLE				
BMP	AREA (SF)	AREA (AC.)	DMA	AREA (AC.)
BMP-A	2866	0.065798	DMA-1.1	1.76
			DMA-1.2	
			DMA-1.3	
			DMA-1.4	
BMP-B	963	0.022117	DMA-2	0.45

DMA Table for Pre-Development for South Pacific

HYDROMODIFICATION TABLE				
SOIL	DMA	AREA (ACRE)	% IMPERV.	POC
SOIL D	DMA-1	2.88	0	1
SOIL D	DMA-2	0.079	0	1

SECTION II. SYSTEM REPRESENTATION

SWMM is a distributed model, which means that a study area can be subdivided into any number of irregular sub-catchments to best capture the effect that spatial variability in topography, drainage pathways, land cover, and soil characteristics have on runoff generation. For modeling of Hydromodification calculations, there are four main system representations: Rain gage, Sub-catchment (contributing basin or LID area), Nodes and Links.

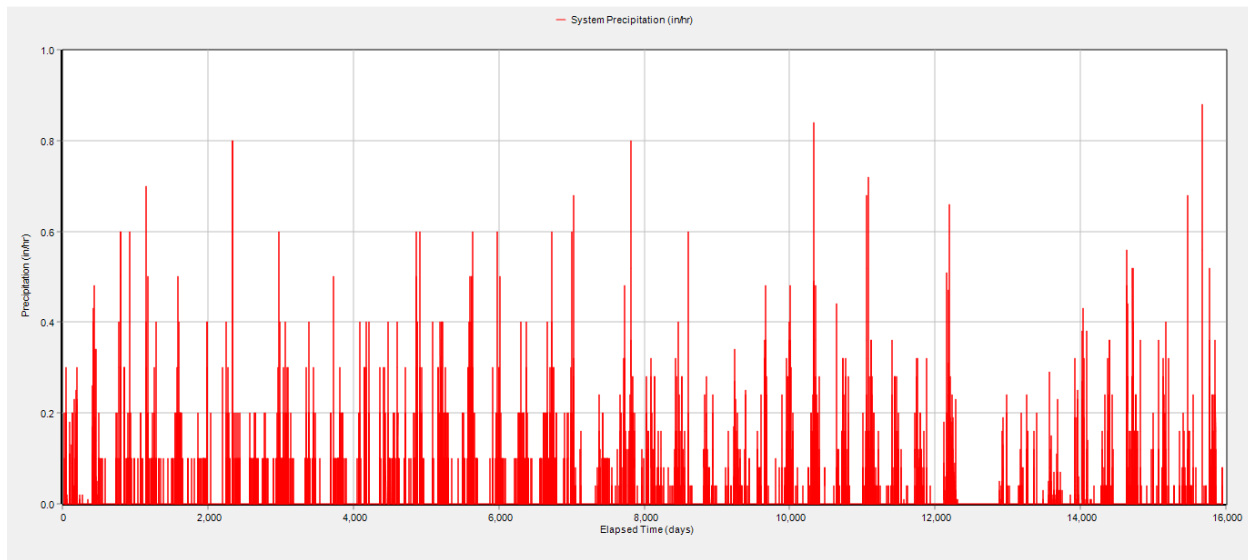

Fig. 2.1 – Time series rain data, which corresponds to runoff estimates for each of the 385,440 time steps (each date and hour) of the 44-year simulation period. (Inches/hour vs. elapsed time)

Rain Gauge

The properties of a rain gauge describe the source and format of the precipitation data that are applied to the study area. In this project, The Escondido rain station was chosen due to its data quality and its location to the project site.

The rain gauge supplies precipitation data for one or more sub-catchment areas in a study region taken from the Project Clean Water website (www.projectcleanwater.org). This data file contains rainfall intensity, hourly-recorded time interval, and the dates of recorded precipitation each hour. The Escondido rain data has approximately 44 years of hourly precipitation data from 9/24/1964 to 5/23/2008 and generates 44 years of hourly runoff estimates, which corresponds to runoff estimates for each of the 385,440 time steps (each date and hour) of the 58 year simulation period. See figure 2.1 for hourly precipitation intensity graph for 44 years in inches.

Sub-catchment (contributing basin or LID area)

A basin is modeled using a sub-catchment object, which contains some of the following properties:

Rain Gauge

The rate of stormwater runoff and volume depends directly on the precipitation magnitude and its spatial and temporal distribution over the catchment. Each sub-catchment in SWMM is linked to a rain gauge object that describes the format and source of the rainfall input for the sub-catchment.

Area

This area is bounded by the sub-catchment boundary. Its value is determined directly from maps or field surveys of the site or by using SWMM's Auto-length tool when the sub-catchment is drawn to scale on SWMM's study area map. This Project is divided into several sub-catchments based on its outfall.

Width

Width can be defined as the sub-catchment's area divided by the length of the longest overland flow path that water can travel. When there are several such paths, one would use an average of their lengths to compute a width. If overland flow is visualized as running down -slope off an idealized, rectangular catchment, then the width of the sub-catchment is the physical width of overland flow.

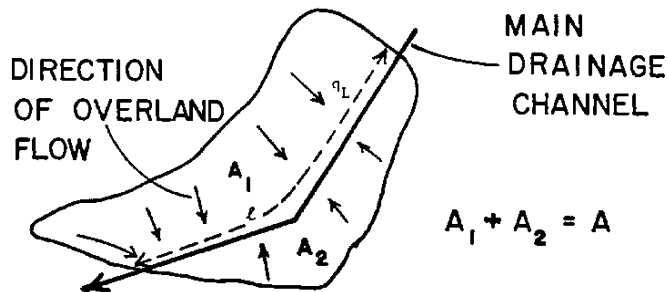

Figure-2-2 Irregular subcatchment shape for width calculations (DiGiano et al., 1977, p.165).

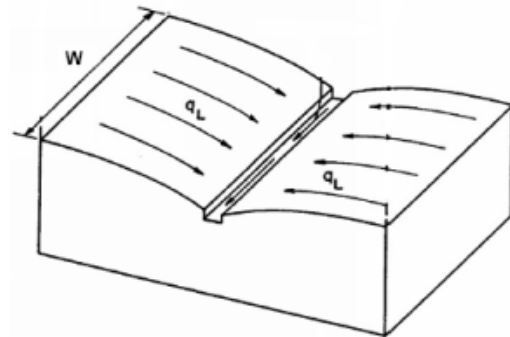

Figure-2-3 Idealized representation of a subcatchment.

Source: STORM WATER MANAGEMENT MODEL REFERENCE MANUAL VOLUME 1- JANUARY 2016

The method of calculations used following Figure 2-2 involves an estimation by Guo and Urbonas (2007). As stated in the Storm Water Management Model Reference Manual Vol. 1

A more fundamental approach to estimating both subcatchment width and slope has recently been developed by Guo and Urbonas (2007). The idea is to use "shape factors" to convert a natural watershed as pictured in Figure 2-2 into the idealized overland flow plane of Figure 2-3. A shape factor is an index that reflects how overland flows are collected in a watershed. The shape factor X for the actual watershed is defined as A/L^2 where A is the watershed area and L is the length of the watershed's main drainage channel (not necessarily the length of overland flow). The shape factor Y for the idealized watershed is W/L . Requiring that the areas of the actual and idealized watersheds be the same and that the potential energy in terms of the vertical fall along the drainage channel be preserved, Guo and Urbonas (2007) derive the following expression for the shape factor Y of the idealized watershed:

$$Y = 2X(1.5 - Z)(2K - X)/(2K - 1) \quad (2-1)$$

where K is an upper limit on the watershed shape factor. Guo and Urbonas (2007) recommend that K be between 4 and 6 and note that a value of 4 is used by Denver's Urban Drainage and Flood Control District. Once Y is determined, the equivalent width W for the idealized watershed is computed

as YL.

Applying this approach:

$$X = (A \cdot 43,560 \text{ ft}^2/\text{acre}) / (L^2)$$

$$Z = A_m/A$$

Z = skew factor, $0.5 \leq Z \leq 1$,

A_m = larger of the two areas on each side of the channel A = total area.

$$W = L \cdot Y$$

This width value is considerably lower than those derived from direct estimates of either the longest flow path length or the drainage channel length. As a result, it would most likely produce a longer time to peak for the runoff hydrograph.

Slope

This is the slope of the land surface over which runoff flows and is the same for both the pervious and impervious surfaces. It is the slope of what one considers being the overland flow path or its area-weighted average if there are several paths in the sub-catchment.

Imperviousness

This is the percentage of sub-catchment area covered by impervious surfaces such as sidewalks and roadways or whatever surfaces that rainfall cannot infiltrate.

Roughness Coefficient

The roughness coefficient reflects the amount of resistance that overland flow encounters as it runs off of the sub-catchment surface.

Infiltration Model

The pre-development condition is primarily empty land with moderate vegetation cover. In the model, clay soil was used for the post-development condition and the pre-development condition for a conservative approach (yield to a higher runoff). Infiltration of rainfall from the pervious area of a sub-catchment into the unsaturated upper soil zone can be described using three different infiltration models: Horton, Green-Ampt, and Curve Number. There is no general agreement on which method of these three is the best.

The Green-Ampt method was chosen to calculate the infiltration of the pervious areas based on the availability of data for this project. It is invoked when editing the infiltration property of a sub-catchment.

Table 2.1 – Soil Infiltration Parameter

SWMM Parameter Name	Unit	Range	Use in San Diego
Infiltration	Method	HORTON GREEN_AMPT CURVE_NUMBER	GREEN_AMPT
Suction Head (Green-Ampt)	Inches	1.93 – 12.60 presented in Table A.2 of SWMM Manual	Hydrologic Soil Group A: 1.5 Hydrologic Soil Group B: 3.0 Hydrologic Soil Group C: 6.0 Hydrologic Soil Group D: 9.0
Conductivity (Green-Ampt)	Inches per hour	0.01 – 4.74 presented in Table A.2 of SWMM Manual by soil texture class 0.00 – 0.45 presented in Table A.3 of SWMM Manual by hydrologic soil group	Hydrologic Soil Group A: 0.3 Hydrologic Soil Group B: 0.2 Hydrologic Soil Group C: 0.1 Hydrologic Soil Group D: 0.025 Note: reduce conductivity by 25% in the post-project condition when native soils will be compacted. Conductivity may also be reduced by 25% in the pre-development condition model for redevelopment areas that are currently concrete or asphalt but must be modeled according to their underlying soil characteristics. For fill soils in postproject condition, see Section G.1.4.3.
Initial Deficit (Green-Ampt)		The difference between soil porosity and initial moisture content. Based on the values provided in Table A.2 of SWMM Manual, the range for completely dry soil would be 0.097 to 0.375	Hydrologic Soil Group A: 0.30 Hydrologic Soil Group B: 0.31 Hydrologic Soil Group C: 0.32 Hydrologic Soil Group D: 0.33 Note: in long-term continuous simulation, this value is not important as the soil will reach equilibrium after a few storm events regardless of the initial moisture content specified.
Groundwater	yes/no	yes/no	NO
LID Controls			Project Specific
Snow Pack Land Uses Initial Buildup Curb Length			Not applicable to hydromodification management studies

Source: Model BMP Design Manual San Diego Region Appendices, February 26, 2016

LID controls

Utilizing LID controls within a SWMM project is a two-step process that:

- Creates a set of scale-independent LID controls that can be deployed throughout the study area,
- Assign any desired mix and sizing of these controls to designated sub-catchments.

The LID control type that was selected was a bio-filtration cell that contains vegetation grown in an engineered soil mixture placed above a gravel drainage bed. Bio-filtration provides storage, infiltration (depending on the soil type) and evaporation of both direct rainfall and runoff captured from surrounding areas. For this project, we do not allow infiltration to the existing/filled soil.

SECTION III. CONTINUES SIMULATION OPTIONS

Simulation Dates

These dates determine the starting and ending dates/times of a simulation and are chosen based on the rain data availability.

Start analysis on 09/24/1964
Start Reporting on 09/24/1964
End Analysis on 05/23/2008

Time Steps

The Time Steps establish the length of the time steps used for runoff computation, routing computation and results reporting. Time steps are specified in days and hours: minutes: seconds except for flow routing which is entered as decimal seconds.

Climatology

-Evaporation Data

The available evaporation data for San Diego County is taken from Table G.1-1: Monthly Average Reference Evapotranspiration by ETo Zone for use in SWMM Models for Hydromodification Management Studies in San Diego County CIMIS Zone 6 (in/day).

January	February	March	April	May	June
0.06	0.08	0.11	0.16	0.18	0.21
July	August	September	October	November	December
0.21	0.20	0.16	0.12	0.08	0.06

SECTION IV. BIO-FILTRATION AS LID CONTROL

LID controls are represented by a combination of vertical layers whose properties are defined on a per-unit-area basis. This allows an LID of the same design but differing coverage area to easily be placed within different sub-catchments of a study area. During a simulation, SWMM performs a moisture balance that keeps track of how much water moves between and is stored within each LID layer. If the bio-filtration basin is full and water is leaving the upper weir, the flow is divided in two flows: the lower flow discharging from the bottom orifice directly draining to the point of compliance and the upper flow is routed at the top of the bio-filtration basin and after routing, discharged to the point of compliance. In this project, we used 100% of the area of this specific sub-catchment for bio-filtration.

1. Surface

Storage Depth

When confining walls or berms are present, this is the maximum depth to which water can pond above the surface of the unit before overflow occurs (in inches). In this project, storage depths vary.

Vegetation Volume Fraction

It is the fraction of the volume within the storage depth that is filled with vegetation. This is the volume occupied by stems and leaves, not their surface area coverage. Normally this volume can be ignored, but may be as high as 0.1 to 0.2 for very dense vegetative growth. In this project we used 0 for the vegetation volume fraction.

Surface Roughness

Manning's n value for overland flow over a vegetative surface.

Surface Slope

Slope of porous pavement surface or vegetative swale (percent).

2. Soil

Thickness

The thickness of the soil layer in inches. We used a value of 21 inches soil thickness for a biofiltration.

The volume of pore space relative to total volume of soil (as a fraction). We designed it with a soil mix porosity of 0.40 maximum for a good percolation rate (Countywide Model BMP Table B1 – Soil Porosity Appendix A: Assumed Water Movement Hydraulics for Modeling BMPs).

Field Capacity

Volume of pore water relative to total volume after the soil has been allowed to drain fully (as a fraction). We used 0.2 for this soil. Below this level, vertical drainage of water through the soil layer does not occur. (See Table 1 – Soil Infiltration Parameter).

Wilting Point

Volume of pore water relative to total volume for a well-dried soil where only bound water remains (as a fraction). The moisture content of the soil cannot fall below this limit. We assumed the minimum moisture content within this bio-filtration soil is 0.1.

Conductivity

Hydraulic conductivity for the fully saturated soil is 5 inches/hour. This is a design minimum value for percolation rate.

Conductivity Slope

Slope of the curve of log (conductivity) versus soil moisture content (dimensionless). Typical values range from 5 for sands to 15 for silty clay. We designed this soil to have a very good percolation rate therefore the conductivity slope is 5.

Suction Head

The average value of soil capillary suction along the wetting front (inches). This is the same parameter as used in the Green-Ampt infiltration model. Table 1 was utilized to determine the capillary of the soil mix top layer of a bio-filtration system. The suction head will be 1.5 inches.

3. Storage Layer

The Storage Layer page of the LID Control Editor describes the properties of the crushed stone or gravel layer used in bio-filtration cells as a bottom storage/drainage layer. The following data fields are displayed:

Height

this is the thickness of a gravel layer (inches). Crushed stone and gravel layers are vary ranging from 12 to 36 inches thick. A table is provided to summarize the BMP configurations.

Void Ratio

The volume of void space relative to the volume of solids in the layer. Typical values range from 0.5 to 0.75 for gravel beds. Note that porosity = void ratio / (1 + void ratio). We designed this void ratio to have a value of 0.67.

Seepage Rate

The rate at which water infiltrates into the native soil below the layer (in inches/hour). This would typically be the Saturated Hydraulic Conductivity of the surrounding sub-catchment if Green-Ampt infiltration is used. Since the liner beneath the gravel layer is proposed, the seepage rate is assumed to be 0 in/hr.

Clogging Factor

Total volume of treated runoff it takes to completely clog the bottom of the layer divided by the void volume of the layer. For south east bio-filtration, a value of 0 was used to ignore clogging since the system does NOT consider infiltration to the native soils. Clogging progressively reduces the Infiltration Rate in direct proportion to the cumulative volume of runoff treated and may only be of concern for infiltration trenches with permeable bottoms and no under drains. We assumed zero for the clogging factor since the infiltration rate is not considered.

4. Underdrain Layer

LID storage layers can contain an optional underdrain system that collects stored water from the bottom of the layer and conveys it to a conventional storm drain. The Underdrain page of the LID Control Editor describes the properties of this system. It contains the following data entry fields:

Drain Coefficient and Drain Exponent

Coefficient C and exponent n that determines the rate of flow through the underdrain as a function of height of stored water above the drain height. The following equation is used to compute this flow rate (per unit area of the LID unit):

$$q = C(h-Hd)^n$$

where q is the outflow (in/hr), h is the height of stored water (inches), and Hd is the drain height. A typical value for n would be 0.5 (making the drain act like an orifice). For this project, we use the flow coefficient as 0.435.

Drain Offset Height

Height of any underdrain piping above the bottom of a storage layer (inches). In this project, this value was set to 3 inches.

Note:

$$q = C(h-Hd)^n$$

$$C = C_o A_o \frac{\sqrt{2g}}{A} \times 12^{0.5} \times 3600$$

SECTION V. RUNNING THE SIMULATION

In general, the Run time will depend on the complexity of the watershed being modeled, the routing method used, and the size of the routing time step used. The larger the time steps, the faster the simulation, but the less detailed the results.

Model Results

SWMM's Status Report summarizes overall results for the 41-yr simulation. The runoff continuity error is -5.11% and the flow routing continuity error is 0.00%. When a run completes successfully, the mass continuity errors for runoff, flow routing, and pollutant routing will be displayed in the Run Status window. These errors represent the percent difference between initial storage + total inflow and final storage + total outflow for the entire drainage system. If they exceed some reasonable level, such as 10 percent, then the validity of the analysis results must be questioned. The most common reasons for an excessive continuity error are computational time steps that are too long or conduits that are too short.

In addition to the system continuity error, the Status Report produced by a run will list those nodes of the drainage network that have the largest flow continuity errors. If the error for a node is excessive, then one should first consider if the node in question is of importance to the purpose of the simulation. If it is, then further study is warranted to determine how the error might be reduced.

The SWMM program ranks the partial duration series, the exceedance frequency and the return period. They are computed using the Weibull formula for plotting position. See the flow duration curve and peak flow frequency on the following pages.

SECTION VI. RESULT ANALYSIS

Development of the Flow Duration Statistics

The flow duration statistics are also developed directly from the SWMM binary output file. It should be noted right from the start that the “durations” that we are talking about in this section have nothing to do with the “storm durations” presented in the peak flow statistics section. Other than using the same sequence of letters for the word, the two concepts have nothing to do with each other and the reader is cautioned not to confuse the two. The goal of the flow duration statistics is to determine, for the flow rates that fall within the hydromorphologically significant range, the length of time that each of those flow rates occur. Since the amount of sediment transported by a river or stream is proportional to the velocity of the water flowing and the length of time that velocity of flow acts on the sediment, knowing the velocity and length of time for each flow rate is very useful.

Methodology

The methodology for determining the flow duration curves comes from a document developed by the U.S. Geological Survey (USGS). The first stop on the journey to find this document was a link to the USGS water site (<http://www.usgs.gov/water/>). This link is found in Appendix E (SDHMP Continuous Simulation Modeling Primer), found in the County Hydromodification Management Plan¹. On this web site a search for “Flow Duration Curves” leads to USGS Publication 1542-A, Flow-duration curves, by James K. Searcy 1959 (<http://pubs.er.usgs.gov/publication/wsp1542A>). In this publication the development of the flow duration curves is discussed in detail.

In Pub 1542-A, beginning on page 7 an example problem is used to illustrate the compilation of data used to create the flow duration plots. A completed form 9-217-c form shows the monthly tabulation of flow rates for Bowie Creek near Hattiesburg, Miss. For each flow range the number of readings is tabulated and then the total number of each flow rate is totaled for the year. It should be noted that while this example is for a stream with a minimum flow rate of 100cfs, for the purposes of run-off studies in Southern California the minimum flow rate of zero (0) cfs is the common low flow value. Once each of the year’s data has been compiled the summary numbers from each year are transferred to form 9-217-d. On this form the total number of each flow rate is again totaled and the percentage of time exceeded calculated (as will be explained later under the discussion of our calculations). Once the data has been compiled a graph of Discharge Rate vs. Percent Time Exceeded is developed. As will be explained in the next section, the use of these curves leads to the amount of time each particular flow can be expected to occur (based on historical data).

How to Read the Graphs²

Figure 6.1 shows a flow duration curve for a hypothetical development. The three curves show what percentage of the time a range of flow rates are exceeded for three different conditions: pre-project,

¹ FINAL HYDROMODIFICATION MANAGEMENT PLAN, Prepared for County of San Diego, California, March 2011, by Brown and Caldwell Engineering of San Diego.

(http://www.projectcleanwater.org/images/stories/Docs/LDS/HMP/0311_SD_HMP_wAppendices.pdf)

² The graph and the explanation were taken directly from Appendix E of the Hydromodification Plan

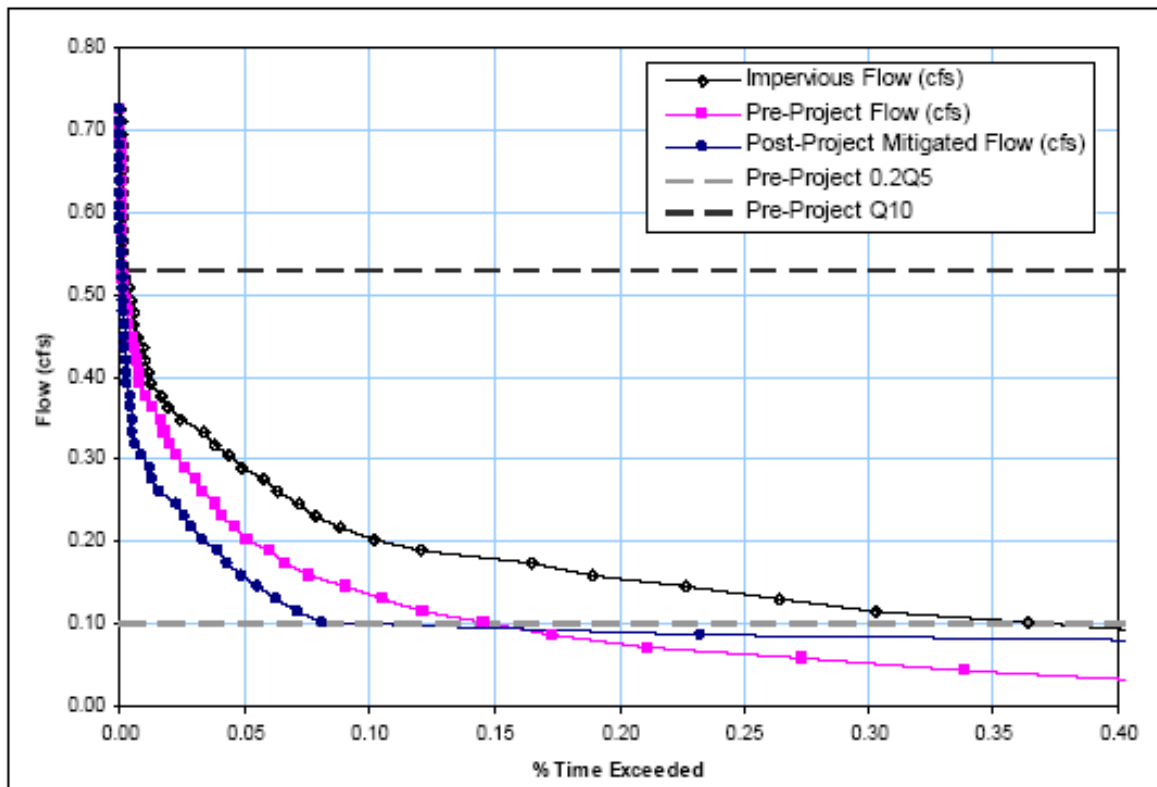

post-project and post-project with storm water mitigation. Under pre-project conditions the minimum geomorphically significant flow rate is 0.10cfs (assumed) and as read from the graph, flows would equal or exceed this value about 0.14% of the time (or about 12 hours per year) ($0.0014 \times 365\text{days} \times 24$ hour/day). For post-project conditions, this flow rate would occur more often – about 0.38% of the time (or about 33 hours per year) ($0.0038 \times 365\text{days} \times 24$ hour/day). This increase in the duration of the geomorphically significant flow after development illustrates why duration control is closely linked to protecting creeks from accelerated erosion.

Development of Flow Duration Curves

The first step in developing the flow duration curves is to count the number of occurrences of each flow rate. This is done by first rounding every non-zero flow value to an appropriate number of decimal places (say two places). This in effect groups each flow into closely related values or “bins” as they are referred to in publication 9-217d. Then the entire runoff record is queried for each value and the number of each value counted. The next step is to enter the results of the query into a grid patterned after form 9-217d. The data is entered in ascending order starting with the lowest flow first. The grid is composed of four columns. They are (from left to right) Discharge Rate, Number of **Periods (count)**, Total Periods Exceeding (the total number of periods equal to or exceeding this value), and Percent Time Exceeded. Starting at the top row (row 1), the flow rate (which is often times zero) is entered with the corresponding number of times that value was found. The next column is the total number of values greater than or equal to that flow rate. For the first flow rate point, by definition all flow rate values are greater than or equal to this value, therefore the total number of runoff records of the rainfall record is entered here. The final column which is the percent of time exceeded is calculated by dividing the total

Figure 6.1 Flow Duration Series Statistics for a Hypothetical Development Scenario

periods exceeded by the total number of periods in the study. For the first row this number should be 100%³

For the next row (row 2), the flow rate, and the flow rate count are entered. The total number of periods exceeding for row 2 is calculated by subtracting Number of Periods of row 1 from the Total Periods Exceeding of line 1. This result is entered in the Total Periods Exceeding on row 2. As was the case for line 1, the final column is calculated by dividing the total periods exceeded by the total number of periods in the study. For the second row this number should be something less than 100% and continually decrease as we move down the chart. If all the calculations are correct, then everything should zero out on the last line of the calculations.

The final step in developing the flow duration curves is to make a plot of the Discharge Rate vs. the Percent Time Exceeded. For the purposes of this report, the first value corresponding to the zero flow rate is not plotted allowing the graph to be focused on the actual flow rate values.

The Flow Duration Analysis

The Peak Flow Statistics analysis is composed of the following series of files:

1. The Flow Duration Plot
2. Comparison of the Un-Mitigated Flow Duration Curve to the Pre-Development Curve (Pass/Fail)
3. Comparison of the Mitigated Flow Duration Curve to the Pre-Development Curve (Pass/Fail)
4. The calculations for the Pre-Development flow duration curve development (USGS9217d)
5. The calculations for the Post-Development flow duration curve development (USGS9217d)
6. The calculations for the Mitigated flow duration curve development (USGS9217d)

The Flow Duration Plot

The Flow Duration Curves Plot is the plotting of all three (pre, un-mitigated and mitigated) sets of Discharge Rate vs. the Percent Time Exceeded data point pair lists. In addition to these curves horizontal lines are plotted corresponding to the Q_{10} and Q_{lf} (low flow threshold) values. Within the geomorphically significant range ($Q_{10} - Q_{lf}$) one can see a visual representation of the relative positions of the flow duration curves. The flow duration curves are compared in an East/West (horizontal) direction to compare post development Discharge Rates to pre-development Discharge Rates. The pre-development curve is plotted in blue, the unmitigated curve is plotted in red, and the mitigated curve is plotted in green. As long as the post development curve lies to the left of the pre-development curve (mostly⁴), the project meets the peak flow hydromodification requirements.

Pass/Fail comparison of the curves

The next two sets of data are the point by point comparison of the post-development curve(s) and the pre-development curve. The Pass/Fail table is helpful in determining compliance since the plotted lines can be difficult to see at the scales suitable for use in a report. Each point on the post-development curve has a corresponding “Y” value (Flow Rate), and “X” value (% Time Exceeded). For each point on the post development curve, the “Y” value is used to interpolate the corresponding Percent Time

⁴ See hydromodification limits for exceedance of pre-development values

Exceeded (X) value from the pre-development curve. Then the Post-development Percent Time Exceeded value is compared to the pre-development Percent Time Exceeded value. Based on the relative values of each point, pass/fail criteria are determined point by point.

For each set of data, the upper right hand header value shows the name of the file being displayed (ex. flowDurationPassFailMitigated.TXT). The first line of the file shows the name of the SWMM output file (*.out). The next line shows the time stamp of the SWMM file that is being analyzed. The time stamps of all of the report files should be within a minute or two of each other, otherwise there may have been tampering with the files. Each report run creates and prints all of the files and reports at one time so all the time stamps should be very close.

The first column is the zero based number of the point. The next two columns show the post development “X” and “Y” values. The next column shows the value interpolated between the two bounding points on the pre-development curve. The next three columns show the true or false values of the comparison of the two “X” values. The last column shows the resultant pass or fail status of the point. There are three ways a point can pass. They are:

1. Q_{post} being outside of the geomorphically significant range Q_{lf} to Q_{10}
2. Q_{post} being less than Q_{pre}
3. Q_{post} being less than 110% of the value of Q_{pre} if the point is between Q_{lf} and Q_{10}

There are two ways that a point can fail. They are:

1. Q_{post} being greater than 110% of Q_{pre} if the point is between Q_{lf} and Q_{10}
2. If more than 10% of the points are between 100% and 110% of Q_{pre} for the points between Q_{lf} and Q_{10}

A quick scan down the last column will quickly tell if there are any points that fail.

At the bottom of each set of data are the date stamp of the report to the left, and to the right is the page number/number of pages for the specific set of data (not the pages of the report!). Each new set of data has its own page numbering. Between the file name in the header row and the page numbering in the footer row, the engineer can readily scan the document for the data of interest.

Plan Check Suggestions

As was described under the peak flow section, is the responsibility of the reviewing agency to confirm that the data sets presented are valid results from consistent calculations, and that any and all results can be duplicated by manual methods and achieve the same results. In light of these goals, the plan checker is invited to consider the following tasks as part of the plan check process.

Compare the Data Stamps for Each of the Statistics Files Used In This Analysis.

As was described in the Peak Flows section, all report files should have time stamps that are nearly identical. If the time values are more than a few minutes apart then the potential for inconsistent results files should be investigated.

Verify the Flow Rate Counts

For each of the pre, un-mitigate and mitigated flow duration tables, a few randomly selected flow value counts should be checked against the values taken directly from the SWMM file. This can be done by

opening the corresponding SWMM file, selecting the outfall node, selecting Report>Table>By Object, Setting the time format to Date/Time, selecting the appropriate node value, and clicking the OK button to generate a table of the date/time/Total Inflow values. Next step is to click in the left most header row of the SWMM table which will select the entire table. Now from the main menu select Edit>Copy To>Clipboard. Now open a new blank sheet in MS Excel (or suitable spread sheet program) select cell A1 and paste the results from the clipboard into the spread sheet. Now sort the values based on the Total Inflow column. This will group all the flow values together enabling the number of occurrences of each value to be counted. At this point the a few (or all) of the counts on the various USGS9217d.txt files can be verified.

Manually Verify That the Percent Exceeded Values (form USGS9217d) are Correctly Calculated

The discharge rates and counts are confirmed as was described above. The top row should be the smallest runoff value (0.00cfs usually). Total Periods Exceeding of the first line should be the total number of rainfall records in the study. The percentage of Time Exceeding should be the total periods Exceeding divided by the total number of rainfall records in the study (100% for the first line). For each successive discharge rate, the total periods exceeding for the current line should be the total periods exceeding from the line above minus the number of periods from the line above. The number of periods and the number of periods exceeding should zero out at the last line.

Compare Plotted Curves to Table Data

Randomly check a few of the plotted points against the values verified above.

Verify by Observation that the plotted values of Q_{10} and Q_{if} are reasonable.

Verify that the correct values for each of these return periods are plotted correctly on the graph.

Development of the Peak Flow Statistics

The peak flow statistics are developed directly from the binary output file produced by the SWMM program. The site is modeled three ways, Pre-Development, Post-Development-Unmitigated, and Post-Development-Mitigated. For each of these files a specific time period differentiating distinct storms is chosen. The SWMM results are extracted and each flow value is queried. The majority of the values for Southern California sites are zero flow. As each successive record is read, as soon as a non-zero value is read the time and flow value of that record are recorded as the beginning of an event. The first record is automatically recorded as the “tentative” peak value. As each successive non-zero value is read and the successive flow value is compared to the peak value and the greater value is retained as the peak value of the storm. As soon as a successive number of zero values equal to the predetermined storm separation value, then the time value of the last non-zero value is recorded as the end of the storm, the duration of the storm is the difference between the end time and the start time, and the peak value is recorded as the highest flow value between the start and end times.

Once the entire SWMM output file is read all of the distinct storm events will have been recorded in a special list. The storms will be in the order of their occurrence. To develop the peak flow statistics table the first step is to sort the storms in descending order of the peak flow value. Once the list is sorted then the relative rank of each storm is assigned with the highest ranking storm being the storm with the highest peak flow. There are several methods that can be used to determine which storm should be ranked above another equally valued storm. For the purposes of these studies an Ordinal ranking is used so that each storm has a unique rank number. Where two or more storms have equal flow values, the earlier storm is assigned the higher rank. This is done consistently throughout the storm record.

Since we are only looking at peak flow statistics, it is assumed that the relative ranking of individual (but equal) storms is irrelevant to the calculations.

The exceedance frequency and return period are both computed using the Weibull formula for plotting position. Therefore, for a specific event the exceedance frequency F and the return period in years T are calculated using the following equations⁵:

$$F=m/(n_R+1) \quad \text{and} \quad T=n+1/m$$

where m is the event's rank, n_R is the total number of events and n is the number of years under analysis.

Once the Peak flow statistics table is complete, a plot of Return Frequency vs. peak flow is created. All three conditions (pre, post and mitigated) are plotted on the same plot.

The Peak Flow Statistics Analysis

The Peak Flow Statistics analysis is composed of the following series of files:

1. The Peak Flow Frequency Plot
2. The Comparison of the Un-Mitigated Peak Flow Curve to the Pre-Development Curve (Pass/Fail)
3. The Comparison of the Mitigated Conditions Curve to the Pre-Development Curve (Pass/Fail)
4. The Peak Flow Statistics Calculation for the Pre-Development Curve.
5. The Peak Flow Statistics Calculation for the Un-Mitigated Curve.
6. The Peak Flow Statistics Calculation for the Mitigated Curve.

The Peak Flow Frequency Plot

The Peak Flow Frequency Curves are the plotting of all three (Pre, Un-Mitigated and Mitigated) sets of return Period vs peak flow data point pair lists. In addition to these curves horizontal lines are plotted corresponding to the Q_{10} , Q_5 , Q_2 and Q_{if} (low flow threshold) values. Within the geomorphically significant range ($Q_{10} - Q_{if}$) one can see a visual representation of the relative positions of the peak flow curves. The peak flow curves are compared in a North/South (vertical) direction to compare post development peak flows to pre-development flows. The Pre-Development curve is plotted in blue, the unmitigated curve is plotted in red, and the mitigated curve is plotted in green. As long as the post development curve lies below the pre-development curve (mostly⁶), the project meets the peak flow hydromodification requirements.

Pass/Fail comparison of the curves

The next two sets of data are the point by point comparison of the post-development curve(s) and the pre-development curve. The Pass/Fail table is helpful in determining compliance since the plotted lines can be difficult to see at the scales suitable for use in a report. Each point on the post-development curve has a corresponding "X" value (Recurrence Interval), and "Y" value (Peak Flow). For each point on the post development curve, the "X" value is used to interpolate the corresponding peak flow value from the pre-development curve. Then the Post-development peak flow value is compared to the pre-development peak flow value. Based on the relative values of each point, pass/fail criteria are determined point by point.

⁵ Pg 169-170 STORM WATER MANAGEMENT MODEL APPLICATIONS MANUAL, EPA/600/R-09/000 July 2009

⁶ See hydromodification limits for exceedance of pre-development values

For each set of data, the upper right hand header value shows the name of the file being displayed (ex. peakFlowPassFailMitigated.TXT). The first line of the file also shows this value. The next line shows the time stamp of the file that is being analyzed. The time stamps of all of the report files should be within a minute or two of each other, otherwise there may have been tampering with the files. Each report run creates and prints all of the files and reports at one time so all the time stamps should be very close. It should be noted that the SWMM.out files will not have related time stamps since each file is developed independently.

The first column is the zero based number of the point. The next two columns show the post development “X” and “Y” values. The next column shows the value interpolated between the two bounding points on the pre-development curve. The next three columns show the true or false values of the comparison of the two “Y” values. The last column shows the resultant pass or fail status of the point. There are three ways a point can pass. They are:

1. Point is outside of the geomorphically significant range $Q_{10} - Q_{lf}$
2. Q_{post} being less than Q_{pre}
3. Q_{post} being less than 110% of the value of Q_{pre} if the point is between Q_5 and Q_{10} ⁷

There are four ways that a point can fail. They are:

1. Q_{post} being greater than Q_{pre} if the point is between Q_{lf} and Q_5
2. Q_{post} being greater than 110% of Q_{pre} if the point is between Q_{lf} and Q_{10}
3. If more than 10% of the points are between 100% and 110% of Q_{pre} for the points between Q_5 and Q_{10}
4. If the frequency interval for points $> 100\%$ of Q_{pre} is greater than 1 year for the points between Q_5 and Q_{10}

A quick scan down the last column will quickly tell if there are any points that fail.

At the bottom of each set of data are the date stamp of the report to the left, and to the right is the page number/number of pages for the specific set of data (not the pages of the report!). Each new set of data has its own page numbering. Between the file name in the header row and the page numbering in the footer row, the engineer can readily scan the document for the data of interest.

The Peak Flow Statistics Calculations

There are three sets of data for the Peak Flow Statistics calculations (Pre-Development, Un-Mitigated, and Mitigated). As was the case for the pass/fail data, the upper right hand corner of each sheet has the file name. The first row of the data is the SWMM file name. The second row is the SWMM file time stamp of the file being analyzed. The 4th, 5th, and 6th rows are the calculated values for Q_{10} , Q_5 , and Q_2 . These values are derived by linear interpolation between the nearest bounding points in the listing. While the relationship between the points in the peak flow analysis is not technically a linear relationship, the error introduced in using linear interpolation between such relatively close data points is assumed to be irrelevant. Finally, the footer row shows the report time and the page/number of pages of the data set.

As was previously discussed, each storm listed was determined by reading the flow values directly from the binary output file from the SWMM program. The storms were then sorted in descending order of

⁷ See section on how a point can fail point number 3 hereon

peak flow values. Then each storm was assigned a unique rank, then the Frequency and Return Period were calculated using Weibull formulas. Every discharge value for the entire rainfall record is listed in each of these lists. It should be noted that the derivation of these peak flow statistics values use full precision (i.e. no rounding off) of the SWMM output values. Since the precision of the calculations may not be the same as the SWMM program uses, and also the assignment of rank to values of equal peak flow value may differ slightly from the way SWMM calculates the tables, minor variances in the data values and/or the order of storms can be expected.

Finally, as was previously stated, the values of the Return Period were plotted vs. the peak flow values to develop the peak flow frequency curves.

Plan Check Suggestions

As is the responsibility of the reviewing agency, any and all methods should be considered to verify that the SWMM analysis adequately models the site as far as hydrologic discharge is concerned, and that the data sets presented are valid results from consistent calculations, and that any and all results can be duplicated by manual methods and achieve the same results. In light of these goals, the plan checker is invited to consider the following tasks as part of the plan check process.

Compare the Data Stamps for Each of the Statistics Files Used In This Analysis.

For each set of calculations and report files, the first step of the process is to list out all the files in the report folder and delete those files. The very first step leaves the reports folder completely empty. Then as each successive step is performed, the results file is placed in the reports folder. Once all of the results files are complete, then the report file is compiled using the data directly from the files placed in the results folder. This means that the time stamps on each of the report files in the report should be within a minute or two depending on the speed of the computer. If the time values are more than a few minutes apart then the potential for inconsistent results files should be investigated.

Verify A Few Random Storm Statistics

For each of the Pre, Un-mitigate and Mitigated peak flow statics tables, a few randomly selected storms should be checked against the values taken directly from the SWMM file. This can be done by opening the corresponding SWMM file, selecting the outfall node, selecting Report>Table>By Object, Setting the time format to Date/Time, selecting the appropriate node value, and clicking the OK button to generate a table of the date/time/Total Inflow values. Now scroll down the list to the start date and time of the randomly selected storm. Verify that the start date, end date, and the highest flow value between the start and end date correspond to the values shown in the statistics table. Do this for a few storm to verify that the data corresponds to the SWMM output file. Verify by hand a few of the frequency and return period values.

Compare Plotted Curves to Table Data

Randomly check a few of the plotted points against the values found in the Peak Flow Frequency Tables.

Verify by Observation that the values of Q_{10} , Q_5 , Q_2 and Q_{1f} are reasonable.

For each value shown on the reports, verify that the value shown for say Q_{10} is in between the next higher return period and the next lower period. Also verify that the correct values for each of these return periods are plotted correctly on the peak flow frequency graph.

Manually Verify That the Pass Fail Table Is Correctly Calculated

Select at random several points on each of the pass/fail tables to verify that the values for post X/Y and interpolated Y look reasonable. Also check that the various test results are shown accurately in the chart and also the final pass/fail result looks accurate.

Drawdown Time of Bio-filtration Surface Ponding

The drawdown time for hydromodification flow control facilities was calculated using the attached draw down calculations included in the SWMM Report

VII. SUMMARY AND CONCLUSION

Hydromodification calculations were performed utilizing continuous simulation to size storm water control facilities. SWMM (Storm Water Management Model) version 5.0 distributed by USEPA was used to generate computed peak flow recurrence and flow duration series statistics.

There are several tributary areas planned for industrial use and treated by 2 biofiltration BMPS on South Pacific labeled as BMP-A and BMP-B (Best Management Practices) with a total tributary area of approximately 2.96 acres. The areas were grouped based on its outfall and were analyzed for pre-development and mitigated post-development conditions.

The analyzed SWMM runs attached show that the proposed bio-filtration facilities provided with variety of orifice flow control at the base of the gravel storage configured as shown in Figure 1 is in compliance with the HMP and BMP Manual.

South Pacific

On POC-1, The flow duration curve on the following page shows the existing condition 4.3 hours ($0.049\% \times 365 \text{ days} \times 24 \text{ hour/day} = 4.3 \text{ hours}$).

With the proposed square footage of LID areas and orifices acting as the low flow restrictor configured as shown in Figure 1 the duration of the flow is 4.2 hours ($0.048\% \times 365 \text{ days} \times 24 \text{ hour/day} = 4.2 \text{ hours}$). This flow duration is lower than the existing condition.

Therefore, this study has demonstrated that the proposed optimized bio-filtration basin is sufficient to meet the current HMP and BMP criteria (See Table 6.1).

(Table 6.1) (Flow Duration Curves)

ON FOLLOWING PAGES

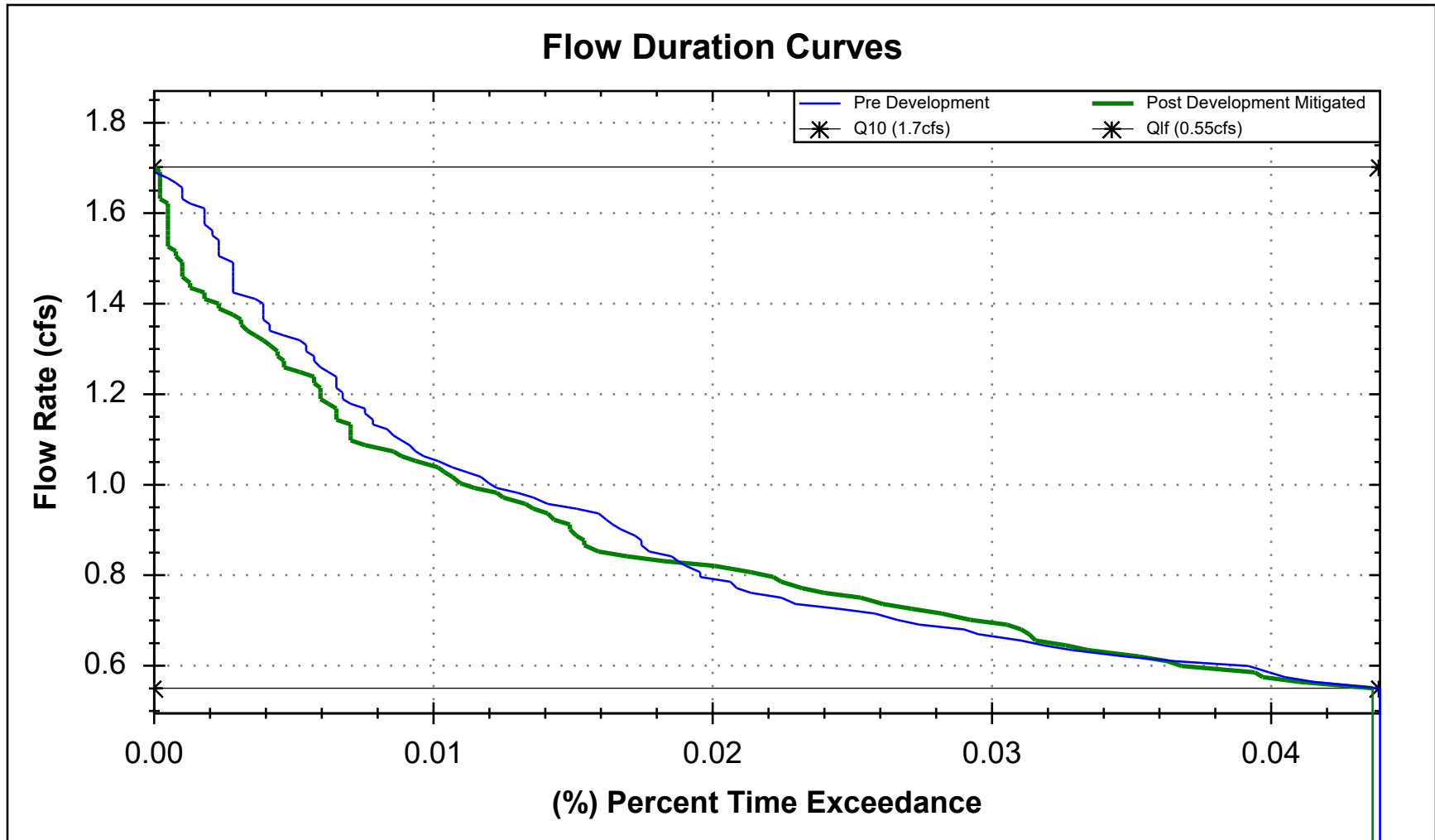

SECTION VII. SUMMARY AND CONCLUSION

INP and RPT FILES

PRE

21088-South Pacific Street Pre Development
Hydromodification .inp File

```

1 [TITLE]
2 ;;Project Title/Notes
3
4 [OPTIONS]
5 ;;Option Value
6 FLOW_UNITS CFS
7 INFILTRATION GREEN_AMPT
8 FLOW_ROUTING KINWAVE
9 LINK_OFFSETS DEPTH
10 MIN_SLOPE 0
11 ALLOW_PONDING NO
12 SKIP_STEADY_STATE NO
13
14 START_DATE 09/24/1964
15 START_TIME 00:00:00
16 REPORT_START_DATE 09/24/1964
17 REPORT_START_TIME 00:00:00
18 END_DATE 05/23/2008
19 END_TIME 06:00:00
20 SWEEP_START 01/01
21 SWEEP_END 12/31
22 DRY_DAYS 0
23 REPORT_STEP 01:00:00
24 WET_STEP 01:00:00
25 DRY_STEP 01:00:00
26 ROUTING_STEP 0:00:30
27 RULE_STEP 01:00:00
28
29 INERTIAL_DAMPING PARTIAL
30 NORMAL_FLOW_LIMITED BOTH
31 FORCE_MAIN_EQUATION H-W
32 VARIABLE_STEP 0.75
33 LENGTHENING_STEP 0
34 MIN_SURFAREA 12.566
35 MAX_TRIALS 8
36 HEAD_TOLERANCE 0.005
37 SYS_FLOW_TOL 5
38 LAT_FLOW_TOL 5
39 MINIMUM_STEP 0.5
40 THREADS 1

```

```

42 [EVAPORATION]
43 ;;Data Source Parameters
44 ;;-----
45 MONTHLY 0.06 0.08 0.11 0.16 0.18 0.21 0.21 0.2
46 0.16 0.12 0.08 0.06
47 DRY_ONLY NO

```

```

48 [RAINGAGES]
49 ;;Name Format Interval SCF Source
50 ;;-----
51 Escondido INTENSITY 1:00 1.0 TIMESERIES Escondido

```

```

53 [SUBCATCHMENTS]
54 ;;Name Rain Gage Outlet Area %Imperv
55 Width %Slope CurbLen SnowPack
56 DMA-1 Escondido POC 2.882096648 0
57 440 2.18 0
58 DMA-2 Escondido POC 0.078803306 0
59 28 0.5 0

```

```

59 [SUBAREAS]
60 ;;Subcatchment N-Imperv N-Perv S-Imperv S-Perv PctZero
61 RouteTo PctRouted
62 DMA-1 0.012 0.15 0.05 0.1 25

```



```

63  OUTLET
    DMA-2          0.012    0.15    0.05    0.1    25
    OUTLET
64
65  [INFILTRATION]
66  ;;Subcatchment  Param1    Param2    Param3    Param4    Param5
67  ;;-----
68  DMA-1          9         0.025    0.33
69  DMA-2          9         0.025    0.33
70
71  [OUTFALLS]
72  ;;Name          Elevation  Type      Stage Data    Gated    Route
    To
73  ;;-----
74  POC            0         FREE
    NO
75
76  [TIMESERIES]
77  ;;Name          Date       Time      Value
78  ;;-----
79  Escondido      FILE      "R:\_Storm\HydMOD\Rain gauge Data\Esccondido\Esccondido.prn"
80
81  [REPORT]
82  ;;Reporting Options
83  SUBCATCHMENTS  ALL
84  NODES          ALL
85  LINKS          ALL
86
87  [TAGS]
88
89  [MAP]
90  DIMENSIONS     -2727.273  0.000    12727.273  10000.000
91  Units          None
92
93  [COORDINATES]
94  ;;Node          X-Coord    Y-Coord
95  ;;-----
96  POC            4822.310   2013.820
97
98  [VERTICES]
99  ;;Link          X-Coord    Y-Coord
100 ;;-----
101
102 [Polygons]
103 ;;Subcatchment  X-Coord    Y-Coord
104 ;;-----
105 DMA-1          2394.917   5366.569
106 DMA-2          5661.402   2517.275
107
108 [SYMBOLS]
109 ;;Gage          X-Coord    Y-Coord
110 ;;-----
111 Escondido      1229.023   7778.875
112
113
114 [BACKDROP]
115 FILE           "V:\21\21088\Engineering\PrelimGP\Storm\Working
    Files\Hydmod\21088-Pre-HMD-EXCEL.jpg"
116 DIMENSIONS     -2727.273  0.000    12727.273  10000.000
117

```

21088-South Pacific
 Street Pre Development
 Hydromodification .rpt
 File

Analysis Options

Flow Units CFS
 Process Models:
 Rainfall/Runoff YES
 RDII NO
 Snowmelt NO
 Groundwater NO
 Flow Routing NO
 Water Quality NO
 Infiltration Method GREEN_AMPT
 Starting Date 09/24/1964 00:00:00
 Ending Date 05/23/2008 06:00:00
 Antecedent Dry Days 0.0
 Report Time Step 01:00:00
 Wet Time Step 01:00:00
 Dry Time Step 01:00:00

*****	Volume	Depth
Runoff Quantity Continuity	acre-feet	inches
*****	-----	-----
Total Precipitation	150.749	610.960
Evaporation Loss	4.459	18.072
Infiltration Loss	116.467	472.021
Surface Runoff	34.077	138.108
Final Storage	0.000	0.000
Continuity Error (%)	-2.822	

*****	Volume	Volume
Flow Routing Continuity	acre-feet	10^6 gal
*****	-----	-----
Dry Weather Inflow	0.000	0.000
Wet Weather Inflow	34.077	11.104
Groundwater Inflow	0.000	0.000
RDII Inflow	0.000	0.000
External Inflow	0.000	0.000
External Outflow	34.077	11.104
Flooding Loss	0.000	0.000
Evaporation Loss	0.000	0.000
Exfiltration Loss	0.000	0.000
Initial Stored Volume	0.000	0.000
Final Stored Volume	0.000	0.000
Continuity Error (%)	0.000	

 Subcatchment Runoff Summary

-----	Total	Total	Total	Total	Imperv
Subcatchment	Perv	Total	Total	Peak	Runoff
in	Runoff	Runoff	Evap	Infil	Runoff
in	in	in	Runoff	Runoff	Coeff
in	in	in	in	in	in
in	in	10^6 gal	CFS		

63	DMA-1		610.96	0.00	18.08	472.00	0.00
	138.10	138.10	10.81	2.25	0.226		
64	DMA-2		610.96	0.00	17.80	472.77	0.00
	138.53	138.53	0.30	0.06	0.227		

65

66

67 Analysis begun on: Thu Jun 2 13:14:07 2022

68 Analysis ended on: Thu Jun 2 13:14:45 2022

69 Total elapsed time: 00:00:38

POST

21088-South Pacific Street Post Development
Hydromodification .inp File

```

1 [TITLE]
2 ;;Project Title/Notes
3
4 [OPTIONS]
5 ;;Option Value
6 FLOW_UNITS CFS
7 INFILTRATION GREEN_AMPT
8 FLOW_ROUTING KINWAVE
9 LINK_OFFSETS DEPTH
10 MIN_SLOPE 0
11 ALLOW_PONDING NO
12 SKIP_STEADY_STATE NO
13
14 START_DATE 09/24/1964
15 START_TIME 00:00:00
16 REPORT_START_DATE 09/24/1964
17 REPORT_START_TIME 00:00:00
18 END_DATE 05/23/2008
19 END_TIME 06:00:00
20 SWEEP_START 01/01
21 SWEEP_END 12/31
22 DRY_DAYS 0
23 REPORT_STEP 01:00:00
24 WET_STEP 00:15:00
25 DRY_STEP 24:00:00
26 ROUTING_STEP 0:00:15
27 RULE_STEP 01:00:00
28
29 INERTIAL_DAMPING PARTIAL
30 NORMAL_FLOW_LIMITED BOTH
31 FORCE_MAIN_EQUATION H-W
32 VARIABLE_STEP 0.75
33 LENGTHENING_STEP 0
34 MIN_SURFAREA 12.566
35 MAX_TRIALS 8
36 HEAD_TOLERANCE 0.005
37 SYS_FLOW_TOL 5
38 LAT_FLOW_TOL 5
39 MINIMUM_STEP 0.5
40 THREADS 1

```

```

42 [EVAPORATION]
43 ;;Data Source Parameters
44 ;;-----
45 MONTHLY 0.06 0.08 0.11 0.16 0.18 0.21 0.21 0.2
46 0.16 0.12 0.08 0.06
47 DRY_ONLY NO

```

```

48 [RAINGAGES]
49 ;;Name Format Interval SCF Source
50 ;;-----
51 Escondido INTENSITY 1:00 1.0 FILE
52 "R:\_Storm\HydMOD\Rain gauge Data\Escondido\Escondido ALERT Station.dat" Escondido
53 IN

```

```

54 [SUBCATCHMENTS]
55 ;;Name Rain Gage Outlet Area %Imperv
56 Width %Slope CurbLen SnowPack
57 ;;-----
58 DMA-1.3 Escondido BMP-A 0.481809504 88
59 85 0.5 0
60 BMP-A Escondido sto 0.065798301 0
61 17.7 0
62 DMA-2 Escondido BMP-B 0.451782553 84
63 92 0.5 0
64 BMP-B Escondido STO 0.022116621 0
65 18.2 0
66 DMA-4 Escondido POC 0.078803306 73

```

61	28	0.5	0	Escondido	MWS	0.497233838	67
	DMA-3						
	80	0.5	0	Escondido	BMP-A	0.451386961	92
62	DMA-1.4						
	90	0.5	0	Escondido	BMP-A	0.349646786	79
63	DMA-1.2						
	55	0.5	0	Escondido	DMA-2	0.473020179	93
64	DMA-1.1						
	92	0.5	0	Escondido	POC	0.052169949	0
65	DMA-5						
	645	50	0	Escondido	POC	0.037131956	0
66	DMA-6						
	645	50	0	Escondido			

67
68 [SUBAREAS]

69	;;Subcatchment		N-Imperv	N-Perv	S-Imperv	S-Perv	PctZero
	RouteTo	PctRouted					

70 ;;;-----

71	DMA-1.3		0.012	0.15	0.05	0.1	25
	OUTLET						
72	BMP-A		0.012	0.15	0.05	0.1	25
	OUTLET						
73	DMA-2		0.012	0.15	0.05	0.1	25
	OUTLET						
74	BMP-B		0.012	0.15	0.05	0.1	25
	OUTLET						
75	DMA-4		0.012	0.15	0.05	0.1	25
	PERVIOUS	100					
76	DMA-3		0.012	0.15	0.05	0.1	25
	OUTLET						
77	DMA-1.4		0.012	0.15	0.05	0.1	25
	OUTLET						
78	DMA-1.2		0.012	0.15	0.05	0.1	25
	OUTLET						
79	DMA-1.1		0.012	0.15	0.05	0.1	25
	OUTLET						
80	DMA-5		0.012	0.15	0.05	0.1	25
	OUTLET						
81	DMA-6		0.012	0.15	0.05	0.1	25
	OUTLET						

82
83 [INFILTRATION]

84	;;Subcatchment	Param1	Param2	Param3	Param4	Param5
85	;;-----	-----	-----	-----	-----	-----

86	DMA-1.3	9	0.01875	0.33		
87	BMP-A	9	0.01875	0.33		
88	DMA-2	9	0.01875	0.33		
89	BMP-B	9	0.01875	0.33		
90	DMA-4	6	0.01875	0.33		
91	DMA-3	9	0.01875	0.33		
92	DMA-1.4	3.5	0.5	0.25		
93	DMA-1.2	3.5	0.5	0.25		
94	DMA-1.1	3.5	0.5	0.25		
95	DMA-5	9	0.025	0.33		
96	DMA-6	9	0.025	0.33		

97
98 [LID_CONTROLS]

99	;;Name	Type/Layer	Parameters			
100	;;-----	-----	-----			

101	BMP-A	BC				
102	BMP-A	SURFACE	0.1	0.0	0.1	1.0
	5					
103	BMP-A	SOIL	21	0.4	0.2	0.1
	5		1.5			
104	BMP-A	STORAGE	15	0.67	0	0
	NO					
105	BMP-A	DRAIN	0.435359717	0.5	3	6
	0					

```

106
107 BMP-B BC
108 BMP-B SURFACE 0.1 0.0 0 0
109 5
109 BMP-B SOIL 21 0.4 0.2 0.1
110 5 5 1.5
110 BMP-B STORAGE 15 0.67 0 0
111 NO
111 BMP-B DRAIN 1.273334039 0.5 3 6
112 0
112
113 [LID_USAGE]
114 ;;Subcatchment LID Process Number Area Width InitSat
114 FromImp ToPerv RptFile DrainTo FromPerv
115 ;;-----
116 BMP-A BMP-A 1 2866.17 0 0
116 0 0 * sto 0
117 BMP-B BMP-B 1 963.40 0 0
117 0 0 * STO 0
118
119 [OUTFALLS]
120 ;;Name Elevation Type Stage Data Gated Route
120 To
121 ;;-----
122 POC 0 FREE
122 NO
123
124 [DIVIDERS]
125 ;;Name Elevation Diverted Link Type Parameters
126 ;;-----
127 MWS 0 0 MWS-Overflow CUTOFF 0.3695 0
127 0 0
128
129 [STORAGE]
130 ;;Name Elev. MaxDepth InitDepth Shape Curve
130 Type/Params SurDepth Fevap Psi Ksat IMD
131 ;;-----
132 STO 525.17 3 0 TABULAR
132 STO 0 0
133
134 [CONDUITS]
135 ;;Name From Node To Node Length Roughness
135 InOffset OutOffset InitFlow MaxFlow
136 ;;-----
137 Const-Flow MWS POC 1 0.01
137 0 0 0 0
138 MWS-Overflow MWS POC 1 0.01
138 0 0 0 0
139
140 [ORIFICES]
141 ;;Name From Node To Node Type Offset
141 Qcoeff Gated CloseTime
142 ;;-----
143 Orifice-B STO POC SIDE 0
143 0.61 NO 0
144 Orifice-C STO POC SIDE 0.53
144 0.61 NO 0
145
146 [WEIRS]
147 ;;Name From Node To Node Type CrestHt
147 Qcoeff Gated EndCon EndCoeff Surcharge RoadWidth RoadSurf
148 Coeff. Curve
148 ;;-----

```

```

149 Weir-B          STO          POC          SIDEFLOW      3.83
    3.33          NO           0           0           YES
150 Weir-C          STO          POC          SIDEFLOW      3.33
    3.33          NO           0           0           YES
151
152 [XSECTIONS]
153 ;;Link          Shape          Geom1          Geom2          Geom3
    Geom4          Barrels          Culvert
154 ;;-----
155 Const-Flow      DUMMY          0              0              0
    0              1
156 MWS-Overflow    DUMMY          0              0              0
    0              1
157 Orifice-B       CIRCULAR       0.1667         0              0              0
158 Orifice-C       RECT_CLOSED    0.5            0.5            0              0
159 Weir-B          RECT_OPEN      1.17           4              0
    0
160 Weir-C          RECT_OPEN      0.5            0.3            0
    0
161
162 [CURVES]
163 ;;Name          Type          X-Value        Y-Value
164 ;;-----
165 STO            Storage       0              0
166 STO            0.4          2000
167 STO            0.8          1460
168 STO            1.2          2755
169 STO            1.6          1890
170 STO            2            2960
171 STO            2.4          1890
172 STO            2.8          2750
173 STO            3.2          1465
174 STO            3.6          2000
175 STO            4            10
176
177 [REPORT]
178 ;;Reporting Options
179 SUBCATCHMENTS  ALL
180 NODES         ALL
181 LINKS         ALL
182
183 [TAGS]
184
185 [MAP]
186 DIMENSIONS    -2727.273    0.000    12727.273    10000.000
187 Units         None
188
189 [COORDINATES]
190 ;;Node          X-Coord        Y-Coord
191 ;;-----
192 POC            5000.000       2309.970
193 MWS            2642.688       2789.149
194 STO            5153.428       4943.305
195
196 [VERTICES]
197 ;;Link          X-Coord        Y-Coord
198 ;;-----
199 Const-Flow     3116.505       2154.136
200 Const-Flow     4161.832       2163.906
201 MWS-Overflow   3092.081       1968.518
202 MWS-Overflow   4239.988       1988.056
203 Orifice-B      5207.160       4728.378
204 Orifice-B      5212.045       3292.274
205 Orifice-C      5402.548       4723.493
206 Orifice-C      5422.087       3609.780
207 Weir-B         4899.423       4679.531
208 Weir-B         4904.308       3077.346

```

209	Weir-C	5065.503	4708.839
210	Weir-C	5031.310	3350.890
211			
212	[Polygons]		
213	;;Subcatchment	X-Coord	Y-Coord
214	;;-----	-----	-----
215	DMA-1.3	2660.415	5695.953
216	BMP-A	5503.455	5715.696
217	DMA-2	2699.901	3593.287
218	BMP-B	5533.070	3346.496
219	DMA-4	5848.963	2704.837
220	DMA-3	992.103	2783.810
221	DMA-1.4	2936.821	4639.684
222	DMA-1.2	2121.212	6832.845
223	DMA-1.1	1248.766	5814.413
224	DMA-5	5014.663	7174.976
225	DMA-6	6060.606	5034.213
226			
227	[SYMBOLS]		
228	;;Gage	X-Coord	Y-Coord
229	;;-----	-----	-----
230	Escondido	1229.023	7778.875
231			
232			
233	[BACKDROP]		
234	FILE	"V:\21\21088\Engineering\PrelimGP\Storm\Working Files\Hydmod\21088-Post-HMD-EXCEL.jpg"	
235	DIMENSIONS	-2727.273	0.000 12727.273 10000.000
236			

WARNING 04: minimum elevation drop used for Conduit Const-Flow
WARNING 04: minimum elevation drop used for Conduit MWS-Overflow

Analysis Options

Flow Units CFS

Process Models:

Rainfall/Runoff YES
RDII NO
Snowmelt NO
Groundwater NO
Flow Routing YES
Ponding Allowed NO
Water Quality NO

Infiltration Method GREEN_AMPT

Flow Routing Method KINWAVE

Starting Date 09/24/1964 00:00:00

Ending Date 05/23/2008 06:00:00

Antecedent Dry Days 0.0

Report Time Step 01:00:00

Wet Time Step 00:15:00

Dry Time Step 00:00:00

Routing Time Step 15.00 sec

Rainfall File Summary

Station ID	First Date	Last Date	Recording Frequency	Periods w/Precip	Periods Missing	Periods Malfunc.
Escondido	09/24/1964	05/23/2008	60 min	7025	0	0

	Volume acre-feet	Depth inches
Runoff Quantity Continuity		
Initial LID Storage	0.015	0.062
Total Precipitation	150.749	610.960
Evaporation Loss	24.394	98.865
Infiltration Loss	22.848	92.600
Surface Runoff	31.317	126.923
LID Drainage	73.672	298.580
Final Storage	0.020	0.080
Continuity Error (%)	-0.986	

	Volume acre-feet	Volume 10 ⁶ gal
Flow Routing Continuity		
Dry Weather Inflow	0.000	0.000
Wet Weather Inflow	104.989	34.212
Groundwater Inflow	0.000	0.000
RDII Inflow	0.000	0.000
External Inflow	0.000	0.000
External Outflow	104.989	34.212
Flooding Loss	0.000	0.000
Evaporation Loss	0.000	0.000
Exfiltration Loss	0.000	0.000
Initial Stored Volume	0.000	0.000
Final Stored Volume	0.000	0.000
Continuity Error (%)	0.000	

70
 71 *****
 72 Highest Flow Instability Indexes
 73 *****
 74 All links are stable.
 75
 76

77 *****
 78 Routing Time Step Summary
 79 *****
 80 Minimum Time Step : 15.00 sec
 81 Average Time Step : 15.00 sec
 82 Maximum Time Step : 15.00 sec
 83 % of Time in Steady State : 0.00
 84 Average Iterations per Step : 1.00
 85 % of Steps Not Converging : 0.00
 86
 87

88 *****
 89 Subcatchment Runoff Summary
 90 *****
 91
 92

Subcatchment	Total Precip Runoff	Total Perv	Total Runon Runoff	Total Evap Runoff	Total Peak Infil Runoff	Imperv Runoff Coeff
in	in	10^6 gal	CFS	in	in	in
DMA-1.3	610.96	0.00	81.51	50.80	464.31	
20.27 484.58	6.34	0.41 0.793				
BMP-A	610.96	9097.98	828.42	0.00	0.00	
0.00 8879.87	15.87	1.07 0.915				
DMA-2	610.96	514.15	83.07	86.96	873.56	
88.77 962.33	11.81	0.77 0.855				
BMP-B	610.96	19657.86	884.56	0.00	0.00	
0.00 19383.19	11.64	0.77 0.956				
DMA-4	610.96	0.00	74.75	152.75	389.94	
394.92 394.92	0.85	0.07 0.646				
DMA-3	610.96	0.00	67.11	142.42	354.49	
52.31 406.80	5.49	0.41 0.666				
DMA-1.4	610.96	0.00	82.03	48.83	486.00	
0.06 486.06	5.96	0.36 0.796				
DMA-1.2	610.96	0.00	70.78	128.21	416.77	
0.10 416.87	3.96	0.25 0.682				
DMA-1.1	610.96	0.00	83.08	42.72	491.01	
0.05 491.06	6.31	0.39 0.804				
DMA-5	610.96	0.00	17.12	453.33	0.00	
151.23 151.23	0.21	0.04 0.248				
DMA-6	610.96	0.00	17.10	453.40	0.00	
151.25 151.25	0.15	0.03 0.248				

108
 109 *****
 110 LID Performance Summary
 111 *****
 112
 113
 114

Total Drain Inflow	Total Evap Initial Loss Storage	Total Infil Final Loss Storage	Surface Continuity Outflow Error
--------------------	---------------------------------	--------------------------------	----------------------------------

117 Subcatchment LID Control in in in in
 118 in in in %

119 BMP-A BMP-A 9708.94 828.45 0.00 690.29
 8189.92 2.10 2.58 -0.00
 120 BMP-B BMP-B 20268.82 884.59 0.00 3775.06
 15608.84 2.10 3.04 -0.00

121 *****
 122 Node Depth Summary
 123 *****
 124 *****

Node	Type	Average Depth Feet	Maximum Depth Feet	Maximum HGL Feet	Time of Max Occurrence days hr:min	Reported Max Depth Feet
POC	OUTFALL	0.00	0.00	0.00	0 00:00	0.00
MWS	DIVIDER	0.00	0.00	0.00	0 00:00	0.00
STO	STORAGE	0.01	1.83	527.00	10332 17:21	1.62

136 *****
 137 Node Inflow Summary
 138 *****
 139 *****
 140 *****

Node	Percent	Type	Maximum Total Lateral Inflow Volume CFS	Maximum Flow Total Inflow Balance Error CFS	Time of Max Occurrence days hr:min	Lateral Inflow Volume 10^6 gal
POC	0.000	OUTFALL	0.14	1.78	10332 17:00	1.21
MWS	0.000	DIVIDER	0.41	0.41	10332 17:00	5.49
STO	0.000	STORAGE	1.85	1.85	10332 17:00	27.5

151 *****
 152 Node Flooding Summary
 153 *****

154 No nodes were flooded.

158 *****
 159 Storage Volume Summary
 160 *****

Storage Unit	Average Max Volume Occurrence	Avg Maximum Pcmt Outflow Full	Evap Pcmt Loss	Exfil Pcmt Loss	Maximum Volume 1000 ft3	Max Pcmt Full	Time of days
--------------	-------------------------------	-------------------------------	----------------	-----------------	-------------------------	---------------	--------------

hr:min CFS

166

167 STO 0.014 0 0 0 3.370 54 10332
17:20 1.40

168

169

Outfall Loading Summary

172

173

174

Outfall Node	Flow Freq Pcnt	Avg Flow CFS	Max Flow CFS	Total Volume 10^6 gal
POC	4.17	0.08	1.78	34.210
System	4.17	0.08	1.78	34.210

178

179

180

181

182

183

184

Link Flow Summary

186

187

188

Link	Type	Maximum Flow CFS	Time of Max Occurrence days hr:min	Maximum Veloc ft/sec	Max/ Full Flow	Max/ Full Depth
Const-Flow	DUMMY	0.37	2343 04:43			
MWS-Overflow	DUMMY	0.04	10332 17:00			
Orifice-B	ORIFICE	0.14	10332 17:21			0.00
Orifice-C	ORIFICE	1.25	10332 17:21			0.00
Weir-B	WEIR	0.00	0 00:00			0.00
Weir-C	WEIR	0.00	0 00:00			0.00

192

193

194

195

196

197

198

199

200

201

Conduit Surcharge Summary

203

204

No conduits were surcharged.

205

206

207

Analysis begun on: Thu Jun 2 17:15:33 2022

Analysis ended on: Thu Jun 2 17:17:35 2022

Total elapsed time: 00:02:02

210

Underdrain and Drawdown Results

The following table summarizes the underdrain coefficients used for each of the BMP units and translates the C factor coefficient to an equivalent round orifice diameter based on 1/16th inch increments. The drawdown equations are based on standard falling head drawdown theory. The primary drawdown number of interest is the surface drawdown based on vector concerns. The various soil and gravel storage layer calculations consider the void ratio and porosity of the respective layer. It should be noted that these drawdown calculations only consider the volume of water within the bioretention units. If the bioretention unit utilizes any storage above the berm height, then that storage drawdown is in addition to the values shown in the table below. Those calculations, if present, are shown elsewhere in the report. The derivation and explanation of the equations used to determine the values displayed in the chart are discussed in the following two sections of this portion of the report.

Sub Cat Name*	LID Process*	LID Area (sf)*	Orifice D (1/16in)	Orifice D (in)	UD C factor*	T surf (in)*	T soil (in)*	T store (in)*	n (soil)*	e (store)*	Drawdown surface (hr)	Drawdown Soil (hr)	Drawdown Storage (hr)	Drawdown total (hr)
BMP-A	BMP-A	1742.4	24	1.5	0.435359717	0.1	21	27	0.4	0.67	0.0	3.3	9.0	12.3
BMP-B	BMP-B	871.2	29	1.8125	1.273334039	0.1	21	15	0.4	0.67	0.0	1.4	2.2	3.6

The character * in the column heading indicates that the values was read directly from the SWMM inp file.
 Assume: orifice coefficient $C_o = 0.60$, void ratio for surface = 1.0, centroid of underdrain orifice is located at $h=0$

Underdrain C Factor Equations

Based on the slotted drain example in the SWMM Drain Advisor (EPA SWMM 5.1 Help/Contents/Reference/Special Dialog Forms/LID Editors/LID Control Editor/LID Drain System/Drain Advisor) the underdrain coefficient C is the ratio of the orifice area (total slot area) to the LID area times a constant (60,000).

SWMM Ex: If the drain consists of slotted pipes where the slots act as orifices, then the drain exponent would be 0.5 and the drain coefficient would be 60,000 times the ratio of total slot area to LID area. For example, drain pipe with five 1/4" diameter holes per foot spaced 50 feet apart would have an area ratio of 0.000035 and a drain coefficient of 2.

The 60,000 constant in the above example corresponds to the combined constants in the standard orifice equation:

(Standard Orifice Equation)

$$q = C_o A_o \sqrt{2g} \sqrt{h} \text{ (cfs)}$$

and

(SWMM Underdrain Equation (per unit area))

$$q = q / A_{LID}$$

or

$$q = C_o A_o / A_{LID} \sqrt{2g} \sqrt{h} \text{ (cfs/sf)}$$

With a $C_o=0.6$ and converting $\sqrt{2g}$ to units of inches and hours the constant becomes 60,046.

So the underdrain C factor per unit area of the LID becomes:

$$C = 60,046 A_o / A_{LID} \text{ (in}^{1/2}\text{/hr)}$$

and

$$q = C * h^{1/2}$$

Drawdown Equations

The drawdown equations presented in the chart are the drawdown times for the respective layers within the bioretention unit (only). If the bioretention unit includes storage ponding above the berm height, then the drawdown time for the storage portion is in addition to the values shown in the chart. Those calculations (if present) are shown elsewhere in the report. For most cases the storage drawdown time will be comparatively short as compared to the bioretention drawdown times.

To derive a general formula that relates drawdown time for each layer of the bioretention unit in terms of the SWMM C factor, we set the change in water volume with respect to time equal to the standard orifice equation (found in the County Hydraulics manual):

$$q = \frac{dh}{dt} nA_p = C_o A_o \sqrt{2gh}$$

Where n = porosity of the layer, A_p = area of the BMP unit, C_o = orifice coefficient, A_o = area of the orifice, and g = gravity constant. The porosity n for the surface layer is 1.0, and the values for the soil and storage layers read from the SWMM LID definitions.

Solving the definite integral from h_1 to h_2

$$\int_{h=h_1}^{h=h_2} h^{-0.5} dh = \int_{t=0}^{t=T} \frac{C_o A_o \sqrt{2g}}{nA_p} dt$$

$$2(\sqrt{h_2} - \sqrt{h_1}) = \frac{C_o A_o \sqrt{2g}}{nA_p} (T)$$

Or

$$2n(\sqrt{h_2} - \sqrt{h_1}) = C (T)$$

$$\text{where: } C = \frac{C_o A_o \sqrt{2g}}{A_p} \text{ (in}^{1/2}/\text{hr)}$$

Solving for T:

$$T = \frac{2n(\sqrt{h_2} - \sqrt{h_1})}{C} \text{ (hr)}$$

Where h_2 (in) is the total beginning head above the underdrain orifice at $t=0$ and h_1 (in) is the total ending head above the orifice at $t=T$. Ex: h_2 for surface = depth of gravel storage plus depth of soil layer plus berm height, and h_1 for surface = depth of gravel storage plus depth of soil layer.

STATISTICS ANALYSIS OF THE SWMM FILES FOR:

DISCHARGE NODE: POC

ANALYSIS DETAILS

Stream Susceptibility to Channel Erosion: Low
Low Flow Threshold = $(0.5)Q_2 = 1.100 = Q_{lf} = 0.5500$ (cfs)
Flow Control Upper Limit = $Q_{10} = 1.700$ (cfs)
Assumed time between storms (hours): 24

PRE-DEVELOPMENT SWMM FILE

SWMM file name: V:\21\21088\Engineering\PrelimGP\Storm\Working Files\Hydmod\600' length-4x3.83 weir - Copy\21088-Pre-HMP2.out
SWMM file time stamp: 6/2/2022 1:14:45 PM
Selected Node to Analyze: POC

POST-DEVELOPMENT MITIGATED SWMM FILE

SWMM file name: V:\21\21088\Engineering\PrelimGP\Storm\Working Files\Hydmod\600' length-4x3.83 weir - Copy\21088-Post-HMP2.out
SWMM file time stamp: 6/2/2022 5:17:35 PM
Selected Node to Analyze: POC

MITIGATED CONDITIONS RESULTS

For the Mitigated Conditions:
Peak Flow Conditions PASS
Flow Duration Conditions PASS

The Mitigated Conditions peak flow frequency curve is composed of 374 points. Of the points, 1 point(s) are above the flow control upper limit ($Q_{10} = 1.7$ (cfs)), 310 point(s) are below the low flow threshold value ($Q_{lf} = 0.55$ (cfs)). Of the points within the flow control range (Q_{lf} to Q_{10}), 63 point(s) have a lower peak flow rate than pre-development conditions. These points all pass. There are no points that failed, therefore the peak flow requirements have been met.

The Mitigated Conditions flow duration curve is composed of 100 flow bins (points). Each point represents the number of hours where the discharge was equal to or greater than the discharge value, but less than the next greater discharge value. Within the flow control range, comparing the post-development flow duration curve to the pre-development flow duration curve, 100 post-development curve point(s) have a lower flow duration than pre-development conditions. These points all pass. There are no points that failed, therefore the flow duration requirements have been met.

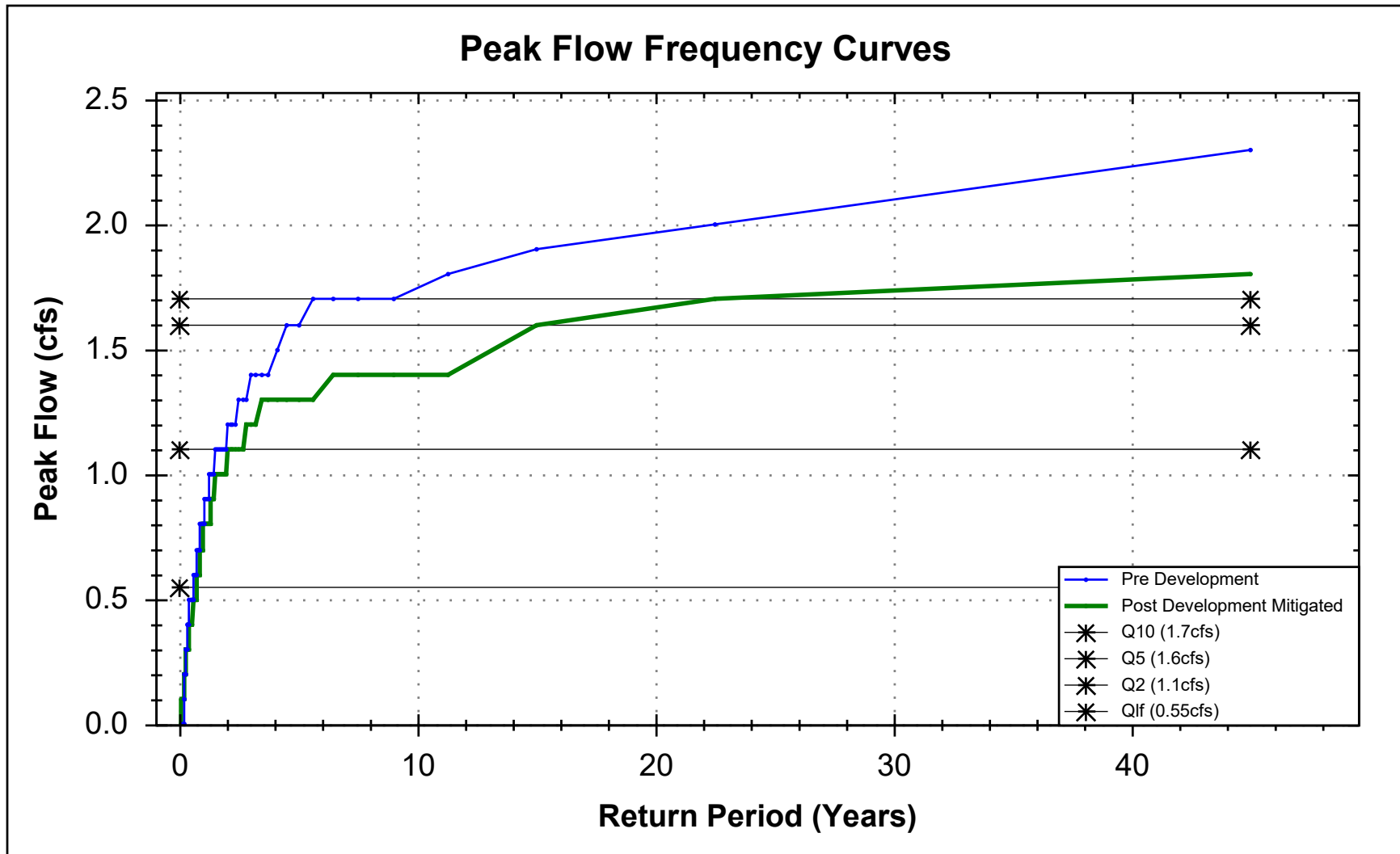

Compare Post-Development Curve to Pre-Development Curve							
Flow Control Upper Limit: 1.7 (cfs)							
Flow Control Lower Limit: 0.55 (cfs)							
post-development SWMM file: V:\21\21088\Engineering\PrelimGP\Storm\Working Files\Hydmod\600' length-4x3.83 weir - Copy\21088-Post-HMP2.out							
post-development time stamp: 6/2/2022 5:17:35 PM							
Compared to:							
pre-development SWMM file: V:\21\21088\Engineering\PrelimGP\Storm\Working Files\Hydmod\600' length-4x3.83 weir - Copy\21088-Pre-HMP2.out							
pre-development time stamp: 6/2/2022 1:14:45 PM							
Post PT #	Rtn Prd (yrs)	Post Dev Q (cfs)	Pre Dev Q (cfs)	Qpost < Qpre	Qpost > Qpre	Qpost > 110% Qpre	Pass/Fail
0	45.00	1.80	2.30	FALSE	FALSE	FALSE	Pass- Qpost Above Q10 (1.7 (cfs))
1	22.50	1.70	2.00	TRUE	FALSE	FALSE	Pass- Qpost < Qpre
2	15.00	1.60	1.90	TRUE	FALSE	FALSE	Pass- Qpost < Qpre
3	11.30	1.40	1.80	TRUE	FALSE	FALSE	Pass- Qpost < Qpre
4	9.00	1.40	1.70	TRUE	FALSE	FALSE	Pass- Qpost < Qpre
5	7.50	1.40	1.70	TRUE	FALSE	FALSE	Pass- Qpost < Qpre
6	6.40	1.40	1.70	TRUE	FALSE	FALSE	Pass- Qpost < Qpre
7	5.60	1.30	1.70	TRUE	FALSE	FALSE	Pass- Qpost < Qpre
8	5.00	1.30	1.60	TRUE	FALSE	FALSE	Pass- Qpost < Qpre
9	4.50	1.30	1.60	TRUE	FALSE	FALSE	Pass- Qpost < Qpre
10	4.10	1.30	1.50	TRUE	FALSE	FALSE	Pass- Qpost < Qpre
11	3.80	1.30	1.40	TRUE	FALSE	FALSE	Pass- Qpost < Qpre
12	3.50	1.30	1.40	TRUE	FALSE	FALSE	Pass- Qpost < Qpre
13	3.20	1.20	1.40	TRUE	FALSE	FALSE	Pass- Qpost < Qpre
14	3.00	1.20	1.40	TRUE	FALSE	FALSE	Pass- Qpost < Qpre
15	2.80	1.20	1.30	TRUE	FALSE	FALSE	Pass- Qpost < Qpre
16	2.60	1.10	1.30	TRUE	FALSE	FALSE	Pass- Qpost < Qpre
17	2.50	1.10	1.30	TRUE	FALSE	FALSE	Pass- Qpost < Qpre
18	2.40	1.10	1.20	TRUE	FALSE	FALSE	Pass- Qpost < Qpre
19	2.30	1.10	1.20	TRUE	FALSE	FALSE	Pass- Qpost < Qpre
20	2.10	1.10	1.20	TRUE	FALSE	FALSE	Pass- Qpost < Qpre
21	2.00	1.10	1.20	TRUE	FALSE	FALSE	Pass- Qpost < Qpre
22	2.00	1.00	1.10	TRUE	FALSE	FALSE	Pass- Qpost < Qpre
23	1.90	1.00	1.10	TRUE	FALSE	FALSE	Pass- Qpost < Qpre
24	1.80	1.00	1.10	TRUE	FALSE	FALSE	Pass- Qpost < Qpre
25	1.70	1.00	1.10	TRUE	FALSE	FALSE	Pass- Qpost < Qpre
26	1.70	1.00	1.10	TRUE	FALSE	FALSE	Pass- Qpost < Qpre
27	1.60	1.00	1.10	TRUE	FALSE	FALSE	Pass- Qpost < Qpre
28	1.60	1.00	1.10	TRUE	FALSE	FALSE	Pass- Qpost < Qpre
29	1.50	1.00	1.10	TRUE	FALSE	FALSE	Pass- Qpost < Qpre
30	1.50	0.90	1.00	TRUE	FALSE	FALSE	Pass- Qpost < Qpre
31	1.40	0.90	1.00	TRUE	FALSE	FALSE	Pass- Qpost < Qpre

Post PT #	Rtn Prd (yrs)	Post Dev Q (cfs)	Pre Dev Q (cfs)	Qpost < Qpre	Qpost > Qpre	Qpost > 110% Qpre	Pass/Fail
32	1.40	0.90	1.00	TRUE	FALSE	FALSE	Pass- Qpost < Qpre
33	1.30	0.90	1.00	TRUE	FALSE	FALSE	Pass- Qpost < Qpre
34	1.30	0.80	1.00	TRUE	FALSE	FALSE	Pass- Qpost < Qpre
35	1.30	0.80	1.00	TRUE	FALSE	FALSE	Pass- Qpost < Qpre
36	1.20	0.80	0.90	TRUE	FALSE	FALSE	Pass- Qpost < Qpre
37	1.20	0.80	0.90	TRUE	FALSE	FALSE	Pass- Qpost < Qpre
38	1.20	0.80	0.90	TRUE	FALSE	FALSE	Pass- Qpost < Qpre
39	1.10	0.80	0.90	TRUE	FALSE	FALSE	Pass- Qpost < Qpre
40	1.10	0.80	0.90	TRUE	FALSE	FALSE	Pass- Qpost < Qpre
41	1.10	0.80	0.90	TRUE	FALSE	FALSE	Pass- Qpost < Qpre
42	1.00	0.80	0.80	TRUE	FALSE	FALSE	Pass- Qpost < Qpre
43	1.00	0.80	0.80	TRUE	FALSE	FALSE	Pass- Qpost < Qpre
44	1.00	0.80	0.80	TRUE	FALSE	FALSE	Pass- Qpost < Qpre
45	1.00	0.70	0.80	TRUE	FALSE	FALSE	Pass- Qpost < Qpre
46	1.00	0.70	0.80	TRUE	FALSE	FALSE	Pass- Qpost < Qpre
47	0.90	0.70	0.80	TRUE	FALSE	FALSE	Pass- Qpost < Qpre
48	0.90	0.70	0.80	TRUE	FALSE	FALSE	Pass- Qpost < Qpre
49	0.90	0.70	0.80	TRUE	FALSE	FALSE	Pass- Qpost < Qpre
50	0.90	0.70	0.80	TRUE	FALSE	FALSE	Pass- Qpost < Qpre
51	0.90	0.70	0.70	TRUE	FALSE	FALSE	Pass- Qpost < Qpre
52	0.80	0.60	0.70	TRUE	FALSE	FALSE	Pass- Qpost < Qpre
53	0.80	0.60	0.70	TRUE	FALSE	FALSE	Pass- Qpost < Qpre
54	0.80	0.60	0.70	TRUE	FALSE	FALSE	Pass- Qpost < Qpre
55	0.80	0.60	0.70	TRUE	FALSE	FALSE	Pass- Qpost < Qpre
56	0.80	0.60	0.70	TRUE	FALSE	FALSE	Pass- Qpost < Qpre
57	0.80	0.60	0.70	TRUE	FALSE	FALSE	Pass- Qpost < Qpre
58	0.80	0.60	0.70	TRUE	FALSE	FALSE	Pass- Qpost < Qpre
59	0.80	0.60	0.70	TRUE	FALSE	FALSE	Pass- Qpost < Qpre
60	0.70	0.60	0.70	TRUE	FALSE	FALSE	Pass- Qpost < Qpre
61	0.70	0.60	0.70	TRUE	FALSE	FALSE	Pass- Qpost < Qpre
62	0.70	0.60	0.70	TRUE	FALSE	FALSE	Pass- Qpost < Qpre
63	0.70	0.60	0.60	TRUE	FALSE	FALSE	Pass- Qpost < Qpre
64	0.70	0.50	0.60	FALSE	FALSE	FALSE	Pass- Qpost Below Qlf (0.55 (cfs))
65	0.70	0.50	0.60	FALSE	FALSE	FALSE	Pass- Qpost Below Qlf (0.55 (cfs))
66	0.70	0.50	0.60	FALSE	FALSE	FALSE	Pass- Qpost Below Qlf (0.55 (cfs))
67	0.70	0.50	0.60	FALSE	FALSE	FALSE	Pass- Qpost Below Qlf (0.55 (cfs))
68	0.70	0.50	0.60	FALSE	FALSE	FALSE	Pass- Qpost Below Qlf (0.55 (cfs))
69	0.60	0.50	0.60	FALSE	FALSE	FALSE	Pass- Qpost Below Qlf (0.55 (cfs))
70	0.60	0.50	0.60	FALSE	FALSE	FALSE	Pass- Qpost Below Qlf (0.55 (cfs))
71	0.60	0.50	0.60	FALSE	FALSE	FALSE	Pass- Qpost Below Qlf (0.55 (cfs))
72	0.60	0.50	0.60	FALSE	FALSE	FALSE	Pass- Qpost Below Qlf (0.55 (cfs))
73	0.60	0.50	0.60	FALSE	FALSE	FALSE	Pass- Qpost Below Qlf (0.55 (cfs))

Post PT #	Rtn Prd (yrs)	Post Dev Q (cfs)	Pre Dev Q (cfs)	Qpost < Qpre	Qpost > Qpre	Qpost > 110% Qpre	Pass/Fail
74	0.60	0.50	0.60	FALSE	FALSE	FALSE	Pass- Qpost Below Qlf (0.55 cfs))
75	0.60	0.50	0.60	FALSE	FALSE	FALSE	Pass- Qpost Below Qlf (0.55 cfs))
76	0.60	0.50	0.60	FALSE	FALSE	FALSE	Pass- Qpost Below Qlf (0.55 cfs))
77	0.60	0.50	0.60	FALSE	FALSE	FALSE	Pass- Qpost Below Qlf (0.55 cfs))
78	0.60	0.50	0.60	FALSE	FALSE	FALSE	Pass- Qpost Below Qlf (0.55 cfs))
79	0.60	0.50	0.50	FALSE	FALSE	FALSE	Pass- Qpost Below Qlf (0.55 cfs))
80	0.60	0.40	0.50	FALSE	FALSE	FALSE	Pass- Qpost Below Qlf (0.55 cfs))
81	0.50	0.40	0.50	FALSE	FALSE	FALSE	Pass- Qpost Below Qlf (0.55 cfs))
82	0.50	0.40	0.50	FALSE	FALSE	FALSE	Pass- Qpost Below Qlf (0.55 cfs))
83	0.50	0.40	0.50	FALSE	FALSE	FALSE	Pass- Qpost Below Qlf (0.55 cfs))
84	0.50	0.40	0.50	FALSE	FALSE	FALSE	Pass- Qpost Below Qlf (0.55 cfs))
85	0.50	0.40	0.50	FALSE	FALSE	FALSE	Pass- Qpost Below Qlf (0.55 cfs))
86	0.50	0.40	0.50	FALSE	FALSE	FALSE	Pass- Qpost Below Qlf (0.55 cfs))
87	0.50	0.40	0.50	FALSE	FALSE	FALSE	Pass- Qpost Below Qlf (0.55 cfs))
88	0.50	0.40	0.50	FALSE	FALSE	FALSE	Pass- Qpost Below Qlf (0.55 cfs))
89	0.50	0.40	0.50	FALSE	FALSE	FALSE	Pass- Qpost Below Qlf (0.55 cfs))
90	0.50	0.40	0.50	FALSE	FALSE	FALSE	Pass- Qpost Below Qlf (0.55 cfs))
91	0.50	0.40	0.50	FALSE	FALSE	FALSE	Pass- Qpost Below Qlf (0.55 cfs))
92	0.50	0.40	0.50	FALSE	FALSE	FALSE	Pass- Qpost Below Qlf (0.55 cfs))
93	0.50	0.40	0.50	FALSE	FALSE	FALSE	Pass- Qpost Below Qlf (0.55 cfs))
94	0.50	0.40	0.50	FALSE	FALSE	FALSE	Pass- Qpost Below Qlf (0.55 cfs))
95	0.50	0.40	0.50	FALSE	FALSE	FALSE	Pass- Qpost Below Qlf (0.55 cfs))
96	0.50	0.40	0.50	FALSE	FALSE	FALSE	Pass- Qpost Below Qlf (0.55 cfs))
97	0.50	0.40	0.50	FALSE	FALSE	FALSE	Pass- Qpost Below Qlf (0.55 cfs))
98	0.50	0.40	0.50	FALSE	FALSE	FALSE	Pass- Qpost Below Qlf (0.55 cfs))
99	0.50	0.40	0.50	FALSE	FALSE	FALSE	Pass- Qpost Below Qlf (0.55 cfs))
100	0.40	0.40	0.50	FALSE	FALSE	FALSE	Pass- Qpost Below Qlf (0.55 cfs))
101	0.40	0.40	0.50	FALSE	FALSE	FALSE	Pass- Qpost Below Qlf (0.55 cfs))
102	0.40	0.40	0.50	FALSE	FALSE	FALSE	Pass- Qpost Below Qlf (0.55 cfs))
103	0.40	0.40	0.50	FALSE	FALSE	FALSE	Pass- Qpost Below Qlf (0.55 cfs))
104	0.40	0.40	0.50	FALSE	FALSE	FALSE	Pass- Qpost Below Qlf (0.55 cfs))
105	0.40	0.40	0.50	FALSE	FALSE	FALSE	Pass- Qpost Below Qlf (0.55 cfs))
106	0.40	0.40	0.50	FALSE	FALSE	FALSE	Pass- Qpost Below Qlf (0.55 cfs))
107	0.40	0.40	0.50	FALSE	FALSE	FALSE	Pass- Qpost Below Qlf (0.55 cfs))
108	0.40	0.40	0.50	FALSE	FALSE	FALSE	Pass- Qpost Below Qlf (0.55 cfs))
109	0.40	0.40	0.40	FALSE	FALSE	FALSE	Pass- Qpost Below Qlf (0.55 cfs))
110	0.40	0.40	0.40	FALSE	FALSE	FALSE	Pass- Qpost Below Qlf (0.55 cfs))
111	0.40	0.30	0.40	FALSE	FALSE	FALSE	Pass- Qpost Below Qlf (0.55 cfs))
112	0.40	0.30	0.40	FALSE	FALSE	FALSE	Pass- Qpost Below Qlf (0.55 cfs))
113	0.40	0.30	0.40	FALSE	FALSE	FALSE	Pass- Qpost Below Qlf (0.55 cfs))
114	0.40	0.30	0.40	FALSE	FALSE	FALSE	Pass- Qpost Below Qlf (0.55 cfs))
115	0.40	0.30	0.40	FALSE	FALSE	FALSE	Pass- Qpost Below Qlf (0.55 cfs))

Post PT #	Rtn Prd (yrs)	Post Dev Q (cfs)	Pre Dev Q (cfs)	Qpost < Qpre	Qpost > Qpre	Qpost > 110% Qpre	Pass/Fail
116	0.40	0.30	0.40	FALSE	FALSE	FALSE	Pass- Qpost Below Qlf (0.55 cfs))
117	0.40	0.30	0.40	FALSE	FALSE	FALSE	Pass- Qpost Below Qlf (0.55 cfs))
118	0.40	0.30	0.40	FALSE	FALSE	FALSE	Pass- Qpost Below Qlf (0.55 cfs))
119	0.40	0.30	0.40	FALSE	FALSE	FALSE	Pass- Qpost Below Qlf (0.55 cfs))
120	0.40	0.30	0.40	FALSE	FALSE	FALSE	Pass- Qpost Below Qlf (0.55 cfs))
121	0.40	0.30	0.40	FALSE	FALSE	FALSE	Pass- Qpost Below Qlf (0.55 cfs))
122	0.40	0.30	0.40	FALSE	FALSE	FALSE	Pass- Qpost Below Qlf (0.55 cfs))
123	0.40	0.30	0.40	FALSE	FALSE	FALSE	Pass- Qpost Below Qlf (0.55 cfs))
124	0.40	0.30	0.40	FALSE	FALSE	FALSE	Pass- Qpost Below Qlf (0.55 cfs))
125	0.40	0.30	0.40	FALSE	FALSE	FALSE	Pass- Qpost Below Qlf (0.55 cfs))
126	0.40	0.30	0.40	FALSE	FALSE	FALSE	Pass- Qpost Below Qlf (0.55 cfs))
127	0.40	0.30	0.40	FALSE	FALSE	FALSE	Pass- Qpost Below Qlf (0.55 cfs))
128	0.30	0.30	0.40	FALSE	FALSE	FALSE	Pass- Qpost Below Qlf (0.55 cfs))
129	0.30	0.30	0.40	FALSE	FALSE	FALSE	Pass- Qpost Below Qlf (0.55 cfs))
130	0.30	0.30	0.40	FALSE	FALSE	FALSE	Pass- Qpost Below Qlf (0.55 cfs))
131	0.30	0.30	0.40	FALSE	FALSE	FALSE	Pass- Qpost Below Qlf (0.55 cfs))
132	0.30	0.30	0.40	FALSE	FALSE	FALSE	Pass- Qpost Below Qlf (0.55 cfs))
133	0.30	0.30	0.40	FALSE	FALSE	FALSE	Pass- Qpost Below Qlf (0.55 cfs))
134	0.30	0.30	0.40	FALSE	FALSE	FALSE	Pass- Qpost Below Qlf (0.55 cfs))
135	0.30	0.30	0.40	FALSE	FALSE	FALSE	Pass- Qpost Below Qlf (0.55 cfs))
136	0.30	0.30	0.40	FALSE	FALSE	FALSE	Pass- Qpost Below Qlf (0.55 cfs))
137	0.30	0.30	0.40	FALSE	FALSE	FALSE	Pass- Qpost Below Qlf (0.55 cfs))
138	0.30	0.30	0.40	FALSE	FALSE	FALSE	Pass- Qpost Below Qlf (0.55 cfs))
139	0.30	0.30	0.40	FALSE	FALSE	FALSE	Pass- Qpost Below Qlf (0.55 cfs))
140	0.30	0.30	0.40	FALSE	FALSE	FALSE	Pass- Qpost Below Qlf (0.55 cfs))
141	0.30	0.30	0.40	FALSE	FALSE	FALSE	Pass- Qpost Below Qlf (0.55 cfs))
142	0.30	0.30	0.40	FALSE	FALSE	FALSE	Pass- Qpost Below Qlf (0.55 cfs))
143	0.30	0.30	0.40	FALSE	FALSE	FALSE	Pass- Qpost Below Qlf (0.55 cfs))
144	0.30	0.30	0.30	FALSE	FALSE	FALSE	Pass- Qpost Below Qlf (0.55 cfs))
145	0.30	0.30	0.30	FALSE	FALSE	FALSE	Pass- Qpost Below Qlf (0.55 cfs))
146	0.30	0.30	0.30	FALSE	FALSE	FALSE	Pass- Qpost Below Qlf (0.55 cfs))
147	0.30	0.30	0.30	FALSE	FALSE	FALSE	Pass- Qpost Below Qlf (0.55 cfs))
148	0.30	0.30	0.30	FALSE	FALSE	FALSE	Pass- Qpost Below Qlf (0.55 cfs))
149	0.30	0.30	0.30	FALSE	FALSE	FALSE	Pass- Qpost Below Qlf (0.55 cfs))
150	0.30	0.30	0.30	FALSE	FALSE	FALSE	Pass- Qpost Below Qlf (0.55 cfs))
151	0.30	0.30	0.30	FALSE	FALSE	FALSE	Pass- Qpost Below Qlf (0.55 cfs))
152	0.30	0.30	0.30	FALSE	FALSE	FALSE	Pass- Qpost Below Qlf (0.55 cfs))
153	0.30	0.30	0.30	FALSE	FALSE	FALSE	Pass- Qpost Below Qlf (0.55 cfs))
154	0.30	0.20	0.30	FALSE	FALSE	FALSE	Pass- Qpost Below Qlf (0.55 cfs))
155	0.30	0.20	0.30	FALSE	FALSE	FALSE	Pass- Qpost Below Qlf (0.55 cfs))
156	0.30	0.20	0.30	FALSE	FALSE	FALSE	Pass- Qpost Below Qlf (0.55 cfs))
157	0.30	0.20	0.30	FALSE	FALSE	FALSE	Pass- Qpost Below Qlf (0.55 cfs))

Post PT #	Rtn Prd (yrs)	Post Dev Q (cfs)	Pre Dev Q (cfs)	Qpost < Qpre	Qpost > Qpre	Qpost > 110% Qpre	Pass/Fail
158	0.30	0.20	0.30	FALSE	FALSE	FALSE	Pass- Qpost Below Qlf (0.55 cfs))
159	0.30	0.20	0.30	FALSE	FALSE	FALSE	Pass- Qpost Below Qlf (0.55 cfs))
160	0.30	0.20	0.30	FALSE	FALSE	FALSE	Pass- Qpost Below Qlf (0.55 cfs))
161	0.30	0.20	0.30	FALSE	FALSE	FALSE	Pass- Qpost Below Qlf (0.55 cfs))
162	0.30	0.20	0.30	FALSE	FALSE	FALSE	Pass- Qpost Below Qlf (0.55 cfs))
163	0.30	0.20	0.30	FALSE	FALSE	FALSE	Pass- Qpost Below Qlf (0.55 cfs))
164	0.30	0.20	0.30	FALSE	FALSE	FALSE	Pass- Qpost Below Qlf (0.55 cfs))
165	0.30	0.20	0.30	FALSE	FALSE	FALSE	Pass- Qpost Below Qlf (0.55 cfs))
166	0.30	0.20	0.30	FALSE	FALSE	FALSE	Pass- Qpost Below Qlf (0.55 cfs))
167	0.30	0.20	0.30	FALSE	FALSE	FALSE	Pass- Qpost Below Qlf (0.55 cfs))
168	0.30	0.20	0.30	FALSE	FALSE	FALSE	Pass- Qpost Below Qlf (0.55 cfs))
169	0.30	0.20	0.30	FALSE	FALSE	FALSE	Pass- Qpost Below Qlf (0.55 cfs))
170	0.30	0.20	0.30	FALSE	FALSE	FALSE	Pass- Qpost Below Qlf (0.55 cfs))
171	0.30	0.20	0.30	FALSE	FALSE	FALSE	Pass- Qpost Below Qlf (0.55 cfs))
172	0.30	0.20	0.30	FALSE	FALSE	FALSE	Pass- Qpost Below Qlf (0.55 cfs))
173	0.30	0.20	0.30	FALSE	FALSE	FALSE	Pass- Qpost Below Qlf (0.55 cfs))
174	0.30	0.20	0.30	FALSE	FALSE	FALSE	Pass- Qpost Below Qlf (0.55 cfs))
175	0.30	0.20	0.30	FALSE	FALSE	FALSE	Pass- Qpost Below Qlf (0.55 cfs))
176	0.30	0.20	0.20	FALSE	FALSE	FALSE	Pass- Qpost Below Qlf (0.55 cfs))
177	0.30	0.20	0.20	FALSE	FALSE	FALSE	Pass- Qpost Below Qlf (0.55 cfs))
178	0.30	0.20	0.20	FALSE	FALSE	FALSE	Pass- Qpost Below Qlf (0.55 cfs))
179	0.30	0.20	0.20	FALSE	FALSE	FALSE	Pass- Qpost Below Qlf (0.55 cfs))
180	0.20	0.20	0.20	FALSE	FALSE	FALSE	Pass- Qpost Below Qlf (0.55 cfs))
181	0.20	0.20	0.20	FALSE	FALSE	FALSE	Pass- Qpost Below Qlf (0.55 cfs))
182	0.20	0.20	0.20	FALSE	FALSE	FALSE	Pass- Qpost Below Qlf (0.55 cfs))
183	0.20	0.20	0.20	FALSE	FALSE	FALSE	Pass- Qpost Below Qlf (0.55 cfs))
184	0.20	0.20	0.20	FALSE	FALSE	FALSE	Pass- Qpost Below Qlf (0.55 cfs))
185	0.20	0.20	0.20	FALSE	FALSE	FALSE	Pass- Qpost Below Qlf (0.55 cfs))
186	0.20	0.20	0.20	FALSE	FALSE	FALSE	Pass- Qpost Below Qlf (0.55 cfs))
187	0.20	0.20	0.20	FALSE	FALSE	FALSE	Pass- Qpost Below Qlf (0.55 cfs))
188	0.20	0.20	0.20	FALSE	FALSE	FALSE	Pass- Qpost Below Qlf (0.55 cfs))
189	0.20	0.20	0.20	FALSE	FALSE	FALSE	Pass- Qpost Below Qlf (0.55 cfs))
190	0.20	0.20	0.20	FALSE	FALSE	FALSE	Pass- Qpost Below Qlf (0.55 cfs))
191	0.20	0.20	0.20	FALSE	FALSE	FALSE	Pass- Qpost Below Qlf (0.55 cfs))
192	0.20	0.20	0.20	FALSE	FALSE	FALSE	Pass- Qpost Below Qlf (0.55 cfs))
193	0.20	0.20	0.20	FALSE	FALSE	FALSE	Pass- Qpost Below Qlf (0.55 cfs))
194	0.20	0.20	0.20	FALSE	FALSE	FALSE	Pass- Qpost Below Qlf (0.55 cfs))
195	0.20	0.20	0.20	FALSE	FALSE	FALSE	Pass- Qpost Below Qlf (0.55 cfs))
196	0.20	0.20	0.20	FALSE	FALSE	FALSE	Pass- Qpost Below Qlf (0.55 cfs))
197	0.20	0.20	0.20	FALSE	FALSE	FALSE	Pass- Qpost Below Qlf (0.55 cfs))
198	0.20	0.20	0.20	FALSE	FALSE	FALSE	Pass- Qpost Below Qlf (0.55 cfs))
199	0.20	0.20	0.20	FALSE	FALSE	FALSE	Pass- Qpost Below Qlf (0.55 cfs))

Post PT #	Rtn Prd (yrs)	Post Dev Q (cfs)	Pre Dev Q (cfs)	Qpost < Qpre	Qpost > Qpre	Qpost > 110% Qpre	Pass/Fail
242	0.20	0.20	0.10	FALSE	FALSE	FALSE	Pass- Qpost Below Qlf (0.55 cfs))
243	0.20	0.20	0.10	FALSE	FALSE	FALSE	Pass- Qpost Below Qlf (0.55 cfs))
244	0.20	0.20	0.10	FALSE	FALSE	FALSE	Pass- Qpost Below Qlf (0.55 cfs))
245	0.20	0.20	0.10	FALSE	FALSE	FALSE	Pass- Qpost Below Qlf (0.55 cfs))
246	0.20	0.20	0.10	FALSE	FALSE	FALSE	Pass- Qpost Below Qlf (0.55 cfs))
247	0.20	0.20	0.10	FALSE	FALSE	FALSE	Pass- Qpost Below Qlf (0.55 cfs))
248	0.20	0.20	0.00	FALSE	FALSE	FALSE	Pass- Qpost Below Qlf (0.55 cfs))
249	0.20	0.20	0.00	FALSE	FALSE	FALSE	Pass- Qpost Below Qlf (0.55 cfs))
250	0.20	0.20	0.00	FALSE	FALSE	FALSE	Pass- Qpost Below Qlf (0.55 cfs))
251	0.20	0.20	0.00	FALSE	FALSE	FALSE	Pass- Qpost Below Qlf (0.55 cfs))
252	0.20	0.10	0.00	FALSE	FALSE	FALSE	Pass- Qpost Below Qlf (0.55 cfs))
253	0.20	0.10	0.00	FALSE	FALSE	FALSE	Pass- Qpost Below Qlf (0.55 cfs))
254	0.20	0.10	0.00	FALSE	FALSE	FALSE	Pass- Qpost Below Qlf (0.55 cfs))
255	0.20	0.10	0.00	FALSE	FALSE	FALSE	Pass- Qpost Below Qlf (0.55 cfs))
256	0.20	0.10	0.00	FALSE	FALSE	FALSE	Pass- Qpost Below Qlf (0.55 cfs))
257	0.20	0.10	0.00	FALSE	FALSE	FALSE	Pass- Qpost Below Qlf (0.55 cfs))
258	0.20	0.10	0.00	FALSE	FALSE	FALSE	Pass- Qpost Below Qlf (0.55 cfs))
259	0.20	0.10	0.00	FALSE	FALSE	FALSE	Pass- Qpost Below Qlf (0.55 cfs))
260	0.20	0.10	0.00	FALSE	FALSE	FALSE	Pass- Qpost Below Qlf (0.55 cfs))
261	0.20	0.10	0.00	FALSE	FALSE	FALSE	Pass- Qpost Below Qlf (0.55 cfs))
262	0.20	0.10	0.00	FALSE	FALSE	FALSE	Pass- Qpost Below Qlf (0.55 cfs))
263	0.20	0.10	0.00	FALSE	FALSE	FALSE	Pass- Qpost Below Qlf (0.55 cfs))
264	0.20	0.10	0.00	FALSE	FALSE	FALSE	Pass- Qpost Below Qlf (0.55 cfs))
265	0.20	0.10	0.00	FALSE	FALSE	FALSE	Pass- Qpost Below Qlf (0.55 cfs))
266	0.20	0.10	0.00	FALSE	FALSE	FALSE	Pass- Qpost Below Qlf (0.55 cfs))
267	0.20	0.10	0.00	FALSE	FALSE	FALSE	Pass- Qpost Below Qlf (0.55 cfs))
268	0.20	0.10	0.00	FALSE	FALSE	FALSE	Pass- Qpost Below Qlf (0.55 cfs))
269	0.20	0.10	0.00	FALSE	FALSE	FALSE	Pass- Qpost Below Qlf (0.55 cfs))
270	0.20	0.10	0.00	FALSE	FALSE	FALSE	Pass- Qpost Below Qlf (0.55 cfs))
271	0.20	0.10	0.00	FALSE	FALSE	FALSE	Pass- Qpost Below Qlf (0.55 cfs))
272	0.20	0.10	0.00	FALSE	FALSE	FALSE	Pass- Qpost Below Qlf (0.55 cfs))
273	0.20	0.10	0.00	FALSE	FALSE	FALSE	Pass- Qpost Below Qlf (0.55 cfs))
274	0.10	0.10	0.00	FALSE	FALSE	FALSE	Pass- Qpost Below Qlf (0.55 cfs))
275	0.10	0.10	0.00	FALSE	FALSE	FALSE	Pass- Qpost Below Qlf (0.55 cfs))
276	0.10	0.10	0.00	FALSE	FALSE	FALSE	Pass- Qpost Below Qlf (0.55 cfs))
277	0.10	0.10	0.00	FALSE	FALSE	FALSE	Pass- Qpost Below Qlf (0.55 cfs))
278	0.10	0.10	0.00	FALSE	FALSE	FALSE	Pass- Qpost Below Qlf (0.55 cfs))
279	0.10	0.10	0.00	FALSE	FALSE	FALSE	Pass- Qpost Below Qlf (0.55 cfs))
280	0.10	0.10	0.00	FALSE	FALSE	FALSE	Pass- Qpost Below Qlf (0.55 cfs))
281	0.10	0.10	0.00	FALSE	FALSE	FALSE	Pass- Qpost Below Qlf (0.55 cfs))
282	0.10	0.10	0.00	FALSE	FALSE	FALSE	Pass- Qpost Below Qlf (0.55 cfs))
283	0.10	0.10	0.00	FALSE	FALSE	FALSE	Pass- Qpost Below Qlf (0.55 cfs))

Post PT #	Rtn Prd (yrs)	Post Dev Q (cfs)	Pre Dev Q (cfs)	Qpost < Qpre	Qpost > Qpre	Qpost > 110% Qpre	Pass/Fail
284	0.10	0.10	0.00	FALSE	FALSE	FALSE	Pass- Qpost Below Qlf (0.55 cfs))
285	0.10	0.10	0.00	FALSE	FALSE	FALSE	Pass- Qpost Below Qlf (0.55 cfs))
286	0.10	0.10	0.00	FALSE	FALSE	FALSE	Pass- Qpost Below Qlf (0.55 cfs))
287	0.10	0.10	0.00	FALSE	FALSE	FALSE	Pass- Qpost Below Qlf (0.55 cfs))
288	0.10	0.10	0.00	FALSE	FALSE	FALSE	Pass- Qpost Below Qlf (0.55 cfs))
289	0.10	0.10	0.00	FALSE	FALSE	FALSE	Pass- Qpost Below Qlf (0.55 cfs))
290	0.10	0.10	0.00	FALSE	FALSE	FALSE	Pass- Qpost Below Qlf (0.55 cfs))
291	0.10	0.10	0.00	FALSE	FALSE	FALSE	Pass- Qpost Below Qlf (0.55 cfs))
292	0.10	0.10	0.00	FALSE	FALSE	FALSE	Pass- Qpost Below Qlf (0.55 cfs))
293	0.10	0.10	0.00	FALSE	FALSE	FALSE	Pass- Qpost Below Qlf (0.55 cfs))
294	0.10	0.10	0.00	FALSE	FALSE	FALSE	Pass- Qpost Below Qlf (0.55 cfs))
295	0.10	0.10	0.00	FALSE	FALSE	FALSE	Pass- Qpost Below Qlf (0.55 cfs))
296	0.10	0.10	0.00	FALSE	FALSE	FALSE	Pass- Qpost Below Qlf (0.55 cfs))
297	0.10	0.10	0.00	FALSE	FALSE	FALSE	Pass- Qpost Below Qlf (0.55 cfs))
298	0.10	0.10	0.00	FALSE	FALSE	FALSE	Pass- Qpost Below Qlf (0.55 cfs))
299	0.10	0.10	0.00	FALSE	FALSE	FALSE	Pass- Qpost Below Qlf (0.55 cfs))
300	0.10	0.10	0.00	FALSE	FALSE	FALSE	Pass- Qpost Below Qlf (0.55 cfs))
301	0.10	0.10	0.00	FALSE	FALSE	FALSE	Pass- Qpost Below Qlf (0.55 cfs))
302	0.10	0.10	0.00	FALSE	FALSE	FALSE	Pass- Qpost Below Qlf (0.55 cfs))
303	0.10	0.10	0.00	FALSE	FALSE	FALSE	Pass- Qpost Below Qlf (0.55 cfs))
304	0.10	0.10	0.00	FALSE	FALSE	FALSE	Pass- Qpost Below Qlf (0.55 cfs))
305	0.10	0.10	0.00	FALSE	FALSE	FALSE	Pass- Qpost Below Qlf (0.55 cfs))
306	0.10	0.10	0.00	FALSE	FALSE	FALSE	Pass- Qpost Below Qlf (0.55 cfs))
307	0.10	0.10	0.00	FALSE	FALSE	FALSE	Pass- Qpost Below Qlf (0.55 cfs))
308	0.10	0.10	0.00	FALSE	FALSE	FALSE	Pass- Qpost Below Qlf (0.55 cfs))
309	0.10	0.10	0.00	FALSE	FALSE	FALSE	Pass- Qpost Below Qlf (0.55 cfs))
310	0.10	0.10	0.00	FALSE	FALSE	FALSE	Pass- Qpost Below Qlf (0.55 cfs))
311	0.10	0.10	0.00	FALSE	FALSE	FALSE	Pass- Qpost Below Qlf (0.55 cfs))
312	0.10	0.10	0.00	FALSE	FALSE	FALSE	Pass- Qpost Below Qlf (0.55 cfs))
313	0.10	0.10	0.00	FALSE	FALSE	FALSE	Pass- Qpost Below Qlf (0.55 cfs))
314	0.10	0.10	0.00	FALSE	FALSE	FALSE	Pass- Qpost Below Qlf (0.55 cfs))
315	0.10	0.10	0.00	FALSE	FALSE	FALSE	Pass- Qpost Below Qlf (0.55 cfs))
316	0.10	0.10	0.00	FALSE	FALSE	FALSE	Pass- Qpost Below Qlf (0.55 cfs))
317	0.10	0.10	0.00	FALSE	FALSE	FALSE	Pass- Qpost Below Qlf (0.55 cfs))
318	0.10	0.10	0.00	FALSE	FALSE	FALSE	Pass- Qpost Below Qlf (0.55 cfs))
319	0.10	0.10	0.00	FALSE	FALSE	FALSE	Pass- Qpost Below Qlf (0.55 cfs))
320	0.10	0.10	0.00	FALSE	FALSE	FALSE	Pass- Qpost Below Qlf (0.55 cfs))
321	0.10	0.10	0.00	FALSE	FALSE	FALSE	Pass- Qpost Below Qlf (0.55 cfs))
322	0.10	0.10	0.00	FALSE	FALSE	FALSE	Pass- Qpost Below Qlf (0.55 cfs))
323	0.10	0.10	0.00	FALSE	FALSE	FALSE	Pass- Qpost Below Qlf (0.55 cfs))
324	0.10	0.10	0.00	FALSE	FALSE	FALSE	Pass- Qpost Below Qlf (0.55 cfs))
325	0.10	0.10	0.00	FALSE	FALSE	FALSE	Pass- Qpost Below Qlf (0.55 cfs))

Post PT #	Rtn Prd (yrs)	Post Dev Q (cfs)	Pre Dev Q (cfs)	Qpost < Qpre	Qpost > Qpre	Qpost > 110% Qpre	Pass/Fail
326	0.10	0.10	0.00	FALSE	FALSE	FALSE	Pass- Qpost Below Qlf (0.55 cfs))
327	0.10	0.10	0.00	FALSE	FALSE	FALSE	Pass- Qpost Below Qlf (0.55 cfs))
328	0.10	0.10	0.00	FALSE	FALSE	FALSE	Pass- Qpost Below Qlf (0.55 cfs))
329	0.10	0.10	0.00	FALSE	FALSE	FALSE	Pass- Qpost Below Qlf (0.55 cfs))
330	0.10	0.10	0.00	FALSE	FALSE	FALSE	Pass- Qpost Below Qlf (0.55 cfs))
331	0.10	0.00	0.00	FALSE	FALSE	FALSE	Pass- Qpost Below Qlf (0.55 cfs))
332	0.10	0.00	0.00	FALSE	FALSE	FALSE	Pass- Qpost Below Qlf (0.55 cfs))
333	0.10	0.00	0.00	FALSE	FALSE	FALSE	Pass- Qpost Below Qlf (0.55 cfs))
334	0.10	0.00	0.00	FALSE	FALSE	FALSE	Pass- Qpost Below Qlf (0.55 cfs))
335	0.10	0.00	0.00	FALSE	FALSE	FALSE	Pass- Qpost Below Qlf (0.55 cfs))
336	0.10	0.00	0.00	FALSE	FALSE	FALSE	Pass- Qpost Below Qlf (0.55 cfs))
337	0.10	0.00	0.00	FALSE	FALSE	FALSE	Pass- Qpost Below Qlf (0.55 cfs))
338	0.10	0.00	0.00	FALSE	FALSE	FALSE	Pass- Qpost Below Qlf (0.55 cfs))
339	0.10	0.00	0.00	FALSE	FALSE	FALSE	Pass- Qpost Below Qlf (0.55 cfs))
340	0.10	0.00	0.00	FALSE	FALSE	FALSE	Pass- Qpost Below Qlf (0.55 cfs))
341	0.10	0.00	0.00	FALSE	FALSE	FALSE	Pass- Qpost Below Qlf (0.55 cfs))
342	0.10	0.00	0.00	FALSE	FALSE	FALSE	Pass- Qpost Below Qlf (0.55 cfs))
343	0.10	0.00	0.00	FALSE	FALSE	FALSE	Pass- Qpost Below Qlf (0.55 cfs))
344	0.10	0.00	0.00	FALSE	FALSE	FALSE	Pass- Qpost Below Qlf (0.55 cfs))
345	0.10	0.00	0.00	FALSE	FALSE	FALSE	Pass- Qpost Below Qlf (0.55 cfs))
346	0.10	0.00	0.00	FALSE	FALSE	FALSE	Pass- Qpost Below Qlf (0.55 cfs))
347	0.10	0.00	0.00	FALSE	FALSE	FALSE	Pass- Qpost Below Qlf (0.55 cfs))
348	0.10	0.00	0.00	FALSE	FALSE	FALSE	Pass- Qpost Below Qlf (0.55 cfs))
349	0.10	0.00	0.00	FALSE	FALSE	FALSE	Pass- Qpost Below Qlf (0.55 cfs))
350	0.10	0.00	0.00	FALSE	FALSE	FALSE	Pass- Qpost Below Qlf (0.55 cfs))
351	0.10	0.00	0.00	FALSE	FALSE	FALSE	Pass- Qpost Below Qlf (0.55 cfs))
352	0.10	0.00	0.00	FALSE	FALSE	FALSE	Pass- Qpost Below Qlf (0.55 cfs))
353	0.10	0.00	0.00	FALSE	FALSE	FALSE	Pass- Qpost Below Qlf (0.55 cfs))
354	0.10	0.00	0.00	FALSE	FALSE	FALSE	Pass- Qpost Below Qlf (0.55 cfs))
355	0.10	0.00	0.00	FALSE	FALSE	FALSE	Pass- Qpost Below Qlf (0.55 cfs))
356	0.10	0.00	0.00	FALSE	FALSE	FALSE	Pass- Qpost Below Qlf (0.55 cfs))
357	0.10	0.00	0.00	FALSE	FALSE	FALSE	Pass- Qpost Below Qlf (0.55 cfs))
358	0.10	0.00	0.00	FALSE	FALSE	FALSE	Pass- Qpost Below Qlf (0.55 cfs))
359	0.10	0.00	0.00	FALSE	FALSE	FALSE	Pass- Qpost Below Qlf (0.55 cfs))
360	0.10	0.00	0.00	FALSE	FALSE	FALSE	Pass- Qpost Below Qlf (0.55 cfs))
361	0.10	0.00	0.00	FALSE	FALSE	FALSE	Pass- Qpost Below Qlf (0.55 cfs))
362	0.10	0.00	0.00	FALSE	FALSE	FALSE	Pass- Qpost Below Qlf (0.55 cfs))
363	0.10	0.00	0.00	FALSE	FALSE	FALSE	Pass- Qpost Below Qlf (0.55 cfs))
364	0.10	0.00	0.00	FALSE	FALSE	FALSE	Pass- Qpost Below Qlf (0.55 cfs))
365	0.10	0.00	0.00	FALSE	FALSE	FALSE	Pass- Qpost Below Qlf (0.55 cfs))
366	0.10	0.00	0.00	FALSE	FALSE	FALSE	Pass- Qpost Below Qlf (0.55 cfs))
367	0.10	0.00	0.00	FALSE	FALSE	FALSE	Pass- Qpost Below Qlf (0.55 cfs))

Post PT #	Rtn Prd (yrs)	Post Dev Q (cfs)	Pre Dev Q (cfs)	Qpost < Qpre	Qpost > Qpre	Qpost > 110% Qpre	Pass/Fail
368	0.10	0.00	0.00	FALSE	FALSE	FALSE	Pass- Qpost Below Qlf (0.55 (cfs))
369	0.10	0.00	0.00	FALSE	FALSE	FALSE	Pass- Qpost Below Qlf (0.55 (cfs))
370	0.10	0.00	0.00	FALSE	FALSE	FALSE	Pass- Qpost Below Qlf (0.55 (cfs))
371	0.10	0.00	0.00	FALSE	FALSE	FALSE	Pass- Qpost Below Qlf (0.55 (cfs))
372	0.10	0.00	0.00	FALSE	FALSE	FALSE	Pass- Qpost Below Qlf (0.55 (cfs))
373	0.10	0.00	0.00	FALSE	FALSE	FALSE	Pass- Qpost Below Qlf (0.55 (cfs))

SWMM.out file name: V:\21\21088\Engineering\PrelimGP\Storm\Working Files\Hydmod\600' length-4x3.83 weir - Copy\21088-Pre-HMP2.out						
SWMM.out time stamp: 6/2/2022 1:14:45 PM						
Q10: 1.700 (cfs)						
Q5: 1.600 (cfs)						
Q2: 1.100 (cfs)						
Peak Flow Statistics Table Values						
Rank	Start Date	End Date	Duration (hr)	Peak (cfs)	Frequency (%)	Return Period (Yr)
1	1993/01/06 16:00:00	1993/01/10 20:00:00	101	2.3	0.30%	45
2	1986/02/15 01:00:00	1986/02/15 12:00:00	12	2	0.70%	22.5
3	1971/02/23 05:00:00	1971/02/23 14:00:00	10	1.9	1.00%	15
4	1995/01/04 15:00:00	1995/01/05 03:00:00	13	1.8	1.40%	11.25
5	1978/03/16 22:00:00	1978/03/18 16:00:00	43	1.7	1.70%	9
6	1983/03/01 14:00:00	1983/03/03 10:00:00	45	1.7	2.00%	7.5
7	1995/01/25 08:00:00	1995/01/26 00:00:00	17	1.7	2.40%	6.43
8	1998/02/14 14:00:00	1998/02/15 02:00:00	13	1.7	2.70%	5.63
9	1966/12/05 01:00:00	1966/12/07 01:00:00	49	1.6	3.00%	5
10	1978/01/14 16:00:00	1978/01/16 15:00:00	48	1.6	3.40%	4.5
11	1983/12/25 06:00:00	1983/12/25 21:00:00	16	1.5	3.70%	4.09
12	1967/11/19 07:00:00	1967/11/20 04:00:00	22	1.4	4.10%	3.75
13	1969/01/24 07:00:00	1969/01/26 22:00:00	64	1.4	4.40%	3.46
14	1981/02/09 05:00:00	1981/02/09 09:00:00	5	1.4	4.70%	3.21
15	1988/04/20 08:00:00	1988/04/22 00:00:00	41	1.4	5.10%	3
16	1972/11/14 14:00:00	1972/11/14 17:00:00	4	1.3	5.40%	2.81
17	1980/01/28 08:00:00	1980/01/30 21:00:00	62	1.3	5.70%	2.65
18	1983/11/25 01:00:00	1983/11/25 04:00:00	4	1.3	6.10%	2.5
19	1965/11/22 04:00:00	1965/11/23 08:00:00	29	1.2	6.40%	2.37
20	1967/04/11 10:00:00	1967/04/12 06:00:00	21	1.2	6.80%	2.25
21	1998/01/09 16:00:00	1998/01/10 21:00:00	30	1.2	7.10%	2.14
22	2007/01/31 00:00:00	2007/01/31 02:00:00	3	1.2	7.40%	2.05
23	1967/12/18 15:00:00	1967/12/19 17:00:00	27	1.1	7.80%	1.96
24	1980/02/16 18:00:00	1980/02/21 02:00:00	105	1.1	8.10%	1.88
25	1993/01/12 23:00:00	1993/01/14 08:00:00	34	1.1	8.40%	1.8
26	1993/02/08 01:00:00	1993/02/08 12:00:00	12	1.1	8.80%	1.73
27	2004/10/18 09:00:00	2004/10/18 12:00:00	4	1.1	9.10%	1.67
28	2005/01/09 04:00:00	2005/01/10 01:00:00	22	1.1	9.50%	1.61
29	2005/01/11 02:00:00	2005/01/11 11:00:00	10	1.1	9.80%	1.55
30	2007/08/26 07:00:00	2007/08/26 10:00:00	4	1.1	10.10%	1.5
31	1979/01/05 08:00:00	1979/01/06 08:00:00	25	1	10.50%	1.45
32	1985/11/25 00:00:00	1985/11/25 09:00:00	10	1	10.80%	1.41
33	1991/03/20 07:00:00	1991/03/21 08:00:00	26	1	11.10%	1.36
34	1992/02/15 14:00:00	1992/02/15 20:00:00	7	1	11.50%	1.32
35	1998/02/03 16:00:00	1998/02/03 23:00:00	8	1	11.80%	1.29
36	2004/10/27 04:00:00	2004/10/27 11:00:00	8	1	12.20%	1.25
37	1970/03/04 23:00:00	1970/03/05 03:00:00	5	0.9	12.50%	1.22
38	1978/02/05 01:00:00	1978/02/07 00:00:00	48	0.9	12.80%	1.18
39	1980/03/02 21:00:00	1980/03/03 05:00:00	9	0.9	13.20%	1.15

Rank	Start Date	End Date	Duration (hr)	Peak (cfs)	Frequency (%)	Return Period (Yr)
40	1982/03/18 04:00:00	1982/03/19 18:00:00	39	0.9	13.50%	1.13
41	2004/02/26 05:00:00	2004/02/26 12:00:00	8	0.9	13.90%	1.1
42	2007/11/30 10:00:00	2007/12/01 02:00:00	17	0.9	14.20%	1.07
43	1969/02/06 08:00:00	1969/02/06 12:00:00	5	0.8	14.50%	1.05
44	1974/12/04 09:00:00	1974/12/04 11:00:00	3	0.8	14.90%	1.02
45	1978/12/17 19:00:00	1978/12/18 15:00:00	21	0.8	15.20%	1
46	1980/01/10 23:00:00	1980/01/12 09:00:00	35	0.8	15.50%	0.98
47	1983/02/27 17:00:00	1983/02/27 23:00:00	7	0.8	15.90%	0.96
48	1991/02/27 16:00:00	1991/03/01 15:00:00	48	0.8	16.20%	0.94
49	1995/03/05 08:00:00	1995/03/06 04:00:00	21	0.8	16.60%	0.92
50	2003/02/11 17:00:00	2003/02/13 21:00:00	53	0.8	16.90%	0.9
51	2004/10/19 16:00:00	2004/10/20 18:00:00	27	0.8	17.20%	0.88
52	1965/04/08 14:00:00	1965/04/10 02:00:00	37	0.7	17.60%	0.87
53	1967/01/24 18:00:00	1967/01/25 03:00:00	10	0.7	17.90%	0.85
54	1974/03/08 02:00:00	1974/03/08 16:00:00	15	0.7	18.20%	0.83
55	1977/05/08 18:00:00	1977/05/09 00:00:00	7	0.7	18.60%	0.82
56	1981/03/19 21:00:00	1981/03/19 23:00:00	3	0.7	18.90%	0.8
57	1982/01/01 09:00:00	1982/01/01 13:00:00	5	0.7	19.30%	0.79
58	1983/03/23 18:00:00	1983/03/24 00:00:00	7	0.7	19.60%	0.78
59	1985/11/29 08:00:00	1985/11/29 19:00:00	12	0.7	19.90%	0.76
60	1991/03/19 01:00:00	1991/03/19 06:00:00	6	0.7	20.30%	0.75
61	1998/02/08 16:00:00	1998/02/09 01:00:00	10	0.7	20.60%	0.74
62	2003/02/25 17:00:00	2003/02/25 21:00:00	5	0.7	20.90%	0.73
63	2006/04/04 23:00:00	2006/04/05 10:00:00	12	0.7	21.30%	0.71
64	1966/12/03 13:00:00	1966/12/03 21:00:00	9	0.6	21.60%	0.7
65	1967/01/22 19:00:00	1967/01/23 03:00:00	9	0.6	22.00%	0.69
66	1967/11/21 13:00:00	1967/11/21 16:00:00	4	0.6	22.30%	0.68
67	1970/02/28 16:00:00	1970/03/02 09:00:00	42	0.6	22.60%	0.67
68	1970/11/29 14:00:00	1970/11/30 04:00:00	15	0.6	23.00%	0.66
69	1970/12/21 03:00:00	1970/12/21 12:00:00	10	0.6	23.30%	0.65
70	1976/02/08 15:00:00	1976/02/09 04:00:00	14	0.6	23.60%	0.64
71	1976/04/14 11:00:00	1976/04/14 13:00:00	3	0.6	24.00%	0.63
72	1979/01/17 12:00:00	1979/01/18 18:00:00	31	0.6	24.30%	0.63
73	1981/03/01 05:00:00	1981/03/01 19:00:00	15	0.6	24.70%	0.62
74	1991/03/25 08:00:00	1991/03/27 15:00:00	56	0.6	25.00%	0.61
75	1992/02/06 17:00:00	1992/02/07 01:00:00	9	0.6	25.30%	0.6
76	1993/11/14 17:00:00	1993/11/14 19:00:00	3	0.6	25.70%	0.59
77	1994/02/17 12:00:00	1994/02/17 15:00:00	4	0.6	26.00%	0.58
78	1996/01/31 18:00:00	1996/02/01 09:00:00	16	0.6	26.40%	0.58
79	2005/01/03 08:00:00	2005/01/04 13:00:00	30	0.6	26.70%	0.57
80	1965/11/16 18:00:00	1965/11/17 01:00:00	8	0.5	27.00%	0.56
81	1965/12/13 01:00:00	1965/12/13 04:00:00	4	0.5	27.40%	0.56
82	1969/01/14 07:00:00	1969/01/14 14:00:00	8	0.5	27.70%	0.55
83	1969/02/23 23:00:00	1969/02/26 01:00:00	51	0.5	28.00%	0.54
84	1970/03/08 12:00:00	1970/03/08 21:00:00	10	0.5	28.40%	0.54
85	1973/01/16 20:00:00	1973/01/17 00:00:00	5	0.5	28.70%	0.53
86	1973/02/11 05:00:00	1973/02/13 03:00:00	47	0.5	29.10%	0.52

Rank	Start Date	End Date	Duration (hr)	Peak (cfs)	Frequency (%)	Return Period (Yr)
87	1973/03/08 13:00:00	1973/03/08 22:00:00	10	0.5	29.40%	0.52
88	1974/01/04 19:00:00	1974/01/05 04:00:00	10	0.5	29.70%	0.51
89	1976/03/03 00:00:00	1976/03/03 05:00:00	6	0.5	30.10%	0.51
90	1978/03/11 21:00:00	1978/03/15 10:00:00	86	0.5	30.40%	0.5
91	1979/03/01 13:00:00	1979/03/01 22:00:00	10	0.5	30.70%	0.5
92	1980/02/14 01:00:00	1980/02/14 12:00:00	12	0.5	31.10%	0.49
93	1980/03/06 02:00:00	1980/03/06 15:00:00	14	0.5	31.40%	0.48
94	1982/12/22 23:00:00	1982/12/23 02:00:00	4	0.5	31.80%	0.48
95	1983/01/27 08:00:00	1983/01/27 15:00:00	8	0.5	32.10%	0.47
96	1986/11/17 22:00:00	1986/11/18 04:00:00	7	0.5	32.40%	0.47
97	1988/12/24 23:00:00	1988/12/25 04:00:00	6	0.5	32.80%	0.46
98	1991/12/29 16:00:00	1991/12/29 19:00:00	4	0.5	33.10%	0.46
99	1992/01/05 15:00:00	1992/01/06 06:00:00	16	0.5	33.40%	0.46
100	1992/02/12 18:00:00	1992/02/13 08:00:00	15	0.5	33.80%	0.45
101	1993/01/15 13:00:00	1993/01/18 20:00:00	80	0.5	34.10%	0.45
102	1994/02/07 15:00:00	1994/02/08 08:00:00	18	0.5	34.50%	0.44
103	1994/03/25 01:00:00	1994/03/25 17:00:00	17	0.5	34.80%	0.44
104	1996/11/21 20:00:00	1996/11/22 05:00:00	10	0.5	35.10%	0.43
105	1998/02/17 17:00:00	1998/02/18 00:00:00	8	0.5	35.50%	0.43
106	1998/02/22 17:00:00	1998/02/24 22:00:00	54	0.5	35.80%	0.43
107	2001/01/11 04:00:00	2001/01/12 10:00:00	31	0.5	36.10%	0.42
108	2005/02/21 03:00:00	2005/02/21 18:00:00	16	0.5	36.50%	0.42
109	2008/02/03 09:00:00	2008/02/03 19:00:00	11	0.5	36.80%	0.41
110	1965/12/09 06:00:00	1965/12/10 12:00:00	31	0.4	37.20%	0.41
111	1965/12/14 15:00:00	1965/12/14 19:00:00	5	0.4	37.50%	0.41
112	1966/11/07 16:00:00	1966/11/07 19:00:00	4	0.4	37.80%	0.4
113	1967/03/13 16:00:00	1967/03/14 00:00:00	9	0.4	38.20%	0.4
114	1969/01/20 09:00:00	1969/01/21 18:00:00	34	0.4	38.50%	0.4
115	1969/02/22 03:00:00	1969/02/22 09:00:00	7	0.4	38.90%	0.39
116	1970/12/19 02:00:00	1970/12/19 07:00:00	6	0.4	39.20%	0.39
117	1971/05/07 20:00:00	1971/05/07 23:00:00	4	0.4	39.50%	0.39
118	1971/12/24 22:00:00	1971/12/26 01:00:00	28	0.4	39.90%	0.38
119	1972/11/16 13:00:00	1972/11/16 19:00:00	7	0.4	40.20%	0.38
120	1974/01/06 13:00:00	1974/01/08 06:00:00	42	0.4	40.50%	0.38
121	1975/03/08 09:00:00	1975/03/08 15:00:00	7	0.4	40.90%	0.37
122	1975/03/10 11:00:00	1975/03/11 16:00:00	30	0.4	41.20%	0.37
123	1975/04/08 03:00:00	1975/04/09 03:00:00	25	0.4	41.60%	0.37
124	1976/02/05 06:00:00	1976/02/07 10:00:00	53	0.4	41.90%	0.36
125	1976/12/31 09:00:00	1976/12/31 13:00:00	5	0.4	42.20%	0.36
126	1978/11/13 23:00:00	1978/11/14 01:00:00	3	0.4	42.60%	0.36
127	1979/03/17 06:00:00	1979/03/17 10:00:00	5	0.4	42.90%	0.35
128	1980/03/10 19:00:00	1980/03/10 22:00:00	4	0.4	43.20%	0.35
129	1981/02/25 21:00:00	1981/02/26 02:00:00	6	0.4	43.60%	0.35
130	1982/02/10 10:00:00	1982/02/10 23:00:00	14	0.4	43.90%	0.35
131	1982/03/15 13:00:00	1982/03/16 01:00:00	13	0.4	44.30%	0.34
132	1983/02/08 04:00:00	1983/02/08 08:00:00	5	0.4	44.60%	0.34
133	1986/02/08 05:00:00	1986/02/08 09:00:00	5	0.4	44.90%	0.34

Rank	Start Date	End Date	Duration (hr)	Peak (cfs)	Frequency (%)	Return Period (Yr)
134	1987/01/07 00:00:00	1987/01/07 10:00:00	11	0.4	45.30%	0.34
135	1988/01/17 12:00:00	1988/01/17 22:00:00	11	0.4	45.60%	0.33
136	1992/12/07 11:00:00	1992/12/07 19:00:00	9	0.4	45.90%	0.33
137	1995/03/11 03:00:00	1995/03/12 03:00:00	25	0.4	46.30%	0.33
138	1998/02/06 17:00:00	1998/02/06 23:00:00	7	0.4	46.60%	0.33
139	1998/03/28 17:00:00	1998/03/29 19:00:00	27	0.4	47.00%	0.32
140	2002/12/20 17:00:00	2002/12/21 00:00:00	8	0.4	47.30%	0.32
141	2003/03/15 17:00:00	2003/03/16 20:00:00	28	0.4	47.60%	0.32
142	2003/04/14 17:00:00	2003/04/14 19:00:00	3	0.4	48.00%	0.32
143	2004/02/22 14:00:00	2004/02/23 09:00:00	20	0.4	48.30%	0.32
144	2005/02/22 19:00:00	2005/02/23 14:00:00	20	0.4	48.60%	0.31
145	1964/11/17 18:00:00	1964/11/18 01:00:00	8	0.3	49.00%	0.31
146	1965/12/16 06:00:00	1965/12/16 11:00:00	6	0.3	49.30%	0.31
147	1965/12/29 20:00:00	1965/12/29 23:00:00	4	0.3	49.70%	0.31
148	1968/03/08 10:00:00	1968/03/08 14:00:00	5	0.3	50.00%	0.3
149	1972/12/04 15:00:00	1972/12/04 20:00:00	6	0.3	50.30%	0.3
150	1973/01/18 21:00:00	1973/01/19 04:00:00	8	0.3	50.70%	0.3
151	1973/11/22 23:00:00	1973/11/23 03:00:00	5	0.3	51.00%	0.3
152	1976/09/10 06:00:00	1976/09/10 22:00:00	17	0.3	51.40%	0.3
153	1977/08/17 01:00:00	1977/08/17 11:00:00	11	0.3	51.70%	0.29
154	1979/03/27 22:00:00	1979/03/28 05:00:00	8	0.3	52.00%	0.29
155	1982/11/30 12:00:00	1982/11/30 21:00:00	10	0.3	52.40%	0.29
156	1983/03/18 04:00:00	1983/03/19 00:00:00	21	0.3	52.70%	0.29
157	1983/04/30 04:00:00	1983/05/01 09:00:00	30	0.3	53.00%	0.29
158	1983/11/20 12:00:00	1983/11/21 11:00:00	24	0.3	53.40%	0.29
159	1986/03/15 22:00:00	1986/03/16 21:00:00	24	0.3	53.70%	0.28
160	1986/09/25 03:00:00	1986/09/25 08:00:00	6	0.3	54.10%	0.28
161	1987/12/16 19:00:00	1987/12/17 00:00:00	6	0.3	54.40%	0.28
162	1990/01/14 04:00:00	1990/01/14 07:00:00	4	0.3	54.70%	0.28
163	1990/01/17 03:00:00	1990/01/17 05:00:00	3	0.3	55.10%	0.28
164	1992/01/07 20:00:00	1992/01/08 00:00:00	5	0.3	55.40%	0.27
165	1993/02/19 18:00:00	1993/02/20 01:00:00	8	0.3	55.70%	0.27
166	1994/04/28 00:00:00	1994/04/28 03:00:00	4	0.3	56.10%	0.27
167	1995/01/12 09:00:00	1995/01/12 16:00:00	8	0.3	56.40%	0.27
168	1995/02/14 09:00:00	1995/02/14 12:00:00	4	0.3	56.80%	0.27
169	1995/04/18 10:00:00	1995/04/18 18:00:00	9	0.3	57.10%	0.27
170	1997/01/12 16:00:00	1997/01/13 13:00:00	22	0.3	57.40%	0.27
171	1998/05/12 17:00:00	1998/05/12 22:00:00	6	0.3	57.80%	0.26
172	2002/12/16 17:00:00	2002/12/16 23:00:00	7	0.3	58.10%	0.26
173	2004/02/03 00:00:00	2004/02/03 02:00:00	3	0.3	58.40%	0.26
174	2004/03/02 03:00:00	2004/03/02 06:00:00	4	0.3	58.80%	0.26
175	2006/01/02 14:00:00	2006/01/02 16:00:00	3	0.3	59.10%	0.26
176	2008/02/22 04:00:00	2008/02/22 14:00:00	11	0.3	59.50%	0.26
177	1971/12/27 16:00:00	1971/12/28 17:00:00	26	0.2	59.80%	0.25
178	1973/03/11 13:00:00	1973/03/11 18:00:00	6	0.2	60.10%	0.25
179	1976/03/01 17:00:00	1976/03/01 20:00:00	4	0.2	60.50%	0.25
180	1976/11/12 02:00:00	1976/11/12 10:00:00	9	0.2	60.80%	0.25

Rank	Start Date	End Date	Duration (hr)	Peak (cfs)	Frequency (%)	Return Period (Yr)
181	1978/04/07 01:00:00	1978/04/07 03:00:00	3	0.2	61.10%	0.25
182	1979/02/21 05:00:00	1979/02/21 23:00:00	19	0.2	61.50%	0.25
183	1979/03/19 01:00:00	1979/03/20 04:00:00	28	0.2	61.80%	0.25
184	1980/01/09 05:00:00	1980/01/09 20:00:00	16	0.2	62.20%	0.25
185	1980/01/19 00:00:00	1980/01/19 02:00:00	3	0.2	62.50%	0.24
186	1982/11/10 04:00:00	1982/11/11 02:00:00	23	0.2	62.80%	0.24
187	1983/01/29 02:00:00	1983/01/29 06:00:00	5	0.2	63.20%	0.24
188	1985/12/02 23:00:00	1985/12/03 04:00:00	6	0.2	63.50%	0.24
189	1986/03/10 16:00:00	1986/03/10 22:00:00	7	0.2	63.90%	0.24
190	1986/03/12 14:00:00	1986/03/12 16:00:00	3	0.2	64.20%	0.24
191	1987/01/04 17:00:00	1987/01/05 02:00:00	10	0.2	64.50%	0.24
192	1987/11/04 17:00:00	1987/11/05 01:00:00	9	0.2	64.90%	0.23
193	1988/11/25 11:00:00	1988/11/25 15:00:00	5	0.2	65.20%	0.23
194	1988/12/21 07:00:00	1988/12/21 09:00:00	3	0.2	65.50%	0.23
195	1992/12/29 14:00:00	1992/12/29 22:00:00	9	0.2	65.90%	0.23
196	1993/03/28 03:00:00	1993/03/28 05:00:00	3	0.2	66.20%	0.23
197	1994/02/20 16:00:00	1994/02/20 18:00:00	3	0.2	66.60%	0.23
198	1995/01/07 19:00:00	1995/01/08 05:00:00	11	0.2	66.90%	0.23
199	1995/03/23 12:00:00	1995/03/23 15:00:00	4	0.2	67.20%	0.23
200	1996/12/09 18:00:00	1996/12/09 22:00:00	5	0.2	67.60%	0.23
201	1996/12/11 14:00:00	1996/12/11 18:00:00	5	0.2	67.90%	0.22
202	1997/01/25 23:00:00	1997/01/26 10:00:00	12	0.2	68.20%	0.22
203	1998/04/11 17:00:00	1998/04/11 21:00:00	5	0.2	68.60%	0.22
204	2000/02/21 17:00:00	2000/02/21 22:00:00	6	0.2	68.90%	0.22
205	2001/11/24 17:00:00	2001/11/24 19:00:00	3	0.2	69.30%	0.22
206	2002/11/08 17:00:00	2002/11/09 18:00:00	26	0.2	69.60%	0.22
207	2002/11/29 17:00:00	2002/11/29 22:00:00	6	0.2	69.90%	0.22
208	2004/12/29 02:00:00	2004/12/29 07:00:00	6	0.2	70.30%	0.22
209	2005/01/07 15:00:00	2005/01/07 18:00:00	4	0.2	70.60%	0.22
210	2006/02/28 00:00:00	2006/02/28 10:00:00	11	0.2	70.90%	0.21
211	2006/03/10 17:00:00	2006/03/11 05:00:00	13	0.2	71.30%	0.21
212	2006/03/28 22:00:00	2006/03/29 02:00:00	5	0.2	71.60%	0.21
213	2008/01/05 05:00:00	2008/01/07 06:00:00	50	0.2	72.00%	0.21
214	1965/04/01 22:00:00	1965/04/02 03:00:00	6	0.1	72.30%	0.21
215	1965/04/03 08:00:00	1965/04/03 21:00:00	14	0.1	72.60%	0.21
216	1967/04/22 03:00:00	1967/04/22 07:00:00	5	0.1	73.00%	0.21
217	1968/04/01 20:00:00	1968/04/01 21:00:00	2	0.1	73.30%	0.21
218	1969/02/18 18:00:00	1969/02/18 21:00:00	4	0.1	73.60%	0.21
219	1969/03/13 14:00:00	1969/03/13 20:00:00	7	0.1	74.00%	0.21
220	1970/03/11 12:00:00	1970/03/11 17:00:00	6	0.1	74.30%	0.21
221	1972/11/11 08:00:00	1972/11/11 10:00:00	3	0.1	74.70%	0.2
222	1972/12/08 13:00:00	1972/12/08 16:00:00	4	0.1	75.00%	0.2
223	1973/03/06 23:00:00	1973/03/07 03:00:00	5	0.1	75.30%	0.2
224	1973/03/20 09:00:00	1973/03/20 12:00:00	4	0.1	75.70%	0.2
225	1973/03/22 00:00:00	1973/03/22 04:00:00	5	0.1	76.00%	0.2
226	1975/04/05 21:00:00	1975/04/06 14:00:00	18	0.1	76.40%	0.2
227	1976/04/13 00:00:00	1976/04/13 05:00:00	6	0.1	76.70%	0.2

Rank	Start Date	End Date	Duration (hr)	Peak (cfs)	Frequency (%)	Return Period (Yr)
228	1977/01/04 00:00:00	1977/01/04 01:00:00	2	0.1	77.00%	0.2
229	1977/12/26 04:00:00	1977/12/26 19:00:00	16	0.1	77.40%	0.2
230	1978/01/30 12:00:00	1978/01/30 14:00:00	3	0.1	77.70%	0.2
231	1978/03/31 03:00:00	1978/03/31 04:00:00	2	0.1	78.00%	0.2
232	1979/01/31 10:00:00	1979/02/01 12:00:00	27	0.1	78.40%	0.19
233	1979/10/20 14:00:00	1979/10/20 16:00:00	3	0.1	78.70%	0.19
234	1981/03/05 08:00:00	1981/03/05 17:00:00	10	0.1	79.10%	0.19
235	1982/01/20 23:00:00	1982/01/21 02:00:00	4	0.1	79.40%	0.19
236	1982/04/02 13:00:00	1982/04/02 17:00:00	5	0.1	79.70%	0.19
237	1983/03/20 20:00:00	1983/03/21 04:00:00	9	0.1	80.10%	0.19
238	1983/04/21 01:00:00	1983/04/21 05:00:00	5	0.1	80.40%	0.19
239	1985/11/11 10:00:00	1985/11/11 17:00:00	8	0.1	80.70%	0.19
240	1990/06/10 04:00:00	1990/06/10 06:00:00	3	0.1	81.10%	0.19
241	1992/03/02 11:00:00	1992/03/02 12:00:00	2	0.1	81.40%	0.19
242	1992/03/23 04:00:00	1992/03/23 05:00:00	2	0.1	81.80%	0.19
243	1993/02/23 23:00:00	1993/02/24 08:00:00	10	0.1	82.10%	0.19
244	1994/04/26 21:00:00	1994/04/26 22:00:00	2	0.1	82.40%	0.18
245	1994/12/25 03:00:00	1994/12/25 04:00:00	2	0.1	82.80%	0.18
246	1996/01/21 19:00:00	1996/01/21 21:00:00	3	0.1	83.10%	0.18
247	1996/02/25 10:00:00	1996/02/26 02:00:00	17	0.1	83.40%	0.18
248	1996/02/27 21:00:00	1996/02/28 00:00:00	4	0.1	83.80%	0.18
249	1997/12/06 17:00:00	1997/12/06 22:00:00	6	0.1	84.10%	0.18
250	1998/03/25 17:00:00	1998/03/26 20:00:00	28	0.1	84.50%	0.18
251	2000/02/13 17:00:00	2000/02/13 21:00:00	5	0.1	84.80%	0.18
252	2002/03/17 23:00:00	2002/03/18 00:00:00	2	0.1	85.10%	0.18
253	2003/12/25 19:00:00	2003/12/25 20:00:00	2	0.1	85.50%	0.18
254	2005/02/18 06:00:00	2005/02/19 01:00:00	20	0.1	85.80%	0.18
255	2005/03/22 23:00:00	2005/03/23 01:00:00	3	0.1	86.10%	0.18
256	2008/02/14 12:00:00	2008/02/14 14:00:00	3	0.1	86.50%	0.18
257	1965/02/06 18:00:00	1965/02/06 19:00:00	2	0	86.80%	0.18
258	1965/11/25 11:00:00	1965/11/25 14:00:00	4	0	87.20%	0.17
259	1969/01/28 20:00:00	1969/01/28 22:00:00	3	0	87.50%	0.17
260	1969/03/21 20:00:00	1969/03/21 21:00:00	2	0	87.80%	0.17
261	1970/03/06 23:00:00	1970/03/07 02:00:00	4	0	88.20%	0.17
262	1973/02/28 05:00:00	1973/02/28 07:00:00	3	0	88.50%	0.17
263	1974/04/02 05:00:00	1974/04/02 08:00:00	4	0	88.90%	0.17
264	1974/10/29 05:00:00	1974/10/29 09:00:00	5	0	89.20%	0.17
265	1975/02/10 03:00:00	1975/02/10 04:00:00	2	0	89.50%	0.17
266	1976/04/15 17:00:00	1976/04/15 18:00:00	2	0	89.90%	0.17
267	1977/03/25 03:00:00	1977/03/25 04:00:00	2	0	90.20%	0.17
268	1978/11/21 19:00:00	1978/11/21 21:00:00	3	0	90.50%	0.17
269	1978/11/23 13:00:00	1978/11/23 14:00:00	2	0	90.90%	0.17
270	1979/02/02 16:00:00	1979/02/02 17:00:00	2	0	91.20%	0.17
271	1980/03/26 00:00:00	1980/03/26 02:00:00	3	0	91.60%	0.17
272	1981/11/28 22:00:00	1981/11/29 00:00:00	3	0	91.90%	0.17
273	1983/02/25 00:00:00	1983/02/25 01:00:00	2	0	92.20%	0.17
274	1983/04/18 05:00:00	1983/04/18 06:00:00	2	0	92.60%	0.16

Rank	Start Date	End Date	Duration (hr)	Peak (cfs)	Frequency (%)	Return Period (Yr)
275	1983/12/03 17:00:00	1983/12/03 18:00:00	2	0	92.90%	0.16
276	1986/03/13 17:00:00	1986/03/13 21:00:00	5	0	93.20%	0.16
277	1986/12/06 18:00:00	1986/12/06 19:00:00	2	0	93.60%	0.16
278	1987/11/02 03:00:00	1987/11/02 05:00:00	3	0	93.90%	0.16
279	1992/03/26 19:00:00	1992/03/26 20:00:00	2	0	94.30%	0.16
280	1993/01/31 02:00:00	1993/01/31 03:00:00	2	0	94.60%	0.16
281	1994/03/19 04:00:00	1994/03/19 05:00:00	2	0	94.90%	0.16
282	1995/01/10 22:00:00	1995/01/10 23:00:00	2	0	95.30%	0.16
283	1995/12/20 17:00:00	1995/12/20 18:00:00	2	0	95.60%	0.16
284	1998/01/29 17:00:00	1998/01/29 20:00:00	4	0	95.90%	0.16
285	2000/02/17 17:00:00	2000/02/17 19:00:00	3	0	96.30%	0.16
286	2000/10/30 00:00:00	2000/10/30 01:00:00	2	0	96.60%	0.16
287	2001/12/21 17:00:00	2001/12/21 21:00:00	5	0	97.00%	0.16
288	2003/05/03 17:00:00	2003/05/03 19:00:00	3	0	97.30%	0.16
289	2004/12/31 16:00:00	2004/12/31 18:00:00	3	0	97.60%	0.16
290	2005/02/12 00:00:00	2005/02/12 14:00:00	15	0	98.00%	0.16
291	2005/04/28 09:00:00	2005/04/28 10:00:00	2	0	98.30%	0.16
292	2006/03/21 02:00:00	2006/03/21 03:00:00	2	0	98.60%	0.15
293	2007/02/13 02:00:00	2007/02/13 03:00:00	2	0	99.00%	0.15
294	2007/02/22 22:00:00	2007/02/22 23:00:00	2	0	99.30%	0.15
295	2007/12/08 07:00:00	2007/12/08 08:00:00	2	0	99.70%	0.15
-End of Data-----						

SWMM.out file name: V:\21\21088\Engineering\PrelimGP\Storm\Working Files\Hydmod\600' length-4x3.83 weir - Copy\21088-Post-HMP2.out

SWMM.out time stamp: 6/2/2022 5:17:35 PM

Peak Flow Statistics Table Values

Rank	Start Date	End Date	Duration (hr)	Peak (cfs)	Frequency (%)	Return Period (Yr)
1	1993/01/06 02:00:00	1993/01/11 02:00:00	121	1.8	0.10%	45
2	1995/01/03 07:00:00	1995/01/05 17:00:00	59	1.7	0.20%	22.5
3	1966/12/03 05:00:00	1966/12/07 11:00:00	103	1.6	0.30%	15
4	1971/02/23 04:00:00	1971/02/24 00:00:00	21	1.4	0.50%	11.25
5	1978/01/14 14:00:00	1978/01/17 00:00:00	59	1.4	0.60%	9
6	1978/03/16 18:00:00	1978/03/18 22:00:00	53	1.4	0.70%	7.5
7	1986/02/14 23:00:00	1986/02/16 09:00:00	35	1.4	0.80%	6.43
8	1967/11/19 03:00:00	1967/11/23 14:00:00	108	1.3	0.90%	5.63
9	1980/01/27 20:00:00	1980/01/31 06:00:00	83	1.3	1.00%	5
10	1983/02/26 12:00:00	1983/03/04 14:00:00	147	1.3	1.10%	4.5
11	1983/12/24 19:00:00	1983/12/27 23:00:00	77	1.3	1.20%	4.09
12	1995/01/23 21:00:00	1995/01/26 09:00:00	61	1.3	1.40%	3.75
13	1998/02/14 02:00:00	1998/02/20 22:00:00	165	1.3	1.50%	3.46
14	1969/01/24 04:00:00	1969/01/29 04:00:00	121	1.2	1.60%	3.21
15	1981/02/08 17:00:00	1981/02/10 14:00:00	46	1.2	1.70%	3
16	2007/08/26 07:00:00	2007/08/26 20:00:00	14	1.2	1.80%	2.81
17	1965/11/21 22:00:00	1965/11/23 17:00:00	44	1.1	1.90%	2.65
18	1967/04/11 08:00:00	1967/04/12 13:00:00	30	1.1	2.00%	2.5
19	1979/01/05 07:00:00	1979/01/06 18:00:00	36	1.1	2.10%	2.37
20	1988/04/19 23:00:00	1988/04/22 09:00:00	59	1.1	2.30%	2.25
21	1993/02/07 12:00:00	1993/02/10 03:00:00	64	1.1	2.40%	2.14
22	2007/01/29 22:00:00	2007/01/31 17:00:00	44	1.1	2.50%	2.05
23	1972/11/14 12:00:00	1972/11/15 02:00:00	15	1	2.60%	1.96
24	1974/12/04 03:00:00	1974/12/04 23:00:00	21	1	2.70%	1.88
25	1980/02/13 12:00:00	1980/02/21 16:00:00	197	1	2.80%	1.8
26	1980/03/02 20:00:00	1980/03/03 23:00:00	28	1	2.90%	1.73
27	1983/11/24 23:00:00	1983/11/25 13:00:00	15	1	3.10%	1.67
28	1985/11/24 15:00:00	1985/11/26 00:00:00	34	1	3.20%	1.61
29	1998/01/09 02:00:00	1998/01/11 05:00:00	52	1	3.30%	1.55
30	2004/10/17 08:00:00	2004/10/21 08:00:00	97	1	3.40%	1.5
31	1995/03/03 05:00:00	1995/03/06 13:00:00	81	0.9	3.50%	1.45
32	1998/02/03 02:00:00	1998/02/05 00:00:00	47	0.9	3.60%	1.41
33	2004/10/27 02:00:00	2004/10/28 15:00:00	38	0.9	3.70%	1.36
34	2007/11/30 07:00:00	2007/12/01 11:00:00	29	0.9	3.80%	1.32
35	1967/01/22 16:00:00	1967/01/23 14:00:00	23	0.8	4.00%	1.29
36	1967/12/18 14:00:00	1967/12/20 13:00:00	48	0.8	4.10%	1.25
37	1970/02/28 13:00:00	1970/03/02 19:00:00	55	0.8	4.20%	1.22
38	1970/03/04 21:00:00	1970/03/05 13:00:00	17	0.8	4.30%	1.18
39	1977/05/08 10:00:00	1977/05/10 05:00:00	44	0.8	4.40%	1.15

Rank	Start Date	End Date	Duration (hr)	Peak (cfs)	Frequency (%)	Return Period (Yr)
40	1980/01/07 14:00:00	1980/01/13 05:00:00	136	0.8	4.50%	1.13
41	1985/11/29 06:00:00	1985/11/30 05:00:00	24	0.8	4.60%	1.1
42	1991/03/19 00:00:00	1991/03/21 15:00:00	64	0.8	4.80%	1.07
43	1993/01/12 14:00:00	1993/01/19 04:00:00	159	0.8	4.90%	1.05
44	2004/02/26 01:00:00	2004/02/28 00:00:00	48	0.8	5.00%	1.02
45	2005/01/07 04:00:00	2005/01/12 06:00:00	123	0.8	5.10%	1
46	1969/02/05 03:00:00	1969/02/07 03:00:00	49	0.7	5.20%	0.98
47	1978/12/16 22:00:00	1978/12/19 17:00:00	68	0.7	5.30%	0.96
48	1981/12/30 07:00:00	1982/01/02 16:00:00	82	0.7	5.40%	0.94
49	1982/03/17 18:00:00	1982/03/20 13:00:00	68	0.7	5.50%	0.92
50	1982/12/22 18:00:00	1982/12/23 12:00:00	19	0.7	5.70%	0.9
51	1986/11/17 18:00:00	1986/11/18 14:00:00	21	0.7	5.80%	0.88
52	2003/02/25 02:00:00	2003/02/28 19:00:00	90	0.7	5.90%	0.87
53	1966/11/07 14:00:00	1966/11/08 07:00:00	18	0.6	6.00%	0.85
54	1967/01/24 15:00:00	1967/01/25 12:00:00	22	0.6	6.10%	0.83
55	1981/03/19 20:00:00	1981/03/20 14:00:00	19	0.6	6.20%	0.82
56	1991/02/27 13:00:00	1991/03/02 00:00:00	60	0.6	6.30%	0.8
57	1991/03/25 06:00:00	1991/03/28 01:00:00	68	0.6	6.40%	0.79
58	1992/02/06 08:00:00	1992/02/07 12:00:00	29	0.6	6.60%	0.78
59	1992/02/15 05:00:00	1992/02/16 06:00:00	26	0.6	6.70%	0.76
60	1994/02/17 11:00:00	1994/02/19 07:00:00	45	0.6	6.80%	0.75
61	1996/11/21 16:00:00	1996/11/23 07:00:00	40	0.6	6.90%	0.74
62	2003/02/11 02:00:00	2003/02/15 04:00:00	99	0.6	7.00%	0.73
63	2005/02/18 04:00:00	2005/02/23 20:00:00	137	0.6	7.10%	0.71
64	2006/04/04 18:00:00	2006/04/05 19:00:00	26	0.6	7.20%	0.7
65	1965/12/09 04:00:00	1965/12/11 03:00:00	48	0.5	7.40%	0.69
66	1969/01/13 17:00:00	1969/01/15 00:00:00	32	0.5	7.50%	0.68
67	1969/02/22 02:00:00	1969/02/26 12:00:00	107	0.5	7.60%	0.67
68	1970/11/28 20:00:00	1970/11/30 12:00:00	41	0.5	7.70%	0.66
69	1972/12/04 12:00:00	1972/12/05 06:00:00	19	0.5	7.80%	0.65
70	1973/01/16 15:00:00	1973/01/17 10:00:00	20	0.5	7.90%	0.64
71	1974/03/06 19:00:00	1974/03/09 01:00:00	55	0.5	8.00%	0.63
72	1976/02/03 17:00:00	1976/02/10 18:00:00	170	0.5	8.10%	0.63
73	1976/11/11 22:00:00	1976/11/12 20:00:00	23	0.5	8.30%	0.62
74	1978/02/05 00:00:00	1978/02/07 06:00:00	55	0.5	8.40%	0.61
75	1981/02/28 15:00:00	1981/03/02 21:00:00	55	0.5	8.50%	0.6
76	1992/02/12 18:00:00	1992/02/13 17:00:00	24	0.5	8.60%	0.59
77	1995/03/11 02:00:00	1995/03/12 10:00:00	33	0.5	8.70%	0.58
78	1996/01/31 04:00:00	1996/02/01 18:00:00	39	0.5	8.80%	0.58
79	2003/04/13 15:00:00	2003/04/16 03:00:00	61	0.5	8.90%	0.57
80	2008/01/05 01:00:00	2008/01/07 15:00:00	63	0.5	9.00%	0.56
81	1965/04/07 04:00:00	1965/04/12 06:00:00	123	0.4	9.20%	0.56
82	1965/11/14 07:00:00	1965/11/18 18:00:00	108	0.4	9.30%	0.55
83	1968/03/07 21:00:00	1968/03/09 00:00:00	28	0.4	9.40%	0.54
84	1970/12/16 22:00:00	1970/12/22 14:00:00	137	0.4	9.50%	0.54
85	1973/11/22 19:00:00	1973/11/23 13:00:00	19	0.4	9.60%	0.53
86	1974/01/04 17:00:00	1974/01/09 21:00:00	125	0.4	9.70%	0.52

Rank	Start Date	End Date	Duration (hr)	Peak (cfs)	Frequency (%)	Return Period (Yr)
87	1975/03/08 08:00:00	1975/03/11 22:00:00	87	0.4	9.80%	0.52
88	1976/03/01 08:00:00	1976/03/03 16:00:00	57	0.4	10.00%	0.51
89	1976/12/30 13:00:00	1976/12/31 23:00:00	35	0.4	10.10%	0.51
90	1977/08/16 14:00:00	1977/08/18 02:00:00	37	0.4	10.20%	0.5
91	1978/03/11 17:00:00	1978/03/15 16:00:00	96	0.4	10.30%	0.5
92	1979/03/01 07:00:00	1979/03/02 07:00:00	25	0.4	10.40%	0.49
93	1980/03/10 14:00:00	1980/03/11 07:00:00	18	0.4	10.50%	0.48
94	1982/03/15 12:00:00	1982/03/16 09:00:00	22	0.4	10.60%	0.48
95	1982/11/29 15:00:00	1982/12/01 06:00:00	40	0.4	10.70%	0.47
96	1983/01/27 07:00:00	1983/01/29 14:00:00	56	0.4	10.90%	0.47
97	1985/11/11 03:00:00	1985/11/12 14:00:00	36	0.4	11.00%	0.46
98	1986/02/07 19:00:00	1986/02/09 03:00:00	33	0.4	11.10%	0.46
99	1986/09/23 20:00:00	1986/09/26 09:00:00	62	0.4	11.20%	0.46
100	1987/01/04 13:00:00	1987/01/07 19:00:00	79	0.4	11.30%	0.45
101	1987/12/16 12:00:00	1987/12/17 21:00:00	34	0.4	11.40%	0.45
102	1988/01/17 03:00:00	1988/01/18 08:00:00	30	0.4	11.50%	0.44
103	1988/12/24 20:00:00	1988/12/26 06:00:00	35	0.4	11.70%	0.44
104	1992/01/02 23:00:00	1992/01/08 07:00:00	129	0.4	11.80%	0.43
105	1992/12/07 08:00:00	1992/12/08 06:00:00	23	0.4	11.90%	0.43
106	1994/02/07 02:00:00	1994/02/08 14:00:00	37	0.4	12.00%	0.43
107	1995/02/13 10:00:00	1995/02/15 17:00:00	56	0.4	12.10%	0.42
108	1998/02/06 02:00:00	1998/02/09 20:00:00	91	0.4	12.20%	0.42
109	2001/01/10 20:00:00	2001/01/12 21:00:00	50	0.4	12.30%	0.41
110	2005/01/03 04:00:00	2005/01/05 05:00:00	50	0.4	12.40%	0.41
111	2008/02/03 06:00:00	2008/02/04 08:00:00	27	0.4	12.60%	0.41
112	1964/11/17 13:00:00	1964/11/18 10:00:00	22	0.3	12.70%	0.4
113	1964/12/27 07:00:00	1964/12/29 10:00:00	52	0.3	12.80%	0.4
114	1965/12/29 08:00:00	1966/01/01 11:00:00	76	0.3	12.90%	0.4
115	1967/03/13 11:00:00	1967/03/14 09:00:00	23	0.3	13.00%	0.39
116	1970/03/06 19:00:00	1970/03/09 05:00:00	59	0.3	13.10%	0.39
117	1971/12/27 13:00:00	1971/12/29 00:00:00	36	0.3	13.20%	0.39
118	1972/11/16 08:00:00	1972/11/17 18:00:00	35	0.3	13.30%	0.38
119	1973/01/18 20:00:00	1973/01/19 12:00:00	17	0.3	13.50%	0.38
120	1973/02/10 22:00:00	1973/02/13 10:00:00	61	0.3	13.60%	0.38
121	1973/03/04 00:00:00	1973/03/09 06:00:00	127	0.3	13.70%	0.37
122	1973/03/20 08:00:00	1973/03/22 12:00:00	53	0.3	13.80%	0.37
123	1975/04/05 21:00:00	1975/04/09 21:00:00	97	0.3	13.90%	0.37
124	1976/04/11 19:00:00	1976/04/16 04:00:00	106	0.3	14.00%	0.36
125	1976/09/09 19:00:00	1976/09/11 08:00:00	38	0.3	14.10%	0.36
126	1979/01/15 14:00:00	1979/01/19 01:00:00	84	0.3	14.30%	0.36
127	1979/02/21 01:00:00	1979/02/23 14:00:00	62	0.3	14.40%	0.35
128	1979/03/17 05:00:00	1979/03/21 11:00:00	103	0.3	14.50%	0.35
129	1979/03/27 03:00:00	1979/03/29 14:00:00	60	0.3	14.60%	0.35
130	1979/10/19 22:00:00	1979/10/21 16:00:00	43	0.3	14.70%	0.35
131	1980/03/06 00:00:00	1980/03/06 22:00:00	23	0.3	14.80%	0.34
132	1982/02/09 16:00:00	1982/02/11 06:00:00	39	0.3	14.90%	0.34
133	1983/03/22 12:00:00	1983/03/24 22:00:00	59	0.3	15.00%	0.34

Rank	Start Date	End Date	Duration (hr)	Peak (cfs)	Frequency (%)	Return Period (Yr)
134	1986/03/08 15:00:00	1986/03/14 09:00:00	139	0.3	15.20%	0.34
135	1988/11/25 05:00:00	1988/11/26 15:00:00	35	0.3	15.30%	0.33
136	1988/12/21 01:00:00	1988/12/21 17:00:00	17	0.3	15.40%	0.33
137	1989/03/25 09:00:00	1989/03/26 15:00:00	31	0.3	15.50%	0.33
138	1990/01/13 03:00:00	1990/01/17 16:00:00	110	0.3	15.60%	0.33
139	1991/12/29 15:00:00	1991/12/30 08:00:00	18	0.3	15.70%	0.32
140	1992/03/02 01:00:00	1992/03/03 22:00:00	46	0.3	15.80%	0.32
141	1993/02/18 13:00:00	1993/02/21 00:00:00	60	0.3	16.00%	0.32
142	1993/11/14 06:00:00	1993/11/15 04:00:00	23	0.3	16.10%	0.32
143	1994/03/24 21:00:00	1994/03/26 02:00:00	30	0.3	16.20%	0.32
144	1995/01/07 16:00:00	1995/01/08 16:00:00	25	0.3	16.30%	0.31
145	1995/01/10 16:00:00	1995/01/13 01:00:00	58	0.3	16.40%	0.31
146	1997/01/12 13:00:00	1997/01/14 05:00:00	41	0.3	16.50%	0.31
147	1998/02/22 02:00:00	1998/02/25 18:00:00	89	0.3	16.60%	0.31
148	2002/11/08 02:00:00	2002/11/10 19:00:00	66	0.3	16.70%	0.3
149	2003/03/15 02:00:00	2003/03/17 17:00:00	64	0.3	16.90%	0.3
150	2004/02/21 15:00:00	2004/02/23 16:00:00	50	0.3	17.00%	0.3
151	2004/12/28 06:00:00	2005/01/01 02:00:00	93	0.3	17.10%	0.3
152	2005/12/31 16:00:00	2006/01/03 04:00:00	61	0.3	17.20%	0.3
153	2006/02/27 19:00:00	2006/02/28 20:00:00	26	0.3	17.30%	0.29
154	2008/02/22 02:00:00	2008/02/22 21:00:00	20	0.3	17.40%	0.29
155	1965/02/06 00:00:00	1965/02/07 07:00:00	32	0.2	17.50%	0.29
156	1965/03/31 14:00:00	1965/04/05 15:00:00	122	0.2	17.60%	0.29
157	1965/12/12 06:00:00	1965/12/16 18:00:00	109	0.2	17.80%	0.29
158	1966/02/06 10:00:00	1966/02/08 07:00:00	46	0.2	17.90%	0.29
159	1967/04/21 12:00:00	1967/04/22 13:00:00	26	0.2	18.00%	0.28
160	1968/04/01 19:00:00	1968/04/02 17:00:00	23	0.2	18.10%	0.28
161	1969/01/18 22:00:00	1969/01/22 04:00:00	79	0.2	18.20%	0.28
162	1969/02/18 09:00:00	1969/02/20 09:00:00	49	0.2	18.30%	0.28
163	1969/03/12 21:00:00	1969/03/14 03:00:00	31	0.2	18.40%	0.28
164	1969/03/21 13:00:00	1969/03/22 06:00:00	18	0.2	18.60%	0.27
165	1970/03/11 10:00:00	1970/03/12 10:00:00	25	0.2	18.70%	0.27
166	1970/10/03 14:00:00	1970/10/04 01:00:00	12	0.2	18.80%	0.27
167	1971/01/02 04:00:00	1971/01/02 23:00:00	20	0.2	18.90%	0.27
168	1971/05/07 18:00:00	1971/05/08 10:00:00	17	0.2	19.00%	0.27
169	1971/12/22 05:00:00	1971/12/23 10:00:00	30	0.2	19.10%	0.27
170	1971/12/24 15:00:00	1971/12/26 09:00:00	43	0.2	19.20%	0.27
171	1972/11/11 01:00:00	1972/11/11 20:00:00	20	0.2	19.30%	0.26
172	1973/02/27 23:00:00	1973/02/28 16:00:00	18	0.2	19.50%	0.26
173	1973/03/11 11:00:00	1973/03/12 11:00:00	25	0.2	19.60%	0.26
174	1973/11/17 06:00:00	1973/11/18 20:00:00	39	0.2	19.70%	0.26
175	1974/04/02 01:00:00	1974/04/02 19:00:00	19	0.2	19.80%	0.26
176	1974/10/28 05:00:00	1974/10/29 22:00:00	42	0.2	19.90%	0.26
177	1975/02/09 06:00:00	1975/02/10 12:00:00	31	0.2	20.00%	0.25
178	1975/12/11 23:00:00	1975/12/13 00:00:00	26	0.2	20.10%	0.25
179	1976/10/22 20:00:00	1976/10/23 19:00:00	24	0.2	20.20%	0.25
180	1977/03/24 11:00:00	1977/03/25 20:00:00	34	0.2	20.40%	0.25

Rank	Start Date	End Date	Duration (hr)	Peak (cfs)	Frequency (%)	Return Period (Yr)
181	1977/12/18 01:00:00	1977/12/18 17:00:00	17	0.2	20.50%	0.25
182	1977/12/25 11:00:00	1977/12/29 21:00:00	107	0.2	20.60%	0.25
183	1978/01/30 07:00:00	1978/01/31 08:00:00	26	0.2	20.70%	0.25
184	1978/03/30 14:00:00	1978/04/01 04:00:00	39	0.2	20.80%	0.25
185	1978/04/07 01:00:00	1978/04/08 14:00:00	38	0.2	20.90%	0.24
186	1978/09/05 17:00:00	1978/09/06 07:00:00	15	0.2	21.00%	0.24
187	1978/11/10 18:00:00	1978/11/12 10:00:00	41	0.2	21.20%	0.24
188	1978/11/13 21:00:00	1978/11/14 17:00:00	21	0.2	21.30%	0.24
189	1978/11/21 18:00:00	1978/11/23 22:00:00	53	0.2	21.40%	0.24
190	1979/01/31 00:00:00	1979/02/02 23:00:00	72	0.2	21.50%	0.24
191	1980/01/18 04:00:00	1980/01/19 10:00:00	31	0.2	21.60%	0.24
192	1980/03/25 22:00:00	1980/03/26 11:00:00	14	0.2	21.70%	0.23
193	1980/12/04 13:00:00	1980/12/05 07:00:00	19	0.2	21.80%	0.23
194	1981/01/28 06:00:00	1981/01/31 00:00:00	67	0.2	21.90%	0.23
195	1981/02/25 05:00:00	1981/02/26 10:00:00	30	0.2	22.10%	0.23
196	1981/03/04 07:00:00	1981/03/05 23:00:00	41	0.2	22.20%	0.23
197	1981/11/26 18:00:00	1981/11/29 15:00:00	70	0.2	22.30%	0.23
198	1982/01/20 03:00:00	1982/01/21 22:00:00	44	0.2	22.40%	0.23
199	1982/03/26 21:00:00	1982/03/27 15:00:00	19	0.2	22.50%	0.23
200	1982/03/31 02:00:00	1982/04/03 13:00:00	84	0.2	22.60%	0.23
201	1982/11/09 13:00:00	1982/11/11 10:00:00	46	0.2	22.70%	0.22
202	1983/02/05 17:00:00	1983/02/08 19:00:00	75	0.2	22.90%	0.22
203	1983/02/24 09:00:00	1983/02/25 10:00:00	26	0.2	23.00%	0.22
204	1983/03/17 04:00:00	1983/03/19 06:00:00	51	0.2	23.10%	0.22
205	1983/03/20 20:00:00	1983/03/21 11:00:00	16	0.2	23.20%	0.22
206	1983/04/29 02:00:00	1983/05/01 17:00:00	64	0.2	23.30%	0.22
207	1983/10/07 07:00:00	1983/10/07 20:00:00	14	0.2	23.40%	0.22
208	1983/11/20 09:00:00	1983/11/21 17:00:00	33	0.2	23.50%	0.22
209	1983/12/03 15:00:00	1983/12/04 06:00:00	16	0.2	23.60%	0.22
210	1985/12/02 12:00:00	1985/12/03 17:00:00	30	0.2	23.80%	0.21
211	1986/01/30 01:00:00	1986/02/01 04:00:00	52	0.2	23.90%	0.21
212	1986/03/15 20:00:00	1986/03/17 16:00:00	45	0.2	24.00%	0.21
213	1986/04/06 05:00:00	1986/04/07 00:00:00	20	0.2	24.10%	0.21
214	1986/10/09 18:00:00	1986/10/11 09:00:00	40	0.2	24.20%	0.21
215	1986/12/06 03:00:00	1986/12/07 14:00:00	36	0.2	24.30%	0.21
216	1987/11/04 15:00:00	1987/11/05 20:00:00	30	0.2	24.40%	0.21
217	1987/12/04 21:00:00	1987/12/05 09:00:00	13	0.2	24.50%	0.21
218	1988/01/05 13:00:00	1988/01/06 03:00:00	15	0.2	24.70%	0.21
219	1988/02/02 03:00:00	1988/02/03 02:00:00	24	0.2	24.80%	0.21
220	1988/04/14 18:00:00	1988/04/16 07:00:00	38	0.2	24.90%	0.21
221	1990/02/17 10:00:00	1990/02/19 10:00:00	49	0.2	25.00%	0.2
222	1992/12/27 16:00:00	1992/12/30 06:00:00	63	0.2	25.10%	0.2
223	1993/01/31 01:00:00	1993/01/31 13:00:00	13	0.2	25.20%	0.2
224	1993/02/23 19:00:00	1993/02/24 15:00:00	21	0.2	25.30%	0.2
225	1993/03/26 00:00:00	1993/03/28 13:00:00	62	0.2	25.50%	0.2
226	1994/02/03 20:00:00	1994/02/05 08:00:00	37	0.2	25.60%	0.2
227	1994/02/20 12:00:00	1994/02/21 03:00:00	16	0.2	25.70%	0.2

Rank	Start Date	End Date	Duration (hr)	Peak (cfs)	Frequency (%)	Return Period (Yr)
228	1994/03/06 05:00:00	1994/03/07 17:00:00	37	0.2	25.80%	0.2
229	1994/03/19 02:00:00	1994/03/20 17:00:00	40	0.2	25.90%	0.2
230	1994/04/25 15:00:00	1994/04/28 10:00:00	68	0.2	26.00%	0.2
231	1994/12/24 05:00:00	1994/12/25 14:00:00	34	0.2	26.10%	0.2
232	1995/03/21 09:00:00	1995/03/22 00:00:00	16	0.2	26.20%	0.19
233	1995/03/23 09:00:00	1995/03/24 07:00:00	23	0.2	26.40%	0.19
234	1995/04/16 06:00:00	1995/04/17 04:00:00	23	0.2	26.50%	0.19
235	1995/04/18 08:00:00	1995/04/19 14:00:00	31	0.2	26.60%	0.19
236	1995/12/20 17:00:00	1995/12/21 04:00:00	12	0.2	26.70%	0.19
237	1996/01/21 18:00:00	1996/01/22 17:00:00	24	0.2	26.80%	0.19
238	1996/02/25 09:00:00	1996/02/26 15:00:00	31	0.2	26.90%	0.19
239	1996/03/12 17:00:00	1996/03/14 10:00:00	42	0.2	27.00%	0.19
240	1996/12/09 15:00:00	1996/12/12 03:00:00	61	0.2	27.10%	0.19
241	1997/01/25 15:00:00	1997/01/27 12:00:00	46	0.2	27.30%	0.19
242	1998/03/25 02:00:00	1998/04/02 17:00:00	208	0.2	27.40%	0.19
243	1998/04/11 02:00:00	1998/04/12 21:00:00	44	0.2	27.50%	0.19
244	1998/05/12 02:00:00	1998/05/13 20:00:00	43	0.2	27.60%	0.18
245	2000/02/21 02:00:00	2000/02/23 04:00:00	51	0.2	27.70%	0.18
246	2000/04/17 16:00:00	2000/04/18 12:00:00	21	0.2	27.80%	0.18
247	2000/10/29 20:00:00	2000/10/30 10:00:00	15	0.2	27.90%	0.18
248	2001/11/24 02:00:00	2001/11/25 07:00:00	30	0.2	28.10%	0.18
249	2002/12/16 02:00:00	2002/12/17 19:00:00	42	0.2	28.20%	0.18
250	2002/12/20 02:00:00	2002/12/22 00:00:00	47	0.2	28.30%	0.18
251	2003/12/24 23:00:00	2003/12/26 06:00:00	32	0.2	28.40%	0.18
252	2004/02/02 23:00:00	2004/02/04 09:00:00	35	0.2	28.50%	0.18
253	2004/03/02 00:00:00	2004/03/03 11:00:00	36	0.2	28.60%	0.18
254	2005/02/11 01:00:00	2005/02/13 09:00:00	57	0.2	28.70%	0.18
255	2005/03/22 19:00:00	2005/03/23 09:00:00	15	0.2	28.80%	0.18
256	2005/04/28 07:00:00	2005/04/29 05:00:00	23	0.2	29.00%	0.18
257	2006/03/10 13:00:00	2006/03/11 19:00:00	31	0.2	29.10%	0.18
258	2006/03/28 02:00:00	2006/03/29 12:00:00	35	0.2	29.20%	0.17
259	2006/05/22 04:00:00	2006/05/22 17:00:00	14	0.2	29.30%	0.17
260	2006/12/09 22:00:00	2006/12/11 04:00:00	31	0.2	29.40%	0.17
261	2008/01/23 19:00:00	2008/01/24 12:00:00	18	0.2	29.50%	0.17
262	2008/02/14 11:00:00	2008/02/15 02:00:00	16	0.2	29.60%	0.17
263	1964/09/24 14:00:00	1964/09/24 18:00:00	5	0.1	29.80%	0.17
264	1964/10/15 09:00:00	1964/10/15 22:00:00	14	0.1	29.90%	0.17
265	1964/11/09 12:00:00	1964/11/12 11:00:00	72	0.1	30.00%	0.17
266	1965/01/24 06:00:00	1965/01/24 17:00:00	12	0.1	30.10%	0.17
267	1965/03/11 07:00:00	1965/03/11 22:00:00	16	0.1	30.20%	0.17
268	1965/03/15 02:00:00	1965/03/15 09:00:00	8	0.1	30.30%	0.17
269	1965/11/24 19:00:00	1965/11/25 21:00:00	27	0.1	30.40%	0.17
270	1965/12/21 23:00:00	1965/12/23 02:00:00	28	0.1	30.50%	0.17
271	1966/10/04 00:00:00	1966/10/05 19:00:00	44	0.1	30.70%	0.17
272	1966/10/10 12:00:00	1966/10/10 22:00:00	11	0.1	30.80%	0.17
273	1967/03/31 10:00:00	1967/04/02 11:00:00	50	0.1	30.90%	0.17
274	1967/04/04 16:00:00	1967/04/05 02:00:00	11	0.1	31.00%	0.16

Rank	Start Date	End Date	Duration (hr)	Peak (cfs)	Frequency (%)	Return Period (Yr)
275	1967/04/18 19:00:00	1967/04/20 01:00:00	31	0.1	31.10%	0.16
276	1967/08/31 02:00:00	1967/08/31 14:00:00	13	0.1	31.20%	0.16
277	1967/11/30 16:00:00	1967/12/01 03:00:00	12	0.1	31.30%	0.16
278	1967/12/13 10:00:00	1967/12/13 19:00:00	10	0.1	31.40%	0.16
279	1967/12/16 13:00:00	1967/12/17 09:00:00	21	0.1	31.60%	0.16
280	1968/01/27 07:00:00	1968/01/28 13:00:00	31	0.1	31.70%	0.16
281	1968/02/13 09:00:00	1968/02/14 08:00:00	24	0.1	31.80%	0.16
282	1968/03/18 13:00:00	1968/03/18 21:00:00	9	0.1	31.90%	0.16
283	1968/11/15 06:00:00	1968/11/16 01:00:00	20	0.1	32.00%	0.16
284	1968/12/19 14:00:00	1968/12/20 19:00:00	30	0.1	32.10%	0.16
285	1968/12/25 18:00:00	1968/12/26 16:00:00	23	0.1	32.20%	0.16
286	1969/02/15 18:00:00	1969/02/16 03:00:00	10	0.1	32.40%	0.16
287	1969/02/28 22:00:00	1969/03/01 08:00:00	11	0.1	32.50%	0.16
288	1969/03/10 02:00:00	1969/03/11 14:00:00	37	0.1	32.60%	0.16
289	1969/04/05 20:00:00	1969/04/06 03:00:00	8	0.1	32.70%	0.16
290	1969/11/06 18:00:00	1969/11/07 12:00:00	19	0.1	32.80%	0.16
291	1969/11/10 00:00:00	1969/11/10 10:00:00	11	0.1	32.90%	0.16
292	1970/01/11 14:00:00	1970/01/12 09:00:00	20	0.1	33.00%	0.15
293	1970/01/16 16:00:00	1970/01/17 03:00:00	12	0.1	33.10%	0.15
294	1970/02/10 01:00:00	1970/02/11 11:00:00	35	0.1	33.30%	0.15
295	1970/04/30 09:00:00	1970/04/30 13:00:00	5	0.1	33.40%	0.15
296	1970/11/25 23:00:00	1970/11/26 17:00:00	19	0.1	33.50%	0.15
297	1970/12/09 05:00:00	1970/12/09 17:00:00	13	0.1	33.60%	0.15
298	1971/01/12 19:00:00	1971/01/13 06:00:00	12	0.1	33.70%	0.15
299	1971/02/16 16:00:00	1971/02/17 16:00:00	25	0.1	33.80%	0.15
300	1971/03/13 06:00:00	1971/03/13 22:00:00	17	0.1	33.90%	0.15
301	1971/04/14 11:00:00	1971/04/14 21:00:00	11	0.1	34.00%	0.15
302	1971/04/15 22:00:00	1971/04/16 13:00:00	16	0.1	34.20%	0.15
303	1971/04/23 07:00:00	1971/04/23 14:00:00	8	0.1	34.30%	0.15
304	1971/05/28 01:00:00	1971/05/29 07:00:00	31	0.1	34.40%	0.15
305	1971/10/16 04:00:00	1971/10/17 16:00:00	37	0.1	34.50%	0.15
306	1971/12/03 00:00:00	1971/12/04 08:00:00	33	0.1	34.60%	0.15
307	1971/12/07 01:00:00	1971/12/07 09:00:00	9	0.1	34.70%	0.15
308	1971/12/31 04:00:00	1971/12/31 12:00:00	9	0.1	34.80%	0.15
309	1972/01/09 09:00:00	1972/01/10 06:00:00	22	0.1	35.00%	0.15
310	1972/04/30 04:00:00	1972/04/30 15:00:00	12	0.1	35.10%	0.15
311	1972/05/19 04:00:00	1972/05/20 18:00:00	39	0.1	35.20%	0.15
312	1972/10/19 03:00:00	1972/10/20 21:00:00	43	0.1	35.30%	0.14
313	1972/12/07 04:00:00	1972/12/09 08:00:00	53	0.1	35.40%	0.14
314	1973/01/04 01:00:00	1973/01/05 00:00:00	24	0.1	35.50%	0.14
315	1973/01/09 10:00:00	1973/01/10 07:00:00	22	0.1	35.60%	0.14
316	1973/02/03 13:00:00	1973/02/04 04:00:00	16	0.1	35.70%	0.14
317	1973/02/06 01:00:00	1973/02/06 09:00:00	9	0.1	35.90%	0.14
318	1973/03/13 12:00:00	1973/03/14 04:00:00	17	0.1	36.00%	0.14
319	1973/04/30 05:00:00	1973/04/30 16:00:00	12	0.1	36.10%	0.14
320	1973/12/01 15:00:00	1973/12/01 22:00:00	8	0.1	36.20%	0.14
321	1974/01/01 04:00:00	1974/01/02 03:00:00	24	0.1	36.30%	0.14

Rank	Start Date	End Date	Duration (hr)	Peak (cfs)	Frequency (%)	Return Period (Yr)
322	1974/01/20 17:00:00	1974/01/21 04:00:00	12	0.1	36.40%	0.14
323	1974/03/02 10:00:00	1974/03/03 19:00:00	34	0.1	36.50%	0.14
324	1974/12/28 06:00:00	1974/12/29 16:00:00	35	0.1	36.70%	0.14
325	1975/01/30 18:00:00	1975/01/31 04:00:00	11	0.1	36.80%	0.14
326	1975/02/03 09:00:00	1975/02/05 14:00:00	54	0.1	36.90%	0.14
327	1975/03/05 14:00:00	1975/03/06 22:00:00	33	0.1	37.00%	0.14
328	1975/03/14 02:00:00	1975/03/14 17:00:00	16	0.1	37.10%	0.14
329	1975/03/22 08:00:00	1975/03/23 19:00:00	36	0.1	37.20%	0.14
330	1975/03/31 21:00:00	1975/04/01 11:00:00	15	0.1	37.30%	0.14
331	1975/11/27 17:00:00	1975/11/29 05:00:00	37	0.1	37.40%	0.14
332	1976/11/27 04:00:00	1976/11/27 15:00:00	12	0.1	37.60%	0.14
333	1977/01/03 12:00:00	1977/01/04 09:00:00	22	0.1	37.70%	0.14
334	1977/01/06 19:00:00	1977/01/07 13:00:00	19	0.1	37.80%	0.14
335	1977/01/28 17:00:00	1977/01/29 01:00:00	9	0.1	37.90%	0.13
336	1977/03/16 12:00:00	1977/03/17 09:00:00	22	0.1	38.00%	0.13
337	1977/12/23 03:00:00	1977/12/23 12:00:00	10	0.1	38.10%	0.13
338	1978/01/10 17:00:00	1978/01/11 05:00:00	13	0.1	38.20%	0.13
339	1978/03/22 04:00:00	1978/03/23 18:00:00	39	0.1	38.30%	0.13
340	1978/04/15 20:00:00	1978/04/16 06:00:00	11	0.1	38.50%	0.13
341	1979/01/09 08:00:00	1979/01/09 20:00:00	13	0.1	38.60%	0.13
342	1979/02/14 03:00:00	1979/02/14 14:00:00	12	0.1	38.70%	0.13
343	1979/11/07 19:00:00	1979/11/09 07:00:00	37	0.1	38.80%	0.13
344	1980/03/21 19:00:00	1980/03/22 06:00:00	12	0.1	38.90%	0.13
345	1980/04/22 15:00:00	1980/04/23 09:00:00	19	0.1	39.00%	0.13
346	1980/12/07 11:00:00	1980/12/07 19:00:00	9	0.1	39.10%	0.13
347	1981/03/26 22:00:00	1981/03/27 08:00:00	11	0.1	39.30%	0.13
348	1982/01/05 04:00:00	1982/01/05 20:00:00	17	0.1	39.40%	0.13
349	1982/01/10 18:00:00	1982/01/11 05:00:00	12	0.1	39.50%	0.13
350	1982/01/28 17:00:00	1982/01/29 08:00:00	16	0.1	39.60%	0.13
351	1982/03/28 18:00:00	1982/03/29 02:00:00	9	0.1	39.70%	0.13
352	1982/09/26 01:00:00	1982/09/26 22:00:00	22	0.1	39.80%	0.13
353	1982/11/19 02:00:00	1982/11/19 21:00:00	20	0.1	39.90%	0.13
354	1982/12/07 23:00:00	1982/12/10 05:00:00	55	0.1	40.00%	0.13
355	1983/01/19 04:00:00	1983/01/19 15:00:00	12	0.1	40.20%	0.13
356	1983/01/23 00:00:00	1983/01/23 10:00:00	11	0.1	40.30%	0.13
357	1983/01/24 18:00:00	1983/01/25 02:00:00	9	0.1	40.40%	0.13
358	1983/02/02 12:00:00	1983/02/03 02:00:00	15	0.1	40.50%	0.13
359	1983/03/06 03:00:00	1983/03/06 17:00:00	15	0.1	40.60%	0.13
360	1983/04/17 22:00:00	1983/04/18 11:00:00	14	0.1	40.70%	0.13
361	1983/04/20 01:00:00	1983/04/21 14:00:00	38	0.1	40.80%	0.13
362	1983/08/16 15:00:00	1983/08/16 22:00:00	8	0.1	41.00%	0.12
363	1983/10/01 04:00:00	1983/10/02 01:00:00	22	0.1	41.10%	0.12
364	1983/11/11 22:00:00	1983/11/13 09:00:00	36	0.1	41.20%	0.12
365	1983/12/09 18:00:00	1983/12/10 04:00:00	11	0.1	41.30%	0.12
366	1984/01/16 16:00:00	1984/01/17 02:00:00	11	0.1	41.40%	0.12
367	1984/04/06 06:00:00	1984/04/06 17:00:00	12	0.1	41.50%	0.12
368	1984/12/07 23:00:00	1984/12/08 08:00:00	10	0.1	41.60%	0.12

Rank	Start Date	End Date	Duration (hr)	Peak (cfs)	Frequency (%)	Return Period (Yr)
369	1984/12/14 14:00:00	1984/12/14 21:00:00	8	0.1	41.70%	0.12
370	1985/02/01 15:00:00	1985/02/03 21:00:00	55	0.1	41.90%	0.12
371	1985/02/09 05:00:00	1985/02/09 23:00:00	19	0.1	42.00%	0.12
372	1985/02/20 20:00:00	1985/02/21 03:00:00	8	0.1	42.10%	0.12
373	1985/03/02 13:00:00	1985/03/03 08:00:00	20	0.1	42.20%	0.12
374	1985/03/27 08:00:00	1985/03/28 14:00:00	31	0.1	42.30%	0.12
375	1985/09/18 08:00:00	1985/09/18 21:00:00	14	0.1	42.40%	0.12
376	1985/10/07 14:00:00	1985/10/07 18:00:00	5	0.1	42.50%	0.12
377	1985/10/09 12:00:00	1985/10/09 23:00:00	12	0.1	42.60%	0.12
378	1985/12/09 16:00:00	1985/12/11 15:00:00	48	0.1	42.80%	0.12
379	1986/07/19 12:00:00	1986/07/19 21:00:00	10	0.1	42.90%	0.12
380	1987/02/23 13:00:00	1987/02/26 08:00:00	68	0.1	43.00%	0.12
381	1987/04/03 04:00:00	1987/04/04 08:00:00	29	0.1	43.10%	0.12
382	1987/10/22 16:00:00	1987/10/24 10:00:00	43	0.1	43.20%	0.12
383	1987/10/28 19:00:00	1987/10/29 06:00:00	12	0.1	43.30%	0.12
384	1987/10/31 00:00:00	1987/11/02 11:00:00	60	0.1	43.40%	0.12
385	1987/12/19 14:00:00	1987/12/20 00:00:00	11	0.1	43.60%	0.12
386	1988/02/29 22:00:00	1988/03/02 07:00:00	34	0.1	43.70%	0.12
387	1988/11/14 05:00:00	1988/11/14 17:00:00	13	0.1	43.80%	0.12
388	1988/12/15 07:00:00	1988/12/16 22:00:00	40	0.1	43.90%	0.12
389	1988/12/18 06:00:00	1988/12/19 08:00:00	27	0.1	44.00%	0.12
390	1989/01/04 08:00:00	1989/01/06 07:00:00	48	0.1	44.10%	0.12
391	1989/02/04 04:00:00	1989/02/04 21:00:00	18	0.1	44.20%	0.12
392	1989/10/21 23:00:00	1989/10/22 11:00:00	13	0.1	44.30%	0.12
393	1990/01/02 01:00:00	1990/01/02 15:00:00	15	0.1	44.50%	0.12
394	1990/01/31 00:00:00	1990/01/31 11:00:00	12	0.1	44.60%	0.11
395	1990/02/04 11:00:00	1990/02/04 18:00:00	8	0.1	44.70%	0.11
396	1990/04/04 09:00:00	1990/04/05 15:00:00	31	0.1	44.80%	0.11
397	1990/06/09 07:00:00	1990/06/10 16:00:00	34	0.1	44.90%	0.11
398	1990/11/19 22:00:00	1990/11/20 12:00:00	15	0.1	45.00%	0.11
399	1990/11/26 02:00:00	1990/11/26 12:00:00	11	0.1	45.10%	0.11
400	1990/12/19 13:00:00	1990/12/20 11:00:00	23	0.1	45.20%	0.11
401	1991/01/03 12:00:00	1991/01/04 18:00:00	31	0.1	45.40%	0.11
402	1991/01/09 09:00:00	1991/01/10 01:00:00	17	0.1	45.50%	0.11
403	1991/03/11 02:00:00	1991/03/11 12:00:00	11	0.1	45.60%	0.11
404	1991/03/13 17:00:00	1991/03/16 02:00:00	58	0.1	45.70%	0.11
405	1991/10/26 20:00:00	1991/10/27 09:00:00	14	0.1	45.80%	0.11
406	1991/12/17 11:00:00	1991/12/19 12:00:00	50	0.1	45.90%	0.11
407	1991/12/28 00:00:00	1991/12/28 11:00:00	12	0.1	46.00%	0.11
408	1992/02/09 23:00:00	1992/02/10 09:00:00	11	0.1	46.20%	0.11
409	1992/03/20 16:00:00	1992/03/23 16:00:00	73	0.1	46.30%	0.11
410	1992/03/26 16:00:00	1992/03/27 04:00:00	13	0.1	46.40%	0.11
411	1992/12/17 22:00:00	1992/12/18 11:00:00	14	0.1	46.50%	0.11
412	1993/01/02 02:00:00	1993/01/03 04:00:00	27	0.1	46.60%	0.11
413	1993/06/05 13:00:00	1993/06/05 23:00:00	11	0.1	46.70%	0.11
414	1993/11/22 22:00:00	1993/11/23 12:00:00	15	0.1	46.80%	0.11
415	1993/12/11 16:00:00	1993/12/12 07:00:00	16	0.1	46.90%	0.11

Rank	Start Date	End Date	Duration (hr)	Peak (cfs)	Frequency (%)	Return Period (Yr)
416	1993/12/14 17:00:00	1993/12/15 13:00:00	21	0.1	47.10%	0.11
417	1994/01/25 00:00:00	1994/01/27 19:00:00	68	0.1	47.20%	0.11
418	1994/04/09 05:00:00	1994/04/09 22:00:00	18	0.1	47.30%	0.11
419	1994/11/10 11:00:00	1994/11/10 18:00:00	8	0.1	47.40%	0.11
420	1994/11/16 08:00:00	1994/11/16 15:00:00	8	0.1	47.50%	0.11
421	1995/01/15 03:00:00	1995/01/17 13:00:00	59	0.1	47.60%	0.11
422	1995/01/21 02:00:00	1995/01/21 12:00:00	11	0.1	47.70%	0.11
423	1995/06/15 21:00:00	1995/06/17 17:00:00	45	0.1	47.90%	0.11
424	1995/12/23 10:00:00	1995/12/23 19:00:00	10	0.1	48.00%	0.11
425	1996/01/16 19:00:00	1996/01/17 05:00:00	11	0.1	48.10%	0.11
426	1996/02/21 02:00:00	1996/02/22 06:00:00	29	0.1	48.20%	0.11
427	1996/02/27 21:00:00	1996/02/28 07:00:00	11	0.1	48.30%	0.11
428	1996/03/04 17:00:00	1996/03/05 09:00:00	17	0.1	48.40%	0.11
429	1996/04/18 00:00:00	1996/04/18 13:00:00	14	0.1	48.50%	0.11
430	1996/10/30 13:00:00	1996/10/31 02:00:00	14	0.1	48.60%	0.11
431	1996/12/05 22:00:00	1996/12/06 15:00:00	18	0.1	48.80%	0.1
432	1996/12/22 15:00:00	1996/12/22 23:00:00	9	0.1	48.90%	0.1
433	1997/01/05 09:00:00	1997/01/05 21:00:00	13	0.1	49.00%	0.1
434	1997/01/15 18:00:00	1997/01/16 04:00:00	11	0.1	49.10%	0.1
435	1997/01/23 03:00:00	1997/01/24 06:00:00	28	0.1	49.20%	0.1
436	1997/02/10 19:00:00	1997/02/11 05:00:00	11	0.1	49.30%	0.1
437	1997/02/27 11:00:00	1997/02/28 07:00:00	21	0.1	49.40%	0.1
438	1997/04/03 17:00:00	1997/04/04 18:00:00	26	0.1	49.50%	0.1
439	1997/12/06 02:00:00	1997/12/08 04:00:00	51	0.1	49.70%	0.1
440	1998/01/19 04:00:00	1998/01/20 02:00:00	23	0.1	49.80%	0.1
441	1998/01/29 02:00:00	1998/01/30 04:00:00	27	0.1	49.90%	0.1
442	2000/02/13 02:00:00	2000/02/14 20:00:00	43	0.1	50.00%	0.1
443	2000/02/17 02:00:00	2000/02/18 04:00:00	27	0.1	50.10%	0.1
444	2000/11/10 04:00:00	2000/11/11 11:00:00	32	0.1	50.20%	0.1
445	2001/01/26 11:00:00	2001/01/28 10:00:00	48	0.1	50.30%	0.1
446	2001/04/21 00:00:00	2001/04/21 18:00:00	19	0.1	50.50%	0.1
447	2001/05/29 15:00:00	2001/05/29 19:00:00	5	0.1	50.60%	0.1
448	2001/12/03 05:00:00	2001/12/04 01:00:00	21	0.1	50.70%	0.1
449	2001/12/09 02:00:00	2001/12/10 04:00:00	27	0.1	50.80%	0.1
450	2001/12/21 02:00:00	2001/12/22 04:00:00	27	0.1	50.90%	0.1
451	2002/03/17 20:00:00	2002/03/18 10:00:00	15	0.1	51.00%	0.1
452	2002/11/29 02:00:00	2002/11/30 18:00:00	41	0.1	51.10%	0.1
453	2003/05/03 02:00:00	2003/05/04 03:00:00	26	0.1	51.20%	0.1
454	2003/11/12 03:00:00	2003/11/12 18:00:00	16	0.1	51.40%	0.1
455	2004/01/28 05:00:00	2004/01/28 13:00:00	9	0.1	51.50%	0.1
456	2004/02/18 16:00:00	2004/02/19 03:00:00	12	0.1	51.60%	0.1
457	2004/04/01 22:00:00	2004/04/02 20:00:00	23	0.1	51.70%	0.1
458	2004/11/21 05:00:00	2004/11/21 17:00:00	13	0.1	51.80%	0.1
459	2004/11/29 12:00:00	2004/11/29 18:00:00	7	0.1	51.90%	0.1
460	2004/12/04 14:00:00	2004/12/06 02:00:00	37	0.1	52.00%	0.1
461	2005/01/28 15:00:00	2005/01/29 09:00:00	19	0.1	52.10%	0.1
462	2005/03/04 15:00:00	2005/03/05 12:00:00	22	0.1	52.30%	0.1

Rank	Start Date	End Date	Duration (hr)	Peak (cfs)	Frequency (%)	Return Period (Yr)
463	2005/10/16 16:00:00	2005/10/18 17:00:00	50	0.1	52.40%	0.1
464	2006/02/17 23:00:00	2006/02/19 10:00:00	36	0.1	52.50%	0.1
465	2006/03/12 21:00:00	2006/03/13 04:00:00	8	0.1	52.60%	0.1
466	2006/03/17 20:00:00	2006/03/19 03:00:00	32	0.1	52.70%	0.1
467	2006/03/20 04:00:00	2006/03/21 12:00:00	33	0.1	52.80%	0.1
468	2006/04/14 13:00:00	2006/04/15 12:00:00	24	0.1	52.90%	0.1
469	2006/10/13 20:00:00	2006/10/14 17:00:00	22	0.1	53.10%	0.1
470	2006/12/16 20:00:00	2006/12/17 12:00:00	17	0.1	53.20%	0.1
471	2007/02/12 22:00:00	2007/02/14 04:00:00	31	0.1	53.30%	0.1
472	2007/02/19 01:00:00	2007/02/20 00:00:00	24	0.1	53.40%	0.1
473	2007/02/22 21:00:00	2007/02/23 10:00:00	14	0.1	53.50%	0.1
474	2007/02/28 05:00:00	2007/02/28 11:00:00	7	0.1	53.60%	0.1
475	2007/04/20 14:00:00	2007/04/21 01:00:00	12	0.1	53.70%	0.1
476	2007/04/22 23:00:00	2007/04/23 07:00:00	9	0.1	53.80%	0.1
477	2007/12/07 04:00:00	2007/12/09 01:00:00	46	0.1	54.00%	0.09
478	2007/12/19 00:00:00	2007/12/19 13:00:00	14	0.1	54.10%	0.09
479	2007/12/20 22:00:00	2007/12/21 10:00:00	13	0.1	54.20%	0.09
480	2008/01/26 21:00:00	2008/01/28 18:00:00	46	0.1	54.30%	0.09
481	2008/02/20 09:00:00	2008/02/20 20:00:00	12	0.1	54.40%	0.09
482	2008/02/24 07:00:00	2008/02/24 17:00:00	11	0.1	54.50%	0.09
483	1964/11/26 12:00:00	1964/11/26 19:00:00	8	0	54.60%	0.09
484	1965/01/07 10:00:00	1965/01/07 18:00:00	9	0	54.80%	0.09
485	1965/03/07 01:00:00	1965/03/07 10:00:00	10	0	54.90%	0.09
486	1965/03/13 06:00:00	1965/03/13 13:00:00	8	0	55.00%	0.09
487	1965/03/24 09:00:00	1965/03/24 20:00:00	12	0	55.10%	0.09
488	1965/05/23 02:00:00	1965/05/24 10:00:00	33	0	55.20%	0.09
489	1965/06/25 06:00:00	1965/06/25 08:00:00	3	0	55.30%	0.09
490	1965/09/05 18:00:00	1965/09/05 18:00:00	1	0	55.40%	0.09
491	1966/01/19 16:00:00	1966/01/20 04:00:00	13	0	55.50%	0.09
492	1966/02/10 15:00:00	1966/02/10 20:00:00	6	0	55.70%	0.09
493	1966/02/25 03:00:00	1966/02/25 06:00:00	4	0	55.80%	0.09
494	1966/03/02 10:00:00	1966/03/02 14:00:00	5	0	55.90%	0.09
495	1966/03/13 15:00:00	1966/03/13 18:00:00	4	0	56.00%	0.09
496	1966/03/24 19:00:00	1966/03/24 22:00:00	4	0	56.10%	0.09
497	1966/05/10 05:00:00	1966/05/10 06:00:00	2	0	56.20%	0.09
498	1966/09/30 00:00:00	1966/09/30 14:00:00	15	0	56.30%	0.09
499	1966/10/18 12:00:00	1966/10/18 15:00:00	4	0	56.40%	0.09
500	1967/01/31 04:00:00	1967/01/31 08:00:00	5	0	56.60%	0.09
501	1967/03/04 00:00:00	1967/03/04 15:00:00	16	0	56.70%	0.09
502	1967/03/11 09:00:00	1967/03/11 13:00:00	5	0	56.80%	0.09
503	1967/03/29 06:00:00	1967/03/29 09:00:00	4	0	56.90%	0.09
504	1967/04/24 11:00:00	1967/04/24 15:00:00	5	0	57.00%	0.09
505	1967/04/28 19:00:00	1967/04/28 23:00:00	5	0	57.10%	0.09
506	1967/06/09 07:00:00	1967/06/09 08:00:00	2	0	57.20%	0.09
507	1967/06/13 12:00:00	1967/06/13 19:00:00	8	0	57.40%	0.09
508	1967/07/26 21:00:00	1967/07/26 22:00:00	2	0	57.50%	0.09
509	1967/09/02 21:00:00	1967/09/03 01:00:00	5	0	57.60%	0.09

Rank	Start Date	End Date	Duration (hr)	Peak (cfs)	Frequency (%)	Return Period (Yr)
510	1967/09/29 21:00:00	1967/09/30 04:00:00	8	0	57.70%	0.09
511	1967/11/28 10:00:00	1967/11/28 14:00:00	5	0	57.80%	0.09
512	1967/12/08 01:00:00	1967/12/08 05:00:00	5	0	57.90%	0.09
513	1968/01/10 05:00:00	1968/01/10 08:00:00	4	0	58.00%	0.09
514	1968/02/10 04:00:00	1968/02/10 08:00:00	5	0	58.10%	0.09
515	1968/03/13 22:00:00	1968/03/14 02:00:00	5	0	58.30%	0.09
516	1968/03/17 02:00:00	1968/03/17 06:00:00	5	0	58.40%	0.09
517	1968/05/12 05:00:00	1968/05/12 11:00:00	7	0	58.50%	0.09
518	1968/06/07 07:00:00	1968/06/07 08:00:00	2	0	58.60%	0.09
519	1968/07/09 21:00:00	1968/07/10 01:00:00	5	0	58.70%	0.09
520	1968/09/13 11:00:00	1968/09/13 12:00:00	2	0	58.80%	0.09
521	1968/10/30 10:00:00	1968/10/30 11:00:00	2	0	58.90%	0.09
522	1968/12/01 11:00:00	1968/12/01 14:00:00	4	0	59.00%	0.09
523	1969/01/17 11:00:00	1969/01/17 16:00:00	6	0	59.20%	0.09
524	1969/04/03 02:00:00	1969/04/03 05:00:00	4	0	59.30%	0.09
525	1969/06/11 09:00:00	1969/06/11 15:00:00	7	0	59.40%	0.09
526	1969/06/17 09:00:00	1969/06/17 12:00:00	4	0	59.50%	0.09
527	1969/08/10 05:00:00	1969/08/10 06:00:00	2	0	59.60%	0.09
528	1969/09/07 00:00:00	1969/09/07 01:00:00	2	0	59.70%	0.09
529	1969/11/15 21:00:00	1969/11/16 01:00:00	5	0	59.80%	0.09
530	1969/12/08 19:00:00	1969/12/09 05:00:00	11	0	60.00%	0.09
531	1969/12/26 10:00:00	1969/12/26 14:00:00	5	0	60.10%	0.09
532	1970/01/10 01:00:00	1970/01/10 05:00:00	5	0	60.20%	0.09
533	1970/01/15 02:00:00	1970/01/15 07:00:00	6	0	60.30%	0.08
534	1970/01/18 14:00:00	1970/01/18 19:00:00	6	0	60.40%	0.08
535	1970/12/02 15:00:00	1970/12/02 20:00:00	6	0	60.50%	0.08
536	1971/02/19 17:00:00	1971/02/20 12:00:00	20	0	60.60%	0.08
537	1971/05/03 09:00:00	1971/05/03 12:00:00	4	0	60.70%	0.08
538	1971/05/06 06:00:00	1971/05/06 16:00:00	11	0	60.90%	0.08
539	1971/06/02 12:00:00	1971/06/02 15:00:00	4	0	61.00%	0.08
540	1971/06/05 14:00:00	1971/06/05 18:00:00	5	0	61.10%	0.08
541	1971/10/22 13:00:00	1971/10/22 17:00:00	5	0	61.20%	0.08
542	1971/10/24 11:00:00	1971/10/25 18:00:00	32	0	61.30%	0.08
543	1971/10/30 10:00:00	1971/10/30 14:00:00	5	0	61.40%	0.08
544	1971/11/13 13:00:00	1971/11/13 16:00:00	4	0	61.50%	0.08
545	1971/11/15 16:00:00	1971/11/15 20:00:00	5	0	61.70%	0.08
546	1971/11/29 06:00:00	1971/11/29 09:00:00	4	0	61.80%	0.08
547	1972/02/05 08:00:00	1972/02/06 13:00:00	30	0	61.90%	0.08
548	1972/04/13 03:00:00	1972/04/13 11:00:00	9	0	62.00%	0.08
549	1972/04/21 09:00:00	1972/04/21 12:00:00	4	0	62.10%	0.08
550	1972/06/07 04:00:00	1972/06/07 05:00:00	2	0	62.20%	0.08
551	1972/06/10 02:00:00	1972/06/10 03:00:00	2	0	62.30%	0.08
552	1972/06/22 13:00:00	1972/06/22 14:00:00	2	0	62.40%	0.08
553	1972/09/06 05:00:00	1972/09/07 00:00:00	20	0	62.60%	0.08
554	1972/10/11 15:00:00	1972/10/11 16:00:00	2	0	62.70%	0.08
555	1972/10/17 09:00:00	1972/10/17 10:00:00	2	0	62.80%	0.08
556	1972/11/08 01:00:00	1972/11/08 04:00:00	4	0	62.90%	0.08

Rank	Start Date	End Date	Duration (hr)	Peak (cfs)	Frequency (%)	Return Period (Yr)
557	1973/01/25 21:00:00	1973/01/26 01:00:00	5	0	63.00%	0.08
558	1973/01/30 13:00:00	1973/01/30 18:00:00	6	0	63.10%	0.08
559	1973/02/07 15:00:00	1973/02/07 20:00:00	6	0	63.20%	0.08
560	1973/02/21 09:00:00	1973/02/21 13:00:00	5	0	63.30%	0.08
561	1973/03/27 03:00:00	1973/03/27 20:00:00	18	0	63.50%	0.08
562	1973/03/28 21:00:00	1973/03/29 02:00:00	6	0	63.60%	0.08
563	1973/04/21 10:00:00	1973/04/21 11:00:00	2	0	63.70%	0.08
564	1973/05/23 15:00:00	1973/05/23 16:00:00	2	0	63.80%	0.08
565	1973/05/28 10:00:00	1973/05/28 11:00:00	2	0	63.90%	0.08
566	1973/05/31 09:00:00	1973/05/31 12:00:00	4	0	64.00%	0.08
567	1973/11/24 19:00:00	1973/11/25 00:00:00	6	0	64.10%	0.08
568	1973/12/16 15:00:00	1973/12/16 19:00:00	5	0	64.30%	0.08
569	1973/12/20 14:00:00	1973/12/20 19:00:00	6	0	64.40%	0.08
570	1973/12/22 03:00:00	1973/12/22 08:00:00	6	0	64.50%	0.08
571	1974/02/18 16:00:00	1974/02/18 18:00:00	3	0	64.60%	0.08
572	1974/02/19 19:00:00	1974/02/19 23:00:00	5	0	64.70%	0.08
573	1974/03/27 09:00:00	1974/03/27 15:00:00	7	0	64.80%	0.08
574	1974/06/08 12:00:00	1974/06/08 13:00:00	2	0	64.90%	0.08
575	1974/11/01 23:00:00	1974/11/02 03:00:00	5	0	65.00%	0.08
576	1974/11/03 16:00:00	1974/11/03 21:00:00	6	0	65.20%	0.08
577	1975/02/14 05:00:00	1975/02/14 09:00:00	5	0	65.30%	0.08
578	1975/03/25 10:00:00	1975/03/26 03:00:00	18	0	65.40%	0.08
579	1975/04/17 03:00:00	1975/04/18 17:00:00	39	0	65.50%	0.08
580	1975/04/23 15:00:00	1975/04/23 18:00:00	4	0	65.60%	0.08
581	1975/05/20 02:00:00	1975/05/20 03:00:00	2	0	65.70%	0.08
582	1975/06/07 14:00:00	1975/06/07 15:00:00	2	0	65.80%	0.08
583	1975/10/28 22:00:00	1975/10/28 23:00:00	2	0	66.00%	0.08
584	1975/12/20 00:00:00	1975/12/20 04:00:00	5	0	66.10%	0.08
585	1976/04/04 09:00:00	1976/04/05 03:00:00	19	0	66.20%	0.08
586	1976/09/03 17:00:00	1976/09/03 18:00:00	2	0	66.30%	0.08
587	1976/09/14 11:00:00	1976/09/14 15:00:00	5	0	66.40%	0.08
588	1977/01/21 15:00:00	1977/01/21 19:00:00	5	0	66.50%	0.08
589	1977/02/22 01:00:00	1977/02/22 07:00:00	7	0	66.60%	0.08
590	1977/02/23 12:00:00	1977/02/24 06:00:00	19	0	66.70%	0.08
591	1977/04/02 01:00:00	1977/04/02 04:00:00	4	0	66.90%	0.08
592	1977/05/05 21:00:00	1977/05/05 22:00:00	2	0	67.00%	0.08
593	1977/05/12 19:00:00	1977/05/13 05:00:00	11	0	67.10%	0.08
594	1977/05/24 06:00:00	1977/05/24 13:00:00	8	0	67.20%	0.08
595	1977/08/12 11:00:00	1977/08/12 12:00:00	2	0	67.30%	0.08
596	1977/10/06 03:00:00	1977/10/06 04:00:00	2	0	67.40%	0.08
597	1977/11/06 02:00:00	1977/11/06 04:00:00	3	0	67.50%	0.08
598	1978/01/12 16:00:00	1978/01/12 21:00:00	6	0	67.60%	0.08
599	1978/01/26 10:00:00	1978/01/26 14:00:00	5	0	67.80%	0.08
600	1978/04/02 17:00:00	1978/04/02 21:00:00	5	0	67.90%	0.08
601	1978/04/26 09:00:00	1978/04/26 12:00:00	4	0	68.00%	0.08
602	1978/05/01 11:00:00	1978/05/01 14:00:00	4	0	68.10%	0.08
603	1978/09/07 12:00:00	1978/09/07 16:00:00	5	0	68.20%	0.08

Rank	Start Date	End Date	Duration (hr)	Peak (cfs)	Frequency (%)	Return Period (Yr)
604	1978/09/19 13:00:00	1978/09/19 14:00:00	2	0	68.30%	0.08
605	1979/01/29 09:00:00	1979/01/29 13:00:00	5	0	68.40%	0.07
606	1979/03/13 10:00:00	1979/03/13 13:00:00	4	0	68.60%	0.07
607	1979/03/15 22:00:00	1979/03/16 02:00:00	5	0	68.70%	0.07
608	1979/05/19 15:00:00	1979/05/19 16:00:00	2	0	68.80%	0.07
609	1979/08/13 15:00:00	1979/08/13 16:00:00	2	0	68.90%	0.07
610	1979/11/04 07:00:00	1979/11/04 10:00:00	4	0	69.00%	0.07
611	1979/11/05 14:00:00	1979/11/05 18:00:00	5	0	69.10%	0.07
612	1979/12/22 10:00:00	1979/12/22 12:00:00	3	0	69.20%	0.07
613	1980/01/15 10:00:00	1980/01/15 15:00:00	6	0	69.30%	0.07
614	1980/03/18 08:00:00	1980/03/19 00:00:00	17	0	69.50%	0.07
615	1980/04/21 04:00:00	1980/04/21 05:00:00	2	0	69.60%	0.07
616	1980/04/24 12:00:00	1980/04/24 16:00:00	5	0	69.70%	0.07
617	1980/04/28 17:00:00	1980/04/30 00:00:00	32	0	69.80%	0.07
618	1980/05/01 23:00:00	1980/05/02 03:00:00	5	0	69.90%	0.07
619	1980/05/10 11:00:00	1980/05/10 17:00:00	7	0	70.00%	0.07
620	1980/10/26 10:00:00	1980/10/26 11:00:00	2	0	70.10%	0.07
621	1980/12/11 14:00:00	1980/12/11 19:00:00	6	0	70.20%	0.07
622	1981/01/11 17:00:00	1981/01/11 20:00:00	4	0	70.40%	0.07
623	1981/03/14 02:00:00	1981/03/14 05:00:00	4	0	70.50%	0.07
624	1981/04/02 06:00:00	1981/04/03 01:00:00	20	0	70.60%	0.07
625	1981/04/18 13:00:00	1981/04/19 14:00:00	26	0	70.70%	0.07
626	1981/05/16 11:00:00	1981/05/16 12:00:00	2	0	70.80%	0.07
627	1981/05/27 01:00:00	1981/05/27 02:00:00	2	0	70.90%	0.07
628	1981/10/01 02:00:00	1981/10/01 03:00:00	2	0	71.00%	0.07
629	1981/10/11 06:00:00	1981/10/11 11:00:00	6	0	71.20%	0.07
630	1981/10/28 23:00:00	1981/10/29 00:00:00	2	0	71.30%	0.07
631	1981/12/21 04:00:00	1981/12/21 07:00:00	4	0	71.40%	0.07
632	1982/02/05 14:00:00	1982/02/05 18:00:00	5	0	71.50%	0.07
633	1982/02/08 03:00:00	1982/02/08 08:00:00	6	0	71.60%	0.07
634	1982/02/16 09:00:00	1982/02/16 13:00:00	5	0	71.70%	0.07
635	1982/03/02 19:00:00	1982/03/03 05:00:00	11	0	71.80%	0.07
636	1982/03/12 14:00:00	1982/03/12 17:00:00	4	0	71.90%	0.07
637	1982/04/05 15:00:00	1982/04/05 19:00:00	5	0	72.10%	0.07
638	1982/05/11 08:00:00	1982/05/11 09:00:00	2	0	72.20%	0.07
639	1982/05/26 13:00:00	1982/05/26 14:00:00	2	0	72.30%	0.07
640	1982/09/16 13:00:00	1982/09/16 14:00:00	2	0	72.40%	0.07
641	1982/09/22 13:00:00	1982/09/22 14:00:00	2	0	72.50%	0.07
642	1982/10/26 10:00:00	1982/10/26 11:00:00	2	0	72.60%	0.07
643	1982/10/31 15:00:00	1982/10/31 16:00:00	2	0	72.70%	0.07
644	1982/12/29 19:00:00	1982/12/30 15:00:00	21	0	72.90%	0.07
645	1983/03/15 10:00:00	1983/03/15 13:00:00	4	0	73.00%	0.07
646	1983/04/10 23:00:00	1983/04/13 04:00:00	54	0	73.10%	0.07
647	1983/08/07 09:00:00	1983/08/07 10:00:00	2	0	73.20%	0.07
648	1983/08/18 09:00:00	1983/08/18 21:00:00	13	0	73.30%	0.07
649	1983/11/18 02:00:00	1983/11/18 06:00:00	5	0	73.40%	0.07
650	1983/12/22 11:00:00	1983/12/22 13:00:00	3	0	73.50%	0.07

Rank	Start Date	End Date	Duration (hr)	Peak (cfs)	Frequency (%)	Return Period (Yr)
651	1984/03/24 13:00:00	1984/03/24 14:00:00	2	0	73.60%	0.07
652	1984/10/17 08:00:00	1984/10/17 09:00:00	2	0	73.80%	0.07
653	1984/11/13 10:00:00	1984/11/13 12:00:00	3	0	73.90%	0.07
654	1984/11/22 16:00:00	1984/11/22 17:00:00	2	0	74.00%	0.07
655	1984/11/24 16:00:00	1984/11/24 17:00:00	2	0	74.10%	0.07
656	1984/12/12 23:00:00	1984/12/13 01:00:00	3	0	74.20%	0.07
657	1984/12/16 04:00:00	1984/12/16 09:00:00	6	0	74.30%	0.07
658	1984/12/18 14:00:00	1984/12/19 22:00:00	33	0	74.40%	0.07
659	1985/01/09 13:00:00	1985/01/09 16:00:00	4	0	74.50%	0.07
660	1985/03/12 11:00:00	1985/03/12 14:00:00	4	0	74.70%	0.07
661	1985/04/21 14:00:00	1985/04/22 05:00:00	16	0	74.80%	0.07
662	1985/05/30 15:00:00	1985/05/30 17:00:00	3	0	74.90%	0.07
663	1985/06/02 22:00:00	1985/06/03 03:00:00	6	0	75.00%	0.07
664	1985/07/18 16:00:00	1985/07/18 17:00:00	2	0	75.10%	0.07
665	1985/08/10 14:00:00	1985/08/10 15:00:00	2	0	75.20%	0.07
666	1985/09/04 11:00:00	1985/09/04 13:00:00	3	0	75.30%	0.07
667	1985/10/22 00:00:00	1985/10/22 04:00:00	5	0	75.50%	0.07
668	1985/11/27 09:00:00	1985/11/27 11:00:00	3	0	75.60%	0.07
669	1986/01/02 15:00:00	1986/01/02 20:00:00	6	0	75.70%	0.07
670	1986/02/13 09:00:00	1986/02/13 10:00:00	2	0	75.80%	0.07
671	1986/02/18 22:00:00	1986/02/19 16:00:00	19	0	75.90%	0.07
672	1986/05/22 10:00:00	1986/05/22 11:00:00	2	0	76.00%	0.07
673	1986/07/22 14:00:00	1986/07/22 17:00:00	4	0	76.10%	0.07
674	1986/08/18 06:00:00	1986/08/18 07:00:00	2	0	76.20%	0.07
675	1986/09/18 11:00:00	1986/09/18 12:00:00	2	0	76.40%	0.07
676	1986/10/08 16:00:00	1986/10/08 17:00:00	2	0	76.50%	0.07
677	1986/12/20 06:00:00	1986/12/20 17:00:00	12	0	76.60%	0.07
678	1986/12/30 16:00:00	1986/12/30 18:00:00	3	0	76.70%	0.07
679	1987/02/01 01:00:00	1987/02/01 02:00:00	2	0	76.80%	0.07
680	1987/02/13 19:00:00	1987/02/14 04:00:00	10	0	76.90%	0.07
681	1987/02/15 15:00:00	1987/02/15 17:00:00	3	0	77.00%	0.07
682	1987/03/06 12:00:00	1987/03/06 13:00:00	2	0	77.10%	0.07
683	1987/03/15 01:00:00	1987/03/15 02:00:00	2	0	77.30%	0.07
684	1987/03/21 16:00:00	1987/03/21 22:00:00	7	0	77.40%	0.07
685	1987/03/23 21:00:00	1987/03/23 22:00:00	2	0	77.50%	0.07
686	1987/05/01 01:00:00	1987/05/01 02:00:00	2	0	77.60%	0.07
687	1987/05/20 08:00:00	1987/05/20 09:00:00	2	0	77.70%	0.07
688	1987/07/18 00:00:00	1987/07/18 01:00:00	2	0	77.80%	0.07
689	1987/08/14 09:00:00	1987/08/14 10:00:00	2	0	77.90%	0.07
690	1987/09/01 01:00:00	1987/09/01 02:00:00	2	0	78.10%	0.07
691	1987/09/13 05:00:00	1987/09/13 06:00:00	2	0	78.20%	0.07
692	1987/10/07 09:00:00	1987/10/07 10:00:00	2	0	78.30%	0.07
693	1987/10/12 18:00:00	1987/10/13 00:00:00	7	0	78.40%	0.07
694	1987/11/14 02:00:00	1987/11/14 07:00:00	6	0	78.50%	0.07
695	1987/11/17 21:00:00	1987/11/18 03:00:00	7	0	78.60%	0.07
696	1987/11/20 16:00:00	1987/11/20 20:00:00	5	0	78.70%	0.07
697	1987/12/07 05:00:00	1987/12/07 08:00:00	4	0	78.80%	0.07

Rank	Start Date	End Date	Duration (hr)	Peak (cfs)	Frequency (%)	Return Period (Yr)
698	1987/12/29 15:00:00	1987/12/30 09:00:00	19	0	79.00%	0.06
699	1988/02/01 01:00:00	1988/02/01 02:00:00	2	0	79.10%	0.06
700	1988/04/23 14:00:00	1988/04/23 15:00:00	2	0	79.20%	0.06
701	1988/05/05 22:00:00	1988/05/05 23:00:00	2	0	79.30%	0.06
702	1988/05/29 04:00:00	1988/05/29 08:00:00	5	0	79.40%	0.06
703	1988/05/31 16:00:00	1988/05/31 17:00:00	2	0	79.50%	0.06
704	1988/11/23 22:00:00	1988/11/24 04:00:00	7	0	79.60%	0.06
705	1988/12/23 00:00:00	1988/12/23 06:00:00	7	0	79.80%	0.06
706	1988/12/28 00:00:00	1988/12/28 03:00:00	4	0	79.90%	0.06
707	1989/01/07 16:00:00	1989/01/07 22:00:00	7	0	80.00%	0.06
708	1989/01/28 14:00:00	1989/01/28 16:00:00	3	0	80.10%	0.06
709	1989/02/02 10:00:00	1989/02/02 17:00:00	8	0	80.20%	0.06
710	1989/03/02 19:00:00	1989/03/03 04:00:00	10	0	80.30%	0.06
711	1989/03/08 20:00:00	1989/03/08 21:00:00	2	0	80.40%	0.06
712	1989/04/12 06:00:00	1989/04/12 07:00:00	2	0	80.50%	0.06
713	1989/04/26 03:00:00	1989/04/26 04:00:00	2	0	80.70%	0.06
714	1989/05/15 12:00:00	1989/05/15 13:00:00	2	0	80.80%	0.06
715	1989/09/17 04:00:00	1989/09/17 18:00:00	15	0	80.90%	0.06
716	1989/09/19 10:00:00	1989/09/19 14:00:00	5	0	81.00%	0.06
717	1989/10/25 20:00:00	1989/10/25 21:00:00	2	0	81.10%	0.06
718	1989/11/26 08:00:00	1989/11/26 21:00:00	14	0	81.20%	0.06
719	1990/03/05 16:00:00	1990/03/05 17:00:00	2	0	81.30%	0.06
720	1990/03/11 01:00:00	1990/03/11 08:00:00	8	0	81.40%	0.06
721	1990/03/12 12:00:00	1990/03/12 23:00:00	12	0	81.60%	0.06
722	1990/03/28 18:00:00	1990/03/28 21:00:00	4	0	81.70%	0.06
723	1990/04/16 21:00:00	1990/04/17 13:00:00	17	0	81.80%	0.06
724	1990/04/18 19:00:00	1990/04/19 20:00:00	26	0	81.90%	0.06
725	1990/04/25 00:00:00	1990/04/25 01:00:00	2	0	82.00%	0.06
726	1990/05/28 04:00:00	1990/05/29 07:00:00	28	0	82.10%	0.06
727	1990/07/13 12:00:00	1990/07/13 13:00:00	2	0	82.20%	0.06
728	1990/08/06 00:00:00	1990/08/06 01:00:00	2	0	82.40%	0.06
729	1990/08/09 16:00:00	1990/08/09 17:00:00	2	0	82.50%	0.06
730	1990/12/15 22:00:00	1990/12/16 00:00:00	3	0	82.60%	0.06
731	1991/04/21 03:00:00	1991/04/21 04:00:00	2	0	82.70%	0.06
732	1991/07/31 11:00:00	1991/07/31 12:00:00	2	0	82.80%	0.06
733	1991/09/20 17:00:00	1991/09/20 19:00:00	3	0	82.90%	0.06
734	1991/11/29 19:00:00	1991/11/29 20:00:00	2	0	83.00%	0.06
735	1991/12/08 17:00:00	1991/12/08 19:00:00	3	0	83.10%	0.06
736	1991/12/09 23:00:00	1991/12/11 11:00:00	37	0	83.30%	0.06
737	1992/03/06 18:00:00	1992/03/08 07:00:00	38	0	83.40%	0.06
738	1992/03/29 11:00:00	1992/03/29 12:00:00	2	0	83.50%	0.06
739	1992/03/31 16:00:00	1992/04/01 15:00:00	24	0	83.60%	0.06
740	1992/05/05 22:00:00	1992/05/05 23:00:00	2	0	83.70%	0.06
741	1992/05/22 17:00:00	1992/05/22 20:00:00	4	0	83.80%	0.06
742	1992/08/13 16:00:00	1992/08/13 18:00:00	3	0	83.90%	0.06
743	1992/10/21 16:00:00	1992/10/21 17:00:00	2	0	84.00%	0.06
744	1992/10/23 04:00:00	1992/10/23 10:00:00	7	0	84.20%	0.06

Rank	Start Date	End Date	Duration (hr)	Peak (cfs)	Frequency (%)	Return Period (Yr)
745	1992/10/28 23:00:00	1992/10/29 06:00:00	8	0	84.30%	0.06
746	1992/10/30 17:00:00	1992/10/31 00:00:00	8	0	84.40%	0.06
747	1992/11/20 16:00:00	1992/11/20 17:00:00	2	0	84.50%	0.06
748	1992/11/22 23:00:00	1992/11/23 00:00:00	2	0	84.60%	0.06
749	1992/12/03 23:00:00	1992/12/04 23:00:00	25	0	84.70%	0.06
750	1992/12/11 17:00:00	1992/12/12 01:00:00	9	0	84.80%	0.06
751	1993/02/22 06:00:00	1993/02/22 08:00:00	3	0	85.00%	0.06
752	1993/02/26 15:00:00	1993/02/27 14:00:00	24	0	85.10%	0.06
753	1993/10/16 06:00:00	1993/10/16 07:00:00	2	0	85.20%	0.06
754	1993/11/11 05:00:00	1993/11/12 20:00:00	40	0	85.30%	0.06
755	1993/11/30 04:00:00	1993/11/30 11:00:00	8	0	85.40%	0.06
756	1993/12/19 04:00:00	1993/12/19 11:00:00	8	0	85.50%	0.06
757	1994/02/11 07:00:00	1994/02/11 08:00:00	2	0	85.60%	0.06
758	1994/04/24 04:00:00	1994/04/24 06:00:00	3	0	85.70%	0.06
759	1994/05/08 09:00:00	1994/05/08 10:00:00	2	0	85.90%	0.06
760	1994/05/15 02:00:00	1994/05/15 03:00:00	2	0	86.00%	0.06
761	1994/11/18 03:00:00	1994/11/18 10:00:00	8	0	86.10%	0.06
762	1994/11/26 11:00:00	1994/11/26 12:00:00	2	0	86.20%	0.06
763	1994/12/13 06:00:00	1994/12/13 08:00:00	3	0	86.30%	0.06
764	1994/12/17 15:00:00	1994/12/17 18:00:00	4	0	86.40%	0.06
765	1994/12/22 07:00:00	1994/12/23 00:00:00	18	0	86.50%	0.06
766	1995/01/27 12:00:00	1995/01/27 16:00:00	5	0	86.70%	0.06
767	1995/04/07 10:00:00	1995/04/07 12:00:00	3	0	86.80%	0.06
768	1995/05/06 02:00:00	1995/05/06 13:00:00	12	0	86.90%	0.06
769	1995/05/13 07:00:00	1995/05/13 13:00:00	7	0	87.00%	0.06
770	1995/05/14 21:00:00	1995/05/15 05:00:00	9	0	87.10%	0.06
771	1995/05/23 13:00:00	1995/05/23 14:00:00	2	0	87.20%	0.06
772	1995/07/16 08:00:00	1995/07/16 09:00:00	2	0	87.30%	0.06
773	1995/10/01 01:00:00	1995/10/01 02:00:00	2	0	87.40%	0.06
774	1995/11/01 03:00:00	1995/11/01 09:00:00	7	0	87.60%	0.06
775	1995/12/13 04:00:00	1995/12/14 12:00:00	33	0	87.70%	0.06
776	1996/01/25 11:00:00	1996/01/25 23:00:00	13	0	87.80%	0.06
777	1996/01/28 08:00:00	1996/01/28 11:00:00	4	0	87.90%	0.06
778	1996/05/24 15:00:00	1996/05/24 16:00:00	2	0	88.00%	0.06
779	1996/07/10 14:00:00	1996/07/10 15:00:00	2	0	88.10%	0.06
780	1996/07/19 10:00:00	1996/07/19 11:00:00	2	0	88.20%	0.06
781	1996/10/25 22:00:00	1996/10/25 23:00:00	2	0	88.30%	0.06
782	1996/11/29 02:00:00	1996/11/29 05:00:00	4	0	88.50%	0.06
783	1996/12/27 16:00:00	1996/12/28 12:00:00	21	0	88.60%	0.06
784	1997/01/02 01:00:00	1997/01/02 06:00:00	6	0	88.70%	0.06
785	1997/02/17 18:00:00	1997/02/18 14:00:00	21	0	88.80%	0.06
786	1997/04/08 10:00:00	1997/04/08 11:00:00	2	0	88.90%	0.06
787	1997/05/24 07:00:00	1997/05/24 08:00:00	2	0	89.00%	0.06
788	1997/12/18 15:00:00	1997/12/18 19:00:00	5	0	89.10%	0.06
789	1997/12/21 08:00:00	1997/12/22 18:00:00	35	0	89.30%	0.06
790	1998/01/02 16:00:00	1998/01/05 00:00:00	57	0	89.40%	0.06
791	1998/01/13 11:00:00	1998/01/13 22:00:00	12	0	89.50%	0.06

Rank	Start Date	End Date	Duration (hr)	Peak (cfs)	Frequency (%)	Return Period (Yr)
792	1998/01/15 15:00:00	1998/01/16 19:00:00	29	0	89.60%	0.06
793	1998/03/01 17:00:00	1998/03/01 17:00:00	1	0	89.70%	0.06
794	1998/03/06 04:00:00	1998/03/07 01:00:00	22	0	89.80%	0.06
795	1998/03/15 11:00:00	1998/03/15 21:00:00	11	0	89.90%	0.06
796	1998/04/06 17:00:00	1998/04/07 18:00:00	26	0	90.00%	0.06
797	1998/04/14 08:00:00	1998/04/16 01:00:00	42	0	90.20%	0.06
798	1998/04/19 15:00:00	1998/04/19 18:00:00	4	0	90.30%	0.06
799	1998/04/28 11:00:00	1998/04/28 19:00:00	9	0	90.40%	0.06
800	1998/05/04 16:00:00	1998/05/06 18:00:00	51	0	90.50%	0.06
801	1998/05/26 17:00:00	1998/05/26 17:00:00	1	0	90.60%	0.06
802	1998/06/12 17:00:00	1998/06/12 17:00:00	1	0	90.70%	0.06
803	2000/01/01 09:00:00	2000/01/02 20:00:00	36	0	90.80%	0.06
804	2000/01/17 17:00:00	2000/01/17 18:00:00	2	0	91.00%	0.06
805	2000/01/25 12:00:00	2000/01/25 22:00:00	11	0	91.10%	0.06
806	2000/02/11 09:00:00	2000/02/11 22:00:00	14	0	91.20%	0.06
807	2000/02/28 15:00:00	2000/02/28 18:00:00	4	0	91.30%	0.06
808	2000/04/14 22:00:00	2000/04/14 23:00:00	2	0	91.40%	0.06
809	2000/04/21 19:00:00	2000/04/22 06:00:00	12	0	91.50%	0.06
810	2000/05/25 23:00:00	2000/05/26 01:00:00	3	0	91.60%	0.06
811	2000/09/23 02:00:00	2000/09/23 03:00:00	2	0	91.70%	0.06
812	2000/10/06 13:00:00	2000/10/06 14:00:00	2	0	91.90%	0.06
813	2000/10/10 08:00:00	2000/10/11 10:00:00	27	0	92.00%	0.06
814	2000/10/21 18:00:00	2000/10/21 19:00:00	2	0	92.10%	0.06
815	2000/10/26 09:00:00	2000/10/27 03:00:00	19	0	92.20%	0.06
816	2000/11/22 21:00:00	2000/11/23 00:00:00	4	0	92.30%	0.06
817	2001/01/08 16:00:00	2001/01/09 07:00:00	16	0	92.40%	0.06
818	2001/01/15 21:00:00	2001/01/16 00:00:00	4	0	92.50%	0.06
819	2001/08/20 15:00:00	2001/08/21 17:00:00	27	0	92.60%	0.06
820	2001/11/04 16:00:00	2001/11/04 18:00:00	3	0	92.80%	0.06
821	2001/11/12 17:00:00	2001/11/13 20:00:00	28	0	92.90%	0.06
822	2001/11/29 09:00:00	2001/11/30 00:00:00	16	0	93.00%	0.06
823	2001/12/14 11:00:00	2001/12/15 18:00:00	32	0	93.10%	0.06
824	2001/12/30 16:00:00	2001/12/30 18:00:00	3	0	93.20%	0.06
825	2002/01/03 17:00:00	2002/01/03 18:00:00	2	0	93.30%	0.06
826	2002/01/28 03:00:00	2002/01/29 13:00:00	35	0	93.40%	0.05
827	2002/02/17 17:00:00	2002/02/18 18:00:00	26	0	93.60%	0.05
828	2002/03/07 11:00:00	2002/03/08 05:00:00	19	0	93.70%	0.05
829	2002/03/16 06:00:00	2002/03/16 12:00:00	7	0	93.80%	0.05
830	2002/03/24 02:00:00	2002/03/24 05:00:00	4	0	93.90%	0.05
831	2002/04/15 09:00:00	2002/04/15 10:00:00	2	0	94.00%	0.05
832	2002/04/24 11:00:00	2002/04/24 17:00:00	7	0	94.10%	0.05
833	2002/04/26 09:00:00	2002/04/26 10:00:00	2	0	94.20%	0.05
834	2002/05/20 23:00:00	2002/05/21 00:00:00	2	0	94.30%	0.05
835	2002/09/06 16:00:00	2002/09/06 18:00:00	3	0	94.50%	0.05
836	2002/12/29 16:00:00	2002/12/29 18:00:00	3	0	94.60%	0.05
837	2003/03/04 16:00:00	2003/03/04 18:00:00	3	0	94.70%	0.05
838	2003/04/05 17:00:00	2003/04/05 17:00:00	1	0	94.80%	0.05

Rank	Start Date	End Date	Duration (hr)	Peak (cfs)	Frequency (%)	Return Period (Yr)
839	2003/04/17 11:00:00	2003/04/17 21:00:00	11	0	94.90%	0.05
840	2003/05/07 17:00:00	2003/05/07 17:00:00	1	0	95.00%	0.05
841	2003/06/10 17:00:00	2003/06/11 17:00:00	25	0	95.10%	0.05
842	2003/06/20 17:00:00	2003/06/20 17:00:00	1	0	95.20%	0.05
843	2003/07/30 07:00:00	2003/07/30 08:00:00	2	0	95.40%	0.05
844	2003/11/01 05:00:00	2003/11/01 06:00:00	2	0	95.50%	0.05
845	2003/11/03 18:00:00	2003/11/04 00:00:00	7	0	95.60%	0.05
846	2003/11/16 01:00:00	2003/11/16 07:00:00	7	0	95.70%	0.05
847	2003/12/07 21:00:00	2003/12/08 04:00:00	8	0	95.80%	0.05
848	2003/12/11 17:00:00	2003/12/11 20:00:00	4	0	95.90%	0.05
849	2004/01/02 19:00:00	2004/01/03 05:00:00	11	0	96.00%	0.05
850	2004/01/19 08:00:00	2004/01/19 13:00:00	6	0	96.20%	0.05
851	2004/01/25 03:00:00	2004/01/25 05:00:00	3	0	96.30%	0.05
852	2004/01/31 07:00:00	2004/01/31 10:00:00	4	0	96.40%	0.05
853	2004/03/26 10:00:00	2004/03/26 11:00:00	2	0	96.50%	0.05
854	2004/04/17 13:00:00	2004/04/17 19:00:00	7	0	96.60%	0.05
855	2004/11/12 12:00:00	2004/11/12 13:00:00	2	0	96.70%	0.05
856	2004/12/08 07:00:00	2004/12/08 10:00:00	4	0	96.80%	0.05
857	2005/01/26 02:00:00	2005/01/27 04:00:00	27	0	96.90%	0.05
858	2005/02/07 08:00:00	2005/02/07 09:00:00	2	0	97.10%	0.05
859	2005/03/18 17:00:00	2005/03/20 09:00:00	41	0	97.20%	0.05
860	2005/03/24 15:00:00	2005/03/24 17:00:00	3	0	97.30%	0.05
861	2005/05/06 02:00:00	2005/05/06 03:00:00	2	0	97.40%	0.05
862	2005/07/23 05:00:00	2005/07/23 06:00:00	2	0	97.50%	0.05
863	2005/09/20 02:00:00	2005/09/20 06:00:00	5	0	97.60%	0.05
864	2005/12/03 02:00:00	2005/12/03 04:00:00	3	0	97.70%	0.05
865	2006/03/03 17:00:00	2006/03/03 18:00:00	2	0	97.90%	0.05
866	2006/03/07 01:00:00	2006/03/08 11:00:00	35	0	98.00%	0.05
867	2006/03/26 00:00:00	2006/03/26 06:00:00	7	0	98.10%	0.05
868	2006/04/23 06:00:00	2006/04/23 07:00:00	2	0	98.20%	0.05
869	2006/07/29 00:00:00	2006/07/29 06:00:00	7	0	98.30%	0.05
870	2006/07/30 08:00:00	2006/07/31 08:00:00	25	0	98.40%	0.05
871	2006/11/27 10:00:00	2006/11/28 03:00:00	18	0	98.50%	0.05
872	2006/12/22 08:00:00	2006/12/22 10:00:00	3	0	98.60%	0.05
873	2006/12/27 07:00:00	2006/12/27 15:00:00	9	0	98.80%	0.05
874	2007/01/04 22:00:00	2007/01/05 05:00:00	8	0	98.90%	0.05
875	2007/02/11 12:00:00	2007/02/11 17:00:00	6	0	99.00%	0.05
876	2007/02/27 00:00:00	2007/02/27 01:00:00	2	0	99.10%	0.05
877	2007/03/21 04:00:00	2007/03/21 13:00:00	10	0	99.20%	0.05
878	2007/03/27 05:00:00	2007/03/27 17:00:00	13	0	99.30%	0.05
879	2007/05/23 01:00:00	2007/05/23 03:00:00	3	0	99.40%	0.05
880	2007/09/22 11:00:00	2007/09/22 12:00:00	2	0	99.50%	0.05
881	2007/10/13 03:00:00	2007/10/13 08:00:00	6	0	99.70%	0.05
882	2007/10/17 09:00:00	2007/10/17 10:00:00	2	0	99.80%	0.05
883	2008/01/21 08:00:00	2008/01/21 13:00:00	6	0	99.90%	0.05
-End of Data-----						

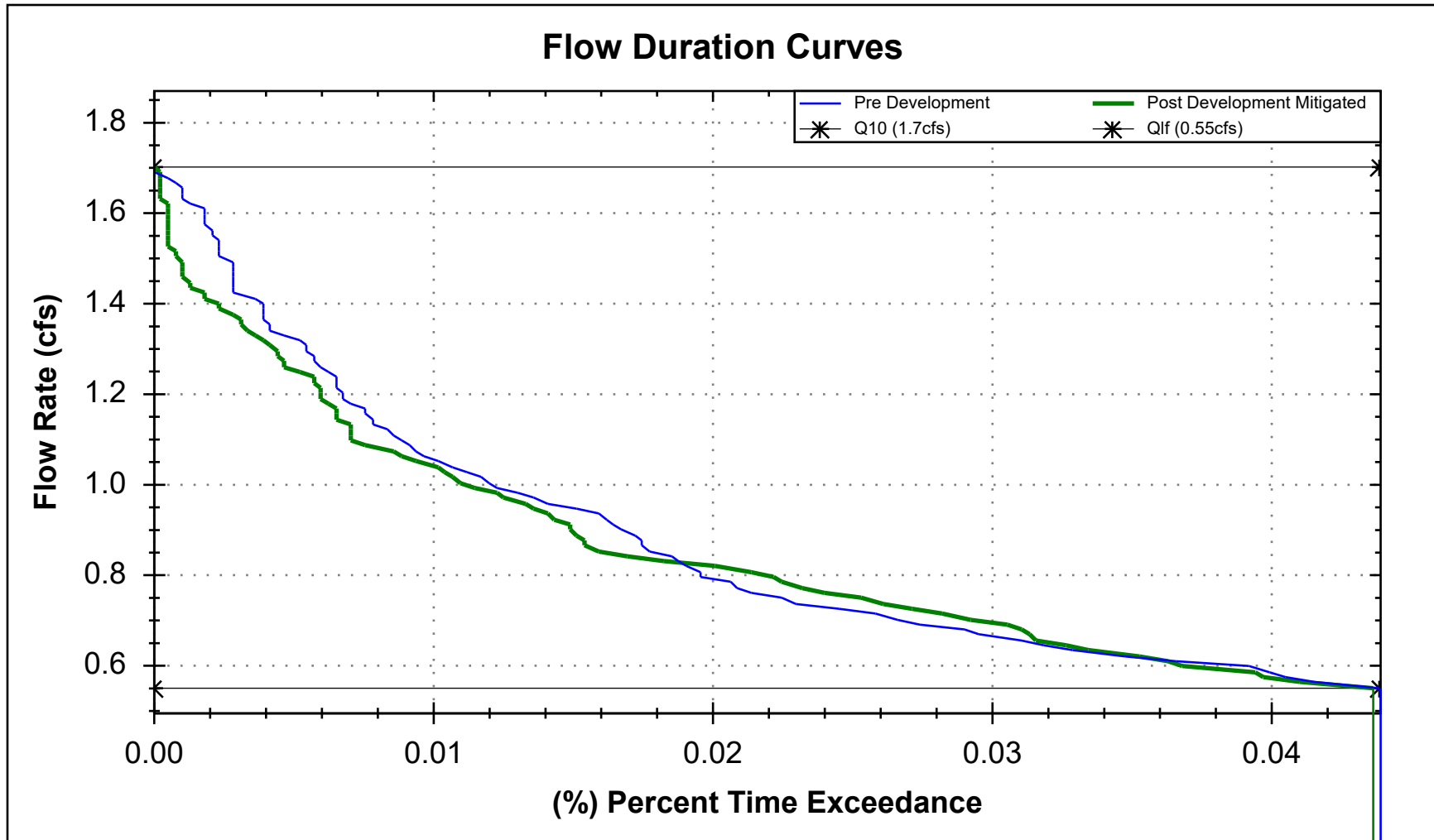

Compare Post-Development Curve to Pre-Development Curve							
Flow Control Upper Limit: 1.7 (cfs)							
Flow Control Lower Limit: 0.55 (cfs)							
post-development SWMM file: V:\21\21088\Engineering\PrelimGP\Storm\Working Files\Hydmod\600' length-4x3.83 weir - Copy\21088-Post-HMP2.out							
post-development time stamp: 6/2/2022 5:17:35 PM							
Compared to:							
pre-development SWMM file: V:\21\21088\Engineering\PrelimGP\Storm\Working Files\Hydmod\600' length-4x3.83 weir - Copy\21088-Pre-HMP2.out							
pre-development time stamp: 6/2/2022 1:14:45 PM							
Post PT #	Flow Rate (cfs)	Post Dev % Exceed	Pre Dev % Exceed	%Ex post < %Ex pre	%Ex post > %Ex pre	%Ex post > 110% %Ex pre	Pass/Fail
0	0.60	0.00	0.00	TRUE	FALSE	FALSE	Pass: Post Duration <= Pre Duration
1	0.60	0.00	0.00	TRUE	FALSE	FALSE	Pass: Post Duration <= Pre Duration
2	0.60	0.00	0.00	TRUE	FALSE	FALSE	Pass: Post Duration <= Pre Duration
3	0.60	0.00	0.00	TRUE	FALSE	FALSE	Pass: Post Duration <= Pre Duration
4	0.60	0.00	0.00	TRUE	FALSE	FALSE	Pass: Post Duration <= Pre Duration
5	0.60	0.00	0.00	TRUE	FALSE	FALSE	Pass: Post Duration <= Pre Duration
6	0.60	0.00	0.00	TRUE	FALSE	FALSE	Pass: Post Duration <= Pre Duration
7	0.60	0.00	0.00	TRUE	FALSE	FALSE	Pass: Post Duration <= Pre Duration
8	0.60	0.00	0.00	TRUE	FALSE	FALSE	Pass: Post Duration <= Pre Duration
9	0.70	0.00	0.00	TRUE	FALSE	FALSE	Pass: Post Duration <= Pre Duration
10	0.70	0.00	0.00	TRUE	FALSE	FALSE	Pass: Post Duration <= Pre Duration
11	0.70	0.00	0.00	TRUE	FALSE	FALSE	Pass: Post Duration <= Pre Duration
12	0.70	0.00	0.00	TRUE	FALSE	FALSE	Pass: Post Duration <= Pre Duration
13	0.70	0.00	0.00	TRUE	FALSE	FALSE	Pass: Post Duration <= Pre Duration
14	0.70	0.00	0.00	TRUE	FALSE	FALSE	Pass: Post Duration <= Pre Duration
15	0.70	0.00	0.00	TRUE	FALSE	FALSE	Pass: Post Duration <= Pre Duration
16	0.70	0.00	0.00	TRUE	FALSE	FALSE	Pass: Post Duration <= Pre Duration
17	0.70	0.00	0.00	TRUE	FALSE	FALSE	Pass: Post Duration <= Pre Duration
18	0.80	0.00	0.00	TRUE	FALSE	FALSE	Pass: Post Duration <= Pre Duration
19	0.80	0.00	0.00	TRUE	FALSE	FALSE	Pass: Post Duration <= Pre Duration
20	0.80	0.00	0.00	TRUE	FALSE	FALSE	Pass: Post Duration <= Pre Duration
21	0.80	0.00	0.00	TRUE	FALSE	FALSE	Pass: Post Duration <= Pre Duration
22	0.80	0.00	0.00	TRUE	FALSE	FALSE	Pass: Post Duration <= Pre Duration
23	0.80	0.00	0.00	TRUE	FALSE	FALSE	Pass: Post Duration <= Pre Duration
24	0.80	0.00	0.00	TRUE	FALSE	FALSE	Pass: Post Duration <= Pre Duration
25	0.80	0.00	0.00	TRUE	FALSE	FALSE	Pass: Post Duration <= Pre Duration
26	0.90	0.00	0.00	TRUE	FALSE	FALSE	Pass: Post Duration <= Pre Duration
27	0.90	0.00	0.00	TRUE	FALSE	FALSE	Pass: Post Duration <= Pre Duration
28	0.90	0.00	0.00	TRUE	FALSE	FALSE	Pass: Post Duration <= Pre Duration
29	0.90	0.00	0.00	TRUE	FALSE	FALSE	Pass: Post Duration <= Pre Duration

Post PT #	Flow Rate (cfs)	Post Dev % Exceed	Pre Dev % Exceed	%Ex post < %Ex pre	%Ex post > %Ex pre	%Ex post > 110% %Ex pre	Pass/Fail
30	0.90	0.00	0.00	TRUE	FALSE	FALSE	Pass: Post Duration <= Pre Duration
31	0.90	0.00	0.00	TRUE	FALSE	FALSE	Pass: Post Duration <= Pre Duration
32	0.90	0.00	0.00	TRUE	FALSE	FALSE	Pass: Post Duration <= Pre Duration
33	0.90	0.00	0.00	TRUE	FALSE	FALSE	Pass: Post Duration <= Pre Duration
34	0.90	0.00	0.00	TRUE	FALSE	FALSE	Pass: Post Duration <= Pre Duration
35	1.00	0.00	0.00	TRUE	FALSE	FALSE	Pass: Post Duration <= Pre Duration
36	1.00	0.00	0.00	TRUE	FALSE	FALSE	Pass: Post Duration <= Pre Duration
37	1.00	0.00	0.00	TRUE	FALSE	FALSE	Pass: Post Duration <= Pre Duration
38	1.00	0.00	0.00	TRUE	FALSE	FALSE	Pass: Post Duration <= Pre Duration
39	1.00	0.00	0.00	TRUE	FALSE	FALSE	Pass: Post Duration <= Pre Duration
40	1.00	0.00	0.00	TRUE	FALSE	FALSE	Pass: Post Duration <= Pre Duration
41	1.00	0.00	0.00	TRUE	FALSE	FALSE	Pass: Post Duration <= Pre Duration
42	1.00	0.00	0.00	TRUE	FALSE	FALSE	Pass: Post Duration <= Pre Duration
43	1.00	0.00	0.00	TRUE	FALSE	FALSE	Pass: Post Duration <= Pre Duration
44	1.10	0.00	0.00	TRUE	FALSE	FALSE	Pass: Post Duration <= Pre Duration
45	1.10	0.00	0.00	TRUE	FALSE	FALSE	Pass: Post Duration <= Pre Duration
46	1.10	0.00	0.00	TRUE	FALSE	FALSE	Pass: Post Duration <= Pre Duration
47	1.10	0.00	0.00	TRUE	FALSE	FALSE	Pass: Post Duration <= Pre Duration
48	1.10	0.00	0.00	TRUE	FALSE	FALSE	Pass: Post Duration <= Pre Duration
49	1.10	0.00	0.00	TRUE	FALSE	FALSE	Pass: Post Duration <= Pre Duration
50	1.10	0.00	0.00	TRUE	FALSE	FALSE	Pass: Post Duration <= Pre Duration
51	1.10	0.00	0.00	TRUE	FALSE	FALSE	Pass: Post Duration <= Pre Duration
52	1.20	0.00	0.00	TRUE	FALSE	FALSE	Pass: Post Duration <= Pre Duration
53	1.20	0.00	0.00	TRUE	FALSE	FALSE	Pass: Post Duration <= Pre Duration
54	1.20	0.00	0.00	TRUE	FALSE	FALSE	Pass: Post Duration <= Pre Duration
55	1.20	0.00	0.00	TRUE	FALSE	FALSE	Pass: Post Duration <= Pre Duration
56	1.20	0.00	0.00	TRUE	FALSE	FALSE	Pass: Post Duration <= Pre Duration
57	1.20	0.00	0.00	TRUE	FALSE	FALSE	Pass: Post Duration <= Pre Duration
58	1.20	0.00	0.00	TRUE	FALSE	FALSE	Pass: Post Duration <= Pre Duration
59	1.20	0.00	0.00	TRUE	FALSE	FALSE	Pass: Post Duration <= Pre Duration
60	1.20	0.00	0.00	TRUE	FALSE	FALSE	Pass: Post Duration <= Pre Duration
61	1.30	0.00	0.00	TRUE	FALSE	FALSE	Pass: Post Duration <= Pre Duration
62	1.30	0.00	0.00	TRUE	FALSE	FALSE	Pass: Post Duration <= Pre Duration
63	1.30	0.00	0.00	TRUE	FALSE	FALSE	Pass: Post Duration <= Pre Duration
64	1.30	0.00	0.00	TRUE	FALSE	FALSE	Pass: Post Duration <= Pre Duration
65	1.30	0.00	0.00	TRUE	FALSE	FALSE	Pass: Post Duration <= Pre Duration
66	1.30	0.00	0.00	TRUE	FALSE	FALSE	Pass: Post Duration <= Pre Duration
67	1.30	0.00	0.00	TRUE	FALSE	FALSE	Pass: Post Duration <= Pre Duration
68	1.30	0.00	0.00	TRUE	FALSE	FALSE	Pass: Post Duration <= Pre Duration
69	1.40	0.00	0.00	TRUE	FALSE	FALSE	Pass: Post Duration <= Pre Duration

Post PT #	Flow Rate (cfs)	Post Dev % Exceed	Pre Dev % Exceed	%Ex post < %Ex pre	%Ex post > %Ex pre	%Ex post > 110% %Ex pre	Pass/Fail
70	1.40	0.00	0.00	TRUE	FALSE	FALSE	Pass: Post Duration <= Pre Duration
71	1.40	0.00	0.00	TRUE	FALSE	FALSE	Pass: Post Duration <= Pre Duration
72	1.40	0.00	0.00	TRUE	FALSE	FALSE	Pass: Post Duration <= Pre Duration
73	1.40	0.00	0.00	TRUE	FALSE	FALSE	Pass: Post Duration <= Pre Duration
74	1.40	0.00	0.00	TRUE	FALSE	FALSE	Pass: Post Duration <= Pre Duration
75	1.40	0.00	0.00	TRUE	FALSE	FALSE	Pass: Post Duration <= Pre Duration
76	1.40	0.00	0.00	TRUE	FALSE	FALSE	Pass: Post Duration <= Pre Duration
77	1.40	0.00	0.00	TRUE	FALSE	FALSE	Pass: Post Duration <= Pre Duration
78	1.50	0.00	0.00	TRUE	FALSE	FALSE	Pass: Post Duration <= Pre Duration
79	1.50	0.00	0.00	TRUE	FALSE	FALSE	Pass: Post Duration <= Pre Duration
80	1.50	0.00	0.00	TRUE	FALSE	FALSE	Pass: Post Duration <= Pre Duration
81	1.50	0.00	0.00	TRUE	FALSE	FALSE	Pass: Post Duration <= Pre Duration
82	1.50	0.00	0.00	TRUE	FALSE	FALSE	Pass: Post Duration <= Pre Duration
83	1.50	0.00	0.00	TRUE	FALSE	FALSE	Pass: Post Duration <= Pre Duration
84	1.50	0.00	0.00	TRUE	FALSE	FALSE	Pass: Post Duration <= Pre Duration
85	1.50	0.00	0.00	TRUE	FALSE	FALSE	Pass: Post Duration <= Pre Duration
86	1.50	0.00	0.00	TRUE	FALSE	FALSE	Pass: Post Duration <= Pre Duration
87	1.60	0.00	0.00	TRUE	FALSE	FALSE	Pass: Post Duration <= Pre Duration
88	1.60	0.00	0.00	TRUE	FALSE	FALSE	Pass: Post Duration <= Pre Duration
89	1.60	0.00	0.00	TRUE	FALSE	FALSE	Pass: Post Duration <= Pre Duration
90	1.60	0.00	0.00	TRUE	FALSE	FALSE	Pass: Post Duration <= Pre Duration
91	1.60	0.00	0.00	TRUE	FALSE	FALSE	Pass: Post Duration <= Pre Duration
92	1.60	0.00	0.00	TRUE	FALSE	FALSE	Pass: Post Duration <= Pre Duration
93	1.60	0.00	0.00	TRUE	FALSE	FALSE	Pass: Post Duration <= Pre Duration
94	1.60	0.00	0.00	TRUE	FALSE	FALSE	Pass: Post Duration <= Pre Duration
95	1.70	0.00	0.00	TRUE	FALSE	FALSE	Pass: Post Duration <= Pre Duration
96	1.70	0.00	0.00	TRUE	FALSE	FALSE	Pass: Post Duration <= Pre Duration
97	1.70	0.00	0.00	TRUE	FALSE	FALSE	Pass: Post Duration <= Pre Duration
98	1.70	0.00	0.00	TRUE	FALSE	FALSE	Pass: Post Duration <= Pre Duration
99	1.70	0.00	0.00	TRUE	FALSE	FALSE	Pass: Post Duration <= Pre Duration

Duration Table Summary at Project Discharge Point				
file name: V:\21\21088\Engineering\PrelimGP\Storm\Working Files\Hydmod\600' length-4x3.83 weir - Copy\21088-Pre-HMP2.out				
time stamp: 6/2/2022 1:14:45 PM				
DISCHARGE		Number of periods when discharge was equal to or greater than DISCHARGE column but less than that shown on the next line		
Bin Number	Discharge Rate (cfs)	Number of Periods	Total Periods Exceeding	Percent Time Exceeded
1	0.6	9	168	0.044
2	0.6	4	159	0.042
3	0.6	2	155	0.040
4	0.6	3	153	0.040
5	0.6	10	150	0.039
6	0.6	7	140	0.037
7	0.6	7	133	0.035
8	0.6	4	126	0.033
9	0.6	3	122	0.032
10	0.7	6	119	0.031
11	0.7	2	113	0.030
12	0.7	6	111	0.029
13	0.7	3	105	0.027
14	0.7	3	102	0.027
15	0.7	5	99	0.026
16	0.7	6	94	0.025
17	0.7	2	88	0.023
18	0.7	4	86	0.022
19	0.8	2	82	0.021
20	0.8	1	80	0.021
21	0.8	4	79	0.021
22	0.8	0	75	0.020
23	0.8	2	75	0.020
24	0.8	1	73	0.019
25	0.8	1	72	0.019
26	0.8	3	71	0.019
27	0.9	1	68	0.018
28	0.9	0	67	0.018
29	0.9	1	67	0.018
30	0.9	2	66	0.017
31	0.9	1	64	0.017
32	0.9	1	63	0.016
33	0.9	1	62	0.016
34	0.9	3	61	0.016
35	0.9	4	58	0.015
36	1.0	2	54	0.014
37	1.0	2	52	0.014
38	1.0	3	50	0.013
39	1.0	1	47	0.012
40	1.0	1	46	0.012
41	1.0	2	45	0.012
42	1.0	2	43	0.011
43	1.0	2	41	0.011
44	1.0	2	39	0.010
45	1.1	1	37	0.010
46	1.1	1	36	0.009
47	1.1	1	35	0.009
48	1.1	1	34	0.009
49	1.1	1	33	0.009
50	1.1	2	32	0.008
51	1.1	0	30	0.008

Bin Number	Discharge Rate (cfs)	Number of Periods	Total Periods Exceeding	Percent Time Exceeded
52	1.1	1	30	0.008
53	1.2	0	29	0.008
54	1.2	2	29	0.008
55	1.2	1	27	0.007
56	1.2	0	26	0.007
57	1.2	1	26	0.007
58	1.2	0	25	0.007
59	1.2	0	25	0.007
60	1.2	1	25	0.007
61	1.2	1	24	0.006
62	1.3	1	23	0.006
63	1.3	0	22	0.006
64	1.3	1	22	0.006
65	1.3	0	21	0.005
66	1.3	1	21	0.005
67	1.3	2	20	0.005
68	1.3	2	18	0.005
69	1.3	0	16	0.004
70	1.4	1	16	0.004
71	1.4	0	15	0.004
72	1.4	0	15	0.004
73	1.4	0	15	0.004
74	1.4	1	15	0.004
75	1.4	3	14	0.004
76	1.4	0	11	0.003
77	1.4	0	11	0.003
78	1.4	0	11	0.003
79	1.5	0	11	0.003
80	1.5	0	11	0.003
81	1.5	0	11	0.003
82	1.5	2	11	0.003
83	1.5	0	9	0.002
84	1.5	0	9	0.002
85	1.5	0	9	0.002
86	1.5	1	9	0.002
87	1.5	0	8	0.002
88	1.6	1	8	0.002
89	1.6	0	7	0.002
90	1.6	0	7	0.002
91	1.6	0	7	0.002
92	1.6	2	7	0.002
93	1.6	1	5	0.001
94	1.6	0	4	0.001
95	1.6	0	4	0.001
96	1.7	1	4	0.001
97	1.7	1	3	0.001
98	1.7	2	2	0.001
99	1.7	0	0	0.000
100	1.7	0	0	0.000
-----End of Data-----				

Duration Table Summary at Project Discharge Point				
file name: V:\21\21088\Engineering\PrelimGP\Storm\Working Files\Hydmod\600' length-4x3.83 weir - Copy\21088-Post-HMP2.out				
time stamp: 6/2/2022 5:17:35 PM				
DISCHARGE		Number of periods when discharge was equal to or greater than DISCHARGE column but less than that shown on the next line		
Bin Number	Discharge Rate (cfs)	Number of Periods	Total Periods Exceeding	Percent Time Exceeded
1	0.6	10	167	0.044
2	0.6	5	157	0.041
3	0.6	1	152	0.040
4	0.6	10	151	0.039
5	0.6	2	141	0.037
6	0.6	4	139	0.036
7	0.6	7	135	0.035
8	0.6	3	128	0.033
9	0.6	4	125	0.033
10	0.7	1	121	0.032
11	0.7	1	120	0.031
12	0.7	2	119	0.031
13	0.7	5	117	0.031
14	0.7	4	112	0.029
15	0.7	4	108	0.028
16	0.7	4	104	0.027
17	0.7	3	100	0.026
18	0.7	5	97	0.025
19	0.8	3	92	0.024
20	0.8	3	89	0.023
21	0.8	1	86	0.022
22	0.8	3	85	0.022
23	0.8	5	82	0.021
24	0.8	7	77	0.020
25	0.8	5	70	0.018
26	0.8	4	65	0.017
27	0.9	2	61	0.016
28	0.9	0	59	0.015
29	0.9	1	59	0.015
30	0.9	1	58	0.015
31	0.9	0	57	0.015
32	0.9	2	57	0.015
33	0.9	1	55	0.014
34	0.9	2	54	0.014
35	0.9	1	52	0.014
36	1.0	3	51	0.013
37	1.0	1	48	0.013
38	1.0	3	47	0.012
39	1.0	2	44	0.011
40	1.0	1	42	0.011
41	1.0	1	41	0.011
42	1.0	1	40	0.010
43	1.0	3	39	0.010
44	1.0	2	36	0.009
45	1.1	1	34	0.009
46	1.1	4	33	0.009
47	1.1	2	29	0.008
48	1.1	0	27	0.007
49	1.1	0	27	0.007
50	1.1	0	27	0.007
51	1.1	2	27	0.007

Bin Number	Discharge Rate (cfs)	Number of Periods	Total Periods Exceeding	Percent Time Exceeded
52	1.1	0	25	0.007
53	1.2	0	25	0.007
54	1.2	1	25	0.007
55	1.2	1	24	0.006
56	1.2	0	23	0.006
57	1.2	0	23	0.006
58	1.2	1	23	0.006
59	1.2	0	22	0.006
60	1.2	2	22	0.006
61	1.2	2	20	0.005
62	1.3	0	18	0.005
63	1.3	1	18	0.005
64	1.3	0	17	0.004
65	1.3	1	17	0.004
66	1.3	1	16	0.004
67	1.3	1	15	0.004
68	1.3	1	14	0.004
69	1.3	1	13	0.003
70	1.4	0	12	0.003
71	1.4	1	12	0.003
72	1.4	2	11	0.003
73	1.4	0	9	0.002
74	1.4	2	9	0.002
75	1.4	0	7	0.002
76	1.4	2	7	0.002
77	1.4	0	5	0.001
78	1.4	1	5	0.001
79	1.5	0	4	0.001
80	1.5	0	4	0.001
81	1.5	0	4	0.001
82	1.5	1	4	0.001
83	1.5	0	3	0.001
84	1.5	1	3	0.001
85	1.5	0	2	0.001
86	1.5	0	2	0.001
87	1.5	0	2	0.001
88	1.6	0	2	0.001
89	1.6	0	2	0.001
90	1.6	0	2	0.001
91	1.6	0	2	0.001
92	1.6	0	2	0.001
93	1.6	1	2	0.001
94	1.6	0	1	0.000
95	1.6	0	1	0.000
96	1.7	0	1	0.000
97	1.7	0	1	0.000
98	1.7	0	1	0.000
99	1.7	1	1	0.000
100	1.7	0	0	0.000
-----End of Data-----				

END OF STATISTICS ANALYSIS

Use this checklist to ensure the required information has been included in the Structural BMP Maintenance Information Attachment:

Preliminary Design / Planning / CEQA level submittal:

Attachment 3a must identify:

- Typical maintenance indicators and actions for proposed structural BMP(s) based on Section 7.7 of the BMP Design Manual

Attachment 3b is not required for preliminary design / planning / CEQA level submittal.

Final Design level submittal:

Attachment 3a must identify:

- Specific maintenance indicators and actions for proposed structural BMP(s). This shall be based on Section 7.7 of the BMP Design Manual and enhanced to reflect actual proposed components of the structural BMP(s)
- How to access the structural BMP(s) to inspect and perform maintenance
- Features that are provided to facilitate inspection (e.g., observation ports, cleanouts, silt posts, or other features that allow the inspector to view necessary components of the structural BMP and compare to maintenance thresholds)
- Manufacturer and part number for proprietary parts of structural BMP(s) when applicable
- Maintenance thresholds specific to the structural BMP(s), with a location-specific frame of reference (e.g., level of accumulated materials that triggers removal of the materials, to be identified based on viewing marks on silt posts or measured with a survey rod with respect to a fixed benchmark within the BMP)
- Recommended equipment to perform maintenance
- When applicable, necessary special training or certification requirements for inspection and maintenance personnel such as confined space entry or hazardous waste management

Attachment 3b: For private entity operation and maintenance, Attachment 3b shall include a draft maintenance agreement in the local jurisdiction's standard format (PDP applicant to contact the [City Engineer] to obtain the current maintenance agreement forms).

BF-1

Biofiltration

BMP MAINTENANCE FACT SHEET FOR STRUCTURAL BMP BF-1 BIOFILTRATION

Biofiltration facilities are vegetated surface water systems that filter water through vegetation, and soil or engineered media prior to discharge via underdrain or overflow to the downstream conveyance system. Biofiltration facilities have limited or no infiltration. They are typically designed to provide enough hydraulic head to move flows through the underdrain connection to the storm drain system. Typical biofiltration components include:

- Inflow distribution mechanisms (e.g., perimeter flow spreader or filter strips)
- Energy dissipation mechanism for concentrated inflows (e.g., splash blocks or riprap)
- Shallow surface ponding for captured flows
- Side slope and basin bottom vegetation selected based on climate and ponding depth
- Non-floating mulch layer
- Media layer (planting mix or engineered media) capable of supporting vegetation growth
- Filter course layer consisting of aggregate to prevent the migration of fines into uncompacted native soils or the aggregate storage layer
- Aggregate storage layer with underdrain(s)
- Impermeable liner or uncompacted native soils at the bottom of the facility
- Overflow structure

Normal Expected Maintenance

Biofiltration requires routine maintenance to: remove accumulated materials such as sediment, trash or debris; maintain vegetation health; maintain infiltration capacity of the media layer; replenish mulch; and maintain integrity of side slopes, inlets, energy dissipators, and outlets. A summary table of standard inspection and maintenance indicators is provided within this Fact Sheet.

Non-Standard Maintenance or BMP Failure

If any of the following scenarios are observed, the BMP is not performing as intended to protect downstream waterways from pollution and/or erosion. Corrective maintenance, increased inspection and maintenance, BMP replacement, or a different BMP type will be required.

- The BMP is not drained between storm events. Surface ponding longer than approximately 24 hours following a storm event may be detrimental to vegetation health, and surface ponding longer than approximately 96 hours following a storm event poses a risk of vector (mosquito) breeding. Poor drainage can result from clogging of the media layer, filter course, aggregate storage layer, underdrain, or outlet structure. The specific cause of the drainage issue must be determined and corrected.
- Sediment, trash, or debris accumulation greater than 25% of the surface ponding volume within one month. This means the load from the tributary drainage area is too high, reducing BMP function or clogging the BMP. This would require pretreatment measures within the tributary area draining to the BMP to intercept the materials. Pretreatment components, especially for sediment, will extend the life of components that are more expensive to replace such as media, filter course, and aggregate layers.
- Erosion due to concentrated storm water runoff flow that is not readily corrected by adding erosion control blankets, adding stone at flow entry points, or minor re-grading to restore proper drainage according to the original plan. If the issue is not corrected by restoring the BMP to the original plan and grade, the [City Engineer] shall be contacted prior to any additional repairs or reconstruction.

BF-1

Biofiltration

Other Special Considerations

Biofiltration is a vegetated structural BMP. Vegetated structural BMPs that are constructed in the vicinity of, or connected to, an existing jurisdictional water or wetland could inadvertently result in creation of expanded waters or wetlands. As such, vegetated structural BMPs have the potential to come under the jurisdiction of the United States Army Corps of Engineers, SDRWQCB, California Department of Fish and Wildlife, or the United States Fish and Wildlife Service. This could result in the need for specific resource agency permits and costly mitigation to perform maintenance of the structural BMP. Along with proper placement of a structural BMP, **routine maintenance is key to preventing this scenario.**

BF-1 Biofiltration

SUMMARY OF STANDARD INSPECTION AND MAINTENANCE FOR BF-1 BIOFILTRATION

The property owner is responsible to ensure inspection, operation and maintenance of permanent BMPs on their property unless responsibility has been formally transferred to an agency, community facilities district, homeowners association, property owners association, or other special district.

Maintenance frequencies listed in this table are average/typical frequencies. Actual maintenance needs are site-specific, and maintenance may be required more frequently. Maintenance must be performed whenever needed, based on maintenance indicators presented in this table. The BMP owner is responsible for conducting regular inspections to see when maintenance is needed based on the maintenance indicators. During the first year of operation of a structural BMP, inspection is recommended at least once prior to August 31 and then monthly from September through May. Inspection during a storm event is also recommended. After the initial period of frequent inspections, the minimum inspection and maintenance frequency can be determined based on the results of the first year inspections.

Threshold/Indicator	Maintenance Action	Typical Maintenance Frequency
Accumulation of sediment, litter, or debris	Remove and properly dispose of accumulated materials, without damage to the vegetation or compaction of the media layer.	<ul style="list-style-type: none"> • Inspect monthly. If the BMP is 25% full* or more in one month, increase inspection frequency to monthly plus after every 0.1-inch or larger storm event. • Remove any accumulated materials found at each inspection.
Obstructed inlet or outlet structure	Clear blockage.	<ul style="list-style-type: none"> • Inspect monthly and after every 0.5-inch or larger storm event. • Remove any accumulated materials found at each inspection.
Damage to structural components such as weirs, inlet or outlet structures	Repair or replace as applicable	<ul style="list-style-type: none"> • Inspect annually. • Maintenance when needed.
Poor vegetation establishment	Re-seed, re-plant, or re-establish vegetation per original plans.	<ul style="list-style-type: none"> • Inspect monthly. • Maintenance when needed.
Dead or diseased vegetation	Remove dead or diseased vegetation, re-seed, re-plant, or re-establish vegetation per original plans.	<ul style="list-style-type: none"> • Inspect monthly. • Maintenance when needed.
Overgrown vegetation	Mow or trim as appropriate.	<ul style="list-style-type: none"> • Inspect monthly. • Maintenance when needed.
2/3 of mulch has decomposed, or mulch has been removed	Remove decomposed fraction and top off with fresh mulch to a total depth of 3 inches.	<ul style="list-style-type: none"> • Inspect monthly. • Replenish mulch annually, or more frequently when needed based on inspection.

*"25% full" is defined as ¼ of the depth from the design bottom elevation to the crest of the outflow structure (e.g., if the height to the outflow opening is 12 inches from the bottom elevation, then the materials must be removed when there is 3 inches of accumulation – this should be marked on the outflow structure).

BF-1

Biofiltration

SUMMARY OF STANDARD INSPECTION AND MAINTENANCE FOR BF-1 BIOFILTRATION (Continued from previous page)		
Threshold/Indicator	Maintenance Action	Typical Maintenance Frequency
Erosion due to concentrated irrigation flow	Repair/re-seed/re-plant eroded areas and adjust the irrigation system.	<ul style="list-style-type: none"> • Inspect monthly. • Maintenance when needed.
Erosion due to concentrated storm water runoff flow	Repair/re-seed/re-plant eroded areas, and make appropriate corrective measures such as adding erosion control blankets, adding stone at flow entry points, or minor re-grading to restore proper drainage according to the original plan. If the issue is not corrected by restoring the BMP to the original plan and grade, the [City Engineer] shall be contacted prior to any additional repairs or reconstruction.	<ul style="list-style-type: none"> • Inspect after every 0.5-inch or larger storm event. If erosion due to storm water flow has been observed, increase inspection frequency to after every 0.1-inch or larger storm event. • Maintenance when needed. If the issue is not corrected by restoring the BMP to the original plan and grade, the [City Engineer] shall be contacted prior to any additional repairs or reconstruction.
<p>Standing water in BMP for longer than 24 hours following a storm event</p> <p>Surface ponding longer than approximately 24 hours following a storm event may be detrimental to vegetation health</p>	Make appropriate corrective measures such as adjusting irrigation system, removing obstructions of debris or invasive vegetation, clearing underdrains, or repairing/replacing clogged or compacted soils.	<ul style="list-style-type: none"> • Inspect monthly and after every 0.5-inch or larger storm event. If standing water is observed, increase inspection frequency to after every 0.1-inch or larger storm event. • Maintenance when needed.
<p>Presence of mosquitos/larvae</p> <p>For images of egg rafts, larva, pupa, and adult mosquitos, see http://www.mosquito.org/biology</p>	<p>If mosquitos/larvae are observed: first, immediately remove any standing water by dispersing to nearby landscaping; second, make corrective measures as applicable to restore BMP drainage to prevent standing water.</p> <p>If mosquitos persist following corrective measures to remove standing water, or if the BMP design does not meet the 96-hour drawdown criteria due to release rates controlled by an orifice installed on the underdrain, the [City Engineer] shall be contacted to determine a solution. A different BMP type, or a Vector Management Plan prepared with concurrence from the County of San Diego Department of Environmental Health, may be required.</p>	<ul style="list-style-type: none"> • Inspect monthly and after every 0.5-inch or larger storm event. If mosquitos are observed, increase inspection frequency to after every 0.1-inch or larger storm event. • Maintenance when needed.
Underdrain clogged	Clear blockage.	<ul style="list-style-type: none"> • Inspect if standing water is observed for longer than 24-96 hours following a storm event. • Maintenance when needed.

BF-1

Biofiltration

References

American Mosquito Control Association.

<http://www.mosquito.org/>

California Storm Water Quality Association (CASQA). 2003. Municipal BMP Handbook.

<https://www.casqa.org/resources/bmp-handbooks/municipal-bmp-handbook>

County of San Diego. 2014. Low Impact Development Handbook.

<http://www.sandiegocounty.gov/content/sdc/dpw/watersheds/susmp/lid.html>

San Diego County Copermittees. 2016. Model BMP Design Manual, Appendix E, Fact Sheet BF-1.

http://www.projectcleanwater.org/index.php?option=com_content&view=article&id=250&Itemid=220

BF-1

Biofiltration

Page Intentionally Blank for Double-Sided Printing

BF-1 Biofiltration

Date:	Inspector:	BMP ID No.: BMP-A
Permit No.:	APN(s): 219-223-20&22	
Property / Development Name:	Responsible Party Name and Phone Number:	
Property Address of BMP:	Responsible Party Address:	

INSPECTION AND MAINTENANCE CHECKLIST FOR BF-1 BIOFILTRATION PAGE 1 of 5			
Threshold/Indicator	Maintenance Recommendation	Date	Description of Maintenance Conducted
Accumulation of sediment, litter, or debris Maintenance Needed? <input type="checkbox"/> YES <input type="checkbox"/> NO <input type="checkbox"/> N/A	<input type="checkbox"/> Remove and properly dispose of accumulated materials, without damage to the vegetation <input type="checkbox"/> If sediment, litter, or debris accumulation exceeds 25% of the surface ponding volume within one month (25% full*), add a forebay or other pre-treatment measures within the tributary area draining to the BMP to intercept the materials. <input type="checkbox"/> Other / Comments:		
Poor vegetation establishment Maintenance Needed? <input type="checkbox"/> YES <input type="checkbox"/> NO <input type="checkbox"/> N/A	<input type="checkbox"/> Re-seed, re-plant, or re-establish vegetation per original plans <input type="checkbox"/> Other / Comments:		

*"25% full" is defined as ¼ of the depth from the design bottom elevation to the crest of the outflow structure (e.g., if the height to the outflow opening is 12 inches from the bottom elevation, then the materials must be removed when there is 3 inches of accumulation – this should be marked on the outflow structure).

BF-1 Biofiltration

Date:	Inspector:	BMP ID No.: BMP-A
Permit No.:	APN(s): 219-223-20&22	

INSPECTION AND MAINTENANCE CHECKLIST FOR BF-1 BIOFILTRATION PAGE 2 of 5			
Threshold/Indicator	Maintenance Recommendation	Date	Description of Maintenance Conducted
Dead or diseased vegetation Maintenance Needed? <input type="checkbox"/> YES <input type="checkbox"/> NO <input type="checkbox"/> N/A	<input type="checkbox"/> Remove dead or diseased vegetation, re-seed, re-plant, or re-establish vegetation per original plans <input type="checkbox"/> Other / Comments:		
Overgrown vegetation Maintenance Needed? <input type="checkbox"/> YES <input type="checkbox"/> NO <input type="checkbox"/> N/A	<input type="checkbox"/> Mow or trim as appropriate <input type="checkbox"/> Other / Comments:		
2/3 of mulch has decomposed, or mulch has been removed Maintenance Needed? <input type="checkbox"/> YES <input type="checkbox"/> NO <input type="checkbox"/> N/A	<input type="checkbox"/> Remove decomposed fraction and top off with fresh mulch to a total depth of 3 inches <input type="checkbox"/> Other / Comments:		

BF-1 Biofiltration

Date:	Inspector:	BMP ID No.: BMP-A
Permit No.:	APN(s): 219-223-20&22	

INSPECTION AND MAINTENANCE CHECKLIST FOR BF-1 BIOFILTRATION PAGE 3 of 5			
Threshold/Indicator	Maintenance Recommendation	Date	Description of Maintenance Conducted
Erosion due to concentrated irrigation flow Maintenance Needed? <input type="checkbox"/> YES <input type="checkbox"/> NO <input type="checkbox"/> N/A	<input type="checkbox"/> Repair/re-seed/re-plant eroded areas and adjust the irrigation system <input type="checkbox"/> Other / Comments:		
Erosion due to concentrated storm water runoff flow Maintenance Needed? <input type="checkbox"/> YES <input type="checkbox"/> NO <input type="checkbox"/> N/A	<input type="checkbox"/> Repair/re-seed/re-plant eroded areas, and make appropriate corrective measures such as adding erosion control blankets, adding stone at flow entry points, or minor re-grading to restore proper drainage according to the original plan <input type="checkbox"/> If the issue is not corrected by restoring the BMP to the original plan and grade, the [City Engineer] shall be contacted prior to any additional repairs or reconstruction <input type="checkbox"/> Other / Comments:		

BF-1 Biofiltration

Date:	Inspector:	BMP ID No.: BMP-A
Permit No.:	APN(s): 219-223-20&22	

INSPECTION AND MAINTENANCE CHECKLIST FOR BF-1 BIOFILTRATION PAGE 4 of 5			
Threshold/Indicator	Maintenance Recommendation	Date	Description of Maintenance Conducted
Obstructed inlet or outlet structure Maintenance Needed? <input type="checkbox"/> YES <input type="checkbox"/> NO <input type="checkbox"/> N/A	<input type="checkbox"/> Clear blockage <input type="checkbox"/> Other / Comments:		
Underdrain clogged (inspect underdrain if standing water is observed for longer than 24-96 hours following a storm event) Maintenance Needed? <input type="checkbox"/> YES <input type="checkbox"/> NO <input type="checkbox"/> N/A	<input type="checkbox"/> Clear blockage <input type="checkbox"/> Other / Comments:		
Damage to structural components such as weirs, inlet or outlet structures Maintenance Needed? <input type="checkbox"/> YES <input type="checkbox"/> NO <input type="checkbox"/> N/A	<input type="checkbox"/> Repair or replace as applicable <input type="checkbox"/> Other / Comments:		

BF-1 Biofiltration

Date:	Inspector:	BMP ID No.: BMP-A
Permit No.:	APN(s): 219-223-20&22	

INSPECTION AND MAINTENANCE CHECKLIST FOR BF-1 BIOFILTRATION PAGE 5 of 5			
Threshold/Indicator	Maintenance Recommendation	Date	Description of Maintenance Conducted
<p>Standing water in BMP for longer than 24-96 hours following a storm event*</p> <p>Surface ponding longer than approximately 24 hours following a storm event may be detrimental to vegetation health</p> <p>Maintenance Needed?</p> <p><input type="checkbox"/> YES <input type="checkbox"/> NO <input type="checkbox"/> N/A</p>	<p><input type="checkbox"/> Make appropriate corrective measures such as adjusting irrigation system, removing obstructions of debris or invasive vegetation, clearing underdrains, or repairing/replacing clogged or compacted soils</p> <p><input type="checkbox"/> Other / Comments:</p>		
<p>Presence of mosquitos/larvae</p> <p>For images of egg rafts, larva, pupa, and adult mosquitos, see http://www.mosquito.org/biology</p> <p>Maintenance Needed?</p> <p><input type="checkbox"/> YES <input type="checkbox"/> NO <input type="checkbox"/> N/A</p>	<p><input type="checkbox"/> Apply corrective measures to remove standing water in BMP when standing water occurs for longer than 24-96 hours following a storm event.**</p> <p><input type="checkbox"/> Other / Comments:</p>		

*Surface ponding longer than approximately 24 hours following a storm event may be detrimental to vegetation health, and surface ponding longer than approximately 96 hours following a storm event poses a risk of vector (mosquito) breeding. Poor drainage can result from clogging of the media layer, filter course, aggregate storage layer, underdrain, or outlet structure. The specific cause of the drainage issue must be determined and corrected.

**If mosquitos persist following corrective measures to remove standing water, or if the BMP design does not meet the 96-hour drawdown criteria due to release rates controlled by an orifice installed on the underdrain, the [City Engineer] shall be contacted to determine a solution. A different BMP type, or a Vector Management Plan prepared with concurrence from the County of San Diego Department of Environmental Health, may be required.

BF-1 Biofiltration

Date:	Inspector:	BMP ID No.: BMP-B
Permit No.:	APN(s): 219-223-20&22	
Property / Development Name:	Responsible Party Name and Phone Number:	
Property Address of BMP:	Responsible Party Address:	

INSPECTION AND MAINTENANCE CHECKLIST FOR BF-1 BIOFILTRATION PAGE 1 of 5			
Threshold/Indicator	Maintenance Recommendation	Date	Description of Maintenance Conducted
Accumulation of sediment, litter, or debris Maintenance Needed? <input type="checkbox"/> YES <input type="checkbox"/> NO <input type="checkbox"/> N/A	<input type="checkbox"/> Remove and properly dispose of accumulated materials, without damage to the vegetation <input type="checkbox"/> If sediment, litter, or debris accumulation exceeds 25% of the surface ponding volume within one month (25% full*), add a forebay or other pre-treatment measures within the tributary area draining to the BMP to intercept the materials. <input type="checkbox"/> Other / Comments:		
Poor vegetation establishment Maintenance Needed? <input type="checkbox"/> YES <input type="checkbox"/> NO <input type="checkbox"/> N/A	<input type="checkbox"/> Re-seed, re-plant, or re-establish vegetation per original plans <input type="checkbox"/> Other / Comments:		

*"25% full" is defined as ¼ of the depth from the design bottom elevation to the crest of the outflow structure (e.g., if the height to the outflow opening is 12 inches from the bottom elevation, then the materials must be removed when there is 3 inches of accumulation – this should be marked on the outflow structure).

BF-1 Biofiltration

Date:	Inspector:	BMP ID No.: BMP-B
Permit No.:	APN(s): 219-223-20&22	

INSPECTION AND MAINTENANCE CHECKLIST FOR BF-1 BIOFILTRATION PAGE 2 of 5			
Threshold/Indicator	Maintenance Recommendation	Date	Description of Maintenance Conducted
Dead or diseased vegetation Maintenance Needed? <input type="checkbox"/> YES <input type="checkbox"/> NO <input type="checkbox"/> N/A	<input type="checkbox"/> Remove dead or diseased vegetation, re-seed, re-plant, or re-establish vegetation per original plans <input type="checkbox"/> Other / Comments:		
Overgrown vegetation Maintenance Needed? <input type="checkbox"/> YES <input type="checkbox"/> NO <input type="checkbox"/> N/A	<input type="checkbox"/> Mow or trim as appropriate <input type="checkbox"/> Other / Comments:		
2/3 of mulch has decomposed, or mulch has been removed Maintenance Needed? <input type="checkbox"/> YES <input type="checkbox"/> NO <input type="checkbox"/> N/A	<input type="checkbox"/> Remove decomposed fraction and top off with fresh mulch to a total depth of 3 inches <input type="checkbox"/> Other / Comments:		

BF-1 Biofiltration

Date:	Inspector:	BMP ID No.: BMP-B
Permit No.:	APN(s): 219-223-20&22	

INSPECTION AND MAINTENANCE CHECKLIST FOR BF-1 BIOFILTRATION PAGE 3 of 5			
Threshold/Indicator	Maintenance Recommendation	Date	Description of Maintenance Conducted
Erosion due to concentrated irrigation flow Maintenance Needed? <input type="checkbox"/> YES <input type="checkbox"/> NO <input type="checkbox"/> N/A	<input type="checkbox"/> Repair/re-seed/re-plant eroded areas and adjust the irrigation system <input type="checkbox"/> Other / Comments:		
Erosion due to concentrated storm water runoff flow Maintenance Needed? <input type="checkbox"/> YES <input type="checkbox"/> NO <input type="checkbox"/> N/A	<input type="checkbox"/> Repair/re-seed/re-plant eroded areas, and make appropriate corrective measures such as adding erosion control blankets, adding stone at flow entry points, or minor re-grading to restore proper drainage according to the original plan <input type="checkbox"/> If the issue is not corrected by restoring the BMP to the original plan and grade, the [City Engineer] shall be contacted prior to any additional repairs or reconstruction <input type="checkbox"/> Other / Comments:		

BF-1 Biofiltration

Date:	Inspector:	BMP ID No.: BMP-B
Permit No.:	APN(s): 219-223-20&22	

INSPECTION AND MAINTENANCE CHECKLIST FOR BF-1 BIOFILTRATION PAGE 4 of 5			
Threshold/Indicator	Maintenance Recommendation	Date	Description of Maintenance Conducted
Obstructed inlet or outlet structure Maintenance Needed? <input type="checkbox"/> YES <input type="checkbox"/> NO <input type="checkbox"/> N/A	<input type="checkbox"/> Clear blockage <input type="checkbox"/> Other / Comments:		
Underdrain clogged (inspect underdrain if standing water is observed for longer than 24-96 hours following a storm event) Maintenance Needed? <input type="checkbox"/> YES <input type="checkbox"/> NO <input type="checkbox"/> N/A	<input type="checkbox"/> Clear blockage <input type="checkbox"/> Other / Comments:		
Damage to structural components such as weirs, inlet or outlet structures Maintenance Needed? <input type="checkbox"/> YES <input type="checkbox"/> NO <input type="checkbox"/> N/A	<input type="checkbox"/> Repair or replace as applicable <input type="checkbox"/> Other / Comments:		

BF-1 Biofiltration

Date:	Inspector:	BMP ID No.: BMP-B
Permit No.:	APN(s): 219-223-20&22	

INSPECTION AND MAINTENANCE CHECKLIST FOR BF-1 BIOFILTRATION PAGE 5 of 5			
Threshold/Indicator	Maintenance Recommendation	Date	Description of Maintenance Conducted
<p>Standing water in BMP for longer than 24-96 hours following a storm event*</p> <p>Surface ponding longer than approximately 24 hours following a storm event may be detrimental to vegetation health</p> <p>Maintenance Needed?</p> <p><input type="checkbox"/> YES <input type="checkbox"/> NO <input type="checkbox"/> N/A</p>	<p><input type="checkbox"/> Make appropriate corrective measures such as adjusting irrigation system, removing obstructions of debris or invasive vegetation, clearing underdrains, or repairing/replacing clogged or compacted soils</p> <p><input type="checkbox"/> Other / Comments:</p>		
<p>Presence of mosquitos/larvae</p> <p>For images of egg rafts, larva, pupa, and adult mosquitos, see http://www.mosquito.org/biology</p> <p>Maintenance Needed?</p> <p><input type="checkbox"/> YES <input type="checkbox"/> NO <input type="checkbox"/> N/A</p>	<p><input type="checkbox"/> Apply corrective measures to remove standing water in BMP when standing water occurs for longer than 24-96 hours following a storm event.**</p> <p><input type="checkbox"/> Other / Comments:</p>		

*Surface ponding longer than approximately 24 hours following a storm event may be detrimental to vegetation health, and surface ponding longer than approximately 96 hours following a storm event poses a risk of vector (mosquito) breeding. Poor drainage can result from clogging of the media layer, filter course, aggregate storage layer, underdrain, or outlet structure. The specific cause of the drainage issue must be determined and corrected.

**If mosquitos persist following corrective measures to remove standing water, or if the BMP design does not meet the 96-hour drawdown criteria due to release rates controlled by an orifice installed on the underdrain, the [City Engineer] shall be contacted to determine a solution. A different BMP type, or a Vector Management Plan prepared with concurrence from the County of San Diego Department of Environmental Health, may be required.

BF-1 Biofiltration

Date:	Inspector:	BMP ID No.: BMP-C
Permit No.:	APN(s): 219-223-20&22	
Property / Development Name:	Responsible Party Name and Phone Number:	
Property Address of BMP:	Responsible Party Address:	

INSPECTION AND MAINTENANCE CHECKLIST FOR BF-1 BIOFILTRATION PAGE 1 of 5			
Threshold/Indicator	Maintenance Recommendation	Date	Description of Maintenance Conducted
Accumulation of sediment, litter, or debris Maintenance Needed? <input type="checkbox"/> YES <input type="checkbox"/> NO <input type="checkbox"/> N/A	<input type="checkbox"/> Remove and properly dispose of accumulated materials, without damage to the vegetation <input type="checkbox"/> If sediment, litter, or debris accumulation exceeds 25% of the surface ponding volume within one month (25% full*), add a forebay or other pre-treatment measures within the tributary area draining to the BMP to intercept the materials. <input type="checkbox"/> Other / Comments:		
Poor vegetation establishment Maintenance Needed? <input type="checkbox"/> YES <input type="checkbox"/> NO <input type="checkbox"/> N/A	<input type="checkbox"/> Re-seed, re-plant, or re-establish vegetation per original plans <input type="checkbox"/> Other / Comments:		

*"25% full" is defined as ¼ of the depth from the design bottom elevation to the crest of the outflow structure (e.g., if the height to the outflow opening is 12 inches from the bottom elevation, then the materials must be removed when there is 3 inches of accumulation – this should be marked on the outflow structure).

BF-1 Biofiltration

Date:	Inspector:	BMP ID No.: BMP-C
Permit No.:	APN(s): 219-223-20&22	

INSPECTION AND MAINTENANCE CHECKLIST FOR BF-1 BIOFILTRATION PAGE 2 of 5			
Threshold/Indicator	Maintenance Recommendation	Date	Description of Maintenance Conducted
Dead or diseased vegetation Maintenance Needed? <input type="checkbox"/> YES <input type="checkbox"/> NO <input type="checkbox"/> N/A	<input type="checkbox"/> Remove dead or diseased vegetation, re-seed, re-plant, or re-establish vegetation per original plans <input type="checkbox"/> Other / Comments:		
Overgrown vegetation Maintenance Needed? <input type="checkbox"/> YES <input type="checkbox"/> NO <input type="checkbox"/> N/A	<input type="checkbox"/> Mow or trim as appropriate <input type="checkbox"/> Other / Comments:		
2/3 of mulch has decomposed, or mulch has been removed Maintenance Needed? <input type="checkbox"/> YES <input type="checkbox"/> NO <input type="checkbox"/> N/A	<input type="checkbox"/> Remove decomposed fraction and top off with fresh mulch to a total depth of 3 inches <input type="checkbox"/> Other / Comments:		

BF-1 Biofiltration

Date:	Inspector:	BMP ID No.: BMP-C
Permit No.:	APN(s): 219-223-20&22	

INSPECTION AND MAINTENANCE CHECKLIST FOR BF-1 BIOFILTRATION PAGE 3 of 5			
Threshold/Indicator	Maintenance Recommendation	Date	Description of Maintenance Conducted
Erosion due to concentrated irrigation flow Maintenance Needed? <input type="checkbox"/> YES <input type="checkbox"/> NO <input type="checkbox"/> N/A	<input type="checkbox"/> Repair/re-seed/re-plant eroded areas and adjust the irrigation system <input type="checkbox"/> Other / Comments:		
Erosion due to concentrated storm water runoff flow Maintenance Needed? <input type="checkbox"/> YES <input type="checkbox"/> NO <input type="checkbox"/> N/A	<input type="checkbox"/> Repair/re-seed/re-plant eroded areas, and make appropriate corrective measures such as adding erosion control blankets, adding stone at flow entry points, or minor re-grading to restore proper drainage according to the original plan <input type="checkbox"/> If the issue is not corrected by restoring the BMP to the original plan and grade, the [City Engineer] shall be contacted prior to any additional repairs or reconstruction <input type="checkbox"/> Other / Comments:		

BF-1 Biofiltration

Date:	Inspector:	BMP ID No.: BMP-C
Permit No.:	APN(s): 219-223-20&22	

INSPECTION AND MAINTENANCE CHECKLIST FOR BF-1 BIOFILTRATION PAGE 4 of 5			
Threshold/Indicator	Maintenance Recommendation	Date	Description of Maintenance Conducted
Obstructed inlet or outlet structure Maintenance Needed? <input type="checkbox"/> YES <input type="checkbox"/> NO <input type="checkbox"/> N/A	<input type="checkbox"/> Clear blockage <input type="checkbox"/> Other / Comments:		
Underdrain clogged (inspect underdrain if standing water is observed for longer than 24-96 hours following a storm event) Maintenance Needed? <input type="checkbox"/> YES <input type="checkbox"/> NO <input type="checkbox"/> N/A	<input type="checkbox"/> Clear blockage <input type="checkbox"/> Other / Comments:		
Damage to structural components such as weirs, inlet or outlet structures Maintenance Needed? <input type="checkbox"/> YES <input type="checkbox"/> NO <input type="checkbox"/> N/A	<input type="checkbox"/> Repair or replace as applicable <input type="checkbox"/> Other / Comments:		

BF-1 Biofiltration

Date:	Inspector:	BMP ID No.: BMP-C
Permit No.:	APN(s): 219-223-20&22	

INSPECTION AND MAINTENANCE CHECKLIST FOR BF-1 BIOFILTRATION PAGE 5 of 5			
Threshold/Indicator	Maintenance Recommendation	Date	Description of Maintenance Conducted
<p>Standing water in BMP for longer than 24-96 hours following a storm event*</p> <p>Surface ponding longer than approximately 24 hours following a storm event may be detrimental to vegetation health</p> <p>Maintenance Needed?</p> <p><input type="checkbox"/> YES <input type="checkbox"/> NO <input type="checkbox"/> N/A</p>	<p><input type="checkbox"/> Make appropriate corrective measures such as adjusting irrigation system, removing obstructions of debris or invasive vegetation, clearing underdrains, or repairing/replacing clogged or compacted soils</p> <p><input type="checkbox"/> Other / Comments:</p>		
<p>Presence of mosquitos/larvae</p> <p>For images of egg rafts, larva, pupa, and adult mosquitos, see http://www.mosquito.org/biology</p> <p>Maintenance Needed?</p> <p><input type="checkbox"/> YES <input type="checkbox"/> NO <input type="checkbox"/> N/A</p>	<p><input type="checkbox"/> Apply corrective measures to remove standing water in BMP when standing water occurs for longer than 24-96 hours following a storm event.**</p> <p><input type="checkbox"/> Other / Comments:</p>		

*Surface ponding longer than approximately 24 hours following a storm event may be detrimental to vegetation health, and surface ponding longer than approximately 96 hours following a storm event poses a risk of vector (mosquito) breeding. Poor drainage can result from clogging of the media layer, filter course, aggregate storage layer, underdrain, or outlet structure. The specific cause of the drainage issue must be determined and corrected.

**If mosquitos persist following corrective measures to remove standing water, or if the BMP design does not meet the 96-hour drawdown criteria due to release rates controlled by an orifice installed on the underdrain, the [City Engineer] shall be contacted to determine a solution. A different BMP type, or a Vector Management Plan prepared with concurrence from the County of San Diego Department of Environmental Health, may be required.

MAINTENANCE

MWS – Linear

Hybrid Stormwater Filtration System



MAINTENANCE –

Maintenance Summary –

- Clean screening filter device a least twice per year (*15 minute service time*).
- Clean separation (sediment) chamber once a year (*30 minute service time*).
- Evaluate and replace primary filtration media (BioMediaGREEN blocks) as needed. Typically replacement occurs once every 12 to 18 months (*60 minute service time*).
- Evaluate condition of wetland media. Replacement of media occurs once every 5 to 20 years (*4 hours*).
- Replace drain down filter media (*BioMediaGREEN block*) once every year (*5 minute service time*).
- Trim vegetation as needed (*15 minute service time*).

Maintenance Procedures –

A. Every installed MWS – Linear unit is to be maintained by the Supplier, or a Supplier approved contractor. The cost of this service varies among providers.

B. The MWS – Linear is a multi-stage self-contained treatment train. Each stage protects subsequent stages from clogging. These stages include: screening, separation, primary filtration, and biological remediation. The biological remediation stage contains plants and therefore requires ongoing landscape maintenance, similar to that of other landscaped areas.

1. Screening is provided by Bio Clean Catch Basin Insert Filters. This screening filter has a capacity of 2 or 4 cubic feet (curb type and grate type respectively). This filter targets gross solids, including litter, and sediments greater than 200 microns. **It is recommended that this screening filter be cleaned at least two times per year.** Cleaning of this device is relatively inexpensive. *This procedure takes approximately 15 minutes.*

2. Separation is provided by a 3' x 3' settling chamber. This chamber has a capacity of approximately 21 cubic feet. This chamber targets smaller sediments, larger TSS, and particulate metals and nutrients. This chamber protects the following filtration stages from premature clogging. **It is recommended that this separation chamber be cleaned out once a year.** This procedure can be performed with a standard vac truck. *This procedure takes approximately 30 minutes.*

3. Primary filtration is provided by a horizontal flow perimeter filter utilizing BioMediaGREEN. The perimeter filter has a default media surface area of 28 square feet. This surface area can also be doubled to 56 square feet, upon request, by a simple physical modification to the media blocks. The greater the surface area, the longer the media will maintain appropriate flow rates before clogging. This perimeter filter and the revolutionary BioMediaGREEN media targets fine TSS, dissolved metals, nutrients, and bacteria. **It is recommended that the filter media be evaluated once per year and recharged if necessary.** Media life depends on local loading conditions and can easily be replaced and disposed of without any equipment. *Replacement of media takes approximately 60 minutes.*

4. Biological remediation (natural filtration) is provided by a 4th generation enhanced sub-surface flow vegetated gravel wetland. This natural filter is 14 feet long and contains 248 cubic feet of filter media and plant material. It targets the finest TSS, nutrients, dissolved metals, and bacteria. This filter provides the final polishing step of treatment. If prior treatment stages are properly maintained, the life of this media can be more than 5 years. **It is recommended the wetland and its plants be inspected once a year.** Replacement of the rock media may be needed as soon as five years or as long as 20 years. *Inspection takes approximately 15 minutes. Replacement of rock media takes approximately 4 hours and requires a vac truck.*

5. A drain down filter, similar in function to the perimeter filter is located in the discharge chamber. This filter allows standing water to be drained and filtered out

of the separation chamber. This addresses any vector issues, by eliminating all standing water within this system. **It is recommended the media of the drain down filter be replaced one a year.** *Replacement of media takes approximately 5 minutes and is performed without any equipment.*

The MWS – Linear catch basin filter, separation chamber, and wetland filter are designed to allow for the use of vacuum removal of captured materials in the filter screens and sediment and wetland chambers, serviceable by centrifugal compressor vacuum units without causing damage to the filter or during normal cleaning and maintenance. Filters can be cleaned and vacuumed from the standard manhole access or at grade.

Maintenance Notes:

1. Modular Wetland Systems, Inc. recommends the **catch basin filter** be inspected and cleaned a minimum of once every six months and replacement of hydrocarbon booms once a year. The procedure is easily done with the use of any standard vacuum truck.
 - Remove grate or manhole to gain access to catch basin filter insert. Remove the deflector shield (grate type only) with the hydrocarbon boom attached. Where possible the maintenance should be performed from the ground surface. Note: entry into an underground stormwater vault such as an inlet vault requires certification in confined space training.
 - Remove all trash, debris, organics, and sediments collected by the inlet filter insert. Removal of the trash and debris can be done manually or with the use of a vacuum truck. The hose of the vacuum truck will not damage the screen of the filter.
 - Evaluation of the hydrocarbon boom shall be performed at each cleaning. If the boom is filled with hydrocarbons and oils it should be replaced. Attach new boom to basket with plastic ties through pre-drilled holes in basket. Place the deflector shield (grate type only) back into the filter.

- Transport all debris, trash, organics and sediments to approved facility for disposal in accordance with local and state requirements.
 - The hydrocarbon boom may be classified as hazardous material and will have to be picked up and disposed of as hazardous waste. Hazardous material can only be handled by a certified hazardous waste trained person (minimum 24-hour hazwoper).
2. Modular Wetland Systems, Inc. recommends the **separation chamber** be inspected and cleaned a minimum of once a year. The procedure is easily done with the use of any standard vacuum truck. Remove grate or manhole, remove catch basin filter, spray down pollutants accumulated on fiberglass media panels (do not spray media directly, doing so can damage the media), vacuum out separation chamber, replace catch basin filter, replace grate or manhole cover.
 3. Modular Wetland Systems, Inc. recommends the **perimeter filter's** media be inspected and cleaned a minimum of once a year. The procedure will require prior maintenance of separation chamber. Remove grate, remove catch basin filter, enter separation chamber, unlatch top and bottom of each media protection panel, remove media protection panels to expose media, power wash surface, evaluate media condition, replace if necessary. New media blocks can be ordered from Modular Wetland Systems, Inc. Replace media protection panels, replace catch basin filter, replace grate or manhole cover.
 4. Modular Wetland Systems, Inc. recommends the **drain down filter** be inspected and maintained a minimum of once a year. Open hatch of discharge chamber, enter chamber, unlatch fiberglass cover, remove media block, replace with new block, replace and latch cover. Exit chamber, close and lock down the hatch.
 5. Modular Wetland Systems, Inc. recommends the **wetland filter** and its plants/vegetation be inspected and maintained a minimum of once a year. It is also recommended that the plants receive the same care as other landscaped areas.

Note: No fertilizer is to be used on this area.

6. Following maintenance and/or inspection, the maintenance operator shall prepare a maintenance/inspection record. The record shall include any maintenance activities performed, amount and description of debris collected, and condition of the system and its various filter mechanism. .
7. The owner shall retain the maintenance/inspection record for a minimum of five years from the date of maintenance. These records shall be made available to the governing municipality for inspection upon request at any time.
8. Any person performing maintenance activities must have completed a minimum of OSHA 24-hour hazardous waste worker (hazwoper) training.
9. Remove access manhole lid or grate to gain access to filter screens and sediment chambers. Where possible the maintenance should be performed from the ground surface. Note: entry into an underground stormwater vault such as an inlet vault requires certification in confined space training.
10. Transport all debris, trash, organics and sediments to approved facility for disposal in accordance with local and state requirements.
11. The hydrocarbon boom is classified as hazardous material and will have to be picked up and disposed of as hazardous waste. Hazardous material can only be handled by a certified hazardous waste trained person (minimum 24-hour hazwoper).

Maintenance Sequence



Service Crews Arrive On Site And Remove Access Manhole To Perform Maintenance Service.



Assess Condition and Pollutant Loading. A Few Gallons Of Water Are Sprayed Into Sediment Chamber To Allow Sediment To Be Vacuumed.



Catch Basin Filters Are Completely Vacuumed Free Of All Pollutants.



Cleaned Catch Basin Filters Are Removed Through Access Manhole To Allow For Unimpeded Access To Sediment Chamber.



Sediment Chamber Is Vacuumed Clean Of All Accumulated Sediment And Associated Pollutants.



Filter Media Shields Are Removed To Expose BioMediaGREEN Filter Media To Be Cleaned Or Replaced.



Exposed Filter Media Will Be Evaluated For Clogging And Loading Condition.



Media To Be Power Washed To Reveal Extent Of Clogging. If Only Surface Is Clogged, Media Can Be Re-Used Once. If Clogged Replace With New Media Blocks. Remove and Replace.



Washed Or New Media Is Now Ready For Use. If Media Was Replaced, Old Media Will Need To Be Properly Disposed Of Properly.



Replace Media Filter Panels And Lock Into Position.



Replace Catch Basin Filters.



Replace Access Manhole. Check Plants For Growth, Trim If Necessary. Service Is Complete. Total Service Time = 45 Minutes.

Maintenance Guidelines for Modular Wetland System - Linear

Maintenance Summary

- Remove Trash from Screening Device – average maintenance interval is 6 to 12 months.
 - *(5 minute average service time).*
- Remove Sediment from Separation Chamber – average maintenance interval is 12 to 24 months.
 - *(10 minute average service time).*
- Replace Cartridge Filter Media – average maintenance interval 12 to 24 months.
 - *(10-15 minute per cartridge average service time).*
- Replace Drain Down Filter Media – average maintenance interval is 12 to 24 months.
 - *(5 minute average service time).*
- Trim Vegetation – average maintenance interval is 6 to 12 months.
 - *(Service time varies).*

System Diagram

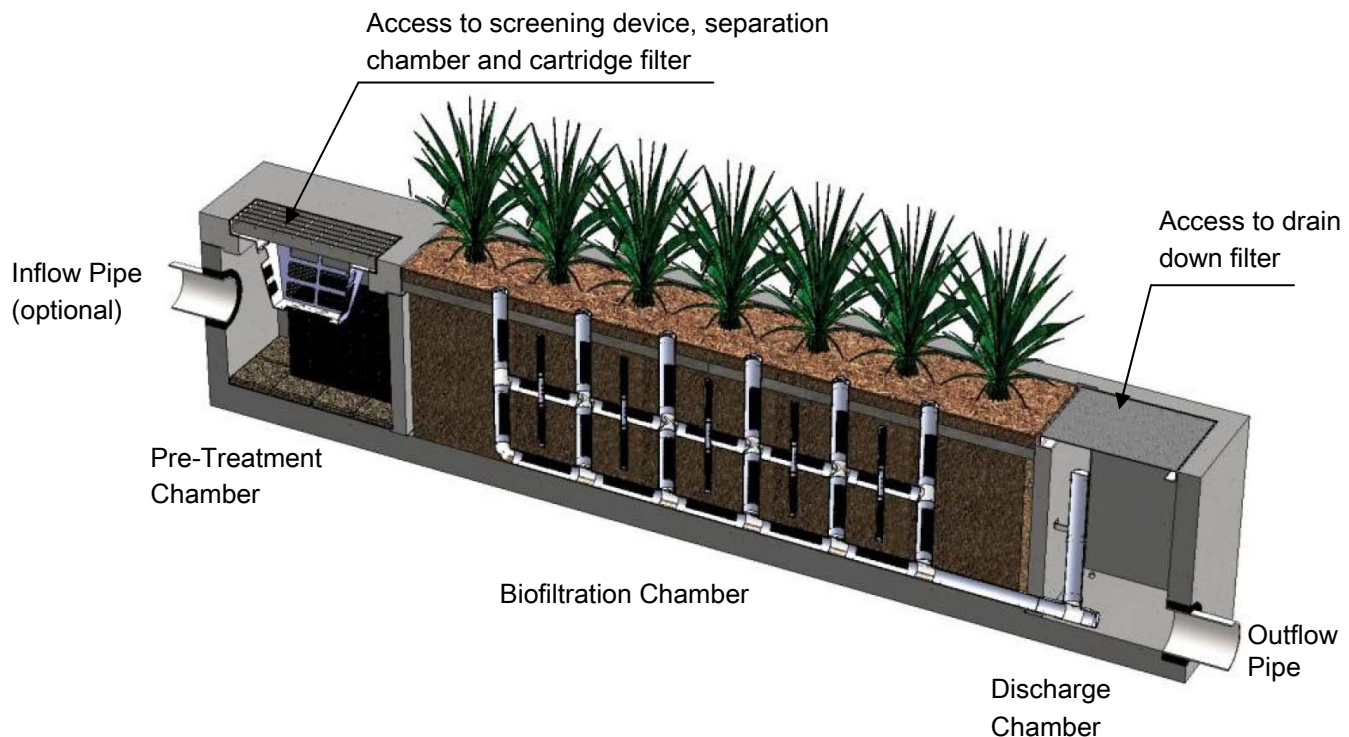

Maintenance Procedures

Screening Device

1. Remove grate or manhole cover to gain access to the screening device in the Pre-Treatment Chamber. Vault type units do not have screening device. Maintenance can be performed without entry.
2. Remove all pollutants collected by the screening device. Removal can be done manually or with the use of a vacuum truck. The hose of the vacuum truck will not damage the screening device.
3. Screening device can easily be removed from the Pre-Treatment Chamber to gain access to separation chamber and media filters below. Replace grate or manhole cover when completed.

Separation Chamber

1. Perform maintenance procedures of screening device listed above before maintaining the separation chamber.
2. With a pressure washer spray down pollutants accumulated on walls and cartridge filters.
3. Vacuum out Separation Chamber and remove all accumulated pollutants. Replace screening device, grate or manhole cover when completed.

Cartridge Filters

1. Perform maintenance procedures on screening device and separation chamber before maintaining cartridge filters.
2. Enter separation chamber.
3. Unscrew the two bolts holding the lid on each cartridge filter and remove lid.
4. Remove each of 4 to 8 media cages holding the media in place.
5. Spray down the cartridge filter to remove any accumulated pollutants.
6. Vacuum out old media and accumulated pollutants.
7. Reinstall media cages and fill with new media from manufacturer or outside supplier. Manufacturer will provide specification of media and sources to purchase.
8. Replace the lid and tighten down bolts. Replace screening device, grate or manhole cover when completed.

Drain Down Filter

1. Remove hatch or manhole cover over discharge chamber and enter chamber.
2. Unlock and lift drain down filter housing and remove old media block. Replace with new media block. Lower drain down filter housing and lock into place.
3. Exit chamber and replace hatch or manhole cover.



Maintenance Notes

1. Following maintenance and/or inspection, it is recommended the maintenance operator prepare a maintenance/inspection record. The record should include any maintenance activities performed, amount and description of debris collected, and condition of the system and its various filter mechanisms.
2. The owner should keep maintenance/inspection record(s) for a minimum of five years from the date of maintenance. These records should be made available to the governing municipality for inspection upon request at any time.
3. Transport all debris, trash, organics and sediments to approved facility for disposal in accordance with local and state requirements.
4. Entry into chambers may require confined space training based on state and local regulations.
5. No fertilizer shall be used in the Biofiltration Chamber.
6. Irrigation should be provided as recommended by manufacturer and/or landscape architect. Amount of irrigation required is dependent on plant species. Some plants may require irrigation.

Maintenance Procedure Illustration

Screening Device

The screening device is located directly under the manhole or grate over the Pre-Treatment Chamber. It's mounted directly underneath for easy access and cleaning. Device can be cleaned by hand or with a vacuum truck.



Separation Chamber

The separation chamber is located directly beneath the screening device. It can be quickly cleaned using a vacuum truck or by hand. A pressure washer is useful to assist in the cleaning process.

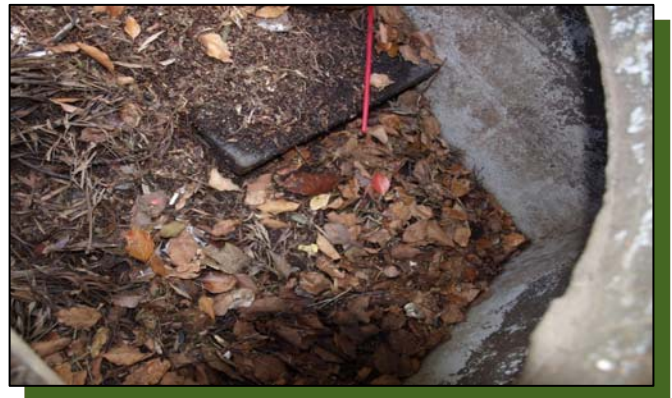

Cartridge Filters

The cartridge filters are located in the Pre-Treatment chamber connected to the wall adjacent to the biofiltration chamber. The cartridges have removable tops to access the individual media filters. Once the cartridge is open media can be easily removed and replaced by hand or a vacuum truck.



Drain Down Filter

The drain down filter is located in the Discharge Chamber. The drain filter unlocks from the wall mount and hinges up. Remove filter block and replace with new block.



Trim Vegetation

Vegetation should be maintained in the same manner as surrounding vegetation and trimmed as needed. No fertilizer shall be used on the plants. Irrigation per the recommendation of the manufacturer and or landscape architect. Different types of vegetation requires different amounts of irrigation.





Inspection Form



Modular Wetland System, Inc.

P. 760.433-7640

F. 760-433-3176

E. Info@modularwetlands.com

www.modularwetlands.com



Inspection Report Modular Wetlands System



Project Name _____

Project Address _____ (city) (Zip Code)

Owner / Management Company _____

Contact _____

Phone () -

Inspector Name _____

Date ____ / ____ / ____

Time _____ AM / PM

Type of Inspection Routine Follow Up Complaint

Storm

Storm Event in Last 72-hours? No Yes

Weather Condition _____

Additional Notes _____

For Office Use Only
(Reviewed By)
(Date) Office personnel to complete section to the left.

Inspection Checklist

Modular Wetland System Type (Curb, Grate or UG Vault): _____ Size (22', 14' or etc.): _____

Structural Integrity:	Yes	No	Comments
Damage to pre-treatment access cover (manhole cover/grate) or cannot be opened using normal lifting pressure?			
Damage to discharge chamber access cover (manhole cover/grate) or cannot be opened using normal lifting pressure?			
Does the MWS unit show signs of structural deterioration (cracks in the wall, damage to frame)?			
Is the inlet/outlet pipe or drain down pipe damaged or otherwise not functioning properly?			
Working Condition:			
Is there evidence of illicit discharge or excessive oil, grease, or other automobile fluids entering and clogging the unit?			
Is there standing water in inappropriate areas after a dry period?			
Is the filter insert (if applicable) at capacity and/or is there an accumulation of debris/trash on the shelf system?			
Does the depth of sediment/trash/debris suggest a blockage of the inflow pipe, bypass or cartridge filter? If yes, specify which one in the comments section. Note depth of accumulation in in pre-treatment chamber.			Depth:
Does the cartridge filter media need replacement in pre-treatment chamber and/or discharge chamber?			Chamber:
Any signs of improper functioning in the discharge chamber? Note issues in comments section.			
Other Inspection Items:			
Is there an accumulation of sediment/trash/debris in the wetland media (if applicable)?			
Is it evident that the plants are alive and healthy (if applicable)? Please note Plant Information below.			
Is there a septic or foul odor coming from inside the system?			

Waste:	Yes	No
Sediment / Silt / Clay		
Trash / Bags / Bottles		
Green Waste / Leaves / Foliage		

Recommended Maintenance	
No Cleaning Needed	
Schedule Maintenance as Planned	
Needs Immediate Maintenance	

Plant Information	
Damage to Plants	
Plant Replacement	
Plant Trimming	

Additional Notes: _____

Maintenance Report



Modular Wetland System, Inc.

P. 760.433-7640

F. 760-433-3176

E. Info@modularwetlands.com

www.modularwetlands.com



Cleaning and Maintenance Report Modular Wetlands System



Project Name _____

Project Address _____ (city) (Zip Code)

Owner / Management Company _____

Contact _____ Phone () -

Inspector Name _____ Date ____ / ____ / ____ Time ____ AM / PM

Type of Inspection Routine Follow Up Complaint Storm Storm Event in Last 72-hours? No Yes

Weather Condition _____ Additional Notes _____

For Office Use Only
(Reviewed By)
(Date) Office personnel to complete section to the left.

Site Map #	GPS Coordinates of Insert	Manufacturer / Description / Sizing	Trash Accumulation	Foliage Accumulation	Sediment Accumulation	Total Debris Accumulation	Condition of Media 25/50/75/100 (will be changed @ 75%)	Operational Per Manufactures' Specifications (If not, why?)
	Lat: Long:	MWS Catch Basins						
		MWS Sedimentation Basin						
		Media Filter Condition						
		Plant Condition						
		Drain Down Media Condition						
		Discharge Chamber Condition						
		Drain Down Pipe Condition						
		Inlet and Outlet Pipe Condition						

Comments:



Inspection Report Modular Wetlands System



Project Name _____

Project Address _____ (city) (Zip Code)

Owner / Management Company _____

Contact _____

Phone () -

Inspector Name _____

Date ____ / ____ / ____

Time _____ AM / PM

Type of Inspection Routine Follow Up Complaint

Storm

Storm Event in Last 72-hours? No Yes

Weather Condition _____

Additional Notes _____

For Office Use Only
(Reviewed By)
(Date) Office personnel to complete section to the left.

Inspection Checklist

Modular Wetland System Type (Curb, Grate or UG Vault): _____ Size (22', 14' or etc.): _____

Structural Integrity:	Yes	No	Comments
Damage to pre-treatment access cover (manhole cover/grate) or cannot be opened using normal lifting pressure?			
Damage to discharge chamber access cover (manhole cover/grate) or cannot be opened using normal lifting pressure?			
Does the MWS unit show signs of structural deterioration (cracks in the wall, damage to frame)?			
Is the inlet/outlet pipe or drain down pipe damaged or otherwise not functioning properly?			
Working Condition:			
Is there evidence of illicit discharge or excessive oil, grease, or other automobile fluids entering and clogging the unit?			
Is there standing water in inappropriate areas after a dry period?			
Is the filter insert (if applicable) at capacity and/or is there an accumulation of debris/trash on the shelf system?			
Does the depth of sediment/trash/debris suggest a blockage of the inflow pipe, bypass or cartridge filter? If yes, specify which one in the comments section. Note depth of accumulation in in pre-treatment chamber.			Depth:
Does the cartridge filter media need replacement in pre-treatment chamber and/or discharge chamber?			Chamber:
Any signs of improper functioning in the discharge chamber? Note issues in comments section.			
Other Inspection Items:			
Is there an accumulation of sediment/trash/debris in the wetland media (if applicable)?			
Is it evident that the plants are alive and healthy (if applicable)? Please note Plant Information below.			
Is there a septic or foul odor coming from inside the system?			

Waste:	Yes	No
Sediment / Silt / Clay		
Trash / Bags / Bottles		
Green Waste / Leaves / Foliage		

Recommended Maintenance	
No Cleaning Needed	
Schedule Maintenance as Planned	
Needs Immediate Maintenance	

Plant Information	
Damage to Plants	
Plant Replacement	
Plant Trimming	

Additional Notes: _____



Cleaning and Maintenance Report Modular Wetlands System



Project Name _____

Project Address _____

(city) (Zip Code)

Owner / Management Company _____

Contact _____

Phone () -

Inspector Name _____

Date ____ / ____ / ____ Time _____ AM / PM

Type of Inspection Routine Follow Up Complaint

Storm Storm Event in Last 72-hours? No Yes

Weather Condition _____

Additional Notes _____

For Office Use Only

(Reviewed By) _____

(Date) _____
Office personnel to complete section to the left.

Site Map #	GPS Coordinates of Insert	Manufacturer / Description / Sizing	Trash Accumulation	Foliage Accumulation	Sediment Accumulation	Total Debris Accumulation	Condition of Media 25/50/75/100 (will be changed @ 75%)	Operational Per Manufactures' Specifications (If not, why?)
	Lat: _____ Long: _____	MWS Catch Basins						
		MWS Sedimentation Basin						
		Media Filter Condition						
		Plant Condition						
		Drain Down Media Condition						
		Discharge Chamber Condition						
		Drain Down Pipe Condition						
		Inlet and Outlet Pipe Condition						

Comments: _____

RECORDING REQUESTED BY:
THE CITY OF SAN MARCOS
AND WHEN RECORDED MAIL TO:

City of San Marcos
Development Services Department
Land Development Division
1 Civic Center Drive
San Marcos, California 92069

The recordation of this document is a benefit to the City.

(THIS SPACE FOR RECORDER'S USE ONLY)

STORM WATER MANAGEMENT AND DISCHARGE CONTROL MAINTENANCE AGREEMENT AND EASEMENT

This agreement is made by and between the City of San Marcos, a municipal corporation [City] and _____, [Property Owner] the owner of property more particularly described as _____ [legal description] in the City of San Marcos, County of San Diego, State of California.

A. Property Owner is required pursuant to the City of San Marcos Municipal Code, Section 14.15, and the City's current local Water Management and Discharge Control Maintenance Agreement [Maintenance Agreement], for the installation and maintenance of Permanent Stormwater Best Management Practices [Permanent Stormwater BMP's], prior to the issuance of permits. Permanent Stormwater BMPs shall include all constructed elements described in the approved project's SWQMP Storm Water Quality Management Plan (SWQMP) and construction plan (e.g., Low Impact Development, Source Control, Site Design, and Treatment Control). The Maintenance Agreement is intended to ensure the installation and maintenance of Permanent Stormwater BMP's, as identified in Attachment A and described in Attachment B (attached hereto), and as also described in the project's SWQMP, approved on _____, and Plan File/Drawing No(s). _____.

B. Property Owner wishes to obtain an engineering and/or building permit according to Plan File/Drawing No(s). _____.

NOW, THEREFORE, the parties agree as follows:

1. Property Owner shall prepare, if qualified, or shall have prepared, an approved Operation and Maintenance Plan [OMP] for Permanent Stormwater BMP's (Attachment B), to ensure the implementation thereof consistent with the intent of the San Diego Regional Water Quality Control Board permit requirements, and satisfactory to the City, as it relates to Plan File/Drawing No(s). _____.
2. Property Owner shall install, maintain, and repair or replace, all Permanent Stormwater BMPs within their property, according to Attachment A & Attachment B.
3. The Property Owner shall maintain annual records into perpetuity identifying the installation, maintenance, and repair or replacement, of any, and all, Permanent Stormwater BMPs, identified in Attachment A & Attachment B and Plan File/Drawing No(s). _____. These records shall be made available to the City for inspection upon request at any time.
4. Property owner is required to submit annually, by October 1, to the City, Attachment A & Attachment B, as proof of meeting the obligations set forth herein, for all the Permanent Stormwater BMPs as described in Attachment A & Attachment B.
4. Additional supplemental information, as it relates to the project's SWQMP, can be found within Master File # _____, located within the Engineering Division at City Hall.
5. By this Agreement, Property Owner hereby grants the City an easement giving the City the right, but not the obligation, to enter onto the Property (and any necessary adjacent land needed for access) to inspect, install, repair or replace, and maintain the BMPs, as required per the project's SWQMP and Plan File/Drawing No(s). _____. The City shall have the right, but not the obligation, to maintain all Permanent Stormwater BMPs to the satisfaction of the City Engineer. The cost for any such inspection, installation, repair or replacement, and or maintenance incurred by the City will be the responsibility of the Property Owner and the Property and may constitute a lien upon the property until paid. Any unpaid amounts shall accrue interest at the rate of ten percent (10%) per year; any payments shall be applied first to accrued interest and then to the outstanding principal amount.

6. This Maintenance Agreement shall become effective upon execution of this document by all parties named hereon, and the obligations hereunder shall constitute a covenant and equitable servitude running with the land, and shall be binding upon Property Owner and his/her/their successors in interest.

Executed by the City of San Marcos and by Property Owner in San Marcos, California.

NOTE: NOTARY ACKNOWLEDGMENTS FOR ALL SIGNATURES MUST BE ATTACHED

(Signature)

(Date)

(Print Name & Title)

APPROVED By: _____
(City Engineer)

(Date)

ATTACHMENT 4
Copy of Plan Sheets Showing Permanent Storm Water BMPs

This is the cover sheet for Attachment 4.

Use this checklist to ensure the required information has been included on the plans:

The plans must identify:

- Structural BMP(s) with ID numbers matching Form I-6 Summary of PDP Structural BMPs
- The grading and drainage design shown on the plans must be consistent with the delineation of DMAs shown on the DMA exhibit
- Details and specifications for construction of structural BMP(s)
- Signage indicating the location and boundary of structural BMP(s) as required by the City Engineer
- How to access the structural BMP(s) to inspect and perform maintenance
- Features that are provided to facilitate inspection (e.g., observation ports, cleanouts, silt posts, or other features that allow the inspector to view necessary components of the structural BMP and compare to maintenance thresholds)
- Manufacturer and part number for proprietary parts of structural BMP(s) when applicable
- Maintenance thresholds specific to the structural BMP(s), with a location-specific frame of reference (e.g., level of accumulated materials that triggers removal of the materials, to be identified based on viewing marks on silt posts or measured with a survey rod with respect to a fixed benchmark within the BMP)
- Recommended equipment to perform maintenance
- When applicable, necessary special training or certification requirements for inspection and maintenance personnel such as confined space entry or hazardous waste management
- Include landscaping plan sheets showing vegetation requirements for vegetated structural BMP(s)
- All BMPs must be fully dimensioned on the plans
- When proprietary BMPs are used, site-specific cross section with outflow, inflow, and model number shall be provided. Photocopies of general brochures are not acceptable.

OWNER'S CERTIFICATE

I (WE) HEREBY CERTIFY THAT I (WE) AM (ARE) THE RECORD OWNER(S) OF THE PROPERTY SHOWN HEREON & THAT WE (US) HAVE CONTIGUOUS OWNERSHIP. I (WE) UNDERSTAND THAT PROPERTY IS CONSIDERED AS CONTIGUOUS EVEN IF IT IS SEPARATED BY ROAD, STREET, UTILITY EASEMENTS OR RAILROAD RIGHT-OF-WAY.

OWNER'S NAME

HUGHES SMCG, LLC
546 S. PACIFIC ST.
SAN MARCOS, CA 92078

APPLICANT'S NAME

HUGHES CIRCUITS, INC
546 S. PACIFIC ST.
SAN MARCOS, CA 92078

OWNER _____

DATE: _____

APPLICANT _____

DATE: _____

DATE PREPARED

JANUARY 2022

SURVEYOR OF WORK

EXCEL ENGINEERING
440 STATE PLACE ESCONDIDO,
CA 92029 (760) 745-8118

Michael D. Levin
MICHAEL D. LEVIN PLS# 6896



ENGINEER OF WORK

EXCEL ENGINEERING
440 STATE PLACE ESCONDIDO,
CA 92029 (760) 745-8118

Robert D. Dentino
ROBERT D. DENTINO RCE# 45629



FIRE DISTRICT

CITY OF SAN MARCOS

SCHOOL DISTRICT

SAN MARCOS UNIFIED

SEWER DISTRICT

VALLECITOS WATER DISTRICT

WATER DISTRICT

VALLECITOS WATER DISTRICT

LEGAL ACCESS

SOUTH PACIFIC STREET

FEMA ZONE

AS SHOWN ON FEMA PANEL 789 OF 2375; MAP 06073C0789H, DATED MAY 16, 2012, THIS PROJECT IS IN ZONE X - "AREA OF MINIMAL FLOOD HAZARD".

WQTR / HYDROLOGY STUDY

STUDY BY EXCEL ENGINEERING & DATED FEBRUARY 2022

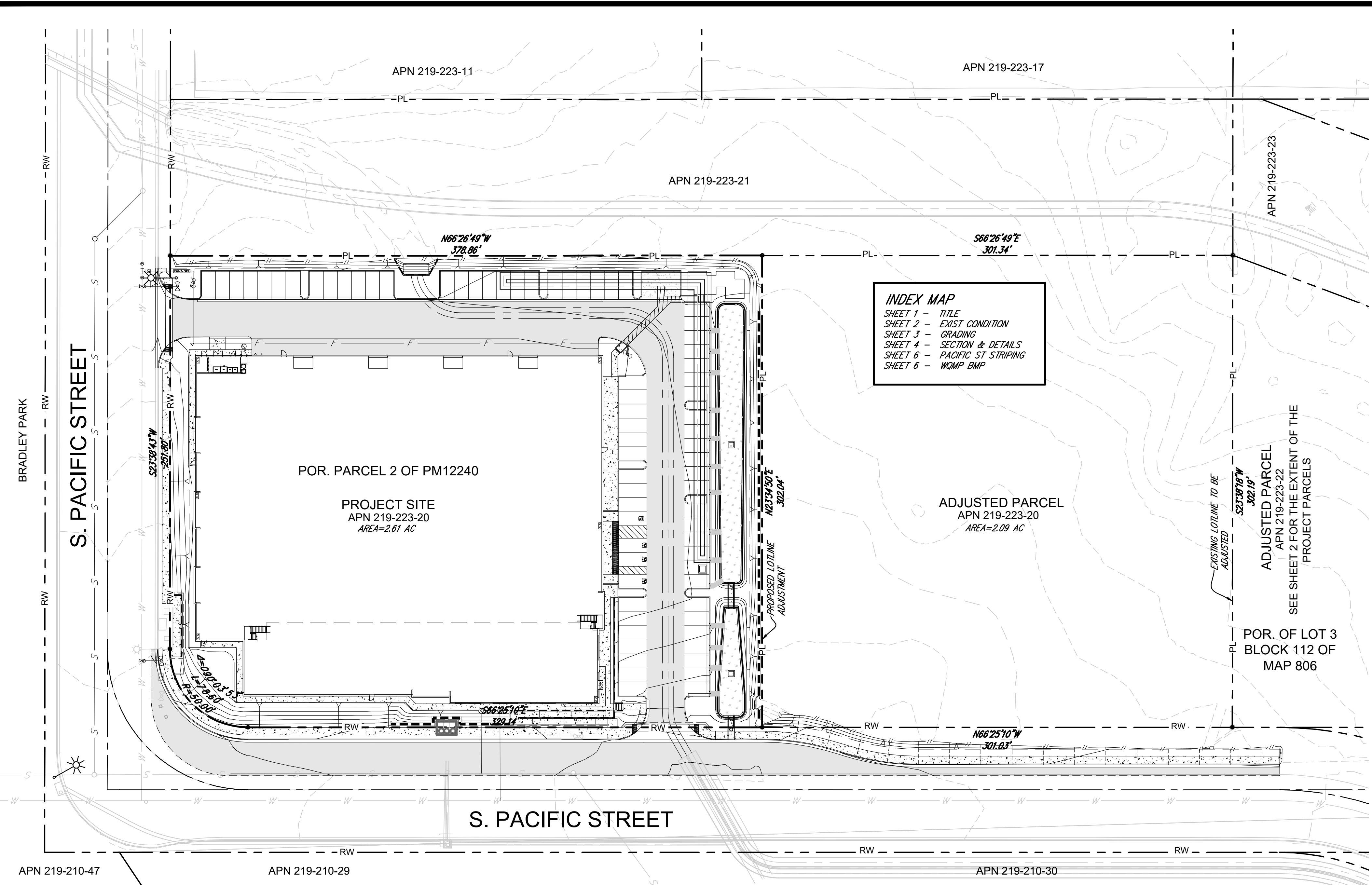
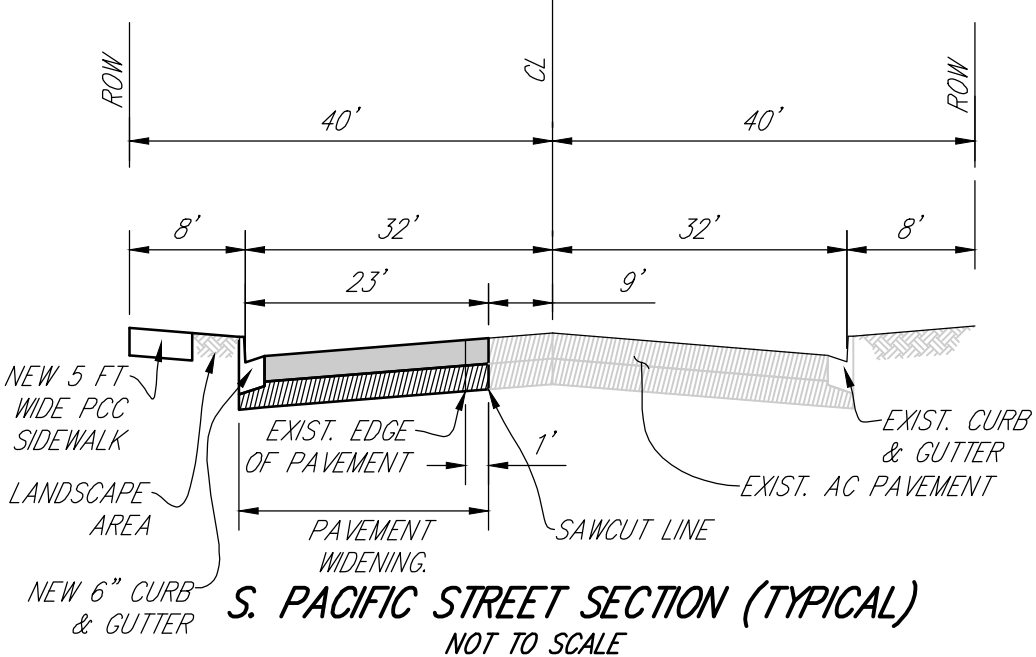

INDEX MAP
SHEET 1 - TITLE
SHEET 2 - EXIST CONDITION
SHEET 3 - GRADING
SHEET 4 - SECTION & DETAILS
SHEET 6 - PACIFIC ST STRIPING
SHEET 6 - WQMP BMP

ADJUSTED PARCEL
APN 219-223-22
SEE SHEET 2 FOR THE EXTENT OF THE
PROJECT PARCELS

POR. OF LOT 3
BLOCK 112 OF
MAP 806

SOURCE OF TOPOGRAPHY

THE EXISTING TOPOGRAPHY SHOWN HEREON IS FROM AN A.L.T.A. PROVIDED BY SPEARS & ASSOCIATES. ELEVATION WERE ADJUSTED TO MATCH CURRENT BENCHMARK. SUPPLEMENTAL FIELD DATA TAKEN LAST 12/07/2021 WERE ADDED BY EXCEL ENGINEERING.

SITE ADDRESS

NE CORNER S. PACIFIC ST.
SAN MARCOS, CA 92078

ZONING

EXISTING: L-1 LIGHT INDUSTRIAL
PROPOSE: L-1 LIGHT INDUSTRIAL

ASSESSOR'S PARCEL NO.

219-223-20-00 & 219-223-22-00

PROJECT SITE LAND AREA

2.61 ACRES

EARTHWORK STATEMENT

PRISMOIDAL METHOD WAS USED TO CALCULATE THE EARTHWORK VOLUME SHOWN HERE. SEE TABLE BELOW FOR DETAILS. THE GRADING PROPOSED FOR THIS PROJECT IS AS SHOWN ON SHEET 3 OF THIS PLAN SET.

IMPORT = 17,000 CY

EARTHWORK CALCULATION DETAIL					
LINE ID	ITEM DESCRIPTION	AREA (SF)	SECTION/LENGTH (FT)	VOL (CY)	ROUNDED
1	RAW CUT			128.5	130.00
2	STREET WIDENING	9,512.74	0.75	264.24	270.00
3	PAVEMENT ONSITE	33,277.93	0.75	924.39	930.00
4	BUILDING	56,172.25	0.75	1,560.34	1,570.00
5	DOUBLE 66" CIPP	28.27	924.00	967.61	970.00
6	WQ BIO BASIN A (5 FT DEEP)	2,866.17	5.00	530.77	540.00
7	WQ BIO BASIN B (5 FT DEEP)	963.40	5.00	178.41	180.00
8	TOTAL CUT			4,554.26	4,590.00
9					
10	RAW FILL			20,575.64	20,580.00
11	WQ BIO SELECT MATERIALS			709.18	710.00
12	SHRINKAGE			0.00	0.00
13	TOTAL FILL			21,284.82	21,290.00
14	IMPORT			-16,730.56	-16,700.00
15	FOR PERMITTING PURPOSES, SAY EARTHWORK IS IMPORT AT (CY)			17,000.00	

LEGAL DESCRIPTION

PORTION OF PARCEL 2 OF PARCEL MAP NO. 12240, IN THE CITY OF SAN MARCOS, COUNTY OF SAN DIEGO, STATE OF CALIFORNIA, FILED IN THE OFFICE OF THE COUNTY RECORDER OF SAN DIEGO COUNTY, JULY 16, 1982 AS INSTRUMENT NO 82-219201 OF OFFICIAL RECORDS.

PROJECT BENCHMARK

THE BENCHMARK FOR THIS PROJECT IS THE CITY OF SAN MARCOS CP-029, LOCATED AT THE WEST SIDE OF DISCOVERY ST 150' ± SE'LY OF THE INTERSECTION OF DISCOVERY ST & SAN MARCOS BLVD.

ELEVATION: 516.41

DATUM: NAVD88

BASIS OF BEARINGS

THE BASIS OF BEARINGS FOR THIS SURVEY IS THE NORTH LINE OF PARCEL MAP NO. 12240, I.E. N.66°25'34"W.

STORM WATER MISC AREA INFORMATION		
AREA DESCRIPTION	SF	AC
PARCEL AREA (NO OFFSITE)	113,908.74	2.61
AREA TO BE DISTURBED BY THE PROJECT	127,456.56	2.93
PROJECT PROPOSED IMPERVIOUS AREA	106,214.09	2.44
PROJECT PROPOSED PERVIOUS AREA	21,242.47	0.49

DATE	REMARKS
02/2022	PLANNING SUBMITTAL
07/2022	PLANNING SUBMITTAL

CITY OF SAN MARCOS			
SHEET:	PRELIMINARY GRADING PLAN		
SITE DEVELOPMENT PLAN NUMBER:	SDP22-0002		
OWNER:	HUGHES SMCG, LLC	PHONE:	760-744-0300
	550 SOUTH PACIFIC STREET, SAN MARCOS CA		
ENGINEER:	EXCEL ENGINEERING	PHONE:	760-745-8118
	440 STATE PLACE, ESCONDIDO, CA 92029		
PROJECT ADDRESS:	NE CORNER OF SOUTH PACIFIC STREET, SAN MARCOS CA		
TYPE OF DEVELOPMENT:	SITE DEVELOPMENT PLAN		
ZONE:	L-1 (LIGHT MANUFACTURING)	APN(S):	219-223-20 & 22
		DWELLING UNITS:	OPEN SPACE:
AREA (SF):	FAR (%): 0.59	COMMON:	PRIVATE:
LOT: 2.61 ACRES	STUDIO:	1 BDRM:	N/A
BUILDING: 67,410 SF	2 BDRM:	N/A	
PARKING:	3 BDRM:	N/A	
LOADING:			
LANDSCAPING:	TOTAL UNITS		
	DRIVEWAY (SIZE & SLOPE)		
GARAGE: N/A	LOADING: N/A	ONE WAY:	FRONT: REAR:
COVERED: 0	HANDICAP: 4	TWO WAY:	LEFT SIDE: RIGHT SIDE:
OPEN: 72	TOTAL: 72	SLOPE:	

SHEET 1 OF 6 SHEETS
TITLE



HUGHES CIRCUITS
PRELIMINARY GRADING PLAN
APN 219-223-20 & 22
NE CORNER OF S. PACIFIC STREET, SAN MARCOS CA
SDP22-0002

K: 121121088 [Engineering] PrelimGP1 Sheets - GP 121088 PrelimGP Title.dwg 9/29/2022 3:00 PM ORIGINAL PLOT SIZE: 11x17

MATCHLINE SEE RIGHT FOR CONTINUATION

MATCHLINE SEE LEFT FOR CONTINUATION

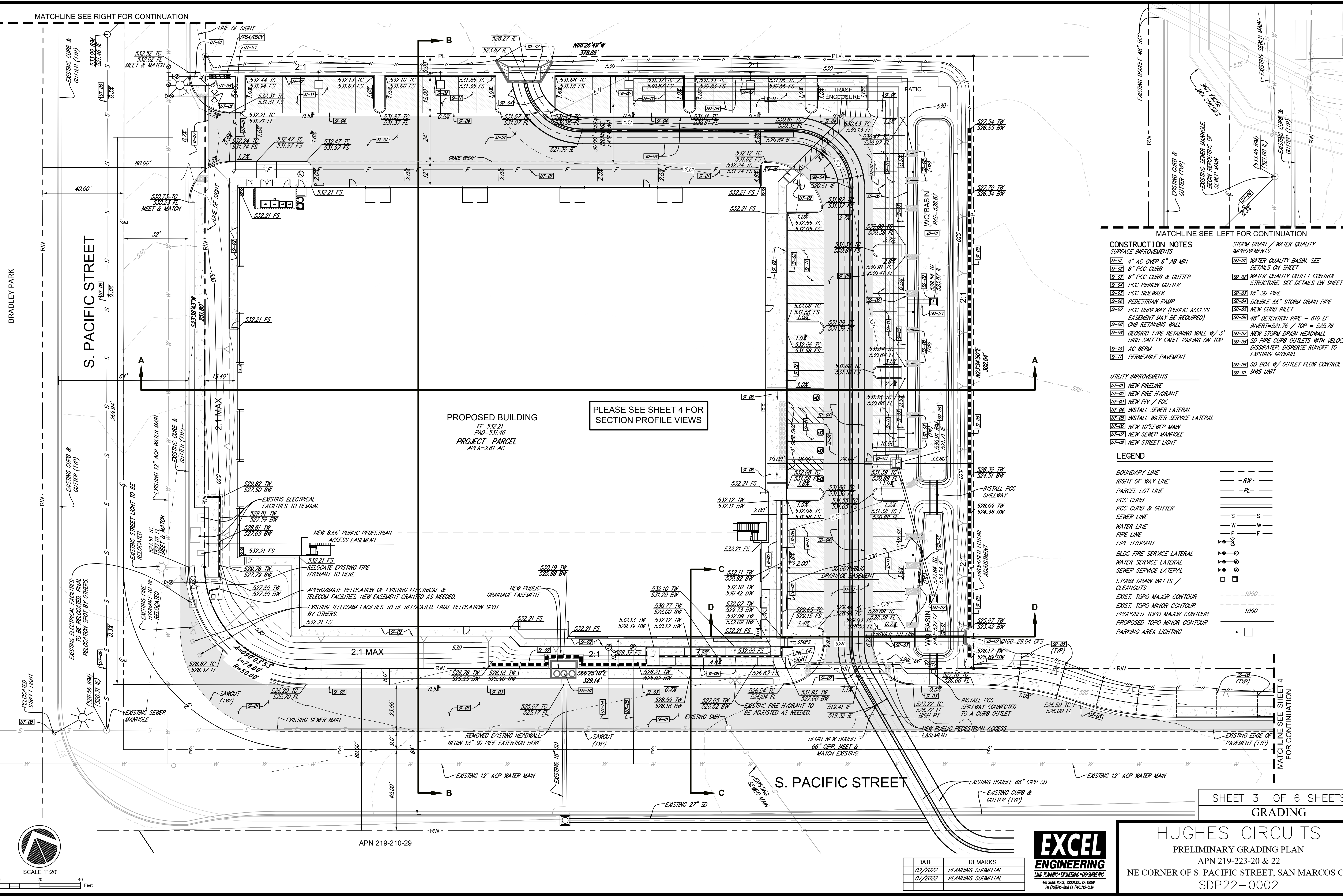

PROPOSED BUILDING
 FF=532.21
 PAD=531.46
 PROJECT PARCEL
 AREA=2.61 AC

PLEASE SEE SHEET 4 FOR
 SECTION PROFILE VIEWS

- CONSTRUCTION NOTES**
- SURFACE IMPROVEMENTS**
- S-01 4" AC OVER 6" AB MIN
 - S-02 6" PCC CURB
 - S-03 6" PCC CURB & GUTTER
 - S-04 PCC RIBBON GUTTER
 - S-05 PCC SIDEWALK
 - S-06 PEDESTRIAN RAMP
 - S-07 PCC DRIVEWAY (PUBLIC ACCESS EASEMENT MAY BE REQUIRED)
 - S-08 CHB RETAINING WALL
 - S-09 GEOGRID TYPE RETAINING WALL W/ 3' HIGH SAFETY CABLE RAILING ON TOP
 - S-10 AC BERM
 - S-11 PERMEABLE PAVEMENT
- STORM DRAIN / WATER QUALITY IMPROVEMENTS**
- SD-01 WATER QUALITY BASIN. SEE DETAILS ON SHEET
 - SD-02 WATER QUALITY OUTLET CONTROL STRUCTURE. SEE DETAILS ON SHEET 6
 - SD-03 18" SD PIPE
 - SD-04 DOUBLE 66" STORM DRAIN PIPE
 - SD-05 NEW CURB INLET
 - SD-06 48" DETENTION PIPE - 610 LF INVERT=521.76 / TOP = 526.76
 - SD-07 NEW STORM DRAIN HEADWALL
 - SD-08 SD PIPE CURB OUTLETS WITH VELOCITY DISSIPATER. DISPERSE RUNOFF TO EXISTING GROUND.
 - SD-09 SD BOX W/ OUTLET FLOW CONTROL
 - SD-10 MWS UNIT
- UTILITY IMPROVEMENTS**
- UT-01 NEW FIRELINE
 - UT-02 NEW FIRE HYDRANT
 - UT-03 NEW PIV / FDC
 - UT-04 INSTALL SEWER LATERAL
 - UT-05 INSTALL WATER SERVICE LATERAL
 - UT-06 NEW TO SEWER MAIN
 - UT-07 NEW SEWER MANHOLE
 - UT-08 NEW STREET LIGHT

- LEGEND**
- BOUNDARY LINE
 - RIGHT OF WAY LINE
 - PARCEL LOT LINE
 - PCC CURB
 - PCC CURB & GUTTER
 - SEWER LINE
 - WATER LINE
 - FIRE LINE
 - FIRE HYDRANT
 - BLDG FIRE SERVICE LATERAL
 - WATER SERVICE LATERAL
 - SEWER SERVICE LATERAL
 - STORM DRAIN INLETS / CLEANOUTS
 - EXIST. TOPO MAJOR CONTOUR
 - EXIST. TOPO MINOR CONTOUR
 - PROPOSED TOPO MAJOR CONTOUR
 - PROPOSED TOPO MINOR CONTOUR
 - PARKING AREA LIGHTING

SHEET 3 OF 6 SHEETS
 GRADING

HUGHES CIRCUITS
 PRELIMINARY GRADING PLAN
 APN 219-223-20 & 22
 NE CORNER OF S. PACIFIC STREET, SAN MARCOS CA
 SDP22-0002



DATE	REMARKS
02/2022	PLANNING SUBMITTAL
07/2022	PLANNING SUBMITTAL

K: 121121088 | Engineering | Preliminary | Sheets - GP 121088 Prelim GP.dwg 9/25/2023 3:01 PM ORIGINAL PLOT SIZE: ---

