

Project Specific Water Quality Management Plan

A Template for Projects located within the **Santa Ana Watershed** Region of Riverside County

Project Title: Patterson Commerce Center

Development No:

Design Review/Case No: 22-00003

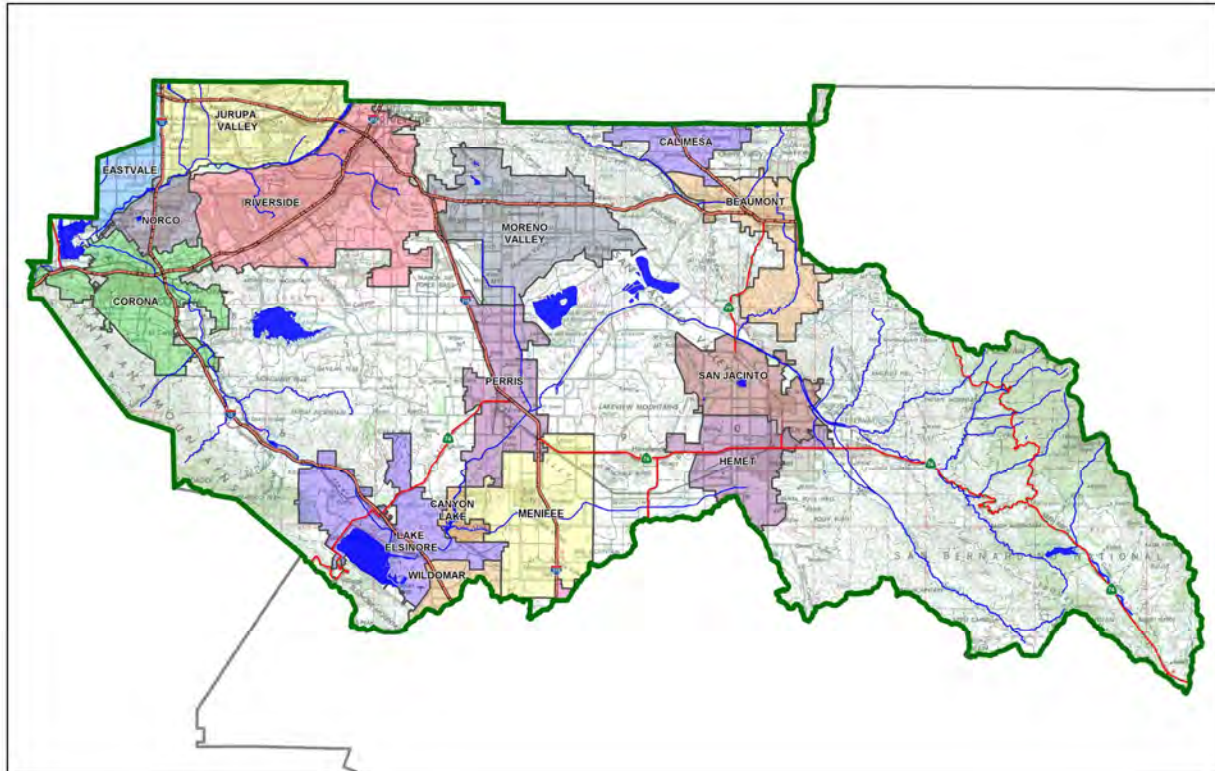

- Preliminary
- Final

Original Date Prepared: 08-12-2022

Revision Date(s): 10-21-2022

*Prepared for Compliance with
Regional Board Order No. **R8-2010-0033***

Template revised June 30, 2016

Contact Information:

Prepared for:

Rockefeller Group Development
4 Park Plaza, Suite 840
Irvine, CA 92614
949-468-1812

Prepared by:

Huitt-Zollars, Inc.
3990 Concourses, Suite 330
Ontario, CA 91764
909-941-7799

A Brief Introduction

This Project-Specific WQMP Template for the **Santa Ana Region** has been prepared to help guide you in documenting compliance for your project. Because this document has been designed to specifically document compliance, you will need to utilize the WQMP Guidance Document as your “how-to” manual to help guide you through this process. Both the Template and Guidance Document go hand-in-hand, and will help facilitate a well prepared Project-Specific WQMP. Below is a flowchart for the layout of this Template that will provide the steps required to document compliance.

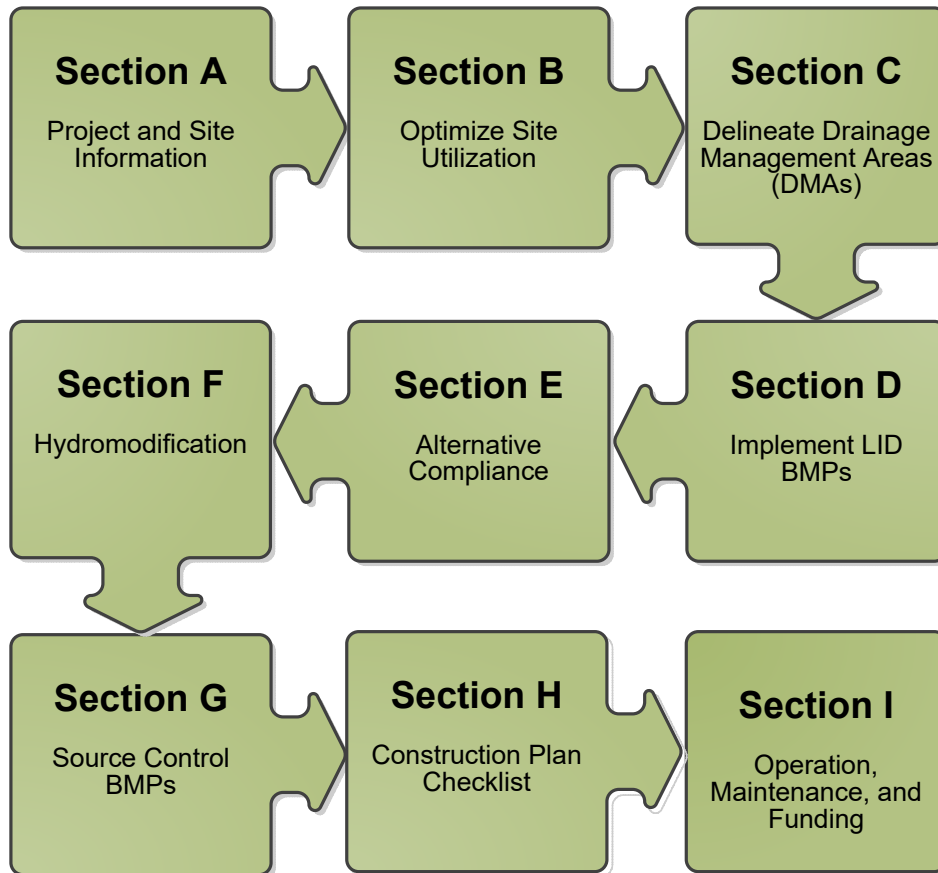

OWNER'S CERTIFICATION

This Project-Specific Water Quality Management Plan (WQMP) has been prepared for Rockefeller Group Development by Huilt-Zollars, inc for the Patterson Commerce Center project (P22-00003).

This WQMP is intended to comply with the requirements of City of Perris Ordinance 1194 which includes the requirement for the preparation and implementation of a Project-Specific WQMP.

The undersigned, while owning the property/project described in the preceding paragraph, shall be responsible for the implementation and funding of this WQMP and will ensure that this WQMP is amended as appropriate to reflect up-to-date conditions on the site. In addition, the property owner accepts responsibility for interim operation and maintenance of Stormwater BMPs until such time as this responsibility is formally transferred to a subsequent owner. This WQMP will be reviewed with the facility operator, facility supervisors, employees, tenants, maintenance and service contractors, or any other party (or parties) having responsibility for implementing portions of this WQMP. At least one copy of this WQMP will be maintained at the project site or project office in perpetuity. The undersigned is authorized to certify and to approve implementation of this WQMP. The undersigned is aware that implementation of this WQMP is enforceable under City of Perris Water Quality Ordinance 1194 (Municipal Code Section 14.22).

"I, the undersigned, certify under penalty of law that the provisions of this WQMP have been reviewed and accepted and that the WQMP will be transferred to future successors in interest."

Michael Sajjad
Owner's Signature

4-14-22
Date

Michael Sajjad,
Owner's Printed Name

VP Design and Construction
Owner's Title/Position

PREPARER'S CERTIFICATION

"The selection, sizing and design of stormwater treatment and other stormwater quality and quantity control measures in this plan meet the requirements of Regional Water Quality Control Board Order No. **R8-2010-0033** and any subsequent amendments thereto."

David White
Preparer's Signature

4-15-22
Date

David White, PE
Preparer's Printed Name

Vice President
Preparer's Title/Position

Preparer's Licensure:

ACKNOWLEDGMENT

A notary public or other officer completing this certificate verifies only the identity of the individual who signed the document to which this certificate is attached, and not the truthfulness, accuracy, or validity of that document.

State of California
County of Orange)

On April 14, 2022 before me, Robbie P. Wittman
(insert name and title of the officer)

personally appeared Michael M. Sajjadi,
who proved to me on the basis of satisfactory evidence to be the person(s) whose name(s) is/are
subscribed to the within instrument and acknowledged to me that he/she/they executed the same in
his/her/their authorized capacity(ies), and that by his/her/their signature(s) on the instrument the
person(s), or the entity upon behalf of which the person(s) acted, executed the instrument.

I certify under PENALTY OF PERJURY under the laws of the State of California that the foregoing
paragraph is true and correct.

WITNESS my hand and official seal.

Signature



(Seal)

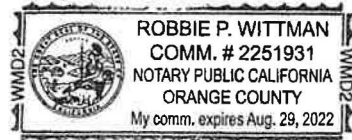

Table of Contents

Section A: Project and Site Information.....	6
A.1 Maps and Site Plans	6
A.2 Identify Receiving Waters	7
A.3 Additional Permits/Approvals required for the Project:	7
Section B: Optimize Site Utilization (LID Principles)	9
Section C: Delineate Drainage Management Areas (DMAs).....	11
Section D: Implement LID BMPs	13
D.1 Infiltration Applicability	13
D.2 Harvest and Use Assessment.....	14
D.3 Bioretention and Biotreatment Assessment	16
D.4 Feasibility Assessment Summaries	17
D.5 LID BMP Sizing	18
Section E: Alternative Compliance (LID Waiver Program)	19
E.1 Identify Pollutants of Concern	20
E.2 Stormwater Credits	21
E.3 Sizing Criteria.....	21
E.4 Treatment Control BMP Selection	22
Section F: Hydromodification	23
F.1 Hydrologic Conditions of Concern (HCOC) Analysis.....	23
F.2 HCOC Mitigation.....	24
Section G: Source Control BMPs	25
Section H: Construction Plan Checklist	25
Section I: Operation, Maintenance and Funding.....	28

List of Tables

Table A.1 Identification of Receiving Waters.....	7
Table A.2 Other Applicable Permits.....	7
Table C.1 DMA Classifications.....	11
Table C.2 Type 'A', Self-Treating Areas (Included with mixed DMA1 above).....	11
Table C.3 Type 'B', Self-Retaining Areas (N/A, included with mixed DMA1).....	11
Table C.4 Type 'C', Areas that Drain to Self-Retaining Areas (N/A).....	12
Table C.5 Type 'D', Areas Draining to BMPs.....	12
Table D.1 Infiltration Feasibility.....	13
Table D.2 LID Prioritization Summary Matrix.....	17
Table D.3 DCV Calculations for LID BMPs.....	18
Table E.1 Potential Pollutants by Land Use Type.....	20
Table E.2 Water Quality Credits.....	21
Table E.3 Treatment Control BMP Sizing.....	21
Table E.4 Treatment Control BMP Selection.....	22
Table F.1 Hydrologic Conditions of Concern Summary.....	23
Table G.1 Permanent and Operational Source Control Measures.....	25
Table H.1 Construction Plan Cross-reference.....	27

List of Appendices

Appendix 1: Maps and Site Plans.....	32
Appendix 2: Construction Plans.....	33
Appendix 3: Soils Information.....	34
Appendix 4: Historical Site Conditions.....	35
Appendix 5: LID Infeasibility.....	36
Appendix 6: BMP Design Details.....	37
Appendix 7: Hydromodification.....	38
Appendix 8: Source Control.....	39
Appendix 9: O&M.....	40
Appendix 10: Educational Materials.....	- 6 -

Section A: Project and Site Information

PROJECT INFORMATION	
Type of Project:	Warehouse Industrial
Planning Area:	616,590 SF
Community Name:	County of Riverside
Development Name:	Patterson Commerce Center
PROJECT LOCATION	
Latitude & Longitude (DMS): 33°51'18.13"N, 117°15'14.62"W	
Project Watershed and Sub-Watershed: Santa Ana Watershed, San Jacinto Sub-Watershed	
Gross Acres: 14.155	
APN(s): 314-110-008, 009, 010, 016, 017, 018, 020, 021, 022, 023, 043, 044, 045, 046, 052, 053, 058, & 059	
Map Book and Page No.: Thomas Brothers Page 747	
PROJECT CHARACTERISTICS	
Proposed or Potential Land Use(s)	Warehouse Industrial
Proposed or Potential SIC Code(s)	4225
Area of Impervious Project Footprint (SF)	473,909
Total Area of <u>proposed</u> Impervious Surfaces within the Project Footprint (SF)/or Replacement	473,909
Does the project consist of offsite road improvements?	<input checked="" type="checkbox"/> Y <input type="checkbox"/> N
Does the project propose to construct unpaved roads?	<input type="checkbox"/> Y <input checked="" type="checkbox"/> N
Is the project part of a larger common plan of development (phased project)?	<input type="checkbox"/> Y <input checked="" type="checkbox"/> N
EXISTING SITE CHARACTERISTICS	
Total area of <u>existing</u> Impervious Surfaces within the Project limits Footprint (SF)	85,000
Is the project located within any MSHCP Criteria Cell?	<input type="checkbox"/> Y <input checked="" type="checkbox"/> N
If so, identify the Cell number:	N/A
Are there any natural hydrologic features on the project site?	<input type="checkbox"/> Y <input checked="" type="checkbox"/> N
Is a Geotechnical Report attached?	<input checked="" type="checkbox"/> Y <input type="checkbox"/> N
If no Geotech. Report, list the NRCS soils type(s) present on the site (A, B, C and/or D)	N/A
What is the Water Quality Design Storm Depth for the project?	0.61"

The proposed project is located between Nance Street, Patterson Avenue, Washington Street, and Wade Avenue in the City of Perris, County of Riverside, CA. The majority of the site is currently being used for trailer storage and the southwest corner is being used as a heavy equipment/construction yard. The proposed project will consist of an industrial warehouse development with a single 263,820 sf industrial warehouse building with approximately 23% landscaping area. The site will also allow for car parking, drive aisles, truck docks and truck courts which comprises approximately 34% of the site. Truck drive entrances are proposed on Washington Street. Additionally, a passenger car access drive is proposed on each street bordering the site. A specific business use is not known at this time, but outdoor storage will not be allowed.

For the onsite water quality treatment, the development will have one (1) drainage area DMA A, and the storm water from the DMA A will be conveyed to the designated bio-retention basin on the east side of the project site through three underground storm drain lines. The bio-retention basin's footprint is ±57' x ±345' totaling 19,956 square feet. The basin has been sized to mitigate the post construction runoff to levels equivalent to the pre-developed condition which provides more than 150% the required DCV volume.

The site landscaping areas are self-retaining, however they are still included in the sizing calculations for DMA A. Recycled water will be used for irrigation, therefore "harvest and use" assessment is not required. Source control BMP's include covered trash enclosures.

A.1 Maps and Site Plans

When completing your Project-Specific WQMP, include a map of the local vicinity and existing site. In addition, include all grading, drainage, landscape/plant palette and other pertinent construction plans in Appendix 2. At a **minimum**, your WQMP Site Plan should include the following:

- Drainage Management Areas
- Proposed Structural BMPs
- Drainage Path
- Drainage Infrastructure, Inlets, Overflows
- Source Control BMPs
- Buildings, Roof Lines, Downspouts
- Impervious Surfaces
- Standard Labeling
- BMP Locations (Lat/Long)

Use your discretion on whether or not you may need to create multiple sheets or can appropriately accommodate these features on one or two sheets. Keep in mind that the Co-Permittee plan reviewer must be able to easily analyze your project utilizing this template and its associated site plans and maps.

A.2 Identify Receiving Waters

Using Table A.1 below, list in order of upstream to downstream, the receiving waters that the project site is tributary to. Continue to fill each row with the Receiving Water's 303(d) listed impairments (if any), designated beneficial uses, and proximity, if any, to a RARE beneficial use. Include a map of the receiving waters in Appendix 1.

Table A.1 Identification of Receiving Waters

Receiving Waters	EPA Approved 303(d) List Impairments	Designated Beneficial Uses	Proximity to RARE Beneficial Use
Perris Valley MDP Line B-5	N/A	-	Not designated as RARE
Perris Valley Channel	N/A	-	Not designated as RARE
San Jacinto River Reach 3, HU#802.11	NONE	AGR, GWR, REC1, REC2, WARM, WILD	Not designated as RARE
Canyon Lake (Railroad Canyon Reservoir), HU#802.11, 802.12	Nutrients, Pathogens	MUN, AGR, GWR, REC1, REC2, WARM, WILD	Not designated as RARE
San Jacinto River Reach 1, HU#802.32,802.31	NONE	MUN, AGR, GWR, REC1, REC2, WARM, WILD	Not designated as RARE
Lake Elsinore	PCBs (Polychlorinated biphenyls), Toxicity	MUN, REC1, REC2, WARM, WILD	Not designated as RARE

A.3 Additional Permits/Approvals required for the Project:

Table A.2 Other Applicable Permits

Agency	Permit Required	
State Department of Fish and Game, 1602 Streambed Alteration Agreement	<input type="checkbox"/> Y	<input checked="" type="checkbox"/> N
State Water Resources Control Board, Clean Water Act (CWA) Section 401 Water Quality Cert.	<input type="checkbox"/> Y	<input checked="" type="checkbox"/> N
US Army Corps of Engineers, CWA Section 404 Permit	<input type="checkbox"/> Y	<input checked="" type="checkbox"/> N
US Fish and Wildlife, Endangered Species Act Section 7 Biological Opinion	<input type="checkbox"/> Y	<input checked="" type="checkbox"/> N
Statewide Construction General Permit Coverage	<input checked="" type="checkbox"/> Y	<input type="checkbox"/> N
Statewide Industrial General Permit Coverage (dependent on tenant)	<input checked="" type="checkbox"/> Y	<input type="checkbox"/> N
Western Riverside MSHCP Consistency Approval (e.g., JPR, DBESP)	<input type="checkbox"/> Y	<input checked="" type="checkbox"/> N

<p><i>Other (please list in the space below as required)</i></p> <p>City of Perris Building and Grading Permits</p> <p>City of Perris – Connection Permit to public storm drain Patterson Avenue</p>	<input checked="" type="checkbox"/> Y	<input type="checkbox"/> N
--	---------------------------------------	----------------------------

If yes is answered to any of the questions above, the Co-Permittee may require proof of approval/coverage from those agencies as applicable including documentation of any associated requirements that may affect this Project-Specific WQMP.

Section B: Optimize Site Utilization (LID Principles)

Review of the information collected in Section 'A' will aid in identifying the principal constraints on site design and selection of LID BMPs as well as opportunities to reduce imperviousness and incorporate LID Principles into the site and landscape design. For example, **constraints** might include impermeable soils, high groundwater, groundwater pollution or contaminated soils, steep slopes, geotechnical instability, high-intensity land use, heavy pedestrian or vehicular traffic, utility locations or safety concerns. **Opportunities** might include existing natural areas, low areas, oddly configured or otherwise unbuildable parcels, easements and landscape amenities including open space and buffers (which can double as locations for bioretention BMPs), and differences in elevation (which can provide hydraulic head). Prepare a brief narrative for each of the site optimization strategies described below. This narrative will help you as you proceed with your LID design and explain your design decisions to others.

The 2010 Santa Ana MS4 Permit further requires that LID Retention BMPs (Infiltration Only or Harvest and Use) be used unless it can be shown that those BMPs are infeasible. Therefore, it is important that your narrative identify and justify if there are any constraints that would prevent the use of those categories of LID BMPs. Similarly, you should also note opportunities that exist which will be utilized during project design. Upon completion of identifying Constraints and Opportunities, include these on your WQMP Site plan in Appendix 1.

Consideration of "highest and best use" of the discharge should also be considered. For example, Lake Elsinore is evaporating faster than runoff from natural precipitation can recharge it. Requiring infiltration of 85% of runoff events for projects tributary to Lake Elsinore would only exacerbate current water quality problems associated with Pollutant concentration due to lake water evaporation. In cases where rainfall events have low potential to recharge Lake Elsinore (i.e. no hydraulic connection between groundwater to Lake Elsinore, or other factors), requiring infiltration of Urban Runoff from projects is counterproductive to the overall watershed goals. Project proponents, in these cases, would be allowed to discharge Urban Runoff, provided they used equally effective filtration-based BMPs.

Site Constraint:

Base on the site specific infiltration tests and report prepared by Southern California Geotechnical, Inc, dated August 3, 2021 (see Appendix 3), the site soils have very poor infiltration characteristics and the use of infiltration facilities is not recommended.

Solution:

The site drainage design has incorporated bio-retention basin located on the east side of the project site. All site drainage will be conveyed to the bio-retention area where the runoff will be allowed to pass through a filter media, stone section, and through perforated a pipe network beneath the basin footprint which will ultimately convey the runoff out to the proposed public storm drain system located in Patterson Avenue.

Site Optimization

The following questions are based upon Section 3.2 of the WQMP Guidance Document. Review of the WQMP Guidance Document will help you determine how best to optimize your site and subsequently identify opportunities and/or constraints, and document compliance.

Did you identify and preserve existing drainage patterns? If so, how? If not, why?

Yes. The site mimics the existing topography by draining from west to east.

Did you identify and protect existing vegetation? If so, how? If not, why?

No, existing vegetation was not protected within the developed site. Currently the site is vacant and does not have existing vegetation. The developed condition will utilize drought tolerant plants within the landscaped areas to maximize water conservation.

Did you identify and preserve natural infiltration capacity? If so, how? If not, why?

*Yes. Natural infiltration capacity was identified by the soil and infiltration report, however it is below the minimum rate and is not expected to be feasible on this project site as a BMP type. **Infiltration rates ranged from 0.32 to 0.92 inches/hour.***

Did you identify and minimize impervious area? If so, how? If not, why?

Yes. The site has more than the minimum amount of landscape required per code with 22% of the land use as landscaping.

Did you identify and disperse runoff to adjacent pervious areas? If so, how? If not, why?

No, runoff from impervious areas is not able to drain into pervious areas. Onsite storm drain systems and surface flow will convey the runoff to the basin on the east side of the project site, and the basin will treat the runoff before allowing it to exit the project site.

Section C: Delineate Drainage Management Areas (DMAs)

Utilizing the procedure in Section 3.3 of the WQMP Guidance Document which discusses the methods of delineating and mapping your project site into individual DMAs, complete Table C.1 below to appropriately categorize the types of classification (e.g., Type A, Type B, etc.) per DMA for your project site. Upon completion of this table, this information will then be used to populate and tabulate the corresponding tables for their respective DMA classifications.

Table C.1 DMA Classifications

DMA Name or ID	Surface Type(s) ¹²	Area (Sq. Ft.)	DMA Type
DMA A	Roofs	263,820	D
	Concrete	210,089	D
	Ornamental Landscaping	142,681	D

¹Reference Table 2-1 in the WQMP Guidance Document to populate this column

²If multi-surface provide back-up

Table C.2 Type 'A', Self-Treating Areas (Included with mixed DMA1 above)

DMA Name or ID	Area (Sq. Ft.)	Stabilization Type	Irrigation Type (if any)
Landscaped Areas (from DMA A)	142,681	Planted and Irrigated	Drip

Table C.3 Type 'B', Self-Retaining Areas (N/A, included with mixed DMA1)

Self-Retaining Area				Type 'C' DMAs that are draining to the Self-Retaining Area		
DMA Name/ ID	Post-project surface type	Area (square feet)	Storm Depth (inches)	DMA Name / ID	[C] from Table C.4	Required Retention Depth (inches)
		[A]	[B]		[C]	[D]

$$[D] = [B] + \frac{[B] \cdot [C]}{[A]}$$

Table C.4 Type 'C', Areas that Drain to Self-Retaining Areas (N/A)

DMA					Receiving Self-Retaining DMA		
DMA Name/ ID	Area (square feet)	Post-project surface type	Impervious fraction	Product	DMA name /ID	Area (square feet)	Ratio
	[A]		[B]			[C] = [A] x [B]	[D]

Table C.5 Type 'D', Areas Draining to BMPs

DMA Name or ID	BMP Name or ID
DMA A	Bio-retention Basin

Note: More than one drainage management area can drain to a single LID BMP, however, one drainage management area may not drain to more than one BMP.

Section D: Implement LID BMPs

D.1 Infiltration Applicability

Is there an approved downstream ‘Highest and Best Use’ for stormwater runoff (see discussion in Chapter 2.4.4 of the WQMP Guidance Document for further details)? Y N

If yes has been checked, Infiltration BMPs shall not be used for the site; proceed to section D.3

If no, continue working through this section to implement your LID BMPs. It is recommended that you contact your Co-Permittee to verify whether or not your project discharges to an approved downstream ‘Highest and Best Use’ feature.

Geotechnical Report

A Geotechnical Report or Phase I Environmental Site Assessment may be required by the Copermitee to confirm present and past site characteristics that may affect the use of Infiltration BMPs. In addition, the Co-Permittee, at their discretion, may not require a geotechnical report for small projects as described in Chapter 2 of the WQMP Guidance Document. If a geotechnical report has been prepared, include it in Appendix 3. In addition, if a Phase I Environmental Site Assessment has been prepared, include it in Appendix 4.

Is this project classified as a small project consistent with the requirements of Chapter 2 of the WQMP Guidance Document? Y N

Infiltration Feasibility

Table D.1 below is meant to provide a simple means of assessing which DMAs on your site support Infiltration BMPs and is discussed in the WQMP Guidance Document in Chapter 2.4.5. Check the appropriate box for each question and then list affected DMAs as applicable. If additional space is needed, add a row below the corresponding answer.

Table D.1 Infiltration Feasibility

Does the project site...	YES	NO
...have any DMAs with a seasonal high groundwater mark shallower than 10 feet? If Yes, list affected DMAs:		X
...have any DMAs located within 100 feet of a water supply well? If Yes, list affected DMAs:		X
...have any areas identified by the geotechnical report as posing a public safety risk where infiltration of stormwater could have a negative impact? If Yes, list affected DMAs:		X
...have measured in-situ infiltration rates of less than 1.6 inches / hour? If Yes, list affected DMAs:	X A	
...have significant cut and/or fill conditions that would preclude in-situ testing of infiltration rates at the final infiltration surface? If Yes, list affected DMAs:		X
...geotechnical report identify other site-specific factors that would preclude effective and safe infiltration? Describe here:		X

If you answered “Yes” to any of the questions above for any DMA, Infiltration BMPs should not be used for those DMAs and you should proceed to the assessment for Harvest and Use below.

D.2 Harvest and Use Assessment

Please check what applies:

- Reclaimed water will be used for the non-potable water demands for the project.
- Downstream water rights may be impacted by Harvest and Use as approved by the Regional Board (verify with the Copermittee).
- The Design Capture Volume will be addressed using Infiltration Only BMPs. In such a case, Harvest and Use BMPs are still encouraged, but it would not be required if the Design Capture Volume will be infiltrated or evapotranspired.

If any of the above boxes have been checked, Harvest and Use BMPs need not be assessed for the site. If none of the above criteria applies, follow the steps below to assess the feasibility of irrigation use, toilet use and other non-potable uses (e.g., industrial use).

Irrigation Use Feasibility

Complete the following steps to determine the feasibility of harvesting stormwater runoff for Irrigation Use BMPs on your site:

Step 1: Identify the total area of irrigated landscape on the site, and the type of landscaping used.

Total Area of Irrigated Landscape: 146,092

Type of Landscaping (Conservation Design or Active Turf): Conservation Design

Step 2: Identify the planned total of all impervious areas on the proposed project from which runoff might be feasibly captured and stored for irrigation use. Depending on the configuration of buildings and other impervious areas on the site, you may consider the site as a whole, or parts of the site, to evaluate reasonable scenarios for capturing and storing runoff and directing the stored runoff to the potential use(s) identified in Step 1 above.

Total Area of Impervious Surfaces: 463,753

Step 3: Cross reference the Design Storm depth for the project site (see Exhibit A of the WQMP Guidance Document) with the left column of Table 2-3 in Chapter 2 to determine the minimum area of Effective Irrigated Area per Tributary Impervious Area (EIATIA).

Enter your EIATIA factor: .84 ac/ac

Step 4: Multiply the unit value obtained from Step 3 by the total of impervious areas from Step 2 to develop the minimum irrigated area that would be required.

Minimum required irrigated area : 389,553

Step 5: Determine if harvesting stormwater runoff for irrigation use is feasible for the project by comparing the total area of irrigated landscape (Step 1) to the minimum required irrigated area (Step 4).

Minimum required irrigated area (Step 4)	Available Irrigated Landscape (Step 1)
389,553	146,433

Toilet Use Feasibility

Complete the following steps to determine the feasibility of harvesting stormwater runoff for toilet flushing uses on your site:

Step 1: Identify the projected total number of daily toilet users during the wet season, and account for any periodic shut downs or other lapses in occupancy:

Projected Number of Daily Toilet Users: 250

Project Type: industrial

Step 2: Identify the planned total of all impervious areas on the proposed project from which runoff might be feasibly captured and stored for toilet use. Depending on the configuration of buildings and other impervious areas on the site, you may consider the site as a whole, or parts of the site, to evaluate reasonable scenarios for capturing and storing runoff and directing the stored runoff to the potential use(s) identified in Step 1 above.

Total Area of Impervious Surfaces: 463,753 sf (10.6 Ac)

Step 3: Enter the Design Storm depth for the project site (see Exhibit A) into the left column of Table 2-2 in Chapter 2 to determine the minimum number of toilet users per tributary impervious acre (TUTIA).

Enter your TUTIA factor: 175 tu/ac

Step 4: Multiply the unit value obtained from Step 3 by the total of impervious areas from Step 2 to develop the minimum number of toilet users that would be required.

Minimum number of toilet users: 1,862

Step 5: Determine if harvesting stormwater runoff for toilet flushing use is feasible for the project by comparing the Number of Daily Toilet Users (Step 1) to the minimum required number of toilet users (Step 4).

Minimum required Toilet Users (Step 4)	Projected number of toilet users (Step 1)
1,862	250

Other Non-Potable Use Feasibility

Are there other non-potable uses for stormwater runoff on the site (e.g. industrial use)? See Chapter 2 of the Guidance for further information. If yes, describe below. If no, write N/A.

N/A

Step 1: Identify the projected average daily non-potable demand, in gallons per day, during the wet season and accounting for any periodic shut downs or other lapses in occupancy or operation.

Average Daily Demand: N/A

Step 2: Identify the planned total of all impervious areas on the proposed project from which runoff might be feasibly captured and stored for the identified non-potable use. Depending on the configuration of buildings and other impervious areas on the site, you may consider the site as a whole, or parts of the site, to evaluate reasonable scenarios for capturing and storing runoff and directing the stored runoff to the potential use(s) identified in Step 1 above.

Total Area of Impervious Surfaces: N/A

Step 3: Enter the Design Storm depth for the project site (see Exhibit A) into the left column of Table 2-4 in Chapter 2 to determine the minimum demand for non-potable uses per tributary impervious acre.

Enter the factor from Table 2-4: N/A

Step 4: Multiply the unit value obtained from Step 3 by the total of impervious areas from Step 2 to develop the minimum number of gallons per day of non-potable use that would be required.

Minimum required use: N/A

Step 5: Determine if harvesting stormwater runoff for other non-potable use is feasible for the project by comparing the projected average daily use (Step 1) to the minimum required non-potable use (Step 4).

Minimum required non-potable use (Step 4)	Projected average daily use (Step 1)
N/A	N/A

If Irrigation, Toilet and Other Use feasibility anticipated demands are less than the applicable minimum values, Harvest and Use BMPs are not required and you should proceed to utilize LID Bioretention and Biotreatment per Section 3.4.2 of the WQMP Guidance Document.

D.3 Bioretention and Biotreatment Assessment

Other LID Bioretention and Biotreatment BMPs as described in Chapter 2.4.7 of the WQMP Guidance Document are feasible on nearly all development sites with sufficient advance planning.

Select one of the following:

- LID Bioretention/Biotreatment BMPs will be used for some or all DMAs of the project as noted below in Section D.4 (note the requirements of Section 3.4.2 in the WQMP Guidance Document).
- A site-specific analysis demonstrating the technical infeasibility of all LID BMPs has been performed and is included in Appendix 5. If you plan to submit an analysis demonstrating the technical infeasibility of LID BMPs, request a pre-submittal meeting with the Copermittee to discuss this option. Proceed to Section E to document your alternative compliance measures.

D.4 Feasibility Assessment Summaries

From the Infiltration, Harvest and Use, Bioretention and Biotreatment Sections above, complete Table D.2 below to summarize which LID BMPs are technically feasible, and which are not, based upon the established hierarchy.

Table D.2 LID Prioritization Summary Matrix

DMA Name/ID	LID BMP Hierarchy				No LID (Alternative Compliance)
	1. Infiltration	2. Harvest and use	3. Bioretention	4. Biotreatment	
DMA A	<input type="checkbox"/>	<input type="checkbox"/>	<input checked="" type="checkbox"/>	<input type="checkbox"/>	<input type="checkbox"/>
	<input type="checkbox"/>	<input type="checkbox"/>	<input type="checkbox"/>	<input type="checkbox"/>	<input type="checkbox"/>
	<input type="checkbox"/>	<input type="checkbox"/>	<input type="checkbox"/>	<input type="checkbox"/>	<input type="checkbox"/>
	<input type="checkbox"/>	<input type="checkbox"/>	<input type="checkbox"/>	<input type="checkbox"/>	<input type="checkbox"/>
	<input type="checkbox"/>	<input type="checkbox"/>	<input type="checkbox"/>	<input type="checkbox"/>	<input type="checkbox"/>
	<input type="checkbox"/>	<input type="checkbox"/>	<input type="checkbox"/>	<input type="checkbox"/>	<input type="checkbox"/>

For those DMAs where LID BMPs are not feasible, provide a brief narrative below summarizing why they are not feasible, include your technical infeasibility criteria in Appendix 5, and proceed to Section E below to document Alternative Compliance measures for those DMAs. Recall that each proposed DMA must pass through the LID BMP hierarchy before alternative compliance measures may be considered.

Base on the information provided in Section D, bio-retention LID BMP will be utilized for the entire site. See Appendix 1 Post-Construction BMP Site Plan for bio-retention basin detail.

D.5 LID BMP Sizing

Each LID BMP must be designed to ensure that the Design Capture Volume will be addressed by the selected BMPs. First, calculate the Design Capture Volume for each LID BMP using the V_{BMP} worksheet in Appendix F of the LID BMP Design Handbook. Second, design the LID BMP to meet the required V_{BMP} using a method approved by the Copermittee. Utilize the worksheets found in the LID BMP Design Handbook or consult with your Copermittee to assist you in correctly sizing your LID BMPs. Complete Table D.3 below to document the Design Capture Volume and the Proposed Volume for each LID BMP. Provide the completed design procedure sheets for each LID BMP in Appendix 6. You may add additional rows to the table below as needed.

Table D.3 DCV Calculations for LID BMPs

DMA Type/ID	DMA Area (square feet)	Post-Project Surface Type	Effective Impervious Fraction, I_f	DMA Runoff Factor	DMA Areas x Runoff Factor	<i>Bio-Retention Basin</i>		
						Design Storm Depth (in)	Design Capture Volume, V_{BMP} (cubic feet)	Proposed Volume on Plans (cubic feet)
	[A]		[B]	[C]	[A] x [C]			
DMA A	142,681	landscape	0.1	0.11	15,695			
DMA A	473,909	Concrete and Asphalt	1.0	0.89	421,779			
	$A_T = \Sigma[A]$ 616,590				$\Sigma = [D]$ 437474	[E] 0.61	$[F] = \frac{[D] \times [E]}{12}$ 22,238	[G] 39,516

[B], [C] is obtained as described in Section 2.3.1 of the WQMP Guidance Document

[E] is obtained from Exhibit A in the WQMP Guidance Document

[G] is obtained from a design procedure sheet, such as in LID BMP Design Handbook and placed in Appendix 6

Section E: Alternative Compliance (LID Waiver Program)

LID BMPs are expected to be feasible on virtually all projects. Where LID BMPs have been demonstrated to be infeasible as documented in Section D, other Treatment Control BMPs must be used (subject to LID waiver approval by the Copermittee). Check one of the following Boxes:

LID Principles and LID BMPs have been incorporated into the site design to fully address all Drainage Management Areas. No alternative compliance measures are required for this project and thus this Section is not required to be completed.

- Or -

The following Drainage Management Areas are unable to be addressed using LID BMPs. A site-specific analysis demonstrating technical infeasibility of LID BMPs has been approved by the Co-Permittee and included in Appendix 5. Additionally, no downstream regional and/or sub-regional LID BMPs exist or are available for use by the project. The following alternative compliance measures on the following pages are being implemented to ensure that any pollutant loads expected to be discharged by not incorporating LID BMPs, are fully mitigated.

E.1 Identify Pollutants of Concern

Utilizing Table A.1 from Section A above which noted your project's receiving waters and their associated EPA approved 303(d) listed impairments, cross reference this information with that of your selected Priority Development Project Category in Table E.1 below. If the identified General Pollutant Categories are the same as those listed for your receiving waters, then these will be your Pollutants of Concern and the appropriate box or boxes will be checked on the last row. The purpose of this is to document compliance and to help you appropriately plan for mitigating your Pollutants of Concern in lieu of implementing LID BMPs.

Table E.1 Potential Pollutants by Land Use Type

Priority Development Project Categories and/or Project Features (check those that apply)	General Pollutant Categories							
	Bacterial Indicators	Metals	Nutrients	Pesticides	Toxic Organic Compounds	Sediments	Trash & Debris	Oil & Grease
<input type="checkbox"/> Detached Residential Development	P	N	P	P	N	P	P	P
<input type="checkbox"/> Attached Residential Development	P	N	P	P	N	P	P	P ⁽²⁾
<input checked="" type="checkbox"/> Commercial/Industrial Development	P ⁽³⁾	P	P ⁽¹⁾	P ⁽¹⁾	P ⁽⁵⁾	P ⁽¹⁾	P	P
<input type="checkbox"/> Automotive Repair Shops	N	P	N	N	P ^(4, 5)	N	P	P
<input type="checkbox"/> Restaurants (>5,000 ft ²)	P	N	N	N	N	N	P	P
<input type="checkbox"/> Hillside Development (>5,000 ft ²)	P	N	P	P	N	P	P	P
<input type="checkbox"/> Parking Lots (>5,000 ft ²)	P ⁽⁶⁾	P	P ⁽¹⁾	P ⁽¹⁾	P ⁽⁴⁾	P ⁽¹⁾	P	P
<input type="checkbox"/> Retail Gasoline Outlets	N	P	N	N	P	N	P	P
Project Priority Pollutant(s) of Concern	<input checked="" type="checkbox"/>	<input checked="" type="checkbox"/>	<input checked="" type="checkbox"/>	<input checked="" type="checkbox"/>	<input checked="" type="checkbox"/>	<input checked="" type="checkbox"/>	<input checked="" type="checkbox"/>	<input checked="" type="checkbox"/>

P = Potential

N = Not Potential

⁽¹⁾ A potential Pollutant if non-native landscaping exists or is proposed onsite; otherwise not expected

⁽²⁾ A potential Pollutant if the project includes uncovered parking areas; otherwise not expected

⁽³⁾ A potential Pollutant is land use involving animal waste

⁽⁴⁾ Specifically petroleum hydrocarbons

⁽⁵⁾ Specifically solvents

⁽⁶⁾ Bacterial indicators are routinely detected in pavement runoff

E.2 Stormwater Credits (N/A)

Projects that cannot implement LID BMPs but nevertheless implement smart growth principles are potentially eligible for Stormwater Credits. Utilize Table 3-8 within the WQMP Guidance Document to identify your Project Category and its associated Water Quality Credit. If not applicable, write N/A.

Table E.2 Water Quality Credits

Qualifying Project Categories	Credit Percentage ²
<i>Total Credit Percentage¹</i>	

¹Cannot Exceed 50%

²Obtain corresponding data from Table 3-8 in the WQMP Guidance Document

E.3 Sizing Criteria (N/A)

After you appropriately considered Stormwater Credits for your project, utilize Table E.3 below to appropriately size them to the DCV, or Design Flow Rate, as applicable. Please reference Chapter 3.5.2 of the WQMP Guidance Document for further information.

Table E.3 Treatment Control BMP Sizing

DMA Type/ID	DMA Area (square feet)	Post-Project Surface Type	Effective Impervious Fraction, I _f	DMA Runoff Factor	DMA Area x Runoff Factor	Enter BMP Name / Identifier Here			
	[A]		[B]	[C]	[A] x [C]				
						Design Storm Depth (in)	Minimum Design Capture Volume or Design Flow Rate (cubic feet or cfs)	Total Storm Water Credit % Reduction	Proposed Volume or Flow on Plans (cubic feet or cfs)
	$A_T = \sum[A]$			$\Sigma = [D]$	[E]	$[F] = \frac{[D] \times [E]}{[G]}$	$[F] \times (1 - [H])$	[I]	

[B], [C] is obtained as described in Section 2.3.1 from the WQMP Guidance Document

[E] is for Flow-Based Treatment Control BMPs [E] = .2, for Volume-Based Control Treatment BMPs, [E] obtained from Exhibit A in the WQMP Guidance Document

[G] is for Flow-Based Treatment Control BMPs [G] = 43,560, for Volume-Based Control Treatment BMPs, [G] = 12

[H] is from the Total Credit Percentage as Calculated from Table E.2 above

[I] as obtained from a design procedure sheet from the BMP manufacturer and should be included in Appendix 6

E.4 Treatment Control BMP Selection

Treatment Control BMPs typically provide proprietary treatment mechanisms to treat potential pollutants in runoff, but do not sustain significant biological processes. Treatment Control BMPs must have a removal efficiency of a medium or high effectiveness as quantified below:

- **High:** equal to or greater than 80% removal efficiency
- **Medium:** between 40% and 80% removal efficiency

Such removal efficiency documentation (e.g., studies, reports, etc.) as further discussed in Chapter 3.5.2 of the WQMP Guidance Document, must be included in Appendix 6. In addition, ensure that proposed Treatment Control BMPs are properly identified on the WQMP Site Plan in Appendix 1.

Table E.4 Treatment Control BMP Selection

Selected Treatment Control BMP Name or ID ¹	Priority Pollutant(s) of Concern to Mitigate ²	Removal Percentage ³	Efficiency
N/A. APPLIES TO PROPRIETARY TREATMENT.			

¹ Treatment Control BMPs must not be constructed within Receiving Waters. In addition, a proposed Treatment Control BMP may be listed more than once if they possess more than one qualifying pollutant removal efficiency.

² Cross Reference Table E.1 above to populate this column.

³ As documented in a Co-Permittee Approved Study and provided in Appendix 6.

Section F: Hydromodification

F.1 Hydrologic Conditions of Concern (HCOC) Analysis

Once you have determined that the LID design is adequate to address water quality requirements, you will need to assess if the proposed LID Design may still create a HCOC. Review Chapters 2 and 3 (including Figure 3-7) of the WQMP Guidance Document to determine if your project must mitigate for Hydromodification impacts. If your project meets one of the following criteria which will be indicated by the check boxes below, you do not need to address Hydromodification at this time. However, if the project does not qualify for Exemptions 1, 2 or 3, then additional measures must be added to the design to comply with HCOC criteria. This is discussed in further detail below in Section F.2.

HCOC EXEMPTION 1: The Priority Development Project disturbs less than one acre. The Copermitttee has the discretion to require a Project-Specific WQMP to address HCOCs on projects less than one acre on a case by case basis. The disturbed area calculation should include all disturbances associated with larger common plans of development.

Does the project qualify for this HCOC Exemption? Y N

If Yes, HCOC criteria do not apply.

HCOC EXEMPTION 2: The volume and time of concentration¹ of storm water runoff for the post-development condition is not significantly different from the pre-development condition for a 2-year return frequency storm (a difference of 5% or less is considered insignificant) using one of the following methods to calculate:

- Riverside County Hydrology Manual
- Technical Release 55 (TR-55): Urban Hydrology for Small Watersheds (NRCS 1986), or derivatives thereof, such as the Santa Barbara Urban Hydrograph Method
- Other methods acceptable to the Co-Permittee

Does the project qualify for this HCOC Exemption? Y N

If Yes, report results in Table F.1 below and provide your substantiated hydrologic analysis in Appendix 7.

Table F.1 Hydrologic Conditions of Concern Summary

	2 year – 24 hour		
	Pre-condition	Post-condition	% Difference
Time of Concentration	N/A	N/A	N/A
Volume (Cubic Feet)	N/A	N/A	N/A

¹ Time of concentration is defined as the time after the beginning of the rainfall when all portions of the drainage basin are contributing to flow at the outlet.

HCOC EXEMPTION 3: All downstream conveyance channels to an adequate sump (for example, Prado Dam, Lake Elsinore, Canyon Lake, Santa Ana River, or other lake, reservoir or naturally erosion resistant feature) that will receive runoff from the project are engineered and regularly maintained to ensure design flow capacity; no sensitive stream habitat areas will be adversely affected; or are not identified on the Co-Permittees Hydromodification Susceptibility Maps.

Does the project qualify for this HCOC Exemption? Y N

If Yes, HCOC criteria do not apply and note below which adequate sump applies to this HCOC qualifier: Project drains to Lake Elsinore.

F.2 HCOC Mitigation

If none of the above HCOC Exemption Criteria are applicable, HCOC criteria is considered mitigated if they meet one of the following conditions:

- a. Additional LID BMPS are implemented onsite or offsite to mitigate potential erosion or habitat impacts as a result of HCOCs. This can be conducted by an evaluation of site-specific conditions utilizing accepted professional methodologies published by entities such as the California Stormwater Quality Association (CASQA), the Southern California Coastal Water Research Project (SCCRWP), or other Co-Permittee approved methodologies for site-specific HCOC analysis.
- b. The project is developed consistent with an approved Watershed Action Plan that addresses HCOC in Receiving Waters.
- c. Mimicking the pre-development hydrograph with the post-development hydrograph, for a 2-year return frequency storm. Generally, the hydrologic conditions of concern are not significant, if the post-development hydrograph is no more than 10% greater than pre-development hydrograph. In cases where excess volume cannot be infiltrated or captured and reused, discharge from the site must be limited to a flow rate no greater than 110% of the pre-development 2-year peak flow.

Site is located within the Riverside County WAP per the HCOC Geodatabase as approved April 20, 2017.

Section G: Source Control BMPs

Source control BMPs include permanent, structural features that may be required in your project plans — such as roofs over and berms around trash and recycling areas — and Operational BMPs, such as regular sweeping and “housekeeping”, that must be implemented by the site’s occupant or user. The MEP standard typically requires both types of BMPs. In general, Operational BMPs cannot be substituted for a feasible and effective permanent BMP. Using the Pollutant Sources/Source Control Checklist in Appendix 8, review the following procedure to specify Source Control BMPs for your site:

1. **Identify Pollutant Sources:** Review Column 1 in the Pollutant Sources/Source Control Checklist. Check off the potential sources of Pollutants that apply to your site.
2. **Note Locations on Project-Specific WQMP Exhibit:** Note the corresponding requirements listed in Column 2 of the Pollutant Sources/Source Control Checklist. Show the location of each Pollutant source and each permanent Source Control BMP in your Project-Specific WQMP Exhibit located in Appendix 1.
3. **Prepare a Table and Narrative:** Check off the corresponding requirements listed in Column 3 in the Pollutant Sources/Source Control Checklist. In the left column of Table G.1 below, list each potential source of runoff Pollutants on your site (from those that you checked in the Pollutant Sources/Source Control Checklist). In the middle column, list the corresponding permanent, Structural Source Control BMPs (from Columns 2 and 3 of the Pollutant Sources/Source Control Checklist) used to prevent Pollutants from entering runoff. **Add additional narrative** in this column that explains any special features, materials or methods of construction that will be used to implement these permanent, Structural Source Control BMPs.
4. **Identify Operational Source Control BMPs:** To complete your table, refer once again to the Pollutant Sources/Source Control Checklist. List in the right column of your table the Operational BMPs that should be implemented as long as the anticipated activities continue at the site. Copermittee stormwater ordinances require that applicable Source Control BMPs be implemented; the same BMPs may also be required as a condition of a use permit or other revocable Discretionary Approval for use of the site.

Table G.1 Permanent and Operational Source Control Measures

Potential Sources of Runoff pollutants	Permanent Structural /Non-Structural Source Control BMPs	Operational Source Control BMPs
On-Site Storm Drain Inlet	Mark all inlets with the words “Only Rain Down the Storm Drain” or similar. Catch Basin Markers may be available from the Riverside County Flood Control and Water Conservation District, call 951.955.1200 to verify.	<ul style="list-style-type: none"> - Maintain and periodically repaint or replace inlet markings as needed. - Provide stormwater pollution prevention information to new site owners, lessees, or operators. - See applicable operational BMPs in Fact Sheet SC-44, “Drainage System Maintenance,” in the CASQA Stormwater Quality Handbooks at www.cabmphandbooks.com - Include the following in lease agreements: “Tenant shall not allow anyone to discharge anything to storm drains or to store or deposit materials so as to create a potential discharge to storm drains.” - Inspect storm drain inlets for trash and debris prior to and after storm events or every 3 months and clean or replace filter as needed.

Loading Docks	The project site will have truck docks which shown on the Post-Construction BMP Site Plan. The truck docks shall be inspected on a weekly basis to help ensure that any trash and debris are collected prior to being washed into the underground storm drain system. All storm water runoff from the loading dock areas will be discharged into infiltration basins and/or underground infiltration chambers prior to conveyance to the public storm drain system. Documentation of such inspection/maintenance shall be kept by the owner in perpetuity.	<ul style="list-style-type: none"> Move loaded and unloaded items indoors as soon as possible. See Fact Sheet SC-30, "Outdoor Loading and Unloading," in the CASQA Stormwater Quality Handbooks at www.cabmphandbooks.com
Fire Sprinkler Test Water	Underground fire protection service and fire sprinklers test will be provided per the uniform fire code and the requirements of the County of Riverside	<ul style="list-style-type: none"> Provide a means to drain fire sprinkler test water to the sanitary sewer.
Plazas, sidewalks, and parking lots.	Documentation of such sweeping shall be kept by the owner in perpetuity. Frequency of sweeping shall be adjusted as needed to maintain a clean site.	<ul style="list-style-type: none"> Sweep plazas, sidewalks, and parking lots monthly to prevent accumulation of litter and debris. Collect debris from pressure washing to prevent entry into the storm drain system. Collect wash water containing any cleaning agent or degreaser and discharge to the sanitary sewer not to a storm drain.
Refuse Trash Storage Areas	Trash container storage areas shall be paved with an impervious surface designed not to allow run-on from adjoining areas. They shall be designed to divert drainage from adjoining roofs and pavements from the surrounding area, and screened or walled to prevent off-site transport of trash. Trash dumpsters (containers) shall be leak proof and have attached covers and lids. Trash enclosures shall be roofed per City standards and the details on the WQMP exhibit in Appendix 1. Trash compactors shall be roofed and set on a concrete pad per City standards. The pad shall be a minimum of one foot larger all around than the trash compactor and sloped to drain to a sanitary sewer line. Connection of trash area drains to the MS4 is prohibited. See CASQA SD-32 BMP fact sheet in Appendix 10 for additional information. Signs shall be posted on or near dumpsters with the words "Do not dump hazardous materials here" or similar.	Adequate number of receptacles shall be provided. Inspect receptacles and clean them out weekly; repair or replace leaky receptacles. Keep receptacles covered. Prohibit/prevent dumping of liquid or hazardous wastes. Post "no hazardous materials" signs. Inspect and pick up litter daily and clean up spills immediately. Keep spill control materials available onsite. See fact sheet SC-34 "Waste Handling and Disposal" in the CASQA Stormwater Quality Handbook at www.cabmphandbooks.com and in Appendix 10.

Section H: Construction Plan Checklist

Populate Table H.1 below to assist the plan checker in an expeditious review of your project. The first two columns will contain information that was prepared in previous steps, while the last column will be populated with the corresponding plan sheets. This table is to be completed with the submittal of your final Project-Specific WQMP.

Table H.1 Construction Plan Cross-reference

BMP No. or ID	BMP Identifier and Description	Corresponding Plan Sheet(s)	BMP Location (Lat/Long)
Basin #1	Bioretention Basin	Sheet 1	Lat: 33°51'17.46"N Long: 117°15'10.48"W
CB#1	Curb Inlet Filter	Sheet 1	Lat: 33°51'15.52"N Long: 117°15'10.43"W
CB#2	Curb Inlet Filter	Sheet 1	Lat: 33°51'13.94"N Long: 117°15'10.22"W
CB#3	Grate Inlet Filter	Sheet 1	Lat: 33°51'14.69"N Long: 117°15'13.14"W
CB#4	Curb Inlet Filter	Sheet 1	Lat: 33°51'13.20"N Long: 117°15'17.06"W
CB#5	Grate Inlet Filter	Sheet 1	Lat: 33°51'19.10"N Long: 117°15'12.01"W
CB#6	Grate Inlet Filter	Sheet 1	Lat: 33°51'19.07"N Long: 117°15'15.96"W
CB#7	Grate Inlet Filter	Sheet 1	Lat: 33°51'17.52"N Long: 117°15'20.19"W
CB#8	Curb Inlet Filter	Sheet 1	Lat: 33°51'17.12"N Long: 117°15'11.42"W

Note that the updated table — or Construction Plan WQMP Checklist — is **only a reference tool** to facilitate an easy comparison of the construction plans to your Project-Specific WQMP. Co-Permittee staff can advise you regarding the process required to propose changes to the approved Project-Specific WQMP.

Section I: Operation, Maintenance and Funding

“This section will be completed and addressed at the time of the final WQMP submittal”

The Copermittee will periodically verify that Stormwater BMPs on your site are maintained and continue to operate as designed. To make this possible, your Copermittee will require that you include in Appendix 9 of this Project-Specific WQMP:

1. A means to finance and implement facility maintenance in perpetuity, including replacement cost.
2. Acceptance of responsibility for maintenance from the time the BMPs are constructed until responsibility for operation and maintenance is legally transferred. A warranty covering a period following construction may also be required.
3. An outline of general maintenance requirements for the Stormwater BMPs you have selected.
4. Figures delineating and designating pervious and impervious areas, location, and type of Stormwater BMP, and tables of pervious and impervious areas served by each facility. Geo-locating the BMPs using a coordinate system of latitude and longitude is recommended to help facilitate a future statewide database system.
5. A separate list and location of self-retaining areas or areas addressed by LID Principles that do not require specialized O&M or inspections but will require typical landscape maintenance as noted in Chapter 5, pages 85-86, in the WQMP Guidance. Include a brief description of typical landscape maintenance for these areas.

Your local Co-Permittee will also require that you prepare and submit a detailed Stormwater BMP Operation and Maintenance Plan that sets forth a maintenance schedule for each of the Stormwater BMPs built on your site. An agreement assigning responsibility for maintenance and providing for inspections and certification may also be required.

Details of these requirements and instructions for preparing a Stormwater BMP Operation and Maintenance Plan are in Chapter 5 of the WQMP Guidance Document.

Maintenance Mechanism:

BMP	Responsible Party(s)	Inspection/Maintenance Activities Required	Minimum Frequency of Activities
Landscape and Irrigation	Owner	<p>See CASQA BMP Fact Sheet SD-10 in Appendix 10</p> <ul style="list-style-type: none"> -Site landscaping design shall be implemented in accordance with the requirements of the site specific WQMP and local agency requirements. -Site landscaping maintenance shall begin immediately after it has been planted. -Maintenance of landscaping shall occur on a weekly basis and adjusted accordingly based on current conditions and seasonal needs. -Inspection of irrigation system shall be provided on a bi-weekly basis to ensure proper function of the irrigation system, no significant overspray is occurring. -Malfunctioning systems shall be repaired or replaced immediately. -Inspect plant health on a monthly basis. Repair or replace unhealthy plants as needed. -Inspect side slopes of basins and sloped areas on a bi-weekly basis and repair as needed. Re-plant and apply erosion protection to those areas to help prevent erosion in the future. -Landscape clippings shall be swept and picked up immediately to prevent it from entering the storm drain system or adjacent sedimentation basins and filtration basins. Dispose of landscape clippings in a legal manner 	Weekly
MS4 Stenciling and Signage	Owner	<p>See CASQA BMP Fact Sheet SD-13 in Appendix 10</p> <ul style="list-style-type: none"> -MS4 Stenciling and signage shall be placed during construction and inspection and maintenance shall begin upon completion of construction. -Inspect catch basin stenciling on a bi-monthly basis. Replace any damaged, missing or faded stencils in a timely manner. 	Bi-monthly
Common area litter control, loading docks and trash storage areas	Owner	<p>See CASQA BMP Fact Sheet SD-32 in Appendix 10</p> <ul style="list-style-type: none"> -Inspection and Maintenance of common areas, loading docks and trash storage areas shall begin upon completion of construction. -Visual inspection of trash storage areas shall take place on a weekly basis and adjusted on an as needed basis. -Inspect areas for trash and debris. Remove any found trash and debris immediately. Dispose of trash and debris in a legal manner. -Inspect areas for any spills. Pick up/clean up found spills immediately. Dispose of spill material in a legal manner. 	Daily

<p>Parking lot sweeping</p>		<p>See CASQA BMP Fact Sheet SE-7 in Appendix 10 -Parking lot sweeping shall begin after the completion of construction and take place on a monthly basis. Dispose of picked up material in a legal manner.</p>	<p>Monthly</p>
<p>Drainage facility (including roof drains) inspection and maintenance</p>		<p>-Inspection and maintenance of site drainage facilities and roof drains shall begin immediately upon completion of construction. -Catch basins and roof drain inlet shall be clear of any debris - prior to any storm event to ensure proper function of the roof drains. Collected debris shall be disposed of in a legal manner. Catch basin filters shall be inspected on a monthly basis. Catch basin filters that have exceeded 50% of the storage capacity shall be cleaned immediately. -Catch basin filters shall be maintained per the manufacturer's specifications. -Damaged catch basin filters shall be replaced with an approved equal prior to the next storm event or as soon as practicable.</p>	<p>Monthly & after rain event</p>
<p>Bioretention Basin (Sand Filters)</p>		<p>See Appendix 10 -Once the sedimentation and sand filter basin have gone on-line, inspections should occur after every major storm for the first year to ensure that proper stabilization and function is achieved. Continuous inspection and maintenance shall be provided once every six months. Special attention should be paid to how long water remains standing in the basin after a storm; standing water within the basin more than 48 hours after a storm indicates that the filtration rates are insufficient and maintenance of the filter basin bottom is needed. If standing water remains after 48 hours, the standing water shall be removed in accordance with the local agency guidelines and maintenance of the filter basin bottom shall be scheduled immediately. Factors that are typically responsible for clogging the filter basin bottom include upstream sediment erosion and excessive compaction of the basin bottom. These should be repaired immediately to help achieve the desired filtration rates. -Observe and document evidence of collected sediments, trash, debris and oils/greases. -Sediments, trash, debris and oils/greases shall be removed and disposed of in a legal manner. -Observe and document evidence of erosion of side slopes or flowlines. -Schedule repair of eroded side slopes or flowlines immediately. -Protection measures against further erosion shall be placed until the eroded areas are repaired. Protection measures should be at a minimum placement of gravel bags and fiber rolls to prevent further erosion of the affected areas until the areas have been repaired and vegetation has been established.</p>	<p>Every 6 months</p>

Will the proposed BMPs be maintained by a Home Owners' Association (HOA) or Property Owners Association (POA)?

Y N

Owner Information:

Michael Sajjadi
 Executive Vice President
 Rockefeller Group Development
 4 Park Plaza, Suite 840
 Irvine, CA 92614
 949-468-1812
 msajjadi@rockefellergroup.com

Include your Operation and Maintenance Plan and Maintenance Mechanism in Appendix 9. Additionally, include all pertinent forms of educational materials for those personnel that will be maintaining the proposed BMPs within this Project-Specific WQMP in Appendix 10.

BMP			Maintenance Responsibility				Funding Mechanism for Maintenance			Maintenance Costs	
	Used	Not Used	Owner **	City	County	Flood District	Owner	Developer	Public *	1-year (\$)	2-year (\$)
Hydro seeding & Mulching	<input checked="" type="checkbox"/>	<input type="checkbox"/>	<input checked="" type="checkbox"/>	<input type="checkbox"/>	<input type="checkbox"/>	<input type="checkbox"/>	<input checked="" type="checkbox"/>	<input type="checkbox"/>	<input type="checkbox"/>	TBD	TBD
Landscape Private	<input checked="" type="checkbox"/>	<input type="checkbox"/>	<input checked="" type="checkbox"/>	<input type="checkbox"/>	<input type="checkbox"/>	<input type="checkbox"/>	<input checked="" type="checkbox"/>	<input type="checkbox"/>	<input type="checkbox"/>	TBD	TBD
Landscape Public	<input checked="" type="checkbox"/>	<input type="checkbox"/>	<input checked="" type="checkbox"/>	<input type="checkbox"/>	<input type="checkbox"/>	<input type="checkbox"/>	<input checked="" type="checkbox"/>	<input type="checkbox"/>	<input type="checkbox"/>	TBD	TBD
Lawns											
Impervious permanent cover (concrete/ asphalt) Private	<input checked="" type="checkbox"/>	<input type="checkbox"/>	<input checked="" type="checkbox"/>	<input type="checkbox"/>	<input type="checkbox"/>	<input type="checkbox"/>	<input checked="" type="checkbox"/>	<input type="checkbox"/>	<input type="checkbox"/>	TBD	TBD
Impervious permanent cover (concrete/ asphalt) Public	<input checked="" type="checkbox"/>	<input type="checkbox"/>	<input checked="" type="checkbox"/>	<input type="checkbox"/>	<input type="checkbox"/>	<input type="checkbox"/>	<input checked="" type="checkbox"/>	<input type="checkbox"/>	<input type="checkbox"/>	TBD	TBD
Pervious permanent cover (gravel)	<input type="checkbox"/>	<input checked="" type="checkbox"/>	<input type="checkbox"/>	<input type="checkbox"/>	<input type="checkbox"/>	<input type="checkbox"/>	<input type="checkbox"/>	<input type="checkbox"/>	<input type="checkbox"/>		
Down drains	<input checked="" type="checkbox"/>	<input type="checkbox"/>	<input checked="" type="checkbox"/>	<input type="checkbox"/>	<input type="checkbox"/>	<input type="checkbox"/>	<input checked="" type="checkbox"/>	<input type="checkbox"/>	<input type="checkbox"/>	TBD	TBD
Ribbon Gutter Public	<input type="checkbox"/>	<input checked="" type="checkbox"/>	<input type="checkbox"/>	<input type="checkbox"/>	<input type="checkbox"/>	<input type="checkbox"/>	<input type="checkbox"/>	<input type="checkbox"/>	<input type="checkbox"/>		
Ribbon Gutter Private	<input type="checkbox"/>	<input checked="" type="checkbox"/>	<input type="checkbox"/>	<input type="checkbox"/>	<input type="checkbox"/>	<input type="checkbox"/>	<input type="checkbox"/>	<input type="checkbox"/>	<input type="checkbox"/>		
Curb & gutter Public	<input checked="" type="checkbox"/>	<input type="checkbox"/>	<input type="checkbox"/>	<input checked="" type="checkbox"/>	<input type="checkbox"/>	<input type="checkbox"/>	<input type="checkbox"/>	<input type="checkbox"/>	<input checked="" type="checkbox"/>	TBD	TBD
Curb & gutter Private	<input checked="" type="checkbox"/>	<input type="checkbox"/>	<input checked="" type="checkbox"/>	<input type="checkbox"/>	<input type="checkbox"/>	<input type="checkbox"/>	<input checked="" type="checkbox"/>	<input type="checkbox"/>	<input type="checkbox"/>	TBD	TBD
Storm Drain	<input checked="" type="checkbox"/>	<input type="checkbox"/>	<input checked="" type="checkbox"/>	<input type="checkbox"/>	<input type="checkbox"/>	<input type="checkbox"/>	<input checked="" type="checkbox"/>	<input type="checkbox"/>	<input type="checkbox"/>	TBD	TBD
Detention Basin	<input checked="" type="checkbox"/>	<input type="checkbox"/>	<input checked="" type="checkbox"/>	<input type="checkbox"/>	<input type="checkbox"/>	<input type="checkbox"/>	<input checked="" type="checkbox"/>	<input type="checkbox"/>	<input type="checkbox"/>	TBD	TBD
Education Materials	<input checked="" type="checkbox"/>	<input type="checkbox"/>	<input checked="" type="checkbox"/>	<input type="checkbox"/>	<input type="checkbox"/>	<input type="checkbox"/>	<input checked="" type="checkbox"/>	<input type="checkbox"/>	<input type="checkbox"/>	TBD	TBD
Vehicle Wash Area	<input type="checkbox"/>	<input checked="" type="checkbox"/>	<input type="checkbox"/>	<input type="checkbox"/>	<input type="checkbox"/>	<input type="checkbox"/>	<input type="checkbox"/>	<input type="checkbox"/>	<input type="checkbox"/>		

Appendix 1: Maps and Site Plans

Location Map, WQMP Site Plan and Receiving Waters Map

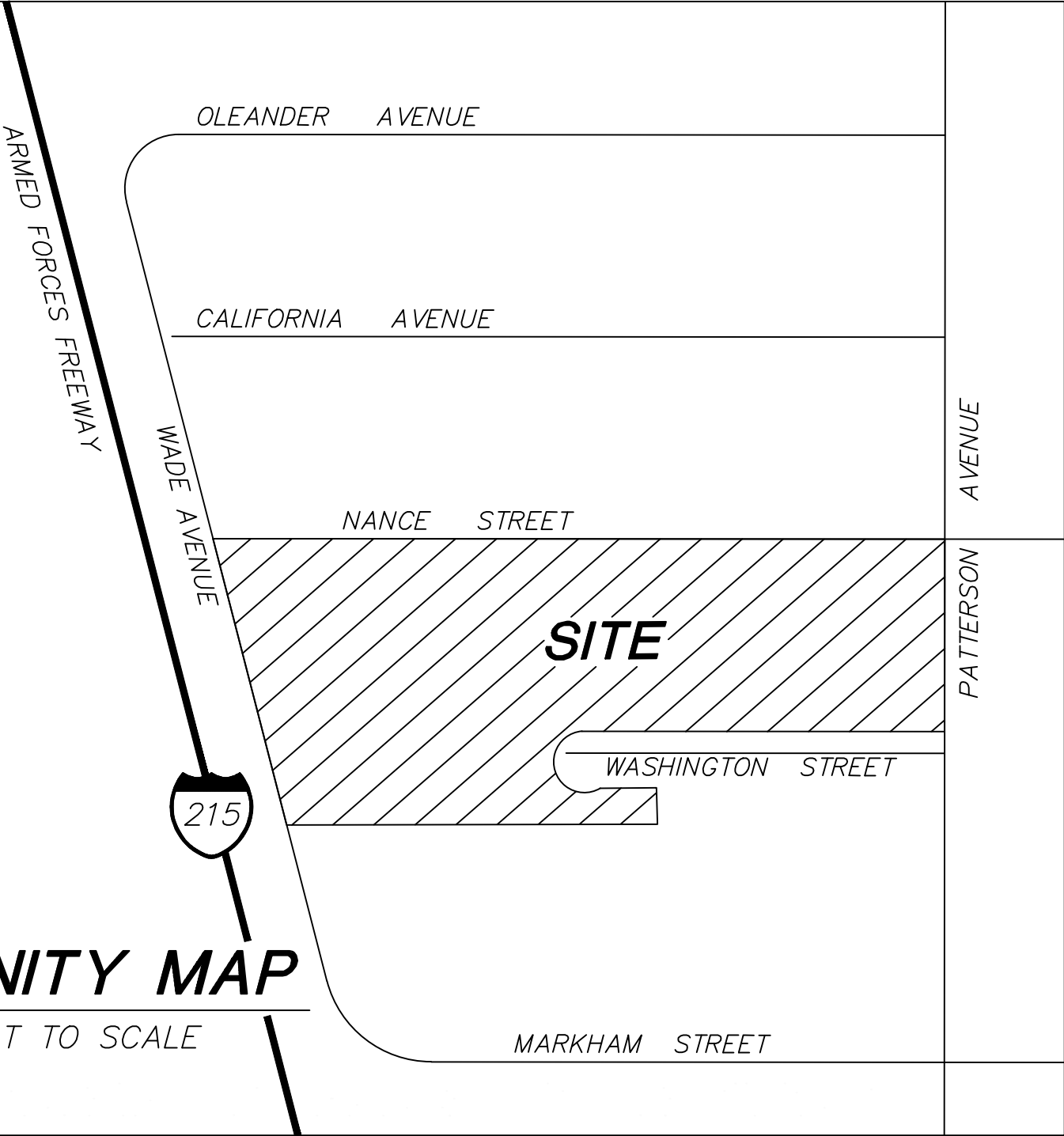

VICINITY MAP

NOT TO SCALE

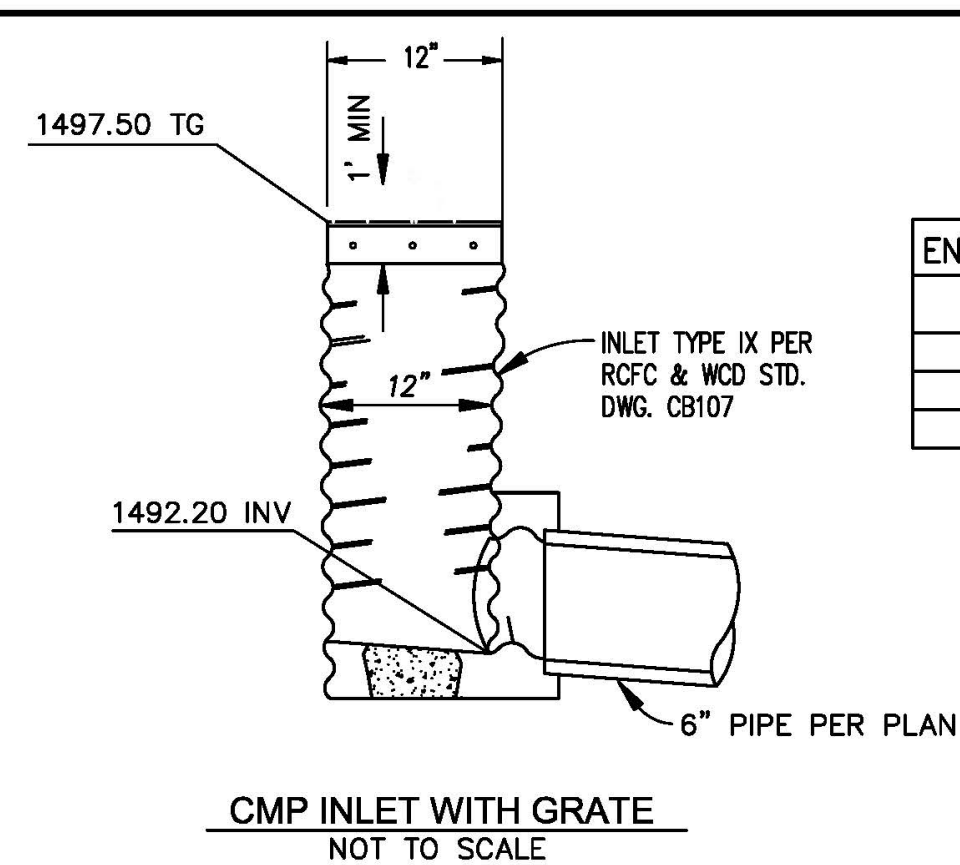
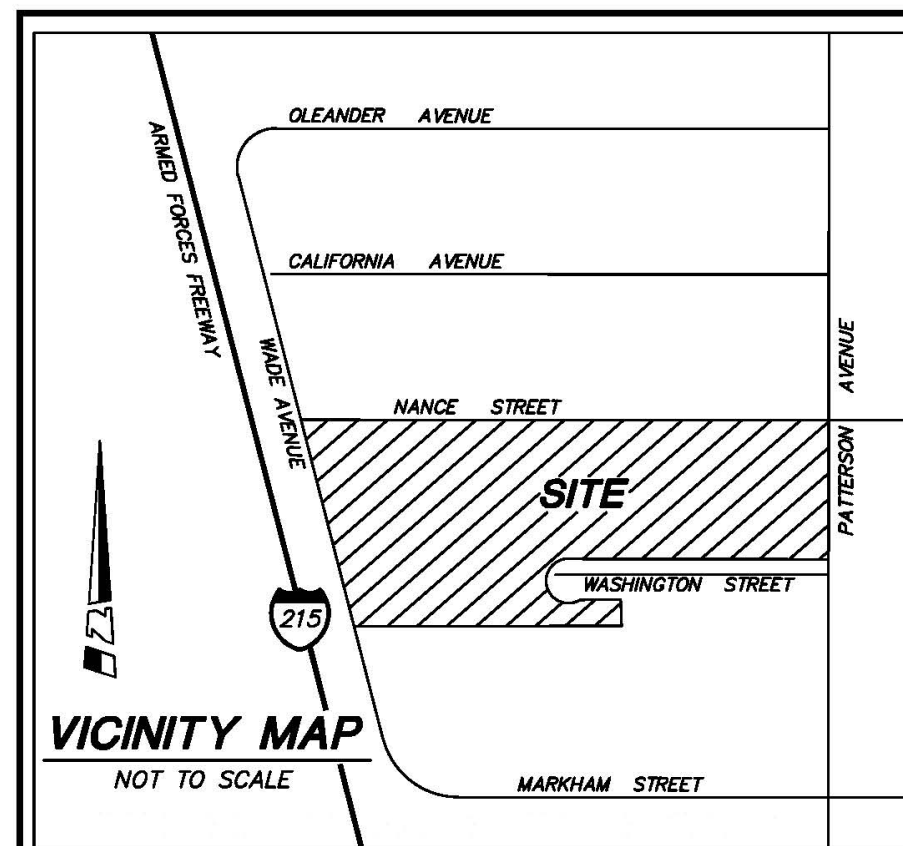

PERCENT RANGE	COMPONENT
70-80	SAND
15-20	SILT
5-10	CLAY

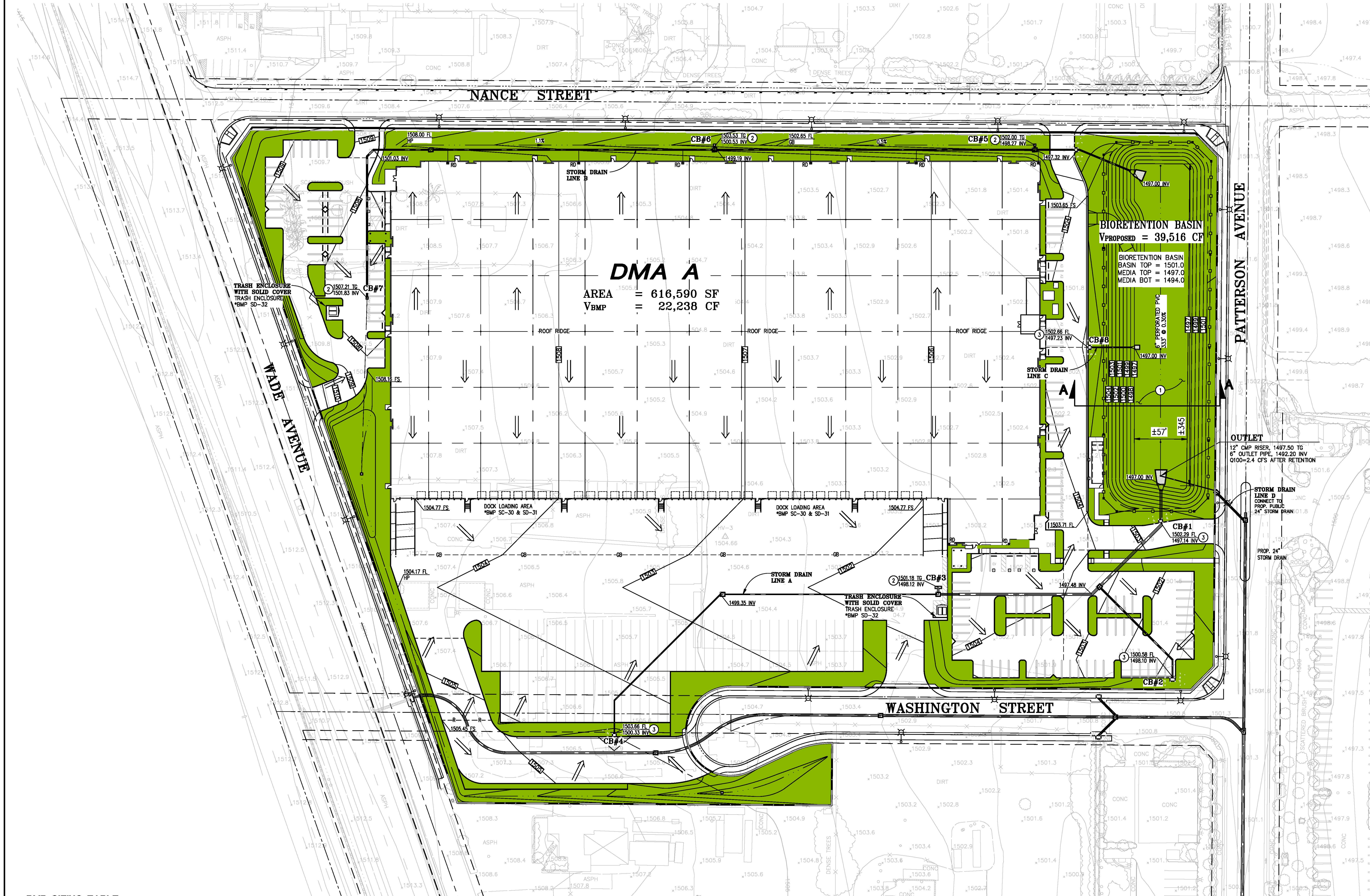
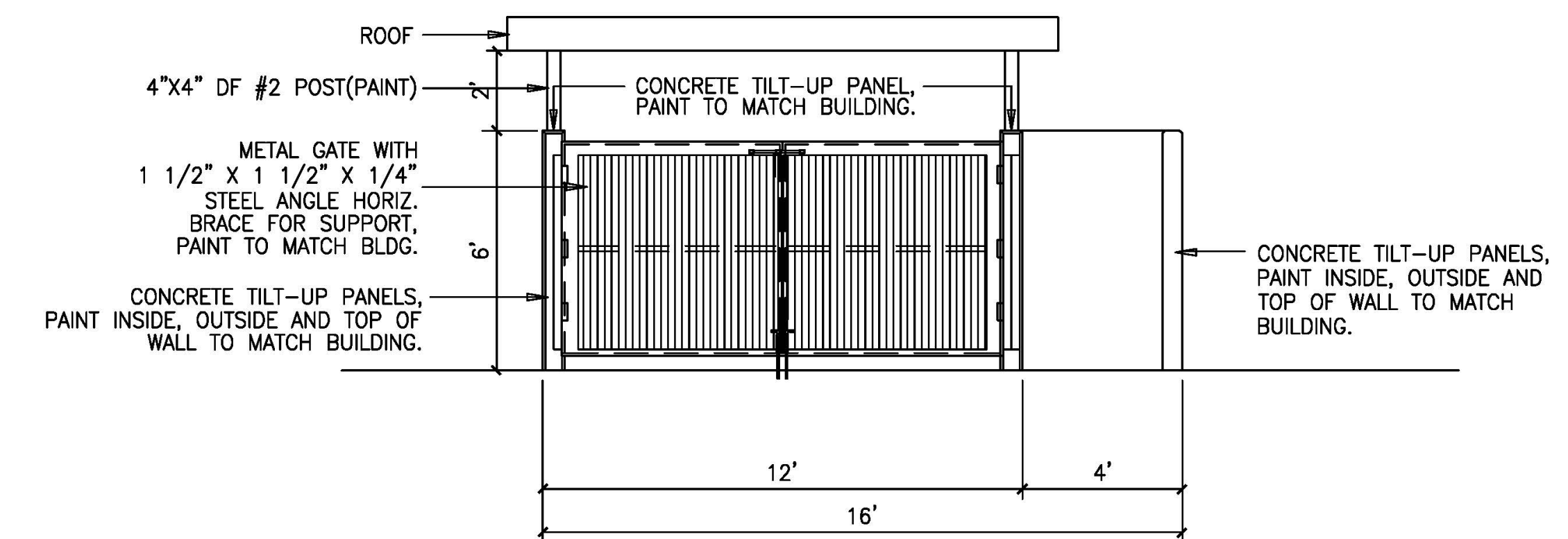
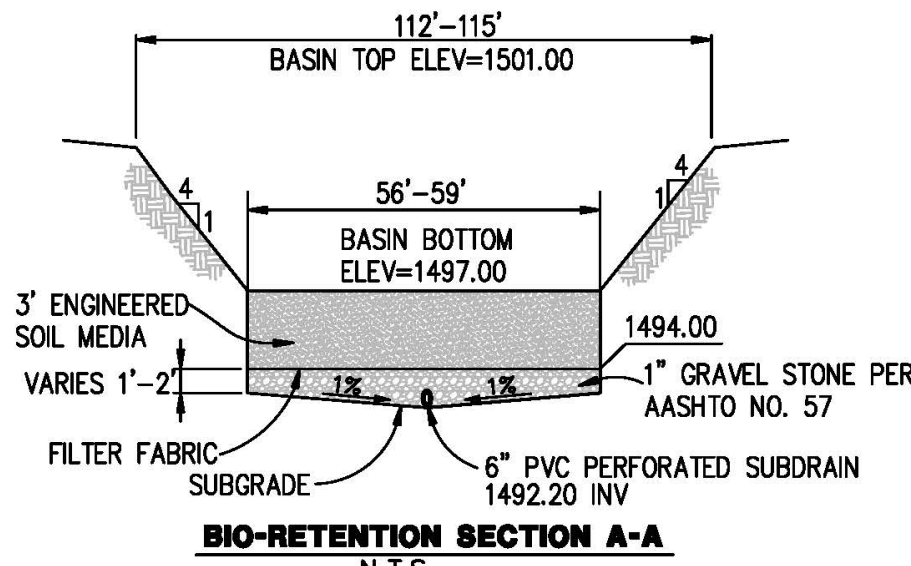
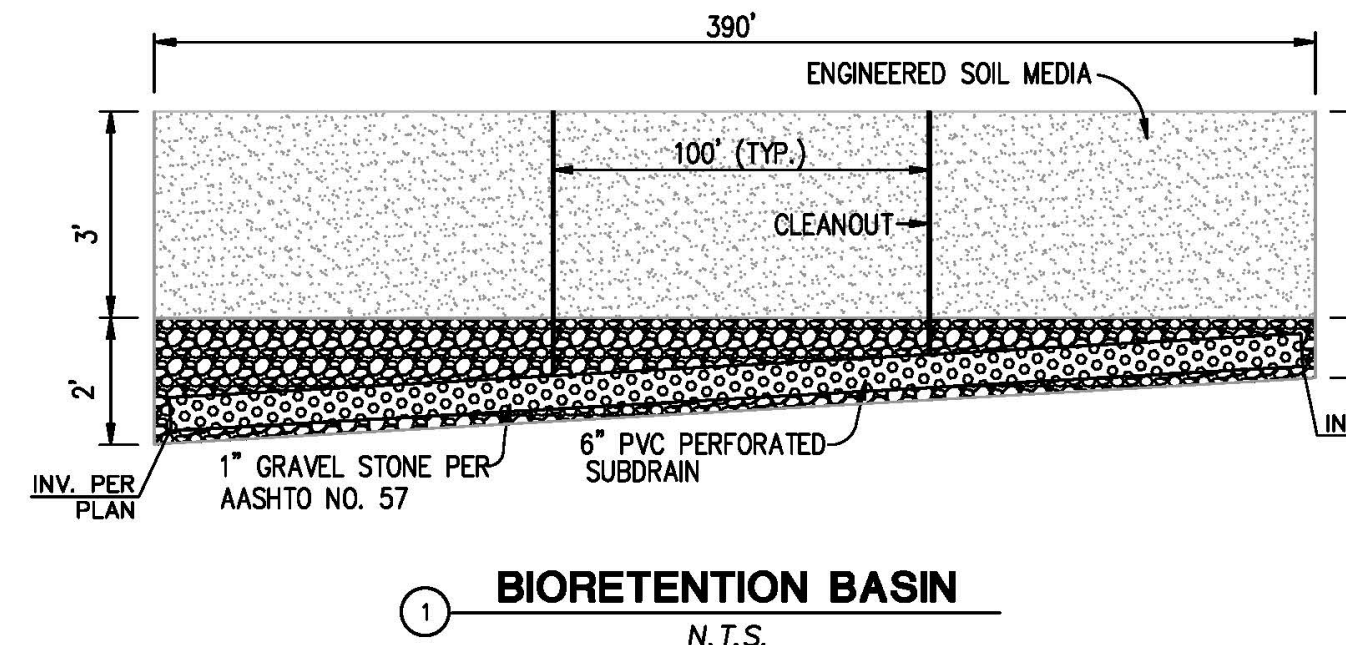

- LEGEND**
- PROPOSED STORM DRAIN
 - - - WQMP BOUNDARY / LIMIT FOR *BMP SC-41 BUILDING & GROUND MAINTENANCE
 - CB — CB GRADE BREAK
 - R — R RIDGE LINE
 - PROPOSED GRATE OPENING INLET W/ FILTER INSERT
 - PROPOSED CURB OPENING INLET W/ FILTER INSERT
 - PROPOSED LANDSCAPING AREA - *BMP SD-10 & SD-12
 - CB CATCH BASIN
 - TG TOP OF GRATE
 - ← FLOW DIRECTION
 - CLEANOUT
 - ☐ TRASH ENCLOSURE WITH ROOF

- WQMP BMP NOTES**
- 1 BIORETENTION BASIN, SEE DETAIL HEREON
 - 2 INSTALL BIO-CLEAN GRATE INLET FILTER OR APPROVED EQUAL*
 - 3 INSTALL BIO-CLEAN CURB INLET FILTER OR APPROVED EQUAL*

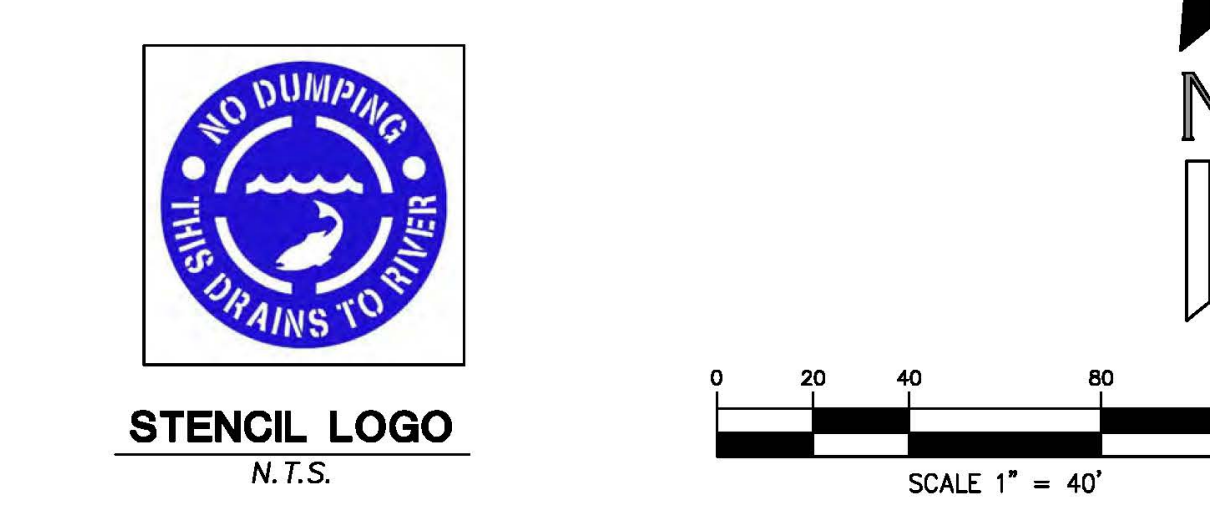
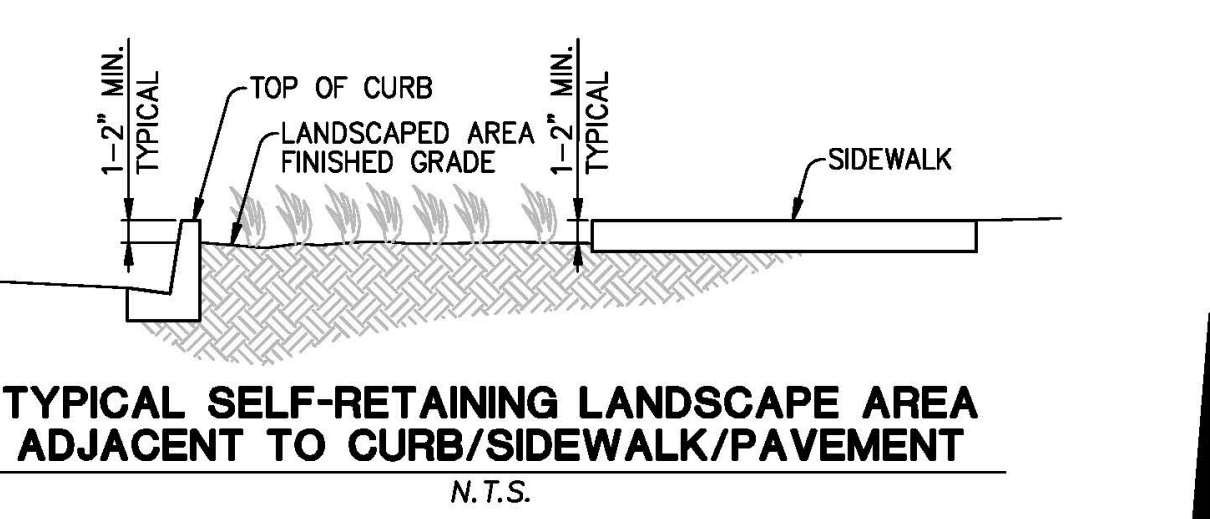
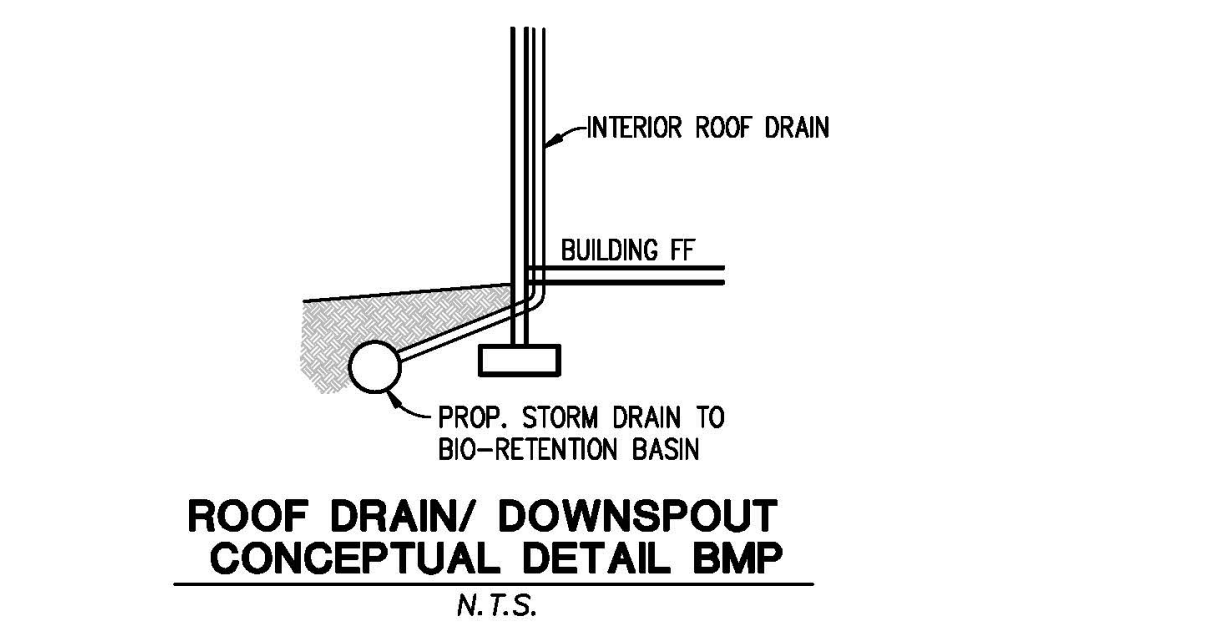

BMP SIZING TABLE

NAME	AREA (SF)	IMPERVIOUS AREA (SF)	PERVIOUS AREA (SF)	i	C	V _{imp} (CF)	BMP	V _{provide} (CF)
DMA A	473,909	473,909	0	1	0.89			
	142,681	14,268	128,413	0.1	0.11			
	609,845					22,238	BIORETENTION BASIN	39,516

NAME	d _s (FT)	d _e (FT)	W _t (FT)	d _e (FT)	AREQUIRED (SF)	APROVIDE (SF)
BIORETENTION BASIN	0.50	3.0	345	1.80	12,343	19,956

- NOTES**
1. NO RUN-ON FLOW TO THE PROJECT SITE.
 2. ROOF DRAIN OUTLET LOCATION AND TRASH ENCLOSURE DETAIL WILL BE PROVIDED IN FINAL POST-CONSTRUCTION BMP SITE MAP.
 3. PROJECT AREA PLAZA, SIDEWALK, AND PARKING LOT WILL BE SWEEP REGULARLY ON A MONTHLY BASIS PER *BMP SD-7.
 4. SEE APPENDIX 2 FOR FURTHER GRADING INFORMATION.

OWNER/DEVELOPER
 ROCKEFELLER GROUP
 4 PARK PLAZA, SUITE 840
 IRVINE, CA 92614
 PHONE (949) 468-1812
 CONTACT PERSON: MICHAEL SAJJADI

ENGINEER
 HUITT-ZOLLARS
 3990 CONCOURS, SUITE 330
 ONTARIO, CA 91764
 PHONE: (909) 941-7799
 CONTACT: DAVID WHITE
 EMAIL: dwhite@huitt-zollars.com

HUITT-ZOLLARS
 Huitt-Zollars, Inc. Ontario
 3990 CONCOURS, SUITE 330 • ONTARIO, CALIFORNIA 91764 • (909) 941-7799

CITY OF PERRIS
 POST-CONSTRUCTION BMP SITE MAP
 IP22-000031
 ROCKEFELLER - PATTERSON COMMERCE CENTER
 NANCE STREET, PATTERSON AVENUE,
 WASHINGTON STREET, & WADE AVENUE
 PERRIS, CA

SHEET 1 OF 2

*SEE WQMP REPORT APPENDIX 10 FOR BMP FACT SHEETS

HUITT-ZOLIARS
Huitt-Zollars, Inc. Ontario
3990 CONCORDS, SUITE 330 • ONTARIO, CALIFORNIA 91764 • (909) 941-7799

CITY OF PERRIS

CONDITIONS OF APPROVAL
ROCKEFELLER - PATTERSON COMMERCE CENTER
NANCE STREET, PATTERSON AVENUE,
WASHINGTON STREET, & WADE AVENUE
PERRIS, CA

SHEET
2 OF 2

NO. 20230001 - ROCKEFELLER - PATTERSON COMMERCE CENTER - PERRIS, CA - 08/15/2023

Appendix 2: Construction Plans

Grading and Drainage Plans

PRECISE GRADING PLANS FOR PATTERSON COMMERCE CENTER CITY OF PERRIS COUNTY OF RIVERSIDE

GENERAL NOTES

- ALL GRADING SHALL CONFORM TO THE UNIFORM BUILDING CODE APPENDIX CHAP. 33 AS AMENDED BY ORDINANCE 457.
- ALL PROPERTY CORNERS SHALL BE CLEARLY DELINEATED IN THE FIELD PRIOR TO COMMENCEMENT OF ANY CONSTRUCTION/GRADING.
- ALL WORK UNDER THIS GRADING PERMIT SHALL BE LIMITED TO WORK WITHIN THE PROPERTY LINES. ALL WORK WITHIN THE ROAD RIGHT-OF-WAY WILL REQUIRE SEPARATE PLANS AND A SEPARATE REVIEW/APPROVAL (PERMIT) FROM THE ENGINEERING DEPARTMENT.
- ALL GRADING MORE THAN 5000 CY SHALL BE DONE UNDER THE SUPERVISION OF A SOILS ENGINEER IN CONFORMANCE WITH RECOMMENDATIONS OF THE PRELIMINARY SOILS INVESTIGATION BY SOUTHERN CALIFORNIA GEOTECHNICAL DATED DECEMBER 1, 2021. TWO SETS OF THE FINAL COMPACTION REPORT SHALL BE SUBMITTED TO THE BUILDING AND SAFETY DEPARTMENT AND SHALL INCLUDE: FOUNDATION DESIGN RECOMMENDATIONS AND CERTIFICATION THAT GRADING HAS BEEN COMPLETED IN CONFORMANCE WITH THE RECOMMENDATIONS OF THE SITE INVESTIGATION REPORT.
- THE CONTRACTOR SHALL NOTIFY THE BUILDING AND SAFETY DEPARTMENT AT LEAST 24 HOURS IN ADVANCE TO REQUEST FINISH LOT GRADE AND DRAINAGE INSPECTION. THIS INSPECTION MUST BE APPROVED PRIOR TO BUILDING PERMIT FINAL INSPECTION FOR EACH LOT.
- THE CONTRACTOR SHALL NOTIFY UNDERGROUND SERVICE ALERT, TWO DAYS BEFORE DIGGING AT 1-800-227-2600.
- MAXIMUM CUT AND FILL SLOPE = 2:1.
- NO FILL SHALL BE PLACED ON EXISTING GROUND UNTIL THE GROUND HAS BEEN CLEARED OF WEEDS, DEBRIS, TOPSOIL AND OTHER DELETERIOUS MATERIAL. FILLS SHOULD BE PLACED IN THIN LIFTS (8-INCH MAX OR AS RECOMMENDED IN SOILS REPORT), COMPACTED AND TESTED AS GRADING PROCESS UNTIL FINAL GRADES ARE ATTAINED. ALL FILLS ON SLOPES STEEPER THAN 5 TO 1 (H/V) AND A HEIGHT GREATER THAN 5 FEET SHALL BE KEYS AND BENCHED INTO FIRM NATURAL SOIL FOR FULL SUPPORT. THE BENCH UNDER THE TOE MUST BE 10 FEET WIDE MIN.
- THE SLOPE STABILITY FOR CUT AND FILL SLOPES OVER 30' IN VERTICAL HEIGHT, OR SLOPES STEEPER THAN 2:1 HAVE BEEN VERIFIED WITH FACTOR OF SAFETY OF AT LEAST 1.5.
- NO ROCK OR SIMILAR IRREDUCIBLE MATERIAL WITH A MAXIMUM DIMENSION GREATER THAN 12 INCHES SHALL BE BURIED OR PLACED IN FILLS CLOSER THAN 10 FEET TO THE FINISHED GRADE.
- A FINAL COMPACTION REPORT SHALL BE SUBMITTED FOR ALL FILLS OVER 1' DEEP.
- PROVIDE A SLOPE INTERCEPTOR DRAIN ALONG THE TOP OF CUT SLOPES WHERE THE DRAINAGE PATH IS GREATER THAN 40 FEET TOWARDS THE CUT SLOPE.
- PROVIDE 5' WIDE BY 1' HIGH BERM ALONG THE TOP OF ALL FILL SLOPES STEEPER THAN 3:1.
- MINIMUM BUILDING PAD DRAINAGE GRADIENT SHALL BE = 1% IF CUT OR FILL IS LESS THAN 10', 2% IF CUT OR FILL IS GREATER THAN 10'. DRAINAGE SWALES SHALL BE A MINIMUM OF 0.2' DEEP AND BE CONSTRUCTED A MINIMUM OF 2' FROM THE TOP OF CUT OR FILL SLOPES WITH A MINIMUM GRADIENT OF 1%.
- NO OBSTRUCTION OF NATURAL WATER COURSES SHALL BE PERMITTED.
- DURING ROUGH GRADING OPERATIONS AND PRIOR TO CONSTRUCTION OF PERMANENT DRAINAGE STRUCTURES, TEMPORARY DRAINAGE CONTROL (BEST MANAGEMENT PRACTICES, BMPs) SHALL BE PROVIDED TO PREVENT PONDING WATER AND DAMAGE TO ADJACENT PROPERTIES.
- DUST SHALL BE CONTROLLED BY WATERING OR OTHER APPROVED METHODS.
- ALL EXISTING DRAINAGE COURSES ON THE PROJECT SITE MUST CONTINUE TO FUNCTION. PROTECTIVE MEASURES AND TEMPORARY DRAINAGE PROVISIONS MUST BE USED TO PROTECT ADJOINING PROPERTIES DURING GRADING OPERATIONS.
- FINISH GRADE SHALL BE SLOPED AWAY FROM ALL EXTERIOR WALLS AT NOT LESS THAN 1/2" PER FOOT FOR A MINIMUM OF 3'.
- ALL SLOPES EQUAL TO OR GREATER THAN 3' IN VERTICAL HEIGHT, ARE REQUIRED TO BE PLANTED WITH GRASS OR ROSEA ICE PLANT (OR EQUAL) GROUND COVER AT A MAXIMUM SPACING OF 12" ON CENTER. SLOPES EXCEEDING 15' IN VERTICAL HEIGHT SHALL BE PLANTED WITH APPROVED SHRUBS NOT TO EXCEED 10' ON CENTER, OR TREES SPACED NOT TO EXCEED 20' ON CENTER OR SHRUBS NOT TO EXCEED 10', OR A COMBINATION OF SHRUBS AND TREES NOT TO EXCEED 15' IN ADDITION TO THE GRASS OR GROUND COVER. SLOPES THAT REQUIRE PLANTING SHALL BE PROVIDED WITH AN IN-GROUND IRRIGATION SYSTEM EQUIPPED WITH AN APPROPRIATE BACKFLOW DEVICE PER U.P.C., CHAPTER 10. THE SLOPE PLANTING AND IRRIGATION SYSTEM SHALL BE INSTALLED PRIOR TO PRECISE GRADING FINAL.
- A REGISTERED CIVIL ENGINEER SHALL SUBMIT TO THE BUILDING AND SAFETY DEPARTMENT WRITTEN CERTIFICATION OF COMPLETION OF GRADING IN ACCORDANCE WITH THE APPROVED GRADING PLAN PRIOR TO REQUESTING INSPECTION AND ISSUANCE OF THE BUILDING PERMIT. CERTIFICATION SHALL INCLUDE LINE, GRADE, SURFACE DRAINAGE, ELEVATION, AND LOCATION OF PERMITTED GRADING ON THE LOT.
- ALL SCREEN AND RETAINING WALLS TO BE CONSTRUCTED UNDER SEPARATE PERMIT.
- THE CONTRACTOR SHALL PROPERLY MAINTAIN AND CLEAN EXISTING STREET. ESPECIALLY AT THE END OF EACH DAY. MECHANICAL STREET SWEEPER SHALL BE PROVIDED AT ALL TIMES DURING GRADING TO CLEAN THE STREETS FROM DUST AND MATERIAL DIRT SPILLAGE.
- HAULING ROUTE SHALL BE SUBMITTED TO THE CITY ENGINEER FOR REVIEW AND APPROVAL PRIOR TO START THE IMPORTATION/EXPORTATION OF DIRT.
- CONSTRUCTION ACTIVITIES SHALL BE LIMITED FROM 7:00 AM TO 6:00 PM. CONTRACTOR SHALL SUBMIT WORK REQUEST 24 HOURS IN ADVANCE TO THE CITY ENGINEER FOR REVIEW AND APPROVAL ON ANY ON ANY SCHEDULED WORKS ON WEEKENDS AND HOLIDAYS. OVERTIME INSPECTIONS SHALL BE AT THE CONTRACTORS EXPENSE.
- ON-SITE STORM DRAIN FACILITIES ARE PRIVATE UNLESS OTHERWISE NOTED, AND SHALL BE MAINTAINED BY THE OWNER. VIDEO OF STORM DRAIN FACILITY SHALL BE SUBMITTED TO THE CITY ENGINEER FOR REVIEW PRIOR TO PAVEMENT CAPPING.
- ON-SITE LAYOUT, LANDSCAPING, LIGHTING AND WALLS SHALL BE REVIEWED AND APPROVED BY THE PLANNING/BUILDING DEPARTMENT.

NOTICE TO CONTRACTORS

CONTRACTOR AGREES THAT HE SHALL ASSUME COMPLETE AND SOLE RESPONSIBILITY FOR JOB SITE CONDITIONS DURING THE COURSE OF CONSTRUCTION, INCLUDING SAFETY OF ALL PERSONS AND PROPERTY; THAT THIS REQUIREMENT SHALL CONTINUOUSLY AND NOT BE LIMITED TO NORMAL WORKING HOURS; AND THAT THE CONTRACTOR FURTHER AGREES TO DEFEND, INDEMNIFY AND HOLD THE OWNER AND ENGINEER HARMLESS FROM ANY AND ALL LIABILITY, REAL OR ALLEGED, IN CONNECTION WITH THE PERFORMANCE OF WORK ON THIS PROJECT, EXCEPTING FROM LIABILITY ARISING FROM THE SOLE NEGLIGENCE OF THE OWNER OR ENGINEER.

THE EXISTENCE AND LOCATION OF ANY UNDERGROUND UTILITY PIPES OR STRUCTURES SHOWN ON THESE PLANS WERE OBTAINED BY A SEARCH OF AVAILABLE RECORDS. THESE LOCATIONS ARE APPROXIMATE AND SHALL BE CONFIRMED IN FIELD BY THE CONTRACTOR, SO THAT ANY NECESSARY ADJUSTMENT CAN BE MADE IN ALIGNMENT AND/OR GRADE OF THE PROPOSED IMPROVEMENT. THE CONTRACTOR IS REQUIRED TO TAKE DUE PRECAUTIONARY MEASURES TO PROTECT ANY UTILITY LINES SHOWN AND ANY OTHER LINES NOT SHOWN ON THESE PLANS.

MAJOR ITEMS TO BE REMOVED HAVE BEEN NOTED ON THESE PLANS, HOWEVER THE CONTRACTOR IS TO WALK THE SITE FOR VERIFICATION OF ADDITIONAL SURFACE FEATURES REQUIRING REMOVAL. THE CONTRACTOR IS RESPONSIBLE TO REMOVE ALL OBJECTS AND MATERIALS (AC, CONCRETE, TREES, BUSHES, FENCING, ETC.) THAT ARE IN CONFLICT WITH THE NEW PROPOSED IMPROVEMENTS WHETHER CALLED-OUT OR NOT ON THE PLANS AND DISPOSE OF LEGALLY. CONTRACTOR IS TO BACKFILL ACCORDINGLY AND LEAVE SITE IN RELATIVELY LEVEL CONDITION.

ALL CONTRACTOR AND SUBCONTRACTORS PERFORMING WORK SHOWN ON OR RELATED TO THESE PLANS SHALL CONDUCT THEIR OPERATIONS SO THAT EMPLOYEES ARE PROVIDED A SAFE PLACE TO WORK AND THE PUBLIC IS PROTECTED. ALL CONTRACTORS AND SUBCONTRACTORS SHALL COMPLY WITH THE "OCCUPATIONAL SAFETY AND HEALTH REGULATIONS" OF THE U.S. DEPARTMENT OF LABOR AND WITH THE STATE OF CALIFORNIA DEPARTMENT OF INDUSTRIAL RELATIONS "CONSTRUCTION SAFETY ORDERS." THE CIVIL ENGINEER SHALL NOT BE RESPONSIBLE IN ANY WAY FOR THE CONTRACTOR OR SUBCONTRACTORS COMPLIANCE WITH SAID REGULATIONS AND ORDERS.

CONTRACTOR IS RESPONSIBLE FOR OBTAINING ALL FAA CLEARANCES FOR THEIR CRANE OPERATION

UNAUTHORIZED CHANGES AND USES

CAUTION: THE ENGINEER PREPARING THESE PLANS WILL NOT BE RESPONSIBLE FOR, OR LIABLE FOR, UNAUTHORIZED CHANGES TO OR USES OF THESE PLANS.

BENCH MARK

MORENO VALLEY, NEAR THE INTERSECTION OF INTERSTATE 215 AND VAN BUREN BLVD. PROCEED WEST ALONG VAN BUREN BLVD TO AVE A, (WEST FRONTAGE RD) THEN 0.10 MILE (0.16 KM) NORTH ALONG AVE A TO A DIRT ROAD LEADING TO THE UNDER PASS OF VAN BUREN BL. 0.35 MILE (0.56 KM) SOUTH ALONG DIRT PATROL ON THE EAST SIDE OF ATSF RAILROAD TRACKS. FOUND A USGS 3-1/4 INCH BRASS DISK STAMPED Z 1143 1961 SET FLUSH ON TOP OF A CONCRETE MONUMENT (ROUND), 15 FEET (4.6 M) SOUTHEAST OF MILEPOST 11, 183 FEET (55.8 M) SOUTHEAST OF A SWITCH STAND, 25 FEET (7.6 M) EAST OF TRACKS, 5.4 FEET (1.6 M) WEST OF 215 FWY RIGHT OF WAY FENCE AND 5 INCHES ABOVE GROUND.

DATUM: PID DX2725 DESIGNATION Z1143 (NGVD), ELEVATION 1532.70'

BASIS OF BEARINGS

BASIS OF BEARINGS: BEARINGS SHOWN HEREON ARE BASED ON THE BEARING BETWEEN GPS NO. MLFP AND GPS NO. PPFB BEING NORTH 53°20'18" WEST PER RECORDS ON FILE WITH THE COUNTY SURVEYOR.

EARTHWORK VOLUMES

	CUT (CY):	FILL (CY):
RAW VOLUMES:	26,244	25,099
OVEREXCAVATION:	48,588	48,588
SUBTOTAL:	74,832	73,687
9% SHRINKAGE:	-6,361	-
0.10' SUBSIDENCE:	-	2,782
ADDITIONAL VOLUME:	1,280	-
SUBTOTAL:	69,751	76,469

NET* ± 6,718 CY SHORT (IMPORT)

* ALL EARTHWORK VOLUMES SHOWN HERE ARE FOR REFERENCE ONLY AND DO NOT REFLECT FINAL EARTHWORK VOLUMES. CONTRACTOR TO PREPARE ITS OWN VOLUME CALCULATIONS.

ABBREVIATIONS

- VC — VERTICAL CURVE
- TP — TOP OF PAVEMENT
- TL — TOP OF CURB
- EL — ELEVATION
- FL — FLOWLINE
- FG — FINISH GRADE
- FS — FINISH SURFACE
- CF — CURB FACE
- GB — GRADE BREAK
- HP — HIGH POINT
- INV — INVERT ELEVATION
- TG — TOP OF GRATE
- TW — TOP OF WALL
- CB — CATCH BASIN
- RD — ROOF DRAIN
- LD — LOCAL DEPRESSION
- EP — EDGE OF PAVEMENT
- COTG — CLEANOUT TOP OF GRATE
- SMH — SEWER MANHOLE
- R — RIDGE LINE
- ROW — RIGHT OF WAY
- P.I.P. — PROTECT IN PLACE
- CL — CENTERLINE
- DWY — DRIVEWAY
- WS EL — WATER SURFACE ELEVATION
- 1000— PROPOSED CONTOUR
- 1000— EXISTING CONTOUR
- S— ONSITE SEWER MAIN
- FW— FIRE WATER LOOP
- W— WATER LINE

GRADING CONSTRUCTION NOTES

THE QUANTITIES SHOWN HEREON ARE ESTIMATES ONLY. THE CONTRACTORS SHALL PREPARE THEIR OWN QUANTITIES AND BID A COMPLETE JOB.

- | | | |
|---|--|------------|
| ① | CONSTRUCT 6" CONCRETE CURB PER DETAIL ON SHEET 2..... | 9,114 LF |
| ② | CONSTRUCT CONCRETE CURB AND GUTTER PER DETAIL ON SHEET 2..... | 583 LF |
| ③ | CONSTRUCT CURB RAMP PER DETAIL ON SHEET 2..... | 7 EA |
| ④ | CONSTRUCT SCREEN WALL PER STRUCTURAL PLANS, UNDER SEPARATE PLAN & PERMIT..... | 953 LF |
| ⑤ | CONSTRUCT 5" PCC PAVEMENT OVER 12" SUBGRADE COMPACTED TO 95%..... | 73,466 SF |
| ⑥ | CONSTRUCT 6.5" PCC PAVEMENT OVER 12" SUBGRADE COMPACTED TO 95%..... | 128,731 SF |
| ⑫ | CONSTRUCT 6" DECORATIVE PCC PAVEMENT OVER 12" SUBGRADE COMPACTED TO 95% (SEE ARCHITECT PLAN FOR DETAILS) | 1,334 SF |
| ⑬ | INSTALL TRUNCATED DOMES PER ADA CALIFORNIA BUILDING CODE AND PER DETAIL ON SHEET 2..... | 283 SF |
| ⑭ | CONSTRUCT 4" CONCRETE SIDEWALK..... | 3,184 SF |
| ⑮ | INSTALL 4' TUBE STEEL FENCE PER ARCHITECT PLANS, UNDER SEPARATE PERMIT..... | 984 LF |
| ⑰ | CONSTRUCT CONCRETE LANDING PER ARCHITECT PLANS, UNDER SEPARATE PERMIT..... | 756 SF |
| ⑱ | INSTALL GATE PER ARCHITECT PLANS, UNDER SEPARATE PERMIT..... | 1 EA |
| ⑳ | CONSTRUCT 12" CURB PER DETAIL ON SHEET 2..... | 258 LF |
| ㉑ | CONSTRUCT 0" TO 6" CURB TRANSITION, 2' UNLESS OTHERWISE NOTED..... | 11 EA |
| ㉒ | ADJUST MANHOLE RIM TO GRADE AFTER FINAL PAVING HAS BEEN INSTALLED..... | 6 EA |
| ㉓ | CONSTRUCT EXTERIOR STAIR STRUCTURE PER ARCHITECT PLANS, UNDER SEPARATE PERMIT..... | 5 EA |
| ㉔ | CONSTRUCT LOCAL DEPRESSION PER DETAIL ON SHEET 2..... | 4 EA |
| ㉕ | WALL/RAMP PER ARCHITECT PLANS, UNDER SEPARATE PERMIT..... | 2 EA |
| ㉖ | CONSTRUCT TRASH ENCLOSURE PER ARCHITECT PLANS, UNDER SEPARATE PERMIT..... | 2 EA |
| ㉗ | INSTALL CONCRETE WHEEL STOP PER ARCHITECT PLANS, UNDER SEPARATE PERMIT..... | 31 EA |
| ㉘ | CONSTRUCT 6" TO 12" CURB TRANSITION..... | 1 EA |

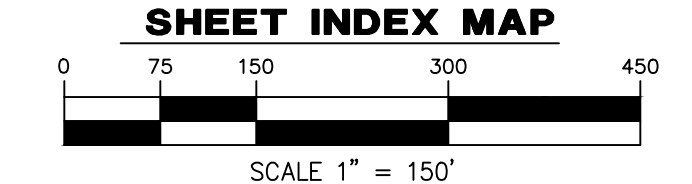
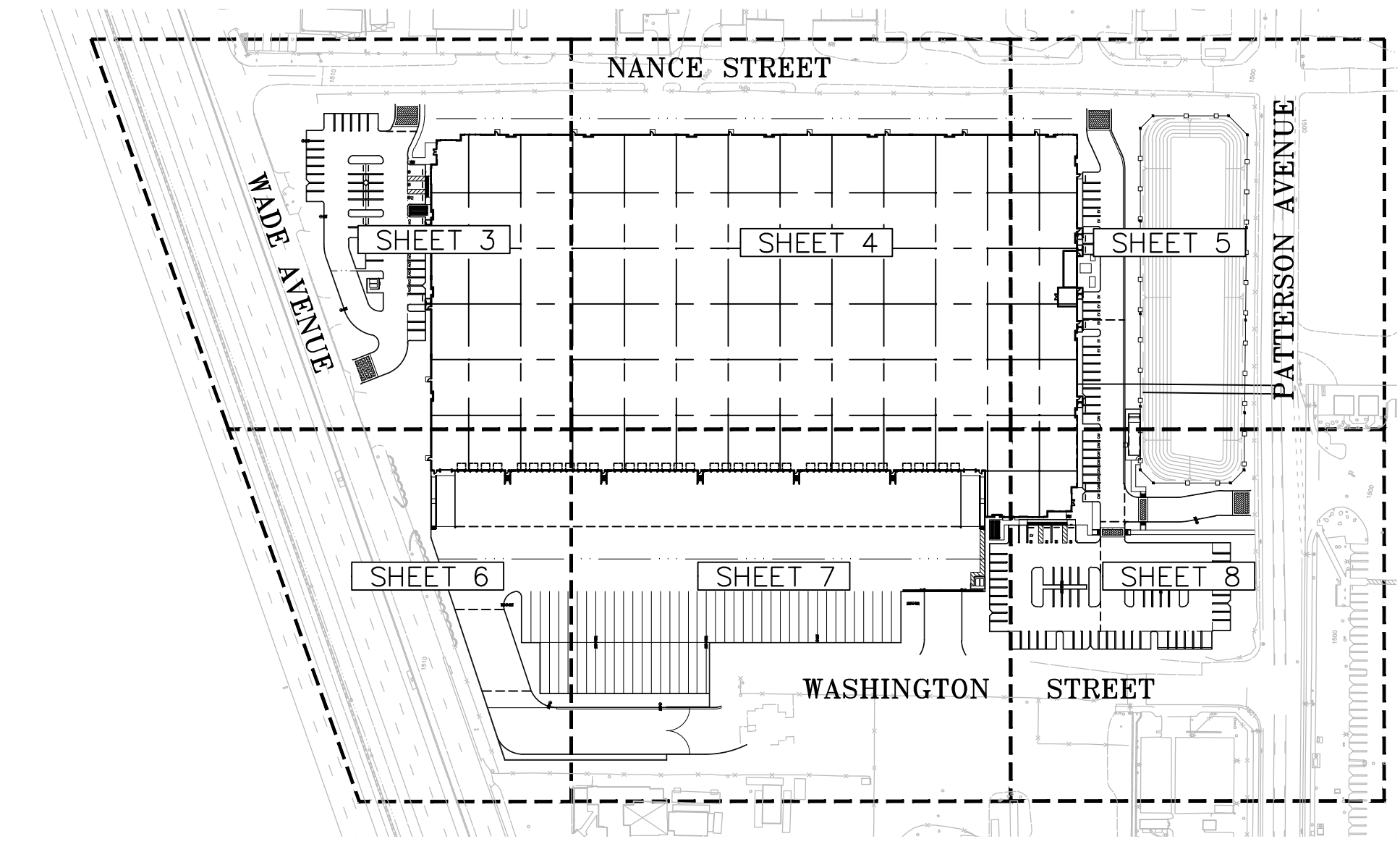
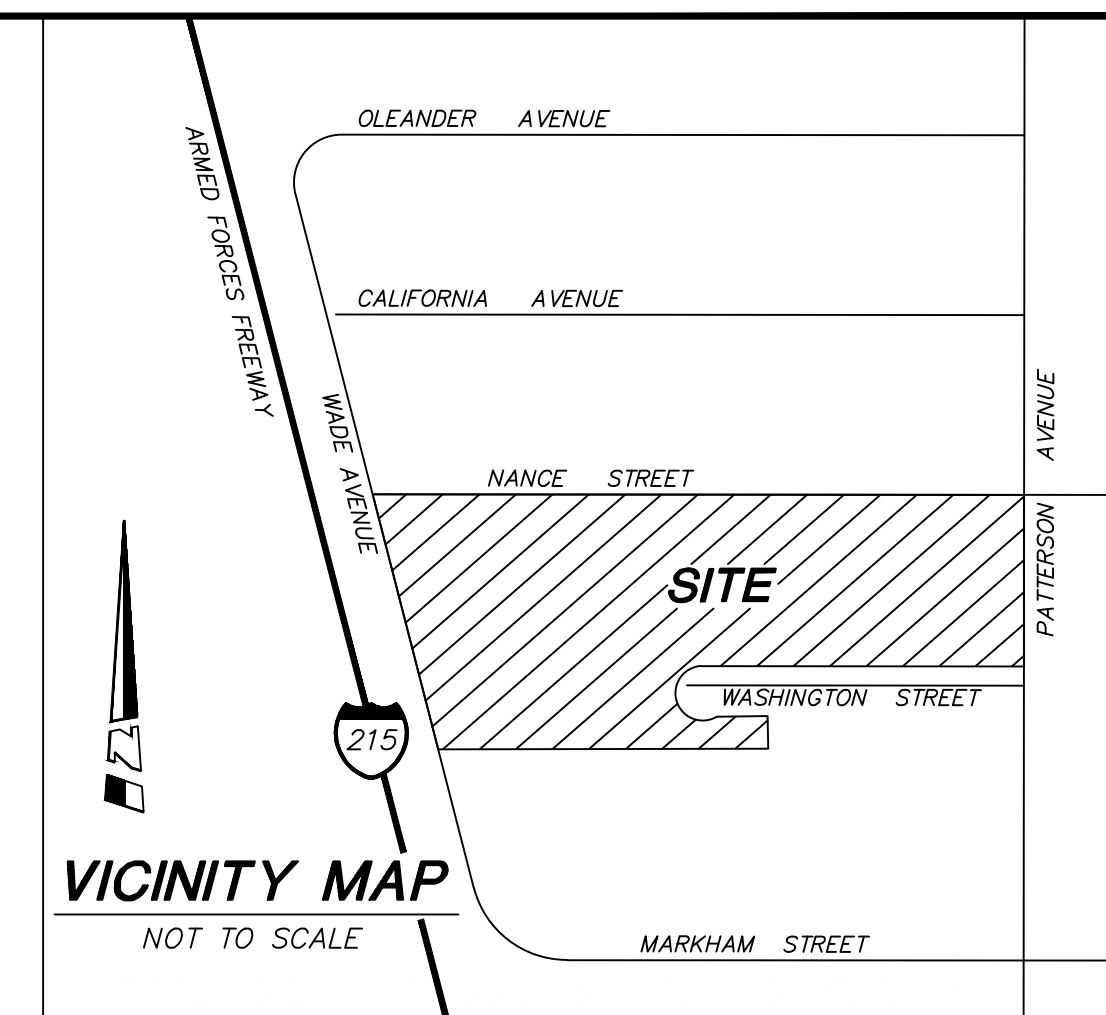

SHEET INDEX	
SHEET NO.	DESCRIPTION
1	TITLE SHEET
2	CROSS SECTIONS AND DETAILS
3-8	PRECISE GRADING PLANS
9-11	ONSITE STORM DRAIN PLAN
12	EROSION CONTROL PLAN
13	PRIVATE SEWER AND WATER PLAN
14-15	HORIZONTAL CONTROL PLAN

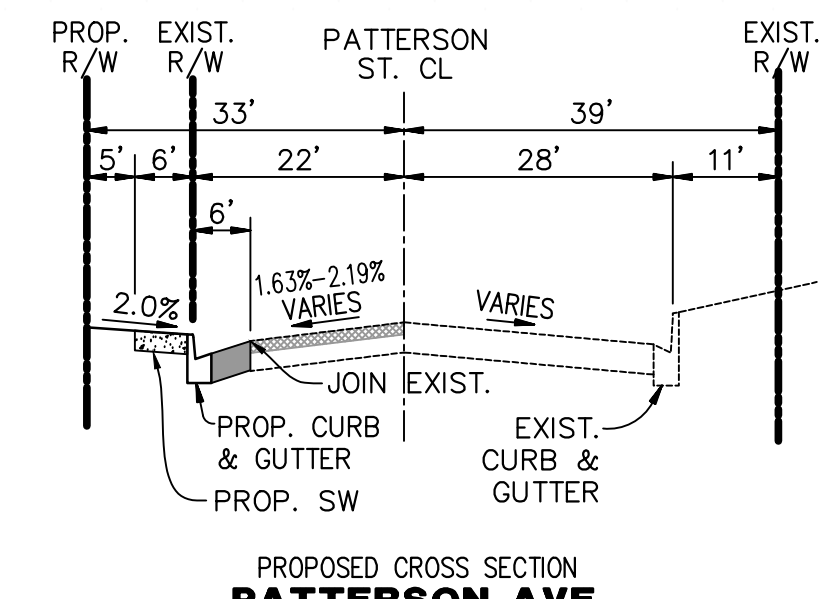
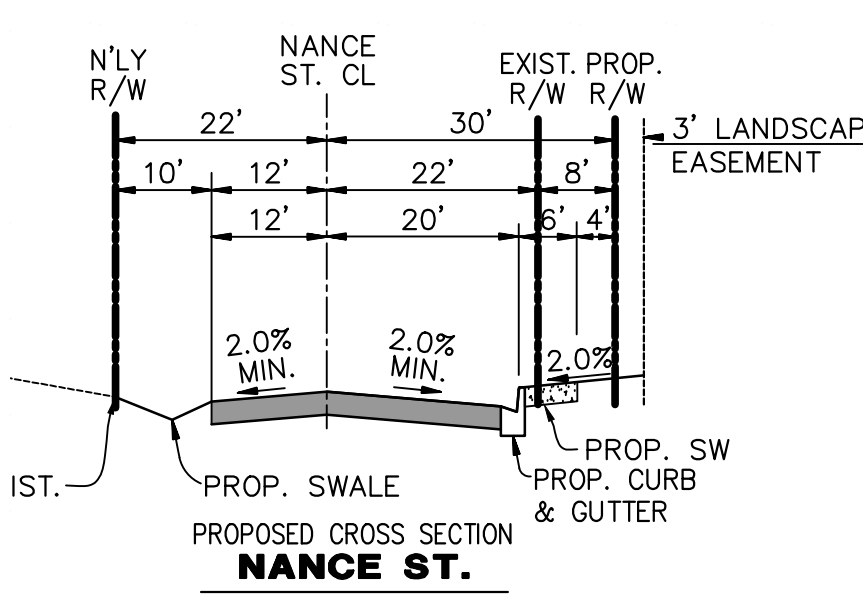
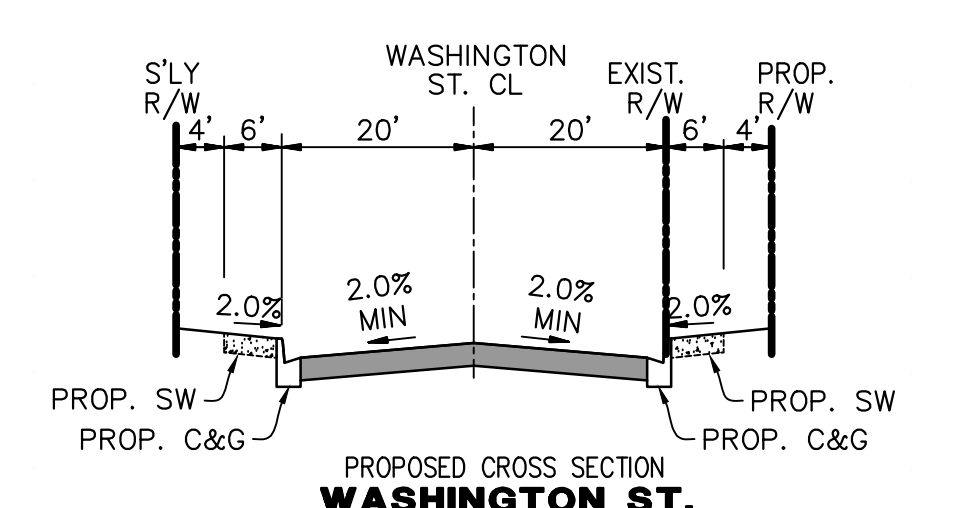
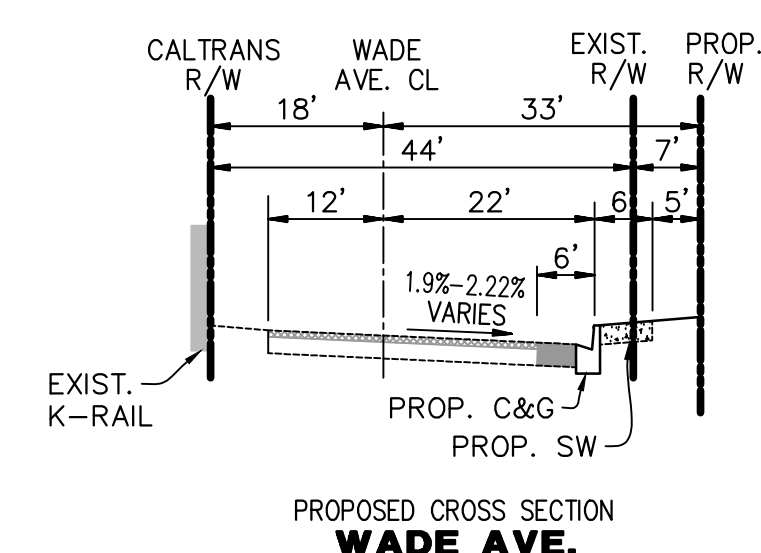

CIVIL ENGINEER
HUITT-ZOLLARS, INC.
3990 CONCOURS, SUITE 330
ONTARIO, CALIFORNIA 91764
PHONE: (909) 941-7799

OWNER
RG-PATTERSON LLC
MR. MICHAEL SAJAJADI
3161 MICHELSON DRIVE, SUITE 900
IRVINE, CA 92612
PHONE: (949) 468-1812

SOILS ENGINEER:
SOUTHERN CALIFORNIA GEOTECHNICAL
22885 SAVI RANCH PARKWAY, SUITE E
YORBA LINDA, CALIFORNIA, 92887
PHONE (714) 685-1115
FAX (714) 685-1118
WWW.SOCALGEO.COM
CONTACT: DANIEL W. NIELSEN

DEVELOPER
ROCKEFELLER GROUP
MR. MICHAEL SAJAJADI
3161 MICHELSON DRIVE, SUITE 900
IRVINE, CA 92612
PHONE: (949) 468-1812

APPROVED BY:
PERRIS FIRE MARSHALL DATE

Underground Service Alert
NOTE:
WORK CONTAINED WITHIN THESE PLANS SHALL NOT COMMENCE UNTIL AN ENCROACHMENT PERMIT AND/OR A GRADING PERMIT HAS BEEN ISSUED.
Call: TOLL FREE
811
WWW.CALL811.COM
TWO WORKING DAYS BEFORE YOU DIG

BY	MARK	DESCRIPTION	APPR.	DATE
ENGINEER		REVISIONS		CITY

DESIGNED BY: D.L.W.
APPROVED BY:
DRAWN BY: H-Z STAFF
CITY OF PERRIS
CHECKED BY: J.M.
DATE:
SCALE: AS SHOWN

PREPARED UNDER THE SUPERVISION OF:
Johnny Murad, R.C.E. NO. 67512
EXPIRATION: 6-30-2023
DATE:

HUITT-ZOLLARS
Ontario
Huitt-Zollars, Inc.
3990 CONCOURS • SUITE 330 • ONTARIO, CALIFORNIA 91764
PHONE (909) 941-7799 • FAX (909) 941-7789

CITY OF PERRIS
PRECISE GRADING PLAN
TITLE SHEET
VESTING PARCEL MAP 38384 / DPR22-00003
FOR: **PATTERSON COMMERCE CENTER** M.O. CITY FILE NO. **P8-1468**
SHEET **1** OF **15** SHEETS

S:\p\2022\38384\38384.dwg - Notice: In:US Design:US1:DWG's\PreciseGrading\UG001-02.dwg, Layout: 01, 16, 2022, 2:58pm

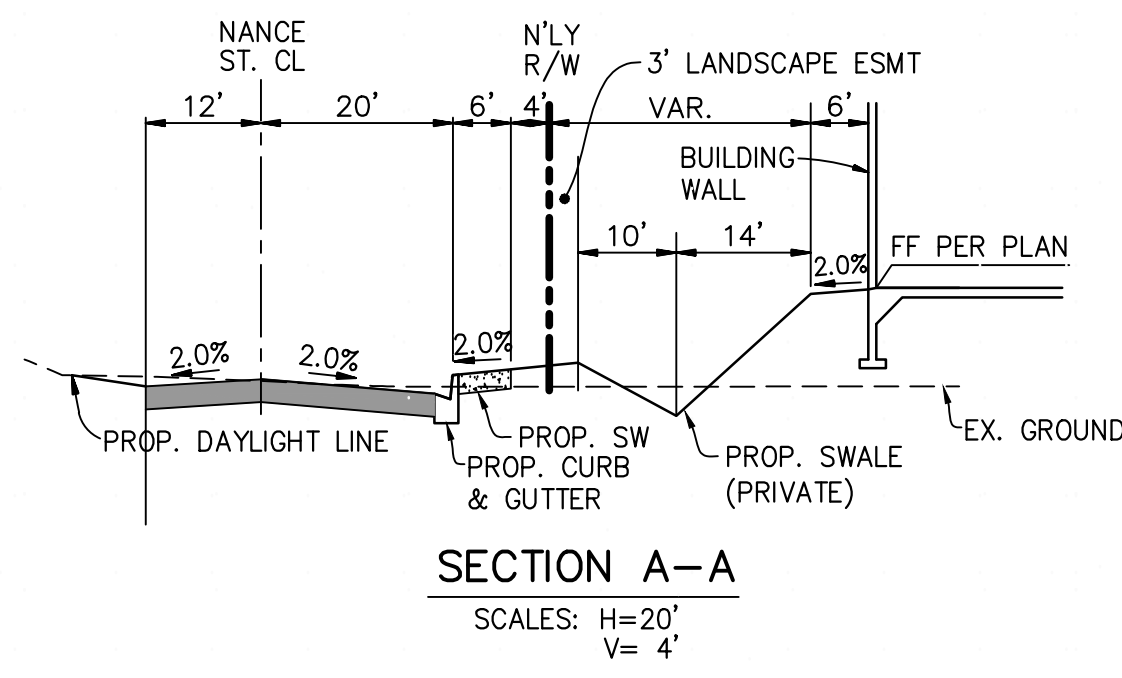

SECTION A-A
 SCALES: H=20'
 V= 4'

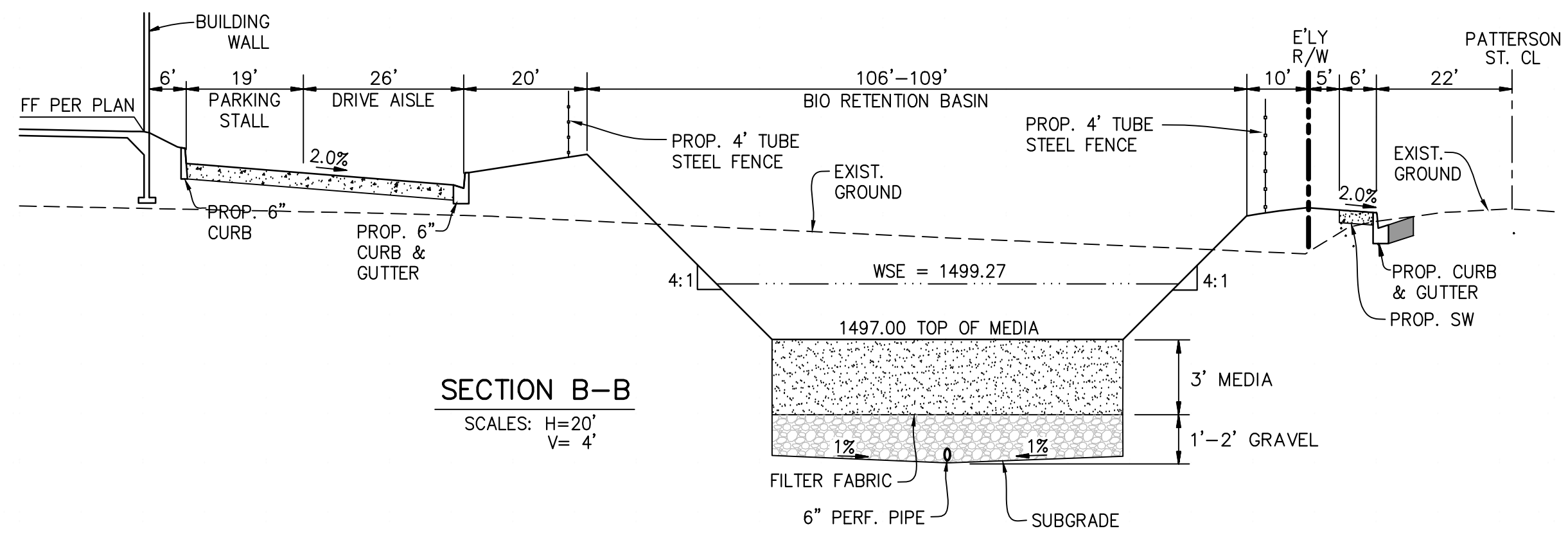

SECTION B-B
 SCALES: H=20'
 V= 4'

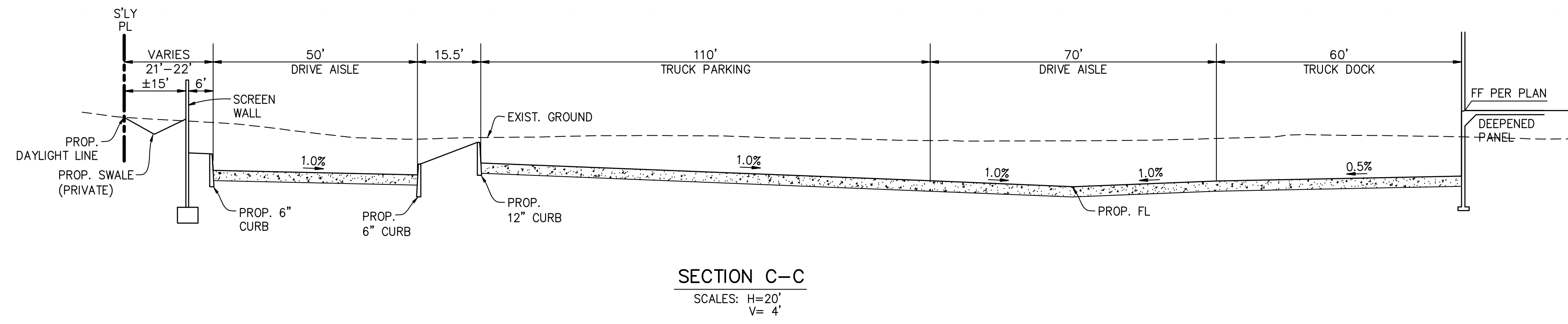

SECTION C-C
 SCALES: H=20'
 V= 4'

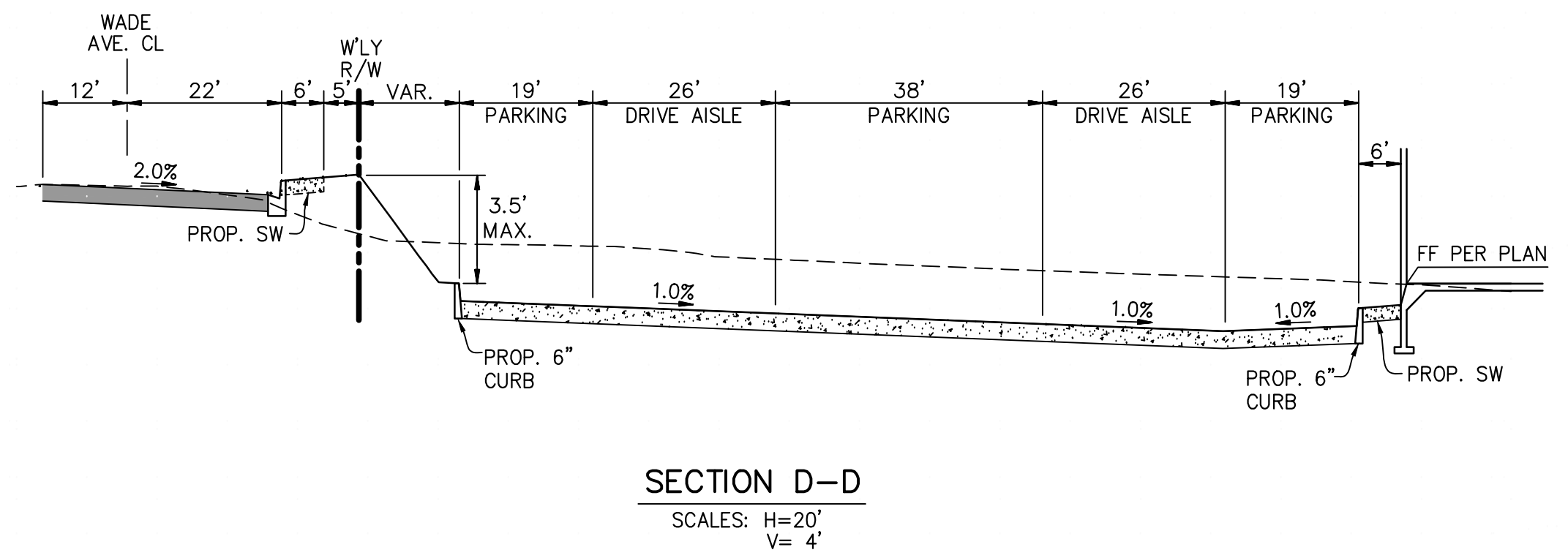

SECTION D-D
 SCALES: H=20'
 V= 4'

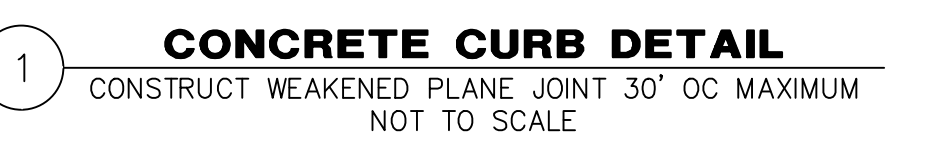

1 CONCRETE CURB DETAIL
 CONSTRUCT WEAKENED PLANE JOINT 30' OC MAXIMUM
 NOT TO SCALE



2 CONCRETE CURB & GUTTER DETAIL
 CONSTRUCT WEAKENED PLANE JOINT 10' OC MAXIMUM
 NOT TO SCALE

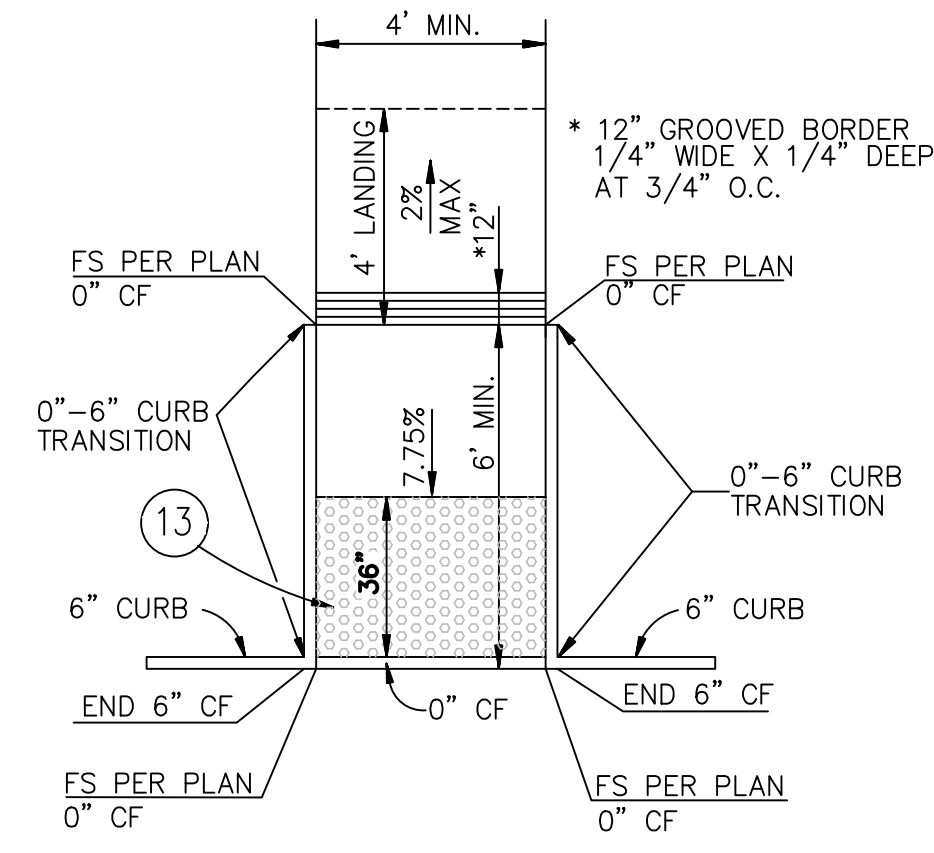

6 CURB RAMP DETAIL
 NOT TO SCALE

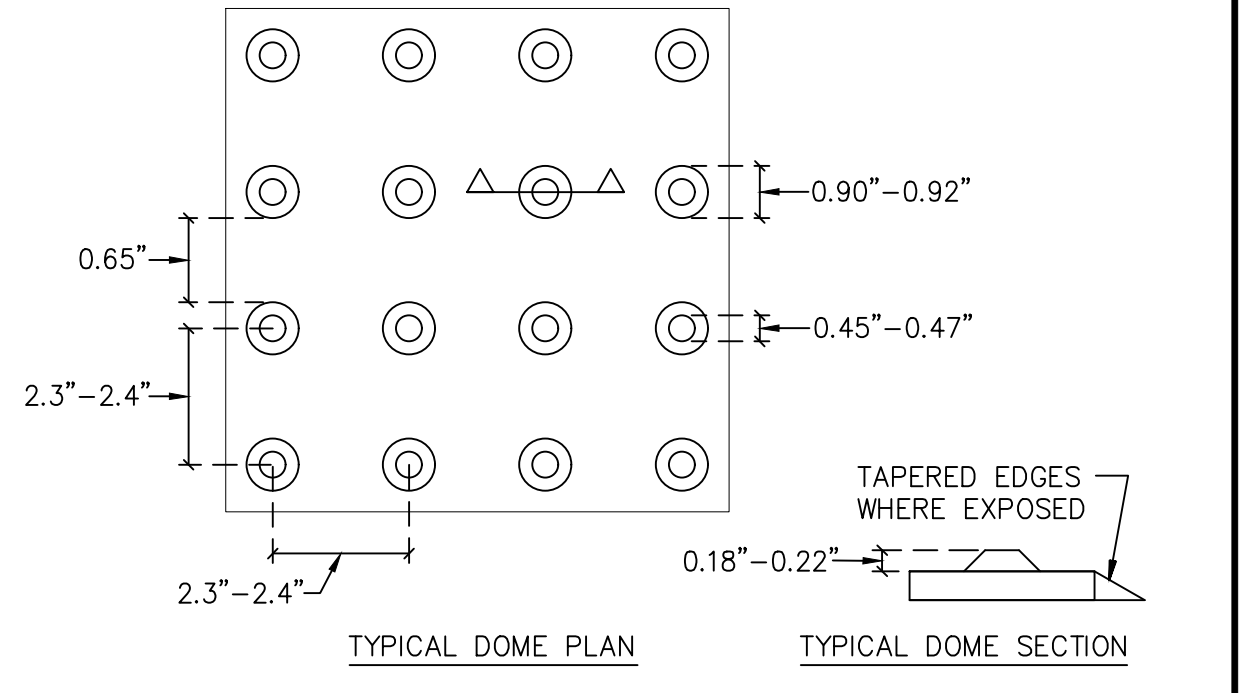

NOTES:
 1. THE DETECTABLE WARNING SURFACE SHALL CONTRAST VISUALLY WITH ADJOINING SURFACES. INSTALL PER MANUFACTURER'S SPECIFICATIONS.
 2. ALL THE PEDESTRIAN AREAS WITH ENHANCED SURFACES MUST BE ACCESSIBLE TYPE FOR THE DISABLED PER CBC 11B-302.1, 11B-403.
 3. ONLY APPROVED DSA-AC DETECTABLE WARNING PRODUCTS (TRUNCATED DOMES) AND DIRECTIONAL SURFACES SHALL BE INSTALLED AS PROVIDED IN THE CALIFORNIA CODE OF REGULATIONS (CCR), TITLE 24, PART 1, CHAPTER 5, ARTICLES 2, 3, AND 4. REFER TO CCR TITLE 24, PART 12, CHAPTERS 11B, SECTION 12-11B.205, FOR BUILDING AND FACILITY ACCESS SPECIFICATIONS FOR PRODUCT APPROVAL FOR DETECTABLE WARNING PRODUCTS AND DIRECTIONAL SURFACES. [CBC 11B-705.3]

13 DETECTABLE TRUNCATED DOMES SURFACING
 NOT TO SCALE

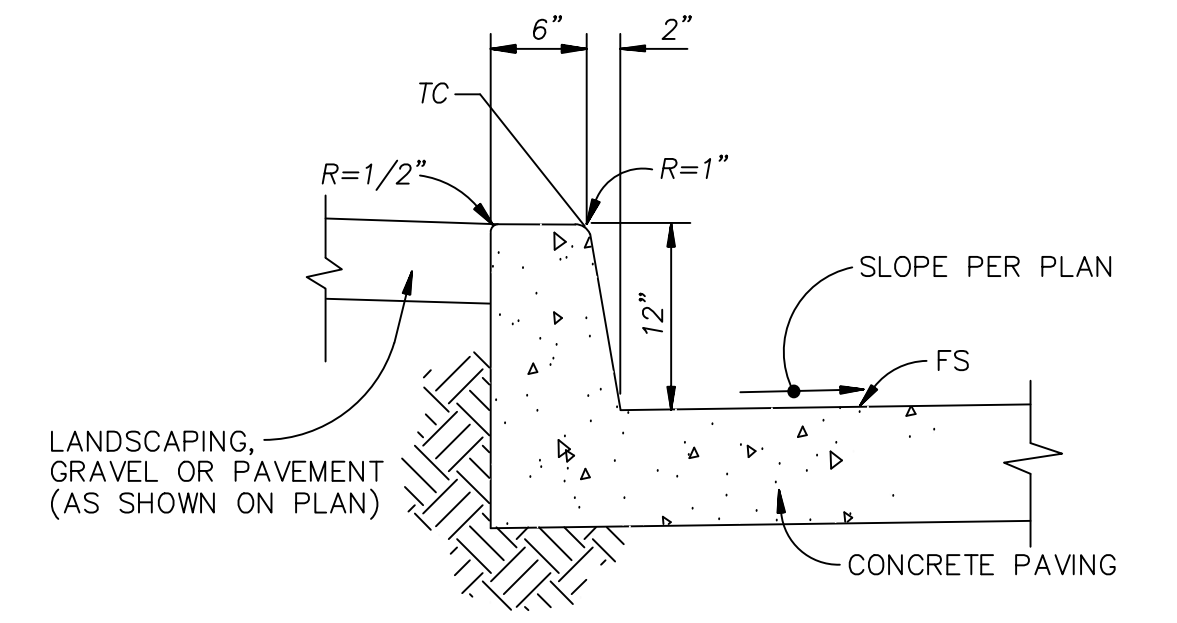

22 12\"/>

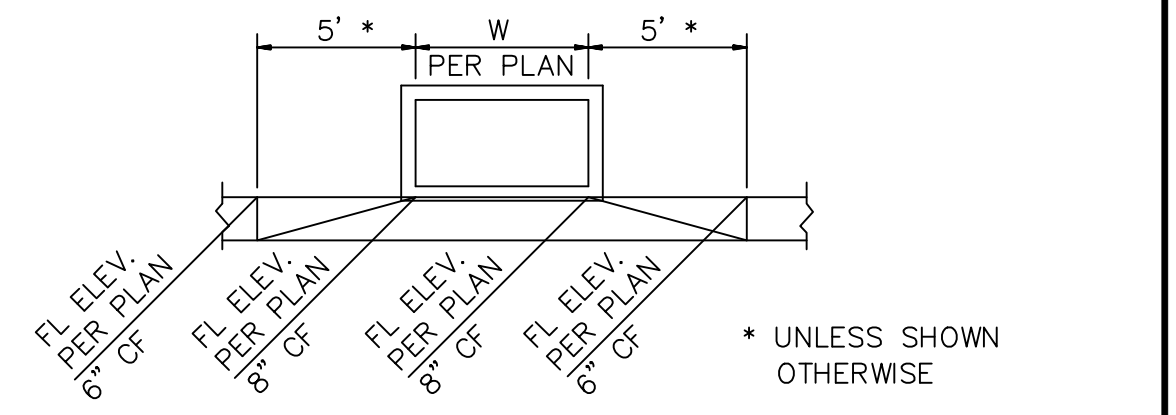

50 LOCAL DEPRESSION
 NOT TO SCALE

Underground Service Alert
 Call: TOLL FREE 811
 www.call811.com
 TWO WORKING DAYS BEFORE YOU DIG

NOTE:
 WORK CONTAINED WITHIN THESE PLANS SHALL NOT COMMENCE UNTIL AN ENCROACHMENT PERMIT AND/OR A GRADING PERMIT HAS BEEN ISSUED.
 THE PRIVATE ENGINEER SIGNING THESE PLANS IS RESPONSIBLE FOR ASSURING THE ACCURACY AND ACCEPTABILITY OF THE DESIGN HEREON. IN THE EVENT OF DISCREPANCIES ARISING AFTER CITY APPROVAL OR DURING CONSTRUCTION, THE PRIVATE ENGINEER SHALL BE RESPONSIBLE FOR DETERMINING AN ACCEPTABLE SOLUTION AND REVISIONS TO THE PLANS FOR APPROVAL BY THE CITY.

BY	MARK	DESCRIPTION	APPR.	DATE
ENGINEER		REVISIONS		CITY

DESIGNED BY: D.L.W.
 REVIEWED BY:
 DRAWN BY: H-Z STAFF
 CHECKED BY: J.M.
 SCALE: AS SHOWN



PREPARED UNDER THE SUPERVISION OF:
 Johnny Murad, R.C.E. NO. 67512
 EXPIRATION: 6-30-2023

HUITT-ZOLLARS
 Ontario
 3990 CONCOURS • SUITE 330 • ONTARIO, CALIFORNIA 91764
 PHONE (909) 941-7799 • FAX (909) 941-7789

WDID NO. _____

CITY OF PERRIS
PRECISE GRADING PLAN
CROSS SECTIONS AND DETAILS
VESTING PARCEL MAP 38384 / DPR22-00003

FOR **PATTERSON COMMERCE CENTER** M.O. CITY FILE NO. **P8-1468**



SHEET **2** OF **15** SHEETS

S:\perry\38384\38384.dwg - Notice: In:US Design\US1 - DWG's\PrcticeGrading\UG001-02.dwg, Layout: 02, Dct: 16, 2802 - 453pm

CONSTRUCTION NOTES

- 1 CONSTRUCT 6" CONCRETE CURB PER DETAIL ON SHEET 2
- 6 CONSTRUCT CURB RAMP PER DETAIL ON SHEET 2
- 6 CONSTRUCT 5" PCC PAVEMENT OVER 12" SUBGRADE COMPACTED TO 95%
- 12 CONSTRUCT 6" DECORATIVE PCC PAVEMENT OVER 12" SUBGRADE COMPACTED TO 95% (SEE ARCHITECT PLAN FOR DETAILS)
- 14 CONSTRUCT 4" CONCRETE SIDEWALK
- 25 CONSTRUCT 0" TO 6" CURB TRANSITION, 2' UNLESS OTHERWISE NOTED
- 103 CONSTRUCT TRASH ENCLOSURE PER ARCHITECT PLANS, UNDER SEPARATE PERMIT
- 112 INSTALL CONCRETE WHEEL STOP PER ARCHITECT PLANS, UNDER SEPARATE PERMIT

HATCH LEGEND

-  PROP. 5" PCC PAVEMENT
-  PROP. SIDEWALK

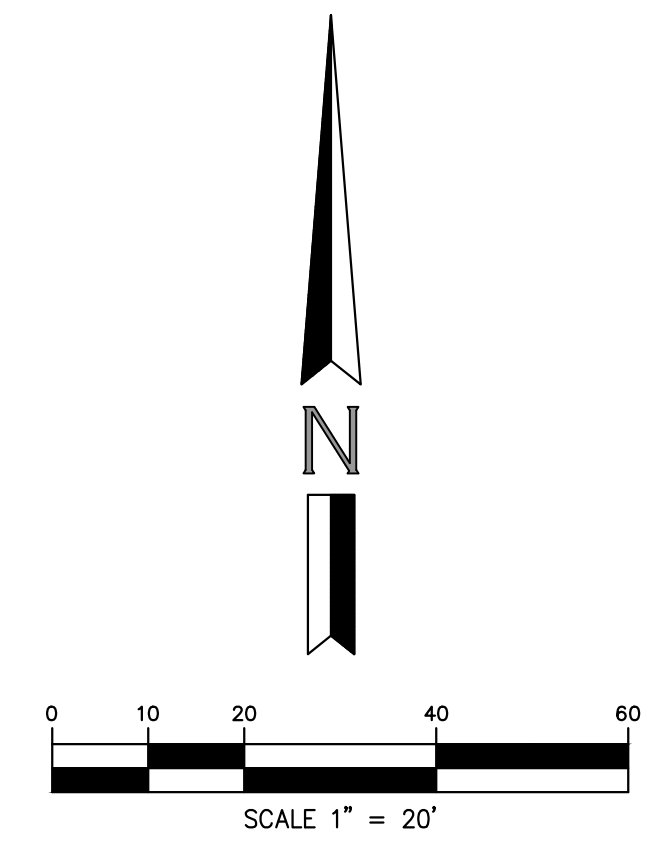
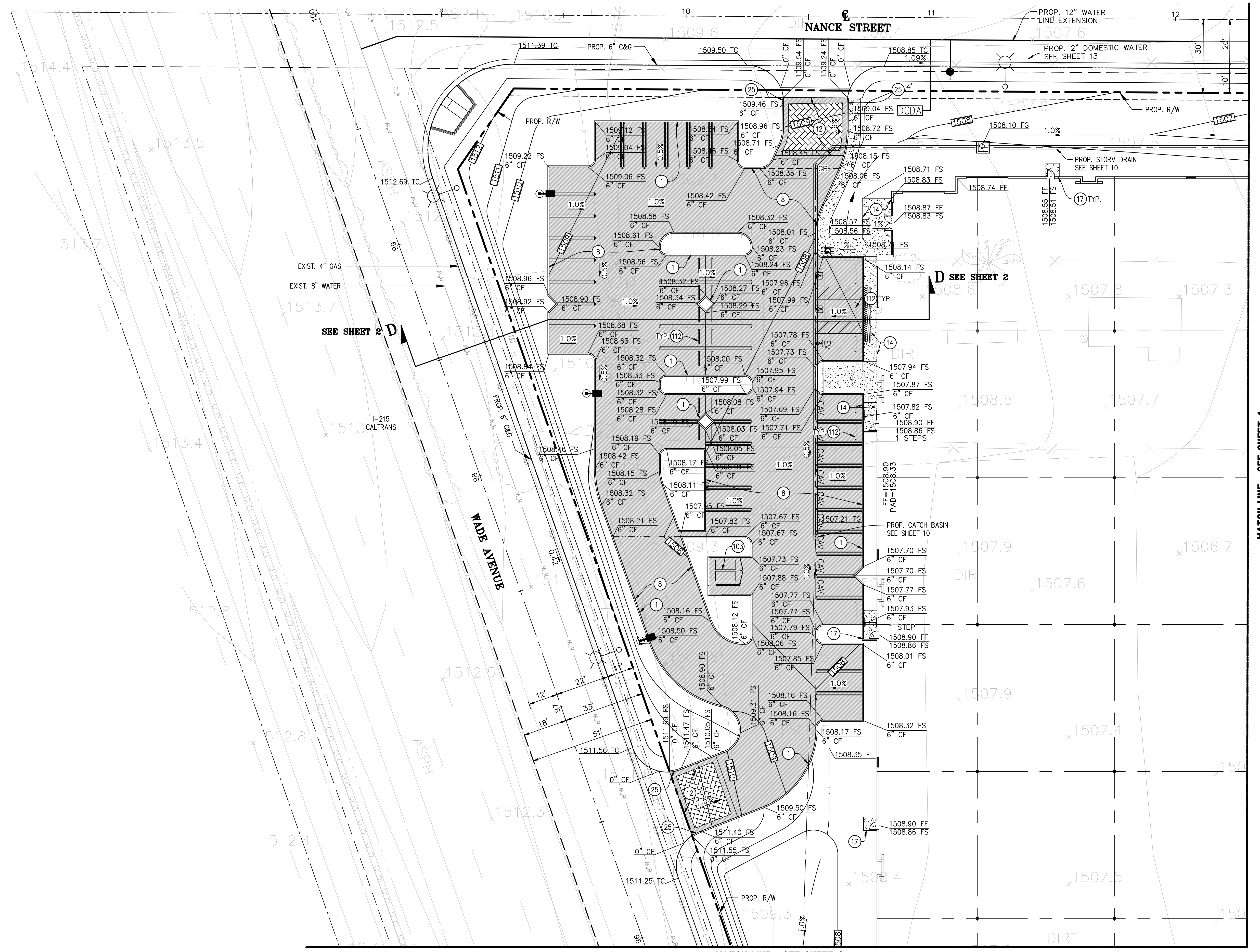

MATCH LINE - SEE SHEET 4

MATCH LINE - SEE SHEET 6

Underground Service Alert
Call: TOLL FREE 811
www.CALL811.COM
TWO WORKING DAYS BEFORE YOU DIG

NOTE:
WORK CONTAINED WITHIN THESE PLANS SHALL NOT COMMENCE UNTIL AN ENCROACHMENT PERMIT AND/OR A GRADING PERMIT HAS BEEN ISSUED.
THE PRIVATE ENGINEER SIGNING THESE PLANS IS RESPONSIBLE FOR ASSURING THE ACCURACY AND ACCEPTABILITY OF THE DESIGN HEREON. IN THE EVENT OF DISCREPANCIES ARISING AFTER CITY APPROVAL OR DURING CONSTRUCTION, THE PRIVATE ENGINEER SHALL BE RESPONSIBLE FOR DETERMINING AN ACCEPTABLE SOLUTION AND REVISING THE PLANS FOR APPROVAL BY THE CITY.

BY	MARK	DESCRIPTION	APPR.	DATE

DESIGNED BY: D.L.W.
APPROVED BY: **CITY OF PERRIS**
DRAWN BY: H-Z STAFF
CHECKED BY: J.M.
SCALE: AS SHOWN



PREPARED UNDER THE SUPERVISION OF:
Johnny Murad, R.C.E. NO. 67512
EXPIRATION: 6-30-2023

HUITT-ZOLLARS
Huitt-Zollars, Inc. Ontario
3990 CONCOURS • SUITE 330 • ONTARIO, CALIFORNIA 91764
PHONE (909) 941-7799 • FAX (909) 941-7789

WDID NO. _____

CITY OF PERRIS

PRECISE GRADING PLAN

VESTING PARCEL MAP 38384 / DPR22-00003

FOR **PATTERSON COMMERCE CENTER** M.O. CITY FILE NO. **P8-1468**

SHEET **3**
OF **15** SHEETS

I:\p\p\38384\Design\031_DWG\3\PreciseGrading\031003-08.dwg, Layout: 03, Oct 16, 2022 6:00pm

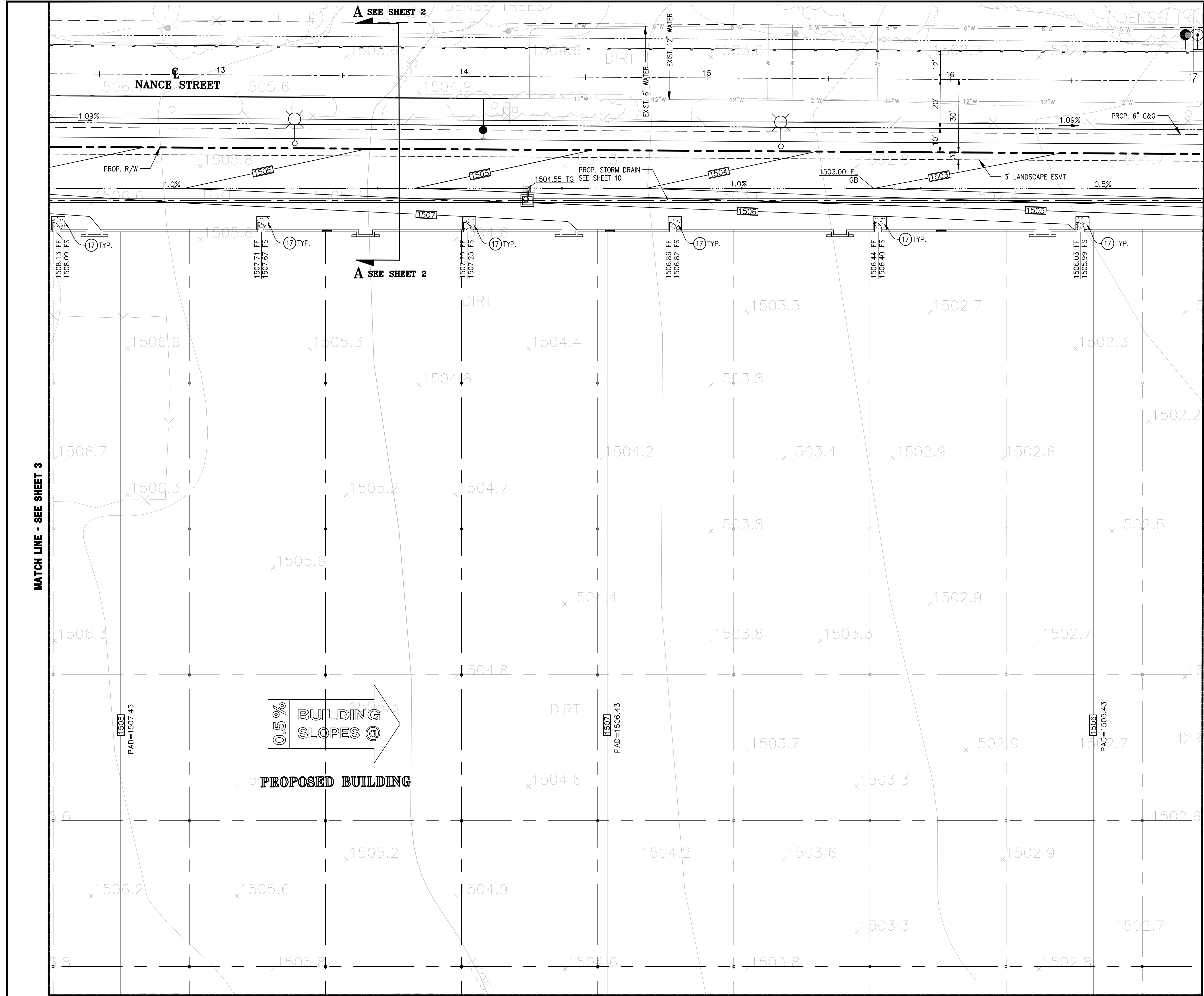

CONSTRUCTION NOTES
 (17) CONSTRUCT CONCRETE LANDING PER ARCHITECT PLANS, UNDER SEPARATE PERMIT

MATCH LINE - SEE SHEET 3

MATCH LINE - SEE SHEET 5



PROPOSED BUILDING

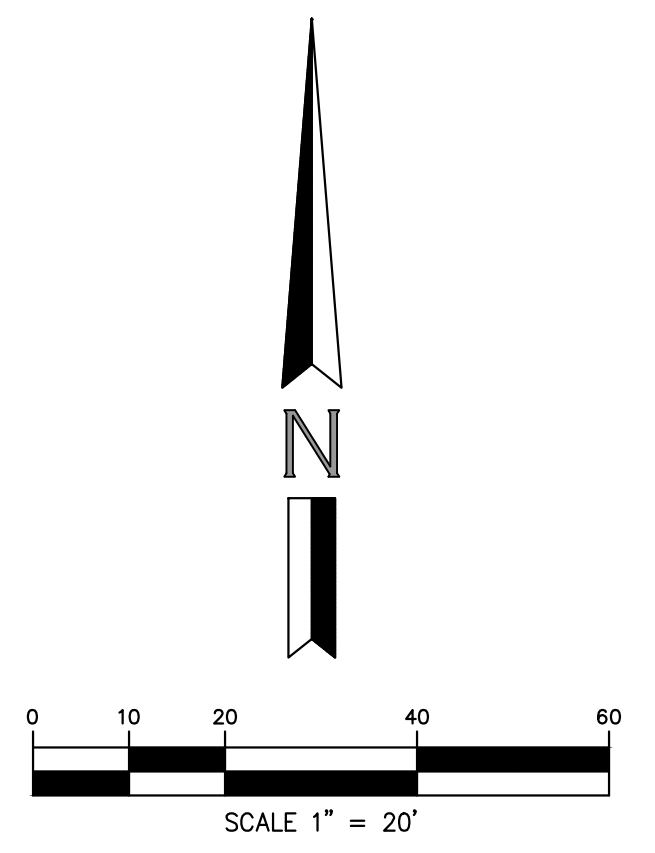

MATCH LINE - SEE SHEET 7

Underground Service Alert
 Call: TOLL FREE 811
 www.call811.com
 TWO WORKING DAYS BEFORE YOU DIG

NOTE:
 WORK CONTAINED WITHIN THESE PLANS SHALL NOT COMMENCE UNTIL AN ENCOACHMENT PERMIT AND/OR A GRADING PERMIT HAS BEEN ISSUED.
 THE PRIVATE ENGINEER SIGNING THESE PLANS IS RESPONSIBLE FOR ASSURING THE ACCURACY AND ACCEPTABILITY OF THE DESIGN HEREON. IN THE EVENT OF DISCREPANCIES ARISING AFTER CITY APPROVAL OR DURING CONSTRUCTION, THE PRIVATE ENGINEER SHALL BE RESPONSIBLE FOR DETERMINING AN ACCEPTABLE SOLUTION AND REVISIONS TO THE PLANS FOR APPROVAL BY THE CITY.

BY	MARK	DESCRIPTION	APPR.	DATE
ENGINEER		REVISIONS		CITY

DESIGNED BY: D.L.W.
 APPROVED BY: **CITY OF PERRIS**
 DRAWN BY: H-Z STAFF
 CHECKED BY: J.M.
 SCALE: AS SHOWN



PREPARED UNDER THE SUPERVISION OF:
 Johnny Murad, R.C.E. NO. 67512
 EXPIRATION: 6-30-2023

HUITT-ZOLLARS
 Huitt-Zollars, Inc. Ontario
 3990 CONCOURS • SUITE 330 • ONTARIO, CALIFORNIA 91764
 PHONE (909) 941-7799 • FAX (909) 941-7789

WDID NO. _____

CITY OF PERRIS

PRECISE GRADING PLAN

VESTING PARCEL MAP 38384 / DPR22-00003

FOR **PATTERSON COMMERCE CENTER** M.O. _____ CITY FILE NO. **P8-1468**

SHEET **4**
OF **15** SHEETS

I:\p\p\38384\38384.dwg - PreciseGrading\38384.dwg - Layout 04, Dec 16, 2022 6:00pm

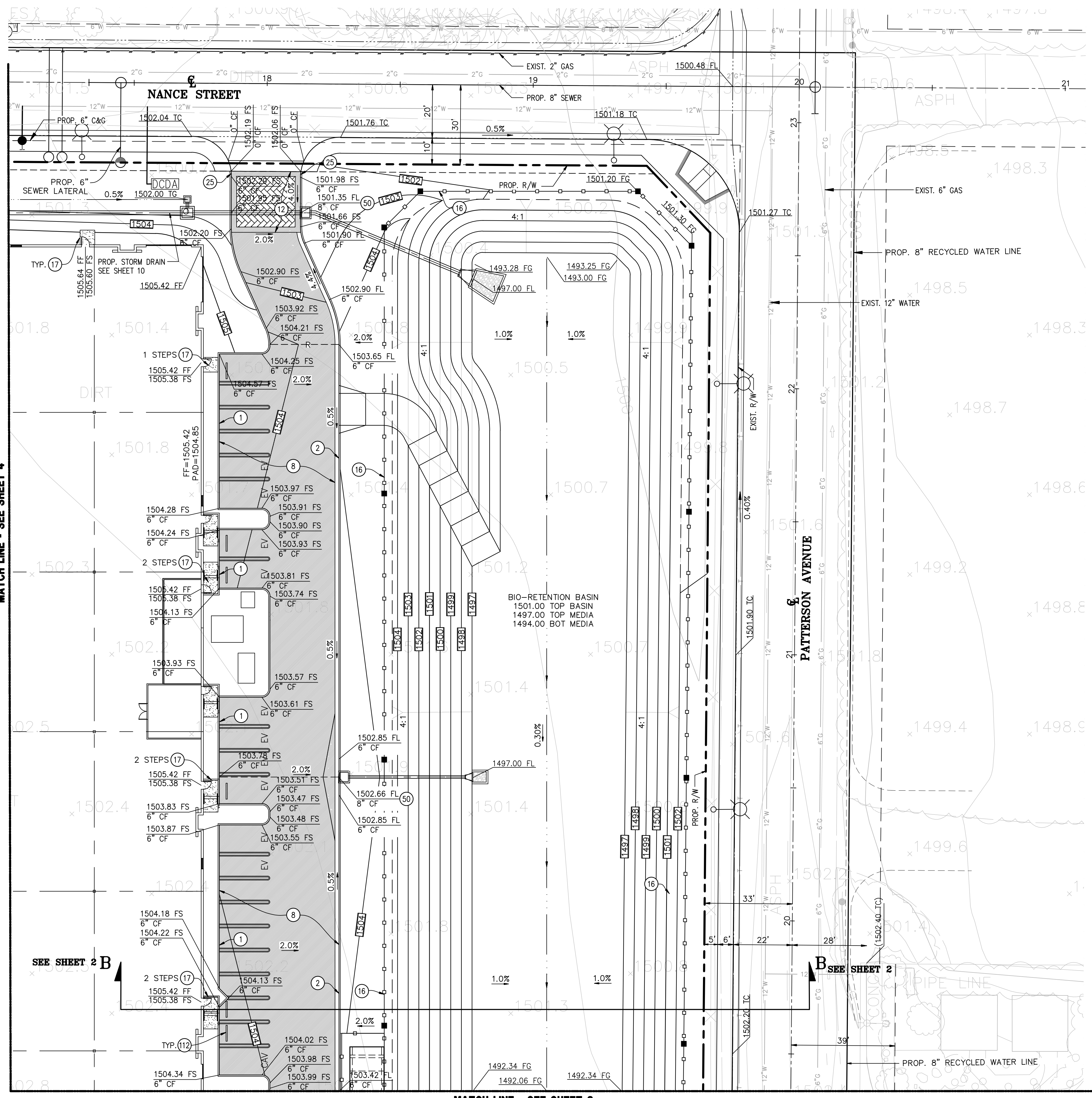

CONSTRUCTION NOTES

- ① CONSTRUCT 6" CONCRETE CURB PER DETAIL ON SHEET 2
- ② CONSTRUCT CONCRETE CURB AND GUTTER PER DETAIL ON SHEET 2
- ⑧ CONSTRUCT 5" PCC PAVEMENT OVER 12" SUBGRADE COMPACTED TO 95%
- ⑫ CONSTRUCT 6" DECORATIVE PCC PAVEMENT OVER 12" SUBGRADE COMPACTED TO 95% (SEE ARCHITECT PLAN FOR DETAILS)
- ⑯ INSTALL 4' TUBE STEEL FENCE PER ARCHITECT PLANS, UNDER SEPARATE PERMIT
- ⑰ CONSTRUCT CONCRETE LANDING PER ARCHITECT PLANS, UNDER SEPARATE PERMIT
- ⑳ CONSTRUCT 0" TO 6" CURB TRANSITION, 2' UNLESS OTHERWISE NOTED
- ㉑ CONSTRUCT LOCAL DEPRESSION PER DETAIL ON SHEET 2
- ㉒ INSTALL CONCRETE WHEEL STOP PER ARCHITECT PLANS, UNDER SEPARATE PERMIT

HATCH LEGEND

- PROP. 5" PCC PAVEMENT
- PROP. SIDEWALK

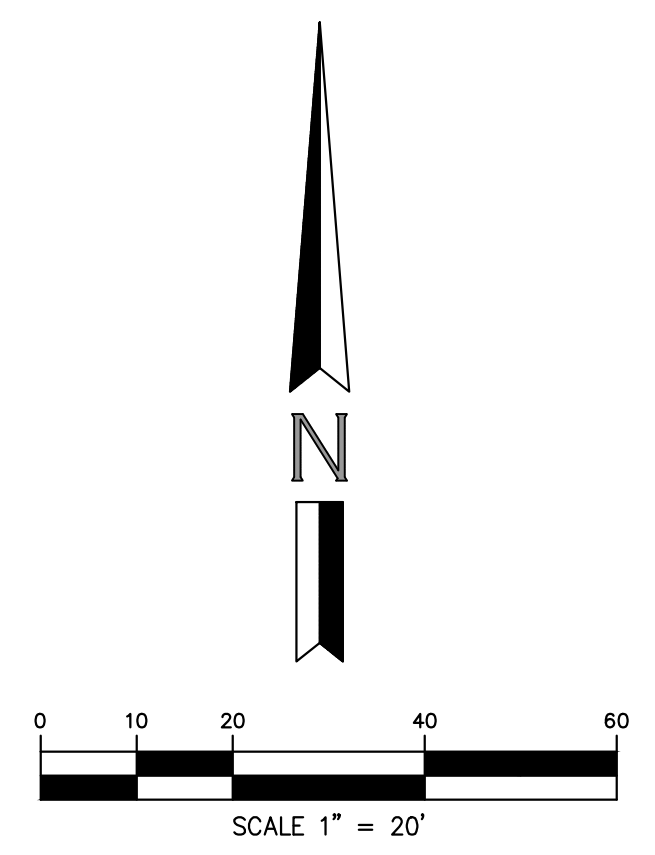

MATCH LINE - SEE SHEET 4

MATCH LINE - SEE SHEET 8

WDID NO. _____

Underground Service Alert

 Call: TOLL FREE
 811
 www.call811.com
 TWO WORKING DAYS BEFORE YOU DIG

NOTE:
 WORK CONTAINED WITHIN THESE PLANS SHALL NOT COMMENCE UNTIL AN ENCROACHMENT PERMIT AND/OR A GRADING PERMIT HAS BEEN ISSUED.
 THE PRIVATE ENGINEER SIGNING THESE PLANS IS RESPONSIBLE FOR ASSURING THE ACCURACY AND ACCEPTABILITY OF THE DESIGN HEREON. IN THE EVENT OF DISCREPANCIES ARISING AFTER CITY APPROVAL OR DURING CONSTRUCTION, THE PRIVATE ENGINEER SHALL BE RESPONSIBLE FOR DETERMINING AN ACCEPTABLE SOLUTION AND REVISING THE PLANS FOR APPROVAL BY THE CITY.

BY	MARK	DESCRIPTION	APPR.	DATE

DESIGNED BY: D.L.W.
 APPROVED BY: _____
 DRAWN BY: H-Z STAFF
 CHECKED BY: J.M.
 CITY OF PERRIS
 DATE: _____



PREPARED UNDER THE SUPERVISION OF:
 Johnny Murad, R.C.E. NO. 67512
 EXPIRATION: 6-30-2023
 DATE: _____

HUITT-ZOLLARS
 Huitt-Zollars, Inc. Ontario
 3990 CONCOURS • SUITE 330 • ONTARIO, CALIFORNIA 91764
 PHONE (909) 941-7799 • FAX (909) 941-7789

CITY OF PERRIS
PRECISE GRADING PLAN
VESTING PARCEL MAP 38384 / DPR22-00003
 SHEET **5** OF **15** SHEETS
 FOR **PATTERSON COMMERCE CENTER** M.O. CITY FILE NO. **P8-1468**

CONSTRUCTION NOTES

- 1 CONSTRUCT 6" CONCRETE CURB PER DETAIL ON SHEET 2
- 7 CONSTRUCT SCREEN WALL PER STRUCTURAL PLANS, UNDER SEPARATE PLAN & PERMIT
- 10 CONSTRUCT 6.5" PCC PAVEMENT OVER 12" SUBGRADE COMPACTED TO 95%
- 13 INSTALL TRUNCATED DOMES PER ADA CALIFORNIA BUILDING CODE AND PER DETAIL ON SHEET 2
- 17 CONSTRUCT CONCRETE LANDING PER ARCHITECT PLANS, UNDER SEPARATE PERMIT
- 22 CONSTRUCT 12" CURB PER DETAIL ON SHEET 2
- 37 CONSTRUCT EXTERIOR STAIR STRUCTURE PER ARCHITECT PLANS, UNDER SEPARATE PERMIT
- 52 WALL/RAMP PER ARCHITECT PLANS, UNDER SEPARATE PERMIT
- 113 CONSTRUCT 6" TO 12" CURB TRANSITION

HATCH LEGEND

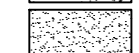
-  PROP. 6.5" PCC PAVEMENT
-  PROP. SIDEWALK

MATCH LINE - SEE SHEET 3

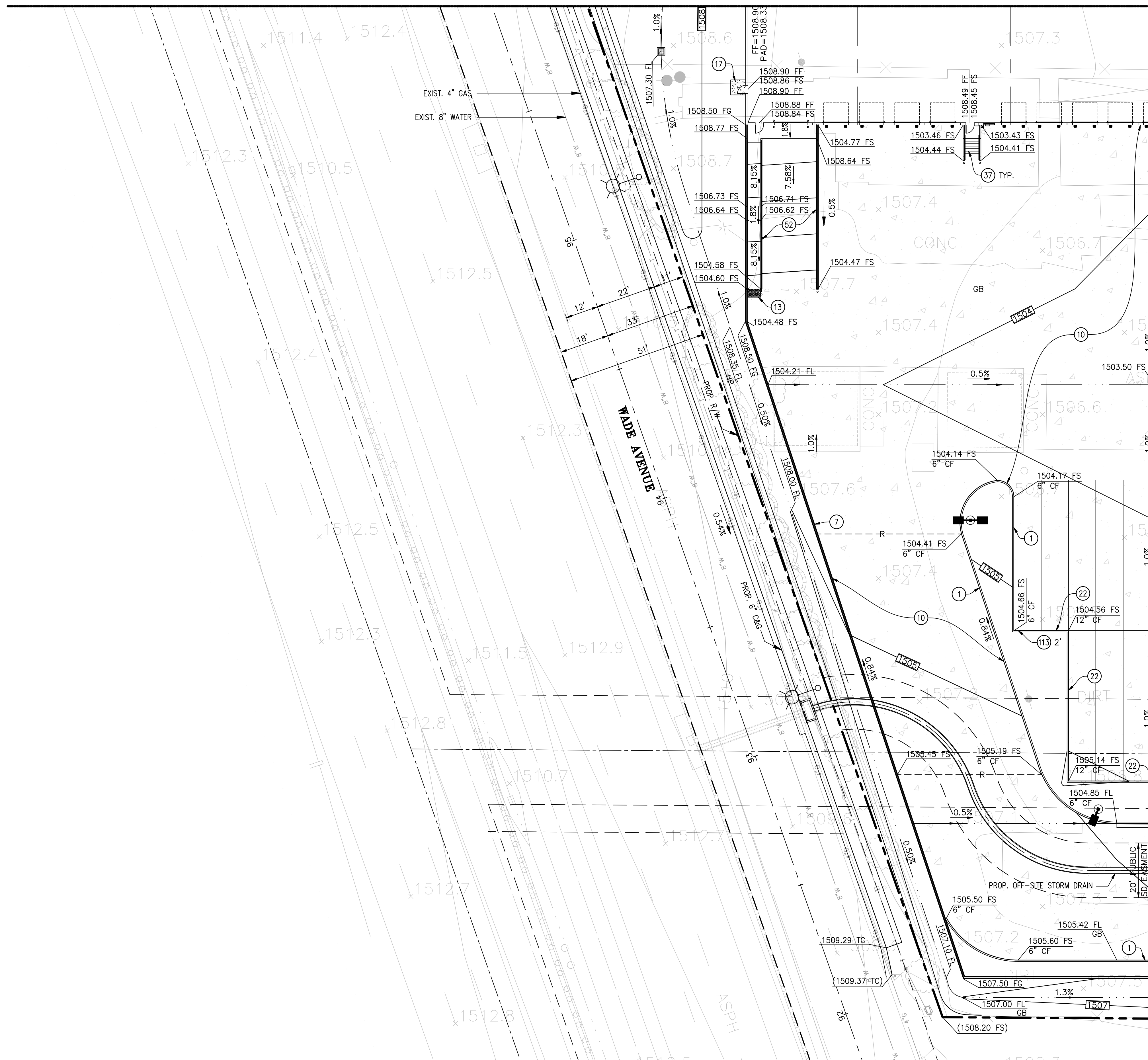

MATCH LINE - SEE SHEET 7

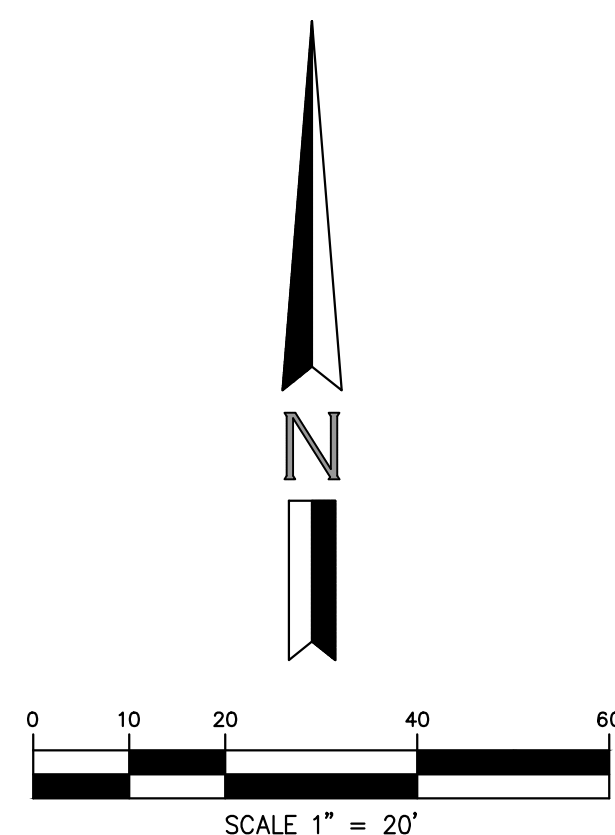

WDID NO. _____

Underground Service Alert

Call: TOLL FREE 811
www.call811.com
TWO WORKING DAYS BEFORE YOU DIG

NOTE:
WORK CONTAINED WITHIN THESE PLANS SHALL NOT COMMENCE UNTIL AN ENCROACHMENT PERMIT AND/OR A GRADING PERMIT HAS BEEN ISSUED.
THE PRIVATE ENGINEER SIGNING THESE PLANS IS RESPONSIBLE FOR ASSURING THE ACCURACY AND ACCEPTABILITY OF THE DESIGN HEREON. IN THE EVENT OF DISCREPANCIES ARISING AFTER CITY APPROVAL OR DURING CONSTRUCTION, THE PRIVATE ENGINEER SHALL BE RESPONSIBLE FOR DETERMINING AN ACCEPTABLE SOLUTION AND REVISING THE PLANS FOR APPROVAL BY THE CITY.

BY	MARK	DESCRIPTION	APPR.	DATE
REVISIONS				

DESIGNED BY: D.L.W.
APPROVED BY: **CITY OF PERRIS**
DRAWN BY: H-Z STAFF
CITY OF PERRIS
CHECKED BY: J.M.
DATE: _____



PREPARED UNDER THE SUPERVISION OF:
Johnny Murad, R.C.E. NO. 67512
EXPIRATION: 6-30-2023
DATE: _____

HUITT-ZOLLARS
Huitt-Zollars, Inc. Ontario
3990 CONCOURS • SUITE 330 • ONTARIO, CALIFORNIA 91764
PHONE (909) 941-7799 • FAX (909) 941-7789

CITY OF PERRIS
PRECISE GRADING PLAN
VESTING PARCEL MAP 38384 / DPR22-00003
FOR **PATTERSON COMMERCE CENTER** M.O. CITY FILE NO. **P8-1468**

SHEET **6**
OF **15** SHEETS

I:\p\p\38384\Design\031_DWG's\PreciseGrading\0303-08.dwg, Layout: 16, Oct 16, 2022 6:08pm

MATCH LINE - SEE SHEET 4

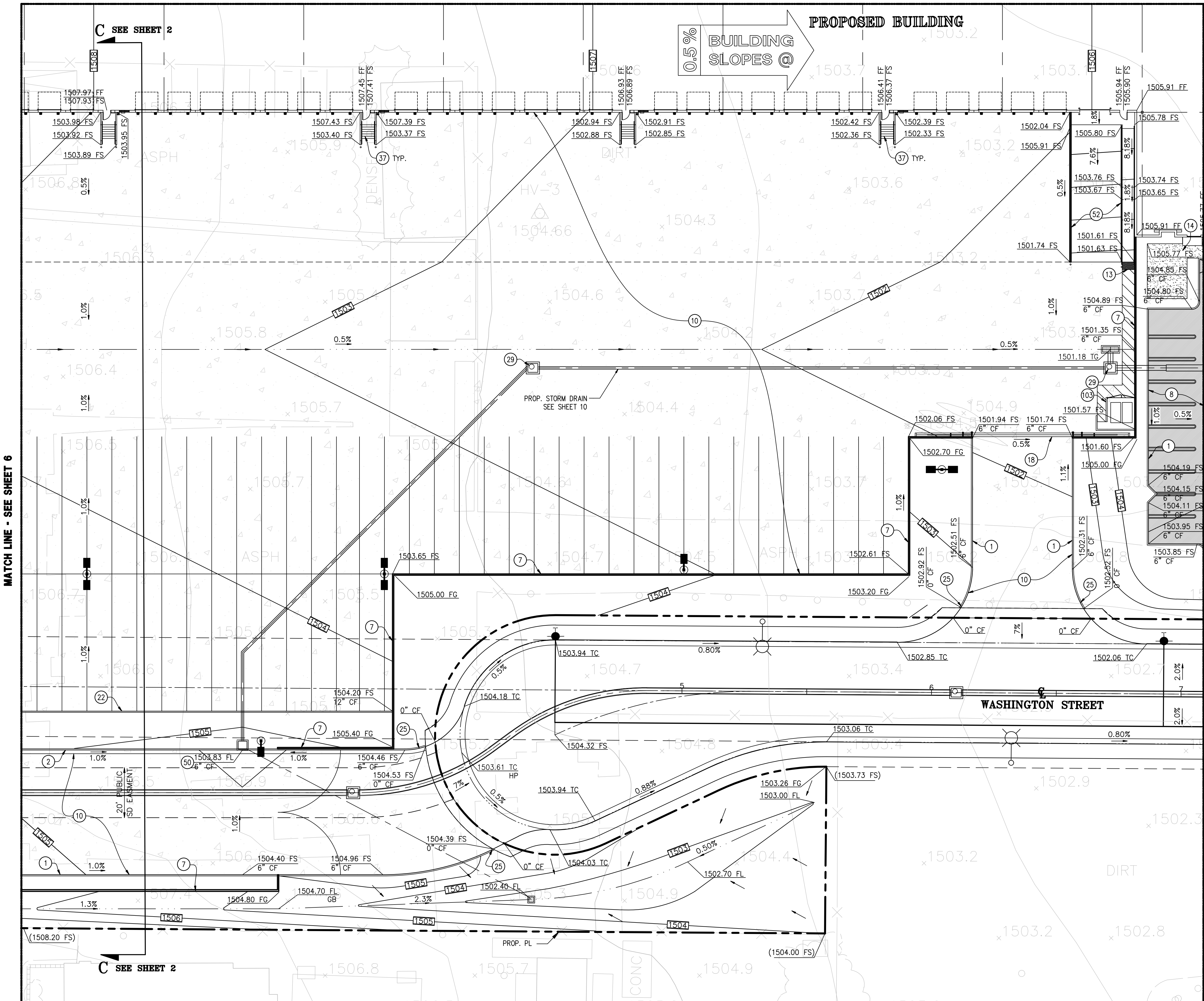

CONSTRUCTION NOTES

- 1 CONSTRUCT 6" CONCRETE CURB PER DETAIL ON SHEET 2
- 2 CONSTRUCT CONCRETE CURB AND GUTTER PER DETAIL ON SHEET 2
- 3 CONSTRUCT SCREEN WALL PER STRUCTURAL PLANS, UNDER SEPARATE PLAN & PERMIT
- 4 CONSTRUCT 5" PCC PAVEMENT OVER 12" SUBGRADE COMPACTED TO 95%
- 5 CONSTRUCT 6.5" PCC PAVEMENT OVER 12" SUBGRADE COMPACTED TO 95%
- 6 INSTALL TRUNCATED DORIES PER ADA CALIFORNIA BUILDING CODE AND PER DETAIL ON SHEET 2
- 7 CONSTRUCT CONCRETE LANDING PER ARCHITECT PLANS, UNDER SEPARATE PERMIT
- 8 INSTALL GATE PER ARCHITECT PLANS, UNDER SEPARATE PERMIT
- 9 CONSTRUCT 12" CURB PER DETAIL ON SHEET 2
- 10 CONSTRUCT 0" TO 6" CURB TRANSITION, 2' UNLESS OTHERWISE NOTED
- 11 ADJUST MANHOLE RIM TO GRADE AFTER FINAL PAVING HAS BEEN INSTALLED
- 12 CONSTRUCT EXTERIOR STAIR STRUCTURE PER ARCHITECT PLANS, UNDER SEPARATE PERMIT
- 13 CONSTRUCT LOCAL DEPRESSION PER DETAIL ON SHEET 2
- 14 WALL/RAMP PER ARCHITECT PLANS, UNDER SEPARATE PERMIT
- 15 CONSTRUCT TRASH ENCLOSURE PER ARCHITECT PLANS, UNDER SEPARATE PERMIT

HATCH LEGEND

- PROP. 5" PCC PAVEMENT
- PROP. 6.5" PCC PAVEMENT
- PROP. SIDEWALK

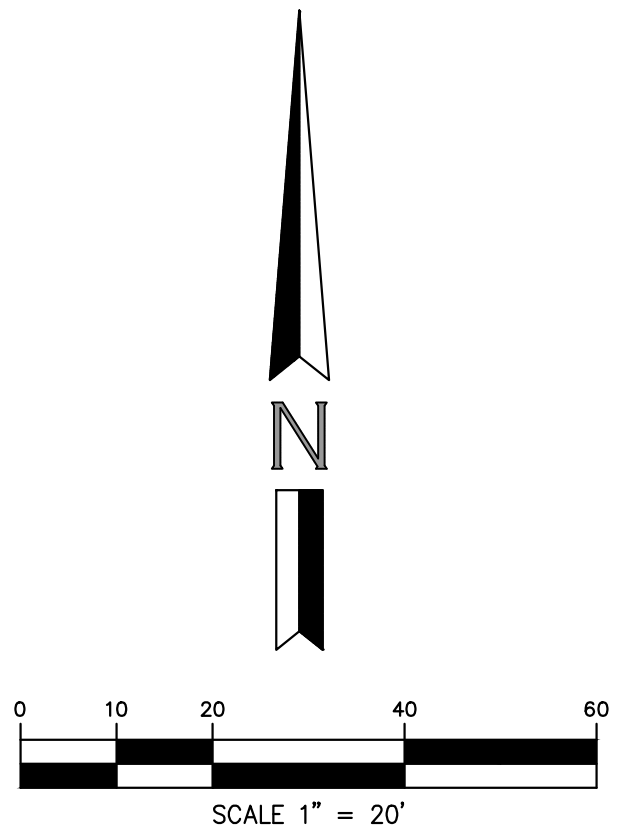

MATCH LINE - SEE SHEET 6

MATCH LINE - SEE SHEET 8

Underground Service Alert
 Call: TOLL FREE 811
 www.call811.com
 TWO WORKING DAYS BEFORE YOU DIG

NOTE:
 WORK CONTAINED WITHIN THESE PLANS SHALL NOT COMMENCE UNTIL AN ENCROACHMENT PERMIT AND/OR A GRADING PERMIT HAS BEEN ISSUED.
 THE PRIVATE ENGINEER SIGNING THESE PLANS IS RESPONSIBLE FOR ASSURING THE ACCURACY AND ACCEPTABILITY OF THE DESIGN HEREON. IN THE EVENT OF DISCREPANCIES ARISING AFTER CITY APPROVAL OR DURING CONSTRUCTION, THE PRIVATE ENGINEER SHALL BE RESPONSIBLE FOR DETERMINING AN ACCEPTABLE SOLUTION AND REVISING THE PLANS FOR APPROVAL BY THE CITY.

BY	MARK	DESCRIPTION	APPR.	DATE
		REVISIONS		

DESIGNED BY: D.L.W.
 APPROVED BY: CITY OF PERRIS
 DRAWN BY: H-Z STAFF
 CHECKED BY: J.M.
 SCALE: AS SHOWN



PREPARED UNDER THE SUPERVISION OF:
 Johnny Murad, R.C.E. NO. 67512
 EXPIRATION: 6-30-2023

HUITT-ZOLLARS
 Huitt-Zollars, Inc. Ontario
 3990 CONCOURS • SUITE 330 • ONTARIO, CALIFORNIA 91764
 PHONE (909) 941-7799 • FAX (909) 941-7789

CITY OF PERRIS
PRECISE GRADING PLAN
 VESTING PARCEL MAP 38384 / DPR22-00003
 SHEET **7** OF **15** SHEETS
 CITY FILE NO. **P8-1468**

MATCH LINE - SEE SHEET 5

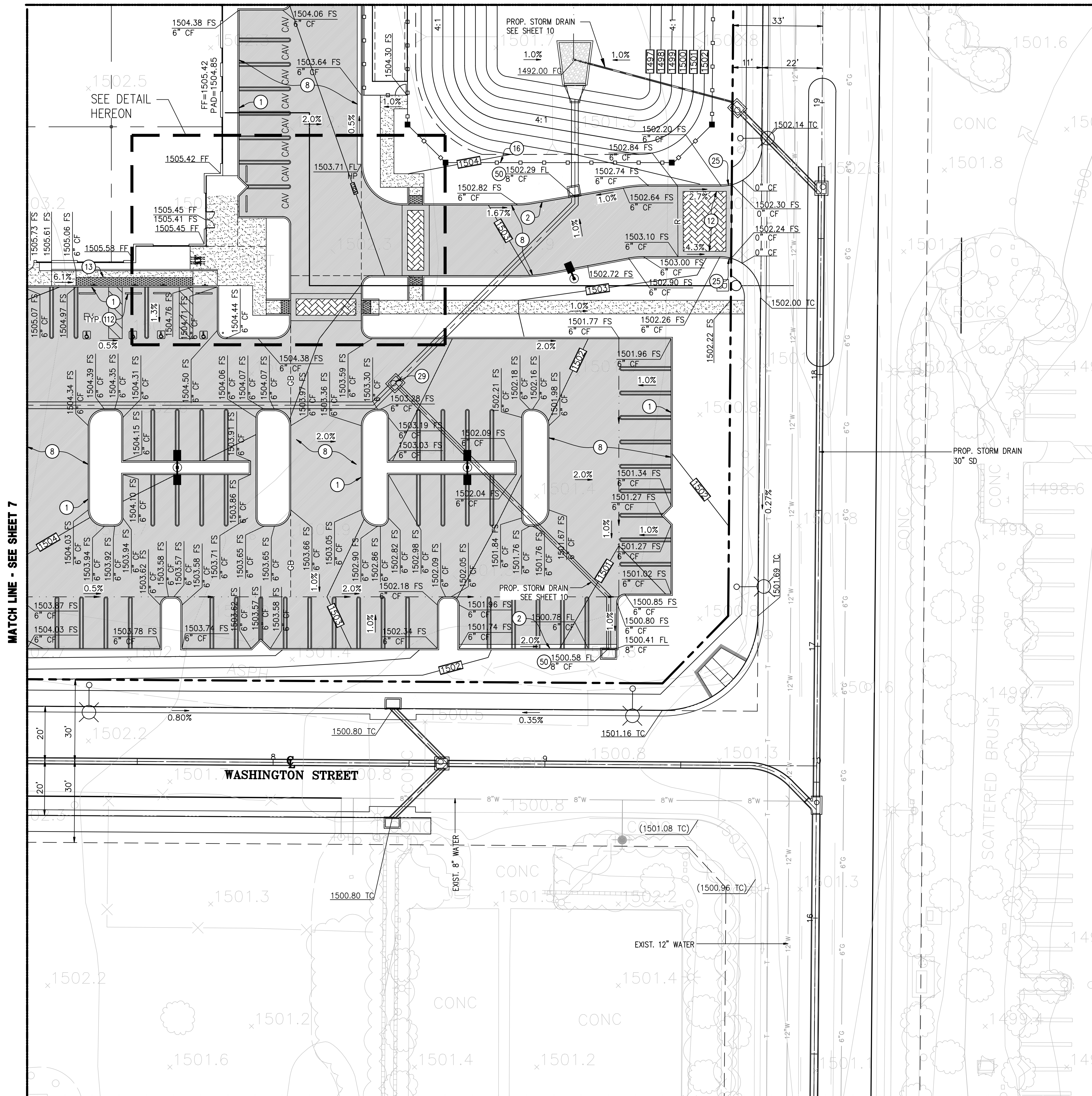

CONSTRUCTION NOTES

- 1 CONSTRUCT 6" CONCRETE CURB PER DETAIL ON SHEET 2
- 2 CONSTRUCT CONCRETE CURB AND GUTTER PER DETAIL ON SHEET 2
- 6 CONSTRUCT CURB RAMP PER DETAIL ON SHEET 2
- 8 CONSTRUCT 5" PCC PAVEMENT OVER 12" SUBGRADE COMPACTED TO 95%
- 12 CONSTRUCT 6" DECORATIVE PCC PAVEMENT OVER 12" SUBGRADE COMPACTED TO 95% (SEE ARCHITECT PLAN FOR DETAILS)
- 13 INSTALL TRUNCATED DOMES PER ADA CALIFORNIA BUILDING CODE AND PER DETAIL ON SHEET 2
- 16 INSTALL 4' TUBE STEEL FENCE PER ARCHITECT PLANS, UNDER SEPARATE PERMIT
- 14 CONSTRUCT 4" CONCRETE SIDEWALK
- 25 CONSTRUCT 0" TO 6" CURB TRANSITION, 2' UNLESS OTHERWISE NOTED
- 29 ADJUST MANHOLE RIM TO GRADE AFTER FINAL PAVING HAS BEEN INSTALLED
- 50 CONSTRUCT LOCAL DEPRESSION PER DETAIL ON SHEET 2
- 17 INSTALL CONCRETE WHEEL STOP PER ARCHITECT PLANS, UNDER SEPARATE PERMIT

HATCH LEGEND

- PROP. 5" PCC PAVEMENT
- PROP. SIDEWALK

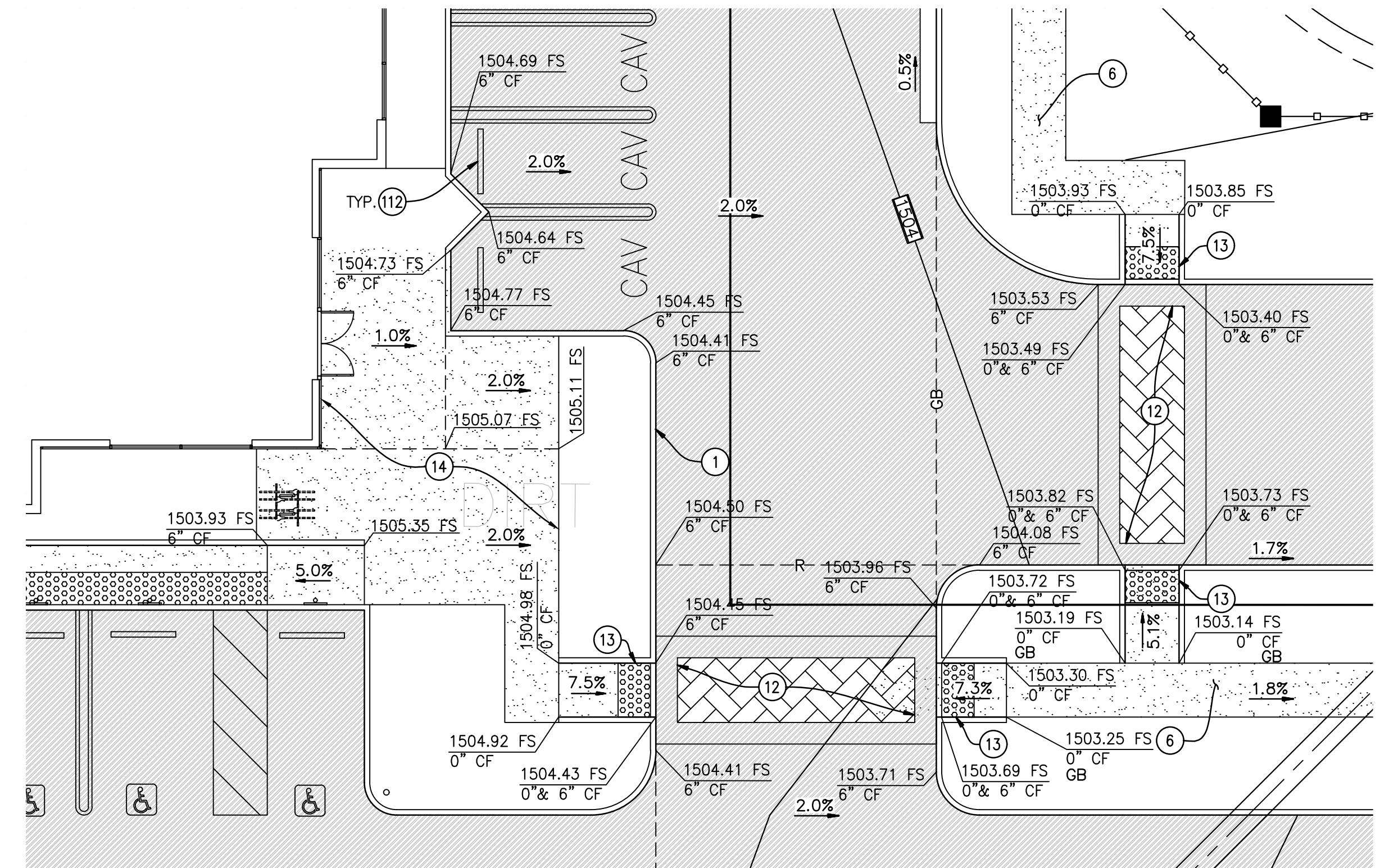

1 DETAIL
1"=10'

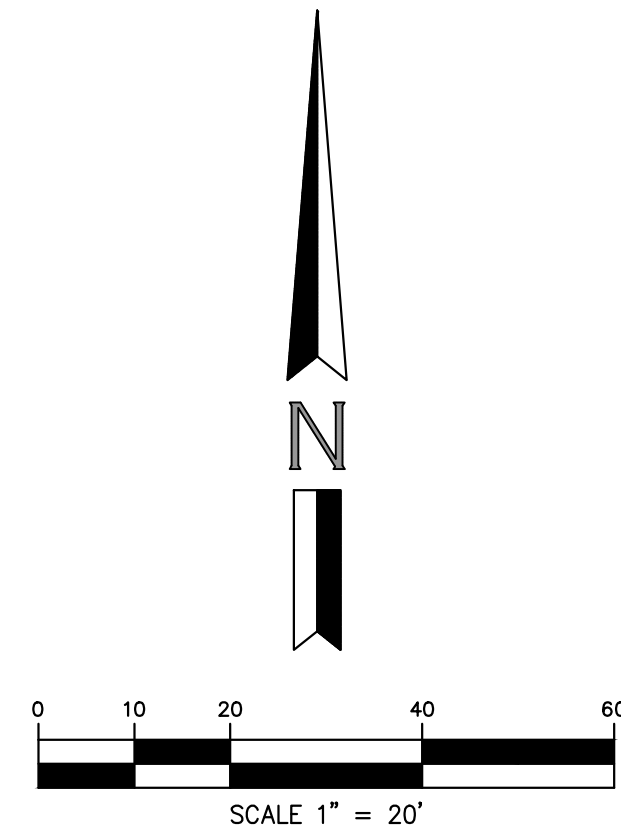

Underground Service Alert
Call: TOLL FREE 811
www.call811.com
TWO WORKING DAYS BEFORE YOU DIG

NOTE:
WORK CONTAINED WITHIN THESE PLANS SHALL NOT COMMENCE UNTIL AN ENCROACHMENT PERMIT AND/OR A GRADING PERMIT HAS BEEN ISSUED.
THE PRIVATE ENGINEER SIGNING THESE PLANS IS RESPONSIBLE FOR ASSURING THE ACCURACY AND ACCEPTABILITY OF THE DESIGN HEREON. IN THE EVENT OF DISCREPANCIES ARISING AFTER CITY APPROVAL OR DURING CONSTRUCTION, THE PRIVATE ENGINEER SHALL BE RESPONSIBLE FOR DETERMINING AN ACCEPTABLE SOLUTION AND REVISING THE PLANS FOR APPROVAL BY THE CITY.

BY	MARK	DESCRIPTION	APPR.	DATE
		REVISIONS		

DESIGNED BY: D.L.W.
APPROVED BY: **CITY OF PERRIS**
DRAWN BY: H-Z STAFF
CITY OF PERRIS
CHECKED BY: J.M.
DATE: _____
SCALE: AS SHOWN

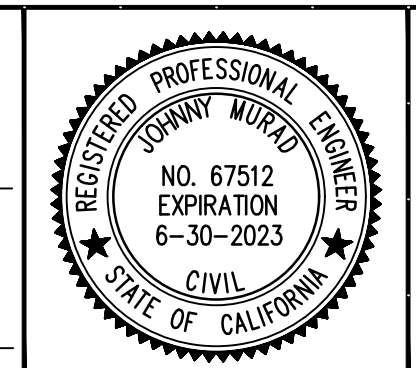

PREPARED UNDER THE SUPERVISION OF:
Johnny Murad, R.C.E. NO. 67512
EXPIRATION: 6-30-2023
DATE: _____

HUITT-ZOLLARS
Huitt-Zollars, Inc. Ontario
3990 CONCOURS • SUITE 330 • ONTARIO, CALIFORNIA 91764
PHONE (909) 941-7799 • FAX (909) 941-7789

CITY OF PERRIS
PRECISE GRADING PLAN
VESTING PARCEL MAP 38384 / DPR22-00003
FOR **PATTERSON COMMERCE CENTER** M.O.
SHEET **8** OF **15** SHEETS
CITY FILE NO. **P8-1468**

L:\pvg\38384\38384.dwg - Name: In\UG Design\UG1 - Dwg's\Process\Grading\UG03-38.dwg, Layout: 08, Oct 16, 2022 6:56pm
 DWID NO. _____

STORM DRAIN CONSTRUCTION NOTES & QUANTITIES

QTY	DESCRIPTION
01	CONSTRUCT BIORETENTION BASIN PER DETAIL ON SHEET 9
04	INSTALL 6" PVC SDR35 PIPE
06	INSTALL ADS N-12 12" HDPE PIPE PER TRENCH INSTALLATION DETAIL ON SHEET 9
07	INSTALL ADS N-12 18" HDPE PIPE PER TRENCH INSTALLATION DETAIL ON SHEET 9
09	INSTALL ADS N-12 24" HDPE PIPE PER TRENCH INSTALLATION DETAIL ON SHEET 9
10	INSTALL ADS N-12 30" HDPE PIPE PER TRENCH INSTALLATION DETAIL ON SHEET 9
13	INSTALL ADS N-12 12" 45° HDPE BEND (1297AN65BB-WT)
13	INSTALL ADS N-12 18" 45° HDPE BEND (1897AN65BB-WT)
13	INSTALL ADS N-12 30" 45° HDPE BEND (3097AN65BB)
04	CONSTRUCT 12" CMP INLET PER DETAIL ON SHEET 9
04	CONSTRUCT CURB OPENING CATCH BASIN PER SPPWC STD. PLAN 300-3, W PER PLAN
03	CONSTRUCT CURBSIDE GRATING CATCH BASIN PER SPPWC STD. PLAN 305-3 (SEE PLAN FOR NUMBER OF GRATES)
07	CONSTRUCT MANHOLE PER SPPWC STD. PLAN 321-2
04	INSTALL BROOKS 24"x24" CATCH BASIN W/ STEEL GRATE PER DETAIL ON SHEET 9 OR APPROVED EQUAL
04	CONSTRUCT STORM DRAIN CLEANOUT FOR BASIN PER DETAIL ON SHEET 9
04	INSTALL 6" PVC SCHEDULE 40 PERFORATED PIPE, WITH 1/2" PERFORATIONS
01	CONSTRUCT RIP RAP & CUT-OFF WALL PER DETAIL ON SHEET 9
01	INSTALL ADS N-12 30"x24" REDUCER (3077AN65B)
03	INSTALL ADS FLARED END SECTION, PIPE DIAMETER PER PLAN

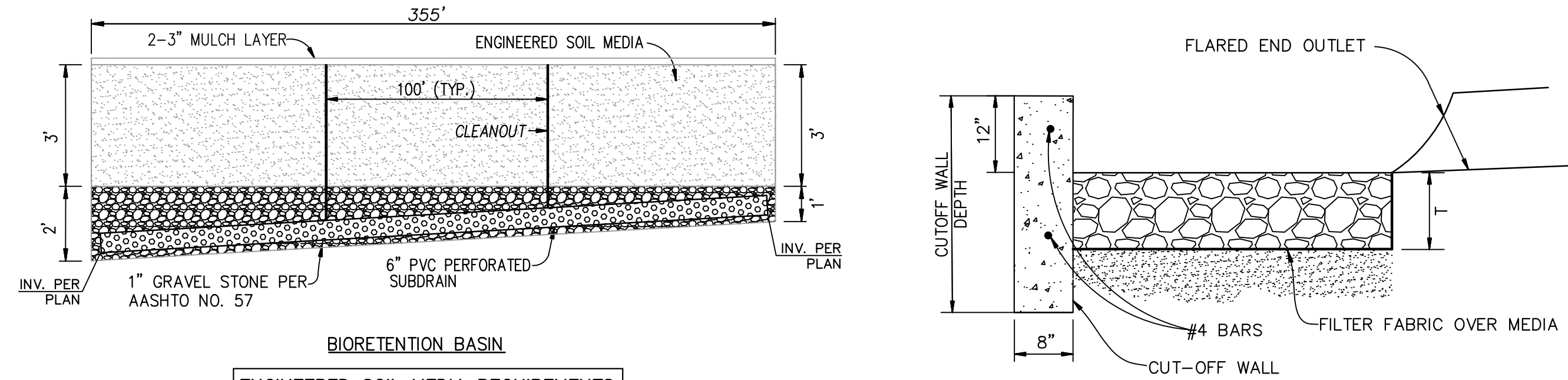

BIORETENTION BASIN

PERCENT RANGE	COMPONENT
70-80	SAND
15-20	SILT
5-10	CLAY

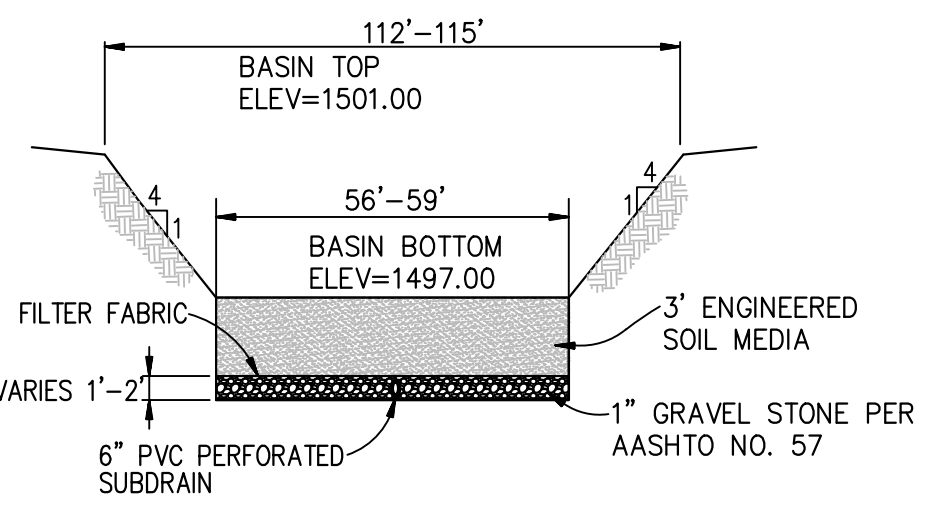

D1 BIORETENTION DETAIL
NOT TO SCALE

LINE	LENGTH	UPSTREAM WIDTH	DOWNSTREAM WIDTH	THICKNESS (T)	CUTOFF WALL DEPTH	ROCK CLASS
A	15'	8'	12'	1'	2.5'	NO. 2 BACKING
B	10'	6'	8'	1'	2.5'	NO. 2 BACKING
C	5'	4'	4'	1'	2.5'	NO. 2 BACKING

D125 RIP RAP AND CUT OFF WALL DETAIL
NOT TO SCALE

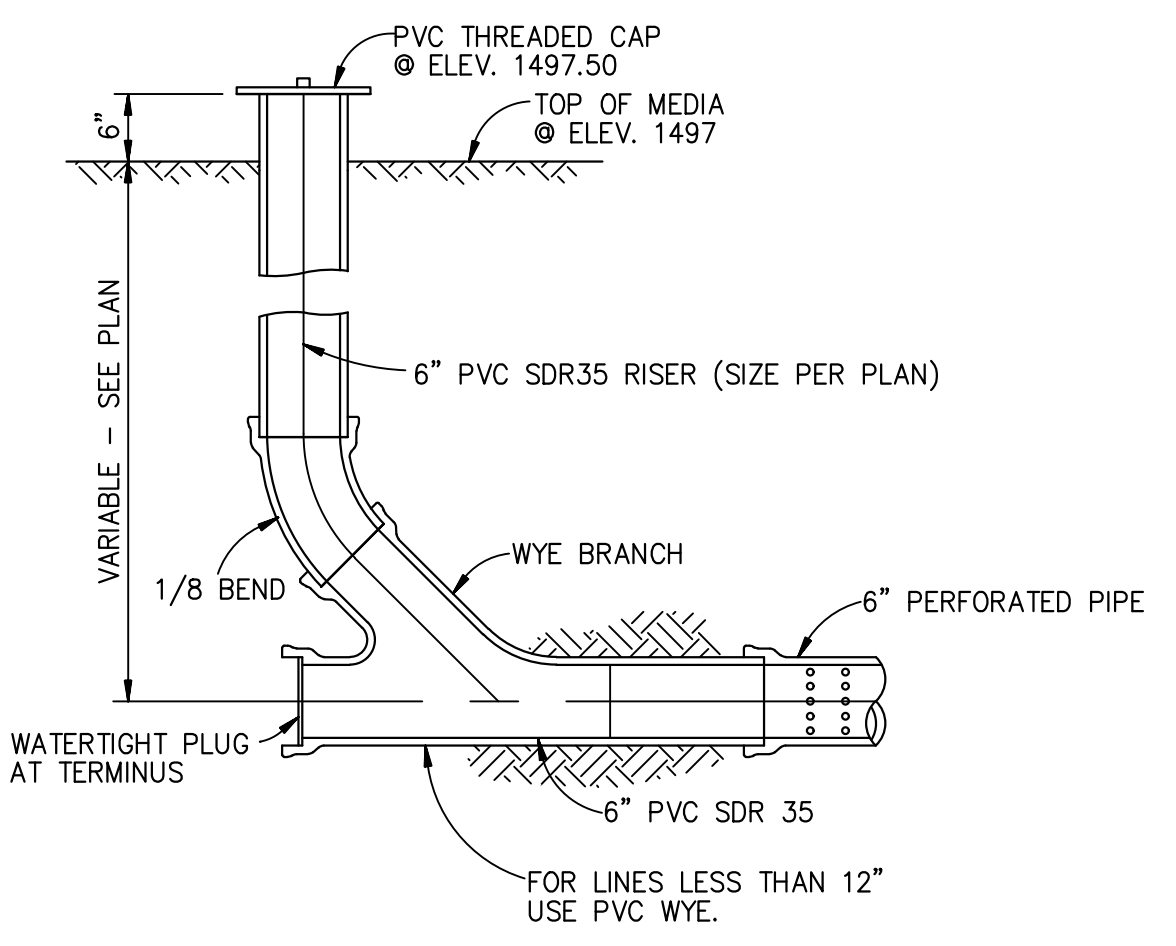

D69 STORM DRAIN CLEANOUT
NOT TO SCALE

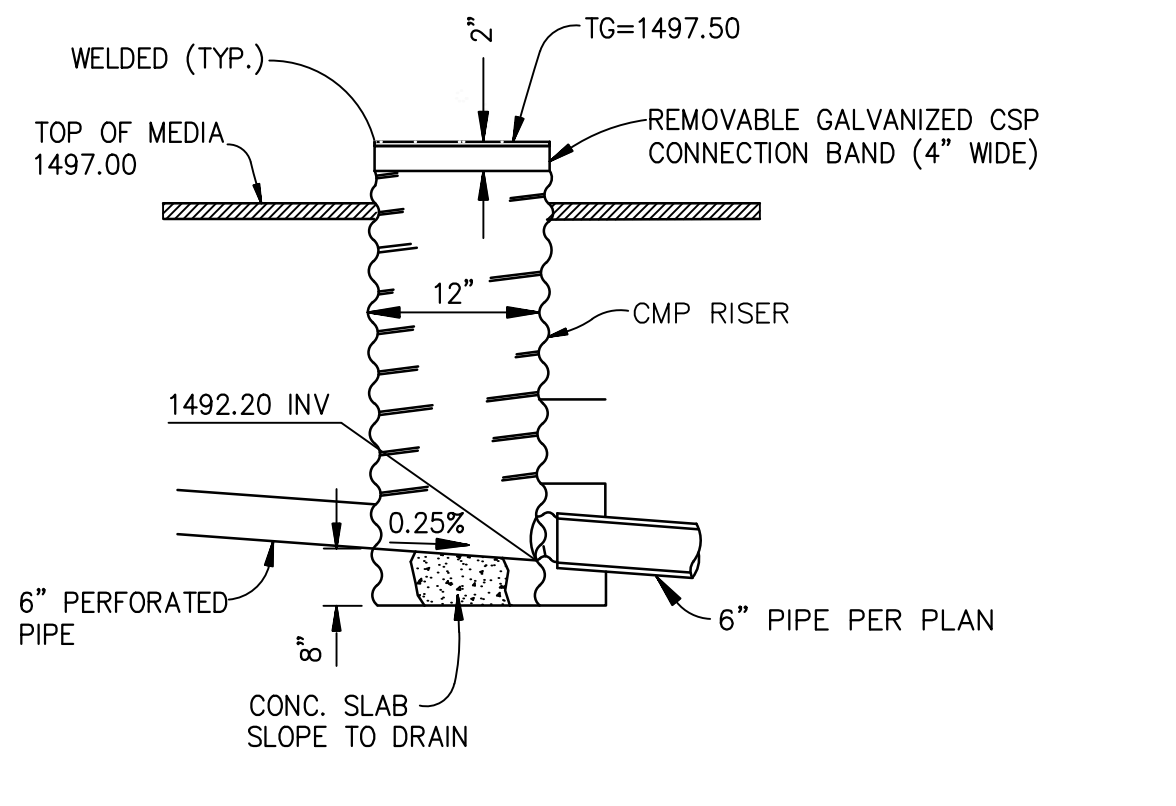

D48 CMP RISER DETAIL
NOT TO SCALE

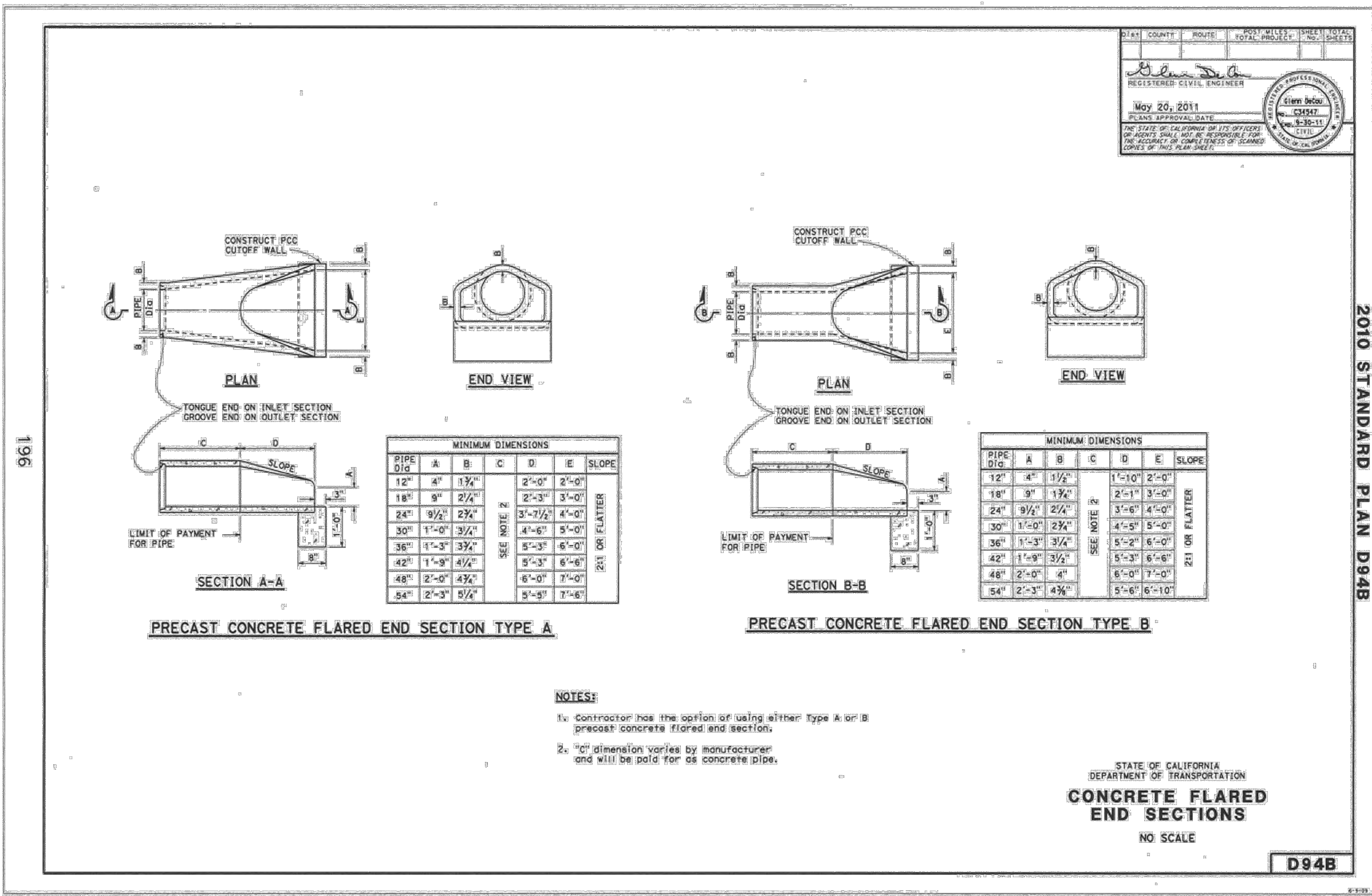

D199 CALTRANS FLARED END SECTION
NOT TO SCALE

THE MANUFACTURER'S REPRESENTATIVE SHALL INSPECT THESE FACILITIES AND CERTIFY PRIOR TO CITY ISSUANCE OF OCCUPANCY PERMIT

RECOMMENDED MINIMUM TRENCH WIDTHS

PIPE DIAM.	MIN. TRENCH WIDTH
4" (100mm)	21"
6" (150mm)	23"
8" (200mm)	25"
10" (250mm)	29"
12" (300mm)	31"
18" (450mm)	39"
24" (600mm)	45"
30" (750mm)	51"
36" (900mm)	57"
42" (1050mm)	63"
48" (1200mm)	69"
54" (1350mm)	75"

MINIMUM RECOMMENDED COVER BASED ON VEHICLE LOADING CONDITIONS

PIPE DIAM.	H-25 SURFACE LIVE LOADING CONDITION (75T AXLE LOAD)	HEAVY CONSTRUCTION (75T AXLE LOAD)
12" - 48" (300mm - 1200mm)	12"	48"
150mm - 1524mm	305mm	1219mm

MAXIMUM RECOMMENDED COVER BASED ON VEHICLE LOADING CONDITIONS

PIPE DIAM.	CLASS I	CLASS II	CLASS III
4" (100mm)	34 (10.4m)	16 (4.9m)	17 (5.2m)
6" (150mm)	40 (12.2m)	19 (5.8m)	20 (6.1m)
8" (200mm)	46 (13.9m)	22 (6.7m)	23 (7.0m)
10" (250mm)	52 (15.7m)	25 (7.6m)	26 (7.9m)
12" (300mm)	58 (17.5m)	28 (8.5m)	29 (9.1m)
18" (450mm)	70 (21.3m)	34 (10.4m)	35 (10.7m)
24" (600mm)	82 (25.0m)	41 (12.4m)	42 (12.7m)
30" (750mm)	94 (28.7m)	48 (14.6m)	49 (14.9m)
36" (900mm)	106 (32.4m)	56 (16.9m)	57 (17.2m)
42" (1050mm)	118 (36.1m)	64 (19.3m)	65 (19.6m)
48" (1200mm)	130 (39.8m)	72 (21.6m)	73 (21.9m)
54" (1350mm)	142 (43.5m)	80 (23.9m)	81 (24.2m)

NOTES:

- ALL PIPE SYSTEMS SHALL BE INSTALLED IN ACCORDANCE WITH ASTM D2321, "STANDARD PRACTICE FOR UNDERGROUND INSTALLATION OF THERMOPLASTIC PIPE FOR SEWERS AND OTHER GRAVITY FLOW APPLICATIONS," LATEST EDITION.
- MEASURES SHOULD BE TAKEN TO PREVENT MIGRATION OF NATIVE FINES INTO BACKFILL MATERIAL, WHEN REQUIRED.
- FOUNDATION: WHERE THE TRENCH BOTTOM IS UNSTABLE, THE CONTRACTOR SHALL EXCAVATE TO A DEPTH REQUIRED BY THE ENGINEER AND REPLACE WITH SUITABLE MATERIAL AS SPECIFIED BY THE ENGINEER. AS AN ALTERNATIVE AND AT THE DISCRETION OF THE DESIGN ENGINEER, THE TRENCH BOTTOM MAY BE STABILIZED USING A GEOTEXTILE MATERIAL.
- BEDDING: SUITABLE MATERIAL SHALL BE CLASS I, II OR III. THE CONTRACTOR SHALL PROVIDE DOCUMENTATION FOR MATERIAL SPECIFICATION TO ENGINEER, UNLESS OTHERWISE NOTED BY THE ENGINEER. MINIMUM BEDDING THICKNESS SHALL BE 4" (100mm) FOR 4"-24" (100mm-600mm), 6" (150mm) FOR 30"-60" (750mm-1500mm).
- INITIAL BACKFILL: SUITABLE MATERIAL SHALL BE CLASS I, II OR III IN THE PIPE ZONE EXTENDING NOT LESS THAN 6" ABOVE CROWN OF PIPE. THE CONTRACTOR SHALL PROVIDE DOCUMENTATION FOR MATERIAL SPECIFICATION TO ENGINEER. MATERIAL SHALL BE INSTALLED AS REQUIRED IN ASTM D2321, LATEST EDITION.
- MINIMUM COVER: MINIMUM COVER, H, IN NON-TRAFFIC APPLICATIONS (GRASS OR LANDSCAPE AREAS) IS 12" FROM THE TOP OF PIPE TO GROUND SURFACE. ADDITIONAL COVER MAY BE REQUIRED TO PREVENT FLOTATION. FOR TRAFFIC APPLICATIONS, MINIMUM COVER, H, IS 12" UP TO 48" DIAMETER PIPE AND 24" OF COVER FOR 60" DIAMETER PIPE, MEASURED FROM TOP OF PIPE TO BOTTOM OF FLEXIBLE PAVEMENT OR TO TOP OF RIGID PAVEMENT. FOR TRAFFIC APPLICATIONS WITH LESS THAN FOUR FEET OF COVER, EMBEDMENT OF THE PIPE SHALL BE USING ONLY A CLASS I OR CLASS II BACKFILL.

ADVANCED DRAINAGE SYSTEMS, INC. (ADS) HAS PREPARED THIS DETAIL BASED ON INFORMATION PROVIDED TO ADS. THIS DRAWING IS INTENDED TO DEPICT THE COMPONENTS AS REQUESTED. ADS HAS NOT PERFORMED ANY ENGINEERING OR DESIGN SERVICES FOR THIS PROJECT. ADS HAS NOT INDEPENDENTLY VERIFIED THE INFORMATION SUPPLIED. THE INSTALLATION DETAILS PROVIDED HEREIN ARE GENERAL RECOMMENDATIONS AND ARE NOT SPECIFIC TO THIS PROJECT. THE USER SHALL REVIEW THESE DETAILS PRIOR TO CONSTRUCTION. IT IS THE DESIGN ENGINEER'S RESPONSIBILITY TO ENSURE THE DETAILS PROVIDED HEREIN MEET OR EXCEEDS THE APPLICABLE NATIONAL, STATE, OR LOCAL REQUIREMENTS AND TO ENSURE THAT THE DETAILS PROVIDED HEREIN ARE ACCEPTABLE FOR THIS PROJECT.

4 REV. DESCRIPTION BY DATE

TRENCH INSTALLATION DETAIL (ASTM F8948)

ADS 440 TRULMAN BLVD. COLUMBUS, OHIO 43058

DRAWING NUMBER: STD-101A

STORM PIPE TRENCH INSTALLATION DETAIL
NOT TO SCALE

2424 CAST IRON GRATE
PARKWAY 112 lbs.

2424 STEEL GRATES
PARKWAY TRAFFIC 48 lbs. 103 lbs.

2424 STEEL COVER
PARKWAY TRAFFIC 81 lbs. 114 lbs.

2424 TOP SECTION (WITH GALVANIZED FRAME)

2424 LOWER SECTION (NO FRAME)
NOTE: USE 12", 18", 24" LOWERS TO INCREASE DEPTH UP TO A MAXIMUM OF 72"

2424 BOTTOM SECTION (WITH OR WITHOUT FRAME)

NOTES:

- GRATES AND COVERS AVAILABLE PAINTED BLACK OR GALVANIZED
- "ADA" GRATES AVAILABLE IN PARKWAY & TRAFFIC
- "HEEL PROOF" GRATES AVAILABLE IN PARKWAY ONLY
- A TOP SECTION WITH FRAME MUST BE USED IF BOLT DOWN REQUIRED

TOP SECTION	HT.	LBS	KNOCK-OUTS
2424 T6	6"	270	NONE
2424 T12	12"	495	(4) 6" x 11"
2424 T18	18"	745	(4) 9" x 12"
2424 T24	24"	870	(4) 14" x 14"

EXTENSION SECTION	HT.	LBS	KNOCK-OUTS
2424 E6	6"	270	NONE

LOWER SECTION	HT.	LBS	KNOCK-OUTS
2424 L12	12"	495	(4) 6" x 11"
2424 L18	18"	745	(4) 9" x 12"
2424 L24	24"	870	(4) 14" x 14"

BOTTOM SECTION	HT.	LBS	KNOCK-OUTS
2424 B30	30"	1595	(4) 18" x 18"
2424 B36	36"	1905	(4) 18" x 18"

24" x 24" CATCH BASIN

JENSEN PRECAST EST. 1968

BROOKS 2424 CB

ONE DATE: 11-23-99 REV. DATE: 02-14-20

D64 BROOKS 24"x24" CATCH BASIN
NOT TO SCALE

Underground Service Alert
Call: TOLL FREE 811
www.call811.com
TWO WORKING DAYS BEFORE YOU DIG

NOTE:
WORK CONTAINED WITHIN THESE PLANS SHALL NOT COMMENCE UNTIL AN ENCROACHMENT PERMIT AND/OR A GRADING PERMIT HAS BEEN ISSUED.

THE PRIVATE ENGINEER SIGNING THESE PLANS IS RESPONSIBLE FOR ASSURING THE ACCURACY AND ACCEPTABILITY OF THE DESIGN HEREON. IN THE EVENT OF DISCREPANCIES ARISING AFTER CITY APPROVAL OR DURING CONSTRUCTION, THE PRIVATE ENGINEER SHALL BE RESPONSIBLE FOR DETERMINING AN ACCEPTABLE SOLUTION AND REVISING THE PLANS FOR APPROVAL BY THE CITY.

BY	MARK	DESCRIPTION	APPR.	DATE
ENGINEER		REVISIONS		CITY

DESIGNED BY: D.L.W.
REVIEWED BY: CITY OF PERRIS
DRAWN BY: H-Z STAFF
CHECKED BY: J.M.
SCALE: AS SHOWN



PREPARED UNDER THE SUPERVISION OF:
Johnny Murad, R.C.E. NO. 67512
EXPIRATION: 6-30-2023

HUITT-ZOLLARS
Ontario
3990 CONCOURS • SUITE 330 • ONTARIO, CALIFORNIA 91764
PHONE (909) 941-7799 • FAX (909) 941-7789

CITY OF PERRIS

ONSITE PRIVATE STORM DRAIN PLAN

VESTING PARCEL MAP 38384 / DPR22-00003

FOR **PATTERSON COMMERCE CENTER** M.O. CITY FILE NO. **P8-1468**

SHEET **9** OF **15** SHEETS

WDID NO. _____

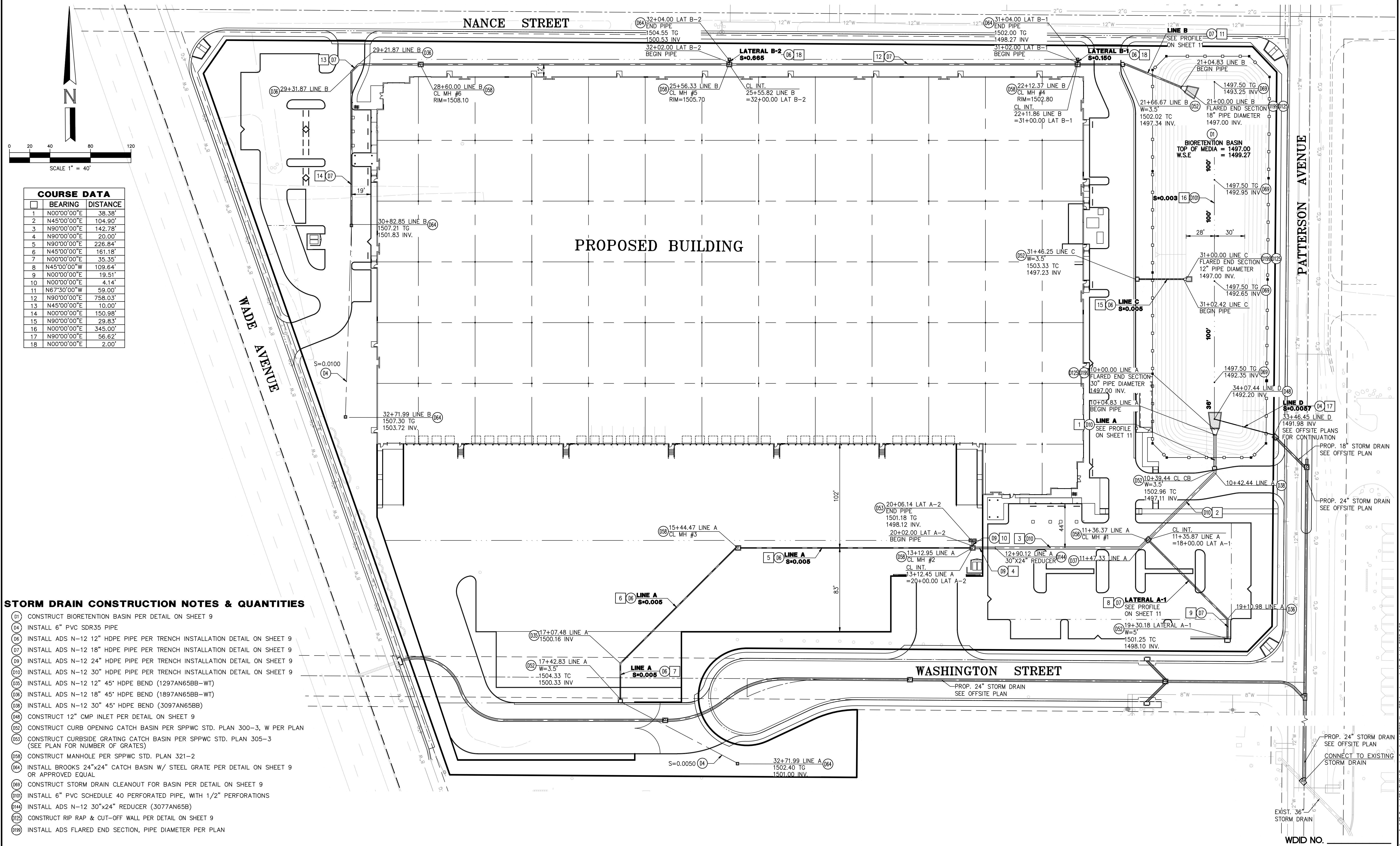

COURSE DATA

BEARING	DISTANCE
1 N00°00'00"E	38.38'
2 N45°00'00"E	104.90'
3 N90°00'00"E	142.78'
4 N90°00'00"E	20.00'
5 N90°00'00"E	226.84'
6 N45°00'00"E	161.18'
7 N00°00'00"E	35.35'
8 N45°00'00"W	109.64'
9 N00°00'00"E	19.51'
10 N00°00'00"E	4.14'
11 N67°30'00"W	59.00'
12 N90°00'00"E	758.03'
13 N45°00'00"E	10.00'
14 N00°00'00"E	150.98'
15 N90°00'00"E	29.83'
16 N00°00'00"E	345.00'
17 N90°00'00"E	56.62'
18 N00°00'00"E	2.00'

STORM DRAIN CONSTRUCTION NOTES & QUANTITIES

- 011 CONSTRUCT BIORETENTION BASIN PER DETAIL ON SHEET 9
- 041 INSTALL 6" PVC SDR35 PIPE
- 061 INSTALL ADS N-12 12" HDPE PIPE PER TRENCH INSTALLATION DETAIL ON SHEET 9
- 071 INSTALL ADS N-12 18" HDPE PIPE PER TRENCH INSTALLATION DETAIL ON SHEET 9
- 091 INSTALL ADS N-12 24" HDPE PIPE PER TRENCH INSTALLATION DETAIL ON SHEET 9
- 0101 INSTALL ADS N-12 30" HDPE PIPE PER TRENCH INSTALLATION DETAIL ON SHEET 9
- 0351 INSTALL ADS N-12 12" 45' HDPE BEND (1297AN65BB-WT)
- 0361 INSTALL ADS N-12 18" 45' HDPE BEND (1897AN65BB-WT)
- 0381 INSTALL ADS N-12 30" 45' HDPE BEND (3097AN65BB)
- 0481 CONSTRUCT 12" CMP INLET PER DETAIL ON SHEET 9
- 0621 CONSTRUCT CURB OPENING CATCH BASIN PER SPPWC STD. PLAN 300-3, W PER PLAN
- 0531 CONSTRUCT CURBSIDE GRATING CATCH BASIN PER SPPWC STD. PLAN 305-3 (SEE PLAN FOR NUMBER OF GRATES)
- 0581 CONSTRUCT MANHOLE PER SPPWC STD. PLAN 321-2
- 0641 INSTALL BROOKS 24"x24" CATCH BASIN W/ STEEL GRATE PER DETAIL ON SHEET 9 OR APPROVED EQUAL
- 0691 CONSTRUCT STORM DRAIN CLEANOUT FOR BASIN PER DETAIL ON SHEET 9
- 01011 INSTALL 6" PVC SCHEDULE 40 PERFORATED PIPE, WITH 1/2" PERFORATIONS
- 01441 INSTALL ADS N-12 30"x24" REDUCER (3077AN65B)
- 011251 CONSTRUCT RIP RAP & CUT-OFF WALL PER DETAIL ON SHEET 9
- 01991 INSTALL ADS FLARED END SECTION, PIPE DIAMETER PER PLAN

Underground Service Alert
 Call: TOLL FREE 811
 www.call811.com
 TWO WORKING DAYS BEFORE YOU DIG

NOTE:
 WORK CONTAINED WITHIN THESE PLANS SHALL NOT COMMENCE UNTIL AN ENCROACHMENT PERMIT AND/OR A GRADING PERMIT HAS BEEN ISSUED.
 THE PRIVATE ENGINEER SIGNING THESE PLANS IS RESPONSIBLE FOR ASSURING THE ACCURACY AND ACCEPTABILITY OF THE DESIGN HEREON. IN THE EVENT OF DISCREPANCIES ARISING AFTER CITY APPROVAL OR DURING CONSTRUCTION, THE PRIVATE ENGINEER SHALL BE RESPONSIBLE FOR DETERMINING AN ACCEPTABLE SOLUTION AND REVISIONS TO THE PLANS FOR APPROVAL BY THE CITY.

BY	MARK	DESCRIPTION	APPR.	DATE
ENGINEER		REVISIONS		CITY

DESIGNED BY: D.L.W.
 APPROVED BY: CITY OF PERRIS
 DRAWN BY: H-Z STAFF
 CHECKED BY: J.M.
 SCALE: AS SHOWN



PREPARED UNDER THE SUPERVISION OF:
 Johnny Murad, R.C.E. NO. 67512
 EXPIRATION: 6-30-2023

HUITT-ZOLLARS
 Ontario
 3990 CONCOURS • SUITE 330 • ONTARIO, CALIFORNIA 91764
 PHONE (909) 941-7799 • FAX (909) 941-7789

CITY OF PERRIS
ONSITE PRIVATE STORM DRAIN PLAN
 VESTING PARCEL MAP 38384 / DPR22-00003
 SHEET 10 OF 15 SHEETS
 PATTERSON COMMERCE CENTER
 CITY FILE NO. P8-1468

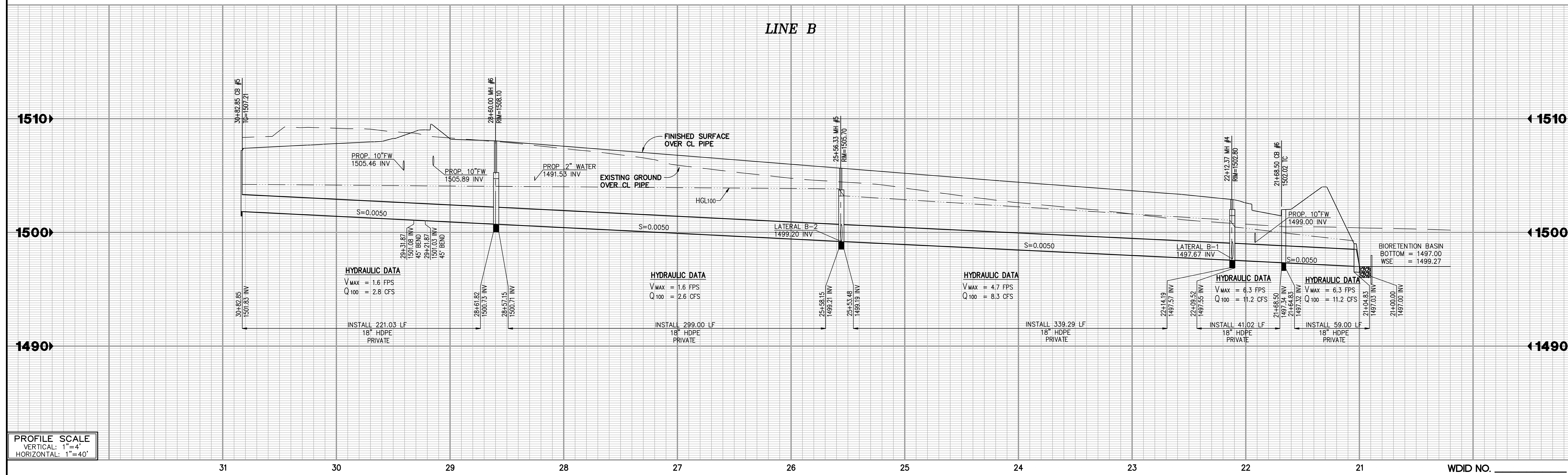
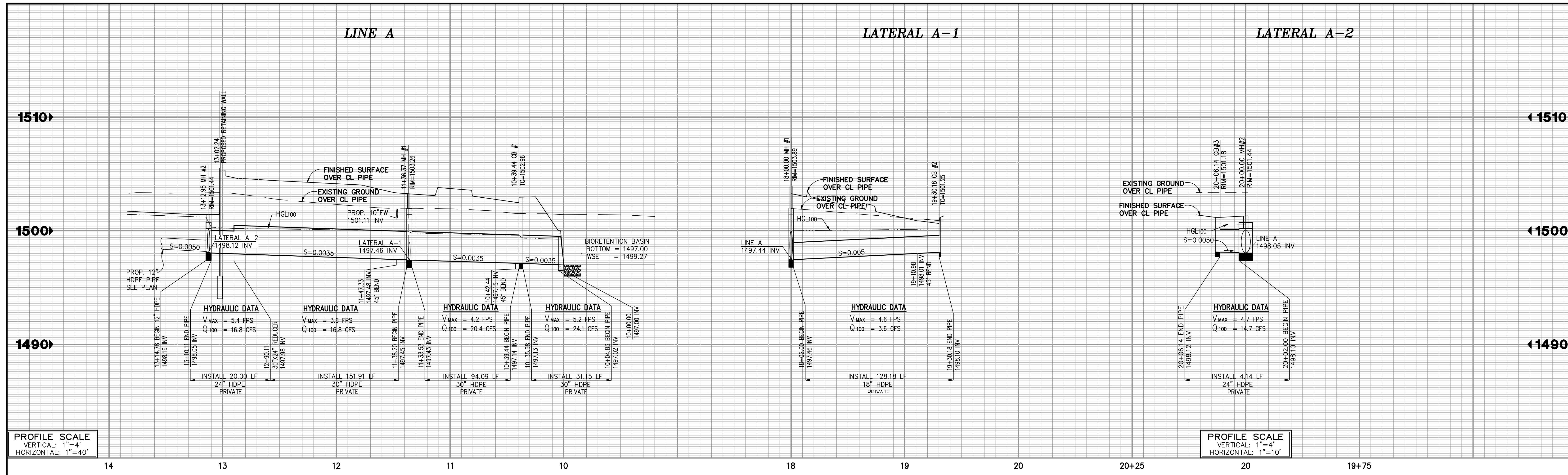

Underground Service Alert
Call: TOLL FREE 811
www.call811.com
TWO WORKING DAYS BEFORE YOU DIG

NOTE:
WORK CONTAINED WITHIN THESE PLANS SHALL NOT COMMENCE UNTIL AN ENCROACHMENT PERMIT AND/OR A GRADING PERMIT HAS BEEN ISSUED.
THE PRIVATE ENGINEER SIGNING THESE PLANS IS RESPONSIBLE FOR ASSURING THE ACCURACY AND ACCEPTABILITY OF THE DESIGN HEREON. IN THE EVENT OF DISCREPANCIES ARISING AFTER CITY APPROVAL OR DURING CONSTRUCTION, THE PRIVATE ENGINEER SHALL BE RESPONSIBLE FOR DETERMINING AN ACCEPTABLE SOLUTION AND REVISIONS TO THE PLANS FOR APPROVAL BY THE CITY.

BY	MARK	DESCRIPTION	APPR.	DATE
ENGINEER		REVISIONS		CITY

DESIGNED BY: D.L.W.
APPROVED BY: **CITY OF PERRIS**
DRAWN BY: H-Z STAFF
CITY OF PERRIS
CHECKED BY: J.M.
SCALE: AS SHOWN



PREPARED UNDER THE SUPERVISION OF:
Johnny Murad, R.C.E. NO. 67512
EXPIRATION: 6-30-2023
DATE:

HUITT-ZOLLARS
Huitt-Zollars, Inc. Ontario
3990 CONCOURS • SUITE 330 • ONTARIO, CALIFORNIA 91764
PHONE (909) 941-7799 • FAX (909) 941-7789

CITY OF PERRIS
ONSITE PRIVATE STORM DRAIN PLAN
VESTING PARCEL MAP 38384 / DPR22-00003
FOR **PATTERSON COMMERCE CENTER** M.O.
CITY FILE NO. **P8-1468**

SHEET **11**
OF **15** SHEETS

L:\proj\38384\38384.dwg - DBAmp - Layout 11, Oct 16 2022 5:23pm

EROSION AND SEDIMENT CONTROL NOTES

- ALL GRADING PROJECTS, WILL REQUIRE AN EROSION CONTROL PLAN TO PREVENT SEDIMENT FROM ENTERING STORM DRAINS OR WATER BODIES.
- THE CONTRACTOR SHALL MAINTAIN THE CONSTRUCTION SITE BY IMPLEMENTATION OF BEST MANAGEMENT PRACTICES (BMPs) IN SUCH A MANNER THAT POLLUTANTS ARE NOT DISCHARGED FROM THE SITE TO THE MAXIMUM EXTENT PRACTICABLE.
- THE CONTRACTOR SHALL PREPARE THE CONSTRUCTION SITE PRIOR TO THE ONSET OF ANY STORM AND SHALL HAVE ALL EROSION AND SEDIMENT CONTROL MEASURES IN PLACE FOR THE WINTER MONTHS FROM OCTOBER 1.
- THE CONTRACTOR SHALL CONSIDER THE FULL RANGE OF EROSION CONTROL BEST MANAGEMENT PRACTICES FOR ALL DISTURBED SURFACES SUCH AS: BUFFER STRIPS, HYDROSEEDING, MULCHING, TRACK WALKING OR IMPRINTING, GEOTEXTILES AND MATS, SOIL STABILIZERS AND BINDERS, EARTHEN DIKES, TEMPORARY DRAINS AND SWALES FOR DIVERSION OF OFF-SITE RUNOFF, TEMPORARY SLOPE DRAINS, STORM OUTLET PROTECTION, CHECK DAMS AND SLOPE ROUGHENING AND TERRACING.
- ALL EROSION CONTROL BMPs SHALL BE INSTALLED ACCORDING TO THE SPECIFICATIONS IN SECTION 3 OF THE CALIFORNIA BMP HANDBOOK FOR CONSTRUCTION ACTIVITY OR EQUIVALENT.
- DUST CONTROL BMPs SHALL BE USED TO STABILIZE SOIL FROM WIND EROSION, AND REDUCE DUST GENERATED BY CONSTRUCTION ACTIVITIES AND MAY INCLUDE STABILIZATION OF UNPAVED CONSTRUCTION ROADS AND PARKING AND STAGING AREAS; WATER SPRAYING; CHEMICAL STABILIZATION; MULCHING; COVERING STOCKPILES WITH TARPS; RAPID CLEANUP OF SEDIMENTS DEPOSITED ON PAVED ROADS AND STABILIZATION OF CONSTRUCTION ENTRY/EXIT POINTS WITH GRAVEL.
- THE CONTRACTOR SHALL CONSTRUCT SEDIMENT CONTROLS SUCH AS FIBER ROLLS, SILT FENCES, STRAW BALE BARRIERS, GRAVEL-FILLED BURLAP BAG BARRIERS, BRUSH OR ROCK FILTERS, SEDIMENT BASINS AND STORM DRAIN INLET PROTECTION.
- ALL SEDIMENT CONTROL STRUCTURES SHALL BE CONSTRUCTED PURSUANT TO THE SPECIFICATIONS IN SECTION 3 OF THE CALIFORNIA BMP HANDBOOK FOR CONSTRUCTION ACTIVITY OR EQUIVALENT, UNLESS OTHERWISE REQUIRED IN THE AGENCY'S STANDARD CONSTRUCTION NOTES.
- THE CONTRACTOR SHALL PROTECT ALL STORM DRAIN INLETS WHICH MAY RECEIVE STORM WATER RUNOFF FROM THE CONSTRUCTION ACTIVITIES WITH A MINIMUM 2'-BAG HIGH, GRAVEL FILLED BURLAP BAG BARRIER AND FABRIC FILTERS INSTALLED BETWEEN THE BARRIER AND THE INLET DRAIN.
- SUBCONTRACTORS & EMPLOYEES MUST BE TRAINED ON GOOD BMP HOUSE KEEPING MEASURES.
- THE CONTRACTOR SHALL INSTALL STABILIZED CONSTRUCTION ENTRANCE(S)/EXIT(S) MEASURING A MINIMUM OF 50 FEET LONG AND 30 FEET WIDE AND CONSISTING OF A 6 INCH LAYER OF 1-3 INCH STONES PRIOR TO COMMENCEMENT OF GRADING. THE LOCATION OF THE ENTRANCES MAY BE ADJUSTED BY THE CONTRACTOR TO FACILITATE CONSTRUCTION SITE, TO OR FROM A PUBLIC RIGHT-OF-WAY, TO FACILITATE ALLEY, SIDEWALK, OR PARKING AREA, MUST CROSS THE STABILIZED CONSTRUCTION ENTRANCE(S). THE STABILIZED CONSTRUCTION ENTRANCE(S) SHALL REMAIN IN PLACE UNTIL THE ROAD BASE ROCK COURSE IS COMPLETED. WHEEL WASH OVER A WASH RACK IS RECOMMENDED FOR CLAY SOILS.
- ALL SEDIMENT DEPOSITED ON PAVED ROADWAYS SHALL BE SWEEPED AT THE END OF EACH WORKING DAY. WASHING OF ACCUMULATED SEDIMENT INTO THE STORM DRAIN IS PROHIBITED.
- IN ALL AREAS WHERE SOIL IS EXPOSED, PROMPT REPLANTING, WITH NATIVE COMPATIBLE, DROUGHT-RESISTANT VEGETATION OR OTHER ACCEPTABLE SOIL STABILIZATION MATERIALS, IS REQUIRED. ANY SLOPE WITH MORE THAN 3" HEIGHT MUST BE PLANTED.
- CONTRACTOR SHALL REPORT PROHIBITED DISCHARGES:

THE FOLLOWING DISCHARGES INTO THE STORM DRAIN SYSTEM ARE PROHIBITED: DISCHARGES THAT COULD HAVE AN IMPACT ON HUMAN HEALTH AND THE ENVIRONMENT, CAUSE OR THREATEN TO CAUSE POLLUTION, CONTAMINATION, OR NUISANCE; DISCHARGES THAT EXCEED ANY WATER QUALITY STANDARD CONTAINED IN THE STATEWIDE WATER QUALITY CONTROL PLAN OR LOCAL BASIN PLAN; AND DISCHARGES CONTAINING A HAZARDOUS SUBSTANCE EQUAL TO OR IN EXCESS OF A REPORTABLE QUANTITY LISTED IN THE FEDERAL REGULATIONS 40 CFR PARTS 117 AND 302.

MATERIALS THAT CAN CAUSE OR CONTRIBUTE TO POLLUTION OR A VIOLATION OF ANY APPLICABLE WATER QUALITY STANDARD INCLUDE, BUT ARE NOT LIMITED TO: SEDIMENTS, CONTAMINATED SOIL, SOLID OR LIQUID CHEMICAL SPILLS; WASTES FROM PAINTS, STAINS, SEALANTS, GLUES, LIMES, PESTICIDES OR HERBICIDES, WOOD PRESERVATIVES, OR SOLVENTS; ASBESTOS FIBERS, PAINT FLAKES, OR STUCCO FRAGMENTS; FUELS, OILS, LUBRICANTS, OR HYDRAULIC, RADIATOR AND BATTERY FLUIDS; FERTILIZERS; VEHICLE/EQUIPMENT WASHWATER OR CONCRETE WASH WATER; CONCRETE, DETERGENT OR FLOATABLE WASTES; WASTES FROM ANY ENGINE/EQUIPMENT STEAM CLEANING OR CHEMICAL DEGREASING; CONTAMINATED GROUNDWATER AND CHLORINATED POTABLE WATER LINE FLUSHING.

- THE CONTRACTOR SHALL IMPLEMENT EROSION CONTROL BMP'S FOR AREAS OF CONSTRUCTION ACTIVITY THAT HAVE BEEN DISTURBED AND ARE NOT SCHEDULED TO BE RE-DISTURBED FOR AT LEAST 14 DAYS. MEASURES MAY INCLUDE: HYDROMULCH OR MULCH, TRACK WALKING OR IMPRINTING, CHIPPED NATIVE VEGETATION, BONDED FIBER MATRICES, SOIL STABILIZERS, BINDERS, TEMPORARY SEEDINGS AND EROSION CONTROL BLANKETS.
- STOCKPILES OF SOIL SHALL BE PROPERLY CONTAINED TO ELIMINATE OR REDUCE SEDIMENT TRANSPORT FROM THAT SITE TO STREETS, DRAINAGE FACILITIES OR ADJACENT PROPERTIES VIA RUNOFF, VEHICLE TRACKING, OR WIND.
- ALL REMOVABLE PROTECTIVE DEVICES SHALL BE IN PLACE AT THE END OF EACH WORKING DAY WHENEVER THERE IS A NOAA FORECAST THAT HAS A 50% OR GREATER PROBABILITY OF RAIN WITHIN THE NEXT 48 HOURS.
- THE CONTRACTOR SHALL BE RESPONSIBLE FOR PROVIDING A QUALIFIED SWPPP PRACTITIONER (OSP) TO IMPLEMENT AND MONITOR THE BMPs AS INDICATED IN THE SWPPP DOCUMENTS AND THE EROSION CONTROL PLAN.
- THE CONTRACTOR SHALL PROVIDE MECHANICAL SWEEPER TO CLEAN ANY SPILLAGE ALONG THE VICINITY ROADS AT ALL TIME.
- THE CONTRACTOR SHALL HIRE A SWPPP MANAGER THAT IS OSP CERTIFIED, WHO WILL MANAGE THE SWPPP, ONGOING INSPECTIONS, ANNUAL REPORTS, FINAL CLOSE OUT, AND PREPARATION OF A NOTICE OF TERMINATION IN SMARTS.

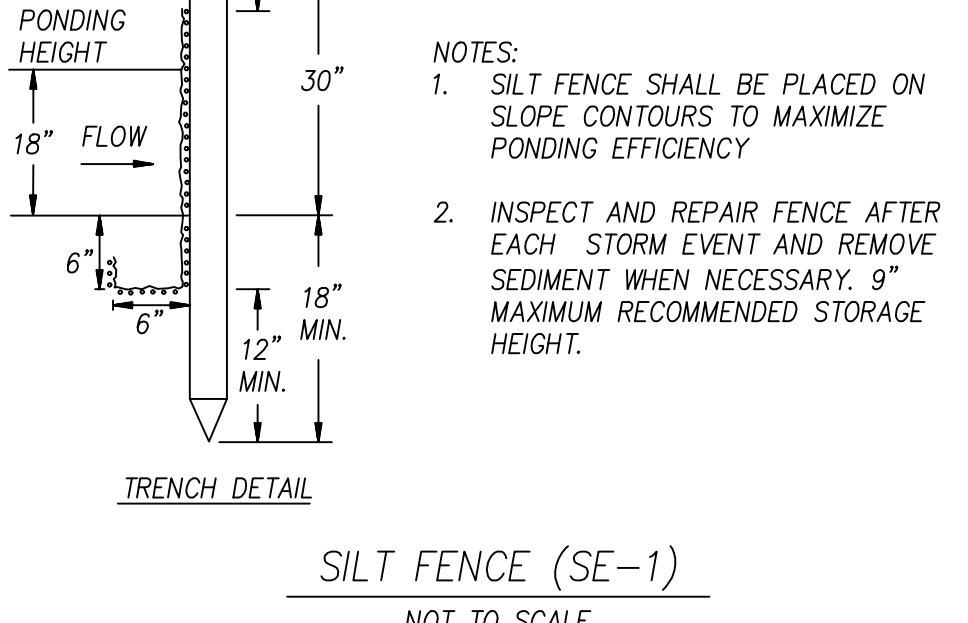
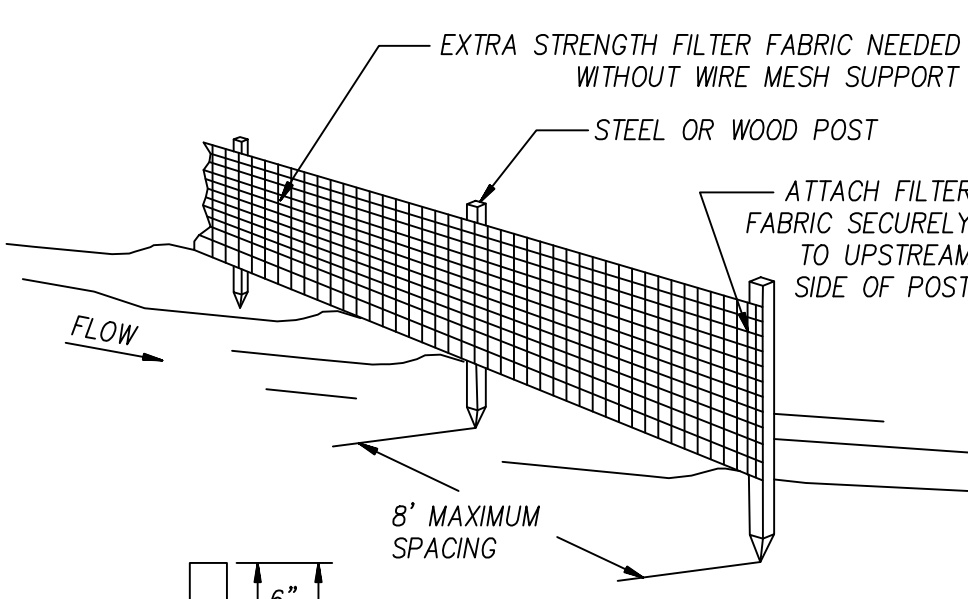
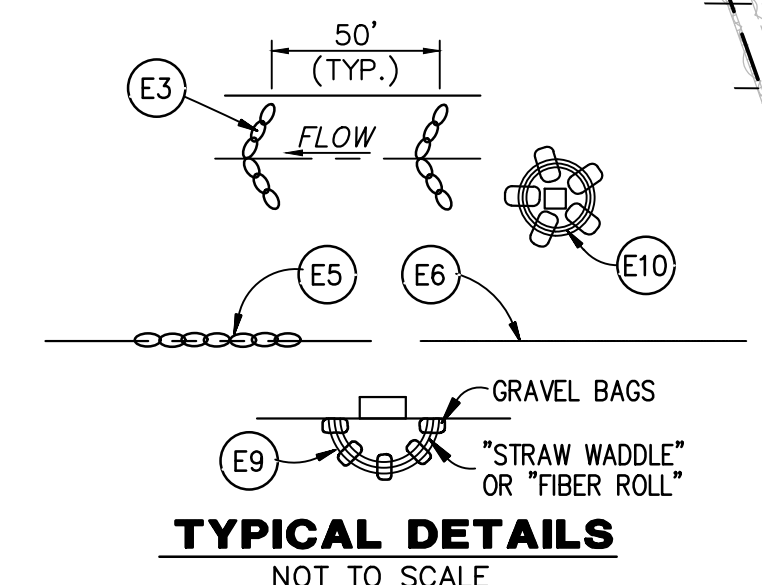

EROSION CONTROL NOTES:

- (E1) INSTALL STABILIZED CONSTRUCTION ENTRANCE PER CASQA BMP TC-1
- (E2) INSTALL FIBER ROLL SEDIMENT BARRIER PER CASQA SE-5
- (E3) INSTALL A 15' LONG DOUBLE ROW OF GRAVEL BAGS, 2 BAGS HIGH. OMIT ONE BAG AT THE FLOWLINE
- (E4) CONTRACTOR YARD, DESIGNED MANAGEMENT AREAS AS INDICATED
- (E5) INSTALL 2 LAYERS OF GRAVEL BAGS AS SHOWN ON PLAN
- (E6) INSTALL SILT FENCE PER CASQA BMP EC SE1
- (E7) INSTALL DUST CONTROL SIGN
- (E8) APPLY A SOIL BINDING MATERIAL IF LEFT UNATTENDED FOR MORE THAN 14 DAYS
- (E9) INSTALL A SEMI-CIRCLE OF GRAVEL BAGS; 2 ROWS X 2 HIGH PLACE A "STRAW WADDLE" IN FRONT OF ALL CURB INLETS, WEIGHTED DOWN BY A GRAVEL BAG AT EACH END AND A GRAVEL BAG IN THE CENTER.
- (E10) INSTALL A CIRCLE OF GRAVEL BAGS; 2 ROWS X 2 HIGH WITH FILTER FABRIC OVER GRATE

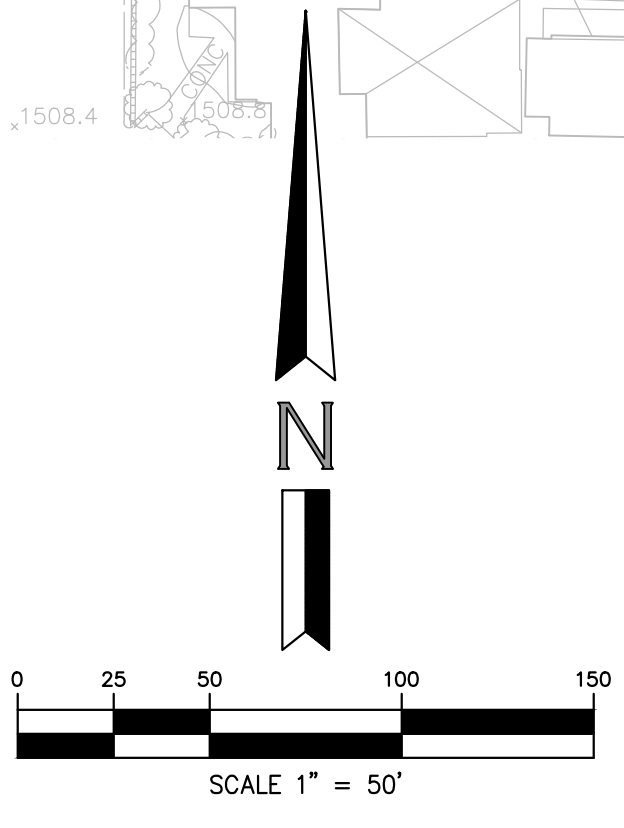
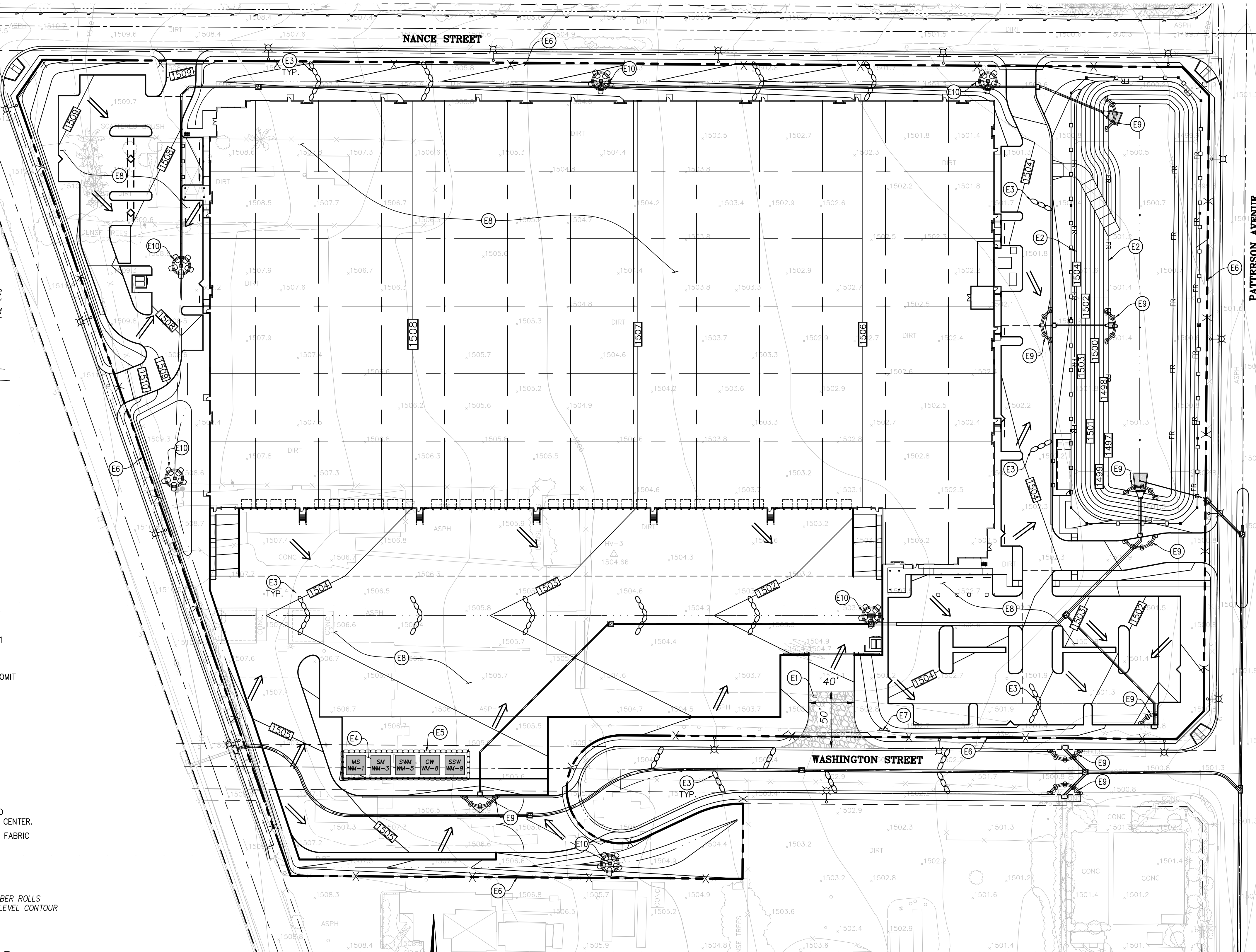
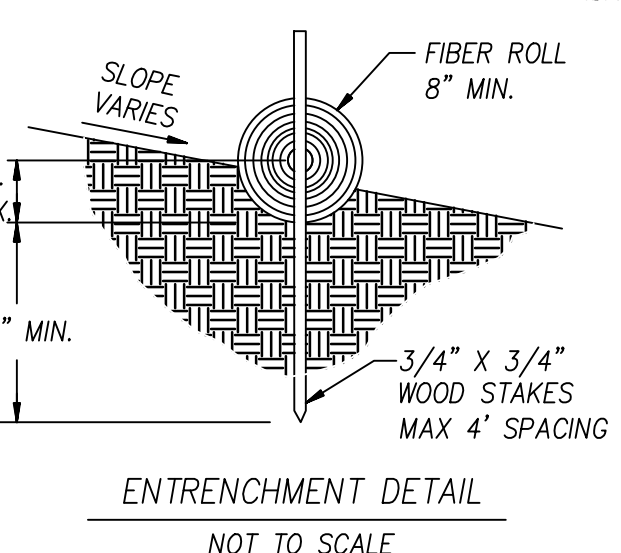
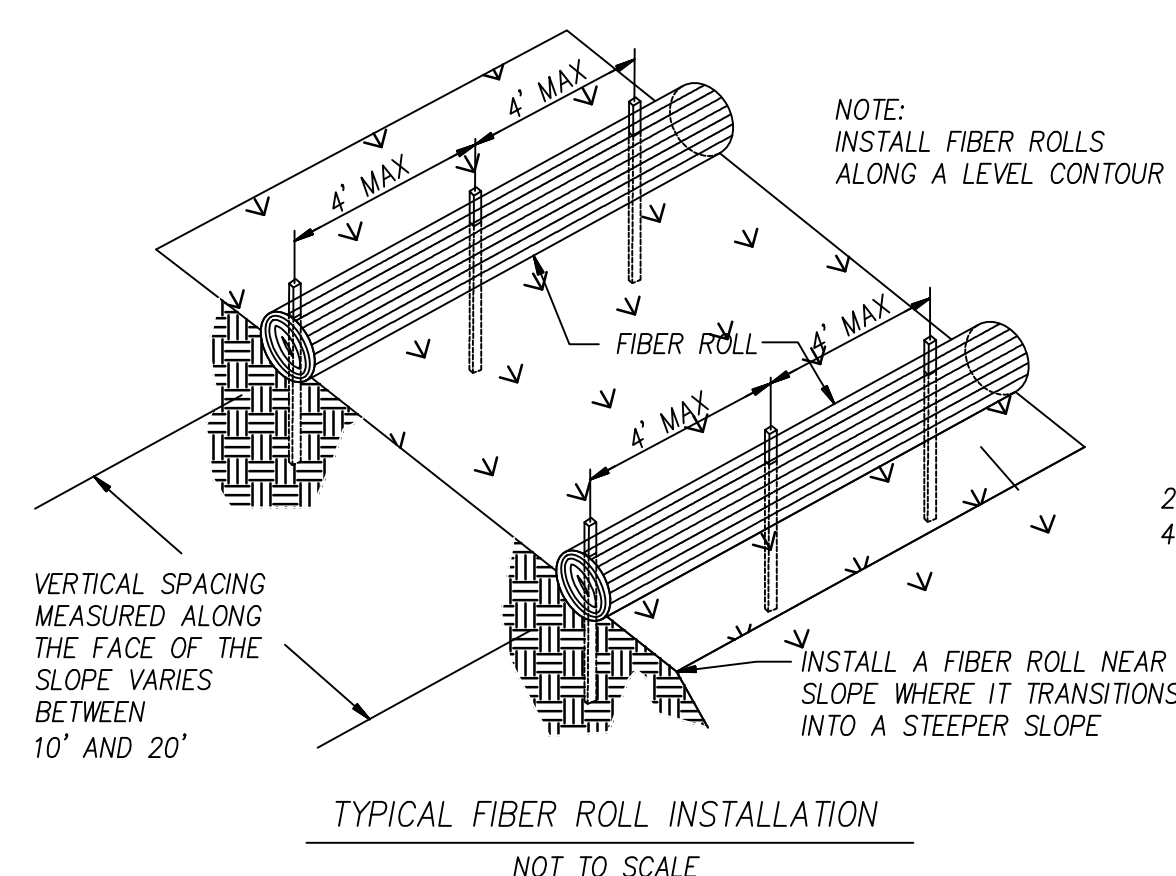

- MS WM-1 MATERIAL STORAGE PER CASQA BMP WM-1
- SM WM-3 STOCKPILE MANAGEMENT PER CASQA BMP WM-3
- SSW WM-5 SOLID WASTE MANAGEMENT PER CASQA BMP WM-5
- CW WM-8 CONCRETE WASTE MANAGEMENT PER CASQA BMP WM-8
- SSW WM-9 SANITARY & SEPTIC WASTE PER CASQA BMP WM-9

DIRECTION OF WATER FLOW
S&M-XX SAMPLE AND MONITORING LOCATION
*THE CONCRETE WASHOUT CONTAINER MUST BE A LEAK PROOF DESIGNED METAL CONTAINER SPECIFICALLY USED FOR CONCRETE WASHOUT

Underground Service Alert
Call: TOLL FREE 811
www.call811.com
TWO WORKING DAYS BEFORE YOU DIG

NOTE:
WORK CONTAINED WITHIN THESE PLANS SHALL NOT COMMENCE UNTIL AN ENCROACHMENT PERMIT AND/OR A GRADING PERMIT HAS BEEN ISSUED.
THE PRIVATE ENGINEER SIGNING THESE PLANS IS RESPONSIBLE FOR ASSURING THE ACCURACY AND ACCEPTABILITY OF THE DESIGN HEREON. IN THE EVENT OF DISCREPANCIES ARISING AFTER CITY APPROVAL OR DURING CONSTRUCTION, THE PRIVATE ENGINEER SHALL BE RESPONSIBLE FOR DETERMINING AN ACCEPTABLE SOLUTION AND REVISIONS TO THE PLANS FOR APPROVAL BY THE CITY.

BY	MARK	DESCRIPTION	APPR.	DATE	SCALE
ENGINEER		REVISIONS		CITY	AS SHOWN

DESIGNED BY: D.L.W.
DRAWN BY: H-Z STAFF
CHECKED BY: J.M.
SCALE: AS SHOWN



PREPARED UNDER THE SUPERVISION OF:
Johnny Murad, R.C.E. NO. 67512
EXPIRATION: 6-30-2023
DATE:

HUITT-ZOLLARS
Ontario
3990 CONCOURS • SUITE 330 • ONTARIO, CALIFORNIA 91764
PHONE (909) 941-7799 • FAX (909) 941-7789

CITY OF PERRIS
EROSION CONTROL PLAN
VESTING PARCEL MAP 38384 / DPR22-00003
FOR **PATTERSON COMMERCE CENTER** M.O. CITY FILE NO. **P8-1468**

WDID NO. _____

SHEET **12** OF **15** SHEETS

L:\proj\N8199501 - Nance Inc\02 Design\01 Dwg\Submittal\Grading\EROSION.dwg, Layer: 12, Dec 16, 2022 5:38pm
 Receiver:

COURSE DATA		
LENGTH	DIRECTION	
1	26.00'	N00°21'39"E
2	150.00'	N89°59'15"W
3	64.00'	N00°00'00"E
4	31.00'	N90°00'00"W

NOTE:
APPROVAL OF THESE PLANS BY CITY IS NOT FOR FIRE SYSTEM. FIRE WATER SYSTEM IS PER SEPARATE PLANS, BY OTHERS.

* NOTE:
1. HORIZONTAL AND VERTICAL LOCATIONS TO BE VERIFIED IN THE FIELD AND ENGINEER NOTIFIED OF ANY DISCREPANCIES PRIOR TO CONSTRUCTION.
2. ALL SEWER LATERALS AND WATER LINES IN PRIVATE PROPERTY SHALL BE PRIVATELY MAINTAINED.

PRIVATE WATER GENERAL NOTES

1. WATER PIPELINE AND APPURTENANT CONSTRUCTION SHALL BE IN ACCORDANCE WITH GREEN BOOK SPECIFICATIONS.
2. PRIOR TO INSTALLATION OF PIPELINE, CONTRACTOR SHALL EXPOSE EXISTING WATER SYSTEM AND VERIFY ITS EXISTING ELEVATION AND LOCATION.
3. APPROVED REDUCED PRESSURE BACKFLOW PREVENTION DEVICE REQUIRED FOR ALL INDUSTRIAL, COMMERCIAL, APARTMENT COMPLEXES AND LANDSCAPE SERVICES.

PRIVATE SEWER GENERAL NOTES

1. SEWER SYSTEM CONSTRUCTION AND MATERIALS SHALL BE IN ACCORDANCE WITH GREEN BOOK SPECIFICATIONS.
2. CONTRACTOR HAS THE OPTION TO INSTALL PLASTIC OR VCP SEWERS EXCEPT WHERE SPECIFICALLY DESIGNATED ON PLANS.
3. ALL LATERALS SHALL HAVE AN ON-SITE CLEANOUT IN ACCORDANCE WITH CITY OF FONTANA STAND DRAWING 2005 & 2007
4. MAINLINE CLEANOUTS, WHERE CALLED FOR ON THE PLANS, SHALL BE CONSTRUCTED IN ACCORDANCE WITH DETAIL HEREON.
5. PRIOR TO CONSTRUCTION OF SEWER, CONTRACTOR SHALL EXPOSE EXISTING SEWER AND VERIFY ITS EXISTING ELEVATION AND LOCATION. WHERE CONNECTING TO EXISTING MANHOLES AND INLET SUB OF PROPER SIZE EXISTS, NO ALTERATIONS SHALL BE MADE TO EXISTING MANHOLE BASE OR STUB EXCEPT AS SPECIFICALLY AUTHORIZED BY CITY.
6. THE CONTRACTOR IS ADVISED THAT THE WORK ON THIS PROJECT MAY INVOLVE WORKING IN A CONFINED AIR SPACE. CONTRACTOR SHALL BE RESPONSIBLE FOR "CONFINED AIR SPACE" ARTICLE 108, TITLE 8, CALIFORNIA ADMINISTRATIVE CODE.
7. BACKWATER VALVES SHALL BE INSTALLED PER SECTION 710.1 OF THE UNIFORM PLUMBING CODE.
8. ALL PIPE ZONE BEDDING & TRENCH BACKFILL SHALL COMPLY WITH DETAIL HEREON.

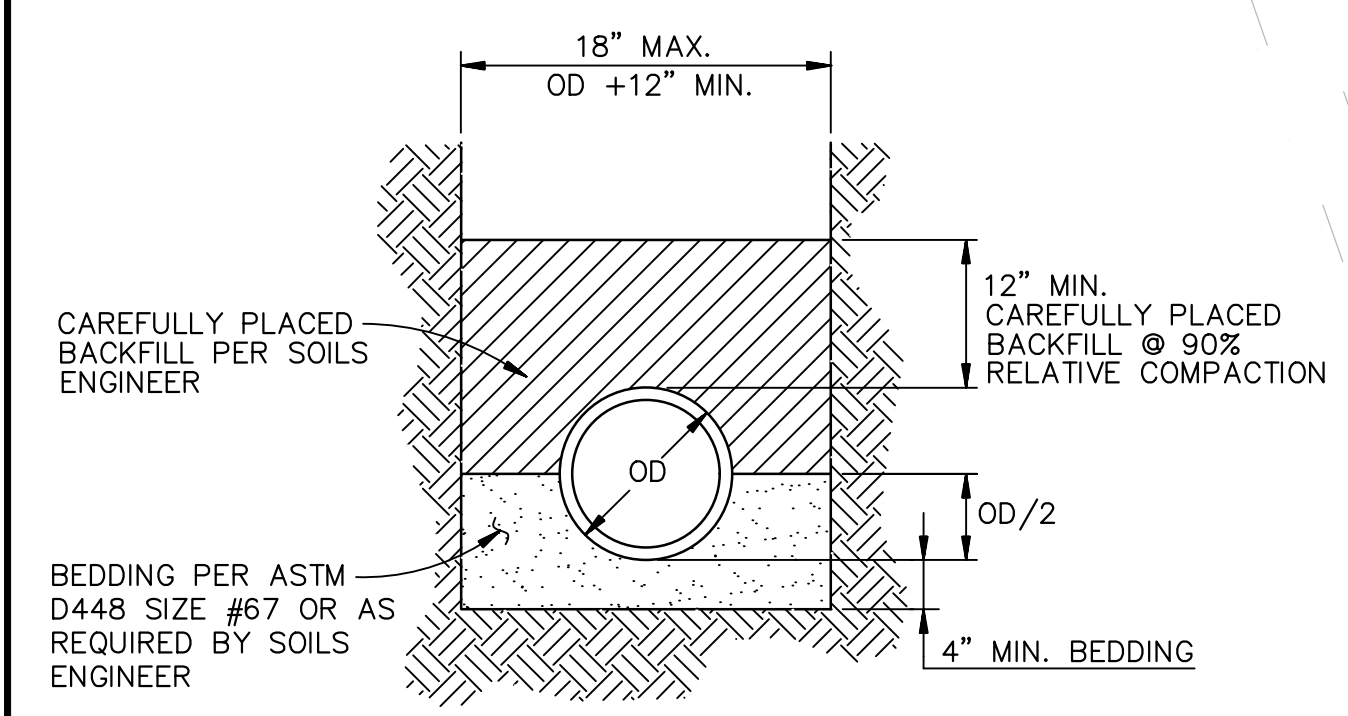

SEWER BEDDING DETAIL
NOT TO SCALE

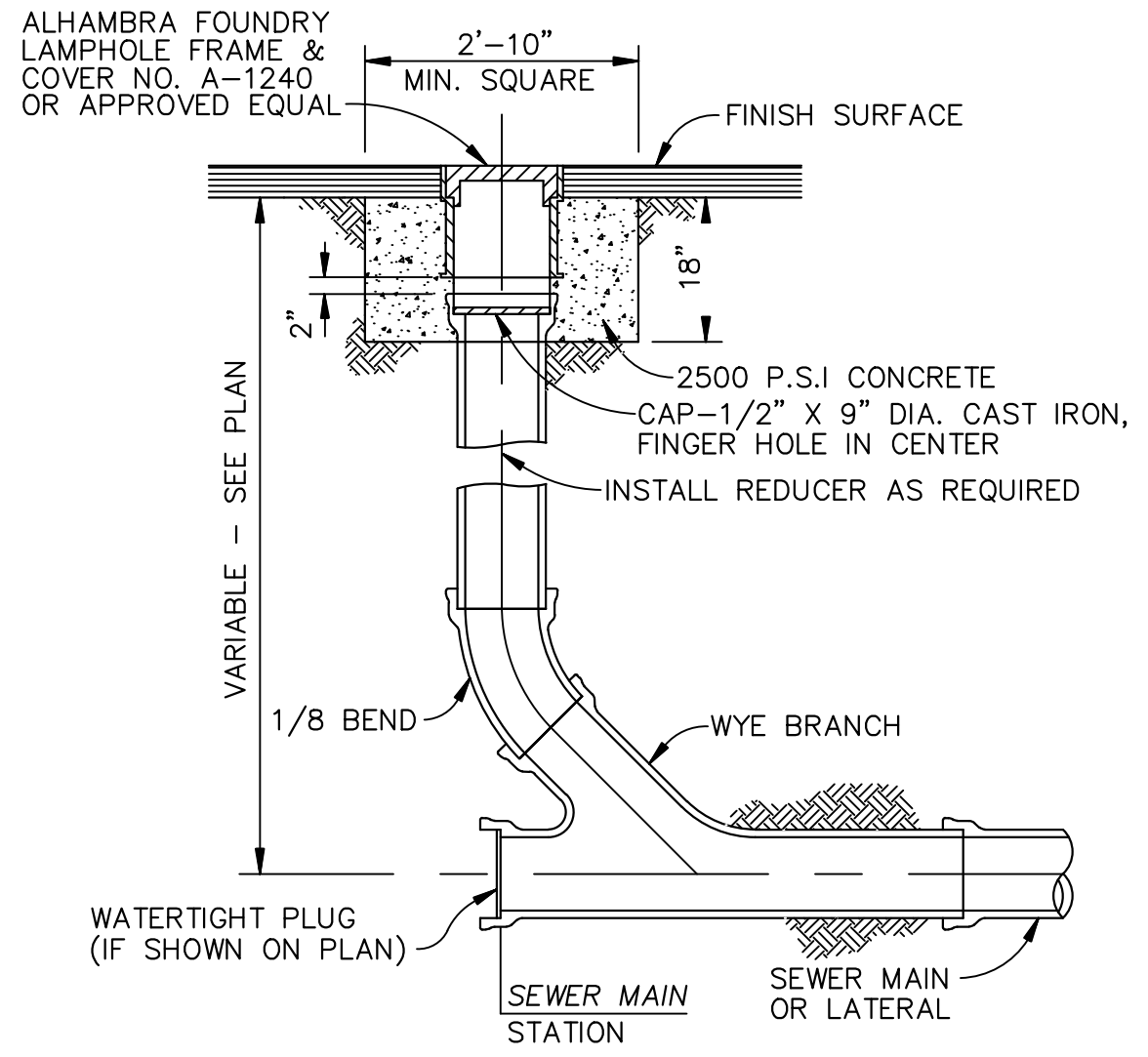

SEWER CLEANOUT
NOT TO SCALE

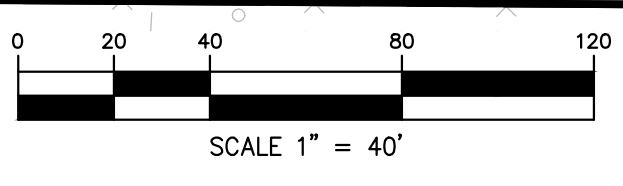

SEWER CONSTRUCTION NOTES AND QUANTITIES

- (S2) INSTALL 6" PVC (SCH. 40) SEWER LINE (BEDDING PER DETAIL HEREON) 26 LF
- (S14) INSTALL SEWER CLEANOUT PER DETAIL HEREON 2 EA

WATER CONSTRUCTION NOTES AND QUANTITIES

- (W4) INSTALL 3" PVC (SCH. 80) WATER LINE 245 LF
- (W33) INSTALL 2" BACKFLOW PREVENTION ASSEMBLY PER EMWD STD. NO. B-597A 1 EA

WDID NO. _____

Underground Service Alert
Call: TOLL FREE
811
www.call811.com
TWO WORKING DAYS BEFORE YOU DIG

NOTE:
WORK CONTAINED WITHIN THESE PLANS SHALL NOT COMMENCE UNTIL AN ENCROACHMENT PERMIT AND/OR A GRADING PERMIT HAS BEEN ISSUED.
THE PRIVATE ENGINEER SIGNING THESE PLANS IS RESPONSIBLE FOR ASSURING THE ACCURACY AND ACCEPTABILITY OF THE DESIGN HEREON. IN THE EVENT OF DISCREPANCIES ARISING AFTER CITY APPROVAL OR DURING CONSTRUCTION, THE PRIVATE ENGINEER SHALL BE RESPONSIBLE FOR DETERMINING AN ACCEPTABLE SOLUTION AND REVISING THE PLANS FOR APPROVAL BY THE CITY.

BY	MARK	DESCRIPTION	APPR.	DATE
REVISIONS				

DESIGNED BY: D.L.W.
APPROVED BY: CITY OF PERRIS
DRAWN BY: H-Z STAFF
CHECKED BY: J.M.
SCALE: AS SHOWN



PREPARED UNDER THE SUPERVISION OF:
Johnny Murad, R.C.E. NO. 67512
EXPIRATION: 6-30-2023
DATE: _____

HUITT-ZOLLARS
Ontario
3990 CONCOURS • SUITE 330 • ONTARIO, CALIFORNIA 91764
PHONE (909) 941-7799 • FAX (909) 941-7789

CITY OF PERRIS

ONSITE PRIVATE SEWER & WATER PLAN

VESTING PARCEL MAP 38384 / DPR22-00003

FOR **PATTERSON COMMERCE CENTER** M.O. CITY FILE NO. **P8-1468**

SHEET **13**
OF **15** SHEETS

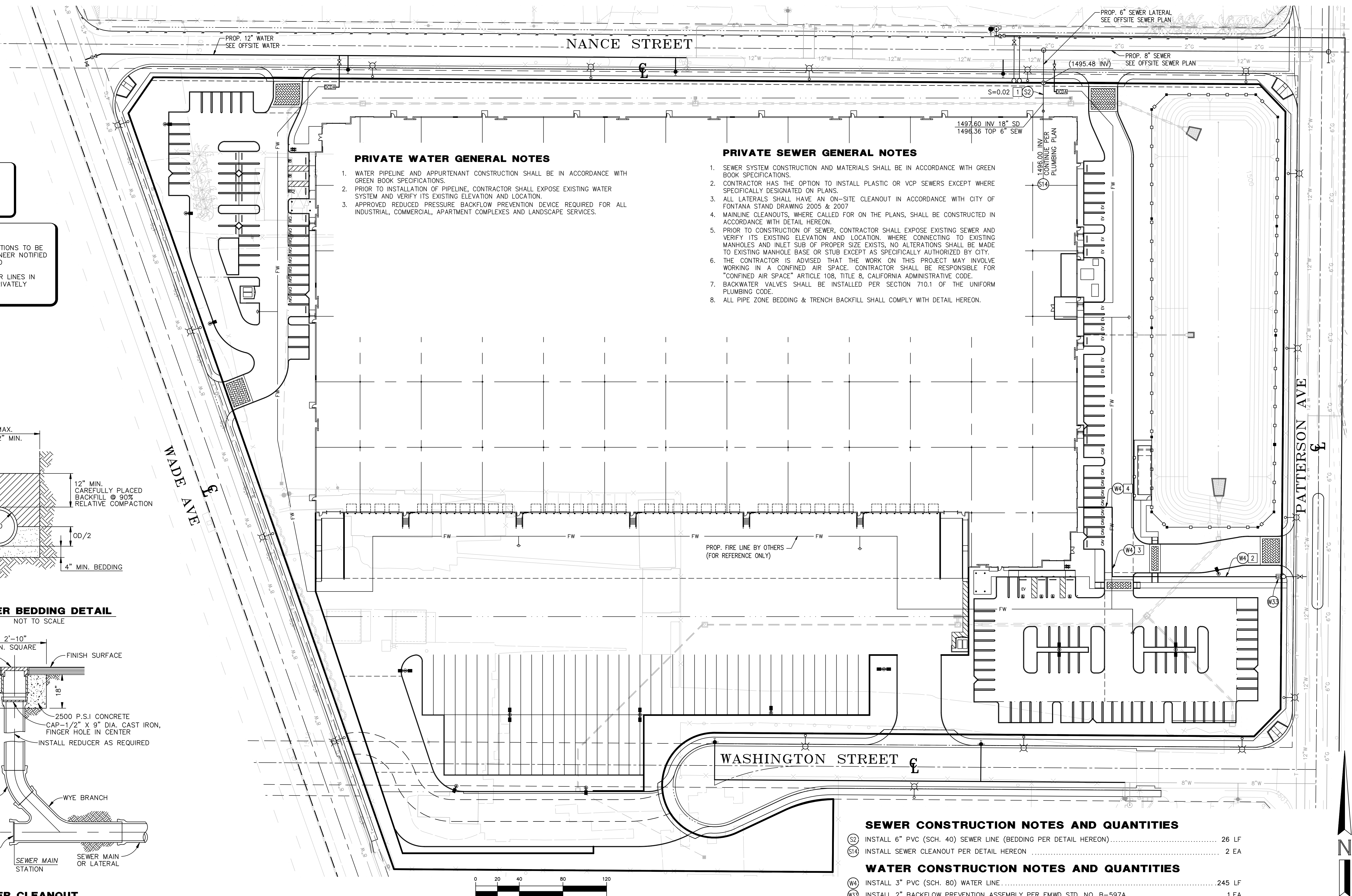

Nance Inlet Design 031 - Dwg's/Process/Grading/UGRIS-SV.dwg, Layout: 09, Dct: 16, 08/25/2023
 User: JMH
 Title: P8-1468

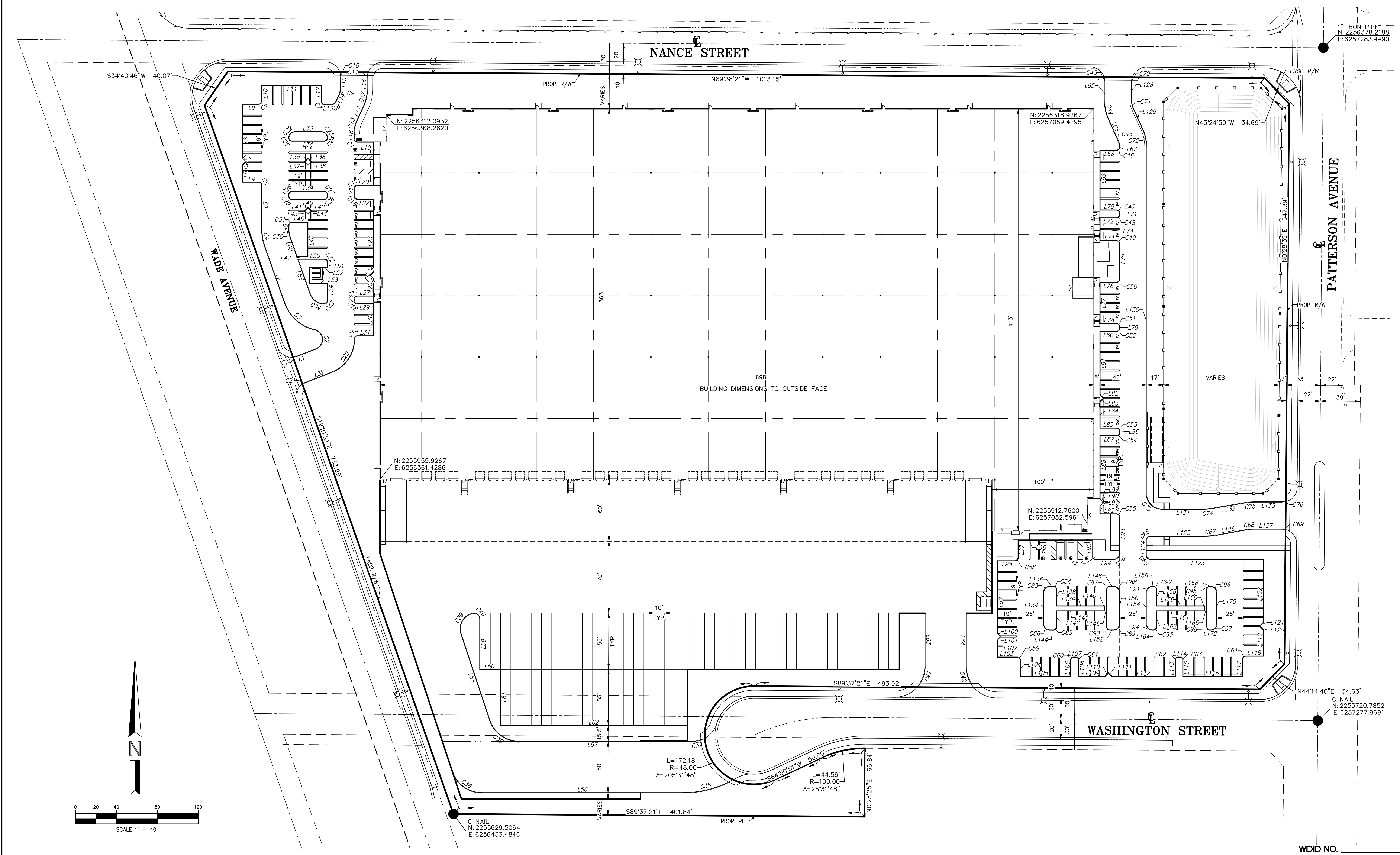

Underground Service Alert
Call: TOLL FREE 811
www.call811.com
TWO WORKING DAYS BEFORE YOU DIG

NOTE:
WORK CONTAINED WITHIN THESE PLANS SHALL NOT COMMENCE UNTIL AN ENCROACHMENT PERMIT AND/OR A GRADING PERMIT HAS BEEN ISSUED.

THE PRIVATE ENGINEER SIGNING THESE PLANS IS RESPONSIBLE FOR ASSURING THE ACCURACY AND ACCEPTABILITY OF THE DESIGN HEREON. IN THE EVENT OF DISCREPANCIES ARISING AFTER CITY APPROVAL OR DURING CONSTRUCTION, THE PRIVATE ENGINEER SHALL BE RESPONSIBLE FOR DETERMINING AN ACCEPTABLE SOLUTION AND REVISIONS TO THE PLANS FOR APPROVAL BY THE CITY.

BY	MARK	DESCRIPTION	APPR.	DATE
ENGINEER		REVISIONS		CITY

DESIGNED BY: D.L.W.

DRAWN BY: H-Z STAFF

CHECKED BY: J.M.

SCALE: AS SHOWN

PREPARED UNDER THE SUPERVISION OF:
Johnny Murad, R.C.E. NO. 67512
EXPIRATION: 6-30-2023

DATE



HUITT-ZOLLARS
Huitt-Zollars, Inc. Ontario
3990 CONCOURS • SUITE 330 • ONTARIO, CALIFORNIA 91764
PHONE (909) 941-7799 • FAX (909) 941-7789

CITY OF PERRIS

HORIZONTAL CONTROL PLAN

VESTING PARCEL MAP 38384 / DPR22-00003

FOR **PATTERSON COMMERCE CENTER** M.O. CITY FILE NO. **P8-1468**

SHEET **14** OF **15** SHEETS

L:\p\p\38384\Design\031_DWG\3\Process\Grading_V0814-15 - HRZ.dwg, Layout: 14, Dec 15 2022 9:59pm
 L:\p\p\38384\Design\031 - Recorder\HRZ.dwg

Parcel Line Table		
Line #	Length	Direction
L1	19.42	S68° 35' 25.04"W
L2	59.69	S19° 29' 47.78"E
L3	43.89	S0° 00' 00.00"E
L4	16.00	N90° 00' 00.00"E
L5	16.46	S0° 00' 00.00"E
L6	5.00	S45° 00' 00.00"W
L7	5.00	S45° 00' 00.00"E
L8	52.46	S0° 00' 00.00"E
L9	16.00	N90° 00' 00.00"W
L10	15.40	S0° 00' 00.00"E
L11	58.00	N90° 00' 00.00"W
L12	16.00	N0° 00' 00.00"E
L13	6.11	N90° 00' 00.00"W
L14	6.80	S24° 38' 18.61"W
L15	11.16	S0° 21' 30.35"W
L16	11.15	N0° 21' 39.23"E
L17	16.21	N24° 38' 18.61"E
L18	9.09	N0° 00' 00.00"E
L19	16.00	N90° 00' 00.00"W
L20	16.00	N90° 00' 00.00"E

Parcel Line Table		
Line #	Length	Direction
L21	8.00	N0° 00' 00.00"E
L22	16.00	N90° 00' 00.00"W
L23	70.46	N0° 00' 00.00"E
L24	5.00	N45° 00' 00.00"E
L25	5.00	N45° 00' 00.00"W
L26	16.46	N0° 00' 00.00"E
L27	16.00	N90° 00' 00.00"E
L28	2.00	N0° 00' 00.00"E
L29	16.00	N90° 00' 00.00"W
L30	31.00	N0° 00' 00.00"E
L31	16.00	N90° 00' 00.00"E
L32	27.24	N68° 35' 25.04"E
L33	26.00	N90° 00' 00.00"E
L34	32.00	N90° 00' 00.00"W
L35	5.00	N45° 00' 00.00"E
L36	5.00	S45° 00' 00.00"E
L37	5.00	N45° 00' 00.00"W
L38	5.00	S45° 00' 00.00"W
L39	16.00	N90° 00' 00.00"W
L40	16.00	N90° 00' 00.00"E

Parcel Line Table		
Line #	Length	Direction
L41	5.00	N45° 00' 00.00"E
L42	5.00	S45° 00' 00.00"E
L43	5.00	N45° 00' 00.00"W
L44	5.00	S45° 00' 00.00"W
L45	16.00	N90° 00' 00.00"E
L46	34.00	S0° 00' 00.00"E
L47	10.98	N90° 00' 00.00"W
L48	20.68	N19° 29' 48.53"W
L49	7.00	N0° 00' 00.00"E
L50	26.27	N90° 00' 00.00"W
L51	5.50	N0° 00' 00.00"E
L52	5.06	N90° 00' 00.00"E
L53	12.17	N90° 00' 00.00"W
L54	17.50	N0° 00' 00.00"E
L55	36.78	S19° 29' 48.53"E
L56	197.05	N90° 00' 00.00"W
L57	169.75	N90° 00' 00.00"E
L58	89.94	S18° 22' 08.48"E
L59	48.97	N0° 00' 00.00"E
L60	20.00	N90° 00' 00.00"W

Parcel Line Table		
Line #	Length	Direction
L61	55.00	N0° 00' 00.00"E
L62	182.45	N90° 00' 00.00"W
L63	52.38	N0° 00' 05.24"W
L64	53.19	S0° 00' 04.69"E
L65	19.72	S0° 00' 01.34"E
L66	23.25	S24° 13' 49.36"E
L67	0.59	S0° 00' 00.00"E
L68	16.00	N90° 00' 00.00"W
L69	58.00	S0° 00' 00.00"E
L70	16.00	N90° 00' 00.00"E
L71	2.00	S0° 00' 00.00"E
L72	16.00	N90° 00' 00.00"W
L73	22.00	S0° 00' 00.00"E
L74	16.00	N90° 00' 00.00"E
L75	35.00	S0° 00' 00.00"E
L76	16.00	N90° 00' 00.00"W
L77	40.00	S0° 00' 00.00"E
L78	16.00	N90° 00' 00.00"E
L79	2.00	N0° 00' 00.00"E
L80	16.00	N90° 00' 00.00"W

Curve Table			
Curve #	Length	Radius	Delta
C1	4.59	15.00	17°31'12"
C2	25.46	10.00	145°52'50"
C3	40.35	40.00	57°47'31"
C4	15.48	46.04	19°15'45"
C5	4.71	3.00	90°00'00"
C6	4.71	3.00	90°00'00"
C7	4.71	3.00	90°00'00"
C8	6.84	6.00	65°21'41"
C9	6.36	15.00	24°16'39"
C10	2.00	16.72	6°51'32"
C11	2.01	15.00	7°39'40"
C12	17.37	41.00	24°16'39"
C13	10.75	25.00	24°38'19"
C14	4.71	3.00	90°00'00"
C15	4.71	3.00	90°00'00"
C16	4.71	3.00	90°00'00"
C17	4.71	3.00	90°00'00"
C18	4.71	3.00	90°00'00"
C19	4.71	3.00	90°00'00"
C20	41.46	34.02	69°49'23"

Curve Table			
Curve #	Length	Radius	Delta
C21	4.05	15.00	15°27'57"
C22	9.42	6.00	90°00'00"
C23	9.42	6.00	90°00'00"
C24	4.71	3.00	90°00'00"
C25	4.71	3.00	90°00'00"
C26	4.71	3.00	90°00'00"
C27	4.71	3.00	90°00'00"
C28	4.71	3.00	90°00'00"
C29	4.71	3.00	90°00'00"
C30	5.22	20.04	14°54'32"
C31	4.12	3.00	78°43'55"
C32	4.71	3.00	90°00'00"
C33	4.42	3.00	84°26'39"
C34	18.32	14.06	74°38'48"
C35	45.73	100.00	26°12'11"
C36	35.89	30.00	68°32'34"
C37	8.44	25.00	19°19'58"
C38	37.51	30.00	71°37'52"
C39	26.83	15.45	99°28'50"
C40	9.42	6.00	90°00'00"

Curve Table			
Curve #	Length	Radius	Delta
C41	17.07	30.00	32°36'36"
C42	16.54	29.95	31°39'13"
C43	1.91	15.00	7°18'04"
C44	16.63	40.89	23°18'20"
C45	6.34	15.00	24°13'49"
C46	4.72	2.99	90°18'56"
C47	4.71	3.00	90°00'00"
C48	4.71	3.00	90°00'00"
C49	4.71	3.00	90°00'00"
C50	4.71	3.00	90°00'00"
C51	4.71	3.00	90°00'00"
C52	4.71	3.00	90°00'00"
C53	4.71	3.00	90°00'00"
C54	4.71	3.00	90°00'00"
C55	4.71	3.00	90°00'00"
C56	9.42	6.00	90°00'00"
C57	4.71	3.00	90°00'00"
C58	4.71	3.00	90°00'00"
C59	4.71	3.00	89°59'45"
C60	4.71	3.00	90°00'00"

Parcel Line Table		
Line #	Length	Direction
L81	61.46	S0° 00' 00.00"E
L82	5.00	S45° 00' 00.00"E
L83	5.00	S45° 00' 00.00"W
L84	25.46	S0° 00' 00.00"E
L85	16.00	N90° 00' 00.00"E
L86	2.00	S0° 00' 00.00"E
L87	16.00	N90° 00' 00.00"W
L88	61.46	S0° 00' 00.00"E
L89	5.00	S45° 00' 00.00"E
L90	5.00	S45° 00' 00.00"W
L91	7.46	S0° 00' 00.00"E
L92	16.00	N90° 00' 00.00"E
L93	35.89	S0° 00' 00.00"E
L94	18.00	N89° 59' 59.70"W
L95	16.00	N0° 00' 00.00"E
L96	20.00	N90° 00' 00.00"W
L97	17.00	S0° 00' 00.00"E
L98	17.50	N90° 00' 00.00"W
L99	70.46	S0° 00' 00.00"E
L100	5.00	S45° 00' 00.00"E

Parcel Line Table		
Line #	Length	Direction
L101	5.00	S45° 00' 00.00"W
L102	16.46	S0° 00' 00.00"E
L103	19.50	N90° 00' 00.00"E
L104	16.00	S0° 00' 14.43"E
L105	49.00	N90° 00' 00.00"E
L106	16.00	N0° 00' 00.00"E
L107	2.00	N90° 00' 00.00"E
L108	16.00	S0° 00' 00.00"E
L109	25.46	N90° 00' 00.00"E
L110	5.00	N45° 00' 00.00"E
L111	5.00	S45° 00' 00.00"E
L112	61.46	N90° 00' 00.00"E
L113	16.00	N0° 00' 00.00"E
L114	2.00	N90° 00' 00.00"E
L115	16.00	S0° 00' 00.00"E
L116	58.00	N90° 00' 00.00"E
L117	17.00	N0° 00' 00.00"E
L118	17.00	N90° 00' 00.00"E
L119	25.46	N0° 00' 00.00"E
L120	5.00	N45° 00' 00.00"W

Parcel Line Table		
Line #	Length	Direction
L121	5.00	N45° 00' 00.00"E
L122	61.46	N0° 00' 00.00"E
L123	110.00	S89° 59' 59.95"W
L124	15.17	N0° 00' 00.00"E
L125	54.55	N89° 59' 59.90"E
L126	30.00	N79° 26' 01.55"E
L127	28.03	N89° 59' 54.46"E
L128	19.29	N0° 00' 01.34"W
L129	23.25	N24° 13' 49.36"W
L130	339.31	S0° 00' 01.40"E
L131	42.51	N89° 59' 56.84"W
L132	34.34	S80° 22' 03.99"W
L133	26.69	N89° 59' 55.82"W
L134	30.96	S0° 00' 00.00"E
L136	3.75	S89° 43' 21.43"W
L138	16.00	N0° 00' 00.00"E
L139	47.00	N90° 00' 00.00"W
L140	5.00	N0° 00' 00.00"E
L141	47.00	N90° 00' 00.00"E
L142	16.00	N0° 00' 00.00"E

Parcel Line Table		
Line #	Length	Direction
L144	3.75	S89° 43' 24.33"E
L146	37.00	N0° 00' 00.00"E
L148	3.77	S89° 43' 22.87"E
L150	30.96	S0° 00' 00.00"E
L152	3.77	S89° 43' 30.99"W
L154	30.96	S0° 00' 00.00"E
L156	1.00	S88° 57' 40.38"W
L158	15.90	N0° 00' 00.00"E
L159	47.00	N90° 00' 00.00"W
L160	5.00	N0° 00' 00.00"E
L161	47.00	N90° 00' 00.00"E
L162	16.10	N0° 00' 00.00"E
L164	1.00	S88° 57' 40.38"E
L166	21.00	N0° 00' 00.00"E
L168	1.00	S88° 57' 42.73"E
L170	30.96	S0° 00' 00.00"E
L172	1.00	S88° 57' 31.89"W

Curve Table			
Curve #	Length	Radius	Delta
C61	4.71	3.00	90°00'00"
C62	4.71	3.00	90°00'00"
C63	4.71	3.00	90°00'00"
C64	4.71	3.00	90°00'00"
C65	6.28	4.00	90°00'00"
C66	6.28	4.00	90°00'02"
C67	10.33	56.00	10°33'58"
C68	5.67	30.00	10°49'35"
C69	4.17	15.00	15°56'44"
C70	2.10	15.00	8°01'25"
C71	5.71	15.45	21°11'38"
C72	17.34	41.00	24°16'39"
C73	23.56	15.00	90°00'00"
C74	5.04	30.00	9°37'56"
C75	9.42	56.00	9°38'01"
C76	3.92	15.00	14°58'58"
C83	9.43	6.00	90°03'05"
C84	4.71	3.00	90°00'00"
C85	4.71	3.00	90°00'00"
C86	9.42	6.00	90°00'00"

Curve Table			
Curve #	Length	Radius	Delta
C87	4.71	3.00	90°00'00"
C88	9.42	6.00	90°00'00"
C89	9.42	6.00	90°00'00"
C90	4.71	3.00	90°00'00"
C91	9.42	6.00	90°00'00"
C92	4.82	3.00	91°52'57"
C93	4.61	3.00	87°57'19"
C94	9.42	6.00	90°00'00"
C95	4.82	3.00	91°52'57"
C96	9.42	6.00	90°00'00"
C97	9.42	6.00	90°00'00"
C98	4.61	3.00	87°57'19"

Underground Service Alert
Call: TOLL FREE 811
www.call811.com
TWO WORKING DAYS BEFORE YOU DIG

NOTE: WORK CONTAINED WITHIN THESE PLANS SHALL NOT COMMENCE UNTIL AN ENCROACHMENT PERMIT AND/OR A GRADING PERMIT HAS BEEN ISSUED.
THE PRIVATE ENGINEER SIGNING THESE PLANS IS RESPONSIBLE FOR ASSURING THE ACCURACY AND ACCEPTABILITY OF THE DESIGN HEREON. IN THE EVENT OF DISCREPANCIES ARISING AFTER CITY APPROVAL OR DURING CONSTRUCTION, THE PRIVATE ENGINEER SHALL BE RESPONSIBLE FOR DETERMINING AN ACCEPTABLE SOLUTION AND REVISING THE PLANS FOR APPROVAL BY THE CITY.

BY	MARK	DESCRIPTION	APPR.	DATE	SCALE:
					AS SHOWN
REVISIONS			CITY		

DESIGNED BY: D.L.W.
DRAWN BY: H-Z STAFF
CHECKED BY: J.M.
SCALE: AS SHOWN



PREPARED UNDER THE SUPERVISION OF:
Johnny Murad, R.C.E. NO. 67512
EXPIRATION: 6-30-2023
DATE: _____

Appendix 3: Soils Information

Geotechnical Study and Other Infiltration Testing Data

August 3, 2021

Rockefeller Group Development Corporation
4 Park Plaza, Suite 840
Irvine, California 92614



**SOUTHERN
CALIFORNIA
GEOTECHNICAL**
A California Corporation

Attention: Mr. Michael Sajjadi
Vice President Design and Construction

Project No.: 21G174-2

Subject: Results of Infiltration Testing
Proposed Industrial Building
SWC Patterson Avenue and Nance Street
Perris, California

Reference: Geotechnical Investigation, Proposed Industrial Building, SWC Patterson Avenue and Nance Street, Perris, California, prepared for Rockefeller Group Development Corporation, by Southern California Geotechnical, Inc. (SCG), SCG Project No. 21G174-2, dated August 2, 2021.

Mr. Sajjadi:

In accordance with your request, we have conducted infiltration testing at the subject site. We are pleased to present this report summarizing the results of the infiltration testing and our design recommendations.

Scope of Services

The scope of services performed for this project was in general accordance with our Proposal No. 21P261, dated May 18, 2021. The scope of services included site reconnaissance, subsurface exploration, field testing, and engineering analysis to determine the infiltration rates of the onsite soils. The infiltration testing was performed in general accordance with ASTM Test Method D-3385-03, Standard Test Method for Infiltration Rate of Soils in Field Using Double Ring Infiltrometer.

Site and Project Description

The subject site is located at the southwest corner of Patterson Avenue and Nance Street in Perris, California. The site is bounded to the north by Nance Street and a truck trailer parking lot, to the west by the Escondido Freeway (Interstate 215) and Wade Avenue, to the south by Washington Street terminus, and to the east by Patterson Avenue. The general location of the site is illustrated on the Site Location Map, included as Plate 1 of this report.

The site consists of an irregular-shaped parcel, 12.1± acres in size. The northwestern portion of the site is currently being utilized for mobile office trailer storage. The ground surface in this area consists of exposed soil and sparse to moderate grass and weed growth. The eastern portion of the site is currently being utilized for trailer storage. The ground surface cover in this area consists of crushed aggregate base (CAB). The southern area of the site is currently being

utilized for construction equipment storage. Approximately eight (8) buildings/canopies are located in the southern area of the site. These building/canopies range from 850± to 2,000± ft² in size. The ground surface cover consists of exposed soil with numerous trench plates. It should be noted that the northwestern portion of the site was inaccessible to drilling equipment at the time of the investigation due to a locked chain-link fence.

Detailed topographic information was not available at the time of this report. Based on elevations obtained from Google Earth, and visual observations made at the time of the subsurface investigation, the overall site topography slopes gently downward to the northeast at a gradient of 1± percent. There is approximately 10 feet of elevation differential across the overall site.

Proposed Development

SCG was provided with a conceptual site plan (Scheme 2) prepared by HPA Architecture. Based on this site plan, the site will be developed with one (1) new industrial building, 255,000± ft² in size, located in the south-central area of the site. Dock-high doors will be constructed along portions of the north building wall. The building will be surrounded by asphaltic concrete (AC) pavements in the parking and drive lanes, Portland cement concrete (PCC) pavements in the loading dock areas, and limited areas of concrete flatwork and landscape planters throughout.

We understand that the proposed development will include on-site stormwater infiltration. The type of infiltration system was not available at the time of our infiltration testing. It is expected that the infiltration system will consist of shallow detention basins, below-grade chambers, or bio-swales, extending to a depth of 6± feet below the existing site grades.

Concurrent Study

SCG concurrently conducted a geotechnical investigation at the subject site, which is referenced above. As part of this study, five (5) borings were advanced to depths of 5 to 30± feet below existing site grades. A surficial layer of aggregate base (AB) was encountered at all of the boring locations, measuring 5 to 6± inches in thickness. Artificial fill soils were encountered beneath the existing AB at Boring No. B-2, extending to a depth of 2± feet below the existing site grades. The fill soils generally consist of medium dense silty fine sands. The fill soils possess a disturbed appearance, resulting in their classification as artificial fill. Native alluvium was encountered beneath the AB pavements or beneath the fill soils at all of the boring locations. The native upper strata of alluvial soils encountered at Boring Nos. B-2 through B-5 were classified as younger alluvium and extend to depths of 5 to 8± feet below the existing site grades. The younger alluvium generally possesses lower densities than the soils classified as older alluvium. The younger alluvium generally consists of loose to medium dense silty sands and clayey sands, with varying amounts of clay and silt content. Boring No. B-5 was terminated in younger alluvium at a depth of 5± feet below the existing site grades. Older native alluvial soils were encountered beneath the AB and/or beneath the younger alluvium at Boring Nos. B-1 through B-4. The soils classified as older alluvium generally possess higher densities than the younger alluvial soils and many samples were observed to be cemented. Most of the older alluvial soils encountered at the boring locations consist of medium dense to very dense silty sands and clayey sands. Boring Nos. B-1 and B-4 also encountered interbedded layers of hard

sandy clays. The older native alluvial soils extend to at least the maximum depth explored of 30± feet below the existing site grades.

Groundwater

Groundwater was not encountered at any of the boring locations. Based on the lack of any water within the borings, and the moisture contents of the recovered soil samples, the static groundwater table is considered to have existed at a depth in excess of 30± feet below existing site grades, at the time of the subsurface investigation.

Recent water level data was obtained from the California Department of Water Resources Water Data Library website, <http://wdl.water.ca.gov/>. The nearest monitoring well on record is located 60± feet south of the site. Water level readings within this monitoring well indicate a groundwater level of 67.1± feet below the ground surface in March 2021.

Subsurface Exploration

Scope of Exploration

The subsurface exploration for the infiltration testing consisted of three (3) backhoe-excavated trenches, extending to a depth of 6± feet below existing site grades. The trenches were logged during excavation by a member of our staff. The approximate locations of the infiltration trenches (identified as I-1 through I-3) are indicated on the Infiltration Test Location Plan, enclosed as Plate 2 of this report.

Geotechnical Conditions

A surficial layer of AB was encountered at all of the infiltration test locations, measuring 8± inches in thickness. Native younger alluvium was encountered beneath the AB at all of the infiltration testing locations, extending to at least the maximum explored depth of 6± feet below existing site grades. The alluvial soils consist of very dense silty sands and clayey sands with varying silt and clay content. The Trench Logs, which illustrate the conditions encountered at the infiltration test locations, are presented in this report.

Infiltration Testing

We understand that the results of the testing will be used to prepare a preliminary design for the storm water infiltration system that will be used at the subject site. As previously mentioned, the infiltration testing was performed in general accordance with ASTM Test Method D-3385-03, Standard Test Method for Infiltration Rate of Soils in Field Using Double Ring Infiltrometer.

Two stainless steel infiltration rings were used for the infiltration testing. The outer infiltration ring is 2 feet in diameter and 20 inches in height. The inner infiltration ring is 1 foot in diameter and 20 inches in height. At the test locations, the outer ring was driven 3± inches into the soil at the base of each trench. The inner ring was centered inside the outer ring and subsequently driven 3± inches into the soil at the base of the trench. The rings were driven into the soil using

a ten-pound sledge hammer. The soil surrounding the wall of the infiltration rings was only slightly disturbed during the driving process.

Infiltration Testing Procedure

Infiltration testing was performed at both of the trench locations. The infiltration testing consisted of filling the inner ring and the annular space (the space between the inner and outer rings) with water, approximately 3 to 4 inches above the soil. To prevent the flow of water from one ring to the other, the water level in both the inner ring and the annular space between the rings was maintained using constant-head float valves. The volume of water that was added to maintain a constant head in the inner ring and the annular space during each time interval was determined and recorded. A cap was placed over the rings to minimize the evaporation of water during the tests.

The schedule for readings was determined based on the observed soil type at the base of each backhoe-excavated trench. Based on the existing soils at the trench locations, the volumetric measurements were made at 15-minute increments. The water volume measurements are presented on the spreadsheets enclosed with this report. The infiltration rates for each of the timed intervals are also tabulated on these spreadsheets.

The infiltration rates for the infiltration tests are calculated in centimeters per hour and then converted to inches per hour. The rates are summarized below:

<u>Infiltration Test No.</u>	<u>Depth (feet)</u>	<u>Soil Description</u>	<u>Infiltration Rate (inches/hour)</u>
I-1	6	Brown Silty fine to coarse Sand, trace Clay, trace fine Gravel	0.92
I-2	6	Brown Silty fine to medium Sand, trace coarse Sand	0.65
I-3	6	Brown Clayey fine to medium Sand, little Silt, trace coarse Sand	0.32

Design Recommendations

Three (3) infiltration tests were performed at the subject site. As note above, the calculated infiltration rates at the infiltration test locations range from 0.3 to 0.9 inches per hour. Based on the results of infiltration testing, we recommend that an infiltration rate of 0.6 inches per hour be used for the proposed infiltration system located in the eastern most region of the site. No factor of safety has been applied to this infiltration rate. As discussed further below, the project civil engineer or system designer should apply any appropriate safety factors.

We recommend that a representative from the geotechnical engineer be on-site during the construction of the proposed infiltration system to identify the soil classification at the base of the infiltration basin. It should be confirmed that the soils at the base of the proposed infiltration system corresponds with those presented in this report to ensure that the performance of the system will be consistent with the rates reported herein.

The design of the storm water infiltration system should be performed by the project civil engineer, in accordance with the City of Perris and/or County of Riverside guidelines. It is recommended that the system be constructed so as to facilitate removal of silt and clay, or other deleterious materials from any water that may enter the systems. The presence of such materials would decrease the effective infiltration rates. It is recommended that the project civil engineer apply an appropriate factor of safety. The infiltration rates recommended above is based on the assumption that only clean water will be introduced to the subsurface profile. Any fines, debris, or organic materials could significantly impact the infiltration rate. It should be noted that the recommended infiltration rates are based on infiltration testing at three (3) discrete locations and that the overall infiltration rates of the proposed infiltration systems could vary considerably.

Infiltration Rate Considerations

The infiltration rates presented herein was determined in accordance with the Riverside County guidelines and are considered valid only for the time and place of the actual test. Varying subsurface conditions will exist in other areas of the site, which could alter the recommended infiltration rates presented above. The infiltration rates will decline over time between maintenance cycles as silt or clay particles accumulate on the BMP surface. The infiltration rate is highly dependent upon a number of factors, including density, silt and clay content, grainsize distribution throughout the range of particle sizes, and particle shape. Small changes in these factors can cause large changes in the infiltration rates.

Infiltration rates are based on unsaturated flow. As water is introduced into soils by infiltration, the soils become saturated and the wetting front advances from the unsaturated zone to the saturated zone. Once the soils become saturated, infiltration rates become zero, and water can only move through soils by hydraulic conductivity at a rate determined by pressure head and soil permeability. Changes in soil moisture content will affect the infiltration rate. Infiltration rates should be expected to decrease until the soils become saturated. Soil permeability values will then govern groundwater movement. Permeability values may be on the order of 10 to 20 times less than infiltration rates. The system designer should incorporate adequate factors of safety and allow for overflow design into appropriate traditional storm drain systems, which would transport storm water off-site.

Construction Considerations

The infiltration rates presented in this report are specific to the tested locations and tested depths. Infiltration rates can be significantly reduced if the soils are exposed to excessive disturbance or compaction during construction. Compaction of the soils at the bottom of the infiltration system can significantly reduce the infiltration ability of the basins. Therefore, the subgrade soils within proposed infiltration system areas should not be over-excavated, undercut or compacted in any significant manner. It is recommended that a note to this effect be added to the project plans and/or specifications.

We recommend that a representative from the geotechnical engineer be on-site during the construction of the proposed infiltration systems to identify the soil classification at the base of each system. It should be confirmed that the soils at the base of the proposed infiltration

systems correspond with those presented in this report to ensure that the performance of the systems will be consistent with the rates reported herein.

We recommend that scrapers and other rubber-tired heavy equipment not be operated on the basin bottom, or at levels lower than 2 feet above the bottom of the system, particularly within basins. As such, the bottom 24 inches of the infiltration systems should be excavated with non-rubber-tired equipment, such as excavators.

Infiltration Chamber Maintenance

The proposed project may include infiltration chambers. Water flowing into these chambers will carry some level of sediment. This layer has the potential to significantly reduce the infiltration rate of the chamber subgrade soils. Therefore, a formal chamber maintenance program should be established to ensure that these silt and clay deposits are removed from the chamber on a regular basis.

Basin Maintenance

The proposed project may include infiltration basins. Water flowing into these basins will carry some level of sediment. Wind-blown sediments and erosion of the basin side walls will also contribute to sediment deposition at the bottom of the basin. This layer has the potential to significantly reduce the infiltration rate of the basin subgrade soils. Therefore, a formal basin maintenance program should be established to ensure that these silt and clay deposits are removed from the basin on a regular basis. Appropriate vegetation on the basin sidewalls and bottom may reduce erosion and sediment deposition.

Basin maintenance should also include measures to prevent animal burrows, and to repair any burrows or damage caused by such. Animal burrows in the basin sidewalls can significantly increase the risk of erosion and piping failures.

Location of Infiltration Systems

The use of on-site storm water infiltration systems carries a risk of creating adverse geotechnical conditions. Increasing the moisture content of the soil can cause the soil to lose internal shear strength and increase its compressibility, resulting in a change in the designed engineering properties. Overlying structures and pavements in the infiltration area could potentially be damaged due to saturation of the subgrade soils. The proposed infiltration systems for this site should be located at least 25 feet away from any structures, including retaining walls. Even with this provision of locating the infiltration system at least 25 feet from the building(s), it is possible that infiltrating water into the subsurface soils could have an adverse effect on the proposed or existing structures. It should also be noted that utility trenches which happen to collect storm water can also serve as conduits to transmit storm water toward the structure, depending on the slope of the utility trench. Therefore, consideration should also be given to the proposed locations of underground utilities which may pass near the proposed infiltration system.

The infiltration system designer should also give special consideration to the effect that the proposed infiltration systems may have on nearby subterranean structures,

open excavations, or descending slopes. In particular, infiltration systems should not be located near the crest of descending slopes, particularly where the slopes are comprised of granular soils. Such systems will require specialized design and analysis to evaluate the potential for slope instability, piping failures and other phenomena that typically apply to earthen dam design. This type of analysis is beyond the scope of this infiltration test report, but these factors should be considered by the infiltration system designer when locating the infiltration systems.

Closure

We sincerely appreciate the opportunity to be of service on this project. We look forward to providing additional consulting services during the course of the project. If we may be of further assistance in any manner, please contact our office.

Respectfully Submitted,

SOUTHERN CALIFORNIA GEOTECHNICAL, INC.



Ricardo Frias, RCE 91772
Project Engineer

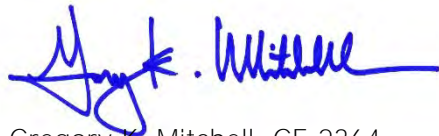

Gregory K. Mitchell, GE 2364
Principal Engineer



Distribution: (1) Addressee

Enclosures: Plate 1 - Site Location Map
Plate 2: Infiltration Test Location Plan
Trench Log Legend and Logs (5 pages)
Infiltration Test Results Spreadsheets (3 pages)
Grainsize Distribution Graphs (3 pages)

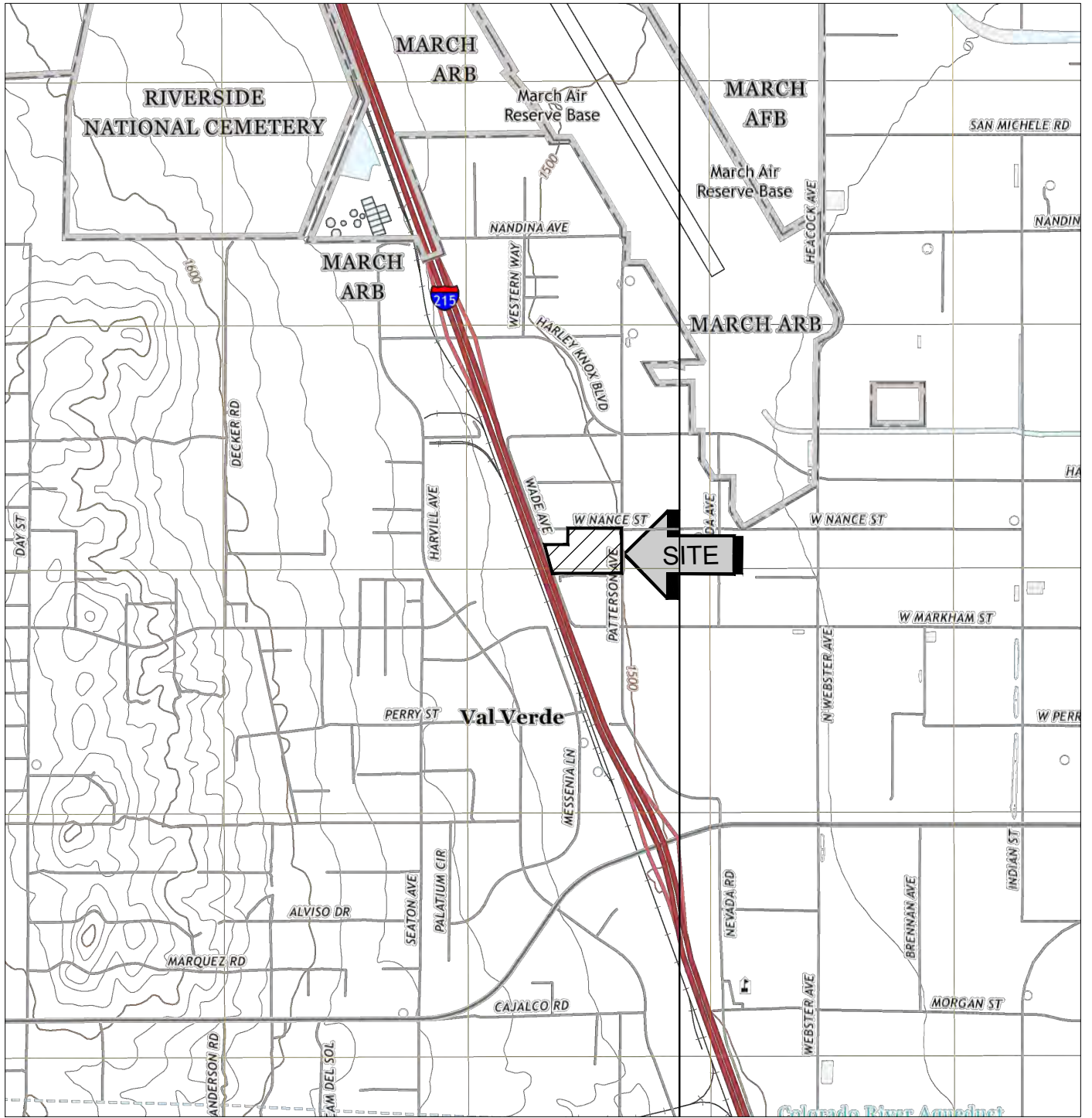

SOURCE: USGS TOPOGRAPHIC MAP OF THE STEELE PEAK & PERRIS QUADRANGLES, RIVERSIDE COUNTY, CALIFORNIA, 2018



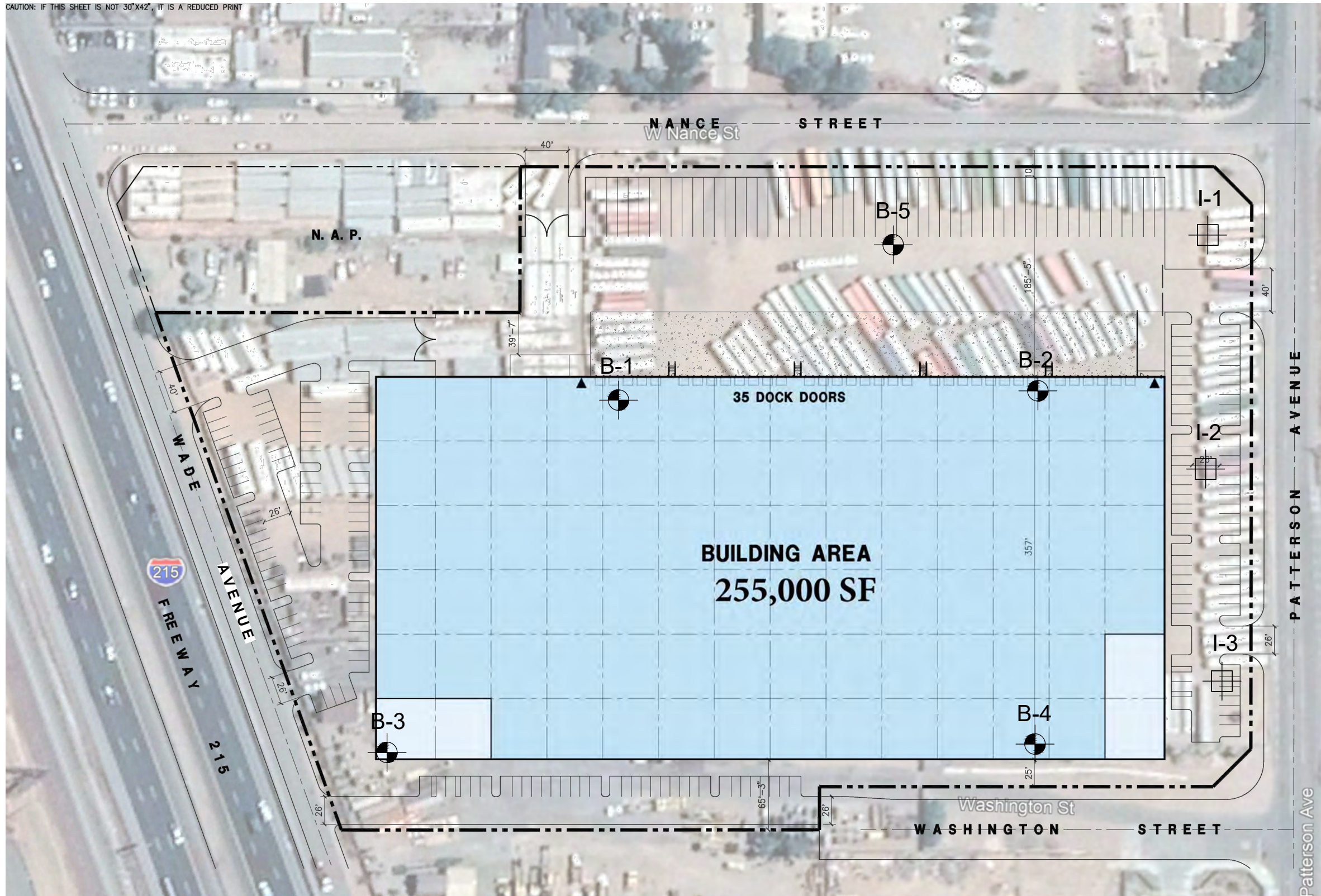

SITE LOCATION MAP	
PROPOSED INDUSTRIAL BUILDING	
PERRIS, CALIFORNIA	
SCALE: 1" = 2000'	
DRAWN: MD	
CHKD: RGT	
SCG PROJECT 21G174-2	
PLATE 1	
	SOUTHERN CALIFORNIA GEOTECHNICAL

CAUTION: IF THIS SHEET IS NOT 30"x42", IT IS A REDUCED PRINT



GEOTECHNICAL LEGEND



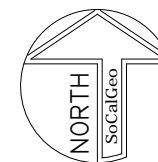



-  APPROXIMATE INFILTRATION LOCATION
-  APPROXIMATE BORING LOCATION (SCG PROJECT NO. 21G174-1)

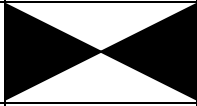

NOTE: BASE MAP PREPARED BY HPA ARCHITECTURE, INC.

INFILTRATION TEST LOCATION PLAN	
PROPOSED INDUSTRIAL BUILDING	
PERRIS, CALIFORNIA	
SCALE: 1" = 100'	 SOUTHERN CALIFORNIA GEOTECHNICAL
DRAWN: MD	
CHKD: GKM	
SCG PROJECT 21G174-2	
PLATE 2	

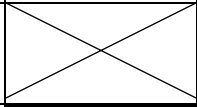
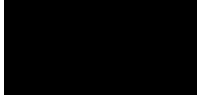
TRENCH LOG LEGEND

SAMPLE TYPE	GRAPHICAL SYMBOL	SAMPLE DESCRIPTION
AUGER		SAMPLE COLLECTED FROM AUGER CUTTINGS, NO FIELD MEASUREMENT OF SOIL STRENGTH. (DISTURBED)
CORE		ROCK CORE SAMPLE: TYPICALLY TAKEN WITH A DIAMOND-TIPPED CORE BARREL. TYPICALLY USED ONLY IN HIGHLY CONSOLIDATED BEDROCK.
GRAB		SOIL SAMPLE TAKEN WITH NO SPECIALIZED EQUIPMENT, SUCH AS FROM A STOCKPILE OR THE GROUND SURFACE. (DISTURBED)
CS		CALIFORNIA SAMPLER: 2-1/2 INCH I.D. SPLIT BARREL SAMPLER, LINED WITH 1-INCH HIGH BRASS RINGS. DRIVEN WITH SPT HAMMER. (RELATIVELY UNDISTURBED)
NSR		NO RECOVERY: THE SAMPLING ATTEMPT DID NOT RESULT IN RECOVERY OF ANY SIGNIFICANT SOIL OR ROCK MATERIAL.
SPT		STANDARD PENETRATION TEST: SAMPLER IS A 1.4 INCH INSIDE DIAMETER SPLIT BARREL, DRIVEN 18 INCHES WITH THE SPT HAMMER. (DISTURBED)
SH		SHELBY TUBE: TAKEN WITH A THIN WALL SAMPLE TUBE, PUSHED INTO THE SOIL AND THEN EXTRACTED. (UNDISTURBED)
VANE		VANE SHEAR TEST: SOIL STRENGTH OBTAINED USING A 4 BLADED SHEAR DEVICE. TYPICALLY USED IN SOFT CLAYS-NO SAMPLE RECOVERED.

COLUMN DESCRIPTIONS

DEPTH:

Distance in feet below the ground surface.

SAMPLE:

Sample Type as depicted above.

BLOW COUNT:

Number of blows required to advance the sampler 12 inches using a 140 lb hammer with a 30-inch **drop. 50/3" indicates penetration refusal** (>50 blows) at 3 inches. WH indicates that the weight of the hammer was sufficient to push the sampler 6 inches or more.

POCKET PEN.:

Approximate shear strength of a cohesive soil sample as measured by pocket penetrometer.

GRAPHIC LOG:

Graphic Soil Symbol as depicted on the following page.

DRY DENSITY:

Dry density of an undisturbed or relatively undisturbed sample in lbs/ft³.

MOISTURE CONTENT:

Moisture content of a soil sample, expressed as a percentage of the dry weight.

LIQUID LIMIT:

The moisture content above which a soil behaves as a liquid.

PLASTIC LIMIT:

The moisture content above which a soil behaves as a plastic.

PASSING #200 SIEVE:

The percentage of the sample finer than the #200 standard sieve.

UNCONFINED SHEAR:

The shear strength of a cohesive soil sample, as measured in the unconfined state.

SOIL CLASSIFICATION CHART

MAJOR DIVISIONS			SYMBOLS		TYPICAL DESCRIPTIONS		
			GRAPH	LETTER			
<p>COARSE GRAINED SOILS</p> <p>MORE THAN 50% OF MATERIAL IS LARGER THAN NO. 200 SIEVE SIZE</p>	<p>GRAVEL AND GRAVELLY SOILS</p>	<p>CLEAN GRAVELS</p> <p>(LITTLE OR NO FINES)</p>		GW	WELL-GRADED GRAVELS, GRAVEL - SAND MIXTURES, LITTLE OR NO FINES		
		<p>GRAVELS WITH FINES</p> <p>(APPRECIABLE AMOUNT OF FINES)</p>		GP	POORLY-GRADED GRAVELS, GRAVEL - SAND MIXTURES, LITTLE OR NO FINES		
		<p>MORE THAN 50% OF COARSE FRACTION RETAINED ON NO. 4 SIEVE</p>		GM	SILTY GRAVELS, GRAVEL - SAND - SILT MIXTURES		
		<p>(APPRECIABLE AMOUNT OF FINES)</p>		GC	CLAYEY GRAVELS, GRAVEL - SAND - CLAY MIXTURES		
	<p>SAND AND SANDY SOILS</p>	<p>CLEAN SANDS</p> <p>(LITTLE OR NO FINES)</p>		SW	WELL-GRADED SANDS, GRAVELLY SANDS, LITTLE OR NO FINES		
				SP	POORLY-GRADED SANDS, GRAVELLY SAND, LITTLE OR NO FINES		
		<p>MORE THAN 50% OF COARSE FRACTION PASSING ON NO. 4 SIEVE</p>	<p>SANDS WITH FINES</p> <p>(APPRECIABLE AMOUNT OF FINES)</p>		SM	SILTY SANDS, SAND - SILT MIXTURES	
					SC	CLAYEY SANDS, SAND - CLAY MIXTURES	
			<p>FINE GRAINED SOILS</p> <p>MORE THAN 50% OF MATERIAL IS SMALLER THAN NO. 200 SIEVE SIZE</p>	<p>SILTS AND CLAYS</p> <p>LIQUID LIMIT LESS THAN 50</p>		ML	INORGANIC SILTS AND VERY FINE SANDS, ROCK FLOUR, SILTY OR CLAYEY FINE SANDS OR CLAYEY SILTS WITH SLIGHT PLASTICITY
						CL	INORGANIC CLAYS OF LOW TO MEDIUM PLASTICITY, GRAVELLY CLAYS, SANDY CLAYS, SILTY CLAYS, LEAN CLAYS
	OL	ORGANIC SILTS AND ORGANIC SILTY CLAYS OF LOW PLASTICITY					
<p>SILTS AND CLAYS</p> <p>LIQUID LIMIT GREATER THAN 50</p>		MH		INORGANIC SILTS, MICACEOUS OR DIATOMACEOUS FINE SAND OR SILTY SOILS			
		CH		INORGANIC CLAYS OF HIGH PLASTICITY			
		OH		ORGANIC CLAYS OF MEDIUM TO HIGH PLASTICITY, ORGANIC SILTS			
<p>HIGHLY ORGANIC SOILS</p>				PT	PEAT, HUMUS, SWAMP SOILS WITH HIGH ORGANIC CONTENTS		

NOTE: DUAL SYMBOLS ARE USED TO INDICATE BORDERLINE SOIL CLASSIFICATIONS



JOB NO.: 21G174-2	EXCAVATION DATE: 7/12/21	WATER DEPTH: Dry
PROJECT: Proposed Industrial Building	EXCAVATION METHOD: Backhoe	CAVE DEPTH: --
LOCATION: Perris, California	LOGGED BY: Caleb Brackett	READING TAKEN: At Completion

FIELD RESULTS					DESCRIPTION	LABORATORY RESULTS						COMMENTS
DEPTH (FEET)	SAMPLE	BLOW COUNT	POCKET PEN. (TSF)	GRAPHIC LOG		DRY DENSITY (PCF)	MOISTURE CONTENT (%)	LIQUID LIMIT	PLASTIC LIMIT	PASSING #200 SIEVE (%)	ORGANIC CONTENT (%)	
					SURFACE ELEVATION: --- MSL AGGREGATE BASE: 8± inches Aggregate Base YOUNGER ALLUVIUM: Brown Silty fine to coarse Sand, trace Clay, trace fine Gravel, dense-damp							
5					Trench Terminated at 6'		4					

TBL 21G174-2.GPJ_SOCALGEO.GDT 8/3/21



JOB NO.: 21G174-2	EXCAVATION DATE: 7/12/21	WATER DEPTH: Dry
PROJECT: Proposed Industrial Building	EXCAVATION METHOD: Backhoe	CAVE DEPTH: --
LOCATION: Perris, California	LOGGED BY: Caleb Brackett	READING TAKEN: At Completion

FIELD RESULTS					DESCRIPTION	LABORATORY RESULTS						COMMENTS
DEPTH (FEET)	SAMPLE	BLOW COUNT	POCKET PEN. (TSF)	GRAPHIC LOG		DRY DENSITY (PCF)	MOISTURE CONTENT (%)	LIQUID LIMIT	PLASTIC LIMIT	PASSING #200 SIEVE (%)	ORGANIC CONTENT (%)	
SURFACE ELEVATION: --- MSL												
5					AGGREGATE BASE: 8± inches Aggregate Base YOUNGER ALLUVIUM: Brown Silty fine to medium Sand, trace coarse Sand, dense-damp		6					
					Trench Terminated at 6'							

TBL 21G174-2.GPJ_SOCALGEO.GDT 8/3/21



JOB NO.: 21G174-2	EXCAVATION DATE: 7/12/21	WATER DEPTH: Dry
PROJECT: Proposed Industrial Building	EXCAVATION METHOD: Backhoe	CAVE DEPTH: --
LOCATION: Perris, California	LOGGED BY: Caleb Brackett	READING TAKEN: At Completion

FIELD RESULTS					DESCRIPTION	LABORATORY RESULTS						COMMENTS
DEPTH (FEET)	SAMPLE	BLOW COUNT	POCKET PEN. (TSF)	GRAPHIC LOG		DRY DENSITY (PCF)	MOISTURE CONTENT (%)	LIQUID LIMIT	PLASTIC LIMIT	PASSING #200 SIEVE (%)	ORGANIC CONTENT (%)	
					SURFACE ELEVATION: --- MSL							
					AGGREGATE BASE: 8± inches Aggregate Base							
5					YOUNGER ALLUVIUM: Brown Clayey fine to medium Sand, little Silt, trace coarse Sand, dense-damp		6					
					Trench Terminated at 6'							

TBL 21G174-2.GPJ_SOCALGEO.GDT 8/3/21

INFILTRATION CALCULATIONS

Project Name	Proposed Industrial Building
Project Location	Perris, California
Project Number	21G174-2
Engineer	Caleb Brackett

Infiltration Test No I-1

Constants			
	Diameter (ft)	Area (ft ²)	Area (cm ²)
Inner	1	0.79	730
Anlr. Spac	2	2.36	2189

*Note: The infiltration rate was calculated based on current time interval

Test Interval		Time (hr)	Interval Elapsed (min)	Flow Readings				Infiltration Rates			
				Inner Ring (ml)	Ring Flow (cm ³)	Annular Ring (ml)	Space Flow (cm ³)	Inner Ring* (cm/hr)	Annular Space* (cm/hr)	Inner Ring* (in/hr)	Annular Space* (in/hr)
1	Initial	12:00 PM	15	0	900	0	4200	4.93	7.68	1.94	3.02
	Final	12:15 PM	15	900		4200					
2	Initial	12:15 PM	15	0	650	0	3200	3.56	5.85	1.40	2.30
	Final	12:30 PM	30	650		3200					
3	Initial	12:30 PM	15	0	550	0	3200	3.02	5.85	1.19	2.30
	Final	12:45 PM	45	550		3200					
4	Initial	12:45 PM	15	0	500	0	3050	2.74	5.57	1.08	2.19
	Final	1:00 PM	60	500		3050					
5	Initial	1:00 PM	15	0	500	0	3000	2.74	5.48	1.08	2.16
	Final	1:15 PM	75	500		3000					
6	Initial	1:15 PM	15	0	450	0	2600	2.47	4.75	0.97	1.87
	Final	1:30 PM	90	450		2600					
7	Initial	1:30 PM	15	0	425	0	2500	2.33	4.57	0.92	1.80
	Final	1:45 PM	105	425		2500					
8	Initial	1:45 PM	15	0	400	0	2500	2.19	4.57	0.86	1.80
	Final	2:00 PM	120	400		2500					
9	Initial	2:00 PM	15	0	425	0	2500	2.33	4.57	0.92	1.80
	Final	2:15 PM	135	425		2500					

INFILTRATION CALCULATIONS

Project Name	Proposed Industrial Building
Project Location	Perris, California
Project Number	21G174-2
Engineer	Caleb Brackett

Infiltration Test No I-2

Constants			
	Diameter (ft)	Area (ft ²)	Area (cm ²)
Inner	1	0.79	730
Anlr. Spac	2	2.36	2189

*Note: The infiltration rate was calculated based on current time interval

Test Interval		Time (hr)	Interval Elapsed (min)	Flow Readings				Infiltration Rates			
				Inner Ring (ml)	Ring Flow (cm ³)	Annular Ring (ml)	Space Flow (cm ³)	Inner Ring* (cm/hr)	Annular Space* (cm/hr)	Inner Ring* (in/hr)	Annular Space* (in/hr)
1	Initial	2:30 PM	15	0	650	0	2600	3.56	4.75	1.40	1.87
	Final	2:45 PM	15	650		2600					
2	Initial	2:45 PM	15	0	450	0	2700	2.47	4.93	0.97	1.94
	Final	3:00 PM	30	450		2700					
3	Initial	3:00 PM	15	0	350	0	2600	1.92	4.75	0.76	1.87
	Final	3:15 PM	45	350		2600					
4	Initial	3:15 PM	15	0	400	0	2500	2.19	4.57	0.86	1.80
	Final	3:30 PM	60	400		2500					
5	Initial	3:30 PM	15	0	350	0	2300	1.92	4.20	0.76	1.65
	Final	3:45 PM	75	350		2300					
6	Initial	3:45 PM	15	0	250	0	2300	1.37	4.20	0.54	1.65
	Final	4:00 PM	90	250		2300					
7	Initial	4:00 PM	15	0	250	0	2200	1.37	4.02	0.54	1.58
	Final	4:15 PM	105	250		2200					
8	Initial	4:15 PM	15	0	300	0	2100	1.64	3.84	0.65	1.51
	Final	4:30 PM	120	300		2100					
9	Initial	4:30 PM	15	0	300	0	2100	1.64	3.84	0.65	1.51
	Final	4:45 PM	135	300		2100					

INFILTRATION CALCULATIONS

Project Name	Proposed Industrial Building
Project Location	Perris, California
Project Number	21G174-2
Engineer	Caleb Brackett

Infiltration Test No I-3

Constants			
	Diameter (ft)	Area (ft ²)	Area (cm ²)
Inner	1	0.79	730
Anlr. Spac	2	2.36	2189

*Note: The infiltration rate was calculated based on current time interval

Test Interval		Time (hr)	Interval Elapsed (min)	Flow Readings				Infiltration Rates			
				Inner Ring (ml)	Ring Flow (cm ³)	Annular Ring (ml)	Space Flow (cm ³)	Inner Ring* (cm/hr)	Annular Space* (cm/hr)	Inner Ring* (in/hr)	Annular Space* (in/hr)
1	Initial	8:25 PM	25	0	600	0	3200	1.97	3.51	0.78	1.38
	Final	8:50 PM	25	600	600	3200					
2	Initial	8:50 PM	15	0	300	0	2500	1.64	4.57	0.65	1.80
	Final	9:05 PM	40	300	300	2500					
3	Initial	9:05 PM	15	0	250	0	2500	1.37	4.57	0.54	1.80
	Final	9:20 PM	55	250	250	2500					
4	Initial	9:20 PM	15	0	250	0	2200	1.37	4.02	0.54	1.58
	Final	9:35 PM	70	250	250	2200					
5	Initial	9:35 PM	15	0	225	0	2100	1.23	3.84	0.49	1.51
	Final	9:50 PM	85	225	225	2100					
6	Initial	9:50 PM	15	0	200	0	2050	1.10	3.75	0.43	1.47
	Final	10:05 PM	100	200	200	2050					
7	Initial	10:05 PM	15	0	150	0	2000	0.82	3.65	0.32	1.44
	Final	10:20 PM	115	150	150	2000					
8	Initial	10:20 PM	15	0	150	0	2000	0.82	3.65	0.32	1.44
	Final	10:35 PM	130	150	150	2000					
9	Initial	10:35 PM	15	0	150	0	2000	0.82	3.65	0.32	1.44
	Final	10:50 PM	145	150	150	2000					

Grain Size Distribution

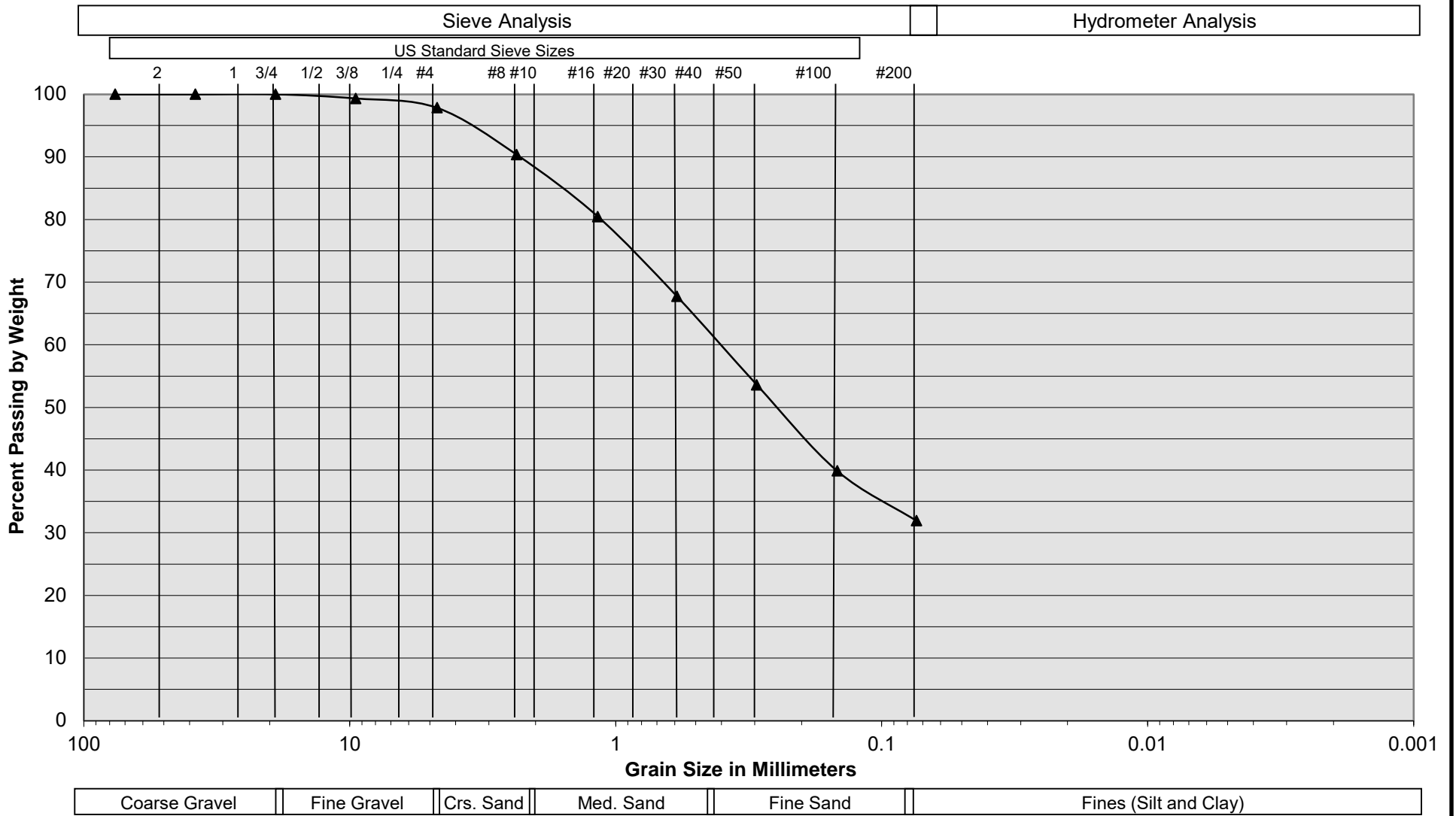

Sample Description	I-1 @ 6'
Soil Classification	Brown Silty fine to coarse Sand, trace Clay, trace fine Gravel

Proposed Industrial Building
 Perris, California
 Project No. 21G174-2
PLATE C- 1

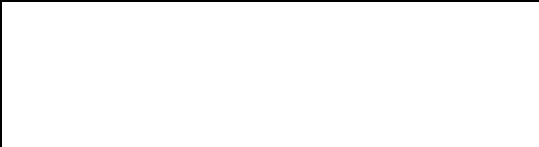



SOUTHERN CALIFORNIA GEOTECHNICAL
A California Corporation

Grain Size Distribution

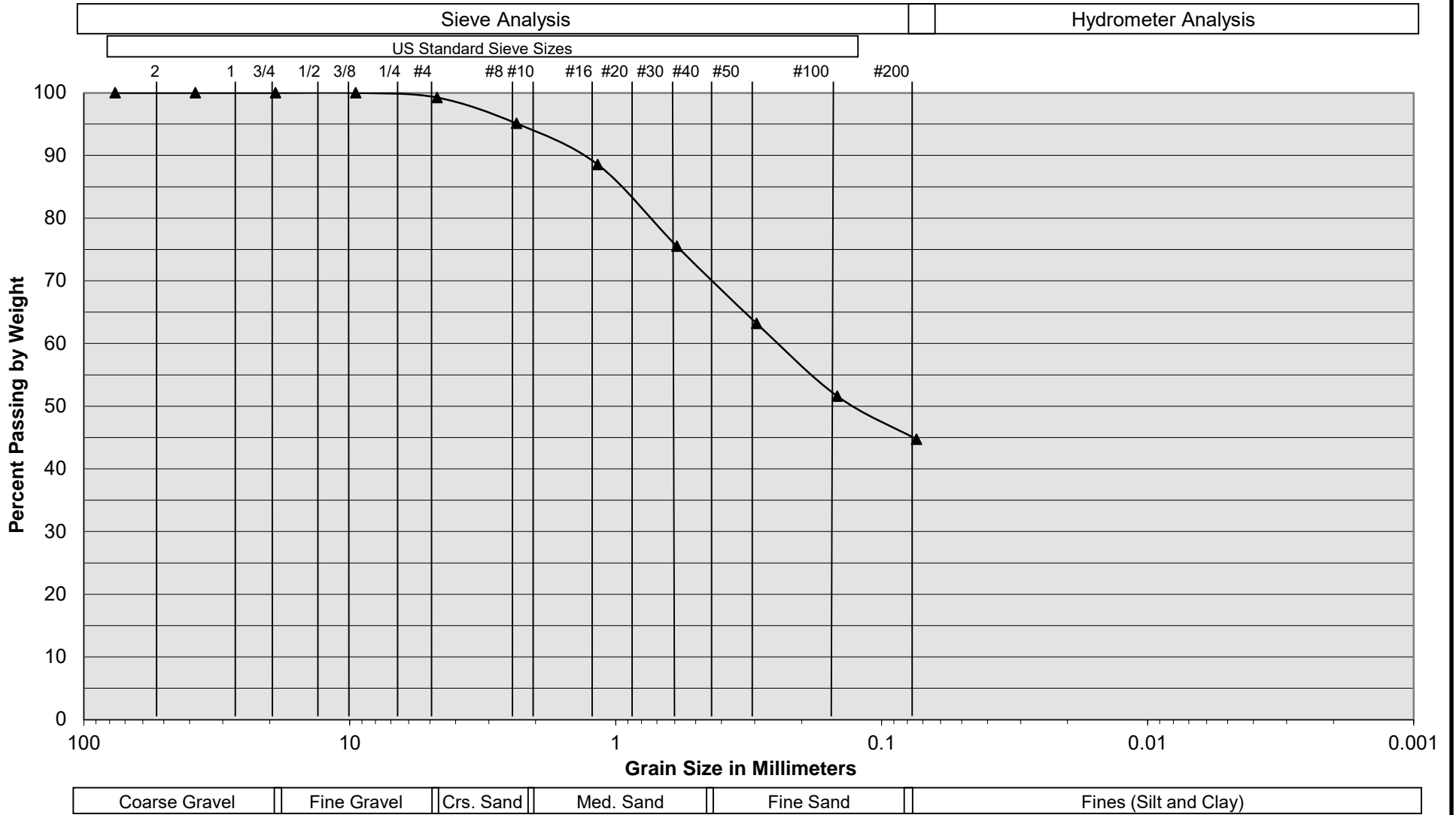

Sample Description	I-2 @ 6'
Soil Classification	Brown Silty fine to medium Sand, trace coarse Sand

Proposed Industrial Building
 Perris, California
 Project No. 21G174-2
PLATE C- 2



SOUTHERN CALIFORNIA GEOTECHNICAL
A California Corporation

Grain Size Distribution

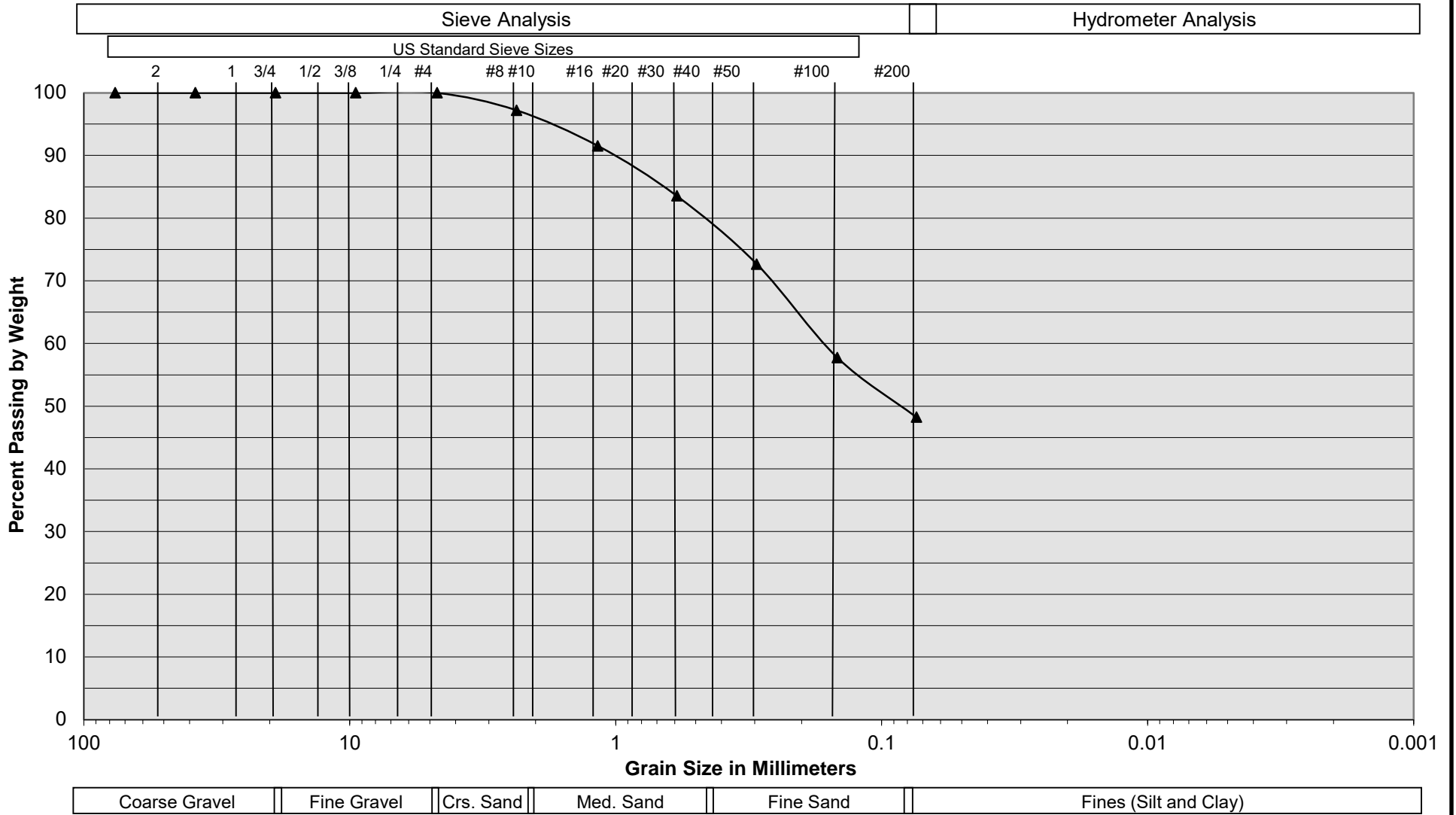

Sample Description	I-3 @ 6'
Soil Classification	Brown Clayey fine to medium Sand, little Silt, trace coarse Sand

Proposed Industrial Building
 Perris, California
 Project No. 21G174-2
PLATE C- 3



SOUTHERN CALIFORNIA GEOTECHNICAL
A California Corporation

Appendix 4: Historical Site Conditions(N/A)

Phase I Environmental Site Assessment or Other Information on Past Site Use

Appendix 5: LID Infeasibility

LID Technical Infeasibility Analysis

CHAPTER 3: PREPARING YOUR PROJECT-SPECIFIC WQMP

TABLE 3-4. LID BMP Applicability

LID BMP Hierarchy	A	B	C	D
	$K_{SAT} > 1.6"/hr.$, and no restrictions on infiltration	Are Harvest and Use BMPs feasible?	$0.3"/hr. < K_{SAT} < 1.6"/hr.$, or unpredictable or unknown	$K_{SAT} < 0.3"/hr.$
LID Infiltration BMPs*	✓			
Harvest and Use BMPs		✓		✓
LID Bioretention	✓		✓	✓
LID Biotreatment				✓

Notes for Table 3-5:

See also Figure 3-6 for guidance in selecting appropriate BMPs

Column A: Selections from this column may be used in locations where the infiltration rate of underlying soils is at least 1.6" per hour and no restrictions on infiltration apply to these locations.

Column B: Harvest and Use BMPs may be used where it can be shown that there is sufficient demand for harvested water and where LID Infiltration BMPs are not feasible.

Column C: Selections in this column may be used in locations where the measured infiltration rate of underlying soils is between 0.3" and 1.6" per hour or where, in accordance with recommendations of a licensed geotechnical engineer, the post-development saturated hydraulic conductivity is uncertain or unknown or cannot be reliably predicted because of soil disturbance or fill, anisotropic soil characteristics, presence of clay lenses, or other factors.

Column D: Selections in this column may be used in locations where the infiltration rate of underlying soils is 0.3" per hour or less. See Chapter 2 for more information.

* Permeable Pavement, when designed with a maximum of a 2:1 ratio of impervious area to pervious pavement areas, or less, is considered a self-retaining area, and is not considered an LID BMP for the purposes of this table. This table focuses on the 'special case' included in the discussion of 'areas draining to self-retaining areas' above, where a project proponent can choose to design the pervious pavement as a LID BMP in accordance with an approved design, such as the LID BMP Design handbook, and in return drain additional impervious area onto the pervious pavement beyond the 2:1 ratio.

3.4.2.a. Laying out your LID BMPs

Finding the right location for LID BMPs on your site involves a careful and creative integration of several factors:

- ✓ To make the most efficient use of the site and to maximize aesthetic value, **integrate BMPs with site landscaping**. Many local zoning codes may require landscape setbacks or buffers, or may specify that a minimum portion of the site be landscaped. It may be possible to locate some or all of your site's Stormwater BMPs within this same area, or within utility easements or other non-buildable areas.
- ✓ Bioretention BMPs must be **level or nearly level** all the way around. When configured in a linear fashion (similar to swales) bioretention BMPs may be gently sloped end to end, but opposite sides must be at the same

Appendix 6: BMP Design Details

BMP Sizing, Design Details and other Supporting Documentation

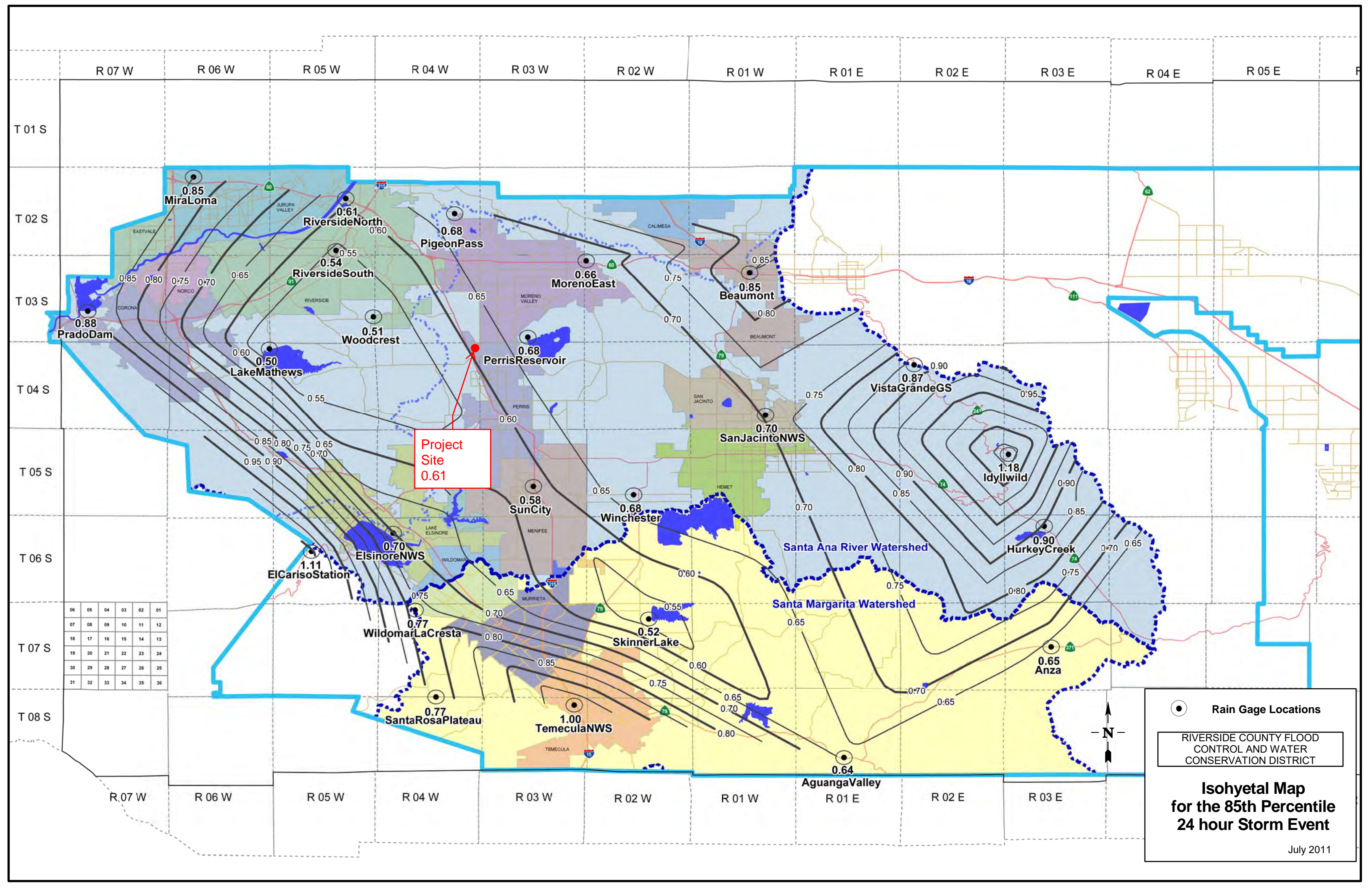

06	05	04	03	02	01
07	08	09	10	11	12
18	17	16	15	14	13
19	20	21	22	23	24
30	29	28	27	26	25
31	32	33	34	35	36

● Rain Gage Locations

RIVERSIDE COUNTY FLOOD CONTROL AND WATER CONSERVATION DISTRICT

Isohyetal Map for the 85th Percentile 24 hour Storm Event

July 2011

Santa Ana Watershed - BMP Design Volume, V_{BMP}

(Rev. 10-2011)

Legend:

Required Entries

Calculated Cells

*(Note this worksheet shall **only** be used in conjunction with BMP designs from the **LID BMP Design Handbook**)*

Company Name **Huitt-Zollars, Inc**

Date **7/18/2022**

Designed by **Christopher Borunda**

Case No

Company Project Number/Name

Rockefeller - Patterson Commerce Center

BMP Identification

BMP NAME / ID **DMA A**

Must match Name/ID used on BMP Design Calculation Sheet

Design Rainfall Depth

85th Percentile, 24-hour Rainfall Depth,
from the Isohyetal Map in Handbook Appendix E

D_{85} = **0.61** inches

Drainage Management Area Tabulation

Insert additional rows if needed to accommodate all DMAs draining to the BMP

DMA Type/ID	DMA Area (square feet)	Post-Project Surface Type	Effective Imperivous Fraction, I_f	DMA Runoff Factor	DMA Areas x Runoff Factor	Design Storm Depth (in)	Design Capture Volume, V_{BMP} (cubic feet)	Proposed Volume on Plans (cubic feet)
DMA A	137390	Ornamental Landscaping	0.1	0.11	15175.8			
	472455	Concrete or Asphalt	1	0.89	421429.9			
	609845		Total		436605.7	0.61	22194.1	39,516

Notes:

Bioretention Facility - Design Procedure		BMP ID For DMA A	Legend:	Required Entries
				Calculated Cells
Company Name:	Huitt-Zollars, Inc		Date:	8/12/2022
Designed by:	Christopher Borunda		County/City Case No.:	22-00003
Design Volume				
Enter the area tributary to this feature			$A_T =$	14 acres
Enter V_{BMP} determined from Section 2.1 of this Handbook			$V_{BMP} =$	22,194 ft ³
Type of Bioretention Facility Design				
<input checked="" type="radio"/> Side slopes required (parallel to parking spaces or adjacent to walkways) <input type="radio"/> No side slopes required (perpendicular to parking space or Planter Boxes)				
Bioretention Facility Surface Area				
Depth of Soil Filter Media Layer			$d_S =$	3.0 ft
Top Width of Bioretention Facility, excluding curb			$w_T =$	345.0 ft
Total Effective Depth, d_E $d_E = (0.3) \times d_S + (0.4) \times 1 - (0.7/w_T) + 0.5$			$d_E =$	1.80 ft
Minimum Surface Area, A_m $A_M (ft^2) = \frac{V_{BMP} (ft^3)}{d_E (ft)}$			$A_M =$	12,344 ft ²
Proposed Surface Area			$A =$	19,956 ft ²
Bioretention Facility Properties				
Side Slopes in Bioretention Facility			$z =$	4 :1
Diameter of Underdrain				6 inches
Longitudinal Slope of Site (3% maximum)				0.5 %
6" Check Dam Spacing				0 feet
Describe Vegetation:			Natural Grasses	
Notes:	Bio-retention basin is +/- 57.8' x 345' = 19,956 sf			

3.5 Bioretention Facility

Type of BMP	LID – Bioretention
Treatment Mechanisms	Infiltration, Evapotranspiration, Evaporation, Biofiltration
Maximum Drainage Area	This BMP is intended to be integrated into a project’s landscaped area in a distributed manner. Typically, contributing drainage areas to Bioretention Facilities range from less than 1 acre to a maximum of around 10 acres.
Other Names	Rain Garden, Bioretention Cell, Bioretention Basin, Biofiltration Basin, Landscaped Filter Basin, Porous Landscape Detention

Description

Bioretention Facilities are shallow, vegetated basins underlain by an engineered soil media. Healthy plant and biological activity in the root zone maintain and renew the macro-pore space in the soil and maximize plant uptake of pollutants and runoff. This keeps the Best Management Practice (BMP) from becoming clogged and allows more of the soil column to function as both a sponge (retaining water) and a highly effective and self-maintaining biofilter. In most cases, the bottom of a Bioretention Facility is unlined, which also provides an opportunity for infiltration to the extent the underlying onsite soil can accommodate. When the infiltration rate of the underlying soil is exceeded, fully biotreated flows are discharged via underdrains. Bioretention Facilities therefore will inherently achieve the maximum feasible level of infiltration and evapotranspiration and achieve the minimum feasible (but highly biotreated) discharge to the storm drain system.

Siting Considerations

These facilities work best when they are designed in a relatively level area. Unlike other BMPs, Bioretention Facilities can be used in smaller landscaped spaces on the site, such as:

- ✓ Parking islands
- ✓ Medians
- ✓ Site entrances

Landscaped areas on the site (such as may otherwise be required through minimum landscaping ordinances), can often be designed as Bioretention Facilities. This can be accomplished by:

- *Depressing* landscaped areas below adjacent impervious surfaces, rather than elevating those areas
- Grading the site to direct runoff from those impervious surfaces *into* the Bioretention Facility, rather than away from the landscaping
- Sizing and designing the depressed landscaped area as a Bioretention Facility as described in this Fact Sheet

Bioretention Facilities should however not be used downstream of areas where large amounts of sediment can clog the system. Placing a Bioretention Facility at the toe of a steep slope should also be avoided due to the potential for clogging the engineered soil media with erosion from the slope, as well as the potential for damaging the vegetation.

Design and Sizing Criteria

The recommended cross section necessary for a Bioretention Facility includes:

- Vegetated area
- 18' minimum depth of engineered soil media
- 12' minimum gravel layer depth with 6' perforated pipes (added flow control features such as orifice plates may be required to mitigate for HCOC conditions)

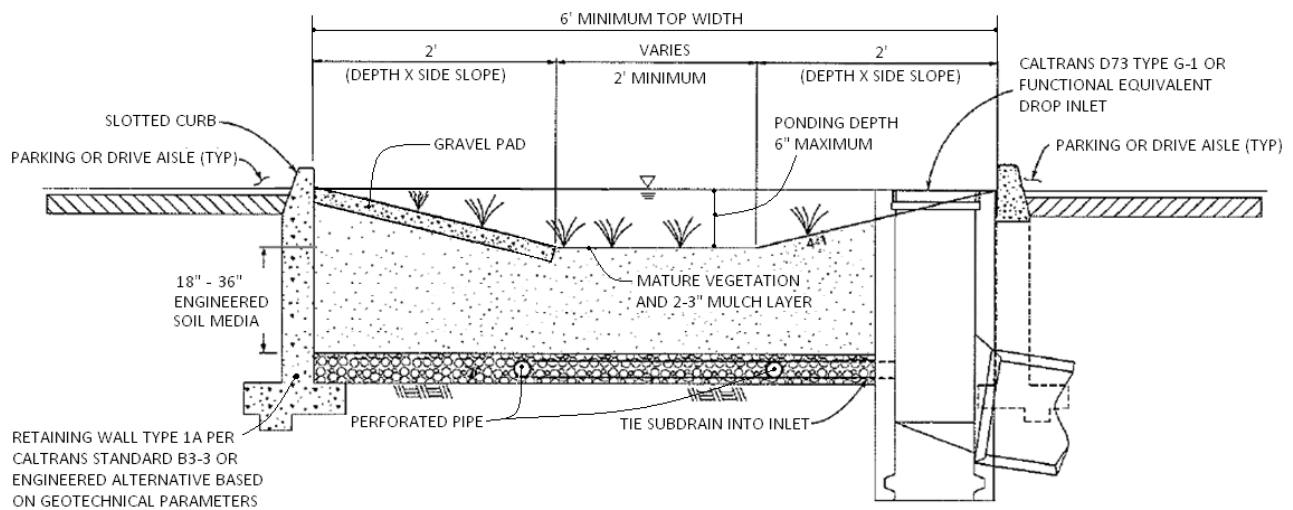

While the 18-inch minimum engineered soil media depth can be used in some cases, it is recommended to use 24 inches or a preferred 36 inches to provide an adequate root zone for the chosen plant palate. Such a design also provides for improved removal effectiveness for nutrients. The recommended ponding depth inside of a Bioretention Facility is 6 inches; measured from the flat bottom surface to the top of the water surface as shown in Figure 1.

Because this BMP is filled with an engineered soil media, pore space in the soil and gravel layer is assumed to provide storage volume. However, several considerations must be noted:

- Surcharge storage above the soil surface (6 inches) is important to assure that design flows do not bypass the BMP when runoff exceeds the soil's absorption rate.
- In cases where the Bioretention Facility contains engineered soil media deeper than 36 inches, the pore space within the engineered soil media can only be counted to the 36-inch depth.
- A maximum of 30 percent pore space can be used for the soil media whereas a maximum of 40 percent pore space can be use for the gravel layer.

Figure 1: Standard Layout for a Bioretention Facility

BIORETENTION FACILITY BMP FACT SHEET

Engineered Soil Media Requirements

The engineered soil media shall be comprised of 85 percent mineral component and 15 percent organic component, by volume, drum mixed prior to placement. The mineral component shall be a Class A sandy loam topsoil that meets the range specified in Table 1 below. The organic component shall be nitrogen stabilized compost¹, such that nitrogen does not leach from the media.

Table 1: Mineral Component Range Requirements

Percent Range	Component
70-80	Sand
15-20	Silt
5-10	Clay

The trip ticket, or certificate of compliance, shall be made available to the inspector to prove the engineered mix meets this specification.

Vegetation Requirements

Vegetative cover is important to minimize erosion and ensure that treatment occurs in the Bioretention Facility. The area should be designed for at least 70 percent mature coverage throughout the Bioretention Facility. To prevent the BMP from being used as walkways, Bioretention Facilities shall be planted with a combination of small trees, densely planted shrubs, and natural grasses. Grasses shall be native or ornamental; preferably ones that do not need to be mowed. The application of fertilizers and pesticides should be minimal. To maintain oxygen levels for the vegetation and promote biodegradation, it is important that vegetation not be completely submerged for any extended period of time. Therefore, a maximum of 6 inches of ponded water shall be used in the design to ensure that plants within the Bioretention Facility remain healthy.

A 2 to 3-inch layer of standard shredded aged hardwood mulch shall be placed as the top layer inside the Bioretention Facility. The 6-inch ponding depth shown in Figure 1 above shall be measured from the top surface of the 2 to 3-inch mulch layer.

Curb Cuts

To allow water to flow into the Bioretention Facility, 1-foot-wide (minimum) curb cuts should be placed approximately every 10 feet around the perimeter of the Bioretention Facility. Figure 2 shows a curb cut in a Bioretention Facility. Curb cut flow lines must be at or above the V_{BMP} water surface level.

¹ For more information on compost, visit the US Composting Council website at: <http://compostingcouncil.org/>

BIORETENTION FACILITY BMP FACT SHEET



Figure 2: Curb Cut located in a Bioretention Facility

To reduce erosion, a gravel pad shall be placed at each inlet point to the Bioretention Facility. The gravel should be 1- to 1.5-inch diameter in size. The gravel should overlap the curb cut opening a minimum of 6 inches. The gravel pad inside the Bioretention Facility should be flush with the finished surface at the curb cut and extend to the bottom of the slope.

In addition, place an apron of stone or concrete, a foot square or larger, inside each inlet to prevent vegetation from growing up and blocking the inlet. See Figure 3.

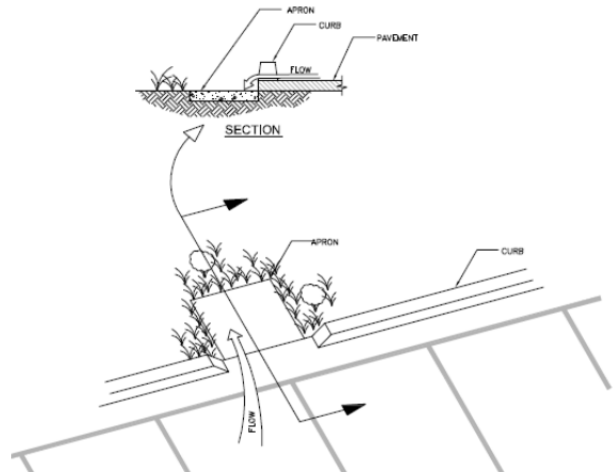

Figure 3: Apron located in a Bioretention Facility

Terracing the Landscaped Filter Basin

It is recommended that Bioretention Facilities be level. In the event the facility site slopes and lacks proper design, water would fill the lowest point of the BMP and then discharge from the basin without being treated. To ensure that the water will be held within the Bioretention Facility on sloped sites, the BMP must be terraced with nonporous check dams to provide the required storage and treatment capacity.

The terraced version of this BMP shall be used on non-flat sites with no more than a 3 percent slope. The surcharge depth cannot exceed 0.5 feet, and side slopes shall not exceed 4:1. Table 2 below shows the spacing of the check dams, and slopes shall be rounded up (i.e., 2.5 percent slope shall use 10' spacing for check dams).

Table 2: Check Dam Spacing

6" Check Dam Spacing	
Slope	Spacing
1%	25'
2%	15'
3%	10'

BIORETENTION FACILITY BMP FACT SHEET

Roof Runoff

Roof downspouts may be directed towards Bioretention Facilities. However, the downspouts must discharge onto a concrete splash block to protect the Bioretention Facility from erosion.

Retaining Walls

It is recommended that Retaining Wall Type 1A, per Caltrans Standard B3-3 or equivalent, be constructed around the entire perimeter of the Bioretention Facility. This practice will protect the sides of the Bioretention Facility from collapsing during construction and maintenance or from high service loads adjacent to the BMP. Where such service loads would not exist adjacent to the BMP, an engineered alternative may be used if signed by a licensed civil engineer.

Side Slope Requirements

Bioretention Facilities Requiring Side Slopes

The design should assure that the Bioretention Facility does not present a tripping hazard. Bioretention Facilities proposed near pedestrian areas, such as areas parallel to parking spaces or along a walkway, must have a gentle slope to the bottom of the facility. Side slopes inside of a Bioretention Facility shall be 4:1. A typical cross section for the Bioretention Facility is shown in Figure 1.

Bioretention Facilities Not Requiring Side Slopes

Where cars park perpendicular to the Bioretention Facility, side slopes are not required. A 6-inch maximum drop may be used, and the Bioretention Facility must be planted with trees and shrubs to prevent pedestrian access. In this case, a curb is not placed around the Bioretention Facility, but wheel stops shall be used to prevent vehicles from entering the Bioretention Facility, as shown in Figure 4.

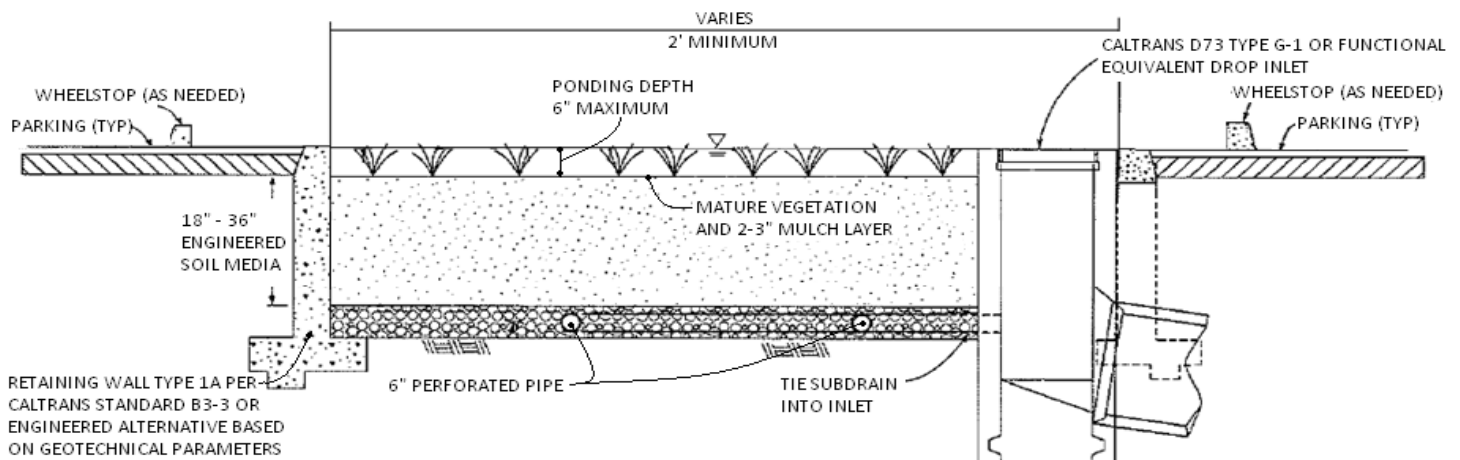

BIORETENTION FACILITY BMP FACT SHEET

Planter Boxes

Bioretention Facilities can also be placed above ground as planter boxes. Planter boxes must have a minimum width of 2 feet, a maximum surcharge depth of 6 inches, and no side slopes are necessary. Planter boxes must be constructed so as to ensure that the top surface of the engineered soil media will remain level. This option may be constructed of concrete, brick, stone or other stable materials that will not warp or bend. Chemically treated wood or galvanized steel, which has the ability to contaminate stormwater, should not be used. Planter boxes must be lined with an impermeable liner on all sides, including the bottom. Due to the impermeable liner, the inside bottom of the planter box shall be designed and constructed with a cross fall, directing treated flows within the subdrain layer toward the point where subdrain exits the planter box, and subdrains shall be oriented with drain holes oriented down. These provisions will help avoid excessive stagnant water within the gravel underdrain layer. Similar to the in-ground Bioretention Facility versions, this BMP benefits from healthy plants and biological activity in the root zone. Planter boxes should be planted with appropriately selected vegetation.



Figure 5: Planter Box

Source: LA Team Effort

Overflow

An overflow route is needed in the Bioretention Facility design to bypass stored runoff from storm events larger than V_{BMP} or in the event of facility or subdrain clogging. Overflow systems must connect to an acceptable discharge point, such as a downstream conveyance system as shown in Figure 1 and Figure 4. The inlet to the overflow structure shall be elevated inside the Bioretention Facility to be flush with the ponding surface for the design capture volume (V_{BMP}) as shown in Figure 4. This will allow the design capture volume to be fully treated by the Bioretention Facility, and for larger events to safely be conveyed to downstream systems. The overflow inlet shall **not** be located in the entrance of a Bioretention Facility, as shown in Figure 6.

BIORETENTION FACILITY BMP FACT SHEET

Underdrain Gravel and Pipes

An underdrain gravel layer and pipes shall be provided in accordance with Appendix B – Underdrains.



Figure 6: Incorrect Placement of an Overflow Inlet.

Inspection and Maintenance Schedule

The Bioretention Facility area shall be inspected for erosion, dead vegetation, soggy soils, or standing water. The use of fertilizers and pesticides on the plants inside the Bioretention Facility should be minimized.

Schedule	Activity
Ongoing	<ul style="list-style-type: none">• Keep adjacent landscape areas maintained. Remove clippings from landscape maintenance activities.• Remove trash and debris• Replace damaged grass and/or plants• Replace surface mulch layer as needed to maintain a 2-3 inch soil cover.
After storm events	<ul style="list-style-type: none">• Inspect areas for ponding
Annually	<ul style="list-style-type: none">• Inspect/clean inlets and outlets

Bioretention Facility Design Procedure

- 1) Enter the area tributary, A_T , to the Bioretention Facility.
- 2) Enter the Design Volume, V_{BMP} , determined from Section 2.1 of this Handbook.
- 3) Select the type of design used. There are two types of Bioretention Facility designs: the standard design used for most project sites that include side slopes, and the modified design used when the BMP is located perpendicular to the parking spaces or with planter boxes that do not use side slopes.
- 4) Enter the depth of the engineered soil media, d_s . The minimum depth for the engineered soil media can be 18' in limited cases, but it is recommended to use 24' or a preferred 36' to provide an adequate root zone for the chosen plant palette. Engineered soil media deeper than 36' will only get credit for the pore space in the first 36'.
- 5) Enter the top width of the Bioretention Facility.
- 6) Calculate the total effective depth, d_E , within the Bioretention Facility. The maximum allowable pore space of the soil media is 30% while the maximum allowable pore space for the gravel layer is 40%. Gravel layer deeper than 12' will only get credit for the pore space in the first 12'.

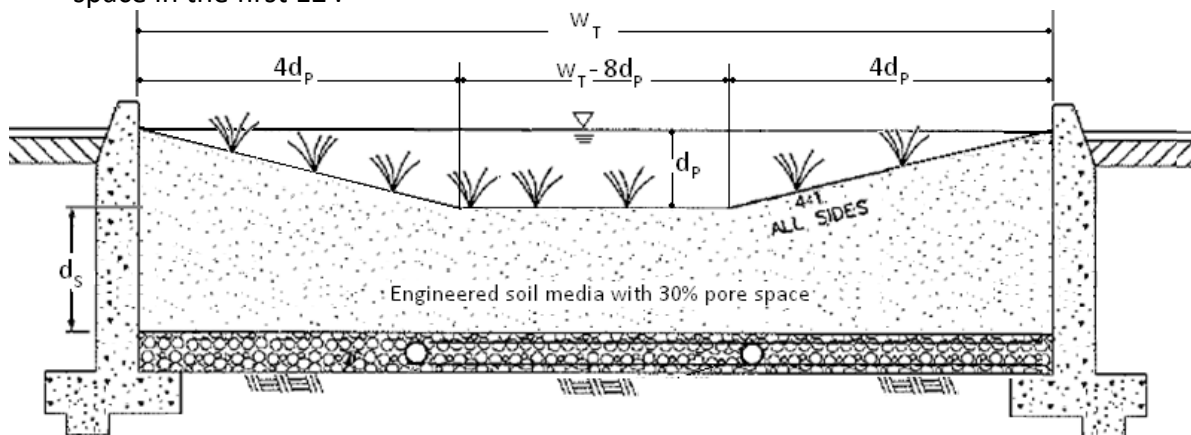

- a. For the design with side slopes the following equation shall be used to determine the total effective depth. Where, d_p is the depth of ponding within the basin.

$$d_E(\text{ft}) = \frac{0.3 \times \left[(w_T(\text{ft}) \times d_s(\text{ft})) + 4(d_p(\text{ft}))^2 \right] + 0.4 \times 1(\text{ft}) + d_p(\text{ft}) \left[4d_p(\text{ft}) + (w_T(\text{ft}) - 8d_p(\text{ft})) \right]}{w_T(\text{ft})}$$

This above equation can be simplified if the maximum ponding depth of 0.5' is used. The equation below is used on the worksheet to find the minimum area required for the Bioretention Facility:

$$d_E(\text{ft}) = (0.3 \times d_s(\text{ft}) + 0.4 \times 1(\text{ft})) - \left(\frac{0.7(\text{ft}^2)}{w_T(\text{ft})} \right) + 0.5(\text{ft})$$

- b. For the design without side slopes the following equation shall be used to determine the total effective depth:

$$d_E(\text{ft}) = d_p(\text{ft}) + [(0.3) \times d_s(\text{ft}) + (0.4) \times 1(\text{ft})]$$

The equation below, using the maximum ponding depth of 0.5', is used on the worksheet to find the minimum area required for the Bioretention Facility:

$$d_E(\text{ft}) = 0.5 (\text{ft}) + [(0.3) \times d_s(\text{ft}) + (0.4) \times 1(\text{ft})]$$

- 7) Calculate the minimum surface area, A_M , required for the Bioretention Facility. This does not include the curb surrounding the Bioretention Facility or side slopes.

$$A_M(\text{ft}^2) = \frac{V_{\text{BMP}}(\text{ft}^3)}{d_E (\text{ft})}$$

- 8) Enter the proposed surface area. This area shall not be less than the minimum required surface area.
- 9) Verify that side slopes are no steeper than 4:1 in the standard design, and are not required in the modified design.
- 10) Provide the diameter, minimum 6 inches, of the perforated underdrain used in the Bioretention Facility. See Appendix B for specific information regarding perforated pipes.
- 11) Provide the slope of the site around the Bioretention Facility, if used. The maximum slope is 3 percent for a standard design.
- 12) Provide the check dam spacing, if the site around the Bioretention Facility is sloped.
- 13) Describe the vegetation used within the Bioretention Facility.

References Used to Develop this Fact Sheet

Anderson, Dale V. "Landscaped Filter Basin Soil Requirements." Riverside, May 2010.

California Department of Transportation. CalTrans Standard Plans. 15 September 2005. May 2010 <http://www.dot.ca.gov/hq/esc/oe/project_plans/HTM/stdplns-met-new99.htm>.

Camp Dresser and McKee Inc.; Larry Walker Associates. California Stormwater Best Management Practice Handbook for New Development and Redevelopment. California Stormwater Quality Association (CASQA), 2004.

Contra Costa Clean Water Program. Stormwater Quality Requirements for Development Applications. 3rd Edition. Contra Costa, 2006.

County of Los Angeles Public Works. Stormwater Best Management Practice Design and Maintenance Manual. Los Angeles, 2009.

Kim, Hunho, Eric A. Seagren and Allen P. Davis. "Engineered Bioretention for Removal of Nitrate from Stormwater Runoff." Water Environment Research 75.4 (2003): 355-366.

LA Team Effort. LA Team Effort: FREE Planter Boxes for Businesses. 2 November 2009. May 2010 <<http://lateameffort.blogspot.com/2009/11/free-planter-boxes-for-businesses-est.html>>.

Montgomery County Maryland Department of Permitting Services Water Resources Section. Biofiltration (BF). Montgomery County, 2005.

Program, Ventura Countywide Stormwater Quality Management. Technical Guidance Manual for Stormwater Quality Control Measures. Ventura, 2002.

United States Environmental Protection Agency. Storm Water Technology Fact Sheet Bioretention. Washington D.C, 1999.

Urban Drainage and Flood Control District. Urban Storm Drainage Criteria Manual Volume 3 - Best Management Practices. Vol. 3. Denver, 2008. 3 vols.

Urbonas, Ben R. Stormwater Sand Filter Sizing and Design: A Unit Operations Approach. Denver: Urban Drainage and Flood Control District, 2002.

EXCERPS FROM HYDROLOGY REPORT
INCLUDED FOR REFERENCE

- EX. 100YR 24 HR UNIT HYDROGRAPH
- PROP. 100YR 24HR BASIN ROUTING

Unit Hydrograph Analysis

Copyright (c) CIVILCADD/CIVILDESIGN, 1989 - 2004, Version 7.0
Study date 07/18/22 File: 2995q100uhp24100.out

Riverside County Synthetic Unit Hydrology Method
RCFC & WCD Manual date - April 1978

Program License Serial Number 6145

English (in-lb) Input Units Used
English Rainfall Data (Inches) Input Values Used

English Units used in output format

Rockefeller - Patterson Commerce Center
Unit Hydrograph for 24 Hour 100 Year Storm Event - Proposed Condition
2995q100uhp
CB

Drainage Area = 14.00(Ac.) = 0.022 Sq. Mi.
Drainage Area for Depth-Area Areal Adjustment = 14.00(Ac.) = 0.022 Sq. Mi.
USER Entry of lag time in hours
Lag time = 0.142 Hr.
Lag time = 8.54 Min.
25% of lag time = 2.14 Min.
40% of lag time = 3.42 Min.
Unit time = 5.00 Min.
Duration of storm = 24 Hour(s)
User Entered Base Flow = 0.00(CFS)

2 YEAR Area rainfall data:

Area(Ac.)[1]	Rainfall(In)[2]	Weighting[1*2]
14.00	1.77	24.78

100 YEAR Area rainfall data:

Area(Ac.)[1]	Rainfall(In)[2]	Weighting[1*2]
14.00	4.50	63.00

STORM EVENT (YEAR) = 100.00
Area Averaged 2-Year Rainfall = 1.770(In)
Area Averaged 100-Year Rainfall = 4.500(In)

Point rain (area averaged) = 4.500(In)
Areal adjustment factor = 100.00 %
Adjusted average point rain = 4.500(In)

Sub-Area Data:
Area(Ac.) Runoff Index Impervious %

14.000 56.00 0.750
 Total Area Entered = 14.00(Ac.)

RI	RI	Infil. Rate	Impervious	Adj. Infil. Rate	Area%	F
AMC2	AMC-3	(In/Hr)	(Dec.%)	(In/Hr)	(Dec.)	(In/Hr)
56.0	74.8	0.305	0.750	0.099	1.000	0.099
						Sum (F) = 0.099

Area averaged mean soil loss (F) (In/Hr) = 0.099
 Minimum soil loss rate ((In/Hr)) = 0.050
 (for 24 hour storm duration)
 Soil low loss rate (decimal) = 0.300

 U n i t H y d r o g r a p h
 VALLEY S-Curve

Unit Hydrograph Data

Unit time period (hrs)	Time % of lag	Distribution Graph %	Unit Hydrograph (CFS)
1	0.083	58.521	7.883
2	0.167	117.041	32.906
3	0.250	175.562	27.050
4	0.333	234.082	10.583
5	0.417	292.603	6.184
6	0.500	351.124	4.200
7	0.583	409.644	3.021
8	0.667	468.165	2.112
9	0.750	526.685	1.735
10	0.833	585.206	1.314
11	0.917	643.727	1.007
12	1.000	702.247	0.733
13	1.083	760.768	0.587
14	1.167	819.288	0.685
		Sum = 100.000	Sum= 14.109

Unit Time (Hr.)	Pattern Percent	Storm Rain (In/Hr)	Loss rate(In./Hr)		Effective (In/Hr)	
			Max	Low		
1	0.08	0.07	0.036	0.176	0.011	0.03
2	0.17	0.07	0.036	0.175	0.011	0.03
3	0.25	0.07	0.036	0.175	0.011	0.03
4	0.33	0.10	0.054	0.174	0.016	0.04
5	0.42	0.10	0.054	0.173	0.016	0.04
6	0.50	0.10	0.054	0.173	0.016	0.04
7	0.58	0.10	0.054	0.172	0.016	0.04
8	0.67	0.10	0.054	0.171	0.016	0.04
9	0.75	0.10	0.054	0.171	0.016	0.04
10	0.83	0.13	0.072	0.170	0.022	0.05
11	0.92	0.13	0.072	0.169	0.022	0.05
12	1.00	0.13	0.072	0.169	0.022	0.05
13	1.08	0.10	0.054	0.168	0.016	0.04
14	1.17	0.10	0.054	0.167	0.016	0.04
15	1.25	0.10	0.054	0.167	0.016	0.04
16	1.33	0.10	0.054	0.166	0.016	0.04
17	1.42	0.10	0.054	0.165	0.016	0.04
18	1.50	0.10	0.054	0.165	0.016	0.04
19	1.58	0.10	0.054	0.164	0.016	0.04
20	1.67	0.10	0.054	0.163	0.016	0.04
21	1.75	0.10	0.054	0.163	0.016	0.04

22	1.83	0.13	0.072	0.162	0.022	0.05
23	1.92	0.13	0.072	0.161	0.022	0.05
24	2.00	0.13	0.072	0.161	0.022	0.05
25	2.08	0.13	0.072	0.160	0.022	0.05
26	2.17	0.13	0.072	0.159	0.022	0.05
27	2.25	0.13	0.072	0.159	0.022	0.05
28	2.33	0.13	0.072	0.158	0.022	0.05
29	2.42	0.13	0.072	0.157	0.022	0.05
30	2.50	0.13	0.072	0.157	0.022	0.05
31	2.58	0.17	0.090	0.156	0.027	0.06
32	2.67	0.17	0.090	0.155	0.027	0.06
33	2.75	0.17	0.090	0.155	0.027	0.06
34	2.83	0.17	0.090	0.154	0.027	0.06
35	2.92	0.17	0.090	0.154	0.027	0.06
36	3.00	0.17	0.090	0.153	0.027	0.06
37	3.08	0.17	0.090	0.152	0.027	0.06
38	3.17	0.17	0.090	0.152	0.027	0.06
39	3.25	0.17	0.090	0.151	0.027	0.06
40	3.33	0.17	0.090	0.150	0.027	0.06
41	3.42	0.17	0.090	0.150	0.027	0.06
42	3.50	0.17	0.090	0.149	0.027	0.06
43	3.58	0.17	0.090	0.149	0.027	0.06
44	3.67	0.17	0.090	0.148	0.027	0.06
45	3.75	0.17	0.090	0.147	0.027	0.06
46	3.83	0.20	0.108	0.147	0.032	0.08
47	3.92	0.20	0.108	0.146	0.032	0.08
48	4.00	0.20	0.108	0.145	0.032	0.08
49	4.08	0.20	0.108	0.145	0.032	0.08
50	4.17	0.20	0.108	0.144	0.032	0.08
51	4.25	0.20	0.108	0.144	0.032	0.08
52	4.33	0.23	0.126	0.143	0.038	0.09
53	4.42	0.23	0.126	0.142	0.038	0.09
54	4.50	0.23	0.126	0.142	0.038	0.09
55	4.58	0.23	0.126	0.141	0.038	0.09
56	4.67	0.23	0.126	0.141	0.038	0.09
57	4.75	0.23	0.126	0.140	0.038	0.09
58	4.83	0.27	0.144	0.139	---	0.00
59	4.92	0.27	0.144	0.139	---	0.01
60	5.00	0.27	0.144	0.138	---	0.01
61	5.08	0.20	0.108	0.137	0.032	0.08
62	5.17	0.20	0.108	0.137	0.032	0.08
63	5.25	0.20	0.108	0.136	0.032	0.08
64	5.33	0.23	0.126	0.136	0.038	0.09
65	5.42	0.23	0.126	0.135	0.038	0.09
66	5.50	0.23	0.126	0.135	0.038	0.09
67	5.58	0.27	0.144	0.134	---	0.01
68	5.67	0.27	0.144	0.133	---	0.01
69	5.75	0.27	0.144	0.133	---	0.01
70	5.83	0.27	0.144	0.132	---	0.01
71	5.92	0.27	0.144	0.132	---	0.01
72	6.00	0.27	0.144	0.131	---	0.01
73	6.08	0.30	0.162	0.130	---	0.03
74	6.17	0.30	0.162	0.130	---	0.03
75	6.25	0.30	0.162	0.129	---	0.03
76	6.33	0.30	0.162	0.129	---	0.03
77	6.42	0.30	0.162	0.128	---	0.03
78	6.50	0.30	0.162	0.128	---	0.03
79	6.58	0.33	0.180	0.127	---	0.05
80	6.67	0.33	0.180	0.126	---	0.05
81	6.75	0.33	0.180	0.126	---	0.05
82	6.83	0.33	0.180	0.125	---	0.05
83	6.92	0.33	0.180	0.125	---	0.06
84	7.00	0.33	0.180	0.124	---	0.06

85	7.08	0.33	0.180	0.124	---	0.06
86	7.17	0.33	0.180	0.123	---	0.06
87	7.25	0.33	0.180	0.122	---	0.06
88	7.33	0.37	0.198	0.122	---	0.08
89	7.42	0.37	0.198	0.121	---	0.08
90	7.50	0.37	0.198	0.121	---	0.08
91	7.58	0.40	0.216	0.120	---	0.10
92	7.67	0.40	0.216	0.120	---	0.10
93	7.75	0.40	0.216	0.119	---	0.10
94	7.83	0.43	0.234	0.119	---	0.12
95	7.92	0.43	0.234	0.118	---	0.12
96	8.00	0.43	0.234	0.117	---	0.12
97	8.08	0.50	0.270	0.117	---	0.15
98	8.17	0.50	0.270	0.116	---	0.15
99	8.25	0.50	0.270	0.116	---	0.15
100	8.33	0.50	0.270	0.115	---	0.15
101	8.42	0.50	0.270	0.115	---	0.16
102	8.50	0.50	0.270	0.114	---	0.16
103	8.58	0.53	0.288	0.114	---	0.17
104	8.67	0.53	0.288	0.113	---	0.17
105	8.75	0.53	0.288	0.113	---	0.18
106	8.83	0.57	0.306	0.112	---	0.19
107	8.92	0.57	0.306	0.112	---	0.19
108	9.00	0.57	0.306	0.111	---	0.19
109	9.08	0.63	0.342	0.110	---	0.23
110	9.17	0.63	0.342	0.110	---	0.23
111	9.25	0.63	0.342	0.109	---	0.23
112	9.33	0.67	0.360	0.109	---	0.25
113	9.42	0.67	0.360	0.108	---	0.25
114	9.50	0.67	0.360	0.108	---	0.25
115	9.58	0.70	0.378	0.107	---	0.27
116	9.67	0.70	0.378	0.107	---	0.27
117	9.75	0.70	0.378	0.106	---	0.27
118	9.83	0.73	0.396	0.106	---	0.29
119	9.92	0.73	0.396	0.105	---	0.29
120	10.00	0.73	0.396	0.105	---	0.29
121	10.08	0.50	0.270	0.104	---	0.17
122	10.17	0.50	0.270	0.104	---	0.17
123	10.25	0.50	0.270	0.103	---	0.17
124	10.33	0.50	0.270	0.103	---	0.17
125	10.42	0.50	0.270	0.102	---	0.17
126	10.50	0.50	0.270	0.102	---	0.17
127	10.58	0.67	0.360	0.101	---	0.26
128	10.67	0.67	0.360	0.101	---	0.26
129	10.75	0.67	0.360	0.100	---	0.26
130	10.83	0.67	0.360	0.100	---	0.26
131	10.92	0.67	0.360	0.099	---	0.26
132	11.00	0.67	0.360	0.099	---	0.26
133	11.08	0.63	0.342	0.098	---	0.24
134	11.17	0.63	0.342	0.098	---	0.24
135	11.25	0.63	0.342	0.097	---	0.24
136	11.33	0.63	0.342	0.097	---	0.25
137	11.42	0.63	0.342	0.096	---	0.25
138	11.50	0.63	0.342	0.096	---	0.25
139	11.58	0.57	0.306	0.095	---	0.21
140	11.67	0.57	0.306	0.095	---	0.21
141	11.75	0.57	0.306	0.095	---	0.21
142	11.83	0.60	0.324	0.094	---	0.23
143	11.92	0.60	0.324	0.094	---	0.23
144	12.00	0.60	0.324	0.093	---	0.23
145	12.08	0.83	0.450	0.093	---	0.36
146	12.17	0.83	0.450	0.092	---	0.36
147	12.25	0.83	0.450	0.092	---	0.36

148	12.33	0.87	0.468	0.091	---	0.38
149	12.42	0.87	0.468	0.091	---	0.38
150	12.50	0.87	0.468	0.090	---	0.38
151	12.58	0.93	0.504	0.090	---	0.41
152	12.67	0.93	0.504	0.089	---	0.41
153	12.75	0.93	0.504	0.089	---	0.42
154	12.83	0.97	0.522	0.089	---	0.43
155	12.92	0.97	0.522	0.088	---	0.43
156	13.00	0.97	0.522	0.088	---	0.43
157	13.08	1.13	0.612	0.087	---	0.52
158	13.17	1.13	0.612	0.087	---	0.53
159	13.25	1.13	0.612	0.086	---	0.53
160	13.33	1.13	0.612	0.086	---	0.53
161	13.42	1.13	0.612	0.085	---	0.53
162	13.50	1.13	0.612	0.085	---	0.53
163	13.58	0.77	0.414	0.085	---	0.33
164	13.67	0.77	0.414	0.084	---	0.33
165	13.75	0.77	0.414	0.084	---	0.33
166	13.83	0.77	0.414	0.083	---	0.33
167	13.92	0.77	0.414	0.083	---	0.33
168	14.00	0.77	0.414	0.082	---	0.33
169	14.08	0.90	0.486	0.082	---	0.40
170	14.17	0.90	0.486	0.082	---	0.40
171	14.25	0.90	0.486	0.081	---	0.40
172	14.33	0.87	0.468	0.081	---	0.39
173	14.42	0.87	0.468	0.080	---	0.39
174	14.50	0.87	0.468	0.080	---	0.39
175	14.58	0.87	0.468	0.080	---	0.39
176	14.67	0.87	0.468	0.079	---	0.39
177	14.75	0.87	0.468	0.079	---	0.39
178	14.83	0.83	0.450	0.078	---	0.37
179	14.92	0.83	0.450	0.078	---	0.37
180	15.00	0.83	0.450	0.078	---	0.37
181	15.08	0.80	0.432	0.077	---	0.35
182	15.17	0.80	0.432	0.077	---	0.36
183	15.25	0.80	0.432	0.076	---	0.36
184	15.33	0.77	0.414	0.076	---	0.34
185	15.42	0.77	0.414	0.076	---	0.34
186	15.50	0.77	0.414	0.075	---	0.34
187	15.58	0.63	0.342	0.075	---	0.27
188	15.67	0.63	0.342	0.074	---	0.27
189	15.75	0.63	0.342	0.074	---	0.27
190	15.83	0.63	0.342	0.074	---	0.27
191	15.92	0.63	0.342	0.073	---	0.27
192	16.00	0.63	0.342	0.073	---	0.27
193	16.08	0.13	0.072	0.073	0.022	0.05
194	16.17	0.13	0.072	0.072	0.022	0.05
195	16.25	0.13	0.072	0.072	---	0.00
196	16.33	0.13	0.072	0.071	---	0.00
197	16.42	0.13	0.072	0.071	---	0.00
198	16.50	0.13	0.072	0.071	---	0.00
199	16.58	0.10	0.054	0.070	0.016	0.04
200	16.67	0.10	0.054	0.070	0.016	0.04
201	16.75	0.10	0.054	0.070	0.016	0.04
202	16.83	0.10	0.054	0.069	0.016	0.04
203	16.92	0.10	0.054	0.069	0.016	0.04
204	17.00	0.10	0.054	0.069	0.016	0.04
205	17.08	0.17	0.090	0.068	---	0.02
206	17.17	0.17	0.090	0.068	---	0.02
207	17.25	0.17	0.090	0.068	---	0.02
208	17.33	0.17	0.090	0.067	---	0.02
209	17.42	0.17	0.090	0.067	---	0.02
210	17.50	0.17	0.090	0.067	---	0.02

211	17.58	0.17	0.090	0.066	---	0.02
212	17.67	0.17	0.090	0.066	---	0.02
213	17.75	0.17	0.090	0.066	---	0.02
214	17.83	0.13	0.072	0.065	---	0.01
215	17.92	0.13	0.072	0.065	---	0.01
216	18.00	0.13	0.072	0.065	---	0.01
217	18.08	0.13	0.072	0.064	---	0.01
218	18.17	0.13	0.072	0.064	---	0.01
219	18.25	0.13	0.072	0.064	---	0.01
220	18.33	0.13	0.072	0.063	---	0.01
221	18.42	0.13	0.072	0.063	---	0.01
222	18.50	0.13	0.072	0.063	---	0.01
223	18.58	0.10	0.054	0.062	0.016	0.04
224	18.67	0.10	0.054	0.062	0.016	0.04
225	18.75	0.10	0.054	0.062	0.016	0.04
226	18.83	0.07	0.036	0.061	0.011	0.03
227	18.92	0.07	0.036	0.061	0.011	0.03
228	19.00	0.07	0.036	0.061	0.011	0.03
229	19.08	0.10	0.054	0.061	0.016	0.04
230	19.17	0.10	0.054	0.060	0.016	0.04
231	19.25	0.10	0.054	0.060	0.016	0.04
232	19.33	0.13	0.072	0.060	---	0.01
233	19.42	0.13	0.072	0.059	---	0.01
234	19.50	0.13	0.072	0.059	---	0.01
235	19.58	0.10	0.054	0.059	0.016	0.04
236	19.67	0.10	0.054	0.059	0.016	0.04
237	19.75	0.10	0.054	0.058	0.016	0.04
238	19.83	0.07	0.036	0.058	0.011	0.03
239	19.92	0.07	0.036	0.058	0.011	0.03
240	20.00	0.07	0.036	0.058	0.011	0.03
241	20.08	0.10	0.054	0.057	0.016	0.04
242	20.17	0.10	0.054	0.057	0.016	0.04
243	20.25	0.10	0.054	0.057	0.016	0.04
244	20.33	0.10	0.054	0.057	0.016	0.04
245	20.42	0.10	0.054	0.056	0.016	0.04
246	20.50	0.10	0.054	0.056	0.016	0.04
247	20.58	0.10	0.054	0.056	0.016	0.04
248	20.67	0.10	0.054	0.056	0.016	0.04
249	20.75	0.10	0.054	0.055	0.016	0.04
250	20.83	0.07	0.036	0.055	0.011	0.03
251	20.92	0.07	0.036	0.055	0.011	0.03
252	21.00	0.07	0.036	0.055	0.011	0.03
253	21.08	0.10	0.054	0.055	0.016	0.04
254	21.17	0.10	0.054	0.054	0.016	0.04
255	21.25	0.10	0.054	0.054	0.016	0.04
256	21.33	0.07	0.036	0.054	0.011	0.03
257	21.42	0.07	0.036	0.054	0.011	0.03
258	21.50	0.07	0.036	0.054	0.011	0.03
259	21.58	0.10	0.054	0.053	---	0.00
260	21.67	0.10	0.054	0.053	---	0.00
261	21.75	0.10	0.054	0.053	---	0.00
262	21.83	0.07	0.036	0.053	0.011	0.03
263	21.92	0.07	0.036	0.053	0.011	0.03
264	22.00	0.07	0.036	0.052	0.011	0.03
265	22.08	0.10	0.054	0.052	---	0.00
266	22.17	0.10	0.054	0.052	---	0.00
267	22.25	0.10	0.054	0.052	---	0.00
268	22.33	0.07	0.036	0.052	0.011	0.03
269	22.42	0.07	0.036	0.052	0.011	0.03
270	22.50	0.07	0.036	0.051	0.011	0.03
271	22.58	0.07	0.036	0.051	0.011	0.03
272	22.67	0.07	0.036	0.051	0.011	0.03
273	22.75	0.07	0.036	0.051	0.011	0.03

274	22.83	0.07	0.036	0.051	0.011	0.03
275	22.92	0.07	0.036	0.051	0.011	0.03
276	23.00	0.07	0.036	0.051	0.011	0.03
277	23.08	0.07	0.036	0.050	0.011	0.03
278	23.17	0.07	0.036	0.050	0.011	0.03
279	23.25	0.07	0.036	0.050	0.011	0.03
280	23.33	0.07	0.036	0.050	0.011	0.03
281	23.42	0.07	0.036	0.050	0.011	0.03
282	23.50	0.07	0.036	0.050	0.011	0.03
283	23.58	0.07	0.036	0.050	0.011	0.03
284	23.67	0.07	0.036	0.050	0.011	0.03
285	23.75	0.07	0.036	0.050	0.011	0.03
286	23.83	0.07	0.036	0.050	0.011	0.03
287	23.92	0.07	0.036	0.050	0.011	0.03
288	24.00	0.07	0.036	0.050	0.011	0.03

Sum = 100.0 Sum = 36.4

Flood volume = Effective rainfall 3.04(In)
times area 14.0(Ac.)/[(In)/(Ft.)] = 3.5(Ac.Ft)
Total soil loss = 1.46(In)
Total soil loss = 1.707(Ac.Ft)
Total rainfall = 4.50(In)
Flood volume = 154309.1 Cubic Feet
Total soil loss = 74374.7 Cubic Feet

Peak flow rate of this hydrograph = 7.264(CFS)

+++++

24 - H O U R S T O R M
R u n o f f H y d r o g r a p h

Hydrograph in 5 Minute intervals ((CFS))

Time(h+m)	Volume Ac.Ft	Q(CFS)	0	2.5	5.0	7.5	10.0
0+ 5	0.0002	0.03	Q				
0+10	0.0012	0.15	Q				
0+15	0.0029	0.24	Q				
0+20	0.0049	0.29	VQ				
0+25	0.0074	0.37	VQ				
0+30	0.0105	0.44	VQ				
0+35	0.0137	0.47	VQ				
0+40	0.0170	0.48	VQ				
0+45	0.0204	0.50	VQ				
0+50	0.0240	0.52	V Q				
0+55	0.0281	0.59	V Q				
1+ 0	0.0325	0.64	V Q				
1+ 5	0.0370	0.65	V Q				
1+10	0.0412	0.61	V Q				
1+15	0.0451	0.57	V Q				
1+20	0.0489	0.56	V Q				
1+25	0.0527	0.55	V Q				
1+30	0.0565	0.55	V Q				
1+35	0.0602	0.54	V Q				
1+40	0.0639	0.54	V Q				
1+45	0.0676	0.54	V Q				
1+50	0.0714	0.55	V Q				
1+55	0.0756	0.61	V Q				
2+ 0	0.0802	0.66	V Q				
2+ 5	0.0848	0.67	V Q				
2+10	0.0895	0.68	VQ				
2+15	0.0943	0.69	VQ				
2+20	0.0991	0.70	VQ				

2+25	0.1039	0.70	VQ
2+30	0.1088	0.70	VQ
2+35	0.1137	0.72	VQ
2+40	0.1191	0.78	V Q
2+45	0.1248	0.83	V Q
2+50	0.1307	0.85	V Q
2+55	0.1366	0.86	V Q
3+ 0	0.1426	0.87	V Q
3+ 5	0.1486	0.87	V Q
3+10	0.1547	0.88	V Q
3+15	0.1607	0.88	V Q
3+20	0.1668	0.88	V Q
3+25	0.1729	0.89	V Q
3+30	0.1790	0.89	VQ
3+35	0.1851	0.89	VQ
3+40	0.1913	0.89	VQ
3+45	0.1974	0.89	VQ
3+50	0.2036	0.90	VQ
3+55	0.2102	0.96	VQ
4+ 0	0.2172	1.01	V Q
4+ 5	0.2243	1.03	V Q
4+10	0.2314	1.04	V Q
4+15	0.2387	1.05	V Q
4+20	0.2460	1.07	V Q
4+25	0.2538	1.13	V Q
4+30	0.2619	1.18	V Q
4+35	0.2702	1.20	VQ
4+40	0.2785	1.21	VQ
4+45	0.2870	1.22	VQ
4+50	0.2948	1.14	VQ
4+55	0.3000	0.75	Q
5+ 0	0.3030	0.44	Q V
5+ 5	0.3058	0.40	Q V
5+10	0.3103	0.66	QV
5+15	0.3164	0.88	Q
5+20	0.3230	0.96	Q
5+25	0.3303	1.06	VQ
5+30	0.3380	1.13	VQ
5+35	0.3454	1.07	VQ
5+40	0.3505	0.73	QV
5+45	0.3536	0.45	Q V
5+50	0.3560	0.35	Q V
5+55	0.3581	0.30	Q V
6+ 0	0.3599	0.27	Q V
6+ 5	0.3618	0.27	Q V
6+10	0.3642	0.35	Q V
6+15	0.3670	0.41	Q V
6+20	0.3699	0.43	Q V
6+25	0.3730	0.44	Q V
6+30	0.3761	0.45	Q V
6+35	0.3794	0.48	Q V
6+40	0.3833	0.57	Q V
6+45	0.3878	0.65	Q V
6+50	0.3925	0.69	Q V
6+55	0.3975	0.72	Q V
7+ 0	0.4025	0.74	Q V
7+ 5	0.4077	0.75	QV
7+10	0.4130	0.77	QV
7+15	0.4184	0.78	QV
7+20	0.4240	0.81	QV
7+25	0.4302	0.91	QV
7+30	0.4370	0.99	QV
7+35	0.4442	1.04	QV

7+40	0.4521	1.15	QV			
7+45	0.4606	1.24	QV			
7+50	0.4696	1.30	Q			
7+55	0.4793	1.41	Q			
8+ 0	0.4897	1.50	VQ			
8+ 5	0.5006	1.59	VQ			
8+10	0.5130	1.79	V Q			
8+15	0.5264	1.95	V Q			
8+20	0.5403	2.02	V Q			
8+25	0.5546	2.07	V Q			
8+30	0.5691	2.11	V Q			
8+35	0.5840	2.16	V Q			
8+40	0.5996	2.26	V Q			
8+45	0.6157	2.35	V Q			
8+50	0.6324	2.41	V Q			
8+55	0.6498	2.53	V Q			
9+ 0	0.6678	2.62	V Q			
9+ 5	0.6864	2.70	V Q			
9+10	0.7064	2.90	V Q			
9+15	0.7274	3.06	V Q			
9+20	0.7492	3.15	V Q			
9+25	0.7718	3.28	V Q			
9+30	0.7951	3.39	V Q			
9+35	0.8189	3.46	V Q			
9+40	0.8436	3.58	V Q			
9+45	0.8690	3.68	V Q			
9+50	0.8948	3.75	V Q			
9+55	0.9215	3.87	V Q			
10+ 0	0.9488	3.96	V Q			
10+ 5	0.9754	3.87	V Q			
10+10	0.9983	3.32	V Q			
10+15	1.0180	2.86	Q			
10+20	1.0366	2.70	QV			
10+25	1.0545	2.60	QV			
10+30	1.0720	2.54	Q V			
10+35	1.0899	2.60	Q V			
10+40	1.1105	2.99	QV			
10+45	1.1333	3.31	VQ			
10+50	1.1570	3.43	Q			
10+55	1.1811	3.50	VQ			
11+ 0	1.2055	3.55	VQ			
11+ 5	1.2301	3.56	VQ			
11+10	1.2542	3.50	Q			
11+15	1.2781	3.46	QV			
11+20	1.3019	3.46	QV			
11+25	1.3257	3.46	QV			
11+30	1.3496	3.47	Q V			
11+35	1.3733	3.43	Q V			
11+40	1.3958	3.28	Q V			
11+45	1.4175	3.14	Q V			
11+50	1.4389	3.11	Q V			
11+55	1.4607	3.17	Q V			
12+ 0	1.4829	3.22	Q V			
12+ 5	1.5062	3.38	Q V			
12+10	1.5335	3.97	Q V			
12+15	1.5643	4.46	Q			
12+20	1.5965	4.68	Q			
12+25	1.6301	4.88	VQ			
12+30	1.6647	5.03	V Q			
12+35	1.7002	5.16	VQ			
12+40	1.7373	5.38	V Q			
12+45	1.7757	5.57	V Q			
12+50	1.8148	5.68	V Q			

12+55	1.8549	5.83				V	Q		
13+ 0	1.8959	5.94				V	Q		
13+ 5	1.9379	6.11				V	Q		
13+10	1.9832	6.57				V	Q		
13+15	2.0310	6.94				V	Q		
13+20	2.0799	7.10				V	Q		
13+25	2.1294	7.20				V	Q		
13+30	2.1795	7.26				V	Q		
13+35	2.2283	7.09				V	Q		
13+40	2.2711	6.21				QV			
13+45	2.3089	5.49				Q	V		
13+50	2.3448	5.22				Q	V		
13+55	2.3797	5.06				Q	V		
14+ 0	2.4139	4.96				Q	V		
14+ 5	2.4481	4.97				Q	V		
14+10	2.4843	5.26				Q	V		
14+15	2.5222	5.49				Q	V		
14+20	2.5604	5.55				Q	V		
14+25	2.5983	5.51				Q	V		
14+30	2.6360	5.47				Q	V		
14+35	2.6736	5.46				Q	V		
14+40	2.7111	5.45				Q	V		
14+45	2.7488	5.46				Q	V		
14+50	2.7863	5.46				Q	V		
14+55	2.8234	5.38				Q	V		
15+ 0	2.8601	5.32				Q	V		
15+ 5	2.8965	5.28				Q	V		
15+10	2.9323	5.20				Q	V		
15+15	2.9675	5.12				Q	V		
15+20	3.0024	5.07				Q	V		
15+25	3.0366	4.97				Q	V		
15+30	3.0703	4.89				Q	V		
15+35	3.1032	4.78				Q	V		
15+40	3.1337	4.43				Q	V		
15+45	3.1622	4.14				Q	V		
15+50	3.1899	4.02				Q	V		
15+55	3.2172	3.96				Q	V		
16+ 0	3.2441	3.91				Q	V		
16+ 5	3.2692	3.64				Q	V		
16+10	3.2871	2.60			Q		V		
16+15	3.2987	1.69		Q			V		
16+20	3.3064	1.12		Q			V		
16+25	3.3115	0.73		Q			V		
16+30	3.3150	0.52		Q			V		
16+35	3.3179	0.42		Q			V		
16+40	3.3213	0.49		Q			V		
16+45	3.3251	0.56		Q			V		
16+50	3.3290	0.56		Q			V		
16+55	3.3327	0.55		Q			V		
17+ 0	3.3364	0.54		Q			V		
17+ 5	3.3399	0.51		Q			V		
17+10	3.3428	0.42		Q			V		
17+15	3.3453	0.36		Q			V		
17+20	3.3477	0.35		Q			V		
17+25	3.3501	0.34		Q			V		
17+30	3.3524	0.34		Q			V		
17+35	3.3547	0.34		Q			V		
17+40	3.3571	0.34		Q			V		
17+45	3.3595	0.34		Q			V		
17+50	3.3617	0.33		Q			V		
17+55	3.3634	0.24		Q			V		
18+ 0	3.3646	0.18		Q			V		
18+ 5	3.3657	0.15		Q			V		

18+10	3.3667	0.14	Q	V
18+15	3.3676	0.14	Q	V
18+20	3.3685	0.13	Q	V
18+25	3.3694	0.13	Q	V
18+30	3.3703	0.13	Q	V
18+35	3.3714	0.16	Q	V
18+40	3.3735	0.30	Q	V
18+45	3.3763	0.40	Q	V
18+50	3.3792	0.43	Q	V
18+55	3.3820	0.40	Q	V
19+ 0	3.3845	0.37	Q	V
19+ 5	3.3871	0.37	Q	V
19+10	3.3900	0.43	Q	V
19+15	3.3933	0.48	Q	V
19+20	3.3966	0.47	Q	V
19+25	3.3991	0.36	Q	V
19+30	3.4009	0.27	Q	V
19+35	3.4028	0.27	Q	V
19+40	3.4054	0.37	Q	V
19+45	3.4085	0.45	Q	V
19+50	3.4117	0.47	Q	V
19+55	3.4146	0.42	Q	V
20+ 0	3.4173	0.39	Q	V
20+ 5	3.4200	0.39	Q	V
20+10	3.4230	0.44	Q	V
20+15	3.4264	0.49	Q	V
20+20	3.4298	0.50	Q	V
20+25	3.4333	0.51	Q	V
20+30	3.4369	0.52	Q	V
20+35	3.4405	0.52	Q	V
20+40	3.4441	0.53	Q	V
20+45	3.4477	0.53	Q	V
20+50	3.4513	0.52	Q	V
20+55	3.4544	0.46	Q	V
21+ 0	3.4573	0.41	Q	V
21+ 5	3.4601	0.41	Q	V
21+10	3.4632	0.46	Q	V
21+15	3.4666	0.50	Q	V
21+20	3.4700	0.50	Q	V
21+25	3.4731	0.44	Q	V
21+30	3.4759	0.40	Q	V
21+35	3.4783	0.36	Q	V
21+40	3.4799	0.23	Q	V
21+45	3.4809	0.14	Q	V
21+50	3.4817	0.12	Q	V
21+55	3.4832	0.21	Q	V
22+ 0	3.4852	0.29	Q	V
22+ 5	3.4872	0.29	Q	V
22+10	3.4885	0.19	Q	V
22+15	3.4893	0.11	Q	V
22+20	3.4900	0.11	Q	V
22+25	3.4914	0.20	Q	V
22+30	3.4933	0.28	Q	V
22+35	3.4954	0.30	Q	V
22+40	3.4976	0.32	Q	V
22+45	3.4998	0.33	Q	V
22+50	3.5022	0.34	Q	V
22+55	3.5045	0.34	Q	V
23+ 0	3.5069	0.35	Q	V
23+ 5	3.5093	0.35	Q	V
23+10	3.5117	0.35	Q	V
23+15	3.5141	0.35	Q	V
23+20	3.5165	0.35	Q	V

23+25	3.5190	0.36	Q				V
23+30	3.5214	0.36	Q				V
23+35	3.5239	0.36	Q				V
23+40	3.5263	0.36	Q				V
23+45	3.5288	0.36	Q				V
23+50	3.5312	0.36	Q				V
23+55	3.5337	0.36	Q				V
24+ 0	3.5361	0.36	Q				V
24+ 5	3.5384	0.33	Q				V
24+10	3.5399	0.21	Q				V
24+15	3.5406	0.11	Q				V
24+20	3.5412	0.08	Q				V
24+25	3.5415	0.05	Q				V
24+30	3.5418	0.04	Q				V
24+35	3.5420	0.03	Q				V
24+40	3.5422	0.02	Q				V
24+45	3.5423	0.02	Q				V
24+50	3.5424	0.01	Q				V
24+55	3.5424	0.01	Q				V
25+ 0	3.5424	0.00	Q				V
25+ 5	3.5424	0.00	Q				V

FLOOD HYDROGRAPH ROUTING PROGRAM
 Copyright (c) CIVILCADD/CIVILDESIGN, 1989 - 2005
 Study date: 07/18/22

 Rockefeller - Patterson Commerce Center
 Basin Routing Study - 24 Hour 100 Year Storm
 2995routing24100
 CB

Program License Serial Number 6145

 ***** HYDROGRAPH INFORMATION *****

From study/file name: 2995q100uhp24100.rte
 *****HYDROGRAPH DATA*****

Number of intervals = 301
 Time interval = 5.0 (Min.)
 Maximum/Peak flow rate = 7.264 (CFS)
 Total volume = 3.542 (Ac.Ft)
 Status of hydrographs being held in storage

	Stream 1	Stream 2	Stream 3	Stream 4	Stream 5
Peak (CFS)	0.000	0.000	0.000	0.000	0.000
Vol (Ac.Ft)	0.000	0.000	0.000	0.000	0.000

+++++
 Process from Point/Station 1.000 to Point/Station 1.000
 **** RETARDING BASIN ROUTING ****

 User entry of depth-outflow-storage data

 Total number of inflow hydrograph intervals = 301
 Hydrograph time unit = 5.000 (Min.)
 Initial depth in storage basin = 0.00(Ft.)

 Initial basin depth = 0.00 (Ft.)
 Initial basin storage = 0.00 (Ac.Ft)
 Initial basin outflow = 0.00 (CFS)

 Depth vs. Storage and Depth vs. Discharge data:

Basin Depth (Ft.)	Storage (Ac.Ft)	Outflow (CFS)	(S-O*dt/2) (Ac.Ft)	(S+O*dt/2) (Ac.Ft)
0.000	0.000	0.000	0.000	0.000
0.800	0.001	0.520	-0.001	0.003
1.800	0.249	1.080	0.245	0.253
2.800	0.435	1.430	0.430	0.440
3.800	0.621	1.720	0.615	0.627
4.800	0.808	1.960	0.801	0.815
5.300	1.128	2.070	1.121	1.135

5.800	1.469	2.180	1.461	1.477
6.800	2.210	2.370	2.202	2.218
7.800	3.035	2.550	3.026	3.044
8.800	3.946	2.720	3.937	3.955

Hydrograph Detention Basin Routing

Graph values: 'I'= unit inflow; 'O'=outflow at time shown

Time (Hours)	Inflow (CFS)	Outflow (CFS)	Storage (Ac.Ft)	.0	1.8	3.63	5.45	7.26	Depth (Ft.)
0.083	0.03	0.02	0.000	O					0.03
0.167	0.15	0.11	0.000	O					0.16
0.250	0.24	0.22	0.000	OI					0.34
0.333	0.29	0.28	0.001	O					0.43
0.417	0.37	0.35	0.001	O					0.54
0.500	0.44	0.42	0.001	O					0.65
0.583	0.47	0.46	0.001	O					0.71
0.667	0.48	0.48	0.001	O					0.74
0.750	0.50	0.49	0.001	O					0.76
0.833	0.52	0.51	0.001	O					0.79
0.917	0.59	0.52	0.001	O					0.80
1.000	0.64	0.52	0.002	O					0.80
1.083	0.65	0.52	0.003	O					0.81
1.167	0.61	0.53	0.003	O					0.81
1.250	0.57	0.53	0.004	O					0.81
1.333	0.56	0.53	0.004	O					0.81
1.417	0.55	0.53	0.004	O					0.81
1.500	0.55	0.53	0.004	O					0.81
1.583	0.54	0.53	0.005	O					0.81
1.667	0.54	0.53	0.005	O					0.81
1.750	0.54	0.53	0.005	O					0.82
1.833	0.55	0.53	0.005	O					0.82
1.917	0.61	0.53	0.005	O					0.82
2.000	0.66	0.53	0.006	O					0.82
2.083	0.67	0.53	0.007	O					0.82
2.167	0.68	0.54	0.008	OI					0.83
2.250	0.69	0.54	0.009	OI					0.83
2.333	0.70	0.54	0.010	OI					0.84
2.417	0.70	0.54	0.011	OI					0.84
2.500	0.70	0.55	0.012	OI					0.84
2.583	0.72	0.55	0.013	OI					0.85
2.667	0.78	0.55	0.015	OI					0.86
2.750	0.83	0.55	0.016	OI					0.86
2.833	0.85	0.56	0.018	OI					0.87
2.917	0.86	0.56	0.020	OI					0.88
3.000	0.87	0.57	0.022	OI					0.89
3.083	0.87	0.57	0.025	OI					0.89
3.167	0.88	0.58	0.027	OI					0.90
3.250	0.88	0.58	0.029	OI					0.91
3.333	0.88	0.59	0.031	OI					0.92
3.417	0.89	0.59	0.033	OI					0.93
3.500	0.89	0.60	0.035	OI					0.94
3.583	0.89	0.60	0.037	OI					0.94
3.667	0.89	0.61	0.039	OI					0.95
3.750	0.89	0.61	0.041	OI					0.96
3.833	0.90	0.61	0.043	OI					0.97
3.917	0.96	0.62	0.045	O I					0.98
4.000	1.01	0.62	0.047	O I					0.99
4.083	1.03	0.63	0.050	O I					1.00
4.167	1.04	0.64	0.053	O I					1.01
4.250	1.05	0.64	0.056	O I					1.02

4.333	1.07	0.65	0.058	O I					1.03
4.417	1.13	0.66	0.061	O I					1.04
4.500	1.18	0.66	0.065	O I					1.06
4.583	1.20	0.67	0.068	O I					1.07
4.667	1.21	0.68	0.072	O I					1.09
4.750	1.22	0.69	0.076	O I					1.10
4.833	1.14	0.70	0.079	O I					1.11
4.917	0.75	0.70	0.081	O					1.12
5.000	0.44	0.70	0.080	I O					1.12
5.083	0.40	0.69	0.078	I O					1.11
5.167	0.66	0.69	0.077	IO					1.11
5.250	0.88	0.69	0.078	O					1.11
5.333	0.96	0.70	0.079	OI					1.12
5.417	1.06	0.70	0.081	OI					1.12
5.500	1.13	0.71	0.084	OI					1.13
5.583	1.07	0.71	0.087	OI					1.15
5.667	0.73	0.72	0.088	O					1.15
5.750	0.45	0.71	0.087	I O					1.15
5.833	0.35	0.71	0.085	I O					1.14
5.917	0.30	0.70	0.082	I O					1.13
6.000	0.27	0.70	0.079	I O					1.12
6.083	0.27	0.69	0.077	I O					1.10
6.167	0.35	0.68	0.074	I O					1.09
6.250	0.41	0.68	0.072	IO					1.09
6.333	0.43	0.68	0.070	IO					1.08
6.417	0.44	0.67	0.068	IO					1.07
6.500	0.45	0.67	0.067	IO					1.07
6.583	0.48	0.67	0.065	O					1.06
6.667	0.57	0.66	0.065	O					1.06
6.750	0.65	0.66	0.064	O					1.05
6.833	0.69	0.66	0.064	OI					1.05
6.917	0.72	0.66	0.064	OI					1.06
7.000	0.74	0.66	0.065	OI					1.06
7.083	0.75	0.67	0.065	OI					1.06
7.167	0.77	0.67	0.066	OI					1.06
7.250	0.78	0.67	0.067	OI					1.07
7.333	0.81	0.67	0.068	OI					1.07
7.417	0.91	0.67	0.069	OI					1.07
7.500	0.99	0.68	0.071	O I					1.08
7.583	1.04	0.68	0.073	OI					1.09
7.667	1.15	0.69	0.076	O I					1.10
7.750	1.24	0.70	0.079	O I					1.12
7.833	1.30	0.71	0.083	O I					1.13
7.917	1.41	0.72	0.088	O I					1.15
8.000	1.50	0.73	0.093	O I					1.17
8.083	1.59	0.74	0.098	O I					1.19
8.167	1.79	0.75	0.105	O I					1.22
8.250	1.95	0.77	0.113	O I					1.25
8.333	2.02	0.79	0.121	O I					1.28
8.417	2.07	0.81	0.129	O I					1.32
8.500	2.11	0.83	0.138	O I					1.35
8.583	2.16	0.85	0.147	O I					1.39
8.667	2.26	0.87	0.156	O I					1.43
8.750	2.35	0.89	0.166	O I					1.47
8.833	2.41	0.92	0.176	O I					1.51
8.917	2.53	0.94	0.187	O I					1.55
9.000	2.62	0.97	0.198	O I					1.59
9.083	2.70	0.99	0.210	O I					1.64
9.167	2.90	1.02	0.222	O I					1.69
9.250	3.06	1.05	0.236	O I					1.75
9.333	3.15	1.08	0.250	O I					1.80
9.417	3.28	1.11	0.264	O I					1.88
9.500	3.39	1.14	0.279	O I					1.96

9.583	3.46	1.17	0.295	O		I				2.05
9.667	3.58	1.20	0.311	O		I				2.13
9.750	3.68	1.23	0.328	O		I				2.22
9.833	3.75	1.26	0.345	O		I				2.32
9.917	3.87	1.29	0.362	O		I				2.41
10.000	3.96	1.33	0.380	O		I				2.51
10.083	3.87	1.36	0.398	O		I				2.60
10.167	3.32	1.39	0.413	O		I				2.68
10.250	2.86	1.41	0.425	O		I				2.75
10.333	2.70	1.43	0.434	O		I				2.80
10.417	2.60	1.44	0.443	O		I				2.84
10.500	2.54	1.45	0.450	O		I				2.88
10.583	2.60	1.47	0.458	O		I				2.92
10.667	2.99	1.48	0.467	O		I				2.97
10.750	3.31	1.50	0.479	O		I				3.03
10.833	3.43	1.52	0.491	O		I				3.10
10.917	3.50	1.54	0.505	O		I				3.18
11.000	3.55	1.56	0.518	O		I				3.25
11.083	3.56	1.58	0.532	O		I				3.32
11.167	3.50	1.60	0.546	O		I				3.39
11.250	3.46	1.62	0.558	O		I				3.46
11.333	3.46	1.64	0.571	O		I				3.53
11.417	3.46	1.66	0.583	O		I				3.60
11.500	3.47	1.68	0.596	O		I				3.66
11.583	3.43	1.70	0.608	O		I				3.73
11.667	3.28	1.72	0.619	O		I				3.79
11.750	3.14	1.73	0.630	O		I				3.85
11.833	3.11	1.74	0.639	O		I				3.90
11.917	3.17	1.76	0.649	O		I				3.95
12.000	3.22	1.77	0.659	O		I				4.00
12.083	3.38	1.78	0.669	O		I				4.06
12.167	3.97	1.80	0.682	O		I				4.13
12.250	4.46	1.82	0.699	O		I				4.21
12.333	4.68	1.84	0.717	O		I				4.32
12.417	4.88	1.87	0.738	O		I				4.42
12.500	5.03	1.90	0.759	O		I				4.54
12.583	5.16	1.92	0.781	O		I				4.65
12.667	5.38	1.95	0.804	O		I				4.78
12.750	5.57	1.97	0.828	O		I				4.83
12.833	5.68	1.98	0.853	O		I				4.87
12.917	5.83	1.98	0.879	O		I				4.91
13.000	5.94	1.99	0.906	O		I				4.95
13.083	6.11	2.00	0.934	O		I				5.00
13.167	6.57	2.01	0.963	O		I				5.04
13.250	6.94	2.02	0.996	O		I				5.09
13.333	7.10	2.04	1.030	O		I				5.15
13.417	7.20	2.05	1.066	O		I				5.20
13.500	7.26	2.06	1.101	O		I				5.26
13.583	7.09	2.07	1.136	O		I				5.31
13.667	6.21	2.08	1.168	O		I				5.36
13.750	5.49	2.09	1.194	O		I				5.40
13.833	5.22	2.10	1.216	O		I				5.43
13.917	5.06	2.11	1.237	O		I				5.46
14.000	4.96	2.11	1.257	O		I				5.49
14.083	4.97	2.12	1.277	O		I				5.52
14.167	5.26	2.12	1.297	O		I				5.55
14.250	5.49	2.13	1.320	O		I				5.58
14.333	5.55	2.14	1.343	O		I				5.62
14.417	5.51	2.15	1.366	O		I				5.65
14.500	5.47	2.15	1.389	O		I				5.68
14.583	5.46	2.16	1.412	O		I				5.72
14.667	5.45	2.17	1.435	O		I				5.75
14.750	5.46	2.18	1.457	O		I				5.78

14.833	5.46	2.18	1.480			O		I	5.81
14.917	5.38	2.19	1.502			O		I	5.84
15.000	5.32	2.19	1.524			O		I	5.87
15.083	5.28	2.20	1.545			O		I	5.90
15.167	5.20	2.20	1.566			O		I	5.93
15.250	5.12	2.21	1.587			O		I	5.96
15.333	5.07	2.22	1.607			O		I	5.99
15.417	4.97	2.22	1.626			O		I	6.01
15.500	4.89	2.23	1.645			O		I	6.04
15.583	4.78	2.23	1.662			O		I	6.06
15.667	4.43	2.23	1.679			O		I	6.08
15.750	4.14	2.24	1.693			O		I	6.10
15.833	4.02	2.24	1.706			O		I	6.12
15.917	3.96	2.24	1.718			O		I	6.14
16.000	3.91	2.25	1.729			O		I	6.15
16.083	3.64	2.25	1.740			O		I	6.17
16.167	2.60	2.25	1.746			O	I		6.17
16.250	1.69	2.25	1.745			O	I		6.17
16.333	1.12	2.25	1.739		I	O			6.16
16.417	0.73	2.25	1.730		I	O			6.15
16.500	0.52	2.24	1.719		I	O			6.14
16.583	0.42	2.24	1.707		I	O			6.12
16.667	0.49	2.24	1.694		I	O			6.10
16.750	0.56	2.23	1.683		I	O			6.09
16.833	0.56	2.23	1.671		I	O			6.07
16.917	0.55	2.23	1.660		I	O			6.06
17.000	0.54	2.23	1.648		I	O			6.04
17.083	0.51	2.22	1.636		I	O			6.03
17.167	0.42	2.22	1.624		I	O			6.01
17.250	0.36	2.22	1.611		I	O			5.99
17.333	0.35	2.21	1.599		I	O			5.98
17.417	0.34	2.21	1.586		I	O			5.96
17.500	0.34	2.21	1.573		I	O			5.94
17.583	0.34	2.20	1.560		I	O			5.92
17.667	0.34	2.20	1.547		I	O			5.91
17.750	0.34	2.20	1.535		I	O			5.89
17.833	0.33	2.19	1.522		I	O			5.87
17.917	0.24	2.19	1.509		I	O			5.85
18.000	0.18	2.19	1.495		I	O			5.84
18.083	0.15	2.18	1.481		I	O			5.82
18.167	0.14	2.18	1.467		I	O			5.80
18.250	0.14	2.17	1.453		I	O			5.78
18.333	0.13	2.17	1.439		I	O			5.76
18.417	0.13	2.17	1.425		I	O			5.74
18.500	0.13	2.16	1.411		I	O			5.71
18.583	0.16	2.16	1.397		I	O			5.69
18.667	0.30	2.15	1.384		I	O			5.68
18.750	0.40	2.15	1.371		I	O			5.66
18.833	0.43	2.14	1.360		I	O			5.64
18.917	0.40	2.14	1.348		I	O			5.62
19.000	0.37	2.14	1.336		I	O			5.60
19.083	0.37	2.13	1.323		I	O			5.59
19.167	0.43	2.13	1.311		I	O			5.57
19.250	0.48	2.13	1.300		I	O			5.55
19.333	0.47	2.12	1.289		I	O			5.54
19.417	0.36	2.12	1.277		I	O			5.52
19.500	0.27	2.11	1.264		I	O			5.50
19.583	0.27	2.11	1.252		I	O			5.48
19.667	0.37	2.11	1.240		I	O			5.46
19.750	0.45	2.10	1.228		I	O			5.45
19.833	0.47	2.10	1.217		I	O			5.43
19.917	0.42	2.09	1.205		I	O			5.41
20.000	0.39	2.09	1.194		I	O			5.40

20.083	0.39	2.09	1.182	I	O	5.38
20.167	0.44	2.08	1.170	I	O	5.36
20.250	0.49	2.08	1.159	I	O	5.35
20.333	0.50	2.08	1.148	I	O	5.33
20.417	0.51	2.07	1.137	I	O	5.31
20.500	0.52	2.07	1.127	I	O	5.30
20.583	0.52	2.07	1.116	I	O	5.28
20.667	0.53	2.06	1.105	I	O	5.26
20.750	0.53	2.06	1.095	I	O	5.25
20.833	0.52	2.05	1.084	I	O	5.23
20.917	0.46	2.05	1.074	I	O	5.21
21.000	0.41	2.05	1.062	I	O	5.20
21.083	0.41	2.04	1.051	I	O	5.18
21.167	0.46	2.04	1.040	I	O	5.16
21.250	0.50	2.04	1.029	I	O	5.15
21.333	0.50	2.03	1.019	I	O	5.13
21.417	0.44	2.03	1.008	I	O	5.11
21.500	0.40	2.02	0.997	I	O	5.10
21.583	0.36	2.02	0.986	I	O	5.08
21.667	0.23	2.02	0.974	I	O	5.06
21.750	0.14	2.01	0.961	I	O	5.04
21.833	0.12	2.01	0.948	I	O	5.02
21.917	0.21	2.00	0.936	I	O	5.00
22.000	0.29	2.00	0.923	I	O	4.98
22.083	0.29	2.00	0.912	I	O	4.96
22.167	0.19	1.99	0.900	I	O	4.94
22.250	0.11	1.99	0.887	I	O	4.92
22.333	0.11	1.98	0.874	I	O	4.90
22.417	0.20	1.98	0.861	I	O	4.88
22.500	0.28	1.97	0.849	I	O	4.86
22.583	0.30	1.97	0.838	I	O	4.85
22.667	0.32	1.97	0.827	I	O	4.83
22.750	0.33	1.96	0.815	I	O	4.81
22.833	0.34	1.95	0.804	I	O	4.78
22.917	0.34	1.94	0.793	I	O	4.72
23.000	0.35	1.93	0.782	I	O	4.66
23.083	0.35	1.91	0.771	I	O	4.60
23.167	0.35	1.90	0.760	I	O	4.55
23.250	0.35	1.89	0.750	I	O	4.49
23.333	0.35	1.87	0.739	I	O	4.43
23.417	0.36	1.86	0.729	I	O	4.38
23.500	0.36	1.85	0.719	I	O	4.32
23.583	0.36	1.83	0.708	I	O	4.27
23.667	0.36	1.82	0.698	I	O	4.21
23.750	0.36	1.81	0.688	I	O	4.16
23.833	0.36	1.79	0.678	I	O	4.11
23.917	0.36	1.78	0.668	I	O	4.05
24.000	0.36	1.77	0.659	I	O	4.00
24.083	0.33	1.76	0.649	I	O	3.95
24.167	0.21	1.74	0.639	I	O	3.89
24.250	0.11	1.73	0.628	I	O	3.84
24.333	0.08	1.71	0.617	I	O	3.78
24.417	0.05	1.70	0.605	I	O	3.72
24.500	0.04	1.68	0.594	I	O	3.66
24.583	0.03	1.66	0.583	I	O	3.59
24.667	0.02	1.64	0.572	I	O	3.53
24.750	0.02	1.63	0.560	I	O	3.47
24.833	0.01	1.61	0.549	I	O	3.42
24.917	0.01	1.59	0.538	I	O	3.36
25.000	0.00	1.57	0.528	I	O	3.30
25.083	0.00	1.56	0.517	I	O	3.24
25.167	0.00	1.54	0.506	I	O	3.18
25.250	0.00	1.52	0.496	I	O	3.13

25.333	0.00	1.51	0.485	I	O	3.07
25.417	0.00	1.49	0.475	I	O	3.01
25.500	0.00	1.48	0.465	I	O	2.96
25.583	0.00	1.46	0.455	I	O	2.90
25.667	0.00	1.44	0.445	I	O	2.85
25.750	0.00	1.43	0.435	I	O	2.80
25.833	0.00	1.41	0.425	I	O	2.75
25.917	0.00	1.39	0.415	I	O	2.69
26.000	0.00	1.37	0.406	I	O	2.64
26.083	0.00	1.36	0.396	I	O	2.59
26.167	0.00	1.34	0.387	I	O	2.54
26.250	0.00	1.32	0.378	I	O	2.49
26.333	0.00	1.31	0.369	I	O	2.44
26.417	0.00	1.29	0.360	I	O	2.40
26.500	0.00	1.27	0.351	I	O	2.35
26.583	0.00	1.26	0.342	I	O	2.30
26.667	0.00	1.24	0.334	I	O	2.26
26.750	0.00	1.22	0.325	I	O	2.21
26.833	0.00	1.21	0.317	I	O	2.16
26.917	0.00	1.19	0.309	I	O	2.12
27.000	0.00	1.18	0.300	I	O	2.08
27.083	0.00	1.16	0.292	I	O	2.03
27.167	0.00	1.15	0.284	I	O	1.99
27.250	0.00	1.13	0.277	I	O	1.95
27.333	0.00	1.12	0.269	I	O	1.91
27.417	0.00	1.10	0.261	I	O	1.87
27.500	0.00	1.09	0.254	I	O	1.82
27.583	0.00	1.07	0.246	I	O	1.79
27.667	0.00	1.06	0.239	I	O	1.76
27.750	0.00	1.04	0.232	I	O	1.73
27.833	0.00	1.02	0.225	I	O	1.70
27.917	0.00	1.01	0.218	I	O	1.67
28.000	0.00	0.99	0.211	I	O	1.65
28.083	0.00	0.98	0.204	I	O	1.62
28.167	0.00	0.96	0.197	I	O	1.59
28.250	0.00	0.95	0.191	I	O	1.56
28.333	0.00	0.93	0.184	I	O	1.54
28.417	0.00	0.92	0.178	I	O	1.51
28.500	0.00	0.90	0.171	I	O	1.49
28.583	0.00	0.89	0.165	I	O	1.46
28.667	0.00	0.88	0.159	I	O	1.44
28.750	0.00	0.86	0.153	I	O	1.41
28.833	0.00	0.85	0.147	I	O	1.39
28.917	0.00	0.84	0.141	I	O	1.37
29.000	0.00	0.82	0.136	I	O	1.34
29.083	0.00	0.81	0.130	I	O	1.32
29.167	0.00	0.80	0.125	I	O	1.30
29.250	0.00	0.79	0.119	I	O	1.28
29.333	0.00	0.77	0.114	I	O	1.25
29.417	0.00	0.76	0.108	I	O	1.23
29.500	0.00	0.75	0.103	I	O	1.21
29.583	0.00	0.74	0.098	I	O	1.19
29.667	0.00	0.73	0.093	I	O	1.17
29.750	0.00	0.72	0.088	I	O	1.15
29.833	0.00	0.71	0.083	I	O	1.13
29.917	0.00	0.69	0.078	I	O	1.11
30.000	0.00	0.68	0.074	I	O	1.09
30.083	0.00	0.67	0.069	I	O	1.07
30.167	0.00	0.66	0.064	I	O	1.06
30.250	0.00	0.65	0.060	I	O	1.04
30.333	0.00	0.64	0.055	I	O	1.02
30.417	0.00	0.63	0.051	I	O	1.00
30.500	0.00	0.62	0.047	I	O	0.98

30.583	0.00	0.61	0.042	I O					0.97
30.667	0.00	0.60	0.038	I O					0.95
30.750	0.00	0.59	0.034	I O					0.93
30.833	0.00	0.59	0.030	I O					0.92
30.917	0.00	0.58	0.026	I O					0.90
31.000	0.00	0.57	0.022	I O					0.88
31.083	0.00	0.56	0.018	I O					0.87
31.167	0.00	0.55	0.014	I O					0.85
31.250	0.00	0.54	0.011	I O					0.84
31.333	0.00	0.53	0.007	I O					0.82
31.417	0.00	0.53	0.003	I O					0.81
31.500	0.00	0.26	0.001	IO					0.41
31.583	0.00	0.00	0.000	O					0.00

*****HYDROGRAPH DATA*****

Number of intervals = 379

Time interval = 5.0 (Min.)

Maximum/Peak flow rate = 2.251 (CFS)

Total volume = 3.543 (Ac.Ft)

Status of hydrographs being held in storage

	Stream 1	Stream 2	Stream 3	Stream 4	Stream 5
Peak (CFS)	0.000	0.000	0.000	0.000	0.000
Vol (Ac.Ft)	0.000	0.000	0.000	0.000	0.000

Appendix 7: Hydromodification

Supporting Detail Relating to Hydrologic Conditions of Concern

Site is located within mapped HCOC Exemption area as presented in the approved WAP dated April 20, 2017.

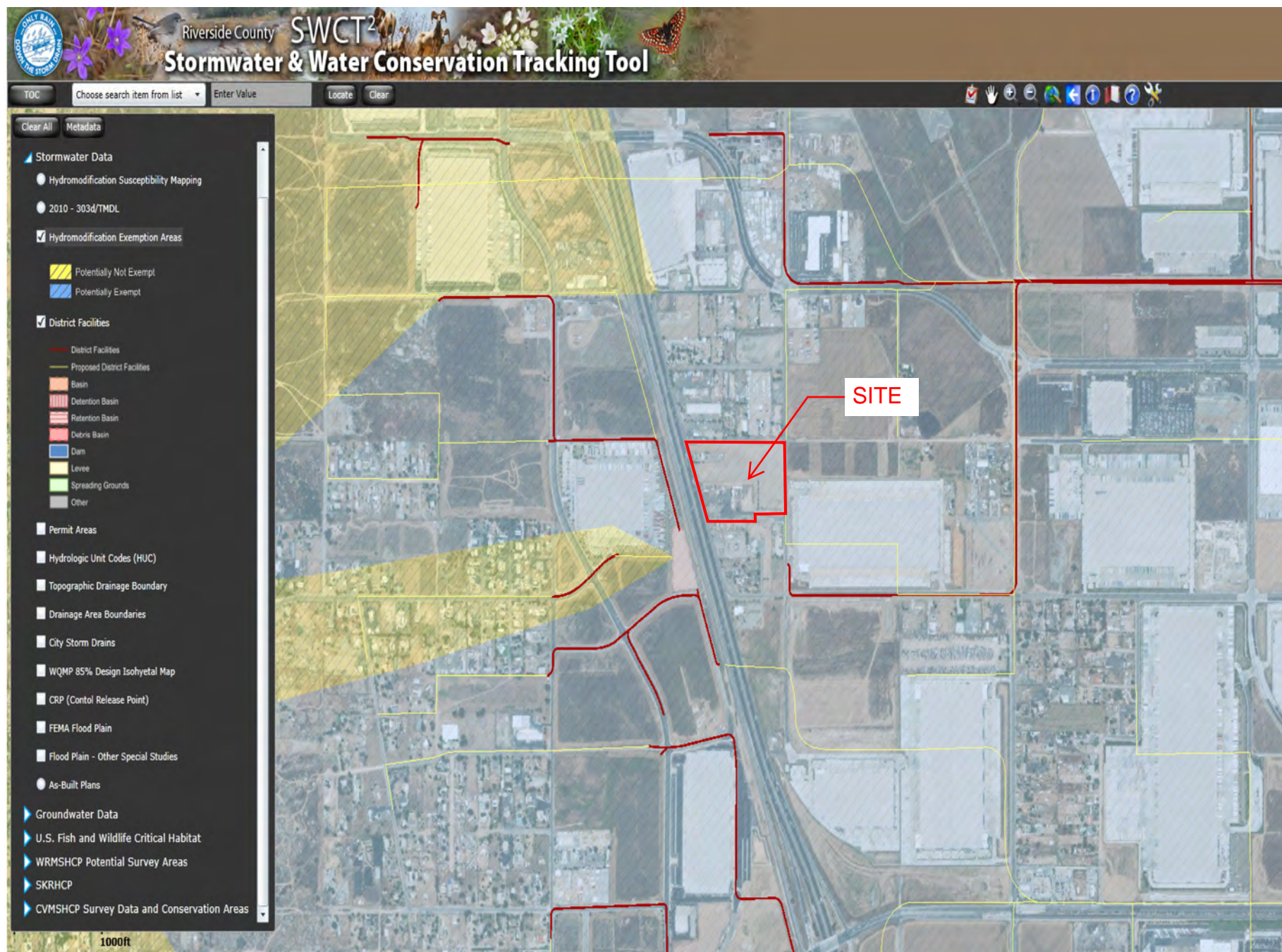

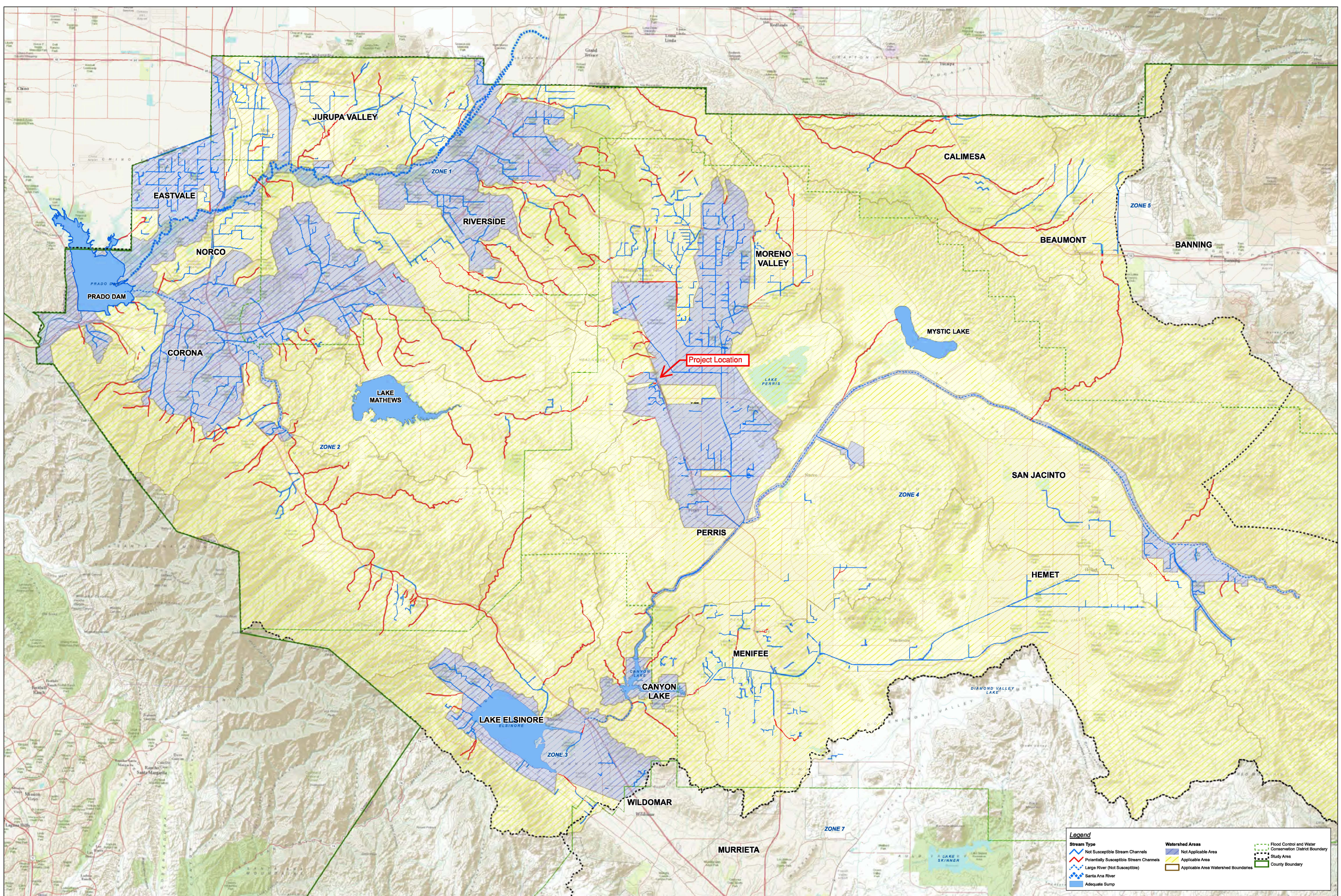

Legend

Stream Type	Watershed Areas	Flood Control and Water Conservation District Boundary
Not Susceptible Stream Channels	Not Applicable Area	Study Area
Potentially Susceptible Stream Channels	Applicable Area	County Boundary
Large River (Not Susceptible)	Applicable Area Watershed Boundaries	
Santa Ana River		
Adequate Sump		

Appendix 8: Source Control

Pollutant Sources/Source Control Checklist

STORMWATER POLLUTANT SOURCES/SOURCE CONTROL CHECKLIST

How to use this worksheet (also see instructions in Section G of the WQMP Template):

1. Review Column 1 and identify which of these potential sources of stormwater pollutants apply to your site. Check each box that applies.
2. Review Column 2 and incorporate all of the corresponding applicable BMPs in your WQMP Exhibit.
3. Review Columns 3 and 4 and incorporate all of the corresponding applicable permanent controls and operational BMPs in your WQMP. Use the format shown in Table G.1 on page 23 of this WQMP Template. Describe your specific BMPs in an accompanying narrative, and explain any special conditions or situations that required omitting BMPs or substituting alternative BMPs for those shown here.

IF THESE SOURCES WILL BE ON THE PROJECT SITE THEN YOUR WQMP SHOULD INCLUDE THESE SOURCE CONTROL BMPs, AS APPLICABLE		
1 Potential Sources of Runoff Pollutants	2 Permanent Controls—Show on WQMP Drawings	3 Permanent Controls—List in WQMP Table and Narrative	4 Operational BMPs—Include in WQMP Table and Narrative
<input checked="" type="checkbox"/> A. On-site storm drain inlets	<input checked="" type="checkbox"/> Locations of inlets.	<input checked="" type="checkbox"/> Mark all inlets with the words “Only Rain Down the Storm Drain” or similar. Catch Basin Markers may be available from the Riverside County Flood Control and Water Conservation District, call 951.955.1200 to verify.	<input checked="" type="checkbox"/> Maintain and periodically repaint or replace inlet markings. <input checked="" type="checkbox"/> Provide stormwater pollution prevention information to new site owners, lessees, or operators. <input checked="" type="checkbox"/> See applicable operational BMPs in Fact Sheet SC-44, “Drainage System Maintenance,” in the CASQA Stormwater Quality Handbooks at www.cabmphandbooks.com <input checked="" type="checkbox"/> Include the following in lease agreements: “Tenant shall not allow anyone to discharge anything to storm drains or to store or deposit materials so as to create a potential discharge to storm drains.”
<input type="checkbox"/> B. Interior floor drains and elevator shaft sump pumps		<input type="checkbox"/> State that interior floor drains and elevator shaft sump pumps will be plumbed to sanitary sewer.	<input type="checkbox"/> Inspect and maintain drains to prevent blockages and overflow.
<input type="checkbox"/> C. Interior parking garages		<input type="checkbox"/> State that parking garage floor drains will be plumbed to the sanitary sewer.	<input type="checkbox"/> Inspect and maintain drains to prevent blockages and overflow.

STORMWATER POLLUTANT SOURCES/SOURCE CONTROL CHECKLIST

IF THESE SOURCES WILL BE ON THE PROJECT SITE THEN YOUR WQMP SHOULD INCLUDE THESE SOURCE CONTROL BMPs, AS APPLICABLE		
1 Potential Sources of Runoff Pollutants	2 Permanent Controls—Show on WQMP Drawings	3 Permanent Controls—List in WQMP Table and Narrative	4 Operational BMPs—Include in WQMP Table and Narrative
<input type="checkbox"/> D1. Need for future indoor & structural pest control		<input type="checkbox"/> Note building design features that discourage entry of pests.	<input type="checkbox"/> Provide Integrated Pest Management information to owners, lessees, and operators.
<input checked="" type="checkbox"/> D2. Landscape/ Outdoor Pesticide Use	<input type="checkbox"/> Show locations of native trees or areas of shrubs and ground cover to be undisturbed and retained. <i>N/A</i> <input type="checkbox"/> Show self-retaining landscape areas, if any. <i>N/A</i> <input checked="" type="checkbox"/> Show stormwater treatment and hydrograph modification management BMPs. (See instructions in Chapter 3, Step 5 and guidance in Chapter 5.)	<p>State that final landscape plans will accomplish all of the following.</p> <input checked="" type="checkbox"/> Preserve existing native trees, shrubs, and ground cover to the maximum extent possible. <input checked="" type="checkbox"/> Design landscaping to minimize irrigation and runoff, to promote surface infiltration where appropriate, and to minimize the use of fertilizers and pesticides that can contribute to stormwater pollution. <input checked="" type="checkbox"/> Where landscaped areas are used to retain or detain stormwater, specify plants that are tolerant of saturated soil conditions. <input checked="" type="checkbox"/> Consider using pest-resistant plants, especially adjacent to hardscape. <p>To insure successful establishment, select plants appropriate to site soils, slopes, climate, sun, wind, rain, land use, air movement, ecological consistency, and plant interactions.</p>	<input checked="" type="checkbox"/> Maintain landscaping using minimum or no pesticides. <input checked="" type="checkbox"/> See applicable operational BMPs in “What you should know for.....Landscape and Gardening” at http://rcflood.org/stormwater/Error! <small>Hyperlink reference not valid.</small> <input checked="" type="checkbox"/> Provide IPM information to new owners, lessees and operators.

STORMWATER POLLUTANT SOURCES/SOURCE CONTROL CHECKLIST

IF THESE SOURCES WILL BE ON THE PROJECT SITE THEN YOUR WQMP SHOULD INCLUDE THESE SOURCE CONTROL BMPs, AS APPLICABLE		
1 Potential Sources of Runoff Pollutants	2 Permanent Controls—Show on WQMP Drawings	3 Permanent Controls—List in WQMP Table and Narrative	4 Operational BMPs—Include in WQMP Table and Narrative
<input type="checkbox"/> E. Pools, spas, ponds, decorative fountains, and other water features.	<input type="checkbox"/> Show location of water feature and a sanitary sewer cleanout in an accessible area within 10 feet. (Exception: Public pools must be plumbed according to County Department of Environmental Health Guidelines.)	If the Co-Permittee requires pools to be plumbed to the sanitary sewer, place a note on the plans and state in the narrative that this connection will be made according to local requirements.	<input type="checkbox"/> See applicable operational BMPs in “Guidelines for Maintaining Your Swimming Pool, Jacuzzi and Garden Fountain” at http://rcflood.org/stormwater/
<input type="checkbox"/> F. Food service	<input type="checkbox"/> For restaurants, grocery stores, and other food service operations, show location (indoors or in a covered area outdoors) of a floor sink or other area for cleaning floor mats, containers, and equipment. <input type="checkbox"/> On the drawing, show a note that this drain will be connected to a grease interceptor before discharging to the sanitary sewer.	<input type="checkbox"/> Describe the location and features of the designated cleaning area. <input type="checkbox"/> Describe the items to be cleaned in this facility and how it has been sized to insure that the largest items can be accommodated.	<input type="checkbox"/> See the brochure, “The Food Service Industry Best Management Practices for: Restaurants, Grocery Stores, Delicatessens and Bakeries” at http://rcflood.org/stormwater/ Provide this brochure to new site owners, lessees, and operators.
<input checked="" type="checkbox"/> G. Refuse areas	<input checked="" type="checkbox"/> Show where site refuse and recycled materials will be handled and stored for pickup. See local municipal requirements for sizes and other details of refuse areas. <input checked="" type="checkbox"/> If dumpsters or other receptacles are outdoors, show how the designated area will be covered, graded, and paved to prevent run-on and show locations of berms to prevent runoff from the area. <input checked="" type="checkbox"/> Any drains from dumpsters, compactors, and tallow bin areas shall be connected to a grease removal device before discharge to sanitary sewer.	<input checked="" type="checkbox"/> State how site refuse will be handled and provide supporting detail to what is shown on plans. <input checked="" type="checkbox"/> State that signs will be posted on or near dumpsters with the words “Do not dump hazardous materials here” or similar.	<input checked="" type="checkbox"/> State how the following will be implemented: Provide adequate number of receptacles. Inspect receptacles regularly; repair or replace leaky receptacles. Keep receptacles covered. Prohibit/prevent dumping of liquid or hazardous wastes. Post “no hazardous materials” signs. Inspect and pick up litter daily and clean up spills immediately. Keep spill control materials available on-site. See Fact Sheet SC-34, “Waste Handling and Disposal” in the CASQA Stormwater Quality Handbooks at www.cabmphandbooks.com

STORMWATER POLLUTANT SOURCES/SOURCE CONTROL CHECKLIST

IF THESE SOURCES WILL BE ON THE PROJECT SITE THEN YOUR WQMP SHOULD INCLUDE THESE SOURCE CONTROL BMPs, AS APPLICABLE		
1 Potential Sources of Runoff Pollutants	2 Permanent Controls—Show on WQMP Drawings	3 Permanent Controls—List in WQMP Table and Narrative	4 Operational BMPs—Include in WQMP Table and Narrative
<input type="checkbox"/> H. Industrial processes.	<input type="checkbox"/> Show process area.	<input type="checkbox"/> If industrial processes are to be located on site, state: “All process activities to be performed indoors. No processes to drain to exterior or to storm drain system.”	<input type="checkbox"/> See Fact Sheet SC-10, “Non-Stormwater Discharges” in the CASQA Stormwater Quality Handbooks at www.cabmphandbooks.com See the brochure “Industrial & Commercial Facilities Best Management Practices for: Industrial, Commercial Facilities” at http://rcflood.org/stormwater/

STORMWATER POLLUTANT SOURCES/SOURCE CONTROL CHECKLIST

IF THESE SOURCES WILL BE ON THE PROJECT SITE THEN YOUR WQMP SHOULD INCLUDE THESE SOURCE CONTROL BMPs, AS APPLICABLE		
1 Potential Sources of Runoff Pollutants	2 Permanent Controls—Show on WQMP Drawings	3 Permanent Controls—List in WQMP Table and Narrative	4 Operational BMPs—Include in WQMP Table and Narrative
<p><input type="checkbox"/> I. Outdoor storage of equipment or materials. (See rows J and K for source control measures for vehicle cleaning, repair, and maintenance.)</p>	<p><input type="checkbox"/> Show any outdoor storage areas, including how materials will be covered. Show how areas will be graded and bermed to prevent run-on or run-off from area.</p> <p><input type="checkbox"/> Storage of non-hazardous liquids shall be covered by a roof and/or drain to the sanitary sewer system, and be contained by berms, dikes, liners, or vaults.</p> <p><input type="checkbox"/> Storage of hazardous materials and wastes must be in compliance with the local hazardous materials ordinance and a Hazardous Materials Management Plan for the site.</p>	<p>Include a detailed description of materials to be stored, storage areas, and structural features to prevent pollutants from entering storm drains.</p> <p>Where appropriate, reference documentation of compliance with the requirements of Hazardous Materials Programs for:</p> <ul style="list-style-type: none"> ▪ Hazardous Waste Generation ▪ Hazardous Materials Release Response and Inventory ▪ California Accidental Release (CalARP) ▪ Aboveground Storage Tank ▪ Uniform Fire Code Article 80 Section 103(b) & (c) 1991 ▪ Underground Storage Tank <p>www.cchealth.org/groups/hazmat/</p>	<p><input type="checkbox"/> See the Fact Sheets SC-31, “Outdoor Liquid Container Storage” and SC-33, “Outdoor Storage of Raw Materials ” in the CASQA Stormwater Quality Handbooks at www.cabmphandbooks.com</p>

STORMWATER POLLUTANT SOURCES/SOURCE CONTROL CHECKLIST

IF THESE SOURCES WILL BE ON THE PROJECT SITE THEN YOUR WQMP SHOULD INCLUDE THESE SOURCE CONTROL BMPs, AS APPLICABLE		
1 Potential Sources of Runoff Pollutants	2 Permanent Controls—Show on WQMP Drawings	3 Permanent Controls—List in WQMP Table and Narrative	4 Operational BMPs—Include in WQMP Table and Narrative
<input type="checkbox"/> J. Vehicle and Equipment Cleaning	<input type="checkbox"/> Show on drawings as appropriate: (1) Commercial/industrial facilities having vehicle/equipment cleaning needs shall either provide a covered, bermed area for washing activities or discourage vehicle/equipment washing by removing hose bibs and installing signs prohibiting such uses. (2) Multi-dwelling complexes shall have a paved, bermed, and covered car wash area (unless car washing is prohibited on-site and hoses are provided with an automatic shut-off to discourage such use). (3) Washing areas for cars, vehicles, and equipment shall be paved, designed to prevent run-on to or runoff from the area, and plumbed to drain to the sanitary sewer. (4) Commercial car wash facilities shall be designed such that no runoff from the facility is discharged to the storm drain system. Wastewater from the facility shall discharge to the sanitary sewer, or a wastewater reclamation system shall be installed.	<input type="checkbox"/> If a car wash area is not provided, describe any measures taken to discourage on-site car washing and explain how these will be enforced.	Describe operational measures to implement the following (if applicable): <input type="checkbox"/> Washwater from vehicle and equipment washing operations shall not be discharged to the storm drain system. Refer to “Outdoor Cleaning Activities and Professional Mobile Service Providers” for many of the Potential Sources of Runoff Pollutants categories below. Brochure can be found at http://rcflood.org/stormwater/ <input type="checkbox"/> Car dealerships and similar may rinse cars with water only.

STORMWATER POLLUTANT SOURCES/SOURCE CONTROL CHECKLIST

IF THESE SOURCES WILL BE ON THE PROJECT SITE THEN YOUR WQMP SHOULD INCLUDE THESE SOURCE CONTROL BMPs, AS APPLICABLE		
1 Potential Sources of Runoff Pollutants	2 Permanent Controls—Show on WQMP Drawings	3 Permanent Controls—List in WQMP Table and Narrative	4 Operational BMPs—Include in WQMP Table and Narrative
<p><input type="checkbox"/> K. Vehicle/Equipment Repair and Maintenance</p>	<p><input type="checkbox"/> Accommodate all vehicle equipment repair and maintenance indoors. Or designate an outdoor work area and design the area to prevent run-on and runoff of stormwater.</p> <p><input type="checkbox"/> Show secondary containment for exterior work areas where motor oil, brake fluid, gasoline, diesel fuel, radiator fluid, acid-containing batteries or other hazardous materials or hazardous wastes are used or stored. Drains shall not be installed within the secondary containment areas.</p> <p><input type="checkbox"/> Add a note on the plans that states either (1) there are no floor drains, or (2) floor drains are connected to wastewater pretreatment systems prior to discharge to the sanitary sewer and an industrial waste discharge permit will be obtained.</p>	<p><input type="checkbox"/> State that no vehicle repair or maintenance will be done outdoors, or else describe the required features of the outdoor work area.</p> <p><input type="checkbox"/> State that there are no floor drains or if there are floor drains, note the agency from which an industrial waste discharge permit will be obtained and that the design meets that agency’s requirements.</p> <p><input type="checkbox"/> State that there are no tanks, containers or sinks to be used for parts cleaning or rinsing or, if there are, note the agency from which an industrial waste discharge permit will be obtained and that the design meets that agency’s requirements.</p>	<p>In the Stormwater Control Plan, note that all of the following restrictions apply to use the site:</p> <p><input type="checkbox"/> No person shall dispose of, nor permit the disposal, directly or indirectly of vehicle fluids, hazardous materials, or rinsewater from parts cleaning into storm drains.</p> <p><input type="checkbox"/> No vehicle fluid removal shall be performed outside a building, nor on asphalt or ground surfaces, whether inside or outside a building, except in such a manner as to ensure that any spilled fluid will be in an area of secondary containment. Leaking vehicle fluids shall be contained or drained from the vehicle immediately.</p> <p><input type="checkbox"/> No person shall leave unattended drip parts or other open containers containing vehicle fluid, unless such containers are in use or in an area of secondary containment.</p> <p>Refer to “Automotive Maintenance & Car Care Best Management Practices for Auto Body Shops, Auto Repair Shops, Car Dealerships, Gas Stations and Fleet Service Operations”. Brochure can be found at http://rcflood.org/stormwater/</p> <p>Refer to Outdoor Cleaning Activities and Professional Mobile Service Providers for many of the Potential Sources of Runoff Pollutants categories below. Brochure can be found at http://rcflood.org/stormwater/</p>

STORMWATER POLLUTANT SOURCES/SOURCE CONTROL CHECKLIST

IF THESE SOURCES WILL BE ON THE PROJECT SITE THEN YOUR WQMP SHOULD INCLUDE THESE SOURCE CONTROL BMPs, AS APPLICABLE		
1 Potential Sources of Runoff Pollutants	2 Permanent Controls—Show on WQMP Drawings	3 Permanent Controls—List in WQMP Table and Narrative	4 Operational BMPs—Include in WQMP Table and Narrative
<input type="checkbox"/> L. Fuel Dispensing Areas	<input type="checkbox"/> Fueling areas ⁶ shall have impermeable floors (i.e., portland cement concrete or equivalent smooth impervious surface) that are: a) graded at the minimum slope necessary to prevent ponding; and b) separated from the rest of the site by a grade break that prevents run-on of stormwater to the maximum extent practicable. <input type="checkbox"/> Fueling areas shall be covered by a canopy that extends a minimum of ten feet in each direction from each pump. [Alternative: The fueling area must be covered and the cover's minimum dimensions must be equal to or greater than the area within the grade break or fuel dispensing area ¹ .] The canopy [or cover] shall not drain onto the fueling area.		<input type="checkbox"/> The property owner shall dry sweep the fueling area routinely. <input type="checkbox"/> See the Fact Sheet SD-30 , “Fueling Areas” in the CASQA Stormwater Quality Handbooks at www.cabmphandbooks.com

⁶ The fueling area shall be defined as the area extending a minimum of 6.5 feet from the corner of each fuel dispenser or the length at which the hose and nozzle assembly may be operated plus a minimum of one foot, whichever is greater.

STORMWATER POLLUTANT SOURCES/SOURCE CONTROL CHECKLIST

IF THESE SOURCES WILL BE ON THE PROJECT SITE THEN YOUR WQMP SHOULD INCLUDE THESE SOURCE CONTROL BMPs, AS APPLICABLE		
1 Potential Sources of Runoff Pollutants	2 Permanent Controls—Show on WQMP Drawings	3 Permanent Controls—List in WQMP Table and Narrative	4 Operational BMPs—Include in WQMP Table and Narrative
<ul style="list-style-type: none"> ■ M. Loading Docks 	<ul style="list-style-type: none"> ■ Show a preliminary design for the loading dock area, including roofing and drainage. Loading docks shall be covered and/or graded to minimize run-on to and runoff from the loading area. Roof downspouts shall be positioned to direct stormwater away from the loading area. Water from loading dock areas shall be drained to the sanitary sewer, or diverted and collected for ultimate discharge to the sanitary sewer. ■ Loading dock areas draining directly to the sanitary sewer shall be equipped with a spill control valve or equivalent device, which shall be kept closed during periods of operation. ■ Provide a roof overhang over the loading area or install door skirts (cowling) at each bay that enclose the end of the trailer. 		<ul style="list-style-type: none"> ■ Move loaded and unloaded items indoors as soon as possible. ■ See Fact Sheet SC-30, “Outdoor Loading and Unloading,” in the CASQA Stormwater Quality Handbooks at www.cabmphandbooks.com

STORMWATER POLLUTANT SOURCES/SOURCE CONTROL CHECKLIST

IF THESE SOURCES WILL BE ON THE PROJECT SITE THEN YOUR WQMP SHOULD INCLUDE THESE SOURCE CONTROL BMPs, AS APPLICABLE		
1 Potential Sources of Runoff Pollutants	2 Permanent Controls—Show on WQMP Drawings	3 Permanent Controls—List in WQMP Table and Narrative	4 Operational BMPs—Include in WQMP Table and Narrative
<ul style="list-style-type: none"> <input checked="" type="checkbox"/> N. Fire Sprinkler Test Water 		<ul style="list-style-type: none"> <input checked="" type="checkbox"/> Provide a means to drain fire sprinkler test water to the sanitary sewer. 	<ul style="list-style-type: none"> <input checked="" type="checkbox"/> See the note in Fact Sheet SC-41, “Building and Grounds Maintenance,” in the CASQA Stormwater Quality Handbooks at www.cabmphandbooks.com
<p>O. Miscellaneous Drain or Wash Water or Other Sources</p> <ul style="list-style-type: none"> <input type="checkbox"/> Boiler drain lines <input type="checkbox"/> Condensate drain lines <input type="checkbox"/> Rooftop equipment <input type="checkbox"/> Drainage sumps <input checked="" type="checkbox"/> Roofing, gutters, and trim. <input type="checkbox"/> Other sources 		<ul style="list-style-type: none"> <input type="checkbox"/> Boiler drain lines shall be directly or indirectly connected to the sanitary sewer system and may not discharge to the storm drain system. <input type="checkbox"/> Condensate drain lines may discharge to landscaped areas if the flow is small enough that runoff will not occur. Condensate drain lines may not discharge to the storm drain system. <input type="checkbox"/> Rooftop equipment with potential to produce pollutants shall be roofed and/or have secondary containment. <input type="checkbox"/> Any drainage sumps on-site shall feature a sediment sump to reduce the quantity of sediment in pumped water. <input checked="" type="checkbox"/> Avoid roofing, gutters, and trim made of copper or other unprotected metals that may leach into runoff. <p>Include controls for other sources as specified by local reviewer.</p>	

STORMWATER POLLUTANT SOURCES/SOURCE CONTROL CHECKLIST

IF THESE SOURCES WILL BE ON THE PROJECT SITE THEN YOUR WQMP SHOULD INCLUDE THESE SOURCE CONTROL BMPs, AS APPLICABLE		
1 Potential Sources of Runoff Pollutants	2 Permanent Controls—Show on WQMP Drawings	3 Permanent Controls—List in WQMP Table and Narrative	4 Operational BMPs—Include in WQMP Table and Narrative
<ul style="list-style-type: none"> ■ P. Plazas, sidewalks, and parking lots. 			<ul style="list-style-type: none"> ■ Sweep plazas, sidewalks, and parking lots regularly to prevent accumulation of litter and debris. Collect debris from pressure washing to prevent entry into the storm drain system. Collect washwater containing any cleaning agent or degreaser and discharge to the sanitary sewer not to a storm drain.

Appendix 9: O&M

Operation and Maintenance Plan and Documentation of Finance, Maintenance and Recording Mechanisms

Patterson Commerce Center Operation & Maintenance Plan

I. Inspection and Maintenance Log.

See Attachment A of this document.

II. Updates, Revision and Errata

None.

III. Introduction

The project is a new development of an industrial warehouse facility located between Patterson Avenue, Nance Street, Wade Avenue, and Washington Street in City of Perris, CA. The proposed building is approximately 264,000 square feet in size on approximately 14.0 acres of land. The site is currently being used for trailer storage and the southwest corner is being used as a heavy equipment/construction yard. New curb, gutter and commercial driveway entrances will be installed along Patterson Avenue, Nance Street, Wade Avenue, and Washington Street. There is no reclaimed water to be served for project landscaping area, and "harvest and use" is not feasible for this development. Existing topography results in the north half of the site draining onto Patterson Avenue and flowing to the north, draining to Riverside County Flood Control Storm Drain Lateral B-6. While the south half of the site drains onto Patterson Avenue and flows to the south to Riverside County Flood Control Storm Drain Lateral B-5.2.

IV. Responsibility for Maintenance

A. General

(1) Name and contact information for responsible individual(s):

Rockefeller Group Development

Michael Sajjadi, Executive Vice President

4 Park Plaza, Suite 840

Irvine, CA 92614

Phone: 949-468-1812

(2) Organization chart or charts showing organization of the maintenance function and location within the overall organization:

Rockefeller Group Development– Site Maintenance Department

(3) Reference to Operation and Maintenance Agreement (if any):

Maintenance Covenant is attached.

(4) Maintenance Funding

Rockefeller Group Development will be responded for the maintenance found. See Attachment B of this document.

B. Staff Training Program

Rockefeller Group Development will accommodate initial training of staff or contractors regarding the purpose, mode of operation, and maintenance requirements for the Stormwater BMPs per California Stormwater Quality Association (CASQA) Stormwater Best Management Practice Handbook.

C. Records

Rockefeller Group Development shall record the training day and designate the training program annually or upon hiring.

D. Safety

Rockefeller Group Development (or maintenance contractor) will be responsible for maintenance specialists' safety.

V. Summary of Drainage Management Areas and Stormwater BMP.

See WQMP Site Map in Appendix 1 for drainage area.

The below Source Control and Treatment Control BMP's shall be started once construction is complete and certificate of occupancy has been obtained.

Source Control BMP's Requiring ongoing operation and maintenance

- Landscape and Irrigation Design and Maintenance:
See CASQA BMP Fact Sheet SD-10 in Appendix 10
 - o Site landscaping design shall be implemented in accordance with the requirements of the site specific WQMP and local agency requirements.
 - o Site landscaping maintenance shall begin immediately after it has been planted.
 - o Maintenance of landscaping shall occur on a weekly basis and adjusted accordingly based on current conditions and seasonal needs.
 - o Inspection of irrigation system shall be provided on a bi-weekly basis to ensure proper function of the irrigation system, no significant overspray is occurring.
 - o Malfunctioning systems shall be repaired or replaced immediately.
 - o Inspect plant health on a monthly basis. Repair or replace unhealthy plants as needed.
 - o Inspect side slopes of basins and sloped areas on a bi-weekly basis and repair as needed. Re-plant and apply erosion protection to those areas to help prevent erosion in the future.
 - o Landscape clippings shall be swept and picked up immediately to prevent it from entering the storm drain system or adjacent sedimentation basins and filtration basins. Dispose of landscape clippings in a legal manner

- MS4 Stenciling and Signage:
See CASQA BMP Fact Sheet SD-13 in Appendix 10
 - o MS4 Stenciling and signage shall be placed during construction and inspection and maintenance shall begin upon completion of construction.
 - o Inspect catch basin stenciling on a bi-monthly basis. Replace any damaged, missing or faded stencils in a timely manner.

- Common area litter control, loading docks and trash storage areas:
See CASQA BMP Fact Sheet SD-32 in Appendix 10
 - o Inspection and Maintenance of common areas, loading docks and trash storage areas shall begin upon completion of construction.
 - o Visual inspection of common areas and loading docks shall take place on a daily basis and adjusted on an as needed basis. Visual inspection of trash storage areas shall take place on a weekly basis and adjusted on an as needed basis.
 - o Inspect areas for trash and debris. Remove any found trash and debris immediately. Dispose of trash and debris in a legal manner.

- Inspect areas for any spills. Pick up/clean up found spills immediately. Dispose of spill material in a legal manner.

- Parking lot sweeping:
See CASQA BMP Fact Sheet SE-7 in Appendix 10
 - Parking lot sweeping shall begin after the completion of construction and take place on a monthly basis.
 - Dispose of picked up material in a legal manner.

- Drainage facility (including roof drains) inspection and maintenance:
 - Inspection and maintenance of site drainage facilities and roof drains shall begin immediately upon completion of construction.
 - Catch basin and roof drain inspections shall take place on a monthly basis, prior to a rain event and after a rain event.
 - Collected debris shall be removed. Catch basins and roof drain inlet shall be clear of any debris prior to any storm event to ensure proper function of the roof drains. Collected debris shall be disposed of in a legal manner.
 - Catch basin filters shall be inspected on a monthly basis.
 - Catch basin filters that have exceeded 50% of the storage capacity shall be cleaned immediately.
 - Catch basin filters shall be maintained per the manufacturer's specifications.
 - Damaged catch basin filters shall be replaced with an approved equal prior to the next storm event or as soon as practicable.

A sample Inspection and Maintenance Form has been provided in Attachment C of this document. The owner shall ensure that documentation of all inspections and maintenance is provided for all above source control and Treatment Control BMP's. Documentation shall be kept in perpetuity.

The entity responsible for ongoing inspection and maintenance of the above described Source Control and Treatment Control BMP's is:

Michael Sajjadi
Executive Vice President
Rockefeller Group Development
4 Park Plaza, Suite 840
Irvine, CA 92614
Phone: 949-468-1812

VI. Stormwater BMP Design Documentation.

See Appendix 1 and 6 for WQMP Site Map and BMP Design Details for project site BMP design documents.

VII. Maintenance Schedule or Matrix

See Attachment B of this document and maintenance covenant is attached.

Attachment A

BMP INSPECTION & MAINTENANCE LOG

Today's Date: _____

**Name of Person Performing Activity
(Printed):** _____

Signature: _____

BMP Name (As Shown in O&M Plan)	Brief Description of Implementation, Maintenance, and Inspection Activity Performed
Bioretention Basin	<ol style="list-style-type: none"> 1. Inspect/Maintain UG-Infiltration Basin Systems 2. Remove trash, sediments and debris by jet-vac and pump and dispose of trash, sediments and debris in a legal manner. 3. Inspect system for standing water. If system has standing water, perform reinspection within 48 hours. If system still has standing water then the system shall be jet-vacuumed and pumped and removed debris shall be disposed of in a legal manner
Refuse/ Trash Storage Areas and Letter Control	Inspect trash container, lids, screens and clean trash storage areas.
Efficient Irrigation	<ol style="list-style-type: none"> 1. Inspect irrigation system general operation and durations. 2. Repair damaged sprinkler and drip irrigation lines as needed. 3. Reduce durations during the winter season to prevent over irrigation
Truck dock	Inspect loading dock for trash debris and sediments. Inspect loading dock for evidence of spills and broken containers. Clean up spills and dispose of collected material in a legal manner.
Planting	Inspect helth of planting and erosion of landscape area. Trimming trees and bushes when needed.
Loading Dock and Parking Lot Sweeping	Sweep loading dock and parking lot and truck courts.
Roof Runoff Controls	Inspect / repair roof drains
Employee Training / Education Program	Building tenants to provide BMP training and hand out educational materials.

Attachment B

BMP Inspection and Maintenance Schedule								
Treatment Control BMP	BMP #	BMP or Pollution Control Device	Latitude	Longitude	Inspection/ Maintenance Activities Required	Maintenance Provided By	Frequency	Cost
		1	Bioretention Basin 1	33°51'17.46"N	117°15'10.48"W	1. Inspect/Maintain bioretention basins. 2. Remove trash, sediments and debris and dispose of trash, sediments and debris in a legal manner.	Owner	Bi-monthly and Prior to storm event and 48 hours after storm has passed
Source Control BMP	4	Refuse/ Trash Storage Areas and Letter Control	33°51'17.43"N	117°15'21.03"W	Inspect trash container, lids, screens and clean trash storage areas.	Owner	Weekly	\$100/ per inspection & maintenance
			33°51'14.51"N	117°15'13.36"W				
	5	Efficient Irrigation*	N/A	N/A	1. Inspect irrigation system general operation and durations. 2. Repair damaged sprinkler and drip irrigation lines as needed. 3. Reduce durations during the winter season to prevent over irrigation	Owner	Monthly	\$200/ per inspection & maintenance
Non-Structural Source Control BMP	6	Truck dock*	N/A	N/A	Inspect loading dock for trash debris and sediments. Inspect loading dock for evidence of spills and broken containers. Clean up spills and dispose of collected material in a legal manner.	Owner	Weekly / Daily	\$100/ per inspection & maintenance
	7	Planting*	N/A	N/A	Inspect helth of planting and erosion of landscape area. Trimming trees and bushes when needed.	Owner	Monthly	\$200/ per inspection & maintenance
	8	Employee Training / Education Program*	N/A	N/A	Building tenants to provide BMP training and hand out educational materials.	Owner	Annually or upon hire	Vary
	9	Loading Dock and Parking Lot Sweeping*	N/A	N/A	Sweep loading dock and parking lot and truck courts.	Owner	Monthly / As needed.	\$300/ per inspection & maintenance
	10	Roof Runoff Controls*	N/A	N/A	Inspect / repair roof drains	Owner	Quarterly	\$200/ per inspection & maintenance

* Latitudinal/Longitudinal coordinate is not applicable

Covenant and Agreement

Water Quality Management Plan and Urban Runoff BMP Transfer, Access and Maintenance Agreement (adapted from documents from Ventura County Stormwater Management Program)

Recorded at the request of:

City of Perris

After recording, return to:

City of Perris

City Clerk _____

Water Quality Management Plan and Urban Runoff BMP
Transfer, Access and Maintenance Agreement

OWNER: Rockefeller Group Development

PROPERTY LOCATION: Between Patterson Avenue, Nance Street, Wade Avenue,
and Washington Street

APNS: 314-110-008, 009, 010, 016, 017, 018, 020, 021, 022, 023, 043, 044, 045, 046, 052, 053, 058, &
059

THIS AGREEMENT is made and entered into in

Perris, California, this ____ day of _____, 2022

by and between:

Rockefeller Group Development, herein after

Referred to as "Owner" and the City of Perris, a Municipal corporation, located in the County of Riverside, State of California hereinafter referred to as "CITY".

WHEREAS, the Owner owns real property ("Property") in the City of Perris, County of Riverside, State of California, more specifically described in Exhibit "A" and depicted in Exhibit "B", each of which exhibits is attached hereto and incorporated herein by this reference;

WHEREAS, at the time of initial approval of the development project known as Patterson Commerce Center (Planning #22-00003) within the Property described herein, the City required the project to employ Best Management Practices, hereinafter referred to as "BMPs," to minimize pollutants in urban runoff;

WHEREAS, the Owner has chosen to install and/or implement BMPs as described in the Water Quality Management Plan, on file with the City, hereinafter referred to as "WQMP", to minimize pollutants in urban runoff and to minimize other adverse impacts of urban runoff;

WHEREAS, said WQMP has been certified by the Owner and reviewed and approved by the City;

WHEREAS, said BMPS, with installation and/or implementation on private property and draining only private property, are part of a private facility with all maintenance or replacement therefore, the sole responsibility of the Owner in accordance with the terms of this Agreement;

WHEREAS, the Owner is aware that periodic and continuous maintenance, including, but not necessarily limited to, filter material replacement and sediment removal, is required to assure peak performance of all BMPS's in the WQMP and that, furthermore, such maintenance activity will require compliance with all Local, State, or Federal laws and regulations, including those pertaining to confined space and waste disposal methods, in effect at the time such maintenance occurs;

NOW THEREFORE, it is mutually stipulated and agreed as follows:

1. Owner hereby provides the City of City's designee complete access, of any duration, to the BMPs and their immediate vicinity at any time, upon reasonable notice, or in the event of emergency, as determined by City's Director of Public Works no advance notice, for the purpose of inspection, sampling, testing of the Device, and in case of emergency, to undertake all necessary repairs or other preventative measures at owner's expense as provided in paragraph 3 below. City shall make every effort at all times to minimize or avoid interference with Owner's use of the Property.
2. Owner shall use its best efforts diligently to maintain all BMPs in a manner assuring peak performance at all times. All reasonable precautions shall be exercised by Owner and Owner's representative or contractor in the removal and extraction of any material(s) from the BMPs and the ultimate disposal of the material(s) in a manner consistent with all relevant laws and regulations in effect at the time. As may be requested from time to time by the City, the Owner shall provide the City with documentation identifying the material(s) removed, the quantity, and disposal destination.
3. In the event Owner, or its successors or assigns, fails to accomplish the necessary maintenance contemplated by this Agreement, within five (5) days of being given written notice by the City, the City is hereby authorized to cause any maintenance necessary to be done and charge the entire cost and expense to the Owner or Owner's successors or assigns, including administrative costs, attorney's fees and interest thereon at the maximum rate authorized by the Civil Code from the date of the notice of expense until paid in full.
4. The City may require the owner to post security in form and for a time period satisfactory to the city to guarantee the performance of the obligations state herein. Should the Owner fail to perform the obligations under the Agreement, the City may, in the case of a cash bond, act for the Owner using the proceeds from it, or in the case of a surety bond, require the sureties to perform the obligations of the Agreement. As an additional remedy, the Director may withdraw any previous urban Runoff-related approval with respect to the property on which BMPs have been installed and/or implemented until such time as Owner repays to City its reasonable costs incurred in accordance with paragraph 3 above.
5. This agreement shall be recorded in the Office of the Recorder of Riverside County, California, at the expense of the Owner and shall constitute notice to all successors and assigns of the title to said Property of the obligation herein set forth, and also a lien in such amount as will fully reimburse the City, including interest as herein above set forth, subject to foreclosure in event of default in payment.
6. In event of legal action occasioned by any default or action of the Owner, or its successors or assigns, then the Owner and its successors or assigns agree(s) to pay all costs incurred by the City in enforcing the terms of this Agreement, including reasonable attorney's fees and costs, and that the same shall become a part of the lien against said Property.

7. It is the intent of the parties hereto that burdens and benefits herein undertaken shall constitute covenants that run with said Property and constitute a lien there against.

8. The obligations herein undertaken shall be binding upon the heirs, successors, executors, administrators and assigns of the parties hereto. The term "Owner" shall include not only the present Owner, but also its heirs, successors, executors, administrators, and assigns. Owner shall notify any successor to title of all or part of the Property about the existence of this Agreement. Owner shall provide such notice prior to such successor obtaining an interest in or part of the Property. Owner shall provide a copy of such notice to the City at the same time such notice is provided to the successor.

9. Time is of the essence in the performance of this Agreement.

10. Any notice to a party required or called for in this agreement shall be served in person, or be deposit in the U.S. Mail, first class postage prepaid, to the address set forth below. Notice(s) shall be deemed effective upon receipt, or seventy-two (72) hours after deposit in the U.S. Mail, whichever is earlier. A party may change a notice address only by providing written notice thereof to the other party.

IF TO THE CITY:

City Manager
City of Perris
101 North D Street
Perris, CA 92570

IF TO OWNER:

Rockefeller Group Development
Attn: Michael Sajjadi
4 Park Plaza, Suite 840
Irvine, CA 92614

IN WITNESS THEREOF, the parties hereto have affixed their signatures as of the date fist written above.

APPROVED AS TO FORM:

City Attorney

City of Perris

Eric Dunn
Name
City Attorney
Title

OWNER:

By:

By: _____

Name: _____

Title: _____

OWNER:

N/A

Name

N/A

Title

ATTEST:

City Clerk Date

NOTARIES ON FOLLOWING PAGE

Clara Miramontes
City Manager of City of Perris

**EXHIBIT A
LEGAL DESCRIPTION**

ALL THAT CERTAIN REAL PROPERTY SITUATED IN THE COUNTY OF SAN BERNARDINO, STATE OF CALIFORNIA, DESCRIBED AS FOLLOWS:

PARCEL ONE:

LOT 1, BLOCK 3 OF GOLDEN VALLEY FARM UNIT NO. 2, AS PER MAP RECORDED IN BOOK 15, PAGES 10 AND 11, OF MAPS, IN THE OFFICE OF THE COUNTY RECORDER OF RIVERSIDE COUNTY, STATE OF CALIFORNIA.

EXCEPTING THEREFROM THAT PARCEL OF LAND AS CONVEYED TO STATE OF CALIFORNIA, BY DEED RECORDED JANUARY 30, 1952, AS INSTRUMENT NO. 4214 IN BOOK 1337, PAGE 565, OFFICIAL RECORDS, OF SAID COUNTY.

ALSO EXCEPTING THEREFROM THAT PORTION CONVEYED TO THE STATE OF CALIFORNIA BY DEED RECORDED JULY 17, 1990 AS INSTRUMENT NO. 262977, OFFICIAL RECORDS, DESCRIBED AS FOLLOWS:

BEGINNING AT THE INTERSECTION OF THE SOUTH LINE OF NANCE STREET, 44 FEET WIDE, WITH THE EASTERLY LINE OF THAT PARCEL OF LAND AS CONVEYED TO STATE OF CALIFORNIA BY DEED RECORDED JANUARY 30, 1952, IN BOOK 1337, PAGE 565, OFFICIAL RECORDS OF SAID COUNTY;

THENCE ALONG SAID SOUTH LINE SOUTH 89° 39' 53" EAST, 30.00 FEET;

THENCE SOUTH 29° 15' 28" WEST, 37.65 FEET TO SAID EASTERLY LINE;

THENCE ALONG SAID EASTERLY LINE NORTH 19° 21' 10" WEST, 35.00 FEET TO THE POINT OF BEGINNING.

THE BEARINGS AND DISTANCES USED IN THE ABOVE DESCRIPTION ARE ON THE CALIFORNIA COORDINATE SYSTEM OF 1927, ZONE VI. MULTIPLY DISTANCES SHOWN BY 1.0000843 TO OBTAIN GROUND LEVEL DISTANCES.

PARCEL TWO:

LOT 3 IN BLOCK 3 OF GOLDEN VALLEY FARM UNIT NO. 2, AS PER MAP RECORDED IN BOOK 15, PAGES 10 AND 11, OF MAPS, IN THE OFFICE OF THE COUNTY RECORDER OF RIVERSIDE COUNTY, STATE OF CALIFORNIA.

EXCEPTING THEREFROM THAT PORTION CONVEYED TO THE STATE OF CALIFORNIA BY DEED RECORDED JANUARY 30, 1952 AS INSTRUMENT NO. 4215, OF OFFICIAL RECORDS.

PARCEL THREE:

LOTS 4 AND 5 IN BLOCK 3 OF GOLDEN VALLEY FARMS, UNIT NO. 2, AS SHOWN BY MAP ON FILE IN BOOK 15, PAGES 10 AND 11, OF MAPS, RIVERSIDE COUNTY RECORDS;

EXCEPTING THEREFROM THAT PORTION GRANTED TO THE STATE OF CALIFORNIA BY DEED RECORDED FEBRUARY 15, 1952 AS INSTRUMENT NO. 6611 IN BOOK 1342, PAGE 185, OF OFFICIAL RECORDS, RIVERSIDE COUNTY RECORDS.

PARCEL FOUR:

LOTS 9 THROUGH 17, INCLUSIVE, IN BLOCK 3 OF GOLDEN VALLEY FARMS, UNIT NO. 2, AS SHOWN BY MAP ON FILE IN BOOK 15, PAGES 10 AND 11, OF MAPS, RECORDS OF RIVERSIDE COUNTY, CALIFORNIA;

EXCEPTING THEREFROM THE EASTERLY 11 FEET OF LOTS 13 AND 14, AS CONVEYED BY DEED TO THE COUNTY OF RIVERSIDE BY DEED RECORDED OCTOBER 5, 1966 AS INSTRUMENT NO. 98574, OF OFFICIAL RECORDS OF RIVERSIDE COUNTY, CALIFORNIA.

PARCEL FIVE:

LOT 6, IN BLOCK 3 OF GOLDEN VALLEY FARMS UNIT NO. 2, AS SHOWN BY MAP ON FILE IN BOOK 15, PAGES 10 AND 11 OF MAPS, RIVERSIDE COUNTY RECORDS.

EXCEPTING THEREFROM THAT PORTION CONVEYED TO THE STATE OF CALIFORNIA FOR FREEWAY PURPOSES, BY DEED RECORDED FEBRUARY 01, 1952 AS INSTRUMENT NO. 4592.

EXCEPTING THEREFROM AN UNDIVIDED ONE-HALF INTEREST IN AND OIL, GAS OTHER MINERAL RIGHTS IN, ON, OR UNDER THE SURFACE OF SAID LAND AND ALL RIGHTS OF OWNERSHIP THEREIN BUT WITHOUT THE RIGHT OF SURFACE ENTRY.

PARCEL SIX:

LOT 7, IN BLOCK 3 OF GOLDEN VALLEY FARMS UNIT NO. 2, AS SHOWN BY MAP ON FILE IN BOOK 15, PAGES 10 AND 11 OF MAPS, RIVERSIDE COUNTY RECORDS.

EXCEPTING THEREFROM A 60 FOOT STRIP OF LAND CONVEYED TO THE COUNTY OF RIVERSIDE BY DEED RECORDED JUNE 13, 1914, IN BOOK 398, PAGE 362, OF DEEDS, RECORDS OF RIVERSIDE COUNTY, CALIFORNIA;

ALSO EXCEPTING THEREFROM THAT PORTION CONVEYED TO THE STATE OF CALIFORNIA, BY DEED RECORDED SEPTEMBER 16, 1952 AS INSTRUMENT NO. 39499, IN BOOK 1400, PAGE 386 OF OFFICIAL RECORDS OF RIVERSIDE COUNTY, STATE OF CALIFORNIA.

PARCEL SEVEN:

LOT 8, IN BLOCK 3 OF GOLDEN VALLEY FARMS UNIT NO. 2, AS SHOWN BY MAP ON FILE IN BOOK 15, PAGES 10 AND 11 OF MAPS, RIVERSIDE COUNTY RECORDS.

EXCEPTING THAT PORTION LYING WITHIN HIGHWAY 395, AS DEEDED TO THE STATE OF CALIFORNIA, IN BOOK 1371, PAGE 188, OF OFFICIAL RECORDS OF RIVERSIDE COUNTY, CALIFORNIA.

PARCEL EIGHT:

LOT 1 IN BLOCK 4 OF GOLDEN VALLEY FARMS UNIT NO. 2, ON FILE IN BOOK 15, PAGES 10 AND 11 OF MAPS, RECORDS OF RIVERSIDE COUNTY, CALIFORNIA;

EXCEPTING THEREFROM THAT PORTION THEREOF CONVEYED TO THE STATE OF CALIFORNIA BY DEED RECORDED NOVEMBER 24, 1952, IN BOOK 1418, PAGE 288, OF OFFICIAL RECORDS OF RIVERSIDE COUNTY, CALIFORNIA.

**EXHIBIT B
MAP/ILLUSTRATION**

SEE NEXT PAGE

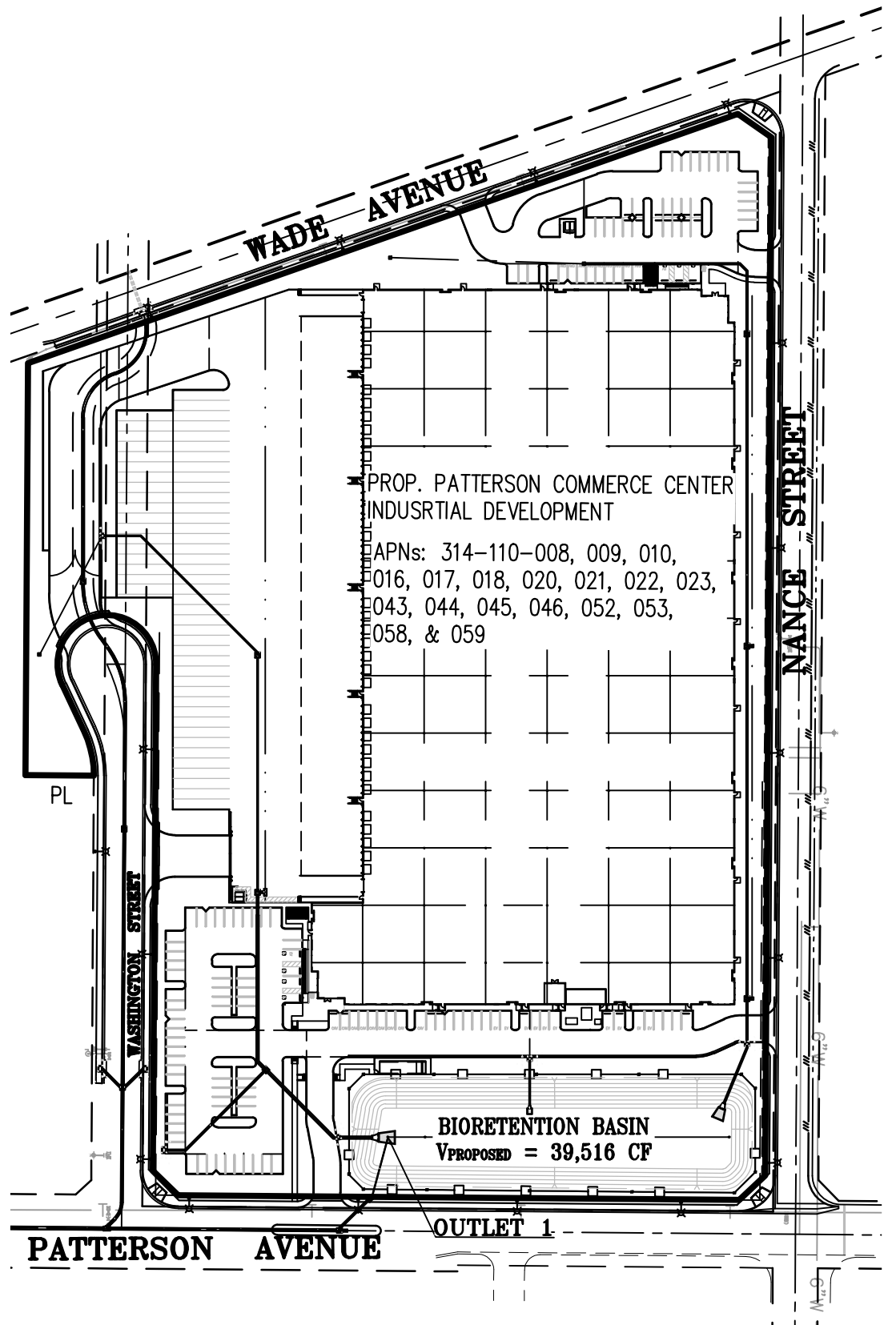

SCALE 1" = 150'

Appendix 10: Educational Materials

BMP Fact Sheets, Maintenance Guidelines and Other End-User BMP Information

Description

Drain inserts are manufactured filters or fabric placed in a drop inlet to remove sediment and debris. There are a multitude of inserts of various shapes and configurations, typically falling into one of three different groups: socks, boxes, and trays. The sock consists of a fabric, usually constructed of polypropylene. The fabric may be attached to a frame or the grate of the inlet holds the sock. Socks are meant for vertical (drop) inlets. Boxes are constructed of plastic or wire mesh. Typically a polypropylene “bag” is placed in the wire mesh box. The bag takes the form of the box. Most box products are one box; that is, the setting area and filtration through media occur in the same box. Some products consist of one or more trays or mesh grates. The trays may hold different types of media. Filtration media vary by manufacturer. Types include polypropylene, porous polymer, treated cellulose, and activated carbon.

California Experience

The number of installations is unknown but likely exceeds a thousand. Some users have reported that these systems require considerable maintenance to prevent plugging and bypass.

Advantages

- Does not require additional space as inserts as the drain inlets are already a component of the standard drainage systems.
- Easy access for inspection and maintenance.
- As there is no standing water, there is little concern for mosquito breeding.
- A relatively inexpensive retrofit option.

Limitations

Performance is likely significantly less than treatment systems that are located at the end of the drainage system such as ponds and vaults. Usually not suitable for large areas or areas with trash or leaves than can plug the insert.

Design and Sizing Guidelines

Refer to manufacturer’s guidelines. Drain inserts come any many configurations but can be placed into three general groups: socks, boxes, and trays. The sock consists of a fabric, usually constructed of polypropylene. The fabric may be attached to a frame or the grate of the inlet holds the sock. Socks are meant for vertical (drop) inlets. Boxes are constructed of plastic or wire mesh. Typically a polypropylene “bag” is placed in the wire mesh box. The bag takes the form of the box. Most box products are

Design Considerations

- Use with other BMPs
- Fit and Seal Capacity within Inlet

Targeted Constituents

- ✓ Sediment
- ✓ Nutrients
- ✓ Trash
- ✓ Metals
- ✓ Bacteria
- ✓ Oil and Grease
- ✓ Organics

Removal Effectiveness

See New Development and Redevelopment Handbook-Section 5.



one box; that is, the setting area and filtration through media occurs in the same box. One manufacturer has a double-box. Stormwater enters the first box where setting occurs. The stormwater flows into the second box where the filter media is located. Some products consist of one or more trays or mesh grates. The trays can hold different types of media. Filtration media vary with the manufacturer: types include polypropylene, porous polymer, treated cellulose, and activated carbon.

Construction/Inspection Considerations

Be certain that installation is done in a manner that makes certain that the stormwater enters the unit and does not leak around the perimeter. Leakage between the frame of the insert and the frame of the drain inlet can easily occur with vertical (drop) inlets.

Performance

Few products have performance data collected under field conditions.

Siting Criteria

It is recommended that inserts be used only for retrofit situations or as pretreatment where other treatment BMPs presented in this section area used.

Additional Design Guidelines

Follow guidelines provided by individual manufacturers.

Maintenance

Likely require frequent maintenance, on the order of several times per year.

Cost

- The initial cost of individual inserts ranges from less than \$100 to about \$2,000. The cost of using multiple units in curb inlet drains varies with the size of the inlet.
- The low cost of inserts may tend to favor the use of these systems over other, more effective treatment BMPs. However, the low cost of each unit may be offset by the number of units that are required, more frequent maintenance, and the shorter structural life (and therefore replacement).

References and Sources of Additional Information

Hrachovec, R., and G. Minton, 2001, Field testing of a sock-type catch basin insert, Planet CPR, Seattle, Washington

Interagency Catch Basin Insert Committee, Evaluation of Commercially-Available Catch Basin Inserts for the Treatment of Stormwater Runoff from Developed Sites, 1995

Larry Walker Associates, June 1998, NDMP Inlet/In-Line Control Measure Study Report

Manufacturers literature

Santa Monica (City), Santa Monica Bay Municipal Stormwater/Urban Runoff Project - Evaluation of Potential Catch basin Retrofits, Woodward Clyde, September 24, 1998

Woodward Clyde, June 11, 1996, Parking Lot Monitoring Report, Santa Clara Valley Nonpoint Source Pollution Control Program.



Objectives

- Cover
- Contain
- Educate
- Reduce/Minimize
- Product Substitution

Description

The loading/unloading of materials usually takes place outside on docks or terminals; therefore, materials spilled, leaked, or lost during loading/unloading may collect in the soil or on other surfaces and have the potential to be carried away by stormwater runoff or when the area is cleaned. Additionally, rainfall may wash pollutants from machinery used to unload or move materials. Implementation of the following protocols will prevent or reduce the discharge of pollutants to stormwater from outdoor loading/unloading of materials.

Approach

Reduce potential for pollutant discharge through source control pollution prevention and BMP implementation. Successful implementation depends on effective training of employees on applicable BMPs and general pollution prevention strategies and objectives.

Pollution Prevention

- Keep accurate maintenance logs to evaluate materials removed and improvements made.
- Park tank trucks or delivery vehicles in designated areas so that spills or leaks can be contained.
- Limit exposure of material to rainfall whenever possible.
- Prevent stormwater run-on.
- Check equipment regularly for leaks.

Targeted Constituents

Sediment	✓
Nutrients	✓
Trash	
Metals	✓
Bacteria	
Oil and Grease	✓
Organics	✓



Suggested Protocols***Loading and Unloading – General Guidelines***

- Develop an operations plan that describes procedures for loading and/or unloading.
- Conduct loading and unloading in dry weather if possible.
- Cover designated loading/unloading areas to reduce exposure of materials to rain.
- Consider placing a seal or door skirt between delivery vehicles and building to prevent exposure to rain.
- Design loading/unloading area to prevent stormwater run-on, which would include grading or berming the area, and position roof downspouts so they direct stormwater away from the loading/unloading areas.
- Have employees load and unload all materials and equipment in covered areas such as building overhangs at loading docks if feasible.
- Load/unload only at designated loading areas.
- Use drip pans underneath hose and pipe connections and other leak-prone spots during liquid transfer operations, and when making and breaking connections. Several drip pans should be stored in a covered location near the liquid transfer area so that they are always available, yet protected from precipitation when not in use. Drip pans can be made specifically for railroad tracks. Drip pans must be cleaned periodically, and drip collected materials must be disposed of properly.
- Pave loading areas with concrete instead of asphalt.
- Avoid placing storm drains in the area.
- Grade and/or berm the loading/unloading area to a drain that is connected to a deadend.

Inspection

- Check loading and unloading equipment regularly for leaks, including valves, pumps, flanges and connections.
- Look for dust or fumes during loading or unloading operations.

Training

- Train employees (e.g., fork lift operators) and contractors on proper spill containment and cleanup.
- Have employees trained in spill containment and cleanup present during loading/unloading.
- Train employees in proper handling techniques during liquid transfers to avoid spills.
- Make sure forklift operators are properly trained on loading and unloading procedures.

Spill Response and Prevention

- Keep your Spill Prevention Control and Countermeasure (SPCC) Plan up-to-date.
- Contain leaks during transfer.
- Store and maintain appropriate spill cleanup materials in a location that is readily accessible and known to all and ensure that employees are familiar with the site's spill control plan and proper spill cleanup procedures.
- Have an emergency spill cleanup plan readily available.
- Use drip pans or comparable devices when transferring oils, solvents, and paints.

Other Considerations (Limitations and Regulations)

- Space and time limitations may preclude all transfers from being performed indoors or under cover.
- It may not be possible to conduct transfers only during dry weather.

Requirements

Costs

Costs should be low except when covering a large loading/unloading area.

Maintenance

- Conduct regular inspections and make repairs as necessary. The frequency of repairs will depend on the age of the facility.
- Check loading and unloading equipment regularly for leaks.
- Conduct regular broom dry-sweeping of area.

Supplemental Information

Further Detail of the BMP

Special Circumstances for Indoor Loading/Unloading of Materials

Loading or unloading of liquids should occur in the manufacturing building so that any spills that are not completely retained can be discharged to the sanitary sewer, treatment plant, or treated in a manner consistent with local sewer authorities and permit requirements.

- For loading and unloading tank trucks to above and below ground storage tanks, the following procedures should be used:
 - The area where the transfer takes place should be paved. If the liquid is reactive with the asphalt, Portland cement should be used to pave the area.
 - The transfer area should be designed to prevent run-on of stormwater from adjacent areas. Sloping the pad and using a curb, like a speed bump, around the uphill side of the transfer area should reduce run-on.

- The transfer area should be designed to prevent runoff of spilled liquids from the area. Sloping the area to a drain should prevent runoff. The drain should be connected to a dead-end sump or to the sanitary sewer. A positive control valve should be installed on the drain.
- For transfer from rail cars to storage tanks that must occur outside, use the following procedures:
 - Drip pans should be placed at locations where spillage may occur, such as hose connections, hose reels, and filler nozzles. Use drip pans when making and breaking connections.
 - Drip pan systems should be installed between the rails to collect spillage from tank cars.

References and Resources

California's Nonpoint Source Program Plan <http://www.swrcb.ca.gov/nps/index.html>

Clark County Storm Water Pollution Control Manual
<http://www.co.clark.wa.us/pubworks/bmpman.pdf>

King County Storm Water Pollution Control Manual <http://dnr.metrokc.gov/wlr/dss/spcm.htm>

Santa Clara Valley Urban Runoff Pollution Prevention Program <http://www.scvurppp.org>

The Storm Water Managers Resource Center <http://www.stormwatercenter.net/>

Description

Improper storage and handling of solid wastes can allow toxic compounds, oils and greases, heavy metals, nutrients, suspended solids, and other pollutants to enter stormwater runoff. The discharge of pollutants to stormwater from waste handling and disposal can be prevented and reduced by tracking waste generation, storage, and disposal; reducing waste generation and disposal through source reduction, reuse, and recycling; and preventing run-on and runoff.

Approach

Reduce potential for pollutant discharge through source control pollution prevention and BMP implementation. Successful implementation depends on effective training of employees on applicable BMPs and general pollution prevention strategies and objectives.

General Pollution Prevention Protocols

- Accomplish reduction in the amount of waste generated using the following source controls:
 - ✓ Production planning and sequencing;
 - ✓ Process or equipment modification;
 - ✓ Raw material substitution or elimination;
 - ✓ Loss prevention and housekeeping;
 - ✓ Waste segregation and separation; and
 - ✓ Close loop recycling.
- Establish a material tracking system to increase awareness about material usage. This may reduce spills and minimize contamination, thus reducing the amount of waste produced.
- Recycle materials whenever possible.

Objectives

- Cover
- Contain
- Educate
- Reduce/Minimize
- Product Substitution

Targeted Constituents

Sediment	
Nutrients	
Trash	
Metals	✓
Bacteria	✓
Oil and Grease	✓
Organics	✓

Minimum BMPs Covered

 Good Housekeeping	✓
 Preventative Maintenance	✓
 Spill and Leak Prevention and Response	✓
 Material Handling & Waste Management	✓
 Erosion and Sediment Controls	
 Employee Training Program	✓
 Quality Assurance Record Keeping	✓



CALIFORNIA STORMWATER
QUALITY ASSOCIATION

- ❑ Use the entire product before disposing of the container.
- ❑ To the extent possible, store wastes under cover or indoors after ensuring all safety concerns such as fire hazard and ventilation are addressed.
- ❑ Provide containers for each waste stream at each work station. Allow time after shift to clean area.



Good Housekeeping

- ❑ Cover storage containers with leak proof lids or some other means. If waste is not in containers, cover all waste piles (plastic tarps are acceptable coverage) and prevent stormwater run-on and runoff with a berm. The waste containers or piles must be covered except when in use.
- ❑ Use drip pans or absorbent materials whenever grease containers are emptied by vacuum trucks or other means. Grease cannot be left on the ground. Collected grease must be properly disposed of as garbage.
- ❑ Dispose of rinse and wash water from cleaning waste containers into a sanitary sewer if allowed by the local sewer authority. Do not discharge wash water to the street or storm drain. Clean in a designated wash area that drains to a clarifier.
- ❑ Transfer waste from damaged containers into safe containers.
- ❑ Take special care when loading or unloading wastes to minimize losses. Loading systems can be used to minimize spills and fugitive emission losses such as dust or mist. Vacuum transfer systems can minimize waste loss.
- ❑ Keep the waste management area clean at all times by sweeping and cleaning up spills immediately.
- ❑ Use dry methods when possible (e.g., sweeping, use of absorbents) when cleaning around restaurant/food handling dumpster areas. If water must be used after sweeping/using absorbents, collect water and discharge through grease interceptor to the sewer.
- ❑ Stencil or demarcate storm drains on the facility's property with prohibitive message regarding waste disposal.
- ❑ Cover waste piles with temporary covering material such as reinforced tarpaulin, polyethylene, polyurethane, polypropylene or hypalon.
- ❑ If possible, move the activity indoor after ensuring all safety concerns such as fire hazard and ventilation are addressed.



Preventative Maintenance

- ❑ Prevent stormwater run-on from entering the waste management area by enclosing the area or building a berm around the area.
- ❑ Prevent waste materials from directly contacting rain.

- ❑ Cover waste piles with temporary covering material such as reinforced tarpaulin, polyethylene, polyurethane, polypropylene or hypalon.
- ❑ Cover the area with a permanent roof if feasible.
- ❑ Cover dumpsters to prevent rain from washing waste out of holes or cracks in the bottom of the dumpster.
- ❑ Check waste containers weekly for leaks and to ensure that lids are on tightly. Replace any that are leaking, corroded, or otherwise deteriorating.
- ❑ Sweep and clean the waste management area regularly. Use dry methods when possible (e.g., sweeping, vacuuming, use of absorbents) when cleaning around restaurant/food handling dumpster areas. If water must be used after sweeping/using absorbents, collect water and discharge through grease interceptor to the sewer.
- ❑ Inspect and replace faulty pumps or hoses regularly to minimize the potential of releases and spills.
- ❑ Repair leaking equipment including valves, lines, seals, or pumps promptly.



Spill Response and Prevention Procedures

- ❑ Keep your spill prevention and plan up-to-date.
- ❑ Have an emergency plan, equipment and trained personnel ready at all times to deal immediately with major spills.
- ❑ Collect all spilled liquids and properly dispose of them.
- ❑ Store and maintain appropriate spill cleanup materials in a location known to all near the designated wash area.
- ❑ Ensure that vehicles transporting waste have spill prevention equipment that can prevent spills during transport. Spill prevention equipment includes:
 - ✓ Vehicles equipped with baffles for liquid waste; and
 - ✓ Trucks with sealed gates and spill guards for solid waste.



Material Handling and Waste Management

Litter Control

- ❑ Post “No Littering” signs and enforce anti-litter laws.
- ❑ Provide a sufficient number of litter receptacles for the facility.
- ❑ Clean out and cover litter receptacles frequently to prevent spillage.

Waste Collection

- ❑ Keep waste collection areas clean.

- Inspect solid waste containers for structural damage regularly. Repair or replace damaged containers as necessary.
- Secure solid waste containers; containers must be closed tightly when not in use.
- Do not fill waste containers with washout water or any other liquid.
- Ensure that only appropriate solid wastes are added to the solid waste container. Certain wastes such as hazardous wastes, appliances, fluorescent lamps, pesticides, etc., may not be disposed of in solid waste containers (see chemical/ hazardous waste collection section below).
- Do not mix wastes; this can cause chemical reactions, make recycling impossible, and complicate disposal. Affix labels to all waste containers.

Chemical/Hazardous Wastes

- Select designated hazardous waste collection areas on-site.
- Store hazardous materials and wastes in covered containers and protect them from vandalism.
- Place hazardous waste containers in secondary containment.
- Make sure that hazardous waste is collected, removed, and disposed of only at authorized disposal areas.
- Hazardous waste cannot be reused or recycled; it must be disposed of by a licensed hazardous waste hauler.



Employee Training Program

- Educate employees about pollution prevention measures and goals.
- Train employees how to properly handle and dispose of waste using the source control BMPs described above.
- Train employees and subcontractors in proper hazardous waste management.
- Use a training log or similar method to document training.
- Ensure that employees are familiar with the site's spill control plan and/or proper spill cleanup procedures.



Quality Assurance and Record Keeping

- Keep accurate maintenance logs that document minimum BMP activities performed for waste handling and disposal, types and quantities of waste disposed of, and any improvement actions.
- Keep accurate logs of spill response actions that document what was spilled, how it was cleaned up, and how the waste was disposed.

- Establish procedures to complete logs and file them in the central office.

Potential Capital Facility Costs and Operation & Maintenance Requirements

Facilities

- Capital costs will vary substantially depending on the size of the facility and the types of waste handled. Significant capital costs may be associated with reducing wastes by modifying processes or implementing closed-loop recycling.
- Many facilities will already have indoor covered areas where waste materials will be stored and will require no additional capital expenditures for providing cover.
- If outdoor storage of wastes is required, construction of berms or other means to prevent stormwater run-on and runoff may require appropriate constructed systems for containment.
- Capital investments will likely be required at some sites if adequate cover and containment facilities do not exist and can vary significantly depending upon site conditions.

Maintenance

- Check waste containers weekly for leaks and to ensure that lids are on tightly. Replace any that are leaking, corroded, or otherwise deteriorating.
- Sweep and clean the waste management area regularly. Use dry methods when possible (e.g., sweeping, use of absorbents) when cleaning around restaurant/food handling dumpster areas. If water must be used after sweeping/using absorbents, collect water and discharge through grease interceptor to the sewer.
- Inspect and replace faulty pumps or hoses regularly to minimize the potential of releases and spills.
- Repair leaking equipment including valves, lines, seals, or pumps promptly.

References and Resources

Minnesota Pollution Control Agency, *Industrial Stormwater Best Management Practices Guidebook*. Available online at: <http://www.pca.state.mn.us/index.php/view-document.html?gid=10557>.

New Jersey Department of Environmental Protection, 2013. *Basic Industrial Stormwater General Permit Guidance Document NJPDES General Permit No NJ0088315*, Revised. Available online at: http://www.nj.gov/dep/dwq/pdf/5G2_guidance_color.pdf.

Orange County Stormwater Program, Best Management Practices for Industrial/Commercial Business Activities. Available online at: <http://ocwatersheds.com/documents/bmp/industrialcommercialbusinessesactivities>

Oregon Department of Environmental Quality, 2013. *Industrial Stormwater Best Management Practices Manual- BMP 26 Fueling and Liquid Loading/Unloading Operations*. Available online at:

<http://www.deq.state.or.us/wq/wqpermit/docs/IndBMP021413.pdf>.

Sacramento Stormwater Management Program. *Best Management Practices for Industrial Storm Water Pollution Control*. Available online at:

<http://www.msa.saccounty.net/sactostormwater/documents/guides/industrial-BMP-manual.pdf>.

Sacramento County Environmental Management Stormwater Program: Best Management Practices. Available online at:

<http://www.emd.saccounty.net/EnvHealth/Stormwater/Stormwater-BMPs.html>.

Santa Clara Valley Urban Runoff Pollution Prevention Program. <http://www.scvurppp-w2k.com/>

US EPA. National Pollutant Discharge Elimination System – Industrial Fact Sheet Series for Activities Covered by EPA’s Multi Sector General Permit. Available online at:

<http://cfpub.epa.gov/npdes/stormwater/swsectors.cfm>.



Description

Stormwater runoff from building and grounds maintenance activities can be contaminated with toxic hydrocarbons in solvents, fertilizers and pesticides, suspended solids, heavy metals, abnormal pH, and oils and greases. Utilizing the protocols in this fact sheet will prevent or reduce the discharge of pollutants to stormwater from building and grounds maintenance activities by washing and cleaning up with as little water as possible, following good landscape management practices, preventing and cleaning up spills immediately, keeping debris from entering the storm drains, and maintaining the stormwater collection system.

Approach

Reduce potential for pollutant discharge through source control pollution prevention and BMP implementation. Successful implementation depends on effective training of employees on applicable BMPs and general pollution prevention strategies and objectives.

Pollution Prevention

- Switch to non-toxic chemicals for maintenance when possible.
- Choose cleaning agents that can be recycled.
- Encourage proper lawn management and landscaping, including use of native vegetation.

Objectives

- Cover
- Contain
- Educate
- Reduce/Minimize
- Product Substitution

Targeted Constituents

Sediment	✓
Nutrients	✓
Trash	
Metals	✓
Bacteria	✓
Oil and Grease	
Organics	



SC-41 Building & Grounds Maintenance

- Encourage use of Integrated Pest Management techniques for pest control.
- Encourage proper onsite recycling of yard trimmings.
- Recycle residual paints, solvents, lumber, and other material as much as possible.

Suggested Protocols

Pressure Washing of Buildings, Rooftops, and Other Large Objects

- In situations where soaps or detergents are used and the surrounding area is paved, pressure washers must use a water collection device that enables collection of wash water and associated solids. A sump pump, wet vacuum or similarly effective device must be used to collect the runoff and loose materials. The collected runoff and solids must be disposed of properly.
- If soaps or detergents are not used, and the surrounding area is paved, wash runoff does not have to be collected but must be screened. Pressure washers must use filter fabric or some other type of screen on the ground and/or in the catch basin to trap the particles in wash water runoff.
- If you are pressure washing on a grassed area (with or without soap), runoff must be dispersed as sheet flow as much as possible, rather than as a concentrated stream. The wash runoff must remain on the grass and not drain to pavement.

Landscaping Activities

- Dispose of grass clippings, leaves, sticks, or other collected vegetation as garbage, or by composting. Do not dispose of collected vegetation into waterways or storm drainage systems.
- Use mulch or other erosion control measures on exposed soils.

Building Repair, Remodeling, and Construction

- Do not dump any toxic substance or liquid waste on the pavement, the ground, or toward a storm drain.
- Use ground or drop cloths underneath outdoor painting, scraping, and sandblasting work, and properly dispose of collected material daily.
- Use a ground cloth or oversized tub for activities such as paint mixing and tool cleaning.
- Clean paintbrushes and tools covered with water-based paints in sinks connected to sanitary sewers or in portable containers that can be dumped into a sanitary sewer drain. Brushes and tools covered with non-water-based paints, finishes, or other materials must be cleaned in a manner that enables collection of used solvents (e.g., paint thinner, turpentine, etc.) for recycling or proper disposal.
- Use a storm drain cover, filter fabric, or similarly effective runoff control mechanism if dust, grit, wash water, or other pollutants may escape the work area and enter a catch basin. This is particularly necessary on rainy days. The containment device(s) must be in place at the beginning of the work day, and accumulated dirty runoff and solids must be collected and disposed of before removing the containment device(s) at the end of the work day.

Building & Grounds Maintenance SC-41

- If you need to de-water an excavation site, you may need to filter the water before discharging to a catch basin or off-site. If directed off-site, you should direct the water through hay bales and filter fabric or use other sediment filters or traps.
- Store toxic material under cover during precipitation events and when not in use. A cover would include tarps or other temporary cover material.

Mowing, Trimming, and Planting

- Dispose of leaves, sticks, or other collected vegetation as garbage, by composting or at a permitted landfill. Do not dispose of collected vegetation into waterways or storm drainage systems.
- Use mulch or other erosion control measures when soils are exposed.
- Place temporarily stockpiled material away from watercourses and drain inlets, and berm or cover stockpiles to prevent material releases to the storm drain system.
- Consider an alternative approach when bailing out muddy water: do not put it in the storm drain; pour over landscaped areas.
- Use hand weeding where practical.

Fertilizer and Pesticide Management

- Follow all federal, state, and local laws and regulations governing the use, storage, and disposal of fertilizers and pesticides and training of applicators and pest control advisors.
- Use less toxic pesticides that will do the job when applicable. Avoid use of copper-based pesticides if possible.
- Do not use pesticides if rain is expected.
- Do not mix or prepare pesticides for application near storm drains.
- Use the minimum amount needed for the job.
- Calibrate fertilizer distributors to avoid excessive application.
- Employ techniques to minimize off-target application (e.g., spray drift) of pesticides, including consideration of alternative application techniques.
- Apply pesticides only when wind speeds are low.
- Fertilizers should be worked into the soil rather than dumped or broadcast onto the surface.
- Irrigate slowly to prevent runoff and then only as much as is needed.
- Clean pavement and sidewalk if fertilizer is spilled on these surfaces before applying irrigation water.
- Dispose of empty pesticide containers according to the instructions on the container label.

SC-41 Building & Grounds Maintenance

- Use up the pesticides. Rinse containers, and use rinse water as product. Dispose of unused pesticide as hazardous waste.
- Implement storage requirements for pesticide products with guidance from the local fire department and County Agricultural Commissioner. Provide secondary containment for pesticides.

Inspection

- Inspect irrigation system periodically to ensure that the right amount of water is being applied and that excessive runoff is not occurring. Minimize excess watering and repair leaks in the irrigation system as soon as they are observed.

Training

- Educate and train employees on pesticide use and in pesticide application techniques to prevent pollution.
- Train employees and contractors in proper techniques for spill containment and cleanup.
- Be sure the frequency of training takes into account the complexity of the operations and the nature of the staff.

Spill Response and Prevention

- Keep your Spill Prevention Control and Countermeasure (SPCC) Plan up-to-date.
- Place a stockpile of spill cleanup materials, such as brooms, dustpans, and vacuum sweepers (if desired) near the storage area where it will be readily accessible.
- Have employees trained in spill containment and cleanup present during the loading/unloading of dangerous wastes, liquid chemicals, or other materials.
- Familiarize employees with the Spill Prevention Control and Countermeasure Plan.
- Clean up spills immediately.

Other Considerations

Alternative pest/weed controls may not be available, suitable, or effective in many cases.

Requirements

Costs

- Cost will vary depending on the type and size of facility.
- Overall costs should be low in comparison to other BMPs.

Maintenance

Sweep paved areas regularly to collect loose particles. Wipe up spills with rags and other absorbent material immediately, do not hose down the area to a storm drain.

Supplemental Information

Further Detail of the BMP

Fire Sprinkler Line Flushing

Building fire sprinkler line flushing may be a source of non-stormwater runoff pollution. The water entering the system is usually potable water, though in some areas it may be non-potable reclaimed wastewater. There are subsequent factors that may drastically reduce the quality of the water in such systems. Black iron pipe is usually used since it is cheaper than potable piping, but it is subject to rusting and results in lower quality water. Initially, the black iron pipe has an oil coating to protect it from rusting between manufacture and installation; this will contaminate the water from the first flush but not from subsequent flushes. Nitrates, polyphosphates and other corrosion inhibitors, as well as fire suppressants and antifreeze may be added to the sprinkler water system. Water generally remains in the sprinkler system a long time (typically a year) and between flushes may accumulate iron, manganese, lead, copper, nickel, and zinc. The water generally becomes anoxic and contains living and dead bacteria and breakdown products from chlorination. This may result in a significant BOD problem and the water often smells. Consequently dispose fire sprinkler line flush water into the sanitary sewer. Do not allow discharge to storm drain or infiltration due to potential high levels of pollutants in fire sprinkler line water.

References and Resources

California's Nonpoint Source Program Plan <http://www.swrcb.ca.gov/nps/index.html>

Clark County Storm Water Pollution Control Manual
<http://www.co.clark.wa.us/pubworks/bmpman.pdf>

King County Storm Water Pollution Control Manual <http://dnr.metrokc.gov/wlr/dss/spcm.htm>

Mobile Cleaners Pilot Program: Final Report. 1997. Bay Area Stormwater Management Agencies Association (BASMAA). <http://www.basmaa.org/>

Pollution from Surface Cleaning Folder. 1996. Bay Area Stormwater Management Agencies Association (BASMAA). <http://www.basmaa.org/>

Santa Clara Valley Urban Runoff Pollution Prevention Program <http://www.scvurppp.org>

The Storm Water Managers Resource Center <http://www.stormwatercenter.net/>

Site Design & Landscape Planning SD-10



Design Objectives

- Maximize Infiltration
- Provide Retention
- Slow Runoff
- Minimize Impervious Land Coverage
- Prohibit Dumping of Improper Materials
- Contain Pollutants
- Collect and Convey

Description

Each project site possesses unique topographic, hydrologic, and vegetative features, some of which are more suitable for development than others. Integrating and incorporating appropriate landscape planning methodologies into the project design is the most effective action that can be done to minimize surface and groundwater contamination from stormwater.

Approach

Landscape planning should couple consideration of land suitability for urban uses with consideration of community goals and projected growth. Project plan designs should conserve natural areas to the extent possible, maximize natural water storage and infiltration opportunities, and protect slopes and channels.

Suitable Applications

Appropriate applications include residential, commercial and industrial areas planned for development or redevelopment.

Design Considerations

Design requirements for site design and landscapes planning should conform to applicable standards and specifications of agencies with jurisdiction and be consistent with applicable General Plan and Local Area Plan policies.



SD-10 Site Design & Landscape Planning

Designing New Installations

Begin the development of a plan for the landscape unit with attention to the following general principles:

- Formulate the plan on the basis of clearly articulated community goals. Carefully identify conflicts and choices between retaining and protecting desired resources and community growth.
- Map and assess land suitability for urban uses. Include the following landscape features in the assessment: wooded land, open unwooded land, steep slopes, erosion-prone soils, foundation suitability, soil suitability for waste disposal, aquifers, aquifer recharge areas, wetlands, floodplains, surface waters, agricultural lands, and various categories of urban land use. When appropriate, the assessment can highlight outstanding local or regional resources that the community determines should be protected (e.g., a scenic area, recreational area, threatened species habitat, farmland, fish run). Mapping and assessment should recognize not only these resources but also additional areas needed for their sustenance.

Project plan designs should conserve natural areas to the extent possible, maximize natural water storage and infiltration opportunities, and protect slopes and channels.

Conserve Natural Areas during Landscape Planning

If applicable, the following items are required and must be implemented in the site layout during the subdivision design and approval process, consistent with applicable General Plan and Local Area Plan policies:

- Cluster development on least-sensitive portions of a site while leaving the remaining land in a natural undisturbed condition.
- Limit clearing and grading of native vegetation at a site to the minimum amount needed to build lots, allow access, and provide fire protection.
- Maximize trees and other vegetation at each site by planting additional vegetation, clustering tree areas, and promoting the use of native and/or drought tolerant plants.
- Promote natural vegetation by using parking lot islands and other landscaped areas.
- Preserve riparian areas and wetlands.

Maximize Natural Water Storage and Infiltration Opportunities Within the Landscape Unit

- Promote the conservation of forest cover. Building on land that is already deforested affects basin hydrology to a lesser extent than converting forested land. Loss of forest cover reduces interception storage, detention in the organic forest floor layer, and water losses by evapotranspiration, resulting in large peak runoff increases and either their negative effects or the expense of countering them with structural solutions.
- Maintain natural storage reservoirs and drainage corridors, including depressions, areas of permeable soils, swales, and intermittent streams. Develop and implement policies and

Site Design & Landscape Planning SD-10

regulations to discourage the clearing, filling, and channelization of these features. Utilize them in drainage networks in preference to pipes, culverts, and engineered ditches.

- Evaluating infiltration opportunities by referring to the stormwater management manual for the jurisdiction and pay particular attention to the selection criteria for avoiding groundwater contamination, poor soils, and hydrogeological conditions that cause these facilities to fail. If necessary, locate developments with large amounts of impervious surfaces or a potential to produce relatively contaminated runoff away from groundwater recharge areas.

Protection of Slopes and Channels during Landscape Design

- Convey runoff safely from the tops of slopes.
- Avoid disturbing steep or unstable slopes.
- Avoid disturbing natural channels.
- Stabilize disturbed slopes as quickly as possible.
- Vegetate slopes with native or drought tolerant vegetation.
- Control and treat flows in landscaping and/or other controls prior to reaching existing natural drainage systems.
- Stabilize temporary and permanent channel crossings as quickly as possible, and ensure that increases in run-off velocity and frequency caused by the project do not erode the channel.
- Install energy dissipaters, such as riprap, at the outlets of new storm drains, culverts, conduits, or channels that enter unlined channels in accordance with applicable specifications to minimize erosion. Energy dissipaters shall be installed in such a way as to minimize impacts to receiving waters.
- Line on-site conveyance channels where appropriate, to reduce erosion caused by increased flow velocity due to increases in tributary impervious area. The first choice for linings should be grass or some other vegetative surface, since these materials not only reduce runoff velocities, but also provide water quality benefits from filtration and infiltration. If velocities in the channel are high enough to erode grass or other vegetative linings, riprap, concrete, soil cement, or geo-grid stabilization are other alternatives.
- Consider other design principles that are comparable and equally effective.

Redeveloping Existing Installations

Various jurisdictional stormwater management and mitigation plans (SUSMP, WQMP, etc.) define “redevelopment” in terms of amounts of additional impervious area, increases in gross floor area and/or exterior construction, and land disturbing activities with structural or impervious surfaces. The definition of “redevelopment” must be consulted to determine whether or not the requirements for new development apply to areas intended for redevelopment. If the definition applies, the steps outlined under “designing new installations” above should be followed.

SD-10 Site Design & Landscape Planning

Redevelopment may present significant opportunity to add features which had not previously been implemented. Examples include incorporation of depressions, areas of permeable soils, and swales in newly redeveloped areas. While some site constraints may exist due to the status of already existing infrastructure, opportunities should not be missed to maximize infiltration, slow runoff, reduce impervious areas, disconnect directly connected impervious areas.

Other Resources

A Manual for the Standard Urban Stormwater Mitigation Plan (SUSMP), Los Angeles County Department of Public Works, May 2002.

Stormwater Management Manual for Western Washington, Washington State Department of Ecology, August 2001.

Model Standard Urban Storm Water Mitigation Plan (SUSMP) for San Diego County, Port of San Diego, and Cities in San Diego County, February 14, 2002.

Model Water Quality Management Plan (WQMP) for County of Orange, Orange County Flood Control District, and the Incorporated Cities of Orange County, Draft February 2003.

Ventura Countywide Technical Guidance Manual for Stormwater Quality Control Measures, July 2002.



Rain Garden

Design Objectives

- Maximize Infiltration
- Provide Retention
- Slow Runoff
- Minimize Impervious Land Coverage
- Prohibit Dumping of Improper Materials
- Contain Pollutants
- Collect and Convey

Description

Various roof runoff controls are available to address stormwater that drains off rooftops. The objective is to reduce the total volume and rate of runoff from individual lots, and retain the pollutants on site that may be picked up from roofing materials and atmospheric deposition. Roof runoff controls consist of directing the roof runoff away from paved areas and mitigating flow to the storm drain system through one of several general approaches: cisterns or rain barrels; dry wells or infiltration trenches; pop-up emitters, and foundation planting. The first three approaches require the roof runoff to be contained in a gutter and downspout system. Foundation planting provides a vegetated strip under the drip line of the roof.

Approach

Design of individual lots for single-family homes as well as lots for higher density residential and commercial structures should consider site design provisions for containing and infiltrating roof runoff or directing roof runoff to vegetative swales or buffer areas. Retained water can be reused for watering gardens, lawns, and trees. Benefits to the environment include reduced demand for potable water used for irrigation, improved stormwater quality, increased groundwater recharge, decreased runoff volume and peak flows, and decreased flooding potential.

Suitable Applications

Appropriate applications include residential, commercial and industrial areas planned for development or redevelopment.

Design Considerations

Designing New Installations

Cisterns or Rain Barrels

One method of addressing roof runoff is to direct roof downspouts to cisterns or rain barrels. A cistern is an above ground storage vessel with either a manually operated valve or a permanently open outlet. Roof runoff is temporarily stored and then released for irrigation or infiltration between storms. The number of rain



barrels needed is a function of the rooftop area. Some low impact developers recommend that every house have at least 2 rain barrels, with a minimum storage capacity of 1000 liters. Roof barrels serve several purposes including mitigating the first flush from the roof which has a high volume, amount of contaminants, and thermal load. Several types of rain barrels are commercially available. Consideration must be given to selecting rain barrels that are vector proof and childproof. In addition, some barrels are designed with a bypass valve that filters out grit and other contaminants and routes overflow to a soak-away pit or rain garden.

If the cistern has an operable valve, the valve can be closed to store stormwater for irrigation or infiltration between storms. This system requires continual monitoring by the resident or grounds crews, but provides greater flexibility in water storage and metering. If a cistern is provided with an operable valve and water is stored inside for long periods, the cistern must be covered to prevent mosquitoes from breeding.

A cistern system with a permanently open outlet can also provide for metering stormwater runoff. If the cistern outlet is significantly smaller than the size of the downspout inlet (say $\frac{1}{4}$ to $\frac{1}{2}$ inch diameter), runoff will build up inside the cistern during storms, and will empty out slowly after peak intensities subside. This is a feasible way to mitigate the peak flow increases caused by rooftop impervious land coverage, especially for the frequent, small storms.

Dry wells and Infiltration Trenches

Roof downspouts can be directed to dry wells or infiltration trenches. A dry well is constructed by excavating a hole in the ground and filling it with an open graded aggregate, and allowing the water to fill the dry well and infiltrate after the storm event. An underground connection from the downspout conveys water into the dry well, allowing it to be stored in the voids. To minimize sedimentation from lateral soil movement, the sides and top of the stone storage matrix can be wrapped in a permeable filter fabric, though the bottom may remain open. A perforated observation pipe can be inserted vertically into the dry well to allow for inspection and maintenance.

In practice, dry wells receiving runoff from single roof downspouts have been successful over long periods because they contain very little sediment. They must be sized according to the amount of rooftop runoff received, but are typically 4 to 5 feet square, and 2 to 3 feet deep, with a minimum of 1-foot soil cover over the top (maximum depth of 10 feet).

To protect the foundation, dry wells must be set away from the building at least 10 feet. They must be installed in solids that accommodate infiltration. In poorly drained soils, dry wells have very limited feasibility.

Infiltration trenches function in a similar manner and would be particularly effective for larger roof areas. An infiltration trench is a long, narrow, rock-filled trench with no outlet that receives stormwater runoff. These are described under Treatment Controls.

Pop-up Drainage Emitter

Roof downspouts can be directed to an underground pipe that daylights some distance from the building foundation, releasing the roof runoff through a pop-up emitter. Similar to a pop-up irrigation head, the emitter only opens when there is flow from the roof. The emitter remains flush to the ground during dry periods, for ease of lawn or landscape maintenance.

Foundation Planting

Landscape planting can be provided around the base to allow increased opportunities for stormwater infiltration and protect the soil from erosion caused by concentrated sheet flow coming off the roof. Foundation plantings can reduce the physical impact of water on the soil and provide a subsurface matrix of roots that encourage infiltration. These plantings must be sturdy enough to tolerate the heavy runoff sheet flows, and periodic soil saturation.

Redeveloping Existing Installations

Various jurisdictional stormwater management and mitigation plans (SUSMP, WQMP, etc.) define “redevelopment” in terms of amounts of additional impervious area, increases in gross floor area and/or exterior construction, and land disturbing activities with structural or impervious surfaces. The definition of “redevelopment” must be consulted to determine whether or not the requirements for new development apply to areas intended for redevelopment. If the definition applies, the steps outlined under “designing new installations” above should be followed.

Supplemental Information

Examples

- City of Ottawa’s Water Links Surface –Water Quality Protection Program
- City of Toronto Downspout Disconnection Program
- City of Boston, MA, Rain Barrel Demonstration Program

Other Resources

Hager, Marty Catherine, Stormwater, “Low-Impact Development”, January/February 2003.
www.stormh2o.com

Low Impact Urban Design Tools, Low Impact Development Design Center, Beltsville, MD.
www.lid-stormwater.net

Start at the Source, Bay Area Stormwater Management Agencies Association, 1999 Edition



Design Objectives

- Maximize Infiltration
- Provide Retention
- Slow Runoff
- Minimize Impervious Land Coverage
- Prohibit Dumping of Improper Materials
- Contain Pollutants
- Collect and Convey

Description

Irrigation water provided to landscaped areas may result in excess irrigation water being conveyed into stormwater drainage systems.

Approach

Project plan designs for development and redevelopment should include application methods of irrigation water that minimize runoff of excess irrigation water into the stormwater conveyance system.

Suitable Applications

Appropriate applications include residential, commercial and industrial areas planned for development or redevelopment. (Detached residential single-family homes are typically excluded from this requirement.)

Design Considerations

Designing New Installations

The following methods to reduce excessive irrigation runoff should be considered, and incorporated and implemented where determined applicable and feasible by the Permittee:

- Employ rain-triggered shutoff devices to prevent irrigation after precipitation.
- Design irrigation systems to each landscape area's specific water requirements.
- Include design featuring flow reducers or shutoff valves triggered by a pressure drop to control water loss in the event of broken sprinkler heads or lines.
- Implement landscape plans consistent with County or City water conservation resolutions, which may include provision of water sensors, programmable irrigation times (for short cycles), etc.



- Design timing and application methods of irrigation water to minimize the runoff of excess irrigation water into the storm water drainage system.
- Group plants with similar water requirements in order to reduce excess irrigation runoff and promote surface filtration. Choose plants with low irrigation requirements (for example, native or drought tolerant species). Consider design features such as:
 - Using mulches (such as wood chips or bar) in planter areas without ground cover to minimize sediment in runoff
 - Installing appropriate plant materials for the location, in accordance with amount of sunlight and climate, and use native plant materials where possible and/or as recommended by the landscape architect
 - Leaving a vegetative barrier along the property boundary and interior watercourses, to act as a pollutant filter, where appropriate and feasible
 - Choosing plants that minimize or eliminate the use of fertilizer or pesticides to sustain growth
- Employ other comparable, equally effective methods to reduce irrigation water runoff.

Redeveloping Existing Installations

Various jurisdictional stormwater management and mitigation plans (SUSMP, WQMP, etc.) define “redevelopment” in terms of amounts of additional impervious area, increases in gross floor area and/or exterior construction, and land disturbing activities with structural or impervious surfaces. The definition of “redevelopment” must be consulted to determine whether or not the requirements for new development apply to areas intended for redevelopment. If the definition applies, the steps outlined under “designing new installations” above should be followed.

Other Resources

A Manual for the Standard Urban Stormwater Mitigation Plan (SUSMP), Los Angeles County Department of Public Works, May 2002.

Model Standard Urban Storm Water Mitigation Plan (SUSMP) for San Diego County, Port of San Diego, and Cities in San Diego County, February 14, 2002.

Model Water Quality Management Plan (WQMP) for County of Orange, Orange County Flood Control District, and the Incorporated Cities of Orange County, Draft February 2003.

Ventura Countywide Technical Guidance Manual for Stormwater Quality Control Measures, July 2002.



Design Objectives

- Maximize Infiltration
- Provide Retention
- Slow Runoff
- Minimize Impervious Land Coverage
- Prohibit Dumping of Improper Materials
- Contain Pollutants
- Collect and Convey

Description

Waste materials dumped into storm drain inlets can have severe impacts on receiving and ground waters. Posting notices regarding discharge prohibitions at storm drain inlets can prevent waste dumping. Storm drain signs and stencils are highly visible source controls that are typically placed directly adjacent to storm drain inlets.

Approach

The stencil or affixed sign contains a brief statement that prohibits dumping of improper materials into the urban runoff conveyance system. Storm drain messages have become a popular method of alerting the public about the effects of and the prohibitions against waste disposal.

Suitable Applications

Stencils and signs alert the public to the destination of pollutants discharged to the storm drain. Signs are appropriate in residential, commercial, and industrial areas, as well as any other area where contributions or dumping to storm drains is likely.

Design Considerations

Storm drain message markers or placards are recommended at all storm drain inlets within the boundary of a development project. The marker should be placed in clear sight facing toward anyone approaching the inlet from either side. All storm drain inlet locations should be identified on the development site map.

Designing New Installations

The following methods should be considered for inclusion in the project design and show on project plans:

- Provide stenciling or labeling of all storm drain inlets and catch basins, constructed or modified, within the project area with prohibitive language. Examples include “NO DUMPING



– DRAINS TO OCEAN” and/or other graphical icons to discourage illegal dumping.

- Post signs with prohibitive language and/or graphical icons, which prohibit illegal dumping at public access points along channels and creeks within the project area.

Note - Some local agencies have approved specific signage and/or storm drain message placards for use. Consult local agency stormwater staff to determine specific requirements for placard types and methods of application.

Redeveloping Existing Installations

Various jurisdictional stormwater management and mitigation plans (SUSMP, WQMP, etc.) define “redevelopment” in terms of amounts of additional impervious area, increases in gross floor area and/or exterior construction, and land disturbing activities with structural or impervious surfaces. If the project meets the definition of “redevelopment”, then the requirements stated under “designing new installations” above should be included in all project design plans.

Additional Information

Maintenance Considerations

- Legibility of markers and signs should be maintained. If required by the agency with jurisdiction over the project, the owner/operator or homeowner’s association should enter into a maintenance agreement with the agency or record a deed restriction upon the property title to maintain the legibility of placards or signs.

Placement

- Signage on top of curbs tends to weather and fade.
- Signage on face of curbs tends to be worn by contact with vehicle tires and sweeper brooms.

Supplemental Information

Examples

- Most MS4 programs have storm drain signage programs. Some MS4 programs will provide stencils, or arrange for volunteers to stencil storm drains as part of their outreach program.

Other Resources

A Manual for the Standard Urban Stormwater Mitigation Plan (SUSMP), Los Angeles County Department of Public Works, May 2002.

Model Standard Urban Storm Water Mitigation Plan (SUSMP) for San Diego County, Port of San Diego, and Cities in San Diego County, February 14, 2002.

Model Water Quality Management Plan (WQMP) for County of Orange, Orange County Flood Control District, and the Incorporated Cities of Orange County, Draft February 2003.

Ventura Countywide Technical Guidance Manual for Stormwater Quality Control Measures, July 2002.



Design Objectives

- Maximize Infiltration
- Provide Retention
- Slow Runoff
- Minimize Impervious Land Coverage
- Prohibit Dumping of Improper Materials
- Contain Pollutants
- Collect and Convey

Description

Several measures can be taken to prevent operations at maintenance bays and loading docks from contributing a variety of toxic compounds, oil and grease, heavy metals, nutrients, suspended solids, and other pollutants to the stormwater conveyance system.

Approach

In designs for maintenance bays and loading docks, containment is encouraged. Preventative measures include overflow containment structures and dead-end sumps. However, in the case of loading docks from grocery stores and warehouse/distribution centers, engineered infiltration systems may be considered.

Suitable Applications

Appropriate applications include commercial and industrial areas planned for development or redevelopment.

Design Considerations

Design requirements for vehicle maintenance and repair are governed by Building and Fire Codes, and by current local agency ordinances, and zoning requirements. The design criteria described in this fact sheet are meant to enhance and be consistent with these code requirements.

Designing New Installations

Designs of maintenance bays should consider the following:

- Repair/maintenance bays and vehicle parts with fluids should be indoors; or designed to preclude urban run-on and runoff.
- Repair/maintenance floor areas should be paved with Portland cement concrete (or equivalent smooth impervious surface).



- Repair/maintenance bays should be designed to capture all wash water leaks and spills. Provide impermeable berms, drop inlets, trench catch basins, or overflow containment structures around repair bays to prevent spilled materials and wash-down waters from entering the storm drain system. Connect drains to a sump for collection and disposal. Direct connection of the repair/maintenance bays to the storm drain system is prohibited. If required by local jurisdiction, obtain an Industrial Waste Discharge Permit.
- Other features may be comparable and equally effective.

The following designs of loading/unloading dock areas should be considered:

- Loading dock areas should be covered, or drainage should be designed to preclude urban run-on and runoff.
- Direct connections into storm drains from depressed loading docks (truck wells) are prohibited.
- Below-grade loading docks from grocery stores and warehouse/distribution centers of fresh food items should drain through water quality inlets, or to an engineered infiltration system, or an equally effective alternative. Pre-treatment may also be required.
- Other features may be comparable and equally effective.

Redeveloping Existing Installations

Various jurisdictional stormwater management and mitigation plans (SUSMP, WQMP, etc.) define “redevelopment” in terms of amounts of additional impervious area, increases in gross floor area and/or exterior construction, and land disturbing activities with structural or impervious surfaces. The definition of “redevelopment” must be consulted to determine whether or not the requirements for new development apply to areas intended for redevelopment. If the definition applies, the steps outlined under “designing new installations” above should be followed.

Additional Information

Stormwater and non-stormwater will accumulate in containment areas and sumps with impervious surfaces. Contaminated accumulated water must be disposed of in accordance with applicable laws and cannot be discharged directly to the storm drain or sanitary sewer system without the appropriate permit.

Other Resources

A Manual for the Standard Urban Stormwater Mitigation Plan (SUSMP), Los Angeles County Department of Public Works, May 2002.

Model Standard Urban Storm Water Mitigation Plan (SUSMP) for San Diego County, Port of San Diego, and Cities in San Diego County, February 14, 2002.

Model Water Quality Management Plan (WQMP) for County of Orange, Orange County Flood Control District, and the Incorporated Cities of Orange County, Draft February 2003.

Ventura Countywide Technical Guidance Manual for Stormwater Quality Control Measures, July 2002.

Description

Trash storage areas are areas where a trash receptacle (s) are located for use as a repository for solid wastes. Stormwater runoff from areas where trash is stored or disposed of can be polluted. In addition, loose trash and debris can be easily transported by water or wind into nearby storm drain inlets, channels, and/or creeks. Waste handling operations that may be sources of stormwater pollution include dumpsters, litter control, and waste piles.

Approach

This fact sheet contains details on the specific measures required to prevent or reduce pollutants in stormwater runoff associated with trash storage and handling. Preventative measures including enclosures, containment structures, and impervious pavements to mitigate spills, should be used to reduce the likelihood of contamination.

Suitable Applications

Appropriate applications include residential, commercial and industrial areas planned for development or redevelopment. (Detached residential single-family homes are typically excluded from this requirement.)

Design Considerations

Design requirements for waste handling areas are governed by Building and Fire Codes, and by current local agency ordinances and zoning requirements. The design criteria described in this fact sheet are meant to enhance and be consistent with these code and ordinance requirements. Hazardous waste should be handled in accordance with legal requirements established in Title 22, California Code of Regulation.

Wastes from commercial and industrial sites are typically hauled by either public or commercial carriers that may have design or access requirements for waste storage areas. The design criteria in this fact sheet are recommendations and are not intended to be in conflict with requirements established by the waste hauler. The waste hauler should be contacted prior to the design of your site trash collection areas. Conflicts or issues should be discussed with the local agency.

Designing New Installations

Trash storage areas should be designed to consider the following structural or treatment control BMPs:

- Design trash container areas so that drainage from adjoining roofs and pavement is diverted around the area(s) to avoid run-on. This might include berming or grading the waste handling area to prevent run-on of stormwater.
- Make sure trash container areas are screened or walled to prevent off-site transport of trash.

Design Objectives

- Maximize Infiltration
- Provide Retention
- Slow Runoff
- Minimize Impervious Land Coverage
- Prohibit Dumping of Improper Materials
- Contain Pollutants
- Collect and Convey



- Use lined bins or dumpsters to reduce leaking of liquid waste.
- Provide roofs, awnings, or attached lids on all trash containers to minimize direct precipitation and prevent rainfall from entering containers.
- Pave trash storage areas with an impervious surface to mitigate spills.
- Do not locate storm drains in immediate vicinity of the trash storage area.
- Post signs on all dumpsters informing users that hazardous materials are not to be disposed of therein.

Redeveloping Existing Installations

Various jurisdictional stormwater management and mitigation plans (SUSMP, WQMP, etc.) define “redevelopment” in terms of amounts of additional impervious area, increases in gross floor area and/or exterior construction, and land disturbing activities with structural or impervious surfaces. The definition of “redevelopment” must be consulted to determine whether or not the requirements for new development apply to areas intended for redevelopment. If the definition applies, the steps outlined under “designing new installations” above should be followed.

Additional Information***Maintenance Considerations***

The integrity of structural elements that are subject to damage (i.e., screens, covers, and signs) must be maintained by the owner/operator. Maintenance agreements between the local agency and the owner/operator may be required. Some agencies will require maintenance deed restrictions to be recorded of the property title. If required by the local agency, maintenance agreements or deed restrictions must be executed by the owner/operator before improvement plans are approved.

Other Resources

A Manual for the Standard Urban Stormwater Mitigation Plan (SUSMP), Los Angeles County Department of Public Works, May 2002.

Model Standard Urban Storm Water Mitigation Plan (SUSMP) for San Diego County, Port of San Diego, and Cities in San Diego County, February 14, 2002.

Model Water Quality Management Plan (WQMP) for County of Orange, Orange County Flood Control District, and the Incorporated Cities of Orange County, Draft February 2003.

Ventura Countywide Technical Guidance Manual for Stormwater Quality Control Measures, July 2002.



Description and Purpose

Street sweeping and vacuuming includes use of self-propelled and walk-behind equipment to remove sediment from streets and roadways, and to clean paved surfaces in preparation for final paving. Sweeping and vacuuming prevents sediment from the project site from entering storm drains or receiving waters.

Suitable Applications

Sweeping and vacuuming are suitable anywhere sediment is tracked from the project site onto public or private paved streets and roads, typically at points of egress. Sweeping and vacuuming are also applicable during preparation of paved surfaces for final paving.

Limitations

Sweeping and vacuuming may not be effective when sediment is wet or when tracked soil is caked (caked soil may need to be scraped loose).

Implementation

- Controlling the number of points where vehicles can leave the site will allow sweeping and vacuuming efforts to be focused, and perhaps save money.
- Inspect potential sediment tracking locations daily.
- Visible sediment tracking should be swept or vacuumed on a daily basis.
- Do not use kick brooms or sweeper attachments. These tend to spread the dirt rather than remove it.

Categories

EC	Erosion Control	
SE	Sediment Control	<input checked="" type="checkbox"/>
TC	Tracking Control	<input checked="" type="checkbox"/>
WE	Wind Erosion Control	
NS	Non-Stormwater Management Control	
WM	Waste Management and Materials Pollution Control	

Legend:

- Primary Objective
- Secondary Objective

Targeted Constituents

Sediment	<input checked="" type="checkbox"/>
Nutrients	
Trash	<input checked="" type="checkbox"/>
Metals	
Bacteria	
Oil and Grease	<input checked="" type="checkbox"/>
Organics	

Potential Alternatives

None



- If not mixed with debris or trash, consider incorporating the removed sediment back into the project

Costs

Rental rates for self-propelled sweepers vary depending on hopper size and duration of rental. Expect rental rates from \$58/hour (3 yd³ hopper) to \$88/hour (9 yd³ hopper), plus operator costs. Hourly production rates vary with the amount of area to be swept and amount of sediment. Match the hopper size to the area and expect sediment load to minimize time spent dumping.

Inspection and Maintenance

- Inspect BMPs in accordance with General Permit requirements for the associated project type and risk level. It is recommended that at a minimum, BMPs be inspected weekly, prior to forecasted rain events, daily during extended rain events, and after the conclusion of rain events.
- When actively in use, points of ingress and egress must be inspected daily.
- When tracked or spilled sediment is observed outside the construction limits, it must be removed at least daily. More frequent removal, even continuous removal, may be required in some jurisdictions.
- Be careful not to sweep up any unknown substance or any object that may be potentially hazardous.
- Adjust brooms frequently; maximize efficiency of sweeping operations.
- After sweeping is finished, properly dispose of sweeper wastes at an approved dumpsite.

References

Stormwater Quality Handbooks - Construction Site Best Management Practices (BMPs) Manual, State of California Department of Transportation (Caltrans), November 2000.

Labor Surcharge and Equipment Rental Rates, State of California Department of Transportation (Caltrans), April 1, 2002 – March 31, 2003.

For Information:

For more information on the General Industrial Storm Water Permit contact:

State Water Resources Control Board (SWRCB)
(916) 657-1146 or www.swrcb.ca.gov/ or, at your
Regional Water Quality Control Board (RWQCB):

Santa Ana Region (8)
California Tower
3737 Main Street, Ste. 500
Riverside, CA 92501-3339
(909) 782-4130

San Diego Region (9)
9771 Clairemont Mesa Blvd., Ste. A
San Diego, CA 92124
(619) 467-2962

Colorado River Basin Region (7)
73-720 Fred Waring Dr., Ste. 100
Palm Desert, CA 92260
(760) 346-7491

SPILL RESPONSE AGENCY:

HAZ-MAT: (909) 358-5055

HAZARDOUS WASTE DISPOSAL: (909) 358-5055

RECYCLING INFORMATION: 1-800-366-SAVE

TO REPORT ILLEGAL DUMPING OR A CLOGGED

STORM DRAIN: 1-800-506-2555

To order additional brochures or to obtain information on other pollution prevention activities, call: (909) 955-1111.



Riverside County gratefully acknowledges the State Water Quality Control Board and the American Public Works Association, Storm Water Quality Task Force for the information provided in this brochure.

DID YOU KNOW . . .

YOUR FACILITY MAY NEED A STORM WATER PERMIT?



Many industrial facilities and manufacturing operations must obtain coverage under the Industrial Activities Storm Water General Permit

**FIND OUT
IF YOUR FACILITY
MUST OBTAIN A PERMIT**

StormWater Pollution . . . What you should know

Riverside County has two drainage systems - sanitary sewers and storm drains. The storm drain system is designed to help prevent flooding by carrying excess rainwater away from streets. Since the storm drain system does not provide for water treatment, it also serves the unintended function of transporting pollutants directly to our waterways.

Unlike sanitary sewers, storm drains are not connected to a treatment plant - they flow directly to our local streams, rivers and lakes.

In recent years, awareness of the need to protect water quality has increased. As a result, federal, state, and local programs have been established to reduce polluted stormwater discharges to our waterways. The emphasis of these programs is to prevent stormwater pollution since it's much easier, and less costly, than cleaning up "after the fact."

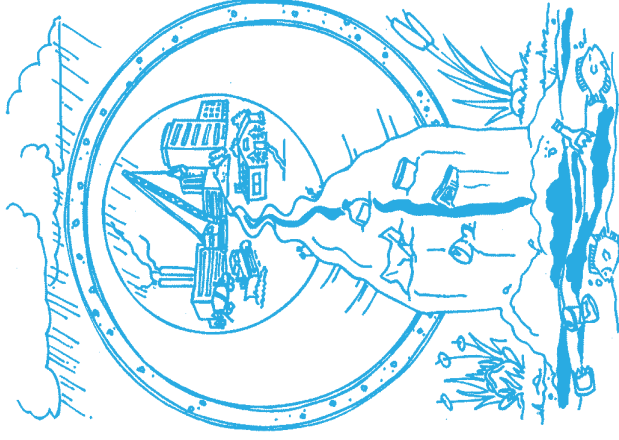

National Pollutant Discharge Elimination System (NPDES)

In 1987, the Federal Clean Water Act was amended to establish a framework for regulating industrial stormwater discharges under the NPDES permit program. In California, NPDES permits are issued by the State Water Resources Control Board (SWRCB) and the nine (9) Regional Water Quality Control Boards (RWQCB). In general, certain industrial facilities and manufacturing operations must obtain coverage under the Industrial Activities Storm Water General Permit if the type of facilities or operations falls into one of the several categories described in this brochure.

How Do I Know If I Need A Permit?

Following are **general descriptions** of the industry categories types that are regulated by the Industrial Activities Storm Water General Permit. Contact your local Region Water Quality Control Board to determine if your facility/operation requires coverage under the Permit.

- Facilities such as cement manufacturing; feedlots; fertilizer manufacturing; petroleum refining; phosphate manufacturing; steam electric power generation; coal mining; mineral mining and processing; ore mining and dressing; and asphalt emulsion;
- Facilities classified as lumber and wood products (except wood kitchen cabinets); pulp, paper, and paperboard mills; chemical producers (except some pharmaceutical and biological products); petroleum and coal products; leather production and products; stone, clay and glass products; primary metal industries; fabricated structural metal; ship and boat building and repairing;
- Active or inactive mining operations and oil and gas exploration, production, processing, or treatment operations;
- Hazardous waste treatment, storage, or disposal facilities;

How do I obtain coverage under the Industrial Activities Storm Water General Permit?

Obtain a permit application package from your local Regional Water Quality Control Board listed on the back of this brochure or the State Water Resources Control Board (SWRCB). Submit a completed Notice of Intent (NOI) form, site map and the appropriate fee (\$250 or \$500) to the SWRCB. Facilities must submit an NOI thirty (30) days prior to beginning operation. Once you submit the NOI, the State Board will send you a letter acknowledging receipt of your NOI and will assign your facility a waste discharge identification number (WDID No.). You will also receive an annual fee billing. These billings should roughly coincide with the date the State Board processed your original NOI submittal.

What are the requirements of the Industrial Activities Storm Water General Permit?

The basic requirements of the Permit are:

1. The facility must eliminate any non-stormwater discharges or obtain a separate permit for such discharges.
2. The facility must develop and implement a Storm Water Pollution Prevention Plan (SWPPP). The SWPPP must identify sources of pollutants that may be exposed to stormwater. Once the sources of pollutants have been identified, the facility operator must develop and implement Best Management Practices (BMPs) to minimize or prevent polluted runoff.
Guidance in preparing a SWPPP is available from a document prepared by the California Storm Water Quality Task Force called the California Storm Water Best Management Practice Handbook.
3. The facility must develop and implement a Monitoring Program that includes conducting visual observations and collecting samples of the facility's storm water discharges associated with industrial activity. The General Permit requires that the analysis be conducted by a laboratory that is certified by the State of California.
4. The facility must submit to the Regional Board, every July 1, an annual report that includes the results of its monitoring program.

A Non-Storm Water Discharge is... any discharge to a storm drain system that is not composed entirely of storm water. The following non-storm water discharges are authorized by the General Permit: fire hydrant flushing; potable water sources, including potable water related to the operation, maintenance, or testing of potable water systems; drinking fountain water; atmospheric condensates including refrigeration, air conditioning, and compressor condensate; irrigation drainage; landscape watering; springs; non-contaminated ground water; foundation or footing drainage; and sea water infiltration where the sea waters are discharged back into the sea water source.

A BMP is . . . a technique, process, activity, or structure used to reduce the pollutant content of a storm water discharge. BMPs may include simple, non-structural methods such as good housekeeping, staff training and preventive maintenance. Additionally, BMPs may include structural modifications such as the installation of berms, canopies or treatment control (e.g. setting basins, oil/water separators, etc.)



WARNING: There are significant penalties for non-compliance: a minimum fine of \$5,000 for failing to obtain permit coverage, and, up to \$10,000 per day, per violation plus \$10 per gallon of discharge in excess of 1,000 gallons.

Stormwater Pollution

What you should know for...



Best Management Practices (BMPs) for:

- Developers
- General Contractors
- Home Builders
- Construction Inspectors
- Anyone in the construction business

To report a hazardous materials spill, call:

Riverside County Hazardous Materials

Emergency Response Team

(909) 358-5055 8:00 a.m. – 5:00 p.m.

(909) 358-5245 after 5:00 p.m.

In an emergency call: 911

For recycling and hazardous waste disposal, call:

(909) 358-5055

To report an illegal dumping or a clogged storm drain, call:

1-800-506-2555

To order additional brochures or to obtain information on other pollution prevention activities, please call (909) 955-1200 or visit the StormWater/CleanWater Protection Program website at:
www.co.riverside.ca.us/depts/flood/waterquality/pdps.asp



The StormWater/CleanWater Protection Program gratefully acknowledges the Santa Clara Valley Nonpoint Pollution Control Program, Alameda Countywide CleanWater Program and the City of Los Angeles Stormwater Management Division for information provided in this brochure.

Resources

State Water Resources Control Board

Division of Water Quality

1001 I Street

Sacramento CA 95814

(916) 341-5455

www.swrcb.ca.gov/stormwtr/

Colorado River Basin Regional Water

Quality Control Board - Region 7

73-720 Fred Waring Drive, Suite 100

Palm Desert, CA 92260

(760) 346-7491

www.swrcb.ca.gov/~rwqcb7/

Santa Ana Regional Water

Quality Control Board - Region 8

3737 Main Street, Suite 500

Riverside, CA 92501-3348

(909) 782-4130

www.swrcb.ca.gov/~rwqcb8/

San Diego Regional Water

Quality Control Board - Region 9

9771 Clairemont Mesa Blvd., Suite A

San Diego, CA 92124

(858) 467-2952

www.swrcb.ca.gov/~rwqcb9/

STORMWATER POLLUTION FROM CONSTRUCTION ACTIVITIES

The two most common sources of stormwater pollution problems associated with construction activities are **erosion** and **sedimentation**. Failure to maintain adequate erosion and sediment controls at construction sites often results in sediment discharges into the storm drain system, creating multiple problems once it enters local waterways.

Construction vehicles and heavy equipment can also track significant amounts of mud and sediment onto adjacent streets. Additionally, wind may transport construction materials and wastes into streets storm drains, or directly into our local waterways.



The Cities and County of Riverside StormWater/CleanWater Protection Program

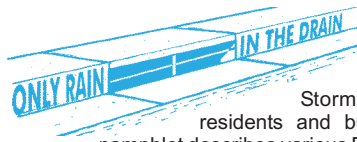

Because preventing pollution is much easier and less costly than cleaning up "after the fact," the Cities and County of Riverside

StormWater/CleanWater Protection Program informs residents and businesses on pollution prevention activities. This pamphlet describes various Best Management Practices (BMPs) that construction site operators can use to prevent stormwater pollution.

In accordance with applicable federal and state law, the Cities and County of Riverside have adopted ordinances for stormwater management and discharge control that **prohibit** the discharge of pollutants into the storm drain system or local surface water. This includes discharges from construction sites containing sediment, concrete, mortar, paint, solvents, lubricants, vehicle fluids, fuel, pesticides, and construction debris.

PLEASE NOTE: The Federal, State and local regulations strictly prohibit the discharge of sediment and pollutants into the streets, the storm drain system or waterways. As an owner, operator or supervisor of a construction site, you may be held financially responsible for any environmental damage caused by your subcontractors or employees.



What Should You Do? Advance Planning to Prevent Pollution

- Remove existing vegetation only as needed.
- Schedule excavation, grading, and paving operations for dry weather periods, if possible.
- Designate a specific area of the construction site, well away from storm drain inlets or watercourses, for material storage and equipment maintenance.
- Develop and implement an effective combination of erosion and sediment controls for the construction site.
- Practice source reduction by ordering only the amount of materials that are needed to finish the project.
- Educate your employees and subcontractors about stormwater management requirements and their pollution prevention responsibilities.
- Control the amount of surface runoff at the construction site by impeding internally generated flows and using berms or drainage ditches to direct incoming offsite flows to go around the site. *Note: Consult local drainage policies for more information.*

BEST MANAGEMENT PRACTICES

The following Best Management Practices (BMPs) can significantly reduce pollutant discharges from your construction site. Compliance with stormwater regulations can be as simple as minimizing stormwater contact with potential pollutants by providing covers and secondary containment for construction materials, designating areas away from storm drain systems for storing equipment and materials and implementing good housekeeping practices at the construction site.

- Protect all storm drain inlets and streams located near the construction site to prevent sediment-laden water from entering the storm drain system.
- Limit access to and from the site. Stabilize construction entrances/exits to minimize the track out of dirt and mud onto adjacent streets. Conduct frequent street sweeping.
- Protect stockpiles and construction materials from winds and rain by storing them under a roof, secured impermeable tarp or plastic sheeting.
- Avoid storing or stockpiling materials near storm drain inlets, gullies or streams.
- Phase grading operations to limit disturbed areas and duration of exposure.
- Perform major maintenance and repairs of vehicles and equipment offsite.
- Wash out concrete mixers only in designated washout areas at the construction site.
- Set-up and operate small concrete mixers on tarps or heavy plastic drop cloths.
- Keep construction sites clean by removing trash, debris, wastes, etc. on a regular basis.
- Clean-up spills immediately using dry clean-up methods (e.g., absorbent materials such as cat litter, sand or rags for liquid spills; sweeping for dry spills such as cement, mortar or fertilizer) and by removing the contaminated soil from spills on dirt areas.
- Prevent erosion by implementing any or a combination of soil stabilization practices such as mulching, surface roughening, permanent or temporary seeding.
- Maintain all vehicles and equipment in good working condition. Inspect frequently for leaks, and repair promptly.
- Practice proper waste disposal. Many construction materials and wastes, including solvents, water-based paint, vehicle fluids, broken asphalt and concrete, wood, and cleared vegetation can be recycled. Materials that cannot be recycled must be taken to an appropriate landfill or disposed of as hazardous waste.
- Cover open dumpsters with secured tarps or plastic sheeting. Never clean out a dumpster by washing it down on the construction site.
- Arrange for an adequate debris disposal schedule to insure that dumpsters do not overflow.

GENERAL CONSTRUCTION ACTIVITIES STORMWATER PERMIT (Construction Activities General Permit)

The State Water Resources Control Board (SWRCB) adopted a new Construction Activities General Permit (WQ Order No. 99-08DWQ) on August 19, 1999, superseding the now expired SWRCB statewide General Permit (WQ Order No. 92-08DWQ). This permit is administered and enforced by the SWRCB and the local Regional Water Quality Control Boards (RWQCB). The updated Construction Activities General Permit establishes a number of new stormwater management requirements for construction site operator.

NOTE: Some construction activities stormwater permits are issued on a regional basis. Consult your local RWQCB to find out if your project requires coverage under any of these permits.

Frequently Asked Questions:

Does my construction site require coverage under the Construction Activities General Permit?

Yes, if construction activity results in the disturbance of five or more acres of total land area or is part of a common plan of development that results in the disturbance of five or more acres.

How do I obtain coverage under the Construction Activities General Permit?

Obtain the permit package and submit the completed Notice of Intent (NOI) form to the

SWRCB prior to grading or disturbing soil at the construction site. For ongoing construction activity involving a change of ownership, the new owner must submit a new NOI within 30 days of the date of change of ownership. The completed NOI along with the required fee should be mailed to the SWRCB.

What must I do to comply with the requirements of the Construction Activities General Permit?

- Implement BMPs for non-stormwater discharges year-round.
- Prepare and implement a Stormwater Pollution Prevention Plan (SWPPP) prior to commencing construction activities.
- Keep a copy of the SWPPP at the construction site for the entire duration of the project.
- Calculate the anticipated stormwater runoff.
- Implement an effective combination of erosion and sediment control on all soil disturbed areas.
- Conduct site inspections prior to anticipated storm events, every 24-hours during extended storm events, and after actual storm event.
- Perform repair and maintenance of BMPs as soon as possible after storm events depending upon worker safety.

- Update the SWPPP as needed, to manage pollutants or reflect changes in site conditions.
- Include description of post construction BMPs at the construction site, including parties responsible for long-term maintenance.

NOTE: Please refer to the Construction Activities General Permit for detailed information. You may contact the SWRCB, your local RWQCB, or visit the SWRCB website at www.swrcb.ca.gov/stormwtr/ to obtain a State Construction Activities Stormwater General Permit packet.

How long is this Construction Activities General Permit in effect?

The Permit coverage stays in effect until you submit a Notice of Termination (NOT) to the SWRCB. For the purpose of submitting a NOT, all soil disturbing activities have to be completed and one of the three following criteria has to be met:

1. Change of ownership;
2. A uniform vegetative cover with 70 percent coverage has been established; or,
3. Equivalent stabilization measures such as the use of reinforced channel liners, soil cement, fiber matrices, geotextiles, etc., have been employed.



A Citizen's Guide to Understanding Stormwater



EPA 833-B-03-002
February 2003
U.S. Environmental Protection Agency
EPA
United States Environmental Protection Agency
Chlorine has an Ozone Depletion Potential of 0.05. Hydrochlorofluorocarbons (HCFCs) have an Ozone Depletion Potential of 0.1 to 1.0. Hydrofluorocarbons (HFCs) have an Ozone Depletion Potential of 0.001 to 0.01. Perfluorocarbons (PFCs) have an Ozone Depletion Potential of 0.0001 to 0.001.

After the Storm

or visit
www.epa.gov/npdes/stormwater
www.epa.gov/nps

For more information contact:



What is stormwater runoff?



Stormwater runoff occurs when precipitation from rain or snowmelt flows over the ground. Impervious surfaces like driveways, sidewalks, and streets prevent stormwater from naturally soaking into the ground.

Why is stormwater runoff a problem?



Stormwater can pick up debris, chemicals, dirt, and other pollutants and flow into a storm sewer system or directly to a lake, stream, river, wetland, or coastal water. Anything that enters a storm sewer system is discharged untreated into the waterbodies we use for swimming, fishing, and providing drinking water.

The effects of pollution

Polluted stormwater runoff can have many adverse effects on plants, fish, animals, and people.

- ◆ Sediment can cloud the water and make it difficult or impossible for aquatic plants to grow. Sediment also can destroy aquatic habitats.
- ◆ Excess nutrients can cause algae blooms. When algae die, they sink to the bottom and decompose in a process that removes oxygen from the water. Fish and other aquatic organisms can't exist in water with low dissolved oxygen levels.
- ◆ Bacteria and other pathogens can wash into swimming areas and create health hazards, often making beach closures necessary.
- ◆ Debris—plastic bags, six-pack rings, bottles, and cigarette butts—washed into waterbodies can choke, suffocate, or disable aquatic life like ducks, fish, turtles, and birds.
- ◆ Household hazardous wastes like insecticides, pesticides, paint, solvents, used motor oil, and other auto fluids can poison aquatic life. Land animals and people can become sick or die from eating diseased fish and shellfish or ingesting polluted water.



- ◆ Polluted stormwater often affects drinking water sources. This, in turn, can affect human health and increase drinking water treatment costs.



Stormwater Pollution Solutions

Residential

Recycle or properly dispose of household products that contain chemicals, such as insecticides, pesticides, paint, solvents, and used motor oil and other auto fluids. Don't pour them onto the ground or into storm drains.

Lawn care

Excess fertilizers and pesticides applied to lawns and gardens wash off and pollute streams. In addition, yard clippings and leaves can wash into storm drains and contribute nutrients and organic matter to streams.



- ◆ Don't overwater your lawn. Consider using a soaker hose instead of a sprinkler.
- ◆ Use pesticides and fertilizers sparingly. When use is necessary, use these chemicals in the recommended amounts. Use organic mulch or safer pest control methods whenever possible.
- ◆ Compost or mulch yard waste. Don't leave it in the street or sweep it into storm drains or streams.
- ◆ Cover piles of dirt or mulch being used in landscaping projects.

Septic systems

Leaking and poorly maintained septic systems release nutrients and pathogens (bacteria and viruses) that can be picked up by stormwater and discharged into nearby waterbodies. Pathogens can cause public health problems and environmental concerns.



- ◆ Inspect your system every 3 years and pump your tank as necessary (every 3 to 5 years).
- ◆ Don't dispose of household hazardous waste in sinks or toilets.

Auto care

Washing your car and degreasing auto parts at home can send detergents and other contaminants through the storm sewer system. Dumping automotive fluids into storm drains has the same result as dumping the materials directly into a waterbody.



- ◆ Use a commercial car wash that treats or recycles its wastewater, or wash your car on your yard so the water infiltrates into the ground.
- ◆ Repair leaks and dispose of used auto fluids and batteries at designated drop-off or recycling locations.

Pet waste

Pet waste can be a major source of bacteria and excess nutrients in local waters.



- ◆ When walking your pet, remember to pick up the waste and dispose of it properly. Flushing pet waste is the best disposal method. Leaving pet waste on the ground increases public health risks by allowing harmful bacteria and nutrients to wash into the storm drain and eventually into local waterbodies.

Residential landscaping

Permeable Pavement—Traditional concrete and asphalt don't allow water to soak into the ground. Instead these surfaces rely on storm drains to divert unwanted water. Permeable pavement systems allow rain and snowmelt to soak through, decreasing stormwater runoff.

Rain Barrels—You can collect rainwater from rooftops in mosquito-proof containers. The water can be used later on lawn or garden areas.



Rain Gardens and Grassy Swales—Specially designed areas planted with native plants can provide natural places for rainwater to collect and soak into the ground. Rain from rooftop areas or paved areas can be diverted into these areas rather than into storm drains.



Vegetated Filter Strips—Filter strips are areas of native grass or plants created along roadways or streams. They trap the pollutants stormwater picks up as it flows across driveways and streets.

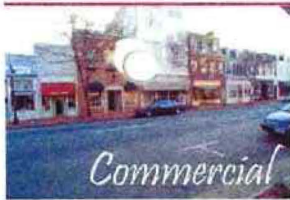

Commercial

Dirt, oil, and debris that collect in parking lots and paved areas can be washed into the storm sewer system and eventually enter local waterbodies.

- ◆ Sweep up litter and debris from sidewalks, driveways and parking lots, especially around storm drains.
- ◆ Cover grease storage and dumpsters and keep them clean to avoid leaks.
- ◆ Report any chemical spill to the local hazardous waste cleanup team. They'll know the best way to keep spills from harming the environment.

Erosion controls that aren't maintained can cause excessive amounts of sediment and debris to be washed into the stormwater system. Construction vehicles can leak fuel, oil, and other harmful fluids that can be picked up by stormwater and deposited into local waterbodies.

- ◆ Divert stormwater away from disturbed or exposed areas of the construction site.
- ◆ Install silt fences, vehicle mud removal areas, vegetative cover, and other sediment and erosion controls and properly maintain them, especially after rainstorms.
- ◆ Prevent soil erosion by minimizing disturbed areas during construction projects, and seed and mulch bare areas as soon as possible.

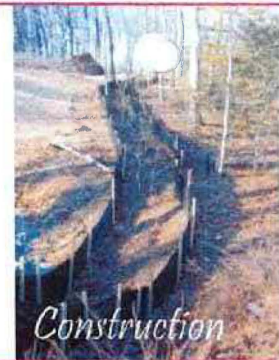

Construction



Agriculture

Lack of vegetation on streambanks can lead to erosion. Overgrazed pastures can also contribute excessive amounts of sediment to local waterbodies. Excess fertilizers and pesticides can poison aquatic animals and lead to destructive algae blooms. Livestock in streams can contaminate waterways with bacteria, making them unsafe for human contact.



- ◆ Keep livestock away from streambanks and provide them a water source away from waterbodies.
- ◆ Store and apply manure away from waterbodies and in accordance with a nutrient management plan.
- ◆ Vegetate riparian areas along waterways.
- ◆ Rotate animal grazing to prevent soil erosion in fields.
- ◆ Apply fertilizers and pesticides according to label instructions to save money and minimize pollution.



Forestry

Improperly managed logging operations can result in erosion and sedimentation.

- ◆ Conduct preharvest planning to prevent erosion and lower costs.
- ◆ Use logging methods and equipment that minimize soil disturbance.
- ◆ Plan and design skid trails, yard areas, and truck access roads to minimize stream crossings and avoid disturbing the forest floor.
- ◆ Construct stream crossings so that they minimize erosion and physical changes to streams.
- ◆ Expedite revegetation of cleared areas.

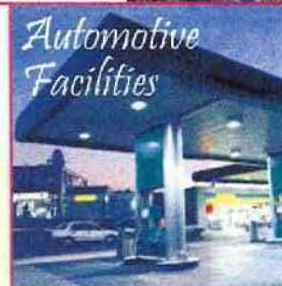

Automotive Facilities

Uncovered fueling stations allow spills to be washed into storm drains. Cars waiting to be repaired can leak fuel, oil, and other harmful fluids that can be picked up by stormwater.

- ◆ Clean up spills immediately and properly dispose of cleanup materials.
- ◆ Provide cover over fueling stations and design or retrofit facilities for spill containment.
- ◆ Properly maintain fleet vehicles to prevent oil, gas, and other discharges from being washed into local waterbodies.
- ◆ Install and maintain oil/water separators.

Help Protect Our Waterways!

Use these guidelines for Outdoor Cleaning Activities and Wash Water Disposal

Did you know that disposing of pollutants into the street, gutter, storm drain or body of water is **PROHIBITED** by law and can result in stiff penalties?

Best Management Practices

Waste wash water from Mechanics, Plumbers, Window/Power Washers, Carpet Cleaners, Car Washing and Mobile Detailing activities may contain significant quantities of motor oil, grease, chemicals, dirt, detergents, brake pad dust, litter and other materials.

Best Management Practices, or BMPs as they are known, are guides to prevent pollutants from entering the storm drains. *Each of us* can do our part to keep stormwater clean by using the suggested BMPs below:

Simple solutions for both light and heavy duty jobs:

Do...consider dry cleaning methods first such as a mop, broom, rag or wire brush. Always keep a spill response kit on site.

Do...prepare the work area before power cleaning by using sand bags, rubber mats, vacuum booms, containment pads or temporary berms to keep wash water away from the gutters and storm drains.

Do...use vacuums or other machines to remove and collect loose debris or litter before applying water.

Do...obtain the property owner's permission to dispose of *small amounts* of power washing waste water on to landscaped, gravel or unpaved surfaces.

Do...check your local sanitary sewer agency's policies on wash water disposal regulations before disposing of wash water into the sewer. (See list on reverse side)

Do...be aware that if discharging to landscape areas, soapy wash water may damage landscaping. Residual wash water may remain on paved surfaces to evaporate. Sweep up solid residuals and dispose of properly. Vacuum booms are another option for capturing and collecting wash water.

Do...check to see if local ordinances prevent certain activities.

Do not let...wash or waste water from sidewalk, plaza or building cleaning go into a street or storm drain.



Report illegal storm drain disposal
Call Toll Free
1-800-506-2555

Using Cleaning Agents

Try using biodegradable/phosphate-free products. They are easier on the environment, but don't confuse them with being toxic free. Soapy water entering the storm drain system can impact the delicate aquatic environment.



When cleaning surfaces with a *high-pressure washer* or *steam cleaner*, additional precautions should be taken to prevent the discharge of pollutants into the storm drain system. These two methods of surface cleaning can loosen additional material that can contaminate local waterways.

Think Water Conservation

Minimize water use by using high pressure, low volume nozzles. Be sure to check all hoses for leaks. Water is a precious resource, don't let it flow freely and be sure to shut it off in between uses.

Screening Wash Water

Conduct thorough dry cleanup before washing exterior surfaces, such as buildings and decks *with loose paint*, sidewalks or plaza areas. Keep debris from entering the storm drain after cleaning by first passing the wash water through a "20 mesh" or finer screen to catch the solid materials, then dispose of the mesh in a refuse container. Do not let the remaining wash water enter a street, gutter or storm drain.

Drain Inlet Protection & Collection of Wash Water

- Prior to any washing, block all storm drains with an impervious barrier such as sandbags or berms, or seal the storm drain with plugs or other appropriate materials.
- Create a containment area with berms and traps or take advantage of a low spot to keep wash water contained.
- Wash vehicles and equipment on grassy or gravel areas so that the wash water can seep into the ground.
- Pump or vacuum up all wash water in the contained area.

Concrete/Coring/Saw Cutting and Drilling Projects

Protect any down-gradient inlets by using dry activity techniques whenever possible. If water is used, minimize the amount of water used during the coring/drilling or saw cutting process. Place a barrier of sandbags and/or absorbent berms to protect the storm drain inlet or watercourse. Use a shovel or wet vacuum to remove the residue from the pavement. Do not wash residue or particulate matter into a storm drain inlet or watercourse.

Helpful telephone numbers and links:

Riverside County Stormwater Protection Partners

Flood Control District	(951) 955-1200
County of Riverside	(951) 955-1000
City of Banning	(951) 922-3105
City of Beaumont	(951) 769-8520
City of Calimesa	(909) 795-9801
City of Canyon Lake	(951) 244-2955
Cathedral City	(760) 770-0327
City of Coachella	(760) 398-4978
City of Corona	(951) 736-2447
City of Desert Hot Springs	(760) 329-6411
City of Eastvale	(951) 361-0900
City of Hemet	(951) 765-2300
City of Indian Wells	(760) 346-2489
City of Indio	(760) 391-4000
City of Lake Elsinore	(951) 674-3124
City of La Quinta	(760) 777-7000
City of Menifee	(951) 672-6777
City of Moreno Valley	(951) 413-3000
City of Murrieta	(951) 304-2489
City of Norco	(951) 270-5607
City of Palm Desert	(760) 346-0611
City of Palm Springs	(760) 323-8299
City of Perris	(951) 943-6100
City of Rancho Mirage	(760) 324-4511
City of Riverside	(951) 361-0900
City of San Jacinto	(951) 654-7337
City of Temecula	(951) 694-6444
City of Wildomar	(951) 677-7751

REPORT ILLEGAL STORM DRAIN DISPOSAL
1-800-506-2555 or e-mail us at
fenpdes@rcflood.org

- Riverside County Flood Control and Water Conservation District
www.rcflood.org

Online resources include:

- California Storm Water Quality Association
www.casqa.org
- State Water Resources Control Board
www.waterboards.ca.gov
- Power Washers of North America
www.thepwna.org

Stormwater Pollution

What you should know for...

Outdoor Cleaning Activities and Professional Mobile Service Providers



Storm drain pollution prevention information for:

- Car Washing / Mobile Detailers
- Window and Carpet Cleaners
- Power Washers
- Waterproofers / Street Sweepers
- Equipment cleaners or degreasers and all mobile service providers

Do you know where street flows actually go?

Storm drains are NOT connected to sanitary sewer systems and treatment plants!



The primary purpose of storm drains is to carry rain water away from developed areas to prevent flooding. Pollutants discharged to storm drains are transported directly into rivers, lakes and streams. Soaps, degreasers, automotive fluids, litter and a host of materials are washed off buildings, sidewalks, plazas and parking areas. Vehicles and equipment must be properly managed to prevent the pollution of local waterways.

Unintentional spills by mobile service operators can flow into storm drains and pollute our waterways. **Avoid mishaps.** Always have a **Spill Response Kit** on hand to clean up unintentional spills. Only emergency **Mechanical** repairs should be done in City streets, using drip pans for spills. **Plumbing** should be done on private property. Always store chemicals in a leak-proof container and keep covered when not in use. **Window/Power Washing** waste water shouldn't be released into the streets, but should be disposed of in a sanitary sewer, landscaped area or in the soil. Soiled **Carpet Cleaning** wash water should be filtered before being discharged into the sanitary sewer. Dispose of all filter debris properly. **Car Washing/Detailing** operators should wash cars on private property and use a regulated hose nozzle for water flow control and runoff prevention. Capture and dispose of waste water and chemicals properly. Remember, storm drains are for receiving rain water runoff only.

REPORT ILLEGAL STORM DRAIN DISPOSAL
1-800-506-2555

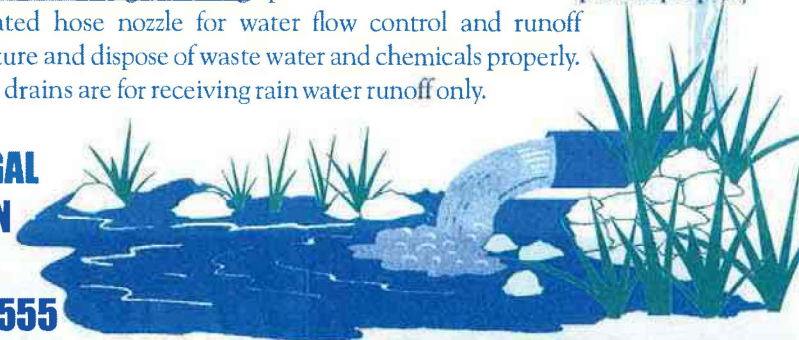



Landscaping and garden maintenance activities can be major contributors to water pollution. Soils, yard wastes, over-watering and garden chemicals become part of the urban runoff mix that winds its way through streets, gutters and storm drains before entering lakes, rivers, streams, etc. Urban runoff pollution contaminates water and harms aquatic life!

In Riverside County, report illegal discharges into the storm drain, call
1-800-506-2555
"Only Rain Down the Storm Drain"

Important Links:

Riverside County Household Hazardous Waste Collection Information
1-800-304-2226 or www.rivcowm.org

Riverside County Backyard Composting Program
1-800-366-SAVE

Integrated Pest Management (IPM) Solutions
www.ipm.ucdavis.edu

California Master Gardener Programs
www.mastergardeners.org
www.camastergardeners.ucdavis.edu

California Native Plant Society
www.cnps.org

The Riverside County "Only Rain Down the Storm Drain" Pollution Prevention Program gratefully acknowledges Orange County's Storm Water Program for their contribution to this brochure.



...Only Rain Down ...the Storm Drain

*What you should know for...
Landscape and Gardening*

Best Management tips for:

- Professionals
- Novices
- Landscapers
- Gardeners
- Cultivators

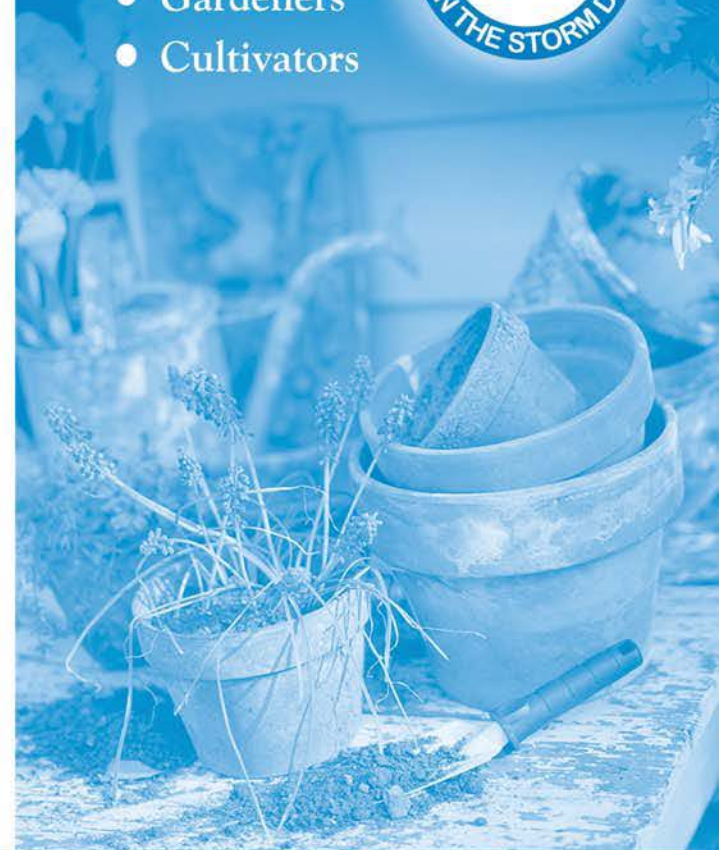

Tips for Landscape & Gardening

This brochure will help you to get the most of your lawn and gardening efforts and keep our waterways clean. Clean waterways provide recreation, establish thriving fish habitats, secure safe sanctuaries for wildlife, and add beauty to our communities. NEVER allow gardening products or waste water to enter the street, gutter or storm drain.

General Landscaping Tips

- Protect stockpiles and materials from wind and rain by storing them under tarps or secured plastic sheeting.
- Prevent erosion of slopes by planting fast-growing, dense ground covering plants. These will shield and bind the soil.
- Plant native vegetation to reduce the amount of water, fertilizers and pesticides applied to the landscape.
- Never apply pesticides or fertilizers when rain is predicted within the next 48 hours.



Garden & Lawn Maintenance

- Do not overwater. Use irrigation practices such as drip irrigation, soaker hoses or micro-spray systems. Periodically inspect and fix leaks and misdirected sprinklers.

- Do not rake or blow leaves, clippings or pruning waste into the street, gutter or storm drain. Instead, dispose of green waste by composting, hauling it to a permitted landfill, or recycling it through your city's program.



- Consider recycling your green waste and adding "nature's own fertilizer" to your lawn or garden.
- Read labels and use only as directed. Do not over-apply pesticides or fertilizers. Apply to spots as needed, rather than blanketing an entire area.
- Store pesticides, fertilizers and other chemicals in a dry covered area to prevent exposure that may result in the deterioration of containers and packaging.
- Rinse empty pesticide containers and re-use rinse water as you would use the product. Do not dump rinse water down storm drains or sewers. Dispose of empty containers in the trash.
- When available, use non-toxic alternatives to traditional pesticides, and use pesticides specifically designed to control the pest you are targeting.

- Try natural long-term common sense solutions first. Integrated Pest Management (IPM) can provide landscaping guidance and solutions, such as:

- ◆ **Physical Controls** - Try hand picking, barriers, traps or caulking holes to control weeds and pests.
- ◆ **Biological Controls** - Use predatory insects to control harmful pests.
- ◆ **Chemical Controls** - Check out www.ipm.ucdavis.edu before using chemicals. Remember, all chemicals should be used cautiously and in moderation.

- If fertilizer is spilled, sweep up the spill before irrigating. If the spill is liquid, apply an absorbent material such as cat litter, and then sweep it up and dispose of it in the trash.
- Take unwanted pesticides to a Household Waste Collection Center to be recycled.
- *Dumping toxics into the street, gutter or storm drain is illegal!*

www.bewaterwise.com Great water conservation tips and drought tolerant garden designs.

www.ourwaterourworld.com Learn how to safely manage home and garden pests.

Additional information can also be found on the back of this brochure.



ILLEGAL DUMPING IS RUBBISH

Properly dump your garbage to reduce California's stormwater pollution!
Five easy tips to reduce pollutants:



APPLIANCES



When illegally dumped, appliances can release toxins that get washed away with rain and end up in our water bodies, polluting our water.

- TIP 1: Donate or recycle appliances.**
- TIP 2: Properly dispose at your local dump.**



FURNITURE



When dumped on the side of the roadway all furniture not only causes a safety hazard, but can also breakdown and get into local water bodies, causing pollution.

- TIP 3: Contact local waste management for bulky pick-up or locate a dump for drop-off.**



VEGETATION



Improperly dumped vegetation can flow to waterways, creating an imbalance of nitrates in water and thus harm aquatic life.

- TIP 4: Tarp loads to reduce biodegradable waste on highways.**
- TIP 5: Use a green waste bin or consider composting biodegradable waste.**

Don't risk a \$10k fine & up to 6 months in jail

Simple changes in disposal of rubbish can help keep California's highways, waterways and bodies of water clean!

FOLLOW US ON SOCIAL MEDIA



#ProtectEveryDrop

FIND US ONLINE



www.protecteverydrop.com

Stormwater can pick up debris, chemicals, dirt, and other pollutants and flow into a storm sewer system or directly to a lake, stream, river, wetland, or coastal water. Anything that enters a storm sewer system is discharged untreated into the waterbodies we use for swimming, fishing, and providing drinking water.



Why is stormwater runoff a problem?

Stormwater runoff occurs when precipitation from rain or snowmelt flows over the ground. Impervious surfaces like driveways, sidewalks, and streets prevent stormwater from naturally soaking into the ground.



What is stormwater runoff?



◆ Polluted stormwater often affects drinking water sources. This, in turn, can affect human health and increase drinking water treatment costs.

◆ Debris—plastic bags, six-pack rings, bottles, and cigarette butts—washed into waterbodies can choke, suffocate, or disable aquatic life like ducks, fish, turtles, and birds.



◆ Household hazardous wastes like insecticides, paint, solvents, used motor oil, and other auto fluids can poison aquatic life. Land animals and people can become sick or die from eating diseased fish and shellfish or ingesting polluted water.

◆ Excess nutrients can cause algae blooms. When algae die, they sink to the bottom and decompose in a process that removes oxygen from the water. Fish and other aquatic organisms can't exist in water with low dissolved oxygen levels.



The effects of pollution

◆ Sediment can cloud the water and make it difficult or impossible for aquatic plants to grow. Sediment also can destroy aquatic habitats.

◆ Polluted stormwater runoff can have many adverse effects on plants, fish, animals, and people.



After the Storm

For more information contact:

or visit
www.epa.gov/npdes/stormwater
www.epa.gov/nps



EPA 833-B-03-002

January 2003



Internet Address (URL) • [HTTP://www.epa.gov](http://www.epa.gov)
 Recycled/Recyclable • Printed With Vegetable
 Oil Based Inks on 100% Postconsumer,
 Process Chlorine Free Recycled Paper

A Citizen's Guide to
 Understanding Stormwater



Stormwater Pollution Solutions

Residential

Recycle or properly dispose of household products that contain chemicals, such as insecticides, pesticides, paint, solvents, and used motor oil and other auto fluids. Don't pour them onto the ground or into storm drains.

Lawn care

Excess fertilizers and pesticides applied to lawns and gardens wash off and pollute streams. In addition, yard clippings and leaves can wash into storm drains and contribute nutrients and organic matter to streams.



- ◆ Don't overwater your lawn. Consider using a soaker hose instead of a sprinkler.
- ◆ Use pesticides and fertilizers sparingly. When use is necessary, use these chemicals in the recommended amounts. Use organic mulch or safer pest control methods whenever possible.
- ◆ Compost or mulch yard waste. Don't leave it in the street or sweep it into storm drains or streams.
- ◆ Cover piles of dirt or mulch being used in landscaping projects.

Septic systems

Leaking and poorly maintained septic systems release nutrients and pathogens (bacteria and viruses) that can be picked up by stormwater and discharged into nearby waterbodies. Pathogens can cause public health problems and environmental concerns.



- ◆ Inspect your system every 3 years and pump your tank as necessary (every 3 to 5 years).
- ◆ Don't dispose of household hazardous waste in sinks or toilets.

Auto care

Washing your car and degreasing auto parts at home can send detergents and other contaminants through the storm sewer system. Dumping automotive fluids into storm drains has the same result as dumping the materials directly into a waterbody.



- ◆ Use a commercial car wash that treats or recycles its wastewater, or wash your car on your yard so the water infiltrates into the ground.
- ◆ Repair leaks and dispose of used auto fluids and batteries at designated drop-off or recycling locations.

Pet waste

Pet waste can be a major source of bacteria and excess nutrients in local waters.



- ◆ When walking your pet, remember to pick up the waste and dispose of it properly. Flushing pet waste is the best disposal method. Leaving pet waste on the ground increases public health risks by allowing harmful bacteria and nutrients to wash into the storm drain and eventually into local waterbodies.



Education is essential to changing people's behavior. Signs and markers near storm drains warn residents that pollutants entering the drains will be carried untreated into a local waterbody.

Residential landscaping

Permeable Pavement—Traditional concrete and asphalt don't allow water to soak into the ground. Instead these surfaces rely on storm drains to divert unwanted water. Permeable pavement systems allow rain and snowmelt to soak through, decreasing stormwater runoff.

Rain Barrels—You can collect rainwater from rooftops in mosquito-proof containers. The water can be used later on lawn or garden areas.

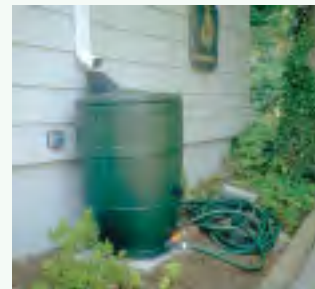

Rain Gardens and Grassy Swales—Specially designed areas planted with native plants can provide natural places for rainwater to collect and soak into the ground. Rain from rooftop areas or paved areas can be diverted into these areas rather than into storm drains.



Vegetated Filter Strips—Filter strips are areas of native grass or plants created along roadways or streams. They trap the pollutants stormwater picks up as it flows across driveways and streets.



Commercial

Dirt, oil, and debris that collect in parking lots and paved areas can be washed into the storm sewer system and eventually enter local waterbodies.

- ◆ Sweep up litter and debris from sidewalks, driveways and parking lots, especially around storm drains.
- ◆ Cover grease storage and dumpsters and keep them clean to avoid leaks.
- ◆ Report any chemical spill to the local hazardous waste cleanup team. They'll know the best way to keep spills from harming the environment.

Erosion controls that aren't maintained can cause excessive amounts of sediment and debris to be carried into the stormwater system. Construction vehicles can leak fuel, oil, and other harmful fluids that can be picked up by stormwater and deposited into local waterbodies.

- ◆ Divert stormwater away from disturbed or exposed areas of the construction site.
- ◆ Install silt fences, vehicle mud removal areas, vegetative cover, and other sediment and erosion controls and properly maintain them, especially after rainstorms.
- ◆ Prevent soil erosion by minimizing disturbed areas during construction projects, and seed and mulch bare areas as soon as possible.



Construction



Agriculture

Lack of vegetation on streambanks can lead to erosion. Overgrazed pastures can also contribute excessive amounts of sediment to local waterbodies. Excess fertilizers and pesticides can poison aquatic animals and lead to destructive algae blooms. Livestock in streams can contaminate waterways with bacteria, making them unsafe for human contact.

- ◆ Keep livestock away from streambanks and provide them a water source away from waterbodies.
- ◆ Store and apply manure away from waterbodies and in accordance with a nutrient management plan.
- ◆ Vegetate riparian areas along waterways.
- ◆ Rotate animal grazing to prevent soil erosion in fields.
- ◆ Apply fertilizers and pesticides according to label instructions to save money and minimize pollution.



Forestry

Improperly managed logging operations can result in erosion and sedimentation.

- ◆ Conduct preharvest planning to prevent erosion and lower costs.
- ◆ Use logging methods and equipment that minimize soil disturbance.
- ◆ Plan and design skid trails, yard areas, and truck access roads to minimize stream crossings and avoid disturbing the forest floor.
- ◆ Construct stream crossings so that they minimize erosion and physical changes to streams.
- ◆ Expedite revegetation of cleared areas.

Automotive Facilities

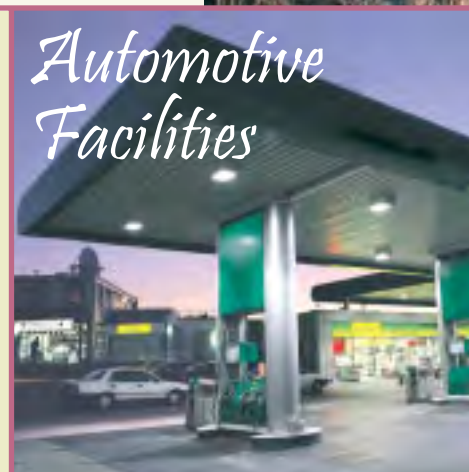

Uncovered fueling stations allow spills to be washed into storm drains. Cars waiting to be repaired can leak fuel, oil, and other harmful fluids that can be picked up by stormwater.

- ◆ Clean up spills immediately and properly dispose of cleanup materials.
- ◆ Provide cover over fueling stations and design or retrofit facilities for spill containment.
- ◆ Properly maintain fleet vehicles to prevent oil, gas, and other discharges from being washed into local waterbodies.
- ◆ Install and maintain oil/water separators.



RIVERSIDE COUNTY
WATERSHED PROTECTION

BECOME A
WATERWISE EXPERT

WATER-EFFICIENT LANDSCAPE DESIGN



Water runoff (from rain or irrigation) may collect pollutants as it flows through landscape, often taking harmful chemicals and soils to low-lying creeks and rivers.

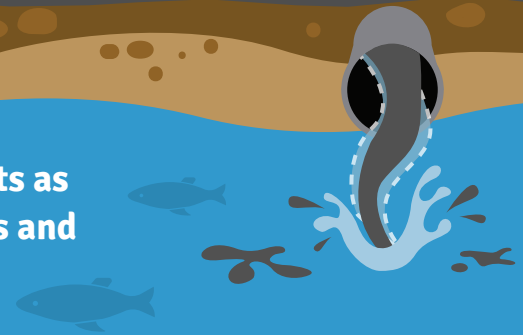

Lead the way with eco-urban landscaping by considering these tips when providing design and installation landscape services.

1 ROOF AND DRIVEWAY

PROBLEM:

The roof and driveway likely generate the most runoff from the home.

SOLUTIONS:

Rain Garden



- Captures stormwater runoff and allows water to sink into the ground

Downspout Outlet Protection



- Slows down and spreads water over an area where it can soak in over time

Gutters and Downspouts



- Directs water away from bare soil and buildings toward planted areas

YOU CAN REDUCE
THE IMPACT OF WATER
RUNOFF BY:

- ✓ SLOWING WATER DOWN
- ✓ SPREADING WATER OUT
- ✓ SINKING WATER INTO THE LAND

2 GROUNDS AND HARDSCAPE

PROBLEM:

Bare soils and impervious surfaces can carry pollutants offsite.

SOLUTIONS:

Turf Blocks

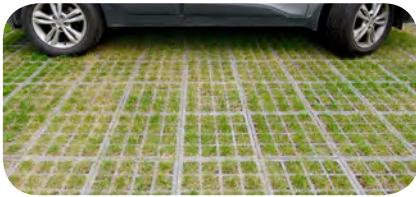

- Provides soil stability and allows water to soak into the ground

Ground Cover



- Allows for more runoff to absorb into the ground

Pervious Hardscapes



- Promotes infiltration while acting as a durable surface for high traffic areas

3 GARDEN AND IRRIGATION

PROBLEM:

Overwatering the landscape is a prohibited activity that wastes water.

SOLUTIONS:

Native Plants



- Reduces the need for fertilizers, pesticides, overall maintenance and irrigation

Swales



- Slows runoff and conveys water to a safe infiltration area

Water-Smart Technologies



- Shuts off irrigation during rain

By following water-efficient landscaping practices that prevent urban runoff, you can:

- 💧 Protect our creeks, streams, and rivers from chemicals and pollutants
- 💧 Protect infrastructure and reduce flooding through simple landscape designs
- 💧 Create healthier homes and communities with efficient green spaces

LEARN ABOUT REBATE PROGRAMS OFFERED BY THE METROPOLITAN WATER DISTRICT, SUCH AS THE TURF REPLACEMENT PROGRAM, AT BEWATERWISE.COM.



THE SAN JACINTO WATERSHED

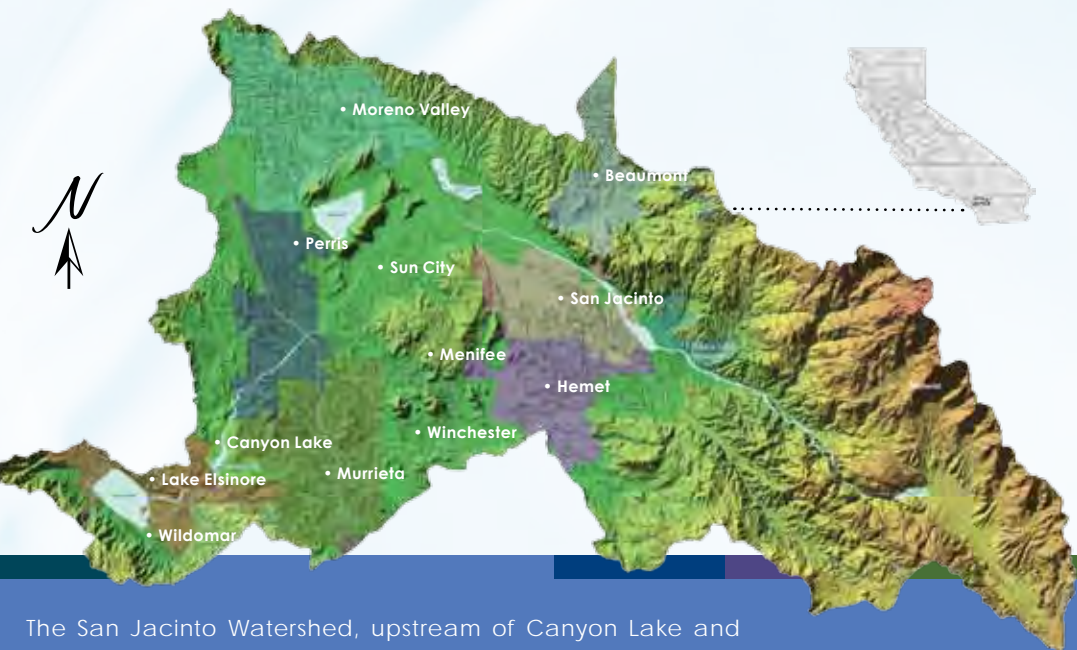

The San Jacinto Watershed, upstream of Canyon Lake and Lake Elsinore, covers 720 square miles in the western half of Riverside County. It begins in the San Jacinto Mountains and runs west through Canyon Lake, ending in Lake Elsinore.

Legend	
	City Limits
	Water
	Road
	Elevation
	Watershed Boundary
	County Boundary
	State Boundary

Threats to the Watershed

The natural flow of water through the San Jacinto Watershed carries nutrient-rich sediment into our lakes each year. The sediment carries with it high levels of nitrogen and phosphorus that hurt water quality and threaten marine life in Canyon Lake and Lake Elsinore.

Enclosed you will find a brief history of the steps we have taken in the last decade to restore our water ways, and an update on what still needs to be done. Keeping our watershed clean and healthy will require the cooperation of stakeholders throughout our region, ultimately improving the quality of life for local residents.

YOUR ROLE & RESPONSIBILITY

You Can Help Protect Our Waterways!

- **Avoid the use of salt-based water softening systems.**
The average water softener discharges an additional 360 lbs of salt into the wastewater system every year.
- **Convert from septic to sewer service, where available.**

While stormwater systems route rainwater quickly off the streets, this water usually carries pollutants, sediment and harmful nutrients directly to our lakes.

Here are some tips to avoid sending pollutants into the stormwater system:

- **Don't dump waste on the ground or in the street.**
Automobile fluids, pet waste or other materials left on the ground are washed into storm sewers, and could end up in our streams and lakes.
- **Don't use excess pesticides and fertilizer or over-water landscaping.**
In addition to wasting scarce water supplies, runoff carries contaminants and washes waste into storm sewers.
- **Don't wash cars in driveways or in the street.**
Commercial car washes are required to remove the detergents, oils and grease that would otherwise flow into storm sewers.

Get More Information!

For more information about our local water resources, and to view a short video about LESJWA's efforts to-date visit www.MyWatersheds.com.

To schedule a presentation to your city council, board of directors or community organization, visit www.MyWatersheds.com or call **951-354-4221**.

Lake Elsinore & San Jacinto Watersheds Authority



City of Lake Elsinore • City of Canyon Lake • County of Riverside
Elsinore Valley Municipal Water District • Santa Ana Watershed Project Authority

LAKE ELSINORE & SAN JACINTO WATERSHEDS AUTHORITY

A Decade of Achievement, A Future of Action



Lake Elsinore & San Jacinto Watersheds Authority



City of Lake Elsinore • City of Canyon Lake • County of Riverside
Elsinore Valley Municipal Water District • Santa Ana Watershed Project Authority

ABOUT LESJWA

Lake Elsinore & San Jacinto Watersheds Authority



Formed in 2000, the Lake Elsinore and San Jacinto Watersheds Authority (LESJWA) was entrusted with \$15 million in state and local funding to improve water quality and wildlife habitats in Lake Elsinore, Canyon Lake and the surrounding San Jacinto watershed.

Thanks to this critical funding, a successful clean-up plan has been enacted over the last decade to improve the water quality in the over 720-square mile San Jacinto watershed with an emphasis on Canyon Lake and Lake Elsinore, two of the region's major recreational destinations.



What Is A Watershed?

A watershed is an area of land that drains into a lake or river. All land is part of a watershed. As rainwater and melting snow run downhill they carry sediment and other materials into local streams, lakes and groundwater.

LAKE ELSINORE & CANYON LAKE,

A History...

1920s-1990s: Fluctuating lake levels, including both dry and flood periods, and periodic fish kills in Lake Elsinore.



1927: Canyon Lake is formed after the Railroad Canyon dam is built.



1953: EVMWD and Temescal Water Company agree to store 3,000 acre-feet of water in Canyon Lake for domestic use. Today, Canyon Lake still serves as a drinking water reservoir.

2000: LESJWA is formed to improve water quality and wildlife habitats in Lake Elsinore, Canyon Lake and the surrounding San Jacinto watershed.



Clean Up Solutions

Scientific research identified the best methods for improving the water quality in Lake Elsinore and Canyon Lake, all of which are the basis for LESJWA's projects:

- Aeration
- In-lake Treatments
- Oxygenation
- Increased Lake Levels
- Fish Harvesting
- Silt/Sediment Removal



LESJWA IMPROVEMENTS TO-DATE

2000 – 2011: Improvement Projects Take Place

Lake Elsinore Carp Removal

Removed more than 1 million pounds of carp from Lake Elsinore. Carp stir up nutrients on the lake bottom, which can cause harmful algae blooms.



Island Well Pump Station Improvements

Island wells produce one million gallons of water a day to help stabilize Lake Elsinore's water level.



Striped Bass Stocking

Added hybrid striped bass in Lake Elsinore to help control overpopulation of fish that disrupt lake water quality.



Lake Elsinore Destratification & Mixing System

Mixes lake water to increase oxygen levels, improve water quality and reduce harmful algae growth.



Canyon Lake Dredging Project

Removed 20,000 cubic yards of excess sediment from Canyon Lake and improved water quality for recreational use.



Recycled Water Nutrient Removal & Conveyance Pipeline

Removes excess nutrients from recycled water and brings the water to Lake Elsinore, improving water quality and helping to stabilize the lake level.



Lake Habitat Improvements

In addition to new shallow water habitat in the Lake Elsinore Back Basin wetlands area, future efforts will help establish diverse aquatic plant communities at both lakes to increase biodiversity and improve water quality.



PLANNED FUTURE EFFORTS

Moving Forward: Local Projects & Regional Partnerships

Canyon Lake Treatment Processes

In order to reduce excessive nutrients that have plagued Canyon Lake for decades, a variety of approaches are being considered for in-lake treatment including a system that would pump additional oxygen into the lake along with the application of chemical algae-control treatments.

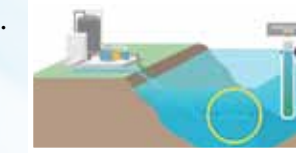

These efforts would improve water quality in Canyon Lake while also limiting nutrients that would otherwise flow from Canyon Lake into Lake Elsinore.

Regional Collaboration

Reducing harmful nutrients in Lake Elsinore and Canyon Lake is the responsibility of every citizen of the San Jacinto Watershed, which stretches from Lake Elsinore north all the way to the San Jacinto Mountains. By working together, our region has the opportunity to improve water quality in the San Jacinto Watershed more than ever before.



What's Next...

Excessive nutrients entering Canyon Lake and Lake Elsinore hurt water quality and threaten marine life in Lake Elsinore and Canyon Lake. These nutrients are naturally occurring and therefore, not easily controlled. Currently, LESJWA's main priority is working with local stakeholders to reduce excessive nutrients in the lakes and ensure compliance with local and federal guidelines.

In order to protect water quality, the Environmental Protection Agency (EPA) and the Santa Ana Regional Water Quality Control Board have established limits on nutrient levels called Total Maximum Daily Loads (TMDLs). These limits are established through extensive monitoring, modeling and studies with local stakeholders and are intended to help achieve lake water quality targets by future deadlines.

TAKING RESPONSIBILITY for LOCAL WATER QUALITY

The Lake Elsinore & Canyon Lake TMDL Task Force

LESJWA now serves as the administrator of a task force of more than 20 agencies and organizations who have been identified by the Regional Water Quality Control Board as watershed nutrient contributors to both lakes.



A Promising Future

As indicated by the TMDLs and other stormwater control requirements issued by the Regional Water Quality Control Board, agencies and organizations in the TMDL task force are responsible for contributing to regional efforts that protect water quality in Lake Elsinore and Canyon Lake.

These efforts will include both regional compliance strategies as well as the construction and operation of new in-lake projects. By working together to fund and implement these projects, the TMDL Task Force can help assure that the region's water quality targets are met by 2015 (interim) and 2020 (final).



My Watersheds LESJWA Fast Facts

Lake Elsinore & San Jacinto Watersheds Authority



City of Lake Elsinore • City of Canyon Lake • County of Riverside
Elsinore Valley Municipal Water District • Santa Ana Watershed Project Authority

Watershed: (def.) noun Area of land that drains into a lake or river.



Lake Elsinore & San Jacinto Watersheds Authority

Joint powers authority, formed in year 2000 to improve water quality and wildlife habitats in Canyon Lake, Lake Elsinore and surrounding San Jacinto Watersheds.



\$ 5 improvement projects -
\$10.5 million spent

San Jacinto River Watershed



People impacted -
647,000



Cities involved in lake cleanup efforts -
11



Total Maximum Daily Load (TMDL) Task Force

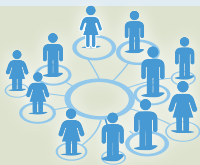

Conducts stormwater and lake water quality monitoring, modeling, studies and projects to help meet water quality targets and improvements.

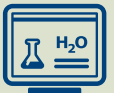

Involved task force agencies: 11 cities, 1 county, 2 water agencies, 1 flood control district, 1 state transportation agency, 1 air force reserve base, 1 redevelopment agency, 1 state fish and wildlife agency and 1 agricultural and dairy coalition

Major lake and watershed projects completed

10

1 Recreational lake - Lake Elsinore



1 Drinking water reservoir and recreational lake - Canyon Lake



Lake Elsinore Water Replenishment
Average runoff flows 1,400 acre-feet/year
Recycled water 4,800 acre-feet/year
Non-potable groundwater 1,000 acre-feet/year
Evaporation water loss 15,200 acre-feet/year
Deficit results in unstable lake levels

Internationally recognized lake experts involved =

10



Number of lake studies conducted on Lake Elsinore and Canyon Lake since year 2000 =

120

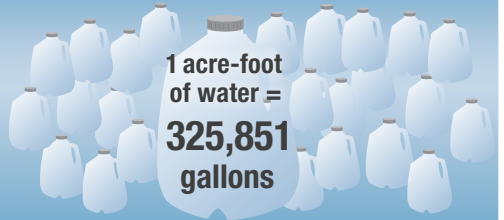

1 acre-foot of water =
325,851 gallons

Years of collaboration to implement projects =

16



Invasive carp removed from Lake Elsinore =

1 million lbs

Amount of sediment removed from Canyon Lake =
20,000 cubic yards

Recycled water delivered to Lake Elsinore to offset evaporation since 2002 = 58,500 acre-feet or
19 billion gal



21 Clean up solutions

Aeration
In-lake treatments
Oxygenation
Alum treatments
Increased lake levels
Fish harvesting
Silt/sediment removal





Irrigation Runoff Stormwater Fact Sheet

Report Irrigation Runoff or
Stormwater Pollution
800.506.2555



Be the Solution. Prevent Runoff Pollution.

The water that flows into storm drains is not treated before flowing into Riverside County's creeks, rivers, lakes, and eventually the ocean (unlike the sanitary sewer system). It should never contain washwater or pollutants like pesticides, fertilizer, dirt, leaves, and other hazardous substances generated by irrigation runoff. If these pollutants are not properly contained, they can runoff into the storm drain and harm our waterways.

Preventing runoff pollution while maintaining your property protects aquatic life, water quality, and keeps our waterways thriving. To take care of your green spaces, make sure to only use pesticides and fertilizers when absolutely necessary and never before rain, prevent overwatering, and sweep debris regularly.

Irrigation Pollutant Sources

Overwatering

Overwatering can cause dirt, pesticides, fertilizers, pet waste, and organic waste to flow into the storm drain.

Pesticide, Fertilizer, or Herbicide Use

Pesticide, fertilizer, or herbicide use 48 hours before or during rain can lead to these chemicals going untreated into our waterways.

Improper Maintenance Before Rain

Leaving pet waste, leaves, grass clippings, and chemicals on the ground (from property neglect or landscape maintenance) before or during rain can cause them to flow into the storm drain.

Runoff From Commercial Properties

Commercial properties, like golf courses, can cause pesticides, dirt, oil, and other hazardous waste to runoff.

Best Management Practices for Irrigation

Protect our waterways while maintaining your green spaces by implementing these BMPs (best management practices):



For more information about stormwater-safe irrigation practices, visit: rcwatershed.org/residents/at-home/overwatering/.

Who We Are

Riverside County Watershed Protection is a partnership program between Riverside County, the Flood Control & Water Conservation District, Coachella Valley Water District, and 27 cities that manage watershed programs which protect, preserve, and enhance the quality of the water and the natural environment of our watersheds.

What We Do

The partnership uses a combination of public education, best management practices, evaluation, and water quality monitoring to eliminate stormwater pollution in our waterways and comply with all federal, state, and local regulations. Our aim is to empower residents with information about pollution prevention and implement tactics that keep our watersheds healthy.

Contact Us

To report pollution:

 Call (800) 506-2555

 Visit rcwatershed.org/get-involved/report-pollution

 For emergencies, dial 911



Prevent Overwatering

- ✓ Only give your lawn and garden the amount of water it needs, and use drip irrigation, soaker hoses, or micro-spray systems. Do not water when it is raining and use an irrigation timer to pre-set watering times.
- ✓ Conduct a Sprinkler Spruce Up regularly to ensure overwatering and runoff aren't occurring. If you notice a leak in your irrigation system, repair it immediately.
- ✓ Redirect your downspout to a rain garden, dry creek bed, rain barrel, or underwatered part of your lawn.



Plant Riverside County-Native Vegetation

- ✓ Plant native vegetation like foothill penstemon and red bush monkeyflower to reduce the amount of water, fertilizers, and pesticides needed.
- ✓ Plant fast-growing and dense ground covering plants like California fuchsia and Angelita daisy to prevent erosion. For landscaping ideas visit: www.bewaterwise.com.



Utilize Business Best Practices

- ✓ Wash golf carts and lawn mowers over permeable surfaces.
- ✓ Cover storm drains when conducting washing and maintenance activities to prevent washwater from flowing into the storm drain.
- ✓ If your golf course handles reportable quantities of hazardous waste, you are required to submit a Hazardous Materials Business Plan through the California Environmental Reporting System. Visit rcwaste.org/business/hw for more info.
- ✓ Keep stockpiles at least 50 feet from concentrated flows of stormwater, drainage courses, and inlets.
- ✓ Regularly inspect and maintain oil storage tanks, drums, and areas to keep them in good condition.
- ✓ Utilize a commercial water broom to wash hard surfaces like tennis courts, patios, parking areas, and sidewalks, and make sure washwater never enters the storm drain system.



Riverside's Solution to Runoff Pollution

What is Runoff?

When water from rain and outdoor water use runs off roofs, driveways, and sidewalks, it brings everything it touches with it. This runoff can include trash, fertilizer, pet waste, home solvents, and other pollutants which ends up in Riverside County's waterways.

Water that goes into Riverside County's storm drains is NOT TREATED

Whether residents or businesses intentionally or accidentally let runoff flow into storm drains, it can harm our creeks, rivers, lakes, and eventually the ocean. While wastewater from toilets, sinks, and showers gets treated, water that flows into the storm drain goes untreated into our waterways.

What Common Pollutants are Found in Runoff?

Here are some common pollutants and actions you can take to prevent them from flowing into Riverside County's storm drains and waterways.



Pollutants and Prevention

Pet Waste

Pet waste has harmful bacteria that can contaminate Riverside County's bodies of water and neighboring ecosystems. This can lead to residents getting sick, algal blooms, and plants and animals dying. Always pick up after your pet on walks and in your yard, especially before it rains.

Trash

Litter like cigarette butts, candy and food wrappers/containers, and straws can harm our waterways and cause drainage issues. Make sure to place all trash in covered trash cans to prevent wind or rain from taking it into the storm drain system.

Automotive Chemicals

Liquids like motor oil, fuels, lubricants, and antifreeze can damage water quality and harm wildlife if they get into our creeks, rivers, and lakes. Make sure to repair leaking vehicles as soon as possible and clean spills with absorbents available at home and auto supply shops. Used engine oil can be recycled at the Murrieta, Beaumont, or Moreno Valley ABOP and PaintCare Facilities or where the oil was purchased.

Yard Clippings

If yard clippings aren't properly disposed of, they can cause erosion, flooding, and prevent stormwater drainage. Collect all clippings after doing yard work and properly dispose of them by composting or placing them in a green waste bin.

Fertilizers and Pesticides

These can enter the storm drain after it rains or when landscaped areas are over irrigated. Limit your pesticide, fertilizer, and herbicide use by using non-chemical methods whenever possible. If they are necessary, follow the manufacturer's instructions and do not apply them 48 hours before predicted rain.

Soapy Car Wash Water

Dirt and debris from your car, along with chemicals in the soap, can harm our creeks, rivers, and lakes if they flow untreated into our waterways. Wash your car over a gravel or grassy area, or take it to a commercial car wash to limit runoff pollution.

Household Chemicals

Paint and other household chemicals like solvents, degreasers, and drain cleaners are hazardous to aquatic life and human health if they get into the storm drain system. Make sure to follow the manufacturer's instructions, clean spills with absorbents, and dispose of unused paints and household chemicals at the Murrieta, Beaumont, or Moreno Valley ABOP and PaintCare Facilities (rcwaste.org/hhw).



For more information about keeping our waterways clean, visit: rcwatershed.org/about/stormwater-pollution-prevention.

Who We Are

Riverside County Watershed Protection is a partnership program between Riverside County, the Flood Control & Water Conservation District, Coachella Valley Water District, and 27 cities that manage watershed programs which protect, preserve, and enhance the quality of the water and the natural environment of our watersheds.

What We Do

The partnership uses a combination of public education, best management practices, evaluation, and water quality monitoring to eliminate stormwater pollution in our waterways and comply with all federal, state, and local regulations. Our aim is to empower residents with information about pollution prevention and implement tactics that keep our watersheds healthy.

Contact Us:

To report pollution:

 Call (800) 506-2555

 Visit rcwatershed.org/get-involved/report-pollution

 For emergencies, dial 911



RIVERSIDE COUNTY
WATERSHED PROTECTION

TRAINING / EDUCATIONAL LOG

Date of Training/Educational Activity: _____

Name of Person Performing Activity
(Printed): _____

Signature: _____

Topic of Training/Educational Activity: _____

Name of Participant	Signature of Participant

For newsletter or mailer educational activities, please include the following information:

- **Date of mailing**
- **Number distributed**
- **Method of distribution**
- **Topics addressed**

If a newsletter article was distributed, please include a copy of it.

Employee Training Self-Certification

Project Name: _____

Date: _____

Stormwater Quality Management Topic: (provide brief description of training)

Course Length (hours): _____

Certification:

Attendee Name: _____

Signature: _____

Date: _____