

- GENERAL CODES:**
- SMOKE DETECTORS SHALL BE INSTALLED IN EVERY SLEEPING ROOM AND AT POINTS CENTRALLY LOCATED IN THE CORRIDOR OR AREA GIVING ACCESS TO EACH SEPARATE SLEEPING AREA. IN NEW CONSTRUCTION, ALL SMOKE DETECTORS SHALL BE HARD WIRED WITH BATTERY BACK-UP.
 - TEMPERED SAFETY GLASS IS REQUIRED AT ALL SLIDING GLASS DOORS, SIDELIGHTS ADJACENT TO DOORS, AND GLAZING LOCATED LESS THAN 18" FROM THE FLOOR, SHOWERS AND TUB ENCLOSURES, OR ANY HAZARDOUS LOCATIONS FOR GLAZING WHICH COULD BE SUBJECT TO HUMAN IMPACT.
 - ALL DOORS AND WINDOWS TO OUTSIDE OR UNCONDITIONED AREAS SHALL BE WEATHER STRIPPED. ALL MANUFACTURERS OF PRODUCTS SHALL BE APPROVED BY A.N.S.I
 - PROVIDE APPROVED FLASHING AT ALL OPENINGS AT THE EXTERIOR WALLS, SUCH AS DOOR, WINDOWS, SKYLIGHTS, VENTS, PIPES, DUCTS, UNLESS OTHERWISE NOTED.
 - ALL LATH AND PLASTER SHALL CONFORM TO U.B.C. CHAPTER 25. EXTERIOR PLASTER SHALL BE APPLIED WITH 3 COATS, 7/8" THICK MINIMUM APPLIED OVER 2 LAYERS OF #15 GRADE "D" FELT, WITH GALVANIZED METAL SCREEDS AND WEEP SCREEDS.
 - ALL WATER CLOSETS AND BIDETS SHALL BE PROVIDED WITH A MINIMUM OF 30" CLEAR FLOOR SPACE OR 15" MINIMUM FROM CENTERLINE OF THE FIXTURE TO ANY WALL OR VERTICAL SURFACE ON EITHER SIDE OF THE FIXTURE.
 - ALL HALLWAYS WILL PROVIDES MINIMUM CLEAR WIDTH OF 36".
 - AN APPROVED AUTOMATIC FIRE SPRINKLER SYSTEM MEETING THE REQUIREMENTS OF NFPA-13D MUST BE SUBMITTED. THE ENTIRE STRUCTURE SHALL HAVE FIRE SPRINKLERS, THEY MUST BE DRAWN BY A CONTRACTOR HAVING A C-16 LICENSE. THE SUBCONTRACTOR SHALL PRODUCE DRAWINGS FOR APPROVAL BY THE CITY, COUNTY OR FIRE DEPARTMENT.

SITE ANALYSIS. PROPERTY OWNERS:
Rodrigo and Elizabeth Lacasia
4 El Sereno Dr.
San Carlos CA, 94070

ZONING REQUIREMENTS AND BUILDING DATA
The proposed project conforms to the San Mateo County Planning Division standards for One/Two Family Residential Development in the Midcoast Section 6565.20.

ZONING: R-1, S-17 One family Residential Mid-Coast District
APN: 047-105-020, 779 San Carlos Avenue, El Granada CA 94019
Site frontage 50.33 ft.
Site rear 50.00 ft.
Site left 138.52 ft.
Site right 144.28 ft.
Lot size 7070 sq.ft.
Lot slope greater than 1 foot fall per 7 feet run.

SETBACKS S-17 STANDARDS PROPOSED
Facade Articulation Compliance
*For structures 16 feet in height or less: 5 feet each side. For structures over 16 feet in height: combined total of 15 feet with a minimum of 5 feet on any side

REQUIRED	PROPOSED
Right set back	5 ft. 10 ft.
Left set back	5min.* 5 ft.
Front set back	20 ft. 13'-0" for entry with variance. Garage is permitted per SMC Section 6411.
Area of requested variance outline =	65 sqft.
Rear set back	20 ft. 70'-9"

SECTION 6411. Detached accessory buildings shall conform to the following additional regulations as to their location upon the parcel. (a) Where the slope of the front half of the lot is greater than one (1) foot rise or fall in a distance of seven (7) feet from the established street elevation at the property line, or where the elevation of the lot at the street line is five (5) feet or more above or below the established street elevation, a garage or carport, attached or detached, may be built to the front lot line. Such garage shall hold the side yard setbacks required for the main building and a maximum height specified for such carports and garages by the district, or when not specified by the district, a maximum height of 28 feet.

EASEMENTS OF RECORD: None.
ENCROACHMENTS: Cantilevered 1st floor deck encroaches seven feet into riparian buffer zone and is permitted to accommodate the minimum sized patio furniture seating for four people per industry design standards.

LANDSCAPING: Limited to less than 534 sqft due to buffer zone.

PARKING SPACES: 2 covered, 1 uncovered

BUILDING HEIGHT:
Allowable: 36ft. vertically above natural grade Per Chapter 20, Sec 6300.2 (6) for lot slopes over 1:7. Lot slope is greater than 1:7.
Proposed: 29'-5" max building height above natural grade at ridge

GRADING: Combined Approx. Cut And Fill: 100 cy total grading, Net Cut is 60 cy, and Fill is 40 cy. Ref. SigmaPrime sheet C-1.

CRAWL SPACES: If the crawlspace does not have a "floor" it's not included in FAR.

PAGE	LABEL	TITLE
1	G010	COVER SHEET & PROJECT INFORMATION
2	G010.1	COLOR BOARD
3	G10.2	MASSING MODELS
4	G020	TOPO, BOUNDARY AND BIOLOGICAL SURVEY
5	G020.1	OVERALL SITE BOUNDARY & TOPO MAP
6	G021	SEWER MAIN LOCATION/ANALYSIS
7	A100	SITE PLAN
8	A101	ADU FLOOR PLAN
9	A102	FIRST FLOOR PLAN
10	A103	SECOND FLOOR PLAN
11	A104	ROOF PLANS
12	A105	WINDOW SCHEDULES
13	A201	N / S ELEVATIONS
14	A202	W/E ELEVATIONS
15	A301	CROSS SECTIONS
16	L-100	LANDSCAPE PLAN

ALL CONSTRUCTION SHALL CONFORM TO:
2022 CA RESIDENTIAL CODE
2022 CA BUILDING CODE
2022 CA PLUMBING CODE
2022 CA MECHANICAL CODE
2022 CA ELECTRICAL CODE
2022 CA FIRE CODE
2022 CA ENERGY CODE
2022 CA GREEN BUILDING CODE STANDARDS

- MISC. NOTES & CONSTRUCTION OPERATIONS.**
- THE CONSTRUCTION AREA SHALL BE IDENTIFIED AND DELINEATED BY FENCING OR FLAGGING TO LIMIT CONSTRUCTION ACTIVITY TO THE CONSTRUCTION AREA AND PROTECTION TO THE RIPARIAN BUFFER ZONE.
 - SPECIAL INSPECTION REQUIRED FOR CONCRETE FOUNDATIONS GREATER THAN 2,500 P.S.I, EPOXY HOLDOWNS, HIGH STRENGTH BOLTS, SEISMIC RESISTANCE AND STRUCTURAL STEEL WELDING AND FOR SHEAR WALL NAILING SPACED 4" OR LESS. COMPLETE AND SUBMIT A STAMPED AND SIGNED SPECIAL INSPECTION FORM PRIOR TO PERMIT ISSUANCE.
 - THE APPLICANT/CONTRACTOR SHALL ADHERE TO ALL REQUIREMENTS OF THE BLDG. INSPECTION SECTION, THE DEPT OF PUBLIC WORKS AND THE COASTSIDE FIRE PROTECTION DISTRICT.
 - INCLUDE HOUSE ADDRESS: NUMERALS SHALL BE A MIN. 4" IN HEIGHT AND 3/4" STROKE OF CONTRASTING COLOR TO THEIR BACKGROUND AND MUST BE LIGHTED DURING THE HOURS OF DARKNESS.
 - GENERAL CONTRACTOR (G.C.) TO VERIFY UTILITIES ARE MAINTAINED IN SAFE CONDITION AT ALL TIME, OR REMOVE FROM SITE. G.C. TO VERIFY ALL HAZARDOUS MATERIALS HAVE BEEN REMOVED. G.C. TO VERIFY THAT THE WATER LINE HAS A HOSE BIB WITH A VACUUM BREAKER TYPE BACKFLOW PREVENTION DEVICE IS PROVIDED FOR DUST CONTROL.
 - IF THERE IS NO CONSTRUCTION TRAILER USED FOR THIS PROJECT, THE APPLICANT/CONTRACTOR SHALL REMOVE ALL CONSTRUCTION EQUIPMENT FROM THE SITE UPON COMPLETION OF THE USE AND/OR NEED OF EACH PIECE OF EQUIPMENT WHICH SHALL INCLUDE BUT NOT BE LIMITED TO TRACTORS, BACK HOES, CEMENT MIXERS, ETC.
 - A DEBRIS BIN IS TO BE LOCATED SOMEWHERE ON THE SITE. DEBRIS IS TO BE HAULED OF-SITE AS NECESSARY. THE APPLICANT/CONTRACTOR SHALL MONITOR THE SITE TO ENSURE THAT TRASH IS PICKED UP AND APPROPRIATELY DISPOSED OF WEEKLY.
 - THE APPLICANT/CONTRACTOR SHALL ENSURE THAT NO CONSTRUCTION-RELATED VEHICLES SHALL IMPEDE THROUGH TRAFFIC ALONG THE RIGHT-OF-WAY- ON SAN CARLOS AVE. ALL CONSTRUCTION VEHICLES SHALL BE PARKED ON-SITE OUTSIDE OF THE PUBLIC RIGHT-OF-WAY, OR IN LOCATIONS WHICH DO NOT IMPEDED SAFE ACCESS ON SAN CARLOS AVE. THERE SHALL BE NO STORAGE OF CONSTRUCTION VEHICLES IN THE PUBLIC RIGHT-OF-WAY.
 - NO SITE DISTURBANCES SHALL OCCUR, INCLUDING ANY GRADING OR TREE REMOVAL, UNTIL A BUILDING PERMIT HAS BEEN ISSUED. NOISE LEVELS PRODUCED BY THE PROPOSED CONSTRUCTION ACTIVITIES SHALL NOT EXCEED THE 80 DBAS LEVEL AT ANY ONE MOMENT. CONSTRUCTION ACTIVITIES SHALL BE LIMITED TO THE HOURS FROM 7:00 AM TO 6 P.M., MONDAY THROUGH FRIDAY AND 9 A.M. TO 5 P.M. ON SATURDAYS. CONSTRUCTION OPERATIONS SHALL BE PROHIBITED ON SUNDAYS AND NATIONAL HOLIDAYS.
 - WATER SHALL BE AVAILABLE ON SITE FOR DUST CONTROL DURING ALL GRADING OPERATIONS.
 - NO PROPOSED CONSTRUCTION WORK WITHIN THE COUNTY RIGHT-OF-WAY SHALL BEGIN UNTIL THE COUNTY REQUIREMENTS FOR THE ISSUANCE OF AN ENCROACHMENT PERMIT, INCLUDING REVIEW OF THE PLANS HAVE BEEN MET AND AN ENCROACHMENT PERMIT ISSUED. THE APPLICANT / CONTRACTOR SHALL CONTACT THE DEPT. OF PUBLIC WORKS INSPECTOR 48 HOURS PRIOR TO COMMENCING WORK IN THE RIGHT OF WAY.
 - PRIOR TO THE ISSUANCE OF THE BUILDING PERMIT, THE APPLICANT MAY BE REQUIRED TO PROVIDE PAYMENT OF "ROADWAY MITIGATION FEES" BASED ON THE SQUARE FOOTAGE (ASSESSABLE SPACE) OF THE PROPOSED BUILDING PER ORDINANCE NO. 3211
 - THE APPLICANT SHALL SUBMIT A PERMANENT STORM WATER MANAGEMENT PLAN IN COMPLIANCE WITH THE COUNTY DRAINAGE POLICY, AND NATIONAL POLLUTANT DISCHARGE ELIMINATION SYSTEM (NPDES) REQUIREMENT FOR REVIEW AND APPROVAL BY THE DEPARTMENT OF PUBLIC WORKS.
 - SCHEDULE WORK SO AS NOT TO INTERFERE UNDULY WITH THE NORMAL HOUSEHOLD OPERATIONS.
 - NO SITE DISTURBANCES SHALL OCCUR, INCLUDING ANY GRADING OR TREE REMOVAL, UNTIL A BUILDING PERMIT HAS BEEN ISSUED.

- GENERAL SYMBOLS**
- ELEVATION View Reference $\begin{matrix} 1 \\ \text{A201} \end{matrix}$ Detail call out W/ leader line $\begin{matrix} 6 \\ \text{A501} \end{matrix}$ View Direction $\begin{matrix} A \\ \text{ROOM NAME} \\ B \\ C \end{matrix}$
- SECTION / VIEW Reference $\begin{matrix} A \\ \text{A301} \end{matrix}$
- Grnd = Ground
 - Hyd = Fire Hydrant
 - IMC = intermediate metal conduit
 - Appl = appliance
 - Kw = kilowatts
 - L&L = listed & labeled
 - LAVY = lavatory (bathroom sink)
 - LFMC = liquid tight flexible metal conduit ("sealtight")
 - LFNC = liquid tight flexible nonmetallic conduit
 - Loc = located, location
 - (N) = New Condition
 - O.C. = on center
 - PB = polybutylene plastic pipe
 - PE = polyethylene plastic pipe
 - Pending = likely to be adopted, check with local jurisdiction
 - PEX = cross-linked polyethylene plastic pipe
 - PL = property line
 - Prefab = prefabricated
 - PMI = per manufacturer, instructions
 - PSI = pounds per square inch
 - PVC = polyvinyl-chloride plastic, pipe or electrical conduit
 - (R) = Relocated Condition
 - Recep = receptacle outlet (electrical)
 - Rqmt = Requirements
 - RMC = rigid metal conduit
 - RNC = rigid nonmetallic conduit (PVC electrical conduit)
 - SA = small appliance (branch circuits)
 - Sch. = schedule of pipe, i.e., schedule 40 PVC
 - SDC = Seismic Design Category
 - SW = single-wall gas flue pipe
 - SZ = seismic zone
 - TOFF = Top of finished floor
 - TOP = Top of plate
 - Typ = Typical
 - UL = Underwriter's Laboratories, Inc.
 - VA = volt amps (input power vs. output power-watts)
 - W = electrical conductors rated for wet location
 - WH = water heater
 - WSFU = water supply fixture unit(s)

AREA ANALYSIS. Calculated using CAD s/w polylines

DATE COVERED	FLOOR AREA	FOURNE FOOTAGE	LOCATION
X	795		BELOW GRADE ADU UNDER 1ST FLOOR
X	88		MECH ROOM
X	120		BELOW GRADE ADU COVERED PATIO UNDER 1ST FLOOR
X	1113		1ST FLOOR OVER ADU & STORAGE (EXCL. GARAGE)
X	179		1ST FLOOR DECK (UNCOVERED)
X	57		2ND FLOOR DECK (UNCOVERED)
X	85		SETBACK AREA REQUESTED (DIFF. BETWEEN 20' VS 15')
X	381		GARAGE
X	0		ENTRY PORCH (48" COVERED, EXCLUDED)
X	0		2ND FLOOR NOT OVER 1ST FLOOR
X	707		FLOOR OVER 1ST FLOOR
X	44		ROOF DECK (UNCOVERED, OVER 1ST FLOOR)
X	1170		IMPERVIOUS AREA ALLOWED, SECTION 6300.2 (7)
X	289		IMPERVIOUS AREA PROPOSED
1675	1239		TTL AREAS PROPOSED WITHOUT ADU
1675	3204		TTL AREAS PROPOSED
2475	3747		TTL AREAS ALLOWED
-802	-1458		UNDER/OVER

ALLOWED	PROPOSED	PERCENT	DESCRIPTION
7070	7070		SITE AREA
35%	24%		SITE COVERAGE %
93%	92%		FLOOR AREA %

Max coverage allowed is 35% for structures over 16 ft. in height.
Max FAR allowed is 53%
(SLOPE SIZE OF 5,000-13,698 sqft)

DESIGNER:
ROD LACASIA-BARRIOS
4 EL SERENO DR.
SAN CARLOS, CA
650 766-2463

STRUCTURAL ENGINEER:
TBD

ENERGY CALCS:
TBD

REVISION	BY	DESC.
A	3/29/22	RLB / SMC PLNG COMMENT 1
B	11/20/22	RLB / POST 8/11/22 CDRC
C	1/15/23	RLB / POST 11/22/23 CDRC

779 SAN CARLOS AVE
EL GRANADA, CALIFORNIA
NEW RESIDENCE

COVER SHEET & PROJECT INFORMATION

SHEET TITLE

SCALE: AS SHOWN

ISSUE DATE: 12-14-2021

DRAWN BY: ROD LACASIA-BARRIOS

SHEET NO.: G010

ALL INFORMATION IS COPYRIGHTED 2021

SITE PLAN GENERAL NOTES:

1. INFORMATION FOR SPECIFICATIONS AND CONSTRUCTION DETAILS FOR COAST SIDE WATER DISTRICT WATER CONNECTIONS CAN BE OBTAINED AT <http://www.coastsidewater.org/ccwd-forms.html>.
2. INFORMATION FOR SPECIFICATIONS AND CONSTRUCTION DETAILS FOR PG&E GAS AND ELECTRICAL CONNECTIONS CAN BE OBTAINED AT https://www.pge.com/en_US/large-business/services/building-and-renovation/greenbook-manual-online/greenbook-manual-online.page.
3. AN ENCROACHMENT PERMIT FROM THE PUBLIC WORKS DEPARTMENT IS REQUIRED PRIOR TO COMMENCING ANY WORK WITHIN THE MUNICIPALITY'S RIGHT OF WAY.
4. LOCATION AND DISTANCES SHOWN FOR IN-STREET UTILITIES ARE AS MEASURED USING USA PAINTED MARKINGS ON ROADWAY TO THE SURVEYED PROPERTY LINES.
5. UNDERGROUND ELECTRICAL SERVICES SHALL BE PROVIDED IN ALL NEW CONSTRUCTION. UNDERGROUND SERVICE SHALL BE INSTALLED IAW THE MOST RECENT EDITION OF PG&E GREEN BOOK REQUIREMENTS PER MUNICIPAL CODE 14.04.070 (A).
6. COORDINATE UNDERGROUND CONSTRUCTION ACTIVITIES TO UTILIZE THE SAME JOINT TRENCH. MINIMIZE THE AMOUNT OF TIME THE DISTURBED SOIL IS EXPOSED. THE SOIL IS TO BE REPLACED USING ACCEPTED COMPACTION METHODS. STOCKPILE AND PROTECT DISPLACED TOPSOIL FOR REUSE.
7. SEWER CLEAN OUTS SHALL BE INSTALLED PER COUNTY REGULATIONS AND STANDARDS. CLEANOUTS IN BLDG SEWERS SHALL BE APPROVED IN ACCORDANCE WITH THE RULES, REGULATIONS AND ORDINANCES OF THE SEWER AUTHORITY. ALL CLEANOUTS SHALL BE MAINTAINED WATER TIGHT.
8. SANITARY FACILITIES SHALL BE LOCATED ON THE NORTH WEST END OF THE PROPERTY.
9. CLEAN-UP AREA SHALL BE LOCATED ON THE NORTH EAST END OF THE PROPERTY.
10. CONSTRUCTION MATERIALS AND STORAGE SHALL BE LOCATED ON THE NORTH SIDE OF THE PROPERTY.
11. SURFACE RUNOFF FROM ALL IMPERVIOUS SURFACES SHALL BE DIRECTED TO THE WATER DETENTION AREAS. SEE CIVIL PLANS.
12. IT IS THE INTENT OF THESE DRAWINGS TO PROVIDE POSITIVE DRAINAGE IN ALL PAVED AND LANDSCAPE AREAS SEE "GRADING, DRAINAGE EROSION CONTROL PLAN" ON CIVIL SHEETS. SEE SEPARATE DRAINAGE PLAN BY CIVIL ENGINEER FOR OFFICIAL DESIGN OF EROSION CONTROL AND DRAINAGE PLAN.
13. RAINWATER LEADERS (DOWNSPOUTS) TO TIE INTO UNDERGROUND DRAIN; SEE DRAINAGE PLAN BY CIVIL ENGINEER ON CIVIL SHEETS.
14. MAINTAIN 6" MINIMUM CLEARANCE FROM SOIL TO BOTTOM OF SIDING. 8" FROM SILL.
15. DRAIN WATER AWAY FROM THE BUILDING. MAKE CERTAIN THAT ALL WATER DRAINS AND THERE IS NO PONDING PRIOR TO THE ISSUANCE OF THE BLDG. PERMIT, THE APPLICANT/ CONTRACTOR SHALL SUBMIT A DRIVEWAY "PLAN AND PROFILE" TO THE DEPT. OF PUBLIC WORKS, SHOWING THE DRIVEWAY ACCESS TO THE PARCEL (GARAGE SLAB) COMPLYING WITH THE COUNTY STANDARDS FOR DRIVEWAY SLOPES (NOT TO EXCEED 20%) AND TO COUNTY STANDARDS (AT THE PROPERTY LINE) BEING THE SAME ELEVATION AS THE CENTER OF THE ACCESS ROADWAY.
16. WHEN APPROPRIATE, AS DETERMINED BY THE DEPT. OF PUBLIC WORKS, THIS "PLAN AND PROFILE" SHALL BE PREPARED FROM ELEVATIONS AND ALIGNMENT SHOW ON THE ROADWAY IMPROVEMENT PLANS, THE DRIVEWAY PLAN SHALL ALSO INCLUDE AND SHOW SPECIFIC PROVISIONS AND DETAILS FOR BOTH THE EXISTING AND THE PROPOSED DRAINAGE PATTERNS AND DRAINAGE FACILITIES.
17. APPROXIMATE CUT & FILL BASED ON AVERAGE SECTION AREA TIMES WIDTH FOR AFFECTED SECTION OF BUILDING. REFERENCE ELEVATIONS AND SECTIONS SHEETS.

CUT & FILL CALCS			
SECTION	AREA (SQFT)	WIDTH (FT)	VOLUME CUYDS
CUT			
LEFT STAIRS	110.0	5.0	-20
UNDER ADU	46.0	35.0	-60
FILL			
LEFT PATHWAY	26	5	5
UNDER ADU	58.0	17.0	37
COMBINED			121
NET			-18

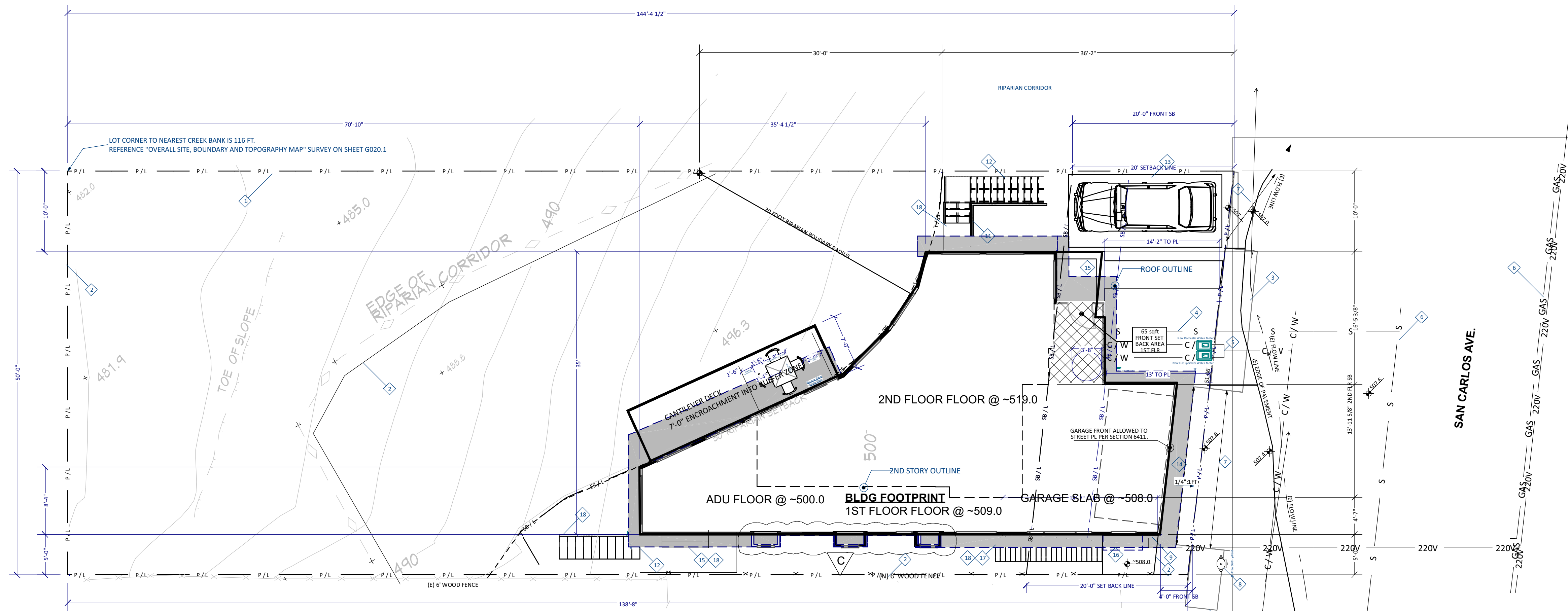

BENCH MARK
518.25
± 1.5 HT SA
ON TOP OF BANK OF VACANT LOT

SURVEY DATUM

DESIGNER:
ROD LACASIA-BARRIOS
4 EL SERENO DR.
SAN CARLOS, CA
650 766-2463

STRUCTURAL ENGINEER:
TBD

ENERGY CALCS:
TBD

REVISION	DATE	BY	DESC.
A	3/29/22	RLB	SMC COMMENTS #1
B	11/20/22	RLB	POST 8/11/22 CDCR
C	1/15/23	RLB	POST 1/12/23 CDCR

779 SAN CARLOS AVE
EL GRANADA, CALIFORNIA
NEW RESIDENCE

1 SITE PLAN Ground Level
scale 1/8" = 1'-0"

COASTSIDE FIRE PROTECTION DISTRICT NOTES:

1. ADDRESS NUMBERS: PER THE CFPDC 2016-01, BUILDING IDENTIFICATION SHALL BE CONSPICUOUSLY POSTED AND VISIBLE FROM THE STREET. TEMPORARY ADDRESS NUMBERS SHALL BE POSTED PRIOR TO COMBUSTIBLES BEING PLACED ON-SITE. THE LETTERS/NUMERALS FOR PERMANENT ADDRESS SIGNS SHALL BE 4 INCHES IN HEIGHT WITH A MINIMUM 3/4-INCH STROKE. SUCH LETTERS/NUMERALS SHALL BE INTERNALLY ILLUMINATED AND FACING THE DIRECTION OF ACCESS. FINISHED HEIGHT OF BOTTOM OF ADDRESS LIGHT UNIT SHALL BE GREATER THAN OR EQUAL TO 6 FEET FROM FINISHED GRADE. WHEN THE BUILDING IS SERVED BY A LONG DRIVEWAY OR IS OTHERWISE OBSCURED, A 6-INCH BY 18-INCH GREEN REFLECTIVE METAL SIGN WITH 3-INCH REFLECTIVE NUMBERS/LETTERS SIMILAR TO HY-KO 911 OR EQUIVALENT SHALL BE PLACED AT THE ENTRANCE FROM THE NEAREST PUBLIC ROADWAY. SEE CFPDC FOR STANDARD SIGN.
2. ROOF COVERING: PER THE CFPDC 2016-01, THE ROOF COVERING OF EVERY NEW BUILDING OR STRUCTURE, AND MATERIALS APPLIED AS PART OF A ROOF COVERING ASSEMBLY, SHALL HAVE A MINIMUM FIRE RATING OF CLASS "B" OR HIGHER AS DEFINED IN THE CURRENT EDITION OF THE CALIFORNIA BUILDING CODE.
3. VEGETATION MANAGEMENT: PER THE CFPDC 2016-01, THE 2016 CALIFORNIA FIRE CODE (CFC), AND THE PUBLIC RESOURCES CODE (PRC) 4291:
 - A. A FUEL BREAK OF DEFENSIBLE SPACE IS REQUIRED AROUND THE PERIMETER OF ALL STRUCTURES TO A DISTANCE OF NOT LESS THAN 30 FEET AND MAY BE REQUIRED TO A DISTANCE OF 100 FEET OR TO THE PROPERTY LINE. IN THE STATE RESPONSIBLE AREA (SRA), THE FUEL BREAK IS 100 FEET OR TO THE PROPERTY LINE.
 - B. TREES LOCATED WITHIN THE DEFENSIBLE SPACE SHALL BE PRUNED TO REMOVE DEAD AND DYING PORTIONS, AND LIMBED UP 6 TO 10 FEET ABOVE THE GROUND. NEW TREES PLANTED IN THE DEFENSIBLE SPACE SHALL BE LOCATED NO CLOSER THAN 10 FEET TO ADJACENT TREES WHEN FULLY GROWN OR AT MATURITY.
 - C. REMOVE THAT PORTION OF ANY EXISTING TREE, WHICH EXTENDS WITHIN 10 FEET OF THE OUTLET OF A CHIMNEY OR STOVEPIPE OR IS WITHIN 5 FEET OF ANY STRUCTURE.
4. FIRE HYDRANT: PER THE 2016 CFC, APPENDICES B AND C, A FIRE DISTRICT APPROVED FIRE HYDRANT (CLAW 960) MUST BE LOCATED WITHIN 500 FEET OF THE PROPOSED SINGLE FAMILY DWELLING UNIT MEASURED BY WAY OF DRIVABLE ACCESS. PER THE 2016 CFC, APPENDIX B, THE HYDRANT MUST PRODUCE A MINIMUM FIRE FLOW OF 1,000 GALLONS PER MINUTE AT 20 POUNDS PER SQUARE INCH RESIDUAL PRESSURE FOR 2 HOURS. CONTACT THE LOCAL WATER PURVEYOR FOR WATER FLOW DETAILS. THE APPLICANT SHALL PROVIDE DOCUMENTATION INCLUDING HYDRANT LOCATION, MAIN SIZE, AND FIRE FLOW REPORT AT THE BUILDING PERMIT APPLICATION STAGE. INSPECTION REQUIRED PRIOR TO FIRE'S FINAL APPROVAL OF THE BUILDING PERMIT OR BEFORE COMBUSTIBLES ARE BROUGHT ON-SITE.
5. AUTOMATIC FIRE SPRINKLER SYSTEM: AS PER SAN MATEO COUNTY BUILDING STANDARDS AND CFPD ORDINANCE 2016-01, THE APPLICANT IS REQUIRED TO INSTALL AN APPROVED AUTOMATIC FIRE SPRINKLER SYSTEM MEETING THE REQUIREMENTS OF NFPA-13D THROUGHOUT THE PROPOSED OR IMPROVED DWELLING AND GARAGE. ALL ATTIC ACCESS LOCATIONS WILL BE PROVIDED WITH A PILOT HEAD ON A METAL UPRIGHT. ALL AREAS THAT ARE ACCESSIBLE FOR STORAGE PURPOSES SHALL BE EQUIPPED WITH FIRE SPRINKLERS INCLUDING CLOSETS AND BATHROOMS. THE ONLY EXCEPTION IS SMALL LINEN CLOSETS LESS THAN 24 SQUARE FEET WITH FULL DEPTH SHELVING. THE PLANS FOR THIS SYSTEM MUST BE SUBMITTED TO THE SAN MATEO COUNTY PLANNING AND BUILDING DEPARTMENT. A BUILDING PERMIT WILL NOT BE ISSUED UNTIL PLANS ARE RECEIVED, REVIEWED, AND APPROVED. UPON SUBMISSION OF THE PLANS, THE COUNTY WILL FORWARD A COMPLETE SET TO THE COASTSIDE FIRE PROTECTION DISTRICT FOR REVIEW. FEES SHALL BE PAID PRIOR TO PLAN REVIEW.
7. EXTERIOR BELL AND INTERIOR HORN/STROBE: ARE REQUIRED TO BE WIRED INTO THE REQUIRED FLOW SWITCH ON YOUR FIRE SPRINKLER SYSTEM. THE BELL, HORN/STROBE AND FLOW SWITCH, ALONG WITH THE GARAGE DOOR OPENER, ARE TO BE WIRED INTO A SEPARATE CIRCUIT BREAKER AT THE MAIN ELECTRICAL PANEL AND LABELED.
8. ADD NOTE TO THE TITLE PAGE THAT THE BUILDING WILL BE PROTECTED BY AN AUTOMATIC FIRE SPRINKLER SYSTEM.
9. ALL FIRE CONDITIONS AND REQUIREMENTS MUST BE INCORPORATED INTO YOUR BUILDING PLANS PRIOR TO BUILDING PERMIT ISSUANCE.

COASTSIDE COUNTY WATER DISTRICT

1. THE PROJECT WILL BE REQUIRED TO COMPLY WITH COASTSIDE COUNTY WATER DISTRICT'S (DISTRICT) INDOOR WATER USE EFFICIENCY ORDINANCE WHICH INCLUDES REGULATIONS ON WATER METERING AND WATER USE EFFICIENCY SPECIFICATIONS FOR PLUMBING FIXTURES AND APPLIANCES. THE DISTRICT WILL PERFORM INSPECTIONS TO VERIFY COMPLIANCE WITH ALL DISTRICT REGULATIONS DURING AND AFTER CONSTRUCTION.
2. NO PASSIVE PURGE SYSTEMS ARE TO BE INSTALLED ON FIRE PROTECTION SERVICES. FIRE PROTECTION SERVICES ARE AUTHORIZED FOR THE SOLE PURPOSE OF FIRE PROTECTION. THERE SHALL BE NO CROSS CONNECTIONS, AND APPROVED BACKFLOW PROTECTION IS REQUIRED.
3. BEFORE ISSUANCE OF A BUILDING PERMIT, THE DISTRICT WILL NEED TO EVALUATE A COMPLETE SET OF BUILDING PLANS TO DETERMINE IF THE WATER SERVICE CAPABILITY AVAILABILITY IS ADEQUATE FOR THIS DEVELOPMENT AND COMPLIES WITH ALL DISTRICT REGULATIONS.

SITE PLAN KEY NOTES

1. INSTALL NEW 6 FOOT TALL DEAR FENCING WITH 6"x6" STEEL WIRE MESH BETWEEN PT POSTS, AT 8-10 FOOT CENTERS, ALONG THE RIGHT PROPERTY LINE AND RIPARIAN BOUNDARY.
2. INSTALL A NEW REDWOOD GOOD-NEIGHBOR FENCE WITH A MAXIMUM 6-FT. HEIGHT AT THE REAR AND LEFT PROPERTY LINES W/GATE.
3. (N) SIDEWALK PER SMC DESIGN STANDARDS.
4. (N) SEWER LATERAL W/ C.O. PER SMC ENG. DETAILS WITHIN 5FT OF PL.
5. TWO NEW DEDICATED WATER METERS WILL BE REQUIRED. ONE FOR DOMESTIC CONSUMPTION, AND ONE FOR DEDICATED FIRE SPRINKLER SYSTEM OPERATION. PLANS AT THE TIME OF BUILDING PERMIT SUBMITTAL MUST SHOW FIRE SERVICE AND METER, AND DOMESTIC SERVICE AND METER PER COASTSIDE WATER DISTRICT STANDARDS CC-06 AND CC-18 AS APPLICABLE.
6. (E) WATER, SEWER, ELECT. IN STREET PER U.S.A. MARKINGS.
7. (N) COUNTY STANDARD ASPHALT DRIVEWAY APPROACH W/ DRAINAGE SWALE WITH A MIN. OF 2" ASPHALT CONCRETE OVER 6" CLASS 2 AGGREGATE BASE W/ A SLIGHT SWALE FOR BOTH DRIVEWAYS.
8. (E) CLAW 960 HYDRANT.
9. (N) 240 VAC POWER TO METER PANEL.
10. RESERVED
11. RETAINING WALL WITH 42" RAILING ABOVE GRADE WITH VERTICAL BALUSTERS NOT MORE THAN 4" APART.
12. REDWOOD STAIRS/RAILINGS WITH VERTICAL BALUSTERS NOT MORE THAN 4" APART. 36" MIN CLR WIDE STAIRS WITH HANDRAILS.
13. CHAPTER 3.3, SEC. 6119: 9'X19' ADU PARKING SPACE @ ~507.0
14. (N) CONC. DRIVE WITH 1/2" PER FOOT SLOPE AWAY.
15. CONC. STEPS AT ENTRANCE WITH EQUAL RISE TO GRADE.
16. CONC. SLAB GARAGE CAN STORAGE AREA WITH SLAB APPROXIMATELY @ ~508.0 EVEN WITH GARAGE SLAB.
17. RAIL ROAD TIE STEPS.
18. FOR EXISTING CONTOURS, NEW GRADES, AND GRADING - REF. CIVIL PLANS.

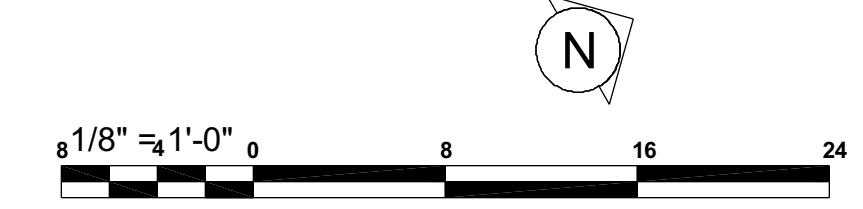

ALL INFORMATION IS COPYRIGHTED 2021

SHEET TITLE

SITE PLAN

SCALE: AS SHOWN

ISSUE DATE: 12-14-2021

DRAWN BY: ROD LACASIA-BARRIOS

SHEET NO.: **A100**

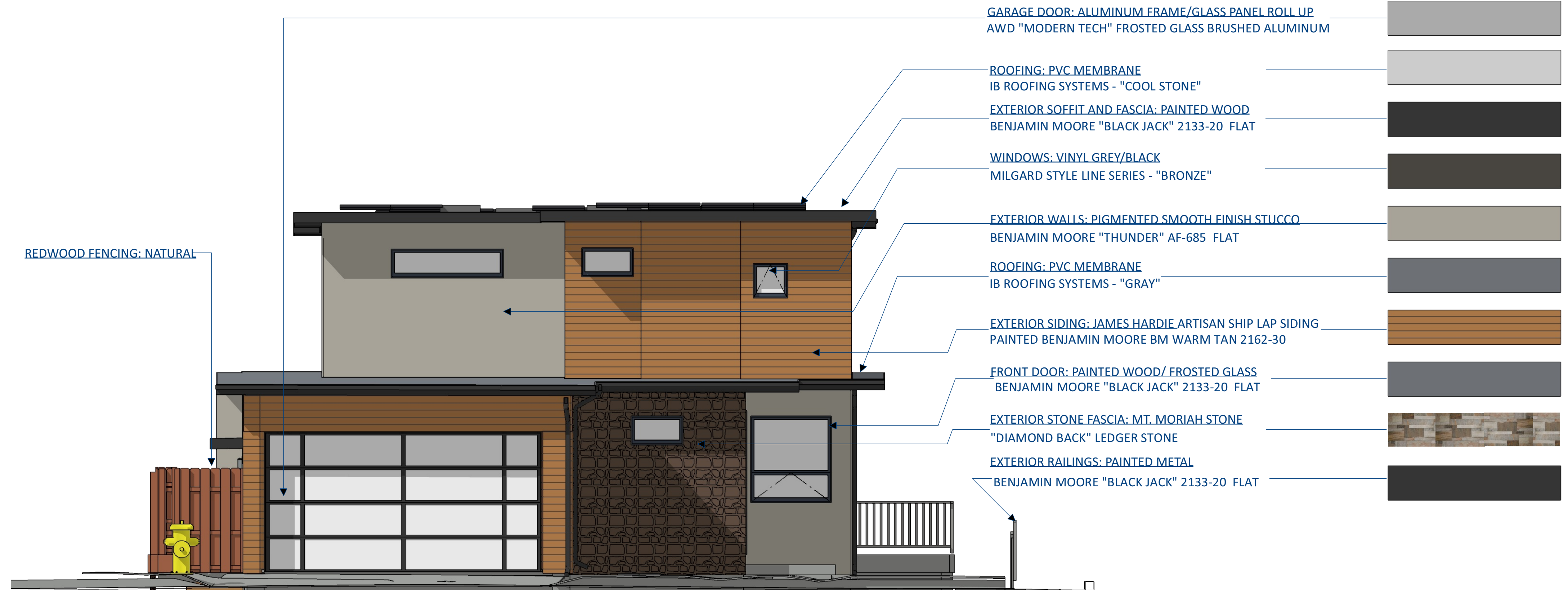

- GARAGE DOOR: ALUMINUM FRAME/GLASS PANEL ROLL UP
AWD "MODERN TECH" FROSTED GLASS BRUSHED ALUMINUM
- ROOFING: PVC MEMBRANE
IB ROOFING SYSTEMS - "COOL STONE"
- EXTERIOR SOFFIT AND FASCIA: PAINTED WOOD
BENJAMIN MOORE "BLACK JACK" 2133-20 FLAT
- WINDOWS: VINYL GREY/BLACK
MILGARD STYLE LINE SERIES - "BRONZE"
- EXTERIOR WALLS: PIGMENTED SMOOTH FINISH STUCCO
BENJAMIN MOORE "THUNDER" AF-685 FLAT
- ROOFING: PVC MEMBRANE
IB ROOFING SYSTEMS - "GRAY"
- EXTERIOR SIDING: JAMES HARDIE ARTISAN SHIP LAP SIDING
PAINTED BENJAMIN MOORE BM WARM TAN 2162-30
- FRONT DOOR: PAINTED WOOD/ FROSTED GLASS
BENJAMIN MOORE "BLACK JACK" 2133-20 FLAT
- EXTERIOR STONE FASCIA: MT. MORIAH STONE
"DIAMOND BACK" LEDGER STONE
- EXTERIOR RAILINGS: PAINTED METAL
BENJAMIN MOORE "BLACK JACK" 2133-20 FLAT

REDWOOD FENCING: NATURAL

SAMPLE PRIMARY BUILDING ELEVATION - MATERIALS BOARD - 779 SAN CARLOS AVE, EL GRANADA
RE-CONSTRUCTION, 4 EL SERENO DR. SAN CARLOS, 650-766-2463

DESIGNER:
ROD LACASIA-BARRIOS
4 EL SERENO DR.
SAN CARLOS, CA
650 766-2463

STRUCTURAL ENGINEER:
TBD

ENERGY CALCS:
TBD

REVISION	DATE	BY	DESC.
A	11/20/22	RLB	POST 8/11/22 CDRC
B	1/15/23	RLB	POST 11/22/23 CDRC

779 SAN CARLOS AVE
EL GRANADA, CALIFORNIA
NEW RESIDENCE



ALL INFORMATION IS
COPYRIGHTED 2021

COLOR BOARD

SHEET TITLE

SCALE: AS SHOWN

ISSUE DATE: 12-14-2021

DRAWN BY: ROD LACASIA-BARRIOS

SHEET NO. G010.1

EXTERIOR ELEVATIONS FINISH SCHEDULE

- 1 50 mil IB SYSTEMS PVC Single Ply Class "A" Roof System, GREY LOWER WHITE UPPER,. REF ROOF PLAN.
- 2 7/8" STUCCO OVER LATH WITH DOUBLED "D" PAPER OVER 1/2" SHEATHING.
- 3 TEMPERED GLASS 8FT X16FT GARAGE DOOR.
- 4 SOLAR PANEL ARRAY FOR APPROXIMATE NET ZERO.
- 5 SQUARE EDGE, 1"X6" JAMESHARDIE SIDING OVER TYVEK AND 1/2" SHEATHING.
- 6 MILGARD DARK VINYL WINDOWS, CLEAR VIEW SERIES, TYP.
- 7 SOFFITED EAVES WITH LINEAR VENTS, TYP.
- 8 UNDER SOFFIT RECESSED "DARK SKY" LED LIGHTING, TYP AT ALL EXTERIOR.
- 9 5 1/4" GALV. GUTTER AND DOWNSPOUTS CONNECTED TO ON SITE DRY WELL FOR DRAINAGE CONTROL.
- 10 36" REDWOOD STAIRS/RAILINGS WITH VERTICAL BALUSTERS NOT MORE THAN 4" APART, 36" MIN CLR WIDTH.
- 11 42" TALL GUARD RAIL WITH STAINLESS STEEL CABLING AND POSTS, WITH MAX. 4" CABLE SEPARATION.
- 12 42" REDWOOD RAILINGS WITH VERTICAL BALUSTERS NOT MORE THAN 4" APART.
- 13 SHADING USED TO ISOLATE AND INDICATE ADU STRUCTURE.
- 14 RAIL ROAD TIE STEPS, 36" MIN CLR WIDTH.
- 15 MT. MORIAH 1" NOMINAL STONE VENEER - DIAMOND BACK PATTERN INSTALLED P.M.I.
- 16 60 mil IB SYSTEMS PVC Single Ply Class "A" DECK System. REF ROOF PLAN.
- 17 SKYLIGHT WITH 6" CURB.
- 18 (N) ELECTRIC METER
- 19 TBD
- 20 CONC STEPS WITH EQ. RISE
- 21 2X12 FASCIA BOARD
- 22 TEMPERED GLASS
- 23 CLAW 960 FH
- 24 TBD
- 25 (N) REDWOOD FENCING TO MATCH (E)

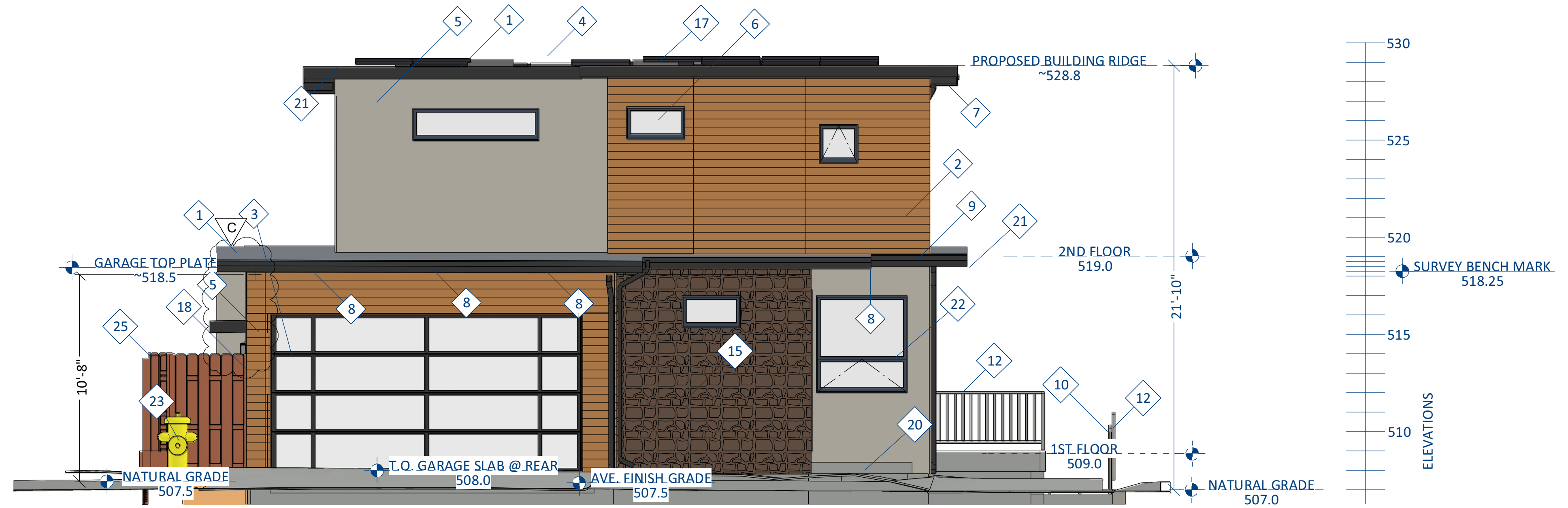

2 FRONT ELEVATION (NE)
scale 1/4" = 1'-0"

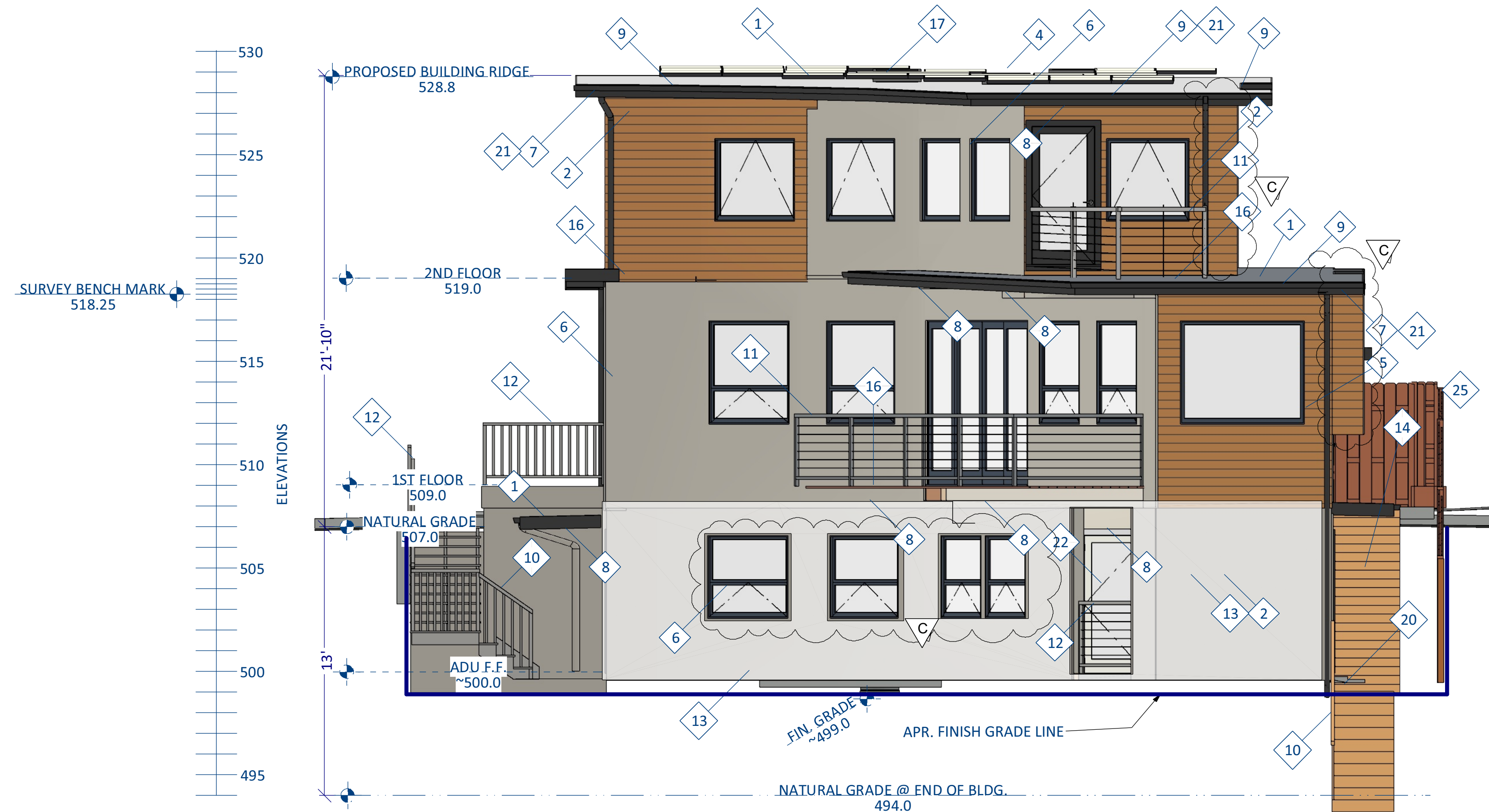

1 REAR ELEVATION (SW)
scale 1/4" = 1'-0"

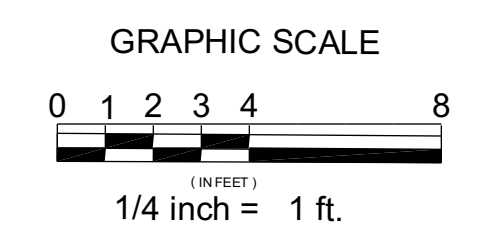

DESIGNER:
ROD LACASIA-BARRIOS
4 EL SERENO DR.
SAN CARLOS, CA
650 766-2463

STRUCTURAL ENGINEER:
TBD

ENERGY CALCS:
TBD

REVISION	BY	DESC.
A	3/29/22	RLB / SMC PLNG COMMENT 1
B	1/12/22	RLB / POST 8/11/22 RDRG
C	1/15/23	RLB / POST 1/12/23 CDRC

**779 SAN CARLOS AVE
EL GRANADA, CALIFORNIA
NEW RESIDENCE**

N / S ELEVATIONS

SHEET TITLE

SCALE: 1/4"=1'-0"

ISSUE DATE: 12-14-2021

DRAWN BY: ROD LACASIA-BARRIOS

SHEET NO.:

A201

ALL INFORMATION IS
COPYRIGHTED 2021

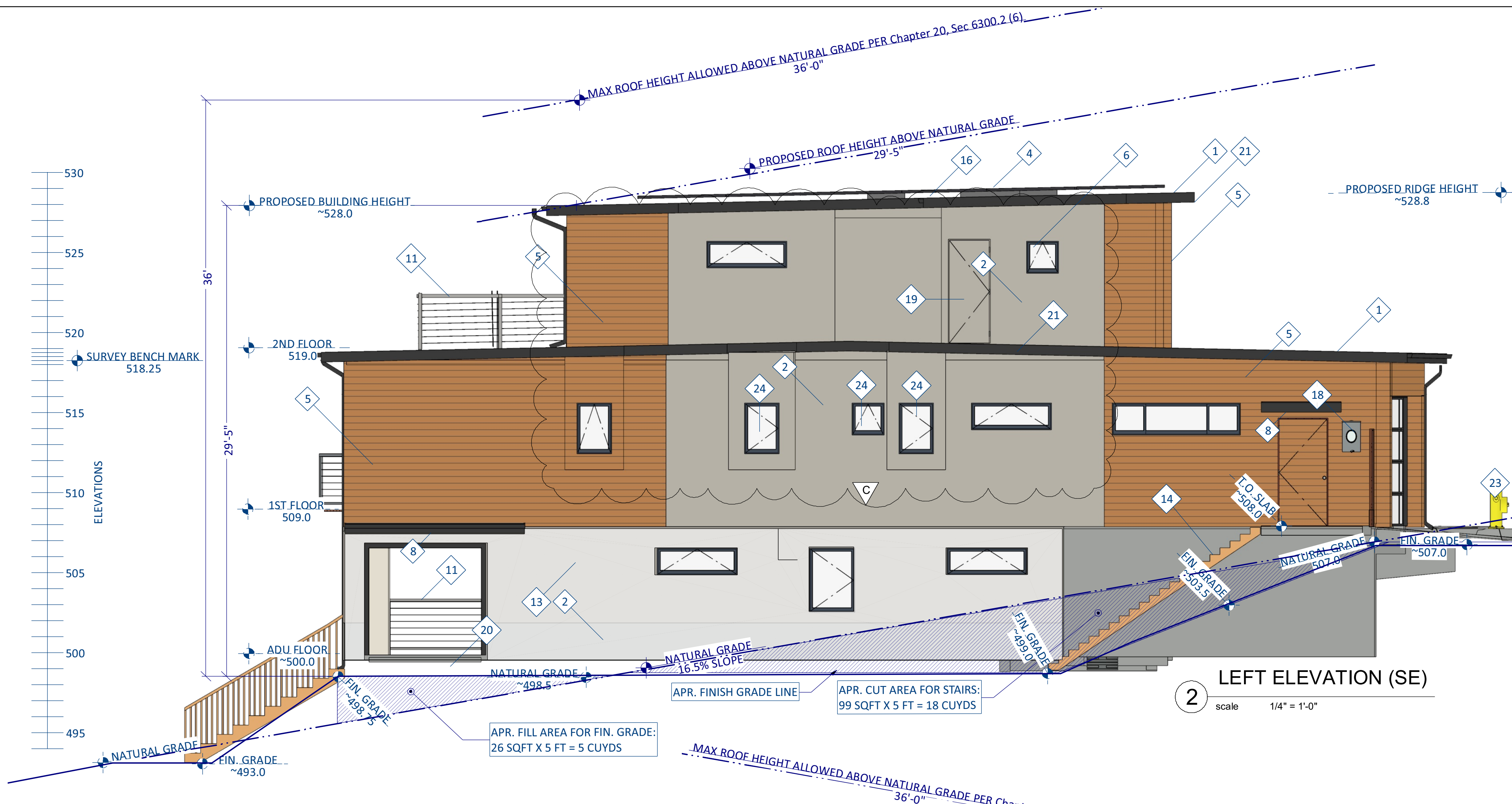

2 LEFT ELEVATION (SE)
scale 1/4" = 1'-0"

EXTERIOR ELEVATIONS FINISH SCHEDULE

- 1 50 MIL IB SYSTEMS PVC SINGLE PLY CLASS "A" ROOF SYSTEM, GREY LOWER WHITE UPPER., REF ROOF PLAN.
- 2 7/8" STUCCO OVER LATH WITH DOUBLED "D" PAPER OVER 1/2" SHEATHING.
- 3 TEMPERED GLASS 8FT X16FT GARAGE DOOR.
- 4 SOLAR PANEL ARRAY FOR APPROXIMATE NET ZERO SIZING.
- 5 SQUARE EDGE, 1"X6" JAMESHARDIE SIDING OVER TYVEK AND 1/2" SHEATHING.
- 6 MILGARD DARK VINYL WINDOWS, CLEAR VIEW SERIES, TYP.
- 7 SOFFITED EAVES WITH LINEAR VENTS, TYP.
- 8 UNDER SOFFIT RECESSED "DARK SKY" LED LIGHTING, TYP AT ALL EXTERIOR.
- 9 5 1/4" GALV. GUTTER AND DOWNSPOUTS CONNECTED TO ON SITE DRY WELL FOR DRAINAGE CONTROL.
- 10 36" REDWOOD STAIRS/RAILINGS WITH VERTICAL BALUSTERS NOT MORE THAN 4" APART, 36" MIN CLR WIDTH.
- 11 42" TALL GUARD RAIL WITH STAINLESS STEEL CABLING AND POSTS, WITH MAX. 4" CABLE SEPARATION.
- 12 42" REDWOOD RAILINGS WITH VERTICAL BALUSTERS NOT MORE THAN 4" APART.
- 13 SHADING USED TO ISOLATE AND INDICATE ADU STRUCTURE.
- 14 RAIL ROAD TIE STEPS, 36" MIN CLR WIDTH.
- 15 MT. MORIAH 1" NOMINAL STONE VENEER - DIAMOND BACK PATTERN INSTALLED P.M.I.
- 16 60 MIL IB SYSTEMS PVC SINGLE PLY CLASS "A" DECK SYSTEM. REF ROOF PLAN.
- 17 SKYLIGHT WITH 6" CURB.
- 18 (N) ELECTRIC METER
- 19 DOOR FOR MECH ROOM
- 20 CONC STEPS WITH EQ. RISE
- 21 2X12 FASCIA BOARD
- 22 TEMPERED GLASS
- 23 CLAW 960 FH
- 24 OBSCURE GLASS
- 25 (N) REDWOOD FENCING TO MATCH (E)

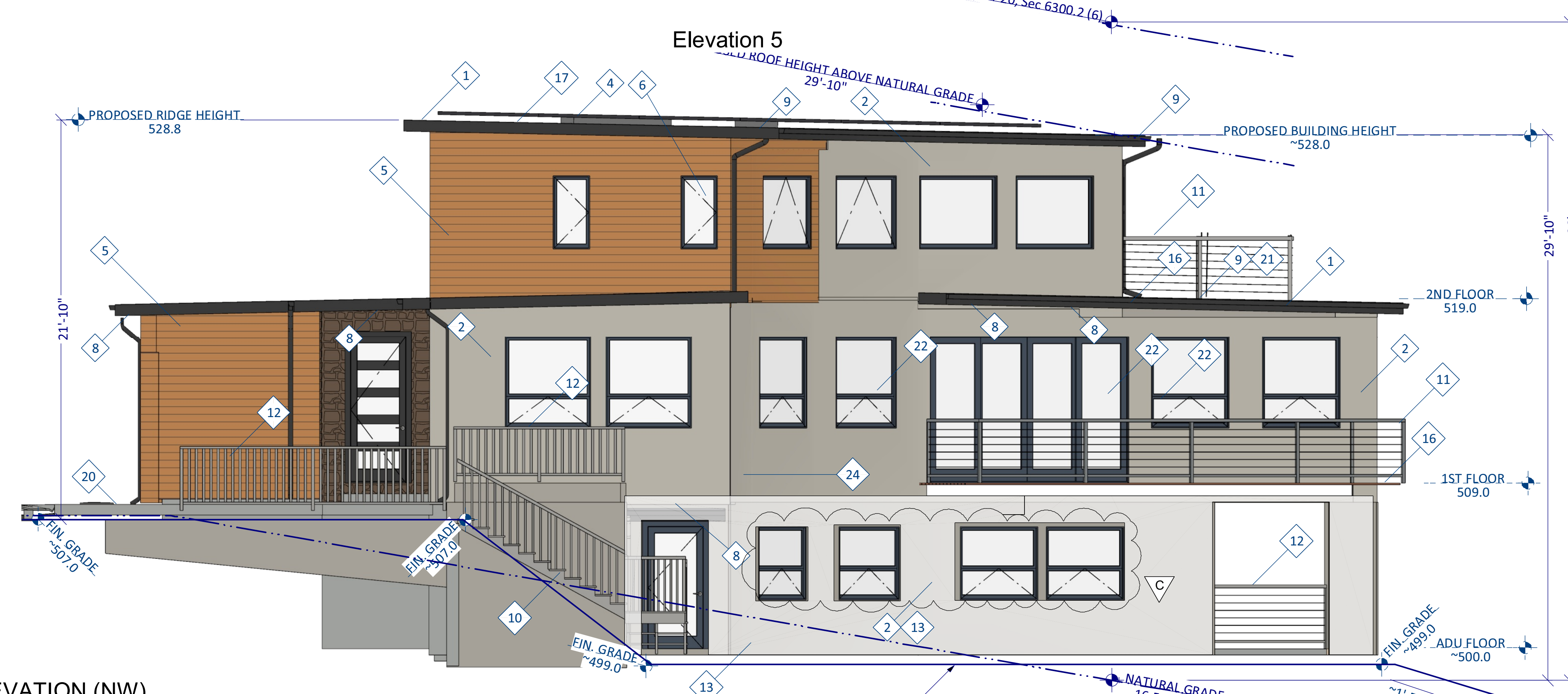

1 RIGHT ELEVATION (NW)
scale 1/4" = 1'-0"

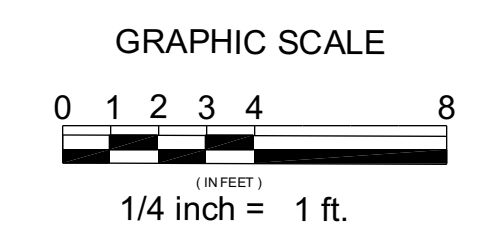

DESIGNER:
ROD LACASIA-BARRIOS
4 EL SERENO DR.
SAN CARLOS, CA
650 766-2463

STRUCTURAL ENGINEER:
TBD

ENERGY CALCS:
TBD

REVISION	DATE	BY	DESC.
A	3/29/22	RLB	S/MC PLNG COMMENT 1
B	1/12/22	RLB	POST 8/11/22 RDRC
C	1/15/23	RLB	POST 1/12/23 CDRC

**779 SAN CARLOS AVE
EL GRANADA, CALIFORNIA
NEW RESIDENCE**

W/E ELEVATIONS

SHEET TITLE

ALL INFORMATION IS
COPYRIGHTED 2021

SCALE: AS SHOWN
ISSUE DATE: 12-14-2021
DRAWN BY: ROD LACASIA-BARRIOS
SHEET NO.: **A202**

DESIGNER:
 ROD LACASIA-BARRIOS
 4 EL SERENO DR.
 SAN CARLOS, CA
 650 766-2463

STRUCTURAL ENGINEER:
 TBD

ENERGY CALCS:
 TBD

REVISION	BY	DESC.
A	1/15/23	RLB POST 1/12/23 CDRC

779 SAN CARLOS AVE
 EL GRANADA, CALIFORNIA
 NEW RESIDENCE

MASSING MODELS

SHEET TITLE

ALL INFORMATION IS
 COPYRIGHTED 2021

SCALE: AS SHOWN

ISSUE DATE: 1/12/2022

DRAWN BY: ROD LACASIA-BARRIOS

SHEET NO. G10.2

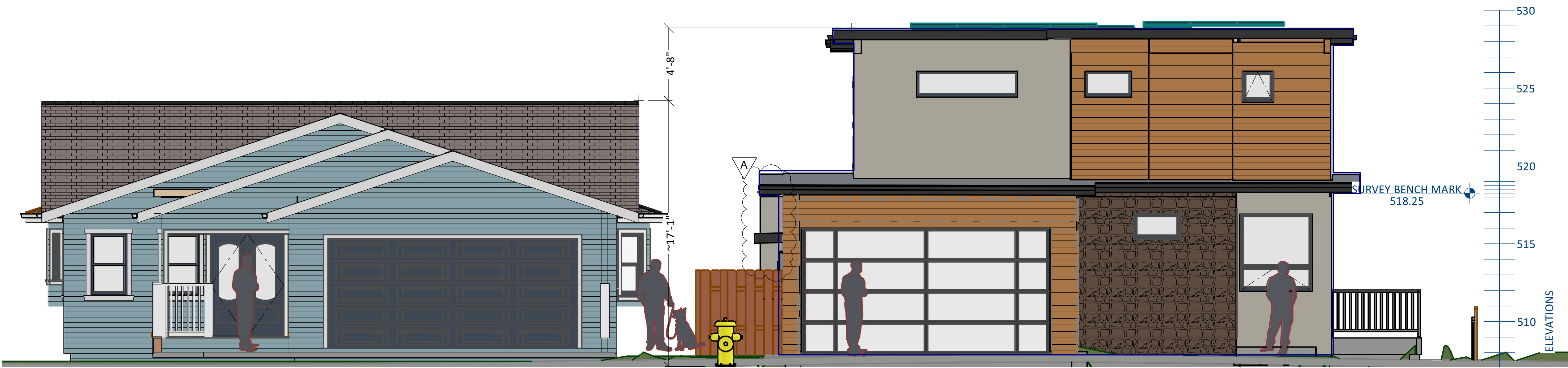

3 FRONT ELEVATION MASSING WITH NEIGHBORING HOUSE
 scale 1/4" = 1'-0"

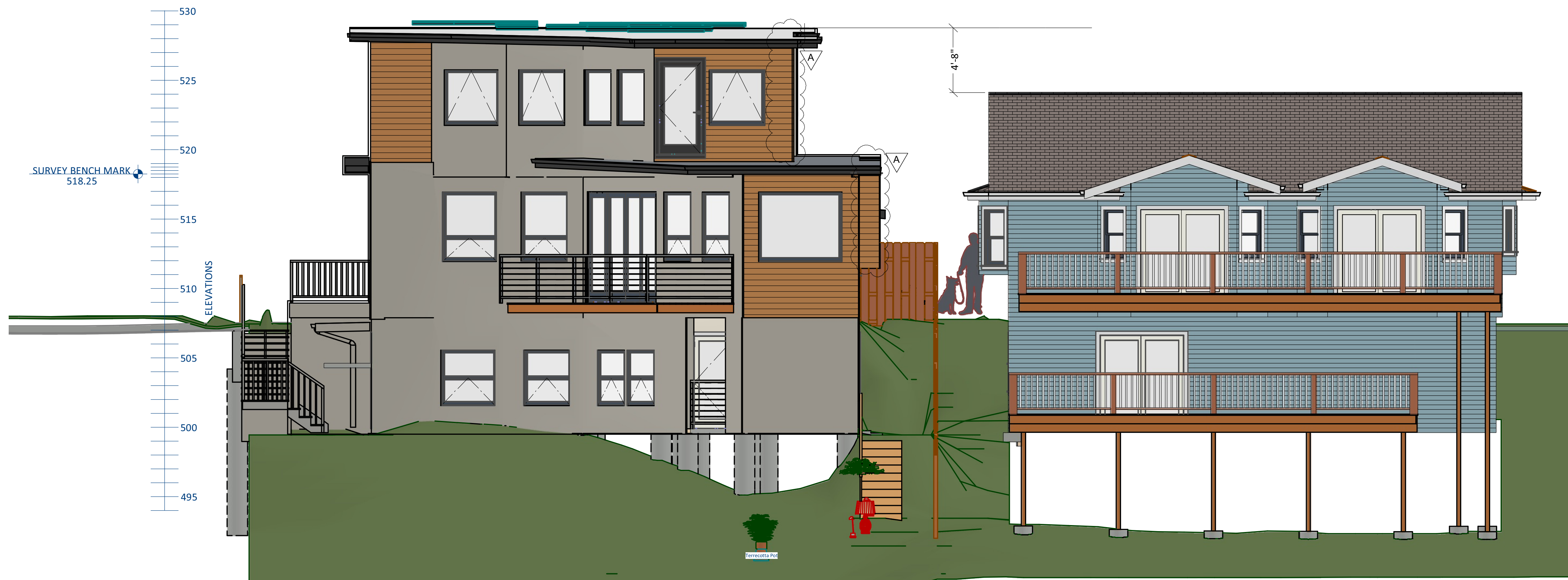

4 REAR ELEVATION MASSING WITH NEIGHBORING HOUSE
 scale 1/4" = 1'-0"

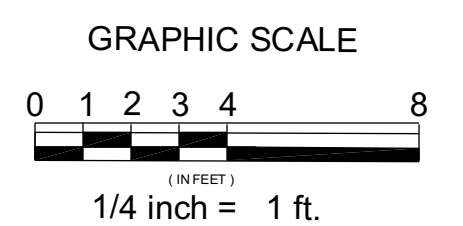

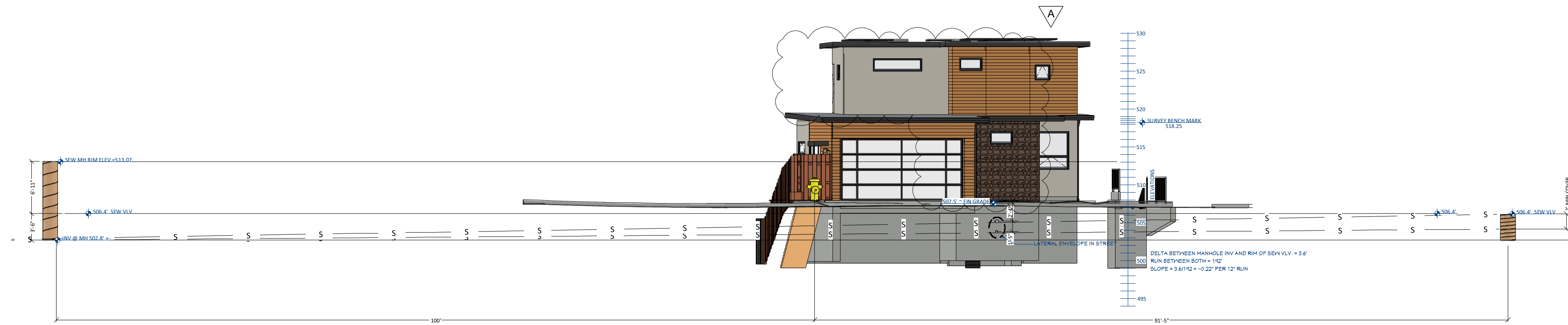

1 SURVEYED SEWER PROFILE IN STREET
scale: 1" = 8.0'

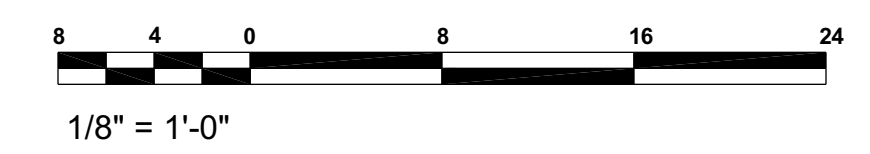

DESIGNER:
ROD LACASIA-BARRIOS
4 EL SERENO DR.
SAN CARLOS, CA
650 766-2463

STRUCTURAL ENGINEER:
TBD

ENERGY CALCS:
TBD

REVISION	BY	DESC.
A	RLB	POST 8/11/22 CDRC

779 SAN CARLOS AVE
EL GRANADA, CALIFORNIA
NEW RESIDENCE

SHEET TITLE
**SEWER MAIN
LOCATION/ANALYSIS**

ALL INFORMATION IS
COPYRIGHTED 2021

SCALE: AS SHOWN

ISSUE DATE: 12-14-2021

DRAWN BY: ROD LACASIA-BARRIOS

SHEET NO. G021

DESIGNER:
 ROD LACASIA-BARRIOS
 4 EL SERENO DR.
 SAN CARLOS, CA
 650 766-2463

STRUCTURAL ENGINEER:
 TBD

ENERGY CALCS:
 TBD

REVISION	BY	DESC.
A	1/1/2022	RLB POST 8/11/22 RDRG
B	1/15/23	RLB POST 1/12/23 CDRG

779 SAN CARLOS AVE
 EL GRANADA, CALIFORNIA
 NEW RESIDENCE

CROSS SECTIONS

SHEET TITLE

SCALE: AS SHOWN

ISSUE DATE: 12-14-2021

DRAWN BY: ROD LACASIA-BARRIOS

SHEET NO. A301

ALL INFORMATION IS
 COPYRIGHTED 2021

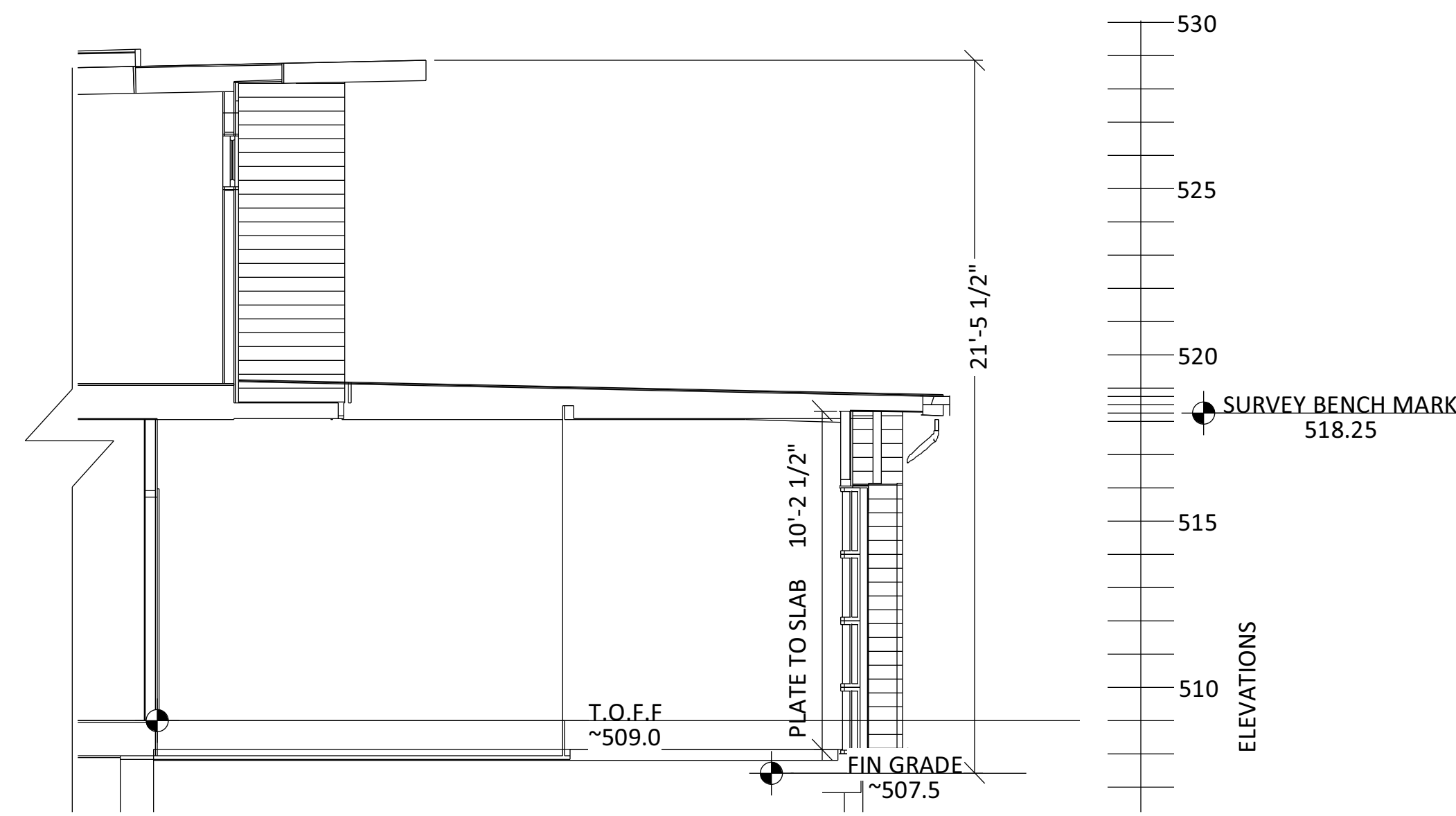

2 CROSS SECTION 3-3
 Scale 1/4" = 1'-0"

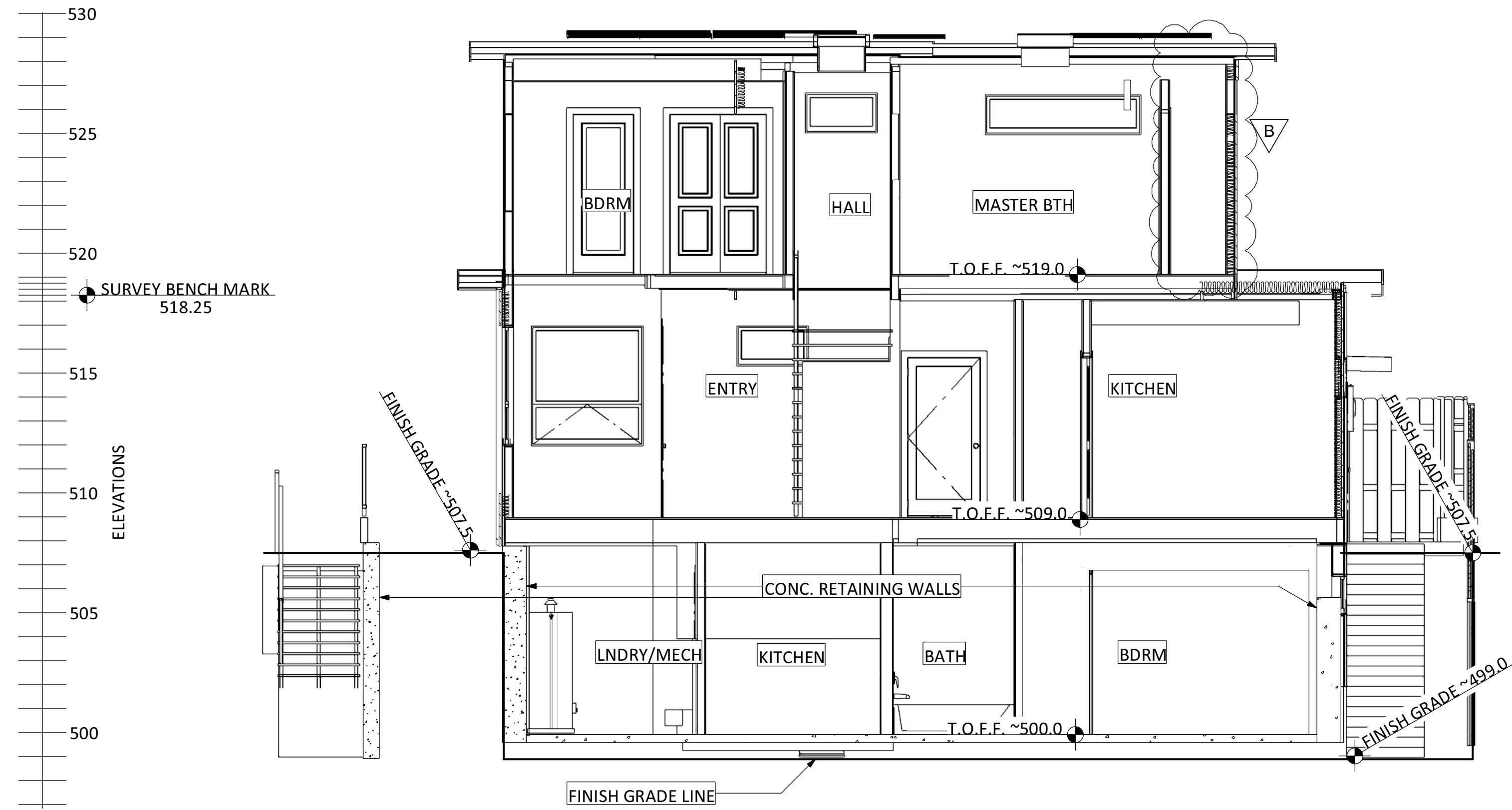

2 CROSS SECTION 2-2
 Scale 1/4" = 1'-0"

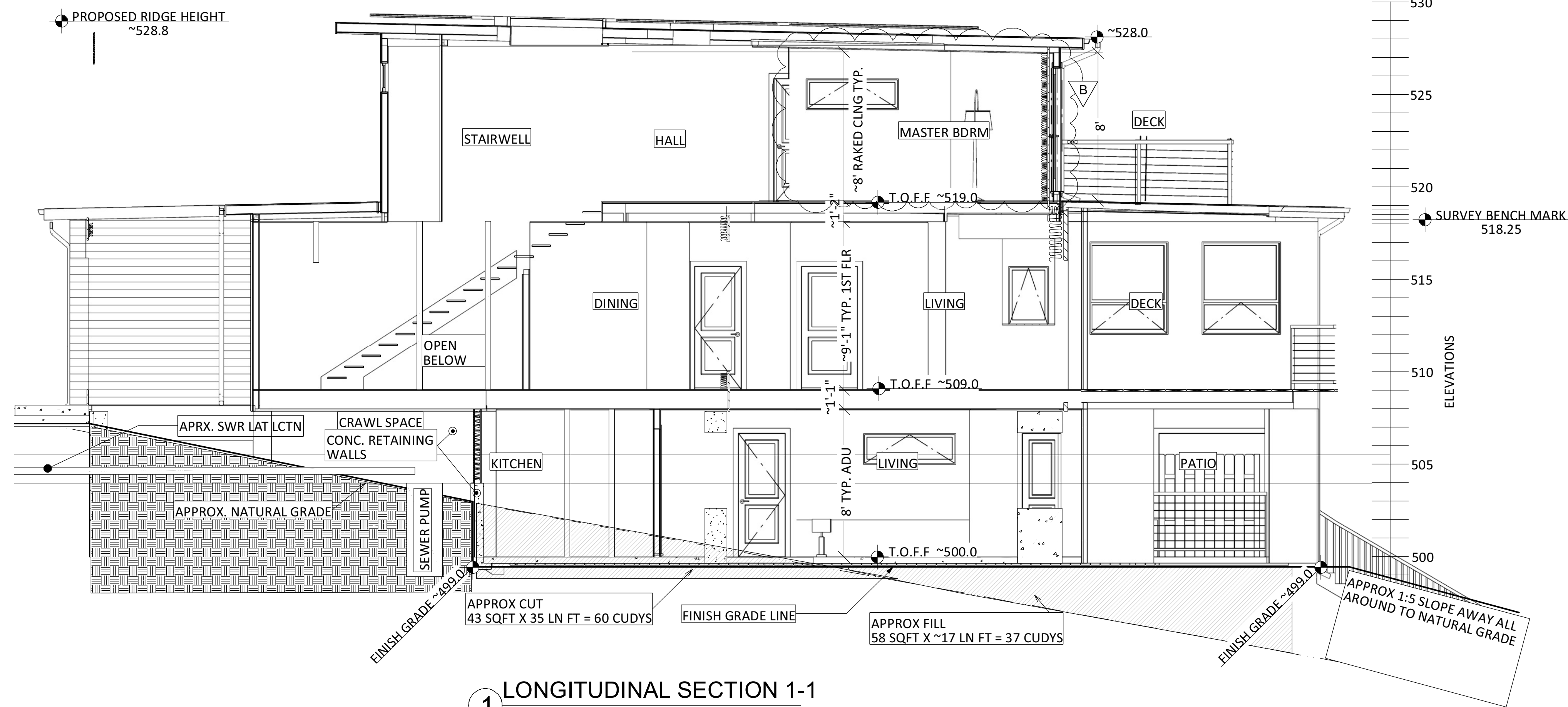

1 LONGITUDINAL SECTION 1-1
 Scale 1/4" = 1'-0"

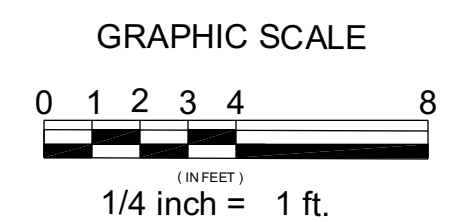

DESIGNER:
 ROD LACASIA-BARRIOS
 4 EL SERENO DR.
 SAN CARLOS, CA
 650 766-2463

STRUCTURAL ENGINEER:
 TBD

ENERGY CALCS:
 TBD

REVISION	BY	DESC.

779 SAN CARLOS AVE
 EL GRANADA, CALIFORNIA
 NEW RESIDENCE

SHEET TITLE
**TOPO, BOUNDARY
 AND BIOLOGICAL
 SURVEY**
 ALL INFORMATION IS
 COPYRIGHTED 2021

SCALE: AS SHOWN

ISSUE DATE: 12-14-2021

DRAWN BY: ROD LACASIA-BARRIOS

SHEET NO.

G020

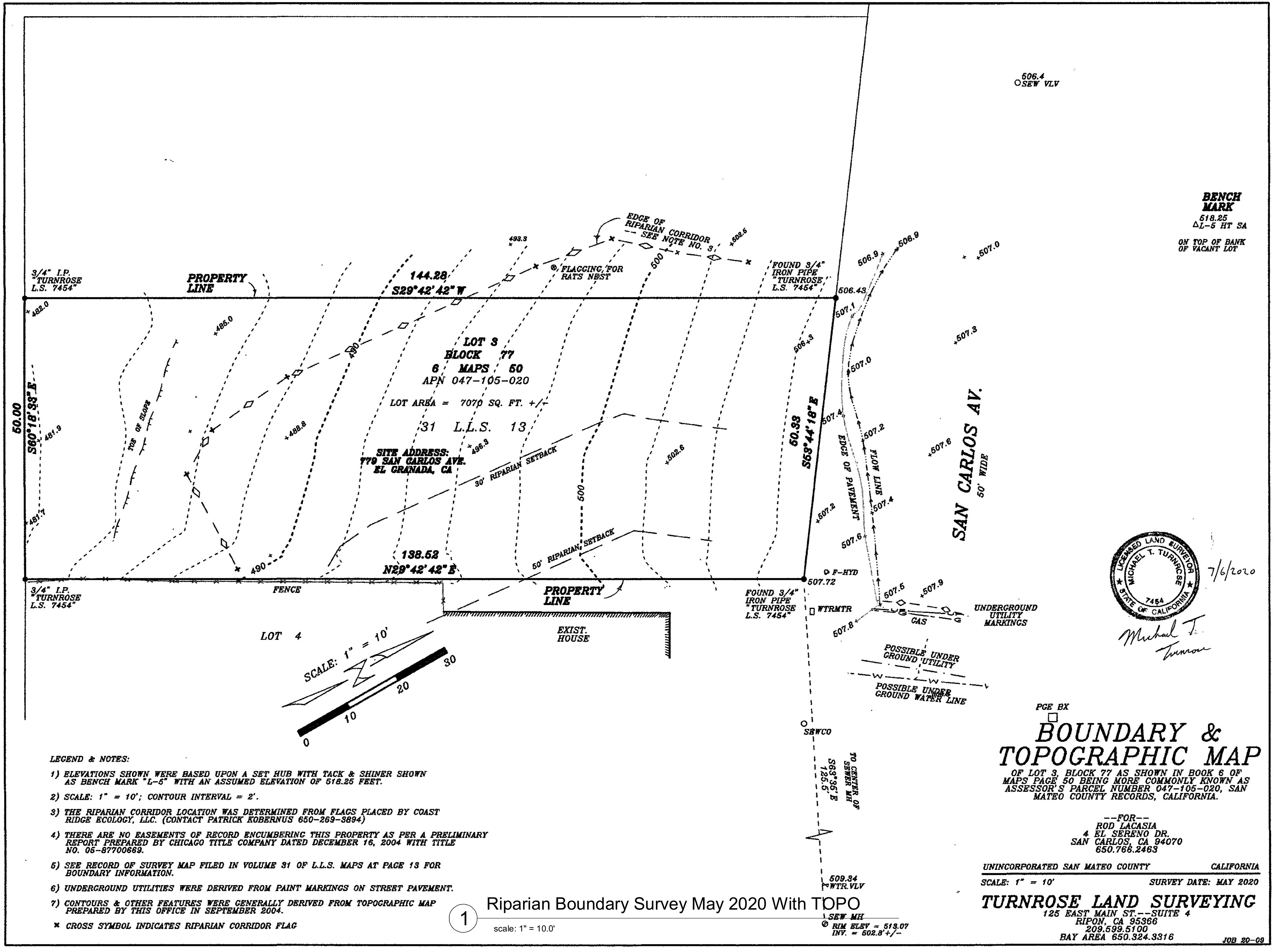

DESIGNER:
 ROD LACASIA-BARRIOS
 4 EL SERENO DR.
 SAN CARLOS, CA
 650 766-2463

STRUCTURAL ENGINEER:
 TBD

ENERGY CALCS:
 TBD

REVISION	DATE	BY	DESC.

779 SAN CARLOS AVE
 EL GRANADA, CALIFORNIA
 NEW RESIDENCE

**OVERALL SITE
 BOUNDARY & TOPO
 MAP**

ALL INFORMATION IS
 COPYRIGHTED 2021

NOTES:

- ELEVATIONS SHOWN WERE BASED UPON A SET HUB WITH TACK & SHINER SHOWN AS BENCH MARK "L-5" WITH AN ASSUMED ELEVATION OF 518.25 FEET.
- SCALE: 1" = 10'; CONTOUR INTERVAL = 2'.
- THE RIPARIAN CORRIDOR LOCATION WAS DETERMINED FROM FLAGS PLACED BY COAST RIDGE ECOLOGY, LLC. (CONTACT PATRICK KOBERNUS 650-269-3894)
- THERE ARE NO EASEMENTS OF RECORD ENCUMBERING THIS PROPERTY AS PER A PRELIMINARY REPORT PREPARED BY CHICAGO TITLE COMPANY DATED DECEMBER 16, 2004 WITH TITLE NO. 05-87700669.
- SEE RECORD OF SURVEY MAP FILED IN VOLUME 31 OF L.L.S. MAPS AT PAGE 13 FOR BOUNDARY INFORMATION.
- UNDERGROUND UTILITIES WERE DERIVED FROM PAINT MARKINGS ON STREET PAVEMENT.
- CONTOURS & OTHER FEATURES WERE GENERALLY DERIVED FROM TOPOGRAPHIC MAP PREPARED BY THIS OFFICE IN SEPTEMBER 2004.
- CROSS SYMBOL INDICATES RIPARIAN CORRIDOR FLAG
- THE LOCATION OF THE NEAREST CREEK BANK WAS TAKEN FROM GPS READINGS DONE BY PATRICK KOBERNUS WITH COAST RIDGE ECOLOGY, LLC ON OCTOBER 23, 2020.

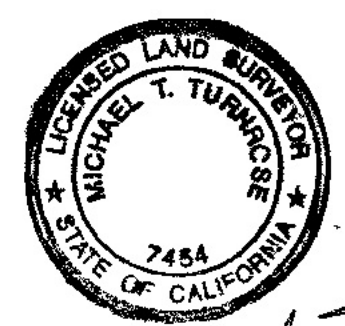
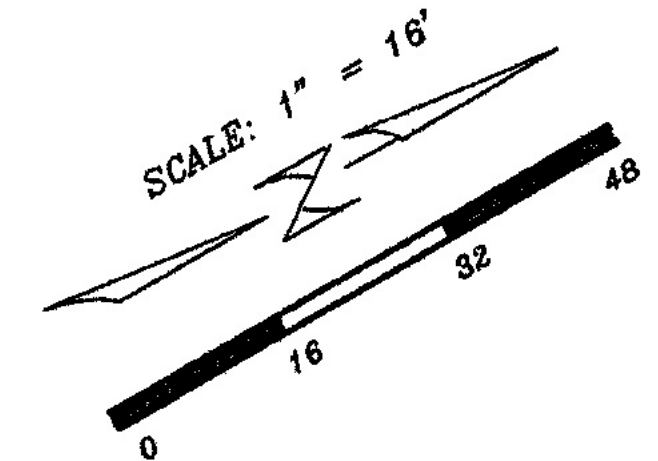
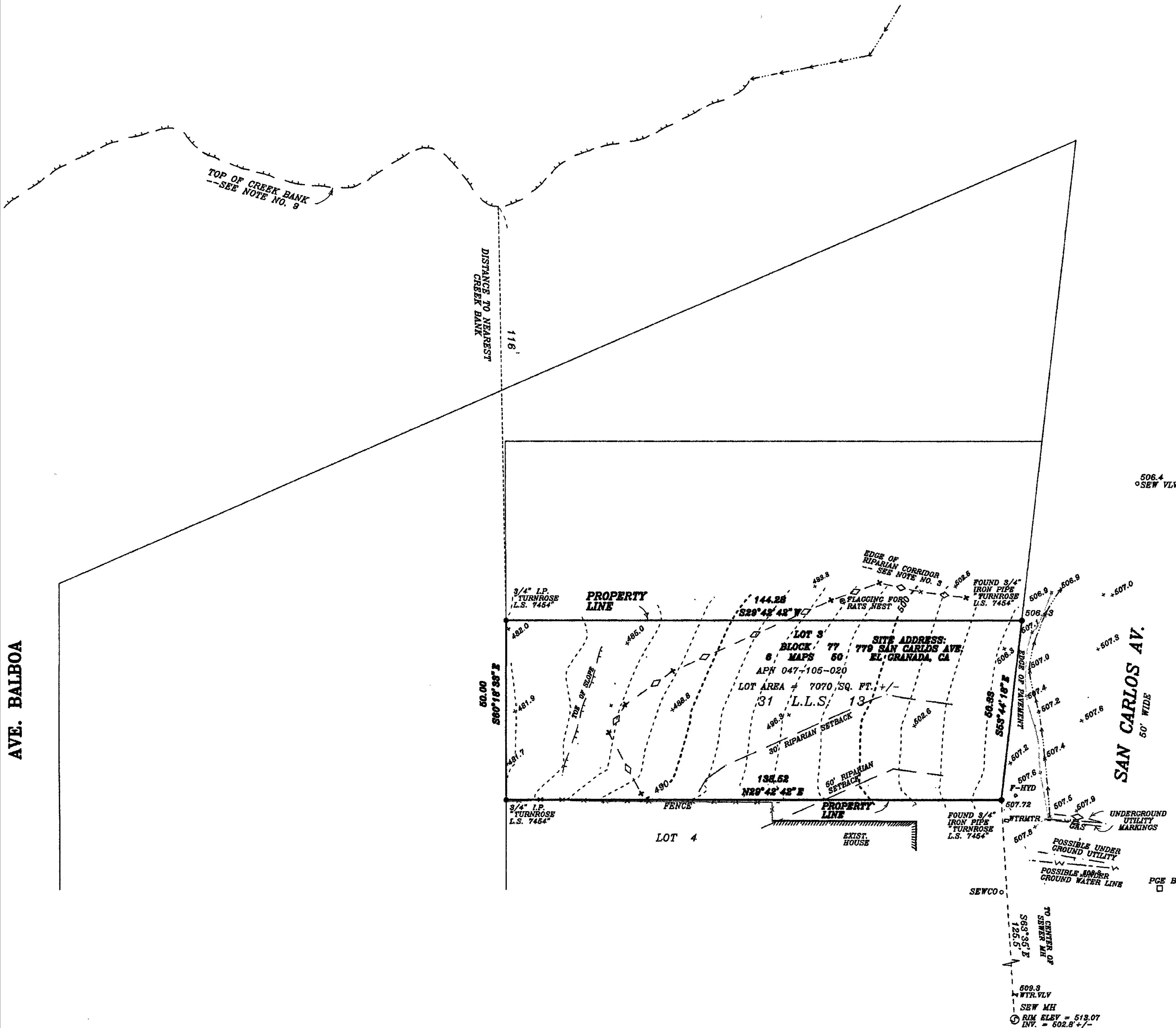

12/9/2020
 Michael T. Turnrose

**OVERALL SITE
 BOUNDARY &
 TOPOGRAPHIC MAP**

OF LOT 3, BLOCK 77 AS SHOWN IN BOOK 6 OF MAPS AT PAGE 50 BEING MORE COMMONLY KNOWN AS ASSESSORS PARCEL NUMBER 047-105-020, SAN MATEO COUNTY RECORDS, CALIFORNIA.

--FOR--
 ROD LACASIA
 4 EL SERENO DRIVE
 SAN CARLOS, CA 94070
 650.766.2463

UNINCORPORATED SAN MATEO COUNTY CALIFORNIA
 SCALE: 1" = 16' DATE OF SURVEY: MAY, 2020

TURNROSE LAND SURVEYING
 125 EAST MAIN ST. - SUITE 4
 RIFON, CA 95366
 209.599.5100
 BAY AREA 650.324.3316 JOB NO. 20-06

SCALE: 1" = 16'-0"

ISSUE DATE: 05/05/2022

DRAWN BY: ROD LACASIA-BARRIOS

SHEET NO.:

G020.1

GENERAL CONDITIONS:

- 1 THE APPLICANT IS REQUIRED TO INSTALL STATE FIRE MARSHAL APPROVED AND LISTED SMOKE DETECTORS WHICH ARE HARD WIRED, INTERCONNECTED, AND HAVE BATTERY BACKUP. THESE DETECTORS ARE REQUIRED TO BE PLACED IN EACH NEW AND RECONDITIONED SLEEPING ROOM AND AT A POINT CENTRALLY LOCATED IN THE CORRIDOR OR AREA GIVING ACCESS TO EACH SEPARATE SLEEPING AREA. IN EXISTING SLEEPING ROOMS, AREAS MAY HAVE BATTERY POWERED SMOKE ALARMS. A MINIMUM OF ONE DETECTOR SHALL BE PLACED ON EACH FLOOR. SMOKE DETECTORS SHALL BE TESTED AND APPROVED PRIOR TO THE BUILDING FINAL INSPECTION.
- 2 ESCAPE OR RESCUE WINDOWS SHALL HAVE A MINIMUM NET CLEAR OPENABLE AREA OF 5.7 SQ. FT. 5.0 SQ. FT. IS ALLOWED AT GRADE. THE MINIMUM NET CLEAR OPENABLE HEIGHT DIMENSION SHALL BE 24 INCHES. THE NET CLEAR OPENABLE WIDTH DIMENSION SHALL BE 20 INCHES. FINISHED SILL HEIGHT SHALL BE NOT MORE THAN 44 INCHES ABOVE THE FINISHED FLOOR. IDENTIFY RESCUE WINDOWS IN EACH BEDROOM AND VERIFY THAT THEY MEET ALL REQUIREMENTS. INCLUDE IN BUILDING PLANS.
- 3 OCCUPANCY SEPARATION: PER THE 2016 CBC, SECTION 406.1.4, A ONE-HOUR OCCUPANCY SEPARATION WALL SHALL BE INSTALLED WITH A SOLID CORE, 20-MINUTE FIRE RATED, SELF-CLOSING DOOR ASSEMBLY WITH SMOKE GASKET BETWEEN THE GARAGE AND THE RESIDENCE. ALL ELECTRICAL BOXES INSTALLED IN RATED WALLS SHALL BE METAL OR PROTECTED. PLANS AT THE BUILDING PERMIT APPLICATION STAGE SHALL INCLUDE LISTING AND CONSTRUCTION DETAILS. INSPECTIONS WILL OCCUR THROUGHOUT CONSTRUCTION AND PRIOR TO FIRE'S FINAL APPROVAL.

DESIGNER:
ROD LACASIA-BARRIOS
4 EL SERENO DR.
SAN CARLOS, CA
650 766-2463

STRUCTURAL ENGINEER:
TBD

ENERGY CALCS:
TBD

REVISION	DATE	BY	DESC.
A	11/20/22	RLB	POST 8/11/22 CDRC

779 SAN CARLOS AVE
EL GRANADA, CALIFORNIA
NEW RESIDENCE

ADU FLOOR PLAN

ALL INFORMATION IS
COPYRIGHTED 2021

SHEET TITLE

SCALE: AS SHOWN

ISSUE DATE: 12-14-2021

DRAWN BY: ROD LACASIA-BARRIOS

SHEET NO. A101

KEY FLOOR PLAN NOTES:

- 1 EGRESS WINDOW.
- 2 36" MIN. CLR. WIDTH
- 3 AREAS CALCULATED USING CAD S/W POLYLINES
- 4 CONCRETE STEPS

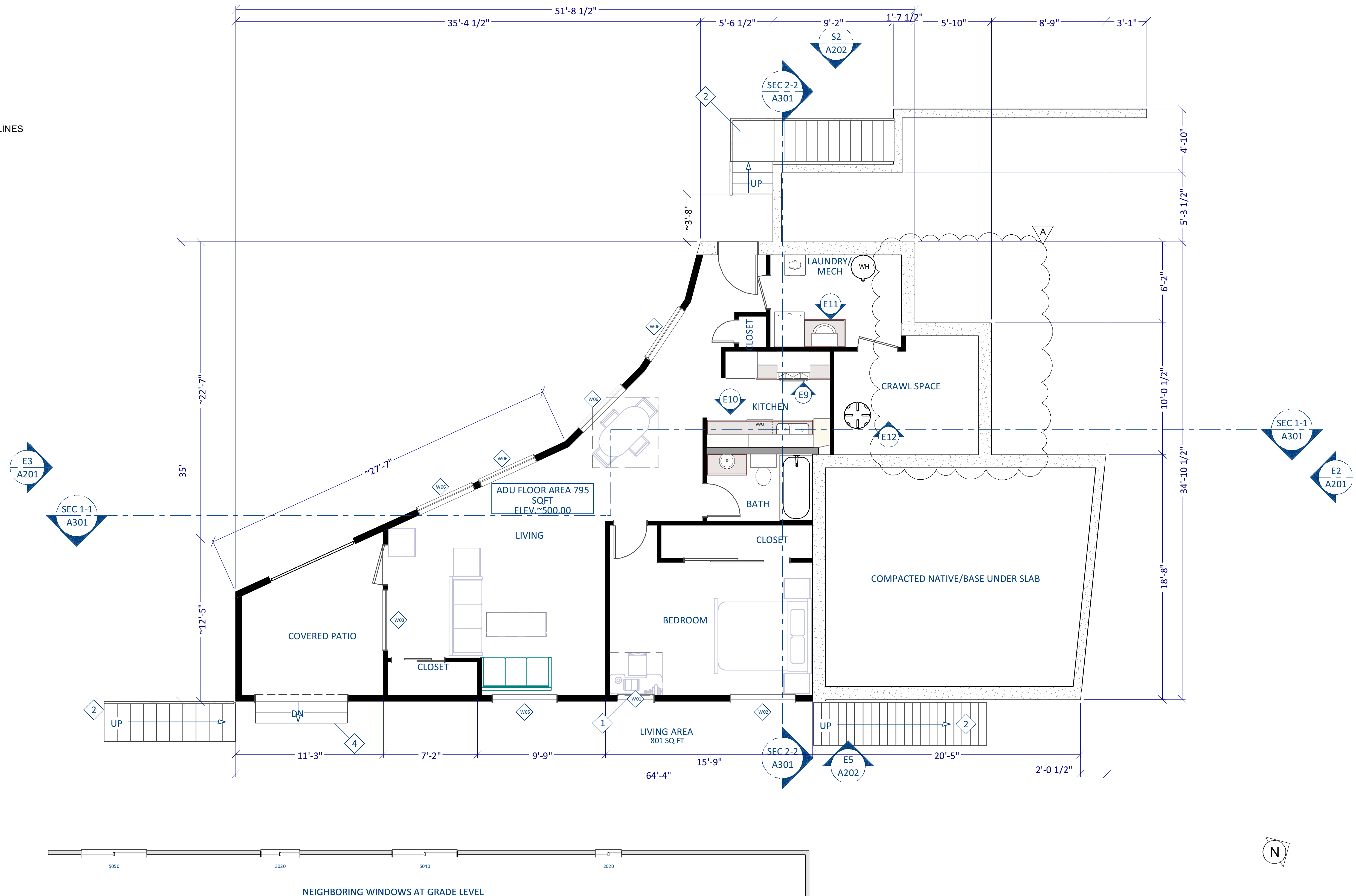

1 ADU Grade Level Floor Plan (795 sqft)
scale 1/4" = 1'-0"



KEY FLOOR PLAN NOTES:

- 1 EGRESS WINDOW.
- 2 36" MIN. CLR. WIDTH
- 3 AREAS CALCULATED USING CAD S/W POLYLINES
- 4 CONCRETE STEPS

DESIGNER:
 ROD LACASIA-BARRIOS
 4 EL SERENO DR.
 SAN CARLOS, CA
 650 766-2463

STRUCTURAL ENGINEER:
 TBD

ENERGY CALCS:
 TBD

REVISION	DATE	BY	DESC.
A	11/20/22	RLB	POST 8/11/22 CDCR
B	1/15/23	RLB	POST 11/22/23 CDCR

**779 SAN CARLOS AVE
 EL GRANADA, CALIFORNIA
 NEW RESIDENCE**

FIRST FLOOR PLAN

ALL INFORMATION IS
 COPYRIGHTED 2021

SHEET TITLE

SCALE: AS SHOWN

ISSUE DATE: 12-14-2021

DRAWN BY: ROD LACASIA-BARRIOS

SHEET NO. A102

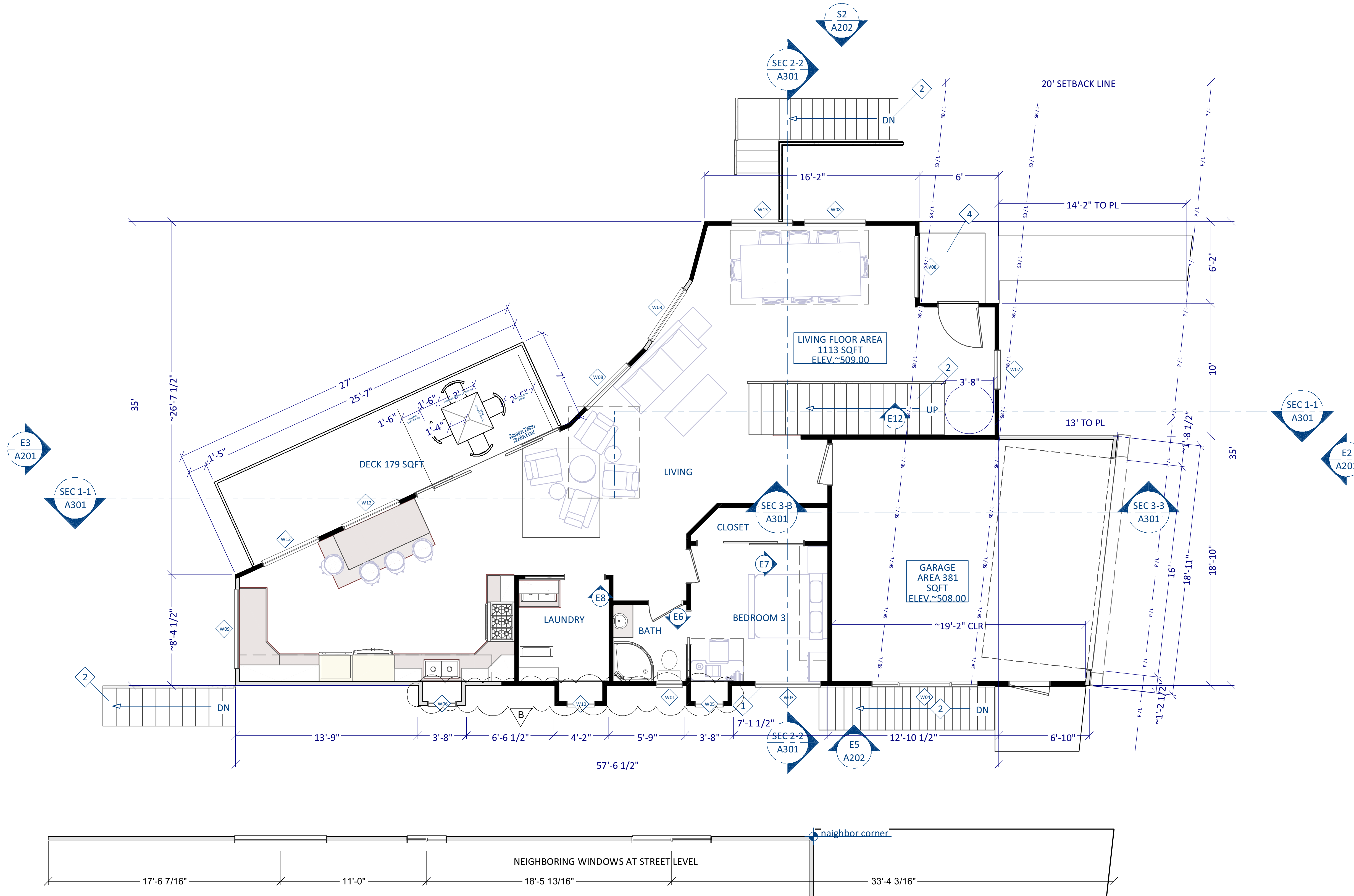

1 Street Level Floor Plan (1113 sqft)
 scale 1/4" = 1'-0"

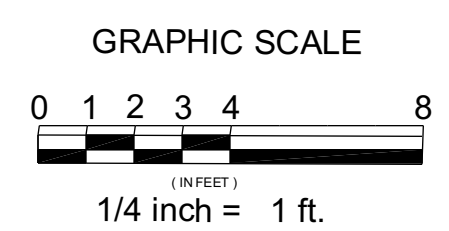

KEY FLOOR PLAN NOTES:

- 1 EGRESS WINDOW.
- 2 36" MIN. CLR. WIDTH
- 3 AREAS CALCULATED USING CAD S/W POLYLINES
- 4 CONCRETE STEPS

DESIGNER:
ROD LACASIA-BARRIOS
4 EL SERENO DR.
SAN CARLOS, CA
650 766-2463

STRUCTURAL ENGINEER:
TBD

ENERGY CALCS:
TBD

REVISION	BY	DESC.
A	1/1/2022	RLB POST 8/11/22 CDRC
B	1/15/23	RLB POST 1/12/23 CDRC

**779 SAN CARLOS AVE
EL GRANADA, CALIFORNIA
NEW RESIDENCE**

ALL INFORMATION IS
COPYRIGHTED 2021

SHEET TITLE

**SECOND FLOOR
PLAN**

SCALE: AS SHOWN

ISSUE DATE: 12-14-2021

DRAWN BY: ROD LACASIA-BARRIOS

SHEET NO. A103

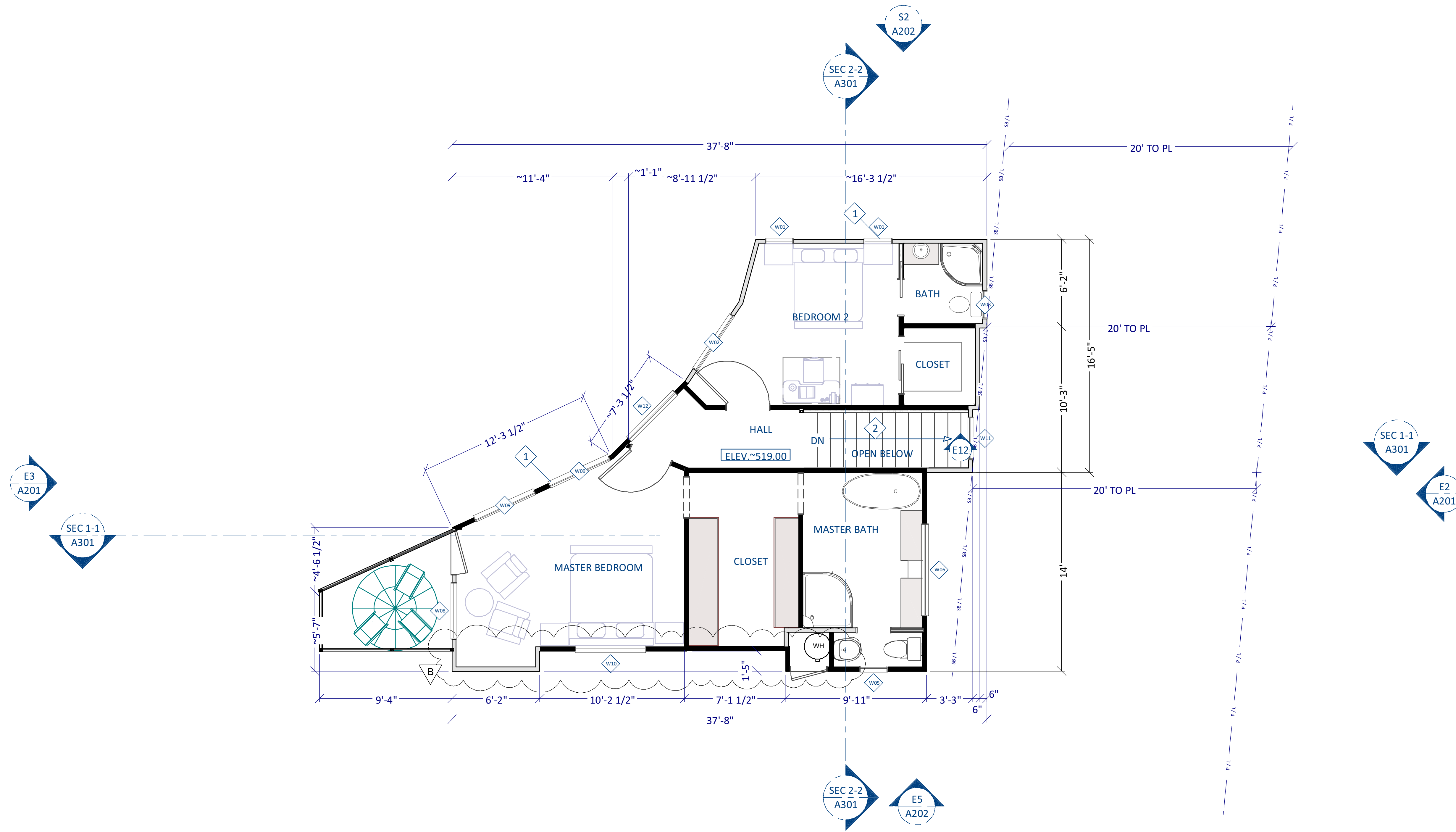

2 Upper Level Floor Plan (691 sqft)
scale 1/4" = 1'-0"

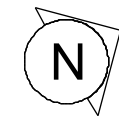
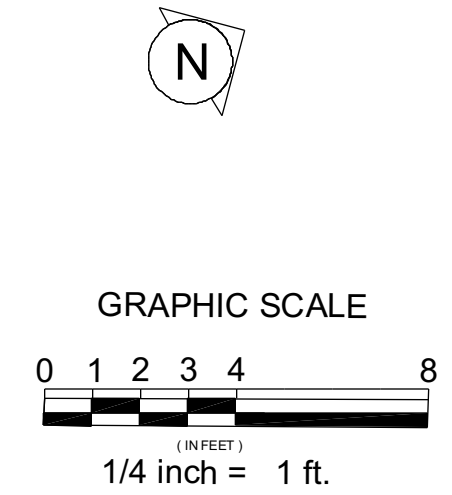

KEY ROOF PLAN NOTES:

- 1 24" X 60" SKYLIGHT
- 2 GRAY 50 MIL IB SYSTEMS PVC SINGLE PLY CLASS "A" ROOF SYSTEM. GRAY AT LOWER, WHITE AT UPPER.
- 3 60MIL, GRAY IB PVC SINGLE PLY DECK SHIELD ROOF SYSTEM, WITH 1/4" RIGID BOARD TAPER SYSTEM SOLID ADHERED TO THE 1/4" SECUROCK COVER BOARD, AS PER MANUFACTURE'S SPECIFICATIONS AT BOTH FIRST AND SECOND STORY DECKS.
- 4 1/4" SECUROCK CLASS "A" ROOF COVER BOARD SYSTEM OVER PLYWOOD DECK SUBSTRATE.
- 5 BONDERIZED 5 1/4" FASCIA GUTTERS WITH 2 1/4" X 1 3/4" RECTANGLE DOWNSPOUTS.
- 6 PV SOLAR PANELS WITH 36" CLEAR WALKWAY ALL AROUND

2 CLASS "A" PVC MEMBRANE TORCH DOWN ROOF ASSY P.M.I.
4

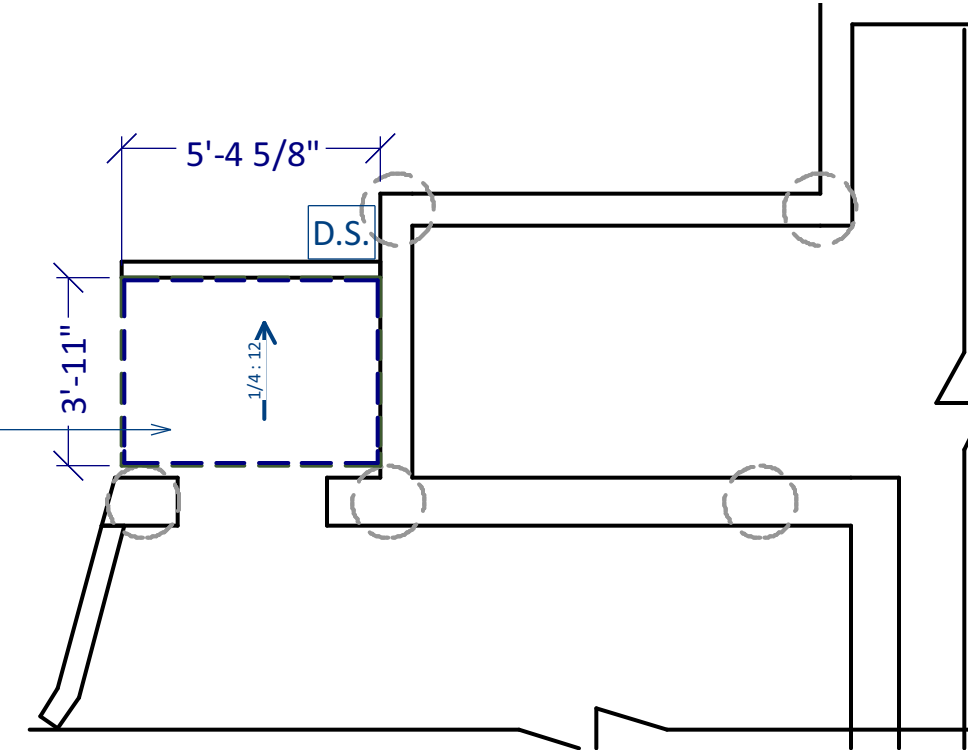

3 ADU ENTRANCE ROOF PLAN
scale 1/4" = 1'-0"

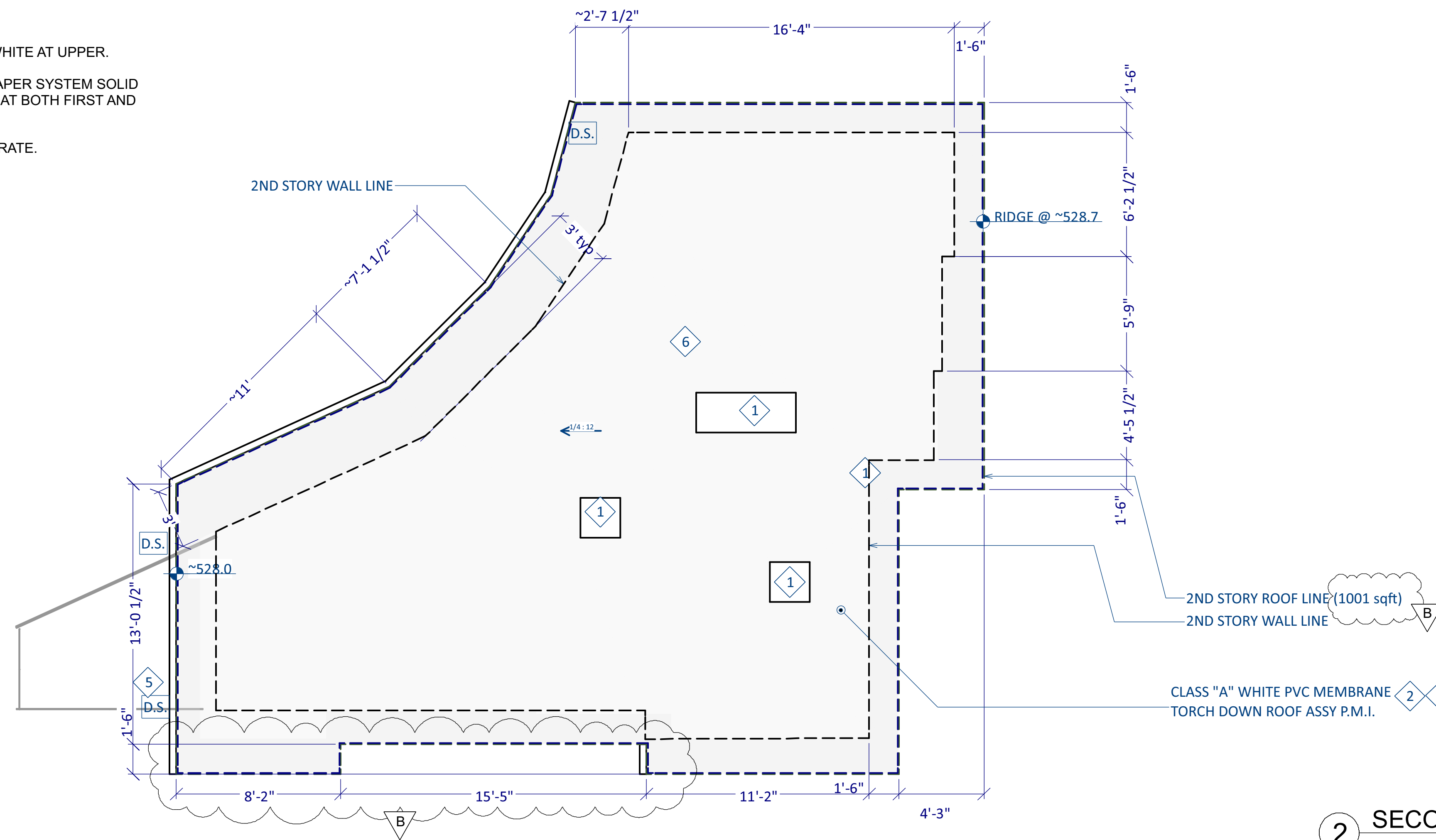

2 SECOND FLOOR ROOF PLAN
scale 1/4" = 1'-0"

3 PVC MEMBRANE TORCH DOWN @ DECK ON 1ST AND 2ND STORY.
4

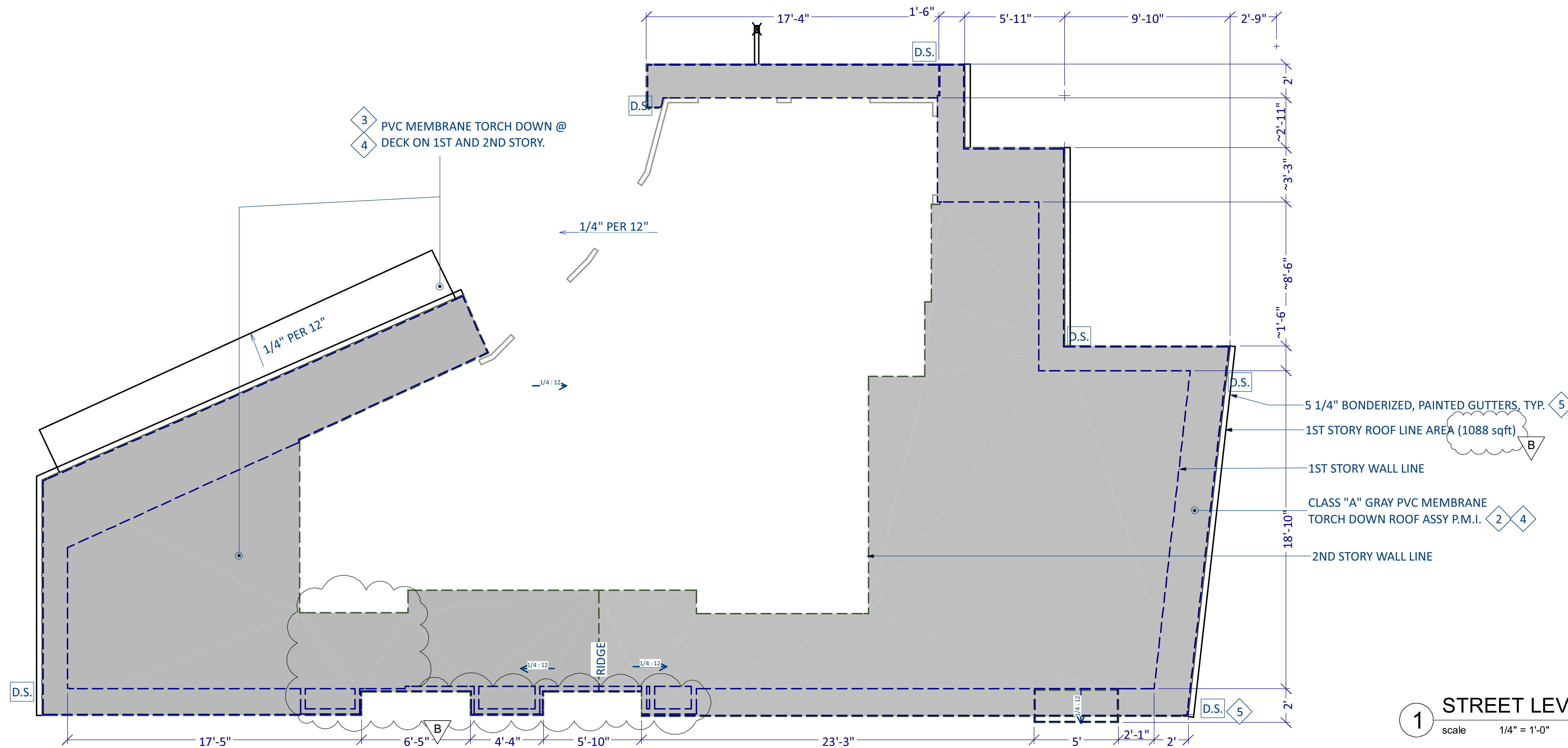

1 STREET LEVEL ROOF PLAN
scale 1/4" = 1'-0"

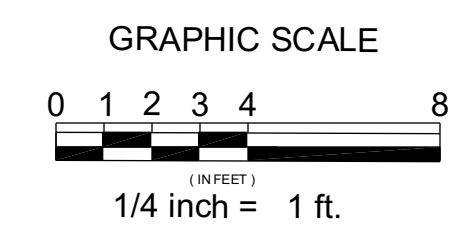

DESIGNER:
ROD LACASIA-BARRIOS
4 EL SERENO DR.
SAN CARLOS, CA
650 766-2463

STRUCTURAL ENGINEER:
TBD

ENERGY CALCS:
TBD

REVISION	DATE	BY	DESC.
A	1/17/2022	RLB	POST 8/11/22 CDRC
B	1/15/23	RLB	POST 1/12/23 CDRC

779 SAN CARLOS AVE
EL GRANADA, CALIFORNIA
NEW RESIDENCE

ALL INFORMATION IS
COPYRIGHTED 2021

ROOF PLANS

SCALE: AS SHOWN

ISSUE DATE: 12-14-2021

DRAWN BY: ROD LACASIA-BARRIOS

SHEET NO. A104

NOTES:

- MILGARD DARK VINYL WINDOWS, CLEAR VIEW SERIES, TYP.
- LOW "E", ARGON FILL.

NO.	EXTERIOR ELEVATION	NUMBER	ROOM NAME	LABEL	QTY	FINISH	TYPE	U-VALUE	TEMPERATURE	AREA	ACTUAL (SQ FT)	DESCRIPTION	HEADER	MANUFACTURER	SHG	LEAF	FACTR
		W01	BEDROOM	W01-21040	1	0	21040	57"x49"	YES	11.33		SINGLE CASEMENT-HR	2X6X38" (2)		0.3	0.3	
		W02	BEDROOM	W02-5018	1	0	5018	61"x21"		8.33		SINGLE AWNING	2X6X64" (2)		0.3	0.3	
		W03	COVERED PATIO/LIVING	W03-4840	1	0	4840	57"x49"		18.67		DOUBLE AWNING-B	2X6X60" (2)		0.3	0.3	
		W05	LIVING	W05-5018	1	0	5018	61"x21"		8.33		SINGLE AWNING	2X6X64" (2)		0.3	0.3	
		W06	LIVING	W06-4840	4	0	4840	57"x49"		18.67		DOUBLE AWNING-B	2X6X60" (2)		0.3	0.3	
TOTALS:										121.34							

1 ADU WINDOW SCHEDULE

NO.	EXTERIOR ELEVATION	NUMBER	ROOM NAME	LABEL	QTY	FINISH	TYPE	U-VALUE	TEMPERATURE	AREA	ACTUAL (SQ FT)	DESCRIPTION	HEADER	MANUFACTURER	SHG	LEAF	FACTR
		W01	BATH	W01-2020AW	1	1	2020AW	25"x25"		4.0		SINGLE AWNING	2X6X28" (2)		0.3	0.3	
		W03	BEDROOM 3	5018	1	1	5018	61"x21"		8.33		SINGLE AWNING	2X6X64" (2)		0.3	0.3	
		W04	GARAGE 381 SQFT/OPEN BELOW	W04-8020TS	1	1	8020TS	97"x25"		16.0		TRIPLE SLIDING	2X6X103" (2)		0.3	0.3	
		W05		2232SC	1	1	2232SC	27"x39"	YES	6.86		SINGLE CASEMENT-HR	2X6X27" (2)		0.3	0.3	
		W06		2232AW	1	1	2232AW	27"x39"		6.86		SINGLE AWNING	2X6X27" (2)		0.3	0.3	
		W07	LIVING	W07-3018FX	1	1	3018FX	37"x21"		5.0		FIXED GLASS	2X6X40" (2)		0.3	0.3	
		W08	LIVING	W08-4850FA	4	1	4850FA	57"x61"		23.33		DOUBLE AWNING-B	2X6X60" (2)		0.3	0.3	
		W09	LIVING	W09-6050FX	1	1	6050FX	77"x61"		30.0		FIXED GLASS	2X6X76" (2)		0.3	0.3	
		W10		2232SC	1	1	2232SC	27"x39"		6.86		SINGLE CASEMENT-HR	2X6X27" (2)		0.3	0.3	
		W11	LIVING/DECK 179 SQFT	111080	1	1	111080 L/R EX	142 1/2"x96"	YES	93.84		EXT. QUAD SLIDER-GLASS PANEL	2X12X145 1/2" (2)		0.3	0.3	
		W12	LIVING/DECK 179 SQFT	W12-4850FA	2	1	4850FA	57"x61"		23.33		DOUBLE AWNING-B	2X6X60" (2)		0.3	0.3	
		W13	LIVING/OPEN BELOW	W13-4850FA	1	1	4850FA	57"x61"		23.33		DOUBLE AWNING-B	2X6X60" (2)		0.3	0.3	
TOTALS:										311.06							

2 FIRST FLOOR WINDOW SCHEDULE

NO.	EXTERIOR ELEVATION	NUMBER	ROOM NAME	LABEL	QTY	FINISH	TYPE	U-VALUE	TEMPERATURE	AREA	ACTUAL (SQ FT)	DESCRIPTION	HEADER	MANUFACTURER	SHG	LEAF	FACTR
		W01	BEDROOM 2	W01-2040SC	2	2	2040SC	25"x49"		8.0		SINGLE CASEMENT-HR	2X6X28" (2)		0.3	0.3	
		W02	BEDROOM 2	4840AW	1	2	4840AW	57"x49"		18.67		SINGLE AWNING	2X6X60" (2)		0.3	0.3	
		W03	BATH	2020AW	1	2	2020AW	25"x25"		4.0		SINGLE AWNING	2X6X28" (2)		0.3	0.3	
		W05	MASTER BATH	2020AW	1	2	2020AW	25"x25"		4.0		SINGLE AWNING	2X6X28" (2)		0.3	0.3	
		W06	MASTER BATH	W06-6618FX	1	2	6618FX	79"x21"		10.83		FIXED GLASS	2X6X82" (2)		0.3	0.3	
		W08	MASTER BEDROOM	W08-4040AW	1	2	4040AW	49"x49"		16.0		SINGLE AWNING	2X6X52" (2)		0.3	0.3	
		W09	MASTER BEDROOM	4840FX	2	2	4840FX	57"x49"		18.67		FIXED GLASS	2X6X60" (2)		0.3	0.3	
		W10	MASTER BEDROOM	W10-5018AW	1	2	5018AW	61"x21"		8.33		SINGLE AWNING	2X6X64" (2)		0.3	0.3	
		W11	OPEN BELOW	W11-3018FX	1	2	3018FX	37"x21"		5.0		FIXED GLASS	2X6X40" (2)		0.3	0.3	
		W12	HALL	W12-4840AW	1	2	4840AW	57"x49"		18.67		SINGLE AWNING	2X6X60" (2)		0.3	0.3	
TOTALS:										138.84							

3 SECOND FLOOR WINDOW SCHEDULE

DESIGNER:
ROD LACASIA-BARRIOS
4 EL SERENO DR.
SAN CARLOS, CA
650 766-2463

STRUCTURAL ENGINEER:
TBD

ENERGY CALCS:
TBD

REVISION	DATE	BY	DESC.
A	11/20/22	RLB	POST 8/11/22 RDRRC

779 SAN CARLOS AVE
EL GRANADA, CALIFORNIA
NEW RESIDENCE

ALL INFORMATION IS
COPYRIGHTED 2021

SHEET TITLE

WINDOW
SCHEDULES

SCALE: AS SHOWN

ISSUE DATE: 12/14/2021

DRAWN BY: ROD LACASIA-BARRIOS

SHEET NO.:

A105

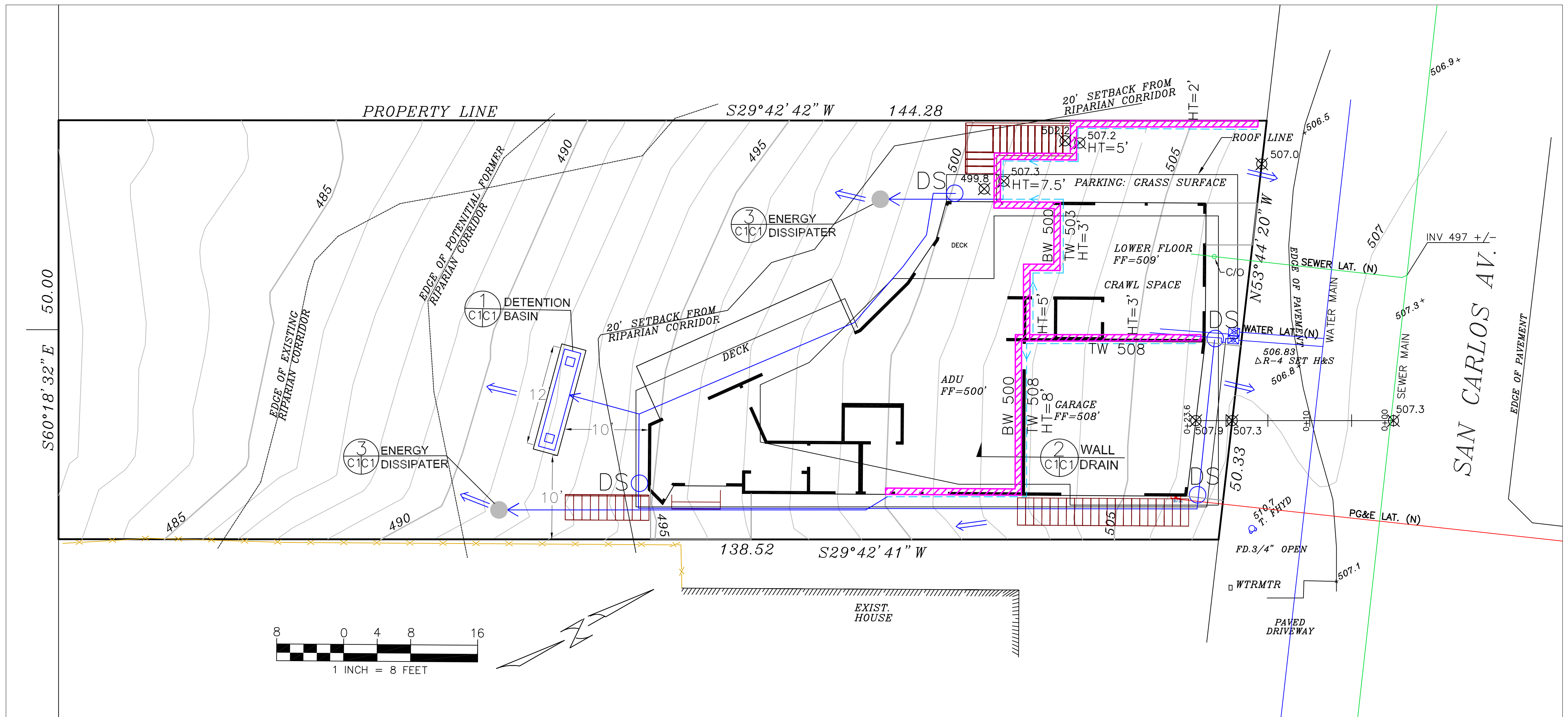

- LEGEND**
- EXISTING CONTOURS
 - PROPOSED SPOT ELEVATION
 - ENERGY DISSIPATER - PER DETAIL 3
 - DS
 - 4" MIN SOLID DRAIN PIPE
 - 4" MIN PERFORATED DRAIN PIPE

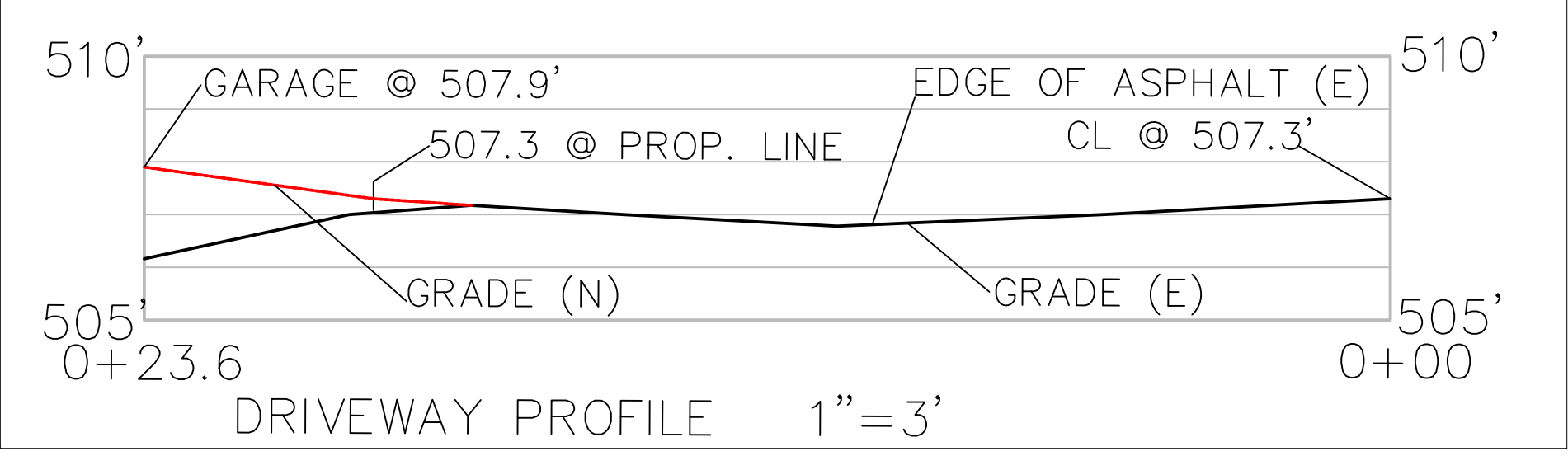
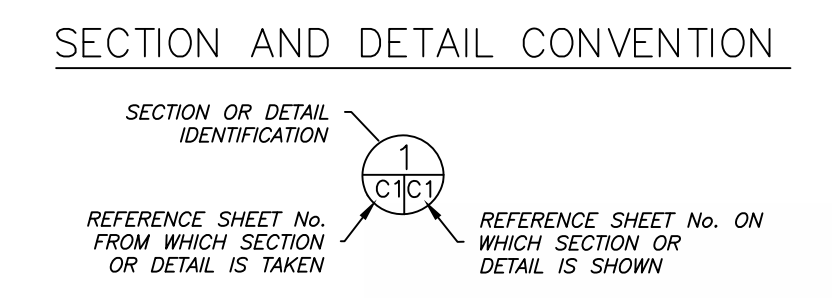
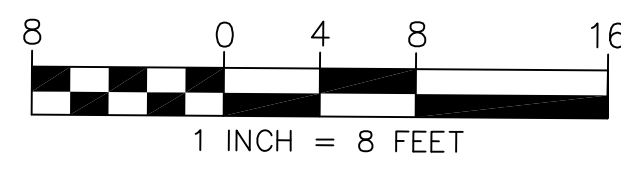

GENERAL NOTES

1. PLANS PREPARED AT THE REQUEST OF: ROD LACASIA, OWNER
2. TOPOGRAPHY BY M. TURNROSE, UNDATED.
3. THIS IS NOT A BOUNDARY SURVEY.
4. ELEVATION DATUM ASSUMED.
5. GEOTECHNICAL REPORT: PENDING
6. STORMWATER MANAGEMENT CONSTRUCTION INSPECTIONS SHALL BE SCHEDULED FOR APPLICABLE DRAINAGE INSPECTIONS, WHICH INCLUDE SITE CLEARANCE AND EROSION CONTROL MEASURES INSTALLATION AS WELL AS INSPECTION OF MAJOR DRAINAGE CONTAINMENT, TREATMENT, AND CONVEYANCE DEVICES BEFORE BEING BURIED (INCLUDING REQUIRED MATERIAL LABELS, E.G. PIPES, SUB-GRADE MATERIALS, ETC.). PLEASE FOLLOW THE INSPECTION CARD INSTRUCTIONS AND PHONE NUMBER (650-306-8405 EXT 181) TO SCHEDULE COUNTY DRAINAGE INSPECTIONS ACCORDINGLY. THERE SHALL BE THREE INSPECTIONS: ONE FOR EROSION CONTROL INSTALLATION, ONE BEFORE DRAINAGE FACILITIES ARE BURIED, AND ONE FOR FINAL WALK AROUND.

DRAINAGE NOTES

1. DRAINAGE INTENT: IT IS THE INTENT OF THE DRAINAGE SYSTEM TO CONVEY ROOF RUNOFF TO A SAFE LOCATION, AND TO MINIMIZE EXCESSIVE MOISTURE AROUND FOUNDATIONS. DIRECT SLOPES SUCH THAT STORMWATER WILL NOT BE DIVERTED ONTO ADJACENT PROPERTIES.
2. ALL DOWNSPOUT DRAIN LINES SHALL LEAD TO DETENTION BASIN, AS SHOWN.
3. ALL ROOF DRAINAGE PIPES SHALL BE 4" DIAMETER MINIMUM SOLID PIPE, SLOPED AT 1% MINIMUM.
4. IT IS THE PROPERTY OWNER'S RESPONSIBILITY TO CHECK ON ALL STORMWATER FACILITIES SUCH AS ROOF GUTTERS, DOWNSPOUT LINES, AND THE DETENTION BASIN/ENERGY DISSIPATER TO BE SURE THAT THEY ARE CLEAR OF EXCESSIVE DEBRIS AND OPERATING EFFICIENTLY. THE FACILITIES SHALL BE CHECKED EVERY FALL AND PERIODICALLY DURING THE RAINY SEASON.

GRADING NOTES

CUT VOLUME: 60 CY
 FILL VOLUME: 40 CY
 TOTAL: 100 CY

VOLUMES ABOVE ARE APPROXIMATE.

THE SUBGRADE BELOW ALL PAVED AREAS SHALL BE BASEROCK COMPACTED TO 95%.

ALL GRADING SHALL CONFORM TO LOCAL CODES AND ORDINANCES.

ALL TRENCHES UNDER PROPOSED PAVED AREAS OR CONCRETE SHALL BE BACKFILLED TO SUBGRADE ELEVATION WITH COMPACTED APPROVED GRANULAR MATERIALS. IF TRENCHES ARE IN PROPOSED LANDSCAPE AREAS, THEY SHALL BE BACKFILLED WITH COMPACTED APPROVED GRANULAR MATERIAL TO WITHIN ONE FOOT OF FINISHED GRADE, AND THEN FILLED WITH HAND TAMPED SOILS.

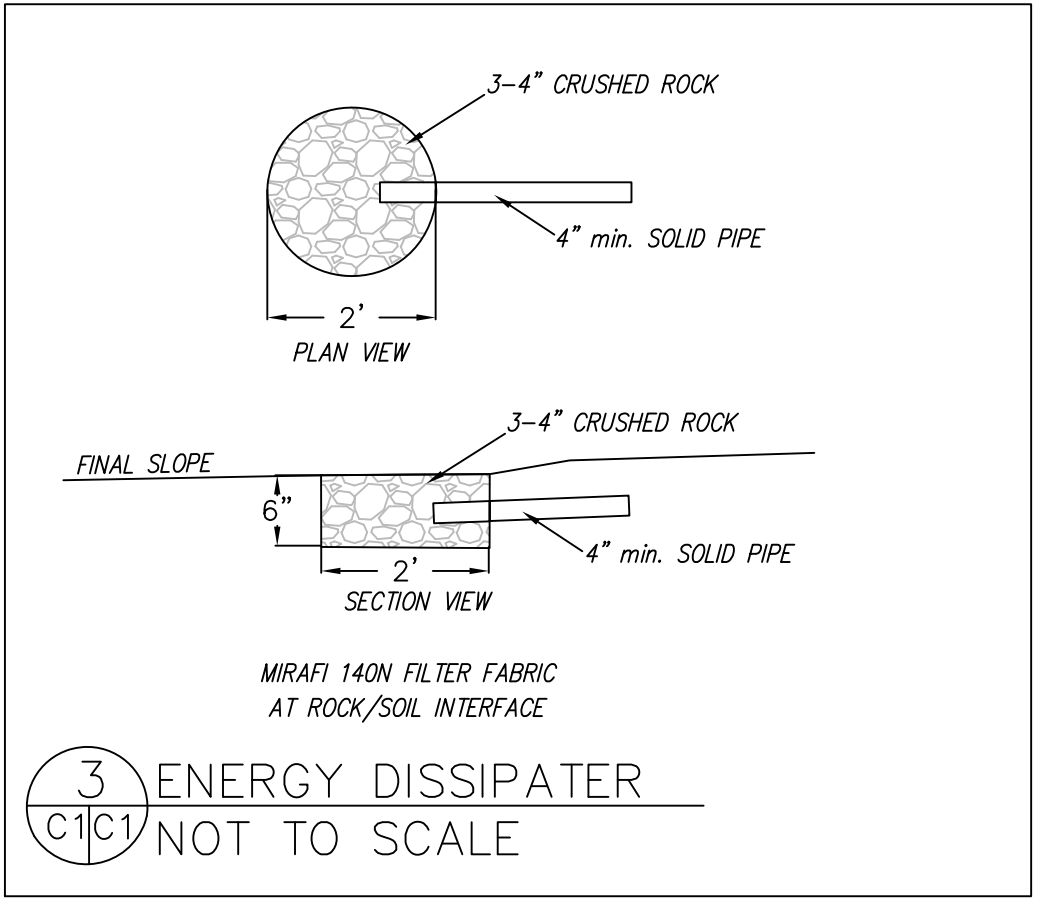
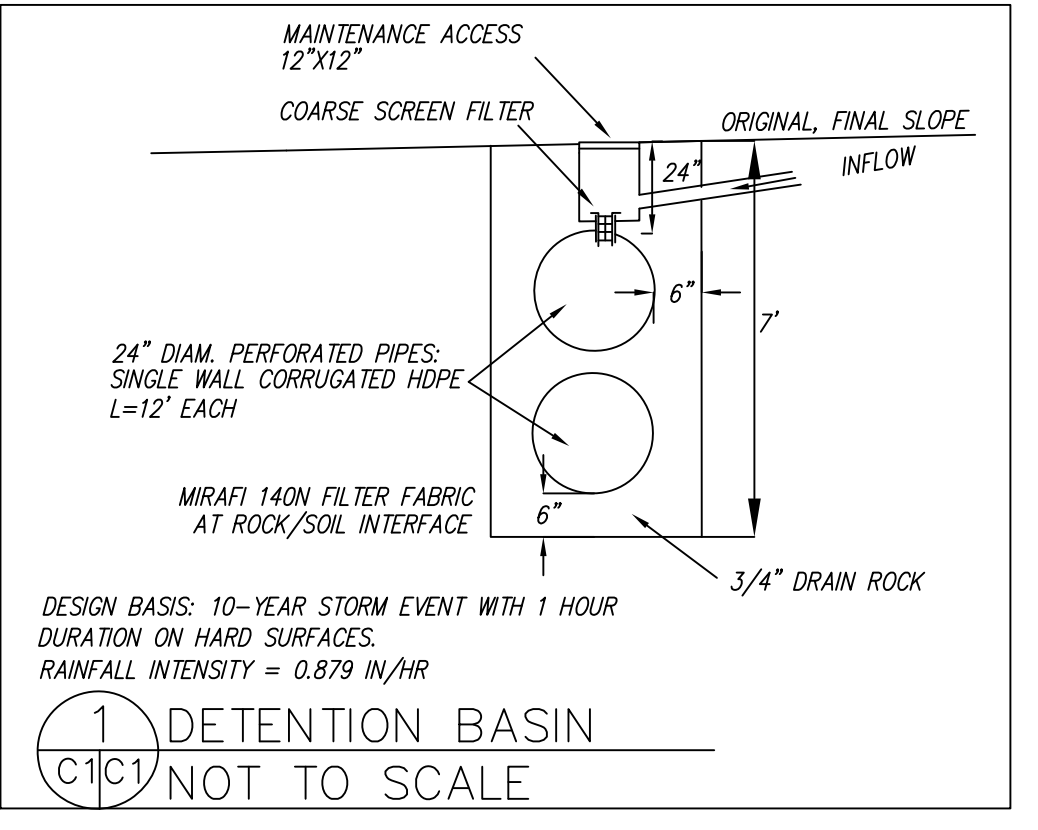
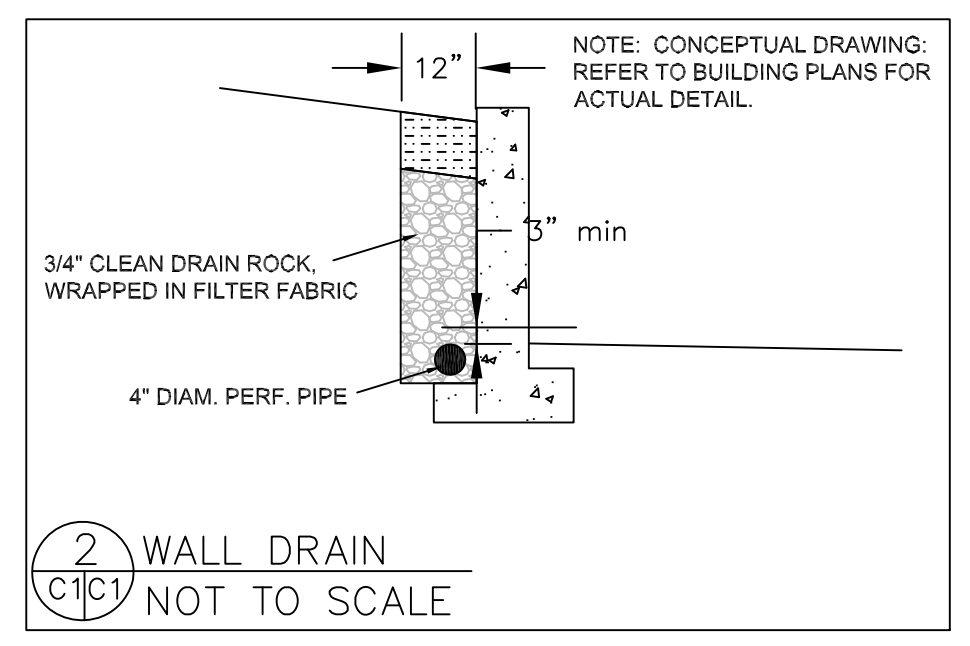
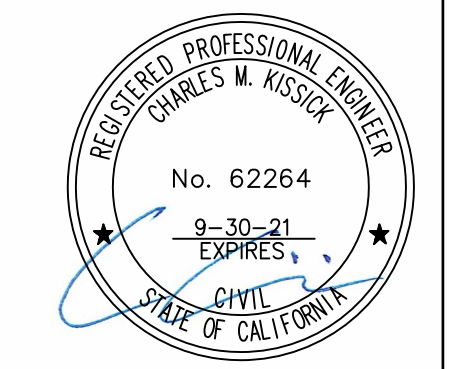

GRADING AND DRAINAGE PLAN

LACASIA PROPERTY
 779 SAN CARLOS AVE.
 EL GRANADA
 APN 047-105-020

SHEET C-1

DATE: 12-3-20
 DRAWN BY: CMK
 CHECKED BY: AZG
 REV. DATE: _____
 REV. DATE: _____
 REV. DATE: _____

Sigma Prime Geosciences, Inc.
 SIGMA PRIME GEOSCIENCES, INC.
 333 F. PRINCETON AVENUE
 PRINCETON, CA 94019
 (650) 739-3690
 FAX 726-3693

GENERAL EROSION AND SEDIMENT CONTROL NOTES

FIBER ROLL
INSTALL AT LOCATIONS SHOWN.
AFIX AS SHOWN IN DETAIL SE-5

- There will be no stockpiling of soil. All excavated soil will be hauled off-site as it is excavated.
- Perform clearing and earth-moving activities only during dry weather. Measures to ensure adequate erosion and sediment control shall be installed prior to earth-moving activities and construction.
- Erosion control materials to be on-site during off-season.
- Measures to ensure adequate erosion and sediment control are required year-round. Stabilize all denuded areas and maintain erosion control measures continuously between October 1 and April 30.
- Store, handle, and dispose of construction materials and wastes properly, so as to prevent their contact with stormwater.
- Control and prevent the discharge of all potential pollutants, including pavement cutting wastes, paints, concrete, petroleum products, chemicals, wash water or sediments, and non-stormwater discharges to storm drains and watercourses.
- Avoid cleaning, fueling, or maintaining vehicles on-site, except in a designated area where wash water is contained and treated.
- Limit and time applications of pesticides and fertilizers to prevent polluted runoff.
- Limit construction access routes to stabilized, designated access points
- Avoid tracking dirt or other materials off-site; clean off-site paved areas and sidewalks using dry sweeping methods.
- Train and provide instruction to all employees and subcontractors regarding the Watershed Protection Maintenance Standards and construction Best Management Practices.
- Placement of erosion materials is required on weekends and during rain events.
- The areas delineated on the plans for parking, grubbing, storage etc., shall not be enlarged or "run over."
- Dust control is required year-round.
- Erosion control materials shall be stored on-site.
- There are no trees or driplines on the site.

EROSION CONTROL POINT OF CONTACT

THIS PERSON WILL BE RESPONSIBLE FOR EROSION CONTROL AT THE SITE AND WILL BE THE COUNTY'S MAIN POINT OF CONTACT IF CORRECTIONS ARE REQUIRED.

NAME: ROD LACASIA
TITLE/QUALIFICATION: OWNER
PHONE: 650-766-2463
PHONE:
E-MAIL: ROD@MYRECONSTRUCTION.COM

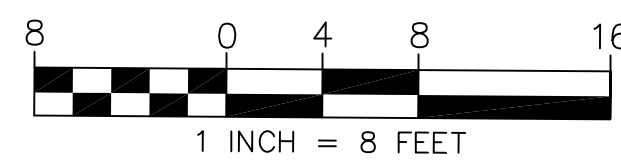
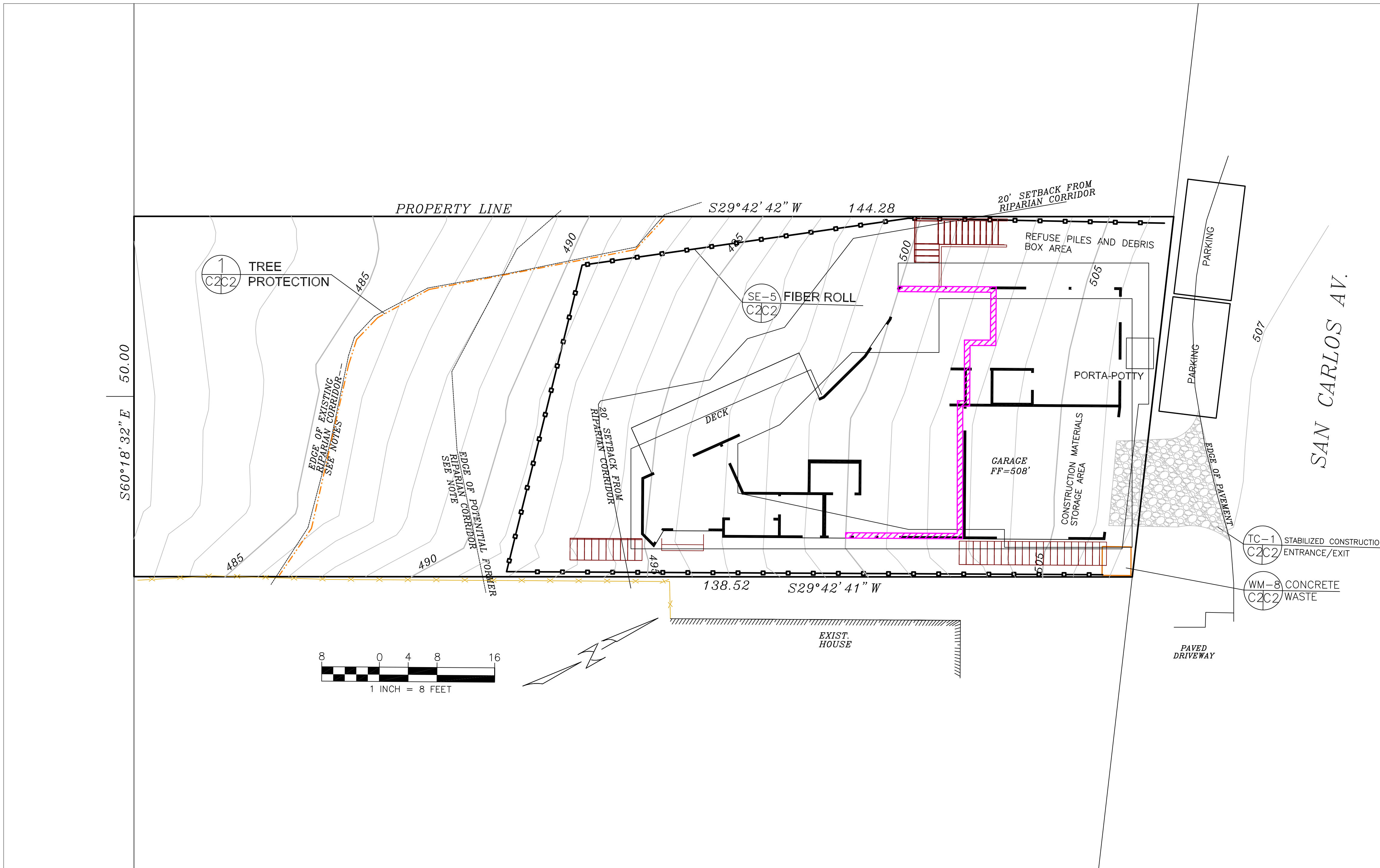
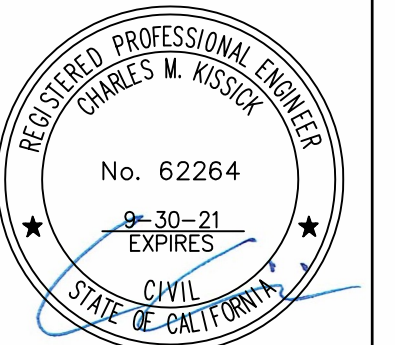

TREE PROTECTION NOTES

1. TREE PROTECTION FENCING SHALL BE INSTALLED PRIOR TO ANY GRADING AND REMAIN ON-SITE THROUGHOUT CONSTRUCTION PROCESS.
2. TREE PROTECTION FENCES SHALL BE INSTALLED AS CLOSE TO DRIP LINES AS POSSIBLE.
3. OWNER/BUILDER SHALL MAINTAIN TREE PROTECTION ZONES FREE OF EQUIPMENT AND MATERIALS STORAGE AND SHALL NOT CLEAN ANY EQUIPMENT WITHIN THESE AREAS.
4. ANY LARGE ROOTS THAT NEED TO BE CUT SHALL BE INSPECTED BY A CERTIFIED ARBORIST OR REGISTERED FORESTER PRIOR TO CUTTING, AND MONITORED AND DOCUMENTED.
5. ROOTS TO BE CUT SHALL BE SEVERED WITH A SAW OR TOPPER.
6. PRE-CONSTRUCTION SITE INSPECTION WILL BE REQUIRED PRIOR TO ISSUANCE OF BUILDING PERMIT.

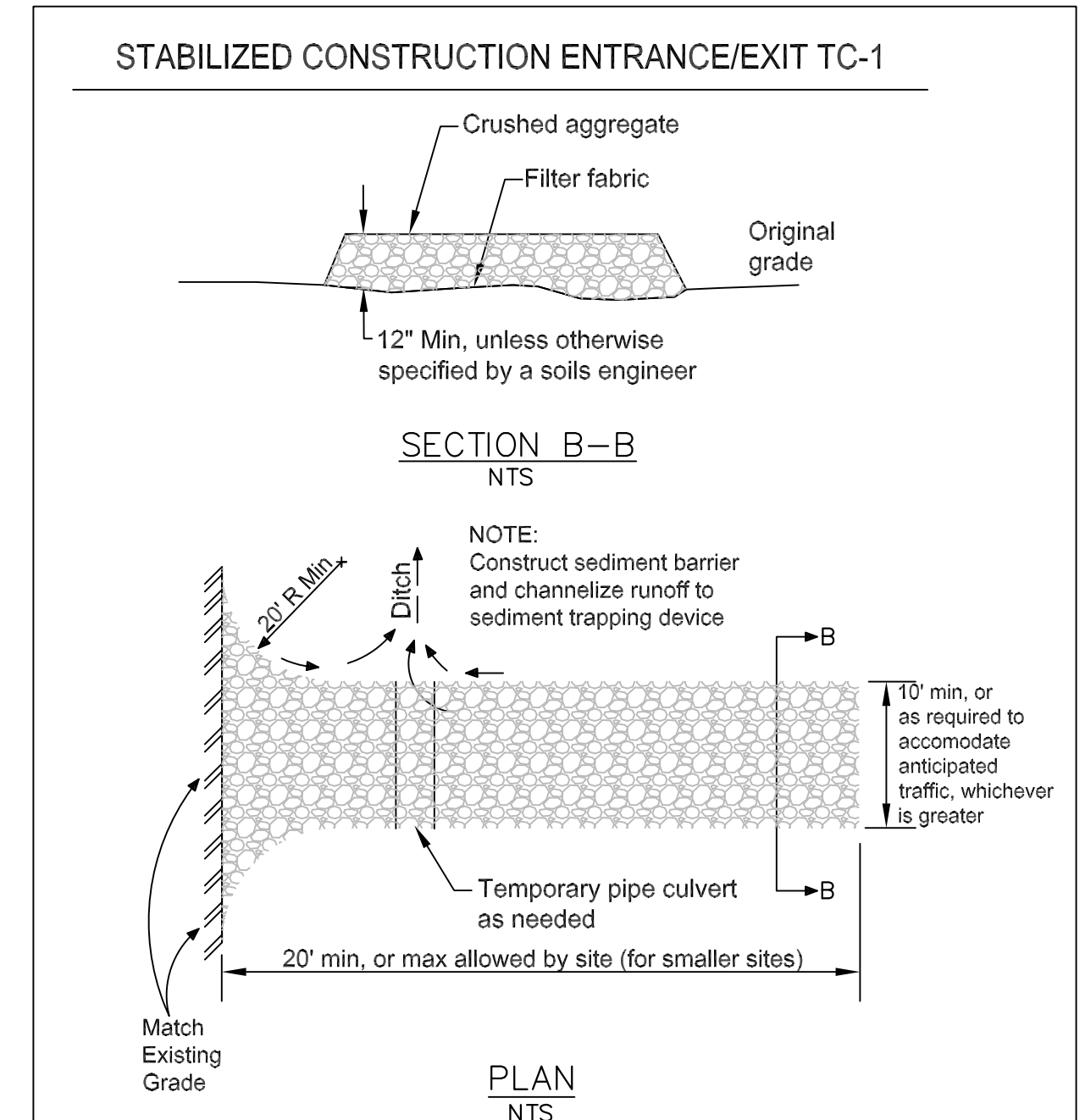
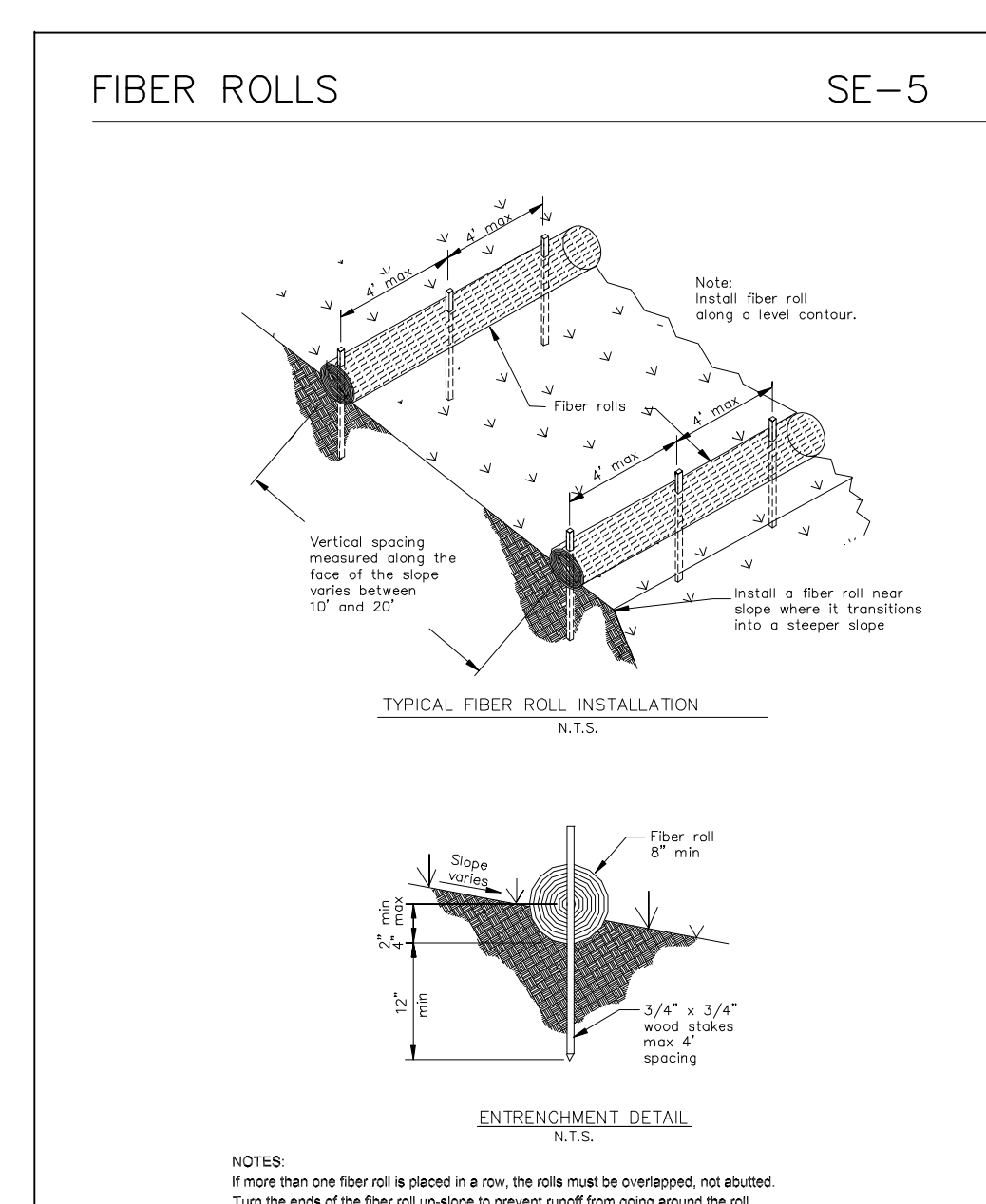
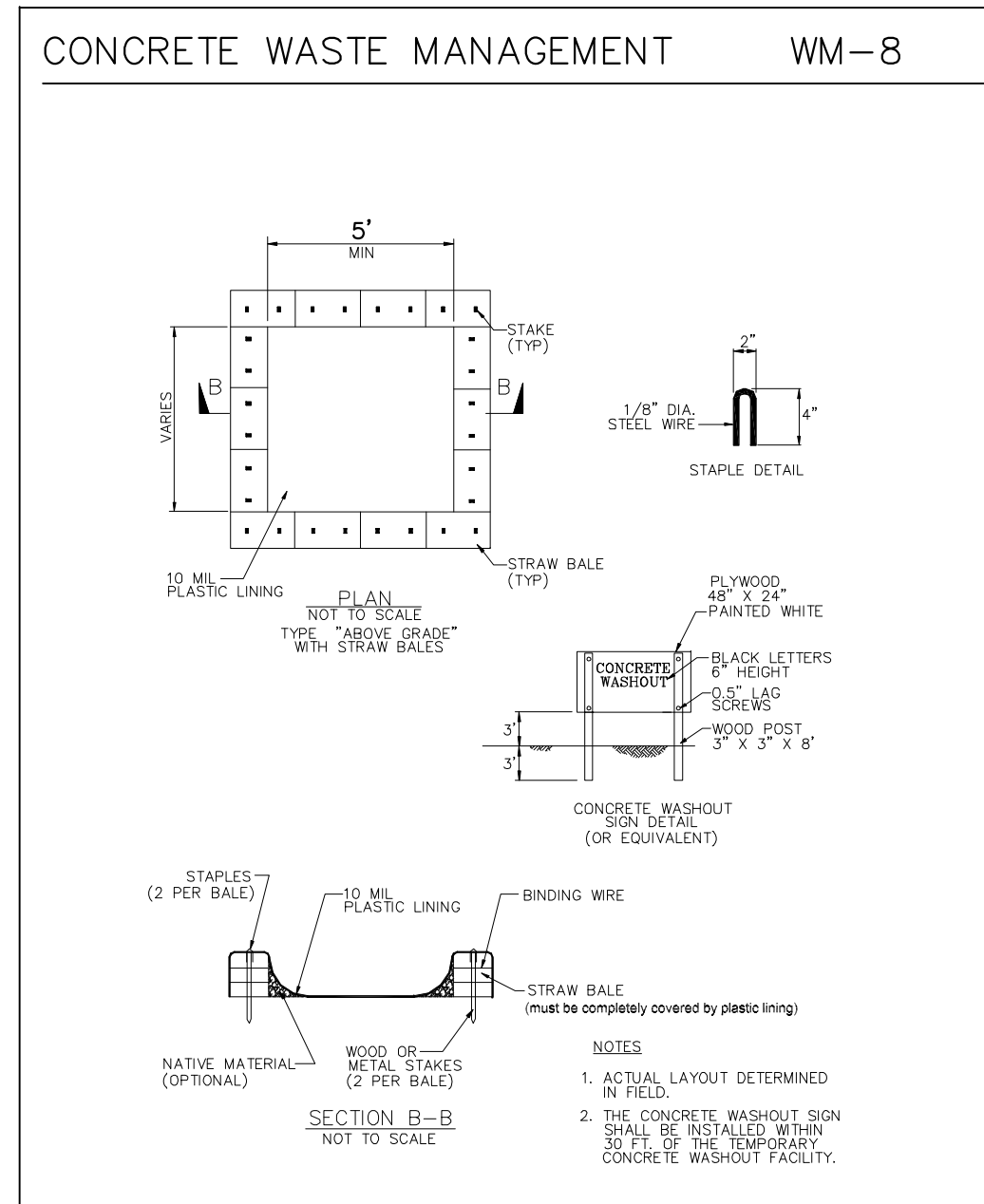
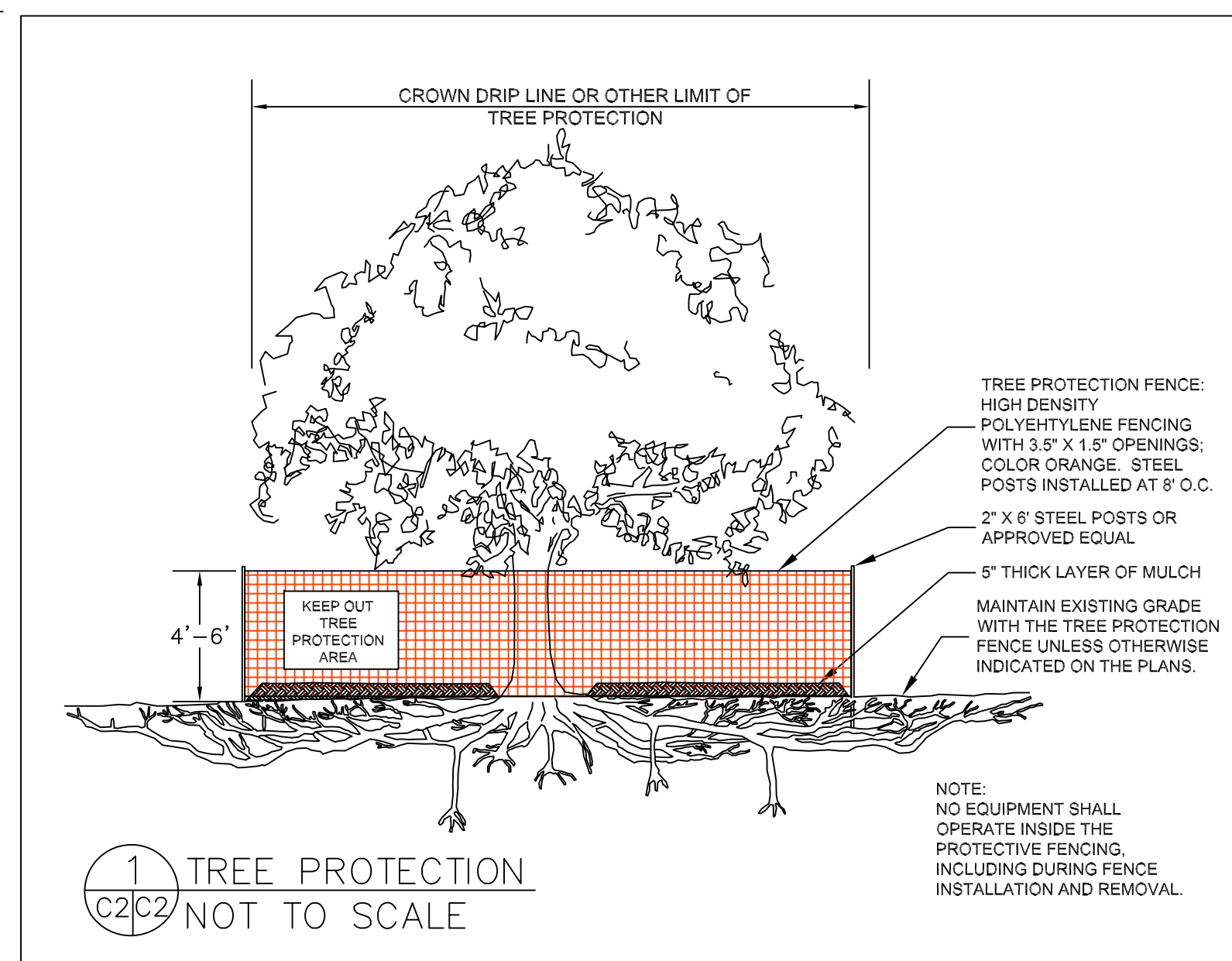

REGISTERED PROFESSIONAL ENGINEER
CHARLES M. KUSSAK
No. 62264
9-30-21 EXPIRES
CIVIL
STATE OF CALIFORNIA

DATE: 12-3-20
DRAWN BY: CMK
CHECKED BY: AZG
REV. DATE:
REV. DATE:
REV. DATE:

EROSION AND SEDIMENT CONTROL PLAN
LACASIA PROPERTY
779 SAN CARLOS AVE.
EL GRANADA
APN 047-105-020

SHEET
C-2