

**Attachment 5
Green Handle Farms**

HYDROGEOLOGIC ASSESSMENT REPORT

**3050 Big Valley Road
Kelseyville, CA 95451
APN 008-037-01 and 008-037-14**

PREPARED FOR:

Matt Schlegel
Green Handle Farms, LLC
1784 Peterson Pond Lane
Redwood Valley, CA 95470

January 6, 2021

PREPARED BY:

HURVITZ ENVIRONMENTAL SERVICES INC.

105 Morris Street, Suite 188
Sebastopol, California 95472

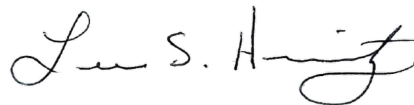

Lee S. Hurvitz, PG #7573 CHG #1015
Certified Hydrogeologist



PROJECT No. 5177.01

January 6, 2021

Matt Schlegel
Green Handle Farms, LLC
1784 Peterson Pond Lane
Redwood Valley, CA 95470

RE: Hydrogeological Assessment Report
3050 Big Valley Road
Kelseyville, CA 95451
APN 008-037-01 and 008-037-14
Hurvitz Environmental Project No. 5177.01

Mr. Schlegel:

Hurvitz Environmental Services, Inc. (HES) is pleased to submit this Hydrogeologic Assessment Report for the above referenced property. HES prepared this Report in accordance with the Lake County Cannabis Ordinance. The purpose of this Report was to outline the sites proposed water usage rates and water conveyance systems as well as to evaluate whether or not the project water supply can adequately meet the proposed water demands.

Based on the information and assessments contained herein, we conclude that the wells discharge capacity and rate of recharge are sufficient to sustainably provide for the projected annual water use at the site. The quantity of groundwater to be used for the project is unlikely to result in significant declines in regional groundwater availability or depletion of groundwater resources over time. The potential for the project water-use to cause well interference or impacts to creeks are also considered minimal.

We appreciate the opportunity to provide you with these services. Please do not hesitate to contact us at your convenience, should you have any questions or comments regarding this report or our recommendations.

Sincerely,
HURVITZ ENVIRONMENTAL SERVICES, INC

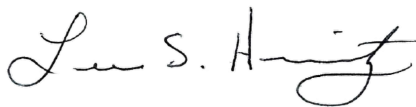

Lee S. Hurvitz, PG #7573 CHG #1015
Certified Hydrogeologist

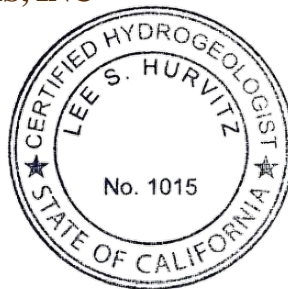

TABLE OF CONTENTS

1.0	INTRODUCTION AND SCOPE OF SERVICES	1
2.0	SITE DESCRIPTION	2
2.1	USGS 7.5 MINUTE QUADRANGLE MAP	2
2.2	GEOLOGICAL CONDITIONS.....	2
2.3	REGIONAL GROUNDWATER.....	3
3.0	SITE DEVELOPMENT AND WATER USE.....	4
3.1	MIXED LIGHT CULTIVATION.....	4
3.2	CANNABIS NURSERY	5
3.3	RESIDENTIAL WATER USE	5
3.4	SWIMMING POOL.....	5
3.5	EMPLOYEE WATER USE.....	6
3.6	TOTAL ANNUAL SITE WATER USE.....	6
3.7	IRRIGATION AND DOMESTIC WELL INFORMATION.....	7
3.8	WELL YIELD TEST	8
3.9	MONITORING AND REPORTING	9
4.0	WATER BALANCE INFORMATION	10
4.1	PRECIPITATION.....	10
4.2	GROUNDWATER STORAGE.....	10
4.3	GROUNDWATER RECHARGE	10
4.4	DROUGHT CONDITIONS.....	11
5.0	POTENTIAL IMPACTS TO STREAMS AND NEIGHBORING WELLS	12
6.0	WATER QUALITY.....	13
7.0	DROUGHT MANAGEMENT.....	14
8.0	CONCLUSIONS	15
9.0	LIMITATIONS.....	16

FIGURES

- PLATE 1 SITE LOCATION MAP**
- PLATE 2 ASSESSORS PARCEL MAP (A AND B)**
- PLATE 3 USGS TOPOGRAPHIC MAP**
- PLATE 4 SITE PLAN WITH WELL LOCATIONS**
- PLATE 5 GEOLOGIC MAP**

APPENDICES

- APPENDIX A SITE PHOTOGRAPHS**
- APPENDIX B ENGINEERING DESIGN PLANS**
- APPENDIX C WELL YIELD TEST**
- APPENDIX D RADIUS OF PUMPING INFLUENCE**
- APPENDIX E LABORATORY ANALYTICAL REPORT**

TABLES

- TABLE 1 TOTAL SITE WATER USAGE**
- TABLE 2 WATER QUALITY DATA**

1.0 INTRODUCTION AND SCOPE OF SERVICES

We understand that Matt Schlegel, Green Handle Farms, LLC (the applicant) is applying to Lake County for approval to develop a 29,500 ft² mixed light cannabis cultivation facility and a 5,000 ft² cannabis nursery (the project) at the property identified as 3050 Big Valley Road, Kelseyville, CA 95451 (the site). The proposed project will be utilizing two parcels (008-037-01 and 008-037-14) with a total area of 29.25 acres.

We understand that on July 27, 2021, the Lake County Board of Supervisor's adopted Ordinance 3106, where it states that: "Due to the exceptional drought.... All projects that require a CEQA analysis of water use must include these additional items: a Hydrology Report and a Drought Management Plan. Therefore, on behalf of the applicant, Hurvitz Environmental Services (HES) prepared a Hydrogeological Assessment Report and Drought Management Plan in accordance with the Lake County requirements.

This Assessment Report includes the following elements:

- Estimates of existing and proposed water uses for the property.
- Characterization of local geologic and hydrogeologic conditions including defining water sheds and sub-basins.
- Performance of a well yield test and recharge evaluation.
- Well Completion Report investigation.
- Discussion on proposed methods for water level and water usage monitoring.
- Severe drought condition assessment and management.
- Assess potential for well interference between the project well and neighboring wells and between the project well and nearby streams.

2.0 SITE DESCRIPTION

The site is located in unincorporated Lake County, California, approximately 1.5 miles northwest of Kelseyville. Access to the property is obtained from Big Valley Road (County Road 541) northwest of Kelseyville (**PLATE 1 – SITE LOCATION MAP**). The Lake County Assessor’s Office identified the site as Assessor’s Parcel No. (APN) 008-037-01 (deeded 19.29 acres) and 008-037-14 (deeded 9.96 acres) together the site is 29.25 acres (**PLATE 2A AND 2B ASSESSOR’S PARCEL MAPS**). Cultivation activities are only slated to occur on the eastern parcel (APN 008-037-01).

The site lies in the Mayacama Mountains of the California Coast Ranges. The site and surrounding area consist of agricultural lands with a residence located on the eastern parcel (APN 008-037-01) (**PLATE 3 – TOPOGRAPHIC MAP**). An Irrigation Well is located on the southeastern corner of the eastern parcel (APN 008-037-01) and is the proposed water source for the cannabis cultivation project. Two domestic wells are also located on the eastern site parcel and proximate to the residence. The domestic wells are utilized for residential purposes. The locations of relevant site features are shown on **PLATE 4 – SITE PLAN**. Site photographs are presented in **APPENDIX A-SITE PHOTOGRAPHS**.

2.1 USGS 7.5 MINUTE QUADRANGLE MAP

HES reviewed the United States Geological Survey (USGS) Kelseyville 7.5-minute Quadrangle Maps, 2015, (**PLATE 3 – USGS TOPOGRAPHIC MAP**). The approximately 29.25-acre site is located in “Big Valley” a large alluvial plain which drains into Clearlake. The site is generally flat with less than 10 feet elevation change across the site. The maximum elevation is 1,355 feet above mean sea level (MSL) located along the northern boundaries the lowest elevation is approximately 1,350 feet MSL located along the northwest site boundary. Surface water onsite flows to the north into a man-made drainage ditch that then flows north and west for approximately 1,200 feet before discharging into the McGaugh Slough.

2.2 GEOLOGICAL CONDITIONS

HES reviewed the USGS, Geologic Map of The Santa Rosa Quadrangle¹. According to the Map reviewed, the site lies completely on top of Quaternary Alluvium deposits. Alluvial deposits typically consist of well-sorted to semi-sorted clay, silt, sand and gravel. **PLATE 5 – GEOLOGIC MAP**.

¹USGS, Geologic Map of The Santa Rosa Quadrangle, California 1:250,000, D.L, Wagner and E.J. Bortugno, 1982.

2.3 REGIONAL GROUNDWATER

According to USGS² maps the project site is located within the McGaugh Slough- Frontal Clear Lake Sub-watershed (HUC-12 -180201160305) within the Big Valley Groundwater Basin which is also within the jurisdiction of the Central Valley Regional Water Quality Control Board. The McGaugh Slough flows north and drains into Clear Lake.

The Big Valley Groundwater Basin is bordered by Clear Lake to the north, the Clear Lake Volcanics to the east and the Franciscan Formation borders the basin to the west and south. Big Valley Basin is roughly triangular shaped, and is at most six miles wide and approximately eight miles long. Hydrogeology in Big Valley is comprised of two distinct areas: the younger alluvial and basin deposits in the north, and raised uplands comprised of the Kelseyville Formation in the south. The two areas are separated by the Big Valley Fault, which uplifted the Kelseyville Formation and created the uplands in the south.

Big Valley Groundwater Basin is a medium priority groundwater basin according to the Department of Water Resources (DWRs) Sustainable Groundwater Management Act (SGMA). This requires that a groundwater sustainability agency (GSA) be formed for the basin to develop groundwater sustainability plans (GSPs) by 2022. The Big Valley Subbasin Groundwater Sustainability Agency which includes the subject site is in the process of developing a GSP.

We understand that the Big Valley Basin has been monitored by the Lake County Watershed Protection District for many years and that the Basin is considered to have plentiful groundwater resources. Historically, most of the lowland area was cultivated with pears and walnut and some of the upland areas have more recently been developed into grapes with irrigation, but much of the land in these areas is still undeveloped. The Big Valley Groundwater Basin is the source of water supply for Kelseyville, which has the largest agricultural area in Lake County. Much of the undeveloped land in Big Valley is covered with dense California chaparral type brush, though areas of open grassland with scattered brush and trees exist near the head of the Valley.

Groundwater in storage in Big Valley has been estimated several times over the past 60 years. DWR estimated groundwater in storage to be 105,000 acre-feet for a saturated depth interval of 10 to 100 feet in 1960. In 2004, DWR estimated usable storage to be 60,000 acre-feet. DWR estimated specific yield in 1957 to be 8 percent. Average-year agricultural groundwater demand in the Big Valley basin is approximately 11,360 acre-feet per year.³

Land use changes have occurred through the past several decades with a decrease in pear and walnut farming and an increase in residential development and more recently commercial cannabis cultivation. Currently, water resources are generally considered to be substantial with more than enough to sustain the current demands in most of the Big Valley Basin. However, with local land use changes and current drought conditions, there is an increased regulatory framework designed to protect the water resources while sustainably providing groundwater for residential, agricultural and industrial uses.

² <https://apps.nationalmap.gov/viewer/>

³ California Department of Water Resources (DWR), Northern District, March 2006. Lake County Water Inventory and Analysis (Final) CDM

3.0 SITE DEVELOPMENT AND WATER USE

The proposed project will consist of developing 29,500 ft² of mixed light greenhouses for cannabis cultivation as well as 5,000 ft² of greenhouse nurseries for cannabis propagation. The proposed cannabis cultivation will be on the southeastern portion of the site and south of the onsite residence. Irrigation for the project will be performed from an onsite groundwater well (Irrigation Well) located at the southeast corner of the site. The onsite Irrigation Well will also be used for potable drinking water for project employees. The proposed cultivation areas and Irrigation Well are located as shown on **PLATE 4 –SITE PLAN**. Discussions on the well construction and well yield are presented in Section 3.7 and 3.8 of this Report.

As part of the development plans the applicant also plans to install three (3), 2,500-gallon, poly, water-storage tanks and two (2) 500-gallon mixing tanks on the property. The irrigation water intended for cannabis cultivation will be pumped directly from the project Irrigation Well and into the storage tanks before being transferred to the mixing tanks located adjacent to the proposed cultivation areas. The 2,500-gallon tanks will be kept full as a backup water supply and for general landscaping, fire suppression, and dust control measures. Engineering design plans for the site layout are presented in **APPENDIX B**.

The estimated annual water use for the entire 34,500 ft² cultivation project (mixed light cultivation cannabis nursery, and employees) is 973,925 gallons, which is approximately 2.99 acre-feet of groundwater/yr. The project plans do not involve any water diversions, or imported water so all project water will be derived from the project Irrigation Well. Details on the cultivation projects water usage, including breakdowns of average and peak monthly usage, are presented in **TABLE 1**.

3.1 MIXED LIGHT CULTIVATION

The applicant plans to cultivate 29,500 ft² of mixed light cannabis at the site. The applicant has not had any specific experience growing cannabis at this location but the applicant is working with experienced cannabis cultivators and is designing the system to use the least amount of water possible. The applicant plans to grow year-round in the mixed light greenhouses and harvest approximately 4 crops/yr. Cannabis harvests will be occurring approximately every three months and re-planting from the proposed site nursery following each harvest. The applicant plans to utilize soil moisture monitors and point emitter drip irrigation to efficiently irrigate the cannabis plants.

It is our understanding that a cannabis water usage rate of 4 acre-feet/acre/year for year-round greenhouse cultivation is considered to be an average water usage rate in Sonoma County⁴. Therefore, if we scale the published Sonoma County water usage rate to the applicants proposed mixed light development (29,500 ft²) we end up with an estimated annual water use of 2.71 acre-feet/year or approximately 882,700 gallons/year.

$$29,500 \text{ ft}^2 \text{ (mixed light)} / 43,560 \text{ ft}^2/\text{acre} \times 4 \text{ acre-feet/year (So Co published rates)} =$$

2.71 acre-feet/year or 882,700 gallons/year for Mixed Light Cultivation

⁴ Sonoma County Permit and Resource Management Department, Policy and Procedure 8-2-1; Water Supply, Use and Conservation Assessment Guidelines, Adopted January 7, 2020.

3.2 CANNABIS NURSERY

The applicant also plans to propagate cannabis plants in a greenhouse nursery onsite. The proposed 5,000 ft² cannabis nursery will be utilized to support the 29,500 ft² mixed light cannabis cultivation, also proposed onsite. The proposed cannabis nursery will be utilized year-round and will develop cannabis plants from seedling, and into the plants vegetative cycle before being transported to the mixed light cultivating facilities.

Water used in the cannabis nursery will come from the project Irrigation Well and it is expected that nursery water use will be less than 1/2/ft², than the mixed light cultivation water use. Therefore, if we scale the published Sonoma County water usage rate to the applicants proposed nursery development (5,000 ft²) we end up with an estimated annual water use of 0.23 acre-feet/year or approximately 74,800 gallons/year.

$$5,000 \text{ ft}^2 \text{ (mixed light)} / 43,560 \text{ ft}^2/\text{acre} \times 2 \text{ acre-feet/year (1/2 of mixed light cultivation)} = \mathbf{0.23 \text{ acre-feet/year or 74,800 gallons/year for Cannabis Nursey}}$$

3.3 RESIDENTIAL WATER USE

The site is developed with a single-family residence and garage, a swimming pool and some minor landscaping. According to the USGS, the average person within the Santa Rosa Plain Watershed uses 0.19 acre-feet/year for domestic purposes⁵. This value includes landscaping and could be considered representative of the proposed domestic use at the site (not including swimming pool). Using this value for domestic water use and assuming that four people currently live or could potentially live in the existing residence, we calculated the following onsite domestic water usage.

$$4 \text{ residents} \times 0.19 \text{ acre-feet/year} = \mathbf{0.76 \text{ acre-feet/year or 247,647 gallons/year} = \text{Domestic Groundwater Usage}}$$

3.4 SWIMMING POOL

The site is currently developed with a 415 ft² swimming pool installed proximate to the residence. On average swimming pools can lose 1/4-inch of water per day due to evaporation alone. If we assume that the only water loss is from evaporation and the evaporation losses occur 240 days/year, we can estimate the amount of water required annually to keep the swimming pool full.

$$\begin{aligned} 415 \text{ ft}^2 \text{ (pool size)} / 43,560 \text{ ft}^2/\text{acre} &= 0.0095 \text{ acres} \\ \frac{1}{4} \text{ inch (daily water loss)} / 12 \text{ inches/foot} &= 0.0208 \text{ feet} \\ 0.0095 \text{ acres (pool size)} \times 0.0208 \text{ ft. (daily water loss)} \times 240 \text{ days (evap. days/year)} &= \mathbf{0.0474 \text{ acre-feet/year or 15,453 gallons/year} = \text{Annual Swimming Pool Loss}} \end{aligned}$$

⁵ Santa Rosa Plain Groundwater Management Plan, Sonoma County Water Agency, 2014

3.5 EMPLOYEE WATER USE

We understand that the Project will require one full-time farm manger, as well as, several part-time seasonal employees. Therefore, for the purpose of this assessment we estimate that the project will require an average of three full-time employees throughout the growing season. Potable water for farm workers will come from the proposed Irrigation Well. Using the Napa County Water Availability Guidance Document⁶ estimate of 15 gallons of water utilized per day per cultivation worker on site, we calculated the following groundwater usage for the Project:

- Annual Onsite Worker Water Use = 3 (average number of daily employees) x 15 gallons/day (daily employee water usage) x 365 days/year) = **16,425 gallons /year = 0.05 acre-feet/year = Worker Groundwater Use**

So, the annual Project water use estimate is 882,700 gallons (Mixed Light Cultivation) + 74,800 gallons (Cannabis Nursery) + 247,647 (Residential Water Usage) + 15,453 gallons (Swimming Pool) + 16,425 (Employee Water Usage) = **1,237,025 gallons or 3.8 acre-feet/year = Total Site Water Usage**

3.6 TOTAL ANNUAL SITE WATER USE

The total water use including Mixed Light Cannabis Cultivation, Nursery Cultivation, residence, employees, and swimming pool from the groundwater resources onsite is calculated below and tabulated on **TABLE 1 – TOTAL ANNUAL SITE WATER USAGE**.

882,700 gallons (mixed light cultivation 4 annual harvests) +
74,800 gallons (nursery cultivation year-round) +
16,425 gallons (employee water use) +
247,647 gallons (1 residence + landscaping) +
15,453 gallons (swimming pool) =
1,237,025 gallons or 3.8 acre-feet/year = Total Annual Site Water Usage

⁶ Water Availability Analysis (WAA) Guidance Document, Napa County, Adopted May 12, 2015.

TABLE 1 – TOTAL PROJECT AND SITE WATER USAGE

Source	Jan	Feb	Mar	Apr	May	June	July	Aug	Sept	Oct	Nov	Dec	Total
	-----Gallons-----												
Mixed Light Cultivation	65,000	70,000	70,000	75,000	75,000	77,700	80,000	80,000	80,000	75,000	70,000	65,000	882,700
Cannabis Nursery	6,000	6,000	6,000	6,250	6,250	6,250	6,500	6,500	6,500	6,200	6,200	6,150	74,800
Employees	1,370	1,370	1,370	1,370	1,370	1,370	1,370	1,370	1,370	1,370	1,370	1,355	16,425
Residential	18,000	18,000	20,000	20,000	21,000	22,000	23,000	23,000	23,000	21,647	20,000	18,000	247,647
Swimming Pool	0	0	300	1,600	2,000	2,200	2,500	2,500	2,500	1,600	253	0	15,453
TOTAL USAGE	90,370	95,370	97,670	104,220	105,620	109,520	113,370	113,370	113,370	105,817	97,823	90,505	1,237,025

Based on these estimates for onsite water use it appears that the peak water demand at the site will occur annually between July and September with peak daily water demand being approximately **3,697** gallons/day. Average daily water demand at the site over the entire year is expected to be approximately **3,389** gallons/day.

Since the residential developments onsite including the home, the swimming pool and landscaping are in already in existence the only new proposed water use is cannabis related. Therefore, is we look at annual water use at the site we see that it can be further broken down into existing and proposed. Cannabis water use (mixed light, nursery, employees) is the only new proposed water use and is expected to be approximately 2.99 acre-feet/year while the existing non-cannabis water use is estimated to be approximately 0.81 acre-feet/year.

3.7 IRRIGATION AND DOMESTIC WELL INFORMATION

The project Irrigation Well is located at the southeast corner of the site and the two (2) domestic wells are located north of the onsite residence on the eastern parcel, as shown on the **SITE PLAN, PLATE 4**. The Irrigation Well is not currently used but will provide water for cannabis irrigation and employee drinking water, while the sites domestic well will be dedicated for residential and landscaping purposes.

No well completion reports were identified for the project Irrigation Well or either of the two domestic wells. However, a well inspection was performed by Cal-Tech Pump, Well, and Water Treatment, of Middletown CA on November 4, 2021. HES also performed a well yield test on the Irrigation Well on November 2, 2021. Based on the inspections and testing performed we understand that the Irrigation Well is constructed with 10-inch diameter steel casing to a total depth of approximately 100 feet below grade (bg). The Irrigation Well is equipped with a 230 volt, 3-phase submersible pump with a 6-inch discharge pipe installed at the well head. The well was not plumbed to anything at the time of inspection.

The domestic wells have not been inspected at the site. We understand that the property was developed sometime between 2006 and 2008 and that the domestic wells were installed as part of the property development.

3.8 WELL YIELD TEST

On November 2, 2021 HES performed a 1-hour well yield test on the project Irrigation Well and on November 4, 2021 Cal-Tech Pump, Well, and Water Treatment performed a 4-hour well yield test on the same well. During the November 2, 2021 well test, the initial static water level was measured at 27.35 feet below the top of the well casing. The existing 230 volt, 3-phase submersible pump was used to perform the well test and the discharge pipe was reduced to 4-inch diameter. The yield test began at 11:31am and ended at 12:30pm (59 minutes) the same day. During the early portion of the test, the well produced blackish water and a relatively large amount of sand. However, after approximately 20 minutes of pumping the water turned clear and only minor amounts of sand were produced.

The well yield sustained approximately 350 gallons per minute (gpm) throughout the 1-hr test. During the test water levels stabilized at 41.15 feet below the top of well casing. Flow was measured by filling a 50-gallon reservoir which took approximately 8.5 seconds. Approximately 20,000 gallons of water was pumped from the well during the 59-minute test. The specific capacity was calculated to be 25.36 gpm/foot of drawdown (i.e., 350 gpm/13.8 ft). The HES well yield test data and calculations are attached in **APPENDIX C**.

Well recovery data was collected for 25 minutes following completion of the approximately 1-hour well test. Approximately 25-minutes after the well pump was turned off the static water level had recovered fully to a depth of 27.35 feet. This indicates that the aquifer was not in overdraft as a result of the pumping.

During the November 4, 2021 Cal-Tech well test the initial static water level was measured at 27.5 feet below the top of the well casing. The existing 230 volt, 3-phase submersible pump was used to perform the well test and the 6- inch diameter discharge pipe was not reduced. The yield test began at 1:17pm and ended at 5:17pm (4-hours) the same day. The well pumped sediment clear water throughout the Cal-Tech inspection. The water quality started off with blackish coloration but cleared as the test went on.

According to Cal-Tech, the well yield sustained approximately 800 gpm throughout the well test. During the test water levels stabilized at 43.5 feet below the top of well casing. A flow meter was not used during the test and the flow rate was estimated by the test operator. According to Cal-Tech approximately 192,000 gallons of water was pumped from the well during the 4-hour test. The specific capacity was calculated to be 50 gpm/foot of drawdown (i.e., 800 gpm/16 ft). The Cal-Tech well yield test data is also attached in **APPENDIX C**.

Well recovery data was collected for 30 minutes following completion of the 4-hour well test. Approximately 30-minutes after the well pump was turned off the static water level had recovered to a depth of 32 feet. This indicates a recovery of 72%.

The variance in flow rates and specific capacity from the two tests can be attributed to the reduced pipe diameter used during the November 2, 2021 test, and the methods used to measure the flow resulting in estimations only. With an estimated flow rate between 350-800 gpm and a peak daily water demand of 3,397 gallons (including residential and swimming pool), we estimate that it would only require between 5 and 11 minutes of pumping to meet the sites maximum daily demand. The average daily water demand of 3,389 gallons/day could be met with approximately 4 to 10 minutes of pumping. Based on the results of the well yield test and recovery observations it is apparent that the well can produce the water necessary for the proposed cultivation project without causing overdraft conditions.

3.9 MONITORING AND REPORTING

A totalizing water meter is not currently installed on the well and the well is not plumbed to any irrigation features. However, once cannabis operations begin at the site the applicant must monitor total monthly and annual usage using an inline totalizing meter or equivalent. Monthly water usage totals will be recorded by the applicant in a log book that will be kept onsite and provided to the oversight agencies upon request.

Depth to water measurements will also be recorded from the project well on a monthly basis throughout the year. The applicant will utilize a Solinist® Water Level Meter or equivalent to obtain monthly depth to water readings directly from the Irrigation Well. The readings will be taken on the same day of each month and prior to daily pumping activities. Results of the water level measurements will also be recorded in a log book and stored onsite and provided to the oversight agencies upon request.

4.0 WATER BALANCE INFORMATION

4.1 PRECIPITATION

Precipitation, primarily as rainfall is the major source of inflow to the Big Valley Basin. Though there are no climate stations on site, seasonal precipitation data for the area was obtained from published data to be approximately 40-inches/year (3.33 feet)⁷. Based on this precipitation it can be reasonably expected that annual precipitation is 97.4 acre-feet over the entire 29.25-acre property.

$$29.25\text{-acres} \times 3.33 \text{ feet (Annual precipitation in Cumulative Impact Area)} = \\ \text{Estimated Annual Precipitation Onsite} = \mathbf{97.4 \text{ acre-feet}}$$

4.2 GROUNDWATER STORAGE

As discussed in Section 2.3 of this Report, the overall water storage available in the Big Valley Groundwater Basin has most recently been estimated to be 60,000 acre-feet⁸. However, this storage capacity is not uniform over the entire watershed which includes steep upland areas, as well as low lying natural recharge basins. Recharge to the aquifer is also not uniform across the Watershed as discussed in more detail below.

4.3 GROUNDWATER RECHARGE

Groundwater recharge is the replenishment of an aquifer with water from the land surface. It is usually expressed as an average rate of inches of water per year, similar to precipitation. Thus, the volume of recharge is the rate times the land area under consideration times the time period, and is usually expressed as acre-feet per year. In addition to precipitation, other sources of recharge to an aquifer are stream and lake or pond seepage, irrigation return flow (both from canals and fields), inter-aquifer flows, and urban recharge (from water mains, septic tanks, sewers, drainage ditches).

Long-term hydrographs in Lake County show that during drought periods the groundwater basins do not fully recover, possibly leading to short-term overdraft. However, long term trends in the hydrographs in Lake County appear to indicate that annual groundwater extractions are not exceeding annual groundwater recharge in groundwater basins.⁹

For this site, the alluvial aquifer is considered to be unconfined. Drainage features that intersect and border the site have likely eroded through some of the overlying layers and are contributing to the recharge of the site's aquifer through the stream bottom. However, it is also likely that a significant portion of the rain water falling directly on the site infiltrates the ground surface and migrates downward through the soil matrix and recharges the relatively shallow aquifer.

⁷ Figure 2-3 California Department of Water Resources (DWR), Northern District, March 2006. Lake County Water Inventory and Analysis (Final) CDM

⁸ California Department of Water Resources (DWR), Northern District, March 2006. Lake County Water Inventory and Analysis (Final) CDM

⁹ California Department of Water Resources (DWR), Northern District, March 2006. Lake County Water Inventory and Analysis (Final) CDM

To estimate the groundwater recharge at the site we first assumed that the recharge to the aquifer is primarily through rainfall and that all rainfall accumulated within the 29.25-acre property drains to the manmade drainage swale that borders the site to the north. As discussed in section 4.1 the Estimated Annual Precipitation onsite is 97.4 acre-feet.

However, this estimate does not account for surface run-off, stream underflow, and evapo-transpiration that occurs in all watersheds. According to the USGS, the long-term average precipitation that recharges groundwater in these northern California regions is approximately 15% but can be as low as 1.67%. Since this site has very consistent topography, alluvial soils, and shallow groundwater, we estimate that the long-term average precipitation that recharges groundwater within the entire site is above the regional average at approximately 18%. With this data and the precipitation data presented above, we can re-estimate the groundwater recharge within the Cumulative Impact Area using the following equation.

$$97.4 \text{ acre-feet (Annual precipitation onsite)} \times 0.18 \text{ (long term average for recharge)} =$$

Estimated Groundwater Recharge = 17.53 acre-feet/year

Based on the estimated annual recharge to the site aquifer (17.53 acre-feet/year) and the estimated annual project usage (2.99 acre-feet/year), it appears that the applicant will have enough water to meet their demands without causing aquifer overdraft conditions.

4.4 DROUGHT CONDITIONS

The recharge assessment presented above is based on a 10-year average from 2010 through 2020 which includes at least one year of heavy rains (2018) as well as two years of severe drought (2020, 2021). The variations in rainfall over the 61-year dataset shows a high of 53.49 inches of precipitation and a low of 10.05 inches¹⁰. If we were to perform a recharge analysis of one single year using the lowest recorded rainfall for the area, we could estimate the possible low-end value for annual aquifer recharge as follows.

$$0.8375 \text{ ft/year (severe drought rainfall)} \times 29.25\text{-acres (property size)} \times 0.18 \text{ (long-term average for recharge)} =$$

4.41 acre-feet/year - Estimated Groundwater Recharge for Severe Drought Year

Based on the estimated annual recharge to the site aquifer during extreme drought (4.41 acre-feet/year) and the estimated annual project usage (2.99 acre-feet/year) and residential related water use (0.81 acre-feet/year), it appears that the applicant would still have enough water to meet their demands without causing aquifer overdraft conditions.

¹⁰ Table 2-2 California Department of Water Resources (DWR), Northern District, March 2006. Lake County Water Inventory and Analysis (Final) CDM

5.0 POTENTIAL IMPACTS TO STREAMS AND NEIGHBORING WELLS

To evaluate potential well pumping impacts to surface water bodies or wells on other properties, the potential lateral extent of pumping from the planned project well was estimated. Using general relationships discussed in Driscoll (1986)¹¹, we estimated the lateral pumping influence using information from the 2021 well yield tests. An approximate relationship between specific capacity calculated from the well yield tests, and aquifer transmissivity was used to obtain aquifer characteristics and estimate a potential radius of pumping influence. Transmissivity was estimated for an unconfined aquifer using the relationship of Specific Capacity (yield/drawdown) x the coefficient of 1,500 (unconfined aquifer). To develop the slope of the drawdown curve from the pumping well, the value of Δs (drawdown over one log graph cycle) was calculated for a distance-drawdown relationship, where $T = 528Q/\Delta s$ (Driscoll, 1986, Equation 9.11). The analysis from the 11/2/21 HES and 11/4/21 Cal-Tech well yield tests are shown on the attached semi-log plot, **APPENDIX D – RADIUS OF PUMPING INFLUENCE**.

As estimated from the HES well yield test, pumping the project well at 350 gpm with a drawdown of 13.8 feet indicates a specific capacity of 25.36 gallons/foot drawdown. Using this data and applying it to the site, we calculated a zone of pumping influence extending approximately 290 feet from the well for an unconfined aquifer. Similarly, the analysis from the 11/4/21 Cal-Tech well yield test resulted in radius of pumping influence extending approximately 290 feet from the site Irrigation Well.

No additional wells were identified within the calculated radius of pumping influence. Based on the irrigation wells pumping rate of 350-800 gpm and the sites peak daily water demand of 3,697 gallons/day, we estimate it would require only 10-11 minutes of pumping each day. Therefore, the actual radius of pumping influence is likely smaller than estimated.

¹¹ Groundwater and Wells, Second Edition, Fletcher G. Driscoll, 1986, published by Johnson Division, St. Paul Minnesota, 1089p.

6.0 WATER QUALITY

A limited water quality assessment of the project Irrigation Well was performed by Cal-Tech Pump and Well. The results of the limited assessment did not find any contaminants that are considered hazardous. However, we recommend that additional water quality analysis be performed that includes total coliform and e-coli bacteria as well as common contaminants such as arsenic and chromium prior to using the Irrigation Well as a potable water source. The laboratory analytical results are tabulated on **TABLE 2 – Water Quality Data**, and the laboratory analytical report is attached in **APPENDIX E**.

TABLE 2 – WATER QUALITY DATA

Location (APN)	pH	SAR	Nitrate as N	Chloride	Sulfate as SO4	Hardness	TDS	Specific Conductance
	Mg/L							Umhos/cm
Irrigation Well	7.62	0.23	<0.20	8.2	38	315	350	550
< = Less than the indicated laboratory detection limit.								

TABLE 2 Continued– WATER QUALITY DATA

Location (APN)	Boron	Calcium	Iron	Magnesium	Manganese	Potassium	Sodium	Bi- Carbonate	Carbonate
	mg/L								
Irrigation Well	<0.20	23	0.12	63	<0.020	1.4	9.3	310	<5.0
< = Less than the indicated laboratory detection limit.									

7.0 DROUGHT MANAGEMENT

Due to the recent drought conditions in California, Lake County has requested that cannabis applicants provide plans on how they will minimize water use if a drought emergency is declared in Lake County. As previously discussed in Section 3.1 of this Report the project applicant is planning on using best management practices to maximize water efficiency onsite. In addition to the best water management practices listed above, the applicant will perform these additional water saving measures if the County declares a drought emergency.

- Spreading of mulch or similar material throughout the entire cultivation area to decrease evaporation losses and decrease watering frequency.
- Install wind barriers at the site to decrease evaporation losses from dry windy conditions.
- Use previously saved rainwater to supplement cannabis irrigation and eliminate landscape watering.

8.0 CONCLUSIONS

The project site is located in the McGaugh Slough- Frontal Clear Lake Sub-watershed within the Big Valley Groundwater Basin. The groundwater aquifer at the site consists primarily of Quaternary Alluvial deposits. The estimated groundwater usage for the entire site including the proposed project is approximately 3.8 acre-feet/year and approximately 2.99 acre-feet of that is proposed as new groundwater use at the site. Average annual recharge to the site aquifer is estimated at 17.53 acre-feet/year while severe drought conditions could produce as low as 4.41 acre-feet/year of aquifer recharge. Based on well yield test data collected at the site, it appears that the aquifer storage and recharge area are sufficient to provide for sustainable annual water use at the site and within the area.

In summary:

Estimated Water for Cultivation = **2.94-acre-feet/year**

Residential Water Use = **0.81 acre-feet/year**

Employee Water Use = **0.05 acre-feet/year**

Total Estimated Site Water Use = **3.8 acre-feet/year**

Estimated Annual Recharge = **17.53 acre-feet**

Estimated Recharge During Severe Drought – **4.41 acre-feet/year**

Sustained Well Yield = **350-800 gpm**

Peak Daily Water Demand = **3,697 gallons/day gallons**

- The quantity of groundwater to be used for the project compared to the quantity of available groundwater indicates that pumping for the proposed project is unlikely to result in significant declines in groundwater elevations or depletion of groundwater resources over time.
- The horizontal and vertical separations between the project wells and the nearest streams and neighboring properties should not result in significant well interference or impacts to creeks.
- No water quality issues have been identified however additional analysis may be necessary before using as a potable water source.

9.0 LIMITATIONS

HES is not responsible for the independent conclusions, opinions or recommendations made by others based on the records review, site inspection, field exploration, laboratory test data and interpretations presented in this report.

Groundwater systems of Lake County are typically complex, and available data rarely allows for more than general assessment of groundwater conditions and delineation of aquifers. Hydrogeologic interpretations are based on the drillers' reports made available to us through the California Department of Water Resources, available geologic maps and hydrogeologic studies and professional judgment. This analysis is based on limited available data and relies significantly on interpretation of data from disparate sources of disparate quality.

It should be noted that hydro-geological assessments are inherently limited in the sense that conclusions are drawn and recommendations developed from information obtained from limited research and site evaluation. Additionally, the passage of time may result in a change in the environmental characteristics at this site and surrounding properties. This report does not warrant against future operations or conditions, nor does this warrant operations or conditions present of a type or at a location not investigated.

This study is not intended to assess if any soil contamination, waste emplacement, or groundwater contamination exists by subsurface sampling through the completion of soil borings and the installation of monitoring wells. The scope of work, determined by the client, did not include these activities.

This Report is for the exclusive use of Green Handle Farms, LLC, its affiliates, designates and assignees and no other party shall have any right to rely on any service provided by Hurvitz Environmental Services without prior written consent.

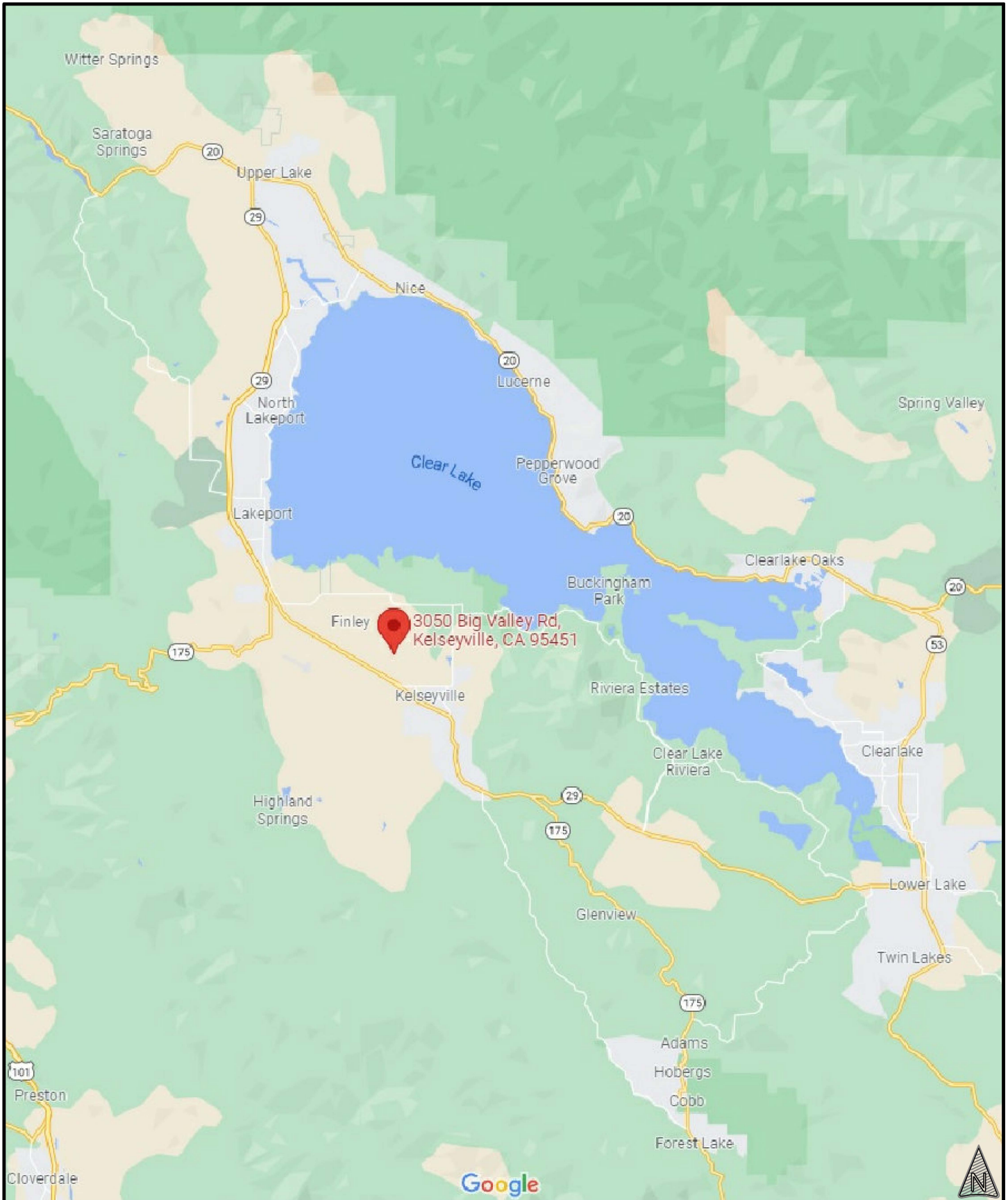

HURVITZ ENVIRONMENTAL
 105 MORRIS ST, STE 188
 SEBASTOPOL, CA 95472
 PH: 707.824.1690
 FX: 707.824.2675
 HURVITZ.ENVIRONMENTAL@GMAIL.COM
 CA PG# 7573

SITE LOCATION MAP

008-035-014 & 008-037-001
 3050 BIG VALLEY RD
 KELSEYVILLE, CALIFORNIA 95451

JOB NUMBER:
 5177.01

DATE:
 12/20/21

PLATE:
 1



N 1/2 Sec 9 T 13N R 9W
and Portion of
Argonaut Pear Orchard Subdivision

T.R.A.
56-021
56-026
56-038

8-035

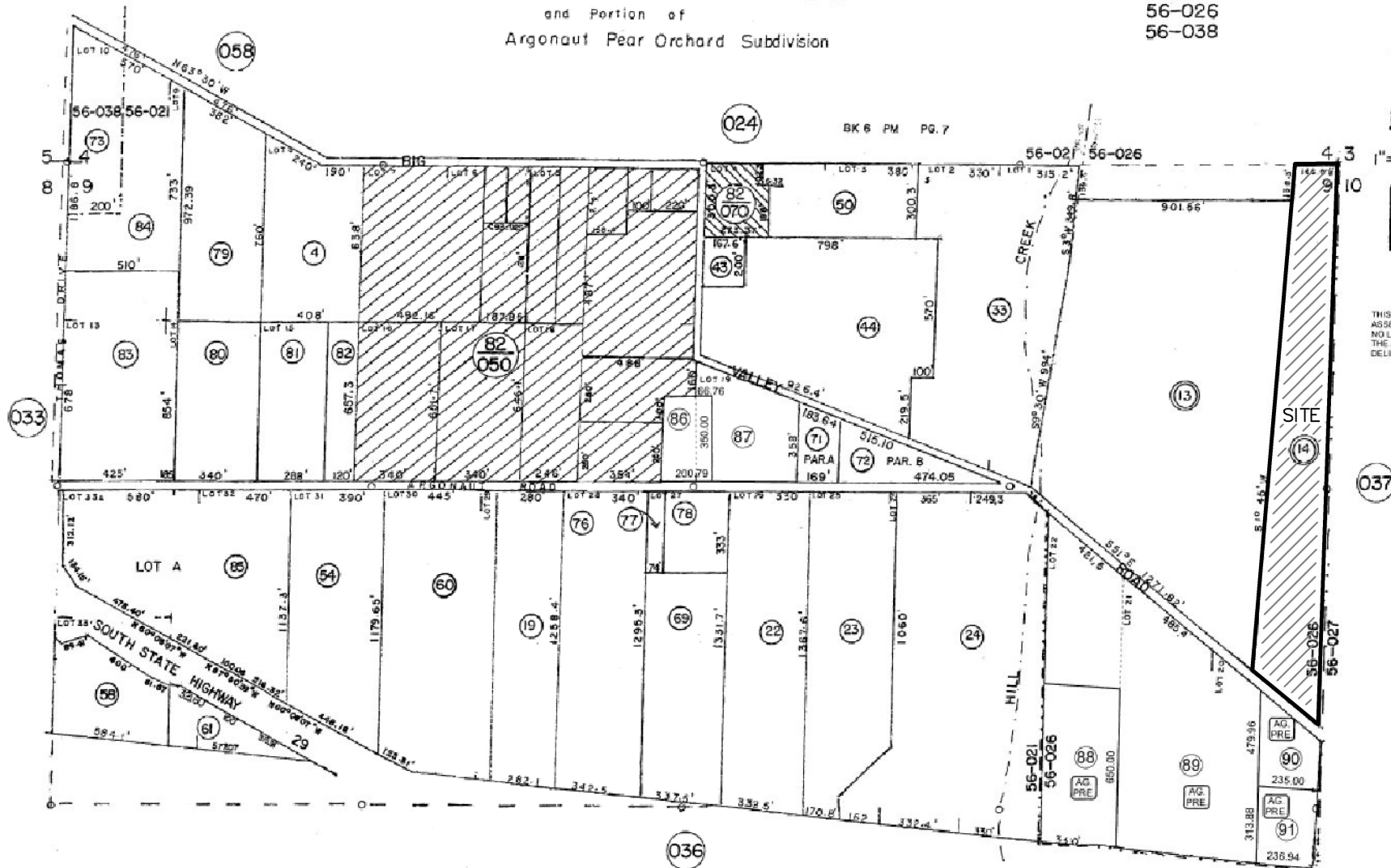

THIS MAP WAS PREPARED FOR ASSESSMENT PURPOSES ONLY. NO LIABILITY IS ASSUMED FOR THE ACCURACY OF THE DATA DELINEATED HEREON.

HURVITZ ENVIRONMENTAL
 105 MORRIS ST, STE 188
 SEBASTOPOL, CA 95472
 PH: 707.824.1690
 FX: 707.824.2675
 HURVITZ.ENVIRONMENTAL@GMAIL.COM
 CA PG# 7573

ASSESSORS PARCEL MAP
 008-035-014 & 008-037-001
 3050 BIG VALLEY RD
 KELSEYVILLE, CALIFORNIA 95451

JOB NUMBER: 5177.01
DATE: 12/20/21
PLATE: 2A

NORTH 1/2 OF SECTION 10 T 13 N, R 9 W

T.R.A.
 56-027

8-037

THIS MAP WAS PREPARED FOR ASSESSMENT PURPOSES ONLY. NO LIABILITY IS ASSUMED FOR THE ACCURACY OF THE DATA DELINEATED HEREON.

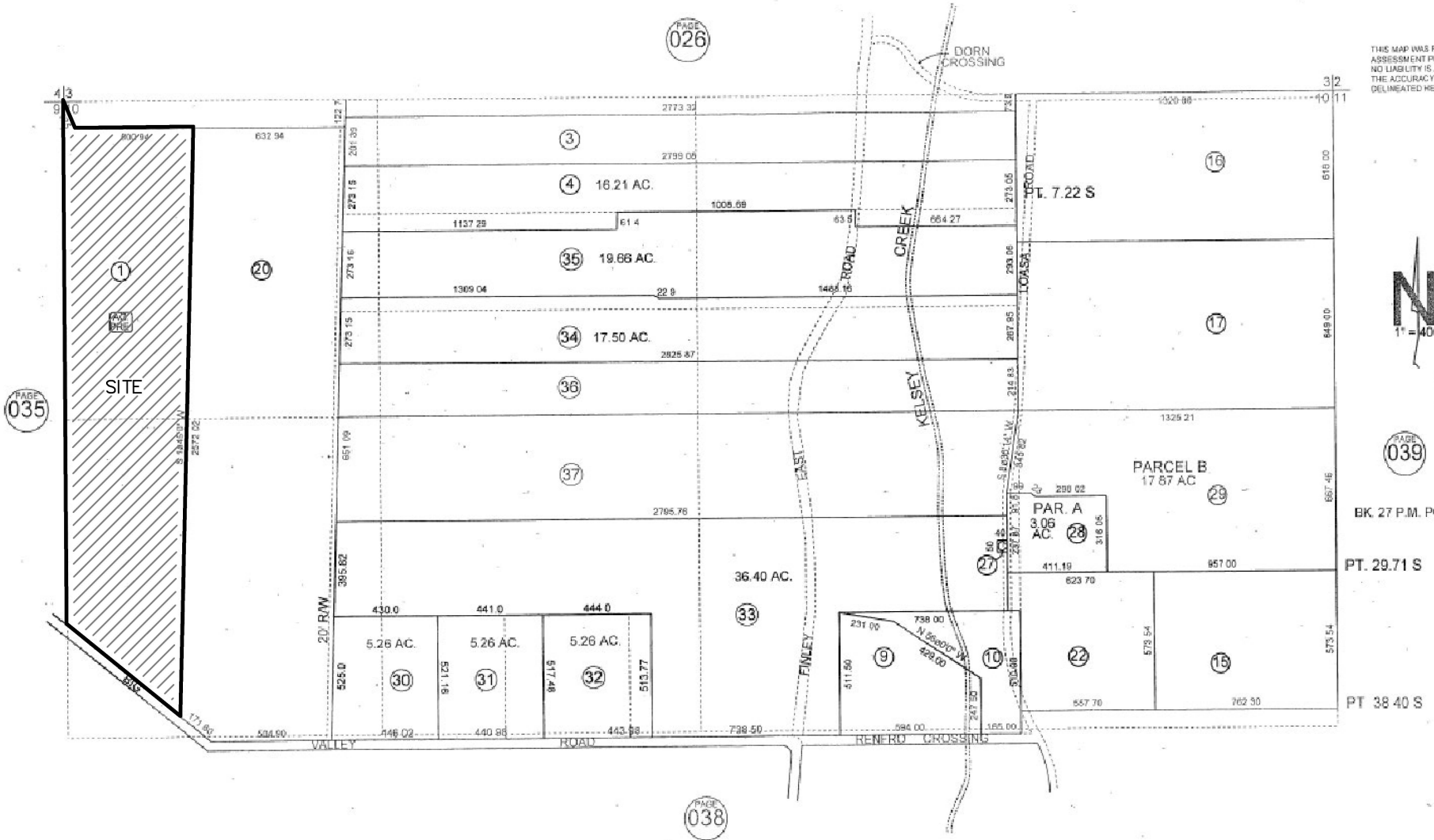

BK. 27 P.M. PG. 32
 PT. 29.71 S
 PT. 38.40 S

 **HURVITZ ENVIRONMENTAL**
 105 MORRIS ST, STE 188
 SEBASTOPOL, CA 95472
 PH: 707.824.1690
 FX: 707.824.2675
 HURVITZ.ENVIRONMENTAL@GMAIL.COM
 CA PG# 7573

ASSESSORS PARCEL MAP
 008-035-014 & 008-037-001
 3050 BIG VALLEY RD
 KELSEYVILLE, CALIFORNIA 95451

JOB NUMBER:
 5177.01
 DATE:
 12/20/21
 PLATE:
 2B

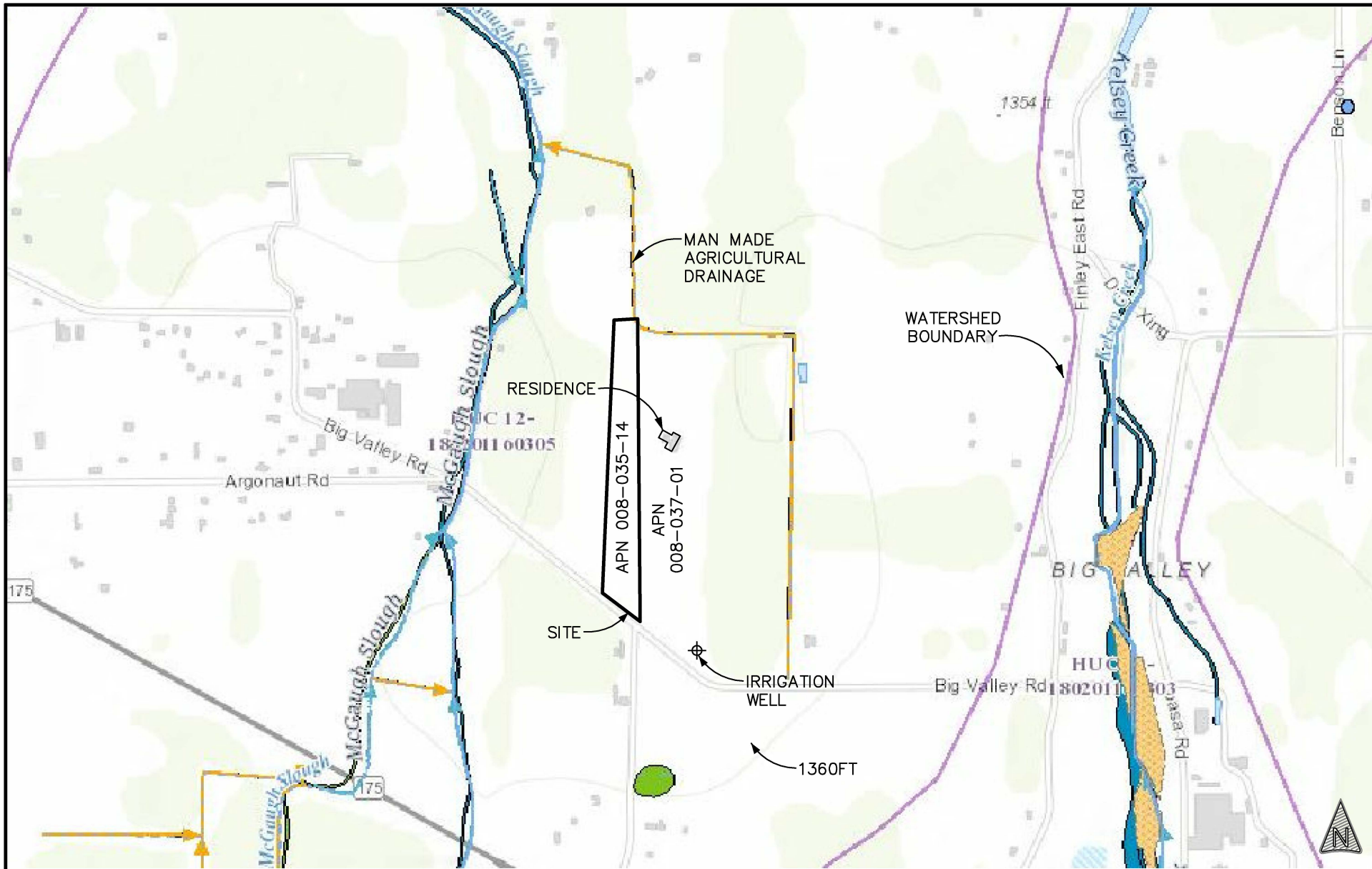

SOURCE: USGS 7.5 MINUTE

	HURVITZ ENVIRONMENTAL
	105 MORRIS ST, STE 188
	SEBASTOPOL, CA 95472
	PH: 707.824.1690
	FX: 707.824.2675
	HURVITZ.ENVIRONMENTAL@GMAIL.COM CA PG# 7573

USGS TOPOGRAPHIC MAP

008-035-014 & 008-037-001
3050 BIG VALLEY RD
KELSEYVILLE, CALIFORNIA 95451

JOB NUMBER:
5177.01

DATE:
12/20/21

PLATE:
3

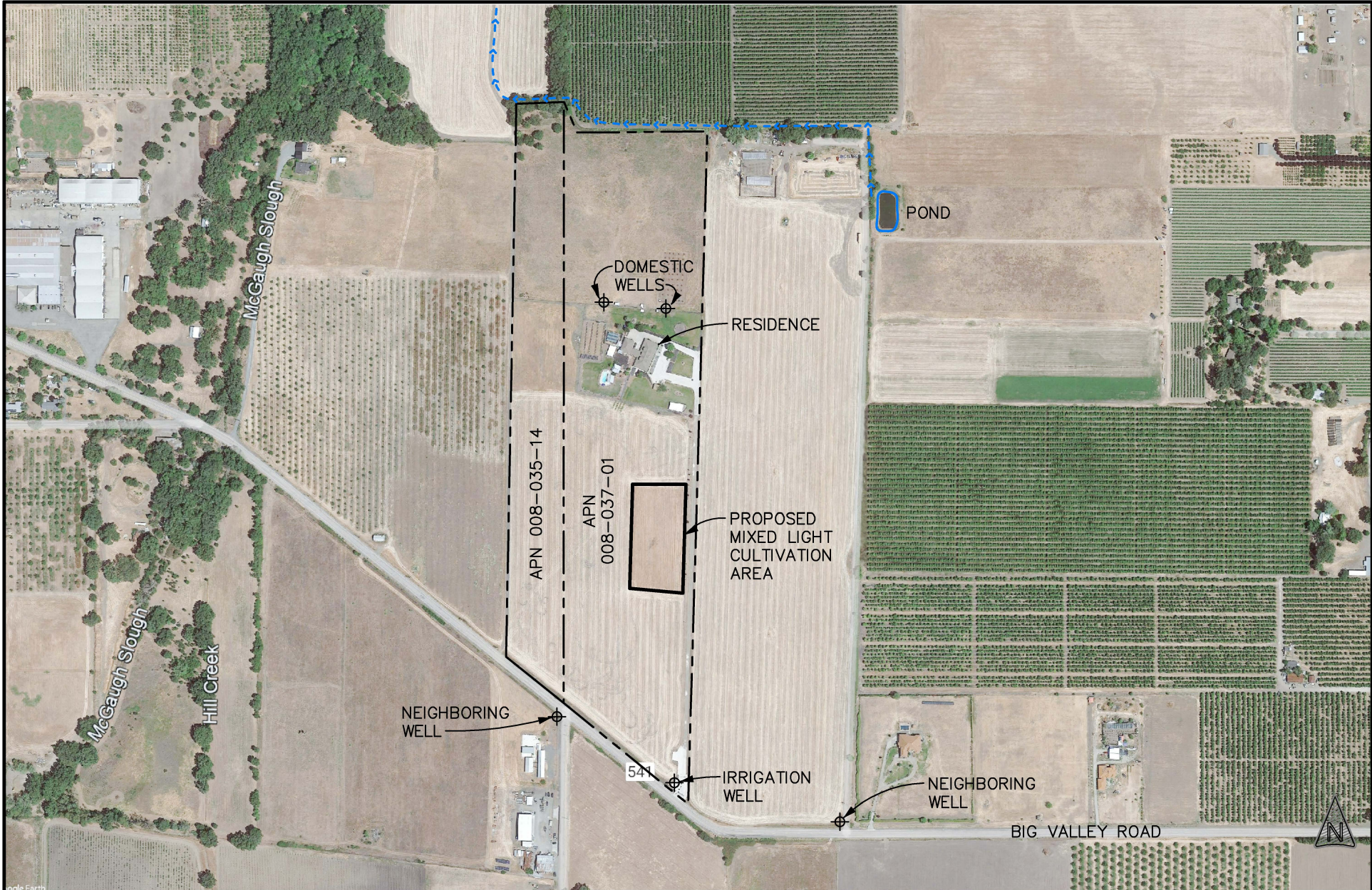

HURVITZ ENVIRONMENTAL
 105 MORRIS ST, STE 188
 SEBASTOPOL, CA 95472
 PH: 707.824.1690
 FX: 707.824.2675
 HURVITZ.ENVIRONMENTAL@GMAIL.COM
 CA PG# 7573

SITE PLAN
 008-035-014 & 008-037-001
 3050 BIG VALLEY RD
 KELSEYVILLE, CALIFORNIA 95451

JOB NUMBER:
5177.01

DATE:
12/20/21

PLATE:
4



SOURCE: USGS, GEOLOGIC MAP OF THE SANTA ROSA QUADRANGLE, CALIFORNIA 1:250,000, D.L. WAGNER AND E.J. BORTUGNO, 1982

Q = QUATERNARY ALLUVIUM
 Qtc - CACHE FORMATION (PEBBLY SANDSTONE, CONGLOMERATE, SILTSTONE AND TUFF)

	HURVITZ ENVIRONMENTAL
	105 MORRIS ST, STE 188
	SEBASTOPOL, CA 95472
	PH: 707.824.1690
	FX: 707.824.2675
HURVITZ.ENVIRONMENTAL@GMAIL.COM	
CA PG# 7573	

GEOLOGIC MAP	
008-035-014 & 008-037-001	
3050 BIG VALLEY RD	
KELSEYVILLE, CALIFORNIA 95451	

JOB NUMBER: 5177.01
DATE: 12/20/21
PLATE: 5

APPENDIX A
SITE PHOTOGRAPHS

SITE PHOTOGRAPHS



Photo 1: View control Panel for project Irrigation Well.

SITE PHOTOGRAPHS

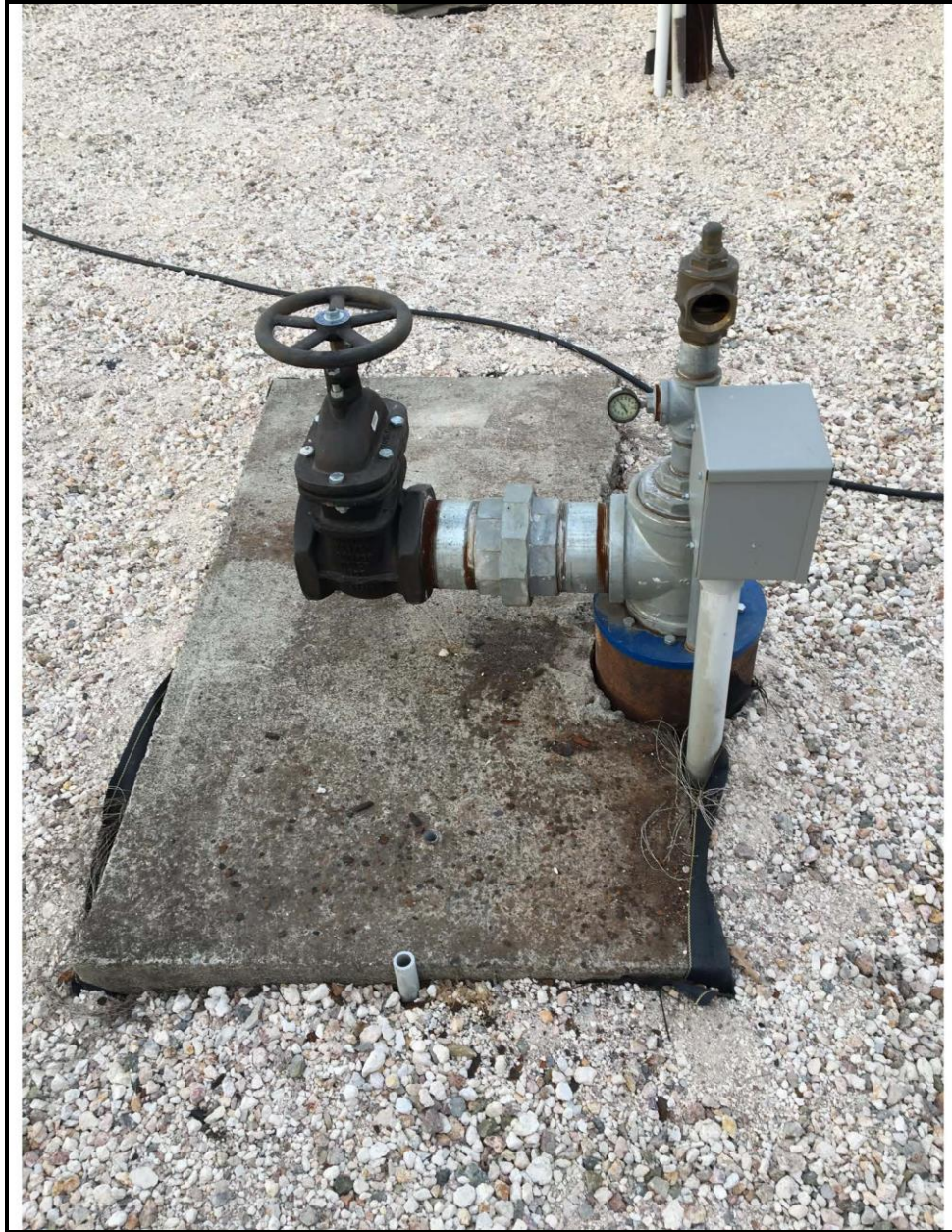

Photo 2: Closeup View of project Irrigation Well.

SITE PHOTOGRAPHS



Photo 3: View of project Irrigation Well and Control Box located at southeast corner of the Site.



Photo 4: View of Irrigation Well during the Nov. 2, 2021 Test w/ 4-inch diameter discharge pipe

APPENDIX B
ENGINEERING DESIGN PLANS

PROJECT INFORMATION

PROJECT ADDRESS: 3050 BIG VALLEY RD
KELSEYVILLE, CA 95451

OWNER/DEVELOPER: GARTH MARKSON
1784 PETERSON POND LN
REDWOOD VALLEY, CA 95470
(310) 429-7354
GARTHMARKSON@GMAIL.COM

CIVIL ENGINEER: ANDREW S. WILLIS, P.E.
BC ENGINEERING GROUP, INC.
418 B STREET, THIRD FLOOR
SANTA ROSA, CA 95401
(707) 542-4321
AW@BCENGINEERINGGROUP.COM

SURVEYOR: NA

AREA: 28.89 ACRES

SHEET INDEX

- C1.0 PROJECT INFORMATION
- C1.1 SURROUNDING AREA AERIAL
- C1.2 EXISTING CONDITIONS
- C1.3 PROPOSED CONDITIONS
- C1.4 CANNABIS CULTIVATION SITE
- C1.5 CANNABIS RELATED BUILDING LAYOUTS
- C1.6 SECURITY PLAN

PURPOSE STATEMENT

THE PURPOSE OF THIS PROJECT IS TO SUPPORT OBTAINING A COMMERCIAL CANNABIS USE PERMIT FOR 22,000 SF OF COMMERCIAL MIXED LIGHT CANNABIS CULTIVATION IN THE COUNTY OF LAKE.

PROJECT SITE INFORMATION

FEMA DESIGNATION ZONE	X & 0.2 PCT ANNUAL CHANCE FLOOD HAZARD
BASE FLOOD ELEVATION	1350'
CULTIVATION AREA ELEVATION	1354' TO 1355'
FLOOD PROOFING REQUIRED	NO
STATE FARMLAND	FARMLAND OF LOCAL IMPORTANCE
ZONING	A - AGRICULTURE

LEGEND

EXISTING	PROPOSED	DEFINITION
---	---	PROPERTY LINE
---	---	ROAD CENTERLINE
---	---	ELECTRICAL (UNDERGROUND)
---	---	ELECTRICAL (OVERHEAD WIRE)
---	---	GAS LINE
---	---	GATE VALVE
---	---	HYDRANT
---	---	PIPE CAP
---	---	POINT OF COORDINATION
---	---	SANITARY SEWER PIPE
---	---	STORM WATER DRAIN PIPE
---	---	STREET LIGHT
---	---	SUB-DRAIN
---	---	WATER LINE
---	---	BUILDING OVERHEAD
---	---	DAYLIGHT LINE
---	---	DRAINAGE SWALE FLOW LINE
---	---	EDGE OF PAVEMENT
---	---	FENCE
---	---	FEATURE TO BE REMOVED
---	---	FIBER ROLL
---	---	GRADE BREAK
---	---	LIMITS OF DISTURBANCE
---	---	RETAINING WALL
---	---	ROADSIDE SIGN
---	---	SAWCUT
---	---	TREE TO BE REMOVED
---	---	CONCRETE
---	---	ROCK DISSIPATER/RIP RAP

**CULTIVATION SITE EXHIBIT FOR
GREEN HANDLE FARMS, LLC
3050 BIG VALLEY RD KELSEYVILLE, CA 95451
APN: 008-037-01, 008-035-14**

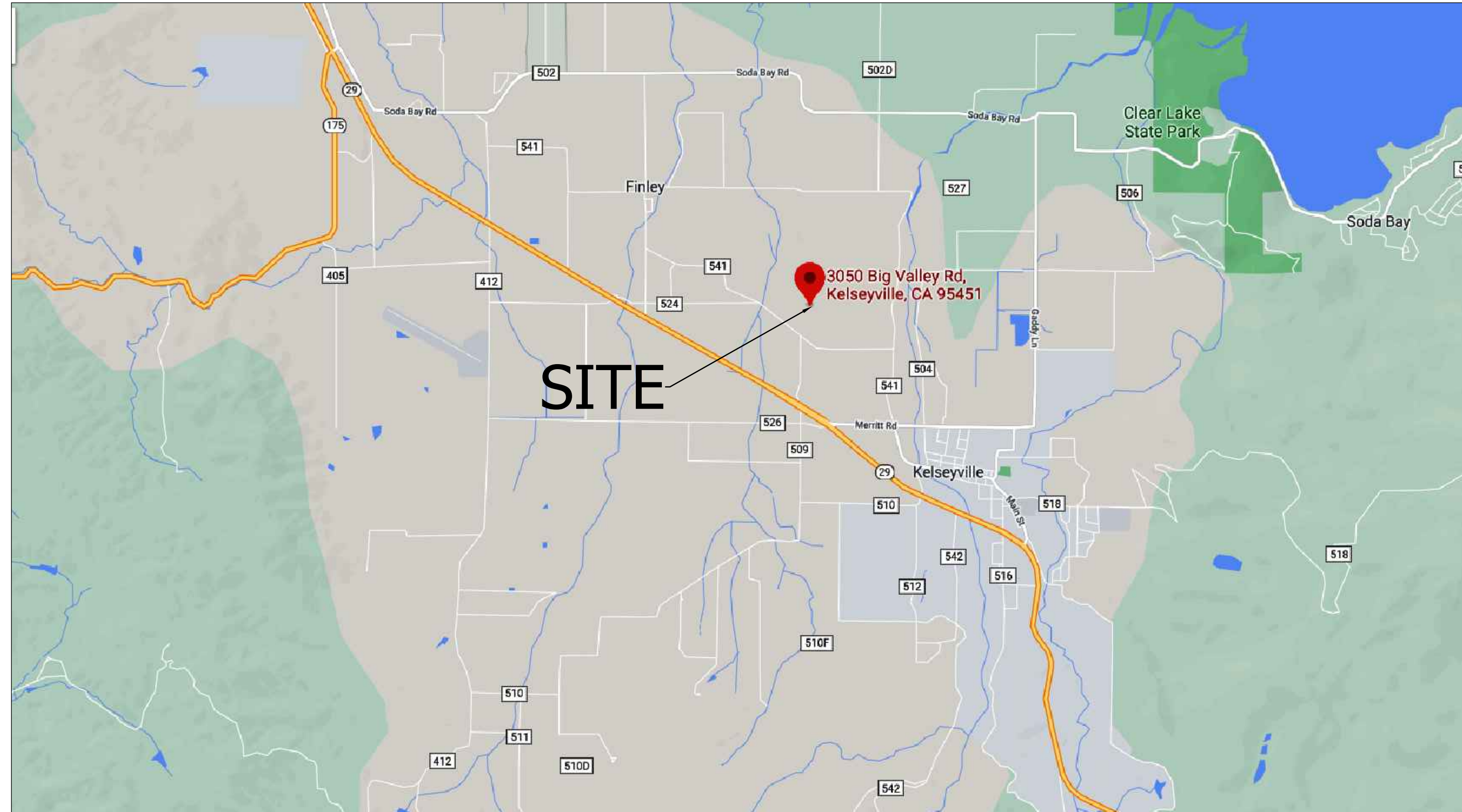

LOCATION MAP
NTS

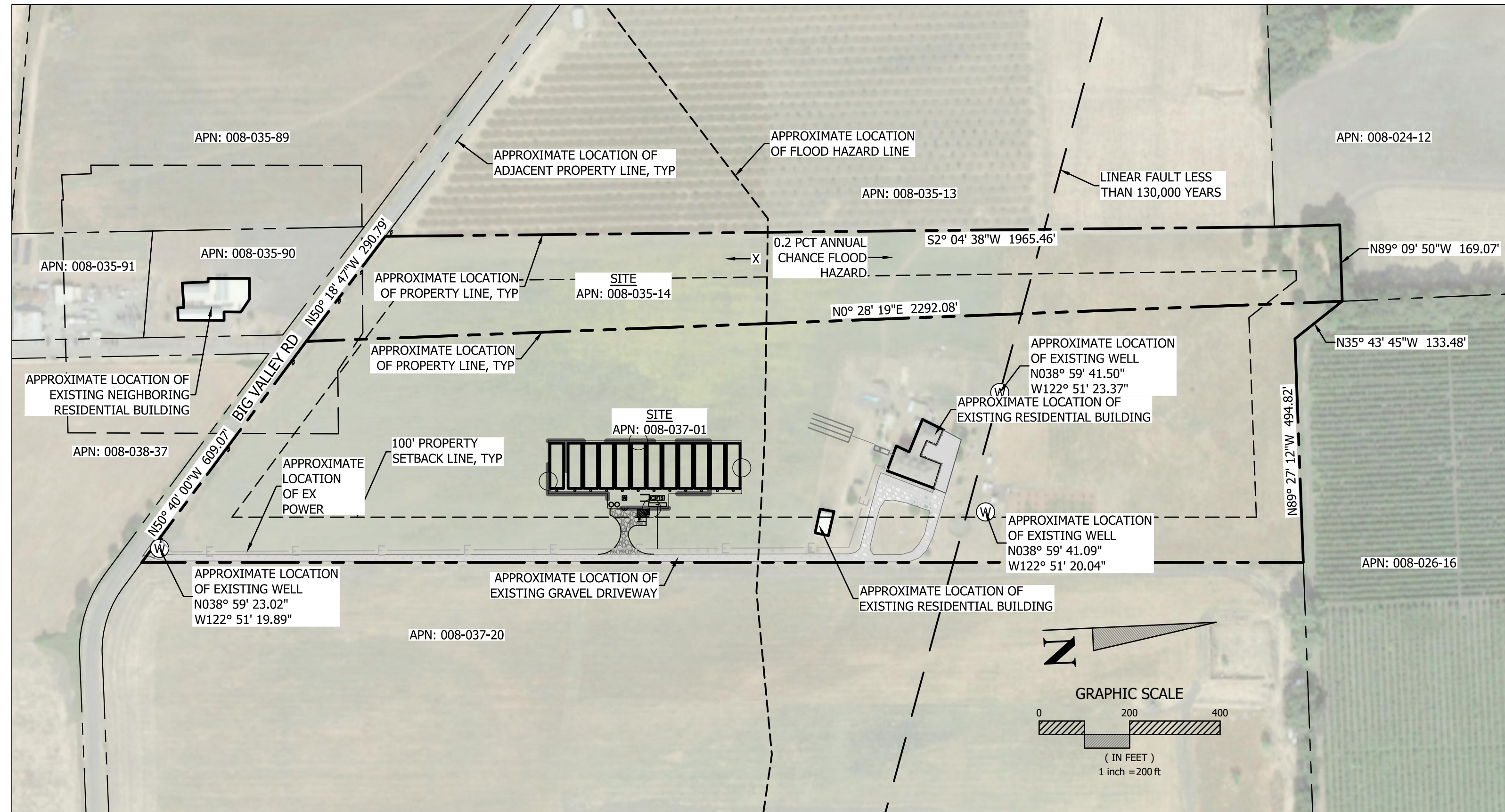

PARCEL EXHIBIT
SCALE: 1"=200'

ABBREVIATIONS

&	AND	HP	HIGH POINT
AT	ANCHOR	HT	HEIGHT
CL	CENTERLINE	ID	INSIDE DIAMETER
DEG	DEGREE	IG	INVERT GRADE
Ø	DIAMETER	IN	INCH
#	NUMBER	INT	INTERIOR
//	PARALLEL	INV	INVERT
%	PERCENT	I	"I" JOIST
⊥	PERPENDICULAR	JST	JOIST
PL	PROPERTY LINE/ PLATE	JT	JOINT TRENCH
±	PLUS OR MINUS	L	LENGTH
AB	AGGREGATE BASE	LAT	LATERAL
AC	ASPHALT CONCRETE	LF	LINEAL FOOT
AD	AREA DRAIN	LGW	LIMITS OF GRADING WORK
ADDL	ADDITIONAL	MAX	MAXIMUM
AFF	ABOVE FINISHED FLOOR	ME	MATCH EXISTING
AG	AGGREGATE	MIN	MINIMUM
ALT	ALTERNATE	MISC	MISCELLANEOUS
ANCH	ANCHOR	MO	MASONRY OPENING
APN	ASSESSOR'S PARCEL NUMBER	MUTCD	MANUAL ON UNIFORM TRAFFIC CONTROL DEVICES
APPROX	APPROXIMATE	(N)	NEW
ARCH	ARCHITECT / ARCHITECTURAL	NTS	NOT TO SCALE
AVG	AVERAGE	OC	ON CENTER
BC	BEGIN CURVE	OD	OUTSIDE DIAMETER OF OUTSIDE FACE
BD	BOARD	OH	OVERHEAD
BFF	BELOW FINISHED FLOOR	OPNG	OPENING
BLDG	BUILDING	OPP	OPPOSITE
BLK	BLOCK	ORIG	ORIGINAL
BLKG	BLOCKING	PCC	POINT OF COMPOUND CURVE
BM	BENCHMARK	PL	PROPERTY LINE
BOF	BOTTOM OF FOOTING	POC	POINT OF CURVATURE
BOT	BOTTOM	PRC	POINT OF RETURN CURVE
BRG	BEARING	PUE	PUBLIC UTILITY EASEMENT
BSL	BUILDING SETBACK LINE	PVC	POLYVINYLCHLORIDE
BT	BEGIN TRANSITION	PVMT	PAVEMENT
BTWN	BETWEEN	R or RAD	RADIUS
BW	BOTTOM OF WALL	RC	RELATIVE COMPACTION
CIP	CAST IN PLACE	REF	REFERENCE
CB	CATCH BASIN	REINF	REINFORCING
CL	CENTERLINE	REQD	REQUIRED
CLR	CLEAR	RFR	RAFTER
CMU	CONCRETE MASONRY UNIT	RO	ROUGH OPENING
CONC	CONCRETE	ROW	RIGHT OF WAY
CONN	CONNECTION	RT	RIGHT
CONST	CONSTRUCTION	RWD	REDWOOD
CONT	CONTINUOUS	S	SLOPE
CPP	CORRUGATED PLASTIC PIPE	SAD	SEE ARCHITECTURAL DRAWINGS
CTR	CENTER	SB	SOLID BLOCK
CY	CUBIC YARD	SC	SPIRAL CURVE
D	DEPTH	SCD	SEE CIVIL DRAWINGS
DBL	DOUBLE	SCH	SCHEDULE
DI	DROP INLET	SD	STORM DRAIN
DIA	DIAMETER	SDCO	STORM DRAIN CLEANOUT
DIAG	DIAGONAL	SDMH	STORM DRAIN MANHOLE
DIM	DIMENSION	SED	SEE ELECTRICAL DRAWINGS
DIST	DISTANCE	SF	SQUARE FOOT
DL	DAYLIGHT	SG	SUBGRADE
DN	DOWN	SHT	SHEET
DWG	DRAWING	SHTG	SHEATHING
EACH	EACH	SIM	SIMILAR
EC	END CURVE	SLAD	SEE LANDSCAPE ARCHITECTS' DRAWINGS
EE	EACH END	SMD	SEE MECHANICAL DRAWINGS
EF	EACH FACE	SO	SIDE OPENING
EG	EXISTING GROUND	SPEC	SPECIFICATION
EL or ELEV	ELEVATION	SPD	SEE PLUMBING DRAWINGS
ELEC	ELECTRICAL	SQ	SQUARE
EN	EDGE NAILING	SS	SANITARY SEWER
EP	EDGE OF PAVEMENT	SSCO	SANITARY SEWER CLEANOUT
EQPT	EQUIPMENT	SSMH	SANITARY SEWER MANHOLE
EQ	EQUAL	STA	STATION
ES	EACH SIDE	STD	STANDARD
ESMT	EASEMENT	STRUC	STRUCTURAL
ET	END TRANSITION	SWE	SIDEWALK EASEMENT
EW	EACH WAY	SYM	SYMMETRICAL
EX or (E)	EXISTING	T&B	TOP AND BOTTOM
EXC	EXCAVATION / EXCAVATE	TB	TOP OF BANK
EXT	EXTERIOR	TC	TOP OF CONCRETE
FC	FACE OF CURB	TCC	TOP OF CONCRETE CURB
FD	FLOOR DRAIN	TD	TRENCH DRAIN
FDN	FOUNDATION	TG	TOP OF GRATE
FF	FINISH FLOOR	THK	THICK
FG	FINISH GRADE	TOF	TOP OF FOOTING
FIN	FINISH	TOS	TOP OF STEEL / TOP OF STRUCTURE
FL	FLOWLINE	TOT	TOTAL
FLR	FLOOR	TP	TOP OF PAVEMENT
FO	FACE OF	TW	TOP OF WALL
FOW	FACE OF WALL	TYP	TYPICAL
FS	FINISHED SURFACE	UNO	UNLESS NOTED OTHERWISE
FT	FOOT / FEET	VC	VERTICAL CURVE
GB	GRADE BREAK OR GRAVEL BASIN	VERT	VERTICAL
GR	GRATE	VIF	VERIFY IN FIELD
GRD	GRADE	W	WATER / WIDTH
GRND	GROUND	W/	WITH
HDPE	HIGH DENSITY POLYETHYLENE	W/O	WITHOUT
HDR	HEADER	YD, YDS	YARD, YARDS
HORIZ	HORIZONTAL	Z	DITCH SIDE SLOPE

BC ENGINEERING GROUP, INC.
CIVIL ENGINEERING & LAND PLANNING
www.bcegroup.com
Phone: 707.542.4321
SANTA ROSA OFFICE:
418 B Street, Third Floor, Santa Rosa CA 95401
UKAR OFFICE:
603 S. State Street, Ukiah CA 95422

GREEN HANDLE FARMS, LLC
PROJECT INFORMATION
GARTH MARKSON
3050 BIG VALLEY RD
KELSEYVILLE, CA 95451

Date: 11/10/2021
Job: 2042-20
Drawn: TSL
Scale: AS SHOWN
APN: 008-037-01, 008-035-14
Permit #:
Sheet: **C1.0**
1 of 7

NOT FOR CONSTRUCTION

S:\Clients\2042-20_Garth Markson - 3050 Big Valley Rd, Kelseyville, CA\CADD\Civil Engineering\2042-20_Cultivation Plans.dwg
11/9/2021 10:59 AM Plotted by Andrew

11/9/2021 10:59 AM Plotted by Andrew S:\Clients\2042-20 Garth Markson - 3050 Big Valley Rd, Kelseyville, CA\CAD\Civil Engineering\2042-20_Cultivation Plans.dwg

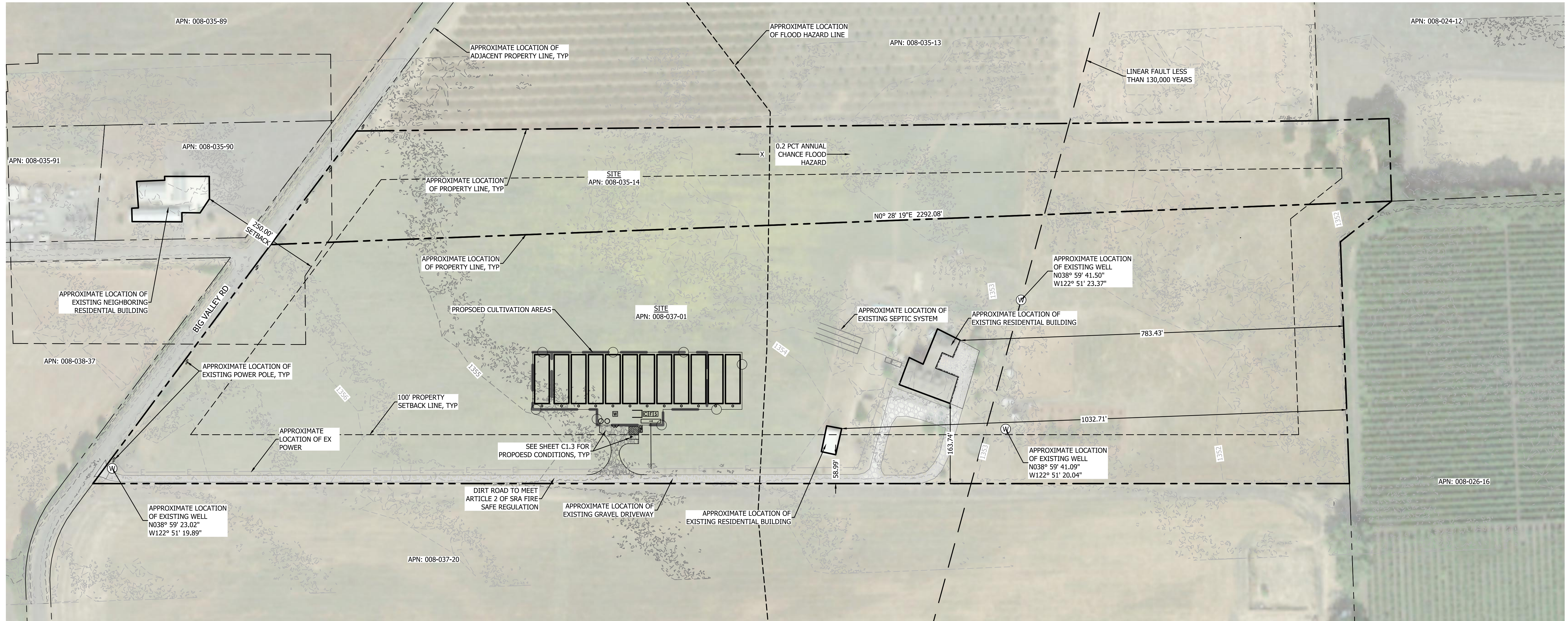

SURROUNDING AREA AERIAL
SCALE: 1"=100'

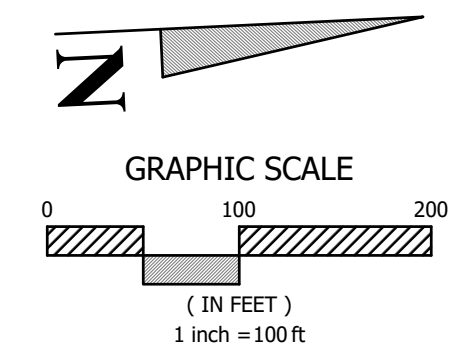

NOTES

1. PROPERTY LINES, EASEMENTS, AND TOPOGRAPHIC INFORMATION IS APPROXIMATE AND WAS OBTAINED FROM PUBLICLY AVAILABLE INFORMATION.
2. THERE IS NO PUBLIC OR PRIVATE SCHOOL, GRADES 1 THROUGH 12, DEVELOPED PARK CONTAINING PLAYGROUND EQUIPMENT, DRUG OR ALCOHOL REHABILITATION FACILITY, LICENSED CHILD CARE FACILITY OR NURSERY SCHOOL, OR CHURCH OR YOUTH-ORIENTED FACILITY CATERING TO OR PROVIDING SERVICES PRIMARILY INTENDED FOR MINORS WITHIN 1,250 FEET OF THE PROPERTY.
3. LOCATION MAP IS LOCATED ON SHEET 1.0
4. FOR PARCEL BOUNDARIES AND ADJACENT PARCEL BOUNDARIES, SEE SHEET C1.0

NOT FOR CONSTRUCTION

REV.	DESCRIPTION	BY	DATE

BC ENGINEERING & LAND PLANNING
 CIVIL ENGINEERING & LAND PLANNING
 www.bcegroup.com
 Phone: 707.582.4321
 SA/TA ROSA OFFICE:
 418 B Street, Third Floor, Santa Rosa CA 95401
 OAKRIDGE OFFICE:
 603 S. State Street, Ukiah CA 95482

GREEN HANDLE FARMS, LLC
 SURROUNDING AREA AERIAL
 GARTH MARKSON
 3050 BIG VALLEY RD
 KELSEYVILLE, CA 95451

Date:	11/10/2021
Job:	2042-20
Drawn:	TSL
Scale:	AS SHOWN
APN:	008-037-01, 008-035-14
Permit #:	
Sheet:	C1.1 2 of 7

11/9/2021 10:59 AM Plotted by Andrew S:\Clients\2042-20 Garth Markson - 3050 Big Valley Rd, Kelseyville, CA\CADD\Civil Engineering\2042-20_Cultivation Plans.dwg



EXISTING CONDITIONS
SCALE: 1"=100'

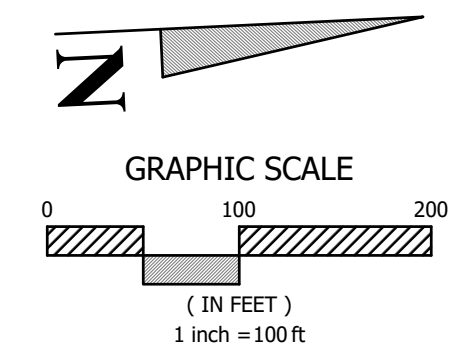

NOTES

1. PROPERTY LINES, EASEMENTS, AND TOPOGRAPHIC INFORMATION IS APPROXIMATE AND WAS OBTAINED FROM PUBLICLY AVAILABLE INFORMATION.
2. LOCATION MAP IS LOCATED ON SHEET C1.0
3. FOR PARCEL BOUNDARIES AND ADJACENT PARCEL BOUNDARIES, SEE SHEET C1.0

REV.	DESCRIPTION	BY	DATE

BC ENGINEERING & LAND PLANNING
 CIVIL ENGINEERING & LAND PLANNING
 www.bceengineering.com
 Phone: 707.582.4321
 SAULTY, ROSA OFFICE:
 418 B Street, Third Floor, Santa Rosa CA 95401
 OZARK OFFICE:
 603 S. State Street, Ukiah CA 95482

GREEN HANDLE FARMS, LLC
 EXISTING CONDITIONS
 GARTH MARKSON
 3050 BIG VALLEY RD
 KELSEYVILLE, CA 95451

Date:	11/10/2021
Job:	2042-20
Drawn:	TSL
Scale:	AS SHOWN
APN:	008-037-01, 008-035-14
Permit #:	

Sheet:
C1.2
3 of 7

NOT FOR CONSTRUCTION

11/9/2021 10:59 AM Plotted by Andrew S:\Clients\2042-20 Garth Markson - 3050 Big Valley Rd, Kelseyville, CA\CADD\Civil Engineering\2042-20_Cultivation Plans.dwg

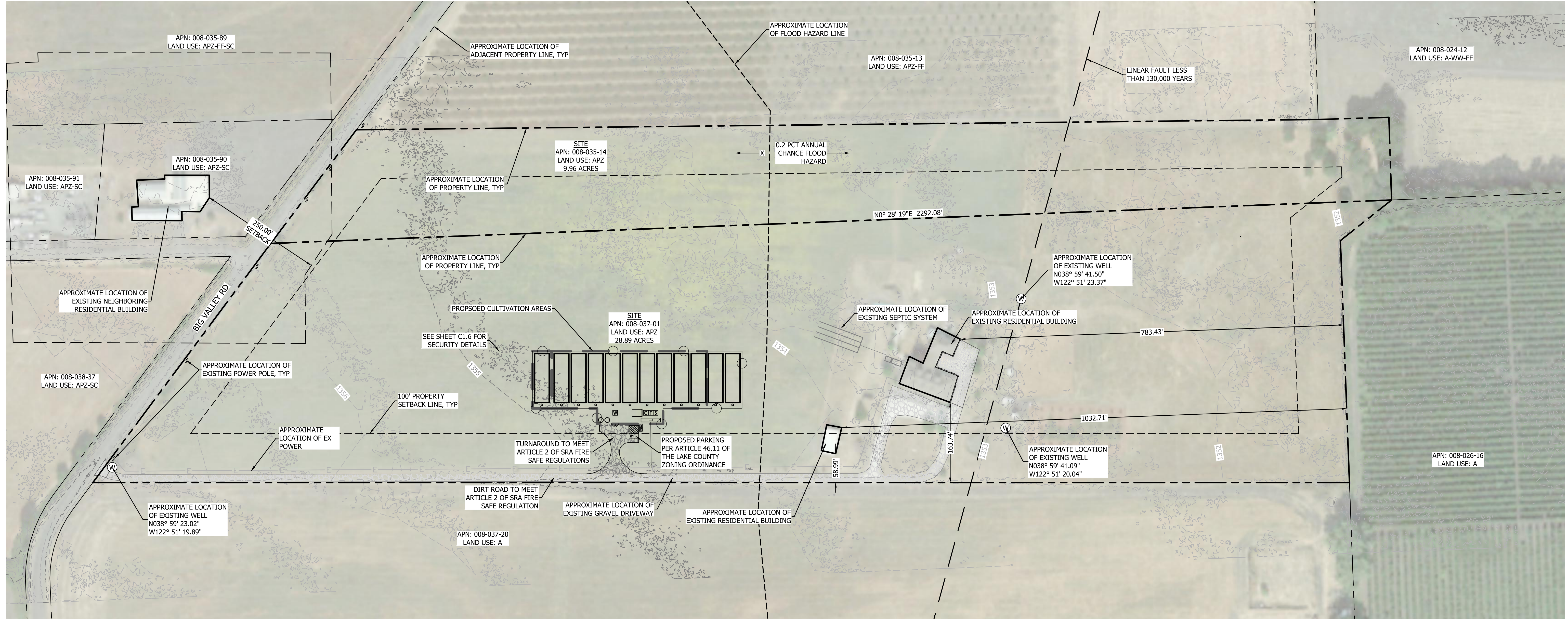

PROPOSED CONDITIONS
SCALE: 1"=100'

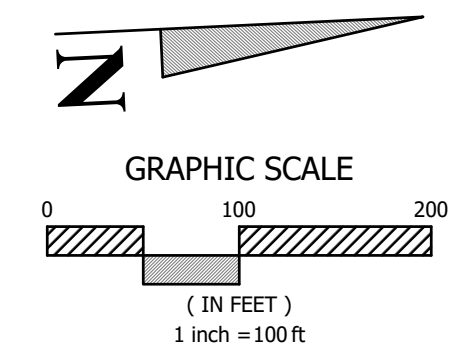

NOTES

1. PROPERTY LINES, EASEMENTS, AND TOPOGRAPHIC INFORMATION IS APPROXIMATE AND WAS OBTAINED FROM PUBLICLY AVAILABLE INFORMATION.
2. LOCATION MAP IS LOCATED ON SHEET C1.0
3. FOR PARCEL BOUNDARIES AND ADJACENT PARCEL BOUNDARIES, SEE SHEET C1.0

REV.	DESCRIPTION	BY	DATE

BC ENGINEERING & LAND PLANNING
CIVIL ENGINEERING & LAND PLANNING
www.bcegroup.com
Phone: 707.582.4321
SAVITA ROSA OFFICE:
418 B Street, Third Floor, Santa Rosa CA 95401
DARIN OFFICE:
603 S. State Street, Ukiah CA 95482



GREEN HANDLE FARMS, LLC
PROPOSED CONDITIONS
GARTH MARKSON
3050 BIG VALLEY RD
KELSEYVILLE, CA 95451

Date: 11/10/2021

Job: 2042-20

Drawn: TSL

Scale: AS SHOWN

APN: 008-037-01,
008-035-14

Permit #:

Sheet:
C1.3
4 of 7

NOT FOR CONSTRUCTION

11/9/2021 11:00 AM Plotted by Andrew S:\Clients\2042-20 Garth Markson - 3050 Big Valley Rd, Kelseyville, CA\CADD\Civil Engineering\2042-20_Cultivation Plans.dwg

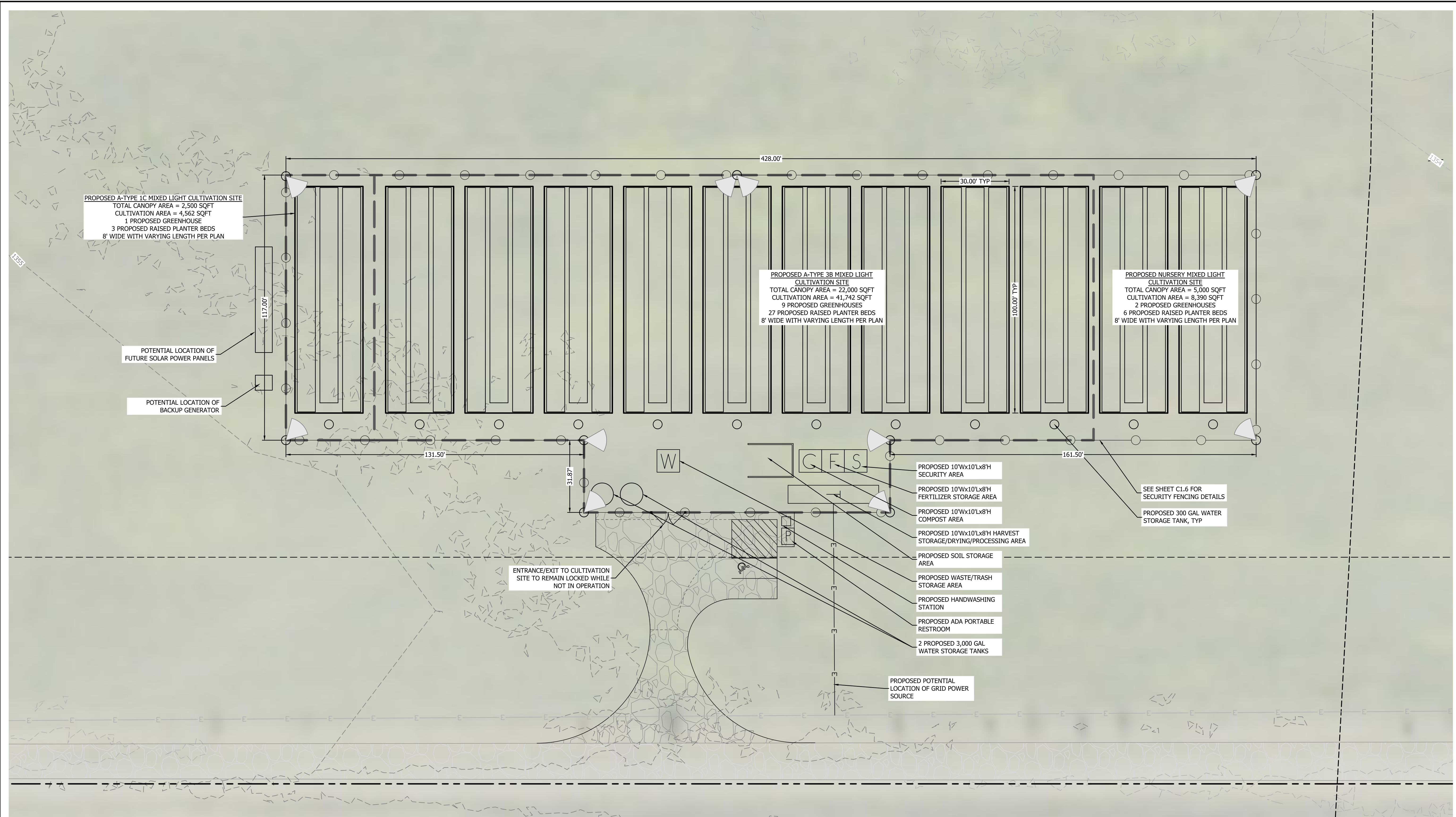

PROPOSED A-TYPE 1C MIXED LIGHT CULTIVATION SITE
 TOTAL CANOPY AREA = 2,500 SQFT
 CULTIVATION AREA = 4,562 SQFT
 1 PROPOSED GREENHOUSE
 3 PROPOSED RAISED PLANTER BEDS
 8' WIDE WITH VARYING LENGTH PER PLAN

PROPOSED A-TYPE 3B MIXED LIGHT CULTIVATION SITE
 TOTAL CANOPY AREA = 22,000 SQFT
 CULTIVATION AREA = 41,742 SQFT
 9 PROPOSED GREENHOUSES
 27 PROPOSED RAISED PLANTER BEDS
 8' WIDE WITH VARYING LENGTH PER PLAN

PROPOSED NURSERY MIXED LIGHT CULTIVATION SITE
 TOTAL CANOPY AREA = 5,000 SQFT
 CULTIVATION AREA = 8,390 SQFT
 2 PROPOSED GREENHOUSES
 6 PROPOSED RAISED PLANTER BEDS
 8' WIDE WITH VARYING LENGTH PER PLAN

- PROPOSED 10'Wx10'Lx8'H SECURITY AREA
- PROPOSED 10'Wx10'Lx8'H FERTILIZER STORAGE AREA
- PROPOSED 10'Wx10'Lx8'H COMPOST AREA
- PROPOSED 10'Wx10'Lx8'H HARVEST STORAGE/DRYING/PROCESSING AREA
- PROPOSED SOIL STORAGE AREA
- PROPOSED WASTE/TRASH STORAGE AREA
- PROPOSED HANDWASHING STATION
- PROPOSED ADA PORTABLE RESTROOM
- 2 PROPOSED 3,000 GAL WATER STORAGE TANKS
- PROPOSED POTENTIAL LOCATION OF GRID POWER SOURCE
- SEE SHEET C1.6 FOR SECURITY FENCING DETAILS
- PROPOSED 300 GAL WATER STORAGE TANK, TYP

ENTRANCE/EXIT TO CULTIVATION SITE TO REMAIN LOCKED WHILE NOT IN OPERATION

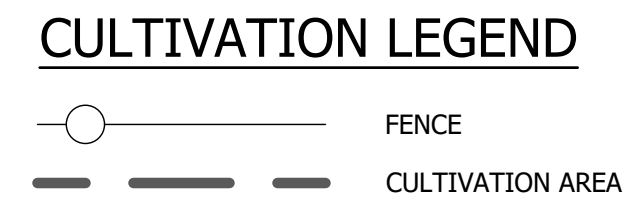
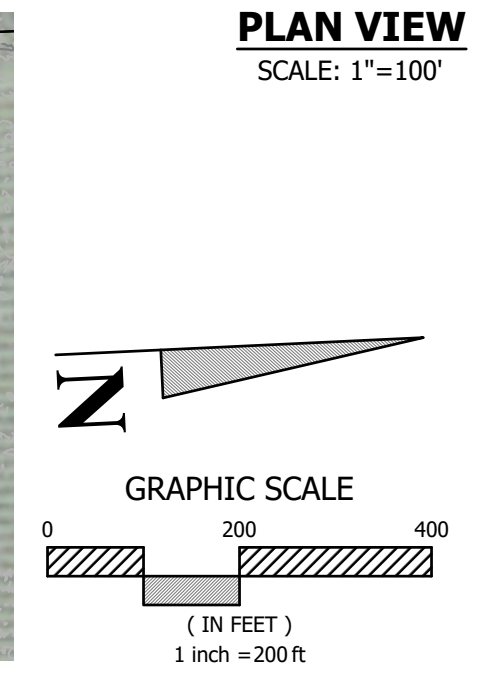
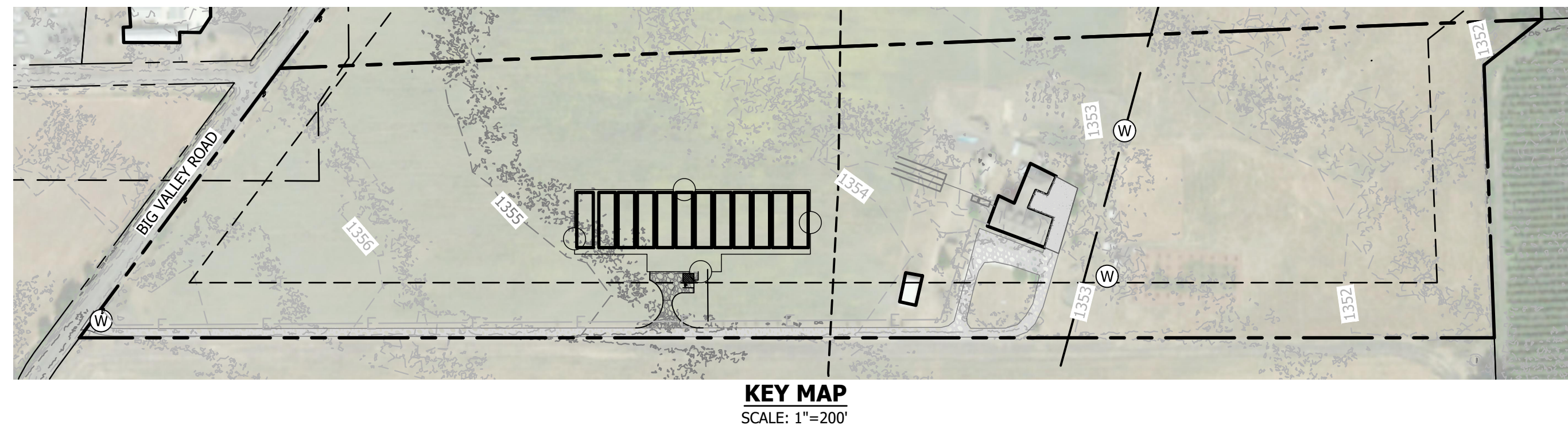

NOTES

1. PROPERTY LINES, EASEMENTS, AND TOPOGRAPHIC INFORMATION IS APPROXIMATE AND WAS OBTAINED FROM PUBLICLY AVAILABLE INFORMATION.
2. LOCATION MAP IS LOCATED ON SHEET C1.0
3. FOR PARCEL BOUNDARIES AND ADJACENT PARCEL BOUNDARIES, SEE SHEET C1.0
4. STRAW WATTLES WILL BE PLACED AROUND CULTIVATION SITE TO PREVENT STORMWATER RUNOFF
5. THE ENTIRE CULTIVATION SITE WILL BE SEEDED TO STABILIZE THE SOIL

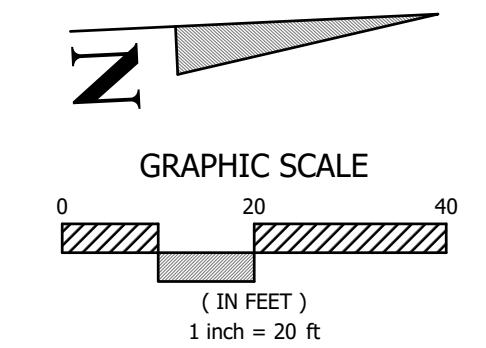

NOT FOR CONSTRUCTION

REV.	DESCRIPTION	BY	DATE

BC ENGINEERING & LAND PLANNING	
www.bceengineering.com	
Phone: 707.542.4321	
SAVITA ROSA OFFICE:	
418 B Street, Third Floor, Santa Rosa CA 95401	
ORAR OFFICE:	
603 S. State Street, Ukiah CA 95682	

GREEN HANDLE FARMS, LLC	
CANNABIS CULTIVATION SITE	
GARTH MARKSON	
3050 BIG VALLEY RD	
KELSEYVILLE, CA 95451	

Date:	11/10/2021
Job:	2042-20
Drawn:	TSL
Scale:	AS SHOWN
APN:	008-037-01, 008-035-14
Permit #:	
Sheet:	C1.4 5 of 7

11/9/2021 11:00 AM Plotted by Andrew S:\Clients\2042-20 Garth Markson - 3050 Big Valley Rd, Kelseyville, CA\CADD\Civil Engineering\2042-20_Cultivation Plans.dwg

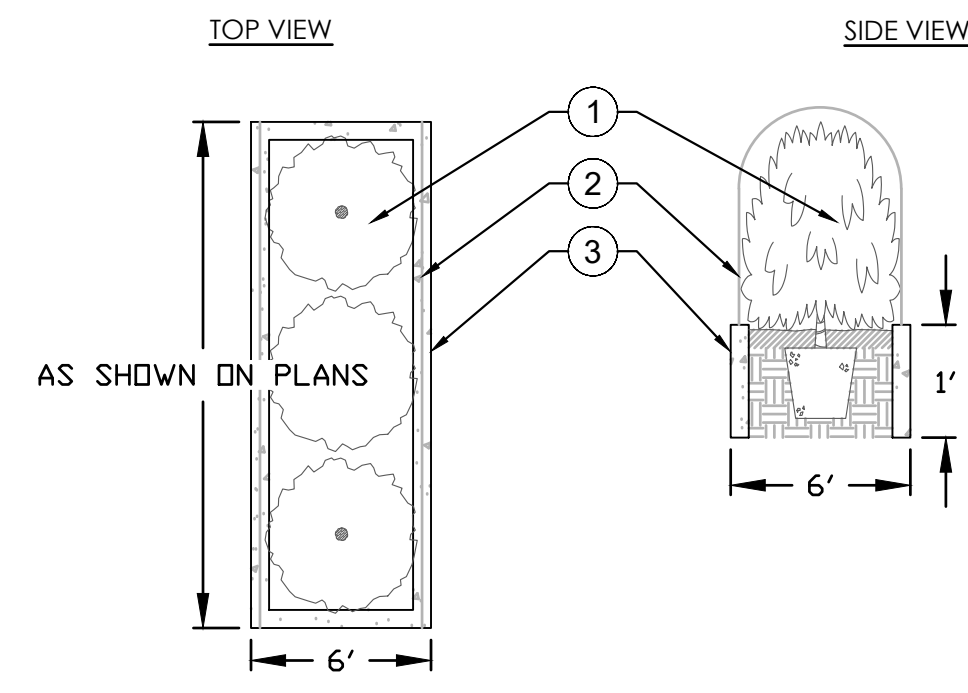
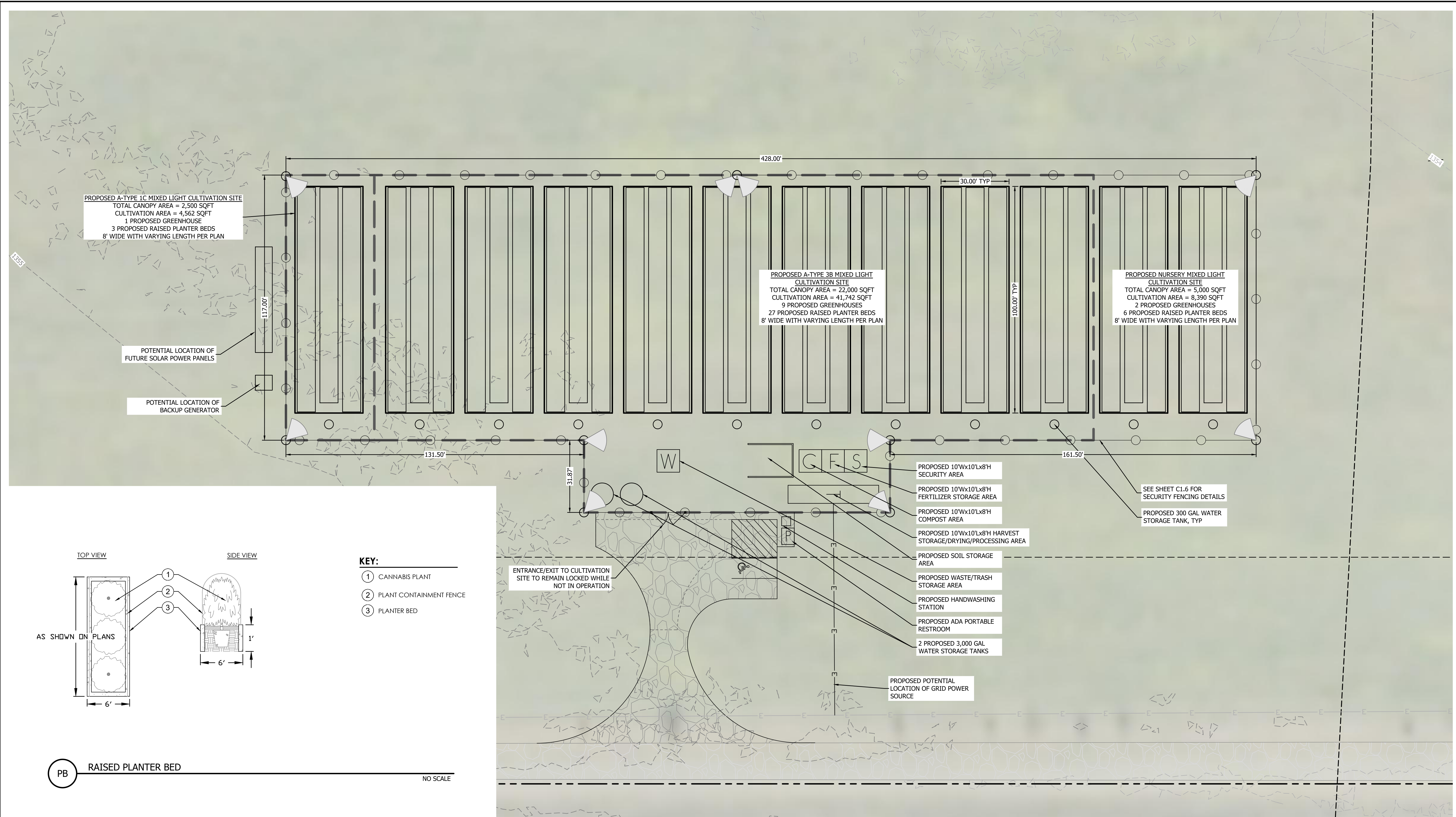

- KEY:**
- ① CANNABIS PLANT
 - ② PLANT CONTAINMENT FENCE
 - ③ PLANTER BED

PB RAISED PLANTER BED
NO SCALE

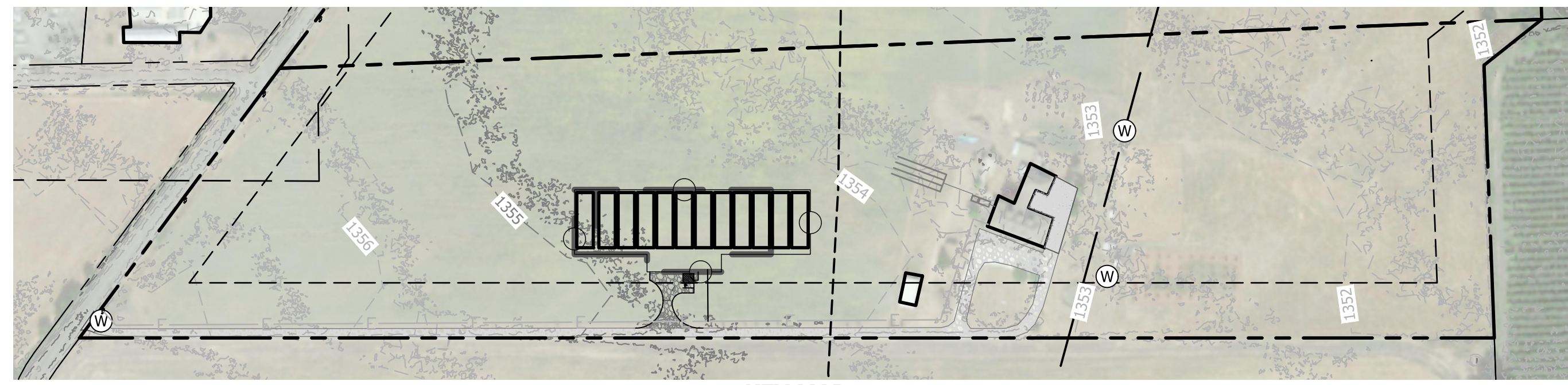

KEY MAP
SCALE: 1"=200'

PLAN VIEW
SCALE: 1"=100'

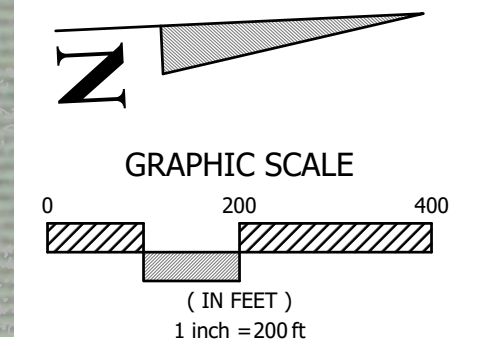

CULTIVATION LEGEND

- FENCE
- CULTIVATION AREA

NOTES

1. PROPERTY LINES, EASEMENTS, AND TOPOGRAPHIC INFORMATION IS APPROXIMATE AND WAS OBTAINED FROM PUBLICLY AVAILABLE INFORMATION.
2. LOCATION MAP IS LOCATED ON SHEET C1.0
3. FOR PARCEL BOUNDARIES AND ADJACENT PARCEL BOUNDARIES, SEE SHEET C1.0

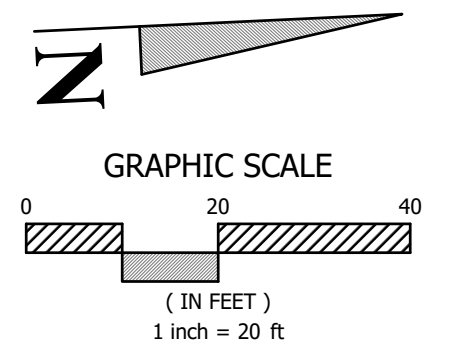

NOT FOR CONSTRUCTION

REV.	DESCRIPTION	BY	DATE

<p>BC ENGINEERING & LAND PLANNING CIVIL ENGINEERING & LAND PLANNING www.bceengineering.com Phone: 707.582.4321 SA/VA, ROSA OFFICE: 418 B Street, Third Floor, Santa Rosa CA 95401 ROSA OFFICE: 603 S. State Street, Ukiah CA 95482</p>		<p>GREEN HANDLE FARMS, LLC CANNABIS RELATED BUILDING LAYOUTS GARTH MARKSON 3050 BIG VALLEY RD KELSEYVILLE, CA 95451</p>
--	---	--

Date:	11/10/2021
Job:	2042-20
Drawn:	TSL
Scale:	AS SHOWN
APN:	008-037-01, 008-035-14
Permit #:	
Sheet:	C1.5 6 of 7

11/9/2021 11:00 AM Plotted by Andrew S:\Clients\2042-20 Garth Markson - 3050 Big Valley Rd, Kelseyville, CA\CADD\Civil Engineering\2042-20_Cultivation Plans.dwg

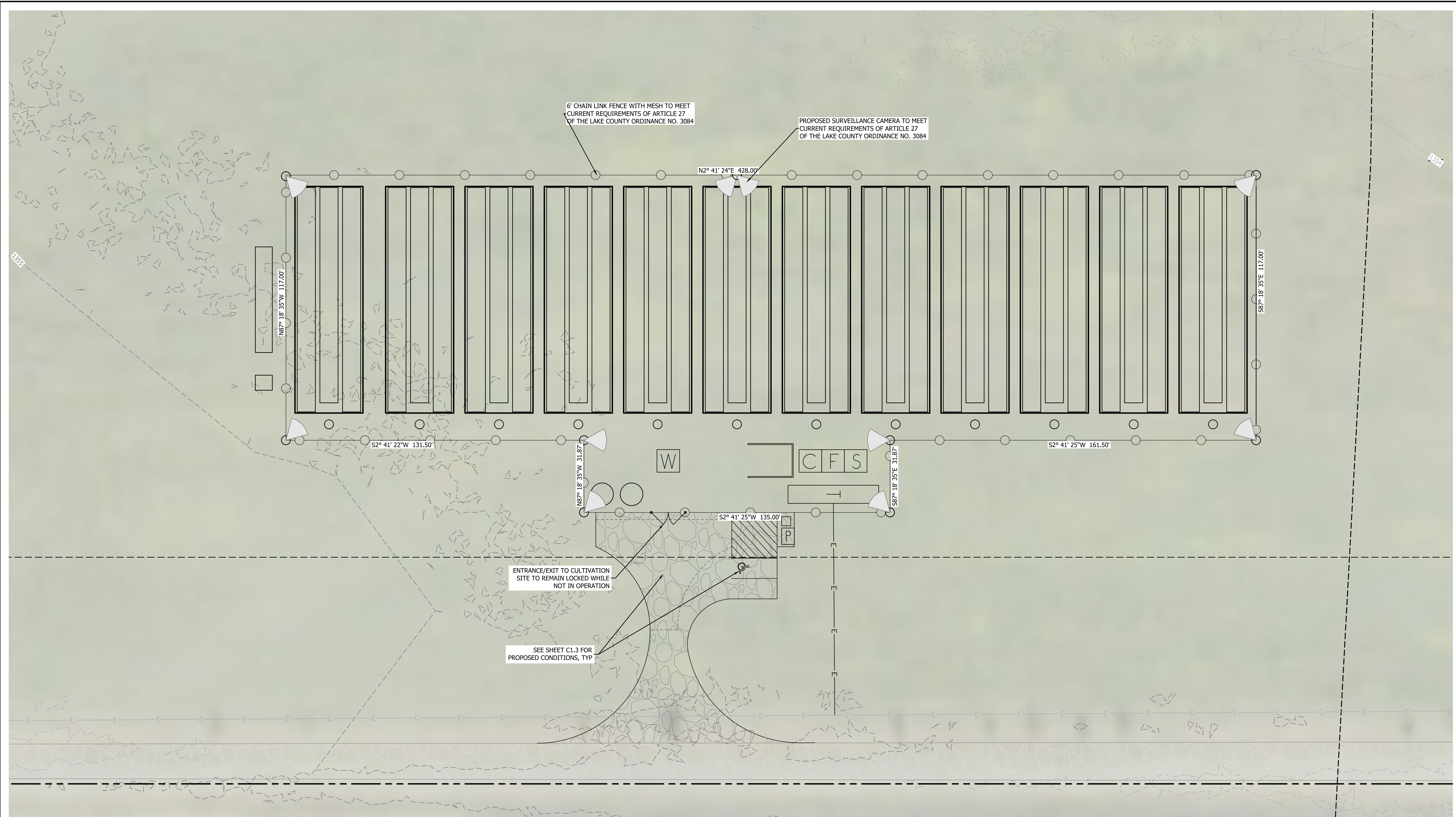

PLAN VIEW
SCALE: 1"=100'

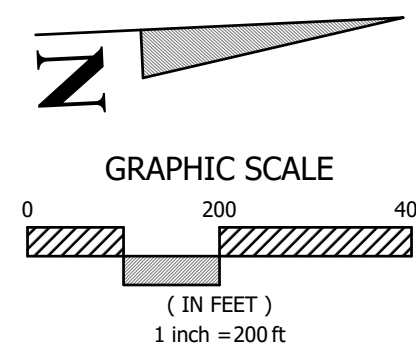

NOTES

1. PROPERTY LINES, EASEMENTS, AND TOPOGRAPHIC INFORMATION IS APPROXIMATE AND WAS OBTAINED FROM PUBLICLY AVAILABLE INFORMATION.
2. LOCATION MAP IS LOCATED ON SHEET C1.0
3. FOR PARCEL BOUNDARIES AND ADJACENT PARCEL BOUNDARIES, SEE SHEET C1.0
4. LIGHTS WILL BE PLACED AT ALL ENTRY POINTS TO THE CULTIVATION SITE AND ALSO AT THE ENTRY GATE OF THE PROPERTY
5. THE SECURITY CAMERAS ARE TO BE WEATHERPROOF CAMERAS FEATURING 1080P. THE SECURITY CAMERAS WILL CAPTURE EVERY PART OF THE CULTIVATION AREAS.

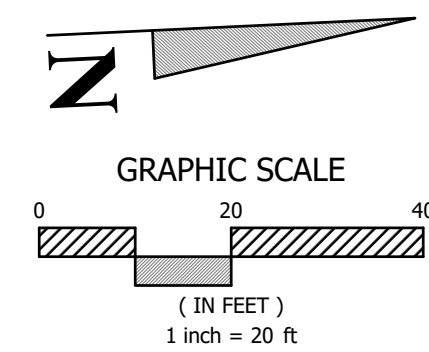

NOT FOR CONSTRUCTION

REV.	DESCRIPTION	BY	DATE

<p>GREEN HANDLE FARMS, LLC SECURITY PLAN GARTH MARKSON 3050 BIG VALLEY RD KELSEYVILLE, CA 95451</p>	<p>BC ENGINEERING & LAND PLANNING CIVIL ENGINEERING & LAND PLANNING www.bceengineering.com Phone: 707.542.4331 SAVITA ROSA OFFICE: 418 B Street, Third Floor, Santa Rosa CA 95401 DARIN OFFICE: 603 S. State Street, Ukiah CA 95482</p>
--	--

Date:	11/10/2021
Job:	2042-20
Drawn:	TSL
Scale:	AS SHOWN
APN:	008-037-01, 008-035-14
Permit #:	
Sheet:	C1.6 7 of 7

APPENDIX C
WELL YIELD TEST

Water Yield Number _____ Well Permit Number _____

1. Individual performing test: Lee S. Hurvitz

2. Type of license/registration, number and expiration date: Certified Hydrogeologist #1015

3. Location of well: Southeast corner of property

4. Address: 3050 Big Valley Road, Kelseyville, CA APN: 008-037-01

5. Type and model of test pump: 10 hp submersible pump

6. Test pump setting depth: ~100 feet

7. Maximum reported yield for this pump type at this setting: NA

8. Type of discharge measurement method: discharge into tank with know capacity

9. Type and model of flow meter (or provide an accurate description of weir or orifice plate):
NA

10. Geographic coordinates (Plane Coordinate Method or distance from fixed landmarks):
39.9872 / -122.8555

11. Estimated elevation of well head: 1357 feet above sea level

12. Initial static water level (include measuring points such as top of casing, surface seal, access port): 27.35

13. Date & time of initial static water level measurement: 11 / 2 / 2021 9:00am AM/PM

- a. Dynamic Water Level: 41.15
- b. Specific Capacity: 25.36
- c. Pump Test duration: 1 hour

14. Immediately after the test take the following measurements:

- a. Dynamic water level: 41.15
- b. Final discharge rate: 350 gpm

15. Post - Test Measurement:

- a. Dynamic water level: 41.15
- b. Static water level: 27.35
- c. Percentage of recovery of final static level: 100

Testing performed by (signature): _____ Date: _____

Company _____ Phone Number: _____

Specialist _____ Date _____

CERTIFICATION OF WATER YIELD IN WATER SCARCITY AREAS

WELL PUMP TEST DATA RECORDATION

ADDRESS:

Date	Time	Interval	SWL	GPM	Comments
11-2-21	11:31	1 Min	27.35		
	11:32	1 Min	40.7	350	
	11:33	1 Min	40.8	350	
	11:34	1 Min	40.9	350	
	11:35	1 Min	40.9	350	
	11:40	5 Mins	41.1	350	
	11:45	5 Mins	41.1	350	
	11:50	5 Mins	41.1	350	
	11:55	5 Mins	41.1	350	
	12:00	5 Mins	41.15	350	
	12:05	5 Mins	41.15	350	
	12:10	5 Mins	41.15	350	
	12:15	5 Mins	41.15	350	
	12:20	5 Mins	41.15	350	
	12:25	5 Mins	41.15	350	
	12:30	5 Mins	41.15	350	
		5 Mins			
		20 Mins			Recharge Analysis
		20 Mins			Time DTW(ft.)
		20 Mins			12:35 34.7
					12:40 29.1
		30 Mins			12:45 28.0
		30 Mins			12:50 27.6
		30 Mins			1:00 27.35
		30 Mins			
		30 Mins			
		30 Mins			
		30 Mins			
		30 Mins			
		30 Mins			
		30 Mins			
		30 Mins			
		30 Mins			
		30 Mins			
		30 Mins			
		30 Mins			
		30 Mins			
		30 Mins			
		30 Mins			
		30 Mins			
		30 Mins			
11-2-21	1:00pm	72 Hrs. or	27.35		

CALCULATION OF WELL RECOVERY

1. Determine the water level draw down by subtracting the initial static water level measurement from the stabilized pumping level. Record this result as the well draw down.
2. Next determine the water level recovery by subtracting the post test (within 72 hours) static water level from the stabilized dynamic pumping level. Record this result as the well recovery.
3. Next determine the percent recovery of the well. Divide the water level recovery by the water level draw down and multiply by 100. Record this result as the percent well recovery.

Example:

a.	Initial static water level:	(measured value)	<u>27.35 feet</u>
b.	Post test static water level*:	(measured value)	<u>27.35 feet</u>
b.1.	Time (hours) of measurement:	(within 72 hours)	<u>0.5 hours</u>
c.	Stabilized pumping level**:	(measured value)	<u>41.15 feet</u>
d.	Draw down:	(calculate by subtracting A from C)	<u>13.8 feet</u>
e.	Recovery:	(calculate by subtracting B from C)	<u>13.8 feet</u>
f.	Percent recovery:	(calculate by dividing E by D and multiplying result by 100)	<u>100%</u>

Well percent recovery (F) must be 90% or greater within a 72 hour period.

* The static water level after 72 hours or less post pump test.

** Kleinfelder refers to this as the dynamic pumping level.



CAL-TECH PUMP WELL & WATER TREATMENT

P.O. Box 1261
 Middletown, CA 95461
 Ph. 707-987-4488

www.cal-techpump.com
 State License # 923640
 Fax. 707-987-4411

Well Inspection Log

For: Garth Markson	Site: 3050 Big Valley Rd
Ph: (310) 429-7354	Project:
Email: garthmarkson@gmail.com	

Start Date: 11/4/21				Technician: Joe					
WELL DEPTH	CASING SIZE	STATIC LEVEL	PUMP TYPE	PUMP SETTING	MAX PUMP OUTPUT	TOTAL DRAWDOWN	DEAD HEAD	AMPS	VOLTAGE
N/A	10" St.	27.5'	N/A	6" St.	800 Gpm	43.5	N/A	63A	230v-3
DATE	TIME	TECH	WATER LEVEL	GAL.PER MINUTE	WATER COLOR	WATER METER	COMMENTS		
11/4/2021	1:17	Joe	27.5'	800	Brown				
	1:24		40'	800	Brown				
	1:34		42'	800	Brown				
	1:40		42'	800	Clearing up				
	1:54		42'	800	Clearing up				
	2:20		42'	800	Clear/Cold				
	3:28		43'	800	Clear/Cold				
	5:00		43.5'	800	Clear/Cold				
	5:17		43.5'	800	Clear/Cold				
Recovery:	5:47		32'						

Water Quality Sample Taken: Yes Pump Broke Suction During Test: No	Total Pumping Time: 4 Hrs. Estimated Total Volume Pumped: 192,000 Well Yield For Duration Of Test: 800 GPM
---	---

NOTES & RECOMMENDATIONS:
 Well pumped sediment clear water throughout the inspection. The water quality started off with a black coloration, but began to clear as the test went on. Well casing is above grade and properly sealed, it is currently not plumbed into anything. The 800 Gpm is an approximation, as we had to use measurements.

APPENDIX D
RADIUS OF PUMPING INFLUENCE

Radius of Pumping Influence
3050 Big Valley Road
Kelseyville, CA

HES, 11/02/201

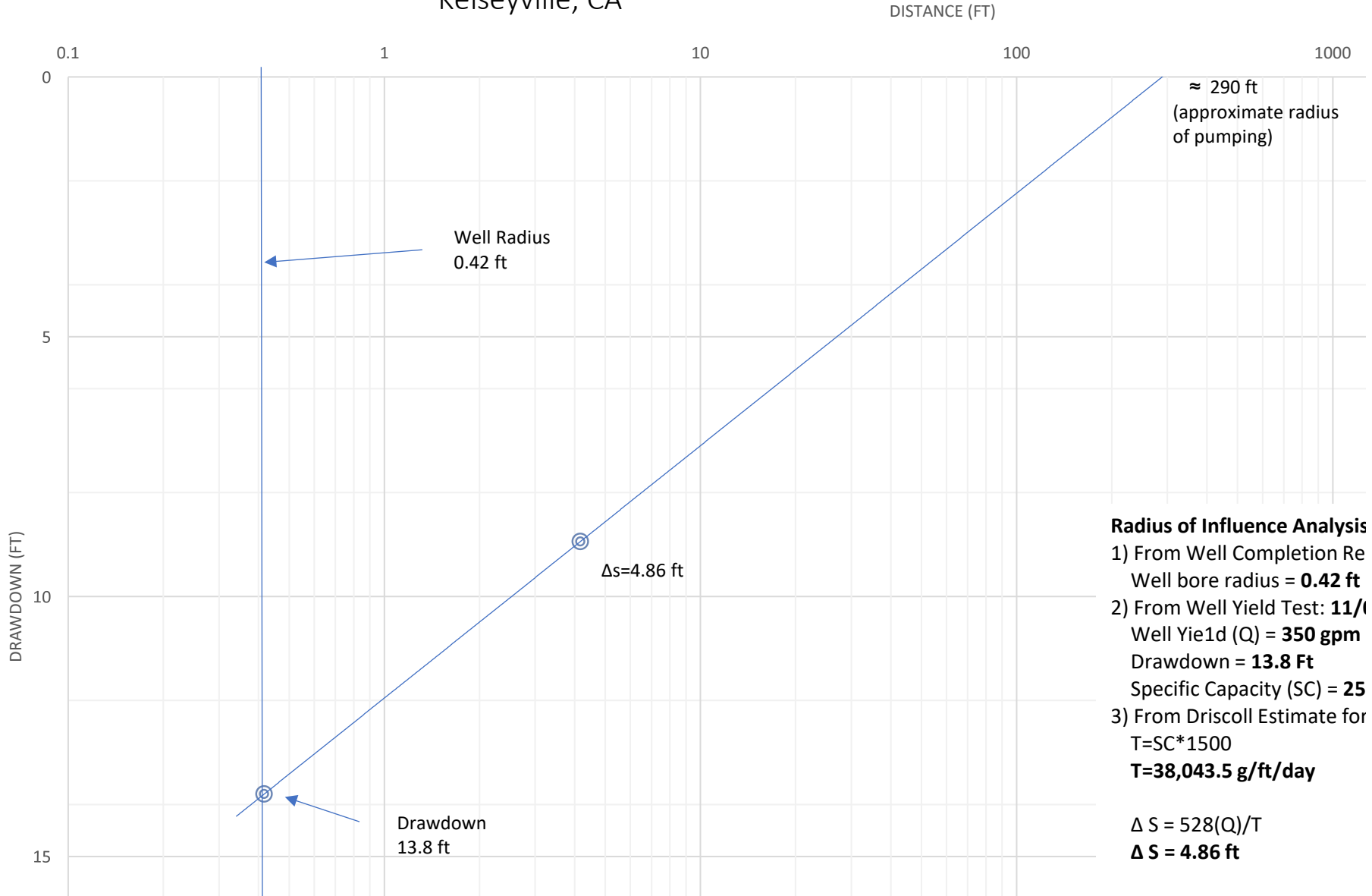

Radius of Pumping Influence
3050 Big Valley Road
Kelseyville, CA

CAL-TECH, 11/04/2011

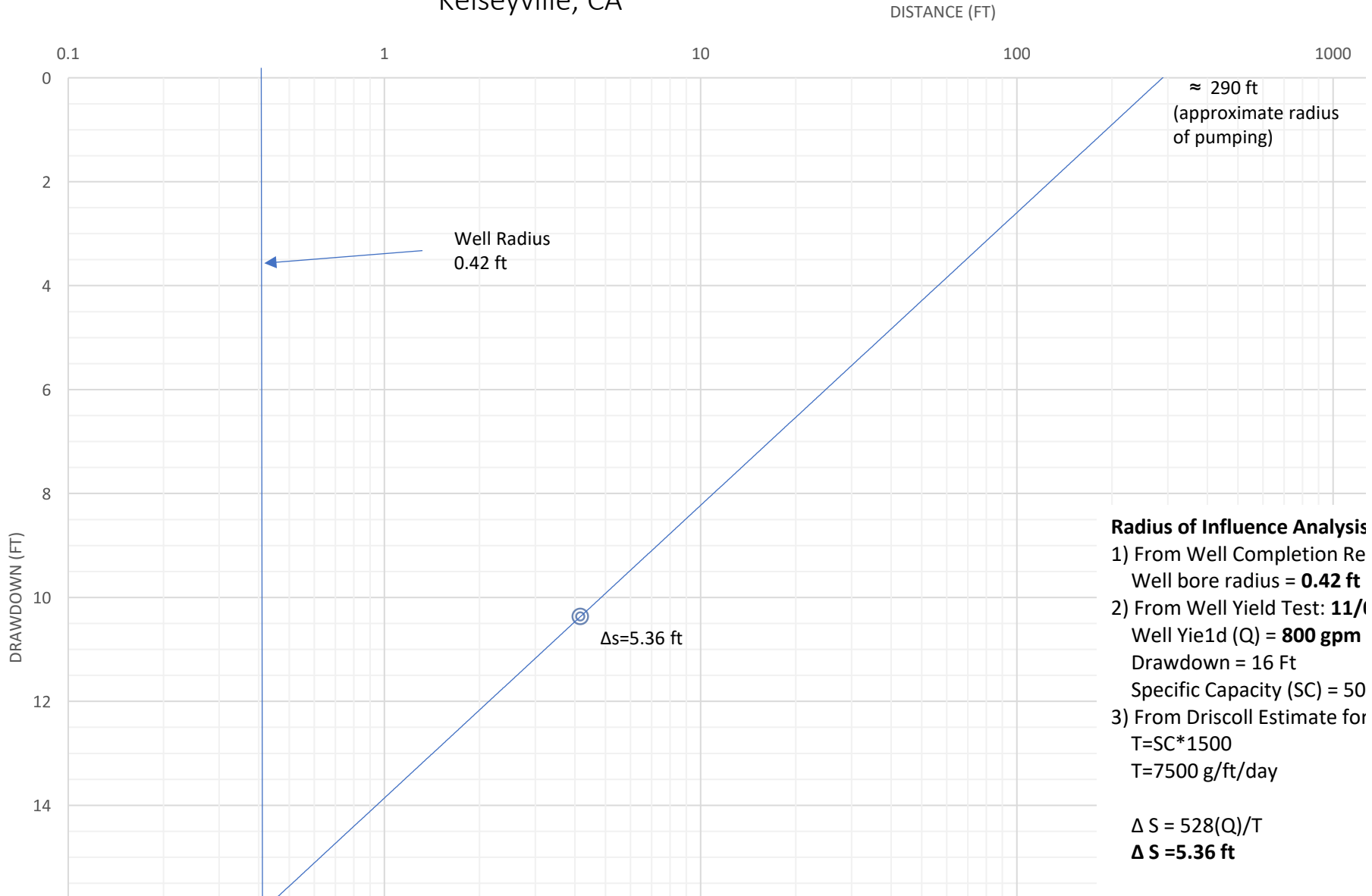

APPENDIX E
LABORATORY ANALYTICAL REPORT



Alpha

Alpha Analytical Laboratories, Inc.

email: clientservices@alpha-labs.com

Corporate: 208 Mason Street | Ukiah, CA 95482 | T: 707-468-0401 | F: 707-468-5267 | ELAP# 1551

30 November 2021

LC - Cal Tech Pump

Attn: Scott Brown

PO Box 1261

Middletown, CA 95461

RE: Water Quality

Work Order: 21K1095

Enclosed are the results of analyses for samples received by the laboratory on 11/05/21 14:20. If you have any questions concerning this report, please feel free to contact me.

Sincerely,

Jeanette L. Poplin For Sheri L. Speaks

Project Manager



Alpha Analytical Laboratories, Inc. email: clientservices@alpha-labs.com
Corporate: 208 Mason Street | Ukiah, CA 95482 | T: 707-468-0401 | F: 707-468-5267 | ELAP# 1551

LC - Cal Tech Pump
PO Box 1261
Middletown, CA 95461

Project Manager: Scott Brown
Project: Water Quality
Project Number: 3050 Big Valley Rd

Reported:
11/30/21 13:33

Bay Area: 262 Rickenbacker Circle | Livermore, CA 94551 | T: 925-828-6226 | F: 925-828-6309 | ELAP# 2728
Central Valley: 9090 Union Park Way Suite 113 | Elk Grove, CA 95624 | T: 916-686-5190 | F: 916-686-5192 | ELAP# 2922
North Bay: 110 Liberty Street | Petaluma, CA 94952 | T: 707-769-3128 | F: 707-769-8093 | ELAP# 2303
San Diego: 2722 Loker Avenue West Suite A | Carlsbad, CA 92010 | T: 760-930-2555 | F: 760-930-2510 | ELAP# 3055

ANALYTICAL REPORT FOR SAMPLES

Sample ID	Laboratory ID	Matrix	Date Sampled	Date Received
3050 Big Valley Rd	21K1095-01	Water	11/05/21 06:00	11/05/21 14:20



Alpha Analytical Laboratories, Inc.

email: clientservices@alpha-labs.com

Corporate: 208 Mason Street | Ukiah, CA 95482 | T: 707-468-0401 | F: 707-468-5267 | ELAP# 1551

LC - Cal Tech Pump
PO Box 1261
Middletown, CA 95461

Project Manager: Scott Brown
Project: Water Quality
Project Number: 3050 Big Valley Rd

Reported:
11/30/21 13:33

	Result	Units	Reporting Limit	Dilution	Batch	Prepared	Analyzed	ELAP#	Method	Note
3050 Big Valley Rd (21K1095-01)										
Sample Type: Water										
Sampled: 11/05/21 06:00										
Metals by EPA 200 Series Methods										
Boron	ND	mg/L	0.20	1	AK14422	11/19/21 10:35	11/22/21 15:32	1551	EPA 200.7	
Calcium	23	mg/L	1.0	1	AK14422	11/19/21 10:35	11/22/21 15:32	1551	EPA 200.7	
Iron	0.12	mg/L	0.10	1	AK14422	11/19/21 10:35	11/22/21 15:32	1551	EPA 200.7	
Magnesium	63	mg/L	1.0	1	AK14422	11/19/21 10:35	11/22/21 15:32	1551	EPA 200.7	
Manganese	ND	mg/L	0.020	1	AK14422	11/19/21 10:35	11/22/21 15:32	1551	EPA 200.7	
Potassium	1.4	mg/L	1.0	1	AK14422	11/19/21 10:35	11/22/21 15:32	1551	EPA 200.7	
Sodium	9.3	mg/L	1.0	1	AK14422	11/19/21 10:35	11/22/21 15:32	1551	EPA 200.7	
Conventional Chemistry Parameters by APHA/EPA Methods										
Bicarbonate	310	mg/L	5.0	1	AK14308	11/17/21 08:00	11/17/21 17:00	1551	SM2320B	
Carbonate	ND	mg/L	5.0	1	AK14308	11/17/21 08:00	11/17/21 17:00	1551	SM2320B	
pH	7.62	pH Units	1.68	1	AK13662	11/05/21 16:00	11/05/21 17:00	1551	SM4500-H+ B	T-14
Specific Conductance (EC)	550	umhos/cm	20	1	AK13662	11/05/21 16:00	11/05/21 17:00	1551	SM2510B	
Total Dissolved Solids	350	mg/L	10	1	AK13662	11/05/21 16:00	11/05/21 17:00	1551	Calculation	
Hardness, Total	315	mg/L	5	1	AK14422	11/19/21 10:35	11/22/21 15:32	1551	SM2340B	
Miscellaneous Physical/Conventional Chemistry Parameters										
Sodium Adsorption Ratio-Adj RNa	0.23	NA		1	AK14502	11/18/21 17:11	11/30/21 10:06	1551	SAR	
Anions by EPA Method 300.0										
Chloride	8.2	mg/L	0.50	1	AK13424	11/06/21 00:56	11/06/21 00:56	1551	EPA 300.0	
Nitrate as N	ND	mg/L	0.20	1	AK13424	11/06/21 00:56	11/06/21 00:56	1551	EPA 300.0	
Sulfate as SO4	38	mg/L	0.50	1	AK13424	11/06/21 00:56	11/06/21 00:56	1551	EPA 300.0	



Alpha Analytical Laboratories, Inc. email: clientservices@alpha-labs.com
Corporate: 208 Mason Street | Ukiah, CA 95482 | T: 707-468-0401 | F: 707-468-5267 | ELAP# 1551

LC - Cal Tech Pump
PO Box 1261
Middletown, CA 95461

Project Manager: Scott Brown
Project: Water Quality
Project Number: 3050 Big Valley Rd

Reported:
11/30/21 13:33

Notes and Definitions

- P-05 Sample was received unpreserved. Sample preserved by the laboratory prior to preparation.
- QM-01 The spike recovery for this QC sample is outside of established control limits possibly due to a sample matrix interference.
- T-14 Residual chlorine, dissolved oxygen, sulfite, and pH must be analyzed in the field to meet the EPA specified 15 minute hold time.
- ND Analyte NOT DETECTED at or above the reporting limit
- dry Sample results reported on a dry weight basis
- RPD Relative Percent Difference

Non-accredited analytes are reported only when ELAP accreditation for a requested analyte is not available. For a list of accredited analytes, view our certificates at the Company link on our website at www.alpha-labs.com or contact your Project Manager directly.



Alpha Analytical Laboratories Inc.
www.alpha-labs.com

WATERS, SEDIMENTS, SOLIDS

Water Quality Guidelines for Irrigation

Interpretation is related to type of problem and its severity but modified by circumstances of soil, crop, and local experience.

Type of Issue	Degree of Issue		
	<u>None</u>	<u>Increasing</u>	<u>Severe</u>
Salinity ¹			
Conductivity (EC) umhos/cm	less than 750	750 - 3,000	more than 3,000
Total Dissolved Solids (TDS) mg/L	less than 480	480 - 1,920	more than 1,920
Permeability			
Low Conductivity umhos/cm	more than 0.5	0.5 - 0	NA
Low TDS (mg/L)	more than 320	320 - 0	NA
SAR ² CO ₃ + HCO ₃ ³	less than 6.0	6.0 - 9.0	more than 9.0
Toxicity ⁴ of specific ions to sensitive crops	NA	NA	NA
Related to soil			
Sodium (Na) - evaluated by SAR	SAR less than 3	3.0 - 9.0	more than 9.0
Chloride (mg/L)	less than 70	70 - 345	more than 345
Boron (mg/L)	1.0	1.0 - 2.0	more than 2.0
Related to foliar absorption			
Sprinkler irrigated ⁵			
Sodium - mg/L	less than 70	more than 70	NA
Chloride (mg/L)	less than 100	more than 100	NA
Miscellaneous ⁶			
Nitrate as Nitrogen (mg/L)	less than 5	5.0 - 30.0	more than 30
Bicarbonate (mg/L)	less than 40	40 - 520	more than 520
pH			

¹Assumes water for crop plus needed water for leaching requirement will be applied. Crops vary in tolerance to salinity. Refer to crop tolerance tables.

²SAR means sodium absorption ratio. Calculated from SAR equals Na divided by the square root of ((HCO₃ divided by Ca) + Mg divided by 2)

³High CO₃+HCO₃ can result in permeability problems due to precipitation of Ca as lime, which will reduce Ca and increase SAR.

⁴Most tree crops and woody ornamentals are sensitive to sodium and chloride. Most annual crops are not sensitive (Use salinity tolerance tables). For boron sensitivity, refer to boron sensitivity tables.

⁵Occurrence and sensitivity is directly related to low humidity - high evaporation climatic conditions ⁶Nitrate as N is problem with certain crops, e.g. sugar, beets, grapes; HCO₃ can be a problem in sprinkler irrigation due to white carbonate deposit on fruit or leaves.

Signature below authorizes work under terms stated on reverse side.

Report to	Invoice to (if different)	Project Information			Analysis Request				TAT	TEMP °C																
my: <u>Cactech Pump</u> <u>SCOTT / JOE</u>	Contact:	Project ID: <u>3050 Berkeley</u>	Total Number of Containers per Sample ID <u>AC7 STAFF</u>	<input checked="checked" type="radio"/> Standard 10 days <input type="radio"/> RUSH: 5 days <input type="radio"/> 48 hours <input type="radio"/> Other: <u> </u> days <input type="radio"/> Preapproval required	Ukiah <u>4.0</u>	Livermore	Elk Grove	Petaluma	Carlsbad																	
Address:	Project No:																									
Phone/Fax:	PO Number:																									
Address: <u>ALTECH PUMP @ HOTMAIL.COM / JOSEPH @ CACTECH PUMP @ OUTLOOK.COM</u>																										
Sampler - Printed Name & Signature: <u>SCOTT BROWN</u> <i>[Signature]</i>																										
Sample Identification	Sampling		Matrix																							
<u>3050 Berkeley</u>	Date	Time	40ml VOA Vial		Plastic	Glass	Sleeve	Other	HCl	HNO3	H2SO4	Other	None	Drinking Water	Wastewater	Soil	Other									
	<u>11/5/21</u>	<u>6:00am</u>																								
Relinquished by <u>[Signature]</u>			Received by <u>[Signature]</u>			Date <u>11/5/21</u>		Time <u>1050</u>		DDW Write On EDT Transmission? <input type="radio"/> Yes <input type="radio"/> No																
State System Number:			Date <u>11/5/21</u>			Time <u>1020</u>		If "Y" please enter the Source Number(s) in the column above																		
CA Geotracker EDF Report? <input type="radio"/> Yes <input type="radio"/> No			Global ID:			Sampling Company Log Code:																				
EDF to (Email Address):			Travel and Site Time:			Meager:		Misc. Supplies:																		