

CITY OF RANCHO MIRAGE



**CITY OF RANCHO MIRAGE**

69-825 Highway 111  
Rancho Mirage, California 92270  
Phone: (760) 328-2266  
Fax: (760) 324-9851

---

## **DESERT ISLAND HOTEL ENVIRONMENTAL INITIAL STUDY APPENDIX**

### ***Appendix A***

*California Emissions Estimator Model (CalEEMod), Version 2020.4.0*

### ***Appendix B***

*Noise and Vibration Impact Analysis, Urban Crossroads, Inc. May 2022*

### ***Appendix C***

*Desert Island VMT Evaluation, Urban Crossroads, Inc., May 2022*

### ***Appendix D***

*Desert Island Hotel Focused Traffic Analysis, Urban Crossroads, Inc. May 2022*

### ***Appendix E***

*Agua Caliente Band of Cahuilla Indians Letter, September 2022*

### ***Appendix F***

*Comment Letters Received from Initial Circulation of Draft IS/MND, May 2023*



## **DESERT ISLAND HOTEL APPENDIX**

### ***Appendix A***

*California Emissions Estimator Model (CalEEMod),  
Version 2020.4.0.*

Desert Island SP - Amendment - Riverside-Salton Sea County, Annual

**EMFAC Off-Model Adjustment Factors for Gasoline Light Duty Vehicle to Account for the SAFE Vehicle Rule Applied**

**Desert Island SP - Amendment  
Riverside-Salton Sea County, Annual**

**1.0 Project Characteristics**

**1.1 Land Usage**

Land Uses	Size	Metric	Lot Acreage	Floor Surface Area	Population
General Light Industry	8.00	1000sqft	0.18	8,000.00	0
Parking Lot	228.00	Space	2.05	91,200.00	0
Golf Course	3.50	Acre	3.50	152,460.00	0
Health Club	6.30	1000sqft	0.14	6,300.00	0
Hotel	42.00	Room	1.40	60,984.00	0
Recreational Swimming Pool	13.10	1000sqft	0.30	13,100.00	0
Single Family Housing	11.00	Dwelling Unit	3.57	19,800.00	21

**1.2 Other Project Characteristics**

<b>Urbanization</b>	Urban	<b>Wind Speed (m/s)</b>	2.4	<b>Precipitation Freq (Days)</b>	28
<b>Climate Zone</b>	15			<b>Operational Year</b>	2025
<b>Utility Company</b>	Southern California Edison				
<b>CO2 Intensity (lb/MW hr)</b>	390.98	<b>CH4 Intensity (lb/MW hr)</b>	0.033	<b>N2O Intensity (lb/MW hr)</b>	0.004

**1.3 User Entered Comments & Non-Default Data**

Project Characteristics - This model accounts for the proposed SP build-out condition with a tentative construction start date of May 1, 2023 for modeling purposes.

Land Use - Population total is based on 1.87 PPH for RM per CADF. GC size is based on combined driving range and desert gardens acreage. Health Club includes pool cafe, yoga pavilion, and restroom SF. GLI solely applies to the 8,000 SF golf course maintenance building for modeling purposes and does not imply the presence of traditional general light industry uses.

Demolition - This model accounts for 5,400 tons of debris associated with 2,700 CY of hardscape and building material removal at a conservative rate of 2 tons per CY.

Architectural Coating - SCAQMD Rule 1113 VOC Content Limits Apply as a Requirement

Desert Island SP - Amendment - Riverside-Salton Sea County, Annual

**EMFAC Off-Model Adjustment Factors for Gasoline Light Duty Vehicle to Account for the SAFE Vehicle Rule Applied**

Vehicle Trips - Consistent with the traffic assessment, the trip generating uses are the hotel rooms/keys, residential units, and golf course driving range facilities. The trip rates are default to the CalEEMod parameters.

Woodstoves - SCAQMD Rule 445 is applied pertaining to wood burning.

Area Coating - SCAQMD Rule 1113 VOC Content Limits are applied

Construction Off-road Equipment Mitigation - Dust control measures are a requirement under SCAQMD Rule 403/403.1 and Section 15.64.630 of the Rancho Mirage Municipal Code.

Area Mitigation - SCAQMD Rule 1113 VOC Content Limits Apply

Energy Mitigation - High efficiency lighting would be in the form of LED.

Waste Mitigation -

Trips and VMT -

Grading - Exported material (2,700 CY) corresponds to demolition of existing facilities.

Table Name	Column Name	Default Value	New Value
tblArchitecturalCoating	EF_Nonresidential_Exterior	250.00	50.00
tblArchitecturalCoating	EF_Nonresidential_Interior	250.00	50.00
tblArchitecturalCoating	EF_Parking	250.00	100.00
tblArchitecturalCoating	EF_Residential_Exterior	250.00	50.00
tblArchitecturalCoating	EF_Residential_Interior	250.00	50.00
tblAreaCoating	Area_EF_Nonresidential_Exterior	250	50
tblAreaCoating	Area_EF_Nonresidential_Interior	250	50
tblAreaCoating	Area_EF_Parking	250	100
tblAreaCoating	Area_EF_Residential_Exterior	250	50
tblAreaCoating	Area_EF_Residential_Interior	250	50
tblAreaMitigation	UseLowVOCPaintParkingCheck	False	True
tblConstDustMitigation	CleanPavedRoadPercentReduction	0	20
tblConstDustMitigation	WaterUnpavedRoadMoistureContent	0	50
tblConstDustMitigation	WaterUnpavedRoadVehicleSpeed	0	15
tblFireplaces	NumberWood	1.10	0.00
tblGrading	MaterialExported	0.00	2,700.00
tblLandUse	Population	31.00	21.00



Desert Island SP - Amendment - Riverside-Salton Sea County, Annual

**EMFAC Off-Model Adjustment Factors for Gasoline Light Duty Vehicle to Account for the SAFE Vehicle Rule Applied**

tblVehicleTrips	ST_TR	1.99	0.00
tblVehicleTrips	ST_TR	20.87	0.00
tblVehicleTrips	ST_TR	9.10	0.00
tblVehicleTrips	SU_TR	5.00	0.00
tblVehicleTrips	SU_TR	26.73	0.00
tblVehicleTrips	SU_TR	13.60	0.00
tblVehicleTrips	WD_TR	4.96	0.00
tblVehicleTrips	WD_TR	32.93	0.00
tblVehicleTrips	WD_TR	28.82	0.00

**2.0 Emissions Summary**

---

Desert Island SP - Amendment - Riverside-Salton Sea County, Annual

**EMFAC Off-Model Adjustment Factors for Gasoline Light Duty Vehicle to Account for the SAFE Vehicle Rule Applied**

**2.1 Overall Construction**

**Unmitigated Construction**

	ROG	NOx	CO	SO2	Fugitive PM10	Exhaust PM10	PM10 Total	Fugitive PM2.5	Exhaust PM2.5	PM2.5 Total	Bio- CO2	NBio- CO2	Total CO2	CH4	N2O	CO2e
Year	tons/yr										MT/yr					
2023	0.2045	1.8555	1.9134	4.3500e-003	0.3902	0.0795	0.4697	0.1400	0.0741	0.2141	0.0000	388.4797	388.4797	0.0755	0.0117	393.8507
2024	0.4397	1.5278	2.0441	4.3800e-003	0.1381	0.0637	0.2018	0.0373	0.0599	0.0971	0.0000	391.1172	391.1172	0.0604	0.0125	396.3503
<b>Maximum</b>	<b>0.4397</b>	<b>1.8555</b>	<b>2.0441</b>	<b>4.3800e-003</b>	<b>0.3902</b>	<b>0.0795</b>	<b>0.4697</b>	<b>0.1400</b>	<b>0.0741</b>	<b>0.2141</b>	<b>0.0000</b>	<b>391.1172</b>	<b>391.1172</b>	<b>0.0755</b>	<b>0.0125</b>	<b>396.3503</b>

**Mitigated Construction**

	ROG	NOx	CO	SO2	Fugitive PM10	Exhaust PM10	PM10 Total	Fugitive PM2.5	Exhaust PM2.5	PM2.5 Total	Bio- CO2	NBio- CO2	Total CO2	CH4	N2O	CO2e
Year	tons/yr										MT/yr					
2023	0.2045	1.8555	1.9134	4.3500e-003	0.1716	0.0795	0.2511	0.0575	0.0741	0.1317	0.0000	388.4794	388.4794	0.0755	0.0117	393.8504
2024	0.4397	1.5278	2.0441	4.3800e-003	0.1150	0.0637	0.1787	0.0316	0.0599	0.0915	0.0000	391.1169	391.1169	0.0604	0.0125	396.3501
<b>Maximum</b>	<b>0.4397</b>	<b>1.8555</b>	<b>2.0441</b>	<b>4.3800e-003</b>	<b>0.1716</b>	<b>0.0795</b>	<b>0.2511</b>	<b>0.0575</b>	<b>0.0741</b>	<b>0.1317</b>	<b>0.0000</b>	<b>391.1169</b>	<b>391.1169</b>	<b>0.0755</b>	<b>0.0125</b>	<b>396.3501</b>

Desert Island SP - Amendment - Riverside-Salton Sea County, Annual

**EMFAC Off-Model Adjustment Factors for Gasoline Light Duty Vehicle to Account for the SAFE Vehicle Rule Applied**

	ROG	NOx	CO	SO2	Fugitive PM10	Exhaust PM10	PM10 Total	Fugitive PM2.5	Exhaust PM2.5	PM2.5 Total	Bio- CO2	NBio-CO2	Total CO2	CH4	N2O	CO2e
Percent Reduction	0.00	0.00	0.00	0.00	45.76	0.00	36.00	49.71	0.00	28.31	0.00	0.00	0.00	0.00	0.00	0.00

Quarter	Start Date	End Date	Maximum Unmitigated ROG + NOX (tons/quarter)	Maximum Mitigated ROG + NOX (tons/quarter)
1	5-1-2023	7-31-2023	1.0496	1.0496
2	8-1-2023	10-31-2023	0.6022	0.6022
3	11-1-2023	1-31-2024	0.5915	0.5915
4	2-1-2024	4-30-2024	0.5545	0.5545
5	5-1-2024	7-31-2024	0.5653	0.5653
6	8-1-2024	9-30-2024	0.3362	0.3362
		Highest	1.0496	1.0496

Desert Island SP - Amendment - Riverside-Salton Sea County, Annual

**EMFAC Off-Model Adjustment Factors for Gasoline Light Duty Vehicle to Account for the SAFE Vehicle Rule Applied**

**2.2 Overall Operational**

**Unmitigated Operational**

	ROG	NOx	CO	SO2	Fugitive PM10	Exhaust PM10	PM10 Total	Fugitive PM2.5	Exhaust PM2.5	PM2.5 Total	Bio- CO2	NBio- CO2	Total CO2	CH4	N2O	CO2e
Category	tons/yr										MT/yr					
Area	0.4107	7.5000e-003	0.1206	1.5000e-004		6.4400e-003	6.4400e-003		6.4400e-003	6.4400e-003	0.7362	7.0701	7.8063	3.7200e-003	1.3000e-004	7.9370
Energy	0.0237	0.2148	0.1745	1.2900e-003		0.0164	0.0164		0.0164	0.0164	0.0000	469.8604	469.8604	0.0243	6.7100e-003	472.4683
Mobile	0.1587	0.1985	1.2819	2.6500e-003	0.2833	2.2300e-003	0.2855	0.0757	2.0900e-003	0.0778	0.0000	250.7839	250.7839	0.0163	0.0141	255.3884
Waste						0.0000	0.0000		0.0000	0.0000	31.5387	0.0000	31.5387	1.8639	0.0000	78.1358
Water						0.0000	0.0000		0.0000	0.0000	1.5163	21.7625	23.2788	0.1576	3.9000e-003	28.3804
<b>Total</b>	<b>0.5931</b>	<b>0.4207</b>	<b>1.5770</b>	<b>4.0900e-003</b>	<b>0.2833</b>	<b>0.0251</b>	<b>0.3083</b>	<b>0.0757</b>	<b>0.0249</b>	<b>0.1006</b>	<b>33.7912</b>	<b>749.4768</b>	<b>783.2680</b>	<b>2.0658</b>	<b>0.0248</b>	<b>842.3100</b>

Desert Island SP - Amendment - Riverside-Salton Sea County, Annual

**EMFAC Off-Model Adjustment Factors for Gasoline Light Duty Vehicle to Account for the SAFE Vehicle Rule Applied**

**2.2 Overall Operational**

**Mitigated Operational**

	ROG	NOx	CO	SO2	Fugitive PM10	Exhaust PM10	PM10 Total	Fugitive PM2.5	Exhaust PM2.5	PM2.5 Total	Bio- CO2	NBio- CO2	Total CO2	CH4	N2O	CO2e
Category	tons/yr										MT/yr					
Area	0.3785	9.6000e-004	0.0844	0.0000		4.6000e-004	4.6000e-004		4.6000e-004	4.6000e-004	0.0000	0.1388	0.1388	1.4000e-004	0.0000	0.1423
Energy	0.0237	0.2148	0.1745	1.2900e-003		0.0164	0.0164		0.0164	0.0164	0.0000	457.8500	457.8500	0.0233	6.5900e-003	460.3960
Mobile	0.1587	0.1985	1.2819	2.6500e-003	0.2833	2.2300e-003	0.2855	0.0757	2.0900e-003	0.0778	0.0000	250.7839	250.7839	0.0163	0.0141	255.3884
Waste						0.0000	0.0000		0.0000	0.0000	0.0000	0.0000	0.0000	0.0000	0.0000	0.0000
Water						0.0000	0.0000		0.0000	0.0000	1.2131	18.9008	20.1139	0.1262	3.1400e-003	24.2029
<b>Total</b>	<b>0.5610</b>	<b>0.4142</b>	<b>1.5408</b>	<b>3.9400e-003</b>	<b>0.2833</b>	<b>0.0191</b>	<b>0.3023</b>	<b>0.0757</b>	<b>0.0189</b>	<b>0.0946</b>	<b>1.2131</b>	<b>727.6735</b>	<b>728.8866</b>	<b>0.1659</b>	<b>0.0238</b>	<b>740.1296</b>

	ROG	NOx	CO	SO2	Fugitive PM10	Exhaust PM10	PM10 Total	Fugitive PM2.5	Exhaust PM2.5	PM2.5 Total	Bio- CO2	NBio- CO2	Total CO2	CH4	N2O	CO2e
<b>Percent Reduction</b>	<b>5.42</b>	<b>1.55</b>	<b>2.30</b>	<b>3.67</b>	<b>0.00</b>	<b>23.86</b>	<b>1.94</b>	<b>0.00</b>	<b>24.00</b>	<b>5.94</b>	<b>96.41</b>	<b>2.91</b>	<b>6.94</b>	<b>91.97</b>	<b>4.07</b>	<b>12.13</b>

**3.0 Construction Detail**

**Construction Phase**

Phase Number	Phase Name	Phase Type	Start Date	End Date	Num Days Week	Num Days	Phase Description
1	Demolition	Demolition	5/1/2023	5/26/2023	5	20	
2	Site Preparation	Site Preparation	5/27/2023	6/9/2023	5	10	
3	Grading	Grading	6/10/2023	7/21/2023	5	30	

Desert Island SP - Amendment - Riverside-Salton Sea County, Annual

**EMFAC Off-Model Adjustment Factors for Gasoline Light Duty Vehicle to Account for the SAFE Vehicle Rule Applied**

4	Building Construction	Building Construction	7/22/2023	9/13/2024	5	300
5	Paving	Paving	9/14/2024	10/11/2024	5	20
6	Architectural Coating	Architectural Coating	10/12/2024	11/8/2024	5	20

**Acres of Grading (Site Preparation Phase): 15**

**Acres of Grading (Grading Phase): 90**

**Acres of Paving: 2.05**

**Residential Indoor: 40,095; Residential Outdoor: 13,365; Non-Residential Indoor: 112,926; Non-Residential Outdoor: 37,642; Striped Parking Area: 5,472 (Architectural Coating – sqft)**

**OffRoad Equipment**

Phase Name	Offroad Equipment Type	Amount	Usage Hours	Horse Power	Load Factor
Demolition	Concrete/Industrial Saws	1	8.00	81	0.73
Demolition	Excavators	3	8.00	158	0.38
Demolition	Rubber Tired Dozers	2	8.00	247	0.40
Site Preparation	Rubber Tired Dozers	3	8.00	247	0.40
Site Preparation	Tractors/Loaders/Backhoes	4	8.00	97	0.37
Grading	Excavators	2	8.00	158	0.38
Grading	Graders	1	8.00	187	0.41
Grading	Rubber Tired Dozers	1	8.00	247	0.40
Grading	Tractors/Loaders/Backhoes	2	8.00	97	0.37
Building Construction	Cranes	1	7.00	231	0.29
Building Construction	Forklifts	3	8.00	89	0.20
Building Construction	Generator Sets	1	8.00	84	0.74
Building Construction	Tractors/Loaders/Backhoes	3	7.00	97	0.37
Building Construction	Welders	1	8.00	46	0.45
Paving	Pavers	2	8.00	130	0.42
Paving	Paving Equipment	2	8.00	132	0.36
Paving	Rollers	2	8.00	80	0.38

Desert Island SP - Amendment - Riverside-Salton Sea County, Annual

**EMFAC Off-Model Adjustment Factors for Gasoline Light Duty Vehicle to Account for the SAFE Vehicle Rule Applied**

Architectural Coating	Air Compressors	1	6.00	78	0.48
Grading	Scrapers	2	8.00	367	0.48

**Trips and VMT**

Phase Name	Offroad Equipment Count	Worker Trip Number	Vendor Trip Number	Hauling Trip Number	Worker Trip Length	Vendor Trip Length	Hauling Trip Length	Worker Vehicle Class	Vendor Vehicle Class	Hauling Vehicle Class
Demolition	6	15.00	0.00	534.00	11.00	5.40	20.00	LD_Mix	HDT_Mix	HHDT
Site Preparation	7	18.00	0.00	338.00	11.00	5.40	20.00	LD_Mix	HDT_Mix	HHDT
Grading	8	20.00	0.00	0.00	11.00	5.40	20.00	LD_Mix	HDT_Mix	HHDT
Building Construction	9	143.00	56.00	0.00	11.00	5.40	20.00	LD_Mix	HDT_Mix	HHDT
Paving	6	15.00	0.00	0.00	11.00	5.40	20.00	LD_Mix	HDT_Mix	HHDT
Architectural Coating	1	29.00	0.00	0.00	11.00	5.40	20.00	LD_Mix	HDT_Mix	HHDT

**3.1 Mitigation Measures Construction**

Use Soil Stabilizer

Replace Ground Cover

Water Exposed Area

Water Unpaved Roads

Reduce Vehicle Speed on Unpaved Roads

Clean Paved Roads

Desert Island SP - Amendment - Riverside-Salton Sea County, Annual

**EMFAC Off-Model Adjustment Factors for Gasoline Light Duty Vehicle to Account for the SAFE Vehicle Rule Applied**

**3.2 Demolition - 2023**

**Unmitigated Construction On-Site**

	ROG	NOx	CO	SO2	Fugitive PM10	Exhaust PM10	PM10 Total	Fugitive PM2.5	Exhaust PM2.5	PM2.5 Total	Bio- CO2	NBio- CO2	Total CO2	CH4	N2O	CO2e
Category	tons/yr										MT/yr					
Fugitive Dust					0.0581	0.0000	0.0581	8.8000e-003	0.0000	8.8000e-003	0.0000	0.0000	0.0000	0.0000	0.0000	0.0000
Off-Road	0.0227	0.2148	0.1964	3.9000e-004		9.9800e-003	9.9800e-003		9.2800e-003	9.2800e-003	0.0000	33.9921	33.9921	9.5200e-003	0.0000	34.2301
<b>Total</b>	<b>0.0227</b>	<b>0.2148</b>	<b>0.1964</b>	<b>3.9000e-004</b>	<b>0.0581</b>	<b>9.9800e-003</b>	<b>0.0681</b>	<b>8.8000e-003</b>	<b>9.2800e-003</b>	<b>0.0181</b>	<b>0.0000</b>	<b>33.9921</b>	<b>33.9921</b>	<b>9.5200e-003</b>	<b>0.0000</b>	<b>34.2301</b>

**Unmitigated Construction Off-Site**

	ROG	NOx	CO	SO2	Fugitive PM10	Exhaust PM10	PM10 Total	Fugitive PM2.5	Exhaust PM2.5	PM2.5 Total	Bio- CO2	NBio- CO2	Total CO2	CH4	N2O	CO2e
Category	tons/yr										MT/yr					
Hauling	5.6000e-004	0.0281	7.4000e-003	1.5000e-004	4.6100e-003	3.2000e-004	4.9300e-003	1.2600e-003	3.1000e-004	1.5700e-003	0.0000	14.2226	14.2226	2.0000e-004	2.2400e-003	14.8955
Vendor	0.0000	0.0000	0.0000	0.0000	0.0000	0.0000	0.0000	0.0000	0.0000	0.0000	0.0000	0.0000	0.0000	0.0000	0.0000	0.0000
Worker	4.1000e-004	2.9000e-004	3.7100e-003	1.0000e-005	1.2300e-003	1.0000e-005	1.2400e-003	3.3000e-004	1.0000e-005	3.3000e-004	0.0000	0.9565	0.9565	3.0000e-005	3.0000e-005	0.9653
<b>Total</b>	<b>9.7000e-004</b>	<b>0.0284</b>	<b>0.0111</b>	<b>1.6000e-004</b>	<b>5.8400e-003</b>	<b>3.3000e-004</b>	<b>6.1700e-003</b>	<b>1.5900e-003</b>	<b>3.2000e-004</b>	<b>1.9000e-003</b>	<b>0.0000</b>	<b>15.1791</b>	<b>15.1791</b>	<b>2.3000e-004</b>	<b>2.2700e-003</b>	<b>15.8607</b>



Desert Island SP - Amendment - Riverside-Salton Sea County, Annual

**EMFAC Off-Model Adjustment Factors for Gasoline Light Duty Vehicle to Account for the SAFE Vehicle Rule Applied**

**3.2 Demolition - 2023**

**Mitigated Construction On-Site**

	ROG	NOx	CO	SO2	Fugitive PM10	Exhaust PM10	PM10 Total	Fugitive PM2.5	Exhaust PM2.5	PM2.5 Total	Bio- CO2	NBio- CO2	Total CO2	CH4	N2O	CO2e
Category	tons/yr										MT/yr					
Fugitive Dust					0.0181	0.0000	0.0181	2.7500e-003	0.0000	2.7500e-003	0.0000	0.0000	0.0000	0.0000	0.0000	0.0000
Off-Road	0.0227	0.2148	0.1964	3.9000e-004		9.9800e-003	9.9800e-003		9.2800e-003	9.2800e-003	0.0000	33.9920	33.9920	9.5200e-003	0.0000	34.2300
<b>Total</b>	<b>0.0227</b>	<b>0.2148</b>	<b>0.1964</b>	<b>3.9000e-004</b>	<b>0.0181</b>	<b>9.9800e-003</b>	<b>0.0281</b>	<b>2.7500e-003</b>	<b>9.2800e-003</b>	<b>0.0120</b>	<b>0.0000</b>	<b>33.9920</b>	<b>33.9920</b>	<b>9.5200e-003</b>	<b>0.0000</b>	<b>34.2300</b>

**Mitigated Construction Off-Site**

	ROG	NOx	CO	SO2	Fugitive PM10	Exhaust PM10	PM10 Total	Fugitive PM2.5	Exhaust PM2.5	PM2.5 Total	Bio- CO2	NBio- CO2	Total CO2	CH4	N2O	CO2e
Category	tons/yr										MT/yr					
Hauling	5.6000e-004	0.0281	7.4000e-003	1.5000e-004	3.9100e-003	3.2000e-004	4.2300e-003	1.0900e-003	3.1000e-004	1.4000e-003	0.0000	14.2226	14.2226	2.0000e-004	2.2400e-003	14.8955
Vendor	0.0000	0.0000	0.0000	0.0000	0.0000	0.0000	0.0000	0.0000	0.0000	0.0000	0.0000	0.0000	0.0000	0.0000	0.0000	0.0000
Worker	4.1000e-004	2.9000e-004	3.7100e-003	1.0000e-005	1.0200e-003	1.0000e-005	1.0300e-003	2.8000e-004	1.0000e-005	2.8000e-004	0.0000	0.9565	0.9565	3.0000e-005	3.0000e-005	0.9653
<b>Total</b>	<b>9.7000e-004</b>	<b>0.0284</b>	<b>0.0111</b>	<b>1.6000e-004</b>	<b>4.9300e-003</b>	<b>3.3000e-004</b>	<b>5.2600e-003</b>	<b>1.3700e-003</b>	<b>3.2000e-004</b>	<b>1.6800e-003</b>	<b>0.0000</b>	<b>15.1791</b>	<b>15.1791</b>	<b>2.3000e-004</b>	<b>2.2700e-003</b>	<b>15.8607</b>

Desert Island SP - Amendment - Riverside-Salton Sea County, Annual

**EMFAC Off-Model Adjustment Factors for Gasoline Light Duty Vehicle to Account for the SAFE Vehicle Rule Applied**

**3.3 Site Preparation - 2023**

**Unmitigated Construction On-Site**

	ROG	NOx	CO	SO2	Fugitive PM10	Exhaust PM10	PM10 Total	Fugitive PM2.5	Exhaust PM2.5	PM2.5 Total	Bio- CO2	NBio- CO2	Total CO2	CH4	N2O	CO2e
Category	tons/yr										MT/yr					
Fugitive Dust					0.0985	0.0000	0.0985	0.0505	0.0000	0.0505	0.0000	0.0000	0.0000	0.0000	0.0000	0.0000
Off-Road	0.0133	0.1376	0.0912	1.9000e-004		6.3300e-003	6.3300e-003		5.8200e-003	5.8200e-003	0.0000	16.7254	16.7254	5.4100e-003	0.0000	16.8606
<b>Total</b>	<b>0.0133</b>	<b>0.1376</b>	<b>0.0912</b>	<b>1.9000e-004</b>	<b>0.0985</b>	<b>6.3300e-003</b>	<b>0.1048</b>	<b>0.0505</b>	<b>5.8200e-003</b>	<b>0.0564</b>	<b>0.0000</b>	<b>16.7254</b>	<b>16.7254</b>	<b>5.4100e-003</b>	<b>0.0000</b>	<b>16.8606</b>

**Unmitigated Construction Off-Site**

	ROG	NOx	CO	SO2	Fugitive PM10	Exhaust PM10	PM10 Total	Fugitive PM2.5	Exhaust PM2.5	PM2.5 Total	Bio- CO2	NBio- CO2	Total CO2	CH4	N2O	CO2e
Category	tons/yr										MT/yr					
Hauling	3.6000e-004	0.0178	4.6800e-003	9.0000e-005	2.9100e-003	2.0000e-004	3.1200e-003	8.0000e-004	1.9000e-004	1.0000e-003	0.0000	9.0023	9.0023	1.3000e-004	1.4200e-003	9.4282
Vendor	0.0000	0.0000	0.0000	0.0000	0.0000	0.0000	0.0000	0.0000	0.0000	0.0000	0.0000	0.0000	0.0000	0.0000	0.0000	0.0000
Worker	2.5000e-004	1.7000e-004	2.2300e-003	1.0000e-005	7.4000e-004	0.0000	7.4000e-004	2.0000e-004	0.0000	2.0000e-004	0.0000	0.5739	0.5739	2.0000e-005	2.0000e-005	0.5792
<b>Total</b>	<b>6.1000e-004</b>	<b>0.0180</b>	<b>6.9100e-003</b>	<b>1.0000e-004</b>	<b>3.6500e-003</b>	<b>2.0000e-004</b>	<b>3.8600e-003</b>	<b>1.0000e-003</b>	<b>1.9000e-004</b>	<b>1.2000e-003</b>	<b>0.0000</b>	<b>9.5762</b>	<b>9.5762</b>	<b>1.5000e-004</b>	<b>1.4400e-003</b>	<b>10.0074</b>

Desert Island SP - Amendment - Riverside-Salton Sea County, Annual

**EMFAC Off-Model Adjustment Factors for Gasoline Light Duty Vehicle to Account for the SAFE Vehicle Rule Applied**

**3.3 Site Preparation - 2023**

**Mitigated Construction On-Site**

	ROG	NOx	CO	SO2	Fugitive PM10	Exhaust PM10	PM10 Total	Fugitive PM2.5	Exhaust PM2.5	PM2.5 Total	Bio- CO2	NBio- CO2	Total CO2	CH4	N2O	CO2e
Category	tons/yr										MT/yr					
Fugitive Dust					0.0307	0.0000	0.0307	0.0158	0.0000	0.0158	0.0000	0.0000	0.0000	0.0000	0.0000	0.0000
Off-Road	0.0133	0.1376	0.0912	1.9000e-004		6.3300e-003	6.3300e-003		5.8200e-003	5.8200e-003	0.0000	16.7253	16.7253	5.4100e-003	0.0000	16.8606
<b>Total</b>	<b>0.0133</b>	<b>0.1376</b>	<b>0.0912</b>	<b>1.9000e-004</b>	<b>0.0307</b>	<b>6.3300e-003</b>	<b>0.0371</b>	<b>0.0158</b>	<b>5.8200e-003</b>	<b>0.0216</b>	<b>0.0000</b>	<b>16.7253</b>	<b>16.7253</b>	<b>5.4100e-003</b>	<b>0.0000</b>	<b>16.8606</b>

**Mitigated Construction Off-Site**

	ROG	NOx	CO	SO2	Fugitive PM10	Exhaust PM10	PM10 Total	Fugitive PM2.5	Exhaust PM2.5	PM2.5 Total	Bio- CO2	NBio- CO2	Total CO2	CH4	N2O	CO2e
Category	tons/yr										MT/yr					
Hauling	3.6000e-004	0.0178	4.6800e-003	9.0000e-005	2.4800e-003	2.0000e-004	2.6800e-003	6.9000e-004	1.9000e-004	8.9000e-004	0.0000	9.0023	9.0023	1.3000e-004	1.4200e-003	9.4282
Vendor	0.0000	0.0000	0.0000	0.0000	0.0000	0.0000	0.0000	0.0000	0.0000	0.0000	0.0000	0.0000	0.0000	0.0000	0.0000	0.0000
Worker	2.5000e-004	1.7000e-004	2.2300e-003	1.0000e-005	6.1000e-004	0.0000	6.2000e-004	1.7000e-004	0.0000	1.7000e-004	0.0000	0.5739	0.5739	2.0000e-005	2.0000e-005	0.5792
<b>Total</b>	<b>6.1000e-004</b>	<b>0.0180</b>	<b>6.9100e-003</b>	<b>1.0000e-004</b>	<b>3.0900e-003</b>	<b>2.0000e-004</b>	<b>3.3000e-003</b>	<b>8.6000e-004</b>	<b>1.9000e-004</b>	<b>1.0600e-003</b>	<b>0.0000</b>	<b>9.5762</b>	<b>9.5762</b>	<b>1.5000e-004</b>	<b>1.4400e-003</b>	<b>10.0074</b>

Desert Island SP - Amendment - Riverside-Salton Sea County, Annual

**EMFAC Off-Model Adjustment Factors for Gasoline Light Duty Vehicle to Account for the SAFE Vehicle Rule Applied**

**3.4 Grading - 2023**

**Unmitigated Construction On-Site**

	ROG	NOx	CO	SO2	Fugitive PM10	Exhaust PM10	PM10 Total	Fugitive PM2.5	Exhaust PM2.5	PM2.5 Total	Bio- CO2	NBio- CO2	Total CO2	CH4	N2O	CO2e
Category	tons/yr										MT/yr					
Fugitive Dust					0.1381	0.0000	0.1381	0.0548	0.0000	0.0548	0.0000	0.0000	0.0000	0.0000	0.0000	0.0000
Off-Road	0.0498	0.5177	0.4208	9.3000e-004		0.0214	0.0214		0.0197	0.0197	0.0000	81.8028	81.8028	0.0265	0.0000	82.4642
<b>Total</b>	<b>0.0498</b>	<b>0.5177</b>	<b>0.4208</b>	<b>9.3000e-004</b>	<b>0.1381</b>	<b>0.0214</b>	<b>0.1594</b>	<b>0.0548</b>	<b>0.0197</b>	<b>0.0745</b>	<b>0.0000</b>	<b>81.8028</b>	<b>81.8028</b>	<b>0.0265</b>	<b>0.0000</b>	<b>82.4642</b>

**Unmitigated Construction Off-Site**

	ROG	NOx	CO	SO2	Fugitive PM10	Exhaust PM10	PM10 Total	Fugitive PM2.5	Exhaust PM2.5	PM2.5 Total	Bio- CO2	NBio- CO2	Total CO2	CH4	N2O	CO2e
Category	tons/yr										MT/yr					
Hauling	0.0000	0.0000	0.0000	0.0000	0.0000	0.0000	0.0000	0.0000	0.0000	0.0000	0.0000	0.0000	0.0000	0.0000	0.0000	0.0000
Vendor	0.0000	0.0000	0.0000	0.0000	0.0000	0.0000	0.0000	0.0000	0.0000	0.0000	0.0000	0.0000	0.0000	0.0000	0.0000	0.0000
Worker	8.2000e-004	5.8000e-004	7.4300e-003	2.0000e-005	2.4700e-003	1.0000e-005	2.4800e-003	6.6000e-004	1.0000e-005	6.7000e-004	0.0000	1.9131	1.9131	6.0000e-005	5.0000e-005	1.9305
<b>Total</b>	<b>8.2000e-004</b>	<b>5.8000e-004</b>	<b>7.4300e-003</b>	<b>2.0000e-005</b>	<b>2.4700e-003</b>	<b>1.0000e-005</b>	<b>2.4800e-003</b>	<b>6.6000e-004</b>	<b>1.0000e-005</b>	<b>6.7000e-004</b>	<b>0.0000</b>	<b>1.9131</b>	<b>1.9131</b>	<b>6.0000e-005</b>	<b>5.0000e-005</b>	<b>1.9305</b>

Desert Island SP - Amendment - Riverside-Salton Sea County, Annual

**EMFAC Off-Model Adjustment Factors for Gasoline Light Duty Vehicle to Account for the SAFE Vehicle Rule Applied**

**3.4 Grading - 2023**

**Mitigated Construction On-Site**

	ROG	NOx	CO	SO2	Fugitive PM10	Exhaust PM10	PM10 Total	Fugitive PM2.5	Exhaust PM2.5	PM2.5 Total	Bio- CO2	NBio- CO2	Total CO2	CH4	N2O	CO2e
Category	tons/yr										MT/yr					
Fugitive Dust					0.0431	0.0000	0.0431	0.0171	0.0000	0.0171	0.0000	0.0000	0.0000	0.0000	0.0000	0.0000
Off-Road	0.0498	0.5177	0.4208	9.3000e-004		0.0214	0.0214		0.0197	0.0197	0.0000	81.8027	81.8027	0.0265	0.0000	82.4641
<b>Total</b>	<b>0.0498</b>	<b>0.5177</b>	<b>0.4208</b>	<b>9.3000e-004</b>	<b>0.0431</b>	<b>0.0214</b>	<b>0.0644</b>	<b>0.0171</b>	<b>0.0197</b>	<b>0.0368</b>	<b>0.0000</b>	<b>81.8027</b>	<b>81.8027</b>	<b>0.0265</b>	<b>0.0000</b>	<b>82.4641</b>

**Mitigated Construction Off-Site**

	ROG	NOx	CO	SO2	Fugitive PM10	Exhaust PM10	PM10 Total	Fugitive PM2.5	Exhaust PM2.5	PM2.5 Total	Bio- CO2	NBio- CO2	Total CO2	CH4	N2O	CO2e
Category	tons/yr										MT/yr					
Hauling	0.0000	0.0000	0.0000	0.0000	0.0000	0.0000	0.0000	0.0000	0.0000	0.0000	0.0000	0.0000	0.0000	0.0000	0.0000	0.0000
Vendor	0.0000	0.0000	0.0000	0.0000	0.0000	0.0000	0.0000	0.0000	0.0000	0.0000	0.0000	0.0000	0.0000	0.0000	0.0000	0.0000
Worker	8.2000e-004	5.8000e-004	7.4300e-003	2.0000e-005	2.0400e-003	1.0000e-005	2.0500e-003	5.5000e-004	1.0000e-005	5.6000e-004	0.0000	1.9131	1.9131	6.0000e-005	5.0000e-005	1.9305
<b>Total</b>	<b>8.2000e-004</b>	<b>5.8000e-004</b>	<b>7.4300e-003</b>	<b>2.0000e-005</b>	<b>2.0400e-003</b>	<b>1.0000e-005</b>	<b>2.0500e-003</b>	<b>5.5000e-004</b>	<b>1.0000e-005</b>	<b>5.6000e-004</b>	<b>0.0000</b>	<b>1.9131</b>	<b>1.9131</b>	<b>6.0000e-005</b>	<b>5.0000e-005</b>	<b>1.9305</b>

Desert Island SP - Amendment - Riverside-Salton Sea County, Annual

**EMFAC Off-Model Adjustment Factors for Gasoline Light Duty Vehicle to Account for the SAFE Vehicle Rule Applied**

**3.5 Building Construction - 2023**

**Unmitigated Construction On-Site**

	ROG	NOx	CO	SO2	Fugitive PM10	Exhaust PM10	PM10 Total	Fugitive PM2.5	Exhaust PM2.5	PM2.5 Total	Bio- CO2	NBio- CO2	Total CO2	CH4	N2O	CO2e
Category	tons/yr										MT/yr					
Off-Road	0.0904	0.8271	0.9340	1.5500e-003		0.0402	0.0402		0.0379	0.0379	0.0000	133.2877	133.2877	0.0317	0.0000	134.0804
<b>Total</b>	<b>0.0904</b>	<b>0.8271</b>	<b>0.9340</b>	<b>1.5500e-003</b>		<b>0.0402</b>	<b>0.0402</b>		<b>0.0379</b>	<b>0.0379</b>	<b>0.0000</b>	<b>133.2877</b>	<b>133.2877</b>	<b>0.0317</b>	<b>0.0000</b>	<b>134.0804</b>

**Unmitigated Construction Off-Site**

	ROG	NOx	CO	SO2	Fugitive PM10	Exhaust PM10	PM10 Total	Fugitive PM2.5	Exhaust PM2.5	PM2.5 Total	Bio- CO2	NBio- CO2	Total CO2	CH4	N2O	CO2e
Category	tons/yr										MT/yr					
Hauling	0.0000	0.0000	0.0000	0.0000	0.0000	0.0000	0.0000	0.0000	0.0000	0.0000	0.0000	0.0000	0.0000	0.0000	0.0000	0.0000
Vendor	3.2400e-003	0.0954	0.0420	4.5000e-004	0.0159	7.2000e-004	0.0167	4.6000e-003	6.9000e-004	5.2900e-003	0.0000	43.5694	43.5694	4.6000e-004	6.4500e-003	45.5044
Worker	0.0226	0.0158	0.2036	5.6000e-004	0.0677	3.3000e-004	0.0680	0.0180	3.1000e-004	0.0183	0.0000	52.4339	52.4339	1.5100e-003	1.4800e-003	52.9124
<b>Total</b>	<b>0.0258</b>	<b>0.1112</b>	<b>0.2455</b>	<b>1.0100e-003</b>	<b>0.0836</b>	<b>1.0500e-003</b>	<b>0.0846</b>	<b>0.0226</b>	<b>1.0000e-003</b>	<b>0.0236</b>	<b>0.0000</b>	<b>96.0033</b>	<b>96.0033</b>	<b>1.9700e-003</b>	<b>7.9300e-003</b>	<b>98.4168</b>

Desert Island SP - Amendment - Riverside-Salton Sea County, Annual

**EMFAC Off-Model Adjustment Factors for Gasoline Light Duty Vehicle to Account for the SAFE Vehicle Rule Applied**

**3.5 Building Construction - 2023**

**Mitigated Construction On-Site**

	ROG	NOx	CO	SO2	Fugitive PM10	Exhaust PM10	PM10 Total	Fugitive PM2.5	Exhaust PM2.5	PM2.5 Total	Bio- CO2	NBio- CO2	Total CO2	CH4	N2O	CO2e
Category	tons/yr										MT/yr					
Off-Road	0.0904	0.8271	0.9340	1.5500e-003		0.0402	0.0402		0.0379	0.0379	0.0000	133.2876	133.2876	0.0317	0.0000	134.0803
<b>Total</b>	<b>0.0904</b>	<b>0.8271</b>	<b>0.9340</b>	<b>1.5500e-003</b>		<b>0.0402</b>	<b>0.0402</b>		<b>0.0379</b>	<b>0.0379</b>	<b>0.0000</b>	<b>133.2876</b>	<b>133.2876</b>	<b>0.0317</b>	<b>0.0000</b>	<b>134.0803</b>

**Mitigated Construction Off-Site**

	ROG	NOx	CO	SO2	Fugitive PM10	Exhaust PM10	PM10 Total	Fugitive PM2.5	Exhaust PM2.5	PM2.5 Total	Bio- CO2	NBio- CO2	Total CO2	CH4	N2O	CO2e
Category	tons/yr										MT/yr					
Hauling	0.0000	0.0000	0.0000	0.0000	0.0000	0.0000	0.0000	0.0000	0.0000	0.0000	0.0000	0.0000	0.0000	0.0000	0.0000	0.0000
Vendor	3.2400e-003	0.0954	0.0420	4.5000e-004	0.0137	7.2000e-004	0.0144	4.0500e-003	6.9000e-004	4.7400e-003	0.0000	43.5694	43.5694	4.6000e-004	6.4500e-003	45.5044
Worker	0.0226	0.0158	0.2036	5.6000e-004	0.0559	3.3000e-004	0.0563	0.0151	3.1000e-004	0.0154	0.0000	52.4339	52.4339	1.5100e-003	1.4800e-003	52.9124
<b>Total</b>	<b>0.0258</b>	<b>0.1112</b>	<b>0.2455</b>	<b>1.0100e-003</b>	<b>0.0696</b>	<b>1.0500e-003</b>	<b>0.0707</b>	<b>0.0191</b>	<b>1.0000e-003</b>	<b>0.0201</b>	<b>0.0000</b>	<b>96.0033</b>	<b>96.0033</b>	<b>1.9700e-003</b>	<b>7.9300e-003</b>	<b>98.4168</b>

Desert Island SP - Amendment - Riverside-Salton Sea County, Annual

**EMFAC Off-Model Adjustment Factors for Gasoline Light Duty Vehicle to Account for the SAFE Vehicle Rule Applied**

**3.5 Building Construction - 2024**

**Unmitigated Construction On-Site**

	ROG	NOx	CO	SO2	Fugitive PM10	Exhaust PM10	PM10 Total	Fugitive PM2.5	Exhaust PM2.5	PM2.5 Total	Bio- CO2	NBio- CO2	Total CO2	CH4	N2O	CO2e
Category	tons/yr										MT/yr					
Off-Road	0.1361	1.2436	1.4954	2.4900e-003		0.0567	0.0567		0.0534	0.0534	0.0000	214.4604	214.4604	0.0507	0.0000	215.7283
<b>Total</b>	<b>0.1361</b>	<b>1.2436</b>	<b>1.4954</b>	<b>2.4900e-003</b>		<b>0.0567</b>	<b>0.0567</b>		<b>0.0534</b>	<b>0.0534</b>	<b>0.0000</b>	<b>214.4604</b>	<b>214.4604</b>	<b>0.0507</b>	<b>0.0000</b>	<b>215.7283</b>

**Unmitigated Construction Off-Site**

	ROG	NOx	CO	SO2	Fugitive PM10	Exhaust PM10	PM10 Total	Fugitive PM2.5	Exhaust PM2.5	PM2.5 Total	Bio- CO2	NBio- CO2	Total CO2	CH4	N2O	CO2e
Category	tons/yr										MT/yr					
Hauling	0.0000	0.0000	0.0000	0.0000	0.0000	0.0000	0.0000	0.0000	0.0000	0.0000	0.0000	0.0000	0.0000	0.0000	0.0000	0.0000
Vendor	5.1300e-003	0.1534	0.0668	7.2000e-004	0.0256	1.1600e-003	0.0268	7.4000e-003	1.1100e-003	8.5100e-003	0.0000	69.0097	69.0097	7.6000e-004	0.0102	72.0708
Worker	0.0339	0.0227	0.3073	8.8000e-004	0.1088	5.1000e-004	0.1093	0.0289	4.7000e-004	0.0294	0.0000	82.3287	82.3287	2.2100e-003	2.2100e-003	83.0436
<b>Total</b>	<b>0.0390</b>	<b>0.1761</b>	<b>0.3741</b>	<b>1.6000e-003</b>	<b>0.1345</b>	<b>1.6700e-003</b>	<b>0.1361</b>	<b>0.0363</b>	<b>1.5800e-003</b>	<b>0.0379</b>	<b>0.0000</b>	<b>151.3384</b>	<b>151.3384</b>	<b>2.9700e-003</b>	<b>0.0124</b>	<b>155.1144</b>



Desert Island SP - Amendment - Riverside-Salton Sea County, Annual

**EMFAC Off-Model Adjustment Factors for Gasoline Light Duty Vehicle to Account for the SAFE Vehicle Rule Applied**

**3.5 Building Construction - 2024**

**Mitigated Construction On-Site**

	ROG	NOx	CO	SO2	Fugitive PM10	Exhaust PM10	PM10 Total	Fugitive PM2.5	Exhaust PM2.5	PM2.5 Total	Bio- CO2	NBio- CO2	Total CO2	CH4	N2O	CO2e
Category	tons/yr										MT/yr					
Off-Road	0.1361	1.2436	1.4954	2.4900e-003		0.0567	0.0567		0.0534	0.0534	0.0000	214.4602	214.4602	0.0507	0.0000	215.7280
<b>Total</b>	<b>0.1361</b>	<b>1.2436</b>	<b>1.4954</b>	<b>2.4900e-003</b>		<b>0.0567</b>	<b>0.0567</b>		<b>0.0534</b>	<b>0.0534</b>	<b>0.0000</b>	<b>214.4602</b>	<b>214.4602</b>	<b>0.0507</b>	<b>0.0000</b>	<b>215.7280</b>

**Mitigated Construction Off-Site**

	ROG	NOx	CO	SO2	Fugitive PM10	Exhaust PM10	PM10 Total	Fugitive PM2.5	Exhaust PM2.5	PM2.5 Total	Bio- CO2	NBio- CO2	Total CO2	CH4	N2O	CO2e
Category	tons/yr										MT/yr					
Hauling	0.0000	0.0000	0.0000	0.0000	0.0000	0.0000	0.0000	0.0000	0.0000	0.0000	0.0000	0.0000	0.0000	0.0000	0.0000	0.0000
Vendor	5.1300e-003	0.1534	0.0668	7.2000e-004	0.0220	1.1600e-003	0.0232	6.5100e-003	1.1100e-003	7.6200e-003	0.0000	69.0097	69.0097	7.6000e-004	0.0102	72.0708
Worker	0.0339	0.0227	0.3073	8.8000e-004	0.0900	5.1000e-004	0.0905	0.0243	4.7000e-004	0.0247	0.0000	82.3287	82.3287	2.2100e-003	2.2100e-003	83.0436
<b>Total</b>	<b>0.0390</b>	<b>0.1761</b>	<b>0.3741</b>	<b>1.6000e-003</b>	<b>0.1120</b>	<b>1.6700e-003</b>	<b>0.1136</b>	<b>0.0308</b>	<b>1.5800e-003</b>	<b>0.0324</b>	<b>0.0000</b>	<b>151.3384</b>	<b>151.3384</b>	<b>2.9700e-003</b>	<b>0.0124</b>	<b>155.1144</b>

Desert Island SP - Amendment - Riverside-Salton Sea County, Annual

**EMFAC Off-Model Adjustment Factors for Gasoline Light Duty Vehicle to Account for the SAFE Vehicle Rule Applied**

**3.6 Paving - 2024**

**Unmitigated Construction On-Site**

	ROG	NOx	CO	SO2	Fugitive PM10	Exhaust PM10	PM10 Total	Fugitive PM2.5	Exhaust PM2.5	PM2.5 Total	Bio- CO2	NBio- CO2	Total CO2	CH4	N2O	CO2e
Category	tons/yr										MT/yr					
Off-Road	9.8800e-003	0.0953	0.1463	2.3000e-004		4.6900e-003	4.6900e-003		4.3100e-003	4.3100e-003	0.0000	20.0265	20.0265	6.4800e-003	0.0000	20.1885
Paving	2.6900e-003					0.0000	0.0000		0.0000	0.0000	0.0000	0.0000	0.0000	0.0000	0.0000	0.0000
<b>Total</b>	<b>0.0126</b>	<b>0.0953</b>	<b>0.1463</b>	<b>2.3000e-004</b>		<b>4.6900e-003</b>	<b>4.6900e-003</b>		<b>4.3100e-003</b>	<b>4.3100e-003</b>	<b>0.0000</b>	<b>20.0265</b>	<b>20.0265</b>	<b>6.4800e-003</b>	<b>0.0000</b>	<b>20.1885</b>

**Unmitigated Construction Off-Site**

	ROG	NOx	CO	SO2	Fugitive PM10	Exhaust PM10	PM10 Total	Fugitive PM2.5	Exhaust PM2.5	PM2.5 Total	Bio- CO2	NBio- CO2	Total CO2	CH4	N2O	CO2e
Category	tons/yr										MT/yr					
Hauling	0.0000	0.0000	0.0000	0.0000	0.0000	0.0000	0.0000	0.0000	0.0000	0.0000	0.0000	0.0000	0.0000	0.0000	0.0000	0.0000
Vendor	0.0000	0.0000	0.0000	0.0000	0.0000	0.0000	0.0000	0.0000	0.0000	0.0000	0.0000	0.0000	0.0000	0.0000	0.0000	0.0000
Worker	3.8000e-004	2.6000e-004	3.4800e-003	1.0000e-005	1.2300e-003	1.0000e-005	1.2400e-003	3.3000e-004	1.0000e-005	3.3000e-004	0.0000	0.9336	0.9336	3.0000e-005	3.0000e-005	0.9417
<b>Total</b>	<b>3.8000e-004</b>	<b>2.6000e-004</b>	<b>3.4800e-003</b>	<b>1.0000e-005</b>	<b>1.2300e-003</b>	<b>1.0000e-005</b>	<b>1.2400e-003</b>	<b>3.3000e-004</b>	<b>1.0000e-005</b>	<b>3.3000e-004</b>	<b>0.0000</b>	<b>0.9336</b>	<b>0.9336</b>	<b>3.0000e-005</b>	<b>3.0000e-005</b>	<b>0.9417</b>

Desert Island SP - Amendment - Riverside-Salton Sea County, Annual

**EMFAC Off-Model Adjustment Factors for Gasoline Light Duty Vehicle to Account for the SAFE Vehicle Rule Applied**

**3.6 Paving - 2024**

**Mitigated Construction On-Site**

	ROG	NOx	CO	SO2	Fugitive PM10	Exhaust PM10	PM10 Total	Fugitive PM2.5	Exhaust PM2.5	PM2.5 Total	Bio- CO2	NBio- CO2	Total CO2	CH4	N2O	CO2e
Category	tons/yr										MT/yr					
Off-Road	9.8800e-003	0.0953	0.1463	2.3000e-004		4.6900e-003	4.6900e-003		4.3100e-003	4.3100e-003	0.0000	20.0265	20.0265	6.4800e-003	0.0000	20.1884
Paving	2.6900e-003					0.0000	0.0000		0.0000	0.0000	0.0000	0.0000	0.0000	0.0000	0.0000	0.0000
<b>Total</b>	<b>0.0126</b>	<b>0.0953</b>	<b>0.1463</b>	<b>2.3000e-004</b>		<b>4.6900e-003</b>	<b>4.6900e-003</b>		<b>4.3100e-003</b>	<b>4.3100e-003</b>	<b>0.0000</b>	<b>20.0265</b>	<b>20.0265</b>	<b>6.4800e-003</b>	<b>0.0000</b>	<b>20.1884</b>

**Mitigated Construction Off-Site**

	ROG	NOx	CO	SO2	Fugitive PM10	Exhaust PM10	PM10 Total	Fugitive PM2.5	Exhaust PM2.5	PM2.5 Total	Bio- CO2	NBio- CO2	Total CO2	CH4	N2O	CO2e
Category	tons/yr										MT/yr					
Hauling	0.0000	0.0000	0.0000	0.0000	0.0000	0.0000	0.0000	0.0000	0.0000	0.0000	0.0000	0.0000	0.0000	0.0000	0.0000	0.0000
Vendor	0.0000	0.0000	0.0000	0.0000	0.0000	0.0000	0.0000	0.0000	0.0000	0.0000	0.0000	0.0000	0.0000	0.0000	0.0000	0.0000
Worker	3.8000e-004	2.6000e-004	3.4800e-003	1.0000e-005	1.0200e-003	1.0000e-005	1.0300e-003	2.8000e-004	1.0000e-005	2.8000e-004	0.0000	0.9336	0.9336	3.0000e-005	3.0000e-005	0.9417
<b>Total</b>	<b>3.8000e-004</b>	<b>2.6000e-004</b>	<b>3.4800e-003</b>	<b>1.0000e-005</b>	<b>1.0200e-003</b>	<b>1.0000e-005</b>	<b>1.0300e-003</b>	<b>2.8000e-004</b>	<b>1.0000e-005</b>	<b>2.8000e-004</b>	<b>0.0000</b>	<b>0.9336</b>	<b>0.9336</b>	<b>3.0000e-005</b>	<b>3.0000e-005</b>	<b>0.9417</b>

Desert Island SP - Amendment - Riverside-Salton Sea County, Annual

**EMFAC Off-Model Adjustment Factors for Gasoline Light Duty Vehicle to Account for the SAFE Vehicle Rule Applied**

**3.7 Architectural Coating - 2024**

**Unmitigated Construction On-Site**

	ROG	NOx	CO	SO2	Fugitive PM10	Exhaust PM10	PM10 Total	Fugitive PM2.5	Exhaust PM2.5	PM2.5 Total	Bio- CO2	NBio- CO2	Total CO2	CH4	N2O	CO2e
Category	tons/yr										MT/yr					
Archit. Coating	0.2491					0.0000	0.0000		0.0000	0.0000	0.0000	0.0000	0.0000	0.0000	0.0000	0.0000
Off-Road	1.8100e-003	0.0122	0.0181	3.0000e-005		6.1000e-004	6.1000e-004		6.1000e-004	6.1000e-004	0.0000	2.5533	2.5533	1.4000e-004	0.0000	2.5569
<b>Total</b>	<b>0.2509</b>	<b>0.0122</b>	<b>0.0181</b>	<b>3.0000e-005</b>		<b>6.1000e-004</b>	<b>6.1000e-004</b>		<b>6.1000e-004</b>	<b>6.1000e-004</b>	<b>0.0000</b>	<b>2.5533</b>	<b>2.5533</b>	<b>1.4000e-004</b>	<b>0.0000</b>	<b>2.5569</b>

**Unmitigated Construction Off-Site**

	ROG	NOx	CO	SO2	Fugitive PM10	Exhaust PM10	PM10 Total	Fugitive PM2.5	Exhaust PM2.5	PM2.5 Total	Bio- CO2	NBio- CO2	Total CO2	CH4	N2O	CO2e
Category	tons/yr										MT/yr					
Hauling	0.0000	0.0000	0.0000	0.0000	0.0000	0.0000	0.0000	0.0000	0.0000	0.0000	0.0000	0.0000	0.0000	0.0000	0.0000	0.0000
Vendor	0.0000	0.0000	0.0000	0.0000	0.0000	0.0000	0.0000	0.0000	0.0000	0.0000	0.0000	0.0000	0.0000	0.0000	0.0000	0.0000
Worker	7.4000e-004	5.0000e-004	6.7400e-003	2.0000e-005	2.3900e-003	1.0000e-005	2.4000e-003	6.3000e-004	1.0000e-005	6.4000e-004	0.0000	1.8050	1.8050	5.0000e-005	5.0000e-005	1.8207
<b>Total</b>	<b>7.4000e-004</b>	<b>5.0000e-004</b>	<b>6.7400e-003</b>	<b>2.0000e-005</b>	<b>2.3900e-003</b>	<b>1.0000e-005</b>	<b>2.4000e-003</b>	<b>6.3000e-004</b>	<b>1.0000e-005</b>	<b>6.4000e-004</b>	<b>0.0000</b>	<b>1.8050</b>	<b>1.8050</b>	<b>5.0000e-005</b>	<b>5.0000e-005</b>	<b>1.8207</b>

Desert Island SP - Amendment - Riverside-Salton Sea County, Annual

**EMFAC Off-Model Adjustment Factors for Gasoline Light Duty Vehicle to Account for the SAFE Vehicle Rule Applied**

**3.7 Architectural Coating - 2024**

**Mitigated Construction On-Site**

	ROG	NOx	CO	SO2	Fugitive PM10	Exhaust PM10	PM10 Total	Fugitive PM2.5	Exhaust PM2.5	PM2.5 Total	Bio- CO2	NBio- CO2	Total CO2	CH4	N2O	CO2e
Category	tons/yr										MT/yr					
Archit. Coating	0.2491					0.0000	0.0000		0.0000	0.0000	0.0000	0.0000	0.0000	0.0000	0.0000	0.0000
Off-Road	1.8100e-003	0.0122	0.0181	3.0000e-005		6.1000e-004	6.1000e-004		6.1000e-004	6.1000e-004	0.0000	2.5533	2.5533	1.4000e-004	0.0000	2.5568
<b>Total</b>	<b>0.2509</b>	<b>0.0122</b>	<b>0.0181</b>	<b>3.0000e-005</b>		<b>6.1000e-004</b>	<b>6.1000e-004</b>		<b>6.1000e-004</b>	<b>6.1000e-004</b>	<b>0.0000</b>	<b>2.5533</b>	<b>2.5533</b>	<b>1.4000e-004</b>	<b>0.0000</b>	<b>2.5568</b>

**Mitigated Construction Off-Site**

	ROG	NOx	CO	SO2	Fugitive PM10	Exhaust PM10	PM10 Total	Fugitive PM2.5	Exhaust PM2.5	PM2.5 Total	Bio- CO2	NBio- CO2	Total CO2	CH4	N2O	CO2e
Category	tons/yr										MT/yr					
Hauling	0.0000	0.0000	0.0000	0.0000	0.0000	0.0000	0.0000	0.0000	0.0000	0.0000	0.0000	0.0000	0.0000	0.0000	0.0000	0.0000
Vendor	0.0000	0.0000	0.0000	0.0000	0.0000	0.0000	0.0000	0.0000	0.0000	0.0000	0.0000	0.0000	0.0000	0.0000	0.0000	0.0000
Worker	7.4000e-004	5.0000e-004	6.7400e-003	2.0000e-005	1.9700e-003	1.0000e-005	1.9800e-003	5.3000e-004	1.0000e-005	5.4000e-004	0.0000	1.8050	1.8050	5.0000e-005	5.0000e-005	1.8207
<b>Total</b>	<b>7.4000e-004</b>	<b>5.0000e-004</b>	<b>6.7400e-003</b>	<b>2.0000e-005</b>	<b>1.9700e-003</b>	<b>1.0000e-005</b>	<b>1.9800e-003</b>	<b>5.3000e-004</b>	<b>1.0000e-005</b>	<b>5.4000e-004</b>	<b>0.0000</b>	<b>1.8050</b>	<b>1.8050</b>	<b>5.0000e-005</b>	<b>5.0000e-005</b>	<b>1.8207</b>

Desert Island SP - Amendment - Riverside-Salton Sea County, Annual

**EMFAC Off-Model Adjustment Factors for Gasoline Light Duty Vehicle to Account for the SAFE Vehicle Rule Applied**

**4.0 Operational Detail - Mobile**

**4.1 Mitigation Measures Mobile**

	ROG	NOx	CO	SO2	Fugitive PM10	Exhaust PM10	PM10 Total	Fugitive PM2.5	Exhaust PM2.5	PM2.5 Total	Bio- CO2	NBio- CO2	Total CO2	CH4	N2O	CO2e
Category	tons/yr										MT/yr					
Mitigated	0.1587	0.1985	1.2819	2.6500e-003	0.2833	2.2300e-003	0.2855	0.0757	2.0900e-003	0.0778	0.0000	250.7839	250.7839	0.0163	0.0141	255.3884
Unmitigated	0.1587	0.1985	1.2819	2.6500e-003	0.2833	2.2300e-003	0.2855	0.0757	2.0900e-003	0.0778	0.0000	250.7839	250.7839	0.0163	0.0141	255.3884

**4.2 Trip Summary Information**

Land Use	Average Daily Trip Rate			Unmitigated	Mitigated
	Weekday	Saturday	Sunday	Annual VMT	Annual VMT
General Light Industry	0.00	0.00	0.00		
Golf Course	13.09	13.09	13.09	21,130	21,130
Health Club	0.00	0.00	0.00		
Hotel	351.12	343.98	249.90	498,439	498,439
Parking Lot	0.00	0.00	0.00		
Recreational Swimming Pool	0.00	0.00	0.00		
Single Family Housing	103.84	104.94	94.05	229,505	229,505
Total	468.05	462.01	357.04	749,074	749,074

**4.3 Trip Type Information**

Land Use	Miles			Trip %			Trip Purpose %		
	H-W or C-W	H-S or C-C	H-O or C-NW	H-W or C-W	H-S or C-C	H-O or C-NW	Primary	Diverted	Pass-by
General Light Industry	12.50	4.20	5.40	59.00	28.00	13.00	92	5	3

Desert Island SP - Amendment - Riverside-Salton Sea County, Annual

**EMFAC Off-Model Adjustment Factors for Gasoline Light Duty Vehicle to Account for the SAFE Vehicle Rule Applied**

Land Use	Miles			Trip %			Trip Purpose %		
	H-W or C-W	H-S or C-C	H-O or C-NW	H-W or C-W	H-S or C-C	H-O or C-NW	Primary	Diverted	Pass-by
Golf Course	12.50	4.20	5.40	33.00	48.00	19.00	52	39	9
Health Club	12.50	4.20	5.40	16.90	64.10	19.00	52	39	9
Hotel	12.50	4.20	5.40	19.40	61.60	19.00	58	38	4
Parking Lot	12.50	4.20	5.40	0.00	0.00	0.00	0	0	0
Recreational Swimming Pool	12.50	4.20	5.40	33.00	48.00	19.00	52	39	9
Single Family Housing	11.00	3.50	4.50	40.20	19.20	40.60	86	11	3

**4.4 Fleet Mix**

Land Use	LDA	LDT1	LDT2	MDV	LHD1	LHD2	MHD	HHD	OBUS	UBUS	MCY	SBUS	MH
General Light Industry	0.540541	0.056458	0.173793	0.136090	0.025268	0.007074	0.011525	0.018705	0.000610	0.000304	0.023606	0.001094	0.004932
Golf Course	0.540541	0.056458	0.173793	0.136090	0.025268	0.007074	0.011525	0.018705	0.000610	0.000304	0.023606	0.001094	0.004932
Health Club	0.540541	0.056458	0.173793	0.136090	0.025268	0.007074	0.011525	0.018705	0.000610	0.000304	0.023606	0.001094	0.004932
Hotel	0.540541	0.056458	0.173793	0.136090	0.025268	0.007074	0.011525	0.018705	0.000610	0.000304	0.023606	0.001094	0.004932
Parking Lot	0.540541	0.056458	0.173793	0.136090	0.025268	0.007074	0.011525	0.018705	0.000610	0.000304	0.023606	0.001094	0.004932
Recreational Swimming Pool	0.540541	0.056458	0.173793	0.136090	0.025268	0.007074	0.011525	0.018705	0.000610	0.000304	0.023606	0.001094	0.004932
Single Family Housing	0.540541	0.056458	0.173793	0.136090	0.025268	0.007074	0.011525	0.018705	0.000610	0.000304	0.023606	0.001094	0.004932

**5.0 Energy Detail**

Historical Energy Use: N

**5.1 Mitigation Measures Energy**

Install High Efficiency Lighting

Desert Island SP - Amendment - Riverside-Salton Sea County, Annual

**EMFAC Off-Model Adjustment Factors for Gasoline Light Duty Vehicle to Account for the SAFE Vehicle Rule Applied**

	ROG	NOx	CO	SO2	Fugitive PM10	Exhaust PM10	PM10 Total	Fugitive PM2.5	Exhaust PM2.5	PM2.5 Total	Bio- CO2	NBio- CO2	Total CO2	CH4	N2O	CO2e
Category	tons/yr										MT/yr					
Electricity Mitigated						0.0000	0.0000		0.0000	0.0000	0.0000	223.0714	223.0714	0.0188	2.2800e-003	224.2222
Electricity Unmitigated						0.0000	0.0000		0.0000	0.0000	0.0000	235.0818	235.0818	0.0198	2.4100e-003	236.2946
Natural Gas Mitigated	0.0237	0.2148	0.1745	1.2900e-003		0.0164	0.0164		0.0164	0.0164	0.0000	234.7786	234.7786	4.5000e-003	4.3000e-003	236.1737
Natural Gas Unmitigated	0.0237	0.2148	0.1745	1.2900e-003		0.0164	0.0164		0.0164	0.0164	0.0000	234.7786	234.7786	4.5000e-003	4.3000e-003	236.1737



Desert Island SP - Amendment - Riverside-Salton Sea County, Annual

**EMFAC Off-Model Adjustment Factors for Gasoline Light Duty Vehicle to Account for the SAFE Vehicle Rule Applied**

**5.2 Energy by Land Use - NaturalGas**

**Unmitigated**

	NaturalGas Use	ROG	NOx	CO	SO2	Fugitive PM10	Exhaust PM10	PM10 Total	Fugitive PM2.5	Exhaust PM2.5	PM2.5 Total	Bio- CO2	NBio- CO2	Total CO2	CH4	N2O	CO2e
Land Use	kBTU/yr	tons/yr										MT/yr					
General Light Industry	258640	1.3900e-003	0.0127	0.0107	8.0000e-005		9.6000e-004	9.6000e-004		9.6000e-004	9.6000e-004	0.0000	13.8020	13.8020	2.6000e-004	2.5000e-004	13.8840
Golf Course	0	0.0000	0.0000	0.0000	0.0000		0.0000	0.0000		0.0000	0.0000	0.0000	0.0000	0.0000	0.0000	0.0000	0.0000
Health Club	203679	1.1000e-003	9.9800e-003	8.3900e-003	6.0000e-005		7.6000e-004	7.6000e-004		7.6000e-004	7.6000e-004	0.0000	10.8691	10.8691	2.1000e-004	2.0000e-004	10.9337
Hotel	3.62611e+006	0.0196	0.1778	0.1493	1.0700e-003		0.0135	0.0135		0.0135	0.0135	0.0000	193.5030	193.5030	3.7100e-003	3.5500e-003	194.6529
Parking Lot	0	0.0000	0.0000	0.0000	0.0000		0.0000	0.0000		0.0000	0.0000	0.0000	0.0000	0.0000	0.0000	0.0000	0.0000
Recreational Swimming Pool	0	0.0000	0.0000	0.0000	0.0000		0.0000	0.0000		0.0000	0.0000	0.0000	0.0000	0.0000	0.0000	0.0000	0.0000
Single Family Housing	311156	1.6800e-003	0.0143	6.1000e-003	9.0000e-005		1.1600e-003	1.1600e-003		1.1600e-003	1.1600e-003	0.0000	16.6045	16.6045	3.2000e-004	3.0000e-004	16.7032
<b>Total</b>		<b>0.0237</b>	<b>0.2148</b>	<b>0.1745</b>	<b>1.3000e-003</b>		<b>0.0164</b>	<b>0.0164</b>		<b>0.0164</b>	<b>0.0164</b>	<b>0.0000</b>	<b>234.7786</b>	<b>234.7786</b>	<b>4.5000e-003</b>	<b>4.3000e-003</b>	<b>236.1737</b>

Desert Island SP - Amendment - Riverside-Salton Sea County, Annual

**EMFAC Off-Model Adjustment Factors for Gasoline Light Duty Vehicle to Account for the SAFE Vehicle Rule Applied**

**5.2 Energy by Land Use - NaturalGas**

**Mitigated**

	NaturalGas Use	ROG	NOx	CO	SO2	Fugitive PM10	Exhaust PM10	PM10 Total	Fugitive PM2.5	Exhaust PM2.5	PM2.5 Total	Bio- CO2	NBio- CO2	Total CO2	CH4	N2O	CO2e
Land Use	kBTU/yr	tons/yr										MT/yr					
General Light Industry	258640	1.3900e-003	0.0127	0.0107	8.0000e-005		9.6000e-004	9.6000e-004		9.6000e-004	9.6000e-004	0.0000	13.8020	13.8020	2.6000e-004	2.5000e-004	13.8840
Golf Course	0	0.0000	0.0000	0.0000	0.0000		0.0000	0.0000		0.0000	0.0000	0.0000	0.0000	0.0000	0.0000	0.0000	0.0000
Health Club	203679	1.1000e-003	9.9800e-003	8.3900e-003	6.0000e-005		7.6000e-004	7.6000e-004		7.6000e-004	7.6000e-004	0.0000	10.8691	10.8691	2.1000e-004	2.0000e-004	10.9337
Hotel	3.62611e+006	0.0196	0.1778	0.1493	1.0700e-003		0.0135	0.0135		0.0135	0.0135	0.0000	193.5030	193.5030	3.7100e-003	3.5500e-003	194.6529
Parking Lot	0	0.0000	0.0000	0.0000	0.0000		0.0000	0.0000		0.0000	0.0000	0.0000	0.0000	0.0000	0.0000	0.0000	0.0000
Recreational Swimming Pool	0	0.0000	0.0000	0.0000	0.0000		0.0000	0.0000		0.0000	0.0000	0.0000	0.0000	0.0000	0.0000	0.0000	0.0000
Single Family Housing	311156	1.6800e-003	0.0143	6.1000e-003	9.0000e-005		1.1600e-003	1.1600e-003		1.1600e-003	1.1600e-003	0.0000	16.6045	16.6045	3.2000e-004	3.0000e-004	16.7032
<b>Total</b>		<b>0.0237</b>	<b>0.2148</b>	<b>0.1745</b>	<b>1.3000e-003</b>		<b>0.0164</b>	<b>0.0164</b>		<b>0.0164</b>	<b>0.0164</b>	<b>0.0000</b>	<b>234.7786</b>	<b>234.7786</b>	<b>4.5000e-003</b>	<b>4.3000e-003</b>	<b>236.1737</b>

Desert Island SP - Amendment - Riverside-Salton Sea County, Annual

**EMFAC Off-Model Adjustment Factors for Gasoline Light Duty Vehicle to Account for the SAFE Vehicle Rule Applied**

**5.3 Energy by Land Use - Electricity**

**Unmitigated**

	Electricity Use	Total CO2	CH4	N2O	CO2e
Land Use	kWh/yr	MT/yr			
General Light Industry	79360	14.0741	1.1900e-003	1.4000e-004	14.1468
Golf Course	0	0.0000	0.0000	0.0000	0.0000
Health Club	62496	11.0834	9.4000e-004	1.1000e-004	11.1406
Hotel	1.06417e+006	188.7260	0.0159	1.9300e-003	189.6996
Parking Lot	31920	5.6609	4.8000e-004	6.0000e-005	5.6901
Recreational Swimming Pool	0	0.0000	0.0000	0.0000	0.0000
Single Family Housing	87611.3	15.5375	1.3100e-003	1.6000e-004	15.6176
<b>Total</b>		<b>235.0818</b>	<b>0.0199</b>	<b>2.4000e-003</b>	<b>236.2946</b>

Desert Island SP - Amendment - Riverside-Salton Sea County, Annual

**EMFAC Off-Model Adjustment Factors for Gasoline Light Duty Vehicle to Account for the SAFE Vehicle Rule Applied**

**5.3 Energy by Land Use - Electricity**

**Mitigated**

	Electricity Use	Total CO2	CH4	N2O	CO2e
Land Use	kWh/yr	MT/yr			
General Light Industry	75609.6	13.4090	1.1300e-003	1.4000e-004	13.4782
Golf Course	0	0.0000	0.0000	0.0000	0.0000
Health Club	59542.6	10.5596	8.9000e-004	1.1000e-004	10.6141
Hotel	1.01109e+006	179.3124	0.0151	1.8300e-003	180.2374
Parking Lot	26812.8	4.7551	4.0000e-004	5.0000e-005	4.7797
Recreational Swimming Pool	0	0.0000	0.0000	0.0000	0.0000
Single Family Housing	84779.7	15.0353	1.2700e-003	1.5000e-004	15.1129
<b>Total</b>		<b>223.0714</b>	<b>0.0188</b>	<b>2.2800e-003</b>	<b>224.2222</b>

**6.0 Area Detail**

**6.1 Mitigation Measures Area**

- Use Low VOC Paint - Residential Interior
- Use Low VOC Paint - Residential Exterior
- Use Low VOC Paint - Non-Residential Interior
- Use Low VOC Paint - Non-Residential Exterior
- No Hearths Installed

Desert Island SP - Amendment - Riverside-Salton Sea County, Annual

**EMFAC Off-Model Adjustment Factors for Gasoline Light Duty Vehicle to Account for the SAFE Vehicle Rule Applied**

Use Low VOC Cleaning Supplies

	ROG	NOx	CO	SO2	Fugitive PM10	Exhaust PM10	PM10 Total	Fugitive PM2.5	Exhaust PM2.5	PM2.5 Total	Bio- CO2	NBio- CO2	Total CO2	CH4	N2O	CO2e
Category	tons/yr										MT/yr					
Mitigated	0.3785	9.6000e-004	0.0844	0.0000		4.6000e-004	4.6000e-004		4.6000e-004	4.6000e-004	0.0000	0.1388	0.1388	1.4000e-004	0.0000	0.1423
Unmitigated	0.4107	7.5000e-003	0.1206	1.5000e-004		6.4400e-003	6.4400e-003		6.4400e-003	6.4400e-003	0.7362	7.0701	7.8063	3.7200e-003	1.3000e-004	7.9370

**6.2 Area by SubCategory**

Unmitigated

	ROG	NOx	CO	SO2	Fugitive PM10	Exhaust PM10	PM10 Total	Fugitive PM2.5	Exhaust PM2.5	PM2.5 Total	Bio- CO2	NBio- CO2	Total CO2	CH4	N2O	CO2e
SubCategory	tons/yr										MT/yr					
Architectural Coating	0.0249					0.0000	0.0000		0.0000	0.0000	0.0000	0.0000	0.0000	0.0000	0.0000	0.0000
Consumer Products	0.3787					0.0000	0.0000		0.0000	0.0000	0.0000	0.0000	0.0000	0.0000	0.0000	0.0000
Hearth	4.4100e-003	6.5300e-003	0.0363	1.5000e-004		5.9800e-003	5.9800e-003		5.9800e-003	5.9800e-003	0.7362	6.9313	7.6675	3.5700e-003	1.3000e-004	7.7947
Landscaping	2.7000e-003	9.6000e-004	0.0844	0.0000		4.6000e-004	4.6000e-004		4.6000e-004	4.6000e-004	0.0000	0.1388	0.1388	1.4000e-004	0.0000	0.1423
<b>Total</b>	<b>0.4107</b>	<b>7.4900e-003</b>	<b>0.1206</b>	<b>1.5000e-004</b>		<b>6.4400e-003</b>	<b>6.4400e-003</b>		<b>6.4400e-003</b>	<b>6.4400e-003</b>	<b>0.7362</b>	<b>7.0701</b>	<b>7.8063</b>	<b>3.7100e-003</b>	<b>1.3000e-004</b>	<b>7.9370</b>

Desert Island SP - Amendment - Riverside-Salton Sea County, Annual

**EMFAC Off-Model Adjustment Factors for Gasoline Light Duty Vehicle to Account for the SAFE Vehicle Rule Applied**

**6.2 Area by SubCategory**

Mitigated

	ROG	NOx	CO	SO2	Fugitive PM10	Exhaust PM10	PM10 Total	Fugitive PM2.5	Exhaust PM2.5	PM2.5 Total	Bio- CO2	NBio- CO2	Total CO2	CH4	N2O	CO2e
SubCategory	tons/yr										MT/yr					
Architectural Coating	0.0249					0.0000	0.0000		0.0000	0.0000	0.0000	0.0000	0.0000	0.0000	0.0000	0.0000
Consumer Products	0.3509					0.0000	0.0000		0.0000	0.0000	0.0000	0.0000	0.0000	0.0000	0.0000	0.0000
Hearth	0.0000	0.0000	0.0000	0.0000		0.0000	0.0000		0.0000	0.0000	0.0000	0.0000	0.0000	0.0000	0.0000	0.0000
Landscaping	2.7000e-003	9.6000e-004	0.0844	0.0000		4.6000e-004	4.6000e-004		4.6000e-004	4.6000e-004	0.0000	0.1388	0.1388	1.4000e-004	0.0000	0.1423
<b>Total</b>	<b>0.3785</b>	<b>9.6000e-004</b>	<b>0.0844</b>	<b>0.0000</b>		<b>4.6000e-004</b>	<b>4.6000e-004</b>		<b>4.6000e-004</b>	<b>4.6000e-004</b>	<b>0.0000</b>	<b>0.1388</b>	<b>0.1388</b>	<b>1.4000e-004</b>	<b>0.0000</b>	<b>0.1423</b>

**7.0 Water Detail**

**7.1 Mitigation Measures Water**

- Install Low Flow Bathroom Faucet
- Install Low Flow Kitchen Faucet
- Install Low Flow Toilet
- Install Low Flow Shower
- Use Water Efficient Irrigation System

Desert Island SP - Amendment - Riverside-Salton Sea County, Annual

**EMFAC Off-Model Adjustment Factors for Gasoline Light Duty Vehicle to Account for the SAFE Vehicle Rule Applied**

	Total CO2	CH4	N2O	CO2e
Category	MT/yr			
Mitigated	20.1139	0.1262	3.1400e-003	24.2029
Unmitigated	23.2788	0.1576	3.9000e-003	28.3804

Desert Island SP - Amendment - Riverside-Salton Sea County, Annual

**EMFAC Off-Model Adjustment Factors for Gasoline Light Duty Vehicle to Account for the SAFE Vehicle Rule Applied**

**7.2 Water by Land Use**

**Unmitigated**

	Indoor/Outdoor Use	Total CO2	CH4	N2O	CO2e
Land Use	Mgal	MT/yr			
General Light Industry	1.85 / 0	4.8590	0.0606	1.4700e-003	6.8122
Golf Course	0 / 4.17018	8.2166	6.9000e-004	8.0000e-005	8.2589
Health Club	0.372602 / 0.228369	1.4286	0.0123	3.0000e-004	1.8243
Hotel	1.0654 / 0.118378	3.0315	0.0349	8.5000e-004	4.1576
Parking Lot	0 / 0	0.0000	0.0000	0.0000	0.0000
Recreational Swimming Pool	0.774775 / 0.474862	2.9706	0.0255	6.2000e-004	3.7934
Single Family Housing	0.716694 / 0.451829	2.7726	0.0236	5.8000e-004	3.5339
<b>Total</b>		<b>23.2788</b>	<b>0.1576</b>	<b>3.9000e-003</b>	<b>28.3804</b>



Desert Island SP - Amendment - Riverside-Salton Sea County, Annual

**EMFAC Off-Model Adjustment Factors for Gasoline Light Duty Vehicle to Account for the SAFE Vehicle Rule Applied**

**7.2 Water by Land Use**

Mitigated

	Indoor/Outdoor Use	Total CO2	CH4	N2O	CO2e
Land Use	Mgal	MT/yr			
General Light Industry	1.48 / 0	3.8872	0.0485	1.1700e-003	5.4498
Golf Course	0 / 3.9158	7.7153	6.5000e-004	8.0000e-005	7.7551
Health Club	0.298081 / 0.214438	1.2054	9.8100e-003	2.4000e-004	1.5223
Hotel	0.852323 / 0.111157	2.4576	0.0280	6.8000e-004	3.3587
Parking Lot	0 / 0	0.0000	0.0000	0.0000	0.0000
Recreational Swimming Pool	0.61982 / 0.445896	2.5065	0.0204	5.0000e-004	3.1654
Single Family Housing	0.573355 / 0.424267	2.3418	0.0189	4.6000e-004	2.9515
<b>Total</b>		<b>20.1139</b>	<b>0.1262</b>	<b>3.1300e-003</b>	<b>24.2028</b>

**8.0 Waste Detail**

---

**8.1 Mitigation Measures Waste**

Institute Recycling and Composting Services

Desert Island SP - Amendment - Riverside-Salton Sea County, Annual

**EMFAC Off-Model Adjustment Factors for Gasoline Light Duty Vehicle to Account for the SAFE Vehicle Rule Applied**

**Category/Year**

	Total CO2	CH4	N2O	CO2e
	MT/yr			
Mitigated	0.0000	0.0000	0.0000	0.0000
Unmitigated	31.5387	1.8639	0.0000	78.1358

## Desert Island SP - Amendment - Riverside-Salton Sea County, Annual

**EMFAC Off-Model Adjustment Factors for Gasoline Light Duty Vehicle to Account for the SAFE Vehicle Rule Applied****8.2 Waste by Land Use****Unmitigated**

	Waste Disposed	Total CO2	CH4	N2O	CO2e
Land Use	tons	MT/yr			
General Light Industry	9.92	2.0137	0.1190	0.0000	4.9888
Golf Course	3.26	0.6618	0.0391	0.0000	1.6395
Health Club	35.91	7.2894	0.4308	0.0000	18.0592
Hotel	23	4.6688	0.2759	0.0000	11.5667
Parking Lot	0	0.0000	0.0000	0.0000	0.0000
Recreational Swimming Pool	74.67	15.1573	0.8958	0.0000	37.5517
Single Family Housing	8.61	1.7478	0.1033	0.0000	4.3300
<b>Total</b>		<b>31.5387</b>	<b>1.8639</b>	<b>0.0000</b>	<b>78.1358</b>

Desert Island SP - Amendment - Riverside-Salton Sea County, Annual

**EMFAC Off-Model Adjustment Factors for Gasoline Light Duty Vehicle to Account for the SAFE Vehicle Rule Applied**

**8.2 Waste by Land Use**

Mitigated

	Waste Disposed	Total CO2	CH4	N2O	CO2e
Land Use	tons	MT/yr			
General Light Industry		0.0000	0.0000	0.0000	0.0000
Golf Course		0.0000	0.0000	0.0000	0.0000
Health Club		0.0000	0.0000	0.0000	0.0000
Hotel		0.0000	0.0000	0.0000	0.0000
Parking Lot		0.0000	0.0000	0.0000	0.0000
Recreational Swimming Pool		0.0000	0.0000	0.0000	0.0000
Single Family Housing		0.0000	0.0000	0.0000	0.0000
<b>Total</b>		<b>0.0000</b>	<b>0.0000</b>	<b>0.0000</b>	<b>0.0000</b>

**9.0 Operational Offroad**

Equipment Type	Number	Hours/Day	Days/Year	Horse Power	Load Factor	Fuel Type
----------------	--------	-----------	-----------	-------------	-------------	-----------

**10.0 Stationary Equipment**

Fire Pumps and Emergency Generators

Equipment Type	Number	Hours/Day	Hours/Year	Horse Power	Load Factor	Fuel Type
----------------	--------	-----------	------------	-------------	-------------	-----------

Desert Island SP - Amendment - Riverside-Salton Sea County, Annual

**EMFAC Off-Model Adjustment Factors for Gasoline Light Duty Vehicle to Account for the SAFE Vehicle Rule Applied**

**Boilers**

Equipment Type	Number	Heat Input/Day	Heat Input/Year	Boiler Rating	Fuel Type
----------------	--------	----------------	-----------------	---------------	-----------

**User Defined Equipment**

Equipment Type	Number
----------------	--------

**11.0 Vegetation**

---

Desert Island SP - Amendment - Riverside-Salton Sea County, Summer

**EMFAC Off-Model Adjustment Factors for Gasoline Light Duty Vehicle to Account for the SAFE Vehicle Rule Applied**

**Desert Island SP - Amendment  
Riverside-Salton Sea County, Summer**

**1.0 Project Characteristics**

**1.1 Land Usage**

Land Uses	Size	Metric	Lot Acreage	Floor Surface Area	Population
General Light Industry	8.00	1000sqft	0.18	8,000.00	0
Parking Lot	228.00	Space	2.05	91,200.00	0
Golf Course	3.50	Acre	3.50	152,460.00	0
Health Club	6.30	1000sqft	0.14	6,300.00	0
Hotel	42.00	Room	1.40	60,984.00	0
Recreational Swimming Pool	13.10	1000sqft	0.30	13,100.00	0
Single Family Housing	11.00	Dwelling Unit	3.57	19,800.00	21

**1.2 Other Project Characteristics**

<b>Urbanization</b>	Urban	<b>Wind Speed (m/s)</b>	2.4	<b>Precipitation Freq (Days)</b>	28
<b>Climate Zone</b>	15			<b>Operational Year</b>	2025
<b>Utility Company</b>	Southern California Edison				
<b>CO2 Intensity (lb/MW hr)</b>	390.98	<b>CH4 Intensity (lb/MW hr)</b>	0.033	<b>N2O Intensity (lb/MW hr)</b>	0.004

**1.3 User Entered Comments & Non-Default Data**

Project Characteristics - This model accounts for the proposed SP build-out condition with a tentative construction start date of May 1, 2023 for modeling purposes.

Land Use - Population total is based on 1.87 PPH for RM per CADF. GC size is based on combined driving range and desert gardens acreage. Health Club includes pool cafe, yoga pavilion, and restroom SF. GLI solely applies to the 8,000 SF golf course maintenance building for modeling purposes and does not imply the presence of traditional general light industry uses.

Demolition - This model accounts for 5,400 tons of debris associated with 2,700 CY of hardscape and building material removal at a conservative rate of 2 tons per CY.

Architectural Coating - SCAQMD Rule 1113 VOC Content Limits Apply as a Requirement

Desert Island SP - Amendment - Riverside-Salton Sea County, Summer

**EMFAC Off-Model Adjustment Factors for Gasoline Light Duty Vehicle to Account for the SAFE Vehicle Rule Applied**

Vehicle Trips - Consistent with the traffic assessment, the trip generating uses are the hotel rooms/keys, residential units, and golf course driving range facilities. The trip rates are default to the CalEEMod parameters.

Woodstoves - SCAQMD Rule 445 is applied pertaining to wood burning.

Area Coating - SCAQMD Rule 1113 VOC Content Limits are applied

Construction Off-road Equipment Mitigation - Dust control measures are a requirement under SCAQMD Rule 403/403.1 and Section 15.64.630 of the Rancho Mirage Municipal Code.

Area Mitigation - SCAQMD Rule 1113 VOC Content Limits Apply

Energy Mitigation - High efficiency lighting would be in the form of LED.

Waste Mitigation -

Trips and VMT -

Grading - Exported material (2,700 CY) corresponds to demolition of existing facilities.

Table Name	Column Name	Default Value	New Value
tblArchitecturalCoating	EF_Nonresidential_Exterior	250.00	50.00
tblArchitecturalCoating	EF_Nonresidential_Interior	250.00	50.00
tblArchitecturalCoating	EF_Parking	250.00	100.00
tblArchitecturalCoating	EF_Residential_Exterior	250.00	50.00
tblArchitecturalCoating	EF_Residential_Interior	250.00	50.00
tblAreaCoating	Area_EF_Nonresidential_Exterior	250	50
tblAreaCoating	Area_EF_Nonresidential_Interior	250	50
tblAreaCoating	Area_EF_Parking	250	100
tblAreaCoating	Area_EF_Residential_Exterior	250	50
tblAreaCoating	Area_EF_Residential_Interior	250	50
tblAreaMitigation	UseLowVOCPaintParkingCheck	False	True
tblConstDustMitigation	CleanPavedRoadPercentReduction	0	20
tblConstDustMitigation	WaterUnpavedRoadMoistureContent	0	50
tblConstDustMitigation	WaterUnpavedRoadVehicleSpeed	0	15
tblFireplaces	NumberWood	1.10	0.00
tblGrading	MaterialExported	0.00	2,700.00
tblLandUse	Population	31.00	21.00

Desert Island SP - Amendment - Riverside-Salton Sea County, Summer

**EMFAC Off-Model Adjustment Factors for Gasoline Light Duty Vehicle to Account for the SAFE Vehicle Rule Applied**

tblVehicleTrips	ST_TR	1.99	0.00
tblVehicleTrips	ST_TR	20.87	0.00
tblVehicleTrips	ST_TR	9.10	0.00
tblVehicleTrips	SU_TR	5.00	0.00
tblVehicleTrips	SU_TR	26.73	0.00
tblVehicleTrips	SU_TR	13.60	0.00
tblVehicleTrips	WD_TR	4.96	0.00
tblVehicleTrips	WD_TR	32.93	0.00
tblVehicleTrips	WD_TR	28.82	0.00

**2.0 Emissions Summary**

---



Desert Island SP - Amendment - Riverside-Salton Sea County, Summer

**EMFAC Off-Model Adjustment Factors for Gasoline Light Duty Vehicle to Account for the SAFE Vehicle Rule Applied**

**2.1 Overall Construction (Maximum Daily Emission)**

**Unmitigated Construction**

	ROG	NOx	CO	SO2	Fugitive PM10	Exhaust PM10	PM10 Total	Fugitive PM2.5	Exhaust PM2.5	PM2.5 Total	Bio- CO2	NBio- CO2	Total CO2	CH4	N2O	CO2e
Year	lb/day										lb/day					
2023	3.3845	34.5517	28.6229	0.0636	20.4334	1.4253	21.7409	10.3098	1.3113	11.5141	0.0000	6,163.0505	6,163.0505	1.9482	0.3160	6,212.8904
2024	25.1755	15.2572	20.7096	0.0449	1.4775	0.6313	2.1088	0.3983	0.5939	0.9922	0.0000	4,434.5976	4,434.5976	0.7167	0.1468	4,494.3148
<b>Maximum</b>	<b>25.1755</b>	<b>34.5517</b>	<b>28.6229</b>	<b>0.0636</b>	<b>20.4334</b>	<b>1.4253</b>	<b>21.7409</b>	<b>10.3098</b>	<b>1.3113</b>	<b>11.5141</b>	<b>0.0000</b>	<b>6,163.0505</b>	<b>6,163.0505</b>	<b>1.9482</b>	<b>0.3160</b>	<b>6,212.8904</b>

**Mitigated Construction**

	ROG	NOx	CO	SO2	Fugitive PM10	Exhaust PM10	PM10 Total	Fugitive PM2.5	Exhaust PM2.5	PM2.5 Total	Bio- CO2	NBio- CO2	Total CO2	CH4	N2O	CO2e
Year	lb/day										lb/day					
2023	3.3845	34.5517	28.6229	0.0636	6.7703	1.4253	8.0778	3.3273	1.3113	4.5317	0.0000	6,163.0505	6,163.0505	1.9482	0.3160	6,212.8904
2024	25.1755	15.2572	20.7096	0.0449	1.2295	0.6313	1.8608	0.3374	0.5939	0.9314	0.0000	4,434.5976	4,434.5976	0.7167	0.1468	4,494.3148
<b>Maximum</b>	<b>25.1755</b>	<b>34.5517</b>	<b>28.6229</b>	<b>0.0636</b>	<b>6.7703</b>	<b>1.4253</b>	<b>8.0778</b>	<b>3.3273</b>	<b>1.3113</b>	<b>4.5317</b>	<b>0.0000</b>	<b>6,163.0505</b>	<b>6,163.0505</b>	<b>1.9482</b>	<b>0.3160</b>	<b>6,212.8904</b>

## Desert Island SP - Amendment - Riverside-Salton Sea County, Summer

**EMFAC Off-Model Adjustment Factors for Gasoline Light Duty Vehicle to Account for the SAFE Vehicle Rule Applied**

	ROG	NOx	CO	SO2	Fugitive PM10	Exhaust PM10	PM10 Total	Fugitive PM2.5	Exhaust PM2.5	PM2.5 Total	Bio- CO2	NBio-CO2	Total CO2	CH4	N2O	CO2e
Percent Reduction	0.00	0.00	0.00	0.00	63.49	0.00	58.33	65.78	0.00	56.32	0.00	0.00	0.00	0.00	0.00	0.00

Desert Island SP - Amendment - Riverside-Salton Sea County, Summer

**EMFAC Off-Model Adjustment Factors for Gasoline Light Duty Vehicle to Account for the SAFE Vehicle Rule Applied**

**2.2 Overall Operational**

**Unmitigated Operational**

	ROG	NOx	CO	SO2	Fugitive PM10	Exhaust PM10	PM10 Total	Fugitive PM2.5	Exhaust PM2.5	PM2.5 Total	Bio- CO2	NBio- CO2	Total CO2	CH4	N2O	CO2e
Category	lb/day										lb/day					
Area	2.3491	0.1701	1.8214	3.6600e-003		0.1510	0.1510		0.1510	0.1510	19.7921	188.0529	207.8450	0.0978	3.4200e-003	211.3089
Energy	0.1300	1.1767	0.9559	7.0900e-003		0.0898	0.0898		0.0898	0.0898		1,418.0770	1,418.0770	0.0272	0.0260	1,426.5040
Mobile	1.0968	1.0673	7.7570	0.0160	1.6421	0.0128	1.6549	0.4381	0.0119	0.4500		1,668.0799	1,668.0799	0.0980	0.0864	1,696.2836
<b>Total</b>	<b>3.5759</b>	<b>2.4141</b>	<b>10.5343</b>	<b>0.0267</b>	<b>1.6421</b>	<b>0.2536</b>	<b>1.8957</b>	<b>0.4381</b>	<b>0.2528</b>	<b>0.6908</b>	<b>19.7921</b>	<b>3,274.2098</b>	<b>3,294.0019</b>	<b>0.2230</b>	<b>0.1158</b>	<b>3,334.0964</b>

**Mitigated Operational**

	ROG	NOx	CO	SO2	Fugitive PM10	Exhaust PM10	PM10 Total	Fugitive PM2.5	Exhaust PM2.5	PM2.5 Total	Bio- CO2	NBio- CO2	Total CO2	CH4	N2O	CO2e
Category	lb/day										lb/day					
Area	2.0894	0.0107	0.9373	5.0000e-005		5.1400e-003	5.1400e-003		5.1400e-003	5.1400e-003	0.0000	1.6999	1.6999	1.7400e-003	0.0000	1.7433
Energy	0.1300	1.1767	0.9559	7.0900e-003		0.0898	0.0898		0.0898	0.0898		1,418.0770	1,418.0770	0.0272	0.0260	1,426.5040
Mobile	1.0968	1.0673	7.7570	0.0160	1.6421	0.0128	1.6549	0.4381	0.0119	0.4500		1,668.0799	1,668.0799	0.0980	0.0864	1,696.2836
<b>Total</b>	<b>3.3162</b>	<b>2.2547</b>	<b>9.6502</b>	<b>0.0231</b>	<b>1.6421</b>	<b>0.1077</b>	<b>1.7498</b>	<b>0.4381</b>	<b>0.1069</b>	<b>0.5449</b>	<b>0.0000</b>	<b>3,087.8569</b>	<b>3,087.8569</b>	<b>0.1269</b>	<b>0.1124</b>	<b>3,124.5309</b>

Desert Island SP - Amendment - Riverside-Salton Sea County, Summer

**EMFAC Off-Model Adjustment Factors for Gasoline Light Duty Vehicle to Account for the SAFE Vehicle Rule Applied**

	ROG	NOx	CO	SO2	Fugitive PM10	Exhaust PM10	PM10 Total	Fugitive PM2.5	Exhaust PM2.5	PM2.5 Total	Bio- CO2	NBio-CO2	Total CO2	CH4	N2O	CO2e
Percent Reduction	7.26	6.60	8.39	13.51	0.00	57.53	7.70	0.00	57.71	21.12	100.00	5.69	6.26	43.09	2.95	6.29

**3.0 Construction Detail**

**Construction Phase**

Phase Number	Phase Name	Phase Type	Start Date	End Date	Num Days Week	Num Days	Phase Description
1	Demolition	Demolition	5/1/2023	5/26/2023	5	20	
2	Site Preparation	Site Preparation	5/27/2023	6/9/2023	5	10	
3	Grading	Grading	6/10/2023	7/21/2023	5	30	
4	Building Construction	Building Construction	7/22/2023	9/13/2024	5	300	
5	Paving	Paving	9/14/2024	10/11/2024	5	20	
6	Architectural Coating	Architectural Coating	10/12/2024	11/8/2024	5	20	

**Acres of Grading (Site Preparation Phase): 15**

**Acres of Grading (Grading Phase): 90**

**Acres of Paving: 2.05**

**Residential Indoor: 40,095; Residential Outdoor: 13,365; Non-Residential Indoor: 112,926; Non-Residential Outdoor: 37,642; Striped Parking Area: 5,472 (Architectural Coating – sqft)**

**OffRoad Equipment**

Phase Name	Offroad Equipment Type	Amount	Usage Hours	Horse Power	Load Factor
Demolition	Concrete/Industrial Saws	1	8.00	81	0.73
Demolition	Excavators	3	8.00	158	0.38
Demolition	Rubber Tired Dozers	2	8.00	247	0.40
Site Preparation	Rubber Tired Dozers	3	8.00	247	0.40
Site Preparation	Tractors/Loaders/Backhoes	4	8.00	97	0.37

Desert Island SP - Amendment - Riverside-Salton Sea County, Summer

**EMFAC Off-Model Adjustment Factors for Gasoline Light Duty Vehicle to Account for the SAFE Vehicle Rule Applied**

Grading	Excavators	2	8.00	158	0.38
Grading	Graders	1	8.00	187	0.41
Grading	Rubber Tired Dozers	1	8.00	247	0.40
Grading	Tractors/Loaders/Backhoes	2	8.00	97	0.37
Building Construction	Cranes	1	7.00	231	0.29
Building Construction	Forklifts	3	8.00	89	0.20
Building Construction	Generator Sets	1	8.00	84	0.74
Building Construction	Tractors/Loaders/Backhoes	3	7.00	97	0.37
Building Construction	Welders	1	8.00	46	0.45
Paving	Pavers	2	8.00	130	0.42
Paving	Paving Equipment	2	8.00	132	0.36
Paving	Rollers	2	8.00	80	0.38
Architectural Coating	Air Compressors	1	6.00	78	0.48
Grading	Scrapers	2	8.00	367	0.48

**Trips and VMT**

Phase Name	Offroad Equipment Count	Worker Trip Number	Vendor Trip Number	Hauling Trip Number	Worker Trip Length	Vendor Trip Length	Hauling Trip Length	Worker Vehicle Class	Vendor Vehicle Class	Hauling Vehicle Class
Demolition	6	15.00	0.00	534.00	11.00	5.40	20.00	LD_Mix	HDT_Mix	HHDT
Site Preparation	7	18.00	0.00	338.00	11.00	5.40	20.00	LD_Mix	HDT_Mix	HHDT
Grading	8	20.00	0.00	0.00	11.00	5.40	20.00	LD_Mix	HDT_Mix	HHDT
Building Construction	9	143.00	56.00	0.00	11.00	5.40	20.00	LD_Mix	HDT_Mix	HHDT
Paving	6	15.00	0.00	0.00	11.00	5.40	20.00	LD_Mix	HDT_Mix	HHDT
Architectural Coating	1	29.00	0.00	0.00	11.00	5.40	20.00	LD_Mix	HDT_Mix	HHDT

**3.1 Mitigation Measures Construction**

Use Soil Stabilizer

Replace Ground Cover

Desert Island SP - Amendment - Riverside-Salton Sea County, Summer

**EMFAC Off-Model Adjustment Factors for Gasoline Light Duty Vehicle to Account for the SAFE Vehicle Rule Applied**

Water Exposed Area

Water Unpaved Roads

Reduce Vehicle Speed on Unpaved Roads

Clean Paved Roads

**3.2 Demolition - 2023**

**Unmitigated Construction On-Site**

	ROG	NOx	CO	SO2	Fugitive PM10	Exhaust PM10	PM10 Total	Fugitive PM2.5	Exhaust PM2.5	PM2.5 Total	Bio- CO2	NBio- CO2	Total CO2	CH4	N2O	CO2e
Category	lb/day										lb/day					
Fugitive Dust					5.8134	0.0000	5.8134	0.8802	0.0000	0.8802			0.0000			0.0000
Off-Road	2.2691	21.4844	19.6434	0.0388		0.9975	0.9975		0.9280	0.9280		3,746.9840	3,746.9840	1.0494		3,773.2183
<b>Total</b>	<b>2.2691</b>	<b>21.4844</b>	<b>19.6434</b>	<b>0.0388</b>	<b>5.8134</b>	<b>0.9975</b>	<b>6.8109</b>	<b>0.8802</b>	<b>0.9280</b>	<b>1.8082</b>		<b>3,746.9840</b>	<b>3,746.9840</b>	<b>1.0494</b>		<b>3,773.2183</b>

Desert Island SP - Amendment - Riverside-Salton Sea County, Summer

**EMFAC Off-Model Adjustment Factors for Gasoline Light Duty Vehicle to Account for the SAFE Vehicle Rule Applied**

**3.2 Demolition - 2023**

**Unmitigated Construction Off-Site**

	ROG	NOx	CO	SO2	Fugitive PM10	Exhaust PM10	PM10 Total	Fugitive PM2.5	Exhaust PM2.5	PM2.5 Total	Bio- CO2	NBio- CO2	Total CO2	CH4	N2O	CO2e
Category	lb/day										lb/day					
Hauling	0.0584	2.6664	0.7332	0.0147	0.4673	0.0322	0.4995	0.1281	0.0308	0.1589		1,566.7445	1,566.7445	0.0222	0.2469	1,640.8698
Vendor	0.0000	0.0000	0.0000	0.0000	0.0000	0.0000	0.0000	0.0000	0.0000	0.0000		0.0000	0.0000	0.0000	0.0000	0.0000
Worker	0.0471	0.0271	0.4288	1.1100e-003	0.1255	6.1000e-004	0.1261	0.0333	5.6000e-004	0.0339		113.6796	113.6796	2.9900e-003	2.8600e-003	114.6051
<b>Total</b>	<b>0.1055</b>	<b>2.6935</b>	<b>1.1620</b>	<b>0.0158</b>	<b>0.5928</b>	<b>0.0328</b>	<b>0.6256</b>	<b>0.1614</b>	<b>0.0314</b>	<b>0.1928</b>		<b>1,680.4240</b>	<b>1,680.4240</b>	<b>0.0252</b>	<b>0.2497</b>	<b>1,755.4750</b>

**Mitigated Construction On-Site**

	ROG	NOx	CO	SO2	Fugitive PM10	Exhaust PM10	PM10 Total	Fugitive PM2.5	Exhaust PM2.5	PM2.5 Total	Bio- CO2	NBio- CO2	Total CO2	CH4	N2O	CO2e
Category	lb/day										lb/day					
Fugitive Dust					1.8138	0.0000	1.8138	0.2746	0.0000	0.2746			0.0000			0.0000
Off-Road	2.2691	21.4844	19.6434	0.0388		0.9975	0.9975		0.9280	0.9280	0.0000	3,746.9840	3,746.9840	1.0494		3,773.2183
<b>Total</b>	<b>2.2691</b>	<b>21.4844</b>	<b>19.6434</b>	<b>0.0388</b>	<b>1.8138</b>	<b>0.9975</b>	<b>2.8113</b>	<b>0.2746</b>	<b>0.9280</b>	<b>1.2026</b>	<b>0.0000</b>	<b>3,746.9840</b>	<b>3,746.9840</b>	<b>1.0494</b>		<b>3,773.2183</b>

Desert Island SP - Amendment - Riverside-Salton Sea County, Summer

**EMFAC Off-Model Adjustment Factors for Gasoline Light Duty Vehicle to Account for the SAFE Vehicle Rule Applied**

**3.2 Demolition - 2023**

**Mitigated Construction Off-Site**

	ROG	NOx	CO	SO2	Fugitive PM10	Exhaust PM10	PM10 Total	Fugitive PM2.5	Exhaust PM2.5	PM2.5 Total	Bio- CO2	NBio- CO2	Total CO2	CH4	N2O	CO2e
Category	lb/day										lb/day					
Hauling	0.0584	2.6664	0.7332	0.0147	0.3967	0.0322	0.4289	0.1108	0.0308	0.1416		1,566.7445	1,566.7445	0.0222	0.2469	1,640.8698
Vendor	0.0000	0.0000	0.0000	0.0000	0.0000	0.0000	0.0000	0.0000	0.0000	0.0000		0.0000	0.0000	0.0000	0.0000	0.0000
Worker	0.0471	0.0271	0.4288	1.1100e-003	0.1037	6.1000e-004	0.1043	0.0279	5.6000e-004	0.0285		113.6796	113.6796	2.9900e-003	2.8600e-003	114.6051
<b>Total</b>	<b>0.1055</b>	<b>2.6935</b>	<b>1.1620</b>	<b>0.0158</b>	<b>0.5004</b>	<b>0.0328</b>	<b>0.5332</b>	<b>0.1387</b>	<b>0.0314</b>	<b>0.1701</b>		<b>1,680.4240</b>	<b>1,680.4240</b>	<b>0.0252</b>	<b>0.2497</b>	<b>1,755.4750</b>

**3.3 Site Preparation - 2023**

**Unmitigated Construction On-Site**

	ROG	NOx	CO	SO2	Fugitive PM10	Exhaust PM10	PM10 Total	Fugitive PM2.5	Exhaust PM2.5	PM2.5 Total	Bio- CO2	NBio- CO2	Total CO2	CH4	N2O	CO2e
Category	lb/day										lb/day					
Fugitive Dust					19.6912	0.0000	19.6912	10.1076	0.0000	10.1076			0.0000			0.0000
Off-Road	2.6595	27.5242	18.2443	0.0381		1.2660	1.2660		1.1647	1.1647		3,687.3081	3,687.3081	1.1926		3,717.1219
<b>Total</b>	<b>2.6595</b>	<b>27.5242</b>	<b>18.2443</b>	<b>0.0381</b>	<b>19.6912</b>	<b>1.2660</b>	<b>20.9572</b>	<b>10.1076</b>	<b>1.1647</b>	<b>11.2724</b>		<b>3,687.3081</b>	<b>3,687.3081</b>	<b>1.1926</b>		<b>3,717.1219</b>



Desert Island SP - Amendment - Riverside-Salton Sea County, Summer

**EMFAC Off-Model Adjustment Factors for Gasoline Light Duty Vehicle to Account for the SAFE Vehicle Rule Applied**

**3.3 Site Preparation - 2023**

**Unmitigated Construction Off-Site**

	ROG	NOx	CO	SO2	Fugitive PM10	Exhaust PM10	PM10 Total	Fugitive PM2.5	Exhaust PM2.5	PM2.5 Total	Bio- CO2	NBio- CO2	Total CO2	CH4	N2O	CO2e
Category	lb/day										lb/day					
Hauling	0.0740	3.3754	0.9282	0.0186	0.5916	0.0407	0.6323	0.1622	0.0390	0.2012		1,983.3694	1,983.3694	0.0281	0.3125	2,077.2060
Vendor	0.0000	0.0000	0.0000	0.0000	0.0000	0.0000	0.0000	0.0000	0.0000	0.0000		0.0000	0.0000	0.0000	0.0000	0.0000
Worker	0.0565	0.0325	0.5146	1.3300e-003	0.1506	7.3000e-004	0.1513	0.0400	6.7000e-004	0.0406		136.4155	136.4155	3.5900e-003	3.4300e-003	137.5262
<b>Total</b>	<b>0.1305</b>	<b>3.4079</b>	<b>1.4428</b>	<b>0.0199</b>	<b>0.7422</b>	<b>0.0415</b>	<b>0.7836</b>	<b>0.2021</b>	<b>0.0397</b>	<b>0.2418</b>		<b>2,119.7849</b>	<b>2,119.7849</b>	<b>0.0317</b>	<b>0.3160</b>	<b>2,214.7322</b>

**Mitigated Construction On-Site**

	ROG	NOx	CO	SO2	Fugitive PM10	Exhaust PM10	PM10 Total	Fugitive PM2.5	Exhaust PM2.5	PM2.5 Total	Bio- CO2	NBio- CO2	Total CO2	CH4	N2O	CO2e
Category	lb/day										lb/day					
Fugitive Dust					6.1437	0.0000	6.1437	3.1536	0.0000	3.1536			0.0000			0.0000
Off-Road	2.6595	27.5242	18.2443	0.0381		1.2660	1.2660		1.1647	1.1647	0.0000	3,687.3081	3,687.3081	1.1926		3,717.1219
<b>Total</b>	<b>2.6595</b>	<b>27.5242</b>	<b>18.2443</b>	<b>0.0381</b>	<b>6.1437</b>	<b>1.2660</b>	<b>7.4097</b>	<b>3.1536</b>	<b>1.1647</b>	<b>4.3183</b>	<b>0.0000</b>	<b>3,687.3081</b>	<b>3,687.3081</b>	<b>1.1926</b>		<b>3,717.1219</b>

Desert Island SP - Amendment - Riverside-Salton Sea County, Summer

**EMFAC Off-Model Adjustment Factors for Gasoline Light Duty Vehicle to Account for the SAFE Vehicle Rule Applied**

**3.3 Site Preparation - 2023**

**Mitigated Construction Off-Site**

	ROG	NOx	CO	SO2	Fugitive PM10	Exhaust PM10	PM10 Total	Fugitive PM2.5	Exhaust PM2.5	PM2.5 Total	Bio- CO2	NBio- CO2	Total CO2	CH4	N2O	CO2e
Category	lb/day										lb/day					
Hauling	0.0740	3.3754	0.9282	0.0186	0.5022	0.0407	0.5429	0.1402	0.0390	0.1792		1,983.3694	1,983.3694	0.0281	0.3125	2,077.2060
Vendor	0.0000	0.0000	0.0000	0.0000	0.0000	0.0000	0.0000	0.0000	0.0000	0.0000		0.0000	0.0000	0.0000	0.0000	0.0000
Worker	0.0565	0.0325	0.5146	1.3300e-003	0.1244	7.3000e-004	0.1252	0.0335	6.7000e-004	0.0342		136.4155	136.4155	3.5900e-003	3.4300e-003	137.5262
<b>Total</b>	<b>0.1305</b>	<b>3.4079</b>	<b>1.4428</b>	<b>0.0199</b>	<b>0.6266</b>	<b>0.0415</b>	<b>0.6681</b>	<b>0.1738</b>	<b>0.0397</b>	<b>0.2134</b>		<b>2,119.7849</b>	<b>2,119.7849</b>	<b>0.0317</b>	<b>0.3160</b>	<b>2,214.7322</b>

**3.4 Grading - 2023**

**Unmitigated Construction On-Site**

	ROG	NOx	CO	SO2	Fugitive PM10	Exhaust PM10	PM10 Total	Fugitive PM2.5	Exhaust PM2.5	PM2.5 Total	Bio- CO2	NBio- CO2	Total CO2	CH4	N2O	CO2e
Category	lb/day										lb/day					
Fugitive Dust					9.2036	0.0000	9.2036	3.6538	0.0000	3.6538			0.0000			0.0000
Off-Road	3.3217	34.5156	28.0512	0.0621		1.4245	1.4245		1.3105	1.3105		6,011.4777	6,011.4777	1.9442		6,060.0836
<b>Total</b>	<b>3.3217</b>	<b>34.5156</b>	<b>28.0512</b>	<b>0.0621</b>	<b>9.2036</b>	<b>1.4245</b>	<b>10.6281</b>	<b>3.6538</b>	<b>1.3105</b>	<b>4.9643</b>		<b>6,011.4777</b>	<b>6,011.4777</b>	<b>1.9442</b>		<b>6,060.0836</b>

Desert Island SP - Amendment - Riverside-Salton Sea County, Summer

**EMFAC Off-Model Adjustment Factors for Gasoline Light Duty Vehicle to Account for the SAFE Vehicle Rule Applied**

**3.4 Grading - 2023**

**Unmitigated Construction Off-Site**

	ROG	NOx	CO	SO2	Fugitive PM10	Exhaust PM10	PM10 Total	Fugitive PM2.5	Exhaust PM2.5	PM2.5 Total	Bio- CO2	NBio- CO2	Total CO2	CH4	N2O	CO2e
Category	lb/day										lb/day					
Hauling	0.0000	0.0000	0.0000	0.0000	0.0000	0.0000	0.0000	0.0000	0.0000	0.0000		0.0000	0.0000	0.0000	0.0000	0.0000
Vendor	0.0000	0.0000	0.0000	0.0000	0.0000	0.0000	0.0000	0.0000	0.0000	0.0000		0.0000	0.0000	0.0000	0.0000	0.0000
Worker	0.0628	0.0361	0.5718	1.4800e-003	0.1673	8.1000e-004	0.1681	0.0444	7.4000e-004	0.0451		151.5728	151.5728	3.9800e-003	3.8100e-003	152.8069
<b>Total</b>	<b>0.0628</b>	<b>0.0361</b>	<b>0.5718</b>	<b>1.4800e-003</b>	<b>0.1673</b>	<b>8.1000e-004</b>	<b>0.1681</b>	<b>0.0444</b>	<b>7.4000e-004</b>	<b>0.0451</b>		<b>151.5728</b>	<b>151.5728</b>	<b>3.9800e-003</b>	<b>3.8100e-003</b>	<b>152.8069</b>

**Mitigated Construction On-Site**

	ROG	NOx	CO	SO2	Fugitive PM10	Exhaust PM10	PM10 Total	Fugitive PM2.5	Exhaust PM2.5	PM2.5 Total	Bio- CO2	NBio- CO2	Total CO2	CH4	N2O	CO2e
Category	lb/day										lb/day					
Fugitive Dust					2.8715	0.0000	2.8715	1.1400	0.0000	1.1400			0.0000			0.0000
Off-Road	3.3217	34.5156	28.0512	0.0621		1.4245	1.4245		1.3105	1.3105	0.0000	6,011.4777	6,011.4777	1.9442		6,060.0836
<b>Total</b>	<b>3.3217</b>	<b>34.5156</b>	<b>28.0512</b>	<b>0.0621</b>	<b>2.8715</b>	<b>1.4245</b>	<b>4.2960</b>	<b>1.1400</b>	<b>1.3105</b>	<b>2.4505</b>	<b>0.0000</b>	<b>6,011.4777</b>	<b>6,011.4777</b>	<b>1.9442</b>		<b>6,060.0836</b>

Desert Island SP - Amendment - Riverside-Salton Sea County, Summer

**EMFAC Off-Model Adjustment Factors for Gasoline Light Duty Vehicle to Account for the SAFE Vehicle Rule Applied**

**3.4 Grading - 2023**

**Mitigated Construction Off-Site**

	ROG	NOx	CO	SO2	Fugitive PM10	Exhaust PM10	PM10 Total	Fugitive PM2.5	Exhaust PM2.5	PM2.5 Total	Bio- CO2	NBio- CO2	Total CO2	CH4	N2O	CO2e
Category	lb/day										lb/day					
Hauling	0.0000	0.0000	0.0000	0.0000	0.0000	0.0000	0.0000	0.0000	0.0000	0.0000		0.0000	0.0000	0.0000	0.0000	0.0000
Vendor	0.0000	0.0000	0.0000	0.0000	0.0000	0.0000	0.0000	0.0000	0.0000	0.0000		0.0000	0.0000	0.0000	0.0000	0.0000
Worker	0.0628	0.0361	0.5718	1.4800e-003	0.1383	8.1000e-004	0.1391	0.0372	7.4000e-004	0.0380		151.5728	151.5728	3.9800e-003	3.8100e-003	152.8069
<b>Total</b>	<b>0.0628</b>	<b>0.0361</b>	<b>0.5718</b>	<b>1.4800e-003</b>	<b>0.1383</b>	<b>8.1000e-004</b>	<b>0.1391</b>	<b>0.0372</b>	<b>7.4000e-004</b>	<b>0.0380</b>		<b>151.5728</b>	<b>151.5728</b>	<b>3.9800e-003</b>	<b>3.8100e-003</b>	<b>152.8069</b>

**3.5 Building Construction - 2023**

**Unmitigated Construction On-Site**

	ROG	NOx	CO	SO2	Fugitive PM10	Exhaust PM10	PM10 Total	Fugitive PM2.5	Exhaust PM2.5	PM2.5 Total	Bio- CO2	NBio- CO2	Total CO2	CH4	N2O	CO2e
Category	lb/day										lb/day					
Off-Road	1.5728	14.3849	16.2440	0.0269		0.6997	0.6997		0.6584	0.6584		2,555.2099	2,555.2099	0.6079		2,570.4061
<b>Total</b>	<b>1.5728</b>	<b>14.3849</b>	<b>16.2440</b>	<b>0.0269</b>		<b>0.6997</b>	<b>0.6997</b>		<b>0.6584</b>	<b>0.6584</b>		<b>2,555.2099</b>	<b>2,555.2099</b>	<b>0.6079</b>		<b>2,570.4061</b>

Desert Island SP - Amendment - Riverside-Salton Sea County, Summer

**EMFAC Off-Model Adjustment Factors for Gasoline Light Duty Vehicle to Account for the SAFE Vehicle Rule Applied**

**3.5 Building Construction - 2023**

**Unmitigated Construction Off-Site**

	ROG	NOx	CO	SO2	Fugitive PM10	Exhaust PM10	PM10 Total	Fugitive PM2.5	Exhaust PM2.5	PM2.5 Total	Bio- CO2	NBio- CO2	Total CO2	CH4	N2O	CO2e
Category	lb/day										lb/day					
Hauling	0.0000	0.0000	0.0000	0.0000	0.0000	0.0000	0.0000	0.0000	0.0000	0.0000		0.0000	0.0000	0.0000	0.0000	0.0000
Vendor	0.0587	1.5832	0.7178	7.8700e-003	0.2810	0.0126	0.2936	0.0810	0.0120	0.0930		834.1701	834.1701	8.8500e-003	0.1235	871.1950
Worker	0.4491	0.2581	4.0882	0.0106	1.1964	5.7800e-003	1.2022	0.3174	5.3200e-003	0.3227		1,083.7452	1,083.7452	0.0285	0.0272	1,092.5690
<b>Total</b>	<b>0.5077</b>	<b>1.8414</b>	<b>4.8060</b>	<b>0.0185</b>	<b>1.4775</b>	<b>0.0183</b>	<b>1.4958</b>	<b>0.3983</b>	<b>0.0173</b>	<b>0.4156</b>		<b>1,917.9153</b>	<b>1,917.9153</b>	<b>0.0373</b>	<b>0.1507</b>	<b>1,963.7640</b>

**Mitigated Construction On-Site**

	ROG	NOx	CO	SO2	Fugitive PM10	Exhaust PM10	PM10 Total	Fugitive PM2.5	Exhaust PM2.5	PM2.5 Total	Bio- CO2	NBio- CO2	Total CO2	CH4	N2O	CO2e
Category	lb/day										lb/day					
Off-Road	1.5728	14.3849	16.2440	0.0269		0.6997	0.6997		0.6584	0.6584	0.0000	2,555.2099	2,555.2099	0.6079		2,570.4061
<b>Total</b>	<b>1.5728</b>	<b>14.3849</b>	<b>16.2440</b>	<b>0.0269</b>		<b>0.6997</b>	<b>0.6997</b>		<b>0.6584</b>	<b>0.6584</b>	<b>0.0000</b>	<b>2,555.2099</b>	<b>2,555.2099</b>	<b>0.6079</b>		<b>2,570.4061</b>

Desert Island SP - Amendment - Riverside-Salton Sea County, Summer

**EMFAC Off-Model Adjustment Factors for Gasoline Light Duty Vehicle to Account for the SAFE Vehicle Rule Applied**

**3.5 Building Construction - 2023**

**Mitigated Construction Off-Site**

	ROG	NOx	CO	SO2	Fugitive PM10	Exhaust PM10	PM10 Total	Fugitive PM2.5	Exhaust PM2.5	PM2.5 Total	Bio- CO2	NBio- CO2	Total CO2	CH4	N2O	CO2e
Category	lb/day										lb/day					
Hauling	0.0000	0.0000	0.0000	0.0000	0.0000	0.0000	0.0000	0.0000	0.0000	0.0000		0.0000	0.0000	0.0000	0.0000	0.0000
Vendor	0.0587	1.5832	0.7178	7.8700e-003	0.2411	0.0126	0.2536	0.0711	0.0120	0.0832		834.1701	834.1701	8.8500e-003	0.1235	871.1950
Worker	0.4491	0.2581	4.0882	0.0106	0.9885	5.7800e-003	0.9943	0.2663	5.3200e-003	0.2716		1,083.7452	1,083.7452	0.0285	0.0272	1,092.5690
<b>Total</b>	<b>0.5077</b>	<b>1.8414</b>	<b>4.8060</b>	<b>0.0185</b>	<b>1.2295</b>	<b>0.0183</b>	<b>1.2479</b>	<b>0.3374</b>	<b>0.0173</b>	<b>0.3548</b>		<b>1,917.9153</b>	<b>1,917.9153</b>	<b>0.0373</b>	<b>0.1507</b>	<b>1,963.7640</b>

**3.5 Building Construction - 2024**

**Unmitigated Construction On-Site**

	ROG	NOx	CO	SO2	Fugitive PM10	Exhaust PM10	PM10 Total	Fugitive PM2.5	Exhaust PM2.5	PM2.5 Total	Bio- CO2	NBio- CO2	Total CO2	CH4	N2O	CO2e
Category	lb/day										lb/day					
Off-Road	1.4716	13.4438	16.1668	0.0270		0.6133	0.6133		0.5769	0.5769		2,555.6989	2,555.6989	0.6044		2,570.8077
<b>Total</b>	<b>1.4716</b>	<b>13.4438</b>	<b>16.1668</b>	<b>0.0270</b>		<b>0.6133</b>	<b>0.6133</b>		<b>0.5769</b>	<b>0.5769</b>		<b>2,555.6989</b>	<b>2,555.6989</b>	<b>0.6044</b>		<b>2,570.8077</b>

Desert Island SP - Amendment - Riverside-Salton Sea County, Summer

**EMFAC Off-Model Adjustment Factors for Gasoline Light Duty Vehicle to Account for the SAFE Vehicle Rule Applied**

**3.5 Building Construction - 2024**

**Unmitigated Construction Off-Site**

	ROG	NOx	CO	SO2	Fugitive PM10	Exhaust PM10	PM10 Total	Fugitive PM2.5	Exhaust PM2.5	PM2.5 Total	Bio- CO2	NBio- CO2	Total CO2	CH4	N2O	CO2e
Category	lb/day										lb/day					
Hauling	0.0000	0.0000	0.0000	0.0000	0.0000	0.0000	0.0000	0.0000	0.0000	0.0000		0.0000	0.0000	0.0000	0.0000	0.0000
Vendor	0.0578	1.5828	0.7102	7.7400e-003	0.2810	0.0125	0.2935	0.0810	0.0119	0.0929		821.3058	821.3058	9.1400e-003	0.1214	857.7174
Worker	0.4182	0.2306	3.8326	0.0103	1.1964	5.5200e-003	1.2020	0.3174	5.0800e-003	0.3224		1,057.5929	1,057.5929	0.0259	0.0253	1,065.7897
<b>Total</b>	<b>0.4760</b>	<b>1.8135</b>	<b>4.5428</b>	<b>0.0180</b>	<b>1.4775</b>	<b>0.0180</b>	<b>1.4955</b>	<b>0.3983</b>	<b>0.0170</b>	<b>0.4153</b>		<b>1,878.8987</b>	<b>1,878.8987</b>	<b>0.0350</b>	<b>0.1468</b>	<b>1,923.5071</b>

**Mitigated Construction On-Site**

	ROG	NOx	CO	SO2	Fugitive PM10	Exhaust PM10	PM10 Total	Fugitive PM2.5	Exhaust PM2.5	PM2.5 Total	Bio- CO2	NBio- CO2	Total CO2	CH4	N2O	CO2e
Category	lb/day										lb/day					
Off-Road	1.4716	13.4438	16.1668	0.0270		0.6133	0.6133		0.5769	0.5769	0.0000	2,555.6989	2,555.6989	0.6044		2,570.8077
<b>Total</b>	<b>1.4716</b>	<b>13.4438</b>	<b>16.1668</b>	<b>0.0270</b>		<b>0.6133</b>	<b>0.6133</b>		<b>0.5769</b>	<b>0.5769</b>	<b>0.0000</b>	<b>2,555.6989</b>	<b>2,555.6989</b>	<b>0.6044</b>		<b>2,570.8077</b>

Desert Island SP - Amendment - Riverside-Salton Sea County, Summer

**EMFAC Off-Model Adjustment Factors for Gasoline Light Duty Vehicle to Account for the SAFE Vehicle Rule Applied**

**3.5 Building Construction - 2024**

**Mitigated Construction Off-Site**

	ROG	NOx	CO	SO2	Fugitive PM10	Exhaust PM10	PM10 Total	Fugitive PM2.5	Exhaust PM2.5	PM2.5 Total	Bio- CO2	NBio- CO2	Total CO2	CH4	N2O	CO2e
Category	lb/day										lb/day					
Hauling	0.0000	0.0000	0.0000	0.0000	0.0000	0.0000	0.0000	0.0000	0.0000	0.0000		0.0000	0.0000	0.0000	0.0000	0.0000
Vendor	0.0578	1.5828	0.7102	7.7400e-003	0.2410	0.0125	0.2535	0.0711	0.0119	0.0831		821.3058	821.3058	9.1400e-003	0.1214	857.7174
Worker	0.4182	0.2306	3.8326	0.0103	0.9885	5.5200e-003	0.9940	0.2663	5.0800e-003	0.2714		1,057.5929	1,057.5929	0.0259	0.0253	1,065.7897
<b>Total</b>	<b>0.4760</b>	<b>1.8135</b>	<b>4.5428</b>	<b>0.0180</b>	<b>1.2295</b>	<b>0.0180</b>	<b>1.2475</b>	<b>0.3374</b>	<b>0.0170</b>	<b>0.3545</b>		<b>1,878.8987</b>	<b>1,878.8987</b>	<b>0.0350</b>	<b>0.1468</b>	<b>1,923.5071</b>

**3.6 Paving - 2024**

**Unmitigated Construction On-Site**

	ROG	NOx	CO	SO2	Fugitive PM10	Exhaust PM10	PM10 Total	Fugitive PM2.5	Exhaust PM2.5	PM2.5 Total	Bio- CO2	NBio- CO2	Total CO2	CH4	N2O	CO2e
Category	lb/day										lb/day					
Off-Road	0.9882	9.5246	14.6258	0.0228		0.4685	0.4685		0.4310	0.4310		2,207.5472	2,207.5472	0.7140		2,225.3963
Paving	0.2686					0.0000	0.0000		0.0000	0.0000			0.0000			0.0000
<b>Total</b>	<b>1.2567</b>	<b>9.5246</b>	<b>14.6258</b>	<b>0.0228</b>		<b>0.4685</b>	<b>0.4685</b>		<b>0.4310</b>	<b>0.4310</b>		<b>2,207.5472</b>	<b>2,207.5472</b>	<b>0.7140</b>		<b>2,225.3963</b>



Desert Island SP - Amendment - Riverside-Salton Sea County, Summer

**EMFAC Off-Model Adjustment Factors for Gasoline Light Duty Vehicle to Account for the SAFE Vehicle Rule Applied**

**3.6 Paving - 2024**

**Unmitigated Construction Off-Site**

	ROG	NOx	CO	SO2	Fugitive PM10	Exhaust PM10	PM10 Total	Fugitive PM2.5	Exhaust PM2.5	PM2.5 Total	Bio- CO2	NBio- CO2	Total CO2	CH4	N2O	CO2e
Category	lb/day										lb/day					
Hauling	0.0000	0.0000	0.0000	0.0000	0.0000	0.0000	0.0000	0.0000	0.0000	0.0000		0.0000	0.0000	0.0000	0.0000	0.0000
Vendor	0.0000	0.0000	0.0000	0.0000	0.0000	0.0000	0.0000	0.0000	0.0000	0.0000		0.0000	0.0000	0.0000	0.0000	0.0000
Worker	0.0439	0.0242	0.4020	1.0800e-003	0.1255	5.8000e-004	0.1261	0.0333	5.3000e-004	0.0338		110.9363	110.9363	2.7100e-003	2.6600e-003	111.7961
<b>Total</b>	<b>0.0439</b>	<b>0.0242</b>	<b>0.4020</b>	<b>1.0800e-003</b>	<b>0.1255</b>	<b>5.8000e-004</b>	<b>0.1261</b>	<b>0.0333</b>	<b>5.3000e-004</b>	<b>0.0338</b>		<b>110.9363</b>	<b>110.9363</b>	<b>2.7100e-003</b>	<b>2.6600e-003</b>	<b>111.7961</b>

**Mitigated Construction On-Site**

	ROG	NOx	CO	SO2	Fugitive PM10	Exhaust PM10	PM10 Total	Fugitive PM2.5	Exhaust PM2.5	PM2.5 Total	Bio- CO2	NBio- CO2	Total CO2	CH4	N2O	CO2e
Category	lb/day										lb/day					
Off-Road	0.9882	9.5246	14.6258	0.0228		0.4685	0.4685		0.4310	0.4310	0.0000	2,207.547 2	2,207.547 2	0.7140		2,225.396 3
Paving	0.2686					0.0000	0.0000		0.0000	0.0000			0.0000			0.0000
<b>Total</b>	<b>1.2567</b>	<b>9.5246</b>	<b>14.6258</b>	<b>0.0228</b>		<b>0.4685</b>	<b>0.4685</b>		<b>0.4310</b>	<b>0.4310</b>	<b>0.0000</b>	<b>2,207.547 2</b>	<b>2,207.547 2</b>	<b>0.7140</b>		<b>2,225.396 3</b>

Desert Island SP - Amendment - Riverside-Salton Sea County, Summer

**EMFAC Off-Model Adjustment Factors for Gasoline Light Duty Vehicle to Account for the SAFE Vehicle Rule Applied**

**3.6 Paving - 2024**

**Mitigated Construction Off-Site**

	ROG	NOx	CO	SO2	Fugitive PM10	Exhaust PM10	PM10 Total	Fugitive PM2.5	Exhaust PM2.5	PM2.5 Total	Bio- CO2	NBio- CO2	Total CO2	CH4	N2O	CO2e
Category	lb/day										lb/day					
Hauling	0.0000	0.0000	0.0000	0.0000	0.0000	0.0000	0.0000	0.0000	0.0000	0.0000		0.0000	0.0000	0.0000	0.0000	0.0000
Vendor	0.0000	0.0000	0.0000	0.0000	0.0000	0.0000	0.0000	0.0000	0.0000	0.0000		0.0000	0.0000	0.0000	0.0000	0.0000
Worker	0.0439	0.0242	0.4020	1.0800e-003	0.1037	5.8000e-004	0.1043	0.0279	5.3000e-004	0.0285		110.9363	110.9363	2.7100e-003	2.6600e-003	111.7961
<b>Total</b>	<b>0.0439</b>	<b>0.0242</b>	<b>0.4020</b>	<b>1.0800e-003</b>	<b>0.1037</b>	<b>5.8000e-004</b>	<b>0.1043</b>	<b>0.0279</b>	<b>5.3000e-004</b>	<b>0.0285</b>		<b>110.9363</b>	<b>110.9363</b>	<b>2.7100e-003</b>	<b>2.6600e-003</b>	<b>111.7961</b>

**3.7 Architectural Coating - 2024**

**Unmitigated Construction On-Site**

	ROG	NOx	CO	SO2	Fugitive PM10	Exhaust PM10	PM10 Total	Fugitive PM2.5	Exhaust PM2.5	PM2.5 Total	Bio- CO2	NBio- CO2	Total CO2	CH4	N2O	CO2e
Category	lb/day										lb/day					
Archit. Coating	24.9099					0.0000	0.0000		0.0000	0.0000			0.0000			0.0000
Off-Road	0.1808	1.2188	1.8101	2.9700e-003		0.0609	0.0609		0.0609	0.0609		281.4481	281.4481	0.0159		281.8443
<b>Total</b>	<b>25.0906</b>	<b>1.2188</b>	<b>1.8101</b>	<b>2.9700e-003</b>		<b>0.0609</b>	<b>0.0609</b>		<b>0.0609</b>	<b>0.0609</b>		<b>281.4481</b>	<b>281.4481</b>	<b>0.0159</b>		<b>281.8443</b>

Desert Island SP - Amendment - Riverside-Salton Sea County, Summer

**EMFAC Off-Model Adjustment Factors for Gasoline Light Duty Vehicle to Account for the SAFE Vehicle Rule Applied**

**3.7 Architectural Coating - 2024**

**Unmitigated Construction Off-Site**

	ROG	NOx	CO	SO2	Fugitive PM10	Exhaust PM10	PM10 Total	Fugitive PM2.5	Exhaust PM2.5	PM2.5 Total	Bio- CO2	NBio- CO2	Total CO2	CH4	N2O	CO2e
Category	lb/day										lb/day					
Hauling	0.0000	0.0000	0.0000	0.0000	0.0000	0.0000	0.0000	0.0000	0.0000	0.0000		0.0000	0.0000	0.0000	0.0000	0.0000
Vendor	0.0000	0.0000	0.0000	0.0000	0.0000	0.0000	0.0000	0.0000	0.0000	0.0000		0.0000	0.0000	0.0000	0.0000	0.0000
Worker	0.0848	0.0468	0.7773	2.0800e-003	0.2426	1.1200e-003	0.2438	0.0644	1.0300e-003	0.0654		214.4769	214.4769	5.2400e-003	5.1400e-003	216.1392
<b>Total</b>	<b>0.0848</b>	<b>0.0468</b>	<b>0.7773</b>	<b>2.0800e-003</b>	<b>0.2426</b>	<b>1.1200e-003</b>	<b>0.2438</b>	<b>0.0644</b>	<b>1.0300e-003</b>	<b>0.0654</b>		<b>214.4769</b>	<b>214.4769</b>	<b>5.2400e-003</b>	<b>5.1400e-003</b>	<b>216.1392</b>

**Mitigated Construction On-Site**

	ROG	NOx	CO	SO2	Fugitive PM10	Exhaust PM10	PM10 Total	Fugitive PM2.5	Exhaust PM2.5	PM2.5 Total	Bio- CO2	NBio- CO2	Total CO2	CH4	N2O	CO2e
Category	lb/day										lb/day					
Archit. Coating	24.9099					0.0000	0.0000		0.0000	0.0000			0.0000			0.0000
Off-Road	0.1808	1.2188	1.8101	2.9700e-003		0.0609	0.0609		0.0609	0.0609	0.0000	281.4481	281.4481	0.0159		281.8443
<b>Total</b>	<b>25.0906</b>	<b>1.2188</b>	<b>1.8101</b>	<b>2.9700e-003</b>		<b>0.0609</b>	<b>0.0609</b>		<b>0.0609</b>	<b>0.0609</b>	<b>0.0000</b>	<b>281.4481</b>	<b>281.4481</b>	<b>0.0159</b>		<b>281.8443</b>

Desert Island SP - Amendment - Riverside-Salton Sea County, Summer

**EMFAC Off-Model Adjustment Factors for Gasoline Light Duty Vehicle to Account for the SAFE Vehicle Rule Applied**

**3.7 Architectural Coating - 2024**

**Mitigated Construction Off-Site**

	ROG	NOx	CO	SO2	Fugitive PM10	Exhaust PM10	PM10 Total	Fugitive PM2.5	Exhaust PM2.5	PM2.5 Total	Bio- CO2	NBio- CO2	Total CO2	CH4	N2O	CO2e
Category	lb/day										lb/day					
Hauling	0.0000	0.0000	0.0000	0.0000	0.0000	0.0000	0.0000	0.0000	0.0000	0.0000		0.0000	0.0000	0.0000	0.0000	0.0000
Vendor	0.0000	0.0000	0.0000	0.0000	0.0000	0.0000	0.0000	0.0000	0.0000	0.0000		0.0000	0.0000	0.0000	0.0000	0.0000
Worker	0.0848	0.0468	0.7773	2.0800e-003	0.2005	1.1200e-003	0.2016	0.0540	1.0300e-003	0.0550		214.4769	214.4769	5.2400e-003	5.1400e-003	216.1392
<b>Total</b>	<b>0.0848</b>	<b>0.0468</b>	<b>0.7773</b>	<b>2.0800e-003</b>	<b>0.2005</b>	<b>1.1200e-003</b>	<b>0.2016</b>	<b>0.0540</b>	<b>1.0300e-003</b>	<b>0.0550</b>		<b>214.4769</b>	<b>214.4769</b>	<b>5.2400e-003</b>	<b>5.1400e-003</b>	<b>216.1392</b>

**4.0 Operational Detail - Mobile**

---

**4.1 Mitigation Measures Mobile**

Desert Island SP - Amendment - Riverside-Salton Sea County, Summer

**EMFAC Off-Model Adjustment Factors for Gasoline Light Duty Vehicle to Account for the SAFE Vehicle Rule Applied**

	ROG	NOx	CO	SO2	Fugitive PM10	Exhaust PM10	PM10 Total	Fugitive PM2.5	Exhaust PM2.5	PM2.5 Total	Bio- CO2	NBio- CO2	Total CO2	CH4	N2O	CO2e
Category	lb/day										lb/day					
Mitigated	1.0968	1.0673	7.7570	0.0160	1.6421	0.0128	1.6549	0.4381	0.0119	0.4500		1,668.0799	1,668.0799	0.0980	0.0864	1,696.2836
Unmitigated	1.0968	1.0673	7.7570	0.0160	1.6421	0.0128	1.6549	0.4381	0.0119	0.4500		1,668.0799	1,668.0799	0.0980	0.0864	1,696.2836

**4.2 Trip Summary Information**

Land Use	Average Daily Trip Rate			Unmitigated	Mitigated
	Weekday	Saturday	Sunday	Annual VMT	Annual VMT
General Light Industry	0.00	0.00	0.00		
Golf Course	13.09	13.09	13.09	21,130	21,130
Health Club	0.00	0.00	0.00		
Hotel	351.12	343.98	249.90	498,439	498,439
Parking Lot	0.00	0.00	0.00		
Recreational Swimming Pool	0.00	0.00	0.00		
Single Family Housing	103.84	104.94	94.05	229,505	229,505
<b>Total</b>	<b>468.05</b>	<b>462.01</b>	<b>357.04</b>	<b>749,074</b>	<b>749,074</b>

**4.3 Trip Type Information**

Land Use	Miles			Trip %			Trip Purpose %		
	H-W or C-W	H-S or C-C	H-O or C-NW	H-W or C-W	H-S or C-C	H-O or C-NW	Primary	Diverted	Pass-by
General Light Industry	12.50	4.20	5.40	59.00	28.00	13.00	92	5	3
Golf Course	12.50	4.20	5.40	33.00	48.00	19.00	52	39	9
Health Club	12.50	4.20	5.40	16.90	64.10	19.00	52	39	9
Hotel	12.50	4.20	5.40	19.40	61.60	19.00	58	38	4
Parking Lot	12.50	4.20	5.40	0.00	0.00	0.00	0	0	0

Desert Island SP - Amendment - Riverside-Salton Sea County, Summer

**EMFAC Off-Model Adjustment Factors for Gasoline Light Duty Vehicle to Account for the SAFE Vehicle Rule Applied**

Land Use	Miles			Trip %			Trip Purpose %		
	H-W or C-W	H-S or C-C	H-O or C-NW	H-W or C-W	H-S or C-C	H-O or C-NW	Primary	Diverted	Pass-by
Recreational Swimming Pool	12.50	4.20	5.40	33.00	48.00	19.00	52	39	9
Single Family Housing	11.00	3.50	4.50	40.20	19.20	40.60	86	11	3

**4.4 Fleet Mix**

Land Use	LDA	LDT1	LDT2	MDV	LHD1	LHD2	MHD	HHD	OBUS	UBUS	MCY	SBUS	MH
General Light Industry	0.540541	0.056458	0.173793	0.136090	0.025268	0.007074	0.011525	0.018705	0.000610	0.000304	0.023606	0.001094	0.004932
Golf Course	0.540541	0.056458	0.173793	0.136090	0.025268	0.007074	0.011525	0.018705	0.000610	0.000304	0.023606	0.001094	0.004932
Health Club	0.540541	0.056458	0.173793	0.136090	0.025268	0.007074	0.011525	0.018705	0.000610	0.000304	0.023606	0.001094	0.004932
Hotel	0.540541	0.056458	0.173793	0.136090	0.025268	0.007074	0.011525	0.018705	0.000610	0.000304	0.023606	0.001094	0.004932
Parking Lot	0.540541	0.056458	0.173793	0.136090	0.025268	0.007074	0.011525	0.018705	0.000610	0.000304	0.023606	0.001094	0.004932
Recreational Swimming Pool	0.540541	0.056458	0.173793	0.136090	0.025268	0.007074	0.011525	0.018705	0.000610	0.000304	0.023606	0.001094	0.004932
Single Family Housing	0.540541	0.056458	0.173793	0.136090	0.025268	0.007074	0.011525	0.018705	0.000610	0.000304	0.023606	0.001094	0.004932

**5.0 Energy Detail**

Historical Energy Use: N

**5.1 Mitigation Measures Energy**

Install High Efficiency Lighting

Desert Island SP - Amendment - Riverside-Salton Sea County, Summer

**EMFAC Off-Model Adjustment Factors for Gasoline Light Duty Vehicle to Account for the SAFE Vehicle Rule Applied**

	ROG	NOx	CO	SO2	Fugitive PM10	Exhaust PM10	PM10 Total	Fugitive PM2.5	Exhaust PM2.5	PM2.5 Total	Bio- CO2	NBio- CO2	Total CO2	CH4	N2O	CO2e
Category	lb/day										lb/day					
NaturalGas Mitigated	0.1300	1.1767	0.9559	7.0900e-003		0.0898	0.0898		0.0898	0.0898		1,418.0770	1,418.0770	0.0272	0.0260	1,426.5040
NaturalGas Unmitigated	0.1300	1.1767	0.9559	7.0900e-003		0.0898	0.0898		0.0898	0.0898		1,418.0770	1,418.0770	0.0272	0.0260	1,426.5040

Desert Island SP - Amendment - Riverside-Salton Sea County, Summer

**EMFAC Off-Model Adjustment Factors for Gasoline Light Duty Vehicle to Account for the SAFE Vehicle Rule Applied**

**5.2 Energy by Land Use - NaturalGas**

**Unmitigated**

	NaturalGas Use	ROG	NOx	CO	SO2	Fugitive PM10	Exhaust PM10	PM10 Total	Fugitive PM2.5	Exhaust PM2.5	PM2.5 Total	Bio- CO2	NBio- CO2	Total CO2	CH4	N2O	CO2e
Land Use	kBTU/yr	lb/day										lb/day					
General Light Industry	708.603	7.6400e-003	0.0695	0.0584	4.2000e-004		5.2800e-003	5.2800e-003		5.2800e-003	5.2800e-003		83.3650	83.3650	1.6000e-003	1.5300e-003	83.8604
Golf Course	0	0.0000	0.0000	0.0000	0.0000		0.0000	0.0000		0.0000	0.0000		0.0000	0.0000	0.0000	0.0000	0.0000
Health Club	558.025	6.0200e-003	0.0547	0.0460	3.3000e-004		4.1600e-003	4.1600e-003		4.1600e-003	4.1600e-003		65.6500	65.6500	1.2600e-003	1.2000e-003	66.0401
Hotel	9934.54	0.1071	0.9740	0.8181	5.8400e-003		0.0740	0.0740		0.0740	0.0740		1,168.7699	1,168.7699	0.0224	0.0214	1,175.7153
Parking Lot	0	0.0000	0.0000	0.0000	0.0000		0.0000	0.0000		0.0000	0.0000		0.0000	0.0000	0.0000	0.0000	0.0000
Recreational Swimming Pool	0	0.0000	0.0000	0.0000	0.0000		0.0000	0.0000		0.0000	0.0000		0.0000	0.0000	0.0000	0.0000	0.0000
Single Family Housing	852.483	9.1900e-003	0.0786	0.0334	5.0000e-004		6.3500e-003	6.3500e-003		6.3500e-003	6.3500e-003		100.2921	100.2921	1.9200e-003	1.8400e-003	100.8881
<b>Total</b>		<b>0.1300</b>	<b>1.1767</b>	<b>0.9559</b>	<b>7.0900e-003</b>		<b>0.0898</b>	<b>0.0898</b>		<b>0.0898</b>	<b>0.0898</b>		<b>1,418.0770</b>	<b>1,418.0770</b>	<b>0.0272</b>	<b>0.0260</b>	<b>1,426.5039</b>



Desert Island SP - Amendment - Riverside-Salton Sea County, Summer

**EMFAC Off-Model Adjustment Factors for Gasoline Light Duty Vehicle to Account for the SAFE Vehicle Rule Applied**

**5.2 Energy by Land Use - NaturalGas**

Mitigated

	NaturalGas Use	ROG	NOx	CO	SO2	Fugitive PM10	Exhaust PM10	PM10 Total	Fugitive PM2.5	Exhaust PM2.5	PM2.5 Total	Bio- CO2	NBio- CO2	Total CO2	CH4	N2O	CO2e
Land Use	kBTU/yr	lb/day										lb/day					
General Light Industry	0.708603	7.6400e-003	0.0695	0.0584	4.2000e-004		5.2800e-003	5.2800e-003		5.2800e-003	5.2800e-003		83.3650	83.3650	1.6000e-003	1.5300e-003	83.8604
Golf Course	0	0.0000	0.0000	0.0000	0.0000		0.0000	0.0000		0.0000	0.0000		0.0000	0.0000	0.0000	0.0000	0.0000
Health Club	0.558025	6.0200e-003	0.0547	0.0460	3.3000e-004		4.1600e-003	4.1600e-003		4.1600e-003	4.1600e-003		65.6500	65.6500	1.2600e-003	1.2000e-003	66.0401
Hotel	9.93454	0.1071	0.9740	0.8181	5.8400e-003		0.0740	0.0740		0.0740	0.0740		1,168.7699	1,168.7699	0.0224	0.0214	1,175.7153
Parking Lot	0	0.0000	0.0000	0.0000	0.0000		0.0000	0.0000		0.0000	0.0000		0.0000	0.0000	0.0000	0.0000	0.0000
Recreational Swimming Pool	0	0.0000	0.0000	0.0000	0.0000		0.0000	0.0000		0.0000	0.0000		0.0000	0.0000	0.0000	0.0000	0.0000
Single Family Housing	0.852483	9.1900e-003	0.0786	0.0334	5.0000e-004		6.3500e-003	6.3500e-003		6.3500e-003	6.3500e-003		100.2921	100.2921	1.9200e-003	1.8400e-003	100.8881
<b>Total</b>		<b>0.1300</b>	<b>1.1767</b>	<b>0.9559</b>	<b>7.0900e-003</b>		<b>0.0898</b>	<b>0.0898</b>		<b>0.0898</b>	<b>0.0898</b>		<b>1,418.0770</b>	<b>1,418.0770</b>	<b>0.0272</b>	<b>0.0260</b>	<b>1,426.5039</b>

**6.0 Area Detail**

**6.1 Mitigation Measures Area**

- Use Low VOC Paint - Residential Interior
- Use Low VOC Paint - Residential Exterior
- Use Low VOC Paint - Non-Residential Interior
- Use Low VOC Paint - Non-Residential Exterior
- No Hearths Installed

Desert Island SP - Amendment - Riverside-Salton Sea County, Summer

**EMFAC Off-Model Adjustment Factors for Gasoline Light Duty Vehicle to Account for the SAFE Vehicle Rule Applied**

Use Low VOC Cleaning Supplies

	ROG	NOx	CO	SO2	Fugitive PM10	Exhaust PM10	PM10 Total	Fugitive PM2.5	Exhaust PM2.5	PM2.5 Total	Bio- CO2	NBio- CO2	Total CO2	CH4	N2O	CO2e
Category	lb/day										lb/day					
Mitigated	2.0894	0.0107	0.9373	5.0000e-005		5.1400e-003	5.1400e-003		5.1400e-003	5.1400e-003	0.0000	1.6999	1.6999	1.7400e-003	0.0000	1.7433
Unmitigated	2.3491	0.1701	1.8214	3.6600e-003		0.1510	0.1510		0.1510	0.1510	19.7921	188.0529	207.8450	0.0978	3.4200e-003	211.3089

**6.2 Area by SubCategory**

Unmitigated

	ROG	NOx	CO	SO2	Fugitive PM10	Exhaust PM10	PM10 Total	Fugitive PM2.5	Exhaust PM2.5	PM2.5 Total	Bio- CO2	NBio- CO2	Total CO2	CH4	N2O	CO2e
SubCategory	lb/day										lb/day					
Architectural Coating	0.1365					0.0000	0.0000		0.0000	0.0000			0.0000			0.0000
Consumer Products	2.0750					0.0000	0.0000		0.0000	0.0000			0.0000			0.0000
Hearth	0.1076	0.1594	0.8841	3.6100e-003		0.1459	0.1459		0.1459	0.1459	19.7921	186.3529	206.1450	0.0961	3.4200e-003	209.5655
Landscaping	0.0300	0.0107	0.9373	5.0000e-005		5.1400e-003	5.1400e-003		5.1400e-003	5.1400e-003		1.6999	1.6999	1.7400e-003		1.7433
<b>Total</b>	<b>2.3491</b>	<b>0.1701</b>	<b>1.8214</b>	<b>3.6600e-003</b>		<b>0.1510</b>	<b>0.1510</b>		<b>0.1510</b>	<b>0.1510</b>	<b>19.7921</b>	<b>188.0529</b>	<b>207.8450</b>	<b>0.0978</b>	<b>3.4200e-003</b>	<b>211.3089</b>

Desert Island SP - Amendment - Riverside-Salton Sea County, Summer

**EMFAC Off-Model Adjustment Factors for Gasoline Light Duty Vehicle to Account for the SAFE Vehicle Rule Applied**

**6.2 Area by SubCategory**

Mitigated

	ROG	NOx	CO	SO2	Fugitive PM10	Exhaust PM10	PM10 Total	Fugitive PM2.5	Exhaust PM2.5	PM2.5 Total	Bio- CO2	NBio- CO2	Total CO2	CH4	N2O	CO2e
SubCategory	lb/day										lb/day					
Architectural Coating	0.1365					0.0000	0.0000		0.0000	0.0000			0.0000			0.0000
Consumer Products	1.9228					0.0000	0.0000		0.0000	0.0000			0.0000			0.0000
Hearth	0.0000	0.0000	0.0000	0.0000		0.0000	0.0000		0.0000	0.0000	0.0000	0.0000	0.0000	0.0000	0.0000	0.0000
Landscaping	0.0300	0.0107	0.9373	5.0000e-005		5.1400e-003	5.1400e-003		5.1400e-003	5.1400e-003		1.6999	1.6999	1.7400e-003		1.7433
<b>Total</b>	<b>2.0894</b>	<b>0.0107</b>	<b>0.9373</b>	<b>5.0000e-005</b>		<b>5.1400e-003</b>	<b>5.1400e-003</b>		<b>5.1400e-003</b>	<b>5.1400e-003</b>	<b>0.0000</b>	<b>1.6999</b>	<b>1.6999</b>	<b>1.7400e-003</b>	<b>0.0000</b>	<b>1.7433</b>

**7.0 Water Detail**

---

**7.1 Mitigation Measures Water**

Install Low Flow Bathroom Faucet

Install Low Flow Kitchen Faucet

Install Low Flow Toilet

Install Low Flow Shower

Use Water Efficient Irrigation System

Desert Island SP - Amendment - Riverside-Salton Sea County, Summer

**EMFAC Off-Model Adjustment Factors for Gasoline Light Duty Vehicle to Account for the SAFE Vehicle Rule Applied**

**8.0 Waste Detail**

---

**8.1 Mitigation Measures Waste**

Institute Recycling and Composting Services

**9.0 Operational Offroad**

---

Equipment Type	Number	Hours/Day	Days/Year	Horse Power	Load Factor	Fuel Type
----------------	--------	-----------	-----------	-------------	-------------	-----------

**10.0 Stationary Equipment**

---

**Fire Pumps and Emergency Generators**

Equipment Type	Number	Hours/Day	Hours/Year	Horse Power	Load Factor	Fuel Type
----------------	--------	-----------	------------	-------------	-------------	-----------

**Boilers**

Equipment Type	Number	Heat Input/Day	Heat Input/Year	Boiler Rating	Fuel Type
----------------	--------	----------------	-----------------	---------------	-----------

**User Defined Equipment**

Equipment Type	Number
----------------	--------

**11.0 Vegetation**

---

Desert Island SP - Amendment - Riverside-Salton Sea County, Winter

**EMFAC Off-Model Adjustment Factors for Gasoline Light Duty Vehicle to Account for the SAFE Vehicle Rule Applied**

**Desert Island SP - Amendment  
Riverside-Salton Sea County, Winter**

**1.0 Project Characteristics**

**1.1 Land Usage**

Land Uses	Size	Metric	Lot Acreage	Floor Surface Area	Population
General Light Industry	8.00	1000sqft	0.18	8,000.00	0
Parking Lot	228.00	Space	2.05	91,200.00	0
Golf Course	3.50	Acre	3.50	152,460.00	0
Health Club	6.30	1000sqft	0.14	6,300.00	0
Hotel	42.00	Room	1.40	60,984.00	0
Recreational Swimming Pool	13.10	1000sqft	0.30	13,100.00	0
Single Family Housing	11.00	Dwelling Unit	3.57	19,800.00	21

**1.2 Other Project Characteristics**

<b>Urbanization</b>	Urban	<b>Wind Speed (m/s)</b>	2.4	<b>Precipitation Freq (Days)</b>	28
<b>Climate Zone</b>	15			<b>Operational Year</b>	2025
<b>Utility Company</b>	Southern California Edison				
<b>CO2 Intensity (lb/MW hr)</b>	390.98	<b>CH4 Intensity (lb/MW hr)</b>	0.033	<b>N2O Intensity (lb/MW hr)</b>	0.004

**1.3 User Entered Comments & Non-Default Data**

Project Characteristics - This model accounts for the proposed SP build-out condition with a tentative construction start date of May 1, 2023 for modeling purposes.

Land Use - Population total is based on 1.87 PPH for RM per CADF. GC size is based on combined driving range and desert gardens acreage. Health Club includes pool cafe, yoga pavilion, and restroom SF. GLI solely applies to the 8,000 SF golf course maintenance building for modeling purposes and does not imply the presence of traditional general light industry uses.

Demolition - This model accounts for 5,400 tons of debris associated with 2,700 CY of hardscape and building material removal at a conservative rate of 2 tons per CY.

Architectural Coating - SCAQMD Rule 1113 VOC Content Limits Apply as a Requirement

Desert Island SP - Amendment - Riverside-Salton Sea County, Winter

**EMFAC Off-Model Adjustment Factors for Gasoline Light Duty Vehicle to Account for the SAFE Vehicle Rule Applied**

Vehicle Trips - Consistent with the traffic assessment, the trip generating uses are the hotel rooms/keys, residential units, and golf course driving range facilities. The trip rates are default to the CalEEMod parameters.

Woodstoves - SCAQMD Rule 445 is applied pertaining to wood burning.

Area Coating - SCAQMD Rule 1113 VOC Content Limits are applied

Construction Off-road Equipment Mitigation - Dust control measures are a requirement under SCAQMD Rule 403/403.1 and Section 15.64.630 of the Rancho Mirage Municipal Code.

Area Mitigation - SCAQMD Rule 1113 VOC Content Limits Apply

Energy Mitigation - High efficiency lighting would be in the form of LED.

Waste Mitigation -

Trips and VMT -

Grading - Exported material (2,700 CY) corresponds to demolition of existing facilities.

Table Name	Column Name	Default Value	New Value
tblArchitecturalCoating	EF_Nonresidential_Exterior	250.00	50.00
tblArchitecturalCoating	EF_Nonresidential_Interior	250.00	50.00
tblArchitecturalCoating	EF_Parking	250.00	100.00
tblArchitecturalCoating	EF_Residential_Exterior	250.00	50.00
tblArchitecturalCoating	EF_Residential_Interior	250.00	50.00
tblAreaCoating	Area_EF_Nonresidential_Exterior	250	50
tblAreaCoating	Area_EF_Nonresidential_Interior	250	50
tblAreaCoating	Area_EF_Parking	250	100
tblAreaCoating	Area_EF_Residential_Exterior	250	50
tblAreaCoating	Area_EF_Residential_Interior	250	50
tblAreaMitigation	UseLowVOCPaintParkingCheck	False	True
tblConstDustMitigation	CleanPavedRoadPercentReduction	0	20
tblConstDustMitigation	WaterUnpavedRoadMoistureContent	0	50
tblConstDustMitigation	WaterUnpavedRoadVehicleSpeed	0	15
tblFireplaces	NumberWood	1.10	0.00
tblGrading	MaterialExported	0.00	2,700.00
tblLandUse	Population	31.00	21.00

Desert Island SP - Amendment - Riverside-Salton Sea County, Winter

**EMFAC Off-Model Adjustment Factors for Gasoline Light Duty Vehicle to Account for the SAFE Vehicle Rule Applied**

tblVehicleTrips	ST_TR	1.99	0.00
tblVehicleTrips	ST_TR	20.87	0.00
tblVehicleTrips	ST_TR	9.10	0.00
tblVehicleTrips	SU_TR	5.00	0.00
tblVehicleTrips	SU_TR	26.73	0.00
tblVehicleTrips	SU_TR	13.60	0.00
tblVehicleTrips	WD_TR	4.96	0.00
tblVehicleTrips	WD_TR	32.93	0.00
tblVehicleTrips	WD_TR	28.82	0.00

**2.0 Emissions Summary**

---

Desert Island SP - Amendment - Riverside-Salton Sea County, Winter

**EMFAC Off-Model Adjustment Factors for Gasoline Light Duty Vehicle to Account for the SAFE Vehicle Rule Applied**

**2.1 Overall Construction (Maximum Daily Emission)**

**Unmitigated Construction**

	ROG	NOx	CO	SO2	Fugitive PM10	Exhaust PM10	PM10 Total	Fugitive PM2.5	Exhaust PM2.5	PM2.5 Total	Bio- CO2	NBio- CO2	Total CO2	CH4	N2O	CO2e
Year	lb/day										lb/day					
2023	3.3792	34.5531	28.5229	0.0634	20.4334	1.4253	21.7409	10.3098	1.3113	11.5142	0.0000	6,148.883 4	6,148.883 4	1.9483	0.3165	6,198.752 5
2024	25.1684	15.3636	20.0671	0.0440	1.4775	0.6314	2.1088	0.3983	0.5940	0.9923	0.0000	4,338.477 4	4,338.477 4	0.7167	0.1478	4,398.525 4
<b>Maximum</b>	<b>25.1684</b>	<b>34.5531</b>	<b>28.5229</b>	<b>0.0634</b>	<b>20.4334</b>	<b>1.4253</b>	<b>21.7409</b>	<b>10.3098</b>	<b>1.3113</b>	<b>11.5142</b>	<b>0.0000</b>	<b>6,148.883 4</b>	<b>6,148.883 4</b>	<b>1.9483</b>	<b>0.3165</b>	<b>6,198.752 5</b>

**Mitigated Construction**

	ROG	NOx	CO	SO2	Fugitive PM10	Exhaust PM10	PM10 Total	Fugitive PM2.5	Exhaust PM2.5	PM2.5 Total	Bio- CO2	NBio- CO2	Total CO2	CH4	N2O	CO2e
Year	lb/day										lb/day					
2023	3.3792	34.5531	28.5229	0.0634	6.7703	1.4253	8.0778	3.3273	1.3113	4.5318	0.0000	6,148.883 4	6,148.883 4	1.9483	0.3165	6,198.752 5
2024	25.1684	15.3636	20.0671	0.0440	1.2295	0.6314	1.8609	0.3374	0.5940	0.9314	0.0000	4,338.477 4	4,338.477 4	0.7167	0.1478	4,398.525 4
<b>Maximum</b>	<b>25.1684</b>	<b>34.5531</b>	<b>28.5229</b>	<b>0.0634</b>	<b>6.7703</b>	<b>1.4253</b>	<b>8.0778</b>	<b>3.3273</b>	<b>1.3113</b>	<b>4.5318</b>	<b>0.0000</b>	<b>6,148.883 4</b>	<b>6,148.883 4</b>	<b>1.9483</b>	<b>0.3165</b>	<b>6,198.752 5</b>





Desert Island SP - Amendment - Riverside-Salton Sea County, Winter

**EMFAC Off-Model Adjustment Factors for Gasoline Light Duty Vehicle to Account for the SAFE Vehicle Rule Applied**

**2.2 Overall Operational**

**Unmitigated Operational**

	ROG	NOx	CO	SO2	Fugitive PM10	Exhaust PM10	PM10 Total	Fugitive PM2.5	Exhaust PM2.5	PM2.5 Total	Bio- CO2	NBio- CO2	Total CO2	CH4	N2O	CO2e
Category	lb/day										lb/day					
Area	2.3491	0.1701	1.8214	3.6600e-003		0.1510	0.1510		0.1510	0.1510	19.7921	188.0529	207.8450	0.0978	3.4200e-003	211.3089
Energy	0.1300	1.1767	0.9559	7.0900e-003		0.0898	0.0898		0.0898	0.0898		1,418.0770	1,418.0770	0.0272	0.0260	1,426.5040
Mobile	0.8942	1.1325	7.1438	0.0149	1.6421	0.0128	1.6549	0.4381	0.0120	0.4500		1,552.6760	1,552.6760	0.1031	0.0884	1,581.5819
<b>Total</b>	<b>3.3732</b>	<b>2.4793</b>	<b>9.9211</b>	<b>0.0256</b>	<b>1.6421</b>	<b>0.2536</b>	<b>1.8957</b>	<b>0.4381</b>	<b>0.2528</b>	<b>0.6908</b>	<b>19.7921</b>	<b>3,158.8059</b>	<b>3,178.5979</b>	<b>0.2282</b>	<b>0.1178</b>	<b>3,219.3947</b>

**Mitigated Operational**

	ROG	NOx	CO	SO2	Fugitive PM10	Exhaust PM10	PM10 Total	Fugitive PM2.5	Exhaust PM2.5	PM2.5 Total	Bio- CO2	NBio- CO2	Total CO2	CH4	N2O	CO2e
Category	lb/day										lb/day					
Area	2.0894	0.0107	0.9373	5.0000e-005		5.1400e-003	5.1400e-003		5.1400e-003	5.1400e-003	0.0000	1.6999	1.6999	1.7400e-003	0.0000	1.7433
Energy	0.1300	1.1767	0.9559	7.0900e-003		0.0898	0.0898		0.0898	0.0898		1,418.0770	1,418.0770	0.0272	0.0260	1,426.5040
Mobile	0.8942	1.1325	7.1438	0.0149	1.6421	0.0128	1.6549	0.4381	0.0120	0.4500		1,552.6760	1,552.6760	0.1031	0.0884	1,581.5819
<b>Total</b>	<b>3.1135</b>	<b>2.3199</b>	<b>9.0370</b>	<b>0.0220</b>	<b>1.6421</b>	<b>0.1077</b>	<b>1.7498</b>	<b>0.4381</b>	<b>0.1069</b>	<b>0.5450</b>	<b>0.0000</b>	<b>2,972.4529</b>	<b>2,972.4529</b>	<b>0.1321</b>	<b>0.1144</b>	<b>3,009.8292</b>

Desert Island SP - Amendment - Riverside-Salton Sea County, Winter

**EMFAC Off-Model Adjustment Factors for Gasoline Light Duty Vehicle to Account for the SAFE Vehicle Rule Applied**

	ROG	NOx	CO	SO2	Fugitive PM10	Exhaust PM10	PM10 Total	Fugitive PM2.5	Exhaust PM2.5	PM2.5 Total	Bio- CO2	NBio-CO2	Total CO2	CH4	N2O	CO2e
Percent Reduction	7.70	6.43	8.91	14.09	0.00	57.53	7.70	0.00	57.71	21.12	100.00	5.90	6.49	42.12	2.90	6.51

**3.0 Construction Detail**

**Construction Phase**

Phase Number	Phase Name	Phase Type	Start Date	End Date	Num Days Week	Num Days	Phase Description
1	Demolition	Demolition	5/1/2023	5/26/2023	5	20	
2	Site Preparation	Site Preparation	5/27/2023	6/9/2023	5	10	
3	Grading	Grading	6/10/2023	7/21/2023	5	30	
4	Building Construction	Building Construction	7/22/2023	9/13/2024	5	300	
5	Paving	Paving	9/14/2024	10/11/2024	5	20	
6	Architectural Coating	Architectural Coating	10/12/2024	11/8/2024	5	20	

**Acres of Grading (Site Preparation Phase): 15**

**Acres of Grading (Grading Phase): 90**

**Acres of Paving: 2.05**

**Residential Indoor: 40,095; Residential Outdoor: 13,365; Non-Residential Indoor: 112,926; Non-Residential Outdoor: 37,642; Striped Parking Area: 5,472 (Architectural Coating – sqft)**

**OffRoad Equipment**

Phase Name	Offroad Equipment Type	Amount	Usage Hours	Horse Power	Load Factor
Demolition	Concrete/Industrial Saws	1	8.00	81	0.73
Demolition	Excavators	3	8.00	158	0.38
Demolition	Rubber Tired Dozers	2	8.00	247	0.40
Site Preparation	Rubber Tired Dozers	3	8.00	247	0.40
Site Preparation	Tractors/Loaders/Backhoes	4	8.00	97	0.37

Desert Island SP - Amendment - Riverside-Salton Sea County, Winter

**EMFAC Off-Model Adjustment Factors for Gasoline Light Duty Vehicle to Account for the SAFE Vehicle Rule Applied**

Grading	Excavators	2	8.00	158	0.38
Grading	Graders	1	8.00	187	0.41
Grading	Rubber Tired Dozers	1	8.00	247	0.40
Grading	Tractors/Loaders/Backhoes	2	8.00	97	0.37
Building Construction	Cranes	1	7.00	231	0.29
Building Construction	Forklifts	3	8.00	89	0.20
Building Construction	Generator Sets	1	8.00	84	0.74
Building Construction	Tractors/Loaders/Backhoes	3	7.00	97	0.37
Building Construction	Welders	1	8.00	46	0.45
Paving	Pavers	2	8.00	130	0.42
Paving	Paving Equipment	2	8.00	132	0.36
Paving	Rollers	2	8.00	80	0.38
Architectural Coating	Air Compressors	1	6.00	78	0.48
Grading	Scrapers	2	8.00	367	0.48

**Trips and VMT**

Phase Name	Offroad Equipment Count	Worker Trip Number	Vendor Trip Number	Hauling Trip Number	Worker Trip Length	Vendor Trip Length	Hauling Trip Length	Worker Vehicle Class	Vendor Vehicle Class	Hauling Vehicle Class
Demolition	6	15.00	0.00	534.00	11.00	5.40	20.00	LD_Mix	HDT_Mix	HHDT
Site Preparation	7	18.00	0.00	338.00	11.00	5.40	20.00	LD_Mix	HDT_Mix	HHDT
Grading	8	20.00	0.00	0.00	11.00	5.40	20.00	LD_Mix	HDT_Mix	HHDT
Building Construction	9	143.00	56.00	0.00	11.00	5.40	20.00	LD_Mix	HDT_Mix	HHDT
Paving	6	15.00	0.00	0.00	11.00	5.40	20.00	LD_Mix	HDT_Mix	HHDT
Architectural Coating	1	29.00	0.00	0.00	11.00	5.40	20.00	LD_Mix	HDT_Mix	HHDT

**3.1 Mitigation Measures Construction**

Use Soil Stabilizer

Replace Ground Cover

Desert Island SP - Amendment - Riverside-Salton Sea County, Winter

**EMFAC Off-Model Adjustment Factors for Gasoline Light Duty Vehicle to Account for the SAFE Vehicle Rule Applied**

Water Exposed Area

Water Unpaved Roads

Reduce Vehicle Speed on Unpaved Roads

Clean Paved Roads

**3.2 Demolition - 2023**

**Unmitigated Construction On-Site**

	ROG	NOx	CO	SO2	Fugitive PM10	Exhaust PM10	PM10 Total	Fugitive PM2.5	Exhaust PM2.5	PM2.5 Total	Bio- CO2	NBio- CO2	Total CO2	CH4	N2O	CO2e
Category	lb/day										lb/day					
Fugitive Dust					5.8134	0.0000	5.8134	0.8802	0.0000	0.8802			0.0000			0.0000
Off-Road	2.2691	21.4844	19.6434	0.0388		0.9975	0.9975		0.9280	0.9280		3,746.9840	3,746.9840	1.0494		3,773.2183
<b>Total</b>	<b>2.2691</b>	<b>21.4844</b>	<b>19.6434</b>	<b>0.0388</b>	<b>5.8134</b>	<b>0.9975</b>	<b>6.8109</b>	<b>0.8802</b>	<b>0.9280</b>	<b>1.8082</b>		<b>3,746.9840</b>	<b>3,746.9840</b>	<b>1.0494</b>		<b>3,773.2183</b>

Desert Island SP - Amendment - Riverside-Salton Sea County, Winter

**EMFAC Off-Model Adjustment Factors for Gasoline Light Duty Vehicle to Account for the SAFE Vehicle Rule Applied**

**3.2 Demolition - 2023**

**Unmitigated Construction Off-Site**

	ROG	NOx	CO	SO2	Fugitive PM10	Exhaust PM10	PM10 Total	Fugitive PM2.5	Exhaust PM2.5	PM2.5 Total	Bio- CO2	NBio- CO2	Total CO2	CH4	N2O	CO2e
Category	lb/day										lb/day					
Hauling	0.0537	2.8252	0.7487	0.0147	0.4673	0.0322	0.4995	0.1281	0.0308	0.1589		1,569.1947	1,569.1947	0.0220	0.2473	1,643.4299
Vendor	0.0000	0.0000	0.0000	0.0000	0.0000	0.0000	0.0000	0.0000	0.0000	0.0000		0.0000	0.0000	0.0000	0.0000	0.0000
Worker	0.0431	0.0281	0.3538	1.0100e-003	0.1255	6.1000e-004	0.1261	0.0333	5.6000e-004	0.0339		103.0543	103.0543	3.0500e-003	2.9200e-003	104.0017
<b>Total</b>	<b>0.0968</b>	<b>2.8533</b>	<b>1.1024</b>	<b>0.0157</b>	<b>0.5928</b>	<b>0.0328</b>	<b>0.6256</b>	<b>0.1614</b>	<b>0.0314</b>	<b>0.1928</b>		<b>1,672.2490</b>	<b>1,672.2490</b>	<b>0.0251</b>	<b>0.2502</b>	<b>1,747.4315</b>

**Mitigated Construction On-Site**

	ROG	NOx	CO	SO2	Fugitive PM10	Exhaust PM10	PM10 Total	Fugitive PM2.5	Exhaust PM2.5	PM2.5 Total	Bio- CO2	NBio- CO2	Total CO2	CH4	N2O	CO2e
Category	lb/day										lb/day					
Fugitive Dust					1.8138	0.0000	1.8138	0.2746	0.0000	0.2746			0.0000			0.0000
Off-Road	2.2691	21.4844	19.6434	0.0388		0.9975	0.9975		0.9280	0.9280	0.0000	3,746.9840	3,746.9840	1.0494		3,773.2183
<b>Total</b>	<b>2.2691</b>	<b>21.4844</b>	<b>19.6434</b>	<b>0.0388</b>	<b>1.8138</b>	<b>0.9975</b>	<b>2.8113</b>	<b>0.2746</b>	<b>0.9280</b>	<b>1.2026</b>	<b>0.0000</b>	<b>3,746.9840</b>	<b>3,746.9840</b>	<b>1.0494</b>		<b>3,773.2183</b>

Desert Island SP - Amendment - Riverside-Salton Sea County, Winter

**EMFAC Off-Model Adjustment Factors for Gasoline Light Duty Vehicle to Account for the SAFE Vehicle Rule Applied**

**3.2 Demolition - 2023**

**Mitigated Construction Off-Site**

	ROG	NOx	CO	SO2	Fugitive PM10	Exhaust PM10	PM10 Total	Fugitive PM2.5	Exhaust PM2.5	PM2.5 Total	Bio- CO2	NBio- CO2	Total CO2	CH4	N2O	CO2e
Category	lb/day										lb/day					
Hauling	0.0537	2.8252	0.7487	0.0147	0.3967	0.0322	0.4289	0.1108	0.0308	0.1416		1,569.1947	1,569.1947	0.0220	0.2473	1,643.4299
Vendor	0.0000	0.0000	0.0000	0.0000	0.0000	0.0000	0.0000	0.0000	0.0000	0.0000		0.0000	0.0000	0.0000	0.0000	0.0000
Worker	0.0431	0.0281	0.3538	1.0100e-003	0.1037	6.1000e-004	0.1043	0.0279	5.6000e-004	0.0285		103.0543	103.0543	3.0500e-003	2.9200e-003	104.0017
<b>Total</b>	<b>0.0968</b>	<b>2.8533</b>	<b>1.1024</b>	<b>0.0157</b>	<b>0.5004</b>	<b>0.0328</b>	<b>0.5332</b>	<b>0.1387</b>	<b>0.0314</b>	<b>0.1701</b>		<b>1,672.2490</b>	<b>1,672.2490</b>	<b>0.0251</b>	<b>0.2502</b>	<b>1,747.4315</b>

**3.3 Site Preparation - 2023**

**Unmitigated Construction On-Site**

	ROG	NOx	CO	SO2	Fugitive PM10	Exhaust PM10	PM10 Total	Fugitive PM2.5	Exhaust PM2.5	PM2.5 Total	Bio- CO2	NBio- CO2	Total CO2	CH4	N2O	CO2e
Category	lb/day										lb/day					
Fugitive Dust					19.6912	0.0000	19.6912	10.1076	0.0000	10.1076			0.0000			0.0000
Off-Road	2.6595	27.5242	18.2443	0.0381		1.2660	1.2660		1.1647	1.1647		3,687.3081	3,687.3081	1.1926		3,717.1219
<b>Total</b>	<b>2.6595</b>	<b>27.5242</b>	<b>18.2443</b>	<b>0.0381</b>	<b>19.6912</b>	<b>1.2660</b>	<b>20.9572</b>	<b>10.1076</b>	<b>1.1647</b>	<b>11.2724</b>		<b>3,687.3081</b>	<b>3,687.3081</b>	<b>1.1926</b>		<b>3,717.1219</b>

Desert Island SP - Amendment - Riverside-Salton Sea County, Winter

**EMFAC Off-Model Adjustment Factors for Gasoline Light Duty Vehicle to Account for the SAFE Vehicle Rule Applied**

**3.3 Site Preparation - 2023**

**Unmitigated Construction Off-Site**

	ROG	NOx	CO	SO2	Fugitive PM10	Exhaust PM10	PM10 Total	Fugitive PM2.5	Exhaust PM2.5	PM2.5 Total	Bio- CO2	NBio- CO2	Total CO2	CH4	N2O	CO2e
Category	lb/day										lb/day					
Hauling	0.0680	3.5765	0.9477	0.0186	0.5916	0.0408	0.6324	0.1622	0.0390	0.2012		1,986.471 2	1,986.471 2	0.0278	0.3130	2,080.446 8
Vendor	0.0000	0.0000	0.0000	0.0000	0.0000	0.0000	0.0000	0.0000	0.0000	0.0000		0.0000	0.0000	0.0000	0.0000	0.0000
Worker	0.0517	0.0337	0.4245	1.2100e-003	0.1506	7.3000e-004	0.1513	0.0400	6.7000e-004	0.0406		123.6651	123.6651	3.6600e-003	3.5100e-003	124.8020
<b>Total</b>	<b>0.1197</b>	<b>3.6103</b>	<b>1.3723</b>	<b>0.0198</b>	<b>0.7422</b>	<b>0.0415</b>	<b>0.7837</b>	<b>0.2021</b>	<b>0.0397</b>	<b>0.2418</b>		<b>2,110.136 3</b>	<b>2,110.136 3</b>	<b>0.0315</b>	<b>0.3165</b>	<b>2,205.248 8</b>

**Mitigated Construction On-Site**

	ROG	NOx	CO	SO2	Fugitive PM10	Exhaust PM10	PM10 Total	Fugitive PM2.5	Exhaust PM2.5	PM2.5 Total	Bio- CO2	NBio- CO2	Total CO2	CH4	N2O	CO2e
Category	lb/day										lb/day					
Fugitive Dust					6.1437	0.0000	6.1437	3.1536	0.0000	3.1536			0.0000			0.0000
Off-Road	2.6595	27.5242	18.2443	0.0381		1.2660	1.2660		1.1647	1.1647	0.0000	3,687.308 1	3,687.308 1	1.1926		3,717.121 9
<b>Total</b>	<b>2.6595</b>	<b>27.5242</b>	<b>18.2443</b>	<b>0.0381</b>	<b>6.1437</b>	<b>1.2660</b>	<b>7.4097</b>	<b>3.1536</b>	<b>1.1647</b>	<b>4.3183</b>	<b>0.0000</b>	<b>3,687.308 1</b>	<b>3,687.308 1</b>	<b>1.1926</b>		<b>3,717.121 9</b>



Desert Island SP - Amendment - Riverside-Salton Sea County, Winter

**EMFAC Off-Model Adjustment Factors for Gasoline Light Duty Vehicle to Account for the SAFE Vehicle Rule Applied**

**3.3 Site Preparation - 2023**

**Mitigated Construction Off-Site**

	ROG	NOx	CO	SO2	Fugitive PM10	Exhaust PM10	PM10 Total	Fugitive PM2.5	Exhaust PM2.5	PM2.5 Total	Bio- CO2	NBio- CO2	Total CO2	CH4	N2O	CO2e
Category	lb/day										lb/day					
Hauling	0.0680	3.5765	0.9477	0.0186	0.5022	0.0408	0.5430	0.1402	0.0390	0.1793		1,986.471 2	1,986.471 2	0.0278	0.3130	2,080.446 8
Vendor	0.0000	0.0000	0.0000	0.0000	0.0000	0.0000	0.0000	0.0000	0.0000	0.0000		0.0000	0.0000	0.0000	0.0000	0.0000
Worker	0.0517	0.0337	0.4245	1.2100e-003	0.1244	7.3000e-004	0.1252	0.0335	6.7000e-004	0.0342		123.6651	123.6651	3.6600e-003	3.5100e-003	124.8020
<b>Total</b>	<b>0.1197</b>	<b>3.6103</b>	<b>1.3723</b>	<b>0.0198</b>	<b>0.6266</b>	<b>0.0415</b>	<b>0.6681</b>	<b>0.1738</b>	<b>0.0397</b>	<b>0.2135</b>		<b>2,110.136 3</b>	<b>2,110.136 3</b>	<b>0.0315</b>	<b>0.3165</b>	<b>2,205.248 8</b>

**3.4 Grading - 2023**

**Unmitigated Construction On-Site**

	ROG	NOx	CO	SO2	Fugitive PM10	Exhaust PM10	PM10 Total	Fugitive PM2.5	Exhaust PM2.5	PM2.5 Total	Bio- CO2	NBio- CO2	Total CO2	CH4	N2O	CO2e
Category	lb/day										lb/day					
Fugitive Dust					9.2036	0.0000	9.2036	3.6538	0.0000	3.6538			0.0000			0.0000
Off-Road	3.3217	34.5156	28.0512	0.0621		1.4245	1.4245		1.3105	1.3105		6,011.477 7	6,011.477 7	1.9442		6,060.083 6
<b>Total</b>	<b>3.3217</b>	<b>34.5156</b>	<b>28.0512</b>	<b>0.0621</b>	<b>9.2036</b>	<b>1.4245</b>	<b>10.6281</b>	<b>3.6538</b>	<b>1.3105</b>	<b>4.9643</b>		<b>6,011.477 7</b>	<b>6,011.477 7</b>	<b>1.9442</b>		<b>6,060.083 6</b>

Desert Island SP - Amendment - Riverside-Salton Sea County, Winter

**EMFAC Off-Model Adjustment Factors for Gasoline Light Duty Vehicle to Account for the SAFE Vehicle Rule Applied**

**3.4 Grading - 2023**

**Unmitigated Construction Off-Site**

	ROG	NOx	CO	SO2	Fugitive PM10	Exhaust PM10	PM10 Total	Fugitive PM2.5	Exhaust PM2.5	PM2.5 Total	Bio- CO2	NBio- CO2	Total CO2	CH4	N2O	CO2e
Category	lb/day										lb/day					
Hauling	0.0000	0.0000	0.0000	0.0000	0.0000	0.0000	0.0000	0.0000	0.0000	0.0000		0.0000	0.0000	0.0000	0.0000	0.0000
Vendor	0.0000	0.0000	0.0000	0.0000	0.0000	0.0000	0.0000	0.0000	0.0000	0.0000		0.0000	0.0000	0.0000	0.0000	0.0000
Worker	0.0575	0.0375	0.4717	1.3400e-003	0.1673	8.1000e-004	0.1681	0.0444	7.4000e-004	0.0451		137.4057	137.4057	4.0600e-003	3.9000e-003	138.6689
<b>Total</b>	<b>0.0575</b>	<b>0.0375</b>	<b>0.4717</b>	<b>1.3400e-003</b>	<b>0.1673</b>	<b>8.1000e-004</b>	<b>0.1681</b>	<b>0.0444</b>	<b>7.4000e-004</b>	<b>0.0451</b>		<b>137.4057</b>	<b>137.4057</b>	<b>4.0600e-003</b>	<b>3.9000e-003</b>	<b>138.6689</b>

**Mitigated Construction On-Site**

	ROG	NOx	CO	SO2	Fugitive PM10	Exhaust PM10	PM10 Total	Fugitive PM2.5	Exhaust PM2.5	PM2.5 Total	Bio- CO2	NBio- CO2	Total CO2	CH4	N2O	CO2e
Category	lb/day										lb/day					
Fugitive Dust					2.8715	0.0000	2.8715	1.1400	0.0000	1.1400			0.0000			0.0000
Off-Road	3.3217	34.5156	28.0512	0.0621		1.4245	1.4245		1.3105	1.3105	0.0000	6,011.4777	6,011.4777	1.9442		6,060.0836
<b>Total</b>	<b>3.3217</b>	<b>34.5156</b>	<b>28.0512</b>	<b>0.0621</b>	<b>2.8715</b>	<b>1.4245</b>	<b>4.2960</b>	<b>1.1400</b>	<b>1.3105</b>	<b>2.4505</b>	<b>0.0000</b>	<b>6,011.4777</b>	<b>6,011.4777</b>	<b>1.9442</b>		<b>6,060.0836</b>

Desert Island SP - Amendment - Riverside-Salton Sea County, Winter

**EMFAC Off-Model Adjustment Factors for Gasoline Light Duty Vehicle to Account for the SAFE Vehicle Rule Applied**

**3.4 Grading - 2023**

**Mitigated Construction Off-Site**

	ROG	NOx	CO	SO2	Fugitive PM10	Exhaust PM10	PM10 Total	Fugitive PM2.5	Exhaust PM2.5	PM2.5 Total	Bio- CO2	NBio- CO2	Total CO2	CH4	N2O	CO2e
Category	lb/day										lb/day					
Hauling	0.0000	0.0000	0.0000	0.0000	0.0000	0.0000	0.0000	0.0000	0.0000	0.0000		0.0000	0.0000	0.0000	0.0000	0.0000
Vendor	0.0000	0.0000	0.0000	0.0000	0.0000	0.0000	0.0000	0.0000	0.0000	0.0000		0.0000	0.0000	0.0000	0.0000	0.0000
Worker	0.0575	0.0375	0.4717	1.3400e-003	0.1383	8.1000e-004	0.1391	0.0372	7.4000e-004	0.0380		137.4057	137.4057	4.0600e-003	3.9000e-003	138.6689
<b>Total</b>	<b>0.0575</b>	<b>0.0375</b>	<b>0.4717</b>	<b>1.3400e-003</b>	<b>0.1383</b>	<b>8.1000e-004</b>	<b>0.1391</b>	<b>0.0372</b>	<b>7.4000e-004</b>	<b>0.0380</b>		<b>137.4057</b>	<b>137.4057</b>	<b>4.0600e-003</b>	<b>3.9000e-003</b>	<b>138.6689</b>

**3.5 Building Construction - 2023**

**Unmitigated Construction On-Site**

	ROG	NOx	CO	SO2	Fugitive PM10	Exhaust PM10	PM10 Total	Fugitive PM2.5	Exhaust PM2.5	PM2.5 Total	Bio- CO2	NBio- CO2	Total CO2	CH4	N2O	CO2e
Category	lb/day										lb/day					
Off-Road	1.5728	14.3849	16.2440	0.0269		0.6997	0.6997		0.6584	0.6584		2,555.2099	2,555.2099	0.6079		2,570.4061
<b>Total</b>	<b>1.5728</b>	<b>14.3849</b>	<b>16.2440</b>	<b>0.0269</b>		<b>0.6997</b>	<b>0.6997</b>		<b>0.6584</b>	<b>0.6584</b>		<b>2,555.2099</b>	<b>2,555.2099</b>	<b>0.6079</b>		<b>2,570.4061</b>

Desert Island SP - Amendment - Riverside-Salton Sea County, Winter

**EMFAC Off-Model Adjustment Factors for Gasoline Light Duty Vehicle to Account for the SAFE Vehicle Rule Applied**

**3.5 Building Construction - 2023**

**Unmitigated Construction Off-Site**

	ROG	NOx	CO	SO2	Fugitive PM10	Exhaust PM10	PM10 Total	Fugitive PM2.5	Exhaust PM2.5	PM2.5 Total	Bio- CO2	NBio- CO2	Total CO2	CH4	N2O	CO2e
Category	lb/day										lb/day					
Hauling	0.0000	0.0000	0.0000	0.0000	0.0000	0.0000	0.0000	0.0000	0.0000	0.0000		0.0000	0.0000	0.0000	0.0000	0.0000
Vendor	0.0539	1.6809	0.7436	7.8900e-003	0.2810	0.0126	0.2936	0.0810	0.0121	0.0930		836.7457	836.7457	8.6500e-003	0.1240	873.9115
Worker	0.4109	0.2679	3.3725	9.6000e-003	1.1964	5.7800e-003	1.2022	0.3174	5.3200e-003	0.3227		982.4505	982.4505	0.0290	0.0279	991.4826
<b>Total</b>	<b>0.4648</b>	<b>1.9488</b>	<b>4.1161</b>	<b>0.0175</b>	<b>1.4775</b>	<b>0.0184</b>	<b>1.4959</b>	<b>0.3983</b>	<b>0.0174</b>	<b>0.4157</b>		<b>1,819.1962</b>	<b>1,819.1962</b>	<b>0.0377</b>	<b>0.1519</b>	<b>1,865.3941</b>

**Mitigated Construction On-Site**

	ROG	NOx	CO	SO2	Fugitive PM10	Exhaust PM10	PM10 Total	Fugitive PM2.5	Exhaust PM2.5	PM2.5 Total	Bio- CO2	NBio- CO2	Total CO2	CH4	N2O	CO2e
Category	lb/day										lb/day					
Off-Road	1.5728	14.3849	16.2440	0.0269		0.6997	0.6997		0.6584	0.6584	0.0000	2,555.2099	2,555.2099	0.6079		2,570.4061
<b>Total</b>	<b>1.5728</b>	<b>14.3849</b>	<b>16.2440</b>	<b>0.0269</b>		<b>0.6997</b>	<b>0.6997</b>		<b>0.6584</b>	<b>0.6584</b>	<b>0.0000</b>	<b>2,555.2099</b>	<b>2,555.2099</b>	<b>0.6079</b>		<b>2,570.4061</b>

Desert Island SP - Amendment - Riverside-Salton Sea County, Winter

**EMFAC Off-Model Adjustment Factors for Gasoline Light Duty Vehicle to Account for the SAFE Vehicle Rule Applied**

**3.5 Building Construction - 2023**

**Mitigated Construction Off-Site**

	ROG	NOx	CO	SO2	Fugitive PM10	Exhaust PM10	PM10 Total	Fugitive PM2.5	Exhaust PM2.5	PM2.5 Total	Bio- CO2	NBio- CO2	Total CO2	CH4	N2O	CO2e
Category	lb/day										lb/day					
Hauling	0.0000	0.0000	0.0000	0.0000	0.0000	0.0000	0.0000	0.0000	0.0000	0.0000		0.0000	0.0000	0.0000	0.0000	0.0000
Vendor	0.0539	1.6809	0.7436	7.8900e-003	0.2411	0.0126	0.2537	0.0711	0.0121	0.0832		836.7457	836.7457	8.6500e-003	0.1240	873.9115
Worker	0.4109	0.2679	3.3725	9.6000e-003	0.9885	5.7800e-003	0.9943	0.2663	5.3200e-003	0.2716		982.4505	982.4505	0.0290	0.0279	991.4826
<b>Total</b>	<b>0.4648</b>	<b>1.9488</b>	<b>4.1161</b>	<b>0.0175</b>	<b>1.2295</b>	<b>0.0184</b>	<b>1.2479</b>	<b>0.3374</b>	<b>0.0174</b>	<b>0.3548</b>		<b>1,819.1962</b>	<b>1,819.1962</b>	<b>0.0377</b>	<b>0.1519</b>	<b>1,865.3941</b>

**3.5 Building Construction - 2024**

**Unmitigated Construction On-Site**

	ROG	NOx	CO	SO2	Fugitive PM10	Exhaust PM10	PM10 Total	Fugitive PM2.5	Exhaust PM2.5	PM2.5 Total	Bio- CO2	NBio- CO2	Total CO2	CH4	N2O	CO2e
Category	lb/day										lb/day					
Off-Road	1.4716	13.4438	16.1668	0.0270		0.6133	0.6133		0.5769	0.5769		2,555.6989	2,555.6989	0.6044		2,570.8077
<b>Total</b>	<b>1.4716</b>	<b>13.4438</b>	<b>16.1668</b>	<b>0.0270</b>		<b>0.6133</b>	<b>0.6133</b>		<b>0.5769</b>	<b>0.5769</b>		<b>2,555.6989</b>	<b>2,555.6989</b>	<b>0.6044</b>		<b>2,570.8077</b>

Desert Island SP - Amendment - Riverside-Salton Sea County, Winter

**EMFAC Off-Model Adjustment Factors for Gasoline Light Duty Vehicle to Account for the SAFE Vehicle Rule Applied**

**3.5 Building Construction - 2024**

**Unmitigated Construction Off-Site**

	ROG	NOx	CO	SO2	Fugitive PM10	Exhaust PM10	PM10 Total	Fugitive PM2.5	Exhaust PM2.5	PM2.5 Total	Bio- CO2	NBio- CO2	Total CO2	CH4	N2O	CO2e
Category	lb/day										lb/day					
Hauling	0.0000	0.0000	0.0000	0.0000	0.0000	0.0000	0.0000	0.0000	0.0000	0.0000		0.0000	0.0000	0.0000	0.0000	0.0000
Vendor	0.0531	1.6806	0.7358	7.7700e-003	0.2810	0.0125	0.2936	0.0810	0.0120	0.0929		823.8593	823.8593	8.9300e-003	0.1219	860.4089
Worker	0.3836	0.2392	3.1645	9.3000e-003	1.1964	5.5200e-003	1.2020	0.3174	5.0800e-003	0.3224		958.9192	958.9192	0.0264	0.0259	967.3088
<b>Total</b>	<b>0.4367</b>	<b>1.9199</b>	<b>3.9003</b>	<b>0.0171</b>	<b>1.4775</b>	<b>0.0181</b>	<b>1.4955</b>	<b>0.3983</b>	<b>0.0171</b>	<b>0.4154</b>		<b>1,782.7785</b>	<b>1,782.7785</b>	<b>0.0353</b>	<b>0.1478</b>	<b>1,827.7178</b>

**Mitigated Construction On-Site**

	ROG	NOx	CO	SO2	Fugitive PM10	Exhaust PM10	PM10 Total	Fugitive PM2.5	Exhaust PM2.5	PM2.5 Total	Bio- CO2	NBio- CO2	Total CO2	CH4	N2O	CO2e
Category	lb/day										lb/day					
Off-Road	1.4716	13.4438	16.1668	0.0270		0.6133	0.6133		0.5769	0.5769	0.0000	2,555.6989	2,555.6989	0.6044		2,570.8077
<b>Total</b>	<b>1.4716</b>	<b>13.4438</b>	<b>16.1668</b>	<b>0.0270</b>		<b>0.6133</b>	<b>0.6133</b>		<b>0.5769</b>	<b>0.5769</b>	<b>0.0000</b>	<b>2,555.6989</b>	<b>2,555.6989</b>	<b>0.6044</b>		<b>2,570.8077</b>

Desert Island SP - Amendment - Riverside-Salton Sea County, Winter

**EMFAC Off-Model Adjustment Factors for Gasoline Light Duty Vehicle to Account for the SAFE Vehicle Rule Applied**

**3.5 Building Construction - 2024**

**Mitigated Construction Off-Site**

	ROG	NOx	CO	SO2	Fugitive PM10	Exhaust PM10	PM10 Total	Fugitive PM2.5	Exhaust PM2.5	PM2.5 Total	Bio- CO2	NBio- CO2	Total CO2	CH4	N2O	CO2e
Category	lb/day										lb/day					
Hauling	0.0000	0.0000	0.0000	0.0000	0.0000	0.0000	0.0000	0.0000	0.0000	0.0000		0.0000	0.0000	0.0000	0.0000	0.0000
Vendor	0.0531	1.6806	0.7358	7.7700e-003	0.2410	0.0125	0.2536	0.0711	0.0120	0.0831		823.8593	823.8593	8.9300e-003	0.1219	860.4089
Worker	0.3836	0.2392	3.1645	9.3000e-003	0.9885	5.5200e-003	0.9940	0.2663	5.0800e-003	0.2714		958.9192	958.9192	0.0264	0.0259	967.3088
<b>Total</b>	<b>0.4367</b>	<b>1.9199</b>	<b>3.9003</b>	<b>0.0171</b>	<b>1.2295</b>	<b>0.0181</b>	<b>1.2476</b>	<b>0.3374</b>	<b>0.0171</b>	<b>0.3545</b>		<b>1,782.7785</b>	<b>1,782.7785</b>	<b>0.0353</b>	<b>0.1478</b>	<b>1,827.7178</b>

**3.6 Paving - 2024**

**Unmitigated Construction On-Site**

	ROG	NOx	CO	SO2	Fugitive PM10	Exhaust PM10	PM10 Total	Fugitive PM2.5	Exhaust PM2.5	PM2.5 Total	Bio- CO2	NBio- CO2	Total CO2	CH4	N2O	CO2e
Category	lb/day										lb/day					
Off-Road	0.9882	9.5246	14.6258	0.0228		0.4685	0.4685		0.4310	0.4310		2,207.5472	2,207.5472	0.7140		2,225.3963
Paving	0.2686					0.0000	0.0000		0.0000	0.0000			0.0000			0.0000
<b>Total</b>	<b>1.2567</b>	<b>9.5246</b>	<b>14.6258</b>	<b>0.0228</b>		<b>0.4685</b>	<b>0.4685</b>		<b>0.4310</b>	<b>0.4310</b>		<b>2,207.5472</b>	<b>2,207.5472</b>	<b>0.7140</b>		<b>2,225.3963</b>

Desert Island SP - Amendment - Riverside-Salton Sea County, Winter

**EMFAC Off-Model Adjustment Factors for Gasoline Light Duty Vehicle to Account for the SAFE Vehicle Rule Applied**

**3.6 Paving - 2024**

**Unmitigated Construction Off-Site**

	ROG	NOx	CO	SO2	Fugitive PM10	Exhaust PM10	PM10 Total	Fugitive PM2.5	Exhaust PM2.5	PM2.5 Total	Bio- CO2	NBio- CO2	Total CO2	CH4	N2O	CO2e
Category	lb/day										lb/day					
Hauling	0.0000	0.0000	0.0000	0.0000	0.0000	0.0000	0.0000	0.0000	0.0000	0.0000		0.0000	0.0000	0.0000	0.0000	0.0000
Vendor	0.0000	0.0000	0.0000	0.0000	0.0000	0.0000	0.0000	0.0000	0.0000	0.0000		0.0000	0.0000	0.0000	0.0000	0.0000
Worker	0.0402	0.0251	0.3319	9.8000e-004	0.1255	5.8000e-004	0.1261	0.0333	5.3000e-004	0.0338		100.5859	100.5859	2.7700e-003	2.7200e-003	101.4660
<b>Total</b>	<b>0.0402</b>	<b>0.0251</b>	<b>0.3319</b>	<b>9.8000e-004</b>	<b>0.1255</b>	<b>5.8000e-004</b>	<b>0.1261</b>	<b>0.0333</b>	<b>5.3000e-004</b>	<b>0.0338</b>		<b>100.5859</b>	<b>100.5859</b>	<b>2.7700e-003</b>	<b>2.7200e-003</b>	<b>101.4660</b>

**Mitigated Construction On-Site**

	ROG	NOx	CO	SO2	Fugitive PM10	Exhaust PM10	PM10 Total	Fugitive PM2.5	Exhaust PM2.5	PM2.5 Total	Bio- CO2	NBio- CO2	Total CO2	CH4	N2O	CO2e
Category	lb/day										lb/day					
Off-Road	0.9882	9.5246	14.6258	0.0228		0.4685	0.4685		0.4310	0.4310	0.0000	2,207.5472	2,207.5472	0.7140		2,225.3963
Paving	0.2686					0.0000	0.0000		0.0000	0.0000			0.0000			0.0000
<b>Total</b>	<b>1.2567</b>	<b>9.5246</b>	<b>14.6258</b>	<b>0.0228</b>		<b>0.4685</b>	<b>0.4685</b>		<b>0.4310</b>	<b>0.4310</b>	<b>0.0000</b>	<b>2,207.5472</b>	<b>2,207.5472</b>	<b>0.7140</b>		<b>2,225.3963</b>



Desert Island SP - Amendment - Riverside-Salton Sea County, Winter

**EMFAC Off-Model Adjustment Factors for Gasoline Light Duty Vehicle to Account for the SAFE Vehicle Rule Applied**

**3.6 Paving - 2024**

**Mitigated Construction Off-Site**

	ROG	NOx	CO	SO2	Fugitive PM10	Exhaust PM10	PM10 Total	Fugitive PM2.5	Exhaust PM2.5	PM2.5 Total	Bio- CO2	NBio- CO2	Total CO2	CH4	N2O	CO2e
Category	lb/day										lb/day					
Hauling	0.0000	0.0000	0.0000	0.0000	0.0000	0.0000	0.0000	0.0000	0.0000	0.0000		0.0000	0.0000	0.0000	0.0000	0.0000
Vendor	0.0000	0.0000	0.0000	0.0000	0.0000	0.0000	0.0000	0.0000	0.0000	0.0000		0.0000	0.0000	0.0000	0.0000	0.0000
Worker	0.0402	0.0251	0.3319	9.8000e-004	0.1037	5.8000e-004	0.1043	0.0279	5.3000e-004	0.0285		100.5859	100.5859	2.7700e-003	2.7200e-003	101.4660
<b>Total</b>	<b>0.0402</b>	<b>0.0251</b>	<b>0.3319</b>	<b>9.8000e-004</b>	<b>0.1037</b>	<b>5.8000e-004</b>	<b>0.1043</b>	<b>0.0279</b>	<b>5.3000e-004</b>	<b>0.0285</b>		<b>100.5859</b>	<b>100.5859</b>	<b>2.7700e-003</b>	<b>2.7200e-003</b>	<b>101.4660</b>

**3.7 Architectural Coating - 2024**

**Unmitigated Construction On-Site**

	ROG	NOx	CO	SO2	Fugitive PM10	Exhaust PM10	PM10 Total	Fugitive PM2.5	Exhaust PM2.5	PM2.5 Total	Bio- CO2	NBio- CO2	Total CO2	CH4	N2O	CO2e
Category	lb/day										lb/day					
Archit. Coating	24.9099					0.0000	0.0000		0.0000	0.0000			0.0000			0.0000
Off-Road	0.1808	1.2188	1.8101	2.9700e-003		0.0609	0.0609		0.0609	0.0609		281.4481	281.4481	0.0159		281.8443
<b>Total</b>	<b>25.0906</b>	<b>1.2188</b>	<b>1.8101</b>	<b>2.9700e-003</b>		<b>0.0609</b>	<b>0.0609</b>		<b>0.0609</b>	<b>0.0609</b>		<b>281.4481</b>	<b>281.4481</b>	<b>0.0159</b>		<b>281.8443</b>

Desert Island SP - Amendment - Riverside-Salton Sea County, Winter

**EMFAC Off-Model Adjustment Factors for Gasoline Light Duty Vehicle to Account for the SAFE Vehicle Rule Applied**

**3.7 Architectural Coating - 2024**

**Unmitigated Construction Off-Site**

	ROG	NOx	CO	SO2	Fugitive PM10	Exhaust PM10	PM10 Total	Fugitive PM2.5	Exhaust PM2.5	PM2.5 Total	Bio- CO2	NBio- CO2	Total CO2	CH4	N2O	CO2e
Category	lb/day										lb/day					
Hauling	0.0000	0.0000	0.0000	0.0000	0.0000	0.0000	0.0000	0.0000	0.0000	0.0000		0.0000	0.0000	0.0000	0.0000	0.0000
Vendor	0.0000	0.0000	0.0000	0.0000	0.0000	0.0000	0.0000	0.0000	0.0000	0.0000		0.0000	0.0000	0.0000	0.0000	0.0000
Worker	0.0778	0.0485	0.6418	1.8900e-003	0.2426	1.1200e-003	0.2438	0.0644	1.0300e-003	0.0654		194.4661	194.4661	5.3600e-003	5.2600e-003	196.1675
<b>Total</b>	<b>0.0778</b>	<b>0.0485</b>	<b>0.6418</b>	<b>1.8900e-003</b>	<b>0.2426</b>	<b>1.1200e-003</b>	<b>0.2438</b>	<b>0.0644</b>	<b>1.0300e-003</b>	<b>0.0654</b>		<b>194.4661</b>	<b>194.4661</b>	<b>5.3600e-003</b>	<b>5.2600e-003</b>	<b>196.1675</b>

**Mitigated Construction On-Site**

	ROG	NOx	CO	SO2	Fugitive PM10	Exhaust PM10	PM10 Total	Fugitive PM2.5	Exhaust PM2.5	PM2.5 Total	Bio- CO2	NBio- CO2	Total CO2	CH4	N2O	CO2e
Category	lb/day										lb/day					
Archit. Coating	24.9099					0.0000	0.0000		0.0000	0.0000			0.0000			0.0000
Off-Road	0.1808	1.2188	1.8101	2.9700e-003		0.0609	0.0609		0.0609	0.0609	0.0000	281.4481	281.4481	0.0159		281.8443
<b>Total</b>	<b>25.0906</b>	<b>1.2188</b>	<b>1.8101</b>	<b>2.9700e-003</b>		<b>0.0609</b>	<b>0.0609</b>		<b>0.0609</b>	<b>0.0609</b>	<b>0.0000</b>	<b>281.4481</b>	<b>281.4481</b>	<b>0.0159</b>		<b>281.8443</b>

Desert Island SP - Amendment - Riverside-Salton Sea County, Winter

**EMFAC Off-Model Adjustment Factors for Gasoline Light Duty Vehicle to Account for the SAFE Vehicle Rule Applied**

**3.7 Architectural Coating - 2024**

**Mitigated Construction Off-Site**

	ROG	NOx	CO	SO2	Fugitive PM10	Exhaust PM10	PM10 Total	Fugitive PM2.5	Exhaust PM2.5	PM2.5 Total	Bio- CO2	NBio- CO2	Total CO2	CH4	N2O	CO2e
Category	lb/day										lb/day					
Hauling	0.0000	0.0000	0.0000	0.0000	0.0000	0.0000	0.0000	0.0000	0.0000	0.0000		0.0000	0.0000	0.0000	0.0000	0.0000
Vendor	0.0000	0.0000	0.0000	0.0000	0.0000	0.0000	0.0000	0.0000	0.0000	0.0000		0.0000	0.0000	0.0000	0.0000	0.0000
Worker	0.0778	0.0485	0.6418	1.8900e-003	0.2005	1.1200e-003	0.2016	0.0540	1.0300e-003	0.0550		194.4661	194.4661	5.3600e-003	5.2600e-003	196.1675
<b>Total</b>	<b>0.0778</b>	<b>0.0485</b>	<b>0.6418</b>	<b>1.8900e-003</b>	<b>0.2005</b>	<b>1.1200e-003</b>	<b>0.2016</b>	<b>0.0540</b>	<b>1.0300e-003</b>	<b>0.0550</b>		<b>194.4661</b>	<b>194.4661</b>	<b>5.3600e-003</b>	<b>5.2600e-003</b>	<b>196.1675</b>

**4.0 Operational Detail - Mobile**

---

**4.1 Mitigation Measures Mobile**

Desert Island SP - Amendment - Riverside-Salton Sea County, Winter

**EMFAC Off-Model Adjustment Factors for Gasoline Light Duty Vehicle to Account for the SAFE Vehicle Rule Applied**

	ROG	NOx	CO	SO2	Fugitive PM10	Exhaust PM10	PM10 Total	Fugitive PM2.5	Exhaust PM2.5	PM2.5 Total	Bio- CO2	NBio- CO2	Total CO2	CH4	N2O	CO2e
Category	lb/day										lb/day					
Mitigated	0.8942	1.1325	7.1438	0.0149	1.6421	0.0128	1.6549	0.4381	0.0120	0.4500		1,552.6760	1,552.6760	0.1031	0.0884	1,581.5819
Unmitigated	0.8942	1.1325	7.1438	0.0149	1.6421	0.0128	1.6549	0.4381	0.0120	0.4500		1,552.6760	1,552.6760	0.1031	0.0884	1,581.5819

**4.2 Trip Summary Information**

Land Use	Average Daily Trip Rate			Unmitigated	Mitigated
	Weekday	Saturday	Sunday	Annual VMT	Annual VMT
General Light Industry	0.00	0.00	0.00		
Golf Course	13.09	13.09	13.09	21,130	21,130
Health Club	0.00	0.00	0.00		
Hotel	351.12	343.98	249.90	498,439	498,439
Parking Lot	0.00	0.00	0.00		
Recreational Swimming Pool	0.00	0.00	0.00		
Single Family Housing	103.84	104.94	94.05	229,505	229,505
<b>Total</b>	<b>468.05</b>	<b>462.01</b>	<b>357.04</b>	<b>749,074</b>	<b>749,074</b>

**4.3 Trip Type Information**

Land Use	Miles			Trip %			Trip Purpose %		
	H-W or C-W	H-S or C-C	H-O or C-NW	H-W or C-W	H-S or C-C	H-O or C-NW	Primary	Diverted	Pass-by
General Light Industry	12.50	4.20	5.40	59.00	28.00	13.00	92	5	3
Golf Course	12.50	4.20	5.40	33.00	48.00	19.00	52	39	9
Health Club	12.50	4.20	5.40	16.90	64.10	19.00	52	39	9
Hotel	12.50	4.20	5.40	19.40	61.60	19.00	58	38	4
Parking Lot	12.50	4.20	5.40	0.00	0.00	0.00	0	0	0

Desert Island SP - Amendment - Riverside-Salton Sea County, Winter

**EMFAC Off-Model Adjustment Factors for Gasoline Light Duty Vehicle to Account for the SAFE Vehicle Rule Applied**

Land Use	Miles			Trip %			Trip Purpose %		
	H-W or C-W	H-S or C-C	H-O or C-NW	H-W or C-W	H-S or C-C	H-O or C-NW	Primary	Diverted	Pass-by
Recreational Swimming Pool	12.50	4.20	5.40	33.00	48.00	19.00	52	39	9
Single Family Housing	11.00	3.50	4.50	40.20	19.20	40.60	86	11	3

**4.4 Fleet Mix**

Land Use	LDA	LDT1	LDT2	MDV	LHD1	LHD2	MHD	HHD	OBUS	UBUS	MCY	SBUS	MH
General Light Industry	0.540541	0.056458	0.173793	0.136090	0.025268	0.007074	0.011525	0.018705	0.000610	0.000304	0.023606	0.001094	0.004932
Golf Course	0.540541	0.056458	0.173793	0.136090	0.025268	0.007074	0.011525	0.018705	0.000610	0.000304	0.023606	0.001094	0.004932
Health Club	0.540541	0.056458	0.173793	0.136090	0.025268	0.007074	0.011525	0.018705	0.000610	0.000304	0.023606	0.001094	0.004932
Hotel	0.540541	0.056458	0.173793	0.136090	0.025268	0.007074	0.011525	0.018705	0.000610	0.000304	0.023606	0.001094	0.004932
Parking Lot	0.540541	0.056458	0.173793	0.136090	0.025268	0.007074	0.011525	0.018705	0.000610	0.000304	0.023606	0.001094	0.004932
Recreational Swimming Pool	0.540541	0.056458	0.173793	0.136090	0.025268	0.007074	0.011525	0.018705	0.000610	0.000304	0.023606	0.001094	0.004932
Single Family Housing	0.540541	0.056458	0.173793	0.136090	0.025268	0.007074	0.011525	0.018705	0.000610	0.000304	0.023606	0.001094	0.004932

**5.0 Energy Detail**

Historical Energy Use: N

**5.1 Mitigation Measures Energy**

Install High Efficiency Lighting

Desert Island SP - Amendment - Riverside-Salton Sea County, Winter

**EMFAC Off-Model Adjustment Factors for Gasoline Light Duty Vehicle to Account for the SAFE Vehicle Rule Applied**

	ROG	NOx	CO	SO2	Fugitive PM10	Exhaust PM10	PM10 Total	Fugitive PM2.5	Exhaust PM2.5	PM2.5 Total	Bio- CO2	NBio- CO2	Total CO2	CH4	N2O	CO2e
Category	lb/day										lb/day					
NaturalGas Mitigated	0.1300	1.1767	0.9559	7.0900e-003		0.0898	0.0898		0.0898	0.0898		1,418.0770	1,418.0770	0.0272	0.0260	1,426.5040
NaturalGas Unmitigated	0.1300	1.1767	0.9559	7.0900e-003		0.0898	0.0898		0.0898	0.0898		1,418.0770	1,418.0770	0.0272	0.0260	1,426.5040

Desert Island SP - Amendment - Riverside-Salton Sea County, Winter

**EMFAC Off-Model Adjustment Factors for Gasoline Light Duty Vehicle to Account for the SAFE Vehicle Rule Applied**

**5.2 Energy by Land Use - NaturalGas**

**Unmitigated**

	NaturalGas Use	ROG	NOx	CO	SO2	Fugitive PM10	Exhaust PM10	PM10 Total	Fugitive PM2.5	Exhaust PM2.5	PM2.5 Total	Bio- CO2	NBio- CO2	Total CO2	CH4	N2O	CO2e
Land Use	kBTU/yr	lb/day										lb/day					
General Light Industry	708.603	7.6400e-003	0.0695	0.0584	4.2000e-004		5.2800e-003	5.2800e-003		5.2800e-003	5.2800e-003		83.3650	83.3650	1.6000e-003	1.5300e-003	83.8604
Golf Course	0	0.0000	0.0000	0.0000	0.0000		0.0000	0.0000		0.0000	0.0000		0.0000	0.0000	0.0000	0.0000	0.0000
Health Club	558.025	6.0200e-003	0.0547	0.0460	3.3000e-004		4.1600e-003	4.1600e-003		4.1600e-003	4.1600e-003		65.6500	65.6500	1.2600e-003	1.2000e-003	66.0401
Hotel	9934.54	0.1071	0.9740	0.8181	5.8400e-003		0.0740	0.0740		0.0740	0.0740		1,168.7699	1,168.7699	0.0224	0.0214	1,175.7153
Parking Lot	0	0.0000	0.0000	0.0000	0.0000		0.0000	0.0000		0.0000	0.0000		0.0000	0.0000	0.0000	0.0000	0.0000
Recreational Swimming Pool	0	0.0000	0.0000	0.0000	0.0000		0.0000	0.0000		0.0000	0.0000		0.0000	0.0000	0.0000	0.0000	0.0000
Single Family Housing	852.483	9.1900e-003	0.0786	0.0334	5.0000e-004		6.3500e-003	6.3500e-003		6.3500e-003	6.3500e-003		100.2921	100.2921	1.9200e-003	1.8400e-003	100.8881
<b>Total</b>		<b>0.1300</b>	<b>1.1767</b>	<b>0.9559</b>	<b>7.0900e-003</b>		<b>0.0898</b>	<b>0.0898</b>		<b>0.0898</b>	<b>0.0898</b>		<b>1,418.0770</b>	<b>1,418.0770</b>	<b>0.0272</b>	<b>0.0260</b>	<b>1,426.5039</b>

Desert Island SP - Amendment - Riverside-Salton Sea County, Winter

**EMFAC Off-Model Adjustment Factors for Gasoline Light Duty Vehicle to Account for the SAFE Vehicle Rule Applied**

**5.2 Energy by Land Use - NaturalGas**

**Mitigated**

	NaturalGas Use	ROG	NOx	CO	SO2	Fugitive PM10	Exhaust PM10	PM10 Total	Fugitive PM2.5	Exhaust PM2.5	PM2.5 Total	Bio- CO2	NBio- CO2	Total CO2	CH4	N2O	CO2e
Land Use	kBTU/yr	lb/day										lb/day					
General Light Industry	0.708603	7.6400e-003	0.0695	0.0584	4.2000e-004		5.2800e-003	5.2800e-003		5.2800e-003	5.2800e-003		83.3650	83.3650	1.6000e-003	1.5300e-003	83.8604
Golf Course	0	0.0000	0.0000	0.0000	0.0000		0.0000	0.0000		0.0000	0.0000		0.0000	0.0000	0.0000	0.0000	0.0000
Health Club	0.558025	6.0200e-003	0.0547	0.0460	3.3000e-004		4.1600e-003	4.1600e-003		4.1600e-003	4.1600e-003		65.6500	65.6500	1.2600e-003	1.2000e-003	66.0401
Hotel	9.93454	0.1071	0.9740	0.8181	5.8400e-003		0.0740	0.0740		0.0740	0.0740		1,168.7699	1,168.7699	0.0224	0.0214	1,175.7153
Parking Lot	0	0.0000	0.0000	0.0000	0.0000		0.0000	0.0000		0.0000	0.0000		0.0000	0.0000	0.0000	0.0000	0.0000
Recreational Swimming Pool	0	0.0000	0.0000	0.0000	0.0000		0.0000	0.0000		0.0000	0.0000		0.0000	0.0000	0.0000	0.0000	0.0000
Single Family Housing	0.852483	9.1900e-003	0.0786	0.0334	5.0000e-004		6.3500e-003	6.3500e-003		6.3500e-003	6.3500e-003		100.2921	100.2921	1.9200e-003	1.8400e-003	100.8881
<b>Total</b>		<b>0.1300</b>	<b>1.1767</b>	<b>0.9559</b>	<b>7.0900e-003</b>		<b>0.0898</b>	<b>0.0898</b>		<b>0.0898</b>	<b>0.0898</b>		<b>1,418.0770</b>	<b>1,418.0770</b>	<b>0.0272</b>	<b>0.0260</b>	<b>1,426.5039</b>

**6.0 Area Detail**

**6.1 Mitigation Measures Area**

- Use Low VOC Paint - Residential Interior
- Use Low VOC Paint - Residential Exterior
- Use Low VOC Paint - Non-Residential Interior
- Use Low VOC Paint - Non-Residential Exterior
- No Hearths Installed



Desert Island SP - Amendment - Riverside-Salton Sea County, Winter

**EMFAC Off-Model Adjustment Factors for Gasoline Light Duty Vehicle to Account for the SAFE Vehicle Rule Applied**

Use Low VOC Cleaning Supplies

	ROG	NOx	CO	SO2	Fugitive PM10	Exhaust PM10	PM10 Total	Fugitive PM2.5	Exhaust PM2.5	PM2.5 Total	Bio- CO2	NBio- CO2	Total CO2	CH4	N2O	CO2e
Category	lb/day										lb/day					
Mitigated	2.0894	0.0107	0.9373	5.0000e-005		5.1400e-003	5.1400e-003		5.1400e-003	5.1400e-003	0.0000	1.6999	1.6999	1.7400e-003	0.0000	1.7433
Unmitigated	2.3491	0.1701	1.8214	3.6600e-003		0.1510	0.1510		0.1510	0.1510	19.7921	188.0529	207.8450	0.0978	3.4200e-003	211.3089

**6.2 Area by SubCategory**

Unmitigated

	ROG	NOx	CO	SO2	Fugitive PM10	Exhaust PM10	PM10 Total	Fugitive PM2.5	Exhaust PM2.5	PM2.5 Total	Bio- CO2	NBio- CO2	Total CO2	CH4	N2O	CO2e
SubCategory	lb/day										lb/day					
Architectural Coating	0.1365					0.0000	0.0000		0.0000	0.0000			0.0000			0.0000
Consumer Products	2.0750					0.0000	0.0000		0.0000	0.0000			0.0000			0.0000
Hearth	0.1076	0.1594	0.8841	3.6100e-003		0.1459	0.1459		0.1459	0.1459	19.7921	186.3529	206.1450	0.0961	3.4200e-003	209.5655
Landscaping	0.0300	0.0107	0.9373	5.0000e-005		5.1400e-003	5.1400e-003		5.1400e-003	5.1400e-003		1.6999	1.6999	1.7400e-003		1.7433
<b>Total</b>	<b>2.3491</b>	<b>0.1701</b>	<b>1.8214</b>	<b>3.6600e-003</b>		<b>0.1510</b>	<b>0.1510</b>		<b>0.1510</b>	<b>0.1510</b>	<b>19.7921</b>	<b>188.0529</b>	<b>207.8450</b>	<b>0.0978</b>	<b>3.4200e-003</b>	<b>211.3089</b>

Desert Island SP - Amendment - Riverside-Salton Sea County, Winter

**EMFAC Off-Model Adjustment Factors for Gasoline Light Duty Vehicle to Account for the SAFE Vehicle Rule Applied**

**6.2 Area by SubCategory**

Mitigated

	ROG	NOx	CO	SO2	Fugitive PM10	Exhaust PM10	PM10 Total	Fugitive PM2.5	Exhaust PM2.5	PM2.5 Total	Bio- CO2	NBio- CO2	Total CO2	CH4	N2O	CO2e
SubCategory	lb/day										lb/day					
Architectural Coating	0.1365					0.0000	0.0000		0.0000	0.0000			0.0000			0.0000
Consumer Products	1.9228					0.0000	0.0000		0.0000	0.0000			0.0000			0.0000
Hearth	0.0000	0.0000	0.0000	0.0000		0.0000	0.0000		0.0000	0.0000	0.0000	0.0000	0.0000	0.0000	0.0000	0.0000
Landscaping	0.0300	0.0107	0.9373	5.0000e-005		5.1400e-003	5.1400e-003		5.1400e-003	5.1400e-003		1.6999	1.6999	1.7400e-003		1.7433
<b>Total</b>	<b>2.0894</b>	<b>0.0107</b>	<b>0.9373</b>	<b>5.0000e-005</b>		<b>5.1400e-003</b>	<b>5.1400e-003</b>		<b>5.1400e-003</b>	<b>5.1400e-003</b>	<b>0.0000</b>	<b>1.6999</b>	<b>1.6999</b>	<b>1.7400e-003</b>	<b>0.0000</b>	<b>1.7433</b>

**7.0 Water Detail**

**7.1 Mitigation Measures Water**

- Install Low Flow Bathroom Faucet
- Install Low Flow Kitchen Faucet
- Install Low Flow Toilet
- Install Low Flow Shower
- Use Water Efficient Irrigation System

Desert Island SP - Amendment - Riverside-Salton Sea County, Winter

**EMFAC Off-Model Adjustment Factors for Gasoline Light Duty Vehicle to Account for the SAFE Vehicle Rule Applied**

**8.0 Waste Detail**

---

**8.1 Mitigation Measures Waste**

Institute Recycling and Composting Services

**9.0 Operational Offroad**

---

Equipment Type	Number	Hours/Day	Days/Year	Horse Power	Load Factor	Fuel Type
----------------	--------	-----------	-----------	-------------	-------------	-----------

**10.0 Stationary Equipment**

---

**Fire Pumps and Emergency Generators**

Equipment Type	Number	Hours/Day	Hours/Year	Horse Power	Load Factor	Fuel Type
----------------	--------	-----------	------------	-------------	-------------	-----------

**Boilers**

Equipment Type	Number	Heat Input/Day	Heat Input/Year	Boiler Rating	Fuel Type
----------------	--------	----------------	-----------------	---------------	-----------

**User Defined Equipment**

Equipment Type	Number
----------------	--------

**11.0 Vegetation**

---



## **DESERT ISLAND HOTEL APPENDIX**

### ***Appendix B***

*Noise and Vibration Impact Analysis, Urban Crossroads,  
Inc. May 2022.*



---

# **Desert Island Hotel**

## **NOISE AND VIBRATION IMPACT ANALYSIS**

### **CITY OF RANCHO MIRAGE**

PREPARED BY:

William Maddux  
bmaddux@urbanxroads.com  
(619) 778-1971

MAY 26, 2022



## TABLE OF CONTENTS

<b>TABLE OF CONTENTS</b> .....	<b>III</b>
<b>APPENDICES</b> .....	<b>IV</b>
<b>LIST OF EXHIBITS</b> .....	<b>IV</b>
<b>LIST OF TABLES</b> .....	<b>V</b>
<b>LIST OF ABBREVIATED TERMS</b> .....	<b>VI</b>
<b>EXECUTIVE SUMMARY</b> .....	<b>1</b>
<b>1 INTRODUCTION</b> .....	<b>3</b>
1.1 Site Location.....	3
1.2 Project Description.....	3
<b>2 FUNDAMENTALS</b> .....	<b>7</b>
2.1 Range of Noise .....	7
2.2 Noise Descriptors .....	8
2.3 Sound Propagation.....	8
2.4 Noise Control .....	9
2.5 Noise Barrier Attenuation .....	9
2.6 Land Use Compatibility With Noise .....	10
2.7 Community Response to Noise .....	10
2.8 Vibration .....	11
<b>3 REGULATORY SETTING</b> .....	<b>13</b>
3.1 State of California Noise Requirements.....	13
3.2 City of Rancho Mirage General Plan Noise Element.....	14
3.3 Operational Noise Standards .....	15
3.4 Construction Noise Standards.....	17
3.5 Vibration Standards .....	17
<b>4 SIGNIFICANCE CRITERIA</b> .....	<b>19</b>
4.1 Noise Level Increases (Threshold A) .....	19
4.2 Vibration (Threshold B).....	20
4.3 CEQA Guidelines Not Further Analyzed (Threshold C) .....	20
4.4 Significance Criteria Summary .....	20
<b>5 EXISTING NOISE LEVEL MEASUREMENTS</b> .....	<b>23</b>
5.1 Measurement Procedure and Criteria .....	23
5.2 Noise Measurement Locations .....	23
5.3 Noise Measurement Results .....	24
<b>6 TRAFFIC NOISE METHODS AND PROCEDURES</b> .....	<b>27</b>
6.1 FHWA Traffic Noise Prediction Model .....	27
<b>7 OFF-SITE TRAFFIC NOISE ANALYSIS</b> .....	<b>31</b>
7.1 Noise Contours.....	31
7.2 Existing Project Traffic Noise Level Increases .....	35
7.3 Existing Plus Ambient Growth Project Traffic Noise Level Increases.....	35
7.4 Existing Plus Ambient Growth Plus Cumulative Project Traffic Noise Level Increases.....	35
<b>8 RECEIVER LOCATIONS</b> .....	<b>39</b>
<b>9 OPERATIONAL NOISE IMPACTS</b> .....	<b>41</b>

9.1 Operational Noise Sources..... 41

9.2 Reference Noise Levels ..... 41

9.3 CadnaA Noise Prediction Model ..... 44

9.4 Project Operational Noise Levels ..... 45

9.6 Project Operational Noise Level Increases ..... 46

**10 CONSTRUCTION IMPACTS ..... 49**

10.1 Construction Noise Levels..... 49

10.2 Construction Reference Noise Levels ..... 49

10.3 Construction Noise Analysis..... 51

10.4 Construction Noise Level Compliance ..... 52

10.5 Construction Vibration Analysis..... 53

**11 REFERENCES..... 55**

**12 CERTIFICATION..... 57**

**APPENDICES**

- APPENDIX 3.1: CITY OF RANCHO MIRAGE MUNICIPAL CODE
- APPENDIX 5.1: STUDY AREA PHOTOS
- APPENDIX 5.2: NOISE LEVEL MEASUREMENT WORKSHEETS
- APPENDIX 7.1: OFF-SITE TRAFFIC NOISE LEVEL CALCULATIONS
- APPENDIX 9.1: CADNAA OPERATIONAL NOISE MODEL INPUTS
- APPENDIX 10.1: CADNAA CONSTRUCTION NOISE MODEL INPUTS

**LIST OF EXHIBITS**

EXHIBIT 1-A: LOCATION MAP ..... 4

EXHIBIT 1-B: SITE PLAN..... 5

EXHIBIT 2-A: TYPICAL NOISE LEVELS ..... 7

EXHIBIT 2-B: NOISE LEVEL INCREASE PERCEPTION ..... 10

EXHIBIT 2-C: TYPICAL LEVELS OF GROUND-BORNE VIBRATION ..... 12

EXHIBIT 3-A: NOISE LEVEL AND LAND USE COMPATIBILITY ..... 16

EXHIBIT 5-A: NOISE MEASUREMENT LOCATIONS..... 25

EXHIBIT 8-A: RECEIVER LOCATIONS ..... 40

EXHIBIT 9-A: STATIONARY SOURCE NOISE LOCATIONS ..... 42

EXHIBIT 10-A: TYPICAL CONSTRUCTION NOISE SOURCE LOCATIONS ..... 50



## LIST OF TABLES

TABLE ES-1: SUMMARY OF CEQA SIGNIFICANCE FINDINGS .....	1
TABLE 3-1: OPERATIONAL NOISE STANDARDS .....	15
TABLE 4-1: SIGNIFICANCE CRITERIA SUMMARY .....	21
TABLE 5-1: AMBIENT NOISE LEVEL MEASUREMENTS .....	24
TABLE 6-1: OFF-SITE ROADWAY PARAMETERS.....	27
TABLE 6-2: AVERAGE DAILY TRAFFIC VOLUMES .....	28
TABLE 6-3: TIME OF DAY VEHICLE SPLITS .....	29
TABLE 6-4: TRAFFIC FLOW BY VEHICLE TYPE (VEHICLE MIX) .....	29
TABLE 7-1: EXISTING WITHOUT PROJECT CONTOURS .....	32
TABLE 7-2: EXISTING WITH PROJECT CONTOURS .....	32
TABLE 7-3: EA WITHOUT PROJECT CONTOURS.....	33
TABLE 7-4: EA WITH PROJECT CONTOURS .....	33
TABLE 7-5: EAC WITHOUR PROJECT CONTOURS .....	34
TABLE 7-6: EAC WITH PROJECT CONTOURS .....	34
TABLE 7-7: EXISTING WITH PROJECT TRAFFIC NOISE LEVEL INCREASES .....	36
TABLE 7-8: E+A WITH PROJECT TRAFFIC NOISE LEVEL INCREASES .....	36
TABLE 7-9: E+A+C WITH PROJECT TRAFFIC NOISE LEVEL INCREASES.....	37
TABLE 9-1: REFERENCE NOISE LEVEL MEASUREMENTS .....	43
TABLE 9-2: PROJECT OPERATIONAL NOISE LEVELS.....	45
TABLE 9-3: DAYTIME PROJECT STATIONARY SOURCE NOISE LEVEL INCREASES .....	47
TABLE 9-4: EVENING PROJECT STATIONARY SOURCE NOISE LEVEL INCREASES .....	47
TABLE 9-5: NIGHTTIME PROJECT STATIONARY SOURCE NOISE LEVEL INCREASES .....	48
TABLE 10-1: CONSTRUCTION REFERENCE NOISE LEVELS .....	51
TABLE 10-2: CONSTRUCTION EQUIPMENT NOISE LEVEL SUMMARY.....	52
TABLE 10-3: CONSTRUCTION NOISE LEVEL COMPLIANCE .....	52
TABLE 10-4: VIBRATION SOURCE LEVELS FOR CONSTRUCTION EQUIPMENT .....	53
TABLE 10-5: PROJECT CONSTRUCTION VIBRATION LEVELS.....	54

## **LIST OF ABBREVIATED TERMS**

(1)	Reference
ANSI	American National Standards Institute
Calveno	California Vehicle Noise
CEQA	California Environmental Quality Act
CNEL	Community Noise Equivalent Level
dBA	A-weighted decibels
EPA	Environmental Protection Agency
FHWA	Federal Highway Administration
FTA	Federal Transit Administration
INCE	Institute of Noise Control Engineering
$L_{eq}$	Equivalent continuous (average) sound level
$L_{max}$	Maximum level measured over the time interval
mph	Miles per hour
PPV	Peak Particle Velocity
Project	Desert Island Hotel
REMEL	Reference Energy Mean Emission Level
RMS	Root-mean-square
VdB	Vibration Decibels

## EXECUTIVE SUMMARY

Urban Crossroads, Inc. has prepared this noise study to determine the noise exposure and the necessary noise mitigation measures for the proposed Desert Island Hotel development (“Project”). The Project site is located south of Frank Sinatra Drive and adjacent to Island Drive in the City of Rancho Mirage. The Project proposes to develop a 42-key boutique hotel (with tennis, pool, and yoga amenities), 11 private residences, and a golf training facility. This noise study has been prepared to satisfy applicable City of Rancho Mirage noise standards and significance criteria based on Appendix G of the California Environmental Quality Act (CEQA) Guidelines (1).

The results of this Noise and Vibration Impact Analysis are summarized below based on the significance criteria in Section 4 of this report consistent with Appendix G of the California Environmental Quality Act (CEQA) Guidelines. (1) Table ES-1 shows the findings of significance for each potential noise and/or vibration impact under CEQA before and after any required mitigation measures.

**TABLE ES-1: SUMMARY OF CEQA SIGNIFICANCE FINDINGS**

Analysis	Report Section	Significance Findings	
		Unmitigated	Mitigated
Off-Site Traffic Noise	7	<i>Less Than Significant</i>	-
Operational Noise	9	<i>Less Than Significant</i>	-
Construction Noise	10	<i>Less Than Significant</i>	-
Construction Vibration		<i>Less Than Significant</i>	-

*This page intentionally left blank*

# 1 INTRODUCTION

This noise analysis has been completed to determine the noise impacts associated with the development of the proposed Desert Island Hotel (“Project”). This noise study briefly describes the proposed Project, provides information regarding noise fundamentals, sets out the regulatory setting, presents the study methods and procedures for noise analysis, evaluates the future off-site noise impacts, evaluates long-term stationary-source noise, and evaluated short-term construction noise and vibration impacts.

## 1.1 SITE LOCATION

The proposed Project is located south of Frank Sinatra Drive and adjacent to Island Drive in the City of Rancho Mirage, as shown on Exhibit 1-A.

## 1.2 PROJECT DESCRIPTION

The Project is proposed to repurpose approximately 13.3 acres of the existing golf driving range and a portion of the existing golf course with new facilities to accommodate a 42-key boutique hotel (with tennis, pool, and yoga amenities), 11 private residences, and a golf training facility.

The existing driving range will be removed to make room for the new facilities. The existing golf maintenance structure will be replaced by a new building along with an expanded parking lot east of the main entry. The existing clubhouse will remain and continue to provide services to golfers, Desert Island residents, and the general public, with occasional events for up to 300 persons. It is anticipated that events with more than 300 persons in the existing clubhouse building would require a Temporary Use Permit, accompanied by a parking and traffic management plan if necessary. The existing golf course will continue to operate as an 18-hole facility with minor routing adjustments to 9th and 18th Fairways to accommodate the hotel.

Amenities which are complementary to the new hotel include a hotel pool, a small pool café, a tennis court for hotel guests, and a shaded yoga platform located on the island south of the lake accessed by foot from the existing bridge.

The new private duplex-style condominium residences (11 units) will be managed and maintained by the hotel operator. When not in use by individual owners, these units will be made available for rental by the hotel operator.

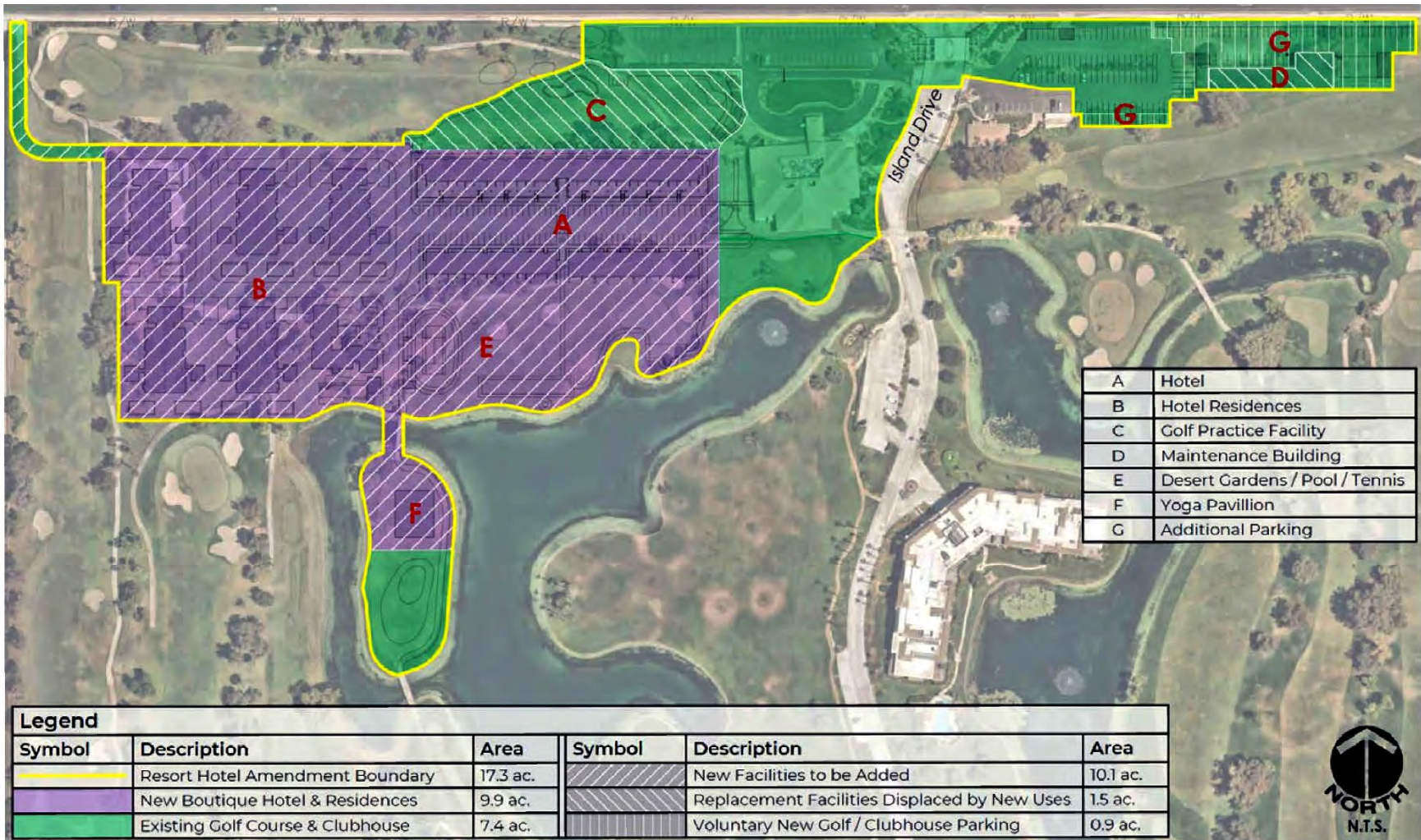
The new golf training park will replace the current driving range. It will consist of an 18-hole tournament putting green, short game training areas, and virtual golf simulator stations. In order to evaluate the potential increase in practice golf park activity which maybe higher than the existing driving range, the employment associated with golf practice activity is estimated to increase by 10 employees.

EXHIBIT 1-A: LOCATION MAP





EXHIBIT 1-B: SITE PLAN



*This page intentionally left blank*



## 2 FUNDAMENTALS

Noise is simply defined as "unwanted sound." Sound becomes unwanted when it interferes with normal activities, when it causes actual physical harm or when it has adverse effects on health. Noise is measured on a logarithmic scale of sound pressure level known as a decibel (dB). A-weighted decibels (dBA) approximate the subjective response of the human ear to broad frequency noise source by discriminating against very low and very high frequencies of the audible spectrum. They are adjusted to reflect only those frequencies which are audible to the human ear. Exhibit 2-A presents a summary of the typical noise levels and their subjective loudness and effects that are described in more detail below.

**EXHIBIT 2-A: TYPICAL NOISE LEVELS**

<b>COMMON OUTDOOR ACTIVITIES</b>	<b>COMMON INDOOR ACTIVITIES</b>	<b>A - WEIGHTED SOUND LEVEL dBA</b>	<b>SUBJECTIVE LOUDNESS</b>	<b>EFFECTS OF NOISE</b>
THRESHOLD OF PAIN		140	<b>INTOLERABLE OR DEAFENING</b>	<b>HEARING LOSS</b>
NEAR JET ENGINE		130		
		120		
JET FLY-OVER AT 300m (1000 ft)	ROCK BAND	110		
LOUD AUTO HORN		100	<b>VERY NOISY</b>	<b>SPEECH INTERFERENCE</b>
GAS LAWN MOWER AT 1m (3 ft)		90		
DIESEL TRUCK AT 15m (50 ft), at 80 km/hr (50 mph)	FOOD BLENDER AT 1m (3 ft)	80	<b>LOUD</b>	
NOISY URBAN AREA, DAYTIME	VACUUM CLEANER AT 3m (10 ft)	70		
HEAVY TRAFFIC AT 90m (300 ft)	NORMAL SPEECH AT 1m (3 ft)	60	<b>MODERATE</b>	<b>SLEEP DISTURBANCE</b>
QUIET URBAN DAYTIME	LARGE BUSINESS OFFICE	50		
QUIET URBAN NIGHTTIME	THEATER, LARGE CONFERENCE ROOM (BACKGROUND)	40	<b>FAINT</b>	<b>NO EFFECT</b>
QUIET SUBURBAN NIGHTTIME	LIBRARY	30		
QUIET RURAL NIGHTTIME	BEDROOM AT NIGHT, CONCERT HALL (BACKGROUND)	20		
	BROADCAST/RECORDING STUDIO	10		
LOWEST THRESHOLD OF HUMAN HEARING	LOWEST THRESHOLD OF HUMAN HEARING	0	<b>VERY FAINT</b>	

Source: Environmental Protection Agency Office of Noise Abatement and Control, Information on Levels of Environmental Noise Requisite to Protect Public Health and Welfare with an Adequate Margin of Safety (EPA/ONAC 550/9-74-004) March 1974.

### 2.1 RANGE OF NOISE

Since the range of intensities that the human ear can detect is so large, the scale frequently used to measure intensity is a scale based on multiples of 10, the logarithmic scale. The scale for measuring intensity is the decibel scale. Each interval of 10 decibels indicates a sound energy ten times greater than before, which is perceived by the human ear as being roughly twice as loud. (2) The most common sounds vary between 40 dBA (very quiet) to 100 dBA (very loud). Normal conversation at three feet is roughly at 60 dBA, while loud jet engine noises equate to 110 dBA

at approximately 1,000 feet, which can cause serious discomfort. (3) Another important aspect of noise is the duration of the sound and the way it is described and distributed in time.

## 2.2 NOISE DESCRIPTORS

Environmental noise descriptors are generally based on averages, rather than instantaneous, noise levels. The most used metric is the equivalent level ( $L_{eq}$ ). Equivalent sound levels are not measured directly but are calculated from sound pressure levels typically measured in A-weighted decibels (dBA). The equivalent sound level ( $L_{eq}$ ) represents a steady state sound level containing the same total energy as a time varying signal over a given sample period and is commonly used to describe the “average” noise levels within the environment.

Peak hour or average noise levels, while useful, do not completely describe a given noise environment. Noise levels lower than peak hour may be disturbing if they occur during times when quiet is most desirable, namely evening and nighttime (sleeping) hours. To account for this, the Community Noise Equivalent Level (CNEL), representing a composite 24-hour noise level is utilized. The CNEL is the weighted average of the intensity of a sound, with corrections for time of day, and averaged over 24 hours. The time-of-day corrections require the addition of 5 decibels to dBA  $L_{eq}$  sound levels in the evening from 7:00 p.m. to 10:00 p.m., and the addition of 10 decibels to dBA  $L_{eq}$  sound levels at night between 10:00 p.m. and 7:00 a.m. These additions are made to account for the noise sensitive time periods during the evening and night hours when noise can become more intrusive. CNEL does not represent the actual sound level heard at any time, but rather represents the total sound exposure. The City of Rancho Mirage relies on the 24-hour CNEL level to assess land use compatibility with transportation related noise sources.

## 2.3 SOUND PROPAGATION

When sound propagates over a distance, it changes in level and frequency content. The way noise reduces with distance depends on the following factors.

### 2.3.1 GEOMETRIC SPREADING

Sound from a localized source (i.e., a stationary point source) propagates uniformly outward in a spherical pattern. The sound level attenuates (or decreases) at a rate of 6 dB for each doubling of distance from a point source. Highways consist of several localized noise sources on a defined path and hence can be treated as a line source, which approximates the effect of several point sources. Noise from a line source propagates outward in a cylindrical pattern, often referred to as cylindrical spreading. Sound levels attenuate at a rate of 3 dB for each doubling of distance from a line source. (2)

### 2.3.2 GROUND ABSORPTION

The propagation path of noise from a highway to a receiver is usually very close to the ground. Noise attenuation from ground absorption and reflective wave canceling adds to the attenuation associated with geometric spreading. Traditionally, the excess attenuation has also been expressed in terms of attenuation per doubling of distance. This approximation is usually

sufficiently accurate for distances of less than 200 ft. For acoustically hard sites (i.e., sites with a reflective surface between the source and the receiver, such as a parking lot or body of water), no excess ground attenuation is assumed. For acoustically absorptive or soft sites (i.e., those sites with an absorptive ground surface between the source and the receiver such as soft dirt, grass, or scattered bushes and trees), an excess ground attenuation value of 1.5 dB per doubling of distance is normally assumed. When added to the cylindrical spreading, the excess ground attenuation results in an overall drop-off rate of 4.5 dB per doubling of distance from a line source. (4)

### **2.3.3 ATMOSPHERIC EFFECTS**

Receivers located downwind from a source can be exposed to increased noise levels relative to calm conditions, whereas locations upwind can have lowered noise levels. Sound levels can be increased at large distances (e.g., more than 500 feet) due to atmospheric temperature inversion (i.e., increasing temperature with elevation). Other factors such as air temperature, humidity, and turbulence can also have significant effects. (2)

### **2.3.4 SHIELDING**

A large object or barrier in the path between a noise source and a receiver can substantially attenuate noise levels at the receiver. The amount of attenuation provided by shielding depends on the size of the object and the frequency content of the noise source. Shielding by trees and other such vegetation typically only has an “out of sight, out of mind” effect. That is, the perception of noise impact tends to decrease when vegetation blocks the line-of-sight to nearby residents. However, for vegetation to provide a substantial, or even noticeable, noise reduction, the vegetation area must be at least 15 feet in height, 100 feet wide and dense enough to completely obstruct the line-of-sight between the source and the receiver. This size of vegetation may provide up to 5 dBA of noise reduction. The Federal Highway Administration (FHWA) does not consider the planting of vegetation to be a noise abatement measure. (5)

## **2.4 NOISE CONTROL**

Noise control is the process of obtaining an acceptable noise environment for an observation point or receiver by controlling the noise source, transmission path, receiver, or all three. This concept is known as the source-path-receiver concept. In general, noise control measures can be applied to these three elements.

## **2.5 NOISE BARRIER ATTENUATION**

Effective noise barriers can reduce noise levels by 10 to 15 dBA, cutting the loudness of traffic noise in half. A noise barrier is most effective when placed close to the noise source or receiver. Noise barriers, however, do have limitations. For a noise barrier to work, it must block the line-of-sight path of sound from the noise source.

## 2.6 LAND USE COMPATIBILITY WITH NOISE

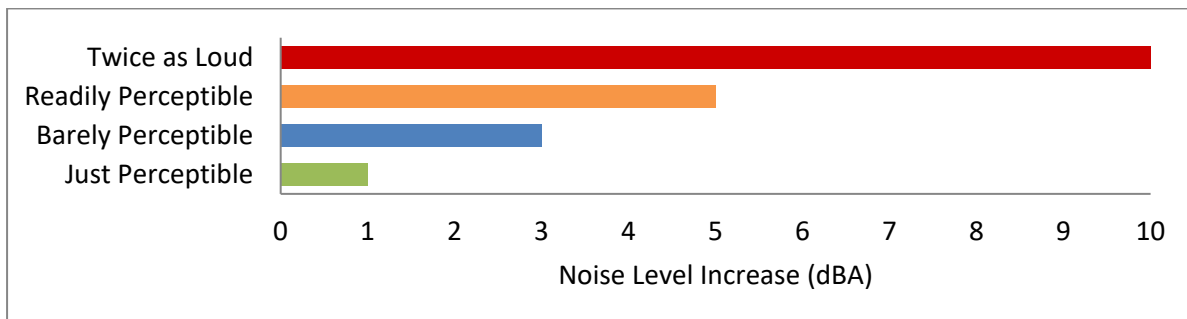
Some land uses are more tolerant of noise than others. For example, schools, hospitals, churches, and residences are more sensitive to noise intrusion than are commercial or industrial developments and related activities. As ambient noise levels affect the perceived amenity or livability of a development, so too can the mismanagement of noise impacts impair the economic health and growth potential of a community by reducing the area's desirability as a place to live, shop and work. For this reason, land use compatibility with the noise environment is an important consideration in the planning and design process. The FHWA encourages State and Local government to regulate land development in such a way that noise-sensitive land uses are either prohibited from being located adjacent to a highway, or that the developments are planned, designed, and constructed in such a way that noise impacts are minimized. (6)

## 2.7 COMMUNITY RESPONSE TO NOISE

Approximately sixteen percent of the population has a very low tolerance for noise and will object to any noise not of their making. Consequently, even in the quietest environment, some complaints may occur. Twenty to thirty percent of the population will not complain even in very severe noise environments. (7 pp. 8-6) Thus, a variety of reactions can be expected from people exposed to any given noise environment.

Surveys have shown that community response to noise varies from no reaction to vigorous action for newly introduced noises averaging from 10 dB below existing to 25 dB above existing. (8) According to research originally published in the Noise Effects Handbook (7), the percentage of high annoyance ranges from approximately 0 percent at 45 dB or less, 10 percent are highly annoyed around 60 dB, and increases rapidly to approximately 70 percent being highly annoyed at approximately 85 dB or greater. Despite this variability in behavior on an individual level, the population can be expected to exhibit the following responses to changes in noise levels as shown on Exhibit 2-B. A change of 3 dBA is considered barely perceptible, and changes of 5 dBA are considered readily perceptible. (4)

**EXHIBIT 2-B: NOISE LEVEL INCREASE PERCEPTION**



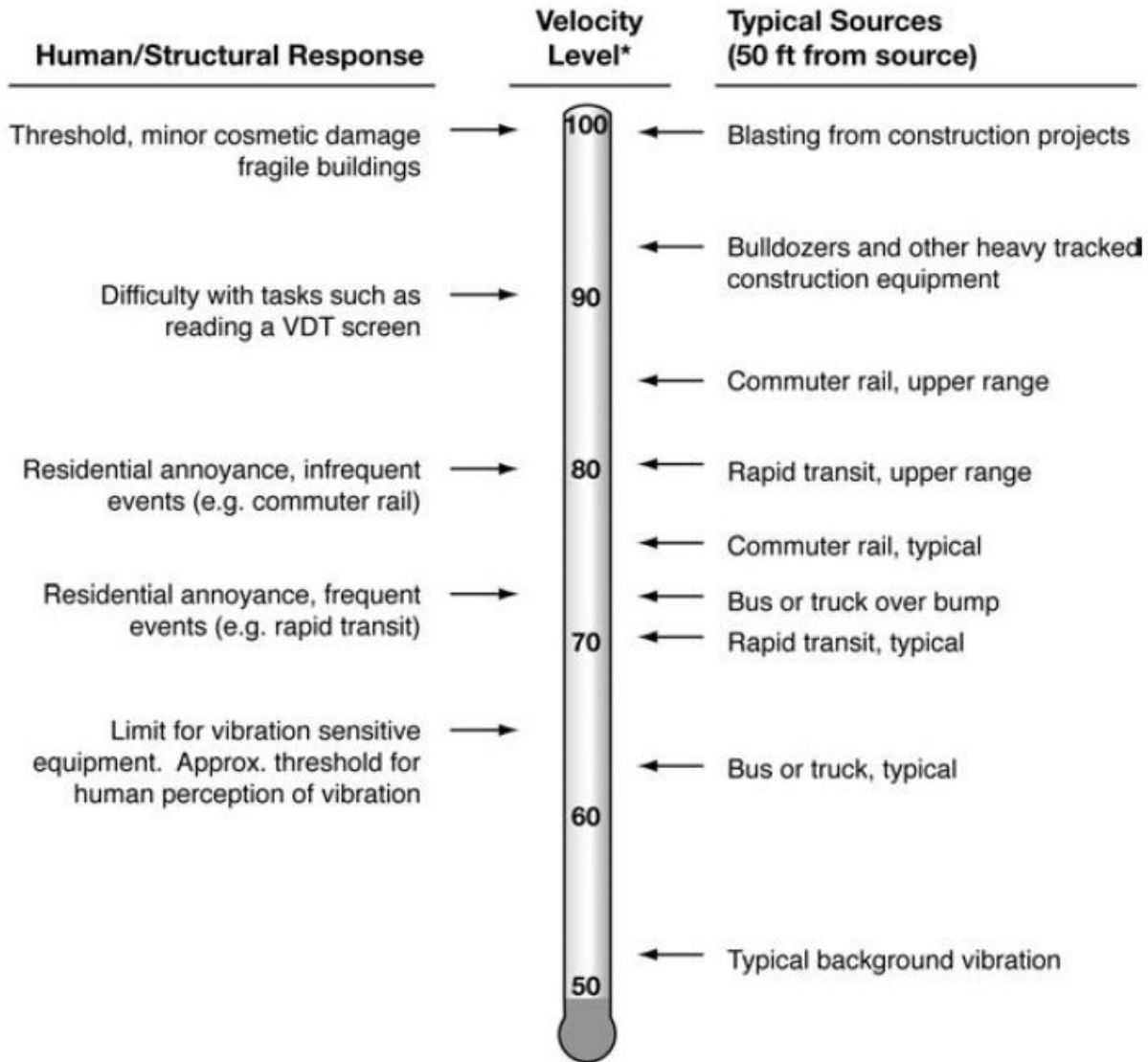
## 2.8 VIBRATION

Per the Federal Transit Administration (FTA) *Transit Noise Impact and Vibration Impact Assessment Manual* (8), vibration is the periodic oscillation of a medium or object. The rumbling sound caused by the vibration of room surfaces is called structure-borne noise. Sources of ground-borne vibrations include natural phenomena (e.g., earthquakes, volcanic eruptions, sea waves, landslides) or human-made causes (e.g., explosions, machinery, traffic, trains, construction equipment). Vibration sources may be continuous, such as factory machinery, or transient, such as explosions. As is the case with airborne sound, ground-borne vibrations may be described by amplitude and frequency.

There are several different methods that are used to quantify vibration. The peak particle velocity (PPV) is defined as the maximum instantaneous peak of the vibration signal. The PPV is most frequently used to describe vibration impacts to buildings but is not always suitable for evaluating human response (annoyance) because it takes some time for the human body to respond to vibration signals. Instead, the human body responds to average vibration amplitude often described as the root mean square (RMS). The RMS amplitude is defined as the average of the squared amplitude of the signal and is most frequently used to describe the effect of vibration on the human body. Decibel notation (VdB) is commonly used to measure RMS. Decibel notation (VdB) serves to reduce the range of numbers used to describe human response to vibration. Typically, ground-borne vibration generated by man-made activities attenuates rapidly with distance from the source of the vibration. Sensitive receivers for vibration include structures (especially older masonry structures), people (especially residents, the elderly, and sick), and vibration-sensitive equipment and/or activities.

The background vibration-velocity level in residential areas is generally 50 VdB. Ground-borne vibration is normally perceptible to humans at approximately 65 VdB. For most people, a vibration-velocity level of 75 VdB is the approximate dividing line between barely perceptible and distinctly perceptible levels. Typical outdoor sources of perceptible ground-borne vibration are construction equipment, steel-wheeled trains, and traffic on rough roads. If a roadway is smooth, the ground-borne vibration is rarely perceptible. The range of interest is from approximately 50 VdB, which is the typical background vibration-velocity level, to 100 VdB, which is the general threshold where minor damage can occur in fragile buildings. Exhibit 2-C illustrates common vibration sources and the human and structural response to ground-borne vibration.

**EXHIBIT 2-C: TYPICAL LEVELS OF GROUND-BORNE VIBRATION**



\* RMS Vibration Velocity Level in VdB relative to 10<sup>-6</sup> inches/second

Source: Federal Transit Administration (FTA) Transit Noise and Vibration Impact Assessment Manual.

### 3 REGULATORY SETTING

To limit population exposure to physically and/or psychologically damaging as well as intrusive noise levels, the federal government, the State of California, various county governments, and most municipalities in the state have established standards and ordinances to control noise. In most areas, automobile and truck traffic is the major source of environmental noise. Traffic activity generally produces an average sound level that remains constant with time. Air and rail traffic, and commercial and industrial activities are also major sources of noise in some areas. Federal, state, and local agencies regulate different aspects of environmental noise. Federal and state agencies generally set noise standards for mobile sources such as aircraft and motor vehicles, while regulation of stationary sources is left to local agencies.

#### 3.1 STATE OF CALIFORNIA NOISE REQUIREMENTS

The State of California regulates freeway noise, sets standards for sound transmission, provides occupational noise control criteria, identifies noise standards, and provides guidance for local land use compatibility. State law requires that each county and city adopt a General Plan that includes a Noise Element which is to be prepared per guidelines adopted by the Governor's Office of Planning and Research (OPR). (9) The purpose of the Noise Element is to *limit the exposure of the community to excessive noise levels*. In addition, the California Environmental Quality Act (CEQA) requires that all known environmental effects of a project be analyzed, including environmental noise impacts.

##### 3.1.1 RESIDENTIAL CONSTRUCTION

The State of California's noise insulation standards for all residential units are codified in the California Code of Regulations (CCR), Title 24, Building Standards Administrative Code, Section 1206 to 1207.11.2. These noise standards are applied to new construction that contains dwelling units or sleeping units, such as residential and hotel or motel uses, in California for controlling interior noise levels resulting from exterior noise sources. For new buildings, the acceptable interior noise limit is 45 dBA CNEL in habitable rooms (10).

##### 3.1.2 NON-RESIDENTIAL CONSTRUCTION

The State of California's Green Building Standards Code contains mandatory measures for non-residential building construction in Section 5.507 on Environmental Comfort (11). These noise standards are applied to new construction in California for controlling interior noise levels resulting from exterior noise sources. The regulations specify that acoustical studies must be prepared when non-residential structures are developed in areas where the exterior noise levels exceed 65 dBA CNEL, such as within a noise contour of an airport, freeway, railroad, and other noise source. If the development falls within an airport or freeway 65 dBA CNEL noise contour, buildings shall be constructed to provide an interior noise level environment attributable to exterior sources that does not exceed an hourly equivalent level of 50 dBA  $L_{eq}$  in occupied areas during any hour of operation.

### 3.2 CITY OF RANCHO MIRAGE GENERAL PLAN NOISE ELEMENT

The City of Rancho Mirage has adopted a Noise Element of the General Plan (2017) to control and abate environmental noise, and to protect the citizens of and visitors to the City of Rancho Mirage from excessive exposure to noise. The Noise Element is intended to help align the community's various land uses with the existing and future noise environment and thus ensure that any negative effects of noise are minimized or completely avoided.

The noise criteria identified in the City of Rancho Mirage Noise Element are guidelines to evaluate the land use compatibility of transportation related noise. To assist the City in the planning compatible uses, a range of exterior noise thresholds for various land uses have been developed. Particularly sensitive land uses include residences, schools, libraries, churches, hospitals and nursing homes, and destination resort areas. In addition, parks, golf courses, and other outdoor activity areas can be sensitive to noise disturbances. Less sensitive land uses include commercial uses, conventional hotels and motels, and playgrounds. Least sensitive to noise are heavy commercial uses, transportation, communication, and utility land uses.

To protect noise sensitive land uses, and minimize the effects of excessive and nuisance noise, the City of Rancho Mirage General Plan Noise Element has outlined the following noise policies with the goal (Goal N 1) of a noise environment providing peace and quiet that complements and is consistent with Rancho Mirage's resort residential character:

- Policy N 1.1: Land use patterns, associated traffic and its distribution, and individual developments shall be assessed for their potential to generate adverse and incompatible noise impacts. Noise exceeding normally acceptable levels shall be appropriately mitigated.
- Policy N 1.2 Noise sensitive land uses, including residences, resorts, community open space, schools, libraries, churches, hospitals, and convalescent homes, shall be protected from high noise levels emitted by both existing and future noise sources.
- Policy N 1.3 Project designs shall be required to include measures that assure that interior noise levels for residential development do not exceed 45 dBA CNEL.
- Policy N 1.4 Land uses allowed adjacent to Rancho Mirage's major arterial roads and highways, or the Southern Pacific Railroad/I-10 corridor, should generally be limited to those that are compatible with higher noise levels to maximize noise-related land use compatibility.
- Policy N 1.5 Develop and maintain a circulation plan that is consistent with the resort residential character of Rancho Mirage, avoids impacts to existing and planned sensitive receptors/uses, and provides fixed routes for existing and future truck traffic.

The Noise Level and Land Use Compatibility matrix in the Noise Element shown on Exhibit 3-A provides guidelines to evaluate the acceptability of the transportation related noise level impacts. Single-family residential land uses are considered *normally acceptable* with exterior noise levels below 60 dBA CNEL and *conditionally acceptable* with noise levels below 70 dBA CNEL. Multi-family residential land uses are considered *normally acceptable* with exterior noise levels below 65 dBA CNEL and *conditionally acceptable* with noise levels below 70 dBA CNEL. For



conditionally acceptable land use, new construction or development undertaken only after a detailed analysis of the noise reduction requirements is made and necessary noise insulation features are included in the design. Conventional construction, but with closed windows and fresh air supply system or air conditioning will normally suffice. Outdoor environment will seem noisy.

### 3.3 OPERATIONAL NOISE STANDARDS

To analyze noise impacts originating from a designated fixed location or private property such as the Desert Island Hotel Project, stationary-source (operational) noise such as the expected outdoor recreational and training activities, trash enclosure activities, roof-top air conditioning units, ground mounted air conditioning units, packaged terminal air conditioning units, swimming pools, and parking lot activities are typically evaluated against standards established under a jurisdiction's Municipal Code. The City of Rancho Mirage Municipal Code noise standards are provided in Appendix 3.1. The City of Rancho Mirage Municipal Code (RMMC), Chapter 8.45 establishes the noise level standards for stationary noise sources. The Project's land use will potentially impact nearby noise-sensitive uses in the Project study area. For nearby noise-sensitive residential land uses in the Project study area, Section 8.45.030 identifies the base exterior noise level standard of 55 dBA  $L_{eq}$  during the daytime hours (7:00 a.m. to 6:00 p.m.), 50 dBA  $L_{eq}$  during the evening hours (6:00 p.m. to 10:00 p.m.) and 45 dBA  $L_{eq}$  during the nighttime hours (10:00 p.m. to 7:00 a.m.). (12) Table 3-1 provides a summary of the City of Rancho Mirage operational exterior noise level standards for all land use types.

**TABLE 3-1: OPERATIONAL NOISE STANDARDS**

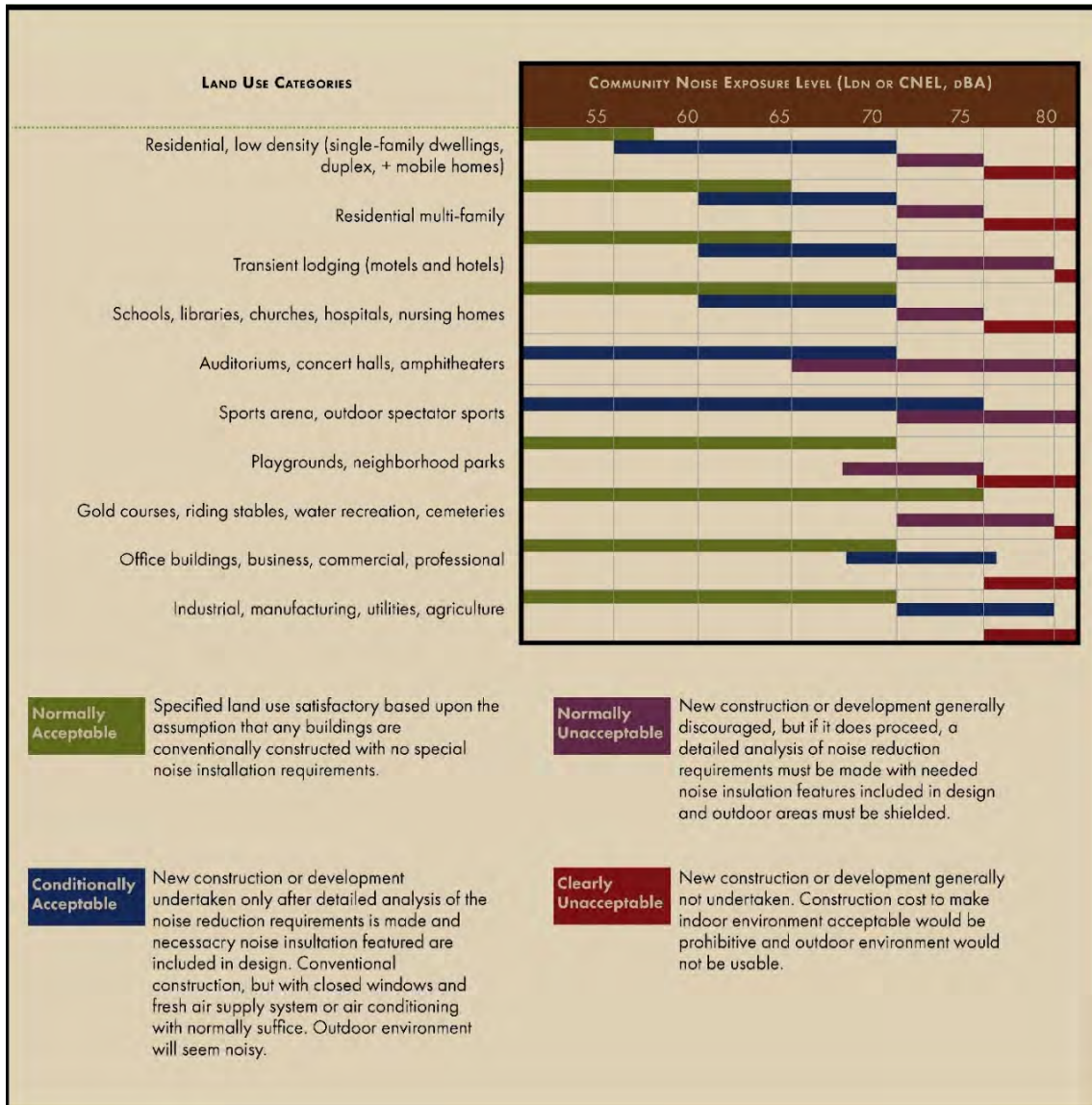
Land Use <sup>1</sup>	Zone <sup>2</sup>	Time Period	Exterior Noise Level Standards (dBA $L_{eq}$ ) <sup>3</sup>
Residential (Low Density)	R-E, H-R, R-L-2, R-L-3	Daytime (7:00 a.m. to 6:00 p.m.)	55
		Evening (6:00 p.m. to 10:00 p.m.)	50
		Nighttime (10:00 p.m. to 7:00 a.m.)	45
Residential (Medium and High Density, Hospital, Open Space)	OS, R-M, R-H, MHP	Daytime (7:00 a.m. to 6:00 p.m.)	60
		Evening (6:00 p.m. to 10:00 p.m.)	55
		Nighttime (10:00 p.m. to 7:00 a.m.)	50
Commercial Office, Resort Commercial, Mixed Use, Institutional	O, P, Rs-H, M-U	Daytime (7:00 a.m. to 6:00 p.m.)	65
		Evening (6:00 p.m. to 10:00 p.m.)	60
		Nighttime (10:00 p.m. to 7:00 a.m.)	55
Commercial Neighborhood, General Commercial, Commercial Recreation, Light Industrial	C-N, C-G, I-L	Daytime (7:00 a.m. to 6:00 p.m.)	70
		Evening (6:00 p.m. to 10:00 p.m.)	65
		Nighttime (10:00 p.m. to 7:00 a.m.)	60

<sup>1</sup> City of Rancho Mirage Municipal Code, Section 8.45.030 Exterior noise level limits (Appendix 3.1).

<sup>2</sup> City of Rancho Mirage Land Use and Zoning Map

<sup>3</sup>  $L_{eq}$  represents a steady state sound level containing the same total energy as a time varying signal over a given sample period.

**EXHIBIT 3-A: NOISE LEVEL AND LAND USE COMPATIBILITY**



Source: City of Rancho Mirage General Plan Noise Element (2017) Exhibit 20

### 3.4 CONSTRUCTION NOISE STANDARDS

To analyze noise impacts originating from the construction of Desert Island Hotel, noise from construction activities is typically evaluated against standards established under a City's Municipal Code. To control noise impacts associated with the construction of the proposed Project, the City has established limits to the hours of operation. The RMMC Section 15.04.030[A][11] indicates that construction, shall be limited to the hours of 7:00 a.m. and 7:00 p.m. with no activity on Sundays and holidays (13). The City recognizes that construction noise is difficult to control and restricts allowable hours for this intrusion. Still, construction, even when restricted to within these hours, presents a nuisance value when conducted in proximity to sensitive receptors (14). However, neither the City of Rancho Mirage General Plan nor Municipal Code establish numeric maximum acceptable construction source noise levels at potentially affected receivers. Therefore, a numerical construction threshold based on Federal Transit Administration (FTA) *Transit Noise and Vibration Impact Assessment Manual* is used for analysis of daytime construction impacts, as discussed below.

According to the FTA, local noise ordinances are typically not very useful in evaluating construction noise. They usually relate to nuisance and hours of allowed activity, and sometimes specify limits in terms of maximum levels, but are generally not practical for assessing the impact of a construction project. Project construction noise criteria should account for the existing noise environment, the absolute noise levels during construction activities, the duration of the construction, and the adjacent land use. Due to the lack of standardized construction noise thresholds, the FTA provides guidelines that can be considered reasonable criteria for construction noise assessment. The FTA considers a daytime exterior construction noise level of 80 dBA  $L_{eq}$  as a reasonable threshold for noise sensitive residential land use (8 p. 179).

### 3.5 VIBRATION STANDARDS

Construction activity can result in varying degrees of ground-borne vibration, depending on the equipment and methods used, distance to the affected structures and soil type. Construction vibration is generally associated with pile driving and rock blasting. Other construction equipment such as air compressors, light trucks, hydraulic loaders, etc., generates little or no ground vibration (8).

To analyze vibration impacts associated with the Desert Island Hotel, vibration-generating activities are appropriately evaluated against standards established under a City's Municipal Code if such standards exist. While Section 17.18.080 of the RMMC requires that *no vibration associated with any use shall be allowed which is discernable beyond the boundary line of the subject property*, the City of Rancho Mirage does not identify specific construction vibration level limits. Therefore, for analysis purposes, the Caltrans *Transportation and Construction Vibration Guidance Manual*, (15 p. 38) Table 19, vibration damage are used in this noise study to assess potential temporary construction-related impacts at adjacent building locations. The nearest noise sensitive buildings adjacent to the Project site can best be described as "older residential structures" with a maximum acceptable continuous vibration threshold of 0.3 PPV (in/sec).

*This page intentionally left blank*

## 4 SIGNIFICANCE CRITERIA

The following significance criteria are based on currently adopted guidance provided by Appendix G of the California Environmental Quality Act (CEQA) Guidelines (1). For the purposes of this report, impacts would be potentially significant if the Project results in or causes:

- A. Generation of a substantial temporary or permanent increase in ambient noise levels in the vicinity of the project in excess of standards established in the local general plan or noise ordinance, or applicable standards of other agencies?
- B. Generation of excessive ground-borne vibration or ground-borne noise levels?
- C. For a project located within the vicinity of a private airstrip or an airport land use plan or, where such a plan has not been adopted, within two miles of a public airport or public use airport, would the project expose people residing or working in the project area to excessive noise levels?

### 4.1 NOISE LEVEL INCREASES (THRESHOLD A)

Noise level increases resulting from the Project are evaluated based on the Appendix G CEQA Guidelines described above at the closest sensitive receiver locations. Under CEQA, consideration must be given to the magnitude of the increase, the existing ambient noise levels, and the location of noise-sensitive receivers to determine if a noise increase represents a significant adverse environmental impact. This approach *recognizes that there is no single noise increase that renders the noise impact significant.* (16) This is primarily because of the wide variation in individual thresholds of annoyance and differing individual experiences with noise. Thus, an important way of determining a person's subjective reaction to a new noise is the comparison of it to the existing environment to which one has adapted—the so-called *ambient* environment.

In general, the more a new noise exceeds the previously existing ambient noise level, the less acceptable the new noise will typically be judged. The Federal Interagency Committee on Noise (FICON) (17) developed guidance to be used for the assessment of project-generated increases in noise levels that consider the ambient noise level. The FICON recommendations are based on studies that relate aircraft noise levels to the percentage of persons highly annoyed by aircraft noise. Although the FICON recommendations were specifically developed to assess aircraft noise impacts, these recommendations are often used in environmental noise impact assessments involving the use of cumulative noise exposure metrics, such as the average-daily noise level (CNEL) and equivalent continuous noise level ( $L_{eq}$ ). The FICON guidance provides an established source of criteria to assess the impacts of substantial temporary or permanent increase in ambient noise levels. Based on the FICON criteria, the amount to which a given noise level increase is considered acceptable is reduced when the without Project noise levels are already shown to exceed certain land-use specific exterior noise level criteria. The specific levels are based on typical responses to noise level increases of 5 dBA or *readily perceptible*, 3 dBA or *barely perceptible*, and 1.5 dBA depending on the underlying without Project noise levels for noise-sensitive uses. These levels of increases and their perceived acceptance are consistent with guidance provided by both the Federal Highway Administration (4 p. 9) and Caltrans (18 p. 2\_48).

## 4.2 VIBRATION (THRESHOLD B)

As described in Section 3.5, the vibration impacts originating from the construction of the Desert Island Hotel, vibration-generating activities are appropriately evaluated using the Caltrans vibration damage thresholds to assess potential temporary construction-related impacts at adjacent building locations. The nearest noise sensitive buildings adjacent to the Project site can best be described as “older residential structures” with a maximum acceptable continuous vibration threshold of 0.3 PPV (in/sec).

## 4.3 CEQA GUIDELINES NOT FURTHER ANALYZED (THRESHOLD C)

CEQA Noise Threshold C applies when there are nearby public and private airports and/or air strips and focuses on land use compatibility of the Project to nearby airports and airstrips. The Project site is not located within two miles of an airport or airstrip. The closest airport is the Palm Springs International Airport located approximately 5.7 miles northwest of the Project site. As such, the Project site would not be exposed to excessive noise levels from airport operations, and therefore, impacts are considered *less than significant*, and no further noise analysis is conducted in relation to Appendix G to the CEQA Guidelines, Noise Threshold C.

## 4.4 SIGNIFICANCE CRITERIA SUMMARY

Noise impacts shall be considered significant if any of the following occur as a direct result of the proposed development. Table 4-1 shows the significance criteria summary matrix that includes the allowable criteria used to identify potentially significant incremental noise level increases.

**TABLE 4-1: SIGNIFICANCE CRITERIA SUMMARY**

Analysis	Receiving Land Use	Condition(s)	Significance Criteria
Off-Site Traffic	Noise-Sensitive <sup>1</sup>	If ambient is < 60 dBA CNEL	≥ 5 dBA CNEL Project increase
		If ambient is 60 - 65 dBA CNEL	≥ 3 dBA CNEL Project increase
		If ambient is > 65 dBA CNEL	≥ 1.5 dBA CNEL Project increase
	Non-Noise-Sensitive <sup>1,2</sup>	If ambient is < 70 dBA CNEL	≥ 5 dBA CNEL Project increase
		If ambient is > 70 dBA CNEL	≥ 3 dBA CNEL Project increase
Operational	All <sup>3</sup>	Exterior Noise Level Standards	See Table 3-1
Construction	Noise-Sensitive	Shall be limited to the hours of 7:00 a.m. and 7:00 p.m. with no activity on Sundays and holidays <sup>4</sup>	
		Noise Level Threshold <sup>5</sup>	80 dBA L <sub>eq</sub>
	All	Vibration Level Threshold <sup>6</sup>	0.3 PPV (in/sec)

<sup>1</sup> FICON, 1992.<sup>2</sup> City of Rancho Mirage General Plan Noise Element.<sup>3</sup> City of Rancho Mirage General Plan Municipal Code, Section 8.45.030<sup>4</sup> City of Rancho Mirage General Plan Municipal Code, Section 15.04.030[A][10].<sup>5</sup> Federal Transit Administration, Transit Noise and Vibration Impact Assessment Manual.<sup>6</sup> Caltrans Transportation and Construction Vibration Manual, April 2020 Table 19.

"Daytime" = 7:00 a.m. to 10:00 p.m.; "Nighttime" = 10:00 p.m. to 7:00 a.m.

*This page intentionally left blank*



## 5 EXISTING NOISE LEVEL MEASUREMENTS

To assess the existing noise level environment, 24-hour noise level measurements were taken at six locations in the Project study area. The receiver locations were selected to describe and document the existing noise environment within the Project study area. Exhibit 5-A provides the boundaries of the Project study area and the noise level measurement locations. To fully describe the existing noise conditions, noise level measurements were collected by Urban Crossroads, Inc. on Tuesday, April 5, 2022. Appendix 5.1 includes study area photos.

### 5.1 MEASUREMENT PROCEDURE AND CRITERIA

To describe the existing noise environment, the hourly noise levels were measured during typical weekday conditions over a 24-hour period. By collecting individual hourly noise level measurements, it is possible to describe the equivalent daytime and nighttime hourly noise levels. The long-term noise readings were recorded using Piccolo Type 2 integrating sound level meter and dataloggers. The Piccolo sound level meters were calibrated using a Larson-Davis calibrator, Model CAL 150. All noise meters were programmed in "slow" mode to record noise levels in "A" weighted form. The sound level meters and microphones were equipped with a windscreen during all measurements. All noise level measurement equipment satisfies the American National Standards Institute (ANSI) standard specifications for sound level meters ANSI S1.4-2014/IEC 61672-1:2013. (19)

### 5.2 NOISE MEASUREMENT LOCATIONS

The long-term noise level measurements were positioned as close to the nearest sensitive receiver locations as possible to assess the existing ambient hourly noise levels surrounding the Project site. Both Caltrans and the FTA recognize that it is not reasonable to collect noise level measurements that can fully represent every part of a private yard, patio, deck, or balcony normally used for human activity when estimating impacts for new development projects. This is demonstrated in the Caltrans general site location guidelines which indicate that, *sites must be free of noise contamination by sources other than sources of interest. Avoid sites located near sources such as barking dogs, lawnmowers, pool pumps, and air conditioners unless it is the express intent of the analyst to measure these sources.* (2) Further, FTA guidance states, *that it is not necessary nor recommended that existing noise exposure be determined by measuring at every noise-sensitive location in the project area. Rather, the recommended approach is to characterize the noise environment for clusters of sites based on measurements or estimates at representative locations in the community* (8).

Based on recommendations of Caltrans and the FTA, it is not necessary to collect measurements at each individual building or residence, because each receiver measurement represents a group of buildings that share acoustical equivalence (8). In other words, the area represented by the receiver shares similar shielding, terrain, and geometric relationship to the reference noise source. Receivers represent a location of noise sensitive areas and are used to estimate the future noise level impacts. Collecting reference ambient noise level measurements at the nearby sensitive receiver locations allows for a comparison of the before and after Project noise levels

and is necessary to assess potential noise impacts due to the Project's contribution to the ambient noise levels.

### 5.3 NOISE MEASUREMENT RESULTS

The noise measurements presented below focus on the equivalent or the hourly energy average sound levels ( $L_{eq}$ ). The equivalent sound level ( $L_{eq}$ ) represents a steady state sound level containing the same total energy as a time varying signal over a given sample period. Table 5-1 identifies the hourly daytime (7:00 a.m. to 6:00 p.m.), evening (6:00 p.m. to 10:00 p.m.) and nighttime (10:00 p.m. to 7:00 a.m.) noise levels at each noise level measurement location.

**TABLE 5-1: AMBIENT NOISE LEVEL MEASUREMENTS**

Location <sup>1</sup>	Description	Energy Average Noise Level (dBA $L_{eq}$ ) <sup>2</sup>		
		Daytime	Evening	Nighttime
L1	Located northwest of the Project site near single-family residence at 1 Von Dehn Road.	70.9	66.3	63.7
L2	Located south of the Project site near multi-family residence at 910 Island Drive.	54.8	48.8	48.9
L3	Located south of the Project site near multi-family residence at 900 Island Drive.	53.5	47.5	47.9
L4	Located south of the Project site near multi-family residence at 899 Island Drive.	49.4	46.3	45.0
L5	Located southwest of the Project site near single-family residence at 3 Vohn Dehn Road.	53.1	49.6	51.0
L6	Located west of the Project site near single-family residence at 1 Vohn Dehn Road.	54.1	51.6	51.9

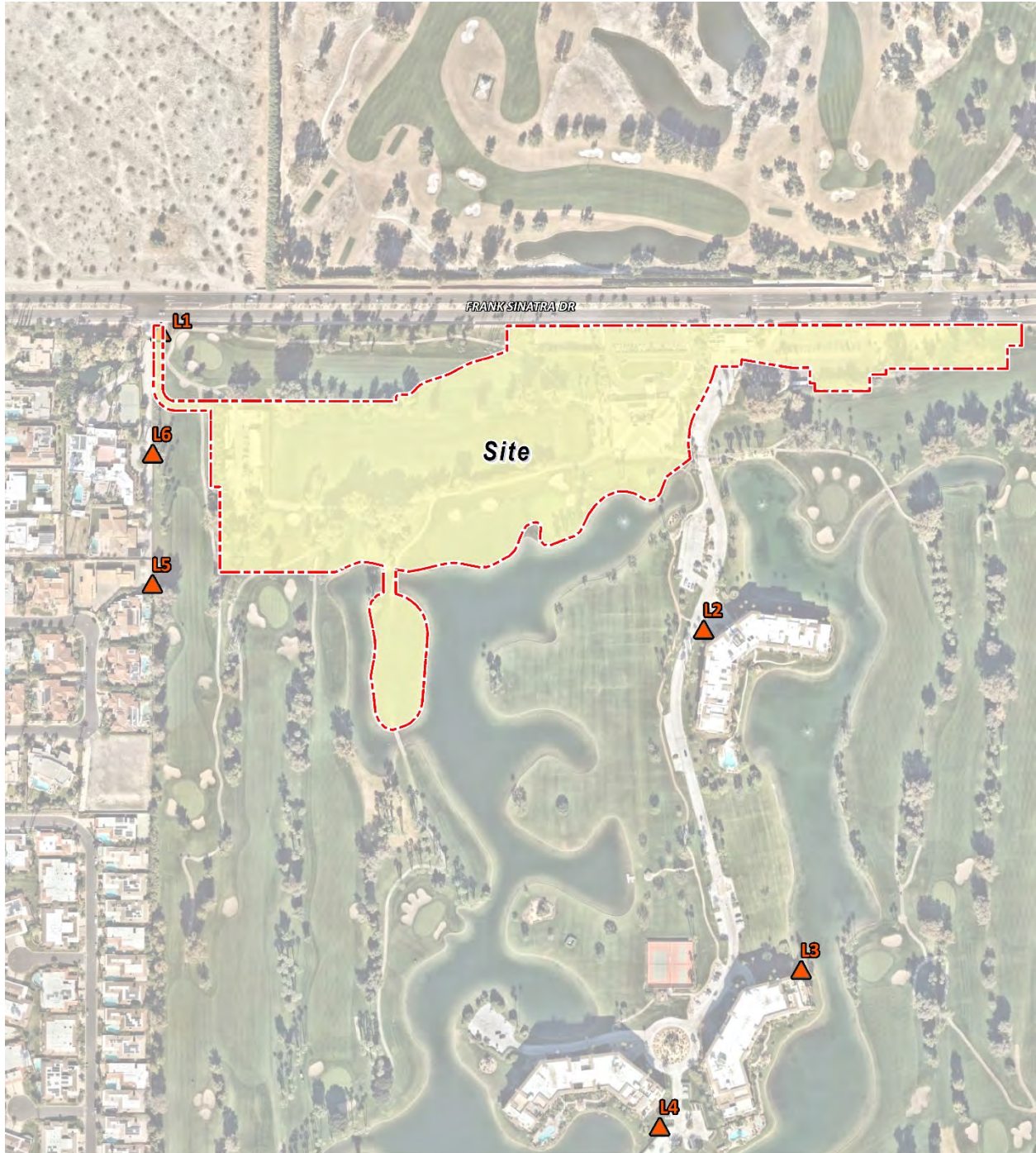
<sup>1</sup> See Exhibit 5-A for the noise level measurement locations.

<sup>2</sup> Energy (logarithmic) average levels. The long-term 24-hour measurement worksheets are included in Appendix 5.2.

"Daytime" = 7:00 a.m. to 6:00 p.m.; "Evening" = 6:00 p.m. to 10:00 p.m.; "Nighttime" = 10:00 p.m. to 7:00 a.m.

Table 5-1 provides the equivalent noise levels used to describe the daytime, evening, and nighttime ambient conditions. These daytime and nighttime energy average noise levels represent the average of all hourly noise levels observed during these time periods expressed as a single number. Appendix 5.2 provides summary worksheets of the noise levels for each of the daytime and nighttime hours.

EXHIBIT 5-A: NOISE MEASUREMENT LOCATIONS



*This page intentionally left blank*

## 6 TRAFFIC NOISE METHODS AND PROCEDURES

The following section outlines the methods and procedures used to estimate and analyze the future traffic noise environment. Consistent with the City of Rancho Mirage *Land Use Compatibility* guidelines, all transportation related noise levels are presented in terms of the 24-hour CNEL.

### 6.1 FHWA TRAFFIC NOISE PREDICTION MODEL

The expected roadway noise level increases from vehicular traffic were calculated by Urban Crossroads, Inc. using a computer program that replicates the Federal Highway Administration (FHWA) Traffic Noise Prediction Model- FHWA-RD-77-108. (20) The FHWA Model arrives at a predicted noise level through a series of adjustments to the Reference Energy Mean Emission Level (REMEL). In California, the national REMELs are substituted with the California Vehicle Noise (Calveno) Emission Levels. (21) Adjustments are then made to the REMEL to account for: the roadway classification (e.g., collector, secondary, major or arterial), the roadway active width (i.e., the distance between the center of the outermost travel lanes on each side of the roadway), the total average daily traffic (ADT), the travel speed, the percentages of automobiles, medium trucks, and heavy trucks in the traffic volume, the roadway grade, the angle of view (e.g., whether the roadway view is blocked), the site conditions ("hard" or "soft" relates to the absorption of the ground, pavement, or landscaping), and the percentage of total ADT which flows each hour throughout a 24-hour period. Research conducted by Caltrans has shown that the use of soft site conditions is appropriate for the application of the FHWA traffic noise prediction model used in this analysis. (22)

#### 6.1.1 OFF-SITE TRAFFIC NOISE PREDICTION MODEL INPUTS

Table 6-1 presents the roadway parameters used to assess the Project's off-site transportation noise impacts. Table 6-1 identifies the six off-site study area roadway segments, the distance from the centerline to adjacent receiving land use based on the functional roadway classifications per the City of Rancho Mirage General Plans Circulation Element, and the posted vehicle speeds. The ADT volumes used in this study are presented on Table 6-2 are based on the *Desert Island Hotel Focused Traffic Analysis*, prepared by Urban Crossroads, Inc. (23) for the following traffic conditions:

- Existing Without Project Conditions
- Existing With Project Conditions
- Existing Plus Ambient Growth (EA) Without Project Conditions (EA)
- EA With Project Conditions (with a proposed roadway connection completed) (EA with Project)
- Existing Plus Ambient Growth Plus Cumulative (EAC) Without Project Conditions (EAC)
- EAC With Project Conditions (with a proposed roadway connection completed) (EAC with Project)

**TABLE 6-1: OFF-SITE ROADWAY PARAMETERS**

ID	Roadway	Segment	Classification <sup>1</sup>	Distance from Centerline to Receiving Land Use (Feet) <sup>3</sup>	Vehicle Speed (mph)
1	Frank Sinatra Drive	w/o Island Drive	Minor Arterial	55'	45
2	Frank Sinatra Drive	e/o Island Drive	Minor Arterial	55'	45
3	Frank Sinatra Drive	e/o Bob Hope Drive	Minor Arterial	55'	45
4	Bob Hope Drive	n/o Frank Sinatra Drive	Major Arterial	60'	45
5	Bob Hope Drive	s/o Frank Sinatra Drive	Minor Arterial	55'	45
6	Island Drive	s/o Frank Sinatra Drive	Local	30'	25

<sup>1</sup> City of Rancho Mirage General Plans Circulation Element

<sup>2</sup> Distance to receiving land use is based upon the right-of-way distances.

**TABLE 6-2: AVERAGE DAILY TRAFFIC VOLUMES**

ID	Roadway	Segment	Average Daily Traffic Volumes <sup>1</sup>					
			Existing		Existing Plus Ambient Growth		Existing Plus Ambient Growth Plus Cumulative	
			Without Project	With Project	Without Project	With Project	Without Project	With Project
1	Frank Sinatra Drive	w/o Island Drive	13,700	13,950	14,250	14,500	17,550	17,800
2	Frank Sinatra Drive	e/o Island Drive	13,300	14,050	13,850	14,600	17,050	17,800
3	Frank Sinatra Drive	e/o Bob Hope Drive	13,100	13,300	13,600	13,800	16,000	16,200
4	Bob Hope Drive	n/o Frank Sinatra Drive	18,600	18,900	19,400	19,700	22,900	23,200
5	Bob Hope Drive	s/o Frank Sinatra Drive	21,300	21,320	22,380	22,400	25,980	26,000
6	Island Drive	s/o Frank Sinatra Drive	1,000	1,100	1,900	2,000	1,900	2,000

<sup>1</sup> Desert Island Focused Traffic Analysis, Urban Crossroads.

The ADT volumes vary for each roadway segment based on the existing traffic volumes and the combination of project traffic distributions. Table 6-3 provides the time of day (daytime, evening, and nighttime) vehicle splits and Table 6-4 presents the traffic flow distributions (vehicle mix) used for this analysis. The vehicle mix provides the hourly distribution percentages of automobile, medium trucks, and heavy trucks for input into the FHWA noise prediction model.

**TABLE 6-3: TIME OF DAY VEHICLE SPLITS**

Vehicle Type	Time of Day Splits <sup>1</sup>			Total of Time of Day Splits
	Daytime	Evening	Nighttime	
Autos	77.50%	12.90%	9.60%	100.00%
Medium Trucks	84.80%	4.90%	10.30%	100.00%
Heavy Trucks	86.50%	2.70%	10.80%	100.00%

<sup>1</sup>Typical Southern California vehicle mix.

"Daytime" = 7:00 a.m. to 7:00 p.m.; "Evening" = 7:00 p.m. to 10:00 p.m.; "Nighttime" = 10:00 p.m. to 7:00 a.m.

**TABLE 6-4: TRAFFIC FLOW BY VEHICLE TYPE (VEHICLE MIX)**

Classification	Total % Traffic Flow			Total
	Autos	Medium Trucks	Heavy Trucks	
All Roadways <sup>1</sup>	97.42%	1.84%	0.74%	100.00%

<sup>1</sup> Typical Southern California vehicle mix.

*This page intentionally left blank*



## 7 OFF-SITE TRAFFIC NOISE ANALYSIS

To assess the off-site transportation CNEL noise level impacts associated with development of the proposed Project, noise contours were developed based on the Desert Island Hotel Focused Traffic Analysis. (23) Noise contour boundaries represent the equal levels of noise exposure and are measured in CNEL from the center of the roadway.

### 7.1 NOISE CONTOURS

Noise contours were used to assess the Project's incremental 24-hour dBA CNEL traffic-related noise impacts at receiving land uses adjacent to roadways conveying Project traffic. The noise contours represent the distance to noise levels of a constant value and are measured from the center of the roadway for the 70, 65, and 60 dBA CNEL noise levels. The noise contours do not consider the effect of any existing noise barriers or topography that may attenuate ambient noise levels. In addition, because the noise contours reflect modeling of vehicular noise on area roadways, they appropriately do not reflect noise contributions from the surrounding stationary noise sources within the Project study area.

Tables 7-1 through 7-6 present a summary of the exterior dBA CNEL traffic noise levels without barrier attenuation. Roadway segments are analyzed from the without Project to the with Project conditions in each of the following timeframes:

- Existing Without Project Conditions
- Existing With Project Conditions
- EA Without Project Conditions
- EA With Project Conditions (with a proposed roadway connection completed)
- EAC Without Project Conditions
- EAC With Project Conditions (with a proposed roadway connection completed)

Appendix 7.1 includes a summary of the dBA CNEL traffic noise level contours for each of the traffic scenarios.

**TABLE 7-1: EXISTING WITHOUT PROJECT CONTOURS**

ID	Road	Segment	CNEL at Receiving Land Use (dBA) <sup>1</sup>	Distance to Contour from Centerline (Feet)		
				70 dBA CNEL	65 dBA CNEL	60 dBA CNEL
1	Frank Sinatra Drive	w/o Island Drive	68.2	42	91	195
2	Frank Sinatra Drive	e/o Island Drive	68.1	41	89	191
3	Frank Sinatra Drive	e/o Bob Hope Drive	68.1	41	88	189
4	Bob Hope Drive	n/o Frank Sinatra Drive	70.3	63	135	291
5	Bob Hope Drive	s/o Frank Sinatra Drive	70.2	56	122	262
6	Island Drive	s/o Frank Sinatra Drive	53.7	2	5	11

<sup>1</sup> The CNEL is calculated at the boundary of the right-of-way of the receiving adjacent land use.  
 "RW" = Location of the respective noise contour falls within the right-of-way of the road.

**TABLE 7-2: EXISTING WITH PROJECT CONTOURS**

ID	Road	Segment	CNEL at Receiving Land Use (dBA) <sup>1</sup>	Distance to Contour from Centerline (Feet)		
				70 dBA CNEL	65 dBA CNEL	60 dBA CNEL
1	Frank Sinatra Drive	w/o Island Drive	68.3	43	92	197
2	Frank Sinatra Drive	e/o Island Drive	68.4	43	92	198
3	Frank Sinatra Drive	e/o Bob Hope Drive	68.1	41	89	191
4	Bob Hope Drive	n/o Frank Sinatra Drive	70.4	63	137	294
5	Bob Hope Drive	s/o Frank Sinatra Drive	70.2	56	122	262
6	Island Drive	s/o Frank Sinatra Drive	54.1	3	6	12

<sup>1</sup> The CNEL is calculated at the boundary of the right-of-way of the receiving adjacent land use.  
 "RW" = Location of the respective noise contour falls within the right-of-way of the road.

**TABLE 7-3: EA WITHOUT PROJECT CONTOURS**

ID	Road	Segment	CNEL at Receiving Land Use (dBA) <sup>1</sup>	Distance to Contour from Centerline (Feet)		
				70 dBA CNEL	65 dBA CNEL	60 dBA CNEL
1	Frank Sinatra Drive	w/o Island Drive	68.4	43	93	200
2	Frank Sinatra Drive	e/o Island Drive	68.3	42	91	197
3	Frank Sinatra Drive	e/o Bob Hope Drive	68.2	42	90	194
4	Bob Hope Drive	n/o Frank Sinatra Drive	70.5	65	139	299
5	Bob Hope Drive	s/o Frank Sinatra Drive	70.4	58	126	271
6	Island Drive	s/o Frank Sinatra Drive	56.5	4	8	18

<sup>1</sup> The CNEL is calculated at the boundary of the right-of-way of the receiving adjacent land use.

"RW" = Location of the respective noise contour falls within the right-of-way of the road.

**TABLE 7-4: EA WITH PROJECT CONTOURS**

ID	Road	Segment	CNEL at Receiving Land Use (dBA) <sup>1</sup>	Distance to Contour from Centerline (Feet)		
				70 dBA CNEL	65 dBA CNEL	60 dBA CNEL
1	Frank Sinatra Drive	w/o Island Drive	68.5	44	94	203
2	Frank Sinatra Drive	e/o Island Drive	68.5	44	94	204
3	Frank Sinatra Drive	e/o Bob Hope Drive	68.3	42	91	196
4	Bob Hope Drive	n/o Frank Sinatra Drive	70.5	65	140	302
5	Bob Hope Drive	s/o Frank Sinatra Drive	70.4	58	126	271
6	Island Drive	s/o Frank Sinatra Drive	56.7	4	8	18

<sup>1</sup> The CNEL is calculated at the boundary of the right-of-way of the receiving adjacent land use.

"RW" = Location of the respective noise contour falls within the right-of-way of the road.

**TABLE 7-5: EAC WITHOUR PROJECT CONTOURS**

ID	Road	Segment	CNEL at Receiving Land Use (dBA) <sup>1</sup>	Distance to Contour from Centerline (Feet)		
				70 dBA CNEL	65 dBA CNEL	60 dBA CNEL
1	Frank Sinatra Drive	w/o Island Drive	69.3	50	107	230
2	Frank Sinatra Drive	e/o Island Drive	69.2	49	105	226
3	Frank Sinatra Drive	e/o Bob Hope Drive	68.9	47	100	216
4	Bob Hope Drive	n/o Frank Sinatra Drive	71.2	72	155	334
5	Bob Hope Drive	s/o Frank Sinatra Drive	71.0	64	139	299
6	Island Drive	s/o Frank Sinatra Drive	56.5	4	8	18

<sup>1</sup> The CNEL is calculated at the boundary of the right-of-way of the receiving adjacent land use.

"RW" = Location of the respective noise contour falls within the right-of-way of the road.

**TABLE 7-6: EAC WITH PROJECT CONTOURS**

ID	Road	Segment	CNEL at Receiving Land Use (dBA) <sup>1</sup>	Distance to Contour from Centerline (Feet)		
				70 dBA CNEL	65 dBA CNEL	60 dBA CNEL
1	Frank Sinatra Drive	w/o Island Drive	69.4	50	108	232
2	Frank Sinatra Drive	e/o Island Drive	69.4	50	108	232
3	Frank Sinatra Drive	e/o Bob Hope Drive	69.0	47	101	218
4	Bob Hope Drive	n/o Frank Sinatra Drive	71.2	73	157	337
5	Bob Hope Drive	s/o Frank Sinatra Drive	71.0	64	139	299
6	Island Drive	s/o Frank Sinatra Drive	56.7	4	8	18

<sup>1</sup> The CNEL is calculated at the boundary of the right-of-way of the receiving adjacent land use.

"RW" = Location of the respective noise contour falls within the right-of-way of the road.

## 7.2 EXISTING PROJECT TRAFFIC NOISE LEVEL INCREASES

An analysis of existing traffic noise levels plus traffic noise generated by the proposed Project has been included in this report to fully analyze all the existing traffic scenarios identified in the *Desert Island Hotel Specific Plan Traffic Analysis*. This condition is provided solely for informational purposes and will not occur, since the Project will not be fully developed and occupied under Existing conditions. Table 7-1 shows the Existing without Project conditions CNEL noise levels. The Existing without Project exterior noise levels are expected to range from 53.7 to 70.3 dBA CNEL, without accounting for any noise attenuation features such as noise barriers or topography. Table 7-2 shows the Existing with Project conditions will range from 54.1 to 70.4 dBA CNEL. Table 7-7 shows that the Project off-site traffic noise level impacts will range from 0.0 to 0.4 dBA CNEL. Based on the significance criteria for off-site traffic noise presented in Table 4-1, land uses adjacent to the study area roadway segments would experience *less than significant* noise level impacts due to unmitigated Project-related traffic noise levels.

## 7.3 EXISTING PLUS AMBIENT GROWTH PROJECT TRAFFIC NOISE LEVEL INCREASES

Table 7-3 presents the EA without Project conditions CNEL noise levels. The EA without Project exterior noise levels are expected to range from 56.5 to 70.5 dBA CNEL, without accounting for any noise attenuation features such as noise barriers or topography. Table 7-4 presents the E+A with Project conditions CNEL noise levels. The EA with Project exterior noise levels are expected to range from 56.7 to 70.5 dBA CNEL, without accounting for any noise attenuation features such as noise barriers or topography. Table 7-8 shows that the Project off-site traffic noise level increases will range from 0.0 to 0.2 dBA CNEL. Based on the significance criteria for off-site traffic noise presented in Table 4-1, land uses adjacent to the study area roadway segments would experience *less than significant* noise level impacts due to unmitigated Project-related traffic noise levels.

## 7.4 EXISTING PLUS AMBIENT GROWTH PLUS CUMULATIVE PROJECT TRAFFIC NOISE LEVEL INCREASES

Table 7-5 presents the EAC without Project conditions CNEL noise levels. The EAC without Project exterior noise levels are expected to range from 56.5 to 71.2 dBA CNEL, without accounting for any noise attenuation features such as noise barriers or topography. Table 7-6 shows the EAC with Project conditions will range from 56.7 to 71.2 dBA CNEL. Table 7-9 shows that the Project off-site traffic noise level increases will range from 0.0 to 0.2 dBA CNEL. Based on the significance criteria for off-site traffic noise presented in Table 4-1, land uses adjacent to the study area roadway segments would experience *less than significant* noise level impacts due to unmitigated Project-related traffic noise levels.

**TABLE 7-7: EXISTING WITH PROJECT TRAFFIC NOISE LEVEL INCREASES**

ID	Road	Segment	CNEL at Receiving Land Use (dBA) <sup>1</sup>			Incremental Noise Level Increase Threshold <sup>2</sup>	
			No Project	With Project	Project Addition	Limit	Exceeded?
1	Frank Sinatra Drive	w/o Island Drive	68.2	68.3	0.1	1.5	No
2	Frank Sinatra Drive	e/o Island Drive	68.1	68.4	0.3	1.5	No
3	Frank Sinatra Drive	e/o Bob Hope Drive	68.1	68.1	0.0	1.5	No
4	Bob Hope Drive	n/o Frank Sinatra Drive	70.3	70.4	0.1	1.5	No
5	Bob Hope Drive	s/o Frank Sinatra Drive	70.2	70.2	0.0	1.5	No
6	Island Drive	s/o Frank Sinatra Drive	53.7	54.1	0.4	5.0	No

<sup>1</sup> The CNEL is calculated at the boundary of the right-of-way of each roadway and the property line of the receiving land use.

<sup>2</sup> Does the Project create an incremental noise level increase exceeding the significance criteria (Table 4-1)?

**TABLE 7-8: E+A WITH PROJECT TRAFFIC NOISE LEVEL INCREASES**

ID	Road	Segment	CNEL at Receiving Land Use (dBA) <sup>1</sup>			Incremental Noise Level Increase Threshold <sup>2</sup>	
			No Project	With Project	Project Addition	Limit	Exceeded?
1	Frank Sinatra Drive	w/o Island Drive	68.4	68.5	0.1	1.5	No
2	Frank Sinatra Drive	e/o Island Drive	68.3	68.5	0.2	1.5	No
3	Frank Sinatra Drive	e/o Bob Hope Drive	68.2	68.3	0.1	1.5	No
4	Bob Hope Drive	n/o Frank Sinatra Drive	70.5	70.5	0.0	1.5	No
5	Bob Hope Drive	s/o Frank Sinatra Drive	70.4	70.4	0.0	1.5	No
6	Island Drive	s/o Frank Sinatra Drive	56.5	56.7	0.2	5.0	No

<sup>1</sup> The CNEL is calculated at the boundary of the right-of-way of each roadway and the property line of the receiving land use.

<sup>2</sup> Does the Project create an incremental noise level increase exceeding the significance criteria (Table 4-1)?

**TABLE 7-9: E+A+C WITH PROJECT TRAFFIC NOISE LEVEL INCREASES**

ID	Road	Segment	CNEL at Receiving Land Use (dBA) <sup>1</sup>			Incremental Noise Level Increase Threshold <sup>2</sup>	
			No Project	With Project	Project Addition	Limit	Exceeded?
1	Frank Sinatra Drive	w/o Island Drive	69.3	69.4	0.1	1.5	No
2	Frank Sinatra Drive	e/o Island Drive	69.2	69.4	0.2	1.5	No
3	Frank Sinatra Drive	e/o Bob Hope Drive	68.9	69.0	0.1	1.5	No
4	Bob Hope Drive	n/o Frank Sinatra Drive	71.2	71.2	0.0	1.5	No
5	Bob Hope Drive	s/o Frank Sinatra Drive	71.0	71.0	0.0	1.5	No
6	Island Drive	s/o Frank Sinatra Drive	56.5	56.7	0.2	5.0	No

<sup>1</sup> The CNEL is calculated at the boundary of the right-of-way of each roadway and the property line of the receiving land use.

<sup>2</sup> Does the Project create an incremental noise level increase exceeding the significance criteria (Table 4-1)?

*This page intentionally left blank*



## 8 RECEIVER LOCATIONS

To assess the potential for long-term operational and short-term construction noise impacts, the following sensitive receiver locations, as shown on Exhibit 8-A, were identified as representative locations for analysis. Sensitive receivers are generally defined as locations where people reside or where the presence of unwanted sound could otherwise adversely affect the use of the land. Noise-sensitive land uses are generally considered to include schools, hospitals, single-family dwellings, mobile home parks, churches, libraries, and recreation areas. Moderately noise-sensitive land uses typically include multi-family dwellings, hotels, motels, dormitories, outpatient clinics, cemeteries, golf courses, country clubs, athletic/tennis clubs, and equestrian clubs. Land uses that are considered relatively insensitive to noise include business, commercial, and professional developments. Land uses that are typically not affected by noise include: industrial, manufacturing, utilities, agriculture, undeveloped land, parking lots, warehousing, liquid and solid waste facilities, salvage yards, and transit terminals.

To describe the potential off-site Project noise levels, six receiver locations in the vicinity of the Project site were identified. All distances are measured from the Project site boundary to the outdoor living areas (e.g., private backyards) or at the building façade, whichever is closer to the Project site. The selection of receiver locations is based on FHWA guidelines and is consistent with additional guidance provided by Caltrans and the FTA, as previously described in Section 5.2. Other sensitive land uses in the Project study area that are located at greater distances than those identified in this noise study will experience lower noise levels than those presented in this report due to the additional attenuation from distance and the shielding of intervening structures. Distance is measured in a straight line from the project boundary to each receiver location.

- R1: Location R1 represents the existing noise sensitive residence at 1 Von Dehn Road, approximately 244 feet northwest of the Project site. Receiver R1 is placed in the private outdoor living areas (backyards) facing the Project site. A 24-hour noise measurement was taken near this location, L1, to describe the existing ambient noise environment.
- R2: Location R2 represents the existing noise sensitive residence at 910 Island Drive, approximately 395 feet southeast of the Project site. Since there are no private outdoor living areas (backyards) facing the Project site, receiver R2 is placed at the building façade. A 24-hour noise measurement was taken near this location, L2, to describe the existing ambient noise environment.
- R3: Location R3 represents the existing noise sensitive residence at 900 Island Drive, approximately 1,114 feet southeast of the Project site. Since there are no private outdoor living areas (backyards) facing the Project site, receiver R3 is placed at the building façade. A 24-hour noise measurement was taken near this location, L3, to describe the existing ambient noise environment.
- R4: Location R4 represents the existing noise sensitive residence at 899 Island Drive, approximately 961 feet south of the Project site. Since there are no private outdoor living areas (backyards) facing the Project site, receiver R4 is placed at the building façade. A 24-hour noise measurement was taken near this location, L4, to describe the existing ambient noise environment.

- R5: Location R5 represents the existing noise sensitive residence at 30 Villaggio Place, approximately 193 feet southwest of the Project site. Receiver R5 is placed in the private outdoor living areas (backyards) facing the Project site. A 24-hour noise measurement was taken near this location, L5, to describe the existing ambient noise environment.
- R6: Location R6 represents the existing noise sensitive residence at 3 Von Dehn Road, approximately 231 feet west of the Project site. Since there are no private outdoor living areas (backyards) facing the Project site, receiver R6 is placed at the building façade. A 24-hour noise measurement was taken near this location, L6, to describe the existing ambient noise environment.

**EXHIBIT 8-A: RECEIVER LOCATIONS**



## 9 OPERATIONAL NOISE IMPACTS

This section analyzes the potential stationary-source operational noise impacts at the nearest receiver locations, identified in Section 8, resulting from the operation of uses allowed by the Desert Island Hotel. The residential areas within the Desert Island Hotel are considered a noise-sensitive receiving land use and are not expected to include any meaningful sources of noise activity. Exhibit 9-A identifies the representative noise source locations used to assess stationary noise sources.

### 9.1 OPERATIONAL NOISE SOURCES

This operational noise analysis is intended to describe noise level impacts associated with the expected typical daytime and nighttime activities at the Project site. The on-site Project-related noise sources are expected to include: outdoor recreational and training activities, trash enclosure activities, roof-top air conditioning units, ground mounted air conditioning units, packaged terminal air conditioning units, swimming pools, and parking lot activities.

### 9.2 REFERENCE NOISE LEVELS

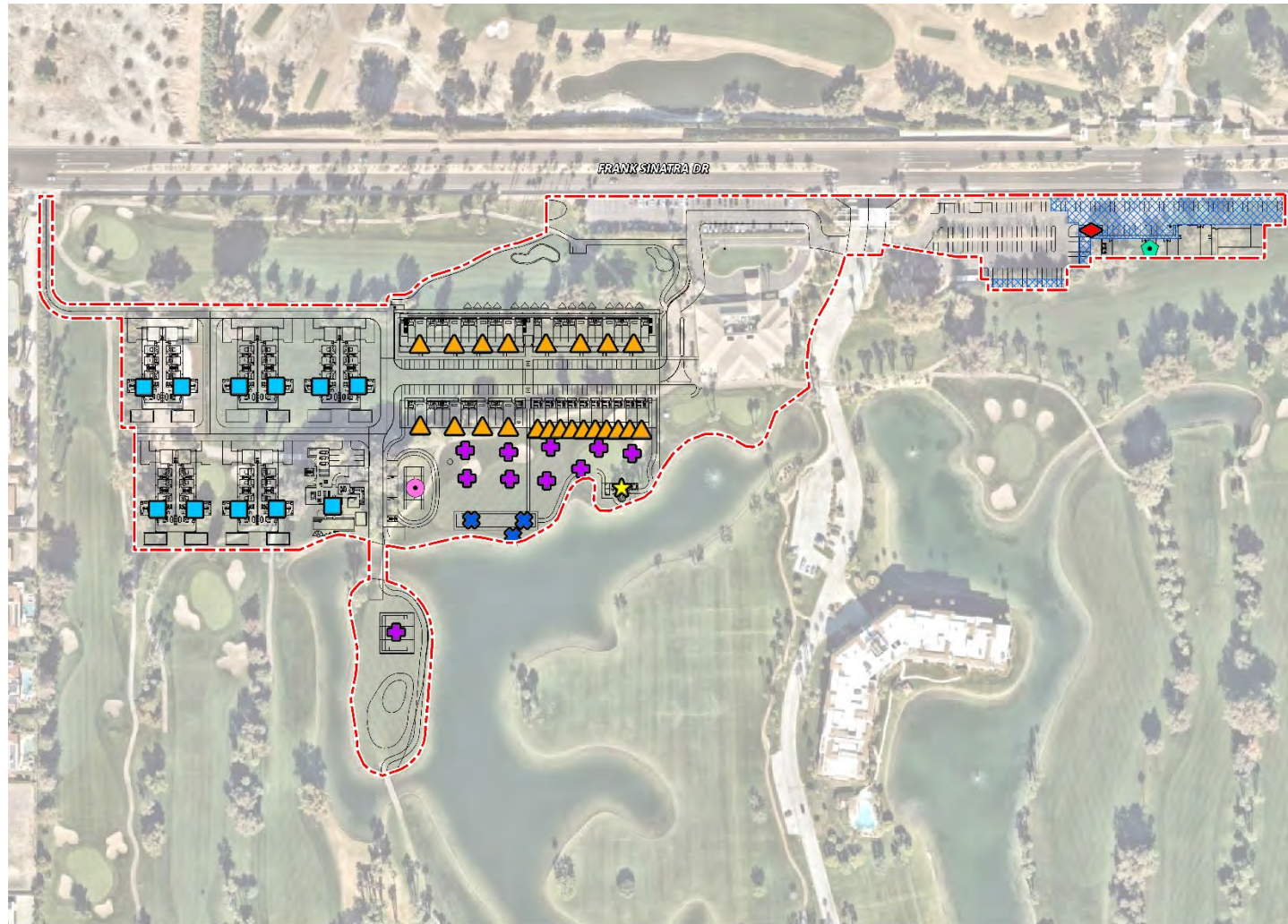
To estimate the Project operational noise impacts, reference noise level measurements were collected from similar types of activities, or taken from manufactures specification sheets, to represent the noise levels expected with the development of the proposed Project. This section provides a detailed description of the reference noise levels shown on Table 9-1 used to estimate the Project operational noise impacts. It is important to note that the following projected noise levels assume the worst-case noise environment with the outdoor recreational and training activities, trash enclosure activities, roof-top air conditioning units, ground mounted air conditioning units, packaged terminal air conditioning units, swimming pools, and parking lot activities all operating at the same time. These sources of noise activity will likely vary throughout the day.

#### 9.2.1 MEASUREMENT PROCEDURES

Unless noted in the following descriptions, the reference noise level measurements presented in this section were collected using a Larson Davis LxT Type 1 precisions sound level meter (serial number 01146). The LxT sound level meter was calibrated using a Larson-Davis calibrator, Model CAL 200, was programmed in "slow" mode to record noise levels in "A" weighted form and was located at approximately five feet above the ground elevation for each measurement. The sound level meters and microphones were equipped with a windscreen during all measurements. All noise level measurement equipment satisfies the American National Standards Institute (ANSI) standard specifications for sound level meters ANSI S1.4-2014/IEC 61672-1:2013. (19)



EXHIBIT 9-A: STATIONARY SOURCE NOISE LOCATIONS



- LEGEND:**
- N
  - Site Boundary
  - Air Conditioning Unit
  - Outdoor Activity Area
  - Trash Enclosure Activity
  - Roof-Top Air Conditioning Unit
  - Parking Lot Movements
  - PTAC
  - Pool Cafe
  - Pool Activity
  - Tennis Court

**TABLE 9-1: REFERENCE NOISE LEVEL MEASUREMENTS**

Noise Source	Noise Source Height (Feet)	Min./Hour <sup>1</sup>			Reference Noise Level @50 feet (dBA L <sub>eq</sub> )	Sound Power Level (dBA) <sup>2</sup>
		Day	Eve.	Night		
Outdoor Recreational Activities	5'	60'	60'	0'	59.8	91.5
Trash Enclosure Activities	8'	10'	10'	10'	56.8	89.0
Roof-Top Air Conditioning Units	5'	39'	39'	28'	57.2	88.9
Ground Air Conditioning Units	4'	60'	60'	60'	43.4	75.0
Packaged Terminal Air Conditioning Units	4'	60'	60'	60'	29.6	61.2
Swimming Pool Activities	5'	60'	60'	0'	57.7	89.3
Parking Lot Activities	5'	60'	60'	30'	56.1	87.8

<sup>1</sup> Anticipated duration (minutes within the hour) of noise activity during typical hourly conditions expected at the Project site.

<sup>2</sup> Sound power level represents the total amount of acoustical energy (noise level) produced by a sound source independent of distance or surroundings. Sound power levels calculated using the CadnaA noise model at the reference distance to the noise source.

"Day" = 7:00 a.m. to 6:00 p.m.; "Evening" = 6:00 p.m. to 10:00 p.m.; "Night" = 10:00 p.m. to 7:00 a.m.

### 9.2.2 OUTDOOR RECREATIONAL ACTIVITIES

To describe the outdoor recreational and golf training activities within common areas, courtyards, and golf warm up locations a reference noise level measurement a reference noise level is 59.8 dBA L<sub>eq</sub> at 50 feet was used. The reference noise level measurement included outdoor dining, drinking, laughing and talking, dancing, and background music. This noise level is considered representative of several other activities, including golf training activities. Outdoor recreational activities are modeled at 5 feet above ground level and are limited to the daytime and evening hours with 30 minutes per hour of activity during the nighttime hours to represent reduced activity at night.

### 9.2.3 TRASH ENCLOSURE ACTIVITIES

To describe the noise levels associated with a trash enclosure activity, Urban Crossroads collected a reference noise level measurement at an existing trash enclosure containing two dumpster bins. The trash enclosure noise levels describe metal gates opening and closing, metal scraping against concrete floor sounds, dumpster movement on metal wheels, and trash dropping into the metal dumpster. The reference noise levels describe trash enclosure noise activities when trash is dropped into an empty metal dumpster, as would occur at the Project site. The measured reference noise level at the uniform 50-foot reference distance is 56.8 dBA L<sub>eq</sub> for the trash enclosure activity. The reference noise level describes the expected noise source activities associated with the trash enclosures for the Project's proposed buildings. Typical trash enclosure activities are estimated to occur for 10 minutes per hour.

### 9.2.4 ROOF-TOP AIR CONDITIONING UNITS

To assess the noise levels created by the roof-top air conditioning units, reference noise level measurements were collected from a Lennox SCA120 series 10-ton model packaged air conditioning unit. At the uniform reference distance of 50 feet, the reference noise levels are

57.2 dBA  $L_{eq}$ . For this noise analysis, the air conditioning units are expected operate continuously for 60 minutes per hour and will be located four feet above the roof elevation of the Project buildings. This reference noise level describes the expected roof-top air conditioning units located 5 feet above the roof for the planned air conditioning units at the Project site.

### **9.2.5 GROUND MOUNTED AIR CONDITIONING UNITS**

To assess the noise levels created by the residential air conditioning units, reference noise levels were taken from the Carrier model 24ACC4 product data sheet. The product data sheet for Carrier model 24ACC4 planned for the Project will produce a maximum sound power level of 75 dBA  $L_w$ . For this noise analysis, the air conditioning units are expected operate continuously for 60 minutes per hour and will be located four feet above the ground elevation.

### **9.2.6 PACKAGED TERMINAL AIR CONDITIONING UNITS**

To assess the noise levels created by the hotel packaged terminal air conditioning (PTAC) units, reference noise levels were taken from the Trane model TEF1502HAA product data sheet. The product data sheet for Trane model TEF1502HAA will produce a maximum sound power level of 61.2 dBA  $L_w$ . For this noise analysis, the air conditioning units are expected operate continuously for 60 minutes per hour and will be located four feet above the ground elevation.

### **9.2.7 SWIMMING POOL ACTIVITIES**

To represent the noise levels associated with pool activities, Urban Crossroads collected a reference noise level measurement at an existing outdoor pool and spa. The measured reference noise level at the uniform 50-foot reference distance is 54.7 dBA  $L_{eq}$  for pool activity. The pool activity noise levels include kids playing, running, screaming, splashing, playing with a ball, and parents talking. Noise associated with pool activities is expected to occur for the entire hour (60 minutes) during daytime and evening hours with 30 minutes of activity during the nighttime hours to represent reduced activity at night.

### **9.2.8 PARKING LOT ACTIVITIES**

To describe the on-site parking lot activity a reference noise level of 56.1 dBA  $L_{eq}$  at 50 feet is used. Parking lot activity are expected to take place during the full hour (60 minutes) throughout the daytime and evening hours with 30 minutes of activity during the nighttime hours. The parking lot noise levels are mainly due to cars pulling in and out of parking spaces.

## **9.3 CADNAA NOISE PREDICTION MODEL**

To fully describe the exterior operational noise levels from the Project, Urban Crossroads, Inc. developed a noise prediction model using the CadnaA (Computer Aided Noise Abatement) computer program. CadnaA can analyze multiple types of noise sources using the spatially accurate Project site plan, georeferenced Nearmap aerial imagery, topography, buildings, and barriers in its calculations to predict outdoor noise levels.

Using the ISO 9613-2 protocol, CadnaA will calculate the distance from each noise source to the noise receiver locations, using the ground absorption, distance, and barrier/building attenuation

inputs to provide a summary of noise level at each receiver and the partial noise level contributions by noise source. Consistent with the ISO 9613-2 protocol, the CadnaA noise prediction model relies on the reference sound power level ( $L_w$ ) to describe individual noise sources. While sound pressure levels (e.g.,  $L_{eq}$ ) quantify in decibels the intensity of given sound sources at a reference distance, sound power levels ( $L_w$ ) are connected to the sound source and are independent of distance. Sound pressure levels vary substantially with distance from the source and diminish because of intervening obstacles and barriers, air absorption, wind, and other factors. Sound power is the acoustical energy emitted by the sound source and is an absolute value that is not affected by the environment. The operational noise level calculations provided in this noise study account for the distance attenuation provided due to geometric spreading, when sound from a localized stationary source (i.e., a point source) propagates uniformly outward in a spherical pattern. A default ground attenuation factor of 0.5 was used in the noise analysis to account for mixed ground representing a combination of hard and soft surfaces.

#### 9.4 PROJECT OPERATIONAL NOISE LEVELS

Using the reference noise levels to represent the proposed Project operations that include, Urban Crossroads, Inc. calculated the operational source noise levels that are expected to be generated from the Project site and the Project-related noise level increases that would be experienced at each of the sensitive receiver locations. Tables 9-2 shows the calculated Project operational noise levels during the daytime hours of 7:00 a.m. to 6:00 p.m., evening hours of 6:00 p.m. to 10:00 p.m. and the nighttime hours of 10:00 p.m. to 7:00 a.m. Table 9-2 shows that the Project operational noise levels will range from 26.0 to 43.3 dBA  $L_{eq}$ .

**TABLE 9-2: PROJECT OPERATIONAL NOISE LEVELS**

Receiver Location <sup>1</sup>	Project Operational Noise Levels (dBA Leq) <sup>2</sup>			Noise Level Standards (dBA Leq) <sup>3</sup>			Threshold Exceeded? <sup>4</sup>		
	Day	Eve.	Night	Day	Eve.	Night	Day	Eve.	Night
R1	43.3	43.3	34.6	55	50	45	No	No	No
R2	37.0	37.0	27.6	55	50	45	No	No	No
R3	36.8	36.8	26.0	55	50	45	No	No	No
R4	39.4	39.4	28.8	55	50	45	No	No	No
R5	40.9	40.9	30.3	55	50	45	No	No	No
R6	40.6	40.6	30.6	55	50	45	No	No	No

<sup>1</sup> See Exhibit 8-A for the receiver locations.

<sup>2</sup> Proposed Project operational noise level calculations included in Appendix 9.1.

<sup>3</sup> City of Rancho Mirage exterior noise level standards by land use, as shown on Table 3-1.

<sup>4</sup> Do the estimated Project operational noise source activities exceed the noise level standards?

"Day" = 7:00 a.m. to 6:00 p.m.; "Evening" = 6:00 p.m. to 10:00 p.m.; "Night" = 10:00 p.m. to 7:00 a.m.

To demonstrate compliance with local noise regulations, the Project-only operational noise levels are evaluated against exterior noise level thresholds based on the City of Rancho Mirage exterior noise level standards at nearby noise-sensitive receiver locations. Table 9-2 shows that the

operational noise levels associated with Desert Island Hotel Project will satisfy the City of Rancho Mirage daytime, evening, and nighttime exterior noise level standards at all nearby receiver locations. Therefore, the operational noise impacts are considered *less than significant* at the nearby noise-sensitive receiver locations.

## 9.6 PROJECT OPERATIONAL NOISE LEVEL INCREASES

To describe the Project operational noise level increases, the Project operational noise levels are combined with the existing ambient noise levels measurements for the nearby receiver locations potentially impacted by Project operational noise sources. Since the units used to measure noise, decibels (dB), are logarithmic units, the Project-stationary source and existing ambient noise levels cannot be combined using standard arithmetic equations. (2) Instead, they must be logarithmically added using the following base equation:

$$SPL_{Total} = 10\log_{10}[10^{SPL1/10} + 10^{SPL2/10} + \dots 10^{SPLn/10}]$$

Where “SPL1,” “SPL2,” etc. are equal to the sound pressure levels being combined, or in this case, the Project operational and existing ambient noise levels. The difference between the combined Project and ambient noise levels describes the Project noise level increases to the existing ambient noise environment. Noise levels that would be experienced at receiver locations when Project-source noise is added to the daytime, evening, and nighttime ambient conditions are presented on Tables 9-3, 9-4, and 9-5, respectively. As indicated on Tables 9-3, 9-4 and 9-5, the Project will generate an unmitigated operational noise level increases ranging from 0.0 to 0.8 dBA  $L_{eq}$  at the nearby receiver locations.

Tables 9-3, 9-4 and 9-5 show that the Project operational noise level contributions satisfy the operational noise level increase significance criteria presented in Table 4-1. Therefore, the Project related operational noise level increases at all sensitive receiver locations will be *less than significant*.



**TABLE 9-3: DAYTIME PROJECT STATIONARY SOURCE NOISE LEVEL INCREASES**

Receiver Location <sup>1</sup>	Total Project Operational Noise Level <sup>2</sup>	Measurement Location <sup>3</sup>	Reference Ambient Noise Levels <sup>4</sup>	Combined Project and Ambient <sup>5</sup>	Project Increase <sup>6</sup>	Increase Criteria <sup>7</sup>	Increase Criteria Exceeded? <sup>7</sup>
R1	43.3	L1	70.9	70.9	0.0	1.5	No
R2	37.0	L2	54.8	54.9	0.1	5.0	No
R3	36.8	L3	53.5	53.6	0.1	5.0	No
R4	39.4	L4	49.4	49.8	0.4	5.0	No
R5	40.9	L5	53.1	53.4	0.3	5.0	No

<sup>1</sup> See Exhibit 8-A for the receiver locations.

<sup>2</sup> Total Project operational noise levels as shown on Table 9-2.

<sup>3</sup> Reference noise level measurement locations as shown on Exhibit 5-A.

<sup>4</sup> Observed daytime ambient noise levels as shown on Table 5-1.

<sup>5</sup> Represents the combined ambient conditions plus the Project activities.

<sup>6</sup> The noise level increase expected with the addition of the proposed Project activities.

<sup>7</sup> Significance Criteria as defined in Section 4.

**TABLE 9-4: EVENING PROJECT STATIONARY SOURCE NOISE LEVEL INCREASES**

Receiver Location <sup>1</sup>	Total Project Operational Noise Level <sup>2</sup>	Measurement Location <sup>3</sup>	Reference Ambient Noise Levels <sup>4</sup>	Combined Project and Ambient <sup>5</sup>	Project Increase <sup>6</sup>	Increase Criteria <sup>7</sup>	Increase Criteria Exceeded? <sup>7</sup>
R1	43.3	L1	66.3	66.3	0.0	1.5	No
R2	37.0	L2	48.8	49.1	0.3	5.0	No
R3	36.8	L3	47.5	47.9	0.4	5.0	No
R4	39.4	L4	46.3	47.1	0.8	5.0	No
R5	40.9	L5	49.6	50.1	0.5	5.0	No

<sup>1</sup> See Exhibit 8-A for the receiver locations.

<sup>2</sup> Total Project operational noise levels as shown on Table 9-2.

<sup>3</sup> Reference noise level measurement locations as shown on Exhibit 5-A.

<sup>4</sup> Observed evening ambient noise levels as shown on Table 5-1.

<sup>5</sup> Represents the combined ambient conditions plus the Project activities.

<sup>6</sup> The noise level increase expected with the addition of the proposed Project activities.

<sup>7</sup> Significance Criteria as defined in Section 4.

**TABLE 9-5: NIGHTTIME PROJECT STATIONARY SOURCE NOISE LEVEL INCREASES**

Receiver Location <sup>1</sup>	Total Project Operational Noise Level <sup>2</sup>	Measurement Location <sup>3</sup>	Reference Ambient Noise Levels <sup>4</sup>	Combined Project and Ambient <sup>5</sup>	Project Increase <sup>6</sup>	Increase Criteria <sup>7</sup>	Increase Criteria Exceeded? <sup>7</sup>
R1	34.6	L1	63.7	63.7	0.0	3.0	No
R2	27.6	L2	48.9	48.9	0.0	5.0	No
R3	26.0	L3	47.9	47.9	0.0	5.0	No
R4	28.8	L4	45.0	45.1	0.1	5.0	No
R5	30.3	L5	51.0	51.0	0.0	5.0	No

<sup>1</sup> See Exhibit 8-A for the receiver locations.

<sup>2</sup> Total Project operational noise levels as shown on Table 9-2.

<sup>3</sup> Reference noise level measurement locations as shown on Exhibit 5-A.

<sup>4</sup> Observed nighttime ambient noise levels as shown on Table 5-1.

<sup>5</sup> Represents the combined ambient conditions plus the Project activities.

<sup>6</sup> The noise level increase expected with the addition of the proposed Project activities.

<sup>7</sup> Significance Criteria as defined in Section 4.

## 10 CONSTRUCTION IMPACTS

This section analyzes potential impacts resulting from the short-term construction activities associated with the development of the Project. Exhibit 10-A shows the construction noise source locations in relation to the nearest sensitive receiver locations previously described in Section 8.

### 10.1 CONSTRUCTION NOISE LEVELS

The FTA *Transit Noise and Vibration Impact Assessment Manual* recognizes that construction projects are accomplished in several different stages and outlines the procedures for assessing noise impacts during construction. Each stage has a specific equipment mix, depending on the work to be completed during that stage. As a result of the equipment mix, each stage has its own noise characteristics; some stages have higher continuous noise levels than others, and some have higher impact noise levels than others. The Project construction activities are expected to occur in the following stages:

- Site Preparation
- Grading
- Building Construction
- Paving
- Architectural Coating

### 10.2 CONSTRUCTION REFERENCE NOISE LEVELS

To describe construction noise activities, this construction noise analysis was prepared using reference construction equipment noise levels from the Federal Highway Administration (FHWA) published the Roadway Construction Noise Model (RCNM), which includes a national database of construction equipment reference noise emission levels. (24) The RCNM equipment database, provides a comprehensive list of the noise generating characteristics for specific types of construction equipment. In addition, the database provides an acoustical usage factor to estimate the fraction of time each piece of construction equipment is operating at full power (i.e., its loudest condition) during a construction operation.

EXHIBIT 10-A: TYPICAL CONSTRUCTION NOISE SOURCE LOCATIONS



### 10.3 CONSTRUCTION NOISE ANALYSIS

Using the reference construction equipment noise levels and the CadnaA noise prediction model, calculations of the Project construction noise level impacts at the nearby sensitive receiver locations were completed. Consistent with FTA guidance for general construction noise assessment, Table 10-1 presents the combined noise levels for the loudest construction equipment, assuming they operate at the same time. As shown on Table 10-2, the construction noise levels are expected to range from 48.8 to 63.0 dBA  $L_{eq}$  at the nearby receiver locations. Appendix 10.1 includes the detailed CadnaA construction noise model inputs.

**TABLE 10-1: CONSTRUCTION REFERENCE NOISE LEVELS**

Construction Stage	Reference Construction Activity	Reference Noise Level @ 50 Feet (dBA $L_{eq}$ ) <sup>1</sup>	Combined Noise Level (dBA $L_{eq}$ ) <sup>2</sup>	Combined Sound Power Level (PWL) <sup>3</sup>
Site Preparation	Crawler Tractors	78.0	80.0	111.6
	Hauling Trucks	72.0		
	Rubber Tired Dozers	75.0		
Grading	Graders	81.0	83.0	114.6
	Excavators	77.0		
	Compactors	76.0		
Building Construction	Cranes	73.0	81.0	112.6
	Tractors	80.0		
	Welders	70.0		
Paving	Pavers	74.0	83.0	114.6
	Paving Equipment	82.0		
	Rollers	73.0		
Architectural Coating	Cranes	73.0	77.0	108.6
	Air Compressors	74.0		
	Generator Sets	70.0		

<sup>1</sup> FHWA Roadway Construction Noise Model (RCNM).

<sup>2</sup> Represents the combined noise level for all equipment assuming they operate at the same time consistent with FTA Transit Noise and Vibration Impact Assessment guidance.

<sup>3</sup> Sound power level represents the total amount of acoustical energy (noise level) produced by a sound source independent of distance or surroundings. Sound power levels calibrated using the CadnaA noise model at the reference distance to the noise source.

**TABLE 10-2: CONSTRUCTION EQUIPMENT NOISE LEVEL SUMMARY**

Receiver Location <sup>1</sup>	Construction Noise Levels (dBA L <sub>eq</sub> )					
	Site Preparation	Grading	Building Construction	Paving	Architectural Coating	Highest Levels <sup>2</sup>
R1	60.0	63.0	61.0	63.0	57.0	63.0
R2	58.8	61.8	59.8	61.8	55.8	61.8
R3	52.4	55.4	53.4	55.4	49.4	55.4
R4	51.8	54.8	52.8	54.8	48.8	54.8
R5	58.6	61.6	59.6	61.6	55.6	61.6
R6	59.0	62.0	60.0	62.0	56.0	62.0

<sup>1</sup>Noise receiver locations are shown on Exhibit 10-A.

<sup>2</sup>Construction noise level calculations based on distance from the construction activity, which is measured from the Project site boundary to the nearest receiver locations. CadnaA construction noise model inputs are included in Appendix 10.1.

#### 10.4 CONSTRUCTION NOISE LEVEL COMPLIANCE

To evaluate whether the Project will generate potentially significant short-term noise levels at nearest receiver locations, a construction-related daytime noise level threshold of 80 dBA L<sub>eq</sub> is used as a reasonable threshold to assess the daytime construction noise level impacts. The construction noise analysis shows that the nearest receiver locations will satisfy the reasonable daytime 80 dBA L<sub>eq</sub> significance threshold during Project construction activities as shown on Table 10-3. Therefore, the noise impacts due to Project construction noise are considered *less than significant* at all receiver locations.

**TABLE 10-3: CONSTRUCTION NOISE LEVEL COMPLIANCE**

Receiver Location <sup>1</sup>	Construction Noise Levels (dBA L <sub>eq</sub> )		
	Highest Construction Noise Levels <sup>2</sup>	Threshold <sup>3</sup>	Threshold Exceeded? <sup>4</sup>
R1	63.0	80	No
R2	61.8	80	No
R3	55.4	80	No
R4	54.8	80	No
R5	61.6	80	No
R6	62.0	80	No

<sup>1</sup>Noise receiver locations are shown on Exhibit 10-A.

<sup>2</sup>Highest construction noise level calculations based on distance from the construction noise source activity to the nearest receiver locations as shown on Table 10-2.

<sup>3</sup>Construction noise level thresholds as shown on Table 4-1.

<sup>4</sup>Do the estimated Project construction noise levels exceed the construction noise level threshold?

## 10.5 CONSTRUCTION VIBRATION ANALYSIS

Construction activity can result in varying degrees of ground vibration, depending on the equipment and methods employed. Operation of construction equipment causes ground vibrations that spread through the ground and diminish in strength with distance. Ground vibration levels associated with various types of construction equipment are summarized on Table 10-4. Based on the representative vibration levels presented for various construction equipment types, it is possible to estimate the potential for human response (annoyance) and building damage using the following vibration assessment methods defined by Caltrans. To calculate vibration levels at distance, Caltrans provides the following equation:  $PPV_{\text{equip}} = PPV_{\text{ref}} \times (25/D)^{1.5}$

**TABLE 10-4: VIBRATION SOURCE LEVELS FOR CONSTRUCTION EQUIPMENT**

Equipment	PPV (in/sec) at 25 feet
Small bulldozer	0.003
Jackhammer	0.035
Loaded Trucks	0.076
Large bulldozer	0.089
Vibratory Roller	0.210

Caltrans Transportation and Construction Vibration Guidance Manual, April 2020.

Table 10-5 presents the expected Project related vibration levels at the nearby receiver building façade locations. At distances ranging from 52 to 1,222 feet from the building façade to the Project construction activities, construction vibration velocity levels are estimated to range from 0.00 to 0.07 in/sec PPV. Based on maximum acceptable continuous vibration threshold of 0.3 PPV (in/sec), the typical Project construction vibration levels will fall below the building damage thresholds at all the noise sensitive receiver locations. Therefore, the Project-related vibration impacts are considered *less than significant* during typical construction activities at the Project site. Moreover, the vibration levels reported at the sensitive receiver locations are unlikely to be sustained during the entire construction period but will occur rather only during the times that heavy construction equipment is operating adjacent to the Project site perimeter.

**TABLE 10-5: PROJECT CONSTRUCTION VIBRATION LEVELS**

Location <sup>1</sup>	Distance to Const. Activity (Feet) <sup>2</sup>	Typical Construction Vibration Levels PPV (in/sec) <sup>3</sup>						Thresholds PPV (in/sec) <sup>4</sup>	Thresholds Exceeded? <sup>5</sup>
		Small bulldozer	Jackhammer	Loaded Trucks	Large bulldozer	Vibratory Roller	Highest Vibration Level		
R1	52'	0.00	0.01	0.03	0.03	0.07	0.07	0.30	No
R2	495'	0.00	0.00	0.00	0.00	0.00	0.00	0.30	No
R3	1,222'	0.00	0.00	0.00	0.00	0.00	0.00	0.30	No
R4	1,122'	0.00	0.00	0.00	0.00	0.00	0.00	0.30	No
R5	193'	0.00	0.00	0.00	0.00	0.01	0.01	0.30	No
R6	231'	0.00	0.00	0.00	0.00	0.01	0.01	0.30	No

<sup>1</sup> Receiver locations are shown on Exhibit 10-A.

<sup>2</sup> Distance from receiver building facade to Project construction boundary (Project site boundary).

<sup>3</sup> Based on the Vibration Source Levels of Construction Equipment (Table 10-4).

<sup>4</sup> Caltrans Transportation and Construction Vibration Guidance Manual, April 2020, Table 19, p. 38.

<sup>5</sup> Does the peak vibration exceed the acceptable vibration thresholds?

"PPV" = Peak Particle Velocity

Moreover, the impacts at the site of the nearest sensitive receiver locations are unlikely to be sustained during the entire construction period but will occur rather only during the times that heavy construction equipment is operating adjacent to the Project site perimeter.



## 11 REFERENCES

1. **State of California.** *California Environmental Quality Act, Appendix G.* 2018.
2. **California Department of Transportation Environmental Program.** *Technical Noise Supplement - A Technical Supplement to the Traffic Noise Analysis Protocol.* Sacramento, CA : s.n., September 2013.
3. **Environmental Protection Agency Office of Noise Abatement and Control.** *Information on Levels of Environmental Noise Requisite to Protect Public Health and Welfare with an Adequate Margin of Safety.* March 1974. EPA/ONAC 550/9/74-004.
4. **U.S. Department of Transportation, Federal Highway Administration, Office of Environment and Planning, Noise and Air Quality Branch.** *Highway Traffic Noise Analysis and Abatement Policy and Guidance.* December 2011.
5. **U.S. Department of Transportation Federal Highway Administration.** *Highway Noise Barrier Design Handbook.* 2001.
6. **U.S. Department of Transportation, Federal Highway Administration.** *Highway Traffic Noise in the United States, Problem and Response.* April 2000. p. 3.
7. **U.S. Environmental Protection Agency Office of Noise Abatement and Control.** *Noise Effects Handbook-A Desk Reference to Health and Welfare Effects of Noise.* October 1979 (revised July 1981). EPA 550/9/82/106.
8. **U.S. Department of Transportation, Federal Transit Administration.** *Transit Noise and Vibration Impact Assessment Manual.* September 2018.
9. **Office of Planning and Research.** *State of California General Plan Guidelines.* October 2017.
10. **State of California.** California Code of Regulations, Title 24, Part 2, Volume 1, Chapter 12, Section 1206.4, Allowable Interior Noise Level. *ICC Digital Coes.* [Online] 2019. <https://codes.iccsafe.org/content/CABCV12019/chapter-12-interior-environment>.
11. —. *2019 California Green Building Standards Code.* January 2020.
12. **City of Rancho Mirage.** *Municipal Code, Chapter 8.45 Noise.*
13. —. *Municipal Code, Sections 15.04.030.*
14. —. *General Plan Update Draft Environmental Impact Report.* 2005.
15. **California Department of Transportation.** *Transportation and Construction Vibration Guidance Manual.* April 2020.
16. **California Court of Appeal.** *Gray v. County of Madera, F053661.* 167 Cal.App.4th 1099; - Cal.Rptr.3d, October 2008.
17. **Federal Interagency Committee on Noise.** *Federal Agency Review of Selected Airport Noise Analysis Issues.* August 1992.
18. **California Department of Transportation.** *Technical Noise Supplement.* November 2009.
19. **American National Standards Institute (ANSI).** *Specification for Sound Level Meters ANSI S1.4-2014/IEC 61672-1:2013.*
20. **U.S. Department of Transportation, Federal Highway Administration.** *FHWA Highway Traffic Noise Prediction Model.* December 1978. FHWA-RD-77-108.

21. **California Department of Transportation Environmental Program, Office of Environmental Engineering.** *Use of California Vehicle Noise Reference Energy Mean Emission Levels (Calveno REMELs) in FHWA Highway Traffic Noise Prediction.* September 1995. TAN 95-03.
22. **California Department of Transportation.** *Traffic Noise Attenuation as a Function of Ground and Vegetation Final Report.* June 1995. FHWA/CA/TL-95/23.
23. **Urban Crossroads, Inc.** *Desert Island Hotel Focused Traffic Analysis.* 2022.
24. **U.S. Department of Transportation, Federal Highway Administration, Office of Environment and Planning.** *FHWA Roadway Construction Noise Model.* January, 2006.

## 12 CERTIFICATION

The contents of this noise study report represent an accurate depiction of the noise environment and impacts associated with the proposed Desert Island Hotel Project. The information contained in this noise study report is based on the best available data at the time of preparation. If you have any questions, please contact me directly at (619) 788-1971.

William Maddux  
Senior Associate  
URBAN CROSSROADS, INC.  
(619) 788-1971  
[bmaddux@urbanxroads.com](mailto:bmaddux@urbanxroads.com)

### EDUCATION

Bachelor of Science in Urban and Regional Planning  
California Polytechnic State University, Pomona • June 2000

### PROFESSIONAL AFFILIATIONS

ASA – Acoustical Society of America  
AEP – Association of Environmental Planners  
AWMA – Air and Waste Management Association  
INCE – Institute of Noise Control Engineers

### PROFESSIONAL CERTIFICATIONS

Approved Acoustical Consultant • County of San Diego  
FHWA Traffic Noise Model of Training • November 2004  
CadnaA Basic and Advanced Training Certificate • October 2008.

*This page intentionally left blank*

**APPENDIX 3.1:**

**CITY OF RANCHO MIRAGE MUNICIPAL CODE**

*This page intentionally left blank*

## Rancho Mirage, California Municipal Code

## Title 8 HEALTH AND SAFETY

**Chapter 8.45 NOISE**

8.45.010 Purpose.

8.45.020 Definitions.

8.45.030 Exterior noise level limits.

8.45.040 Noise level measurement.

8.45.050 Special provisions and exemptions.

8.45.060 Additional prohibition.

8.45.065 Landscape maintenance.

8.45.070 Administration.

8.45.080 Violations and enforcement procedures.

**8.45.010 Purpose.**

The city has established a quality of life and environment in which peace and quiet is highly valued by its residents, visitors and businesses. The existence of excessive noise within the city is a condition which is detrimental to the health, safety, comfort, welfare and quality of life of the citizenry and shall be regulated in the public interest. This chapter has been created to implement the goals and policies of the noise element of the city's general plan and to prohibit undesirable noises in the community. This chapter shall be referred to and cited as the Rancho Mirage noise ordinance. (Ord. 633 § 1(Exh. A), 1995)

**8.45.020 Definitions.**

Ambient noise level means the all encompassing noise level associated with a given environment, being a composite of sounds from all sources, excluding the alleged offensive noise, at the location and approximate time at which a comparison with the alleged offensive noise is to be made.

Cumulative period means an additive period of time consisting of individual time segments which may be continuous or interrupted.

Decibel (dBA) means a unit of sound level measured on a sound level meter using the A-weighting network.

Emergency means any occurrence or set of circumstances involving actual or imminent physical danger, crisis, trauma or property damage which demands immediate action.

Noise level means the same as sound level the terms are interchangeable.

Person means any individual, association, partnership, corporation, organization, or public agency, including associated officer(s), employee(s) or department(s).

Sound level means the quantity of decibels measured using the frequency weighting of A of a sound level meter.

Sound level meter means an instrument meeting the American National Standards Institute's standard S1.4-1983 or later revision, for Type 1 or Type 2 specifications; or an instrument and the associated recording and analyzing equipment which will provide equivalent data. (Ord. 633 § 1(Exh. A), 1995)

### 8.45.030 Exterior noise level limits.

No person shall operate or cause to be operated any source of sound or allow the creation of sound or noise on property owned, leased, occupied or otherwise controlled by such person which causes the noise level, as measured on any other property, to exceed:

A. The noise level for the applicable zone specified in Table A-1 for a cumulative period of more than thirty minutes in any hour of the applicable time period.

**Table A-1**

Land Use/Zone	Time of Day	Noise Level (dBA)
Residential, Low Density (R-E, H-R, R-L-2, R-L-3)	7:00 a.m. to 6:00 p.m.	55
	6:00 p.m. to 10:00 p.m.	50
	10:00 p.m. to 7:00 a.m.	45
Residential, Medium and High Density, Hospital, Open Space (OS, R-M, R-H, MHP)	7:00 a.m. to 6:00 p.m.	60
	6:00 p.m. to 10:00 p.m.	55
	10:00 p.m. to 7:00 a.m.	50
Commercial Office, Resort Commercial, Mixed Use, Institutional (O, P, Rs-H, M-U)	7:00 a.m. to 6:00 p.m.	65
	6:00 p.m. to 10:00 p.m.	60
	10:00 p.m. to 7:00 a.m.	55
Commercial Neighborhood, General Commercial, Commercial Recreation, Light Industrial (C-N, C-G, I-L)	7:00 a.m. to 6:00 p.m.	70
	6:00 p.m. to 10:00 p.m.	65
	10:00 p.m. to 7:00 a.m.	60

B. For cumulative periods of time less than thirty minutes in an hour, all the noise standards in Table A-1 are increased according to Table B-1.

**Table B-1**

Duration of Sound	dBA Adjustment
15—30 minutes per hour	+ 3
10—15 minutes per hour	+ 5
5—10 minutes per hour	+ 10
1—5 minutes per hour	+ 15
Any period of time less than 1 minute per hour	+ 20

C. If the measured ambient noise level exceeds the dBA limits in Table A-1, the noise limits and their adjustments for the first three categories in Table B-1 shall be increased in five dBA increments as needed to encompass or reflect said ambient noise level. The maximum noise level under the last two categories in Table B-1 shall be increased, if necessary, only to equal the ambient noise level. (Ord. 1015 § 2, 2011; Ord. 633 § 1(Exh. A), 1995)



### **8.45.040 Noise level measurement.**

- A. The location selected for measuring exterior noise levels shall be at the point of the property line of the affected property nearest the alleged offending noise source. If possible, the ambient noise shall be measured at the same location along the property line.
- B. If the measurement location is on a boundary between two different locations, the noise level limit applicable to the lower noise zone shall apply.
- C. Upon receipt of a complaint or a request to investigate, the code compliance officer, equipped with an American National Standards Institute Type 2 or better sound level meter, may investigate the complaint. The investigation shall consist of measurements and the gathering of data to adequately define the noise problem and shall include the following:
1. Type and measurement of noise source;
  2. Location of noise source relative to complainant's or affected property;
  3. Time period during which noise source is considered to be intrusive;
  4. Total duration of noise levels measured;
  5. Date(s) and time(s) of noise measurement survey. (Ord. 633 § 1(Exh. A), 1995)

### **8.45.050 Special provisions and exemptions.**

The following activities and noise sources shall be exempted from the provisions of this chapter:

- A. School bands, school athletic and other activities occurring on a school campus;
- B. Outdoor gatherings, dance, shows, entertainment for events authorized through the city's special events process;
- C. Activities conducted in public parks and public playgrounds that are dependent upon such facilities for their operation;
- D. Any emission of sound for purposes of alerting persons to an emergency or the general emission of sound during performance of emergency work;
- E. Construction, alteration, repair, grading or improvement of any building, structure, road or improvement to real property for which a permit has been issued by the city if said construction occurs within the allowable hours set forth in Section 15.04.030(A)(10);
- F. The operation of any equipment and machinery at any time within any zone by the city, its employees, or any agent or franchisee of the city in the course of performing maintenance, construction or trash collection. (Ord. 633 § 1(Exh. A), 1995)

### **8.45.060 Additional prohibition.**

It is unlawful and a nuisance for any person to keep, maintain or permit upon any lot or parcel of land within the city under his or her control any animal, including any fowl, which by any sound or cry shall habitually disturb the peace and comfort of any person in the reasonable and comfortable enjoyment of life or property. (Ord. 633 § 1(Exh. A), 1995)

### **8.45.065 Landscape maintenance.**

A. It is unlawful and a public nuisance for any person to permit or perform for-hire landscape and non-emergency exterior hardscape maintenance activities such as, but not limited to, tree trimming, re-seeding, lawn mowing, leaf blowing, dust and debris clearing and any other landscaping or nonemergency exterior hardscape maintenance activities which utilize any motorized saw, sander, drill, grinder, leaf-blower, lawnmower, hedge trimmer, edger, or any other similar tool or device any time on Saturday and Sunday and between the hours of six p.m. and seven a.m. the next day during weekdays, unless otherwise provided in this section.

B. The regular mowing or grooming of golf courses, grass tennis courts, grass croquet courts, and lawn bowling areas shall be exempt from the restrictions set forth in this section. The allowed work hours for mowing or green preparation for golf courses, grass tennis courts, grass croquet courts, and lawn bowling areas shall be between five thirty a.m. and seven p.m., seven days per week and during all seasons of the year.

C. Nothing set forth in this section shall permit any person from engaging in any activities that exceed the exterior noise level limits set forth in Section 8.45.030 or otherwise constitute a public nuisance as set forth in Section 14.60.325 of the Municipal Code. (Ord. 979, § 1, 2009; Ord. 936, § 3, 2006)

### **8.45.070 Administration.**

The noise control program established by this chapter shall be administered by and is the responsibility of the code compliance division as directed by the director of the community development department. (Ord. 633 § 1(Exh. A), 1995)

### **8.45.080 Violations and enforcement procedures.**

Violations of this chapter are declared to be a nuisance and subject to the procedures, remedies and penalties set forth in Title 14. (Ord. 916 §4, 2006; Ord. 633 § 1(Exh. A), 1995)

---

## **Contact:**

City Clerk: 760-324-4511

Published by Quality Code Publishing, Seattle, WA. By using this site, you agree to the terms of use.

**APPENDIX 5.1:**  
**STUDY AREA PHOTOS**

*This page intentionally left blank*

### JN: 14747 Study Area Photos



L1\_E  
33, 46' 20.200000"116, 25' 0.350000"



L1\_N  
33, 46' 20.230000"116, 25' 0.320000"



L1\_S  
33, 46' 20.240000"116, 25' 0.320000"



L1\_W  
33, 46' 20.210000"116, 25' 0.350000"



L2\_E  
33, 46' 12.500000"116, 24' 43.400000"



L2\_N  
33, 46' 12.540000"116, 24' 43.370000"



## JN: 14747 Study Area Photos



L2\_S

33, 46' 12.520000"116, 24' 43.460000"



L2\_W

33, 46' 12.500000"116, 24' 43.400000"



L3\_E

33, 46' 3.620000"116, 24' 40.330000"



L3\_N

33, 46' 3.830000"116, 24' 40.410000"



L3\_S

33, 46' 3.680000"116, 24' 40.410000"



L3\_W

33, 46' 3.650000"116, 24' 40.330000"



## JN: 14747 Study Area Photos



L4\_E  
33, 45' 59.410000"116, 24' 44.770000"



L4\_N  
33, 45' 59.600000"116, 24' 44.800000"



L4\_S  
33, 45' 59.610000"116, 24' 44.800000"



L4\_W  
33, 45' 59.440000"116, 24' 44.770000"



L5\_E  
33, 46' 17.040000"116, 25' 0.600000"



L5\_N  
33, 46' 17.060000"116, 25' 0.570000"



### JN: 14747 Study Area Photos



L5\_S  
33, 46' 17.030000"116, 25' 0.620000"



L5\_W  
33, 46' 17.060000"116, 25' 0.600000"



L6\_E  
33, 46' 13.680000"116, 25' 0.600000"



L6\_N  
33, 46' 13.570000"116, 25' 0.620000"



L6\_S  
33, 46' 13.570000"116, 25' 0.600000"



L6\_W  
33, 46' 13.620000"116, 25' 0.600000"



**APPENDIX 5.2:**  
**NOISE LEVEL MEASUREMENT WORKSHEETS**

*This page intentionally left blank*

## 24-Hour Noise Level Measurement Summary

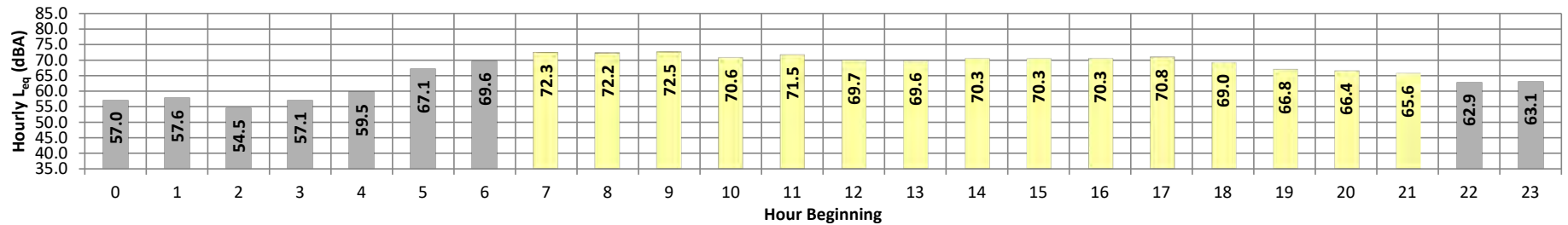
Date: Tuesday, April 5, 2022  
Project: 2717 Desert Island

Location: L1 - Located northwest of the Project site near single-family  
Source: residence at 1 Von Dehn Road.

Meter: Piccolo II

JN: 14747  
Analyst: A. Khan

Hourly  $L_{eq}$  dBA Readings (unadjusted)



Timeframe	Hour	$L_{eq}$	$L_{max}$	$L_{min}$	L1%	L2%	L5%	L8%	L25%	L50%	L90%	L95%	L99%	$L_{eq}$	Adj.	Adj. $L_{eq}$
Night	0	57.0	71.0	36.7	70.3	69.0	65.1	61.4	48.0	41.0	37.5	37.2	36.8	57.0	10.0	67.0
	1	57.6	72.4	36.4	71.8	70.3	65.0	60.3	45.6	40.3	37.0	36.8	36.5	57.6	10.0	67.6
	2	54.5	68.3	39.1	67.6	66.3	62.4	59.2	46.7	41.9	39.7	39.5	39.2	54.5	10.0	64.5
	3	57.1	71.1	38.5	70.4	69.1	64.7	61.5	49.5	42.8	39.2	38.9	38.6	57.1	10.0	67.1
	4	59.5	72.7	42.4	72.0	70.7	67.0	64.6	55.8	47.4	43.0	42.8	42.5	59.5	10.0	69.5
	5	67.1	78.3	53.1	77.7	76.6	74.0	72.4	66.2	61.5	54.9	54.1	53.3	67.1	10.0	77.1
Day	6	69.6	80.4	52.5	79.7	78.6	76.1	74.7	69.8	63.7	54.4	53.4	52.7	69.6	10.0	79.6
	7	72.3	83.4	54.8	82.7	81.5	78.3	76.5	72.7	68.2	57.9	56.0	55.0	72.3	0.0	72.3
	8	72.2	81.1	59.8	80.5	79.5	77.6	76.5	73.5	69.1	62.0	61.1	60.1	72.2	0.0	72.2
	9	72.5	80.3	59.3	79.8	79.1	77.8	76.9	73.8	70.1	62.2	61.0	59.6	72.5	0.0	72.5
	10	70.6	79.9	51.6	79.2	78.3	76.5	75.5	71.7	67.3	56.8	54.4	51.9	70.6	0.0	70.6
	11	71.5	84.0	52.2	83.0	81.5	77.4	75.2	71.1	66.8	56.0	54.0	52.4	71.5	0.0	71.5
	12	69.7	78.8	50.6	78.2	77.4	75.6	74.6	70.9	66.4	54.9	52.6	50.8	69.7	0.0	69.7
	13	69.6	79.7	51.0	79.1	78.1	75.5	74.1	70.4	65.8	55.3	53.0	51.3	69.6	0.0	69.6
	14	70.3	80.4	50.6	79.7	78.6	75.9	74.7	71.1	67.0	55.7	53.3	51.1	70.3	0.0	70.3
	15	70.3	79.4	50.8	78.8	77.9	76.0	74.9	71.6	67.3	56.6	53.7	51.1	70.3	0.0	70.3
	16	70.3	79.9	49.0	79.2	78.1	76.0	74.9	71.5	66.8	54.2	51.3	49.4	70.3	0.0	70.3
	17	70.8	82.0	49.4	81.3	79.9	76.8	75.3	71.1	66.3	54.2	52.1	49.9	70.8	0.0	70.8
	18	69.0	78.6	47.3	78.0	77.1	75.4	74.4	70.1	63.8	51.2	49.9	47.8	69.0	0.0	69.0
	19	66.8	77.8	46.3	77.1	76.1	73.6	72.3	66.8	59.0	48.3	47.0	46.6	66.8	5.0	71.8
	20	66.4	78.5	43.9	77.8	76.7	73.5	71.6	65.5	57.4	46.2	44.9	44.0	66.4	5.0	71.4
21	65.6	77.1	45.3	76.4	75.3	72.8	71.3	64.9	56.3	46.7	46.0	45.4	65.6	5.0	70.6	
Night	22	62.9	75.3	41.2	74.7	73.6	70.4	68.3	60.3	51.0	42.5	42.0	41.4	62.9	10.0	72.9
Night	23	63.1	76.6	40.4	75.7	74.2	70.3	68.1	59.7	50.8	42.1	41.3	40.6	63.1	10.0	73.1
Timeframe	Hour	$L_{eq}$	$L_{max}$	$L_{min}$	L1%	L2%	L5%	L8%	L25%	L50%	L90%	L95%	L99%	$L_{eq}$ (dBA)		
Day	Min	65.6	77.1	43.9	76.4	75.3	72.8	71.3	64.9	56.3	46.2	44.9	44.0	24-Hour	Daytime (7am-10pm)	Nighttime (10pm-7am)
	Max	72.5	84.0	59.8	83.0	81.5	78.3	76.9	73.8	70.1	62.2	61.1	60.1			
Energy Average		70.3	Average:		79.4	78.3	75.9	74.6	70.5	65.2	54.5	52.7	51.1	68.8	70.3	63.7
Night	Min	54.5	68.3	36.4	67.6	66.3	62.4	59.2	45.6	40.3	37.0	36.8	36.5			
	Max	69.6	80.4	53.1	79.7	78.6	76.1	74.7	69.8	63.7	54.9	54.1	53.3			
Energy Average		63.7	Average:		73.3	72.0	68.3	65.6	55.7	48.9	43.4	42.9	42.4			

## 24-Hour Noise Level Measurement Summary

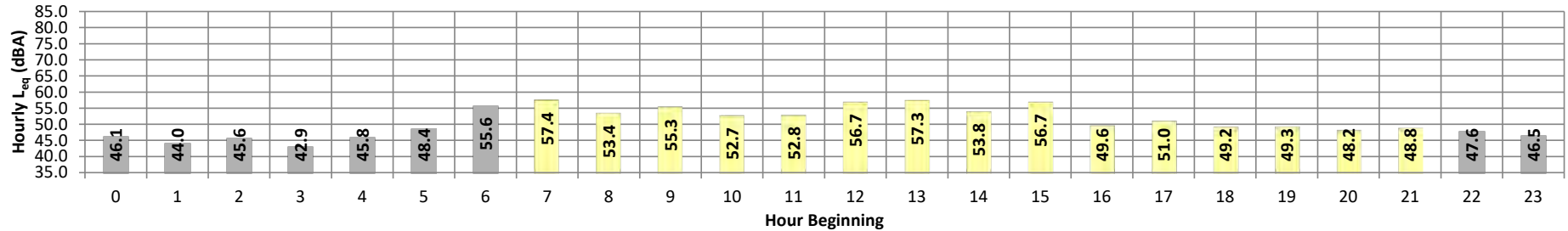
Date: Wednesday, March 23, 2022  
Project: 2717 Desert Island

Location: L2 - Located south of the Project site near multi-family  
Source: residence at 910 Island Drive.

Meter: Piccolo II

JN: 14747  
Analyst: A. Khan

Hourly  $L_{eq}$  dBA Readings (unadjusted)



Timeframe	Hour	$L_{eq}$	$L_{max}$	$L_{min}$	L1%	L2%	L5%	L8%	L25%	L50%	L90%	L95%	L99%	$L_{eq}$	Adj.	Adj. $L_{eq}$
Night	0	46.1	51.1	42.5	50.8	50.4	49.7	49.2	47.2	45.2	42.8	42.7	42.5	46.1	10.0	56.1
	1	44.0	48.3	41.9	48.1	47.7	46.8	46.0	44.4	43.3	42.3	42.1	41.9	44.0	10.0	54.0
	2	45.6	53.5	40.7	53.3	52.9	52.2	50.9	44.6	42.2	41.0	40.9	40.7	45.6	10.0	55.6
	3	42.9	47.1	40.3	46.8	46.4	45.5	45.0	43.6	42.4	40.8	40.6	40.4	42.9	10.0	52.9
	4	45.8	52.3	43.2	51.8	51.3	49.7	47.6	45.8	45.0	43.8	43.5	43.3	45.8	10.0	55.8
	5	48.4	53.5	45.1	53.2	52.6	51.7	51.0	49.3	47.4	45.7	45.5	45.2	48.4	10.0	58.4
Day	6	55.6	62.1	53.0	61.1	60.1	58.2	57.3	55.9	55.0	53.7	53.5	53.2	55.6	10.0	65.6
	7	57.4	61.8	55.0	61.5	61.2	60.0	59.3	57.8	56.9	55.6	55.3	55.1	57.4	0.0	57.4
	8	53.4	60.9	50.3	60.4	59.9	57.9	56.3	53.3	52.0	50.8	50.6	50.4	53.4	0.0	53.4
	9	55.3	62.7	48.2	62.0	61.4	59.9	58.8	56.0	53.8	50.2	49.4	48.5	55.3	0.0	55.3
	10	52.7	62.5	46.2	61.9	61.2	59.0	56.8	51.9	49.6	47.2	46.8	46.3	52.7	0.0	52.7
	11	52.8	62.9	45.7	61.8	60.8	58.3	56.9	53.1	49.8	46.6	46.3	45.9	52.8	0.0	52.8
	12	56.7	63.4	48.2	63.2	62.8	61.7	60.7	57.2	55.4	51.0	49.6	48.5	56.7	0.0	56.7
	13	57.3	66.0	45.8	65.7	65.3	63.6	62.5	57.9	53.3	46.8	46.4	45.9	57.3	0.0	57.3
	14	53.8	66.7	43.5	66.0	64.7	60.6	57.4	51.4	47.8	44.3	43.9	43.6	53.8	0.0	53.8
	15	56.7	67.3	48.7	65.8	64.8	61.9	60.6	57.2	53.6	49.3	49.1	48.8	56.7	0.0	56.7
	16	49.6	58.7	43.1	58.3	57.8	55.6	53.6	49.6	46.8	44.0	43.6	43.2	49.6	0.0	49.6
	17	51.0	61.6	43.6	60.7	59.6	57.2	55.1	50.4	47.7	44.6	44.3	43.8	51.0	0.0	51.0
	18	49.2	58.5	43.5	58.1	57.4	54.7	52.6	49.0	46.5	44.5	44.2	43.7	49.2	0.0	49.2
	19	49.3	57.4	43.4	56.9	56.5	55.0	53.5	49.8	46.6	44.0	43.8	43.5	49.3	5.0	54.3
	20	48.2	55.4	44.9	54.8	54.2	52.6	51.2	48.2	46.9	45.5	45.3	45.0	48.2	5.0	53.2
21	48.8	54.8	44.7	54.4	54.1	53.0	52.1	49.5	47.4	45.4	45.1	44.8	48.8	5.0	53.8	
Night	22	47.6	51.8	44.7	51.5	51.2	50.5	49.9	48.3	47.0	45.2	45.0	44.8	47.6	10.0	57.6
Night	23	46.5	51.9	43.3	51.6	51.2	49.8	49.2	47.0	45.6	43.9	43.7	43.4	46.5	10.0	56.5
Timeframe	Hour	$L_{eq}$	$L_{max}$	$L_{min}$	L1%	L2%	L5%	L8%	L25%	L50%	L90%	L95%	L99%	$L_{eq}$ (dBA)		
Day	Min	48.2	54.8	43.1	54.4	54.1	52.6	51.2	48.2	46.5	44.0	43.6	43.2	24-Hour	Daytime (7am-10pm)	Nighttime (10pm-7am)
	Max	57.4	67.3	55.0	66.0	65.3	63.6	62.5	57.9	56.9	55.6	55.3	55.1			
Energy Average		53.9	Average:		60.8	60.1	58.1	56.5	52.8	50.3	47.3	46.9	46.5			
Night	Min	42.9	47.1	40.3	46.8	46.4	45.5	45.0	43.6	42.2	40.8	40.6	40.4	52.6	53.9	48.9
	Max	55.6	62.1	53.0	61.1	60.1	58.2	57.3	55.9	55.0	53.7	53.5	53.2			
Energy Average		48.9	Average:		52.0	51.5	50.5	49.6	47.3	45.9	44.4	44.2	43.9			

## 24-Hour Noise Level Measurement Summary

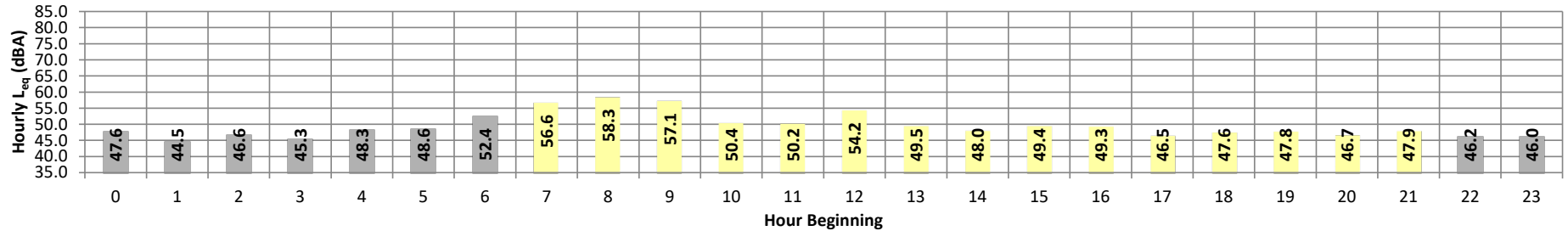
Date: Wednesday, March 23, 2022  
Project: 2717 Desert Island

Location: L3 - Located south of the Project site near multi-family  
Source: residence at 900 Island Drive.

Meter: Piccolo II

JN: 14747  
Analyst: A. Khan

Hourly  $L_{eq}$  dBA Readings (unadjusted)



Timeframe	Hour	$L_{eq}$	$L_{max}$	$L_{min}$	L1%	L2%	L5%	L8%	L25%	L50%	L90%	L95%	L99%	$L_{eq}$	Adj.	Adj. $L_{eq}$	
Night	0	47.6	52.9	44.0	52.5	52.2	51.3	50.8	48.7	46.2	44.5	44.3	44.0	47.6	10.0	57.6	
	1	44.5	48.2	42.6	47.8	47.5	47.0	46.5	45.0	44.0	43.0	42.9	42.6	44.5	10.0	54.5	
	2	46.6	53.1	41.3	52.8	52.6	52.1	51.6	47.0	43.8	41.8	41.6	41.6	41.4	10.0	56.6	
	3	45.3	47.9	43.6	47.7	47.5	47.0	46.7	45.9	45.1	44.0	43.8	43.8	43.6	45.3	10.0	55.3
	4	48.3	51.9	46.6	51.7	51.4	50.4	49.8	48.7	48.0	47.0	46.8	46.7	46.7	48.3	10.0	58.3
	5	48.6	52.3	46.2	52.0	51.7	51.0	50.5	50.5	49.0	48.1	46.8	46.6	46.3	48.6	10.0	58.6
Day	6	52.4	58.6	49.8	57.9	57.6	56.4	54.8	52.3	51.6	50.3	50.1	49.9	52.4	10.0	62.4	
	7	56.6	59.6	54.0	59.3	59.1	58.7	58.5	57.6	56.1	54.7	54.4	54.1	56.6	0.0	56.6	
	8	58.3	63.9	54.8	63.0	62.5	61.3	60.6	58.9	57.7	55.8	55.3	54.9	58.3	0.0	58.3	
	9	57.1	62.3	50.8	61.8	61.4	60.9	60.5	58.2	56.1	52.5	51.7	51.0	57.1	0.0	57.1	
	10	50.4	56.7	46.5	56.0	55.4	54.0	53.4	51.0	49.6	47.3	46.9	46.6	50.4	0.0	50.4	
	11	50.2	55.8	46.0	55.2	54.7	53.8	53.2	51.4	49.1	46.8	46.5	46.1	50.2	0.0	50.2	
	12	54.2	68.4	44.3	66.7	64.7	59.4	57.5	52.5	48.2	45.3	44.9	44.5	54.2	0.0	54.2	
	13	49.5	55.6	44.5	55.1	54.7	54.0	53.2	50.4	47.8	45.2	45.0	44.6	49.5	0.0	49.5	
	14	48.0	56.0	43.0	55.2	54.5	52.6	51.6	48.6	46.0	43.7	43.4	43.1	48.0	0.0	48.0	
	15	49.4	55.9	43.6	55.4	54.9	53.8	53.2	50.6	47.5	44.8	44.2	43.7	49.4	0.0	49.4	
	16	49.3	54.7	46.4	54.2	53.6	52.5	52.0	49.7	48.6	46.7	46.6	46.4	49.3	0.0	49.3	
	17	46.5	51.7	43.0	51.0	50.6	49.7	49.2	47.4	45.5	43.7	43.5	43.2	46.5	0.0	46.5	
	18	47.6	52.7	44.5	52.3	51.9	50.8	50.1	48.4	46.6	45.0	44.8	44.6	47.6	0.0	47.6	
	19	47.8	53.1	44.4	52.7	52.2	51.3	50.7	48.5	46.7	45.0	44.8	44.5	47.8	5.0	52.8	
	20	46.7	50.6	44.0	50.4	50.2	49.3	48.9	47.3	46.1	44.7	44.4	44.1	46.7	5.0	51.7	
21	47.9	53.5	44.3	53.2	52.7	51.6	51.2	48.7	46.6	44.8	44.6	44.3	47.9	5.0	52.9		
Night	22	46.2	50.3	43.7	49.9	49.5	48.8	48.3	46.8	45.6	44.2	44.0	43.8	46.2	10.0	56.2	
	23	46.0	49.8	43.6	49.2	48.6	48.6	48.2	46.8	45.2	44.1	43.9	43.7	46.0	10.0	56.0	
<b>Timeframe</b>	<b>Hour</b>	<b><math>L_{eq}</math></b>	<b><math>L_{max}</math></b>	<b><math>L_{min}</math></b>	<b>L1%</b>	<b>L2%</b>	<b>L5%</b>	<b>L8%</b>	<b>L25%</b>	<b>L50%</b>	<b>L90%</b>	<b>L95%</b>	<b>L99%</b>	<b><math>L_{eq}</math> (dBA)</b>			
Day	Min	46.5	50.6	43.0	50.4	50.2	49.3	48.9	47.3	45.5	43.7	43.4	43.1	<b>24-Hour</b>	<b>Daytime</b>	<b>(7am-10pm)</b>	
	Max	58.3	68.4	54.8	66.7	64.7	61.3	60.6	58.9	57.7	55.8	55.3	54.9				<b>Nighttime</b>
Energy Average		52.6	Average:		56.1	55.5	54.2	53.6	51.3	49.2	47.1	46.7	46.4	<b>51.4</b>	<b>52.6</b>	<b>47.9</b>	
Night	Min	44.5	47.9	41.3	47.7	47.5	47.0	46.5	45.0	43.8	41.8	41.6	41.4				<b>51.4</b>
	Max	52.4	58.6	49.8	57.9	57.6	56.4	54.8	52.3	51.6	50.3	50.1	49.9	<b>51.4</b>	<b>52.6</b>	<b>47.9</b>	
Energy Average		47.9	Average:		51.3	51.0	50.3	49.7	47.8	46.4	45.1	44.9	44.7				<b>51.4</b>

## 24-Hour Noise Level Measurement Summary

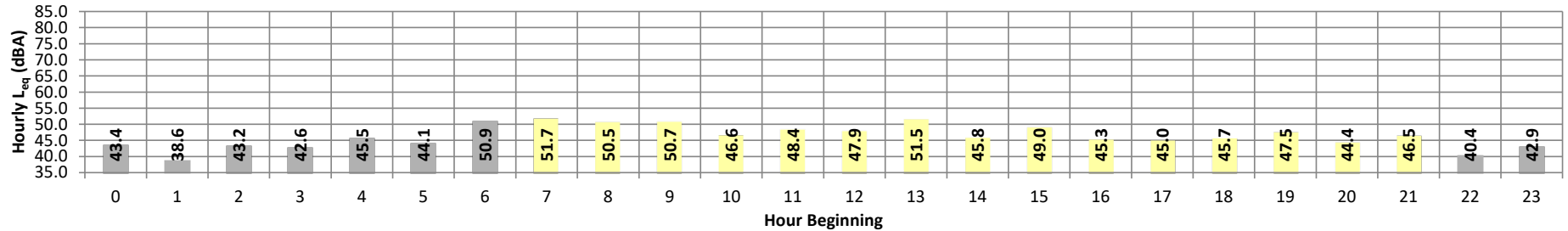
Date: Wednesday, March 23, 2022  
Project: 2717 Desert Island

Location: L4 - Located south of the Project site near multi-family  
Source: residence at 899 Island Drive.

Meter: Piccolo II

JN: 14747  
Analyst: A. Khan

Hourly  $L_{eq}$  dBA Readings (unadjusted)



Timeframe	Hour	$L_{eq}$	$L_{max}$	$L_{min}$	L1%	L2%	L5%	L8%	L25%	L50%	L90%	L95%	L99%	$L_{eq}$	Adj.	Adj. $L_{eq}$
Night	0	43.4	47.8	39.8	47.5	47.3	46.7	46.3	44.6	42.5	40.3	40.1	39.9	43.4	10.0	53.4
	1	38.6	42.1	37.4	41.8	41.5	40.7	40.1	38.7	38.3	37.7	37.6	37.5	38.6	10.0	48.6
	2	43.2	49.6	37.6	49.4	49.3	48.8	48.4	43.5	40.1	38.1	37.9	37.7	43.2	10.0	53.2
	3	42.6	45.6	41.1	45.2	44.8	44.2	43.8	43.1	42.3	41.4	41.3	41.2	42.6	10.0	52.6
	4	45.5	48.9	43.9	48.5	48.2	47.6	47.2	45.9	45.1	44.3	44.2	44.0	45.5	10.0	55.5
	5	44.1	48.3	42.3	47.8	47.4	46.5	45.8	44.4	44.4	43.7	42.8	42.6	42.4	44.1	10.0
Day	6	50.9	53.6	48.6	53.3	53.1	52.8	52.5	51.5	50.6	49.3	49.1	48.8	50.9	10.0	60.9
	7	51.7	54.8	49.5	54.5	54.3	53.8	53.4	52.3	51.3	50.1	49.9	49.6	51.7	0.0	51.7
	8	50.5	57.8	46.7	57.0	56.5	55.2	54.1	50.8	48.8	47.4	47.2	46.9	50.5	0.0	50.5
	9	50.7	57.1	45.8	56.6	56.0	55.1	54.6	51.5	48.9	46.7	46.4	46.0	50.7	0.0	50.7
	10	46.6	52.7	43.3	52.0	51.4	50.2	49.4	47.1	45.5	44.0	43.7	43.5	46.6	0.0	46.6
	11	48.4	55.6	42.9	54.7	54.0	52.9	52.2	49.6	46.0	43.7	43.4	43.1	48.4	0.0	48.4
	12	47.9	54.5	43.5	53.9	53.2	52.1	51.1	48.6	46.3	44.4	44.0	43.7	47.9	0.0	47.9
	13	51.5	58.8	43.4	58.3	58.0	57.3	56.6	52.2	48.1	44.4	44.1	43.8	51.5	0.0	51.5
	14	45.8	52.5	40.9	51.9	51.5	50.2	49.4	46.8	44.2	41.6	41.3	41.1	45.8	0.0	45.8
	15	49.0	57.2	40.3	56.6	55.9	54.4	53.7	50.5	45.1	41.4	41.0	40.5	49.0	0.0	49.0
	16	45.3	53.3	39.7	52.6	52.0	50.4	49.2	46.1	43.1	40.3	40.1	39.8	45.3	0.0	45.3
	17	45.0	51.6	40.4	51.0	50.3	48.8	48.1	46.0	43.7	41.1	40.9	40.6	45.0	0.0	45.0
	18	45.7	51.4	41.8	51.0	50.7	49.7	49.0	46.7	44.2	42.5	42.2	41.9	45.7	0.0	45.7
	19	47.5	52.9	42.9	52.5	52.0	51.3	50.9	48.9	45.9	43.7	43.4	43.1	47.5	5.0	52.5
	20	44.4	49.8	42.1	49.2	48.4	47.4	46.6	45.0	43.7	42.6	42.4	42.2	44.4	5.0	49.4
21	46.5	53.2	40.4	52.9	52.7	51.9	51.5	47.4	42.7	40.9	40.7	40.5	46.5	5.0	51.5	
Night	22	40.4	44.6	38.1	44.1	43.6	42.7	42.3	41.0	39.9	38.6	38.4	38.2	40.4	10.0	50.4
	23	42.9	48.5	38.3	48.0	47.6	47.0	46.5	43.9	41.5	38.9	38.7	38.5	42.9	10.0	52.9
<b>Timeframe</b>	<b>Hour</b>	<b><math>L_{eq}</math></b>	<b><math>L_{max}</math></b>	<b><math>L_{min}</math></b>	<b>L1%</b>	<b>L2%</b>	<b>L5%</b>	<b>L8%</b>	<b>L25%</b>	<b>L50%</b>	<b>L90%</b>	<b>L95%</b>	<b>L99%</b>	<b><math>L_{eq}</math> (dBA)</b>		
Day	Min	44.4	49.8	39.7	49.2	48.4	47.4	46.6	45.0	42.7	40.3	40.1	39.8	<b>24-Hour</b>	<b>Daytime</b> (7am-10pm)	<b>Nighttime</b> (10pm-7am)
	Max	51.7	58.8	49.5	58.3	58.0	57.3	56.6	52.3	51.3	50.1	49.9	49.6			
Energy Average		48.4	Average:		53.6	53.1	52.1	51.3	48.6	45.8	43.7	43.4	43.1			
Night	Min	38.6	42.1	37.4	41.8	41.5	40.7	40.1	38.7	38.3	37.7	37.6	37.5	<b>47.4</b>	<b>48.4</b>	<b>45.0</b>
	Max	50.9	53.6	48.6	53.3	53.1	52.8	52.5	51.5	50.6	49.3	49.1	48.8			
Energy Average		45.0	Average:		47.3	47.0	46.3	45.9	44.1	42.7	41.3	41.1	40.9			

## 24-Hour Noise Level Measurement Summary

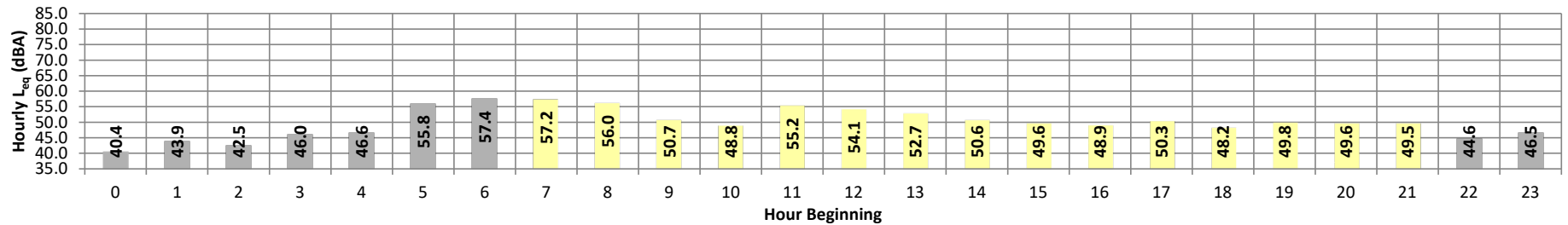
Date: Tuesday, April 5, 2022  
Project: 2717 Desert Island

Location: L5 - Located southwest of the Project site near single-family  
Source: residence at 3 Vohn Dehn Road.

Meter: Piccolo II

JN: 14747  
Analyst: A. Khan

Hourly  $L_{eq}$  dBA Readings (unadjusted)



Timeframe	Hour	$L_{eq}$	$L_{max}$	$L_{min}$	L1%	L2%	L5%	L8%	L25%	L50%	L90%	L95%	L99%	$L_{eq}$	Adj.	Adj. $L_{eq}$
Night	0	40.4	45.0	37.5	44.8	44.5	43.7	43.0	41.1	39.6	38.0	37.8	37.6	40.4	10.0	50.4
	1	43.9	51.0	39.6	50.3	49.9	48.8	47.8	44.3	42.1	40.1	39.9	39.7	43.9	10.0	53.9
	2	42.5	49.1	39.3	48.7	48.2	47.1	45.7	42.7	41.0	39.7	39.6	39.3	42.5	10.0	52.5
	3	46.0	53.0	42.0	52.8	52.4	51.4	49.9	45.8	43.8	42.5	42.3	42.1	46.0	10.0	56.0
	4	46.6	49.2	44.7	49.0	48.8	48.4	48.2	47.2	46.2	45.2	45.1	44.9	46.6	10.0	56.6
	5	55.8	60.4	51.3	60.2	60.0	59.5	58.8	56.8	54.9	52.6	52.0	51.5	55.8	10.0	65.8
Day	6	57.4	62.0	54.5	61.6	61.4	60.3	59.6	58.0	56.9	55.1	54.9	54.6	57.4	10.0	67.4
	7	57.2	60.5	54.8	60.3	60.1	59.4	59.0	57.7	56.8	55.6	55.3	55.0	57.2	0.0	57.2
	8	56.0	59.8	52.7	59.5	59.3	58.8	58.5	56.7	55.3	53.4	53.2	52.8	56.0	0.0	56.0
	9	50.7	54.5	47.2	54.2	54.0	53.5	53.0	51.4	50.2	48.0	47.7	47.3	50.7	0.0	50.7
	10	48.8	55.1	42.7	54.6	54.3	53.5	52.9	49.9	47.1	43.9	43.4	42.8	48.8	0.0	48.8
	11	55.2	59.6	52.5	59.4	59.1	58.3	57.6	55.6	54.4	53.1	52.9	52.6	55.2	0.0	55.2
	12	54.1	60.6	48.2	60.1	59.7	58.3	57.6	55.4	52.3	49.2	48.8	48.3	54.1	0.0	54.1
	13	52.7	70.3	49.2	68.5	66.6	64.5	63.7	58.6	54.9	50.5	50.0	49.4	52.7	0.0	52.7
	14	50.6	59.6	44.1	59.1	58.7	57.3	56.6	53.9	49.0	45.1	44.7	44.2	50.6	0.0	50.6
	15	49.6	56.3	43.1	55.8	55.3	54.6	54.0	50.5	47.5	44.2	43.7	43.3	49.6	0.0	49.6
	16	48.9	54.8	42.9	54.5	54.2	53.5	52.7	49.9	47.6	44.1	43.6	43.1	48.9	0.0	48.9
	17	50.3	57.6	43.1	57.2	56.7	55.9	54.8	50.8	47.9	44.2	43.7	43.2	50.3	0.0	50.3
	18	48.2	54.6	43.4	54.1	53.3	52.1	51.3	48.9	47.1	44.2	43.9	43.6	48.2	0.0	48.2
	19	49.8	56.5	44.3	56.1	55.8	55.1	54.2	50.4	47.5	45.1	44.8	44.4	49.8	5.0	54.8
	20	49.6	55.1	45.0	54.8	54.5	53.9	53.4	50.4	48.0	45.7	45.4	45.2	49.6	5.0	54.6
21	49.5	56.5	45.4	55.8	55.1	53.7	53.0	50.0	47.9	46.0	45.8	45.5	49.5	5.0	54.5	
Night	22	44.6	49.0	40.8	48.8	48.6	48.0	47.5	45.5	43.7	41.6	41.3	40.9	44.6	10.0	54.6
Night	23	46.5	53.9	39.5	53.5	53.2	52.4	51.6	47.1	43.4	40.2	40.0	39.6	46.5	10.0	56.5
Timeframe	Hour	$L_{eq}$	$L_{max}$	$L_{min}$	L1%	L2%	L5%	L8%	L25%	L50%	L90%	L95%	L99%	$L_{eq}$ (dBA)		
Day	Min	48.2	54.5	42.7	54.1	53.3	52.1	51.3	48.9	47.1	43.9	43.4	42.8	24-Hour	Daytime (7am-10pm)	Nighttime (10pm-7am)
	Max	57.2	70.3	54.8	68.5	66.6	64.5	63.7	58.6	56.8	55.6	55.3	55.0			
Energy Average		52.4	Average:		57.6	57.1	56.2	55.5	52.7	50.2	47.5	47.1	46.7	51.9	52.4	51.0
Night	Min	40.4	45.0	37.5	44.8	44.5	43.7	43.0	41.1	39.6	38.0	37.8	37.6			
	Max	57.4	62.0	54.5	61.6	61.4	60.3	59.6	58.0	56.9	55.1	54.9	54.6			
Energy Average		51.0	Average:		52.2	51.9	51.1	50.2	47.6	45.7	43.9	43.6	43.4			

## 24-Hour Noise Level Measurement Summary

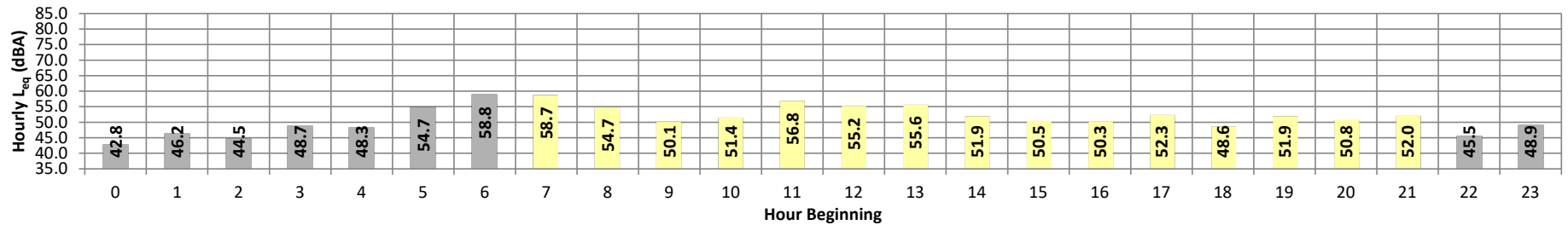
Date: Tuesday, April 5, 2022  
Project: 2717 Desert Island

Location: L6 - Located west of the Project site near single-family  
Source: residence at 1 Vohn Dehn Road.

Meter: Piccolo II

JN: 14747  
Analyst: A. Khan

Hourly  $L_{eq}$  dBA Readings (unadjusted)



Timeframe	Hour	$L_{eq}$	$L_{max}$	$L_{min}$	L1%	L2%	L5%	L8%	L25%	L50%	L90%	L95%	L99%	$L_{eq}$	Adj.	Adj. $L_{eq}$
Night	0	42.8	46.3	40.3	45.9	45.6	45.0	44.7	43.5	42.4	40.9	40.7	40.4	42.8	10.0	52.8
	1	46.2	51.1	43.3	50.8	50.4	49.4	48.8	46.9	45.2	43.8	43.5	43.4	46.2	10.0	56.2
	2	44.5	49.5	42.2	49.1	48.8	47.4	46.7	44.7	43.7	42.8	42.5	42.3	44.5	10.0	54.5
	3	48.7	55.1	44.3	54.8	54.7	53.9	53.3	48.7	46.7	44.8	44.6	44.4	48.7	10.0	58.7
	4	48.3	50.5	46.6	50.3	50.1	49.7	49.5	48.8	48.0	47.0	46.8	46.6	48.3	10.0	58.3
	5	54.7	58.6	50.8	58.4	58.3	57.7	57.2	55.8	54.2	51.8	51.3	51.0	54.7	10.0	64.7
Day	6	58.8	64.6	56.6	64.2	63.9	63.0	62.5	59.9	58.7	57.2	57.0	56.7	58.8	10.0	68.8
	7	58.7	61.0	56.8	60.8	60.5	60.1	59.8	59.2	58.5	57.4	57.2	56.9	58.7	0.0	58.7
	8	54.7	60.0	53.3	59.7	59.5	59.1	58.8	57.7	56.4	54.2	53.9	53.4	54.7	0.0	54.7
	9	50.1	55.0	47.4	54.3	53.7	52.8	52.3	50.6	49.6	48.2	47.9	47.6	50.1	0.0	50.1
	10	51.4	58.9	44.2	58.5	57.9	57.0	56.2	51.7	48.8	45.5	45.0	44.4	51.4	0.0	51.4
	11	56.8	63.4	52.9	62.8	62.4	61.0	59.9	57.2	55.5	53.7	53.4	53.1	56.8	0.0	56.8
	12	55.2	63.2	50.6	62.6	62.2	61.2	60.5	57.0	54.2	51.6	51.2	50.7	55.2	0.0	55.2
	13	55.6	72.9	49.7	71.8	70.9	66.0	63.8	59.4	56.2	51.3	50.7	49.9	55.6	0.0	55.6
	14	51.9	63.5	45.6	62.7	62.1	60.9	60.1	55.3	50.3	46.5	46.1	45.8	51.9	0.0	51.9
	15	50.5	57.1	44.4	56.8	56.6	56.0	55.2	51.2	47.4	45.2	44.8	44.5	50.5	0.0	50.5
	16	50.3	55.9	45.8	55.4	54.9	54.2	53.7	51.2	48.8	46.5	46.2	45.9	50.3	0.0	50.3
	17	52.3	59.7	44.6	59.3	58.9	58.2	57.3	53.1	49.0	45.5	45.2	44.7	52.3	0.0	52.3
	18	48.6	52.9	44.7	52.6	52.4	51.6	51.2	49.6	47.9	45.5	45.2	44.9	48.6	0.0	48.6
	19	51.9	58.6	46.2	58.3	58.0	57.2	56.3	52.8	49.3	46.9	46.7	46.4	51.9	5.0	56.9
	20	50.8	55.7	46.7	55.5	55.3	54.5	53.9	51.8	49.8	47.3	47.0	46.8	50.8	5.0	55.8
21	52.0	58.3	47.6	57.8	57.3	56.4	55.8	52.9	50.1	48.2	48.0	47.7	52.0	5.0	57.0	
Night	22	45.5	49.8	42.7	49.5	49.1	48.4	48.0	46.0	44.8	43.3	43.1	42.8	45.5	10.0	55.5
Night	23	48.9	62.0	43.5	59.5	58.4	56.4	55.3	50.7	46.5	44.1	43.8	43.6	48.9	10.0	58.9
Timeframe	Hour	$L_{eq}$	$L_{max}$	$L_{min}$	L1%	L2%	L5%	L8%	L25%	L50%	L90%	L95%	L99%	$L_{eq}$ (dBA)		
Day	Min	48.6	52.9	44.2	52.6	52.4	51.6	51.2	49.6	47.4	45.2	44.8	44.4	24-Hour	Daytime (7am-10pm)	Nighttime (10pm-7am)
	Max	58.7	72.9	56.8	71.8	70.9	66.0	63.8	59.4	58.5	57.4	57.2	56.9			
Energy Average		53.7	Average:		59.3	58.9	57.7	57.0	54.1	51.5	48.9	48.6	48.2	53.1	53.7	51.9
Night	Min	42.8	46.3	40.3	45.9	45.6	45.0	44.7	43.5	42.4	40.9	40.7	40.4			
	Max	58.8	64.6	56.6	64.2	63.9	63.0	62.5	59.9	58.7	57.2	57.0	56.7			
Energy Average		51.9	Average:		53.6	53.3	52.3	51.8	49.4	47.8	46.2	45.9	45.7			



**APPENDIX 7.1:**  
**OFF-SITE TRAFFIC NOISE LEVEL CALCULATIONS**

*This page intentionally left blank*

**FHWA-RD-77-108 HIGHWAY NOISE PREDICTION MODEL**

Scenario: E  
 Road Name: Frank Sinatra Drive  
 Road Segment: w/o Island Drive

Project Name: Desert Islands Hotel  
 Job Number: 14747

SITE SPECIFIC INPUT DATA		NOISE MODEL INPUTS				
<b>Highway Data</b>		<b>Site Conditions (Hard = 10, Soft = 15)</b>				
Average Daily Traffic (Adt): 13,700 vehicles		Autos: 15				
Peak Hour Percentage: 10.00%		Medium Trucks (2 Axles): 15				
Peak Hour Volume: 1,370 vehicles		Heavy Trucks (3+ Axles): 15				
Vehicle Speed: 45 mph		<b>Vehicle Mix</b>				
Near/Far Lane Distance: 58 feet		VehicleType	Day	Evening	Night	Daily
<b>Site Data</b>		Autos: 77.5% 12.9% 9.6% 97.42%				
Barrier Height: 0.0 feet		Medium Trucks: 84.8% 4.9% 10.3% 1.84%				
Barrier Type (0-Wall, 1-Berm): 0.0		Heavy Trucks: 86.5% 2.7% 10.8% 0.74%				
Centerline Dist. to Barrier: 55.0 feet		<b>Noise Source Elevations (in feet)</b>				
Centerline Dist. to Observer: 55.0 feet		Autos: 0.000				
Barrier Distance to Observer: 0.0 feet		Medium Trucks: 2.297				
Observer Height (Above Pad): 5.0 feet		Heavy Trucks: 8.006      Grade Adjustment: 0.0				
Pad Elevation: 0.0 feet		<b>Lane Equivalent Distance (in feet)</b>				
Road Elevation: 0.0 feet		Autos: 47.000				
Road Grade: 0.0%		Medium Trucks: 46.811				
Left View: -90.0 degrees		Heavy Trucks: 46.830				
Right View: 90.0 degrees						

**FHWA Noise Model Calculations**

VehicleType	REMEL	Traffic Flow	Distance	Finite Road	Fresnel	Barrier Atten	Berm Atten
Autos:	68.46	-0.58	0.30	-1.20	-4.67	0.000	0.000
Medium Trucks:	79.45	-17.82	0.33	-1.20	-4.87	0.000	0.000
Heavy Trucks:	84.25	-21.78	0.32	-1.20	-5.38	0.000	0.000

**Unmitigated Noise Levels (without Topo and barrier attenuation)**

VehicleType	Leq Peak Hour	Leq Day	Leq Evening	Leq Night	Ldn	CNEL
Autos:	67.0	65.1	63.3	57.3	65.9	66.5
Medium Trucks:	60.8	59.2	52.9	51.3	59.8	60.0
Heavy Trucks:	61.6	60.2	51.1	52.4	60.7	60.9
Vehicle Noise:	68.8	67.1	63.9	59.2	67.8	68.2

**Centerline Distance to Noise Contour (in feet)**

	70 dBA	65 dBA	60 dBA	55 dBA
Ldn:	39	84	182	392
CNEL:	42	91	195	420

**FHWA-RD-77-108 HIGHWAY NOISE PREDICTION MODEL**

Scenario: E  
 Road Name: Frank Sinatra Drive  
 Road Segment: e/o Island Drive

Project Name: Desert Islands Hotel  
 Job Number: 14747

SITE SPECIFIC INPUT DATA		NOISE MODEL INPUTS				
<b>Highway Data</b>		<b>Site Conditions (Hard = 10, Soft = 15)</b>				
Average Daily Traffic (Adt): 13,300 vehicles		Autos: 15				
Peak Hour Percentage: 10.00%		Medium Trucks (2 Axles): 15				
Peak Hour Volume: 1,330 vehicles		Heavy Trucks (3+ Axles): 15				
Vehicle Speed: 45 mph		<b>Vehicle Mix</b>				
Near/Far Lane Distance: 58 feet		VehicleType	Day	Evening	Night	Daily
<b>Site Data</b>		Autos: 77.5% 12.9% 9.6% 97.42%				
Barrier Height: 0.0 feet		Medium Trucks: 84.8% 4.9% 10.3% 1.84%				
Barrier Type (0-Wall, 1-Berm): 0.0		Heavy Trucks: 86.5% 2.7% 10.8% 0.74%				
Centerline Dist. to Barrier: 55.0 feet		<b>Noise Source Elevations (in feet)</b>				
Centerline Dist. to Observer: 55.0 feet		Autos: 0.000				
Barrier Distance to Observer: 0.0 feet		Medium Trucks: 2.297				
Observer Height (Above Pad): 5.0 feet		Heavy Trucks: 8.006      Grade Adjustment: 0.0				
Pad Elevation: 0.0 feet		<b>Lane Equivalent Distance (in feet)</b>				
Road Elevation: 0.0 feet		Autos: 47.000				
Road Grade: 0.0%		Medium Trucks: 46.811				
Left View: -90.0 degrees		Heavy Trucks: 46.830				
Right View: 90.0 degrees						

<b>FHWA Noise Model Calculations</b>							
VehicleType	REMEL	Traffic Flow	Distance	Finite Road	Fresnel	Barrier Atten	Berm Atten
Autos:	68.46	-0.71	0.30	-1.20	-4.67	0.000	0.000
Medium Trucks:	79.45	-17.95	0.33	-1.20	-4.87	0.000	0.000
Heavy Trucks:	84.25	-21.91	0.32	-1.20	-5.38	0.000	0.000

<b>Unmitigated Noise Levels (without Topo and barrier attenuation)</b>							
VehicleType	Leq Peak Hour	Leq Day	Leq Evening	Leq Night	Ldn	CNEL	
Autos:	66.8	64.9	63.2	57.1	65.8	66.4	
Medium Trucks:	60.6	59.1	52.8	51.2	59.7	59.9	
Heavy Trucks:	61.5	60.0	51.0	52.3	60.6	60.7	
Vehicle Noise:	68.7	66.9	63.8	59.1	67.7	68.1	

<b>Centerline Distance to Noise Contour (in feet)</b>				
	70 dBA	65 dBA	60 dBA	55 dBA
Ldn:	38	83	178	384
CNEL:	41	89	191	412

**FHWA-RD-77-108 HIGHWAY NOISE PREDICTION MODEL**

Scenario: E  
 Road Name: Frank Sinatra Drive  
 Road Segment: e/o Bob Hope Drive

Project Name: Desert Islands Hotel  
 Job Number: 14747

SITE SPECIFIC INPUT DATA		NOISE MODEL INPUTS				
<b>Highway Data</b>		<b>Site Conditions (Hard = 10, Soft = 15)</b>				
Average Daily Traffic (Adt): 13,100 vehicles		Autos: 15				
Peak Hour Percentage: 10.00%		Medium Trucks (2 Axles): 15				
Peak Hour Volume: 1,310 vehicles		Heavy Trucks (3+ Axles): 15				
Vehicle Speed: 45 mph		<b>Vehicle Mix</b>				
Near/Far Lane Distance: 58 feet		VehicleType	Day	Evening	Night	Daily
<b>Site Data</b>		Autos: 77.5% 12.9% 9.6% 97.42%				
Barrier Height: 0.0 feet		Medium Trucks: 84.8% 4.9% 10.3% 1.84%				
Barrier Type (0-Wall, 1-Berm): 0.0		Heavy Trucks: 86.5% 2.7% 10.8% 0.74%				
Centerline Dist. to Barrier: 55.0 feet		<b>Noise Source Elevations (in feet)</b>				
Centerline Dist. to Observer: 55.0 feet		Autos: 0.000				
Barrier Distance to Observer: 0.0 feet		Medium Trucks: 2.297				
Observer Height (Above Pad): 5.0 feet		Heavy Trucks: 8.006 Grade Adjustment: 0.0				
Pad Elevation: 0.0 feet		<b>Lane Equivalent Distance (in feet)</b>				
Road Elevation: 0.0 feet		Autos: 47.000				
Road Grade: 0.0%		Medium Trucks: 46.811				
Left View: -90.0 degrees		Heavy Trucks: 46.830				
Right View: 90.0 degrees						

**FHWA Noise Model Calculations**

VehicleType	REMEL	Traffic Flow	Distance	Finite Road	Fresnel	Barrier Atten	Berm Atten
Autos:	68.46	-0.78	0.30	-1.20	-4.67	0.000	0.000
Medium Trucks:	79.45	-18.02	0.33	-1.20	-4.87	0.000	0.000
Heavy Trucks:	84.25	-21.97	0.32	-1.20	-5.38	0.000	0.000

**Unmitigated Noise Levels (without Topo and barrier attenuation)**

VehicleType	Leq Peak Hour	Leq Day	Leq Evening	Leq Night	Ldn	CNEL
Autos:	66.8	64.9	63.1	57.1	65.7	66.3
Medium Trucks:	60.6	59.1	52.7	51.1	59.6	59.8
Heavy Trucks:	61.4	60.0	50.9	52.2	60.6	60.7
Vehicle Noise:	68.6	66.9	63.7	59.1	67.6	68.1

**Centerline Distance to Noise Contour (in feet)**

	70 dBA	65 dBA	60 dBA	55 dBA
Ldn:	38	82	177	380
CNEL:	41	88	189	408

**FHWA-RD-77-108 HIGHWAY NOISE PREDICTION MODEL**

Scenario: E  
 Road Name: Bob Hope Drive  
 Road Segment: n/o Frank Sinatra Drive

Project Name: Desert Islands Hotel  
 Job Number: 14747

SITE SPECIFIC INPUT DATA		NOISE MODEL INPUTS				
<b>Highway Data</b>		<b>Site Conditions (Hard = 10, Soft = 15)</b>				
Average Daily Traffic (Adt):	18,600 vehicles	Autos: 15				
Peak Hour Percentage:	10.00%	Medium Trucks (2 Axles): 15				
Peak Hour Volume:	1,860 vehicles	Heavy Trucks (3+ Axles): 15				
Vehicle Speed:	45 mph	<b>Vehicle Mix</b>				
Near/Far Lane Distance:	86 feet	VehicleType	Day	Evening	Night	Daily
<b>Site Data</b>		Autos: 77.5% 12.9% 9.6% 97.42%				
<b>Barrier Height:</b>	<b>0.0 feet</b>	Medium Trucks: 84.8% 4.9% 10.3% 1.84%				
Barrier Type (0-Wall, 1-Berm):	0.0	Heavy Trucks: 86.5% 2.7% 10.8% 0.74%				
Centerline Dist. to Barrier:	60.0 feet	<b>Noise Source Elevations (in feet)</b>				
Centerline Dist. to Observer:	60.0 feet	Autos: 0.000				
Barrier Distance to Observer:	0.0 feet	Medium Trucks: 2.297				
Observer Height (Above Pad):	5.0 feet	Heavy Trucks: 8.006      Grade Adjustment: 0.0				
Pad Elevation:	0.0 feet	<b>Lane Equivalent Distance (in feet)</b>				
Road Elevation:	0.0 feet	Autos: 42.143				
Road Grade:	0.0%	Medium Trucks: 41.932				
Left View:	-90.0 degrees	Heavy Trucks: 41.953				
Right View:	90.0 degrees					

<b>FHWA Noise Model Calculations</b>							
VehicleType	REMEL	Traffic Flow	Distance	Finite Road	Fresnel	Barrier Atten	Berm Atten
Autos:	68.46	0.74	1.01	-1.20	-4.69	0.000	0.000
Medium Trucks:	79.45	-16.49	1.04	-1.20	-4.88	0.000	0.000
Heavy Trucks:	84.25	-20.45	1.04	-1.20	-5.34	0.000	0.000

<b>Unmitigated Noise Levels (without Topo and barrier attenuation)</b>							
VehicleType	Leq Peak Hour	Leq Day	Leq Evening	Leq Night	Ldn	CNEL	
Autos:	69.0	67.1	65.3	59.3	67.9	68.5	
Medium Trucks:	62.8	61.3	54.9	53.4	61.8	62.1	
Heavy Trucks:	63.6	62.2	53.2	54.4	62.8	62.9	
Vehicle Noise:	70.9	69.1	66.0	61.3	69.8	70.3	

<b>Centerline Distance to Noise Contour (in feet)</b>				
	70 dBA	65 dBA	60 dBA	55 dBA
Ldn:	58	126	271	585
CNEL:	63	135	291	627

**FHWA-RD-77-108 HIGHWAY NOISE PREDICTION MODEL**

Scenario: E  
 Road Name: Bob Hope Drive  
 Road Segment: s/o Frank Sinatra Drive

Project Name: Desert Islands Hotel  
 Job Number: 14747

SITE SPECIFIC INPUT DATA		NOISE MODEL INPUTS				
<b>Highway Data</b>		<b>Site Conditions (Hard = 10, Soft = 15)</b>				
Average Daily Traffic (Adt): 21,300 vehicles		Autos: 15				
Peak Hour Percentage: 10.00%		Medium Trucks (2 Axles): 15				
Peak Hour Volume: 2,130 vehicles		Heavy Trucks (3+ Axles): 15				
Vehicle Speed: 45 mph		<b>Vehicle Mix</b>				
Near/Far Lane Distance: 58 feet		VehicleType	Day	Evening	Night	Daily
<b>Site Data</b>		Autos: 77.5% 12.9% 9.6% 97.42%				
Barrier Height: 0.0 feet		Medium Trucks: 84.8% 4.9% 10.3% 1.84%				
Barrier Type (0-Wall, 1-Berm): 0.0		Heavy Trucks: 86.5% 2.7% 10.8% 0.74%				
Centerline Dist. to Barrier: 55.0 feet		<b>Noise Source Elevations (in feet)</b>				
Centerline Dist. to Observer: 55.0 feet		Autos: 0.000				
Barrier Distance to Observer: 0.0 feet		Medium Trucks: 2.297				
Observer Height (Above Pad): 5.0 feet		Heavy Trucks: 8.006      Grade Adjustment: 0.0				
Pad Elevation: 0.0 feet		<b>Lane Equivalent Distance (in feet)</b>				
Road Elevation: 0.0 feet		Autos: 47.000				
Road Grade: 0.0%		Medium Trucks: 46.811				
Left View: -90.0 degrees		Heavy Trucks: 46.830				
Right View: 90.0 degrees						

**FHWA Noise Model Calculations**

VehicleType	REMEL	Traffic Flow	Distance	Finite Road	Fresnel	Barrier Atten	Berm Atten
Autos:	68.46	1.33	0.30	-1.20	-4.67	0.000	0.000
Medium Trucks:	79.45	-15.91	0.33	-1.20	-4.87	0.000	0.000
Heavy Trucks:	84.25	-19.86	0.32	-1.20	-5.38	0.000	0.000

**Unmitigated Noise Levels (without Topo and barrier attenuation)**

VehicleType	Leq Peak Hour	Leq Day	Leq Evening	Leq Night	Ldn	CNEL
Autos:	68.9	67.0	65.2	59.2	67.8	68.4
Medium Trucks:	62.7	61.2	54.8	53.3	61.7	61.9
Heavy Trucks:	63.5	62.1	53.1	54.3	62.7	62.8
Vehicle Noise:	70.7	69.0	65.8	61.2	69.7	70.2

**Centerline Distance to Noise Contour (in feet)**

	70 dBA	65 dBA	60 dBA	55 dBA
Ldn:	53	113	244	526
CNEL:	56	122	262	564

**FHWA-RD-77-108 HIGHWAY NOISE PREDICTION MODEL**

Scenario: E  
 Road Name: Island Drive  
 Road Segment: s/o Frank Sinatra Drive

Project Name: Desert Islands Hotel  
 Job Number: 14747

SITE SPECIFIC INPUT DATA		NOISE MODEL INPUTS				
<b>Highway Data</b>		<b>Site Conditions (Hard = 10, Soft = 15)</b>				
Average Daily Traffic (Adt):	1,000 vehicles	Autos: 15				
Peak Hour Percentage:	10.00%	Medium Trucks (2 Axles): 15				
Peak Hour Volume:	100 vehicles	Heavy Trucks (3+ Axles): 15				
Vehicle Speed:	25 mph	<b>Vehicle Mix</b>				
Near/Far Lane Distance:	12 feet	VehicleType	Day	Evening	Night	Daily
<b>Site Data</b>		Autos: 77.5% 12.9% 9.6% 97.42%				
<b>Barrier Height:</b>	<b>0.0 feet</b>	Medium Trucks: 84.8% 4.9% 10.3% 1.84%				
Barrier Type (0-Wall, 1-Berm):	0.0	Heavy Trucks: 86.5% 2.7% 10.8% 0.74%				
Centerline Dist. to Barrier:	30.0 feet	<b>Noise Source Elevations (in feet)</b>				
Centerline Dist. to Observer:	30.0 feet	Autos: 0.000				
Barrier Distance to Observer:	0.0 feet	Medium Trucks: 2.297				
Observer Height (Above Pad):	5.0 feet	Heavy Trucks: 8.006      Grade Adjustment: 0.0				
Pad Elevation:	0.0 feet	<b>Lane Equivalent Distance (in feet)</b>				
Road Elevation:	0.0 feet	Autos: 29.816				
Road Grade:	0.0%	Medium Trucks: 29.518				
Left View:	-90.0 degrees	Heavy Trucks: 29.547				
Right View:	90.0 degrees					

**FHWA Noise Model Calculations**

VehicleType	REMEL	Traffic Flow	Distance	Finite Road	Fresnel	Barrier Atten	Berm Atten
Autos:	58.73	-9.40	3.26	-1.20	-4.49	0.000	0.000
Medium Trucks:	70.80	-26.64	3.33	-1.20	-4.86	0.000	0.000
Heavy Trucks:	77.97	-30.59	3.32	-1.20	-5.77	0.000	0.000

**Unmitigated Noise Levels (without Topo and barrier attenuation)**

VehicleType	Leq Peak Hour	Leq Day	Leq Evening	Leq Night	Ldn	CNEL
Autos:	51.4	49.5	47.7	41.7	50.3	50.9
Medium Trucks:	46.3	44.8	38.4	36.9	45.3	45.6
Heavy Trucks:	49.5	48.1	39.0	40.3	48.7	48.8
Vehicle Noise:	54.3	52.6	48.7	44.8	53.3	53.7

**Centerline Distance to Noise Contour (in feet)**

	70 dBA	65 dBA	60 dBA	55 dBA
Ldn:	2	5	11	23
CNEL:	2	5	11	25



**FHWA-RD-77-108 HIGHWAY NOISE PREDICTION MODEL**

Scenario: E+P  
 Road Name: Frank Sinatra Drive  
 Road Segment: w/o Island Drive

Project Name: Desert Islands Hotel  
 Job Number: 14747

SITE SPECIFIC INPUT DATA		NOISE MODEL INPUTS				
<b>Highway Data</b>		<b>Site Conditions (Hard = 10, Soft = 15)</b>				
Average Daily Traffic (Adt): 13,950 vehicles		Autos: 15				
Peak Hour Percentage: 10.00%		Medium Trucks (2 Axles): 15				
Peak Hour Volume: 1,395 vehicles		Heavy Trucks (3+ Axles): 15				
Vehicle Speed: 45 mph		<b>Vehicle Mix</b>				
Near/Far Lane Distance: 58 feet		VehicleType	Day	Evening	Night	Daily
<b>Site Data</b>		Autos: 77.5% 12.9% 9.6% 97.42%				
Barrier Height: 0.0 feet		Medium Trucks: 84.8% 4.9% 10.3% 1.84%				
Barrier Type (0-Wall, 1-Berm): 0.0		Heavy Trucks: 86.5% 2.7% 10.8% 0.74%				
Centerline Dist. to Barrier: 55.0 feet		<b>Noise Source Elevations (in feet)</b>				
Centerline Dist. to Observer: 55.0 feet		Autos: 0.000				
Barrier Distance to Observer: 0.0 feet		Medium Trucks: 2.297				
Observer Height (Above Pad): 5.0 feet		Heavy Trucks: 8.006      Grade Adjustment: 0.0				
Pad Elevation: 0.0 feet		<b>Lane Equivalent Distance (in feet)</b>				
Road Elevation: 0.0 feet		Autos: 47.000				
Road Grade: 0.0%		Medium Trucks: 46.811				
Left View: -90.0 degrees		Heavy Trucks: 46.830				
Right View: 90.0 degrees						

**FHWA Noise Model Calculations**

VehicleType	REMEL	Traffic Flow	Distance	Finite Road	Fresnel	Barrier Atten	Berm Atten
Autos:	68.46	-0.51	0.30	-1.20	-4.67	0.000	0.000
Medium Trucks:	79.45	-17.74	0.33	-1.20	-4.87	0.000	0.000
Heavy Trucks:	84.25	-21.70	0.32	-1.20	-5.38	0.000	0.000

**Unmitigated Noise Levels (without Topo and barrier attenuation)**

VehicleType	Leq Peak Hour	Leq Day	Leq Evening	Leq Night	Ldn	CNEL
Autos:	67.1	65.2	63.4	57.3	66.0	66.6
Medium Trucks:	60.8	59.3	53.0	51.4	59.9	60.1
Heavy Trucks:	61.7	60.3	51.2	52.5	60.8	61.0
Vehicle Noise:	68.9	67.2	64.0	59.3	67.9	68.3

**Centerline Distance to Noise Contour (in feet)**

	70 dBA	65 dBA	60 dBA	55 dBA
Ldn:	40	85	184	397
CNEL:	43	92	197	425

**FHWA-RD-77-108 HIGHWAY NOISE PREDICTION MODEL**

Scenario: E+P  
 Road Name: Frank Sinatra Drive  
 Road Segment: e/o Island Drive

Project Name: Desert Islands Hotel  
 Job Number: 14747

SITE SPECIFIC INPUT DATA		NOISE MODEL INPUTS				
<b>Highway Data</b>		<b>Site Conditions (Hard = 10, Soft = 15)</b>				
Average Daily Traffic (Adt): 14,050 vehicles		Autos: 15				
Peak Hour Percentage: 10.00%		Medium Trucks (2 Axles): 15				
Peak Hour Volume: 1,405 vehicles		Heavy Trucks (3+ Axles): 15				
Vehicle Speed: 45 mph		<b>Vehicle Mix</b>				
Near/Far Lane Distance: 58 feet		VehicleType	Day	Evening	Night	Daily
<b>Site Data</b>		Autos: 77.5% 12.9% 9.6% 97.42%				
Barrier Height: 0.0 feet		Medium Trucks: 84.8% 4.9% 10.3% 1.84%				
Barrier Type (0-Wall, 1-Berm): 0.0		Heavy Trucks: 86.5% 2.7% 10.8% 0.74%				
Centerline Dist. to Barrier: 55.0 feet		<b>Noise Source Elevations (in feet)</b>				
Centerline Dist. to Observer: 55.0 feet		Autos: 0.000				
Barrier Distance to Observer: 0.0 feet		Medium Trucks: 2.297				
Observer Height (Above Pad): 5.0 feet		Heavy Trucks: 8.006      Grade Adjustment: 0.0				
Pad Elevation: 0.0 feet		<b>Lane Equivalent Distance (in feet)</b>				
Road Elevation: 0.0 feet		Autos: 47.000				
Road Grade: 0.0%		Medium Trucks: 46.811				
Left View: -90.0 degrees		Heavy Trucks: 46.830				
Right View: 90.0 degrees						

**FHWA Noise Model Calculations**

VehicleType	REMEL	Traffic Flow	Distance	Finite Road	Fresnel	Barrier Atten	Berm Atten
Autos:	68.46	-0.47	0.30	-1.20	-4.67	0.000	0.000
Medium Trucks:	79.45	-17.71	0.33	-1.20	-4.87	0.000	0.000
Heavy Trucks:	84.25	-21.67	0.32	-1.20	-5.38	0.000	0.000

**Unmitigated Noise Levels (without Topo and barrier attenuation)**

VehicleType	Leq Peak Hour	Leq Day	Leq Evening	Leq Night	Ldn	CNEL
Autos:	67.1	65.2	63.4	57.4	66.0	66.6
Medium Trucks:	60.9	59.4	53.0	51.4	59.9	60.1
Heavy Trucks:	61.7	60.3	51.2	52.5	60.9	61.0
Vehicle Noise:	68.9	67.2	64.0	59.4	67.9	68.4

**Centerline Distance to Noise Contour (in feet)**

	70 dBA	65 dBA	60 dBA	55 dBA
Ldn:	40	86	185	398
CNEL:	43	92	198	427

**FHWA-RD-77-108 HIGHWAY NOISE PREDICTION MODEL**

Scenario: E+P  
 Road Name: Frank Sinatra Drive  
 Road Segment: e/o Bob Hope Drive

Project Name: Desert Islands Hotel  
 Job Number: 14747

SITE SPECIFIC INPUT DATA		NOISE MODEL INPUTS				
<b>Highway Data</b>		<b>Site Conditions (Hard = 10, Soft = 15)</b>				
Average Daily Traffic (Adt): 13,300 vehicles		Autos: 15				
Peak Hour Percentage: 10.00%		Medium Trucks (2 Axles): 15				
Peak Hour Volume: 1,330 vehicles		Heavy Trucks (3+ Axles): 15				
Vehicle Speed: 45 mph		<b>Vehicle Mix</b>				
Near/Far Lane Distance: 58 feet		VehicleType	Day	Evening	Night	Daily
<b>Site Data</b>		Autos: 77.5% 12.9% 9.6% 97.42%				
Barrier Height: 0.0 feet		Medium Trucks: 84.8% 4.9% 10.3% 1.84%				
Barrier Type (0-Wall, 1-Berm): 0.0		Heavy Trucks: 86.5% 2.7% 10.8% 0.74%				
Centerline Dist. to Barrier: 55.0 feet		<b>Noise Source Elevations (in feet)</b>				
Centerline Dist. to Observer: 55.0 feet		Autos: 0.000				
Barrier Distance to Observer: 0.0 feet		Medium Trucks: 2.297				
Observer Height (Above Pad): 5.0 feet		Heavy Trucks: 8.006      Grade Adjustment: 0.0				
Pad Elevation: 0.0 feet		<b>Lane Equivalent Distance (in feet)</b>				
Road Elevation: 0.0 feet		Autos: 47.000				
Road Grade: 0.0%		Medium Trucks: 46.811				
Left View: -90.0 degrees		Heavy Trucks: 46.830				
Right View: 90.0 degrees						

<b>FHWA Noise Model Calculations</b>							
VehicleType	REMEL	Traffic Flow	Distance	Finite Road	Fresnel	Barrier Atten	Berm Atten
Autos:	68.46	-0.71	0.30	-1.20	-4.67	0.000	0.000
Medium Trucks:	79.45	-17.95	0.33	-1.20	-4.87	0.000	0.000
Heavy Trucks:	84.25	-21.91	0.32	-1.20	-5.38	0.000	0.000

<b>Unmitigated Noise Levels (without Topo and barrier attenuation)</b>							
VehicleType	Leq Peak Hour	Leq Day	Leq Evening	Leq Night	Ldn	CNEL	
Autos:	66.8	64.9	63.2	57.1	65.8	66.4	
Medium Trucks:	60.6	59.1	52.8	51.2	59.7	59.9	
Heavy Trucks:	61.5	60.0	51.0	52.3	60.6	60.7	
Vehicle Noise:	68.7	66.9	63.8	59.1	67.7	68.1	

<b>Centerline Distance to Noise Contour (in feet)</b>				
	70 dBA	65 dBA	60 dBA	55 dBA
Ldn:	38	83	178	384
CNEL:	41	89	191	412

**FHWA-RD-77-108 HIGHWAY NOISE PREDICTION MODEL**

Scenario: E+P  
 Road Name: Bob Hope Drive  
 Road Segment: n/o Frank Sinatra Drive

Project Name: Desert Islands Hotel  
 Job Number: 14747

SITE SPECIFIC INPUT DATA		NOISE MODEL INPUTS				
<b>Highway Data</b>		<b>Site Conditions (Hard = 10, Soft = 15)</b>				
Average Daily Traffic (Adt): 18,900 vehicles		Autos: 15				
Peak Hour Percentage: 10.00%		Medium Trucks (2 Axles): 15				
Peak Hour Volume: 1,890 vehicles		Heavy Trucks (3+ Axles): 15				
Vehicle Speed: 45 mph		<b>Vehicle Mix</b>				
Near/Far Lane Distance: 86 feet		VehicleType	Day	Evening	Night	Daily
<b>Site Data</b>		Autos: 77.5% 12.9% 9.6% 97.42%				
Barrier Height: 0.0 feet		Medium Trucks: 84.8% 4.9% 10.3% 1.84%				
Barrier Type (0-Wall, 1-Berm): 0.0		Heavy Trucks: 86.5% 2.7% 10.8% 0.74%				
Centerline Dist. to Barrier: 60.0 feet		<b>Noise Source Elevations (in feet)</b>				
Centerline Dist. to Observer: 60.0 feet		Autos: 0.000				
Barrier Distance to Observer: 0.0 feet		Medium Trucks: 2.297				
Observer Height (Above Pad): 5.0 feet		Heavy Trucks: 8.006      Grade Adjustment: 0.0				
Pad Elevation: 0.0 feet		<b>Lane Equivalent Distance (in feet)</b>				
Road Elevation: 0.0 feet		Autos: 42.143				
Road Grade: 0.0%		Medium Trucks: 41.932				
Left View: -90.0 degrees		Heavy Trucks: 41.953				
Right View: 90.0 degrees						

<b>FHWA Noise Model Calculations</b>							
VehicleType	REMEL	Traffic Flow	Distance	Finite Road	Fresnel	Barrier Atten	Berm Atten
Autos:	68.46	0.81	1.01	-1.20	-4.69	0.000	0.000
Medium Trucks:	79.45	-16.42	1.04	-1.20	-4.88	0.000	0.000
Heavy Trucks:	84.25	-20.38	1.04	-1.20	-5.34	0.000	0.000

<b>Unmitigated Noise Levels (without Topo and barrier attenuation)</b>							
VehicleType	Leq Peak Hour	Leq Day	Leq Evening	Leq Night	Ldn	CNEL	
Autos:	69.1	67.2	65.4	59.4	68.0	68.6	
Medium Trucks:	62.9	61.4	55.0	53.5	61.9	62.1	
Heavy Trucks:	63.7	62.3	53.3	54.5	62.9	63.0	
Vehicle Noise:	70.9	69.2	66.0	61.4	69.9	70.4	

<b>Centerline Distance to Noise Contour (in feet)</b>				
	70 dBA	65 dBA	60 dBA	55 dBA
Ldn:	59	127	274	591
CNEL:	63	137	294	634

**FHWA-RD-77-108 HIGHWAY NOISE PREDICTION MODEL**

Scenario: E+P  
 Road Name: Bob Hope Drive  
 Road Segment: s/o Frank Sinatra Drive

Project Name: Desert Islands Hotel  
 Job Number: 14747

SITE SPECIFIC INPUT DATA		NOISE MODEL INPUTS				
<b>Highway Data</b>		<b>Site Conditions (Hard = 10, Soft = 15)</b>				
Average Daily Traffic (Adt): 21,320 vehicles		Autos: 15				
Peak Hour Percentage: 10.00%		Medium Trucks (2 Axles): 15				
Peak Hour Volume: 2,132 vehicles		Heavy Trucks (3+ Axles): 15				
Vehicle Speed: 45 mph		<b>Vehicle Mix</b>				
Near/Far Lane Distance: 58 feet		VehicleType	Day	Evening	Night	Daily
<b>Site Data</b>		Autos: 77.5% 12.9% 9.6% 97.42%				
Barrier Height: 0.0 feet		Medium Trucks: 84.8% 4.9% 10.3% 1.84%				
Barrier Type (0-Wall, 1-Berm): 0.0		Heavy Trucks: 86.5% 2.7% 10.8% 0.74%				
Centerline Dist. to Barrier: 55.0 feet		<b>Noise Source Elevations (in feet)</b>				
Centerline Dist. to Observer: 55.0 feet		Autos: 0.000				
Barrier Distance to Observer: 0.0 feet		Medium Trucks: 2.297				
Observer Height (Above Pad): 5.0 feet		Heavy Trucks: 8.006      Grade Adjustment: 0.0				
Pad Elevation: 0.0 feet		<b>Lane Equivalent Distance (in feet)</b>				
Road Elevation: 0.0 feet		Autos: 47.000				
Road Grade: 0.0%		Medium Trucks: 46.811				
Left View: -90.0 degrees		Heavy Trucks: 46.830				
Right View: 90.0 degrees						

<b>FHWA Noise Model Calculations</b>							
VehicleType	REMEL	Traffic Flow	Distance	Finite Road	Fresnel	Barrier Atten	Berm Atten
Autos:	68.46	1.34	0.30	-1.20	-4.67	0.000	0.000
Medium Trucks:	79.45	-15.90	0.33	-1.20	-4.87	0.000	0.000
Heavy Trucks:	84.25	-19.86	0.32	-1.20	-5.38	0.000	0.000

<b>Unmitigated Noise Levels (without Topo and barrier attenuation)</b>							
VehicleType	Leq Peak Hour	Leq Day	Leq Evening	Leq Night	Ldn	CNEL	
Autos:	68.9	67.0	65.2	59.2	67.8	68.4	
Medium Trucks:	62.7	61.2	54.8	53.3	61.7	62.0	
Heavy Trucks:	63.5	62.1	53.1	54.3	62.7	62.8	
Vehicle Noise:	70.7	69.0	65.8	61.2	69.7	70.2	

<b>Centerline Distance to Noise Contour (in feet)</b>				
	70 dBA	65 dBA	60 dBA	55 dBA
Ldn:	53	113	244	526
CNEL:	56	122	262	564

**FHWA-RD-77-108 HIGHWAY NOISE PREDICTION MODEL**

Scenario: E+P  
 Road Name: Island Drive  
 Road Segment: s/o Frank Sinatra Drive

Project Name: Desert Islands Hotel  
 Job Number: 14747

SITE SPECIFIC INPUT DATA		NOISE MODEL INPUTS				
<b>Highway Data</b>		<b>Site Conditions (Hard = 10, Soft = 15)</b>				
Average Daily Traffic (Adt):	1,100 vehicles	Autos:				15
Peak Hour Percentage:	10.00%	Medium Trucks (2 Axles):				15
Peak Hour Volume:	110 vehicles	Heavy Trucks (3+ Axles):				15
Vehicle Speed:	25 mph	<b>Vehicle Mix</b>				
Near/Far Lane Distance:	12 feet	VehicleType	Day	Evening	Night	Daily
<b>Site Data</b>		Autos: 77.5% 12.9% 9.6% 97.42%				
Barrier Height:	0.0 feet	Medium Trucks: 84.8% 4.9% 10.3% 1.84%				
Barrier Type (0-Wall, 1-Berm):	0.0	Heavy Trucks: 86.5% 2.7% 10.8% 0.74%				
Centerline Dist. to Barrier:	30.0 feet	<b>Noise Source Elevations (in feet)</b>				
Centerline Dist. to Observer:	30.0 feet	Autos: 0.000				
Barrier Distance to Observer:	0.0 feet	Medium Trucks: 2.297				
Observer Height (Above Pad):	5.0 feet	Heavy Trucks: 8.006      Grade Adjustment: 0.0				
Pad Elevation:	0.0 feet	<b>Lane Equivalent Distance (in feet)</b>				
Road Elevation:	0.0 feet	Autos: 29.816				
Road Grade:	0.0%	Medium Trucks: 29.518				
Left View:	-90.0 degrees	Heavy Trucks: 29.547				
Right View:	90.0 degrees					

<b>FHWA Noise Model Calculations</b>							
VehicleType	REMEL	Traffic Flow	Distance	Finite Road	Fresnel	Barrier Atten	Berm Atten
Autos:	58.73	-8.98	3.26	-1.20	-4.49	0.000	0.000
Medium Trucks:	70.80	-26.22	3.33	-1.20	-4.86	0.000	0.000
Heavy Trucks:	77.97	-30.18	3.32	-1.20	-5.77	0.000	0.000

<b>Unmitigated Noise Levels (without Topo and barrier attenuation)</b>							
VehicleType	Leq Peak Hour	Leq Day	Leq Evening	Leq Night	Ldn	CNEL	
Autos:	51.8	49.9	48.1	42.1	50.7	51.3	
Medium Trucks:	46.7	45.2	38.8	37.3	45.7	46.0	
Heavy Trucks:	49.9	48.5	39.5	40.7	49.1	49.2	
Vehicle Noise:	54.7	53.1	49.1	45.2	53.7	54.1	

<b>Centerline Distance to Noise Contour (in feet)</b>				
	70 dBA	65 dBA	60 dBA	55 dBA
Ldn:	2	5	11	25
CNEL:	3	6	12	26

**FHWA-RD-77-108 HIGHWAY NOISE PREDICTION MODEL**

Scenario: EA  
 Road Name: Frank Sinatra Drive  
 Road Segment: w/o Island Drive

Project Name: Desert Islands Hotel  
 Job Number: 14747

SITE SPECIFIC INPUT DATA		NOISE MODEL INPUTS				
<b>Highway Data</b>		<b>Site Conditions (Hard = 10, Soft = 15)</b>				
Average Daily Traffic (Adt): 14,250 vehicles		Autos: 15				
Peak Hour Percentage: 10.00%		Medium Trucks (2 Axles): 15				
Peak Hour Volume: 1,425 vehicles		Heavy Trucks (3+ Axles): 15				
Vehicle Speed: 45 mph		<b>Vehicle Mix</b>				
Near/Far Lane Distance: 58 feet		VehicleType	Day	Evening	Night	Daily
<b>Site Data</b>		Autos: 77.5% 12.9% 9.6% 97.42%				
Barrier Height: 0.0 feet		Medium Trucks: 84.8% 4.9% 10.3% 1.84%				
Barrier Type (0-Wall, 1-Berm): 0.0		Heavy Trucks: 86.5% 2.7% 10.8% 0.74%				
Centerline Dist. to Barrier: 55.0 feet		<b>Noise Source Elevations (in feet)</b>				
Centerline Dist. to Observer: 55.0 feet		Autos: 0.000				
Barrier Distance to Observer: 0.0 feet		Medium Trucks: 2.297				
Observer Height (Above Pad): 5.0 feet		Heavy Trucks: 8.006      Grade Adjustment: 0.0				
Pad Elevation: 0.0 feet		<b>Lane Equivalent Distance (in feet)</b>				
Road Elevation: 0.0 feet		Autos: 47.000				
Road Grade: 0.0%		Medium Trucks: 46.811				
Left View: -90.0 degrees		Heavy Trucks: 46.830				
Right View: 90.0 degrees						

<b>FHWA Noise Model Calculations</b>							
VehicleType	REMEL	Traffic Flow	Distance	Finite Road	Fresnel	Barrier Atten	Berm Atten
Autos:	68.46	-0.41	0.30	-1.20	-4.67	0.000	0.000
Medium Trucks:	79.45	-17.65	0.33	-1.20	-4.87	0.000	0.000
Heavy Trucks:	84.25	-21.61	0.32	-1.20	-5.38	0.000	0.000

<b>Unmitigated Noise Levels (without Topo and barrier attenuation)</b>							
VehicleType	Leq Peak Hour	Leq Day	Leq Evening	Leq Night	Ldn	CNEL	
Autos:	67.1	65.2	63.5	57.4	66.0	66.7	
Medium Trucks:	60.9	59.4	53.1	51.5	60.0	60.2	
Heavy Trucks:	61.8	60.3	51.3	52.6	60.9	61.0	
Vehicle Noise:	69.0	67.2	64.1	59.4	68.0	68.4	

<b>Centerline Distance to Noise Contour (in feet)</b>				
	70 dBA	65 dBA	60 dBA	55 dBA
Ldn:	40	87	187	402
CNEL:	43	93	200	431

**FHWA-RD-77-108 HIGHWAY NOISE PREDICTION MODEL**

Scenario: EA  
 Road Name: Frank Sinatra Drive  
 Road Segment: e/o Island Drive

Project Name: Desert Islands Hotel  
 Job Number: 14747

SITE SPECIFIC INPUT DATA		NOISE MODEL INPUTS				
<b>Highway Data</b>		<b>Site Conditions (Hard = 10, Soft = 15)</b>				
Average Daily Traffic (Adt): 13,850 vehicles		Autos: 15				
Peak Hour Percentage: 10.00%		Medium Trucks (2 Axles): 15				
Peak Hour Volume: 1,385 vehicles		Heavy Trucks (3+ Axles): 15				
Vehicle Speed: 45 mph		<b>Vehicle Mix</b>				
Near/Far Lane Distance: 58 feet		VehicleType	Day	Evening	Night	Daily
<b>Site Data</b>		Autos: 77.5% 12.9% 9.6% 97.42%				
Barrier Height: 0.0 feet		Medium Trucks: 84.8% 4.9% 10.3% 1.84%				
Barrier Type (0-Wall, 1-Berm): 0.0		Heavy Trucks: 86.5% 2.7% 10.8% 0.74%				
Centerline Dist. to Barrier: 55.0 feet		<b>Noise Source Elevations (in feet)</b>				
Centerline Dist. to Observer: 55.0 feet		Autos: 0.000				
Barrier Distance to Observer: 0.0 feet		Medium Trucks: 2.297				
Observer Height (Above Pad): 5.0 feet		Heavy Trucks: 8.006      Grade Adjustment: 0.0				
Pad Elevation: 0.0 feet		<b>Lane Equivalent Distance (in feet)</b>				
Road Elevation: 0.0 feet		Autos: 47.000				
Road Grade: 0.0%		Medium Trucks: 46.811				
Left View: -90.0 degrees		Heavy Trucks: 46.830				
Right View: 90.0 degrees						

**FHWA Noise Model Calculations**

VehicleType	REMEL	Traffic Flow	Distance	Finite Road	Fresnel	Barrier Atten	Berm Atten
Autos:	68.46	-0.54	0.30	-1.20	-4.67	0.000	0.000
Medium Trucks:	79.45	-17.77	0.33	-1.20	-4.87	0.000	0.000
Heavy Trucks:	84.25	-21.73	0.32	-1.20	-5.38	0.000	0.000

**Unmitigated Noise Levels (without Topo and barrier attenuation)**

VehicleType	Leq Peak Hour	Leq Day	Leq Evening	Leq Night	Ldn	CNEL
Autos:	67.0	65.1	63.4	57.3	65.9	66.5
Medium Trucks:	60.8	59.3	52.9	51.4	59.8	60.1
Heavy Trucks:	61.6	60.2	51.2	52.4	60.8	60.9
Vehicle Noise:	68.9	67.1	64.0	59.3	67.8	68.3

**Centerline Distance to Noise Contour (in feet)**

	70 dBA	65 dBA	60 dBA	55 dBA
Ldn:	39	85	183	395
CNEL:	42	91	197	423



**FHWA-RD-77-108 HIGHWAY NOISE PREDICTION MODEL**

Scenario: EA  
 Road Name: Frank Sinatra Drive  
 Road Segment: e/o Bob Hope Drive

Project Name: Desert Islands Hotel  
 Job Number: 14747

SITE SPECIFIC INPUT DATA		NOISE MODEL INPUTS				
<b>Highway Data</b>		<b>Site Conditions (Hard = 10, Soft = 15)</b>				
Average Daily Traffic (Adt): 13,600 vehicles		Autos: 15				
Peak Hour Percentage: 10.00%		Medium Trucks (2 Axles): 15				
Peak Hour Volume: 1,360 vehicles		Heavy Trucks (3+ Axles): 15				
Vehicle Speed: 45 mph		<b>Vehicle Mix</b>				
Near/Far Lane Distance: 58 feet		VehicleType	Day	Evening	Night	Daily
<b>Site Data</b>		Autos: 77.5% 12.9% 9.6% 97.42%				
Barrier Height: 0.0 feet		Medium Trucks: 84.8% 4.9% 10.3% 1.84%				
Barrier Type (0-Wall, 1-Berm): 0.0		Heavy Trucks: 86.5% 2.7% 10.8% 0.74%				
Centerline Dist. to Barrier: 55.0 feet		<b>Noise Source Elevations (in feet)</b>				
Centerline Dist. to Observer: 55.0 feet		Autos: 0.000				
Barrier Distance to Observer: 0.0 feet		Medium Trucks: 2.297				
Observer Height (Above Pad): 5.0 feet		Heavy Trucks: 8.006      Grade Adjustment: 0.0				
Pad Elevation: 0.0 feet		<b>Lane Equivalent Distance (in feet)</b>				
Road Elevation: 0.0 feet		Autos: 47.000				
Road Grade: 0.0%		Medium Trucks: 46.811				
Left View: -90.0 degrees		Heavy Trucks: 46.830				
Right View: 90.0 degrees						

<b>FHWA Noise Model Calculations</b>							
VehicleType	REMEL	Traffic Flow	Distance	Finite Road	Fresnel	Barrier Atten	Berm Atten
Autos:	68.46	-0.62	0.30	-1.20	-4.67	0.000	0.000
Medium Trucks:	79.45	-17.85	0.33	-1.20	-4.87	0.000	0.000
Heavy Trucks:	84.25	-21.81	0.32	-1.20	-5.38	0.000	0.000

<b>Unmitigated Noise Levels (without Topo and barrier attenuation)</b>							
VehicleType	Leq Peak Hour	Leq Day	Leq Evening	Leq Night	Ldn	CNEL	
Autos:	66.9	65.0	63.3	57.2	65.8	66.5	
Medium Trucks:	60.7	59.2	52.9	51.3	59.8	60.0	
Heavy Trucks:	61.6	60.1	51.1	52.4	60.7	60.8	
Vehicle Noise:	68.8	67.0	63.9	59.2	67.8	68.2	

<b>Centerline Distance to Noise Contour (in feet)</b>				
	70 dBA	65 dBA	60 dBA	55 dBA
Ldn:	39	84	181	390
CNEL:	42	90	194	418

**FHWA-RD-77-108 HIGHWAY NOISE PREDICTION MODEL**

Scenario: EA  
 Road Name: Bob Hope Drive  
 Road Segment: n/o Frank Sinatra Drive

Project Name: Desert Islands Hotel  
 Job Number: 14747

SITE SPECIFIC INPUT DATA		NOISE MODEL INPUTS				
<b>Highway Data</b>		<b>Site Conditions (Hard = 10, Soft = 15)</b>				
Average Daily Traffic (Adt): 19,400 vehicles		Autos: 15				
Peak Hour Percentage: 10.00%		Medium Trucks (2 Axles): 15				
Peak Hour Volume: 1,940 vehicles		Heavy Trucks (3+ Axles): 15				
Vehicle Speed: 45 mph		<b>Vehicle Mix</b>				
Near/Far Lane Distance: 86 feet		VehicleType	Day	Evening	Night	Daily
<b>Site Data</b>		Autos: 77.5% 12.9% 9.6% 97.42%				
Barrier Height: 0.0 feet		Medium Trucks: 84.8% 4.9% 10.3% 1.84%				
Barrier Type (0-Wall, 1-Berm): 0.0		Heavy Trucks: 86.5% 2.7% 10.8% 0.74%				
Centerline Dist. to Barrier: 60.0 feet		<b>Noise Source Elevations (in feet)</b>				
Centerline Dist. to Observer: 60.0 feet		Autos: 0.000				
Barrier Distance to Observer: 0.0 feet		Medium Trucks: 2.297				
Observer Height (Above Pad): 5.0 feet		Heavy Trucks: 8.006      Grade Adjustment: 0.0				
Pad Elevation: 0.0 feet		<b>Lane Equivalent Distance (in feet)</b>				
Road Elevation: 0.0 feet		Autos: 42.143				
Road Grade: 0.0%		Medium Trucks: 41.932				
Left View: -90.0 degrees		Heavy Trucks: 41.953				
Right View: 90.0 degrees						

<b>FHWA Noise Model Calculations</b>							
VehicleType	REMEL	Traffic Flow	Distance	Finite Road	Fresnel	Barrier Atten	Berm Atten
Autos:	68.46	0.93	1.01	-1.20	-4.69	0.000	0.000
Medium Trucks:	79.45	-16.31	1.04	-1.20	-4.88	0.000	0.000
Heavy Trucks:	84.25	-20.27	1.04	-1.20	-5.34	0.000	0.000

<b>Unmitigated Noise Levels (without Topo and barrier attenuation)</b>							
VehicleType	Leq Peak Hour	Leq Day	Leq Evening	Leq Night	Ldn	CNEL	
Autos:	69.2	67.3	65.5	59.5	68.1	68.7	
Medium Trucks:	63.0	61.5	55.1	53.6	62.0	62.3	
Heavy Trucks:	63.8	62.4	53.4	54.6	63.0	63.1	
Vehicle Noise:	71.0	69.3	66.1	61.5	70.0	70.5	

<b>Centerline Distance to Noise Contour (in feet)</b>				
	70 dBA	65 dBA	60 dBA	55 dBA
Ldn:	60	130	279	601
CNEL:	65	139	299	645

**FHWA-RD-77-108 HIGHWAY NOISE PREDICTION MODEL**

Scenario: EA  
 Road Name: Bob Hope Drive  
 Road Segment: s/o Frank Sinatra Drive

Project Name: Desert Islands Hotel  
 Job Number: 14747

SITE SPECIFIC INPUT DATA		NOISE MODEL INPUTS				
<b>Highway Data</b>		<b>Site Conditions (Hard = 10, Soft = 15)</b>				
Average Daily Traffic (Adt): 22,380 vehicles		Autos: 15				
Peak Hour Percentage: 10.00%		Medium Trucks (2 Axles): 15				
Peak Hour Volume: 2,238 vehicles		Heavy Trucks (3+ Axles): 15				
Vehicle Speed: 45 mph		<b>Vehicle Mix</b>				
Near/Far Lane Distance: 58 feet		VehicleType	Day	Evening	Night	Daily
<b>Site Data</b>		Autos: 77.5% 12.9% 9.6% 97.42%				
Barrier Height: 0.0 feet		Medium Trucks: 84.8% 4.9% 10.3% 1.84%				
Barrier Type (0-Wall, 1-Berm): 0.0		Heavy Trucks: 86.5% 2.7% 10.8% 0.74%				
Centerline Dist. to Barrier: 55.0 feet		<b>Noise Source Elevations (in feet)</b>				
Centerline Dist. to Observer: 55.0 feet		Autos: 0.000				
Barrier Distance to Observer: 0.0 feet		Medium Trucks: 2.297				
Observer Height (Above Pad): 5.0 feet		Heavy Trucks: 8.006      Grade Adjustment: 0.0				
Pad Elevation: 0.0 feet		<b>Lane Equivalent Distance (in feet)</b>				
Road Elevation: 0.0 feet		Autos: 47.000				
Road Grade: 0.0%		Medium Trucks: 46.811				
Left View: -90.0 degrees		Heavy Trucks: 46.830				
Right View: 90.0 degrees						

<b>FHWA Noise Model Calculations</b>							
VehicleType	REMEL	Traffic Flow	Distance	Finite Road	Fresnel	Barrier Atten	Berm Atten
Autos:	68.46	1.55	0.30	-1.20	-4.67	0.000	0.000
Medium Trucks:	79.45	-15.69	0.33	-1.20	-4.87	0.000	0.000
Heavy Trucks:	84.25	-19.65	0.32	-1.20	-5.38	0.000	0.000

<b>Unmitigated Noise Levels (without Topo and barrier attenuation)</b>							
VehicleType	Leq Peak Hour	Leq Day	Leq Evening	Leq Night	Ldn	CNEL	
Autos:	69.1	67.2	65.4	59.4	68.0	68.6	
Medium Trucks:	62.9	61.4	55.0	53.5	61.9	62.2	
Heavy Trucks:	63.7	62.3	53.3	54.5	62.9	63.0	
Vehicle Noise:	71.0	69.2	66.1	61.4	69.9	70.4	

<b>Centerline Distance to Noise Contour (in feet)</b>				
	70 dBA	65 dBA	60 dBA	55 dBA
Ldn:	54	117	252	544
CNEL:	58	126	271	583

**FHWA-RD-77-108 HIGHWAY NOISE PREDICTION MODEL**

Scenario: EA  
 Road Name: Island Drive  
 Road Segment: s/o Frank Sinatra Drive

Project Name: Desert Islands Hotel  
 Job Number: 14747

SITE SPECIFIC INPUT DATA		NOISE MODEL INPUTS				
<b>Highway Data</b>		<b>Site Conditions (Hard = 10, Soft = 15)</b>				
Average Daily Traffic (Adt):	1,900 vehicles	Autos: 15				
Peak Hour Percentage:	10.00%	Medium Trucks (2 Axles): 15				
Peak Hour Volume:	190 vehicles	Heavy Trucks (3+ Axles): 15				
Vehicle Speed:	25 mph	<b>Vehicle Mix</b>				
Near/Far Lane Distance:	12 feet	VehicleType	Day	Evening	Night	Daily
<b>Site Data</b>		Autos: 77.5% 12.9% 9.6% 97.42%				
<b>Barrier Height:</b>	<b>0.0 feet</b>	Medium Trucks: 84.8% 4.9% 10.3% 1.84%				
Barrier Type (0-Wall, 1-Berm):	0.0	Heavy Trucks: 86.5% 2.7% 10.8% 0.74%				
Centerline Dist. to Barrier:	30.0 feet	<b>Noise Source Elevations (in feet)</b>				
Centerline Dist. to Observer:	30.0 feet	Autos: 0.000				
Barrier Distance to Observer:	0.0 feet	Medium Trucks: 2.297				
Observer Height (Above Pad):	5.0 feet	Heavy Trucks: 8.006      Grade Adjustment: 0.0				
Pad Elevation:	0.0 feet	<b>Lane Equivalent Distance (in feet)</b>				
Road Elevation:	0.0 feet	Autos: 29.816				
Road Grade:	0.0%	Medium Trucks: 29.518				
Left View:	-90.0 degrees	Heavy Trucks: 29.547				
Right View:	90.0 degrees					

<b>FHWA Noise Model Calculations</b>							
VehicleType	REMEL	Traffic Flow	Distance	Finite Road	Fresnel	Barrier Atten	Berm Atten
Autos:	58.73	-6.61	3.26	-1.20	-4.49	0.000	0.000
Medium Trucks:	70.80	-23.85	3.33	-1.20	-4.86	0.000	0.000
Heavy Trucks:	77.97	-27.80	3.32	-1.20	-5.77	0.000	0.000

<b>Unmitigated Noise Levels (without Topo and barrier attenuation)</b>							
VehicleType	Leq Peak Hour	Leq Day	Leq Evening	Leq Night	Ldn	CNEL	
Autos:	54.2	52.3	50.5	44.5	53.1	53.7	
Medium Trucks:	49.1	47.6	41.2	39.7	48.1	48.4	
Heavy Trucks:	52.3	50.9	41.8	43.1	51.4	51.6	
Vehicle Noise:	57.1	55.4	51.5	47.6	56.1	56.5	

<b>Centerline Distance to Noise Contour (in feet)</b>				
	70 dBA	65 dBA	60 dBA	55 dBA
Ldn:	4	8	17	36
CNEL:	4	8	18	38

**FHWA-RD-77-108 HIGHWAY NOISE PREDICTION MODEL**

Scenario: EAP  
 Road Name: Frank Sinatra Drive  
 Road Segment: w/o Island Drive

Project Name: Desert Islands Hotel  
 Job Number: 14747

SITE SPECIFIC INPUT DATA		NOISE MODEL INPUTS				
<b>Highway Data</b>		<b>Site Conditions (Hard = 10, Soft = 15)</b>				
Average Daily Traffic (Adt): 14,500 vehicles		Autos: 15				
Peak Hour Percentage: 10.00%		Medium Trucks (2 Axles): 15				
Peak Hour Volume: 1,450 vehicles		Heavy Trucks (3+ Axles): 15				
Vehicle Speed: 45 mph		<b>Vehicle Mix</b>				
Near/Far Lane Distance: 58 feet		VehicleType	Day	Evening	Night	Daily
<b>Site Data</b>		Autos: 77.5% 12.9% 9.6% 97.42%				
Barrier Height: 0.0 feet		Medium Trucks: 84.8% 4.9% 10.3% 1.84%				
Barrier Type (0-Wall, 1-Berm): 0.0		Heavy Trucks: 86.5% 2.7% 10.8% 0.74%				
Centerline Dist. to Barrier: 55.0 feet		<b>Noise Source Elevations (in feet)</b>				
Centerline Dist. to Observer: 55.0 feet		Autos: 0.000				
Barrier Distance to Observer: 0.0 feet		Medium Trucks: 2.297				
Observer Height (Above Pad): 5.0 feet		Heavy Trucks: 8.006 Grade Adjustment: 0.0				
Pad Elevation: 0.0 feet		<b>Lane Equivalent Distance (in feet)</b>				
Road Elevation: 0.0 feet		Autos: 47.000				
Road Grade: 0.0%		Medium Trucks: 46.811				
Left View: -90.0 degrees		Heavy Trucks: 46.830				
Right View: 90.0 degrees						

**FHWA Noise Model Calculations**

VehicleType	REMEL	Traffic Flow	Distance	Finite Road	Fresnel	Barrier Atten	Berm Atten
Autos:	68.46	-0.34	0.30	-1.20	-4.67	0.000	0.000
Medium Trucks:	79.45	-17.58	0.33	-1.20	-4.87	0.000	0.000
Heavy Trucks:	84.25	-21.53	0.32	-1.20	-5.38	0.000	0.000

**Unmitigated Noise Levels (without Topo and barrier attenuation)**

VehicleType	Leq Peak Hour	Leq Day	Leq Evening	Leq Night	Ldn	CNEL
Autos:	67.2	65.3	63.6	57.5	66.1	66.7
Medium Trucks:	61.0	59.5	53.1	51.6	60.0	60.3
Heavy Trucks:	61.8	60.4	51.4	52.6	61.0	61.1
Vehicle Noise:	69.1	67.3	64.2	59.5	68.0	68.5

**Centerline Distance to Noise Contour (in feet)**

	70 dBA	65 dBA	60 dBA	55 dBA
Ldn:	41	88	189	407
CNEL:	44	94	203	437

**FHWA-RD-77-108 HIGHWAY NOISE PREDICTION MODEL**

Scenario: EAP  
 Road Name: Frank Sinatra Drive  
 Road Segment: e/o Island Drive

Project Name: Desert Islands Hotel  
 Job Number: 14747

SITE SPECIFIC INPUT DATA		NOISE MODEL INPUTS				
<b>Highway Data</b>		<b>Site Conditions (Hard = 10, Soft = 15)</b>				
Average Daily Traffic (Adt): 14,600 vehicles		Autos: 15				
Peak Hour Percentage: 10.00%		Medium Trucks (2 Axles): 15				
Peak Hour Volume: 1,460 vehicles		Heavy Trucks (3+ Axles): 15				
Vehicle Speed: 45 mph		<b>Vehicle Mix</b>				
Near/Far Lane Distance: 58 feet		VehicleType	Day	Evening	Night	Daily
<b>Site Data</b>		Autos: 77.5% 12.9% 9.6% 97.42%				
Barrier Height: 0.0 feet		Medium Trucks: 84.8% 4.9% 10.3% 1.84%				
Barrier Type (0-Wall, 1-Berm): 0.0		Heavy Trucks: 86.5% 2.7% 10.8% 0.74%				
Centerline Dist. to Barrier: 55.0 feet		<b>Noise Source Elevations (in feet)</b>				
Centerline Dist. to Observer: 55.0 feet		Autos: 0.000				
Barrier Distance to Observer: 0.0 feet		Medium Trucks: 2.297				
Observer Height (Above Pad): 5.0 feet		Heavy Trucks: 8.006      Grade Adjustment: 0.0				
Pad Elevation: 0.0 feet		<b>Lane Equivalent Distance (in feet)</b>				
Road Elevation: 0.0 feet		Autos: 47.000				
Road Grade: 0.0%		Medium Trucks: 46.811				
Left View: -90.0 degrees		Heavy Trucks: 46.830				
Right View: 90.0 degrees						

<b>FHWA Noise Model Calculations</b>							
VehicleType	REMEL	Traffic Flow	Distance	Finite Road	Fresnel	Barrier Atten	Berm Atten
Autos:	68.46	-0.31	0.30	-1.20	-4.67	0.000	0.000
Medium Trucks:	79.45	-17.55	0.33	-1.20	-4.87	0.000	0.000
Heavy Trucks:	84.25	-21.50	0.32	-1.20	-5.38	0.000	0.000

<b>Unmitigated Noise Levels (without Topo and barrier attenuation)</b>							
VehicleType	Leq Peak Hour	Leq Day	Leq Evening	Leq Night	Ldn	CNEL	
Autos:	67.3	65.4	63.6	57.5	66.2	66.8	
Medium Trucks:	61.0	59.5	53.2	51.6	60.1	60.3	
Heavy Trucks:	61.9	60.5	51.4	52.7	61.0	61.1	
Vehicle Noise:	69.1	67.4	64.2	59.5	68.1	68.5	

<b>Centerline Distance to Noise Contour (in feet)</b>				
	70 dBA	65 dBA	60 dBA	55 dBA
Ldn:	41	88	190	409
CNEL:	44	94	204	439

**FHWA-RD-77-108 HIGHWAY NOISE PREDICTION MODEL**

Scenario: EAP  
 Road Name: Frank Sinatra Drive  
 Road Segment: e/o Bob Hope Drive

Project Name: Desert Islands Hotel  
 Job Number: 14747

SITE SPECIFIC INPUT DATA		NOISE MODEL INPUTS				
<b>Highway Data</b>		<b>Site Conditions (Hard = 10, Soft = 15)</b>				
Average Daily Traffic (Adt): 13,800 vehicles		Autos: 15				
Peak Hour Percentage: 10.00%		Medium Trucks (2 Axles): 15				
Peak Hour Volume: 1,380 vehicles		Heavy Trucks (3+ Axles): 15				
Vehicle Speed: 45 mph		<b>Vehicle Mix</b>				
Near/Far Lane Distance: 58 feet		VehicleType	Day	Evening	Night	Daily
<b>Site Data</b>		Autos: 77.5% 12.9% 9.6% 97.42%				
Barrier Height: 0.0 feet		Medium Trucks: 84.8% 4.9% 10.3% 1.84%				
Barrier Type (0-Wall, 1-Berm): 0.0		Heavy Trucks: 86.5% 2.7% 10.8% 0.74%				
Centerline Dist. to Barrier: 55.0 feet		<b>Noise Source Elevations (in feet)</b>				
Centerline Dist. to Observer: 55.0 feet		Autos: 0.000				
Barrier Distance to Observer: 0.0 feet		Medium Trucks: 2.297				
Observer Height (Above Pad): 5.0 feet		Heavy Trucks: 8.006      Grade Adjustment: 0.0				
Pad Elevation: 0.0 feet		<b>Lane Equivalent Distance (in feet)</b>				
Road Elevation: 0.0 feet		Autos: 47.000				
Road Grade: 0.0%		Medium Trucks: 46.811				
Left View: -90.0 degrees		Heavy Trucks: 46.830				
Right View: 90.0 degrees						

<b>FHWA Noise Model Calculations</b>							
VehicleType	REMEL	Traffic Flow	Distance	Finite Road	Fresnel	Barrier Atten	Berm Atten
Autos:	68.46	-0.55	0.30	-1.20	-4.67	0.000	0.000
Medium Trucks:	79.45	-17.79	0.33	-1.20	-4.87	0.000	0.000
Heavy Trucks:	84.25	-21.75	0.32	-1.20	-5.38	0.000	0.000

<b>Unmitigated Noise Levels (without Topo and barrier attenuation)</b>							
VehicleType	Leq Peak Hour	Leq Day	Leq Evening	Leq Night	Ldn	CNEL	
Autos:	67.0	65.1	63.3	57.3	65.9	66.5	
Medium Trucks:	60.8	59.3	52.9	51.4	59.8	60.1	
Heavy Trucks:	61.6	60.2	51.2	52.4	60.8	60.9	
Vehicle Noise:	68.9	67.1	64.0	59.3	67.8	68.3	

<b>Centerline Distance to Noise Contour (in feet)</b>				
	70 dBA	65 dBA	60 dBA	55 dBA
Ldn:	39	85	183	394
CNEL:	42	91	196	422

**FHWA-RD-77-108 HIGHWAY NOISE PREDICTION MODEL**

Scenario: EAP  
 Road Name: Bob Hope Drive  
 Road Segment: n/o Frank Sinatra Drive

Project Name: Desert Islands Hotel  
 Job Number: 14747

SITE SPECIFIC INPUT DATA		NOISE MODEL INPUTS				
<b>Highway Data</b>		<b>Site Conditions (Hard = 10, Soft = 15)</b>				
Average Daily Traffic (Adt): 19,700 vehicles		Autos: 15				
Peak Hour Percentage: 10.00%		Medium Trucks (2 Axles): 15				
Peak Hour Volume: 1,970 vehicles		Heavy Trucks (3+ Axles): 15				
Vehicle Speed: 45 mph		<b>Vehicle Mix</b>				
Near/Far Lane Distance: 86 feet		VehicleType	Day	Evening	Night	Daily
<b>Site Data</b>		Autos: 77.5% 12.9% 9.6% 97.42%				
Barrier Height: 0.0 feet		Medium Trucks: 84.8% 4.9% 10.3% 1.84%				
Barrier Type (0-Wall, 1-Berm): 0.0		Heavy Trucks: 86.5% 2.7% 10.8% 0.74%				
Centerline Dist. to Barrier: 60.0 feet		<b>Noise Source Elevations (in feet)</b>				
Centerline Dist. to Observer: 60.0 feet		Autos: 0.000				
Barrier Distance to Observer: 0.0 feet		Medium Trucks: 2.297				
Observer Height (Above Pad): 5.0 feet		Heavy Trucks: 8.006      Grade Adjustment: 0.0				
Pad Elevation: 0.0 feet		<b>Lane Equivalent Distance (in feet)</b>				
Road Elevation: 0.0 feet		Autos: 42.143				
Road Grade: 0.0%		Medium Trucks: 41.932				
Left View: -90.0 degrees		Heavy Trucks: 41.953				
Right View: 90.0 degrees						

**FHWA Noise Model Calculations**

VehicleType	REMEL	Traffic Flow	Distance	Finite Road	Fresnel	Barrier Atten	Berm Atten
Autos:	68.46	0.99	1.01	-1.20	-4.69	0.000	0.000
Medium Trucks:	79.45	-16.24	1.04	-1.20	-4.88	0.000	0.000
Heavy Trucks:	84.25	-20.20	1.04	-1.20	-5.34	0.000	0.000

**Unmitigated Noise Levels (without Topo and barrier attenuation)**

VehicleType	Leq Peak Hour	Leq Day	Leq Evening	Leq Night	Ldn	CNEL
Autos:	69.3	67.4	65.6	59.5	68.2	68.8
Medium Trucks:	63.0	61.5	55.2	53.6	62.1	62.3
Heavy Trucks:	63.9	62.5	53.4	54.7	63.0	63.2
Vehicle Noise:	71.1	69.4	66.2	61.5	70.1	70.5

**Centerline Distance to Noise Contour (in feet)**

	70 dBA	65 dBA	60 dBA	55 dBA
Ldn:	61	131	282	608
CNEL:	65	140	302	652



**FHWA-RD-77-108 HIGHWAY NOISE PREDICTION MODEL**

Scenario: EAP  
 Road Name: Bob Hope Drive  
 Road Segment: s/o Frank Sinatra Drive

Project Name: Desert Islands Hotel  
 Job Number: 14747

SITE SPECIFIC INPUT DATA		NOISE MODEL INPUTS				
<b>Highway Data</b>		<b>Site Conditions (Hard = 10, Soft = 15)</b>				
Average Daily Traffic (Adt): 22,400 vehicles		Autos: 15				
Peak Hour Percentage: 10.00%		Medium Trucks (2 Axles): 15				
Peak Hour Volume: 2,240 vehicles		Heavy Trucks (3+ Axles): 15				
Vehicle Speed: 45 mph		<b>Vehicle Mix</b>				
Near/Far Lane Distance: 58 feet		VehicleType	Day	Evening	Night	Daily
<b>Site Data</b>		Autos: 77.5% 12.9% 9.6% 97.42%				
Barrier Height: 0.0 feet		Medium Trucks: 84.8% 4.9% 10.3% 1.84%				
Barrier Type (0-Wall, 1-Berm): 0.0		Heavy Trucks: 86.5% 2.7% 10.8% 0.74%				
Centerline Dist. to Barrier: 55.0 feet		<b>Noise Source Elevations (in feet)</b>				
Centerline Dist. to Observer: 55.0 feet		Autos: 0.000				
Barrier Distance to Observer: 0.0 feet		Medium Trucks: 2.297				
Observer Height (Above Pad): 5.0 feet		Heavy Trucks: 8.006      Grade Adjustment: 0.0				
Pad Elevation: 0.0 feet		<b>Lane Equivalent Distance (in feet)</b>				
Road Elevation: 0.0 feet		Autos: 47.000				
Road Grade: 0.0%		Medium Trucks: 46.811				
Left View: -90.0 degrees		Heavy Trucks: 46.830				
Right View: 90.0 degrees						

**FHWA Noise Model Calculations**

VehicleType	REMEL	Traffic Flow	Distance	Finite Road	Fresnel	Barrier Atten	Berm Atten
Autos:	68.46	1.55	0.30	-1.20	-4.67	0.000	0.000
Medium Trucks:	79.45	-15.69	0.33	-1.20	-4.87	0.000	0.000
Heavy Trucks:	84.25	-19.64	0.32	-1.20	-5.38	0.000	0.000

**Unmitigated Noise Levels (without Topo and barrier attenuation)**

VehicleType	Leq Peak Hour	Leq Day	Leq Evening	Leq Night	Ldn	CNEL
Autos:	69.1	67.2	65.4	59.4	68.0	68.6
Medium Trucks:	62.9	61.4	55.0	53.5	61.9	62.2
Heavy Trucks:	63.7	62.3	53.3	54.5	62.9	63.0
Vehicle Noise:	71.0	69.2	66.1	61.4	69.9	70.4

**Centerline Distance to Noise Contour (in feet)**

	70 dBA	65 dBA	60 dBA	55 dBA
Ldn:	54	117	252	544
CNEL:	58	126	271	583

**FHWA-RD-77-108 HIGHWAY NOISE PREDICTION MODEL**

Scenario: EAP  
 Road Name: Island Drive  
 Road Segment: s/o Frank Sinatra Drive

Project Name: Desert Islands Hotel  
 Job Number: 14747

SITE SPECIFIC INPUT DATA		NOISE MODEL INPUTS				
<b>Highway Data</b>		<b>Site Conditions (Hard = 10, Soft = 15)</b>				
Average Daily Traffic (Adt):	2,000 vehicles	Autos: 15				
Peak Hour Percentage:	10.00%	Medium Trucks (2 Axles): 15				
Peak Hour Volume:	200 vehicles	Heavy Trucks (3+ Axles): 15				
Vehicle Speed:	25 mph	<b>Vehicle Mix</b>				
Near/Far Lane Distance:	12 feet	VehicleType	Day	Evening	Night	Daily
<b>Site Data</b>		Autos: 77.5% 12.9% 9.6% 97.42%				
<b>Barrier Height:</b>	<b>0.0 feet</b>	Medium Trucks: 84.8% 4.9% 10.3% 1.84%				
Barrier Type (0-Wall, 1-Berm):	0.0	Heavy Trucks: 86.5% 2.7% 10.8% 0.74%				
Centerline Dist. to Barrier:	30.0 feet	<b>Noise Source Elevations (in feet)</b>				
Centerline Dist. to Observer:	30.0 feet	Autos: 0.000				
Barrier Distance to Observer:	0.0 feet	Medium Trucks: 2.297				
Observer Height (Above Pad):	5.0 feet	Heavy Trucks: 8.006    Grade Adjustment: 0.0				
Pad Elevation:	0.0 feet	<b>Lane Equivalent Distance (in feet)</b>				
Road Elevation:	0.0 feet	Autos: 29.816				
Road Grade:	0.0%	Medium Trucks: 29.518				
Left View:	-90.0 degrees	Heavy Trucks: 29.547				
Right View:	90.0 degrees					

**FHWA Noise Model Calculations**

VehicleType	REMEL	Traffic Flow	Distance	Finite Road	Fresnel	Barrier Atten	Berm Atten
Autos:	58.73	-6.39	3.26	-1.20	-4.49	0.000	0.000
Medium Trucks:	70.80	-23.63	3.33	-1.20	-4.86	0.000	0.000
Heavy Trucks:	77.97	-27.58	3.32	-1.20	-5.77	0.000	0.000

**Unmitigated Noise Levels (without Topo and barrier attenuation)**

VehicleType	Leq Peak Hour	Leq Day	Leq Evening	Leq Night	Ldn	CNEL
Autos:	54.4	52.5	50.7	44.7	53.3	53.9
Medium Trucks:	49.3	47.8	41.4	39.9	48.3	48.6
Heavy Trucks:	52.5	51.1	42.1	43.3	51.7	51.8
Vehicle Noise:	57.3	55.6	51.7	47.8	56.3	56.7

**Centerline Distance to Noise Contour (in feet)**

	70 dBA	65 dBA	60 dBA	55 dBA
Ldn:	4	8	17	37
CNEL:	4	8	18	39

**FHWA-RD-77-108 HIGHWAY NOISE PREDICTION MODEL**

Scenario: EAC  
 Road Name: Frank Sinatra Drive  
 Road Segment: w/o Island Drive

Project Name: Desert Islands Hotel  
 Job Number: 14747

SITE SPECIFIC INPUT DATA		NOISE MODEL INPUTS				
<b>Highway Data</b>		<b>Site Conditions (Hard = 10, Soft = 15)</b>				
Average Daily Traffic (Adt): 17,550 vehicles		Autos: 15				
Peak Hour Percentage: 10.00%		Medium Trucks (2 Axles): 15				
Peak Hour Volume: 1,755 vehicles		Heavy Trucks (3+ Axles): 15				
Vehicle Speed: 45 mph		<b>Vehicle Mix</b>				
Near/Far Lane Distance: 58 feet		VehicleType	Day	Evening	Night	Daily
<b>Site Data</b>		Autos: 77.5% 12.9% 9.6% 97.42%				
Barrier Height: 0.0 feet		Medium Trucks: 84.8% 4.9% 10.3% 1.84%				
Barrier Type (0-Wall, 1-Berm): 0.0		Heavy Trucks: 86.5% 2.7% 10.8% 0.74%				
Centerline Dist. to Barrier: 55.0 feet		<b>Noise Source Elevations (in feet)</b>				
Centerline Dist. to Observer: 55.0 feet		Autos: 0.000				
Barrier Distance to Observer: 0.0 feet		Medium Trucks: 2.297				
Observer Height (Above Pad): 5.0 feet		Heavy Trucks: 8.006      Grade Adjustment: 0.0				
Pad Elevation: 0.0 feet		<b>Lane Equivalent Distance (in feet)</b>				
Road Elevation: 0.0 feet		Autos: 47.000				
Road Grade: 0.0%		Medium Trucks: 46.811				
Left View: -90.0 degrees		Heavy Trucks: 46.830				
Right View: 90.0 degrees						

**FHWA Noise Model Calculations**

VehicleType	REMEL	Traffic Flow	Distance	Finite Road	Fresnel	Barrier Atten	Berm Atten
Autos:	68.46	0.49	0.30	-1.20	-4.67	0.000	0.000
Medium Trucks:	79.45	-16.75	0.33	-1.20	-4.87	0.000	0.000
Heavy Trucks:	84.25	-20.70	0.32	-1.20	-5.38	0.000	0.000

**Unmitigated Noise Levels (without Topo and barrier attenuation)**

VehicleType	Leq Peak Hour	Leq Day	Leq Evening	Leq Night	Ldn	CNEL
Autos:	68.1	66.2	64.4	58.3	67.0	67.6
Medium Trucks:	61.8	60.3	54.0	52.4	60.9	61.1
Heavy Trucks:	62.7	61.3	52.2	53.5	61.8	61.9
Vehicle Noise:	69.9	68.2	65.0	60.3	68.9	69.3

**Centerline Distance to Noise Contour (in feet)**

	70 dBA	65 dBA	60 dBA	55 dBA
Ldn:	46	100	215	462
CNEL:	50	107	230	496

**FHWA-RD-77-108 HIGHWAY NOISE PREDICTION MODEL**

Scenario: EAC  
 Road Name: Frank Sinatra Drive  
 Road Segment: e/o Island Drive

Project Name: Desert Islands Hotel  
 Job Number: 14747

SITE SPECIFIC INPUT DATA		NOISE MODEL INPUTS				
<b>Highway Data</b>		<b>Site Conditions (Hard = 10, Soft = 15)</b>				
Average Daily Traffic (Adt): 17,050 vehicles		Autos: 15				
Peak Hour Percentage: 10.00%		Medium Trucks (2 Axles): 15				
Peak Hour Volume: 1,705 vehicles		Heavy Trucks (3+ Axles): 15				
Vehicle Speed: 45 mph		<b>Vehicle Mix</b>				
Near/Far Lane Distance: 58 feet		VehicleType	Day	Evening	Night	Daily
<b>Site Data</b>		Autos: 77.5% 12.9% 9.6% 97.42%				
Barrier Height: 0.0 feet		Medium Trucks: 84.8% 4.9% 10.3% 1.84%				
Barrier Type (0-Wall, 1-Berm): 0.0		Heavy Trucks: 86.5% 2.7% 10.8% 0.74%				
Centerline Dist. to Barrier: 55.0 feet		<b>Noise Source Elevations (in feet)</b>				
Centerline Dist. to Observer: 55.0 feet		Autos: 0.000				
Barrier Distance to Observer: 0.0 feet		Medium Trucks: 2.297				
Observer Height (Above Pad): 5.0 feet		Heavy Trucks: 8.006      Grade Adjustment: 0.0				
Pad Elevation: 0.0 feet		<b>Lane Equivalent Distance (in feet)</b>				
Road Elevation: 0.0 feet		Autos: 47.000				
Road Grade: 0.0%		Medium Trucks: 46.811				
Left View: -90.0 degrees		Heavy Trucks: 46.830				
Right View: 90.0 degrees						

<b>FHWA Noise Model Calculations</b>							
VehicleType	REMEL	Traffic Flow	Distance	Finite Road	Fresnel	Barrier Atten	Berm Atten
Autos:	68.46	0.37	0.30	-1.20	-4.67	0.000	0.000
Medium Trucks:	79.45	-16.87	0.33	-1.20	-4.87	0.000	0.000
Heavy Trucks:	84.25	-20.83	0.32	-1.20	-5.38	0.000	0.000

<b>Unmitigated Noise Levels (without Topo and barrier attenuation)</b>							
VehicleType	Leq Peak Hour	Leq Day	Leq Evening	Leq Night	Ldn	CNEL	
Autos:	67.9	66.0	64.3	58.2	66.8	67.4	
Medium Trucks:	61.7	60.2	53.8	52.3	60.7	61.0	
Heavy Trucks:	62.5	61.1	52.1	53.3	61.7	61.8	
Vehicle Noise:	69.8	68.0	64.9	60.2	68.7	69.2	

<b>Centerline Distance to Noise Contour (in feet)</b>				
	70 dBA	65 dBA	60 dBA	55 dBA
Ldn:	45	98	210	453
CNEL:	49	105	226	486

## FHWA-RD-77-108 HIGHWAY NOISE PREDICTION MODEL

Scenario: EAC  
 Road Name: Frank Sinatra Drive  
 Road Segment: e/o Bob Hope Drive

Project Name: Desert Islands Hotel  
 Job Number: 14747

SITE SPECIFIC INPUT DATA	NOISE MODEL INPUTS				
<b>Highway Data</b>	<b>Site Conditions (Hard = 10, Soft = 15)</b>				
Average Daily Traffic (Adt): 16,000 vehicles	Autos: 15				
Peak Hour Percentage: 10.00%	Medium Trucks (2 Axles): 15				
Peak Hour Volume: 1,600 vehicles	Heavy Trucks (3+ Axles): 15				
Vehicle Speed: 45 mph	<b>Vehicle Mix</b>				
Near/Far Lane Distance: 58 feet	VehicleType	Day	Evening	Night	Daily
<b>Site Data</b>	Autos: 77.5% 12.9% 9.6% 97.42%				
<b>Barrier Height:</b> 0.0 feet	Medium Trucks: 84.8% 4.9% 10.3% 1.84%				
Barrier Type (0-Wall, 1-Berm): 0.0	Heavy Trucks: 86.5% 2.7% 10.8% 0.74%				
Centerline Dist. to Barrier: 55.0 feet	<b>Noise Source Elevations (in feet)</b>				
Centerline Dist. to Observer: 55.0 feet	Autos: 0.000				
Barrier Distance to Observer: 0.0 feet	Medium Trucks: 2.297				
Observer Height (Above Pad): 5.0 feet	Heavy Trucks: 8.006      Grade Adjustment: 0.0				
Pad Elevation: 0.0 feet	<b>Lane Equivalent Distance (in feet)</b>				
Road Elevation: 0.0 feet	Autos: 47.000				
Road Grade: 0.0%	Medium Trucks: 46.811				
Left View: -90.0 degrees	Heavy Trucks: 46.830				
Right View: 90.0 degrees					

<b>FHWA Noise Model Calculations</b>							
VehicleType	REMEL	Traffic Flow	Distance	Finite Road	Fresnel	Barrier Atten	Berm Atten
Autos:	68.46	0.09	0.30	-1.20	-4.67	0.000	0.000
Medium Trucks:	79.45	-17.15	0.33	-1.20	-4.87	0.000	0.000
Heavy Trucks:	84.25	-21.10	0.32	-1.20	-5.38	0.000	0.000

<b>Unmitigated Noise Levels (without Topo and barrier attenuation)</b>							
VehicleType	Leq Peak Hour	Leq Day	Leq Evening	Leq Night	Ldn	CNEL	
Autos:	67.7	65.8	64.0	57.9	66.6	67.2	
Medium Trucks:	61.4	59.9	53.6	52.0	60.5	60.7	
Heavy Trucks:	62.3	60.9	51.8	53.1	61.4	61.5	
Vehicle Noise:	69.5	67.8	64.6	59.9	68.5	68.9	

<b>Centerline Distance to Noise Contour (in feet)</b>				
	70 dBA	65 dBA	60 dBA	55 dBA
Ldn:	43	94	202	435
CNEL:	47	100	216	466

**FHWA-RD-77-108 HIGHWAY NOISE PREDICTION MODEL**

Scenario: EAC  
 Road Name: Bob Hope Drive  
 Road Segment: n/o Frank Sinatra Drive

Project Name: Desert Islands Hotel  
 Job Number: 14747

SITE SPECIFIC INPUT DATA		NOISE MODEL INPUTS				
<b>Highway Data</b>		<b>Site Conditions (Hard = 10, Soft = 15)</b>				
Average Daily Traffic (Adt): 22,900 vehicles		Autos: 15				
Peak Hour Percentage: 10.00%		Medium Trucks (2 Axles): 15				
Peak Hour Volume: 2,290 vehicles		Heavy Trucks (3+ Axles): 15				
Vehicle Speed: 45 mph		<b>Vehicle Mix</b>				
Near/Far Lane Distance: 86 feet		VehicleType	Day	Evening	Night	Daily
<b>Site Data</b>		Autos: 77.5% 12.9% 9.6% 97.42%				
Barrier Height: 0.0 feet		Medium Trucks: 84.8% 4.9% 10.3% 1.84%				
Barrier Type (0-Wall, 1-Berm): 0.0		Heavy Trucks: 86.5% 2.7% 10.8% 0.74%				
Centerline Dist. to Barrier: 60.0 feet		<b>Noise Source Elevations (in feet)</b>				
Centerline Dist. to Observer: 60.0 feet		Autos: 0.000				
Barrier Distance to Observer: 0.0 feet		Medium Trucks: 2.297				
Observer Height (Above Pad): 5.0 feet		Heavy Trucks: 8.006      Grade Adjustment: 0.0				
Pad Elevation: 0.0 feet		<b>Lane Equivalent Distance (in feet)</b>				
Road Elevation: 0.0 feet		Autos: 42.143				
Road Grade: 0.0%		Medium Trucks: 41.932				
Left View: -90.0 degrees		Heavy Trucks: 41.953				
Right View: 90.0 degrees						

**FHWA Noise Model Calculations**

VehicleType	REMEL	Traffic Flow	Distance	Finite Road	Fresnel	Barrier Atten	Berm Atten
Autos:	68.46	1.65	1.01	-1.20	-4.69	0.000	0.000
Medium Trucks:	79.45	-15.59	1.04	-1.20	-4.88	0.000	0.000
Heavy Trucks:	84.25	-19.55	1.04	-1.20	-5.34	0.000	0.000

**Unmitigated Noise Levels (without Topo and barrier attenuation)**

VehicleType	Leq Peak Hour	Leq Day	Leq Evening	Leq Night	Ldn	CNEL
Autos:	69.9	68.0	66.3	60.2	68.8	69.4
Medium Trucks:	63.7	62.2	55.8	54.3	62.7	63.0
Heavy Trucks:	64.5	63.1	54.1	55.3	63.7	63.8
Vehicle Noise:	71.8	70.0	66.9	62.2	70.7	71.2

**Centerline Distance to Noise Contour (in feet)**

	70 dBA	65 dBA	60 dBA	55 dBA
Ldn:	67	145	312	672
CNEL:	72	155	334	720

**FHWA-RD-77-108 HIGHWAY NOISE PREDICTION MODEL**

Scenario: EAC  
 Road Name: Bob Hope Drive  
 Road Segment: s/o Frank Sinatra Drive

Project Name: Desert Islands Hotel  
 Job Number: 14747

SITE SPECIFIC INPUT DATA		NOISE MODEL INPUTS				
<b>Highway Data</b>		<b>Site Conditions (Hard = 10, Soft = 15)</b>				
Average Daily Traffic (Adt): 25,980 vehicles		Autos: 15				
Peak Hour Percentage: 10.00%		Medium Trucks (2 Axles): 15				
Peak Hour Volume: 2,598 vehicles		Heavy Trucks (3+ Axles): 15				
Vehicle Speed: 45 mph		<b>Vehicle Mix</b>				
Near/Far Lane Distance: 58 feet		VehicleType	Day	Evening	Night	Daily
<b>Site Data</b>		Autos: 77.5% 12.9% 9.6% 97.42%				
Barrier Height: 0.0 feet		Medium Trucks: 84.8% 4.9% 10.3% 1.84%				
Barrier Type (0-Wall, 1-Berm): 0.0		Heavy Trucks: 86.5% 2.7% 10.8% 0.74%				
Centerline Dist. to Barrier: 55.0 feet		<b>Noise Source Elevations (in feet)</b>				
Centerline Dist. to Observer: 55.0 feet		Autos: 0.000				
Barrier Distance to Observer: 0.0 feet		Medium Trucks: 2.297				
Observer Height (Above Pad): 5.0 feet		Heavy Trucks: 8.006      Grade Adjustment: 0.0				
Pad Elevation: 0.0 feet		<b>Lane Equivalent Distance (in feet)</b>				
Road Elevation: 0.0 feet		Autos: 47.000				
Road Grade: 0.0%		Medium Trucks: 46.811				
Left View: -90.0 degrees		Heavy Trucks: 46.830				
Right View: 90.0 degrees						

**FHWA Noise Model Calculations**

VehicleType	REMEL	Traffic Flow	Distance	Finite Road	Fresnel	Barrier Atten	Berm Atten
Autos:	68.46	2.20	0.30	-1.20	-4.67	0.000	0.000
Medium Trucks:	79.45	-15.04	0.33	-1.20	-4.87	0.000	0.000
Heavy Trucks:	84.25	-19.00	0.32	-1.20	-5.38	0.000	0.000

**Unmitigated Noise Levels (without Topo and barrier attenuation)**

VehicleType	Leq Peak Hour	Leq Day	Leq Evening	Leq Night	Ldn	CNEL
Autos:	69.8	67.9	66.1	60.0	68.7	69.3
Medium Trucks:	63.5	62.0	55.7	54.1	62.6	62.8
Heavy Trucks:	64.4	63.0	53.9	55.2	63.5	63.7
Vehicle Noise:	71.6	69.9	66.7	62.0	70.6	71.0

**Centerline Distance to Noise Contour (in feet)**

	70 dBA	65 dBA	60 dBA	55 dBA
Ldn:	60	129	279	600
CNEL:	64	139	299	644

**FHWA-RD-77-108 HIGHWAY NOISE PREDICTION MODEL**

Scenario: EAC  
 Road Name: Island Drive  
 Road Segment: s/o Frank Sinatra Drive

Project Name: Desert Islands Hotel  
 Job Number: 14747

SITE SPECIFIC INPUT DATA		NOISE MODEL INPUTS				
<b>Highway Data</b>		<b>Site Conditions (Hard = 10, Soft = 15)</b>				
Average Daily Traffic (Adt):	1,900 vehicles	Autos: 15				
Peak Hour Percentage:	10.00%	Medium Trucks (2 Axles): 15				
Peak Hour Volume:	190 vehicles	Heavy Trucks (3+ Axles): 15				
Vehicle Speed:	25 mph	<b>Vehicle Mix</b>				
Near/Far Lane Distance:	12 feet	VehicleType	Day	Evening	Night	Daily
<b>Site Data</b>		Autos: 77.5% 12.9% 9.6% 97.42%				
<b>Barrier Height:</b>	<b>0.0 feet</b>	Medium Trucks: 84.8% 4.9% 10.3% 1.84%				
Barrier Type (0-Wall, 1-Berm):	0.0	Heavy Trucks: 86.5% 2.7% 10.8% 0.74%				
Centerline Dist. to Barrier:	30.0 feet	<b>Noise Source Elevations (in feet)</b>				
Centerline Dist. to Observer:	30.0 feet	Autos: 0.000				
Barrier Distance to Observer:	0.0 feet	Medium Trucks: 2.297				
Observer Height (Above Pad):	5.0 feet	Heavy Trucks: 8.006      Grade Adjustment: 0.0				
Pad Elevation:	0.0 feet	<b>Lane Equivalent Distance (in feet)</b>				
Road Elevation:	0.0 feet	Autos: 29.816				
Road Grade:	0.0%	Medium Trucks: 29.518				
Left View:	-90.0 degrees	Heavy Trucks: 29.547				
Right View:	90.0 degrees					

<b>FHWA Noise Model Calculations</b>							
VehicleType	REMEL	Traffic Flow	Distance	Finite Road	Fresnel	Barrier Atten	Berm Atten
Autos:	58.73	-6.61	3.26	-1.20	-4.49	0.000	0.000
Medium Trucks:	70.80	-23.85	3.33	-1.20	-4.86	0.000	0.000
Heavy Trucks:	77.97	-27.80	3.32	-1.20	-5.77	0.000	0.000

<b>Unmitigated Noise Levels (without Topo and barrier attenuation)</b>							
VehicleType	Leq Peak Hour	Leq Day	Leq Evening	Leq Night	Ldn	CNEL	
Autos:	54.2	52.3	50.5	44.5	53.1	53.7	
Medium Trucks:	49.1	47.6	41.2	39.7	48.1	48.4	
Heavy Trucks:	52.3	50.9	41.8	43.1	51.4	51.6	
Vehicle Noise:	57.1	55.4	51.5	47.6	56.1	56.5	

<b>Centerline Distance to Noise Contour (in feet)</b>				
	70 dBA	65 dBA	60 dBA	55 dBA
Ldn:	4	8	17	36
CNEL:	4	8	18	38



**FHWA-RD-77-108 HIGHWAY NOISE PREDICTION MODEL**

Scenario: EAPC  
 Road Name: Frank Sinatra Drive  
 Road Segment: w/o Island Drive

Project Name: Desert Islands Hotel  
 Job Number: 14747

SITE SPECIFIC INPUT DATA		NOISE MODEL INPUTS				
<b>Highway Data</b>		<b>Site Conditions (Hard = 10, Soft = 15)</b>				
Average Daily Traffic (Adt): 17,800 vehicles		Autos: 15				
Peak Hour Percentage: 10.00%		Medium Trucks (2 Axles): 15				
Peak Hour Volume: 1,780 vehicles		Heavy Trucks (3+ Axles): 15				
Vehicle Speed: 45 mph		<b>Vehicle Mix</b>				
Near/Far Lane Distance: 58 feet		VehicleType	Day	Evening	Night	Daily
<b>Site Data</b>		Autos: 77.5% 12.9% 9.6% 97.42%				
Barrier Height: 0.0 feet		Medium Trucks: 84.8% 4.9% 10.3% 1.84%				
Barrier Type (0-Wall, 1-Berm): 0.0		Heavy Trucks: 86.5% 2.7% 10.8% 0.74%				
Centerline Dist. to Barrier: 55.0 feet		<b>Noise Source Elevations (in feet)</b>				
Centerline Dist. to Observer: 55.0 feet		Autos: 0.000				
Barrier Distance to Observer: 0.0 feet		Medium Trucks: 2.297				
Observer Height (Above Pad): 5.0 feet		Heavy Trucks: 8.006 Grade Adjustment: 0.0				
Pad Elevation: 0.0 feet		<b>Lane Equivalent Distance (in feet)</b>				
Road Elevation: 0.0 feet		Autos: 47.000				
Road Grade: 0.0%		Medium Trucks: 46.811				
Left View: -90.0 degrees		Heavy Trucks: 46.830				
Right View: 90.0 degrees						

<b>FHWA Noise Model Calculations</b>							
VehicleType	REMEL	Traffic Flow	Distance	Finite Road	Fresnel	Barrier Atten	Berm Atten
Autos:	68.46	0.55	0.30	-1.20	-4.67	0.000	0.000
Medium Trucks:	79.45	-16.69	0.33	-1.20	-4.87	0.000	0.000
Heavy Trucks:	84.25	-20.64	0.32	-1.20	-5.38	0.000	0.000

<b>Unmitigated Noise Levels (without Topo and barrier attenuation)</b>							
VehicleType	Leq Peak Hour	Leq Day	Leq Evening	Leq Night	Ldn	CNEL	
Autos:	68.1	66.2	64.4	58.4	67.0	67.6	
Medium Trucks:	61.9	60.4	54.0	52.5	60.9	61.2	
Heavy Trucks:	62.7	61.3	52.3	53.5	61.9	62.0	
Vehicle Noise:	70.0	68.2	65.1	60.4	68.9	69.4	

<b>Centerline Distance to Noise Contour (in feet)</b>				
	70 dBA	65 dBA	60 dBA	55 dBA
Ldn:	47	101	217	467
CNEL:	50	108	232	500

**FHWA-RD-77-108 HIGHWAY NOISE PREDICTION MODEL**

Scenario: EAPC  
 Road Name: Frank Sinatra Drive  
 Road Segment: e/o Island Drive

Project Name: Desert Islands Hotel  
 Job Number: 14747

SITE SPECIFIC INPUT DATA		NOISE MODEL INPUTS				
<b>Highway Data</b>		<b>Site Conditions (Hard = 10, Soft = 15)</b>				
Average Daily Traffic (Adt): 17,800 vehicles		Autos: 15				
Peak Hour Percentage: 10.00%		Medium Trucks (2 Axles): 15				
Peak Hour Volume: 1,780 vehicles		Heavy Trucks (3+ Axles): 15				
Vehicle Speed: 45 mph		<b>Vehicle Mix</b>				
Near/Far Lane Distance: 58 feet		VehicleType	Day	Evening	Night	Daily
<b>Site Data</b>		Autos: 77.5% 12.9% 9.6% 97.42%				
Barrier Height: 0.0 feet		Medium Trucks: 84.8% 4.9% 10.3% 1.84%				
Barrier Type (0-Wall, 1-Berm): 0.0		Heavy Trucks: 86.5% 2.7% 10.8% 0.74%				
Centerline Dist. to Barrier: 55.0 feet		<b>Noise Source Elevations (in feet)</b>				
Centerline Dist. to Observer: 55.0 feet		Autos: 0.000				
Barrier Distance to Observer: 0.0 feet		Medium Trucks: 2.297				
Observer Height (Above Pad): 5.0 feet		Heavy Trucks: 8.006      Grade Adjustment: 0.0				
Pad Elevation: 0.0 feet		<b>Lane Equivalent Distance (in feet)</b>				
Road Elevation: 0.0 feet		Autos: 47.000				
Road Grade: 0.0%		Medium Trucks: 46.811				
Left View: -90.0 degrees		Heavy Trucks: 46.830				
Right View: 90.0 degrees						

**FHWA Noise Model Calculations**

VehicleType	REMEL	Traffic Flow	Distance	Finite Road	Fresnel	Barrier Atten	Berm Atten
Autos:	68.46	0.55	0.30	-1.20	-4.67	0.000	0.000
Medium Trucks:	79.45	-16.69	0.33	-1.20	-4.87	0.000	0.000
Heavy Trucks:	84.25	-20.64	0.32	-1.20	-5.38	0.000	0.000

**Unmitigated Noise Levels (without Topo and barrier attenuation)**

VehicleType	Leq Peak Hour	Leq Day	Leq Evening	Leq Night	Ldn	CNEL
Autos:	68.1	66.2	64.4	58.4	67.0	67.6
Medium Trucks:	61.9	60.4	54.0	52.5	60.9	61.2
Heavy Trucks:	62.7	61.3	52.3	53.5	61.9	62.0
Vehicle Noise:	70.0	68.2	65.1	60.4	68.9	69.4

**Centerline Distance to Noise Contour (in feet)**

	70 dBA	65 dBA	60 dBA	55 dBA
Ldn:	47	101	217	467
CNEL:	50	108	232	500

**FHWA-RD-77-108 HIGHWAY NOISE PREDICTION MODEL**

Scenario: EAPC  
 Road Name: Frank Sinatra Drive  
 Road Segment: e/o Bob Hope Drive

Project Name: Desert Islands Hotel  
 Job Number: 14747

SITE SPECIFIC INPUT DATA		NOISE MODEL INPUTS				
<b>Highway Data</b>		<b>Site Conditions (Hard = 10, Soft = 15)</b>				
Average Daily Traffic (Adt): 16,200 vehicles		Autos: 15				
Peak Hour Percentage: 10.00%		Medium Trucks (2 Axles): 15				
Peak Hour Volume: 1,620 vehicles		Heavy Trucks (3+ Axles): 15				
Vehicle Speed: 45 mph		<b>Vehicle Mix</b>				
Near/Far Lane Distance: 58 feet		VehicleType	Day	Evening	Night	Daily
<b>Site Data</b>		Autos: 77.5% 12.9% 9.6% 97.42%				
Barrier Height: 0.0 feet		Medium Trucks: 84.8% 4.9% 10.3% 1.84%				
Barrier Type (0-Wall, 1-Berm): 0.0		Heavy Trucks: 86.5% 2.7% 10.8% 0.74%				
Centerline Dist. to Barrier: 55.0 feet		<b>Noise Source Elevations (in feet)</b>				
Centerline Dist. to Observer: 55.0 feet		Autos: 0.000				
Barrier Distance to Observer: 0.0 feet		Medium Trucks: 2.297				
Observer Height (Above Pad): 5.0 feet		Heavy Trucks: 8.006      Grade Adjustment: 0.0				
Pad Elevation: 0.0 feet		<b>Lane Equivalent Distance (in feet)</b>				
Road Elevation: 0.0 feet		Autos: 47.000				
Road Grade: 0.0%		Medium Trucks: 46.811				
Left View: -90.0 degrees		Heavy Trucks: 46.830				
Right View: 90.0 degrees						

<b>FHWA Noise Model Calculations</b>							
VehicleType	REMEL	Traffic Flow	Distance	Finite Road	Fresnel	Barrier Atten	Berm Atten
Autos:	68.46	0.14	0.30	-1.20	-4.67	0.000	0.000
Medium Trucks:	79.45	-17.09	0.33	-1.20	-4.87	0.000	0.000
Heavy Trucks:	84.25	-21.05	0.32	-1.20	-5.38	0.000	0.000

<b>Unmitigated Noise Levels (without Topo and barrier attenuation)</b>							
VehicleType	Leq Peak Hour	Leq Day	Leq Evening	Leq Night	Ldn	CNEL	
Autos:	67.7	65.8	64.0	58.0	66.6	67.2	
Medium Trucks:	61.5	60.0	53.6	52.1	60.5	60.8	
Heavy Trucks:	62.3	60.9	51.9	53.1	61.5	61.6	
Vehicle Noise:	69.5	67.8	64.7	60.0	68.5	69.0	

<b>Centerline Distance to Noise Contour (in feet)</b>				
	70 dBA	65 dBA	60 dBA	55 dBA
Ldn:	44	94	203	438
CNEL:	47	101	218	470

**FHWA-RD-77-108 HIGHWAY NOISE PREDICTION MODEL**

Scenario: EAPC  
 Road Name: Bob Hope Drive  
 Road Segment: n/o Frank Sinatra Drive

Project Name: Desert Islands Hotel  
 Job Number: 14747

SITE SPECIFIC INPUT DATA		NOISE MODEL INPUTS				
<b>Highway Data</b>		<b>Site Conditions (Hard = 10, Soft = 15)</b>				
Average Daily Traffic (Adt): 23,200 vehicles		Autos: 15				
Peak Hour Percentage: 10.00%		Medium Trucks (2 Axles): 15				
Peak Hour Volume: 2,320 vehicles		Heavy Trucks (3+ Axles): 15				
Vehicle Speed: 45 mph		<b>Vehicle Mix</b>				
Near/Far Lane Distance: 86 feet		VehicleType	Day	Evening	Night	Daily
<b>Site Data</b>		Autos: 77.5% 12.9% 9.6% 97.42%				
Barrier Height: 0.0 feet		Medium Trucks: 84.8% 4.9% 10.3% 1.84%				
Barrier Type (0-Wall, 1-Berm): 0.0		Heavy Trucks: 86.5% 2.7% 10.8% 0.74%				
Centerline Dist. to Barrier: 60.0 feet		<b>Noise Source Elevations (in feet)</b>				
Centerline Dist. to Observer: 60.0 feet		Autos: 0.000				
Barrier Distance to Observer: 0.0 feet		Medium Trucks: 2.297				
Observer Height (Above Pad): 5.0 feet		Heavy Trucks: 8.006      Grade Adjustment: 0.0				
Pad Elevation: 0.0 feet		<b>Lane Equivalent Distance (in feet)</b>				
Road Elevation: 0.0 feet		Autos: 42.143				
Road Grade: 0.0%		Medium Trucks: 41.932				
Left View: -90.0 degrees		Heavy Trucks: 41.953				
Right View: 90.0 degrees						

<b>FHWA Noise Model Calculations</b>							
VehicleType	REMEL	Traffic Flow	Distance	Finite Road	Fresnel	Barrier Atten	Berm Atten
Autos:	68.46	1.70	1.01	-1.20	-4.69	0.000	0.000
Medium Trucks:	79.45	-15.53	1.04	-1.20	-4.88	0.000	0.000
Heavy Trucks:	84.25	-19.49	1.04	-1.20	-5.34	0.000	0.000

<b>Unmitigated Noise Levels (without Topo and barrier attenuation)</b>							
VehicleType	Leq Peak Hour	Leq Day	Leq Evening	Leq Night	Ldn	CNEL	
Autos:	70.0	68.1	66.3	60.3	68.9	69.5	
Medium Trucks:	63.8	62.2	55.9	54.3	62.8	63.0	
Heavy Trucks:	64.6	63.2	54.1	55.4	63.7	63.9	
Vehicle Noise:	71.8	70.1	66.9	62.2	70.8	71.2	

<b>Centerline Distance to Noise Contour (in feet)</b>				
	70 dBA	65 dBA	60 dBA	55 dBA
Ldn:	68	146	314	678
CNEL:	73	157	337	727

**FHWA-RD-77-108 HIGHWAY NOISE PREDICTION MODEL**

Scenario: EAPC  
 Road Name: Bob Hope Drive  
 Road Segment: s/o Frank Sinatra Drive

Project Name: Desert Islands Hotel  
 Job Number: 14747

SITE SPECIFIC INPUT DATA		NOISE MODEL INPUTS				
<b>Highway Data</b>		<b>Site Conditions (Hard = 10, Soft = 15)</b>				
Average Daily Traffic (Adt): 26,000 vehicles		Autos: 15				
Peak Hour Percentage: 10.00%		Medium Trucks (2 Axles): 15				
Peak Hour Volume: 2,600 vehicles		Heavy Trucks (3+ Axles): 15				
Vehicle Speed: 45 mph		<b>Vehicle Mix</b>				
Near/Far Lane Distance: 58 feet		VehicleType	Day	Evening	Night	Daily
<b>Site Data</b>		Autos: 77.5% 12.9% 9.6% 97.42%				
Barrier Height: 0.0 feet		Medium Trucks: 84.8% 4.9% 10.3% 1.84%				
Barrier Type (0-Wall, 1-Berm): 0.0		Heavy Trucks: 86.5% 2.7% 10.8% 0.74%				
Centerline Dist. to Barrier: 55.0 feet		<b>Noise Source Elevations (in feet)</b>				
Centerline Dist. to Observer: 55.0 feet		Autos: 0.000				
Barrier Distance to Observer: 0.0 feet		Medium Trucks: 2.297				
Observer Height (Above Pad): 5.0 feet		Heavy Trucks: 8.006      Grade Adjustment: 0.0				
Pad Elevation: 0.0 feet		<b>Lane Equivalent Distance (in feet)</b>				
Road Elevation: 0.0 feet		Autos: 47.000				
Road Grade: 0.0%		Medium Trucks: 46.811				
Left View: -90.0 degrees		Heavy Trucks: 46.830				
Right View: 90.0 degrees						

**FHWA Noise Model Calculations**

VehicleType	REMEL	Traffic Flow	Distance	Finite Road	Fresnel	Barrier Atten	Berm Atten
Autos:	68.46	2.20	0.30	-1.20	-4.67	0.000	0.000
Medium Trucks:	79.45	-15.04	0.33	-1.20	-4.87	0.000	0.000
Heavy Trucks:	84.25	-19.00	0.32	-1.20	-5.38	0.000	0.000

**Unmitigated Noise Levels (without Topo and barrier attenuation)**

VehicleType	Leq Peak Hour	Leq Day	Leq Evening	Leq Night	Ldn	CNEL
Autos:	69.8	67.9	66.1	60.0	68.7	69.3
Medium Trucks:	63.5	62.0	55.7	54.1	62.6	62.8
Heavy Trucks:	64.4	63.0	53.9	55.2	63.5	63.7
Vehicle Noise:	71.6	69.9	66.7	62.0	70.6	71.0

**Centerline Distance to Noise Contour (in feet)**

	70 dBA	65 dBA	60 dBA	55 dBA
Ldn:	60	129	279	601
CNEL:	64	139	299	644

**FHWA-RD-77-108 HIGHWAY NOISE PREDICTION MODEL**

Scenario: EAPC  
 Road Name: Island Drive  
 Road Segment: s/o Frank Sinatra Drive

Project Name: Desert Islands Hotel  
 Job Number: 14747

SITE SPECIFIC INPUT DATA		NOISE MODEL INPUTS				
<b>Highway Data</b>		<b>Site Conditions (Hard = 10, Soft = 15)</b>				
Average Daily Traffic (Adt):	2,000 vehicles	Autos: 15				
Peak Hour Percentage:	10.00%	Medium Trucks (2 Axles): 15				
Peak Hour Volume:	200 vehicles	Heavy Trucks (3+ Axles): 15				
Vehicle Speed:	25 mph	<b>Vehicle Mix</b>				
Near/Far Lane Distance:	12 feet	VehicleType	Day	Evening	Night	Daily
<b>Site Data</b>		Autos: 77.5% 12.9% 9.6% 97.42%				
<b>Barrier Height:</b>	<b>0.0 feet</b>	Medium Trucks: 84.8% 4.9% 10.3% 1.84%				
Barrier Type (0-Wall, 1-Berm):	0.0	Heavy Trucks: 86.5% 2.7% 10.8% 0.74%				
Centerline Dist. to Barrier:	30.0 feet	<b>Noise Source Elevations (in feet)</b>				
Centerline Dist. to Observer:	30.0 feet	Autos: 0.000				
Barrier Distance to Observer:	0.0 feet	Medium Trucks: 2.297				
Observer Height (Above Pad):	5.0 feet	Heavy Trucks: 8.006    Grade Adjustment: 0.0				
Pad Elevation:	0.0 feet	<b>Lane Equivalent Distance (in feet)</b>				
Road Elevation:	0.0 feet	Autos: 29.816				
Road Grade:	0.0%	Medium Trucks: 29.518				
Left View:	-90.0 degrees	Heavy Trucks: 29.547				
Right View:	90.0 degrees					

**FHWA Noise Model Calculations**

VehicleType	REMEL	Traffic Flow	Distance	Finite Road	Fresnel	Barrier Atten	Berm Atten
Autos:	58.73	-6.39	3.26	-1.20	-4.49	0.000	0.000
Medium Trucks:	70.80	-23.63	3.33	-1.20	-4.86	0.000	0.000
Heavy Trucks:	77.97	-27.58	3.32	-1.20	-5.77	0.000	0.000

**Unmitigated Noise Levels (without Topo and barrier attenuation)**

VehicleType	Leq Peak Hour	Leq Day	Leq Evening	Leq Night	Ldn	CNEL
Autos:	54.4	52.5	50.7	44.7	53.3	53.9
Medium Trucks:	49.3	47.8	41.4	39.9	48.3	48.6
Heavy Trucks:	52.5	51.1	42.1	43.3	51.7	51.8
Vehicle Noise:	57.3	55.6	51.7	47.8	56.3	56.7

**Centerline Distance to Noise Contour (in feet)**

	70 dBA	65 dBA	60 dBA	55 dBA
Ldn:	4	8	17	37
CNEL:	4	8	18	39

**APPENDIX 9.1:**  
**CADNAA OPERATIONAL NOISE MODEL INPUTS**

*This page intentionally left blank*



# 14747 - Desert Island Hotel - Operation

CadnaA Noise Prediction Model: 14747-03\_Operation.cna

Date: 25.05.22

Analyst: B. Maddux

## Calculation Configuration

Configuration	
Parameter	Value
<b>General</b>	
Max. Error (dB)	0.00
Max. Search Radius #(Unit,LEN)	2000.01
Min. Dist Src to Rcvr	0.00
<b>Partition</b>	
Raster Factor	0.50
Max. Length of Section #(Unit,LEN)	999.99
Min. Length of Section #(Unit,LEN)	1.01
Min. Length of Section (%)	0.00
Proj. Line Sources	On
Proj. Area Sources	On
<b>Ref. Time</b>	
Reference Time Day (min)	960.00
Reference Time Night (min)	480.00
Daytime Penalty (dB)	0.00
Recr. Time Penalty (dB)	5.00
Night-time Penalty (dB)	10.00
<b>DTM</b>	
Standard Height (m)	0.00
Model of Terrain	Triangulation
<b>Reflection</b>	
max. Order of Reflection	2
Search Radius Src	100.00
Search Radius Rcvr	100.00
Max. Distance Source - Rcvr	1000.00 1000.00
Min. Distance Rcvr - Reflector	1.00 1.00
Min. Distance Source - Reflector	0.10
<b>Industrial (ISO 9613)</b>	
Lateral Diffraction	some Obj
Obst. within Area Src do not shield	On
Screening	Incl. Ground Att. over Barrier
<b>Dz with limit (20/25)</b>	
Barrier Coefficients C1,2,3	3.0 20.0 0.0
Temperature #(Unit,TEMP)	10
rel. Humidity (%)	70
Ground Absorption G	0.50
Wind Speed for Dir. #(Unit,SPEED)	3.0
<b>Roads (TNM)</b>	
<b>Railways (FTA/FRA)</b>	
<b>Aircraft (???)</b>	
<b>Strictly acc. to AzB</b>	

## Receiver Noise Levels

Name	M.	ID	Level Lr				Limit. Value				Land Use		Height	Coordinates			
			Day	Evening	Night	CNEL	Day	Evening	Night	CNEL	Type	Auto		Noise Type	X	Y	Z
			(dBA)	(dBA)	(dBA)	(dBA)	(dBA)	(dBA)	(dBA)	(dBA)			(ft)	(ft)	(ft)	(ft)	
R1		R1	43.3	43.3	34.6	44.8	80.0	0.0	0.0	0.0			5.00	a	6512536.02	2223944.43	5.00
R2		R2	37.0	37.0	27.6	38.2	80.0	0.0	0.0	0.0			5.00	a	6512512.98	2222941.00	5.00
R3		R3	36.8	36.8	26.0	37.6	80.0	0.0	0.0	0.0			5.00	a	6511990.78	2222760.18	5.00
R4		R4	39.4	39.4	28.8	40.3	80.0	0.0	0.0	0.0			5.00	a	6510916.51	2224659.94	5.00
R5		R5	40.9	40.9	30.3	41.8	80.0	0.0	0.0	0.0			5.00	a	6510959.06	2223991.34	5.00
R6		R6	40.6	40.6	30.6	41.7	80.0	0.0	0.0	0.0			5.00	a	6510913.61	2224164.76	5.00

## Point Source(s)

Name	M.	ID	Result. PWL			Lw / Li		Operating Time			Height	Coordinates			
			Day	Evening	Night	Type	Value	norm.	Day	Special		Night	X	Y	Z
			(dBA)	(dBA)	(dBA)		dB(A)	(min)	(min)	(min)	(ft)	(ft)	(ft)	(ft)	
POINTSOURCE		GAC01	75.0	75.0	75.0	Lw	75				4.00	a	6511551.20	2224346.39	4.00
POINTSOURCE		GAC02	75.0	75.0	75.0	Lw	75				4.00	a	6511482.19	2224344.65	4.00
POINTSOURCE		GAC03	75.0	75.0	75.0	Lw	75				4.00	a	6511401.46	2224345.96	4.00
POINTSOURCE		GAC04	75.0	75.0	75.0	Lw	75				4.00	a	6511333.75	2224345.09	4.00
POINTSOURCE		GAC05	75.0	75.0	75.0	Lw	75				4.00	a	6511228.72	2224344.65	4.00
POINTSOURCE		GAC06	75.0	75.0	75.0	Lw	75	720.00	180.00	540.00	4.00	a	6511159.71	2224343.79	4.00
POINTSOURCE		GAC07	75.0	75.0	75.0	Lw	75	720.00	180.00	540.00	4.00	a	6511184.44	2224120.70	4.00
POINTSOURCE		GAC08	75.0	75.0	75.0	Lw	75	720.00	180.00	540.00	4.00	a	6511252.59	2224120.26	4.00
POINTSOURCE		GAC09	75.0	75.0	75.0	Lw	75	720.00	180.00	540.00	4.00	a	6511333.32	2224120.26	4.00
POINTSOURCE		GAC10	75.0	75.0	75.0	Lw	75	720.00	180.00	540.00	4.00	a	6511402.76	2224121.13	4.00
POINTSOURCE		GAC11	75.0	75.0	75.0	Lw	75	720.00	180.00	540.00	4.00	a	6511482.62	2224119.39	4.00
POINTSOURCE		PTAC01	61.2	61.2	61.2	Lw	61.2	720.00	180.00	540.00	4.00	a	6511664.91	2224273.47	4.00

Name	M.	ID	Result. PWL			Lw / Li			Operating Time			Height		Coordinates		
			Day	Evening	Night	Type	Value	norm.	Day	Special	Night	(ft)		X	Y	Z
			(dBA)	(dBA)	(dBA)		dB(A)		(min)	(min)	(min)			(ft)	(ft)	(ft)
POINTSOURCE		PTAC02	61.2	61.2	61.2	Lw	61.2		720.00	180.00	540.00	4.00	a	6511727.85	2224272.17	4.00
POINTSOURCE		PTAC03	61.2	61.2	61.2	Lw	61.2		720.00	180.00	540.00	4.00	a	6511779.06	2224272.17	4.00
POINTSOURCE		PTAC04	61.2	61.2	61.2	Lw	61.2		720.00	180.00	540.00	4.00	a	6511825.94	2224271.30	4.00
POINTSOURCE		PTAC05	61.2	61.2	61.2	Lw	61.2		720.00	180.00	540.00	4.00	a	6511664.05	2224422.78	4.00
POINTSOURCE		PTAC06	61.2	61.2	61.2	Lw	61.2		720.00	180.00	540.00	4.00	a	6511726.98	2224423.21	4.00
POINTSOURCE		PTAC07	61.2	61.2	61.2	Lw	61.2		720.00	180.00	540.00	4.00	a	6511778.63	2224423.65	4.00
POINTSOURCE		PTAC08	61.2	61.2	61.2	Lw	61.2		720.00	180.00	540.00	4.00	a	6511825.50	2224424.08	4.00
POINTSOURCE		PTAC09	61.2	61.2	61.2	Lw	61.2		720.00	180.00	540.00	4.00	a	6511894.95	2224424.08	4.00
POINTSOURCE		PTAC10	61.2	61.2	61.2	Lw	61.2		720.00	180.00	540.00	4.00	a	6511957.88	2224424.08	4.00
POINTSOURCE		PTAC11	61.2	61.2	61.2	Lw	61.2		720.00	180.00	540.00	4.00	a	6512008.23	2224424.51	4.00
POINTSOURCE		PTAC12	61.2	61.2	61.2	Lw	61.2		720.00	180.00	540.00	4.00	a	6512055.54	2224424.08	4.00
POINTSOURCE		PTAC13	61.2	61.2	61.2	Lw	61.2		720.00	180.00	540.00	4.00	a	6511879.76	2224267.83	4.00
POINTSOURCE		PTAC14	61.2	61.2	61.2	Lw	61.2		720.00	180.00	540.00	4.00	a	6511901.02	2224266.53	4.00
POINTSOURCE		PTAC15	61.2	61.2	61.2	Lw	61.2		720.00	180.00	540.00	4.00	a	6511921.42	2224267.40	4.00
POINTSOURCE		PTAC16	61.2	61.2	61.2	Lw	61.2		720.00	180.00	540.00	4.00	a	6511942.69	2224266.96	4.00
POINTSOURCE		PTAC17	61.2	61.2	61.2	Lw	61.2		720.00	180.00	540.00	4.00	a	6511963.96	2224266.53	4.00
POINTSOURCE		PTAC18	61.2	61.2	61.2	Lw	61.2		720.00	180.00	540.00	4.00	a	6511984.79	2224266.96	4.00
POINTSOURCE		PTAC19	61.2	61.2	61.2	Lw	61.2		720.00	180.00	540.00	4.00	a	6512005.63	2224266.53	4.00
POINTSOURCE		PTAC20	61.2	61.2	61.2	Lw	61.2		720.00	180.00	540.00	4.00	a	6512026.89	2224266.09	4.00
POINTSOURCE		PTAC21	61.2	61.2	61.2	Lw	61.2		720.00	180.00	540.00	4.00	a	6512047.73	2224266.53	4.00
POINTSOURCE		PTAC22	61.2	61.2	61.2	Lw	61.2		720.00	180.00	540.00	4.00	a	6512069.43	2224266.09	4.00
POINTSOURCE		RAC01	88.9	88.9	88.9	Lw	88.9		720.00	180.00	540.00	14.00	a	6513044.22	2224590.57	14.00
POINTSOURCE		Trash1	89.0	89.0	89.0	Lw	89		720.00	180.00	90.00	8.00	a	6512908.63	2224596.55	8.00
POINTSOURCE		Pool01	89.3	89.3	89.3	Lw	89.3		720.00	180.00	0.00	5.00	a	6511858.46	2224115.31	5.00
POINTSOURCE		Pool02	89.3	89.3	89.3	Lw	89.3		720.00	180.00	0.00	5.00	a	6511772.35	2224116.01	5.00
POINTSOURCE		Pool03	89.3	89.3	89.3	Lw	89.3		720.00	180.00	0.00	5.00	a	6511780.68	2224077.12	5.00
POINTSOURCE		REC01	91.5	91.5	91.5	Lw	91.5		720.00	180.00	0.00	5.00	a	6511655.87	2224159.41	5.00
POINTSOURCE		REC02	91.5	91.5	91.5	Lw	91.5		720.00	180.00	0.00	5.00	a	6512033.46	2224160.45	5.00
POINTSOURCE		REC03	91.5	91.5	91.5	Lw	91.5		720.00	180.00	0.00	5.00	a	6511747.42	2224228.16	5.00
POINTSOURCE		REC04	91.5	91.5	91.5	Lw	91.5		720.00	180.00	0.00	5.00	a	6511826.63	2224224.90	5.00
POINTSOURCE		REC05	91.5	91.5	91.5	Lw	91.5		720.00	180.00	0.00	5.00	a	6511750.67	2224177.16	5.00
POINTSOURCE		REC06	91.5	91.5	91.5	Lw	91.5		720.00	180.00	0.00	5.00	a	6511828.80	2224176.07	5.00
POINTSOURCE		REC07	91.5	91.5	91.5	Lw	91.5		720.00	180.00	0.00	5.00	a	6511896.07	2224172.82	5.00
POINTSOURCE		REC08	91.5	91.5	91.5	Lw	91.5		720.00	180.00	0.00	5.00	a	6511959.01	2224194.52	5.00
POINTSOURCE		REC09	91.5	91.5	91.5	Lw	91.5		720.00	180.00	0.00	5.00	a	6511903.67	2224234.67	5.00
POINTSOURCE		REC10	91.5	91.5	91.5	Lw	91.5		720.00	180.00	0.00	5.00	a	6511991.56	2224232.50	5.00
POINTSOURCE		REC11	91.5	91.5	91.5	Lw	91.5		720.00	180.00	0.00	5.00	a	6512052.32	2224222.73	5.00
POINTSOURCE		REC18	91.5	91.5	91.5	Lw	91.5		720.00	180.00	0.00	5.00	a	6511615.04	2223863.57	5.00

### Area Source(s)

Name	M.	ID	Result. PWL			Result. PWL"			Type	Lw / Li		Operating Time			Height (ft)	
			Day	Evening	Night	Day	Evening	Night		Value	norm.	Day	Special	Night		
			(dBA)	(dBA)	(dBA)	(dBA)	(dBA)	(dBA)		dB(A)		(min)	(min)	(min)		
Parking_lot3		Parking3	98.0	98.0	98.0	64.1	64.1	64.1	Lw"	64.1					0.	a

Name	Height		Coordinates			
	Begin (ft)	End (ft)	x (ft)	y (ft)	z (ft)	Ground (ft)
Parking_lot3	0.00	a	6512831.91	2224540.92	0.00	0.00
			6512831.14	2224551.57	0.00	0.00
			6512831.55	2224563.48	0.00	0.00
			6512830.52	2224673.59	0.00	0.00
			6513157.25	2224674.69	0.00	0.00
			6513157.25	2224614.96	0.00	0.00
			6512882.95	2224614.96	0.00	0.00
			6512886.98	2224559.16	0.00	0.00
			6512841.28	2224559.41	0.00	0.00
			6512841.98	2224521.91	0.00	0.00
			6512608.64	2224521.91	0.00	0.00
			6512607.95	2224538.57	0.00	0.00
			6512711.47	2224539.18	0.00	0.00

**APPENDIX 10.1:**

**CADNAA CONSTRUCTION NOISE MODEL INPUTS**

*This page intentionally left blank*

# 14747 - Desert Island Hotel - Construction

CadnaA Noise Prediction Model: 14747-02\_Construction.cna

Date: 26.05.22

Analyst: B. Maddux

## Calculation Configuration

Configuration	
Parameter	Value
<b>General</b>	
Max. Error (dB)	0.00
Max. Search Radius #(Unit,LEN)	2000.01
Min. Dist Src to Rcvr	0.00
Partition	
Raster Factor	0.50
Max. Length of Section #(Unit,LEN)	999.99
Min. Length of Section #(Unit,LEN)	1.01
Min. Length of Section (%)	0.00
Proj. Line Sources	On
Proj. Area Sources	On
Ref. Time	
Reference Time Day (min)	960.00
Reference Time Night (min)	480.00
Daytime Penalty (dB)	0.00
Recr. Time Penalty (dB)	5.00
Night-time Penalty (dB)	10.00
DTM	
Standard Height (m)	0.00
Model of Terrain	Triangulation
Reflection	
max. Order of Reflection	2
Search Radius Src	100.00
Search Radius Rcvr	100.00
Max. Distance Source - Rcvr	1000.00 1000.00
Min. Distance Rcvr - Reflector	1.00 1.00
Min. Distance Source - Reflector	0.10
Industrial (ISO 9613)	
Lateral Diffraction	some Obj
Obst. within Area Src do not shield	On
Screening	Incl. Ground Att. over Barrier
	Dz with limit (20/25)
Barrier Coefficients C1,2,3	3.0 20.0 0.0
Temperature #(Unit,TEMP)	10
rel. Humidity (%)	70
Ground Absorption G	0.50
Wind Speed for Dir. #(Unit,SPEED)	3.0
Roads (TNM)	
Railways (FTA/FRA)	
Aircraft (???)	
Strictly acc. to AzB	

## Receiver Noise Levels

Name	M.	ID	Level Lr			Limit. Value			Land Use			Height	Coordinates			
			Day	Night	CNEL	Day	Night	CNEL	Type	Auto	Noise Type		X	Y	Z	
			(dBA)	(dBA)	(dBA)	(dBA)	(dBA)	(dBA)				(ft)	(ft)	(ft)	(ft)	
R1		R1	61.8	-39.1	58.8	80.0	0.0	0.0				5.00	a	6512536.02	2223944.43	5.00
R2		R2	55.4	-45.9	52.4	80.0	0.0	0.0				5.00	a	6512512.98	2222941.00	5.00
R3		R3	54.8	-46.9	51.7	80.0	0.0	0.0				5.00	a	6511990.78	2222760.18	5.00
R4		R4	63.0	-39.8	60.0	80.0	0.0	0.0				5.00	a	6510916.51	2224659.94	5.00
R5		R5	61.6	-41.1	58.6	80.0	0.0	0.0				5.00	a	6510959.06	2223991.34	5.00
R6		R6	62.0	-40.7	59.0	80.0	0.0	0.0				5.00	a	6510913.61	2224164.76	5.00

## Area Source(s)

Name	M.	ID	Result. PWL			Result. PWL"			Lw / Li			Operating Time			Height	
			Day	Evening	Night	Day	Evening	Night	Type	Value	norm.	Day	Special	Night		(ft)
			(dBA)	(dBA)	(dBA)	(dBA)	(dBA)	(dBA)		dB(A)		(min)	(min)	(min)		
CONSTRUCTION_ACTIVITY		CA1	118.6	15.6	15.6	72.0	-31.0	-31.0	PWL-Pt	115.6					8	a
CONSTRUCTION_ACTIVITY		CA2	115.6	15.6	15.6	91.2	-8.8	-8.8	PWL-Pt	115.6					8	a
CONSTRUCTION_ACTIVITY		CA3	115.6	15.6	15.6	79.5	-20.5	-20.5	PWL-Pt	115.6					8	a

Name	Height		Coordinates			
	Begin	End	x	y	z	Ground
	(ft)	(ft)	(ft)	(ft)	(ft)	(ft)
CONSTRUCTION_ACTIVITY	8.00	a	6510992.81	2224693.04	8.00	0.00
			6510992.38	2224529.44	8.00	0.00
			6510997.90	2224510.48	8.00	0.00
			6511017.50	2224495.77	8.00	0.00
			6511604.74	2224494.35	8.00	0.00

Name	Height		Coordinates			
	Begin (ft)	End (ft)	x (ft)	y (ft)	z (ft)	Ground (ft)
			6511607.60	2224510.48	8.00	0.00
			6511647.10	2224517.06	8.00	0.00
			6511681.89	2224545.32	8.00	0.00
			6511748.01	2224568.46	8.00	0.00
			6511810.98	2224599.19	8.00	0.00
			6511896.01	2224627.47	8.00	0.00
			6511915.41	2224629.76	8.00	0.00
			6511941.80	2224615.17	8.00	0.00
			6512155.69	2224615.87	8.00	0.00
			6512156.38	2224563.09	8.00	0.00
			6512163.33	2224540.17	8.00	0.00
			6512152.22	2224523.51	8.00	0.00
			6512119.58	2224495.73	8.00	0.00
			6512116.11	2224486.01	8.00	0.00
			6512118.89	2224210.44	8.00	0.00
			6512087.20	2224153.27	8.00	0.00
			6512073.94	2224142.42	8.00	0.00
			6512010.59	2224117.68	8.00	0.00
			6511993.11	2224118.78	8.00	0.00
			6511983.62	2224129.32	8.00	0.00
			6511981.83	2224173.32	8.00	0.00
			6511960.94	2224176.15	8.00	0.00
			6511947.01	2224168.11	8.00	0.00
			6511937.81	2224154.92	8.00	0.00
			6511916.38	2224103.61	8.00	0.00
			6511903.12	2224090.14	8.00	0.00
			6511855.88	2224063.85	8.00	0.00
			6511825.71	2224059.26	8.00	0.00
			6511755.79	2224071.32	8.00	0.00
			6511639.01	2224048.52	8.00	0.00
			6511604.33	2224054.39	8.00	0.00
			6511604.30	2223989.79	8.00	0.00
			6511644.53	2223971.77	8.00	0.00
			6511677.86	2223930.92	8.00	0.00
			6511687.13	2223879.02	8.00	0.00
			6511684.06	2223839.22	8.00	0.00
			6511548.76	2223837.23	8.00	0.00
			6511548.70	2223870.75	8.00	0.00
			6511534.75	2223945.97	8.00	0.00
			6511539.51	2223969.00	8.00	0.00
			6511555.24	2223986.49	8.00	0.00
			6511571.74	2223992.99	8.00	0.00
			6511571.74	2224063.01	8.00	0.00
			6511514.94	2224074.75	8.00	0.00
			6511443.85	2224046.35	8.00	0.00
			6511142.74	2224046.35	8.00	0.00
			6511142.74	2224270.35	8.00	0.00
			6511118.74	2224270.35	8.00	0.00
			6511118.74	2224470.35	8.00	0.00
			6511027.38	2224470.35	8.00	0.00
			6511001.74	2224476.21	8.00	0.00
			6510985.60	2224487.68	8.00	0.00
			6510974.17	2224503.85	8.00	0.00
			6510968.38	2224529.50	8.00	0.00
			6510968.81	2224693.08	8.00	0.00
CONSTRUCTION_ACTIVITY	8.00	a	6512703.80	2224541.83	8.00	0.00
			6512847.85	2224543.49	8.00	0.00
			6512847.80	2224521.93	8.00	0.00
			6512704.56	2224521.93	8.00	0.00
CONSTRUCTION_ACTIVITY	8.00	a	6512869.83	2224564.93	8.00	0.00
			6512869.83	2224644.18	8.00	0.00
			6512850.39	2224644.18	8.00	0.00
			6512849.69	2224666.40	8.00	0.00
			6512819.14	2224666.40	8.00	0.00
			6512819.13	2224694.95	8.00	0.00
			6513246.86	2224696.03	8.00	0.00
			6513246.86	2224640.08	8.00	0.00
			6513209.21	2224640.08	8.00	0.00
			6513209.21	2224580.49	8.00	0.00
			6512890.80	2224580.49	8.00	0.00
			6512890.80	2224564.93	8.00	0.00



## **DESERT ISLAND HOTEL APPENDIX**

### ***Appendix C***

*Desert Island VMT Evaluation, Urban Crossroads, Inc.,  
May 2022.*

May 16, 2022

Mr. Ryan Stendell  
City of Rancho Mirage  
69-825 Highway 111  
Rancho Mirage, CA 92270

## **DESERT ISLAND HOTEL VEHICLE MILES TRAVELED (VMT) EVALUATION**

Mr. Ryan Stendell,

Urban Crossroads, Inc. is pleased to provide the following Vehicle Miles Traveled (VMT) Evaluation for the Desert Island Hotel development (**Project**) located south of Frank Sinatra Drive and adjacent to Island Drive in the City of Rancho Mirage (See Attachment A).

### **PROJECT OVERVIEW**

It is our understanding that the Project is proposed to repurpose approximately 13.3 acres of the existing golf driving range and a portion of the existing golf course with new facilities to accommodate a 42-key boutique hotel (with tennis, pool, and yoga amenities), 11 private residences, and a golf training facility (See Attachment A).

### **BACKGROUND**

Changes to California Environmental Quality Act (CEQA) Guidelines were adopted in December 2018, which require all lead agencies to adopt VMT as a replacement for automobile delay-based level of service (LOS) as the measure for identifying transportation impacts for land use projects. This statewide mandate went into effect July 1, 2020. To aid in this transition, the Governor's Office of Planning and Research (OPR) released a [Technical Advisory on Evaluating Transportation Impacts in CEQA](#) (December of 2018) (**Technical Advisory**) (1). City of Rancho Mirage Resolution 2021-06 aligns the City's VMT analysis policy (**City Guidelines**) (2) with SB 743 and the City's goals as set forth in the General Plan Update (2017). The purpose of the policy is to comply with State laws while maintaining the resort residential character of the community. The City's VMT policy establishes VMT as the metric to measure transportation impacts in conformance with. This VMT analysis has been developed based on the adopted City Guidelines.

### **VMT SCREENING**

In addition, Exhibit A of Resolution 2021-06 sets forth screening criteria under which Projects are not required to submit detailed VMT analysis. This guidance for determination of non-significant VMT impact is primarily intended to avoid unnecessary analysis and findings that would be



inconsistent with the intent of SB 743. VMT screening criteria for development projects include the following:

- **Small Projects** with low trip generation based on the County Greenhouse Gas Emissions Screening Tables resulting in a 3,000 metric tons of Carbon Dioxide Equivalent per year screening level threshold. Specific examples include retail buildings with area less than or equal to 60,000 sf,
- **Projects Near High Quality Transit** within a half mile of an existing major transit stop which maintains a service interval frequency of 15 minutes or less during peak commute periods,
- **Map Based Screening** within an area of development under threshold as shown on screening map allowed by the Engineering Department, and

### **STEP 1: HIGH QUALITY TRANSIT SCREENING**

Consistent with guidance identified in the City Guidelines, projects located within a high quality transit area (i.e., within ½ mile of an existing “major transit stop”<sup>1</sup> or an existing stop along a “high-quality transit corridor”<sup>2</sup>) may be presumed to have a less than significant impact absent substantial evidence to the contrary. However, the presumption may not be appropriate if a project:

- Has a Floor Area Ratio (FAR) of less than 0.75;
- Includes more parking for use by residents, customers, or employees of the project than required by the jurisdiction (if the jurisdiction requires the project to supply parking);
- Is inconsistent with the applicable Sustainable Communities Strategy (as determined by the lead agency, with input from the Metropolitan Planning Organization); or
- Replaces affordable residential units with a smaller number of moderate or high-income residential units.

Southern California Councils of Governments (SCAG) provides TPA data through their graphical information system (GIS). This data was utilized to locate if the Project site and its proximity to a TPA. Results as shown in Attachment B, identify the Project Site is not located within ½ mile of an existing major transit stop, or along a high-quality transit corridor.

**TPA screening criteria is not met.**

---

<sup>1</sup> Pub. Resources Code, § 21064.3 (“Major transit stop’ means a site containing an existing rail transit station, a ferry terminal served by either a bus or rail transit service, or the intersection of two or more major bus routes with a frequency of service interval of 15 minutes or less during the morning and afternoon peak commute periods.”).

<sup>2</sup> Pub. Resources Code, § 21155 (“For purposes of this section, a high-quality transit corridor means a corridor with fixed route bus service with service intervals no longer than 15 minutes during peak commute hours.”).

## **STEP 2: LOW VMT AREA SCREENING**

As noted in the Technical Advisory, “Residential and office projects that locate in areas with low VMT and that incorporate similar features (density, mix of uses, and transit accessibility) will tend to exhibit similarly low VMT.”

City Guidelines state that the map-based screening method eliminates the need for complex analyses for projects in low VMT areas, but the screening is limited to residential and office projects.

For the residential portion of the Project, the Riverside County screening map for residential land uses indicates that the Project is in a low VMT area. Therefore, further VMT analysis of the Residential portion of the Project is not necessary. The nature of the non-residential Project land uses excludes the Golf Practice Facility and Hotel land uses from low VMT area screening.

**Low VMT Area screening criteria is met for residential land uses.**

## **STEP 3: PROJECT TYPE SCREENING**

The City Guidelines state that local serving retail projects with area less than 60,000 SF may be presumed to have a less than significant impact, subject to discretionary approval by the City. The combination of land uses on-site that includes golf, tennis facilities with hotel uses could potentially serve travelers from other areas, rather than being locally serving.

**The Project Type screening threshold is not met.**

## **PROJECT VMT ASSESSMENT**

RIVTAM is a useful tool to estimate VMT as it considers interaction between different land uses based on socio-economic data such as population and employment. The City Guidelines identifies RIVTAM as the appropriate tool for conducting VMT analysis for land use projects in Riverside County.

Project VMT has been calculated using the most current version of RIVTAM. Adjustments in socio-economic data (SED) (i.e., employment) have been made to a separate TAZ within the RIVTAM model to reflect the Project’s proposed employment uses. Separate TAZs are used to isolate the Project’s VMT.

The Project is comprised of residential and non-residential use that includes retail (hotel) and golf practice facility land uses. The Project non-residential land uses have been converted to SED. It should be noted that the employment estimates have been developed from land use to employment generation factors based upon information from the Institute of Transportation Engineers (ITE) traffic generating factors, similar project representation, local knowledge, and discussions with Project team members. Approximately 220 employees represent the non-residential portion of the Project.

Adjustments to employment factors for the Project TAZ data were made to the RIVTAM base year model (2012) and the cumulative year model (2040). Each model was then run with the updated SED factors included for the Project.

## **PROJECT EMPLOYMENT IMPACT ON VMT**

The City guidelines state that the threshold of significance for VMT impacts related to a retail project (including hotel) is a net increase in total existing VMT for the area. Consistent with Technical Advisory recommendations, it is appropriate to measure the total net change in VMT related to the implementation of a retail land use project.

Citywide VMT was extracted from the RIVTAM model for both “without Project” and “with Project” model runs. This procedure is commonly referred to as “boundary method” and includes the sum of all weekday VMT on a roadway network within a designated boundary (i.e., City of Rancho Mirage). The boundary method VMT includes all trips, including those trips that do not begin or end in the designated boundary.

The boundary method procedures are performed for 2012 and 2040 conditions, then interpolated for baseline (2022) conditions. Table 1 provides a comparison of total citywide VMT without and with the land use changes proposed by the Project for the various years. The proposed Project is forecast to result in a net **decrease** in citywide VMT of approximately 0.28%.

**TABLE 1: RANCHO MIRAGE CITYWIDE VMT**

	Without Project	With Project	Variance
2012 VMT	758,238	751,843	-6,395
2040 VMT	874,210	879,428	+5,218
2022 Interpolated VMT	799,657	797,409	-2,248
2022 Project % Change			-0.28%

To determine whether or not there is a significant impact using the boundary method, Rancho Mirage VMT with the project employment is compared to without project conditions. The project’s effect on VMT is not considered a significant impact because it results in a cumulative Citywide VMT decrease under the plus project condition compared to the no project condition.

In summary, travel demand modeling of VMT for the Project based upon City of Rancho Mirage guidelines indicates there is no Project VMT impact.

If you have any questions, please contact us at [jkain@urbanxroads.com](mailto:jkain@urbanxroads.com) for John Kain or [mwhiteman@urbanxroads.com](mailto:mwhiteman@urbanxroads.com) for Marlie Whiteman.

Respectfully submitted,

URBAN CROSSROADS, INC.



John Kain, AICP  
Principal

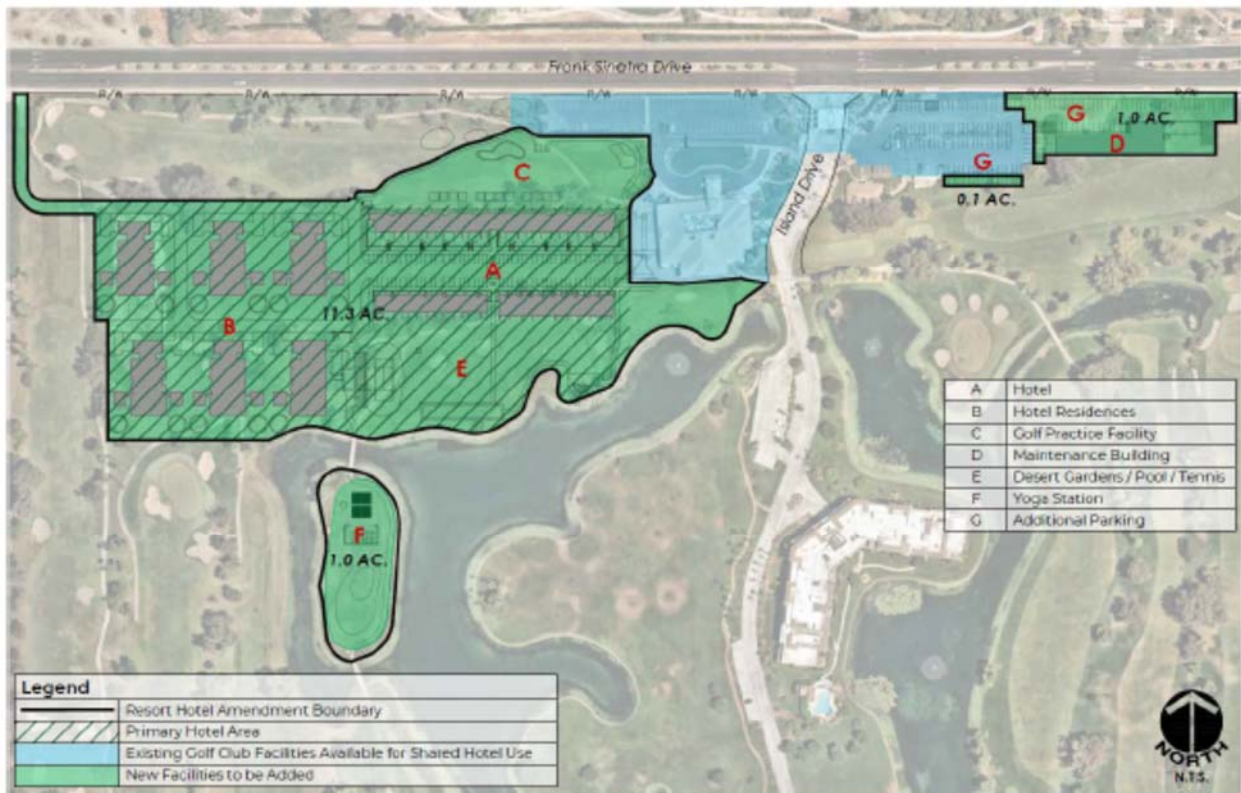


Marlie Whiteman, P.E.  
Senior Associate

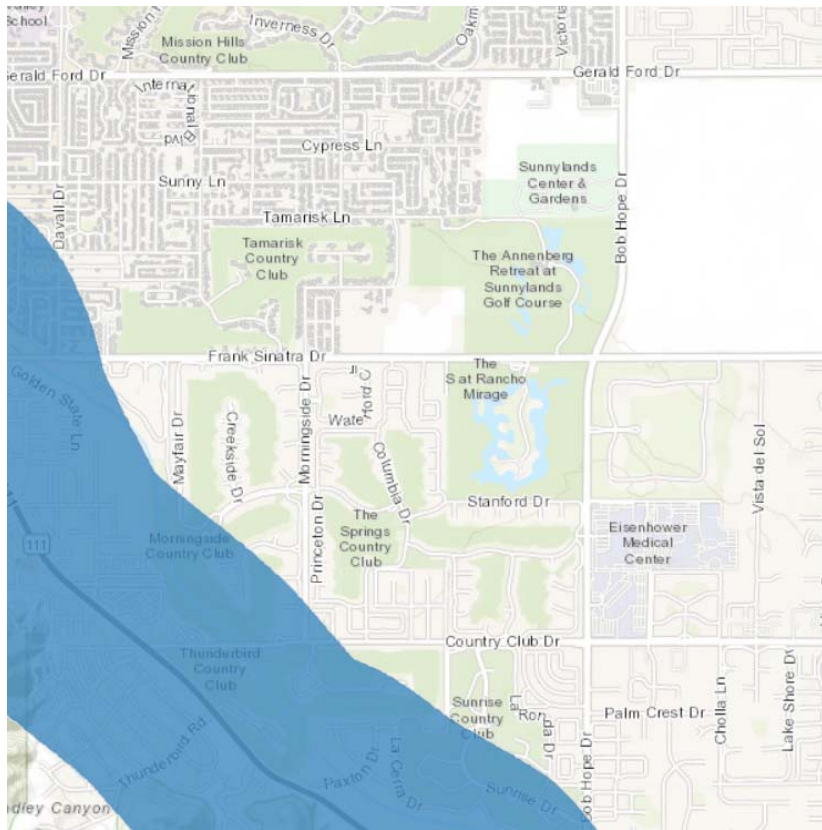
## REFERENCES

1. **Office of Planning and Research.** *Technical Advisory on Evaluating Transportation Impacts in CEQA.* State of California : s.n., December 2018.
2. **City of Rancho Mirage.** *City of Rancho Mirage Transportation Analysis Policy, Resolution No. 2021-06.* February 2021.
3. **Institute of Transportation Engineers.** *Trip Generation Manual.* 11th Edition. 2021.

**ATTACHMENT A**  
**PRELIMINARY SITE PLAN**



**ATTACHMENT B**  
**TPA MAP**



The blue shaded area is the high quality transit area.





## **DESERT ISLAND HOTEL APPENDIX**

### ***Appendix D***

*Desert Island Hotel Focused Traffic Analysis, Urban  
Crossroads, Inc. May 2022.*

# DESERT ISLAND HOTEL

## FOCUSED TRAFFIC ANALYSIS

PREPARED BY:      Janette Cachola      |      jcachola@urbanxroads.com  
                         Marlie Whiteman, P.E.      |      mwhiteman@urbanxroads.com  
                         John Kain, AICP                      |      jkain@urbanxroads.com

# TABLE OF CONTENTS

Table of Contents .....	ii
Appendices.....	iv
List of Exhibits.....	v
List of Tables .....	vi
List of Abbreviated Terms .....	vii
1 Introduction.....	1
1.1 Summary of Findings.....	1
1.2 Project Overview.....	1
1.3 Analysis Scenarios.....	3
1.4 Study Area.....	6
1.5 Analysis Findings .....	7
1.6 Queueing Analysis.....	7
2 Methodologies .....	9
2.1 Level of Service .....	9
2.2 Intersection Capacity Analysis .....	9
2.3 Traffic Signal Warrant Analysis Methodology.....	11
2.4 Minimum Acceptable Levels of Service (LOS).....	12
2.5 Deficiency Criteria.....	12
3 Area Conditions .....	13
3.1 Existing Circulation Network.....	13
3.2 City of Rancho Mirage General Plan Circulation Element .....	13
3.3 Transit Service .....	13
3.4 Pedestrian and Bicycle Facilities .....	17
3.5 Existing (2022) Traffic Counts .....	17
3.6 Intersection Operations Analysis .....	17
3.7 Traffic Signal Warrants Analysis.....	19
4 Projected Future Traffic.....	21
4.1 Project Trip Generation.....	21
4.2 Project Trip Distribution.....	22
4.3 Modal Split .....	22
4.4 Project Trip Assignment.....	22
4.5 Background Traffic .....	25
4.6 Cumulative Development Traffic .....	25

4.7	Near-Term Conditions.....	25
5	EAP (2024) Traffic Conditions.....	31
5.1	Roadway Improvements .....	31
5.2	EAP Traffic Volume Forecasts .....	31
5.3	Intersection Operations Analysis .....	31
5.4	Traffic Signal Warrants Analysis.....	33
5.5	Project Deficiencies and Recommended Improvements.....	33
6	EAPC (2024) Traffic Conditions .....	35
6.1	Roadway Improvements .....	35
6.2	EAPC (2024) Traffic Volume Forecasts.....	35
6.3	Intersection Operations Analysis .....	35
6.4	Traffic Signal Warrants Analysis.....	37
6.5	Project Deficiencies and Recommended Improvements.....	37
7	References.....	39

## **APPENDICES**

Appendix 1.1: Approved Traffic Study Scoping Agreement

Appendix 1.2: Site Adjacent Queues

Appendix 3.1: Traffic Counts – May 2022

Appendix 3.2: Existing (2022) Conditions Intersection Operations Analysis Worksheets

Appendix 3.3: Traffic Signal Warrant Analysis Worksheets

Appendix 5.1: EAP (2024) Conditions Intersection Operations Analysis Worksheets

Appendix 6.1: EAPC (2024) Conditions Intersection Operations Analysis Worksheets

## LIST OF EXHIBITS

Exhibit 1-1: Preliminary Site Plan .....	2
Exhibit 1-2: Study Area.....	4
Exhibit 1-3: On-Site Traffic Circulation.....	5
Exhibit 3-1: Existing Number of Through Lanes and Intersection Controls.....	14
Exhibit 3-2: City of Rancho Mirage General Plan Circulation Element.....	15
Exhibit 3-3: City of Rancho Mirage General Plan Roadway Cross-Sections.....	16
Exhibit 3-4: Existing (2022) Traffic Volumes.....	18
Exhibit 4-1: Project Trip Distribution.....	23
Exhibit 4-2: Project Only Traffic volumes .....	24
Exhibit 4-3: Cumulative Development Location Map .....	27
Exhibit 4-4: Cumulative Only Traffic Volumes .....	28
Exhibit 5-1: EAP (2024) Traffic Volumes.....	32
Exhibit 6-1: EAPC (2024) Traffic Volumes .....	36

## LIST OF TABLES

Table 1-1: Intersection Analysis Locations .....	6
Table 1-2: Project Access Queueing Analysis for EAPC .....	8
Table 2-1: Signalized Intersection LOS Thresholds.....	10
Table 2-2: Unsignalized Intersection LOS Thresholds .....	11
Table 3-1: Intersection Analysis for Existing (2022) Conditions .....	19
Table 4-1: Project Trip Generation Summary .....	22
Table 4-2: Cumulative Development land use Summary .....	29
Table 5-1: Intersection Analysis for EAP Conditions .....	31
Table 6-1: Intersection Analysis for EAPC (2024) Conditions.....	35

## LIST OF ABBREVIATED TERMS

(1)	Reference
ADT	Average Daily Traffic
CAMUTCD	California Manual on Uniform Traffic Control Devices
Caltrans	California Department of Transportation
DIF	Development Impact Fee
HCM	Highway Capacity Manual
ITE	Institute of Transportation Engineers
LOS	Level of Service
NCHRP	National Cooperative Highway Research Program
PHF	Peak Hour Factor
Project	Desert Island hotel
sf	Square Feet
TA	Traffic Analysis



This page intentionally left blank

# 1 INTRODUCTION

This report presents the results of the focused traffic analysis (TA) for Desert Island hotel (“Project”), which is located south of Frank Sinatra Drive and adjacent to Island Drive in the City of Rancho Mirage, as shown on Exhibit 1-1.

The purpose of this focused TA is to evaluate the potential circulation system deficiencies that may result from the development of the proposed Project, and recommend improvements to achieve acceptable circulation system operational conditions. This focused TA has been prepared based in accordance with the County of Riverside’s Transportation Analysis Guidelines for Level of Service & Vehicle Miles Traveled (December 2020), as the City of Rancho Mirage utilizes the County LOS analysis guidelines. (1) To ensure that this TA satisfies the City of Rancho Mirage’s traffic study requirements, Urban Crossroads, Inc. prepared a traffic study scoping package for review by City staff prior to the preparation of this report. The Agreement provides an outline of the Project study area, trip generation, trip distribution, and analysis methodology. The Agreement approved by the City is included in Appendix 1.1.

## 1.1 SUMMARY OF FINDINGS

For both Existing (2022) and Opening Year Cumulative (2024) traffic conditions the addition of Project traffic to study area intersections did not result in deficient intersection operations. The proposed Project is not anticipated to require the construction of any off-site improvements.

## 1.2 PROJECT OVERVIEW

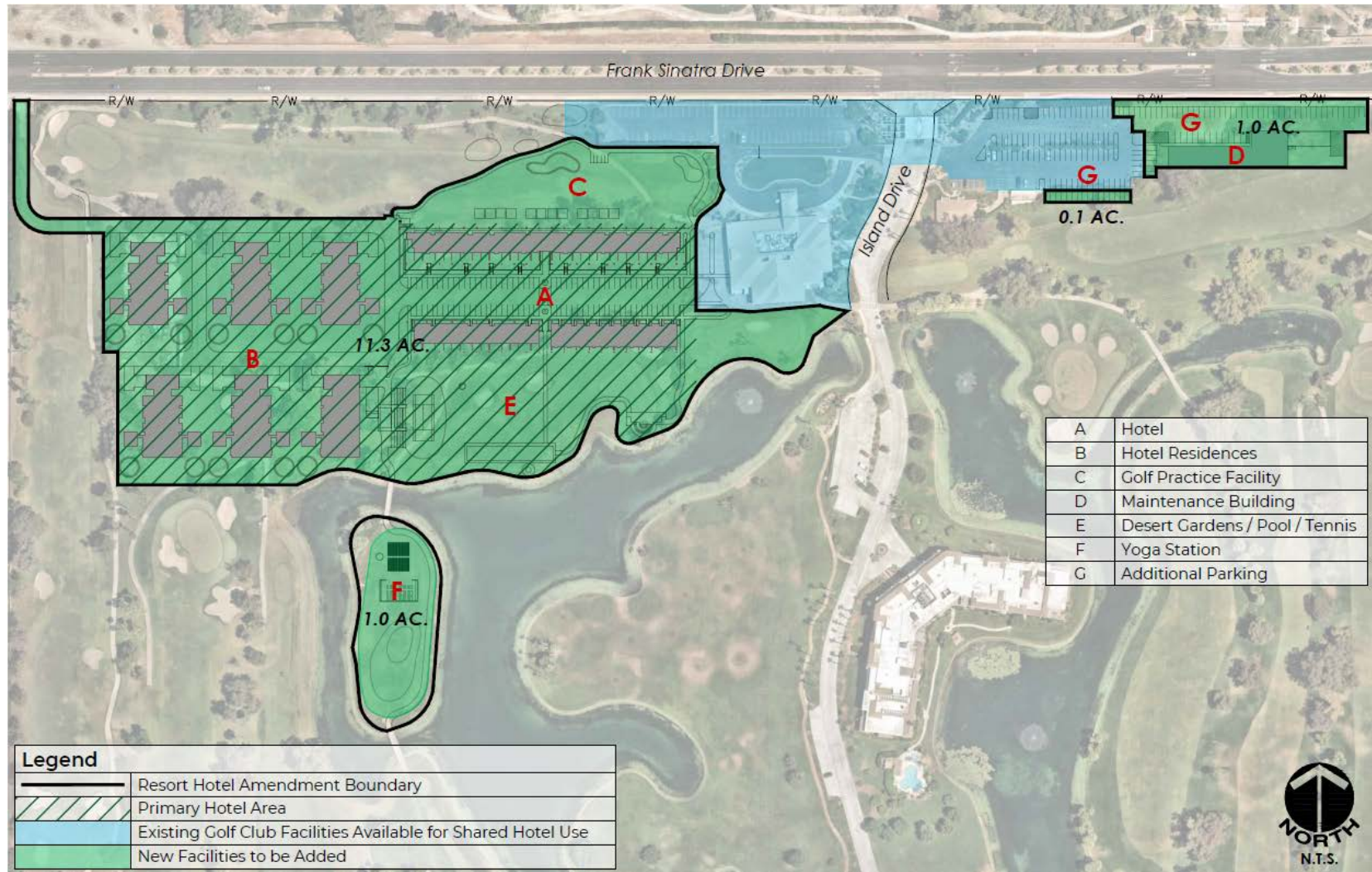
The Project is proposed to repurpose approximately 13.3 acres of the existing golf driving range and a portion of the existing golf course with new facilities to accommodate a 42-key boutique hotel (with tennis, pool, and yoga amenities), 11 private residences, and a golf training facility.

The existing driving range will be removed to make room for the new facilities. The existing golf maintenance structure will be replaced by a new building along with an expanded parking lot east of the main entry. The existing clubhouse will remain and continue to provide services to golfers, Desert Island residents, and the general public, with occasional events for up to 300 persons. It is anticipated that events with more than 300 persons in the existing clubhouse building would require a Temporary Use Permit, accompanied by a parking and traffic management plan if necessary. The existing golf course will continue to operate as an 18-hole facility with minor routing adjustments to 9th and 18th Fairways to accommodate the hotel.

Amenities which are complementary to the new hotel include a hotel pool, a small pool café, a tennis court for hotel guests, and a shaded yoga platform located on the island south of the lake accessed by foot from the existing bridge.

The new private duplex-style condominium residences (11 units) will be managed and maintained by the hotel operator. When not in use by individual owners, these units will be made available for rental by the hotel operator. For traffic analysis purposes, these 11 units are addressed as single family residences in order to include trip rates which are higher than those associated with multifamily units.

**EXHIBIT 1-1: PRELIMINARY SITE PLAN**



The new golf training park will replace the current driving range. It will consist of an 18-hole tournament putting green, short game training areas, and virtual golf simulator stations. In order to evaluate the potential increase in practice golf park activity which maybe higher than the existing driving range, the employment associated with golf practice activity is estimated to increase by 10 employees.

The hotel will take primary access from the existing Desert Island main gate on Frank Sinatra Drive. No physical changes are proposed to the existing entry gatehouse, other than to keep the gates open during operating hours to eliminate any vehicle stacking onto Frank Sinatra Drive. Likewise, the resident gate and turnaround on Island Drive will be retained in its existing condition without change. Secondary access to Frank Sinatra will be accommodated by widening the existing gated entry at the northwest corner of the golf course from 12-feet to 24-feet to provide secondary emergency vehicle access.

Exhibit 1-3 shows the on-site traffic circulation. Southbound golf and hotel traffic will enter the project using the right-hand lane with a free-flow right turn where an attendant will greet and direct guests to the appropriate parking area. Resident traffic will use the left-hand entry lane and proceed straight to the resident gate as they always have. Traffic exiting the hotel will use the existing clubhouse driveway.

In order to develop the traffic characteristics of the proposed project, trip-generation statistics published in the Institute of Transportation Engineers (ITE) *Trip Generation* (11th Edition, 2021) manual for the proposed land uses (ITE Land Use Codes: 330 – Resort Hotel; 210 – Single Family Residential; 432 – Golf Practice) are used. The Project is anticipated to generate a total of 991 new trip-ends per day with 39 new AM peak hour trips and 83 new PM peak hour trips. The assumptions and methods used to estimate the Project's trip generation characteristics are discussed in greater detail in Section 4.1 *Project Trip Generation* of this report.

## 1.3 ANALYSIS SCENARIOS

For the purposes of this traffic study, potential deficiencies to traffic and circulation have been assessed for each of the following conditions:

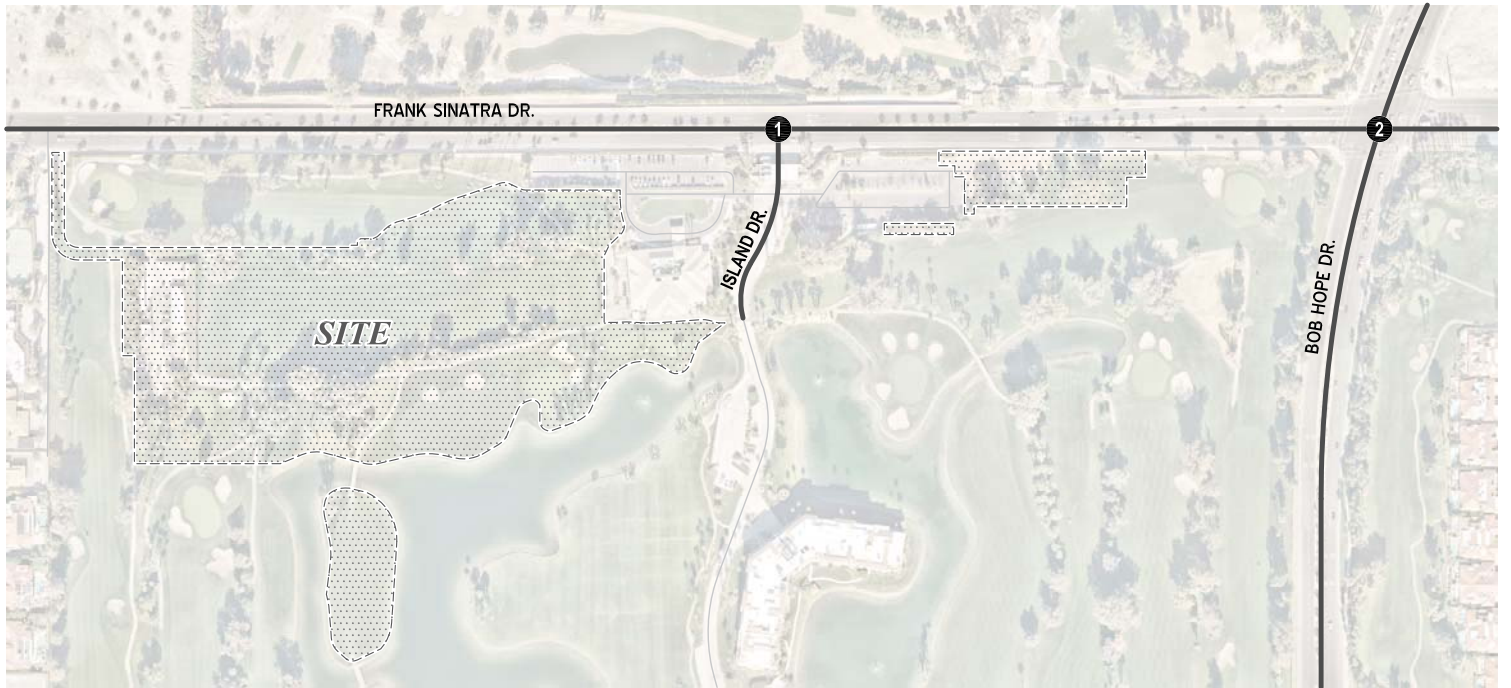
- Existing (2022) Conditions
- Existing plus Ambient Growth plus Project (EAP) (2024) Conditions
- Existing plus Ambient Growth plus Project plus Cumulative (EAPC) (2024) Conditions

### 1.3.1 EXISTING (2022) CONDITIONS

Information for Existing (2021) conditions is disclosed to represent the baseline traffic conditions as they existed at the time this report was prepared. For a detailed discussion on the existing traffic counts, see Section 3.6 *Existing Traffic Counts*.



**EXHIBIT 1-2: STUDY AREA**

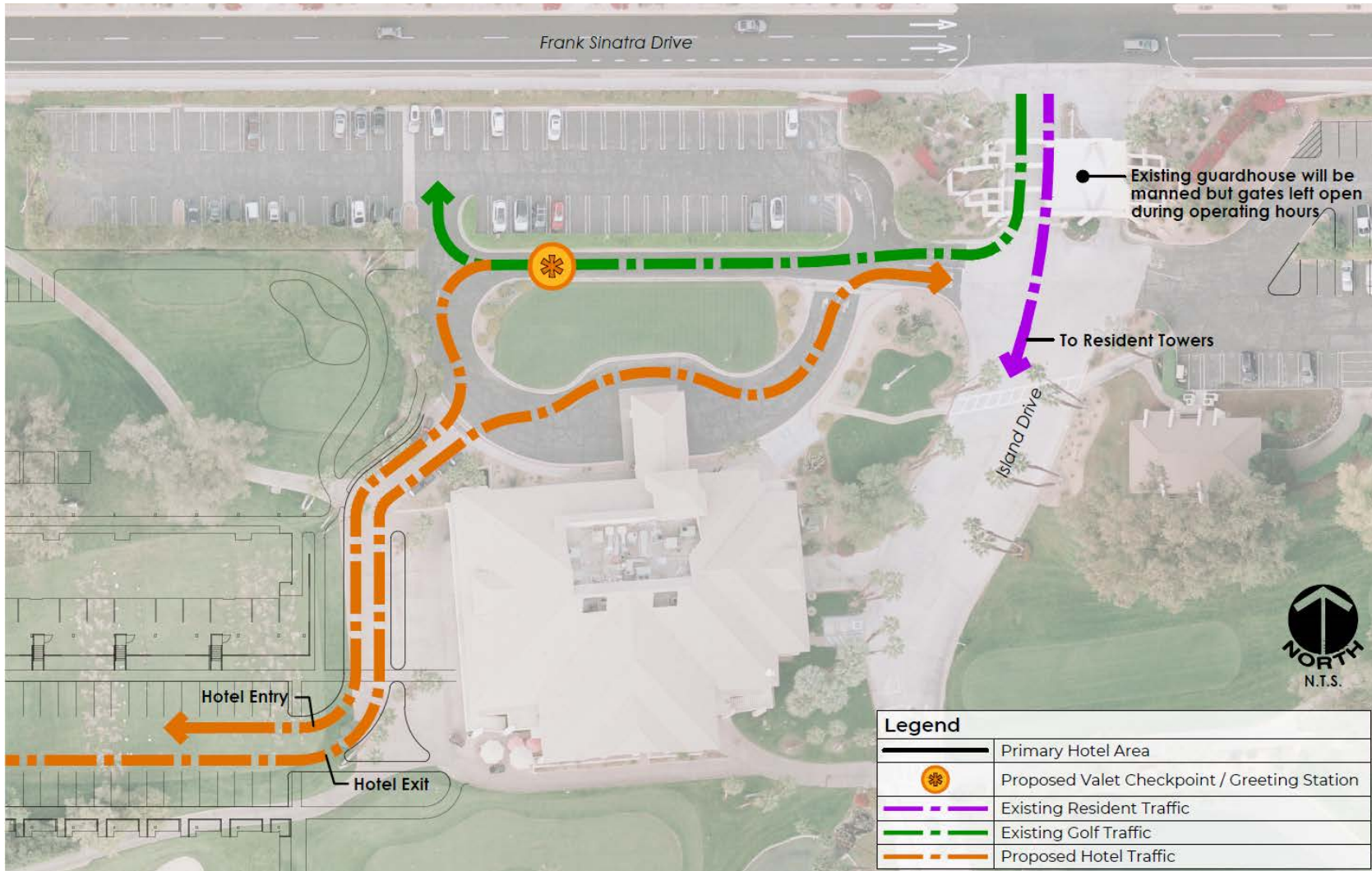


**LEGEND:**

② = INTERSECTION ANALYSIS LOCATION



**EXHIBIT 1-3: ON-SITE TRAFFIC CIRCULATION**



**1.3.2 EAP (2024) CONDITIONS**

The Existing plus Ambient Growth plus Project (EAP) conditions analysis determines traffic deficiencies that would occur on the existing roadway system with the addition of Project traffic. To account for background traffic growth, traffic associated with other known cumulative development projects in conjunction with an ambient growth factor from Existing conditions of 4.04% (2% per year, compounded annually over 2 years) is included for EAP (2024) traffic conditions. The ambient growth is consistent with the growth used by other projects in the area within the City of Rancho Mirage.

**1.3.3 EAPC (2024) CONDITIONS**

The Existing plus Project plus Ambient Growth plus Cumulative (EAPC) (2024) traffic conditions analysis determines the potential near-term cumulative circulation system deficiencies. To account for background traffic growth, traffic associated with other known cumulative development projects in conjunction with an ambient growth factor from Existing conditions of 4.04% is included for EAPC (2024) traffic conditions. The ambient growth is consistent with the growth used by other projects in the area. This comprehensive list was compiled from information provided by the City of Rancho Mirage.

**1.4 STUDY AREA**

The Project study area was defined in coordination with the City of Rancho Mirage. Consistent with County of Riverside traffic study guidelines, the study area includes any intersection of “Collector” or higher classification street, with “Collector” or higher classification streets, at which the proposed project will add 50 or more peak hour trips. Exhibit 1-2 presents the study area and intersection analysis locations.

The “50 peak hour trip” criteria generally represents a minimum number of trips at which a typical intersection would have the potential to be substantively impacted by a given development proposal. Although each intersection may have unique operating characteristics, this traffic engineering rule of thumb is a widely utilized tool for estimating a potential area of impact (i.e., study area).

To ensure that this TA satisfies the needs of the City of Palm Desert, Urban Crossroads, Inc. prepared a Project specific traffic study scoping agreement for review by City staff prior to the preparation of this TA. The agreement provides an outline of the study area, trip generation, trip distribution, and analysis methodology. The agreement approved by the City of Palm Desert is included in Appendix 1.1.

The following 2 study area intersections shown on Exhibit 1-2 and listed in Table 1-1 were selected for this TA based on consultation with City of Rancho Mirage.

**TABLE 1-1: INTERSECTION ANALYSIS LOCATIONS**

#	Intersection
1	Island Dr. / Frank Sinatra Dr.
2	Bob Hope Dr. / Frank Sinatra Dr.

## 1.5 ANALYSIS FINDINGS

This section provides a summary of the analysis results for Existing (2022), EAP (2024), and EAPC (2024) conditions.

### 1.5.1 EXISTING (2022) CONDITIONS

For Existing (2022) traffic conditions, the study intersections were found to operate at an acceptable LOS (i.e., LOS "D" or better) during AM and PM peak hours.

### 1.5.2 EAP 2024 CONDITIONS

For EAP (2024) traffic conditions, the study intersections were found to continue to operate at an acceptable LOS (i.e., LOS "D" or better) during AM and PM peak hours.

### 1.5.3 EAPC 2024 CONDITIONS

For EAPC (2024) traffic conditions, the study intersections were found to continue to operate at an acceptable LOS (i.e., LOS "D" or better) during AM and PM peak hours.

The intersection of Island Drive / Frank Sinatra Drive (#1) is anticipated to meet warrants under EAPC (2024) conditions. It should be noted that a signal warrant defines the minimum condition under which the installation of a traffic signal might be warranted. Meeting this condition does not require that a traffic control signal be installed, but rather, that other traffic factors and conditions be evaluated in order to determine whether the signal is truly justified. It should also be noted that signal warrants do not necessarily correlate with LOS. An intersection may satisfy a signal warrant condition and operate at or above acceptable LOS or operate below acceptable LOS and not meet a signal warrant which is the case for Island Drive / Frank Sinatra Drive (#1).

## 1.6 QUEUEING ANALYSIS

A queuing analysis was conducted along the Project Driveway, intersection of Island Drive and Frank Sinatra Drive for EAPC (2024) traffic conditions to determine the turn pocket lengths and lane geometric necessary to accommodate near-term 95th percentile queues and recommend storage lengths for the turning movements shown on Exhibit 1-4. The analysis was conducted for the weekday AM and weekday PM peak hours using the SimTraffic modeling software. The EAPC (2024) queuing results are provided in Table 1-2 and Appendix 1.2 of this TA.

SimTraffic is designed to model networks of signalized and unsignalized intersections, with the primary purpose of checking and fine-tuning signal operations. SimTraffic uses the input parameters from Synchro (Version 11) to generate random simulations. The 95<sup>th</sup> percentile queue is not necessarily ever observed; it is simply based on statistical calculations (or Average Queue plus 1.65 standard deviations). The random simulations generated by SimTraffic have been utilized to determine the 95<sup>th</sup> percentile queue lengths observed for each turn lane.



**TABLE 1-2: PROJECT ACCESS QUEUEING ANALYSIS FOR EAPC**

ID	Intersection	Movement	# of Lanes	EAPC (2024)				Storage Length <sup>2</sup> (ft.)	95th Percentile Queue Length <sup>1</sup>	
				AM	PM	Peak Hour	Volume		AM	PM
1	Island Dr. / Frank Sinatra Dr.	NBL	1	78	69	AM	78	30	49 <sup>3</sup>	43 <sup>3</sup>
		NBR	1	46	39	AM	46	75	52	55
		WBL	1	40	32	AM	40	95	44	40

<sup>1</sup> Queue length calculated using SimTraffic.

<sup>2</sup> Existing/Proposed length of storage.

<sup>3</sup> Review of SimTraffic simulation results indicate that the turn lane queue is anticipated to clear in a timely manner and that the provided pocket length is adequate to accommodate the 95th percentile queue.

## 2 METHODOLOGIES

This section of the report presents the methodologies used to perform the traffic analyses summarized in this report. The methodologies described are consistent with City of Rancho Mirage's Traffic Study Guidelines.

### 2.1 LEVEL OF SERVICE

Traffic operations of roadway facilities are described using the term "Level of Service" (LOS). LOS is a qualitative description of traffic flow based on several factors, such as speed, travel time, delay, and freedom to maneuver. Six levels are typically defined ranging from LOS A, representing completely free-flow conditions, to LOS F, representing breakdown in flow resulting in stop-and-go conditions. LOS E represents operations at or near capacity, an unstable level where vehicles are operating with the minimum spacing for maintaining uniform flow.

### 2.2 INTERSECTION CAPACITY ANALYSIS

The definitions of LOS for interrupted traffic flow (flow restrained by the existence of traffic signals and other traffic control devices) differ slightly depending on the type of traffic control. The LOS is typically dependent on the quality of traffic flow at the intersections along a roadway. The 6<sup>th</sup> Edition Highway Capacity Manual (HCM) methodology expresses the LOS at an intersection in terms of delay time for the various intersection approaches. (2) The HCM uses different procedures depending on the type of intersection control.

#### 2.2.1 SIGNALIZED INTERSECTIONS

The City of Rancho Mirage requires signalized intersection operations analysis based on the methodology described in the HCM. (2) Intersection LOS operations are based on an intersection's average control delay. Control delay includes initial deceleration delay, queue move-up time, stopped delay, and final acceleration delay. For signalized intersections LOS is related to the average control delay per vehicle and is correlated to a LOS designation as described on Table 2-1.

The traffic modeling and signal timing optimization software package Synchro (Version 11) has been utilized to analyze signalized intersections. Synchro is a macroscopic traffic software program that is based on the signalized intersection capacity analysis as specified in the HCM. Macroscopic level models represent traffic in terms of aggregate measures for each movement at the study intersections. Equations are used to determine measures of effectiveness such as delay and queue length. The level of service and capacity analysis performed by Synchro takes into consideration optimization and coordination of signalized intersections within a network.

The peak hour traffic volumes have been adjusted using a peak hour factor (PHF) to reflect peak 15-minute volumes. Customary practice for LOS analysis is to use a peak 15-minute rate of flow. However, flow rates are typically expressed in vehicles per hour. The PHF is the relationship between the peak 15-minute flow rate and the full hourly volume (e.g.,  $PHF = \frac{[Hourly Volume]}{[4 \times Peak 15\text{-minute Flow Rate}]}$ ). The use of a 15-minute PHF produces a more detailed analysis as compared to

analyzing vehicles per hour. Existing PHFs have been used for all analysis scenarios. Per the HCM, PHF values over 0.95 often are indicative of high traffic volumes with capacity constraints on peak hour flows while lower PHF values are indicative of greater variability of flow during the peak hour.  
(2)

**TABLE 2-1: SIGNALIZED INTERSECTION LOS THRESHOLDS**

Description	Average Control Delay (Seconds), $V/C \leq 1.0$	Level of Service, $V/C \leq 1.0^1$
Operations with very low delay occurring with favorable progression and/or short cycle length.	0 to 10.00	A
Operations with low delay occurring with good progression and/or short cycle lengths.	10.01 to 20.00	B
Operations with average delays resulting from fair progression and/or longer cycle lengths. Individual cycle failures begin to appear.	20.01 to 35.00	C
Operations with longer delays due to a combination of unfavorable progression, long cycle lengths, or high V/C ratios. Many vehicles stop and individual cycle failures are noticeable.	35.01 to 55.00	D
Operations with high delay values indicating poor progression, long cycle lengths, and high V/C ratios. Individual cycle failures are frequent occurrences. This is considered to be the limit of acceptable delay.	55.01 to 80.00	E
Operation with delays unacceptable to most drivers occurring due to over saturation, poor progression, or very long cycle lengths.	80.01 and up	F

Source: HCM, 6th Edition

<sup>1</sup> If V/C is greater than 1.0 then LOS is F per HCM.

**2.2.2 UNSIGNALIZED INTERSECTIONS**

The City of Rancho Mirage requires the operations of unsignalized intersections be evaluated using the methodology described in the HCM. (2) The LOS rating is based on the weighted average control delay expressed in seconds per vehicle (see Table 2-2). At two-way or side-street stop-controlled intersections, LOS is calculated for each controlled movement and for the left turn movement from the major street, as well as for the intersection as a whole. For approaches composed of a single lane, the delay is computed as the average of all movements in that lane. Delay for the intersection is reported for the worst individual movement at a two-way stop-controlled intersection. For all-way stop controlled intersections, LOS is computed for the intersection as a whole (average delay).

**TABLE 2-2: UNSIGNALIZED INTERSECTION LOS THRESHOLDS**

Description	Average Control Delay (Seconds), V/C ≤ 1.0	Level of Service, V/C ≤ 1.0 <sup>1</sup>
Little or no delays.	0 to 10.00	A
Short traffic delays.	10.01 to 15.00	B
Average traffic delays.	15.01 to 25.00	C
Long traffic delays.	25.01 to 35.00	D
Very long traffic delays.	35.01 to 50.00	E
Extreme traffic delays with intersection capacity exceeded.	> 50.00	F

Source: HCM, 6th Edition

<sup>1</sup> If V/C is greater than 1.0 then LOS is F per HCM.

### 2.3 TRAFFIC SIGNAL WARRANT ANALYSIS METHODOLOGY

The term "signal warrants" refers to the list of established criteria used by Caltrans and other public agencies to quantitatively justify or determine the potential need for installation of a traffic signal at an otherwise unsignalized intersection. This TA uses the signal warrant criteria presented in the latest edition of the Caltrans California Manual on Uniform Traffic Control Devices (CA MUTCD). (3)

The signal warrant criteria for Existing study area intersections are based upon several factors, including volume of vehicular and pedestrian traffic, frequency of accidents, and location of school areas. The CA MUTCD indicates that the installation of a traffic signal should be considered if one or more of the signal warrants are met. (3) Specifically, this TA utilizes the Peak Hour Volume-based Warrant 3 as the appropriate representative traffic signal warrant analysis for existing traffic conditions and for all future analysis scenarios for existing unsignalized intersections. Warrant 3 is appropriate to use for this TA because it provides specialized warrant criteria for intersections with rural characteristics. For the purposes of this study, the speed limit was the basis for determining whether Urban or Rural warrants were used for a given intersection. Urban warrants have been used as posted speed limits on the major roadways with unsignalized intersections are 40 miles per hour or below and rural warrants have been used on roadways with speeds greater than 40 miles per hour.

Future intersections that do not currently exist have been assessed regarding the potential need for new traffic signals based on future average daily traffic (ADT) volumes, using the Caltrans planning level ADT-based signal warrant analysis worksheets. Similarly, the speed limit has been used as the basis for determining the use of Urban and Rural warrants. Traffic signal warrant analyses were performed for the intersection of Island Drive / Frank Sinatra Drive (#1).

The Existing conditions traffic signal warrant analysis is presented in the subsequent section, Section 3 *Area Conditions* of this report. The traffic signal warrant analyses for future conditions are presented in Section 5 *EAP (2024) Traffic Conditions* and Section 6 *EAPC (2024) Traffic Conditions* of this report. It is important to note that a signal warrant defines the minimum condition under which the installation of a traffic signal might be warranted. Meeting this threshold condition does not require that a traffic

control signal be installed at a particular location, but rather, that other traffic factors and conditions be evaluated in order to determine whether the signal is truly justified. It should also be noted that signal warrants do not necessarily correlate with LOS. An intersection may satisfy a signal warrant condition and operate at or above acceptable LOS or operate below acceptable LOS and not meet a signal warrant.

## 2.4 MINIMUM ACCEPTABLE LEVELS OF SERVICE (LOS)

Minimum Acceptable LOS and associated definitions of intersection deficiencies has been obtained from each of the applicable surrounding jurisdictions.

The City of Rancho Mirage's General Plan recommends a LOS standard of LOS D. If during the LOS evaluations an intersection or roadway segment is found to not meet the requisite LOS standard as established by the City's General Plan, improvement modifications will be evaluated to bring the forecasted deficiency to within acceptable LOS thresholds. It is assumed that for purposes of this Project that most facilities are built to ultimate and only in limited instances would additional improvements be needed. Improvements could include signal timing changes or other that could be achieved within the existing curb to curb distance of the intersection or roadway segment.

## 2.5 DEFICIENCY CRITERIA

This section outlines the methodology used in this analysis related to identifying circulation system deficiencies. To determine whether the addition of project traffic at a study intersection or roadway segment results in a traffic deficiency, the following thresholds will be utilized:

- A traffic deficiency occurs at a signalized study area intersection if the addition of project traffic results in the intersection operations to go from LOS "D" or better (i.e., acceptable) to LOS "E" or "F."
- A traffic deficiency occurs at an unsignalized study area intersection if the addition of project traffic results in the intersection operations to go from LOS "D" or better (i.e., acceptable) to LOS "E" or "F."
- A traffic deficiency occurs at a study area roadway segment if the addition of project traffic results in the roadway segment operations to go from LOS "D" or better (i.e., acceptable) to LOS "E" or "F."

### 3 AREA CONDITIONS

This section provides a summary of the existing circulation network, the City of Rancho Mirage General Plan Circulation Network, and a review of existing peak hour intersection operations and traffic signal warrant analyses.

#### 3.1 EXISTING CIRCULATION NETWORK

Pursuant to the agreement with City of Rancho Mirage staff (Appendix 1.1), the study area includes 2 existing intersections as shown previously on Exhibit 1-2. Exhibit 3-1 illustrates the study area intersections located near the proposed Project and identifies the number of through traffic lanes for existing roadways and intersection traffic controls.

#### 3.2 CITY OF RANCHO MIRAGE GENERAL PLAN CIRCULATION ELEMENT

As noted previously, the Project site is located within the City of Rancho Mirage. The roadway classifications and planned (ultimate) roadway cross-sections of the major roadways within the study area, as identified on the City of Rancho Mirage General Plan Circulation Element, are described subsequently. Exhibit 3-2 shows the City of Rancho Mirage General Plan Circulation Element and Exhibit 3-3 illustrates the City of Rancho Mirage General Plan roadway cross-sections.

The study area roadway that is classified as a Major Arterial is identified as having a 120-foot right-of-way and 106-foot curb-to-curb measurement. Major Arterials include three lanes of travel in each direction and a 16-foot curbed and/or landscaped median. The following study area roadway within the City of Rancho Mirage is classified as a Major Arterial:

- Bob Hope Drive, north of Frank Sinatra Drive.

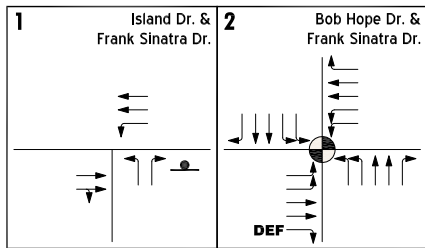
The study area roadway that is classified as a Minor Arterial is identified as having a 110-foot right-of-way and 86-foot curb-to-curb measurement. Minor Arterial includes two lanes of travel in each direction and a 16-foot curbed and/or landscaped median. The following study area roadway within the City of Rancho Mirage is classified as a Modified Major Arterial II:

- Bob Hope Drive, south of Frank Sinatra Drive
- Frank Sinatra Drive

#### 3.3 TRANSIT SERVICE

The City of Rancho Mirage is currently served by the SunLine Transit Agency (STA), a public transit agency serving various jurisdictions throughout Coachella Valley. Route 4 runs along Bob Hope Drive within the study area. Transit service is reviewed and updated by STA periodically to address ridership, budget and community demand needs. Changes in land use can affect these periodic adjustments which may lead to either enhanced or reduced service where appropriate. It should also be noted that SunDial service provides special services for the disabled and seniors (60+). Route 4 runs along Bob Hope Drive within the study area.

**EXHIBIT 3-1: EXISTING NUMBER OF THROUGH LANES AND INTERSECTION CONTROLS**



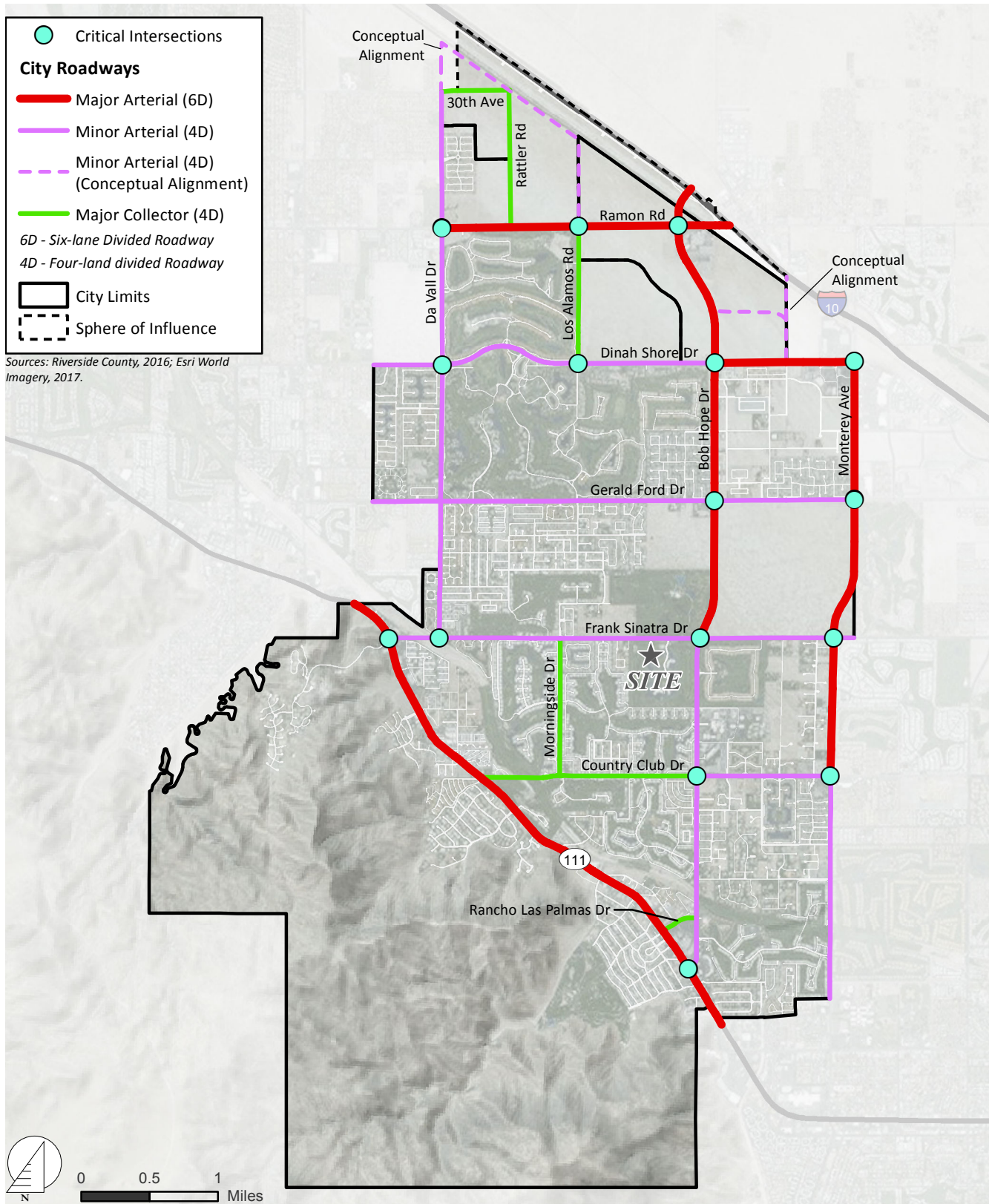
**LEGEND:**

- INTERSECTION ID
- TRAFFIC SIGNAL
- STOP SIGN
- DEF** DEFACTO RIGHT TURN LANE
- 4** NUMBER OF LANES
- D** DIVIDED
- U** UNDIVIDED



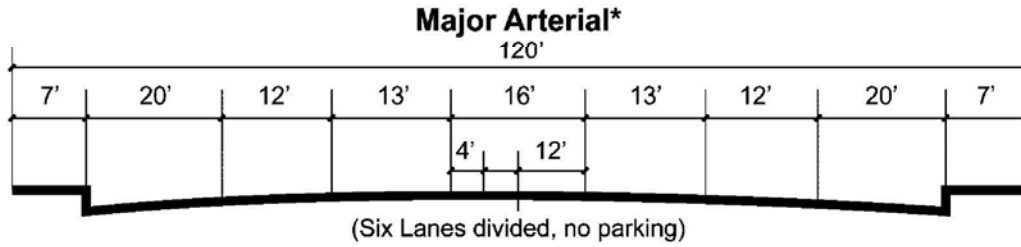


**EXHIBIT 3-2: CITY OF RANCHO MIRAGE GENERAL PLAN CIRCULATION ELEMENT**

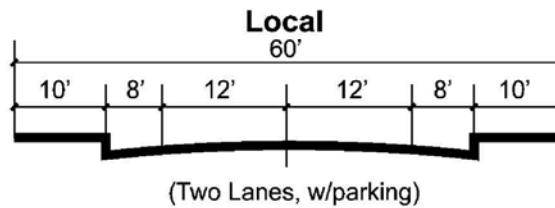
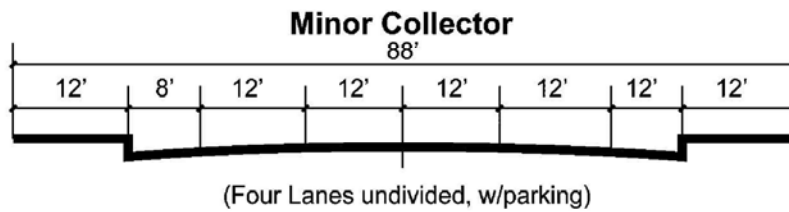
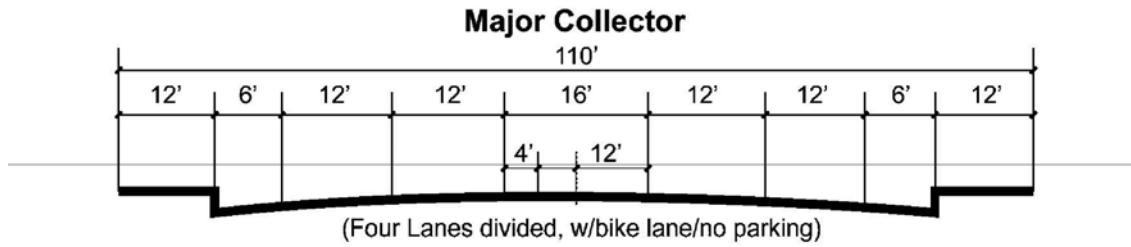
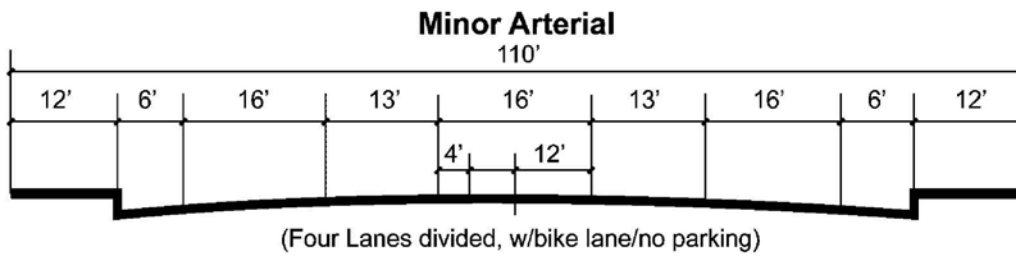




**EXHIBIT 3-3: CITY OF RANCHO MIRAGE GENERAL PLAN ROADWAY CROSS-SECTIONS**



\*Highway 111 has special design geometrics, See Rancho Mirage Highway 111 Alignment Study, 1996.



SOURCE: CITY OF RANCHO MIRAGE

### 3.4 PEDESTRIAN AND BICYCLE FACILITIES

Existing on-street bike lanes are located on both sides of the roadways along Bob Hope Drive and Frank Sinatra Drive. Sidewalks exist on the south side of Frank Sinatra Drive and east side for Bob Hope Drive, south of Frank Sinatra Drive.

### 3.5 EXISTING (2022) TRAFFIC COUNTS

The intersection LOS analysis is based on the traffic volumes observed during the peak hour conditions using traffic count data collected in May 2022. The following peak hours were selected for analysis:

- Weekday AM Peak Hour (peak hour between 7:00 AM and 9:00 AM)
- Weekday PM Peak Hour (peak hour between 4:00 PM and 6:00 PM)

The raw manual peak hour turning movement traffic count data sheets are included in Appendix 3.1.

The weekday AM and PM peak hour count data are representative of typical peak hour traffic conditions in the study area. There were no observations made in the field that would indicate atypical traffic conditions on the count dates, such as construction activity that would prevent or limit roadway access and detour routes. These raw turning volumes have been flow conserved between intersections with limited access, no access and where there are currently no uses generating traffic.

Existing weekday ADT volumes are shown on Exhibit 3-4. Where actual 24-hour tube count data was not available, Existing ADT volumes were based upon factored intersection peak hour counts collected by Urban Crossroads, Inc. using the following formula for each intersection leg:

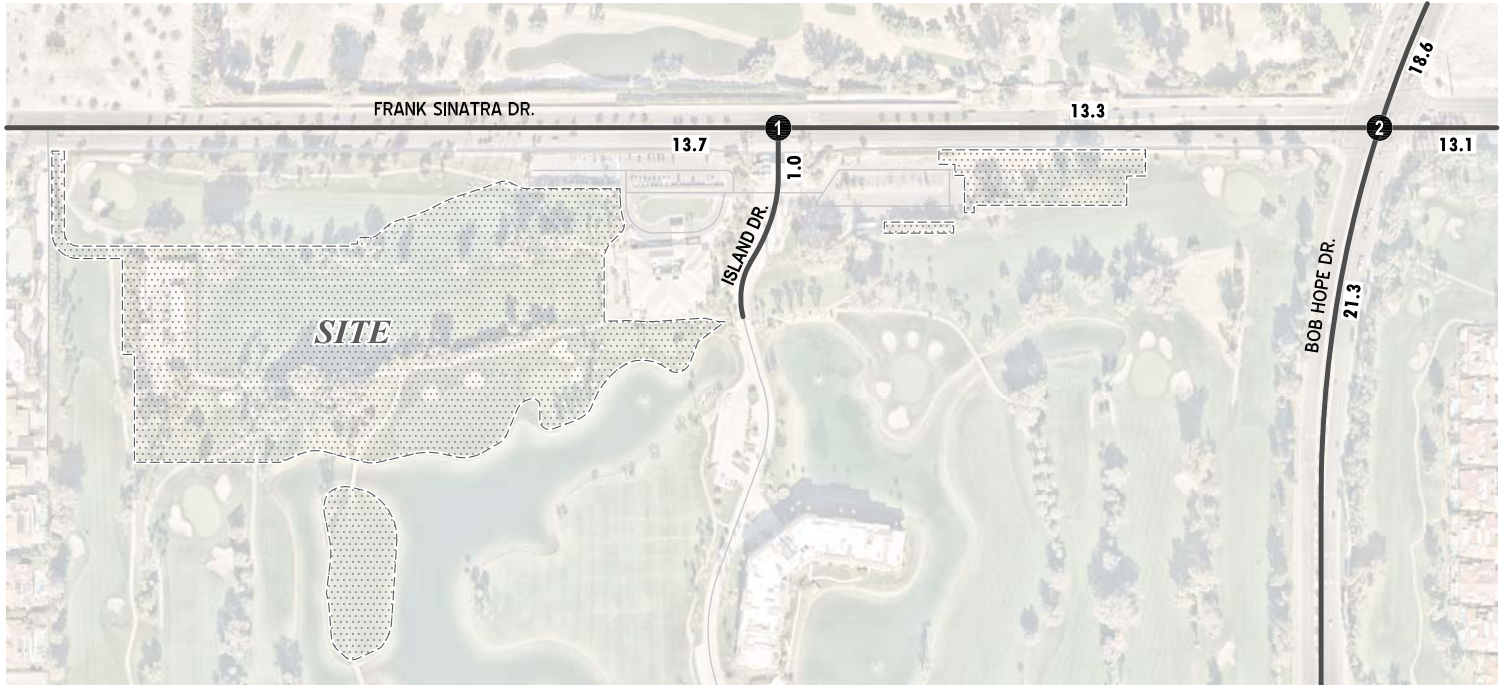
$$\text{Weekday PM Peak Hour (Approach Volume + Exit Volume)} \times 12.195 = \text{Leg Volume}$$

A comparison of the PM peak hour and daily traffic volumes of various roadway segments within the study area indicated that the peak-to-daily relationship is approximately 8.20 percent. As such, the above equation utilizing a factor of 12.195 estimates the ADT volumes on the study area roadway segments assuming a peak-to-daily relationship of approximately 8.20 percent (i.e.,  $1/0.0820 = 12.195$ ) and was assumed to sufficiently estimate average daily traffic (ADT) volumes for planning-level analyses. Existing weekday peak hour intersection volumes are also shown on Exhibit 3-4.

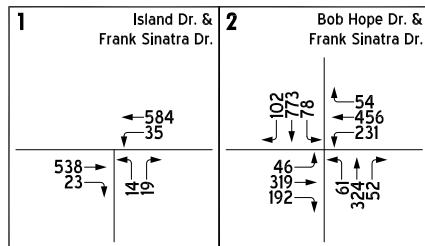
### 3.6 INTERSECTION OPERATIONS ANALYSIS

Existing peak hour traffic operations have been evaluated for the study area intersections based on the analysis methodologies presented in Section 2.2 *Intersection Capacity Analysis* of this report. The intersection operations analysis results are summarized on Table 3-1, which indicates that all existing study area intersections are currently operating at acceptable LOS during the peak hours. The intersection operations analysis worksheets are included in Appendix 3.2 of this TA.

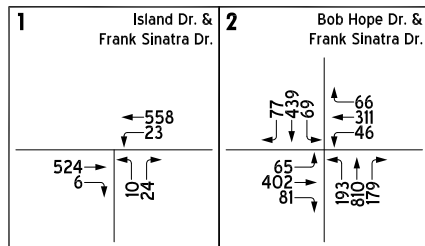
**EXHIBIT 3-4: EXISTING (2022) TRAFFIC VOLUMES**



**AM PEAK HOUR**



**PM PEAK HOUR**



**LEGEND:**

- = INTERSECTION ID
- = PEAK HOUR INTERSECTION VOLUMES
- 10.0** = VEHICLES PER DAY (1000'S)



**TABLE 3-1: INTERSECTION ANALYSIS FOR EXISTING (2022) CONDITIONS**

#	Intersection	Traffic Control <sup>1</sup>	Intersection Approach Lanes <sup>2</sup>												Delay <sup>3</sup> (secs.)		Level of Service	
			Northbound			Southbound			Eastbound			Westbound			AM	PM	AM	PM
			L	T	R	L	T	R	L	T	R	L	T	R				
1	Island Dr. / Frank Sinatra Dr.	CSS	1	0	1	0	0	0	0	2	0	1	2	0	23.7	18.6	C	C
2	Bob Hope Dr. / Frank Sinatra Dr.	TS	2	2	1	2	2	1	2	2	d	2	2	1	31.2	27.2	C	C

<sup>1</sup> TS = Traffic Signal; CSS = Cross-street Stop

<sup>2</sup> When a right turn is designated, the lane can either be striped or unstriped. To function as a right turn lane there must be sufficient width for right turning vehicles to travel outside the through lanes.

L = Left; T = Through; R = Right; d = Defacto Right Turn Lane

<sup>3</sup> Per the Highway Capacity Manual (6th Edition), overall average intersection delay and level of service are shown for intersections with a traffic signal or all way stop control. For intersections with cross street stop control, the delay and level of service for the worst individual movement (or movements sharing a single lane) are shown.

### 3.7 TRAFFIC SIGNAL WARRANTS ANALYSIS

Traffic signal warrants for Existing traffic conditions are based on existing peak hour intersection turning volumes. The unsignalized intersection of Island Drive / Frank Sinatra Drive (#1) does not currently warrant a traffic signal for Existing traffic conditions. Existing conditions traffic signal warrant analysis worksheets are provided in Appendix 3.3.

This page intentionally left blank

## 4 PROJECTED FUTURE TRAFFIC

This section presents the traffic volumes estimated to be generated by the Project, as well as the Project's trip assignment onto the study area roadway network.

The Project is proposed to repurpose approximately 13.3 acres of the existing golf driving range and a portion of the existing golf course with new facilities to accommodate a 42-key boutique hotel (with tennis, pool, and yoga amenities), 11 private residences, and a golf training facility.

The existing driving range will be removed to make room for the new facilities. The existing golf maintenance structure will be replaced by a new building along with an expanded parking lot east of the main entry. The existing clubhouse will remain and continue to provide services to golfers, Desert Island residents, and the general public, with occasional events for up to 300 persons. It is anticipated that events with more than 300 persons in the existing clubhouse building would require a Temporary Use Permit, accompanied by a parking and traffic management plan if necessary. The existing golf course will continue to operate as an 18-hole facility with minor routing adjustments to 9th and 18th Fairways to accommodate the hotel.

Amenities which are complementary to the new hotel include a hotel pool, a small pool café, a tennis court for hotel guests, and a shaded yoga platform located on the island south of the lake accessed by foot from the existing bridge.

The new private duplex-style condominium residences (11 units) will be managed and maintained by the hotel operator. When not in use by individual owners, these units will be made available for rental by the hotel operator. For traffic analysis purposes, these 11 units are addressed as single family residences in order to include trip rates which are higher than those associated with multifamily units.

The new golf training park will replace the current driving range. It will consist of an 18-hole tournament putting green, short game training areas, and virtual golf simulator stations. In order to evaluate the potential increase in practice golf park activity which maybe higher than the existing driving range, the employment associated with golf practice activity is estimated to increase by 10 employees.

It is anticipated that the Project would be fully developed by year 2024. The Project will take primary access from the existing Desert Island Main gate on Frank Sinatra Drive.

Regional access to the Project site is available from the I-10 Freeway via Bob Hope Drive.

### 4.1 PROJECT TRIP GENERATION

Trip generation represents the amount of traffic which is both attracted to and produced by a development. Determining traffic generation for a specific project is therefore based upon forecasting the amount of traffic that is expected to be both attracted to and produced by the specific land uses being proposed for a given development.

In order to develop the traffic characteristics of the proposed project, trip-generation statistics published in the ITE Trip Generation Manual (11th Edition, 2021) for the proposed land uses (ITE Land

Use Codes: 330 – Resort Hotel; 210 – Single Family Residential; 432 – Golf Practice) are used. (4) Table 4-1 presents the trip generation rates and the resulting trip generation summary for the proposed Project. As shown in Table 4-1, the Project is anticipated to generate a total of 991 new trip-ends per day with 39 new AM peak hour trips and 83 new PM peak hour trips.

**TABLE 4-1: PROJECT TRIP GENERATION SUMMARY**

Trip Generation Rates <sup>1</sup>										
Land Use	ITE LU Code	Quantity <sup>2</sup>		AM Peak Hour			PM Peak Hour			Daily
				In	Out	Total	In	Out	Total	
Resort Hotel	330	42	OCC RM	0.27	0.10	0.37	0.20	0.27	0.47	7.87
Single Family Units	210	11	DU	0.18	0.52	0.70	0.59	0.35	0.94	9.43
Golf Practice	432	10	EMP	1.00	0.64	1.64	2.74	2.74	5.48	55.57

Trip Generation Results										
Land Use	ITE LU Code	Quantity <sup>2</sup>		AM Peak Hour			PM Peak Hour			Daily
				In	Out	Total	In	Out	Total	
Resort Hotel	330	42	OCC RM	11	4	15	8	11	19	331
Single Family Units	210	11	DU	2	6	8	6	4	10	104
Golf Practice	432	10	EMP	10	6	16	27	27	54	556
<b>TOTAL</b>				<b>23</b>	<b>16</b>	<b>39</b>	<b>41</b>	<b>42</b>	<b>83</b>	<b>991</b>

<sup>1</sup> Trip Generation Source: Institute of Transportation Engineers (ITE), Trip Generation Manual, 11th Edition (2021).

<sup>2</sup> Occ. RM = Occupied Room; DU = Dwelling Unit; EMP = Employee

## 4.2 PROJECT TRIP DISTRIBUTION

The Project trip distribution and assignment process represents the directional orientation of traffic to and from the Project site. The trip distribution pattern is heavily influenced by the geographical location of the site, the location of surrounding uses, and the proximity to the regional freeway system. Exhibit 4-1 trip distribution patterns for the Project.

## 4.3 MODAL SPLIT

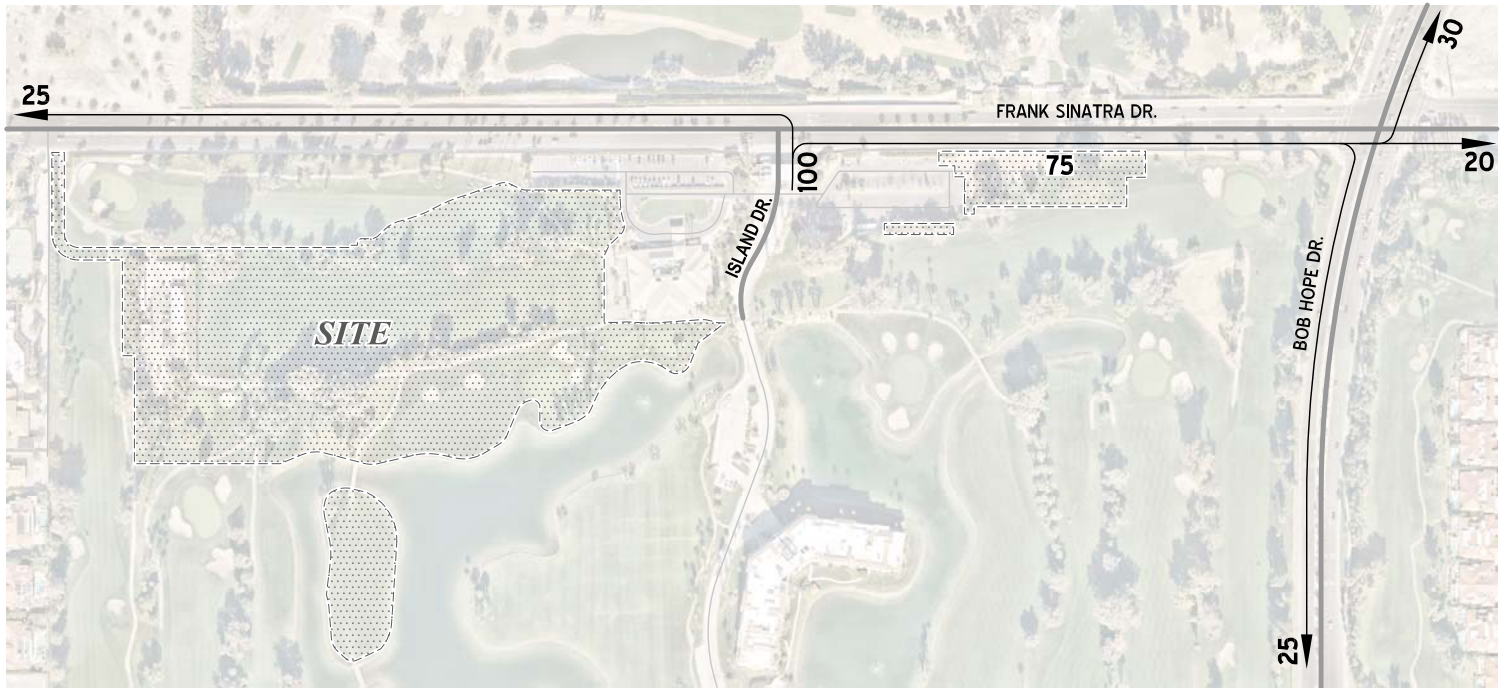
The potential for Project trips (non-truck) to be reduced by the use of public transit, walking or bicycling have not been included as part of the Project’s estimated trip generation. Essentially, the Project’s traffic projections are "conservative" in that these alternative travel modes would reduce the forecasted traffic volumes.

## 4.4 PROJECT TRIP ASSIGNMENT

The assignment of traffic from the Project area to the adjoining roadway system is based upon the Project trip generation, trip distribution, and the arterial highway and local street system improvements that would be in place by the time of initial occupancy of the Project. Based on the identified Project traffic generation and trip distribution patterns, Project weekday ADT and weekday peak hour intersection turning movement volumes are shown on Exhibit 4-2.



**EXHIBIT 4-1: PROJECT TRIP DISTRIBUTION**



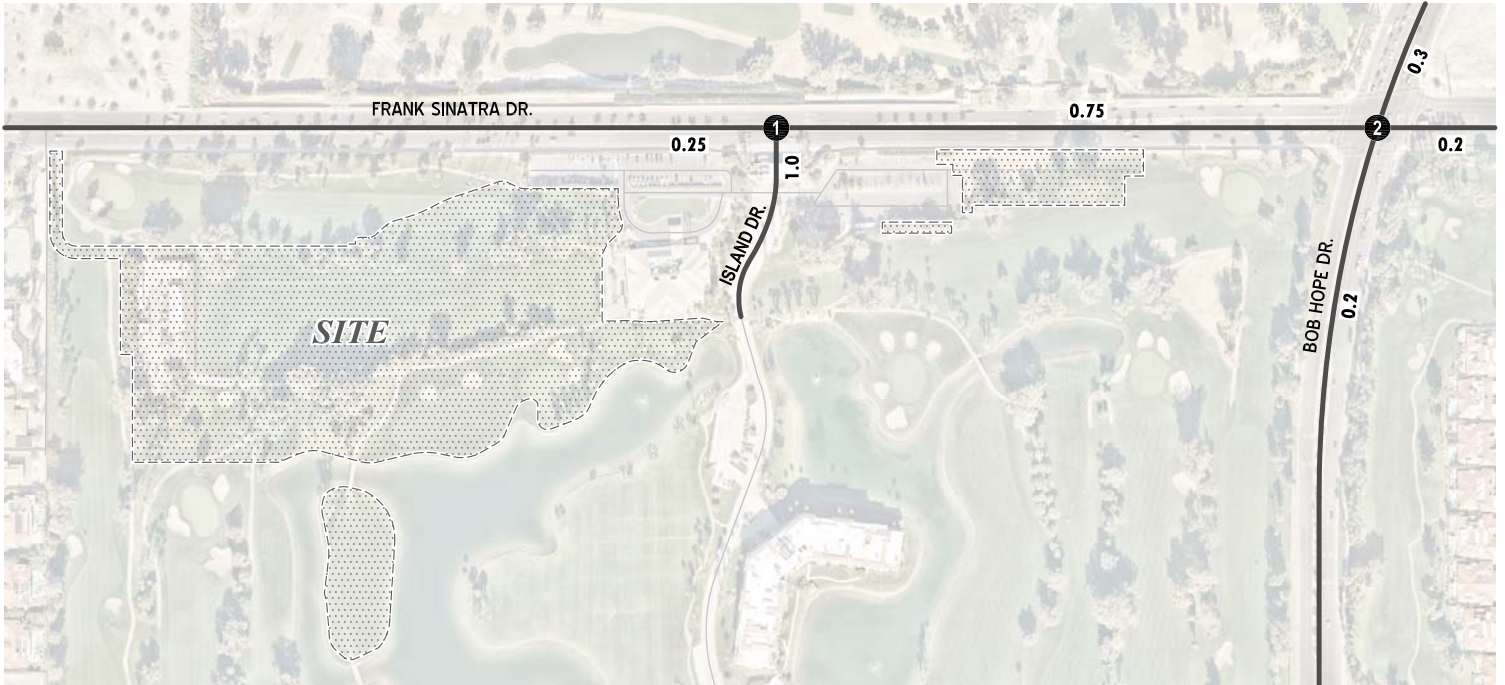
**LEGEND:**

10 ■ PERCENT TO/FROM PROJECT

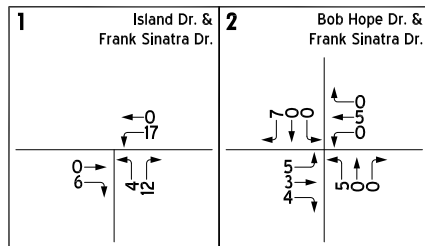




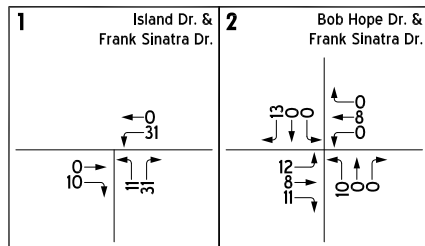
**EXHIBIT 4-2: PROJECT ONLY TRAFFIC VOLUMES**



**AM PEAK HOUR**



**PM PEAK HOUR**



**LEGEND:**

- = INTERSECTION ID
- = PEAK HOUR INTERSECTION VOLUMES
- 10.0** = VEHICLES PER DAY (1000'S)



## 4.5 BACKGROUND TRAFFIC

Future year traffic forecasts have been based upon background (ambient) growth at 2% per year for 2024 traffic conditions. The total ambient growth is 4.04% for 2024 traffic conditions. The ambient growth factor is intended to approximate regional traffic growth. This ambient growth rate is added to existing traffic volumes to account for area-wide growth not reflected by cumulative development projects. Ambient growth has been added to daily and peak hour traffic volumes on surrounding roadways, in conjunction with traffic generated by the development of future projects that have been approved but not yet built and/or for which development applications have been filed and are under consideration by governing agencies. Opening Year Cumulative (2024) traffic volumes are provided in Section 4.6 of this report. The traffic generated by the proposed Project was then manually added to the base volume to determine EAP/EAPC forecasts.

The near-term traffic analysis includes the following traffic conditions, with the various traffic components:

- EAP (2024)
  - Existing (2022) volumes
  - Ambient growth traffic (4.04% over 2 years)
  - Project Traffic
- EAPC (2024)
  - Existing (2022) volumes
  - Ambient growth traffic (4.04% over 2 years)
  - Project Traffic
  - Cumulative Development traffic

## 4.6 CUMULATIVE DEVELOPMENT TRAFFIC

A cumulative project list was developed for the purposes of this analysis through consultation with planning and engineering staff from the City of Rancho Mirage. The cumulative projects listed are those that would generate traffic and would contribute traffic to study area intersections.

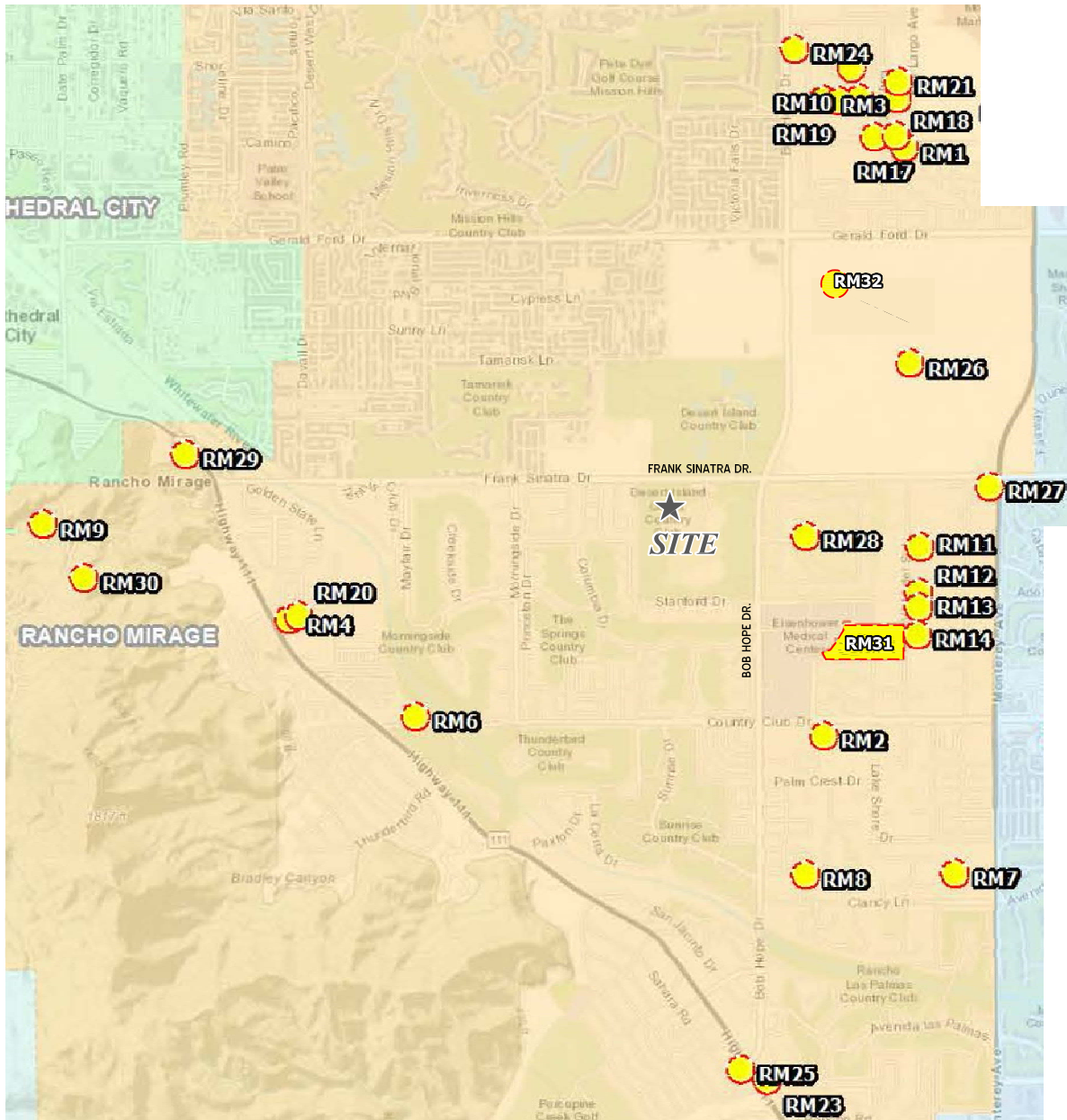
Exhibit 4-3 illustrates the cumulative development location map. A summary of cumulative development projects and their proposed land uses are shown on Table 4-2. If applicable, the traffic generated by individual cumulative projects was manually added to the Opening Year Cumulative forecasts to ensure that traffic generated by the listed cumulative development projects on Table 4-3 are reflected as part of the background traffic. In an effort to conduct a conservative analysis, the cumulative projects are added in conjunction with the ambient growth identified in Section 4.5 *Background Traffic*. Cumulative ADT and peak hour intersection turning movement volumes are shown on Exhibit 4-4.

## 4.7 NEAR-TERM CONDITIONS

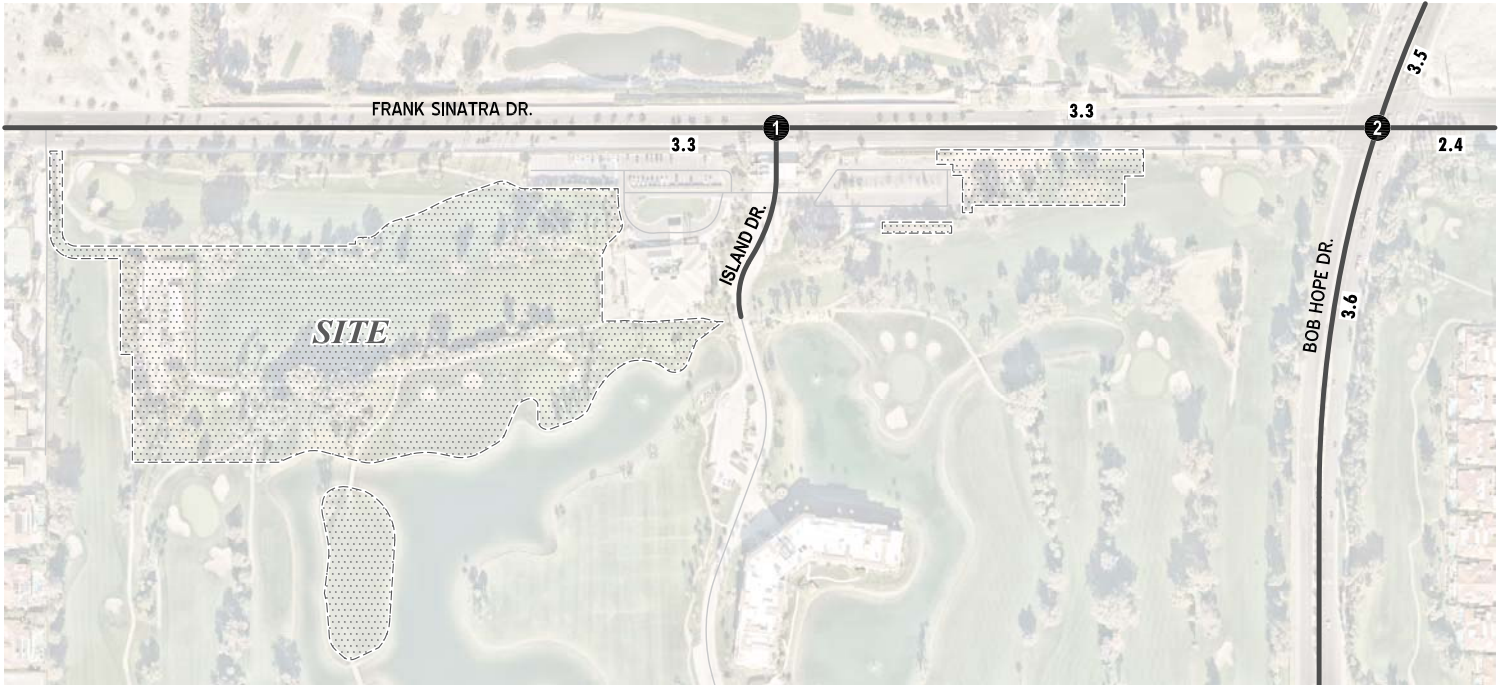
The “buildup” approach has been utilized which combines existing traffic counts with a background ambient growth factor to forecast the EAP (2024) and EAPC (2024) traffic conditions. An ambient growth factor of 4.04% accounts for background (area-wide) traffic increases that occur over time up to the year 2024 from the year 2022 (2.0% per year, compounded over a 2-year period). Project traffic is added to assess EAP (2024) and EAPC (2024) traffic conditions, respectively. Traffic volumes generated by cumulative development projects are included to assess the EAPC (2024) traffic conditions. The 2024 roadway

networks are similar to the existing conditions roadway network with the exception of future roadways and intersections proposed to be developed by the Project. It should be noted that Existing plus Ambient Growth plus Cumulative (EAC) traffic forecasts were also developed for applicable study area intersections only to determine the change in delay and identify whether the Project has an adverse effect on a pre-project deficiency.

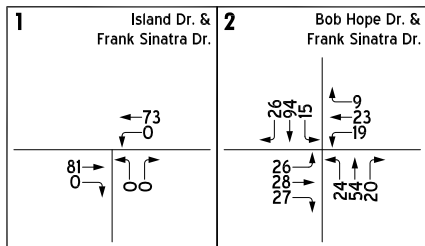
EXHIBIT 4-3: CUMULATIVE DEVELOPMENT LOCATION MAP



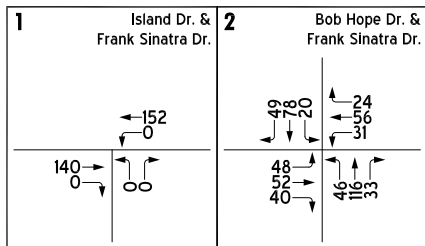
**EXHIBIT 4-4: CUMULATIVE DEVELOPMENT ONLY TRAFFIC VOLUMES**



**AM PEAK HOUR**



**PM PEAK HOUR**



**LEGEND:**

- = INTERSECTION ID
- = PEAK HOUR INTERSECTION VOLUMES
- 10.0** = VEHICLES PER DAY (1000'S)





**TABLE 4-2: CUMULATIVE DEVELOPMENT LAND USE SUMMARY**

TAZ	Project	Case Number	Land Use	Quantity	Units <sup>1</sup>
RM1	RM 38 JV LLC	DA190002 / TTM36620	Residential	82	DU
RM2	Carefield Senior Living	PDP18004 / DA180003 / EA180002	Residential	84	DU
RM3	ECHO at Rancho Mirage	PDP18003	Residential	9	DU
RM4	Santa Barbara Cove Estates	PDP18001 / TTM35573	Residential	20	DU
RM6	Veneto	MOD16019	Residential	34	DU
RM7	Revelle	PDP13003 / FDP13004	Residential	32	DU
RM8	Bella Clancy	ZTA05003 / EA050025 / MOD05016 / FDP04002 / PDP03015	Residential	20	DU
RM9	Mirada Villas	FDP05004 / PDP04011 / MOD06024 / MOD11040	Residential	46	DU
RM10	Estilo	PDP12003 / FDP12005	Residential	39	DU
RM11	RM Five-1 LLC/Kilani	TPM37222R / EA190008	Residential	4	DU
RM12	Heinrich/Steinberg	TPM34232 / TPPMX34232 / TPM34233 / TPMX34233	Residential	4	DU
RM13	Rancho Mirage LLC	TPM34741 / EA060009 / TPMX-34741 / PDPX34741	Residential	4	DU
RM14	La Paloma Homes, Inc.	TTM37637	Residential	13	DU
RM17	38 JV, LLC c/o Meriwether Companies	TTM36620 / EA130006 / SPA13001 / TTM2X36620	Residential	97	DU
RM18	38 JV, LLC c/o Meriwether Companies	TTM36622 / EA130008 / TTM3X36622	Residential	10	DU
RM19	GRV Mirage, LLC (ECHO)	TTM35619 / EA070011	Residential	9	DU
RM20	Ken Catanzarite	TTM35573	Residential	20	DU
RM21	Mirage dunes Properties	TTM05004 / TTM33329 / TTM2X33329	Residential	9	DU
RM23	IN-N-OUT Burgers	PDP19002 / EA190004 / CUP19007 / ZTA19002 / DA190001	Commercial	3.995	DU
RM24	DHO Medical Office Building	PDP19001 / EA190001	Medical Office	13.800	TSF
RM25	Chase Bank	PDP18005	Bank	3.470	TSF
RM26	Section 31 Specific Plan Project	SP180001 / EIR18001 / GPZMA18003	Hotel	400	Rooms
			Commercial	175.000	TSF
			Residential	1,932	DU
RM27	Tower Energy Group	CUP18004 / TPM37486 / EA180004	Commercial	5.565	TSF
RM28	Oasis Ranch LLC	PDP18002 / TTM37461	Hotel	60	Rooms
			Residential	108	DU
RM29	Horizon Pacific Rancho Cove MSA Consulting	PDP16003 / TTM37122	Commercial	20.000	TSF
			Hotel	100	Rooms
			Residential	35	DU
RM30	Ritz-Carlton Residences	--	Residential	106	DU
			Commercial	6.966	TSF
RM31	Hazelden Betty Ford Center	--	Office	6.399	TSF
			Drug/Alcohol Treatment Ctr.	56	Beds
RM32	ED Rancho Mirage	TTM 37856/TTM 37563/PDP19004/EA 190009	Residential	354	DU

<sup>1</sup> DU = Dwelling Units; TSF = Thousand Square Feet

This page intentionally left blank

## 5 EAP (2024) TRAFFIC CONDITIONS

This section discusses the traffic forecasts for Existing plus Ambient Growth plus Project (EAP) conditions and the resulting intersection operations and traffic signal warrant analyses.

### 5.1 ROADWAY IMPROVEMENTS

The lane configurations and traffic controls assumed to be in place for EAP (2024) conditions are consistent with those shown previously on Exhibit 3-1, with the exception of the following:

- Project driveways and those facilities assumed to be constructed by the Project to provide site access are also assumed to be in place for EAP (2024) conditions only (e.g., intersection and roadway improvements at the Project’s frontage and driveways).

### 5.2 EAP TRAFFIC VOLUME FORECASTS

This scenario includes Existing traffic volumes plus an ambient growth factor of 4.04% and the addition of Project traffic. The weekday ADT and weekday peak hour intersection turning movement volumes which can be expected for EAP (2024) traffic conditions are shown on Exhibit 5-1.

### 5.3 INTERSECTION OPERATIONS ANALYSIS

EAP (2024) peak hour traffic operations have been evaluated for the study area intersections based on the analysis methodologies presented in Section 2 *Methodologies* of this TA. The intersection analysis results are summarized on Table 5-1 for EAP (2024) traffic conditions, which indicate that the study area intersections are anticipated to continue to operate at an acceptable LOS (LOS “D” or better) under EAP (2024) traffic conditions. The intersection operations analysis worksheets for EAP (2024) traffic conditions are included in Appendix 5.1 of this TA.

**TABLE 5-1: INTERSECTION ANALYSIS FOR EAP CONDITIONS**

#	Intersection	Traffic Control <sup>1</sup>	Intersection Approach Lanes <sup>2</sup>												Delay <sup>3</sup> (secs.)		Level of Service	
			Northbound			Southbound			Eastbound			Westbound			AM	PM	AM	PM
			L	T	R	L	T	R	L	T	R	L	T	R				
1	Island Dr. / Frank Sinatra Dr.	CSS	1	0	1	0	0	0	0	2	0	1	2	0	27.9	22.5	D	C
2	Bob Hope Dr. / Frank Sinatra Dr.	TS	2	2	1	2	2	1	2	2	d	2	2	1	31.8	28.1	C	C

<sup>1</sup> TS = Traffic Signal; CSS = Cross-street Stop

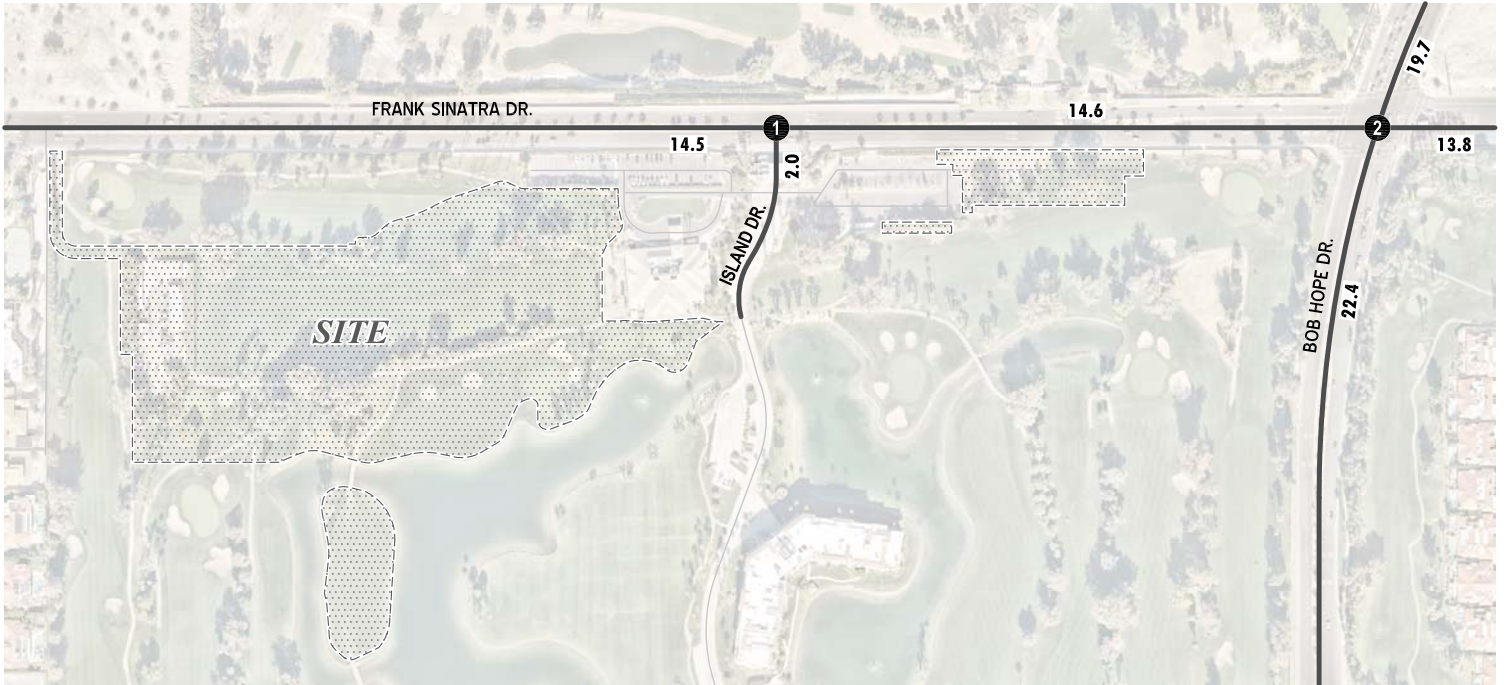
<sup>2</sup> When a right turn is designated, the lane can either be striped or unstriped. To function as a right turn lane there must be sufficient width for right turning vehicles to travel outside the through lanes.

L = Left; T = Through; R = Right; d = Defacto Right Turn Lane

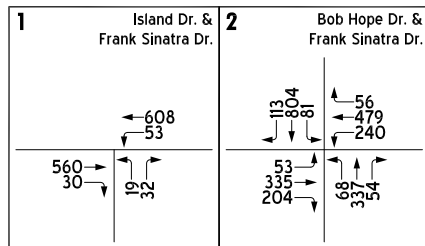
<sup>3</sup> Per the Highway Capacity Manual (6th Edition), overall average intersection delay and level of service are shown for intersections with a traffic signal or all way stop control. For intersections with cross street stop control, the delay and level of service for the worst individual movement (or movements sharing a single lane) are shown.



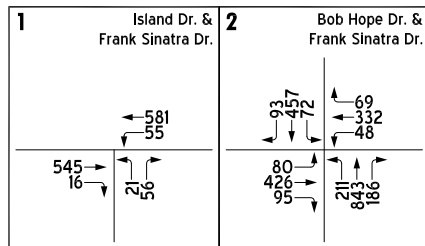
**EXHIBIT 5-1: EAP (2024) TRAFFIC VOLUMES**



**AM PEAK HOUR**



**PM PEAK HOUR**



**LEGEND:**

- = INTERSECTION ID
- = PEAK HOUR INTERSECTION VOLUMES
- 10.0** = VEHICLES PER DAY (1000'S)



## **5.4 TRAFFIC SIGNAL WARRANTS ANALYSIS**

The traffic signal warrant analysis for EAP (2024) traffic conditions are based on the peak hour volume-based traffic signal warrants. The unsignalized intersection of Island Drive / Frank Sinatra Drive is not anticipated to meet peak hour volume-based warrants with the addition of Project traffic (see Appendix 3.3).

## **5.5 PROJECT DEFICIENCIES AND RECOMMENDED IMPROVEMENTS**

The study area intersections are anticipated to operate at an acceptable LOS with the addition of Project traffic. As such, no additional improvements aside from those that are needed to facilitate site access have been recommended.

This page intentionally left blank

## 6 EAPC (2024) TRAFFIC CONDITIONS

This section discusses the methods used to develop Existing plus Ambient Growth plus Project plus Cumulative (EAPC) (2024) traffic forecasts, and the resulting intersection operations and traffic signal warrant analyses.

### 6.1 ROADWAY IMPROVEMENTS

The lane configurations and traffic controls assumed to be in place for EAPC (2024) conditions are consistent with those shown previously on Exhibit 3-1, with the exception of the following:

- Project driveways and those facilities assumed to be constructed by the Project to provide site access are also assumed to be in place for Opening Year Cumulative conditions only (e.g., intersection and roadway improvements along the Project's frontage and driveways).
- If applicable, driveways and those facilities assumed to be constructed by cumulative developments to provide site access are also assumed to be in place for Opening Year Cumulative conditions only.

### 6.2 EAPC (2024) TRAFFIC VOLUME FORECASTS

This scenario includes Existing traffic volumes plus an ambient growth factor of 4.04% plus traffic from pending and approved but not yet constructed known development projects in the area. The weekday ADT and weekday peak hour volumes which can be expected for EAPC (2024) traffic conditions are shown on Exhibit 6-1.

### 6.3 INTERSECTION OPERATIONS ANALYSIS

LOS calculations were conducted for the study intersections to evaluate their operations under EAPC (2024) traffic conditions with roadway and intersection geometrics consistent with Section 6.1 *Roadway Improvements*. As shown on Table 6-1, the study area intersections are anticipated to continue to operate at an acceptable LOS (LOS "D" or better) under EAPC (2024) traffic conditions. The intersection operations analysis worksheets for EAPC (2024) traffic conditions are included in Appendix 6.1 of this TA.

**TABLE 6-1: INTERSECTION ANALYSIS FOR EAPC (2024) CONDITIONS**

#	Intersection	Traffic Control <sup>1</sup>	Intersection Approach Lanes <sup>2</sup>												Delay <sup>3</sup>		Level of Service	
			Northbound			Southbound			Eastbound			Westbound			AM	PM	AM	PM
			L	T	R	L	T	R	L	T	R	L	T	R				
1	Island Dr. / Frank Sinatra Dr.	CSS	1	0	1	0	0	0	0	2	0	1	2	0	34.2	30.7	D	D
2	Bob Hope Dr. / Frank Sinatra Dr.	TS	2	2	1	2	2	1	2	2	d	2	2	1	34.8	30.4	C	C

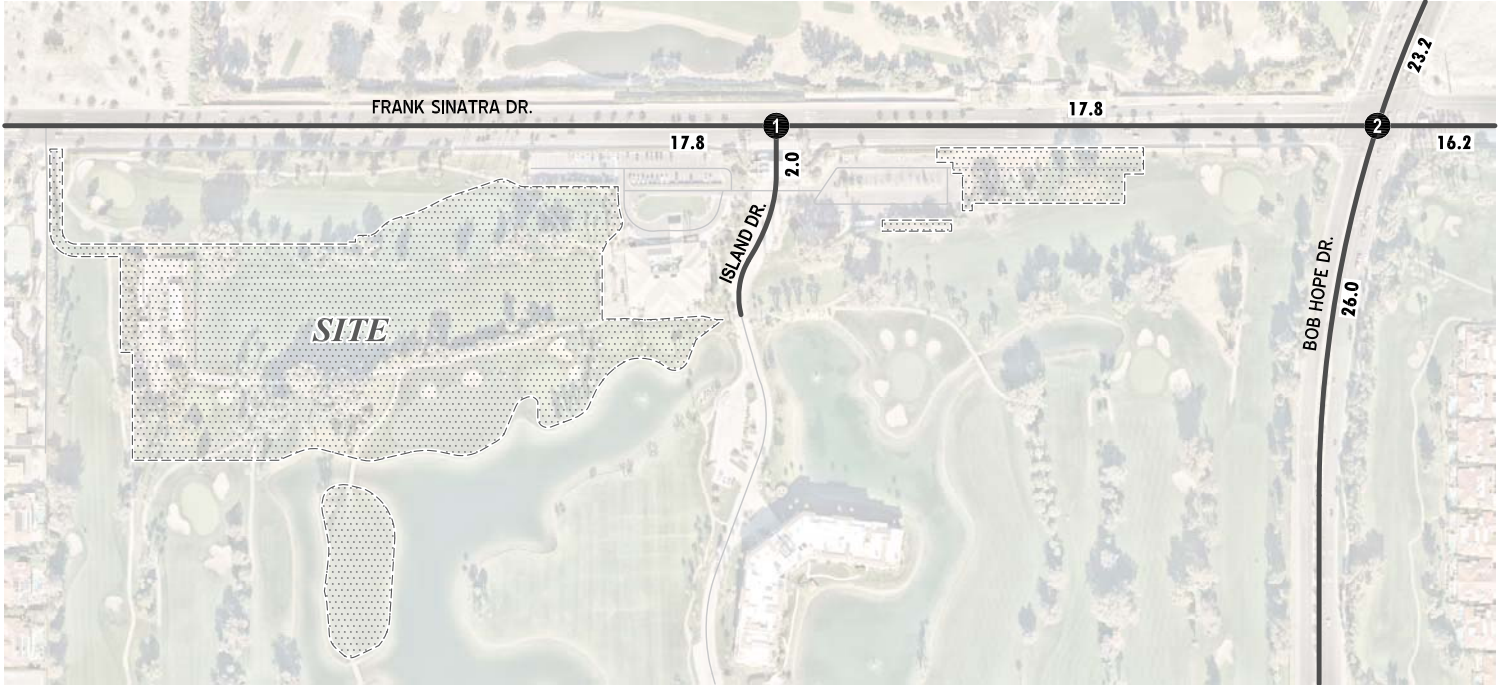
<sup>1</sup> TS = Traffic Signal; CSS = Cross-street Stop

<sup>2</sup> When a right turn is designated, the lane can either be striped or unstriped. To function as a right turn lane there must be sufficient width for right turning vehicles to travel outside the through lanes.

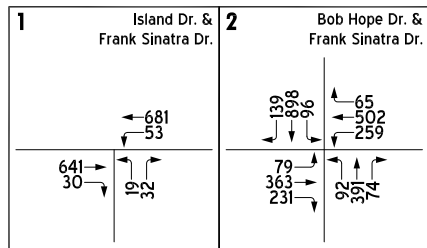
L = Left; T = Through; R = Right; d = Defacto Right Turn Lane

<sup>3</sup> Per the Highway Capacity Manual (6th Edition), overall average intersection delay and level of service are shown for intersections with a traffic signal or all way stop control. For intersections with cross street stop control, the delay and level of service for the worst individual movement (or movements sharing a single lane) are shown.

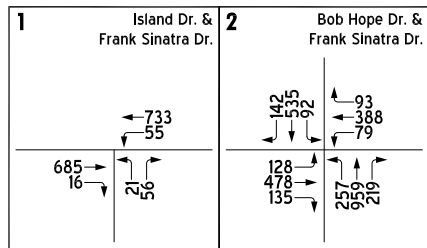
**EXHIBIT 6-1: EAPC (2024) TRAFFIC VOLUMES**



**AM PEAK HOUR**



**PM PEAK HOUR**



**LEGEND:**

- = INTERSECTION ID
- = PEAK HOUR INTERSECTION VOLUMES
- 10.0** = VEHICLES PER DAY (1000'S)



## 6.4 TRAFFIC SIGNAL WARRANTS ANALYSIS

The traffic signal warrant analysis for EAPC (2024) traffic conditions are based on the peak hour volume-based traffic signal warrants. The unsignalized intersection of Island Drive / Frank Sinatra Drive is anticipated to meet peak hour volume-based warrants for EAPC (2024) traffic conditions (see Appendix 3.3).

As mentioned previously, a signal warrant defines the minimum condition under which the installation of a traffic signal might be warranted. Meeting this condition does not require that a traffic control signal be installed at a particular location, but rather, that other traffic factors and conditions be evaluated in order to determine whether the signal is truly justified. It should also be noted that signal warrants do not necessarily correlate with LOS. An intersection may satisfy a signal warrant condition and operate at or above acceptable LOS or operate below acceptable LOS and not meet a signal warrant.

## 6.5 PROJECT DEFICIENCIES AND RECOMMENDED IMPROVEMENTS

The study area intersections are anticipated to operate at an acceptable LOS with the addition of Project traffic. As such, no additional improvements aside from those that are needed to facilitate site access have been recommended.

This page intentionally left blank

## 7 REFERENCES

1. **Riverside County Transportation Department.** *Transportation Analysis Guideines for Level of Service & Vehicle Miles Traveled.* County of Riverside : s.n., December 2020.
2. **Transportation Research Board.** *Highway Capacity Manual (HCM), 6th Edition.* s.l. : National Academy of Sciences, 2016.
3. **California Department of Transportation.** California Manual on Uniform Traffic Control Devices (CA MUTCD). [book auth.] California Department of Transportation. *California Manual on Uniform Traffic Control Devices (CA MUTCD).* 2014, Updated March 30, 2021 (Revision 6).
4. **Institute of Transportation Engineers.** Trip Generation Manual. 11th Edition, 2021.



This page intentionally left blank

## **APPENDIX 1.1: APPROVED TRAFFIC STUDY SCOPING AGREEMENT**

This Page Intentionally Left Blank

April 18, 2022

Mr. Ryan Stendell  
City of Rancho Mirage, Director of Public Works  
69-825 Highway 111  
Rancho Mirage, CA 92270

**SUBJECT: DESERT ISLAND HOTEL FOCUSED LOS ANALYSIS AND VMT SCREENING - SCOPING  
AGREEMENT**

Dear Mr. Ryan Stendell:

Urban Crossroads, Inc. is pleased to submit this scoping letter to the City of Rancho Mirage regarding the Focused Level of Service (LOS) Analysis and Vehicle Miles Traveled (VMT) Screening for the proposed Desert Island Specific Plan Hotel Amendment (“Project”). The Project is located south of Frank Sinatra Drive and adjacent to Island Drive in the City of Rancho Mirage. It is our understanding that the Project will repurpose approximately 13.3 acres of the existing golf driving range and a portion of the existing golf course with new facilities to accommodate a 42-key boutique hotel (with tennis, pool, and yoga amenities), 11 private residences, and a golf training facility.

The existing driving range will be removed to make room for the new facilities. The existing golf maintenance structure will be replaced by a new building along with an expanded parking lot east of the main entry. The existing clubhouse will remain and continue to provide services to golfers, Desert Island residents, and the general public, with occasional events for up to 300 persons. It is anticipated that events with more than 300 persons in the existing clubhouse building would require a Temporary Use Permit, accompanied by a parking and traffic management plan if necessary. The existing golf course will continue to operate as an 18-hole facility with minor routing adjustments to 9th and 18th Fairways to accommodate the hotel.

Amenities which are complementary to the new hotel include a hotel pool, a small pool café, a tennis court for hotel guests, and a shaded yoga platform located on the island south of the lake accessed by foot from the existing bridge.

The new private duplex-style condominium residences (11 units) will be managed and maintained by the hotel operator. When not in use by individual owners, these units will be made available for rental by the hotel operator. For traffic analysis purposes, these 11 units are addressed as single family residences in order to include trip rates which are higher than those associated with multifamily units.

The new golf training park will replace the current driving range. It will consist of an 18-hole tournament putting green, short game training areas, and virtual golf simulator stations. In order to evaluate the potential increase in practice golf park activity which maybe higher than the existing driving range, the employment associated with golf practice activity is estimated to increase by 10 employees.

The remainder of this letter describes the proposed analysis methodology, Project trip generation, trip distribution, and Project traffic assignment/project trips on the surrounding roadway network. The following scoping assumptions have been prepared in accordance with the County of Riverside's Transportation Analysis Guidelines for Level of Service & Vehicle Miles Traveled (December 2020) as the City of Rancho Mirage utilized the County guidelines.

A preliminary site plan the proposed Project is shown on Exhibit 1. Exhibit 2 depicts the location of the proposed project in relation to the existing roadway network. It is anticipated that the Project would be fully developed by year 2024. The Project will take primary access from the existing Desert Island Main gate on Frank Sinatra Drive.

## **TRIP GENERATION**

In order to develop the traffic characteristics of the proposed project, trip-generation statistics published in the Institute of Transportation Engineers (ITE) *Trip Generation* (11<sup>th</sup> Edition, 2021) manual for the proposed land uses (ITE Land Use Codes: 330 – Resort Hotel; 210 – Single Family Residential; 432 – Golf Practice) are used. Table 1 presents the trip generation rates and the resulting trip generation summary for the proposed Project. As shown in Table 1, the Project is anticipated to generate a total of 991 new trip-ends per day with 66 new AM peak hour trips and 86 new PM peak hour trips.

## **TRIP DISTRIBUTION**

The trip distribution pattern is heavily influenced by the geographical location of the site, the location of surrounding uses, and the proximity to the regional freeway system. Exhibit 3 presents the Project distribution pattern. Based on the identified Project traffic generation and trip distribution patterns, Project ADT and peak hour intersection turning movement volumes are shown on Exhibit 4.

## **ANALYSIS SCENARIOS**

Consistent with the County's LOS guidelines, intersection analysis will be provided for the following analysis scenarios:

- Existing (2022) Conditions
- Existing plus Ambient plus Project (EAP) (2024)
- Existing plus Ambient plus Project plus Cumulative (EAPC) (2024)

The City of Rancho Mirage General Plan Circulation Element is depicted on Exhibit 5, while the accompanying roadway cross-sections are presented on Exhibit 6.

## STUDY AREA

The traffic impact study area was defined in conformance with the requirements of County of Riverside’s Transportation Analysis Guidelines for Level of Service & Vehicle Miles Traveled. Consistent with the County’s LOS guidelines, study area intersections have been identified for the Project based on the contribution of 50 or more peak hour trips. Based on this criterion, anticipated trip generation and trip distribution, the intersections of Island Drive / Frank Sinatra Drive (#1) and Bob Hope Drive / Frank Sinatra Drive (#2) will be evaluated. Exhibit 2 identifies the proposed study area intersection analysis locations.

In addition, 24-hour roadway volumes at the following locations within the study area will be evaluated:

- Island Drive, south of Frank Sinatra Drive
- Frank Sinatra Drive, west of Island Drive
- Frank Sinatra Drive, east of Island Drive

## LEVEL OF SERVICE (LOS) CRITERIA

The City of Rancho Mirage states that “While LOS C has long been considered the desirable and optimal level of traffic volume on any given roadway, it represents a standard that is progressively more difficult and less cost effective to achieve in urban areas. For peak operating periods, LOS D or a maximum volume to capacity ratio of 0.90 is now considered the generally acceptable service level.”

Where the average daily traffic volume (ADT) based roadway segment analysis indicates a deficiency (unacceptable LOS), a review of the more detailed peak hour intersection analysis is undertaken. The more detailed peak hour intersection analysis explicitly accounts for factors that affect roadway capacity. While this traffic study recognizes LOS D is the City’s target LOS for roadway segments, a review of the more detailed peak hour intersection analysis is necessary to determine whether roadway widening along the segment is necessary. For the purposes of this analysis, if the peak hour intersection operations on either side of the roadway segment are anticipated to operate at LOS D or better, then additional roadway segment widening is not recommended. Therefore, for the purposes of this analysis, roadway segment widening is typically only recommended if the peak hour intersection analysis indicates the need for additional through lanes.

## TRAFFIC COUNTS

Traffic count data will be collected in April 2022 during the AM peak period of 7:00 AM to 9:00 AM and PM peak period of 4:00 PM to 6:00 PM.

## SITE ACCESS

The hotel will take primary access from the existing Desert Island main gate on Frank Sinatra Drive. No physical changes are proposed to the existing entry gatehouse, other than to keep the gates open during operating hours to eliminate any vehicle stacking onto Frank Sinatra Drive. Likewise, the resident gate and turnaround on Island Drive will be retained in its existing condition without change. Secondary access to Frank Sinatra will be accommodated by widening the existing gated entry at the northwest corner of the golf course from 12-feet to 24-feet to provide secondary emergency vehicle access.

Exhibit 7 shows the on-site traffic circulation. Southbound golf and hotel traffic will enter the project using the right-hand lane with a free-flow right turn where an attendant will greet and direct guests to the appropriate parking area. Resident traffic will use the left-hand entry lane and proceed straight to the resident gate as they always have. Traffic exiting the hotel will use the existing clubhouse driveway.

The focused traffic LOS assessment will include evaluation of peak hour queues at the Project entry.

## CUMULATIVE DEVELOPMENT TRAFFIC

It is requested that City staff review the list of cumulative development projects (shown on Exhibit 8 and listed on Table 2) for inclusion in the traffic study. Consistent with other studies performed in the area, an ambient growth rate of 2% per year will be utilized as a minimum if necessary. The rate will be compounded over a 2-year period (i.e.,  $1.02^{2\text{years}} = 1.0404$  or 4.04%) for Interim Year (2024) conditions.

## VEHICLE MILES TRAVELED (VMT)

The VMT screening assessment will be prepared under separate cover in accordance with SB743 and consistent with the methodology and thresholds outlined in the County of Riverside's December 2020 VMT methodology guidelines.

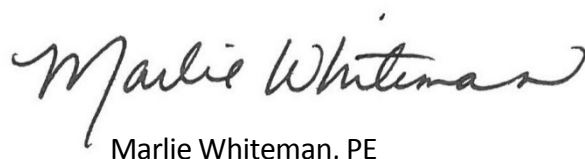
Please review this scoping agreement let us know if it is acceptable, or if the City requests any changes to this proposed scope of work. If you have any questions, please contact John Kain at (949) 375-2435 or Marlie Whiteman (714) 585-0574.

Respectfully submitted,

URBAN CROSSROADS, INC.

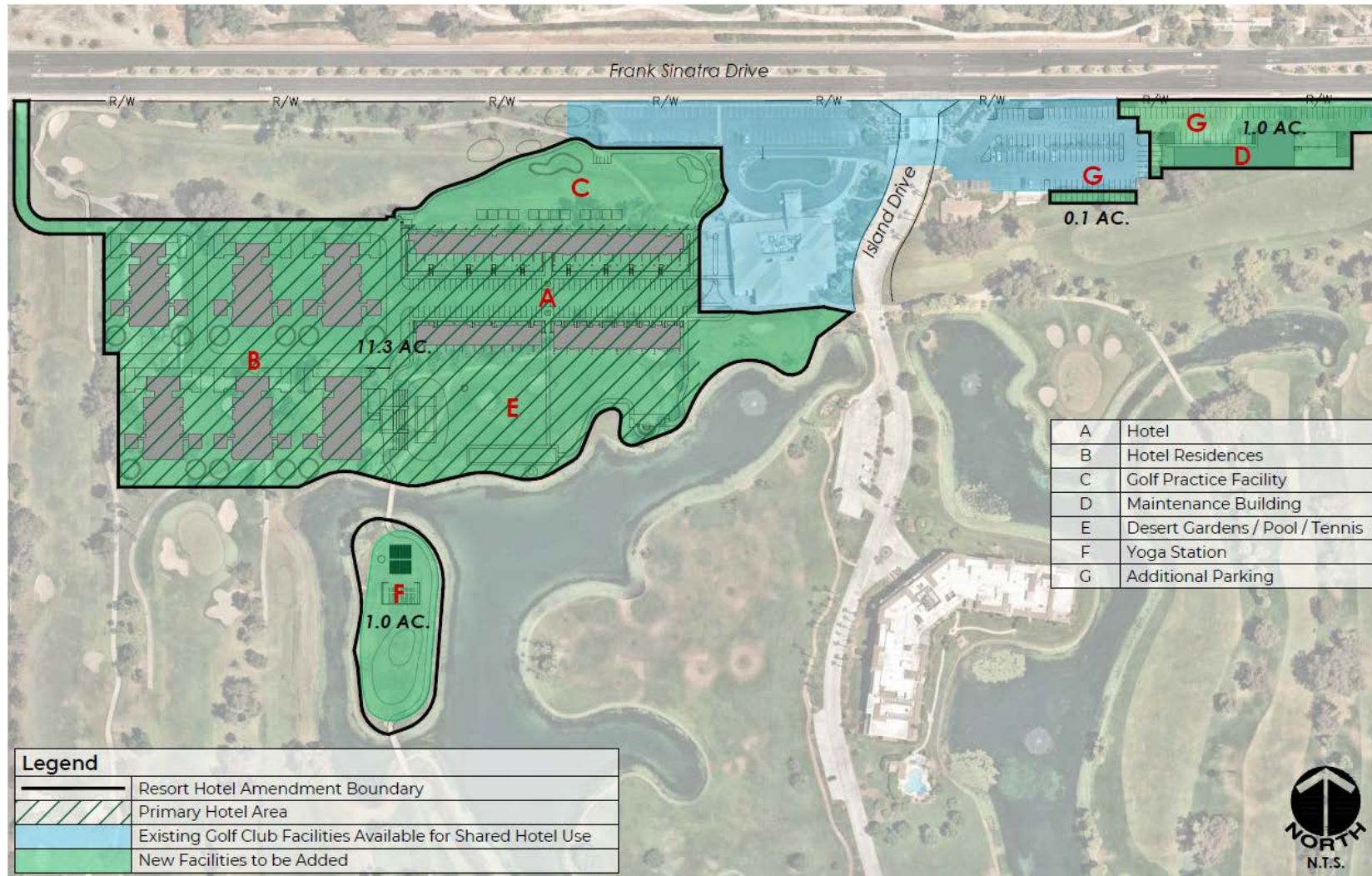


John Kain, AICP  
Principal



Marlie Whiteman, PE  
Senior Associate

### EXHIBIT 1: PRELIMINARY SITE PLAN





**EXHIBIT 2: STUDY AREA**



**LEGEND:**

① = INTERSECTION ANALYSIS LOCATION



**TABLE 1: PROJECT TRIP GENERATION SUMMARY**

Trip Generation Rates <sup>1</sup>									
Land Use	ITE LU Code	Quantity <sup>2</sup>	AM Peak Hour			PM Peak Hour			Daily
			In	Out	Total	In	Out	Total	
Resort Hotel	330	42 Occ. RM	0.27	0.10	0.37	0.20	0.27	0.47	7.87
Single Family Units	210	11 DU	0.18	0.52	0.70	0.59	0.35	0.94	9.43
Golf Practice	432	10 EMP	1.00	0.64	1.64	2.74	2.74	5.48	55.57

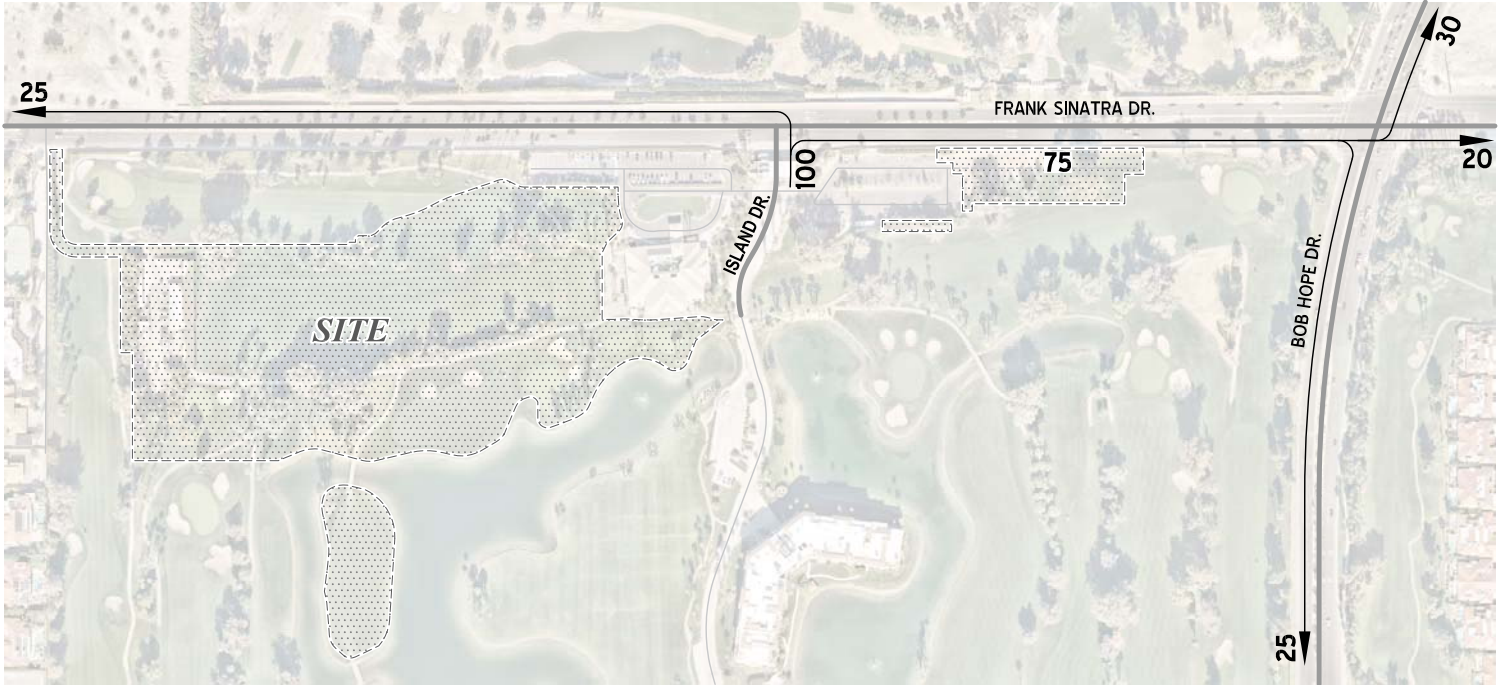
Trip Generation Results									
Land Use	ITE LU Code	Quantity <sup>2</sup>	AM Peak Hour			PM Peak Hour			Daily
			In	Out	Total	In	Out	Total	
Resort Hotel	330	42 Occ. RM	11	4	15	8	11	19	331
Single Family Units	210	11 DU	2	6	8	6	4	10	104
Golf Practice	432	10 EMP	10	6	16	27	27	54	556
<b>TOTAL</b>			<b>23</b>	<b>16</b>	<b>39</b>	<b>41</b>	<b>42</b>	<b>83</b>	<b>991</b>

<sup>1</sup> Trip Generation Source: Institute of Transportation Engineers (ITE), Trip Generation Manual, 11th Edition (2021).

<sup>2</sup> Occ. RM = Occupied Room; DU = Dwelling Unit; EMP = Employee

F:\UXRjobs\14600-15000\14747\02\_LOS\Excel\[14747 - Scope.xlsx]14747-TG

### EXHIBIT 3: PROJECT TRIP DISTRIBUTION

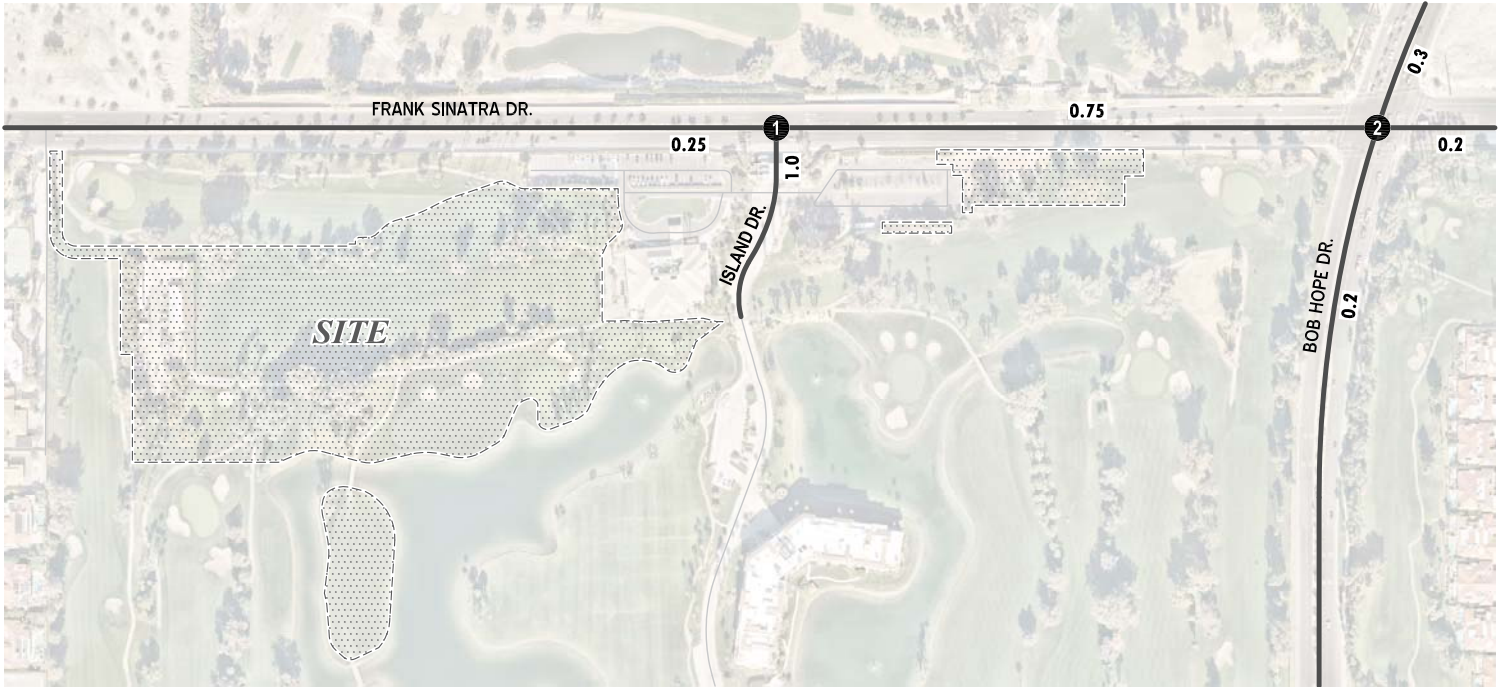


**LEGEND:**

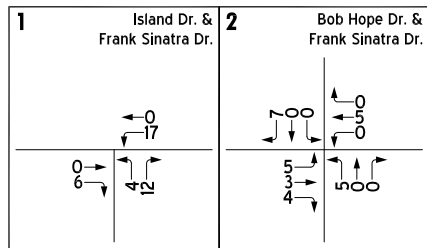
10 ■ PERCENT TO/FROM PROJECT



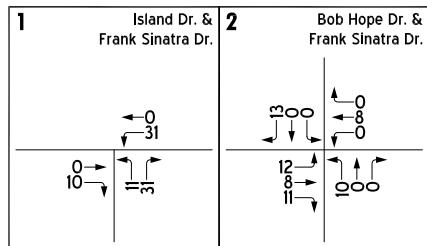
**EXHIBIT 4: PROJECT ONLY TRAFFIC VOLUMES**



**AM PEAK HOUR**



**PM PEAK HOUR**



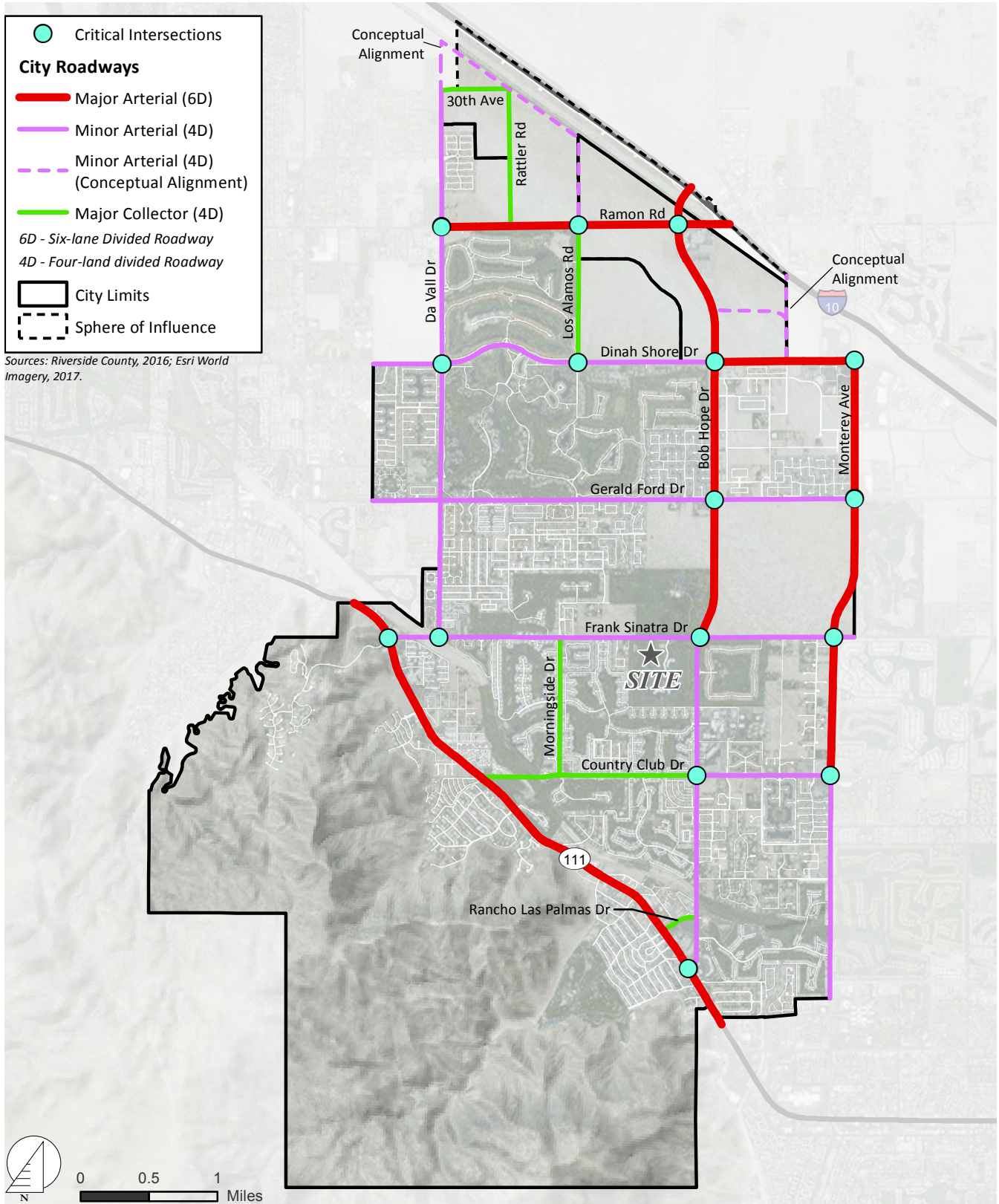
**LEGEND:**

- = INTERSECTION ID
- = PEAK HOUR INTERSECTION VOLUMES
- 10.0** = VEHICLES PER DAY (1000'S)

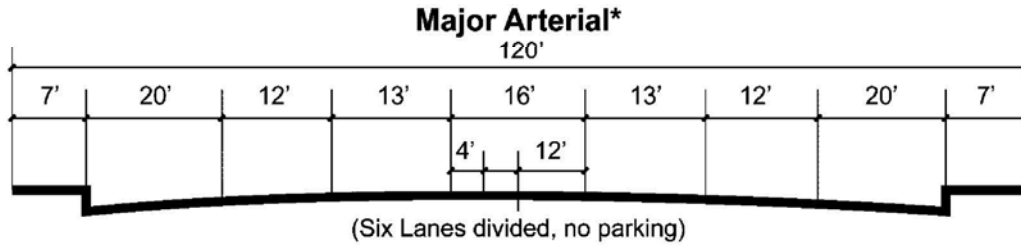




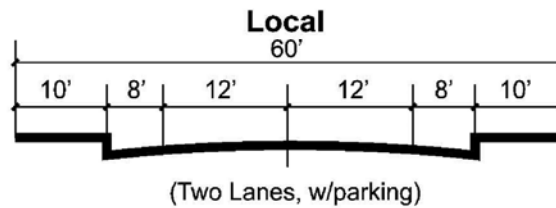
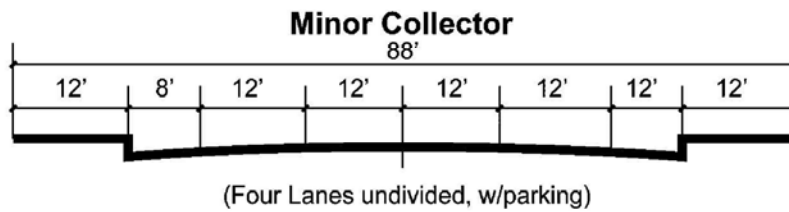
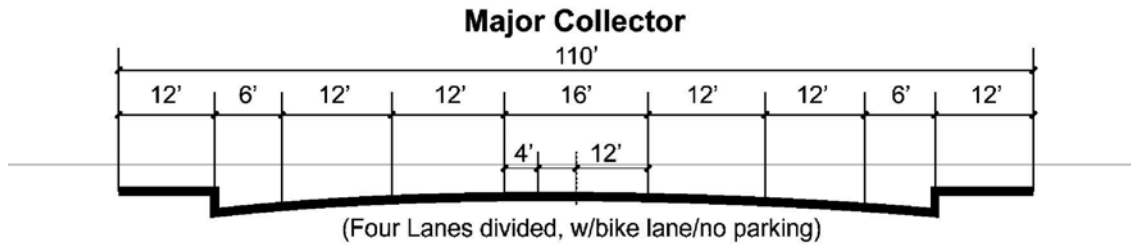
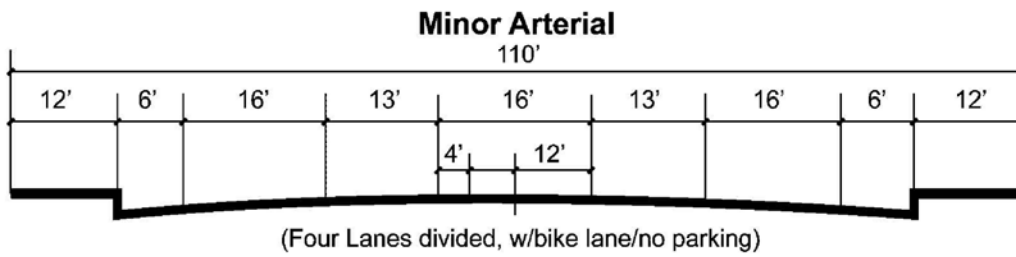
**EXHIBIT 5: CITY OF RANCHO MIRAGE GENERAL PLAN CIRCULATION ELEMENT**



**EXHIBIT 6: CITY OF RANCHO MIRAGE GENERAL PLAN ROADWAY CROSS-SECTIONS**

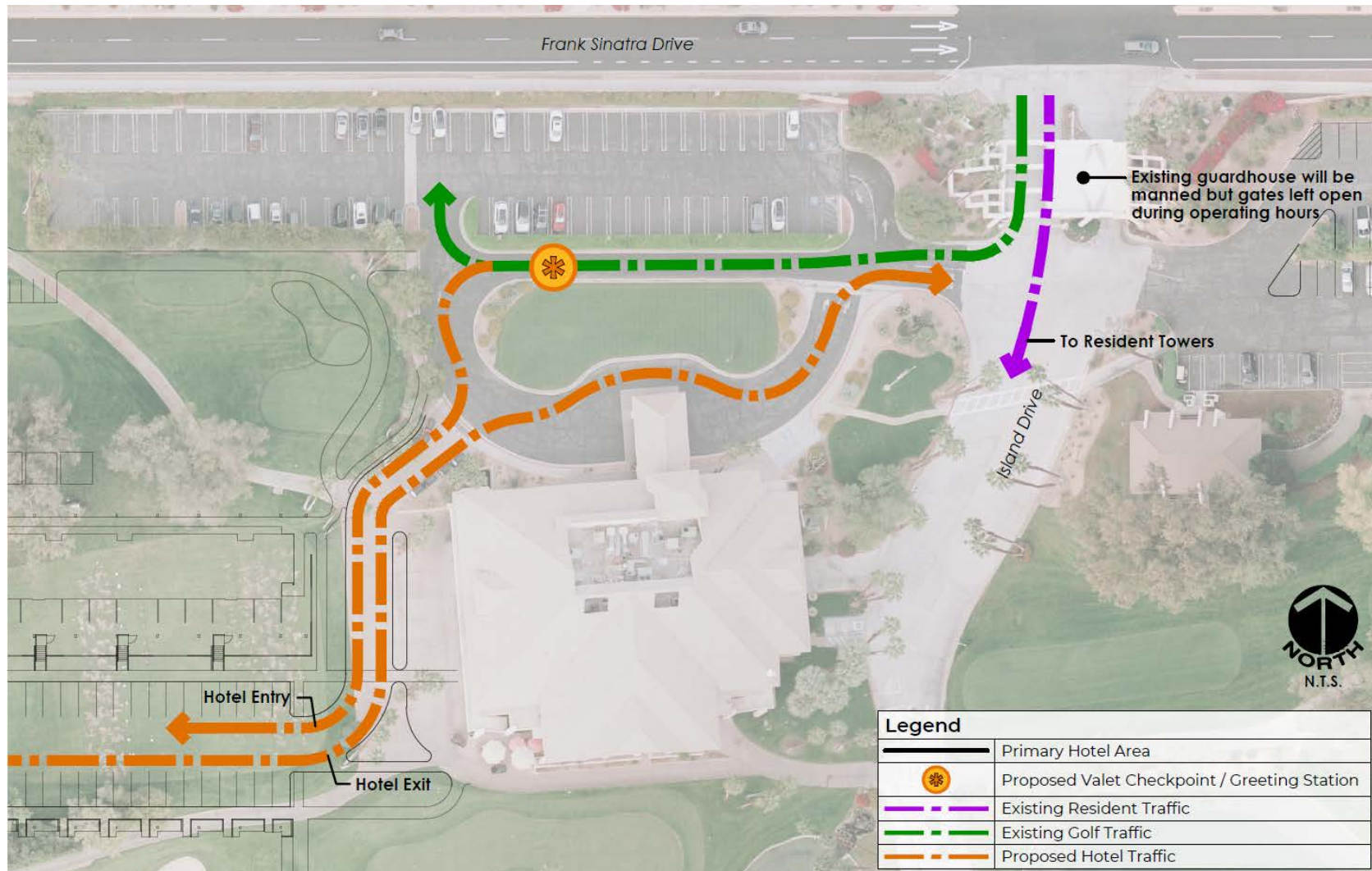


\*Highway 111 has special design geometrics, See Rancho Mirage Highway 111 Alignment Study, 1996.



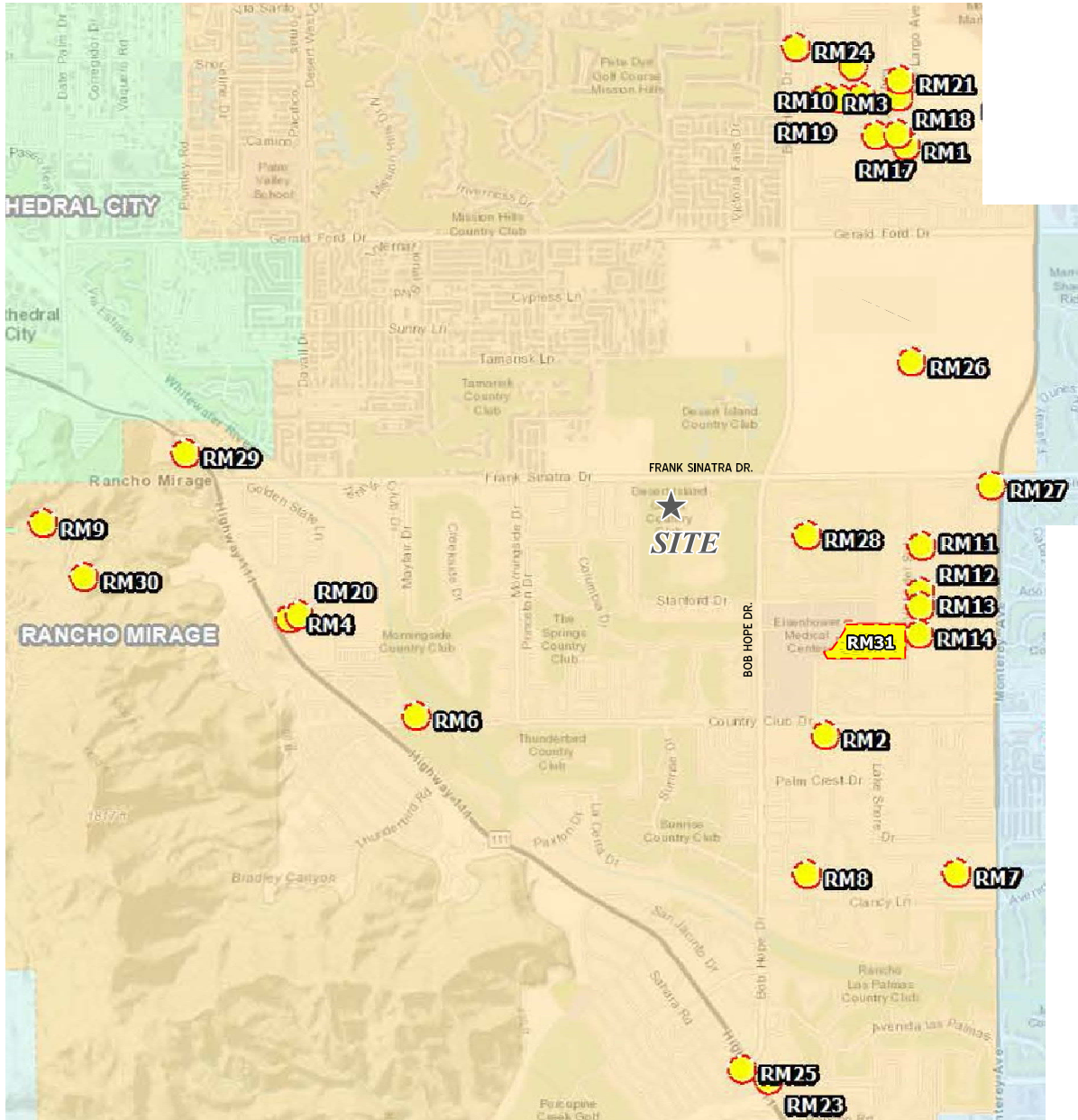
SOURCE: CITY OF RANCHO MIRAGE

### EXHIBIT 7: ON-SITE TRAFFIC CIRCULATION





### EXHIBIT 8: CUMULATIVE DEVELOPMENT LOCATION MAP





**TABLE 2: CUMULATIVE DEVELOPMENT LAND USE SUMMARY**

TAZ	Project	Case Number	Land Use	Quantity	Units <sup>1</sup>
RM1	RM 38 JV LLC	DA190002 / TTM36620	Residential	82	DU
RM2	Carefield Senior Living	PDP18004 / DA180003 / EA180002	Residential	84	DU
RM3	ECHO at Rancho Mirage	PDP18003	Residential	9	DU
RM4	Santa Barbara Cove Estates	PDP18001 / TTM35573	Residential	20	DU
RM6	Veneto	MOD16019	Residential	34	DU
RM7	Revelle	PDP13003 / FDP13004	Residential	32	DU
RM8	Bella Clancy	ZTA05003 / EA050025 / MOD05016 / FDP04002 / PDP03015	Residential	20	DU
RM9	Mirada Villas	FDP05004 / PDP04011 / MOD06024 / MOD11040	Residential	46	DU
RM10	Estilo	PDP12003 / FDP12005	Residential	39	DU
RM11	RM Five-1 LLC/Kilani	TPM37222R / EA190008	Residential	4	DU
RM12	Heinrich/Steinberg	TPM34232 / TPPMX34232 / TPM34233 / TPMX34233	Residential	4	DU
RM13	Rancho Mirage LLC	TPM34741 / EA060009 / TPMX-34741 / PDPX34741	Residential	4	DU
RM14	La Paloma Homes, Inc.	TTM37637	Residential	13	DU
RM17	38 JV, LLC c/o Meriwether Companies	TTM36620 / EA130006 / SPA13001 / TTM2X36620	Residential	97	DU
RM18	38 JV, LLC c/o Meriwether Companies	TTM36622 / EA130008 / TTM3X36622	Residential	10	DU
RM19	GRV Mirage, LLC (ECHO)	TTM35619 / EA070011	Residential	9	DU
RM20	Ken Catanzarite	TTM35573	Residential	20	DU
RM21	Miragedunes Properties	TTM05004 / TTM33329 / TTM2X33329	Residential	9	DU
RM24	DHO Medical Office Building	PDP19001 / EA190001	Medical Office	13.800	TSF
RM26	Section 31 Specific Plan Project	SP180001 / EIR18001 / GPZMA18003	Hotel	400	Rooms
			Commercial	175.000	TSF
			Residential	1,932	DU
RM27	Tower Energy Group	CUP18004 / TPM37486 / EA180004	Commercial	5.565	TSF
RM28	Oasis Ranch LLC	PDP18002 / TTM37461	Hotel	60	Rooms
			Residential	108	DU
RM29	Horizon Pacific Rancho Cove MSA Consulting	PDP16003 / TTM37122	Commercial	20.000	TSF
			Hotel	100	Rooms
			Residential	35	DU
RM30	Ritz-Carlton Residences	--	Residential	106	DU
			Commercial	6.966	TSF
RM31	Hazelden Betty Ford Center	--	Office	6.399	TSF
			Drug/Alcohol Treatment Ctr.	56	Beds

<sup>1</sup> DU = Dwelling Units; TSF = Thousand Square Feet

## **APPENDIX 1.2: SITE ADJACENT QUEUES**

This Page Intentionally Left Blank

Intersection: 1: Island Dr. & Frank Sinatra Dr.

Movement	WB	NB	NB
Directions Served	L	L	R
Maximum Queue (ft)	38	42	42
Average Queue (ft)	19	22	23
95th Queue (ft)	44	49	52
Link Distance (ft)			160
Upstream Blk Time (%)			
Queuing Penalty (veh)			
Storage Bay Dist (ft)	90	30	
Storage Blk Time (%)		10	4
Queuing Penalty (veh)		4	1

Intersection: 1: Island Dr. & Frank Sinatra Dr.

Movement	WB	NB	NB
Directions Served	L	L	R
Maximum Queue (ft)	37	34	48
Average Queue (ft)	15	18	27
95th Queue (ft)	40	43	55
Link Distance (ft)			160
Upstream Blk Time (%)			
Queuing Penalty (veh)			
Storage Bay Dist (ft)	90	30	
Storage Blk Time (%)		7	6
Queuing Penalty (veh)		4	1

## **APPENDIX 3.1: TRAFFIC COUNTS – MAY 2022**

This Page Intentionally Left Blank

City of Rancho Mirage  
 N/S: Island Drive  
 E/W: Frank Sinatra Drive  
 Weather: Clear

File Name : 01\_RNM\_Island\_Frank AM  
 Site Code : 05122394  
 Start Date : 5/3/2022  
 Page No : 1

Groups Printed- Total Volume

Start Time	Frank Sinatra Drive Westbound			Island Drive Northbound			Frank Sinatra Drive Eastbound			Int. Total
	Left	Thru	App. Total	Left	Right	App. Total	Thru	Right	App. Total	
07:00 AM	3	114	117	1	1	2	65	1	66	185
07:15 AM	8	110	118	0	1	1	109	0	109	228
07:30 AM	9	143	152	3	2	5	123	5	128	285
07:45 AM	10	168	178	3	5	8	162	4	166	352
Total	30	535	565	7	9	16	459	10	469	1050
08:00 AM	13	128	141	4	9	13	143	12	155	309
08:15 AM	3	143	146	4	3	7	110	2	112	265
08:30 AM	6	109	115	4	6	10	113	3	116	241
08:45 AM	6	132	138	3	7	10	113	0	113	261
Total	28	512	540	15	25	40	479	17	496	1076
Grand Total	58	1047	1105	22	34	56	938	27	965	2126
Apprch %	5.2	94.8		39.3	60.7		97.2	2.8		
Total %	2.7	49.2	52	1	1.6	2.6	44.1	1.3	45.4	

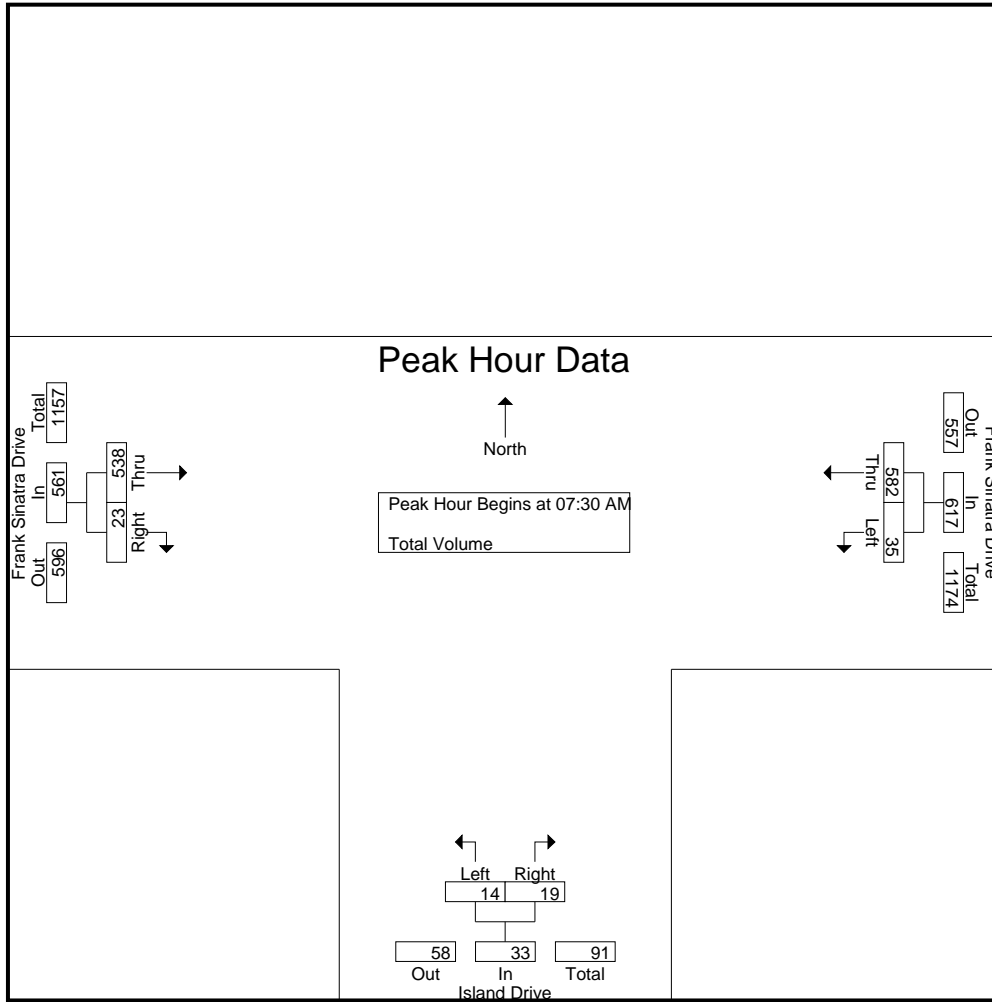
Start Time	Frank Sinatra Drive Westbound			Island Drive Northbound			Frank Sinatra Drive Eastbound			Int. Total
	Left	Thru	App. Total	Left	Right	App. Total	Thru	Right	App. Total	
07:30 AM	9	143	152	3	2	5	123	5	128	285
07:45 AM	10	<b>168</b>	<b>178</b>	3	5	8	<b>162</b>	4	<b>166</b>	<b>352</b>
08:00 AM	<b>13</b>	128	141	<b>4</b>	<b>9</b>	<b>13</b>	143	<b>12</b>	155	309
08:15 AM	3	143	146	4	3	7	110	2	112	265
Total Volume	35	582	617	14	19	33	538	23	561	1211
% App. Total	5.7	94.3		42.4	57.6		95.9	4.1		
PHF	.673	.866	.867	.875	.528	.635	.830	.479	.845	.860

Peak Hour Analysis From 07:00 AM to 08:45 AM - Peak 1 of 1  
 Peak Hour for Entire Intersection Begins at 07:30 AM



City of Rancho Mirage  
 N/S: Island Drive  
 E/W: Frank Sinatra Drive  
 Weather: Clear

File Name : 01\_RNM\_Island\_Frank AM  
 Site Code : 05122394  
 Start Date : 5/3/2022  
 Page No : 2



Peak Hour Analysis From 07:00 AM to 08:45 AM - Peak 1 of 1  
 Peak Hour for Each Approach Begins at:

	07:30 AM			08:00 AM			07:30 AM		
+0 mins.	9	143	152	4	9	13	123	5	128
+15 mins.	10	<b>168</b>	<b>178</b>	4	3	7	<b>162</b>	4	<b>166</b>
+30 mins.	<b>13</b>	128	141	4	6	10	143	<b>12</b>	155
+45 mins.	3	143	146	3	7	10	110	2	112
Total Volume	35	582	617	15	25	40	538	23	561
% App. Total	5.7	94.3		37.5	62.5		95.9	4.1	
PHF	.673	.866	.867	.938	.694	.769	.830	.479	.845

City of Rancho Mirage  
 N/S: Island Drive  
 E/W: Frank Sinatra Drive  
 Weather: Clear

File Name : 01\_RNM\_Island\_Frank PM  
 Site Code : 05122394  
 Start Date : 5/3/2022  
 Page No : 1

Groups Printed- Total Volume

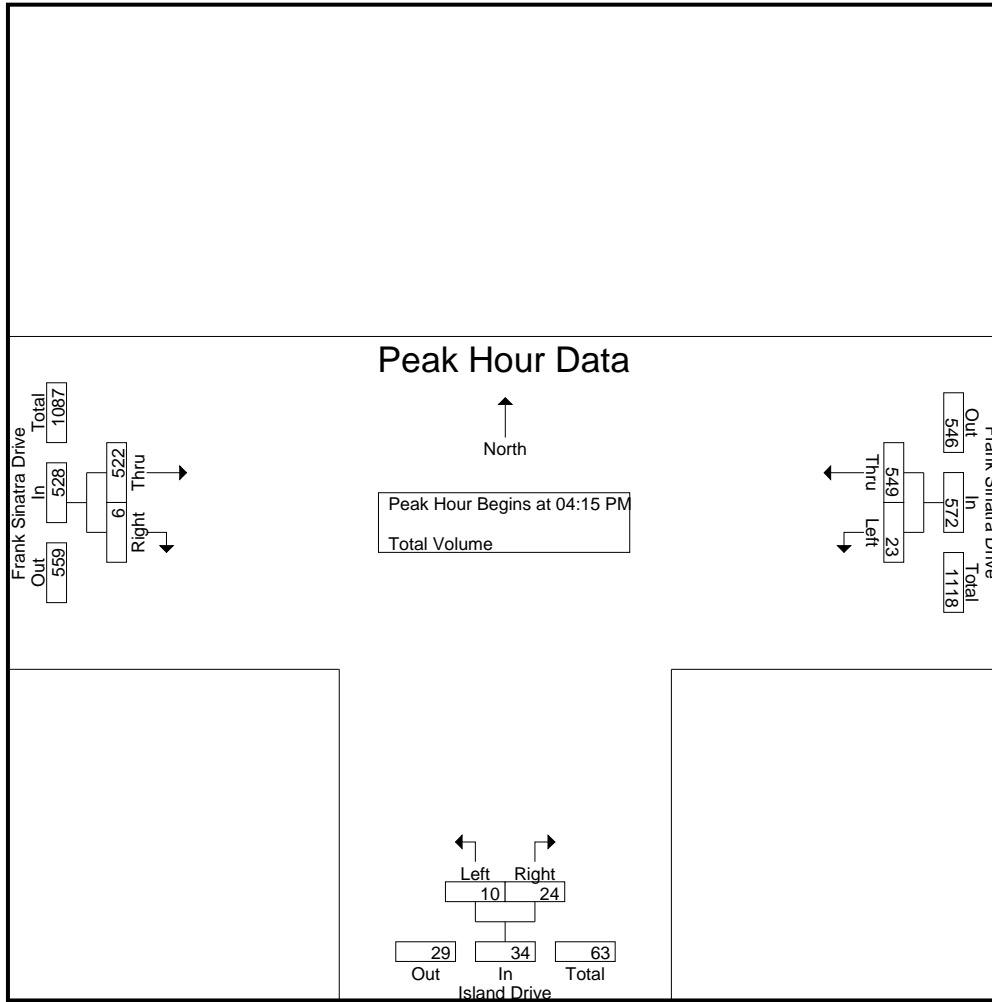
Start Time	Frank Sinatra Drive Westbound			Island Drive Northbound			Frank Sinatra Drive Eastbound			Int. Total
	Left	Thru	App. Total	Left	Right	App. Total	Thru	Right	App. Total	
04:00 PM	9	134	143	0	2	2	134	1	135	280
04:15 PM	11	135	146	1	6	7	140	1	141	294
04:30 PM	3	164	167	2	9	11	117	1	118	296
04:45 PM	5	132	137	5	2	7	114	2	116	260
Total	28	565	593	8	19	27	505	5	510	1130
05:00 PM	4	118	122	2	7	9	151	2	153	284
05:15 PM	6	121	127	0	1	1	116	1	117	245
05:30 PM	4	98	102	1	1	2	77	0	77	181
05:45 PM	2	72	74	3	3	6	108	1	109	189
Total	16	409	425	6	12	18	452	4	456	899
Grand Total	44	974	1018	14	31	45	957	9	966	2029
Apprch %	4.3	95.7		31.1	68.9		99.1	0.9		
Total %	2.2	48	50.2	0.7	1.5	2.2	47.2	0.4	47.6	

Start Time	Frank Sinatra Drive Westbound			Island Drive Northbound			Frank Sinatra Drive Eastbound			Int. Total
	Left	Thru	App. Total	Left	Right	App. Total	Thru	Right	App. Total	
04:15 PM	11	135	146	1	6	7	140	1	141	294
04:30 PM	3	164	167	2	9	11	117	1	118	296
04:45 PM	5	132	137	5	2	7	114	2	116	260
05:00 PM	4	118	122	2	7	9	151	2	153	284
Total Volume	23	549	572	10	24	34	522	6	528	1134
% App. Total	4	96		29.4	70.6		98.9	1.1		
PHF	.523	.837	.856	.500	.667	.773	.864	.750	.863	.958

Peak Hour Analysis From 04:00 PM to 05:45 PM - Peak 1 of 1  
 Peak Hour for Entire Intersection Begins at 04:15 PM

City of Rancho Mirage  
 N/S: Island Drive  
 E/W: Frank Sinatra Drive  
 Weather: Clear

File Name : 01\_RNM\_Island\_Frank PM  
 Site Code : 05122394  
 Start Date : 5/3/2022  
 Page No : 2



Peak Hour Analysis From 04:00 PM to 05:45 PM - Peak 1 of 1  
 Peak Hour for Each Approach Begins at:

	04:00 PM			04:15 PM			04:15 PM		
+0 mins.	9	134	143	1	6	7	140	1	141
+15 mins.	11	135	146	2	9	11	117	1	118
+30 mins.	3	164	167	5	2	7	114	2	116
+45 mins.	5	132	137	2	7	9	151	2	153
Total Volume	28	565	593	10	24	34	522	6	528
% App. Total	4.7	95.3		29.4	70.6		98.9	1.1	
PHF	.636	.861	.888	.500	.667	.773	.864	.750	.863

City of Rancho Mirage  
 N/S: Bob Hope Drive  
 E/W: Frank Sinatra Drive  
 Weather: Clear

File Name : 02\_RNM\_Bob\_Frank AM  
 Site Code : 05122394  
 Start Date : 5/3/2022  
 Page No : 1

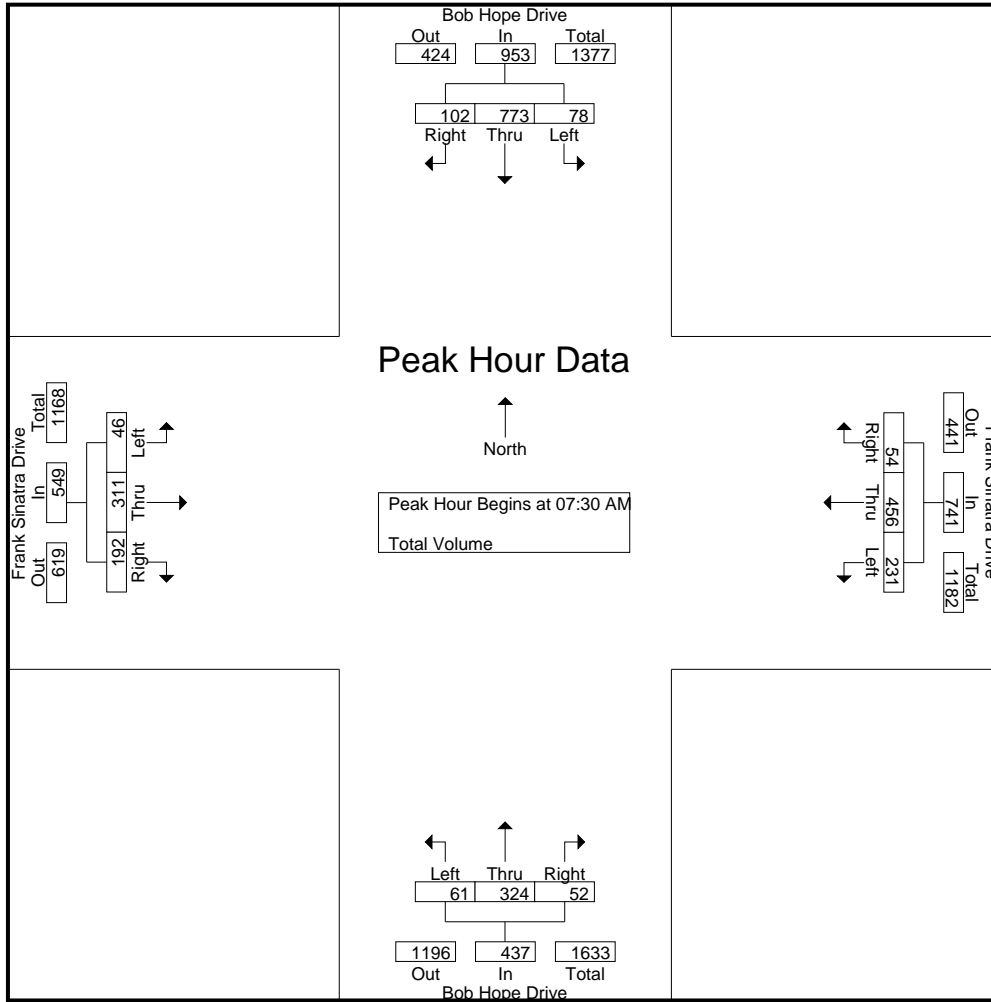
Groups Printed- Total Volume

Start Time	Bob Hope Drive Southbound				Frank Sinatra Drive Westbound				Bob Hope Drive Northbound				Frank Sinatra Drive Eastbound				Int. Total
	Left	Thru	Right	App. Total	Left	Thru	Right	App. Total	Left	Thru	Right	App. Total	Left	Thru	Right	App. Total	
07:00 AM	3	123	22	148	28	95	5	128	9	50	7	66	11	35	21	67	409
07:15 AM	10	156	12	178	31	88	13	132	8	55	12	75	5	58	39	102	487
07:30 AM	13	210	24	247	50	118	10	178	11	92	19	122	7	67	45	119	666
07:45 AM	23	227	28	278	78	137	18	233	21	78	11	110	8	91	68	167	788
Total	49	716	86	851	187	438	46	671	49	275	49	373	31	251	173	455	2350
08:00 AM	19	170	31	220	61	96	12	169	15	78	12	105	19	89	45	153	647
08:15 AM	23	166	19	208	42	105	14	161	14	76	10	100	12	64	34	110	579
08:30 AM	22	220	26	268	43	75	11	129	18	82	18	118	9	62	38	109	624
08:45 AM	19	170	18	207	32	81	11	124	32	98	19	149	13	72	46	131	611
Total	83	726	94	903	178	357	48	583	79	334	59	472	53	287	163	503	2461
Grand Total	132	1442	180	1754	365	795	94	1254	128	609	108	845	84	538	336	958	4811
Apprch %	7.5	82.2	10.3		29.1	63.4	7.5		15.1	72.1	12.8		8.8	56.2	35.1		
Total %	2.7	30	3.7	36.5	7.6	16.5	2	26.1	2.7	12.7	2.2	17.6	1.7	11.2	7	19.9	

Start Time	Bob Hope Drive Southbound				Frank Sinatra Drive Westbound				Bob Hope Drive Northbound				Frank Sinatra Drive Eastbound				Int. Total
	Left	Thru	Right	App. Total	Left	Thru	Right	App. Total	Left	Thru	Right	App. Total	Left	Thru	Right	App. Total	
Peak Hour Analysis From 07:00 AM to 08:45 AM - Peak 1 of 1																	
Peak Hour for Entire Intersection Begins at 07:30 AM																	
07:30 AM	13	210	24	247	50	118	10	178	11	<b>92</b>	<b>19</b>	<b>122</b>	7	67	45	119	666
07:45 AM	<b>23</b>	<b>227</b>	28	<b>278</b>	<b>78</b>	<b>137</b>	<b>18</b>	<b>233</b>	<b>21</b>	78	11	110	8	<b>91</b>	<b>68</b>	<b>167</b>	<b>788</b>
08:00 AM	19	170	<b>31</b>	220	61	96	12	169	15	78	12	105	<b>19</b>	89	45	153	647
08:15 AM	23	166	19	208	42	105	14	161	14	76	10	100	12	64	34	110	579
Total Volume	78	773	102	953	231	456	54	741	61	324	52	437	46	311	192	549	2680
% App. Total	8.2	81.1	10.7		31.2	61.5	7.3		14	74.1	11.9		8.4	56.6	35		
PHF	.848	.851	.823	.857	.740	.832	.750	.795	.726	.880	.684	.895	.605	.854	.706	.822	.850

City of Rancho Mirage  
 N/S: Bob Hope Drive  
 E/W: Frank Sinatra Drive  
 Weather: Clear

File Name : 02\_RNM\_Bob\_Frank AM  
 Site Code : 05122394  
 Start Date : 5/3/2022  
 Page No : 2



Peak Hour Analysis From 07:00 AM to 08:45 AM - Peak 1 of 1  
 Peak Hour for Each Approach Begins at:

	07:45 AM				07:30 AM				08:00 AM				07:30 AM			
+0 mins.	23	227	28	278	50	118	10	178	15	78	12	105	7	67	45	119
+15 mins.	19	170	31	220	78	137	18	233	14	76	10	100	8	91	68	167
+30 mins.	23	166	19	208	61	96	12	169	18	82	18	118	19	89	45	153
+45 mins.	22	220	26	268	42	105	14	161	32	98	19	149	12	64	34	110
Total Volume	87	783	104	974	231	456	54	741	79	334	59	472	46	311	192	549
% App. Total	8.9	80.4	10.7		31.2	61.5	7.3		16.7	70.8	12.5		8.4	56.6	35	
PHF	.946	.862	.839	.876	.740	.832	.750	.795	.617	.852	.776	.792	.605	.854	.706	.822

City of Rancho Mirage  
 N/S: Bob Hope Drive  
 E/W: Frank Sinatra Drive  
 Weather: Clear

File Name : 02\_RNM\_Bob\_Frank PM  
 Site Code : 05122394  
 Start Date : 5/3/2022  
 Page No : 1

Groups Printed- Total Volume

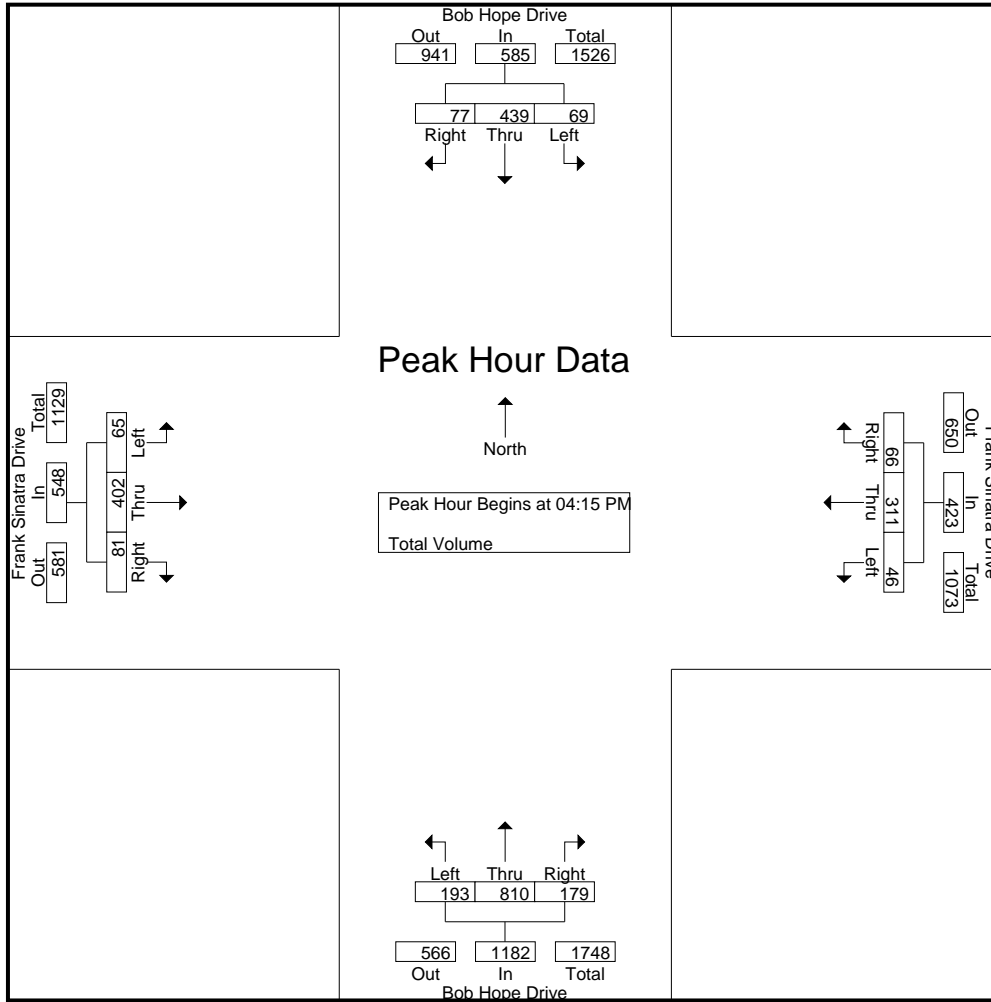
Start Time	Bob Hope Drive Southbound				Frank Sinatra Drive Westbound				Bob Hope Drive Northbound				Frank Sinatra Drive Eastbound				Int. Total
	Left	Thru	Right	App. Total	Left	Thru	Right	App. Total	Left	Thru	Right	App. Total	Left	Thru	Right	App. Total	
04:00 PM	27	119	15	161	11	81	21	113	56	198	27	281	19	81	32	132	687
04:15 PM	15	130	23	168	11	99	19	129	35	201	32	268	13	115	25	153	718
04:30 PM	20	95	17	132	11	78	15	104	55	210	55	320	22	85	17	124	680
04:45 PM	13	116	16	145	5	69	10	84	50	196	43	289	13	88	17	118	636
Total	75	460	71	606	38	327	65	430	196	805	157	1158	67	369	91	527	2721
05:00 PM	21	98	21	140	19	65	22	106	53	203	49	305	17	114	22	153	704
05:15 PM	18	116	10	144	16	72	9	97	37	190	32	259	17	86	17	120	620
05:30 PM	15	102	6	123	13	66	14	93	26	136	47	209	11	52	17	80	505
05:45 PM	12	104	10	126	13	47	9	69	18	136	21	175	13	70	21	104	474
Total	66	420	47	533	61	250	54	365	134	665	149	948	58	322	77	457	2303
Grand Total	141	880	118	1139	99	577	119	795	330	1470	306	2106	125	691	168	984	5024
Apprch %	12.4	77.3	10.4		12.5	72.6	15		15.7	69.8	14.5		12.7	70.2	17.1		
Total %	2.8	17.5	2.3	22.7	2	11.5	2.4	15.8	6.6	29.3	6.1	41.9	2.5	13.8	3.3	19.6	

Start Time	Bob Hope Drive Southbound				Frank Sinatra Drive Westbound				Bob Hope Drive Northbound				Frank Sinatra Drive Eastbound				Int. Total
	Left	Thru	Right	App. Total	Left	Thru	Right	App. Total	Left	Thru	Right	App. Total	Left	Thru	Right	App. Total	
04:15 PM	15	<b>130</b>	<b>23</b>	<b>168</b>	11	<b>99</b>	19	<b>129</b>	35	201	32	268	13	<b>115</b>	<b>25</b>	<b>153</b>	<b>718</b>
04:30 PM	20	95	17	132	11	78	15	104	<b>55</b>	<b>210</b>	<b>55</b>	<b>320</b>	<b>22</b>	85	17	124	680
04:45 PM	13	116	16	145	5	69	10	84	50	196	43	289	13	88	17	118	636
05:00 PM	<b>21</b>	98	21	140	<b>19</b>	65	<b>22</b>	106	53	203	49	305	17	114	22	153	704
Total Volume	69	439	77	585	46	311	66	423	193	810	179	1182	65	402	81	548	2738
% App. Total	11.8	75	13.2		10.9	73.5	15.6		16.3	68.5	15.1		11.9	73.4	14.8		
PHF	.821	.844	.837	.871	.605	.785	.750	.820	.877	.964	.814	.923	.739	.874	.810	.895	.953

Peak Hour Analysis From 04:00 PM to 05:45 PM - Peak 1 of 1  
 Peak Hour for Entire Intersection Begins at 04:15 PM

City of Rancho Mirage  
 N/S: Bob Hope Drive  
 E/W: Frank Sinatra Drive  
 Weather: Clear

File Name : 02\_RNM\_Bob\_Frank PM  
 Site Code : 05122394  
 Start Date : 5/3/2022  
 Page No : 2



Peak Hour Analysis From 04:00 PM to 05:45 PM - Peak 1 of 1  
 Peak Hour for Each Approach Begins at:

	04:00 PM				04:00 PM				04:15 PM				04:15 PM			
+0 mins.	27	119	15	161	11	81	21	113	35	201	32	268	13	115	25	153
+15 mins.	15	130	23	168	11	99	19	129	55	210	55	320	22	85	17	124
+30 mins.	20	95	17	132	11	78	15	104	50	196	43	289	13	88	17	118
+45 mins.	13	116	16	145	5	69	10	84	53	203	49	305	17	114	22	153
Total Volume	75	460	71	606	38	327	65	430	193	810	179	1182	65	402	81	548
% App. Total	12.4	75.9	11.7		8.8	76	15.1		16.3	68.5	15.1		11.9	73.4	14.8	
PHF	.694	.885	.772	.902	.864	.826	.774	.833	.877	.964	.814	.923	.739	.874	.810	.895

# Counts Unlimited, Inc.

City of Rancho Mirage  
 Frank Sinatra Drive  
 E/ Island Drive  
 24 Hour Directional Volume Count

PO Box 1178  
 Corona, CA 92878  
 Phone: (951) 268-6268  
 email: counts@countsunlimited.com

RNM003  
 Site Code: 051-22394

Start Time	03-May-22 Tue	Eastbound		Hour Totals		Westbound		Hour Totals		Combined Totals	
		Morning	Afternoon	Morning	Afternoon	Morning	Afternoon	Morning	Afternoon	Morning	Afternoon
12:00		4	139			5	114				
12:15		6	108			3	95				
12:30		3	129			3	126				
12:45		1	126	14	502	8	100	19	435	33	937
01:00		10	128			7	87				
01:15		4	131			1	102				
01:30		4	129			2	100				
01:45		4	130	22	518	3	125	13	414	35	932
02:00		0	131			1	122				
02:15		1	117			2	118				
02:30		3	143			5	124				
02:45		2	137	6	528	1	135	9	499	15	1027
03:00		1	147			1	134				
03:15		0	156			2	148				
03:30		3	140			1	139				
03:45		3	162	7	605	4	113	8	534	15	1139
04:00		1	136			5	143				
04:15		6	146			7	146				
04:30		8	126			15	167				
04:45		21	116	36	524	18	137	45	593	81	1117
05:00		17	158			18	122				
05:15		14	117			23	127				
05:30		18	78			44	102				
05:45		29	111	78	464	51	74	136	425	214	889
06:00		41	85			24	82				
06:15		54	102			53	73				
06:30		70	72			77	65				
06:45		82	59	247	318	121	72	275	292	522	610
07:00		66	53			117	41				
07:15		110	42			118	62				
07:30		125	48			152	55				
07:45		167	41	468	184	178	45	565	203	1033	387
08:00		152	40			141	42				
08:15		113	39			146	33				
08:30		129	37			115	29				
08:45		120	32	514	148	138	37	540	141	1054	289
09:00		122	26			124	31				
09:15		99	39			122	30				
09:30		128	16			116	36				
09:45		124	23	473	104	149	30	511	127	984	231
10:00		111	35			118	27				
10:15		129	20			125	29				
10:30		100	22			108	12				
10:45		120	12	460	89	122	23	473	91	933	180
11:00		111	22			111	15				
11:15		110	15			123	7				
11:30		136	10			125	12				
11:45		112	8	469	55	133	5	492	39	961	94
<b>Total</b>		<b>2794</b>	<b>4039</b>	<b>2794</b>	<b>4039</b>	<b>3086</b>	<b>3793</b>	<b>3086</b>	<b>3793</b>	<b>5880</b>	<b>7832</b>
<b>Combined Total</b>		<b>6833</b>		<b>6833</b>		<b>6879</b>		<b>6879</b>		<b>13712</b>	
AM Peak	-	07:45	-	-	-	07:30	-	-	-	-	-
Vol.	-	561	-	-	-	617	-	-	-	-	-
P.H.F.	-	0.840				0.867					
PM Peak	-	-	03:00	-	-	-	04:00	-	-	-	-
Vol.	-	-	605	-	-	-	593	-	-	-	-
P.H.F.	-	-	0.934				0.888				
Percentage		40.9%	59.1%			44.9%	55.1%				
ADT/AADT		ADT 13,712	AADT 13,712								



# Counts Unlimited, Inc.

City of Rancho Mirage  
 Frank Sinatra Drive  
 W/ Island Drive  
 24 Hour Directional Volume Count

PO Box 1178  
 Corona, CA 92878  
 Phone: (951) 268-6268  
 email: counts@countsunlimited.com

RNM002  
 Site Code: 051-22394

Start Time	03-May-22 Tue	Eastbound		Hour Totals		Westbound		Hour Totals		Combined Totals	
		Morning	Afternoon	Morning	Afternoon	Morning	Afternoon	Morning	Afternoon	Morning	Afternoon
12:00		4	137			5	110				
12:15		6	103			3	93				
12:30		3	123			3	116				
12:45		1	115	14	478	8	94	19	413	33	891
01:00		10	119			6	85				
01:15		4	124			1	92				
01:30		4	128			2	98				
01:45		4	127	22	498	3	121	12	396	34	894
02:00		0	122			1	121				
02:15		1	110			2	114				
02:30		3	140			4	118				
02:45		2	125	6	497	1	136	8	489	14	986
03:00		1	<b>142</b>			1	134				
03:15		0	<b>144</b>			2	150				
03:30		3	<b>135</b>			1	133				
03:45		3	<b>152</b>	7	573	4	112	8	529	15	1102
04:00		1	135			5	<b>134</b>				
04:15		6	141			7	<b>136</b>				
04:30		8	118			14	<b>166</b>				
04:45		21	116	36	510	19	<b>137</b>	45	573	81	1083
05:00		17	153			14	120				
05:15		14	117			21	121				
05:30		19	77			43	99				
05:45		29	109	79	456	48	75	126	415	205	871
06:00		41	81			23	79				
06:15		53	104			51	69				
06:30		70	67			73	64				
06:45		79	58	243	310	112	70	259	282	502	592
07:00		66	52			115	40				
07:15		109	42			110	60				
07:30		<b>128</b>	47			<b>146</b>	52				
07:45		<b>166</b>	40	469	181	<b>171</b>	43	542	195	1011	376
08:00		<b>155</b>	38			<b>132</b>	39				
08:15		<b>112</b>	39			<b>147</b>	33				
08:30		126	40			113	27				
08:45		113	31	506	148	135	35	527	134	1033	282
09:00		114	26			118	26				
09:15		95	39			118	29				
09:30		126	16			113	37				
09:45		120	23	455	104	142	29	491	121	946	225
10:00		109	36			116	28				
10:15		126	19			120	29				
10:30		91	22			104	12				
10:45		123	12	449	89	117	24	457	93	906	182
11:00		107	22			106	15				
11:15		100	15			125	7				
11:30		127	10			123	12				
11:45		109	8	443	55	123	5	477	39	920	94
<b>Total</b>		2729	3899	2729	3899	2971	3679	2971	3679	5700	7578
<b>Combined Total</b>		6628		6628		6650		6650		13278	
AM Peak	-	07:30	-	-	-	07:30	-	-	-	-	-
Vol.	-	561	-	-	-	596	-	-	-	-	-
P.H.F.	-	0.845	-	-	-	0.871	-	-	-	-	-
PM Peak	-	-	03:00	-	-	-	04:00	-	-	-	-
Vol.	-	-	573	-	-	-	573	-	-	-	-
P.H.F.	-	-	0.942	-	-	-	0.863	-	-	-	-
Percentage		41.2%	58.8%			44.7%	55.3%				
ADT/AADT		ADT 13,278		AADT 13,278							

# Counts Unlimited, Inc.

City of Rancho Mirage  
 Island Drive  
 S/ Frank Sinatra Drive  
 24 Hour Directional Volume Count

PO Box 1178  
 Corona, CA 92878  
 Phone: (951) 268-6268  
 email: counts@countsunlimited.com

RNM001  
 Site Code: 051-22394

Start Time	03-May-22 Tue	Northbound		Hour Totals		Southbound		Hour Totals		Combined Totals	
		Morning	Afternoon	Morning	Afternoon	Morning	Afternoon	Morning	Afternoon	Morning	Afternoon
12:00		0	10			0	11				
12:15		0	21			0	18				
12:30		0	12			0	15				
12:45		0	14	0	57	0	9	0	53	0	110
01:00		0	12			1	5				
01:15		0	11			0	14				
01:30		0	6			0	7				
01:45		0	3	0	32	0	4	1	30	1	62
02:00		0	15			0	7				
02:15		0	9			0	6				
02:30		0	10			1	13				
02:45		0	17	0	51	0	4	1	30	1	81
03:00		0	9			0	4				
03:15		0	20			0	6				
03:30		0	11			0	12				
03:45		0	18	0	58	0	8	0	30	0	88
04:00		0	2			0	10				
04:15		0	7			0	12				
04:30		0	11			1	4				
04:45		1	7	1	27	0	7	1	33	2	60
05:00		0	9			3	6				
05:15		0	1			2	7				
05:30		0	2			2	4				
05:45		1	6	1	18	4	3	11	20	12	38
06:00		1	6			2	5				
06:15		4	2			5	8				
06:30		1	7			5	3				
06:45		4	1	10	16	10	2	22	18	32	34
07:00		2	1			4	1				
07:15		1	4			8	6				
07:30		5	1			14	3				
07:45		8	1	16	7	14	2	40	12	56	19
08:00		13	3			25	4				
08:15		7	3			5	3				
08:30		10	0			9	5				
08:45		10	2	40	8	6	3	45	15	85	23
09:00		11	1			9	6				
09:15		8	1			8	2				
09:30		10	2			11	1				
09:45		8	0	37	4	10	1	38	10	75	14
10:00		10	1			10	1				
10:15		8	1			10	0				
10:30		11	0			6	0				
10:45		7	1	36	3	15	0	41	1	77	4
11:00		8	0			9	0				
11:15		16	0			4	0				
11:30		19	0			12	0				
11:45		11	0	54	0	18	0	43	0	97	0
<b>Total</b>		<b>195</b>	<b>281</b>	<b>195</b>	<b>281</b>	<b>243</b>	<b>252</b>	<b>243</b>	<b>252</b>	<b>438</b>	<b>533</b>
<b>Combined Total</b>		<b>476</b>		<b>476</b>		<b>495</b>		<b>495</b>		<b>971</b>	
AM Peak	-	11:00	-	-	-	07:15	-	-	-	-	-
Vol.	-	54	-	-	-	61	-	-	-	-	-
P.H.F.	-	0.711	-	-	-	0.610	-	-	-	-	-
PM Peak	-	-	00:15	-	-	-	12:00	-	-	-	-
Vol.	-	-	59	-	-	-	53	-	-	-	-
P.H.F.	-	-	0.702	-	-	-	0.736	-	-	-	-
Percentage		41.0%	59.0%			49.1%	50.9%				
ADT/AADT		ADT 971		AADT 971							

This page intentionally left blank

**APPENDIX 3.2: EXISTING (2022) CONDITIONS INTERSECTION  
OPERATIONS ANALYSIS WORKSHEETS**

This Page Intentionally Left Blank

Lanes, Volumes, Timings  
 1: Island Dr. & Frank Sinatra Dr.

Existing (2022) AM Peak Hour

	→	↘	↙	←	↖	↗
Lane Group	EBT	EBR	WBL	WBT	NBL	NBR
Lane Configurations	↑↑		↘	↑↑	↘	↗
Traffic Volume (vph)	538	23	35	584	14	19
Future Volume (vph)	538	23	35	584	14	19
Ideal Flow (vphpl)	1900	1900	1900	1900	1900	1900
Storage Length (ft)		0	90		30	0
Storage Lanes		0	1		1	1
Taper Length (ft)			90		90	
Link Speed (mph)	50			50	30	
Link Distance (ft)	1498			1234	212	
Travel Time (s)	20.4			16.8	4.8	
Peak Hour Factor	0.86	0.86	0.86	0.86	0.86	0.86
Shared Lane Traffic (%)						
Sign Control	Free			Free	Stop	
<b>Intersection Summary</b>						
Area Type:	Other					
Control Type:	Unsignalized					

Intersection						
Int Delay, s/veh	0.7					
Movement	EBT	EBR	WBL	WBT	NBL	NBR
Lane Configurations	↑↑		↘	↑↑	↘	↘
Traffic Vol, veh/h	538	23	35	584	14	19
Future Vol, veh/h	538	23	35	584	14	19
Conflicting Peds, #/hr	0	0	0	0	0	0
Sign Control	Free	Free	Free	Free	Stop	Stop
RT Channelized	-	None	-	None	-	None
Storage Length	-	-	90	-	30	0
Veh in Median Storage, #	0	-	-	0	0	-
Grade, %	0	-	-	0	0	-
Peak Hour Factor	86	86	86	86	86	86
Heavy Vehicles, %	2	2	2	2	2	2
Mvmt Flow	626	27	41	679	16	22

Major/Minor	Major1	Major2	Minor1	Minor2	Minor3
Conflicting Flow All	0	0	653	0	1062
Stage 1	-	-	-	-	640
Stage 2	-	-	-	-	422
Critical Hdwy	-	-	4.14	-	6.84
Critical Hdwy Stg 1	-	-	-	-	5.84
Critical Hdwy Stg 2	-	-	-	-	5.84
Follow-up Hdwy	-	-	2.22	-	3.52
Pot Cap-1 Maneuver	-	-	930	-	219
Stage 1	-	-	-	-	487
Stage 2	-	-	-	-	629
Platoon blocked, %	-	-	-	-	-
Mov Cap-1 Maneuver	-	-	930	-	209
Mov Cap-2 Maneuver	-	-	-	-	209
Stage 1	-	-	-	-	487
Stage 2	-	-	-	-	601

Approach	EB	WB	NB
HCM Control Delay, s	0	0.5	16.2
HCM LOS			C

Minor Lane/Major Mvmt	NBLn1	NBLn2	EBT	EBR	WBL	WBT
Capacity (veh/h)	209	669	-	-	930	-
HCM Lane V/C Ratio	0.078	0.033	-	-	0.044	-
HCM Control Delay (s)	23.7	10.6	-	-	9	-
HCM Lane LOS	C	B	-	-	A	-
HCM 95th %tile Q(veh)	0.3	0.1	-	-	0.1	-

Lanes, Volumes, Timings  
2: Bob Hope Dr. & Frank Sinatra Dr.

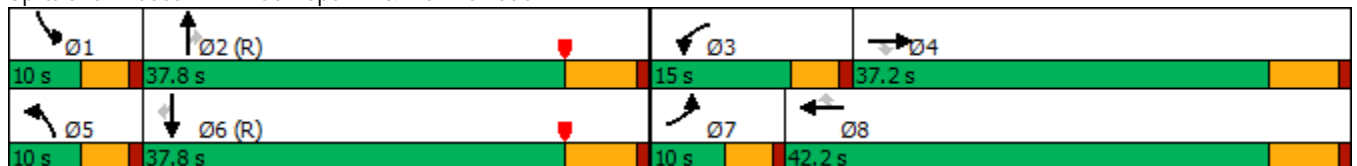
Existing (2022) AM Peak Hour

Lane Group	EBL	EBT	EBR	WBL	WBT	WBR	NBL	NBT	NBR	SBL	SBT	SBR
Lane Configurations												
Traffic Volume (vph)	46	319	192	231	456	54	61	324	52	78	773	102
Future Volume (vph)	46	319	192	231	456	54	61	324	52	78	773	102
Ideal Flow (vphpl)	1900	1900	1900	1900	1900	1900	1900	1900	1900	1900	1900	1900
Storage Length (ft)	275		50	125		205	330		150	325		150
Storage Lanes	2		1	2		1	2		1	2		1
Taper Length (ft)	180			140			160			160		
Right Turn on Red			Yes			Yes			Yes			Yes
Link Speed (mph)		50			50			50			55	
Link Distance (ft)		1234			2356			976			711	
Travel Time (s)		16.8			32.1			13.3			8.8	
Confl. Bikes (#/hr)			7						2			1
Peak Hour Factor	0.85	0.85	0.85	0.85	0.85	0.85	0.85	0.85	0.85	0.85	0.85	0.85
Shared Lane Traffic (%)												
Turn Type	Prot	NA	Perm	Prot	NA	Perm	Prot	NA	Perm	Prot	NA	Perm
Protected Phases	7	4		3	8		5	2		1	6	
Permitted Phases			4			8			2			6
Detector Phase	7	4	4	3	8	8	5	2	2	1	6	6
Switch Phase												
Minimum Initial (s)	5.0	10.0	10.0	5.0	10.0	10.0	5.0	10.0	10.0	5.0	10.0	10.0
Minimum Split (s)	10.0	37.2	37.2	10.0	40.2	40.2	10.0	37.5	37.5	10.0	33.5	33.5
Total Split (s)	10.0	37.2	37.2	15.0	42.2	42.2	10.0	37.8	37.8	10.0	37.8	37.8
Total Split (%)	10.0%	37.2%	37.2%	15.0%	42.2%	42.2%	10.0%	37.8%	37.8%	10.0%	37.8%	37.8%
Yellow Time (s)	3.6	5.2	5.2	3.6	5.2	5.2	3.6	5.5	5.5	3.6	5.5	5.5
All-Red Time (s)	1.0	1.0	1.0	1.0	1.0	1.0	1.0	1.0	1.0	1.0	1.0	1.0
Lost Time Adjust (s)	0.0	0.0	0.0	0.0	0.0	0.0	0.0	0.0	0.0	0.0	0.0	0.0
Total Lost Time (s)	4.6	6.2	6.2	4.6	6.2	6.2	4.6	6.5	6.5	4.6	6.5	6.5
Lead/Lag	Lead	Lag	Lag	Lead	Lag	Lag	Lead	Lag	Lag	Lead	Lag	Lag
Lead-Lag Optimize?	Yes	Yes	Yes	Yes	Yes	Yes	Yes	Yes	Yes	Yes	Yes	Yes
Recall Mode	None	None	None	None	None	None	None	C-Max	C-Max	None	C-Max	C-Max

Intersection Summary

Area Type: Other  
 Cycle Length: 100  
 Actuated Cycle Length: 100  
 Offset: 0 (0%), Referenced to phase 2:NBT and 6:SBT, Start of Yellow, Master Intersection  
 Natural Cycle: 100  
 Control Type: Actuated-Coordinated

























Splits and Phases: 2: Bob Hope Dr. & Frank Sinatra Dr.





HCM 6th Signalized Intersection Summary  
2: Bob Hope Dr. & Frank Sinatra Dr.

Existing (2022) AM Peak Hour

												
Movement	EBL	EBT	EBR	WBL	WBT	WBR	NBL	NBT	NBR	SBL	SBT	SBR
Lane Configurations												
Traffic Volume (veh/h)	46	319	192	231	456	54	61	324	52	78	773	102
Future Volume (veh/h)	46	319	192	231	456	54	61	324	52	78	773	102
Initial Q (Qb), veh	0	0	0	0	0	0	0	0	0	0	0	0
Ped-Bike Adj(A_pbT)	1.00		0.98	1.00		1.00	1.00		0.99	1.00		0.99
Parking Bus, Adj	1.00	1.00	1.00	1.00	1.00	1.00	1.00	1.00	1.00	1.00	1.00	1.00
Work Zone On Approach		No			No			No			No	
Adj Sat Flow, veh/h/ln	1870	1870	1870	1870	1870	1870	1870	1870	1870	1870	1870	1870
Adj Flow Rate, veh/h	54	375	226	272	536	64	72	381	61	92	909	120
Peak Hour Factor	0.85	0.85	0.85	0.85	0.85	0.85	0.85	0.85	0.85	0.85	0.85	0.85
Percent Heavy Veh, %	2	2	2	2	2	2	2	2	2	2	2	2
Cap, veh/h	134	655	286	337	864	385	149	1610	709	159	1620	714
Arrive On Green	0.04	0.18	0.18	0.10	0.24	0.24	0.04	0.45	0.45	0.05	0.46	0.46
Sat Flow, veh/h	3456	3554	1553	3456	3554	1585	3456	3554	1564	3456	3554	1565
Grp Volume(v), veh/h	54	375	226	272	536	64	72	381	61	92	909	120
Grp Sat Flow(s),veh/h/ln	1728	1777	1553	1728	1777	1585	1728	1777	1564	1728	1777	1565
Q Serve(g_s), s	1.5	9.6	13.9	7.7	13.4	3.2	2.0	6.6	2.2	2.6	18.7	4.5
Cycle Q Clear(g_c), s	1.5	9.6	13.9	7.7	13.4	3.2	2.0	6.6	2.2	2.6	18.7	4.5
Prop In Lane	1.00		1.00	1.00		1.00	1.00		1.00	1.00		1.00
Lane Grp Cap(c), veh/h	134	655	286	337	864	385	149	1610	709	159	1620	714
V/C Ratio(X)	0.40	0.57	0.79	0.81	0.62	0.17	0.48	0.24	0.09	0.58	0.56	0.17
Avail Cap(c_a), veh/h	187	1102	481	359	1279	571	187	1610	709	187	1620	714
HCM Platoon Ratio	1.00	1.00	1.00	1.00	1.00	1.00	1.00	1.00	1.00	1.00	1.00	1.00
Upstream Filter(I)	1.00	1.00	1.00	1.00	1.00	1.00	1.00	1.00	1.00	1.00	1.00	1.00
Uniform Delay (d), s/veh	46.9	37.2	38.9	44.2	33.7	29.9	46.7	16.8	15.6	46.7	19.9	16.0
Incr Delay (d2), s/veh	0.7	0.8	4.8	11.0	0.7	0.2	0.9	0.3	0.2	1.2	1.4	0.5
Initial Q Delay(d3),s/veh	0.0	0.0	0.0	0.0	0.0	0.0	0.0	0.0	0.0	0.0	0.0	0.0
%ile BackOfQ(50%),veh/ln	0.6	4.0	5.4	3.7	5.5	1.2	0.9	2.5	0.8	1.1	7.1	1.6
Unsig. Movement Delay, s/veh												
LnGrp Delay(d),s/veh	47.6	38.0	43.8	55.2	34.5	30.1	47.6	17.1	15.8	48.0	21.3	16.5
LnGrp LOS	D	D	D	E	C	C	D	B	B	D	C	B
Approach Vol, veh/h		655			872			514			1121	
Approach Delay, s/veh		40.8			40.6			21.2			23.0	
Approach LOS		D			D			C			C	
Timer - Assigned Phs	1	2	3	4	5	6	7	8				
Phs Duration (G+Y+Rc), s	9.2	51.8	14.3	24.6	8.9	52.1	8.5	30.5				
Change Period (Y+Rc), s	4.6	6.5	4.6	6.2	4.6	6.5	4.6	6.2				
Max Green Setting (Gmax), s	5.4	31.3	10.4	31.0	5.4	31.3	5.4	36.0				
Max Q Clear Time (g_c+I1), s	4.6	8.6	9.7	15.9	4.0	20.7	3.5	15.4				
Green Ext Time (p_c), s	0.0	2.3	0.0	2.5	0.0	4.3	0.0	3.3				
<b>Intersection Summary</b>												
HCM 6th Ctrl Delay				31.2								
HCM 6th LOS				C								

Lanes, Volumes, Timings  
 1: Island Dr. & Frank Sinatra Dr.

Existing (2022) PM Peak Hour

	→	↘	↙	←	↖	↗
Lane Group	EBT	EBR	WBL	WBT	NBL	NBR
Lane Configurations	↑↑		↘	↑↑	↘	↗
Traffic Volume (vph)	524	6	23	558	10	24
Future Volume (vph)	524	6	23	558	10	24
Ideal Flow (vphpl)	1900	1900	1900	1900	1900	1900
Storage Length (ft)		0	90		30	0
Storage Lanes		0	1		1	1
Taper Length (ft)			90		90	
Link Speed (mph)	50			50	30	
Link Distance (ft)	1498			1234	212	
Travel Time (s)	20.4			16.8	4.8	
Peak Hour Factor	0.96	0.96	0.96	0.96	0.96	0.96
Shared Lane Traffic (%)						
Sign Control	Free			Free	Stop	
<b>Intersection Summary</b>						
Area Type:	Other					
Control Type:	Unsignalized					

Intersection						
Int Delay, s/veh	0.5					
Movement	EBT	EBR	WBL	WBT	NBL	NBR
Lane Configurations	↑↑		↘	↑↑	↘	↘
Traffic Vol, veh/h	524	6	23	558	10	24
Future Vol, veh/h	524	6	23	558	10	24
Conflicting Peds, #/hr	0	0	0	0	0	0
Sign Control	Free	Free	Free	Free	Stop	Stop
RT Channelized	-	None	-	None	-	None
Storage Length	-	-	90	-	30	0
Veh in Median Storage, #	0	-	-	0	0	-
Grade, %	0	-	-	0	0	-
Peak Hour Factor	96	96	96	96	96	96
Heavy Vehicles, %	2	2	2	2	2	2
Mvmt Flow	546	6	24	581	10	25

Major/Minor	Major1	Major2	Minor1		
Conflicting Flow All	0	0	552	0	888 276
Stage 1	-	-	-	-	549 -
Stage 2	-	-	-	-	339 -
Critical Hdwy	-	-	4.14	-	6.84 6.94
Critical Hdwy Stg 1	-	-	-	-	5.84 -
Critical Hdwy Stg 2	-	-	-	-	5.84 -
Follow-up Hdwy	-	-	2.22	-	3.52 3.32
Pot Cap-1 Maneuver	-	-	1014	-	283 721
Stage 1	-	-	-	-	542 -
Stage 2	-	-	-	-	693 -
Platoon blocked, %	-	-	-	-	-
Mov Cap-1 Maneuver	-	-	1014	-	276 721
Mov Cap-2 Maneuver	-	-	-	-	276 -
Stage 1	-	-	-	-	542 -
Stage 2	-	-	-	-	676 -

Approach	EB	WB	NB
HCM Control Delay, s	0	0.3	12.7
HCM LOS			B

Minor Lane/Major Mvmt	NBLn1	NBLn2	EBT	EBR	WBL	WBT
Capacity (veh/h)	276	721	-	-	1014	-
HCM Lane V/C Ratio	0.038	0.035	-	-	0.024	-
HCM Control Delay (s)	18.6	10.2	-	-	8.6	-
HCM Lane LOS	C	B	-	-	A	-
HCM 95th %tile Q(veh)	0.1	0.1	-	-	0.1	-

Lanes, Volumes, Timings  
2: Bob Hope Dr. & Frank Sinatra Dr.

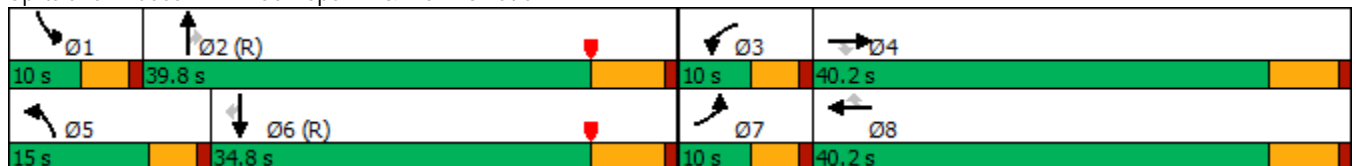
Existing (2022) PM Peak Hour

Lane Group	EBL	EBT	EBR	WBL	WBT	WBR	NBL	NBT	NBR	SBL	SBT	SBR
Lane Configurations												
Traffic Volume (vph)	65	402	81	46	311	66	193	810	179	69	439	77
Future Volume (vph)	65	402	81	46	311	66	193	810	179	69	439	77
Ideal Flow (vphpl)	1900	1900	1900	1900	1900	1900	1900	1900	1900	1900	1900	1900
Storage Length (ft)	275		50	125		205	330		150	325		150
Storage Lanes	2		1	2		1	2		1	2		1
Taper Length (ft)	180			140			160			160		
Right Turn on Red			Yes			Yes			Yes			Yes
Link Speed (mph)		50			50			50			55	
Link Distance (ft)		1234			2356			976			711	
Travel Time (s)		16.8			32.1			13.3			8.8	
Confl. Bikes (#/hr)			7						2			1
Peak Hour Factor	0.95	0.95	0.95	0.95	0.95	0.95	0.95	0.95	0.95	0.95	0.95	0.95
Shared Lane Traffic (%)												
Turn Type	Prot	NA	Perm	Prot	NA	Perm	Prot	NA	Perm	Prot	NA	Perm
Protected Phases	7	4		3	8		5	2		1	6	
Permitted Phases			4			8			2			6
Detector Phase	7	4	4	3	8	8	5	2	2	1	6	6
Switch Phase												
Minimum Initial (s)	5.0	10.0	10.0	5.0	10.0	10.0	5.0	10.0	10.0	5.0	10.0	10.0
Minimum Split (s)	10.0	37.2	37.2	10.0	40.2	40.2	10.0	37.5	37.5	10.0	33.5	33.5
Total Split (s)	10.0	40.2	40.2	10.0	40.2	40.2	15.0	39.8	39.8	10.0	34.8	34.8
Total Split (%)	10.0%	40.2%	40.2%	10.0%	40.2%	40.2%	15.0%	39.8%	39.8%	10.0%	34.8%	34.8%
Yellow Time (s)	3.6	5.2	5.2	3.6	5.2	5.2	3.6	5.5	5.5	3.6	5.5	5.5
All-Red Time (s)	1.0	1.0	1.0	1.0	1.0	1.0	1.0	1.0	1.0	1.0	1.0	1.0
Lost Time Adjust (s)	0.0	0.0	0.0	0.0	0.0	0.0	0.0	0.0	0.0	0.0	0.0	0.0
Total Lost Time (s)	4.6	6.2	6.2	4.6	6.2	6.2	4.6	6.5	6.5	4.6	6.5	6.5
Lead/Lag	Lead	Lag	Lag	Lead	Lag	Lag	Lead	Lag	Lag	Lead	Lag	Lag
Lead-Lag Optimize?	Yes	Yes	Yes	Yes	Yes	Yes	Yes	Yes	Yes	Yes	Yes	Yes
Recall Mode	None	None	None	None	None	None	None	C-Max	C-Max	None	C-Max	C-Max

Intersection Summary

























Area Type: Other  
 Cycle Length: 100  
 Actuated Cycle Length: 100  
 Offset: 0 (0%), Referenced to phase 2:NBT and 6:SBT, Start of Yellow, Master Intersection  
 Natural Cycle: 100  
 Control Type: Actuated-Coordinated

Splits and Phases: 2: Bob Hope Dr. & Frank Sinatra Dr.



HCM 6th Signalized Intersection Summary  
2: Bob Hope Dr. & Frank Sinatra Dr.

Existing (2022) PM Peak Hour

												
Movement	EBL	EBT	EBR	WBL	WBT	WBR	NBL	NBT	NBR	SBL	SBT	SBR
Lane Configurations												
Traffic Volume (veh/h)	65	402	81	46	311	66	193	810	179	69	439	77
Future Volume (veh/h)	65	402	81	46	311	66	193	810	179	69	439	77
Initial Q (Qb), veh	0	0	0	0	0	0	0	0	0	0	0	0
Ped-Bike Adj(A_pbT)	1.00		0.98	1.00		1.00	1.00		0.99	1.00		0.99
Parking Bus, Adj	1.00	1.00	1.00	1.00	1.00	1.00	1.00	1.00	1.00	1.00	1.00	1.00
Work Zone On Approach		No			No			No			No	
Adj Sat Flow, veh/h/ln	1870	1870	1870	1870	1870	1870	1870	1870	1870	1870	1870	1870
Adj Flow Rate, veh/h	68	423	85	48	327	69	203	853	188	73	462	81
Peak Hour Factor	0.95	0.95	0.95	0.95	0.95	0.95	0.95	0.95	0.95	0.95	0.95	0.95
Percent Heavy Veh, %	2	2	2	2	2	2	2	2	2	2	2	2
Cap, veh/h	147	567	248	127	547	244	270	1923	847	150	1800	793
Arrive On Green	0.04	0.16	0.16	0.04	0.15	0.15	0.08	0.54	0.54	0.04	0.51	0.51
Sat Flow, veh/h	3456	3554	1551	3456	3554	1585	3456	3554	1565	3456	3554	1565
Grp Volume(v), veh/h	68	423	85	48	327	69	203	853	188	73	462	81
Grp Sat Flow(s),veh/h/ln	1728	1777	1551	1728	1777	1585	1728	1777	1565	1728	1777	1565
Q Serve(g_s), s	1.9	11.4	4.9	1.4	8.6	3.9	5.8	14.5	6.3	2.1	7.4	2.7
Cycle Q Clear(g_c), s	1.9	11.4	4.9	1.4	8.6	3.9	5.8	14.5	6.3	2.1	7.4	2.7
Prop In Lane	1.00		1.00	1.00		1.00	1.00		1.00	1.00		1.00
Lane Grp Cap(c), veh/h	147	567	248	127	547	244	270	1923	847	150	1800	793
V/C Ratio(X)	0.46	0.75	0.34	0.38	0.60	0.28	0.75	0.44	0.22	0.49	0.26	0.10
Avail Cap(c_a), veh/h	187	1208	527	187	1208	539	359	1923	847	187	1800	793
HCM Platoon Ratio	1.00	1.00	1.00	1.00	1.00	1.00	1.00	1.00	1.00	1.00	1.00	1.00
Upstream Filter(I)	1.00	1.00	1.00	1.00	1.00	1.00	1.00	1.00	1.00	1.00	1.00	1.00
Uniform Delay (d), s/veh	46.8	40.1	37.4	47.0	39.4	37.4	45.1	13.9	12.0	46.7	14.0	12.8
Incr Delay (d2), s/veh	0.8	2.0	0.8	0.7	1.0	0.6	3.9	0.7	0.6	0.9	0.3	0.3
Initial Q Delay(d3),s/veh	0.0	0.0	0.0	0.0	0.0	0.0	0.0	0.0	0.0	0.0	0.0	0.0
%ile BackOfQ(50%),veh/ln	0.8	4.9	1.8	0.6	3.6	1.5	2.5	5.2	2.1	0.9	2.7	0.9
Unsig. Movement Delay, s/veh												
LnGrp Delay(d),s/veh	47.6	42.1	38.2	47.7	40.5	38.0	49.0	14.6	12.6	47.6	14.3	13.1
LnGrp LOS	D	D	D	D	D	D	D	B	B	D	B	B
Approach Vol, veh/h		576			444			1244			616	
Approach Delay, s/veh		42.1			40.9			19.9			18.1	
Approach LOS		D			D			B			B	
Timer - Assigned Phs	1	2	3	4	5	6	7	8				
Phs Duration (G+Y+Rc), s	8.9	60.6	8.3	22.2	12.4	57.1	8.8	21.6				
Change Period (Y+Rc), s	4.6	6.5	4.6	6.2	4.6	6.5	4.6	6.2				
Max Green Setting (Gmax), s	5.4	33.3	5.4	34.0	10.4	28.3	5.4	34.0				
Max Q Clear Time (g_c+I1), s	4.1	16.5	3.4	13.4	7.8	9.4	3.9	10.6				
Green Ext Time (p_c), s	0.0	5.5	0.0	2.6	0.1	2.7	0.0	2.0				
<b>Intersection Summary</b>												
HCM 6th Ctrl Delay				27.2								
HCM 6th LOS				C								

## **APPENDIX 3.3: TRAFFIC SIGNAL WARRANT ANALYSIS WORKSHEETS**

This Page Intentionally Left Blank

### Figure 4C-4. Warrant 3, Peak Hour (70% Factor)

(COMMUNITY LESS THAN 10,000 POPULATION OR ABOVE 64 km/h OR ABOVE 40 mph ON MAJOR STREET)

Traffic Conditions = **EXISTING (2022) AM PEAK HOUR WARRANTS**

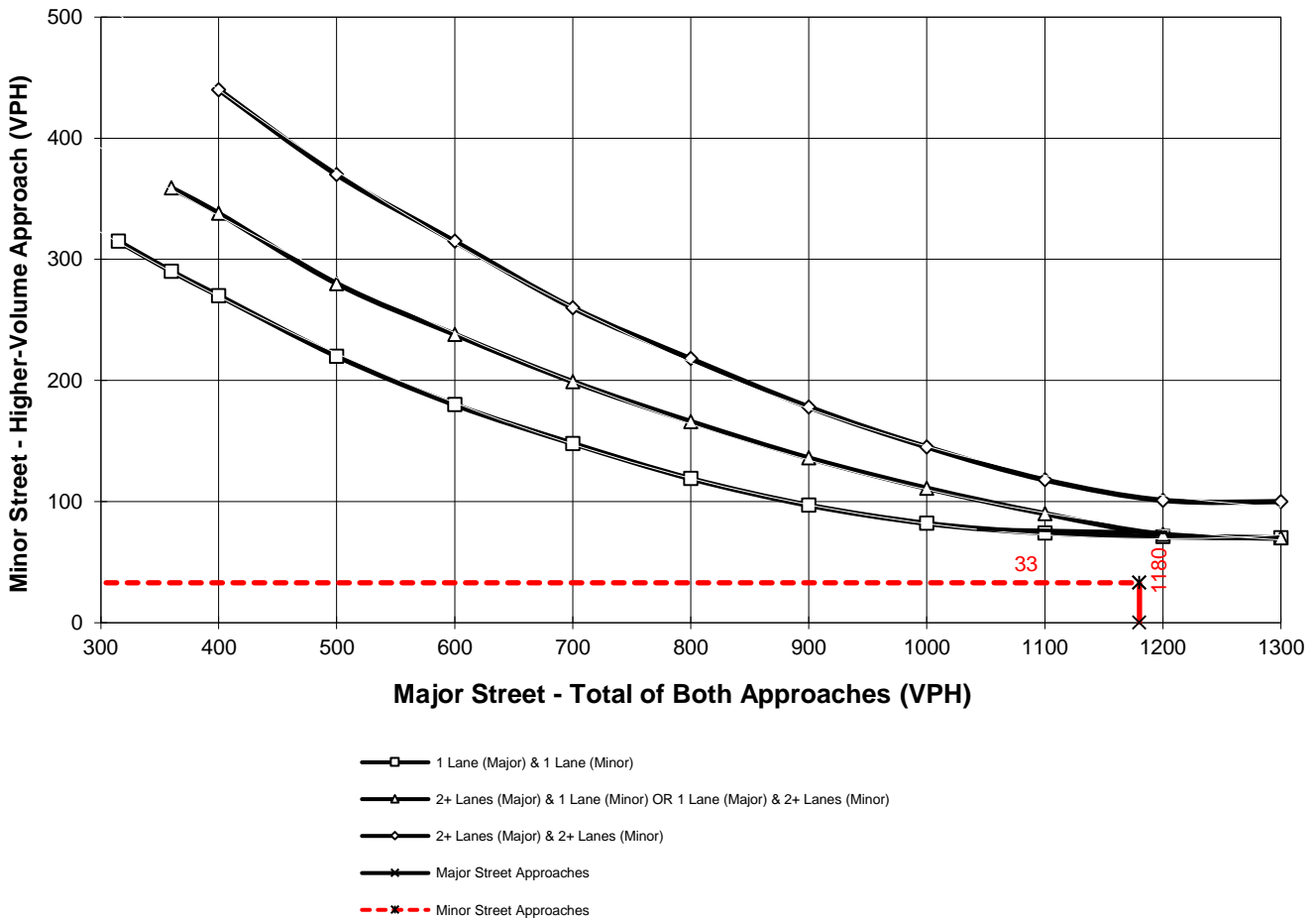
Major Street Name = **Frank Sinatra Dr.**

Total of Both Approaches (VPH) = **1,180**  
 Number of Approach Lanes Major Street = **2**

Minor Street Name = **Island Dr.**

High Volume Approach (VPH) = **33**  
 Number of Approach Lanes Minor Street = **1**

**SIGNAL WARRANT NOT SATISFIED**



\*Note: 100 vph applies as the lower threshold for a minor-street approach with two or more lanes and 75 vph applies as the lower threshold for a minor-street approach with one lane

Intersection ID: #1



**Figure 4C-4. Warrant 3, Peak Hour (70% Factor)**

(COMMUNITY LESS THAN 10,000 POPULATION OR ABOVE 64 km/h OR ABOVE 40 mph ON MAJOR STREET)

Traffic Conditions = **EXISTING (2022) PM PEAK HOUR WARRANTS**

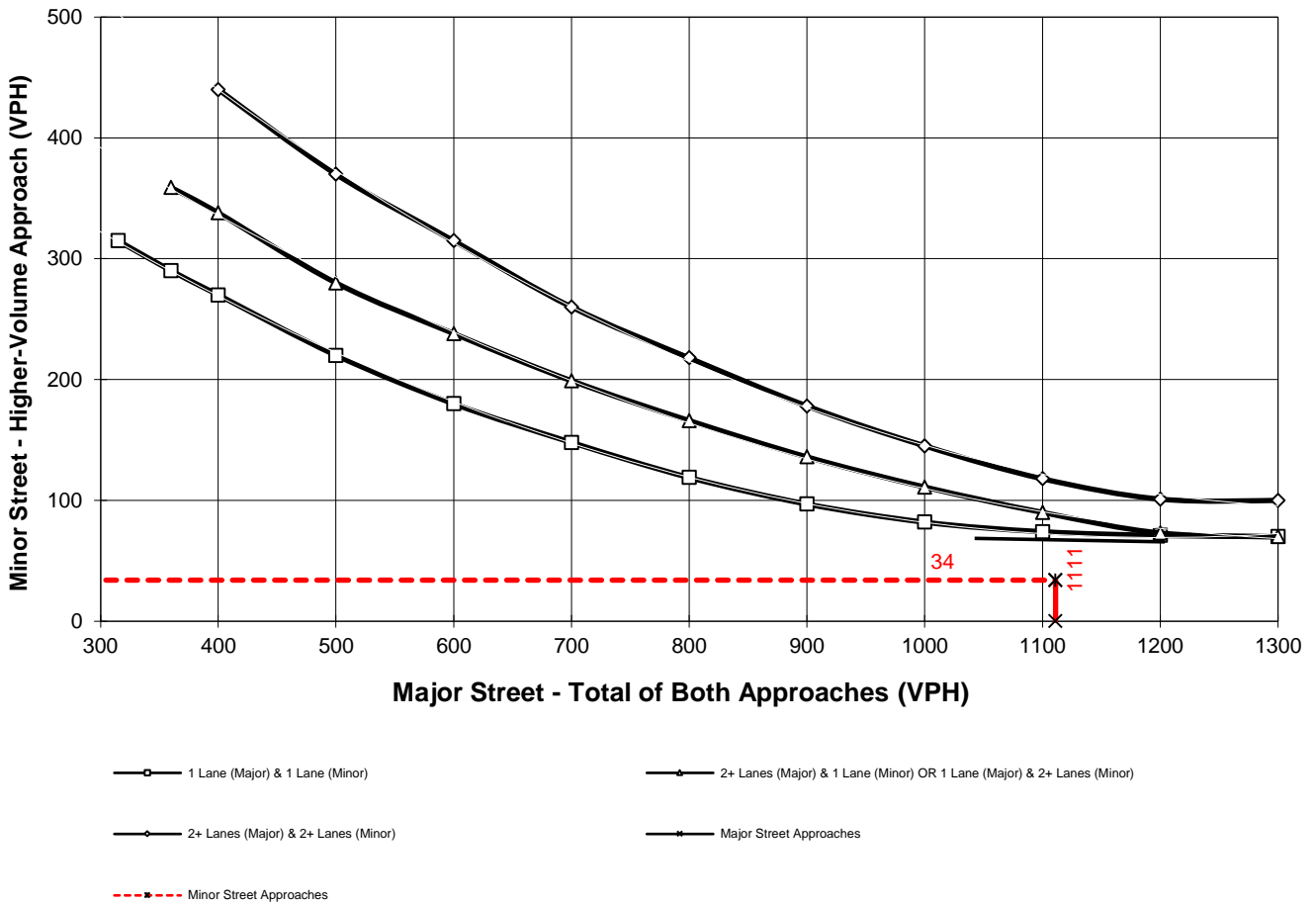
Major Street Name = **Frank Sinatra Dr.**

Total of Both Approaches (VPH) = **1,111**  
 Number of Approach Lanes Major Street = **2**

Minor Street Name = **Island Dr.**

High Volume Approach (VPH) = **34**  
 Number of Approach Lanes Minor Street = **1**

**SIGNAL WARRANT NOT SATISFIED**



\*Note: 100 vph applies as the lower threshold for a minor-street approach with two or more lanes and 75 vph applies as the lower threshold for a minor-street approach with one lane

Intersection ID: #1

### Figure 4C-4. Warrant 3, Peak Hour (70% Factor)

(COMMUNITY LESS THAN 10,000 POPULATION OR ABOVE 64 km/h OR ABOVE 40 mph ON MAJOR STREET)

Traffic Conditions = **E+A+P AM PEAK HOUR WARRANTS**

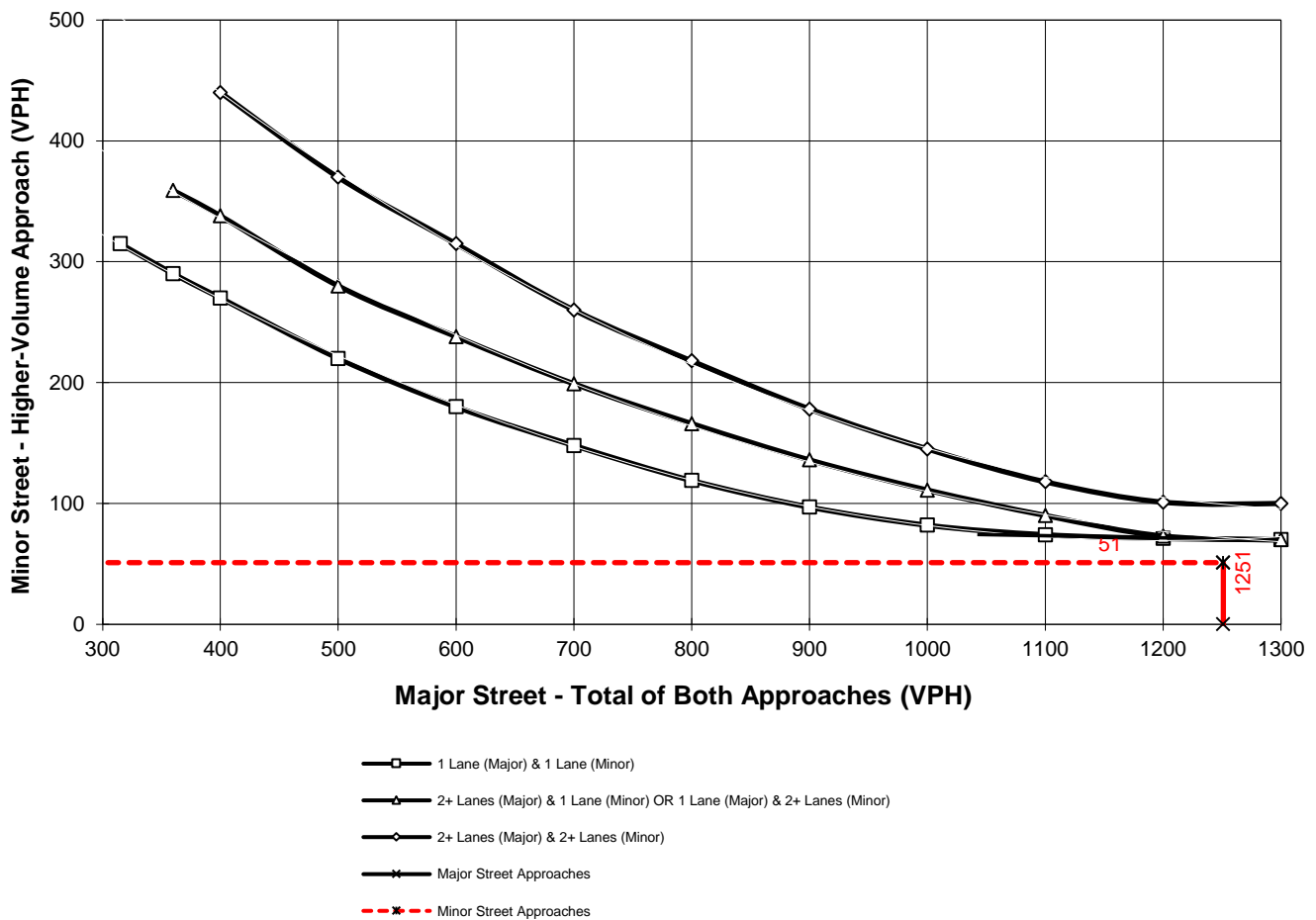
Major Street Name = **Frank Sinatra Dr.**

Total of Both Approaches (VPH) = **1,251**  
 Number of Approach Lanes Major Street = **2**

Minor Street Name = **Island Dr.**

High Volume Approach (VPH) = **51**  
 Number of Approach Lanes Minor Street = **1**

**SIGNAL WARRANT NOT SATISFIED**



\*Note: 100 vph applies as the lower threshold for a minor-street approach with two or more lanes and 75 vph applies as the lower threshold for a minor-street approach with one lane

Intersection ID: #1

### Figure 4C-4. Warrant 3, Peak Hour (70% Factor)

(COMMUNITY LESS THAN 10,000 POPULATION OR ABOVE 64 km/h OR ABOVE 40 mph ON MAJOR STREET)

Traffic Conditions = **E+A+P PM PEAK HOUR WARRANTS**

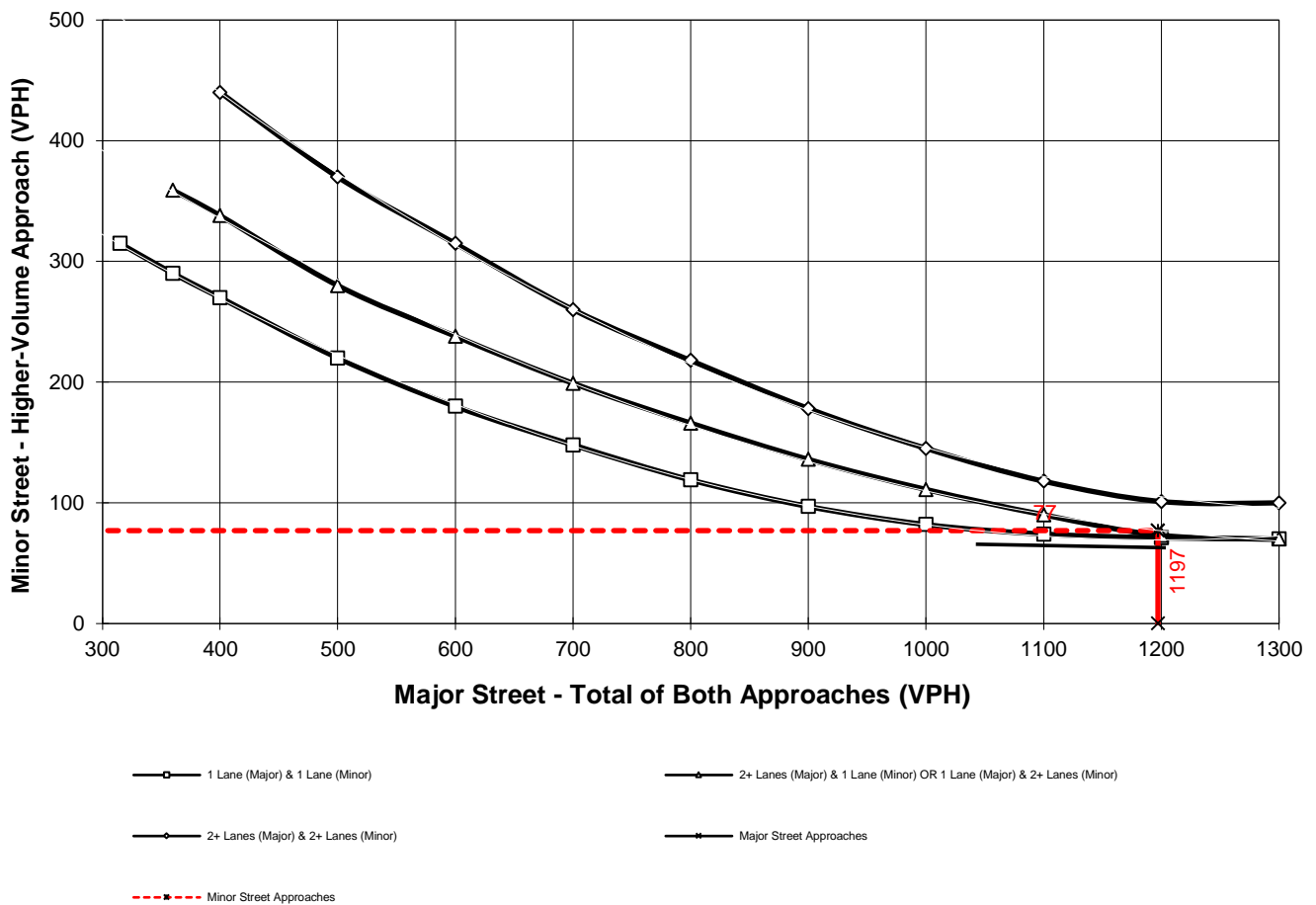
Major Street Name = **Frank Sinatra Dr.**

Total of Both Approaches (VPH) = **1,197**  
 Number of Approach Lanes Major Street = **2**

Minor Street Name = **Island Dr.**

High Volume Approach (VPH) = **77**  
 Number of Approach Lanes Minor Street = **1**

#### SIGNAL WARRANT NOT SATISFIED



\*Note: 100 vph applies as the lower threshold for a minor-street approach with two or more lanes and 75 vph applies as the lower threshold for a minor-street approach with one lane

Intersection ID: #1

### Figure 4C-4. Warrant 3, Peak Hour (70% Factor)

(COMMUNITY LESS THAN 10,000 POPULATION OR ABOVE 64 km/h OR ABOVE 40 mph ON MAJOR STREET)

Traffic Conditions = **EXISTING (2022) AM PEAK HOUR WARRANTS**

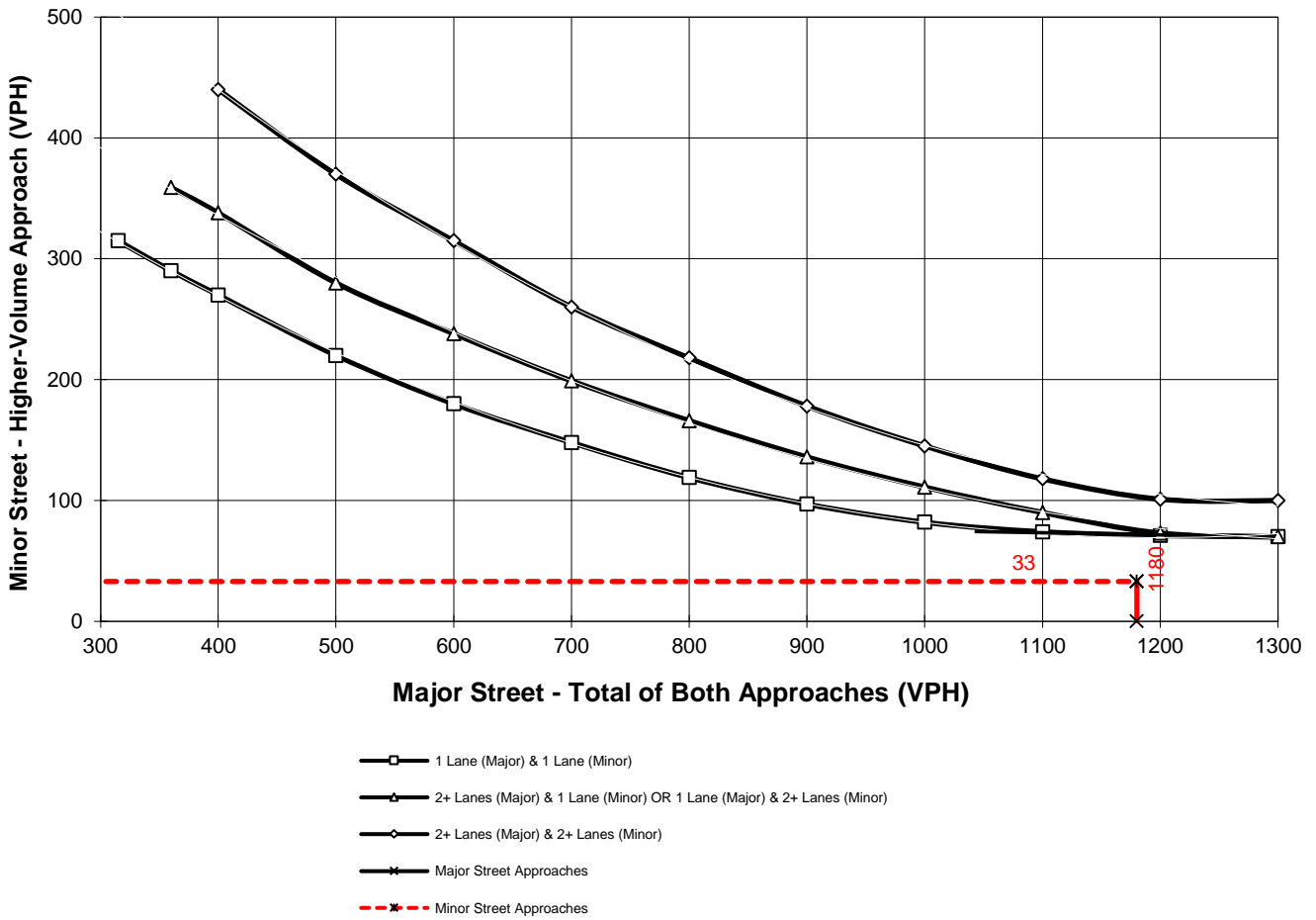
Major Street Name = **Frank Sinatra Dr.**

Total of Both Approaches (VPH) = **1,180**  
 Number of Approach Lanes Major Street = **2**

Minor Street Name = **Island Dr.**

High Volume Approach (VPH) = **33**  
 Number of Approach Lanes Minor Street = **1**

**SIGNAL WARRANT NOT SATISFIED**



\*Note: 100 vph applies as the lower threshold for a minor-street approach with two or more lanes and 75 vph applies as the lower threshold for a minor-street approach with one lane

Intersection ID: #1

### Figure 4C-4. Warrant 3, Peak Hour (70% Factor)

(COMMUNITY LESS THAN 10,000 POPULATION OR ABOVE 64 km/h OR ABOVE 40 mph ON MAJOR STREET)

Traffic Conditions = **EAPC (FINAL) PM PEAK HOUR WARRANTS**

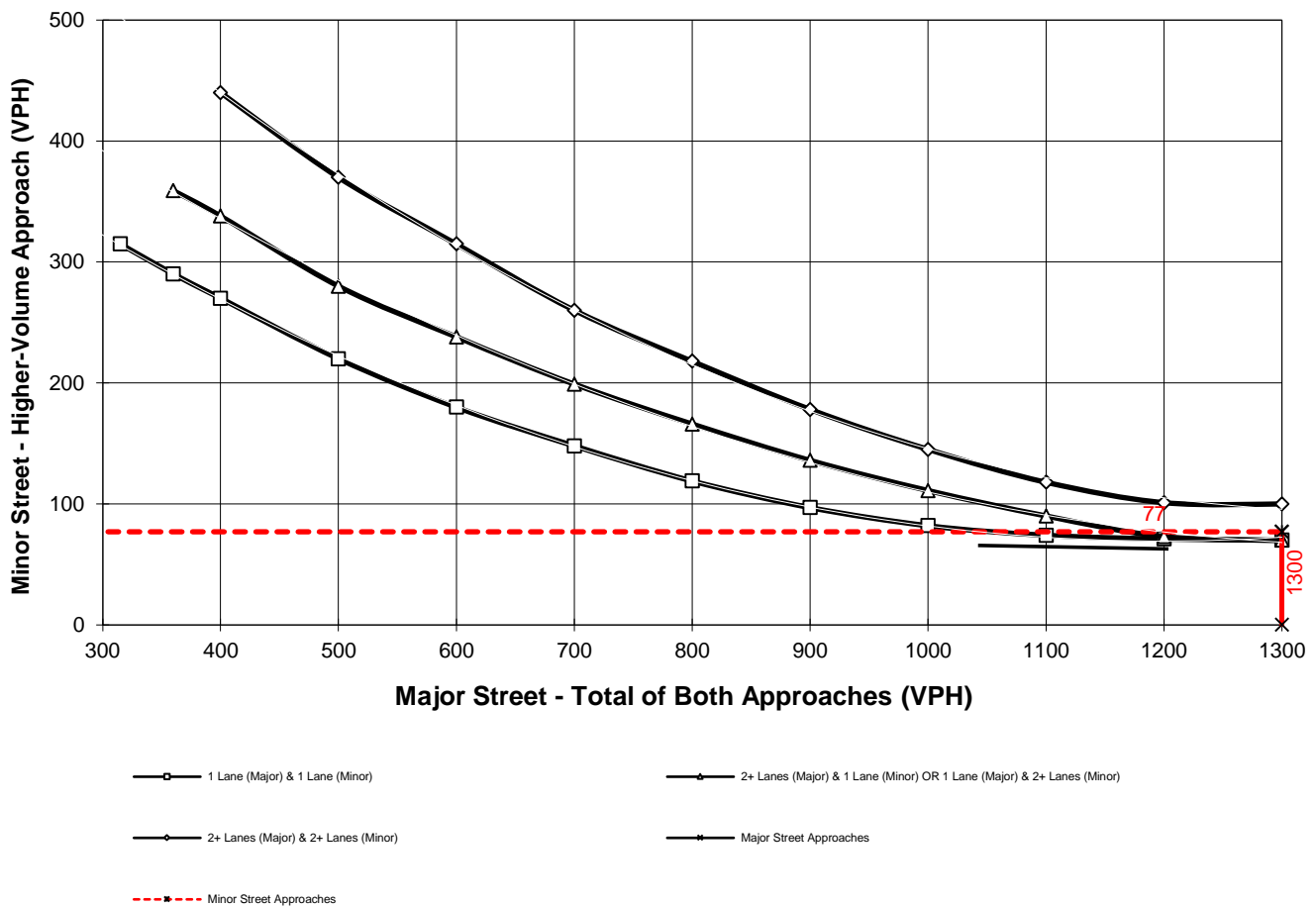
Major Street Name = **Frank Sinatra Dr.**

Total of Both Approaches (VPH) = **1,489**  
 Number of Approach Lanes Major Street = **2**

Minor Street Name = **Island Dr.**

High Volume Approach (VPH) = **77**  
 Number of Approach Lanes Minor Street = **1**

**WARRANTED FOR A SIGNAL**



\*Note: 100 vph applies as the lower threshold for a minor-street approach with two or more lanes and 75 vph applies as the lower threshold for a minor-street approach with one lane

Intersection ID: #1

## **APPENDIX 5.1: EAP (2024) CONDITIONS INTERSECTION OPERATIONS ANALYSIS WORKSHEETS**

This Page Intentionally Left Blank

Lanes, Volumes, Timings  
 1: Island Dr. & Frank Sinatra Dr.

EAP (2024) AM Peak Hour



Lane Group	EBT	EBR	WBL	WBT	NBL	NBR
Lane Configurations	↑↑		↙	↑↑	↙	↙
Traffic Volume (vph)	560	30	53	608	19	32
Future Volume (vph)	560	30	53	608	19	32
Ideal Flow (vphpl)	1900	1900	1900	1900	1900	1900
Storage Length (ft)		0	90		30	0
Storage Lanes		0	1		1	1
Taper Length (ft)			90		90	
Link Speed (mph)	50			50	30	
Link Distance (ft)	1498			1234	212	
Travel Time (s)	20.4			16.8	4.8	
Peak Hour Factor	0.86	0.86	0.86	0.86	0.86	0.86
Shared Lane Traffic (%)						
Sign Control	Free			Free	Stop	

Intersection Summary

Area Type: Other

Control Type: Unsignalized



Intersection						
Int Delay, s/veh	1					
Movement	EBT	EBR	WBL	WBT	NBL	NBR
Lane Configurations	↑↑		↘	↑↑	↘	↘
Traffic Vol, veh/h	560	30	53	608	19	32
Future Vol, veh/h	560	30	53	608	19	32
Conflicting Peds, #/hr	0	0	0	0	0	0
Sign Control	Free	Free	Free	Free	Stop	Stop
RT Channelized	-	None	-	None	-	None
Storage Length	-	-	90	-	30	0
Veh in Median Storage, #	0	-	-	0	0	-
Grade, %	0	-	-	0	0	-
Peak Hour Factor	86	86	86	86	86	86
Heavy Vehicles, %	2	2	2	2	2	2
Mvmt Flow	651	35	62	707	22	37

Major/Minor	Major1	Major2	Minor1		
Conflicting Flow All	0	0	686	0	1147 343
Stage 1	-	-	-	-	669 -
Stage 2	-	-	-	-	478 -
Critical Hdwy	-	-	4.14	-	6.84 6.94
Critical Hdwy Stg 1	-	-	-	-	5.84 -
Critical Hdwy Stg 2	-	-	-	-	5.84 -
Follow-up Hdwy	-	-	2.22	-	3.52 3.32
Pot Cap-1 Maneuver	-	-	904	-	192 653
Stage 1	-	-	-	-	471 -
Stage 2	-	-	-	-	590 -
Platoon blocked, %	-	-	-	-	-
Mov Cap-1 Maneuver	-	-	904	-	179 653
Mov Cap-2 Maneuver	-	-	-	-	179 -
Stage 1	-	-	-	-	471 -
Stage 2	-	-	-	-	549 -

Approach	EB	WB	NB
HCM Control Delay, s	0	0.7	17.2
HCM LOS			C

Minor Lane/Major Mvmt	NBLn1	NBLn2	EBT	EBR	WBL	WBT
Capacity (veh/h)	179	653	-	-	904	-
HCM Lane V/C Ratio	0.123	0.057	-	-	0.068	-
HCM Control Delay (s)	27.9	10.8	-	-	9.3	-
HCM Lane LOS	D	B	-	-	A	-
HCM 95th %tile Q(veh)	0.4	0.2	-	-	0.2	-

Lanes, Volumes, Timings  
2: Bob Hope Dr. & Frank Sinatra Dr.

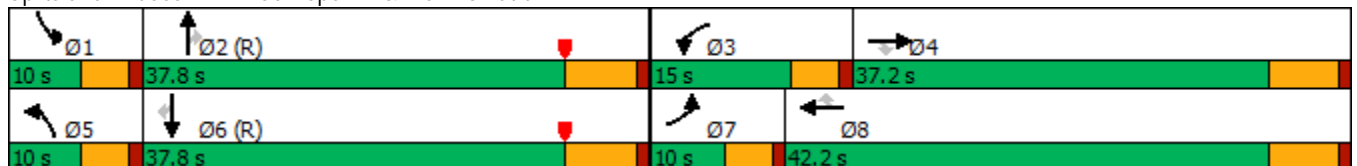
EAP (2024) AM Peak Hour

Lane Group	EBL	EBT	EBR	WBL	WBT	WBR	NBL	NBT	NBR	SBL	SBT	SBR
Lane Configurations												
Traffic Volume (vph)	53	335	204	240	479	56	68	337	54	81	804	113
Future Volume (vph)	53	335	204	240	479	56	68	337	54	81	804	113
Ideal Flow (vphpl)	1900	1900	1900	1900	1900	1900	1900	1900	1900	1900	1900	1900
Storage Length (ft)	275		50	125		205	330		150	325		150
Storage Lanes	2		1	2		1	2		1	2		1
Taper Length (ft)	180			140			160			160		
Right Turn on Red			Yes			Yes			Yes			Yes
Link Speed (mph)		50			50			50			55	
Link Distance (ft)		1234			2356			976			711	
Travel Time (s)		16.8			32.1			13.3			8.8	
Confl. Bikes (#/hr)			7						2			1
Peak Hour Factor	0.85	0.85	0.85	0.85	0.85	0.85	0.85	0.85	0.85	0.85	0.85	0.85
Shared Lane Traffic (%)												
Turn Type	Prot	NA	Perm	Prot	NA	Perm	Prot	NA	Perm	Prot	NA	Perm
Protected Phases	7	4		3	8		5	2		1	6	
Permitted Phases			4			8			2			6
Detector Phase	7	4	4	3	8	8	5	2	2	1	6	6
Switch Phase												
Minimum Initial (s)	5.0	10.0	10.0	5.0	10.0	10.0	5.0	10.0	10.0	5.0	10.0	10.0
Minimum Split (s)	10.0	37.2	37.2	10.0	40.2	40.2	10.0	37.5	37.5	10.0	33.5	33.5
Total Split (s)	10.0	37.2	37.2	15.0	42.2	42.2	10.0	37.8	37.8	10.0	37.8	37.8
Total Split (%)	10.0%	37.2%	37.2%	15.0%	42.2%	42.2%	10.0%	37.8%	37.8%	10.0%	37.8%	37.8%
Yellow Time (s)	3.6	5.2	5.2	3.6	5.2	5.2	3.6	5.5	5.5	3.6	5.5	5.5
All-Red Time (s)	1.0	1.0	1.0	1.0	1.0	1.0	1.0	1.0	1.0	1.0	1.0	1.0
Lost Time Adjust (s)	0.0	0.0	0.0	0.0	0.0	0.0	0.0	0.0	0.0	0.0	0.0	0.0
Total Lost Time (s)	4.6	6.2	6.2	4.6	6.2	6.2	4.6	6.5	6.5	4.6	6.5	6.5
Lead/Lag	Lead	Lag	Lag	Lead	Lag	Lag	Lead	Lag	Lag	Lead	Lag	Lag
Lead-Lag Optimize?	Yes	Yes	Yes	Yes	Yes	Yes	Yes	Yes	Yes	Yes	Yes	Yes
Recall Mode	None	None	None	None	None	None	None	C-Max	C-Max	None	C-Max	C-Max

Intersection Summary

























Area Type: Other  
 Cycle Length: 100  
 Actuated Cycle Length: 100  
 Offset: 0 (0%), Referenced to phase 2:NBT and 6:SBT, Start of Yellow, Master Intersection  
 Natural Cycle: 100  
 Control Type: Actuated-Coordinated

Splits and Phases: 2: Bob Hope Dr. & Frank Sinatra Dr.



HCM 6th Signalized Intersection Summary  
2: Bob Hope Dr. & Frank Sinatra Dr.

EAP (2024) AM Peak Hour

												
Movement	EBL	EBT	EBR	WBL	WBT	WBR	NBL	NBT	NBR	SBL	SBT	SBR
Lane Configurations												
Traffic Volume (veh/h)	53	335	204	240	479	56	68	337	54	81	804	113
Future Volume (veh/h)	53	335	204	240	479	56	68	337	54	81	804	113
Initial Q (Qb), veh	0	0	0	0	0	0	0	0	0	0	0	0
Ped-Bike Adj(A_pbT)	1.00		0.98	1.00		1.00	1.00		0.99	1.00		0.99
Parking Bus, Adj	1.00	1.00	1.00	1.00	1.00	1.00	1.00	1.00	1.00	1.00	1.00	1.00
Work Zone On Approach		No			No			No			No	
Adj Sat Flow, veh/h/ln	1870	1870	1870	1870	1870	1870	1870	1870	1870	1870	1870	1870
Adj Flow Rate, veh/h	62	394	240	282	564	66	80	396	64	95	946	133
Peak Hour Factor	0.85	0.85	0.85	0.85	0.85	0.85	0.85	0.85	0.85	0.85	0.85	0.85
Percent Heavy Veh, %	2	2	2	2	2	2	2	2	2	2	2	2
Cap, veh/h	142	689	301	346	899	401	154	1566	689	160	1572	693
Arrive On Green	0.04	0.19	0.19	0.10	0.25	0.25	0.04	0.44	0.44	0.05	0.44	0.44
Sat Flow, veh/h	3456	3554	1553	3456	3554	1585	3456	3554	1564	3456	3554	1565
Grp Volume(v), veh/h	62	394	240	282	564	66	80	396	64	95	946	133
Grp Sat Flow(s),veh/h/ln	1728	1777	1553	1728	1777	1585	1728	1777	1564	1728	1777	1565
Q Serve(g_s), s	1.8	10.1	14.7	8.0	14.1	3.2	2.3	7.0	2.4	2.7	20.2	5.2
Cycle Q Clear(g_c), s	1.8	10.1	14.7	8.0	14.1	3.2	2.3	7.0	2.4	2.7	20.2	5.2
Prop In Lane	1.00		1.00	1.00		1.00	1.00		1.00	1.00		1.00
Lane Grp Cap(c), veh/h	142	689	301	346	899	401	154	1566	689	160	1572	693
V/C Ratio(X)	0.44	0.57	0.80	0.81	0.63	0.16	0.52	0.25	0.09	0.59	0.60	0.19
Avail Cap(c_a), veh/h	187	1102	482	359	1279	571	187	1566	689	187	1572	693
HCM Platoon Ratio	1.00	1.00	1.00	1.00	1.00	1.00	1.00	1.00	1.00	1.00	1.00	1.00
Upstream Filter(I)	1.00	1.00	1.00	1.00	1.00	1.00	1.00	1.00	1.00	1.00	1.00	1.00
Uniform Delay (d), s/veh	46.8	36.6	38.4	44.1	33.2	29.1	46.7	17.6	16.3	46.8	21.2	17.0
Incr Delay (d2), s/veh	0.8	0.8	4.8	12.1	0.7	0.2	1.0	0.4	0.3	1.6	1.7	0.6
Initial Q Delay(d3),s/veh	0.0	0.0	0.0	0.0	0.0	0.0	0.0	0.0	0.0	0.0	0.0	0.0
%ile BackOfQ(50%),veh/ln	0.7	4.2	5.7	3.8	5.8	1.2	1.0	2.7	0.8	1.1	7.8	1.8
Unsig. Movement Delay, s/veh												
LnGrp Delay(d),s/veh	47.6	37.3	43.3	56.1	33.9	29.3	47.7	18.0	16.6	48.3	22.9	17.6
LnGrp LOS	D	D	D	E	C	C	D	B	B	D	C	B
Approach Vol, veh/h		696			912			540			1174	
Approach Delay, s/veh		40.3			40.4			22.2			24.4	
Approach LOS		D			D			C			C	
Timer - Assigned Phs	1	2	3	4	5	6	7	8				
Phs Duration (G+Y+Rc), s	9.2	50.6	14.6	25.6	9.1	50.7	8.7	31.5				
Change Period (Y+Rc), s	4.6	6.5	4.6	6.2	4.6	6.5	4.6	6.2				
Max Green Setting (Gmax), s	5.4	31.3	10.4	31.0	5.4	31.3	5.4	36.0				
Max Q Clear Time (g_c+I1), s	4.7	9.0	10.0	16.7	4.3	22.2	3.8	16.1				
Green Ext Time (p_c), s	0.0	2.4	0.0	2.6	0.0	4.1	0.0	3.4				
<b>Intersection Summary</b>												
HCM 6th Ctrl Delay				31.8								
HCM 6th LOS				C								

Lanes, Volumes, Timings  
 1: Island Dr. & Frank Sinatra Dr.

EAP (2024) PM Peak Hour

	→	↘	↙	←	↖	↗
Lane Group	EBT	EBR	WBL	WBT	NBL	NBR
Lane Configurations	↑↑		↘	↑↑	↘	↗
Traffic Volume (vph)	545	16	55	581	21	56
Future Volume (vph)	545	16	55	581	21	56
Ideal Flow (vphpl)	1900	1900	1900	1900	1900	1900
Storage Length (ft)		0	90		30	0
Storage Lanes		0	1		1	1
Taper Length (ft)			90		90	
Link Speed (mph)	50			50	30	
Link Distance (ft)	1498			1234	212	
Travel Time (s)	20.4			16.8	4.8	
Peak Hour Factor	0.96	0.96	0.96	0.96	0.96	0.96
Shared Lane Traffic (%)						
Sign Control	Free			Free	Stop	
<b>Intersection Summary</b>						
Area Type:	Other					
Control Type:	Unsignalized					

Intersection						
Int Delay, s/veh	1.2					
Movement	EBT	EBR	WBL	WBT	NBL	NBR
Lane Configurations	↑↑		↘	↑↑	↘	↘
Traffic Vol, veh/h	545	16	55	581	21	56
Future Vol, veh/h	545	16	55	581	21	56
Conflicting Peds, #/hr	0	0	0	0	0	0
Sign Control	Free	Free	Free	Free	Stop	Stop
RT Channelized	-	None	-	None	-	None
Storage Length	-	-	90	-	30	0
Veh in Median Storage, #	0	-	-	0	0	-
Grade, %	0	-	-	0	0	-
Peak Hour Factor	96	96	96	96	96	96
Heavy Vehicles, %	2	2	2	2	2	2
Mvmt Flow	568	17	57	605	22	58

Major/Minor	Major1	Major2	Minor1	Minor2	Minor3
Conflicting Flow All	0	0	585	0	994
Stage 1	-	-	-	-	577
Stage 2	-	-	-	-	417
Critical Hdwy	-	-	4.14	-	6.84
Critical Hdwy Stg 1	-	-	-	-	5.84
Critical Hdwy Stg 2	-	-	-	-	5.84
Follow-up Hdwy	-	-	2.22	-	3.52
Pot Cap-1 Maneuver	-	-	986	-	242
Stage 1	-	-	-	-	525
Stage 2	-	-	-	-	633
Platoon blocked, %	-	-	-	-	-
Mov Cap-1 Maneuver	-	-	986	-	228
Mov Cap-2 Maneuver	-	-	-	-	228
Stage 1	-	-	-	-	525
Stage 2	-	-	-	-	596

Approach	EB	WB	NB
HCM Control Delay, s	0	0.8	13.8
HCM LOS			B

Minor Lane/Major Mvmt	NBLn1	NBLn2	EBT	EBR	WBL	WBT
Capacity (veh/h)	228	703	-	-	986	-
HCM Lane V/C Ratio	0.096	0.083	-	-	0.058	-
HCM Control Delay (s)	22.5	10.6	-	-	8.9	-
HCM Lane LOS	C	B	-	-	A	-
HCM 95th %tile Q(veh)	0.3	0.3	-	-	0.2	-

Lanes, Volumes, Timings  
2: Bob Hope Dr. & Frank Sinatra Dr.

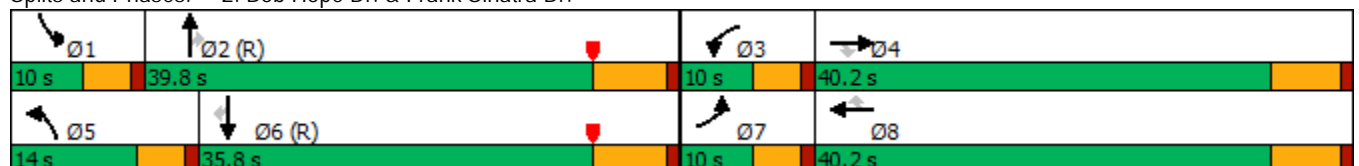
EAP (2024) PM Peak Hour

Lane Group	EBL	EBT	EBR	WBL	WBT	WBR	NBL	NBT	NBR	SBL	SBT	SBR
Lane Configurations												
Traffic Volume (vph)	80	426	95	48	332	69	211	843	186	72	457	93
Future Volume (vph)	80	426	95	48	332	69	211	843	186	72	457	93
Ideal Flow (vphpl)	1900	1900	1900	1900	1900	1900	1900	1900	1900	1900	1900	1900
Storage Length (ft)	275		50	125		205	330		150	325		150
Storage Lanes	2		1	2		1	2		1	2		1
Taper Length (ft)	180			140			160			160		
Right Turn on Red			Yes			Yes			Yes			Yes
Link Speed (mph)		50			50			50			55	
Link Distance (ft)		1234			2356			976			711	
Travel Time (s)		16.8			32.1			13.3			8.8	
Confl. Bikes (#/hr)			7						2			1
Peak Hour Factor	0.95	0.95	0.95	0.95	0.95	0.95	0.95	0.95	0.95	0.95	0.95	0.95
Shared Lane Traffic (%)												
Turn Type	Prot	NA	Perm	Prot	NA	Perm	Prot	NA	Perm	Prot	NA	Perm
Protected Phases	7	4		3	8		5	2		1	6	
Permitted Phases			4			8			2			6
Detector Phase	7	4	4	3	8	8	5	2	2	1	6	6
Switch Phase												
Minimum Initial (s)	5.0	10.0	10.0	5.0	10.0	10.0	5.0	10.0	10.0	5.0	10.0	10.0
Minimum Split (s)	10.0	37.2	37.2	10.0	40.2	40.2	10.0	37.5	37.5	10.0	33.5	33.5
Total Split (s)	10.0	40.2	40.2	10.0	40.2	40.2	14.0	39.8	39.8	10.0	35.8	35.8
Total Split (%)	10.0%	40.2%	40.2%	10.0%	40.2%	40.2%	14.0%	39.8%	39.8%	10.0%	35.8%	35.8%
Yellow Time (s)	3.6	5.2	5.2	3.6	5.2	5.2	3.6	5.5	5.5	3.6	5.5	5.5
All-Red Time (s)	1.0	1.0	1.0	1.0	1.0	1.0	1.0	1.0	1.0	1.0	1.0	1.0
Lost Time Adjust (s)	0.0	0.0	0.0	0.0	0.0	0.0	0.0	0.0	0.0	0.0	0.0	0.0
Total Lost Time (s)	4.6	6.2	6.2	4.6	6.2	6.2	4.6	6.5	6.5	4.6	6.5	6.5
Lead/Lag	Lead	Lag	Lag	Lead	Lag	Lag	Lead	Lag	Lag	Lead	Lag	Lag
Lead-Lag Optimize?	Yes	Yes	Yes	Yes	Yes	Yes	Yes	Yes	Yes	Yes	Yes	Yes
Recall Mode	None	None	None	None	None	None	None	C-Max	C-Max	None	C-Max	C-Max

Intersection Summary

























Area Type: Other  
 Cycle Length: 100  
 Actuated Cycle Length: 100  
 Offset: 0 (0%), Referenced to phase 2:NBT and 6:SBT, Start of Yellow, Master Intersection  
 Natural Cycle: 100  
 Control Type: Actuated-Coordinated

Splits and Phases: 2: Bob Hope Dr. & Frank Sinatra Dr.



HCM 6th Signalized Intersection Summary  
 2: Bob Hope Dr. & Frank Sinatra Dr.

EAP (2024) PM Peak Hour

												
Movement	EBL	EBT	EBR	WBL	WBT	WBR	NBL	NBT	NBR	SBL	SBT	SBR
Lane Configurations												
Traffic Volume (veh/h)	80	426	95	48	332	69	211	843	186	72	457	93
Future Volume (veh/h)	80	426	95	48	332	69	211	843	186	72	457	93
Initial Q (Qb), veh	0	0	0	0	0	0	0	0	0	0	0	0
Ped-Bike Adj(A_pbT)	1.00		0.98	1.00		1.00	1.00		0.99	1.00		0.99
Parking Bus, Adj	1.00	1.00	1.00	1.00	1.00	1.00	1.00	1.00	1.00	1.00	1.00	1.00
Work Zone On Approach		No			No			No			No	
Adj Sat Flow, veh/h/ln	1870	1870	1870	1870	1870	1870	1870	1870	1870	1870	1870	1870
Adj Flow Rate, veh/h	84	448	100	51	349	73	222	887	196	76	481	98
Peak Hour Factor	0.95	0.95	0.95	0.95	0.95	0.95	0.95	0.95	0.95	0.95	0.95	0.95
Percent Heavy Veh, %	2	2	2	2	2	2	2	2	2	2	2	2
Cap, veh/h	156	597	261	131	571	255	288	1888	831	152	1748	770
Arrive On Green	0.05	0.17	0.17	0.04	0.16	0.16	0.08	0.53	0.53	0.04	0.49	0.49
Sat Flow, veh/h	3456	3554	1551	3456	3554	1585	3456	3554	1565	3456	3554	1565
Grp Volume(v), veh/h	84	448	100	51	349	73	222	887	196	76	481	98
Grp Sat Flow(s),veh/h/ln	1728	1777	1551	1728	1777	1585	1728	1777	1565	1728	1777	1565
Q Serve(g_s), s	2.4	12.0	5.7	1.4	9.1	4.1	6.3	15.6	6.7	2.1	8.0	3.4
Cycle Q Clear(g_c), s	2.4	12.0	5.7	1.4	9.1	4.1	6.3	15.6	6.7	2.1	8.0	3.4
Prop In Lane	1.00		1.00	1.00		1.00	1.00		1.00	1.00		1.00
Lane Grp Cap(c), veh/h	156	597	261	131	571	255	288	1888	831	152	1748	770
V/C Ratio(X)	0.54	0.75	0.38	0.39	0.61	0.29	0.77	0.47	0.24	0.50	0.28	0.13
Avail Cap(c_a), veh/h	187	1208	527	187	1208	539	325	1888	831	187	1748	770
HCM Platoon Ratio	1.00	1.00	1.00	1.00	1.00	1.00	1.00	1.00	1.00	1.00	1.00	1.00
Upstream Filter(I)	1.00	1.00	1.00	1.00	1.00	1.00	1.00	1.00	1.00	1.00	1.00	1.00
Uniform Delay (d), s/veh	46.7	39.6	37.0	47.0	39.1	36.9	44.9	14.6	12.6	46.7	14.9	13.8
Incr Delay (d2), s/veh	1.1	1.9	0.9	0.7	1.1	0.6	8.2	0.8	0.7	0.9	0.4	0.3
Initial Q Delay(d3),s/veh	0.0	0.0	0.0	0.0	0.0	0.0	0.0	0.0	0.0	0.0	0.0	0.0
%ile BackOfQ(50%),veh/ln	1.0	5.1	2.1	0.6	3.9	1.5	2.9	5.7	2.2	0.9	2.9	1.2
Unsig. Movement Delay, s/veh												
LnGrp Delay(d),s/veh	47.8	41.5	37.9	47.7	40.1	37.5	53.1	15.5	13.2	47.7	15.3	14.1
LnGrp LOS	D	D	D	D	D	D	D	B	B	D	B	B
Approach Vol, veh/h		632			473			1305			655	
Approach Delay, s/veh		41.8			40.5			21.5			18.9	
Approach LOS		D			D			C			B	
Timer - Assigned Phs	1	2	3	4	5	6	7	8				
Phs Duration (G+Y+Rc), s	9.0	59.6	8.4	23.0	12.9	55.7	9.1	22.3				
Change Period (Y+Rc), s	4.6	6.5	4.6	6.2	4.6	6.5	4.6	6.2				
Max Green Setting (Gmax), s	5.4	33.3	5.4	34.0	9.4	29.3	5.4	34.0				
Max Q Clear Time (g_c+I1), s	4.1	17.6	3.4	14.0	8.3	10.0	4.4	11.1				
Green Ext Time (p_c), s	0.0	5.6	0.0	2.8	0.0	2.9	0.0	2.2				
<b>Intersection Summary</b>												
HCM 6th Ctrl Delay			28.1									
HCM 6th LOS			C									

## **APPENDIX 6.1: EAPC (2024) CONDITIONS INTERSECTION OPERATIONS ANALYSIS WORKSHEETS**



This Page Intentionally Left Blank

Lanes, Volumes, Timings  
 1: Island Dr. & Frank Sinatra Dr.

EAPC (2024) AM Peak Hour

	→	↘	↙	←	↖	↗
Lane Group	EBT	EBR	WBL	WBT	NBL	NBR
Lane Configurations	↑↑		↘	↑↑	↘	↗
Traffic Volume (vph)	641	30	53	681	19	32
Future Volume (vph)	641	30	53	681	19	32
Ideal Flow (vphpl)	1900	1900	1900	1900	1900	1900
Storage Length (ft)		0	90		30	0
Storage Lanes		0	1		1	1
Taper Length (ft)			90		90	
Link Speed (mph)	50			50	30	
Link Distance (ft)	1498			1234	212	
Travel Time (s)	20.4			16.8	4.8	
Peak Hour Factor	0.86	0.86	0.86	0.86	0.86	0.86
Shared Lane Traffic (%)						
Sign Control	Free			Free	Stop	
<b>Intersection Summary</b>						
Area Type:	Other					
Control Type:	Unsignalized					

Intersection						
Int Delay, s/veh	1					
Movement	EBT	EBR	WBL	WBT	NBL	NBR
Lane Configurations	↑↑		↘	↑↑	↘	↘
Traffic Vol, veh/h	641	30	53	681	19	32
Future Vol, veh/h	641	30	53	681	19	32
Conflicting Peds, #/hr	0	0	0	0	0	0
Sign Control	Free	Free	Free	Free	Stop	Stop
RT Channelized	-	None	-	None	-	None
Storage Length	-	-	90	-	30	0
Veh in Median Storage, #	0	-	-	0	0	-
Grade, %	0	-	-	0	0	-
Peak Hour Factor	86	86	86	86	86	86
Heavy Vehicles, %	2	2	2	2	2	2
Mvmt Flow	745	35	62	792	22	37

Major/Minor	Major1	Major2	Minor1		
Conflicting Flow All	0	0	780	0	1283
Stage 1	-	-	-	-	763
Stage 2	-	-	-	-	520
Critical Hdwy	-	-	4.14	-	6.84
Critical Hdwy Stg 1	-	-	-	-	5.84
Critical Hdwy Stg 2	-	-	-	-	5.84
Follow-up Hdwy	-	-	2.22	-	3.52
Pot Cap-1 Maneuver	-	-	833	-	157
Stage 1	-	-	-	-	421
Stage 2	-	-	-	-	561
Platoon blocked, %	-	-	-	-	-
Mov Cap-1 Maneuver	-	-	833	-	145
Mov Cap-2 Maneuver	-	-	-	-	145
Stage 1	-	-	-	-	421
Stage 2	-	-	-	-	519

Approach	EB	WB	NB
HCM Control Delay, s	0	0.7	19.8
HCM LOS			C

Minor Lane/Major Mvmt	NBLn1	NBLn2	EBT	EBR	WBL	WBT
Capacity (veh/h)	145	609	-	-	833	-
HCM Lane V/C Ratio	0.152	0.061	-	-	0.074	-
HCM Control Delay (s)	34.2	11.3	-	-	9.7	-
HCM Lane LOS	D	B	-	-	A	-
HCM 95th %tile Q(veh)	0.5	0.2	-	-	0.2	-

Lanes, Volumes, Timings  
2: Bob Hope Dr. & Frank Sinatra Dr.

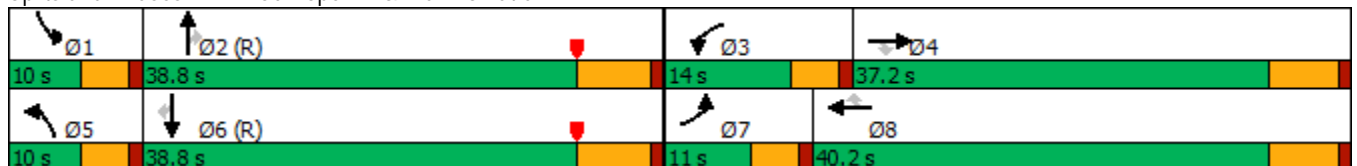
EAPC (2024) AM Peak Hour

Lane Group	EBL	EBT	EBR	WBL	WBT	WBR	NBL	NBT	NBR	SBL	SBT	SBR
Lane Configurations												
Traffic Volume (vph)	79	363	231	259	502	65	92	391	74	96	898	139
Future Volume (vph)	79	363	231	259	502	65	92	391	74	96	898	139
Ideal Flow (vphpl)	1900	1900	1900	1900	1900	1900	1900	1900	1900	1900	1900	1900
Storage Length (ft)	275		50	125		205	330		150	325		150
Storage Lanes	2		1	2		1	2		1	2		1
Taper Length (ft)	180			140			160			160		
Right Turn on Red			Yes			Yes			Yes			Yes
Link Speed (mph)		50			50			50			55	
Link Distance (ft)		1234			2356			976			711	
Travel Time (s)		16.8			32.1			13.3			8.8	
Confl. Bikes (#/hr)			7						2			1
Peak Hour Factor	0.85	0.85	0.85	0.85	0.85	0.85	0.85	0.85	0.85	0.85	0.85	0.85
Shared Lane Traffic (%)												
Turn Type	Prot	NA	Perm	Prot	NA	Perm	Prot	NA	Perm	Prot	NA	Perm
Protected Phases	7	4		3	8		5	2		1	6	
Permitted Phases			4			8			2			6
Detector Phase	7	4	4	3	8	8	5	2	2	1	6	6
Switch Phase												
Minimum Initial (s)	5.0	10.0	10.0	5.0	10.0	10.0	5.0	10.0	10.0	5.0	10.0	10.0
Minimum Split (s)	10.0	37.2	37.2	10.0	40.2	40.2	10.0	37.5	37.5	10.0	33.5	33.5
Total Split (s)	11.0	37.2	37.2	14.0	40.2	40.2	10.0	38.8	38.8	10.0	38.8	38.8
Total Split (%)	11.0%	37.2%	37.2%	14.0%	40.2%	40.2%	10.0%	38.8%	38.8%	10.0%	38.8%	38.8%
Yellow Time (s)	3.6	5.2	5.2	3.6	5.2	5.2	3.6	5.5	5.5	3.6	5.5	5.5
All-Red Time (s)	1.0	1.0	1.0	1.0	1.0	1.0	1.0	1.0	1.0	1.0	1.0	1.0
Lost Time Adjust (s)	0.0	0.0	0.0	0.0	0.0	0.0	0.0	0.0	0.0	0.0	0.0	0.0
Total Lost Time (s)	4.6	6.2	6.2	4.6	6.2	6.2	4.6	6.5	6.5	4.6	6.5	6.5
Lead/Lag	Lead	Lag	Lag	Lead	Lag	Lag	Lead	Lag	Lag	Lead	Lag	Lag
Lead-Lag Optimize?	Yes	Yes	Yes	Yes	Yes	Yes	Yes	Yes	Yes	Yes	Yes	Yes
Recall Mode	None	None	None	None	None	None	None	C-Max	C-Max	None	C-Max	C-Max

Intersection Summary

































Area Type: Other  
 Cycle Length: 100  
 Actuated Cycle Length: 100  
 Offset: 0 (0%), Referenced to phase 2:NBT and 6:SBT, Start of Yellow, Master Intersection  
 Natural Cycle: 100  
 Control Type: Actuated-Coordinated

Splits and Phases: 2: Bob Hope Dr. & Frank Sinatra Dr.



HCM 6th Signalized Intersection Summary  
2: Bob Hope Dr. & Frank Sinatra Dr.

EAPC (2024) AM Peak Hour

												
Movement	EBL	EBT	EBR	WBL	WBT	WBR	NBL	NBT	NBR	SBL	SBT	SBR
Lane Configurations	 	 		 	 		 	 		 	 	
Traffic Volume (veh/h)	79	363	231	259	502	65	92	391	74	96	898	139
Future Volume (veh/h)	79	363	231	259	502	65	92	391	74	96	898	139
Initial Q (Qb), veh	0	0	0	0	0	0	0	0	0	0	0	0
Ped-Bike Adj(A_pbT)	1.00		0.98	1.00		1.00	1.00		0.99	1.00		0.99
Parking Bus, Adj	1.00	1.00	1.00	1.00	1.00	1.00	1.00	1.00	1.00	1.00	1.00	1.00
Work Zone On Approach		No			No			No			No	
Adj Sat Flow, veh/h/ln	1870	1870	1870	1870	1870	1870	1870	1870	1870	1870	1870	1870
Adj Flow Rate, veh/h	93	427	272	305	591	76	108	460	87	113	1056	164
Peak Hour Factor	0.85	0.85	0.85	0.85	0.85	0.85	0.85	0.85	0.85	0.85	0.85	0.85
Percent Heavy Veh, %	2	2	2	2	2	2	2	2	2	2	2	2
Cap, veh/h	160	761	333	325	931	415	167	1503	662	172	1509	665
Arrive On Green	0.05	0.21	0.21	0.09	0.26	0.26	0.05	0.42	0.42	0.05	0.42	0.42
Sat Flow, veh/h	3456	3554	1555	3456	3554	1585	3456	3554	1564	3456	3554	1565
Grp Volume(v), veh/h	93	427	272	305	591	76	108	460	87	113	1056	164
Grp Sat Flow(s),veh/h/ln	1728	1777	1555	1728	1777	1585	1728	1777	1564	1728	1777	1565
Q Serve(g_s), s	2.6	10.7	16.7	8.8	14.7	3.7	3.1	8.6	3.4	3.2	24.3	6.7
Cycle Q Clear(g_c), s	2.6	10.7	16.7	8.8	14.7	3.7	3.1	8.6	3.4	3.2	24.3	6.7
Prop In Lane	1.00		1.00	1.00		1.00	1.00		1.00	1.00		1.00
Lane Grp Cap(c), veh/h	160	761	333	325	931	415	167	1503	662	172	1509	665
V/C Ratio(X)	0.58	0.56	0.82	0.94	0.63	0.18	0.65	0.31	0.13	0.66	0.70	0.25
Avail Cap(c_a), veh/h	221	1102	482	325	1208	539	187	1503	662	187	1509	665
HCM Platoon Ratio	1.00	1.00	1.00	1.00	1.00	1.00	1.00	1.00	1.00	1.00	1.00	1.00
Upstream Filter(I)	1.00	1.00	1.00	1.00	1.00	1.00	1.00	1.00	1.00	1.00	1.00	1.00
Uniform Delay (d), s/veh	46.7	35.1	37.4	45.0	32.7	28.6	46.8	19.1	17.6	46.7	23.6	18.5
Incr Delay (d2), s/veh	1.3	0.7	7.0	33.9	0.7	0.2	4.4	0.5	0.4	5.3	2.7	0.9
Initial Q Delay(d3),s/veh	0.0	0.0	0.0	0.0	0.0	0.0	0.0	0.0	0.0	0.0	0.0	0.0
%ile BackOfQ(50%),veh/ln	1.1	4.4	6.6	5.1	6.0	1.4	1.4	3.3	1.2	1.4	9.6	2.4
Unsig. Movement Delay, s/veh												
LnGrp Delay(d),s/veh	48.0	35.7	44.5	78.9	33.4	28.8	51.1	19.7	18.0	51.9	26.3	19.4
LnGrp LOS	D	D	D	E	C	C	D	B	B	D	C	B
Approach Vol, veh/h		792			972			655			1333	
Approach Delay, s/veh		40.2			47.3			24.6			27.6	
Approach LOS		D			D			C			C	
Timer - Assigned Phs	1	2	3	4	5	6	7	8				
Phs Duration (G+Y+Rc), s	9.6	48.8	14.0	27.6	9.4	49.0	9.2	32.4				
Change Period (Y+Rc), s	4.6	6.5	4.6	6.2	4.6	6.5	4.6	6.2				
Max Green Setting (Gmax), s	5.4	32.3	9.4	31.0	5.4	32.3	6.4	34.0				
Max Q Clear Time (g_c+I1), s	5.2	10.6	10.8	18.7	5.1	26.3	4.6	16.7				
Green Ext Time (p_c), s	0.0	2.9	0.0	2.8	0.0	3.4	0.0	3.5				
<b>Intersection Summary</b>												
HCM 6th Ctrl Delay			34.8									
HCM 6th LOS			C									

Lanes, Volumes, Timings  
 1: Island Dr. & Frank Sinatra Dr.

EAPC (2024) PM Peak Hour

	→	↘	↙	←	↖	↗
Lane Group	EBT	EBR	WBL	WBT	NBL	NBR
Lane Configurations	↑↑		↘	↑↑	↘	↗
Traffic Volume (vph)	685	16	55	733	21	56
Future Volume (vph)	685	16	55	733	21	56
Ideal Flow (vphpl)	1900	1900	1900	1900	1900	1900
Storage Length (ft)		0	90		30	0
Storage Lanes		0	1		1	1
Taper Length (ft)			90		90	
Link Speed (mph)	50			50	30	
Link Distance (ft)	1498			1234	212	
Travel Time (s)	20.4			16.8	4.8	
Peak Hour Factor	0.96	0.96	0.96	0.96	0.96	0.96
Shared Lane Traffic (%)						
Sign Control	Free			Free	Stop	
<b>Intersection Summary</b>						
Area Type:	Other					
Control Type:	Unsignalized					

Intersection						
Int Delay, s/veh	1.2					
Movement	EBT	EBR	WBL	WBT	NBL	NBR
Lane Configurations	↑↑		↘	↑↑	↘	↘
Traffic Vol, veh/h	685	16	55	733	21	56
Future Vol, veh/h	685	16	55	733	21	56
Conflicting Peds, #/hr	0	0	0	0	0	0
Sign Control	Free	Free	Free	Free	Stop	Stop
RT Channelized	-	None	-	None	-	None
Storage Length	-	-	90	-	30	0
Veh in Median Storage, #	0	-	-	0	0	-
Grade, %	0	-	-	0	0	-
Peak Hour Factor	96	96	96	96	96	96
Heavy Vehicles, %	2	2	2	2	2	2
Mvmt Flow	714	17	57	764	22	58

Major/Minor	Major1	Major2	Minor1		
Conflicting Flow All	0	0	731	0	1219
Stage 1	-	-	-	-	723
Stage 2	-	-	-	-	496
Critical Hdwy	-	-	4.14	-	6.84
Critical Hdwy Stg 1	-	-	-	-	5.84
Critical Hdwy Stg 2	-	-	-	-	5.84
Follow-up Hdwy	-	-	2.22	-	3.52
Pot Cap-1 Maneuver	-	-	869	-	173
Stage 1	-	-	-	-	441
Stage 2	-	-	-	-	577
Platoon blocked, %	-	-	-	-	-
Mov Cap-1 Maneuver	-	-	869	-	162
Mov Cap-2 Maneuver	-	-	-	-	162
Stage 1	-	-	-	-	441
Stage 2	-	-	-	-	539

Approach	EB	WB	NB
HCM Control Delay, s	0	0.7	16.6
HCM LOS			C

Minor Lane/Major Mvmt	NBLn1	NBLn2	EBT	EBR	WBL	WBT
Capacity (veh/h)	162	631	-	-	869	-
HCM Lane V/C Ratio	0.135	0.092	-	-	0.066	-
HCM Control Delay (s)	30.7	11.3	-	-	9.4	-
HCM Lane LOS	D	B	-	-	A	-
HCM 95th %tile Q(veh)	0.5	0.3	-	-	0.2	-

Lanes, Volumes, Timings  
2: Bob Hope Dr. & Frank Sinatra Dr.

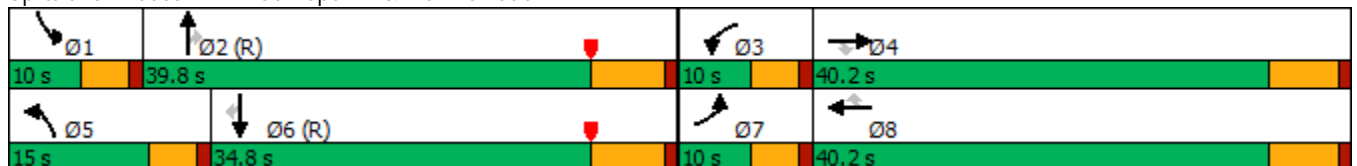
EAPC (2024) PM Peak Hour

Lane Group	EBL	EBT	EBR	WBL	WBT	WBR	NBL	NBT	NBR	SBL	SBT	SBR
Lane Configurations												
Traffic Volume (vph)	128	478	135	79	388	93	257	959	219	92	535	142
Future Volume (vph)	128	478	135	79	388	93	257	959	219	92	535	142
Ideal Flow (vphpl)	1900	1900	1900	1900	1900	1900	1900	1900	1900	1900	1900	1900
Storage Length (ft)	275		50	125		205	330		150	325		150
Storage Lanes	2		1	2		1	2		1	2		1
Taper Length (ft)	180			140			160			160		
Right Turn on Red			Yes			Yes			Yes			Yes
Link Speed (mph)		50			50			50			55	
Link Distance (ft)		1234			2356			976			711	
Travel Time (s)		16.8			32.1			13.3			8.8	
Confl. Bikes (#/hr)			7						2			1
Peak Hour Factor	0.95	0.95	0.95	0.95	0.95	0.95	0.95	0.95	0.95	0.95	0.95	0.95
Shared Lane Traffic (%)												
Turn Type	Prot	NA	Perm	Prot	NA	Perm	Prot	NA	Perm	Prot	NA	Perm
Protected Phases	7	4		3	8		5	2		1	6	
Permitted Phases			4			8			2			6
Detector Phase	7	4	4	3	8	8	5	2	2	1	6	6
Switch Phase												
Minimum Initial (s)	5.0	10.0	10.0	5.0	10.0	10.0	5.0	10.0	10.0	5.0	10.0	10.0
Minimum Split (s)	10.0	37.2	37.2	10.0	40.2	40.2	10.0	37.5	37.5	10.0	33.5	33.5
Total Split (s)	10.0	40.2	40.2	10.0	40.2	40.2	15.0	39.8	39.8	10.0	34.8	34.8
Total Split (%)	10.0%	40.2%	40.2%	10.0%	40.2%	40.2%	15.0%	39.8%	39.8%	10.0%	34.8%	34.8%
Yellow Time (s)	3.6	5.2	5.2	3.6	5.2	5.2	3.6	5.5	5.5	3.6	5.5	5.5
All-Red Time (s)	1.0	1.0	1.0	1.0	1.0	1.0	1.0	1.0	1.0	1.0	1.0	1.0
Lost Time Adjust (s)	0.0	0.0	0.0	0.0	0.0	0.0	0.0	0.0	0.0	0.0	0.0	0.0
Total Lost Time (s)	4.6	6.2	6.2	4.6	6.2	6.2	4.6	6.5	6.5	4.6	6.5	6.5
Lead/Lag	Lead	Lag	Lag	Lead	Lag	Lag	Lead	Lag	Lag	Lead	Lag	Lag
Lead-Lag Optimize?	Yes	Yes	Yes	Yes	Yes	Yes	Yes	Yes	Yes	Yes	Yes	Yes
Recall Mode	None	None	None	None	None	None	None	C-Max	C-Max	None	C-Max	C-Max

Intersection Summary

Area Type: Other  
 Cycle Length: 100  
 Actuated Cycle Length: 100  
 Offset: 0 (0%), Referenced to phase 2:NBT and 6:SBT, Start of Yellow, Master Intersection  
 Natural Cycle: 100  
 Control Type: Actuated-Coordinated

























Splits and Phases: 2: Bob Hope Dr. & Frank Sinatra Dr.





HCM 6th Signalized Intersection Summary  
2: Bob Hope Dr. & Frank Sinatra Dr.

EAPC (2024) PM Peak Hour

												
Movement	EBL	EBT	EBR	WBL	WBT	WBR	NBL	NBT	NBR	SBL	SBT	SBR
Lane Configurations												
Traffic Volume (veh/h)	128	478	135	79	388	93	257	959	219	92	535	142
Future Volume (veh/h)	128	478	135	79	388	93	257	959	219	92	535	142
Initial Q (Qb), veh	0	0	0	0	0	0	0	0	0	0	0	0
Ped-Bike Adj(A_pbT)	1.00		0.98	1.00		1.00	1.00		0.99	1.00		0.99
Parking Bus, Adj	1.00	1.00	1.00	1.00	1.00	1.00	1.00	1.00	1.00	1.00	1.00	1.00
Work Zone On Approach		No			No			No			No	
Adj Sat Flow, veh/h/ln	1870	1870	1870	1870	1870	1870	1870	1870	1870	1870	1870	1870
Adj Flow Rate, veh/h	135	503	142	83	408	98	271	1009	231	97	563	149
Peak Hour Factor	0.95	0.95	0.95	0.95	0.95	0.95	0.95	0.95	0.95	0.95	0.95	0.95
Percent Heavy Veh, %	2	2	2	2	2	2	2	2	2	2	2	2
Cap, veh/h	187	662	289	156	630	281	336	1788	787	161	1608	708
Arrive On Green	0.05	0.19	0.19	0.05	0.18	0.18	0.10	0.50	0.50	0.05	0.45	0.45
Sat Flow, veh/h	3456	3554	1553	3456	3554	1585	3456	3554	1565	3456	3554	1565
Grp Volume(v), veh/h	135	503	142	83	408	98	271	1009	231	97	563	149
Grp Sat Flow(s),veh/h/ln	1728	1777	1553	1728	1777	1585	1728	1777	1565	1728	1777	1565
Q Serve(g_s), s	3.8	13.4	8.2	2.4	10.7	5.4	7.7	19.7	8.6	2.8	10.3	5.8
Cycle Q Clear(g_c), s	3.8	13.4	8.2	2.4	10.7	5.4	7.7	19.7	8.6	2.8	10.3	5.8
Prop In Lane	1.00		1.00	1.00		1.00	1.00		1.00	1.00		1.00
Lane Grp Cap(c), veh/h	187	662	289	156	630	281	336	1788	787	161	1608	708
V/C Ratio(X)	0.72	0.76	0.49	0.53	0.65	0.35	0.81	0.56	0.29	0.60	0.35	0.21
Avail Cap(c_a), veh/h	187	1208	528	187	1208	539	359	1788	787	187	1608	708
HCM Platoon Ratio	1.00	1.00	1.00	1.00	1.00	1.00	1.00	1.00	1.00	1.00	1.00	1.00
Upstream Filter(I)	1.00	1.00	1.00	1.00	1.00	1.00	1.00	1.00	1.00	1.00	1.00	1.00
Uniform Delay (d), s/veh	46.6	38.6	36.4	46.7	38.2	36.1	44.2	17.2	14.5	46.8	17.8	16.6
Incr Delay (d2), s/veh	11.4	1.8	1.3	1.1	1.1	0.7	10.9	1.3	0.9	2.0	0.6	0.7
Initial Q Delay(d3),s/veh	0.0	0.0	0.0	0.0	0.0	0.0	0.0	0.0	0.0	0.0	0.0	0.0
%ile BackOfQ(50%),veh/ln	1.9	5.7	0.1	1.0	4.5	2.0	3.6	7.4	2.9	1.2	3.9	2.0
Unsig. Movement Delay, s/veh												
LnGrp Delay(d),s/veh	57.9	40.4	37.7	47.8	39.4	36.8	55.1	18.5	15.4	48.7	18.4	17.2
LnGrp LOS	E	D	D	D	D	D	E	B	B	D	B	B
Approach Vol, veh/h		780			589			1511			809	
Approach Delay, s/veh		42.9			40.1			24.6			21.8	
Approach LOS		D			D			C			C	
Timer - Assigned Phs	1	2	3	4	5	6	7	8				
Phs Duration (G+Y+Rc), s	9.3	56.8	9.1	24.8	14.3	51.7	10.0	23.9				
Change Period (Y+Rc), s	4.6	6.5	4.6	6.2	4.6	6.5	4.6	6.2				
Max Green Setting (Gmax), s	5.4	33.3	5.4	34.0	10.4	28.3	5.4	34.0				
Max Q Clear Time (g_c+I1), s	4.8	21.7	4.4	15.4	9.7	12.3	5.8	12.7				
Green Ext Time (p_c), s	0.0	5.4	0.0	3.2	0.0	3.3	0.0	2.6				
<b>Intersection Summary</b>												
HCM 6th Ctrl Delay				30.4								
HCM 6th LOS				C								



## **DESERT ISLAND HOTEL APPENDIX**

### ***Appendix E***

*Agua Caliente Band of Cahuilla Indians Letter, September  
2022*



03-008-2022-004

September 07, 2022

[VIA EMAIL TO:pilarl@ranchomirageca.gov]  
City of Rancho Mirage  
Pilar Lopez  
68-825 Highway 111  
Rancho Mirage, California 92270

**Re: Desert Island Hotel**

Dear Pilar Lopez,

The Agua Caliente Band of Cahuilla Indians (ACBCI) appreciates your efforts to include the Tribal Historic Preservation Office (THPO) in the Desert Island Hotel project. The project area is not located within the boundaries of the ACBCI Reservation. However, it is within the Tribe's Traditional Use Area. For this reason, the ACBCI THPO requests the following:

\*Copies of any cultural resource documentation (report and site records) generated in connection with this project.

Again, the Agua Caliente appreciates your interest in our cultural heritage. If you have questions or require additional information, please call me at (760)699-6956. You may also email me at ACBCI-THPO@aguacaliente.net.

Cordially,

Lacy Padilla  
Operations Manager  
Tribal Historic Preservation Office  
AGUA CALIENTE BAND  
OF CAHUILLA INDIANS



## **DESERT ISLAND HOTEL APPENDIX**

### ***Appendix F***

*Comment Letters Received from Initial Circulation of Draft  
IS/MND, May 2023*



P: (626) 381-9248  
F: (626) 389-5414  
E: info@mitchtsailaw.com

**Mitchell M. Tsai**  
Attorney At Law

139 South Hudson Avenue  
Suite 200  
Pasadena, California 91101

**VIA E-MAIL**

May 23, 2023

Pilar Lopez  
Senior Planner  
City of Rancho Mirage  
69-825 Highway 111  
Rancho Mirage, California 92270  
Em: pilarl@ranchomirageca.gov

**RE: City of Rancho Mirage's Desert Island Hotel Project.**

Dear Pilar Lopez,

On behalf of the Southwest Mountain States Regional Council of Carpenters (“**Southwest Mountain States Carpenters**” or “**SWMSRCC**”), my Office is submitting these comments for the City of Rancho Mirage’s (“**City**”) Desert Island Hotel Project (“**Project**”).

As defined in the Project’s Initial Study/Negative Declaration (**IS/ND**), “The project will repurpose approximately 17.2 acres of the existing Desert Island community with a new 34-key boutique hotel, 11 private residences, hotel grounds for guest use with tennis, pool, café, cabana and yoga amenities, along with additional onsite parking. A new golf training park, and golf maintenance building will replace the existing driving range and old maintenance building that will be eliminated to make room for the new facilities. The proposed hotel is intended for use as a high-end venue with guests booking multi-day overnight stays. The proposed residences will be privately owned, but fully managed and maintained by the hotel operator. The proposed hotel and residences will be located west of the existing clubhouse.” IS/ND, p. 7.

The Southwest Mountain States Carpenters is a labor union representing 63,000 union carpenters in 10 states, including California, and has a strong interest in well-ordered land use planning and in addressing the environmental impacts of development projects. Individual members of SWMSRCC live, work, and recreate in the City and

surrounding communities and would be directly affected by the Project’s environmental impacts.

The Southwest Mountain States Carpenters expressly reserves the right to supplement these comments at or prior to hearings on the Project, and at any later hearing and proceeding related to this Project. Gov. Code, § 65009, subd. (b); Pub. Res. Code, § 21177, subd. (a); see *Bakersfield Citizens for Local Control v. Bakersfield* (2004) 124 Cal.App.4th 1184, 1199-1203; see also *Galante Vineyards v. Monterey Water Dist.* (1997) 60 Cal.App.4th 1109, 1121. The Southwest Mountain States Carpenters incorporates by reference all comments raising issues regarding environmental and land use documents submitted prior to approval of the Project. See *Citizens for Clean Energy v. City of Woodland* (2014) 225 Cal.App.4th 173, 191 (finding that any party who has objected to the project’s environmental documentation may assert any issue timely raised by other parties).

A-1

Moreover, the Southwest Mountain States Carpenters requests that the City provide notice for any and all notices referring or related to the Project issued under the California Environmental Quality Act (**CEQA**) (Pub. Res. Code, § 21000 *et seq.*), and the California Planning and Zoning Law (“**Planning and Zoning Law**”) (Gov. Code, §§ 65000–65010). California Public Resources Code Sections 21092.2, and 21167(f) and California Government Code Section 65092 require agencies to mail such notices to any person who has filed a written request for them with the clerk of the agency’s governing body.

**I. THE CITY SHOULD REQUIRE THE USE OF A LOCAL WORKFORCE TO BENEFIT THE COMMUNITY’S ECONOMIC DEVELOPMENT AND ENVIRONMENT.**

The City should require the Project to be built using a local workers who have graduated from a Joint Labor-Management Apprenticeship Program approved by the State of California, have at least as many hours of on-the-job experience in the applicable craft which would be required to graduate from such a state-approved apprenticeship training program, or who are registered apprentices in a state-approved apprenticeship training program.

A-2

Community benefits such as local hire can also be helpful to reduce environmental impacts and improve the positive economic impact of the Project. Local hire provisions requiring that a certain percentage of workers reside within 10 miles or less

of the Project site can reduce the length of vendor trips, reduce greenhouse gas emissions, and provide localized economic benefits. As environmental consultants Matt Hagemann and Paul E. Rosenfeld note:

[A]ny local hire requirement that results in a decreased worker trip length from the default value has the potential to result in a reduction of construction-related GHG emissions, though the significance of the reduction would vary based on the location and urbanization level of the project site.

March 8, 2021, SWAPE Letter to Mitchell M. Tsai re Local Hire Requirements and Considerations for Greenhouse Gas Modeling.

Workforce requirements promote the development of skilled trades that yield sustainable economic development. As the California Workforce Development Board and the University of California, Berkeley Center for Labor Research and Education concluded:

[L]abor should be considered an investment rather than a cost—and investments in growing, diversifying, and upskilling California’s workforce can positively affect returns on climate mitigation efforts. In other words, well-trained workers are key to delivering emissions reductions and moving California closer to its climate targets.<sup>1</sup>

Furthermore, workforce policies have significant environmental benefits given that they improve an area’s jobs-housing balance, decreasing the amount and length of job commutes and the associated greenhouse gas (GHG) emissions. In fact, on May 7, 2021, the South Coast Air Quality Management District found that that the “[u]se of a local state-certified apprenticeship program” can result in air pollutant reductions.<sup>2</sup>

---

<sup>1</sup> California Workforce Development Board (2020) Putting California on the High Road: A Jobs and Climate Action Plan for 2030 at p. ii, *available at* <https://laborcenter.berkeley.edu/wp-content/uploads/2020/09/Putting-California-on-the-High-Road.pdf>.

<sup>2</sup> South Coast Air Quality Management District (May 7, 2021) Certify Final Environmental Assessment and Adopt Proposed Rule 2305 – Warehouse Indirect Source Rule – Warehouse Actions and Investments to Reduce Emissions Program, and Proposed Rule 316 – Fees for Rule 2305, Submit Rule 2305 for Inclusion Into the SIP, and Approve Supporting Budget Actions, *available at* <http://www.aqmd.gov/docs/default-source/Agendas/Governing-Board/2021/2021-May7-027.pdf?sfvrsn=10>.

Locating jobs closer to residential areas can have significant environmental benefits. As the California Planning Roundtable noted in 2008:

People who live and work in the same jurisdiction would be more likely to take transit, walk, or bicycle to work than residents of less balanced communities and their vehicle trips would be shorter. Benefits would include potential reductions in both vehicle miles traveled and vehicle hours traveled.<sup>3</sup>

Moreover, local hire mandates and skill-training are critical facets of a strategy to reduce vehicle miles traveled (“**VMT**”). As planning experts Robert Cervero and Michael Duncan have noted, simply placing jobs near housing stock is insufficient to achieve VMT reductions given that the skill requirements of available local jobs must match those held by local residents.<sup>4</sup> Some municipalities have even tied local hire and other workforce policies to local development permits to address transportation issues. Cervero and Duncan note that:

In nearly built-out Berkeley, CA, the approach to balancing jobs and housing is to create local jobs rather than to develop new housing. The city’s First Source program encourages businesses to hire local residents, especially for entry- and intermediate-level jobs, and sponsors vocational training to ensure residents are employment-ready. While the program is voluntary, some 300 businesses have used it to date, placing more than 3,000 city residents in local jobs since it was launched in 1986. When needed, these carrots are matched by sticks, since the city is not shy about negotiating corporate participation in First Source as a condition of approval for development permits.

Recently, the State of California verified its commitment towards workforce development through the Affordable Housing and High Road Jobs Act of 2022, otherwise known as Assembly Bill No. 2011 (“**AB2011**”). AB2011 amended the

---

<sup>3</sup> California Planning Roundtable (2008) Deconstructing Jobs-Housing Balance at p. 6, available at <https://cproundtable.org/static/media/uploads/publications/cpr-jobs-housing.pdf>

<sup>4</sup> Cervero, Robert and Duncan, Michael (2006) Which Reduces Vehicle Travel More: Jobs-Housing Balance or Retail-Housing Mixing? Journal of the American Planning Association 72 (4), 475-490, 482, available at <http://reconnectingamerica.org/assets/Uploads/UTCT-825.pdf>.



Planning and Zoning Law to allow ministerial, by-right approval for projects being built alongside commercial corridors that meet affordability and labor requirements.

The City should consider utilizing local workforce policies and requirements to benefit the local area economically and to mitigate greenhouse gas, improve air quality, and reduce transportation impacts.

## **II. THE CITY SHOULD IMPOSE TRAINING REQUIREMENTS FOR THE PROJECT'S CONSTRUCTION ACTIVITIES TO PREVENT COMMUNITY SPREAD OF COVID-19 AND OTHER INFECTIOUS DISEASES.**

Construction work has been defined as a Lower to High-risk activity for COVID-19 spread by the Occupational Safety and Health Administration. Several construction sites have been identified as sources of community spread of COVID-19.<sup>5</sup>

Southwest Mountain States Carpenters recommend that the Lead Agency adopt additional requirements to mitigate public health risks from the Project's construction activities. SWMSRCC requests that the Lead Agency require safe on-site construction work practices as well as training and certification for any construction workers on the Project Site.

In particular, based upon Southwest Mountain States Carpenters' experience with safe construction site work practices, SWMSRCC recommends that the Lead Agency require that while construction activities are being conducted at the Project Site:

### **Construction Site Design:**

- The Project Site will be limited to two controlled entry points.
- Entry points will have temperature screening technicians taking temperature readings when the entry point is open.
- The Temperature Screening Site Plan shows details regarding access to the Project Site and Project Site logistics for conducting temperature screening.

---

<sup>5</sup> Santa Clara County Public Health (June 12, 2020) COVID-19 CASES AT CONSTRUCTION SITES HIGHLIGHT NEED FOR CONTINUED VIGILANCE IN SECTORS THAT HAVE REOPENED, available at <https://www.sccgov.org/sites/covid19/Pages/press-release-06-12-2020-cases-at-construction-sites.aspx>.

A-2

A-3

- A 48-hour advance notice will be provided to all trades prior to the first day of temperature screening.
- The perimeter fence directly adjacent to the entry points will be clearly marked indicating the appropriate 6-foot social distancing position for when you approach the screening area. Please reference the Apex temperature screening site map for additional details.
- There will be clear signage posted at the project site directing you through temperature screening.
- Provide hand washing stations throughout the construction site.

**Testing Procedures:**

- The temperature screening being used are non-contact devices.
- Temperature readings will not be recorded.
- Personnel will be screened upon entering the testing center and should only take 1-2 seconds per individual.
- Hard hats, head coverings, sweat, dirt, sunscreen or any other cosmetics must be removed on the forehead before temperature screening.
- Anyone who refuses to submit to a temperature screening or does not answer the health screening questions will be refused access to the Project Site.
- Screening will be performed at both entrances from 5:30 am to 7:30 am.; main gate [ZONE 1] and personnel gate [ZONE 2]
- After 7:30 am only the main gate entrance [ZONE 1] will continue to be used for temperature testing for anybody gaining entry to the project site such as returning personnel, deliveries, and visitors.

- If the digital thermometer displays a temperature reading above 100.0 degrees Fahrenheit, a second reading will be taken to verify an accurate reading.
- If the second reading confirms an elevated temperature, DHS will instruct the individual that he/she will not be allowed to enter the Project Site. DHS will also instruct the individual to promptly notify his/her supervisor and his/her human resources (HR) representative and provide them with a copy of Annex A.

### **Planning**

- Require the development of an Infectious Disease Preparedness and Response Plan that will include basic infection prevention measures (requiring the use of personal protection equipment), policies and procedures for prompt identification and isolation of sick individuals, social distancing (prohibiting gatherings of no more than 10 people including all-hands meetings and all-hands lunches) communication and training and workplace controls that meet standards that may be promulgated by the Center for Disease Control, Occupational Safety and Health Administration, Cal/OSHA, California Department of Public Health or applicable local public health agencies.<sup>6</sup>

The United Brotherhood of Carpenters and Carpenters International Training Fund has developed COVID-19 Training and Certification to ensure that Carpenter union members and apprentices conduct safe work practices. The Agency should require that all construction workers undergo COVID-19 Training and Certification before being allowed to conduct construction activities at the Project Site.

---

<sup>6</sup> See also The Center for Construction Research and Training, North America's Building Trades Unions (April 27 2020) NABTU and CPWR COVID-19 Standards for U.S. Construction Sites, available at [https://www.cpwr.com/sites/default/files/NABTU\\_CPWR\\_Standards\\_COVID-19.pdf](https://www.cpwr.com/sites/default/files/NABTU_CPWR_Standards_COVID-19.pdf); Los Angeles County Department of Public Works (2020) Guidelines for Construction Sites During COVID-19 Pandemic, available at [https://dpw.lacounty.gov/building-and-safety/docs/pw\\_guidelines-construction-sites.pdf](https://dpw.lacounty.gov/building-and-safety/docs/pw_guidelines-construction-sites.pdf).

Southwest Mountain States Carpenters has also developed a rigorous Infection Control Risk Assessment (“**ICRA**”) training program to ensure it delivers a workforce that understands how to identify and control infection risks by implementing protocols to protect themselves and all others during renovation and construction projects in healthcare environments.<sup>7</sup>

ICRA protocols are intended to contain pathogens, control airflow, and protect patients during the construction, maintenance and renovation of healthcare facilities. ICRA protocols prevent cross contamination, minimizing the risk of secondary infections in patients at hospital facilities.

The City should require the Project to be built using a workforce trained in ICRA protocols.

### **III. THE PROJECT WOULD BE APPROVED IN VIOLATION OF THE CALIFORNIA ENVIRONMENTAL QUALITY ACT.**

#### **A. Background Concerning the California Environmental Quality Act.**

The California Environmental Quality Act is a California statute designed to inform decision-makers and the public about the potential significant environmental effects of a project. 14 California Code of Regulations (“**CEQA Guidelines**”), § 15002, subd. (a)(1).<sup>8</sup> At its core, its purpose is to “inform the public and its responsible officials of the environmental consequences of their decisions *before* they are made.” *Citizens of Goleta Valley v. Board of Supervisors* (1990) 52 Cal.3d 553, 564.

CEQA directs public agencies to avoid or reduce environmental damage, when possible, by requiring alternatives or mitigation measures. CEQA Guidelines, § 15002, subds. (a)(2)-(3); see also *Berkeley Keep Jets Over the Bay Committee v. Board of Port Comes* (2001) 91 Cal.App.4th 1344, 1354 (“*Berkeley Jets*”); *Citizens of Goleta Valley v. Board of Supervisors* (1990) 52 Cal.3d 553; *Laurel Heights Improvement Assn.*, 47 Cal.3d at p. 400. The EIR serves to provide public agencies and the public in general with information about the effect that a proposed project is likely to have on the

---

<sup>7</sup> For details concerning Southwest Carpenters’ ICRA training program, see <https://icrahealthcare.com/>.

<sup>8</sup> The CEQA Guidelines, codified in Title 14 of the California Code of Regulations, section 15000 et seq., are regulatory guidelines promulgated by the state Natural Resources Agency for the implementation of CEQA. Cal. Pub. Res. Code, § 21083. The CEQA Guidelines are given “great weight in interpreting CEQA except when . . . clearly unauthorized or erroneous.” *Center for Biological Diversity v. Dept. of Fish & Wildlife* (2015) 62 Cal.4th 204, 217.

environment and to “identify ways that environmental damage can be avoided or significantly reduced.” CEQA Guidelines, § 15002, subd. (a)(2). If the project has a significant effect on the environment, the agency may approve the project only upon finding that it has “eliminated or substantially lessened all significant effects on the environment where feasible” and that any unavoidable significant effects on the environment are “acceptable due to overriding concerns” specified in Public Resources Code section 21081. See CEQA Guidelines, § 15092, subds. (b)(2)(A)-(B).

While the courts review an EIR using an ‘abuse of discretion’ standard, the reviewing court is not to *uncritically* rely on every study or analysis presented by a project proponent in support of its position. *Berkeley Jets*, 91 Cal.App.4th at p. 1355 (quoting *Laurel Heights Improvement Assn.*, 47 Cal.3d at pp. 391, 409 fn. 12) (internal quotations omitted). A clearly inadequate or unsupported study is entitled to no judicial deference. *Id.* Drawing this line and determining whether the EIR complies with CEQA’s information disclosure requirements presents a question of law subject to independent review by the courts. *Sierra Club v. County of Fresno* (2018) 6 Cal.5th 502, 515; *Madera Oversight Coalition, Inc. v. County of Madera* (2011) 199 Cal.App.4th 48, 102, 131. As the court stated in *Berkeley Jets*, prejudicial abuse of discretion occurs if the failure to include relevant information precludes informed decision-making and informed public participation, thereby thwarting the statutory goals of the EIR process. 91 Cal.App.4th at p. 1355 (internal quotations omitted).

The preparation and circulation of an EIR is more than a set of technical hurdles for agencies and developers to overcome. *Communities for a Better Environment v. Richmond* (2010) 184 Cal.App.4th 70, 80 (quoting *Vineyard Area Citizens for Responsible Growth, Inc. v. City of Rancho Cordova* (2007) 40 Cal.4th 412, 449-450). The EIR’s function is to ensure that government officials who decide to build or approve a project do so with a full understanding of the environmental consequences and, equally important, that the public is assured those consequences have been considered. *Id.* For the EIR to serve these goals it must present information so that the foreseeable impacts of pursuing the project can be understood and weighed, and the public must be given an adequate opportunity to comment on that presentation before the decision to go forward is made. *Id.*

A strong presumption in favor of requiring preparation of an EIR is built into CEQA. This presumption is reflected in what is known as the “fair argument” standard under which an EIR must be prepared whenever substantial evidence in the record supports

a fair argument that a project may have a significant effect on the environment. *Quail Botanical Gardens Found., Inc. v. City of Encinitas* (1994) 29 Cal.App.4th 1597, 1602; *Friends of “B” St. v. City of Hayward* (1980) 106 Cal.3d 988, 1002.

The fair argument test stems from the statutory mandate that an EIR be prepared for any project that “may have a significant effect on the environment.” PRC, § 21151; see *No Oil, Inc. v. City of Los Angeles* (1974) 13 Cal.App.3d 68, 75; accord *Jensen v. City of Santa Rosa* (2018) 23 Cal.App.5th 877, 884. Under this test, if a proposed project is not exempt and may cause a significant effect on the environment, the lead agency must prepare an EIR. PRC, §§ 21100 (a), 21151; CEQA Guidelines, § 15064 (a)(1), (f)(1). An EIR may be dispensed with only if the lead agency finds no substantial evidence in the initial study or elsewhere in the record that the project may have a significant effect on the environment. *Parker Shattuck Neighbors v. Berkeley City Council* (2013) 222 Cal.App.4th 768, 785. In such a situation, the agency must adopt a negative declaration. PRC, § 21080, subd. (c)(1); CEQA Guidelines, §§ 15063 (b)(2), 15064(f)(3).

“Significant effect upon the environment” is defined as “a substantial or potentially substantial adverse change in the environment.” PRC, § 21068; CEQA Guidelines, § 15382. A project may have a significant effect on the environment if there is a reasonable probability that it will result in a significant impact. *No Oil, Inc.*, 13 Cal.3d at p. 83 fn. 16; see *Sundstrom v. County of Mendocino* (1988) 202 Cal.App.3d 296, 309. If any aspect of the project may result in a significant impact on the environment, an EIR must be prepared even if the overall effect of the project is beneficial. CEQA Guidelines, § 15063(b)(1); see *County Sanitation Dist. No. 2 v. County of Kern* (2005) 127 Cal.App.4th 1544, 1580.

This standard sets a “low threshold” for preparation of an EIR. *Consolidated Irrigation Dist. v. City of Selma* (2012) 204 Cal.App.4th 187, 207; *Nelson v. County of Kern* (2010) 190 Cal.App.4th 252; *Pocket Protectors v. City of Sacramento* (2004) 124 Cal.App.4th 903, 928; *Bowman v. City of Berkeley* (2004) 122 Cal.App.4th 572, 580; *Citizen Action to Serve All Students v. Thornley* (1990) 222 Cal.App.3d 748, 754; *Sundstrom*, 202 Cal.App.3d at p. 310. If substantial evidence in the record supports a fair argument that the project may have a significant environmental effect, the lead agency must prepare an EIR even if other substantial evidence before it indicates the project will have no significant effect. See *Jensen*, 23 Cal.App.5th at p. 886; *Clews Land & Livestock v. City of San Diego* (2017) 19 Cal.App.5th 161, 183; *Stanislaus Audubon Society, Inc. v. County of*



*Stanislaus* (1995) 33 Cal.App.4th 144, 150; *Brentwood Assn. for No Drilling, Inc. v. City of Los Angeles* (1982) 134 Cal.App.3d 491; *Friends of “B” St.*, 106 Cal.App.3d 988; CEQA Guidelines, § 15064(f)(1).

- B. The Project Would be Approved in Violation of CEQA as the Negative Declaration Fails to Support Its Findings With Substantial Evidence; The Negative Declaration Is Also Inadequate and Lacking as a Matter of Law.

Under PRC § 21080(c)-(d), an Agency may prepare a negative declaration in very limited cases:

(c) If a lead agency determines that a proposed project, not otherwise exempt from this division, would not have a significant effect on the environment, the lead agency shall adopt a negative declaration to that effect. The **negative declaration** shall be prepared for the proposed project in **either** of the following circumstances:

(1) There is **no substantial evidence**, in light of the whole record before the lead agency, that the project **may** have a significant effect on the environment.

(2) An initial study identifies potentially significant effects on the environment, **but** (A) revisions in the project plans or proposals made by, or agreed to by, the applicant **before** the proposed negative declaration and initial study are released for public review would avoid the effects or mitigate the effects to a **point** where **clearly no significant** effect on the environment would occur, **and** (B) there is **no substantial evidence**, in light of the whole record before the lead agency, that the project, as revised, **may** have a significant effect on the environment.

(d) **If** there is **substantial evidence**, in light of the whole record before the lead agency, that the project **may** have a significant effect on the environment, an environmental impact report **shall** be prepared.

As such, the City here must prepare an EIR if the Project *may* have impacts and can dispose of an EIR only in case “clearly no significant effects” will occur. The Project does not meet this stringent fair argument standard.

Also, a lead agency must provide substantial evidence to support its findings, which must be based upon facts, reasonable assumptions based on facts, and expert opinion, rather than mere speculation. CEQA Guidelines § 15384, subd. (a); *Save Our Big Trees v.*

A-4

A-5

*City of Santa Cruz* (2015) 241 Cal.App.4th 694, 710-711 citing *Muzzy Ranch Co. v. Solano County Airport Land Use Com.* (2007) 41 Cal.4th 372, 386.

Here, despite the mass and scale of the Project extending on 17.2 acres of land, the Project’s ND (Negative Declaration) concludes the Project will have no significant impacts. Such findings, however, fall short of the low bar of the fair argument to support an ND. Specifically, there is a fair argument that the Project, with its mass and scale and proposed density and intensity, may have impacts on traffic, aesthetics, hazards and hazardous materials, biological resources, geology and soils, hydrology and water, land use and planning, and public service impacts, and therefore requires an EIR to study and mitigate those, as required by CEQA.

*i. There is a fair argument that the Project may have traffic impacts.*

The ND erroneously concludes the Project will not have a significant environmental impact to traffic and congestion, but renders such conclusion without providing substantial evidence to support its finding. The City should conduct a project-specific analysis in the EIR and mitigate the traffic and congestion impacts in order to comply with CEQA’s mandates. As stated earlier, while the courts review an EIR using an “abuse of discretion” standard, “the reviewing court is not to ‘uncritically rely on every study or analysis presented by a project proponent in support of its position. A ‘clearly inadequate or unsupported study is entitled to no judicial deference.’” (*Berkeley Jets, supra*, 91 Cal.App.4th 1344, 1355, [quoting *Laurel Heights Improvement Ass’n v. Regents of University of Cal.* (1988) 47 Cal.3d 376, 391 409, fn. 12].)

The ND states that the “hotel will take primary access from the existing Desert Island main gate on Frank Sinatra Drive. Currently, the main gate remains closed to the public, however, to eliminate potential vehicle stacking on Frank Sinatra Drive, the project proposes to keep the gates open during operating hours. Additionally, the resident gate and turnaround on Island Drive will be retained in its existing condition without change. Secondary access to Frank Sinatra Drive will be accommodated by widening the existing gated entry at the northwest corner of the golf course from 12-foot to 24 feet to provide secondary emergency vehicle access.” ND, page 9. This shows that the City is aware that there may be significant traffic and congestion impacts and is mitigating the impacts by opening the main gate to eliminate vehicle stacking and widening the secondary access to Frank Sinatra Drive in order to allow for easier traffic circulation. The City should be required to provide a comprehensive analysis on mitigating traffic and congestion in order to determine whether such

A-5

A-6



measures are sufficient to address the inevitable traffic and congestion impacts. It must also address and study the impacts of that very mitigation measure of “opening the main gate to eliminate vehicle stacking and widening the secondary access to Frank Sinatra Drive.”

In addition, it is likely that such mitigation measures posed by the City here are insufficient. For example, it is very likely that the resident gate and turnaround on Island Drive may require expansion or some other change, as the City claims “it will be retained in its existing condition without change.” *Id.* There are no guarantees that would be the case. As such, the City should require respective conditions of approval or restrictive covenants in all land use documents, include leases, to ensure that the resident gate and turnaround on Island Drive will indeed be retained in its existing condition; the City should also impose a condition of approval that – in the event a change is proposed later – then a new discretionary approval would be required.

As a result, the ND erroneously concludes the Project will not have significant traffic impacts, but renders such conclusion without providing substantial evidence to support the finding. The ND’s no impact findings are also fatally lacking, as a matter of law, for failure to account for the traffic impacts of the mitigation measures and for relying on unsupported speculations that no further expansion will take place, including as a result of the dramatic increase in the intensity and density of land uses the Project proposes.

ii. *There is a fair argument that the Project may have aesthetics impacts.*

The ND concedes that “[t]he subjective value of views is generally affected by the presence and intensity of neighboring man-made improvements, such as structures, overhead utilities, and landscaping, often in relation to the aesthetic quality offered by a natural background that may include open space, mountain ranges, or a natural landmark feature. The proximity and massing of structures, landscaping and other visual barriers interact with the visibility of surrounding environments to restrict or enhance the value of local scenic views. The evaluation of scenic vistas takes into consideration the physical compatibility of proposed projects in relation to land uses, transportation corridors, or other vantage points, where the enjoyment of unique vistas may exist, such as residential areas or scenic roads.” *Id.* at 14.

The City claims that the Project will not result in any significant environmental impact to aesthetics because the Desert Island Specific Plan contemplated the Project.

A-6

A-7

However, a closer read of the Desert Island Specific Plan will show that this is not factually accurate. The Desert Island Specific Plan contemplated the construction of two additional residential towers along with tennis and clubhouse expansions. *Id.* The Project here far exceeds that scope. The Project includes the development of a 34-key boutique hotel with 11 private residences, outdoor gatherings areas, a pool, a yoga facility, a new golf training park, a maintenance building with parking. *Id.* Moreover, the proposed hotel will include four (4) one-story buildings. Because such developments, and their consequential environmental impacts, were not contemplated or studied in the Desert Island Specific Plan, the City must conduct a comprehensive environmental assessment to account for these new and additional developments and draft an EIR to mitigate such impacts. Because the proposed Project was, in fact, *not* contemplated by the Desert Island Specific Plan, the City’s argument that there is no impact to aesthetics fails as wholly unsupported.

Also, the ND states that “Existing sources of light and glare surrounding the project are primarily attributed to the existing residential buildings southeast of the project and the clubhouse east of the project. The lighting utilized for the residential buildings typically consists of low-intensity, wall-mounted or postmounted, downward-oriented fixtures illuminating sidewalks, doorways, outdoor areas, signs, landscaping, and parking lots.” *Id.* at 31.

As such, the proposed Project will contribute greatly to the light impacts to the surrounding neighborhood. This is because the “Project development includes a 34-key hotel with supporting amenities, 11 residential units, a golf training facility, a maintenance building, overflow parking area, and associated infrastructure.” *Id.* Although the ND declares that the Project will utilize low-intensity and non-reflective lights, there is no guarantee for such optimism and no analysis that evaluates what the overall cumulative impacts will be from using such lights; neither is there any enforceable mitigation measure by which to gauge that such lights will be used so as not to impact the adjacent residential community or migratory birds.

In addition, the ND concedes that the current topography remains relatively flat: “The approximately 17.2-acre project site has been previously developed, and currently operates as a part of the Desert Island golf course and overflow parking area. The site exhibits a predominantly flat topography with parking stalls, landscaped golf features, developed drive aisles, clubhouse, and maintenance building.” *Id.* at 15.

The proposed developments here will significantly change the flat topography and obstruct views of scenic vistas.

For these reasons, a comprehensive environmental assessment must be conducted and the City should draft an EIR to study and mitigate the Project's reasonably foreseeable and in fact inevitable environmental impacts to aesthetics.

*iii. There is a fair argument that the Project may have hazards and hazardous materials impacts.*

The ND lacks an adequate analysis of whether the Project would create a significant hazard to the public or the environment through the routine transport, use, or disposal of hazardous materials, including both during the construction and operation of the Project. The IS/MND also lacks the necessary analysis to adequately determine whether the Project would create a significant hazard to the public or the environment through reasonably foreseeable upset and accident conditions involving the release of hazardous materials into the environment.

The Project's construction will involve the management and use of oils, fuels and other potentially flammable substances. ND, page 74. The ND does not state the quantities or nature of these products, but rather states that it "would be limited to what is necessary to carry out construction of the project." *Id.* The Project anticipates the transportation of hazardous materials to the Project site as well as the storage of the same in designated controlled areas at the Project site. *Id.*

The ND does not state where such hazardous materials will be stored or what protocols will be followed in the transportation or storage of such materials, but rather states that "the risk involved with handling these materials is considerably reduced" if the materials are "handled properly by trained individuals and consistent with the manufacturer's instructions." *Id.* at 74. As such, the ND concedes that there may be a risk in handling and transportation of such materials, but fails to provide any discussion about what those risks are, who those risks can affect, any potential environmental impacts that may result from such risks, and enforceable and binding ways to mitigate damages resulting therefrom.

Further, the ND states that "perimeter controls (fencing with wind screen), linear sediment barriers (gravel bags, fiber rolls, or silt fencing), and access restrictions (gates) would help prevent temporary impacts." *Id.* at 74. However, it is not clear where such controls will be placed, in what quantities, what impacts such controls will be reducing,

A-7

A-8

and whether such controls are effective at reducing the environmental impacts anticipated during the Project’s construction. The ND states that “[w]ith such standard measures in place, less than significant impacts are anticipated during construction.” *Id.*

Apart from being unsupported, the ND’s reliance on standard or regulatory measures is legally improper in an ND context. CEQA expressly prohibits the City’s blanket inference that compliance with regulations will necessarily and automatically reduce impacts to the level of insignificance, especially for purposes of *fair argument* in NDs, as here. “Compliance with the threshold does not relieve a lead agency of the obligation to consider substantial evidence indicating that the project’s environmental effects may still be significant.” CEQA Guidelines § 15064(b)(2) (emph. added). In fact, the City’s above-noted reasoning and reliance on thresholds or regulatory compliance has been rejected since 2002:

“In the wake of our decision in *Communities for a Better Environment*, however, **such thresholds cannot** be used to determine **automatically** whether a given effect will or will not be significant. . . . notwithstanding compliance with a pertinent threshold of significance, the agency **must still** consider **any fair** argument that a certain environmental effect **may** be significant.” *Protect the Historic Amador Waterways v. Amador Water Agency* (2004) 116 Cal.App.4th 1099, 1108–1109 (“*Amador*”), referencing *Communities for a Better Environment v. California Resources Agency* (2002) 103 Cal.App.4th 98, 110-114, which invalidated the proposed Guidelines 15064(h) for fair argument. (Emph. added).

In addition, for impacts during the Project’s operations, the ND states that the hazardous materials that would be used “involve the handling and application of cleaning agents, building maintenance products, paints and solvents, and similar items [that will] be stored on-site.” *Id.* The ND circumvents any discussion about the quantity, nature, use, handling, and storage of such materials, and merely states “[t]hese potentially hazardous materials would not be present in significant quantities to pose a significant hazard to public health and safety or the environment.” *Id.*

In rendering its less than significant finding, the ND relies on regulatory compliance without conducting any fact specific analysis. It states, “By following the appropriate federal, state, and regional regulatory standards, less than significant impacts are

expected pertaining to significant hazards to the public or the environment through the routine transport, use, or disposal of hazardous materials, and accident conditions involving the release of hazardous materials into the environment. Less than significant impacts are expected.” *Id.* As noted earlier, such reliance on regulatory compliance is legally improper for purposes of the ND.

The ND has provided little to no information to adequately conclude that there will be a “less than significant impact” with respect to hazards and hazardous materials and deferring such critical analysis to after the Project is approved violates CEQA. *See San Joaquin Raptor Rescue Center v. County of Merced* (2007) 149 Cal. App. 4th 645 (mitigation measures requiring future surveys and management plans for listed wildlife species improperly deferred analysis and rendered an EIR inadequate); *see also Preserve Wild Santee v. City of Santee* (2012) 210 Cal. App. 4th 260 (found an impermissible deferral of mitigation to address a protected species, the Quino checkerspot butterfly).

In sum, the City should be required to provide specific information on hazards and hazardous materials before the Project can proceed and before its ND could be issued. The ND fails to describe: (i) the nature, quantity, and types of hazardous materials that will be transported to and used at the Project site; (ii) the types of risks associated with the handling of such materials; or (iii) any potential mitigation measures to prevent or lower risks from such hazardous materials to human health and the environment. Without an adequate analysis of what the Project operations will entail, including what measures the Applicant will propose to protect employees, visitors, and the natural environment from foreseeable spills and accidents in the transport, handling, and use of such hazardous materials, the City lacks substantial evidence to support its hazard findings in the ND and there is a fair argument that the Project, on the known facts, may indeed have hazards impacts, requiring an EIR.

*iv. There is a fair argument the Project may have impacts to biological resources.*

The ND claims that “given the project sites current use as a golf course, and its proximity to other existing development, the project site would not be expected to be a part of or contain migratory wildlife corridors or native wildlife nursery sites. The project is site not located near any existing drainages that would support wildlife corridors nor is it located in a known wildlife corridor. Therefore, the proposed project will not interfere with movement of any native resident or migratory fish or wildlife species and no impacts are expected.” *Id.* at 45.

A-8

A-9

However, Coachella Valley is known to have migratory birds fly through. “When snow birds return to the desert from northern climes, migratory birds are arriving here from all over the Americas. We have a rare inland climate that supports active bird populations throughout the winter months. This is the payoff for living here, because while everywhere else it's dormant and cold, the birds and bees also enjoy the winter sun and warm days.”<sup>9</sup>

A-9

Because the Coachella Valley is known for having migratory birds pass through, a comprehensive environmental analysis should be conducted to determine the Project's light and noise impacts to these migratory species and an EIR should be drafted to include mitigation measures to reduce such impacts.

*v. There is a fair argument the Project may have impacts to geology and soils.*

The ND provides: “Seismically induced ground shaking is anticipated in the entire Coachella Valley, due to the multiple northwest-southeast trending faults in the region. Although these faults produced the unique topography in the Coachella Valley (high mountain ranges and a low valley floor), the major faults, such as the San Andreas Fault, have the potential to produce strong shaking during a seismic event. The strength of ground shaking is accredited to the distance from the fault; where the intensity of the seismic shaking decreases the further it is from the causative fault. The Rancho Mirage 2017 General Plan Update Safety Element indicates that ground shaking during an earthquake is the most significant seismic hazard that will impact Rancho Mirage.” *Id.* at page 62.

A-10

In fact, the approximately 17.2-acre Project property proposes the development of a 34-key boutique hotel, 11 private duplex-style residences, outdoor gathering areas and amenities, expanded onsite parking, a golf training park, a new maintenance building, and associated improvements. The ND's admissions of seismic impacts potential along with the mass of the Project creates a fair argument that the Project may exacerbate the impacts on the environment.

Yet, the ND does not provide any analysis on the safety of the Project site against strong seismic ground shaking, and instead relies on regulatory compliance in

---

<sup>9</sup> Desert Sun (2017) “Many birds visit the Coachella Valley in the winter. Make your backyard a wildlife oasis” *available at*, <https://www.desertsun.com/story/life/home-garden/maureen-gilmer/2017/11/17/many-birds-visit-coachella-valley-winter-make-your-backyard-wildlife-oasis/862734001/>.



rendering a less than significant impact. It reads: “To ensure the safety of the project site against strong seismic ground shaking, structures shall be designed and constructed in accordance with the most current edition of the California Building Code (CBC). The project shall comply with the most current seismic design coefficients and ground motion parameters and all applicable provisions of the CBC.” *Id.* Yet, as mentioned earlier, the City’s reliance on regulatory compliance is legally improper. Moreover, there is no evidence that the CBC was enacted to reduce and mitigate the impacts of any project on the environment to the level of insignificance, required for an ND here.

Moreover, not only does the ND erroneously conclude that the Project’s impacts are “less than significant,” it defers any analysis of such impacts for after the Project is approved. The ND has provided little to no information to adequately conclude that there will be a “less than significant impact” on seismically induced ground shaking and deferring such critical analysis to after the Project is approved does not comport with CEQA. *See San Joaquin Raptor Rescue Center v. County of Merced* (2007) 149 Cal. App. 4th 645 (mitigation measures requiring future surveys and management plans for listed wildlife species improperly deferred analysis and rendered an EIR inadequate); *see also Preserve Wild Santee v. City of Santee* (2012) 210 Cal. App. 4th 260 (found an impermissible deferral of mitigation to address a protected species, the Quino checkerspot butterfly).

The City should be required to provide such information and study/mitigate the Project’s geology impacts before issuing an ND and before the Project can proceed.

*vi. There is a fair argument the Project may have hydrology and water impacts.*

CEQA requires the City to quantify and analyze the Project’s impact on water resources. The City should analyze whether the Project will need to rely upon groundwater resources, and if so, the amount of groundwater it will be relying on in order to supply the Project. This Project lies within the Indio Subbasin, which is governed by the Sustainable Groundwater Management Act (“**SGMA**”), a state law requiring that groundwater basins are managed to achieve sustainability. The Coachella Valley Water District submitted the Coachella Valley Water Management Plan (“**Alternative Plan**”) as an alternative to SGMA’s required Groundwater Sustainability Plan, which was approved by the Department of Water Resources in 2019.

Coachella Valley Water District claims that recharge of the Coachella Valley Groundwater Basin is “possible due to a supply of imported water from the State

A-10

A-11

Water Project and the Colorado River.”<sup>10</sup> However, State Water Project and Colorado River water resources are decreasing given the current state of our climate. On March 28, 2022, the California Governor called on all water agencies to move to Level 2 of their Water Shortage Contingency Plans and take conservation actions to reduce water use. Negative Declaration, page 83. The Director of California’s Department of Water Resources (“DWR”) stated, “[w]e are experiencing climate change whiplash in real time” and “[w]hile we had hoped for more rain and snow, DWR has been preparing for a third consecutive year of drought” by reducing State Water Project allocation to 5% of requested supplies for 2022, which is 10% less than the 15% allocation previously set by DWR.<sup>11</sup> The Colorado River is also in an extreme state of drought, with water supply at historically low levels. The U.S. Department of Interior stated that “[p]rolonged drought and low runoff conditions accelerated by climate change have led to historically low water levels in Lakes Powell and Mead,”<sup>12</sup> and in August 2021, federal officials cut Colorado River water allocations to several southwestern states.<sup>13</sup>

A-11

Without a detailed assessment of the Project’s water demands, it is unclear whether it will be able to meet or significantly impact the Alternative Plan’s goal to reliably meet current and future water demands in a sustainable yet cost-effective manner.

*vii. The Project is not consistent with the City’s land use and planning policies, suggesting that the Project may have land use impacts.*

The project is located within the Desert Island and Desert Island Specific Plan area. As stated above, the City claims that the Project will not result in any significant environmental impacts because the Desert Island Specific Plan contemplated the Project. However, a closer read of the Desert Island Specific Plan will show that this

A-12

<sup>10</sup> Coachella Valley Water District (2022) Groundwater Replenishment and Imported Water, available at <http://www.cvwd.org/162/Groundwater-Replenishment-Imported-Water>.

<sup>11</sup> California Department of Water Resources (2022) Historically Dry Conditions Impact Planned State Water Project Deliveries, available at <https://water.ca.gov/news/news-releases/2022/march-22/swp-allocation-march#:~:text=%E2%80%9CWhile%20we%20had%20hoped%20for,deliveries%20for%20millions%20of%20Californians.%E2%80%9D>

<sup>12</sup> U.S. Department of Interior Press Releases (2022) Interior Department Announces Actions To Protect Colorado River System, Sets 2023 Operating Conditions for Lake Powell and Lake Mead, available at <https://www.doi.gov/pressreleases/interior-department-announces-actions-protect-colorado-river-system-sets-2023>.

<sup>13</sup> UCLA Newsroom (2022) Megadrought in Southwestern North America Is Region’s Driest In At Least 1,200 Years, available at <https://newsroom.ucla.edu/releases/megadrought-southwestern-north-america>.



is not factually accurate. The Desert Island Specific Plan contemplated the construction of two additional residential towers along with tennis and clubhouse expansions. *Id.* However, the Project here involves more than what was contemplated by the Specific Plan. The Project includes the development of a 34-key boutique hotel with 11 private residences, outdoor gatherings areas, tennis, pool, and yoga facilities, a new golf training park, expanded onsite parking, and a maintenance building with parking. *Id.* Moreover, the proposed hotel will include four (4) one-story buildings. The existing driving range and maintenance building will be removed to make room for the new facilities. The new hotel, in conjunction with the existing clubhouse, are intended to be used as a high-end wedding venue with guests booking overnight stays. Because such developments are not contemplated in the Desert Island Specific Plan, the Project is inconsistent with the City’s land use and planning policies.

A-12

viii. *The ND fails to support its public services impacts with substantial evidence.*

The ND states that the “hotel will take primary access from the existing Desert Island main gate on Frank Sinatra Drive. Currently, the main gate remains closed to the public, however, to eliminate potential vehicle stacking on Frank Sinatra Drive, the project proposes to keep the gates open during operating hours. Additionally, the resident gate and turnaround on Island Drive will be retained in its existing condition without change. Secondary access to Frank Sinatra Drive will be accommodated by widening the existing gated entry at the northwest corner of the golf course from 12-feet to 24 feet to provide secondary emergency vehicle access.” ND, page 9.

A-13

As stated above, this demonstrates that the City is aware that there may be a significant impact to public services access such as emergency vehicles/services, and is mitigating the impacts by opening the main gate to eliminate vehicle stacking and widening the secondary access to Frank Sinatra Drive in order to allow for easier traffic circulation. The City should be required to provide a comprehensive analysis on mitigating any impacts to public and emergency services impacts in order to determine whether such measures proposed here are sufficient.

In addition, it is likely that such mitigation measures posed by the City here are insufficient. For example, it is very likely that the resident gate and turnaround on Island Drive may require expansion or some other change, as the City claims “it will be retained in its existing condition without change.” *Id.* As a result, the ND erroneously

concludes the Project will not have significant public services impacts, but renders such conclusion without providing substantial evidence to support the finding.

The ND's findings are also fatally lacking, as a matter of law, for failure to account for the public services impacts, including as a result of the dramatic increase in the intensity and density of land uses the Project proposes.

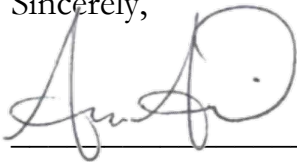
A-13

#### **IV. CONCLUSION.**

In view of the above-noted concerns, SWMSRCC respectfully requests that the City conduct a comprehensive environmental review of the Project and draft an EIR to assess and mitigate the Project's environmental impacts in order to comply with CEQA.

A-14

Sincerely,



---

Armita A. Ariano  
Attorneys for Southwest Mountain  
States Regional Council of Carpenters

Attached:

March 8, 2021, SWAPE Letter to Mitchell M. Tsai re Local Hire Requirements and Considerations for Greenhouse Gas Modeling (Exhibit A);

Air Quality and GHG Expert Paul Rosenfeld CV (Exhibit B); and

Air Quality and GHG Expert Matt Hagemann CV (Exhibit C).

**EXHIBIT A**



Technical Consultation, Data Analysis and  
Litigation Support for the Environment

2656 29<sup>th</sup> Street, Suite 201  
Santa Monica, CA 90405

Matt Hagemann, P.G, C.Hg.  
(949) 887-9013  
[mhagemann@swape.com](mailto:mhagemann@swape.com)

Paul E. Rosenfeld, PhD  
(310) 795-2335  
[prosenfeld@swape.com](mailto:prosenfeld@swape.com)

March 8, 2021

Mitchell M. Tsai  
155 South El Molino, Suite 104  
Pasadena, CA 91101

**Subject: Local Hire Requirements and Considerations for Greenhouse Gas Modeling**

---

Dear Mr. Tsai,

Soil Water Air Protection Enterprise (“SWAPE”) is pleased to provide the following draft technical report explaining the significance of worker trips required for construction of land use development projects with respect to the estimation of greenhouse gas (“GHG”) emissions. The report will also discuss the potential for local hire requirements to reduce the length of worker trips, and consequently, reduced or mitigate the potential GHG impacts.

### Worker Trips and Greenhouse Gas Calculations

The California Emissions Estimator Model (“CalEEMod”) is a “statewide land use emissions computer model designed to provide a uniform platform for government agencies, land use planners, and environmental professionals to quantify potential criteria pollutant and greenhouse gas (GHG) emissions associated with both construction and operations from a variety of land use projects.”<sup>1</sup> CalEEMod quantifies construction-related emissions associated with land use projects resulting from off-road construction equipment; on-road mobile equipment associated with workers, vendors, and hauling; fugitive dust associated with grading, demolition, truck loading, and on-road vehicles traveling along paved and unpaved roads; and architectural coating activities; and paving.<sup>2</sup>

The number, length, and vehicle class of worker trips are utilized by CalEEMod to calculate emissions associated with the on-road vehicle trips required to transport workers to and from the Project site during construction.<sup>3</sup>

---

<sup>1</sup> “California Emissions Estimator Model.” CAPCOA, 2017, available at: <http://www.aqmd.gov/caleemod/home>.

<sup>2</sup> “California Emissions Estimator Model.” CAPCOA, 2017, available at: <http://www.aqmd.gov/caleemod/home>.

<sup>3</sup> “CalEEMod User’s Guide.” CAPCOA, November 2017, available at: [http://www.aqmd.gov/docs/default-source/caleemod/01\\_user-39-s-guide2016-3-2\\_15november2017.pdf?sfvrsn=4](http://www.aqmd.gov/docs/default-source/caleemod/01_user-39-s-guide2016-3-2_15november2017.pdf?sfvrsn=4), p. 34.

Specifically, the number and length of vehicle trips is utilized to estimate the vehicle miles travelled (“VMT”) associated with construction. Then, utilizing vehicle-class specific EMFAC 2014 emission factors, CalEEMod calculates the vehicle exhaust, evaporative, and dust emissions resulting from construction-related VMT, including personal vehicles for worker commuting.<sup>4</sup>

Specifically, in order to calculate VMT, CalEEMod multiplies the average daily trip rate by the average overall trip length (see excerpt below):

$$\text{“VMT}_d = \Sigma(\text{Average Daily Trip Rate}_i * \text{Average Overall Trip Length}_i)_n$$

Where:

$n$  = Number of land uses being modeled.”<sup>5</sup>

Furthermore, to calculate the on-road emissions associated with worker trips, CalEEMod utilizes the following equation (see excerpt below):

$$\text{“Emissions}_{\text{pollutant}} = \text{VMT} * \text{EF}_{\text{running,pollutant}}$$

Where:

$\text{Emissions}_{\text{pollutant}}$  = emissions from vehicle running for each pollutant

VMT = vehicle miles traveled

$\text{EF}_{\text{running,pollutant}}$  = emission factor for running emissions.”<sup>6</sup>

Thus, there is a direct relationship between trip length and VMT, as well as a direct relationship between VMT and vehicle running emissions. In other words, when the trip length is increased, the VMT and vehicle running emissions increase as a result. Thus, vehicle running emissions can be reduced by decreasing the average overall trip length, by way of a local hire requirement or otherwise.

## Default Worker Trip Parameters and Potential Local Hire Requirements

As previously discussed, the number, length, and vehicle class of worker trips are utilized by CalEEMod to calculate emissions associated with the on-road vehicle trips required to transport workers to and from the Project site during construction.<sup>7</sup> In order to understand how local hire requirements and associated worker trip length reductions impact GHG emissions calculations, it is important to consider the CalEEMod default worker trip parameters. CalEEMod provides recommended default values based on site-specific information, such as land use type, meteorological data, total lot acreage, project type and typical equipment associated with project type. If more specific project information is known, the user can change the default values and input project-specific values, but the California Environmental Quality Act (“CEQA”) requires that such changes be justified by substantial evidence.<sup>8</sup> The default number of construction-related worker trips is calculated by multiplying the

---

<sup>4</sup> “Appendix A Calculation Details for CalEEMod.” CAPCOA, October 2017, available at: [http://www.aqmd.gov/docs/default-source/caleemod/02\\_appendix-a2016-3-2.pdf?sfvrsn=6](http://www.aqmd.gov/docs/default-source/caleemod/02_appendix-a2016-3-2.pdf?sfvrsn=6), p. 14-15.

<sup>5</sup> “Appendix A Calculation Details for CalEEMod.” CAPCOA, October 2017, available at: [http://www.aqmd.gov/docs/default-source/caleemod/02\\_appendix-a2016-3-2.pdf?sfvrsn=6](http://www.aqmd.gov/docs/default-source/caleemod/02_appendix-a2016-3-2.pdf?sfvrsn=6), p. 23.

<sup>6</sup> “Appendix A Calculation Details for CalEEMod.” CAPCOA, October 2017, available at: [http://www.aqmd.gov/docs/default-source/caleemod/02\\_appendix-a2016-3-2.pdf?sfvrsn=6](http://www.aqmd.gov/docs/default-source/caleemod/02_appendix-a2016-3-2.pdf?sfvrsn=6), p. 15.

<sup>7</sup> “CalEEMod User’s Guide.” CAPCOA, November 2017, available at: [http://www.aqmd.gov/docs/default-source/caleemod/01\\_user-39-s-guide2016-3-2\\_15november2017.pdf?sfvrsn=4](http://www.aqmd.gov/docs/default-source/caleemod/01_user-39-s-guide2016-3-2_15november2017.pdf?sfvrsn=4), p. 34.

<sup>8</sup> CalEEMod User Guide, available at: <http://www.caleemod.com/>, p. 1, 9.

number of pieces of equipment for all phases by 1.25, with the exception of worker trips required for the building construction and architectural coating phases.<sup>9</sup> Furthermore, the worker trip vehicle class is a 50/25/25 percent mix of light duty autos, light duty truck class 1 and light duty truck class 2, respectively.”<sup>10</sup> Finally, the default worker trip length is consistent with the length of the operational home-to-work vehicle trips.<sup>11</sup> The operational home-to-work vehicle trip lengths are:

“[B]ased on the *location* and *urbanization* selected on the project characteristic screen. These values were *supplied by the air districts or use a default average for the state*. Each district (or county) also assigns trip lengths for urban and rural settings” (emphasis added).<sup>12</sup>

Thus, the default worker trip length is based on the location and urbanization level selected by the User when modeling emissions. The below table shows the CalEEMod default rural and urban worker trip lengths by air basin (see excerpt below and Attachment A).<sup>13</sup>

Worker Trip Length by Air Basin		
Air Basin	Rural (miles)	Urban (miles)
Great Basin Valleys	16.8	10.8
Lake County	16.8	10.8
Lake Tahoe	16.8	10.8
Mojave Desert	16.8	10.8
Mountain Counties	16.8	10.8
North Central Coast	17.1	12.3
North Coast	16.8	10.8
Northeast Plateau	16.8	10.8
Sacramento Valley	16.8	10.8
Salton Sea	14.6	11
San Diego	16.8	10.8
San Francisco Bay Area	10.8	10.8
San Joaquin Valley	16.8	10.8
South Central Coast	16.8	10.8
South Coast	19.8	14.7
<b>Average</b>	<b>16.47</b>	<b>11.17</b>
<b>Minimum</b>	<b>10.80</b>	<b>10.80</b>
<b>Maximum</b>	<b>19.80</b>	<b>14.70</b>
<b>Range</b>	<b>9.00</b>	<b>3.90</b>

<sup>9</sup> “CalEEMod User’s Guide.” CAPCOA, November 2017, available at: [http://www.aqmd.gov/docs/default-source/caleemod/01\\_user-39-s-guide2016-3-2\\_15november2017.pdf?sfvrsn=4](http://www.aqmd.gov/docs/default-source/caleemod/01_user-39-s-guide2016-3-2_15november2017.pdf?sfvrsn=4), p. 34.

<sup>10</sup> “Appendix A Calculation Details for CalEEMod.” CAPCOA, October 2017, available at: [http://www.aqmd.gov/docs/default-source/caleemod/02\\_appendix-a2016-3-2.pdf?sfvrsn=6](http://www.aqmd.gov/docs/default-source/caleemod/02_appendix-a2016-3-2.pdf?sfvrsn=6), p. 15.

<sup>11</sup> “Appendix A Calculation Details for CalEEMod.” CAPCOA, October 2017, available at: [http://www.aqmd.gov/docs/default-source/caleemod/02\\_appendix-a2016-3-2.pdf?sfvrsn=6](http://www.aqmd.gov/docs/default-source/caleemod/02_appendix-a2016-3-2.pdf?sfvrsn=6), p. 14.

<sup>12</sup> “Appendix A Calculation Details for CalEEMod.” CAPCOA, October 2017, available at: [http://www.aqmd.gov/docs/default-source/caleemod/02\\_appendix-a2016-3-2.pdf?sfvrsn=6](http://www.aqmd.gov/docs/default-source/caleemod/02_appendix-a2016-3-2.pdf?sfvrsn=6), p. 21.

<sup>13</sup> “Appendix D Default Data Tables.” CAPCOA, October 2017, available at: [http://www.aqmd.gov/docs/default-source/caleemod/05\\_appendix-d2016-3-2.pdf?sfvrsn=4](http://www.aqmd.gov/docs/default-source/caleemod/05_appendix-d2016-3-2.pdf?sfvrsn=4), p. D-84 – D-86.

As demonstrated above, default rural worker trip lengths for air basins in California vary from 10.8- to 19.8- miles, with an average of 16.47 miles. Furthermore, default urban worker trip lengths vary from 10.8- to 14.7- miles, with an average of 11.17 miles. Thus, while default worker trip lengths vary by location, default urban worker trip lengths tend to be shorter in length. Based on these trends evident in the CalEEMod default worker trip lengths, we can reasonably assume that the efficacy of a local hire requirement is especially dependent upon the urbanization of the project site, as well as the project location.

### Practical Application of a Local Hire Requirement and Associated Impact

To provide an example of the potential impact of a local hire provision on construction-related GHG emissions, we estimated the significance of a local hire provision for the Village South Specific Plan (“Project”) located in the City of Claremont (“City”). The Project proposed to construct 1,000 residential units, 100,000-SF of retail space, 45,000-SF of office space, as well as a 50-room hotel, on the 24-acre site. The Project location is classified as Urban and lies within the Los Angeles-South Coast County. As a result, the Project has a default worker trip length of 14.7 miles.<sup>14</sup> In an effort to evaluate the potential for a local hire provision to reduce the Project’s construction-related GHG emissions, we prepared an updated model, reducing all worker trip lengths to 10 miles (see Attachment B). Our analysis estimates that if a local hire provision with a 10-mile radius were to be implemented, the GHG emissions associated with Project construction would decrease by approximately 17% (see table below and Attachment C).

<b>Local Hire Provision Net Change</b>	
<b>Without Local Hire Provision</b>	
Total Construction GHG Emissions (MT CO <sub>2</sub> e)	3,623
Amortized Construction GHG Emissions (MT CO <sub>2</sub> e/year)	120.77
<b>With Local Hire Provision</b>	
Total Construction GHG Emissions (MT CO <sub>2</sub> e)	3,024
Amortized Construction GHG Emissions (MT CO <sub>2</sub> e/year)	100.80
<b>% Decrease in Construction-related GHG Emissions</b>	<b>17%</b>

As demonstrated above, by implementing a local hire provision requiring 10 mile worker trip lengths, the Project could reduce potential GHG emissions associated with construction worker trips. More broadly, any local hire requirement that results in a decreased worker trip length from the default value has the potential to result in a reduction of construction-related GHG emissions, though the significance of the reduction would vary based on the location and urbanization level of the project site.

This serves as an example of the potential impacts of local hire requirements on estimated project-level GHG emissions, though it does not indicate that local hire requirements would result in reduced construction-related GHG emission for all projects. As previously described, the significance of a local hire requirement depends on the worker trip length enforced and the default worker trip length for the project’s urbanization level and location.

<sup>14</sup> “Appendix D Default Data Tables.” CAPCOA, October 2017, available at: [http://www.aqmd.gov/docs/default-source/caleemod/05\\_appendix-d2016-3-2.pdf?sfvrsn=4](http://www.aqmd.gov/docs/default-source/caleemod/05_appendix-d2016-3-2.pdf?sfvrsn=4), p. D-85.

## Disclaimer

SWAPE has received limited discovery. Additional information may become available in the future; thus, we retain the right to revise or amend this report when additional information becomes available. Our professional services have been performed using that degree of care and skill ordinarily exercised, under similar circumstances, by reputable environmental consultants practicing in this or similar localities at the time of service. No other warranty, expressed or implied, is made as to the scope of work, work methodologies and protocols, site conditions, analytical testing results, and findings presented. This report reflects efforts which were limited to information that was reasonably accessible at the time of the work, and may contain informational gaps, inconsistencies, or otherwise be incomplete due to the unavailability or uncertainty of information obtained or provided by third parties.

Sincerely,

A handwritten signature in blue ink that reads "Matt Hagemann".

Matt Hagemann, P.G., C.Hg.

A handwritten signature in blue ink that reads "Paul Rosenfeld".

Paul E. Rosenfeld, Ph.D.



## Attachment A

<b>Location Type</b>	<b>Location Name</b>	<b>Rural H-W (miles)</b>	<b>Urban H-W (miles)</b>
Air Basin	Great Basin	16.8	10.8
Air Basin	Lake County	16.8	10.8
Air Basin	Lake Tahoe	16.8	10.8
Air Basin	Mojave Desert	16.8	10.8
Air Basin	Mountain	16.8	10.8
Air Basin	North Central	17.1	12.3
Air Basin	North Coast	16.8	10.8
Air Basin	Northeast	16.8	10.8
Air Basin	Sacramento	16.8	10.8
Air Basin	Salton Sea	14.6	11
Air Basin	San Diego	16.8	10.8
Air Basin	San Francisco	10.8	10.8
Air Basin	San Joaquin	16.8	10.8
Air Basin	South Central	16.8	10.8
Air Basin	South Coast	19.8	14.7
Air District	Amador County	16.8	10.8
Air District	Antelope Valley	16.8	10.8
Air District	Bay Area AQMD	10.8	10.8
Air District	Butte County	12.54	12.54
Air District	Calaveras	16.8	10.8
Air District	Colusa County	16.8	10.8
Air District	El Dorado	16.8	10.8
Air District	Feather River	16.8	10.8
Air District	Glenn County	16.8	10.8
Air District	Great Basin	16.8	10.8
Air District	Imperial County	10.2	7.3
Air District	Kern County	16.8	10.8
Air District	Lake County	16.8	10.8
Air District	Lassen County	16.8	10.8
Air District	Mariposa	16.8	10.8
Air District	Mendocino	16.8	10.8
Air District	Modoc County	16.8	10.8
Air District	Mojave Desert	16.8	10.8
Air District	Monterey Bay	16.8	10.8
Air District	North Coast	16.8	10.8
Air District	Northern Sierra	16.8	10.8
Air District	Northern	16.8	10.8
Air District	Placer County	16.8	10.8
Air District	Sacramento	15	10

Air District	San Diego	16.8	10.8
Air District	San Joaquin	16.8	10.8
Air District	San Luis Obispo	13	13
Air District	Santa Barbara	8.3	8.3
Air District	Shasta County	16.8	10.8
Air District	Siskiyou County	16.8	10.8
Air District	South Coast	19.8	14.7
Air District	Tehama County	16.8	10.8
Air District	Tuolumne	16.8	10.8
Air District	Ventura County	16.8	10.8
Air District	Yolo/Solano	15	10
County	Alameda	10.8	10.8
County	Alpine	16.8	10.8
County	Amador	16.8	10.8
County	Butte	12.54	12.54
County	Calaveras	16.8	10.8
County	Colusa	16.8	10.8
County	Contra Costa	10.8	10.8
County	Del Norte	16.8	10.8
County	El Dorado-Lake	16.8	10.8
County	El Dorado-	16.8	10.8
County	Fresno	16.8	10.8
County	Glenn	16.8	10.8
County	Humboldt	16.8	10.8
County	Imperial	10.2	7.3
County	Inyo	16.8	10.8
County	Kern-Mojave	16.8	10.8
County	Kern-San	16.8	10.8
County	Kings	16.8	10.8
County	Lake	16.8	10.8
County	Lassen	16.8	10.8
County	Los Angeles-	16.8	10.8
County	Los Angeles-	19.8	14.7
County	Madera	16.8	10.8
County	Marin	10.8	10.8
County	Mariposa	16.8	10.8
County	Mendocino-	16.8	10.8
County	Mendocino-	16.8	10.8
County	Mendocino-	16.8	10.8
County	Mendocino-	16.8	10.8
County	Merced	16.8	10.8
County	Modoc	16.8	10.8
County	Mono	16.8	10.8
County	Monterey	16.8	10.8
County	Napa	10.8	10.8

County	Nevada	16.8	10.8
County	Orange	19.8	14.7
County	Placer-Lake	16.8	10.8
County	Placer-Mountain	16.8	10.8
County	Placer-	16.8	10.8
County	Plumas	16.8	10.8
County	Riverside-	16.8	10.8
County	Riverside-	19.8	14.7
County	Riverside-Salton	14.6	11
County	Riverside-South	19.8	14.7
County	Sacramento	15	10
County	San Benito	16.8	10.8
County	San Bernardino-	16.8	10.8
County	San Bernardino-	19.8	14.7
County	San Diego	16.8	10.8
County	San Francisco	10.8	10.8
County	San Joaquin	16.8	10.8
County	San Luis Obispo	13	13
County	San Mateo	10.8	10.8
County	Santa Barbara-	8.3	8.3
County	Santa Barbara-	8.3	8.3
County	Santa Clara	10.8	10.8
County	Santa Cruz	16.8	10.8
County	Shasta	16.8	10.8
County	Sierra	16.8	10.8
County	Siskiyou	16.8	10.8
County	Solano-	15	10
County	Solano-San	16.8	10.8
County	Sonoma-North	16.8	10.8
County	Sonoma-San	10.8	10.8
County	Stanislaus	16.8	10.8
County	Sutter	16.8	10.8
County	Tehama	16.8	10.8
County	Trinity	16.8	10.8
County	Tulare	16.8	10.8
County	Tuolumne	16.8	10.8
County	Ventura	16.8	10.8
County	Yolo	15	10
County	Yuba	16.8	10.8
Statewide	Statewide	16.8	10.8

<b>Worker Trip Length by Air Basin</b>		
<b>Air Basin</b>	<b>Rural (miles)</b>	<b>Urban (miles)</b>
Great Basin Valleys	16.8	10.8
Lake County	16.8	10.8
Lake Tahoe	16.8	10.8
Mojave Desert	16.8	10.8
Mountain Counties	16.8	10.8
North Central Coast	17.1	12.3
North Coast	16.8	10.8
Northeast Plateau	16.8	10.8
Sacramento Valley	16.8	10.8
Salton Sea	14.6	11
San Diego	16.8	10.8
San Francisco Bay Area	10.8	10.8
San Joaquin Valley	16.8	10.8
South Central Coast	16.8	10.8
South Coast	19.8	14.7
<b>Average</b>	<b>16.47</b>	<b>11.17</b>
<b>Minimum</b>	<b>10.80</b>	<b>10.80</b>
<b>Maximum</b>	<b>19.80</b>	<b>14.70</b>
<b>Range</b>	<b>9.00</b>	<b>3.90</b>

## Village South Specific Plan (Proposed) - Los Angeles-South Coast County, Annual

**Village South Specific Plan (Proposed)**  
**Los Angeles-South Coast County, Annual**

**1.0 Project Characteristics****1.1 Land Usage**

Land Uses	Size	Metric	Lot Acreage	Floor Surface Area	Population
General Office Building	45.00	1000sqft	1.03	45,000.00	0
High Turnover (Sit Down Restaurant)	36.00	1000sqft	0.83	36,000.00	0
Hotel	50.00	Room	1.67	72,600.00	0
Quality Restaurant	8.00	1000sqft	0.18	8,000.00	0
Apartments Low Rise	25.00	Dwelling Unit	1.56	25,000.00	72
Apartments Mid Rise	975.00	Dwelling Unit	25.66	975,000.00	2789
Regional Shopping Center	56.00	1000sqft	1.29	56,000.00	0

**1.2 Other Project Characteristics**

<b>Urbanization</b>	Urban	<b>Wind Speed (m/s)</b>	2.2	<b>Precipitation Freq (Days)</b>	33
<b>Climate Zone</b>	9			<b>Operational Year</b>	2028
<b>Utility Company</b>	Southern California Edison				
<b>CO2 Intensity (lb/MW hr)</b>	702.44	<b>CH4 Intensity (lb/MW hr)</b>	0.029	<b>N2O Intensity (lb/MW hr)</b>	0.006

**1.3 User Entered Comments & Non-Default Data**

Village South Specific Plan (Proposed) - Los Angeles-South Coast County, Annual

Project Characteristics - Consistent with the DEIR's model.

Land Use - See SWAPE comment regarding residential and retail land uses.

Construction Phase - See SWAPE comment regarding individual construction phase lengths.

Demolition - Consistent with the DEIR's model. See SWAPE comment regarding demolition.

Vehicle Trips - Saturday trips consistent with the DEIR's model. See SWAPE comment regarding weekday and Sunday trips.

Woodstoves - Woodstoves and wood-burning fireplaces consistent with the DEIR's model. See SWAPE comment regarding gas fireplaces.

Energy Use -

Construction Off-road Equipment Mitigation - See SWAPE comment on construction-related mitigation.

Area Mitigation - See SWAPE comment regarding operational mitigation measures.

Water Mitigation - See SWAPE comment regarding operational mitigation measures.

Table Name	Column Name	Default Value	New Value
tblFireplaces	FireplaceWoodMass	1,019.20	0.00
tblFireplaces	FireplaceWoodMass	1,019.20	0.00
tblFireplaces	NumberWood	1.25	0.00
tblFireplaces	NumberWood	48.75	0.00
tblVehicleTrips	ST_TR	7.16	6.17
tblVehicleTrips	ST_TR	6.39	3.87
tblVehicleTrips	ST_TR	2.46	1.39
tblVehicleTrips	ST_TR	158.37	79.82
tblVehicleTrips	ST_TR	8.19	3.75
tblVehicleTrips	ST_TR	94.36	63.99
tblVehicleTrips	ST_TR	49.97	10.74
tblVehicleTrips	SU_TR	6.07	6.16
tblVehicleTrips	SU_TR	5.86	4.18
tblVehicleTrips	SU_TR	1.05	0.69
tblVehicleTrips	SU_TR	131.84	78.27

Village South Specific Plan (Proposed) - Los Angeles-South Coast County, Annual

tblVehicleTrips	SU_TR	5.95	3.20
tblVehicleTrips	SU_TR	72.16	57.65
tblVehicleTrips	SU_TR	25.24	6.39
tblVehicleTrips	WD_TR	6.59	5.83
tblVehicleTrips	WD_TR	6.65	4.13
tblVehicleTrips	WD_TR	11.03	6.41
tblVehicleTrips	WD_TR	127.15	65.80
tblVehicleTrips	WD_TR	8.17	3.84
tblVehicleTrips	WD_TR	89.95	62.64
tblVehicleTrips	WD_TR	42.70	9.43
tblWoodstoves	NumberCatalytic	1.25	0.00
tblWoodstoves	NumberCatalytic	48.75	0.00
tblWoodstoves	NumberNoncatalytic	1.25	0.00
tblWoodstoves	NumberNoncatalytic	48.75	0.00
tblWoodstoves	WoodstoveDayYear	25.00	0.00
tblWoodstoves	WoodstoveDayYear	25.00	0.00
tblWoodstoves	WoodstoveWoodMass	999.60	0.00
tblWoodstoves	WoodstoveWoodMass	999.60	0.00

**2.0 Emissions Summary**

---

Village South Specific Plan (Proposed) - Los Angeles-South Coast County, Annual

**2.1 Overall Construction**

**Unmitigated Construction**

	ROG	NOx	CO	SO2	Fugitive PM10	Exhaust PM10	PM10 Total	Fugitive PM2.5	Exhaust PM2.5	PM2.5 Total	Bio- CO2	NBio- CO2	Total CO2	CH4	N2O	CO2e
Year	tons/yr										MT/yr					
2021	0.1713	1.8242	1.1662	2.4000e-003	0.4169	0.0817	0.4986	0.1795	0.0754	0.2549	0.0000	213.1969	213.1969	0.0601	0.0000	214.6993
2022	0.6904	4.1142	6.1625	0.0189	1.3058	0.1201	1.4259	0.3460	0.1128	0.4588	0.0000	1,721.6826	1,721.6826	0.1294	0.0000	1,724.9187
2023	0.6148	3.3649	5.6747	0.0178	1.1963	0.0996	1.2959	0.3203	0.0935	0.4138	0.0000	1,627.5295	1,627.5295	0.1185	0.0000	1,630.4925
2024	4.1619	0.1335	0.2810	5.9000e-004	0.0325	6.4700e-003	0.0390	8.6300e-003	6.0400e-003	0.0147	0.0000	52.9078	52.9078	8.0200e-003	0.0000	53.1082
<b>Maximum</b>	<b>4.1619</b>	<b>4.1142</b>	<b>6.1625</b>	<b>0.0189</b>	<b>1.3058</b>	<b>0.1201</b>	<b>1.4259</b>	<b>0.3460</b>	<b>0.1128</b>	<b>0.4588</b>	<b>0.0000</b>	<b>1,721.6826</b>	<b>1,721.6826</b>	<b>0.1294</b>	<b>0.0000</b>	<b>1,724.9187</b>



Village South Specific Plan (Proposed) - Los Angeles-South Coast County, Annual

**2.1 Overall Construction**

**Mitigated Construction**

	ROG	NOx	CO	SO2	Fugitive PM10	Exhaust PM10	PM10 Total	Fugitive PM2.5	Exhaust PM2.5	PM2.5 Total	Bio- CO2	NBio- CO2	Total CO2	CH4	N2O	CO2e
Year	tons/yr										MT/yr					
2021	0.1713	1.8242	1.1662	2.4000e-003	0.4169	0.0817	0.4986	0.1795	0.0754	0.2549	0.0000	213.1967	213.1967	0.0601	0.0000	214.6991
2022	0.6904	4.1142	6.1625	0.0189	1.3058	0.1201	1.4259	0.3460	0.1128	0.4588	0.0000	1,721.6823	1,721.6823	0.1294	0.0000	1,724.9183
2023	0.6148	3.3648	5.6747	0.0178	1.1963	0.0996	1.2959	0.3203	0.0935	0.4138	0.0000	1,627.5291	1,627.5291	0.1185	0.0000	1,630.4921
2024	4.1619	0.1335	0.2810	5.9000e-004	0.0325	6.4700e-003	0.0390	8.6300e-003	6.0400e-003	0.0147	0.0000	52.9077	52.9077	8.0200e-003	0.0000	53.1082
<b>Maximum</b>	<b>4.1619</b>	<b>4.1142</b>	<b>6.1625</b>	<b>0.0189</b>	<b>1.3058</b>	<b>0.1201</b>	<b>1.4259</b>	<b>0.3460</b>	<b>0.1128</b>	<b>0.4588</b>	<b>0.0000</b>	<b>1,721.6823</b>	<b>1,721.6823</b>	<b>0.1294</b>	<b>0.0000</b>	<b>1,724.9183</b>

	ROG	NOx	CO	SO2	Fugitive PM10	Exhaust PM10	PM10 Total	Fugitive PM2.5	Exhaust PM2.5	PM2.5 Total	Bio- CO2	NBio-CO2	Total CO2	CH4	N2O	CO2e
<b>Percent Reduction</b>	<b>0.00</b>	<b>0.00</b>	<b>0.00</b>	<b>0.00</b>	<b>0.00</b>	<b>0.00</b>	<b>0.00</b>	<b>0.00</b>	<b>0.00</b>	<b>0.00</b>	<b>0.00</b>	<b>0.00</b>	<b>0.00</b>	<b>0.00</b>	<b>0.00</b>	<b>0.00</b>

Quarter	Start Date	End Date	Maximum Unmitigated ROG + NOX (tons/quarter)	Maximum Mitigated ROG + NOX (tons/quarter)
1	9-1-2021	11-30-2021	1.4103	1.4103
2	12-1-2021	2-28-2022	1.3613	1.3613
3	3-1-2022	5-31-2022	1.1985	1.1985
4	6-1-2022	8-31-2022	1.1921	1.1921
5	9-1-2022	11-30-2022	1.1918	1.1918
6	12-1-2022	2-28-2023	1.0774	1.0774
7	3-1-2023	5-31-2023	1.0320	1.0320
8	6-1-2023	8-31-2023	1.0260	1.0260

Village South Specific Plan (Proposed) - Los Angeles-South Coast County, Annual

9	9-1-2023	11-30-2023	1.0265	1.0265
10	12-1-2023	2-29-2024	2.8857	2.8857
11	3-1-2024	5-31-2024	1.6207	1.6207
		Highest	2.8857	2.8857

**2.2 Overall Operational**  
**Unmitigated Operational**

	ROG	NOx	CO	SO2	Fugitive PM10	Exhaust PM10	PM10 Total	Fugitive PM2.5	Exhaust PM2.5	PM2.5 Total	Bio- CO2	NBio- CO2	Total CO2	CH4	N2O	CO2e
Category	tons/yr										MT/yr					
Area	5.1437	0.2950	10.3804	1.6700e-003		0.0714	0.0714		0.0714	0.0714	0.0000	220.9670	220.9670	0.0201	3.7400e-003	222.5835
Energy	0.1398	1.2312	0.7770	7.6200e-003		0.0966	0.0966		0.0966	0.0966	0.0000	3,896.0732	3,896.0732	0.1303	0.0468	3,913.2833
Mobile	1.5857	7.9962	19.1834	0.0821	7.7979	0.0580	7.8559	2.0895	0.0539	2.1434	0.0000	7,620.4986	7,620.4986	0.3407	0.0000	7,629.0162
Waste						0.0000	0.0000		0.0000	0.0000	207.8079	0.0000	207.8079	12.2811	0.0000	514.8354
Water						0.0000	0.0000		0.0000	0.0000	29.1632	556.6420	585.8052	3.0183	0.0755	683.7567
<b>Total</b>	<b>6.8692</b>	<b>9.5223</b>	<b>30.3407</b>	<b>0.0914</b>	<b>7.7979</b>	<b>0.2260</b>	<b>8.0240</b>	<b>2.0895</b>	<b>0.2219</b>	<b>2.3114</b>	<b>236.9712</b>	<b>12,294.1807</b>	<b>12,531.1519</b>	<b>15.7904</b>	<b>0.1260</b>	<b>12,963.4751</b>

Village South Specific Plan (Proposed) - Los Angeles-South Coast County, Annual

**2.2 Overall Operational**

**Mitigated Operational**

	ROG	NOx	CO	SO2	Fugitive PM10	Exhaust PM10	PM10 Total	Fugitive PM2.5	Exhaust PM2.5	PM2.5 Total	Bio- CO2	NBio- CO2	Total CO2	CH4	N2O	CO2e
Category	tons/yr										MT/yr					
Area	5.1437	0.2950	10.3804	1.6700e-003		0.0714	0.0714		0.0714	0.0714	0.0000	220.9670	220.9670	0.0201	3.7400e-003	222.5835
Energy	0.1398	1.2312	0.7770	7.6200e-003		0.0966	0.0966		0.0966	0.0966	0.0000	3,896.0732	3,896.0732	0.1303	0.0468	3,913.2833
Mobile	1.5857	7.9962	19.1834	0.0821	7.7979	0.0580	7.8559	2.0895	0.0539	2.1434	0.0000	7,620.4986	7,620.4986	0.3407	0.0000	7,629.0162
Waste						0.0000	0.0000		0.0000	0.0000	207.8079	0.0000	207.8079	12.2811	0.0000	514.8354
Water						0.0000	0.0000		0.0000	0.0000	29.1632	556.6420	585.8052	3.0183	0.0755	683.7567
<b>Total</b>	<b>6.8692</b>	<b>9.5223</b>	<b>30.3407</b>	<b>0.0914</b>	<b>7.7979</b>	<b>0.2260</b>	<b>8.0240</b>	<b>2.0895</b>	<b>0.2219</b>	<b>2.3114</b>	<b>236.9712</b>	<b>12,294.1807</b>	<b>12,531.1519</b>	<b>15.7904</b>	<b>0.1260</b>	<b>12,963.4751</b>

	ROG	NOx	CO	SO2	Fugitive PM10	Exhaust PM10	PM10 Total	Fugitive PM2.5	Exhaust PM2.5	PM2.5 Total	Bio- CO2	NBio- CO2	Total CO2	CH4	N2O	CO2e
Percent Reduction	0.00	0.00	0.00	0.00	0.00	0.00	0.00	0.00	0.00	0.00	0.00	0.00	0.00	0.00	0.00	0.00

**3.0 Construction Detail**

**Construction Phase**

Village South Specific Plan (Proposed) - Los Angeles-South Coast County, Annual

Phase Number	Phase Name	Phase Type	Start Date	End Date	Num Days Week	Num Days	Phase Description
1	Demolition	Demolition	9/1/2021	10/12/2021	5	30	
2	Site Preparation	Site Preparation	10/13/2021	11/9/2021	5	20	
3	Grading	Grading	11/10/2021	1/11/2022	5	45	
4	Building Construction	Building Construction	1/12/2022	12/12/2023	5	500	
5	Paving	Paving	12/13/2023	1/30/2024	5	35	
6	Architectural Coating	Architectural Coating	1/31/2024	3/19/2024	5	35	

**Acres of Grading (Site Preparation Phase): 0**

**Acres of Grading (Grading Phase): 112.5**

**Acres of Paving: 0**

**Residential Indoor: 2,025,000; Residential Outdoor: 675,000; Non-Residential Indoor: 326,400; Non-Residential Outdoor: 108,800; Striped Parking Area: 0 (Architectural Coating – sqft)**

**OffRoad Equipment**

## Village South Specific Plan (Proposed) - Los Angeles-South Coast County, Annual

Phase Name	Offroad Equipment Type	Amount	Usage Hours	Horse Power	Load Factor
Demolition	Concrete/Industrial Saws	1	8.00	81	0.73
Demolition	Excavators	3	8.00	158	0.38
Demolition	Rubber Tired Dozers	2	8.00	247	0.40
Site Preparation	Rubber Tired Dozers	3	8.00	247	0.40
Site Preparation	Tractors/Loaders/Backhoes	4	8.00	97	0.37
Grading	Excavators	2	8.00	158	0.38
Grading	Graders	1	8.00	187	0.41
Grading	Rubber Tired Dozers	1	8.00	247	0.40
Grading	Scrapers	2	8.00	367	0.48
Grading	Tractors/Loaders/Backhoes	2	8.00	97	0.37
Building Construction	Cranes	1	7.00	231	0.29
Building Construction	Forklifts	3	8.00	89	0.20
Building Construction	Generator Sets	1	8.00	84	0.74
Building Construction	Tractors/Loaders/Backhoes	3	7.00	97	0.37
Building Construction	Welders	1	8.00	46	0.45
Paving	Pavers	2	8.00	130	0.42
Paving	Paving Equipment	2	8.00	132	0.36
Paving	Rollers	2	8.00	80	0.38
Architectural Coating	Air Compressors	1	6.00	78	0.48

**Trips and VMT**

Village South Specific Plan (Proposed) - Los Angeles-South Coast County, Annual

Phase Name	Offroad Equipment Count	Worker Trip Number	Vendor Trip Number	Hauling Trip Number	Worker Trip Length	Vendor Trip Length	Hauling Trip Length	Worker Vehicle Class	Vendor Vehicle Class	Hauling Vehicle Class
Demolition	6	15.00	0.00	458.00	14.70	6.90	20.00	LD_Mix	HDT_Mix	HHDT
Site Preparation	7	18.00	0.00	0.00	14.70	6.90	20.00	LD_Mix	HDT_Mix	HHDT
Grading	8	20.00	0.00	0.00	14.70	6.90	20.00	LD_Mix	HDT_Mix	HHDT
Building Construction	9	801.00	143.00	0.00	14.70	6.90	20.00	LD_Mix	HDT_Mix	HHDT
Paving	6	15.00	0.00	0.00	14.70	6.90	20.00	LD_Mix	HDT_Mix	HHDT
Architectural Coating	1	160.00	0.00	0.00	14.70	6.90	20.00	LD_Mix	HDT_Mix	HHDT

**3.1 Mitigation Measures Construction**

**3.2 Demolition - 2021**

**Unmitigated Construction On-Site**

	ROG	NOx	CO	SO2	Fugitive PM10	Exhaust PM10	PM10 Total	Fugitive PM2.5	Exhaust PM2.5	PM2.5 Total	Bio- CO2	NBio- CO2	Total CO2	CH4	N2O	CO2e
Category	tons/yr										MT/yr					
Fugitive Dust					0.0496	0.0000	0.0496	7.5100e-003	0.0000	7.5100e-003	0.0000	0.0000	0.0000	0.0000	0.0000	0.0000
Off-Road	0.0475	0.4716	0.3235	5.8000e-004		0.0233	0.0233		0.0216	0.0216	0.0000	51.0012	51.0012	0.0144	0.0000	51.3601
<b>Total</b>	<b>0.0475</b>	<b>0.4716</b>	<b>0.3235</b>	<b>5.8000e-004</b>	<b>0.0496</b>	<b>0.0233</b>	<b>0.0729</b>	<b>7.5100e-003</b>	<b>0.0216</b>	<b>0.0291</b>	<b>0.0000</b>	<b>51.0012</b>	<b>51.0012</b>	<b>0.0144</b>	<b>0.0000</b>	<b>51.3601</b>

Village South Specific Plan (Proposed) - Los Angeles-South Coast County, Annual

**3.2 Demolition - 2021**

**Unmitigated Construction Off-Site**

	ROG	NOx	CO	SO2	Fugitive PM10	Exhaust PM10	PM10 Total	Fugitive PM2.5	Exhaust PM2.5	PM2.5 Total	Bio- CO2	NBio- CO2	Total CO2	CH4	N2O	CO2e
Category	tons/yr										MT/yr					
Hauling	1.9300e-003	0.0634	0.0148	1.8000e-004	3.9400e-003	1.9000e-004	4.1300e-003	1.0800e-003	1.8000e-004	1.2600e-003	0.0000	17.4566	17.4566	1.2100e-003	0.0000	17.4869
Vendor	0.0000	0.0000	0.0000	0.0000	0.0000	0.0000	0.0000	0.0000	0.0000	0.0000	0.0000	0.0000	0.0000	0.0000	0.0000	0.0000
Worker	9.7000e-004	7.5000e-004	8.5100e-003	2.0000e-005	2.4700e-003	2.0000e-005	2.4900e-003	6.5000e-004	2.0000e-005	6.7000e-004	0.0000	2.2251	2.2251	7.0000e-005	0.0000	2.2267
<b>Total</b>	<b>2.9000e-003</b>	<b>0.0641</b>	<b>0.0233</b>	<b>2.0000e-004</b>	<b>6.4100e-003</b>	<b>2.1000e-004</b>	<b>6.6200e-003</b>	<b>1.7300e-003</b>	<b>2.0000e-004</b>	<b>1.9300e-003</b>	<b>0.0000</b>	<b>19.6816</b>	<b>19.6816</b>	<b>1.2800e-003</b>	<b>0.0000</b>	<b>19.7136</b>

**Mitigated Construction On-Site**

	ROG	NOx	CO	SO2	Fugitive PM10	Exhaust PM10	PM10 Total	Fugitive PM2.5	Exhaust PM2.5	PM2.5 Total	Bio- CO2	NBio- CO2	Total CO2	CH4	N2O	CO2e
Category	tons/yr										MT/yr					
Fugitive Dust					0.0496	0.0000	0.0496	7.5100e-003	0.0000	7.5100e-003	0.0000	0.0000	0.0000	0.0000	0.0000	0.0000
Off-Road	0.0475	0.4716	0.3235	5.8000e-004		0.0233	0.0233		0.0216	0.0216	0.0000	51.0011	51.0011	0.0144	0.0000	51.3600
<b>Total</b>	<b>0.0475</b>	<b>0.4716</b>	<b>0.3235</b>	<b>5.8000e-004</b>	<b>0.0496</b>	<b>0.0233</b>	<b>0.0729</b>	<b>7.5100e-003</b>	<b>0.0216</b>	<b>0.0291</b>	<b>0.0000</b>	<b>51.0011</b>	<b>51.0011</b>	<b>0.0144</b>	<b>0.0000</b>	<b>51.3600</b>

Village South Specific Plan (Proposed) - Los Angeles-South Coast County, Annual

**3.2 Demolition - 2021**

**Mitigated Construction Off-Site**

	ROG	NOx	CO	SO2	Fugitive PM10	Exhaust PM10	PM10 Total	Fugitive PM2.5	Exhaust PM2.5	PM2.5 Total	Bio- CO2	NBio- CO2	Total CO2	CH4	N2O	CO2e
Category	tons/yr										MT/yr					
Hauling	1.9300e-003	0.0634	0.0148	1.8000e-004	3.9400e-003	1.9000e-004	4.1300e-003	1.0800e-003	1.8000e-004	1.2600e-003	0.0000	17.4566	17.4566	1.2100e-003	0.0000	17.4869
Vendor	0.0000	0.0000	0.0000	0.0000	0.0000	0.0000	0.0000	0.0000	0.0000	0.0000	0.0000	0.0000	0.0000	0.0000	0.0000	0.0000
Worker	9.7000e-004	7.5000e-004	8.5100e-003	2.0000e-005	2.4700e-003	2.0000e-005	2.4900e-003	6.5000e-004	2.0000e-005	6.7000e-004	0.0000	2.2251	2.2251	7.0000e-005	0.0000	2.2267
<b>Total</b>	<b>2.9000e-003</b>	<b>0.0641</b>	<b>0.0233</b>	<b>2.0000e-004</b>	<b>6.4100e-003</b>	<b>2.1000e-004</b>	<b>6.6200e-003</b>	<b>1.7300e-003</b>	<b>2.0000e-004</b>	<b>1.9300e-003</b>	<b>0.0000</b>	<b>19.6816</b>	<b>19.6816</b>	<b>1.2800e-003</b>	<b>0.0000</b>	<b>19.7136</b>

**3.3 Site Preparation - 2021**

**Unmitigated Construction On-Site**

	ROG	NOx	CO	SO2	Fugitive PM10	Exhaust PM10	PM10 Total	Fugitive PM2.5	Exhaust PM2.5	PM2.5 Total	Bio- CO2	NBio- CO2	Total CO2	CH4	N2O	CO2e
Category	tons/yr										MT/yr					
Fugitive Dust					0.1807	0.0000	0.1807	0.0993	0.0000	0.0993	0.0000	0.0000	0.0000	0.0000	0.0000	0.0000
Off-Road	0.0389	0.4050	0.2115	3.8000e-004		0.0204	0.0204		0.0188	0.0188	0.0000	33.4357	33.4357	0.0108	0.0000	33.7061
<b>Total</b>	<b>0.0389</b>	<b>0.4050</b>	<b>0.2115</b>	<b>3.8000e-004</b>	<b>0.1807</b>	<b>0.0204</b>	<b>0.2011</b>	<b>0.0993</b>	<b>0.0188</b>	<b>0.1181</b>	<b>0.0000</b>	<b>33.4357</b>	<b>33.4357</b>	<b>0.0108</b>	<b>0.0000</b>	<b>33.7061</b>



Village South Specific Plan (Proposed) - Los Angeles-South Coast County, Annual

**3.3 Site Preparation - 2021**

**Unmitigated Construction Off-Site**

	ROG	NOx	CO	SO2	Fugitive PM10	Exhaust PM10	PM10 Total	Fugitive PM2.5	Exhaust PM2.5	PM2.5 Total	Bio- CO2	NBio- CO2	Total CO2	CH4	N2O	CO2e
Category	tons/yr										MT/yr					
Hauling	0.0000	0.0000	0.0000	0.0000	0.0000	0.0000	0.0000	0.0000	0.0000	0.0000	0.0000	0.0000	0.0000	0.0000	0.0000	0.0000
Vendor	0.0000	0.0000	0.0000	0.0000	0.0000	0.0000	0.0000	0.0000	0.0000	0.0000	0.0000	0.0000	0.0000	0.0000	0.0000	0.0000
Worker	7.7000e-004	6.0000e-004	6.8100e-003	2.0000e-005	1.9700e-003	2.0000e-005	1.9900e-003	5.2000e-004	1.0000e-005	5.4000e-004	0.0000	1.7801	1.7801	5.0000e-005	0.0000	1.7814
<b>Total</b>	<b>7.7000e-004</b>	<b>6.0000e-004</b>	<b>6.8100e-003</b>	<b>2.0000e-005</b>	<b>1.9700e-003</b>	<b>2.0000e-005</b>	<b>1.9900e-003</b>	<b>5.2000e-004</b>	<b>1.0000e-005</b>	<b>5.4000e-004</b>	<b>0.0000</b>	<b>1.7801</b>	<b>1.7801</b>	<b>5.0000e-005</b>	<b>0.0000</b>	<b>1.7814</b>

**Mitigated Construction On-Site**

	ROG	NOx	CO	SO2	Fugitive PM10	Exhaust PM10	PM10 Total	Fugitive PM2.5	Exhaust PM2.5	PM2.5 Total	Bio- CO2	NBio- CO2	Total CO2	CH4	N2O	CO2e
Category	tons/yr										MT/yr					
Fugitive Dust					0.1807	0.0000	0.1807	0.0993	0.0000	0.0993	0.0000	0.0000	0.0000	0.0000	0.0000	0.0000
Off-Road	0.0389	0.4050	0.2115	3.8000e-004		0.0204	0.0204		0.0188	0.0188	0.0000	33.4357	33.4357	0.0108	0.0000	33.7060
<b>Total</b>	<b>0.0389</b>	<b>0.4050</b>	<b>0.2115</b>	<b>3.8000e-004</b>	<b>0.1807</b>	<b>0.0204</b>	<b>0.2011</b>	<b>0.0993</b>	<b>0.0188</b>	<b>0.1181</b>	<b>0.0000</b>	<b>33.4357</b>	<b>33.4357</b>	<b>0.0108</b>	<b>0.0000</b>	<b>33.7060</b>

Village South Specific Plan (Proposed) - Los Angeles-South Coast County, Annual

**3.3 Site Preparation - 2021**

**Mitigated Construction Off-Site**

	ROG	NOx	CO	SO2	Fugitive PM10	Exhaust PM10	PM10 Total	Fugitive PM2.5	Exhaust PM2.5	PM2.5 Total	Bio- CO2	NBio- CO2	Total CO2	CH4	N2O	CO2e
Category	tons/yr										MT/yr					
Hauling	0.0000	0.0000	0.0000	0.0000	0.0000	0.0000	0.0000	0.0000	0.0000	0.0000	0.0000	0.0000	0.0000	0.0000	0.0000	0.0000
Vendor	0.0000	0.0000	0.0000	0.0000	0.0000	0.0000	0.0000	0.0000	0.0000	0.0000	0.0000	0.0000	0.0000	0.0000	0.0000	0.0000
Worker	7.7000e-004	6.0000e-004	6.8100e-003	2.0000e-005	1.9700e-003	2.0000e-005	1.9900e-003	5.2000e-004	1.0000e-005	5.4000e-004	0.0000	1.7801	1.7801	5.0000e-005	0.0000	1.7814
<b>Total</b>	<b>7.7000e-004</b>	<b>6.0000e-004</b>	<b>6.8100e-003</b>	<b>2.0000e-005</b>	<b>1.9700e-003</b>	<b>2.0000e-005</b>	<b>1.9900e-003</b>	<b>5.2000e-004</b>	<b>1.0000e-005</b>	<b>5.4000e-004</b>	<b>0.0000</b>	<b>1.7801</b>	<b>1.7801</b>	<b>5.0000e-005</b>	<b>0.0000</b>	<b>1.7814</b>

**3.4 Grading - 2021**

**Unmitigated Construction On-Site**

	ROG	NOx	CO	SO2	Fugitive PM10	Exhaust PM10	PM10 Total	Fugitive PM2.5	Exhaust PM2.5	PM2.5 Total	Bio- CO2	NBio- CO2	Total CO2	CH4	N2O	CO2e
Category	tons/yr										MT/yr					
Fugitive Dust					0.1741	0.0000	0.1741	0.0693	0.0000	0.0693	0.0000	0.0000	0.0000	0.0000	0.0000	0.0000
Off-Road	0.0796	0.8816	0.5867	1.1800e-003		0.0377	0.0377		0.0347	0.0347	0.0000	103.5405	103.5405	0.0335	0.0000	104.3776
<b>Total</b>	<b>0.0796</b>	<b>0.8816</b>	<b>0.5867</b>	<b>1.1800e-003</b>	<b>0.1741</b>	<b>0.0377</b>	<b>0.2118</b>	<b>0.0693</b>	<b>0.0347</b>	<b>0.1040</b>	<b>0.0000</b>	<b>103.5405</b>	<b>103.5405</b>	<b>0.0335</b>	<b>0.0000</b>	<b>104.3776</b>

Village South Specific Plan (Proposed) - Los Angeles-South Coast County, Annual

**3.4 Grading - 2021**

**Unmitigated Construction Off-Site**

	ROG	NOx	CO	SO2	Fugitive PM10	Exhaust PM10	PM10 Total	Fugitive PM2.5	Exhaust PM2.5	PM2.5 Total	Bio- CO2	NBio- CO2	Total CO2	CH4	N2O	CO2e
Category	tons/yr										MT/yr					
Hauling	0.0000	0.0000	0.0000	0.0000	0.0000	0.0000	0.0000	0.0000	0.0000	0.0000	0.0000	0.0000	0.0000	0.0000	0.0000	0.0000
Vendor	0.0000	0.0000	0.0000	0.0000	0.0000	0.0000	0.0000	0.0000	0.0000	0.0000	0.0000	0.0000	0.0000	0.0000	0.0000	0.0000
Worker	1.6400e-003	1.2700e-003	0.0144	4.0000e-005	4.1600e-003	3.0000e-005	4.2000e-003	1.1100e-003	3.0000e-005	1.1400e-003	0.0000	3.7579	3.7579	1.1000e-004	0.0000	3.7607
<b>Total</b>	<b>1.6400e-003</b>	<b>1.2700e-003</b>	<b>0.0144</b>	<b>4.0000e-005</b>	<b>4.1600e-003</b>	<b>3.0000e-005</b>	<b>4.2000e-003</b>	<b>1.1100e-003</b>	<b>3.0000e-005</b>	<b>1.1400e-003</b>	<b>0.0000</b>	<b>3.7579</b>	<b>3.7579</b>	<b>1.1000e-004</b>	<b>0.0000</b>	<b>3.7607</b>

**Mitigated Construction On-Site**

	ROG	NOx	CO	SO2	Fugitive PM10	Exhaust PM10	PM10 Total	Fugitive PM2.5	Exhaust PM2.5	PM2.5 Total	Bio- CO2	NBio- CO2	Total CO2	CH4	N2O	CO2e
Category	tons/yr										MT/yr					
Fugitive Dust					0.1741	0.0000	0.1741	0.0693	0.0000	0.0693	0.0000	0.0000	0.0000	0.0000	0.0000	0.0000
Off-Road	0.0796	0.8816	0.5867	1.1800e-003		0.0377	0.0377		0.0347	0.0347	0.0000	103.5403	103.5403	0.0335	0.0000	104.3775
<b>Total</b>	<b>0.0796</b>	<b>0.8816</b>	<b>0.5867</b>	<b>1.1800e-003</b>	<b>0.1741</b>	<b>0.0377</b>	<b>0.2118</b>	<b>0.0693</b>	<b>0.0347</b>	<b>0.1040</b>	<b>0.0000</b>	<b>103.5403</b>	<b>103.5403</b>	<b>0.0335</b>	<b>0.0000</b>	<b>104.3775</b>

Village South Specific Plan (Proposed) - Los Angeles-South Coast County, Annual

**3.4 Grading - 2021**

**Mitigated Construction Off-Site**

	ROG	NOx	CO	SO2	Fugitive PM10	Exhaust PM10	PM10 Total	Fugitive PM2.5	Exhaust PM2.5	PM2.5 Total	Bio- CO2	NBio- CO2	Total CO2	CH4	N2O	CO2e
Category	tons/yr										MT/yr					
Hauling	0.0000	0.0000	0.0000	0.0000	0.0000	0.0000	0.0000	0.0000	0.0000	0.0000	0.0000	0.0000	0.0000	0.0000	0.0000	0.0000
Vendor	0.0000	0.0000	0.0000	0.0000	0.0000	0.0000	0.0000	0.0000	0.0000	0.0000	0.0000	0.0000	0.0000	0.0000	0.0000	0.0000
Worker	1.6400e-003	1.2700e-003	0.0144	4.0000e-005	4.1600e-003	3.0000e-005	4.2000e-003	1.1100e-003	3.0000e-005	1.1400e-003	0.0000	3.7579	3.7579	1.1000e-004	0.0000	3.7607
<b>Total</b>	<b>1.6400e-003</b>	<b>1.2700e-003</b>	<b>0.0144</b>	<b>4.0000e-005</b>	<b>4.1600e-003</b>	<b>3.0000e-005</b>	<b>4.2000e-003</b>	<b>1.1100e-003</b>	<b>3.0000e-005</b>	<b>1.1400e-003</b>	<b>0.0000</b>	<b>3.7579</b>	<b>3.7579</b>	<b>1.1000e-004</b>	<b>0.0000</b>	<b>3.7607</b>

**3.4 Grading - 2022**

**Unmitigated Construction On-Site**

	ROG	NOx	CO	SO2	Fugitive PM10	Exhaust PM10	PM10 Total	Fugitive PM2.5	Exhaust PM2.5	PM2.5 Total	Bio- CO2	NBio- CO2	Total CO2	CH4	N2O	CO2e
Category	tons/yr										MT/yr					
Fugitive Dust					0.0807	0.0000	0.0807	0.0180	0.0000	0.0180	0.0000	0.0000	0.0000	0.0000	0.0000	0.0000
Off-Road	0.0127	0.1360	0.1017	2.2000e-004		5.7200e-003	5.7200e-003		5.2600e-003	5.2600e-003	0.0000	19.0871	19.0871	6.1700e-003	0.0000	19.2414
<b>Total</b>	<b>0.0127</b>	<b>0.1360</b>	<b>0.1017</b>	<b>2.2000e-004</b>	<b>0.0807</b>	<b>5.7200e-003</b>	<b>0.0865</b>	<b>0.0180</b>	<b>5.2600e-003</b>	<b>0.0233</b>	<b>0.0000</b>	<b>19.0871</b>	<b>19.0871</b>	<b>6.1700e-003</b>	<b>0.0000</b>	<b>19.2414</b>

Village South Specific Plan (Proposed) - Los Angeles-South Coast County, Annual

**3.4 Grading - 2022**

**Unmitigated Construction Off-Site**

	ROG	NOx	CO	SO2	Fugitive PM10	Exhaust PM10	PM10 Total	Fugitive PM2.5	Exhaust PM2.5	PM2.5 Total	Bio- CO2	NBio- CO2	Total CO2	CH4	N2O	CO2e
Category	tons/yr										MT/yr					
Hauling	0.0000	0.0000	0.0000	0.0000	0.0000	0.0000	0.0000	0.0000	0.0000	0.0000	0.0000	0.0000	0.0000	0.0000	0.0000	0.0000
Vendor	0.0000	0.0000	0.0000	0.0000	0.0000	0.0000	0.0000	0.0000	0.0000	0.0000	0.0000	0.0000	0.0000	0.0000	0.0000	0.0000
Worker	2.8000e-004	2.1000e-004	2.4400e-003	1.0000e-005	7.7000e-004	1.0000e-005	7.7000e-004	2.0000e-004	1.0000e-005	2.1000e-004	0.0000	0.6679	0.6679	2.0000e-005	0.0000	0.6684
<b>Total</b>	<b>2.8000e-004</b>	<b>2.1000e-004</b>	<b>2.4400e-003</b>	<b>1.0000e-005</b>	<b>7.7000e-004</b>	<b>1.0000e-005</b>	<b>7.7000e-004</b>	<b>2.0000e-004</b>	<b>1.0000e-005</b>	<b>2.1000e-004</b>	<b>0.0000</b>	<b>0.6679</b>	<b>0.6679</b>	<b>2.0000e-005</b>	<b>0.0000</b>	<b>0.6684</b>

**Mitigated Construction On-Site**

	ROG	NOx	CO	SO2	Fugitive PM10	Exhaust PM10	PM10 Total	Fugitive PM2.5	Exhaust PM2.5	PM2.5 Total	Bio- CO2	NBio- CO2	Total CO2	CH4	N2O	CO2e
Category	tons/yr										MT/yr					
Fugitive Dust					0.0807	0.0000	0.0807	0.0180	0.0000	0.0180	0.0000	0.0000	0.0000	0.0000	0.0000	0.0000
Off-Road	0.0127	0.1360	0.1017	2.2000e-004		5.7200e-003	5.7200e-003		5.2600e-003	5.2600e-003	0.0000	19.0871	19.0871	6.1700e-003	0.0000	19.2414
<b>Total</b>	<b>0.0127</b>	<b>0.1360</b>	<b>0.1017</b>	<b>2.2000e-004</b>	<b>0.0807</b>	<b>5.7200e-003</b>	<b>0.0865</b>	<b>0.0180</b>	<b>5.2600e-003</b>	<b>0.0233</b>	<b>0.0000</b>	<b>19.0871</b>	<b>19.0871</b>	<b>6.1700e-003</b>	<b>0.0000</b>	<b>19.2414</b>

Village South Specific Plan (Proposed) - Los Angeles-South Coast County, Annual

**3.4 Grading - 2022**

**Mitigated Construction Off-Site**

	ROG	NOx	CO	SO2	Fugitive PM10	Exhaust PM10	PM10 Total	Fugitive PM2.5	Exhaust PM2.5	PM2.5 Total	Bio- CO2	NBio- CO2	Total CO2	CH4	N2O	CO2e
Category	tons/yr										MT/yr					
Hauling	0.0000	0.0000	0.0000	0.0000	0.0000	0.0000	0.0000	0.0000	0.0000	0.0000	0.0000	0.0000	0.0000	0.0000	0.0000	0.0000
Vendor	0.0000	0.0000	0.0000	0.0000	0.0000	0.0000	0.0000	0.0000	0.0000	0.0000	0.0000	0.0000	0.0000	0.0000	0.0000	0.0000
Worker	2.8000e-004	2.1000e-004	2.4400e-003	1.0000e-005	7.7000e-004	1.0000e-005	7.7000e-004	2.0000e-004	1.0000e-005	2.1000e-004	0.0000	0.6679	0.6679	2.0000e-005	0.0000	0.6684
<b>Total</b>	<b>2.8000e-004</b>	<b>2.1000e-004</b>	<b>2.4400e-003</b>	<b>1.0000e-005</b>	<b>7.7000e-004</b>	<b>1.0000e-005</b>	<b>7.7000e-004</b>	<b>2.0000e-004</b>	<b>1.0000e-005</b>	<b>2.1000e-004</b>	<b>0.0000</b>	<b>0.6679</b>	<b>0.6679</b>	<b>2.0000e-005</b>	<b>0.0000</b>	<b>0.6684</b>

**3.5 Building Construction - 2022**

**Unmitigated Construction On-Site**

	ROG	NOx	CO	SO2	Fugitive PM10	Exhaust PM10	PM10 Total	Fugitive PM2.5	Exhaust PM2.5	PM2.5 Total	Bio- CO2	NBio- CO2	Total CO2	CH4	N2O	CO2e
Category	tons/yr										MT/yr					
Off-Road	0.2158	1.9754	2.0700	3.4100e-003		0.1023	0.1023		0.0963	0.0963	0.0000	293.1324	293.1324	0.0702	0.0000	294.8881
<b>Total</b>	<b>0.2158</b>	<b>1.9754</b>	<b>2.0700</b>	<b>3.4100e-003</b>		<b>0.1023</b>	<b>0.1023</b>		<b>0.0963</b>	<b>0.0963</b>	<b>0.0000</b>	<b>293.1324</b>	<b>293.1324</b>	<b>0.0702</b>	<b>0.0000</b>	<b>294.8881</b>

Village South Specific Plan (Proposed) - Los Angeles-South Coast County, Annual

**3.5 Building Construction - 2022**

**Unmitigated Construction Off-Site**

	ROG	NOx	CO	SO2	Fugitive PM10	Exhaust PM10	PM10 Total	Fugitive PM2.5	Exhaust PM2.5	PM2.5 Total	Bio- CO2	NBio- CO2	Total CO2	CH4	N2O	CO2e
Category	tons/yr										MT/yr					
Hauling	0.0000	0.0000	0.0000	0.0000	0.0000	0.0000	0.0000	0.0000	0.0000	0.0000	0.0000	0.0000	0.0000	0.0000	0.0000	0.0000
Vendor	0.0527	1.6961	0.4580	4.5500e-003	0.1140	3.1800e-003	0.1171	0.0329	3.0400e-003	0.0359	0.0000	441.9835	441.9835	0.0264	0.0000	442.6435
Worker	0.4088	0.3066	3.5305	0.0107	1.1103	8.8700e-003	1.1192	0.2949	8.1700e-003	0.3031	0.0000	966.8117	966.8117	0.0266	0.0000	967.4773
<b>Total</b>	<b>0.4616</b>	<b>2.0027</b>	<b>3.9885</b>	<b>0.0152</b>	<b>1.2243</b>	<b>0.0121</b>	<b>1.2363</b>	<b>0.3278</b>	<b>0.0112</b>	<b>0.3390</b>	<b>0.0000</b>	<b>1,408.7952</b>	<b>1,408.7952</b>	<b>0.0530</b>	<b>0.0000</b>	<b>1,410.1208</b>

**Mitigated Construction On-Site**

	ROG	NOx	CO	SO2	Fugitive PM10	Exhaust PM10	PM10 Total	Fugitive PM2.5	Exhaust PM2.5	PM2.5 Total	Bio- CO2	NBio- CO2	Total CO2	CH4	N2O	CO2e
Category	tons/yr										MT/yr					
Off-Road	0.2158	1.9754	2.0700	3.4100e-003		0.1023	0.1023		0.0963	0.0963	0.0000	293.1321	293.1321	0.0702	0.0000	294.8877
<b>Total</b>	<b>0.2158</b>	<b>1.9754</b>	<b>2.0700</b>	<b>3.4100e-003</b>		<b>0.1023</b>	<b>0.1023</b>		<b>0.0963</b>	<b>0.0963</b>	<b>0.0000</b>	<b>293.1321</b>	<b>293.1321</b>	<b>0.0702</b>	<b>0.0000</b>	<b>294.8877</b>

Village South Specific Plan (Proposed) - Los Angeles-South Coast County, Annual

**3.5 Building Construction - 2022**

**Mitigated Construction Off-Site**

	ROG	NOx	CO	SO2	Fugitive PM10	Exhaust PM10	PM10 Total	Fugitive PM2.5	Exhaust PM2.5	PM2.5 Total	Bio- CO2	NBio- CO2	Total CO2	CH4	N2O	CO2e
Category	tons/yr										MT/yr					
Hauling	0.0000	0.0000	0.0000	0.0000	0.0000	0.0000	0.0000	0.0000	0.0000	0.0000	0.0000	0.0000	0.0000	0.0000	0.0000	0.0000
Vendor	0.0527	1.6961	0.4580	4.5500e-003	0.1140	3.1800e-003	0.1171	0.0329	3.0400e-003	0.0359	0.0000	441.9835	441.9835	0.0264	0.0000	442.6435
Worker	0.4088	0.3066	3.5305	0.0107	1.1103	8.8700e-003	1.1192	0.2949	8.1700e-003	0.3031	0.0000	966.8117	966.8117	0.0266	0.0000	967.4773
<b>Total</b>	<b>0.4616</b>	<b>2.0027</b>	<b>3.9885</b>	<b>0.0152</b>	<b>1.2243</b>	<b>0.0121</b>	<b>1.2363</b>	<b>0.3278</b>	<b>0.0112</b>	<b>0.3390</b>	<b>0.0000</b>	<b>1,408.7952</b>	<b>1,408.7952</b>	<b>0.0530</b>	<b>0.0000</b>	<b>1,410.1208</b>

**3.5 Building Construction - 2023**

**Unmitigated Construction On-Site**

	ROG	NOx	CO	SO2	Fugitive PM10	Exhaust PM10	PM10 Total	Fugitive PM2.5	Exhaust PM2.5	PM2.5 Total	Bio- CO2	NBio- CO2	Total CO2	CH4	N2O	CO2e
Category	tons/yr										MT/yr					
Off-Road	0.1942	1.7765	2.0061	3.3300e-003		0.0864	0.0864		0.0813	0.0813	0.0000	286.2789	286.2789	0.0681	0.0000	287.9814
<b>Total</b>	<b>0.1942</b>	<b>1.7765</b>	<b>2.0061</b>	<b>3.3300e-003</b>		<b>0.0864</b>	<b>0.0864</b>		<b>0.0813</b>	<b>0.0813</b>	<b>0.0000</b>	<b>286.2789</b>	<b>286.2789</b>	<b>0.0681</b>	<b>0.0000</b>	<b>287.9814</b>



Village South Specific Plan (Proposed) - Los Angeles-South Coast County, Annual

**3.5 Building Construction - 2023**

**Unmitigated Construction Off-Site**

	ROG	NOx	CO	SO2	Fugitive PM10	Exhaust PM10	PM10 Total	Fugitive PM2.5	Exhaust PM2.5	PM2.5 Total	Bio- CO2	NBio- CO2	Total CO2	CH4	N2O	CO2e
Category	tons/yr										MT/yr					
Hauling	0.0000	0.0000	0.0000	0.0000	0.0000	0.0000	0.0000	0.0000	0.0000	0.0000	0.0000	0.0000	0.0000	0.0000	0.0000	0.0000
Vendor	0.0382	1.2511	0.4011	4.3000e-003	0.1113	1.4600e-003	0.1127	0.0321	1.4000e-003	0.0335	0.0000	417.9930	417.9930	0.0228	0.0000	418.5624
Worker	0.3753	0.2708	3.1696	0.0101	1.0840	8.4100e-003	1.0924	0.2879	7.7400e-003	0.2957	0.0000	909.3439	909.3439	0.0234	0.0000	909.9291
<b>Total</b>	<b>0.4135</b>	<b>1.5218</b>	<b>3.5707</b>	<b>0.0144</b>	<b>1.1953</b>	<b>9.8700e-003</b>	<b>1.2051</b>	<b>0.3200</b>	<b>9.1400e-003</b>	<b>0.3292</b>	<b>0.0000</b>	<b>1,327.3369</b>	<b>1,327.3369</b>	<b>0.0462</b>	<b>0.0000</b>	<b>1,328.4916</b>

**Mitigated Construction On-Site**

	ROG	NOx	CO	SO2	Fugitive PM10	Exhaust PM10	PM10 Total	Fugitive PM2.5	Exhaust PM2.5	PM2.5 Total	Bio- CO2	NBio- CO2	Total CO2	CH4	N2O	CO2e
Category	tons/yr										MT/yr					
Off-Road	0.1942	1.7765	2.0061	3.3300e-003		0.0864	0.0864		0.0813	0.0813	0.0000	286.2785	286.2785	0.0681	0.0000	287.9811
<b>Total</b>	<b>0.1942</b>	<b>1.7765</b>	<b>2.0061</b>	<b>3.3300e-003</b>		<b>0.0864</b>	<b>0.0864</b>		<b>0.0813</b>	<b>0.0813</b>	<b>0.0000</b>	<b>286.2785</b>	<b>286.2785</b>	<b>0.0681</b>	<b>0.0000</b>	<b>287.9811</b>

Village South Specific Plan (Proposed) - Los Angeles-South Coast County, Annual

**3.5 Building Construction - 2023**

**Mitigated Construction Off-Site**

	ROG	NOx	CO	SO2	Fugitive PM10	Exhaust PM10	PM10 Total	Fugitive PM2.5	Exhaust PM2.5	PM2.5 Total	Bio- CO2	NBio- CO2	Total CO2	CH4	N2O	CO2e
Category	tons/yr										MT/yr					
Hauling	0.0000	0.0000	0.0000	0.0000	0.0000	0.0000	0.0000	0.0000	0.0000	0.0000	0.0000	0.0000	0.0000	0.0000	0.0000	0.0000
Vendor	0.0382	1.2511	0.4011	4.3000e-003	0.1113	1.4600e-003	0.1127	0.0321	1.4000e-003	0.0335	0.0000	417.9930	417.9930	0.0228	0.0000	418.5624
Worker	0.3753	0.2708	3.1696	0.0101	1.0840	8.4100e-003	1.0924	0.2879	7.7400e-003	0.2957	0.0000	909.3439	909.3439	0.0234	0.0000	909.9291
<b>Total</b>	<b>0.4135</b>	<b>1.5218</b>	<b>3.5707</b>	<b>0.0144</b>	<b>1.1953</b>	<b>9.8700e-003</b>	<b>1.2051</b>	<b>0.3200</b>	<b>9.1400e-003</b>	<b>0.3292</b>	<b>0.0000</b>	<b>1,327.3369</b>	<b>1,327.3369</b>	<b>0.0462</b>	<b>0.0000</b>	<b>1,328.4916</b>

**3.6 Paving - 2023**

**Unmitigated Construction On-Site**

	ROG	NOx	CO	SO2	Fugitive PM10	Exhaust PM10	PM10 Total	Fugitive PM2.5	Exhaust PM2.5	PM2.5 Total	Bio- CO2	NBio- CO2	Total CO2	CH4	N2O	CO2e
Category	tons/yr										MT/yr					
Off-Road	6.7100e-003	0.0663	0.0948	1.5000e-004		3.3200e-003	3.3200e-003		3.0500e-003	3.0500e-003	0.0000	13.0175	13.0175	4.2100e-003	0.0000	13.1227
Paving	0.0000					0.0000	0.0000		0.0000	0.0000	0.0000	0.0000	0.0000	0.0000	0.0000	0.0000
<b>Total</b>	<b>6.7100e-003</b>	<b>0.0663</b>	<b>0.0948</b>	<b>1.5000e-004</b>		<b>3.3200e-003</b>	<b>3.3200e-003</b>		<b>3.0500e-003</b>	<b>3.0500e-003</b>	<b>0.0000</b>	<b>13.0175</b>	<b>13.0175</b>	<b>4.2100e-003</b>	<b>0.0000</b>	<b>13.1227</b>

Village South Specific Plan (Proposed) - Los Angeles-South Coast County, Annual

**3.6 Paving - 2023**

**Unmitigated Construction Off-Site**

	ROG	NOx	CO	SO2	Fugitive PM10	Exhaust PM10	PM10 Total	Fugitive PM2.5	Exhaust PM2.5	PM2.5 Total	Bio- CO2	NBio- CO2	Total CO2	CH4	N2O	CO2e
Category	tons/yr										MT/yr					
Hauling	0.0000	0.0000	0.0000	0.0000	0.0000	0.0000	0.0000	0.0000	0.0000	0.0000	0.0000	0.0000	0.0000	0.0000	0.0000	0.0000
Vendor	0.0000	0.0000	0.0000	0.0000	0.0000	0.0000	0.0000	0.0000	0.0000	0.0000	0.0000	0.0000	0.0000	0.0000	0.0000	0.0000
Worker	3.7000e-004	2.7000e-004	3.1200e-003	1.0000e-005	1.0700e-003	1.0000e-005	1.0800e-003	2.8000e-004	1.0000e-005	2.9000e-004	0.0000	0.8963	0.8963	2.0000e-005	0.0000	0.8968
<b>Total</b>	<b>3.7000e-004</b>	<b>2.7000e-004</b>	<b>3.1200e-003</b>	<b>1.0000e-005</b>	<b>1.0700e-003</b>	<b>1.0000e-005</b>	<b>1.0800e-003</b>	<b>2.8000e-004</b>	<b>1.0000e-005</b>	<b>2.9000e-004</b>	<b>0.0000</b>	<b>0.8963</b>	<b>0.8963</b>	<b>2.0000e-005</b>	<b>0.0000</b>	<b>0.8968</b>

**Mitigated Construction On-Site**

	ROG	NOx	CO	SO2	Fugitive PM10	Exhaust PM10	PM10 Total	Fugitive PM2.5	Exhaust PM2.5	PM2.5 Total	Bio- CO2	NBio- CO2	Total CO2	CH4	N2O	CO2e
Category	tons/yr										MT/yr					
Off-Road	6.7100e-003	0.0663	0.0948	1.5000e-004		3.3200e-003	3.3200e-003		3.0500e-003	3.0500e-003	0.0000	13.0175	13.0175	4.2100e-003	0.0000	13.1227
Paving	0.0000					0.0000	0.0000		0.0000	0.0000	0.0000	0.0000	0.0000	0.0000	0.0000	0.0000
<b>Total</b>	<b>6.7100e-003</b>	<b>0.0663</b>	<b>0.0948</b>	<b>1.5000e-004</b>		<b>3.3200e-003</b>	<b>3.3200e-003</b>		<b>3.0500e-003</b>	<b>3.0500e-003</b>	<b>0.0000</b>	<b>13.0175</b>	<b>13.0175</b>	<b>4.2100e-003</b>	<b>0.0000</b>	<b>13.1227</b>

Village South Specific Plan (Proposed) - Los Angeles-South Coast County, Annual

**3.6 Paving - 2023**

**Mitigated Construction Off-Site**

	ROG	NOx	CO	SO2	Fugitive PM10	Exhaust PM10	PM10 Total	Fugitive PM2.5	Exhaust PM2.5	PM2.5 Total	Bio- CO2	NBio- CO2	Total CO2	CH4	N2O	CO2e
Category	tons/yr										MT/yr					
Hauling	0.0000	0.0000	0.0000	0.0000	0.0000	0.0000	0.0000	0.0000	0.0000	0.0000	0.0000	0.0000	0.0000	0.0000	0.0000	0.0000
Vendor	0.0000	0.0000	0.0000	0.0000	0.0000	0.0000	0.0000	0.0000	0.0000	0.0000	0.0000	0.0000	0.0000	0.0000	0.0000	0.0000
Worker	3.7000e-004	2.7000e-004	3.1200e-003	1.0000e-005	1.0700e-003	1.0000e-005	1.0800e-003	2.8000e-004	1.0000e-005	2.9000e-004	0.0000	0.8963	0.8963	2.0000e-005	0.0000	0.8968
<b>Total</b>	<b>3.7000e-004</b>	<b>2.7000e-004</b>	<b>3.1200e-003</b>	<b>1.0000e-005</b>	<b>1.0700e-003</b>	<b>1.0000e-005</b>	<b>1.0800e-003</b>	<b>2.8000e-004</b>	<b>1.0000e-005</b>	<b>2.9000e-004</b>	<b>0.0000</b>	<b>0.8963</b>	<b>0.8963</b>	<b>2.0000e-005</b>	<b>0.0000</b>	<b>0.8968</b>

**3.6 Paving - 2024**

**Unmitigated Construction On-Site**

	ROG	NOx	CO	SO2	Fugitive PM10	Exhaust PM10	PM10 Total	Fugitive PM2.5	Exhaust PM2.5	PM2.5 Total	Bio- CO2	NBio- CO2	Total CO2	CH4	N2O	CO2e
Category	tons/yr										MT/yr					
Off-Road	0.0109	0.1048	0.1609	2.5000e-004		5.1500e-003	5.1500e-003		4.7400e-003	4.7400e-003	0.0000	22.0292	22.0292	7.1200e-003	0.0000	22.2073
Paving	0.0000					0.0000	0.0000		0.0000	0.0000	0.0000	0.0000	0.0000	0.0000	0.0000	0.0000
<b>Total</b>	<b>0.0109</b>	<b>0.1048</b>	<b>0.1609</b>	<b>2.5000e-004</b>		<b>5.1500e-003</b>	<b>5.1500e-003</b>		<b>4.7400e-003</b>	<b>4.7400e-003</b>	<b>0.0000</b>	<b>22.0292</b>	<b>22.0292</b>	<b>7.1200e-003</b>	<b>0.0000</b>	<b>22.2073</b>

Village South Specific Plan (Proposed) - Los Angeles-South Coast County, Annual

**3.6 Paving - 2024**

**Unmitigated Construction Off-Site**

	ROG	NOx	CO	SO2	Fugitive PM10	Exhaust PM10	PM10 Total	Fugitive PM2.5	Exhaust PM2.5	PM2.5 Total	Bio- CO2	NBio- CO2	Total CO2	CH4	N2O	CO2e
Category	tons/yr										MT/yr					
Hauling	0.0000	0.0000	0.0000	0.0000	0.0000	0.0000	0.0000	0.0000	0.0000	0.0000	0.0000	0.0000	0.0000	0.0000	0.0000	0.0000
Vendor	0.0000	0.0000	0.0000	0.0000	0.0000	0.0000	0.0000	0.0000	0.0000	0.0000	0.0000	0.0000	0.0000	0.0000	0.0000	0.0000
Worker	5.9000e-004	4.1000e-004	4.9200e-003	2.0000e-005	1.8100e-003	1.0000e-005	1.8200e-003	4.8000e-004	1.0000e-005	4.9000e-004	0.0000	1.4697	1.4697	4.0000e-005	0.0000	1.4706
<b>Total</b>	<b>5.9000e-004</b>	<b>4.1000e-004</b>	<b>4.9200e-003</b>	<b>2.0000e-005</b>	<b>1.8100e-003</b>	<b>1.0000e-005</b>	<b>1.8200e-003</b>	<b>4.8000e-004</b>	<b>1.0000e-005</b>	<b>4.9000e-004</b>	<b>0.0000</b>	<b>1.4697</b>	<b>1.4697</b>	<b>4.0000e-005</b>	<b>0.0000</b>	<b>1.4706</b>

**Mitigated Construction On-Site**

	ROG	NOx	CO	SO2	Fugitive PM10	Exhaust PM10	PM10 Total	Fugitive PM2.5	Exhaust PM2.5	PM2.5 Total	Bio- CO2	NBio- CO2	Total CO2	CH4	N2O	CO2e
Category	tons/yr										MT/yr					
Off-Road	0.0109	0.1048	0.1609	2.5000e-004		5.1500e-003	5.1500e-003		4.7400e-003	4.7400e-003	0.0000	22.0292	22.0292	7.1200e-003	0.0000	22.2073
Paving	0.0000					0.0000	0.0000		0.0000	0.0000	0.0000	0.0000	0.0000	0.0000	0.0000	0.0000
<b>Total</b>	<b>0.0109</b>	<b>0.1048</b>	<b>0.1609</b>	<b>2.5000e-004</b>		<b>5.1500e-003</b>	<b>5.1500e-003</b>		<b>4.7400e-003</b>	<b>4.7400e-003</b>	<b>0.0000</b>	<b>22.0292</b>	<b>22.0292</b>	<b>7.1200e-003</b>	<b>0.0000</b>	<b>22.2073</b>

Village South Specific Plan (Proposed) - Los Angeles-South Coast County, Annual

**3.6 Paving - 2024**

**Mitigated Construction Off-Site**

	ROG	NOx	CO	SO2	Fugitive PM10	Exhaust PM10	PM10 Total	Fugitive PM2.5	Exhaust PM2.5	PM2.5 Total	Bio- CO2	NBio- CO2	Total CO2	CH4	N2O	CO2e
Category	tons/yr										MT/yr					
Hauling	0.0000	0.0000	0.0000	0.0000	0.0000	0.0000	0.0000	0.0000	0.0000	0.0000	0.0000	0.0000	0.0000	0.0000	0.0000	0.0000
Vendor	0.0000	0.0000	0.0000	0.0000	0.0000	0.0000	0.0000	0.0000	0.0000	0.0000	0.0000	0.0000	0.0000	0.0000	0.0000	0.0000
Worker	5.9000e-004	4.1000e-004	4.9200e-003	2.0000e-005	1.8100e-003	1.0000e-005	1.8200e-003	4.8000e-004	1.0000e-005	4.9000e-004	0.0000	1.4697	1.4697	4.0000e-005	0.0000	1.4706
<b>Total</b>	<b>5.9000e-004</b>	<b>4.1000e-004</b>	<b>4.9200e-003</b>	<b>2.0000e-005</b>	<b>1.8100e-003</b>	<b>1.0000e-005</b>	<b>1.8200e-003</b>	<b>4.8000e-004</b>	<b>1.0000e-005</b>	<b>4.9000e-004</b>	<b>0.0000</b>	<b>1.4697</b>	<b>1.4697</b>	<b>4.0000e-005</b>	<b>0.0000</b>	<b>1.4706</b>

**3.7 Architectural Coating - 2024**

**Unmitigated Construction On-Site**

	ROG	NOx	CO	SO2	Fugitive PM10	Exhaust PM10	PM10 Total	Fugitive PM2.5	Exhaust PM2.5	PM2.5 Total	Bio- CO2	NBio- CO2	Total CO2	CH4	N2O	CO2e
Category	tons/yr										MT/yr					
Archit. Coating	4.1372					0.0000	0.0000		0.0000	0.0000	0.0000	0.0000	0.0000	0.0000	0.0000	0.0000
Off-Road	3.1600e-003	0.0213	0.0317	5.0000e-005		1.0700e-003	1.0700e-003		1.0700e-003	1.0700e-003	0.0000	4.4682	4.4682	2.5000e-004	0.0000	4.4745
<b>Total</b>	<b>4.1404</b>	<b>0.0213</b>	<b>0.0317</b>	<b>5.0000e-005</b>		<b>1.0700e-003</b>	<b>1.0700e-003</b>		<b>1.0700e-003</b>	<b>1.0700e-003</b>	<b>0.0000</b>	<b>4.4682</b>	<b>4.4682</b>	<b>2.5000e-004</b>	<b>0.0000</b>	<b>4.4745</b>

Village South Specific Plan (Proposed) - Los Angeles-South Coast County, Annual

**3.7 Architectural Coating - 2024**

**Unmitigated Construction Off-Site**

	ROG	NOx	CO	SO2	Fugitive PM10	Exhaust PM10	PM10 Total	Fugitive PM2.5	Exhaust PM2.5	PM2.5 Total	Bio- CO2	NBio- CO2	Total CO2	CH4	N2O	CO2e
Category	tons/yr										MT/yr					
Hauling	0.0000	0.0000	0.0000	0.0000	0.0000	0.0000	0.0000	0.0000	0.0000	0.0000	0.0000	0.0000	0.0000	0.0000	0.0000	0.0000
Vendor	0.0000	0.0000	0.0000	0.0000	0.0000	0.0000	0.0000	0.0000	0.0000	0.0000	0.0000	0.0000	0.0000	0.0000	0.0000	0.0000
Worker	0.0101	6.9900e-003	0.0835	2.8000e-004	0.0307	2.3000e-004	0.0309	8.1500e-003	2.2000e-004	8.3700e-003	0.0000	24.9407	24.9407	6.1000e-004	0.0000	24.9558
<b>Total</b>	<b>0.0101</b>	<b>6.9900e-003</b>	<b>0.0835</b>	<b>2.8000e-004</b>	<b>0.0307</b>	<b>2.3000e-004</b>	<b>0.0309</b>	<b>8.1500e-003</b>	<b>2.2000e-004</b>	<b>8.3700e-003</b>	<b>0.0000</b>	<b>24.9407</b>	<b>24.9407</b>	<b>6.1000e-004</b>	<b>0.0000</b>	<b>24.9558</b>

**Mitigated Construction On-Site**

	ROG	NOx	CO	SO2	Fugitive PM10	Exhaust PM10	PM10 Total	Fugitive PM2.5	Exhaust PM2.5	PM2.5 Total	Bio- CO2	NBio- CO2	Total CO2	CH4	N2O	CO2e
Category	tons/yr										MT/yr					
Archit. Coating	4.1372					0.0000	0.0000		0.0000	0.0000	0.0000	0.0000	0.0000	0.0000	0.0000	0.0000
Off-Road	3.1600e-003	0.0213	0.0317	5.0000e-005		1.0700e-003	1.0700e-003		1.0700e-003	1.0700e-003	0.0000	4.4682	4.4682	2.5000e-004	0.0000	4.4745
<b>Total</b>	<b>4.1404</b>	<b>0.0213</b>	<b>0.0317</b>	<b>5.0000e-005</b>		<b>1.0700e-003</b>	<b>1.0700e-003</b>		<b>1.0700e-003</b>	<b>1.0700e-003</b>	<b>0.0000</b>	<b>4.4682</b>	<b>4.4682</b>	<b>2.5000e-004</b>	<b>0.0000</b>	<b>4.4745</b>

Village South Specific Plan (Proposed) - Los Angeles-South Coast County, Annual

**3.7 Architectural Coating - 2024**

**Mitigated Construction Off-Site**

	ROG	NOx	CO	SO2	Fugitive PM10	Exhaust PM10	PM10 Total	Fugitive PM2.5	Exhaust PM2.5	PM2.5 Total	Bio- CO2	NBio- CO2	Total CO2	CH4	N2O	CO2e
Category	tons/yr										MT/yr					
Hauling	0.0000	0.0000	0.0000	0.0000	0.0000	0.0000	0.0000	0.0000	0.0000	0.0000	0.0000	0.0000	0.0000	0.0000	0.0000	0.0000
Vendor	0.0000	0.0000	0.0000	0.0000	0.0000	0.0000	0.0000	0.0000	0.0000	0.0000	0.0000	0.0000	0.0000	0.0000	0.0000	0.0000
Worker	0.0101	6.9900e-003	0.0835	2.8000e-004	0.0307	2.3000e-004	0.0309	8.1500e-003	2.2000e-004	8.3700e-003	0.0000	24.9407	24.9407	6.1000e-004	0.0000	24.9558
<b>Total</b>	<b>0.0101</b>	<b>6.9900e-003</b>	<b>0.0835</b>	<b>2.8000e-004</b>	<b>0.0307</b>	<b>2.3000e-004</b>	<b>0.0309</b>	<b>8.1500e-003</b>	<b>2.2000e-004</b>	<b>8.3700e-003</b>	<b>0.0000</b>	<b>24.9407</b>	<b>24.9407</b>	<b>6.1000e-004</b>	<b>0.0000</b>	<b>24.9558</b>

**4.0 Operational Detail - Mobile**

---

**4.1 Mitigation Measures Mobile**



Village South Specific Plan (Proposed) - Los Angeles-South Coast County, Annual

	ROG	NOx	CO	SO2	Fugitive PM10	Exhaust PM10	PM10 Total	Fugitive PM2.5	Exhaust PM2.5	PM2.5 Total	Bio- CO2	NBio- CO2	Total CO2	CH4	N2O	CO2e
Category	tons/yr										MT/yr					
Mitigated	1.5857	7.9962	19.1834	0.0821	7.7979	0.0580	7.8559	2.0895	0.0539	2.1434	0.0000	7,620.4986	7,620.4986	0.3407	0.0000	7,629.0162
Unmitigated	1.5857	7.9962	19.1834	0.0821	7.7979	0.0580	7.8559	2.0895	0.0539	2.1434	0.0000	7,620.4986	7,620.4986	0.3407	0.0000	7,629.0162

4.2 Trip Summary Information

Land Use	Average Daily Trip Rate			Unmitigated	Mitigated
	Weekday	Saturday	Sunday	Annual VMT	Annual VMT
Apartments Low Rise	145.75	154.25	154.00	506,227	506,227
Apartments Mid Rise	4,026.75	3,773.25	4075.50	13,660,065	13,660,065
General Office Building	288.45	62.55	31.05	706,812	706,812
High Turnover (Sit Down Restaurant)	2,368.80	2,873.52	2817.72	3,413,937	3,413,937
Hotel	192.00	187.50	160.00	445,703	445,703
Quality Restaurant	501.12	511.92	461.20	707,488	707,488
Regional Shopping Center	528.08	601.44	357.84	1,112,221	1,112,221
<b>Total</b>	<b>8,050.95</b>	<b>8,164.43</b>	<b>8,057.31</b>	<b>20,552,452</b>	<b>20,552,452</b>

4.3 Trip Type Information

Village South Specific Plan (Proposed) - Los Angeles-South Coast County, Annual

Land Use	Miles			Trip %			Trip Purpose %		
	H-W or C-W	H-S or C-C	H-O or C-NW	H-W or C-W	H-S or C-C	H-O or C-NW	Primary	Diverted	Pass-by
Apartments Low Rise	14.70	5.90	8.70	40.20	19.20	40.60	86	11	3
Apartments Mid Rise	14.70	5.90	8.70	40.20	19.20	40.60	86	11	3
General Office Building	16.60	8.40	6.90	33.00	48.00	19.00	77	19	4
High Turnover (Sit Down Restaurant)	16.60	8.40	6.90	8.50	72.50	19.00	37	20	43
Hotel	16.60	8.40	6.90	19.40	61.60	19.00	58	38	4
Quality Restaurant	16.60	8.40	6.90	12.00	69.00	19.00	38	18	44
Regional Shopping Center	16.60	8.40	6.90	16.30	64.70	19.00	54	35	11

4.4 Fleet Mix

Land Use	LDA	LDT1	LDT2	MDV	LHD1	LHD2	MHD	HHD	OBUS	UBUS	MCY	SBUS	MH
Apartments Low Rise	0.543088	0.044216	0.209971	0.116369	0.014033	0.006332	0.021166	0.033577	0.002613	0.001817	0.005285	0.000712	0.000821
Apartments Mid Rise	0.543088	0.044216	0.209971	0.116369	0.014033	0.006332	0.021166	0.033577	0.002613	0.001817	0.005285	0.000712	0.000821
General Office Building	0.543088	0.044216	0.209971	0.116369	0.014033	0.006332	0.021166	0.033577	0.002613	0.001817	0.005285	0.000712	0.000821
High Turnover (Sit Down Restaurant)	0.543088	0.044216	0.209971	0.116369	0.014033	0.006332	0.021166	0.033577	0.002613	0.001817	0.005285	0.000712	0.000821
Hotel	0.543088	0.044216	0.209971	0.116369	0.014033	0.006332	0.021166	0.033577	0.002613	0.001817	0.005285	0.000712	0.000821
Quality Restaurant	0.543088	0.044216	0.209971	0.116369	0.014033	0.006332	0.021166	0.033577	0.002613	0.001817	0.005285	0.000712	0.000821
Regional Shopping Center	0.543088	0.044216	0.209971	0.116369	0.014033	0.006332	0.021166	0.033577	0.002613	0.001817	0.005285	0.000712	0.000821

5.0 Energy Detail

Historical Energy Use: N

5.1 Mitigation Measures Energy

Village South Specific Plan (Proposed) - Los Angeles-South Coast County, Annual

	ROG	NOx	CO	SO2	Fugitive PM10	Exhaust PM10	PM10 Total	Fugitive PM2.5	Exhaust PM2.5	PM2.5 Total	Bio- CO2	NBio- CO2	Total CO2	CH4	N2O	CO2e
Category	tons/yr										MT/yr					
Electricity Mitigated							0.0000	0.0000		0.0000	0.0000	2,512.6465	2,512.6465	0.1037	0.0215	2,521.6356
Electricity Unmitigated							0.0000	0.0000		0.0000	0.0000	2,512.6465	2,512.6465	0.1037	0.0215	2,521.6356
NaturalGas Mitigated	0.1398	1.2312	0.7770	7.6200e-003			0.0966	0.0966		0.0966	0.0000	1,383.4267	1,383.4267	0.0265	0.0254	1,391.6478
NaturalGas Unmitigated	0.1398	1.2312	0.7770	7.6200e-003			0.0966	0.0966		0.0966	0.0000	1,383.4267	1,383.4267	0.0265	0.0254	1,391.6478

Village South Specific Plan (Proposed) - Los Angeles-South Coast County, Annual

**5.2 Energy by Land Use - NaturalGas**

**Unmitigated**

	NaturalGas Use	ROG	NOx	CO	SO2	Fugitive PM10	Exhaust PM10	PM10 Total	Fugitive PM2.5	Exhaust PM2.5	PM2.5 Total	Bio- CO2	NBio- CO2	Total CO2	CH4	N2O	CO2e
Land Use	kBTU/yr	tons/yr										MT/yr					
Apartments Low Rise	408494	2.2000e-003	0.0188	8.0100e-003	1.2000e-004		1.5200e-003	1.5200e-003		1.5200e-003	1.5200e-003	0.0000	21.7988	21.7988	4.2000e-004	4.0000e-004	21.9284
Apartments Mid Rise	1.30613e+007	0.0704	0.6018	0.2561	3.8400e-003		0.0487	0.0487		0.0487	0.0487	0.0000	696.9989	696.9989	0.0134	0.0128	701.1408
General Office Building	468450	2.5300e-003	0.0230	0.0193	1.4000e-004		1.7500e-003	1.7500e-003		1.7500e-003	1.7500e-003	0.0000	24.9983	24.9983	4.8000e-004	4.6000e-004	25.1468
High Turnover (Sit Down Restaurant)	8.30736e+006	0.0448	0.4072	0.3421	2.4400e-003		0.0310	0.0310		0.0310	0.0310	0.0000	443.3124	443.3124	8.5000e-003	8.1300e-003	445.9468
Hotel	1.74095e+006	9.3900e-003	0.0853	0.0717	5.1000e-004		6.4900e-003	6.4900e-003		6.4900e-003	6.4900e-003	0.0000	92.9036	92.9036	1.7800e-003	1.7000e-003	93.4557
Quality Restaurant	1.84608e+006	9.9500e-003	0.0905	0.0760	5.4000e-004		6.8800e-003	6.8800e-003		6.8800e-003	6.8800e-003	0.0000	98.5139	98.5139	1.8900e-003	1.8100e-003	99.0993
Regional Shopping Center	91840	5.0000e-004	4.5000e-003	3.7800e-003	3.0000e-005		3.4000e-004	3.4000e-004		3.4000e-004	3.4000e-004	0.0000	4.9009	4.9009	9.0000e-005	9.0000e-005	4.9301
<b>Total</b>		<b>0.1398</b>	<b>1.2312</b>	<b>0.7770</b>	<b>7.6200e-003</b>		<b>0.0966</b>	<b>0.0966</b>		<b>0.0966</b>	<b>0.0966</b>	<b>0.0000</b>	<b>1,383.4268</b>	<b>1,383.4268</b>	<b>0.0265</b>	<b>0.0254</b>	<b>1,391.6478</b>

Village South Specific Plan (Proposed) - Los Angeles-South Coast County, Annual

**5.2 Energy by Land Use - NaturalGas**

**Mitigated**

	NaturalGas Use	ROG	NOx	CO	SO2	Fugitive PM10	Exhaust PM10	PM10 Total	Fugitive PM2.5	Exhaust PM2.5	PM2.5 Total	Bio- CO2	NBio- CO2	Total CO2	CH4	N2O	CO2e
Land Use	kBTU/yr	tons/yr										MT/yr					
Apartments Low Rise	408494	2.2000e-003	0.0188	8.0100e-003	1.2000e-004		1.5200e-003	1.5200e-003		1.5200e-003	1.5200e-003	0.0000	21.7988	21.7988	4.2000e-004	4.0000e-004	21.9284
Apartments Mid Rise	1.30613e+007	0.0704	0.6018	0.2561	3.8400e-003		0.0487	0.0487		0.0487	0.0487	0.0000	696.9989	696.9989	0.0134	0.0128	701.1408
General Office Building	468450	2.5300e-003	0.0230	0.0193	1.4000e-004		1.7500e-003	1.7500e-003		1.7500e-003	1.7500e-003	0.0000	24.9983	24.9983	4.8000e-004	4.6000e-004	25.1468
High Turnover (Sit Down Restaurant)	8.30736e+006	0.0448	0.4072	0.3421	2.4400e-003		0.0310	0.0310		0.0310	0.0310	0.0000	443.3124	443.3124	8.5000e-003	8.1300e-003	445.9468
Hotel	1.74095e+006	9.3900e-003	0.0853	0.0717	5.1000e-004		6.4900e-003	6.4900e-003		6.4900e-003	6.4900e-003	0.0000	92.9036	92.9036	1.7800e-003	1.7000e-003	93.4557
Quality Restaurant	1.84608e+006	9.9500e-003	0.0905	0.0760	5.4000e-004		6.8800e-003	6.8800e-003		6.8800e-003	6.8800e-003	0.0000	98.5139	98.5139	1.8900e-003	1.8100e-003	99.0993
Regional Shopping Center	91840	5.0000e-004	4.5000e-003	3.7800e-003	3.0000e-005		3.4000e-004	3.4000e-004		3.4000e-004	3.4000e-004	0.0000	4.9009	4.9009	9.0000e-005	9.0000e-005	4.9301
<b>Total</b>		<b>0.1398</b>	<b>1.2312</b>	<b>0.7770</b>	<b>7.6200e-003</b>		<b>0.0966</b>	<b>0.0966</b>		<b>0.0966</b>	<b>0.0966</b>	<b>0.0000</b>	<b>1,383.4268</b>	<b>1,383.4268</b>	<b>0.0265</b>	<b>0.0254</b>	<b>1,391.6478</b>

Village South Specific Plan (Proposed) - Los Angeles-South Coast County, Annual

**5.3 Energy by Land Use - Electricity**

**Unmitigated**

	Electricity Use	Total CO2	CH4	N2O	CO2e
Land Use	kWh/yr	MT/yr			
Apartments Low Rise	106010	33.7770	1.3900e-003	2.9000e-004	33.8978
Apartments Mid Rise	3.94697e+006	1,257.5879	0.0519	0.0107	1,262.0869
General Office Building	584550	186.2502	7.6900e-003	1.5900e-003	186.9165
High Turnover (Sit Down Restaurant)	1.58904e+006	506.3022	0.0209	4.3200e-003	508.1135
Hotel	550308	175.3399	7.2400e-003	1.5000e-003	175.9672
Quality Restaurant	353120	112.5116	4.6500e-003	9.6000e-004	112.9141
Regional Shopping Center	756000	240.8778	9.9400e-003	2.0600e-003	241.7395
<b>Total</b>		<b>2,512.6465</b>	<b>0.1037</b>	<b>0.0215</b>	<b>2,521.6356</b>

Village South Specific Plan (Proposed) - Los Angeles-South Coast County, Annual

**5.3 Energy by Land Use - Electricity**

**Mitigated**

	Electricity Use	Total CO2	CH4	N2O	CO2e
Land Use	kWh/yr	MT/yr			
Apartments Low Rise	106010	33.7770	1.3900e-003	2.9000e-004	33.8978
Apartments Mid Rise	3.94697e+006	1,257.5879	0.0519	0.0107	1,262.0869
General Office Building	584550	186.2502	7.6900e-003	1.5900e-003	186.9165
High Turnover (Sit Down Restaurant)	1.58904e+006	506.3022	0.0209	4.3200e-003	508.1135
Hotel	550308	175.3399	7.2400e-003	1.5000e-003	175.9672
Quality Restaurant	353120	112.5116	4.6500e-003	9.6000e-004	112.9141
Regional Shopping Center	756000	240.8778	9.9400e-003	2.0600e-003	241.7395
<b>Total</b>		<b>2,512.6465</b>	<b>0.1037</b>	<b>0.0215</b>	<b>2,521.6356</b>

**6.0 Area Detail**

**6.1 Mitigation Measures Area**

Village South Specific Plan (Proposed) - Los Angeles-South Coast County, Annual

	ROG	NOx	CO	SO2	Fugitive PM10	Exhaust PM10	PM10 Total	Fugitive PM2.5	Exhaust PM2.5	PM2.5 Total	Bio- CO2	NBio- CO2	Total CO2	CH4	N2O	CO2e
Category	tons/yr										MT/yr					
Mitigated	5.1437	0.2950	10.3804	1.6700e-003		0.0714	0.0714		0.0714	0.0714	0.0000	220.9670	220.9670	0.0201	3.7400e-003	222.5835
Unmitigated	5.1437	0.2950	10.3804	1.6700e-003		0.0714	0.0714		0.0714	0.0714	0.0000	220.9670	220.9670	0.0201	3.7400e-003	222.5835

6.2 Area by SubCategory

Unmitigated

	ROG	NOx	CO	SO2	Fugitive PM10	Exhaust PM10	PM10 Total	Fugitive PM2.5	Exhaust PM2.5	PM2.5 Total	Bio- CO2	NBio- CO2	Total CO2	CH4	N2O	CO2e
SubCategory	tons/yr										MT/yr					
Architectural Coating	0.4137					0.0000	0.0000		0.0000	0.0000	0.0000	0.0000	0.0000	0.0000	0.0000	0.0000
Consumer Products	4.3998					0.0000	0.0000		0.0000	0.0000	0.0000	0.0000	0.0000	0.0000	0.0000	0.0000
Hearth	0.0206	0.1763	0.0750	1.1200e-003		0.0143	0.0143		0.0143	0.0143	0.0000	204.1166	204.1166	3.9100e-003	3.7400e-003	205.3295
Landscaping	0.3096	0.1187	10.3054	5.4000e-004		0.0572	0.0572		0.0572	0.0572	0.0000	16.8504	16.8504	0.0161	0.0000	17.2540
<b>Total</b>	<b>5.1437</b>	<b>0.2950</b>	<b>10.3804</b>	<b>1.6600e-003</b>		<b>0.0714</b>	<b>0.0714</b>		<b>0.0714</b>	<b>0.0714</b>	<b>0.0000</b>	<b>220.9670</b>	<b>220.9670</b>	<b>0.0201</b>	<b>3.7400e-003</b>	<b>222.5835</b>



Village South Specific Plan (Proposed) - Los Angeles-South Coast County, Annual

**6.2 Area by SubCategory**

**Mitigated**

	ROG	NOx	CO	SO2	Fugitive PM10	Exhaust PM10	PM10 Total	Fugitive PM2.5	Exhaust PM2.5	PM2.5 Total	Bio- CO2	NBio- CO2	Total CO2	CH4	N2O	CO2e
SubCategory	tons/yr										MT/yr					
Architectural Coating	0.4137					0.0000	0.0000		0.0000	0.0000	0.0000	0.0000	0.0000	0.0000	0.0000	0.0000
Consumer Products	4.3998					0.0000	0.0000		0.0000	0.0000	0.0000	0.0000	0.0000	0.0000	0.0000	0.0000
Hearth	0.0206	0.1763	0.0750	1.1200e-003		0.0143	0.0143		0.0143	0.0143	0.0000	204.1166	204.1166	3.9100e-003	3.7400e-003	205.3295
Landscaping	0.3096	0.1187	10.3054	5.4000e-004		0.0572	0.0572		0.0572	0.0572	0.0000	16.8504	16.8504	0.0161	0.0000	17.2540
<b>Total</b>	<b>5.1437</b>	<b>0.2950</b>	<b>10.3804</b>	<b>1.6600e-003</b>		<b>0.0714</b>	<b>0.0714</b>		<b>0.0714</b>	<b>0.0714</b>	<b>0.0000</b>	<b>220.9670</b>	<b>220.9670</b>	<b>0.0201</b>	<b>3.7400e-003</b>	<b>222.5835</b>

**7.0 Water Detail**

**7.1 Mitigation Measures Water**

Village South Specific Plan (Proposed) - Los Angeles-South Coast County, Annual

	Total CO2	CH4	N2O	CO2e
Category	MT/yr			
Mitigated	585.8052	3.0183	0.0755	683.7567
Unmitigated	585.8052	3.0183	0.0755	683.7567

Village South Specific Plan (Proposed) - Los Angeles-South Coast County, Annual

**7.2 Water by Land Use**

**Unmitigated**

	Indoor/Outdoor Use	Total CO2	CH4	N2O	CO2e
Land Use	Mgal	MT/yr			
Apartments Low Rise	1.62885 / 1.02688	10.9095	0.0535	1.3400e-003	12.6471
Apartments Mid Rise	63.5252 / 40.0485	425.4719	2.0867	0.0523	493.2363
General Office Building	7.99802 / 4.90201	53.0719	0.2627	6.5900e-003	61.6019
High Turnover (Sit Down Restaurant)	10.9272 / 0.697482	51.2702	0.3580	8.8200e-003	62.8482
Hotel	1.26834 / 0.140927	6.1633	0.0416	1.0300e-003	7.5079
Quality Restaurant	2.42827 / 0.154996	11.3934	0.0796	1.9600e-003	13.9663
Regional Shopping Center	4.14806 / 2.54236	27.5250	0.1363	3.4200e-003	31.9490
<b>Total</b>		<b>585.8052</b>	<b>3.0183</b>	<b>0.0755</b>	<b>683.7567</b>

Village South Specific Plan (Proposed) - Los Angeles-South Coast County, Annual

**7.2 Water by Land Use**

**Mitigated**

	Indoor/Outdoor Use	Total CO2	CH4	N2O	CO2e
Land Use	Mgal	MT/yr			
Apartments Low Rise	1.62885 / 1.02688	10.9095	0.0535	1.3400e-003	12.6471
Apartments Mid Rise	63.5252 / 40.0485	425.4719	2.0867	0.0523	493.2363
General Office Building	7.99802 / 4.90201	53.0719	0.2627	6.5900e-003	61.6019
High Turnover (Sit Down Restaurant)	10.9272 / 0.697482	51.2702	0.3580	8.8200e-003	62.8482
Hotel	1.26834 / 0.140927	6.1633	0.0416	1.0300e-003	7.5079
Quality Restaurant	2.42827 / 0.154996	11.3934	0.0796	1.9600e-003	13.9663
Regional Shopping Center	4.14806 / 2.54236	27.5250	0.1363	3.4200e-003	31.9490
<b>Total</b>		<b>585.8052</b>	<b>3.0183</b>	<b>0.0755</b>	<b>683.7567</b>

**8.0 Waste Detail**

---

**8.1 Mitigation Measures Waste**

Village South Specific Plan (Proposed) - Los Angeles-South Coast County, Annual

**Category/Year**

	Total CO2	CH4	N2O	CO2e
	MT/yr			
Mitigated	207.8079	12.2811	0.0000	514.8354
Unmitigated	207.8079	12.2811	0.0000	514.8354

Village South Specific Plan (Proposed) - Los Angeles-South Coast County, Annual

**8.2 Waste by Land Use**

**Unmitigated**

	Waste Disposed	Total CO2	CH4	N2O	CO2e
Land Use	tons	MT/yr			
Apartments Low Rise	11.5	2.3344	0.1380	0.0000	5.7834
Apartments Mid Rise	448.5	91.0415	5.3804	0.0000	225.5513
General Office Building	41.85	8.4952	0.5021	0.0000	21.0464
High Turnover (Sit Down Restaurant)	428.4	86.9613	5.1393	0.0000	215.4430
Hotel	27.38	5.5579	0.3285	0.0000	13.7694
Quality Restaurant	7.3	1.4818	0.0876	0.0000	3.6712
Regional Shopping Center	58.8	11.9359	0.7054	0.0000	29.5706
<b>Total</b>		<b>207.8079</b>	<b>12.2811</b>	<b>0.0000</b>	<b>514.8354</b>

Village South Specific Plan (Proposed) - Los Angeles-South Coast County, Annual

**8.2 Waste by Land Use**

**Mitigated**

	Waste Disposed	Total CO2	CH4	N2O	CO2e
Land Use	tons	MT/yr			
Apartments Low Rise	11.5	2.3344	0.1380	0.0000	5.7834
Apartments Mid Rise	448.5	91.0415	5.3804	0.0000	225.5513
General Office Building	41.85	8.4952	0.5021	0.0000	21.0464
High Turnover (Sit Down Restaurant)	428.4	86.9613	5.1393	0.0000	215.4430
Hotel	27.38	5.5579	0.3285	0.0000	13.7694
Quality Restaurant	7.3	1.4818	0.0876	0.0000	3.6712
Regional Shopping Center	58.8	11.9359	0.7054	0.0000	29.5706
<b>Total</b>		<b>207.8079</b>	<b>12.2811</b>	<b>0.0000</b>	<b>514.8354</b>

**9.0 Operational Offroad**

Equipment Type	Number	Hours/Day	Days/Year	Horse Power	Load Factor	Fuel Type
----------------	--------	-----------	-----------	-------------	-------------	-----------

**10.0 Stationary Equipment**

**Fire Pumps and Emergency Generators**

Equipment Type	Number	Hours/Day	Hours/Year	Horse Power	Load Factor	Fuel Type
----------------	--------	-----------	------------	-------------	-------------	-----------

Village South Specific Plan (Proposed) - Los Angeles-South Coast County, Annual

**Boilers**

Equipment Type	Number	Heat Input/Day	Heat Input/Year	Boiler Rating	Fuel Type
----------------	--------	----------------	-----------------	---------------	-----------

**User Defined Equipment**

Equipment Type	Number
----------------	--------

**11.0 Vegetation**

---



Village South Specific Plan (Proposed) - Los Angeles-South Coast County, Summer

**Village South Specific Plan (Proposed)**  
**Los Angeles-South Coast County, Summer**

**1.0 Project Characteristics**

**1.1 Land Usage**

Land Uses	Size	Metric	Lot Acreage	Floor Surface Area	Population
General Office Building	45.00	1000sqft	1.03	45,000.00	0
High Turnover (Sit Down Restaurant)	36.00	1000sqft	0.83	36,000.00	0
Hotel	50.00	Room	1.67	72,600.00	0
Quality Restaurant	8.00	1000sqft	0.18	8,000.00	0
Apartments Low Rise	25.00	Dwelling Unit	1.56	25,000.00	72
Apartments Mid Rise	975.00	Dwelling Unit	25.66	975,000.00	2789
Regional Shopping Center	56.00	1000sqft	1.29	56,000.00	0

**1.2 Other Project Characteristics**

<b>Urbanization</b>	Urban	<b>Wind Speed (m/s)</b>	2.2	<b>Precipitation Freq (Days)</b>	33
<b>Climate Zone</b>	9			<b>Operational Year</b>	2028
<b>Utility Company</b>	Southern California Edison				
<b>CO2 Intensity (lb/MW hr)</b>	702.44	<b>CH4 Intensity (lb/MW hr)</b>	0.029	<b>N2O Intensity (lb/MW hr)</b>	0.006

**1.3 User Entered Comments & Non-Default Data**

Village South Specific Plan (Proposed) - Los Angeles-South Coast County, Summer

Project Characteristics - Consistent with the DEIR's model.

Land Use - See SWAPE comment regarding residential and retail land uses.

Construction Phase - See SWAPE comment regarding individual construction phase lengths.

Demolition - Consistent with the DEIR's model. See SWAPE comment regarding demolition.

Vehicle Trips - Saturday trips consistent with the DEIR's model. See SWAPE comment regarding weekday and Sunday trips.

Woodstoves - Woodstoves and wood-burning fireplaces consistent with the DEIR's model. See SWAPE comment regarding gas fireplaces.

Energy Use -

Construction Off-road Equipment Mitigation - See SWAPE comment on construction-related mitigation.

Area Mitigation - See SWAPE comment regarding operational mitigation measures.

Water Mitigation - See SWAPE comment regarding operational mitigation measures.

Table Name	Column Name	Default Value	New Value
tblFireplaces	FireplaceWoodMass	1,019.20	0.00
tblFireplaces	FireplaceWoodMass	1,019.20	0.00
tblFireplaces	NumberWood	1.25	0.00
tblFireplaces	NumberWood	48.75	0.00
tblVehicleTrips	ST_TR	7.16	6.17
tblVehicleTrips	ST_TR	6.39	3.87
tblVehicleTrips	ST_TR	2.46	1.39
tblVehicleTrips	ST_TR	158.37	79.82
tblVehicleTrips	ST_TR	8.19	3.75
tblVehicleTrips	ST_TR	94.36	63.99
tblVehicleTrips	ST_TR	49.97	10.74
tblVehicleTrips	SU_TR	6.07	6.16
tblVehicleTrips	SU_TR	5.86	4.18
tblVehicleTrips	SU_TR	1.05	0.69
tblVehicleTrips	SU_TR	131.84	78.27

## Village South Specific Plan (Proposed) - Los Angeles-South Coast County, Summer

tblVehicleTrips	SU_TR	5.95	3.20
tblVehicleTrips	SU_TR	72.16	57.65
tblVehicleTrips	SU_TR	25.24	6.39
tblVehicleTrips	WD_TR	6.59	5.83
tblVehicleTrips	WD_TR	6.65	4.13
tblVehicleTrips	WD_TR	11.03	6.41
tblVehicleTrips	WD_TR	127.15	65.80
tblVehicleTrips	WD_TR	8.17	3.84
tblVehicleTrips	WD_TR	89.95	62.64
tblVehicleTrips	WD_TR	42.70	9.43
tblWoodstoves	NumberCatalytic	1.25	0.00
tblWoodstoves	NumberCatalytic	48.75	0.00
tblWoodstoves	NumberNoncatalytic	1.25	0.00
tblWoodstoves	NumberNoncatalytic	48.75	0.00
tblWoodstoves	WoodstoveDayYear	25.00	0.00
tblWoodstoves	WoodstoveDayYear	25.00	0.00
tblWoodstoves	WoodstoveWoodMass	999.60	0.00
tblWoodstoves	WoodstoveWoodMass	999.60	0.00

## 2.0 Emissions Summary

---

Village South Specific Plan (Proposed) - Los Angeles-South Coast County, Summer

**2.1 Overall Construction (Maximum Daily Emission)**

**Unmitigated Construction**

	ROG	NOx	CO	SO2	Fugitive PM10	Exhaust PM10	PM10 Total	Fugitive PM2.5	Exhaust PM2.5	PM2.5 Total	Bio- CO2	NBio- CO2	Total CO2	CH4	N2O	CO2e
Year	lb/day										lb/day					
2021	4.2769	46.4588	31.6840	0.0643	18.2675	2.0461	20.3135	9.9840	1.8824	11.8664	0.0000	6,234.7974	6,234.7974	1.9495	0.0000	6,283.5352
2022	5.3304	38.8967	49.5629	0.1517	9.8688	1.6366	10.7727	3.6558	1.5057	5.1615	0.0000	15,251.5674	15,251.5674	1.9503	0.0000	15,278.5288
2023	4.8957	26.3317	46.7567	0.1472	9.8688	0.7794	10.6482	2.6381	0.7322	3.3702	0.0000	14,807.5269	14,807.5269	1.0250	0.0000	14,833.1521
2024	237.1630	9.5575	15.1043	0.0244	1.7884	0.4698	1.8628	0.4743	0.4322	0.5476	0.0000	2,361.3989	2,361.3989	0.7177	0.0000	2,379.3421
<b>Maximum</b>	<b>237.1630</b>	<b>46.4588</b>	<b>49.5629</b>	<b>0.1517</b>	<b>18.2675</b>	<b>2.0461</b>	<b>20.3135</b>	<b>9.9840</b>	<b>1.8824</b>	<b>11.8664</b>	<b>0.0000</b>	<b>15,251.5674</b>	<b>15,251.5674</b>	<b>1.9503</b>	<b>0.0000</b>	<b>15,278.5288</b>



Village South Specific Plan (Proposed) - Los Angeles-South Coast County, Summer

**2.2 Overall Operational**

**Unmitigated Operational**

	ROG	NOx	CO	SO2	Fugitive PM10	Exhaust PM10	PM10 Total	Fugitive PM2.5	Exhaust PM2.5	PM2.5 Total	Bio- CO2	NBio- CO2	Total CO2	CH4	N2O	CO2e
Category	lb/day										lb/day					
Area	30.5020	15.0496	88.4430	0.0944		1.5974	1.5974		1.5974	1.5974	0.0000	18,148.59 50	18,148.59 50	0.4874	0.3300	18,259.11 92
Energy	0.7660	6.7462	4.2573	0.0418		0.5292	0.5292		0.5292	0.5292		8,355.983 2	8,355.983 2	0.1602	0.1532	8,405.638 7
Mobile	9.8489	45.4304	114.8495	0.4917	45.9592	0.3360	46.2951	12.2950	0.3119	12.6070		50,306.60 34	50,306.60 34	2.1807		50,361.12 08
<b>Total</b>	<b>41.1168</b>	<b>67.2262</b>	<b>207.5497</b>	<b>0.6278</b>	<b>45.9592</b>	<b>2.4626</b>	<b>48.4217</b>	<b>12.2950</b>	<b>2.4385</b>	<b>14.7336</b>	<b>0.0000</b>	<b>76,811.18 16</b>	<b>76,811.18 16</b>	<b>2.8282</b>	<b>0.4832</b>	<b>77,025.87 86</b>

**Mitigated Operational**

	ROG	NOx	CO	SO2	Fugitive PM10	Exhaust PM10	PM10 Total	Fugitive PM2.5	Exhaust PM2.5	PM2.5 Total	Bio- CO2	NBio- CO2	Total CO2	CH4	N2O	CO2e
Category	lb/day										lb/day					
Area	30.5020	15.0496	88.4430	0.0944		1.5974	1.5974		1.5974	1.5974	0.0000	18,148.59 50	18,148.59 50	0.4874	0.3300	18,259.11 92
Energy	0.7660	6.7462	4.2573	0.0418		0.5292	0.5292		0.5292	0.5292		8,355.983 2	8,355.983 2	0.1602	0.1532	8,405.638 7
Mobile	9.8489	45.4304	114.8495	0.4917	45.9592	0.3360	46.2951	12.2950	0.3119	12.6070		50,306.60 34	50,306.60 34	2.1807		50,361.12 08
<b>Total</b>	<b>41.1168</b>	<b>67.2262</b>	<b>207.5497</b>	<b>0.6278</b>	<b>45.9592</b>	<b>2.4626</b>	<b>48.4217</b>	<b>12.2950</b>	<b>2.4385</b>	<b>14.7336</b>	<b>0.0000</b>	<b>76,811.18 16</b>	<b>76,811.18 16</b>	<b>2.8282</b>	<b>0.4832</b>	<b>77,025.87 86</b>

Village South Specific Plan (Proposed) - Los Angeles-South Coast County, Summer

	ROG	NOx	CO	SO2	Fugitive PM10	Exhaust PM10	PM10 Total	Fugitive PM2.5	Exhaust PM2.5	PM2.5 Total	Bio- CO2	NBio-CO2	Total CO2	CH4	N2O	CO2e
Percent Reduction	0.00	0.00	0.00	0.00	0.00	0.00	0.00	0.00	0.00	0.00	0.00	0.00	0.00	0.00	0.00	0.00

### 3.0 Construction Detail

#### Construction Phase

Phase Number	Phase Name	Phase Type	Start Date	End Date	Num Days Week	Num Days	Phase Description
1	Demolition	Demolition	9/1/2021	10/12/2021	5	30	
2	Site Preparation	Site Preparation	10/13/2021	11/9/2021	5	20	
3	Grading	Grading	11/10/2021	1/11/2022	5	45	
4	Building Construction	Building Construction	1/12/2022	12/12/2023	5	500	
5	Paving	Paving	12/13/2023	1/30/2024	5	35	
6	Architectural Coating	Architectural Coating	1/31/2024	3/19/2024	5	35	

Acres of Grading (Site Preparation Phase): 0

Acres of Grading (Grading Phase): 112.5

Acres of Paving: 0

Residential Indoor: 2,025,000; Residential Outdoor: 675,000; Non-Residential Indoor: 326,400; Non-Residential Outdoor: 108,800; Striped Parking Area: 0 (Architectural Coating – sqft)

#### OffRoad Equipment

## Village South Specific Plan (Proposed) - Los Angeles-South Coast County, Summer

Phase Name	Offroad Equipment Type	Amount	Usage Hours	Horse Power	Load Factor
Demolition	Concrete/Industrial Saws	1	8.00	81	0.73
Demolition	Excavators	3	8.00	158	0.38
Demolition	Rubber Tired Dozers	2	8.00	247	0.40
Site Preparation	Rubber Tired Dozers	3	8.00	247	0.40
Site Preparation	Tractors/Loaders/Backhoes	4	8.00	97	0.37
Grading	Excavators	2	8.00	158	0.38
Grading	Graders	1	8.00	187	0.41
Grading	Rubber Tired Dozers	1	8.00	247	0.40
Grading	Scrapers	2	8.00	367	0.48
Grading	Tractors/Loaders/Backhoes	2	8.00	97	0.37
Building Construction	Cranes	1	7.00	231	0.29
Building Construction	Forklifts	3	8.00	89	0.20
Building Construction	Generator Sets	1	8.00	84	0.74
Building Construction	Tractors/Loaders/Backhoes	3	7.00	97	0.37
Building Construction	Welders	1	8.00	46	0.45
Paving	Pavers	2	8.00	130	0.42
Paving	Paving Equipment	2	8.00	132	0.36
Paving	Rollers	2	8.00	80	0.38
Architectural Coating	Air Compressors	1	6.00	78	0.48

Trips and VMT



Village South Specific Plan (Proposed) - Los Angeles-South Coast County, Summer

Phase Name	Offroad Equipment Count	Worker Trip Number	Vendor Trip Number	Hauling Trip Number	Worker Trip Length	Vendor Trip Length	Hauling Trip Length	Worker Vehicle Class	Vendor Vehicle Class	Hauling Vehicle Class
Demolition	6	15.00	0.00	458.00	14.70	6.90	20.00	LD_Mix	HDT_Mix	HHDT
Site Preparation	7	18.00	0.00	0.00	14.70	6.90	20.00	LD_Mix	HDT_Mix	HHDT
Grading	8	20.00	0.00	0.00	14.70	6.90	20.00	LD_Mix	HDT_Mix	HHDT
Building Construction	9	801.00	143.00	0.00	14.70	6.90	20.00	LD_Mix	HDT_Mix	HHDT
Paving	6	15.00	0.00	0.00	14.70	6.90	20.00	LD_Mix	HDT_Mix	HHDT
Architectural Coating	1	160.00	0.00	0.00	14.70	6.90	20.00	LD_Mix	HDT_Mix	HHDT

**3.1 Mitigation Measures Construction**

**3.2 Demolition - 2021**

**Unmitigated Construction On-Site**

	ROG	NOx	CO	SO2	Fugitive PM10	Exhaust PM10	PM10 Total	Fugitive PM2.5	Exhaust PM2.5	PM2.5 Total	Bio- CO2	NBio- CO2	Total CO2	CH4	N2O	CO2e
Category	lb/day										lb/day					
Fugitive Dust					3.3074	0.0000	3.3074	0.5008	0.0000	0.5008			0.0000			0.0000
Off-Road	3.1651	31.4407	21.5650	0.0388		1.5513	1.5513		1.4411	1.4411		3,747.9449	3,747.9449	1.0549		3,774.3174
<b>Total</b>	<b>3.1651</b>	<b>31.4407</b>	<b>21.5650</b>	<b>0.0388</b>	<b>3.3074</b>	<b>1.5513</b>	<b>4.8588</b>	<b>0.5008</b>	<b>1.4411</b>	<b>1.9419</b>		<b>3,747.9449</b>	<b>3,747.9449</b>	<b>1.0549</b>		<b>3,774.3174</b>

Village South Specific Plan (Proposed) - Los Angeles-South Coast County, Summer

**3.2 Demolition - 2021**

**Unmitigated Construction Off-Site**

	ROG	NOx	CO	SO2	Fugitive PM10	Exhaust PM10	PM10 Total	Fugitive PM2.5	Exhaust PM2.5	PM2.5 Total	Bio- CO2	NBio- CO2	Total CO2	CH4	N2O	CO2e
Category	lb/day										lb/day					
Hauling	0.1273	4.0952	0.9602	0.0119	0.2669	0.0126	0.2795	0.0732	0.0120	0.0852		1,292.2413	1,292.2413	0.0877		1,294.4337
Vendor	0.0000	0.0000	0.0000	0.0000	0.0000	0.0000	0.0000	0.0000	0.0000	0.0000		0.0000	0.0000	0.0000		0.0000
Worker	0.0643	0.0442	0.6042	1.7100e-003	0.1677	1.3500e-003	0.1690	0.0445	1.2500e-003	0.0457		170.8155	170.8155	5.0300e-003		170.9413
<b>Total</b>	<b>0.1916</b>	<b>4.1394</b>	<b>1.5644</b>	<b>0.0136</b>	<b>0.4346</b>	<b>0.0139</b>	<b>0.4485</b>	<b>0.1176</b>	<b>0.0133</b>	<b>0.1309</b>		<b>1,463.0568</b>	<b>1,463.0568</b>	<b>0.0927</b>		<b>1,465.3750</b>

**Mitigated Construction On-Site**

	ROG	NOx	CO	SO2	Fugitive PM10	Exhaust PM10	PM10 Total	Fugitive PM2.5	Exhaust PM2.5	PM2.5 Total	Bio- CO2	NBio- CO2	Total CO2	CH4	N2O	CO2e
Category	lb/day										lb/day					
Fugitive Dust					3.3074	0.0000	3.3074	0.5008	0.0000	0.5008			0.0000			0.0000
Off-Road	3.1651	31.4407	21.5650	0.0388		1.5513	1.5513		1.4411	1.4411	0.0000	3,747.9449	3,747.9449	1.0549		3,774.3174
<b>Total</b>	<b>3.1651</b>	<b>31.4407</b>	<b>21.5650</b>	<b>0.0388</b>	<b>3.3074</b>	<b>1.5513</b>	<b>4.8588</b>	<b>0.5008</b>	<b>1.4411</b>	<b>1.9419</b>	<b>0.0000</b>	<b>3,747.9449</b>	<b>3,747.9449</b>	<b>1.0549</b>		<b>3,774.3174</b>

Village South Specific Plan (Proposed) - Los Angeles-South Coast County, Summer

**3.2 Demolition - 2021**

**Mitigated Construction Off-Site**

	ROG	NOx	CO	SO2	Fugitive PM10	Exhaust PM10	PM10 Total	Fugitive PM2.5	Exhaust PM2.5	PM2.5 Total	Bio- CO2	NBio- CO2	Total CO2	CH4	N2O	CO2e
Category	lb/day										lb/day					
Hauling	0.1273	4.0952	0.9602	0.0119	0.2669	0.0126	0.2795	0.0732	0.0120	0.0852		1,292.2413	1,292.2413	0.0877		1,294.4337
Vendor	0.0000	0.0000	0.0000	0.0000	0.0000	0.0000	0.0000	0.0000	0.0000	0.0000		0.0000	0.0000	0.0000		0.0000
Worker	0.0643	0.0442	0.6042	1.7100e-003	0.1677	1.3500e-003	0.1690	0.0445	1.2500e-003	0.0457		170.8155	170.8155	5.0300e-003		170.9413
<b>Total</b>	<b>0.1916</b>	<b>4.1394</b>	<b>1.5644</b>	<b>0.0136</b>	<b>0.4346</b>	<b>0.0139</b>	<b>0.4485</b>	<b>0.1176</b>	<b>0.0133</b>	<b>0.1309</b>		<b>1,463.0568</b>	<b>1,463.0568</b>	<b>0.0927</b>		<b>1,465.3750</b>

**3.3 Site Preparation - 2021**

**Unmitigated Construction On-Site**

	ROG	NOx	CO	SO2	Fugitive PM10	Exhaust PM10	PM10 Total	Fugitive PM2.5	Exhaust PM2.5	PM2.5 Total	Bio- CO2	NBio- CO2	Total CO2	CH4	N2O	CO2e
Category	lb/day										lb/day					
Fugitive Dust					18.0663	0.0000	18.0663	9.9307	0.0000	9.9307			0.0000			0.0000
Off-Road	3.8882	40.4971	21.1543	0.0380		2.0445	2.0445		1.8809	1.8809		3,685.6569	3,685.6569	1.1920		3,715.4573
<b>Total</b>	<b>3.8882</b>	<b>40.4971</b>	<b>21.1543</b>	<b>0.0380</b>	<b>18.0663</b>	<b>2.0445</b>	<b>20.1107</b>	<b>9.9307</b>	<b>1.8809</b>	<b>11.8116</b>		<b>3,685.6569</b>	<b>3,685.6569</b>	<b>1.1920</b>		<b>3,715.4573</b>

Village South Specific Plan (Proposed) - Los Angeles-South Coast County, Summer

**3.3 Site Preparation - 2021**

**Unmitigated Construction Off-Site**

	ROG	NOx	CO	SO2	Fugitive PM10	Exhaust PM10	PM10 Total	Fugitive PM2.5	Exhaust PM2.5	PM2.5 Total	Bio- CO2	NBio- CO2	Total CO2	CH4	N2O	CO2e
Category	lb/day										lb/day					
Hauling	0.0000	0.0000	0.0000	0.0000	0.0000	0.0000	0.0000	0.0000	0.0000	0.0000		0.0000	0.0000	0.0000		0.0000
Vendor	0.0000	0.0000	0.0000	0.0000	0.0000	0.0000	0.0000	0.0000	0.0000	0.0000		0.0000	0.0000	0.0000		0.0000
Worker	0.0772	0.0530	0.7250	2.0600e-003	0.2012	1.6300e-003	0.2028	0.0534	1.5000e-003	0.0549		204.9786	204.9786	6.0400e-003		205.1296
<b>Total</b>	<b>0.0772</b>	<b>0.0530</b>	<b>0.7250</b>	<b>2.0600e-003</b>	<b>0.2012</b>	<b>1.6300e-003</b>	<b>0.2028</b>	<b>0.0534</b>	<b>1.5000e-003</b>	<b>0.0549</b>		<b>204.9786</b>	<b>204.9786</b>	<b>6.0400e-003</b>		<b>205.1296</b>

**Mitigated Construction On-Site**

	ROG	NOx	CO	SO2	Fugitive PM10	Exhaust PM10	PM10 Total	Fugitive PM2.5	Exhaust PM2.5	PM2.5 Total	Bio- CO2	NBio- CO2	Total CO2	CH4	N2O	CO2e
Category	lb/day										lb/day					
Fugitive Dust					18.0663	0.0000	18.0663	9.9307	0.0000	9.9307			0.0000			0.0000
Off-Road	3.8882	40.4971	21.1543	0.0380		2.0445	2.0445		1.8809	1.8809	0.0000	3,685.6569	3,685.6569	1.1920		3,715.4573
<b>Total</b>	<b>3.8882</b>	<b>40.4971</b>	<b>21.1543</b>	<b>0.0380</b>	<b>18.0663</b>	<b>2.0445</b>	<b>20.1107</b>	<b>9.9307</b>	<b>1.8809</b>	<b>11.8116</b>	<b>0.0000</b>	<b>3,685.6569</b>	<b>3,685.6569</b>	<b>1.1920</b>		<b>3,715.4573</b>

Village South Specific Plan (Proposed) - Los Angeles-South Coast County, Summer

**3.3 Site Preparation - 2021**

**Mitigated Construction Off-Site**

	ROG	NOx	CO	SO2	Fugitive PM10	Exhaust PM10	PM10 Total	Fugitive PM2.5	Exhaust PM2.5	PM2.5 Total	Bio- CO2	NBio- CO2	Total CO2	CH4	N2O	CO2e
Category	lb/day										lb/day					
Hauling	0.0000	0.0000	0.0000	0.0000	0.0000	0.0000	0.0000	0.0000	0.0000	0.0000		0.0000	0.0000	0.0000		0.0000
Vendor	0.0000	0.0000	0.0000	0.0000	0.0000	0.0000	0.0000	0.0000	0.0000	0.0000		0.0000	0.0000	0.0000		0.0000
Worker	0.0772	0.0530	0.7250	2.0600e-003	0.2012	1.6300e-003	0.2028	0.0534	1.5000e-003	0.0549		204.9786	204.9786	6.0400e-003		205.1296
<b>Total</b>	<b>0.0772</b>	<b>0.0530</b>	<b>0.7250</b>	<b>2.0600e-003</b>	<b>0.2012</b>	<b>1.6300e-003</b>	<b>0.2028</b>	<b>0.0534</b>	<b>1.5000e-003</b>	<b>0.0549</b>		<b>204.9786</b>	<b>204.9786</b>	<b>6.0400e-003</b>		<b>205.1296</b>

**3.4 Grading - 2021**

**Unmitigated Construction On-Site**

	ROG	NOx	CO	SO2	Fugitive PM10	Exhaust PM10	PM10 Total	Fugitive PM2.5	Exhaust PM2.5	PM2.5 Total	Bio- CO2	NBio- CO2	Total CO2	CH4	N2O	CO2e
Category	lb/day										lb/day					
Fugitive Dust					8.6733	0.0000	8.6733	3.5965	0.0000	3.5965			0.0000			0.0000
Off-Road	4.1912	46.3998	30.8785	0.0620		1.9853	1.9853		1.8265	1.8265		6,007.0434	6,007.0434	1.9428		6,055.6134
<b>Total</b>	<b>4.1912</b>	<b>46.3998</b>	<b>30.8785</b>	<b>0.0620</b>	<b>8.6733</b>	<b>1.9853</b>	<b>10.6587</b>	<b>3.5965</b>	<b>1.8265</b>	<b>5.4230</b>		<b>6,007.0434</b>	<b>6,007.0434</b>	<b>1.9428</b>		<b>6,055.6134</b>

Village South Specific Plan (Proposed) - Los Angeles-South Coast County, Summer

**3.4 Grading - 2021**

**Unmitigated Construction Off-Site**

	ROG	NOx	CO	SO2	Fugitive PM10	Exhaust PM10	PM10 Total	Fugitive PM2.5	Exhaust PM2.5	PM2.5 Total	Bio- CO2	NBio- CO2	Total CO2	CH4	N2O	CO2e
Category	lb/day										lb/day					
Hauling	0.0000	0.0000	0.0000	0.0000	0.0000	0.0000	0.0000	0.0000	0.0000	0.0000		0.0000	0.0000	0.0000		0.0000
Vendor	0.0000	0.0000	0.0000	0.0000	0.0000	0.0000	0.0000	0.0000	0.0000	0.0000		0.0000	0.0000	0.0000		0.0000
Worker	0.0857	0.0589	0.8056	2.2900e-003	0.2236	1.8100e-003	0.2254	0.0593	1.6600e-003	0.0610		227.7540	227.7540	6.7100e-003		227.9217
<b>Total</b>	<b>0.0857</b>	<b>0.0589</b>	<b>0.8056</b>	<b>2.2900e-003</b>	<b>0.2236</b>	<b>1.8100e-003</b>	<b>0.2254</b>	<b>0.0593</b>	<b>1.6600e-003</b>	<b>0.0610</b>		<b>227.7540</b>	<b>227.7540</b>	<b>6.7100e-003</b>		<b>227.9217</b>

**Mitigated Construction On-Site**

	ROG	NOx	CO	SO2	Fugitive PM10	Exhaust PM10	PM10 Total	Fugitive PM2.5	Exhaust PM2.5	PM2.5 Total	Bio- CO2	NBio- CO2	Total CO2	CH4	N2O	CO2e
Category	lb/day										lb/day					
Fugitive Dust					8.6733	0.0000	8.6733	3.5965	0.0000	3.5965			0.0000			0.0000
Off-Road	4.1912	46.3998	30.8785	0.0620		1.9853	1.9853		1.8265	1.8265	0.0000	6,007.0434	6,007.0434	1.9428		6,055.6134
<b>Total</b>	<b>4.1912</b>	<b>46.3998</b>	<b>30.8785</b>	<b>0.0620</b>	<b>8.6733</b>	<b>1.9853</b>	<b>10.6587</b>	<b>3.5965</b>	<b>1.8265</b>	<b>5.4230</b>	<b>0.0000</b>	<b>6,007.0434</b>	<b>6,007.0434</b>	<b>1.9428</b>		<b>6,055.6134</b>

Village South Specific Plan (Proposed) - Los Angeles-South Coast County, Summer

**3.4 Grading - 2021**

**Mitigated Construction Off-Site**

	ROG	NOx	CO	SO2	Fugitive PM10	Exhaust PM10	PM10 Total	Fugitive PM2.5	Exhaust PM2.5	PM2.5 Total	Bio- CO2	NBio- CO2	Total CO2	CH4	N2O	CO2e
Category	lb/day										lb/day					
Hauling	0.0000	0.0000	0.0000	0.0000	0.0000	0.0000	0.0000	0.0000	0.0000	0.0000		0.0000	0.0000	0.0000		0.0000
Vendor	0.0000	0.0000	0.0000	0.0000	0.0000	0.0000	0.0000	0.0000	0.0000	0.0000		0.0000	0.0000	0.0000		0.0000
Worker	0.0857	0.0589	0.8056	2.2900e-003	0.2236	1.8100e-003	0.2254	0.0593	1.6600e-003	0.0610		227.7540	227.7540	6.7100e-003		227.9217
<b>Total</b>	<b>0.0857</b>	<b>0.0589</b>	<b>0.8056</b>	<b>2.2900e-003</b>	<b>0.2236</b>	<b>1.8100e-003</b>	<b>0.2254</b>	<b>0.0593</b>	<b>1.6600e-003</b>	<b>0.0610</b>		<b>227.7540</b>	<b>227.7540</b>	<b>6.7100e-003</b>		<b>227.9217</b>

**3.4 Grading - 2022**

**Unmitigated Construction On-Site**

	ROG	NOx	CO	SO2	Fugitive PM10	Exhaust PM10	PM10 Total	Fugitive PM2.5	Exhaust PM2.5	PM2.5 Total	Bio- CO2	NBio- CO2	Total CO2	CH4	N2O	CO2e
Category	lb/day										lb/day					
Fugitive Dust					8.6733	0.0000	8.6733	3.5965	0.0000	3.5965			0.0000			0.0000
Off-Road	3.6248	38.8435	29.0415	0.0621		1.6349	1.6349		1.5041	1.5041		6,011.4105	6,011.4105	1.9442		6,060.0158
<b>Total</b>	<b>3.6248</b>	<b>38.8435</b>	<b>29.0415</b>	<b>0.0621</b>	<b>8.6733</b>	<b>1.6349</b>	<b>10.3082</b>	<b>3.5965</b>	<b>1.5041</b>	<b>5.1006</b>		<b>6,011.4105</b>	<b>6,011.4105</b>	<b>1.9442</b>		<b>6,060.0158</b>

Village South Specific Plan (Proposed) - Los Angeles-South Coast County, Summer

**3.4 Grading - 2022**

**Unmitigated Construction Off-Site**

	ROG	NOx	CO	SO2	Fugitive PM10	Exhaust PM10	PM10 Total	Fugitive PM2.5	Exhaust PM2.5	PM2.5 Total	Bio- CO2	NBio- CO2	Total CO2	CH4	N2O	CO2e
Category	lb/day										lb/day					
Hauling	0.0000	0.0000	0.0000	0.0000	0.0000	0.0000	0.0000	0.0000	0.0000	0.0000		0.0000	0.0000	0.0000		0.0000
Vendor	0.0000	0.0000	0.0000	0.0000	0.0000	0.0000	0.0000	0.0000	0.0000	0.0000		0.0000	0.0000	0.0000		0.0000
Worker	0.0803	0.0532	0.7432	2.2100e-003	0.2236	1.7500e-003	0.2253	0.0593	1.6100e-003	0.0609		219.7425	219.7425	6.0600e-003		219.8941
<b>Total</b>	<b>0.0803</b>	<b>0.0532</b>	<b>0.7432</b>	<b>2.2100e-003</b>	<b>0.2236</b>	<b>1.7500e-003</b>	<b>0.2253</b>	<b>0.0593</b>	<b>1.6100e-003</b>	<b>0.0609</b>		<b>219.7425</b>	<b>219.7425</b>	<b>6.0600e-003</b>		<b>219.8941</b>

**Mitigated Construction On-Site**

	ROG	NOx	CO	SO2	Fugitive PM10	Exhaust PM10	PM10 Total	Fugitive PM2.5	Exhaust PM2.5	PM2.5 Total	Bio- CO2	NBio- CO2	Total CO2	CH4	N2O	CO2e
Category	lb/day										lb/day					
Fugitive Dust					8.6733	0.0000	8.6733	3.5965	0.0000	3.5965			0.0000			0.0000
Off-Road	3.6248	38.8435	29.0415	0.0621		1.6349	1.6349		1.5041	1.5041	0.0000	6,011.4105	6,011.4105	1.9442		6,060.0158
<b>Total</b>	<b>3.6248</b>	<b>38.8435</b>	<b>29.0415</b>	<b>0.0621</b>	<b>8.6733</b>	<b>1.6349</b>	<b>10.3082</b>	<b>3.5965</b>	<b>1.5041</b>	<b>5.1006</b>	<b>0.0000</b>	<b>6,011.4105</b>	<b>6,011.4105</b>	<b>1.9442</b>		<b>6,060.0158</b>



Village South Specific Plan (Proposed) - Los Angeles-South Coast County, Summer

**3.4 Grading - 2022**

**Mitigated Construction Off-Site**

	ROG	NOx	CO	SO2	Fugitive PM10	Exhaust PM10	PM10 Total	Fugitive PM2.5	Exhaust PM2.5	PM2.5 Total	Bio- CO2	NBio- CO2	Total CO2	CH4	N2O	CO2e
Category	lb/day										lb/day					
Hauling	0.0000	0.0000	0.0000	0.0000	0.0000	0.0000	0.0000	0.0000	0.0000	0.0000		0.0000	0.0000	0.0000		0.0000
Vendor	0.0000	0.0000	0.0000	0.0000	0.0000	0.0000	0.0000	0.0000	0.0000	0.0000		0.0000	0.0000	0.0000		0.0000
Worker	0.0803	0.0532	0.7432	2.2100e-003	0.2236	1.7500e-003	0.2253	0.0593	1.6100e-003	0.0609		219.7425	219.7425	6.0600e-003		219.8941
<b>Total</b>	<b>0.0803</b>	<b>0.0532</b>	<b>0.7432</b>	<b>2.2100e-003</b>	<b>0.2236</b>	<b>1.7500e-003</b>	<b>0.2253</b>	<b>0.0593</b>	<b>1.6100e-003</b>	<b>0.0609</b>		<b>219.7425</b>	<b>219.7425</b>	<b>6.0600e-003</b>		<b>219.8941</b>

**3.5 Building Construction - 2022**

**Unmitigated Construction On-Site**

	ROG	NOx	CO	SO2	Fugitive PM10	Exhaust PM10	PM10 Total	Fugitive PM2.5	Exhaust PM2.5	PM2.5 Total	Bio- CO2	NBio- CO2	Total CO2	CH4	N2O	CO2e
Category	lb/day										lb/day					
Off-Road	1.7062	15.6156	16.3634	0.0269		0.8090	0.8090		0.7612	0.7612		2,554.3336	2,554.3336	0.6120		2,569.6322
<b>Total</b>	<b>1.7062</b>	<b>15.6156</b>	<b>16.3634</b>	<b>0.0269</b>		<b>0.8090</b>	<b>0.8090</b>		<b>0.7612</b>	<b>0.7612</b>		<b>2,554.3336</b>	<b>2,554.3336</b>	<b>0.6120</b>		<b>2,569.6322</b>

Village South Specific Plan (Proposed) - Los Angeles-South Coast County, Summer

**3.5 Building Construction - 2022**

**Unmitigated Construction Off-Site**

	ROG	NOx	CO	SO2	Fugitive PM10	Exhaust PM10	PM10 Total	Fugitive PM2.5	Exhaust PM2.5	PM2.5 Total	Bio- CO2	NBio- CO2	Total CO2	CH4	N2O	CO2e
Category	lb/day										lb/day					
Hauling	0.0000	0.0000	0.0000	0.0000	0.0000	0.0000	0.0000	0.0000	0.0000	0.0000		0.0000	0.0000	0.0000		0.0000
Vendor	0.4079	13.2032	3.4341	0.0364	0.9155	0.0248	0.9404	0.2636	0.0237	0.2873		3,896.548 2	3,896.548 2	0.2236		3,902.138 4
Worker	3.2162	2.1318	29.7654	0.0883	8.9533	0.0701	9.0234	2.3745	0.0646	2.4390		8,800.685 7	8,800.685 7	0.2429		8,806.758 2
<b>Total</b>	<b>3.6242</b>	<b>15.3350</b>	<b>33.1995</b>	<b>0.1247</b>	<b>9.8688</b>	<b>0.0949</b>	<b>9.9637</b>	<b>2.6381</b>	<b>0.0883</b>	<b>2.7263</b>		<b>12,697.23 39</b>	<b>12,697.23 39</b>	<b>0.4665</b>		<b>12,708.89 66</b>

**Mitigated Construction On-Site**

	ROG	NOx	CO	SO2	Fugitive PM10	Exhaust PM10	PM10 Total	Fugitive PM2.5	Exhaust PM2.5	PM2.5 Total	Bio- CO2	NBio- CO2	Total CO2	CH4	N2O	CO2e
Category	lb/day										lb/day					
Off-Road	1.7062	15.6156	16.3634	0.0269		0.8090	0.8090		0.7612	0.7612	0.0000	2,554.333 6	2,554.333 6	0.6120		2,569.632 2
<b>Total</b>	<b>1.7062</b>	<b>15.6156</b>	<b>16.3634</b>	<b>0.0269</b>		<b>0.8090</b>	<b>0.8090</b>		<b>0.7612</b>	<b>0.7612</b>	<b>0.0000</b>	<b>2,554.333 6</b>	<b>2,554.333 6</b>	<b>0.6120</b>		<b>2,569.632 2</b>

Village South Specific Plan (Proposed) - Los Angeles-South Coast County, Summer

**3.5 Building Construction - 2022**

**Mitigated Construction Off-Site**

	ROG	NOx	CO	SO2	Fugitive PM10	Exhaust PM10	PM10 Total	Fugitive PM2.5	Exhaust PM2.5	PM2.5 Total	Bio- CO2	NBio- CO2	Total CO2	CH4	N2O	CO2e
Category	lb/day										lb/day					
Hauling	0.0000	0.0000	0.0000	0.0000	0.0000	0.0000	0.0000	0.0000	0.0000	0.0000		0.0000	0.0000	0.0000		0.0000
Vendor	0.4079	13.2032	3.4341	0.0364	0.9155	0.0248	0.9404	0.2636	0.0237	0.2873		3,896.548 2	3,896.548 2	0.2236		3,902.138 4
Worker	3.2162	2.1318	29.7654	0.0883	8.9533	0.0701	9.0234	2.3745	0.0646	2.4390		8,800.685 7	8,800.685 7	0.2429		8,806.758 2
<b>Total</b>	<b>3.6242</b>	<b>15.3350</b>	<b>33.1995</b>	<b>0.1247</b>	<b>9.8688</b>	<b>0.0949</b>	<b>9.9637</b>	<b>2.6381</b>	<b>0.0883</b>	<b>2.7263</b>		<b>12,697.23 39</b>	<b>12,697.23 39</b>	<b>0.4665</b>		<b>12,708.89 66</b>

**3.5 Building Construction - 2023**

**Unmitigated Construction On-Site**

	ROG	NOx	CO	SO2	Fugitive PM10	Exhaust PM10	PM10 Total	Fugitive PM2.5	Exhaust PM2.5	PM2.5 Total	Bio- CO2	NBio- CO2	Total CO2	CH4	N2O	CO2e
Category	lb/day										lb/day					
Off-Road	1.5728	14.3849	16.2440	0.0269		0.6997	0.6997		0.6584	0.6584		2,555.209 9	2,555.209 9	0.6079		2,570.406 1
<b>Total</b>	<b>1.5728</b>	<b>14.3849</b>	<b>16.2440</b>	<b>0.0269</b>		<b>0.6997</b>	<b>0.6997</b>		<b>0.6584</b>	<b>0.6584</b>		<b>2,555.209 9</b>	<b>2,555.209 9</b>	<b>0.6079</b>		<b>2,570.406 1</b>

Village South Specific Plan (Proposed) - Los Angeles-South Coast County, Summer

**3.5 Building Construction - 2023**

**Unmitigated Construction Off-Site**

	ROG	NOx	CO	SO2	Fugitive PM10	Exhaust PM10	PM10 Total	Fugitive PM2.5	Exhaust PM2.5	PM2.5 Total	Bio- CO2	NBio- CO2	Total CO2	CH4	N2O	CO2e
Category	lb/day										lb/day					
Hauling	0.0000	0.0000	0.0000	0.0000	0.0000	0.0000	0.0000	0.0000	0.0000	0.0000		0.0000	0.0000	0.0000		0.0000
Vendor	0.3027	10.0181	3.1014	0.0352	0.9156	0.0116	0.9271	0.2636	0.0111	0.2747		3,773.876 2	3,773.876 2	0.1982		3,778.830 0
Worker	3.0203	1.9287	27.4113	0.0851	8.9533	0.0681	9.0214	2.3745	0.0627	2.4372		8,478.440 8	8,478.440 8	0.2190		8,483.916 0
<b>Total</b>	<b>3.3229</b>	<b>11.9468</b>	<b>30.5127</b>	<b>0.1203</b>	<b>9.8688</b>	<b>0.0797</b>	<b>9.9485</b>	<b>2.6381</b>	<b>0.0738</b>	<b>2.7118</b>		<b>12,252.31 70</b>	<b>12,252.31 70</b>	<b>0.4172</b>		<b>12,262.74 60</b>

**Mitigated Construction On-Site**

	ROG	NOx	CO	SO2	Fugitive PM10	Exhaust PM10	PM10 Total	Fugitive PM2.5	Exhaust PM2.5	PM2.5 Total	Bio- CO2	NBio- CO2	Total CO2	CH4	N2O	CO2e
Category	lb/day										lb/day					
Off-Road	1.5728	14.3849	16.2440	0.0269		0.6997	0.6997		0.6584	0.6584	0.0000	2,555.209 9	2,555.209 9	0.6079		2,570.406 1
<b>Total</b>	<b>1.5728</b>	<b>14.3849</b>	<b>16.2440</b>	<b>0.0269</b>		<b>0.6997</b>	<b>0.6997</b>		<b>0.6584</b>	<b>0.6584</b>	<b>0.0000</b>	<b>2,555.209 9</b>	<b>2,555.209 9</b>	<b>0.6079</b>		<b>2,570.406 1</b>

Village South Specific Plan (Proposed) - Los Angeles-South Coast County, Summer

**3.5 Building Construction - 2023**

**Mitigated Construction Off-Site**

	ROG	NOx	CO	SO2	Fugitive PM10	Exhaust PM10	PM10 Total	Fugitive PM2.5	Exhaust PM2.5	PM2.5 Total	Bio- CO2	NBio- CO2	Total CO2	CH4	N2O	CO2e
Category	lb/day										lb/day					
Hauling	0.0000	0.0000	0.0000	0.0000	0.0000	0.0000	0.0000	0.0000	0.0000	0.0000		0.0000	0.0000	0.0000		0.0000
Vendor	0.3027	10.0181	3.1014	0.0352	0.9156	0.0116	0.9271	0.2636	0.0111	0.2747		3,773.876 2	3,773.876 2	0.1982		3,778.830 0
Worker	3.0203	1.9287	27.4113	0.0851	8.9533	0.0681	9.0214	2.3745	0.0627	2.4372		8,478.440 8	8,478.440 8	0.2190		8,483.916 0
<b>Total</b>	<b>3.3229</b>	<b>11.9468</b>	<b>30.5127</b>	<b>0.1203</b>	<b>9.8688</b>	<b>0.0797</b>	<b>9.9485</b>	<b>2.6381</b>	<b>0.0738</b>	<b>2.7118</b>		<b>12,252.31 70</b>	<b>12,252.31 70</b>	<b>0.4172</b>		<b>12,262.74 60</b>

**3.6 Paving - 2023**

**Unmitigated Construction On-Site**

	ROG	NOx	CO	SO2	Fugitive PM10	Exhaust PM10	PM10 Total	Fugitive PM2.5	Exhaust PM2.5	PM2.5 Total	Bio- CO2	NBio- CO2	Total CO2	CH4	N2O	CO2e
Category	lb/day										lb/day					
Off-Road	1.0327	10.1917	14.5842	0.0228		0.5102	0.5102		0.4694	0.4694		2,207.584 1	2,207.584 1	0.7140		2,225.433 6
Paving	0.0000					0.0000	0.0000		0.0000	0.0000			0.0000			0.0000
<b>Total</b>	<b>1.0327</b>	<b>10.1917</b>	<b>14.5842</b>	<b>0.0228</b>		<b>0.5102</b>	<b>0.5102</b>		<b>0.4694</b>	<b>0.4694</b>		<b>2,207.584 1</b>	<b>2,207.584 1</b>	<b>0.7140</b>		<b>2,225.433 6</b>

Village South Specific Plan (Proposed) - Los Angeles-South Coast County, Summer

**3.6 Paving - 2023**

**Unmitigated Construction Off-Site**

	ROG	NOx	CO	SO2	Fugitive PM10	Exhaust PM10	PM10 Total	Fugitive PM2.5	Exhaust PM2.5	PM2.5 Total	Bio- CO2	NBio- CO2	Total CO2	CH4	N2O	CO2e
Category	lb/day										lb/day					
Hauling	0.0000	0.0000	0.0000	0.0000	0.0000	0.0000	0.0000	0.0000	0.0000	0.0000		0.0000	0.0000	0.0000		0.0000
Vendor	0.0000	0.0000	0.0000	0.0000	0.0000	0.0000	0.0000	0.0000	0.0000	0.0000		0.0000	0.0000	0.0000		0.0000
Worker	0.0566	0.0361	0.5133	1.5900e-003	0.1677	1.2800e-003	0.1689	0.0445	1.1700e-003	0.0456		158.7723	158.7723	4.1000e-003		158.8748
<b>Total</b>	<b>0.0566</b>	<b>0.0361</b>	<b>0.5133</b>	<b>1.5900e-003</b>	<b>0.1677</b>	<b>1.2800e-003</b>	<b>0.1689</b>	<b>0.0445</b>	<b>1.1700e-003</b>	<b>0.0456</b>		<b>158.7723</b>	<b>158.7723</b>	<b>4.1000e-003</b>		<b>158.8748</b>

**Mitigated Construction On-Site**

	ROG	NOx	CO	SO2	Fugitive PM10	Exhaust PM10	PM10 Total	Fugitive PM2.5	Exhaust PM2.5	PM2.5 Total	Bio- CO2	NBio- CO2	Total CO2	CH4	N2O	CO2e
Category	lb/day										lb/day					
Off-Road	1.0327	10.1917	14.5842	0.0228		0.5102	0.5102		0.4694	0.4694	0.0000	2,207.5841	2,207.5841	0.7140		2,225.4336
Paving	0.0000					0.0000	0.0000		0.0000	0.0000			0.0000			0.0000
<b>Total</b>	<b>1.0327</b>	<b>10.1917</b>	<b>14.5842</b>	<b>0.0228</b>		<b>0.5102</b>	<b>0.5102</b>		<b>0.4694</b>	<b>0.4694</b>	<b>0.0000</b>	<b>2,207.5841</b>	<b>2,207.5841</b>	<b>0.7140</b>		<b>2,225.4336</b>

Village South Specific Plan (Proposed) - Los Angeles-South Coast County, Summer

**3.6 Paving - 2023**

**Mitigated Construction Off-Site**

	ROG	NOx	CO	SO2	Fugitive PM10	Exhaust PM10	PM10 Total	Fugitive PM2.5	Exhaust PM2.5	PM2.5 Total	Bio- CO2	NBio- CO2	Total CO2	CH4	N2O	CO2e
Category	lb/day										lb/day					
Hauling	0.0000	0.0000	0.0000	0.0000	0.0000	0.0000	0.0000	0.0000	0.0000	0.0000		0.0000	0.0000	0.0000		0.0000
Vendor	0.0000	0.0000	0.0000	0.0000	0.0000	0.0000	0.0000	0.0000	0.0000	0.0000		0.0000	0.0000	0.0000		0.0000
Worker	0.0566	0.0361	0.5133	1.5900e-003	0.1677	1.2800e-003	0.1689	0.0445	1.1700e-003	0.0456		158.7723	158.7723	4.1000e-003		158.8748
<b>Total</b>	<b>0.0566</b>	<b>0.0361</b>	<b>0.5133</b>	<b>1.5900e-003</b>	<b>0.1677</b>	<b>1.2800e-003</b>	<b>0.1689</b>	<b>0.0445</b>	<b>1.1700e-003</b>	<b>0.0456</b>		<b>158.7723</b>	<b>158.7723</b>	<b>4.1000e-003</b>		<b>158.8748</b>

**3.6 Paving - 2024**

**Unmitigated Construction On-Site**

	ROG	NOx	CO	SO2	Fugitive PM10	Exhaust PM10	PM10 Total	Fugitive PM2.5	Exhaust PM2.5	PM2.5 Total	Bio- CO2	NBio- CO2	Total CO2	CH4	N2O	CO2e
Category	lb/day										lb/day					
Off-Road	0.9882	9.5246	14.6258	0.0228		0.4685	0.4685		0.4310	0.4310		2,207.5472	2,207.5472	0.7140		2,225.3963
Paving	0.0000					0.0000	0.0000		0.0000	0.0000			0.0000			0.0000
<b>Total</b>	<b>0.9882</b>	<b>9.5246</b>	<b>14.6258</b>	<b>0.0228</b>		<b>0.4685</b>	<b>0.4685</b>		<b>0.4310</b>	<b>0.4310</b>		<b>2,207.5472</b>	<b>2,207.5472</b>	<b>0.7140</b>		<b>2,225.3963</b>

Village South Specific Plan (Proposed) - Los Angeles-South Coast County, Summer

**3.6 Paving - 2024**

**Unmitigated Construction Off-Site**

	ROG	NOx	CO	SO2	Fugitive PM10	Exhaust PM10	PM10 Total	Fugitive PM2.5	Exhaust PM2.5	PM2.5 Total	Bio- CO2	NBio- CO2	Total CO2	CH4	N2O	CO2e
Category	lb/day										lb/day					
Hauling	0.0000	0.0000	0.0000	0.0000	0.0000	0.0000	0.0000	0.0000	0.0000	0.0000		0.0000	0.0000	0.0000		0.0000
Vendor	0.0000	0.0000	0.0000	0.0000	0.0000	0.0000	0.0000	0.0000	0.0000	0.0000		0.0000	0.0000	0.0000		0.0000
Worker	0.0535	0.0329	0.4785	1.5400e-003	0.1677	1.2600e-003	0.1689	0.0445	1.1600e-003	0.0456		153.8517	153.8517	3.7600e-003		153.9458
<b>Total</b>	<b>0.0535</b>	<b>0.0329</b>	<b>0.4785</b>	<b>1.5400e-003</b>	<b>0.1677</b>	<b>1.2600e-003</b>	<b>0.1689</b>	<b>0.0445</b>	<b>1.1600e-003</b>	<b>0.0456</b>		<b>153.8517</b>	<b>153.8517</b>	<b>3.7600e-003</b>		<b>153.9458</b>

**Mitigated Construction On-Site**

	ROG	NOx	CO	SO2	Fugitive PM10	Exhaust PM10	PM10 Total	Fugitive PM2.5	Exhaust PM2.5	PM2.5 Total	Bio- CO2	NBio- CO2	Total CO2	CH4	N2O	CO2e
Category	lb/day										lb/day					
Off-Road	0.9882	9.5246	14.6258	0.0228		0.4685	0.4685		0.4310	0.4310	0.0000	2,207.5472	2,207.5472	0.7140		2,225.3963
Paving	0.0000					0.0000	0.0000		0.0000	0.0000			0.0000			0.0000
<b>Total</b>	<b>0.9882</b>	<b>9.5246</b>	<b>14.6258</b>	<b>0.0228</b>		<b>0.4685</b>	<b>0.4685</b>		<b>0.4310</b>	<b>0.4310</b>	<b>0.0000</b>	<b>2,207.5472</b>	<b>2,207.5472</b>	<b>0.7140</b>		<b>2,225.3963</b>



Village South Specific Plan (Proposed) - Los Angeles-South Coast County, Summer

**3.6 Paving - 2024**

**Mitigated Construction Off-Site**

	ROG	NOx	CO	SO2	Fugitive PM10	Exhaust PM10	PM10 Total	Fugitive PM2.5	Exhaust PM2.5	PM2.5 Total	Bio- CO2	NBio- CO2	Total CO2	CH4	N2O	CO2e
Category	lb/day										lb/day					
Hauling	0.0000	0.0000	0.0000	0.0000	0.0000	0.0000	0.0000	0.0000	0.0000	0.0000		0.0000	0.0000	0.0000		0.0000
Vendor	0.0000	0.0000	0.0000	0.0000	0.0000	0.0000	0.0000	0.0000	0.0000	0.0000		0.0000	0.0000	0.0000		0.0000
Worker	0.0535	0.0329	0.4785	1.5400e-003	0.1677	1.2600e-003	0.1689	0.0445	1.1600e-003	0.0456		153.8517	153.8517	3.7600e-003		153.9458
<b>Total</b>	<b>0.0535</b>	<b>0.0329</b>	<b>0.4785</b>	<b>1.5400e-003</b>	<b>0.1677</b>	<b>1.2600e-003</b>	<b>0.1689</b>	<b>0.0445</b>	<b>1.1600e-003</b>	<b>0.0456</b>		<b>153.8517</b>	<b>153.8517</b>	<b>3.7600e-003</b>		<b>153.9458</b>

**3.7 Architectural Coating - 2024**

**Unmitigated Construction On-Site**

	ROG	NOx	CO	SO2	Fugitive PM10	Exhaust PM10	PM10 Total	Fugitive PM2.5	Exhaust PM2.5	PM2.5 Total	Bio- CO2	NBio- CO2	Total CO2	CH4	N2O	CO2e
Category	lb/day										lb/day					
Archit. Coating	236.4115					0.0000	0.0000		0.0000	0.0000			0.0000			0.0000
Off-Road	0.1808	1.2188	1.8101	2.9700e-003		0.0609	0.0609		0.0609	0.0609		281.4481	281.4481	0.0159		281.8443
<b>Total</b>	<b>236.5923</b>	<b>1.2188</b>	<b>1.8101</b>	<b>2.9700e-003</b>		<b>0.0609</b>	<b>0.0609</b>		<b>0.0609</b>	<b>0.0609</b>		<b>281.4481</b>	<b>281.4481</b>	<b>0.0159</b>		<b>281.8443</b>

Village South Specific Plan (Proposed) - Los Angeles-South Coast County, Summer

**3.7 Architectural Coating - 2024**

**Unmitigated Construction Off-Site**

	ROG	NOx	CO	SO2	Fugitive PM10	Exhaust PM10	PM10 Total	Fugitive PM2.5	Exhaust PM2.5	PM2.5 Total	Bio- CO2	NBio- CO2	Total CO2	CH4	N2O	CO2e
Category	lb/day										lb/day					
Hauling	0.0000	0.0000	0.0000	0.0000	0.0000	0.0000	0.0000	0.0000	0.0000	0.0000		0.0000	0.0000	0.0000		0.0000
Vendor	0.0000	0.0000	0.0000	0.0000	0.0000	0.0000	0.0000	0.0000	0.0000	0.0000		0.0000	0.0000	0.0000		0.0000
Worker	0.5707	0.3513	5.1044	0.0165	1.7884	0.0134	1.8018	0.4743	0.0123	0.4866		1,641.085 2	1,641.085 2	0.0401		1,642.088 6
<b>Total</b>	<b>0.5707</b>	<b>0.3513</b>	<b>5.1044</b>	<b>0.0165</b>	<b>1.7884</b>	<b>0.0134</b>	<b>1.8018</b>	<b>0.4743</b>	<b>0.0123</b>	<b>0.4866</b>		<b>1,641.085 2</b>	<b>1,641.085 2</b>	<b>0.0401</b>		<b>1,642.088 6</b>

**Mitigated Construction On-Site**

	ROG	NOx	CO	SO2	Fugitive PM10	Exhaust PM10	PM10 Total	Fugitive PM2.5	Exhaust PM2.5	PM2.5 Total	Bio- CO2	NBio- CO2	Total CO2	CH4	N2O	CO2e
Category	lb/day										lb/day					
Archit. Coating	236.4115					0.0000	0.0000		0.0000	0.0000			0.0000			0.0000
Off-Road	0.1808	1.2188	1.8101	2.9700e-003		0.0609	0.0609		0.0609	0.0609	0.0000	281.4481	281.4481	0.0159		281.8443
<b>Total</b>	<b>236.5923</b>	<b>1.2188</b>	<b>1.8101</b>	<b>2.9700e-003</b>		<b>0.0609</b>	<b>0.0609</b>		<b>0.0609</b>	<b>0.0609</b>	<b>0.0000</b>	<b>281.4481</b>	<b>281.4481</b>	<b>0.0159</b>		<b>281.8443</b>

Village South Specific Plan (Proposed) - Los Angeles-South Coast County, Summer

**3.7 Architectural Coating - 2024**

**Mitigated Construction Off-Site**

	ROG	NOx	CO	SO2	Fugitive PM10	Exhaust PM10	PM10 Total	Fugitive PM2.5	Exhaust PM2.5	PM2.5 Total	Bio- CO2	NBio- CO2	Total CO2	CH4	N2O	CO2e
Category	lb/day										lb/day					
Hauling	0.0000	0.0000	0.0000	0.0000	0.0000	0.0000	0.0000	0.0000	0.0000	0.0000		0.0000	0.0000	0.0000		0.0000
Vendor	0.0000	0.0000	0.0000	0.0000	0.0000	0.0000	0.0000	0.0000	0.0000	0.0000		0.0000	0.0000	0.0000		0.0000
Worker	0.5707	0.3513	5.1044	0.0165	1.7884	0.0134	1.8018	0.4743	0.0123	0.4866		1,641.085 2	1,641.085 2	0.0401		1,642.088 6
<b>Total</b>	<b>0.5707</b>	<b>0.3513</b>	<b>5.1044</b>	<b>0.0165</b>	<b>1.7884</b>	<b>0.0134</b>	<b>1.8018</b>	<b>0.4743</b>	<b>0.0123</b>	<b>0.4866</b>		<b>1,641.085 2</b>	<b>1,641.085 2</b>	<b>0.0401</b>		<b>1,642.088 6</b>

**4.0 Operational Detail - Mobile**

---

**4.1 Mitigation Measures Mobile**

Village South Specific Plan (Proposed) - Los Angeles-South Coast County, Summer

	ROG	NOx	CO	SO2	Fugitive PM10	Exhaust PM10	PM10 Total	Fugitive PM2.5	Exhaust PM2.5	PM2.5 Total	Bio- CO2	NBio- CO2	Total CO2	CH4	N2O	CO2e
Category	lb/day										lb/day					
Mitigated	9.8489	45.4304	114.8495	0.4917	45.9592	0.3360	46.2951	12.2950	0.3119	12.6070		50,306.60 34	50,306.60 34	2.1807		50,361.12 08
Unmitigated	9.8489	45.4304	114.8495	0.4917	45.9592	0.3360	46.2951	12.2950	0.3119	12.6070		50,306.60 34	50,306.60 34	2.1807		50,361.12 08

4.2 Trip Summary Information

Land Use	Average Daily Trip Rate			Unmitigated	Mitigated
	Weekday	Saturday	Sunday	Annual VMT	Annual VMT
Apartments Low Rise	145.75	154.25	154.00	506,227	506,227
Apartments Mid Rise	4,026.75	3,773.25	4075.50	13,660,065	13,660,065
General Office Building	288.45	62.55	31.05	706,812	706,812
High Turnover (Sit Down Restaurant)	2,368.80	2,873.52	2817.72	3,413,937	3,413,937
Hotel	192.00	187.50	160.00	445,703	445,703
Quality Restaurant	501.12	511.92	461.20	707,488	707,488
Regional Shopping Center	528.08	601.44	357.84	1,112,221	1,112,221
<b>Total</b>	<b>8,050.95</b>	<b>8,164.43</b>	<b>8,057.31</b>	<b>20,552,452</b>	<b>20,552,452</b>

4.3 Trip Type Information

Village South Specific Plan (Proposed) - Los Angeles-South Coast County, Summer

Land Use	Miles			Trip %			Trip Purpose %		
	H-W or C-W	H-S or C-C	H-O or C-NW	H-W or C-W	H-S or C-C	H-O or C-NW	Primary	Diverted	Pass-by
Apartments Low Rise	14.70	5.90	8.70	40.20	19.20	40.60	86	11	3
Apartments Mid Rise	14.70	5.90	8.70	40.20	19.20	40.60	86	11	3
General Office Building	16.60	8.40	6.90	33.00	48.00	19.00	77	19	4
High Turnover (Sit Down Restaurant)	16.60	8.40	6.90	8.50	72.50	19.00	37	20	43
Hotel	16.60	8.40	6.90	19.40	61.60	19.00	58	38	4
Quality Restaurant	16.60	8.40	6.90	12.00	69.00	19.00	38	18	44
Regional Shopping Center	16.60	8.40	6.90	16.30	64.70	19.00	54	35	11

4.4 Fleet Mix

Land Use	LDA	LDT1	LDT2	MDV	LHD1	LHD2	MHD	HHD	OBUS	UBUS	MCY	SBUS	MH
Apartments Low Rise	0.543088	0.044216	0.209971	0.116369	0.014033	0.006332	0.021166	0.033577	0.002613	0.001817	0.005285	0.000712	0.000821
Apartments Mid Rise	0.543088	0.044216	0.209971	0.116369	0.014033	0.006332	0.021166	0.033577	0.002613	0.001817	0.005285	0.000712	0.000821
General Office Building	0.543088	0.044216	0.209971	0.116369	0.014033	0.006332	0.021166	0.033577	0.002613	0.001817	0.005285	0.000712	0.000821
High Turnover (Sit Down Restaurant)	0.543088	0.044216	0.209971	0.116369	0.014033	0.006332	0.021166	0.033577	0.002613	0.001817	0.005285	0.000712	0.000821
Hotel	0.543088	0.044216	0.209971	0.116369	0.014033	0.006332	0.021166	0.033577	0.002613	0.001817	0.005285	0.000712	0.000821
Quality Restaurant	0.543088	0.044216	0.209971	0.116369	0.014033	0.006332	0.021166	0.033577	0.002613	0.001817	0.005285	0.000712	0.000821
Regional Shopping Center	0.543088	0.044216	0.209971	0.116369	0.014033	0.006332	0.021166	0.033577	0.002613	0.001817	0.005285	0.000712	0.000821

5.0 Energy Detail

Historical Energy Use: N

5.1 Mitigation Measures Energy

Village South Specific Plan (Proposed) - Los Angeles-South Coast County, Summer

	ROG	NOx	CO	SO2	Fugitive PM10	Exhaust PM10	PM10 Total	Fugitive PM2.5	Exhaust PM2.5	PM2.5 Total	Bio- CO2	NBio- CO2	Total CO2	CH4	N2O	CO2e
Category	lb/day										lb/day					
NaturalGas Mitigated	0.7660	6.7462	4.2573	0.0418		0.5292	0.5292		0.5292	0.5292		8,355.983 2	8,355.983 2	0.1602	0.1532	8,405.638 7
NaturalGas Unmitigated	0.7660	6.7462	4.2573	0.0418		0.5292	0.5292		0.5292	0.5292		8,355.983 2	8,355.983 2	0.1602	0.1532	8,405.638 7

Village South Specific Plan (Proposed) - Los Angeles-South Coast County, Summer

**5.2 Energy by Land Use - NaturalGas**

**Unmitigated**

	NaturalGas Use	ROG	NOx	CO	SO2	Fugitive PM10	Exhaust PM10	PM10 Total	Fugitive PM2.5	Exhaust PM2.5	PM2.5 Total	Bio- CO2	NBio- CO2	Total CO2	CH4	N2O	CO2e
Land Use	kBTU/yr	lb/day										lb/day					
Apartments Low Rise	1119.16	0.0121	0.1031	0.0439	6.6000e-004		8.3400e-003	8.3400e-003		8.3400e-003	8.3400e-003		131.6662	131.6662	2.5200e-003	2.4100e-003	132.4486
Apartments Mid Rise	35784.3	0.3859	3.2978	1.4033	0.0211		0.2666	0.2666		0.2666	0.2666		4,209.9164	4,209.9164	0.0807	0.0772	4,234.9339
General Office Building	1283.42	0.0138	0.1258	0.1057	7.5000e-004		9.5600e-003	9.5600e-003		9.5600e-003	9.5600e-003		150.9911	150.9911	2.8900e-003	2.7700e-003	151.8884
High Turnover (Sit Down Restaurant)	22759.9	0.2455	2.2314	1.8743	0.0134		0.1696	0.1696		0.1696	0.1696		2,677.6342	2,677.6342	0.0513	0.0491	2,693.5460
Hotel	4769.72	0.0514	0.4676	0.3928	2.8100e-003		0.0355	0.0355		0.0355	0.0355		561.1436	561.1436	0.0108	0.0103	564.4782
Quality Restaurant	5057.75	0.0545	0.4959	0.4165	2.9800e-003		0.0377	0.0377		0.0377	0.0377		595.0298	595.0298	0.0114	0.0109	598.5658
Regional Shopping Center	251.616	2.7100e-003	0.0247	0.0207	1.5000e-004		1.8700e-003	1.8700e-003		1.8700e-003	1.8700e-003		29.6019	29.6019	5.7000e-004	5.4000e-004	29.7778
<b>Total</b>		<b>0.7660</b>	<b>6.7463</b>	<b>4.2573</b>	<b>0.0418</b>		<b>0.5292</b>	<b>0.5292</b>		<b>0.5292</b>	<b>0.5292</b>		<b>8,355.9832</b>	<b>8,355.9832</b>	<b>0.1602</b>	<b>0.1532</b>	<b>8,405.6387</b>

Village South Specific Plan (Proposed) - Los Angeles-South Coast County, Summer

**5.2 Energy by Land Use - NaturalGas**

**Mitigated**

	NaturalGas Use	ROG	NOx	CO	SO2	Fugitive PM10	Exhaust PM10	PM10 Total	Fugitive PM2.5	Exhaust PM2.5	PM2.5 Total	Bio- CO2	NBio- CO2	Total CO2	CH4	N2O	CO2e
Land Use	kBTU/yr	lb/day										lb/day					
Apartments Low Rise	1.11916	0.0121	0.1031	0.0439	6.6000e-004		8.3400e-003	8.3400e-003		8.3400e-003	8.3400e-003		131.6662	131.6662	2.5200e-003	2.4100e-003	132.4486
Apartments Mid Rise	35.7843	0.3859	3.2978	1.4033	0.0211		0.2666	0.2666		0.2666	0.2666		4,209.9164	4,209.9164	0.0807	0.0772	4,234.9339
General Office Building	1.28342	0.0138	0.1258	0.1057	7.5000e-004		9.5600e-003	9.5600e-003		9.5600e-003	9.5600e-003		150.9911	150.9911	2.8900e-003	2.7700e-003	151.8884
High Turnover (Sit Down Restaurant)	22.7599	0.2455	2.2314	1.8743	0.0134		0.1696	0.1696		0.1696	0.1696		2,677.6342	2,677.6342	0.0513	0.0491	2,693.5460
Hotel	4.76972	0.0514	0.4676	0.3928	2.8100e-003		0.0355	0.0355		0.0355	0.0355		561.1436	561.1436	0.0108	0.0103	564.4782
Quality Restaurant	5.05775	0.0545	0.4959	0.4165	2.9800e-003		0.0377	0.0377		0.0377	0.0377		595.0298	595.0298	0.0114	0.0109	598.5658
Regional Shopping Center	0.251616	2.7100e-003	0.0247	0.0207	1.5000e-004		1.8700e-003	1.8700e-003		1.8700e-003	1.8700e-003		29.6019	29.6019	5.7000e-004	5.4000e-004	29.7778
<b>Total</b>		<b>0.7660</b>	<b>6.7463</b>	<b>4.2573</b>	<b>0.0418</b>		<b>0.5292</b>	<b>0.5292</b>		<b>0.5292</b>	<b>0.5292</b>		<b>8,355.9832</b>	<b>8,355.9832</b>	<b>0.1602</b>	<b>0.1532</b>	<b>8,405.6387</b>

**6.0 Area Detail**

**6.1 Mitigation Measures Area**



Village South Specific Plan (Proposed) - Los Angeles-South Coast County, Summer

	ROG	NOx	CO	SO2	Fugitive PM10	Exhaust PM10	PM10 Total	Fugitive PM2.5	Exhaust PM2.5	PM2.5 Total	Bio- CO2	NBio- CO2	Total CO2	CH4	N2O	CO2e
Category	lb/day										lb/day					
Mitigated	30.5020	15.0496	88.4430	0.0944		1.5974	1.5974		1.5974	1.5974	0.0000	18,148.5950	18,148.5950	0.4874	0.3300	18,259.1192
Unmitigated	30.5020	15.0496	88.4430	0.0944		1.5974	1.5974		1.5974	1.5974	0.0000	18,148.5950	18,148.5950	0.4874	0.3300	18,259.1192

6.2 Area by SubCategory

Unmitigated

	ROG	NOx	CO	SO2	Fugitive PM10	Exhaust PM10	PM10 Total	Fugitive PM2.5	Exhaust PM2.5	PM2.5 Total	Bio- CO2	NBio- CO2	Total CO2	CH4	N2O	CO2e
SubCategory	lb/day										lb/day					
Architectural Coating	2.2670					0.0000	0.0000		0.0000	0.0000			0.0000			0.0000
Consumer Products	24.1085					0.0000	0.0000		0.0000	0.0000			0.0000			0.0000
Hearth	1.6500	14.1000	6.0000	0.0900		1.1400	1.1400		1.1400	1.1400	0.0000	18,000.0000	18,000.0000	0.3450	0.3300	18,106.9650
Landscaping	2.4766	0.9496	82.4430	4.3600e-003		0.4574	0.4574		0.4574	0.4574		148.5950	148.5950	0.1424		152.1542
<b>Total</b>	<b>30.5020</b>	<b>15.0496</b>	<b>88.4430</b>	<b>0.0944</b>		<b>1.5974</b>	<b>1.5974</b>		<b>1.5974</b>	<b>1.5974</b>	<b>0.0000</b>	<b>18,148.5950</b>	<b>18,148.5950</b>	<b>0.4874</b>	<b>0.3300</b>	<b>18,259.1192</b>

Village South Specific Plan (Proposed) - Los Angeles-South Coast County, Summer

**6.2 Area by SubCategory**

**Mitigated**

	ROG	NOx	CO	SO2	Fugitive PM10	Exhaust PM10	PM10 Total	Fugitive PM2.5	Exhaust PM2.5	PM2.5 Total	Bio- CO2	NBio- CO2	Total CO2	CH4	N2O	CO2e
SubCategory	lb/day										lb/day					
Architectural Coating	2.2670					0.0000	0.0000		0.0000	0.0000			0.0000			0.0000
Consumer Products	24.1085					0.0000	0.0000		0.0000	0.0000			0.0000			0.0000
Hearth	1.6500	14.1000	6.0000	0.0900		1.1400	1.1400		1.1400	1.1400	0.0000	18,000.0000	18,000.0000	0.3450	0.3300	18,106.9650
Landscaping	2.4766	0.9496	82.4430	4.3600e-003		0.4574	0.4574		0.4574	0.4574		148.5950	148.5950	0.1424		152.1542
<b>Total</b>	<b>30.5020</b>	<b>15.0496</b>	<b>88.4430</b>	<b>0.0944</b>		<b>1.5974</b>	<b>1.5974</b>		<b>1.5974</b>	<b>1.5974</b>	<b>0.0000</b>	<b>18,148.5950</b>	<b>18,148.5950</b>	<b>0.4874</b>	<b>0.3300</b>	<b>18,259.1192</b>

**7.0 Water Detail**

**7.1 Mitigation Measures Water**

**8.0 Waste Detail**

**8.1 Mitigation Measures Waste**

**9.0 Operational Offroad**

Equipment Type	Number	Hours/Day	Days/Year	Horse Power	Load Factor	Fuel Type
----------------	--------	-----------	-----------	-------------	-------------	-----------

**10.0 Stationary Equipment**

Village South Specific Plan (Proposed) - Los Angeles-South Coast County, Summer

**Fire Pumps and Emergency Generators**

Equipment Type	Number	Hours/Day	Hours/Year	Horse Power	Load Factor	Fuel Type
----------------	--------	-----------	------------	-------------	-------------	-----------

**Boilers**

Equipment Type	Number	Heat Input/Day	Heat Input/Year	Boiler Rating	Fuel Type
----------------	--------	----------------	-----------------	---------------	-----------

**User Defined Equipment**

Equipment Type	Number
----------------	--------

**11.0 Vegetation**

---

Village South Specific Plan (Proposed) - Los Angeles-South Coast County, Winter

**Village South Specific Plan (Proposed)**  
**Los Angeles-South Coast County, Winter**

**1.0 Project Characteristics**

**1.1 Land Usage**

Land Uses	Size	Metric	Lot Acreage	Floor Surface Area	Population
General Office Building	45.00	1000sqft	1.03	45,000.00	0
High Turnover (Sit Down Restaurant)	36.00	1000sqft	0.83	36,000.00	0
Hotel	50.00	Room	1.67	72,600.00	0
Quality Restaurant	8.00	1000sqft	0.18	8,000.00	0
Apartments Low Rise	25.00	Dwelling Unit	1.56	25,000.00	72
Apartments Mid Rise	975.00	Dwelling Unit	25.66	975,000.00	2789
Regional Shopping Center	56.00	1000sqft	1.29	56,000.00	0

**1.2 Other Project Characteristics**

<b>Urbanization</b>	Urban	<b>Wind Speed (m/s)</b>	2.2	<b>Precipitation Freq (Days)</b>	33
<b>Climate Zone</b>	9			<b>Operational Year</b>	2028
<b>Utility Company</b>	Southern California Edison				
<b>CO2 Intensity (lb/MW hr)</b>	702.44	<b>CH4 Intensity (lb/MW hr)</b>	0.029	<b>N2O Intensity (lb/MW hr)</b>	0.006

**1.3 User Entered Comments & Non-Default Data**

Village South Specific Plan (Proposed) - Los Angeles-South Coast County, Winter

Project Characteristics - Consistent with the DEIR's model.

Land Use - See SWAPE comment regarding residential and retail land uses.

Construction Phase - See SWAPE comment regarding individual construction phase lengths.

Demolition - Consistent with the DEIR's model. See SWAPE comment regarding demolition.

Vehicle Trips - Saturday trips consistent with the DEIR's model. See SWAPE comment regarding weekday and Sunday trips.

Woodstoves - Woodstoves and wood-burning fireplaces consistent with the DEIR's model. See SWAPE comment regarding gas fireplaces.

Energy Use -

Construction Off-road Equipment Mitigation - See SWAPE comment on construction-related mitigation.

Area Mitigation - See SWAPE comment regarding operational mitigation measures.

Water Mitigation - See SWAPE comment regarding operational mitigation measures.

Table Name	Column Name	Default Value	New Value
tblFireplaces	FireplaceWoodMass	1,019.20	0.00
tblFireplaces	FireplaceWoodMass	1,019.20	0.00
tblFireplaces	NumberWood	1.25	0.00
tblFireplaces	NumberWood	48.75	0.00
tblVehicleTrips	ST_TR	7.16	6.17
tblVehicleTrips	ST_TR	6.39	3.87
tblVehicleTrips	ST_TR	2.46	1.39
tblVehicleTrips	ST_TR	158.37	79.82
tblVehicleTrips	ST_TR	8.19	3.75
tblVehicleTrips	ST_TR	94.36	63.99
tblVehicleTrips	ST_TR	49.97	10.74
tblVehicleTrips	SU_TR	6.07	6.16
tblVehicleTrips	SU_TR	5.86	4.18
tblVehicleTrips	SU_TR	1.05	0.69
tblVehicleTrips	SU_TR	131.84	78.27

## Village South Specific Plan (Proposed) - Los Angeles-South Coast County, Winter

tblVehicleTrips	SU_TR	5.95	3.20
tblVehicleTrips	SU_TR	72.16	57.65
tblVehicleTrips	SU_TR	25.24	6.39
tblVehicleTrips	WD_TR	6.59	5.83
tblVehicleTrips	WD_TR	6.65	4.13
tblVehicleTrips	WD_TR	11.03	6.41
tblVehicleTrips	WD_TR	127.15	65.80
tblVehicleTrips	WD_TR	8.17	3.84
tblVehicleTrips	WD_TR	89.95	62.64
tblVehicleTrips	WD_TR	42.70	9.43
tblWoodstoves	NumberCatalytic	1.25	0.00
tblWoodstoves	NumberCatalytic	48.75	0.00
tblWoodstoves	NumberNoncatalytic	1.25	0.00
tblWoodstoves	NumberNoncatalytic	48.75	0.00
tblWoodstoves	WoodstoveDayYear	25.00	0.00
tblWoodstoves	WoodstoveDayYear	25.00	0.00
tblWoodstoves	WoodstoveWoodMass	999.60	0.00
tblWoodstoves	WoodstoveWoodMass	999.60	0.00

## 2.0 Emissions Summary

---

Village South Specific Plan (Proposed) - Los Angeles-South Coast County, Winter

**2.1 Overall Construction (Maximum Daily Emission)**

**Unmitigated Construction**

	ROG	NOx	CO	SO2	Fugitive PM10	Exhaust PM10	PM10 Total	Fugitive PM2.5	Exhaust PM2.5	PM2.5 Total	Bio- CO2	NBio- CO2	Total CO2	CH4	N2O	CO2e
Year	lb/day										lb/day					
2021	4.2865	46.4651	31.6150	0.0642	18.2675	2.0461	20.3135	9.9840	1.8824	11.8664	0.0000	6,221.4937	6,221.4937	1.9491	0.0000	6,270.2214
2022	5.7218	38.9024	47.3319	0.1455	9.8688	1.6366	10.7736	3.6558	1.5057	5.1615	0.0000	14,630.3099	14,630.3099	1.9499	0.0000	14,657.2663
2023	5.2705	26.4914	44.5936	0.1413	9.8688	0.7800	10.6488	2.6381	0.7328	3.3708	0.0000	14,210.3424	14,210.3424	1.0230	0.0000	14,235.9160
2024	237.2328	9.5610	15.0611	0.0243	1.7884	0.4698	1.8628	0.4743	0.4322	0.5476	0.0000	2,352.4178	2,352.4178	0.7175	0.0000	2,370.3550
<b>Maximum</b>	<b>237.2328</b>	<b>46.4651</b>	<b>47.3319</b>	<b>0.1455</b>	<b>18.2675</b>	<b>2.0461</b>	<b>20.3135</b>	<b>9.9840</b>	<b>1.8824</b>	<b>11.8664</b>	<b>0.0000</b>	<b>14,630.3099</b>	<b>14,630.3099</b>	<b>1.9499</b>	<b>0.0000</b>	<b>14,657.2663</b>





Village South Specific Plan (Proposed) - Los Angeles-South Coast County, Winter

**2.2 Overall Operational**

**Unmitigated Operational**

	ROG	NOx	CO	SO2	Fugitive PM10	Exhaust PM10	PM10 Total	Fugitive PM2.5	Exhaust PM2.5	PM2.5 Total	Bio- CO2	NBio- CO2	Total CO2	CH4	N2O	CO2e
Category	lb/day										lb/day					
Area	30.5020	15.0496	88.4430	0.0944		1.5974	1.5974		1.5974	1.5974	0.0000	18,148.5950	18,148.5950	0.4874	0.3300	18,259.1192
Energy	0.7660	6.7462	4.2573	0.0418		0.5292	0.5292		0.5292	0.5292		8,355.9832	8,355.9832	0.1602	0.1532	8,405.6387
Mobile	9.5233	45.9914	110.0422	0.4681	45.9592	0.3373	46.2965	12.2950	0.3132	12.6083		47,917.8005	47,917.8005	2.1953		47,972.6839
<b>Total</b>	<b>40.7912</b>	<b>67.7872</b>	<b>202.7424</b>	<b>0.6043</b>	<b>45.9592</b>	<b>2.4640</b>	<b>48.4231</b>	<b>12.2950</b>	<b>2.4399</b>	<b>14.7349</b>	<b>0.0000</b>	<b>74,422.3787</b>	<b>74,422.3787</b>	<b>2.8429</b>	<b>0.4832</b>	<b>74,637.4417</b>

**Mitigated Operational**

	ROG	NOx	CO	SO2	Fugitive PM10	Exhaust PM10	PM10 Total	Fugitive PM2.5	Exhaust PM2.5	PM2.5 Total	Bio- CO2	NBio- CO2	Total CO2	CH4	N2O	CO2e
Category	lb/day										lb/day					
Area	30.5020	15.0496	88.4430	0.0944		1.5974	1.5974		1.5974	1.5974	0.0000	18,148.5950	18,148.5950	0.4874	0.3300	18,259.1192
Energy	0.7660	6.7462	4.2573	0.0418		0.5292	0.5292		0.5292	0.5292		8,355.9832	8,355.9832	0.1602	0.1532	8,405.6387
Mobile	9.5233	45.9914	110.0422	0.4681	45.9592	0.3373	46.2965	12.2950	0.3132	12.6083		47,917.8005	47,917.8005	2.1953		47,972.6839
<b>Total</b>	<b>40.7912</b>	<b>67.7872</b>	<b>202.7424</b>	<b>0.6043</b>	<b>45.9592</b>	<b>2.4640</b>	<b>48.4231</b>	<b>12.2950</b>	<b>2.4399</b>	<b>14.7349</b>	<b>0.0000</b>	<b>74,422.3787</b>	<b>74,422.3787</b>	<b>2.8429</b>	<b>0.4832</b>	<b>74,637.4417</b>

Village South Specific Plan (Proposed) - Los Angeles-South Coast County, Winter

	ROG	NOx	CO	SO2	Fugitive PM10	Exhaust PM10	PM10 Total	Fugitive PM2.5	Exhaust PM2.5	PM2.5 Total	Bio- CO2	NBio-CO2	Total CO2	CH4	N2O	CO2e
Percent Reduction	0.00	0.00	0.00	0.00	0.00	0.00	0.00	0.00	0.00	0.00	0.00	0.00	0.00	0.00	0.00	0.00

### 3.0 Construction Detail

#### Construction Phase

Phase Number	Phase Name	Phase Type	Start Date	End Date	Num Days Week	Num Days	Phase Description
1	Demolition	Demolition	9/1/2021	10/12/2021	5	30	
2	Site Preparation	Site Preparation	10/13/2021	11/9/2021	5	20	
3	Grading	Grading	11/10/2021	1/11/2022	5	45	
4	Building Construction	Building Construction	1/12/2022	12/12/2023	5	500	
5	Paving	Paving	12/13/2023	1/30/2024	5	35	
6	Architectural Coating	Architectural Coating	1/31/2024	3/19/2024	5	35	

Acres of Grading (Site Preparation Phase): 0

Acres of Grading (Grading Phase): 112.5

Acres of Paving: 0

Residential Indoor: 2,025,000; Residential Outdoor: 675,000; Non-Residential Indoor: 326,400; Non-Residential Outdoor: 108,800; Striped Parking Area: 0 (Architectural Coating – sqft)

#### OffRoad Equipment

## Village South Specific Plan (Proposed) - Los Angeles-South Coast County, Winter

Phase Name	Offroad Equipment Type	Amount	Usage Hours	Horse Power	Load Factor
Demolition	Concrete/Industrial Saws	1	8.00	81	0.73
Demolition	Excavators	3	8.00	158	0.38
Demolition	Rubber Tired Dozers	2	8.00	247	0.40
Site Preparation	Rubber Tired Dozers	3	8.00	247	0.40
Site Preparation	Tractors/Loaders/Backhoes	4	8.00	97	0.37
Grading	Excavators	2	8.00	158	0.38
Grading	Graders	1	8.00	187	0.41
Grading	Rubber Tired Dozers	1	8.00	247	0.40
Grading	Scrapers	2	8.00	367	0.48
Grading	Tractors/Loaders/Backhoes	2	8.00	97	0.37
Building Construction	Cranes	1	7.00	231	0.29
Building Construction	Forklifts	3	8.00	89	0.20
Building Construction	Generator Sets	1	8.00	84	0.74
Building Construction	Tractors/Loaders/Backhoes	3	7.00	97	0.37
Building Construction	Welders	1	8.00	46	0.45
Paving	Pavers	2	8.00	130	0.42
Paving	Paving Equipment	2	8.00	132	0.36
Paving	Rollers	2	8.00	80	0.38
Architectural Coating	Air Compressors	1	6.00	78	0.48

Trips and VMT

Village South Specific Plan (Proposed) - Los Angeles-South Coast County, Winter

Phase Name	Offroad Equipment Count	Worker Trip Number	Vendor Trip Number	Hauling Trip Number	Worker Trip Length	Vendor Trip Length	Hauling Trip Length	Worker Vehicle Class	Vendor Vehicle Class	Hauling Vehicle Class
Demolition	6	15.00	0.00	458.00	14.70	6.90	20.00	LD_Mix	HDT_Mix	HHDT
Site Preparation	7	18.00	0.00	0.00	14.70	6.90	20.00	LD_Mix	HDT_Mix	HHDT
Grading	8	20.00	0.00	0.00	14.70	6.90	20.00	LD_Mix	HDT_Mix	HHDT
Building Construction	9	801.00	143.00	0.00	14.70	6.90	20.00	LD_Mix	HDT_Mix	HHDT
Paving	6	15.00	0.00	0.00	14.70	6.90	20.00	LD_Mix	HDT_Mix	HHDT
Architectural Coating	1	160.00	0.00	0.00	14.70	6.90	20.00	LD_Mix	HDT_Mix	HHDT

**3.1 Mitigation Measures Construction**

**3.2 Demolition - 2021**

**Unmitigated Construction On-Site**

	ROG	NOx	CO	SO2	Fugitive PM10	Exhaust PM10	PM10 Total	Fugitive PM2.5	Exhaust PM2.5	PM2.5 Total	Bio- CO2	NBio- CO2	Total CO2	CH4	N2O	CO2e
Category	lb/day										lb/day					
Fugitive Dust					3.3074	0.0000	3.3074	0.5008	0.0000	0.5008			0.0000			0.0000
Off-Road	3.1651	31.4407	21.5650	0.0388		1.5513	1.5513		1.4411	1.4411		3,747.9449	3,747.9449	1.0549		3,774.3174
<b>Total</b>	<b>3.1651</b>	<b>31.4407</b>	<b>21.5650</b>	<b>0.0388</b>	<b>3.3074</b>	<b>1.5513</b>	<b>4.8588</b>	<b>0.5008</b>	<b>1.4411</b>	<b>1.9419</b>		<b>3,747.9449</b>	<b>3,747.9449</b>	<b>1.0549</b>		<b>3,774.3174</b>

Village South Specific Plan (Proposed) - Los Angeles-South Coast County, Winter

**3.2 Demolition - 2021**

**Unmitigated Construction Off-Site**

	ROG	NOx	CO	SO2	Fugitive PM10	Exhaust PM10	PM10 Total	Fugitive PM2.5	Exhaust PM2.5	PM2.5 Total	Bio- CO2	NBio- CO2	Total CO2	CH4	N2O	CO2e
Category	lb/day										lb/day					
Hauling	0.1304	4.1454	1.0182	0.0117	0.2669	0.0128	0.2797	0.0732	0.0122	0.0854		1,269.8555	1,269.8555	0.0908		1,272.1252
Vendor	0.0000	0.0000	0.0000	0.0000	0.0000	0.0000	0.0000	0.0000	0.0000	0.0000		0.0000	0.0000	0.0000		0.0000
Worker	0.0715	0.0489	0.5524	1.6100e-003	0.1677	1.3500e-003	0.1690	0.0445	1.2500e-003	0.0457		160.8377	160.8377	4.7300e-003		160.9560
<b>Total</b>	<b>0.2019</b>	<b>4.1943</b>	<b>1.5706</b>	<b>0.0133</b>	<b>0.4346</b>	<b>0.0141</b>	<b>0.4487</b>	<b>0.1176</b>	<b>0.0135</b>	<b>0.1311</b>		<b>1,430.6932</b>	<b>1,430.6932</b>	<b>0.0955</b>		<b>1,433.0812</b>

**Mitigated Construction On-Site**

	ROG	NOx	CO	SO2	Fugitive PM10	Exhaust PM10	PM10 Total	Fugitive PM2.5	Exhaust PM2.5	PM2.5 Total	Bio- CO2	NBio- CO2	Total CO2	CH4	N2O	CO2e
Category	lb/day										lb/day					
Fugitive Dust					3.3074	0.0000	3.3074	0.5008	0.0000	0.5008			0.0000			0.0000
Off-Road	3.1651	31.4407	21.5650	0.0388		1.5513	1.5513		1.4411	1.4411	0.0000	3,747.9449	3,747.9449	1.0549		3,774.3174
<b>Total</b>	<b>3.1651</b>	<b>31.4407</b>	<b>21.5650</b>	<b>0.0388</b>	<b>3.3074</b>	<b>1.5513</b>	<b>4.8588</b>	<b>0.5008</b>	<b>1.4411</b>	<b>1.9419</b>	<b>0.0000</b>	<b>3,747.9449</b>	<b>3,747.9449</b>	<b>1.0549</b>		<b>3,774.3174</b>

Village South Specific Plan (Proposed) - Los Angeles-South Coast County, Winter

**3.2 Demolition - 2021**

**Mitigated Construction Off-Site**

	ROG	NOx	CO	SO2	Fugitive PM10	Exhaust PM10	PM10 Total	Fugitive PM2.5	Exhaust PM2.5	PM2.5 Total	Bio- CO2	NBio- CO2	Total CO2	CH4	N2O	CO2e
Category	lb/day										lb/day					
Hauling	0.1304	4.1454	1.0182	0.0117	0.2669	0.0128	0.2797	0.0732	0.0122	0.0854		1,269.8555	1,269.8555	0.0908		1,272.1252
Vendor	0.0000	0.0000	0.0000	0.0000	0.0000	0.0000	0.0000	0.0000	0.0000	0.0000		0.0000	0.0000	0.0000		0.0000
Worker	0.0715	0.0489	0.5524	1.6100e-003	0.1677	1.3500e-003	0.1690	0.0445	1.2500e-003	0.0457		160.8377	160.8377	4.7300e-003		160.9560
<b>Total</b>	<b>0.2019</b>	<b>4.1943</b>	<b>1.5706</b>	<b>0.0133</b>	<b>0.4346</b>	<b>0.0141</b>	<b>0.4487</b>	<b>0.1176</b>	<b>0.0135</b>	<b>0.1311</b>		<b>1,430.6932</b>	<b>1,430.6932</b>	<b>0.0955</b>		<b>1,433.0812</b>

**3.3 Site Preparation - 2021**

**Unmitigated Construction On-Site**

	ROG	NOx	CO	SO2	Fugitive PM10	Exhaust PM10	PM10 Total	Fugitive PM2.5	Exhaust PM2.5	PM2.5 Total	Bio- CO2	NBio- CO2	Total CO2	CH4	N2O	CO2e
Category	lb/day										lb/day					
Fugitive Dust					18.0663	0.0000	18.0663	9.9307	0.0000	9.9307			0.0000			0.0000
Off-Road	3.8882	40.4971	21.1543	0.0380		2.0445	2.0445		1.8809	1.8809		3,685.6569	3,685.6569	1.1920		3,715.4573
<b>Total</b>	<b>3.8882</b>	<b>40.4971</b>	<b>21.1543</b>	<b>0.0380</b>	<b>18.0663</b>	<b>2.0445</b>	<b>20.1107</b>	<b>9.9307</b>	<b>1.8809</b>	<b>11.8116</b>		<b>3,685.6569</b>	<b>3,685.6569</b>	<b>1.1920</b>		<b>3,715.4573</b>

Village South Specific Plan (Proposed) - Los Angeles-South Coast County, Winter

**3.3 Site Preparation - 2021**

**Unmitigated Construction Off-Site**

	ROG	NOx	CO	SO2	Fugitive PM10	Exhaust PM10	PM10 Total	Fugitive PM2.5	Exhaust PM2.5	PM2.5 Total	Bio- CO2	NBio- CO2	Total CO2	CH4	N2O	CO2e
Category	lb/day										lb/day					
Hauling	0.0000	0.0000	0.0000	0.0000	0.0000	0.0000	0.0000	0.0000	0.0000	0.0000		0.0000	0.0000	0.0000		0.0000
Vendor	0.0000	0.0000	0.0000	0.0000	0.0000	0.0000	0.0000	0.0000	0.0000	0.0000		0.0000	0.0000	0.0000		0.0000
Worker	0.0858	0.0587	0.6629	1.9400e-003	0.2012	1.6300e-003	0.2028	0.0534	1.5000e-003	0.0549		193.0052	193.0052	5.6800e-003		193.1472
<b>Total</b>	<b>0.0858</b>	<b>0.0587</b>	<b>0.6629</b>	<b>1.9400e-003</b>	<b>0.2012</b>	<b>1.6300e-003</b>	<b>0.2028</b>	<b>0.0534</b>	<b>1.5000e-003</b>	<b>0.0549</b>		<b>193.0052</b>	<b>193.0052</b>	<b>5.6800e-003</b>		<b>193.1472</b>

**Mitigated Construction On-Site**

	ROG	NOx	CO	SO2	Fugitive PM10	Exhaust PM10	PM10 Total	Fugitive PM2.5	Exhaust PM2.5	PM2.5 Total	Bio- CO2	NBio- CO2	Total CO2	CH4	N2O	CO2e
Category	lb/day										lb/day					
Fugitive Dust					18.0663	0.0000	18.0663	9.9307	0.0000	9.9307			0.0000			0.0000
Off-Road	3.8882	40.4971	21.1543	0.0380		2.0445	2.0445		1.8809	1.8809	0.0000	3,685.6569	3,685.6569	1.1920		3,715.4573
<b>Total</b>	<b>3.8882</b>	<b>40.4971</b>	<b>21.1543</b>	<b>0.0380</b>	<b>18.0663</b>	<b>2.0445</b>	<b>20.1107</b>	<b>9.9307</b>	<b>1.8809</b>	<b>11.8116</b>	<b>0.0000</b>	<b>3,685.6569</b>	<b>3,685.6569</b>	<b>1.1920</b>		<b>3,715.4573</b>

Village South Specific Plan (Proposed) - Los Angeles-South Coast County, Winter

**3.3 Site Preparation - 2021**

**Mitigated Construction Off-Site**

	ROG	NOx	CO	SO2	Fugitive PM10	Exhaust PM10	PM10 Total	Fugitive PM2.5	Exhaust PM2.5	PM2.5 Total	Bio- CO2	NBio- CO2	Total CO2	CH4	N2O	CO2e
Category	lb/day										lb/day					
Hauling	0.0000	0.0000	0.0000	0.0000	0.0000	0.0000	0.0000	0.0000	0.0000	0.0000		0.0000	0.0000	0.0000		0.0000
Vendor	0.0000	0.0000	0.0000	0.0000	0.0000	0.0000	0.0000	0.0000	0.0000	0.0000		0.0000	0.0000	0.0000		0.0000
Worker	0.0858	0.0587	0.6629	1.9400e-003	0.2012	1.6300e-003	0.2028	0.0534	1.5000e-003	0.0549		193.0052	193.0052	5.6800e-003		193.1472
<b>Total</b>	<b>0.0858</b>	<b>0.0587</b>	<b>0.6629</b>	<b>1.9400e-003</b>	<b>0.2012</b>	<b>1.6300e-003</b>	<b>0.2028</b>	<b>0.0534</b>	<b>1.5000e-003</b>	<b>0.0549</b>		<b>193.0052</b>	<b>193.0052</b>	<b>5.6800e-003</b>		<b>193.1472</b>

**3.4 Grading - 2021**

**Unmitigated Construction On-Site**

	ROG	NOx	CO	SO2	Fugitive PM10	Exhaust PM10	PM10 Total	Fugitive PM2.5	Exhaust PM2.5	PM2.5 Total	Bio- CO2	NBio- CO2	Total CO2	CH4	N2O	CO2e
Category	lb/day										lb/day					
Fugitive Dust					8.6733	0.0000	8.6733	3.5965	0.0000	3.5965			0.0000			0.0000
Off-Road	4.1912	46.3998	30.8785	0.0620		1.9853	1.9853		1.8265	1.8265		6,007.0434	6,007.0434	1.9428		6,055.6134
<b>Total</b>	<b>4.1912</b>	<b>46.3998</b>	<b>30.8785</b>	<b>0.0620</b>	<b>8.6733</b>	<b>1.9853</b>	<b>10.6587</b>	<b>3.5965</b>	<b>1.8265</b>	<b>5.4230</b>		<b>6,007.0434</b>	<b>6,007.0434</b>	<b>1.9428</b>		<b>6,055.6134</b>



Village South Specific Plan (Proposed) - Los Angeles-South Coast County, Winter

**3.4 Grading - 2021**

**Unmitigated Construction Off-Site**

	ROG	NOx	CO	SO2	Fugitive PM10	Exhaust PM10	PM10 Total	Fugitive PM2.5	Exhaust PM2.5	PM2.5 Total	Bio- CO2	NBio- CO2	Total CO2	CH4	N2O	CO2e
Category	lb/day										lb/day					
Hauling	0.0000	0.0000	0.0000	0.0000	0.0000	0.0000	0.0000	0.0000	0.0000	0.0000		0.0000	0.0000	0.0000		0.0000
Vendor	0.0000	0.0000	0.0000	0.0000	0.0000	0.0000	0.0000	0.0000	0.0000	0.0000		0.0000	0.0000	0.0000		0.0000
Worker	0.0954	0.0652	0.7365	2.1500e-003	0.2236	1.8100e-003	0.2254	0.0593	1.6600e-003	0.0610		214.4502	214.4502	6.3100e-003		214.6080
<b>Total</b>	<b>0.0954</b>	<b>0.0652</b>	<b>0.7365</b>	<b>2.1500e-003</b>	<b>0.2236</b>	<b>1.8100e-003</b>	<b>0.2254</b>	<b>0.0593</b>	<b>1.6600e-003</b>	<b>0.0610</b>		<b>214.4502</b>	<b>214.4502</b>	<b>6.3100e-003</b>		<b>214.6080</b>

**Mitigated Construction On-Site**

	ROG	NOx	CO	SO2	Fugitive PM10	Exhaust PM10	PM10 Total	Fugitive PM2.5	Exhaust PM2.5	PM2.5 Total	Bio- CO2	NBio- CO2	Total CO2	CH4	N2O	CO2e
Category	lb/day										lb/day					
Fugitive Dust					8.6733	0.0000	8.6733	3.5965	0.0000	3.5965			0.0000			0.0000
Off-Road	4.1912	46.3998	30.8785	0.0620		1.9853	1.9853		1.8265	1.8265	0.0000	6,007.0434	6,007.0434	1.9428		6,055.6134
<b>Total</b>	<b>4.1912</b>	<b>46.3998</b>	<b>30.8785</b>	<b>0.0620</b>	<b>8.6733</b>	<b>1.9853</b>	<b>10.6587</b>	<b>3.5965</b>	<b>1.8265</b>	<b>5.4230</b>	<b>0.0000</b>	<b>6,007.0434</b>	<b>6,007.0434</b>	<b>1.9428</b>		<b>6,055.6134</b>

Village South Specific Plan (Proposed) - Los Angeles-South Coast County, Winter

**3.4 Grading - 2021**

**Mitigated Construction Off-Site**

	ROG	NOx	CO	SO2	Fugitive PM10	Exhaust PM10	PM10 Total	Fugitive PM2.5	Exhaust PM2.5	PM2.5 Total	Bio- CO2	NBio- CO2	Total CO2	CH4	N2O	CO2e
Category	lb/day										lb/day					
Hauling	0.0000	0.0000	0.0000	0.0000	0.0000	0.0000	0.0000	0.0000	0.0000	0.0000		0.0000	0.0000	0.0000		0.0000
Vendor	0.0000	0.0000	0.0000	0.0000	0.0000	0.0000	0.0000	0.0000	0.0000	0.0000		0.0000	0.0000	0.0000		0.0000
Worker	0.0954	0.0652	0.7365	2.1500e-003	0.2236	1.8100e-003	0.2254	0.0593	1.6600e-003	0.0610		214.4502	214.4502	6.3100e-003		214.6080
<b>Total</b>	<b>0.0954</b>	<b>0.0652</b>	<b>0.7365</b>	<b>2.1500e-003</b>	<b>0.2236</b>	<b>1.8100e-003</b>	<b>0.2254</b>	<b>0.0593</b>	<b>1.6600e-003</b>	<b>0.0610</b>		<b>214.4502</b>	<b>214.4502</b>	<b>6.3100e-003</b>		<b>214.6080</b>

**3.4 Grading - 2022**

**Unmitigated Construction On-Site**

	ROG	NOx	CO	SO2	Fugitive PM10	Exhaust PM10	PM10 Total	Fugitive PM2.5	Exhaust PM2.5	PM2.5 Total	Bio- CO2	NBio- CO2	Total CO2	CH4	N2O	CO2e
Category	lb/day										lb/day					
Fugitive Dust					8.6733	0.0000	8.6733	3.5965	0.0000	3.5965			0.0000			0.0000
Off-Road	3.6248	38.8435	29.0415	0.0621		1.6349	1.6349		1.5041	1.5041		6,011.4105	6,011.4105	1.9442		6,060.0158
<b>Total</b>	<b>3.6248</b>	<b>38.8435</b>	<b>29.0415</b>	<b>0.0621</b>	<b>8.6733</b>	<b>1.6349</b>	<b>10.3082</b>	<b>3.5965</b>	<b>1.5041</b>	<b>5.1006</b>		<b>6,011.4105</b>	<b>6,011.4105</b>	<b>1.9442</b>		<b>6,060.0158</b>

Village South Specific Plan (Proposed) - Los Angeles-South Coast County, Winter

**3.4 Grading - 2022**

**Unmitigated Construction Off-Site**

	ROG	NOx	CO	SO2	Fugitive PM10	Exhaust PM10	PM10 Total	Fugitive PM2.5	Exhaust PM2.5	PM2.5 Total	Bio- CO2	NBio- CO2	Total CO2	CH4	N2O	CO2e
Category	lb/day										lb/day					
Hauling	0.0000	0.0000	0.0000	0.0000	0.0000	0.0000	0.0000	0.0000	0.0000	0.0000		0.0000	0.0000	0.0000		0.0000
Vendor	0.0000	0.0000	0.0000	0.0000	0.0000	0.0000	0.0000	0.0000	0.0000	0.0000		0.0000	0.0000	0.0000		0.0000
Worker	0.0896	0.0589	0.6784	2.0800e-003	0.2236	1.7500e-003	0.2253	0.0593	1.6100e-003	0.0609		206.9139	206.9139	5.7000e-003		207.0563
<b>Total</b>	<b>0.0896</b>	<b>0.0589</b>	<b>0.6784</b>	<b>2.0800e-003</b>	<b>0.2236</b>	<b>1.7500e-003</b>	<b>0.2253</b>	<b>0.0593</b>	<b>1.6100e-003</b>	<b>0.0609</b>		<b>206.9139</b>	<b>206.9139</b>	<b>5.7000e-003</b>		<b>207.0563</b>

**Mitigated Construction On-Site**

	ROG	NOx	CO	SO2	Fugitive PM10	Exhaust PM10	PM10 Total	Fugitive PM2.5	Exhaust PM2.5	PM2.5 Total	Bio- CO2	NBio- CO2	Total CO2	CH4	N2O	CO2e
Category	lb/day										lb/day					
Fugitive Dust					8.6733	0.0000	8.6733	3.5965	0.0000	3.5965			0.0000			0.0000
Off-Road	3.6248	38.8435	29.0415	0.0621		1.6349	1.6349		1.5041	1.5041	0.0000	6,011.4105	6,011.4105	1.9442		6,060.0158
<b>Total</b>	<b>3.6248</b>	<b>38.8435</b>	<b>29.0415</b>	<b>0.0621</b>	<b>8.6733</b>	<b>1.6349</b>	<b>10.3082</b>	<b>3.5965</b>	<b>1.5041</b>	<b>5.1006</b>	<b>0.0000</b>	<b>6,011.4105</b>	<b>6,011.4105</b>	<b>1.9442</b>		<b>6,060.0158</b>

Village South Specific Plan (Proposed) - Los Angeles-South Coast County, Winter

**3.4 Grading - 2022**

**Mitigated Construction Off-Site**

	ROG	NOx	CO	SO2	Fugitive PM10	Exhaust PM10	PM10 Total	Fugitive PM2.5	Exhaust PM2.5	PM2.5 Total	Bio- CO2	NBio- CO2	Total CO2	CH4	N2O	CO2e
Category	lb/day										lb/day					
Hauling	0.0000	0.0000	0.0000	0.0000	0.0000	0.0000	0.0000	0.0000	0.0000	0.0000		0.0000	0.0000	0.0000		0.0000
Vendor	0.0000	0.0000	0.0000	0.0000	0.0000	0.0000	0.0000	0.0000	0.0000	0.0000		0.0000	0.0000	0.0000		0.0000
Worker	0.0896	0.0589	0.6784	2.0800e-003	0.2236	1.7500e-003	0.2253	0.0593	1.6100e-003	0.0609		206.9139	206.9139	5.7000e-003		207.0563
<b>Total</b>	<b>0.0896</b>	<b>0.0589</b>	<b>0.6784</b>	<b>2.0800e-003</b>	<b>0.2236</b>	<b>1.7500e-003</b>	<b>0.2253</b>	<b>0.0593</b>	<b>1.6100e-003</b>	<b>0.0609</b>		<b>206.9139</b>	<b>206.9139</b>	<b>5.7000e-003</b>		<b>207.0563</b>

**3.5 Building Construction - 2022**

**Unmitigated Construction On-Site**

	ROG	NOx	CO	SO2	Fugitive PM10	Exhaust PM10	PM10 Total	Fugitive PM2.5	Exhaust PM2.5	PM2.5 Total	Bio- CO2	NBio- CO2	Total CO2	CH4	N2O	CO2e
Category	lb/day										lb/day					
Off-Road	1.7062	15.6156	16.3634	0.0269		0.8090	0.8090		0.7612	0.7612		2,554.3336	2,554.3336	0.6120		2,569.6322
<b>Total</b>	<b>1.7062</b>	<b>15.6156</b>	<b>16.3634</b>	<b>0.0269</b>		<b>0.8090</b>	<b>0.8090</b>		<b>0.7612</b>	<b>0.7612</b>		<b>2,554.3336</b>	<b>2,554.3336</b>	<b>0.6120</b>		<b>2,569.6322</b>

Village South Specific Plan (Proposed) - Los Angeles-South Coast County, Winter

**3.5 Building Construction - 2022**

**Unmitigated Construction Off-Site**

	ROG	NOx	CO	SO2	Fugitive PM10	Exhaust PM10	PM10 Total	Fugitive PM2.5	Exhaust PM2.5	PM2.5 Total	Bio- CO2	NBio- CO2	Total CO2	CH4	N2O	CO2e
Category	lb/day										lb/day					
Hauling	0.0000	0.0000	0.0000	0.0000	0.0000	0.0000	0.0000	0.0000	0.0000	0.0000		0.0000	0.0000	0.0000		0.0000
Vendor	0.4284	13.1673	3.8005	0.0354	0.9155	0.0256	0.9412	0.2636	0.0245	0.2881		3,789.0750	3,789.0750	0.2381		3,795.0283
Worker	3.5872	2.3593	27.1680	0.0832	8.9533	0.0701	9.0234	2.3745	0.0646	2.4390		8,286.9013	8,286.9013	0.2282		8,292.6058
<b>Total</b>	<b>4.0156</b>	<b>15.5266</b>	<b>30.9685</b>	<b>0.1186</b>	<b>9.8688</b>	<b>0.0957</b>	<b>9.9645</b>	<b>2.6381</b>	<b>0.0891</b>	<b>2.7271</b>		<b>12,075.9763</b>	<b>12,075.9763</b>	<b>0.4663</b>		<b>12,087.6341</b>

**Mitigated Construction On-Site**

	ROG	NOx	CO	SO2	Fugitive PM10	Exhaust PM10	PM10 Total	Fugitive PM2.5	Exhaust PM2.5	PM2.5 Total	Bio- CO2	NBio- CO2	Total CO2	CH4	N2O	CO2e
Category	lb/day										lb/day					
Off-Road	1.7062	15.6156	16.3634	0.0269		0.8090	0.8090		0.7612	0.7612	0.0000	2,554.3336	2,554.3336	0.6120		2,569.6322
<b>Total</b>	<b>1.7062</b>	<b>15.6156</b>	<b>16.3634</b>	<b>0.0269</b>		<b>0.8090</b>	<b>0.8090</b>		<b>0.7612</b>	<b>0.7612</b>	<b>0.0000</b>	<b>2,554.3336</b>	<b>2,554.3336</b>	<b>0.6120</b>		<b>2,569.6322</b>

Village South Specific Plan (Proposed) - Los Angeles-South Coast County, Winter

**3.5 Building Construction - 2022**

**Mitigated Construction Off-Site**

	ROG	NOx	CO	SO2	Fugitive PM10	Exhaust PM10	PM10 Total	Fugitive PM2.5	Exhaust PM2.5	PM2.5 Total	Bio- CO2	NBio- CO2	Total CO2	CH4	N2O	CO2e
Category	lb/day										lb/day					
Hauling	0.0000	0.0000	0.0000	0.0000	0.0000	0.0000	0.0000	0.0000	0.0000	0.0000		0.0000	0.0000	0.0000		0.0000
Vendor	0.4284	13.1673	3.8005	0.0354	0.9155	0.0256	0.9412	0.2636	0.0245	0.2881		3,789.0750	3,789.0750	0.2381		3,795.0283
Worker	3.5872	2.3593	27.1680	0.0832	8.9533	0.0701	9.0234	2.3745	0.0646	2.4390		8,286.9013	8,286.9013	0.2282		8,292.6058
<b>Total</b>	<b>4.0156</b>	<b>15.5266</b>	<b>30.9685</b>	<b>0.1186</b>	<b>9.8688</b>	<b>0.0957</b>	<b>9.9645</b>	<b>2.6381</b>	<b>0.0891</b>	<b>2.7271</b>		<b>12,075.9763</b>	<b>12,075.9763</b>	<b>0.4663</b>		<b>12,087.6341</b>

**3.5 Building Construction - 2023**

**Unmitigated Construction On-Site**

	ROG	NOx	CO	SO2	Fugitive PM10	Exhaust PM10	PM10 Total	Fugitive PM2.5	Exhaust PM2.5	PM2.5 Total	Bio- CO2	NBio- CO2	Total CO2	CH4	N2O	CO2e
Category	lb/day										lb/day					
Off-Road	1.5728	14.3849	16.2440	0.0269		0.6997	0.6997		0.6584	0.6584		2,555.2099	2,555.2099	0.6079		2,570.4061
<b>Total</b>	<b>1.5728</b>	<b>14.3849</b>	<b>16.2440</b>	<b>0.0269</b>		<b>0.6997</b>	<b>0.6997</b>		<b>0.6584</b>	<b>0.6584</b>		<b>2,555.2099</b>	<b>2,555.2099</b>	<b>0.6079</b>		<b>2,570.4061</b>

Village South Specific Plan (Proposed) - Los Angeles-South Coast County, Winter

**3.5 Building Construction - 2023**

**Unmitigated Construction Off-Site**

	ROG	NOx	CO	SO2	Fugitive PM10	Exhaust PM10	PM10 Total	Fugitive PM2.5	Exhaust PM2.5	PM2.5 Total	Bio- CO2	NBio- CO2	Total CO2	CH4	N2O	CO2e
Category	lb/day										lb/day					
Hauling	0.0000	0.0000	0.0000	0.0000	0.0000	0.0000	0.0000	0.0000	0.0000	0.0000		0.0000	0.0000	0.0000		0.0000
Vendor	0.3183	9.9726	3.3771	0.0343	0.9156	0.0122	0.9277	0.2636	0.0116	0.2752		3,671.4007	3,671.4007	0.2096		3,676.6417
Worker	3.3795	2.1338	24.9725	0.0801	8.9533	0.0681	9.0214	2.3745	0.0627	2.4372		7,983.7318	7,983.7318	0.2055		7,988.8683
<b>Total</b>	<b>3.6978</b>	<b>12.1065</b>	<b>28.3496</b>	<b>0.1144</b>	<b>9.8688</b>	<b>0.0803</b>	<b>9.9491</b>	<b>2.6381</b>	<b>0.0743</b>	<b>2.7124</b>		<b>11,655.1325</b>	<b>11,655.1325</b>	<b>0.4151</b>		<b>11,665.5099</b>

**Mitigated Construction On-Site**

	ROG	NOx	CO	SO2	Fugitive PM10	Exhaust PM10	PM10 Total	Fugitive PM2.5	Exhaust PM2.5	PM2.5 Total	Bio- CO2	NBio- CO2	Total CO2	CH4	N2O	CO2e
Category	lb/day										lb/day					
Off-Road	1.5728	14.3849	16.2440	0.0269		0.6997	0.6997		0.6584	0.6584	0.0000	2,555.2099	2,555.2099	0.6079		2,570.4061
<b>Total</b>	<b>1.5728</b>	<b>14.3849</b>	<b>16.2440</b>	<b>0.0269</b>		<b>0.6997</b>	<b>0.6997</b>		<b>0.6584</b>	<b>0.6584</b>	<b>0.0000</b>	<b>2,555.2099</b>	<b>2,555.2099</b>	<b>0.6079</b>		<b>2,570.4061</b>

Village South Specific Plan (Proposed) - Los Angeles-South Coast County, Winter

**3.5 Building Construction - 2023**

**Mitigated Construction Off-Site**

	ROG	NOx	CO	SO2	Fugitive PM10	Exhaust PM10	PM10 Total	Fugitive PM2.5	Exhaust PM2.5	PM2.5 Total	Bio- CO2	NBio- CO2	Total CO2	CH4	N2O	CO2e
Category	lb/day										lb/day					
Hauling	0.0000	0.0000	0.0000	0.0000	0.0000	0.0000	0.0000	0.0000	0.0000	0.0000		0.0000	0.0000	0.0000		0.0000
Vendor	0.3183	9.9726	3.3771	0.0343	0.9156	0.0122	0.9277	0.2636	0.0116	0.2752		3,671.4007	3,671.4007	0.2096		3,676.6417
Worker	3.3795	2.1338	24.9725	0.0801	8.9533	0.0681	9.0214	2.3745	0.0627	2.4372		7,983.7318	7,983.7318	0.2055		7,988.8683
<b>Total</b>	<b>3.6978</b>	<b>12.1065</b>	<b>28.3496</b>	<b>0.1144</b>	<b>9.8688</b>	<b>0.0803</b>	<b>9.9491</b>	<b>2.6381</b>	<b>0.0743</b>	<b>2.7124</b>		<b>11,655.1325</b>	<b>11,655.1325</b>	<b>0.4151</b>		<b>11,665.5099</b>

**3.6 Paving - 2023**

**Unmitigated Construction On-Site**

	ROG	NOx	CO	SO2	Fugitive PM10	Exhaust PM10	PM10 Total	Fugitive PM2.5	Exhaust PM2.5	PM2.5 Total	Bio- CO2	NBio- CO2	Total CO2	CH4	N2O	CO2e
Category	lb/day										lb/day					
Off-Road	1.0327	10.1917	14.5842	0.0228		0.5102	0.5102		0.4694	0.4694		2,207.5841	2,207.5841	0.7140		2,225.4336
Paving	0.0000					0.0000	0.0000		0.0000	0.0000			0.0000			0.0000
<b>Total</b>	<b>1.0327</b>	<b>10.1917</b>	<b>14.5842</b>	<b>0.0228</b>		<b>0.5102</b>	<b>0.5102</b>		<b>0.4694</b>	<b>0.4694</b>		<b>2,207.5841</b>	<b>2,207.5841</b>	<b>0.7140</b>		<b>2,225.4336</b>



Village South Specific Plan (Proposed) - Los Angeles-South Coast County, Winter

**3.6 Paving - 2023**

**Unmitigated Construction Off-Site**

	ROG	NOx	CO	SO2	Fugitive PM10	Exhaust PM10	PM10 Total	Fugitive PM2.5	Exhaust PM2.5	PM2.5 Total	Bio- CO2	NBio- CO2	Total CO2	CH4	N2O	CO2e
Category	lb/day										lb/day					
Hauling	0.0000	0.0000	0.0000	0.0000	0.0000	0.0000	0.0000	0.0000	0.0000	0.0000		0.0000	0.0000	0.0000		0.0000
Vendor	0.0000	0.0000	0.0000	0.0000	0.0000	0.0000	0.0000	0.0000	0.0000	0.0000		0.0000	0.0000	0.0000		0.0000
Worker	0.0633	0.0400	0.4677	1.5000e-003	0.1677	1.2800e-003	0.1689	0.0445	1.1700e-003	0.0456		149.5081	149.5081	3.8500e-003		149.6043
<b>Total</b>	<b>0.0633</b>	<b>0.0400</b>	<b>0.4677</b>	<b>1.5000e-003</b>	<b>0.1677</b>	<b>1.2800e-003</b>	<b>0.1689</b>	<b>0.0445</b>	<b>1.1700e-003</b>	<b>0.0456</b>		<b>149.5081</b>	<b>149.5081</b>	<b>3.8500e-003</b>		<b>149.6043</b>

**Mitigated Construction On-Site**

	ROG	NOx	CO	SO2	Fugitive PM10	Exhaust PM10	PM10 Total	Fugitive PM2.5	Exhaust PM2.5	PM2.5 Total	Bio- CO2	NBio- CO2	Total CO2	CH4	N2O	CO2e
Category	lb/day										lb/day					
Off-Road	1.0327	10.1917	14.5842	0.0228		0.5102	0.5102		0.4694	0.4694	0.0000	2,207.5841	2,207.5841	0.7140		2,225.4336
Paving	0.0000					0.0000	0.0000		0.0000	0.0000			0.0000			0.0000
<b>Total</b>	<b>1.0327</b>	<b>10.1917</b>	<b>14.5842</b>	<b>0.0228</b>		<b>0.5102</b>	<b>0.5102</b>		<b>0.4694</b>	<b>0.4694</b>	<b>0.0000</b>	<b>2,207.5841</b>	<b>2,207.5841</b>	<b>0.7140</b>		<b>2,225.4336</b>

Village South Specific Plan (Proposed) - Los Angeles-South Coast County, Winter

**3.6 Paving - 2023**

**Mitigated Construction Off-Site**

	ROG	NOx	CO	SO2	Fugitive PM10	Exhaust PM10	PM10 Total	Fugitive PM2.5	Exhaust PM2.5	PM2.5 Total	Bio- CO2	NBio- CO2	Total CO2	CH4	N2O	CO2e
Category	lb/day										lb/day					
Hauling	0.0000	0.0000	0.0000	0.0000	0.0000	0.0000	0.0000	0.0000	0.0000	0.0000		0.0000	0.0000	0.0000		0.0000
Vendor	0.0000	0.0000	0.0000	0.0000	0.0000	0.0000	0.0000	0.0000	0.0000	0.0000		0.0000	0.0000	0.0000		0.0000
Worker	0.0633	0.0400	0.4677	1.5000e-003	0.1677	1.2800e-003	0.1689	0.0445	1.1700e-003	0.0456		149.5081	149.5081	3.8500e-003		149.6043
<b>Total</b>	<b>0.0633</b>	<b>0.0400</b>	<b>0.4677</b>	<b>1.5000e-003</b>	<b>0.1677</b>	<b>1.2800e-003</b>	<b>0.1689</b>	<b>0.0445</b>	<b>1.1700e-003</b>	<b>0.0456</b>		<b>149.5081</b>	<b>149.5081</b>	<b>3.8500e-003</b>		<b>149.6043</b>

**3.6 Paving - 2024**

**Unmitigated Construction On-Site**

	ROG	NOx	CO	SO2	Fugitive PM10	Exhaust PM10	PM10 Total	Fugitive PM2.5	Exhaust PM2.5	PM2.5 Total	Bio- CO2	NBio- CO2	Total CO2	CH4	N2O	CO2e
Category	lb/day										lb/day					
Off-Road	0.9882	9.5246	14.6258	0.0228		0.4685	0.4685		0.4310	0.4310		2,207.5472	2,207.5472	0.7140		2,225.3963
Paving	0.0000					0.0000	0.0000		0.0000	0.0000			0.0000			0.0000
<b>Total</b>	<b>0.9882</b>	<b>9.5246</b>	<b>14.6258</b>	<b>0.0228</b>		<b>0.4685</b>	<b>0.4685</b>		<b>0.4310</b>	<b>0.4310</b>		<b>2,207.5472</b>	<b>2,207.5472</b>	<b>0.7140</b>		<b>2,225.3963</b>

Village South Specific Plan (Proposed) - Los Angeles-South Coast County, Winter

**3.6 Paving - 2024**

**Unmitigated Construction Off-Site**

	ROG	NOx	CO	SO2	Fugitive PM10	Exhaust PM10	PM10 Total	Fugitive PM2.5	Exhaust PM2.5	PM2.5 Total	Bio- CO2	NBio- CO2	Total CO2	CH4	N2O	CO2e
Category	lb/day										lb/day					
Hauling	0.0000	0.0000	0.0000	0.0000	0.0000	0.0000	0.0000	0.0000	0.0000	0.0000		0.0000	0.0000	0.0000		0.0000
Vendor	0.0000	0.0000	0.0000	0.0000	0.0000	0.0000	0.0000	0.0000	0.0000	0.0000		0.0000	0.0000	0.0000		0.0000
Worker	0.0601	0.0364	0.4354	1.4500e-003	0.1677	1.2600e-003	0.1689	0.0445	1.1600e-003	0.0456		144.8706	144.8706	3.5300e-003		144.9587
<b>Total</b>	<b>0.0601</b>	<b>0.0364</b>	<b>0.4354</b>	<b>1.4500e-003</b>	<b>0.1677</b>	<b>1.2600e-003</b>	<b>0.1689</b>	<b>0.0445</b>	<b>1.1600e-003</b>	<b>0.0456</b>		<b>144.8706</b>	<b>144.8706</b>	<b>3.5300e-003</b>		<b>144.9587</b>

**Mitigated Construction On-Site**

	ROG	NOx	CO	SO2	Fugitive PM10	Exhaust PM10	PM10 Total	Fugitive PM2.5	Exhaust PM2.5	PM2.5 Total	Bio- CO2	NBio- CO2	Total CO2	CH4	N2O	CO2e
Category	lb/day										lb/day					
Off-Road	0.9882	9.5246	14.6258	0.0228		0.4685	0.4685		0.4310	0.4310	0.0000	2,207.5472	2,207.5472	0.7140		2,225.3963
Paving	0.0000					0.0000	0.0000		0.0000	0.0000			0.0000			0.0000
<b>Total</b>	<b>0.9882</b>	<b>9.5246</b>	<b>14.6258</b>	<b>0.0228</b>		<b>0.4685</b>	<b>0.4685</b>		<b>0.4310</b>	<b>0.4310</b>	<b>0.0000</b>	<b>2,207.5472</b>	<b>2,207.5472</b>	<b>0.7140</b>		<b>2,225.3963</b>

Village South Specific Plan (Proposed) - Los Angeles-South Coast County, Winter

**3.6 Paving - 2024**

**Mitigated Construction Off-Site**

	ROG	NOx	CO	SO2	Fugitive PM10	Exhaust PM10	PM10 Total	Fugitive PM2.5	Exhaust PM2.5	PM2.5 Total	Bio- CO2	NBio- CO2	Total CO2	CH4	N2O	CO2e
Category	lb/day										lb/day					
Hauling	0.0000	0.0000	0.0000	0.0000	0.0000	0.0000	0.0000	0.0000	0.0000	0.0000		0.0000	0.0000	0.0000		0.0000
Vendor	0.0000	0.0000	0.0000	0.0000	0.0000	0.0000	0.0000	0.0000	0.0000	0.0000		0.0000	0.0000	0.0000		0.0000
Worker	0.0601	0.0364	0.4354	1.4500e-003	0.1677	1.2600e-003	0.1689	0.0445	1.1600e-003	0.0456		144.8706	144.8706	3.5300e-003		144.9587
<b>Total</b>	<b>0.0601</b>	<b>0.0364</b>	<b>0.4354</b>	<b>1.4500e-003</b>	<b>0.1677</b>	<b>1.2600e-003</b>	<b>0.1689</b>	<b>0.0445</b>	<b>1.1600e-003</b>	<b>0.0456</b>		<b>144.8706</b>	<b>144.8706</b>	<b>3.5300e-003</b>		<b>144.9587</b>

**3.7 Architectural Coating - 2024**

**Unmitigated Construction On-Site**

	ROG	NOx	CO	SO2	Fugitive PM10	Exhaust PM10	PM10 Total	Fugitive PM2.5	Exhaust PM2.5	PM2.5 Total	Bio- CO2	NBio- CO2	Total CO2	CH4	N2O	CO2e
Category	lb/day										lb/day					
Archit. Coating	236.4115					0.0000	0.0000		0.0000	0.0000			0.0000			0.0000
Off-Road	0.1808	1.2188	1.8101	2.9700e-003		0.0609	0.0609		0.0609	0.0609		281.4481	281.4481	0.0159		281.8443
<b>Total</b>	<b>236.5923</b>	<b>1.2188</b>	<b>1.8101</b>	<b>2.9700e-003</b>		<b>0.0609</b>	<b>0.0609</b>		<b>0.0609</b>	<b>0.0609</b>		<b>281.4481</b>	<b>281.4481</b>	<b>0.0159</b>		<b>281.8443</b>

Village South Specific Plan (Proposed) - Los Angeles-South Coast County, Winter

**3.7 Architectural Coating - 2024**

**Unmitigated Construction Off-Site**

	ROG	NOx	CO	SO2	Fugitive PM10	Exhaust PM10	PM10 Total	Fugitive PM2.5	Exhaust PM2.5	PM2.5 Total	Bio- CO2	NBio- CO2	Total CO2	CH4	N2O	CO2e
Category	lb/day										lb/day					
Hauling	0.0000	0.0000	0.0000	0.0000	0.0000	0.0000	0.0000	0.0000	0.0000	0.0000		0.0000	0.0000	0.0000		0.0000
Vendor	0.0000	0.0000	0.0000	0.0000	0.0000	0.0000	0.0000	0.0000	0.0000	0.0000		0.0000	0.0000	0.0000		0.0000
Worker	0.6406	0.3886	4.6439	0.0155	1.7884	0.0134	1.8018	0.4743	0.0123	0.4866		1,545.2860	1,545.2860	0.0376		1,546.2262
<b>Total</b>	<b>0.6406</b>	<b>0.3886</b>	<b>4.6439</b>	<b>0.0155</b>	<b>1.7884</b>	<b>0.0134</b>	<b>1.8018</b>	<b>0.4743</b>	<b>0.0123</b>	<b>0.4866</b>		<b>1,545.2860</b>	<b>1,545.2860</b>	<b>0.0376</b>		<b>1,546.2262</b>

**Mitigated Construction On-Site**

	ROG	NOx	CO	SO2	Fugitive PM10	Exhaust PM10	PM10 Total	Fugitive PM2.5	Exhaust PM2.5	PM2.5 Total	Bio- CO2	NBio- CO2	Total CO2	CH4	N2O	CO2e
Category	lb/day										lb/day					
Archit. Coating	236.4115					0.0000	0.0000		0.0000	0.0000			0.0000			0.0000
Off-Road	0.1808	1.2188	1.8101	2.9700e-003		0.0609	0.0609		0.0609	0.0609	0.0000	281.4481	281.4481	0.0159		281.8443
<b>Total</b>	<b>236.5923</b>	<b>1.2188</b>	<b>1.8101</b>	<b>2.9700e-003</b>		<b>0.0609</b>	<b>0.0609</b>		<b>0.0609</b>	<b>0.0609</b>	<b>0.0000</b>	<b>281.4481</b>	<b>281.4481</b>	<b>0.0159</b>		<b>281.8443</b>

Village South Specific Plan (Proposed) - Los Angeles-South Coast County, Winter

**3.7 Architectural Coating - 2024**

**Mitigated Construction Off-Site**

	ROG	NOx	CO	SO2	Fugitive PM10	Exhaust PM10	PM10 Total	Fugitive PM2.5	Exhaust PM2.5	PM2.5 Total	Bio- CO2	NBio- CO2	Total CO2	CH4	N2O	CO2e
Category	lb/day										lb/day					
Hauling	0.0000	0.0000	0.0000	0.0000	0.0000	0.0000	0.0000	0.0000	0.0000	0.0000		0.0000	0.0000	0.0000		0.0000
Vendor	0.0000	0.0000	0.0000	0.0000	0.0000	0.0000	0.0000	0.0000	0.0000	0.0000		0.0000	0.0000	0.0000		0.0000
Worker	0.6406	0.3886	4.6439	0.0155	1.7884	0.0134	1.8018	0.4743	0.0123	0.4866		1,545.2860	1,545.2860	0.0376		1,546.2262
<b>Total</b>	<b>0.6406</b>	<b>0.3886</b>	<b>4.6439</b>	<b>0.0155</b>	<b>1.7884</b>	<b>0.0134</b>	<b>1.8018</b>	<b>0.4743</b>	<b>0.0123</b>	<b>0.4866</b>		<b>1,545.2860</b>	<b>1,545.2860</b>	<b>0.0376</b>		<b>1,546.2262</b>

**4.0 Operational Detail - Mobile**

---

**4.1 Mitigation Measures Mobile**

Village South Specific Plan (Proposed) - Los Angeles-South Coast County, Winter

	ROG	NOx	CO	SO2	Fugitive PM10	Exhaust PM10	PM10 Total	Fugitive PM2.5	Exhaust PM2.5	PM2.5 Total	Bio- CO2	NBio- CO2	Total CO2	CH4	N2O	CO2e
Category	lb/day										lb/day					
Mitigated	9.5233	45.9914	110.0422	0.4681	45.9592	0.3373	46.2965	12.2950	0.3132	12.6083		47,917.8005	47,917.8005	2.1953		47,972.6839
Unmitigated	9.5233	45.9914	110.0422	0.4681	45.9592	0.3373	46.2965	12.2950	0.3132	12.6083		47,917.8005	47,917.8005	2.1953		47,972.6839

4.2 Trip Summary Information

Land Use	Average Daily Trip Rate			Unmitigated	Mitigated
	Weekday	Saturday	Sunday	Annual VMT	Annual VMT
Apartments Low Rise	145.75	154.25	154.00	506,227	506,227
Apartments Mid Rise	4,026.75	3,773.25	4075.50	13,660,065	13,660,065
General Office Building	288.45	62.55	31.05	706,812	706,812
High Turnover (Sit Down Restaurant)	2,368.80	2,873.52	2817.72	3,413,937	3,413,937
Hotel	192.00	187.50	160.00	445,703	445,703
Quality Restaurant	501.12	511.92	461.20	707,488	707,488
Regional Shopping Center	528.08	601.44	357.84	1,112,221	1,112,221
<b>Total</b>	<b>8,050.95</b>	<b>8,164.43</b>	<b>8,057.31</b>	<b>20,552,452</b>	<b>20,552,452</b>

4.3 Trip Type Information

Village South Specific Plan (Proposed) - Los Angeles-South Coast County, Winter

Land Use	Miles			Trip %			Trip Purpose %		
	H-W or C-W	H-S or C-C	H-O or C-NW	H-W or C-W	H-S or C-C	H-O or C-NW	Primary	Diverted	Pass-by
Apartments Low Rise	14.70	5.90	8.70	40.20	19.20	40.60	86	11	3
Apartments Mid Rise	14.70	5.90	8.70	40.20	19.20	40.60	86	11	3
General Office Building	16.60	8.40	6.90	33.00	48.00	19.00	77	19	4
High Turnover (Sit Down Restaurant)	16.60	8.40	6.90	8.50	72.50	19.00	37	20	43
Hotel	16.60	8.40	6.90	19.40	61.60	19.00	58	38	4
Quality Restaurant	16.60	8.40	6.90	12.00	69.00	19.00	38	18	44
Regional Shopping Center	16.60	8.40	6.90	16.30	64.70	19.00	54	35	11

4.4 Fleet Mix

Land Use	LDA	LDT1	LDT2	MDV	LHD1	LHD2	MHD	HHD	OBUS	UBUS	MCY	SBUS	MH
Apartments Low Rise	0.543088	0.044216	0.209971	0.116369	0.014033	0.006332	0.021166	0.033577	0.002613	0.001817	0.005285	0.000712	0.000821
Apartments Mid Rise	0.543088	0.044216	0.209971	0.116369	0.014033	0.006332	0.021166	0.033577	0.002613	0.001817	0.005285	0.000712	0.000821
General Office Building	0.543088	0.044216	0.209971	0.116369	0.014033	0.006332	0.021166	0.033577	0.002613	0.001817	0.005285	0.000712	0.000821
High Turnover (Sit Down Restaurant)	0.543088	0.044216	0.209971	0.116369	0.014033	0.006332	0.021166	0.033577	0.002613	0.001817	0.005285	0.000712	0.000821
Hotel	0.543088	0.044216	0.209971	0.116369	0.014033	0.006332	0.021166	0.033577	0.002613	0.001817	0.005285	0.000712	0.000821
Quality Restaurant	0.543088	0.044216	0.209971	0.116369	0.014033	0.006332	0.021166	0.033577	0.002613	0.001817	0.005285	0.000712	0.000821
Regional Shopping Center	0.543088	0.044216	0.209971	0.116369	0.014033	0.006332	0.021166	0.033577	0.002613	0.001817	0.005285	0.000712	0.000821

5.0 Energy Detail

Historical Energy Use: N

5.1 Mitigation Measures Energy



Village South Specific Plan (Proposed) - Los Angeles-South Coast County, Winter

	ROG	NOx	CO	SO2	Fugitive PM10	Exhaust PM10	PM10 Total	Fugitive PM2.5	Exhaust PM2.5	PM2.5 Total	Bio- CO2	NBio- CO2	Total CO2	CH4	N2O	CO2e
Category	lb/day										lb/day					
NaturalGas Mitigated	0.7660	6.7462	4.2573	0.0418		0.5292	0.5292		0.5292	0.5292		8,355.983 2	8,355.983 2	0.1602	0.1532	8,405.638 7
NaturalGas Unmitigated	0.7660	6.7462	4.2573	0.0418		0.5292	0.5292		0.5292	0.5292		8,355.983 2	8,355.983 2	0.1602	0.1532	8,405.638 7

Village South Specific Plan (Proposed) - Los Angeles-South Coast County, Winter

**5.2 Energy by Land Use - NaturalGas**

**Unmitigated**

	NaturalGas Use	ROG	NOx	CO	SO2	Fugitive PM10	Exhaust PM10	PM10 Total	Fugitive PM2.5	Exhaust PM2.5	PM2.5 Total	Bio- CO2	NBio- CO2	Total CO2	CH4	N2O	CO2e
Land Use	kBTU/yr	lb/day										lb/day					
Apartments Low Rise	1119.16	0.0121	0.1031	0.0439	6.6000e-004		8.3400e-003	8.3400e-003		8.3400e-003	8.3400e-003		131.6662	131.6662	2.5200e-003	2.4100e-003	132.4486
Apartments Mid Rise	35784.3	0.3859	3.2978	1.4033	0.0211		0.2666	0.2666		0.2666	0.2666		4,209.9164	4,209.9164	0.0807	0.0772	4,234.9339
General Office Building	1283.42	0.0138	0.1258	0.1057	7.5000e-004		9.5600e-003	9.5600e-003		9.5600e-003	9.5600e-003		150.9911	150.9911	2.8900e-003	2.7700e-003	151.8884
High Turnover (Sit Down Restaurant)	22759.9	0.2455	2.2314	1.8743	0.0134		0.1696	0.1696		0.1696	0.1696		2,677.6342	2,677.6342	0.0513	0.0491	2,693.5460
Hotel	4769.72	0.0514	0.4676	0.3928	2.8100e-003		0.0355	0.0355		0.0355	0.0355		561.1436	561.1436	0.0108	0.0103	564.4782
Quality Restaurant	5057.75	0.0545	0.4959	0.4165	2.9800e-003		0.0377	0.0377		0.0377	0.0377		595.0298	595.0298	0.0114	0.0109	598.5658
Regional Shopping Center	251.616	2.7100e-003	0.0247	0.0207	1.5000e-004		1.8700e-003	1.8700e-003		1.8700e-003	1.8700e-003		29.6019	29.6019	5.7000e-004	5.4000e-004	29.7778
<b>Total</b>		<b>0.7660</b>	<b>6.7463</b>	<b>4.2573</b>	<b>0.0418</b>		<b>0.5292</b>	<b>0.5292</b>		<b>0.5292</b>	<b>0.5292</b>		<b>8,355.9832</b>	<b>8,355.9832</b>	<b>0.1602</b>	<b>0.1532</b>	<b>8,405.6387</b>

Village South Specific Plan (Proposed) - Los Angeles-South Coast County, Winter

**5.2 Energy by Land Use - NaturalGas**

**Mitigated**

	NaturalGas Use	ROG	NOx	CO	SO2	Fugitive PM10	Exhaust PM10	PM10 Total	Fugitive PM2.5	Exhaust PM2.5	PM2.5 Total	Bio- CO2	NBio- CO2	Total CO2	CH4	N2O	CO2e
Land Use	kBTU/yr	lb/day										lb/day					
Apartments Low Rise	1.11916	0.0121	0.1031	0.0439	6.6000e-004		8.3400e-003	8.3400e-003		8.3400e-003	8.3400e-003		131.6662	131.6662	2.5200e-003	2.4100e-003	132.4486
Apartments Mid Rise	35.7843	0.3859	3.2978	1.4033	0.0211		0.2666	0.2666		0.2666	0.2666		4,209.9164	4,209.9164	0.0807	0.0772	4,234.9339
General Office Building	1.28342	0.0138	0.1258	0.1057	7.5000e-004		9.5600e-003	9.5600e-003		9.5600e-003	9.5600e-003		150.9911	150.9911	2.8900e-003	2.7700e-003	151.8884
High Turnover (Sit Down Restaurant)	22.7599	0.2455	2.2314	1.8743	0.0134		0.1696	0.1696		0.1696	0.1696		2,677.6342	2,677.6342	0.0513	0.0491	2,693.5460
Hotel	4.76972	0.0514	0.4676	0.3928	2.8100e-003		0.0355	0.0355		0.0355	0.0355		561.1436	561.1436	0.0108	0.0103	564.4782
Quality Restaurant	5.05775	0.0545	0.4959	0.4165	2.9800e-003		0.0377	0.0377		0.0377	0.0377		595.0298	595.0298	0.0114	0.0109	598.5658
Regional Shopping Center	0.251616	2.7100e-003	0.0247	0.0207	1.5000e-004		1.8700e-003	1.8700e-003		1.8700e-003	1.8700e-003		29.6019	29.6019	5.7000e-004	5.4000e-004	29.7778
<b>Total</b>		<b>0.7660</b>	<b>6.7463</b>	<b>4.2573</b>	<b>0.0418</b>		<b>0.5292</b>	<b>0.5292</b>		<b>0.5292</b>	<b>0.5292</b>		<b>8,355.9832</b>	<b>8,355.9832</b>	<b>0.1602</b>	<b>0.1532</b>	<b>8,405.6387</b>

**6.0 Area Detail**

**6.1 Mitigation Measures Area**

Village South Specific Plan (Proposed) - Los Angeles-South Coast County, Winter

	ROG	NOx	CO	SO2	Fugitive PM10	Exhaust PM10	PM10 Total	Fugitive PM2.5	Exhaust PM2.5	PM2.5 Total	Bio- CO2	NBio- CO2	Total CO2	CH4	N2O	CO2e
Category	lb/day										lb/day					
Mitigated	30.5020	15.0496	88.4430	0.0944		1.5974	1.5974		1.5974	1.5974	0.0000	18,148.5950	18,148.5950	0.4874	0.3300	18,259.1192
Unmitigated	30.5020	15.0496	88.4430	0.0944		1.5974	1.5974		1.5974	1.5974	0.0000	18,148.5950	18,148.5950	0.4874	0.3300	18,259.1192

6.2 Area by SubCategory

Unmitigated

	ROG	NOx	CO	SO2	Fugitive PM10	Exhaust PM10	PM10 Total	Fugitive PM2.5	Exhaust PM2.5	PM2.5 Total	Bio- CO2	NBio- CO2	Total CO2	CH4	N2O	CO2e
SubCategory	lb/day										lb/day					
Architectural Coating	2.2670					0.0000	0.0000		0.0000	0.0000			0.0000			0.0000
Consumer Products	24.1085					0.0000	0.0000		0.0000	0.0000			0.0000			0.0000
Hearth	1.6500	14.1000	6.0000	0.0900		1.1400	1.1400		1.1400	1.1400	0.0000	18,000.0000	18,000.0000	0.3450	0.3300	18,106.9650
Landscaping	2.4766	0.9496	82.4430	4.3600e-003		0.4574	0.4574		0.4574	0.4574		148.5950	148.5950	0.1424		152.1542
<b>Total</b>	<b>30.5020</b>	<b>15.0496</b>	<b>88.4430</b>	<b>0.0944</b>		<b>1.5974</b>	<b>1.5974</b>		<b>1.5974</b>	<b>1.5974</b>	<b>0.0000</b>	<b>18,148.5950</b>	<b>18,148.5950</b>	<b>0.4874</b>	<b>0.3300</b>	<b>18,259.1192</b>

Village South Specific Plan (Proposed) - Los Angeles-South Coast County, Winter

**6.2 Area by SubCategory**

**Mitigated**

	ROG	NOx	CO	SO2	Fugitive PM10	Exhaust PM10	PM10 Total	Fugitive PM2.5	Exhaust PM2.5	PM2.5 Total	Bio- CO2	NBio- CO2	Total CO2	CH4	N2O	CO2e
SubCategory	lb/day										lb/day					
Architectural Coating	2.2670					0.0000	0.0000		0.0000	0.0000			0.0000			0.0000
Consumer Products	24.1085					0.0000	0.0000		0.0000	0.0000			0.0000			0.0000
Hearth	1.6500	14.1000	6.0000	0.0900		1.1400	1.1400		1.1400	1.1400	0.0000	18,000.0000	18,000.0000	0.3450	0.3300	18,106.9650
Landscaping	2.4766	0.9496	82.4430	4.3600e-003		0.4574	0.4574		0.4574	0.4574		148.5950	148.5950	0.1424		152.1542
<b>Total</b>	<b>30.5020</b>	<b>15.0496</b>	<b>88.4430</b>	<b>0.0944</b>		<b>1.5974</b>	<b>1.5974</b>		<b>1.5974</b>	<b>1.5974</b>	<b>0.0000</b>	<b>18,148.5950</b>	<b>18,148.5950</b>	<b>0.4874</b>	<b>0.3300</b>	<b>18,259.1192</b>

**7.0 Water Detail**

**7.1 Mitigation Measures Water**

**8.0 Waste Detail**

**8.1 Mitigation Measures Waste**

**9.0 Operational Offroad**

Equipment Type	Number	Hours/Day	Days/Year	Horse Power	Load Factor	Fuel Type
----------------	--------	-----------	-----------	-------------	-------------	-----------

**10.0 Stationary Equipment**

Village South Specific Plan (Proposed) - Los Angeles-South Coast County, Winter

**Fire Pumps and Emergency Generators**

Equipment Type	Number	Hours/Day	Hours/Year	Horse Power	Load Factor	Fuel Type
----------------	--------	-----------	------------	-------------	-------------	-----------

**Boilers**

Equipment Type	Number	Heat Input/Day	Heat Input/Year	Boiler Rating	Fuel Type
----------------	--------	----------------	-----------------	---------------	-----------

**User Defined Equipment**

Equipment Type	Number
----------------	--------

**11.0 Vegetation**

---

Village South Specific Plan (Proposed) - Los Angeles-South Coast County, Annual

**Village South Specific Plan (Proposed)**  
**Los Angeles-South Coast County, Annual**

**1.0 Project Characteristics**

**1.1 Land Usage**

Land Uses	Size	Metric	Lot Acreage	Floor Surface Area	Population
General Office Building	45.00	1000sqft	1.03	45,000.00	0
High Turnover (Sit Down Restaurant)	36.00	1000sqft	0.83	36,000.00	0
Hotel	50.00	Room	1.67	72,600.00	0
Quality Restaurant	8.00	1000sqft	0.18	8,000.00	0
Apartments Low Rise	25.00	Dwelling Unit	1.56	25,000.00	72
Apartments Mid Rise	975.00	Dwelling Unit	25.66	975,000.00	2789
Regional Shopping Center	56.00	1000sqft	1.29	56,000.00	0

**1.2 Other Project Characteristics**

<b>Urbanization</b>	Urban	<b>Wind Speed (m/s)</b>	2.2	<b>Precipitation Freq (Days)</b>	33
<b>Climate Zone</b>	9			<b>Operational Year</b>	2028
<b>Utility Company</b>	Southern California Edison				
<b>CO2 Intensity (lb/MW hr)</b>	702.44	<b>CH4 Intensity (lb/MW hr)</b>	0.029	<b>N2O Intensity (lb/MW hr)</b>	0.006

**1.3 User Entered Comments & Non-Default Data**

## Village South Specific Plan (Proposed) - Los Angeles-South Coast County, Annual

Project Characteristics - Consistent with the DEIR's model.

Land Use - See SWAPE comment regarding residential and retail land uses.

Construction Phase - See SWAPE comment regarding individual construction phase lengths.

Demolition - Consistent with the DEIR's model. See SWAPE comment regarding demolition.

Vehicle Trips - Saturday trips consistent with the DEIR's model. See SWAPE comment regarding weekday and Sunday trips.

Woodstoves - Woodstoves and wood-burning fireplaces consistent with the DEIR's model. See SWAPE comment regarding gas fireplaces.

Energy Use -

Construction Off-road Equipment Mitigation - See SWAPE comment on construction-related mitigation.

Area Mitigation - See SWAPE comment regarding operational mitigation measures.

Water Mitigation - See SWAPE comment regarding operational mitigation measures.

Trips and VMT - Local hire provision

Table Name	Column Name	Default Value	New Value
tblFireplaces	FireplaceWoodMass	1,019.20	0.00
tblFireplaces	FireplaceWoodMass	1,019.20	0.00
tblFireplaces	NumberWood	1.25	0.00
tblFireplaces	NumberWood	48.75	0.00
tblTripsAndVMT	WorkerTripLength	14.70	10.00
tblTripsAndVMT	WorkerTripLength	14.70	10.00
tblTripsAndVMT	WorkerTripLength	14.70	10.00
tblTripsAndVMT	WorkerTripLength	14.70	10.00
tblTripsAndVMT	WorkerTripLength	14.70	10.00
tblTripsAndVMT	WorkerTripLength	14.70	10.00
tblVehicleTrips	ST_TR	7.16	6.17
tblVehicleTrips	ST_TR	6.39	3.87
tblVehicleTrips	ST_TR	2.46	1.39
tblVehicleTrips	ST_TR	158.37	79.82



Village South Specific Plan (Proposed) - Los Angeles-South Coast County, Annual

tblVehicleTrips	ST_TR	8.19	3.75
tblVehicleTrips	ST_TR	94.36	63.99
tblVehicleTrips	ST_TR	49.97	10.74
tblVehicleTrips	SU_TR	6.07	6.16
tblVehicleTrips	SU_TR	5.86	4.18
tblVehicleTrips	SU_TR	1.05	0.69
tblVehicleTrips	SU_TR	131.84	78.27
tblVehicleTrips	SU_TR	5.95	3.20
tblVehicleTrips	SU_TR	72.16	57.65
tblVehicleTrips	SU_TR	25.24	6.39
tblVehicleTrips	WD_TR	6.59	5.83
tblVehicleTrips	WD_TR	6.65	4.13
tblVehicleTrips	WD_TR	11.03	6.41
tblVehicleTrips	WD_TR	127.15	65.80
tblVehicleTrips	WD_TR	8.17	3.84
tblVehicleTrips	WD_TR	89.95	62.64
tblVehicleTrips	WD_TR	42.70	9.43
tblWoodstoves	NumberCatalytic	1.25	0.00
tblWoodstoves	NumberCatalytic	48.75	0.00
tblWoodstoves	NumberNoncatalytic	1.25	0.00
tblWoodstoves	NumberNoncatalytic	48.75	0.00
tblWoodstoves	WoodstoveDayYear	25.00	0.00
tblWoodstoves	WoodstoveDayYear	25.00	0.00
tblWoodstoves	WoodstoveWoodMass	999.60	0.00
tblWoodstoves	WoodstoveWoodMass	999.60	0.00

**2.0 Emissions Summary**

Village South Specific Plan (Proposed) - Los Angeles-South Coast County, Annual

**2.1 Overall Construction**

**Unmitigated Construction**

	ROG	NOx	CO	SO2	Fugitive PM10	Exhaust PM10	PM10 Total	Fugitive PM2.5	Exhaust PM2.5	PM2.5 Total	Bio- CO2	NBio- CO2	Total CO2	CH4	N2O	CO2e
Year	tons/yr										MT/yr					
2021	0.1704	1.8234	1.1577	2.3800e-003	0.4141	0.0817	0.4958	0.1788	0.0754	0.2542	0.0000	210.7654	210.7654	0.0600	0.0000	212.2661
2022	0.5865	4.0240	5.1546	0.0155	0.9509	0.1175	1.0683	0.2518	0.1103	0.3621	0.0000	1,418.6554	1,418.6554	0.1215	0.0000	1,421.6925
2023	0.5190	3.2850	4.7678	0.0147	0.8497	0.0971	0.9468	0.2283	0.0912	0.3195	0.0000	1,342.4412	1,342.4412	0.1115	0.0000	1,345.2291
2024	4.1592	0.1313	0.2557	5.0000e-004	0.0221	6.3900e-003	0.0285	5.8700e-003	5.9700e-003	0.0118	0.0000	44.6355	44.6355	7.8300e-003	0.0000	44.8311
<b>Maximum</b>	<b>4.1592</b>	<b>4.0240</b>	<b>5.1546</b>	<b>0.0155</b>	<b>0.9509</b>	<b>0.1175</b>	<b>1.0683</b>	<b>0.2518</b>	<b>0.1103</b>	<b>0.3621</b>	<b>0.0000</b>	<b>1,418.6554</b>	<b>1,418.6554</b>	<b>0.1215</b>	<b>0.0000</b>	<b>1,421.6925</b>

Village South Specific Plan (Proposed) - Los Angeles-South Coast County, Annual

**2.1 Overall Construction**

**Mitigated Construction**

	ROG	NOx	CO	SO2	Fugitive PM10	Exhaust PM10	PM10 Total	Fugitive PM2.5	Exhaust PM2.5	PM2.5 Total	Bio- CO2	NBio- CO2	Total CO2	CH4	N2O	CO2e
Year	tons/yr										MT/yr					
2021	0.1704	1.8234	1.1577	2.3800e-003	0.4141	0.0817	0.4958	0.1788	0.0754	0.2542	0.0000	210.7651	210.7651	0.0600	0.0000	212.2658
2022	0.5865	4.0240	5.1546	0.0155	0.9509	0.1175	1.0683	0.2518	0.1103	0.3621	0.0000	1,418.6550	1,418.6550	0.1215	0.0000	1,421.6921
2023	0.5190	3.2850	4.7678	0.0147	0.8497	0.0971	0.9468	0.2283	0.0912	0.3195	0.0000	1,342.4409	1,342.4409	0.1115	0.0000	1,345.2287
2024	4.1592	0.1313	0.2557	5.0000e-004	0.0221	6.3900e-003	0.0285	5.8700e-003	5.9700e-003	0.0118	0.0000	44.6354	44.6354	7.8300e-003	0.0000	44.8311
<b>Maximum</b>	<b>4.1592</b>	<b>4.0240</b>	<b>5.1546</b>	<b>0.0155</b>	<b>0.9509</b>	<b>0.1175</b>	<b>1.0683</b>	<b>0.2518</b>	<b>0.1103</b>	<b>0.3621</b>	<b>0.0000</b>	<b>1,418.6550</b>	<b>1,418.6550</b>	<b>0.1215</b>	<b>0.0000</b>	<b>1,421.6921</b>

	ROG	NOx	CO	SO2	Fugitive PM10	Exhaust PM10	PM10 Total	Fugitive PM2.5	Exhaust PM2.5	PM2.5 Total	Bio- CO2	NBio- CO2	Total CO2	CH4	N2O	CO2e
<b>Percent Reduction</b>	<b>0.00</b>	<b>0.00</b>	<b>0.00</b>	<b>0.00</b>	<b>0.00</b>	<b>0.00</b>	<b>0.00</b>	<b>0.00</b>	<b>0.00</b>	<b>0.00</b>	<b>0.00</b>	<b>0.00</b>	<b>0.00</b>	<b>0.00</b>	<b>0.00</b>	<b>0.00</b>

Quarter	Start Date	End Date	Maximum Unmitigated ROG + NOX (tons/quarter)	Maximum Mitigated ROG + NOX (tons/quarter)
1	9-1-2021	11-30-2021	1.4091	1.4091
2	12-1-2021	2-28-2022	1.3329	1.3329
3	3-1-2022	5-31-2022	1.1499	1.1499
4	6-1-2022	8-31-2022	1.1457	1.1457
5	9-1-2022	11-30-2022	1.1415	1.1415
6	12-1-2022	2-28-2023	1.0278	1.0278
7	3-1-2023	5-31-2023	0.9868	0.9868
8	6-1-2023	8-31-2023	0.9831	0.9831

Village South Specific Plan (Proposed) - Los Angeles-South Coast County, Annual

9	9-1-2023	11-30-2023	0.9798	0.9798
10	12-1-2023	2-29-2024	2.8757	2.8757
11	3-1-2024	5-31-2024	1.6188	1.6188
		Highest	2.8757	2.8757

**2.2 Overall Operational**  
**Unmitigated Operational**

	ROG	NOx	CO	SO2	Fugitive PM10	Exhaust PM10	PM10 Total	Fugitive PM2.5	Exhaust PM2.5	PM2.5 Total	Bio- CO2	NBio- CO2	Total CO2	CH4	N2O	CO2e
Category	tons/yr										MT/yr					
Area	5.1437	0.2950	10.3804	1.6700e-003		0.0714	0.0714		0.0714	0.0714	0.0000	220.9670	220.9670	0.0201	3.7400e-003	222.5835
Energy	0.1398	1.2312	0.7770	7.6200e-003		0.0966	0.0966		0.0966	0.0966	0.0000	3,896.0732	3,896.0732	0.1303	0.0468	3,913.2833
Mobile	1.5857	7.9962	19.1834	0.0821	7.7979	0.0580	7.8559	2.0895	0.0539	2.1434	0.0000	7,620.4986	7,620.4986	0.3407	0.0000	7,629.0162
Waste						0.0000	0.0000		0.0000	0.0000	207.8079	0.0000	207.8079	12.2811	0.0000	514.8354
Water						0.0000	0.0000		0.0000	0.0000	29.1632	556.6420	585.8052	3.0183	0.0755	683.7567
<b>Total</b>	<b>6.8692</b>	<b>9.5223</b>	<b>30.3407</b>	<b>0.0914</b>	<b>7.7979</b>	<b>0.2260</b>	<b>8.0240</b>	<b>2.0895</b>	<b>0.2219</b>	<b>2.3114</b>	<b>236.9712</b>	<b>12,294.1807</b>	<b>12,531.1519</b>	<b>15.7904</b>	<b>0.1260</b>	<b>12,963.4751</b>

Village South Specific Plan (Proposed) - Los Angeles-South Coast County, Annual

**2.2 Overall Operational**

**Mitigated Operational**

	ROG	NOx	CO	SO2	Fugitive PM10	Exhaust PM10	PM10 Total	Fugitive PM2.5	Exhaust PM2.5	PM2.5 Total	Bio- CO2	NBio- CO2	Total CO2	CH4	N2O	CO2e
Category	tons/yr										MT/yr					
Area	5.1437	0.2950	10.3804	1.6700e-003		0.0714	0.0714		0.0714	0.0714	0.0000	220.9670	220.9670	0.0201	3.7400e-003	222.5835
Energy	0.1398	1.2312	0.7770	7.6200e-003		0.0966	0.0966		0.0966	0.0966	0.0000	3,896.0732	3,896.0732	0.1303	0.0468	3,913.2833
Mobile	1.5857	7.9962	19.1834	0.0821	7.7979	0.0580	7.8559	2.0895	0.0539	2.1434	0.0000	7,620.4986	7,620.4986	0.3407	0.0000	7,629.0162
Waste						0.0000	0.0000		0.0000	0.0000	207.8079	0.0000	207.8079	12.2811	0.0000	514.8354
Water						0.0000	0.0000		0.0000	0.0000	29.1632	556.6420	585.8052	3.0183	0.0755	683.7567
<b>Total</b>	<b>6.8692</b>	<b>9.5223</b>	<b>30.3407</b>	<b>0.0914</b>	<b>7.7979</b>	<b>0.2260</b>	<b>8.0240</b>	<b>2.0895</b>	<b>0.2219</b>	<b>2.3114</b>	<b>236.9712</b>	<b>12,294.1807</b>	<b>12,531.1519</b>	<b>15.7904</b>	<b>0.1260</b>	<b>12,963.4751</b>

	ROG	NOx	CO	SO2	Fugitive PM10	Exhaust PM10	PM10 Total	Fugitive PM2.5	Exhaust PM2.5	PM2.5 Total	Bio- CO2	NBio- CO2	Total CO2	CH4	N2O	CO2e
Percent Reduction	0.00	0.00	0.00	0.00	0.00	0.00	0.00	0.00	0.00	0.00	0.00	0.00	0.00	0.00	0.00	0.00

**3.0 Construction Detail**

**Construction Phase**

Village South Specific Plan (Proposed) - Los Angeles-South Coast County, Annual

Phase Number	Phase Name	Phase Type	Start Date	End Date	Num Days Week	Num Days	Phase Description
1	Demolition	Demolition	9/1/2021	10/12/2021	5	30	
2	Site Preparation	Site Preparation	10/13/2021	11/9/2021	5	20	
3	Grading	Grading	11/10/2021	1/11/2022	5	45	
4	Building Construction	Building Construction	1/12/2022	12/12/2023	5	500	
5	Paving	Paving	12/13/2023	1/30/2024	5	35	
6	Architectural Coating	Architectural Coating	1/31/2024	3/19/2024	5	35	

**Acres of Grading (Site Preparation Phase): 0**

**Acres of Grading (Grading Phase): 112.5**

**Acres of Paving: 0**

**Residential Indoor: 2,025,000; Residential Outdoor: 675,000; Non-Residential Indoor: 326,400; Non-Residential Outdoor: 108,800; Striped Parking Area: 0 (Architectural Coating – sqft)**

**OffRoad Equipment**

Village South Specific Plan (Proposed) - Los Angeles-South Coast County, Annual

Phase Name	Offroad Equipment Type	Amount	Usage Hours	Horse Power	Load Factor
Demolition	Concrete/Industrial Saws	1	8.00	81	0.73
Demolition	Excavators	3	8.00	158	0.38
Demolition	Rubber Tired Dozers	2	8.00	247	0.40
Site Preparation	Rubber Tired Dozers	3	8.00	247	0.40
Site Preparation	Tractors/Loaders/Backhoes	4	8.00	97	0.37
Grading	Excavators	2	8.00	158	0.38
Grading	Graders	1	8.00	187	0.41
Grading	Rubber Tired Dozers	1	8.00	247	0.40
Grading	Scrapers	2	8.00	367	0.48
Grading	Tractors/Loaders/Backhoes	2	8.00	97	0.37
Building Construction	Cranes	1	7.00	231	0.29
Building Construction	Forklifts	3	8.00	89	0.20
Building Construction	Generator Sets	1	8.00	84	0.74
Building Construction	Tractors/Loaders/Backhoes	3	7.00	97	0.37
Building Construction	Welders	1	8.00	46	0.45
Paving	Pavers	2	8.00	130	0.42
Paving	Paving Equipment	2	8.00	132	0.36
Paving	Rollers	2	8.00	80	0.38
Architectural Coating	Air Compressors	1	6.00	78	0.48

**Trips and VMT**

Village South Specific Plan (Proposed) - Los Angeles-South Coast County, Annual

Phase Name	Offroad Equipment Count	Worker Trip Number	Vendor Trip Number	Hauling Trip Number	Worker Trip Length	Vendor Trip Length	Hauling Trip Length	Worker Vehicle Class	Vendor Vehicle Class	Hauling Vehicle Class
Demolition	6	15.00	0.00	458.00	10.00	6.90	20.00	LD_Mix	HDT_Mix	HHDT
Site Preparation	7	18.00	0.00	0.00	10.00	6.90	20.00	LD_Mix	HDT_Mix	HHDT
Grading	8	20.00	0.00	0.00	10.00	6.90	20.00	LD_Mix	HDT_Mix	HHDT
Building Construction	9	801.00	143.00	0.00	10.00	6.90	20.00	LD_Mix	HDT_Mix	HHDT
Paving	6	15.00	0.00	0.00	10.00	6.90	20.00	LD_Mix	HDT_Mix	HHDT
Architectural Coating	1	160.00	0.00	0.00	10.00	6.90	20.00	LD_Mix	HDT_Mix	HHDT

**3.1 Mitigation Measures Construction**

**3.2 Demolition - 2021**

**Unmitigated Construction On-Site**

	ROG	NOx	CO	SO2	Fugitive PM10	Exhaust PM10	PM10 Total	Fugitive PM2.5	Exhaust PM2.5	PM2.5 Total	Bio- CO2	NBio- CO2	Total CO2	CH4	N2O	CO2e
Category	tons/yr										MT/yr					
Fugitive Dust					0.0496	0.0000	0.0496	7.5100e-003	0.0000	7.5100e-003	0.0000	0.0000	0.0000	0.0000	0.0000	0.0000
Off-Road	0.0475	0.4716	0.3235	5.8000e-004		0.0233	0.0233		0.0216	0.0216	0.0000	51.0012	51.0012	0.0144	0.0000	51.3601
<b>Total</b>	<b>0.0475</b>	<b>0.4716</b>	<b>0.3235</b>	<b>5.8000e-004</b>	<b>0.0496</b>	<b>0.0233</b>	<b>0.0729</b>	<b>7.5100e-003</b>	<b>0.0216</b>	<b>0.0291</b>	<b>0.0000</b>	<b>51.0012</b>	<b>51.0012</b>	<b>0.0144</b>	<b>0.0000</b>	<b>51.3601</b>



Village South Specific Plan (Proposed) - Los Angeles-South Coast County, Annual

**3.2 Demolition - 2021**

**Unmitigated Construction Off-Site**

	ROG	NOx	CO	SO2	Fugitive PM10	Exhaust PM10	PM10 Total	Fugitive PM2.5	Exhaust PM2.5	PM2.5 Total	Bio- CO2	NBio- CO2	Total CO2	CH4	N2O	CO2e
Category	tons/yr										MT/yr					
Hauling	1.9300e-003	0.0634	0.0148	1.8000e-004	3.9400e-003	1.9000e-004	4.1300e-003	1.0800e-003	1.8000e-004	1.2600e-003	0.0000	17.4566	17.4566	1.2100e-003	0.0000	17.4869
Vendor	0.0000	0.0000	0.0000	0.0000	0.0000	0.0000	0.0000	0.0000	0.0000	0.0000	0.0000	0.0000	0.0000	0.0000	0.0000	0.0000
Worker	7.2000e-004	5.3000e-004	6.0900e-003	2.0000e-005	1.6800e-003	1.0000e-005	1.6900e-003	4.5000e-004	1.0000e-005	4.6000e-004	0.0000	1.5281	1.5281	5.0000e-005	0.0000	1.5293
<b>Total</b>	<b>2.6500e-003</b>	<b>0.0639</b>	<b>0.0209</b>	<b>2.0000e-004</b>	<b>5.6200e-003</b>	<b>2.0000e-004</b>	<b>5.8200e-003</b>	<b>1.5300e-003</b>	<b>1.9000e-004</b>	<b>1.7200e-003</b>	<b>0.0000</b>	<b>18.9847</b>	<b>18.9847</b>	<b>1.2600e-003</b>	<b>0.0000</b>	<b>19.0161</b>

**Mitigated Construction On-Site**

	ROG	NOx	CO	SO2	Fugitive PM10	Exhaust PM10	PM10 Total	Fugitive PM2.5	Exhaust PM2.5	PM2.5 Total	Bio- CO2	NBio- CO2	Total CO2	CH4	N2O	CO2e
Category	tons/yr										MT/yr					
Fugitive Dust					0.0496	0.0000	0.0496	7.5100e-003	0.0000	7.5100e-003	0.0000	0.0000	0.0000	0.0000	0.0000	0.0000
Off-Road	0.0475	0.4716	0.3235	5.8000e-004		0.0233	0.0233		0.0216	0.0216	0.0000	51.0011	51.0011	0.0144	0.0000	51.3600
<b>Total</b>	<b>0.0475</b>	<b>0.4716</b>	<b>0.3235</b>	<b>5.8000e-004</b>	<b>0.0496</b>	<b>0.0233</b>	<b>0.0729</b>	<b>7.5100e-003</b>	<b>0.0216</b>	<b>0.0291</b>	<b>0.0000</b>	<b>51.0011</b>	<b>51.0011</b>	<b>0.0144</b>	<b>0.0000</b>	<b>51.3600</b>

Village South Specific Plan (Proposed) - Los Angeles-South Coast County, Annual

**3.2 Demolition - 2021**

**Mitigated Construction Off-Site**

	ROG	NOx	CO	SO2	Fugitive PM10	Exhaust PM10	PM10 Total	Fugitive PM2.5	Exhaust PM2.5	PM2.5 Total	Bio- CO2	NBio- CO2	Total CO2	CH4	N2O	CO2e
Category	tons/yr										MT/yr					
Hauling	1.9300e-003	0.0634	0.0148	1.8000e-004	3.9400e-003	1.9000e-004	4.1300e-003	1.0800e-003	1.8000e-004	1.2600e-003	0.0000	17.4566	17.4566	1.2100e-003	0.0000	17.4869
Vendor	0.0000	0.0000	0.0000	0.0000	0.0000	0.0000	0.0000	0.0000	0.0000	0.0000	0.0000	0.0000	0.0000	0.0000	0.0000	0.0000
Worker	7.2000e-004	5.3000e-004	6.0900e-003	2.0000e-005	1.6800e-003	1.0000e-005	1.6900e-003	4.5000e-004	1.0000e-005	4.6000e-004	0.0000	1.5281	1.5281	5.0000e-005	0.0000	1.5293
<b>Total</b>	<b>2.6500e-003</b>	<b>0.0639</b>	<b>0.0209</b>	<b>2.0000e-004</b>	<b>5.6200e-003</b>	<b>2.0000e-004</b>	<b>5.8200e-003</b>	<b>1.5300e-003</b>	<b>1.9000e-004</b>	<b>1.7200e-003</b>	<b>0.0000</b>	<b>18.9847</b>	<b>18.9847</b>	<b>1.2600e-003</b>	<b>0.0000</b>	<b>19.0161</b>

**3.3 Site Preparation - 2021**

**Unmitigated Construction On-Site**

	ROG	NOx	CO	SO2	Fugitive PM10	Exhaust PM10	PM10 Total	Fugitive PM2.5	Exhaust PM2.5	PM2.5 Total	Bio- CO2	NBio- CO2	Total CO2	CH4	N2O	CO2e
Category	tons/yr										MT/yr					
Fugitive Dust					0.1807	0.0000	0.1807	0.0993	0.0000	0.0993	0.0000	0.0000	0.0000	0.0000	0.0000	0.0000
Off-Road	0.0389	0.4050	0.2115	3.8000e-004		0.0204	0.0204		0.0188	0.0188	0.0000	33.4357	33.4357	0.0108	0.0000	33.7061
<b>Total</b>	<b>0.0389</b>	<b>0.4050</b>	<b>0.2115</b>	<b>3.8000e-004</b>	<b>0.1807</b>	<b>0.0204</b>	<b>0.2011</b>	<b>0.0993</b>	<b>0.0188</b>	<b>0.1181</b>	<b>0.0000</b>	<b>33.4357</b>	<b>33.4357</b>	<b>0.0108</b>	<b>0.0000</b>	<b>33.7061</b>

Village South Specific Plan (Proposed) - Los Angeles-South Coast County, Annual

**3.3 Site Preparation - 2021**

**Unmitigated Construction Off-Site**

	ROG	NOx	CO	SO2	Fugitive PM10	Exhaust PM10	PM10 Total	Fugitive PM2.5	Exhaust PM2.5	PM2.5 Total	Bio- CO2	NBio- CO2	Total CO2	CH4	N2O	CO2e
Category	tons/yr										MT/yr					
Hauling	0.0000	0.0000	0.0000	0.0000	0.0000	0.0000	0.0000	0.0000	0.0000	0.0000	0.0000	0.0000	0.0000	0.0000	0.0000	0.0000
Vendor	0.0000	0.0000	0.0000	0.0000	0.0000	0.0000	0.0000	0.0000	0.0000	0.0000	0.0000	0.0000	0.0000	0.0000	0.0000	0.0000
Worker	5.8000e-004	4.3000e-004	4.8700e-003	1.0000e-005	1.3400e-003	1.0000e-005	1.3500e-003	3.6000e-004	1.0000e-005	3.7000e-004	0.0000	1.2225	1.2225	4.0000e-005	0.0000	1.2234
<b>Total</b>	<b>5.8000e-004</b>	<b>4.3000e-004</b>	<b>4.8700e-003</b>	<b>1.0000e-005</b>	<b>1.3400e-003</b>	<b>1.0000e-005</b>	<b>1.3500e-003</b>	<b>3.6000e-004</b>	<b>1.0000e-005</b>	<b>3.7000e-004</b>	<b>0.0000</b>	<b>1.2225</b>	<b>1.2225</b>	<b>4.0000e-005</b>	<b>0.0000</b>	<b>1.2234</b>

**Mitigated Construction On-Site**

	ROG	NOx	CO	SO2	Fugitive PM10	Exhaust PM10	PM10 Total	Fugitive PM2.5	Exhaust PM2.5	PM2.5 Total	Bio- CO2	NBio- CO2	Total CO2	CH4	N2O	CO2e
Category	tons/yr										MT/yr					
Fugitive Dust					0.1807	0.0000	0.1807	0.0993	0.0000	0.0993	0.0000	0.0000	0.0000	0.0000	0.0000	0.0000
Off-Road	0.0389	0.4050	0.2115	3.8000e-004		0.0204	0.0204		0.0188	0.0188	0.0000	33.4357	33.4357	0.0108	0.0000	33.7060
<b>Total</b>	<b>0.0389</b>	<b>0.4050</b>	<b>0.2115</b>	<b>3.8000e-004</b>	<b>0.1807</b>	<b>0.0204</b>	<b>0.2011</b>	<b>0.0993</b>	<b>0.0188</b>	<b>0.1181</b>	<b>0.0000</b>	<b>33.4357</b>	<b>33.4357</b>	<b>0.0108</b>	<b>0.0000</b>	<b>33.7060</b>

Village South Specific Plan (Proposed) - Los Angeles-South Coast County, Annual

**3.3 Site Preparation - 2021**

**Mitigated Construction Off-Site**

	ROG	NOx	CO	SO2	Fugitive PM10	Exhaust PM10	PM10 Total	Fugitive PM2.5	Exhaust PM2.5	PM2.5 Total	Bio- CO2	NBio- CO2	Total CO2	CH4	N2O	CO2e
Category	tons/yr										MT/yr					
Hauling	0.0000	0.0000	0.0000	0.0000	0.0000	0.0000	0.0000	0.0000	0.0000	0.0000	0.0000	0.0000	0.0000	0.0000	0.0000	0.0000
Vendor	0.0000	0.0000	0.0000	0.0000	0.0000	0.0000	0.0000	0.0000	0.0000	0.0000	0.0000	0.0000	0.0000	0.0000	0.0000	0.0000
Worker	5.8000e-004	4.3000e-004	4.8700e-003	1.0000e-005	1.3400e-003	1.0000e-005	1.3500e-003	3.6000e-004	1.0000e-005	3.7000e-004	0.0000	1.2225	1.2225	4.0000e-005	0.0000	1.2234
<b>Total</b>	<b>5.8000e-004</b>	<b>4.3000e-004</b>	<b>4.8700e-003</b>	<b>1.0000e-005</b>	<b>1.3400e-003</b>	<b>1.0000e-005</b>	<b>1.3500e-003</b>	<b>3.6000e-004</b>	<b>1.0000e-005</b>	<b>3.7000e-004</b>	<b>0.0000</b>	<b>1.2225</b>	<b>1.2225</b>	<b>4.0000e-005</b>	<b>0.0000</b>	<b>1.2234</b>

**3.4 Grading - 2021**

**Unmitigated Construction On-Site**

	ROG	NOx	CO	SO2	Fugitive PM10	Exhaust PM10	PM10 Total	Fugitive PM2.5	Exhaust PM2.5	PM2.5 Total	Bio- CO2	NBio- CO2	Total CO2	CH4	N2O	CO2e
Category	tons/yr										MT/yr					
Fugitive Dust					0.1741	0.0000	0.1741	0.0693	0.0000	0.0693	0.0000	0.0000	0.0000	0.0000	0.0000	0.0000
Off-Road	0.0796	0.8816	0.5867	1.1800e-003		0.0377	0.0377		0.0347	0.0347	0.0000	103.5405	103.5405	0.0335	0.0000	104.3776
<b>Total</b>	<b>0.0796</b>	<b>0.8816</b>	<b>0.5867</b>	<b>1.1800e-003</b>	<b>0.1741</b>	<b>0.0377</b>	<b>0.2118</b>	<b>0.0693</b>	<b>0.0347</b>	<b>0.1040</b>	<b>0.0000</b>	<b>103.5405</b>	<b>103.5405</b>	<b>0.0335</b>	<b>0.0000</b>	<b>104.3776</b>

Village South Specific Plan (Proposed) - Los Angeles-South Coast County, Annual

**3.4 Grading - 2021**

**Unmitigated Construction Off-Site**

	ROG	NOx	CO	SO2	Fugitive PM10	Exhaust PM10	PM10 Total	Fugitive PM2.5	Exhaust PM2.5	PM2.5 Total	Bio- CO2	NBio- CO2	Total CO2	CH4	N2O	CO2e
Category	tons/yr										MT/yr					
Hauling	0.0000	0.0000	0.0000	0.0000	0.0000	0.0000	0.0000	0.0000	0.0000	0.0000	0.0000	0.0000	0.0000	0.0000	0.0000	0.0000
Vendor	0.0000	0.0000	0.0000	0.0000	0.0000	0.0000	0.0000	0.0000	0.0000	0.0000	0.0000	0.0000	0.0000	0.0000	0.0000	0.0000
Worker	1.2200e-003	9.0000e-004	0.0103	3.0000e-005	2.8300e-003	2.0000e-005	2.8600e-003	7.5000e-004	2.0000e-005	7.8000e-004	0.0000	2.5808	2.5808	8.0000e-005	0.0000	2.5828
<b>Total</b>	<b>1.2200e-003</b>	<b>9.0000e-004</b>	<b>0.0103</b>	<b>3.0000e-005</b>	<b>2.8300e-003</b>	<b>2.0000e-005</b>	<b>2.8600e-003</b>	<b>7.5000e-004</b>	<b>2.0000e-005</b>	<b>7.8000e-004</b>	<b>0.0000</b>	<b>2.5808</b>	<b>2.5808</b>	<b>8.0000e-005</b>	<b>0.0000</b>	<b>2.5828</b>

**Mitigated Construction On-Site**

	ROG	NOx	CO	SO2	Fugitive PM10	Exhaust PM10	PM10 Total	Fugitive PM2.5	Exhaust PM2.5	PM2.5 Total	Bio- CO2	NBio- CO2	Total CO2	CH4	N2O	CO2e
Category	tons/yr										MT/yr					
Fugitive Dust					0.1741	0.0000	0.1741	0.0693	0.0000	0.0693	0.0000	0.0000	0.0000	0.0000	0.0000	0.0000
Off-Road	0.0796	0.8816	0.5867	1.1800e-003		0.0377	0.0377		0.0347	0.0347	0.0000	103.5403	103.5403	0.0335	0.0000	104.3775
<b>Total</b>	<b>0.0796</b>	<b>0.8816</b>	<b>0.5867</b>	<b>1.1800e-003</b>	<b>0.1741</b>	<b>0.0377</b>	<b>0.2118</b>	<b>0.0693</b>	<b>0.0347</b>	<b>0.1040</b>	<b>0.0000</b>	<b>103.5403</b>	<b>103.5403</b>	<b>0.0335</b>	<b>0.0000</b>	<b>104.3775</b>

Village South Specific Plan (Proposed) - Los Angeles-South Coast County, Annual

**3.4 Grading - 2021**

**Mitigated Construction Off-Site**

	ROG	NOx	CO	SO2	Fugitive PM10	Exhaust PM10	PM10 Total	Fugitive PM2.5	Exhaust PM2.5	PM2.5 Total	Bio- CO2	NBio- CO2	Total CO2	CH4	N2O	CO2e
Category	tons/yr										MT/yr					
Hauling	0.0000	0.0000	0.0000	0.0000	0.0000	0.0000	0.0000	0.0000	0.0000	0.0000	0.0000	0.0000	0.0000	0.0000	0.0000	0.0000
Vendor	0.0000	0.0000	0.0000	0.0000	0.0000	0.0000	0.0000	0.0000	0.0000	0.0000	0.0000	0.0000	0.0000	0.0000	0.0000	0.0000
Worker	1.2200e-003	9.0000e-004	0.0103	3.0000e-005	2.8300e-003	2.0000e-005	2.8600e-003	7.5000e-004	2.0000e-005	7.8000e-004	0.0000	2.5808	2.5808	8.0000e-005	0.0000	2.5828
<b>Total</b>	<b>1.2200e-003</b>	<b>9.0000e-004</b>	<b>0.0103</b>	<b>3.0000e-005</b>	<b>2.8300e-003</b>	<b>2.0000e-005</b>	<b>2.8600e-003</b>	<b>7.5000e-004</b>	<b>2.0000e-005</b>	<b>7.8000e-004</b>	<b>0.0000</b>	<b>2.5808</b>	<b>2.5808</b>	<b>8.0000e-005</b>	<b>0.0000</b>	<b>2.5828</b>

**3.4 Grading - 2022**

**Unmitigated Construction On-Site**

	ROG	NOx	CO	SO2	Fugitive PM10	Exhaust PM10	PM10 Total	Fugitive PM2.5	Exhaust PM2.5	PM2.5 Total	Bio- CO2	NBio- CO2	Total CO2	CH4	N2O	CO2e
Category	tons/yr										MT/yr					
Fugitive Dust					0.0807	0.0000	0.0807	0.0180	0.0000	0.0180	0.0000	0.0000	0.0000	0.0000	0.0000	0.0000
Off-Road	0.0127	0.1360	0.1017	2.2000e-004		5.7200e-003	5.7200e-003		5.2600e-003	5.2600e-003	0.0000	19.0871	19.0871	6.1700e-003	0.0000	19.2414
<b>Total</b>	<b>0.0127</b>	<b>0.1360</b>	<b>0.1017</b>	<b>2.2000e-004</b>	<b>0.0807</b>	<b>5.7200e-003</b>	<b>0.0865</b>	<b>0.0180</b>	<b>5.2600e-003</b>	<b>0.0233</b>	<b>0.0000</b>	<b>19.0871</b>	<b>19.0871</b>	<b>6.1700e-003</b>	<b>0.0000</b>	<b>19.2414</b>

Village South Specific Plan (Proposed) - Los Angeles-South Coast County, Annual

**3.4 Grading - 2022**

**Unmitigated Construction Off-Site**

	ROG	NOx	CO	SO2	Fugitive PM10	Exhaust PM10	PM10 Total	Fugitive PM2.5	Exhaust PM2.5	PM2.5 Total	Bio- CO2	NBio- CO2	Total CO2	CH4	N2O	CO2e
Category	tons/yr										MT/yr					
Hauling	0.0000	0.0000	0.0000	0.0000	0.0000	0.0000	0.0000	0.0000	0.0000	0.0000	0.0000	0.0000	0.0000	0.0000	0.0000	0.0000
Vendor	0.0000	0.0000	0.0000	0.0000	0.0000	0.0000	0.0000	0.0000	0.0000	0.0000	0.0000	0.0000	0.0000	0.0000	0.0000	0.0000
Worker	2.1000e-004	1.5000e-004	1.7400e-003	1.0000e-005	5.2000e-004	0.0000	5.3000e-004	1.4000e-004	0.0000	1.4000e-004	0.0000	0.4587	0.4587	1.0000e-005	0.0000	0.4590
<b>Total</b>	<b>2.1000e-004</b>	<b>1.5000e-004</b>	<b>1.7400e-003</b>	<b>1.0000e-005</b>	<b>5.2000e-004</b>	<b>0.0000</b>	<b>5.3000e-004</b>	<b>1.4000e-004</b>	<b>0.0000</b>	<b>1.4000e-004</b>	<b>0.0000</b>	<b>0.4587</b>	<b>0.4587</b>	<b>1.0000e-005</b>	<b>0.0000</b>	<b>0.4590</b>

**Mitigated Construction On-Site**

	ROG	NOx	CO	SO2	Fugitive PM10	Exhaust PM10	PM10 Total	Fugitive PM2.5	Exhaust PM2.5	PM2.5 Total	Bio- CO2	NBio- CO2	Total CO2	CH4	N2O	CO2e
Category	tons/yr										MT/yr					
Fugitive Dust					0.0807	0.0000	0.0807	0.0180	0.0000	0.0180	0.0000	0.0000	0.0000	0.0000	0.0000	0.0000
Off-Road	0.0127	0.1360	0.1017	2.2000e-004		5.7200e-003	5.7200e-003		5.2600e-003	5.2600e-003	0.0000	19.0871	19.0871	6.1700e-003	0.0000	19.2414
<b>Total</b>	<b>0.0127</b>	<b>0.1360</b>	<b>0.1017</b>	<b>2.2000e-004</b>	<b>0.0807</b>	<b>5.7200e-003</b>	<b>0.0865</b>	<b>0.0180</b>	<b>5.2600e-003</b>	<b>0.0233</b>	<b>0.0000</b>	<b>19.0871</b>	<b>19.0871</b>	<b>6.1700e-003</b>	<b>0.0000</b>	<b>19.2414</b>

Village South Specific Plan (Proposed) - Los Angeles-South Coast County, Annual

**3.4 Grading - 2022**

**Mitigated Construction Off-Site**

	ROG	NOx	CO	SO2	Fugitive PM10	Exhaust PM10	PM10 Total	Fugitive PM2.5	Exhaust PM2.5	PM2.5 Total	Bio- CO2	NBio- CO2	Total CO2	CH4	N2O	CO2e
Category	tons/yr										MT/yr					
Hauling	0.0000	0.0000	0.0000	0.0000	0.0000	0.0000	0.0000	0.0000	0.0000	0.0000	0.0000	0.0000	0.0000	0.0000	0.0000	0.0000
Vendor	0.0000	0.0000	0.0000	0.0000	0.0000	0.0000	0.0000	0.0000	0.0000	0.0000	0.0000	0.0000	0.0000	0.0000	0.0000	0.0000
Worker	2.1000e-004	1.5000e-004	1.7400e-003	1.0000e-005	5.2000e-004	0.0000	5.3000e-004	1.4000e-004	0.0000	1.4000e-004	0.0000	0.4587	0.4587	1.0000e-005	0.0000	0.4590
<b>Total</b>	<b>2.1000e-004</b>	<b>1.5000e-004</b>	<b>1.7400e-003</b>	<b>1.0000e-005</b>	<b>5.2000e-004</b>	<b>0.0000</b>	<b>5.3000e-004</b>	<b>1.4000e-004</b>	<b>0.0000</b>	<b>1.4000e-004</b>	<b>0.0000</b>	<b>0.4587</b>	<b>0.4587</b>	<b>1.0000e-005</b>	<b>0.0000</b>	<b>0.4590</b>

**3.5 Building Construction - 2022**

**Unmitigated Construction On-Site**

	ROG	NOx	CO	SO2	Fugitive PM10	Exhaust PM10	PM10 Total	Fugitive PM2.5	Exhaust PM2.5	PM2.5 Total	Bio- CO2	NBio- CO2	Total CO2	CH4	N2O	CO2e
Category	tons/yr										MT/yr					
Off-Road	0.2158	1.9754	2.0700	3.4100e-003		0.1023	0.1023		0.0963	0.0963	0.0000	293.1324	293.1324	0.0702	0.0000	294.8881
<b>Total</b>	<b>0.2158</b>	<b>1.9754</b>	<b>2.0700</b>	<b>3.4100e-003</b>		<b>0.1023</b>	<b>0.1023</b>		<b>0.0963</b>	<b>0.0963</b>	<b>0.0000</b>	<b>293.1324</b>	<b>293.1324</b>	<b>0.0702</b>	<b>0.0000</b>	<b>294.8881</b>



Village South Specific Plan (Proposed) - Los Angeles-South Coast County, Annual

**3.5 Building Construction - 2022**

**Unmitigated Construction Off-Site**

	ROG	NOx	CO	SO2	Fugitive PM10	Exhaust PM10	PM10 Total	Fugitive PM2.5	Exhaust PM2.5	PM2.5 Total	Bio- CO2	NBio- CO2	Total CO2	CH4	N2O	CO2e
Category	tons/yr										MT/yr					
Hauling	0.0000	0.0000	0.0000	0.0000	0.0000	0.0000	0.0000	0.0000	0.0000	0.0000	0.0000	0.0000	0.0000	0.0000	0.0000	0.0000
Vendor	0.0527	1.6961	0.4580	4.5500e-003	0.1140	3.1800e-003	0.1171	0.0329	3.0400e-003	0.0359	0.0000	441.9835	441.9835	0.0264	0.0000	442.6435
Worker	0.3051	0.2164	2.5233	7.3500e-003	0.7557	6.2300e-003	0.7619	0.2007	5.7400e-003	0.2065	0.0000	663.9936	663.9936	0.0187	0.0000	664.4604
<b>Total</b>	<b>0.3578</b>	<b>1.9125</b>	<b>2.9812</b>	<b>0.0119</b>	<b>0.8696</b>	<b>9.4100e-003</b>	<b>0.8790</b>	<b>0.2336</b>	<b>8.7800e-003</b>	<b>0.2424</b>	<b>0.0000</b>	<b>1,105.9771</b>	<b>1,105.9771</b>	<b>0.0451</b>	<b>0.0000</b>	<b>1,107.1039</b>

**Mitigated Construction On-Site**

	ROG	NOx	CO	SO2	Fugitive PM10	Exhaust PM10	PM10 Total	Fugitive PM2.5	Exhaust PM2.5	PM2.5 Total	Bio- CO2	NBio- CO2	Total CO2	CH4	N2O	CO2e
Category	tons/yr										MT/yr					
Off-Road	0.2158	1.9754	2.0700	3.4100e-003		0.1023	0.1023		0.0963	0.0963	0.0000	293.1321	293.1321	0.0702	0.0000	294.8877
<b>Total</b>	<b>0.2158</b>	<b>1.9754</b>	<b>2.0700</b>	<b>3.4100e-003</b>		<b>0.1023</b>	<b>0.1023</b>		<b>0.0963</b>	<b>0.0963</b>	<b>0.0000</b>	<b>293.1321</b>	<b>293.1321</b>	<b>0.0702</b>	<b>0.0000</b>	<b>294.8877</b>

Village South Specific Plan (Proposed) - Los Angeles-South Coast County, Annual

**3.5 Building Construction - 2022**

**Mitigated Construction Off-Site**

	ROG	NOx	CO	SO2	Fugitive PM10	Exhaust PM10	PM10 Total	Fugitive PM2.5	Exhaust PM2.5	PM2.5 Total	Bio- CO2	NBio- CO2	Total CO2	CH4	N2O	CO2e
Category	tons/yr										MT/yr					
Hauling	0.0000	0.0000	0.0000	0.0000	0.0000	0.0000	0.0000	0.0000	0.0000	0.0000	0.0000	0.0000	0.0000	0.0000	0.0000	0.0000
Vendor	0.0527	1.6961	0.4580	4.5500e-003	0.1140	3.1800e-003	0.1171	0.0329	3.0400e-003	0.0359	0.0000	441.9835	441.9835	0.0264	0.0000	442.6435
Worker	0.3051	0.2164	2.5233	7.3500e-003	0.7557	6.2300e-003	0.7619	0.2007	5.7400e-003	0.2065	0.0000	663.9936	663.9936	0.0187	0.0000	664.4604
<b>Total</b>	<b>0.3578</b>	<b>1.9125</b>	<b>2.9812</b>	<b>0.0119</b>	<b>0.8696</b>	<b>9.4100e-003</b>	<b>0.8790</b>	<b>0.2336</b>	<b>8.7800e-003</b>	<b>0.2424</b>	<b>0.0000</b>	<b>1,105.9771</b>	<b>1,105.9771</b>	<b>0.0451</b>	<b>0.0000</b>	<b>1,107.1039</b>

**3.5 Building Construction - 2023**

**Unmitigated Construction On-Site**

	ROG	NOx	CO	SO2	Fugitive PM10	Exhaust PM10	PM10 Total	Fugitive PM2.5	Exhaust PM2.5	PM2.5 Total	Bio- CO2	NBio- CO2	Total CO2	CH4	N2O	CO2e
Category	tons/yr										MT/yr					
Off-Road	0.1942	1.7765	2.0061	3.3300e-003		0.0864	0.0864		0.0813	0.0813	0.0000	286.2789	286.2789	0.0681	0.0000	287.9814
<b>Total</b>	<b>0.1942</b>	<b>1.7765</b>	<b>2.0061</b>	<b>3.3300e-003</b>		<b>0.0864</b>	<b>0.0864</b>		<b>0.0813</b>	<b>0.0813</b>	<b>0.0000</b>	<b>286.2789</b>	<b>286.2789</b>	<b>0.0681</b>	<b>0.0000</b>	<b>287.9814</b>

Village South Specific Plan (Proposed) - Los Angeles-South Coast County, Annual

**3.5 Building Construction - 2023**

**Unmitigated Construction Off-Site**

	ROG	NOx	CO	SO2	Fugitive PM10	Exhaust PM10	PM10 Total	Fugitive PM2.5	Exhaust PM2.5	PM2.5 Total	Bio- CO2	NBio- CO2	Total CO2	CH4	N2O	CO2e
Category	tons/yr										MT/yr					
Hauling	0.0000	0.0000	0.0000	0.0000	0.0000	0.0000	0.0000	0.0000	0.0000	0.0000	0.0000	0.0000	0.0000	0.0000	0.0000	0.0000
Vendor	0.0382	1.2511	0.4011	4.3000e-003	0.1113	1.4600e-003	0.1127	0.0321	1.4000e-003	0.0335	0.0000	417.9930	417.9930	0.0228	0.0000	418.5624
Worker	0.2795	0.1910	2.2635	6.9100e-003	0.7377	5.9100e-003	0.7436	0.1960	5.4500e-003	0.2014	0.0000	624.5363	624.5363	0.0164	0.0000	624.9466
<b>Total</b>	<b>0.3177</b>	<b>1.4420</b>	<b>2.6646</b>	<b>0.0112</b>	<b>0.8490</b>	<b>7.3700e-003</b>	<b>0.8564</b>	<b>0.2281</b>	<b>6.8500e-003</b>	<b>0.2349</b>	<b>0.0000</b>	<b>1,042.5294</b>	<b>1,042.5294</b>	<b>0.0392</b>	<b>0.0000</b>	<b>1,043.5090</b>

**Mitigated Construction On-Site**

	ROG	NOx	CO	SO2	Fugitive PM10	Exhaust PM10	PM10 Total	Fugitive PM2.5	Exhaust PM2.5	PM2.5 Total	Bio- CO2	NBio- CO2	Total CO2	CH4	N2O	CO2e
Category	tons/yr										MT/yr					
Off-Road	0.1942	1.7765	2.0061	3.3300e-003		0.0864	0.0864		0.0813	0.0813	0.0000	286.2785	286.2785	0.0681	0.0000	287.9811
<b>Total</b>	<b>0.1942</b>	<b>1.7765</b>	<b>2.0061</b>	<b>3.3300e-003</b>		<b>0.0864</b>	<b>0.0864</b>		<b>0.0813</b>	<b>0.0813</b>	<b>0.0000</b>	<b>286.2785</b>	<b>286.2785</b>	<b>0.0681</b>	<b>0.0000</b>	<b>287.9811</b>

Village South Specific Plan (Proposed) - Los Angeles-South Coast County, Annual

**3.5 Building Construction - 2023**

**Mitigated Construction Off-Site**

	ROG	NOx	CO	SO2	Fugitive PM10	Exhaust PM10	PM10 Total	Fugitive PM2.5	Exhaust PM2.5	PM2.5 Total	Bio- CO2	NBio- CO2	Total CO2	CH4	N2O	CO2e
Category	tons/yr										MT/yr					
Hauling	0.0000	0.0000	0.0000	0.0000	0.0000	0.0000	0.0000	0.0000	0.0000	0.0000	0.0000	0.0000	0.0000	0.0000	0.0000	0.0000
Vendor	0.0382	1.2511	0.4011	4.3000e-003	0.1113	1.4600e-003	0.1127	0.0321	1.4000e-003	0.0335	0.0000	417.9930	417.9930	0.0228	0.0000	418.5624
Worker	0.2795	0.1910	2.2635	6.9100e-003	0.7377	5.9100e-003	0.7436	0.1960	5.4500e-003	0.2014	0.0000	624.5363	624.5363	0.0164	0.0000	624.9466
<b>Total</b>	<b>0.3177</b>	<b>1.4420</b>	<b>2.6646</b>	<b>0.0112</b>	<b>0.8490</b>	<b>7.3700e-003</b>	<b>0.8564</b>	<b>0.2281</b>	<b>6.8500e-003</b>	<b>0.2349</b>	<b>0.0000</b>	<b>1,042.5294</b>	<b>1,042.5294</b>	<b>0.0392</b>	<b>0.0000</b>	<b>1,043.5090</b>

**3.6 Paving - 2023**

**Unmitigated Construction On-Site**

	ROG	NOx	CO	SO2	Fugitive PM10	Exhaust PM10	PM10 Total	Fugitive PM2.5	Exhaust PM2.5	PM2.5 Total	Bio- CO2	NBio- CO2	Total CO2	CH4	N2O	CO2e
Category	tons/yr										MT/yr					
Off-Road	6.7100e-003	0.0663	0.0948	1.5000e-004		3.3200e-003	3.3200e-003		3.0500e-003	3.0500e-003	0.0000	13.0175	13.0175	4.2100e-003	0.0000	13.1227
Paving	0.0000					0.0000	0.0000		0.0000	0.0000	0.0000	0.0000	0.0000	0.0000	0.0000	0.0000
<b>Total</b>	<b>6.7100e-003</b>	<b>0.0663</b>	<b>0.0948</b>	<b>1.5000e-004</b>		<b>3.3200e-003</b>	<b>3.3200e-003</b>		<b>3.0500e-003</b>	<b>3.0500e-003</b>	<b>0.0000</b>	<b>13.0175</b>	<b>13.0175</b>	<b>4.2100e-003</b>	<b>0.0000</b>	<b>13.1227</b>

Village South Specific Plan (Proposed) - Los Angeles-South Coast County, Annual

**3.6 Paving - 2023**

**Unmitigated Construction Off-Site**

	ROG	NOx	CO	SO2	Fugitive PM10	Exhaust PM10	PM10 Total	Fugitive PM2.5	Exhaust PM2.5	PM2.5 Total	Bio- CO2	NBio- CO2	Total CO2	CH4	N2O	CO2e
Category	tons/yr										MT/yr					
Hauling	0.0000	0.0000	0.0000	0.0000	0.0000	0.0000	0.0000	0.0000	0.0000	0.0000	0.0000	0.0000	0.0000	0.0000	0.0000	0.0000
Vendor	0.0000	0.0000	0.0000	0.0000	0.0000	0.0000	0.0000	0.0000	0.0000	0.0000	0.0000	0.0000	0.0000	0.0000	0.0000	0.0000
Worker	2.8000e-004	1.9000e-004	2.2300e-003	1.0000e-005	7.3000e-004	1.0000e-005	7.3000e-004	1.9000e-004	1.0000e-005	2.0000e-004	0.0000	0.6156	0.6156	2.0000e-005	0.0000	0.6160
<b>Total</b>	<b>2.8000e-004</b>	<b>1.9000e-004</b>	<b>2.2300e-003</b>	<b>1.0000e-005</b>	<b>7.3000e-004</b>	<b>1.0000e-005</b>	<b>7.3000e-004</b>	<b>1.9000e-004</b>	<b>1.0000e-005</b>	<b>2.0000e-004</b>	<b>0.0000</b>	<b>0.6156</b>	<b>0.6156</b>	<b>2.0000e-005</b>	<b>0.0000</b>	<b>0.6160</b>

**Mitigated Construction On-Site**

	ROG	NOx	CO	SO2	Fugitive PM10	Exhaust PM10	PM10 Total	Fugitive PM2.5	Exhaust PM2.5	PM2.5 Total	Bio- CO2	NBio- CO2	Total CO2	CH4	N2O	CO2e
Category	tons/yr										MT/yr					
Off-Road	6.7100e-003	0.0663	0.0948	1.5000e-004		3.3200e-003	3.3200e-003		3.0500e-003	3.0500e-003	0.0000	13.0175	13.0175	4.2100e-003	0.0000	13.1227
Paving	0.0000					0.0000	0.0000		0.0000	0.0000	0.0000	0.0000	0.0000	0.0000	0.0000	0.0000
<b>Total</b>	<b>6.7100e-003</b>	<b>0.0663</b>	<b>0.0948</b>	<b>1.5000e-004</b>		<b>3.3200e-003</b>	<b>3.3200e-003</b>		<b>3.0500e-003</b>	<b>3.0500e-003</b>	<b>0.0000</b>	<b>13.0175</b>	<b>13.0175</b>	<b>4.2100e-003</b>	<b>0.0000</b>	<b>13.1227</b>

Village South Specific Plan (Proposed) - Los Angeles-South Coast County, Annual

**3.6 Paving - 2023**

**Mitigated Construction Off-Site**

	ROG	NOx	CO	SO2	Fugitive PM10	Exhaust PM10	PM10 Total	Fugitive PM2.5	Exhaust PM2.5	PM2.5 Total	Bio- CO2	NBio- CO2	Total CO2	CH4	N2O	CO2e
Category	tons/yr										MT/yr					
Hauling	0.0000	0.0000	0.0000	0.0000	0.0000	0.0000	0.0000	0.0000	0.0000	0.0000	0.0000	0.0000	0.0000	0.0000	0.0000	0.0000
Vendor	0.0000	0.0000	0.0000	0.0000	0.0000	0.0000	0.0000	0.0000	0.0000	0.0000	0.0000	0.0000	0.0000	0.0000	0.0000	0.0000
Worker	2.8000e-004	1.9000e-004	2.2300e-003	1.0000e-005	7.3000e-004	1.0000e-005	7.3000e-004	1.9000e-004	1.0000e-005	2.0000e-004	0.0000	0.6156	0.6156	2.0000e-005	0.0000	0.6160
<b>Total</b>	<b>2.8000e-004</b>	<b>1.9000e-004</b>	<b>2.2300e-003</b>	<b>1.0000e-005</b>	<b>7.3000e-004</b>	<b>1.0000e-005</b>	<b>7.3000e-004</b>	<b>1.9000e-004</b>	<b>1.0000e-005</b>	<b>2.0000e-004</b>	<b>0.0000</b>	<b>0.6156</b>	<b>0.6156</b>	<b>2.0000e-005</b>	<b>0.0000</b>	<b>0.6160</b>

**3.6 Paving - 2024**

**Unmitigated Construction On-Site**

	ROG	NOx	CO	SO2	Fugitive PM10	Exhaust PM10	PM10 Total	Fugitive PM2.5	Exhaust PM2.5	PM2.5 Total	Bio- CO2	NBio- CO2	Total CO2	CH4	N2O	CO2e
Category	tons/yr										MT/yr					
Off-Road	0.0109	0.1048	0.1609	2.5000e-004		5.1500e-003	5.1500e-003		4.7400e-003	4.7400e-003	0.0000	22.0292	22.0292	7.1200e-003	0.0000	22.2073
Paving	0.0000					0.0000	0.0000		0.0000	0.0000	0.0000	0.0000	0.0000	0.0000	0.0000	0.0000
<b>Total</b>	<b>0.0109</b>	<b>0.1048</b>	<b>0.1609</b>	<b>2.5000e-004</b>		<b>5.1500e-003</b>	<b>5.1500e-003</b>		<b>4.7400e-003</b>	<b>4.7400e-003</b>	<b>0.0000</b>	<b>22.0292</b>	<b>22.0292</b>	<b>7.1200e-003</b>	<b>0.0000</b>	<b>22.2073</b>

Village South Specific Plan (Proposed) - Los Angeles-South Coast County, Annual

**3.6 Paving - 2024**

**Unmitigated Construction Off-Site**

	ROG	NOx	CO	SO2	Fugitive PM10	Exhaust PM10	PM10 Total	Fugitive PM2.5	Exhaust PM2.5	PM2.5 Total	Bio- CO2	NBio- CO2	Total CO2	CH4	N2O	CO2e
Category	tons/yr										MT/yr					
Hauling	0.0000	0.0000	0.0000	0.0000	0.0000	0.0000	0.0000	0.0000	0.0000	0.0000	0.0000	0.0000	0.0000	0.0000	0.0000	0.0000
Vendor	0.0000	0.0000	0.0000	0.0000	0.0000	0.0000	0.0000	0.0000	0.0000	0.0000	0.0000	0.0000	0.0000	0.0000	0.0000	0.0000
Worker	4.4000e-004	2.9000e-004	3.5100e-003	1.0000e-005	1.2300e-003	1.0000e-005	1.2400e-003	3.3000e-004	1.0000e-005	3.4000e-004	0.0000	1.0094	1.0094	3.0000e-005	0.0000	1.0100
<b>Total</b>	<b>4.4000e-004</b>	<b>2.9000e-004</b>	<b>3.5100e-003</b>	<b>1.0000e-005</b>	<b>1.2300e-003</b>	<b>1.0000e-005</b>	<b>1.2400e-003</b>	<b>3.3000e-004</b>	<b>1.0000e-005</b>	<b>3.4000e-004</b>	<b>0.0000</b>	<b>1.0094</b>	<b>1.0094</b>	<b>3.0000e-005</b>	<b>0.0000</b>	<b>1.0100</b>

**Mitigated Construction On-Site**

	ROG	NOx	CO	SO2	Fugitive PM10	Exhaust PM10	PM10 Total	Fugitive PM2.5	Exhaust PM2.5	PM2.5 Total	Bio- CO2	NBio- CO2	Total CO2	CH4	N2O	CO2e
Category	tons/yr										MT/yr					
Off-Road	0.0109	0.1048	0.1609	2.5000e-004		5.1500e-003	5.1500e-003		4.7400e-003	4.7400e-003	0.0000	22.0292	22.0292	7.1200e-003	0.0000	22.2073
Paving	0.0000					0.0000	0.0000		0.0000	0.0000	0.0000	0.0000	0.0000	0.0000	0.0000	0.0000
<b>Total</b>	<b>0.0109</b>	<b>0.1048</b>	<b>0.1609</b>	<b>2.5000e-004</b>		<b>5.1500e-003</b>	<b>5.1500e-003</b>		<b>4.7400e-003</b>	<b>4.7400e-003</b>	<b>0.0000</b>	<b>22.0292</b>	<b>22.0292</b>	<b>7.1200e-003</b>	<b>0.0000</b>	<b>22.2073</b>

Village South Specific Plan (Proposed) - Los Angeles-South Coast County, Annual

**3.6 Paving - 2024**

**Mitigated Construction Off-Site**

	ROG	NOx	CO	SO2	Fugitive PM10	Exhaust PM10	PM10 Total	Fugitive PM2.5	Exhaust PM2.5	PM2.5 Total	Bio- CO2	NBio- CO2	Total CO2	CH4	N2O	CO2e
Category	tons/yr										MT/yr					
Hauling	0.0000	0.0000	0.0000	0.0000	0.0000	0.0000	0.0000	0.0000	0.0000	0.0000	0.0000	0.0000	0.0000	0.0000	0.0000	0.0000
Vendor	0.0000	0.0000	0.0000	0.0000	0.0000	0.0000	0.0000	0.0000	0.0000	0.0000	0.0000	0.0000	0.0000	0.0000	0.0000	0.0000
Worker	4.4000e-004	2.9000e-004	3.5100e-003	1.0000e-005	1.2300e-003	1.0000e-005	1.2400e-003	3.3000e-004	1.0000e-005	3.4000e-004	0.0000	1.0094	1.0094	3.0000e-005	0.0000	1.0100
<b>Total</b>	<b>4.4000e-004</b>	<b>2.9000e-004</b>	<b>3.5100e-003</b>	<b>1.0000e-005</b>	<b>1.2300e-003</b>	<b>1.0000e-005</b>	<b>1.2400e-003</b>	<b>3.3000e-004</b>	<b>1.0000e-005</b>	<b>3.4000e-004</b>	<b>0.0000</b>	<b>1.0094</b>	<b>1.0094</b>	<b>3.0000e-005</b>	<b>0.0000</b>	<b>1.0100</b>

**3.7 Architectural Coating - 2024**

**Unmitigated Construction On-Site**

	ROG	NOx	CO	SO2	Fugitive PM10	Exhaust PM10	PM10 Total	Fugitive PM2.5	Exhaust PM2.5	PM2.5 Total	Bio- CO2	NBio- CO2	Total CO2	CH4	N2O	CO2e
Category	tons/yr										MT/yr					
Archit. Coating	4.1372					0.0000	0.0000		0.0000	0.0000	0.0000	0.0000	0.0000	0.0000	0.0000	0.0000
Off-Road	3.1600e-003	0.0213	0.0317	5.0000e-005		1.0700e-003	1.0700e-003		1.0700e-003	1.0700e-003	0.0000	4.4682	4.4682	2.5000e-004	0.0000	4.4745
<b>Total</b>	<b>4.1404</b>	<b>0.0213</b>	<b>0.0317</b>	<b>5.0000e-005</b>		<b>1.0700e-003</b>	<b>1.0700e-003</b>		<b>1.0700e-003</b>	<b>1.0700e-003</b>	<b>0.0000</b>	<b>4.4682</b>	<b>4.4682</b>	<b>2.5000e-004</b>	<b>0.0000</b>	<b>4.4745</b>



Village South Specific Plan (Proposed) - Los Angeles-South Coast County, Annual

**3.7 Architectural Coating - 2024**

**Unmitigated Construction Off-Site**

	ROG	NOx	CO	SO2	Fugitive PM10	Exhaust PM10	PM10 Total	Fugitive PM2.5	Exhaust PM2.5	PM2.5 Total	Bio- CO2	NBio- CO2	Total CO2	CH4	N2O	CO2e
Category	tons/yr										MT/yr					
Hauling	0.0000	0.0000	0.0000	0.0000	0.0000	0.0000	0.0000	0.0000	0.0000	0.0000	0.0000	0.0000	0.0000	0.0000	0.0000	0.0000
Vendor	0.0000	0.0000	0.0000	0.0000	0.0000	0.0000	0.0000	0.0000	0.0000	0.0000	0.0000	0.0000	0.0000	0.0000	0.0000	0.0000
Worker	7.4800e-003	4.9300e-003	0.0596	1.9000e-004	0.0209	1.6000e-004	0.0211	5.5500e-003	1.5000e-004	5.7000e-003	0.0000	17.1287	17.1287	4.3000e-004	0.0000	17.1394
<b>Total</b>	<b>7.4800e-003</b>	<b>4.9300e-003</b>	<b>0.0596</b>	<b>1.9000e-004</b>	<b>0.0209</b>	<b>1.6000e-004</b>	<b>0.0211</b>	<b>5.5500e-003</b>	<b>1.5000e-004</b>	<b>5.7000e-003</b>	<b>0.0000</b>	<b>17.1287</b>	<b>17.1287</b>	<b>4.3000e-004</b>	<b>0.0000</b>	<b>17.1394</b>

**Mitigated Construction On-Site**

	ROG	NOx	CO	SO2	Fugitive PM10	Exhaust PM10	PM10 Total	Fugitive PM2.5	Exhaust PM2.5	PM2.5 Total	Bio- CO2	NBio- CO2	Total CO2	CH4	N2O	CO2e
Category	tons/yr										MT/yr					
Archit. Coating	4.1372					0.0000	0.0000		0.0000	0.0000	0.0000	0.0000	0.0000	0.0000	0.0000	0.0000
Off-Road	3.1600e-003	0.0213	0.0317	5.0000e-005		1.0700e-003	1.0700e-003		1.0700e-003	1.0700e-003	0.0000	4.4682	4.4682	2.5000e-004	0.0000	4.4745
<b>Total</b>	<b>4.1404</b>	<b>0.0213</b>	<b>0.0317</b>	<b>5.0000e-005</b>		<b>1.0700e-003</b>	<b>1.0700e-003</b>		<b>1.0700e-003</b>	<b>1.0700e-003</b>	<b>0.0000</b>	<b>4.4682</b>	<b>4.4682</b>	<b>2.5000e-004</b>	<b>0.0000</b>	<b>4.4745</b>

Village South Specific Plan (Proposed) - Los Angeles-South Coast County, Annual

**3.7 Architectural Coating - 2024**

**Mitigated Construction Off-Site**

	ROG	NOx	CO	SO2	Fugitive PM10	Exhaust PM10	PM10 Total	Fugitive PM2.5	Exhaust PM2.5	PM2.5 Total	Bio- CO2	NBio- CO2	Total CO2	CH4	N2O	CO2e
Category	tons/yr										MT/yr					
Hauling	0.0000	0.0000	0.0000	0.0000	0.0000	0.0000	0.0000	0.0000	0.0000	0.0000	0.0000	0.0000	0.0000	0.0000	0.0000	0.0000
Vendor	0.0000	0.0000	0.0000	0.0000	0.0000	0.0000	0.0000	0.0000	0.0000	0.0000	0.0000	0.0000	0.0000	0.0000	0.0000	0.0000
Worker	7.4800e-003	4.9300e-003	0.0596	1.9000e-004	0.0209	1.6000e-004	0.0211	5.5500e-003	1.5000e-004	5.7000e-003	0.0000	17.1287	17.1287	4.3000e-004	0.0000	17.1394
<b>Total</b>	<b>7.4800e-003</b>	<b>4.9300e-003</b>	<b>0.0596</b>	<b>1.9000e-004</b>	<b>0.0209</b>	<b>1.6000e-004</b>	<b>0.0211</b>	<b>5.5500e-003</b>	<b>1.5000e-004</b>	<b>5.7000e-003</b>	<b>0.0000</b>	<b>17.1287</b>	<b>17.1287</b>	<b>4.3000e-004</b>	<b>0.0000</b>	<b>17.1394</b>

**4.0 Operational Detail - Mobile**

---

**4.1 Mitigation Measures Mobile**

Village South Specific Plan (Proposed) - Los Angeles-South Coast County, Annual

	ROG	NOx	CO	SO2	Fugitive PM10	Exhaust PM10	PM10 Total	Fugitive PM2.5	Exhaust PM2.5	PM2.5 Total	Bio- CO2	NBio- CO2	Total CO2	CH4	N2O	CO2e
Category	tons/yr										MT/yr					
Mitigated	1.5857	7.9962	19.1834	0.0821	7.7979	0.0580	7.8559	2.0895	0.0539	2.1434	0.0000	7,620.4986	7,620.4986	0.3407	0.0000	7,629.0162
Unmitigated	1.5857	7.9962	19.1834	0.0821	7.7979	0.0580	7.8559	2.0895	0.0539	2.1434	0.0000	7,620.4986	7,620.4986	0.3407	0.0000	7,629.0162

4.2 Trip Summary Information

Land Use	Average Daily Trip Rate			Unmitigated	Mitigated
	Weekday	Saturday	Sunday	Annual VMT	Annual VMT
Apartments Low Rise	145.75	154.25	154.00	506,227	506,227
Apartments Mid Rise	4,026.75	3,773.25	4075.50	13,660,065	13,660,065
General Office Building	288.45	62.55	31.05	706,812	706,812
High Turnover (Sit Down Restaurant)	2,368.80	2,873.52	2817.72	3,413,937	3,413,937
Hotel	192.00	187.50	160.00	445,703	445,703
Quality Restaurant	501.12	511.92	461.20	707,488	707,488
Regional Shopping Center	528.08	601.44	357.84	1,112,221	1,112,221
<b>Total</b>	<b>8,050.95</b>	<b>8,164.43</b>	<b>8,057.31</b>	<b>20,552,452</b>	<b>20,552,452</b>

4.3 Trip Type Information

Village South Specific Plan (Proposed) - Los Angeles-South Coast County, Annual

Land Use	Miles			Trip %			Trip Purpose %		
	H-W or C-W	H-S or C-C	H-O or C-NW	H-W or C-W	H-S or C-C	H-O or C-NW	Primary	Diverted	Pass-by
Apartments Low Rise	14.70	5.90	8.70	40.20	19.20	40.60	86	11	3
Apartments Mid Rise	14.70	5.90	8.70	40.20	19.20	40.60	86	11	3
General Office Building	16.60	8.40	6.90	33.00	48.00	19.00	77	19	4
High Turnover (Sit Down Restaurant)	16.60	8.40	6.90	8.50	72.50	19.00	37	20	43
Hotel	16.60	8.40	6.90	19.40	61.60	19.00	58	38	4
Quality Restaurant	16.60	8.40	6.90	12.00	69.00	19.00	38	18	44
Regional Shopping Center	16.60	8.40	6.90	16.30	64.70	19.00	54	35	11

4.4 Fleet Mix

Land Use	LDA	LDT1	LDT2	MDV	LHD1	LHD2	MHD	HHD	OBUS	UBUS	MCY	SBUS	MH
Apartments Low Rise	0.543088	0.044216	0.209971	0.116369	0.014033	0.006332	0.021166	0.033577	0.002613	0.001817	0.005285	0.000712	0.000821
Apartments Mid Rise	0.543088	0.044216	0.209971	0.116369	0.014033	0.006332	0.021166	0.033577	0.002613	0.001817	0.005285	0.000712	0.000821
General Office Building	0.543088	0.044216	0.209971	0.116369	0.014033	0.006332	0.021166	0.033577	0.002613	0.001817	0.005285	0.000712	0.000821
High Turnover (Sit Down Restaurant)	0.543088	0.044216	0.209971	0.116369	0.014033	0.006332	0.021166	0.033577	0.002613	0.001817	0.005285	0.000712	0.000821
Hotel	0.543088	0.044216	0.209971	0.116369	0.014033	0.006332	0.021166	0.033577	0.002613	0.001817	0.005285	0.000712	0.000821
Quality Restaurant	0.543088	0.044216	0.209971	0.116369	0.014033	0.006332	0.021166	0.033577	0.002613	0.001817	0.005285	0.000712	0.000821
Regional Shopping Center	0.543088	0.044216	0.209971	0.116369	0.014033	0.006332	0.021166	0.033577	0.002613	0.001817	0.005285	0.000712	0.000821

5.0 Energy Detail

Historical Energy Use: N

5.1 Mitigation Measures Energy

Village South Specific Plan (Proposed) - Los Angeles-South Coast County, Annual

	ROG	NOx	CO	SO2	Fugitive PM10	Exhaust PM10	PM10 Total	Fugitive PM2.5	Exhaust PM2.5	PM2.5 Total	Bio- CO2	NBio- CO2	Total CO2	CH4	N2O	CO2e
Category	tons/yr										MT/yr					
Electricity Mitigated							0.0000	0.0000		0.0000	0.0000	2,512.6465	2,512.6465	0.1037	0.0215	2,521.6356
Electricity Unmitigated							0.0000	0.0000		0.0000	0.0000	2,512.6465	2,512.6465	0.1037	0.0215	2,521.6356
NaturalGas Mitigated	0.1398	1.2312	0.7770	7.6200e-003		0.0966	0.0966		0.0966	0.0966	0.0000	1,383.4267	1,383.4267	0.0265	0.0254	1,391.6478
NaturalGas Unmitigated	0.1398	1.2312	0.7770	7.6200e-003		0.0966	0.0966		0.0966	0.0966	0.0000	1,383.4267	1,383.4267	0.0265	0.0254	1,391.6478

Village South Specific Plan (Proposed) - Los Angeles-South Coast County, Annual

**5.2 Energy by Land Use - NaturalGas**

**Unmitigated**

	NaturalGas Use	ROG	NOx	CO	SO2	Fugitive PM10	Exhaust PM10	PM10 Total	Fugitive PM2.5	Exhaust PM2.5	PM2.5 Total	Bio- CO2	NBio- CO2	Total CO2	CH4	N2O	CO2e
Land Use	kBTU/yr	tons/yr										MT/yr					
Apartments Low Rise	408494	2.2000e-003	0.0188	8.0100e-003	1.2000e-004		1.5200e-003	1.5200e-003		1.5200e-003	1.5200e-003	0.0000	21.7988	21.7988	4.2000e-004	4.0000e-004	21.9284
Apartments Mid Rise	1.30613e+007	0.0704	0.6018	0.2561	3.8400e-003		0.0487	0.0487		0.0487	0.0487	0.0000	696.9989	696.9989	0.0134	0.0128	701.1408
General Office Building	468450	2.5300e-003	0.0230	0.0193	1.4000e-004		1.7500e-003	1.7500e-003		1.7500e-003	1.7500e-003	0.0000	24.9983	24.9983	4.8000e-004	4.6000e-004	25.1468
High Turnover (Sit Down Restaurant)	8.30736e+006	0.0448	0.4072	0.3421	2.4400e-003		0.0310	0.0310		0.0310	0.0310	0.0000	443.3124	443.3124	8.5000e-003	8.1300e-003	445.9468
Hotel	1.74095e+006	9.3900e-003	0.0853	0.0717	5.1000e-004		6.4900e-003	6.4900e-003		6.4900e-003	6.4900e-003	0.0000	92.9036	92.9036	1.7800e-003	1.7000e-003	93.4557
Quality Restaurant	1.84608e+006	9.9500e-003	0.0905	0.0760	5.4000e-004		6.8800e-003	6.8800e-003		6.8800e-003	6.8800e-003	0.0000	98.5139	98.5139	1.8900e-003	1.8100e-003	99.0993
Regional Shopping Center	91840	5.0000e-004	4.5000e-003	3.7800e-003	3.0000e-005		3.4000e-004	3.4000e-004		3.4000e-004	3.4000e-004	0.0000	4.9009	4.9009	9.0000e-005	9.0000e-005	4.9301
<b>Total</b>		<b>0.1398</b>	<b>1.2312</b>	<b>0.7770</b>	<b>7.6200e-003</b>		<b>0.0966</b>	<b>0.0966</b>		<b>0.0966</b>	<b>0.0966</b>	<b>0.0000</b>	<b>1,383.4268</b>	<b>1,383.4268</b>	<b>0.0265</b>	<b>0.0254</b>	<b>1,391.6478</b>

Village South Specific Plan (Proposed) - Los Angeles-South Coast County, Annual

**5.2 Energy by Land Use - NaturalGas**

**Mitigated**

	NaturalGas Use	ROG	NOx	CO	SO2	Fugitive PM10	Exhaust PM10	PM10 Total	Fugitive PM2.5	Exhaust PM2.5	PM2.5 Total	Bio- CO2	NBio- CO2	Total CO2	CH4	N2O	CO2e
Land Use	kBTU/yr	tons/yr										MT/yr					
Apartments Low Rise	408494	2.2000e-003	0.0188	8.0100e-003	1.2000e-004		1.5200e-003	1.5200e-003		1.5200e-003	1.5200e-003	0.0000	21.7988	21.7988	4.2000e-004	4.0000e-004	21.9284
Apartments Mid Rise	1.30613e+007	0.0704	0.6018	0.2561	3.8400e-003		0.0487	0.0487		0.0487	0.0487	0.0000	696.9989	696.9989	0.0134	0.0128	701.1408
General Office Building	468450	2.5300e-003	0.0230	0.0193	1.4000e-004		1.7500e-003	1.7500e-003		1.7500e-003	1.7500e-003	0.0000	24.9983	24.9983	4.8000e-004	4.6000e-004	25.1468
High Turnover (Sit Down Restaurant)	8.30736e+006	0.0448	0.4072	0.3421	2.4400e-003		0.0310	0.0310		0.0310	0.0310	0.0000	443.3124	443.3124	8.5000e-003	8.1300e-003	445.9468
Hotel	1.74095e+006	9.3900e-003	0.0853	0.0717	5.1000e-004		6.4900e-003	6.4900e-003		6.4900e-003	6.4900e-003	0.0000	92.9036	92.9036	1.7800e-003	1.7000e-003	93.4557
Quality Restaurant	1.84608e+006	9.9500e-003	0.0905	0.0760	5.4000e-004		6.8800e-003	6.8800e-003		6.8800e-003	6.8800e-003	0.0000	98.5139	98.5139	1.8900e-003	1.8100e-003	99.0993
Regional Shopping Center	91840	5.0000e-004	4.5000e-003	3.7800e-003	3.0000e-005		3.4000e-004	3.4000e-004		3.4000e-004	3.4000e-004	0.0000	4.9009	4.9009	9.0000e-005	9.0000e-005	4.9301
<b>Total</b>		<b>0.1398</b>	<b>1.2312</b>	<b>0.7770</b>	<b>7.6200e-003</b>		<b>0.0966</b>	<b>0.0966</b>		<b>0.0966</b>	<b>0.0966</b>	<b>0.0000</b>	<b>1,383.4268</b>	<b>1,383.4268</b>	<b>0.0265</b>	<b>0.0254</b>	<b>1,391.6478</b>

Village South Specific Plan (Proposed) - Los Angeles-South Coast County, Annual

**5.3 Energy by Land Use - Electricity**

**Unmitigated**

	Electricity Use	Total CO2	CH4	N2O	CO2e
Land Use	kWh/yr	MT/yr			
Apartments Low Rise	106010	33.7770	1.3900e-003	2.9000e-004	33.8978
Apartments Mid Rise	3.94697e+006	1,257.5879	0.0519	0.0107	1,262.0869
General Office Building	584550	186.2502	7.6900e-003	1.5900e-003	186.9165
High Turnover (Sit Down Restaurant)	1.58904e+006	506.3022	0.0209	4.3200e-003	508.1135
Hotel	550308	175.3399	7.2400e-003	1.5000e-003	175.9672
Quality Restaurant	353120	112.5116	4.6500e-003	9.6000e-004	112.9141
Regional Shopping Center	756000	240.8778	9.9400e-003	2.0600e-003	241.7395
<b>Total</b>		<b>2,512.6465</b>	<b>0.1037</b>	<b>0.0215</b>	<b>2,521.6356</b>



Village South Specific Plan (Proposed) - Los Angeles-South Coast County, Annual

**5.3 Energy by Land Use - Electricity**

**Mitigated**

	Electricity Use	Total CO2	CH4	N2O	CO2e
Land Use	kWh/yr	MT/yr			
Apartments Low Rise	106010	33.7770	1.3900e-003	2.9000e-004	33.8978
Apartments Mid Rise	3.94697e+006	1,257.5879	0.0519	0.0107	1,262.0869
General Office Building	584550	186.2502	7.6900e-003	1.5900e-003	186.9165
High Turnover (Sit Down Restaurant)	1.58904e+006	506.3022	0.0209	4.3200e-003	508.1135
Hotel	550308	175.3399	7.2400e-003	1.5000e-003	175.9672
Quality Restaurant	353120	112.5116	4.6500e-003	9.6000e-004	112.9141
Regional Shopping Center	756000	240.8778	9.9400e-003	2.0600e-003	241.7395
<b>Total</b>		<b>2,512.6465</b>	<b>0.1037</b>	<b>0.0215</b>	<b>2,521.6356</b>

**6.0 Area Detail**

**6.1 Mitigation Measures Area**

Village South Specific Plan (Proposed) - Los Angeles-South Coast County, Annual

	ROG	NOx	CO	SO2	Fugitive PM10	Exhaust PM10	PM10 Total	Fugitive PM2.5	Exhaust PM2.5	PM2.5 Total	Bio- CO2	NBio- CO2	Total CO2	CH4	N2O	CO2e
Category	tons/yr										MT/yr					
Mitigated	5.1437	0.2950	10.3804	1.6700e-003		0.0714	0.0714		0.0714	0.0714	0.0000	220.9670	220.9670	0.0201	3.7400e-003	222.5835
Unmitigated	5.1437	0.2950	10.3804	1.6700e-003		0.0714	0.0714		0.0714	0.0714	0.0000	220.9670	220.9670	0.0201	3.7400e-003	222.5835

6.2 Area by SubCategory

Unmitigated

	ROG	NOx	CO	SO2	Fugitive PM10	Exhaust PM10	PM10 Total	Fugitive PM2.5	Exhaust PM2.5	PM2.5 Total	Bio- CO2	NBio- CO2	Total CO2	CH4	N2O	CO2e
SubCategory	tons/yr										MT/yr					
Architectural Coating	0.4137					0.0000	0.0000		0.0000	0.0000	0.0000	0.0000	0.0000	0.0000	0.0000	0.0000
Consumer Products	4.3998					0.0000	0.0000		0.0000	0.0000	0.0000	0.0000	0.0000	0.0000	0.0000	0.0000
Hearth	0.0206	0.1763	0.0750	1.1200e-003		0.0143	0.0143		0.0143	0.0143	0.0000	204.1166	204.1166	3.9100e-003	3.7400e-003	205.3295
Landscaping	0.3096	0.1187	10.3054	5.4000e-004		0.0572	0.0572		0.0572	0.0572	0.0000	16.8504	16.8504	0.0161	0.0000	17.2540
<b>Total</b>	<b>5.1437</b>	<b>0.2950</b>	<b>10.3804</b>	<b>1.6600e-003</b>		<b>0.0714</b>	<b>0.0714</b>		<b>0.0714</b>	<b>0.0714</b>	<b>0.0000</b>	<b>220.9670</b>	<b>220.9670</b>	<b>0.0201</b>	<b>3.7400e-003</b>	<b>222.5835</b>

Village South Specific Plan (Proposed) - Los Angeles-South Coast County, Annual

**6.2 Area by SubCategory**

**Mitigated**

	ROG	NOx	CO	SO2	Fugitive PM10	Exhaust PM10	PM10 Total	Fugitive PM2.5	Exhaust PM2.5	PM2.5 Total	Bio- CO2	NBio- CO2	Total CO2	CH4	N2O	CO2e
SubCategory	tons/yr										MT/yr					
Architectural Coating	0.4137					0.0000	0.0000		0.0000	0.0000	0.0000	0.0000	0.0000	0.0000	0.0000	0.0000
Consumer Products	4.3998					0.0000	0.0000		0.0000	0.0000	0.0000	0.0000	0.0000	0.0000	0.0000	0.0000
Hearth	0.0206	0.1763	0.0750	1.1200e-003		0.0143	0.0143		0.0143	0.0143	0.0000	204.1166	204.1166	3.9100e-003	3.7400e-003	205.3295
Landscaping	0.3096	0.1187	10.3054	5.4000e-004		0.0572	0.0572		0.0572	0.0572	0.0000	16.8504	16.8504	0.0161	0.0000	17.2540
<b>Total</b>	<b>5.1437</b>	<b>0.2950</b>	<b>10.3804</b>	<b>1.6600e-003</b>		<b>0.0714</b>	<b>0.0714</b>		<b>0.0714</b>	<b>0.0714</b>	<b>0.0000</b>	<b>220.9670</b>	<b>220.9670</b>	<b>0.0201</b>	<b>3.7400e-003</b>	<b>222.5835</b>

**7.0 Water Detail**

**7.1 Mitigation Measures Water**

Village South Specific Plan (Proposed) - Los Angeles-South Coast County, Annual

	Total CO2	CH4	N2O	CO2e
Category	MT/yr			
Mitigated	585.8052	3.0183	0.0755	683.7567
Unmitigated	585.8052	3.0183	0.0755	683.7567

Village South Specific Plan (Proposed) - Los Angeles-South Coast County, Annual

**7.2 Water by Land Use**

**Unmitigated**

	Indoor/Outdoor Use	Total CO2	CH4	N2O	CO2e
Land Use	Mgal	MT/yr			
Apartments Low Rise	1.62885 / 1.02688	10.9095	0.0535	1.3400e-003	12.6471
Apartments Mid Rise	63.5252 / 40.0485	425.4719	2.0867	0.0523	493.2363
General Office Building	7.99802 / 4.90201	53.0719	0.2627	6.5900e-003	61.6019
High Turnover (Sit Down Restaurant)	10.9272 / 0.697482	51.2702	0.3580	8.8200e-003	62.8482
Hotel	1.26834 / 0.140927	6.1633	0.0416	1.0300e-003	7.5079
Quality Restaurant	2.42827 / 0.154996	11.3934	0.0796	1.9600e-003	13.9663
Regional Shopping Center	4.14806 / 2.54236	27.5250	0.1363	3.4200e-003	31.9490
<b>Total</b>		<b>585.8052</b>	<b>3.0183</b>	<b>0.0755</b>	<b>683.7567</b>

Village South Specific Plan (Proposed) - Los Angeles-South Coast County, Annual

**7.2 Water by Land Use**

**Mitigated**

	Indoor/Outdoor Use	Total CO2	CH4	N2O	CO2e
Land Use	Mgal	MT/yr			
Apartments Low Rise	1.62885 / 1.02688	10.9095	0.0535	1.3400e-003	12.6471
Apartments Mid Rise	63.5252 / 40.0485	425.4719	2.0867	0.0523	493.2363
General Office Building	7.99802 / 4.90201	53.0719	0.2627	6.5900e-003	61.6019
High Turnover (Sit Down Restaurant)	10.9272 / 0.697482	51.2702	0.3580	8.8200e-003	62.8482
Hotel	1.26834 / 0.140927	6.1633	0.0416	1.0300e-003	7.5079
Quality Restaurant	2.42827 / 0.154996	11.3934	0.0796	1.9600e-003	13.9663
Regional Shopping Center	4.14806 / 2.54236	27.5250	0.1363	3.4200e-003	31.9490
<b>Total</b>		<b>585.8052</b>	<b>3.0183</b>	<b>0.0755</b>	<b>683.7567</b>

**8.0 Waste Detail**

---

**8.1 Mitigation Measures Waste**

Village South Specific Plan (Proposed) - Los Angeles-South Coast County, Annual

**Category/Year**

	Total CO2	CH4	N2O	CO2e
	MT/yr			
Mitigated	207.8079	12.2811	0.0000	514.8354
Unmitigated	207.8079	12.2811	0.0000	514.8354

Village South Specific Plan (Proposed) - Los Angeles-South Coast County, Annual

**8.2 Waste by Land Use**

**Unmitigated**

	Waste Disposed	Total CO2	CH4	N2O	CO2e
Land Use	tons	MT/yr			
Apartments Low Rise	11.5	2.3344	0.1380	0.0000	5.7834
Apartments Mid Rise	448.5	91.0415	5.3804	0.0000	225.5513
General Office Building	41.85	8.4952	0.5021	0.0000	21.0464
High Turnover (Sit Down Restaurant)	428.4	86.9613	5.1393	0.0000	215.4430
Hotel	27.38	5.5579	0.3285	0.0000	13.7694
Quality Restaurant	7.3	1.4818	0.0876	0.0000	3.6712
Regional Shopping Center	58.8	11.9359	0.7054	0.0000	29.5706
<b>Total</b>		<b>207.8079</b>	<b>12.2811</b>	<b>0.0000</b>	<b>514.8354</b>



Village South Specific Plan (Proposed) - Los Angeles-South Coast County, Annual

**8.2 Waste by Land Use**

**Mitigated**

	Waste Disposed	Total CO2	CH4	N2O	CO2e
Land Use	tons	MT/yr			
Apartments Low Rise	11.5	2.3344	0.1380	0.0000	5.7834
Apartments Mid Rise	448.5	91.0415	5.3804	0.0000	225.5513
General Office Building	41.85	8.4952	0.5021	0.0000	21.0464
High Turnover (Sit Down Restaurant)	428.4	86.9613	5.1393	0.0000	215.4430
Hotel	27.38	5.5579	0.3285	0.0000	13.7694
Quality Restaurant	7.3	1.4818	0.0876	0.0000	3.6712
Regional Shopping Center	58.8	11.9359	0.7054	0.0000	29.5706
<b>Total</b>		<b>207.8079</b>	<b>12.2811</b>	<b>0.0000</b>	<b>514.8354</b>

**9.0 Operational Offroad**

Equipment Type	Number	Hours/Day	Days/Year	Horse Power	Load Factor	Fuel Type
----------------	--------	-----------	-----------	-------------	-------------	-----------

**10.0 Stationary Equipment**

**Fire Pumps and Emergency Generators**

Equipment Type	Number	Hours/Day	Hours/Year	Horse Power	Load Factor	Fuel Type
----------------	--------	-----------	------------	-------------	-------------	-----------

Village South Specific Plan (Proposed) - Los Angeles-South Coast County, Annual

**Boilers**

Equipment Type	Number	Heat Input/Day	Heat Input/Year	Boiler Rating	Fuel Type
----------------	--------	----------------	-----------------	---------------	-----------

**User Defined Equipment**

Equipment Type	Number
----------------	--------

**11.0 Vegetation**

---

Village South Specific Plan (Proposed) - Los Angeles-South Coast County, Summer

**Village South Specific Plan (Proposed)**  
**Los Angeles-South Coast County, Summer**

**1.0 Project Characteristics**

**1.1 Land Usage**

Land Uses	Size	Metric	Lot Acreage	Floor Surface Area	Population
General Office Building	45.00	1000sqft	1.03	45,000.00	0
High Turnover (Sit Down Restaurant)	36.00	1000sqft	0.83	36,000.00	0
Hotel	50.00	Room	1.67	72,600.00	0
Quality Restaurant	8.00	1000sqft	0.18	8,000.00	0
Apartments Low Rise	25.00	Dwelling Unit	1.56	25,000.00	72
Apartments Mid Rise	975.00	Dwelling Unit	25.66	975,000.00	2789
Regional Shopping Center	56.00	1000sqft	1.29	56,000.00	0

**1.2 Other Project Characteristics**

<b>Urbanization</b>	Urban	<b>Wind Speed (m/s)</b>	2.2	<b>Precipitation Freq (Days)</b>	33
<b>Climate Zone</b>	9			<b>Operational Year</b>	2028
<b>Utility Company</b>	Southern California Edison				
<b>CO2 Intensity (lb/MW hr)</b>	702.44	<b>CH4 Intensity (lb/MW hr)</b>	0.029	<b>N2O Intensity (lb/MW hr)</b>	0.006

**1.3 User Entered Comments & Non-Default Data**

## Village South Specific Plan (Proposed) - Los Angeles-South Coast County, Summer

Project Characteristics - Consistent with the DEIR's model.

Land Use - See SWAPE comment regarding residential and retail land uses.

Construction Phase - See SWAPE comment regarding individual construction phase lengths.

Demolition - Consistent with the DEIR's model. See SWAPE comment regarding demolition.

Vehicle Trips - Saturday trips consistent with the DEIR's model. See SWAPE comment regarding weekday and Sunday trips.

Woodstoves - Woodstoves and wood-burning fireplaces consistent with the DEIR's model. See SWAPE comment regarding gas fireplaces.

Energy Use -

Construction Off-road Equipment Mitigation - See SWAPE comment on construction-related mitigation.

Area Mitigation - See SWAPE comment regarding operational mitigation measures.

Water Mitigation - See SWAPE comment regarding operational mitigation measures.

Trips and VMT - Local hire provision

Table Name	Column Name	Default Value	New Value
tblFireplaces	FireplaceWoodMass	1,019.20	0.00
tblFireplaces	FireplaceWoodMass	1,019.20	0.00
tblFireplaces	NumberWood	1.25	0.00
tblFireplaces	NumberWood	48.75	0.00
tblTripsAndVMT	WorkerTripLength	14.70	10.00
tblTripsAndVMT	WorkerTripLength	14.70	10.00
tblTripsAndVMT	WorkerTripLength	14.70	10.00
tblTripsAndVMT	WorkerTripLength	14.70	10.00
tblTripsAndVMT	WorkerTripLength	14.70	10.00
tblTripsAndVMT	WorkerTripLength	14.70	10.00
tblVehicleTrips	ST_TR	7.16	6.17
tblVehicleTrips	ST_TR	6.39	3.87
tblVehicleTrips	ST_TR	2.46	1.39
tblVehicleTrips	ST_TR	158.37	79.82

## Village South Specific Plan (Proposed) - Los Angeles-South Coast County, Summer

tblVehicleTrips	ST_TR	8.19	3.75
tblVehicleTrips	ST_TR	94.36	63.99
tblVehicleTrips	ST_TR	49.97	10.74
tblVehicleTrips	SU_TR	6.07	6.16
tblVehicleTrips	SU_TR	5.86	4.18
tblVehicleTrips	SU_TR	1.05	0.69
tblVehicleTrips	SU_TR	131.84	78.27
tblVehicleTrips	SU_TR	5.95	3.20
tblVehicleTrips	SU_TR	72.16	57.65
tblVehicleTrips	SU_TR	25.24	6.39
tblVehicleTrips	WD_TR	6.59	5.83
tblVehicleTrips	WD_TR	6.65	4.13
tblVehicleTrips	WD_TR	11.03	6.41
tblVehicleTrips	WD_TR	127.15	65.80
tblVehicleTrips	WD_TR	8.17	3.84
tblVehicleTrips	WD_TR	89.95	62.64
tblVehicleTrips	WD_TR	42.70	9.43
tblWoodstoves	NumberCatalytic	1.25	0.00
tblWoodstoves	NumberCatalytic	48.75	0.00
tblWoodstoves	NumberNoncatalytic	1.25	0.00
tblWoodstoves	NumberNoncatalytic	48.75	0.00
tblWoodstoves	WoodstoveDayYear	25.00	0.00
tblWoodstoves	WoodstoveDayYear	25.00	0.00
tblWoodstoves	WoodstoveWoodMass	999.60	0.00
tblWoodstoves	WoodstoveWoodMass	999.60	0.00

## 2.0 Emissions Summary

---

Village South Specific Plan (Proposed) - Los Angeles-South Coast County, Summer

**2.1 Overall Construction (Maximum Daily Emission)**

**Unmitigated Construction**

	ROG	NOx	CO	SO2	Fugitive PM10	Exhaust PM10	PM10 Total	Fugitive PM2.5	Exhaust PM2.5	PM2.5 Total	Bio- CO2	NBio- CO2	Total CO2	CH4	N2O	CO2e
Year	lb/day										lb/day					
2021	4.2561	46.4415	31.4494	0.0636	18.2032	2.0456	20.2488	9.9670	1.8820	11.8490	0.0000	6,163.4166	6,163.4166	1.9475	0.0000	6,212.1039
2022	4.5441	38.8811	40.8776	0.1240	8.8255	1.6361	10.4616	3.6369	1.5052	5.1421	0.0000	12,493.4403	12,493.4403	1.9485	0.0000	12,518.5707
2023	4.1534	25.7658	38.7457	0.1206	7.0088	0.7592	7.7679	1.8799	0.7136	2.5935	0.0000	12,150.4890	12,150.4890	0.9589	0.0000	12,174.4615
2024	237.0219	9.5478	14.9642	0.0239	1.2171	0.4694	1.2875	0.3229	0.4319	0.4621	0.0000	2,313.1808	2,313.1808	0.7166	0.0000	2,331.0956
<b>Maximum</b>	<b>237.0219</b>	<b>46.4415</b>	<b>40.8776</b>	<b>0.1240</b>	<b>18.2032</b>	<b>2.0456</b>	<b>20.2488</b>	<b>9.9670</b>	<b>1.8820</b>	<b>11.8490</b>	<b>0.0000</b>	<b>12,493.4403</b>	<b>12,493.4403</b>	<b>1.9485</b>	<b>0.0000</b>	<b>12,518.5707</b>



Village South Specific Plan (Proposed) - Los Angeles-South Coast County, Summer

**2.2 Overall Operational**

**Unmitigated Operational**

	ROG	NOx	CO	SO2	Fugitive PM10	Exhaust PM10	PM10 Total	Fugitive PM2.5	Exhaust PM2.5	PM2.5 Total	Bio- CO2	NBio- CO2	Total CO2	CH4	N2O	CO2e
Category	lb/day										lb/day					
Area	30.5020	15.0496	88.4430	0.0944		1.5974	1.5974		1.5974	1.5974	0.0000	18,148.59 50	18,148.59 50	0.4874	0.3300	18,259.11 92
Energy	0.7660	6.7462	4.2573	0.0418		0.5292	0.5292		0.5292	0.5292		8,355.983 2	8,355.983 2	0.1602	0.1532	8,405.638 7
Mobile	9.8489	45.4304	114.8495	0.4917	45.9592	0.3360	46.2951	12.2950	0.3119	12.6070		50,306.60 34	50,306.60 34	2.1807		50,361.12 08
<b>Total</b>	<b>41.1168</b>	<b>67.2262</b>	<b>207.5497</b>	<b>0.6278</b>	<b>45.9592</b>	<b>2.4626</b>	<b>48.4217</b>	<b>12.2950</b>	<b>2.4385</b>	<b>14.7336</b>	<b>0.0000</b>	<b>76,811.18 16</b>	<b>76,811.18 16</b>	<b>2.8282</b>	<b>0.4832</b>	<b>77,025.87 86</b>

**Mitigated Operational**

	ROG	NOx	CO	SO2	Fugitive PM10	Exhaust PM10	PM10 Total	Fugitive PM2.5	Exhaust PM2.5	PM2.5 Total	Bio- CO2	NBio- CO2	Total CO2	CH4	N2O	CO2e
Category	lb/day										lb/day					
Area	30.5020	15.0496	88.4430	0.0944		1.5974	1.5974		1.5974	1.5974	0.0000	18,148.59 50	18,148.59 50	0.4874	0.3300	18,259.11 92
Energy	0.7660	6.7462	4.2573	0.0418		0.5292	0.5292		0.5292	0.5292		8,355.983 2	8,355.983 2	0.1602	0.1532	8,405.638 7
Mobile	9.8489	45.4304	114.8495	0.4917	45.9592	0.3360	46.2951	12.2950	0.3119	12.6070		50,306.60 34	50,306.60 34	2.1807		50,361.12 08
<b>Total</b>	<b>41.1168</b>	<b>67.2262</b>	<b>207.5497</b>	<b>0.6278</b>	<b>45.9592</b>	<b>2.4626</b>	<b>48.4217</b>	<b>12.2950</b>	<b>2.4385</b>	<b>14.7336</b>	<b>0.0000</b>	<b>76,811.18 16</b>	<b>76,811.18 16</b>	<b>2.8282</b>	<b>0.4832</b>	<b>77,025.87 86</b>



Village South Specific Plan (Proposed) - Los Angeles-South Coast County, Summer

	ROG	NOx	CO	SO2	Fugitive PM10	Exhaust PM10	PM10 Total	Fugitive PM2.5	Exhaust PM2.5	PM2.5 Total	Bio- CO2	NBio-CO2	Total CO2	CH4	N2O	CO2e
Percent Reduction	0.00	0.00	0.00	0.00	0.00	0.00	0.00	0.00	0.00	0.00	0.00	0.00	0.00	0.00	0.00	0.00

### 3.0 Construction Detail

#### Construction Phase

Phase Number	Phase Name	Phase Type	Start Date	End Date	Num Days Week	Num Days	Phase Description
1	Demolition	Demolition	9/1/2021	10/12/2021	5	30	
2	Site Preparation	Site Preparation	10/13/2021	11/9/2021	5	20	
3	Grading	Grading	11/10/2021	1/11/2022	5	45	
4	Building Construction	Building Construction	1/12/2022	12/12/2023	5	500	
5	Paving	Paving	12/13/2023	1/30/2024	5	35	
6	Architectural Coating	Architectural Coating	1/31/2024	3/19/2024	5	35	

Acres of Grading (Site Preparation Phase): 0

Acres of Grading (Grading Phase): 112.5

Acres of Paving: 0

Residential Indoor: 2,025,000; Residential Outdoor: 675,000; Non-Residential Indoor: 326,400; Non-Residential Outdoor: 108,800; Striped Parking Area: 0 (Architectural Coating – sqft)

#### OffRoad Equipment

## Village South Specific Plan (Proposed) - Los Angeles-South Coast County, Summer

Phase Name	Offroad Equipment Type	Amount	Usage Hours	Horse Power	Load Factor
Demolition	Concrete/Industrial Saws	1	8.00	81	0.73
Demolition	Excavators	3	8.00	158	0.38
Demolition	Rubber Tired Dozers	2	8.00	247	0.40
Site Preparation	Rubber Tired Dozers	3	8.00	247	0.40
Site Preparation	Tractors/Loaders/Backhoes	4	8.00	97	0.37
Grading	Excavators	2	8.00	158	0.38
Grading	Graders	1	8.00	187	0.41
Grading	Rubber Tired Dozers	1	8.00	247	0.40
Grading	Scrapers	2	8.00	367	0.48
Grading	Tractors/Loaders/Backhoes	2	8.00	97	0.37
Building Construction	Cranes	1	7.00	231	0.29
Building Construction	Forklifts	3	8.00	89	0.20
Building Construction	Generator Sets	1	8.00	84	0.74
Building Construction	Tractors/Loaders/Backhoes	3	7.00	97	0.37
Building Construction	Welders	1	8.00	46	0.45
Paving	Pavers	2	8.00	130	0.42
Paving	Paving Equipment	2	8.00	132	0.36
Paving	Rollers	2	8.00	80	0.38
Architectural Coating	Air Compressors	1	6.00	78	0.48

Trips and VMT

Village South Specific Plan (Proposed) - Los Angeles-South Coast County, Summer

Phase Name	Offroad Equipment Count	Worker Trip Number	Vendor Trip Number	Hauling Trip Number	Worker Trip Length	Vendor Trip Length	Hauling Trip Length	Worker Vehicle Class	Vendor Vehicle Class	Hauling Vehicle Class
Demolition	6	15.00	0.00	458.00	10.00	6.90	20.00	LD_Mix	HDT_Mix	HHDT
Site Preparation	7	18.00	0.00	0.00	10.00	6.90	20.00	LD_Mix	HDT_Mix	HHDT
Grading	8	20.00	0.00	0.00	10.00	6.90	20.00	LD_Mix	HDT_Mix	HHDT
Building Construction	9	801.00	143.00	0.00	10.00	6.90	20.00	LD_Mix	HDT_Mix	HHDT
Paving	6	15.00	0.00	0.00	10.00	6.90	20.00	LD_Mix	HDT_Mix	HHDT
Architectural Coating	1	160.00	0.00	0.00	10.00	6.90	20.00	LD_Mix	HDT_Mix	HHDT

**3.1 Mitigation Measures Construction**

**3.2 Demolition - 2021**

**Unmitigated Construction On-Site**

	ROG	NOx	CO	SO2	Fugitive PM10	Exhaust PM10	PM10 Total	Fugitive PM2.5	Exhaust PM2.5	PM2.5 Total	Bio- CO2	NBio- CO2	Total CO2	CH4	N2O	CO2e
Category	lb/day										lb/day					
Fugitive Dust					3.3074	0.0000	3.3074	0.5008	0.0000	0.5008			0.0000			0.0000
Off-Road	3.1651	31.4407	21.5650	0.0388		1.5513	1.5513		1.4411	1.4411		3,747.9449	3,747.9449	1.0549		3,774.3174
<b>Total</b>	<b>3.1651</b>	<b>31.4407</b>	<b>21.5650</b>	<b>0.0388</b>	<b>3.3074</b>	<b>1.5513</b>	<b>4.8588</b>	<b>0.5008</b>	<b>1.4411</b>	<b>1.9419</b>		<b>3,747.9449</b>	<b>3,747.9449</b>	<b>1.0549</b>		<b>3,774.3174</b>

Village South Specific Plan (Proposed) - Los Angeles-South Coast County, Summer

**3.2 Demolition - 2021**

**Unmitigated Construction Off-Site**

	ROG	NOx	CO	SO2	Fugitive PM10	Exhaust PM10	PM10 Total	Fugitive PM2.5	Exhaust PM2.5	PM2.5 Total	Bio- CO2	NBio- CO2	Total CO2	CH4	N2O	CO2e
Category	lb/day										lb/day					
Hauling	0.1273	4.0952	0.9602	0.0119	0.2669	0.0126	0.2795	0.0732	0.0120	0.0852		1,292.2413	1,292.2413	0.0877		1,294.4337
Vendor	0.0000	0.0000	0.0000	0.0000	0.0000	0.0000	0.0000	0.0000	0.0000	0.0000		0.0000	0.0000	0.0000		0.0000
Worker	0.0487	0.0313	0.4282	1.1800e-003	0.1141	9.5000e-004	0.1151	0.0303	8.8000e-004	0.0311		117.2799	117.2799	3.5200e-003		117.3678
<b>Total</b>	<b>0.1760</b>	<b>4.1265</b>	<b>1.3884</b>	<b>0.0131</b>	<b>0.3810</b>	<b>0.0135</b>	<b>0.3946</b>	<b>0.1034</b>	<b>0.0129</b>	<b>0.1163</b>		<b>1,409.5212</b>	<b>1,409.5212</b>	<b>0.0912</b>		<b>1,411.8015</b>

**Mitigated Construction On-Site**

	ROG	NOx	CO	SO2	Fugitive PM10	Exhaust PM10	PM10 Total	Fugitive PM2.5	Exhaust PM2.5	PM2.5 Total	Bio- CO2	NBio- CO2	Total CO2	CH4	N2O	CO2e
Category	lb/day										lb/day					
Fugitive Dust					3.3074	0.0000	3.3074	0.5008	0.0000	0.5008			0.0000			0.0000
Off-Road	3.1651	31.4407	21.5650	0.0388		1.5513	1.5513		1.4411	1.4411	0.0000	3,747.9449	3,747.9449	1.0549		3,774.3174
<b>Total</b>	<b>3.1651</b>	<b>31.4407</b>	<b>21.5650</b>	<b>0.0388</b>	<b>3.3074</b>	<b>1.5513</b>	<b>4.8588</b>	<b>0.5008</b>	<b>1.4411</b>	<b>1.9419</b>	<b>0.0000</b>	<b>3,747.9449</b>	<b>3,747.9449</b>	<b>1.0549</b>		<b>3,774.3174</b>

Village South Specific Plan (Proposed) - Los Angeles-South Coast County, Summer

**3.2 Demolition - 2021**

**Mitigated Construction Off-Site**

	ROG	NOx	CO	SO2	Fugitive PM10	Exhaust PM10	PM10 Total	Fugitive PM2.5	Exhaust PM2.5	PM2.5 Total	Bio- CO2	NBio- CO2	Total CO2	CH4	N2O	CO2e
Category	lb/day										lb/day					
Hauling	0.1273	4.0952	0.9602	0.0119	0.2669	0.0126	0.2795	0.0732	0.0120	0.0852		1,292.2413	1,292.2413	0.0877		1,294.4337
Vendor	0.0000	0.0000	0.0000	0.0000	0.0000	0.0000	0.0000	0.0000	0.0000	0.0000		0.0000	0.0000	0.0000		0.0000
Worker	0.0487	0.0313	0.4282	1.1800e-003	0.1141	9.5000e-004	0.1151	0.0303	8.8000e-004	0.0311		117.2799	117.2799	3.5200e-003		117.3678
<b>Total</b>	<b>0.1760</b>	<b>4.1265</b>	<b>1.3884</b>	<b>0.0131</b>	<b>0.3810</b>	<b>0.0135</b>	<b>0.3946</b>	<b>0.1034</b>	<b>0.0129</b>	<b>0.1163</b>		<b>1,409.5212</b>	<b>1,409.5212</b>	<b>0.0912</b>		<b>1,411.8015</b>

**3.3 Site Preparation - 2021**

**Unmitigated Construction On-Site**

	ROG	NOx	CO	SO2	Fugitive PM10	Exhaust PM10	PM10 Total	Fugitive PM2.5	Exhaust PM2.5	PM2.5 Total	Bio- CO2	NBio- CO2	Total CO2	CH4	N2O	CO2e
Category	lb/day										lb/day					
Fugitive Dust					18.0663	0.0000	18.0663	9.9307	0.0000	9.9307			0.0000			0.0000
Off-Road	3.8882	40.4971	21.1543	0.0380		2.0445	2.0445		1.8809	1.8809		3,685.6569	3,685.6569	1.1920		3,715.4573
<b>Total</b>	<b>3.8882</b>	<b>40.4971</b>	<b>21.1543</b>	<b>0.0380</b>	<b>18.0663</b>	<b>2.0445</b>	<b>20.1107</b>	<b>9.9307</b>	<b>1.8809</b>	<b>11.8116</b>		<b>3,685.6569</b>	<b>3,685.6569</b>	<b>1.1920</b>		<b>3,715.4573</b>

Village South Specific Plan (Proposed) - Los Angeles-South Coast County, Summer

**3.3 Site Preparation - 2021**

**Unmitigated Construction Off-Site**

	ROG	NOx	CO	SO2	Fugitive PM10	Exhaust PM10	PM10 Total	Fugitive PM2.5	Exhaust PM2.5	PM2.5 Total	Bio- CO2	NBio- CO2	Total CO2	CH4	N2O	CO2e
Category	lb/day										lb/day					
Hauling	0.0000	0.0000	0.0000	0.0000	0.0000	0.0000	0.0000	0.0000	0.0000	0.0000		0.0000	0.0000	0.0000		0.0000
Vendor	0.0000	0.0000	0.0000	0.0000	0.0000	0.0000	0.0000	0.0000	0.0000	0.0000		0.0000	0.0000	0.0000		0.0000
Worker	0.0584	0.0375	0.5139	1.4100e-003	0.1369	1.1400e-003	0.1381	0.0363	1.0500e-003	0.0374		140.7359	140.7359	4.2200e-003		140.8414
<b>Total</b>	<b>0.0584</b>	<b>0.0375</b>	<b>0.5139</b>	<b>1.4100e-003</b>	<b>0.1369</b>	<b>1.1400e-003</b>	<b>0.1381</b>	<b>0.0363</b>	<b>1.0500e-003</b>	<b>0.0374</b>		<b>140.7359</b>	<b>140.7359</b>	<b>4.2200e-003</b>		<b>140.8414</b>

**Mitigated Construction On-Site**

	ROG	NOx	CO	SO2	Fugitive PM10	Exhaust PM10	PM10 Total	Fugitive PM2.5	Exhaust PM2.5	PM2.5 Total	Bio- CO2	NBio- CO2	Total CO2	CH4	N2O	CO2e
Category	lb/day										lb/day					
Fugitive Dust					18.0663	0.0000	18.0663	9.9307	0.0000	9.9307			0.0000			0.0000
Off-Road	3.8882	40.4971	21.1543	0.0380		2.0445	2.0445		1.8809	1.8809	0.0000	3,685.6569	3,685.6569	1.1920		3,715.4573
<b>Total</b>	<b>3.8882</b>	<b>40.4971</b>	<b>21.1543</b>	<b>0.0380</b>	<b>18.0663</b>	<b>2.0445</b>	<b>20.1107</b>	<b>9.9307</b>	<b>1.8809</b>	<b>11.8116</b>	<b>0.0000</b>	<b>3,685.6569</b>	<b>3,685.6569</b>	<b>1.1920</b>		<b>3,715.4573</b>

Village South Specific Plan (Proposed) - Los Angeles-South Coast County, Summer

**3.3 Site Preparation - 2021**

**Mitigated Construction Off-Site**

	ROG	NOx	CO	SO2	Fugitive PM10	Exhaust PM10	PM10 Total	Fugitive PM2.5	Exhaust PM2.5	PM2.5 Total	Bio- CO2	NBio- CO2	Total CO2	CH4	N2O	CO2e
Category	lb/day										lb/day					
Hauling	0.0000	0.0000	0.0000	0.0000	0.0000	0.0000	0.0000	0.0000	0.0000	0.0000		0.0000	0.0000	0.0000		0.0000
Vendor	0.0000	0.0000	0.0000	0.0000	0.0000	0.0000	0.0000	0.0000	0.0000	0.0000		0.0000	0.0000	0.0000		0.0000
Worker	0.0584	0.0375	0.5139	1.4100e-003	0.1369	1.1400e-003	0.1381	0.0363	1.0500e-003	0.0374		140.7359	140.7359	4.2200e-003		140.8414
<b>Total</b>	<b>0.0584</b>	<b>0.0375</b>	<b>0.5139</b>	<b>1.4100e-003</b>	<b>0.1369</b>	<b>1.1400e-003</b>	<b>0.1381</b>	<b>0.0363</b>	<b>1.0500e-003</b>	<b>0.0374</b>		<b>140.7359</b>	<b>140.7359</b>	<b>4.2200e-003</b>		<b>140.8414</b>

**3.4 Grading - 2021**

**Unmitigated Construction On-Site**

	ROG	NOx	CO	SO2	Fugitive PM10	Exhaust PM10	PM10 Total	Fugitive PM2.5	Exhaust PM2.5	PM2.5 Total	Bio- CO2	NBio- CO2	Total CO2	CH4	N2O	CO2e
Category	lb/day										lb/day					
Fugitive Dust					8.6733	0.0000	8.6733	3.5965	0.0000	3.5965			0.0000			0.0000
Off-Road	4.1912	46.3998	30.8785	0.0620		1.9853	1.9853		1.8265	1.8265		6,007.0434	6,007.0434	1.9428		6,055.6134
<b>Total</b>	<b>4.1912</b>	<b>46.3998</b>	<b>30.8785</b>	<b>0.0620</b>	<b>8.6733</b>	<b>1.9853</b>	<b>10.6587</b>	<b>3.5965</b>	<b>1.8265</b>	<b>5.4230</b>		<b>6,007.0434</b>	<b>6,007.0434</b>	<b>1.9428</b>		<b>6,055.6134</b>

Village South Specific Plan (Proposed) - Los Angeles-South Coast County, Summer

**3.4 Grading - 2021**

**Unmitigated Construction Off-Site**

	ROG	NOx	CO	SO2	Fugitive PM10	Exhaust PM10	PM10 Total	Fugitive PM2.5	Exhaust PM2.5	PM2.5 Total	Bio- CO2	NBio- CO2	Total CO2	CH4	N2O	CO2e
Category	lb/day										lb/day					
Hauling	0.0000	0.0000	0.0000	0.0000	0.0000	0.0000	0.0000	0.0000	0.0000	0.0000		0.0000	0.0000	0.0000		0.0000
Vendor	0.0000	0.0000	0.0000	0.0000	0.0000	0.0000	0.0000	0.0000	0.0000	0.0000		0.0000	0.0000	0.0000		0.0000
Worker	0.0649	0.0417	0.5710	1.5700e-003	0.1521	1.2700e-003	0.1534	0.0404	1.1700e-003	0.0415		156.3732	156.3732	4.6900e-003		156.4904
<b>Total</b>	<b>0.0649</b>	<b>0.0417</b>	<b>0.5710</b>	<b>1.5700e-003</b>	<b>0.1521</b>	<b>1.2700e-003</b>	<b>0.1534</b>	<b>0.0404</b>	<b>1.1700e-003</b>	<b>0.0415</b>		<b>156.3732</b>	<b>156.3732</b>	<b>4.6900e-003</b>		<b>156.4904</b>

**Mitigated Construction On-Site**

	ROG	NOx	CO	SO2	Fugitive PM10	Exhaust PM10	PM10 Total	Fugitive PM2.5	Exhaust PM2.5	PM2.5 Total	Bio- CO2	NBio- CO2	Total CO2	CH4	N2O	CO2e
Category	lb/day										lb/day					
Fugitive Dust					8.6733	0.0000	8.6733	3.5965	0.0000	3.5965			0.0000			0.0000
Off-Road	4.1912	46.3998	30.8785	0.0620		1.9853	1.9853		1.8265	1.8265	0.0000	6,007.0434	6,007.0434	1.9428		6,055.6134
<b>Total</b>	<b>4.1912</b>	<b>46.3998</b>	<b>30.8785</b>	<b>0.0620</b>	<b>8.6733</b>	<b>1.9853</b>	<b>10.6587</b>	<b>3.5965</b>	<b>1.8265</b>	<b>5.4230</b>	<b>0.0000</b>	<b>6,007.0434</b>	<b>6,007.0434</b>	<b>1.9428</b>		<b>6,055.6134</b>



Village South Specific Plan (Proposed) - Los Angeles-South Coast County, Summer

**3.4 Grading - 2021**

**Mitigated Construction Off-Site**

	ROG	NOx	CO	SO2	Fugitive PM10	Exhaust PM10	PM10 Total	Fugitive PM2.5	Exhaust PM2.5	PM2.5 Total	Bio- CO2	NBio- CO2	Total CO2	CH4	N2O	CO2e
Category	lb/day										lb/day					
Hauling	0.0000	0.0000	0.0000	0.0000	0.0000	0.0000	0.0000	0.0000	0.0000	0.0000		0.0000	0.0000	0.0000		0.0000
Vendor	0.0000	0.0000	0.0000	0.0000	0.0000	0.0000	0.0000	0.0000	0.0000	0.0000		0.0000	0.0000	0.0000		0.0000
Worker	0.0649	0.0417	0.5710	1.5700e-003	0.1521	1.2700e-003	0.1534	0.0404	1.1700e-003	0.0415		156.3732	156.3732	4.6900e-003		156.4904
<b>Total</b>	<b>0.0649</b>	<b>0.0417</b>	<b>0.5710</b>	<b>1.5700e-003</b>	<b>0.1521</b>	<b>1.2700e-003</b>	<b>0.1534</b>	<b>0.0404</b>	<b>1.1700e-003</b>	<b>0.0415</b>		<b>156.3732</b>	<b>156.3732</b>	<b>4.6900e-003</b>		<b>156.4904</b>

**3.4 Grading - 2022**

**Unmitigated Construction On-Site**

	ROG	NOx	CO	SO2	Fugitive PM10	Exhaust PM10	PM10 Total	Fugitive PM2.5	Exhaust PM2.5	PM2.5 Total	Bio- CO2	NBio- CO2	Total CO2	CH4	N2O	CO2e
Category	lb/day										lb/day					
Fugitive Dust					8.6733	0.0000	8.6733	3.5965	0.0000	3.5965			0.0000			0.0000
Off-Road	3.6248	38.8435	29.0415	0.0621		1.6349	1.6349		1.5041	1.5041		6,011.4105	6,011.4105	1.9442		6,060.0158
<b>Total</b>	<b>3.6248</b>	<b>38.8435</b>	<b>29.0415</b>	<b>0.0621</b>	<b>8.6733</b>	<b>1.6349</b>	<b>10.3082</b>	<b>3.5965</b>	<b>1.5041</b>	<b>5.1006</b>		<b>6,011.4105</b>	<b>6,011.4105</b>	<b>1.9442</b>		<b>6,060.0158</b>

Village South Specific Plan (Proposed) - Los Angeles-South Coast County, Summer

**3.4 Grading - 2022**

**Unmitigated Construction Off-Site**

	ROG	NOx	CO	SO2	Fugitive PM10	Exhaust PM10	PM10 Total	Fugitive PM2.5	Exhaust PM2.5	PM2.5 Total	Bio- CO2	NBio- CO2	Total CO2	CH4	N2O	CO2e
Category	lb/day										lb/day					
Hauling	0.0000	0.0000	0.0000	0.0000	0.0000	0.0000	0.0000	0.0000	0.0000	0.0000		0.0000	0.0000	0.0000		0.0000
Vendor	0.0000	0.0000	0.0000	0.0000	0.0000	0.0000	0.0000	0.0000	0.0000	0.0000		0.0000	0.0000	0.0000		0.0000
Worker	0.0607	0.0376	0.5263	1.5100e-003	0.1521	1.2300e-003	0.1534	0.0404	1.1300e-003	0.0415		150.8754	150.8754	4.2400e-003		150.9813
<b>Total</b>	<b>0.0607</b>	<b>0.0376</b>	<b>0.5263</b>	<b>1.5100e-003</b>	<b>0.1521</b>	<b>1.2300e-003</b>	<b>0.1534</b>	<b>0.0404</b>	<b>1.1300e-003</b>	<b>0.0415</b>		<b>150.8754</b>	<b>150.8754</b>	<b>4.2400e-003</b>		<b>150.9813</b>

**Mitigated Construction On-Site**

	ROG	NOx	CO	SO2	Fugitive PM10	Exhaust PM10	PM10 Total	Fugitive PM2.5	Exhaust PM2.5	PM2.5 Total	Bio- CO2	NBio- CO2	Total CO2	CH4	N2O	CO2e
Category	lb/day										lb/day					
Fugitive Dust					8.6733	0.0000	8.6733	3.5965	0.0000	3.5965			0.0000			0.0000
Off-Road	3.6248	38.8435	29.0415	0.0621		1.6349	1.6349		1.5041	1.5041	0.0000	6,011.4105	6,011.4105	1.9442		6,060.0158
<b>Total</b>	<b>3.6248</b>	<b>38.8435</b>	<b>29.0415</b>	<b>0.0621</b>	<b>8.6733</b>	<b>1.6349</b>	<b>10.3082</b>	<b>3.5965</b>	<b>1.5041</b>	<b>5.1006</b>	<b>0.0000</b>	<b>6,011.4105</b>	<b>6,011.4105</b>	<b>1.9442</b>		<b>6,060.0158</b>

Village South Specific Plan (Proposed) - Los Angeles-South Coast County, Summer

**3.4 Grading - 2022**

**Mitigated Construction Off-Site**

	ROG	NOx	CO	SO2	Fugitive PM10	Exhaust PM10	PM10 Total	Fugitive PM2.5	Exhaust PM2.5	PM2.5 Total	Bio- CO2	NBio- CO2	Total CO2	CH4	N2O	CO2e
Category	lb/day										lb/day					
Hauling	0.0000	0.0000	0.0000	0.0000	0.0000	0.0000	0.0000	0.0000	0.0000	0.0000		0.0000	0.0000	0.0000		0.0000
Vendor	0.0000	0.0000	0.0000	0.0000	0.0000	0.0000	0.0000	0.0000	0.0000	0.0000		0.0000	0.0000	0.0000		0.0000
Worker	0.0607	0.0376	0.5263	1.5100e-003	0.1521	1.2300e-003	0.1534	0.0404	1.1300e-003	0.0415		150.8754	150.8754	4.2400e-003		150.9813
<b>Total</b>	<b>0.0607</b>	<b>0.0376</b>	<b>0.5263</b>	<b>1.5100e-003</b>	<b>0.1521</b>	<b>1.2300e-003</b>	<b>0.1534</b>	<b>0.0404</b>	<b>1.1300e-003</b>	<b>0.0415</b>		<b>150.8754</b>	<b>150.8754</b>	<b>4.2400e-003</b>		<b>150.9813</b>

**3.5 Building Construction - 2022**

**Unmitigated Construction On-Site**

	ROG	NOx	CO	SO2	Fugitive PM10	Exhaust PM10	PM10 Total	Fugitive PM2.5	Exhaust PM2.5	PM2.5 Total	Bio- CO2	NBio- CO2	Total CO2	CH4	N2O	CO2e
Category	lb/day										lb/day					
Off-Road	1.7062	15.6156	16.3634	0.0269		0.8090	0.8090		0.7612	0.7612		2,554.3336	2,554.3336	0.6120		2,569.6322
<b>Total</b>	<b>1.7062</b>	<b>15.6156</b>	<b>16.3634</b>	<b>0.0269</b>		<b>0.8090</b>	<b>0.8090</b>		<b>0.7612</b>	<b>0.7612</b>		<b>2,554.3336</b>	<b>2,554.3336</b>	<b>0.6120</b>		<b>2,569.6322</b>

Village South Specific Plan (Proposed) - Los Angeles-South Coast County, Summer

**3.5 Building Construction - 2022**

**Unmitigated Construction Off-Site**

	ROG	NOx	CO	SO2	Fugitive PM10	Exhaust PM10	PM10 Total	Fugitive PM2.5	Exhaust PM2.5	PM2.5 Total	Bio- CO2	NBio- CO2	Total CO2	CH4	N2O	CO2e
Category	lb/day										lb/day					
Hauling	0.0000	0.0000	0.0000	0.0000	0.0000	0.0000	0.0000	0.0000	0.0000	0.0000		0.0000	0.0000	0.0000		0.0000
Vendor	0.4079	13.2032	3.4341	0.0364	0.9155	0.0248	0.9404	0.2636	0.0237	0.2873		3,896.548 2	3,896.548 2	0.2236		3,902.138 4
Worker	2.4299	1.5074	21.0801	0.0607	6.0932	0.0493	6.1425	1.6163	0.0454	1.6617		6,042.558 5	6,042.558 5	0.1697		6,046.800 0
<b>Total</b>	<b>2.8378</b>	<b>14.7106</b>	<b>24.5142</b>	<b>0.0971</b>	<b>7.0087</b>	<b>0.0741</b>	<b>7.0828</b>	<b>1.8799</b>	<b>0.0691</b>	<b>1.9490</b>		<b>9,939.106 7</b>	<b>9,939.106 7</b>	<b>0.3933</b>		<b>9,948.938 4</b>

**Mitigated Construction On-Site**

	ROG	NOx	CO	SO2	Fugitive PM10	Exhaust PM10	PM10 Total	Fugitive PM2.5	Exhaust PM2.5	PM2.5 Total	Bio- CO2	NBio- CO2	Total CO2	CH4	N2O	CO2e
Category	lb/day										lb/day					
Off-Road	1.7062	15.6156	16.3634	0.0269		0.8090	0.8090		0.7612	0.7612	0.0000	2,554.333 6	2,554.333 6	0.6120		2,569.632 2
<b>Total</b>	<b>1.7062</b>	<b>15.6156</b>	<b>16.3634</b>	<b>0.0269</b>		<b>0.8090</b>	<b>0.8090</b>		<b>0.7612</b>	<b>0.7612</b>	<b>0.0000</b>	<b>2,554.333 6</b>	<b>2,554.333 6</b>	<b>0.6120</b>		<b>2,569.632 2</b>

Village South Specific Plan (Proposed) - Los Angeles-South Coast County, Summer

**3.5 Building Construction - 2022**

**Mitigated Construction Off-Site**

	ROG	NOx	CO	SO2	Fugitive PM10	Exhaust PM10	PM10 Total	Fugitive PM2.5	Exhaust PM2.5	PM2.5 Total	Bio- CO2	NBio- CO2	Total CO2	CH4	N2O	CO2e
Category	lb/day										lb/day					
Hauling	0.0000	0.0000	0.0000	0.0000	0.0000	0.0000	0.0000	0.0000	0.0000	0.0000		0.0000	0.0000	0.0000		0.0000
Vendor	0.4079	13.2032	3.4341	0.0364	0.9155	0.0248	0.9404	0.2636	0.0237	0.2873		3,896.548 2	3,896.548 2	0.2236		3,902.138 4
Worker	2.4299	1.5074	21.0801	0.0607	6.0932	0.0493	6.1425	1.6163	0.0454	1.6617		6,042.558 5	6,042.558 5	0.1697		6,046.800 0
<b>Total</b>	<b>2.8378</b>	<b>14.7106</b>	<b>24.5142</b>	<b>0.0971</b>	<b>7.0087</b>	<b>0.0741</b>	<b>7.0828</b>	<b>1.8799</b>	<b>0.0691</b>	<b>1.9490</b>		<b>9,939.106 7</b>	<b>9,939.106 7</b>	<b>0.3933</b>		<b>9,948.938 4</b>

**3.5 Building Construction - 2023**

**Unmitigated Construction On-Site**

	ROG	NOx	CO	SO2	Fugitive PM10	Exhaust PM10	PM10 Total	Fugitive PM2.5	Exhaust PM2.5	PM2.5 Total	Bio- CO2	NBio- CO2	Total CO2	CH4	N2O	CO2e
Category	lb/day										lb/day					
Off-Road	1.5728	14.3849	16.2440	0.0269		0.6997	0.6997		0.6584	0.6584		2,555.209 9	2,555.209 9	0.6079		2,570.406 1
<b>Total</b>	<b>1.5728</b>	<b>14.3849</b>	<b>16.2440</b>	<b>0.0269</b>		<b>0.6997</b>	<b>0.6997</b>		<b>0.6584</b>	<b>0.6584</b>		<b>2,555.209 9</b>	<b>2,555.209 9</b>	<b>0.6079</b>		<b>2,570.406 1</b>

Village South Specific Plan (Proposed) - Los Angeles-South Coast County, Summer

**3.5 Building Construction - 2023**

**Unmitigated Construction Off-Site**

	ROG	NOx	CO	SO2	Fugitive PM10	Exhaust PM10	PM10 Total	Fugitive PM2.5	Exhaust PM2.5	PM2.5 Total	Bio- CO2	NBio- CO2	Total CO2	CH4	N2O	CO2e
Category	lb/day										lb/day					
Hauling	0.0000	0.0000	0.0000	0.0000	0.0000	0.0000	0.0000	0.0000	0.0000	0.0000		0.0000	0.0000	0.0000		0.0000
Vendor	0.3027	10.0181	3.1014	0.0352	0.9156	0.0116	0.9271	0.2636	0.0111	0.2747		3,773.876 2	3,773.876 2	0.1982		3,778.830 0
Worker	2.2780	1.3628	19.4002	0.0584	6.0932	0.0479	6.1411	1.6163	0.0441	1.6604		5,821.402 8	5,821.402 8	0.1529		5,825.225 4
<b>Total</b>	<b>2.5807</b>	<b>11.3809</b>	<b>22.5017</b>	<b>0.0936</b>	<b>7.0088</b>	<b>0.0595</b>	<b>7.0682</b>	<b>1.8799</b>	<b>0.0552</b>	<b>1.9350</b>		<b>9,595.279 0</b>	<b>9,595.279 0</b>	<b>0.3511</b>		<b>9,604.055 4</b>

**Mitigated Construction On-Site**

	ROG	NOx	CO	SO2	Fugitive PM10	Exhaust PM10	PM10 Total	Fugitive PM2.5	Exhaust PM2.5	PM2.5 Total	Bio- CO2	NBio- CO2	Total CO2	CH4	N2O	CO2e
Category	lb/day										lb/day					
Off-Road	1.5728	14.3849	16.2440	0.0269		0.6997	0.6997		0.6584	0.6584	0.0000	2,555.209 9	2,555.209 9	0.6079		2,570.406 1
<b>Total</b>	<b>1.5728</b>	<b>14.3849</b>	<b>16.2440</b>	<b>0.0269</b>		<b>0.6997</b>	<b>0.6997</b>		<b>0.6584</b>	<b>0.6584</b>	<b>0.0000</b>	<b>2,555.209 9</b>	<b>2,555.209 9</b>	<b>0.6079</b>		<b>2,570.406 1</b>

Village South Specific Plan (Proposed) - Los Angeles-South Coast County, Summer

**3.5 Building Construction - 2023**

**Mitigated Construction Off-Site**

	ROG	NOx	CO	SO2	Fugitive PM10	Exhaust PM10	PM10 Total	Fugitive PM2.5	Exhaust PM2.5	PM2.5 Total	Bio- CO2	NBio- CO2	Total CO2	CH4	N2O	CO2e
Category	lb/day										lb/day					
Hauling	0.0000	0.0000	0.0000	0.0000	0.0000	0.0000	0.0000	0.0000	0.0000	0.0000		0.0000	0.0000	0.0000		0.0000
Vendor	0.3027	10.0181	3.1014	0.0352	0.9156	0.0116	0.9271	0.2636	0.0111	0.2747		3,773.876 2	3,773.876 2	0.1982		3,778.830 0
Worker	2.2780	1.3628	19.4002	0.0584	6.0932	0.0479	6.1411	1.6163	0.0441	1.6604		5,821.402 8	5,821.402 8	0.1529		5,825.225 4
<b>Total</b>	<b>2.5807</b>	<b>11.3809</b>	<b>22.5017</b>	<b>0.0936</b>	<b>7.0088</b>	<b>0.0595</b>	<b>7.0682</b>	<b>1.8799</b>	<b>0.0552</b>	<b>1.9350</b>		<b>9,595.279 0</b>	<b>9,595.279 0</b>	<b>0.3511</b>		<b>9,604.055 4</b>

**3.6 Paving - 2023**

**Unmitigated Construction On-Site**

	ROG	NOx	CO	SO2	Fugitive PM10	Exhaust PM10	PM10 Total	Fugitive PM2.5	Exhaust PM2.5	PM2.5 Total	Bio- CO2	NBio- CO2	Total CO2	CH4	N2O	CO2e
Category	lb/day										lb/day					
Off-Road	1.0327	10.1917	14.5842	0.0228		0.5102	0.5102		0.4694	0.4694		2,207.584 1	2,207.584 1	0.7140		2,225.433 6
Paving	0.0000					0.0000	0.0000		0.0000	0.0000			0.0000			0.0000
<b>Total</b>	<b>1.0327</b>	<b>10.1917</b>	<b>14.5842</b>	<b>0.0228</b>		<b>0.5102</b>	<b>0.5102</b>		<b>0.4694</b>	<b>0.4694</b>		<b>2,207.584 1</b>	<b>2,207.584 1</b>	<b>0.7140</b>		<b>2,225.433 6</b>

Village South Specific Plan (Proposed) - Los Angeles-South Coast County, Summer

**3.6 Paving - 2023**

**Unmitigated Construction Off-Site**

	ROG	NOx	CO	SO2	Fugitive PM10	Exhaust PM10	PM10 Total	Fugitive PM2.5	Exhaust PM2.5	PM2.5 Total	Bio- CO2	NBio- CO2	Total CO2	CH4	N2O	CO2e
Category	lb/day										lb/day					
Hauling	0.0000	0.0000	0.0000	0.0000	0.0000	0.0000	0.0000	0.0000	0.0000	0.0000		0.0000	0.0000	0.0000		0.0000
Vendor	0.0000	0.0000	0.0000	0.0000	0.0000	0.0000	0.0000	0.0000	0.0000	0.0000		0.0000	0.0000	0.0000		0.0000
Worker	0.0427	0.0255	0.3633	1.0900e-003	0.1141	9.0000e-004	0.1150	0.0303	8.3000e-004	0.0311		109.0150	109.0150	2.8600e-003		109.0866
<b>Total</b>	<b>0.0427</b>	<b>0.0255</b>	<b>0.3633</b>	<b>1.0900e-003</b>	<b>0.1141</b>	<b>9.0000e-004</b>	<b>0.1150</b>	<b>0.0303</b>	<b>8.3000e-004</b>	<b>0.0311</b>		<b>109.0150</b>	<b>109.0150</b>	<b>2.8600e-003</b>		<b>109.0866</b>

**Mitigated Construction On-Site**

	ROG	NOx	CO	SO2	Fugitive PM10	Exhaust PM10	PM10 Total	Fugitive PM2.5	Exhaust PM2.5	PM2.5 Total	Bio- CO2	NBio- CO2	Total CO2	CH4	N2O	CO2e
Category	lb/day										lb/day					
Off-Road	1.0327	10.1917	14.5842	0.0228		0.5102	0.5102		0.4694	0.4694	0.0000	2,207.5841	2,207.5841	0.7140		2,225.4336
Paving	0.0000					0.0000	0.0000		0.0000	0.0000			0.0000			0.0000
<b>Total</b>	<b>1.0327</b>	<b>10.1917</b>	<b>14.5842</b>	<b>0.0228</b>		<b>0.5102</b>	<b>0.5102</b>		<b>0.4694</b>	<b>0.4694</b>	<b>0.0000</b>	<b>2,207.5841</b>	<b>2,207.5841</b>	<b>0.7140</b>		<b>2,225.4336</b>



Village South Specific Plan (Proposed) - Los Angeles-South Coast County, Summer

**3.6 Paving - 2023**

**Mitigated Construction Off-Site**

	ROG	NOx	CO	SO2	Fugitive PM10	Exhaust PM10	PM10 Total	Fugitive PM2.5	Exhaust PM2.5	PM2.5 Total	Bio- CO2	NBio- CO2	Total CO2	CH4	N2O	CO2e
Category	lb/day										lb/day					
Hauling	0.0000	0.0000	0.0000	0.0000	0.0000	0.0000	0.0000	0.0000	0.0000	0.0000		0.0000	0.0000	0.0000		0.0000
Vendor	0.0000	0.0000	0.0000	0.0000	0.0000	0.0000	0.0000	0.0000	0.0000	0.0000		0.0000	0.0000	0.0000		0.0000
Worker	0.0427	0.0255	0.3633	1.0900e-003	0.1141	9.0000e-004	0.1150	0.0303	8.3000e-004	0.0311		109.0150	109.0150	2.8600e-003		109.0866
<b>Total</b>	<b>0.0427</b>	<b>0.0255</b>	<b>0.3633</b>	<b>1.0900e-003</b>	<b>0.1141</b>	<b>9.0000e-004</b>	<b>0.1150</b>	<b>0.0303</b>	<b>8.3000e-004</b>	<b>0.0311</b>		<b>109.0150</b>	<b>109.0150</b>	<b>2.8600e-003</b>		<b>109.0866</b>

**3.6 Paving - 2024**

**Unmitigated Construction On-Site**

	ROG	NOx	CO	SO2	Fugitive PM10	Exhaust PM10	PM10 Total	Fugitive PM2.5	Exhaust PM2.5	PM2.5 Total	Bio- CO2	NBio- CO2	Total CO2	CH4	N2O	CO2e
Category	lb/day										lb/day					
Off-Road	0.9882	9.5246	14.6258	0.0228		0.4685	0.4685		0.4310	0.4310		2,207.5472	2,207.5472	0.7140		2,225.3963
Paving	0.0000					0.0000	0.0000		0.0000	0.0000			0.0000			0.0000
<b>Total</b>	<b>0.9882</b>	<b>9.5246</b>	<b>14.6258</b>	<b>0.0228</b>		<b>0.4685</b>	<b>0.4685</b>		<b>0.4310</b>	<b>0.4310</b>		<b>2,207.5472</b>	<b>2,207.5472</b>	<b>0.7140</b>		<b>2,225.3963</b>

Village South Specific Plan (Proposed) - Los Angeles-South Coast County, Summer

**3.6 Paving - 2024**

**Unmitigated Construction Off-Site**

	ROG	NOx	CO	SO2	Fugitive PM10	Exhaust PM10	PM10 Total	Fugitive PM2.5	Exhaust PM2.5	PM2.5 Total	Bio- CO2	NBio- CO2	Total CO2	CH4	N2O	CO2e
Category	lb/day										lb/day					
Hauling	0.0000	0.0000	0.0000	0.0000	0.0000	0.0000	0.0000	0.0000	0.0000	0.0000		0.0000	0.0000	0.0000		0.0000
Vendor	0.0000	0.0000	0.0000	0.0000	0.0000	0.0000	0.0000	0.0000	0.0000	0.0000		0.0000	0.0000	0.0000		0.0000
Worker	0.0403	0.0233	0.3384	1.0600e-003	0.1141	8.8000e-004	0.1150	0.0303	8.1000e-004	0.0311		105.6336	105.6336	2.6300e-003		105.6992
<b>Total</b>	<b>0.0403</b>	<b>0.0233</b>	<b>0.3384</b>	<b>1.0600e-003</b>	<b>0.1141</b>	<b>8.8000e-004</b>	<b>0.1150</b>	<b>0.0303</b>	<b>8.1000e-004</b>	<b>0.0311</b>		<b>105.6336</b>	<b>105.6336</b>	<b>2.6300e-003</b>		<b>105.6992</b>

**Mitigated Construction On-Site**

	ROG	NOx	CO	SO2	Fugitive PM10	Exhaust PM10	PM10 Total	Fugitive PM2.5	Exhaust PM2.5	PM2.5 Total	Bio- CO2	NBio- CO2	Total CO2	CH4	N2O	CO2e
Category	lb/day										lb/day					
Off-Road	0.9882	9.5246	14.6258	0.0228		0.4685	0.4685		0.4310	0.4310	0.0000	2,207.5472	2,207.5472	0.7140		2,225.3963
Paving	0.0000					0.0000	0.0000		0.0000	0.0000			0.0000			0.0000
<b>Total</b>	<b>0.9882</b>	<b>9.5246</b>	<b>14.6258</b>	<b>0.0228</b>		<b>0.4685</b>	<b>0.4685</b>		<b>0.4310</b>	<b>0.4310</b>	<b>0.0000</b>	<b>2,207.5472</b>	<b>2,207.5472</b>	<b>0.7140</b>		<b>2,225.3963</b>

Village South Specific Plan (Proposed) - Los Angeles-South Coast County, Summer

**3.6 Paving - 2024**

**Mitigated Construction Off-Site**

	ROG	NOx	CO	SO2	Fugitive PM10	Exhaust PM10	PM10 Total	Fugitive PM2.5	Exhaust PM2.5	PM2.5 Total	Bio- CO2	NBio- CO2	Total CO2	CH4	N2O	CO2e
Category	lb/day										lb/day					
Hauling	0.0000	0.0000	0.0000	0.0000	0.0000	0.0000	0.0000	0.0000	0.0000	0.0000		0.0000	0.0000	0.0000		0.0000
Vendor	0.0000	0.0000	0.0000	0.0000	0.0000	0.0000	0.0000	0.0000	0.0000	0.0000		0.0000	0.0000	0.0000		0.0000
Worker	0.0403	0.0233	0.3384	1.0600e-003	0.1141	8.8000e-004	0.1150	0.0303	8.1000e-004	0.0311		105.6336	105.6336	2.6300e-003		105.6992
<b>Total</b>	<b>0.0403</b>	<b>0.0233</b>	<b>0.3384</b>	<b>1.0600e-003</b>	<b>0.1141</b>	<b>8.8000e-004</b>	<b>0.1150</b>	<b>0.0303</b>	<b>8.1000e-004</b>	<b>0.0311</b>		<b>105.6336</b>	<b>105.6336</b>	<b>2.6300e-003</b>		<b>105.6992</b>

**3.7 Architectural Coating - 2024**

**Unmitigated Construction On-Site**

	ROG	NOx	CO	SO2	Fugitive PM10	Exhaust PM10	PM10 Total	Fugitive PM2.5	Exhaust PM2.5	PM2.5 Total	Bio- CO2	NBio- CO2	Total CO2	CH4	N2O	CO2e
Category	lb/day										lb/day					
Archit. Coating	236.4115					0.0000	0.0000		0.0000	0.0000			0.0000			0.0000
Off-Road	0.1808	1.2188	1.8101	2.9700e-003		0.0609	0.0609		0.0609	0.0609		281.4481	281.4481	0.0159		281.8443
<b>Total</b>	<b>236.5923</b>	<b>1.2188</b>	<b>1.8101</b>	<b>2.9700e-003</b>		<b>0.0609</b>	<b>0.0609</b>		<b>0.0609</b>	<b>0.0609</b>		<b>281.4481</b>	<b>281.4481</b>	<b>0.0159</b>		<b>281.8443</b>

Village South Specific Plan (Proposed) - Los Angeles-South Coast County, Summer

**3.7 Architectural Coating - 2024**

**Unmitigated Construction Off-Site**

	ROG	NOx	CO	SO2	Fugitive PM10	Exhaust PM10	PM10 Total	Fugitive PM2.5	Exhaust PM2.5	PM2.5 Total	Bio- CO2	NBio- CO2	Total CO2	CH4	N2O	CO2e
Category	lb/day										lb/day					
Hauling	0.0000	0.0000	0.0000	0.0000	0.0000	0.0000	0.0000	0.0000	0.0000	0.0000		0.0000	0.0000	0.0000		0.0000
Vendor	0.0000	0.0000	0.0000	0.0000	0.0000	0.0000	0.0000	0.0000	0.0000	0.0000		0.0000	0.0000	0.0000		0.0000
Worker	0.4296	0.2481	3.6098	0.0113	1.2171	9.4300e-003	1.2266	0.3229	8.6800e-003	0.3315		1,126.7583	1,126.7583	0.0280		1,127.4583
<b>Total</b>	<b>0.4296</b>	<b>0.2481</b>	<b>3.6098</b>	<b>0.0113</b>	<b>1.2171</b>	<b>9.4300e-003</b>	<b>1.2266</b>	<b>0.3229</b>	<b>8.6800e-003</b>	<b>0.3315</b>		<b>1,126.7583</b>	<b>1,126.7583</b>	<b>0.0280</b>		<b>1,127.4583</b>

**Mitigated Construction On-Site**

	ROG	NOx	CO	SO2	Fugitive PM10	Exhaust PM10	PM10 Total	Fugitive PM2.5	Exhaust PM2.5	PM2.5 Total	Bio- CO2	NBio- CO2	Total CO2	CH4	N2O	CO2e
Category	lb/day										lb/day					
Archit. Coating	236.4115					0.0000	0.0000		0.0000	0.0000			0.0000			0.0000
Off-Road	0.1808	1.2188	1.8101	2.9700e-003		0.0609	0.0609		0.0609	0.0609	0.0000	281.4481	281.4481	0.0159		281.8443
<b>Total</b>	<b>236.5923</b>	<b>1.2188</b>	<b>1.8101</b>	<b>2.9700e-003</b>		<b>0.0609</b>	<b>0.0609</b>		<b>0.0609</b>	<b>0.0609</b>	<b>0.0000</b>	<b>281.4481</b>	<b>281.4481</b>	<b>0.0159</b>		<b>281.8443</b>

Village South Specific Plan (Proposed) - Los Angeles-South Coast County, Summer

**3.7 Architectural Coating - 2024**

**Mitigated Construction Off-Site**

	ROG	NOx	CO	SO2	Fugitive PM10	Exhaust PM10	PM10 Total	Fugitive PM2.5	Exhaust PM2.5	PM2.5 Total	Bio- CO2	NBio- CO2	Total CO2	CH4	N2O	CO2e
Category	lb/day										lb/day					
Hauling	0.0000	0.0000	0.0000	0.0000	0.0000	0.0000	0.0000	0.0000	0.0000	0.0000		0.0000	0.0000	0.0000		0.0000
Vendor	0.0000	0.0000	0.0000	0.0000	0.0000	0.0000	0.0000	0.0000	0.0000	0.0000		0.0000	0.0000	0.0000		0.0000
Worker	0.4296	0.2481	3.6098	0.0113	1.2171	9.4300e-003	1.2266	0.3229	8.6800e-003	0.3315		1,126.7583	1,126.7583	0.0280		1,127.4583
<b>Total</b>	<b>0.4296</b>	<b>0.2481</b>	<b>3.6098</b>	<b>0.0113</b>	<b>1.2171</b>	<b>9.4300e-003</b>	<b>1.2266</b>	<b>0.3229</b>	<b>8.6800e-003</b>	<b>0.3315</b>		<b>1,126.7583</b>	<b>1,126.7583</b>	<b>0.0280</b>		<b>1,127.4583</b>

**4.0 Operational Detail - Mobile**

---

**4.1 Mitigation Measures Mobile**

Village South Specific Plan (Proposed) - Los Angeles-South Coast County, Summer

	ROG	NOx	CO	SO2	Fugitive PM10	Exhaust PM10	PM10 Total	Fugitive PM2.5	Exhaust PM2.5	PM2.5 Total	Bio- CO2	NBio- CO2	Total CO2	CH4	N2O	CO2e
Category	lb/day										lb/day					
Mitigated	9.8489	45.4304	114.8495	0.4917	45.9592	0.3360	46.2951	12.2950	0.3119	12.6070		50,306.60 34	50,306.60 34	2.1807		50,361.12 08
Unmitigated	9.8489	45.4304	114.8495	0.4917	45.9592	0.3360	46.2951	12.2950	0.3119	12.6070		50,306.60 34	50,306.60 34	2.1807		50,361.12 08

4.2 Trip Summary Information

Land Use	Average Daily Trip Rate			Unmitigated	Mitigated
	Weekday	Saturday	Sunday	Annual VMT	Annual VMT
Apartments Low Rise	145.75	154.25	154.00	506,227	506,227
Apartments Mid Rise	4,026.75	3,773.25	4075.50	13,660,065	13,660,065
General Office Building	288.45	62.55	31.05	706,812	706,812
High Turnover (Sit Down Restaurant)	2,368.80	2,873.52	2817.72	3,413,937	3,413,937
Hotel	192.00	187.50	160.00	445,703	445,703
Quality Restaurant	501.12	511.92	461.20	707,488	707,488
Regional Shopping Center	528.08	601.44	357.84	1,112,221	1,112,221
<b>Total</b>	<b>8,050.95</b>	<b>8,164.43</b>	<b>8,057.31</b>	<b>20,552,452</b>	<b>20,552,452</b>

4.3 Trip Type Information

Village South Specific Plan (Proposed) - Los Angeles-South Coast County, Summer

Land Use	Miles			Trip %			Trip Purpose %		
	H-W or C-W	H-S or C-C	H-O or C-NW	H-W or C-W	H-S or C-C	H-O or C-NW	Primary	Diverted	Pass-by
Apartments Low Rise	14.70	5.90	8.70	40.20	19.20	40.60	86	11	3
Apartments Mid Rise	14.70	5.90	8.70	40.20	19.20	40.60	86	11	3
General Office Building	16.60	8.40	6.90	33.00	48.00	19.00	77	19	4
High Turnover (Sit Down Restaurant)	16.60	8.40	6.90	8.50	72.50	19.00	37	20	43
Hotel	16.60	8.40	6.90	19.40	61.60	19.00	58	38	4
Quality Restaurant	16.60	8.40	6.90	12.00	69.00	19.00	38	18	44
Regional Shopping Center	16.60	8.40	6.90	16.30	64.70	19.00	54	35	11

4.4 Fleet Mix

Land Use	LDA	LDT1	LDT2	MDV	LHD1	LHD2	MHD	HHD	OBUS	UBUS	MCY	SBUS	MH
Apartments Low Rise	0.543088	0.044216	0.209971	0.116369	0.014033	0.006332	0.021166	0.033577	0.002613	0.001817	0.005285	0.000712	0.000821
Apartments Mid Rise	0.543088	0.044216	0.209971	0.116369	0.014033	0.006332	0.021166	0.033577	0.002613	0.001817	0.005285	0.000712	0.000821
General Office Building	0.543088	0.044216	0.209971	0.116369	0.014033	0.006332	0.021166	0.033577	0.002613	0.001817	0.005285	0.000712	0.000821
High Turnover (Sit Down Restaurant)	0.543088	0.044216	0.209971	0.116369	0.014033	0.006332	0.021166	0.033577	0.002613	0.001817	0.005285	0.000712	0.000821
Hotel	0.543088	0.044216	0.209971	0.116369	0.014033	0.006332	0.021166	0.033577	0.002613	0.001817	0.005285	0.000712	0.000821
Quality Restaurant	0.543088	0.044216	0.209971	0.116369	0.014033	0.006332	0.021166	0.033577	0.002613	0.001817	0.005285	0.000712	0.000821
Regional Shopping Center	0.543088	0.044216	0.209971	0.116369	0.014033	0.006332	0.021166	0.033577	0.002613	0.001817	0.005285	0.000712	0.000821

5.0 Energy Detail

Historical Energy Use: N

5.1 Mitigation Measures Energy

Village South Specific Plan (Proposed) - Los Angeles-South Coast County, Summer

	ROG	NOx	CO	SO2	Fugitive PM10	Exhaust PM10	PM10 Total	Fugitive PM2.5	Exhaust PM2.5	PM2.5 Total	Bio- CO2	NBio- CO2	Total CO2	CH4	N2O	CO2e
Category	lb/day										lb/day					
NaturalGas Mitigated	0.7660	6.7462	4.2573	0.0418		0.5292	0.5292		0.5292	0.5292		8,355.983 2	8,355.983 2	0.1602	0.1532	8,405.638 7
NaturalGas Unmitigated	0.7660	6.7462	4.2573	0.0418		0.5292	0.5292		0.5292	0.5292		8,355.983 2	8,355.983 2	0.1602	0.1532	8,405.638 7



Village South Specific Plan (Proposed) - Los Angeles-South Coast County, Summer

**5.2 Energy by Land Use - NaturalGas**

**Unmitigated**

	NaturalGas Use	ROG	NOx	CO	SO2	Fugitive PM10	Exhaust PM10	PM10 Total	Fugitive PM2.5	Exhaust PM2.5	PM2.5 Total	Bio- CO2	NBio- CO2	Total CO2	CH4	N2O	CO2e
Land Use	kBTU/yr	lb/day										lb/day					
Apartments Low Rise	1119.16	0.0121	0.1031	0.0439	6.6000e-004		8.3400e-003	8.3400e-003		8.3400e-003	8.3400e-003		131.6662	131.6662	2.5200e-003	2.4100e-003	132.4486
Apartments Mid Rise	35784.3	0.3859	3.2978	1.4033	0.0211		0.2666	0.2666		0.2666	0.2666		4,209.9164	4,209.9164	0.0807	0.0772	4,234.9339
General Office Building	1283.42	0.0138	0.1258	0.1057	7.5000e-004		9.5600e-003	9.5600e-003		9.5600e-003	9.5600e-003		150.9911	150.9911	2.8900e-003	2.7700e-003	151.8884
High Turnover (Sit Down Restaurant)	22759.9	0.2455	2.2314	1.8743	0.0134		0.1696	0.1696		0.1696	0.1696		2,677.6342	2,677.6342	0.0513	0.0491	2,693.5460
Hotel	4769.72	0.0514	0.4676	0.3928	2.8100e-003		0.0355	0.0355		0.0355	0.0355		561.1436	561.1436	0.0108	0.0103	564.4782
Quality Restaurant	5057.75	0.0545	0.4959	0.4165	2.9800e-003		0.0377	0.0377		0.0377	0.0377		595.0298	595.0298	0.0114	0.0109	598.5658
Regional Shopping Center	251.616	2.7100e-003	0.0247	0.0207	1.5000e-004		1.8700e-003	1.8700e-003		1.8700e-003	1.8700e-003		29.6019	29.6019	5.7000e-004	5.4000e-004	29.7778
<b>Total</b>		<b>0.7660</b>	<b>6.7463</b>	<b>4.2573</b>	<b>0.0418</b>		<b>0.5292</b>	<b>0.5292</b>		<b>0.5292</b>	<b>0.5292</b>		<b>8,355.9832</b>	<b>8,355.9832</b>	<b>0.1602</b>	<b>0.1532</b>	<b>8,405.6387</b>

Village South Specific Plan (Proposed) - Los Angeles-South Coast County, Summer

**5.2 Energy by Land Use - NaturalGas**

**Mitigated**

	NaturalGas Use	ROG	NOx	CO	SO2	Fugitive PM10	Exhaust PM10	PM10 Total	Fugitive PM2.5	Exhaust PM2.5	PM2.5 Total	Bio- CO2	NBio- CO2	Total CO2	CH4	N2O	CO2e
Land Use	kBTU/yr	lb/day										lb/day					
Apartments Low Rise	1.11916	0.0121	0.1031	0.0439	6.6000e-004		8.3400e-003	8.3400e-003		8.3400e-003	8.3400e-003		131.6662	131.6662	2.5200e-003	2.4100e-003	132.4486
Apartments Mid Rise	35.7843	0.3859	3.2978	1.4033	0.0211		0.2666	0.2666		0.2666	0.2666		4,209.9164	4,209.9164	0.0807	0.0772	4,234.9339
General Office Building	1.28342	0.0138	0.1258	0.1057	7.5000e-004		9.5600e-003	9.5600e-003		9.5600e-003	9.5600e-003		150.9911	150.9911	2.8900e-003	2.7700e-003	151.8884
High Turnover (Sit Down Restaurant)	22.7599	0.2455	2.2314	1.8743	0.0134		0.1696	0.1696		0.1696	0.1696		2,677.6342	2,677.6342	0.0513	0.0491	2,693.5460
Hotel	4.76972	0.0514	0.4676	0.3928	2.8100e-003		0.0355	0.0355		0.0355	0.0355		561.1436	561.1436	0.0108	0.0103	564.4782
Quality Restaurant	5.05775	0.0545	0.4959	0.4165	2.9800e-003		0.0377	0.0377		0.0377	0.0377		595.0298	595.0298	0.0114	0.0109	598.5658
Regional Shopping Center	0.251616	2.7100e-003	0.0247	0.0207	1.5000e-004		1.8700e-003	1.8700e-003		1.8700e-003	1.8700e-003		29.6019	29.6019	5.7000e-004	5.4000e-004	29.7778
<b>Total</b>		<b>0.7660</b>	<b>6.7463</b>	<b>4.2573</b>	<b>0.0418</b>		<b>0.5292</b>	<b>0.5292</b>		<b>0.5292</b>	<b>0.5292</b>		<b>8,355.9832</b>	<b>8,355.9832</b>	<b>0.1602</b>	<b>0.1532</b>	<b>8,405.6387</b>

**6.0 Area Detail**

**6.1 Mitigation Measures Area**

Village South Specific Plan (Proposed) - Los Angeles-South Coast County, Summer

	ROG	NOx	CO	SO2	Fugitive PM10	Exhaust PM10	PM10 Total	Fugitive PM2.5	Exhaust PM2.5	PM2.5 Total	Bio- CO2	NBio- CO2	Total CO2	CH4	N2O	CO2e
Category	lb/day										lb/day					
Mitigated	30.5020	15.0496	88.4430	0.0944		1.5974	1.5974		1.5974	1.5974	0.0000	18,148.5950	18,148.5950	0.4874	0.3300	18,259.1192
Unmitigated	30.5020	15.0496	88.4430	0.0944		1.5974	1.5974		1.5974	1.5974	0.0000	18,148.5950	18,148.5950	0.4874	0.3300	18,259.1192

6.2 Area by SubCategory

Unmitigated

	ROG	NOx	CO	SO2	Fugitive PM10	Exhaust PM10	PM10 Total	Fugitive PM2.5	Exhaust PM2.5	PM2.5 Total	Bio- CO2	NBio- CO2	Total CO2	CH4	N2O	CO2e
SubCategory	lb/day										lb/day					
Architectural Coating	2.2670					0.0000	0.0000		0.0000	0.0000			0.0000			0.0000
Consumer Products	24.1085					0.0000	0.0000		0.0000	0.0000			0.0000			0.0000
Hearth	1.6500	14.1000	6.0000	0.0900		1.1400	1.1400		1.1400	1.1400	0.0000	18,000.0000	18,000.0000	0.3450	0.3300	18,106.9650
Landscaping	2.4766	0.9496	82.4430	4.3600e-003		0.4574	0.4574		0.4574	0.4574		148.5950	148.5950	0.1424		152.1542
<b>Total</b>	<b>30.5020</b>	<b>15.0496</b>	<b>88.4430</b>	<b>0.0944</b>		<b>1.5974</b>	<b>1.5974</b>		<b>1.5974</b>	<b>1.5974</b>	<b>0.0000</b>	<b>18,148.5950</b>	<b>18,148.5950</b>	<b>0.4874</b>	<b>0.3300</b>	<b>18,259.1192</b>

Village South Specific Plan (Proposed) - Los Angeles-South Coast County, Summer

**6.2 Area by SubCategory**

**Mitigated**

	ROG	NOx	CO	SO2	Fugitive PM10	Exhaust PM10	PM10 Total	Fugitive PM2.5	Exhaust PM2.5	PM2.5 Total	Bio- CO2	NBio- CO2	Total CO2	CH4	N2O	CO2e
SubCategory	lb/day										lb/day					
Architectural Coating	2.2670					0.0000	0.0000		0.0000	0.0000			0.0000			0.0000
Consumer Products	24.1085					0.0000	0.0000		0.0000	0.0000			0.0000			0.0000
Hearth	1.6500	14.1000	6.0000	0.0900		1.1400	1.1400		1.1400	1.1400	0.0000	18,000.0000	18,000.0000	0.3450	0.3300	18,106.9650
Landscaping	2.4766	0.9496	82.4430	4.3600e-003		0.4574	0.4574		0.4574	0.4574		148.5950	148.5950	0.1424		152.1542
<b>Total</b>	<b>30.5020</b>	<b>15.0496</b>	<b>88.4430</b>	<b>0.0944</b>		<b>1.5974</b>	<b>1.5974</b>		<b>1.5974</b>	<b>1.5974</b>	<b>0.0000</b>	<b>18,148.5950</b>	<b>18,148.5950</b>	<b>0.4874</b>	<b>0.3300</b>	<b>18,259.1192</b>

**7.0 Water Detail**

---

**7.1 Mitigation Measures Water**

**8.0 Waste Detail**

---

**8.1 Mitigation Measures Waste**

**9.0 Operational Offroad**

---

Equipment Type	Number	Hours/Day	Days/Year	Horse Power	Load Factor	Fuel Type
----------------	--------	-----------	-----------	-------------	-------------	-----------

**10.0 Stationary Equipment**

---

Village South Specific Plan (Proposed) - Los Angeles-South Coast County, Summer

**Fire Pumps and Emergency Generators**

Equipment Type	Number	Hours/Day	Hours/Year	Horse Power	Load Factor	Fuel Type
----------------	--------	-----------	------------	-------------	-------------	-----------

**Boilers**

Equipment Type	Number	Heat Input/Day	Heat Input/Year	Boiler Rating	Fuel Type
----------------	--------	----------------	-----------------	---------------	-----------

**User Defined Equipment**

Equipment Type	Number
----------------	--------

**11.0 Vegetation**

---

Village South Specific Plan (Proposed) - Los Angeles-South Coast County, Winter

**Village South Specific Plan (Proposed)**  
**Los Angeles-South Coast County, Winter**

**1.0 Project Characteristics**

**1.1 Land Usage**

Land Uses	Size	Metric	Lot Acreage	Floor Surface Area	Population
General Office Building	45.00	1000sqft	1.03	45,000.00	0
High Turnover (Sit Down Restaurant)	36.00	1000sqft	0.83	36,000.00	0
Hotel	50.00	Room	1.67	72,600.00	0
Quality Restaurant	8.00	1000sqft	0.18	8,000.00	0
Apartments Low Rise	25.00	Dwelling Unit	1.56	25,000.00	72
Apartments Mid Rise	975.00	Dwelling Unit	25.66	975,000.00	2789
Regional Shopping Center	56.00	1000sqft	1.29	56,000.00	0

**1.2 Other Project Characteristics**

<b>Urbanization</b>	Urban	<b>Wind Speed (m/s)</b>	2.2	<b>Precipitation Freq (Days)</b>	33
<b>Climate Zone</b>	9			<b>Operational Year</b>	2028
<b>Utility Company</b>	Southern California Edison				
<b>CO2 Intensity (lb/MW hr)</b>	702.44	<b>CH4 Intensity (lb/MW hr)</b>	0.029	<b>N2O Intensity (lb/MW hr)</b>	0.006

**1.3 User Entered Comments & Non-Default Data**

## Village South Specific Plan (Proposed) - Los Angeles-South Coast County, Winter

Project Characteristics - Consistent with the DEIR's model.

Land Use - See SWAPE comment regarding residential and retail land uses.

Construction Phase - See SWAPE comment regarding individual construction phase lengths.

Demolition - Consistent with the DEIR's model. See SWAPE comment regarding demolition.

Vehicle Trips - Saturday trips consistent with the DEIR's model. See SWAPE comment regarding weekday and Sunday trips.

Woodstoves - Woodstoves and wood-burning fireplaces consistent with the DEIR's model. See SWAPE comment regarding gas fireplaces.

Energy Use -

Construction Off-road Equipment Mitigation - See SWAPE comment on construction-related mitigation.

Area Mitigation - See SWAPE comment regarding operational mitigation measures.

Water Mitigation - See SWAPE comment regarding operational mitigation measures.

Trips and VMT - Local hire provision

Table Name	Column Name	Default Value	New Value
tblFireplaces	FireplaceWoodMass	1,019.20	0.00
tblFireplaces	FireplaceWoodMass	1,019.20	0.00
tblFireplaces	NumberWood	1.25	0.00
tblFireplaces	NumberWood	48.75	0.00
tblTripsAndVMT	WorkerTripLength	14.70	10.00
tblTripsAndVMT	WorkerTripLength	14.70	10.00
tblTripsAndVMT	WorkerTripLength	14.70	10.00
tblTripsAndVMT	WorkerTripLength	14.70	10.00
tblTripsAndVMT	WorkerTripLength	14.70	10.00
tblTripsAndVMT	WorkerTripLength	14.70	10.00
tblVehicleTrips	ST_TR	7.16	6.17
tblVehicleTrips	ST_TR	6.39	3.87
tblVehicleTrips	ST_TR	2.46	1.39
tblVehicleTrips	ST_TR	158.37	79.82

## Village South Specific Plan (Proposed) - Los Angeles-South Coast County, Winter

tblVehicleTrips	ST_TR	8.19	3.75
tblVehicleTrips	ST_TR	94.36	63.99
tblVehicleTrips	ST_TR	49.97	10.74
tblVehicleTrips	SU_TR	6.07	6.16
tblVehicleTrips	SU_TR	5.86	4.18
tblVehicleTrips	SU_TR	1.05	0.69
tblVehicleTrips	SU_TR	131.84	78.27
tblVehicleTrips	SU_TR	5.95	3.20
tblVehicleTrips	SU_TR	72.16	57.65
tblVehicleTrips	SU_TR	25.24	6.39
tblVehicleTrips	WD_TR	6.59	5.83
tblVehicleTrips	WD_TR	6.65	4.13
tblVehicleTrips	WD_TR	11.03	6.41
tblVehicleTrips	WD_TR	127.15	65.80
tblVehicleTrips	WD_TR	8.17	3.84
tblVehicleTrips	WD_TR	89.95	62.64
tblVehicleTrips	WD_TR	42.70	9.43
tblWoodstoves	NumberCatalytic	1.25	0.00
tblWoodstoves	NumberCatalytic	48.75	0.00
tblWoodstoves	NumberNoncatalytic	1.25	0.00
tblWoodstoves	NumberNoncatalytic	48.75	0.00
tblWoodstoves	WoodstoveDayYear	25.00	0.00
tblWoodstoves	WoodstoveDayYear	25.00	0.00
tblWoodstoves	WoodstoveWoodMass	999.60	0.00
tblWoodstoves	WoodstoveWoodMass	999.60	0.00

## 2.0 Emissions Summary

---



Village South Specific Plan (Proposed) - Los Angeles-South Coast County, Winter

**2.1 Overall Construction (Maximum Daily Emission)**

**Unmitigated Construction**

	ROG	NOx	CO	SO2	Fugitive PM10	Exhaust PM10	PM10 Total	Fugitive PM2.5	Exhaust PM2.5	PM2.5 Total	Bio- CO2	NBio- CO2	Total CO2	CH4	N2O	CO2e
Year	lb/day										lb/day					
2021	4.2621	46.4460	31.4068	0.0635	18.2032	2.0456	20.2488	9.9670	1.8820	11.8490	0.0000	6,154.3377	6,154.3377	1.9472	0.0000	6,203.0186
2022	4.7966	38.8851	39.6338	0.1195	8.8255	1.6361	10.4616	3.6369	1.5052	5.1421	0.0000	12,035.3440	12,035.3440	1.9482	0.0000	12,060.6013
2023	4.3939	25.8648	37.5031	0.1162	7.0088	0.7598	7.7685	1.8799	0.7142	2.5940	0.0000	11,710.4080	11,710.4080	0.9617	0.0000	11,734.4497
2024	237.0656	9.5503	14.9372	0.0238	1.2171	0.4694	1.2875	0.3229	0.4319	0.4621	0.0000	2,307.0517	2,307.0517	0.7164	0.0000	2,324.9627
<b>Maximum</b>	<b>237.0656</b>	<b>46.4460</b>	<b>39.6338</b>	<b>0.1195</b>	<b>18.2032</b>	<b>2.0456</b>	<b>20.2488</b>	<b>9.9670</b>	<b>1.8820</b>	<b>11.8490</b>	<b>0.0000</b>	<b>12,035.3440</b>	<b>12,035.3440</b>	<b>1.9482</b>	<b>0.0000</b>	<b>12,060.6013</b>



Village South Specific Plan (Proposed) - Los Angeles-South Coast County, Winter

**2.2 Overall Operational**

**Unmitigated Operational**

	ROG	NOx	CO	SO2	Fugitive PM10	Exhaust PM10	PM10 Total	Fugitive PM2.5	Exhaust PM2.5	PM2.5 Total	Bio- CO2	NBio- CO2	Total CO2	CH4	N2O	CO2e
Category	lb/day										lb/day					
Area	30.5020	15.0496	88.4430	0.0944		1.5974	1.5974		1.5974	1.5974	0.0000	18,148.5950	18,148.5950	0.4874	0.3300	18,259.1192
Energy	0.7660	6.7462	4.2573	0.0418		0.5292	0.5292		0.5292	0.5292		8,355.9832	8,355.9832	0.1602	0.1532	8,405.6387
Mobile	9.5233	45.9914	110.0422	0.4681	45.9592	0.3373	46.2965	12.2950	0.3132	12.6083		47,917.8005	47,917.8005	2.1953		47,972.6839
<b>Total</b>	<b>40.7912</b>	<b>67.7872</b>	<b>202.7424</b>	<b>0.6043</b>	<b>45.9592</b>	<b>2.4640</b>	<b>48.4231</b>	<b>12.2950</b>	<b>2.4399</b>	<b>14.7349</b>	<b>0.0000</b>	<b>74,422.3787</b>	<b>74,422.3787</b>	<b>2.8429</b>	<b>0.4832</b>	<b>74,637.4417</b>

**Mitigated Operational**

	ROG	NOx	CO	SO2	Fugitive PM10	Exhaust PM10	PM10 Total	Fugitive PM2.5	Exhaust PM2.5	PM2.5 Total	Bio- CO2	NBio- CO2	Total CO2	CH4	N2O	CO2e
Category	lb/day										lb/day					
Area	30.5020	15.0496	88.4430	0.0944		1.5974	1.5974		1.5974	1.5974	0.0000	18,148.5950	18,148.5950	0.4874	0.3300	18,259.1192
Energy	0.7660	6.7462	4.2573	0.0418		0.5292	0.5292		0.5292	0.5292		8,355.9832	8,355.9832	0.1602	0.1532	8,405.6387
Mobile	9.5233	45.9914	110.0422	0.4681	45.9592	0.3373	46.2965	12.2950	0.3132	12.6083		47,917.8005	47,917.8005	2.1953		47,972.6839
<b>Total</b>	<b>40.7912</b>	<b>67.7872</b>	<b>202.7424</b>	<b>0.6043</b>	<b>45.9592</b>	<b>2.4640</b>	<b>48.4231</b>	<b>12.2950</b>	<b>2.4399</b>	<b>14.7349</b>	<b>0.0000</b>	<b>74,422.3787</b>	<b>74,422.3787</b>	<b>2.8429</b>	<b>0.4832</b>	<b>74,637.4417</b>

Village South Specific Plan (Proposed) - Los Angeles-South Coast County, Winter

	ROG	NOx	CO	SO2	Fugitive PM10	Exhaust PM10	PM10 Total	Fugitive PM2.5	Exhaust PM2.5	PM2.5 Total	Bio- CO2	NBio-CO2	Total CO2	CH4	N2O	CO2e
Percent Reduction	0.00	0.00	0.00	0.00	0.00	0.00	0.00	0.00	0.00	0.00	0.00	0.00	0.00	0.00	0.00	0.00

### 3.0 Construction Detail

#### Construction Phase

Phase Number	Phase Name	Phase Type	Start Date	End Date	Num Days Week	Num Days	Phase Description
1	Demolition	Demolition	9/1/2021	10/12/2021	5	30	
2	Site Preparation	Site Preparation	10/13/2021	11/9/2021	5	20	
3	Grading	Grading	11/10/2021	1/11/2022	5	45	
4	Building Construction	Building Construction	1/12/2022	12/12/2023	5	500	
5	Paving	Paving	12/13/2023	1/30/2024	5	35	
6	Architectural Coating	Architectural Coating	1/31/2024	3/19/2024	5	35	

Acres of Grading (Site Preparation Phase): 0

Acres of Grading (Grading Phase): 112.5

Acres of Paving: 0

Residential Indoor: 2,025,000; Residential Outdoor: 675,000; Non-Residential Indoor: 326,400; Non-Residential Outdoor: 108,800; Striped Parking Area: 0 (Architectural Coating – sqft)

#### OffRoad Equipment

## Village South Specific Plan (Proposed) - Los Angeles-South Coast County, Winter

Phase Name	Offroad Equipment Type	Amount	Usage Hours	Horse Power	Load Factor
Demolition	Concrete/Industrial Saws	1	8.00	81	0.73
Demolition	Excavators	3	8.00	158	0.38
Demolition	Rubber Tired Dozers	2	8.00	247	0.40
Site Preparation	Rubber Tired Dozers	3	8.00	247	0.40
Site Preparation	Tractors/Loaders/Backhoes	4	8.00	97	0.37
Grading	Excavators	2	8.00	158	0.38
Grading	Graders	1	8.00	187	0.41
Grading	Rubber Tired Dozers	1	8.00	247	0.40
Grading	Scrapers	2	8.00	367	0.48
Grading	Tractors/Loaders/Backhoes	2	8.00	97	0.37
Building Construction	Cranes	1	7.00	231	0.29
Building Construction	Forklifts	3	8.00	89	0.20
Building Construction	Generator Sets	1	8.00	84	0.74
Building Construction	Tractors/Loaders/Backhoes	3	7.00	97	0.37
Building Construction	Welders	1	8.00	46	0.45
Paving	Pavers	2	8.00	130	0.42
Paving	Paving Equipment	2	8.00	132	0.36
Paving	Rollers	2	8.00	80	0.38
Architectural Coating	Air Compressors	1	6.00	78	0.48

**Trips and VMT**

Village South Specific Plan (Proposed) - Los Angeles-South Coast County, Winter

Phase Name	Offroad Equipment Count	Worker Trip Number	Vendor Trip Number	Hauling Trip Number	Worker Trip Length	Vendor Trip Length	Hauling Trip Length	Worker Vehicle Class	Vendor Vehicle Class	Hauling Vehicle Class
Demolition	6	15.00	0.00	458.00	10.00	6.90	20.00	LD_Mix	HDT_Mix	HHDT
Site Preparation	7	18.00	0.00	0.00	10.00	6.90	20.00	LD_Mix	HDT_Mix	HHDT
Grading	8	20.00	0.00	0.00	10.00	6.90	20.00	LD_Mix	HDT_Mix	HHDT
Building Construction	9	801.00	143.00	0.00	10.00	6.90	20.00	LD_Mix	HDT_Mix	HHDT
Paving	6	15.00	0.00	0.00	10.00	6.90	20.00	LD_Mix	HDT_Mix	HHDT
Architectural Coating	1	160.00	0.00	0.00	10.00	6.90	20.00	LD_Mix	HDT_Mix	HHDT

**3.1 Mitigation Measures Construction**

**3.2 Demolition - 2021**

**Unmitigated Construction On-Site**

	ROG	NOx	CO	SO2	Fugitive PM10	Exhaust PM10	PM10 Total	Fugitive PM2.5	Exhaust PM2.5	PM2.5 Total	Bio- CO2	NBio- CO2	Total CO2	CH4	N2O	CO2e
Category	lb/day										lb/day					
Fugitive Dust					3.3074	0.0000	3.3074	0.5008	0.0000	0.5008			0.0000			0.0000
Off-Road	3.1651	31.4407	21.5650	0.0388		1.5513	1.5513		1.4411	1.4411		3,747.9449	3,747.9449	1.0549		3,774.3174
<b>Total</b>	<b>3.1651</b>	<b>31.4407</b>	<b>21.5650</b>	<b>0.0388</b>	<b>3.3074</b>	<b>1.5513</b>	<b>4.8588</b>	<b>0.5008</b>	<b>1.4411</b>	<b>1.9419</b>		<b>3,747.9449</b>	<b>3,747.9449</b>	<b>1.0549</b>		<b>3,774.3174</b>

Village South Specific Plan (Proposed) - Los Angeles-South Coast County, Winter

**3.2 Demolition - 2021**

**Unmitigated Construction Off-Site**

	ROG	NOx	CO	SO2	Fugitive PM10	Exhaust PM10	PM10 Total	Fugitive PM2.5	Exhaust PM2.5	PM2.5 Total	Bio- CO2	NBio- CO2	Total CO2	CH4	N2O	CO2e
Category	lb/day										lb/day					
Hauling	0.1304	4.1454	1.0182	0.0117	0.2669	0.0128	0.2797	0.0732	0.0122	0.0854		1,269.8555	1,269.8555	0.0908		1,272.1252
Vendor	0.0000	0.0000	0.0000	0.0000	0.0000	0.0000	0.0000	0.0000	0.0000	0.0000		0.0000	0.0000	0.0000		0.0000
Worker	0.0532	0.0346	0.3963	1.1100e-003	0.1141	9.5000e-004	0.1151	0.0303	8.8000e-004	0.0311		110.4707	110.4707	3.3300e-003		110.5539
<b>Total</b>	<b>0.1835</b>	<b>4.1800</b>	<b>1.4144</b>	<b>0.0128</b>	<b>0.3810</b>	<b>0.0137</b>	<b>0.3948</b>	<b>0.1034</b>	<b>0.0131</b>	<b>0.1165</b>		<b>1,380.3262</b>	<b>1,380.3262</b>	<b>0.0941</b>		<b>1,382.6791</b>

**Mitigated Construction On-Site**

	ROG	NOx	CO	SO2	Fugitive PM10	Exhaust PM10	PM10 Total	Fugitive PM2.5	Exhaust PM2.5	PM2.5 Total	Bio- CO2	NBio- CO2	Total CO2	CH4	N2O	CO2e
Category	lb/day										lb/day					
Fugitive Dust					3.3074	0.0000	3.3074	0.5008	0.0000	0.5008			0.0000			0.0000
Off-Road	3.1651	31.4407	21.5650	0.0388		1.5513	1.5513		1.4411	1.4411	0.0000	3,747.9449	3,747.9449	1.0549		3,774.3174
<b>Total</b>	<b>3.1651</b>	<b>31.4407</b>	<b>21.5650</b>	<b>0.0388</b>	<b>3.3074</b>	<b>1.5513</b>	<b>4.8588</b>	<b>0.5008</b>	<b>1.4411</b>	<b>1.9419</b>	<b>0.0000</b>	<b>3,747.9449</b>	<b>3,747.9449</b>	<b>1.0549</b>		<b>3,774.3174</b>

Village South Specific Plan (Proposed) - Los Angeles-South Coast County, Winter

**3.2 Demolition - 2021**

**Mitigated Construction Off-Site**

	ROG	NOx	CO	SO2	Fugitive PM10	Exhaust PM10	PM10 Total	Fugitive PM2.5	Exhaust PM2.5	PM2.5 Total	Bio- CO2	NBio- CO2	Total CO2	CH4	N2O	CO2e
Category	lb/day										lb/day					
Hauling	0.1304	4.1454	1.0182	0.0117	0.2669	0.0128	0.2797	0.0732	0.0122	0.0854		1,269.8555	1,269.8555	0.0908		1,272.1252
Vendor	0.0000	0.0000	0.0000	0.0000	0.0000	0.0000	0.0000	0.0000	0.0000	0.0000		0.0000	0.0000	0.0000		0.0000
Worker	0.0532	0.0346	0.3963	1.1100e-003	0.1141	9.5000e-004	0.1151	0.0303	8.8000e-004	0.0311		110.4707	110.4707	3.3300e-003		110.5539
<b>Total</b>	<b>0.1835</b>	<b>4.1800</b>	<b>1.4144</b>	<b>0.0128</b>	<b>0.3810</b>	<b>0.0137</b>	<b>0.3948</b>	<b>0.1034</b>	<b>0.0131</b>	<b>0.1165</b>		<b>1,380.3262</b>	<b>1,380.3262</b>	<b>0.0941</b>		<b>1,382.6791</b>

**3.3 Site Preparation - 2021**

**Unmitigated Construction On-Site**

	ROG	NOx	CO	SO2	Fugitive PM10	Exhaust PM10	PM10 Total	Fugitive PM2.5	Exhaust PM2.5	PM2.5 Total	Bio- CO2	NBio- CO2	Total CO2	CH4	N2O	CO2e
Category	lb/day										lb/day					
Fugitive Dust					18.0663	0.0000	18.0663	9.9307	0.0000	9.9307			0.0000			0.0000
Off-Road	3.8882	40.4971	21.1543	0.0380		2.0445	2.0445		1.8809	1.8809		3,685.6569	3,685.6569	1.1920		3,715.4573
<b>Total</b>	<b>3.8882</b>	<b>40.4971</b>	<b>21.1543</b>	<b>0.0380</b>	<b>18.0663</b>	<b>2.0445</b>	<b>20.1107</b>	<b>9.9307</b>	<b>1.8809</b>	<b>11.8116</b>		<b>3,685.6569</b>	<b>3,685.6569</b>	<b>1.1920</b>		<b>3,715.4573</b>



Village South Specific Plan (Proposed) - Los Angeles-South Coast County, Winter

**3.3 Site Preparation - 2021**

**Unmitigated Construction Off-Site**

	ROG	NOx	CO	SO2	Fugitive PM10	Exhaust PM10	PM10 Total	Fugitive PM2.5	Exhaust PM2.5	PM2.5 Total	Bio- CO2	NBio- CO2	Total CO2	CH4	N2O	CO2e
Category	lb/day										lb/day					
Hauling	0.0000	0.0000	0.0000	0.0000	0.0000	0.0000	0.0000	0.0000	0.0000	0.0000		0.0000	0.0000	0.0000		0.0000
Vendor	0.0000	0.0000	0.0000	0.0000	0.0000	0.0000	0.0000	0.0000	0.0000	0.0000		0.0000	0.0000	0.0000		0.0000
Worker	0.0638	0.0415	0.4755	1.3300e-003	0.1369	1.1400e-003	0.1381	0.0363	1.0500e-003	0.0374		132.5649	132.5649	3.9900e-003		132.6646
<b>Total</b>	<b>0.0638</b>	<b>0.0415</b>	<b>0.4755</b>	<b>1.3300e-003</b>	<b>0.1369</b>	<b>1.1400e-003</b>	<b>0.1381</b>	<b>0.0363</b>	<b>1.0500e-003</b>	<b>0.0374</b>		<b>132.5649</b>	<b>132.5649</b>	<b>3.9900e-003</b>		<b>132.6646</b>

**Mitigated Construction On-Site**

	ROG	NOx	CO	SO2	Fugitive PM10	Exhaust PM10	PM10 Total	Fugitive PM2.5	Exhaust PM2.5	PM2.5 Total	Bio- CO2	NBio- CO2	Total CO2	CH4	N2O	CO2e
Category	lb/day										lb/day					
Fugitive Dust					18.0663	0.0000	18.0663	9.9307	0.0000	9.9307			0.0000			0.0000
Off-Road	3.8882	40.4971	21.1543	0.0380		2.0445	2.0445		1.8809	1.8809	0.0000	3,685.6569	3,685.6569	1.1920		3,715.4573
<b>Total</b>	<b>3.8882</b>	<b>40.4971</b>	<b>21.1543</b>	<b>0.0380</b>	<b>18.0663</b>	<b>2.0445</b>	<b>20.1107</b>	<b>9.9307</b>	<b>1.8809</b>	<b>11.8116</b>	<b>0.0000</b>	<b>3,685.6569</b>	<b>3,685.6569</b>	<b>1.1920</b>		<b>3,715.4573</b>

Village South Specific Plan (Proposed) - Los Angeles-South Coast County, Winter

**3.3 Site Preparation - 2021**

**Mitigated Construction Off-Site**

	ROG	NOx	CO	SO2	Fugitive PM10	Exhaust PM10	PM10 Total	Fugitive PM2.5	Exhaust PM2.5	PM2.5 Total	Bio- CO2	NBio- CO2	Total CO2	CH4	N2O	CO2e
Category	lb/day										lb/day					
Hauling	0.0000	0.0000	0.0000	0.0000	0.0000	0.0000	0.0000	0.0000	0.0000	0.0000		0.0000	0.0000	0.0000		0.0000
Vendor	0.0000	0.0000	0.0000	0.0000	0.0000	0.0000	0.0000	0.0000	0.0000	0.0000		0.0000	0.0000	0.0000		0.0000
Worker	0.0638	0.0415	0.4755	1.3300e-003	0.1369	1.1400e-003	0.1381	0.0363	1.0500e-003	0.0374		132.5649	132.5649	3.9900e-003		132.6646
<b>Total</b>	<b>0.0638</b>	<b>0.0415</b>	<b>0.4755</b>	<b>1.3300e-003</b>	<b>0.1369</b>	<b>1.1400e-003</b>	<b>0.1381</b>	<b>0.0363</b>	<b>1.0500e-003</b>	<b>0.0374</b>		<b>132.5649</b>	<b>132.5649</b>	<b>3.9900e-003</b>		<b>132.6646</b>

**3.4 Grading - 2021**

**Unmitigated Construction On-Site**

	ROG	NOx	CO	SO2	Fugitive PM10	Exhaust PM10	PM10 Total	Fugitive PM2.5	Exhaust PM2.5	PM2.5 Total	Bio- CO2	NBio- CO2	Total CO2	CH4	N2O	CO2e
Category	lb/day										lb/day					
Fugitive Dust					8.6733	0.0000	8.6733	3.5965	0.0000	3.5965			0.0000			0.0000
Off-Road	4.1912	46.3998	30.8785	0.0620		1.9853	1.9853		1.8265	1.8265		6,007.0434	6,007.0434	1.9428		6,055.6134
<b>Total</b>	<b>4.1912</b>	<b>46.3998</b>	<b>30.8785</b>	<b>0.0620</b>	<b>8.6733</b>	<b>1.9853</b>	<b>10.6587</b>	<b>3.5965</b>	<b>1.8265</b>	<b>5.4230</b>		<b>6,007.0434</b>	<b>6,007.0434</b>	<b>1.9428</b>		<b>6,055.6134</b>

Village South Specific Plan (Proposed) - Los Angeles-South Coast County, Winter

**3.4 Grading - 2021**

**Unmitigated Construction Off-Site**

	ROG	NOx	CO	SO2	Fugitive PM10	Exhaust PM10	PM10 Total	Fugitive PM2.5	Exhaust PM2.5	PM2.5 Total	Bio- CO2	NBio- CO2	Total CO2	CH4	N2O	CO2e
Category	lb/day										lb/day					
Hauling	0.0000	0.0000	0.0000	0.0000	0.0000	0.0000	0.0000	0.0000	0.0000	0.0000		0.0000	0.0000	0.0000		0.0000
Vendor	0.0000	0.0000	0.0000	0.0000	0.0000	0.0000	0.0000	0.0000	0.0000	0.0000		0.0000	0.0000	0.0000		0.0000
Worker	0.0709	0.0462	0.5284	1.4800e-003	0.1521	1.2700e-003	0.1534	0.0404	1.1700e-003	0.0415		147.2943	147.2943	4.4300e-003		147.4051
<b>Total</b>	<b>0.0709</b>	<b>0.0462</b>	<b>0.5284</b>	<b>1.4800e-003</b>	<b>0.1521</b>	<b>1.2700e-003</b>	<b>0.1534</b>	<b>0.0404</b>	<b>1.1700e-003</b>	<b>0.0415</b>		<b>147.2943</b>	<b>147.2943</b>	<b>4.4300e-003</b>		<b>147.4051</b>

**Mitigated Construction On-Site**

	ROG	NOx	CO	SO2	Fugitive PM10	Exhaust PM10	PM10 Total	Fugitive PM2.5	Exhaust PM2.5	PM2.5 Total	Bio- CO2	NBio- CO2	Total CO2	CH4	N2O	CO2e
Category	lb/day										lb/day					
Fugitive Dust					8.6733	0.0000	8.6733	3.5965	0.0000	3.5965			0.0000			0.0000
Off-Road	4.1912	46.3998	30.8785	0.0620		1.9853	1.9853		1.8265	1.8265	0.0000	6,007.0434	6,007.0434	1.9428		6,055.6134
<b>Total</b>	<b>4.1912</b>	<b>46.3998</b>	<b>30.8785</b>	<b>0.0620</b>	<b>8.6733</b>	<b>1.9853</b>	<b>10.6587</b>	<b>3.5965</b>	<b>1.8265</b>	<b>5.4230</b>	<b>0.0000</b>	<b>6,007.0434</b>	<b>6,007.0434</b>	<b>1.9428</b>		<b>6,055.6134</b>

Village South Specific Plan (Proposed) - Los Angeles-South Coast County, Winter

**3.4 Grading - 2021**

**Mitigated Construction Off-Site**

	ROG	NOx	CO	SO2	Fugitive PM10	Exhaust PM10	PM10 Total	Fugitive PM2.5	Exhaust PM2.5	PM2.5 Total	Bio- CO2	NBio- CO2	Total CO2	CH4	N2O	CO2e
Category	lb/day										lb/day					
Hauling	0.0000	0.0000	0.0000	0.0000	0.0000	0.0000	0.0000	0.0000	0.0000	0.0000		0.0000	0.0000	0.0000		0.0000
Vendor	0.0000	0.0000	0.0000	0.0000	0.0000	0.0000	0.0000	0.0000	0.0000	0.0000		0.0000	0.0000	0.0000		0.0000
Worker	0.0709	0.0462	0.5284	1.4800e-003	0.1521	1.2700e-003	0.1534	0.0404	1.1700e-003	0.0415		147.2943	147.2943	4.4300e-003		147.4051
<b>Total</b>	<b>0.0709</b>	<b>0.0462</b>	<b>0.5284</b>	<b>1.4800e-003</b>	<b>0.1521</b>	<b>1.2700e-003</b>	<b>0.1534</b>	<b>0.0404</b>	<b>1.1700e-003</b>	<b>0.0415</b>		<b>147.2943</b>	<b>147.2943</b>	<b>4.4300e-003</b>		<b>147.4051</b>

**3.4 Grading - 2022**

**Unmitigated Construction On-Site**

	ROG	NOx	CO	SO2	Fugitive PM10	Exhaust PM10	PM10 Total	Fugitive PM2.5	Exhaust PM2.5	PM2.5 Total	Bio- CO2	NBio- CO2	Total CO2	CH4	N2O	CO2e
Category	lb/day										lb/day					
Fugitive Dust					8.6733	0.0000	8.6733	3.5965	0.0000	3.5965			0.0000			0.0000
Off-Road	3.6248	38.8435	29.0415	0.0621		1.6349	1.6349		1.5041	1.5041		6,011.4105	6,011.4105	1.9442		6,060.0158
<b>Total</b>	<b>3.6248</b>	<b>38.8435</b>	<b>29.0415</b>	<b>0.0621</b>	<b>8.6733</b>	<b>1.6349</b>	<b>10.3082</b>	<b>3.5965</b>	<b>1.5041</b>	<b>5.1006</b>		<b>6,011.4105</b>	<b>6,011.4105</b>	<b>1.9442</b>		<b>6,060.0158</b>

Village South Specific Plan (Proposed) - Los Angeles-South Coast County, Winter

**3.4 Grading - 2022**

**Unmitigated Construction Off-Site**

	ROG	NOx	CO	SO2	Fugitive PM10	Exhaust PM10	PM10 Total	Fugitive PM2.5	Exhaust PM2.5	PM2.5 Total	Bio- CO2	NBio- CO2	Total CO2	CH4	N2O	CO2e
Category	lb/day										lb/day					
Hauling	0.0000	0.0000	0.0000	0.0000	0.0000	0.0000	0.0000	0.0000	0.0000	0.0000		0.0000	0.0000	0.0000		0.0000
Vendor	0.0000	0.0000	0.0000	0.0000	0.0000	0.0000	0.0000	0.0000	0.0000	0.0000		0.0000	0.0000	0.0000		0.0000
Worker	0.0665	0.0416	0.4861	1.4300e-003	0.1521	1.2300e-003	0.1534	0.0404	1.1300e-003	0.0415		142.1207	142.1207	4.0000e-003		142.2207
<b>Total</b>	<b>0.0665</b>	<b>0.0416</b>	<b>0.4861</b>	<b>1.4300e-003</b>	<b>0.1521</b>	<b>1.2300e-003</b>	<b>0.1534</b>	<b>0.0404</b>	<b>1.1300e-003</b>	<b>0.0415</b>		<b>142.1207</b>	<b>142.1207</b>	<b>4.0000e-003</b>		<b>142.2207</b>

**Mitigated Construction On-Site**

	ROG	NOx	CO	SO2	Fugitive PM10	Exhaust PM10	PM10 Total	Fugitive PM2.5	Exhaust PM2.5	PM2.5 Total	Bio- CO2	NBio- CO2	Total CO2	CH4	N2O	CO2e
Category	lb/day										lb/day					
Fugitive Dust					8.6733	0.0000	8.6733	3.5965	0.0000	3.5965			0.0000			0.0000
Off-Road	3.6248	38.8435	29.0415	0.0621		1.6349	1.6349		1.5041	1.5041	0.0000	6,011.4105	6,011.4105	1.9442		6,060.0158
<b>Total</b>	<b>3.6248</b>	<b>38.8435</b>	<b>29.0415</b>	<b>0.0621</b>	<b>8.6733</b>	<b>1.6349</b>	<b>10.3082</b>	<b>3.5965</b>	<b>1.5041</b>	<b>5.1006</b>	<b>0.0000</b>	<b>6,011.4105</b>	<b>6,011.4105</b>	<b>1.9442</b>		<b>6,060.0158</b>

Village South Specific Plan (Proposed) - Los Angeles-South Coast County, Winter

**3.4 Grading - 2022**

**Mitigated Construction Off-Site**

	ROG	NOx	CO	SO2	Fugitive PM10	Exhaust PM10	PM10 Total	Fugitive PM2.5	Exhaust PM2.5	PM2.5 Total	Bio- CO2	NBio- CO2	Total CO2	CH4	N2O	CO2e
Category	lb/day										lb/day					
Hauling	0.0000	0.0000	0.0000	0.0000	0.0000	0.0000	0.0000	0.0000	0.0000	0.0000		0.0000	0.0000	0.0000		0.0000
Vendor	0.0000	0.0000	0.0000	0.0000	0.0000	0.0000	0.0000	0.0000	0.0000	0.0000		0.0000	0.0000	0.0000		0.0000
Worker	0.0665	0.0416	0.4861	1.4300e-003	0.1521	1.2300e-003	0.1534	0.0404	1.1300e-003	0.0415		142.1207	142.1207	4.0000e-003		142.2207
<b>Total</b>	<b>0.0665</b>	<b>0.0416</b>	<b>0.4861</b>	<b>1.4300e-003</b>	<b>0.1521</b>	<b>1.2300e-003</b>	<b>0.1534</b>	<b>0.0404</b>	<b>1.1300e-003</b>	<b>0.0415</b>		<b>142.1207</b>	<b>142.1207</b>	<b>4.0000e-003</b>		<b>142.2207</b>

**3.5 Building Construction - 2022**

**Unmitigated Construction On-Site**

	ROG	NOx	CO	SO2	Fugitive PM10	Exhaust PM10	PM10 Total	Fugitive PM2.5	Exhaust PM2.5	PM2.5 Total	Bio- CO2	NBio- CO2	Total CO2	CH4	N2O	CO2e
Category	lb/day										lb/day					
Off-Road	1.7062	15.6156	16.3634	0.0269		0.8090	0.8090		0.7612	0.7612		2,554.3336	2,554.3336	0.6120		2,569.6322
<b>Total</b>	<b>1.7062</b>	<b>15.6156</b>	<b>16.3634</b>	<b>0.0269</b>		<b>0.8090</b>	<b>0.8090</b>		<b>0.7612</b>	<b>0.7612</b>		<b>2,554.3336</b>	<b>2,554.3336</b>	<b>0.6120</b>		<b>2,569.6322</b>

Village South Specific Plan (Proposed) - Los Angeles-South Coast County, Winter

**3.5 Building Construction - 2022**

**Unmitigated Construction Off-Site**

	ROG	NOx	CO	SO2	Fugitive PM10	Exhaust PM10	PM10 Total	Fugitive PM2.5	Exhaust PM2.5	PM2.5 Total	Bio- CO2	NBio- CO2	Total CO2	CH4	N2O	CO2e
Category	lb/day										lb/day					
Hauling	0.0000	0.0000	0.0000	0.0000	0.0000	0.0000	0.0000	0.0000	0.0000	0.0000		0.0000	0.0000	0.0000		0.0000
Vendor	0.4284	13.1673	3.8005	0.0354	0.9155	0.0256	0.9412	0.2636	0.0245	0.2881		3,789.0750	3,789.0750	0.2381		3,795.0283
Worker	2.6620	1.6677	19.4699	0.0571	6.0932	0.0493	6.1425	1.6163	0.0454	1.6617		5,691.9354	5,691.9354	0.1602		5,695.9408
<b>Total</b>	<b>3.0904</b>	<b>14.8350</b>	<b>23.2704</b>	<b>0.0926</b>	<b>7.0087</b>	<b>0.0749</b>	<b>7.0836</b>	<b>1.8799</b>	<b>0.0699</b>	<b>1.9498</b>		<b>9,481.0104</b>	<b>9,481.0104</b>	<b>0.3984</b>		<b>9,490.9691</b>

**Mitigated Construction On-Site**

	ROG	NOx	CO	SO2	Fugitive PM10	Exhaust PM10	PM10 Total	Fugitive PM2.5	Exhaust PM2.5	PM2.5 Total	Bio- CO2	NBio- CO2	Total CO2	CH4	N2O	CO2e
Category	lb/day										lb/day					
Off-Road	1.7062	15.6156	16.3634	0.0269		0.8090	0.8090		0.7612	0.7612	0.0000	2,554.3336	2,554.3336	0.6120		2,569.6322
<b>Total</b>	<b>1.7062</b>	<b>15.6156</b>	<b>16.3634</b>	<b>0.0269</b>		<b>0.8090</b>	<b>0.8090</b>		<b>0.7612</b>	<b>0.7612</b>	<b>0.0000</b>	<b>2,554.3336</b>	<b>2,554.3336</b>	<b>0.6120</b>		<b>2,569.6322</b>

Village South Specific Plan (Proposed) - Los Angeles-South Coast County, Winter

**3.5 Building Construction - 2022**

**Mitigated Construction Off-Site**

	ROG	NOx	CO	SO2	Fugitive PM10	Exhaust PM10	PM10 Total	Fugitive PM2.5	Exhaust PM2.5	PM2.5 Total	Bio- CO2	NBio- CO2	Total CO2	CH4	N2O	CO2e
Category	lb/day										lb/day					
Hauling	0.0000	0.0000	0.0000	0.0000	0.0000	0.0000	0.0000	0.0000	0.0000	0.0000		0.0000	0.0000	0.0000		0.0000
Vendor	0.4284	13.1673	3.8005	0.0354	0.9155	0.0256	0.9412	0.2636	0.0245	0.2881		3,789.0750	3,789.0750	0.2381		3,795.0283
Worker	2.6620	1.6677	19.4699	0.0571	6.0932	0.0493	6.1425	1.6163	0.0454	1.6617		5,691.9354	5,691.9354	0.1602		5,695.9408
<b>Total</b>	<b>3.0904</b>	<b>14.8350</b>	<b>23.2704</b>	<b>0.0926</b>	<b>7.0087</b>	<b>0.0749</b>	<b>7.0836</b>	<b>1.8799</b>	<b>0.0699</b>	<b>1.9498</b>		<b>9,481.0104</b>	<b>9,481.0104</b>	<b>0.3984</b>		<b>9,490.9691</b>

**3.5 Building Construction - 2023**

**Unmitigated Construction On-Site**

	ROG	NOx	CO	SO2	Fugitive PM10	Exhaust PM10	PM10 Total	Fugitive PM2.5	Exhaust PM2.5	PM2.5 Total	Bio- CO2	NBio- CO2	Total CO2	CH4	N2O	CO2e
Category	lb/day										lb/day					
Off-Road	1.5728	14.3849	16.2440	0.0269		0.6997	0.6997		0.6584	0.6584		2,555.2099	2,555.2099	0.6079		2,570.4061
<b>Total</b>	<b>1.5728</b>	<b>14.3849</b>	<b>16.2440</b>	<b>0.0269</b>		<b>0.6997</b>	<b>0.6997</b>		<b>0.6584</b>	<b>0.6584</b>		<b>2,555.2099</b>	<b>2,555.2099</b>	<b>0.6079</b>		<b>2,570.4061</b>



Village South Specific Plan (Proposed) - Los Angeles-South Coast County, Winter

**3.5 Building Construction - 2023**

**Unmitigated Construction Off-Site**

	ROG	NOx	CO	SO2	Fugitive PM10	Exhaust PM10	PM10 Total	Fugitive PM2.5	Exhaust PM2.5	PM2.5 Total	Bio- CO2	NBio- CO2	Total CO2	CH4	N2O	CO2e
Category	lb/day										lb/day					
Hauling	0.0000	0.0000	0.0000	0.0000	0.0000	0.0000	0.0000	0.0000	0.0000	0.0000		0.0000	0.0000	0.0000		0.0000
Vendor	0.3183	9.9726	3.3771	0.0343	0.9156	0.0122	0.9277	0.2636	0.0116	0.2752		3,671.4007	3,671.4007	0.2096		3,676.6417
Worker	2.5029	1.5073	17.8820	0.0550	6.0932	0.0479	6.1411	1.6163	0.0441	1.6604		5,483.7974	5,483.7974	0.1442		5,487.4020
<b>Total</b>	<b>2.8211</b>	<b>11.4799</b>	<b>21.2591</b>	<b>0.0893</b>	<b>7.0088</b>	<b>0.0601</b>	<b>7.0688</b>	<b>1.8799</b>	<b>0.0557</b>	<b>1.9356</b>		<b>9,155.1981</b>	<b>9,155.1981</b>	<b>0.3538</b>		<b>9,164.0437</b>

**Mitigated Construction On-Site**

	ROG	NOx	CO	SO2	Fugitive PM10	Exhaust PM10	PM10 Total	Fugitive PM2.5	Exhaust PM2.5	PM2.5 Total	Bio- CO2	NBio- CO2	Total CO2	CH4	N2O	CO2e
Category	lb/day										lb/day					
Off-Road	1.5728	14.3849	16.2440	0.0269		0.6997	0.6997		0.6584	0.6584	0.0000	2,555.2099	2,555.2099	0.6079		2,570.4061
<b>Total</b>	<b>1.5728</b>	<b>14.3849</b>	<b>16.2440</b>	<b>0.0269</b>		<b>0.6997</b>	<b>0.6997</b>		<b>0.6584</b>	<b>0.6584</b>	<b>0.0000</b>	<b>2,555.2099</b>	<b>2,555.2099</b>	<b>0.6079</b>		<b>2,570.4061</b>

Village South Specific Plan (Proposed) - Los Angeles-South Coast County, Winter

**3.5 Building Construction - 2023**

**Mitigated Construction Off-Site**

	ROG	NOx	CO	SO2	Fugitive PM10	Exhaust PM10	PM10 Total	Fugitive PM2.5	Exhaust PM2.5	PM2.5 Total	Bio- CO2	NBio- CO2	Total CO2	CH4	N2O	CO2e
Category	lb/day										lb/day					
Hauling	0.0000	0.0000	0.0000	0.0000	0.0000	0.0000	0.0000	0.0000	0.0000	0.0000		0.0000	0.0000	0.0000		0.0000
Vendor	0.3183	9.9726	3.3771	0.0343	0.9156	0.0122	0.9277	0.2636	0.0116	0.2752		3,671.4007	3,671.4007	0.2096		3,676.6417
Worker	2.5029	1.5073	17.8820	0.0550	6.0932	0.0479	6.1411	1.6163	0.0441	1.6604		5,483.7974	5,483.7974	0.1442		5,487.4020
<b>Total</b>	<b>2.8211</b>	<b>11.4799</b>	<b>21.2591</b>	<b>0.0893</b>	<b>7.0088</b>	<b>0.0601</b>	<b>7.0688</b>	<b>1.8799</b>	<b>0.0557</b>	<b>1.9356</b>		<b>9,155.1981</b>	<b>9,155.1981</b>	<b>0.3538</b>		<b>9,164.0437</b>

**3.6 Paving - 2023**

**Unmitigated Construction On-Site**

	ROG	NOx	CO	SO2	Fugitive PM10	Exhaust PM10	PM10 Total	Fugitive PM2.5	Exhaust PM2.5	PM2.5 Total	Bio- CO2	NBio- CO2	Total CO2	CH4	N2O	CO2e
Category	lb/day										lb/day					
Off-Road	1.0327	10.1917	14.5842	0.0228		0.5102	0.5102		0.4694	0.4694		2,207.5841	2,207.5841	0.7140		2,225.4336
Paving	0.0000					0.0000	0.0000		0.0000	0.0000			0.0000			0.0000
<b>Total</b>	<b>1.0327</b>	<b>10.1917</b>	<b>14.5842</b>	<b>0.0228</b>		<b>0.5102</b>	<b>0.5102</b>		<b>0.4694</b>	<b>0.4694</b>		<b>2,207.5841</b>	<b>2,207.5841</b>	<b>0.7140</b>		<b>2,225.4336</b>

Village South Specific Plan (Proposed) - Los Angeles-South Coast County, Winter

**3.6 Paving - 2023**

**Unmitigated Construction Off-Site**

	ROG	NOx	CO	SO2	Fugitive PM10	Exhaust PM10	PM10 Total	Fugitive PM2.5	Exhaust PM2.5	PM2.5 Total	Bio- CO2	NBio- CO2	Total CO2	CH4	N2O	CO2e
Category	lb/day										lb/day					
Hauling	0.0000	0.0000	0.0000	0.0000	0.0000	0.0000	0.0000	0.0000	0.0000	0.0000		0.0000	0.0000	0.0000		0.0000
Vendor	0.0000	0.0000	0.0000	0.0000	0.0000	0.0000	0.0000	0.0000	0.0000	0.0000		0.0000	0.0000	0.0000		0.0000
Worker	0.0469	0.0282	0.3349	1.0300e-003	0.1141	9.0000e-004	0.1150	0.0303	8.3000e-004	0.0311		102.6928	102.6928	2.7000e-003		102.7603
<b>Total</b>	<b>0.0469</b>	<b>0.0282</b>	<b>0.3349</b>	<b>1.0300e-003</b>	<b>0.1141</b>	<b>9.0000e-004</b>	<b>0.1150</b>	<b>0.0303</b>	<b>8.3000e-004</b>	<b>0.0311</b>		<b>102.6928</b>	<b>102.6928</b>	<b>2.7000e-003</b>		<b>102.7603</b>

**Mitigated Construction On-Site**

	ROG	NOx	CO	SO2	Fugitive PM10	Exhaust PM10	PM10 Total	Fugitive PM2.5	Exhaust PM2.5	PM2.5 Total	Bio- CO2	NBio- CO2	Total CO2	CH4	N2O	CO2e
Category	lb/day										lb/day					
Off-Road	1.0327	10.1917	14.5842	0.0228		0.5102	0.5102		0.4694	0.4694	0.0000	2,207.5841	2,207.5841	0.7140		2,225.4336
Paving	0.0000					0.0000	0.0000		0.0000	0.0000			0.0000			0.0000
<b>Total</b>	<b>1.0327</b>	<b>10.1917</b>	<b>14.5842</b>	<b>0.0228</b>		<b>0.5102</b>	<b>0.5102</b>		<b>0.4694</b>	<b>0.4694</b>	<b>0.0000</b>	<b>2,207.5841</b>	<b>2,207.5841</b>	<b>0.7140</b>		<b>2,225.4336</b>

Village South Specific Plan (Proposed) - Los Angeles-South Coast County, Winter

**3.6 Paving - 2023**

**Mitigated Construction Off-Site**

	ROG	NOx	CO	SO2	Fugitive PM10	Exhaust PM10	PM10 Total	Fugitive PM2.5	Exhaust PM2.5	PM2.5 Total	Bio- CO2	NBio- CO2	Total CO2	CH4	N2O	CO2e
Category	lb/day										lb/day					
Hauling	0.0000	0.0000	0.0000	0.0000	0.0000	0.0000	0.0000	0.0000	0.0000	0.0000		0.0000	0.0000	0.0000		0.0000
Vendor	0.0000	0.0000	0.0000	0.0000	0.0000	0.0000	0.0000	0.0000	0.0000	0.0000		0.0000	0.0000	0.0000		0.0000
Worker	0.0469	0.0282	0.3349	1.0300e-003	0.1141	9.0000e-004	0.1150	0.0303	8.3000e-004	0.0311		102.6928	102.6928	2.7000e-003		102.7603
<b>Total</b>	<b>0.0469</b>	<b>0.0282</b>	<b>0.3349</b>	<b>1.0300e-003</b>	<b>0.1141</b>	<b>9.0000e-004</b>	<b>0.1150</b>	<b>0.0303</b>	<b>8.3000e-004</b>	<b>0.0311</b>		<b>102.6928</b>	<b>102.6928</b>	<b>2.7000e-003</b>		<b>102.7603</b>

**3.6 Paving - 2024**

**Unmitigated Construction On-Site**

	ROG	NOx	CO	SO2	Fugitive PM10	Exhaust PM10	PM10 Total	Fugitive PM2.5	Exhaust PM2.5	PM2.5 Total	Bio- CO2	NBio- CO2	Total CO2	CH4	N2O	CO2e
Category	lb/day										lb/day					
Off-Road	0.9882	9.5246	14.6258	0.0228		0.4685	0.4685		0.4310	0.4310		2,207.5472	2,207.5472	0.7140		2,225.3963
Paving	0.0000					0.0000	0.0000		0.0000	0.0000			0.0000			0.0000
<b>Total</b>	<b>0.9882</b>	<b>9.5246</b>	<b>14.6258</b>	<b>0.0228</b>		<b>0.4685</b>	<b>0.4685</b>		<b>0.4310</b>	<b>0.4310</b>		<b>2,207.5472</b>	<b>2,207.5472</b>	<b>0.7140</b>		<b>2,225.3963</b>

Village South Specific Plan (Proposed) - Los Angeles-South Coast County, Winter

**3.6 Paving - 2024**

**Unmitigated Construction Off-Site**

	ROG	NOx	CO	SO2	Fugitive PM10	Exhaust PM10	PM10 Total	Fugitive PM2.5	Exhaust PM2.5	PM2.5 Total	Bio- CO2	NBio- CO2	Total CO2	CH4	N2O	CO2e
Category	lb/day										lb/day					
Hauling	0.0000	0.0000	0.0000	0.0000	0.0000	0.0000	0.0000	0.0000	0.0000	0.0000		0.0000	0.0000	0.0000		0.0000
Vendor	0.0000	0.0000	0.0000	0.0000	0.0000	0.0000	0.0000	0.0000	0.0000	0.0000		0.0000	0.0000	0.0000		0.0000
Worker	0.0444	0.0257	0.3114	1.0000e-003	0.1141	8.8000e-004	0.1150	0.0303	8.1000e-004	0.0311		99.5045	99.5045	2.4700e-003		99.5663
<b>Total</b>	<b>0.0444</b>	<b>0.0257</b>	<b>0.3114</b>	<b>1.0000e-003</b>	<b>0.1141</b>	<b>8.8000e-004</b>	<b>0.1150</b>	<b>0.0303</b>	<b>8.1000e-004</b>	<b>0.0311</b>		<b>99.5045</b>	<b>99.5045</b>	<b>2.4700e-003</b>		<b>99.5663</b>

**Mitigated Construction On-Site**

	ROG	NOx	CO	SO2	Fugitive PM10	Exhaust PM10	PM10 Total	Fugitive PM2.5	Exhaust PM2.5	PM2.5 Total	Bio- CO2	NBio- CO2	Total CO2	CH4	N2O	CO2e
Category	lb/day										lb/day					
Off-Road	0.9882	9.5246	14.6258	0.0228		0.4685	0.4685		0.4310	0.4310	0.0000	2,207.5472	2,207.5472	0.7140		2,225.3963
Paving	0.0000					0.0000	0.0000		0.0000	0.0000			0.0000			0.0000
<b>Total</b>	<b>0.9882</b>	<b>9.5246</b>	<b>14.6258</b>	<b>0.0228</b>		<b>0.4685</b>	<b>0.4685</b>		<b>0.4310</b>	<b>0.4310</b>	<b>0.0000</b>	<b>2,207.5472</b>	<b>2,207.5472</b>	<b>0.7140</b>		<b>2,225.3963</b>

Village South Specific Plan (Proposed) - Los Angeles-South Coast County, Winter

**3.6 Paving - 2024**

**Mitigated Construction Off-Site**

	ROG	NOx	CO	SO2	Fugitive PM10	Exhaust PM10	PM10 Total	Fugitive PM2.5	Exhaust PM2.5	PM2.5 Total	Bio- CO2	NBio- CO2	Total CO2	CH4	N2O	CO2e
Category	lb/day										lb/day					
Hauling	0.0000	0.0000	0.0000	0.0000	0.0000	0.0000	0.0000	0.0000	0.0000	0.0000		0.0000	0.0000	0.0000		0.0000
Vendor	0.0000	0.0000	0.0000	0.0000	0.0000	0.0000	0.0000	0.0000	0.0000	0.0000		0.0000	0.0000	0.0000		0.0000
Worker	0.0444	0.0257	0.3114	1.0000e-003	0.1141	8.8000e-004	0.1150	0.0303	8.1000e-004	0.0311		99.5045	99.5045	2.4700e-003		99.5663
<b>Total</b>	<b>0.0444</b>	<b>0.0257</b>	<b>0.3114</b>	<b>1.0000e-003</b>	<b>0.1141</b>	<b>8.8000e-004</b>	<b>0.1150</b>	<b>0.0303</b>	<b>8.1000e-004</b>	<b>0.0311</b>		<b>99.5045</b>	<b>99.5045</b>	<b>2.4700e-003</b>		<b>99.5663</b>

**3.7 Architectural Coating - 2024**

**Unmitigated Construction On-Site**

	ROG	NOx	CO	SO2	Fugitive PM10	Exhaust PM10	PM10 Total	Fugitive PM2.5	Exhaust PM2.5	PM2.5 Total	Bio- CO2	NBio- CO2	Total CO2	CH4	N2O	CO2e
Category	lb/day										lb/day					
Archit. Coating	236.4115					0.0000	0.0000		0.0000	0.0000			0.0000			0.0000
Off-Road	0.1808	1.2188	1.8101	2.9700e-003		0.0609	0.0609		0.0609	0.0609		281.4481	281.4481	0.0159		281.8443
<b>Total</b>	<b>236.5923</b>	<b>1.2188</b>	<b>1.8101</b>	<b>2.9700e-003</b>		<b>0.0609</b>	<b>0.0609</b>		<b>0.0609</b>	<b>0.0609</b>		<b>281.4481</b>	<b>281.4481</b>	<b>0.0159</b>		<b>281.8443</b>

Village South Specific Plan (Proposed) - Los Angeles-South Coast County, Winter

**3.7 Architectural Coating - 2024**

**Unmitigated Construction Off-Site**

	ROG	NOx	CO	SO2	Fugitive PM10	Exhaust PM10	PM10 Total	Fugitive PM2.5	Exhaust PM2.5	PM2.5 Total	Bio- CO2	NBio- CO2	Total CO2	CH4	N2O	CO2e
Category	lb/day										lb/day					
Hauling	0.0000	0.0000	0.0000	0.0000	0.0000	0.0000	0.0000	0.0000	0.0000	0.0000		0.0000	0.0000	0.0000		0.0000
Vendor	0.0000	0.0000	0.0000	0.0000	0.0000	0.0000	0.0000	0.0000	0.0000	0.0000		0.0000	0.0000	0.0000		0.0000
Worker	0.4734	0.2743	3.3220	0.0107	1.2171	9.4300e-003	1.2266	0.3229	8.6800e-003	0.3315		1,061.3818	1,061.3818	0.0264		1,062.0410
<b>Total</b>	<b>0.4734</b>	<b>0.2743</b>	<b>3.3220</b>	<b>0.0107</b>	<b>1.2171</b>	<b>9.4300e-003</b>	<b>1.2266</b>	<b>0.3229</b>	<b>8.6800e-003</b>	<b>0.3315</b>		<b>1,061.3818</b>	<b>1,061.3818</b>	<b>0.0264</b>		<b>1,062.0410</b>

**Mitigated Construction On-Site**

	ROG	NOx	CO	SO2	Fugitive PM10	Exhaust PM10	PM10 Total	Fugitive PM2.5	Exhaust PM2.5	PM2.5 Total	Bio- CO2	NBio- CO2	Total CO2	CH4	N2O	CO2e
Category	lb/day										lb/day					
Archit. Coating	236.4115					0.0000	0.0000		0.0000	0.0000			0.0000			0.0000
Off-Road	0.1808	1.2188	1.8101	2.9700e-003		0.0609	0.0609		0.0609	0.0609	0.0000	281.4481	281.4481	0.0159		281.8443
<b>Total</b>	<b>236.5923</b>	<b>1.2188</b>	<b>1.8101</b>	<b>2.9700e-003</b>		<b>0.0609</b>	<b>0.0609</b>		<b>0.0609</b>	<b>0.0609</b>	<b>0.0000</b>	<b>281.4481</b>	<b>281.4481</b>	<b>0.0159</b>		<b>281.8443</b>

Village South Specific Plan (Proposed) - Los Angeles-South Coast County, Winter

**3.7 Architectural Coating - 2024**

**Mitigated Construction Off-Site**

	ROG	NOx	CO	SO2	Fugitive PM10	Exhaust PM10	PM10 Total	Fugitive PM2.5	Exhaust PM2.5	PM2.5 Total	Bio- CO2	NBio- CO2	Total CO2	CH4	N2O	CO2e
Category	lb/day										lb/day					
Hauling	0.0000	0.0000	0.0000	0.0000	0.0000	0.0000	0.0000	0.0000	0.0000	0.0000		0.0000	0.0000	0.0000		0.0000
Vendor	0.0000	0.0000	0.0000	0.0000	0.0000	0.0000	0.0000	0.0000	0.0000	0.0000		0.0000	0.0000	0.0000		0.0000
Worker	0.4734	0.2743	3.3220	0.0107	1.2171	9.4300e-003	1.2266	0.3229	8.6800e-003	0.3315		1,061.3818	1,061.3818	0.0264		1,062.0410
<b>Total</b>	<b>0.4734</b>	<b>0.2743</b>	<b>3.3220</b>	<b>0.0107</b>	<b>1.2171</b>	<b>9.4300e-003</b>	<b>1.2266</b>	<b>0.3229</b>	<b>8.6800e-003</b>	<b>0.3315</b>		<b>1,061.3818</b>	<b>1,061.3818</b>	<b>0.0264</b>		<b>1,062.0410</b>

**4.0 Operational Detail - Mobile**

---

**4.1 Mitigation Measures Mobile**



Village South Specific Plan (Proposed) - Los Angeles-South Coast County, Winter

	ROG	NOx	CO	SO2	Fugitive PM10	Exhaust PM10	PM10 Total	Fugitive PM2.5	Exhaust PM2.5	PM2.5 Total	Bio- CO2	NBio- CO2	Total CO2	CH4	N2O	CO2e
Category	lb/day										lb/day					
Mitigated	9.5233	45.9914	110.0422	0.4681	45.9592	0.3373	46.2965	12.2950	0.3132	12.6083		47,917.8005	47,917.8005	2.1953		47,972.6839
Unmitigated	9.5233	45.9914	110.0422	0.4681	45.9592	0.3373	46.2965	12.2950	0.3132	12.6083		47,917.8005	47,917.8005	2.1953		47,972.6839

4.2 Trip Summary Information

Land Use	Average Daily Trip Rate			Unmitigated	Mitigated
	Weekday	Saturday	Sunday	Annual VMT	Annual VMT
Apartments Low Rise	145.75	154.25	154.00	506,227	506,227
Apartments Mid Rise	4,026.75	3,773.25	4075.50	13,660,065	13,660,065
General Office Building	288.45	62.55	31.05	706,812	706,812
High Turnover (Sit Down Restaurant)	2,368.80	2,873.52	2817.72	3,413,937	3,413,937
Hotel	192.00	187.50	160.00	445,703	445,703
Quality Restaurant	501.12	511.92	461.20	707,488	707,488
Regional Shopping Center	528.08	601.44	357.84	1,112,221	1,112,221
<b>Total</b>	<b>8,050.95</b>	<b>8,164.43</b>	<b>8,057.31</b>	<b>20,552,452</b>	<b>20,552,452</b>

4.3 Trip Type Information

Village South Specific Plan (Proposed) - Los Angeles-South Coast County, Winter

Land Use	Miles			Trip %			Trip Purpose %		
	H-W or C-W	H-S or C-C	H-O or C-NW	H-W or C-W	H-S or C-C	H-O or C-NW	Primary	Diverted	Pass-by
Apartments Low Rise	14.70	5.90	8.70	40.20	19.20	40.60	86	11	3
Apartments Mid Rise	14.70	5.90	8.70	40.20	19.20	40.60	86	11	3
General Office Building	16.60	8.40	6.90	33.00	48.00	19.00	77	19	4
High Turnover (Sit Down Restaurant)	16.60	8.40	6.90	8.50	72.50	19.00	37	20	43
Hotel	16.60	8.40	6.90	19.40	61.60	19.00	58	38	4
Quality Restaurant	16.60	8.40	6.90	12.00	69.00	19.00	38	18	44
Regional Shopping Center	16.60	8.40	6.90	16.30	64.70	19.00	54	35	11

4.4 Fleet Mix

Land Use	LDA	LDT1	LDT2	MDV	LHD1	LHD2	MHD	HHD	OBUS	UBUS	MCY	SBUS	MH
Apartments Low Rise	0.543088	0.044216	0.209971	0.116369	0.014033	0.006332	0.021166	0.033577	0.002613	0.001817	0.005285	0.000712	0.000821
Apartments Mid Rise	0.543088	0.044216	0.209971	0.116369	0.014033	0.006332	0.021166	0.033577	0.002613	0.001817	0.005285	0.000712	0.000821
General Office Building	0.543088	0.044216	0.209971	0.116369	0.014033	0.006332	0.021166	0.033577	0.002613	0.001817	0.005285	0.000712	0.000821
High Turnover (Sit Down Restaurant)	0.543088	0.044216	0.209971	0.116369	0.014033	0.006332	0.021166	0.033577	0.002613	0.001817	0.005285	0.000712	0.000821
Hotel	0.543088	0.044216	0.209971	0.116369	0.014033	0.006332	0.021166	0.033577	0.002613	0.001817	0.005285	0.000712	0.000821
Quality Restaurant	0.543088	0.044216	0.209971	0.116369	0.014033	0.006332	0.021166	0.033577	0.002613	0.001817	0.005285	0.000712	0.000821
Regional Shopping Center	0.543088	0.044216	0.209971	0.116369	0.014033	0.006332	0.021166	0.033577	0.002613	0.001817	0.005285	0.000712	0.000821

5.0 Energy Detail

Historical Energy Use: N

5.1 Mitigation Measures Energy

Village South Specific Plan (Proposed) - Los Angeles-South Coast County, Winter

	ROG	NOx	CO	SO2	Fugitive PM10	Exhaust PM10	PM10 Total	Fugitive PM2.5	Exhaust PM2.5	PM2.5 Total	Bio- CO2	NBio- CO2	Total CO2	CH4	N2O	CO2e
Category	lb/day										lb/day					
NaturalGas Mitigated	0.7660	6.7462	4.2573	0.0418		0.5292	0.5292		0.5292	0.5292		8,355.983 2	8,355.983 2	0.1602	0.1532	8,405.638 7
NaturalGas Unmitigated	0.7660	6.7462	4.2573	0.0418		0.5292	0.5292		0.5292	0.5292		8,355.983 2	8,355.983 2	0.1602	0.1532	8,405.638 7

Village South Specific Plan (Proposed) - Los Angeles-South Coast County, Winter

**5.2 Energy by Land Use - NaturalGas**

**Unmitigated**

	NaturalGas Use	ROG	NOx	CO	SO2	Fugitive PM10	Exhaust PM10	PM10 Total	Fugitive PM2.5	Exhaust PM2.5	PM2.5 Total	Bio- CO2	NBio- CO2	Total CO2	CH4	N2O	CO2e
Land Use	kBTU/yr	lb/day										lb/day					
Apartments Low Rise	1119.16	0.0121	0.1031	0.0439	6.6000e-004		8.3400e-003	8.3400e-003		8.3400e-003	8.3400e-003		131.6662	131.6662	2.5200e-003	2.4100e-003	132.4486
Apartments Mid Rise	35784.3	0.3859	3.2978	1.4033	0.0211		0.2666	0.2666		0.2666	0.2666		4,209.9164	4,209.9164	0.0807	0.0772	4,234.9339
General Office Building	1283.42	0.0138	0.1258	0.1057	7.5000e-004		9.5600e-003	9.5600e-003		9.5600e-003	9.5600e-003		150.9911	150.9911	2.8900e-003	2.7700e-003	151.8884
High Turnover (Sit Down Restaurant)	22759.9	0.2455	2.2314	1.8743	0.0134		0.1696	0.1696		0.1696	0.1696		2,677.6342	2,677.6342	0.0513	0.0491	2,693.5460
Hotel	4769.72	0.0514	0.4676	0.3928	2.8100e-003		0.0355	0.0355		0.0355	0.0355		561.1436	561.1436	0.0108	0.0103	564.4782
Quality Restaurant	5057.75	0.0545	0.4959	0.4165	2.9800e-003		0.0377	0.0377		0.0377	0.0377		595.0298	595.0298	0.0114	0.0109	598.5658
Regional Shopping Center	251.616	2.7100e-003	0.0247	0.0207	1.5000e-004		1.8700e-003	1.8700e-003		1.8700e-003	1.8700e-003		29.6019	29.6019	5.7000e-004	5.4000e-004	29.7778
<b>Total</b>		<b>0.7660</b>	<b>6.7463</b>	<b>4.2573</b>	<b>0.0418</b>		<b>0.5292</b>	<b>0.5292</b>		<b>0.5292</b>	<b>0.5292</b>		<b>8,355.9832</b>	<b>8,355.9832</b>	<b>0.1602</b>	<b>0.1532</b>	<b>8,405.6387</b>

Village South Specific Plan (Proposed) - Los Angeles-South Coast County, Winter

**5.2 Energy by Land Use - NaturalGas**

**Mitigated**

	NaturalGas Use	ROG	NOx	CO	SO2	Fugitive PM10	Exhaust PM10	PM10 Total	Fugitive PM2.5	Exhaust PM2.5	PM2.5 Total	Bio- CO2	NBio- CO2	Total CO2	CH4	N2O	CO2e
Land Use	kBTU/yr	lb/day										lb/day					
Apartments Low Rise	1.11916	0.0121	0.1031	0.0439	6.6000e-004		8.3400e-003	8.3400e-003		8.3400e-003	8.3400e-003		131.6662	131.6662	2.5200e-003	2.4100e-003	132.4486
Apartments Mid Rise	35.7843	0.3859	3.2978	1.4033	0.0211		0.2666	0.2666		0.2666	0.2666		4,209.9164	4,209.9164	0.0807	0.0772	4,234.9339
General Office Building	1.28342	0.0138	0.1258	0.1057	7.5000e-004		9.5600e-003	9.5600e-003		9.5600e-003	9.5600e-003		150.9911	150.9911	2.8900e-003	2.7700e-003	151.8884
High Turnover (Sit Down Restaurant)	22.7599	0.2455	2.2314	1.8743	0.0134		0.1696	0.1696		0.1696	0.1696		2,677.6342	2,677.6342	0.0513	0.0491	2,693.5460
Hotel	4.76972	0.0514	0.4676	0.3928	2.8100e-003		0.0355	0.0355		0.0355	0.0355		561.1436	561.1436	0.0108	0.0103	564.4782
Quality Restaurant	5.05775	0.0545	0.4959	0.4165	2.9800e-003		0.0377	0.0377		0.0377	0.0377		595.0298	595.0298	0.0114	0.0109	598.5658
Regional Shopping Center	0.251616	2.7100e-003	0.0247	0.0207	1.5000e-004		1.8700e-003	1.8700e-003		1.8700e-003	1.8700e-003		29.6019	29.6019	5.7000e-004	5.4000e-004	29.7778
<b>Total</b>		<b>0.7660</b>	<b>6.7463</b>	<b>4.2573</b>	<b>0.0418</b>		<b>0.5292</b>	<b>0.5292</b>		<b>0.5292</b>	<b>0.5292</b>		<b>8,355.9832</b>	<b>8,355.9832</b>	<b>0.1602</b>	<b>0.1532</b>	<b>8,405.6387</b>

**6.0 Area Detail**

**6.1 Mitigation Measures Area**

Village South Specific Plan (Proposed) - Los Angeles-South Coast County, Winter

	ROG	NOx	CO	SO2	Fugitive PM10	Exhaust PM10	PM10 Total	Fugitive PM2.5	Exhaust PM2.5	PM2.5 Total	Bio- CO2	NBio- CO2	Total CO2	CH4	N2O	CO2e
Category	lb/day										lb/day					
Mitigated	30.5020	15.0496	88.4430	0.0944		1.5974	1.5974		1.5974	1.5974	0.0000	18,148.5950	18,148.5950	0.4874	0.3300	18,259.1192
Unmitigated	30.5020	15.0496	88.4430	0.0944		1.5974	1.5974		1.5974	1.5974	0.0000	18,148.5950	18,148.5950	0.4874	0.3300	18,259.1192

6.2 Area by SubCategory

Unmitigated

	ROG	NOx	CO	SO2	Fugitive PM10	Exhaust PM10	PM10 Total	Fugitive PM2.5	Exhaust PM2.5	PM2.5 Total	Bio- CO2	NBio- CO2	Total CO2	CH4	N2O	CO2e
SubCategory	lb/day										lb/day					
Architectural Coating	2.2670					0.0000	0.0000		0.0000	0.0000			0.0000			0.0000
Consumer Products	24.1085					0.0000	0.0000		0.0000	0.0000			0.0000			0.0000
Hearth	1.6500	14.1000	6.0000	0.0900		1.1400	1.1400		1.1400	1.1400	0.0000	18,000.0000	18,000.0000	0.3450	0.3300	18,106.9650
Landscaping	2.4766	0.9496	82.4430	4.3600e-003		0.4574	0.4574		0.4574	0.4574		148.5950	148.5950	0.1424		152.1542
<b>Total</b>	<b>30.5020</b>	<b>15.0496</b>	<b>88.4430</b>	<b>0.0944</b>		<b>1.5974</b>	<b>1.5974</b>		<b>1.5974</b>	<b>1.5974</b>	<b>0.0000</b>	<b>18,148.5950</b>	<b>18,148.5950</b>	<b>0.4874</b>	<b>0.3300</b>	<b>18,259.1192</b>

Village South Specific Plan (Proposed) - Los Angeles-South Coast County, Winter

**6.2 Area by SubCategory**

**Mitigated**

	ROG	NOx	CO	SO2	Fugitive PM10	Exhaust PM10	PM10 Total	Fugitive PM2.5	Exhaust PM2.5	PM2.5 Total	Bio- CO2	NBio- CO2	Total CO2	CH4	N2O	CO2e
SubCategory	lb/day										lb/day					
Architectural Coating	2.2670					0.0000	0.0000		0.0000	0.0000			0.0000			0.0000
Consumer Products	24.1085					0.0000	0.0000		0.0000	0.0000			0.0000			0.0000
Hearth	1.6500	14.1000	6.0000	0.0900		1.1400	1.1400		1.1400	1.1400	0.0000	18,000.0000	18,000.0000	0.3450	0.3300	18,106.9650
Landscaping	2.4766	0.9496	82.4430	4.3600e-003		0.4574	0.4574		0.4574	0.4574		148.5950	148.5950	0.1424		152.1542
<b>Total</b>	<b>30.5020</b>	<b>15.0496</b>	<b>88.4430</b>	<b>0.0944</b>		<b>1.5974</b>	<b>1.5974</b>		<b>1.5974</b>	<b>1.5974</b>	<b>0.0000</b>	<b>18,148.5950</b>	<b>18,148.5950</b>	<b>0.4874</b>	<b>0.3300</b>	<b>18,259.1192</b>

**7.0 Water Detail**

---

**7.1 Mitigation Measures Water**

**8.0 Waste Detail**

---

**8.1 Mitigation Measures Waste**

**9.0 Operational Offroad**

---

Equipment Type	Number	Hours/Day	Days/Year	Horse Power	Load Factor	Fuel Type
----------------	--------	-----------	-----------	-------------	-------------	-----------

**10.0 Stationary Equipment**

---

Village South Specific Plan (Proposed) - Los Angeles-South Coast County, Winter

**Fire Pumps and Emergency Generators**

Equipment Type	Number	Hours/Day	Hours/Year	Horse Power	Load Factor	Fuel Type
----------------	--------	-----------	------------	-------------	-------------	-----------

**Boilers**

Equipment Type	Number	Heat Input/Day	Heat Input/Year	Boiler Rating	Fuel Type
----------------	--------	----------------	-----------------	---------------	-----------

**User Defined Equipment**

Equipment Type	Number
----------------	--------

**11.0 Vegetation**

---



Attachment C

<b>Local Hire Provision Net Change</b>	
<b>Without Local Hire Provision</b>	
Total Construction GHG Emissions (MT CO2e)	3,623
Amortized (MT CO2e/year)	120.77
<b>With Local Hire Provision</b>	
Total Construction GHG Emissions (MT CO2e)	3,024
Amortized (MT CO2e/year)	100.80
<b><i>% Decrease in Construction-related GHG Emissions</i></b>	<b>17%</b>

**EXHIBIT B**



## ***Paul Rosenfeld, Ph.D.***

*Principal Environmental Chemist*

**Chemical Fate and Transport & Air Dispersion Modeling**

**Risk Assessment & Remediation Specialist**

### **Education**

Ph.D. Soil Chemistry, University of Washington, 1999. Dissertation on volatile organic compound filtration.

M.S. Environmental Science, U.C. Berkeley, 1995. Thesis on organic waste economics.

B.A. Environmental Studies, U.C. Santa Barbara, 1991. Thesis on wastewater treatment.

### **Professional Experience**

Dr. Rosenfeld has over 25 years' experience conducting environmental investigations and risk assessments for evaluating impacts to human health, property, and ecological receptors. His expertise focuses on the fate and transport of environmental contaminants, human health risk, exposure assessment, and ecological restoration. Dr. Rosenfeld has evaluated and modeled emissions from unconventional oil drilling operations, oil spills, landfills, boilers and incinerators, process stacks, storage tanks, confined animal feeding operations, and many other industrial and agricultural sources. His project experience ranges from monitoring and modeling of pollution sources to evaluating impacts of pollution on workers at industrial facilities and residents in surrounding communities.

Dr. Rosenfeld has investigated and designed remediation programs and risk assessments for contaminated sites containing lead, heavy metals, mold, bacteria, particulate matter, petroleum hydrocarbons, chlorinated solvents, pesticides, radioactive waste, dioxins and furans, semi- and volatile organic compounds, PCBs, PAHs, perchlorate, asbestos, per- and poly-fluoroalkyl substances (PFOA/PFOS), unusual polymers, fuel oxygenates (MTBE), among other pollutants. Dr. Rosenfeld also has experience evaluating greenhouse gas emissions from various projects and is an expert on the assessment of odors from industrial and agricultural sites, as well as the evaluation of odor nuisance impacts and technologies for abatement of odorous emissions. As a principal scientist at SWAPE, Dr. Rosenfeld directs air dispersion modeling and exposure assessments. He has served as an expert witness and testified about pollution sources causing nuisance and/or personal injury at dozens of sites and has testified as an expert witness on more than ten cases involving exposure to air contaminants from industrial sources.

## **Professional History:**

Soil Water Air Protection Enterprise (SWAPE); 2003 to present; Principal and Founding Partner  
UCLA School of Public Health; 2007 to 2011; Lecturer (Assistant Researcher)  
UCLA School of Public Health; 2003 to 2006; Adjunct Professor  
UCLA Environmental Science and Engineering Program; 2002-2004; Doctoral Intern Coordinator  
UCLA Institute of the Environment, 2001-2002; Research Associate  
Komex H<sub>2</sub>O Science, 2001 to 2003; Senior Remediation Scientist  
National Groundwater Association, 2002-2004; Lecturer  
San Diego State University, 1999-2001; Adjunct Professor  
Anteon Corp., San Diego, 2000-2001; Remediation Project Manager  
Ogden (now Amec), San Diego, 2000-2000; Remediation Project Manager  
Bechtel, San Diego, California, 1999 – 2000; Risk Assessor  
King County, Seattle, 1996 – 1999; Scientist  
James River Corp., Washington, 1995-96; Scientist  
Big Creek Lumber, Davenport, California, 1995; Scientist  
Plumas Corp., California and USFS, Tahoe 1993-1995; Scientist  
Peace Corps and World Wildlife Fund, St. Kitts, West Indies, 1991-1993; Scientist

## **Publications:**

Remy, L.L., Clay T., Byers, V., **Rosenfeld P. E.** (2019) Hospital, Health, and Community Burden After Oil Refinery Fires, Richmond, California 2007 and 2012. *Environmental Health*. 18:48

Simons, R.A., Seo, Y. **Rosenfeld, P.**, (2015) Modeling the Effect of Refinery Emission On Residential Property Value. *Journal of Real Estate Research*. 27(3):321-342

Chen, J. A, Zapata A. R., Sutherland A. J., Molmen, D.R., Chow, B. S., Wu, L. E., **Rosenfeld, P. E.**, Hesse, R. C., (2012) Sulfur Dioxide and Volatile Organic Compound Exposure To A Community In Texas City Texas Evaluated Using Aermol and Empirical Data. *American Journal of Environmental Science*, 8(6), 622-632.

**Rosenfeld, P.E.** & Feng, L. (2011). *The Risks of Hazardous Waste*. Amsterdam: Elsevier Publishing.

Cheremisinoff, N.P., & **Rosenfeld, P.E.** (2011). *Handbook of Pollution Prevention and Cleaner Production: Best Practices in the Agrochemical Industry*, Amsterdam: Elsevier Publishing.

Gonzalez, J., Feng, L., Sutherland, A., Waller, C., Sok, H., Hesse, R., **Rosenfeld, P.** (2010). PCBs and Dioxins/Furans in Attic Dust Collected Near Former PCB Production and Secondary Copper Facilities in Sauget, IL. *Procedia Environmental Sciences*. 113–125.

Feng, L., Wu, C., Tam, L., Sutherland, A.J., Clark, J.J., **Rosenfeld, P.E.** (2010). Dioxin and Furan Blood Lipid and Attic Dust Concentrations in Populations Living Near Four Wood Treatment Facilities in the United States. *Journal of Environmental Health*. 73(6), 34-46.

Cheremisinoff, N.P., & **Rosenfeld, P.E.** (2010). *Handbook of Pollution Prevention and Cleaner Production: Best Practices in the Wood and Paper Industries*. Amsterdam: Elsevier Publishing.

Cheremisinoff, N.P., & **Rosenfeld, P.E.** (2009). *Handbook of Pollution Prevention and Cleaner Production: Best Practices in the Petroleum Industry*. Amsterdam: Elsevier Publishing.

Wu, C., Tam, L., Clark, J., **Rosenfeld, P.** (2009). Dioxin and furan blood lipid concentrations in populations living near four wood treatment facilities in the United States. *WIT Transactions on Ecology and the Environment, Air Pollution*, 123 (17), 319-327.

Tam L. K., Wu C. D., Clark J. J. and **Rosenfeld, P.E.** (2008). A Statistical Analysis Of Attic Dust And Blood Lipid Concentrations Of Tetrachloro-p-Dibenzodioxin (TCDD) Toxicity Equivalency Quotients (TEQ) In Two Populations Near Wood Treatment Facilities. *Organohalogen Compounds*, 70, 002252-002255.

Tam L. K., Wu C. D., Clark J. J. and **Rosenfeld, P.E.** (2008). Methods For Collect Samples For Assessing Dioxins And Other Environmental Contaminants In Attic Dust: A Review. *Organohalogen Compounds*, 70, 000527-000530.

Hensley, A.R. A. Scott, J. J. J. Clark, **Rosenfeld, P.E.** (2007). Attic Dust and Human Blood Samples Collected near a Former Wood Treatment Facility. *Environmental Research*. 105, 194-197.

**Rosenfeld, P.E.**, J. J. J. Clark, A. R. Hensley, M. Suffet. (2007). The Use of an Odor Wheel Classification for Evaluation of Human Health Risk Criteria for Compost Facilities. *Water Science & Technology* 55(5), 345-357.

**Rosenfeld, P. E.**, M. Suffet. (2007). The Anatomy Of Odour Wheels For Odours Of Drinking Water, Wastewater, Compost And The Urban Environment. *Water Science & Technology* 55(5), 335-344.

Sullivan, P. J. Clark, J.J.J., Agardy, F. J., **Rosenfeld, P.E.** (2007). *Toxic Legacy, Synthetic Toxins in the Food, Water, and Air in American Cities*. Boston Massachusetts: Elsevier Publishing

**Rosenfeld, P.E.**, and Suffet I.H. (2004). Control of Compost Odor Using High Carbon Wood Ash. *Water Science and Technology*. 49(9),171-178.

**Rosenfeld P. E.**, J.J. Clark, I.H. (Mel) Suffet (2004). The Value of An Odor-Quality-Wheel Classification Scheme For The Urban Environment. *Water Environment Federation's Technical Exhibition and Conference (WEFTEC) 2004*. New Orleans, October 2-6, 2004.

**Rosenfeld, P.E.**, and Suffet, I.H. (2004). Understanding Odorants Associated With Compost, Biomass Facilities, and the Land Application of Biosolids. *Water Science and Technology*. 49(9), 193-199.

**Rosenfeld, P.E.**, and Suffet I.H. (2004). Control of Compost Odor Using High Carbon Wood Ash, *Water Science and Technology*, 49(9), 171-178.

**Rosenfeld, P. E.**, Grey, M. A., Sellev, P. (2004). Measurement of Biosolids Odor and Odorant Emissions from Windrows, Static Pile and Biofilter. *Water Environment Research*. 76(4), 310-315.

**Rosenfeld, P.E.**, Grey, M and Suffet, M. (2002). Compost Demonstration Project, Sacramento California Using High-Carbon Wood Ash to Control Odor at a Green Materials Composting Facility. *Integrated Waste Management Board Public Affairs Office, Publications Clearinghouse (MS-6)*, Sacramento, CA Publication #442-02-008.

**Rosenfeld, P.E.**, and C.L. Henry. (2001). Characterization of odor emissions from three different biosolids. *Water Soil and Air Pollution*. 127(1-4), 173-191.

**Rosenfeld, P.E.**, and Henry C. L., (2000). Wood ash control of odor emissions from biosolids application. *Journal of Environmental Quality*. 29, 1662-1668.

**Rosenfeld, P.E.**, C.L. Henry and D. Bennett. (2001). Wastewater dewatering polymer affect on biosolids odor emissions and microbial activity. *Water Environment Research*. 73(4), 363-367.

**Rosenfeld, P.E.**, and C.L. Henry. (2001). Activated Carbon and Wood Ash Sorption of Wastewater, Compost, and Biosolids Odorants. *Water Environment Research*, 73, 388-393.

**Rosenfeld, P.E.**, and Henry C. L., (2001). High carbon wood ash effect on biosolids microbial activity and odor. *Water Environment Research*. 131(1-4), 247-262.

Chollack, T. and **P. Rosenfeld**. (1998). Compost Amendment Handbook For Landscaping. Prepared for and distributed by the City of Redmond, Washington State.

**Rosenfeld, P. E.** (1992). The Mount Liamuiga Crater Trail. *Heritage Magazine of St. Kitts*, 3(2).

**Rosenfeld, P. E.** (1993). High School Biogas Project to Prevent Deforestation On St. Kitts. *Biomass Users Network*, 7(1).

**Rosenfeld, P. E.** (1998). Characterization, Quantification, and Control of Odor Emissions From Biosolids Application To Forest Soil. Doctoral Thesis. University of Washington College of Forest Resources.

**Rosenfeld, P. E.** (1994). Potential Utilization of Small Diameter Trees on Sierra County Public Land. Masters thesis reprinted by the Sierra County Economic Council. Sierra County, California.

**Rosenfeld, P. E.** (1991). How to Build a Small Rural Anaerobic Digester & Uses Of Biogas In The First And Third World. Bachelors Thesis. University of California.

## **Presentations:**

**Rosenfeld, P.E.**, Sutherland, A; Hesse, R.; Zapata, A. (October 3-6, 2013). Air dispersion modeling of volatile organic emissions from multiple natural gas wells in Decatur, TX. *44th Western Regional Meeting, American Chemical Society*. Lecture conducted from Santa Clara, CA.

Sok, H.L.; Waller, C.C.; Feng, L.; Gonzalez, J.; Sutherland, A.J.; Wisdom-Stack, T.; Sahai, R.K.; Hesse, R.C.; **Rosenfeld, P.E.** (June 20-23, 2010). Atrazine: A Persistent Pesticide in Urban Drinking Water. *Urban Environmental Pollution*. Lecture conducted from Boston, MA.

Feng, L.; Gonzalez, J.; Sok, H.L.; Sutherland, A.J.; Waller, C.C.; Wisdom-Stack, T.; Sahai, R.K.; La, M.; Hesse, R.C.; **Rosenfeld, P.E.** (June 20-23, 2010). Bringing Environmental Justice to East St. Louis, Illinois. *Urban Environmental Pollution*. Lecture conducted from Boston, MA.

**Rosenfeld, P.E.** (April 19-23, 2009). Perfluorooctanoic Acid (PFOA) and Perfluorooctane Sulfonate (PFOS) Contamination in Drinking Water From the Use of Aqueous Film Forming Foams (AFFF) at Airports in the United States. *2009 Ground Water Summit and 2009 Ground Water Protection Council Spring Meeting*, Lecture conducted from Tuscon, AZ.

**Rosenfeld, P.E.** (April 19-23, 2009). Cost to Filter Atrazine Contamination from Drinking Water in the United States” Contamination in Drinking Water From the Use of Aqueous Film Forming Foams (AFFF) at Airports in the United States. *2009 Ground Water Summit and 2009 Ground Water Protection Council Spring Meeting*. Lecture conducted from Tuscon, AZ.

Wu, C., Tam, L., Clark, J., **Rosenfeld, P.** (20-22 July, 2009). Dioxin and furan blood lipid concentrations in populations living near four wood treatment facilities in the United States. Brebbia, C.A. and Popov, V., eds., *Air Pollution XVII: Proceedings of the Seventeenth International Conference on Modeling, Monitoring and Management of Air Pollution*. Lecture conducted from Tallinn, Estonia.

**Rosenfeld, P. E.** (October 15-18, 2007). Moss Point Community Exposure To Contaminants From A Releasing Facility. *The 23<sup>rd</sup> Annual International Conferences on Soils Sediment and Water*. Platform lecture conducted from University of Massachusetts, Amherst MA.

**Rosenfeld, P. E.** (October 15-18, 2007). The Repeated Trespass of Tritium-Contaminated Water Into A Surrounding Community Form Repeated Waste Spills From A Nuclear Power Plant. *The 23<sup>rd</sup> Annual International Conferences on Soils Sediment and Water*. Platform lecture conducted from University of Massachusetts, Amherst MA.

**Rosenfeld, P. E.** (October 15-18, 2007). Somerville Community Exposure To Contaminants From Wood Treatment Facility Emissions. The *23<sup>rd</sup> Annual International Conferences on Soils Sediment and Water*. Lecture conducted from University of Massachusetts, Amherst MA.

**Rosenfeld P. E.** (March 2007). Production, Chemical Properties, Toxicology, & Treatment Case Studies of 1,2,3-Trichloropropane (TCP). *The Association for Environmental Health and Sciences (AEHS) Annual Meeting*. Lecture conducted from San Diego, CA.

**Rosenfeld P. E.** (March 2007). Blood and Attic Sampling for Dioxin/Furan, PAH, and Metal Exposure in Florida, Alabama. *The AEHS Annual Meeting*. Lecture conducted from San Diego, CA.

Hensley A.R., Scott, A., **Rosenfeld P.E.**, Clark, J.J.J. (August 21 – 25, 2006). Dioxin Containing Attic Dust And Human Blood Samples Collected Near A Former Wood Treatment Facility. *The 26th International Symposium on Halogenated Persistent Organic Pollutants – DIOXIN2006*. Lecture conducted from Radisson SAS Scandinavia Hotel in Oslo Norway.

Hensley A.R., Scott, A., **Rosenfeld P.E.**, Clark, J.J.J. (November 4-8, 2006). Dioxin Containing Attic Dust And Human Blood Samples Collected Near A Former Wood Treatment Facility. *APHA 134 Annual Meeting & Exposition*. Lecture conducted from Boston Massachusetts.

**Paul Rosenfeld Ph.D.** (October 24-25, 2005). Fate, Transport and Persistence of PFOA and Related Chemicals. Mealey's C8/PFOA. *Science, Risk & Litigation Conference*. Lecture conducted from The Rittenhouse Hotel, Philadelphia, PA.

**Paul Rosenfeld Ph.D.** (September 19, 2005). Brominated Flame Retardants in Groundwater: Pathways to Human Ingestion, *Toxicology and Remediation PEMA Emerging Contaminant Conference*. Lecture conducted from Hilton Hotel, Irvine California.

**Paul Rosenfeld Ph.D.** (September 19, 2005). Fate, Transport, Toxicity, And Persistence of 1,2,3-TCP. *PEMA Emerging Contaminant Conference*. Lecture conducted from Hilton Hotel in Irvine, California.

**Paul Rosenfeld Ph.D.** (September 26-27, 2005). Fate, Transport and Persistence of PDBEs. *Mealey's Groundwater Conference*. Lecture conducted from Ritz Carlton Hotel, Marina Del Ray, California.

**Paul Rosenfeld Ph.D.** (June 7-8, 2005). Fate, Transport and Persistence of PFOA and Related Chemicals. *International Society of Environmental Forensics: Focus On Emerging Contaminants*. Lecture conducted from Sheraton Oceanfront Hotel, Virginia Beach, Virginia.

**Paul Rosenfeld Ph.D.** (July 21-22, 2005). Fate Transport, Persistence and Toxicology of PFOA and Related Perfluorochemicals. *2005 National Groundwater Association Ground Water And Environmental Law Conference*. Lecture conducted from Wyndham Baltimore Inner Harbor, Baltimore Maryland.

**Paul Rosenfeld Ph.D.** (July 21-22, 2005). Brominated Flame Retardants in Groundwater: Pathways to Human Ingestion, Toxicology and Remediation. *2005 National Groundwater Association Ground Water and Environmental Law Conference*. Lecture conducted from Wyndham Baltimore Inner Harbor, Baltimore Maryland.

**Paul Rosenfeld, Ph.D.** and James Clark Ph.D. and Rob Hesse R.G. (May 5-6, 2004). Tert-butyl Alcohol Liability and Toxicology, A National Problem and Unquantified Liability. *National Groundwater Association. Environmental Law Conference*. Lecture conducted from Congress Plaza Hotel, Chicago Illinois.

**Paul Rosenfeld, Ph.D.** (March 2004). Perchlorate Toxicology. *Meeting of the American Groundwater Trust*. Lecture conducted from Phoenix Arizona.

Hagemann, M.F., **Paul Rosenfeld, Ph.D.** and Rob Hesse (2004). Perchlorate Contamination of the Colorado River. *Meeting of tribal representatives*. Lecture conducted from Parker, AZ.

**Paul Rosenfeld, Ph.D.** (April 7, 2004). A National Damage Assessment Model For PCE and Dry Cleaners. *Drycleaner Symposium. California Ground Water Association*. Lecture conducted from Radison Hotel, Sacramento, California.

**Rosenfeld, P. E.,** Grey, M., (June 2003) Two stage biofilter for biosolids composting odor control. *Seventh International In Situ And On Site Bioremediation Symposium Battelle Conference* Orlando, FL.

**Paul Rosenfeld, Ph.D.** and James Clark Ph.D. (February 20-21, 2003) Understanding Historical Use, Chemical Properties, Toxicity and Regulatory Guidance of 1,4 Dioxane. *National Groundwater Association. Southwest Focus Conference. Water Supply and Emerging Contaminants..* Lecture conducted from Hyatt Regency Phoenix Arizona.

**Paul Rosenfeld, Ph.D.** (February 6-7, 2003). Underground Storage Tank Litigation and Remediation. *California CUPA Forum*. Lecture conducted from Marriott Hotel, Anaheim California.

**Paul Rosenfeld, Ph.D.** (October 23, 2002) Underground Storage Tank Litigation and Remediation. *EPA Underground Storage Tank Roundtable*. Lecture conducted from Sacramento California.

**Rosenfeld, P.E.** and Suffet, M. (October 7- 10, 2002). Understanding Odor from Compost, *Wastewater and Industrial Processes. Sixth Annual Symposium On Off Flavors in the Aquatic Environment. International Water Association*. Lecture conducted from Barcelona Spain.

**Rosenfeld, P.E.** and Suffet, M. (October 7- 10, 2002). Using High Carbon Wood Ash to Control Compost Odor. *Sixth Annual Symposium On Off Flavors in the Aquatic Environment. International Water Association*. Lecture conducted from Barcelona Spain.

**Rosenfeld, P.E.** and Grey, M. A. (September 22-24, 2002). Biocycle Composting For Coastal Sage Restoration. *Northwest Biosolids Management Association*. Lecture conducted from Vancouver Washington..

**Rosenfeld, P.E.** and Grey, M. A. (November 11-14, 2002). Using High-Carbon Wood Ash to Control Odor at a Green Materials Composting Facility. *Soil Science Society Annual Conference*. Lecture conducted from Indianapolis, Maryland.

**Rosenfeld, P.E.** (September 16, 2000). Two stage biofilter for biosolids composting odor control. *Water Environment Federation*. Lecture conducted from Anaheim California.

**Rosenfeld, P.E.** (October 16, 2000). Wood ash and biofilter control of compost odor. *Biofest*. Lecture conducted from Ocean Shores, California.

**Rosenfeld, P.E.** (2000). Bioremediation Using Organic Soil Amendments. *California Resource Recovery Association*. Lecture conducted from Sacramento California.

**Rosenfeld, P.E.,** C.L. Henry, R. Harrison. (1998). Oat and Grass Seed Germination and Nitrogen and Sulfur Emissions Following Biosolids Incorporation With High-Carbon Wood-Ash. *Water Environment Federation 12th Annual Residuals and Biosolids Management Conference Proceedings*. Lecture conducted from Bellevue Washington.

**Rosenfeld, P.E.,** and C.L. Henry. (1999). An evaluation of ash incorporation with biosolids for odor reduction. *Soil Science Society of America*. Lecture conducted from Salt Lake City Utah.

**Rosenfeld, P.E.,** C.L. Henry, R. Harrison. (1998). Comparison of Microbial Activity and Odor Emissions from Three Different Biosolids Applied to Forest Soil. *Brown and Caldwell*. Lecture conducted from Seattle Washington.

**Rosenfeld, P.E.,** C.L. Henry. (1998). Characterization, Quantification, and Control of Odor Emissions from Biosolids Application To Forest Soil. *Biofest*. Lecture conducted from Lake Chelan, Washington.



**Rosenfeld, P.E.,** C.L. Henry, R. Harrison. (1998). Oat and Grass Seed Germination and Nitrogen and Sulfur Emissions Following Biosolids Incorporation With High-Carbon Wood-Ash. Water Environment Federation 12th Annual Residuals and Biosolids Management Conference Proceedings. Lecture conducted from Bellevue Washington.

**Rosenfeld, P.E.,** C.L. Henry, R. B. Harrison, and R. Dills. (1997). Comparison of Odor Emissions From Three Different Biosolids Applied to Forest Soil. *Soil Science Society of America*. Lecture conducted from Anaheim California.

## **Teaching Experience:**

UCLA Department of Environmental Health (Summer 2003 through 20010) Taught Environmental Health Science 100 to students, including undergrad, medical doctors, public health professionals and nurses. Course focused on the health effects of environmental contaminants.

National Ground Water Association, Successful Remediation Technologies. Custom Course in Sante Fe, New Mexico. May 21, 2002. Focused on fate and transport of fuel contaminants associated with underground storage tanks.

National Ground Water Association; Successful Remediation Technologies Course in Chicago Illinois. April 1, 2002. Focused on fate and transport of contaminants associated with Superfund and RCRA sites.

California Integrated Waste Management Board, April and May, 2001. Alternative Landfill Caps Seminar in San Diego, Ventura, and San Francisco. Focused on both prescriptive and innovative landfill cover design.

UCLA Department of Environmental Engineering, February 5, 2002. Seminar on Successful Remediation Technologies focusing on Groundwater Remediation.

University Of Washington, Soil Science Program, Teaching Assistant for several courses including: Soil Chemistry, Organic Soil Amendments, and Soil Stability.

U.C. Berkeley, Environmental Science Program Teaching Assistant for Environmental Science 10.

## **Academic Grants Awarded:**

California Integrated Waste Management Board. \$41,000 grant awarded to UCLA Institute of the Environment. Goal: To investigate effect of high carbon wood ash on volatile organic emissions from compost. 2001.

Synagro Technologies, Corona California: \$10,000 grant awarded to San Diego State University. Goal: investigate effect of biosolids for restoration and remediation of degraded coastal sage soils. 2000.

King County, Department of Research and Technology, Washington State. \$100,000 grant awarded to University of Washington: Goal: To investigate odor emissions from biosolids application and the effect of polymers and ash on VOC emissions. 1998.

Northwest Biosolids Management Association, Washington State. \$20,000 grant awarded to investigate effect of polymers and ash on VOC emissions from biosolids. 1997.

James River Corporation, Oregon: \$10,000 grant was awarded to investigate the success of genetically engineered Poplar trees with resistance to round-up. 1996.

United State Forest Service, Tahoe National Forest: \$15,000 grant was awarded to investigating fire ecology of the Tahoe National Forest. 1995.

Kellogg Foundation, Washington D.C. \$500 grant was awarded to construct a large anaerobic digester on St. Kitts in West Indies. 1993

## **Deposition and/or Trial Testimony:**

In the United States District Court For The District of New Jersey

Duarte et al, *Plaintiffs*, vs. United States Metals Refining Company et. al. *Defendant*.

Case No.: 2:17-cv-01624-ES-SCM

Rosenfeld Deposition. 6-7-2019

In the United States District Court of Southern District of Texas Galveston Division

M/T Carla Maersk, *Plaintiffs*, vs. Conti 168., Schiffahrts-GMBH & Co. Bulker KG MS “Conti Perdido”  
*Defendant*.

Case No.: 3:15-CV-00106 consolidated with 3:15-CV-00237

Rosenfeld Deposition. 5-9-2019

In The Superior Court of the State of California In And For The County Of Los Angeles – Santa Monica

Carole-Taddeo-Bates et al., vs. Ifran Khan et al., Defendants

Case No.: No. BC615636

Rosenfeld Deposition, 1-26-2019

In The Superior Court of the State of California In And For The County Of Los Angeles – Santa Monica

The San Gabriel Valley Council of Governments et al. vs El Adobe Apts. Inc. et al., Defendants

Case No.: No. BC646857

Rosenfeld Deposition, 10-6-2018; Trial 3-7-19

In United States District Court For The District of Colorado

Bells et al. Plaintiff vs. The 3M Company et al., Defendants

Case: No 1:16-cv-02531-RBJ

Rosenfeld Deposition, 3-15-2018 and 4-3-2018

In The District Court Of Regan County, Texas, 112<sup>th</sup> Judicial District

Phillip Bales et al., Plaintiff vs. Dow Agrosiences, LLC, et al., Defendants

Cause No 1923

Rosenfeld Deposition, 11-17-2017

In The Superior Court of the State of California In And For The County Of Contra Costa

Simons et al., Plaintiffs vs. Chevron Corporation, et al., Defendants

Cause No C12-01481

Rosenfeld Deposition, 11-20-2017

In The Circuit Court Of The Twentieth Judicial Circuit, St Clair County, Illinois

Martha Custer et al., Plaintiff vs. Cerro Flow Products, Inc., Defendants

Case No.: No. 0i9-L-2295

Rosenfeld Deposition, 8-23-2017

In The Superior Court of the State of California, For The County of Los Angeles

Warrn Gilbert and Penny Gilber, Plaintiff vs. BMW of North America LLC

Case No.: LC102019 (c/w BC582154)

Rosenfeld Deposition, 8-16-2017, Trail 8-28-2018

In the Northern District Court of Mississippi, Greenville Division

Brenda J. Cooper, et al., *Plaintiffs*, vs. Meritor Inc., et al., *Defendants*

Case Number: 4:16-cv-52-DMB-JVM

Rosenfeld Deposition: July 2017

In The Superior Court of the State of Washington, County of Snohomish  
Michael Davis and Julie Davis et al., Plaintiff vs. Cedar Grove Composting Inc., Defendants  
Case No.: No. 13-2-03987-5  
Rosenfeld Deposition, February 2017  
Trial, March 2017

In The Superior Court of the State of California, County of Alameda  
Charles Spain., Plaintiff vs. Thermo Fisher Scientific, et al., Defendants  
Case No.: RG14711115  
Rosenfeld Deposition, September 2015

In The Iowa District Court In And For Poweshiek County  
Russell D. Winburn, et al., Plaintiffs vs. Doug Hoksbergen, et al., Defendants  
Case No.: LALA002187  
Rosenfeld Deposition, August 2015

In The Iowa District Court For Wapello County  
Jerry Dovico, et al., Plaintiffs vs. Valley View Sine LLC, et al., Defendants  
Law No.: LALA105144 - Division A  
Rosenfeld Deposition, August 2015

In The Iowa District Court For Wapello County  
Doug Pauls, et al., et al., Plaintiffs vs. Richard Warren, et al., Defendants  
Law No.: LALA105144 - Division A  
Rosenfeld Deposition, August 2015

In The Circuit Court of Ohio County, West Virginia  
Robert Andrews, et al. v. Antero, et al.  
Civil Action NO. 14-C-30000  
Rosenfeld Deposition, June 2015

In The Third Judicial District County of Dona Ana, New Mexico  
Betty Gonzalez, et al. Plaintiffs vs. Del Oro Dairy, Del Oro Real Estate LLC, Jerry Settles and Deward  
DeRuyter, Defendants  
Rosenfeld Deposition: July 2015

In The Iowa District Court For Muscatine County  
Laurie Freeman et. al. Plaintiffs vs. Grain Processing Corporation, Defendant  
Case No 4980  
Rosenfeld Deposition: May 2015

In the Circuit Court of the 17<sup>th</sup> Judicial Circuit, in and For Broward County, Florida  
Walter Hinton, et. al. Plaintiff, vs. City of Fort Lauderdale, Florida, a Municipality, Defendant.  
Case Number CACE07030358 (26)  
Rosenfeld Deposition: December 2014

In the United States District Court Western District of Oklahoma  
Tommy McCarty, et al., Plaintiffs, v. Oklahoma City Landfill, LLC d/b/a Southeast Oklahoma City  
Landfill, et al. Defendants.  
Case No. 5:12-cv-01152-C  
Rosenfeld Deposition: July 2014

In the County Court of Dallas County Texas  
Lisa Parr et al, *Plaintiff*, vs. Aruba et al, *Defendant*.  
Case Number cc-11-01650-E  
Rosenfeld Deposition: March and September 2013  
Rosenfeld Trial: April 2014

In the Court of Common Pleas of Tuscarawas County Ohio  
John Michael Abicht, et al., *Plaintiffs*, vs. Republic Services, Inc., et al., *Defendants*  
Case Number: 2008 CT 10 0741 (Cons. w/ 2009 CV 10 0987)  
Rosenfeld Deposition: October 2012

In the United States District Court of Southern District of Texas Galveston Division  
Kyle Cannon, Eugene Donovan, Genaro Ramirez, Carol Sassler, and Harvey Walton, each Individually and on behalf of those similarly situated, *Plaintiffs*, vs. BP Products North America, Inc., *Defendant*.  
Case 3:10-cv-00622  
Rosenfeld Deposition: February 2012  
Rosenfeld Trial: April 2013

In the Circuit Court of Baltimore County Maryland  
Philip E. Cvach, II et al., *Plaintiffs* vs. Two Farms, Inc. d/b/a Royal Farms, Defendants  
Case Number: 03-C-12-012487 OT  
Rosenfeld Deposition: September 2013

**EXHIBIT C**



Technical Consultation, Data Analysis and  
Litigation Support for the Environment

1640 5<sup>th</sup> St., Suite 204 Santa  
Santa Monica, California 90401  
Tel: (949) 887-9013  
Email: [mhagemann@swape.com](mailto:mhagemann@swape.com)

**Matthew F. Hagemann, P.G., C.Hg., QSD, QSP**

**Geologic and Hydrogeologic Characterization  
Industrial Stormwater Compliance  
Investigation and Remediation Strategies  
Litigation Support and Testifying Expert  
CEQA Review**

**Education:**

M.S. Degree, Geology, California State University Los Angeles, Los Angeles, CA, 1984.

B.A. Degree, Geology, Humboldt State University, Arcata, CA, 1982.

**Professional Certifications:**

California Professional Geologist

California Certified Hydrogeologist

Qualified SWPPP Developer and Practitioner

**Professional Experience:**

Matt has 25 years of experience in environmental policy, assessment and remediation. He spent nine years with the U.S. EPA in the RCRA and Superfund programs and served as EPA's Senior Science Policy Advisor in the Western Regional Office where he identified emerging threats to groundwater from perchlorate and MTBE. While with EPA, Matt also served as a Senior Hydrogeologist in the oversight of the assessment of seven major military facilities undergoing base closure. He led numerous enforcement actions under provisions of the Resource Conservation and Recovery Act (RCRA) while also working with permit holders to improve hydrogeologic characterization and water quality monitoring.

Matt has worked closely with U.S. EPA legal counsel and the technical staff of several states in the application and enforcement of RCRA, Safe Drinking Water Act and Clean Water Act regulations. Matt has trained the technical staff in the States of California, Hawaii, Nevada, Arizona and the Territory of Guam in the conduct of investigations, groundwater fundamentals, and sampling techniques.

Positions Matt has held include:

- Founding Partner, Soil/Water/Air Protection Enterprise (SWAPE) (2003 – present);
- Geology Instructor, Golden West College, 2010 – 2014;
- Senior Environmental Analyst, Komex H2O Science, Inc. (2000 -- 2003);

- Executive Director, Orange Coast Watch (2001 – 2004);
- Senior Science Policy Advisor and Hydrogeologist, U.S. Environmental Protection Agency (1989–1998);
- Hydrogeologist, National Park Service, Water Resources Division (1998 – 2000);
- Adjunct Faculty Member, San Francisco State University, Department of Geosciences (1993 – 1998);
- Instructor, College of Marin, Department of Science (1990 – 1995);
- Geologist, U.S. Forest Service (1986 – 1998); and
- Geologist, Dames & Moore (1984 – 1986).

**Senior Regulatory and Litigation Support Analyst:**

With SWAPE, Matt’s responsibilities have included:

- Lead analyst and testifying expert in the review of over 100 environmental impact reports since 2003 under CEQA that identify significant issues with regard to hazardous waste, water resources, water quality, air quality, Valley Fever, greenhouse gas emissions, and geologic hazards. Make recommendations for additional mitigation measures to lead agencies at the local and county level to include additional characterization of health risks and implementation of protective measures to reduce worker exposure to hazards from toxins and Valley Fever.
- Stormwater analysis, sampling and best management practice evaluation at industrial facilities.
- Manager of a project to provide technical assistance to a community adjacent to a former Naval shipyard under a grant from the U.S. EPA.
- Technical assistance and litigation support for vapor intrusion concerns.
- Lead analyst and testifying expert in the review of environmental issues in license applications for large solar power plants before the California Energy Commission.
- Manager of a project to evaluate numerous formerly used military sites in the western U.S.
- Manager of a comprehensive evaluation of potential sources of perchlorate contamination in Southern California drinking water wells.
- Manager and designated expert for litigation support under provisions of Proposition 65 in the review of releases of gasoline to sources drinking water at major refineries and hundreds of gas stations throughout California.
- Expert witness on two cases involving MTBE litigation.
- Expert witness and litigation support on the impact of air toxins and hazards at a school.
- Expert witness in litigation at a former plywood plant.

With Komex H2O Science Inc., Matt’s duties included the following:

- Senior author of a report on the extent of perchlorate contamination that was used in testimony by the former U.S. EPA Administrator and General Counsel.
- Senior researcher in the development of a comprehensive, electronically interactive chronology of MTBE use, research, and regulation.
- Senior researcher in the development of a comprehensive, electronically interactive chronology of perchlorate use, research, and regulation.
- Senior researcher in a study that estimates nationwide costs for MTBE remediation and drinking water treatment, results of which were published in newspapers nationwide and in testimony against provisions of an energy bill that would limit liability for oil companies.
- Research to support litigation to restore drinking water supplies that have been contaminated by MTBE in California and New York.

- Expert witness testimony in a case of oil production-related contamination in Mississippi.
- Lead author for a multi-volume remedial investigation report for an operating school in Los Angeles that met strict regulatory requirements and rigorous deadlines.



- Development of strategic approaches for cleanup of contaminated sites in consultation with clients and regulators.

### **Executive Director:**

As Executive Director with Orange Coast Watch, Matt led efforts to restore water quality at Orange County beaches from multiple sources of contamination including urban runoff and the discharge of wastewater. In reporting to a Board of Directors that included representatives from leading Orange County universities and businesses, Matt prepared issue papers in the areas of treatment and disinfection of wastewater and control of the discharge of grease to sewer systems. Matt actively participated in the development of countywide water quality permits for the control of urban runoff and permits for the discharge of wastewater. Matt worked with other nonprofits to protect and restore water quality, including Surfrider, Natural Resources Defense Council and Orange County CoastKeeper as well as with business institutions including the Orange County Business Council.

### **Hydrogeology:**

As a Senior Hydrogeologist with the U.S. Environmental Protection Agency, Matt led investigations to characterize and cleanup closing military bases, including Mare Island Naval Shipyard, Hunters Point Naval Shipyard, Treasure Island Naval Station, Alameda Naval Station, Moffett Field, Mather Army Airfield, and Sacramento Army Depot. Specific activities were as follows:

- Led efforts to model groundwater flow and contaminant transport, ensured adequacy of monitoring networks, and assessed cleanup alternatives for contaminated sediment, soil, and groundwater.
- Initiated a regional program for evaluation of groundwater sampling practices and laboratory analysis at military bases.
- Identified emerging issues, wrote technical guidance, and assisted in policy and regulation development through work on four national U.S. EPA workgroups, including the Superfund Groundwater Technical Forum and the Federal Facilities Forum.

At the request of the State of Hawaii, Matt developed a methodology to determine the vulnerability of groundwater to contamination on the islands of Maui and Oahu. He used analytical models and a GIS to show zones of vulnerability, and the results were adopted and published by the State of Hawaii and County of Maui.

As a hydrogeologist with the EPA Groundwater Protection Section, Matt worked with provisions of the Safe Drinking Water Act and NEPA to prevent drinking water contamination. Specific activities included the following:

- Received an EPA Bronze Medal for his contribution to the development of national guidance for the protection of drinking water.
- Managed the Sole Source Aquifer Program and protected the drinking water of two communities through designation under the Safe Drinking Water Act. He prepared geologic reports, conducted public hearings, and responded to public comments from residents who were very concerned about the impact of designation.

- Reviewed a number of Environmental Impact Statements for planned major developments, including large hazardous and solid waste disposal facilities, mine reclamation, and water transfer.

Matt served as a hydrogeologist with the RCRA Hazardous Waste program. Duties were as follows:

- Supervised the hydrogeologic investigation of hazardous waste sites to determine compliance with Subtitle C requirements.
- Reviewed and wrote "part B" permits for the disposal of hazardous waste.
- Conducted RCRA Corrective Action investigations of waste sites and led inspections that formed the basis for significant enforcement actions that were developed in close coordination with U.S. EPA legal counsel.
- Wrote contract specifications and supervised contractor's investigations of waste sites.

With the National Park Service, Matt directed service-wide investigations of contaminant sources to prevent degradation of water quality, including the following tasks:

- Applied pertinent laws and regulations including CERCLA, RCRA, NEPA, NRDA, and the Clean Water Act to control military, mining, and landfill contaminants.
- Conducted watershed-scale investigations of contaminants at parks, including Yellowstone and Olympic National Park.
- Identified high-levels of perchlorate in soil adjacent to a national park in New Mexico and advised park superintendent on appropriate response actions under CERCLA.
- Served as a Park Service representative on the Interagency Perchlorate Steering Committee, a national workgroup.
- Developed a program to conduct environmental compliance audits of all National Parks while serving on a national workgroup.
- Co-authored two papers on the potential for water contamination from the operation of personal watercraft and snowmobiles, these papers serving as the basis for the development of nation-wide policy on the use of these vehicles in National Parks.
- Contributed to the Federal Multi-Agency Source Water Agreement under the Clean Water Action Plan.

**Policy:**

Served senior management as the Senior Science Policy Advisor with the U.S. Environmental Protection Agency, Region 9. Activities included the following:

- Advised the Regional Administrator and senior management on emerging issues such as the potential for the gasoline additive MTBE and ammonium perchlorate to contaminate drinking water supplies.
- Shaped EPA's national response to these threats by serving on workgroups and by contributing to guidance, including the Office of Research and Development publication, *Oxygenates in Water: Critical Information and Research Needs*.
- Improved the technical training of EPA's scientific and engineering staff.
- Earned an EPA Bronze Medal for representing the region's 300 scientists and engineers in negotiations with the Administrator and senior management to better integrate scientific principles into the policy-making process.
- Established national protocol for the peer review of scientific documents.

### **Geology:**

With the U.S. Forest Service, Matt led investigations to determine hillslope stability of areas proposed for timber harvest in the central Oregon Coast Range. Specific activities were as follows:

- Mapped geology in the field, and used aerial photographic interpretation and mathematical models to determine slope stability.
- Coordinated his research with community members who were concerned with natural resource protection.
- Characterized the geology of an aquifer that serves as the sole source of drinking water for the city of Medford, Oregon.

As a consultant with Dames and Moore, Matt led geologic investigations of two contaminated sites (later listed on the Superfund NPL) in the Portland, Oregon, area and a large hazardous waste site in eastern Oregon. Duties included the following:

- Supervised year-long effort for soil and groundwater sampling.
- Conducted aquifer tests.
- Investigated active faults beneath sites proposed for hazardous waste disposal.

### **Teaching:**

From 1990 to 1998, Matt taught at least one course per semester at the community college and university levels:

- At San Francisco State University, held an adjunct faculty position and taught courses in environmental geology, oceanography (lab and lecture), hydrogeology, and groundwater contamination.
- Served as a committee member for graduate and undergraduate students.
- Taught courses in environmental geology and oceanography at the College of Marin.

Matt taught physical geology (lecture and lab and introductory geology at Golden West College in Huntington Beach, California from 2010 to 2014.

### **Invited Testimony, Reports, Papers and Presentations:**

**Hagemann, M.F.**, 2008. Disclosure of Hazardous Waste Issues under CEQA. Presentation to the Public Environmental Law Conference, Eugene, Oregon.

**Hagemann, M.F.**, 2008. Disclosure of Hazardous Waste Issues under CEQA. Invited presentation to U.S. EPA Region 9, San Francisco, California.

**Hagemann, M.F.**, 2005. Use of Electronic Databases in Environmental Regulation, Policy Making and Public Participation. Brownfields 2005, Denver, Colorado.

**Hagemann, M.F.**, 2004. Perchlorate Contamination of the Colorado River and Impacts to Drinking Water in Nevada and the Southwestern U.S. Presentation to a meeting of the American Groundwater Trust, Las Vegas, NV (served on conference organizing committee).

**Hagemann, M.F.**, 2004. Invited testimony to a California Senate committee hearing on air toxins at schools in Southern California, Los Angeles.

Brown, A., Farrow, J., Gray, A. and **Hagemann, M.**, 2004. An Estimate of Costs to Address MTBE Releases from Underground Storage Tanks and the Resulting Impact to Drinking Water Wells. Presentation to the Ground Water and Environmental Law Conference, National Groundwater Association.

**Hagemann, M.F.**, 2004. Perchlorate Contamination of the Colorado River and Impacts to Drinking Water in Arizona and the Southwestern U.S. Presentation to a meeting of the American Groundwater Trust, Phoenix, AZ (served on conference organizing committee).

**Hagemann, M.F.**, 2003. Perchlorate Contamination of the Colorado River and Impacts to Drinking Water in the Southwestern U.S. Invited presentation to a special committee meeting of the National Academy of Sciences, Irvine, CA.

**Hagemann, M.F.**, 2003. Perchlorate Contamination of the Colorado River. Invited presentation to a tribal EPA meeting, Pechanga, CA.

**Hagemann, M.F.**, 2003. Perchlorate Contamination of the Colorado River. Invited presentation to a meeting of tribal representatives, Parker, AZ.

**Hagemann, M.F.**, 2003. Impact of Perchlorate on the Colorado River and Associated Drinking Water Supplies. Invited presentation to the Inter-Tribal Meeting, Torres Martinez Tribe.

**Hagemann, M.F.**, 2003. The Emergence of Perchlorate as a Widespread Drinking Water Contaminant. Invited presentation to the U.S. EPA Region 9.

**Hagemann, M.F.**, 2003. A Deductive Approach to the Assessment of Perchlorate Contamination. Invited presentation to the California Assembly Natural Resources Committee.

**Hagemann, M.F.**, 2003. Perchlorate: A Cold War Legacy in Drinking Water. Presentation to a meeting of the National Groundwater Association.

**Hagemann, M.F.**, 2002. From Tank to Tap: A Chronology of MTBE in Groundwater. Presentation to a meeting of the National Groundwater Association.

**Hagemann, M.F.**, 2002. A Chronology of MTBE in Groundwater and an Estimate of Costs to Address Impacts to Groundwater. Presentation to the annual meeting of the Society of Environmental Journalists.

**Hagemann, M.F.**, 2002. An Estimate of the Cost to Address MTBE Contamination in Groundwater (and Who Will Pay). Presentation to a meeting of the National Groundwater Association.

**Hagemann, M.F.**, 2002. An Estimate of Costs to Address MTBE Releases from Underground Storage Tanks and the Resulting Impact to Drinking Water Wells. Presentation to a meeting of the U.S. EPA and State Underground Storage Tank Program managers.

**Hagemann, M.F.**, 2001. From Tank to Tap: A Chronology of MTBE in Groundwater. Unpublished report.

**Hagemann, M.F.**, 2001. Estimated Cleanup Cost for MTBE in Groundwater Used as Drinking Water. Unpublished report.

**Hagemann, M.F.**, 2001. Estimated Costs to Address MTBE Releases from Leaking Underground Storage Tanks. Unpublished report.

**Hagemann, M.F.**, and VanMouwerik, M., 1999. Potential Water Quality Concerns Related to Snowmobile Usage. Water Resources Division, National Park Service, Technical Report.

VanMouwerik, M. and **Hagemann, M.F.** 1999, Water Quality Concerns Related to Personal Watercraft Usage. Water Resources Division, National Park Service, Technical Report.

**Hagemann, M.F.**, 1999, Is Dilution the Solution to Pollution in National Parks? The George Wright Society Biannual Meeting, Asheville, North Carolina.

**Hagemann, M.F.**, 1997, The Potential for MTBE to Contaminate Groundwater. U.S. EPA Superfund Groundwater Technical Forum Annual Meeting, Las Vegas, Nevada.

**Hagemann, M.F.**, and Gill, M., 1996, Impediments to Intrinsic Remediation, Moffett Field Naval Air Station, Conference on Intrinsic Remediation of Chlorinated Hydrocarbons, Salt Lake City.

**Hagemann, M.F.**, Fukunaga, G.L., 1996, The Vulnerability of Groundwater to Anthropogenic Contaminants on the Island of Maui, Hawaii. Hawaii Water Works Association Annual Meeting, Maui, October 1996.

**Hagemann, M. F.**, Fukanaga, G. L., 1996, Ranking Groundwater Vulnerability in Central Oahu, Hawaii. Proceedings, Geographic Information Systems in Environmental Resources Management, Air and Waste Management Association Publication VIP-61.

**Hagemann, M.F.**, 1994. Groundwater Characterization and Cleanup at Closing Military Bases in California. Proceedings, California Groundwater Resources Association Meeting.

**Hagemann, M.F.** and Sabol, M.A., 1993. Role of the U.S. EPA in the High Plains States Groundwater Recharge Demonstration Program. Proceedings, Sixth Biennial Symposium on the Artificial Recharge of Groundwater.

**Hagemann, M.F.**, 1993. U.S. EPA Policy on the Technical Impracticability of the Cleanup of DNAPL-contaminated Groundwater. California Groundwater Resources Association Meeting.

**Hagemann, M.F.**, 1992. Dense Nonaqueous Phase Liquid Contamination of Groundwater: An Ounce of Prevention... Proceedings, Association of Engineering Geologists Annual Meeting, v. 35.

**Other Experience:**

Selected as subject matter expert for the California Professional Geologist licensing examination, 2009-2011.



State of California – Natural Resources Agency  
DEPARTMENT OF FISH AND WILDLIFE  
Inland Deserts Region  
3602 Inland Empire Blvd, Suite C-220  
Ontario, CA 91764  
www.wildlife.ca.gov

GAVIN NEWSOM, Governor  
CHARLTON H. BONHAM, Director



May 23, 2023  
Sent via e-mail

Pilar Lopez  
Senior Planner  
City of Rancho Mirage  
69-825 Highway 111  
Rancho Mirage, CA 92270

**DESERT ISLAND HOTEL (PROJECT)  
NEGATIVE DECLARATION (ND)  
SCH# 2023040562**

Dear Ms. Lopez:

The California Department of Fish and Wildlife (CDFW) received a Notice of Intent to Adopt an ND from the City of Rancho Mirage for the Project pursuant the California Environmental Quality Act (CEQA) and CEQA Guidelines.<sup>1</sup>

Thank you for the opportunity to provide comments and recommendations regarding those activities involved in the Project that may affect California fish and wildlife. Likewise, we appreciate the opportunity to provide comments regarding those aspects of the Project that CDFW, by law, may be required to carry out or approve through the exercise of its own regulatory authority under the Fish and Game Code.

B-1

**CDFW ROLE**

CDFW is California’s **Trustee Agency** for fish and wildlife resources and holds those resources in trust by statute for all the people of the State. (Fish & G. Code, §§ 711.7, subd. (a) & 1802; Pub. Resources Code, § 21070; CEQA Guidelines § 15386, subd. (a).) CDFW, in its trustee capacity, has jurisdiction over the conservation, protection, and management of fish, wildlife, native plants, and habitat necessary for biologically sustainable populations of those species. (*Id.*, § 1802.) Similarly, for purposes of CEQA, CDFW is charged by law to provide, as available, biological expertise during public agency environmental review efforts, focusing specifically on projects and related activities that have the potential to adversely affect fish and wildlife resources.

B-2

CDFW is also submitting comments as a **Responsible Agency** under CEQA. (Pub. Resources Code, § 21069; CEQA Guidelines, § 15381.) CDFW expects that it may need to exercise regulatory authority as provided by the Fish and Game Code. As proposed, for example, the Project may be subject to CDFW’s lake and streambed alteration regulatory authority. (Fish & G. Code, § 1600 et seq.) Likewise, to the extent implementation of the Project as proposed may result in “take” as defined by State law of any species protected under the California Endangered Species Act (CESA) (Fish & G. Code, § 2050 et seq.), the project proponent may seek related take authorization as provided by the Fish and Game Code.

**PROJECT DESCRIPTION SUMMARY**

**Proponent:** City of Rancho Mirage

**Objective:** The objective of the Project is to develop a resort hotel within the Desert Island community. A General Plan Zoning Map Amendment (GPZMA22-0002) will change the zoning from “Open Space-Private (OS-PV)” to “Resort Hotel (Rs-H)” for the proposed hotel and residences, and a Specific Plan Amendment (SPA22-0002) will introduce hotel use to the Desert Island Specific Plan. The land (17.2 acres) within the Desert Island community will be repurposed to include a new 34-key hotel comprised of four 1-story buildings totaling 33,940 square feet, 11 private residences totaling 56,844 square feet, hotel

B-3

<sup>1</sup> CEQA is codified in the California Public Resources Code in section 21000 et seq. The “CEQA Guidelines” are found in Title 14 of the California Code of Regulations, commencing with section 15000.

grounds for guest use with tennis, pool, 852 square foot café, cabana, and 2,572 square feet for yoga amenities, along with additional onsite parking totaling 376 spaces. The proposed hotel and residences will be located west of the existing clubhouse. A new golf training park and 7,818 square foot golf maintenance building will replace the existing driving range and old maintenance building. Secondary access to Frank Sinatra Drive will be accommodated by widening the existing gated entry at the northwest corner of the golf course from 12 feet to 24 feet.

The Project would be constructed in four phases. The first phase would develop a portion of the southerly hotel with outdoor recreation activities, yoga pavilion, maintenance building with parking, and the proposed secondary access to Frank Sinatra Drive. Phase two would develop residences 7 and 8 on the western side of the site. Phase three would develop residences 5, 6, 9, and 10. Phase four would develop the northerly hotel, residences 1, 2, 3, and 4, and the proposed golf training facility. The southern hotel pad would be left or reseeded with live turf until constructed. The Project construction activities are expected to occur in the following stages: site preparation, grading, building construction, paving, and architectural coating.

**Location:** The Project is located at the southwest corner of Frank Sinatra Drive and Bob Hope Drive, on approximately 17.2 acres within the Desert Island Residential Community and Golf Course in the City of Rancho Mirage, Riverside County, California (33.771990, -116.412801). The Project encompasses Accessor's Parcel Numbers 688-040-001, 688-050-005, 688-060-006, and 688-060-008. Land surrounding the parcels includes residential communities with accompanying golf courses. Lands to the northeast and northwest corners of the property across Frank Sinatra Drive are vacant. The Project is located within the Coachella Valley Multiple Species Habitat Conservation Plan (CVMSHCP) boundary. The Project is within the Indio subbasin of the Coachella Valley Groundwater Basin.

**Timeframe:** Construction is expected to begin in 2023 with full buildout by 2024.

## COMMENTS AND RECOMMENDATIONS

CDFW has jurisdiction over the conservation, protection, and management of fish, wildlife, native plants, and habitat necessary for biologically sustainable populations of those species (i.e., biological resources). CDFW offers the comments and recommendations below to assist the City of Rancho Mirage in adequately identifying and/or mitigating the Project's significant, or potentially significant, direct and indirect impacts on fish and wildlife (biological) resources. The ND has not adequately identified and disclosed the Project's impacts (i.e., direct, indirect, and cumulative) to biological resources and whether those impacts are less than significant.

CDFW's comments and recommendations on the ND are explained in greater detail below and summarized here. The ND lacks a complete and accurate assessment of biological resources on the Project site. CDFW recommends that additional information and analyses be added to a revised ND, along with avoidance, minimization, and mitigation measures that reduce impacts to less than significant.

### Existing Environmental Setting

Compliance with CEQA is predicated on a complete and accurate description of the environmental setting that may be affected by the proposed Project. CDFW is concerned that the assessment of the existing environmental setting has not been adequately analyzed in the ND. CDFW is concerned that without a complete and accurate description of the existing environmental setting, the ND may provide an incomplete analysis of Project-related environmental impacts.

CDFW is concerned that no biological field assessment was conducted for the ND. The Project site is currently located with the Desert Island golf course and is adjacent to a 25-acre lake. Vegetation and water features associated with golf courses frequently attract migratory and nesting birds; graded areas left vacant during pauses in construction can

B-3

B-4



attract ground squirrels and burrowing owls; and construction noise and artificial light at night can impact wildlife on the Project site and in the surrounding area.

### Mitigation Measures

CDFW is concerned that no mitigation measures are proposed in the ND to avoid or reduce impacts to biological resources to below a level of significance. To support the City of Rancho Mirage in ensuring that Project impacts to biological resources are reduced to a level that is less than significant, CDFW recommends adding mitigation measures for Coachella Valley MSHCP compliance, burrowing owl (*Athene cunicularia*), nesting birds, construction noise, and artificial nighttime lightning.

B-4

## **I. Project Description and Related Impact Shortcoming**

### **COMMENT #1: Number of Residences**

#### **Initial Study/Negative Declaration (IS/ND) document, Pages #7 & 9**

**Issue:** There is a discrepancy in the IS/ND Project description and phasing timeline regarding the number of private residences to be constructed.

**Specific impact:** The IS/ND states (p. 7) that the Project will repurpose 17.2 acres of the existing Desert Island community to include 11 private residences. However, the phasing timeline in the IS/ND (p. 9) lists the construction timeline of residences 1 through 10 (10 total). The IS/ND should clarify the correct number of private residences to be constructed and provide an accurate description of the accompanying Project timeline.

B-5

**Evidence impact would be significant:** CEQA is predicated on a complete and accurate description of the proposed Project. Without a complete and accurate project description, the ND likely provides an incomplete assessment of Project-related impacts to biological resources. CDFW has identified gaps in information related to the project description.

**CDFW Recommendation:** The ND should include the appropriate number of private residences to be constructed. Analysis and appropriate mitigation measures to avoid and reduce impacts to biological resources resulting from construction for the Project should be included in a revised ND.

### **COMMENT #2: Timing of Construction and Site Inactivity**

#### **IS/ND document, Page #9**

**Issue:** The ND does not analyze impacts to biological resources associated with the timing of Project construction.

**Specific impact:** The IS/ND states (p. 9) that the southern hotel pad will be left or reseeded with live turf until constructed. In the interim period between grading and construction of the hotel, environmental conditions may change. Grading and leaving a site inactive may result in the area becoming occupied by wildlife that utilize disturbed areas (e.g., ground squirrels and burrowing owl).

B-6

**Evidence impact would be significant:** CEQA is predicated on a complete and accurate description of the proposed Project. Without a complete and accurate project description, the ND likely provides an incomplete assessment of Project-related impacts to biological resources. CDFW has identified gaps in information related to the project description.

**CDFW Recommendation:** The ND should analyze impacts to biological resources resulting from an extended timeline for Project activities and pauses in construction. The ND should acknowledge that wildlife may move into disturbed or graded sites

when construction is paused. The ND should acknowledge that preconstruction surveys for biological resources will need to be repeated prior Project activities and after pauses in construction to assess the presence of biological resources and to avoid or reduce impacts to less than significant. Analysis and appropriate mitigation measures to avoid and reduce impacts to biological resources resulting from the timing of construction for the Project should be included in a revised ND.

B-6

### COMMENT #3: Landscaping

#### IS/ND document, Page #8

**Issue:** The ND lacks a description of the type of landscaping that will be installed and maintained over the life of the Project.

**Specific impact:** The IS/ND states (p. 8) that landscaping, including trees, shrubs, and accent plants to complement the desert environment, is planned throughout the Project site. However, no further details are provided.

**Evidence impact would be significant:** CEQA is predicated on a complete and accurate description of the proposed Project. Without a complete and accurate project description, the ND likely provides an incomplete assessment of Project-related impacts to biological resources. CDFW has identified gaps in information related to the project description.

B-7

**CDFW Recommendation:** To ameliorate the water demands of this Project, CDFW recommends incorporation of water-wise concepts in any Project landscape design plans. In particular, CDFW recommends xeriscaping with locally native California species and installing water-efficient and targeted irrigation systems (such as drip irrigation). Native plants support butterflies, birds, reptiles, amphibians, small mammals, bees, and other pollinators that evolved with those plants, more information on native plants suitable for the Project location and nearby nurseries is available at CALSCAPE: <https://calscape.org/>. Local water agencies/districts and resource conservation districts in your area may be able to provide information on plant nurseries that carry locally native species, and some facilities display drought-tolerant locally native species demonstration gardens. Information on drought-tolerant landscaping and water-efficient irrigation systems is available on California's Save our Water website: <https://saveourwater.com/>. CDFW also recommends that the ND include recommendations regarding landscaping from Section 4.0 of the CVMSHCP "Table 4-112: Coachella Valley Native Plants Recommended for Landscaping" (pp. 4-180 to 4-182; <https://cvmshcp.org/plan-documents/>).

## II. Environmental Setting and Related Impact Shortcoming

### COMMENT #4: Assessment of Biological Resources

#### IS/ND document, Section #4, Pages #44 & 45

**Issue:** The ND does not adequately identify or mitigate the Project's significant, or potentially significant, impacts to biological resources.

**Specific impact:** The ND lacks a recent general field assessment of biological resources located within the Project footprint and surrounding areas. The Project site is located with the Desert Island golf course and is adjacent to a 25-acre lake. Vegetation and water features associated with golf courses frequently attract migratory and nesting birds; graded areas left vacant during pauses in construction can attract ground squirrels and burrowing owls; and construction noise and artificial light at night can impact wildlife in the surrounding area.

B-8

**Evidence impact would be significant:** Compliance with CEQA is predicated on a complete and accurate description of the environmental setting that may be affected by the proposed Project. CDFW is concerned that the assessment of the existing

environmental setting with respect to biological resources has not been adequately analyzed in the ND. CDFW is concerned that without a complete and accurate description of the existing environmental setting, the ND likely provides an incomplete or inaccurate analysis of Project-related environmental impacts and whether those impacts have been mitigated to a level that is less than significant.

**CDFW Recommendation:** To establish the existing environmental setting with respect to biological resources, CDFW recommends that a revised ND include the results of a complete, recent inventory of rare, threatened, endangered, and other sensitive species (e.g., nesting and migratory birds, bats, and crepuscular and nocturnal wildlife) located within the Project footprint and within off-site areas with the potential to be affected, including California Species of Special Concern (CSSC) and California Fully Protected Species (Fish and Game Code § 3511). Species to be addressed should include all those which meet the CEQA definition (CEQA Guidelines § 15380). The inventory should address seasonal variations in use of the Project area and should not be limited to resident species. CDFW suggests this information, and any necessary mitigation measures, be addressed in a revised ND. Note that CDFW generally considers biological field assessments for wildlife to be valid for a one-year period, and assessments for rare plants may be considered valid for a period of up to three years. Some aspects of the proposed Project may warrant periodic updated surveys for certain sensitive taxa, particularly if the Project is proposed to occur over a protracted time frame, or in phases where construction may be paused.

B-8

### III. CDFW Proposed Mitigation Measures or Related Impacts

#### **COMMENT #5: Coachella Valley Multiple Species Habitat Conservation Plan (CVMSHCP)**

**IS/ND document, Section #4.2f, Page #45**

**Issue:** The Project occurs within the CVMSHCP plan area and is subject to provisions and policies of the CVMSHCP.

**Specific impact:** The Project does not occur within or share a common boundary with a Conservation Area of the CVMSHCP; however, the Santa Rosa and San Jacinto Mountains Conservation Area is 1.7 miles southwest of the Project. To be considered a covered activity, Permittees should demonstrate that proposed actions are consistent with the CVMSHCP and its associated Implementing Agreement. The City of Rancho Mirage is the Lead Agency and a Permittee of the CVMSHCP.

**Evidence impact would be significant:** Within the Inland Deserts Region, CDFW issued Natural Community Conservation Plan Approval and Take Authorization for the CVMSHCP per Section 2800 et seq. of the California Fish and Game Code on September 9, 2008. The CVMSHCP establishes a multiple species conservation program to minimize and mitigate habitat loss and provides for the incidental take of covered species in association with activities covered under the permit. Compliance with approved habitat plans, such as the CVMSHCP, is discussed in CEQA. Specifically, Section 15125(d) of the CEQA Guidelines requires that the CEQA document discuss any inconsistencies between a proposed Project and applicable general plans and regional plans, including habitat conservation plans and natural community conservation plans. An assessment of the impacts to the CVMSHCP as a result of this Project is necessary to address CEQA requirements. To obtain additional information regarding the CVMSHCP please go to: <http://www.cvmshcp.org/>.

B-9

#### **Recommended Potentially Feasible Mitigation Measure(s)**

##### **MM BIO-[A]: CVMSHCP Compliance**

**Prior to construction and issuance of any grading permit, the City of Rancho Mirage shall ensure compliance with the Coachella Valley Multiple Species Habitat Conservation Plan (CVMSHCP) and its associated Implementing**

**Agreement and shall ensure the collection of payment of the CVMSHCP Local Development Mitigation Fee.**

Pursuant to the CEQA Guidelines, section 15097(f), CDFW has prepared a draft mitigation monitoring and reporting program (MMRP) for proposed MM BIO-[A] through [E] (see Attachment 1).

B-9

**COMMENT #6: Burrowing Owl Surveys**

**Section #4.2, Pages #44 & 45**

**Issue:** The ND does not analyze potential impacts to burrowing owl (*Athene cunicularia*) and includes no mitigation measures to avoid or reduce impacts to a level less than significant.

**Specific impact:** CDFW is concerned about the potential for burrowing owl to occur on the Project site and to move into disturbed or graded sites when construction is paused between phases of Project construction. Impacts to burrowing owl from the Project could include take of burrowing owls, their nests or eggs, or destroying nesting or foraging habitat; impacting burrowing owl populations through changes in vegetation via the destruction, conversion, or degradation of burrowing owl habitat.

**Evidence impact would be significant:** Burrowing owl is a California Species of Special Concern. Take of individual burrowing owls and their nests is defined by Fish and Game Code section 86, and prohibited by sections 3503, 3503.5, and 3513. Fish and Game Code section 3513 makes it unlawful to take or possess any migratory nongame bird except as provided by rules and regulations adopted by the Secretary of the Interior under provisions of the Migratory Bird Treaty Act of 1918, as amended (16 U.S.C. § 703 et seq.). Burrowing owl is a Covered Species under the CVMSHCP, which requires that avoidance and minimization measures be implemented for this species.

B-10

**Recommended Potentially Feasible Mitigation Measure(s)**

CDFW recommends that prior to commencing Project activities for all phases of Project construction, surveys for burrowing owl be conducted by a qualified biologist in accordance with the *Staff Report on Burrowing Owl Mitigation* (CDFG 2012 or most recent version). CDFW recommends the revised ND include specific avoidance and minimization measures to ensure that impacts to burrowing owls are reduced to less than significant.

**MM BIO-[B]: Burrowing Owl Surveys**

**No less than 60 days prior to the start of Project-related activities, a burrowing owl habitat assessment shall be conducted by a qualified biologist according to the specifications of the *Staff Report on Burrowing Owl Mitigation* (Department of Fish and Game, March 2012 or most recent version).**

**If the habitat assessment demonstrates suitable burrowing owl habitat, then focused burrowing owl surveys shall be conducted by a qualified biologist according to the *Staff Report on Burrowing Owl Mitigation*. If burrowing owls are detected during the focused surveys, the qualified biologist and Project Applicant shall prepare a Burrowing Owl Plan that shall be submitted to CDFW for review and approval prior to commencing Project activities. The Burrowing Owl Plan shall describe proposed avoidance, minimization, and monitoring actions. The Burrowing Owl Plan shall include the number and location of occupied burrow sites, acres of burrowing owl habitat that will be impacted, details of site monitoring, and details on proposed buffers and other avoidance measures if avoidance is proposed. If impacts to occupied burrowing owl habitat or burrow cannot be avoided, the Burrowing Owl Plan**



shall also describe relocation actions that will be implemented. Proposed implementation of burrow exclusion and closure should only be considered as a last resort, after all other options have been evaluated as exclusion is not in itself an avoidance, minimization, or mitigation method and has the possibility to result in take. If impacts to occupied burrows cannot be avoided, information shall be provided regarding adjacent or nearby suitable habitat available to owls along with proposed relocation actions. The Permittee shall implement the Burrowing Owl Plan following CDFW review and approval.

Preconstruction burrowing owl surveys shall be conducted no less than 14 days prior to the start of Project-related activities and within 24 hours prior to ground disturbance, in accordance with the *Staff Report on Burrowing Owl Mitigation (2012 or most recent version)*. Preconstruction surveys should be performed by a qualified biologist following the recommendations and guidelines provided in the *Staff Report on Burrowing Owl Mitigation*. If the preconstruction surveys confirm occupied burrowing owl habitat, Project activities shall be immediately halted. The qualified biologist shall coordinate with CDFW and prepare a Burrowing Owl Plan that shall be submitted to CDFW for review and approval prior to commencing Project activities.

B-10

#### COMMENT #7: Nesting Birds

##### Section #4.2, Pages #44 & 45

**Issue:** The ND does not analyze potential impacts to nesting birds and includes no mitigation measures to avoid or reduce impacts to a level less than significant.

**Specific impact:** CDFW is concerned that impacts to nesting birds have not been analyzed in the ND. The golf course includes vegetation and a water feature that may attract nesting and migratory birds. Nesting birds may also utilize trees in the area surrounding the Project and could be impacted by Project construction. Impacts to nesting birds may occur from ground-disturbing activities, vegetation removal, construction noise, and artificial light at night.

**Evidence impact would be significant:** It is the Project proponent's responsibility to comply with all applicable laws related to nesting birds and birds of prey. Fish and Game Code sections 3503, 3503.5, and 3513 afford protective measures as follows: Fish and Game Code section 3503 states that it is unlawful to take, possess, or needlessly destroy the nest or eggs of any bird, except as otherwise provided by Fish and Game Code or any regulation made pursuant thereto. Fish and Game Code section 3503.5 makes it unlawful to take, possess, or destroy any birds in the orders Falconiformes or Strigiformes (birds-of-prey) or to take, possess, or destroy the nest or eggs of any such bird except as otherwise provided by Fish and Game Code or any regulation adopted pursuant thereto. Fish and Game Code section 3513 makes it unlawful to take or possess any migratory nongame bird except as provided by rules and regulations adopted by the Secretary of the Interior under provisions of the Migratory Bird Treaty Act of 1918, as amended (16 U.S.C. § 703 et seq.).

B-11

##### Recommended Potentially Feasible Mitigation Measure(s)

CDFW recommends the revised ND include specific avoidance and minimization measures to ensure that impacts to nesting birds do not occur. Project-specific avoidance and minimization measures may include, but are not limited to, Project phasing and timing, monitoring of Project-related noise (where applicable), sound walls, and buffers, where appropriate. CDFW recommends that disturbance of occupied nests of migratory birds and raptors within the Project site be avoided **any time birds are nesting on-site**. Preconstruction nesting bird surveys shall be performed within 3 days prior to Project activities to determine the presence and location of nesting birds.

##### MM BIO-[C]: Avoidance of Nesting Birds

**Nesting bird surveys shall be performed by a qualified avian biologist no more than (3) days prior to vegetation removal or ground-disturbing activities. Pre-construction surveys shall focus on both direct and indirect evidence of nesting, including nest locations and nesting behavior. The qualified avian biologist will make every effort to avoid potential nest predation as a result of survey and monitoring efforts. If active nests are found during the pre-construction nesting bird surveys, a qualified biologist shall establish an appropriate nest buffer to be marked on the ground. Nest buffers are species specific and shall be at least 300 feet for passerines and 500 feet for raptors. A smaller or larger buffer may be determined by the qualified biologist familiar with the nesting phenology of the nesting species and based on nest and buffer monitoring results. Established buffers shall remain on-site until a qualified biologist determines the young have fledged or the nest is no longer active. Active nests and adequacy of the established buffer distance shall be monitored daily by the qualified biologist until the qualified biologist has determined the young have fledged or the Project has been completed. The qualified biologist has the authority to stop work if nesting pairs exhibit signs of disturbance.**

B-11

#### **COMMENT #8: Construction Noise**

##### **Section #13.2, Pages #98 & 99**

**Issue:** The ND does not analyze impacts to biological resources from construction noise and includes no mitigation measures to avoid or reduce impacts to a level less than significant.

**Specific impact:** The ND (p. 98) states equipment used during the construction phases is expected generate both steady state and episodic noise increases that would be heard both on and off the Project site, but includes no analysis of the impacts of construction noise on biological resources. The ND indicates noise levels have the potential to reach 46.7 to 60.4 dBA during the hours when construction is permitted. Exposure levels that may adversely affect wildlife species can occur at 55 to 60 dBA. Because of the potential for construction noise to negatively impact wildlife, CDFW recommends the revised ND include an analysis of impacts to biological resources and specific avoidance and minimization measures to ensure that impacts to wildlife are reduced to less than significant.

B-12

**Evidence impact would be significant:** Construction may result in substantial noise through road use, equipment, and other Project-related activities. This may adversely affect wildlife species in several ways as wildlife responses to noise can occur at exposure levels of only 55 to 60 dB (Barber et al. 2009). Anthropogenic noise can disrupt the communication of many wildlife species including frogs, birds, and bats (Sun and Narins 2005, Patricelli and Blickley 2006, Gillam and McCracken 2007, Slabbekoorn and Ripmeester 2008). Noise can also affect predator-prey relationships as many nocturnal animals such as bats and owls primarily use auditory cues (i.e., hearing) to hunt. Additionally, many prey species increase their vigilance behavior when exposed to noise because they need to rely more on visual detection of predators when auditory cues may be masked by noise (Rabin et al. 2006, Quinn et al. 2017). Noise has also been shown to reduce the density of nesting birds (Francis et al. 2009) and cause increased stress that results in decreased immune responses (Kight and Swaddle 2011).

##### **Recommended Potentially Feasible Mitigation Measure(s)**

##### **MM BIO-[C]: Construction Noise**

**During all Project construction, the City of Rancho Mirage shall restrict use of equipment to hours least likely to disrupt wildlife (e.g., not at night or in early morning) and restrict use of generators except for temporary use in**

**emergencies. Power to sites can be provided by solar PV (photovoltaic) systems, cogeneration systems (natural gas generator), small micro-hydroelectric systems, or small wind turbine systems. The City shall ensure use of noise suppression devices such as mufflers or enclosure for generators. Sounds generated from any means must be below the 55-60 dB range within 50-feet from the source.**

B-12

#### **COMMENT #9: Artificial Light**

##### **Section #1.2, Page #31**

**Issue:** The ND does not analyze impacts to biological resources from artificial light and includes no mitigation measures to avoid or reduce impacts to a level less than significant.

**Specific impact:** The ND (p. 31) indicates that the development of the Project will introduce new sources of lighting, including lighting fixtures along pedestrian pathways, and lighting for existing landscape features along Frank Sinatra Drive; however, impacts to biological resources are not analyzed and no mitigation measures are proposed. The direct and indirect impacts of artificial nighttime lighting on biological resources including migratory birds that fly at night, bats, and other nocturnal and crepuscular wildlife should be analyzed, and appropriate avoidance and minimization measures should be included in the revised ND.

**Evidence impact would be significant:** Artificial nighttime lighting often results in light pollution, which has the potential to significantly and adversely affect fish and wildlife. Artificial lighting alters ecological processes including, but not limited to, the temporal niches of species; the repair and recovery of physiological function; the measurement of time through interference with the detection of circadian and lunar and seasonal cycles; and the detection of resources and natural enemies and navigation (Gatson et al. 2013). Many species use photoperiod cues for communication (e.g., bird song; Miller 2006), determining when to begin foraging (Stone et al. 2009), behavior thermoregulation (Beiswenger 1977), and migration (Longcore and Rich 2004). Phototaxis, a phenomenon which results in attraction and movement towards light, can disorient, entrap, and temporarily blind wildlife species that experience it (Longcore and Rich 2004).

B-13

#### **Recommended Potentially Feasible Mitigation Measure(s)**

##### **MM BIO-[D]: Artificial Light**

**During Project construction and operation, the City of Rancho Mirage shall eliminate all nonessential lighting throughout the Project area and avoid or limit the use of artificial light during the hours of dawn and dusk when many wildlife species are most active. The City shall ensure that lighting for Project activities is shielded, cast downward, and does not spill over onto other properties or upward into the night sky (see the International Dark-Sky Association standards at <http://darksky.org/>). The City shall ensure use LED lighting with a correlated color temperature of 3,000 Kelvins or less, proper disposal of hazardous waste, and recycling of lighting that contains toxic compounds with a qualified recycler.**

#### **ENVIRONMENTAL DATA**

CEQA requires that information developed in environmental impact reports and negative declarations be incorporated into a database which may be used to make subsequent or supplemental environmental determinations. (Pub. Resources Code, § 21003, subd. (e).) Accordingly, please report any special status species and natural communities detected during Project surveys to the California Natural Diversity Database (CNDDDB). The CNDDDB field survey form can be filled out and submitted online at the following link: <https://wildlife.ca.gov/Data/CNDDDB/Submitting-Data>. The types of information reported to

B-14

CNDDDB can be found at the following link: <https://www.wildlife.ca.gov/Data/CNDDDB/Plants-and-Animals>.

B-14

## ENVIRONMENTAL DOCUMENT FILING FEES

The Project, as proposed, would have an impact on fish and/or wildlife, and assessment of environmental document filing fees is necessary. Fees are payable upon filing of the Notice of Determination by the Lead Agency and serve to help defray the cost of environmental review by CDFW. Payment of the environmental document filing fee is required in order for the underlying project approval to be operative, vested, and final. (Cal. Code Regs, tit. 14, § 753.5; Fish & G. Code, § 711.4; Pub. Resources Code, § 21089.)

B-15

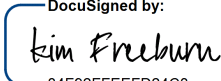
## CONCLUSION

CDFW appreciates the opportunity to comment on the ND to assist the City of Rancho Mirage in identifying and mitigating Project impacts on biological resources. CDFW concludes that the ND does not adequately identify or mitigate the Project's significant, or potentially significant impacts on biological resources. The CEQA Guidelines (§ 15073.5) indicate that recirculation is required when a new significant effect is identified and additional mitigation measures are necessary. CDFW recommends that a revised ND with a recent and complete assessment of impacts to biological resources, and mitigation to avoid and reduce those impacts to less than significant, be recirculated for public comment.

B-16

CDFW personnel are available for consultation regarding biological resources and strategies to minimize impacts. Questions regarding this letter or further coordination should be directed to Alyssa Hockaday, Senior Environmental Scientist (Specialist) at (760) 920-8252 or [Alyssa.Hockaday@wildlife.ca.gov](mailto:Alyssa.Hockaday@wildlife.ca.gov).

Sincerely,

DocuSigned by:  
  
84F92FFEEFD24C8...

Kim Freeburn  
Environmental Program Manager

Attachment 1: MMRP for CDFW-Proposed Mitigation Measures

ec: Heather Brashear, Senior Environmental Scientist (Supervisor), CDFW  
[Heather.Brashear@wildlife.ca.gov](mailto:Heather.Brashear@wildlife.ca.gov)

Rollie White, U.S. Fish and Wildlife Service  
[Rollie\\_white@fws.gov](mailto:Rollie_white@fws.gov)

Vincent James, U.S. Fish and Wildlife Service  
[Vincent\\_james@fws.gov](mailto:Vincent_james@fws.gov)

Office of Planning and Research, State Clearinghouse, Sacramento  
[State.clearinghouse@opr.ca.gov](mailto:State.clearinghouse@opr.ca.gov)

## REFERENCES

- Barber, J. R., K. R. Crooks, and K. M. Fristrup. 2009. The costs of chronic noise exposure for terrestrial organisms. *Trends in Ecology and Evolution* 25:180-189.
- Beiswenger, R. E. 1977. Diet patterns of aggregative behavior in tadpoles of *Bufo americanus*, in relation to light and temperature. *Ecology* 58:98-108.
- Francis, C. D., C. P. Ortega, and A. Cruz. 2009. Noise pollution changes avian communities and species interactions. *Current Biology* 19:1415-1419.
- Gatson, K. J., Bennie, J., Davies, T., Hopkins, J. 2013. The ecological impacts of nighttime light pollution: a mechanistic appraisal. *Biological Reviews*.
- Gillam, E. H., and G. F. McCracken. 2007. Variability in the echolocation of *Tadarida brasiliensis*: effects of geography and local acoustic environment. *Animal Behaviour* 74:277-286.



Kight, C. R., and J. P. Swaddle. 2011. How and why environmental noise impacts animals: An integrative, mechanistic review. *Ecology Letters* 14:1052–1061.

Longcore, T., and C. Rich. 2004. Ecological light pollution – Review. *Frontiers in Ecology and the Environment* 2:191–198.

Miller, M. W. 2006. Apparent effects of light pollution on singing behavior of American robins. *The Condor* 108:130–139.

Patricelli, G., and J. J. L. Blickley. 2006. Avian communication in urban noise: causes and consequences of vocal adjustment. *Auk* 123:639–649.

Quinn, J. L., M. J. Whittingham, S. J. Butler, W. Cresswell, J. L. Quinn, M. J. Whittingham, S. J. Butler, W. Cresswell, and W. Noise. 2017. Noise, predation risk compensation and vigilance in the chaffinch *Fringilla coelebs*. *Journal of Avian Biology* 37:601–608.

Rabin, L. A., R. G. Coss, and D. H. Owings. 2006. The effects of wind turbines on antipredator behavior in California ground squirrels (*Spermophilus beecheyi*). *Biological Conservation* 131:410–420.

Slabbekoorn, H., and E. A. P. Ripmeester. 2008. Birdsong and anthropogenic noise: Implications and applications for conservation. *Molecular Ecology* 17:72–83.

Stone, E. L., G. Jones, and S. Harris. 2009. Street lighting disturbs commuting bats. *Current Biology* 19:1123–1127. Elsevier Ltd.

Sun, J. W. C., and P. M. Narins. 2005. Anthropogenic sounds differentially affect amphibian call rate. *Biological Conservation* 121:419–427.

**ATTACHMENT 1: MITIGATION MONITORING AND REPORTING PROGRAM (MMRP)**

<b>Biological Resources (BIO)</b>		
<b>Mitigation Measure (MM) Description</b>	<b>Implementation Schedule</b>	<b>Responsible Party</b>
<p><b>MM BIO-[A]: CVMSHCP Compliance</b>            Prior to construction and issuance of any grading permit, the City of Rancho Mirage shall ensure compliance with the Coachella Valley Multiple Species Habitat Conservation Plan (CVMSHCP) and its associated Implementing Agreement and shall ensure the collection of payment of the CVMSHCP Local Development Mitigation Fee.</p>	<p>Prior to construction and issuance of any grading permit</p>	<p>City of Rancho Mirage</p>
<p><b>MM BIO-[B]: Burrowing Owl Surveys</b>            No less than 60 days prior to the start of Project-related activities, a burrowing owl habitat assessment shall be conducted by a qualified biologist according to the specifications of the Staff Report on Burrowing Owl Mitigation (Department of Fish and Game, March 2012 or most recent version).</p> <p>If the habitat assessment demonstrates suitable burrowing owl habitat, then focused burrowing owl surveys shall be conducted by a qualified biologist according to the Staff Report on Burrowing Owl Mitigation. If burrowing owls are detected during the focused surveys, the qualified biologist and Project Applicant shall prepare a Burrowing Owl Plan that shall be submitted to CDFW for review and approval prior to commencing Project activities. The Burrowing Owl Plan shall describe proposed avoidance, minimization, and monitoring actions. The Burrowing Owl Plan shall include the number and location of occupied burrow sites, acres of burrowing owl habitat that will be impacted, details of site monitoring, and details on proposed buffers and other avoidance measures if avoidance is proposed. If impacts to occupied burrowing owl habitat or burrow cannot be avoided, the Burrowing Owl Plan shall also describe relocation actions that will be implemented. Proposed implementation of burrow exclusion and closure should only be considered as a last resort, after all other options have been evaluated as exclusion is not in itself an avoidance, minimization, or mitigation method and has the possibility to result in take. If impacts to occupied burrows cannot be avoided, information shall be provided regarding adjacent or nearby suitable habitat available to owls along with proposed relocation actions. The Permittee shall</p>	<p><b>Habitat assessment and focused surveys:</b> No less than 60 days prior to the start of Project-related activities.</p> <p><b>Pre-construction surveys:</b> No less than 14 days prior to start of Project-related activities and within 24 hours prior to ground disturbance.</p>	<p>City of Rancho Mirage</p>

<p>implement the Burrowing Owl Plan following CDFW review and approval.</p> <p>Preconstruction burrowing owl surveys shall be conducted no less than 14 days prior to the start of Project-related activities and within 24 hours prior to ground disturbance, in accordance with the <i>Staff Report on Burrowing Owl Mitigation</i> (2012 or most recent version). Preconstruction surveys should be performed by a qualified biologist following the recommendations and guidelines provided in the <i>Staff Report on Burrowing Owl Mitigation</i>. If the preconstruction surveys confirm occupied burrowing owl habitat, Project activities shall be immediately halted. The qualified biologist shall coordinate with CDFW and prepare a Burrowing Owl Plan that shall be submitted to CDFW for review and approval prior to commencing Project activities.</p>		
<p><b>MM BIO-[C]: Avoidance of Nesting Birds</b>        Nesting bird surveys shall be performed by a qualified avian biologist no more than (3) days prior to vegetation removal or ground-disturbing activities. Pre-construction surveys shall focus on both direct and indirect evidence of nesting, including nest locations and nesting behavior. The qualified avian biologist will make every effort to avoid potential nest predation as a result of survey and monitoring efforts. If active nests are found during the pre-construction nesting bird surveys, a qualified biologist shall establish an appropriate nest buffer to be marked on the ground. Nest buffers are species specific and shall be at least 300 feet for passerines and 500 feet for raptors. A smaller or larger buffer may be determined by the qualified biologist familiar with the nesting phenology of the nesting species and based on nest and buffer monitoring results. Established buffers shall remain on-site until a qualified biologist determines the young have fledged or the nest is no longer active. Active nests and adequacy of the established buffer distance shall be monitored daily by the qualified biologist until the qualified biologist has determined the young have fledged or the Project has been completed. The qualified biologist has the authority to stop work if nesting pairs exhibit signs of disturbance.</p>	<p>No more than three (3) days prior to vegetation clearing or ground-disturbing activities.</p>	<p>City of Rancho Mirage</p>
<p><b>MM BIO-[D]: Construction Noise</b>        During all Project construction, the City of Rancho Mirage shall restrict use of equipment to hours least likely to disrupt wildlife (e.g., not at night or in early morning) and restrict use of generators except for temporary use in emergencies. Power to sites can be provided by solar PV (photovoltaic) systems, cogeneration systems (natural gas generator), small micro-hydroelectric systems, or small wind turbine systems. The City shall ensure use of noise suppression devices such as mufflers or enclosure for generators. Sounds generated from any means must be below the 55-60 dB range within 50-feet from the source.</p>	<p>During Project activities.</p>	<p>City of Rancho Mirage</p>
<p><b>MM BIO-[E]: Artificial Light</b>        During Project construction and operation, the City of Rancho Mirage shall eliminate all nonessential lighting throughout the Project area and avoid or limit the use of artificial light during the hours of dawn and dusk when many wildlife species are most active. The City shall ensure that lighting for Project activities is shielded, cast downward, and does not spill over onto other properties or upward into the night sky (see the International Dark-Sky Association standards at <a href="http://darksky.org/">http://darksky.org/</a>). The City shall ensure use LED lighting with a correlated color</p>	<p>During Project construction and operation.</p>	<p>City of Rancho Mirage</p>

temperature of 3,000 Kelvins or less, proper disposal of hazardous waste, and recycling of lighting that contains toxic compounds with a qualified recycler.		
--	--	--