

Appendix F
Transportation Impact Study

THIS PAGE INTENTIONALLY LEFT BLANK

TRANSPORTATION IMPACT STUDY

Town Center Village Phase II

Prepared for:
City of El Centro
Planning Development
1275 W. Main Street
El Centro, CA 92243

March 9, 2023

TABLE OF CONTENTS

1	EXECUTIVE SUMMARY	4
1.1	CEQA Analysis Summary	4
1.2	Local Mobility Assessment (Level of Service) Summary	4
2	INTRODUCTION	6
2.1	Project Description.....	6
2.2	Project Location	6
2.3	CEQA VMT Analysis Scope	6
2.4	Local Mobility Analysis Scope	6
3	PROJECT TRIP GENERATION	9
3.1	Proposed Project.....	9
3.1.1	Project Forecast Trip Generation	9
3.1.2	Proposed Project Trip Distribution & Trip Assignment.....	9
4	STUDY AREA SELECTION & ANALYSIS METHODOLOGY	12
4.1	LMA Analysis Methodology	12
4.1.1	Intersection Analysis Methodology	12
4.1.1	Roadway Segment Analysis Methodology.....	13
4.1.2	Thresholds of Improvements	13
4.1.3	Caltrans Facilities	14
4.2	Study Area.....	14
4.3	Data Collection.....	15
5	CEQA VMT ANALYSIS	17
5.1	VMT Screening Criteria	17
6	EXISTING CONDITIONS	21
6.1	Surrounding Roadway Network.....	21
6.2	Existing Conditions Traffic Analysis.....	23
6.2.1	Existing Intersection Evaluation	23
6.2.2	Existing Roadway Segment Evaluation	26
6.3	Active Transportation	27
6.3.1	Pedestrian Facilities	27
6.3.2	Existing Bicycle Facilities	29
6.3.3	Existing Transit Facilities	29
7	OPENING YEAR 2024 WITHOUT PROJECT CONDITIONS	30

7.1	Opening Year 2024 Without Project Analysis	30
7.1.1	Cumulative Traffic	30
7.1.2	Opening Year 2024 Without Project Intersection Evaluation.....	34
7.1.3	Opening Year 2024 Without Project Roadway Segment Evaluation	36
8	OPENING YEAR 2024 PLUS PROJECT CONDITIONS.....	37
8.1.1	Opening Year 2024 Plus Project Intersection Evaluation	37
8.1.2	Opening Year 2024 Plus Project Roadway Segment Evaluation	39
8.2	Queuing Analysis.....	40
9	SUMMARY & CONCLUSIONS	41
9.1	CEQA Analysis Summary	41
9.2	Local Mobility Assessment (Level of Service) Summary	41

LIST OF EXHIBITS

Exhibit 1	– Project Location Map	7
Exhibit 2	– Project Site Plan	8
Exhibit 3	– Project Trip Distribution.....	10
Exhibit 4	– Project Trip Assignment	11
Exhibit 5	– Study Area	16
Exhibit 6	– VMT Efficient Area (VMT Per Capita)	19
Exhibit 7	– VMT Efficient Area (VMT Per Employee)	20
Exhibit 8	– City of El Centro General Plan Mobility Element Planned Roadway Network.....	22
Exhibit 9	– Existing Intersection Lane Geometry	24
Exhibit 10	– Existing Daily and AM/PM Peak Hour Intersection Volumes.....	25
Exhibit 11	– Existing Pedestrian, Bicycle, and Transit Facilities	28
Exhibit 12	– Cumulative Project Location Map.....	32
Exhibit 13	– Cumulative Project Only Daily and AM/PM Peak Hour Traffic Volumes	33
Exhibit 14	– Opening Year 2024 Without Project Daily and AM/PM Peak Hour Traffic Volumes.....	35
Exhibit 15	– Opening Year 2024 Plus Project Daily and AM/PM Peak Hour Traffic Volumes.....	38

LIST OF TABLES

Table 1	– ITE Trip Generation Rates.....	9
Table 2	– Proposed Project Trip Generation.....	9
Table 3	- Level of Service & Delay Range	12
Table 4	– El Centro Roadway Segment Daily Capacity & LOS Standards.....	13
Table 5	: VMT Screening Criteria Evaluation.....	17
Table 6	– Existing Conditions AM/PM Peak Hour Intersection LOS.....	23
Table 7	– Existing Conditions Roadway Segment LOS	26
Table 8	– Cumulative Projects Trip Generation Summary	31
Table 9	– Opening Year 2024 Without Project AM/PM Peak Hour Intersection LOS.....	34
Table 10	– Opening Year 2024 Without Project Conditions Roadway Segment LOS	36

Table 11 – Opening Year 2024 Plus Project AM/PM Peak Hour Intersection LOS 37
Table 12 – Opening Year 2024 WO Project & Opening Year 2024 Plus Project Roadway Segment LOS
Comparison 39
Table 13 – Opening Year 2024 Plus Project Intersection Queuing Analysis 40

APPENDICES

- Appendix A: Project Information Form
- Appendix B: Traffic Count Data & Signal Timing Sheets
- Appendix C: Existing HCM Worksheets
- Appendix D: Opening Year 2024 Without Project HCM Worksheets
- Appendix E: Opening Year 2024 Plus Project HCM Worksheets

1 EXECUTIVE SUMMARY

This transportation impact study analyzes the forecast transportation conditions associated with the proposed Town Center Village Phase II development (project). The project site is located at the northeast corner of Cruickshank Drive and 8th Street in the City of El Centro. The project proposes to construct 102 single-family dwelling units and 17.26 acres of manufacturing. This project requires a tentative subdivision map, conditional use permit and zone change to accommodate residential use.

1.1 CEQA ANALYSIS SUMMARY

In December 2018, new California Environmental Quality Act (CEQA) guidelines were approved that shift transportation analysis from delay and operations to vehicle miles traveled (VMT) when evaluating transportation impacts under CEQA. This change in methodology is a result of Senate Bill 743 (SB743), which was signed into law in September 2013. The Governor's Office of Planning and Research (OPR) released *Technical Advisory on Evaluating Transportation Impacts in CEQA* in December 2018 (Technical Advisory) that contains recommendations regarding assessment of VMT, screening criteria, thresholds of significance, and approach to mitigating impacts. Statewide implementation VMT as the metric for evaluating transportation impacts under CEQA occurred on July 1, 2020. The City of El Centro recently prepared and adopted new *Transportation Study Guidelines* (TSG) dated June 2022 which comply with SB743. Therefore, the City's TSG was used to evaluate the project's transportation impacts based on VMT. The project is located within a VMT efficient area and is determined to have a less than significant impact for both the residential and industrial components of the site. As such, a detailed VMT analysis is not required.

1.2 LOCAL MOBILITY ASSESSMENT (LEVEL OF SERVICE) SUMMARY

While transportation impacts are based on VMT, the City also requires analysis of intersection and roadway segment operating conditions for their Local Mobility Assessment (LMA). The City has established level of service (LOS) C as the standard for acceptable operating conditions. LOS D, E and F are considered deficient operating conditions. However, the City's Mobility Element Policy 4.4 states,

"Although VMT will be utilized as the new traffic impact metric for California Environmental Quality Act (CEQA) review process, Level of Service (LOS) is still a critical measure and indicator of traffic operations. Level of Service (LOS) C shall be the threshold for all Mobility Element roadways and intersections, except that Level of Service (LOS) D would be acceptable upon review and approval by the City Engineer after consideration of impacts to the public and lack of feasibility of attaining Level of Service (LOS) C due to right-of-way constraints. With the additional exception of Imperial Avenue between Ocotillo Drive and I-8 westbound ramps, where LOS E would be acceptable due to right of-way constraints, unless otherwise approved by the City Engineer."

For the intersection of Cruickshank Drive & Imperial Avenue, the City has accepted LOS D as acceptable operating conditions since widening the intersection to improve operations to LOS C or better would be infeasible due to right-of-way constraints. Under the Existing, Opening Year 2024 Without and With Project scenarios, the intersection of Cruickshank Drive & Imperial Avenue is shown to operate at LOS D. Since this location is considered acceptable operating conditions, no improvements are required.

The results of the roadway segment analysis show that all three study segments currently operate better than the City's LOS C standard under Existing, Opening Year 2024 Without Project and Opening Year 2024 Plus Project conditions. Therefore, improvements are not warranted on any of the study roadway segments.

The project driveways on 10th Street and 12th Street should be free and clear of any obstructions to provide adequate sight distance ensuing exiting vehicles from the new driveways can adequately see not only other vehicles, but also pedestrians and bicyclists. Any landscaping and signage at the project driveways should not obstruct the drivers view from exiting the project site.

2 INTRODUCTION

This study analyzes the forecast transportation conditions associated with the proposed project located at the northeast corner of Cruickshank Drive and 8th Street in the City of El Centro.

2.1 PROJECT DESCRIPTION

The project proposes to subdivide the property to allow for a mixture of single-family residential and industrial uses including 102 single-family dwelling units and 17.26 acres of manufacturing. This project requires a tentative subdivision map, conditional use permit and zone change to accommodate residential use. The project site is currently vacant and undeveloped. Vehicular access to the residential portion of the project will be provided via 12th Street. 10th Street will provide direct access to the industrial uses.

2.2 PROJECT LOCATION

The project site is bounded by Cruickshank Drive to the south, existing commercial development to the west and 8th Street to the east. The Central Drain and a high voltage transmission line operated by the Imperial Irrigation District run along the northern boundary of the site.

Exhibit 1 shows the location of the project site. **Exhibit 2** provides the project site plan.

2.3 CEQA VMT ANALYSIS SCOPE

The CEQA transportation analysis scope is based on the City's TSG dated June 2022. According to the TSGs, a project that meets at least one of the screening criteria would not be required to prepare a detailed VMT analysis and would be presumed to have a less-than-significant VMT impact. The proposed project is located within a VMT efficient area based on the VMT per Capita map and VMT per Employee map contained in Appendix C (VMT Screening Maps) in the City's TSG. Therefore, the proposed project would not be required to prepare a detailed CEQA VMT analysis and would also have a less-than-significant VMT impact on the environment.

2.4 LOCAL MOBILITY ANALYSIS SCOPE

A LMA has been prepared in accordance with the City's TSG dated June 2022. While not part of the CEQA review, the LMA is provided to address localized operational and safety concerns for all transportation modes. The proposed project is consistent with the General Plan and is expected to generate approximately 1,728 daily trips. According to the City's TSG, projects that generate more than 800 daily trips are required to prepare a full LMA. Therefore, traffic generated by the proposed project is being analyzed and a LMA is required.

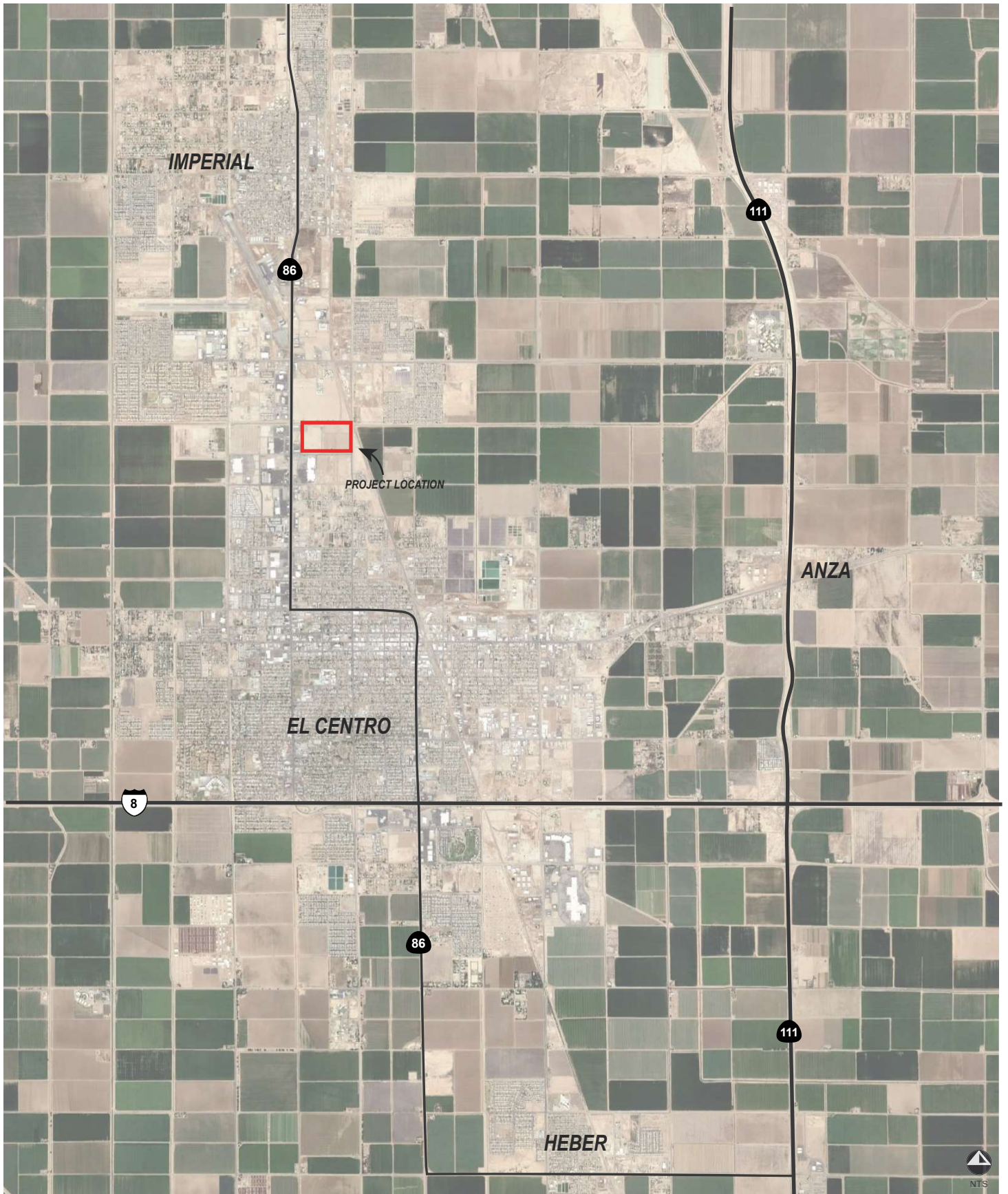

TENTATIVE SUBDIVISION MAP

EL CENTRO INDUSTRIAL DEVELOPMENT

CITY OF EL CENTRO, COUNTY OF IMPERIAL, STATE OF CALIFORNIA

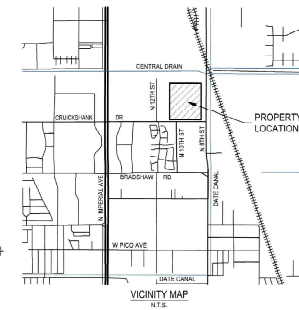

TYPICAL STREET SECTIONS

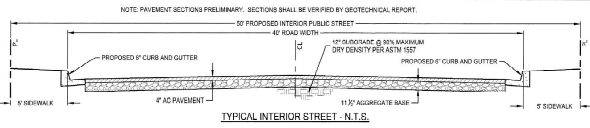

LEGEND

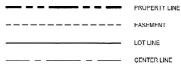

PROJECT INFORMATION

PROPERTY INFORMATION	
PROPERTY OWNER	TOWN CENTER COURTYARD II, LLC 9601 FLAIR DRIVE EL MONTE, CA 91731
ENGINEER	MICHAEL BAKER INCLEDON CONSULTING GROUP 1575 CORPORATE DRIVE, SUITE A DUSTY MEADOWS, CA 92526 P.O. BOX 1048
ASSISTANT ENGINEER	044-020-023
LEGAL DESCRIPTION	A PORTION OF BEMER ROSSER LOT 1 AS SHOWN ON EL CENTRO TOWN CENTER MAPS SITING MAPS RECORDED IN BOOK 26, PAGES 17 THROUGH 19, INCLUSIVE, IN THE OFFICE OF THE COUNTY RECORDER IN IMPERIAL COUNTY.
EXISTING ZONING	ML - LIGHT MANUFACTURING
PROPOSED ZONING	ML - LIGHT MANUFACTURING
EXISTING LAND USE	VACANT
PROPOSED LAND USE	LIGHT MANUFACTURING
EXISTING TREES	THERE ARE NO EXISTING TREES ON THE SITE.
EXISTING STRUCTURES	THERE ARE NO EXISTING STRUCTURES ON THE SITE.
DATE MAP PREPARED	MAY 2022
LINEAR STREET FOOTAGE TOTAL	3,100.0 FT
FLOOD ZONE	ZONING X, ACCORDING TO FEMA FLOOD MAP NO. 18050C020C
MINIMUM PROPOSED LOT AREA	4,980 SF
TOTAL PROPERTY AREA	17.28 ACRES

EASEMENTS & SETBACKS

- BUREAU OF LAND MANAGEMENT AREA AS DESCRIBED IN THE 1822 ABSTRACT AND 11, 2001 AND 2002 MAPS.
- FOUNDING BARR AREA AS DESCRIBED IN THE DOCUMENT RECORDED JUNE 10, 2003 AS INSTRUMENT NO. 2003-01733 OF OFFICIAL RECORDS.
- PL ZONE 4 PER "EL CENTRO INDUSTRIAL ANALYSIS" MEMORANDUM, DATED JANUARY 18, 2019 BY MICHAEL BAKER INTERNATIONAL.
- PL ZONE 4 PER "EL CENTRO ZONING ANALYSIS" MEMORANDUM, DATED JUNE 10, 2019 BY MICHAEL BAKER INTERNATIONAL.

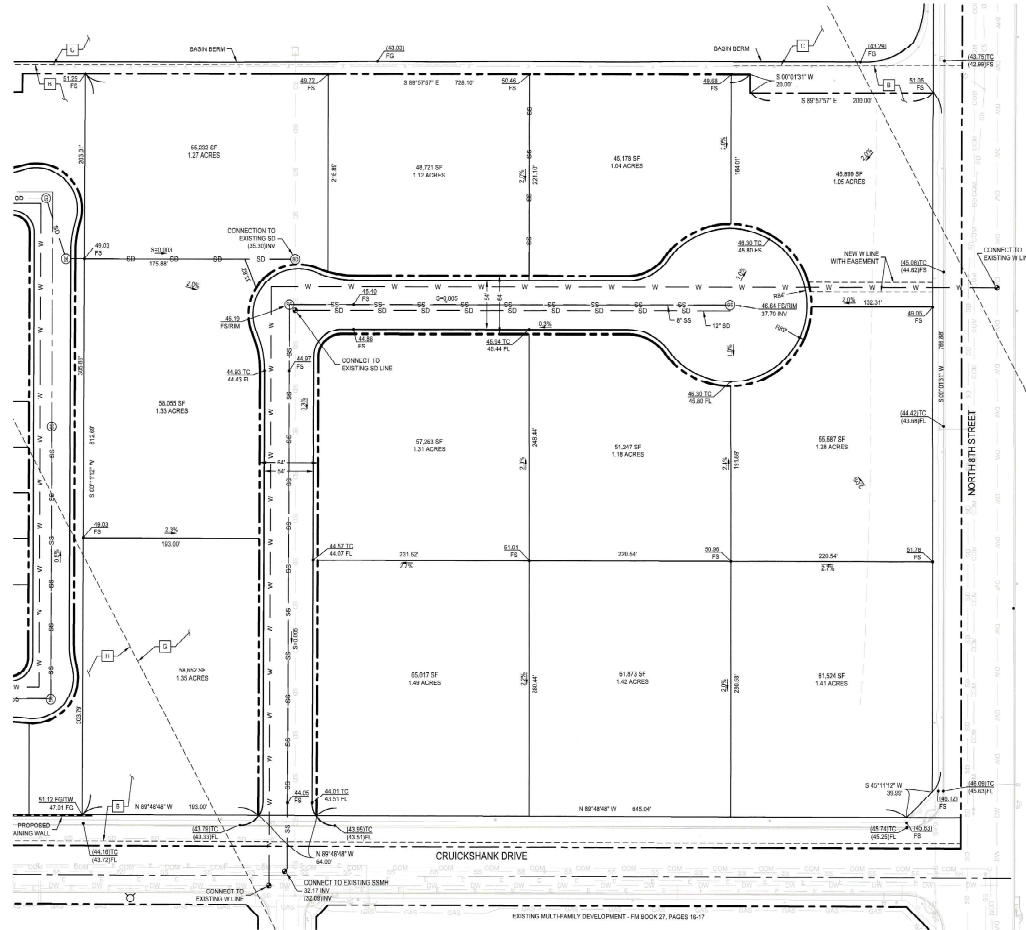

TOWN CENTER VILLAGE, LLC
9601 FLAIR DRIVE
EL MONTE, CA 91731

INCLEDON CONSULTING GROUP
Civil Engineering • Surveying • Planning
5700 Green Hills Drive, Suite 100, El Monte, CA 91734
Tel: 626.251.1111 • www.incledon.com

EL CENTRO TOWN CENTER
VILLAGE RESIDENTIAL AND
INDUSTRIAL DEVELOPMENT
EL CENTRO, CA 92243

REV.	DATE	DESCRIPTION



TENTATIVE
SUBDIVISION MAP

SHEET TITLE: 458.011
JOB #:
DATE: 5/20/2022

3
SHEET #

TENTATIVE SUBDIVISION MAP

EL CENTRO SINGLE FAMILY DEVELOPMENT
CITY OF EL CENTRO, COUNTY OF IMPERIAL,
STATE OF CALIFORNIA

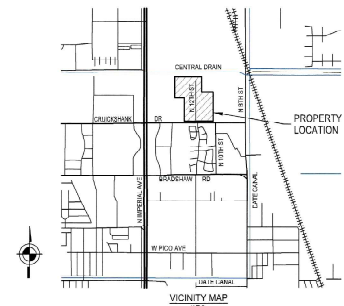
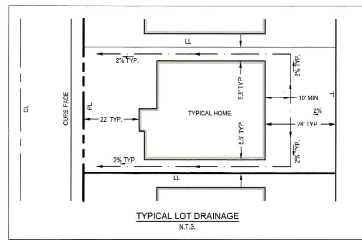
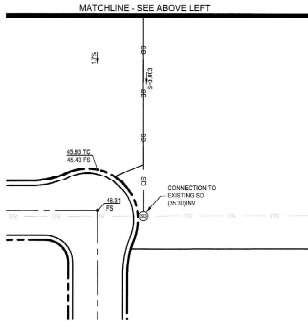

LEGEND

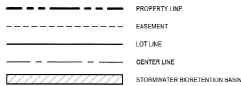

PROJECT INFORMATION

PROPERTY INFORMATION
PROPERTY OWNER: TOWN CENTER COURTYARD II, LLC
 8001 PLAINS DRIVE,
 EL MORA, CA 91731
MANAGER: MICHAEL BAKER
 3425 RIVER CENTER DRIVE SUITE A
 COVINA, CA 91724
ASSESSOR'S NUMBER(S): 044620322, 044620327, 044620328, 044620329, 044620330, 044620331, 044620332, 044620333
LOCAL DESCRIPTIONS: A PORTION OF REMAINDER LOT 4 AND LOTS 13, 14, 15 AND 16 AS SHOWN ON EL CENTRO TOWN CENTER PLANNING MAP RECORDED RECORD NO. 11 THRU 16 IN EL CENTRO COUNTY, PARCELS 13, 14 AND 15 AS RECORDED ON 07/10/2018 AS RECORDING NO. 202201124, 02 OFFICIAL RECORD, AND PARCELS 13, 14 AND 15 AS RECORDED ON 07/10/2018 AS RECORDING NO. 202201125, 02 OFFICIAL RECORD.
EXISTING ZONING: RL - LIGHT MANUFACTURING
 CO - GENERAL COMMERCIAL
PROPOSED ZONING: R1 - SINGLE FAMILY RESIDENTIAL
EXISTING LAND USE: VACANT
PROPOSED LAND USE: SINGLE FAMILY RESIDENTIAL
EXISTING TREES: THERE ARE NO EXISTING TREES ON THE SITE
EXISTING UTILITIES: 12" WATER MAIN EXISTING STRUCTURES ON THE SITE
DATE MAP PREPARED: MAY 2022
LINEAR STREET FOOTAGE TOTAL: 5,206.67 FT
FLOOD ZONE: ZONE X ACCORDING TO FEMA FLOOD MAP NO. 060301210C
RESIDENTIAL DENSITY: 102 HOMES / 18.52 ACRES = 5.5 DWELLING UNITS PER ACRE
MINIMUM PROPOSED LOT AREA: 4,980 SF
TOTAL PROPERTY AREA: 18.52 ACRES
CONVERSION PROPOSAL: TO SUBDIVIDE THE PROPERTY TO CREATE 102 LOTS FOR PROPOSED RESIDENTIAL DETACHED SINGLE FAMILY DWELLING UNITS, AND LOTS 13 THROUGH 16, INCORPORATING PRIVATE STREETS, CONCRETE SIDEWALKS, UNDERGROUND UTILITIES, AND OTHER SPACES.

EASEMENTS & SETBACKS

- A. 10' SETBACK FROM ALL SIDES (SEE EASEMENT FOR CANAL FLOOD LINES RECORDED UNDER 19, 1929 IN BOOK 532 PAGE 270 OF OFFICIAL RECORDS)
- B. SUPERVISED OVERNIGHT HABITAT AREA AS DESCRIBED IN THE DOCUMENT RECORDED JUNE 13, 2005 AS INSTRUMENT NO. 2005-071723 OF OFFICIAL RECORDS
- C. 10' SETBACK FROM ALL SIDES (SEE EASEMENT FOR CANAL FLOOD LINES RECORDED UNDER 19, 1929 IN BOOK 532 PAGE 270 OF OFFICIAL RECORDS)
- D. STORM DRAIN EASEMENT AS DESCRIBED IN THE DOCUMENT RECORDED JUNE 13, 2005 AS INSTRUMENT NO. 2005-071723 OF OFFICIAL RECORDS
- E. FANSHEAF (SHEAF) 10' (10) SETBACK FROM CALIFORNIA GAS COMPANY FOR THE PURPOSE OF PUBLIC UTILITIES (SEE INSTRUMENT NO. 1, 1981 AS INSTRUMENT NO. 1981-231, RECORDED)
- F. DECLARATION ESTABLISHING GOVERNMENT, CONDITIONS, RECIPROCAL EASEMENTS AND RESTRICTIONS RECORDED UNDER 102, 0211 AS INSTRUMENT NO. 2011-001077 OF OFFICIAL RECORDS
- G. R1 ZONE 6 PER "EL CENTRO REZONING ANALYSIS" MEMORANDUM, DATED JUNE 16, 2019 BY MICHAEL BAKER (19-0494-1783)
- H. R1 ZONE 6 PER "EL CENTRO REZONING ANALYSIS" MEMORANDUM, DATED JUNE 16, 2019 BY MICHAEL BAKER (19-0494-1783)

TYPICAL STREET SECTIONS

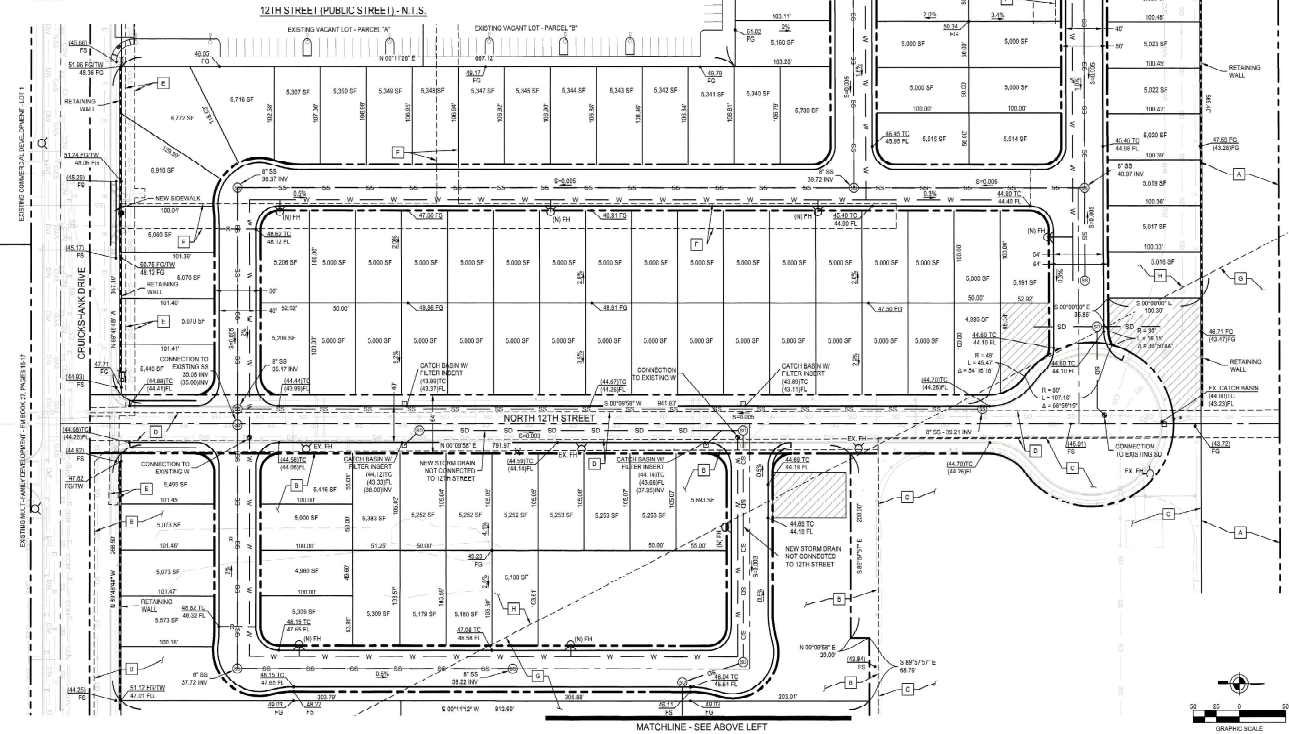
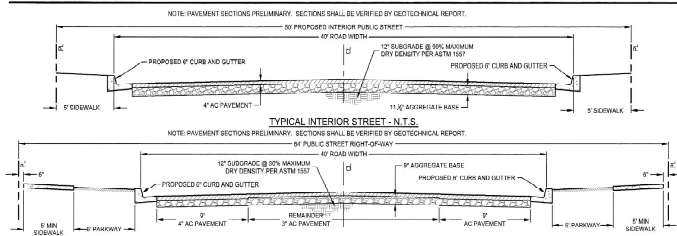

100W CENTER VILLAGE, LLC
 8600 PLAIN DRIVE
 EL MORA, CA 91731

INCLEDON
 CONSULTING ENGINEERS
 1035 GARDNER ROAD, SUITE 100, EL CENTRO, CA 91731
 (760) 865-1111
 WWW.INCLEDON.COM

EL CENTRO TOWN CENTER VILLAGE RESIDENTIAL AND INDUSTRIAL DEVELOPMENT
 EL CENTRO, CA 92243

REV.	DATE	DESCRIPTION

RESIDENTIAL TENTATIVE SUBDIVISION MAP
 SHEET TITLE
 JOB # 158-012
 DATE 5/20/2022
 SHEET # 2

3 PROJECT TRIP GENERATION

3.1 PROPOSED PROJECT

The project proposes to construct 102 single-family dwelling units and 17.26 acres of manufacturing. The project site is currently vacant and undeveloped. Vehicular access to the project site will be provided via 12th Street for the residential portion of the project and 10th Street for the industrial portion.

3.1.1 Project Forecast Trip Generation

In order to calculate the vehicular trips forecast to be generated by the project, the *Institute of Transportation Engineers (ITE) 11th Edition Trip Generation Manual* rates were utilized as summarized in **Table 1**.

TABLE 1 – ITE TRIP GENERATION RATES

Trip Generation Rates¹

Land Use	ITE Code ¹	Daily Trip Rate	AM Peak Hour Rate			PM Peak Hour Rate		
			Total	In : Out		Total	In : Out	
Single-Family Detached Housing	210	$\ln(T)=0.92\ln(X) + 2.68$	$\ln(T)=0.91 \ln(X)+0.12$	26% : 74%		$\ln(T)=0.94 \ln(X) + 0.27$	63% : 37%	
Manufacturing	140	$T = 37.05(X) + 60.72$	$T=4.05(X) + 16.16$	86% : 14%		$T = 3.32(X) + 28.91$	39% : 61%	

¹ Source: ITE Trip Generation Manual, 11th Edition. Rates shown are based on fitted curve equation.

Table 2 summarizes the project trip generation using the rates shown in **Table 1**. As shown, the project is forecast to generate approximately 1,728 daily trips with 162 AM peak hour trips (94 in / 68 out) and 187 PM peak hour trips (98 in / 89 out).

TABLE 2 – PROPOSED PROJECT TRIP GENERATION

Land Use	Intensity	Daily Trips	AM Peak Hour Trips		PM Peak Hour Trips	
			Total	In : Out	Total	In : Out
Single-Family Residential	102 DU	1028	76	20 : 56	101	64 : 37
Manufacturing	17.26 AC	700	86	74 : 12	86	34 : 52
TOTAL		1,728	162	94 : 68	187	98 : 89

DU = Dwelling Unit

AC = Acres

3.1.2 Proposed Project Trip Distribution & Trip Assignment

Project trips were distributed onto the surrounding roadway network based on existing travel patterns using existing traffic count data. **Exhibit 3** shows the forecast trip percent distribution of the proposed project within the study area. As shown, 48% of project traffic is expected to travel to/from the west on Cruickshank Drive and 42% to/from 8th Street. On 10th Street, 10% of traffic is assumed to use this roadway. **Exhibit 4** shows the corresponding forecast assignment of AM and PM peak hour project-generated trips assuming the trip percent distribution.

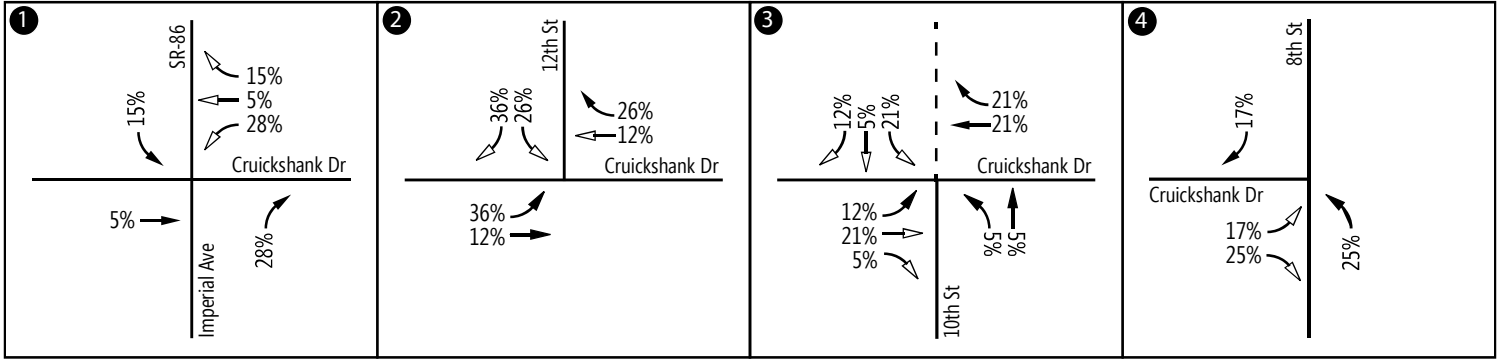

Legend

- ← = Inbound Dist.
- ↔ = Outbound Dist.

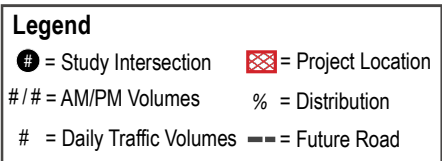
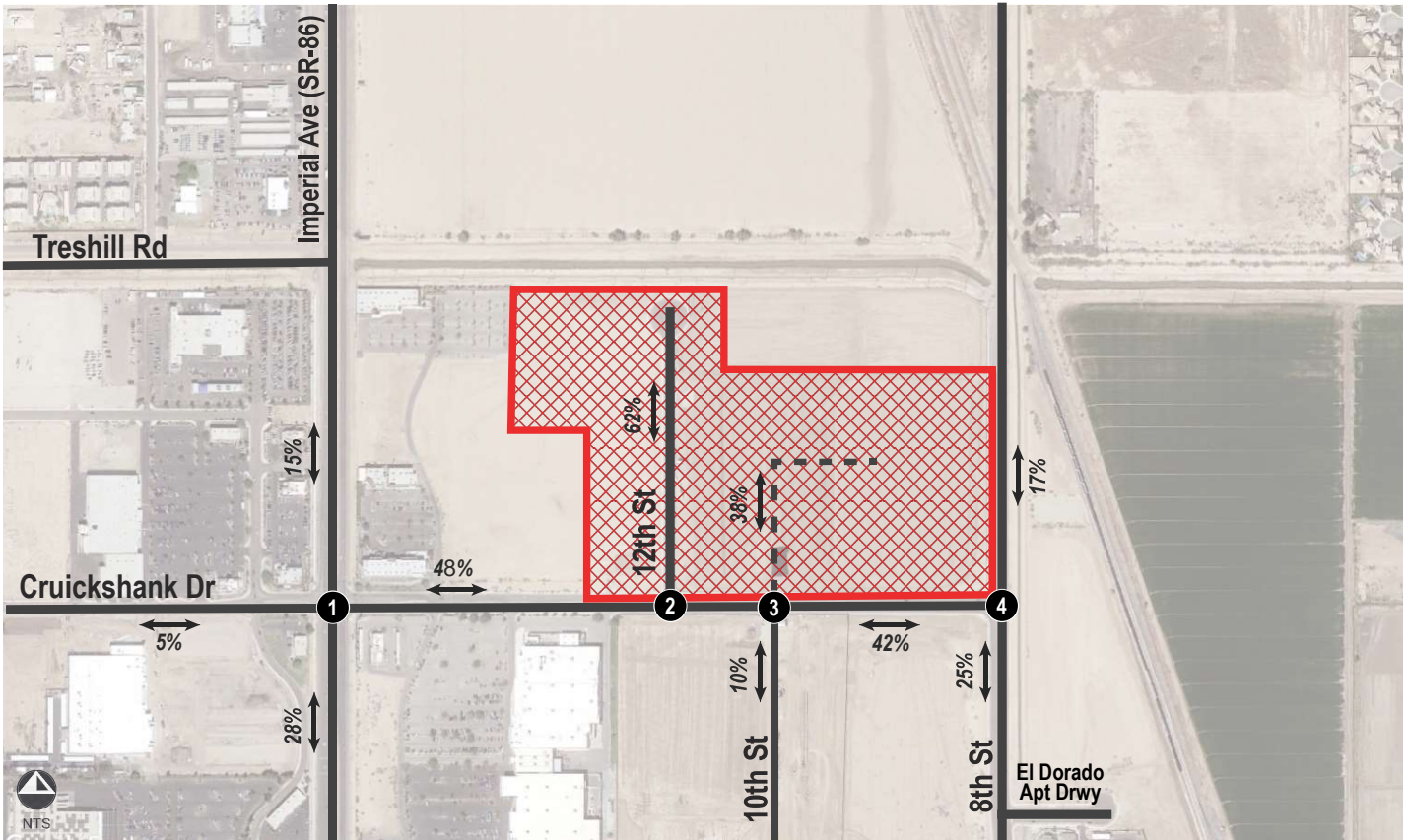

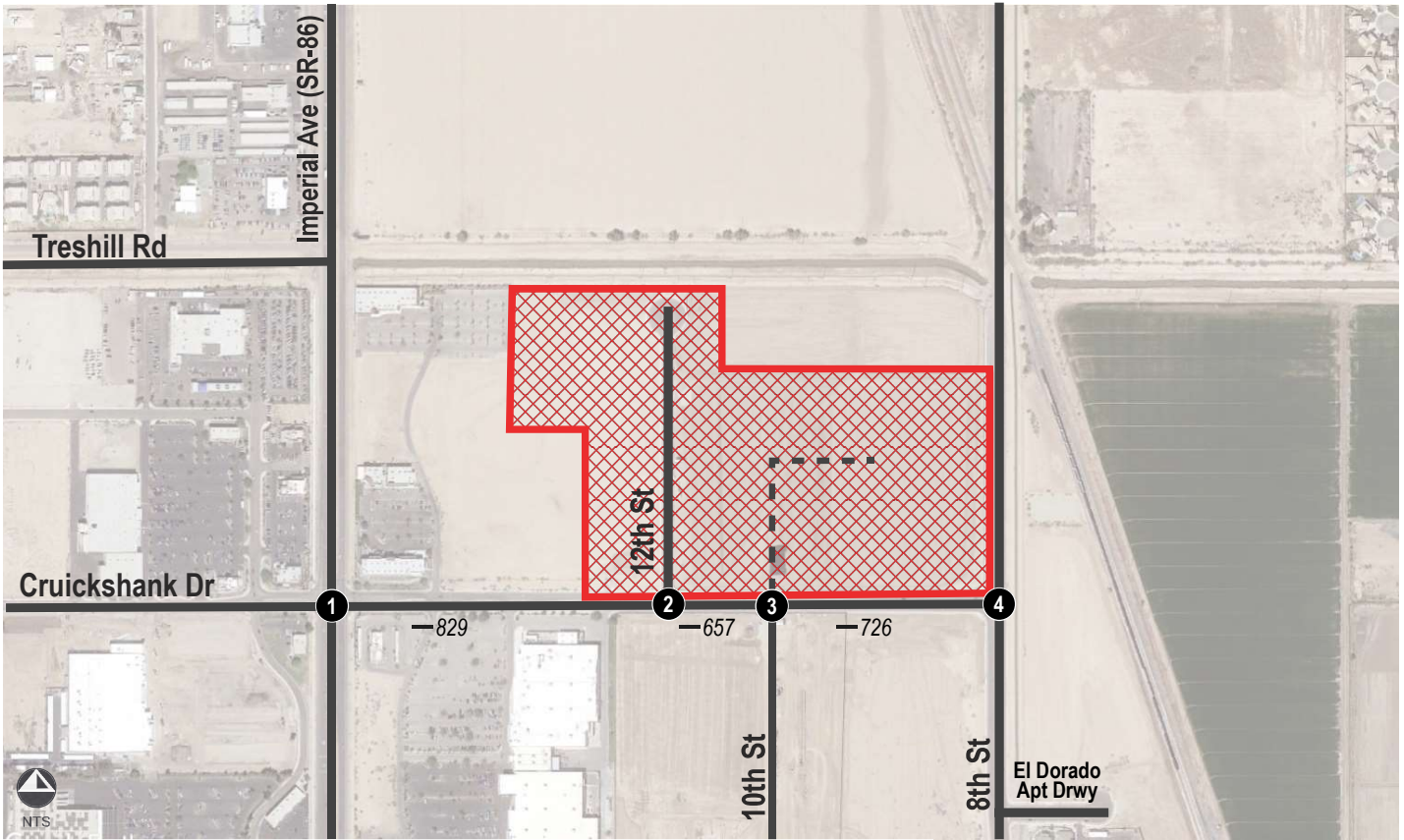
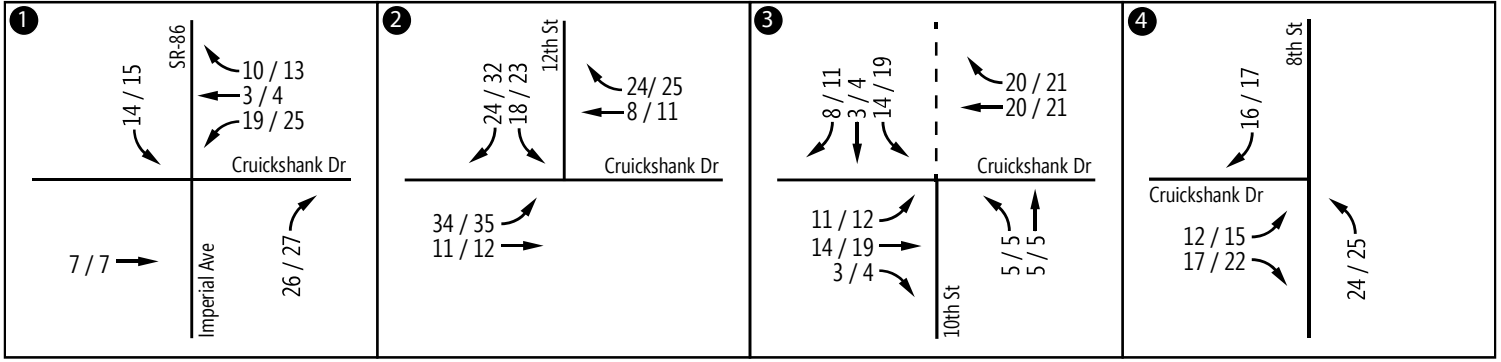

Legend	
● = Study Intersection	▨ = Project Location
#/# = AM/PM Volumes	--- = Future Road
# = Daily Traffic Volumes	

4 STUDY AREA SELECTION & ANALYSIS METHODOLOGY

4.1 LMA ANALYSIS METHODOLOGY

4.1.1 Intersection Analysis Methodology

Level of Service (LOS) is commonly used as a qualitative description of intersection operation and is based on the capacity of the travel lanes approaching the intersection, the volume of traffic using the intersection, and the average vehicle delay. The intersection analysis conforms to the operational analysis methodology outlined in the *Highway Capacity Manual (HCM 6th Edition)* and performed utilizing *Synchro 10* traffic analysis software.

The *HCM* analysis methodology describes the operation of an intersection using a range of level of service from LOS A (free-flow conditions) to LOS F (severely congested conditions), based on the corresponding stopped delay experienced per vehicle for study intersections as shown in **Table 3**.

For signalized intersections, signal timing data and parameters such as cycle lengths, splits, clearance intervals, etc. were obtained from the current signal timing data sheets provided by City staff and incorporated into the Synchro model. Synchro reports average vehicle delay for a signalized intersection, which correspond to a particular LOS, to describe the overall operation of an intersection.

Unsignalized intersection LOS for all-way stops and roundabouts is based on the average vehicle delay for all approaches. Average vehicle delay for one-way or two-way stop-controlled intersections is influenced by available gaps in traffic flow on the non-controlled approaches and LOS is based on the approach with the worst delay. The City of El Centro has adopted level of service "C" or better as the standard for acceptable operating conditions for intersections except for the intersection of Cruickshank Drive and Imperial Avenue where LOS D is considered acceptable operating conditions per Mobility Element Policy 4.4.

TABLE 3 - LEVEL OF SERVICE & DELAY RANGE

Level of Service	Control Delay (seconds/vehicle)		Description
	Signalized Intersections	Unsignalized Intersections	
A	≤ 10.0	≤ 10.0	Operates with very low delay and most vehicles do not stop.
B	> 10.0 to 20.0	> 10.0 to 15.0	Operates with good progression with some restricted movements.
C	> 20.0 to 35.0	>15.1 to 25.0	Operates with significant number of vehicles stopping with some backup and light congestion.
D	> 35.0 to 55.0	> 25.0 to 35.0	Operates with noticeable congestion, longer delays occur, and many vehicles stop.
E	> 55.0 to 80.0	> 35.1 to 50.0	Operates with significant delay, extensive queuing and unfavorable progression.
F	> 80.0	> 50.0	Operates at a level that is unacceptable to most drivers. Arrival rates exceed capacity of the intersection. Extensive queuing occurs.

Source: Highway Capacity Manual (HCM) 6th Edition.

4.1.1 Roadway Segment Analysis Methodology

The basis for roadway segment analysis is the relationship between the measured daily traffic volume and the Level of Service (LOS) capacity thresholds established according to roadway classifications. The analysis results provide a planning-level assessment of whether a segment is under, approaching, or over the planning level capacity threshold. The City of El Centro has adopted level of service “C” or better as the standard for acceptable operating conditions for roadway segments. **Table 4** presents the roadway segment capacity thresholds by LOS contained in Table ME.3 from the City’s TSG.

TABLE 4 – EL CENTRO ROADWAY SEGMENT DAILY CAPACITY & LOS STANDARDS

Roadway Functional Classification	Level of Service Capacity (ADT)				
	LOS A	LOS B	LOS C	LOS D	LOS E
6-Lane Arterial	32,000	38,000	43,000	49,000	54,000
4-Lane Arterial	22,000	25,000	29,000	32,300	36,000
2-Lane Arterial	11,000	12,500	14,500	16,000	18,000
2-Lane Collector	6,000	7,500	9,000	10,500	12,000

4.1.2 Thresholds of Improvements

The City of El Centro has adopted level of service “C” or better as the standard for acceptable operating conditions for intersections and roadway segments. According to the City’s TSG, the following thresholds are used to determine a project’s substantial traffic effect on vehicular intersections:

Roadway Segment:

- Proposed project causes roadway capacity to degrade to LOS D or below. The proposed project shall build a roadway segment to its ultimate mobility element classification if not currently constructed as such.

Signalized Intersection:

- Proposed project adds traffic to an intersection that currently operates or is projected to operate at LOS D or below.
- Proposed project causes an intersection’s operations to degrade to LOS D or below.
- Proposed project traffic either contributes to or is responsible for the 95th percentile queue length to exceed the available storage length.

Side-Street Stop Control:

- Proposed project contributes to a critical movement of an intersection that currently operates or is projected to operate at LOS D or below.

4.1.3 Caltrans Facilities

Within the study area, Imperial Avenue (SR-86) is a Caltrans facility. The signalized intersection of Cruickshank Drive & Imperial Avenue (SR-86) is operated by Caltrans. Caltrans endeavors to maintain a target LOS at the transition between LOS C and LOS D on State Highway System (SHS) facilities, however, Caltrans acknowledges that this may not always be feasible and recommends that lead agency consult with Caltrans to determine appropriate target LOS. For purposes of this analysis, LOS C is considered the standard for acceptable operating conditions for the intersection of Cruickshank Drive & Imperial Avenue (SR-86).

4.2 STUDY AREA

According to the City's TSG, projects that generate 801 or more daily unadjusted driveway trips are required to analyze the following facilities:

- Roadway segments fronting the project and between the analyzed intersections.
- Project driveways and all intersections where two (2) mobility element roadways intersect, and the project adds 50 or more peak hour trips.
- Bicycle, pedestrian, and transit facilities at the project frontage.

Based on the study area criteria listed above and the Project Information Form (PIF) process confirmed by City staff, the study evaluates the following four (4) intersections during the AM/PM peak hours within the study area:

1. Cruickshank Drive / Imperial Avenue (SR-86)
2. Cruickshank Drive / 12th Street
3. Cruickshank Drive / 10th Street
4. Cruickshank Drive / 8th Street

The study also evaluates the following three (3) roadway segments for average daily (24-hour) traffic volumes:

- A. Cruickshank Drive – between Imperial Avenue (SR-86) and 12th Street
- B. Cruickshank Drive – between 12th Street and 10th Street
- C. Cruickshank Drive – between 10th Street and 8th Street

Exhibit 5 shows the study locations.

The following study scenarios will be evaluated as part of this LMA:

- Existing Conditions
- Opening Year 2024 Without Project Conditions
- Opening Year 2024 Plus Project Conditions

Michael Baker coordinated with City staff on the study assumptions and completed the PIF process which identified the project's trip generation, trip distribution and assignment, study locations and scenarios, and study methodology which can be found in **Appendix A**.

4.3 DATA COLLECTION

New traffic counts were collected at the study locations along Cruickshank Drive on Wednesday, September 21, 2022 while schools were in session. Pedestrian and bicycle counts were also collected at the study intersections during the AM and PM peak periods. Traffic count data is provided in **Appendix B**.

When counts were collected in September 21, 2022, La Brucherie between Cruickshank Drive and Aten Road were closed for construction and traffic was detoured to Imperial Avenue. As such, the City requested new traffic counts be collected at the intersection of Cruickshank Drive & Imperial Avenue. New counts were collected on February 1, 2023 and used in this analysis.

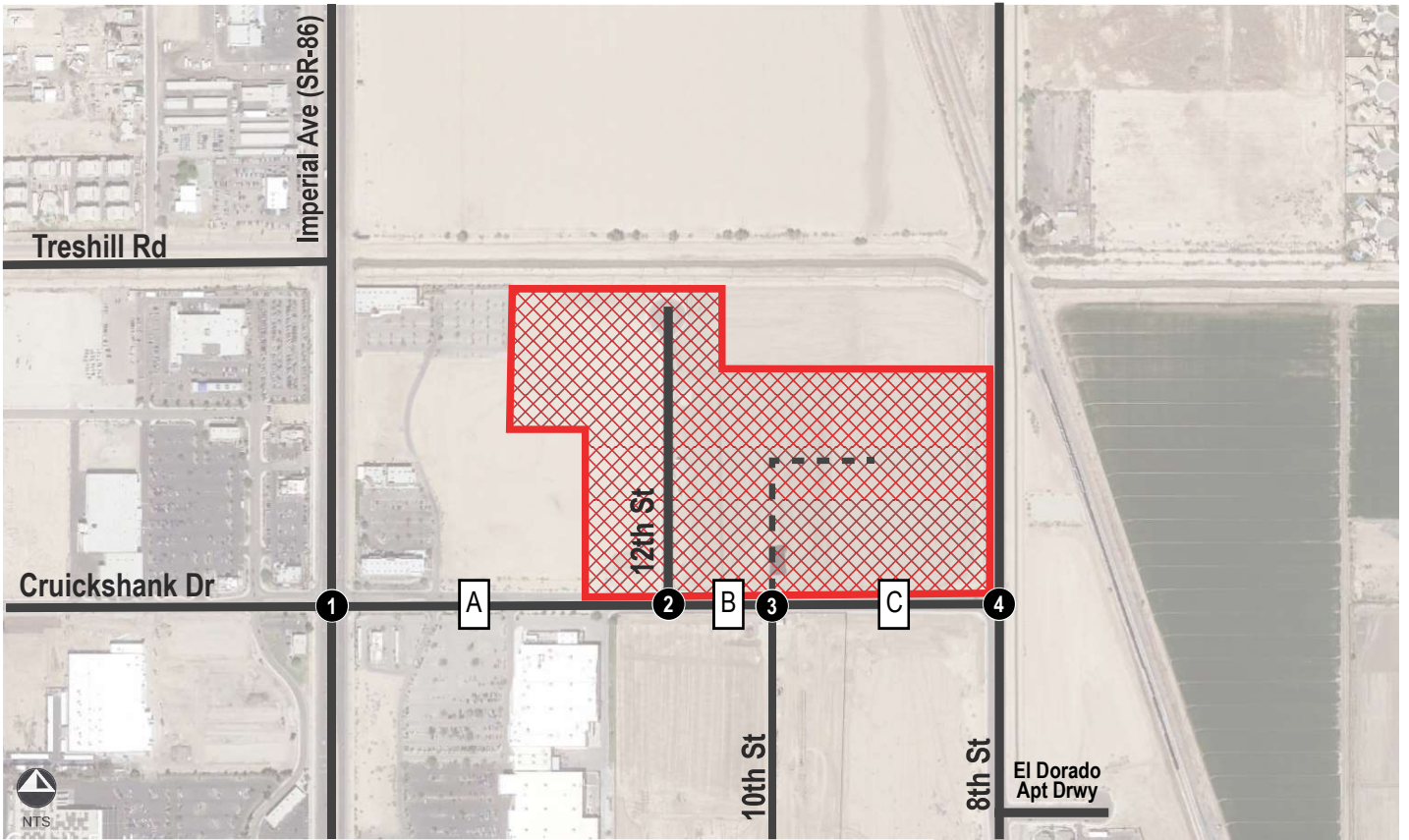

Legend

- = Study Intersection
- ▣ = Study Segments
- ▨ = Project Location

5 CEQA VMT ANALYSIS

In December 2018 new CEQA guidelines were approved that shift traffic analysis from delay and operations to VMT when evaluating Transportation Impacts under CEQA. This change in methodology is a result of SB743, which was signed into law in September 2013. SB743 “creates a process to change the way that transportation impacts are analyzed under CEQA. Specifically, SB743 requires OPR to amend the CEQA Guidelines to provide an alternative to LOS for evaluating transportation impacts. Particularly within areas served by transit, those alternative criteria must ‘promote the reduction of greenhouse gas emissions, the development of multimodal transportation networks, and a diversity of land uses.’¹ ²

As part of the development of the new CEQA guidelines, OPR prepared a Technical Advisory. The final version of the Technical Advisory is dated December 2018 and provides guidance for local jurisdictions in developing methodologies and thresholds for evaluating VMT. The City of El Centro developed their own screening criteria for CEQA VMT analysis and VMT thresholds to determine if the project’s VMT is considered significant which can be found in the City’s recently updated TSG dated June 2022.

5.1 VMT SCREENING CRITERIA

The City’s TSG includes screening criteria for all land development projects. A project that meets at least one of the screening criteria would have a less-than-significant VMT impact due to project characteristics and/or location. Each of the screening criteria have been reviewed to determine if the proposed project meets the screening criteria, see **Table 5**.

TABLE 5 - VMT SCREENING CRITERIA EVALUATION

ID	VMT Screening Criteria	Description	Screening Evaluation	Criteria Met? (Yes / No)
1	Small Residential and Employment Projects	Projects that generate less than 110 daily trips.	The project generates 1,728 daily trips which exceeds the 110 daily trip threshold.	No
2	Projects Located in a VMT-Efficient Area	Projects that are located within a VMT efficient area (15% or more below the base year average VMT/Capita or VMT/Employee) based on the applicable location-based screening map produced by the City of El Centro found in Appendix C of the TSG.	On the VMT per Capita map, the project is located within the 50% to 85% of Regional Mean area identified in green. Refer to Exhibit 6 . On the VMT per Employee map, the project is located within the 50% to 85% of Regional Mean area identified in green. Refer to Exhibit 7 .	YES
3	Locally Serving Retail Projects	Local serving retail projects less than 50,000 square feet and that would serve the local community.	The project is considered a local serving retail project.	No

¹ Public Resources Code Section 21099(b)(1)

² Office of Planning and Research, <http://www.opr.ca.gov/ceqa/updates/sb-743/>

ID	VMT Screening Criteria	Description	Screening Evaluation	Criteria Met? (Yes / No)
4	Local Serving Public Facilities and Community Purpose Facilities	Public facilities that serve the surrounding community or public facilities that are passive uses such as transit centers, public schools, libraries, post offices, police and fire facilities, parks and trailheads, government offices, passive public uses, including communication and utility buildings, water sanitation, and waste management, and other public uses as determined by the City.	The project is not considered a public facility.	No
5	Redevelopment Projects with Greater VMT Efficiency	Redevelopment project that replaces existing uses and results in a net decrease in VMT.	The project is not a redevelopment project since the site is vacant and undeveloped.	No
6	Affordable Housing	Any portion of the project that is composed of deed-restricted affordable housing units.	The project is not constructing any affordable units.	No

The project meets one of the six VMT screening criteria. Since at least one of the VMT screening criteria is satisfied, a detailed VMT analysis is not required, and the proposed project is presumed to have a less-than-significant transportation impact.

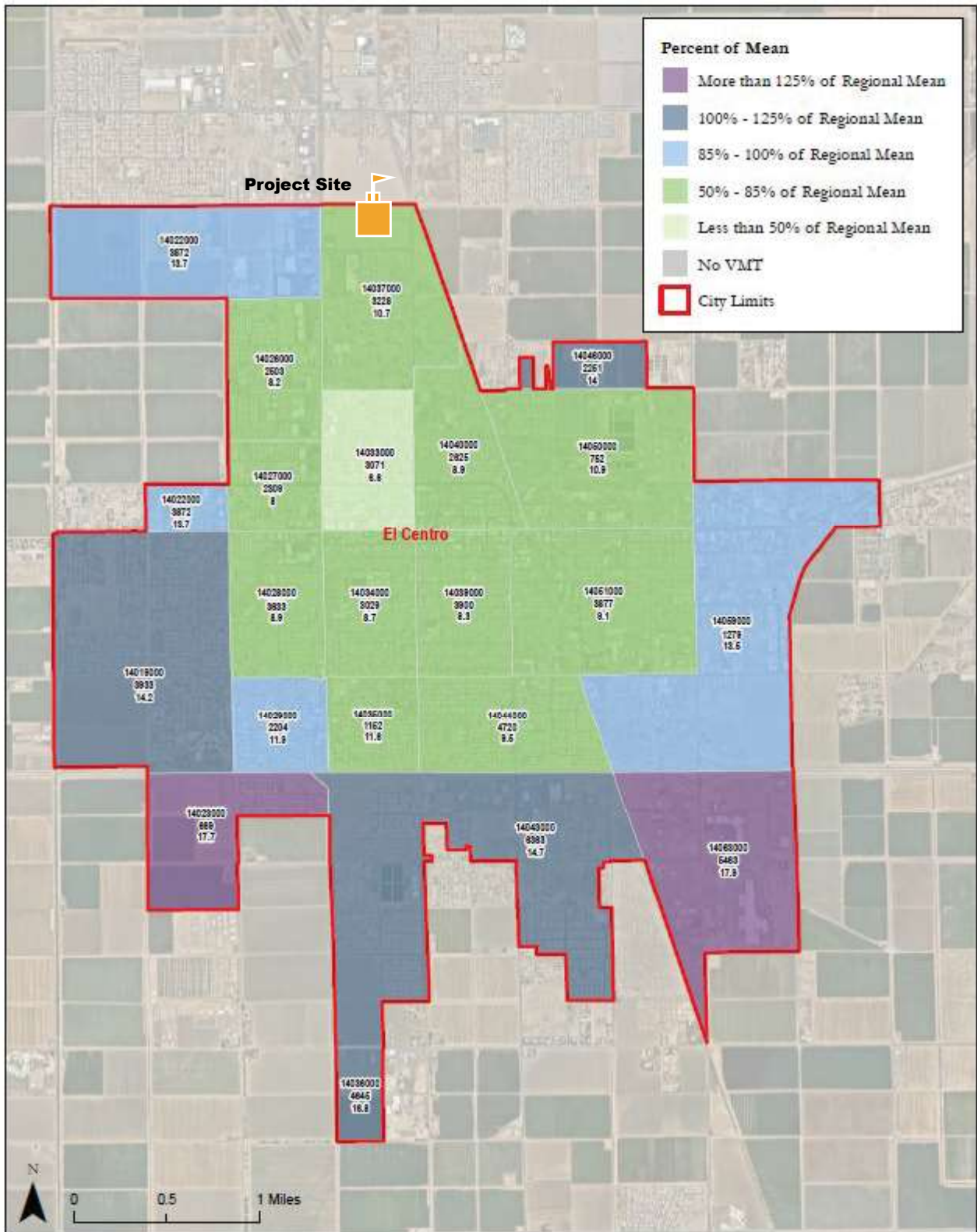

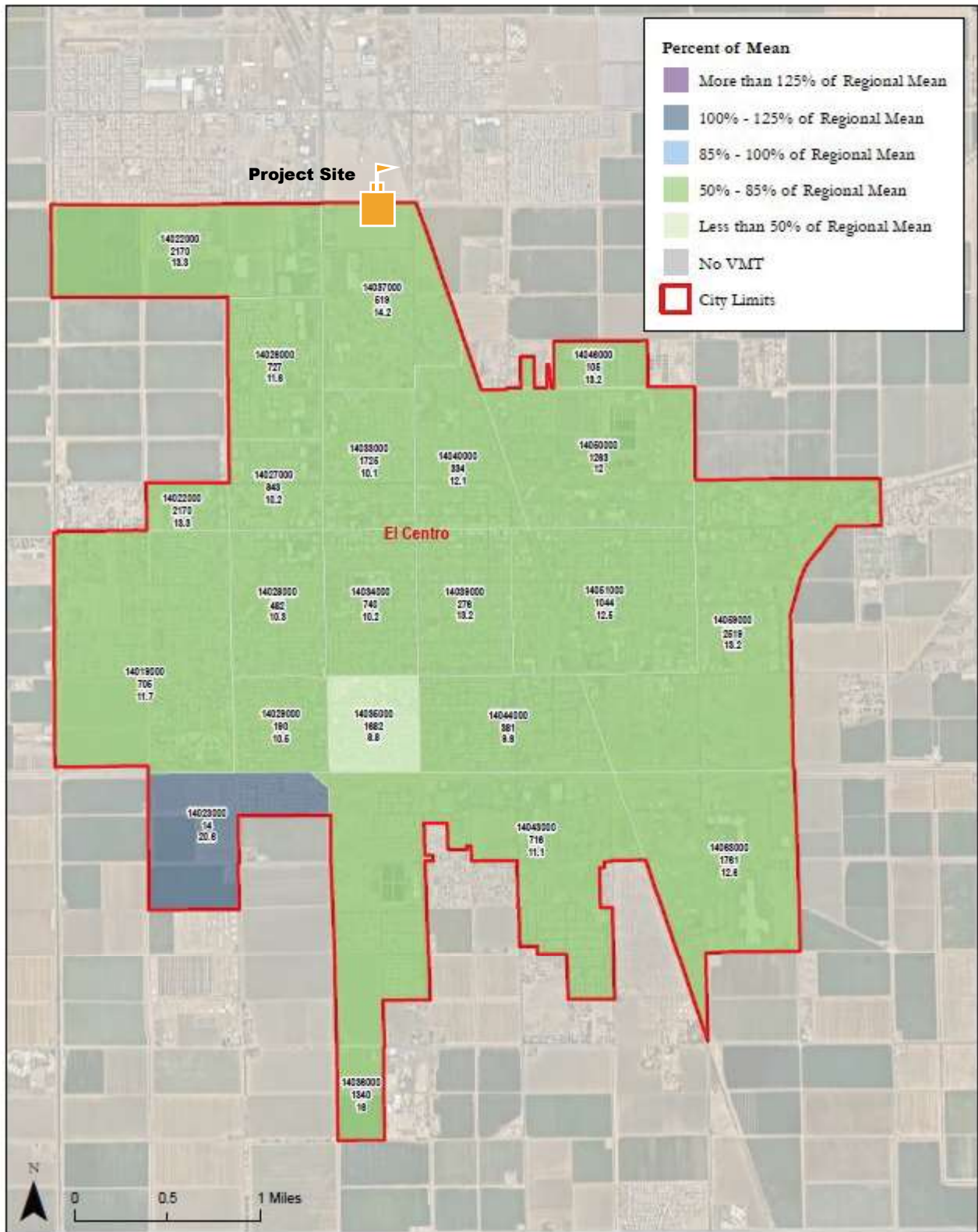

6 EXISTING CONDITIONS

6.1 SURROUNDING ROADWAY NETWORK

The characteristics of the roadway system in the vicinity of the project site are described below:

Imperial Avenue (SR-86) is oriented in the north-south direction and is currently constructed as a 4-lane Arterial. The ultimate classification is a 6-lane Arterial Lanes per the City of El Centro General Plan Circulation Element. Raised medians are provided for the length of the corridor with dedicated left turn lanes at signalized intersections. Within the study area, the posted speed limit is 55 miles per hour (MPH) in the northbound direction and 45 MPH southbound. On-street parking is prohibited in both directions within the study area. There are no bike lanes or sidewalks provided within the study area.

Cruickshank Drive is oriented in the east-west direction and is classified as a 4-lane Arterial east and west of Imperial Avenue per the City of El Centro General Plan Circulation Element. On-street parking is prohibited in both directions within the study area. Class II bike lanes and sidewalks are provided on both sides of the roadway.

8th Street is oriented in the north-south direction and is currently constructed as a 4-lane Arterial north and south of Cruickshank Drive. Two-way left turn-lanes are provided north and south of Cruickshank Drive. Within the study area, the posted speed limit is 40 MPH. On-street parking is prohibited in both directions within the study area. Class II bike lanes are provided north of El Dorado and sidewalks are provided on both sides of the roadway.

10th Street is oriented in a north-south direction and is currently constructed as a 2-lane Collector between Cruickshank Drive and Bradshaw Avenue. The posted speed limit is 25 MPH. On-street parallel parking is permitted along both sides of the road. Class II bike lanes are not provided along this road. Sidewalks are provided on both sides of the road. 10th Street north of Cruickshank Drive will provide direct access to the industrial portion of the project.

12th Street is oriented in a north-south direction and is currently constructed as a 2-lane Collector north of Cruickshank Drive and terminates approximately 1,000 feet north of the intersection. On-street parking is permitted and sidewalks are provided on both sides of the road. This roadway will provide direct access to the residential portion of the project.

Exhibit 8 shows the *City of El Centro General Plan Mobility Element Planned Roadway Network*.

Figure ME-4 Planned Roadway Network Classifications

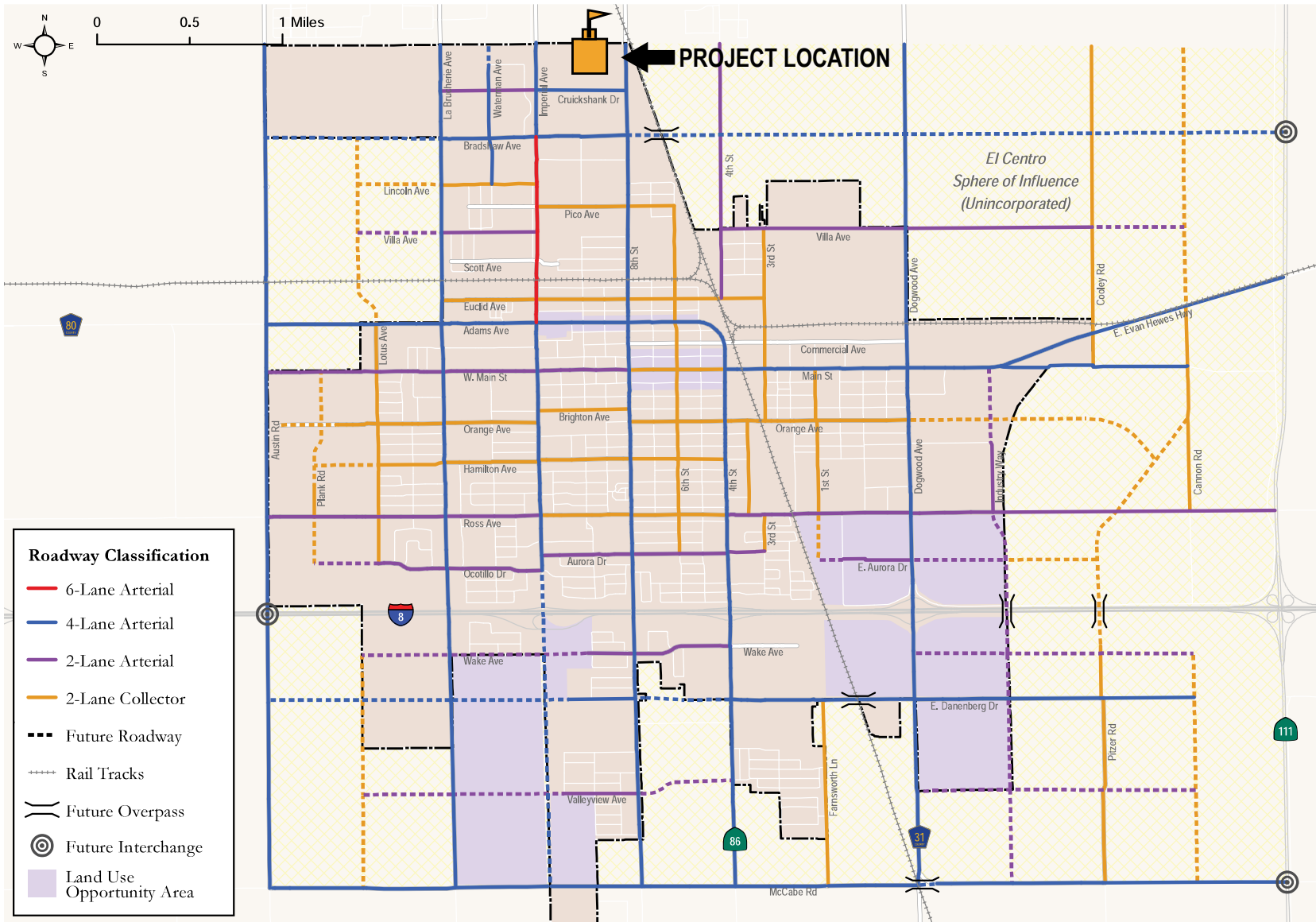

6.2 EXISTING CONDITIONS TRAFFIC ANALYSIS

6.2.1 Existing Intersection Evaluation

Exhibit 9 shows the existing lane geometry at the study intersections.

Exhibit 10 shows the existing daily and AM/PM peak hour traffic volumes at the study intersections.

Table 6 summarizes existing conditions AM/PM peak hour level of service for all study intersections. For unsignalized intersections, the worst minor approach delay is reported if the minor leg is a public street or project driveway. The City of El Centro has adopted level of service “C” (LOS C) or better as the threshold of acceptable operating conditions for intersections. Generally, level of service D, E or F is considered to operate below the acceptable standard. However, Mobility Element Policy 4.4 states the following:

“Although VMT will be utilized as the new traffic impact metric for California Environmental Quality Act (CEQA) review process, Level of Service (LOS) is still a critical measure and indicator of traffic operations. Level of Service (LOS) C shall be the threshold for all Mobility Element roadways and intersections, except that Level of Service (LOS) D would be acceptable upon review and approval by the City Engineer after consideration of impacts to the public and lack of feasibility of attaining Level of Service (LOS) C due to right-of-way constraints. With the additional exception of Imperial Avenue between Ocotillo Drive and I-8 westbound ramps, where LOS E would be acceptable due to right of-way constraints, unless otherwise approved by the City Engineer.”

For the intersection of Cruickshank Drive & Imperial Avenue, the City has accepted LOS D as acceptable operating conditions at this location since widening the intersection to improve operations to LOS C would be infeasible due to right-of-way constraints.

Detailed HCM analysis worksheets are contained in **Appendix C**.

TABLE 6 – EXISTING CONDITIONS AM/PM PEAK HOUR INTERSECTION LOS

Study Intersection	Traffic Control	Existing Conditions	
		AM	PM
		Delay ¹ - LOS	Delay ¹ - LOS
1 - Imperial Avenue (SR-86) / Cruickshank Drive	Signal	37.3 - D	50.2 - D
2 - Cruickshank Drive / 12th Street	OWSC	0.0 - A	0.0 - A
3 - Cruickshank Drive / 10th Street	OWSC	10.0 - A	11.4 - B
4 - Cruickshank Drive / 8th Street	Signal	13.2 - B	18.9 - B

Note: Deficient intersection operation indicated in **bold**.

¹ Average seconds of delay per vehicle.

LOS = level of service.

OWSC = Once Way Stop Control

As shown, the delay reported at Cruickshank Drive & 12th Street is 0.0 since no traffic is currently turning left or right onto 12th Street.

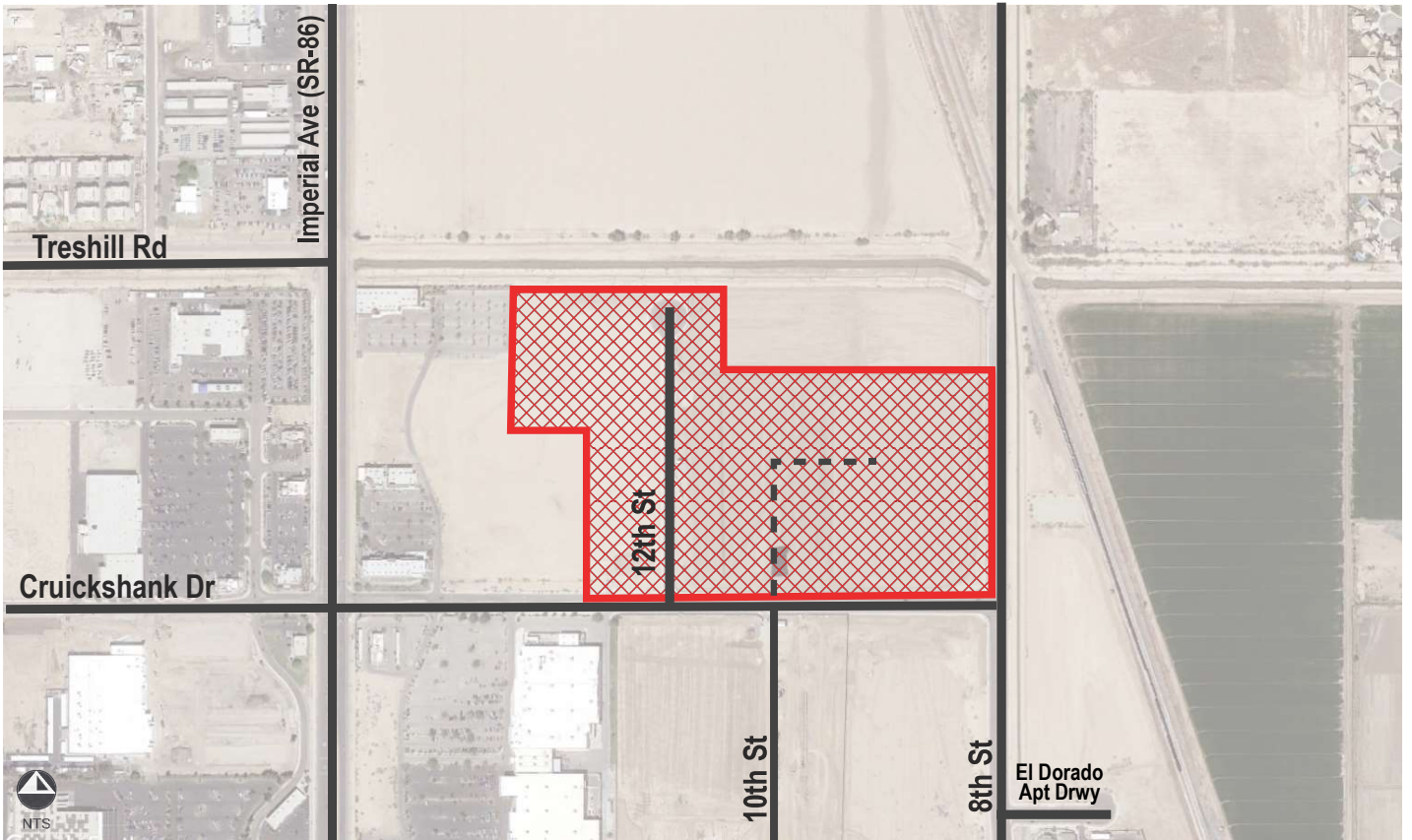
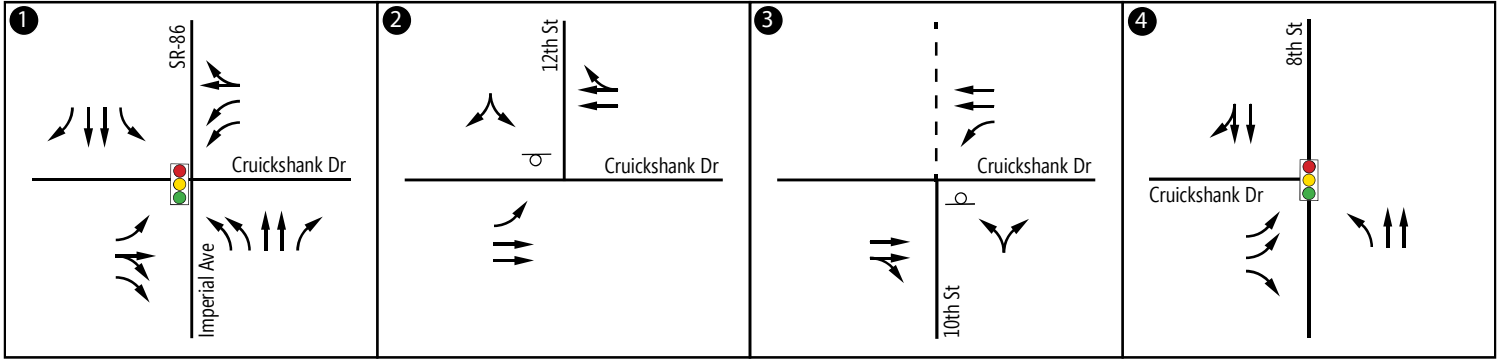

Legend			
#	= Study Intersection		= Signal
	= Project Location		= Stop Controlled
			= Future Road

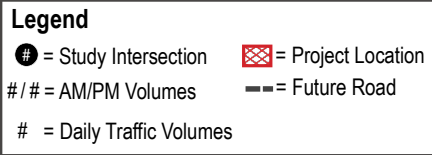
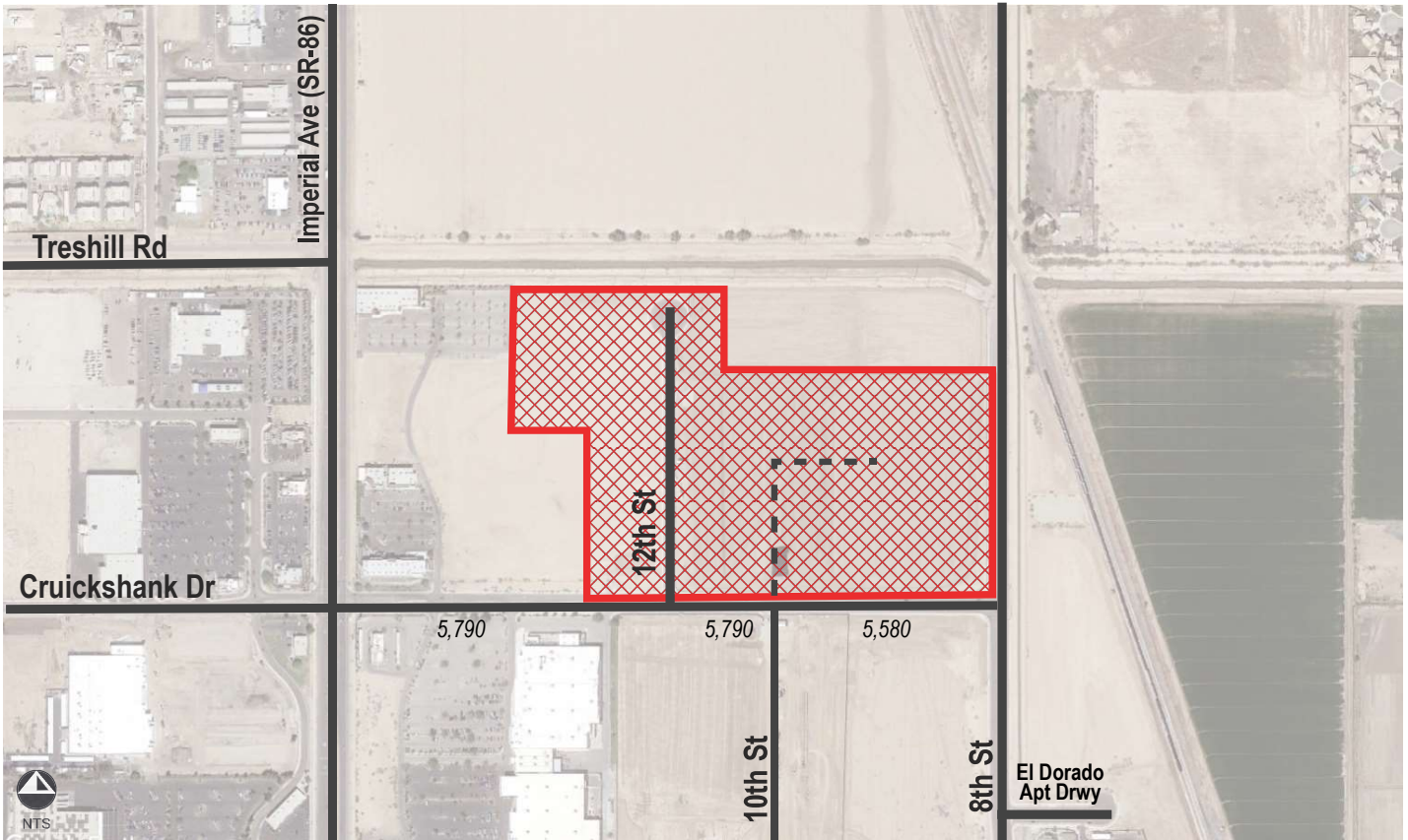
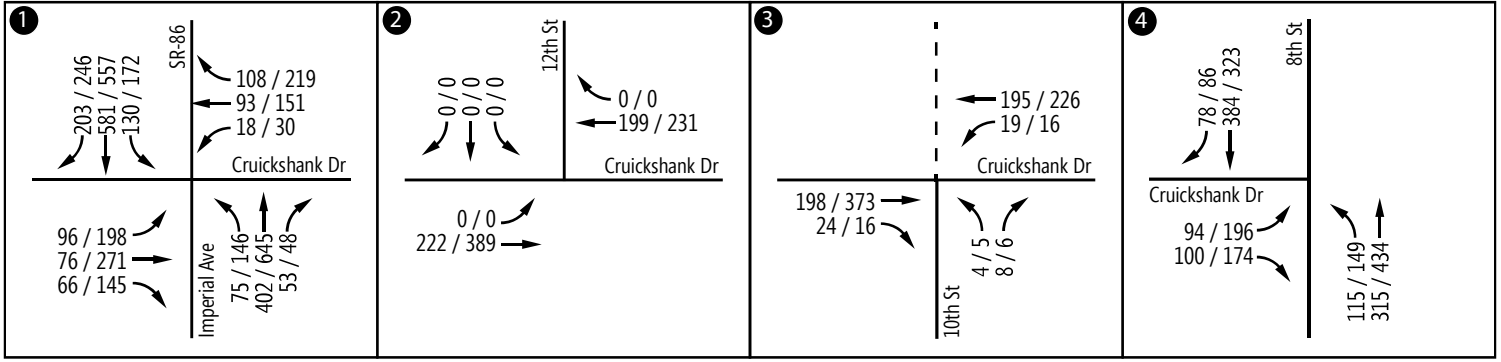

6.2.2 Existing Roadway Segment Evaluation

Operating conditions and LOS for roadway segments are calculated based on the capacity of the roadway determined by the existing functional classification and a comparison to existing daily traffic volumes.

Table 7 summarizes existing conditions average daily traffic level of service for all study roadway segments based on the capacity threshold shown in Table 4. As shown, all study roadway segments are currently operating LOS C or better.

TABLE 7 – EXISTING CONDITIONS ROADWAY SEGMENT LOS

Roadway	Segment	Classification	LOS C Capacity	Existing Condition		
				ADT	V/C	LOS
Cruickshank Drive	Imperial Avenue to 12 th Street	4-Lane Arterial	29,000	5,790	0.19	A
	12 th Street to 10 th Street	4-Lane Arterial	29,000	5,790	0.19	A
	10 th Street to 8 th Street	4-Lane Arterial	29,000	5,580	0.19	A

Note: Deficient roadway segment operations shown in **bold**

ADT= Average Daily Traffic

LOS= Level of Service

V/C= Volume to Capacity Ratio

6.3 ACTIVE TRANSPORTATION

6.3.1 Pedestrian Facilities

6.3.1.1 Sidewalks

Imperial Avenue (SR-86) – Within the study area, there are no sidewalks provided on either side of Imperial Avenue.

Cruickshank Drive – Sidewalks are provided on both sides of Cruickshank Drive between Imperial Avenue (SR-86) and 8th Street.

8th Street – Sidewalks are provided on both sides of 8th Street north and south of Cruickshank Drive. North of Cruickshank Drive, sidewalks are only provided on the west side of 8th Street.

10th Street – Sidewalks are provided on both sides of 10th Street between Cruickshank Drive and Bradshaw Avenue.

12th Street – Sidewalks are provided on both sides of 12th Street north of Cruickshank Drive.

Exhibit 11 shows the sidewalks that are provided within the study area.

6.3.1.2 Crosswalks

Standard marked crosswalks are provided at the intersection of Imperial Avenue (SR-86) and Cruickshank Drive on the south, east and west legs of the intersection. At the intersection of 8th Street/Cruickshank Drive, crosswalks are provided on the south and west legs of the intersection. At 12th Street/Cruickshank Drive, the north leg provides a crosswalk for pedestrians.

6.3.1.3 ADA Facilities

All of the signalized intersections within the study area have controlled crossings; however, these crossings are only partially ADA compliant. The pedestrian ramps on Imperial Avenue (SR-86) are lacking truncated domes.

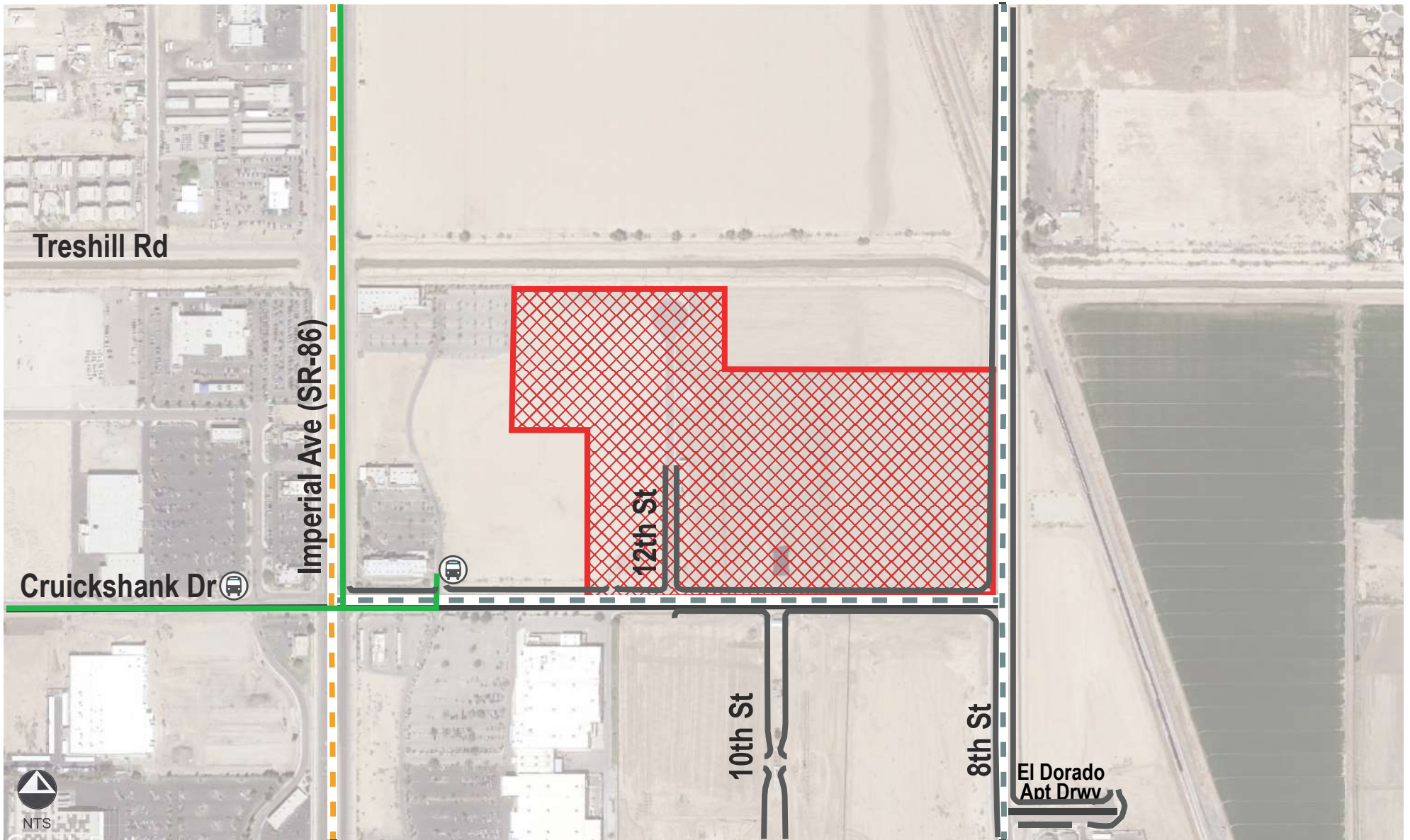

Legend

- ⊙ = Bus Stop
- = IVT Green Line
- = Bike Lane
- = Bike Route
- = Sidewalk
- = Project Location

Existing Pedestrian, Bicycle, and Transit Facilities

6.3.2 Existing Bicycle Facilities

Exhibit 11 shows the existing bicycle facilities within the project study area. As shown, there are currently Class II bicycle lanes provided along the project’s frontage on Cruickshank Drive. As described below, there are three basic types of bikeways, known under state standards as Class I, II, and III bike facilities.

Trail or Path – Class I Bikeway is a facility totally separated from the roadway with dedicated space for bikes, where cars are prohibited. They are often multi-use facilities for bicyclists and pedestrians, 8-12 feet wide. There are no Class I facilities in the study area.

Bike Lane – Class II Bikeway is an on-street facility with dedicated space for bicyclists, usually near the right side of the street. Bike lanes are provided within the paved roadway, approximately 4-5 feet wide, and designated by striping and signage.

Bike Route – Class III Bikeway is an on-street facility that shares space with cars and may be designated with a “sharrow” bicycle marking. On Class III facilities, bicycle usage is secondary to vehicles.

Within the study area, Class II bike lanes are provided on Cruickshank Drive and 8th Street. According to the City of El Centro *Bicycle Master Plan* (October 2010) Imperial Avenue (SR-86) is classified as a Class III Bicycle Route within the study area; however, there are no signs or markings posted on the roadway stating such.

6.3.3 Existing Transit Facilities

Imperial Valley Transit (IVT) operates the local bus service within the City of El Centro and provides access to employment centers, shopping centers, hospitals, the library, government offices, as well as Imperial Valley College.

The El Centro Green Line travels along Cruickshank Drive as shown in **Exhibit 11** which allows transfer at the transit station located at State Street & 7th Street. This transit station also serves the city-wide Blue Line as well as other regional IVT bus routes connection Imperial, Brawley, Calexico and the rest of Imperial Valley. As shown in **Exhibit 11**, the closest bus stop to the project site is located on Cruickshank Drive approximately 500’ east of Imperial Avenue (SR-86).

Due to COVID-19, reduced services were implemented in March 2020, until further notice. According to the IVT Riders Guide, the Green Line follows the Saturday schedule on weekdays providing service between 7:38 AM and 5:03 PM.

7 OPENING YEAR 2024 WITHOUT PROJECT CONDITIONS

7.1 OPENING YEAR 2024 WITHOUT PROJECT ANALYSIS

This scenario evaluates study intersections and roadway segments under the Opening Year 2024 Without Project conditions which represents existing plus cumulative (pending or approved projects) traffic. This analysis assumes the project will be constructed and occupied by Year 2024.

7.1.1 Cumulative Traffic

Based on coordination with City staff, seven cumulative projects were determined to add sufficient traffic to the study area for inclusion within the analysis. The following ten (10) cumulative projects are anticipated to add traffic to the study area as noted below.

- 1.) **Burger King** is located at 2170 North Waterman Avenue. The project consists of a 2,080 square foot fast-food restaurant which is expected to generate approximately 982 daily vehicle trips with 106 AM and 107 PM peak hour trips.
- 2.) **Waterfly Express Car Wash** is located at 2180 North Waterman Avenue. The project would construct a 5,320 square foot wash building with a 150-foot tunnel. This project is expected to generate approximately 119 daily vehicle trips with 78 AM and 41 PM peak hour trips.
- 3.) **Jacaranda Gardens Apartments** is located on the northeast corner of Lincoln Avenue and Waterman Avenue. The project consists of 306 multi-family dwelling units which is expected to generate approximately 1,281 daily vehicle trips with 82 AM and 124 PM peak hour trips.
- 4.) **El Centro Public Library** is a new 20,000 square foot public library to be constructed at 1198 North Imperial Avenue. The library is expected to generate approximately 1,402 daily vehicle trips with 130 AM and 170 PM peak hour trips.
- 5.) **El Dorado Apartments II & III** is located at 1805 North 8th Street. For Phase 2 and 3, the project plans to construct 112 multi-family dwelling units which is expected to generate approximately 557 daily vehicle trips with 12 AM and 17 PM peak hour trips.
- 6.) **Town Center Village Apartments III** is located at 2102 North 8th Street. Phase 3 is constructing 180 multi-family dwelling units which is expected to generate approximately 1,320 daily vehicle trips with 83 AM and 100 PM peak hour trips.
- 7.) **Fronzie Apartments** is located on the southeast corner of Cross Road and Fonzie Avenue. The project would construct 64 multi-family dwelling units which is expected to generate approximately 486 daily vehicle trips with 51 AM and 62 PM peak hour trips.
- 8.) **Imperial Group Medical Building** is located near the northeast corner of Marshall Avenue and Aten Road. The project would consist of a 22,000 square foot medical office building which is expected to generate approximately 864 daily vehicle trips with 66 AM and 62 PM peak hour trips.

9.) **Tucker Commercial Building** is located at 463 West Aten Road. The project would consist of a 10,000 square foot retail building which is expected to generate approximately 166 daily vehicle trips with 28 AM and 26 PM peak hour trips.

10.) **Commercial Development** located at 329 West Aten Road. The project would construct a 16,538 retail building which is expected to generate approximately 926 daily vehicle trips with 125 AM and 218 PM peak hour trips.

Exhibit 12 shows the location of each cumulative project. **Table 8** provides a trip generation summary of the cumulative project traffic.

TABLE 8 – CUMULATIVE PROJECTS TRIP GENERATION SUMMARY

ID	Cumulative Project	Intensity	Daily Trips	AM Peak Hour Trips		PM Peak Hour Trips	
				Total	In : Out	Total	In : Out
1	Burger King	2.08 KSF	982	106	55 : 51	107	55 : 52
2	Waterfly Express Car Wash	1 Tunnel	119	78	39 : 39	41	19 : 22
3	Jacaranda Gardens Apartments	306 DU	1,281	82	21 : 61	124	72 : 52
4	El Centro Public Library	20.0 KSF	1,402	130	64 : 66	170	99 : 82
5	El Dorado Apartments II & III	112 DU	793	58	14 : 44	69	43 : 26
6	Town Center Village Apartments III	180 DU	1,320	83	19 : 64	100	63 : 37
7	Fronzie Apartments	64 DU	486	51	12 : 39	62	38 : 24
8	Imperial Group Medical Building	22.0 KSF	864	66	40 : 26	62	29 : 33
9	Tucker Commercial Building	10.0 KSF	166	28	15 : 13	26	11 : 15
10	Commercial Development	16.5 KSF	926	125	63 : 62	218	118 : 100
Total Cumulative Project Traffic			8,339	807	342 : 465	980	547 : 443

Notes:

DU = Dwelling Unit

KSF = Thousand Square Feet

AC = Acres

Exhibit 13 shows the cumulative project only daily and AM/PM peak hour traffic volumes assigned to the study intersections and roadway segments.

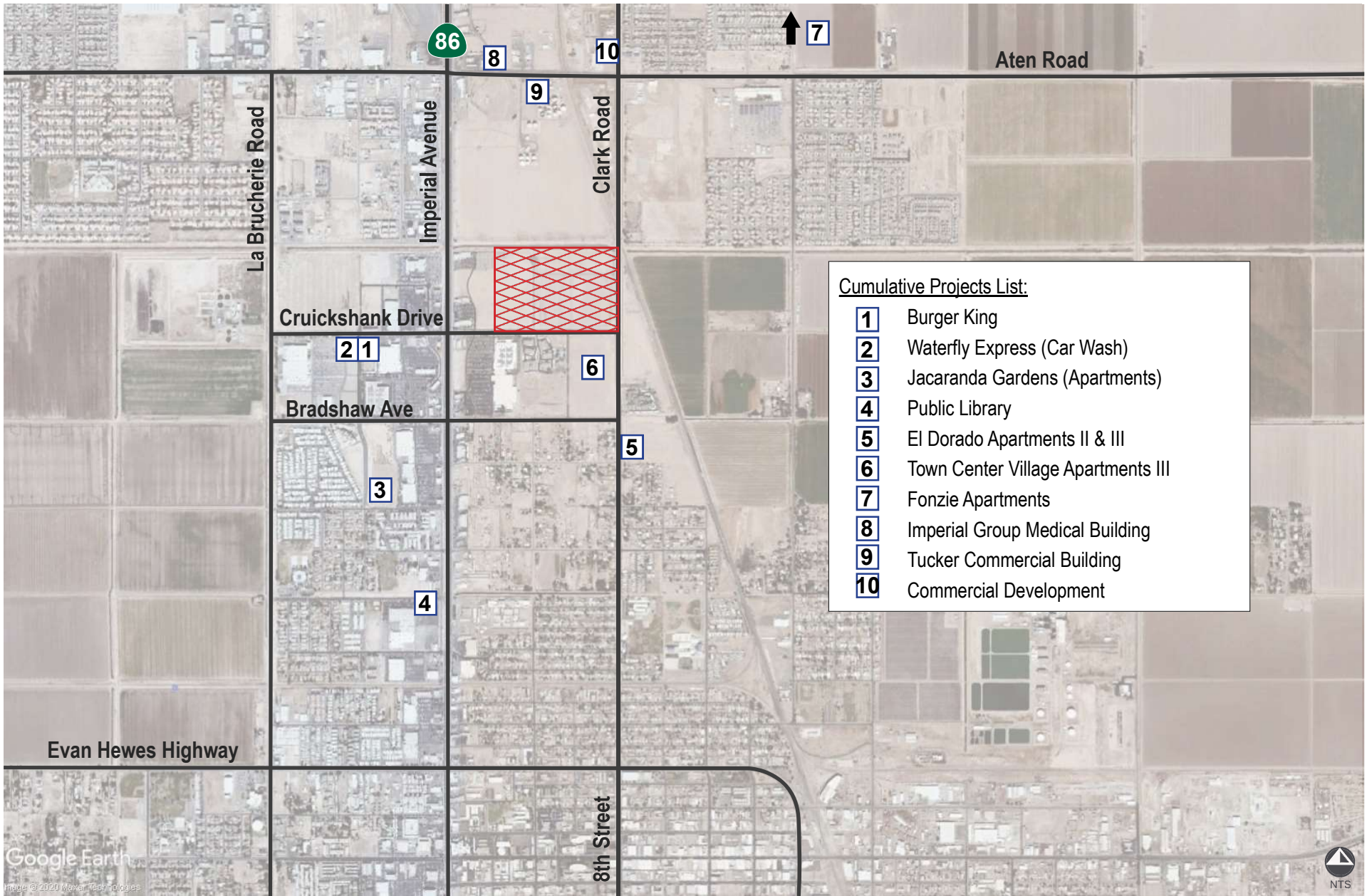

- Cumulative Projects List:**
- 1** Burger King
 - 2** Waterfly Express (Car Wash)
 - 3** Jacaranda Gardens (Apartments)
 - 4** Public Library
 - 5** El Dorado Apartments II & III
 - 6** Town Center Village Apartments III
 - 7** Fonzie Apartments
 - 8** Imperial Group Medical Building
 - 9** Tucker Commercial Building
 - 10** Commercial Development

Legend
 = Project Site

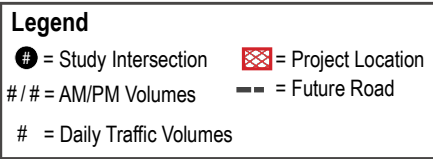
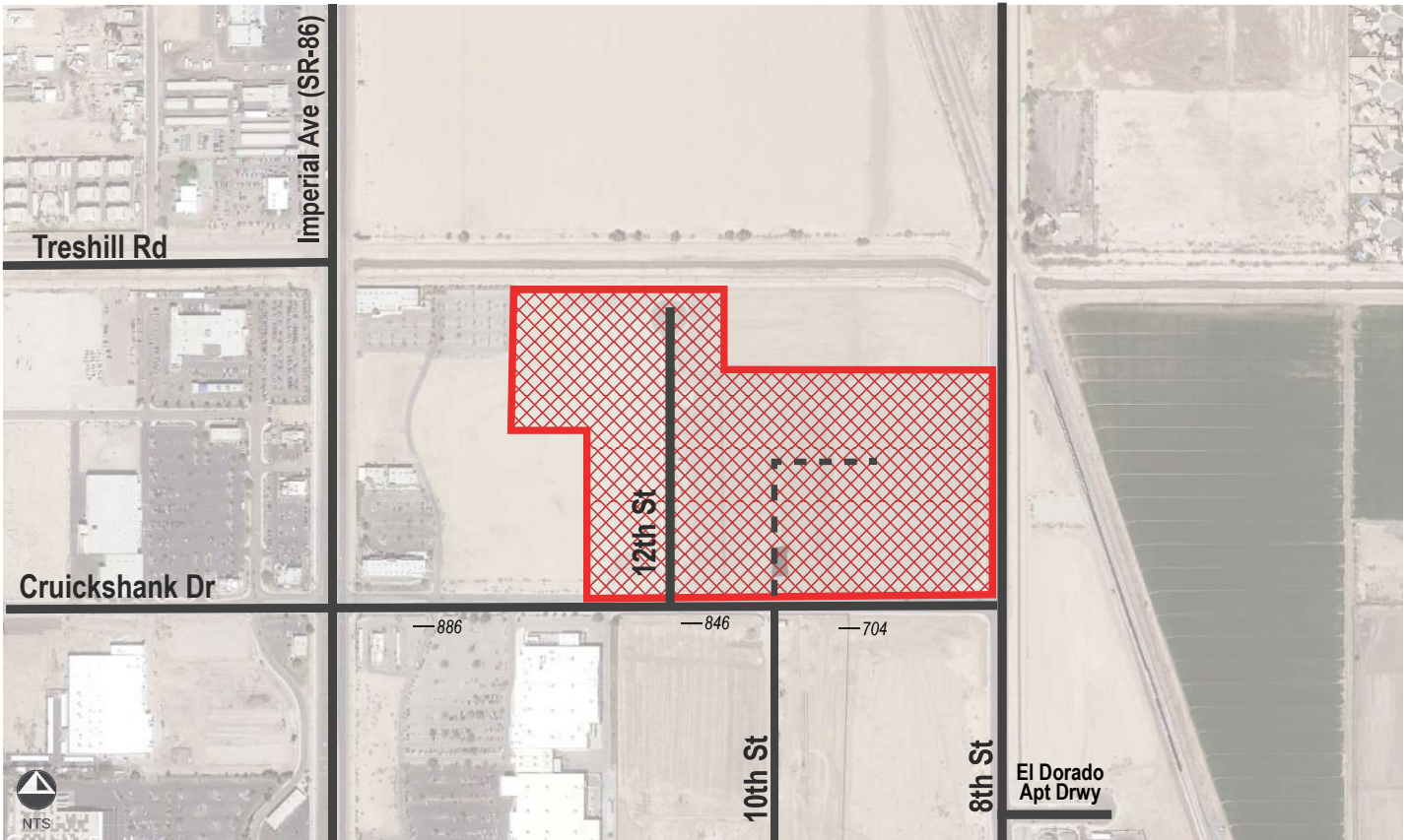
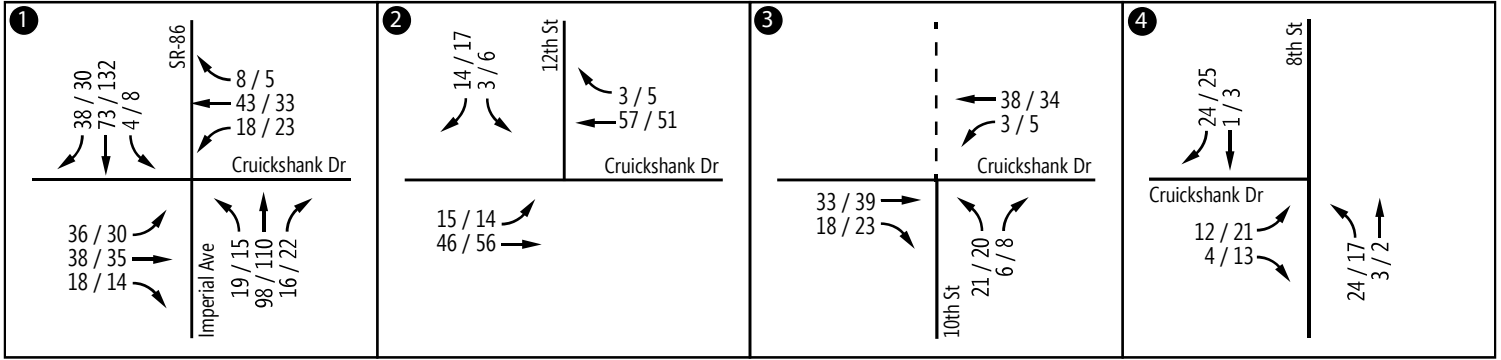

Cumulative Project Only Daily and AM/PM Peak Hour Traffic Volumes

7.1.2 Opening Year 2024 Without Project Intersection Evaluation

The Opening Year 2024 Without Project scenario accounts for the addition of cumulative traffic volumes onto the existing traffic volumes. **Exhibit 14** shows the Opening Year 2024 Without Project daily and AM/PM peak hour volumes within the study area.

Table 9 summarizes Opening Year 2024 Without Project AM/PM peak hour level of service for all study intersections. For unsignalized intersections, the minor street approach delay and level of service is reported. Detailed HCM analysis worksheets are contained in **Appendix D**.

TABLE 9 – OPENING YEAR 2024 WITHOUT PROJECT AM/PM PEAK HOUR INTERSECTION LOS

Study Intersection	Traffic Control	Opening Year 2024 Without Project Conditions			
		AM		PM	
		Delay ¹	LOS	Delay ¹	LOS
1 - Imperial Avenue (SR-86) / Cruickshank Drive	Signal	34.7	C	51.3	D
2 - Cruickshank Drive / 12th Street	OWSC	9.7	A	10.4	B
3 - Cruickshank Drive / 10th Street	TWSC	12.0	B	13.9	B
4 - Cruickshank Drive / 8th Street	Signal	16.1	B	23.5	C

¹ Average seconds of delay per vehicle.

TWSC = Two-Way Stop Control

LOS = level of service.

OWSC = One-Way Stop Control

As shown, all study intersections are forecast to operate LOS C or better during the AM/PM peak hours except for the intersection of Imperial Avenue (SR-86) / Cruickshank Drive which operates at LOS D in the PM Peak Hour.

Mobility Element Policy 4.4 states the following:

“Although VMT will be utilized as the new traffic impact metric for California Environmental Quality Act (CEQA) review process, Level of Service (LOS) is still a critical measure and indicator of traffic operations. Level of Service (LOS) C shall be the threshold for all Mobility Element roadways and intersections, except that Level of Service (LOS) D would be acceptable upon review and approval by the City Engineer after consideration of impacts to the public and lack of feasibility of attaining Level of Service (LOS) C due to right-of-way constraints. With the additional exception of Imperial Avenue between Ocotillo Drive and I-8 westbound ramps, where LOS E would be acceptable due to right of-way constraints, unless otherwise approved by the City Engineer.”

For the intersection of Cruickshank Drive & Imperial Avenue, the City has accepted LOS D as acceptable operating conditions at this location since widening the intersection to improve operations to LOS C would be infeasible due to right-of-way constraints.

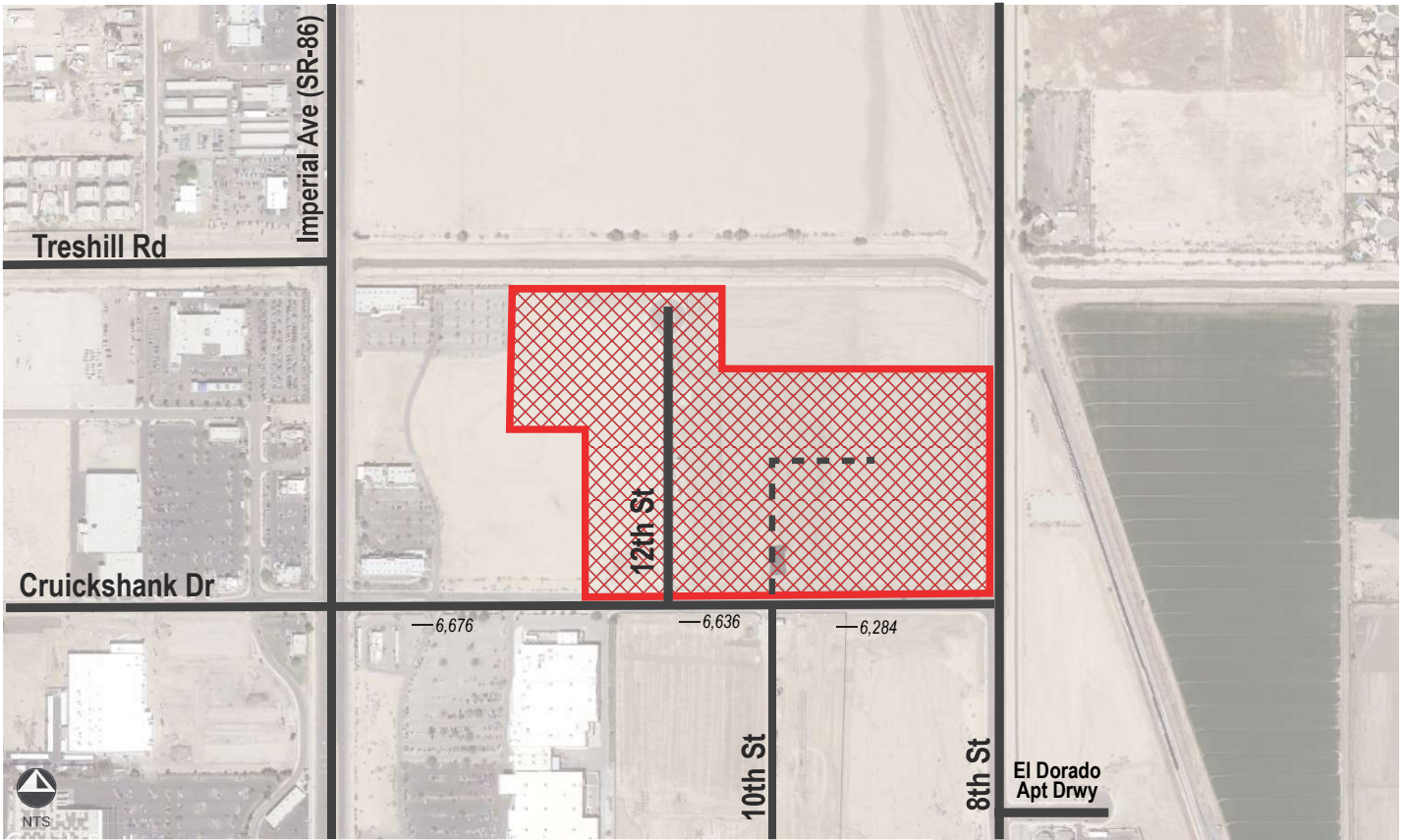
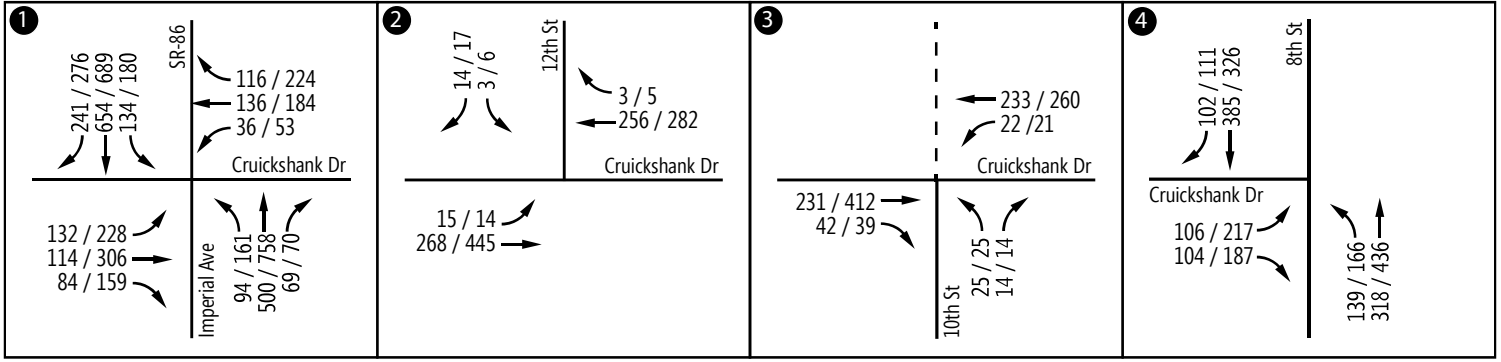

Legend

- = Study Intersection
- ▨ = Project Location
- # / # = AM/PM Volumes
- = Future Road
- # = Daily Traffic Volumes

**Opening Year 2024 Without Project
Daily and AM/PM Peak Hour Traffic Volumes**

7.1.3 Opening Year 2024 Without Project Roadway Segment Evaluation

Table 10 summarizes Opening Year 2024 Without Project conditions average daily traffic level of service for all study roadway segments based on the ADT threshold table. As shown, all study roadway segments are currently operating at LOS C or better under Opening Year 2024 Without Project conditions.

TABLE 10 – OPENING YEAR 2024 WITHOUT PROJECT CONDITIONS ROADWAY SEGMENT LOS

Roadway	Segment	Classification	LOS C Capacity	Opening Year 2024 Without Project		
				ADT	V/C	LOS
Cruickshank Drive	Imperial Avenue to 12 th Street	4-Lane Arterial	29,000	6,676	0.23	A
	12 th Street to 10 th Street	4-Lane Arterial	29,000	6,636	0.23	A
	10th Street to 8th Street	4-Lane Arterial	29,000	6,284	0.22	A

ADT= Average Daily Traffic

LOS= Level of Service

V/C= Volume to Capacity Ratio

8 OPENING YEAR 2024 PLUS PROJECT CONDITIONS

Opening Year 2024 Plus Project traffic volumes were derived by adding trips forecast to be generated by the project to Opening Year 2024 Without Project traffic volumes. **Exhibit 15** shows the Opening Year 2024 Plus Project daily and AM/PM peak hour volumes within the study area.

8.1 OPENING YEAR 2024 PLUS PROJECT INTERSECTION EVALUATION

Table 11 compares Opening Year 2024 Without Project intersection operations to Opening Year 2024 Plus Project intersection operations for all study intersections. Detailed HCM analysis worksheets are contained in **Appendix E**.

TABLE 11 – OPENING YEAR 2024 PLUS PROJECT AM/PM PEAK HOUR INTERSECTION LOS

Study Intersection	Opening Year 2024 Without Project		Opening Year 2024 Plus Project		Improv. Warranted?	
	AM	PM	AM	PM	AM	PM
	Delay ¹ - LOS	Delay ¹ - LOS	Delay ¹ - LOS	Delay ¹ - LOS		
1 Cruickshank Drive & Imperial Avenue (SR-86)	34.7 - C	51.3 - D	36.6 - D	52.0 - D	No	No
2 Cruickshank Drive & 12th Street	9.7 - A	10.4 - B	11.1 - B	12.3 - B	No	No
3 Cruickshank Drive & 10th Street	12.0 - B	13.9 - B	14.5 - B	18.0 - C	No	No
4 Cruickshank Drive & 8th Street	16.1 - B	23.5 - C	23.3 - C	32.7 - C	No	No

¹ Seconds of delay per vehicle.

LOS = level of service.

For the intersection of Cruickshank Drive & Imperial Avenue, the City has accepted LOS D as acceptable operating conditions in accordance with Mobility Element Policy 4.4 since widening the intersection to improve operations to LOS C would be infeasible due to right-of-way constraints. Therefore, improvements to this location are not necessary.

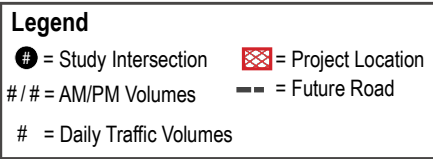
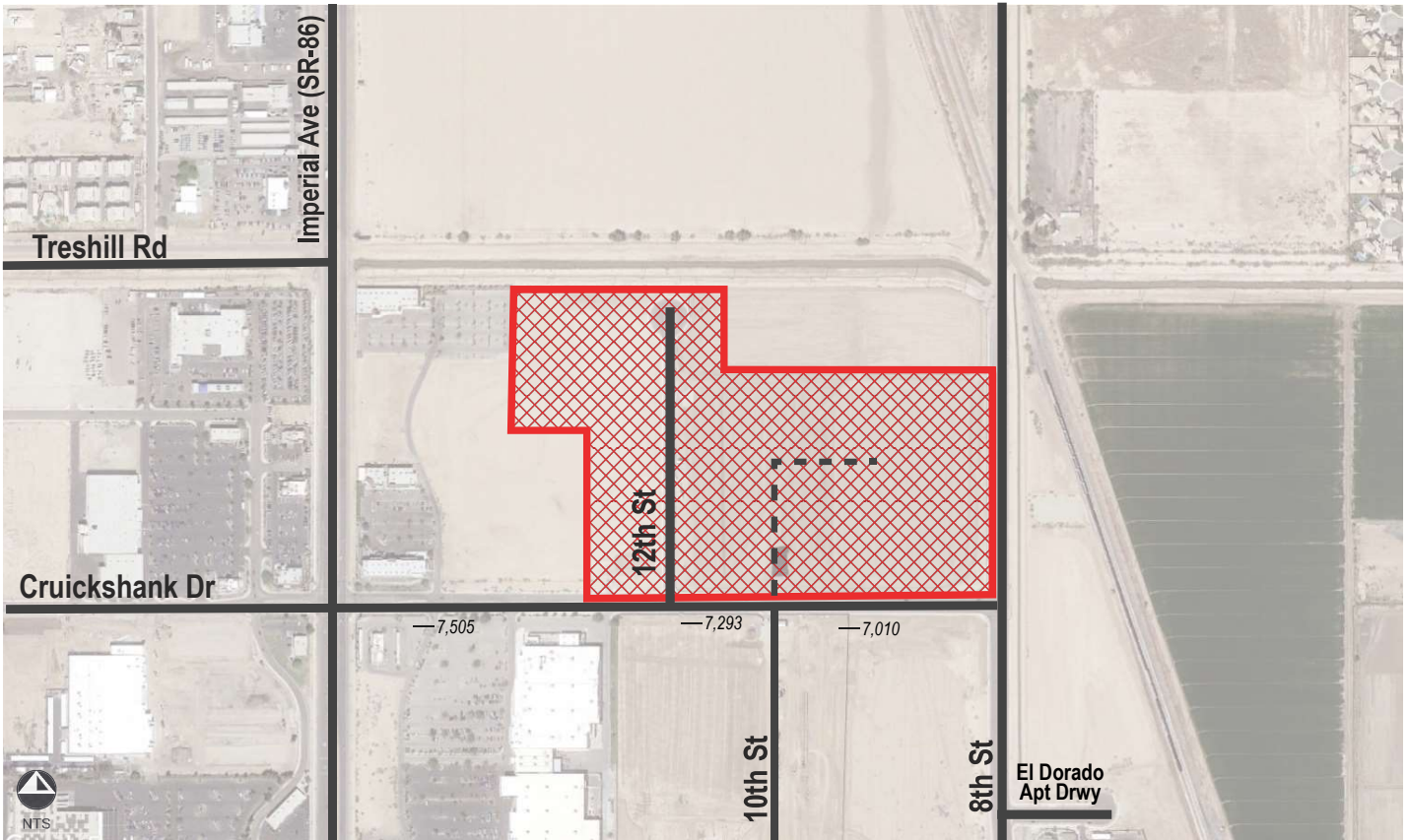
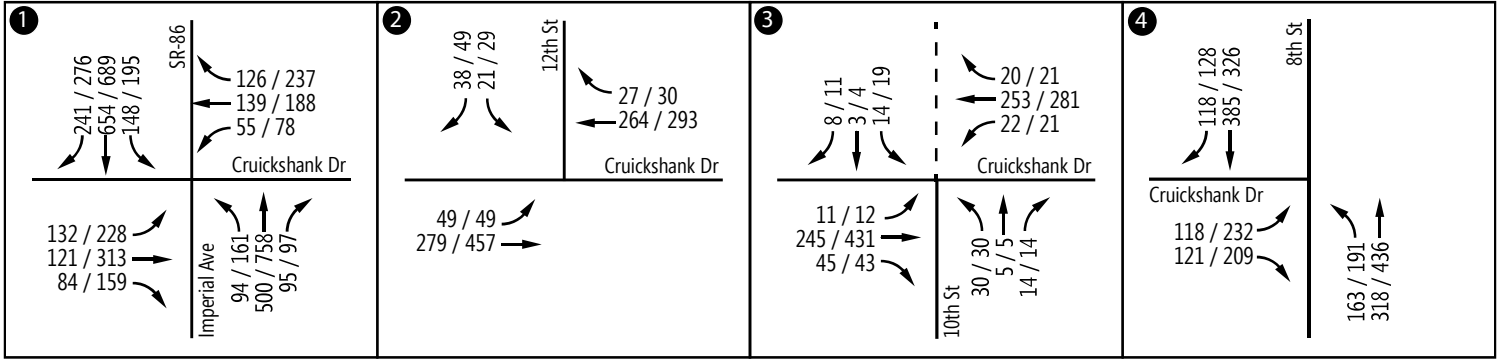

Opening Year 2024 Plus Project Daily and AM/PM Peak Hour Traffic Volumes

8.1.1 Opening Year 2024 Plus Project Roadway Segment Evaluation

Table 12 provides a comparison of Opening Year 2024 Without Project and Opening Year 2024 Plus Project conditions average daily traffic LOS for all study roadway segments based on the V/C ratio.

TABLE 12 – OPENING YEAR 2024 WITHOUT PROJECT & OPENING YEAR 2024 PLUS PROJECT ROADWAY SEGMENT LOS COMPARISON

Roadway	Segment	Classification	LOS C Capacity	Opening Year 2024 Without Project			Opening Year 2024 Plus Project			Improv. Warranted?
				ADT	V/C	LOS	ADT	V/C	LOS	
Cruickshank Drive	Imperial Ave. to 12 th St.	4-Ln Arterial	29,000	6,676	0.23	A	7,505	0.26	A	No
	12 th St. to 10 th St.	4-Ln Arterial	29,000	6,636	0.23	A	7,293	0.26	A	No
	10 th St. to 8 th St.	4-Ln Arterial	29,000	6,284	0.22	A	7,010	0.24	A	No

Note: Deficient roadway segment operations shown in **bold**.

LOS= Level of Service

V/C= Volume to Capacity Ratio

According to the City’s improvements standards, an improvement would be warranted on a roadway segment if the project causes roadway capacity to degrade to LOS D or below. As shown in **Table 12**, project related traffic does not degrade the roadway segment to LOS D or below. Therefore, improvements are not warranted at any of the study roadway segments under Opening Year 2024 Plus Project conditions.

8.2 QUEUING ANALYSIS

In accordance with the City's TSG, a queuing analysis was conducted for the two signalized intersections that are part of the study area which include Cruickshank Drive & Imperial Avenue (SR-86) and Cruickshank Drive & 8th Street. Only turn movements where project traffic would be added were evaluated in this queuing analysis under the Opening Year 2024 Plus Project condition. 95th percentile queue lengths at the study intersections are provided in **Table 13** using the Synchro analysis software program. The 95th percentile queue length value indicates that during the peak hour, a queue of this length or less would occur on 95 percent of the signal cycles. As shown in the Table 13, the 95th percentile queue for the studied turn movements does not exceed the available storage. Therefore, adequate storage is expected under the Opening Year 2024 Plus Project conditions at these two study intersections.

TABLE 13 – OPENING YEAR 2024 PLUS PROJECT INTERSECTION QUEUING ANALYSIS

Movement	No. Lanes	Storage Length Per Lane (ft)	Peak Hour Volume		95th % Queue (ft) ¹		Adequate Storage Provided?
			AM	PM	AM	PM	
1. Cruickshank Drive & Imperial Avenue (SR-86)							
NBR	1	400	88	90	0	0	Yes
SBL	1	450	188	189	294	328	Yes
WBL	1	150	47	79	109	122	Yes
WBR	1	300	132	261	0	108	Yes
4. Cruickshank Drive & 8th Street							
NBL	1	250	163	42	239	208	Yes

¹ Synchro reports the 95th percentile queue in feet.

9 SUMMARY & CONCLUSIONS

The project proposes to construct 102 single-family dwelling units and 17.26 acres would include manufacturing. This project requires a tentative subdivision map, conditional use permit and zone change to accommodate residential use.

9.1 CEQA ANALYSIS SUMMARY

In December 2018, new California Environmental Quality Act (CEQA) guidelines were approved that shift transportation analysis from delay and operations to vehicle miles traveled (VMT) when evaluating transportation impacts under CEQA. This change in methodology is a result of Senate Bill 743 (SB743), which was signed into law in September 2013. The Governor's Office of Planning and Research (OPR) released *Technical Advisory on Evaluating Transportation Impacts in CEQA* in December 2018 (Technical Advisory) that contains recommendations regarding assessment of VMT, screening criteria, thresholds of significance, and approach to mitigating impacts. Statewide implementation VMT as the metric for evaluating transportation impacts under CEQA occurred on July 1, 2020. The City of El Centro recently prepared and adopted new *Transportation Study Guidelines* (TSG) dated June 2022 which comply with SB743. Therefore, the City's TSG was used to evaluate the project's transportation impacts based on VMT. The project is located within a VMT efficient area and is determined to have a less than significant impact for both the residential and industrial components of the site. As such, a detailed VMT analysis is not required.

9.2 LOCAL MOBILITY ASSESSMENT (LEVEL OF SERVICE) SUMMARY

While transportation impacts are based on VMT, the City also requires analysis of intersection and roadway segment operating conditions for their Local Mobility Assessment (LMA). The City has established level of service (LOS) C as the standard for acceptable operating conditions. LOS D, E and F are considered deficient operating conditions.

For the intersection of Cruickshank Drive & Imperial Avenue, the City has accepted LOS D as acceptable operating conditions in accordance with the City's Mobility Element Policy 4.4 since widening the intersection to improve operations to LOS C or better would be infeasible due to right-of-way constraints. Under the Existing, Opening Year 2024 Without and With Project scenarios, the intersection of Cruickshank Drive & Imperial Avenue is shown to operate at LOS D. Since this location is considered acceptable operating conditions, no improvements are required.

The project driveways on 10th Street and 12th Street should be free and clear of any obstructions to provide adequate sight distance ensuing exiting vehicles from the new driveways can adequately see not only other vehicles, but also pedestrians and bicyclists. Any landscaping and signage at the project driveways should not obstruct the drivers view from exiting the project site.

Appendix A: Project Information Form

Project Information Form

General Project Information and Description

Owner/Applicant Information

Name:	Town Center Courtyard II, LLC
Address:	9680 Flair Drive, El Monte CA 91731
Phone Number:	
Email:	

Project Information

Project Name:	Town Center Village Phase II
Project Address:	North of Cruickshank Dr, east of Hwy 86, and west of 8th Street
APN:	
Land Use Designation:	Single-family residential and light manufacturing
Zoning Designation:	R1- Single family residential and ML- Light manufacturing

Project Description

Land Uses and Intensities: <i>(units, square feet, etc.)</i>	102 Single Family Dwelling Units & 17.26 Acres of Light Manufacturing (Warehouse)		
Gross and Developable Acreage:	Gross Acreage = 35.78 (18.52 AC Res & 17.26 AC LM)		
Parking			
Vehicle Parking Required: <i>per relevant City planning document (e.g., CVMC, SPA Plan, etc.)</i>	TBD	Vehicle Parking Proposed:	
Accessible Spaces:		Bicycle Storage Capacity: <i>(racks and secure storage)</i>	
Motorcycle Spaces:		EV Spaces:	

Consultant, Developer or Project Representative

Name/Firm:	Michael Baker International		
Project Manager:	Jacob Swim, TE	License(s):	#2873
Email Address:	jacob.swim@mbakerintl.com		
Telephone:	(619) 456-1410		

Trip Generation (Attach Traffic Generation Table with Rates and Daily and Peak Hour Volumes)

(Use the most current version of the Institute of Transportation Engineers (ITE) Trip Generation Manual)

Trip Type	Total	AM Peak Trips	PM Peak Trips
Daily Trips:	1728	162	187
Pass-By Trips:	0	0	0
Internal Capture:	0	0	0
Previous Use Credits:	0	0	0
<i>(Driveway count or published ITE rate at City's discretion)</i>			
Net Daily Trips:	1728	162	187



Project Information Form

Site Plan

Attach 11x17 copies of the project location/vicinity map and site plan containing the following:

- Driveway locations and access type
- Pedestrian access, bicycle access, on-site pedestrian circulation, and transit stop at project frontage (if available)
- Location of any planned sidewalks or bicycle facilities identified in the City of El Centro Active Transportation Plan or Mobility Element at project frontage

CEQA VMT Analysis Screening

To determine if your project is screened from VMT analysis, review the Project Type Screening and the Project Location Screening tables below. If “No” is checked for any project type of land use applicable to your project, the project is not screened out and must complete VMT analysis in accordance with the analysis requirements outlined in the City of El Centro *Transportation Study Guidelines* (TSG).

Screening Criteria

1. Select the Land Uses that apply to your project 2. Answer the questions for each Land Use that applies to your project <i>(if “Yes” is indicated in any land uses category below, then that land uses (or a portion of the land use) is screened from CEQA VMT Analysis)</i>	Screened Out? (Mark Yes or No)	
	Yes	No
<i>Note: All responses must be documented and supported by substantial evidence.</i>		
1. Small Residential and Employment Projects		
a. Does the project generate less than 110 net daily trips?	<input type="checkbox"/>	<input checked="" type="checkbox"/>
2. Residential/Employment (not including Industrial) project located in a VMT-Efficient Area (see screening maps)		
a. Is the project located in a VMT-efficient area (15% or more below the base year average VMT/Capita or VMT/Employee)?	<input checked="" type="checkbox"/>	<input type="checkbox"/>
3. Locally Serving Retail Project		
a. Is the project less than 50,000 square feet and serving the local community? The City may request a market capture study that identifies local market capture to the City's satisfaction.	<input type="checkbox"/>	<input checked="" type="checkbox"/>
4. Locally Serving Public Facilities and Community Purpose Facilities		
a. Is the project a public facility or Community Purpose Facility that serves the local community? (see TSG Section 3.3)	<input type="checkbox"/>	<input checked="" type="checkbox"/>
5. Redevelopment Project		
a. Does the project result in a net decrease in total Project VMT than the existing use?	<input type="checkbox"/>	<input checked="" type="checkbox"/>
6. Affordable Housing		
a. Is the project composed of deed-restricted affordable housing units? (Does not apply to market-rate housing units)	<input type="checkbox"/>	<input checked="" type="checkbox"/>



Project Information Form

Local Mobility Analysis Screening

Does this project generate less than 800 daily unadjusted driveway trips?	<input type="checkbox"/> Yes	<input checked="" type="checkbox"/> No
---	------------------------------	--

If yes, the project does not need to complete an LMA. If no, refer to the City of El Centro TSG, Chapter 4, to determine extents based on the project's trip generation.

Provide attachment with list or map of the proposed study roadway segments and intersections in accordance with the requirements outlined in the TSG, Chapter 4.



TENTATIVE SUBDIVISION MAP

EL CENTRO RESIDENTIAL AND INDUSTRIAL DEVELOPMENT

CITY OF EL CENTRO, COUNTY OF IMPERIAL, STATE OF CALIFORNIA

PROJECT INFORMATION

PROPERTY INFORMATION

PROPERTY OWNER	TOWN CENTER COURTYARD II, LLC 9680 FLAIR DRIVE EL MONTE, CA 91731
ENGINEER	MICHAEL INCLEDON INCLEDON CONSULTING GROUP 1570 CORPORATE DRIVE, SUITE A COSTA MESA, CA 92626 RCE #52390
ASSESSORS ID NUMBERS	044-620-032, 044-620-037, 044-620-038, 044-620-039, 044-620-040, 044-620-041, 044-620-053, AND 044-620-064
LEGAL DESCRIPTIONS	A PORTION OF REMAINDER LOT A AND LOTS 12, 13, 14, 15, AND 16 AS SHOWN ON EL CENTRO TOWN CENTER PHASE II FINAL MAP, RECORDED IN BOOK 26, PAGES 71 THROUGH 73, INCLUSIVE, IN THE OFFICE OF THE COUNTY RECORDER OF IMPERIAL COUNTY, PARCEL "P" OF LLA NO. 21-05, RECORDED ON 8/18/2022 AS RECORDING NO. 2022011125, OF OFFICIAL RECORDS, AND PARCEL "D" OF LLA NO. 21-03, AS RECORDED DECEMBER 15, 2021, INSTRUMENT NO. 2021031957, OF OFFICIAL RECORDS, RECORDS OF SAID COUNTY.
EXISTING ZONING	ML - LIGHT MANUFACTURING CG - GENERAL COMMERCIAL
PROPOSED ZONING	R1 - SINGLE FAMILY RESIDENTIAL ML - LIGHT MANUFACTURING
EXISTING LAND USE	VACANT
PROPOSED LAND USE	SINGLE FAMILY RESIDENTIAL LIGHT MANUFACTURING
EXISTING TREES	THERE ARE NO EXISTING TREES ON THE SITE
EXISTING STRUCTURES	THERE ARE NO EXISTING STRUCTURES ON THE SITE
DATE MAP PREPARED	MAY 2022
FLOOD ZONE	ZONE X, ACCORDING TO FEMA FLOOD MAP NO. 06025C1729C

UTILITY PROVIDERS:

ELECTRICITY IMPERIAL IRRIGATION DISTRICT 1285 BROADWAY EL CENTRO, CA 92243 760-335-3640	SEWER CITY OF EL CENTRO 2255 NORTH LA BRUCHERIE EL CENTRO, CA 92243 760-337-4562	BUILDING AND SAFETY DIVISION CITY OF EL CENTRO 1275 MAIN STREET EL CENTRO, CA 92243 760-337-4508
WATER CITY OF EL CENTRO 1275 MAIN STREET EL CENTRO, CA 92243 760-337-4510	GAS SOUTHERN CALIFORNIA GAS COMPANY PO BOX 1626 MONTEREY PARK, CA 91754-8626 1-877-238-0092	

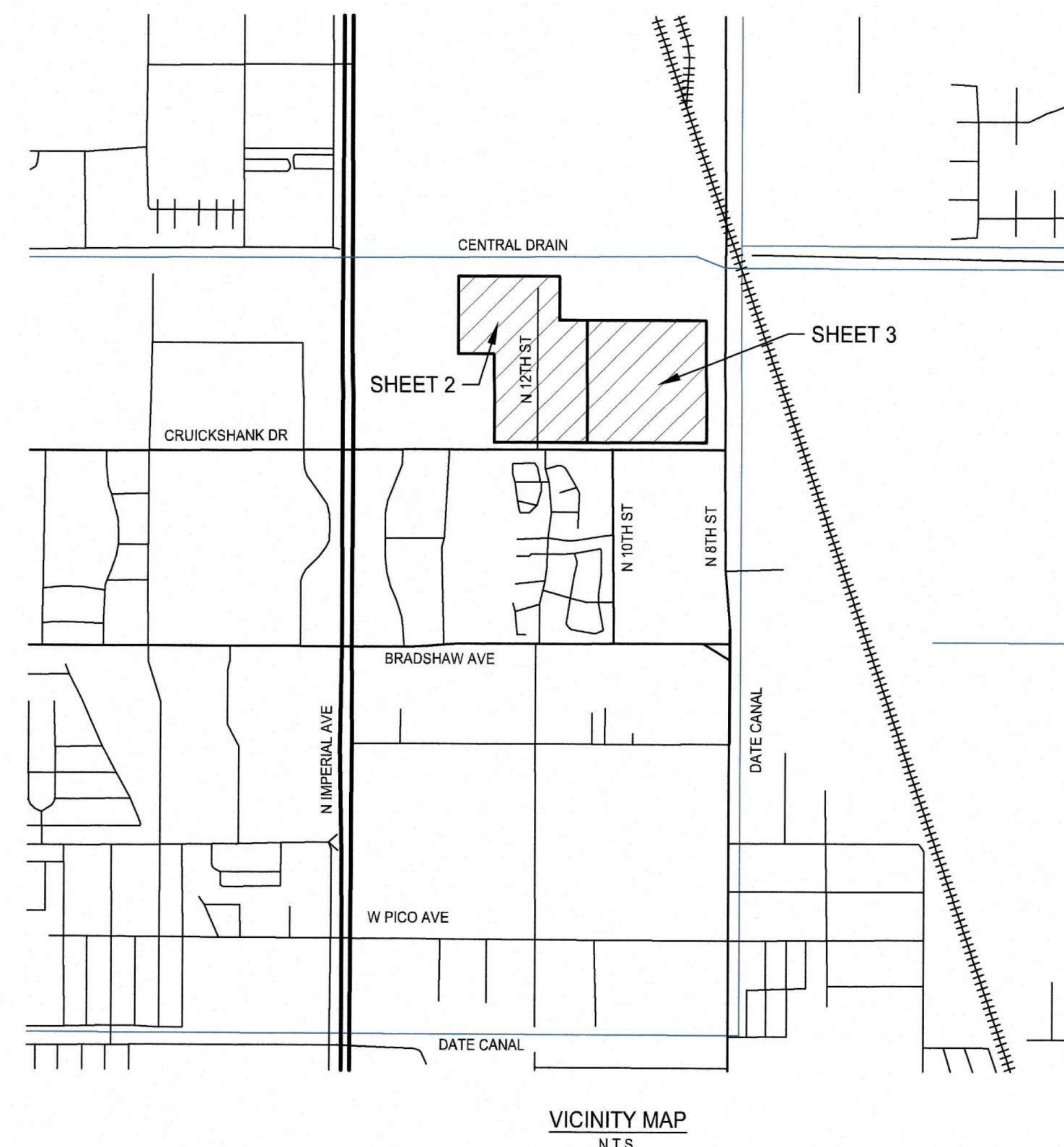

VICINITY MAP
N.T.S.

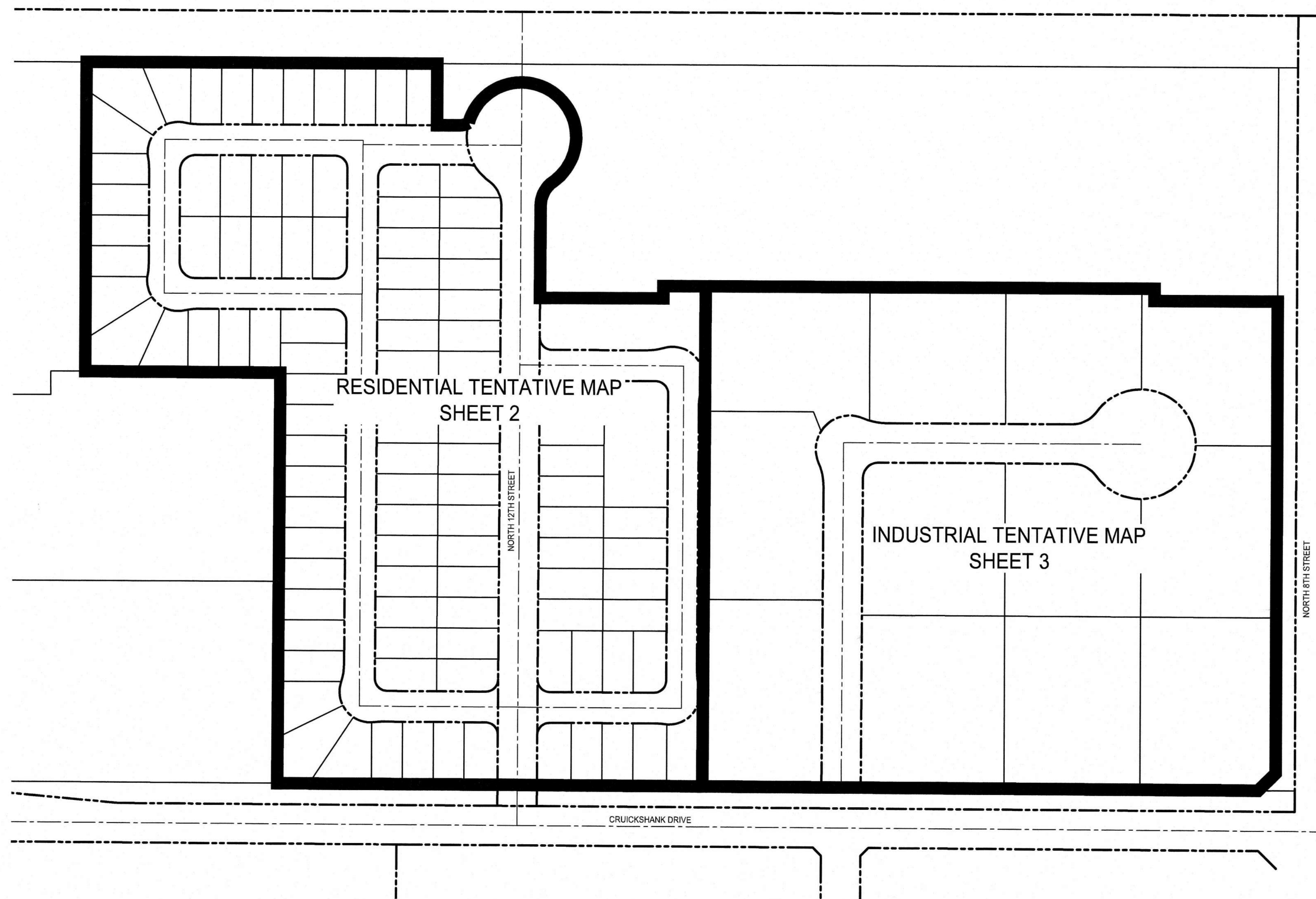

LEGEND

	PROPERTY LINE
	EASEMENT
	LOT LINE
	CENTER LINE
	STORMWATER BIORETENTION BASIN

SURVEY INFORMATION

BENCHMARK

WEST TOP OF CURB RETURN, SOUTHWEST CORNER OF IMPERIAL AVENUE (STATE HIGHWAY 86) AND CRUICKSHANK DRIVE.

ELEVATION = 48.15

AS PER LARS ANDERSEN AND ASSOCIATES, INC. PROJECT NO. 02022.00 (EL CENTRO TOWN CENTER) AND VESTING TENTATIVE MAP ENTITLED "TOWN CENTER VILLAGE APARTMENTS" BY BJ ENGINEERING AND SURVEYING, INC. JOB NO. 11-106.

BASIS OF BEARINGS

THE BASIS OF BEARINGS FOR THIS SURVEY IS THE NORTHERLY LINE OF REMAINDER PARCELS A AND B AS SHOWN ON THE MAP TITLED "EL CENTRO TOWN CENTER" FILED IN BOOK 20, PAGE 87 OF FINAL MAPS IN THE OFFICE OF THE COUNTY RECORDER OF IMPERIAL COUNTY, SHOWN AS S 89°57'57" E.

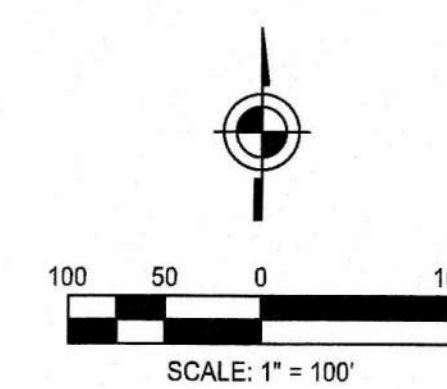

TOWN CENTER VILLAGE, LLC
9680 FLAIR DRIVE
EL MONTE, CA 91731

OWNER

INCLEDON
CONSULTING GROUP
Civil Engineering • Surveying • Planning
1570 Corporate Drive, Suite A, Costa Mesa, CA 92626
P: 657.622.2121 / www.igrid.com

CONSULTANT

**EL CENTRO TOWN CENTER
VILLAGE RESIDENTIAL AND
INDUSTRIAL DEVELOPMENT**
EL CENTRO, CA 92243

REV.	DATE	DESCRIPTION

PROFESSIONAL SEAL
MICHAEL D. INCLEDON
REGISTERED CIVIL ENGINEER
NO. 52390
STATE OF CALIFORNIA
JUN 07 2022

TITLE SHEET

SHEET TITLE
JOB # 458.012
DATE 5/20/2022

SHEET #

TENTATIVE SUBDIVISION MAP

EL CENTRO SINGLE FAMILY DEVELOPMENT
CITY OF EL CENTRO, COUNTY OF IMPERIAL,
STATE OF CALIFORNIA

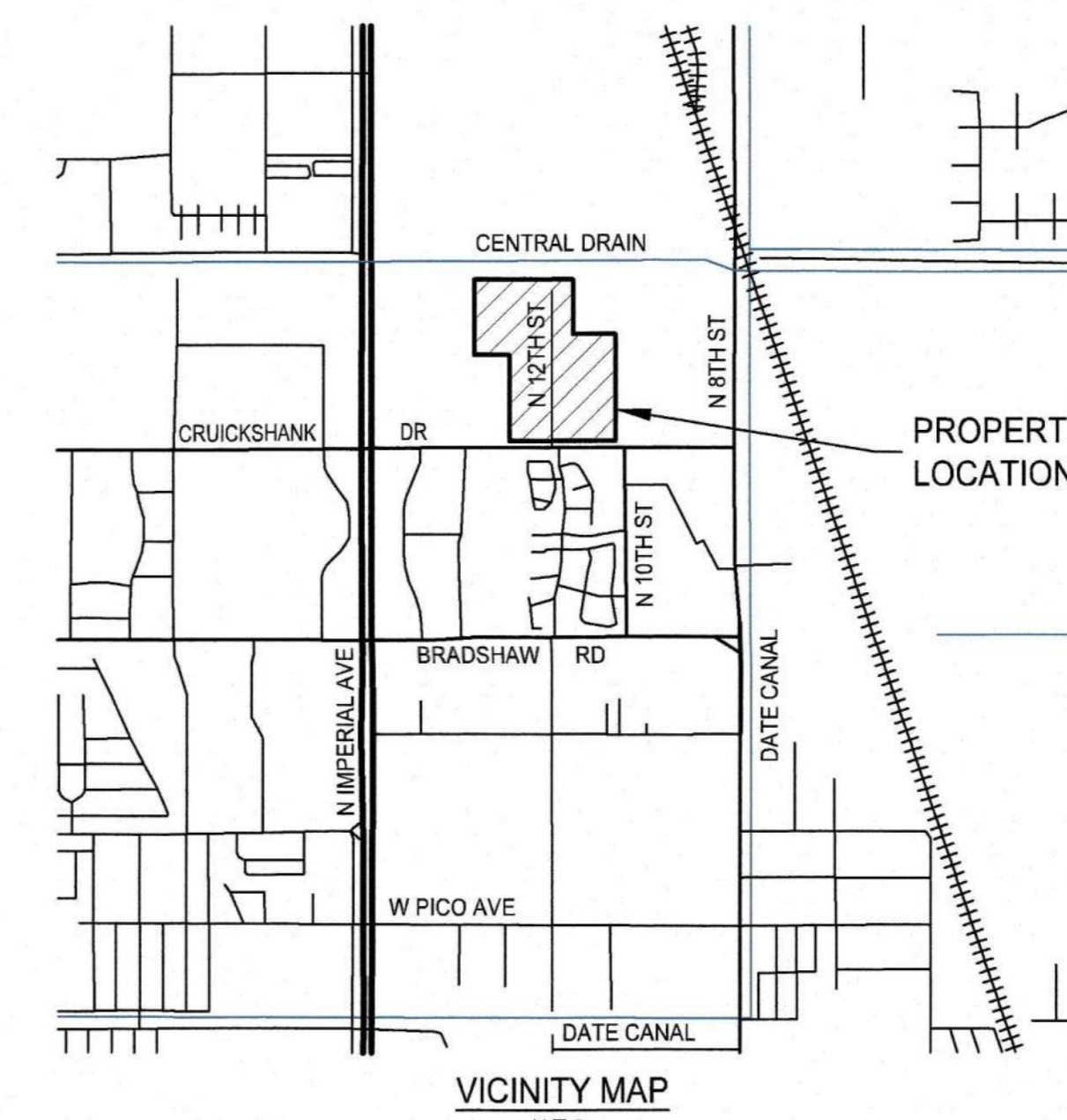
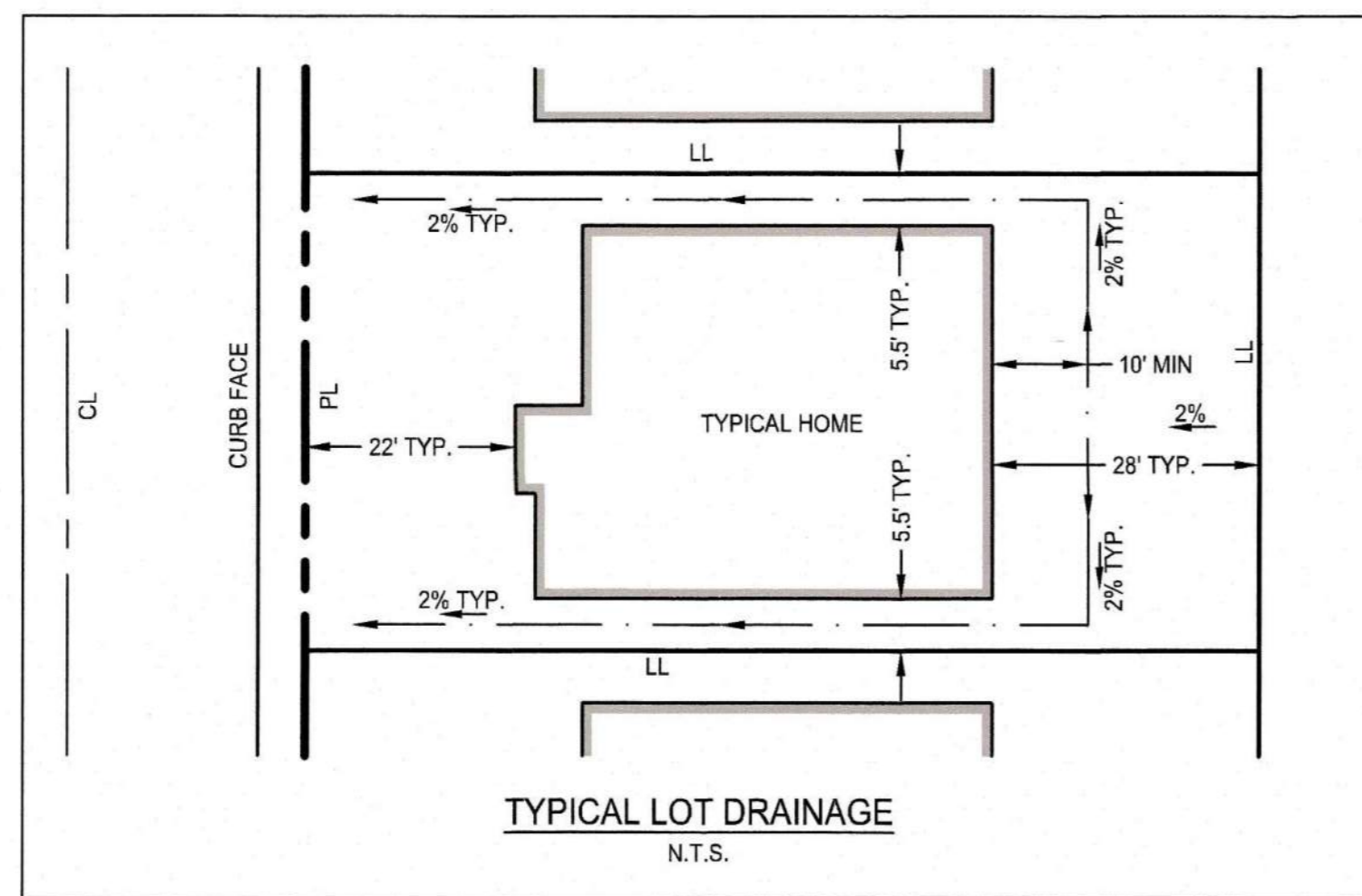
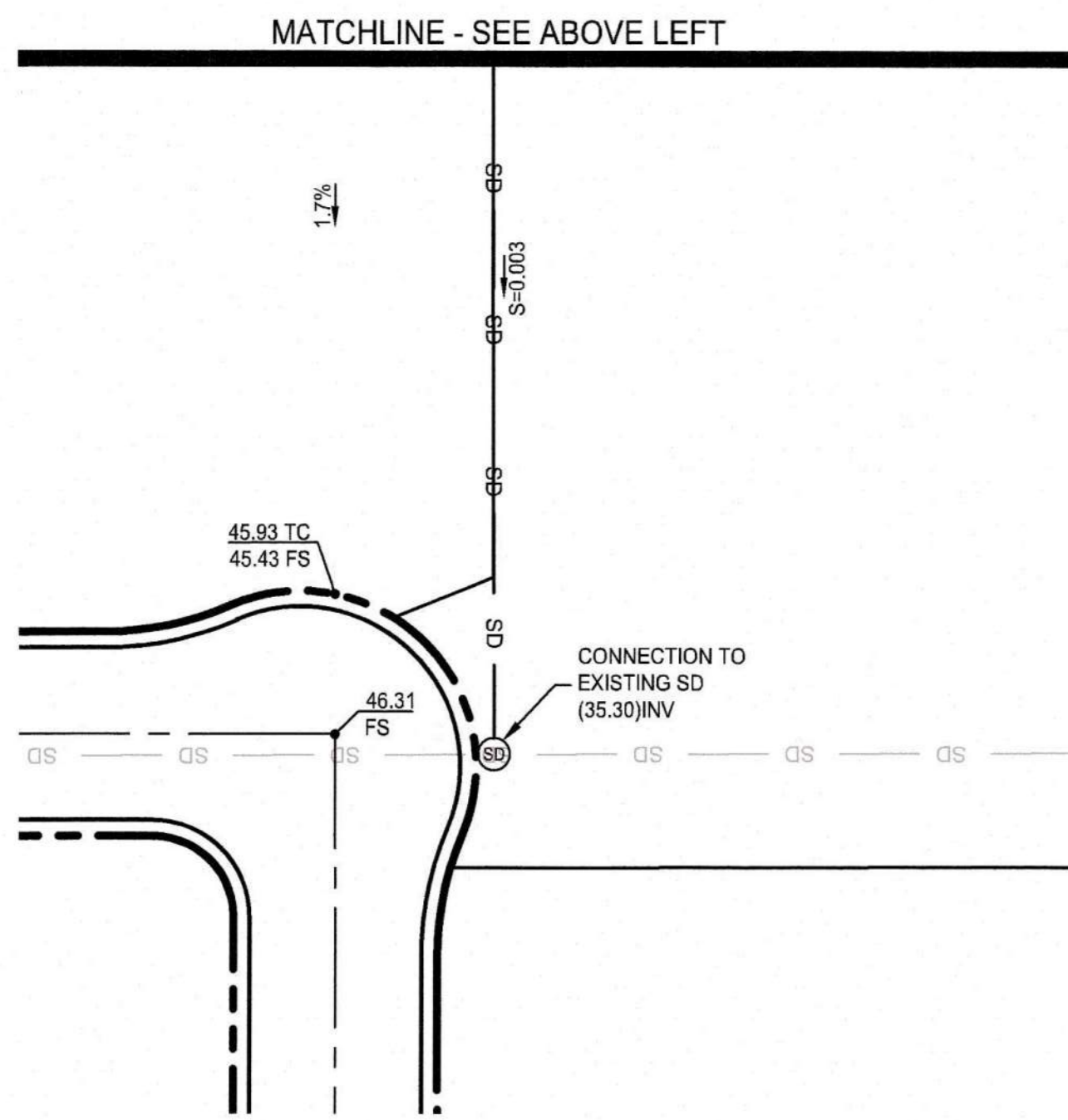

LEGEND

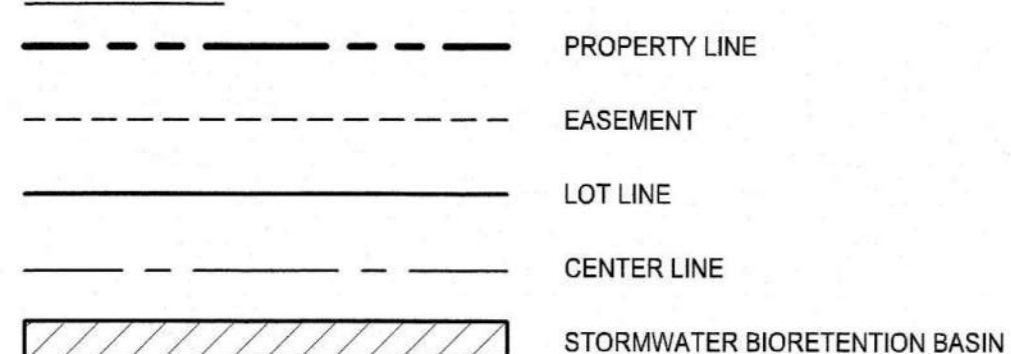

TYPICAL STREET SECTIONS

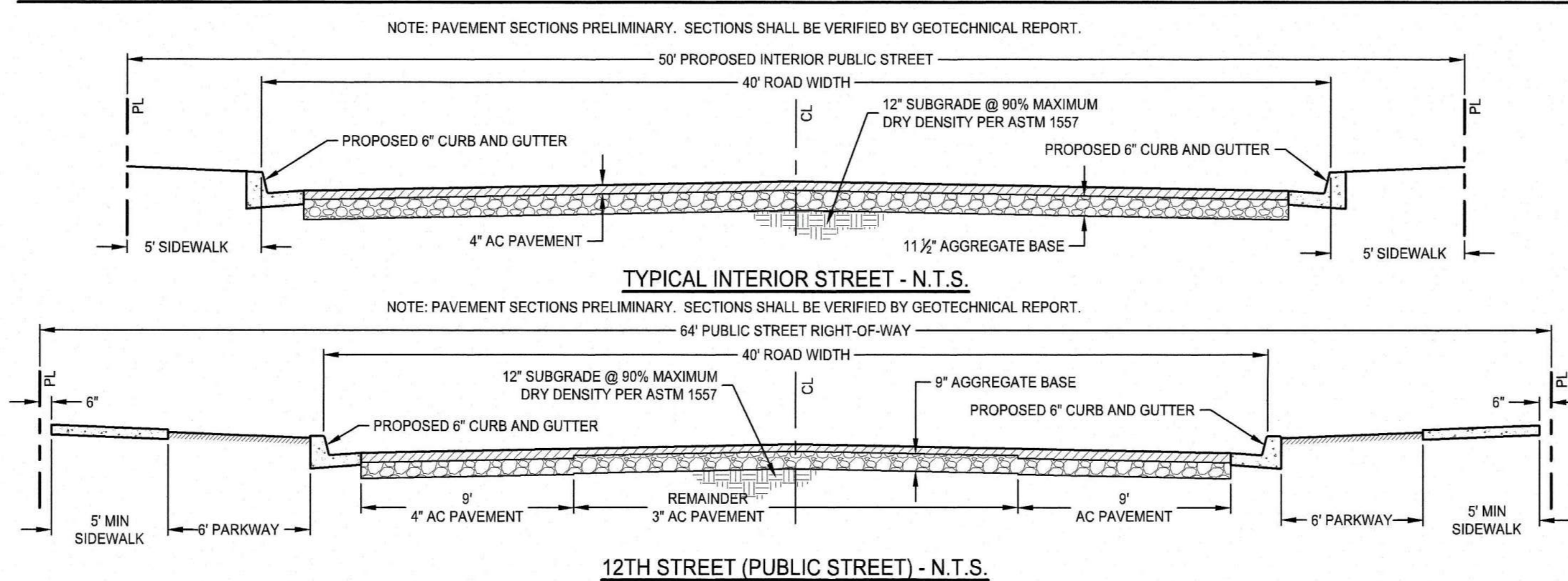

PROJECT INFORMATION

PROPERTY INFORMATION	
PROPERTY OWNER	TOWN CENTER COURTYARD II, LLC 9680 FLAIR DRIVE EL MONTE, CA 91731
ENGINEER	MICHAEL INGLETON INGLEDON CONSULTING GROUP 1570 CORPORATE DRIVE, SUITE A COSTA MESA, CA 92626 RCE #52390
ASSESSORS ID NUMBER(S)	044-620-032, 044-620-037, 044-620-038, 044-620-039, 044-620-040, 044-620-041, 044-620-053, AND 044-620-064
LEGAL DESCRIPTIONS	A PORTION OF REMAINDER LOT A AND LOTS 12, 13, 14, 15, AND 16 AS SHOWN ON EL CENTRO TOWN CENTER PHASE II FINAL MAP, RECORDED IN BOOK 26, PAGES 71 THROUGH 73, INCLUSIVE, IN THE OFFICE OF THE COUNTY RECORDER OF IMPERIAL COUNTY, PARCEL "F" OF LLA NO. 21-05, RECORDED ON 5/19/2022 AS RECORDING NO. 2022011125, OF OFFICIAL RECORDS, AND PARCEL "D" OF LLA NO. 21-03, AS RECORDED DECEMBER 15, 2021, INSTRUMENT NO. 2021031957, OF OFFICIAL RECORDS, RECORDS OF SAID COUNTY.
EXISTING ZONING	ML - LIGHT MANUFACTURING CG - GENERAL COMMERCIAL
PROPOSED ZONING	R1 - SINGLE FAMILY RESIDENTIAL
EXISTING LAND USE	VACANT
PROPOSED LAND USE	SINGLE FAMILY RESIDENTIAL
EXISTING TREES	THERE ARE NO EXISTING TREES ON THE SITE
EXISTING STRUCTURES	THERE ARE NO EXISTING STRUCTURES ON THE SITE
DATE MAP PREPARED	MAY 2022
LINEAR STREET FOOTAGE TOTAL	5,200A FT
FLOOD ZONE	ZONE X, ACCORDING TO FEMA FLOOD MAP NO. 06025C1725C
RESIDENTIAL DENSITY	102 HOMES / 18.52 ACRES = 5.5 DWELLING UNITS PER ACRE
MINIMUM PROPOSED LOT AREA	4,960 SF
TOTAL PROPERTY AREA	18.52 ACRES
SUBDIVISION PROPOSAL	TO SUBDIVIDE THE PROPERTY TO CREATE 103 LOTS FOR PROPOSED RESIDENTIAL DETACHED SINGLE-FAMILY DWELLING UNITS, AND LOTS "A" THROUGH "F," INCORPORATING PRIVATE STREETS, CONCRETE SIDEWALKS, UNDERGROUND UTILITIES, AND OPEN SPACE.

EASEMENTS & SETBACKS

A	IMPERIAL IRRIGATION DISTRICT EASEMENT FOR CANAL POLE LINES RECORDED ON OCTOBER 14, 1939 IN BOOK 535 PAGE 570 OF OFFICIAL RECORDS
B	BURROWING OWL HABITAT AREA AS DESCRIBED IN THE DOCUMENT RECORDED JUNE 13, 2003 AS INSTRUMENT NO. 2003-017123 OF OFFICIAL RECORDS
C	PONDING BASIN AREA AS DESCRIBED IN THE DOCUMENT RECORDED JUNE 13, 2003 AS INSTRUMENT NO. 2003-017123 OF OFFICIAL RECORDS
D	STORM DRAIN EASEMENT AS DESCRIBED IN THE DOCUMENT RECORDED JUNE 13, 2003 AS INSTRUMENT NO. 2003-017123 OF OFFICIAL RECORDS
E	EASEMENT GRANTED TO SOUTHERN CALIFORNIA GAS COMPANY FOR THE PURPOSE OF PUBLIC UTILITIES RECORDED MAY 1, 2009 AS 2009-013084 OF OFFICIAL RECORDS
F	DECLARATION ESTABLISHING COVENANTS, CONDITIONS, RECIPROCAL EASEMENTS AND RESTRICTIONS RECORDED SEPTEMBER 9, 2011 AS 2011-021817 OF OFFICIAL RECORDS
G	IPL ZONE 4 PER "EL CENTRO REZONING ANALYSIS" MEMORANDUM, DATED JUNE 19, 2019 BY MICHAEL BAKER INTERNATIONAL
H	IPL ZONE 6 PER "EL CENTRO REZONING ANALYSIS" MEMORANDUM, DATED JUNE 19, 2019 BY MICHAEL BAKER INTERNATIONAL

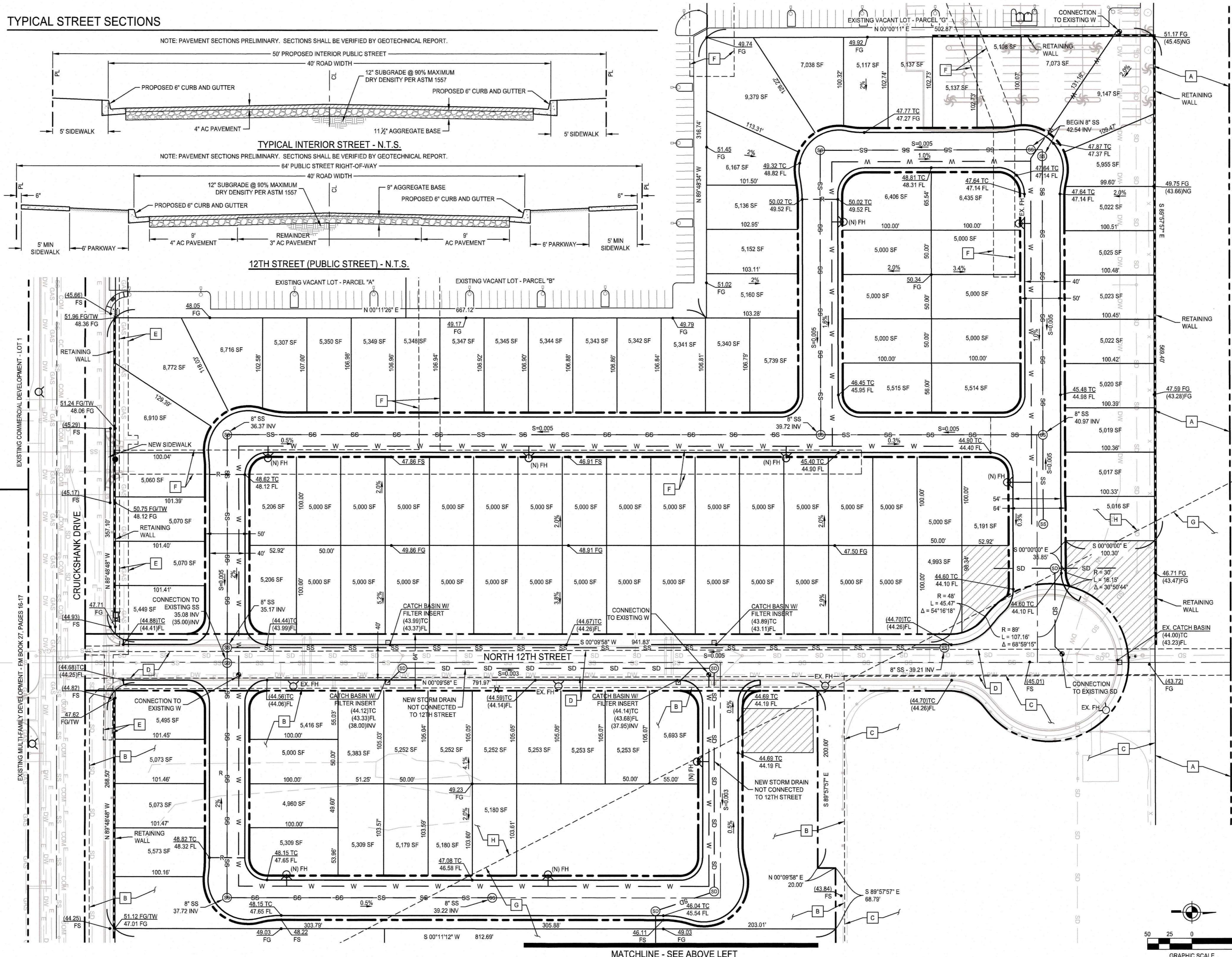

TOWN CENTER VILLAGE, LLC
9680 FLAIR DRIVE
EL MONTE, CA 91731

OWNER
INGLEDON
CONSULTING GROUP
Civil Engineering • Surveying • Planning
1570 Corporate Drive, Suite A, Costa Mesa, CA 92626
P. 657.622.2121 / www.igol.com

CONSULTANT

EL CENTRO, CA 92243

**EL CENTRO TOWN CENTER
VILLAGE RESIDENTIAL AND
INDUSTRIAL DEVELOPMENT**

REV.	DATE	DESCRIPTION



RESIDENTIAL
TENTATIVE
SUBDIVISION MAP

SHEET TITLE	458.012
JOB #	5/20/2022
DATE	
SHEET #	2

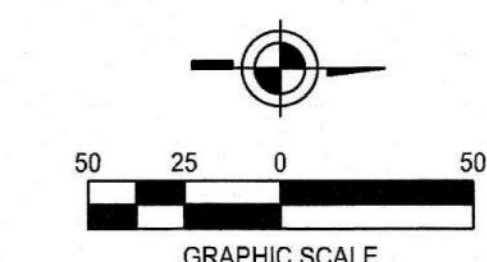

COPYRIGHT © 2020

TENTATIVE SUBDIVISION MAP

EL CENTRO INDUSTRIAL DEVELOPMENT

CITY OF EL CENTRO, COUNTY OF IMPERIAL, STATE OF CALIFORNIA

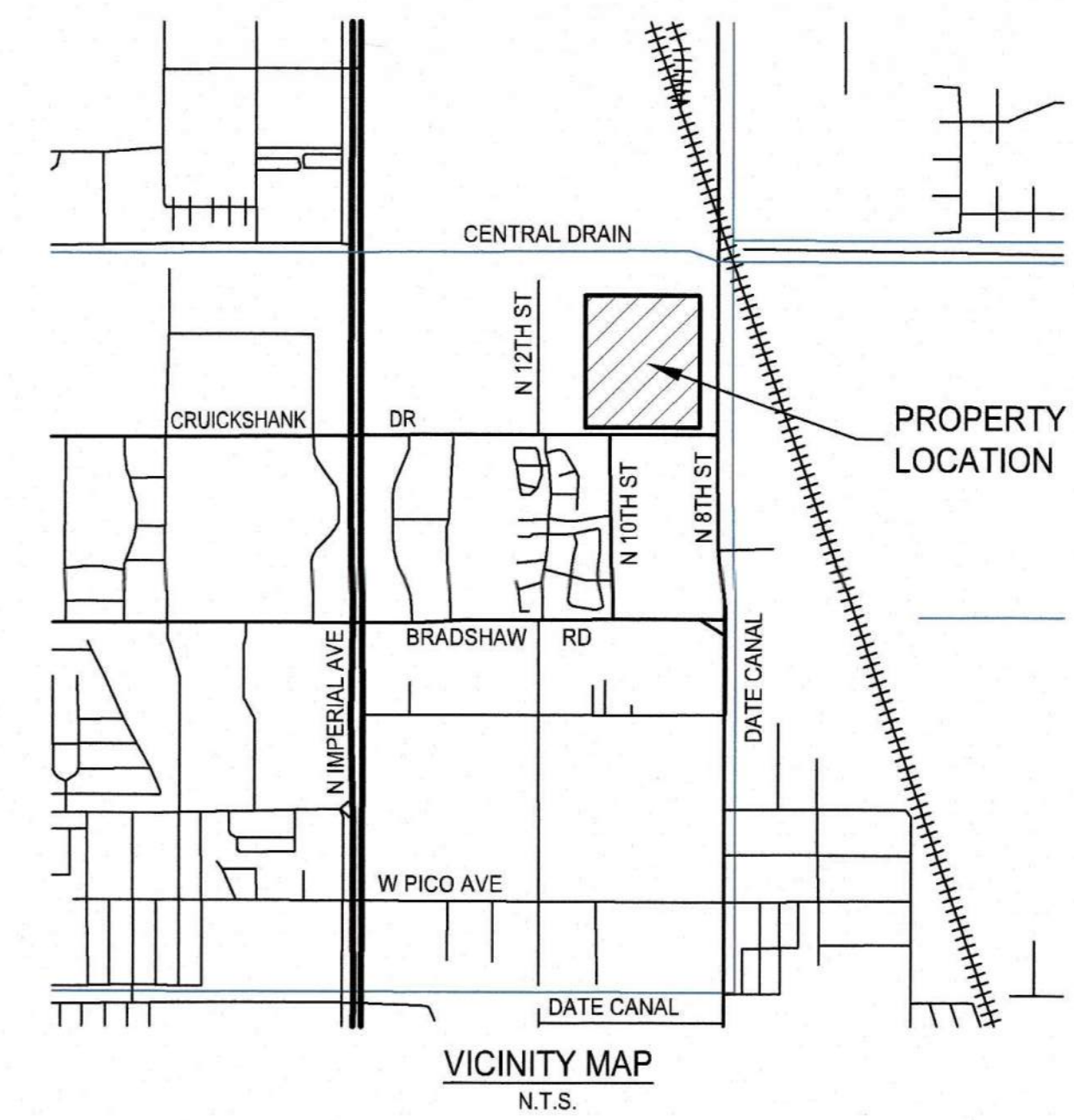

TYPICAL STREET SECTIONS

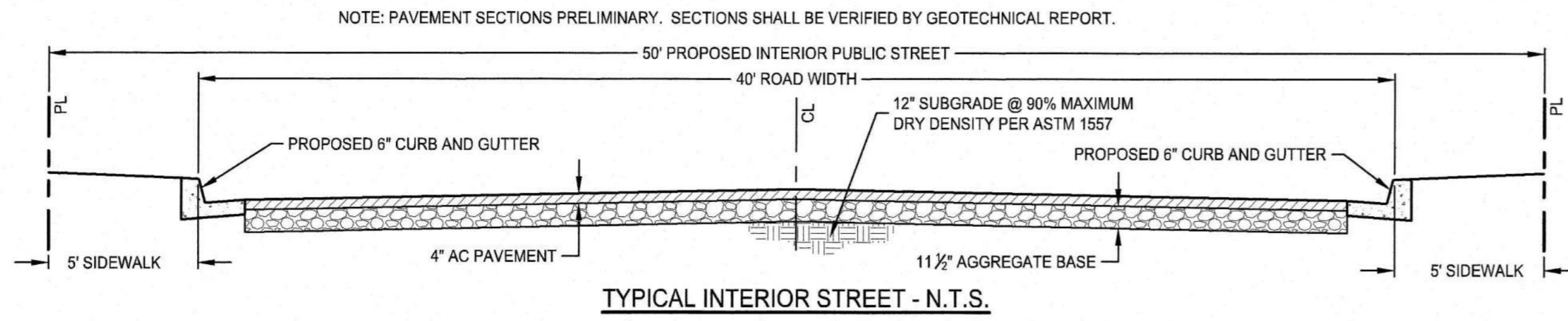

LEGEND

- PROPERTY LINE
- EASEMENT
- LOT LINE
- CENTER LINE

PROJECT INFORMATION

PROPERTY INFORMATION	
PROPERTY OWNER	TOWN CENTER COURTYARD II, LLC 9680 FLAIR DRIVE EL MONTE, CA 91731
ENGINEER	MICHAEL INCLEDON INCLEDON CONSULTING GROUP 1570 CORPORATE DRIVE, SUITE A COSTA MESA, CA 92626 RCE #52390
ASSESSORS ID NUMBER(S)	044-620-053
LEGAL DESCRIPTIONS	A PORTION OF REMAINDER LOT A AS SHOWN ON EL CENTRO TOWN CENTER PHASE II FINAL MAP, RECORDED IN BOOK 26, PAGES 71 THROUGH 73, INCLUSIVE, IN THE OFFICE OF THE COUNTY RECORDER OF IMPERIAL COUNTY.
EXISTING ZONING	ML - LIGHT MANUFACTURING
PROPOSED ZONING	ML - LIGHT MANUFACTURING
EXISTING LAND USE	VACANT
PROPOSED LAND USE	LIGHT MANUFACTURING
EXISTING TREES	THERE ARE NO EXISTING TREES ON THE SITE
EXISTING STRUCTURES	THERE ARE NO EXISTING STRUCTURES ON THE SITE
DATE MAP PREPARED	MAY 2022
LINEAR STREET FOOTAGE TOTAL	3,100± FT
FLOOD ZONE	ZONE X, ACCORDING TO FEMA FLOOD MAP NO. 06025C1725C
MINIMUM PROPOSED LOT AREA	4,960 SF
TOTAL PROPERTY AREA	17.26 ACRES

EASEMENTS & SETBACKS

- B BURROWING OWL HABITAT AREA AS DESCRIBED IN THE DOCUMENT RECORDED JUNE 13, 2003 AS INSTRUMENT NO. 2003-017123 OF OFFICIAL RECORDS
- C PONDING BASIN AREA AS DESCRIBED IN THE DOCUMENT RECORDED JUNE 13, 2003 AS INSTRUMENT NO. 2003-017123 OF OFFICIAL RECORDS
- G IPL ZONE 4 PER "EL CENTRO REZONING ANALYSIS" MEMORANDUM, DATED JUNE 19, 2019 BY MICHAEL BAKER INTERNATIONAL
- H IPL ZONE 6 PER "EL CENTRO REZONING ANALYSIS" MEMORANDUM, DATED JUNE 19, 2019 BY MICHAEL BAKER INTERNATIONAL

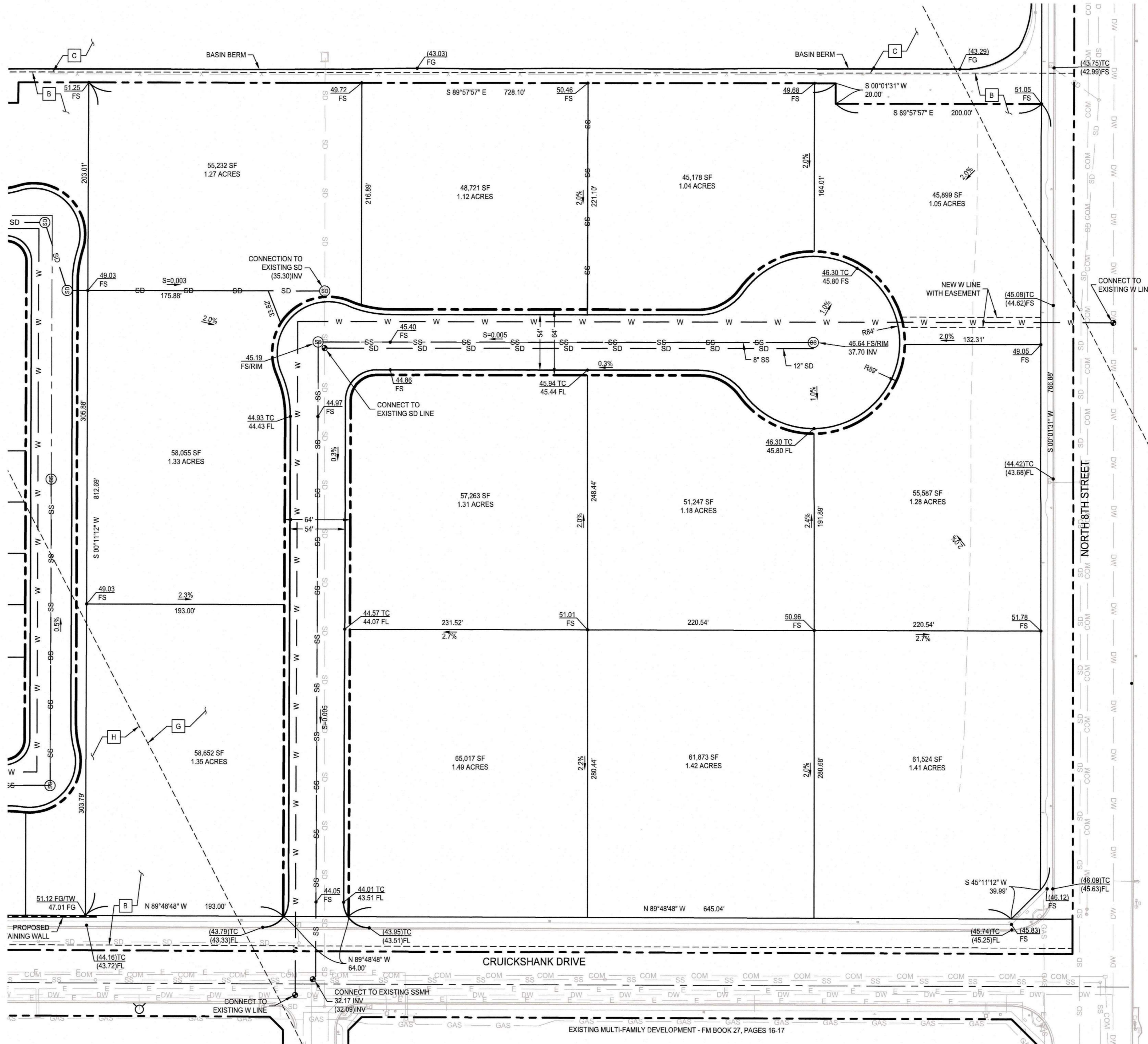

TOWN CENTER VILLAGE, LLC
9680 FLAIR DRIVE
EL MONTE, CA 91731

OWNER



CONSULTANT

**EL CENTRO TOWN CENTER
VILLAGE RESIDENTIAL AND
INDUSTRIAL DEVELOPMENT**
EL CENTRO, CA 92243

REV. DATE DESCRIPTION



TENTATIVE
SUBDIVISION MAP

SHEET TITLE
JOB # 458.012
DATE 5/20/2022
SHEET # 3

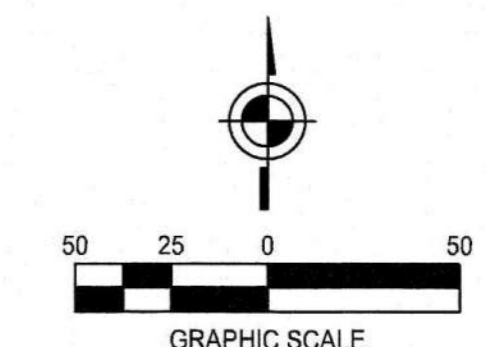

COPYRIGHT © 2020

K:\PROJECTS\68.012 ECTOV - SINGLE FAMILY RESIDENTIAL & INDUSTRIAL MAPPING & OFFSITE DESIGN\SHEETS\T.M.3 - INDUSTRIAL MAPPING & OFFSITE DESIGN.TM.DWG 5/20/2022 4:43 PM

Trip Generation Rates¹

Land Use	ITE Code ¹	Daily Trip Rate	AM Peak Hour Rate			PM Peak Hour Rate		
			Total	In : Out		Total	In : Out	
Single-Family Detached Housing	210	$\ln(T)=0.92\ln(X) + 2.68$	$\ln(T)=0.91 \ln(X)+0.12$	26% : 74%		$\ln(T)=0.94 \ln(X) + 0.27$	63% : 37%	
Manufacturing	140	$T = 37.05(X) + 60.72$	$T=4.05(X) + 16.16$	86% : 14%		$T = 3.32(X) + 28.91$	39% : 61%	

¹ Source: ITE Trip Generation Manual, 11th Edition. Rates shown are based on fitted curve equation.

El Centro Town Center Village Trip Generation

Land Use	Intensity	Daily Trips	AM Peak Hour Trips		PM Peak Hour Trips	
			Total	In : Out	Total	In : Out
Single-Family Detached Housing	102 DU	1028	76	20 : 56	101	64 : 37
Manufacturing	17.26 AC	700	86	74 : 12	86	34 : 52
TOTAL		1728	162	94 : 68	187	98 : 89

DU = Dwelling Unit

AC = Acres

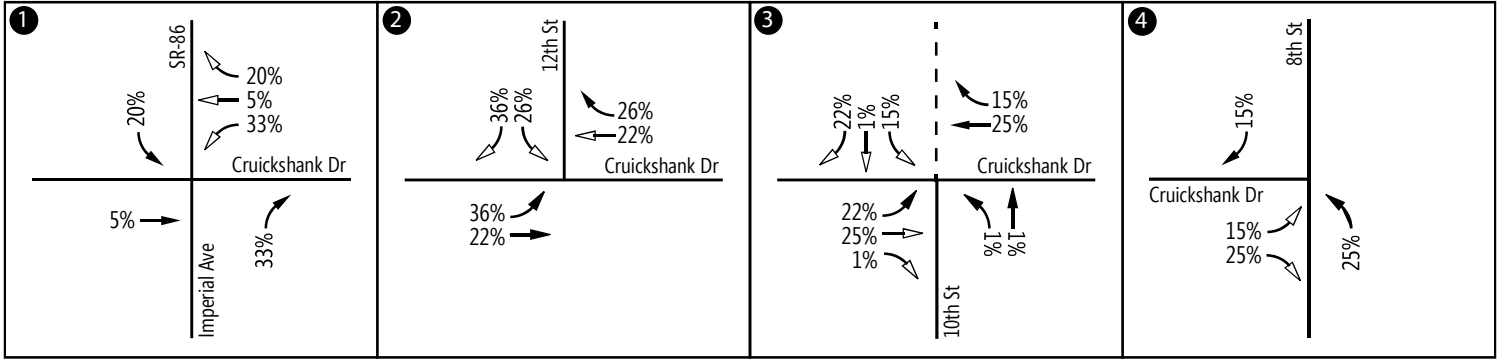

Legend

- ← = Inbound Dist.
- ↔ = Outbound Dist.

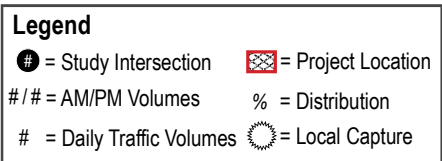
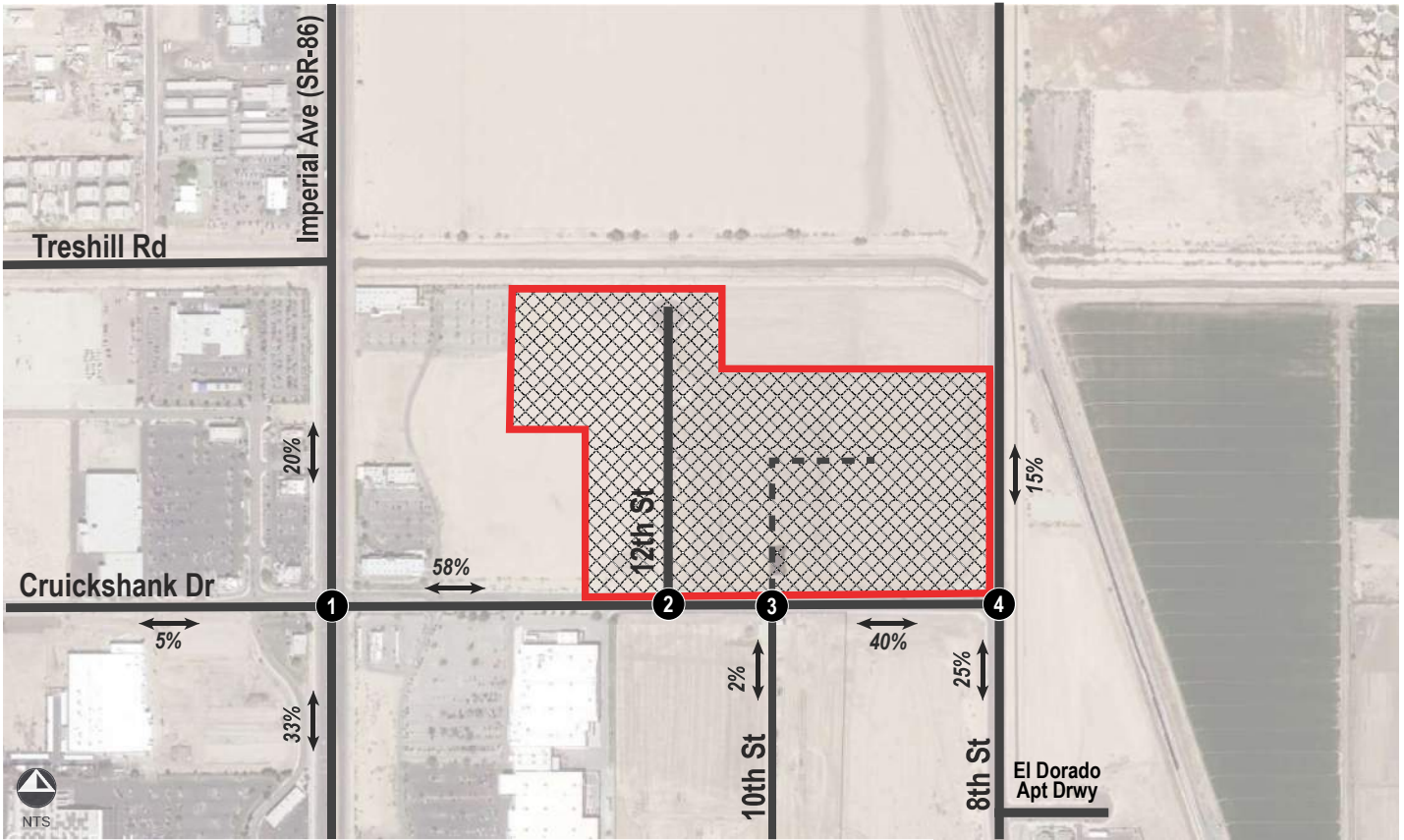

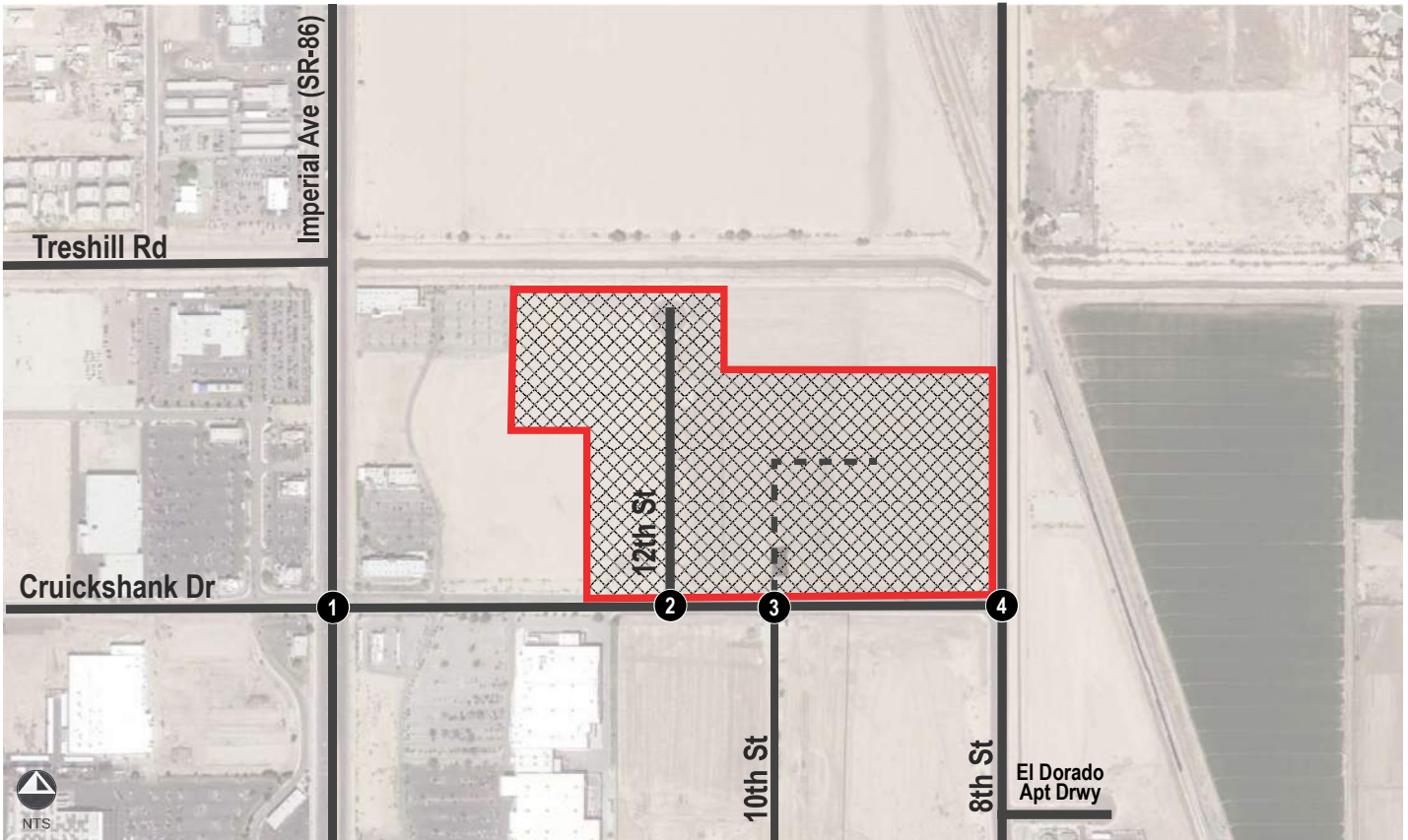
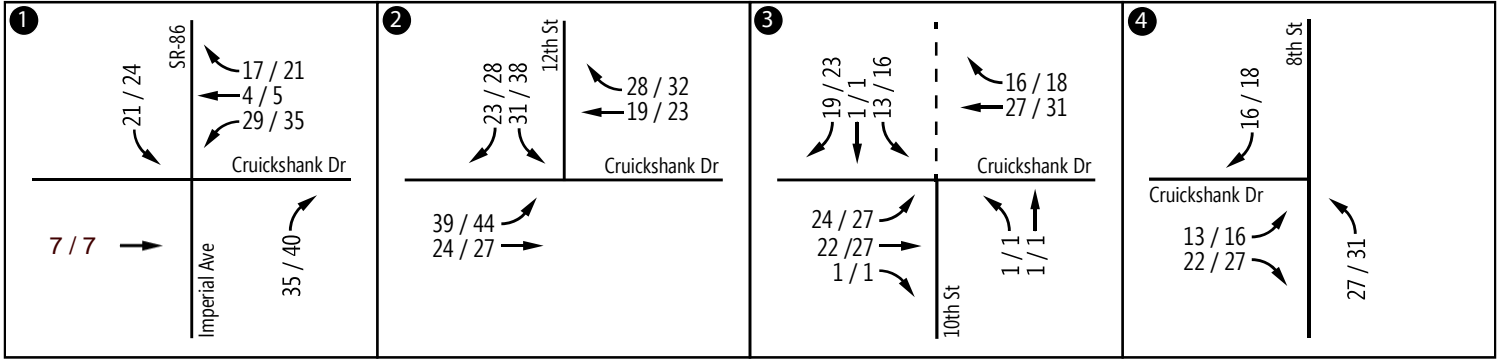

Legend

- = Study Intersection
- ▨ = Project Location
- # / # = AM/PM Volumes
- # = Daily Traffic Volumes

Appendix B: Traffic Count Data & Signal Timing Sheets

City of El Centro
 N/S: SR-86
 E/W: Cruickshank Drive
 Weather: Clear

File Name : ECO_86_Cru AM
 Site Code : 12223098
 Start Date : 2/1/2023
 Page No : 1

Groups Printed- Total Volume

Start Time	SR-86 Southbound				Cruickshank Drive Westbound				SR-86 Northbound				Cruickshank Drive Eastbound				Int. Total
	Left	Thru	Right	App. Total	Left	Thru	Right	App. Total	Left	Thru	Right	App. Total	Left	Thru	Right	App. Total	
07:00 AM	33	72	31	136	0	9	13	22	10	66	4	80	11	10	2	23	261
07:15 AM	24	115	21	160	3	9	17	29	10	78	6	94	14	8	9	31	314
07:30 AM	20	157	26	203	1	11	13	25	16	113	10	139	22	19	7	48	415
07:45 AM	35	176	53	264	1	31	26	58	18	117	17	152	16	16	15	47	521
Total	112	520	131	763	5	60	69	134	54	374	37	465	63	53	33	149	1511
08:00 AM	36	159	63	258	7	20	28	55	24	108	15	147	22	24	16	62	522
08:15 AM	28	117	36	181	6	18	28	52	6	76	10	92	35	21	16	72	397
08:30 AM	31	129	51	211	4	24	26	54	27	101	11	139	23	15	19	57	461
08:45 AM	35	124	57	216	4	35	24	63	25	80	10	115	26	30	28	84	478
Total	130	529	207	866	21	97	106	224	82	365	46	493	106	90	79	275	1858
Grand Total	242	1049	338	1629	26	157	175	358	136	739	83	958	169	143	112	424	3369
Apprch %	14.9	64.4	20.7		7.3	43.9	48.9		14.2	77.1	8.7		39.9	33.7	26.4		
Total %	7.2	31.1	10	48.4	0.8	4.7	5.2	10.6	4	21.9	2.5	28.4	5	4.2	3.3	12.6	

Start Time	SR-86 Southbound				Cruickshank Drive Westbound				SR-86 Northbound				Cruickshank Drive Eastbound				Int. Total
	Left	Thru	Right	App. Total	Left	Thru	Right	App. Total	Left	Thru	Right	App. Total	Left	Thru	Right	App. Total	
Peak Hour Analysis From 07:00 AM to 08:45 AM - Peak 1 of 1																	
Peak Hour for Entire Intersection Begins at 07:45 AM																	
07:45 AM	35	176	53	264	1	31	26	58	18	117	17	152	16	16	15	47	521
08:00 AM	36	159	63	258	7	20	28	55	24	108	15	147	22	24	16	62	522
08:15 AM	28	117	36	181	6	18	28	52	6	76	10	92	35	21	16	72	397
08:30 AM	31	129	51	211	4	24	26	54	27	101	11	139	23	15	19	57	461
Total Volume	130	581	203	914	18	93	108	219	75	402	53	530	96	76	66	238	1901
% App. Total	14.2	63.6	22.2		8.2	42.5	49.3		14.2	75.8	10		40.3	31.9	27.7		
PHF	.903	.825	.806	.866	.643	.750	.964	.944	.694	.859	.779	.872	.686	.792	.868	.826	.910

City of El Centro
 N/S: SR-86
 E/W: Cruickshank Drive
 Weather: Clear

File Name : ECO_86_Cru AM
 Site Code : 12223098
 Start Date : 2/1/2023
 Page No : 2

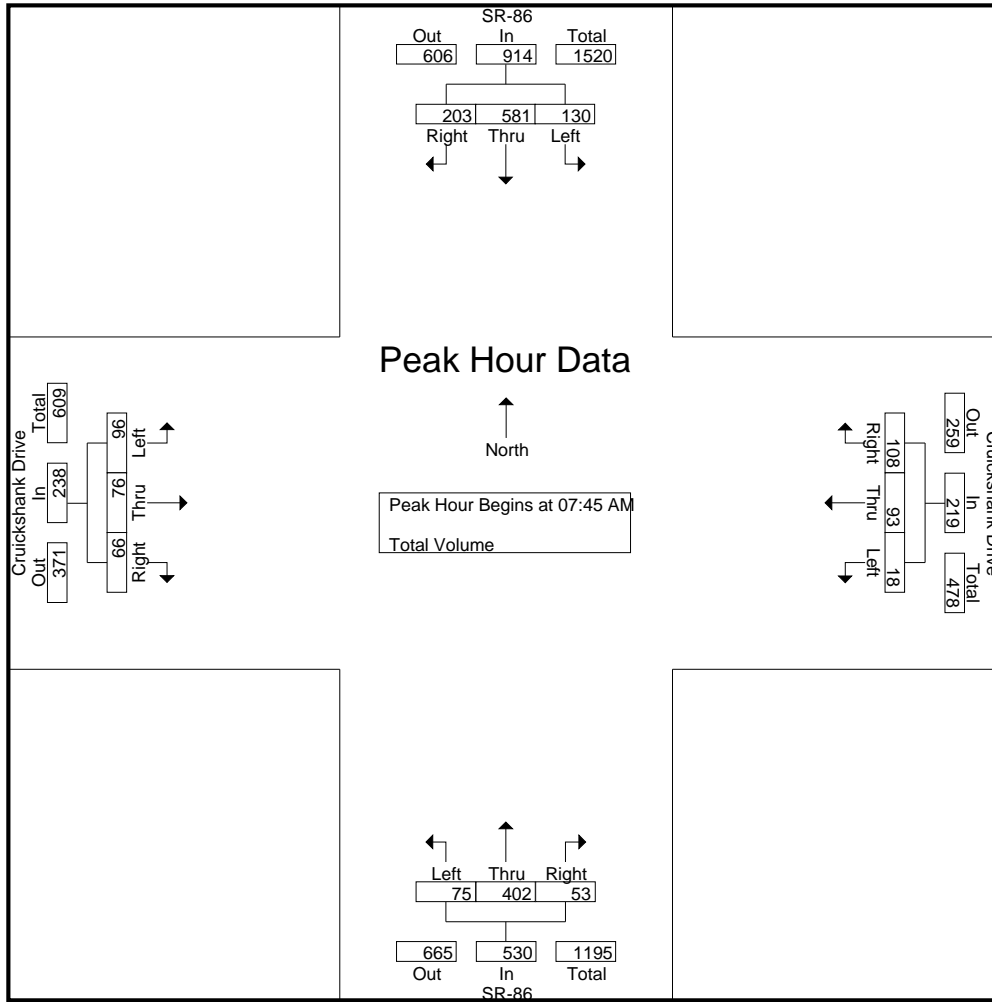

Peak Hour Analysis From 07:00 AM to 08:45 AM - Peak 1 of 1
 Peak Hour for Each Approach Begins at:

	07:45 AM				08:00 AM				07:15 AM				08:00 AM			
+0 mins.	35	176	53	264	7	20	28	55	10	78	6	94	22	24	16	62
+15 mins.	36	159	63	258	6	18	28	52	16	113	10	139	35	21	16	72
+30 mins.	28	117	36	181	4	24	26	54	18	117	17	152	23	15	19	57
+45 mins.	31	129	51	211	4	35	24	63	24	108	15	147	26	30	28	84
Total Volume	130	581	203	914	21	97	106	224	68	416	48	532	106	90	79	275
% App. Total	14.2	63.6	22.2		9.4	43.3	47.3		12.8	78.2	9		38.5	32.7	28.7	
PHF	.903	.825	.806	.866	.750	.693	.946	.889	.708	.889	.706	.875	.757	.750	.705	.818

City of El Centro
 N/S: SR-86
 E/W: Cruickshank Drive
 Weather: Clear

File Name : ECO_86_Cru PM
 Site Code : 12223098
 Start Date : 2/1/2023
 Page No : 1

Groups Printed- Total Volume

Start Time	SR-86 Southbound				Cruickshank Drive Westbound				SR-86 Northbound				Cruickshank Drive Eastbound				Int. Total
	Left	Thru	Right	App. Total	Left	Thru	Right	App. Total	Left	Thru	Right	App. Total	Left	Thru	Right	App. Total	
04:00 PM	32	123	68	223	6	37	51	94	42	151	14	207	56	57	31	144	668
04:15 PM	27	152	66	245	8	43	22	73	28	128	16	172	59	62	44	165	655
04:30 PM	42	142	72	256	8	36	39	83	34	167	12	213	45	65	35	145	697
04:45 PM	34	131	52	217	6	34	43	83	38	148	12	198	59	72	31	162	660
Total	135	548	258	941	28	150	155	333	142	594	54	790	219	256	141	616	2680
05:00 PM	45	144	59	248	8	37	83	128	29	152	12	193	46	76	43	165	734
05:15 PM	51	140	63	254	8	44	54	106	45	181	12	238	48	58	36	142	740
05:30 PM	47	129	71	247	8	39	50	97	32	150	12	194	53	52	39	144	682
05:45 PM	23	144	64	231	8	40	40	88	32	127	9	168	48	75	31	154	641
Total	166	557	257	980	32	160	227	419	138	610	45	793	195	261	149	605	2797
Grand Total	301	1105	515	1921	60	310	382	752	280	1204	99	1583	414	517	290	1221	5477
Apprch %	15.7	57.5	26.8		8	41.2	50.8		17.7	76.1	6.3		33.9	42.3	23.8		
Total %	5.5	20.2	9.4	35.1	1.1	5.7	7	13.7	5.1	22	1.8	28.9	7.6	9.4	5.3	22.3	

Start Time	SR-86 Southbound				Cruickshank Drive Westbound				SR-86 Northbound				Cruickshank Drive Eastbound				Int. Total
	Left	Thru	Right	App. Total	Left	Thru	Right	App. Total	Left	Thru	Right	App. Total	Left	Thru	Right	App. Total	
04:30 PM	42	142	72	256	8	36	39	83	34	167	12	213	45	65	35	145	697
04:45 PM	34	131	52	217	6	34	43	83	38	148	12	198	59	72	31	162	660
05:00 PM	45	144	59	248	8	37	83	128	29	152	12	193	46	76	43	165	734
05:15 PM	51	140	63	254	8	44	54	106	45	181	12	238	48	58	36	142	740
Total Volume	172	557	246	975	30	151	219	400	146	648	48	842	198	271	145	614	2831
% App. Total	17.6	57.1	25.2		7.5	37.8	54.8		17.3	77	5.7		32.2	44.1	23.6		
PHF	.843	.967	.854	.952	.938	.858	.660	.781	.811	.895	1.00	.884	.839	.891	.843	.930	.956

Peak Hour Analysis From 04:00 PM to 05:45 PM - Peak 1 of 1

Peak Hour for Entire Intersection Begins at 04:30 PM

City of El Centro
 N/S: SR-86
 E/W: Cruickshank Drive
 Weather: Clear

File Name : ECO_86_Cru PM
 Site Code : 12223098
 Start Date : 2/1/2023
 Page No : 2

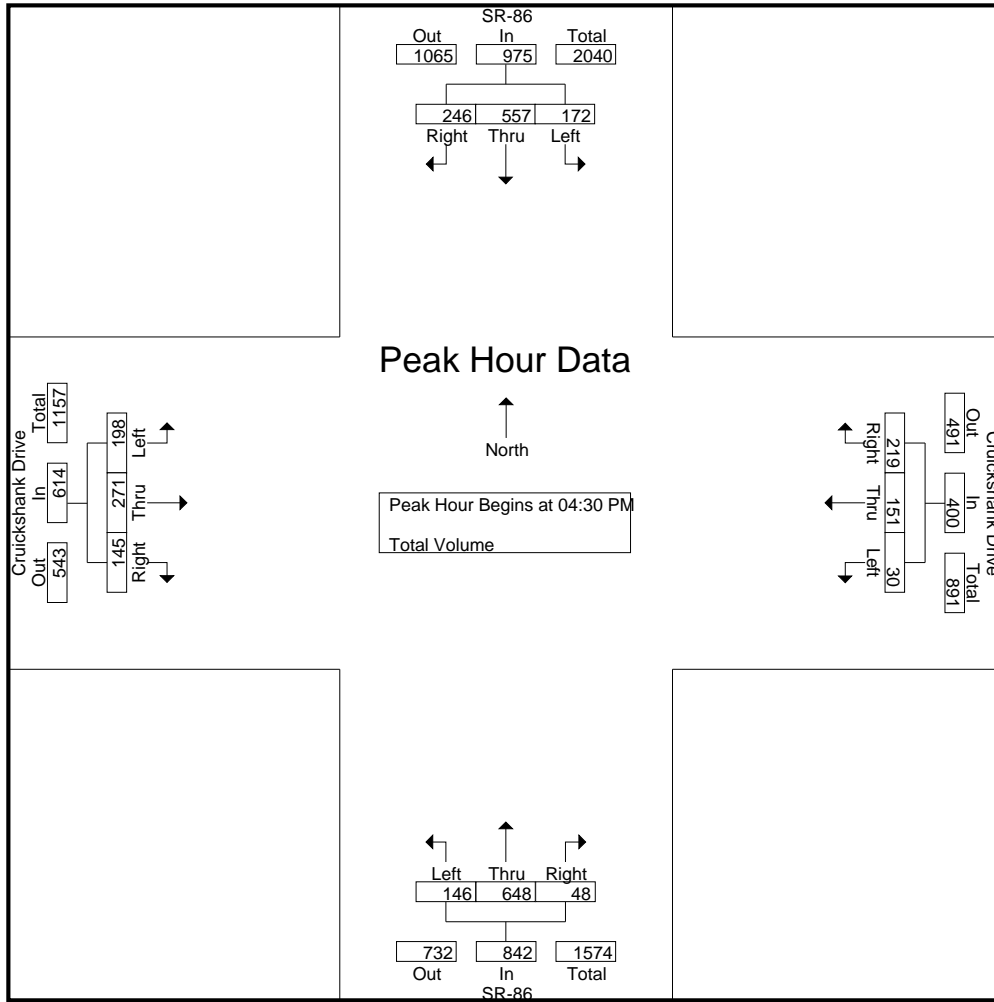

Peak Hour Analysis From 04:00 PM to 05:45 PM - Peak 1 of 1
 Peak Hour for Each Approach Begins at:

	05:00 PM				05:00 PM				04:30 PM				04:15 PM			
+0 mins.	45	144	59	248	8	37	83	128	34	167	12	213	59	62	44	165
+15 mins.	51	140	63	254	8	44	54	106	38	148	12	198	45	65	35	145
+30 mins.	47	129	71	247	8	39	50	97	29	152	12	193	59	72	31	162
+45 mins.	23	144	64	231	8	40	40	88	45	181	12	238	46	76	43	165
Total Volume	166	557	257	980	32	160	227	419	146	648	48	842	209	275	153	637
% App. Total	16.9	56.8	26.2		7.6	38.2	54.2		17.3	77	5.7		32.8	43.2	24	
PHF	.814	.967	.905	.965	1.000	.909	.684	.818	.811	.895	1.000	.884	.886	.905	.869	.965

Location: El Centro
 N/S: SR-86
 E/W: Cruickshank Drive



Date: 2/1/2023
 Day: Wednesday

PEDESTRIANS

	North Leg SR-86	East Leg Cruickshank Drive	South Leg SR-86	West Leg Cruickshank Drive	
	Pedestrians	Pedestrians	Pedestrians	Pedestrians	
7:00 AM	0	0	0	0	0
7:15 AM	0	0	0	0	0
7:30 AM	0	0	1	0	1
7:45 AM	1	0	0	0	1
8:00 AM	1	0	0	0	1
8:15 AM	0	1	1	0	2
8:30 AM	1	2	3	3	9
8:45 AM	0	0	0	0	0
TOTAL VOLUMES:	3	3	5	3	14

	North Leg SR-86	East Leg Cruickshank Drive	South Leg SR-86	West Leg Cruickshank Drive	
	Pedestrians	Pedestrians	Pedestrians	Pedestrians	
4:00 PM	0	1	2	1	4
4:15 PM	0	0	3	2	5
4:30 PM	0	1	1	0	2
4:45 PM	0	0	2	0	2
5:00 PM	0	0	0	0	0
5:15 PM	0	0	0	0	0
5:30 PM	0	0	0	0	0
5:45 PM	0	0	0	0	0
TOTAL VOLUMES:	0	2	8	3	13

Location: El Centro
 N/S: SR-86
 E/W: Cruickshank Drive



Date: 2/1/2023
 Day: Wednesday

BICYCLES

	Southbound SR-86			Westbound Cruickshank Drive			Northbound SR-86			Eastbound Cruickshank Drive			
	Left	Thru	Right	Left	Thru	Right	Left	Thru	Right	Left	Thru	Right	
7:00 AM	0	0	0	0	0	0	0	0	0	0	0	0	0
7:15 AM	0	0	0	0	0	0	0	0	0	0	0	0	0
7:30 AM	0	0	0	0	0	0	0	0	0	0	0	0	0
7:45 AM	0	0	0	0	0	0	0	0	0	0	0	0	0
8:00 AM	0	0	1	0	0	0	0	0	0	0	0	0	1
8:15 AM	0	0	0	0	0	0	0	0	0	0	0	0	0
8:30 AM	0	0	1	0	0	0	0	0	0	1	0	0	2
8:45 AM	0	0	0	0	0	0	0	0	0	0	0	0	0
TOTAL VOLUMES:	0	0	2	0	0	0	0	0	0	1	0	0	3

	Southbound SR-86			Westbound Cruickshank Drive			Northbound SR-86			Eastbound Cruickshank Drive			
	Left	Thru	Right	Left	Thru	Right	Left	Thru	Right	Left	Thru	Right	
4:00 PM	0	0	0	0	0	0	0	0	0	0	1	0	1
4:15 PM	0	0	0	0	0	0	0	0	0	0	0	0	0
4:30 PM	0	1	0	0	1	0	0	0	0	0	0	0	2
4:45 PM	0	0	0	0	0	0	0	0	0	0	0	0	0
5:00 PM	0	0	0	0	0	0	0	0	0	0	0	0	0
5:15 PM	0	0	0	0	0	0	0	0	0	0	1	0	1
5:30 PM	0	0	0	0	0	0	0	0	0	0	0	0	0
5:45 PM	0	0	0	0	0	0	0	0	0	0	0	0	0
TOTAL VOLUMES:	0	1	0	0	1	0	0	0	0	0	2	0	4

County of Imperial
 N/S: 10th Street
 E/W: Cruickshank Drive
 Weather: Clear

File Name : 03_COI_10th_Cru AM
 Site Code : 122819
 Start Date : 9/21/2022
 Page No : 1

Groups Printed- Total Volume

Start Time	Cruickshank Drive Westbound			10th Street Northbound			Cruickshank Drive Eastbound			Int. Total
	Left	Thru	App. Total	Left	Right	App. Total	Thru	Right	App. Total	
07:00 AM	8	28	36	2	5	7	30	2	32	75
07:15 AM	3	22	25	1	2	3	47	3	50	78
07:30 AM	7	35	42	2	3	5	36	4	40	87
07:45 AM	9	46	55	2	2	4	50	9	59	118
Total	27	131	158	7	12	19	163	18	181	358
08:00 AM	5	69	74	0	3	3	41	5	46	123
08:15 AM	2	43	45	0	2	2	50	6	56	103
08:30 AM	3	37	40	2	1	3	57	4	61	104
08:45 AM	2	37	39	1	2	3	53	1	54	96
Total	12	186	198	3	8	11	201	16	217	426
Grand Total	39	317	356	10	20	30	364	34	398	784
Apprch %	11	89		33.3	66.7		91.5	8.5		
Total %	5	40.4	45.4	1.3	2.6	3.8	46.4	4.3	50.8	

Start Time	Cruickshank Drive Westbound			10th Street Northbound			Cruickshank Drive Eastbound			Int. Total
	Left	Thru	App. Total	Left	Right	App. Total	Thru	Right	App. Total	
07:45 AM	9	46	55	2	2	4	50	9	59	118
08:00 AM	5	69	74	0	3	3	41	5	46	123
08:15 AM	2	43	45	0	2	2	50	6	56	103
08:30 AM	3	37	40	2	1	3	57	4	61	104
Total Volume	19	195	214	4	8	12	198	24	222	448
% App. Total	8.9	91.1		33.3	66.7		89.2	10.8		
PHF	.528	.707	.723	.500	.667	.750	.868	.667	.910	.911

Peak Hour Analysis From 07:00 AM to 08:45 AM - Peak 1 of 1

Peak Hour for Entire Intersection Begins at 07:45 AM

County of Imperial
 N/S: 10th Street
 E/W: Cruickshank Drive
 Weather: Clear

File Name : 03_COI_10th_Cru AM
 Site Code : 122819
 Start Date : 9/21/2022
 Page No : 2

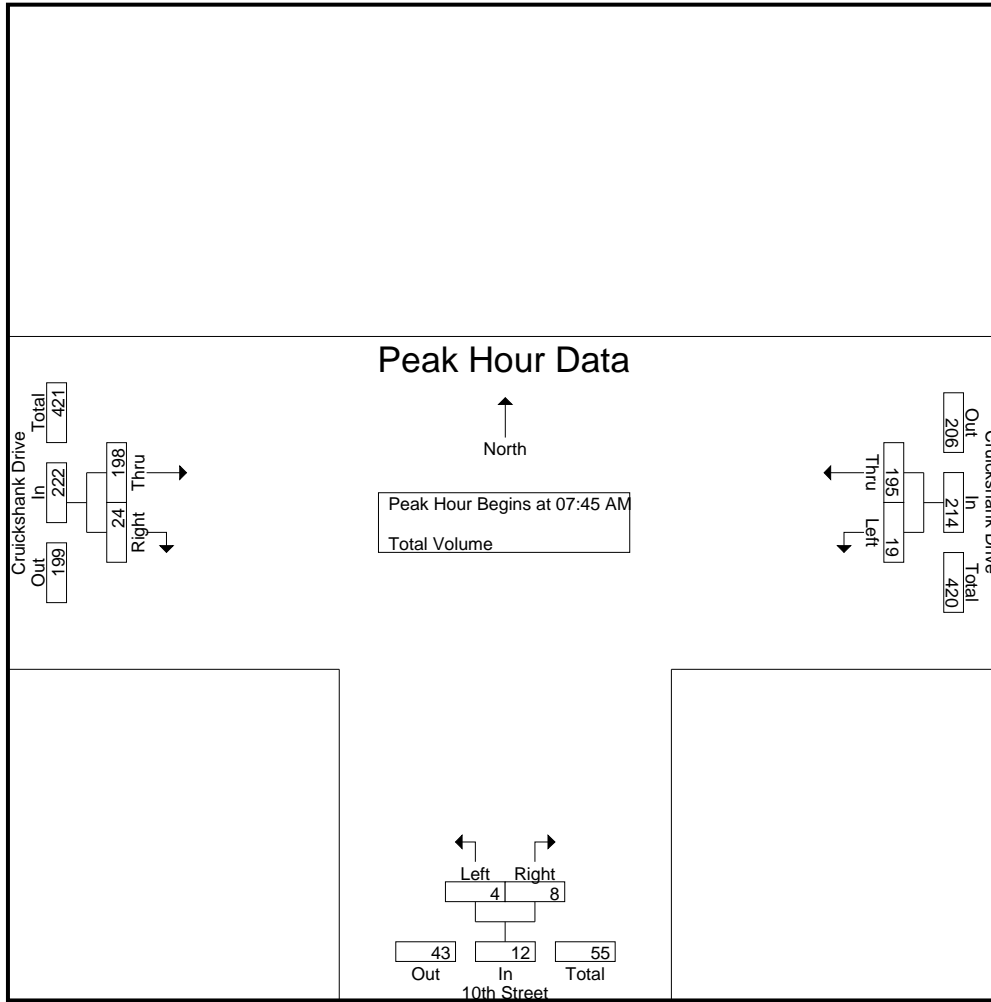

Peak Hour Analysis From 07:00 AM to 08:45 AM - Peak 1 of 1
 Peak Hour for Each Approach Begins at:

	07:30 AM			07:00 AM			07:45 AM		
+0 mins.	7	35	42	2	5	7	50	9	59
+15 mins.	9	46	55	1	2	3	41	5	46
+30 mins.	5	69	74	2	3	5	50	6	56
+45 mins.	2	43	45	2	2	4	57	4	61
Total Volume	23	193	216	7	12	19	198	24	222
% App. Total	10.6	89.4		36.8	63.2		89.2	10.8	
PHF	.639	.699	.730	.875	.600	.679	.868	.667	.910

County of Imperial
 N/S: 10th Street
 E/W: Cruickshank Drive
 Weather: Clear

File Name : 03_COI_10th_Cru PM
 Site Code : 122819
 Start Date : 9/21/2022
 Page No : 1

Groups Printed- Total Volume

Start Time	Cruickshank Drive Westbound			10th Street Northbound			Cruickshank Drive Eastbound			Int. Total
	Left	Thru	App. Total	Left	Right	App. Total	Thru	Right	App. Total	
04:00 PM	4	52	56	0	3	3	88	6	94	153
04:15 PM	4	65	69	3	0	3	88	3	91	163
04:30 PM	3	45	48	2	3	5	94	3	97	150
04:45 PM	5	59	64	0	2	2	98	6	104	170
Total	16	221	237	5	8	13	368	18	386	636
05:00 PM	4	57	61	0	1	1	93	4	97	159
05:15 PM	1	57	58	2	2	4	87	4	91	153
05:30 PM	4	48	52	1	7	8	86	9	95	155
05:45 PM	3	60	63	0	1	1	76	5	81	145
Total	12	222	234	3	11	14	342	22	364	612
Grand Total	28	443	471	8	19	27	710	40	750	1248
Apprch %	5.9	94.1		29.6	70.4		94.7	5.3		
Total %	2.2	35.5	37.7	0.6	1.5	2.2	56.9	3.2	60.1	

Start Time	Cruickshank Drive Westbound			10th Street Northbound			Cruickshank Drive Eastbound			Int. Total
	Left	Thru	App. Total	Left	Right	App. Total	Thru	Right	App. Total	
04:15 PM	4	65	69	3	0	3	88	3	91	163
04:30 PM	3	45	48	2	3	5	94	3	97	150
04:45 PM	5	59	64	0	2	2	98	6	104	170
05:00 PM	4	57	61	0	1	1	93	4	97	159
Total Volume	16	226	242	5	6	11	373	16	389	642
% App. Total	6.6	93.4		45.5	54.5		95.9	4.1		
PHF	.800	.869	.877	.417	.500	.550	.952	.667	.935	.944

Peak Hour Analysis From 04:00 PM to 05:45 PM - Peak 1 of 1
 Peak Hour for Entire Intersection Begins at 04:15 PM

County of Imperial
 N/S: 10th Street
 E/W: Cruickshank Drive
 Weather: Clear

File Name : 03_COI_10th_Cru PM
 Site Code : 122819
 Start Date : 9/21/2022
 Page No : 2

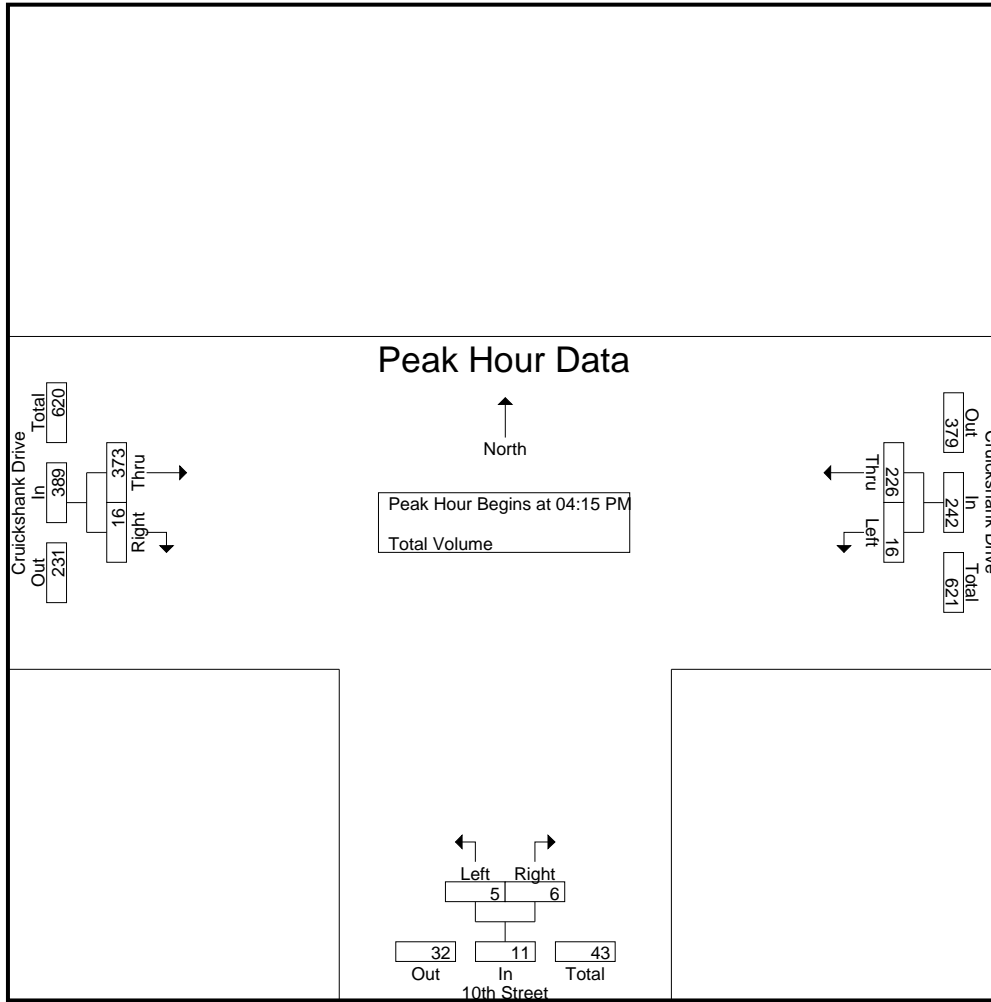

Peak Hour Analysis From 04:00 PM to 05:45 PM - Peak 1 of 1
 Peak Hour for Each Approach Begins at:

	04:15 PM			04:45 PM			04:15 PM		
+0 mins.	4	65	69	0	2	2	88	3	91
+15 mins.	3	45	48	0	1	1	94	3	97
+30 mins.	5	59	64	2	2	4	98	6	104
+45 mins.	4	57	61	1	7	8	93	4	97
Total Volume	16	226	242	3	12	15	373	16	389
% App. Total	6.6	93.4		20	80		95.9	4.1	
PHF	.800	.869	.877	.375	.429	.469	.952	.667	.935

Location: County of Imperial
 N/S: 10th Street
 E/W: Cruickshank Drive



Date: 9/21/2022
 Day: Wednesday

PEDESTRIANS

	North Leg Dead End	East Leg Cruickshank Drive	South Leg 10th Street	West Leg Cruickshank Drive	
	Pedestrians	Pedestrians	Pedestrians	Pedestrians	
7:00 AM	0	0	0	0	0
7:15 AM	0	0	0	0	0
7:30 AM	0	0	0	1	1
7:45 AM	0	0	1	1	2
8:00 AM	0	0	2	0	2
8:15 AM	0	0	1	0	1
8:30 AM	0	0	0	0	0
8:45 AM	0	0	1	0	1
TOTAL VOLUMES:	0	0	5	2	7

	North Leg Dead End	East Leg Cruickshank Drive	South Leg 10th Street	West Leg Cruickshank Drive	
	Pedestrians	Pedestrians	Pedestrians	Pedestrians	
4:00 PM	0	0	0	0	0
4:15 PM	0	0	0	0	0
4:30 PM	0	0	0	0	0
4:45 PM	0	0	0	0	0
5:00 PM	0	0	0	0	0
5:15 PM	0	0	0	0	0
5:30 PM	0	0	0	0	0
5:45 PM	0	0	0	0	0
TOTAL VOLUMES:	0	0	0	0	0

Location: County of Imperial
 N/S: 10th Street
 E/W: Cruickshank Drive



Date: 9/21/2022
 Day: Wednesday

BICYCLES

	Southbound Dead End			Westbound Cruickshank Drive			Northbound 10th Street			Eastbound Cruickshank Drive			
	Left	Thru	Right	Left	Thru	Right	Left	Thru	Right	Left	Thru	Right	
7:00 AM	0	0	0	0	0	0	0	0	0	0	0	0	0
7:15 AM	0	0	0	0	0	0	0	0	0	0	0	0	0
7:30 AM	0	0	0	0	0	0	0	0	0	0	0	0	0
7:45 AM	0	0	0	0	0	0	0	0	0	0	0	0	0
8:00 AM	0	0	0	0	0	0	0	0	0	0	0	0	0
8:15 AM	0	0	0	0	0	0	0	0	0	0	0	0	0
8:30 AM	0	0	0	0	0	0	0	0	0	0	0	0	0
8:45 AM	0	0	0	0	0	0	0	0	0	0	0	0	0
TOTAL VOLUMES:	0	0	0	0	0	0	0	0	0	0	0	0	0

	Southbound Dead End			Westbound Cruickshank Drive			Northbound 10th Street			Eastbound Cruickshank Drive			
	Left	Thru	Right	Left	Thru	Right	Left	Thru	Right	Left	Thru	Right	
4:00 PM	0	0	0	0	0	0	0	0	0	0	0	0	0
4:15 PM	0	0	0	0	0	0	0	0	0	0	0	0	0
4:30 PM	0	0	0	0	0	0	1	0	0	0	0	0	1
4:45 PM	0	0	0	0	0	0	0	0	0	0	0	0	0
5:00 PM	0	0	0	0	0	0	0	0	0	0	0	0	0
5:15 PM	0	0	0	0	1	0	0	0	0	0	0	0	1
5:30 PM	0	0	0	0	1	0	0	0	0	0	0	0	1
5:45 PM	0	0	0	0	0	0	0	0	0	0	0	0	0
TOTAL VOLUMES:	0	0	0	0	2	0	1	0	0	0	0	0	3

County of Imperial
 N/S: 8th Street
 E/W: Cruickshank Drive
 Weather: Clear

File Name : 04_COI_8th_Cru AM
 Site Code : 122819
 Start Date : 9/21/2022
 Page No : 1

Groups Printed- Total Volume

Start Time	8th Street Southbound			8th Street Northbound			Cruickshank Drive Eastbound			Int. Total
	Thru	Right	App. Total	Left	Thru	App. Total	Left	Right	App. Total	
07:00 AM	47	17	64	12	45	57	10	18	28	149
07:15 AM	72	12	84	15	62	77	10	23	33	194
07:30 AM	126	13	139	13	90	103	23	24	47	289
07:45 AM	118	20	138	39	88	127	20	24	44	309
Total	363	62	425	79	285	364	63	89	152	941
08:00 AM	68	24	92	38	89	127	26	24	50	269
08:15 AM	72	21	93	25	48	73	25	28	53	219
08:30 AM	55	17	72	15	53	68	22	39	61	201
08:45 AM	42	26	68	19	41	60	21	24	45	173
Total	237	88	325	97	231	328	94	115	209	862
Grand Total	600	150	750	176	516	692	157	204	361	1803
Apprch %	80	20		25.4	74.6		43.5	56.5		
Total %	33.3	8.3	41.6	9.8	28.6	38.4	8.7	11.3	20	

Start Time	8th Street Southbound			8th Street Northbound			Cruickshank Drive Eastbound			Int. Total
	Thru	Right	App. Total	Left	Thru	App. Total	Left	Right	App. Total	
07:30 AM	126	13	139	13	90	103	23	24	47	289
07:45 AM	118	20	138	39	88	127	20	24	44	309
08:00 AM	68	24	92	38	89	127	26	24	50	269
08:15 AM	72	21	93	25	48	73	25	28	53	219
Total Volume	384	78	462	115	315	430	94	100	194	1086
% App. Total	83.1	16.9		26.7	73.3		48.5	51.5		
PHF	.762	.813	.831	.737	.875	.846	.904	.893	.915	.879

Peak Hour Analysis From 07:00 AM to 08:45 AM - Peak 1 of 1

Peak Hour for Entire Intersection Begins at 07:30 AM

County of Imperial
 N/S: 8th Street
 E/W: Cruickshank Drive
 Weather: Clear

File Name : 04_COI_8th_Cru AM
 Site Code : 122819
 Start Date : 9/21/2022
 Page No : 2

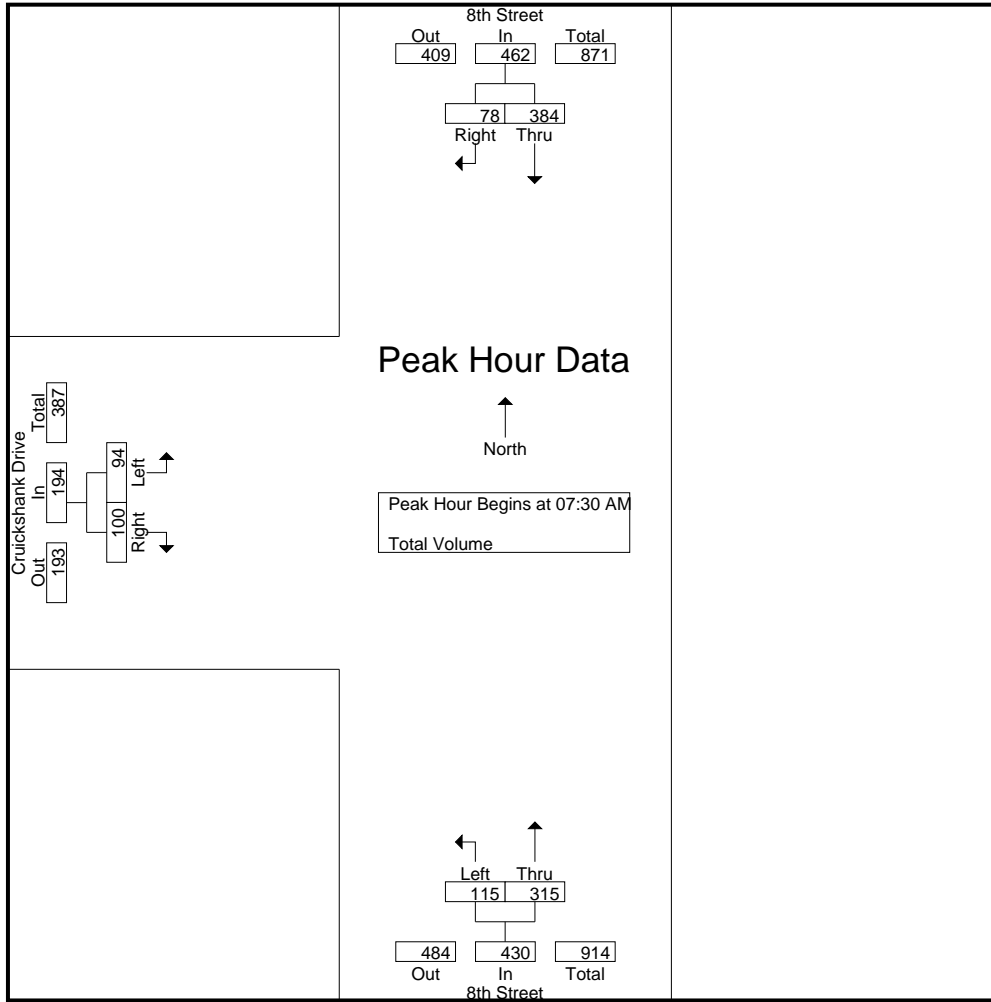

Peak Hour Analysis From 07:00 AM to 08:45 AM - Peak 1 of 1
 Peak Hour for Each Approach Begins at:

	07:30 AM			07:15 AM			08:00 AM		
+0 mins.	126	13	139	15	62	77	26	24	50
+15 mins.	118	20	138	13	90	103	25	28	53
+30 mins.	68	24	92	39	88	127	22	39	61
+45 mins.	72	21	93	38	89	127	21	24	45
Total Volume	384	78	462	105	329	434	94	115	209
% App. Total	83.1	16.9		24.2	75.8		45	55	
PHF	.762	.813	.831	.673	.914	.854	.904	.737	.857

County of Imperial
 N/S: 8th Street
 E/W: Cruickshank Drive
 Weather: Clear

File Name : 04_COI_8th_Cru PM
 Site Code : 122819
 Start Date : 9/21/2022
 Page No : 1

Groups Printed- Total Volume

Start Time	8th Street Southbound			8th Street Northbound			Cruickshank Drive Eastbound			Int. Total
	Thru	Right	App. Total	Left	Thru	App. Total	Left	Right	App. Total	
04:00 PM	86	21	107	32	88	120	45	45	90	317
04:15 PM	67	27	94	42	59	101	46	45	91	286
04:30 PM	72	19	91	30	86	116	47	46	93	300
04:45 PM	66	24	90	42	81	123	56	43	99	312
Total	291	91	382	146	314	460	194	179	373	1215
05:00 PM	77	24	101	37	120	157	45	40	85	343
05:15 PM	103	22	125	36	122	158	44	49	93	376
05:30 PM	77	16	93	34	111	145	51	42	93	331
05:45 PM	79	27	106	38	83	121	47	27	74	301
Total	336	89	425	145	436	581	187	158	345	1351
Grand Total	627	180	807	291	750	1041	381	337	718	2566
Apprch %	77.7	22.3		28	72		53.1	46.9		
Total %	24.4	7	31.4	11.3	29.2	40.6	14.8	13.1	28	

Start Time	8th Street Southbound			8th Street Northbound			Cruickshank Drive Eastbound			Int. Total
	Thru	Right	App. Total	Left	Thru	App. Total	Left	Right	App. Total	
04:45 PM	66	24	90	42	81	123	56	43	99	312
05:00 PM	77	24	101	37	120	157	45	40	85	343
05:15 PM	103	22	125	36	122	158	44	49	93	376
05:30 PM	77	16	93	34	111	145	51	42	93	331
Total Volume	323	86	409	149	434	583	196	174	370	1362
% App. Total	79	21		25.6	74.4		53	47		
PHF	.784	.896	.818	.887	.889	.922	.875	.888	.934	.906

Peak Hour Analysis From 04:00 PM to 05:45 PM - Peak 1 of 1
 Peak Hour for Entire Intersection Begins at 04:45 PM

County of Imperial
 N/S: 8th Street
 E/W: Cruickshank Drive
 Weather: Clear

File Name : 04_COI_8th_Cru PM
 Site Code : 122819
 Start Date : 9/21/2022
 Page No : 2

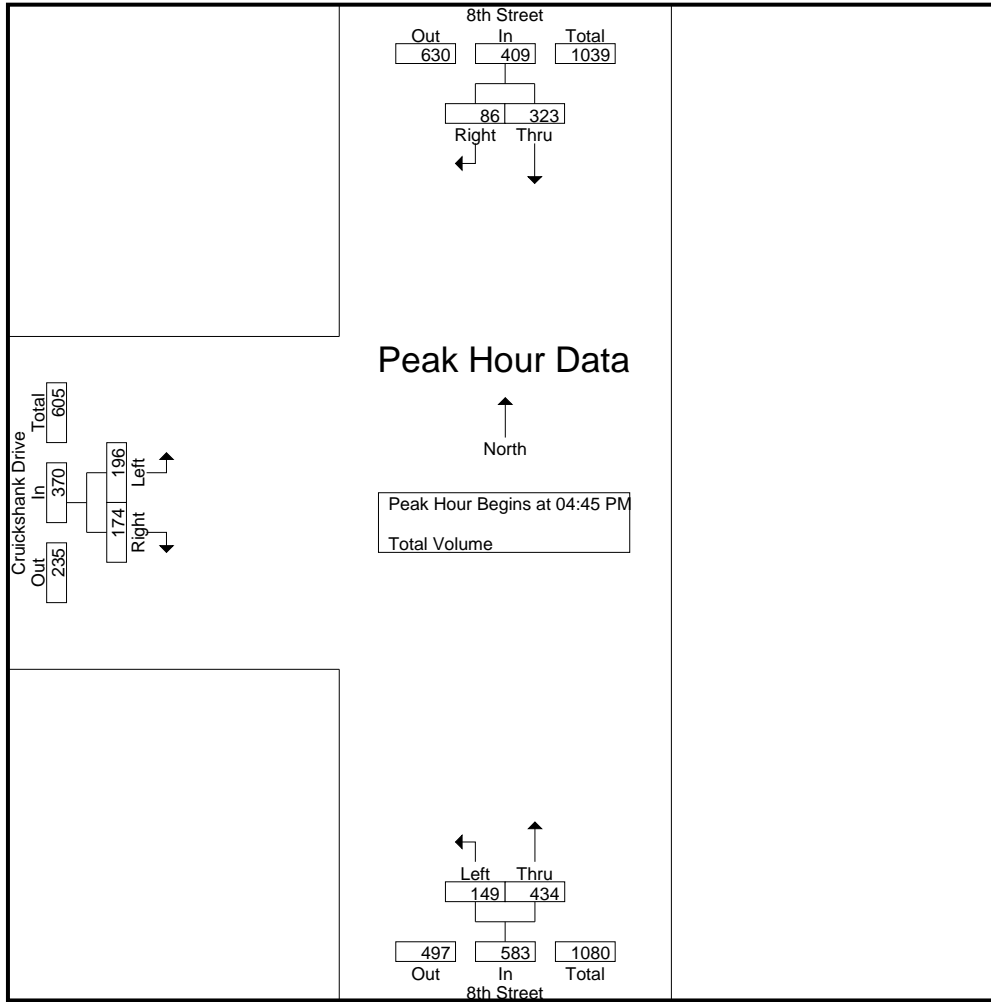

Peak Hour Analysis From 04:00 PM to 05:45 PM - Peak 1 of 1
 Peak Hour for Each Approach Begins at:

	05:00 PM			04:45 PM			04:00 PM		
+0 mins.	77	24	101	42	81	123	45	45	90
+15 mins.	103	22	125	37	120	157	46	45	91
+30 mins.	77	16	93	36	122	158	47	46	93
+45 mins.	79	27	106	34	111	145	56	43	99
Total Volume	336	89	425	149	434	583	194	179	373
% App. Total	79.1	20.9		25.6	74.4		52	48	
PHF	.816	.824	.850	.887	.889	.922	.866	.973	.942

Location: County of Imperial
 N/S: 8th Street
 E/W: Cruickshank Drive



Date: 9/21/2022
 Day: Wednesday

PEDESTRIANS

	North Leg 8th Street	East Leg Dead End	South Leg 8th Street	West Leg Cruickshank Drive	
	Pedestrians	Pedestrians	Pedestrians	Pedestrians	
7:00 AM	0	0	0	0	0
7:15 AM	0	0	0	0	0
7:30 AM	0	0	0	0	0
7:45 AM	0	0	0	0	0
8:00 AM	0	0	0	0	0
8:15 AM	0	0	0	0	0
8:30 AM	0	0	0	0	0
8:45 AM	0	0	0	0	0
TOTAL VOLUMES:	0	0	0	0	0

	North Leg 8th Street	East Leg Dead End	South Leg 8th Street	West Leg Cruickshank Drive	
	Pedestrians	Pedestrians	Pedestrians	Pedestrians	
4:00 PM	0	0	0	0	0
4:15 PM	0	0	0	0	0
4:30 PM	0	0	0	0	0
4:45 PM	0	0	0	0	0
5:00 PM	0	0	0	0	0
5:15 PM	0	0	0	0	0
5:30 PM	0	0	0	0	0
5:45 PM	0	0	0	0	0
TOTAL VOLUMES:	0	0	0	0	0

Location: County of Imperial
 N/S: 8th Street
 E/W: Cruickshank Drive



Date: 9/21/2022
 Day: Wednesday

BICYCLES

	Southbound 8th Street			Westbound Dead End			Northbound 8th Street			Eastbound Cruickshank Drive			
	Left	Thru	Right	Left	Thru	Right	Left	Thru	Right	Left	Thru	Right	
7:00 AM	0	0	0	0	0	0	0	1	0	0	0	0	1
7:15 AM	0	0	0	0	0	0	1	0	0	0	0	0	1
7:30 AM	0	0	0	0	0	0	0	0	0	0	0	0	0
7:45 AM	0	0	0	0	0	0	0	0	0	0	0	0	0
8:00 AM	0	1	0	0	0	0	0	0	0	0	0	0	1
8:15 AM	0	0	1	0	0	0	0	0	0	0	0	0	2
8:30 AM	0	0	0	0	0	0	0	1	0	0	0	0	1
8:45 AM	0	3	0	0	0	0	0	0	0	0	0	0	3
TOTAL VOLUMES:	0	4	1	0	0	0	1	2	0	0	0	1	9

	Southbound 8th Street			Westbound Dead End			Northbound 8th Street			Eastbound Cruickshank Drive			
	Left	Thru	Right	Left	Thru	Right	Left	Thru	Right	Left	Thru	Right	
4:00 PM	0	0	0	0	0	0	0	0	0	0	0	0	0
4:15 PM	0	0	0	0	0	0	0	0	0	0	0	0	0
4:30 PM	0	1	0	0	0	0	0	0	0	0	0	0	1
4:45 PM	0	0	0	0	0	0	0	0	0	0	0	0	0
5:00 PM	0	0	0	0	0	0	0	0	0	0	0	0	0
5:15 PM	0	0	0	0	0	0	1	0	0	0	0	0	1
5:30 PM	0	0	0	0	0	0	0	0	0	0	0	0	0
5:45 PM	0	0	0	0	0	0	0	0	0	0	0	0	0
TOTAL VOLUMES:	0	1	0	0	0	0	1	0	0	0	0	0	2

8th Street / Cruickshank Drive

Group Assignment: **None**
 Field Master Assignment: **None**
 System Reference Number:

N/S Street Name: **8th Street**
 E/W Street Name: **Cruickshank Drive**

Last Database Change: 3/27/2013 11:30

Change Record					
Change	By	Date	Change	By	Date

Notes: RBF 032713

Drop Number	1	<C+0+0>
Zone Number		<C+0+1>
Area Number	1	<C+0+2>
Area Address		<C+0+3>
QuicNet Channel		(QuicNet)

Manual Plan		<C+A+1>
Manual Offset		<C+B+1>

Max Initial	20	<F+0+E>
Red Revert	5.0	<F+0+F>
All Red Start	5.0	<F+C+0>

Communication Addresses

Manual Selection

Start / Revert Times

Row	Phase Names -->	Phase							
		1	2	3	4	5	6	7	8
0	Ped Walk		7		7	0	7		
1	Ped FDW		22		23	0	22		
2	Min Green		8		6	4	8		
3	Type 3 Limit		0		0	0	0		
4	Added Initial		0.0		0.0	0.0	0.0		
5	Veh Extension		5.0		4.0	2.0	5.0		
6	Max Gap		5.0		4.0	2.0	5.0		
7	Min Gap		2.0		2.0	2.0	2.0		
8	Max Limit		50		35	20	50		
9	Max Limit 2		0		0	0	0		
A									
B	Call To Phase		0		0	0	0		
C	Reduce By		0.1		0.1	0.1	0.1		
D	Reduce Every		1.0		1.0	1.0	1.0		
E	Yellow Change		4.4		4.5	3.0	4.4		
F	Red Clear		1.0		1.0	1.0	1.0		

Phase Timing - Bank 1

<F Page>

E		F	
RR-1 Delay	0	Permit	2_456__
RR-1 Clear	10	Red Lock	5
EV-A Delay	0	Yellow Lock	
EV-A Clear	1	Min Recall	2_6
EV-B Delay	0	Ped Recall	
EV-B Clear	1	View Set Peds	
EV-C Delay	0	Rest In Walk	
EV-C Clear	1	Red Rest	
EV-D Delay	0	Dual Entry	
EV-D Clear	1	Max Recall	
RR-2 Delay	0	Soft Recall	
RR-2 Clear	11	Max 2	
View EV Delay	---	Cond. Service	
View EV Clear	---	Man Cntrl Calls	
View RR Delay	---	Yellow Start	4
View RR Clear	---	First Phases	2_6

Preempt Timing

Phase Functions <F Page>

Manual Plan
 0 = Automatic
 1-9 = Plan 1-9
 14 = Free
 15 = Flash

Manual Offset
 0 = Automatic
 1 = Offset A
 2 = Offset B
 3 = Offset C

Appendix C: Existing HCM Worksheets

HCM 6th Signalized Intersection Summary
 1: Cruichshank Dr & Imperial Avenue

Existing AM
 03/07/2023



Movement	EBL	EBT	EBR	WBL	WBT	WBR	NBL	NBT	NBR	SBL	SBT	SBR
Lane Configurations												
Traffic Volume (veh/h)	177	99	54	7	79	110	79	598	41	165	828	295
Future Volume (veh/h)	177	99	54	7	79	110	79	598	41	165	828	295
Initial Q (Qb), veh	0	0	0	0	0	0	0	0	0	0	0	0
Ped-Bike Adj(A_pbT)	1.00		0.98	1.00		0.98	1.00		1.00	1.00		1.00
Parking Bus, Adj	1.00	1.00	1.00	1.00	1.00	1.00	1.00	1.00	1.00	1.00	1.00	1.00
Work Zone On Approach		No			No			No			No	
Adj Sat Flow, veh/h/ln	1870	1870	1870	1870	1870	1870	1870	1841	1870	1870	1841	1870
Adj Flow Rate, veh/h	224	125	68	9	103	143	86	650	45	217	1089	388
Peak Hour Factor	0.79	0.79	0.79	0.77	0.77	0.77	0.92	0.92	0.92	0.76	0.76	0.76
Percent Heavy Veh, %	2	2	2	2	2	2	2	4	2	2	4	2
Cap, veh/h	249	443	368	19	201	166	138	1468	665	232	1784	808
Arrive On Green	0.14	0.24	0.24	0.01	0.11	0.11	0.04	0.42	0.42	0.13	0.51	0.51
Sat Flow, veh/h	1781	1870	1556	1781	1870	1547	3456	3497	1585	1781	3497	1585
Grp Volume(v), veh/h	224	125	68	9	103	143	86	650	45	217	1089	388
Grp Sat Flow(s),veh/h/ln	1781	1870	1556	1781	1870	1547	1728	1749	1585	1781	1749	1585
Q Serve(g_s), s	15.5	6.8	4.4	0.6	6.5	11.4	3.1	16.6	2.1	15.1	27.7	19.9
Cycle Q Clear(g_c), s	15.5	6.8	4.4	0.6	6.5	11.4	3.1	16.6	2.1	15.1	27.7	19.9
Prop In Lane	1.00		1.00	1.00		1.00	1.00		1.00	1.00		1.00
Lane Grp Cap(c), veh/h	249	443	368	19	201	166	138	1468	665	232	1784	808
V/C Ratio(X)	0.90	0.28	0.18	0.47	0.51	0.86	0.62	0.44	0.07	0.93	0.61	0.48
Avail Cap(c_a), veh/h	369	688	572	71	380	314	138	1468	665	232	1784	808
HCM Platoon Ratio	1.00	1.00	1.00	1.00	1.00	1.00	1.00	1.00	1.00	1.00	1.00	1.00
Upstream Filter(I)	1.00	1.00	1.00	1.00	1.00	1.00	1.00	1.00	1.00	1.00	1.00	1.00
Uniform Delay (d), s/veh	52.9	39.0	38.1	61.5	52.7	54.8	59.1	25.9	21.7	53.8	21.8	19.9
Incr Delay (d2), s/veh	13.6	0.1	0.1	6.5	0.7	4.9	19.3	1.0	0.2	44.2	1.6	2.0
Initial Q Delay(d3),s/veh	0.0	0.0	0.0	0.0	0.0	0.0	0.0	0.0	0.0	0.0	0.0	0.0
%ile BackOfQ(50%),veh/ln	7.9	3.2	1.7	0.3	3.1	4.7	1.7	6.7	0.8	9.4	10.9	7.7
Unsig. Movement Delay, s/veh												
LnGrp Delay(d),s/veh	66.5	39.1	38.2	68.0	53.4	59.8	78.3	26.8	21.9	98.0	23.4	21.9
LnGrp LOS	E	D	D	E	D	E	E	C	C	F	C	C
Approach Vol, veh/h		417			255			781			1694	
Approach Delay, s/veh		53.7			57.5			32.2			32.6	
Approach LOS		D			E			C			C	
Timer - Assigned Phs	1	2	3	4	5	6	7	8				
Phs Duration (G+Y+Rc), s	10.7	71.3	23.2	19.8	22.0	60.0	7.0	36.0				
Change Period (Y+Rc), s	* 5.7	7.5	* 5.7	* 6.4	* 5.7	7.5	* 5.7	6.4				
Max Green Setting (Gmax), s	* 5	43.7	* 26	* 25	* 16	32.4	* 5	46.0				
Max Q Clear Time (g_c+I1), s	5.1	29.7	17.5	13.4	17.1	18.6	2.6	8.8				
Green Ext Time (p_c), s	0.0	4.7	0.0	0.1	0.0	2.2	0.0	0.1				

Intersection Summary

HCM 6th Ctrl Delay	37.3
HCM 6th LOS	D

Notes

User approved volume balancing among the lanes for turning movement.
 * HCM 6th computational engine requires equal clearance times for the phases crossing the barrier.

HCM 6th Signalized Intersection Summary
1: Cruichshank Dr & Imperial Avenue

Existing PM
03/07/2023



Movement	EBL	EBT	EBR	WBL	WBT	WBR	NBL	NBT	NBR	SBL	SBT	SBR
Lane Configurations												
Traffic Volume (veh/h)	267	287	120	27	131	238	95	760	36	161	662	381
Future Volume (veh/h)	267	287	120	27	131	238	95	760	36	161	662	381
Initial Q (Qb), veh	0	0	0	0	0	0	0	0	0	0	0	0
Ped-Bike Adj(A_pbT)	1.00		1.00	1.00		0.98	1.00		1.00	1.00		1.00
Parking Bus, Adj	1.00	1.00	1.00	1.00	1.00	1.00	1.00	1.00	1.00	1.00	1.00	1.00
Work Zone On Approach		No			No			No			No	
Adj Sat Flow, veh/h/ln	1870	1870	1870	1870	1870	1870	1870	1841	1870	1870	1841	1870
Adj Flow Rate, veh/h	287	309	129	35	168	305	108	864	41	169	697	401
Peak Hour Factor	0.93	0.93	0.93	0.78	0.78	0.78	0.88	0.88	0.88	0.95	0.95	0.95
Percent Heavy Veh, %	2	2	2	2	2	2	2	4	2	2	4	2
Cap, veh/h	304	657	556	50	391	326	229	1090	494	190	1230	558
Arrive On Green	0.17	0.35	0.35	0.03	0.21	0.21	0.07	0.31	0.31	0.11	0.35	0.35
Sat Flow, veh/h	1781	1870	1584	1781	1870	1560	3456	3497	1585	1781	3497	1585
Grp Volume(v), veh/h	287	309	129	35	168	305	108	864	41	169	697	401
Grp Sat Flow(s),veh/h/ln	1781	1870	1584	1781	1870	1560	1728	1749	1585	1781	1749	1585
Q Serve(g_s), s	19.9	16.0	7.2	2.4	9.8	24.0	3.8	28.2	2.3	11.7	20.2	27.4
Cycle Q Clear(g_c), s	19.9	16.0	7.2	2.4	9.8	24.0	3.8	28.2	2.3	11.7	20.2	27.4
Prop In Lane	1.00		1.00	1.00		1.00	1.00		1.00	1.00		1.00
Lane Grp Cap(c), veh/h	304	657	556	50	391	326	229	1090	494	190	1230	558
V/C Ratio(X)	0.95	0.47	0.23	0.70	0.43	0.94	0.47	0.79	0.08	0.89	0.57	0.72
Avail Cap(c_a), veh/h	304	688	583	71	449	375	229	1090	494	190	1230	558
HCM Platoon Ratio	1.00	1.00	1.00	1.00	1.00	1.00	1.00	1.00	1.00	1.00	1.00	1.00
Upstream Filter(I)	1.00	1.00	1.00	1.00	1.00	1.00	1.00	1.00	1.00	1.00	1.00	1.00
Uniform Delay (d), s/veh	51.3	31.5	28.6	60.2	43.0	48.6	56.2	39.3	30.4	55.1	32.8	35.2
Incr Delay (d2), s/veh	36.9	0.2	0.1	6.4	0.3	27.2	6.8	5.9	0.3	42.0	1.9	7.8
Initial Q Delay(d3),s/veh	0.0	0.0	0.0	0.0	0.0	0.0	0.0	0.0	0.0	0.0	0.0	0.0
%ile BackOfQ(50%),veh/ln	12.0	7.3	2.8	1.2	4.6	11.8	1.8	12.4	0.9	7.3	8.5	11.7
Unsig. Movement Delay, s/veh												
LnGrp Delay(d),s/veh	88.2	31.7	28.7	66.6	43.2	75.8	63.0	45.2	30.7	97.1	34.7	42.9
LnGrp LOS	F	C	C	E	D	E	E	D	C	F	C	D
Approach Vol, veh/h		725			508			1013			1267	
Approach Delay, s/veh		53.5			64.4			46.5			45.6	
Approach LOS		D			E			D			D	
Timer - Assigned Phs	1	2	3	4	5	6	7	8				
Phs Duration (G+Y+Rc), s	14.0	51.5	27.0	32.5	19.0	46.5	9.2	50.3				
Change Period (Y+Rc), s	* 5.7	7.5	* 5.7	* 6.4	* 5.7	7.5	* 5.7	6.4				
Max Green Setting (Gmax), s	* 8.3	40.4	* 21	* 30	* 13	35.4	* 5	46.0				
Max Q Clear Time (g_c+I1), s	5.8	29.4	21.9	26.0	13.7	30.2	4.4	18.0				
Green Ext Time (p_c), s	0.0	2.8	0.0	0.1	0.0	1.8	0.0	0.3				

Intersection Summary

HCM 6th Ctrl Delay	50.2
HCM 6th LOS	D

Notes

User approved volume balancing among the lanes for turning movement.
* HCM 6th computational engine requires equal clearance times for the phases crossing the barrier.

Intersection						
Int Delay, s/veh	0					
Movement	EBL	EBT	WBT	WBR	SBL	SBR
Lane Configurations	↘	↑↑	↑↑		↘	
Traffic Vol, veh/h	0	222	199	0	0	0
Future Vol, veh/h	0	222	199	0	0	0
Conflicting Peds, #/hr	0	0	0	0	0	0
Sign Control	Free	Free	Free	Free	Stop	Stop
RT Channelized	-	None	-	None	-	None
Storage Length	100	-	-	-	0	-
Veh in Median Storage, #	-	0	0	-	0	-
Grade, %	-	0	0	-	0	-
Peak Hour Factor	92	92	92	92	92	92
Heavy Vehicles, %	2	2	2	2	2	2
Mvmt Flow	0	241	216	0	0	0

Major/Minor	Major1	Major2	Minor2		
Conflicting Flow All	216	0	-	0	337 108
Stage 1	-	-	-	-	216 -
Stage 2	-	-	-	-	121 -
Critical Hdwy	4.14	-	-	-	6.84 6.94
Critical Hdwy Stg 1	-	-	-	-	5.84 -
Critical Hdwy Stg 2	-	-	-	-	5.84 -
Follow-up Hdwy	2.22	-	-	-	3.52 3.32
Pot Cap-1 Maneuver	1351	-	-	0	633 925
Stage 1	-	-	-	0	799 -
Stage 2	-	-	-	0	891 -
Platoon blocked, %		-	-		
Mov Cap-1 Maneuver	1351	-	-	-	633 925
Mov Cap-2 Maneuver	-	-	-	-	633 -
Stage 1	-	-	-	-	799 -
Stage 2	-	-	-	-	891 -

Approach	EB	WB	SB
HCM Control Delay, s	0	0	0
HCM LOS			A

Minor Lane/Major Mvmt	EBL	EBT	WBT	SBLn1
Capacity (veh/h)	1351	-	-	-
HCM Lane V/C Ratio	-	-	-	-
HCM Control Delay (s)	0	-	-	0
HCM Lane LOS	A	-	-	A
HCM 95th %tile Q(veh)	0	-	-	-

Intersection						
Int Delay, s/veh	0					
Movement	EBL	EBT	WBT	WBR	SBL	SBR
Lane Configurations	↘	↑↑	↑↑		↘	
Traffic Vol, veh/h	0	389	231	0	0	0
Future Vol, veh/h	0	389	231	0	0	0
Conflicting Peds, #/hr	0	0	0	0	0	0
Sign Control	Free	Free	Free	Free	Stop	Stop
RT Channelized	-	None	-	None	-	None
Storage Length	100	-	-	-	0	-
Veh in Median Storage, #	-	0	0	-	0	-
Grade, %	-	0	0	-	0	-
Peak Hour Factor	92	92	92	92	92	92
Heavy Vehicles, %	2	2	2	2	2	2
Mvmt Flow	0	423	251	0	0	0

Major/Minor	Major1	Major2	Minor2		
Conflicting Flow All	251	0	-	0	463 126
Stage 1	-	-	-	-	251 -
Stage 2	-	-	-	-	212 -
Critical Hdwy	4.14	-	-	-	6.84 6.94
Critical Hdwy Stg 1	-	-	-	-	5.84 -
Critical Hdwy Stg 2	-	-	-	-	5.84 -
Follow-up Hdwy	2.22	-	-	-	3.52 3.32
Pot Cap-1 Maneuver	1311	-	-	0	528 901
Stage 1	-	-	-	0	768 -
Stage 2	-	-	-	0	803 -
Platoon blocked, %		-	-		
Mov Cap-1 Maneuver	1311	-	-	-	528 901
Mov Cap-2 Maneuver	-	-	-	-	528 -
Stage 1	-	-	-	-	768 -
Stage 2	-	-	-	-	803 -

Approach	EB	WB	SB
HCM Control Delay, s	0	0	0
HCM LOS			A

Minor Lane/Major Mvmt	EBL	EBT	WBT	SBLn1
Capacity (veh/h)	1311	-	-	-
HCM Lane V/C Ratio	-	-	-	-
HCM Control Delay (s)	0	-	-	0
HCM Lane LOS	A	-	-	A
HCM 95th %tile Q(veh)	0	-	-	-

Intersection						
Int Delay, s/veh	0.7					
Movement	EBT	EBR	WBL	WBT	NBL	NBR
Lane Configurations	↑↑		↘	↑↑	↘	
Traffic Vol, veh/h	198	24	19	195	4	8
Future Vol, veh/h	198	24	19	195	4	8
Conflicting Peds, #/hr	0	5	5	0	2	0
Sign Control	Free	Free	Free	Free	Stop	Stop
RT Channelized	-	None	-	None	-	None
Storage Length	-	-	90	-	0	-
Veh in Median Storage, #	0	-	-	0	0	-
Grade, %	0	-	-	0	0	-
Peak Hour Factor	91	91	72	72	75	75
Heavy Vehicles, %	2	2	2	2	2	2
Mvmt Flow	218	26	26	271	5	11

Major/Minor	Major1	Major2	Minor1		
Conflicting Flow All	0	0	249	0	426
Stage 1	-	-	-	-	236
Stage 2	-	-	-	-	190
Critical Hdwy	-	-	4.14	-	6.84
Critical Hdwy Stg 1	-	-	-	-	5.84
Critical Hdwy Stg 2	-	-	-	-	5.84
Follow-up Hdwy	-	-	2.22	-	3.52
Pot Cap-1 Maneuver	-	-	1314	-	557
Stage 1	-	-	-	-	781
Stage 2	-	-	-	-	823
Platoon blocked, %	-	-	-	-	-
Mov Cap-1 Maneuver	-	-	1309	-	543
Mov Cap-2 Maneuver	-	-	-	-	543
Stage 1	-	-	-	-	778
Stage 2	-	-	-	-	805

Approach	EB	WB	NB
HCM Control Delay, s	0	0.7	10
HCM LOS			B

Minor Lane/Major Mvmt	NBLn1	EBT	EBR	WBL	WBT
Capacity (veh/h)	736	-	-	1309	-
HCM Lane V/C Ratio	0.022	-	-	0.02	-
HCM Control Delay (s)	10	-	-	7.8	-
HCM Lane LOS	B	-	-	A	-
HCM 95th %tile Q(veh)	0.1	-	-	0.1	-

Intersection						
Int Delay, s/veh	0.5					
Movement	EBT	EBR	WBL	WBT	NBL	NBR
Lane Configurations	↑↑		↘	↑↑	↘	
Traffic Vol, veh/h	373	16	16	226	5	6
Future Vol, veh/h	373	16	16	226	5	6
Conflicting Peds, #/hr	0	0	0	0	0	0
Sign Control	Free	Free	Free	Free	Stop	Stop
RT Channelized	-	None	-	None	-	None
Storage Length	-	-	90	-	0	-
Veh in Median Storage, #	0	-	-	0	0	-
Grade, %	0	-	-	0	0	-
Peak Hour Factor	94	94	88	88	55	55
Heavy Vehicles, %	2	2	2	2	2	2
Mvmt Flow	397	17	18	257	9	11

Major/Minor	Major1	Major2	Minor1	Minor2	Minor3
Conflicting Flow All	0	0	414	0	571
Stage 1	-	-	-	-	406
Stage 2	-	-	-	-	165
Critical Hdwy	-	-	4.14	-	6.84
Critical Hdwy Stg 1	-	-	-	-	5.84
Critical Hdwy Stg 2	-	-	-	-	5.84
Follow-up Hdwy	-	-	2.22	-	3.52
Pot Cap-1 Maneuver	-	-	1141	-	451
Stage 1	-	-	-	-	641
Stage 2	-	-	-	-	847
Platoon blocked, %	-	-	-	-	-
Mov Cap-1 Maneuver	-	-	1141	-	444
Mov Cap-2 Maneuver	-	-	-	-	444
Stage 1	-	-	-	-	641
Stage 2	-	-	-	-	833

Approach	EB	WB	NB
HCM Control Delay, s	0	0.5	11.4
HCM LOS			B

Minor Lane/Major Mvmt	NBLn1	EBT	EBR	WBL	WBT
Capacity (veh/h)	586	-	-	1141	-
HCM Lane V/C Ratio	0.034	-	-	0.016	-
HCM Control Delay (s)	11.4	-	-	8.2	-
HCM Lane LOS	B	-	-	A	-
HCM 95th %tile Q(veh)	0.1	-	-	0	-

HCM 6th Signalized Intersection Summary
4: 8th St

Existing AM
11/02/2022



Movement	EBL	EBR	NBL	NBT	SBT	SBR
Lane Configurations						
Traffic Volume (veh/h)	94	100	115	315	384	78
Future Volume (veh/h)	94	100	115	315	384	78
Initial Q (Qb), veh	0	0	0	0	0	0
Ped-Bike Adj(A_pbT)	1.00	1.00	1.00			0.98
Parking Bus, Adj	1.00	1.00	1.00	1.00	1.00	1.00
Work Zone On Approach	No			No	No	
Adj Sat Flow, veh/h/ln	1870	1870	1870	1870	1870	1870
Adj Flow Rate, veh/h	102	109	135	371	463	94
Peak Hour Factor	0.92	0.92	0.85	0.85	0.83	0.83
Percent Heavy Veh, %	2	2	2	2	2	2
Cap, veh/h	398	183	172	2459	1539	310
Arrive On Green	0.12	0.12	0.10	0.69	0.52	0.52
Sat Flow, veh/h	3456	1585	1781	3647	3027	591
Grp Volume(v), veh/h	102	109	135	371	279	278
Grp Sat Flow(s),veh/h/ln	1728	1585	1781	1777	1777	1748
Q Serve(g_s), s	1.5	3.7	4.2	2.0	5.0	5.1
Cycle Q Clear(g_c), s	1.5	3.7	4.2	2.0	5.0	5.1
Prop In Lane	1.00	1.00	1.00			0.34
Lane Grp Cap(c), veh/h	398	183	172	2459	932	917
V/C Ratio(X)	0.26	0.60	0.79	0.15	0.30	0.30
Avail Cap(c_a), veh/h	1834	841	189	2459	932	917
HCM Platoon Ratio	1.00	1.00	1.00	1.00	1.00	1.00
Upstream Filter(I)	1.00	1.00	1.00	1.00	1.00	1.00
Uniform Delay (d), s/veh	22.8	23.8	25.0	3.0	7.6	7.6
Incr Delay (d2), s/veh	0.5	4.4	15.7	0.1	0.8	0.9
Initial Q Delay(d3),s/veh	0.0	0.0	0.0	0.0	0.0	0.0
%ile BackOfQ(50%),veh/ln	0.6	0.2	2.4	0.5	1.7	1.7
Unsig. Movement Delay, s/veh						
LnGrp Delay(d),s/veh	23.3	28.1	40.7	3.1	8.4	8.4
LnGrp LOS	C	C	D	A	A	A
Approach Vol, veh/h	211			506	557	
Approach Delay, s/veh	25.8			13.2	8.4	
Approach LOS	C			B	A	
Timer - Assigned Phs		2		4	5	6
Phs Duration (G+Y+Rc), s		44.5		12.0	9.4	35.1
Change Period (Y+Rc), s		5.4		5.5	4.0	5.4
Max Green Setting (Gmax), s		39.1		30.0	6.0	29.1
Max Q Clear Time (g_c+I1), s		4.0		5.7	6.2	7.1
Green Ext Time (p_c), s		5.0		1.1	0.0	6.3
Intersection Summary						
HCM 6th Ctrl Delay			13.2			
HCM 6th LOS			B			

HCM 6th Signalized Intersection Summary
4: 8th St

Existing PM
11/02/2022



Movement	EBL	EBR	NBL	NBT	SBT	SBR
Lane Configurations						
Traffic Volume (veh/h)	196	174	149	434	323	86
Future Volume (veh/h)	196	174	149	434	323	86
Initial Q (Qb), veh	0	0	0	0	0	0
Ped-Bike Adj(A_pbT)	1.00	1.00	1.00			0.98
Parking Bus, Adj	1.00	1.00	1.00	1.00	1.00	1.00
Work Zone On Approach	No			No	No	
Adj Sat Flow, veh/h/ln	1870	1870	1870	1870	1870	1870
Adj Flow Rate, veh/h	211	187	162	472	394	105
Peak Hour Factor	0.93	0.93	0.92	0.92	0.82	0.82
Percent Heavy Veh, %	2	2	2	2	2	2
Cap, veh/h	614	281	176	2286	1325	349
Arrive On Green	0.18	0.18	0.10	0.64	0.48	0.48
Sat Flow, veh/h	3456	1585	1781	3647	2862	729
Grp Volume(v), veh/h	211	187	162	472	251	248
Grp Sat Flow(s),veh/h/ln	1728	1585	1781	1777	1777	1721
Q Serve(g_s), s	3.3	6.7	5.5	3.3	5.2	5.3
Cycle Q Clear(g_c), s	3.3	6.7	5.5	3.3	5.2	5.3
Prop In Lane	1.00	1.00	1.00			0.42
Lane Grp Cap(c), veh/h	614	281	176	2286	851	824
V/C Ratio(X)	0.34	0.66	0.92	0.21	0.30	0.30
Avail Cap(c_a), veh/h	1705	782	176	2286	851	824
HCM Platoon Ratio	1.00	1.00	1.00	1.00	1.00	1.00
Upstream Filter(I)	1.00	1.00	1.00	1.00	1.00	1.00
Uniform Delay (d), s/veh	21.9	23.3	27.2	4.5	9.6	9.7
Incr Delay (d2), s/veh	0.5	3.8	45.1	0.2	0.9	0.9
Initial Q Delay(d3),s/veh	0.0	0.0	0.0	0.0	0.0	0.0
%ile BackOfQ(50%),veh/ln	1.3	6.0	4.4	0.9	1.9	1.9
Unsig. Movement Delay, s/veh						
LnGrp Delay(d),s/veh	22.4	27.1	72.3	4.7	10.5	10.6
LnGrp LOS	C	C	E	A	B	B
Approach Vol, veh/h	398			634	499	
Approach Delay, s/veh	24.6			22.0	10.5	
Approach LOS	C			C	B	
Timer - Assigned Phs		2		4	5	6
Phs Duration (G+Y+Rc), s		44.5		16.3	10.0	34.5
Change Period (Y+Rc), s		5.4		5.5	4.0	5.4
Max Green Setting (Gmax), s		39.1		30.0	6.0	29.1
Max Q Clear Time (g_c+I1), s		5.3		8.7	7.5	7.3
Green Ext Time (p_c), s		6.5		2.1	0.0	5.6
Intersection Summary						
HCM 6th Ctrl Delay			18.9			
HCM 6th LOS			B			

**Appendix D:
Opening Year 2024
Without Project
HCM Worksheets**

HCM 6th Signalized Intersection Summary
 1: Cruichshank Dr & Imperial Avenue



Movement	EBL	EBT	EBR	WBL	WBT	WBR	NBL	NBT	NBR	SBL	SBT	SBR
Lane Configurations												
Traffic Volume (veh/h)	132	114	84	36	136	116	94	500	69	134	654	241
Future Volume (veh/h)	132	114	84	36	136	116	94	500	69	134	654	241
Initial Q (Qb), veh	0	0	0	0	0	0	0	0	0	0	0	0
Ped-Bike Adj(A_pbT)	1.00		0.99	1.00		1.00	1.00		1.00	1.00		0.99
Parking Bus, Adj	1.00	1.00	1.00	1.00	1.00	1.00	1.00	1.00	1.00	1.00	1.00	1.00
Work Zone On Approach		No			No			No			No	
Adj Sat Flow, veh/h/ln	1870	1870	1870	1870	1870	1870	1870	1841	1870	1870	1841	1870
Adj Flow Rate, veh/h	159	137	101	43	162	138	108	575	79	154	752	277
Peak Hour Factor	0.83	0.83	0.83	0.84	0.84	0.84	0.87	0.87	0.87	0.87	0.87	0.87
Percent Heavy Veh, %	2	2	2	2	2	2	2	4	2	2	4	2
Cap, veh/h	185	328	276	55	192	163	229	1640	742	218	1836	820
Arrive On Green	0.10	0.18	0.18	0.03	0.10	0.10	0.07	0.47	0.47	0.12	0.52	0.52
Sat Flow, veh/h	1781	1870	1574	1781	1870	1585	3456	3497	1582	1781	3497	1562
Grp Volume(v), veh/h	159	137	101	43	162	138	108	575	79	154	752	277
Grp Sat Flow(s),veh/h/ln	1781	1870	1574	1781	1870	1585	1728	1749	1582	1781	1749	1562
Q Serve(g_s), s	11.0	8.1	7.1	3.0	10.6	10.7	3.8	13.1	3.5	10.4	16.3	12.8
Cycle Q Clear(g_c), s	11.0	8.1	7.1	3.0	10.6	10.7	3.8	13.1	3.5	10.4	16.3	12.8
Prop In Lane	1.00		1.00	1.00		1.00	1.00		1.00	1.00		1.00
Lane Grp Cap(c), veh/h	185	328	276	55	192	163	229	1640	742	218	1836	820
V/C Ratio(X)	0.86	0.42	0.37	0.78	0.84	0.85	0.47	0.35	0.11	0.71	0.41	0.34
Avail Cap(c_a), veh/h	286	688	579	76	471	399	229	1640	742	218	1836	820
HCM Platoon Ratio	1.00	1.00	1.00	1.00	1.00	1.00	1.00	1.00	1.00	1.00	1.00	1.00
Upstream Filter(I)	1.00	1.00	1.00	1.00	1.00	1.00	1.00	1.00	1.00	1.00	1.00	1.00
Uniform Delay (d), s/veh	55.1	45.9	45.4	60.1	55.1	55.1	56.2	21.1	18.6	52.7	18.0	17.1
Incr Delay (d2), s/veh	9.5	0.3	0.3	19.8	3.8	4.6	6.8	0.6	0.3	17.5	0.7	1.1
Initial Q Delay(d3),s/veh	0.0	0.0	0.0	0.0	0.0	0.0	0.0	0.0	0.0	0.0	0.0	0.0
%ile BackOfQ(50%),veh/ln	5.4	3.8	2.8	1.7	5.2	4.5	1.8	5.2	1.3	5.6	6.3	4.8
Unsig. Movement Delay, s/veh												
LnGrp Delay(d),s/veh	64.7	46.2	45.7	80.0	58.9	59.7	63.0	21.7	18.8	70.2	18.7	18.3
LnGrp LOS	E	D	D	E	E	E	E	C	B	E	B	B
Approach Vol, veh/h		397			343			762			1183	
Approach Delay, s/veh		53.5			61.9			27.3			25.3	
Approach LOS		D			E			C			C	
Timer - Assigned Phs	1	2	3	4	5	6	7	8				
Phs Duration (G+Y+Rc), s	14.0	73.1	18.7	19.2	21.0	66.1	9.6	28.3				
Change Period (Y+Rc), s	* 5.7	7.5	* 5.7	* 6.4	* 5.7	7.5	* 5.7	6.4				
Max Green Setting (Gmax), s	* 8.3	40.1	* 20	* 32	* 15	33.1	* 5.3	46.0				
Max Q Clear Time (g_c+I1), s	5.8	18.3	13.0	12.7	12.4	15.1	5.0	10.1				
Green Ext Time (p_c), s	0.0	3.4	0.0	0.1	0.0	2.2	0.0	0.1				

Intersection Summary

HCM 6th Ctrl Delay	34.7
HCM 6th LOS	C

Notes

- User approved pedestrian interval to be less than phase max green.
- User approved volume balancing among the lanes for turning movement.
- * HCM 6th computational engine requires equal clearance times for the phases crossing the barrier.

HCM 6th Signalized Intersection Summary
1: Cruichshank Dr & Imperial Avenue

OY 2024 PM
03/08/2023



Movement	EBL	EBT	EBR	WBL	WBT	WBR	NBL	NBT	NBR	SBL	SBT	SBR
Lane Configurations												
Traffic Volume (veh/h)	276	228	306	53	184	224	161	758	70	180	689	276
Future Volume (veh/h)	276	228	306	53	184	224	161	758	70	180	689	276
Initial Q (Qb), veh	0	0	0	0	0	0	0	0	0	0	0	0
Ped-Bike Adj(A_pbT)	1.00		1.00	1.00		1.00	1.00		1.00	1.00		1.00
Parking Bus, Adj	1.00	1.00	1.00	1.00	1.00	1.00	1.00	1.00	1.00	1.00	1.00	1.00
Work Zone On Approach		No			No			No			No	
Adj Sat Flow, veh/h/ln	1870	1870	1870	1870	1870	1870	1870	1841	1870	1870	1841	1870
Adj Flow Rate, veh/h	297	308	287	68	236	287	183	861	80	189	725	291
Peak Hour Factor	0.93	0.93	0.93	0.78	0.78	0.78	0.88	0.88	0.88	0.95	0.95	0.95
Percent Heavy Veh, %	2	2	2	2	2	2	2	4	2	2	4	2
Cap, veh/h	321	352	297	323	364	309	254	1086	492	204	1229	556
Arrive On Green	0.18	0.19	0.19	0.18	0.19	0.19	0.07	0.31	0.31	0.11	0.35	0.35
Sat Flow, veh/h	1781	1870	1577	1781	1870	1585	3456	3497	1585	1781	3497	1584
Grp Volume(v), veh/h	297	308	287	68	236	287	183	861	80	189	725	291
Grp Sat Flow(s),veh/h/ln	1781	1870	1577	1781	1870	1585	1728	1749	1585	1781	1749	1584
Q Serve(g_s), s	20.5	20.0	17.8	4.1	14.5	22.3	6.5	28.1	2.7	13.1	21.2	18.3
Cycle Q Clear(g_c), s	20.5	20.0	17.8	4.1	14.5	22.3	6.5	28.1	2.7	13.1	21.2	18.3
Prop In Lane	1.00		1.00	1.00		1.00	1.00		1.00	1.00		1.00
Lane Grp Cap(c), veh/h	321	352	297	323	364	309	254	1086	492	204	1229	556
V/C Ratio(X)	0.92	0.88	0.97	0.21	0.65	0.93	0.72	0.79	0.16	0.93	0.59	0.52
Avail Cap(c_a), veh/h	369	688	581	323	392	332	254	1086	492	204	1229	556
HCM Platoon Ratio	1.00	1.00	1.00	1.00	1.00	1.00	1.00	1.00	1.00	1.00	1.00	1.00
Upstream Filter(I)	1.00	1.00	1.00	1.00	1.00	1.00	1.00	1.00	1.00	1.00	1.00	1.00
Uniform Delay (d), s/veh	50.4	49.3	31.4	43.6	46.4	49.5	56.6	39.4	10.5	54.8	33.2	32.2
Incr Delay (d2), s/veh	25.3	2.7	8.9	0.1	2.4	29.8	16.1	6.0	0.7	46.6	2.1	3.5
Initial Q Delay(d3),s/veh	0.0	0.0	0.0	0.0	0.0	0.0	0.0	0.0	0.0	0.0	0.0	0.0
%ile BackOfQ(50%),veh/ln	11.4	9.6	7.5	1.8	7.0	11.3	3.3	12.4	1.8	8.3	8.9	7.5
Unsig. Movement Delay, s/veh												
LnGrp Delay(d),s/veh	75.7	52.1	40.4	43.7	48.8	79.3	72.7	45.4	11.2	101.4	35.3	35.7
LnGrp LOS	E	D	D	D	D	E	E	D	B	F	D	D
Approach Vol, veh/h		892			591			1124			1205	
Approach Delay, s/veh		56.2			63.0			47.4			45.7	
Approach LOS		E			E			D			D	
Timer - Assigned Phs	1	2	3	4	5	6	7	8				
Phs Duration (G+Y+Rc), s	14.9	51.4	28.2	30.4	20.0	46.3	28.8	29.9				
Change Period (Y+Rc), s	* 5.7	7.5	* 5.7	6.1	* 5.7	7.5	6.1	* 6.4				
Max Green Setting (Gmax), s	* 9.2	38.7	* 26	26.2	* 14	33.6	5.8	* 46				
Max Q Clear Time (g_c+I1), s	8.5	23.2	22.5	24.3	15.1	30.1	6.1	22.0				
Green Ext Time (p_c), s	0.0	3.0	0.0	0.1	0.0	1.3	0.0	0.3				

Intersection Summary

HCM 6th Ctrl Delay	51.3
HCM 6th LOS	D

Notes

User approved volume balancing among the lanes for turning movement.
* HCM 6th computational engine requires equal clearance times for the phases crossing the barrier.

Intersection						
Int Delay, s/veh	0.5					
Movement	EBL	EBT	WBT	WBR	SBL	SBR
Lane Configurations	↘	↑↑	↑↑		↘	
Traffic Vol, veh/h	15	268	256	3	3	14
Future Vol, veh/h	15	268	256	3	3	14
Conflicting Peds, #/hr	0	0	0	0	0	0
Sign Control	Free	Free	Free	Free	Stop	Stop
RT Channelized	-	None	-	None	-	None
Storage Length	100	-	-	-	0	-
Veh in Median Storage, #	-	0	0	-	0	-
Grade, %	-	0	0	-	0	-
Peak Hour Factor	92	92	92	92	92	92
Heavy Vehicles, %	2	2	2	2	2	2
Mvmt Flow	16	291	278	3	3	15

Major/Minor	Major1	Major2	Minor2		
Conflicting Flow All	281	0	-	0	458 141
Stage 1	-	-	-	-	280 -
Stage 2	-	-	-	-	178 -
Critical Hdwy	4.14	-	-	-	6.84 6.94
Critical Hdwy Stg 1	-	-	-	-	5.84 -
Critical Hdwy Stg 2	-	-	-	-	5.84 -
Follow-up Hdwy	2.22	-	-	-	3.52 3.32
Pot Cap-1 Maneuver	1278	-	-	-	531 881
Stage 1	-	-	-	-	742 -
Stage 2	-	-	-	-	835 -
Platoon blocked, %		-	-	-	
Mov Cap-1 Maneuver	1278	-	-	-	524 881
Mov Cap-2 Maneuver	-	-	-	-	524 -
Stage 1	-	-	-	-	732 -
Stage 2	-	-	-	-	835 -

Approach	EB	WB	SB
HCM Control Delay, s	0.4	0	9.7
HCM LOS			A

Minor Lane/Major Mvmt	EBL	EBT	WBT	WBR	SBLn1
Capacity (veh/h)	1278	-	-	-	786
HCM Lane V/C Ratio	0.013	-	-	-	0.024
HCM Control Delay (s)	7.9	-	-	-	9.7
HCM Lane LOS	A	-	-	-	A
HCM 95th %tile Q(veh)	0	-	-	-	0.1

Intersection						
Int Delay, s/veh	0.4					
Movement	EBL	EBT	WBT	WBR	SBL	SBR
Lane Configurations	↘	↑↑	↑↑		↘	
Traffic Vol, veh/h	14	445	282	5	6	17
Future Vol, veh/h	14	445	282	5	6	17
Conflicting Peds, #/hr	0	0	0	0	0	0
Sign Control	Free	Free	Free	Free	Stop	Stop
RT Channelized	-	None	-	None	-	None
Storage Length	100	-	-	-	0	-
Veh in Median Storage, #	-	0	0	-	0	-
Grade, %	-	0	0	-	0	-
Peak Hour Factor	92	92	92	92	92	92
Heavy Vehicles, %	2	2	2	2	2	2
Mvmt Flow	15	484	307	5	7	18

Major/Minor	Major1	Major2	Minor2		
Conflicting Flow All	312	0	-	0	582 156
Stage 1	-	-	-	-	310 -
Stage 2	-	-	-	-	272 -
Critical Hdwy	4.14	-	-	-	6.84 6.94
Critical Hdwy Stg 1	-	-	-	-	5.84 -
Critical Hdwy Stg 2	-	-	-	-	5.84 -
Follow-up Hdwy	2.22	-	-	-	3.52 3.32
Pot Cap-1 Maneuver	1245	-	-	-	444 862
Stage 1	-	-	-	-	717 -
Stage 2	-	-	-	-	749 -
Platoon blocked, %		-	-	-	
Mov Cap-1 Maneuver	1245	-	-	-	439 862
Mov Cap-2 Maneuver	-	-	-	-	439 -
Stage 1	-	-	-	-	708 -
Stage 2	-	-	-	-	749 -

Approach	EB	WB	SB
HCM Control Delay, s	0.2	0	10.4
HCM LOS			B

Minor Lane/Major Mvmt	EBL	EBT	WBT	WBR	SBLn1
Capacity (veh/h)	1245	-	-	-	689
HCM Lane V/C Ratio	0.012	-	-	-	0.036
HCM Control Delay (s)	7.9	-	-	-	10.4
HCM Lane LOS	A	-	-	-	B
HCM 95th %tile Q(veh)	0	-	-	-	0.1

Intersection						
Int Delay, s/veh	1.2					
Movement	EBT	EBR	WBL	WBT	NBL	NBR
Lane Configurations	↑↑		↘	↑↑	↘	
Traffic Vol, veh/h	231	42	22	233	25	14
Future Vol, veh/h	231	42	22	233	25	14
Conflicting Peds, #/hr	0	5	5	0	2	0
Sign Control	Free	Free	Free	Free	Stop	Stop
RT Channelized	-	None	-	None	-	None
Storage Length	-	-	90	-	0	-
Veh in Median Storage, #	0	-	-	0	0	-
Grade, %	0	-	-	0	0	-
Peak Hour Factor	91	91	72	72	75	75
Heavy Vehicles, %	2	2	2	2	2	2
Mvmt Flow	254	46	31	324	33	19

Major/Minor	Major1	Major2	Minor1	Minor2	Minor3
Conflicting Flow All	0	0	305	0	508
Stage 1	-	-	-	-	282
Stage 2	-	-	-	-	226
Critical Hdwy	-	-	4.14	-	6.84
Critical Hdwy Stg 1	-	-	-	-	5.84
Critical Hdwy Stg 2	-	-	-	-	5.84
Follow-up Hdwy	-	-	2.22	-	3.52
Pot Cap-1 Maneuver	-	-	1253	-	494
Stage 1	-	-	-	-	741
Stage 2	-	-	-	-	790
Platoon blocked, %	-	-	-	-	-
Mov Cap-1 Maneuver	-	-	1248	-	479
Mov Cap-2 Maneuver	-	-	-	-	479
Stage 1	-	-	-	-	738
Stage 2	-	-	-	-	769

Approach	EB	WB	NB
HCM Control Delay, s	0	0.7	12
HCM LOS			B

Minor Lane/Major Mvmt	NBLn1	EBT	EBR	WBL	WBT
Capacity (veh/h)	569	-	-	1248	-
HCM Lane V/C Ratio	0.091	-	-	0.024	-
HCM Control Delay (s)	12	-	-	8	-
HCM Lane LOS	B	-	-	A	-
HCM 95th %tile Q(veh)	0.3	-	-	0.1	-

Intersection						
Int Delay, s/veh	1.4					
Movement	EBT	EBR	WBL	WBT	NBL	NBR
Lane Configurations	↑↑		↘	↑↑	↘	
Traffic Vol, veh/h	412	39	21	260	25	14
Future Vol, veh/h	412	39	21	260	25	14
Conflicting Peds, #/hr	0	0	0	0	0	0
Sign Control	Free	Free	Free	Free	Stop	Stop
RT Channelized	-	None	-	None	-	None
Storage Length	-	-	90	-	0	-
Veh in Median Storage, #	0	-	-	0	0	-
Grade, %	0	-	-	0	0	-
Peak Hour Factor	94	94	88	88	55	55
Heavy Vehicles, %	2	2	2	2	2	2
Mvmt Flow	438	41	24	295	45	25

Major/Minor	Major1	Major2	Minor1		
Conflicting Flow All	0	0	479	0	655
Stage 1	-	-	-	-	459
Stage 2	-	-	-	-	196
Critical Hdwy	-	-	4.14	-	6.84
Critical Hdwy Stg 1	-	-	-	-	5.84
Critical Hdwy Stg 2	-	-	-	-	5.84
Follow-up Hdwy	-	-	2.22	-	3.52
Pot Cap-1 Maneuver	-	-	1080	-	399
Stage 1	-	-	-	-	603
Stage 2	-	-	-	-	818
Platoon blocked, %	-	-	-	-	-
Mov Cap-1 Maneuver	-	-	1080	-	390
Mov Cap-2 Maneuver	-	-	-	-	390
Stage 1	-	-	-	-	603
Stage 2	-	-	-	-	800

Approach	EB	WB	NB
HCM Control Delay, s	0	0.6	13.9
HCM LOS			B

Minor Lane/Major Mvmt	NBLn1	EBT	EBR	WBL	WBT
Capacity (veh/h)	473	-	-	1080	-
HCM Lane V/C Ratio	0.15	-	-	0.022	-
HCM Control Delay (s)	13.9	-	-	8.4	-
HCM Lane LOS	B	-	-	A	-
HCM 95th %tile Q(veh)	0.5	-	-	0.1	-

HCM 6th Signalized Intersection Summary
4: 8th St & Cruickshank Dr

OY 2024 AM

Page 1



Movement	EBL	EBR	NBL	NBT	SBT	SBR
Lane Configurations						
Traffic Volume (veh/h)	106	104	139	318	385	102
Future Volume (veh/h)	106	104	139	318	385	102
Initial Q (Qb), veh	0	0	0	0	0	0
Ped-Bike Adj(A_pbT)	1.00	1.00	1.00			0.98
Parking Bus, Adj	1.00	1.00	1.00	1.00	1.00	1.00
Work Zone On Approach	No			No	No	
Adj Sat Flow, veh/h/ln	1870	1870	1870	1870	1870	1870
Adj Flow Rate, veh/h	115	113	164	374	464	123
Peak Hour Factor	0.92	0.92	0.85	0.85	0.83	0.83
Percent Heavy Veh, %	2	2	2	2	2	2
Cap, veh/h	414	190	188	2446	1418	373
Arrive On Green	0.12	0.12	0.11	0.69	0.51	0.51
Sat Flow, veh/h	3456	1585	1781	3647	2862	728
Grp Volume(v), veh/h	115	113	164	374	296	291
Grp Sat Flow(s),veh/h/ln	1728	1585	1781	1777	1777	1719
Q Serve(g_s), s	1.7	3.8	5.2	2.1	5.5	5.6
Cycle Q Clear(g_c), s	1.7	3.8	5.2	2.1	5.5	5.6
Prop In Lane	1.00	1.00	1.00			0.42
Lane Grp Cap(c), veh/h	414	190	188	2446	910	881
V/C Ratio(X)	0.28	0.59	0.87	0.15	0.33	0.33
Avail Cap(c_a), veh/h	1825	837	188	2446	910	881
HCM Platoon Ratio	1.00	1.00	1.00	1.00	1.00	1.00
Upstream Filter(I)	1.00	1.00	1.00	1.00	1.00	1.00
Uniform Delay (d), s/veh	22.8	23.7	25.0	3.1	8.1	8.1
Incr Delay (d2), s/veh	0.5	4.2	32.0	0.1	1.0	1.0
Initial Q Delay(d3),s/veh	0.0	0.0	0.0	0.0	0.0	0.0
%ile BackOfQ(50%),veh/ln	0.7	0.2	3.7	0.5	2.0	1.9
Unsig. Movement Delay, s/veh						
LnGrp Delay(d),s/veh	23.3	27.9	57.0	3.2	9.1	9.1
LnGrp LOS	C	C	E	A	A	A
Approach Vol, veh/h	228			538	587	
Approach Delay, s/veh	25.6			19.6	9.1	
Approach LOS	C			B	A	
Timer - Assigned Phs		2		4	5	6
Phs Duration (G+Y+Rc), s		44.5		12.3	10.0	34.5
Change Period (Y+Rc), s		5.4		5.5	4.0	5.4
Max Green Setting (Gmax), s		39.1		30.0	6.0	29.1
Max Q Clear Time (g_c+I1), s		4.1		5.8	7.2	7.6
Green Ext Time (p_c), s		5.1		1.2	0.0	6.7
Intersection Summary						
HCM 6th Ctrl Delay			16.1			
HCM 6th LOS			B			

HCM 6th Signalized Intersection Summary
4: 8th St & Cruickshank Dr

OY 2024 PM
03/07/2023



Movement	EBL	EBR	NBL	NBT	SBT	SBR
Lane Configurations						
Traffic Volume (veh/h)	217	187	166	436	326	111
Future Volume (veh/h)	217	187	166	436	326	111
Initial Q (Qb), veh	0	0	0	0	0	0
Ped-Bike Adj(A_pbT)	1.00	1.00	1.00			0.98
Parking Bus, Adj	1.00	1.00	1.00	1.00	1.00	1.00
Work Zone On Approach	No			No	No	
Adj Sat Flow, veh/h/ln	1870	1870	1870	1870	1870	1870
Adj Flow Rate, veh/h	233	201	180	474	398	135
Peak Hour Factor	0.93	0.93	0.92	0.92	0.82	0.82
Percent Heavy Veh, %	2	2	2	2	2	2
Cap, veh/h	650	298	174	2257	1228	411
Arrive On Green	0.19	0.19	0.10	0.64	0.47	0.47
Sat Flow, veh/h	3456	1585	1781	3647	2693	870
Grp Volume(v), veh/h	233	201	180	474	270	263
Grp Sat Flow(s),veh/h/ln	1728	1585	1781	1777	1777	1692
Q Serve(g_s), s	3.6	7.3	6.0	3.5	5.8	6.0
Cycle Q Clear(g_c), s	3.6	7.3	6.0	3.5	5.8	6.0
Prop In Lane	1.00	1.00	1.00			0.51
Lane Grp Cap(c), veh/h	650	298	174	2257	840	800
V/C Ratio(X)	0.36	0.67	1.04	0.21	0.32	0.33
Avail Cap(c_a), veh/h	1684	772	174	2257	840	800
HCM Platoon Ratio	1.00	1.00	1.00	1.00	1.00	1.00
Upstream Filter(I)	1.00	1.00	1.00	1.00	1.00	1.00
Uniform Delay (d), s/veh	21.8	23.2	27.8	4.7	10.1	10.1
Incr Delay (d2), s/veh	0.5	3.8	78.4	0.2	1.0	1.1
Initial Q Delay(d3),s/veh	0.0	0.0	0.0	0.0	0.0	0.0
%ile BackOfQ(50%),veh/ln	1.4	6.5	6.2	1.0	2.2	2.1
Unsig. Movement Delay, s/veh						
LnGrp Delay(d),s/veh	22.2	27.0	106.2	4.9	11.1	11.2
LnGrp LOS	C	C	F	A	B	B
Approach Vol, veh/h	434			654	533	
Approach Delay, s/veh	24.5			32.8	11.2	
Approach LOS	C			C	B	
Timer - Assigned Phs		2		4	5	6
Phs Duration (G+Y+Rc), s		44.5		17.1	10.0	34.5
Change Period (Y+Rc), s		5.4		5.5	4.0	5.4
Max Green Setting (Gmax), s		39.1		30.0	6.0	29.1
Max Q Clear Time (g_c+I1), s		5.5		9.3	8.0	8.0
Green Ext Time (p_c), s		6.6		2.3	0.0	6.0
Intersection Summary						
HCM 6th Ctrl Delay			23.5			
HCM 6th LOS			C			

**Appendix E:
Opening Year 2024
Plus Project
HCM Worksheets**

HCM 6th Signalized Intersection Summary
 1: Cruichshank Dr & Imperial Avenue

OY 2024 + P AM
 With Improvement 03/08/2023



Movement	EBL	EBT	EBR	WBL	WBT	WBR	NBL	NBT	NBR	SBL	SBT	SBR
Lane Configurations												
Traffic Volume (veh/h)	132	121	84	55	139	126	94	500	95	148	654	241
Future Volume (veh/h)	132	121	84	55	139	126	94	500	95	148	654	241
Initial Q (Qb), veh	0	0	0	0	0	0	0	0	0	0	0	0
Ped-Bike Adj(A_pbT)	1.00		0.99	1.00		1.00	1.00		1.00	1.00		0.99
Parking Bus, Adj	1.00	1.00	1.00	1.00	1.00	1.00	1.00	1.00	1.00	1.00	1.00	1.00
Work Zone On Approach		No			No			No			No	
Adj Sat Flow, veh/h/ln	1870	1870	1870	1870	1870	1870	1870	1841	1870	1870	1841	1870
Adj Flow Rate, veh/h	159	146	101	65	165	150	108	575	109	170	752	277
Peak Hour Factor	0.83	0.83	0.83	0.84	0.84	0.84	0.87	0.87	0.87	0.87	0.87	0.87
Percent Heavy Veh, %	2	2	2	2	2	2	2	4	2	2	4	2
Cap, veh/h	185	313	263	83	206	175	229	1642	743	204	1810	808
Arrive On Green	0.10	0.17	0.17	0.05	0.11	0.11	0.07	0.47	0.47	0.11	0.52	0.52
Sat Flow, veh/h	1781	1870	1574	1781	1870	1585	3456	3497	1582	1781	3497	1562
Grp Volume(v), veh/h	159	146	101	65	165	150	108	575	109	170	752	277
Grp Sat Flow(s),veh/h/ln	1781	1870	1574	1781	1870	1585	1728	1749	1582	1781	1749	1562
Q Serve(g_s), s	11.0	8.8	7.1	4.5	10.8	11.6	3.8	13.0	4.9	11.7	16.5	13.0
Cycle Q Clear(g_c), s	11.0	8.8	7.1	4.5	10.8	11.6	3.8	13.0	4.9	11.7	16.5	13.0
Prop In Lane	1.00		1.00	1.00		1.00	1.00		1.00	1.00		1.00
Lane Grp Cap(c), veh/h	185	313	263	83	206	175	229	1642	743	204	1810	808
V/C Ratio(X)	0.86	0.47	0.38	0.78	0.80	0.86	0.47	0.35	0.15	0.83	0.42	0.34
Avail Cap(c_a), veh/h	286	688	579	90	486	412	229	1642	743	204	1810	808
HCM Platoon Ratio	1.00	1.00	1.00	1.00	1.00	1.00	1.00	1.00	1.00	1.00	1.00	1.00
Upstream Filter(I)	1.00	1.00	1.00	1.00	1.00	1.00	1.00	1.00	1.00	1.00	1.00	1.00
Uniform Delay (d), s/veh	55.1	47.0	46.3	59.0	54.3	54.7	56.2	21.1	18.9	54.2	18.5	17.7
Incr Delay (d2), s/veh	9.5	0.4	0.3	29.4	2.7	4.7	6.8	0.6	0.4	31.3	0.7	1.2
Initial Q Delay(d3),s/veh	0.0	0.0	0.0	0.0	0.0	0.0	0.0	0.0	0.0	0.0	0.0	0.0
%ile BackOfQ(50%),veh/ln	5.4	4.2	2.8	2.7	5.2	4.9	1.8	5.2	1.9	6.8	6.4	4.9
Unsig. Movement Delay, s/veh												
LnGrp Delay(d),s/veh	64.7	47.4	46.7	88.4	57.0	59.3	63.0	21.6	19.3	85.5	19.2	18.8
LnGrp LOS	E	D	D	F	E	E	E	C	B	F	B	B
Approach Vol, veh/h		406			380			792			1199	
Approach Delay, s/veh		54.0			63.3			27.0			28.5	
Approach LOS		D			E			C			C	
Timer - Assigned Phs	1	2	3	4	5	6	7	8				
Phs Duration (G+Y+Rc), s	14.0	72.2	18.7	20.2	20.0	66.2	11.5	27.3				
Change Period (Y+Rc), s	* 5.7	7.5	* 5.7	* 6.4	* 5.7	7.5	* 5.7	6.4				
Max Green Setting (Gmax), s	* 8.3	39.1	* 20	* 33	* 14	33.1	* 6.3	46.0				
Max Q Clear Time (g_c+I1), s	5.8	18.5	13.0	13.6	13.7	15.0	6.5	10.8				
Green Ext Time (p_c), s	0.0	3.4	0.0	0.1	0.0	2.2	0.0	0.1				

Intersection Summary

HCM 6th Ctrl Delay	36.6
HCM 6th LOS	D

Notes

User approved volume balancing among the lanes for turning movement.
 * HCM 6th computational engine requires equal clearance times for the phases crossing the barrier.

HCM 6th Signalized Intersection Summary
 1: Cruichshank Dr & Imperial Avenue

OY 2024 + P PM
 With Improvements 03/08/2023



Movement	EBL	EBT	EBR	WBL	WBT	WBR	NBL	NBT	NBR	SBL	SBT	SBR
Lane Configurations												
Traffic Volume (veh/h)	228	313	159	78	188	237	161	758	97	195	689	276
Future Volume (veh/h)	228	313	159	78	188	237	161	758	97	195	689	276
Initial Q (Qb), veh	0	0	0	0	0	0	0	0	0	0	0	0
Ped-Bike Adj(A_pbT)	1.00		1.00	1.00		1.00	1.00		1.00	1.00		1.00
Parking Bus, Adj	1.00	1.00	1.00	1.00	1.00	1.00	1.00	1.00	1.00	1.00	1.00	1.00
Work Zone On Approach		No			No			No			No	
Adj Sat Flow, veh/h/ln	1870	1870	1870	1870	1870	1870	1870	1841	1870	1870	1841	1870
Adj Flow Rate, veh/h	245	337	171	100	241	304	183	861	110	205	725	291
Peak Hour Factor	0.93	0.93	0.93	0.78	0.78	0.78	0.88	0.88	0.88	0.95	0.95	0.95
Percent Heavy Veh, %	2	2	2	2	2	2	2	4	2	2	4	2
Cap, veh/h	270	558	471	105	385	326	254	1148	520	200	1282	581
Arrive On Green	0.15	0.30	0.30	0.06	0.21	0.21	0.07	0.33	0.33	0.11	0.37	0.37
Sat Flow, veh/h	1781	1870	1580	1781	1870	1585	3456	3497	1585	1781	3497	1584
Grp Volume(v), veh/h	245	337	171	100	241	304	183	861	110	205	725	291
Grp Sat Flow(s),veh/h/ln	1781	1870	1580	1781	1870	1585	1728	1749	1585	1781	1749	1584
Q Serve(g_s), s	16.9	19.3	10.6	7.0	14.7	23.6	6.5	27.4	6.3	14.0	20.7	17.8
Cycle Q Clear(g_c), s	16.9	19.3	10.6	7.0	14.7	23.6	6.5	27.4	6.3	14.0	20.7	17.8
Prop In Lane	1.00		1.00	1.00		1.00	1.00		1.00	1.00		1.00
Lane Grp Cap(c), veh/h	270	558	471	105	385	326	254	1148	520	200	1282	581
V/C Ratio(X)	0.91	0.60	0.36	0.95	0.63	0.93	0.72	0.75	0.21	1.03	0.57	0.50
Avail Cap(c_a), veh/h	314	688	582	105	474	402	254	1148	520	200	1282	581
HCM Platoon Ratio	1.00	1.00	1.00	1.00	1.00	1.00	1.00	1.00	1.00	1.00	1.00	1.00
Upstream Filter(I)	1.00	1.00	1.00	1.00	1.00	1.00	1.00	1.00	1.00	1.00	1.00	1.00
Uniform Delay (d), s/veh	52.2	37.6	34.5	58.6	45.2	48.8	56.6	37.4	30.3	55.5	31.6	30.7
Incr Delay (d2), s/veh	24.7	0.4	0.2	70.4	0.7	23.5	16.1	4.5	0.9	71.1	1.8	3.1
Initial Q Delay(d3),s/veh	0.0	0.0	0.0	0.0	0.0	0.0	0.0	0.0	0.0	0.0	0.0	0.0
%ile BackOfQ(50%),veh/ln	9.4	8.9	4.1	5.2	6.9	11.4	3.3	11.9	2.5	10.0	8.6	7.3
Unsig. Movement Delay, s/veh												
LnGrp Delay(d),s/veh	76.8	37.9	34.7	129.0	46.0	72.3	72.7	41.9	31.2	126.6	33.4	33.8
LnGrp LOS	E	D	C	F	D	E	E	D	C	F	C	C
Approach Vol, veh/h		753			645			1154			1221	
Approach Delay, s/veh		49.9			71.2			45.8			49.2	
Approach LOS		D			E			D			D	
Timer - Assigned Phs	1	2	3	4	5	6	7	8				
Phs Duration (G+Y+Rc), s	14.9	53.3	24.6	32.1	19.7	48.5	13.1	43.7				
Change Period (Y+Rc), s	* 5.7	7.5	* 5.7	* 6.4	* 5.7	7.5	* 5.7	6.4				
Max Green Setting (Gmax), s	* 9.2	37.1	* 22	* 32	* 14	32.3	* 7.4	46.0				
Max Q Clear Time (g_c+I1), s	8.5	22.7	18.9	25.6	16.0	29.4	9.0	21.3				
Green Ext Time (p_c), s	0.0	3.0	0.0	0.2	0.0	1.2	0.0	0.3				

Intersection Summary

HCM 6th Ctrl Delay	52.0
HCM 6th LOS	D

Notes

- User approved volume balancing among the lanes for turning movement.
- * HCM 6th computational engine requires equal clearance times for the phases crossing the barrier.
- User approved changes to right turn type.

Intersection						
Int Delay, s/veh	1.5					
Movement	EBL	EBT	WBT	WBR	SBL	SBR
Lane Configurations	↘	↑↑	↑↑	↗	↘	↘
Traffic Vol, veh/h	49	279	264	27	21	38
Future Vol, veh/h	49	279	264	27	21	38
Conflicting Peds, #/hr	0	0	0	0	0	0
Sign Control	Free	Free	Free	Free	Stop	Stop
RT Channelized	-	None	-	None	-	None
Storage Length	100	-	-	100	0	-
Veh in Median Storage, #	-	0	0	-	0	-
Grade, %	-	0	0	-	0	-
Peak Hour Factor	92	92	92	92	92	92
Heavy Vehicles, %	2	2	2	2	2	2
Mvmt Flow	53	303	287	29	23	41

Major/Minor	Major1	Major2	Minor2		
Conflicting Flow All	316	0	-	0	545 144
Stage 1	-	-	-	-	287 -
Stage 2	-	-	-	-	258 -
Critical Hdwy	4.14	-	-	-	6.84 6.94
Critical Hdwy Stg 1	-	-	-	-	5.84 -
Critical Hdwy Stg 2	-	-	-	-	5.84 -
Follow-up Hdwy	2.22	-	-	-	3.52 3.32
Pot Cap-1 Maneuver	1241	-	-	-	468 877
Stage 1	-	-	-	-	736 -
Stage 2	-	-	-	-	761 -
Platoon blocked, %		-	-	-	
Mov Cap-1 Maneuver	1241	-	-	-	448 877
Mov Cap-2 Maneuver	-	-	-	-	448 -
Stage 1	-	-	-	-	704 -
Stage 2	-	-	-	-	761 -

Approach	EB	WB	SB
HCM Control Delay, s	1.2	0	11.1
HCM LOS			B

Minor Lane/Major Mvmt	EBL	EBT	WBT	WBR	SBLn1
Capacity (veh/h)	1241	-	-	-	654
HCM Lane V/C Ratio	0.043	-	-	-	0.098
HCM Control Delay (s)	8	-	-	-	11.1
HCM Lane LOS	A	-	-	-	B
HCM 95th %tile Q(veh)	0.1	-	-	-	0.3

Intersection						
Int Delay, s/veh	1.6					
Movement	EBL	EBT	WBT	WBR	SBL	SBR
Lane Configurations						
Traffic Vol, veh/h	49	467	302	30	38	40
Future Vol, veh/h	49	467	302	30	38	40
Conflicting Peds, #/hr	0	0	0	0	0	0
Sign Control	Free	Free	Free	Free	Stop	Stop
RT Channelized	-	None	-	None	-	None
Storage Length	100	-	-	90	0	-
Veh in Median Storage, #	-	0	0	-	0	-
Grade, %	-	0	0	-	0	-
Peak Hour Factor	92	92	92	92	92	92
Heavy Vehicles, %	2	2	2	2	2	2
Mvmt Flow	53	508	328	33	41	43

Major/Minor	Major1	Major2	Minor2		
Conflicting Flow All	361	0	-	0	688
Stage 1	-	-	-	-	328
Stage 2	-	-	-	-	360
Critical Hdwy	4.14	-	-	-	6.84
Critical Hdwy Stg 1	-	-	-	-	5.84
Critical Hdwy Stg 2	-	-	-	-	5.84
Follow-up Hdwy	2.22	-	-	-	3.52
Pot Cap-1 Maneuver	1194	-	-	-	380
Stage 1	-	-	-	-	702
Stage 2	-	-	-	-	677
Platoon blocked, %		-	-	-	
Mov Cap-1 Maneuver	1194	-	-	-	363
Mov Cap-2 Maneuver	-	-	-	-	363
Stage 1	-	-	-	-	671
Stage 2	-	-	-	-	677

Approach	EB	WB	SB
HCM Control Delay, s	0.8	0	13.4
HCM LOS			B

Minor Lane/Major Mvmt	EBL	EBT	WBT	WBR	SBLn1
Capacity (veh/h)	1194	-	-	-	514
HCM Lane V/C Ratio	0.045	-	-	-	0.165
HCM Control Delay (s)	8.2	-	-	-	13.4
HCM Lane LOS	A	-	-	-	B
HCM 95th %tile Q(veh)	0.1	-	-	-	0.6

Intersection												
Int Delay, s/veh	1.9											
Movement	EBL	EBT	EBR	WBL	WBT	WBR	NBL	NBT	NBR	SBL	SBT	SBR
Lane Configurations	↘	↑↑		↘	↑↑			↔			↔	
Traffic Vol, veh/h	11	245	45	22	253	20	30	5	14	3	8	11
Future Vol, veh/h	11	245	45	22	253	20	30	5	14	3	8	11
Conflicting Peds, #/hr	0	0	5	5	0	0	2	0	0	0	0	0
Sign Control	Free	Free	Free	Free	Free	Free	Stop	Stop	Stop	Stop	Stop	Stop
RT Channelized	-	-	None	-	-	None	-	-	None	-	-	None
Storage Length	100	-	-	90	-	-	-	-	-	-	-	-
Veh in Median Storage, #	-	0	-	-	0	-	-	0	-	-	0	-
Grade, %	-	0	-	-	0	-	-	0	-	-	0	-
Peak Hour Factor	92	91	91	72	72	92	75	92	75	92	92	92
Heavy Vehicles, %	2	2	2	2	2	2	2	2	2	2	2	2
Mvmt Flow	12	269	49	31	351	22	40	5	19	3	9	12

Major/Minor	Major1			Major2			Minor1			Minor2		
Conflicting Flow All	373	0	0	323	0	0	567	758	164	585	771	189
Stage 1	-	-	-	-	-	-	323	323	-	424	424	-
Stage 2	-	-	-	-	-	-	244	435	-	161	347	-
Critical Hdwy	4.14	-	-	4.14	-	-	7.54	6.54	6.94	7.54	6.54	6.94
Critical Hdwy Stg 1	-	-	-	-	-	-	6.54	5.54	-	6.54	5.54	-
Critical Hdwy Stg 2	-	-	-	-	-	-	6.54	5.54	-	6.54	5.54	-
Follow-up Hdwy	2.22	-	-	2.22	-	-	3.52	4.02	3.32	3.52	4.02	3.32
Pot Cap-1 Maneuver	1182	-	-	1234	-	-	406	335	852	394	329	821
Stage 1	-	-	-	-	-	-	663	649	-	578	585	-
Stage 2	-	-	-	-	-	-	738	579	-	825	633	-
Platoon blocked, %	-	-	-	-	-	-	-	-	-	-	-	-
Mov Cap-1 Maneuver	1182	-	-	1229	-	-	379	322	848	370	316	820
Mov Cap-2 Maneuver	-	-	-	-	-	-	379	322	-	370	316	-
Stage 1	-	-	-	-	-	-	654	640	-	572	570	-
Stage 2	-	-	-	-	-	-	697	565	-	792	624	-

Approach	EB			WB			NB			SB		
HCM Control Delay, s	0.3			0.6			14.5			13.1		
HCM LOS							B			B		

Minor Lane/Major Mvmt	NBLn1	EBL	EBT	EBR	WBL	WBT	WBR	SBLn1
Capacity (veh/h)	444	1182	-	-	1229	-	-	470
HCM Lane V/C Ratio	0.144	0.01	-	-	0.025	-	-	0.051
HCM Control Delay (s)	14.5	8.1	-	-	8	-	-	13.1
HCM Lane LOS	B	A	-	-	A	-	-	B
HCM 95th %tile Q(veh)	0.5	0	-	-	0.1	-	-	0.2

Intersection												
Int Delay, s/veh	2.2											
Movement	EBL	EBT	EBR	WBL	WBT	WBR	NBL	NBT	NBR	SBL	SBT	SBR
Lane Configurations		↑↑		↑	↑↑	↑		↔			↔	
Traffic Vol, veh/h	22	434	40	21	285	15	26	1	14	13	1	20
Future Vol, veh/h	22	434	40	21	285	15	26	1	14	13	1	20
Conflicting Peds, #/hr	0	0	0	0	0	0	0	0	0	0	0	0
Sign Control	Free	Free	Free	Free	Free	Free	Stop	Stop	Stop	Stop	Stop	Stop
RT Channelized	-	-	None	-	-	None	-	-	None	-	-	None
Storage Length	-	-	-	90	-	90	-	-	-	-	-	-
Veh in Median Storage, #	-	0	-	-	0	-	-	0	-	-	0	-
Grade, %	-	0	-	-	0	-	-	0	-	-	0	-
Peak Hour Factor	92	94	94	88	88	92	55	92	55	92	92	92
Heavy Vehicles, %	2	2	2	2	2	2	2	2	2	2	2	2
Mvmt Flow	24	462	43	24	324	16	47	1	25	14	1	22

Major/Minor	Major1			Major2			Minor1			Minor2		
Conflicting Flow All	340	0	0	505	0	0	743	920	253	652	925	162
Stage 1	-	-	-	-	-	-	532	532	-	372	372	-
Stage 2	-	-	-	-	-	-	211	388	-	280	553	-
Critical Hdwy	4.14	-	-	4.14	-	-	7.54	6.54	6.94	7.54	6.54	6.94
Critical Hdwy Stg 1	-	-	-	-	-	-	6.54	5.54	-	6.54	5.54	-
Critical Hdwy Stg 2	-	-	-	-	-	-	6.54	5.54	-	6.54	5.54	-
Follow-up Hdwy	2.22	-	-	2.22	-	-	3.52	4.02	3.32	3.52	4.02	3.32
Pot Cap-1 Maneuver	1216	-	-	1056	-	-	304	269	746	353	268	854
Stage 1	-	-	-	-	-	-	499	524	-	621	617	-
Stage 2	-	-	-	-	-	-	771	607	-	703	513	-
Platoon blocked, %	-	-	-	-	-	-	-	-	-	-	-	-
Mov Cap-1 Maneuver	1216	-	-	1056	-	-	284	256	746	327	255	854
Mov Cap-2 Maneuver	-	-	-	-	-	-	284	256	-	327	255	-
Stage 1	-	-	-	-	-	-	485	509	-	604	603	-
Stage 2	-	-	-	-	-	-	733	593	-	659	499	-

Approach	EB			WB			NB			SB		
HCM Control Delay, s	0.4			0.6			17.6			12.7		
HCM LOS							C			B		

Minor Lane/Major Mvmt	NBLn1	EBL	EBT	EBR	WBL	WBT	WBR	SBLn1
Capacity (veh/h)	360	1216	-	-	1056	-	-	507
HCM Lane V/C Ratio	0.205	0.02	-	-	0.023	-	-	0.073
HCM Control Delay (s)	17.6	8	-	-	8.5	-	-	12.7
HCM Lane LOS	C	A	-	-	A	-	-	B
HCM 95th %tile Q(veh)	0.8	0.1	-	-	0.1	-	-	0.2

HCM 6th Signalized Intersection Summary
4: 8th St & Cruickshank Dr

OY 2024 + P AM
With Improvement 03/08/2023



Movement	EBL	EBR	NBL	NBT	SBT	SBR
Lane Configurations						
Traffic Volume (veh/h)	118	121	163	318	385	118
Future Volume (veh/h)	118	121	163	318	385	118
Initial Q (Qb), veh	0	0	0	0	0	0
Ped-Bike Adj(A_pbT)	1.00	1.00	1.00			0.98
Parking Bus, Adj	1.00	1.00	1.00	1.00	1.00	1.00
Work Zone On Approach	No			No	No	
Adj Sat Flow, veh/h/ln	1870	1870	1870	1870	1870	1870
Adj Flow Rate, veh/h	128	132	192	374	464	142
Peak Hour Factor	0.92	0.92	0.85	0.85	0.83	0.83
Percent Heavy Veh, %	2	2	2	2	2	2
Cap, veh/h	464	213	185	2405	1345	408
Arrive On Green	0.13	0.13	0.10	0.68	0.50	0.50
Sat Flow, veh/h	3456	1585	1781	3647	2763	810
Grp Volume(v), veh/h	128	132	192	374	308	298
Grp Sat Flow(s),veh/h/ln	1728	1585	1781	1777	1777	1702
Q Serve(g_s), s	1.9	4.5	6.0	2.2	6.0	6.1
Cycle Q Clear(g_c), s	1.9	4.5	6.0	2.2	6.0	6.1
Prop In Lane	1.00	1.00	1.00			0.48
Lane Grp Cap(c), veh/h	464	213	185	2405	895	857
V/C Ratio(X)	0.28	0.62	1.04	0.16	0.34	0.35
Avail Cap(c_a), veh/h	1795	823	185	2405	895	857
HCM Platoon Ratio	1.00	1.00	1.00	1.00	1.00	1.00
Upstream Filter(I)	1.00	1.00	1.00	1.00	1.00	1.00
Uniform Delay (d), s/veh	22.5	23.6	25.9	3.4	8.6	8.6
Incr Delay (d2), s/veh	0.5	4.1	76.4	0.1	1.0	1.1
Initial Q Delay(d3),s/veh	0.0	0.0	0.0	0.0	0.0	0.0
%ile BackOfQ(50%),veh/ln	0.8	4.2	6.3	0.5	2.1	2.1
Unsig. Movement Delay, s/veh						
LnGrp Delay(d),s/veh	22.9	27.7	102.3	3.5	9.6	9.7
LnGrp LOS	C	C	F	A	A	A
Approach Vol, veh/h	260			566	606	
Approach Delay, s/veh	25.4			37.0	9.7	
Approach LOS	C			D	A	
Timer - Assigned Phs		2		4	5	6
Phs Duration (G+Y+Rc), s		44.5		13.3	10.0	34.5
Change Period (Y+Rc), s		5.4		5.5	4.0	5.4
Max Green Setting (Gmax), s		39.1		30.0	6.0	29.1
Max Q Clear Time (g_c+I1), s		4.2		6.5	8.0	8.1
Green Ext Time (p_c), s		5.1		1.3	0.0	6.9
Intersection Summary						
HCM 6th Ctrl Delay			23.3			
HCM 6th LOS			C			

HCM 6th Signalized Intersection Summary
4: 8th St & Cruikshank Dr

OY 2024 + P PM
11/03/2022



Movement	EBL	EBR	NBL	NBT	SBT	SBR
Lane Configurations						
Traffic Volume (veh/h)	230	209	191	436	326	126
Future Volume (veh/h)	230	209	191	436	326	126
Initial Q (Qb), veh	0	0	0	0	0	0
Ped-Bike Adj(A_pbT)	1.00	1.00	1.00			0.98
Parking Bus, Adj	1.00	1.00	1.00	1.00	1.00	1.00
Work Zone On Approach	No			No	No	
Adj Sat Flow, veh/h/ln	1870	1870	1870	1870	1870	1870
Adj Flow Rate, veh/h	247	225	208	474	398	154
Peak Hour Factor	0.93	0.93	0.92	0.92	0.82	0.82
Percent Heavy Veh, %	2	2	2	2	2	2
Cap, veh/h	704	323	170	2213	1158	442
Arrive On Green	0.20	0.20	0.10	0.62	0.46	0.46
Sat Flow, veh/h	3456	1585	1781	3647	2592	953
Grp Volume(v), veh/h	247	225	208	474	281	271
Grp Sat Flow(s),veh/h/ln	1728	1585	1781	1777	1777	1675
Q Serve(g_s), s	3.8	8.3	6.0	3.6	6.3	6.5
Cycle Q Clear(g_c), s	3.8	8.3	6.0	3.6	6.3	6.5
Prop In Lane	1.00	1.00	1.00			0.57
Lane Grp Cap(c), veh/h	704	323	170	2213	824	776
V/C Ratio(X)	0.35	0.70	1.22	0.21	0.34	0.35
Avail Cap(c_a), veh/h	1651	757	170	2213	824	776
HCM Platoon Ratio	1.00	1.00	1.00	1.00	1.00	1.00
Upstream Filter(l)	1.00	1.00	1.00	1.00	1.00	1.00
Uniform Delay (d), s/veh	21.4	23.2	28.4	5.2	10.7	10.8
Incr Delay (d2), s/veh	0.4	3.8	141.0	0.2	1.1	1.2
Initial Q Delay(d3),s/veh	0.0	0.0	0.0	0.0	0.0	0.0
%ile BackOfQ(50%),veh/ln	1.5	7.4	9.1	1.1	2.4	2.3
Unsig. Movement Delay, s/veh						
LnGrp Delay(d),s/veh	21.9	27.1	169.4	5.4	11.9	12.0
LnGrp LOS	C	C	F	A	B	B
Approach Vol, veh/h	472			682	552	
Approach Delay, s/veh	24.3			55.4	11.9	
Approach LOS	C			E	B	
Timer - Assigned Phs		2		4	5	6
Phs Duration (G+Y+Rc), s		44.5		18.3	10.0	34.5
Change Period (Y+Rc), s		5.4		5.5	4.0	5.4
Max Green Setting (Gmax), s		39.1		30.0	6.0	29.1
Max Q Clear Time (g_c+I1), s		5.6		10.3	8.0	8.5
Green Ext Time (p_c), s		6.6		2.5	0.0	6.2
Intersection Summary						
HCM 6th Ctrl Delay			32.7			
HCM 6th LOS			C			

OPENING YEAR 2024 PLUS PROJECT

QUEUING WORKSHEETS

Queues
1: Cruichshank Dr & Imperial Avenue

OY 2024 + P AM
11/03/2022



Lane Group	EBL	EBT	EBR	WBL	WBT	WBR	NBL	NBT	NBR	SBL	SBT	SBR
Lane Group Flow (vph)	270	191	82	61	162	171	107	757	96	247	1186	438
v/c Ratio	0.87	0.44	0.16	0.87	0.78	0.44	0.19	0.85	0.17	0.54	0.98	0.54
Control Delay	76.5	40.6	0.7	135.3	77.4	4.8	50.5	54.8	0.6	48.2	61.4	6.7
Queue Delay	0.0	0.0	0.0	0.0	0.0	0.0	0.0	0.0	0.0	0.0	0.0	0.0
Total Delay	76.5	40.6	0.7	135.3	77.4	4.8	50.5	54.8	0.6	48.2	61.4	6.7
Queue Length 50th (ft)	215	137	0	50	130	0	38	307	0	173	495	18
Queue Length 95th (ft)	250	151	0	#109	161	0	#94	#393	0	#294	462	38
Internal Link Dist (ft)		175			309			445			444	
Turn Bay Length (ft)	150		150	140			300			400		300
Base Capacity (vph)	421	647	664	70	320	465	560	888	575	454	1213	816
Starvation Cap Reductn	0	0	0	0	0	0	0	0	0	0	0	0
Spillback Cap Reductn	0	0	0	0	0	0	0	0	0	0	0	0
Storage Cap Reductn	0	0	0	0	0	0	0	0	0	0	0	0
Reduced v/c Ratio	0.64	0.30	0.12	0.87	0.51	0.37	0.19	0.85	0.17	0.54	0.98	0.54

Intersection Summary

95th percentile volume exceeds capacity, queue may be longer.
Queue shown is maximum after two cycles.

Queues
1: Cruichshank Dr & Imperial Avenue

OY 2024 + P PM
11/03/2022



Lane Group	EBL	EBT	EBR	WBL	WBT	WBR	NBL	NBT	NBR	SBL	SBT	SBR
Lane Group Flow (vph)	313	360	127	83	177	275	125	989	102	201	845	437
v/c Ratio	0.93	0.78	0.24	0.93	0.77	0.68	0.23	1.06	0.17	0.53	0.75	0.54
Control Delay	83.1	53.2	1.7	137.3	72.8	18.4	50.7	90.6	0.6	51.9	42.8	5.6
Queue Delay	0.0	0.0	0.0	0.0	0.0	0.0	0.0	0.0	0.0	0.0	0.0	0.0
Total Delay	83.1	53.2	1.7	137.3	72.8	18.4	50.7	90.6	0.6	51.9	42.8	5.6
Queue Length 50th (ft)	246	281	0	68	142	28	46	~462	0	146	320	0
Queue Length 95th (ft)	#387	345	7	#122	201	108	#88	#573	0	#328	398	76
Internal Link Dist (ft)		175			309			445			444	
Turn Bay Length (ft)	150		150	140			300			400		300
Base Capacity (vph)	383	648	665	89	380	507	551	933	592	381	1124	808
Starvation Cap Reductn	0	0	0	0	0	0	0	0	0	0	0	0
Spillback Cap Reductn	0	0	0	0	0	0	0	0	0	0	0	0
Storage Cap Reductn	0	0	0	0	0	0	0	0	0	0	0	0
Reduced v/c Ratio	0.82	0.56	0.19	0.93	0.47	0.54	0.23	1.06	0.17	0.53	0.75	0.54

Intersection Summary

- ~ Volume exceeds capacity, queue is theoretically infinite.
Queue shown is maximum after two cycles.
- # 95th percentile volume exceeds capacity, queue may be longer.
Queue shown is maximum after two cycles.

Queues
4: 8th St & Cruickshank Dr

OY 2024 + P AM
11/03/2022



Lane Group	EBL	EBR	NBL	NBT	SBT
Lane Group Flow (vph)	126	132	192	374	604
v/c Ratio	0.20	0.33	1.12	0.17	0.37
Control Delay	20.9	6.4	138.0	6.3	11.6
Queue Delay	0.0	0.0	0.0	0.0	0.0
Total Delay	20.9	6.4	138.0	6.3	11.6
Queue Length 50th (ft)	20	0	~77	20	55
Queue Length 95th (ft)	38	33	#239	74	138
Internal Link Dist (ft)	689			445	682
Turn Bay Length (ft)	150	155	250		
Base Capacity (vph)	1666	836	171	2258	1650
Starvation Cap Reductn	0	0	0	0	0
Spillback Cap Reductn	0	0	0	0	0
Storage Cap Reductn	0	0	0	0	0
Reduced v/c Ratio	0.08	0.16	1.12	0.17	0.37

Intersection Summary

~ Volume exceeds capacity, queue is theoretically infinite.
Queue shown is maximum after two cycles.

95th percentile volume exceeds capacity, queue may be longer.
Queue shown is maximum after two cycles.



Lane Group	EBL	EBR	NBL	NBT	SBT
Lane Group Flow (vph)	247	225	208	474	552
v/c Ratio	0.35	0.44	1.24	0.22	0.34
Control Delay	22.1	6.0	179.5	6.9	11.3
Queue Delay	0.0	0.0	0.0	0.0	0.0
Total Delay	22.1	6.0	179.5	6.9	11.3
Queue Length 50th (ft)	41	0	~94	31	51
Queue Length 95th (ft)	67	42	#208	100	117
Internal Link Dist (ft)	689			445	682
Turn Bay Length (ft)	150	155	250		
Base Capacity (vph)	1632	870	168	2193	1601
Starvation Cap Reductn	0	0	0	0	0
Spillback Cap Reductn	0	0	0	0	0
Storage Cap Reductn	0	0	0	0	0
Reduced v/c Ratio	0.15	0.26	1.24	0.22	0.34

Intersection Summary

~ Volume exceeds capacity, queue is theoretically infinite.
Queue shown is maximum after two cycles.

95th percentile volume exceeds capacity, queue may be longer.
Queue shown is maximum after two cycles.