



# SOIL EXPLORATION COMPANY, INC.

Soil Engineering, Environmental Engineering, Materials Testing, Geology

January 28, 2020

Project No. 19252-01

TO: Roger Hobbs  
1428 E. Chapman Ave.  
Orange, CA 92866

SUBJECT: Preliminary Soil Investigation, Infiltration Tests and Liquefaction Evaluation Report, Proposed Residential Development Site (34 Lots), 45<sup>th</sup> Street (3.84 Acres/APN 182-190-015, -016 and -017), City of Jurupa Valley, California

## Introduction

In accordance with your authorization, Soil Exploration Co., Inc. has performed a preliminary soil investigation, infiltration tests and liquefaction evaluation for the subject site. The accompanying report presents a summary of our findings, conclusions, recommendations, and limitations of our work for proposed 34 lot, one- and two-story wood frame residential development.

## Scope of Work

- Review soils, geologic, seismic, groundwater data and maps in our files.
- Perform exploration of the site by means of five 8" diameter borings, 15 to 50 feet deep, at readily accessible locations.
- Field engineer (California Registered RCE) for logging of the excavations, sampling of select soils, observation of excavation resistance, record SPT blow counts and water seepage (if any).
- Perform basic laboratory testing of select soil samples, including moisture, density, expansion potential, sieve analysis, direct shear and corrosion potential (pH, chlorides, resistivity and water soluble sulfates).
- Perform digitized search of known faults within a 50-mile radius of the site.
- Determine CBC (2019) seismic parameters.
- Consult with civil/structural design consultants.
- Perform four shallow infiltration tests at locations suggested by civil design engineer for WQMP design purposes.
- Prepare a report of our findings, conclusions and recommendations for site preparation, including overexcavation/removal depth, allowable bearing value, foundation/slab-on-grade depth/thickness/reinforcement recommendations, excavation characteristics of earth materials, lateral earth pressures for retaining walls design, pavement thickness estimates, suitability of onsite soils for compacted fills, liquefaction/dynamic settlement evaluation, general earthwork and grading specifications, California Building Code (2019) seismic design coefficients, Cal/OSHA classification of soils and infiltration rate (inches/hour).

## Site Conditions

The rectangular shaped, relatively flat site is located on the north side of 45<sup>th</sup> Street, east of Opal Street, in the City of Jurupa Valley, Riverside County, California. 45<sup>th</sup> Street is a paved road with curbs, gutter and sidewalks. A wire fence and an iron fence border the site on the east side and a chain link fence on the north and west sides. A horse ranch is located on adjacent property to the north and an existing house on adjacent property to the west. Adjacent properties to the east are vacant. Vegetation consists of very dense grass and scattered trees.

The approximate locations of the above and other features are shown on Exploratory Boring and Infiltration Test Location Map, Plate 1. The base map is Lotting Layout No. 1, dated November 28, 2019, prepared by Robert Beers of Jurupa Valley, California.

### **Proposed Development**

We understand that the site is proposed for a single family, 34 lot residential development and associated improvements. The structures will be light, one- and two-story wood frame construction with concrete floor slabs supported on prepared subgrade. Grading plans are not available for review at this time, however based on the relatively flat topography of the site, modest cut or fill grading and no significant cut or fill slopes are proposed.

### **Field Work**

Five exploratory borings were drilled on January 15, 2020, to a maximum depth of 50 feet below existing ground surface utilizing a B-53 mobile drill rig equipped with 8-inch diameter hollow stem augers. Refer to Plate 1 for boring locations. The borings were logged by a California Registered Civil Engineer. Standard Penetration Tests (SPT) blow counts were recorded for the earth materials. Relatively undisturbed samples of the soils were also obtained by utilizing California Ring Sampler.

In general, these borings revealed that the site alluvial soils consist of silty sand (USCS "SM"). The granular earth materials are generally medium dense to very dense, however loose and very loose soils were noted to depths of 3 to 5 feet in Borings B-1, B-2, B-3 and B-4. Detailed descriptions of the earth materials encountered are presented in the form of Geotechnical Boring Logs in Appendix B.

USGS Geologic Map of the Riverside West Quadrangle shows the site area is underlain with old alluvial-fan deposits and young eolian deposits (see Figure 2).

### **Laboratory Testing**

Basic laboratory tests were performed for select soil samples. The tests consisted primarily of natural moisture contents, dry densities, sieve analysis, direct shear and corrosion potential (pH, chlorides, resistivity and water soluble sulfates). Laboratory test results are presented in Appendix C and with Geotechnical Boring Logs in Appendix B.

### **Groundwater**

Groundwater, seepage or wet soils were not encountered in our exploratory borings, drilled to a maximum depth of 50 feet, at the time this work was performed. Groundwater study is not within the scope of this work. However based on referenced Carson and Matti map, groundwater in the vicinity of the site is 50± feet below ground surface.

### **Liquefaction Evaluation**

Soil liquefaction is a process by which loose, saturated, fine granular deposits, such as fine sands, lose a significant portion of their shear strength due to pore water pressure buildup resulting from cyclic loading, such as that caused by an earthquake. In general, liquefaction potential is higher when the groundwater table is less than 30 feet below ground surface. Soil liquefaction can lead to foundation bearing failures and excessive settlements.

Based on Riverside County GIS map and Riverside County Liquefaction map, the site is located within an area of moderate and high liquefaction potential (see Figures 3 and 3A).

Summary of conditions for the deep boring B-1 are as follows:

Depth (ft)	Class (USCS)	SPT Count (blows/foot)	Moisture (%)	Passing 200 Sieve (%)	Compactness/Consistency
2	SM	4	7.7	-	Very loose
5	SM	7	7.0	12-	Loose
10	SM	88	6.3	26	Very dense
15	SM	50/3"	-	-	Very dense
20	SM	46	3.9	12	Dense
25	SM	35/50	-	-	Very dense
30	SM	70/4"	-	-	Very dense
35	SM	50/1"	-	-	Very dense
40	SM	50/2"	-	-	Very dense
45	SM	50/1"	-	-	Very dense
50	SM	50/2"	-	-	Very dense

### **Liquefaction Analysis/Dynamic Settlement: LiquefyPro**

Liquefaction susceptibility using Standard Penetration Test data and laboratory grain size test results were analyzed using LiquefyPro software (Version 5.5g). Liquefaction analysis performed for this evaluation included: [1] evaluation of soil consistency and compactness influencing liquefaction, [2] correction of penetration resistance data to convert measured SPT N-values to standard  $N_{60}$ -values, [3] calculating the earthquake induced stress ratio (CSR), [4] calculating cyclic resistance ratio (CRR), [5] assume water table at 50 feet below the ground surface, and [6] evaluation of liquefaction potential by calculating a factor of safety against liquefaction (FS), by dividing CRR by CSR. The software output is presented in Appendix G.

The main observations of the results are as follows:

- Onsite soils at the site in general have a Safety Factor of 5.0 against liquefaction. Subsequent to compaction of upper 5 feet of soils, indicated settlement of saturated and unsaturated sands is 0.00 in. and 0.42 in., respectively, with total settlement of saturated and unsaturated sands of 0.42 in., with differential settlement of 0.209 to 0.276 in. in 30 feet.
- Liquefaction also involves lateral or horizontal displacement (lateral spreading) of essentially intact blocks of surficial soils on slopes or toward a free-face slope such as river or canal bank. The potential for and magnitude of lateral spreading is dependent upon many conditions, including the presence of a relatively thick, continuous, potentially liquefiable sand layer and high slopes. Subsurface information obtained for this study indicates that high slopes are not anticipated. Based on currently available procedures, the site does not appear to be susceptible to (lateral spread) ground surface disruption during a moderate seismic event.

### **Seismicity/Faulting**

The site is not located within a currently designated Alquist-Priolo Earthquake Fault Zone or County of Riverside Fault zone.

A computer search of all known Quarternary major faults within 50 miles of the site from USGS Earthquake Hazards Program is presented in Appendix D. Please note that it is probable that not all active or potentially active faults in the region have been identified. Furthermore, seismic potential of the smaller and less notable faults is not sufficiently developed for assignment of maximum magnitudes and associated levels of ground shaking that might occur at the site due to these faults.

## **Conclusions and Recommendations**

### **Conclusions**

- All vegetable matter, old fills, buried utilities/irrigation lines, etc. and deleterious materials would require removal from the proposed building/grading areas.
- Overexcavation and recompaction of the loose and very loose surficial soils (5 feet deep) should be anticipated to provide adequate and uniform support for the proposed structures. All surficial earth materials encountered during our investigation can be excavated with normal grading equipment in good working condition.
- Onsite earth materials, cleansed of oversize cobbles and boulders (over 6 inches, if any), should be suitable for engineered/compacted fills.
- Based on observation and soil classification, the expansion potential of onsite near surface silty sands is expected to be very low ( $EI < 20$ ).
- Subsequent to site preparation, the use of shallow spread footing foundations appears feasible for the proposed construction.
- Flooding potential of the site should be determined by the design civil engineer and considered in planning and construction.
- Site is located approximately 9.22 miles from the San Jacinto fault. The site is located in a region of generally high seismicity, as is all of Southern California. During its design life, the site is expected to experience moderate to strong ground motions from earthquakes on regional and/or nearby causative faults.
- There is a 2 percent probability in 50 years (2475 year return period) that site modified peak ground acceleration at the site ( $PGA_m$ ) will exceed 0.55g (see Appendix D).
- Groundwater was not encountered during subsurface investigation. Our experience indicates that surface or near-surface groundwater conditions can develop in areas where groundwater conditions did not exist prior to site development, especially in areas where a substantial increase in surface water infiltration results from landscape irrigation.

### **Recommendations**

#### **Site Preparation/Overexcavation**

Grading and backfills should be performed in accordance with the City of Jurupa Valley Grading Ordinance and attached General Earthwork and Grading Specifications (Appendix E), except as modified in the text of this report.

Structures should be provided with a compacted fill mat that extends to at least 5 feet beyond the structure lines in plan and to a depth of at least 5 feet below existing or proposed grade, whichever is deeper. The excavated bottom should be cleaned from roots, soft spots, wet spots, porous soils, old foundations, seepage pits and deleterious materials, etc. As a result, deeper excavations should not be precluded and this should be determined by observations and testing of excavated bottoms during grading.

After cleaning of the excavated bottom, the exposed surfaces should be further scarified to a depth of at least 12-inches, moisture conditioned/thoroughly watered and recompactd by utilizing heavy vibratory rollers to at least 90 percent of the maximum dry density, as determined by ASTM D1557-12 Test Method, prior to placement of fill. Oversize material (larger than 6-inch size, if any) should not be utilized for structural fills. All fills should be placed on underlying medium dense native soils and compacted to at least 90 percent of the maximum dry density.

#### Compacted Fills/Imported Soils

Any soil to be placed as fill, whether presently onsite or import, should be approved by the soil engineer or his representative prior to its placement. All onsite soils to be used as fill should be cleansed of any roots or other deleterious materials. Cobbles larger than 3 inches in diameter should not be placed in the vicinity of foundations and utility lines. All fills should be placed in 6 to 8 inch loose lifts, thoroughly watered, mixed and compacted to at least 90 percent relative compaction. This is relative to the maximum dry density determined by ASTM 1557-12 Test Method.

#### Foundation Design/Footings

Following site preparation, the use of shallow spread footings is feasible. An allowable bearing value of 1800 psf is recommended. This bearing pressure has been established based on the assumption that the footings will be embedded into compacted fill mat. Isolated column footings should be at least 18 inches wide and embedded at least 18 inches below lowest adjacent firm grade.

The above bearing value may be increased by one third for temporary (wind or seismic) loads. We recommend footings reinforcement should be at least two No. 5 bars at top and two at the bottom of footings. Conventional foundation should be in accordance with current California Building Code (CBC) 2019, with design by a qualified structural engineer. Additional recommendations for conventional foundations of one and two-story residential structures are presented on Plate 2. Please note that foundation design is under the purview of the structural engineer and structural engineer may have more restrictive requirements which will govern.

#### Conventional Residential Slabs-On-Grade

Residential slabs-on-grade should be at least 4 inches thick and should be reinforced with at least No. 3 bars at 18-inches on-center both ways, properly centered in mid-thickness of slabs (structural recommendations govern). Slabs-on-grade should be underlain with 10-mil Visqueen moisture barrier. The moisture barrier should be underlain by two inches of clean rolled sand.

#### Tentative Pavement Design

Based on the granular nature of the onsite soils, we have assigned an R-value of 45. The recommended sections are outlined as follows:

Street Type	Traffic Index (TI)	Asphalt Concrete (inches)	Aggregate Base (CAB) (inches)
Interior Street	5.5 to 6	3	6

The upper at least 18 inches of the subgrade soils below new pavements should be compacted to at least 90 percent relative compaction. Minimum relative compaction requirements for aggregated base should be 95 percent of the maximum laboratory dry density as determined by ASTM D1557-12.

Final pavement design shall be based on R-value testing of the subgrade soils at the completion of grading.

### Hardscape Areas/Compaction/Concrete Joints

The upper at least 12 inches of subgrade soils for hardscape areas should be scarified and compacted to at least 90 percent.

The joints spacing for concrete slabs should be determined by the project architect. Joints should be laid out to form approximately square panels (equal transverse and longitudinal joint spacing). Rectangular panels, with the long dimension no more than one-and-one-half times the short, may be used when square panels are not feasible. The depth of longitudinal and transverse joints should be one-fourth the depth of the slab thickness.

Joint layout should be adjusted so that the joints will line up with the corners of structures, small foundations and other built-in structures. Acute angles or small pieces of slab curves as a result of joints layout should not be permitted.

### Concrete Curing

Fresh concrete should be cured by protecting it against loss of moisture, rapid temperature change and mechanical injury for at least 3 days after placement. Moist curing, waterproof paper, white polyethylene sheeting, white liquid membrane compound, or a combination thereof may be used. After finishing operations have been completed, the entire surface of the newly place concrete should be covered by whatever curing medium is applicable to local conditions and approved by the engineer. The edges of concrete slabs exposed by the removal of forms should be protected immediately to provide these surfaces with continuous curing treatment equal to the method selected for curing the slab surfaces. The contractor should have at hand, and ready to install before actual placement begins, the equipment needed for adequate curing of the concrete.

In hot or windy weather (80°F or 15 mph), the contractor must take appropriate curing precautions after the placement of concrete. The use of mechanically compacted low slump concrete (not exceeding 4 inches at the time of placement) is recommended. We recommend that a slipsheet (or equivalent) be utilized if grouted tiles or other crack sensitive flooring is planned directly on concrete slabs.

### Special Considerations/Excess Soils from Foundation Excavations

Excess soils generated from foundation excavations should not be placed on slabs and driveways subgrade without proper moisture and compaction. Slab subgrade should be verified to contain 1.2 times the soil optimum moisture content to a depth of 6 inches prior to placement of slab building materials. Moisture content should be tested in the field by the soil engineer. The addition of fiber mesh in the concrete and careful control of water/cement ratios may lessen the potential for slab cracking.

### Lateral Earth Pressures/Retaining Walls

The following lateral earth pressures and soil parameters, in conjunction with the above-recommended bearing value (1800 psf), may be used for design of retaining walls with free draining compacted backfills. If passive earth pressure and friction are combined to provide required resistance to lateral forces, the value of the passive pressure should be reduced to two-thirds the following recommendations:

Active Earth Pressure with level backfill ( $P_a$ )	35 pcf (EFP), drained, yielding
At Rest Pressure ( $P_o$ )	55 pcf (EFP), drained, non-yielding (part of building wall)
Passive Earth Pressure ( $P_p$ )	250 pcf (EFP), drained, maximum of 2500 psf
Horizontal Coefficient of Friction ( $\mu$ )	0.30
Unit Soil Weight ( $\gamma_t$ )	120 pcf

We recommend drainage for retaining walls to be provided in accordance with Plate 3 of this report. Maximum precautions should be taken when placing drainage materials and during backfilling. All wall backfills should be properly compacted to at least 90 percent relative compaction.

#### Seismic Considerations

The site is located approximately 9.22 miles from the San Jacinto fault. Moderate to strong ground shaking can be expected at the site and there is a 2 percent probability in 50 years (2475 year return period) that site modified peak ground acceleration at the site ( $PGA_m$ ) will exceed 0.55g. The site soil profile is Class D. The structural engineer must consider City/County local codes, California Building Code (CBC) 2019 seismic data presented in this report (Appendix D), the latest requirements of the Structural Engineers Association, and any other pertinent data in selecting design parameters.

#### Expansion Index and Corrosion/Soluble Sulfates

Based on observation and soil classification, the expansion potential of the near surface sandy soils is anticipated to be very low ( $EI < 20$ ).

Results of tests performed by Cal Land Engineering, Inc. of Brea, California on a select soil sample indicate negligible soluble sulfate exposure (less than 0.1 percent water soluble sulfates by weight), pH of 8.20, chlorides of 182 ppm and resistivity of 13,000 ohm-cm (see Appendix C). Based on resistivity test results, soil is mildly corrosive to ferrous metals/pipes/reinforcement. Concrete, mix, placement and curing for concrete should comply with ACI guidelines. Tentatively we recommend Type II cement and concrete slump not exceeding 4 inches at the time of placement. If critical, these should be further verified by your structural or a corrosion engineer.

#### Drainage

Positive drainage must be provided and maintained for the life of the project around the perimeter of the structures and all foundations toward streets or approved drainage devices to minimize water infiltration into the underlying soils. In addition, finish subgrade adjacent to exterior footings should be sloped down and away to facilitate surface drainage. Roof drainage should be collected and directed away from foundations and slopes via nonerosive devices. Water, either natural or by irrigation, should not be permitted to pond or saturate the foundation soils.

#### Cal/OSHA Classification/Trench Excavations/Backfills

In general Cal/OSHA classification of onsite soils appears to be Type C.

Temporary trench excavations deeper than 5 feet should be shored or sloped at 1.5:1 in compliance with Cal/OSHA requirements:

- a.) The shoring should be designed by a qualified engineer experienced in the shoring design.
- b.) The tops of any temporary unshored excavations should be barricaded to prevent vehicle and storage loads. If the temporary construction embankments, including shored excavations, are to be maintained during the rainy season, berms are suggested along the tops of the excavations where necessary to prevent runoff from entering the excavation and eroding the slope faces.
- c.) The soils exposed in the excavations should be inspected during excavation by the soils engineer so that modifications can be made if variations in the soil conditions occur.
- d.) All unshored excavations should be stabilized within 30 days of initial excavation.

### **Foundation Plan Review/Additional Observations and/or Testing**

The recommendations provided in this report are based on preliminary design information and subsurface conditions as interpreted from limited exploratory work. Our conclusions and recommendations should be reviewed and verified during construction and revised if necessary.

Soil Exploration Co., Inc. should review the foundation plans and observe and/or test at the following stages of construction:

- During all overexcavations and fill placement.
- Following footing excavations and prior to placement of footing materials.
- During wetting of slab subgrade (1.2X optimum to a depth of at least 6") and prior to placement of slab materials.
- During all trench and retaining wall backfills.
- During subgrade preparation/compaction, prior to paving.
- When any unusual conditions are encountered.

### **Final Compaction Report**

A final report of compaction control should be prepared subsequent to the completion of rough grading. The report should include a summary of work performed, laboratory test results, and the results, locations and elevations of field density tests performed during grading.

### **Limitation of Investigation**

Our investigation was performed using the degree of care and skill ordinarily exercised, under similar circumstances, by reputable Geotechnical Engineers practicing in this or similar locations. No other warranty, expressed or implied, is made as to the conclusions and professional advice included in this report.

The field and laboratory test data are believed representative of the project site; however, soil conditions can vary significantly. As in most projects, conditions revealed during grading may be at variance with preliminary findings. If this condition occurs, the possible variations must be evaluated by the Project Geotechnical Engineer and adjusted as required or alternate design recommended.

This report is issued with the understanding that it is the responsibility of the owner, or his representative, to ensure that the information and recommendations contained herein are brought to the attention of the architect and engineer for the project and incorporated into the plans, and the necessary steps are taken to see that the contractor and subcontractor carry out such recommendations in the field.

This firm does not practice or consult in the field of safety engineering. We do not direct the contractor's operations, and we cannot be responsible for other than our own personnel on the site; therefore, the safety of others is the responsibility of the contractor. The contractor should notify the owner if he considers any of the recommended actions presented herein to be unsafe.

The findings of this report are valid as of the present date. However, changes in the conditions of a property can occur with the passage of time, whether they are due to natural processes or the works of man on this or adjacent properties. In additions, changes in applicable or appropriate standards may occur, whether they result from legislation or the broadening of knowledge.



This report was prepared for the client based on client's needs, directions and requirements at the time. This report is not authorized for use by and is not to be relied upon by any party except the client with whom Soil Exploration Co., Inc. contracted for the work. Use of, or reliance on, this report by any other party is at that party's risk. Unauthorized use of or reliance on this report constitutes an agreement to defend and indemnify Soil Exploration Co., Inc. from and against any liability which may arise as a result of such use or reliance, regardless of any fault, negligence, or strict liability of Soil Exploration Co., Inc.

**Closure**

If you should have any questions or concerns regarding this report, please do not hesitate to call our office. We appreciate this opportunity to be of service.

Very truly yours,  
Soil Exploration Co., Inc.



Gene K. Luu, PE 53417  
Project Engineer\

Distribution: [1] Addressee ([rch@rchobbs.com](mailto:rch@rchobbs.com))  
[1] Robert Beers ([rmbeers777@hotmail.com](mailto:rmbeers777@hotmail.com))

Attachments:

Figure 1	Site Location Map
Figure 2	USGS Geologic Map
Figure 3	Riverside County GIS Map
Figure 3A	Riverside County Landslides and Liquefaction Map
Figure 4	U.S. Geological Survey Faults Map
Plate 1	Exploratory Boring and Infiltration Test Location Map
Plate 2	Minimum Foundation and Slab Recommendations for Expansive Soils
Plate 3	Retaining Wall Backfill and Subdrain Backfill
Appendix A	References
Appendix B	Geotechnical Boring Logs
Appendix C	Laboratory Test Results
Appendix D	USGS National Seismic Hazard Maps-Source Parameters and CBC (2019) Seismic Parameters
Appendix E	General Earthwork and Grading Specifications
Appendix F	Infiltration Test Procedures and Test Results
Appendix G	Liquefaction Analysis Summary

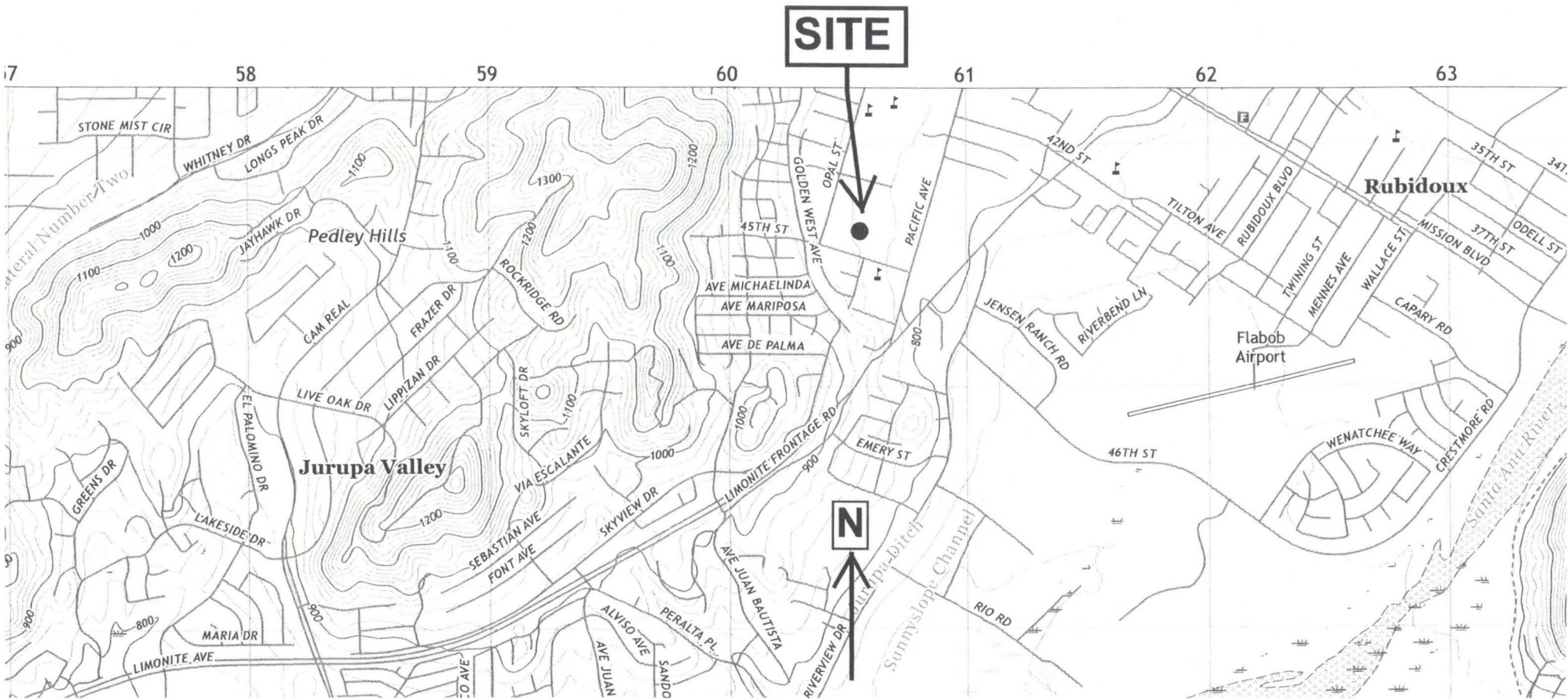

USGS/U.S. Topo/Riverside West Quadrangle, Riverside County, California.

Figure 1

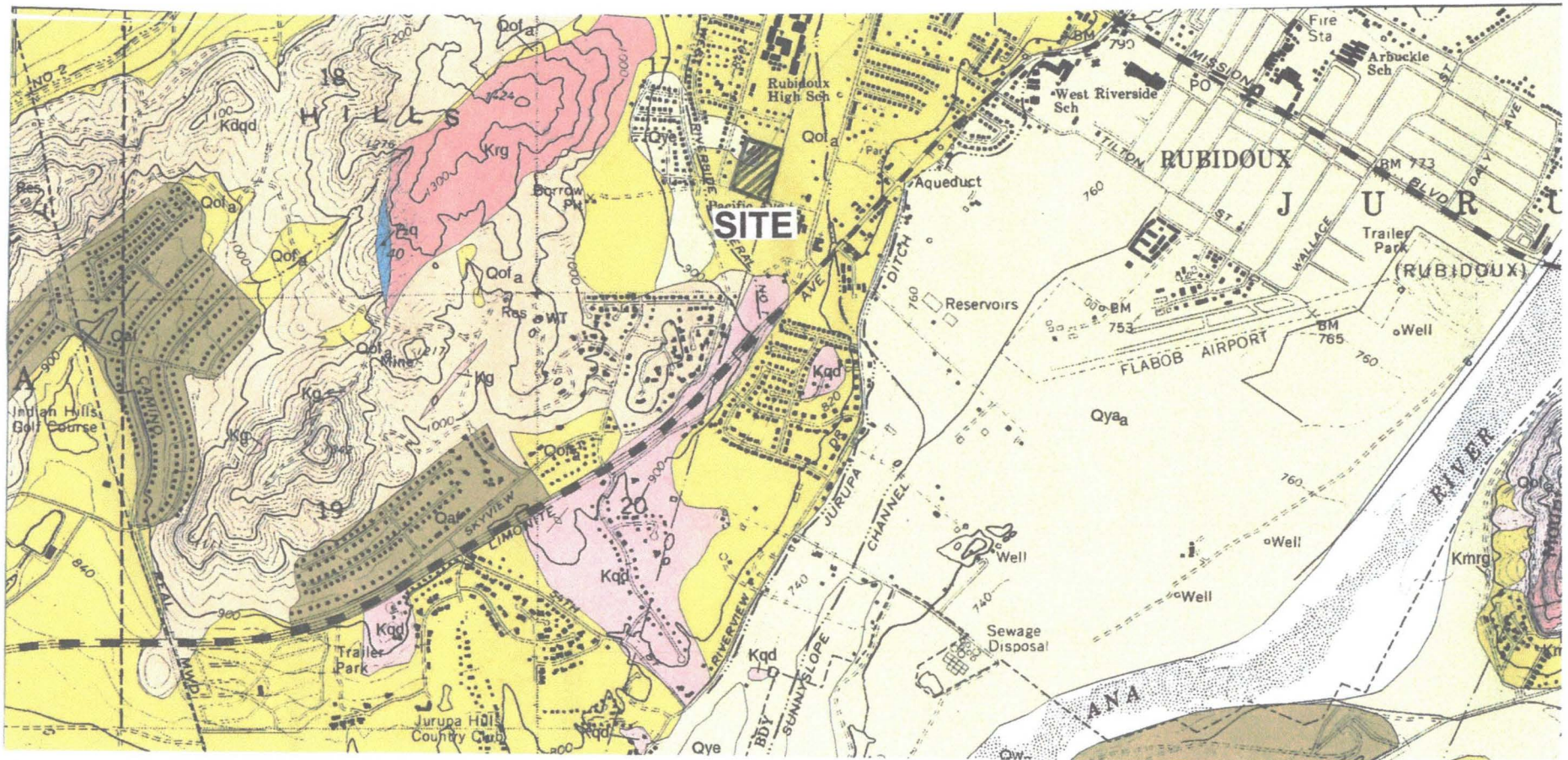

Base Map: USGS Geologic Map of the Riverside West 7.5' Quadrangle, Riverside County, California.

**LEGEND:**

- Qof:** Old alluvial-fan deposits (late to middle Pleistocene) – Indurated to slightly indurated, sandy alluvial-fan deposits. Slightly to moderately dissected and reddish-brown.
- a:** Arenaceous (very coarse sand through very fine sand).
- Qye:** Young eolian deposits (Holocene and late Pleistocene) – Sand dune deposits, inactive except for very minor amount of sediment movement during Santa Ana wind storms. Chiefly consolidated, moderately well sorted fine to medium grained sand.

45<sup>th</sup> Street  
City of Jurupa Valley, California

Soil Exploration Co., Inc.  
Project No.: 19252-01  
Date: January 28, 2020  
Figure: 2

# Map My County Map

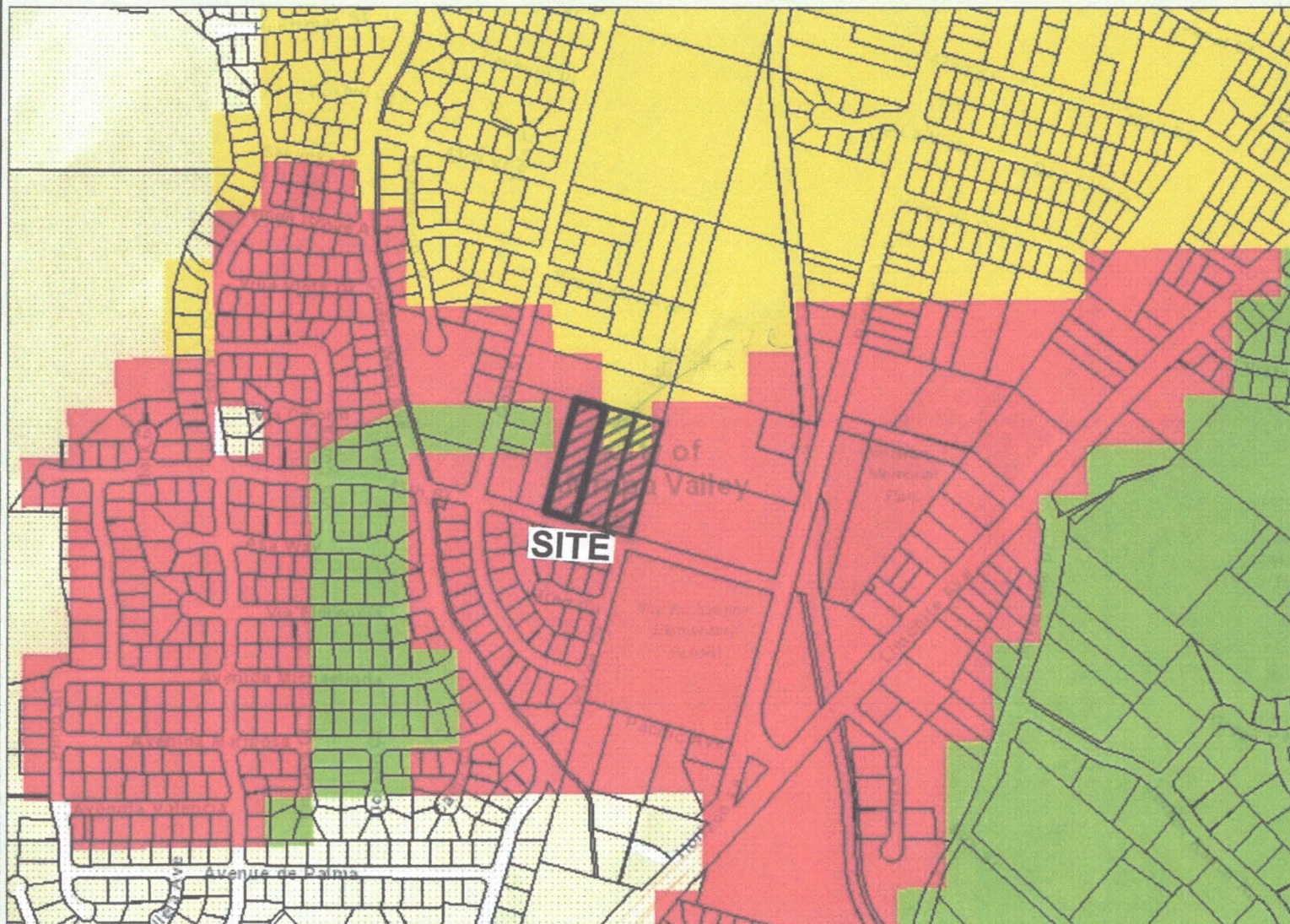

## Legend

- Parcels
- Liquefaction
  - Other Susceptibility
  - High
  - Low
  - Moderate
  - Very High
  - Very low
- Blueline Streams
- City Areas
- World Street Map



**\*IMPORTANT\*** Maps and data are to be used for reference purposes only. Map features are approximate, and are not necessarily accurate to surveying or engineering standards. The County of Riverside makes no warranty or guarantee as to the content (the source is often third party), accuracy, timeliness, or completeness of any of the data provided, and assumes no legal responsibility for the information contained on this map. Any use of this product with respect to accuracy and precision shall be the sole responsibility of the user.

0 752 1,505 Feet

REPORT PRINTED ON... 1/14/2020 3:00:44 PM

© Riverside County GIS

## Notes

APN 182-190-015, 16 & 17

**Figure 3**

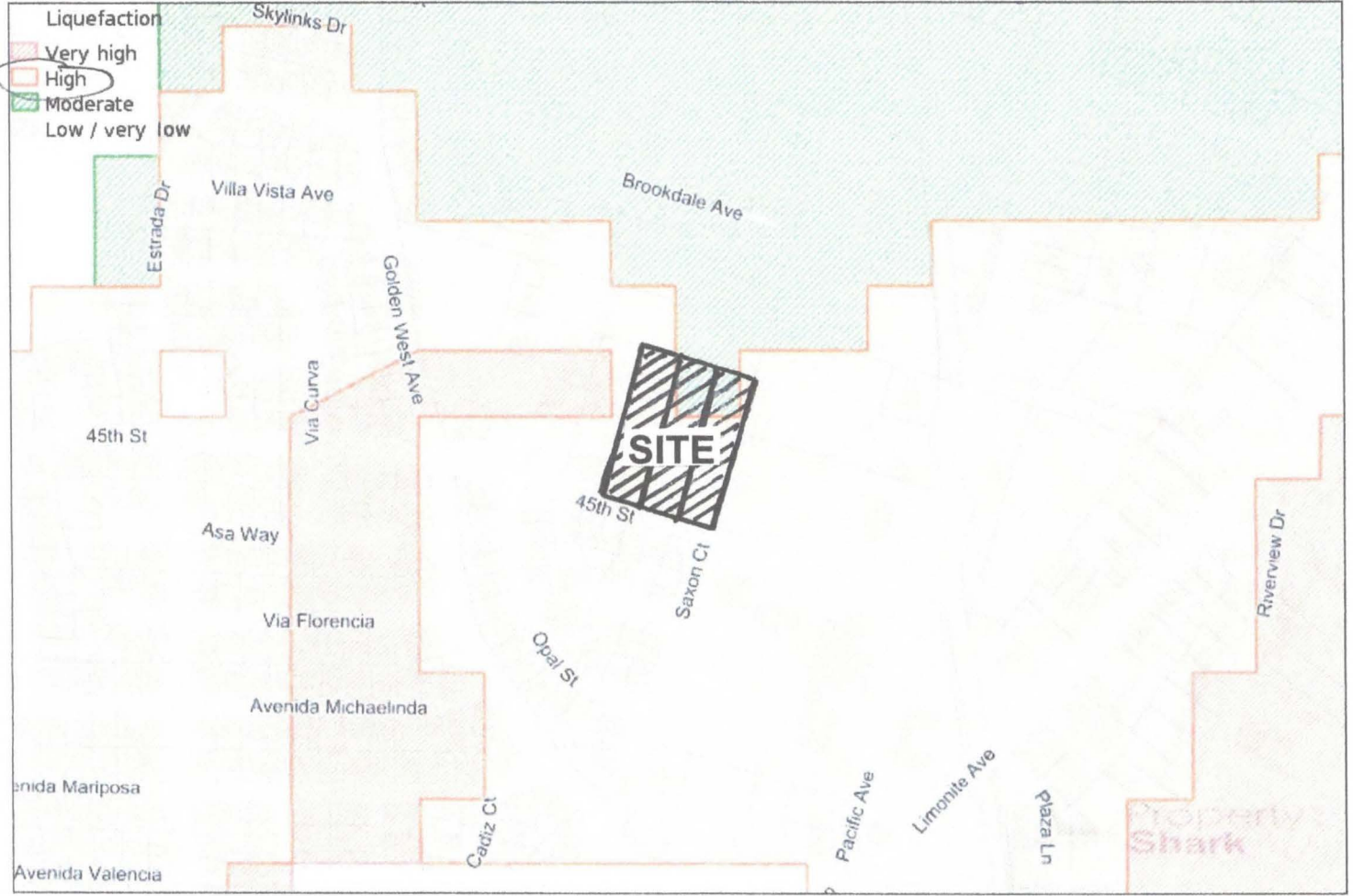

Add notes here ...

**Figure 3A**

# U.S. Geological Survey 2014 Faults



1/28/2020, 3:11:51 PM

1:577,791

- NSHM 2014 Fault Sources
- Thrust
  - Normal
  - Strike Slip
  - Unassigned

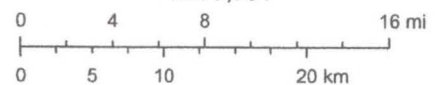

USGS, National Geographic, Esri, Garmin, HERE, UNEP-WCMC, USGS, NASA, ESA, METI, NRCAN, GEBCO, NOAA, increment P Corp.

Figure 4

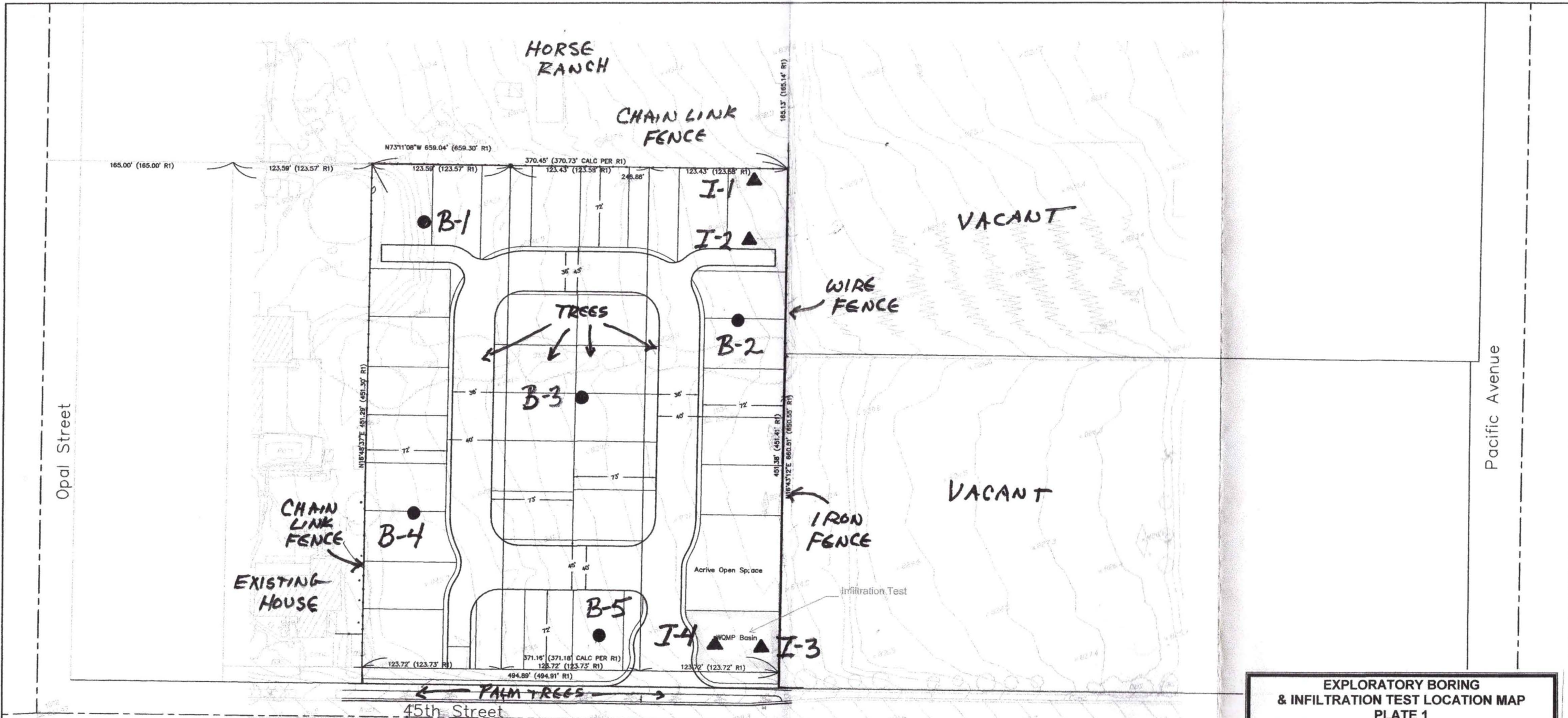

**EXPLORATORY BORING  
& INFILTRATION TEST LOCATION MAP  
PLATE 1**

**LEGEND**

B-5 ● Approximate Location of Boring  
I-4 ▲ Approximate Location of Infiltration Test

Soil Exploration Co., Inc.

Project No. 19252-01	January 28, 2020
----------------------	------------------

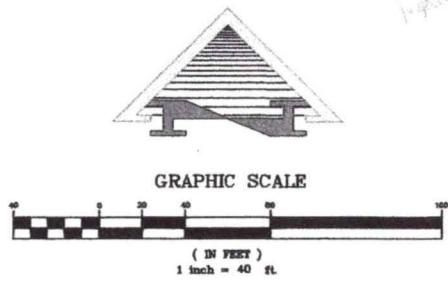

Nominal Lot Size: 43' by 72' and 45' by 72'

Base Layout: 34 Lots

**ROBERT BEERS**  
8175 Limonite Avenue, Suite E  
Jurupa Valley, CA 92509  
Ph. (951) 317-2041 Fax (909) 360-2070

Date \_\_\_\_\_ Robert M. Beers R.C.E. 39405 Expires 12-31-21

MARK	REVISIONS	APPR. DATE

PREPARED FOR:  
**RC Hobbs Companies**  
1428 E. Chapman Avenue  
Orange, CA 92866  
PHONE: (714) 633-8100

**TTM 37857**  
**Lotting Layout No. 1**  
City of Jurupa Valley  
CALIFORNIA

DATE Nov. 28, 2018
JOB NO. _____
DRAWN BY R.A.M.
CHECKED BY R.M.B.
SHEET 1 OF 1

EXPANSION INDEX (ASTM D 4829) 0-20 VERY LOW EXPANSION	
1-Story Footings (See Note 1)	All footings at least 12" deep. Reinforcement for continuous footings: Two No. 5 bars top and two No. 5 bars bottom
2-Story Footings (See Note 1)	All footings at least 18" deep. Reinforcement for continuous footings: Two No. 5 bars top and two No. 5 bars bottom
Minimum Footing Width	Continuous: 12" for 1-story Continuous: 15" for 2-story
Pad Footings	Isolated column: 18" wide and 18" deep, tied to continuous footings in two directions
Garage Door Grade Beam (See Note 2)	A grade beam 12" deep by 12" wide for 1-story and 18" deep by 15" wide for 2-story should be provided across the garage entrance and other large openings
Living Area Floor Slabs* (See Notes 3, 4 and 5)	4" thick slab. No. 3 rebar at 18 inches on-center reinforcement at mid-height with 10-mil Visqueen moisture barrier above 2" sand base
Garage Floor Slabs* (See Notes 4 and 6)	4" thick slab. No. 3 rebar at 18 inches on-center reinforcement at mid-height with 10-mil Visqueen moisture barrier above 2" sand base. Garage slabs should be quarter-sawn.
Presoaking of Living Areas & Garage Slabs Subgrade**	(1.2) times optimum moisture to a depth of at least 6"

**The Above Are Minimum Recommendations.**

**All Work Should Comply with Applicable/Governing Agency Codes and Requirements**

\* Based on California Green Code, a 4" thick base of ½ inch or larger clean aggregate shall be used below the Visqueen.

\*\*Presoaking of living areas and garage slabs should be observed and tested by the project geotechnical engineer.

**NOTES:**

1. Depth of interior or exterior footings to be measured from lowest adjacent finish grade.
2. The base of the grade beam should be at the same elevation as that of the adjoining footings.
3. Living areas slabs may be tied to the footings as directed by the structural engineer.
4. We recommend the use of at least No. 3 bars at 18 inches on-center, each way, for all slabs.
5. 10-mil Visqueen sheeting welded at laps has proved successful. Equivalents are acceptable.
6. Garage slabs should be isolated from stem wall footings with a minimum 3/8" felt expansion joint.
7. Sand base should have a Sand Equivalent (SE) of 30 or greater (e.g., washed concrete sand).

**Post-Tensioned Slabs**

As an alternative to conventional foundations, building may be supported on post-tensioned slabs, to be designed by a structural engineer in consultation with the geotechnical consultant. In addition, a post-tensioned slab is also recommended for VERY HIGH expansion potential (Expansion Index greater than 130), if encountered. Post-tensioned slabs should have perimeter footings embedded a minimum of 12 inches below the adjacent grade. The slabs should be designed such that they can be deformed approximately 1-inch vertically over a width of 30 feet without distress in the event of shrinkage or swelling of the supporting soils. Living area slabs should be underlain by a 10-mil Visqueen moisture barrier covered by a 2-inch layer of sand. Presoaking is recommended for post tensioned slabs: (1.2) x optimum to a depth of 12 inches, (1.3) x optimum to a depth of 18 inches, and (1.4) x optimum to a depth of 24 inches for LOW, MEDIUM, and HIGH expansion potential soils, respectively. LOW and MEDIUM expansive soil lots using conventional foundation should comply with 2019 CBC. For very high expansion potential (Expansion Index greater than 130), specific recommendations by the geotechnical consultant will be required. Placement of 4 inches of sand base is also suggested for post-tensioned slab systems. Unless stated in the attached report, for EI=21-50 use PI=25, and EI=51-90 use PI=35.

**Minimum Foundation and Slab Recommendations  
For Expansive Soils**

**ONE- AND TWO-STORY RESIDENTIAL BUILDINGS**



**Soil Exploration Co. Inc.**

**Plate: 2**



## SUBDRAIN OPTIONS FOR NATIVE MATERIAL BACKFILL

**OPTION N2: Pipe-Surrounded with Class 2 Material:**

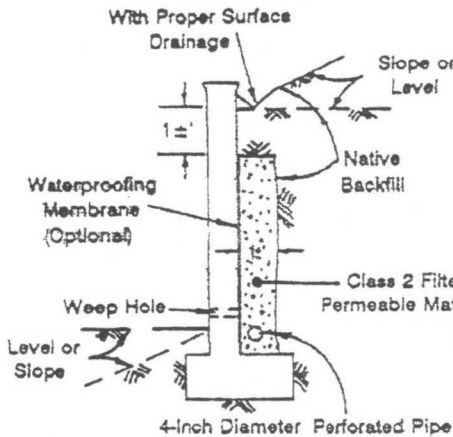

**Class 2 Filter Permeable Material Grading Per Caltrans Specifications**

Sieve Size	Percent Passing
1"	100
3/4"	90-100
3/8"	40-100
No. 4	25-40
No. 8	18-33
No. 30	5-15
No. 50	0-7
No. 200	0-3

**OPTION N1: Gravel Wrapped in Filter Fabric**

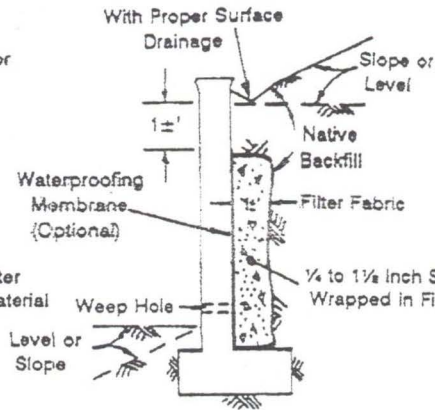

Proper Outlet should be Provided for Gravel Subdrain (See Notes)

**OPTION N3: Geotextile Drain**

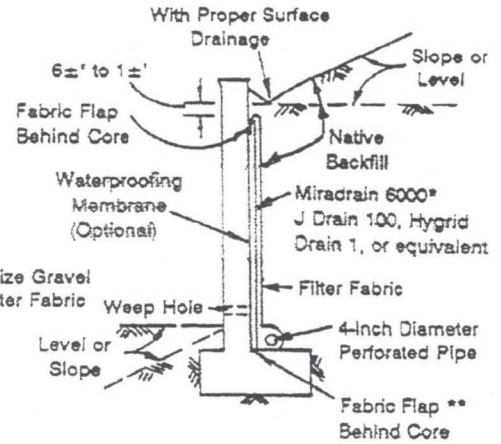

\*Miradrain 6000 or J Drain 100 for non-waterproofed walls; Miradrain 6200 or J Drain 200 for completed waterproofed walls

\*\*Peel back the bottom fabric flap, place pipe next to core, wrap fabric around pipe and tuck behind core.

## SUBDRAIN OPTIONS FOR CLEAN SAND BACKFILL

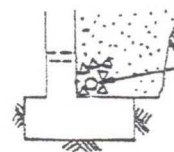
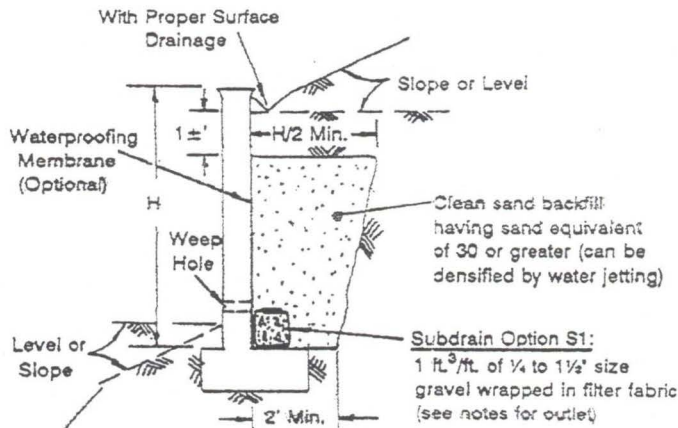

**Subdrain Option S2:**  
4" diameter perforated pipe surrounded with 1 ft<sup>3</sup>/ft. of Class 2 filter material per Caltrans specifications as above

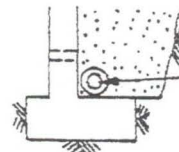

**Subdrain Option S3:**  
4" diameter perforated pipe wrapped in filter fabric

**Notes:**

- Pipe type should be ASTM D1527 Acrylonitrile Butadiene Styrene (ABS) SDR35 or ASTM D1785 Polyvinyl Chloride plastic (PVC), Schedule 40, Armco A2000 PVC, or approved equivalent. Pipe should be installed with perforations down.
- Filter fabric should be Mirafi 140N, 140NS, Supac 4NP, Amoco 4545, Trevira 1114, or approved equivalent.
- All drains should have a gradient of 1 percent minimum.
- Outlet portion for gravel subdrain should have a 4"-diameter pipe with the perforated portion inserted into the gravel approximately 2' minimum and the nonperforated portion extending approximately 1' outside the gravel. Proper sealing should be provided at the pipe insertion enabling water to run from the gravel portion into rather than outside the pipe.
- Waterproofing membrane may be required for a specific retaining wall such as a stucco or basement wall.
- Weephole should be 2" minimum diameter and provided at 25' minimum in length of wall. If exposure is permitted, weephole should be located at 3" above finished grade. If exposure is not permitted such as for a wall adjacent to a sidewalk/curb, a pipe under the sidewalk to discharge through the curb face or equivalent should be provided, or for a basement-type wall, a proper subdrain outlet system should be provided. Open vertical masonry joints (i.e., omit mortar from joints of first course above finished grade) at 32" maximum intervals may be substituted for weepholes. Screening such as with a filter fabric should be provided for weepholes/open joints to prevent earth materials from entering the holes/joints.



# APPENDIX A



## REFERENCES

- USGS Geologic Map of the Riverside West 7.5' Quadrangle, Riverside County, California.
- Riverside County GIS Liquefaction Map.
- Riverside County Landslides and Liquefaction Map.
- Department of the Interior, U.S. Geological Survey, Contour Map Showing Minimum Depth to Ground Water, Upper Santa Ana River Valley, California 1973-1979 (Sheet 2 of 2), By Scott E. Carson and Jonathan C. Matti, Dated 1985.
- U.S. Geological Survey – Earthquake Hazards Program, 2008 National Seismic Hazard Maps – Source Parameters.
- U.S. Geological Survey Faults, 2014.

## APPENDIX B



MAJOR DIVISIONS		SYMBOLS		TYPICAL NAMES
COARSE-GRAINED SOILS (More than 1/2 of soil < No. 200 sieve)	GRAVELS (More than 1/2 of coarse fraction > No. 4 sieve size)	GW		Well-graded gravels or gravel-sand mixtures, little or no fines
		GP		Poorly graded gravels or gravel-sand mixtures, little or no fines
		GM		Silty gravels, gravel-sand-silt mixtures
		GC		Clayey gravels, gravel-sand-clay mixtures
	SANDS (More than 1/2 of coarse fraction < No. 4 sieve size)	SW		Well-graded sands or gravelly sands, little or no fines
		SP		Poorly graded sands or gravelly sands, little or no fines
		SM		Silty sands, sand-silt mixtures
		SC		Clayey sands, sand-clay mixtures
FINE-GRAINED SOILS (More than 1/2 of soil < No. 200 sieve)	SILTS & CLAYS LL < 50	ML		Inorganic silts and very fine sands, rock flour, silty or clayey fine sands or clayey silts with slight plasticity.
		CL		Inorganic clays of low to medium plasticity, gravelly clays, sandy clays, silty clays, lean clays.
		OL		Organic silts and organic silty clays of low plasticity.
	SILTS & CLAYS LL > 50	MH		Inorganic silts, caceous or diatomaceous fine sandy or silty soils, elastic silts
		CH		Inorganic clays of medium to high plasticity, organic silty clays, organic silts
		OH		Organic clays of medium to high plasticity, organic silty clays, organic silts
HIGHLY ORGANIC SOILS	Pt		Peat and other highly organic soils	

**CLASSIFICATION CHART**  
(UNIFIED SOIL CLASSIFICATION SYSTEM)

CLASSIFICATION	RANGE OF GRAIN SIZES		
	U.S. Standard Sieve Size	Grain Size in Millimeters	
BOULDER	ABOVE 12"	ABOVE 305	
COBBLES	3" to 12"	305 to 76.2	
GRAVEL	3" to No. 4	76.2 to 4.76	
	COARSE FINE	3" TO 3/4" 3/4" to No. 4	76.2 to 19.1 19.1 to 4.76
SAND	No. 4 to 200	4.76 to 0.074	
	COARSE	No. 4 to 10	4.76 to 2.00
	MEDIUM FINE	No. 10 to 40 No. 40 to 200	2.00 to 0.420 0.420 to 0.074
SILT & CLAY	BELOW No. 200	BELOW 0.074	

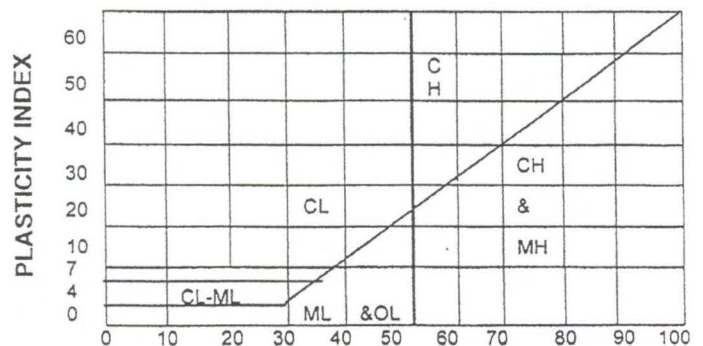

**GRAIN SIZE CHART**

**PLASTICITY CHART**

		<b>NR</b> No Recovery	Classification in accordance with ASTM D2487 Description and visual observation in accordance with ASTM D2488 All Sieve Sizes shown are US Standard SPT Refusal is defined as one of the following: 10 blows for no apparent displacement 50 blows for less than 6 inches advancement 100 blows for 6 to 18 inches advancement

# GEOTECHNICAL BORING LOGS

Drill Hole No.     B-1    

Date: January 15, 2020

Project No. 19252-01

Drilling Company: Larry Harklerode

Type of Rig: B-53

Hole Diameter: 8" Drive Weight: 140 lbs. Drop: 30"

Elevation: Existing Ground

DEPTH (feet)	TYPE OF TEST	SAMPLE TEST	BLOWS PER 6 INCH	DRY DENSITY (%)	MOISTURE (%)	SOIL CLASSIFICATION USCS	GEOTECHNICAL DESCRIPTION LOGGED BY: <u>GL</u> SAMPLED BY: <u>GL</u>	
1						SM	Qye: Young eolian deposits <b>SILTY SAND:</b> Reddish yellow, fine to medium grained, slightly moist, <u>very loose</u>	
2								
3		X	3/1/3	-	7.7			Slightly moist, <u>very loose</u>
4								
5								
6		X	3/3/4	-	7.0			Slightly moist, <u>loose</u> % Passing No. 200 Sieve = 12
7								
8								
9								
10								
11		X	35/47/41	-	6.3			Brownish yellow, slightly moist, very dense % Passing No. 200 Sieve = 26
12								
13								
14								
15								
16		X	45/50/3"	-	-			Slightly moist, very dense
17								
18								
19								
20								
21		X	18/18/28	-	3.9			Fine to coarse grained, dry, dense % Passing No. 200 Sieve = 12
22								
23								
24								
25								

# GEOTECHNICAL BORING LOGS

Drill Hole No.     B-1    

Date:     January 15, 2020      
 Drilling Company:     Larry Harklerode      
 Hole Diameter:     8"     Drive Weight:     140 lbs.    

Project No.     19252-01      
 Type of Rig:     B-53      
 Elevation:     Existing Ground    

DEPTH (feet)	TYPE OF TEST	SAMPLE TEST	BLOWS PER 6 INCH	DRY DENSITY (%)	MOISTURE (%)	SOIL CLASSIFICATION USCS	GEOTECHNICAL DESCRIPTION LOGGED BY: <u>    GL    </u> SAMPLED BY: <u>    GL    </u>
26		X	35/50	-	-	SM	Brownish yellow, fine to coarse grained, slightly moist, very dense
27							
28							
29							
30							
31		X	70/4"	-	-		
32							
33							
34							
35							
36		X	50/1"	-	-		
37							
38							
39							
40							
41		X	50/2"	-	-		
42							
43							
44							
45							
46		X	50/1"	-	-		
47							
48							
49						TOTAL DEPTH = 50 FEET NO GROUNDWATER NO CAVING BORING BACKFILLED	
50		X	50/2"	-	-		

# GEOTECHNICAL BORING LOGS

Drill Hole No.     B-2    

Date: January 15, 2020  
 Drilling Company: Larry Harklerode  
 Hole Diameter: 8" Drive Weight: 140 lbs.

Project No. 19252-01  
 Type of Rig: B-53  
 Elevation: Existing Ground

Drop: 30"

DEPTH (feet)	TYPE OF TEST	SAMPLE TEST	BLOWS PER 6 INCH	DRY DENSITY (%)	MOISTURE (%)	SOIL CLASSIFICATION USCS	GEOTECHNICAL DESCRIPTION LOGGED BY: <u>GL</u> SAMPLED BY: <u>GL</u>										
1						SM	Qof: Old alluvial-fan deposits <b>SILTY SAND:</b> Reddish yellow, fine to medium grained, slightly moist, <u>top 5 feet loose</u>										
2																	
3																	
4																	
5																	
6																	
7			21/25/45	-	-			SM	Brownish yellow, fine to medium grained, dry, dense								
8																	
9																	
10																	
11		X	16/30/43	-	-					SM	Dry, very dense						
12																	
13																	
14																	
15																	
16		X	58/6"	-	-							SM	Dry, very dense				
17																	
18																	
19																	
20																	
21		X	18/20/20	-	-									SM	Dry, dense		
22																	
23																	
24																SM	Dry, very dense at 24.5 feet
25																	
25		X	35/35/37	-	-	SM	Dry, very dense at 24.5 feet  TOTAL DEPTH = 25 FEET NO GROUNDWATER NO CAVING BORING BACKFILLED										



# GEOTECHNICAL BORING LOGS

Drill Hole No.     B-3    

Date: January 15, 2020

Project No. 19252-01

Drilling Company: Larry Harklerode

Type of Rig: B-53

Hole Diameter: 8" Drive Weight: 140 lbs. Drop: 30"

Elevation: Existing Ground

DEPTH (feet)	TYPE OF TEST	SAMPLE TEST	BLOWS PER 6 INCH	DRY DENSITY (%)	MOISTURE (%)	SOIL CLASSIFICATION USCS	GEOTECHNICAL DESCRIPTION LOGGED BY: <u>GL</u> SAMPLED BY: <u>GL</u>	
1						SM	Qof: Old alluvial-fan deposits <b>SILTY SAND:</b> Reddish yellow, fine to medium grained, slightly moist, <u>top 3 feet loose</u>	
2								
3			6/6/7	108.5	7.0			Slightly moist, <u>loose</u>
4								
5								
6			9/25/ 50/5"	114.9	13.1			Brownish yellow, slightly moist, very dense
7								
8								
9								
10								
11		X	50/3"	-	-			Slightly moist, very dense
12								
13								
14								
15		X	50/2"	-	-			Slightly moist, very dense
16						TOTAL DEPTH = 15 FEET NO GROUNDWATER NO CAVING BORING BACKFILLED		
17								
18								
19								
20								
21								
22								
23								
24								
25								

# GEOTECHNICAL BORING LOGS

Drill Hole No.     B-4    

Date:     January 15, 2020    

Project No.     19252-01    

Drilling Company:     Larry Harklerode    

Type of Rig:     B-53    

Hole Diameter:     8"     Drive Weight:     140 lbs.     Drop:     30"    

Elevation:     Existing Ground    

DEPTH (feet)	TYPE OF TEST	SAMPLE TEST	BLOWS PER 6 INCH	DRY DENSITY (%)	MOISTURE (%)	SOIL CLASSIFICATION USCS	GEOTECHNICAL DESCRIPTION LOGGED BY: <u>    GL    </u> SAMPLED BY: <u>    GL    </u>	
1						SM	Qof: Old alluvial-fan deposits <b>SILTY SAND:</b> Reddish brown, fine to medium grained, slightly moist, <u>top 3 feet loose</u>	
2								
3								
4			5/8/20	121.7	13.8			Slightly moist, medium dense
5								
6								
7		X	20/50/5"	-	7.3			Brownish yellow, dry, very dense
8								
9								
10								
11		X	36/50/5"	-	-			Dry, very dense
12								
13								
14								
15								
16		X	45/50/4"	-	-			Dry, very dense
17						TOTAL DEPTH = 16 FEET NO GROUNDWATER NO CAVING BORING BACKFILLED		
18								
19								
20								
21								
22								
23								
24								
25								

# GEOTECHNICAL BORING LOGS

Drill Hole No.     B-5    

Date:     January 15, 2020    

Project No.     19252-01    

Drilling Company:     Larry Harklerode    

Type of Rig:     B-53    

Hole Diameter:     8"     Drive Weight:     140 lbs.     Drop:     30"    

Elevation:     Existing Ground    

DEPTH (feet)	TYPE OF TEST	SAMPLE TEST	BLOWS PER 6 INCH	DRY DENSITY (%)	MOISTURE (%)	SOIL CLASSIFICATION USCS	GEOTECHNICAL DESCRIPTION LOGGED BY: <u>    GL    </u> SAMPLED BY: <u>    GL    </u>
1						SM	Qof: Old alluvial-fan deposits <b>SILTY SAND:</b> Reddish brown, fine to medium grained, slightly moist, medium dense  Slightly moist, medium dense  Dense  Slightly moist, very dense  Slightly moist, very dense  Slightly moist, very dense
2							
3		X	4/5/23	-	14.6		
4							
5							
6		X	26/50	-	9.7		
7							
8							
9							
10							
11		X	37/43/40	-	-		
12							
13							
14							
15		X	40/50	-	-		
16						TOTAL DEPTH = 15 FEET NO GROUNDWATER NO CAVING BORING BACKFILLED	
17							
18							
19							
20							
21							
22							
23							
24							
25							

# APPENDIX C



Proposed Residential Development  
45<sup>th</sup> Street  
City of Jurupa Valley, California

**LABORATORY TEST RESULTS**

<b>SIEVE SIZE</b>	<b>B-1 @ 5' % PASSING</b>	<b>B-1 @ 10' % PASSING</b>	<b>B-1 @ 20' % PASSING</b>
3/8"	-	100	100
No. 4	100	98	98
No. 8	99	93	90
No. 16	97	83	74
No. 30	79	69	53
No. 50	53	53	33
No. 100	30	38	19
No. 200	12	26	12
<b>SIEVE ANALYSIS TEST DATA</b>			

Cal Land Engineering, Inc.  
dba Quartech Consultants  
Geotechnical, Environmental & Civil Engineering

January 24, 2020

Soil Exploration Company Inc.  
7535 Jurupa Avenue, Unit C  
Riverside, California 92504

Attn: Mr. Gene Luu

**RE: LABORATORY TEST RESULTS/REPORT**

Client: Roger Hobb  
Project No.: 19252-01  
QCI Job No.: 20-183-001m

Gentlemen:

We have completed the testing program conducted on sample for above project. The tests were performed in accordance with testing procedures as follows:

Sample ID	Sample Depth (ft)	pH CT-532 (643)	Chloride CT-422 (ppm)	Sulfate CT-417 % By Weight	Resistivity CT-532 (643) (ohm-cm)
B-1	0-5'	8.20	182	0.0295	13,000

**Direct Shear: [Figure 1]**

We appreciate the opportunity to provide testing services to Soil Exploration Company Inc. Should you have any questions, please call the undersigned.

Sincerely yours,

**Cal Land Engineering, Inc. (CLE)  
dba Quartech Consultants (QCI)**

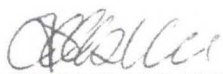
  
\_\_\_\_\_  
Jack C. Lee, GE 2153  
Principle Engineer

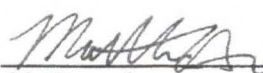

  
\_\_\_\_\_  
Matthew Au  
Project Engineer

Enclosure

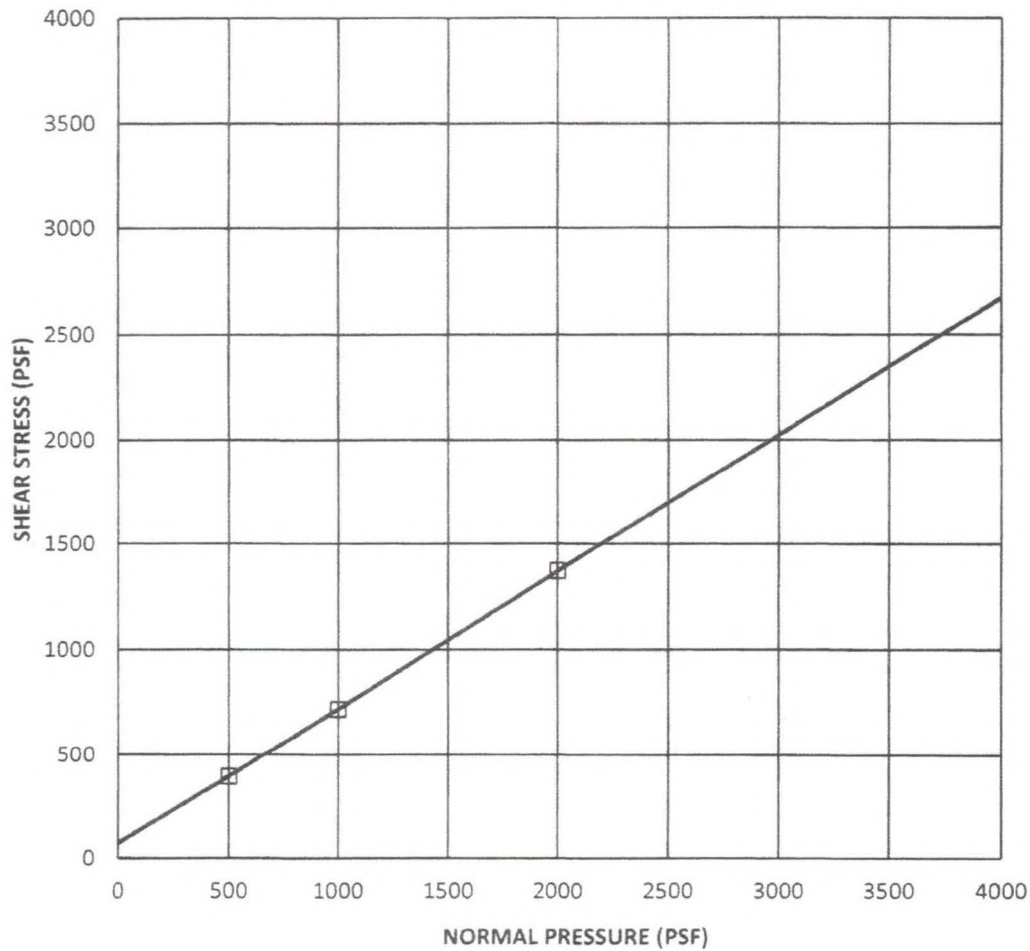

SYMBOL	BORING NO.	SAMPLE NO.	DEPTH (FT)	SAMPLE TYPE	SOIL TYPE	COHESION (PSF)	FRICTION ANGLE (DEG)
□	B-2	N/A	6.0	RING	SM	70	33

Vertical Loads (PSF)	Moisture Content Before Test (%)	Moisture Content After Test (%)
500	2.3	18.7
1000	2.3	18.2
2000	2.3	17.4

**Calland Engineering, Inc**  
**dba Quartech Consultants**  
 Geotechnical, Environmental & Civil  
 Engineering Services

Client:  
 Soil Exploration  
 Project #: 19252-01  
 Roger Hobbs

**DIRECT SHEAR**  
 (ASTM D3080)

## APPENDIX D





## 2008 National Seismic Hazard Maps - Source Parameters

[New Search](#)

Distance in Miles	Name	State	Pref Slip Rate (mm/yr)	Dip (degrees)	Dip Dir	Slip Sense	Rupture Top (km)	Rupture Bottom (km)
9.22	<a href="#">San Jacinto;SBV+SJV</a>	CA	n/a	90	V	strike slip	0	16
9.22	<a href="#">San Jacinto;SBV</a>	CA	6	90	V	strike slip	0	16
9.22	<a href="#">San Jacinto;SBV+SJV+A+CC+B+SM</a>	CA	n/a	90	V	strike slip	0.1	15
9.22	<a href="#">San Jacinto;SBV+SJV+A+CC+B</a>	CA	n/a	90	V	strike slip	0.1	15
9.22	<a href="#">San Jacinto;SBV+SJV+A+CC</a>	CA	n/a	90	V	strike slip	0	16
9.22	<a href="#">San Jacinto;SBV+SJV+A+C</a>	CA	n/a	90	V	strike slip	0	17
9.22	<a href="#">San Jacinto;SBV+SJV+A</a>	CA	n/a	90	V	strike slip	0	16
10.98	<a href="#">San Jacinto;SJV</a>	CA	18	90	V	strike slip	0	16
10.98	<a href="#">San Jacinto;SJV+A+C</a>	CA	n/a	90	V	strike slip	0	17
10.98	<a href="#">San Jacinto;SJV+A</a>	CA	n/a	90	V	strike slip	0	17
10.98	<a href="#">San Jacinto;SJV+A+CC+B+SM</a>	CA	n/a	90	V	strike slip	0.1	15
10.98	<a href="#">San Jacinto;SJV+A+CC+B</a>	CA	n/a	90	V	strike slip	0.1	15
10.98	<a href="#">San Jacinto;SJV+A+CC</a>	CA	n/a	90	V	strike slip	0	16
12.25	<a href="#">Cucamonga</a>	CA	5	45	N	thrust	0	8
13.71	<a href="#">Chino, alt 2</a>	CA	1	65	SW	strike slip	0	14
13.76	<a href="#">Chino, alt 1</a>	CA	1	50	SW	strike slip	0	9
14.33	<a href="#">Elsinore;W+GI+T</a>	CA	n/a	84	NE	strike slip	0	14

14.33	<u>Elsinore;W+GI</u>	CA	n/a	81	NE	strike slip	0	14
14.33	<u>Elsinore;GI</u>	CA	5	90	V	strike slip	0	13
14.33	<u>Elsinore;GI+T+J+CM</u>	CA	n/a	86	NE	strike slip	0	16
14.33	<u>Elsinore;GI+T+J</u>	CA	n/a	86	NE	strike slip	0	17
14.33	<u>Elsinore;GI+T</u>	CA	5	90	V	strike slip	0	14
14.33	<u>Elsinore;W+GI+T+J+CM</u>	CA	n/a	84	NE	strike slip	0	16
14.33	<u>Elsinore;W+GI+T+J</u>	CA	n/a	84	NE	strike slip	0	16
14.79	<u>Elsinore;W</u>	CA	2.5	75	NE	strike slip	0	14
15.08	<u>S. San Andreas;NM+SM+NSB+SSB</u>	CA	n/a	90	V	strike slip	0	13
15.08	<u>S. San Andreas;CH+CC+BB+NM+SM+NSB+SSB+BG+CO</u>	CA	n/a	86		strike slip	0.1	13
15.08	<u>S. San Andreas;NSB+SSB+BG+CO</u>	CA	n/a	79		strike slip	0.2	12
15.08	<u>S. San Andreas;CC+BB+NM+SM+NSB</u>	CA	n/a	90	V	strike slip	0	14
15.08	<u>S. San Andreas;CC+BB+NM+SM+NSB+SSB</u>	CA	n/a	90	V	strike slip	0	14
15.08	<u>S. San Andreas;CC+BB+NM+SM+NSB+SSB+BG</u>	CA	n/a	85		strike slip	0	14
15.08	<u>S. San Andreas;CC+BB+NM+SM+NSB+SSB+BG+CO</u>	CA	n/a	86		strike slip	0.1	13
15.08	<u>S. San Andreas;CH+CC+BB+NM+SM+NSB</u>	CA	n/a	90	V	strike slip	0	14
15.08	<u>S. San Andreas;CH+CC+BB+NM+SM+NSB+SSB</u>	CA	n/a	90	V	strike slip	0	14
15.08	<u>S. San Andreas;CH+CC+BB+NM+SM+NSB+SSB+BG</u>	CA	n/a	86		strike slip	0	14
15.08	<u>S. San Andreas;NM+SM+NSB</u>	CA	n/a	90	V	strike slip	0	13
15.08	<u>S. San Andreas;NM+SM+NSB+SSB+BG</u>	CA	n/a	83		strike slip	0	14
15.08	<u>S. San Andreas;NM+SM+NSB+SSB+BG+CO</u>	CA	n/a	84		strike slip	0.1	13

15.08	<u>S. San Andreas;NSB</u>	CA	22	90	V	strike slip	0	13
15.08	<u>S. San Andreas;NSB+SSB</u>	CA	n/a	90	V	strike slip	0	13
15.08	<u>S. San Andreas;NSB+SSB+BG</u>	CA	n/a	75		strike slip	0	14
15.08	<u>S. San Andreas;PK+CH+CC+BB+NM+SM+NSB</u>	CA	n/a	90	V	strike slip	0.1	13
15.08	<u>S. San Andreas;PK+CH+CC+BB+NM+SM+NSB+SSB</u>	CA	n/a	90	V	strike slip	0.1	13
15.08	<u>S. San Andreas;PK+CH+CC+BB+NM+SM+NSB+SSB+BG</u>	CA	n/a	86		strike slip	0.1	13
15.08	<u>S. San Andreas;PK+CH+CC+BB+NM+SM+NSB+SSB+BG+CO</u>	CA	n/a	86		strike slip	0.1	13
15.08	<u>S. San Andreas;BB+NM+SM+NSB</u>	CA	n/a	90	V	strike slip	0	14
15.08	<u>S. San Andreas;SM+NSB</u>	CA	n/a	90	V	strike slip	0	13
15.08	<u>S. San Andreas;SM+NSB+SSB</u>	CA	n/a	90	V	strike slip	0	13
15.08	<u>S. San Andreas;SM+NSB+SSB+BG</u>	CA	n/a	81		strike slip	0	13
15.08	<u>S. San Andreas;SM+NSB+SSB+BG+CO</u>	CA	n/a	83		strike slip	0.1	13
15.08	<u>S. San Andreas;BB+NM+SM+NSB+SSB</u>	CA	n/a	90	V	strike slip	0	14
15.08	<u>S. San Andreas;BB+NM+SM+NSB+SSB+BG</u>	CA	n/a	84		strike slip	0	14
15.08	<u>S. San Andreas;BB+NM+SM+NSB+SSB+BG+CO</u>	CA	n/a	85		strike slip	0.1	13
15.89	<u>S. San Andreas;SSB</u>	CA	16	90	V	strike slip	0	13
15.89	<u>S. San Andreas;SSB+BG+CO</u>	CA	n/a	77		strike slip	0.2	12
15.89	<u>S. San Andreas;SSB+BG</u>	CA	n/a	71		strike slip	0	13
17.23	<u>San Jose</u>	CA	0.5	74	NW	strike slip	0	15
19.62	<u>San Jacinto;A+CC</u>	CA	n/a	90	V	strike slip	0	16
19.62	<u>San Jacinto;A+C</u>	CA	n/a	90	V	strike slip	0	17

19.62	<u>San Jacinto:A</u>	CA	9	90	V	strike slip	0	17
19.62	<u>San Jacinto:A+CC+B+SM</u>	CA	n/a	90	V	strike slip	0.1	15
19.62	<u>San Jacinto:A+CC+B</u>	CA	n/a	90	V	strike slip	0.1	15
20.06	<u>Sierra Madre</u>	CA	2	53	N	reverse	0	14
20.06	<u>Sierra Madre Connected</u>	CA	2	51		reverse	0	14
20.20	<u>Cleghorn</u>	CA	3	90	V	strike slip	0	16
22.62	<u>Elsinore:T</u>	CA	5	90	V	strike slip	0	14
22.62	<u>Elsinore:T+J+CM</u>	CA	n/a	85	NE	strike slip	0	16
22.62	<u>Elsinore:T+J</u>	CA	n/a	86	NE	strike slip	0	17
23.27	<u>S. San Andreas:CH+CC+BB+NM+SM</u>	CA	n/a	90	V	strike slip	0	14
23.27	<u>S. San Andreas:BB+NM+SM</u>	CA	n/a	90	V	strike slip	0	14
23.27	<u>S. San Andreas:CC+BB+NM+SM</u>	CA	n/a	90	V	strike slip	0	14
23.27	<u>S. San Andreas:NM+SM</u>	CA	n/a	90	V	strike slip	0	14
23.27	<u>S. San Andreas:PK+CH+CC+BB+NM+SM</u>	CA	n/a	90	V	strike slip	0.1	13
23.27	<u>S. San Andreas:SM</u>	CA	29	90	V	strike slip	0	13
23.99	<u>North Frontal (West)</u>	CA	1	49	S	reverse	0	16
26.20	<u>Puente Hills (Coyote Hills)</u>	CA	0.7	26	N	thrust	2.8	15
29.41	<u>Clamshell-Sawpit</u>	CA	0.5	50	NW	reverse	0	14
29.84	<u>San Joaquin Hills</u>	CA	0.5	23	SW	thrust	2	13
34.25	<u>Puente Hills (Santa Fe Springs)</u>	CA	0.7	29	N	thrust	2.8	15
34.35	<u>Raymond</u>	CA	1.5	79	N	strike slip	0	16
36.00	<u>S. San Andreas:BG</u>	CA	n/a	58		strike slip	0	13
36.00	<u>S. San Andreas:BG+CO</u>	CA	n/a	72		strike slip	0.3	12
38.98	<u>Elysian Park (Upper)</u>	CA	1.3	50	NE	reverse	3	15

39.13	<u>Newport Inglewood Connected alt 2</u>	CA	1.3	90	V	strike slip	0	11
39.24	<u>Newport-Inglewood, alt 1</u>	CA	1	88		strike slip	0	15
39.24	<u>Newport Inglewood Connected alt 1</u>	CA	1.3	89		strike slip	0	11
39.40	<u>Newport-Inglewood (Offshore)</u>	CA	1.5	90	V	strike slip	0	10
40.21	<u>Puente Hills (LA)</u>	CA	0.7	27	N	thrust	2.1	15
40.73	<u>Pinto Mtn</u>	CA	2.5	90	V	strike slip	0	16
41.32	<u>Helendale-So Lockhart</u>	CA	0.6	90	V	strike slip	0	13
42.77	<u>Verdugo</u>	CA	0.5	55	NE	reverse	0	15
42.96	<u>North Frontal (East)</u>	CA	0.5	41	S	thrust	0	16
46.91	<u>Hollywood</u>	CA	1	70	N	strike slip	0	17
49.84	<u>Santa Monica Connected alt 2</u>	CA	2.4	44		strike slip	0.8	11

# ASCE 7 Hazards Report

**Address:**  
No Address at This  
Location

**Standard:** ASCE/SEI 7-16  
**Risk Category:** II  
**Soil Class:** D - Stiff Soil

**Elevation:** 836.87 ft (NAVD 88)  
**Latitude:** 33.9945  
**Longitude:** -117.4272





## Seismic

---

**Site Soil Class:** D - Stiff Soil

**Results:**

$S_s$ :	1.5	$S_{D1}$ :	N/A
$S_1$ :	0.6	$T_L$ :	8
$F_a$ :	1	PGA :	0.5
$F_v$ :	N/A	PGA <sub>M</sub> :	0.55
$S_{MS}$ :	1.5	$F_{PGA}$ :	1.1
$S_{M1}$ :	N/A	$I_e$ :	1
$S_{DS}$ :	1	$C_v$ :	1.4

Ground motion hazard analysis may be required. See ASCE/SEI 7-16 Section 11.4.8.

**Data Accessed:** Tue Jan 14 2020

**Date Source:** [USGS Seismic Design Maps](#)

# APPENDIX E





---

## **GENERAL EARTHWORK AND GRADING SPECIFICATIONS**

### **1.0 GENERAL INTENT**

These specifications present general procedures and requirements for grading and earthwork as shown on the approved grading plans, including preparation of areas to be filled, placement of fill, installations of subdrains, and excavations. The recommendations contained in the geotechnical report are a part of the earthwork and grading specifications and shall supersede the provisions contained hereinafter in the case of conflict. Evaluations performed by the consultant during the course of grading may result in new recommendations which could supersede these specifications or the recommendations of the geotechnical report.

### **2.0 EARTHWORK OBSERVATIONS AND TESTING**

Prior to the commencement of grading, a qualified geotechnical consultant (soils engineer and engineering geologist, and their representatives) shall be employed for the purpose of observing earthwork procedures and testing the fills for conformance with the recommendations of the geotechnical report and these specifications. It will be necessary that the consultant provide adequate testing and observations so that he may determine that the work was accomplished as specified. It shall be the responsibility of the contractor to assist the consultant and keep him apprised of work schedules and changes so that he may schedule his personnel accordingly.

It shall be the sole responsibility of the contractor to provide adequate equipment and methods to accomplish the work in accordance with applicable grading codes or agency ordinances, these specifications and approved grading plans. If, in the opinion of the consultant, unsatisfactory conditions, such as questionable soil, poor moisture conditions, inadequate compaction, adverse weather, etc., are resulting in a quality of work less than required in these specifications, the consultant will be empowered to reject the work and recommend that construction be stopped until the unsatisfactory conditions are rectified.

Maximum dry density tests used to determine the degree of compaction will be performed in accordance with the American Society of Testing and Materials, test method ASTM D1557-12.

### **3.0 PREPARATION OF AREAS TO BE FILLED**

#### **3.1 Clearing and Grubbing**

All brush, vegetation, and debris shall be removed or piled and otherwise disposed of.

#### **3.2 Processing**

The existing ground which is determined to be satisfactory for support of fill shall be scarified to a minimum depth of 6 inches. Existing ground which is not satisfactory shall be overexcavated as specified in the following section. Scarification shall continue until the soils are broken down and free of large clay lumps or clods and until the working surface is reasonably uniform and free of uneven features which would inhibit uniform compaction.

#### **3.3 Overexcavation**

Soft, dry, spongy, highly fractured or otherwise unsuitable ground, extending to such depth that surface processing cannot adequately improve the condition, shall be overexcavated down to firm ground, approved by the consultant.

#### **3.4 Moisture Conditioning**

Overexcavated and processed soils shall be watered, dried-back, blended, and/or mixed, as required to attain a uniform moisture content near optimum.

#### **3.5 Recompaction**

Overexcavation and processed soils which have been properly mixed and moisture-conditioned shall be recompacted to a minimum relative compaction of 90 percent.

---

### **3.6 Benching**

Where fills are to be placed on ground with slopes steeper than 5:1 (horizontal : vertical), the ground shall be stepped or benched. The lowest bench shall be a minimum of 15 feet wide, shall be at least 2 feet deep, shall expose firm materials, and shall be approved by the consultant. Other benches shall be excavated in firm materials for a minimum width of 4 feet. Ground sloping flatter than 5:1 (horizontal : vertical) shall be benched or otherwise overexcavated when considered necessary by the consultant.

### **3.7 Approval**

All areas to receive fill, including processed areas, removal areas and toe-of-fill benches shall be approved by the consultant prior to fill placement.

## **4.0 FILL MATERIAL**

### **4.1 General**

Material to be placed as fill shall be free of organic matter and other deleterious substances, and shall be approved by the consultant. Soils of poor gradation, expansion, or strength characteristics shall be placed in areas designated by consultant or shall be mixed with other soils to serve as satisfactory fill material.

### **4.2 Oversize**

Oversize materials defined as rock, or other irreducible material with maximum dimension greater than 12 inches, shall not be buried or placed in fills, unless the location, materials, and disposal methods are specifically approved by the consultant. Oversize disposal operations shall be such that nesting of oversize material does not occur, and such that the oversize material is completely surrounded by compacted or densified fill. Oversize material shall not be placed within 10 feet vertically of finish grade or within the range of future utilities or underground construction, unless specifically approved by the consultant.

### **4.3 Import**

If importing of fill material is required for grading, the import material shall meet the requirements of Section 4.1.

## **5.0 FILL PLACEMENT and COMPACTION**

### **5.1 Fill Lifts**

Approved fill material shall be placed in areas prepared to receive fill in near-horizontal layers not exceeding 6 inches in compacted thickness. The consultant may approve thicker lifts if testing indicates the grading procedures are such that adequate compaction is being achieved with lifts of greater thickness. Each layer shall be spread evenly and shall be thoroughly mixed during spreading to attain uniformity of material and moisture in each layer.

### **5.2 Fill Moisture**

Fill layers at a moisture content less than optimum shall be watered and mixed, and wet fill layers shall be aerated by scarification or shall be blended with drier material. Moisture conditioning and mixing of fill layers shall continue until the fill material is at a uniform moisture content at or near optimum.

### **5.3 Compaction of Fill**

After each layer has been evenly spread, moisture-conditioned, and mixed, it shall be uniformly compacted to not less than 90 percent of maximum dry density. Compaction equipment shall be adequately sized and shall be either specifically designed for soil compaction or of proven reliability, to efficiently achieve the specified degree of compaction.

---

#### **5.4 Fill Slopes**

Compacting of slopes shall be accomplished, in addition to normal compacting procedures, by backrolling of slopes with sheepsfoot rollers at frequent increments of 2 to 3 feet in fill elevation gain, or by other methods producing satisfactory results. At the completion of grading, the relative compaction of the slope out to the slope face shall be at least 90 percent.

#### **5.5 Compaction Testing**

Field-tests to check the fill moisture and degree of compaction will be performed by the consultant. The location and frequency of tests shall be at the consultant's discretion. In general, the tests will be taken at intervals not exceeding 2 feet in vertical rise and/or 1,000 cubic yards of embankment.

#### **6.0 SUBDRAIN INSTALLATION**

Subdrain systems, if required, shall be installed in approved ground to conform to the approximate alignment and details shown on the plans or herein. The subdrain location or materials shall not be changed or modified without the approval of the consultant. The consultant, however, may recommend and upon approval, direct changes in subdrain line, grade or material. All subdrains should be surveyed for line and grade after installation and sufficient time shall be allowed for the surveys, prior to commencement of filling over the subdrain.

#### **7.0 EXCAVATION**

Excavations and cut slopes will be examined during grading. If directed by the consultant, further excavation or overexcavation and refilling of cut areas shall be performed, and/or remedial grading of cut slopes shall be performed. Where fill-over-cut slopes are to be graded, unless otherwise approved, the cut portion of the slope shall be made and approved by the consultant prior to placement of materials for construction of the fill portion of the slope.

#### **8.0 TRENCH BACKFILLS**

Trench excavations for utility pipes shall be backfilled under engineering supervision.

After the utility pipe has been laid, the space under and around the pipe shall be backfilled with clean sand or approved granular soil to a depth of at least one foot over the top of the pipe. The sand backfill shall be uniformly jetted into place before the controlled backfill is placed over the sand.

The onsite materials, or other soils approved by the soil engineer, shall be watered and mixed as necessary prior to placement in lifts over the sand backfill.

The controlled backfill shall be compacted to at least 90 percent of the maximum dry density as determined by the ASTM D1557-12 test method.

Field density tests and inspection of the backfill procedures shall be made by the soil engineer during backfilling to see that proper moisture content and uniform compaction is being maintained. The contractor shall provide test holes and exploratory pits as required by the soil engineer to enable sampling and testing.

# APPENDIX F



**Infiltration Test (Boring Percolation Test Procedure)**

The tests were performed in accordance with Riverside County Stormwater Quality Best Management Practice Design Handbook for Low Impact Development, dated June 2014.

Four 8-inch diameter, 6-deep test holes (I-1, I-2, I-3 and I-4), were drilled at the suggested locations. The soil at the test locations was visually classified as silty sand. To mitigate any possible caving or sloughing of the test holes, a 6-inch diameter perforated pipe was placed in the hole. The bottom of the hole was covered with 2 inches of gravel.

The testing was conducted after presoaking for 24 hours. Two consecutive measurements showed that 6 inches of water seeped away in less than 25 minutes in I-1 and I-2 and more than 25 minutes in I-3 and I-4. The tests were therefore run an additional one hour with measurements taken at 10 minute intervals and an additional six hours with measurements taken at 30 minute intervals, respectively. Water level was adjusted to 20 inches above the bottom of the test hole after each measurement. The drop that occurred during the final reading was used for design rate purposes.

**Infiltration Test/Tabulated Test Results**

Test No.	Depth of Test (feet)	Earth Material	Infiltration Rate (in/hr)
I-1	6	Silty Sand (SM)	1.14
I-2	6	Silty Sand (SM)	1.68
I-3	6	Silty Sand (SM)	0.61
I-4	6	Silty Sand (SM)	1.05

# INFILTRATION TEST DATA (Boring Percolation Test Procedure)

Project: Roger Hobbs Project No.: 192501  
 Test Hole No.: T 1 Date Excavated: 1/15/20  
 Depth of Test Hole, D<sub>t</sub>: 6' Diameter: 8" USCS Soil Classification: SM  
 Diameter: 8" Presoak: 24 hr  
 Tested By: WR Date: 1/27/20

## SANDY SOIL CRITERIA TEST

Trial No.	Time	Time Interval (min)	Initial Water Level (inches)	Final Water Level (inches)	Δ in Water Level (inches)	Greater Than or Equal to 6" (Y/N)
1	11:32:09	25	52	59	7	Y
	11:57:09					
2	11:59:20	25	"	58	6	Y
	12:24:20					

Use Normal Sandy (Circle One) Soil Criteria

Trial No.	Start Time	Stop Time	Δt Time Interval (min.)	D <sub>i</sub> Initial Depth to Water (in.)	D <sub>f</sub> Final Depth to Water (in.)	ΔD Change in Water Level (in.)	Infiltration Rate (in./hr.)
1	12:24:49	12:34:49	10	52	54.125	2.125	
2	12:36:02	12:46:02	10	51	54	2	
3	12:46:40	12:56:40	10	51	51	0	
4	12:59:19	1:09:19	10	51	51	0	
5	1:09:53	1:19:53	10	51	51	0	
6	1:20:45	1:30:45	10	51	51	2	1.14
7							
8							
9							
10							
11							
12							

COMMENTS:

$$\text{Infiltration Rate} = \frac{4 \times 60 \times 2}{10/4 + (20 + (20 - 2))} = 1.14 \text{ in/hr}$$

# INFILTRATION TEST DATA (Boring Percolation Test Procedure)

Project: Roger Hobbs Project No.: 19252-01  
 Test Hole No.: I 2 Date Excavated: 1/15/20  
 Depth of Test Hole, D<sub>T</sub>: 6' Diameter: 8" USCS Soil Classification: SM  
 Diameter: 8" Presoak: 24hr  
 Tested By: WR Date: 1/27/20

## SANDY SOIL CRITERIA TEST

Trial No.	Time	Time Interval (min)	Initial Water Level (inches)	Final Water Level (inches)	Δ in Water Level (inches)	Greater Than or Equal to 6" (Y/N)
1	11:29:21	25	52	62	10	Y
	11:54:21					
2	11:56:03	25	4	61.625	9.625	Y
	11:21:03					

Use Normal Sandy (Circle One) Soil Criteria

Trial No.	Start Time	Stop Time	Δt Time Interval (min.)	D <sub>0</sub> Initial Depth to Water (in.)	D <sub>f</sub> Final Depth to Water (in.)	ΔD Change in Water Level (in.)	Infiltration Rate (in./hr.)
1	12:22:24	12:32:24	10	52	56.625	4.625	
2	12:33:15	12:43:15	10	11	56	4	
3	12:45:08	12:55:08	10	11	54.875	2.875	
4	12:58:08	1:08:08	10	11	11	11	
5	1:08:58	1:18:58	10	11	11	11	
6	1:19:14	1:29:14	10	11	11	2.875	1.68
7							
8							
9							
10							
11							
12							

COMMENTS:

$$\text{Infiltration Rate} = \frac{4 \times 60 \times 2.875}{10 \left[ 4 + (20 + (20 - 2.875)) \right]} = 1.68 \text{ in/hr}$$

# INFILTRATION TEST DATA

## (Boring Percolation Test Procedure)

Project: Roger Hobbs Project No.: 19252-01  
 Test Hole No.: I 3 Date Excavated: 1/15/20  
 Depth of Test Hole, Dt: 6 FEET Diameter: 8" USCS Soil Classification: SM  
 Diameter: 8" Presoak: 94 hr  
 Tested By: DR Date: 1-27-20

### SANDY SOIL CRITERIA TEST

Trial No.	Time	Time Interval (min)	Initial Water Level (inches)	Final Water Level (inches)	Δ in Water Level (inches)	Greater Than or Equal to 6" (Y/N)
1	10:56:16	28	52	57	5	N
	11:21:16					
2	11:22:27	25	"	56	4	N
	11:47:27					

Use Normal Sandy (Circle One) Soil Criteria

Trial No.	Start Time	Stop Time	Δt Time Interval (min.)	D <sub>o</sub> Initial Depth to Water(in.)	D <sub>f</sub> Final Depth to Water(in.)	ΔD Change in Water Level (in.)	Infiltration Rate (in./hr.)
1	11:49:33	12:19:33	30	52	55.375	3.375	
2	12:19:55	12:49:55	30	"	55.125	3.125	
3	12:50:20	1:20:20	30	"	"	"	
4	1:21:36	1:51:36	30	"	"	"	
5	1:52:47	2:22:47	"	"	"	"	
6	2:23:58	2:53:58	"	"	"	"	
7	2:55:00	3:25:00	"	"	"	"	
8	3:26:02	3:56:02	"	"	"	"	
9	3:57:14	4:27:14	"	"	"	"	
10	4:28:26	4:58:26	"	"	"	"	
11	4:59:38	5:29:38	"	"	"	"	
12	5:30:50	6:00:50	"	"	"	3.125	0.61

COMMENTS:

$$\text{Infiltration} = \frac{4 \times 60 \times 3.125}{30(4 + (20 + (20 - 3.125)))} = 0.61 \text{ in/hr}$$



# INFILTRATION TEST DATA (Boring Percolation Test Procedure)

Project: Roger Hobbs Project No.: 19252-01  
 Test Hole No.: I 4 Date Excavated: 1/15/20  
 Depth of Test Hole, Dt: 6' Diameter: 8" USCS Soil Classification: S<sub>01</sub>  
 Diameter: 8" Presoak: 24 hr  
 Tested By: TR Date: 1/27/20

## SANDY SOIL CRITERIA TEST

Trial No.	Time	Time Interval (min)	Initial Water Level (inches)	Final Water Level (inches)	Δ in Water Level (inches)	Greater Than or Equal to 6" (Y/N)
1	11:00:26	25	52	56	4	N
	11:25:26					
2	11:23:37	25	52	55.375	3.375	Y
	11:48:37					

Use Normal Sandy (Circle One) Soil Criteria

Trial No.	Start Time	Stop Time	Δt Time Interval (min.)	D <sub>0</sub> Initial Depth to Water (in.)	D <sub>f</sub> Final Depth to Water (in.)	ΔD Change in Water Level (in.)	Infiltration Rate (in./hr.)
1	11:50:30	12:20:30	30	52	57.625	5.625	
2	12:21:05	12:51:05	30	11	57.125	5.125	
3	12:51:44	1:21:44	30	11	11	11	
4	1:24:20	1:54:20	30	11	11	11	
5	1:55:31	2:25:31	11	11	11	11	
6	2:26:42	2:56:42	11	11	11	11	
7	2:57:53	3:27:53	11	11	11	11	
8	3:29:05	3:59:05	11	11	11	11	
9	4:00:17	4:30:17	11	11	11	11	
10	4:31:29	5:01:29	11	11	11	11	
11	5:02:41	5:32:41	11	11	11	11	
12	5:33:53	6:03:53	11	11	11	11	1.05

COMMENTS:

Infiltration Rate =  $\frac{4 \times 60 \times 5.125}{30(4 + (20 + (20 - 5.125)))} = 1.05 \text{ in/hr}$

# APPENDIX G



\*\*\*\*\*  
\*\*\*\*\*

LIQUEFACTION ANALYSIS SUMMARY

Copyright by CivilTech Software  
www.civiltechsoftware.com

\*\*\*\*\*  
\*\*\*\*\*

Font: Courier New, Regular, Size 8 is recommended for this report.  
Licensed to , 1/27/2020 3:35:27 PM

Input File Name: UNTITLED  
Title: PROJECT NAME: Rogger Hobbs  
Subtitle: Proj No.19252-01

Surface Elev.=Existing Ground  
Hole No.=B-1  
Depth of Hole= 50.00 ft  
Water Table during Earthquake= 50.00 ft  
Water Table during In-Situ Testing= 50.00 ft  
Max. Acceleration= 0.55 g  
Earthquake Magnitude= 7.00

Input Data:

Surface Elev.=Existing Ground  
Hole No.=B-1  
Depth of Hole=50.00 ft  
Water Table during Earthquake= 50.00 ft  
Water Table during In-Situ Testing= 50.00 ft  
Max. Acceleration=0.55 g  
Earthquake Magnitude=7.00

1. SPT or BPT Calculation.
  2. Settlement Analysis Method: Ishihara / Yoshimine
  3. Fines Correction for Liquefaction: Idriss/Seed
  4. Fine Correction for Settlement: During Liquefaction\*
  5. Settlement Calculation in: All zones\*
  6. Hammer Energy Ratio, Ce = 0.89
  7. Borehole Diameter, Cb= 1
  8. Sampling Method, Cs= 1
  9. User request factor of safety (apply to CSR) , User= 1  
Plot one CSR curve (fs1=1)
  10. Use Curve Smoothing: Yes\*
- \* Recommended Options

In-Situ Test Data:

Depth ft	SPT	gamma pcf	Fines %
0.00	4.00	125.00	12.00
5.00	7.00	125.00	12.00
10.00	88.00	125.00	26.00
15.00	100.00	125.00	26.00
20.00	46.00	125.00	12.00
25.00	100.00	125.00	12.00
30.00	100.00	125.00	12.00
35.00	100.00	125.00	12.00
40.00	100.00	125.00	12.00
45.00	100.00	125.00	12.00
50.00	100.00	125.00	12.00

Output Results:

Settlement of Saturated Sands=0.00 in.  
 Settlement of Unsaturated Sands=0.42 in.  
 Total Settlement of Saturated and Unsaturated Sands=0.42 in.  
 Differential Settlement=0.209 to 0.276 in.

Depth ft	CRRm	CSRfs	F.S.	S_sat. in.	S_dry in.	S_all in.
0.00	0.09	0.36	5.00	0.00	0.42	0.42
5.00	0.13	0.35	5.00	0.00	0.18	0.18
10.00	2.39	0.35	5.00	0.00	0.16	0.16
15.00	2.39	0.34	5.00	0.00	0.14	0.14
20.00	2.39	0.34	5.00	0.00	0.13	0.13
25.00	2.39	0.34	5.00	0.00	0.11	0.11
30.00	2.32	0.33	5.00	0.00	0.09	0.09
35.00	2.25	0.32	5.00	0.00	0.06	0.06
40.00	2.19	0.30	5.00	0.00	0.04	0.04
45.00	2.13	0.29	5.00	0.00	0.02	0.02
50.00	2.07	0.27	5.00	0.00	0.00	0.00

\* F.S.<1, Liquefaction Potential Zone  
 (F.S. is limited to 5, CRR is limited to 2, CSR is limited to 2)

Units: Depth = ft, Stress or Pressure = atm (tsf), Unit Weight = pcf,  
 Settlement = in.

---

1 atm (atmosphere) = 1 tsf (ton/ft<sup>2</sup>)  
 CRRm                      Cyclic resistance ratio from soils  
 CSRsf                     Cyclic stress ratio induced by a given earthquake (with user

UNTITLED.sum

request factor of safety)

F.S.	Factor of Safety against liquefaction, $F.S.=CRRm/CSRsf$
S_sat	Settlement from saturated sands
S_dry	Settlement from Unsaturated Sands
S_all	Total Settlement from Saturated and Unsaturated Sands
NoLiq	No-Liquefy Soils