

REPLACEMENT TENTATIVE PARCEL MAP NO. 21278 (DATED MAY 10, 2022)

EASEMENTS:

- (A) INDICATES EXISTING 25' PRIVATE ROAD EASEMENT PER DOC. REC. 11-18-1947 IN BOOK 2538, PAGE 396
- (B) INDICATES EXISTING UTILITY EASEMENT TO SDGE PER DOC. REC. 2-02-1949 IN BOOK 3101, PAGE 129 (NO WIDTH GIVEN)
- (C) INDICATES EXISTING 12' UTILITY EASEMENT TO SDGE PER DOC. REC. 7-15-1975 AS FILE NO. 75-182495
- (D) INDICATES EXISTING 40' PRIVATE ROAD & UTILITY EASEMENT PER DOC. REC. 9-06-1994 AS FILE NO. 94-538736
- (E) INDICATES PROPOSED OPEN SPACE EASEMENT BIOLOGICAL
- (F) INDICATES PROPOSED LIMIT BUILDING ZONE EASEMENT

LAND DIVISION STATEMENT OWNER'S CERTIFICATE ZONING DIVISION

I hereby certify that I am the record owner, as shown on the latest equalized County assessment, of the property shown on the Tentative Parcel Map. All of my contiguous ownership within and beyond the boundaries of the Tentative Parcel Map are shown. The basis of creation of the lots in my ownership (e.g., Parcel Map, Final Map, Certificate of Compliance, Recorded Deed before 2/1/72) is indicated on the Tentative Parcel Map. I understand that property is considered as contiguous even if it is separated by roads, streets, utility easements or railroad right-of-way. "Freeway" as defined in Section 23.5 of the Streets and Highway Code, shall not be considered as roads or streets.

I further certify that I will not, by this application, create or cause to be created, or will not have participated in the creation of more than four parcels on contiguous property unless such contiguous parcels were created by major subdivision. For purposes of this certification, the term "participated" means having cooperated with or acted in a planning, coordinating or decision-making capacity in any formal or informal association or partnership for the purpose of dividing real property.

I certify under penalty of perjury that the foregoing is true and correct.

Executed this 6TH day of JUNE, 2019 at FALLBROOK, California.

ALL OWNERS MUST SIGN

Signature \_\_\_\_\_ Signature \_\_\_\_\_  
 Name: LEHMAN FAMILY TRUST DATED JULY 1, Name: \_\_\_\_\_  
 Address: 1484 MEREDITH ROAD, FALLBROOK, CA. Address: \_\_\_\_\_  
 92028  
 Phone: 760-525-7000 Phone: \_\_\_\_\_

1. Complete Tax Assessor's number is: 123-261-14
2. Abbreviated legal description of the land shown on the Tentative Parcel Map: PORTION OF LOT 26, MAP 2323
3. General Plan Regional Category: SEMI-RURAL RESIDENTIAL (SR-2)
4. Community/Subregional Plan Area: FALLBROOK
5. Land Use Designation(s): LIMITED AGRICULTURAL
6. Associated Permits: NONE
7. Location and status of existing legal access to subject property from a publicly maintained road (i.e., recorded or unrecorded easement - identify and specify width): FRONTAGE ON PUBLIC ROAD (LINDA VISTA DRIVE)
8. Water source/Water District: RAINBOW MUNICIPAL WATER DISTRICT
9. Septic/Sewer District: INDIVIDUAL SEPTIC SYSTEMS
10. Fire District: NORTH COUNTY FIRE PROTECTION DISTRICT
11. School District(s): FALLBROOK UNION HIGH SCHOOL & FALLBROOK ELEMENTARY SCHOOL DISTRICT
12. Existing Zoning:

USE REGULATIONS		A70
<b>ANIMAL REGULATIONS</b>		L
Density		—
Lot Size		2 AC
Building Type		C
Maximum Floor Area		N/A
Floor Area Ratio		N/A
Height		G
Lot Coverage		N/A
Setback		C
Open Space		N/A
<b>SPECIAL AREA REGULATIONS</b>		C

SLOPE TABLE

- PARCEL 1 13%
- PARCEL 2 14%
- PARCEL 3 14%
- PARCEL 4 17%

% OF SLOPE OVER 25% SLOPE IS: 6%  
 AVERAGE SLOPE OF PROPERTY IS: 15%  
 AREA OVER 25% SLOPE IS: 0.63 ACRES  
 SLOPES OVER 25% SHOWN THUS:

NO SLOPES OVER 50%

NO PROPOSED ENCROACHMENT ON AREAS AT 25% SLOPE OR GREATER FOR ALL PARCELS

SOLAR ACCESS STATEMENT:

ALL LOTS WITHIN THIS SUBDIVISION HAVE A MINIMUM OF 100 SQUARE FEET OF SOLAR ACCESS FOR EACH FUTURE DWELLING/COMMERCIAL/INDUSTRIAL UNIT ALLOWED BY THIS SUBDIVISION.

SOURCE OF TOPO: COUNTY OF SAN DIEGO 200 SCALE TOPO INDEX: 422-1701

INDICATES PROPOSED ACCESS RELINQUISHMENT IN & TO LINDA VISTA DRIVE

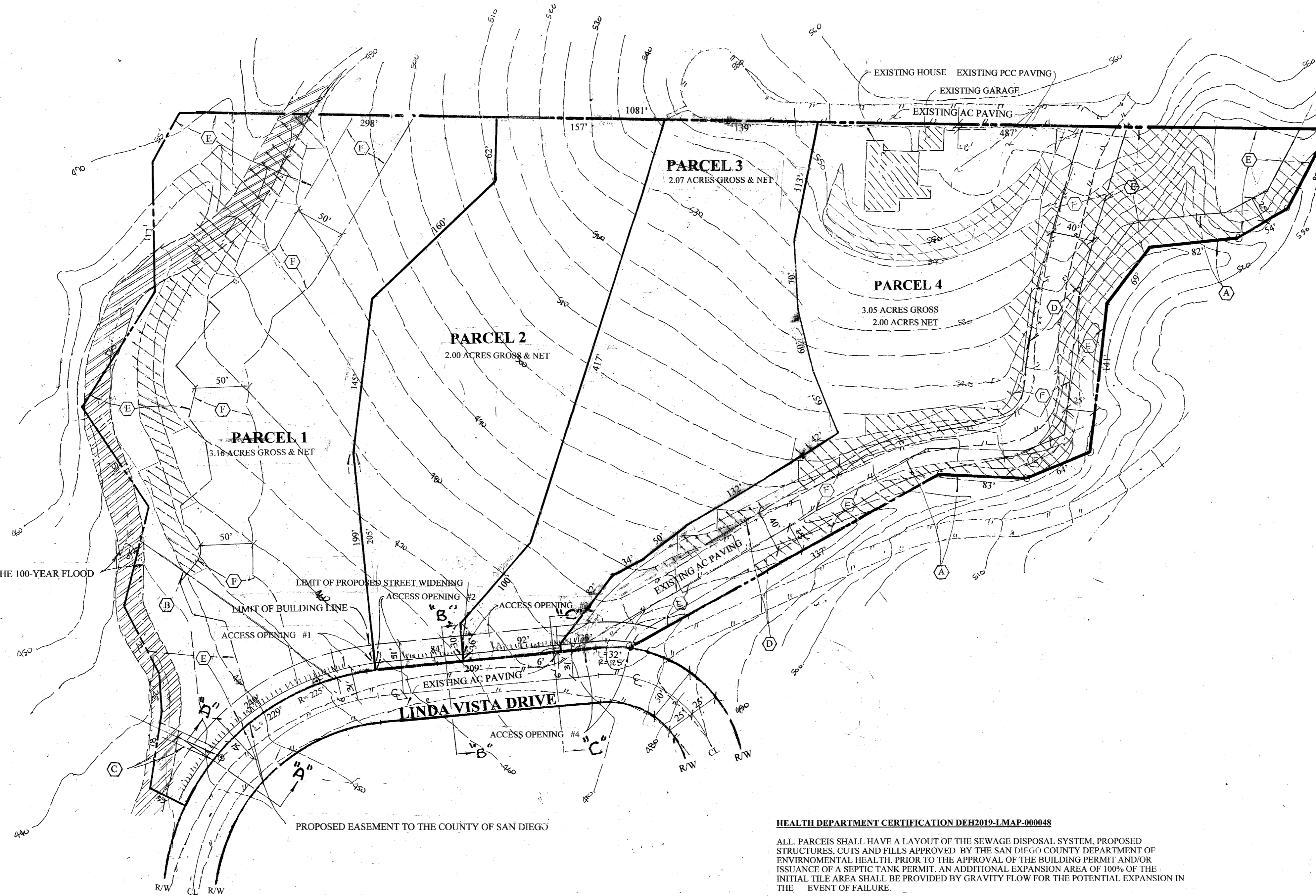

HEALTH DEPARTMENT CERTIFICATION DEH2019-LMAP-000048

ALL PARCELS SHALL HAVE A LAYOUT OF THE SEWAGE DISPOSAL SYSTEM, PROPOSED STRUCTURES, CUTS AND FILLS APPROVED BY THE SAN DIEGO COUNTY DEPARTMENT OF ENVIRONMENTAL HEALTH, PRIOR TO THE APPROVAL OF THE BUILDING PERMIT AND/OR ISSUANCE OF A SEPTIC TANK PERMIT. AN ADDITIONAL EXPANSION AREA OF 100% OF THE INITIAL TILE AREA SHALL BE PROVIDED BY GRAVITY FLOW FOR THE POTENTIAL EXPANSION IN THE EVENT OF FAILURE.

EACH PARCEL IS APPROVED FOR A STANDARD SEPTIC TANK CONNECTED TO \* OF TILE DRAIN FILED TO SERVE A FOUR-BEDROOM DWELLING; PROVIDED THE ORIGINAL SOIL IS NOT DISTURBED IN ANY WAY, SUCH AS CUTTING, FILLING OR RIPPING. THIS DOES NOT CONSTITUTE APPROVAL FOR COMMERCIAL ESTABLISHMENTS

\*DATA AND RECOMMENDATIONS IN THE NAME OF TOD LEHMAN BY DAVID H. LOWEN, RCE 31915

- PARCEL 1, 4 BEDROOM SFD, 410 CLF OF LEACH LINE WITH 5' TRENCH WITH 3' OF ROCK
- PARCEL 2, 4 BEDROOM SFD, 380 CLF OF LEACH LINE WITH 5' TRENCH WITH 3' OF ROCK
- PARCEL 3, 4 BEDROOM SFD, 440 CLF OF LEACH LINE WITH 5' TRENCH WITH 3' OF ROCK
- PARCEL 4, 4 BEDROOM SFD, 410 CLF OF LEACH LINE WITH 5' TRENCH WITH 3' OF ROCK

APPROVED BY: CATHERINE DEAN, REHS 11-20-2019

THIS CERTIFICATION DOES NOT IMPLY ALL CONDITIONS PURSUANT TO THE RESOURCE PROTECTION ORDINANCE HAVE BEEN MET. THE DEPARTMENT OF PLANNING AND LAND USE SHOULD BE CONSULTED REGARDING THE APPLICATION OF THE ORDINANCE RELATIVE TO THIS PROJECT. ANY RESULTANT CHANGES TO THE SEPTIC SYSTEM DESIGN (S) MUST BE RE-EVALUATED BY THE DEPARTMENT OF ENVIRONMENTAL HEALTH

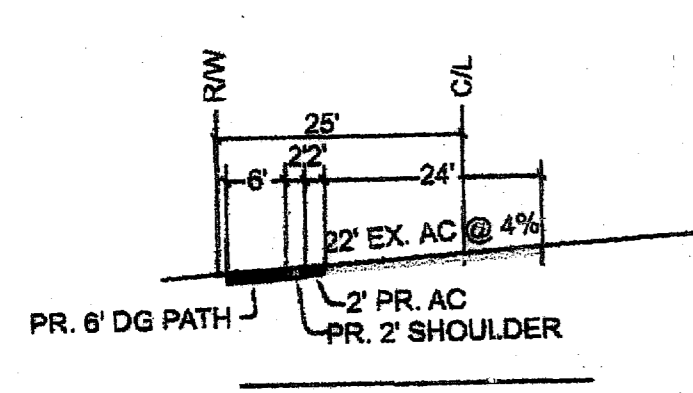
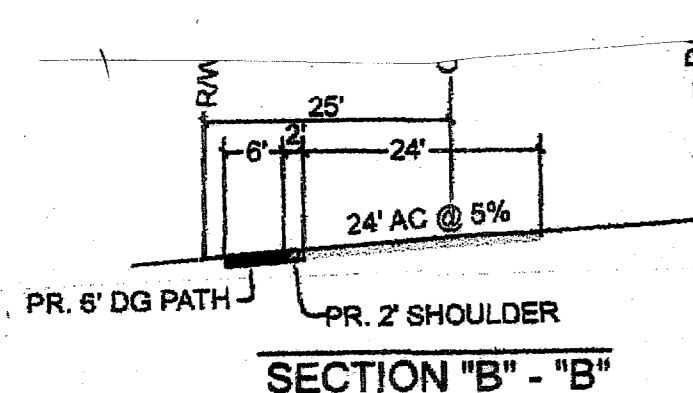
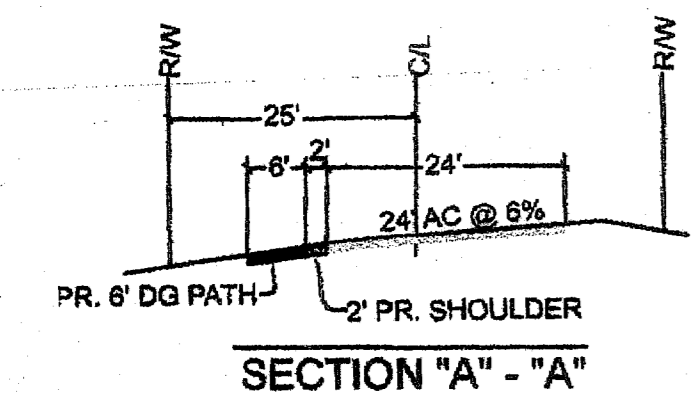

ENGINEER OF WORK:  
 PATRICK W. HARRISON, RCE  
 12090 CREST ROAD  
 POWAY, CA. 92064  
 858-679-8868  
 E-MAIL: HARRISONRCE@AOL.COM

PATRICK W. HARRISON, RCE 29241 DATE 11/20/2019  
 MY CURRENT REGISTRATION EXPIRES 3-31-2023

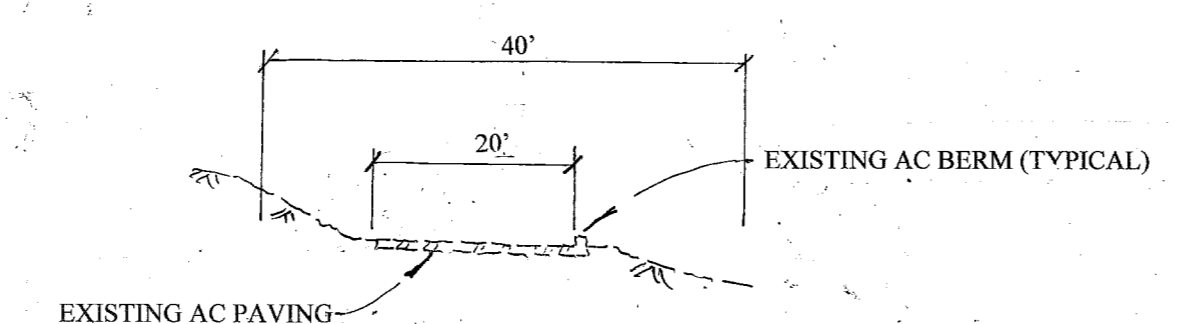
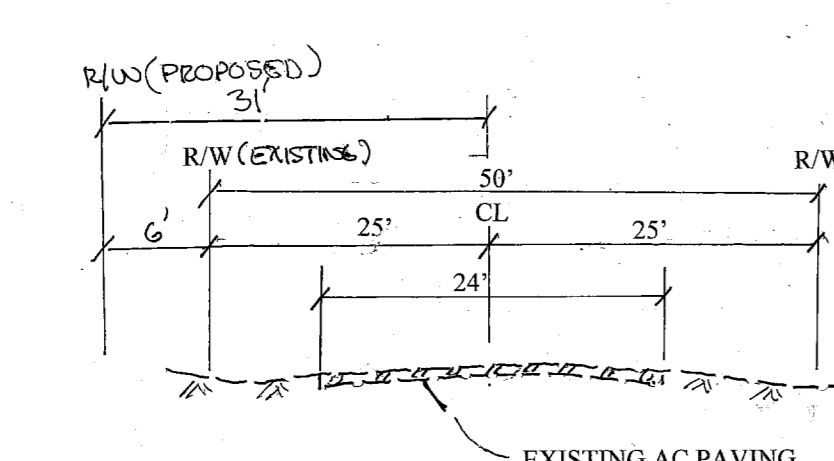
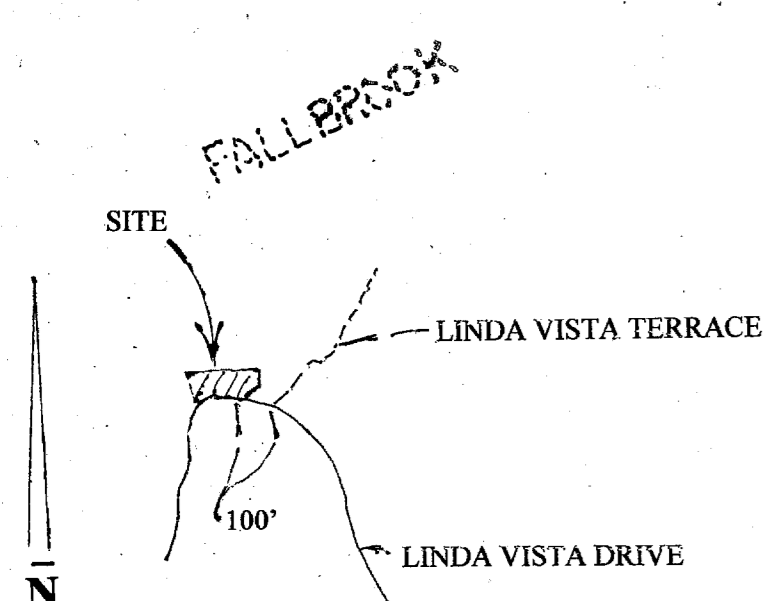
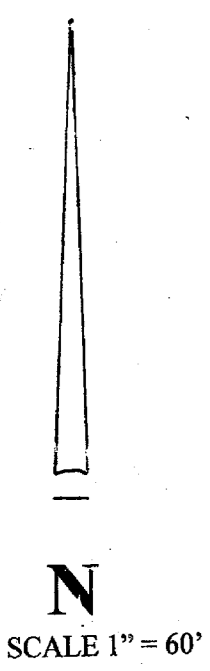

VICINITY MAP  
 NO SCALE

TYPICAL SECTION-LINDA VISTA DRIVE  
 NO SCALE

TYPICAL SECTION 40' WIDE UNNAMED PRIVATE ROAD EASEMENT  
 NO SCALE