

# Project Specific Water Quality Management Plan

A Template for Projects located within the **Santa Ana Watershed** Region of Riverside County

**Project Title:** 100 W. Sinclair Street

**Development No:**

**Design Review/Case No:** PR 21-05184

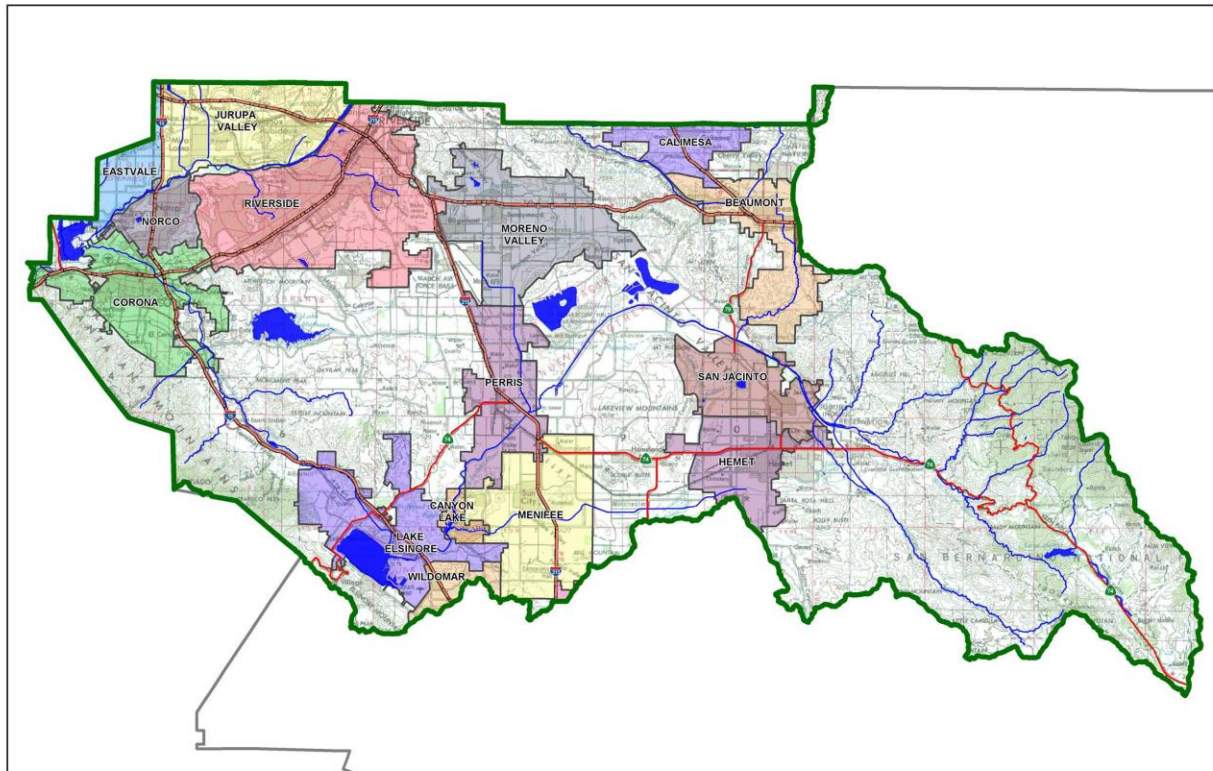

- Preliminary
- Final

**Original Date Prepared:** September 16, 2022

**Revision Date(s):**

*Prepared for Compliance with*

*Regional Board Order No. **R8-2010-0033***

**Template revised June 30, 2016**

## Contact Information:

### Prepared for:

First Industrial Realty Trust, Inc.  
898 N. Pacific Coast Hwy, Suite 175  
El Segundo, CA 90245

### Prepared by:

FM Civil Engineers Inc.  
29995 Technology Drive, Suite 306  
Murrieta, CA 92563  
(951) 973-0201

## A Brief Introduction

This Project-Specific WQMP Template for the **Santa Ana Region** has been prepared to help guide you in documenting compliance for your project. Because this document has been designed to specifically document compliance, you will need to utilize the WQMP Guidance Document as your “how-to” manual to help guide you through this process. Both the Template and Guidance Document go hand-in-hand, and will help facilitate a well prepared Project-Specific WQMP. Below is a flowchart for the layout of this Template that will provide the steps required to document compliance.

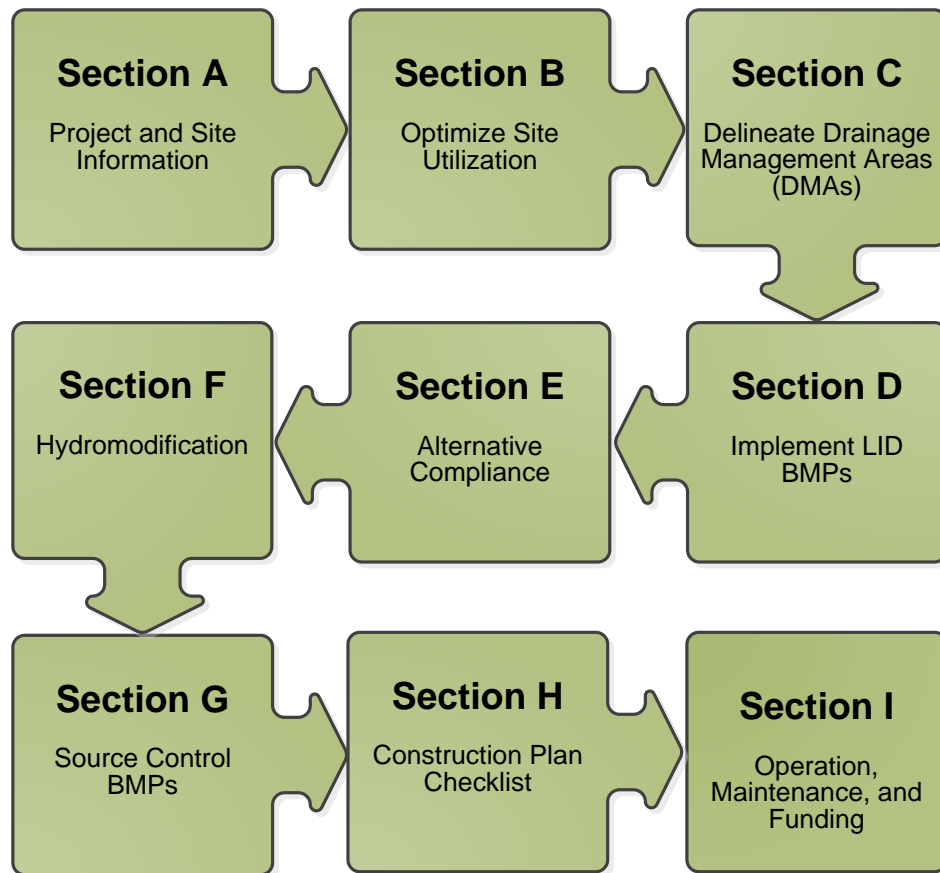



## OWNER'S CERTIFICATION

This Project-Specific Water Quality Management Plan (WQMP) has been prepared for First Industrial Realty Trust, Inc by FMCivil Engineers Inc for the 100 W. Sinclair Street project.

This WQMP is intended to comply with the requirements of the City of Perris for Water Quality Ordinance 1194 which includes the requirement for the preparation and implementation of a Project-Specific WQMP.

The undersigned, while owning the property/project described in the preceding paragraph, shall be responsible for the implementation and funding of this WQMP and will ensure that this WQMP is amended as appropriate to reflect up-to-date conditions on the site. In addition, the property owner accepts responsibility for interim operation and maintenance of Stormwater BMPs until such time as this responsibility is formally transferred to a subsequent owner. This WQMP will be reviewed with the facility operator, facility supervisors, employees, tenants, maintenance and service contractors, or any other party (or parties) having responsibility for implementing portions of this WQMP. At least one copy of this WQMP will be maintained at the project site or project office in perpetuity. The undersigned is authorized to certify and to approve implementation of this WQMP. The undersigned is aware that implementation of this WQMP is enforceable under the City of Perris Water Quality Ordinance 1194 (Municipal Code Section 14.22).

"I, the undersigned, certify under penalty of law that the provisions of this WQMP have been reviewed and accepted and that the WQMP will be transferred to future successors in interest."

*Paul Loubet*

Owner's Signature

Paul Loubet

Owner's Printed Name

09-15-22

Date

Entitlement Officer

Owner's Title/Position

## PREPARER'S CERTIFICATION

"The selection, sizing and design of stormwater treatment and other stormwater quality and quantity control measures in this plan meet the requirements of Regional Water Quality Control Board Order No. **R8-2010-0033** and any subsequent amendments thereto."

*Francisco Martinez, Jr*

Preparer's Signature

Francisco Martinez, Jr

Preparer's Printed Name

September 15, 2022

Date

Principal

Preparer's Title/Position

Preparer's Licensure:



## Table of Contents

Section A: Project and Site Information.....	6
A.1 Maps and Site Plans.....	6
A.2 Identify Receiving Waters.....	7
A.3 Additional Permits/Approvals required for the Project: .....	8
Section B: Optimize Site Utilization (LID Principles) .....	9
Section C: Delineate Drainage Management Areas (DMAs).....	10
Section D: Implement LID BMPs .....	12
D.1 Infiltration Applicability .....	12
D.2 Harvest and Use Assessment.....	13
D.3 Bioretention and Biotreatment Assessment .....	15
D.4 Feasibility Assessment Summaries .....	16
D.5 LID BMP Sizing .....	17
Section E: Alternative Compliance (LID Waiver Program) .....	18
E.1 Identify Pollutants of Concern .....	19
E.2 Stormwater Credits .....	20
E.3 Sizing Criteria.....	20
E.4 Treatment Control BMP Selection .....	21
Section F: Hydromodification .....	22
F.1 Hydrologic Conditions of Concern (HCOC) Analysis.....	22
F.2 HCOC Mitigation.....	23
Section G: Source Control BMPs.....	24
Section H: Construction Plan Checklist .....	26
Section I: Operation, Maintenance and Funding.....	27

## List of Tables

Table A.1 Identification of Receiving Waters.....	7
Table A.2 Other Applicable Permits.....	8
Table C.1 DMA Classifications.....	10
Table C.2 Type 'A', Self-Treating Areas.....	10
Table C.3 Type 'B', Self-Retaining Areas.....	10
Table C.4 Type 'C', Areas that Drain to Self-Retaining Areas.....	11
Table C.5 Type 'D', Areas Draining to BMPs.....	11
Table D.1 Infiltration Feasibility.....	12
Table D.2 LID Prioritization Summary Matrix.....	16
Table D.3 DCV Calculations for LID BMPs.....	17
Table E.1 Potential Pollutants by Land Use Type.....	19
Table E.2 Water Quality Credits.....	20
Table E.3 Treatment Control BMP Sizing.....	20
Table E.4 Treatment Control BMP Selection.....	21
Table F.1 Hydrologic Conditions of Concern Summary.....	22
Table G.1 Permanent and Operational Source Control Measures.....	24
Table H.1 Construction Plan Cross-reference.....	26

## List of Appendices

Appendix 1: Maps and Site Plans.....	28
Appendix 2: Construction Plans.....	29
Appendix 3: Soils Information.....	30
Appendix 4: Historical Site Conditions.....	31
Appendix 5: LID Infeasibility.....	32
Appendix 6: BMP Design Details.....	33
Appendix 7: Hydromodification.....	34
Appendix 8: Source Control.....	35
Appendix 9: O&M.....	36
Appendix 10: Educational Materials.....	- 6 -

## Section A: Project and Site Information

PROJECT INFORMATION	
Type of Project:	Industrial
Planning Area:	848,339 SF
Community Name:	City of Perris
Development Name:	First Industrial Realty – 100 W. Sinclair Street
PROJECT LOCATION	
Latitude & Longitude (DMS): 33°50'07.47", -117°13'42.90"	
Project Watershed and Sub-Watershed: Santa Ana River, San Jacinto Sub-Watershed, HUC 180702020305	
Gross Acres: 19.5	
APN(s): 303-080-013, 303-080-015	
Map Book and Page No.: 777	
PROJECT CHARACTERISTICS	
Proposed or Potential Land Use(s)	General Warehousing
Proposed or Potential SIC Code(s)	4225
Area of Impervious Project Footprint (SF)	792,548
Total Area of <u>proposed</u> Impervious Surfaces within the Project Footprint (SF)/or Replacement	792,548
Does the project consist of offsite road improvements?	<input type="checkbox"/> Y <input checked="" type="checkbox"/> N
Does the project propose to construct unpaved roads?	<input type="checkbox"/> Y <input checked="" type="checkbox"/> N
Is the project part of a larger common plan of development (phased project)?	<input type="checkbox"/> Y <input checked="" type="checkbox"/> N
EXISTING SITE CHARACTERISTICS	
Total area of <u>existing</u> Impervious Surfaces within the Project limits Footprint (SF)	730,000
Is the project located within any MSHCP Criteria Cell?	<input type="checkbox"/> Y <input checked="" type="checkbox"/> N
If so, identify the Cell number:	N/A
Are there any natural hydrologic features on the project site?	<input type="checkbox"/> Y <input checked="" type="checkbox"/> N
Is a Geotechnical Report attached?	<input checked="" type="checkbox"/> Y <input type="checkbox"/> N
If no Geotech. Report, list the NRCS soils type(s) present on the site (A, B, C and/or D)	N/A
What is the Water Quality Design Storm Depth for the project?	0.65

The proposed project is a redevelopment of two existing industrial sites that will be consolidated into a single site at the northwest corner of Sinclair Street and North Perris Boulevard in Perris, CA. The proposed project will consist of an industrial warehouse building totaling ±423,000 SF on approximately 19.5 acres. The site will also incorporate auto parking, drive aisles, truck docks and trailer parking.

The site is comprised of one DMA (DMA 1), which represents a mixed surface type encompassing the entire redevelopment. Flows will be treated by a combination of two bioretention basins and an underground infiltration system. These 3 BMPs will work in tandem and provide a total treatment capacity of 44,587 CF for DMA 1. Flows will be directed to any of the 3 BMPs, however the bioretention basins are configured such that a modified CB110 inlet will collect flows once the bioretention basins reach their maximum 6" ponding depth.

These untreated flows will be directed to the proposed underground infiltration basin. Flows entering the underground chambers directly will be treated a Contech CDS hydrodynamic separator. Infiltration treatment options were limited, with the underground chambers being placed over testing locations that provide a factored design infiltration rate of 1.03in/hr (See testing location #11 on exhibit in Appendix 6).

Flows in excess of the DCV will be discharged into a larger underground detention system, where they will be conveyed via a lift station and onsite storm drain line to an existing city storm drain which heads east through Perris Boulevard, and into RCFCD Perris Valley MDP Lateral G-2.

## A.1 Maps and Site Plans

When completing your Project-Specific WQMP, include a map of the local vicinity and existing site. In addition, include all grading, drainage, landscape/plant palette and other pertinent construction plans in Appendix 2. At a **minimum**, your WQMP Site Plan should include the following:

- Drainage Management Areas
- Proposed Structural BMPs
- Drainage Path
- Drainage Infrastructure, Inlets, Overflows
- Source Control BMPs
- Buildings, Roof Lines, Downspouts
- Impervious Surfaces
- Standard Labeling
- BMP Locations (Lat/Long)

Use your discretion on whether or not you may need to create multiple sheets or can appropriately accommodate these features on one or two sheets. Keep in mind that the Co-Permittee plan reviewer must be able to easily analyze your project utilizing this template and its associated site plans and maps.

## A.2 Identify Receiving Waters

Using Table A.1 below, list in order of upstream to downstream, the receiving waters that the project site is tributary to. Continue to fill each row with the Receiving Water's 303(d) listed impairments (if any), designated beneficial uses, and proximity, if any, to a RARE beneficial use. Include a map of the receiving waters in Appendix 1.

**Table A.1** Identification of Receiving Waters

Receiving Waters	EPA Approved 303(d) List Impairments	Designated Beneficial Uses	Proximity to RARE Beneficial Use
Perris Valley Channel	None Listed	REC2, WILD, RARE	±0.9 Miles downstream of Site
San Jacinto River Reach 3	None Listed	RARE	±5.2 Miles downstream of Site
Canyon Lake (Railroad Canyon Reservoir)	Nutrients, Pathogens	MUN, AGR, GWR, REC1, REC2, COMM, WARM, WILD	Not designated as RARE
San Jacinto River Rach 1	None Listed	RARE	±14.8 Miles downstream of Site
Lake Elsinore	Nutrients, Organic Enrichment/Low Dissolved Oxygen, PCBs (Polychlorinated biphenyls), Sediment Toxicity	REC1, REC2, COMM, WARM, WILD, RARE	±19.2 Miles downstream of Site



### A.3 Additional Permits/Approvals required for the Project:

Table A.2 Other Applicable Permits

Agency	Permit Required	
State Department of Fish and Game, 1602 Streambed Alteration Agreement	<input type="checkbox"/> Y	<input checked="" type="checkbox"/> N
State Water Resources Control Board, Clean Water Act (CWA) Section 401 Water Quality Cert.	<input type="checkbox"/> Y	<input checked="" type="checkbox"/> N
US Army Corps of Engineers, CWA Section 404 Permit	<input type="checkbox"/> Y	<input checked="" type="checkbox"/> N
US Fish and Wildlife, Endangered Species Act Section 7 Biological Opinion	<input type="checkbox"/> Y	<input checked="" type="checkbox"/> N
Statewide Construction General Permit Coverage	<input checked="" type="checkbox"/> Y	<input type="checkbox"/> N
Statewide Industrial General Permit Coverage	<input checked="" type="checkbox"/> Y	<input type="checkbox"/> N
Western Riverside MSHCP Consistency Approval (e.g., JPR, DBESP)	<input type="checkbox"/> Y	<input checked="" type="checkbox"/> N
Other <i>(please list in the space below as required)</i> City of Perris Building and Grading Permits	<input checked="" type="checkbox"/> Y	<input type="checkbox"/> N

If yes is answered to any of the questions above, the Co-Permittee may require proof of approval/coverage from those agencies as applicable including documentation of any associated requirements that may affect this Project-Specific WQMP.

## Section B: Optimize Site Utilization (LID Principles)

Review of the information collected in Section 'A' will aid in identifying the principal constraints on site design and selection of LID BMPs as well as opportunities to reduce imperviousness and incorporate LID Principles into the site and landscape design. For example, **constraints** might include impermeable soils, high groundwater, groundwater pollution or contaminated soils, steep slopes, geotechnical instability, high-intensity land use, heavy pedestrian or vehicular traffic, utility locations or safety concerns. **Opportunities** might include existing natural areas, low areas, oddly configured or otherwise unbuildable parcels, easements and landscape amenities including open space and buffers (which can double as locations for bioretention BMPs), and differences in elevation (which can provide hydraulic head). Prepare a brief narrative for each of the site optimization strategies described below. This narrative will help you as you proceed with your LID design and explain your design decisions to others.

The 2010 Santa Ana MS4 Permit further requires that LID Retention BMPs (Infiltration Only or Harvest and Use) be used unless it can be shown that those BMPs are infeasible. Therefore, it is important that your narrative identify and justify if there are any constraints that would prevent the use of those categories of LID BMPs. Similarly, you should also note opportunities that exist which will be utilized during project design. Upon completion of identifying Constraints and Opportunities, include these on your WQMP Site plan in Appendix 1.

Consideration of "highest and best use" of the discharge should also be considered. For example, Lake Elsinore is evaporating faster than runoff from natural precipitation can recharge it. Requiring infiltration of 85% of runoff events for projects tributary to Lake Elsinore would only exacerbate current water quality problems associated with Pollutant concentration due to lake water evaporation. In cases where rainfall events have low potential to recharge Lake Elsinore (i.e. no hydraulic connection between groundwater to Lake Elsinore, or other factors), requiring infiltration of Urban Runoff from projects is counterproductive to the overall watershed goals. Project proponents, in these cases, would be allowed to discharge Urban Runoff, provided they used equally effective filtration-based BMPs.

### Site Optimization

The following questions are based upon Section 3.2 of the WQMP Guidance Document. Review of the WQMP Guidance Document will help you determine how best to optimize your site and subsequently identify opportunities and/or constraints, and document compliance.

Did you identify and preserve existing drainage patterns? If so, how? If not, why?

**Yes. The existing site drains toward the east via underground storm drain to a channel east of Perris Boulevard. The proposed site will also drain to this existing storm drain.**

Did you identify and protect existing vegetation? If so, how? If not, why?

**Not protected. The project site is a redevelopment, and the current site has minimal vegetation.**

Did you identify and preserve natural infiltration capacity? If so, how? If not, why?

**Not preserved. The project site is a redevelopment, with mostly impervious land cover types. Infiltration will be increased in the proposed site via landscaped areas and a proposed underground infiltration basin.**

Did you identify and minimize impervious area? If so, how? If not, why?

**Landscaping areas are proposed to the maximum extent practicable given the site layout and purpose.**

Did you identify and disperse runoff to adjacent pervious areas? If so, how? If not, why?

**No, runoff from impervious areas is not able to drain into pervious areas. Onsite storm drain systems will convey runoff to underground infiltration chambers for treatment.**

# Section C: Delineate Drainage Management Areas (DMAs)

Utilizing the procedure in Section 3.3 of the WQMP Guidance Document which discusses the methods of delineating and mapping your project site into individual DMAs, complete Table C.1 below to appropriately categorize the types of classification (e.g., Type A, Type B, etc.) per DMA for your project site. Upon completion of this table, this information will then be used to populate and tabulate the corresponding tables for their respective DMA classifications.

**Table C.1 DMA Classifications**

DMA Name or ID	Surface Type(s) <sup>12</sup>	Area (Sq. Ft.)	DMA Type
1	Mixed Surface Type	848,339	D

<sup>1</sup>Reference Table 2-1 in the WQMP Guidance Document to populate this column

<sup>2</sup>If multi-surface provide back-up

**Table C.2 Type 'A', Self-Treating Areas**

DMA Name or ID	Area (Sq. Ft.)	Stabilization Type	Irrigation Type (if any)

**Table C.3 Type 'B', Self-Retaining Areas**

Self-Retaining Area				Type 'C' DMAs that are draining to the Self-Retaining Area		
DMA Name/ ID	Post-project surface type	Area (square feet)	Storm Depth (inches)	DMA Name / ID	[C] from Table C.4 = [C]	Required Retention Depth (inches)
		[A]	[B]			[D]

$$[D] = [B] + \frac{[B] \cdot [C]}{[A]}$$

**Table C.4 Type 'C', Areas that Drain to Self-Retaining Areas**

DMA					Receiving Self-Retaining DMA		
DMA Name/ ID	Area (square feet)	Post-project surface type	Impervious fraction	Product	DMA name /ID	Area (square feet)	Ratio
	[A]		[B]			[C] = [A] x [B]	[D]

**Table C.5 Type 'D', Areas Draining to BMPs**

DMA Name or ID	BMP Name or ID
1	Bioretention Basin 1 & 2, Underground Chamber 1

*Note: More than one drainage management area can drain to a single LID BMP, however, one drainage management area may not drain to more than one BMP.*

## Section D: Implement LID BMPs

### D.1 Infiltration Applicability

Is there an approved downstream ‘Highest and Best Use’ for stormwater runoff (see discussion in Chapter 2.4.4 of the WQMP Guidance Document for further details)?  Y  N

If yes has been checked, Infiltration BMPs shall not be used for the site; proceed to section D.3

If no, continue working through this section to implement your LID BMPs. It is recommended that you contact your Co-Permittee to verify whether or not your project discharges to an approved downstream ‘Highest and Best Use’ feature.

### Geotechnical Report

A Geotechnical Report or Phase I Environmental Site Assessment may be required by the Copermitee to confirm present and past site characteristics that may affect the use of Infiltration BMPs. In addition, the Co-Permittee, at their discretion, may not require a geotechnical report for small projects as described in Chapter 2 of the WQMP Guidance Document. If a geotechnical report has been prepared, include it in Appendix 3. In addition, if a Phase I Environmental Site Assessment has been prepared, include it in Appendix 4.

Is this project classified as a small project consistent with the requirements of Chapter 2 of the WQMP Guidance Document?  Y  N

### Infiltration Feasibility

Table D.1 below is meant to provide a simple means of assessing which DMAs on your site support Infiltration BMPs and is discussed in the WQMP Guidance Document in Chapter 2.4.5. Check the appropriate box for each question and then list affected DMAs as applicable. If additional space is needed, add a row below the corresponding answer.

Table D.1 Infiltration Feasibility

Does the project site...	YES	NO
...have any DMAs with a seasonal high groundwater mark shallower than 10 feet? If Yes, list affected DMAs:		✓
...have any DMAs located within 100 feet of a water supply well? If Yes, list affected DMAs:		✓
...have any areas identified by the geotechnical report as posing a public safety risk where infiltration of stormwater could have a negative impact? If Yes, list affected DMAs:		✓
...have measured in-situ infiltration rates of less than 1.6 inches / hour? If Yes, list affected DMAs:		✓
...have significant cut and/or fill conditions that would preclude in-situ testing of infiltration rates at the final infiltration surface? If Yes, list affected DMAs:		✓
...geotechnical report identify other site-specific factors that would preclude effective and safe infiltration? Describe here:		✓

If you answered “Yes” to any of the questions above for any DMA, Infiltration BMPs should not be used for those DMAs and you should proceed to the assessment for Harvest and Use below.



## D.2 Harvest and Use Assessment

Please check what applies: ***NONE APPLY, SITE WILL BE TREATED WITH COMBINATION OF BIORETENTION AND INFILTRATION SYSTEMS.***

- Reclaimed water will be used for the non-potable water demands for the project.
- Downstream water rights may be impacted by Harvest and Use as approved by the Regional Board (verify with the Copermittee).
- The Design Capture Volume will be addressed using Infiltration Only BMPs. In such a case, Harvest and Use BMPs are still encouraged, but it would not be required if the Design Capture Volume will be infiltrated or evapotranspired.

If any of the above boxes have been checked, Harvest and Use BMPs need not be assessed for the site. If none of the above criteria applies, follow the steps below to assess the feasibility of irrigation use, toilet use and other non-potable uses (e.g., industrial use).

### Irrigation Use Feasibility

Complete the following steps to determine the feasibility of harvesting stormwater runoff for Irrigation Use BMPs on your site:

Step 1: Identify the total area of irrigated landscape on the site, and the type of landscaping used.

*Total Area of Irrigated Landscape: 1.28 AC*

*Type of Landscaping (Conservation Design or Active Turf): Conservation Design*

Step 2: Identify the planned total of all impervious areas on the proposed project from which runoff might be feasibly captured and stored for irrigation use. Depending on the configuration of buildings and other impervious areas on the site, you may consider the site as a whole, or parts of the site, to evaluate reasonable scenarios for capturing and storing runoff and directing the stored runoff to the potential use(s) identified in Step 1 above.

*Total Area of Impervious Surfaces: 18.19 AC*

Step 3: Cross reference the Design Storm depth for the project site (see Exhibit A of the WQMP Guidance Document) with the left column of Table 2-3 in Chapter 2 to determine the minimum area of Effective Irrigated Area per Tributary Impervious Area (EIATIA).

*Enter your EIATIA factor: 1.05*

Step 4: Multiply the unit value obtained from Step 3 by the total of impervious areas from Step 2 to develop the minimum irrigated area that would be required.

*Minimum required irrigated area: 19.10 AC*

Step 5: Determine if harvesting stormwater runoff for irrigation use is feasible for the project by comparing the total area of irrigated landscape (Step 1) to the minimum required irrigated area (Step 4).

Minimum required irrigated area (Step 4)	Available Irrigated Landscape (Step 1)
19.10 AC	1.28 AC

## Toilet Use Feasibility

Complete the following steps to determine the feasibility of harvesting stormwater runoff for toilet flushing uses on your site:

Step 1: Identify the projected total number of daily toilet users during the wet season, and account for any periodic shut downs or other lapses in occupancy:

*Projected Number of Daily Toilet Users: 300*

*Project Type: Industrial*

Step 2: Identify the planned total of all impervious areas on the proposed project from which runoff might be feasibly captured and stored for toilet use. Depending on the configuration of buildings and other impervious areas on the site, you may consider the site as a whole, or parts of the site, to evaluate reasonable scenarios for capturing and storing runoff and directing the stored runoff to the potential use(s) identified in Step 1 above.

*Total Area of Impervious Surfaces: 18.19 AC*

Step 3: Enter the Design Storm depth for the project site (see Exhibit A) into the left column of Table 2-2 in Chapter 2 to determine the minimum number of toilet users per tributary impervious acre (TUTIA).

*Enter your TUTIA factor: 185*

Step 4: Multiply the unit value obtained from Step 3 by the total of impervious areas from Step 2 to develop the minimum number of toilet users that would be required.

*Minimum number of toilet users: 3366*

Step 5: Determine if harvesting stormwater runoff for toilet flushing use is feasible for the project by comparing the Number of Daily Toilet Users (Step 1) to the minimum required number of toilet users (Step 4).

<b>Minimum required Toilet Users (Step 4)</b>	<b>Projected number of toilet users (Step 1)</b>
<b>3366</b>	<b>300</b>

## Other Non-Potable Use Feasibility

Are there other non-potable uses for stormwater runoff on the site (e.g. industrial use)? See Chapter 2 of the Guidance for further information. If yes, describe below. If no, write N/A.

**N/A**

Step 1: Identify the projected average daily non-potable demand, in gallons per day, during the wet season and accounting for any periodic shut downs or other lapses in occupancy or operation.

*Average Daily Demand: Projected Average Daily Use (gpd)*

Step 2: Identify the planned total of all impervious areas on the proposed project from which runoff might be feasibly captured and stored for the identified non-potable use. Depending on the configuration of buildings and other impervious areas on the site, you may consider the site as a whole, or parts of the site, to evaluate reasonable scenarios for capturing and storing runoff and directing the stored runoff to the potential use(s) identified in Step 1 above.

*Total Area of Impervious Surfaces: Insert Area (Acres)*

Step 3: Enter the Design Storm depth for the project site (see Exhibit A) into the left column of Table 2-4 in Chapter 2 to determine the minimum demand for non-potable uses per tributary impervious acre.

*Enter the factor from Table 2-4: Enter Value*

Step 4: Multiply the unit value obtained from Step 3 by the total of impervious areas from Step 2 to develop the minimum number of gallons per day of non-potable use that would be required.

*Minimum required use: Minimum use required (gpd)*

Step 5: Determine if harvesting stormwater runoff for other non-potable use is feasible for the project by comparing the projected average daily use (Step 1) to the minimum required non-potable use (Step 4).

<b>Minimum required non-potable use (Step 4)</b>	<b>Projected average daily use (Step 1)</b>
Minimum use required (gpd)	Projected Average Daily Use (gpd)

If Irrigation, Toilet and Other Use feasibility anticipated demands are less than the applicable minimum values, Harvest and Use BMPs are not required and you should proceed to utilize LID Bioretention and Biotreatment per Section 3.4.2 of the WQMP Guidance Document.

### **D.3 Bioretention and Biotreatment Assessment**

Other LID Bioretention and Biotreatment BMPs as described in Chapter 2.4.7 of the WQMP Guidance Document are feasible on nearly all development sites with sufficient advance planning.

*Select one of the following:*

- LID Bioretention/Biotreatment BMPs will be used for some or all DMAs of the project as noted below in Section D.4 (note the requirements of Section 3.4.2 in the WQMP Guidance Document).
- A site-specific analysis demonstrating the technical infeasibility of all LID BMPs has been performed and is included in Appendix 5. If you plan to submit an analysis demonstrating the technical infeasibility of LID BMPs, request a pre-submittal meeting with the Copermittee to discuss this option. Proceed to Section E to document your alternative compliance measures.

## D.4 Feasibility Assessment Summaries

From the Infiltration, Harvest and Use, Bioretention and Biotreatment Sections above, complete Table D.2 below to summarize which LID BMPs are technically feasible, and which are not, based upon the established hierarchy.

Table D.2 LID Prioritization Summary Matrix

DMA Name/ID	LID BMP Hierarchy				No LID (Alternative Compliance)
	1. Infiltration	2. Harvest and use	3. Bioretention	4. Biotreatment	
1	<input checked="" type="checkbox"/>	<input type="checkbox"/>	<input checked="" type="checkbox"/>	<input type="checkbox"/>	<input type="checkbox"/>
	<input type="checkbox"/>	<input type="checkbox"/>	<input type="checkbox"/>	<input type="checkbox"/>	<input type="checkbox"/>
	<input type="checkbox"/>	<input type="checkbox"/>	<input type="checkbox"/>	<input type="checkbox"/>	<input type="checkbox"/>
	<input type="checkbox"/>	<input type="checkbox"/>	<input type="checkbox"/>	<input type="checkbox"/>	<input type="checkbox"/>
	<input type="checkbox"/>	<input type="checkbox"/>	<input type="checkbox"/>	<input type="checkbox"/>	<input type="checkbox"/>
	<input type="checkbox"/>	<input type="checkbox"/>	<input type="checkbox"/>	<input type="checkbox"/>	<input type="checkbox"/>

For those DMAs where LID BMPs are not feasible, provide a brief narrative below summarizing why they are not feasible, include your technical infeasibility criteria in Appendix 5, and proceed to Section E below to document Alternative Compliance measures for those DMAs. Recall that each proposed DMA must pass through the LID BMP hierarchy before alternative compliance measures may be considered.

Insert narrative description here.

## D.5 LID BMP Sizing

Each LID BMP must be designed to ensure that the Design Capture Volume will be addressed by the selected BMPs. First, calculate the Design Capture Volume for each LID BMP using the  $V_{BMP}$  worksheet in Appendix F of the LID BMP Design Handbook. Second, design the LID BMP to meet the required  $V_{BMP}$  using a method approved by the Copermittee. Utilize the worksheets found in the LID BMP Design Handbook or consult with your Copermittee to assist you in correctly sizing your LID BMPs. Complete Table D.3 below to document the Design Capture Volume and the Proposed Volume for each LID BMP. Provide the completed design procedure sheets for each LID BMP in Appendix 6. You may add additional rows to the table below as needed.

Table D.3 DCV Calculations for LID BMPs

DMA Type/ID	DMA Area (square feet)	Post-Project Surface Type	Effective Impervious Fraction, $I_f$	DMA Runoff Factor	DMA Areas x Runoff Factor	Enter BMP Name / Identifier Here		
	[A]		[B]	[C]	[A] x [C]			
1	848,339	Mixed Surface Types	0.941	0.7926	672373	Design Storm Depth (in)	Design Capture Volume, $V_{BMP}$ (cubic feet)	Proposed Volume on Plans (cubic feet)
	$A_T = 595,239$	$C = 0.858 \cdot I_f3 - 0.78 \cdot I_f2 + 0.774 \cdot I_f + 0.04$			$\Sigma=672373$	0.65	$[F] = \frac{[D] \times [E]}{12} = 36,421$	$[G] = 44,587$

[B], [C] is obtained as described in Section 2.3.1 of the WQMP Guidance Document

[E] is obtained from Exhibit A in the WQMP Guidance Document

[G] is obtained from a design procedure sheet, such as in LID BMP Design Handbook and placed in Appendix 6



## Section E: Alternative Compliance (LID Waiver Program)

LID BMPs are expected to be feasible on virtually all projects. Where LID BMPs have been demonstrated to be infeasible as documented in Section D, other Treatment Control BMPs must be used (subject to LID waiver approval by the Copermittee). Check one of the following Boxes:

LID Principles and LID BMPs have been incorporated into the site design to fully address all Drainage Management Areas. No alternative compliance measures are required for this project and thus this Section is not required to be completed.

- Or -

The following Drainage Management Areas are unable to be addressed using LID BMPs. A site-specific analysis demonstrating technical infeasibility of LID BMPs has been approved by the Co-Permittee and included in Appendix 5. Additionally, no downstream regional and/or sub-regional LID BMPs exist or are available for use by the project. The following alternative compliance measures on the following pages are being implemented to ensure that any pollutant loads expected to be discharged by not incorporating LID BMPs, are fully mitigated.

List DMAs here.

## E.1 Identify Pollutants of Concern

Utilizing Table A.1 from Section A above which noted your project's receiving waters and their associated EPA approved 303(d) listed impairments, cross reference this information with that of your selected Priority Development Project Category in Table E.1 below. If the identified General Pollutant Categories are the same as those listed for your receiving waters, then these will be your Pollutants of Concern and the appropriate box or boxes will be checked on the last row. The purpose of this is to document compliance and to help you appropriately plan for mitigating your Pollutants of Concern in lieu of implementing LID BMPs.

**Table E.1 Potential Pollutants by Land Use Type**

Priority Development Project Categories and/or Project Features (check those that apply)	General Pollutant Categories							
	Bacterial Indicators	Metals	Nutrients	Pesticides	Toxic Organic Compounds	Sediments	Trash & Debris	Oil & Grease
<input type="checkbox"/> Detached Residential Development	P	N	P	P	N	P	P	P
<input type="checkbox"/> Attached Residential Development	P	N	P	P	N	P	P	P <sup>(2)</sup>
<input checked="" type="checkbox"/> Commercial/Industrial Development	P <sup>(3)</sup>	P	P <sup>(1)</sup>	P <sup>(1)</sup>	P <sup>(5)</sup>	P <sup>(1)</sup>	P	P
<input type="checkbox"/> Automotive Repair Shops	N	P	N	N	P <sup>(4, 5)</sup>	N	P	P
<input type="checkbox"/> Restaurants (>5,000 ft <sup>2</sup> )	P	N	N	N	N	N	P	P
<input type="checkbox"/> Hillside Development (>5,000 ft <sup>2</sup> )	P	N	P	P	N	P	P	P
<input type="checkbox"/> Parking Lots (>5,000 ft <sup>2</sup> )	P <sup>(6)</sup>	P	P <sup>(1)</sup>	P <sup>(1)</sup>	P <sup>(4)</sup>	P <sup>(1)</sup>	P	P
<input type="checkbox"/> Retail Gasoline Outlets	N	P	N	N	P	N	P	P
<b>Project Priority Pollutant(s) of Concern</b>	<input type="checkbox"/>	<input checked="" type="checkbox"/>	<input type="checkbox"/>	<input type="checkbox"/>	<input checked="" type="checkbox"/>	<input type="checkbox"/>	<input checked="" type="checkbox"/>	<input checked="" type="checkbox"/>

*P = Potential*

*N = Not Potential*

<sup>(1)</sup> A potential Pollutant if non-native landscaping exists or is proposed onsite; otherwise not expected

<sup>(2)</sup> A potential Pollutant if the project includes uncovered parking areas; otherwise not expected

<sup>(3)</sup> A potential Pollutant is land use involving animal waste

<sup>(4)</sup> Specifically petroleum hydrocarbons

<sup>(5)</sup> Specifically solvents

<sup>(6)</sup> Bacterial indicators are routinely detected in pavement runoff

## E.2 Stormwater Credits

Projects that cannot implement LID BMPs but nevertheless implement smart growth principles are potentially eligible for Stormwater Credits. Utilize Table 3-8 within the WQMP Guidance Document to identify your Project Category and its associated Water Quality Credit. If not applicable, write N/A.

Table E.2 Water Quality Credits

Qualifying Project Categories	Credit Percentage <sup>2</sup>
-	-
-	-
-	-
<i>Total Credit Percentage<sup>1</sup></i>	N/A

<sup>1</sup>Cannot Exceed 50%

<sup>2</sup>Obtain corresponding data from Table 3-8 in the WQMP Guidance Document

## E.3 Sizing Criteria

After you appropriately considered Stormwater Credits for your project, utilize Table E.3 below to appropriately size them to the DCV, or Design Flow Rate, as applicable. Please reference Chapter 3.5.2 of the WQMP Guidance Document for further information.

Table E.3 Treatment Control BMP Sizing

DMA Type /ID	DMA Area (square feet)	Post-Project Surface Type	Effective Impervious Fraction, I <sub>f</sub>	DMA Runoff Factor	DMA Area x Runoff Factor	Enter BMP Name / Identifier Here					
	[A]		[B]	[C]	[A] x [C]						
<b>1</b>	848,339	Mixed Surface Types	0.941	0.7926	672373						
						Design Storm Depth (in)	Minimum Design Capture Volume or Design Flow Rate (cubic feet or cfs)	Total Storm Water Credit % Reduction	Proposed Volume or Flow on Plans (cubic feet or cfs)		
	A <sub>T</sub> = Σ[A]				Σ= 672,373	0.65	36,421	0%	44,587		

[B], [C] is obtained as described in Section 2.3.1 from the WQMP Guidance Document

[E] is for Flow-Based Treatment Control BMPs [E] = .2, for Volume-Based Control Treatment BMPs, [E] obtained from Exhibit A in the WQMP Guidance Document

[G] is for Flow-Based Treatment Control BMPs [G] = 43,560, for Volume-Based Control Treatment BMPs, [G] = 12

[H] is from the Total Credit Percentage as Calculated from Table E.2 above

[I] as obtained from a design procedure sheet from the BMP manufacturer and should be included in Appendix 6

## E.4 Treatment Control BMP Selection

Treatment Control BMPs typically provide proprietary treatment mechanisms to treat potential pollutants in runoff, but do not sustain significant biological processes. Treatment Control BMPs must have a removal efficiency of a medium or high effectiveness as quantified below:

- **High:** equal to or greater than 80% removal efficiency
- **Medium:** between 40% and 80% removal efficiency

Such removal efficiency documentation (e.g., studies, reports, etc.) as further discussed in Chapter 3.5.2 of the WQMP Guidance Document, must be included in Appendix 6. In addition, ensure that proposed Treatment Control BMPs are properly identified on the WQMP Site Plan in Appendix 1.

**Table E.4 Treatment Control BMP Selection**

Selected Treatment Control BMP Name or ID <sup>1</sup>	Priority Pollutant(s) of Concern to Mitigate <sup>2</sup>	Removal Efficiency Percentage <sup>3</sup>
Contech CDS for Pretreatment	Hydrocarbons, Sediment	80%

<sup>1</sup> Treatment Control BMPs must not be constructed within Receiving Waters. In addition, a proposed Treatment Control BMP may be listed more than once if they possess more than one qualifying pollutant removal efficiency.

<sup>2</sup> Cross Reference Table E.1 above to populate this column.

<sup>3</sup> As documented in a Co-Permittee Approved Study and provided in Appendix 6.

## Section F: Hydromodification

### F.1 Hydrologic Conditions of Concern (HCOC) Analysis

Once you have determined that the LID design is adequate to address water quality requirements, you will need to assess if the proposed LID Design may still create a HCOC. Review Chapters 2 and 3 (including Figure 3-7) of the WQMP Guidance Document to determine if your project must mitigate for Hydromodification impacts. If your project meets one of the following criteria which will be indicated by the check boxes below, you do not need to address Hydromodification at this time. However, if the project does not qualify for Exemptions 1, 2 or 3, then additional measures must be added to the design to comply with HCOC criteria. This is discussed in further detail below in Section F.2.

#### PROJECT QUALIFIES FOR EXEMPTION PER EXEMPTION 3

**HCOC EXEMPTION 1:** The Priority Development Project disturbs less than one acre. The Copermitttee has the discretion to require a Project-Specific WQMP to address HCOCs on projects less than one acre on a case by case basis. The disturbed area calculation should include all disturbances associated with larger common plans of development.

Does the project qualify for this HCOC Exemption?  Y  N

If Yes, HCOC criteria do not apply.

**HCOC EXEMPTION 2:** The volume and time of concentration<sup>1</sup> of storm water runoff for the post-development condition is not significantly different from the pre-development condition for a 2-year return frequency storm (a difference of 5% or less is considered insignificant) using one of the following methods to calculate:

- Riverside County Hydrology Manual
- Technical Release 55 (TR-55): Urban Hydrology for Small Watersheds (NRCS 1986), or derivatives thereof, such as the Santa Barbara Urban Hydrograph Method
- Other methods acceptable to the Co-Permittee

Does the project qualify for this HCOC Exemption?  Y  N

If Yes, report results in Table F.1 below and provide your substantiated hydrologic analysis in Appendix 7.

Table F.1 Hydrologic Conditions of Concern Summary

	2 year – 24 hour		
	Pre-condition	Post-condition	% Difference
<b>Time of Concentration</b>	N/A	N/A	N/A
<b>Volume (Cubic Feet)</b>	N/A	N/A	N/A

<sup>1</sup> Time of concentration is defined as the time after the beginning of the rainfall when all portions of the drainage basin are contributing to flow at the outlet.



**HCOC EXEMPTION 3:** All downstream conveyance channels to an adequate sump (for example, Prado Dam, Lake Elsinore, Canyon Lake, Santa Ana River, or other lake, reservoir or naturally erosion resistant feature) that will receive runoff from the project are engineered and regularly maintained to ensure design flow capacity; no sensitive stream habitat areas will be adversely affected; or are not identified on the Co-Permittees Hydromodification Susceptibility Maps.

Does the project qualify for this HCOC Exemption?       Y     N

If Yes, HCOC criteria do not apply and note below which adequate sump applies to this HCOC qualifier:

**Project is HCOC Exempt as project site is a non-applicable area per HCOC Applicability Map KMZ file provided on rcwatershed.org. An exhibit showing the site within the non-applicable area is included in Appendix 7.**

## **F.2 HCOC Mitigation**

If none of the above HCOC Exemption Criteria are applicable, HCOC criteria is considered mitigated if they meet one of the following conditions:

- a. Additional LID BMPS are implemented onsite or offsite to mitigate potential erosion or habitat impacts as a result of HCOCs. This can be conducted by an evaluation of site-specific conditions utilizing accepted professional methodologies published by entities such as the California Stormwater Quality Association (CASQA), the Southern California Coastal Water Research Project (SCCRWP), or other Co-Permittee approved methodologies for site-specific HCOC analysis.
- b. The project is developed consistent with an approved Watershed Action Plan that addresses HCOC in Receiving Waters.
- c. Mimicking the pre-development hydrograph with the post-development hydrograph, for a 2-year return frequency storm. Generally, the hydrologic conditions of concern are not significant, if the post-development hydrograph is no more than 10% greater than pre-development hydrograph. In cases where excess volume cannot be infiltrated or captured and reused, discharge from the site must be limited to a flow rate no greater than 110% of the pre-development 2-year peak flow.

Be sure to include all pertinent documentation used in your analysis of the items a, b or c in Appendix 7.

## Section G: Source Control BMPs

Source control BMPs include permanent, structural features that may be required in your project plans — such as roofs over and berms around trash and recycling areas — and Operational BMPs, such as regular sweeping and “housekeeping”, that must be implemented by the site’s occupant or user. The MEP standard typically requires both types of BMPs. In general, Operational BMPs cannot be substituted for a feasible and effective permanent BMP. Using the Pollutant Sources/Source Control Checklist in Appendix 8, review the following procedure to specify Source Control BMPs for your site:

1. **Identify Pollutant Sources:** Review Column 1 in the Pollutant Sources/Source Control Checklist. Check off the potential sources of Pollutants that apply to your site.
2. **Note Locations on Project-Specific WQMP Exhibit:** Note the corresponding requirements listed in Column 2 of the Pollutant Sources/Source Control Checklist. Show the location of each Pollutant source and each permanent Source Control BMP in your Project-Specific WQMP Exhibit located in Appendix 1.
3. **Prepare a Table and Narrative:** Check off the corresponding requirements listed in Column 3 in the Pollutant Sources/Source Control Checklist. In the left column of Table G.1 below, list each potential source of runoff Pollutants on your site (from those that you checked in the Pollutant Sources/Source Control Checklist). In the middle column, list the corresponding permanent, Structural Source Control BMPs (from Columns 2 and 3 of the Pollutant Sources/Source Control Checklist) used to prevent Pollutants from entering runoff. **Add additional narrative** in this column that explains any special features, materials or methods of construction that will be used to implement these permanent, Structural Source Control BMPs.
4. **Identify Operational Source Control BMPs:** To complete your table, refer once again to the Pollutant Sources/Source Control Checklist. List in the right column of your table the Operational BMPs that should be implemented as long as the anticipated activities continue at the site. Copermittee stormwater ordinances require that applicable Source Control BMPs be implemented; the same BMPs may also be required as a condition of a use permit or other revocable Discretionary Approval for use of the site.

**Table G.1 Permanent and Operational Source Control Measures**

Potential Sources of Runoff pollutants	Permanent Structural Source Control BMPs	Operational Source Control BMPs
On-Site Storm Drain Inlet	Mark all inlets with the words “Only Rain Down the Storm Drain” or similar. Catch basin markers may be available from the Riverside County Flood Control and Water Conservation District, call (951) 955-1200 to verify.	<p>-Maintain and periodically repaint or replace inlet markings.</p> <p>-Provide stormwater pollution prevention information to new site owners, lessees, or operators.</p> <p>-See applicable operational BMPs in Fact Sheet SC-44, “Drainage System Maintenance,” in the CASQA Stormwater Quality Handbooks at <a href="http://www.cabmphandbooks.com">www.cabmphandbooks.com</a></p> <p>-Include the following in lease agreements: “Tenant shall not allow anyone to discharge</p>

		anything to storm drains or to store or deposit materials so as to create a potential discharge to storm drains.”
Loading Docks	The project site will have truck docks which will be shown on the Post-Construction BMP Site Plan. The truck docks shall be inspected on a weekly basis to help ensure that any trash and debris are collected prior to being washed into the underground storm drain system. All storm water runoff from the loading dock areas will be discharged into underground infiltration chambers prior to conveyance to the public storm drain system. Documentation of such inspection/maintenance shall be kept by the owner in perpetuity.	-Move loaded and unloaded items indoors as soon as possible. See fact sheet SC-30, “Outdoor Loading and Unloading,” in Appendix 10.
Hardscape, Sidewalks, and Parking Lots	Documentation of sweeping activities shall be kept by the owner in perpetuity. Frequency of sweeping shall be adjusted as necessary to maintain a clean site.	Sweep hardscape, sidewalks, and parking lots regularly to prevent the accumulation of litter, debris and sediment. Parking lots to be vacuum swept by vacuum truck. Collect debris from pressure washing to prevent entry into the storm drain system. Collect wash water containing any cleaning agent or degreaser and discharge to the sanitary sewer, not the storm drain system.
Trash Storage Areas	Trash container storage area shall be paved with an impervious surface designed not to allow run-on from adjoining areas. They shall be designed to divert drainage from adjoining roofs and pavements from the surrounding area, and screened or walled to prevent off-site transport of trash. Dumpsters shall be leak proof and have attached covers and lids. Trash enclosures shall be roofed. Connection of trash area drains to the MS4 is prohibited. See CASQA SD-32 BMP fact sheet in Appendix 10 for additional information. Signs shall be posted on or near dumpsters with the words “Do not dump hazardous materials here” or similar.	An adequate number of receptacles shall be provided. Inspect receptacles regularly and repair or replace leaky receptacles. Inspect condition of lids and replace as needed. Keep receptacles covered. Prohibit/prevent dumping of liquid or hazardous wastes. Post “no hazardous materials” signs. Inspect and pick up litter daily and clean up spills immediately. Keep spill control materials available onsite. See fact sheet SC-34 “Waste Handling and Disposal” in the CASQA Stormwater Quality Handbook in Appendix 10.
Fire Sprinkler Test Water	Provide a means to drain fire sprinkler test water to the sanitary sewer.	See note in Fact Sheet SC-41 “Building Grounds and Maintenance” in Appendix 10.

## Section H: Construction Plan Checklist

Populate Table H.1 below to assist the plan checker in an expeditious review of your project. The first two columns will contain information that was prepared in previous steps, while the last column will be populated with the corresponding plan sheets. This table is to be completed with the submittal of your final Project-Specific WQMP.

**\*Table to be completed during final WQMP\***

Table H.1 Construction Plan Cross-reference

BMP No. or ID	BMP Identifier and Description	Corresponding Plan Sheet(s)	BMP Location (Lat/Long)

Note that the updated table — or Construction Plan WQMP Checklist — is **only a reference tool** to facilitate an easy comparison of the construction plans to your Project-Specific WQMP. Co-Permittee staff can advise you regarding the process required to propose changes to the approved Project-Specific WQMP.

## Section I: Operation, Maintenance and Funding

The Copermittee will periodically verify that Stormwater BMPs on your site are maintained and continue to operate as designed. To make this possible, your Copermittee will require that you include in Appendix 9 of this Project-Specific WQMP:

1. A means to finance and implement facility maintenance in perpetuity, including replacement cost.
2. Acceptance of responsibility for maintenance from the time the BMPs are constructed until responsibility for operation and maintenance is legally transferred. A warranty covering a period following construction may also be required.
3. An outline of general maintenance requirements for the Stormwater BMPs you have selected.
4. Figures delineating and designating pervious and impervious areas, location, and type of Stormwater BMP, and tables of pervious and impervious areas served by each facility. Geo-locating the BMPs using a coordinate system of latitude and longitude is recommended to help facilitate a future statewide database system.
5. A separate list and location of self-retaining areas or areas addressed by LID Principles that do not require specialized O&M or inspections but will require typical landscape maintenance as noted in Chapter 5, pages 85-86, in the WQMP Guidance. Include a brief description of typical landscape maintenance for these areas.

Your local Co-Permittee will also require that you prepare and submit a detailed Stormwater BMP Operation and Maintenance Plan that sets forth a maintenance schedule for each of the Stormwater BMPs built on your site. An agreement assigning responsibility for maintenance and providing for inspections and certification may also be required.

Details of these requirements and instructions for preparing a Stormwater BMP Operation and Maintenance Plan are in Chapter 5 of the WQMP Guidance Document.

**Maintenance Mechanism:** The proposed Contech underground infiltration chambers and Contech CDS units will be maintained by the owner following the manufacturer's recommendations.

Will the proposed BMPs be maintained by a Home Owners' Association (HOA) or Property Owners Association (POA)?

Y       N

Include your Operation and Maintenance Plan and Maintenance Mechanism in Appendix 9. Additionally, include all pertinent forms of educational materials for those personnel that will be maintaining the proposed BMPs within this Project-Specific WQMP in Appendix 10.

**\*This section will be completed during the Final WQMP Submittal\***

# Appendix 1: Maps and Site Plans

*Location Map, WQMP Site Plan and Receiving Waters Map*

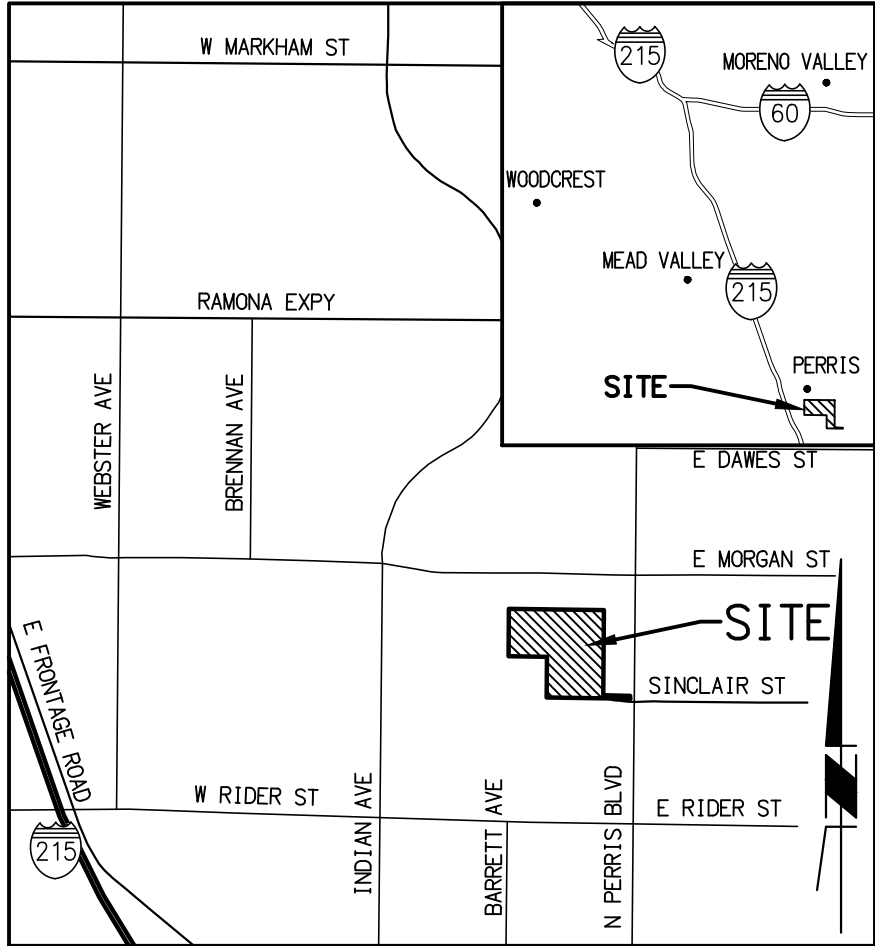

**VICINITY MAP**

NOT TO SCALE

**FMCIVIL**  
ENGINEERS INC.

29995 TECHNOLOGY DRIVE, SUITE  
306 | MURRIETA | CA 92563  
951.331.9873 - FMCIVIL.COM

**100 W SINCLAIR ST**

**FIGURE 1  
VICINITY MAP**



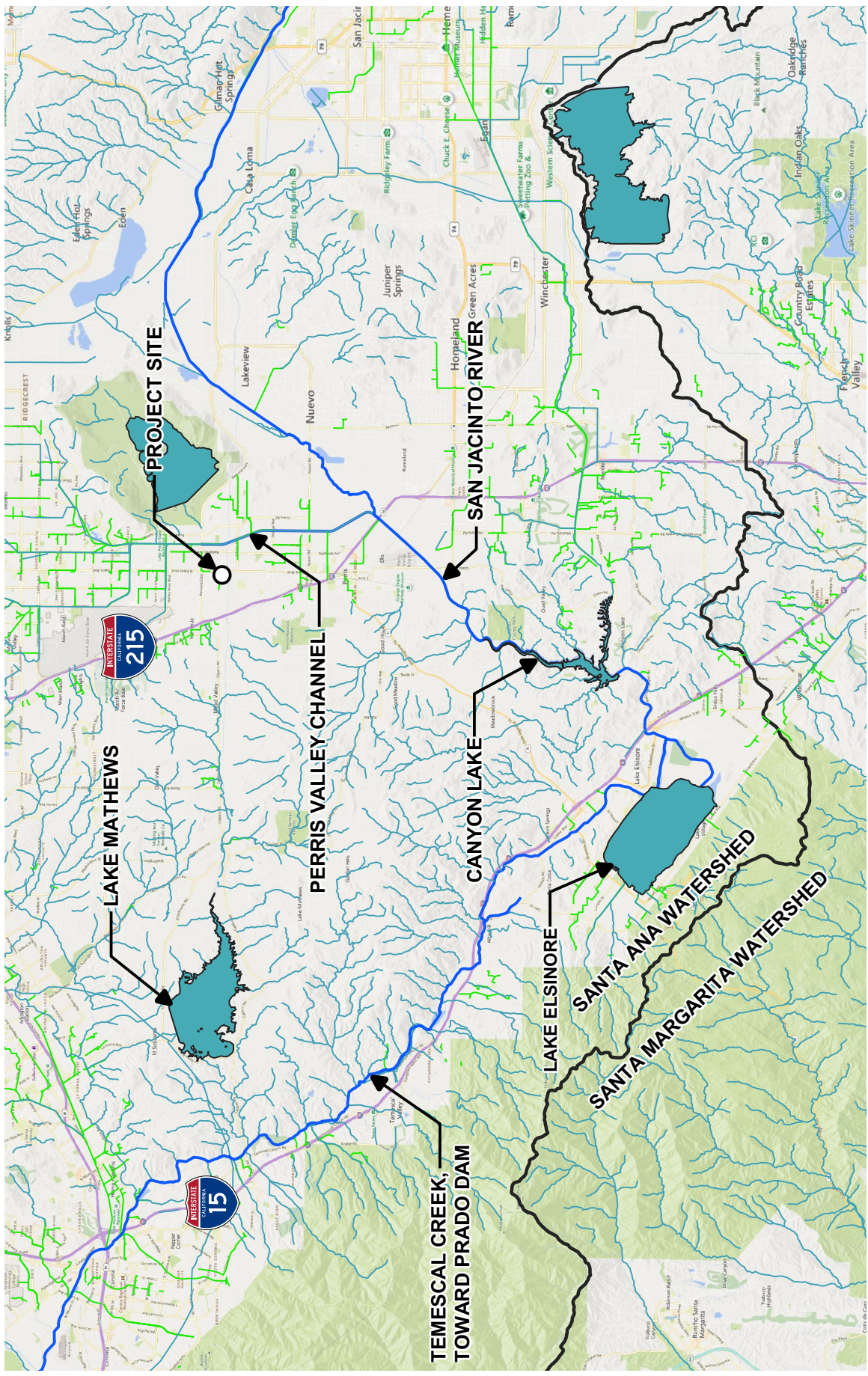

**FMCIVIL**  
 ENGINEERS, INC.  
 29995 TECHNOLOGY DRIVE SUITE 306  
 MURRIETA | CA 92563  
 951.973.0201 - FMCIVIL.COM



# 100 W Sinclair St. Perris

In Perris, County of Riverside  
 Receiving Waters Exhibit



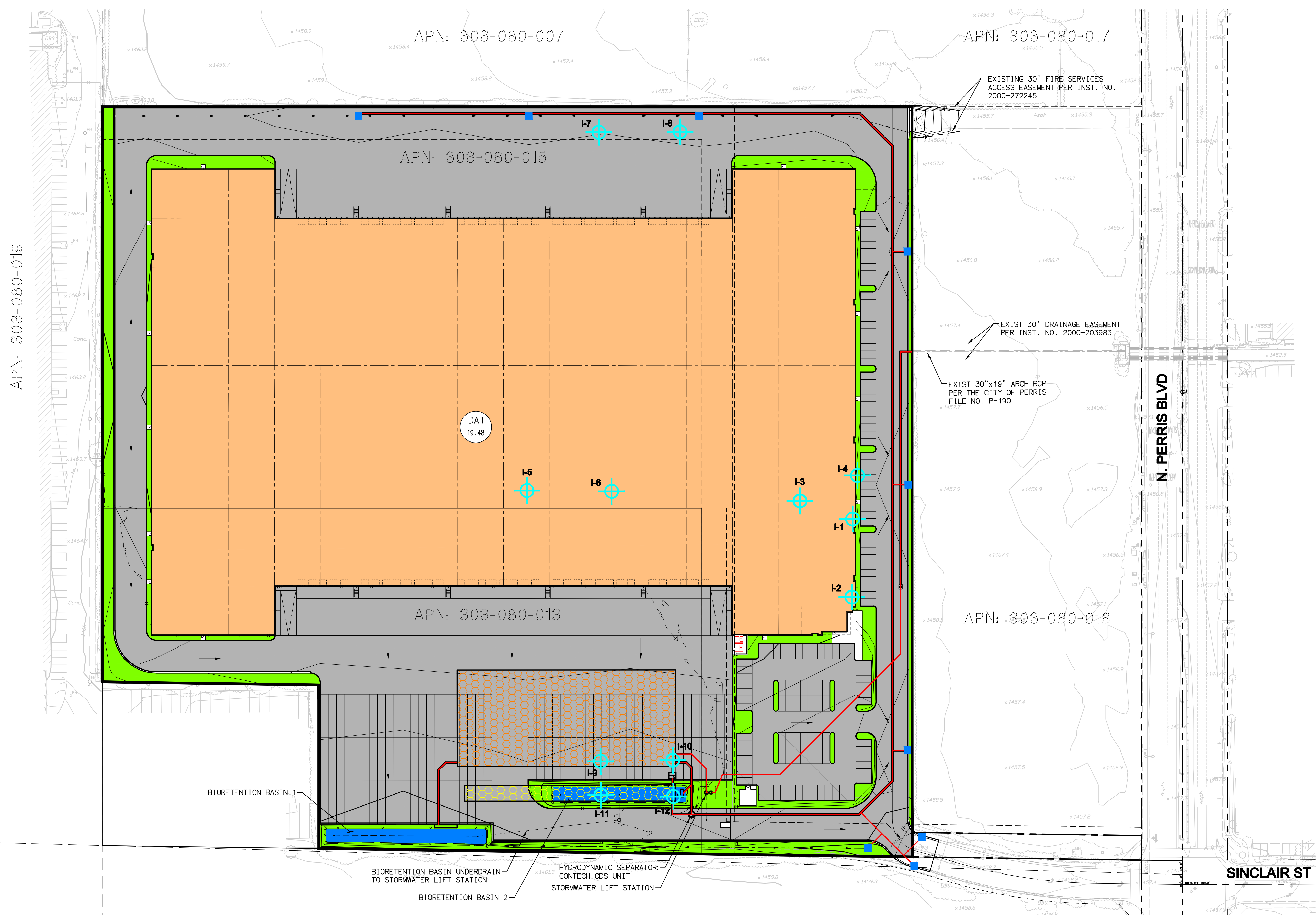

- LEGEND**
- DMA1  
3.38 → DA AREA NUMBER  
AREA IN ACRES
  - LANDSCAPE AREA
  - BASIN BOTTOM
  - PROPOSED ASPHALT DRIVE  
AISLE & PARKING AREAS
  - PROPOSED ROOFTOP
  - PROPOSED HARDSCAPE AREA
  - UNDERGROUND DETENTION (SEE PLANS  
ATTACHED IN APPENDIX 2)
  - UNDERGROUND INFILTRATION (SEE  
PLANS ATTACHED IN APPENDIX 6)
  - DRAIN INLET STENCIL
  - DMA BOUNDARY
  - PROPOSED STORM DRAIN
  - DIRECTION OF FLOW
  - TR TRASH ENCLOSURE
  - + APPROXIMATE INFILTRATION  
TEST LOCATIONS

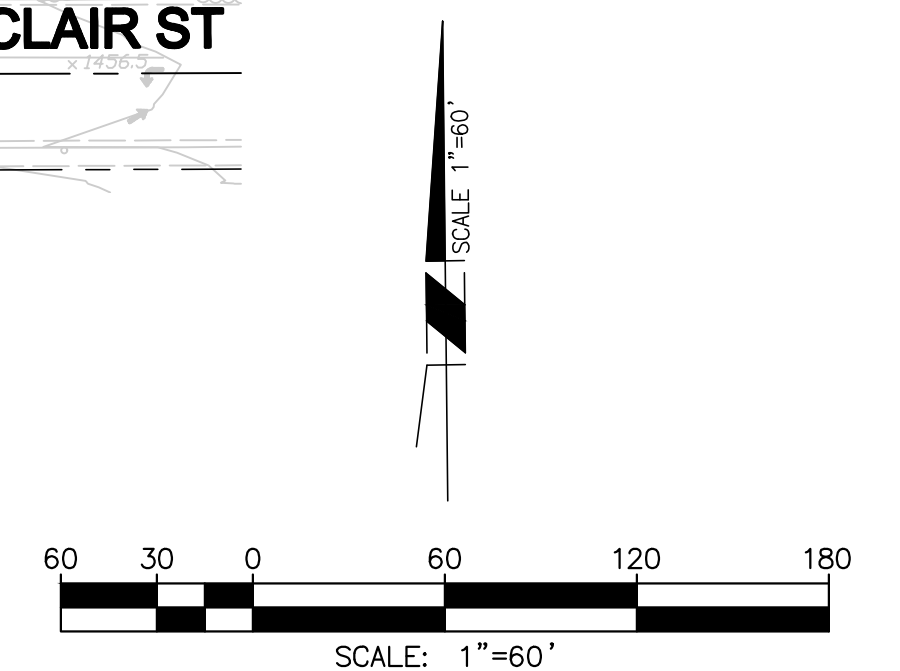

**FM CIVIL** ENGINEERS INC.  
 29995 TECHNOLOGY DRIVE, SUITE 306 | MURRIETA | CA 92563  
 951.973.0201 - FMCIVIL.COM

**100 SINCLAIR STREET**  
 WQMP SITE PLAN

**1**  
 OF 1 SHEETS

# Appendix 2: Construction Plans

*Grading and Drainage Plans*



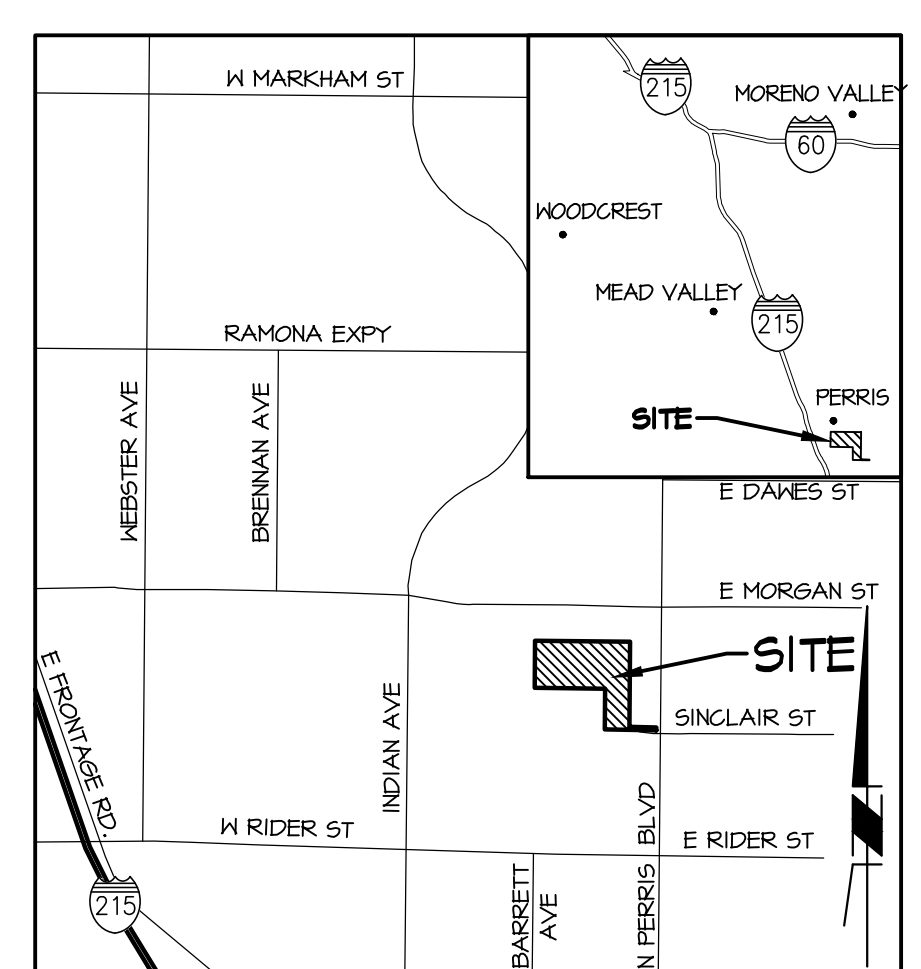
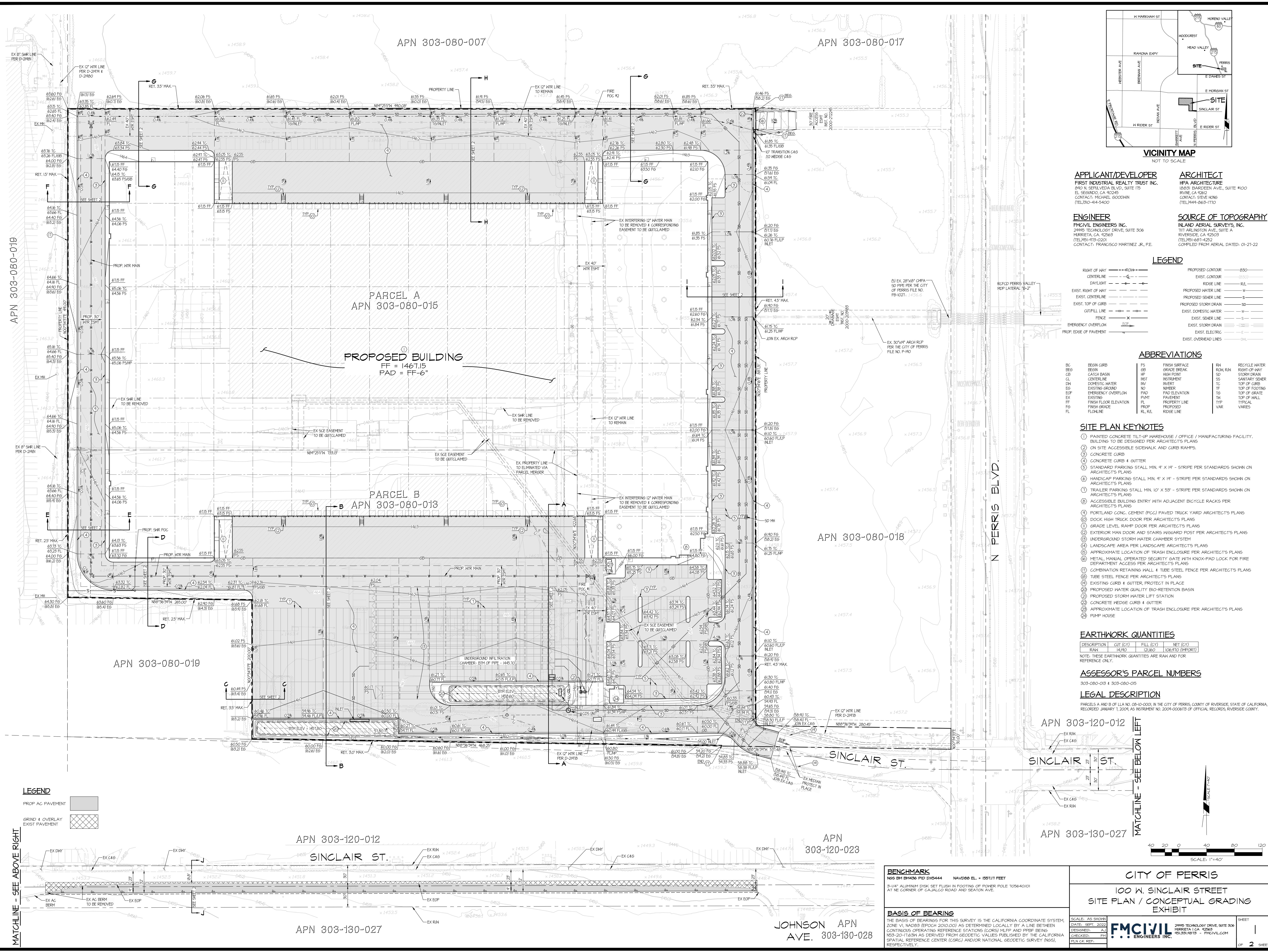

**APPLICANT/DEVELOPER**  
 FIRST INDUSTRIAL REALTY TRUST INC.  
 840 N. SEPULVEDA BLVD, SUITE 175  
 EL SEBINO, CA 92529  
 CONTACT: MICHAEL GOODWIN  
 (TEL) 951-414-5400

**ARCHITECT**  
 HFA ARCHITECTURE  
 10431 BARDEEN AVE, SUITE #100  
 IRVINE, CA 92618  
 CONTACT: STEVE HONG  
 (TEL) 949-663-1170

**ENGINEER**  
 FM CIVIL ENGINEERS INC.  
 2885 TECHNOLOGY DRIVE, SUITE 306  
 HARRIETA, CA 92503  
 (TEL) 951-413-0201  
 CONTACT: FRANCISCO MARTINEZ JR., P.E.

**SOURCE OF TOPOGRAPHY**  
 INLAND AERIAL SURVEYS, INC.  
 1111 ARLINGTON AVE., SUITE A  
 RIVERSIDE, CA 92503  
 (TEL) 951-681-4252  
 COMPILED FROM AERIAL DATED: 01-21-22

**LEGEND**

RIGHT OF WAY	--- 40' ---	PROPOSED CONTOUR	--- 0.50 ---
CENTERLINE	--- 4 ---	EXIST. CONTOUR	--- 0.50 ---
DATUM	--- 4 ---	PROPOSED RIDGE LINE	--- 0.50 ---
EXIST. RIGHT OF WAY	--- 40' ---	PROPOSED WATER LINE	--- 0.50 ---
EXIST. CENTERLINE	--- 4 ---	PROPOSED SEWER LINE	--- 0.50 ---
EXIST. TOP OF CURB	--- 4 ---	PROPOSED STORM DRAIN	--- 0.50 ---
CUT/FILL LINE	--- 4 ---	EXIST. DOMESTIC WATER	--- 0.50 ---
FENCE	--- 4 ---	EXIST. SEWER LINE	--- 0.50 ---
EMERGENCY OVERFLOW	--- 4 ---	EXIST. STORM DRAIN	--- 0.50 ---
PROP. EDGE OF PAVEMENT	--- 4 ---	EXIST. ELECTRIC	--- 0.50 ---
		EXIST. OVERHEAD LINES	--- 0.50 ---

**ABBREVIATIONS**

BC	BEGIN CURB	FS	FINISH SURFACE	DM	RECYCLE WATER
BEG	BEGIN	GB	GRADE BREAK	ROK RM	RIGHT-OF-WAY
CB	CATCH BASIN	HP	HIGH POINT	SD	STORM DRAIN
CL	CENTERLINE	INS	INSTRUMENT	SS	SANITARY SEWER
DN	DOMESTIC WATER	INV	INVERT	TC	TOP OF CURB
EG	EXISTING GROUND	NMBR	NUMBER	TF	TOP OF FOOTING
EM	EMERGENCY OVERFLOW	PAD	PAD ELEVATION	TG	TOP OF GRADE
EX	EXISTING	PMT	PAVEMENT	TH	TOP OF WALL
FF	FINISH FLOOR ELEVATION	PL	PROPERTY LINE	TYP	TYPICAL
FL	FLOWLINE	RL	RIDGE LINE	VAR	VARIABLE

- SITE PLAN KEYNOTES**
- PAINTED CONCRETE TILT-UP WAREHOUSE / OFFICE / MANUFACTURING FACILITY. BUILDING TO BE DESIGNED PER ARCHITECT'S PLANS
  - ON SITE ACCESSIBLE SIDEWALK AND CURB RAMPS
  - CONCRETE CURB
  - CONCRETE CURB & GUTTER
  - STANDARD PARKING STALL MIN. 9' X 18' - STRIPE PER STANDARDS SHOWN ON ARCHITECT'S PLANS
  - HANDICAP PARKING STALL MIN. 9' X 18' - STRIPE PER STANDARDS SHOWN ON ARCHITECT'S PLANS
  - TRAILER PARKING STALL MIN. 10' X 53' - STRIPE PER STANDARDS SHOWN ON ARCHITECT'S PLANS
  - ACCESSIBLE BUILDING ENTRY WITH ADJACENT BICYCLE RACKS PER ARCHITECT'S PLANS
  - PORTLAND CONC. CEMENT (PCG) PAVED TRUCK YARD ARCHITECT'S PLANS
  - DOCK HIGH TRUCK DOOR PER ARCHITECT'S PLANS
  - GRADE LEVEL RAMP DOOR PER ARCHITECT'S PLANS
  - EXTERIOR MAN DOOR AND STAIRS W/SHARD POST PER ARCHITECT'S PLANS
  - UNDERGROUND STORM WATER CHAMBER SYSTEM
  - LANDSCAPE AREA PER LANDSCAPE ARCHITECT'S PLANS
  - APPROXIMATE LOCATION OF TRASH ENCLOSURE PER ARCHITECT'S PLANS
  - METAL MANUAL OPERATED SECURITY GATE WITH KNOX-PAD LOCK FOR FIRE DEPARTMENT ACCESS PER ARCHITECT'S PLANS
  - COMBINATION RETAINING WALL & TUBE STEEL FENCE PER ARCHITECT'S PLANS
  - EXISTING CURB & GUTTER, PROTECT IN PLACE
  - PROPOSED WATER QUALITY BIO-RETENTION BASIN
  - PROPOSED STORM WATER LIFT STATION
  - CONCRETE REDGE CURB & GUTTER
  - APPROXIMATE LOCATION OF TRASH ENCLOSURE PER ARCHITECT'S PLANS
  - PUMP HOUSE

**EARTHWORK QUANTITIES**

DESCRIPTION	CUT (CY)	FILL (CY)	NET (CY)
RAW	143.80	120.80	126.70 (IMPORT)
NOTE: THESE EARTHWORK QUANTITIES ARE RAW AND FOR REFERENCE ONLY.			

**ASSESSOR'S PARCEL NUMBERS**  
 303-080-013 & 303-080-015

**LEGAL DESCRIPTION**  
 PARCELS A AND B OF LLA NO. 08-10-000 IN THE CITY OF PERRIS, COUNTY OF RIVERSIDE, STATE OF CALIFORNIA, RECORDED JANUARY 1, 2004, AS INSTRUMENT NO. 2004-000613 OF OFFICIAL RECORDS, RIVERSIDE COUNTY.

**LEGEND**

PROP AC PAVEMENT	[Pattern]
GRIND & OVERLAY EXIST PAVEMENT	[Pattern]

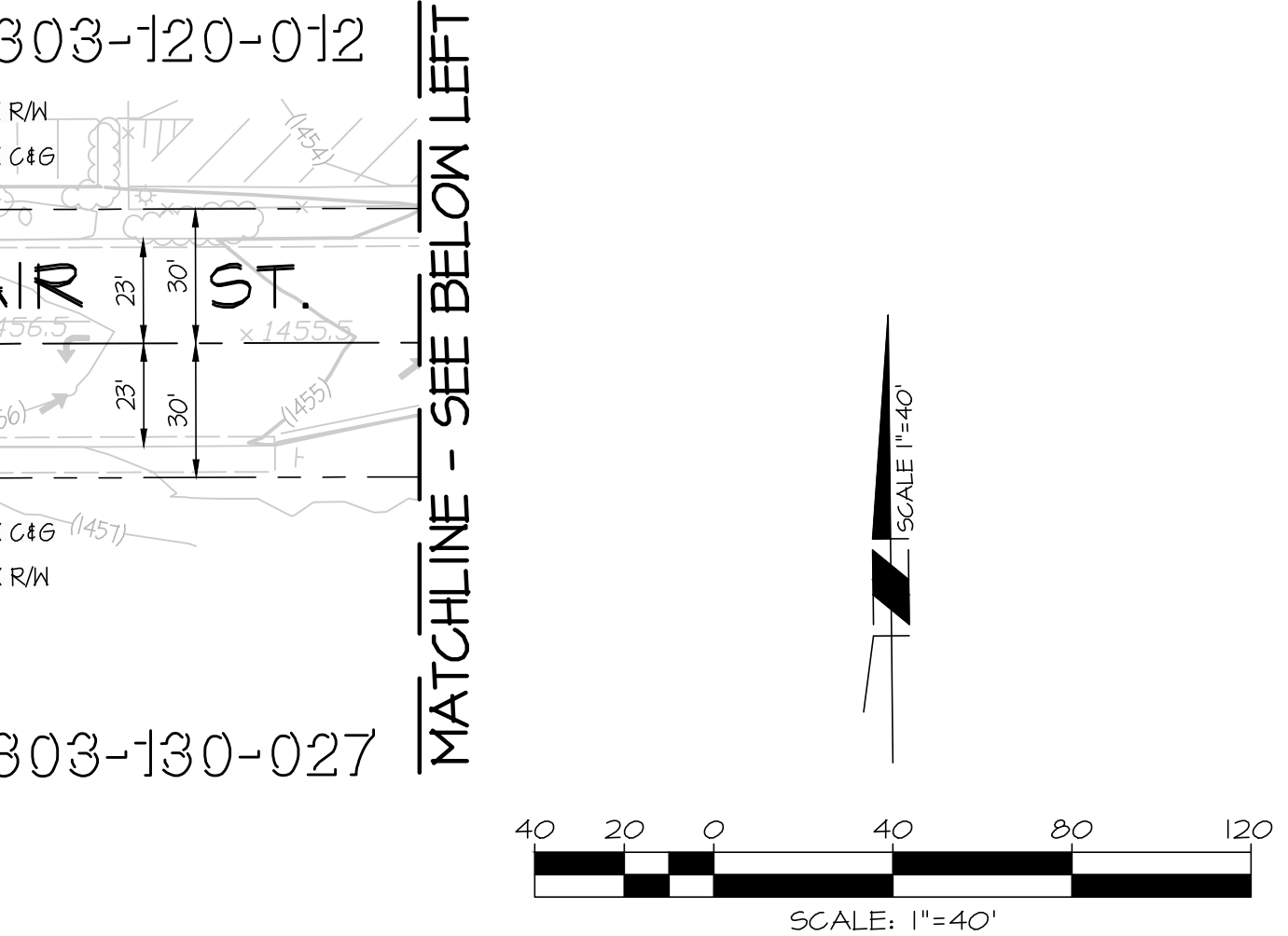

**BENCHMARK**  
 NGS BM 4436 PPD D3444 NAVD83 EL. = 1571.1 FEET  
 3/4" ALUMINUM DISK SET FLUSH IN FOOTING OF POWER POLE T05640/01 AT NE CORNER OF CAJALCO ROAD AND SEATON AVE.

**BASIS OF BEARING**  
 THE BASIS OF BEARINGS FOR THIS SURVEY IS THE CALIFORNIA COORDINATE SYSTEM, ZONE 10, NAD83 (EPOCH 2010.00) AS DETERMINED LOCALLY BY A LINE BETWEEN CONTINUOUS OPERATING REFERENCE STATIONS (CORS) MHPF AND PRSF, BEING NS3-20-17639 AS DERIVED FROM GEODETIC VALUES PUBLISHED BY THE CALIFORNIA SPATIAL REFERENCE CENTER (CSRC) AND/OR NATIONAL GEODETIC SURVEY (NGS), RESPECTIVELY.

**CITY OF PERRIS**  
 100 W. SINCLAIR STREET  
 SITE PLAN / CONCEPTUAL GRADING EXHIBIT

**FM CIVIL ENGINEERS INC.**  
 2885 TECHNOLOGY DRIVE, SUITE 306  
 HARRIETA, CA 92503  
 (TEL) 951-413-0201  
 WWW.FMCIVIL.COM

DATE: 08-20-2024  
 DESIGNED: [Signature]  
 CHECKED: [Signature]  
 PLOT CK REF.

SCALE: AS SHOWN  
 SHEET 1 OF 2 SHEETS

APN 303-080-019

MATCHLINE - SEE ABOVE RIGHT

MATCHLINE - SEE BELOW LEFT

APN 303-120-012

APN 303-120-023

APN 303-130-027

JOHNSON APN 303-130-028



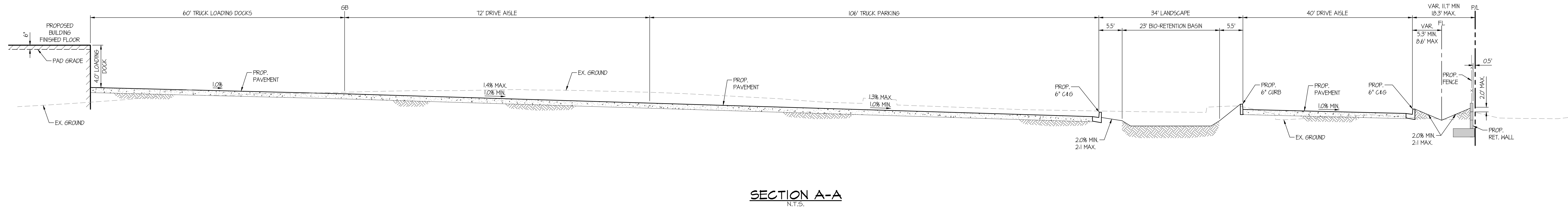

SECTION A-A  
N.T.S.

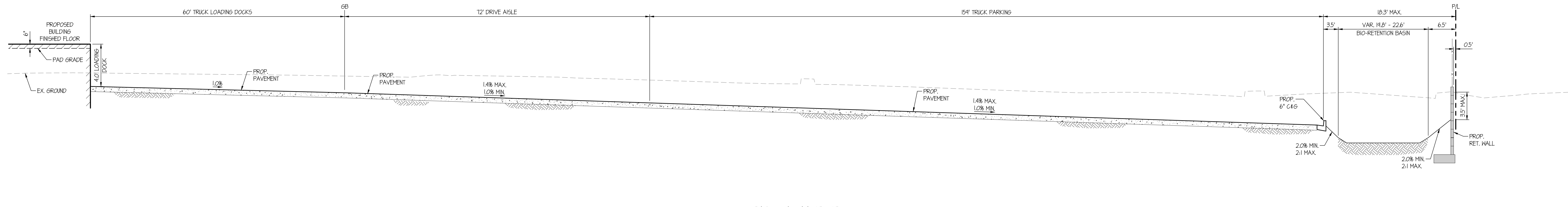

SECTION B-B  
N.T.S.

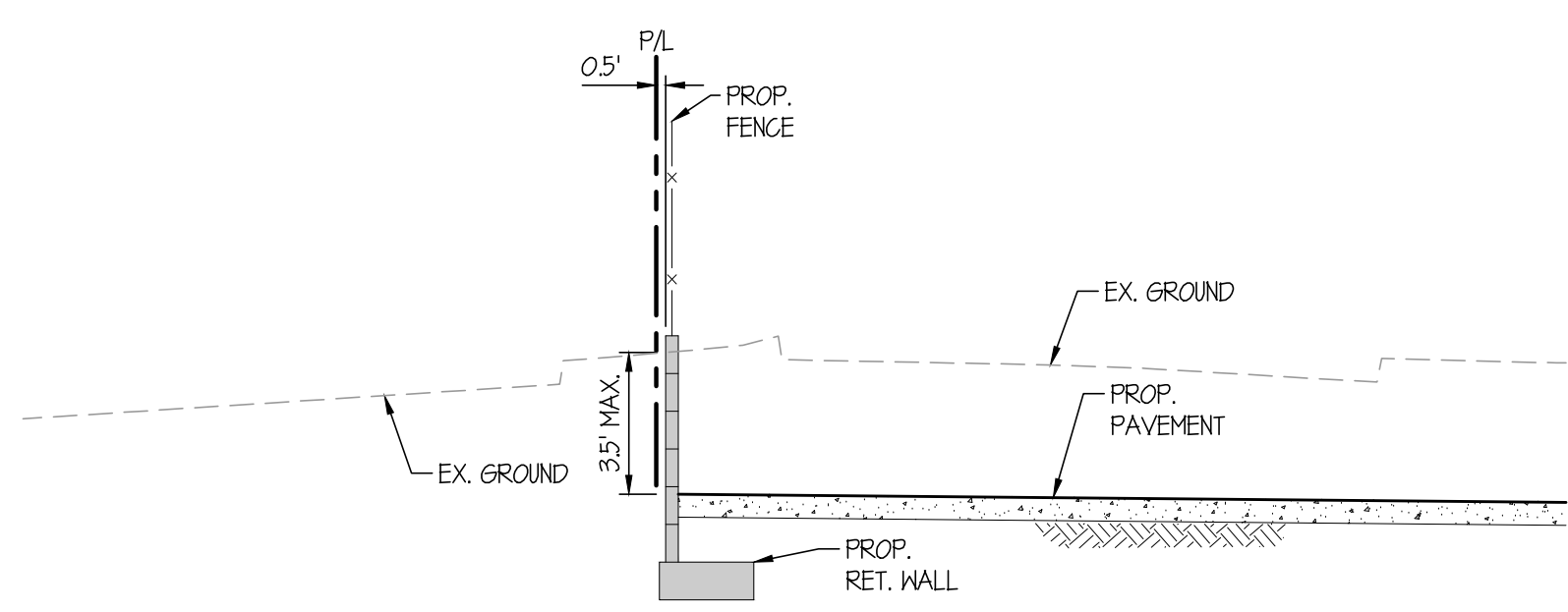

SECTION C-C  
N.T.S.

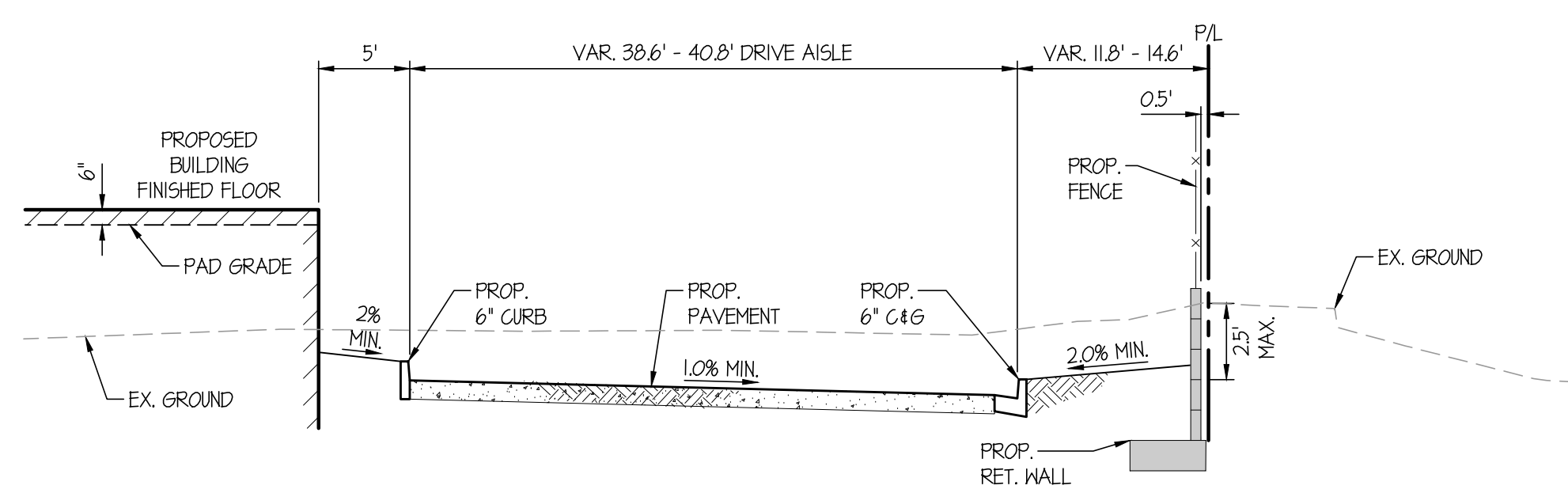

SECTION D-D  
N.T.S.

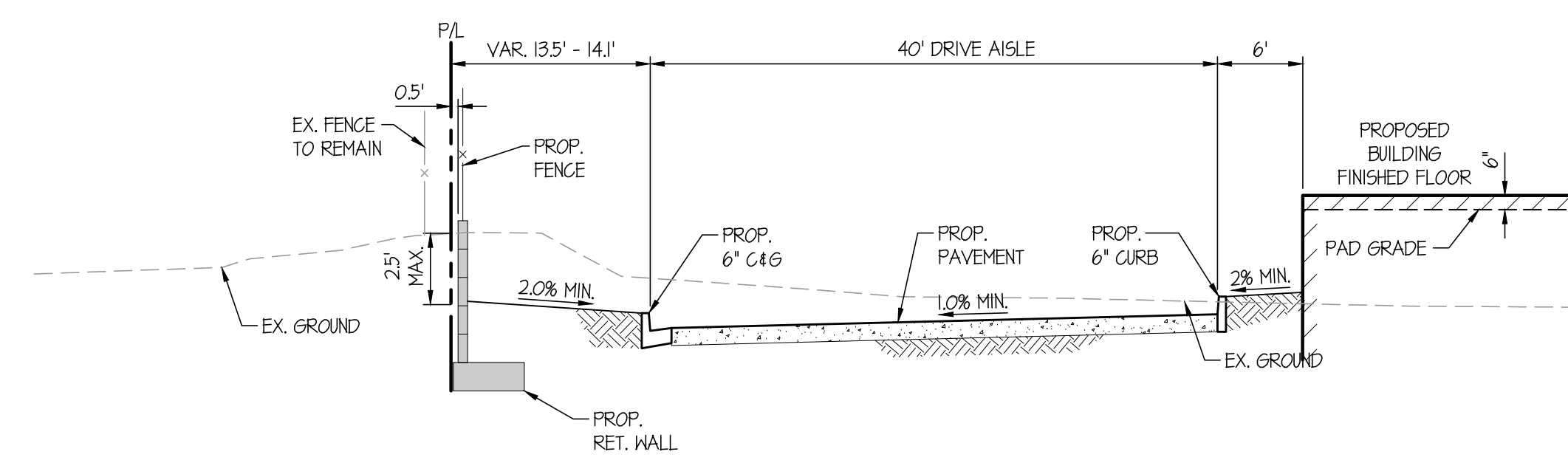

SECTION E-E  
N.T.S.

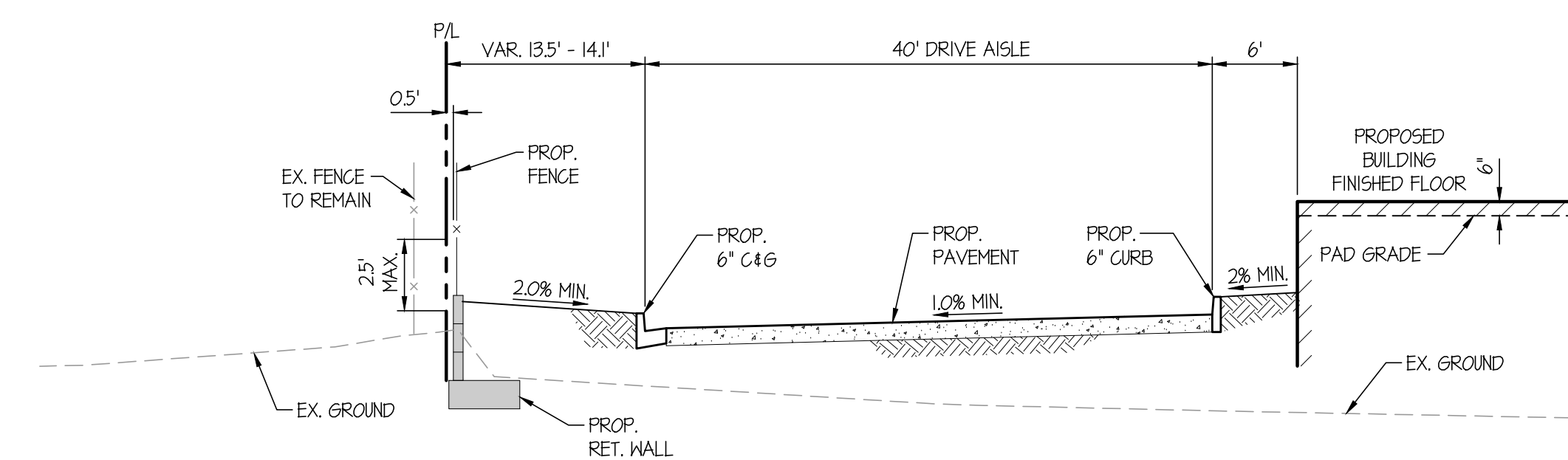

SECTION F-F  
N.T.S.

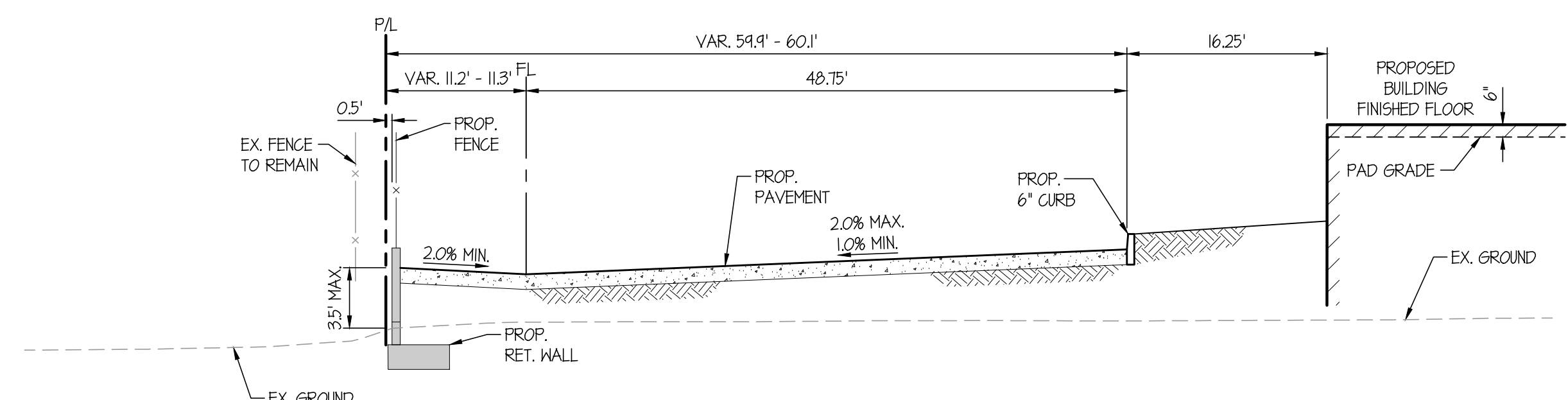

SECTION G-G  
N.T.S.

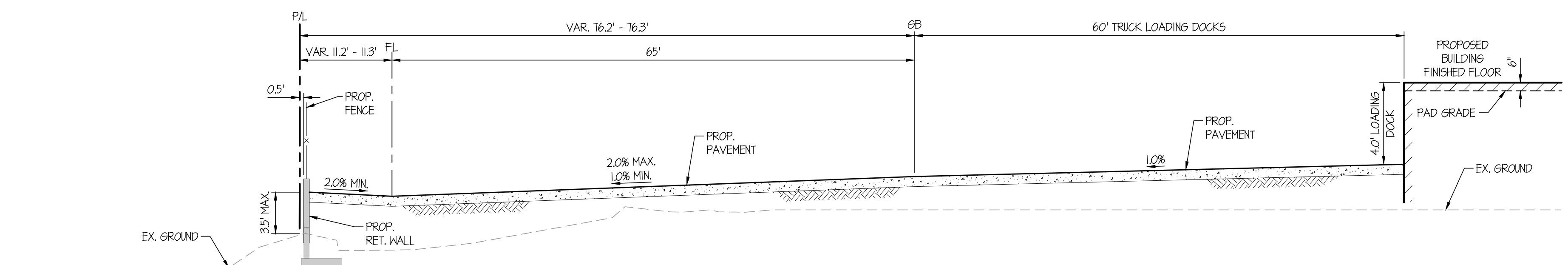

SECTION H-H  
N.T.S.

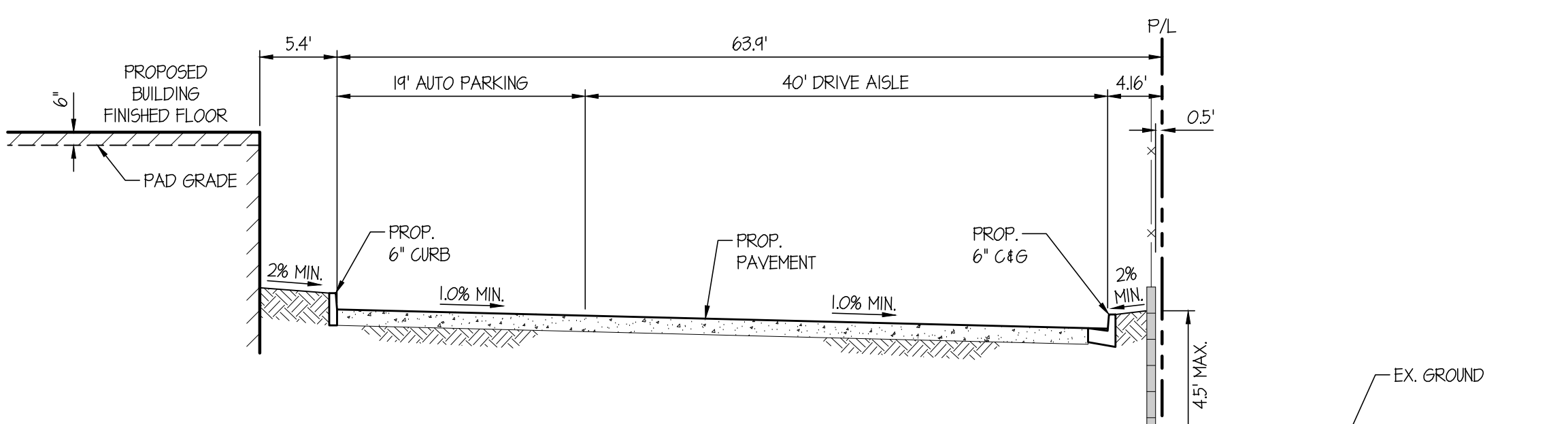

SECTION I-I  
N.T.S.

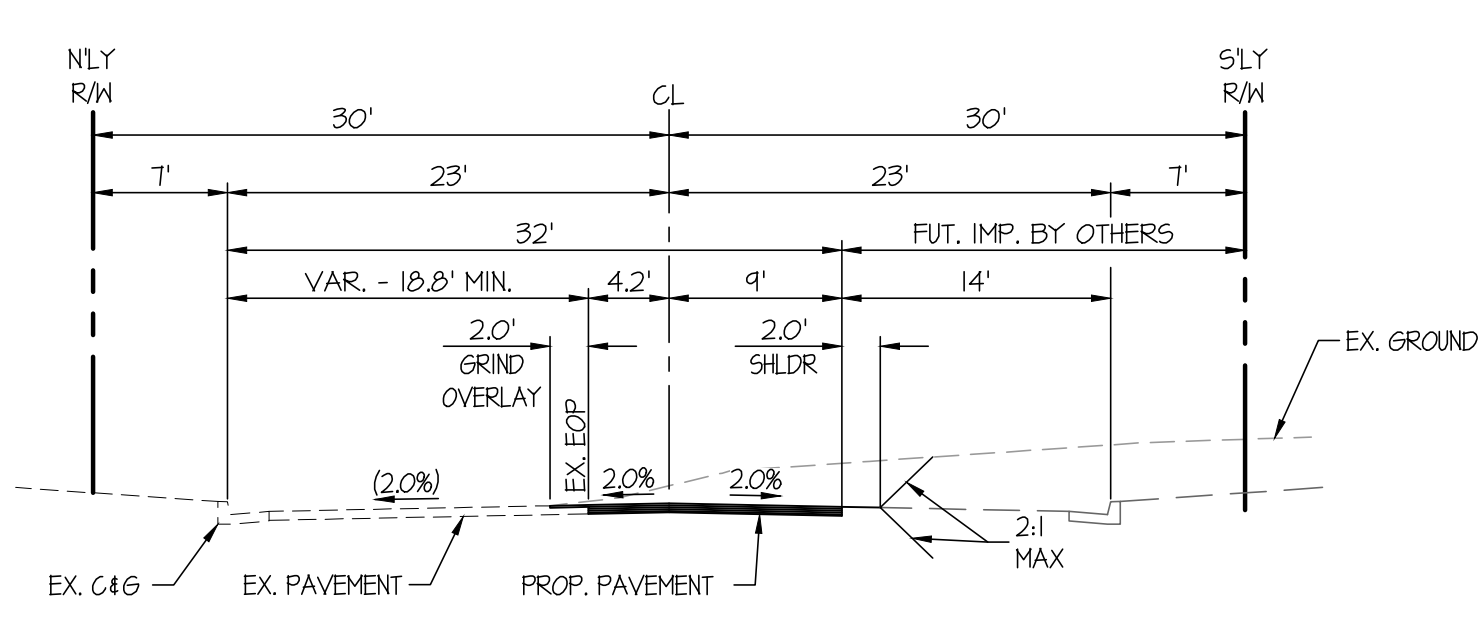

SECTION J-J - SINCLAIR STREET  
HOR. SCALE: 1"=10'

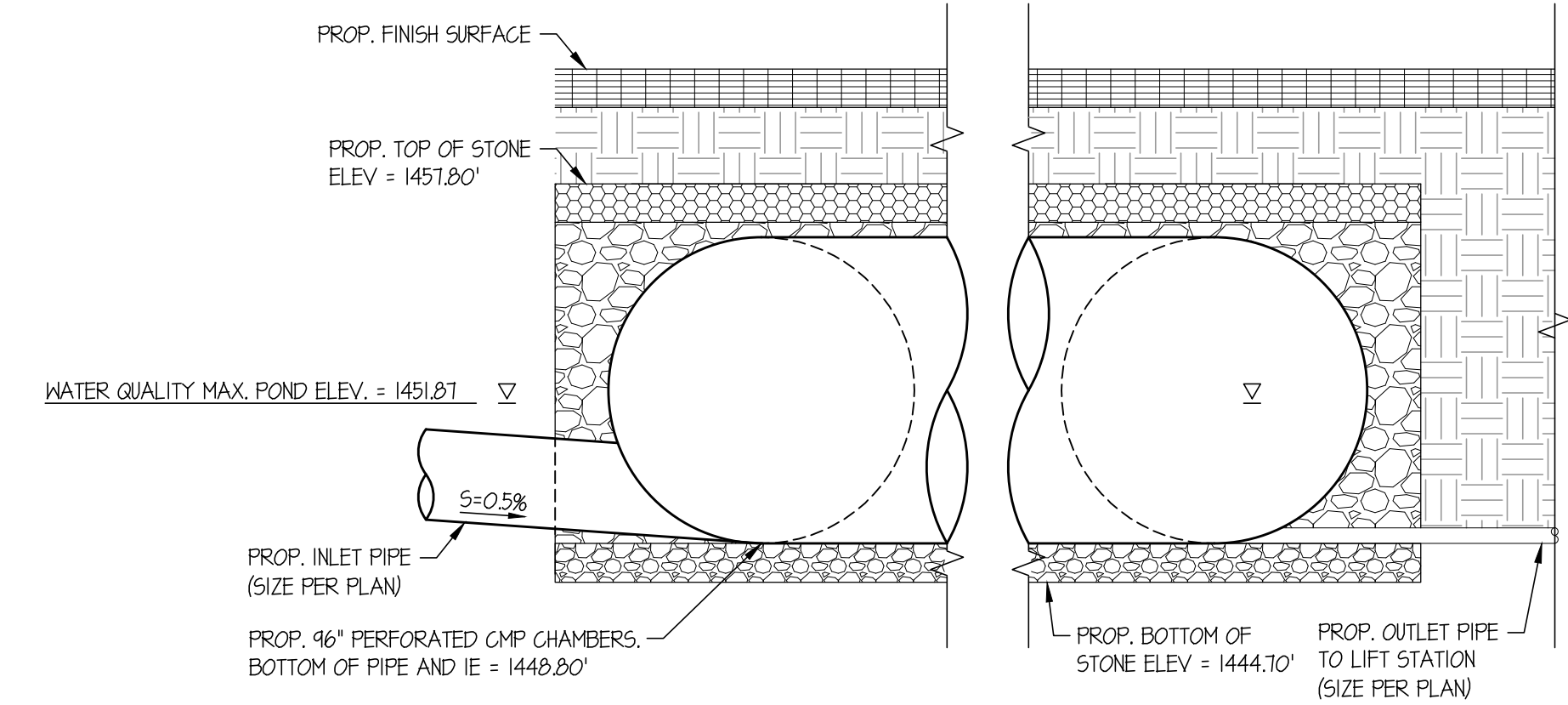

UNDERGROUND CHAMBERS DETAIL  
N.T.S.

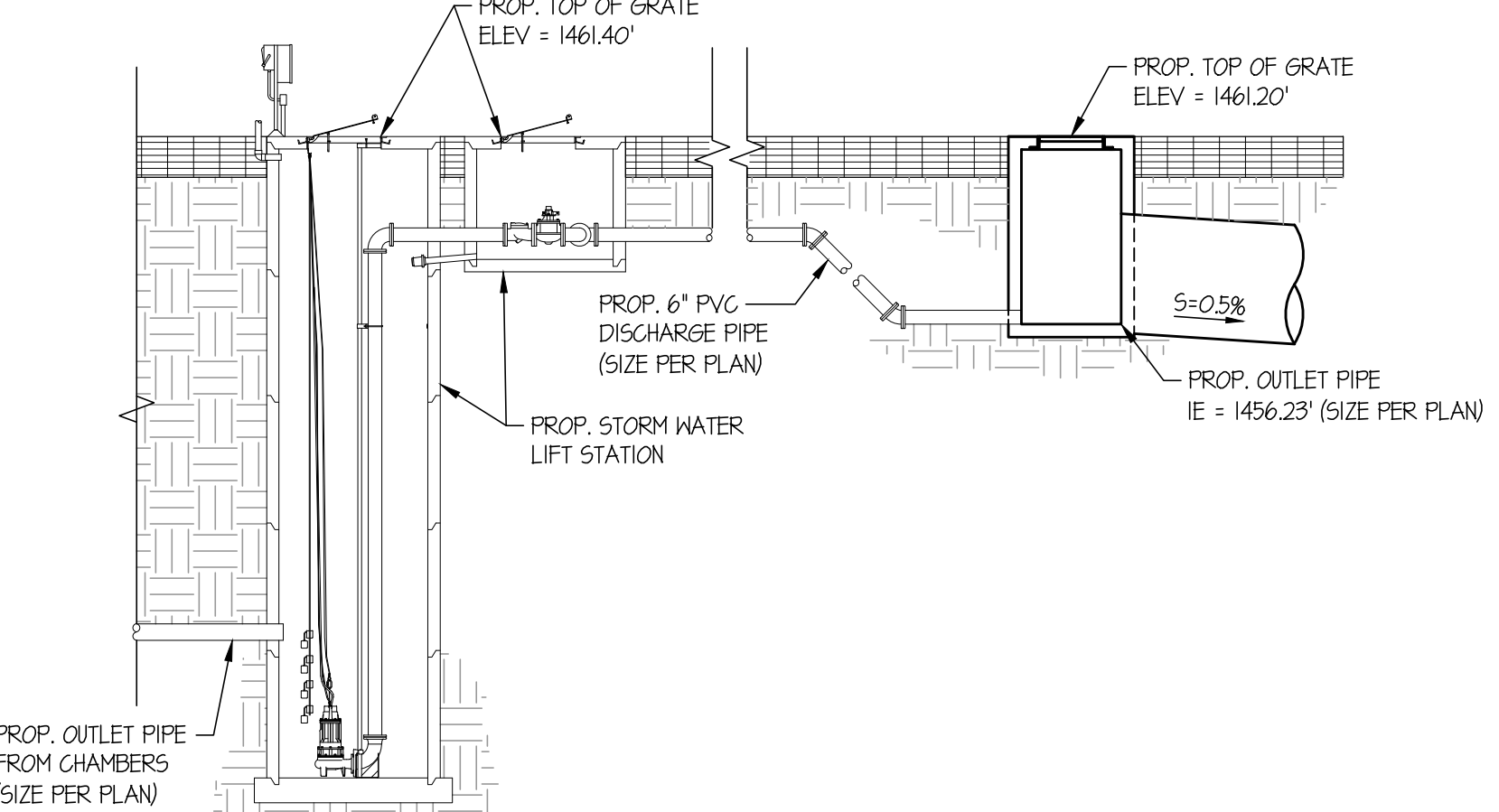

STORM WATER LIFT STATION OUTLET DETAIL  
N.T.S.

<b>BENCHMARK</b> N65 8M 4436 P10 D35444 NAVD83 EL. = 1551.11 FEET 3-1/4" ALUMINUM DISK SET FLUSH IN FOOTING OF POWER POLE T05640/01 AT NE CORNER OF CAJALCO ROAD AND SEATON AVE.		<b>CITY OF PERRIS</b> 100 W. SINCLAIR STREET SITE PLAN / CONCEPTUAL GRADING TYPICAL SECTIONS	
<b>BASIS OF BEARING</b> THE BASIS OF BEARINGS FOR THIS SURVEY IS THE CALIFORNIA COORDINATE SYSTEM, ZONE 10, NAD83 (PROJ. 2010.00) AS DETERMINED LOGICALLY BY A LINE BETWEEN CONTIGUOUS OPERATING REFERENCE STATIONS (CORS) MLIFF AND PRSF BEING N53-20-17.63N AS DERIVED FROM GEODETIC VALUES PUBLISHED BY THE CALIFORNIA SPATIAL REFERENCE CENTER (CSRC) AND/OR NATIONAL GEODETIC SURVEY (NGS), RESPECTIVELY.		SCALE: AS SHOWN DATE: 08/20/2022 DESIGNED: AJ CHECKED: PM PLN. CK. REF.	SHEET <b>2</b> OF 2 SHEETS

1. P:\Projects\2022\100 W. SINCLAIR STREET\CONCEPTUAL GRADING\PLN\CONCEPTUAL GRADING TYPICAL SECTIONS.dwg, DATE: 8/20/2022, 2:42 PM

# PROJECT SUMMARY

## CALCULATION DETAILS

- LOADING = HS20/HS25
- APPROX. LINEAR FOOTAGE = 522 LF

## STORAGE SUMMARY

- STORAGE VOLUME REQUIRED = N/A
- PIPE STORAGE VOLUME = 26,239 CF
- BACKFILL STORAGE VOLUME = 6,977 CF
- TOTAL STORAGE PROVIDED = 33,215 CF

## PIPE DETAILS

- DIAMETER = 96"
- CORRUGATION = 5x1
- GAGE = 16
- COATING = ALT2
- WALL TYPE = PERFORATED
- BARREL SPACING = 36"

## BACKFILL DETAILS

- WIDTH AT ENDS = 12"
- ABOVE PIPE = 0"
- WIDTH AT SIDES = 12"
- BELOW PIPE = 0"

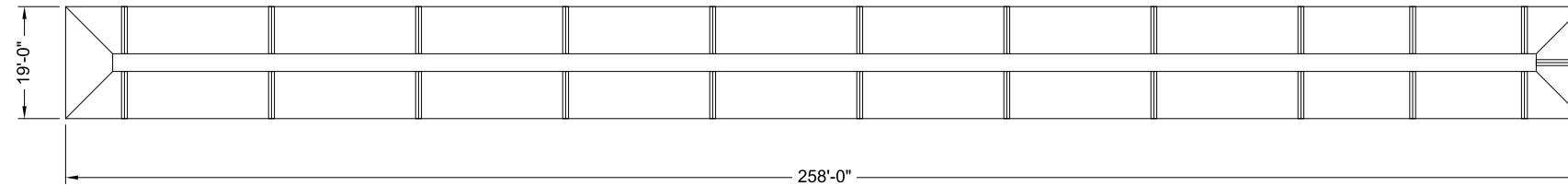

## NOTES

- ALL RISER AND STUB DIMENSIONS ARE TO CENTERLINE. ALL ELEVATIONS, DIMENSIONS, AND LOCATIONS OF RISERS AND INLETS, SHALL BE VERIFIED BY THE ENGINEER OF RECORD PRIOR TO RELEASING FOR FABRICATION.
- ALL FITTINGS AND REINFORCEMENT COMPLY WITH ASTM A998.
- ALL RISERS AND STUBS ARE 2<sup>2</sup>/<sub>3</sub>" x 1<sup>1</sup>/<sub>2</sub>" CORRUGATION AND 16 GAGE UNLESS OTHERWISE NOTED.
- RISERS TO BE FIELD TRIMMED TO GRADE.
- QUANTITY OF PIPE SHOWN DOES NOT PROVIDE EXTRA PIPE FOR CONNECTING THE SYSTEM TO EXISTING PIPE OR DRAINAGE STRUCTURES. OUR SYSTEM AS DETAILED PROVIDES NOMINAL INLET AND/OR OUTLET PIPE STUB FOR CONNECTION TO EXISTING DRAINAGE FACILITIES. IF ADDITIONAL PIPE IS NEEDED IT IS THE RESPONSIBILITY OF THE CONTRACTOR.
- BAND TYPE TO BE DETERMINED UPON FINAL DESIGN.
- THE PROJECT SUMMARY IS REFLECTIVE OF THE DYODS DESIGN, QUANTITIES ARE APPROX. AND SHOULD BE VERIFIED UPON FINAL DESIGN AND APPROVAL. FOR EXAMPLE, TOTAL EXCAVATION DOES NOT CONSIDER ALL VARIABLES SUCH AS SHORING AND ONLY ACCOUNTS FOR MATERIAL WITHIN THE ESTIMATED EXCAVATION FOOTPRINT.
- THESE DRAWINGS ARE FOR CONCEPTUAL PURPOSES AND DO NOT REFLECT ANY LOCAL PREFERENCES OR REGULATIONS. PLEASE CONTACT YOUR LOCAL CONTECH REP FOR MODIFICATIONS.

**ASSEMBLY**  
SCALE: 1" = 30'

C:\EXPORT\TEMPLATES\CMP\_16.DWG 10/18/2019 10:02 AM

The design and information shown on this drawing is provided as a service to the project owner, engineer and contractor by Contech Engineered Solutions LLC ("Contech"). Neither this drawing, nor any part thereof, may be used, reproduced or modified in any manner without the prior written consent of Contech. Failure to comply is done at the user's own risk and Contech expressly disclaims any liability or responsibility for such use.		
If discrepancies between the supplied information upon which the drawing is based and actual field conditions are encountered as site work progresses, these discrepancies must be reported to Contech immediately for re-evaluation of the design. Contech accepts no liability for designs based on missing, incomplete or inaccurate information supplied by others.		
DATE	REVISION DESCRIPTION	BY

**CONTECH**  
ENGINEERED SOLUTIONS LLC  
www.ContechES.com  
9025 Centre Pointe Dr., Suite 400, West Chester, OH 45069  
800-338-1122 513-645-7000 513-645-7993 FAX

**CONTECH**  
CMP DETENTION SYSTEMS  
CONTECH  
**DYODS**  
DRAWING

DYO21274 Sinclair St  
Under Ground Chamber System - Water Quality  
Perris, CA  
DETENTION SYSTEM

PROJECT No.: 13869	SEQ. No.: 21274	DATE: 9/14/2022
DESIGNED: DYO	DRAWN: DYO	
CHECKED: DYO	APPROVED: DYO	
SHEET NO.:		<b>1</b>

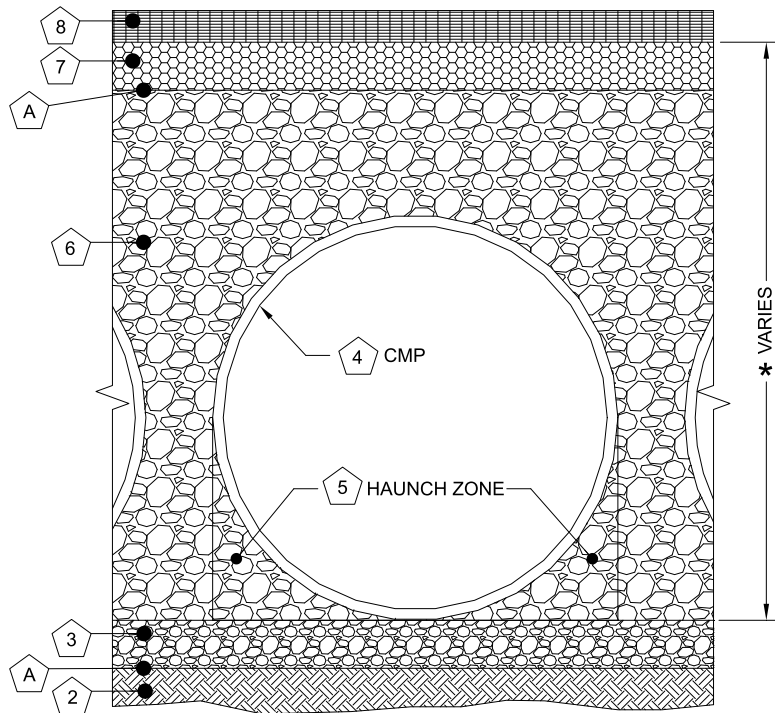

Infiltration Systems - CMP Infiltration & CMP Perforated Drainage Pipe			
Material Location	Description	Material Designation	Designation
8	Rigid or Flexible Pavement (if applicable)		
7	Road Base (if applicable)		
A	Geotextile Layer	Non-Woven Geotextile CONTECH C-40 or C-45	Engineer Decision for consideration to prevent soil migration into varying soil types. Wrap the trench only.
6	Backfill	Infiltration pipe systems have a pipe perforation sized of 3/8" diameter. An open graded, free draining stone, with a particle size of 1/2" - 2 1/2" diameter is recommended.	AASHTO M 145-A-1 or AASHTO M 43 - 3, 4 Material shall be worked into the pipe haunches by means of shovel-slicing, rodding, air-tamper, vibratory rod, or other effective methods. Compaction of all placed fill material is necessary and shall be considered adequate when no further yielding of the material is observed under the compactor, or under foot, and the Project Engineer or his representative is satisfied with the level of compaction"
3	Bedding Stone	Well graded granular bedding material w/maximum particle size of 3"	AASHTO M43 - 3,357,4,467, 5, 56, 57 For soil aggregates larger than 3/8" a dedicated bedding layer is not required for CMP. Pipe may be placed on the trench bottom comprised of native suitable well graded & granular material. For Arch pipes it is recommended to be shaped to a relatively flat bottom or fine-grade the foundation to a slight v-shape. Soil aggregates less than 3/8" and unsuitable material should be over-excavated and re-placed with a 4"-6" layer of well graded & granular stone per the material designation.
A	Geotextile Layer	None	None Contech does not recommend geotextiles be placed under the invert of infiltration systems due to the propensity for geotextiles to clog over time.

\* Note: The listed AASHTO designations are for gradation only. The stone must also be angular and clean.

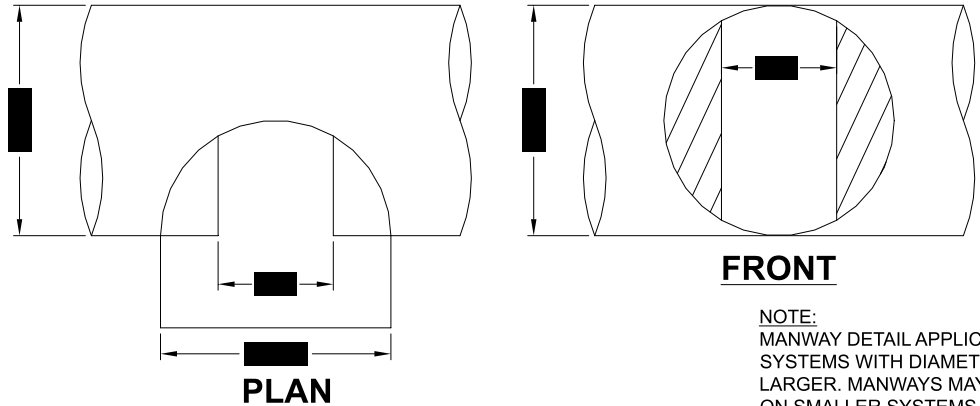

TYPICAL MANWAY DETAIL

NOTE: MANWAY DETAIL APPLICABLE FOR CMP SYSTEMS WITH DIAMETERS 48" AND LARGER. MANWAYS MAY BE REQUIRED ON SMALLER SYSTEMS DEPENDING ON ACTUAL SITE SPECIFIC CONDITIONS.

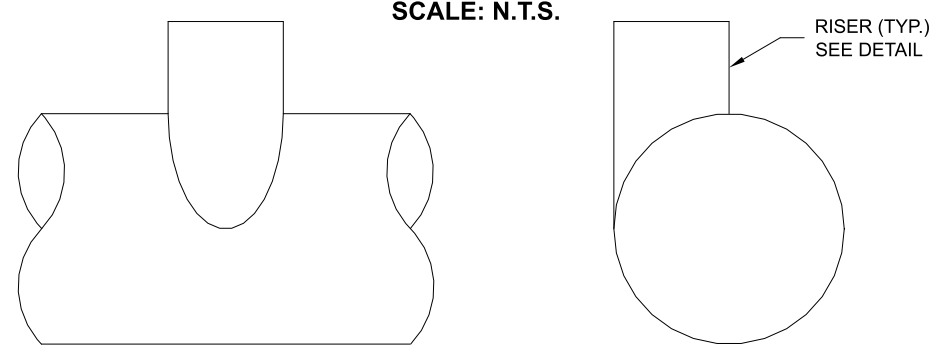

TYPICAL RISER DETAIL

NOTE: LADDERS ARE OPTIONAL AND ARE NOT REQUIRED FOR ALL SYSTEMS.

- 1 MINIMUM WIDTH DEPENDS ON SITE CONDITIONS AND ENGINEERING JUDGEMENT.
- 2 PRIOR TO PLACING THE BEDDING, THE FOUNDATION MUST BE CONSTRUCTED TO A UNIFORM AND STABLE GRADE. IN THE EVENT THAT UNSUITABLE FOUNDATION MATERIALS ARE ENCOUNTERED DURING EXCAVATION, THEY SHALL BE REMOVED AND BROUGHT BACK TO THE GRADE WITH A FILL MATERIAL AS APPROVED BY THE ENGINEER.
- 5 HAUNCH ZONE MATERIAL SHALL BE PLACED AND UNIFORMLY COMPACTED WITHOUT SOFT SPOTS.

**BACKFILL**  
MATERIAL SHALL BE PLACED IN 8"-10" MAXIMUM LIFTS. INADEQUATE COMPACTION CAN LEAD TO EXCESSIVE DEFLECTIONS WITHIN THE SYSTEM AND SETTLEMENT OF THE SOILS OVER THE SYSTEM. BACKFILL SHALL BE PLACED SUCH THAT THERE IS NO MORE THAN A TWO-LIFT DIFFERENTIAL BETWEEN THE SIDES OF ANY PIPE IN THE SYSTEM AT ALL TIMES DURING THE BACKFILL PROCESS. BACKFILL SHALL BE ADVANCED ALONG THE LENGTH OF THE SYSTEM AT THE SAME RATE TO AVOID DIFFERENTIAL LOADING ON ANY PIPES IN THE SYSTEM.

EQUIPMENT USED TO PLACE AND COMPACT THE BACKFILL SHALL BE OF A SIZE AND TYPE SO AS NOT TO DISTORT, DAMAGE, OR DISPLACE THE PIPE. ATTENTION MUST BE GIVEN TO PROVIDING ADEQUATE MINIMUM COVER FOR SUCH EQUIPMENT. MAINTAIN BALANCED LOADING ON ALL PIPES IN THE SYSTEM DURING ALL SUCH OPERATIONS.

OTHER ALTERNATE BACKFILL MATERIAL MAY BE ALLOWED DEPENDING ON SITE SPECIFIC CONDITIONS. REFER TO TYPICAL BACKFILL DETAIL FOR MATERIAL REQUIRED.

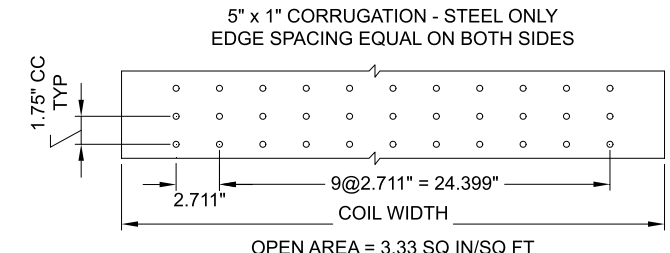
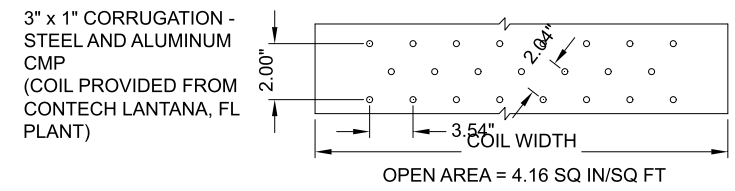
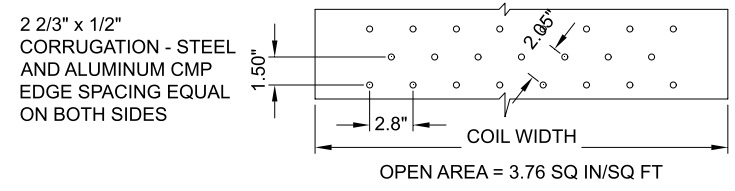

- NOTES:
- PERFORATIONS MEET AASHTO AND ASTM SPECIFICATIONS.
  - PERFORATION OPEN AREA PER SQUARE FOOT OF PIPE IS BASED ON THE NOMINAL DIAMETER AND LENGTH OF PIPE.
  - ALL DIMENSIONS ARE SUBJECT TO MANUFACTURING TOLERANCES.
  - ALL HOLES  $\varnothing$ 3/8".

TYPICAL PERFORATION DETAIL

SCALE: N.T.S.

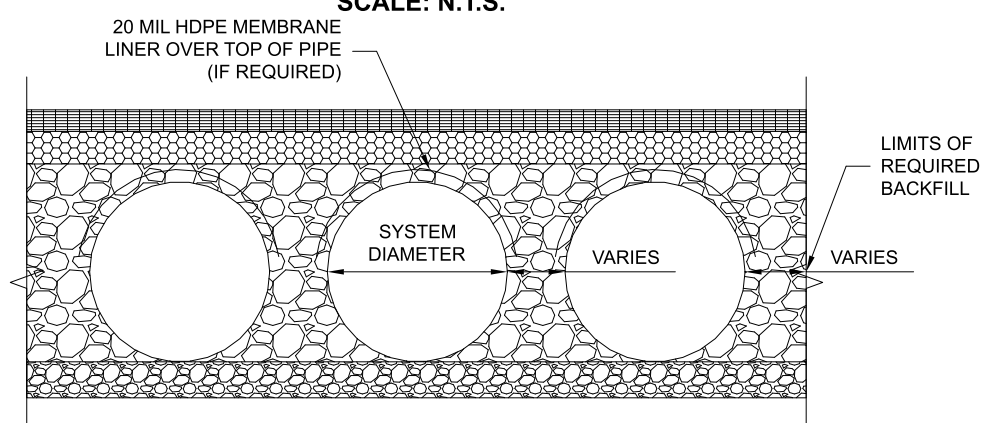

TYPICAL SECTION VIEW

LINER OVER ROWS  
SCALE: N.T.S.

NOTE: IF SALTING AGENTS FOR SNOW AND ICE REMOVAL ARE USED ON OR NEAR THE PROJECT, AN HDPE MEMBRANE LINER IS RECOMMENDED WITH THE SYSTEM. THE IMPERMEABLE LINER IS INTENDED TO HELP PROTECT THE SYSTEM FROM THE POTENTIAL ADVERSE EFFECTS THAT MAY RESULT FROM A CHANGE IN THE SURROUNDING ENVIRONMENT OVER A PERIOD OF TIME. PLEASE REFER TO THE CORRUGATED METAL PIPE DETENTION DESIGN GUIDE FOR ADDITIONAL INFORMATION.

C:\EXPORT\TEMPLATES\CMP\_V8.DWG 10/18/2019 10:02 AM

The design and information shown on this drawing is provided as a service to the project owner, engineer and contractor by Contech Engineered Solutions LLC ("Contech"). Neither this drawing, nor any part thereof, may be used, reproduced or modified in any manner without the prior written consent of Contech. Failure to comply is done at the user's own risk and Contech expressly disclaims any liability or responsibility for such use.

If discrepancies between the supplied information upon which the drawing is based and actual field conditions are encountered as site work progresses, these discrepancies must be reported to Contech immediately for re-evaluation of the design. Contech accepts no liability for designs based on missing, incomplete or inaccurate information supplied by others.

DATE	REVISION DESCRIPTION	BY

**CONTECH**  
ENGINEERED SOLUTIONS LLC  
www.ContechES.com  
9025 Centre Pointe Dr., Suite 400, West Chester, OH 45069  
800-338-1122 513-645-7000 513-645-7993 FAX

**CONTECH**  
CMP DETENTION SYSTEMS  
CONTECH  
DYODS  
DRAWING

DYO21274 Sinclair St  
Under Ground Chamber System - Water Quality  
Perris, CA  
DETENTION SYSTEM

PROJECT No.: 13869	SEQ. No.: 21274	DATE: 9/14/2022
DESIGNED: DYO	DRAWN: DYO	
CHECKED: DYO	APPROVED: DYO	
SHEET NO.:		1



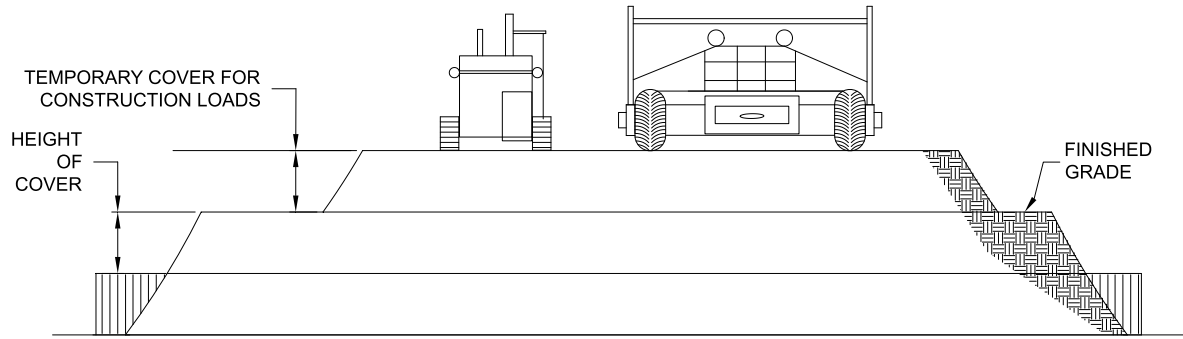

**CONSTRUCTION LOADS**

FOR TEMPORARY CONSTRUCTION VEHICLE LOADS, AN EXTRA AMOUNT OF COMPACTED COVER MAY BE REQUIRED OVER THE TOP OF THE PIPE. THE HEIGHT-OF-COVER SHALL MEET THE MINIMUM REQUIREMENTS SHOWN IN THE TABLE BELOW. THE USE OF HEAVY CONSTRUCTION EQUIPMENT NECESSITATES GREATER PROTECTION FOR THE PIPE THAN FINISHED GRADE COVER MINIMUMS FOR NORMAL HIGHWAY TRAFFIC.

PIPE SPAN, INCHES	AXLE LOADS (kips)			
	18-50	50-75	75-110	110-150
	MINIMUM COVER (FT)			
12-42	2.0	2.5	3.0	3.0
48-72	3.0	3.0	3.5	4.0
78-120	3.0	3.5	4.0	4.0
126-144	3.5	4.0	4.5	4.5

\*MINIMUM COVER MAY VARY, DEPENDING ON LOCAL CONDITIONS. THE CONTRACTOR MUST PROVIDE THE ADDITIONAL COVER REQUIRED TO AVOID DAMAGE TO THE PIPE. MINIMUM COVER IS MEASURED FROM THE TOP OF THE PIPE TO THE TOP OF THE MAINTAINED CONSTRUCTION ROADWAY SURFACE.

**CONSTRUCTION LOADING DIAGRAM**

SCALE: N.T.S.

**SPECIFICATION FOR DESIGNED DETENTION SYSTEM:**

**SCOPE**  
THIS SPECIFICATION COVERS THE MANUFACTURE AND INSTALLATION OF THE DESIGNED DETENTION SYSTEM DETAILED IN THE PROJECT PLANS.

**MATERIAL**  
THE MATERIAL SHALL CONFORM TO THE APPLICABLE REQUIREMENTS LISTED BELOW:

ALUMINIZED TYPE 2 STEEL COILS SHALL CONFORM TO THE REQUIREMENTS OF AASHTO M-274 OR ASTM A-92.

THE GALVANIZED STEEL COILS SHALL CONFORM TO THE REQUIREMENTS OF AASHTO M-218 OR ASTM A-929.

THE POLYMER COATED STEEL COILS SHALL CONFORM TO THE REQUIREMENTS OF AASHTO M-246 OR ASTM A-742.

THE ALUMINUM COILS SHALL CONFORM TO THE APPLICABLE OF AASHTO M-197 OR ASTM B-744.

**CONSTRUCTION LOADS**  
CONSTRUCTION LOADS MAY BE HIGHER THAN FINAL LOADS. FOLLOW THE MANUFACTURER'S OR NCSA GUIDELINES.

**PIPE**  
THE PIPE SHALL BE MANUFACTURED IN ACCORDANCE TO THE APPLICABLE REQUIREMENTS LISTED BELOW:

ALUMINIZED TYPE 2: AASHTO M-36 OR ASTM A-760

GALVANIZED: AASHTO M-36 OR ASTM A-760

POLYMER COATED: AASHTO M-245 OR ASTM A-762

ALUMINUM: AASHTO M-196 OR ASTM B-745

**HANDLING AND ASSEMBLY**  
SHALL BE IN ACCORDANCE WITH NCSP'S (NATIONAL CORRUGATED STEEL ASSOCIATION) FOR ALUMINIZED TYPE 2, GALVANIZED OR POLYMER COATED STEEL. SHALL BE IN ACCORDANCE WITH THE MANUFACTURER'S RECOMMENDATIONS FOR ALUMINUM PIPE.

**INSTALLATION**  
SHALL BE IN ACCORDANCE WITH AASHTO STANDARD SPECIFICATIONS FOR HIGHWAY BRIDGES, SECTION 26, DIVISION II DIVISION II OR ASTM A-798 (FOR ALUMINIZED TYPE 2, GALVANIZED OR POLYMER COATED STEEL) OR ASTM B-788 (FOR ALUMINUM PIPE) AND IN CONFORMANCE WITH THE PROJECT PLANS AND SPECIFICATIONS. IF THERE ARE ANY INCONSISTENCIES OR CONFLICTS THE CONTRACTOR SHOULD DISCUSS AND RESOLVE WITH THE SITE ENGINEER.

IT IS ALWAYS THE RESPONSIBILITY OF THE CONTRACTOR TO FOLLOW OSHA GUIDELINES FOR SAFE PRACTICES.

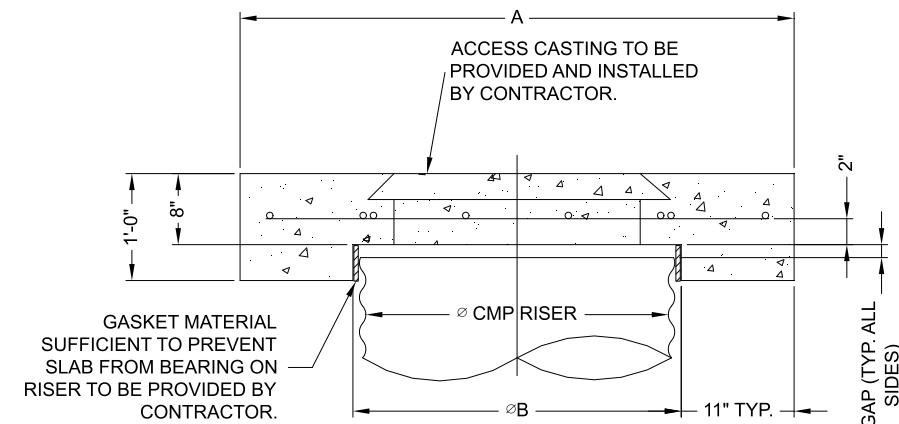

**SECTION VIEW**

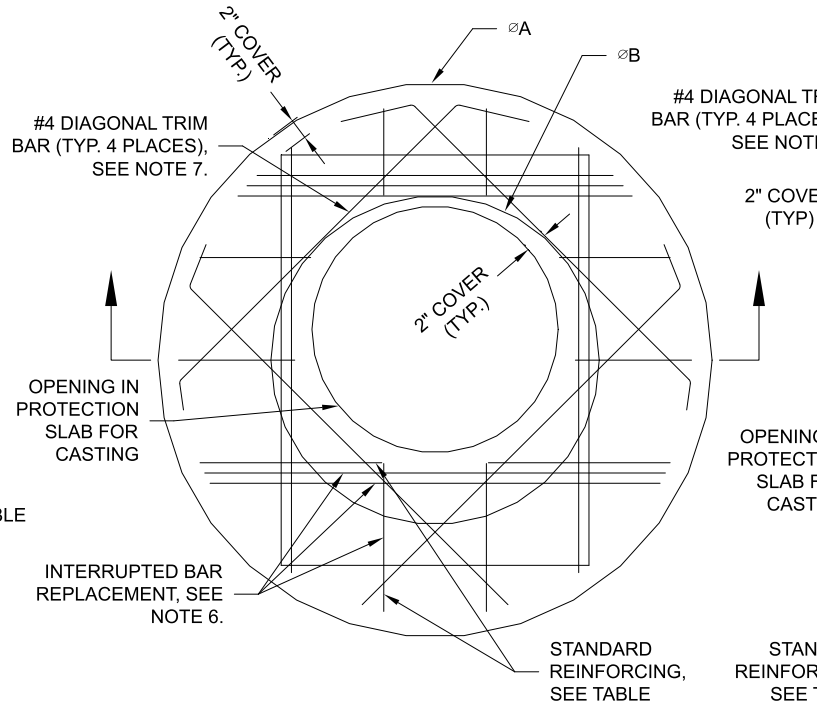

**ROUND OPTION PLAN VIEW**

Ø CMP RISER	A	Ø B	REINFORCING	**BEARING PRESSURE (PSF)
24"	Ø 4' 4'X4'	26"	#5 @ 12" OCEW #5 @ 12" OCEW	2,410 1,780
30"	Ø 4'-6" 4'-6" X 4'-6"	32"	#5 @ 12" OCEW #5 @ 12" OCEW	2,120 1,530
36"	Ø 5' 5' X 5'	38"	#5 @ 10" OCEW #5 @ 10" OCEW	1,890 1,350
42"	Ø 5'-6" 5'-6" X 5'-6"	44"	#5 @ 10" OCEW #5 @ 9" OCEW	1,720 1,210
48"	Ø 6' 6' X 6'	50"	#5 @ 9" OCEW #5 @ 8" OCEW	1,600 1,100

\*\* ASSUMED SOIL BEARING CAPACITY

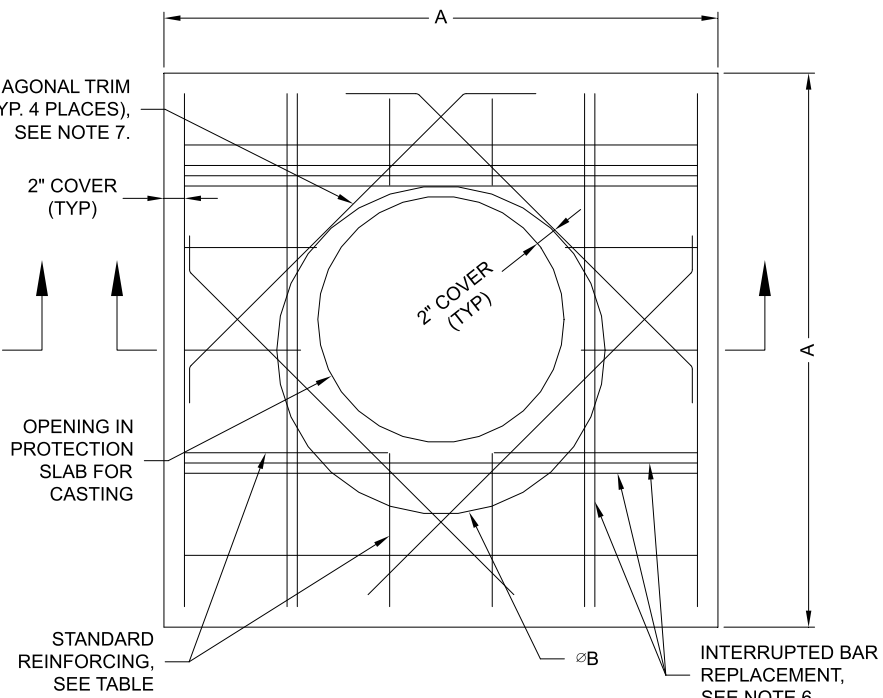

**SQUARE OPTION PLAN VIEW**

- NOTES:**
- DESIGN IN ACCORDANCE WITH AASHTO, 17th EDITION.
  - DESIGN LOAD HS25.
  - EARTH COVER = 1' MAX.
  - CONCRETE STRENGTH = 3,500 psi
  - REINFORCING STEEL = ASTM A615, GRADE 60.
  - PROVIDE ADDITIONAL REINFORCING AROUND OPENINGS EQUAL TO THE BARS INTERRUPTED, HALF EACH SIDE. ADDITIONAL BARS TO BE IN THE SAME PLANE.
  - TRIM OPENING WITH DIAGONAL #4 BARS, EXTEND BARS A MINIMUM OF 12" BEYOND OPENING, BEND BARS AS REQUIRED TO MAINTAIN BAR COVER.
  - PROTECTION SLAB AND ALL MATERIALS TO BE PROVIDED AND INSTALLED BY CONTRACTOR.
  - DETAIL DESIGN BY DELTA ENGINEERING, BINGHAMTON, NY.

**MANHOLE CAP DETAIL**

SCALE: N.T.S.

C:\EXPORT\TEMPLATES\CMP\_V8.DWG 10/18/2019 10:02 AM

**NOTE:**  
THESE DRAWINGS ARE FOR CONCEPTUAL PURPOSES AND DO NOT REFLECT ANY LOCAL PREFERENCES OR REGULATIONS. PLEASE CONTACT YOUR LOCAL CONTECH REP FOR MODIFICATIONS.

The design and information shown on this drawing is provided as a service to the project owner, engineer and contractor by Contech Engineered Solutions LLC ("Contech"). Neither this drawing, nor any part thereof, may be used, reproduced or modified in any manner without the prior written consent of Contech. Failure to comply is done at the user's own risk and Contech expressly disclaims any liability or responsibility for such use.

If discrepancies between the supplied information upon which the drawing is based and actual field conditions are encountered as site work progresses, these discrepancies must be reported to Contech immediately for re-evaluation of the design. Contech accepts no liability for designs based on missing, incomplete or inaccurate information supplied by others.

DATE	REVISION DESCRIPTION	BY

**CONTECH**  
ENGINEERED SOLUTIONS LLC  
www.ContechES.com  
9025 Centre Pointe Dr., Suite 400, West Chester, OH 45069  
800-338-1122 513-645-7000 513-645-7993 FAX

**CONTECH**  
CMP DETENTION SYSTEMS  
CONTECH  
DYODS  
DRAWING

DYO21274 Sinclair St  
Under Ground Chamber System - Water Quality  
Perris, CA  
DETENTION SYSTEM

PROJECT No.: 13869	SEQ. No.: 21274	DATE: 9/14/2022
DESIGNED: DYO	DRAWN: DYO	
CHECKED: DYO	APPROVED: DYO	
SHEET NO.:		1

## CMP DETENTION INSTALLATION GUIDE

PROPER INSTALLATION OF A FLEXIBLE UNDERGROUND DETENTION SYSTEM WILL ENSURE LONG-TERM PERFORMANCE. THE CONFIGURATION OF THESE SYSTEMS OFTEN REQUIRES SPECIAL CONSTRUCTION PRACTICES THAT DIFFER FROM CONVENTIONAL FLEXIBLE PIPE CONSTRUCTION. CONTECH ENGINEERED SOLUTIONS STRONGLY SUGGESTS SCHEDULING A PRE-CONSTRUCTION MEETING WITH YOUR LOCAL SALES ENGINEER TO DETERMINE IF ADDITIONAL MEASURES, NOT COVERED IN THIS GUIDE, ARE APPROPRIATE FOR YOUR SITE.

## FOUNDATION

CONSTRUCT A FOUNDATION THAT CAN SUPPORT THE DESIGN LOADING APPLIED BY THE PIPE AND ADJACENT BACKFILL WEIGHT AS WELL AS MAINTAIN ITS INTEGRITY DURING CONSTRUCTION.

IF SOFT OR UNSUITABLE SOILS ARE ENCOUNTERED, REMOVE THE POOR SOILS DOWN TO A SUITABLE DEPTH AND THEN BUILD UP TO THE APPROPRIATE ELEVATION WITH A COMPETENT BACKFILL MATERIAL. THE STRUCTURAL FILL MATERIAL GRADATION SHOULD NOT ALLOW THE MIGRATION OF FINES, WHICH CAN CAUSE SETTLEMENT OF THE DETENTION SYSTEM OR PAVEMENT ABOVE. IF THE STRUCTURAL FILL MATERIAL IS NOT COMPATIBLE WITH THE UNDERLYING SOILS AN ENGINEERING FABRIC SHOULD BE USED AS A SEPARATOR. IN SOME CASES, USING A STIFF REINFORCING GEOGRID REDUCES OVER EXCAVATION AND REPLACEMENT FILL QUANTITIES.

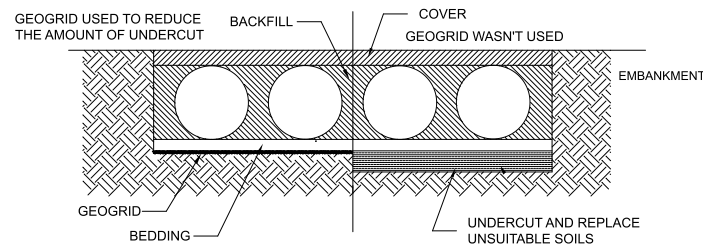

GRADE THE FOUNDATION SUBGRADE TO A UNIFORM OR SLIGHTLY SLOPING GRADE. IF THE SUBGRADE IS CLAY OR RELATIVELY NON-POROUS AND THE CONSTRUCTION SEQUENCE WILL LAST FOR AN EXTENDED PERIOD OF TIME, IT IS BEST TO SLOPE THE GRADE TO ONE END OF THE SYSTEM. THIS WILL ALLOW EXCESS WATER TO DRAIN QUICKLY, PREVENTING SATURATION OF THE SUBGRADE.

## GEOMEMBRANE BARRIER

A SITE'S RESISTIVITY MAY CHANGE OVER TIME WHEN VARIOUS TYPES OF SALTING AGENTS ARE USED, SUCH AS ROAD SALTS FOR DEICING AGENTS. IF SALTING AGENTS ARE USED ON OR NEAR THE PROJECT SITE, A GEOMEMBRANE BARRIER IS RECOMMENDED WITH THE SYSTEM. THE GEOMEMBRANE LINER IS INTENDED TO HELP PROTECT THE SYSTEM FROM THE POTENTIAL ADVERSE EFFECTS THAT MAY RESULT FROM THE USE OF SUCH AGENTS INCLUDING PREMATURE CORROSION AND REDUCED ACTUAL SERVICE LIFE.

THE PROJECT'S ENGINEER OF RECORD IS TO EVALUATE WHETHER SALTING AGENTS WILL BE USED ON OR NEAR THE PROJECT SITE, AND USE HIS/HER BEST JUDGEMENT TO DETERMINE IF ANY ADDITIONAL PROTECTIVE MEASURES ARE REQUIRED. BELOW IS A TYPICAL DETAIL SHOWING THE PLACEMENT OF A GEOMEMBRANE BARRIER FOR PROJECTS WHERE SALTING AGENTS ARE USED ON OR NEAR THE PROJECT SITE.

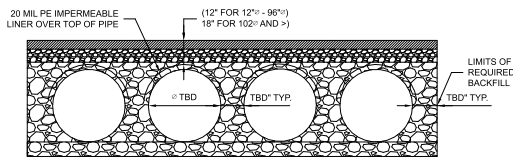

## IN-SITU TRENCH WALL

IF EXCAVATION IS REQUIRED, THE TRENCH WALL NEEDS TO BE CAPABLE OF SUPPORTING THE LOAD THAT THE PIPE SHEDS AS THE SYSTEM IS LOADED. IF SOILS ARE NOT CAPABLE OF SUPPORTING THESE LOADS, THE PIPE CAN DEFLECT. PERFORM A SIMPLE SOIL PRESSURE CHECK USING THE APPLIED LOADS TO DETERMINE THE LIMITS OF EXCAVATION BEYOND THE SPRING LINE OF THE OUTER MOST PIPES.

IN MOST CASES THE REQUIREMENTS FOR A SAFE WORK ENVIRONMENT AND PROPER BACKFILL PLACEMENT AND COMPACTION TAKE CARE OF THIS CONCERN.

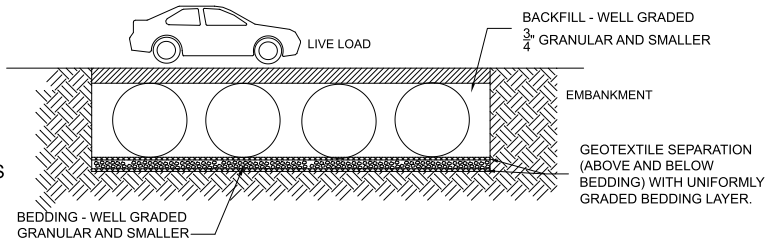

## BACKFILL PLACEMENT

MATERIAL SHALL BE WORKED INTO THE PIPE HAUNCHES BY MEANS OF SHOVEL-SLICING, RODDING, AIR TAMPER, VIBRATORY ROD, OR OTHER EFFECTIVE METHODS.

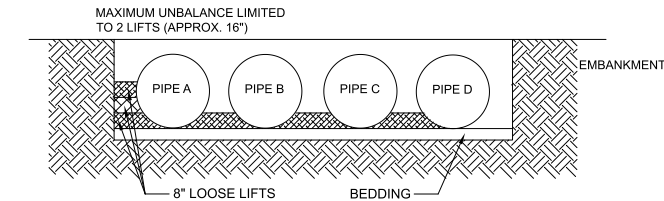

IF AASHTO T99 PROCEDURES ARE DETERMINED INFEASIBLE BY THE GEOTECHNICAL ENGINEER OF RECORD, COMPACTION IS CONSIDERED ADEQUATE WHEN NO FURTHER YIELDING OF THE MATERIAL IS OBSERVED UNDER THE COMPACTOR, OR UNDER FOOT, AND THE GEOTECHNICAL ENGINEER OF RECORD (OR REPRESENTATIVE THEREOF) IS SATISFIED WITH THE LEVEL OF COMPACTION.

FOR LARGE SYSTEMS, CONVEYOR SYSTEMS, BACKHOES WITH LONG REACHES OR DRAGLINES WITH STONE BUCKETS MAY BE USED TO PLACE BACKFILL. ONCE MINIMUM COVER FOR CONSTRUCTION LOADING ACROSS THE ENTIRE WIDTH OF THE SYSTEM IS REACHED, ADVANCE THE EQUIPMENT TO THE END OF THE RECENTLY PLACED FILL, AND BEGIN THE SEQUENCE AGAIN UNTIL THE SYSTEM IS COMPLETELY BACKFILLED. THIS TYPE OF CONSTRUCTION SEQUENCE PROVIDES ROOM FOR STOCKPILED BACKFILL DIRECTLY BEHIND THE BACKHOE, AS WELL AS THE MOVEMENT OF CONSTRUCTION TRAFFIC. MATERIAL STOCKPILES ON TOP OF THE BACKFILLED DETENTION SYSTEM SHOULD BE LIMITED TO 8- TO 10- FEET HIGH AND MUST PROVIDE BALANCED LOADING ACROSS ALL BARRELS. TO DETERMINE THE PROPER COVER OVER THE PIPES TO ALLOW THE MOVEMENT OF CONSTRUCTION EQUIPMENT SEE TABLE 1, OR CONTACT YOUR LOCAL CONTECH SALES ENGINEER.

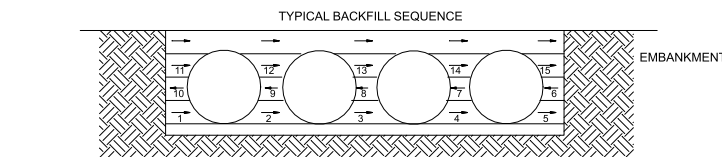

WHEN FLOWABLE FILL IS USED, YOU MUST PREVENT PIPE FLOATATION. TYPICALLY, SMALL LIFTS ARE PLACED BETWEEN THE PIPES AND THEN ALLOWED TO SET-UP PRIOR TO THE PLACEMENT OF THE NEXT LIFT. THE ALLOWABLE THICKNESS OF THE CLSM LIFT IS A FUNCTION OF A PROPER BALANCE BETWEEN THE UPLIFT FORCE OF THE CLSM, THE OPPOSING WEIGHT OF THE PIPE, AND THE EFFECT OF OTHER RESTRAINING MEASURES. THE PIPE CAN CARRY LIMITED FLUID PRESSURE WITHOUT PIPE DISTORTION OR DISPLACEMENT, WHICH ALSO AFFECTS THE CLSM LIFT THICKNESS. YOUR LOCAL CONTECH SALES ENGINEER CAN HELP DETERMINE THE PROPER LIFT THICKNESS.

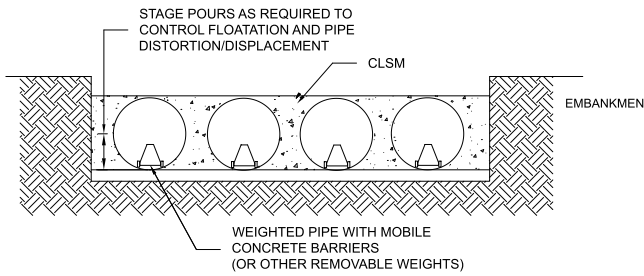

## CONSTRUCTION LOADING

TYPICALLY, THE MINIMUM COVER SPECIFIED FOR A PROJECT ASSUMES H-20 LIVE LOAD. BECAUSE CONSTRUCTION LOADS OFTEN EXCEED DESIGN LIVE LOADS, INCREASED TEMPORARY MINIMUM COVER REQUIREMENTS ARE NECESSARY. SINCE CONSTRUCTION EQUIPMENT VARIES FROM JOB TO JOB, IT IS BEST TO ADDRESS EQUIPMENT SPECIFIC MINIMUM COVER REQUIREMENTS WITH YOUR LOCAL CONTECH SALES ENGINEER DURING YOUR PRE-CONSTRUCTION MEETING.

## ADDITIONAL CONSIDERATIONS

BECAUSE MOST SYSTEMS ARE CONSTRUCTED BELOW-GRADE, RAINFALL CAN RAPIDLY FILL THE EXCAVATION; POTENTIALLY CAUSING FLOATATION AND MOVEMENT OF THE PREVIOUSLY PLACED PIPES. TO HELP MITIGATE POTENTIAL PROBLEMS, IT IS BEST TO START THE INSTALLATION AT THE DOWNSTREAM END WITH THE OUTLET ALREADY CONSTRUCTED TO ALLOW A ROUTE FOR THE WATER TO ESCAPE. TEMPORARY DIVERSION MEASURES MAY BE REQUIRED FOR HIGH FLOWS DUE TO THE RESTRICTED NATURE OF THE OUTLET PIPE.

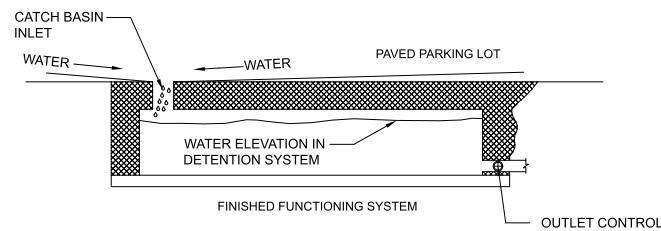

## CMP DETENTION SYSTEM INSPECTION AND MAINTENANCE

UNDERGROUND STORMWATER DETENTION AND INFILTRATION SYSTEMS MUST BE INSPECTED AND MAINTAINED AT REGULAR INTERVALS FOR PURPOSES OF PERFORMANCE AND LONGEVITY.

### INSPECTION

INSPECTION IS THE KEY TO EFFECTIVE MAINTENANCE OF CMP DETENTION SYSTEMS AND IS EASILY PERFORMED. CONTECH RECOMMENDS ONGOING, ANNUAL INSPECTIONS. SITES WITH HIGH TRASH LOAD OR SMALL OUTLET CONTROL ORIFICES MAY NEED MORE FREQUENT INSPECTIONS. THE RATE AT WHICH THE SYSTEM COLLECTS POLLUTANTS WILL DEPEND MORE ON SITE SPECIFIC ACTIVITIES RATHER THAN THE SIZE OR CONFIGURATION OF THE SYSTEM.

INSPECTIONS SHOULD BE PERFORMED MORE OFTEN IN EQUIPMENT WASHDOWN AREAS, IN CLIMATES WHERE SANDING AND/OR SALTING OPERATIONS TAKE PLACE, AND IN OTHER VARIOUS INSTANCES IN WHICH ONE WOULD EXPECT HIGHER ACCUMULATIONS OF SEDIMENT OR ABRASIVE/ CORROSIVE CONDITIONS. A RECORD OF EACH INSPECTION IS TO BE MAINTAINED FOR THE LIFE OF THE SYSTEM

### MAINTENANCE

CMP DETENTION SYSTEMS SHOULD BE CLEANED WHEN AN INSPECTION REVEALS ACCUMULATED SEDIMENT OR TRASH IS CLOGGING THE DISCHARGE ORIFICE.

ACCUMULATED SEDIMENT AND TRASH CAN TYPICALLY BE EVACUATED THROUGH THE MANHOLE OVER THE OUTLET ORIFICE. IF MAINTENANCE IS NOT PERFORMED AS RECOMMENDED, SEDIMENT AND TRASH MAY ACCUMULATE IN FRONT OF THE OUTLET ORIFICE. MANHOLE COVERS SHOULD BE SECURELY SEATED FOLLOWING CLEANING ACTIVITIES. CONTECH SUGGESTS THAT ALL SYSTEMS BE DESIGNED WITH AN ACCESS/INSPECTION MANHOLE SITUATED AT OR NEAR THE INLET AND THE OUTLET ORIFICE. SHOULD IT BE NECESSARY TO GET INSIDE THE SYSTEM TO PERFORM MAINTENANCE ACTIVITIES, ALL APPROPRIATE PRECAUTIONS REGARDING CONFINED SPACE ENTRY AND OSHA REGULATIONS SHOULD BE FOLLOWED.

ANNUAL INSPECTIONS ARE BEST PRACTICE FOR ALL UNDERGROUND SYSTEMS. DURING THIS INSPECTION, IF EVIDENCE OF SALTING/DE-ICING AGENTS IS OBSERVED WITHIN THE SYSTEM, IT IS BEST PRACTICE FOR THE SYSTEM TO BE RINSED, INCLUDING ABOVE THE SPRING LINE SOON AFTER THE SPRING THAW AS PART OF THE MAINTENANCE PROGRAM FOR THE SYSTEM.

MAINTAINING AN UNDERGROUND DETENTION OR INFILTRATION SYSTEM IS EASIEST WHEN THERE IS NO FLOW ENTERING THE SYSTEM. FOR THIS REASON, IT IS A GOOD IDEA TO SCHEDULE THE CLEANOUT DURING DRY WEATHER.

THE FOREGOING INSPECTION AND MAINTENANCE EFFORTS HELP ENSURE UNDERGROUND PIPE SYSTEMS USED FOR STORMWATER STORAGE CONTINUE TO FUNCTION AS INTENDED BY IDENTIFYING RECOMMENDED REGULAR INSPECTION AND MAINTENANCE PRACTICES. INSPECTION AND MAINTENANCE RELATED TO THE STRUCTURAL INTEGRITY OF THE PIPE OR THE SOUNDNESS OF PIPE JOINT CONNECTIONS IS BEYOND THE SCOPE OF THIS GUIDE.

C:\EXPORT\TEMPLATES\CMP\_V8.DWG 10/18/2019 10:02 AM

The design and information shown on this drawing is provided as a service to the project owner, engineer and contractor by Contech Engineered Solutions LLC ("Contech"). Neither this drawing, nor any part thereof, may be used, reproduced or modified in any manner without the prior written consent of Contech. Failure to comply is done at the user's own risk and Contech expressly disclaims any liability or responsibility for such use.

If discrepancies between the supplied information upon which the drawing is based and actual field conditions are encountered as site work progresses, these discrepancies must be reported to Contech immediately for re-evaluation of the design. Contech accepts no liability for designs based on missing, incomplete or inaccurate information supplied by others.

DATE	REVISION DESCRIPTION	BY

**CONTECH**  
ENGINEERED SOLUTIONS LLC  
www.ContechES.com

9025 Centre Pointe Dr., Suite 400, West Chester, OH 45069  
800-338-1122 513-645-7000 513-645-7993 FAX

**CONTECH**  
CMP DETENTION SYSTEMS

CONTECH  
**DYODS**  
DRAWING

DYO21274 Sinclair St  
Under Ground Chamber System - Water Quality  
Perris, CA  
DETENTION SYSTEM

PROJECT No.: 13869	SEQ. No.: 21274	DATE: 9/14/2022
DESIGNED: DYO	DRAWN: DYO	
CHECKED: DYO	APPROVED: DYO	
SHEET NO.:		<b>1</b>



# PROJECT SUMMARY

## CALCULATION DETAILS

- LOADING = HS20/HS25
- APPROX. LINEAR FOOTAGE = 2,998 LF

## STORAGE SUMMARY

- STORAGE VOLUME REQUIRED = N/A
- PIPE STORAGE VOLUME = 150,671 CF
- BACKFILL STORAGE VOLUME = 0 CF
- TOTAL STORAGE PROVIDED = 150,671 CF

## PIPE DETAILS

- DIAMETER = 96"
- CORRUGATION = 5x1
- GAGE = 16
- COATING = ALT2
- WALL TYPE = SOLID
- BARREL SPACING = 36"

## BACKFILL DETAILS

- WIDTH AT ENDS = 12"
- ABOVE PIPE = 0"
- WIDTH AT SIDES = 12"
- BELOW PIPE = 0"

## NOTES

- ALL RISER AND STUB DIMENSIONS ARE TO CENTERLINE. ALL ELEVATIONS, DIMENSIONS, AND LOCATIONS OF RISERS AND INLETS, SHALL BE VERIFIED BY THE ENGINEER OF RECORD PRIOR TO RELEASING FOR FABRICATION.
- ALL FITTINGS AND REINFORCEMENT COMPLY WITH ASTM A998.
- ALL RISERS AND STUBS ARE 2<sup>2</sup>/<sub>3</sub>" x 1<sup>1</sup>/<sub>2</sub>" CORRUGATION AND 16 GAGE UNLESS OTHERWISE NOTED.
- RISERS TO BE FIELD TRIMMED TO GRADE.
- QUANTITY OF PIPE SHOWN DOES NOT PROVIDE EXTRA PIPE FOR CONNECTING THE SYSTEM TO EXISTING PIPE OR DRAINAGE STRUCTURES. OUR SYSTEM AS DETAILED PROVIDES NOMINAL INLET AND/OR OUTLET PIPE STUB FOR CONNECTION TO EXISTING DRAINAGE FACILITIES. IF ADDITIONAL PIPE IS NEEDED IT IS THE RESPONSIBILITY OF THE CONTRACTOR.
- BAND TYPE TO BE DETERMINED UPON FINAL DESIGN.
- THE PROJECT SUMMARY IS REFLECTIVE OF THE DYODS DESIGN, QUANTITIES ARE APPROX. AND SHOULD BE VERIFIED UPON FINAL DESIGN AND APPROVAL. FOR EXAMPLE, TOTAL EXCAVATION DOES NOT CONSIDER ALL VARIABLES SUCH AS SHORING AND ONLY ACCOUNTS FOR MATERIAL WITHIN THE ESTIMATED EXCAVATION FOOTPRINT.
- THESE DRAWINGS ARE FOR CONCEPTUAL PURPOSES AND DO NOT REFLECT ANY LOCAL PREFERENCES OR REGULATIONS. PLEASE CONTACT YOUR LOCAL CONTECH REP FOR MODIFICATIONS.

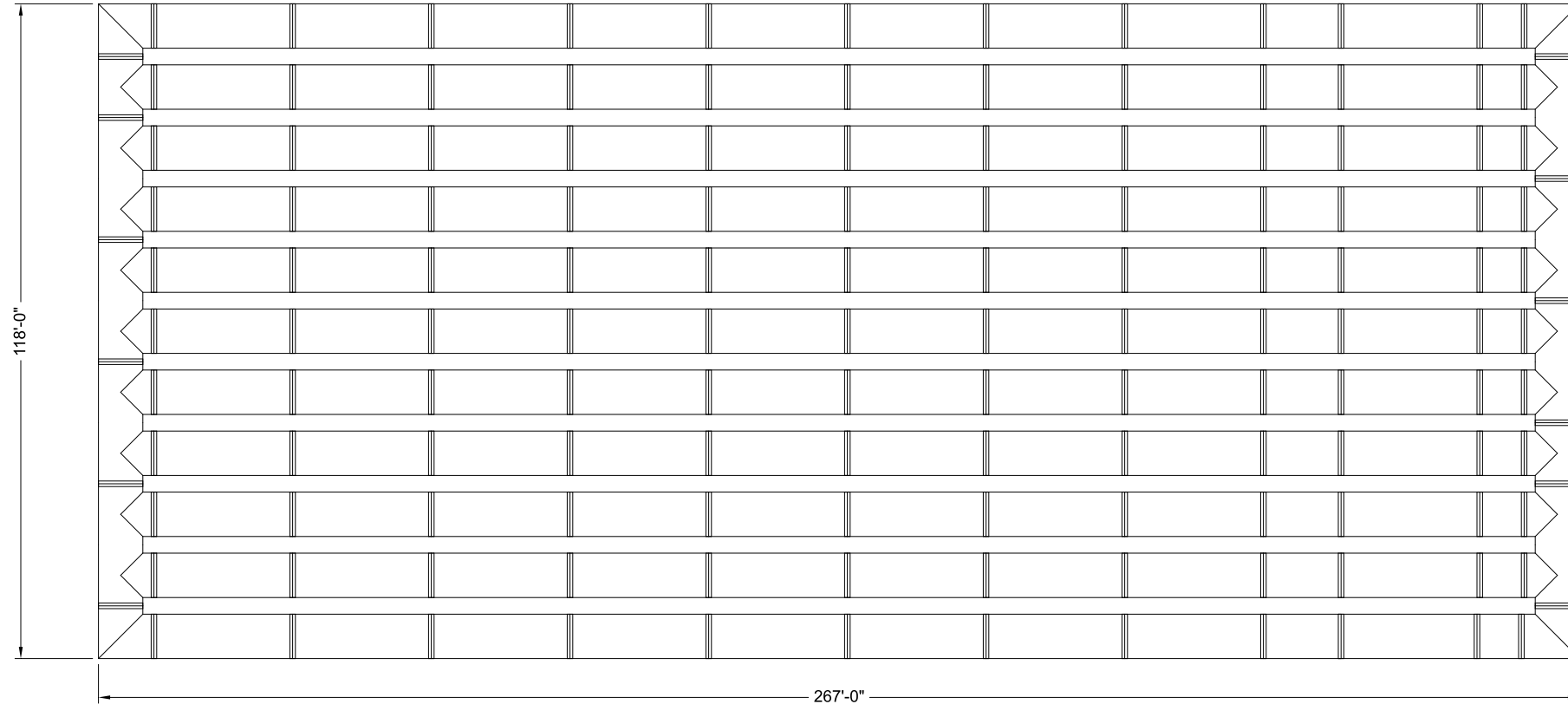

**ASSEMBLY**  
SCALE: 1" = 30'

C:\EXPORT\TEMPLATES\CMP\_V8.DWG 10/18/2019 10:02 AM

The design and information shown on this drawing is provided as a service to the project owner, engineer and contractor by Contech Engineered Solutions LLC ("Contech"). Neither this drawing, nor any part thereof, may be used, reproduced or modified in any manner without the prior written consent of Contech. Failure to comply is done at the user's own risk and Contech expressly disclaims any liability or responsibility for such use.

If discrepancies between the supplied information upon which the drawing is based and actual field conditions are encountered as site work progresses, these discrepancies must be reported to Contech immediately for re-evaluation of the design. Contech accepts no liability for designs based on missing, incomplete or inaccurate information supplied by others.

DATE	REVISION DESCRIPTION	BY

**CONTECH**  
ENGINEERED SOLUTIONS LLC  
www.ContechES.com

9025 Centre Pointe Dr., Suite 400, West Chester, OH 45069  
800-338-1122 513-645-7000 513-645-7993 FAX

**CONTECH**  
CMP DETENTION SYSTEMS

CONTECH  
**DYODS**  
DRAWING

DYO21273 Sinclair St  
Underground Chamber System  
Perris, CA  
DETENTION SYSTEM

PROJECT No.: 13868	SEQ. No.: 21273	DATE: 9/14/2022
DESIGNED: DYO	DRAWN: DYO	
CHECKED: DYO	APPROVED: DYO	
SHEET NO.:		<b>1</b>

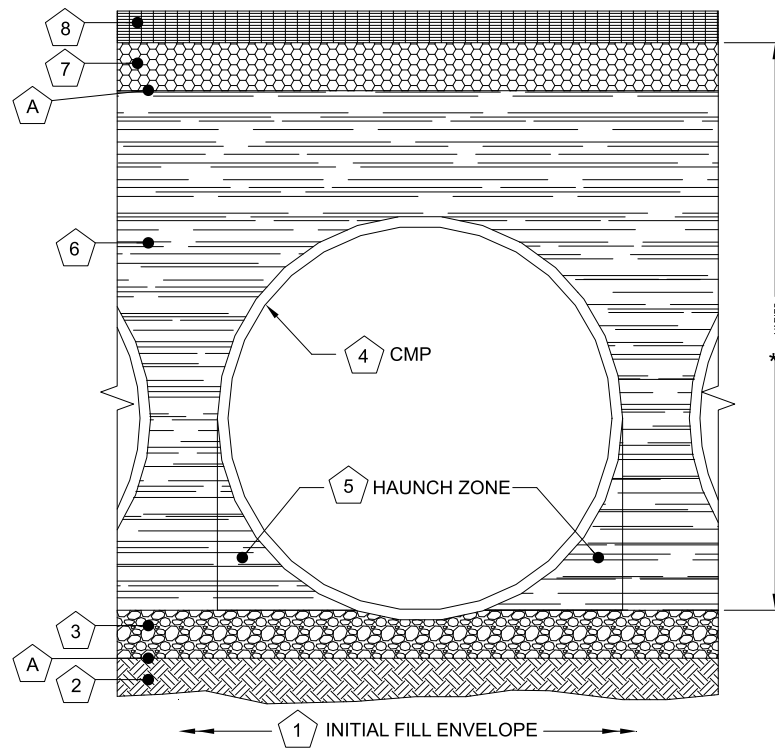

DETENTION SYSTEMS - CMP DETENTION / CMP DRAINAGE			
Material Location	Description	Material Designation	Designation
8	Rigid or Flexible Pavement (if applicable)		
7	Road Base (if applicable)		
A	Geotextile Layer	Non-Woven Geotextile	CONTECH C-40 or C-45
6	Backfill	Well graded granular material which may contain small amounts of silt or clay.	AASHTO M 145- A-1, A-2, A-3
6	Bedding Stone	Well graded granular bedding material w/maximum particle size of 3"	AASHTO M43 - 3,357,4,467, 5, 56, 57
3			Engineer to determine if bedding is required. Pipe may be placed on the trench bottom of a relatively loose, native suitable well graded & granular material. For Arch pipes it is recommended to be shaped to a relatively flat bottom or fine-grade the foundation to a slight v-shape. Unsuitable material should be over-excavated and re-placed with a 4"-6" layer of well graded & granular stone per the material designation. See AASHTO 26.3.8.1 / 26.5.3 Bedding info.
A	Geotextile Layer	Non-Woven Geotextile	CONTECH C-40 or C-45
* Note: Backfill using controlled low-strength material (CLSM, "flash fill" or "flowable fill") when the spacing between the pipes will not allow for placement and adequate compaction of the backfill.			

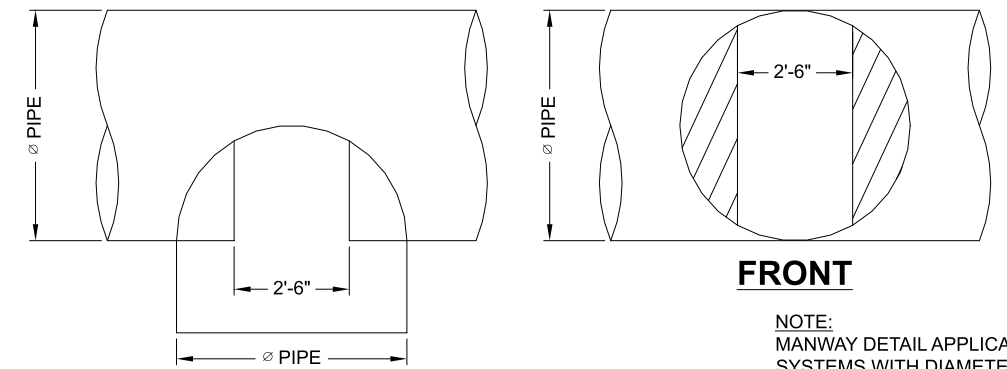

**PLAN**  
**TYPICAL MANWAY DETAIL**

**NOTE:** MANWAY DETAIL APPLICABLE FOR CMP SYSTEMS WITH DIAMETERS 48" AND LARGER. MANWAYS MAY BE REQUIRED ON SMALLER SYSTEMS DEPENDING ON ACTUAL SITE SPECIFIC CONDITIONS.

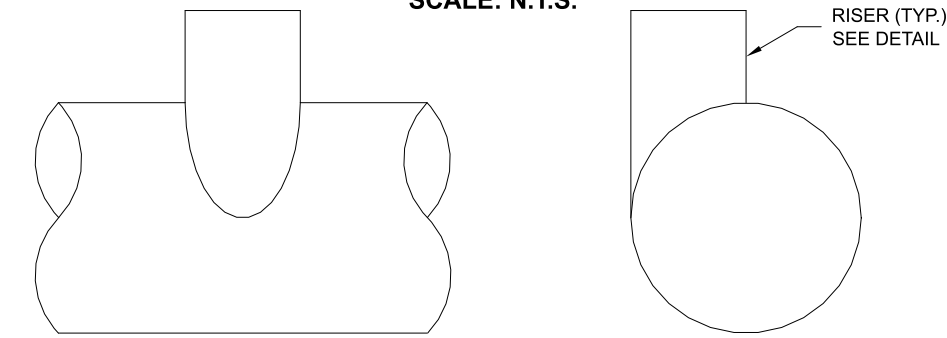

**ELEVATION**  
**TYPICAL RISER DETAIL**

**NOTE:** LADDERS ARE OPTIONAL AND ARE NOT REQUIRED FOR ALL SYSTEMS.

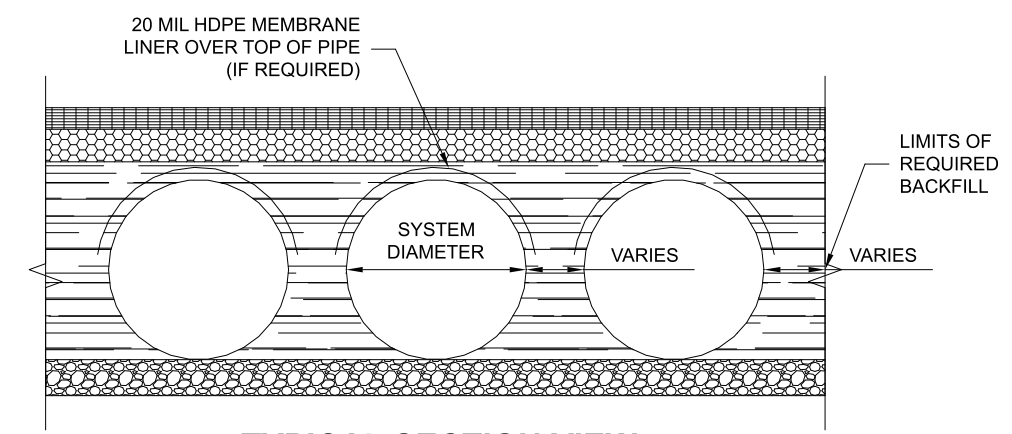

**TYPICAL SECTION VIEW**  
**LINER OVER ROWS**  
**SCALE: N.T.S.**

**NOTE:** IF SALTING AGENTS FOR SNOW AND ICE REMOVAL ARE USED ON OR NEAR THE PROJECT, AN HDPE MEMBRANE LINER IS RECOMMENDED WITH THE SYSTEM. THE IMPERMEABLE LINER IS INTENDED TO HELP PROTECT THE SYSTEM FROM THE POTENTIAL ADVERSE EFFECTS THAT MAY RESULT FROM A CHANGE IN THE SURROUNDING ENVIRONMENT OVER A PERIOD OF TIME. PLEASE REFER TO THE CORRUGATED METAL PIPE DETENTION DESIGN GUIDE FOR ADDITIONAL INFORMATION.

1 MINIMUM WIDTH DEPENDS ON SITE CONDITIONS AND ENGINEERING JUDGEMENT

**FOUNDATION/BEDDING PREPARATION**

2 PRIOR TO PLACING THE BEDDING, THE FOUNDATION MUST BE CONSTRUCTED TO A UNIFORM AND STABLE GRADE. IN THE EVENT THAT UNSUITABLE FOUNDATION MATERIALS ARE ENCOUNTERED DURING EXCAVATION, THEY SHALL BE REMOVED AND BROUGHT BACK TO THE GRADE WITH A FILL MATERIAL AS APPROVED BY THE ENGINEER.

5 HAUNCH ZONE MATERIAL SHALL BE PLACED AND UNIFORMLY COMPACTED WITHOUT SOFT SPOTS.

**BACKFILL**

WHEN PLACING THE FIRST LIFTS OF BACKFILL IT IS IMPORTANT TO MAKE SURE THAT THE BACKFILL IS PROPERLY COMPACTED UNDER AND AROUND THE PIPE HAUNCHES. BACKFILL SHALL BE PLACED SUCH THAT THERE IS NO MORE THAN A TWO LIFT (16") DIFFERENTIAL BETWEEN ANY OF THE PIPES AT ANY TIME DURING THE BACKFILL PROCESS. THE BACKFILL SHALL BE ADVANCED ALONG THE LENGTH OF THE DETENTION SYSTEM AT THE SAME RATE TO AVOID DIFFERENTIAL LOADING ON THE PIPE.

OTHER ALTERNATE BACKFILL MATERIAL MAY BE ALLOWED DEPENDING ON SITE SPECIFIC CONDITIONS, AS APPROVED BY SITE ENGINEER.

C:\EXPORT\TEMPLATES\CMP\_V8.DWG 10/18/2019 10:02 AM

The design and information shown on this drawing is provided as a service to the project owner, engineer and contractor by Contech Engineered Solutions LLC ("Contech"). Neither this drawing, nor any part thereof, may be used, reproduced or modified in any manner without the prior written consent of Contech. Failure to comply is done at the user's own risk and Contech expressly disclaims any liability or responsibility for such use.

If discrepancies between the supplied information upon which the drawing is based and actual field conditions are encountered as site work progresses, these discrepancies must be reported to Contech immediately for re-evaluation of the design. Contech accepts no liability for designs based on missing, incomplete or inaccurate information supplied by others.

DATE	REVISION DESCRIPTION	BY

**CONTECH**  
ENGINEERED SOLUTIONS LLC  
www.ContechES.com  
9025 Centre Pointe Dr., Suite 400, West Chester, OH 45069  
800-338-1122 513-645-7000 513-645-7993 FAX

**CONTECH**  
CMP DETENTION SYSTEMS  
CONTECH  
DYODS  
DRAWING

DYO21273 Sinclair St  
Underground Chamber System  
Perris, CA  
DETENTION SYSTEM

PROJECT No.: 13868	SEQ. No.: 21273	DATE: 9/14/2022
DESIGNED: DYO	DRAWN: DYO	
CHECKED: DYO	APPROVED: DYO	
SHEET NO.:		1

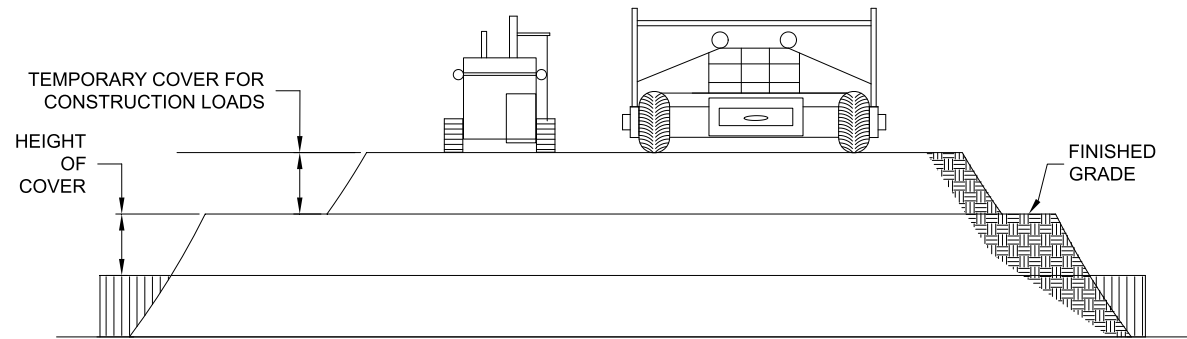

**CONSTRUCTION LOADS**

FOR TEMPORARY CONSTRUCTION VEHICLE LOADS, AN EXTRA AMOUNT OF COMPACTED COVER MAY BE REQUIRED OVER THE TOP OF THE PIPE. THE HEIGHT-OF-COVER SHALL MEET THE MINIMUM REQUIREMENTS SHOWN IN THE TABLE BELOW. THE USE OF HEAVY CONSTRUCTION EQUIPMENT NECESSITATES GREATER PROTECTION FOR THE PIPE THAN FINISHED GRADE COVER MINIMUMS FOR NORMAL HIGHWAY TRAFFIC.

PIPE SPAN, INCHES	AXLE LOADS (kips)			
	18-50	50-75	75-110	110-150
	MINIMUM COVER (FT)			
12-42	2.0	2.5	3.0	3.0
48-72	3.0	3.0	3.5	4.0
78-120	3.0	3.5	4.0	4.0
126-144	3.5	4.0	4.5	4.5

\*MINIMUM COVER MAY VARY, DEPENDING ON LOCAL CONDITIONS. THE CONTRACTOR MUST PROVIDE THE ADDITIONAL COVER REQUIRED TO AVOID DAMAGE TO THE PIPE. MINIMUM COVER IS MEASURED FROM THE TOP OF THE PIPE TO THE TOP OF THE MAINTAINED CONSTRUCTION ROADWAY SURFACE.

**CONSTRUCTION LOADING DIAGRAM**

SCALE: N.T.S.

**SPECIFICATION FOR DESIGNED DETENTION SYSTEM:**

**SCOPE**  
THIS SPECIFICATION COVERS THE MANUFACTURE AND INSTALLATION OF THE DESIGNED DETENTION SYSTEM DETAILED IN THE PROJECT PLANS.

**MATERIAL**  
THE MATERIAL SHALL CONFORM TO THE APPLICABLE REQUIREMENTS LISTED BELOW:

ALUMINIZED TYPE 2 STEEL COILS SHALL CONFORM TO THE REQUIREMENTS OF AASHTO M-274 OR ASTM A-92.

THE GALVANIZED STEEL COILS SHALL CONFORM TO THE REQUIREMENTS OF AASHTO M-218 OR ASTM A-929.

THE POLYMER COATED STEEL COILS SHALL CONFORM TO THE REQUIREMENTS OF AASHTO M-246 OR ASTM A-742.

THE ALUMINUM COILS SHALL CONFORM TO THE APPLICABLE OF AASHTO M-197 OR ASTM B-744.

**CONSTRUCTION LOADS**  
CONSTRUCTION LOADS MAY BE HIGHER THAN FINAL LOADS. FOLLOW THE MANUFACTURER'S OR NCSIPA GUIDELINES.

**PIPE**  
THE PIPE SHALL BE MANUFACTURED IN ACCORDANCE TO THE APPLICABLE REQUIREMENTS LISTED BELOW:

ALUMINIZED TYPE 2: AASHTO M-36 OR ASTM A-760

GALVANIZED: AASHTO M-36 OR ASTM A-760

POLYMER COATED: AASHTO M-245 OR ASTM A-762

ALUMINUM: AASHTO M-196 OR ASTM B-745

**HANDLING AND ASSEMBLY**  
SHALL BE IN ACCORDANCE WITH NCSP'S (NATIONAL CORRUGATED STEEL ASSOCIATION) FOR ALUMINIZED TYPE 2, GALVANIZED OR POLYMER COATED STEEL. SHALL BE IN ACCORDANCE WITH THE MANUFACTURER'S RECOMMENDATIONS FOR ALUMINUM PIPE.

**INSTALLATION**  
SHALL BE IN ACCORDANCE WITH AASHTO STANDARD SPECIFICATIONS FOR HIGHWAY BRIDGES, SECTION 26, DIVISION II DIVISION II OR ASTM A-798 (FOR ALUMINIZED TYPE 2, GALVANIZED OR POLYMER COATED STEEL) OR ASTM B-788 (FOR ALUMINUM PIPE) AND IN CONFORMANCE WITH THE PROJECT PLANS AND SPECIFICATIONS. IF THERE ARE ANY INCONSISTENCIES OR CONFLICTS THE CONTRACTOR SHOULD DISCUSS AND RESOLVE WITH THE SITE ENGINEER.

IT IS ALWAYS THE RESPONSIBILITY OF THE CONTRACTOR TO FOLLOW OSHA GUIDELINES FOR SAFE PRACTICES.

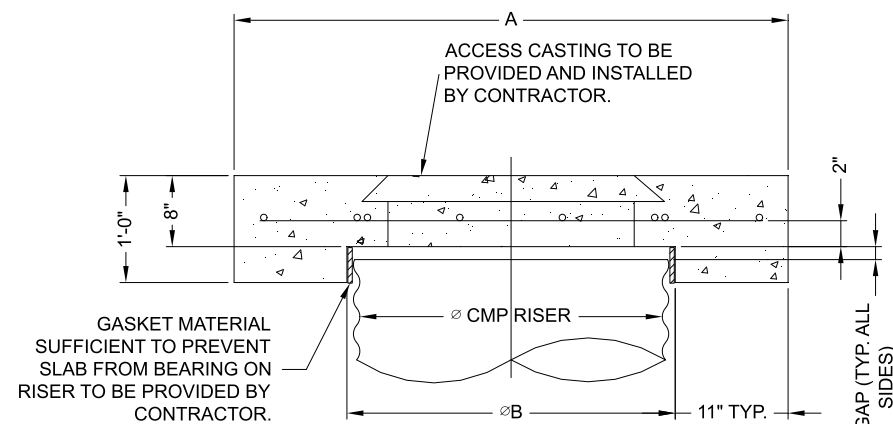

**SECTION VIEW**

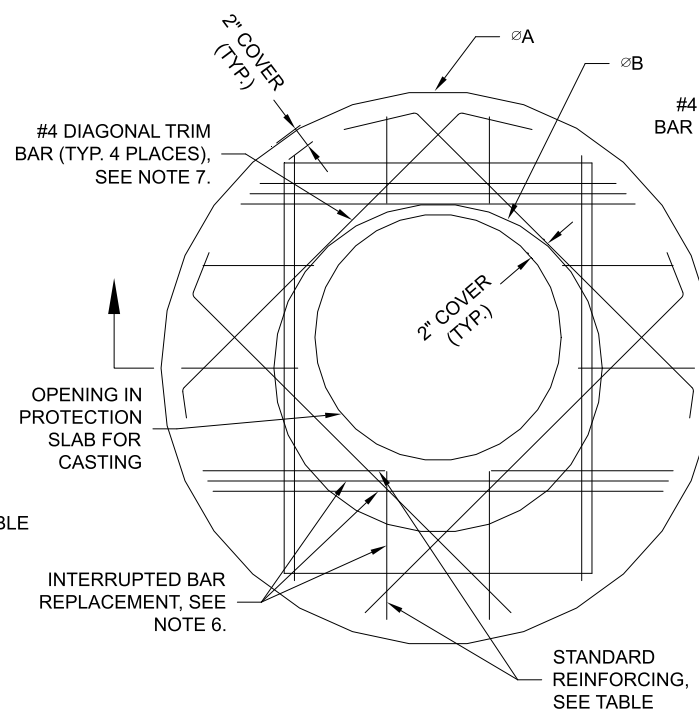

**ROUND OPTION PLAN VIEW**

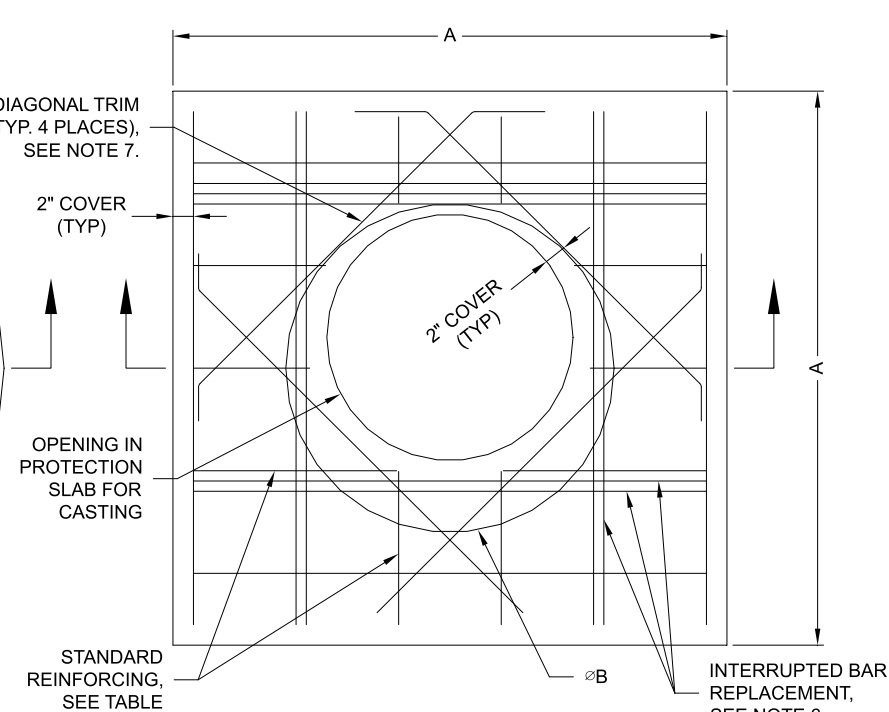

**SQUARE OPTION PLAN VIEW**

**NOTES:**

- DESIGN IN ACCORDANCE WITH AASHTO, 17th EDITION.
- DESIGN LOAD HS25.
- EARTH COVER = 1' MAX.
- CONCRETE STRENGTH = 3,500 psi
- REINFORCING STEEL = ASTM A615, GRADE 60.
- PROVIDE ADDITIONAL REINFORCING AROUND OPENINGS EQUAL TO THE BARS INTERRUPTED, HALF EACH SIDE. ADDITIONAL BARS TO BE IN THE SAME PLANE.
- TRIM OPENING WITH DIAGONAL #4 BARS, EXTEND BARS A MINIMUM OF 12" BEYOND OPENING, BEND BARS AS REQUIRED TO MAINTAIN BAR COVER.
- PROTECTION SLAB AND ALL MATERIALS TO BE PROVIDED AND INSTALLED BY CONTRACTOR.
- DETAIL DESIGN BY DELTA ENGINEERING, BINGHAMTON, NY.

**MANHOLE CAP DETAIL**

SCALE: N.T.S.

REINFORCING TABLE				
Ø CMP RISER	A	Ø B	REINFORCING	**BEARING PRESSURE (PSF)
24"	Ø 4' 4'X4'	26"	#5 @ 12" OCEW #5 @ 12" OCEW	2,410 1,780
30"	Ø 4'-6" 4'-6" X 4'-6"	32"	#5 @ 12" OCEW #5 @ 12" OCEW	2,120 1,530
36"	Ø 5' X 5'	38"	#5 @ 10" OCEW #5 @ 10" OCEW	1,890 1,350
42"	Ø 5'-6" X 5'-6"	44"	#5 @ 10" OCEW #5 @ 9" OCEW	1,720 1,210
48"	Ø 6' X 6'	50"	#5 @ 9" OCEW #5 @ 8" OCEW	1,600 1,100

\*\* ASSUMED SOIL BEARING CAPACITY

C:\EXPORT\TEMPLATES\CMP\_V8.DWG 10/18/2019 10:02 AM

**NOTE:**  
THESE DRAWINGS ARE FOR CONCEPTUAL PURPOSES AND DO NOT REFLECT ANY LOCAL PREFERENCES OR REGULATIONS. PLEASE CONTACT YOUR LOCAL CONTECH REP FOR MODIFICATIONS.

The design and information shown on this drawing is provided as a service to the project owner, engineer and contractor by Contech Engineered Solutions LLC ("Contech"). Neither this drawing, nor any part thereof, may be used, reproduced or modified in any manner without the prior written consent of Contech. Failure to comply is done at the user's own risk and Contech expressly disclaims any liability or responsibility for such use.

If discrepancies between the supplied information upon which the drawing is based and actual field conditions are encountered as site work progresses, these discrepancies must be reported to Contech immediately for re-evaluation of the design. Contech accepts no liability for designs based on missing, incomplete or inaccurate information supplied by others.

DATE	REVISION DESCRIPTION	BY

**CONTECH**  
ENGINEERED SOLUTIONS LLC  
www.ContechES.com  
9025 Centre Pointe Dr., Suite 400, West Chester, OH 45069  
800-338-1122 513-645-7000 513-645-7993 FAX

**CONTECH**  
CMP DETENTION SYSTEMS  
CONTECH  
DYODS  
DRAWING

DYO21273 Sinclair St  
Underground Chamber System  
Perris, CA  
DETENTION SYSTEM

PROJECT No.: 13868	SEQ. No.: 21273	DATE: 9/14/2022
DESIGNED: DYO	DRAWN: DYO	
CHECKED: DYO	APPROVED: DYO	
SHEET NO.:		1

## CMP DETENTION INSTALLATION GUIDE

PROPER INSTALLATION OF A FLEXIBLE UNDERGROUND DETENTION SYSTEM WILL ENSURE LONG-TERM PERFORMANCE. THE CONFIGURATION OF THESE SYSTEMS OFTEN REQUIRES SPECIAL CONSTRUCTION PRACTICES THAT DIFFER FROM CONVENTIONAL FLEXIBLE PIPE CONSTRUCTION. CONTECH ENGINEERED SOLUTIONS STRONGLY SUGGESTS SCHEDULING A PRE-CONSTRUCTION MEETING WITH YOUR LOCAL SALES ENGINEER TO DETERMINE IF ADDITIONAL MEASURES, NOT COVERED IN THIS GUIDE, ARE APPROPRIATE FOR YOUR SITE.

## FOUNDATION

CONSTRUCT A FOUNDATION THAT CAN SUPPORT THE DESIGN LOADING APPLIED BY THE PIPE AND ADJACENT BACKFILL WEIGHT AS WELL AS MAINTAIN ITS INTEGRITY DURING CONSTRUCTION.

IF SOFT OR UNSUITABLE SOILS ARE ENCOUNTERED, REMOVE THE POOR SOILS DOWN TO A SUITABLE DEPTH AND THEN BUILD UP TO THE APPROPRIATE ELEVATION WITH A COMPETENT BACKFILL MATERIAL. THE STRUCTURAL FILL MATERIAL GRADATION SHOULD NOT ALLOW THE MIGRATION OF FINES, WHICH CAN CAUSE SETTLEMENT OF THE DETENTION SYSTEM OR PAVEMENT ABOVE. IF THE STRUCTURAL FILL MATERIAL IS NOT COMPATIBLE WITH THE UNDERLYING SOILS AN ENGINEERING FABRIC SHOULD BE USED AS A SEPARATOR. IN SOME CASES, USING A STIFF REINFORCING GEOGRID REDUCES OVER EXCAVATION AND REPLACEMENT FILL QUANTITIES.

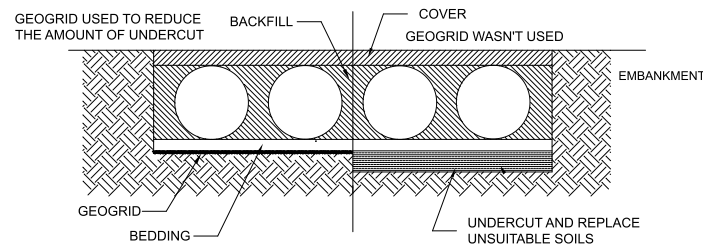

GRADE THE FOUNDATION SUBGRADE TO A UNIFORM OR SLIGHTLY SLOPING GRADE. IF THE SUBGRADE IS CLAY OR RELATIVELY NON-POROUS AND THE CONSTRUCTION SEQUENCE WILL LAST FOR AN EXTENDED PERIOD OF TIME, IT IS BEST TO SLOPE THE GRADE TO ONE END OF THE SYSTEM. THIS WILL ALLOW EXCESS WATER TO DRAIN QUICKLY, PREVENTING SATURATION OF THE SUBGRADE.

## GEOMEMBRANE BARRIER

A SITE'S RESISTIVITY MAY CHANGE OVER TIME WHEN VARIOUS TYPES OF SALTING AGENTS ARE USED, SUCH AS ROAD SALTS FOR DEICING AGENTS. IF SALTING AGENTS ARE USED ON OR NEAR THE PROJECT SITE, A GEOMEMBRANE BARRIER IS RECOMMENDED WITH THE SYSTEM. THE GEOMEMBRANE LINER IS INTENDED TO HELP PROTECT THE SYSTEM FROM THE POTENTIAL ADVERSE EFFECTS THAT MAY RESULT FROM THE USE OF SUCH AGENTS INCLUDING PREMATURE CORROSION AND REDUCED ACTUAL SERVICE LIFE.

THE PROJECT'S ENGINEER OF RECORD IS TO EVALUATE WHETHER SALTING AGENTS WILL BE USED ON OR NEAR THE PROJECT SITE, AND USE HIS/HER BEST JUDGEMENT TO DETERMINE IF ANY ADDITIONAL PROTECTIVE MEASURES ARE REQUIRED. BELOW IS A TYPICAL DETAIL SHOWING THE PLACEMENT OF A GEOMEMBRANE BARRIER FOR PROJECTS WHERE SALTING AGENTS ARE USED ON OR NEAR THE PROJECT SITE.

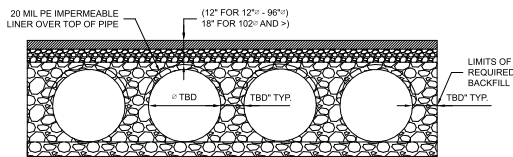

## IN-SITU TRENCH WALL

IF EXCAVATION IS REQUIRED, THE TRENCH WALL NEEDS TO BE CAPABLE OF SUPPORTING THE LOAD THAT THE PIPE SHEDS AS THE SYSTEM IS LOADED. IF SOILS ARE NOT CAPABLE OF SUPPORTING THESE LOADS, THE PIPE CAN DEFLECT. PERFORM A SIMPLE SOIL PRESSURE CHECK USING THE APPLIED LOADS TO DETERMINE THE LIMITS OF EXCAVATION BEYOND THE SPRING LINE OF THE OUTER MOST PIPES.

IN MOST CASES THE REQUIREMENTS FOR A SAFE WORK ENVIRONMENT AND PROPER BACKFILL PLACEMENT AND COMPACTION TAKE CARE OF THIS CONCERN.

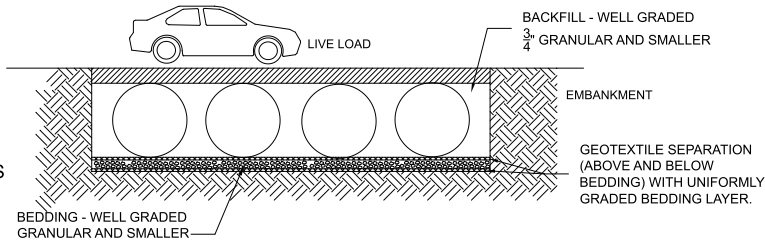

## BACKFILL PLACEMENT

MATERIAL SHALL BE WORKED INTO THE PIPE HAUNCHES BY MEANS OF SHOVEL-SLICING, RODDING, AIR TAMPER, VIBRATORY ROD, OR OTHER EFFECTIVE METHODS.

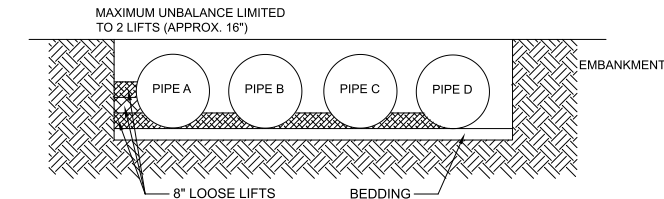

IF AASHTO T99 PROCEDURES ARE DETERMINED INFEASIBLE BY THE GEOTECHNICAL ENGINEER OF RECORD, COMPACTION IS CONSIDERED ADEQUATE WHEN NO FURTHER YIELDING OF THE MATERIAL IS OBSERVED UNDER THE COMPACTOR, OR UNDER FOOT, AND THE GEOTECHNICAL ENGINEER OF RECORD (OR REPRESENTATIVE THEREOF) IS SATISFIED WITH THE LEVEL OF COMPACTION.

FOR LARGE SYSTEMS, CONVEYOR SYSTEMS, BACKHOES WITH LONG REACHES OR DRAGLINES WITH STONE BUCKETS MAY BE USED TO PLACE BACKFILL. ONCE MINIMUM COVER FOR CONSTRUCTION LOADING ACROSS THE ENTIRE WIDTH OF THE SYSTEM IS REACHED, ADVANCE THE EQUIPMENT TO THE END OF THE RECENTLY PLACED FILL, AND BEGIN THE SEQUENCE AGAIN UNTIL THE SYSTEM IS COMPLETELY BACKFILLED. THIS TYPE OF CONSTRUCTION SEQUENCE PROVIDES ROOM FOR STOCKPILED BACKFILL DIRECTLY BEHIND THE BACKHOE, AS WELL AS THE MOVEMENT OF CONSTRUCTION TRAFFIC. MATERIAL STOCKPILES ON TOP OF THE BACKFILLED DETENTION SYSTEM SHOULD BE LIMITED TO 8- TO 10- FEET HIGH AND MUST PROVIDE BALANCED LOADING ACROSS ALL BARRELS. TO DETERMINE THE PROPER COVER OVER THE PIPES TO ALLOW THE MOVEMENT OF CONSTRUCTION EQUIPMENT SEE TABLE 1, OR CONTACT YOUR LOCAL CONTECH SALES ENGINEER.

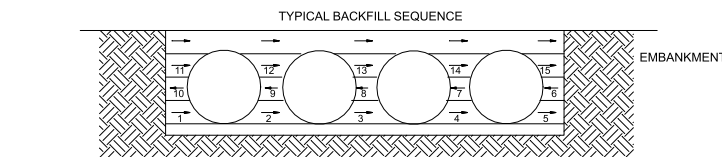

WHEN FLOWABLE FILL IS USED, YOU MUST PREVENT PIPE FLOATATION. TYPICALLY, SMALL LIFTS ARE PLACED BETWEEN THE PIPES AND THEN ALLOWED TO SET-UP PRIOR TO THE PLACEMENT OF THE NEXT LIFT. THE ALLOWABLE THICKNESS OF THE CLSM LIFT IS A FUNCTION OF A PROPER BALANCE BETWEEN THE UPLIFT FORCE OF THE CLSM, THE OPPOSING WEIGHT OF THE PIPE, AND THE EFFECT OF OTHER RESTRAINING MEASURES. THE PIPE CAN CARRY LIMITED FLUID PRESSURE WITHOUT PIPE DISTORTION OR DISPLACEMENT, WHICH ALSO AFFECTS THE CLSM LIFT THICKNESS. YOUR LOCAL CONTECH SALES ENGINEER CAN HELP DETERMINE THE PROPER LIFT THICKNESS.

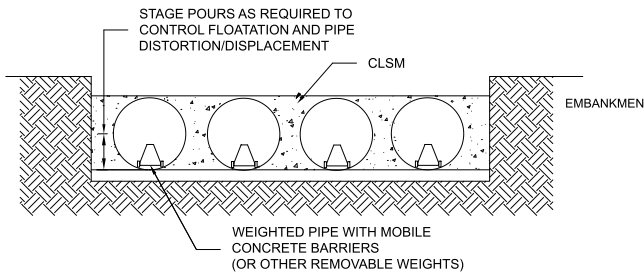

## CONSTRUCTION LOADING

TYPICALLY, THE MINIMUM COVER SPECIFIED FOR A PROJECT ASSUMES H-20 LIVE LOAD. BECAUSE CONSTRUCTION LOADS OFTEN EXCEED DESIGN LIVE LOADS, INCREASED TEMPORARY MINIMUM COVER REQUIREMENTS ARE NECESSARY. SINCE CONSTRUCTION EQUIPMENT VARIES FROM JOB TO JOB, IT IS BEST TO ADDRESS EQUIPMENT SPECIFIC MINIMUM COVER REQUIREMENTS WITH YOUR LOCAL CONTECH SALES ENGINEER DURING YOUR PRE-CONSTRUCTION MEETING.

## ADDITIONAL CONSIDERATIONS

BECAUSE MOST SYSTEMS ARE CONSTRUCTED BELOW-GRADE, RAINFALL CAN RAPIDLY FILL THE EXCAVATION; POTENTIALLY CAUSING FLOATATION AND MOVEMENT OF THE PREVIOUSLY PLACED PIPES. TO HELP MITIGATE POTENTIAL PROBLEMS, IT IS BEST TO START THE INSTALLATION AT THE DOWNSTREAM END WITH THE OUTLET ALREADY CONSTRUCTED TO ALLOW A ROUTE FOR THE WATER TO ESCAPE. TEMPORARY DIVERSION MEASURES MAY BE REQUIRED FOR HIGH FLOWS DUE TO THE RESTRICTED NATURE OF THE OUTLET PIPE.

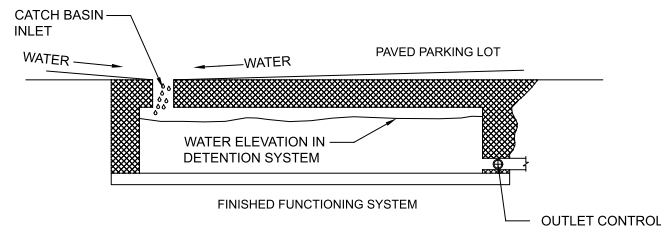

## CMP DETENTION SYSTEM INSPECTION AND MAINTENANCE

UNDERGROUND STORMWATER DETENTION AND INFILTRATION SYSTEMS MUST BE INSPECTED AND MAINTAINED AT REGULAR INTERVALS FOR PURPOSES OF PERFORMANCE AND LONGEVITY.

### INSPECTION

INSPECTION IS THE KEY TO EFFECTIVE MAINTENANCE OF CMP DETENTION SYSTEMS AND IS EASILY PERFORMED. CONTECH RECOMMENDS ONGOING, ANNUAL INSPECTIONS. SITES WITH HIGH TRASH LOAD OR SMALL OUTLET CONTROL ORIFICES MAY NEED MORE FREQUENT INSPECTIONS. THE RATE AT WHICH THE SYSTEM COLLECTS POLLUTANTS WILL DEPEND MORE ON SITE SPECIFIC ACTIVITIES RATHER THAN THE SIZE OR CONFIGURATION OF THE SYSTEM.

INSPECTIONS SHOULD BE PERFORMED MORE OFTEN IN EQUIPMENT WASHDOWN AREAS, IN CLIMATES WHERE SANDING AND/OR SALTING OPERATIONS TAKE PLACE, AND IN OTHER VARIOUS INSTANCES IN WHICH ONE WOULD EXPECT HIGHER ACCUMULATIONS OF SEDIMENT OR ABRASIVE/ CORROSIVE CONDITIONS. A RECORD OF EACH INSPECTION IS TO BE MAINTAINED FOR THE LIFE OF THE SYSTEM

### MAINTENANCE

CMP DETENTION SYSTEMS SHOULD BE CLEANED WHEN AN INSPECTION REVEALS ACCUMULATED SEDIMENT OR TRASH IS CLOGGING THE DISCHARGE ORIFICE.

ACCUMULATED SEDIMENT AND TRASH CAN TYPICALLY BE EVACUATED THROUGH THE MANHOLE OVER THE OUTLET ORIFICE. IF MAINTENANCE IS NOT PERFORMED AS RECOMMENDED, SEDIMENT AND TRASH MAY ACCUMULATE IN FRONT OF THE OUTLET ORIFICE. MANHOLE COVERS SHOULD BE SECURELY SEATED FOLLOWING CLEANING ACTIVITIES. CONTECH SUGGESTS THAT ALL SYSTEMS BE DESIGNED WITH AN ACCESS/INSPECTION MANHOLE SITUATED AT OR NEAR THE INLET AND THE OUTLET ORIFICE. SHOULD IT BE NECESSARY TO GET INSIDE THE SYSTEM TO PERFORM MAINTENANCE ACTIVITIES, ALL APPROPRIATE PRECAUTIONS REGARDING CONFINED SPACE ENTRY AND OSHA REGULATIONS SHOULD BE FOLLOWED.

ANNUAL INSPECTIONS ARE BEST PRACTICE FOR ALL UNDERGROUND SYSTEMS. DURING THIS INSPECTION, IF EVIDENCE OF SALTING/DE-ICING AGENTS IS OBSERVED WITHIN THE SYSTEM, IT IS BEST PRACTICE FOR THE SYSTEM TO BE RINSED, INCLUDING ABOVE THE SPRING LINE SOON AFTER THE SPRING THAW AS PART OF THE MAINTENANCE PROGRAM FOR THE SYSTEM.

MAINTAINING AN UNDERGROUND DETENTION OR INFILTRATION SYSTEM IS EASIEST WHEN THERE IS NO FLOW ENTERING THE SYSTEM. FOR THIS REASON, IT IS A GOOD IDEA TO SCHEDULE THE CLEANOUT DURING DRY WEATHER.

THE FOREGOING INSPECTION AND MAINTENANCE EFFORTS HELP ENSURE UNDERGROUND PIPE SYSTEMS USED FOR STORMWATER STORAGE CONTINUE TO FUNCTION AS INTENDED BY IDENTIFYING RECOMMENDED REGULAR INSPECTION AND MAINTENANCE PRACTICES. INSPECTION AND MAINTENANCE RELATED TO THE STRUCTURAL INTEGRITY OF THE PIPE OR THE SOUNDNESS OF PIPE JOINT CONNECTIONS IS BEYOND THE SCOPE OF THIS GUIDE.

C:\EXPORT\TEMPLATES\CMP\_V8.DWG 10/18/2019 10:02 AM

The design and information shown on this drawing is provided as a service to the project owner, engineer and contractor by Contech Engineered Solutions LLC ("Contech"). Neither this drawing, nor any part thereof, may be used, reproduced or modified in any manner without the prior written consent of Contech. Failure to comply is done at the user's own risk and Contech expressly disclaims any liability or responsibility for such use.

If discrepancies between the supplied information upon which the drawing is based and actual field conditions are encountered as site work progresses, these discrepancies must be reported to Contech immediately for re-evaluation of the design. Contech accepts no liability for designs based on missing, incomplete or inaccurate information supplied by others.

DATE	REVISION DESCRIPTION	BY

**CONTECH**  
ENGINEERED SOLUTIONS LLC  
www.ContechES.com

9025 Centre Pointe Dr., Suite 400, West Chester, OH 45069  
800-338-1122 513-645-7000 513-645-7993 FAX

**CONTECH**  
CMP DETENTION SYSTEMS

CONTECH  
**DYODS**  
DRAWING

DYO21273 Sinclair St  
Underground Chamber System  
Perris, CA  
DETENTION SYSTEM

PROJECT No.: 13868	SEQ. No.: 21273	DATE: 9/14/2022
DESIGNED: DYO	DRAWN: DYO	
CHECKED: DYO	APPROVED: DYO	
SHEET NO.:		1

# Appendix 3: Soils Information

*Geotechnical Study and Other Infiltration Testing Data*



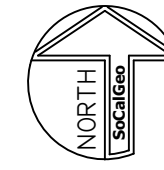
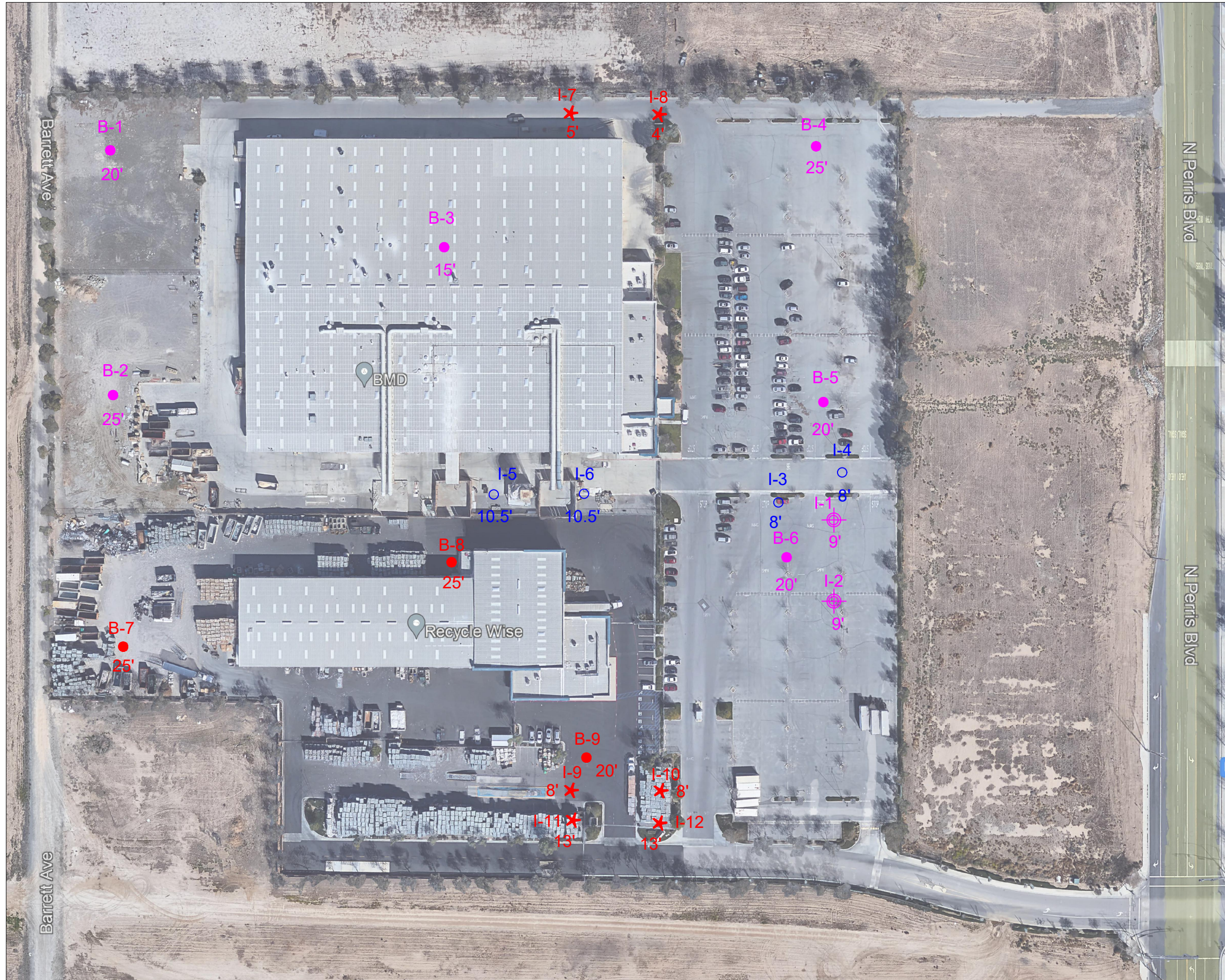

**GEOTECHNICAL LEGEND**

- PROPOSED BORING LOCATION
- ★ PROPOSED INFILTRATION TEST LOCATION
- PREVIOUS BORING LOCATION (SCG PROJECT NO. 22G122-1)
- PREVIOUS INFILTRATION TEST LOCATION (SCG PROJECT NO. 22G122-2)
- PREVIOUS INFILTRATION TEST LOCATION (SCG PROJECT NO. 22G122-3)

<b>PROPOSED BORING LOCATION PLAN</b>	
FIRST SINCLAIR LOGISTICS CENTER	
PERRIS, CALIFORNIA	
SCALE: 1" = 120'	 <b>SOUTHERN CALIFORNIA GEOTECHNICAL</b>
DRAWN: XXX	
CHKD: XXX	
SCG PROJECT 22G122-4	
<b>PLATE 2</b>	



**GEOTECHNICAL INVESTIGATION  
FIRST SINCLAIR LOGISTICS CENTER**

100 West Sinclair Street

Perris, California

for

First Industrial Realty Trust, Inc.



**SOUTHERN  
CALIFORNIA  
GEOTECHNICAL**  
*A California Corporation*

March 4, 2022

First Industrial Realty Trust, Inc.  
898 North Pacific Coast Highway, Suite 175  
El Segundo, California 90245



**SOUTHERN  
CALIFORNIA  
GEOTECHNICAL**  
*A California Corporation*

Attention: Mr. Michael Goodwin  
Director of Development

Project No.: **22G122-1**

Subject: **Geotechnical Investigation**  
First Sinclair Logistics Center  
100 West Sinclair Street  
Perris, California

Dear Mr. Goodwin:

In accordance with your request, we have conducted a geotechnical investigation at the subject site. We are pleased to present this report summarizing the conclusions and recommendations developed from our investigation.

We sincerely appreciate the opportunity to be of service on this project. We look forward to providing additional consulting services during the course of the project. If we may be of further assistance in any manner, please contact our office.

Respectfully Submitted,

SOUTHERN CALIFORNIA GEOTECHNICAL, INC.

A handwritten signature in blue ink, appearing to read "Gregory K. Mitchell".

Gregory K. Mitchell, GE 2364  
Principal Engineer



A handwritten signature in blue ink, appearing to read "Robert G. Trazo".

Robert G. Trazo, GE 2655  
Principal Engineer



Distribution: (1) Addressee



# TABLE OF CONTENTS

<b>1.0 EXECUTIVE SUMMARY</b>	<b>1</b>
<b>2.0 SCOPE OF SERVICES</b>	<b>3</b>
<b>3.0 SITE AND PROJECT DESCRIPTION</b>	<b>4</b>
3.1 Site Conditions	4
3.2 Proposed Development	4
<b>4.0 SUBSURFACE EXPLORATION</b>	<b>5</b>
4.1 Scope of Exploration/Sampling Methods	5
4.2 Geotechnical Conditions	5
<b>5.0 LABORATORY TESTING</b>	<b>7</b>
<b>6.0 CONCLUSIONS AND RECOMMENDATIONS</b>	<b>9</b>
6.1 Seismic Design Considerations	9
6.2 Geotechnical Design Considerations	11
6.3 Site Grading Recommendations	13
6.4 Construction Considerations	16
6.5 Foundation Design and Construction	17
6.6 Floor Slab Design and Construction	19
6.7 Exterior Flatwork Design and Construction	20
6.8 Retaining Wall Design and Construction	20
6.9 Pavement Design Parameters	23
<b>7.0 GENERAL COMMENTS</b>	<b>25</b>
<b>APPENDICES</b>	
A Plate 1: Site Location Map Plate 2: Boring Location Plan	
B Boring Logs	
C Laboratory Test Results	
D Grading Guide Specifications	
E Seismic Design Parameters	

# **1.0 EXECUTIVE SUMMARY**

---

Presented below is a brief summary of the conclusions and recommendations of this investigation. Since this summary is not all inclusive, it should be read in complete context with the entire report.

## **Geotechnical Design Considerations**

- Artificial fill soils were encountered at most of the boring locations, extending from the ground surface to depths of 4½ to 6± feet. The existing fill soils are considered to represent undocumented fill. These soils, in their present condition, are not considered suitable for support of the foundation or floor slab loads of the new structure.
- The artificial fill soils are underlain by native alluvial soils. Results of laboratory testing indicate that these materials possess generally favorable consolidation and collapse characteristics.
- Remedial grading will be necessary to remove and recompact the undocumented fill soils.
- Based on conditions encountered at the boring locations and maps published by Riverside County, liquefaction is not a significant design concern for this project.

## **Site Preparation**

- The site plan provided to our office indicates that the existing structures and pavements at the subject site will be demolished in order to facilitate the construction of the proposed development. Demolition should include all foundations, floor slabs, pavements, utilities and any other subsurface improvements that will not remain in place with the new development. Debris resultant from demolition should be disposed of off-site. Alternatively, concrete and asphalt debris may be pulverized to a maximum 2-inch particle size, mixed with sandy on-site soils, and incorporated into new structural fills or it may be processed into CMB.
- Initial site stripping should include all vegetation and topsoil. Removal of numerous trees will be required. Tree removal should include all significant root masses.
- Remedial grading is recommended to be performed within the proposed building area in order to remove all of the undocumented fill soils, which extend to depths of up to 6 feet at the boring locations. The soils within the proposed building area should also be overexcavated to a depth of 3 feet below existing grade and to a depth of at least 3 feet below proposed building pad subgrade elevations.
- The soils within the proposed foundation influence zones should be overexcavated to a depth of at least 3 feet below proposed foundation bearing grade.
- Following completion of the overexcavation, the exposed soils should be scarified to a depth of at least 12 inches and moisture conditioned to at least 2 to 4 percent above optimum moisture content. The overexcavation subgrade soils should then be recompact to at least 90 percent of the ASTM D-1557 maximum dry density. The previously excavated soils may then be replaced as compacted structural fill.
- The new pavement and flatwork subgrade soils are recommended to be scarified to a depth of 12± inches, moisture conditioned and recompact to at least 90 percent of the ASTM D-1557 maximum dry density.

## **Building Foundations**

- Conventional shallow foundations, supported in newly placed compacted fill.
- 2,500 lbs/ft<sup>2</sup> maximum allowable soil bearing pressure.

- Reinforcement consisting of at least four (4) No. 5 rebar (2 top and 2 bottom) in strip footings, due to the presence of potentially expansive soils. Additional reinforcement may be necessary for structural considerations.

### Building Floor Slab

- Conventional Slab-on-Grade: minimum 6 inches thick.
- Modulus of Subgrade Reaction:  $k = 140$  psi/in.
- Reinforcement is not expected to be necessary for geotechnical considerations. The actual thickness and reinforcement of the floor slab should be determined by the structural engineer.

### Pavement Design Recommendations

ASPHALT PAVEMENTS (R=30)					
Materials	Thickness (inches)				
	Auto Parking and Auto Drive Lanes (TI = 4.0 to 5.0)	Truck Traffic			
		TI = 6.0	TI = 7.0	TI = 8.0	TI = 9.0
Asphalt Concrete	3	3½	4	5	5½
Aggregate Base	6	8	10	11	13
Compacted Subgrade	12	12	12	12	12

PORTLAND CEMENT CONCRETE PAVEMENTS (R=30)				
Materials	Thickness (inches)			
	Autos and Light Truck Traffic (TI = 5.0 to 6.0)	Truck Traffic		
		TI = 7.0	TI = 8.0	TI = 9.0
PCC	5	5½	6½	8
Compacted Subgrade (95% minimum compaction)	12	12	12	12

## **2.0 SCOPE OF SERVICES**

---

The scope of services performed for this project was in accordance with our Proposal No. 22P120, dated January 20, 2022. The scope of services included a visual site reconnaissance, subsurface exploration, field and laboratory testing, and geotechnical engineering analysis to provide criteria for preparing the design of the building foundations, building floor slabs, and parking lot pavements along with site preparation recommendations and construction considerations for the proposed development. The evaluation of the environmental aspects of this site was beyond the scope of services for this geotechnical investigation.

## **3.0 SITE AND PROJECT DESCRIPTION**

---

### **3.1 Site Conditions**

The site is located at 100 West Sinclair Street in Perris, California. The site is bounded to the north and east by vacant parcels and to the west by Barrett Avenue. An existing building is located on the southerly adjacent property. The general location of the site is illustrated on the Site Location Map, included as Plate 1 of this report.

The site consists of an L-shaped parcel, 13.85± acres in size. The site is presently developed with one (1) warehouse building, 161,000± ft<sup>2</sup> in size, located in the north-central area of the site. The building is surrounded by Portland cement concrete pavements in the loading dock areas and asphaltic concrete (AC) pavements in the eastern parking area. The asphaltic concrete pavements were in fair to poor condition with moderate cracking throughout. Ground surface cover in the remaining areas of the site consists of open-graded gravel in the northwestern area and exposed soil in the southwestern area of the site. Concrete flatwork and landscape planters are present throughout the western parking area and along the west, north and east property lines. The planters include medium to large trees and exposed soil.

Detailed topographic information was not available at the time of this report. Based on elevations obtained from Google Earth and visual observations made at the time of the subsurface investigation, the eastern parking area slopes downward to the north at a gradient of less than 1± percent. The western portion of the site has a central low point with gentle ascending slopes to the south, west and north with estimated gradients between 2 and 3± percent.

### **3.2 Proposed Development**

SCG was provided with conceptual site plan prepared by HPA Architecture (Scheme 5). Based on Scheme 5, the site will be developed with one (1) new warehouse building, 271,359± ft<sup>2</sup> in size, located in the north-central area of the site. Dock-high doors will be constructed along most of the southern building wall. The building will be surrounded by asphaltic concrete pavements in the parking and drive lanes, Portland cement concrete pavements in the loading dock areas, and limited areas of concrete flatwork and landscape planters throughout the site.

Detailed structural information has not been provided. It is assumed the building will be of tilt-up concrete construction, typically supported on conventional shallow foundations with a concrete slab-on-grade floor. Based on the assumed construction, maximum column and wall loads are expected to be on the order of 100 kips and 4 to 7 kips per linear foot, respectively.

No significant amounts of below grade construction, such as crawl spaces or new basements, are expected to be included in the proposed development. Based on the assumed topography, cuts and fills of up to 5± feet are expected to be necessary to achieve the proposed site grades.

## **4.0 SUBSURFACE EXPLORATION**

---

### **4.1 Scope of Exploration/Sampling Methods**

The subsurface exploration for this project consisted of six (6) borings advanced to depths of 15 to 25± feet below the existing site grades. All of the borings were logged during drilling by a member of our staff.

The borings were advanced with hollow-stem augers, by a limited-access, track-mounted drilling rig. Representative bulk and relatively undisturbed soil samples were taken during drilling. Relatively undisturbed soil samples were taken with a split barrel "California Sampler" containing a series of one inch long, 2.416± inch diameter brass rings. This sampling method is described in ASTM Test Method D-3550. In-situ samples were also taken using a 1.4± inch inside diameter split spoon sampler, in general accordance with ASTM D-1586. Both of these samplers are driven into the ground with successive blows of a 140-pound weight falling 30 inches. The blow counts obtained during driving are recorded for further analysis. Bulk samples were collected in plastic bags to retain their original moisture content. The relatively undisturbed ring samples were placed in molded plastic sleeves that were then sealed and transported to our laboratory.

The approximate locations of the borings are indicated on the Boring Location Plan, included as Plate 2 in Appendix A of this report. The Boring Logs, which illustrate the conditions encountered at the boring locations, as well as the results of some of the laboratory testing, are included in Appendix B.

### **4.2 Geotechnical Conditions**

#### Pavements

Asphaltic concrete pavements were encountered at the ground surface at Boring Nos. B-4, B-5 and B-6. The pavement sections consist of 3 to 4± inches of asphaltic concrete, underlain by 4 to 6± inches of aggregate base.

A Portland cement concrete slab, 6± inches in thickness, was encountered at the ground surface of Boring No. B-3, which was drilled inside the existing building.

#### Artificial Fill

Fill consisting of open-graded gravel, 1± inch in thickness, was encountered at the ground surface of Boring Nos. B-1 and B-2.

Artificial fill soils were encountered beneath the pavements/slab at Boring Nos. B-3 through B-6, extending to depths of 4½ to 6± feet below ground surface. The fill soils generally consist of

loose to medium dense silty fine to medium sands and fine to medium sandy silts. The fill soils possess a disturbed and mottled appearance, resulting in their classification as artificial fill.

### Alluvium

Native alluvium was encountered beneath the surficial gravel layer at Boring Nos. B-1 and B-2 and beneath the fill at the remaining boring locations, extending to at least the maximum depth explored of 25± feet below ground surface. The alluvial soils generally consist of loose to medium dense fine sandy silts, clayey fine sands, fine to coarse sands, silty fine to medium sands, and stiff to hard silty clays. Very dense clayey sands were encountered at depths of 17 to 20± feet at Boring No. B-1. Occasional soil samples possess slight cementation within the upper 5½ to 12± feet.

### Groundwater

Free water was not encountered during the drilling of any of the borings. Based on the lack of any water within the borings, and the moisture contents of the recovered soil samples, the static groundwater table is considered to have existed at a depth in excess of 25± feet at the time of the subsurface exploration.

Recent water level data was obtained from the California State Water Resources Control Board, GeoTracker, website, <https://geotracker.waterboards.ca.gov/>. One monitoring well on record is located 210± feet south of the site. Water level readings within this monitoring well indicate a high groundwater level of 79± feet below the ground surface in February 2015.

## **5.0 LABORATORY TESTING**

---

The soil samples recovered from the subsurface exploration were returned to our laboratory for further testing to determine selected physical and engineering properties of the soils. The tests are briefly discussed below. It should be noted that the test results are specific to the actual samples tested, and variations could be expected at other locations and depths.

### Classification

All recovered soil samples were classified using the Unified Soil Classification System (USCS), in accordance with ASTM D-2488. Field identifications were then supplemented with additional visual classifications and/or by laboratory testing. The USCS classifications are shown on the Boring Logs and are periodically referenced throughout this report.

### Density and Moisture Content

The density has been determined for selected relatively undisturbed ring samples. These densities were determined in general accordance with the method presented in ASTM D-2937. The results are recorded as dry unit weight in pounds per cubic foot. The moisture contents are determined in accordance with ASTM D-2216, and are expressed as a percentage of the dry weight. These test results are presented on the Boring Logs.

### Consolidation

Selected soil samples have been tested to determine their consolidation and collapse potential, in accordance with ASTM D-2435. The testing apparatus is designed to accept either natural or remolded samples in a one-inch high ring, approximately 2.416 inches in diameter. Each sample is then loaded incrementally in a geometric progression and the resulting deflection is recorded at selected time intervals. Porous stones are in contact with the top and bottom of the sample to permit the addition or release of pore water. The samples are typically inundated with water at an intermediate load to determine their potential for collapse or heave. The results of the consolidation testing are plotted on Plates C-1 through C-4 in Appendix C of this report.

### Maximum Dry Density and Optimum Moisture Content

A representative bulk sample has been tested for its maximum dry density and optimum moisture content. The results have been obtained using the Modified Proctor procedure, per ASTM D-1557, and are presented on Plate C-5 in Appendix C of this report. These tests are generally used to compare the dry densities of undisturbed field samples, and for later compaction testing. Additional testing of other soil types or soil mixes may be necessary at a later date.

### Soluble Sulfates

Representative samples of the near-surface soils were submitted to a subcontracted analytical laboratory for determination of soluble sulfate content. Soluble sulfates are naturally present in soils, and if the concentration is high enough, can result in degradation of concrete which comes into contact with these soils. The result of the soluble sulfate testing is not yet available. The



results of the soluble sulfate testing are presented below, and are discussed further in a subsequent section of this report.

<b><u>Sample Identification</u></b>	<b><u>Soluble Sulfates (%)</u></b>	<b><u>Sulfate Classification</u></b>
B-1 @ 0 to 5 feet	0.017	Not Applicable (S0)
B-5 @ 0 to 5 feet	0.007	Not Applicable (S0)

### Corrosivity Testing

Representative bulk samples of the near-surface soils were submitted to a subcontracted corrosion engineering laboratory to identify potentially corrosive characteristics with respect to common construction materials. The corrosivity testing included a determination of the electrical resistivity, pH, and chloride and nitrate concentrations of the soils, as well as other tests. The results of some of these tests are presented below.

<b><u>Sample Identification</u></b>	<b><u>Saturated Resistivity (ohm-cm)</u></b>	<b><u>pH</u></b>	<b><u>Chlorides (mg/kg)</u></b>	<b><u>Nitrates (mg/kg)</u></b>
B-1 @ 0 to 5 feet	600	7.3	311	145
B-5 @ 0 to 5 feet	3,760	8.3	9.9	6.3

## **6.0 CONCLUSIONS AND RECOMMENDATIONS**

---

Based on the results of our review, field exploration, laboratory testing and geotechnical analysis, the proposed development is considered feasible from a geotechnical standpoint. The recommendations contained in this report should be taken into the design, construction, and grading considerations.

The recommendations are contingent upon all grading and foundation construction activities being monitored by the geotechnical engineer of record. The recommendations are provided with the assumption that an adequate program of client consultation, construction monitoring, and testing will be performed during the final design and construction phases to verify compliance with these recommendations. Maintaining Southern California Geotechnical, Inc., (SCG) as the geotechnical consultant from the beginning to the end of the project will provide continuity of services. The geotechnical engineering firm providing testing and observation services shall assume the responsibility of Geotechnical Engineer of Record.

The Grading Guide Specifications, included as Appendix D, should be considered part of this report, and should be incorporated into the project specifications. The contractor and/or owner of the development should bring to the attention of the geotechnical engineer any conditions that differ from those stated in this report, or which may be detrimental for the development.

### **6.1 Seismic Design Considerations**

The subject site is located in an area which is subject to strong ground motions due to earthquakes. The performance of a site-specific seismic hazards analysis was beyond the scope of this investigation. However, numerous faults capable of producing significant ground motions are located near the subject site. Due to economic considerations, it is not generally considered reasonable to design a structure that is not susceptible to earthquake damage. Therefore, significant damage to structures may be unavoidable during large earthquakes. The proposed structures should, however, be designed to resist structural collapse and thereby provide reasonable protection from serious injury, catastrophic property damage and loss of life.

#### Faulting and Seismicity

Research of available maps indicates that the subject site is not located within an Alquist-Priolo Earthquake Fault Zone. Furthermore, SCG did not identify any evidence of faulting during the geotechnical investigation. Therefore, the possibility of significant fault rupture on the site is considered to be low.

The potential for other geologic hazards such as seismically induced settlement, lateral spreading, tsunamis, inundation, seiches, flooding, and subsidence affecting the site is considered low.

#### Seismic Design Parameters

The 2019 California Building Code (CBC) provides procedures for earthquake resistant structural design that include considerations for on-site soil conditions, occupancy, and the configuration of

the structure including the structural system and height. The seismic design parameters presented below are based on the soil profile and the proximity of known faults with respect to the subject site.

Based on standards in place at the time of this report, the proposed development is expected to be designed in accordance with the requirements of the 2019 edition of the California Building Code (CBC), which was adopted on January 1, 2020.

The 2019 CBC Seismic Design Parameters have been generated using the SEAOC/OSHPD Seismic Design Maps Tool, a web-based software application available at the website [www.seismicmaps.org](http://www.seismicmaps.org). This software application calculates seismic design parameters in accordance with several building code reference documents, including ASCE 7-16, upon which the 2019 CBC is based. The application utilizes a database of risk-targeted maximum considered earthquake ( $MCE_R$ ) site accelerations at 0.01-degree intervals for each of the code documents. The tables below were created using data obtained from the application. The output generated from this program is included as Plate E-1 in Appendix E of this report.

The 2019 CBC requires that a site-specific ground motion study be performed in accordance with Section 11.4.8 of ASCE 7-16 for Site Class D sites with a mapped  $S_1$  value greater than 0.2. However, Section 11.4.8 of ASCE 7-16 also indicates an exception to the requirement for a site-specific ground motion hazard analysis for certain structures on Site Class D sites. The commentary for Section 11 of ASCE 7-16 (Page 534 of Section C11 of ASCE 7-16) indicates that "In general, this exception effectively limits the requirements for site-specific hazard analysis to very tall and or flexible structures at Site Class D sites." **Based on our understanding of the proposed development, the seismic design parameters presented below were calculated assuming that the exception in Section 11.4.8 applies to the proposed structure at this site. However, the structural engineer should verify that this exception is applicable to the proposed structure.** Based on the exception, the spectral response accelerations presented below were calculated using the site coefficients ( $F_a$  and  $F_v$ ) from Tables 1613.2.3(1) and 1613.2.3(2) presented in Section 16.4.4 of the 2019 CBC.

### 2019 CBC SEISMIC DESIGN PARAMETERS

Parameter		Value
Mapped Spectral Acceleration at 0.2 sec Period	$S_S$	1.500
Mapped Spectral Acceleration at 1.0 sec Period	$S_1$	0.572
Site Class	---	D
Site Modified Spectral Acceleration at 0.2 sec Period	$S_{MS}$	1.500
Site Modified Spectral Acceleration at 1.0 sec Period	$S_{M1}$	0.988
Design Spectral Acceleration at 0.2 sec Period	$S_{DS}$	1.000
Design Spectral Acceleration at 1.0 sec Period	$S_{D1}$	0.659

It should be noted that the site coefficient  $F_v$  and the parameters  $S_{M1}$  and  $S_{D1}$  were not included in the SEAOC/OSHPD Seismic Design Maps Tool output for the 2019 CBC. We calculated these parameters-based on Table 1613.2.3(2) in Section 16.4.4 of the 2019 CBC using the value of  $S_1$

obtained from the Seismic Design Maps Tool, assuming that a site-specific ground motion hazards analysis is not required for the proposed buildings at this site.

### Liquefaction

Liquefaction is the loss of strength in generally cohesionless, saturated soils when the pore-water pressure induced in the soil by a seismic event becomes equal to or exceeds the overburden pressure. The primary factors which influence the potential for liquefaction include groundwater table elevation, soil type and plasticity characteristics, relative density of the soil, initial confining pressure, and intensity and duration of ground shaking. The depth within which the occurrence of liquefaction may impact surface improvements is generally identified as the upper 50 feet below the existing ground surface. Liquefaction potential is greater in saturated, loose, poorly graded fine sands with a mean ( $d_{50}$ ) grain size in the range of 0.075 to 0.2 mm (Seed and Idriss, 1971). Non-sensitive clayey (cohesive) soils which possess a plasticity index of at least 18 (Bray and Sancio, 2006) are generally not considered to be susceptible to liquefaction, nor are those soils which are above the historic static groundwater table.

The Riverside County GIS website indicates that the subject site is located within a zone of low liquefaction susceptibility. In addition, the subsurface conditions encountered at the boring locations are not considered to be conducive to liquefaction. These conditions consist of moderate to high strength native alluvial soils and no evidence of a long-term groundwater table within 25 feet of the ground surface. In addition, research of available well data indicates that the groundwater depths in the area of the site are more than 70 feet below grade. Based on these considerations, liquefaction is not considered to be a design concern for this project.

## **6.2 Geotechnical Design Considerations**

### General

Most of the borings encountered artificial fill materials, extending to depths of 4½ to 6± feet. Based their strength characteristics and a lack of documentation regarding the placement and compaction of the existing fill materials, these soils are considered to consist of undocumented fill, likely placed during previous development or grading of the site. Therefore, these materials are not suitable for the support of the foundation and floor slab loads of the proposed building. In addition, significant disturbance of the upper 3 to 4 feet of soil is expected to occur during demolition of the existing structure and other improvements. Based on these conditions, remedial grading is considered warranted within the proposed building area to completely remove the existing artificial fill soils and the upper portion of the near-surface native alluvium and replace these soils as compacted structural fill.

### Settlement

The recommended remedial grading will remove all of the existing fill soils and a portion of the near-surface native alluvium, and replace these soils as compacted structural fill. The native soils that will remain in place below the recommended depth of overexcavation possess favorable consolidation and collapse characteristics and will not be subject to significant load increases from the foundations of the new structure. Provided that the recommended remedial grading is

completed, the post-construction settlement of the proposed structure is expected to be within tolerable limits.

### Expansion

Laboratory testing performed on representative samples of the near-surface soils indicates that these materials possess a low expansion potential (EI = 25 to 36). Based on the presence of potentially expansive soils at this site, care should be given to proper moisture conditioning the building pad subgrade soils to a moisture content of 2 to 4 percent above the ASTM D-1557 optimum during site grading. It is recommended that additional expansion index testing be conducted at the completion of rough grading to verify the expansion potential of the as-graded building pad.

### Soluble Sulfates

The results of the soluble sulfate testing indicate that the tested soil samples possess levels of soluble sulfates that are considered to be "not applicable" (S0) with respect to the American Concrete Institute (ACI) Publication 318-14 Building Code Requirements for Structural Concrete and Commentary, Section 4.3. Therefore, specialized concrete mix designs are not considered to be necessary, with regard to sulfate protection purposes. It is, however, recommended that additional soluble sulfate testing be conducted at the completion of rough grading to verify the soluble sulfate concentrations of the soils which are present at pad grade within the building area.

### Corrosion Potential

The results of laboratory testing indicate that the on-site soils possess saturated resistivities in the range of 600 to 3,760 ohm-cm, and pH values of 7.3 to 8.3. These test results have been evaluated in accordance with guidelines published by the Ductile Iron Pipe Research Association (DIPRA). The DIPRA guidelines consist of a point system by which characteristics of the soils are used to quantify the corrosivity characteristics of the site. Resistivity and pH are two of the five factors that enter into the evaluation procedure. Redox potential, relative soil moisture content and sulfides are also included. Although sulfide testing was not part of the scope of services for this project, we have evaluated the corrosivity characteristics of the on-site soils using resistivity, pH and moisture content. **Based on these factors, and utilizing the DIPRA procedure, the on-site soils are considered to be severely corrosive to ductile iron pipe. Therefore, polyethylene encasement or some other appropriate method of protection will be required for buried iron pipes.**

Low to moderate concentrations (9.9 and 311 mg/kg) of chlorides were detected in the samples submitted for corrosivity testing. In general, soils possessing chloride concentrations in excess of 500 parts per million (ppm) are considered to be corrosive with respect to steel reinforcement within reinforced concrete. Based on these test results, the site is considered to have a C1 chloride exposure in accordance with the American Concrete Institute (ACI) Publication 318 Building Code Requirements for Structural Concrete and Commentary. Therefore, a specialized concrete mix design for reinforced concrete for protection against chloride exposure is not considered warranted.

Nitrates present in soil can be corrosive to copper tubing at concentrations greater than 50 mg/kg. The tested sample possess nitrate concentrations of 6.3 and 145 mg/kg. **Based on these test**

**result, some of the on-site soils are considered to be corrosive to copper pipe, and some type of protection will be required.**

Since SCG does not practice in the area of corrosion engineering, we recommend that the client contact a corrosion engineer to provide a more thorough evaluation.

#### Shrinkage/Subsidence

Based on the results of the laboratory testing, removal and recompaction of the near-surface native alluvium will result in an average shrinkage of 4 to 12 percent. It should be noted that the potential shrinkage estimate is based on dry density testing performed on small-diameter samples taken at the boring locations. If a more accurate and precise shrinkage estimate is desired, SCG can perform a shrinkage study involving several excavated trenches where in-place densities are determined using in-situ testing methods instead of laboratory density testing on small-diameter samples. Please contact SCG for details and a cost estimate regarding a shrinkage study, if desired.

Minor ground subsidence is expected to occur in the soils below the zone of removal, due to settlement and machinery working. The subsidence is estimated to be 0.1 feet. This estimate may be used for grading in areas that are underlain by native alluvial soils.

These estimates are based on previous experience and the subsurface conditions encountered at the boring locations. The actual amount of subsidence is expected to be variable and will be dependent on the type of machinery used, repetitions of use, and dynamic effects, all of which are difficult to assess precisely.

#### Grading and Foundation Plan Review

It is recommended that we be provided with copies of the finalized grading and foundation plans, when they become available, for review with regard to the conclusions, recommendations, and assumptions contained within this report.

### **6.3 Site Grading Recommendations**

The grading recommendations presented below are based on the subsurface conditions encountered at the boring locations and our understanding of the proposed development. We recommend that all grading activities be completed in accordance with the Grading Guide Specifications included as Appendix D of this report, unless superseded by site-specific recommendations presented below.

#### Site Stripping and Demolition

Demolition of the existing structure and pavements should include all foundations, floor slabs, pavements, septic systems, utilities and any other subsurface improvements that will not remain in place with the new development. Debris resultant from demolition should be disposed of off-site. Alternatively, concrete and asphalt debris may be pulverized to a maximum 2-inch particle size, well-mixed with the sandy on-site soils, and incorporated into new structural fills or it may be processed to create crushed miscellaneous base (CMB).

Initial site preparation should also include stripping of any surficial vegetation and organic soils. Based on conditions encountered at the time of the subsurface exploration, removal of numerous medium to large trees will be necessary within landscaped areas along the property lines and within landscaped planters. These landscaped areas also include some shrubs, grass and other vegetation. Any vegetation, organic topsoil, and all tree root masses should be removed during site stripping. These materials should be disposed of off-site. The actual extent of site stripping should be determined in the field by the geotechnical engineer, based on the organic content and stability of the materials encountered. Any soils disturbed during demolition should be removed and replaced with compacted fill soils.

#### Treatment of Existing Soils: Building Pad

Remedial grading should be performed within the proposed building pad area in order to remove all of the existing undocumented fill soils, and a portion of the existing alluvium. The undocumented fill soils extend to depths of 4½ to 6± feet at 3 of the 5 boring locations within the building area. The soils within the proposed building pad area should also be overexcavated to a depth of 3 feet below existing grade and to a depth of at least 3 feet below proposed building pad subgrade elevation. The proposed foundation influence zones within the industrial building should be overexcavated to a depth of at least 3 feet below proposed foundation bearing grade.

The overexcavation areas should extend at least 5 feet beyond the building and foundation perimeters, and to an extent equal to the depth of fill below the new foundations. If the proposed structure incorporates any exterior columns (such as for a canopy or overhang) the area of overexcavation should also encompass these areas.

Following completion of the overexcavation, the subgrade soils within the overexcavation areas should be evaluated by the geotechnical engineer to verify their suitability to serve as the structural fill subgrade, as well as to support the foundation loads of the new structure. This evaluation should include proofrolling and probing to identify any soft, loose, or otherwise unstable soils that must be removed. Some localized areas of deeper excavation may be required if loose, porous, or low-density native soils are encountered at the base of the overexcavation. Deeper undocumented fill soils may also exist at locations not explored by our borings.

After a suitable overexcavation subgrade has been achieved, the exposed soils should be scarified to a depth of at least 12 inches, and moisture conditioned to at 2 to 4 percent above optimum moisture content, and recompacted to at least 90 percent of the ASTM D-1557 maximum dry density. The previously excavated soils may then be replaced as compacted structural fill.

#### Treatment of Existing Soils: Retaining Walls and Site Walls

The existing soils within the areas of proposed retaining and non-retaining site walls should be overexcavated to a depth of at least 3 feet below foundation bearing grade and replaced as compacted structural fill. Any existing fill soils in these areas should be removed. Subgrades for erection pads for concrete tilt-up walls are considered to be a part of the foundation system and should also be overexcavated. Additional overexcavation may be required if porous or collapsible alluvium is encountered, as discussed above. The overexcavation subgrade soils should be evaluated by the geotechnical engineer prior to scarifying, moisture conditioning and recompacting the upper 12 inches of exposed subgrade soils. The previously excavated soils may then be replaced as compacted structural fill.



If the full lateral extent of overexcavation is not achievable for the proposed walls, the foundations should be redesigned using a lower bearing pressure. The geotechnical engineer of record should be contacted for recommendations pertaining to this type of condition.

#### Treatment of Existing Soils: Parking and Drive Areas

Based on economic considerations, overexcavation of the undocumented fill soils and near-surface alluvial soils in the new parking and drive areas is not considered warranted, with the exception of areas where lower strength, or unstable soils are identified by the geotechnical engineer during grading.

Subgrade preparation in the new parking and drive areas should initially consist of removal of all soils disturbed during stripping. The geotechnical engineer should then evaluate the subgrade to identify any areas of additional unsuitable soils. The subgrade soils should then be scarified to a depth of 12± inches, moisture conditioned to 2 to 4 percent above optimum, and recompacted to at least 90 percent of the ASTM D-1557 maximum dry density. Based on the presence of variable strength alluvial soils throughout the site, it is expected that some isolated areas of additional overexcavation may be required to remove zones of lower strength, unsuitable soils.

The grading recommendations presented above for the proposed parking and drive areas assume that the owner and/or developer can tolerate minor amounts of settlement within the proposed parking areas. The grading recommendations presented above do not completely mitigate the extent of existing undocumented fill soils in the parking areas. As such, settlement and associated pavement distress could occur. Typically, repair of such distressed areas involves significantly lower costs than completely mitigating these soils at the time of construction. If the owner cannot tolerate the risk of such settlements, the parking and drive areas should be overexcavated to a depth of 2 feet below proposed pavement subgrade elevation, with the resulting soils replaced as compacted structural fill.

#### Treatment of Existing Soils: Flatwork Areas

Subgrade preparation in the new flatwork areas should initially consist of removal of all soils disturbed during stripping and possible demolition operations. The geotechnical engineer should then evaluate the subgrade to identify any areas of additional unsuitable soils. The subgrade soils should then be scarified to a depth of 12± inches, moisture conditioned or air dried to 2 to 4 percent above optimum, and recompacted to at least 90 percent of the ASTM D-1557 maximum dry density. Based on the presence of variable strength alluvial soils throughout the subject site, it is expected that some isolated areas of additional overexcavation may be required to remove zones of lower strength, unsuitable soils.

As noted previously, the subject site is underlain by low expansive soils. Support of new flatwork on low expansive soils carries minor additional risk with respect to flatwork movement and potential distress. This report provides recommendations for moisture conditioning and additional steel reinforcement in the flatwork areas in order to minimize the potential effects of the expansive soils. However, if additional protection is desired, the client should consider the placement of a 1 to 2-foot thick layer of non-expansive soil beneath all flatwork.



## Fill Placement

- Fill soils should be placed in thin ( $6\pm$  inches), near-horizontal lifts, moisture conditioned to 2 to 4 percent above the optimum moisture content, and compacted.
- On-site soils may be used for fill provided they are cleaned of any debris to the satisfaction of the geotechnical engineer.
- All grading and fill placement activities should be completed in accordance with the requirements of the 2019 CBC and the grading code of the city of Perris and/or the county of Riverside.
- All fill soils should be compacted to at least 90 percent of the ASTM D-1557 maximum dry density. Fill soils should be well mixed.
- Compaction tests should be performed periodically by the geotechnical engineer as random verification of compaction and moisture content. These tests are intended to aid the contractor. Since the tests are taken at discrete locations and depths, they may not be indicative of the entire fill and therefore should not relieve the contractor of his responsibility to meet the job specifications.

## Imported Structural Fill

All imported structural fill should consist of very low expansive ( $EI < 20$ ), well graded soils possessing at least 10 percent fines (that portion of the sample passing the No. 200 sieve). Additional specifications for structural fill are presented in the Grading Guide Specifications, included as Appendix D.

## Utility Trench Backfill

In general, all utility trench backfill soils should be compacted to at least 90 percent of the ASTM D-1557 maximum dry density. As an alternative, a clean sand (minimum Sand Equivalent of 30) may be placed within trenches and compacted in place (jetting or flooding is not recommended). Compacted trench backfill should conform to the requirements of the local grading code, and more restrictive requirements may be indicated by the city of Perris and/or the county of Riverside. All utility trench backfills should be witnessed by the geotechnical engineer. The trench backfill soils should be compaction tested where possible; probed and visually evaluated elsewhere.

Utility trenches which parallel a footing, and extending below a 1h:1v plane projected from the outside edge of the footing should be backfilled with structural fill soils, compacted to at least 90 percent of the ASTM D-1557 standard. Pea gravel backfill should not be used for these trenches.

## **6.4 Construction Considerations**

### Excavation Considerations

The near-surface soils generally consist of silty sands and clayey sands, with some zones of sandy clays and sandy silts. Some of these materials will likely be subject to minor caving within shallow excavations. Where caving occurs within shallow excavations, flattened excavation slopes may be sufficient to provide excavation stability. On a preliminary basis, the inclination of temporary

slopes should not exceed 2h:1v. Deeper excavations may require some form of external stabilization such as shoring or bracing. Maintaining adequate moisture content within the near-surface soils will improve excavation stability. All excavation activities on this site should be conducted in accordance with Cal-OSHA regulations.

### Moisture Sensitive Subgrade Soils

Most of the near surface soils possess appreciable silt and clay content and may become unstable if exposed to significant moisture infiltration or disturbance by construction traffic. In addition, based on their granular content, some of the on-site soils will also be susceptible to erosion. The site should, therefore, be graded to prevent ponding of surface water and to prevent water from running into excavations.

Unstable subgrade soils may be encountered at the base of the overexcavations within the proposed building area. The extent of unstable subgrade soils will, to a large degree depend on methods used by the contractor to avoid adding additional moisture to these soils or disturbing soils which already possess high moisture contents. If grading occurs during a period of relatively wet weather, an increase in subgrade instability should also be expected.

If the construction schedule dictates that site grading will occur during a period of wet weather, allowances should be made for costs and delays associated with drying the on-site soils or import of a drier, less moisture sensitive fill material. Grading during wet or cool weather may also increase the depth of overexcavation in the pad area.

### Groundwater

The static groundwater table is considered to exist at a depth greater than 25± feet below existing grade. Therefore, groundwater is not expected to impact the grading or foundation construction activities.

## **6.5 Foundation Design and Construction**

Based on the preceding grading recommendations, it is assumed that the new building pad will be underlain by newly placed structural fill soils extending to depths of at least 3 feet below foundation bearing grade. Based on this subsurface profile, the proposed structure may be supported on shallow foundations.

### Foundation Design Parameters

New square and rectangular footings may be designed as follows:

- Maximum, net allowable soil bearing pressure: 2,500 lbs/ft<sup>2</sup>.
- Minimum wall/column footing width: 14 inches/24 inches.
- Minimum longitudinal steel reinforcement within strip footings: Four (4) No. 5 rebars (2 top and 2 bottom), due to the presence of potentially expansive soils.

- Minimum foundation embedment: 12 inches into suitable structural fill soils, and at least 18 inches below adjacent exterior grade. Interior column footings may be placed immediately beneath the floor slab.
- It is recommended that the perimeter building foundations be continuous across all exterior doorways. Any flatwork adjacent to the exterior doors should be doweled into the perimeter foundations in a manner determined by the structural engineer.

The allowable bearing pressures presented above may be increased by 1/3 when considering short duration wind or seismic loads. The minimum steel reinforcement recommended above is based on standard geotechnical practice. Additional rigidity may be necessary for structural considerations. The actual design of the foundations should be determined by the structural engineer.

### Foundation Construction

The foundation subgrade soils should be evaluated at the time of overexcavation, as discussed in Section 6.3 of this report. It is further recommended that the foundation subgrade soils be evaluated by the geotechnical engineer immediately prior to steel or concrete placement. Soils suitable for direct foundation support should consist of newly placed structural fill compacted at least 90 percent of the ASTM D-1557 maximum dry density. Any unsuitable materials should be removed to a depth of suitable bearing compacted structural fill, with the resulting excavations backfilled with compacted fill soils. As an alternative, lean concrete slurry (500 to 1,500 psi) may be used to backfill such isolated overexcavations.

The foundation subgrade soils should also be properly moisture conditioned to 2 to 4 percent above the Modified Proctor optimum, to a depth of at least 12 inches below bearing grade. Since it is typically not feasible to increase the moisture content of the floor slab and foundation subgrade soils once rough grading has been completed, care should be taken to maintain the moisture content of the building pad subgrade soils throughout the construction process.

### Estimated Foundation Settlements

Post-construction total and differential settlements of shallow foundations designed and constructed in accordance with the previously presented recommendations are estimated to be less than 1.0 and 0.5 inches, respectively, under static conditions. Differential movements are expected to occur over a 50-foot span, thereby resulting in an angular distortion of less than 0.002 inches per inch.

### Lateral Load Resistance

Lateral load resistance will be developed by a combination of friction acting at the base of foundations and slabs and the passive earth pressure developed by footings below grade. The following friction and passive pressure may be used to resist lateral forces:

- Passive Earth Pressure: 300 lbs/ft<sup>3</sup>
- Friction Coefficient: 0.30

These are allowable values, and include a factor of safety. When combining friction and passive resistance, the passive pressure component should be reduced by one-third. These values assume that footings will be poured directly against compacted structural fill soils. The maximum allowable passive pressure is 3,000 lbs/ft<sup>2</sup>.

## **6.6 Floor Slab Design and Construction**

Subgrades which will support new floor slabs should be prepared in accordance with the recommendations contained in the ***Site Grading Recommendations*** section of this report. Based on the anticipated grading which will occur at this site, the floor of the proposed structure may be constructed as a conventional slab-on-grade, supported on newly placed structural fill, extending to a depth of at least 3 feet below finished pad grade. Based on geotechnical considerations, the floor slab may be designed as follows:

- Minimum slab thickness: 6 inches.
- Modulus of Subgrade Reaction: 140 psi/in.
- Minimum slab reinforcement: Not required for geotechnical considerations. The actual floor slab reinforcement should be determined by the structural engineer, based upon the imposed loading.
- Slab underlayment: If moisture sensitive floor coverings will be used then minimum slab underlayment should consist of a moisture vapor barrier constructed below the entire slab area where such moisture sensitive floor coverings are expected. The moisture vapor barrier should meet or exceed the Class A rating as defined by ASTM E 1745-97 and have a permeance rating less than 0.01 perms as described in ASTM E 96-95 and ASTM E 154-88. A polyolefin material such as Stego® Wrap Vapor Barrier or equivalent will meet these specifications. The moisture vapor barrier should be properly constructed in accordance with all applicable manufacturer specifications. Given that a rock free subgrade is anticipated and that a capillary break is not required, sand below the barrier is not required. The need for sand and/or the amount of sand above the moisture vapor barrier should be specified by the structural engineer or concrete contractor. The selection of sand above the barrier is not a geotechnical engineering issue and hence outside our purview. Where moisture sensitive floor coverings are not anticipated, the vapor barrier may be eliminated.
- Moisture condition the floor slab subgrade soils to 2 to 4 percent above the Modified Proctor optimum moisture content, to a depth of 12 inches. The moisture content of the floor slab subgrade soils should be verified by the geotechnical engineer within 24 hours prior to concrete placement.
- Proper concrete curing techniques should be utilized to reduce the potential for slab curling or the formation of excessive shrinkage cracks.

The actual design of the floor slab should be completed by the structural engineer to verify adequate thickness and reinforcement.

## **6.7 Exterior Flatwork Design and Construction**

Subgrades which will support new exterior slabs-on-grade for sidewalks, patios, and other concrete flatwork, should be prepared in accordance with the recommendations contained in the ***Grading Recommendations*** section of this report. Based on geotechnical considerations, exterior slabs on grade may be designed as follows:

- Minimum slab thickness: 4½ inches.
- Minimum slab reinforcement: No. 3 bars at 18 inches on center, in both directions.
- The flatwork at building entry areas should be structurally connected to the perimeter foundation that is recommended to span across the door opening. This recommendation is designed to reduce the potential for differential movement at this joint.
- Moisture condition the flatwork subgrade soils to at least 2 to 4 percent of optimum moisture content, to a depth of at least 12 inches. Adequate moisture conditioning should be verified by the geotechnical engineer 24 hours prior to concrete placement.
- Proper concrete curing techniques should be utilized to reduce the potential for slab curling or the formation of excessive shrinkage cracks.
- Control joints should be provided at a maximum spacing of 8 feet on center in two directions for slabs and at 6 feet on center for sidewalks. Control joints are intended to direct cracking. Minor cracking of exterior concrete slabs on grade should be expected.

Expansion or felt joints should be used at the interface of exterior slabs on grade and any fixed structures to permit relative movement.

## **6.8 Retaining Wall Design and Construction**

Although not indicated on the site plan, some small (less than 6 feet in height) retaining walls may be required in truck court area and to facilitate the new site grades. The parameters recommended for use in the design of these walls are presented below.

### Retaining Wall Design Parameters

Based on the soil conditions encountered at the boring locations, the following parameters may be used in the design of new retaining walls for this site. We have provided parameters assuming the use of on-site soils for retaining wall backfill. The on-site soils generally consist of silty sands, sandy silts, and clayey sands. Some zones of sandy clays were also encountered near the ground surface. **The sandy clays and silty clays are not recommended to be used as retaining wall backfill.** Based on their classifications, the on-site silty sands, sandy silts and clayey sands are expected to possess a friction angle of at least 30 degrees when compacted to 90 percent of the ASTM-1557 maximum dry density.

If desired, SCG could provide design parameters for an alternative select backfill material behind the retaining walls. The use of select backfill material could result in lower lateral earth pressures. In order to use the design parameters for the imported select fill, this material must be placed within the entire active failure wedge. This wedge is defined as extending from the heel of the retaining wall upwards at an angle of approximately 60° from horizontal. If select backfill material behind the retaining wall is desired, SCG should be contacted for supplementary recommendations.

RETAINING WALL DESIGN PARAMETERS

Design Parameter		Soil Type
		On-Site Silty Sands, Sandy Silts, Clayey Sands
Internal Friction Angle ( $\phi$ )		30°
Unit Weight		135 lbs/ft <sup>3</sup>
Equivalent Fluid Pressure:	Active Condition (level backfill)	45 lbs/ft <sup>3</sup>
	Active Condition (2h:1v backfill)	72 lbs/ft <sup>3</sup>
	At-Rest Condition (level backfill)	67 lbs/ft <sup>3</sup>

Regardless of the backfill type, the walls should be designed using a soil-footing coefficient of friction of 0.30 and an equivalent passive pressure of 300 lbs/ft<sup>3</sup>. The structural engineer should incorporate appropriate factors of safety in the design of the retaining walls.

The active earth pressure may be used for the design of retaining walls that do not directly support structures or support soils that in turn support structures and which will be allowed to deflect. The at-rest earth pressure should be used for walls that will not be allowed to deflect such as those which will support foundation bearing soils, or which will support foundation loads directly.

Where the soils on the toe side of the retaining wall are not covered by a "hard" surface such as a structure or pavement, the upper 1 foot of soil should be neglected when calculating passive resistance due to the potential for the material to become disturbed or degraded during the life of the structure.

Seismic Lateral Earth Pressures

In accordance with the 2019 CBC, any retaining walls more than 6 feet in height must be designed for seismic lateral earth pressures. If walls 6 feet or more are required for this site, the geotechnical engineer should be contacted for supplementary seismic lateral earth pressure recommendations.

Retaining Wall Foundation Design

The retaining wall foundations should be supported within newly placed compacted structural fill, extending to a depth of at least 3 feet below proposed foundation bearing grade. Foundations to

support new retaining walls should be designed in accordance with the general Foundation Design Parameters presented in a previous section of this report.

### Backfill Material

On-site soils may be used to backfill the retaining walls. However, all backfill material placed within 3 feet of the back-wall face should have a particle size no greater than 3 inches. **The on-site sandy clays and silty clays are not recommended to be used as retaining wall backfill.** The retaining wall backfill materials should be well-graded.

It is recommended that a properly installed prefabricated drainage composite such as the MiraDRAIN 6000XL (or approved equivalent), which is specifically designed for use behind retaining walls be used. If the drainage composite material is not covered by an impermeable surface, such as a structure or pavement, a 12-inch thick layer of a low permeability soil should be placed over the backfill to reduce surface water migration to the underlying soils. The drainage composite should be separated from the backfill soils by a suitable geotextile, approved by the geotechnical engineer.

All retaining wall backfill should be placed and compacted under engineering-controlled conditions in the necessary layer thicknesses to ensure an in-place density between 90 and 93 percent of the maximum dry density as determined by the Modified Proctor test (ASTM D1557). Care should be taken to avoid over-compaction of the soils behind the retaining walls, and the use of heavy compaction equipment should be avoided.

### Subsurface Drainage

As previously indicated, the retaining wall design parameters are based upon drained backfill conditions. Consequently, some form of permanent drainage system will be necessary in conjunction with the appropriate backfill material. Subsurface drainage may consist of either:

- A weep hole drainage system typically consisting of a series of 2-inch diameter holes in the wall situated slightly above the ground surface elevation on the exposed side of the wall and at an approximate 10-foot on-center spacing. Alternatively, 4-inch diameter holes at an approximate 20-foot on-center spacing can be used for this type of drainage system. In addition, the weep holes should include a 2 cubic foot pocket of open graded gravel, surrounded by an approved geotextile fabric, at each weep hole location.
- A 4-inch diameter perforated pipe surrounded by 2 cubic feet of gravel per linear foot of drain placed behind the wall, above the retaining wall footing. The gravel layer should be wrapped in a suitable geotextile fabric to reduce the potential for migration of fines. The footing drain should be extended to daylight or tied into a storm drainage system. The actual design of this type of system should be determined by the civil engineer to verify that the drainage system possesses the adequate capacity and slope for its intended use.

Weep holes or a footing drain will not be required for building stem walls.



## **6.9 Pavement Design Parameters**

Site preparation in the pavement area should be completed as previously recommended in the ***Site Grading Recommendations*** section of this report. The subsequent pavement recommendations assume proper drainage and construction monitoring, and are based on either PCA or CALTRANS design parameters for a twenty (20) year design period. However, these designs also assume a routine pavement maintenance program to obtain the anticipated 20-year pavement service life.

### **Pavement Subgrades**

It is anticipated that the new pavements will be primarily supported on a layer of compacted structural fill, consisting of scarified, thoroughly moisture conditioned and recompacted existing soils. The on-site soils generally consist of silty sands, sandy silts, clayey sands, and sandy clays. These soils are generally considered to possess fair pavement support characteristics with estimated R-values ranging from 30 to 40. The subsequent pavement design is therefore based upon an assumed R-value of 30. Any fill material imported to the site should have support characteristics equal to or greater than that of the on-site soils and be placed and compacted under engineering controlled conditions. It is recommended that R-value testing be performed after completion of rough grading. Depending upon the results of the R-value testing, it may be feasible to use thinner pavement sections in some areas of the site.

### **Asphaltic Concrete**

Presented below are the recommended thicknesses for new flexible pavement structures consisting of asphaltic concrete over a granular base. The pavement designs are based on the traffic indices (TI's) indicated. The client and/or civil engineer should verify that these TI's are representative of the anticipated traffic volumes. If the client and/or civil engineer determine that the expected traffic volume will exceed the applicable traffic index, we should be contacted for supplementary recommendations. The design traffic indices equate to the following approximate daily traffic volumes over a 20 year design life, assuming six operational traffic days per week.

<b>Traffic Index</b>	<b>No. of Heavy Trucks per Day</b>
4.0	0
5.0	1
6.0	3
7.0	11
8.0	35
9.0	93

For the purpose of the traffic volumes indicated above, a truck is defined as a 5-axle tractor trailer unit with one 8-kip axle and two 32-kip tandem axles. All of the traffic indices allow for 1,000 automobiles per day.



<b>ASPHALT PAVEMENTS (R=30)</b>					
<b>Materials</b>	<b>Thickness (inches)</b>				
	Auto Parking and Auto Drive Lanes (TI = 4.0 to 5.0)	Truck Traffic			
		TI = 6.0	TI = 7.0	TI = 8.0	TI = 9.0
Asphalt Concrete	3	3½	4	5	5½
Aggregate Base	6	8	10	11	13
Compacted Subgrade	12	12	12	12	12

The aggregate base course should be compacted to at least 95 percent of the ASTM D-1557 maximum dry density. The asphaltic concrete should be compacted to at least 95 percent of the Marshall maximum density, as determined by ASTM D-2726. The aggregate base course may consist of crushed aggregate base (CAB) or crushed miscellaneous base (CMB), which is a recycled gravel, asphalt and concrete material. The gradation, R-Value, Sand Equivalent, and Percentage Wear of the CAB or CMB should comply with appropriate specifications contained in the current edition of the "Greenbook" Standard Specifications for Public Works Construction.

#### Portland Cement Concrete

The preparation of the subgrade soils within concrete pavement areas should be performed as previously described for proposed asphalt pavement areas. The minimum recommended thicknesses for the Portland Cement Concrete pavement sections are as follows:

<b>PORTLAND CEMENT CONCRETE PAVEMENTS (R=30)</b>				
<b>Materials</b>	<b>Thickness (inches)</b>			
	Autos and Light Truck Traffic (TI = 5.0 to 6.0)	Truck Traffic		
		TI = 7.0	TI = 8.0	TI = 9.0
PCC	5	5½	6½	8
Compacted Subgrade (95% minimum compaction)	12	12	12	12

The concrete should have a 28-day compressive strength of at least 3,000 psi. The maximum joint spacing within all of the PCC pavements is recommended to be equal to or less than 30 times the pavement thickness.

## **7.0 GENERAL COMMENTS**

---

This report has been prepared as an instrument of service for use by the client, in order to aid in the evaluation of this property and to assist the architects and engineers in the design and preparation of the project plans and specifications. This report may be provided to the contractor(s) and other design consultants to disclose information relative to the project. However, this report is not intended to be utilized as a specification in and of itself, without appropriate interpretation by the project architect, civil engineer, and/or structural engineer. The reproduction and distribution of this report must be authorized by the client and Southern California Geotechnical, Inc. Furthermore, any reliance on this report by an unauthorized third party is at such party's sole risk, and we accept no responsibility for damage or loss which may occur. The client(s)' reliance upon this report is subject to the Engineering Services Agreement, incorporated into our proposal for this project.

The analysis of this site was based on a subsurface profile interpolated from limited discrete soil samples. While the materials encountered in the project area are considered to be representative of the total area, some variations should be expected between boring locations and sample depths. If the conditions encountered during construction vary significantly from those detailed herein, we should be contacted immediately to determine if the conditions alter the recommendations contained herein.

This report has been based on assumed or provided characteristics of the proposed development. It is recommended that the owner, client, architect, structural engineer, and civil engineer carefully review these assumptions to ensure that they are consistent with the characteristics of the proposed development. If discrepancies exist, they should be brought to our attention to verify that they do not affect the conclusions and recommendations contained herein. We also recommend that the project plans and specifications be submitted to our office for review to verify that our recommendations have been correctly interpreted.

The analysis, conclusions, and recommendations contained within this report have been promulgated in accordance with generally accepted professional geotechnical engineering practice. No other warranty is implied or expressed.



March 8, 2022

First Industrial Realty Trust, Inc.  
898 North Pacific Coast Highway, Suite 175  
El Segundo, California 90245

Attention: Mr. Michael Goodwin  
Director of Development

Project No.: **21G122-2**

Subject: **Results of Infiltration Testing**  
First Sinclair Logistics Center  
100 West Sinclair Street  
Perris, California

Reference: Geotechnical Investigation, First Sinclair Logistics Center, 100 West Sinclair Street, Perris, California, prepared for First Industrial Realty Trust, Inc., by Southern California Geotechnical, Inc. (SCG), SCG Project No. 22G122-1, dated March 4, 2022.

Mr. Goodwin:

In accordance with your request, we have conducted infiltration testing at the subject site. We are pleased to present this report summarizing the results of the infiltration testing and our design recommendations.

### **Scope of Services**

The scope of services performed for this project was in general accordance with our Proposal No. 22P120, dated January 20, 2022. The scope of services included site reconnaissance, subsurface exploration, field testing, and engineering analysis to determine the infiltration rates of the onsite soils. The infiltration testing was performed in general accordance with the guidelines published in Riverside County – Low Impact Development BMP Design Handbook – Section 2.3 of Appendix A, prepared for the Riverside County Department of Environmental Health (RCDEH), dated December, 2013.

### **Site and Project Description**

The site is located at 100 West Sinclair Street in Perris, California. The site is bounded to the north and east by vacant parcels and to the west by Barrett Avenue. An existing building is located on the southerly adjacent property. The general location of the site is illustrated on the Site Location Map, included as Plate 1 of this report.

The site consists of an L-shaped parcel, 13.85± acres in size. The site is presently developed with one (1) warehouse building, 161,000± ft<sup>2</sup> in size, located in the north-central area of the site. The building is surrounded by Portland cement concrete pavements in the loading dock areas and asphaltic concrete (AC) pavements in the eastern parking area. The asphaltic concrete pavements were in fair to poor condition with moderate cracking throughout. Ground surface cover in the

remaining areas of the site consists of open-graded gravel in the northwestern area and exposed soil in the southwestern area of the site. Concrete flatwork and landscape planters are present throughout the western parking area and along the west, north and east property lines. The planters include medium to large trees and exposed soil.

Detailed topographic information was not available at the time of this report. Based on elevations obtained from Google Earth and visual observations made at the time of the subsurface investigation, the eastern parking area slopes downward to the north at a gradient of less than 1± percent. The western portion of the site has a central low point with gentle ascending slopes to the south, west and north with estimated gradients between 2 and 3± percent.

### **Proposed Development**

SCG was provided with conceptual site plan prepared by HPA Architecture (Scheme 5). Based on Scheme 5, the site will be developed with one (1) new warehouse building, 271,359± ft<sup>2</sup> in size, located in the north-central area of the site. Dock-high doors will be constructed along most of the southern building wall. The building will be surrounded by asphaltic concrete pavements in the parking and drive lanes, Portland cement concrete pavements in the loading dock areas, and limited areas of concrete flatwork and landscape planters throughout the site.

We understand that the proposed development will include on-site storm water infiltration. The infiltration system will consist of a below-grade chamber system located in the southeastern area of the site. The bottom of the infiltration system is expected to be 8 to 9± feet below the existing site grades.

### **Concurrent Study**

The subsurface exploration for this phase of the project consisted of six (6) borings advanced to depths of 15 to 25± feet below the existing site grades. Artificial fill soils were encountered beneath the pavements/slab at several of the boring locations, extending to depths of 4½ to 6± feet. The fill soils generally consisted of loose to medium dense silty fine to medium sands and fine to medium sandy silts. Native alluvium was encountered beneath the fill soils at all of the boring locations. The alluvial soils generally consisted of loose to medium dense fine sandy silts, clayey fine sands, fine to coarse sands, silty fine to medium sands, and stiff to hard silty clays extending to at least the maximum depth explored of 25± feet.

### **Groundwater**

Free water was not encountered during the drilling of any of the borings. Based on the lack of any water within the borings, and the moisture contents of the recovered soil samples, the static groundwater table is considered to have existed at a depth in excess of 25± feet at the time of the subsurface exploration.

Recent water level data was obtained from the California State Water Resources Control Board, GeoTracker, website, <https://geotracker.waterboards.ca.gov/>. One monitoring well on record is located 210± feet south of the site. Water level readings within this monitoring well indicate a high groundwater level of 79± feet below the ground surface in February 2015.

## **Subsurface Exploration**

### Scope of Exploration

The subsurface exploration conducted for the infiltration testing consisted of two (2) infiltration test borings, advanced to a depth of 9± feet below the existing site grades. The infiltration borings (identified as Infiltration No. I-1 and I-2) were advanced using a truck-mounted drilling rig, equipped with 8-inch-diameter hollow stem augers and were logged during drilling by a member of our staff. The borings were logged during drilling by a member of our staff. The approximate locations of the infiltration borings are indicated on the Infiltration Test Location Plan, enclosed as Plate 2 of this report.

### Geotechnical Conditions

Fill soils were encountered beneath the pavements at both of the infiltration boring locations. The fill soils consist of medium dense clayey fine to medium sands with varying amounts of silt extended to a depth of 3± feet. Native alluvial soils were encountered beneath the fill soils at both of the infiltration boring locations. The alluvial soils consist of medium dense to dense, silty fine to coarse sands and fine to medium sandy silts extending to the maximum depth explored of 9± feet. The Boring Logs, which illustrate the conditions encountered at the infiltration test locations, are presented in this report.

## **Infiltration Testing**

The infiltration testing was performed in general accordance with the Riverside County guidelines: Riverside County – Low Impact Development BMP Design Handbook – Section 2.3 of Appendix A.

### Pre-soaking

In accordance with the county infiltration standards for sandy soils, all infiltration test borings were pre-soaked 2 hours prior to the infiltration testing or until all of the water had percolated through the test holes. The pre-soaking process consisted of filling test borings by inverting a full 5-gallon bottle of clear water supported over each hole so that the water flow into the hole holds constant at a level at least 5 times the hole's radius above the gravel at the bottom of each hole. Pre-soaking was completed after all of the water had percolated through the test holes.

### Infiltration Testing

Following the pre-soaking process, SCG performed the infiltration testing. Each test hole was filled with water to a depth of at least 5 times the hole's radius above the gravel at the bottom of the test holes. In accordance with the Riverside County guidelines, since "sandy soils" (where 6 inches of water infiltrated into the surrounding soils in less than 25 minutes for two consecutive readings) were encountered at the bottom of Infiltration Test No. I-1, readings were taken at 10-minute intervals for a total of at least 1 hour. Since "non-sandy soils" (where 6 inches of water did not infiltrate into the surrounding soils in less than 25 minutes for two consecutive readings) were encountered at the bottom of Infiltration Test No. I-2, readings were taken at 30-minute intervals for a total of at least 6 hours.

After each reading, water was added to the borings so that the depth of the water was at least 5 times the radius of the hole. The water level readings are presented on the spreadsheets enclosed with this report. The infiltration rates for each of the timed intervals are also tabulated on the spreadsheets.

The infiltration rates from the tests are tabulated in inches per hour. In accordance with the typically accepted practice, it is recommended that the most conservative reading from the latter part of the infiltration tests be used as the design infiltration rate. The rates are summarized below:

<u>Infiltration Test No.</u>	<u>Depth (feet)</u>	<u>Soil Description</u>	<u>Infiltration Rate (inches/hour)</u>
I-1	9	Fine to medium Sandy Silt to Silty fine to medium Sand, trace coarse Sand, trace Clay	2.4
I-2	9	Fine to medium Sandy Silt to Silty fine to medium Sand, trace coarse Sand, trace Clay	0.3

### **Laboratory Testing**

#### Moisture Content

The moisture contents for the recovered soil samples within the borings were determined in accordance with ASTM D-2216 and are expressed as a percentage of the dry weight. These test results are presented on the Boring Logs.

#### Grain Size Analysis

The grain size distribution of selected soils collected from the base of each infiltration test boring have been determined using a range of wire mesh screens. These tests were performed in general accordance with ASTM D-422 and/or ASTM D-1140. The weight of the portion of the sample retained on each screen is recorded and the percentage finer or coarser of the total weight is calculated. The results of these tests are presented on Plates C-1 and C-2 of this report.

### **Design Recommendations**

Two (2) infiltration tests were performed at the subject site. As noted above, the infiltration rates at these locations vary from 0.3 to 2.4 inches per hour. **Based on the infiltration test results, we recommend an average rate of 1.4 inches per hour be used for the infiltration chamber system.**

We recommend that a representative from the geotechnical engineer be on-site during the construction of the proposed infiltration systems to identify the soil classification at the base of each chamber system. It should be confirmed that the soils at the base of the proposed infiltration systems correspond with those presented in this report to ensure that the performance of the systems will be consistent with the rates reported herein.

The design of the storm water infiltration system should be performed by the project civil engineer, in accordance with the City of Perris and/or County of Riverside guidelines. It is recommended that the system be constructed so as to facilitate removal of silt and clay, or other deleterious materials from any water that may enter the systems. The presence of such materials would decrease the effective infiltration rates. **It is recommended that the project civil engineer apply an appropriate factor of safety. The infiltration rates recommended above is based on the assumption that only clean water will be introduced to the subsurface profile. Any fines, debris, or organic materials could significantly impact the infiltration rate.** It should be noted that the recommended infiltration rates are based on infiltration testing at two (2) discrete locations and that the overall infiltration rates of the proposed infiltration systems could vary considerably.

### **Infiltration Rate Considerations**

The infiltration rates presented herein was determined in accordance with the Riverside County guidelines and are considered valid only for the time and place of the actual test. Varying subsurface conditions will exist in other areas of the site, which could alter the recommended infiltration rates presented above. The infiltration rates will decline over time between maintenance cycles as silt or clay particles accumulate on the BMP surface. The infiltration rate is highly dependent upon a number of factors, including density, silt and clay content, grainsize distribution throughout the range of particle sizes, and particle shape. Small changes in these factors can cause large changes in the infiltration rates.

Infiltration rates are based on unsaturated flow. As water is introduced into soils by infiltration, the soils become saturated and the wetting front advances from the unsaturated zone to the saturated zone. Once the soils become saturated, infiltration rates become zero, and water can only move through soils by hydraulic conductivity at a rate determined by pressure head and soil permeability. Changes in soil moisture content will affect the infiltration rate. Infiltration rates should be expected to decrease until the soils become saturated. Soil permeability values will then govern groundwater movement. Permeability values may be on the order of 10 to 20 times less than infiltration rates. The system designer should incorporate adequate factors of safety and allow for overflow design into appropriate traditional storm drain systems, which would transport storm water off-site.

### **Construction Considerations**

The infiltration rates presented in this report are specific to the tested locations and tested depths. Infiltration rates can be significantly reduced if the soils are exposed to excessive disturbance or compaction during construction. Compaction of the soils at the bottom of the infiltration system can significantly reduce the infiltration ability of the basins. Therefore, the subgrade soils within proposed infiltration system areas should not be over-excavated, undercut or compacted in any significant manner. **It is recommended that a note to this effect be added to the project plans and/or specifications.**

We recommend that a representative from the geotechnical engineer be on-site during the construction of the proposed infiltration systems to identify the soil classification at the base of each system. It should be confirmed that the soils at the base of the proposed infiltration systems



correspond with those presented in this report to ensure that the performance of the systems will be consistent with the rates reported herein.

We recommend that scrapers and other rubber-tired heavy equipment not be operated on the basin bottom, or at levels lower than 2 feet above the bottom of the system, particularly within basins. As such, the bottom 24 inches of the infiltration systems should be excavated with non-rubber-tired equipment, such as excavators.

### **Chamber Maintenance**

The proposed project may include infiltration chambers. Water flowing into these chambers will carry some level of sediment. This layer has the potential to significantly reduce the infiltration rate of the chamber subgrade soils. Therefore, a formal chamber maintenance program should be established to ensure that these silt and clay deposits are removed from the chamber on a regular basis.

### **Location of Infiltration Systems**

The use of on-site storm water infiltration systems carries a risk of creating adverse geotechnical conditions. Increasing the moisture content of the soil can cause the soil to lose internal shear strength and increase its compressibility, resulting in a change in the designed engineering properties. Overlying structures and pavements in the infiltration area could potentially be damaged due to saturation of the subgrade soils. **The proposed infiltration systems for this site should be located at least 25 feet away from any structures, including retaining walls.** Even with this provision of locating the infiltration system at least 25 feet from the building(s), it is possible that infiltrating water into the subsurface soils could have an adverse effect on the proposed or existing structures. It should also be noted that utility trenches which happen to collect storm water can also serve as conduits to transmit storm water toward the structure, depending on the slope of the utility trench. Therefore, consideration should also be given to the proposed locations of underground utilities which may pass near the proposed infiltration system.

The infiltration system designer should also give special consideration to the effect that the proposed infiltration systems may have on nearby subterranean structures, open excavations, or descending slopes. In particular, infiltration systems should not be located near the crest of descending slopes, particularly where the slopes are comprised of granular soils. Such systems will require specialized design and analysis to evaluate the potential for slope instability, piping failures and other phenomena that typically apply to earthen dam design. This type of analysis is beyond the scope of this infiltration test report, but these factors should be considered by the infiltration system designer when locating the infiltration systems.

### **General Comments**

This report has been prepared as an instrument of service for use by the client in order to aid in the evaluation of this property and to assist the architects and engineers in the design and preparation of the project plans and specifications. This report may be provided to the contractor(s) and other design consultants to disclose information relative to the project. However, this report is not intended to be utilized as a specification in and of itself, without

appropriate interpretation by the project architect, structural engineer, and/or civil engineer. The design of the proposed storm water infiltration system is the responsibility of the civil engineer. The role of the geotechnical engineer is limited to determination of infiltration rate only. By using the design infiltration rate contained herein, the civil engineer agrees to indemnify, defend, and hold harmless the geotechnical engineer for all aspects of the design and performance of the proposed storm water infiltration system. The reproduction and distribution of this report must be authorized by the client and Southern California Geotechnical, Inc. Furthermore, any reliance on this report by an unauthorized third party is at such party's sole risk, and we accept no responsibility for damage or loss which may occur.

The analysis of this site was based on a subsurface profile interpolated from limited discrete soil samples. While the materials encountered in the project area are considered to be representative of the total area, some variations should be expected between boring locations and testing depths. If the conditions encountered during construction vary significantly from those detailed herein, we should be contacted immediately to determine if the conditions alter the recommendations contained herein.

This report has been based on assumed or provided characteristics of the proposed development. It is recommended that the owner, client, architect, structural engineer, and civil engineer carefully review these assumptions to ensure that they are consistent with the characteristics of the proposed development. If discrepancies exist, they should be brought to our attention to verify that they do not affect the conclusions and recommendations contained herein. We also recommend that the project plans and specifications be submitted to our office for review to verify that our recommendations have been correctly interpreted. The analysis, conclusions, and recommendations contained within this report have been promulgated in accordance with generally accepted professional geotechnical engineering practice. No other warranty is implied or expressed.

**Closure**

We sincerely appreciate the opportunity to be of service on this project. We look forward to providing additional consulting services during the course of the project. If we may be of further assistance in any manner, please contact our office.

Respectfully Submitted,

SOUTHERN CALIFORNIA GEOTECHNICAL, INC.



Jose A. Zuniga  
Staff Engineer



Daryl Kas, CEG 2467  
Senior Geologist



Gregory K. Mitchell, GE 2364  
Principal Engineer



Distribution: (1) Addressee

Enclosures: Plate 1 - Site Location Map  
Plate 2 - Infiltration Test Location Plan  
Boring Log Legend and Logs (4 pages)  
Infiltration Test Results Spreadsheets (2 pages)  
Grain Size Distribution Graphs (3 pages)

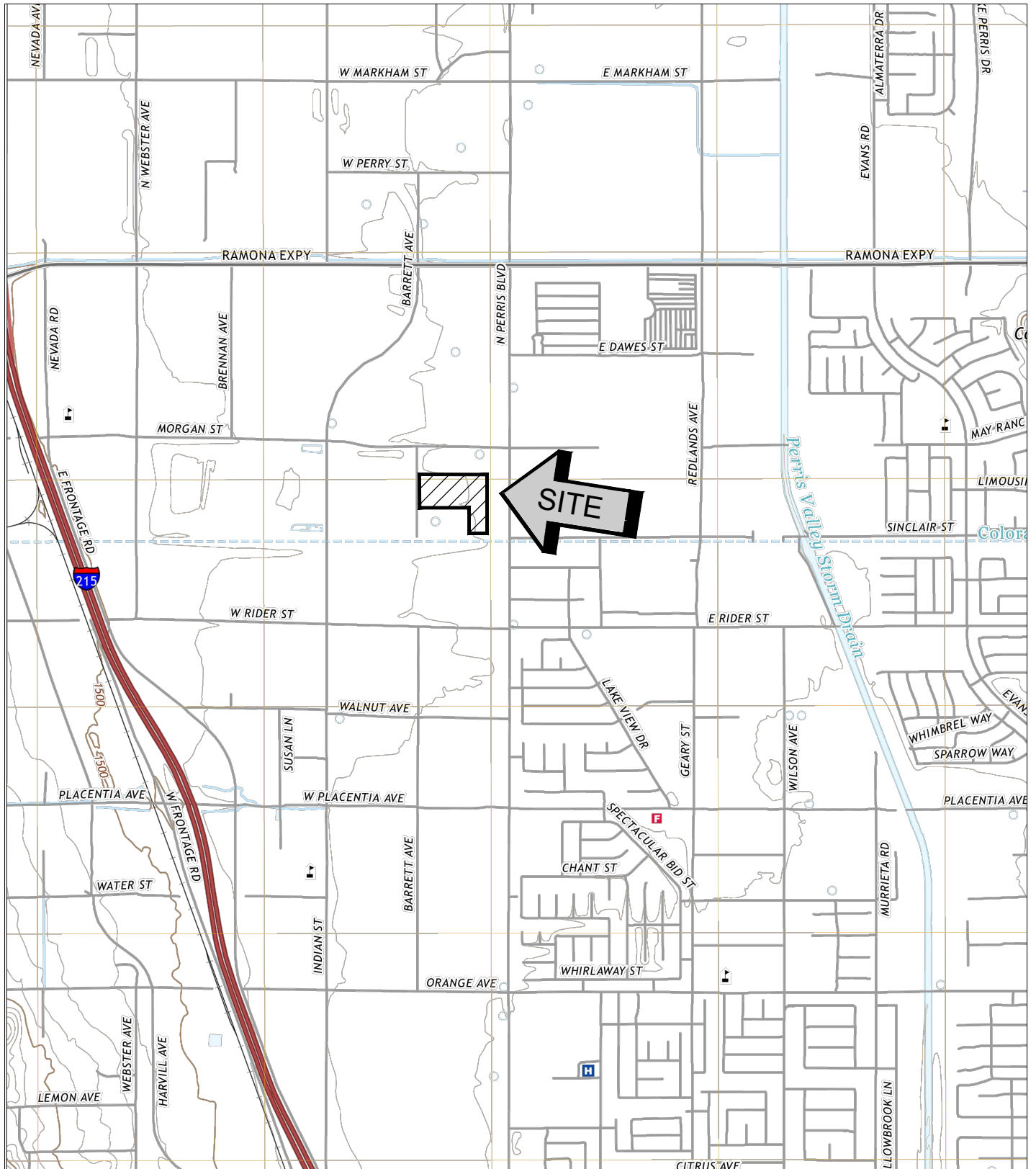

SOURCE: USGS TOPOGRAPHIC MAP OF THE PERRIS QUADRANGLE, RIVERSIDE COUNTY, CALIFORNIA, 2021.





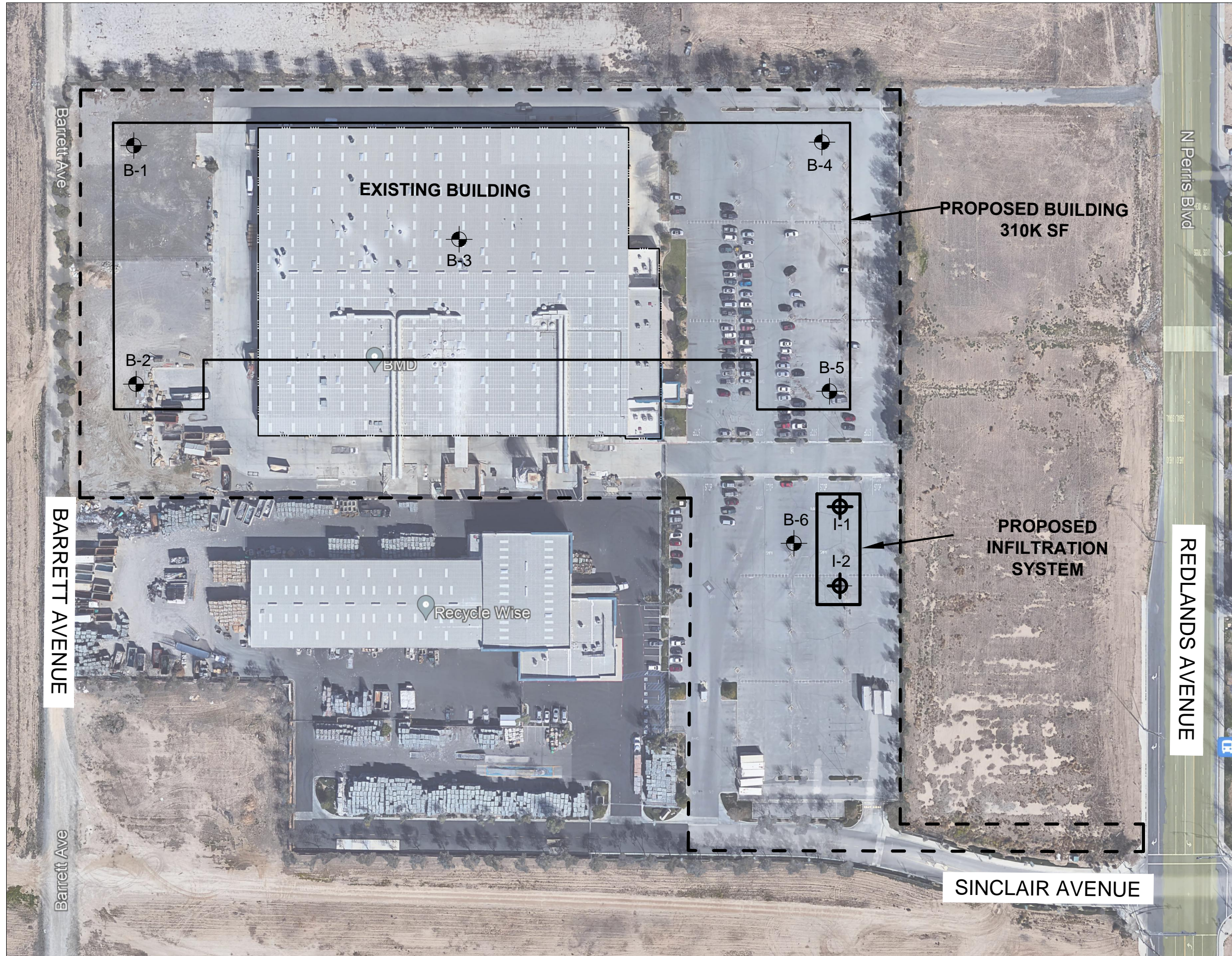

<b>SITE LOCATION MAP</b>	
FIRST SINCLAIR LOGISTICS CENTER	
PERRIS, CALIFORNIA	
SCALE: 1" = 2000'	 <b>SOUTHERN CALIFORNIA GEOTECHNICAL</b>
DRAWN: MD	
CHKD: RGT	
SCG PROJECT 22G122-2	
<b>PLATE 1</b>	



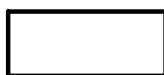
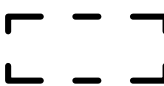

**GEOTECHNICAL LEGEND**







-  APPROXIMATE INFILTRATION TEST LOCATION
-  APPROXIMATE BORING LOCATION (SCG PROJECT NO. 22G122-1)
-  PROPOSED INDUSTRIAL BUILDING OUTLINE
-  PROPERTY LINE
-  EXISTING BUILDING

NOTE: CONCEPTUAL SITE PLAN PREPARED BY HPA ARCHITECTURE. AERIAL PHOTOGRAPH OBTAINED FROM GOOGLE EARTH.

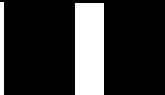
<b>INFILTRATION TEST LOCATION PLAN</b>	
FIRST SINCLAIR LOGISTICS CENTER	
PERRIS, CALIFORNIA	
SCALE: 1" = 120'	 <b>SOUTHERN CALIFORNIA GEOTECHNICAL</b>
DRAWN: MD	
CHKD: GKM	
SCG PROJECT 22G122-2	
<b>PLATE 2</b>	

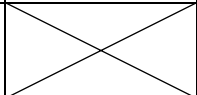
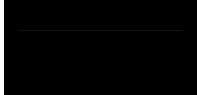

# BORING LOG LEGEND

SAMPLE TYPE	GRAPHICAL SYMBOL	SAMPLE DESCRIPTION
AUGER		SAMPLE COLLECTED FROM AUGER CUTTINGS, NO FIELD MEASUREMENT OF SOIL STRENGTH. (DISTURBED)
CORE		ROCK CORE SAMPLE: TYPICALLY TAKEN WITH A DIAMOND-TIPPED CORE BARREL. TYPICALLY USED ONLY IN HIGHLY CONSOLIDATED BEDROCK.
GRAB		SOIL SAMPLE TAKEN WITH NO SPECIALIZED EQUIPMENT, SUCH AS FROM A STOCKPILE OR THE GROUND SURFACE. (DISTURBED)
CS		CALIFORNIA SAMPLER: 2-1/2 INCH I.D. SPLIT BARREL SAMPLER, LINED WITH 1-INCH HIGH BRASS RINGS. DRIVEN WITH SPT HAMMER. (RELATIVELY UNDISTURBED)
NSR		NO RECOVERY: THE SAMPLING ATTEMPT DID NOT RESULT IN RECOVERY OF ANY SIGNIFICANT SOIL OR ROCK MATERIAL.
SPT		STANDARD PENETRATION TEST: SAMPLER IS A 1.4 INCH INSIDE DIAMETER SPLIT BARREL, DRIVEN 18 INCHES WITH THE SPT HAMMER. (DISTURBED)
SH		SHELBY TUBE: TAKEN WITH A THIN WALL SAMPLE TUBE, PUSHED INTO THE SOIL AND THEN EXTRACTED. (UNDISTURBED)
VANE		VANE SHEAR TEST: SOIL STRENGTH OBTAINED USING A 4 BLADED SHEAR DEVICE. TYPICALLY USED IN SOFT CLAYS-NO SAMPLE RECOVERED.

## COLUMN DESCRIPTIONS

### DEPTH:

Distance in feet below the ground surface.

### SAMPLE:

Sample Type as depicted above.

### BLOW COUNT:

Number of blows required to advance the sampler 12 inches using a 140 lb hammer with a 30-inch drop. 50/3" indicates penetration refusal (>50 blows) at 3 inches. WH indicates that the weight of the hammer was sufficient to push the sampler 6 inches or more.

### POCKET PEN.:

Approximate shear strength of a cohesive soil sample as measured by pocket penetrometer.

### GRAPHIC LOG:

Graphic Soil Symbol as depicted on the following page.

### DRY DENSITY:

Dry density of an undisturbed or relatively undisturbed sample in lbs/ft<sup>3</sup>.

### MOISTURE CONTENT:

Moisture content of a soil sample, expressed as a percentage of the dry weight.

### LIQUID LIMIT:

The moisture content above which a soil behaves as a liquid.

### PLASTIC LIMIT:

The moisture content above which a soil behaves as a plastic.

### PASSING #200 SIEVE:

The percentage of the sample finer than the #200 standard sieve.

### UNCONFINED SHEAR:

The shear strength of a cohesive soil sample, as measured in the unconfined state.

# SOIL CLASSIFICATION CHART

MAJOR DIVISIONS			SYMBOLS		TYPICAL DESCRIPTIONS	
			GRAPH	LETTER		
<p><b>COARSE GRAINED SOILS</b></p> <p>MORE THAN 50% OF MATERIAL IS LARGER THAN NO. 200 SIEVE SIZE</p>	<p><b>GRAVEL AND GRAVELLY SOILS</b></p>	<p>CLEAN GRAVELS</p> <p>(LITTLE OR NO FINES)</p>		<b>GW</b>	WELL-GRADED GRAVELS, GRAVEL - SAND MIXTURES, LITTLE OR NO FINES	
		<p>MORE THAN 50% OF COARSE FRACTION RETAINED ON NO. 4 SIEVE</p>	<p>GRAVELS WITH FINES</p> <p>(APPRECIABLE AMOUNT OF FINES)</p>		<b>GP</b>	POORLY-GRADED GRAVELS, GRAVEL - SAND MIXTURES, LITTLE OR NO FINES
			<p>GRAVELS WITH FINES</p> <p>(APPRECIABLE AMOUNT OF FINES)</p>		<b>GM</b>	SILTY GRAVELS, GRAVEL - SAND - SILT MIXTURES
		<p>MORE THAN 50% OF COARSE FRACTION PASSING ON NO. 4 SIEVE</p>	<p>CLEAN SANDS</p> <p>(LITTLE OR NO FINES)</p>		<b>SW</b>	WELL-GRADED SANDS, GRAVELLY SANDS, LITTLE OR NO FINES
	<p>MORE THAN 50% OF COARSE FRACTION PASSING ON NO. 4 SIEVE</p>		<p>SANDS WITH FINES</p> <p>(APPRECIABLE AMOUNT OF FINES)</p>		<b>SP</b>	POORLY-GRADED SANDS, GRAVELLY SAND, LITTLE OR NO FINES
		<p>SANDS WITH FINES</p> <p>(APPRECIABLE AMOUNT OF FINES)</p>		<b>SM</b>	SILTY SANDS, SAND - SILT MIXTURES	
	<p><b>FINE GRAINED SOILS</b></p> <p>MORE THAN 50% OF MATERIAL IS SMALLER THAN NO. 200 SIEVE SIZE</p>	<p><b>SILTS AND CLAYS</b></p> <p>LIQUID LIMIT LESS THAN 50</p>		<b>ML</b>	INORGANIC SILTS AND VERY FINE SANDS, ROCK FLOUR, SILTY OR CLAYEY FINE SANDS OR CLAYEY SILTS WITH SLIGHT PLASTICITY	
				<b>CL</b>	INORGANIC CLAYS OF LOW TO MEDIUM PLASTICITY, GRAVELLY CLAYS, SANDY CLAYS, SILTY CLAYS, LEAN CLAYS	
				<b>OL</b>	ORGANIC SILTS AND ORGANIC SILTY CLAYS OF LOW PLASTICITY	
		<p><b>SILTS AND CLAYS</b></p> <p>LIQUID LIMIT GREATER THAN 50</p>		<b>MH</b>	INORGANIC SILTS, MICACEOUS OR DIATOMACEOUS FINE SAND OR SILTY SOILS	
			<b>CH</b>	INORGANIC CLAYS OF HIGH PLASTICITY		
			<b>OH</b>	ORGANIC CLAYS OF MEDIUM TO HIGH PLASTICITY, ORGANIC SILTS		
<p><b>HIGHLY ORGANIC SOILS</b></p>				<b>PT</b>	PEAT, HUMUS, SWAMP SOILS WITH HIGH ORGANIC CONTENTS	

NOTE: DUAL SYMBOLS ARE USED TO INDICATE BORDERLINE SOIL CLASSIFICATIONS





JOB NO.: 22G122-2	DRILLING DATE: 2/4/22	WATER DEPTH: Dry
PROJECT: First Sinclair Logistics Center	DRILLING METHOD: Hollow Stem Auger	CAVE DEPTH: ---
LOCATION: Perris, California	LOGGED BY: Jamie Hayward	READING TAKEN: At Completion

FIELD RESULTS				GRAPHIC LOG	DESCRIPTION	LABORATORY RESULTS						COMMENTS
DEPTH (FEET)	SAMPLE	BLOW COUNT	POCKET PEN. (TSF)			DRY DENSITY (PCF)	MOISTURE CONTENT (%)	LIQUID LIMIT	PLASTIC LIMIT	PASSING #200 SIEVE (%)	ORGANIC CONTENT (%)	
SURFACE ELEVATION: MSL												
					3± inches Asphaltic Concrete; 4± inches Aggregate Base							
	X	12			FILL: Brown Clayey fine to coarse Sand, trace Silt, medium dense-moist		10					
5	X	5			ALLUVIUM: Brown Silty fine to coarse Sand, loose to medium dense-moist		9					
	X	22			Brown fine to medium Sandy Silt to Silty fine to medium Sand, trace coarse Sand, trace Clay, medium dense-moist	6			18		46	
					Trench Terminated at 9'							

TBL 22G122-2.GPJ\_SOCALGEO.GDT 3/8/22



JOB NO.: 22G122-2	DRILLING DATE: 2/4/22	WATER DEPTH: Dry
PROJECT: First Sinclair Logistics Center	DRILLING METHOD: Hollow Stem Auger	CAVE DEPTH: ---
LOCATION: Perris, California	LOGGED BY: Jamie Hayward	READING TAKEN: At Completion

FIELD RESULTS				GRAPHIC LOG	DESCRIPTION	LABORATORY RESULTS						COMMENTS
DEPTH (FEET)	SAMPLE	BLOW COUNT	POCKET PEN. (TSF)			DRY DENSITY (PCF)	MOISTURE CONTENT (%)	LIQUID LIMIT	PLASTIC LIMIT	PASSING #200 SIEVE (%)	ORGANIC CONTENT (%)	
SURFACE ELEVATION: MSL												
				3± inches Asphaltic Concrete; 4± inches Aggregate Base								
	X	10		FILL: Brown Clayey fine to medium Sand, little Silt, medium dense-moist		12						
5	X	15		ALLUVIUM: Brown Silty fine Sand, little medium Sand, medium dense-moist		14						
	X	31		Brown fine to medium Sandy Silt to Silty fine to medium Sand, trace coarse Sand, trace Clay, dense-moist		10			44			
Boring Terminated at 9'												

TBL 22G122-2.GPJ\_SOCALGEO.GDT 3/8/22

## INFILTRATION CALCULATIONS

Project Name	First Sinclair Logistics Center
Project Location	Perris, California
Project Number	22G122-2
Engineer	CB

Test Hole Radius	4 (in)
Test Depth	9.00 (ft)

Infiltration Test Hole	I-1
------------------------	-----

Soil Criteria Test							
Interval Number		Time	Time Interval (min)	Water Depth (ft)	Change in Water Level (in)	Did 6 inches of water seep away in less than 25 minutes?	Sandy Soils or Non-Sandy Soils?
1	Initial	7:00 AM	25.00	7.20	10.92	YES	SANDY SOILS
	Final	7:25 AM		8.11			
2	Initial	7:27 AM	25.00	7.20	9.84	YES	SANDY SOILS
	Final	7:52 AM		8.02			

Test Data							
Interval Number		Time	Time Interval (min)	Water Depth (ft)	Change in Water Level (ft)	Average Head Height (ft)	Infiltration Rate Q (in/hr)
1	Initial	7:55 AM	10.00	7.20	0.42	1.59	2.87
	Final	8:05 AM		7.62			
2	Initial	8:07 AM	10.00	7.20	0.41	1.60	2.79
	Final	8:17 AM		7.61			
3	Initial	8:27 AM	10.00	7.20	0.39	1.61	2.64
	Final	8:37 AM		7.59			
4	Initial	8:39 AM	10.00	7.20	0.38	1.61	2.57
	Final	8:49 AM		7.58			
5	Initial	8:51 AM	10.00	7.20	0.36	1.62	2.42
	Final	9:01 AM		7.56			
6	Initial	9:03 AM	10.00	7.20	0.36	1.62	2.42
	Final	9:13 AM		7.56			

Per County Standards, Infiltration Rate calculated as follows:

$$Q = \frac{\Delta H(60r)}{\Delta t(r + 2H_{avg})}$$

- Where:
- Q = Infiltration Rate (in inches per hour)
  - ΔH = Change in Height (Water Level) over the time interval
  - r = Test Hole (Borehole) Radius
  - Δt = Time Interval
  - H<sub>avg</sub> = Average Head Height over the time interval

**INFILTRATION CALCULATIONS**

Project Name	First Sinclair Logistics Center
Project Location	Perris, California
Project Number	22G122-2
Engineer	CB

Test Hole Radius	4 (in)
Test Depth	9.00 (ft)

Infiltration Test Hole I-2

Soil Criteria Test							
Interval Number		Time	Time Interval (min)	Water Depth (ft)	Change in Water Level (in)	Did 6 inches of water seep away in less than 25 minutes?	Sandy Soils or Non-Sandy Soils?
1	Initial	9:30 AM	25.00	7.30	0.96	NO	NON-SANDY SOILS
	Final	9:55 AM		7.38			
2	Initial	9:57 AM	25.00	7.30	0.72	NO	NON-SANDY SOILS
	Final	10:22 AM		7.36			

Test Data							
Interval Number		Time	Time Interval (min)	Water Depth (ft)	Change in Water Level (ft)	Average Head Height (ft)	Infiltration Rate Q (in/hr)
1	Initial	10:25 AM	30.00	7.30	0.29	1.56	0.67
	Final	10:55 AM		7.59			
2	Initial	10:55 AM	30.00	7.30	0.26	1.57	0.60
	Final	11:25 AM		7.56			
3	Initial	11:25 AM	30.00	7.30	0.25	1.58	0.57
	Final	11:55 AM		7.55			
4	Initial	11:55 AM	30.00	7.30	0.23	1.59	0.53
	Final	12:25 PM		7.53			
5	Initial	12:25 PM	30.00	7.30	0.20	1.60	0.45
	Final	12:55 PM		7.50			
6	Initial	12:55 PM	30.00	7.30	0.19	1.61	0.43
	Final	1:25 PM		7.49			
7	Initial	1:25 PM	30.00	7.30	0.18	1.61	0.41
	Final	1:55 PM		7.48			
8	Initial	1:55 PM	30.00	7.30	0.15	1.63	0.33
	Final	2:25 PM		7.45			
9	Initial	2:25 PM	30.00	7.30	0.14	1.63	0.31
	Final	2:55 PM		7.44			
10	Initial	2:55 PM	30.00	7.30	0.13	1.64	0.29
	Final	3:25 PM		7.43			
11	Initial	3:25 PM	30.00	7.30	0.13	1.64	0.29
	Final	3:55 PM		7.43			
12	Initial	3:55 PM	30.00	7.30	0.13	1.64	0.29
	Final	4:25 PM		7.43			

Per County Standards, Infiltration Rate calculated as follows:

$$Q = \frac{\Delta H(60r)}{\Delta t(r + 2H_{avg})}$$

- Where:
- Q = Infiltration Rate (in inches per hour)
  - ΔH = Change in Height (Water Level) over the time interval
  - r = Test Hole (Borehole) Radius
  - Δt = Time Interval
  - H<sub>avg</sub> = Average Head Height over the time interval

# Grain Size Distribution

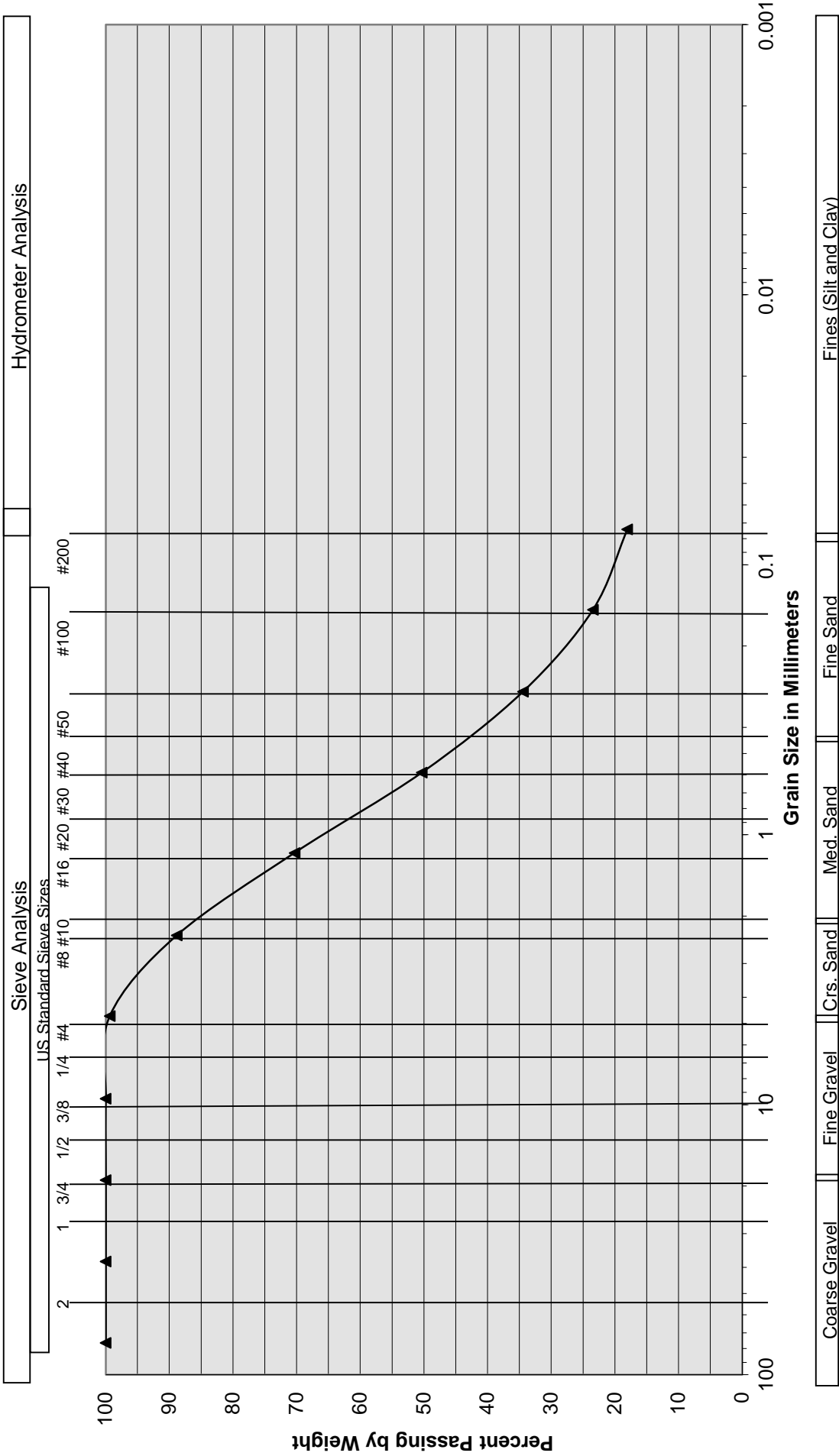

Sample Description	I-1 @ 7.5 to 8'	
Soil Classification	Brown Silty fine to coarse Sand	
Project No.	22G122-2	
Location	First Lsincclair Logistics Center Perris, California	
Plate No.	PLATE C-1	



# Grain Size Distribution

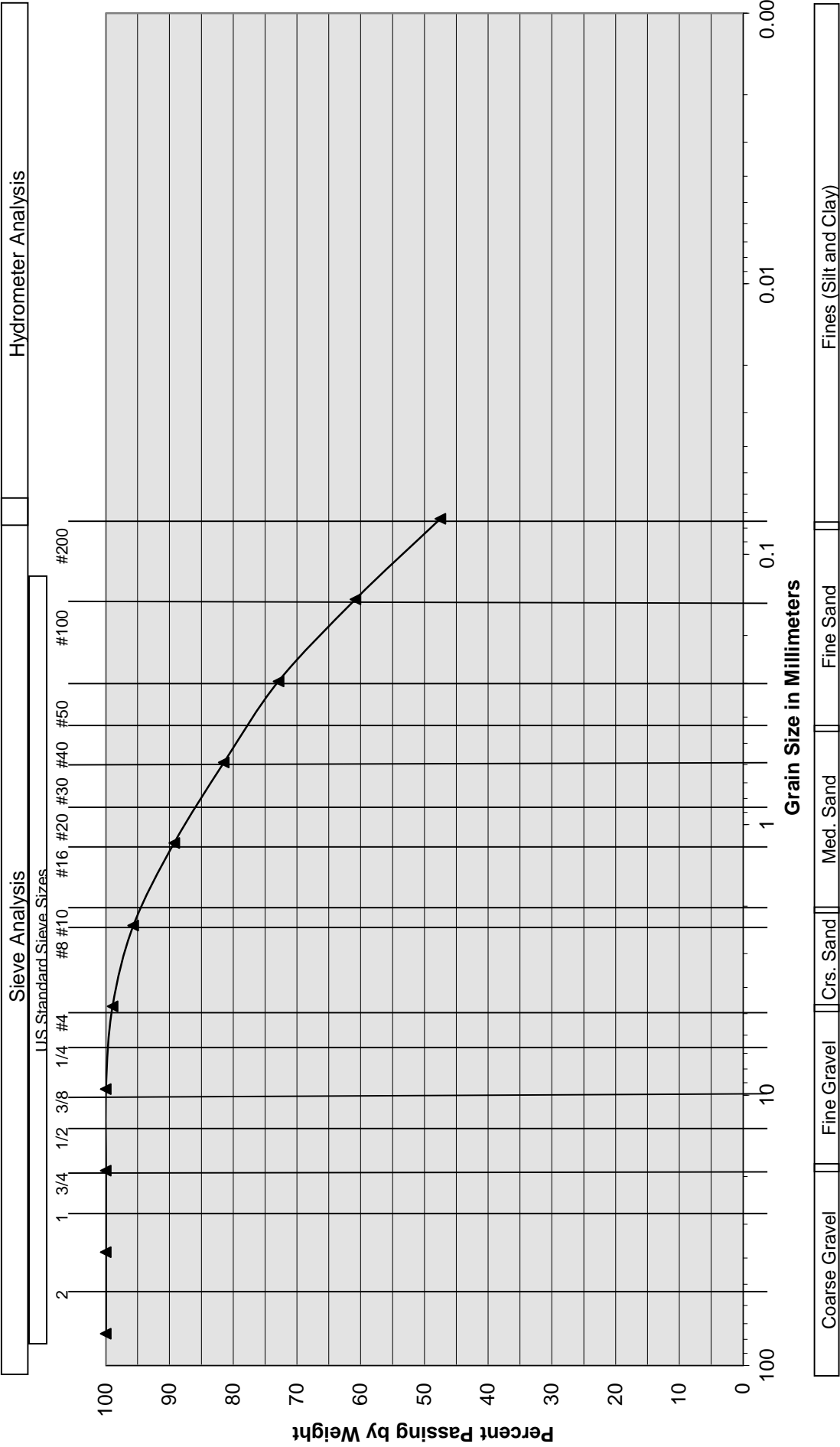

Sample Description: |I-1 @ 8 to 9'

Soil Classification: Brown fine to medium Sandy Silt to Silty fine to medium Sand, trace coarse Sand, trace Clay

First Sinclair Logistics Center  
 Perris, California  
 Project No. 22G122-2  
**PLATE C-2**



# Grain Size Distribution

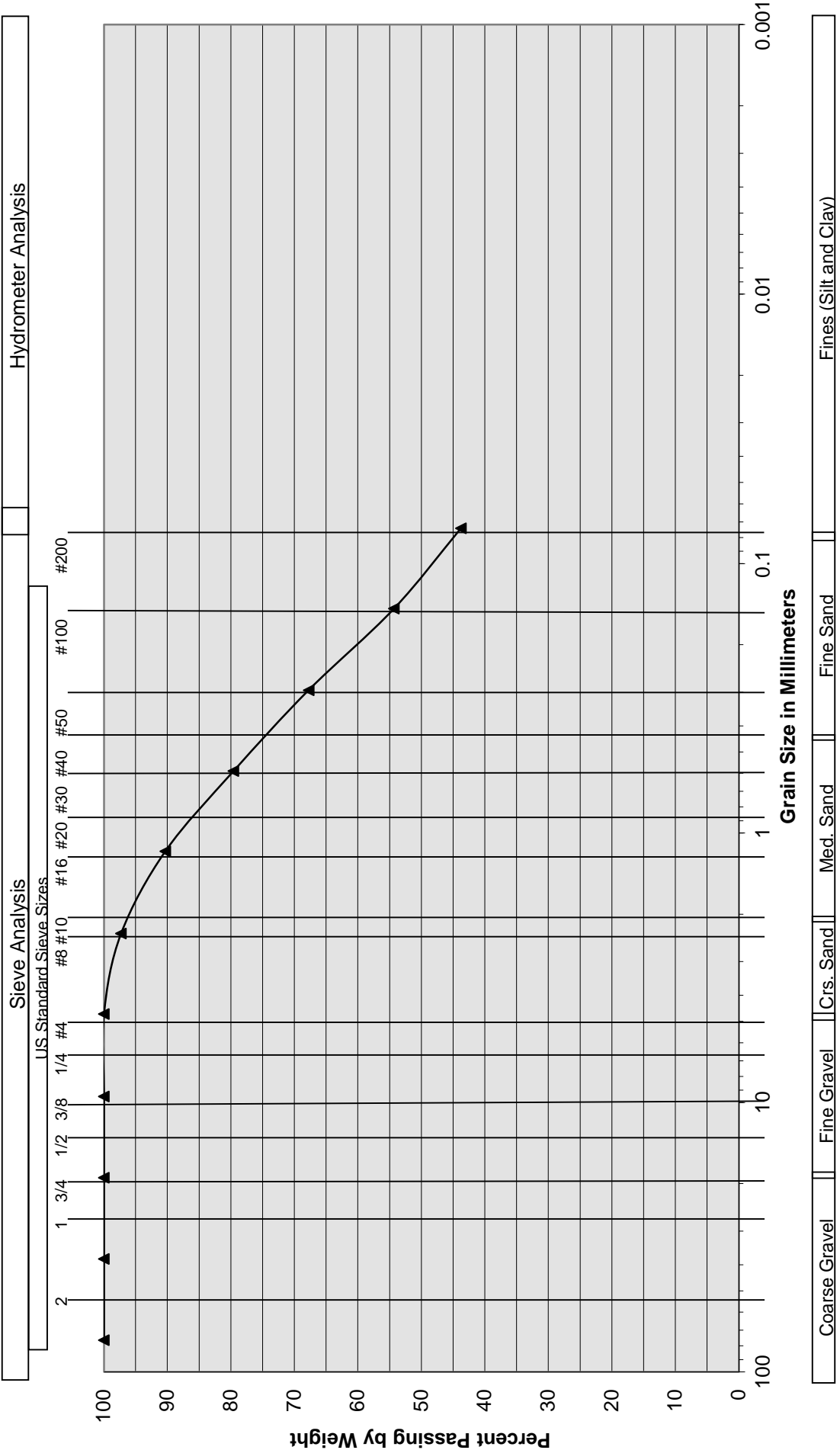

Sample Description	I-2 @ 7.5'
Soil Classification	Brown fine to medium Sandy Silt to Silty fine to medium Sand, trace coarse Sand, trace Clay
Project No.	22G122-2
Location	First Sinclair Logistics Center Perris, California
Plate No.	PLATE C-3



A California Corporation



# APPENDIX A

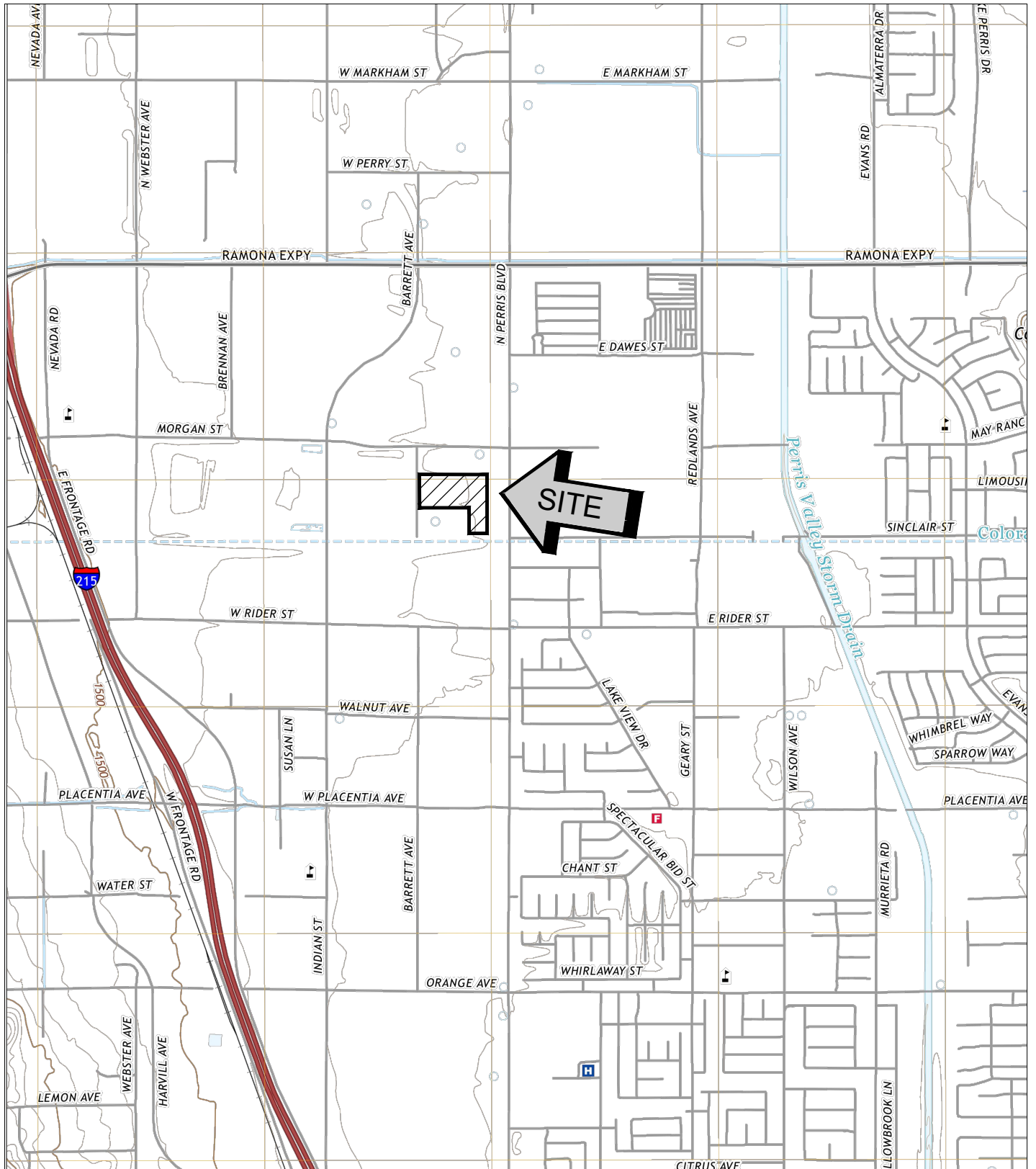

SOURCE: USGS TOPOGRAPHIC MAP OF THE PERRIS QUADRANGLE, RIVERSIDE COUNTY, CALIFORNIA, 2021.







<b>SITE LOCATION MAP</b>	
FIRST SINCLAIR LOGISTICS CENTER	
PERRIS, CALIFORNIA	
SCALE: 1" = 2000'	 <b>SOUTHERN CALIFORNIA GEOTECHNICAL</b>
DRAWN: MD	
CHKD: RGT	
SCG PROJECT 22G122-1	
<b>PLATE 1</b>	



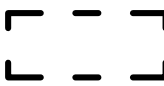

**GEOTECHNICAL LEGEND**







-  APPROXIMATE BORING LOCATION
-  PROPOSED INDUSTRIAL BUILDING OUTLINE
-  PROPERTY LINE
-  EXISTING BUILDING

<b>BORING LOCATION PLAN</b>	
FIRST SINCLAIR LOGISTICS CENTER	
PERRIS, CALIFORNIA	
SCALE: 1" = 120'	 <b>SOUTHERN CALIFORNIA GEOTECHNICAL</b>
DRAWN: MD	
CHKD: GKM	
SCG PROJECT 22G122-1	
<b>PLATE 2</b>	

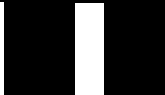

# APPENDIX B

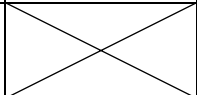
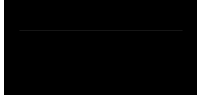
# BORING LOG LEGEND

SAMPLE TYPE	GRAPHICAL SYMBOL	SAMPLE DESCRIPTION
AUGER		SAMPLE COLLECTED FROM AUGER CUTTINGS, NO FIELD MEASUREMENT OF SOIL STRENGTH. (DISTURBED)
CORE		ROCK CORE SAMPLE: TYPICALLY TAKEN WITH A DIAMOND-TIPPED CORE BARREL. TYPICALLY USED ONLY IN HIGHLY CONSOLIDATED BEDROCK.
GRAB		SOIL SAMPLE TAKEN WITH NO SPECIALIZED EQUIPMENT, SUCH AS FROM A STOCKPILE OR THE GROUND SURFACE. (DISTURBED)
CS		CALIFORNIA SAMPLER: 2-1/2 INCH I.D. SPLIT BARREL SAMPLER, LINED WITH 1-INCH HIGH BRASS RINGS. DRIVEN WITH SPT HAMMER. (RELATIVELY UNDISTURBED)
NSR		NO RECOVERY: THE SAMPLING ATTEMPT DID NOT RESULT IN RECOVERY OF ANY SIGNIFICANT SOIL OR ROCK MATERIAL.
SPT		STANDARD PENETRATION TEST: SAMPLER IS A 1.4 INCH INSIDE DIAMETER SPLIT BARREL, DRIVEN 18 INCHES WITH THE SPT HAMMER. (DISTURBED)
SH		SHELBY TUBE: TAKEN WITH A THIN WALL SAMPLE TUBE, PUSHED INTO THE SOIL AND THEN EXTRACTED. (UNDISTURBED)
VANE		VANE SHEAR TEST: SOIL STRENGTH OBTAINED USING A 4 BLADED SHEAR DEVICE. TYPICALLY USED IN SOFT CLAYS-NO SAMPLE RECOVERED.

## COLUMN DESCRIPTIONS

### DEPTH:

Distance in feet below the ground surface.

### SAMPLE:

Sample Type as depicted above.

### BLOW COUNT:

Number of blows required to advance the sampler 12 inches using a 140 lb hammer with a 30-inch drop. 50/3" indicates penetration refusal (>50 blows) at 3 inches. WH indicates that the weight of the hammer was sufficient to push the sampler 6 inches or more.

### POCKET PEN.:

Approximate shear strength of a cohesive soil sample as measured by pocket penetrometer.

### GRAPHIC LOG:

Graphic Soil Symbol as depicted on the following page.

### DRY DENSITY:

Dry density of an undisturbed or relatively undisturbed sample in lbs/ft<sup>3</sup>.

### MOISTURE CONTENT:

Moisture content of a soil sample, expressed as a percentage of the dry weight.

### LIQUID LIMIT:

The moisture content above which a soil behaves as a liquid.

### PLASTIC LIMIT:

The moisture content above which a soil behaves as a plastic.

### PASSING #200 SIEVE:

The percentage of the sample finer than the #200 standard sieve.

### UNCONFINED SHEAR:

The shear strength of a cohesive soil sample, as measured in the unconfined state.

# SOIL CLASSIFICATION CHART

MAJOR DIVISIONS			SYMBOLS		TYPICAL DESCRIPTIONS	
			GRAPH	LETTER		
<p><b>COARSE GRAINED SOILS</b></p> <p>MORE THAN 50% OF MATERIAL IS LARGER THAN NO. 200 SIEVE SIZE</p>	<p><b>GRAVEL AND GRAVELLY SOILS</b></p>	<p>CLEAN GRAVELS</p> <p>(LITTLE OR NO FINES)</p>		<b>GW</b>	WELL-GRADED GRAVELS, GRAVEL - SAND MIXTURES, LITTLE OR NO FINES	
		<p>MORE THAN 50% OF COARSE FRACTION RETAINED ON NO. 4 SIEVE</p>	<p>GRAVELS WITH FINES</p> <p>(APPRECIABLE AMOUNT OF FINES)</p>		<b>GP</b>	POORLY-GRADED GRAVELS, GRAVEL - SAND MIXTURES, LITTLE OR NO FINES
			<p>GRAVELS WITH FINES</p> <p>(APPRECIABLE AMOUNT OF FINES)</p>		<b>GM</b>	SILTY GRAVELS, GRAVEL - SAND - SILT MIXTURES
		<p>MORE THAN 50% OF COARSE FRACTION PASSING ON NO. 4 SIEVE</p>	<p>CLEAN SANDS</p> <p>(LITTLE OR NO FINES)</p>		<b>SW</b>	WELL-GRADED SANDS, GRAVELLY SANDS, LITTLE OR NO FINES
	<p>MORE THAN 50% OF COARSE FRACTION PASSING ON NO. 4 SIEVE</p>		<p>SANDS WITH FINES</p> <p>(APPRECIABLE AMOUNT OF FINES)</p>		<b>SP</b>	POORLY-GRADED SANDS, GRAVELLY SAND, LITTLE OR NO FINES
		<p>SANDS WITH FINES</p> <p>(APPRECIABLE AMOUNT OF FINES)</p>		<b>SM</b>	SILTY SANDS, SAND - SILT MIXTURES	
	<p><b>FINE GRAINED SOILS</b></p> <p>MORE THAN 50% OF MATERIAL IS SMALLER THAN NO. 200 SIEVE SIZE</p>	<p><b>SILTS AND CLAYS</b></p> <p>LIQUID LIMIT LESS THAN 50</p>		<b>ML</b>	INORGANIC SILTS AND VERY FINE SANDS, ROCK FLOUR, SILTY OR CLAYEY FINE SANDS OR CLAYEY SILTS WITH SLIGHT PLASTICITY	
				<b>CL</b>	INORGANIC CLAYS OF LOW TO MEDIUM PLASTICITY, GRAVELLY CLAYS, SANDY CLAYS, SILTY CLAYS, LEAN CLAYS	
				<b>OL</b>	ORGANIC SILTS AND ORGANIC SILTY CLAYS OF LOW PLASTICITY	
		<p><b>SILTS AND CLAYS</b></p> <p>LIQUID LIMIT GREATER THAN 50</p>		<b>MH</b>	INORGANIC SILTS, MICACEOUS OR DIATOMACEOUS FINE SAND OR SILTY SOILS	
			<b>CH</b>	INORGANIC CLAYS OF HIGH PLASTICITY		
			<b>OH</b>	ORGANIC CLAYS OF MEDIUM TO HIGH PLASTICITY, ORGANIC SILTS		
<p><b>HIGHLY ORGANIC SOILS</b></p>				<b>PT</b>	PEAT, HUMUS, SWAMP SOILS WITH HIGH ORGANIC CONTENTS	

NOTE: DUAL SYMBOLS ARE USED TO INDICATE BORDERLINE SOIL CLASSIFICATIONS



JOB NO.: 22G122-1	DRILLING DATE: 2/4/22	WATER DEPTH: Dry
PROJECT: First Sinclair Logistics Center	DRILLING METHOD: Hollow Stem Auger	CAVE DEPTH: 5 feet
LOCATION: Riverside County (Perris), California	LOGGED BY: Jamie Hayward	READING TAKEN: At Completion

FIELD RESULTS				GRAPHIC LOG	DESCRIPTION	LABORATORY RESULTS						COMMENTS
DEPTH (FEET)	SAMPLE	BLOW COUNT	POCKET PEN. (TSF)			DRY DENSITY (PCF)	MOISTURE CONTENT (%)	LIQUID LIMIT	PLASTIC LIMIT	PASSING #200 SIEVE (%)	ORGANIC CONTENT (%)	
SURFACE ELEVATION: --- MSL												
				1± inch open graded gravel								
	5	28		ALLUVIUM: Brown fine Sandy Clay to Clayey fine Sand, some Silt, trace medium to coarse Sand, slightly cemented, very stiff/medium dense-damp to moist	113	6					EI = 36 @ 0 to 5 feet	
		32	4.5		114	7						
		21	4.5		108	7						
		34		Brown Silty fine Sand to fine Sandy Silt, trace medium Sand, medium dense-damp	120	8						
		26		Brown fine to coarse Sand, medium dense-dry to damp	113	2						
	10			Brown Silty fine to medium Sand, trace Clay, slightly cemented, medium dense-dry to damp								
		22		Brown fine Sandy Silt, trace medium Sand, medium dense-moist		10						
	15											
		86		Brown Clayey fine Sand, little Silt, trace Calcareous nodules, very dense-moist		10						
	20											
Boring Terminated at 20'												

TBL\_22G122-1.GPJ\_SOCALGEO.GDT\_3/4/22





JOB NO.: 22G122-1      DRILLING DATE: 2/4/22      WATER DEPTH: Dry  
 PROJECT: First Sinclair Logistics Center      DRILLING METHOD: Hollow Stem Auger      CAVE DEPTH: 8 feet  
 LOCATION: Riverside County (Perris), California      LOGGED BY: Jamie Hayward      READING TAKEN: At Completion

FIELD RESULTS				GRAPHIC LOG	DESCRIPTION	LABORATORY RESULTS					COMMENTS	
DEPTH (FEET)	SAMPLE	BLOW COUNT	POCKET PEN. (TSF)			DRY DENSITY (PCF)	MOISTURE CONTENT (%)	LIQUID LIMIT	PLASTIC LIMIT	PASSING #200 SIEVE (%)		ORGANIC CONTENT (%)
SURFACE ELEVATION: --- MSL												
			3.0	1± inch open graded gravel								
		14		ALLUVIUM: Gray Brown Silty Clay, little fine Sand, little Calcareous nodules/veining, slightly cemented, stiff-moist to very moist		21						EI = 25 @ 0 to 5 feet
		11		Gray Brown fine Sandy Silt, little Clay, slightly cemented, medium dense-very moist		11						
5		18		Brown Silty fine to medium Sand, little Clay, medium dense-damp		8						
		15		Brown fine Sandy Silt, medium dense-damp		7						
10		18		Brown Clayey fine Sand, some Silt, medium dense-moist		12						
		21				12						
		26				13						
25					Boring Terminated at 25'							

TBL 22G122-1.GPJ\_SOCALGEO.GDT 3/4/22



JOB NO.: 22G122-1	DRILLING DATE: 2/4/22	WATER DEPTH: Dry
PROJECT: First Sinclair Logistics Center	DRILLING METHOD: Hollow Stem Auger	CAVE DEPTH: 5 feet
LOCATION: Riverside County (Perris), California	LOGGED BY: Jamie Hayward	READING TAKEN: At Completion

FIELD RESULTS				GRAPHIC LOG	DESCRIPTION	LABORATORY RESULTS					COMMENTS
DEPTH (FEET)	SAMPLE	BLOW COUNT	POCKET PEN. (TSF)			DRY DENSITY (PCF)	MOISTURE CONTENT (%)	LIQUID LIMIT	PLASTIC LIMIT	PASSING #200 SIEVE (%)	
SURFACE ELEVATION: --- MSL											
				6± inches Portland cement concrete							
	X	35		FILL: Brown Silty fine to medium Sand, medium dense-damp to moist	130	9					
	X	24		@ 3 feet, trace Clay	126	9					
5	X	24	4.5	ALLUVIUM: Brown Clayey fine Sand to fine Sandy Clay, little medium Sand, medium dense to very stiff-moist	119	12					
	X	34		Brown Silty fine to medium Sand, little coarse Sand, medium dense-damp	117	5					
10	X	37			115	7					
	X	20		Gray Brown fine to medium Sand, little coarse Sand, medium dense-damp		3					
15	X										
Boring Terminated at 15'											

TBL\_22G122-1.GPJ\_SOCALGEO.GDT\_3/4/22



JOB NO.: 22G122-1	DRILLING DATE: 2/4/22	WATER DEPTH: Dry
PROJECT: First Sinclair Logistics Center	DRILLING METHOD: Hollow Stem Auger	CAVE DEPTH: 8 feet
LOCATION: Riverside County (Perris), California	LOGGED BY: Jamie Hayward	READING TAKEN: At Completion

FIELD RESULTS				GRAPHIC LOG	DESCRIPTION	LABORATORY RESULTS						COMMENTS
DEPTH (FEET)	SAMPLE	BLOW COUNT	POCKET PEN. (TSF)			DRY DENSITY (PCF)	MOISTURE CONTENT (%)	LIQUID LIMIT	PLASTIC LIMIT	PASSING #200 SIEVE (%)	ORGANIC CONTENT (%)	
SURFACE ELEVATION: --- MSL												
					4± inches Asphaltic concrete; 6± inches Aggregate base							
		12			FILL: Brown Silty fine to medium Sand, trace to little Clay, loose to medium dense-damp to moist	113	11					
		8				112	8					
5		5			ALLUVIUM: Brown fine to medium Sand, trace coarse Sand, loose-damp	114	5					
		5										
		14			Gray Brown fine to coarse Sand, medium dense-damp	128	3					
10												
		18			Gray Brown fine to medium Sandy Silt, medium dense-very moist	119	17					
15												
		23	3.0		Brown fine Sandy Clay, some Silt, very stiff-moist		10					
20												
		28			Brown fine Sandy Silt, trace medium Sand, medium dense-moist		14					
25												
Boring Terminated at 25'												

TBL 22G122-1.GPJ\_SOCALGEO.GDT 3/4/22



JOB NO.: 22G122-1	DRILLING DATE: 2/4/22	WATER DEPTH: Dry
PROJECT: First Sinclair Logistics Center	DRILLING METHOD: Hollow Stem Auger	CAVE DEPTH: 11 feet
LOCATION: Riverside County (Perris), California	LOGGED BY: Jamie Hayward	READING TAKEN: At Completion

FIELD RESULTS				GRAPHIC LOG	DESCRIPTION	LABORATORY RESULTS						COMMENTS
DEPTH (FEET)	SAMPLE	BLOW COUNT	POCKET PEN. (TSF)			DRY DENSITY (PCF)	MOISTURE CONTENT (%)	LIQUID LIMIT	PLASTIC LIMIT	PASSING #200 SIEVE (%)	ORGANIC CONTENT (%)	
SURFACE ELEVATION: --- MSL												
					3½± inches Asphaltic concrete; 4± inches Aggregate base							
	X	13			FILL: Brown Silty fine to medium Sand, little Clay, loose-damp to moist	119	8					
	X	14			@ 3 feet, little to some Clay	119	9					
5	X	21			ALLUVIUM: Brown fine Sandy Silt, trace to little medium Sand, trace to little Clay, medium dense-moist	123	10					
	X	23				118	12					
10	X	19			Gray Brown fine to coarse Sand, trace Silt, medium dense-damp	102	3					
	X	22			Brown fine Sandy Silt, trace medium Sand, medium dense-damp to moist		8					
15	X	27			Brown Clayey fine Sand, little Silt, trace medium Sand, little Calcareous nodules/veining, medium dense-moist to very moist		17					
20	X											
Boring Terminated at 20'												

TBL 22G122-1.GPJ\_SOCALGEO.GDT 3/4/22



JOB NO.: 22G122-1	DRILLING DATE: 2/4/22	WATER DEPTH: Dry
PROJECT: First Sinclair Logistics Center	DRILLING METHOD: Hollow Stem Auger	CAVE DEPTH: 13 feet
LOCATION: Riverside County (Perris), California	LOGGED BY: Jamie Hayward	READING TAKEN: At Completion

FIELD RESULTS				GRAPHIC LOG	DESCRIPTION	LABORATORY RESULTS						COMMENTS
DEPTH (FEET)	SAMPLE	BLOW COUNT	POCKET PEN. (TSF)			DRY DENSITY (PCF)	MOISTURE CONTENT (%)	LIQUID LIMIT	PLASTIC LIMIT	PASSING #200 SIEVE (%)	ORGANIC CONTENT (%)	
SURFACE ELEVATION: --- MSL												
					3± inches Asphaltic concrete; 4± inches Aggregate base							
					FILL: Brown fine to medium Sandy Silt, trace coarse Sand, medium dense-moist							
5		15										
					ALLUVIUM: Brown fine Sandy Silt, little medium Sand, medium dense to dense-moist							
10		32										
15		14										
20		38	4.5		Brown Silty Clay, little fine Sand, cemented, hard-moist							
					Boring Terminated at 20'							

TBL\_22G122-1.GPJ\_SOCALGEO.GDT\_3/4/22

# A P P E N D I X C

### Consolidation/Collapse Test Results

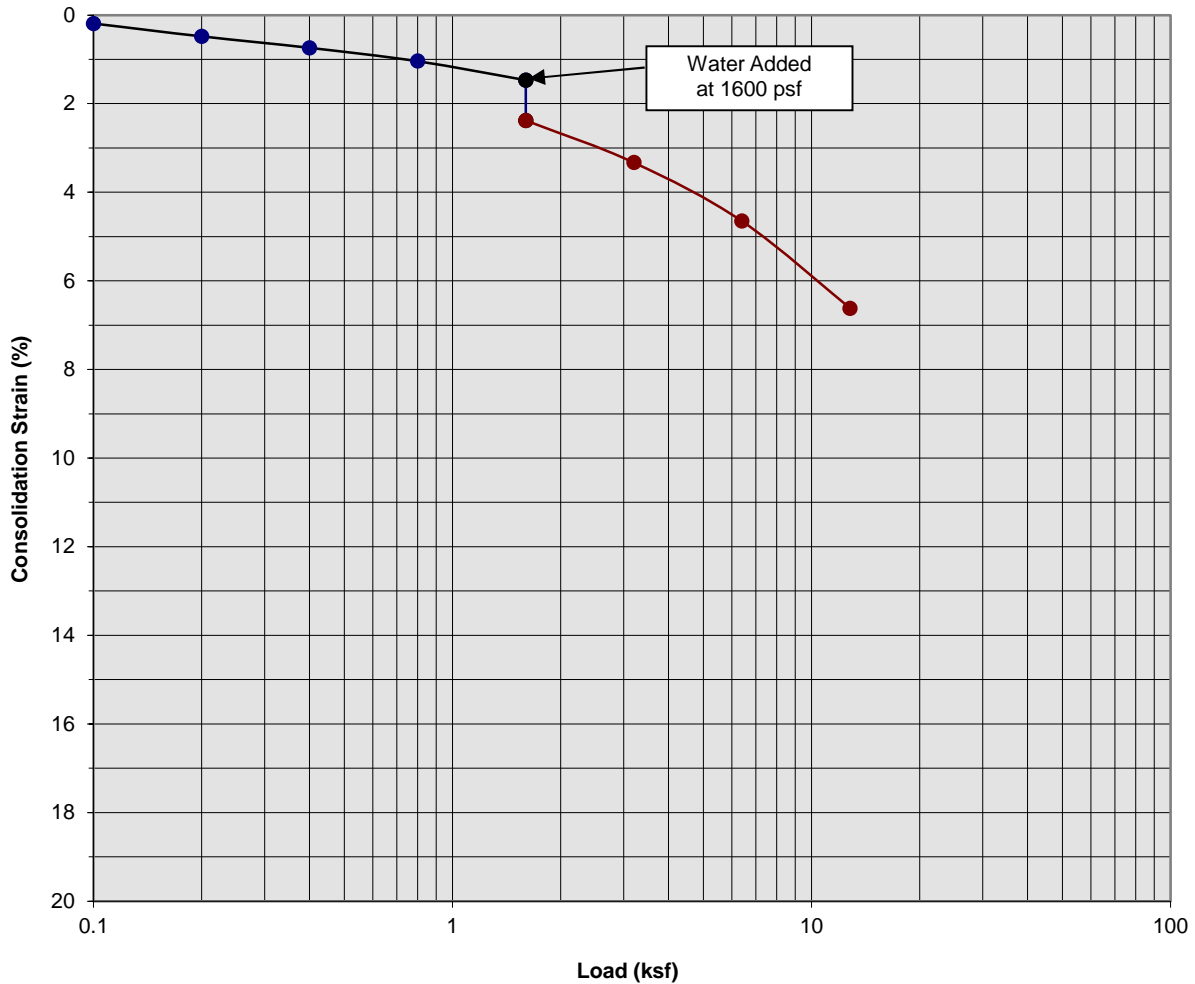

Classification: FILL: Brown Silty fine to medium Sand, little Clay

Boring Number:	B-5	Initial Moisture Content (%)	10
Sample Number:	---	Final Moisture Content (%)	13
Depth (ft)	3 to 4	Initial Dry Density (pcf)	117.5
Specimen Diameter (in)	2.4	Final Dry Density (pcf)	124.5
Specimen Thickness (in)	1.0	Percent Collapse (%)	0.91

First Sinclair Logistics Center  
 Perris, California  
 Project No. 22G122-1  
**PLATE C- 1**



**SOUTHERN CALIFORNIA GEOTECHNICAL**  
*A California Corporation*



### Consolidation/Collapse Test Results

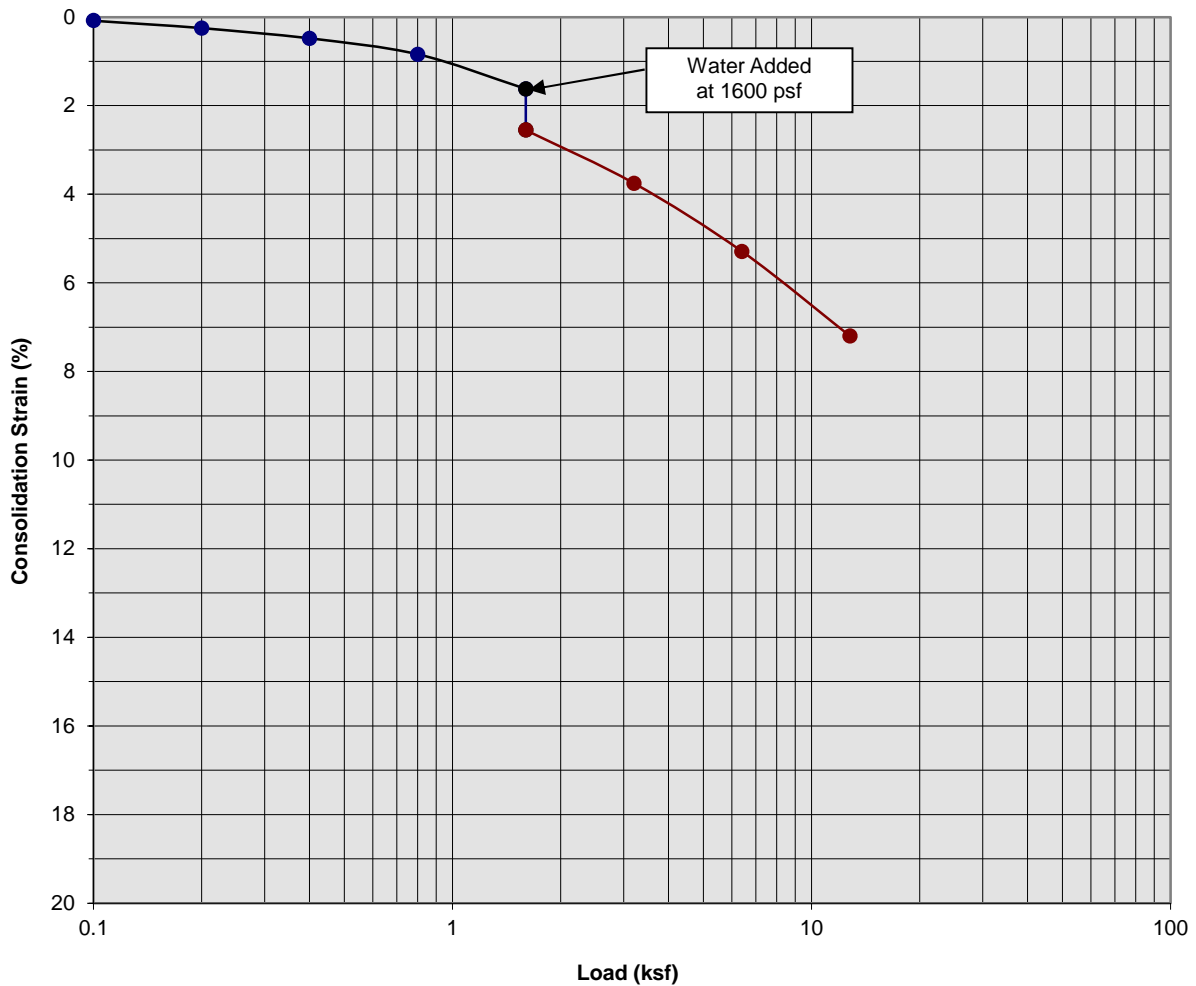

Classification: Brown fine Sandy Silt, trace medium Sand and Clay

Boring Number:	B-5	Initial Moisture Content (%)	10
Sample Number:	---	Final Moisture Content (%)	14
Depth (ft)	5 to 6	Initial Dry Density (pcf)	122.3
Specimen Diameter (in)	2.4	Final Dry Density (pcf)	131.8
Specimen Thickness (in)	1.0	Percent Collapse (%)	0.93

First Sinclair Logistics Center  
 Perris, California  
 Project No. 22G122-1  
**PLATE C- 2**



**SOUTHERN CALIFORNIA GEOTECHNICAL**  
*A California Corporation*

### Consolidation/Collapse Test Results

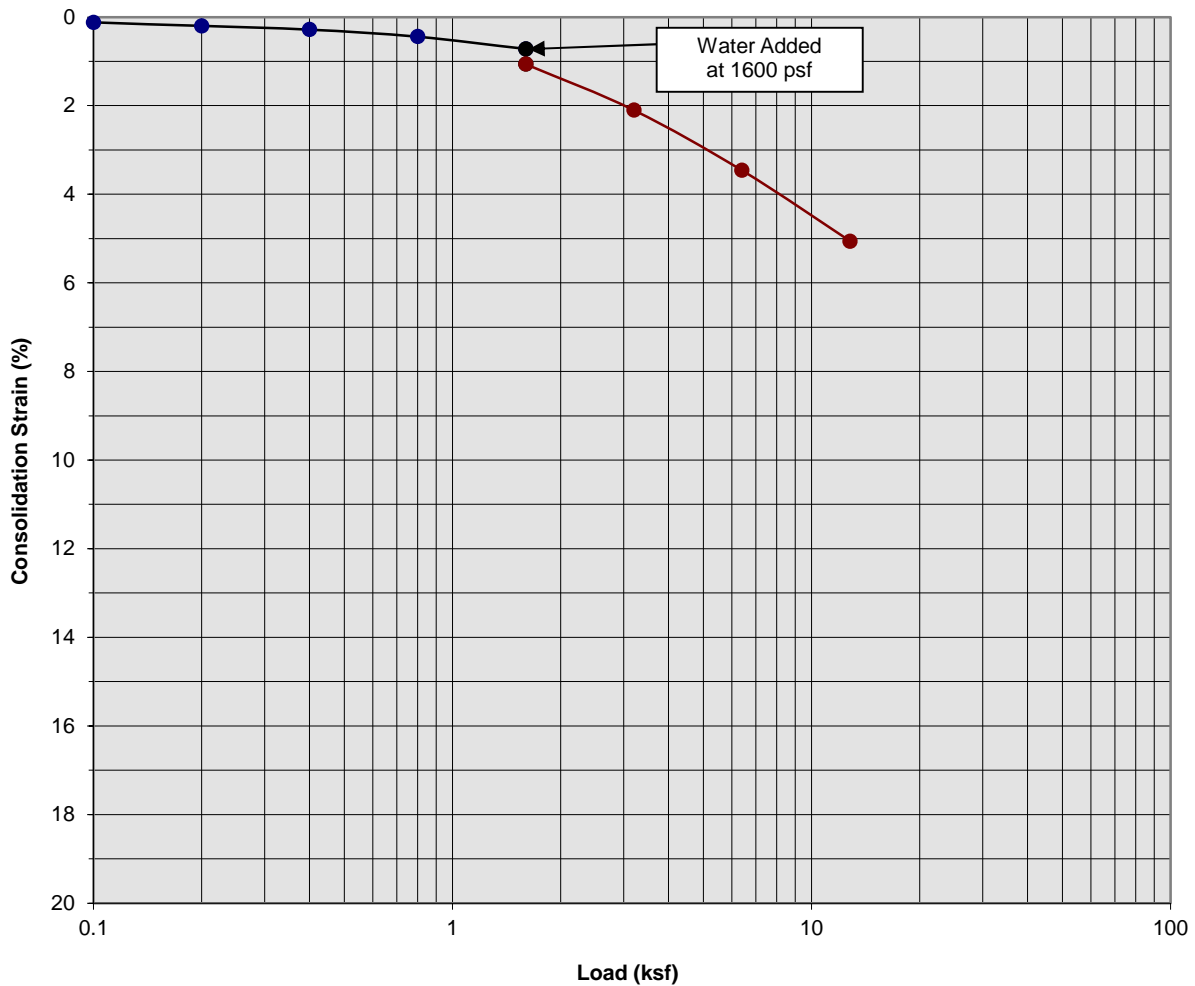

Classification: Brown fine Sandy Silt, trace medium Sand and Clay

Boring Number:	B-5	Initial Moisture Content (%)	11
Sample Number:	---	Final Moisture Content (%)	14
Depth (ft)	7 to 8	Initial Dry Density (pcf)	117.6
Specimen Diameter (in)	2.4	Final Dry Density (pcf)	124.1
Specimen Thickness (in)	1.0	Percent Collapse (%)	0.34

First Sinclair Logistics Center  
 Perris, California  
 Project No. 22G122-1  
**PLATE C- 3**



**SOUTHERN CALIFORNIA GEOTECHNICAL**  
*A California Corporation*

### Consolidation/Collapse Test Results

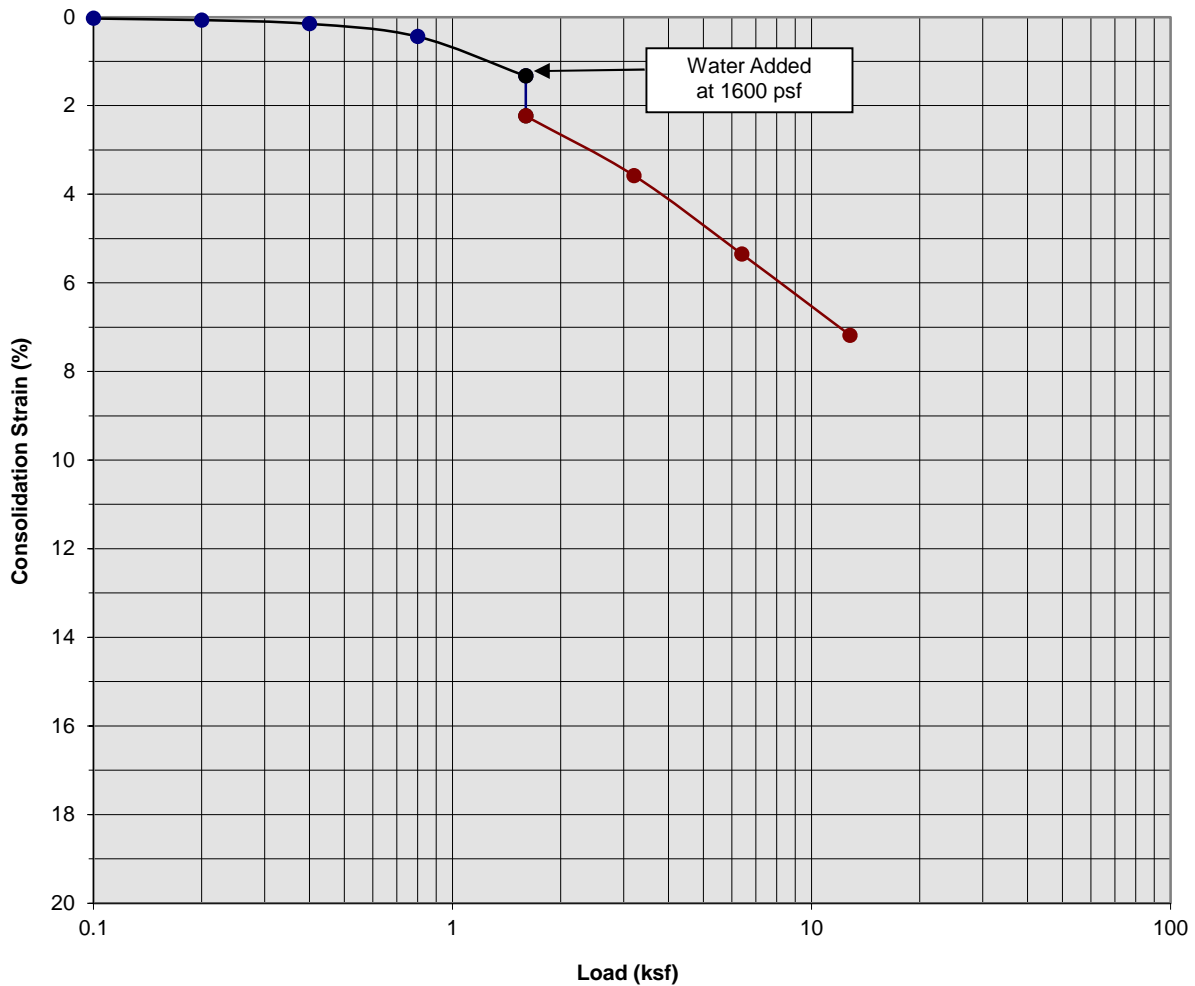

Classification: Gray Brown fine to coarse Sand, trace Silt

Boring Number:	B-5	Initial Moisture Content (%)	3
Sample Number:	---	Final Moisture Content (%)	17
Depth (ft)	9 to 10	Initial Dry Density (pcf)	102.0
Specimen Diameter (in)	2.4	Final Dry Density (pcf)	110.4
Specimen Thickness (in)	1.0	Percent Collapse (%)	0.90

First Sinclair Logistics Center  
 Perris, California  
 Project No. 22G122-1  
**PLATE C- 4**



**SOUTHERN CALIFORNIA GEOTECHNICAL**  
*A California Corporation*

### Moisture/Density Relationship ASTM D-1557

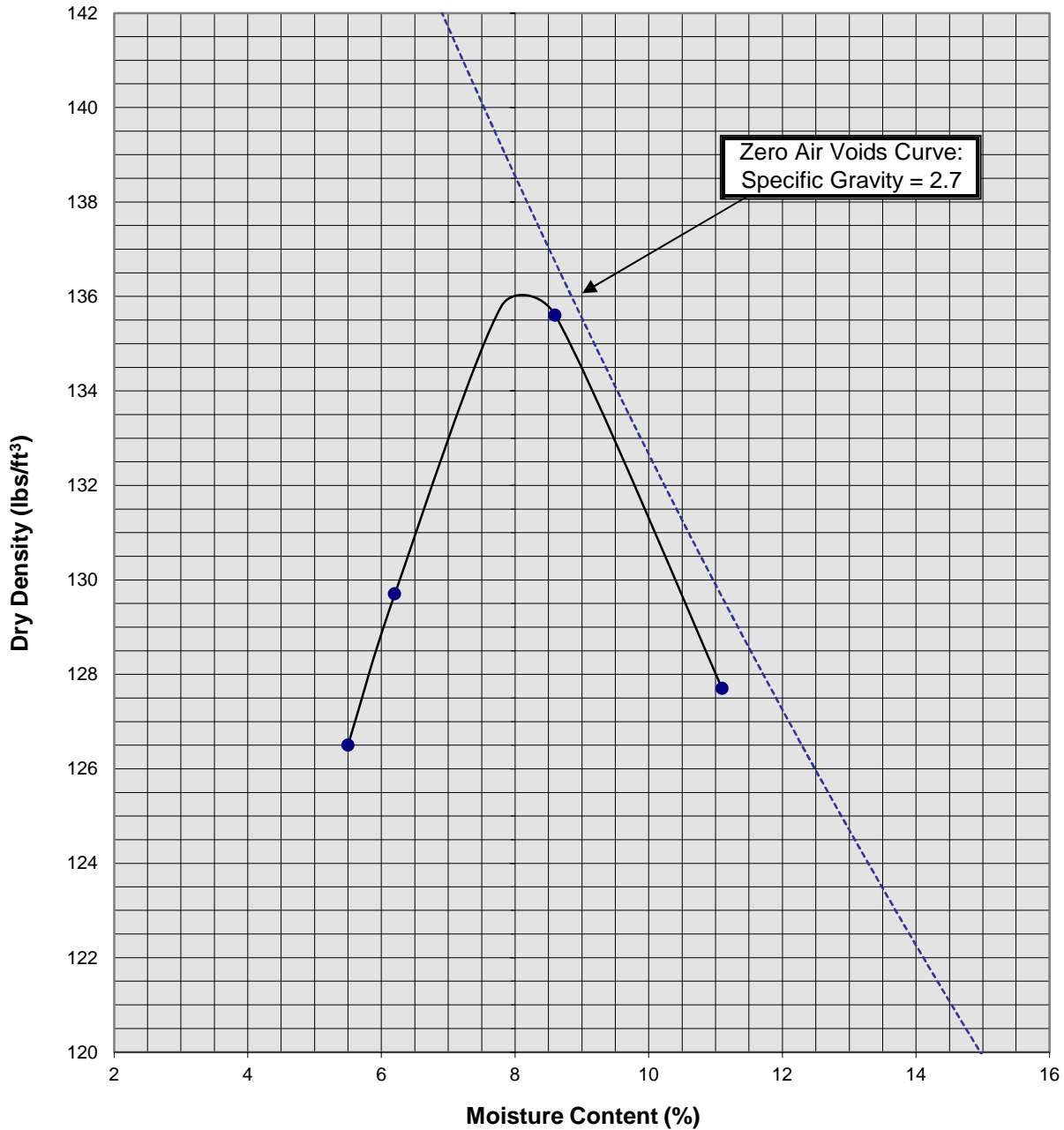

Soil ID Number	B-5 @ 0-5'
Optimum Moisture (%)	8.0
Maximum Dry Density (pcf)	136
Soil Classification	Brown Silty fine to medium Sand little Clay

First Sinclair Logistics Center  
 Perris, California  
 Project No. 22G122-1  
**PLATE C- 5**



**SOUTHERN CALIFORNIA GEOTECHNICAL**  
*A California Corporation*

# APPENDIX D



## **GRADING GUIDE SPECIFICATIONS**

These grading guide specifications are intended to provide typical procedures for grading operations. They are intended to supplement the recommendations contained in the geotechnical investigation report for this project. Should the recommendations in the geotechnical investigation report conflict with the grading guide specifications, the more site specific recommendations in the geotechnical investigation report will govern.

### General

- The Earthwork Contractor is responsible for the satisfactory completion of all earthwork in accordance with the plans and geotechnical reports, and in accordance with city, county, and applicable building codes.
- The Geotechnical Engineer is the representative of the Owner/Builder for the purpose of implementing the report recommendations and guidelines. These duties are not intended to relieve the Earthwork Contractor of any responsibility to perform in a workman-like manner, nor is the Geotechnical Engineer to direct the grading equipment or personnel employed by the Contractor.
- The Earthwork Contractor is required to notify the Geotechnical Engineer of the anticipated work and schedule so that testing and inspections can be provided. If necessary, work may be stopped and redone if personnel have not been scheduled in advance.
- The Earthwork Contractor is required to have suitable and sufficient equipment on the job-site to process, moisture condition, mix and compact the amount of fill being placed to the approved compaction. In addition, suitable support equipment should be available to conform with recommendations and guidelines in this report.
- Canyon cleanouts, overexcavation areas, processed ground to receive fill, key excavations, subdrains and benches should be observed by the Geotechnical Engineer prior to placement of any fill. It is the Earthwork Contractor's responsibility to notify the Geotechnical Engineer of areas that are ready for inspection.
- Excavation, filling, and subgrade preparation should be performed in a manner and sequence that will provide drainage at all times and proper control of erosion. Precipitation, springs, and seepage water encountered shall be pumped or drained to provide a suitable working surface. The Geotechnical Engineer must be informed of springs or water seepage encountered during grading or foundation construction for possible revision to the recommended construction procedures and/or installation of subdrains.

### Site Preparation

- The Earthwork Contractor is responsible for all clearing, grubbing, stripping and site preparation for the project in accordance with the recommendations of the Geotechnical Engineer.
- If any materials or areas are encountered by the Earthwork Contractor which are suspected of having toxic or environmentally sensitive contamination, the Geotechnical Engineer and Owner/Builder should be notified immediately.

- Major vegetation should be stripped and disposed of off-site. This includes trees, brush, heavy grasses and any materials considered unsuitable by the Geotechnical Engineer.
- Underground structures such as basements, cesspools or septic disposal systems, mining shafts, tunnels, wells and pipelines should be removed under the inspection of the Geotechnical Engineer and recommendations provided by the Geotechnical Engineer and/or city, county or state agencies. If such structures are known or found, the Geotechnical Engineer should be notified as soon as possible so that recommendations can be formulated.
- Any topsoil, slopewash, colluvium, alluvium and rock materials which are considered unsuitable by the Geotechnical Engineer should be removed prior to fill placement.
- Remaining voids created during site clearing caused by removal of trees, foundations basements, irrigation facilities, etc., should be excavated and filled with compacted fill.
- Subsequent to clearing and removals, areas to receive fill should be scarified to a depth of 10 to 12 inches, moisture conditioned and compacted
- The moisture condition of the processed ground should be at or slightly above the optimum moisture content as determined by the Geotechnical Engineer. Depending upon field conditions, this may require air drying or watering together with mixing and/or discing.

#### Compacted Fills

- Soil materials imported to or excavated on the property may be utilized in the fill, provided each material has been determined to be suitable in the opinion of the Geotechnical Engineer. Unless otherwise approved by the Geotechnical Engineer, all fill materials shall be free of deleterious, organic, or frozen matter, shall contain no chemicals that may result in the material being classified as "contaminated," and shall be very low to non-expansive with a maximum expansion index (EI) of 50. The top 12 inches of the compacted fill should have a maximum particle size of 3 inches, and all underlying compacted fill material a maximum 6-inch particle size, except as noted below.
- All soils should be evaluated and tested by the Geotechnical Engineer. Materials with high expansion potential, low strength, poor gradation or containing organic materials may require removal from the site or selective placement and/or mixing to the satisfaction of the Geotechnical Engineer.
- Rock fragments or rocks less than 6 inches in their largest dimensions, or as otherwise determined by the Geotechnical Engineer, may be used in compacted fill, provided the distribution and placement is satisfactory in the opinion of the Geotechnical Engineer.
- Rock fragments or rocks greater than 12 inches should be taken off-site or placed in accordance with recommendations and in areas designated as suitable by the Geotechnical Engineer. These materials should be placed in accordance with Plate D-8 of these Grading Guide Specifications and in accordance with the following recommendations:
  - Rocks 12 inches or more in diameter should be placed in rows at least 15 feet apart, 15 feet from the edge of the fill, and 10 feet or more below subgrade. Spaces should be left between each rock fragment to provide for placement and compaction of soil around the fragments.
  - Fill materials consisting of soil meeting the minimum moisture content requirements and free of oversize material should be placed between and over the rows of rock or

concrete. Ample water and compactive effort should be applied to the fill materials as they are placed in order that all of the voids between each of the fragments are filled and compacted to the specified density.

- Subsequent rows of rocks should be placed such that they are not directly above a row placed in the previous lift of fill. A minimum 5-foot offset between rows is recommended.
- To facilitate future trenching, oversized material should not be placed within the range of foundation excavations, future utilities or other underground construction unless specifically approved by the soil engineer and the developer/owner representative.
- Fill materials approved by the Geotechnical Engineer should be placed in areas previously prepared to receive fill and in evenly placed, near horizontal layers at about 6 to 8 inches in loose thickness, or as otherwise determined by the Geotechnical Engineer for the project.
- Each layer should be moisture conditioned to optimum moisture content, or slightly above, as directed by the Geotechnical Engineer. After proper mixing and/or drying, to evenly distribute the moisture, the layers should be compacted to at least 90 percent of the maximum dry density in compliance with ASTM D-1557-78 unless otherwise indicated.
- Density and moisture content testing should be performed by the Geotechnical Engineer at random intervals and locations as determined by the Geotechnical Engineer. These tests are intended as an aid to the Earthwork Contractor, so he can evaluate his workmanship, equipment effectiveness and site conditions. The Earthwork Contractor is responsible for compaction as required by the Geotechnical Report(s) and governmental agencies.
- Fill areas unused for a period of time may require moisture conditioning, processing and recompaction prior to the start of additional filling. The Earthwork Contractor should notify the Geotechnical Engineer of his intent so that an evaluation can be made.
- Fill placed on ground sloping at a 5-to-1 inclination (horizontal-to-vertical) or steeper should be benched into bedrock or other suitable materials, as directed by the Geotechnical Engineer. Typical details of benching are illustrated on Plates D-2, D-4, and D-5.
- Cut/fill transition lots should have the cut portion overexcavated to a depth of at least 3 feet and rebuilt with fill (see Plate D-1), as determined by the Geotechnical Engineer.
- All cut lots should be inspected by the Geotechnical Engineer for fracturing and other bedrock conditions. If necessary, the pads should be overexcavated to a depth of 3 feet and rebuilt with a uniform, more cohesive soil type to impede moisture penetration.
- Cut portions of pad areas above buttresses or stabilizations should be overexcavated to a depth of 3 feet and rebuilt with uniform, more cohesive compacted fill to impede moisture penetration.
- Non-structural fill adjacent to structural fill should typically be placed in unison to provide lateral support. Backfill along walls must be placed and compacted with care to ensure that excessive unbalanced lateral pressures do not develop. The type of fill material placed adjacent to below grade walls must be properly tested and approved by the Geotechnical Engineer with consideration of the lateral earth pressure used in the design.

### Foundations

- The foundation influence zone is defined as extending one foot horizontally from the outside edge of a footing, and proceeding downward at a ½ horizontal to 1 vertical (0.5:1) inclination.
- Where overexcavation beneath a footing subgrade is necessary, it should be conducted so as to encompass the entire foundation influence zone, as described above.
- Compacted fill adjacent to exterior footings should extend at least 12 inches above foundation bearing grade. Compacted fill within the interior of structures should extend to the floor subgrade elevation.

### Fill Slopes

- The placement and compaction of fill described above applies to all fill slopes. Slope compaction should be accomplished by overfilling the slope, adequately compacting the fill in even layers, including the overfilled zone and cutting the slope back to expose the compacted core
- Slope compaction may also be achieved by backrolling the slope adequately every 2 to 4 vertical feet during the filling process as well as requiring the earth moving and compaction equipment to work close to the top of the slope. Upon completion of slope construction, the slope face should be compacted with a sheepsfoot connected to a sideboom and then grid rolled. This method of slope compaction should only be used if approved by the Geotechnical Engineer.
- Sandy soils lacking in adequate cohesion may be unstable for a finished slope condition and therefore should not be placed within 15 horizontal feet of the slope face.
- All fill slopes should be keyed into bedrock or other suitable material. Fill keys should be at least 15 feet wide and inclined at 2 percent into the slope. For slopes higher than 30 feet, the fill key width should be equal to one-half the height of the slope (see Plate D-5).
- All fill keys should be cleared of loose slough material prior to geotechnical inspection and should be approved by the Geotechnical Engineer and governmental agencies prior to filling.
- The cut portion of fill over cut slopes should be made first and inspected by the Geotechnical Engineer for possible stabilization requirements. The fill portion should be adequately keyed through all surficial soils and into bedrock or suitable material. Soils should be removed from the transition zone between the cut and fill portions (see Plate D-2).

### Cut Slopes

- All cut slopes should be inspected by the Geotechnical Engineer to determine the need for stabilization. The Earthwork Contractor should notify the Geotechnical Engineer when slope cutting is in progress at intervals of 10 vertical feet. Failure to notify may result in a delay in recommendations.
- Cut slopes exposing loose, cohesionless sands should be reported to the Geotechnical Engineer for possible stabilization recommendations.
- All stabilization excavations should be cleared of loose slough material prior to geotechnical inspection. Stakes should be provided by the Civil Engineer to verify the location and dimensions of the key. A typical stabilization fill detail is shown on Plate D-5.

- Stabilization key excavations should be provided with subdrains. Typical subdrain details are shown on Plates D-6.

#### Subdrains

- Subdrains may be required in canyons and swales where fill placement is proposed. Typical subdrain details for canyons are shown on Plate D-3. Subdrains should be installed after approval of removals and before filling, as determined by the Soils Engineer.
- Plastic pipe may be used for subdrains provided it is Schedule 40 or SDR 35 or equivalent. Pipe should be protected against breakage, typically by placement in a square-cut (backhoe) trench or as recommended by the manufacturer.
- Filter material for subdrains should conform to CALTRANS Specification 68-1.025 or as approved by the Geotechnical Engineer for the specific site conditions. Clean  $\frac{3}{4}$ -inch crushed rock may be used provided it is wrapped in an acceptable filter cloth and approved by the Geotechnical Engineer. Pipe diameters should be 6 inches for runs up to 500 feet and 8 inches for the downstream continuations of longer runs. Four-inch diameter pipe may be used in buttress and stabilization fills.



CUT LOT

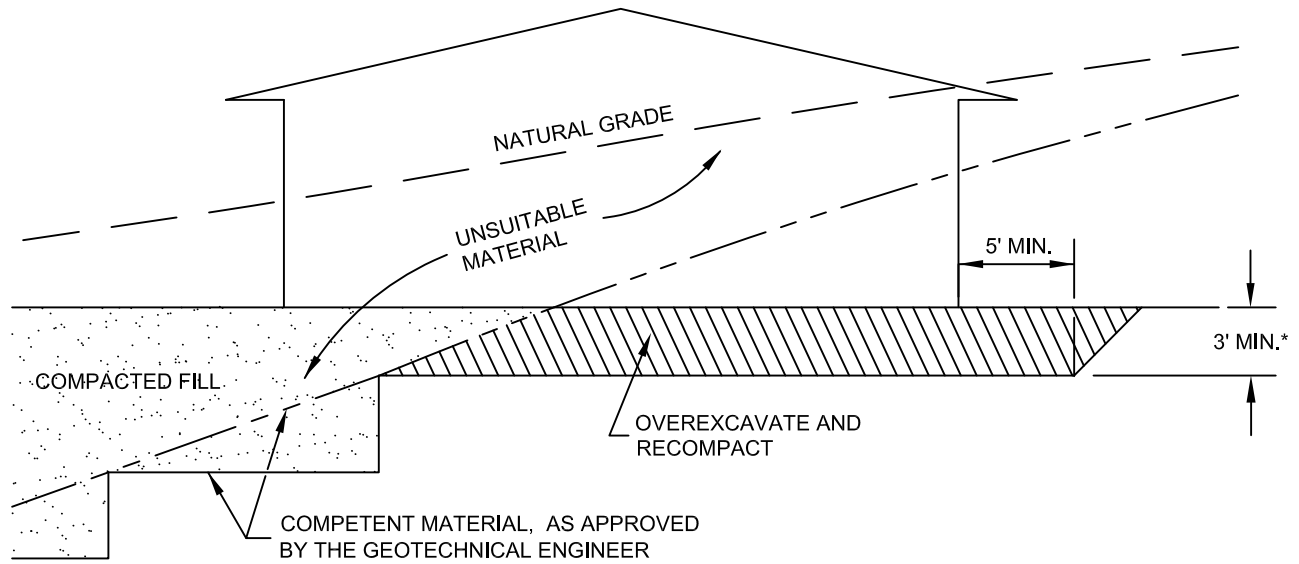

CUT/FILL LOT (TRANSITION)

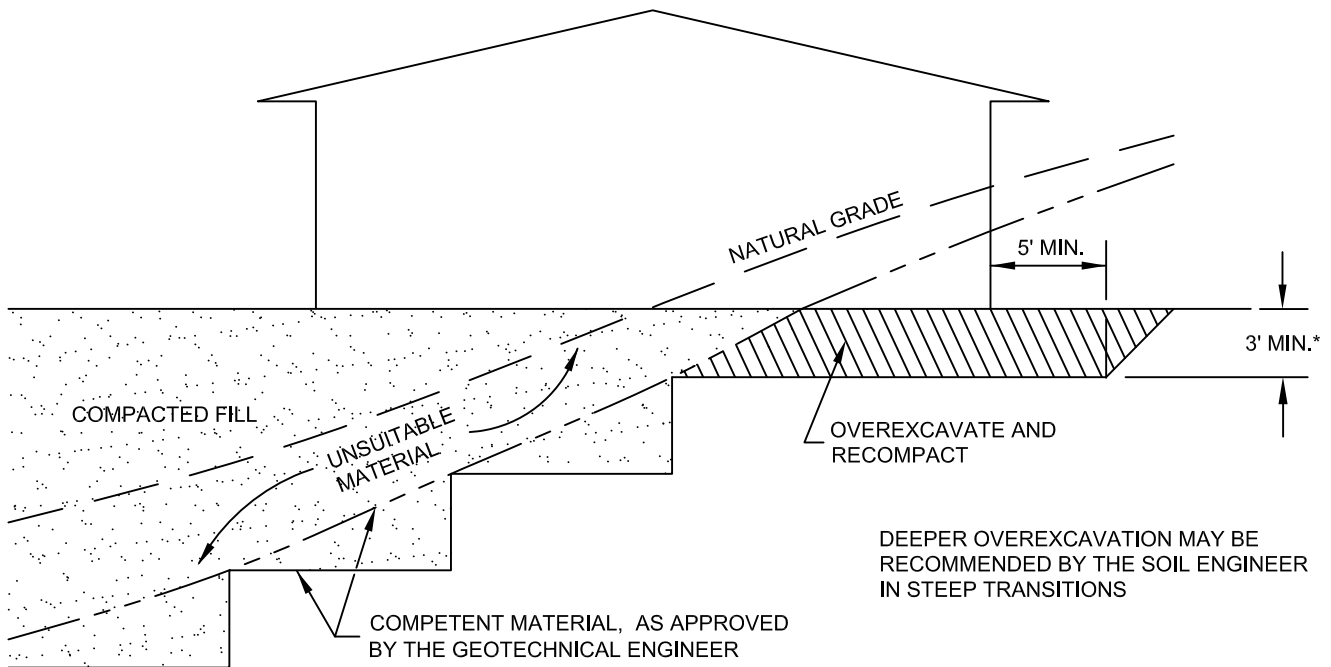

\*SEE TEXT OF REPORT FOR SPECIFIC RECOMMENDATION. ACTUAL DEPTH OF OVEREXCAVATION MAY BE GREATER.

<b>TRANSITION LOT DETAIL</b>	
<b>GRADING GUIDE SPECIFICATIONS</b>	
NOT TO SCALE	 <b>SOUTHERN CALIFORNIA GEOTECHNICAL</b>
DRAWN: JAS CHKD: GKM	
<b>PLATE D-1</b>	

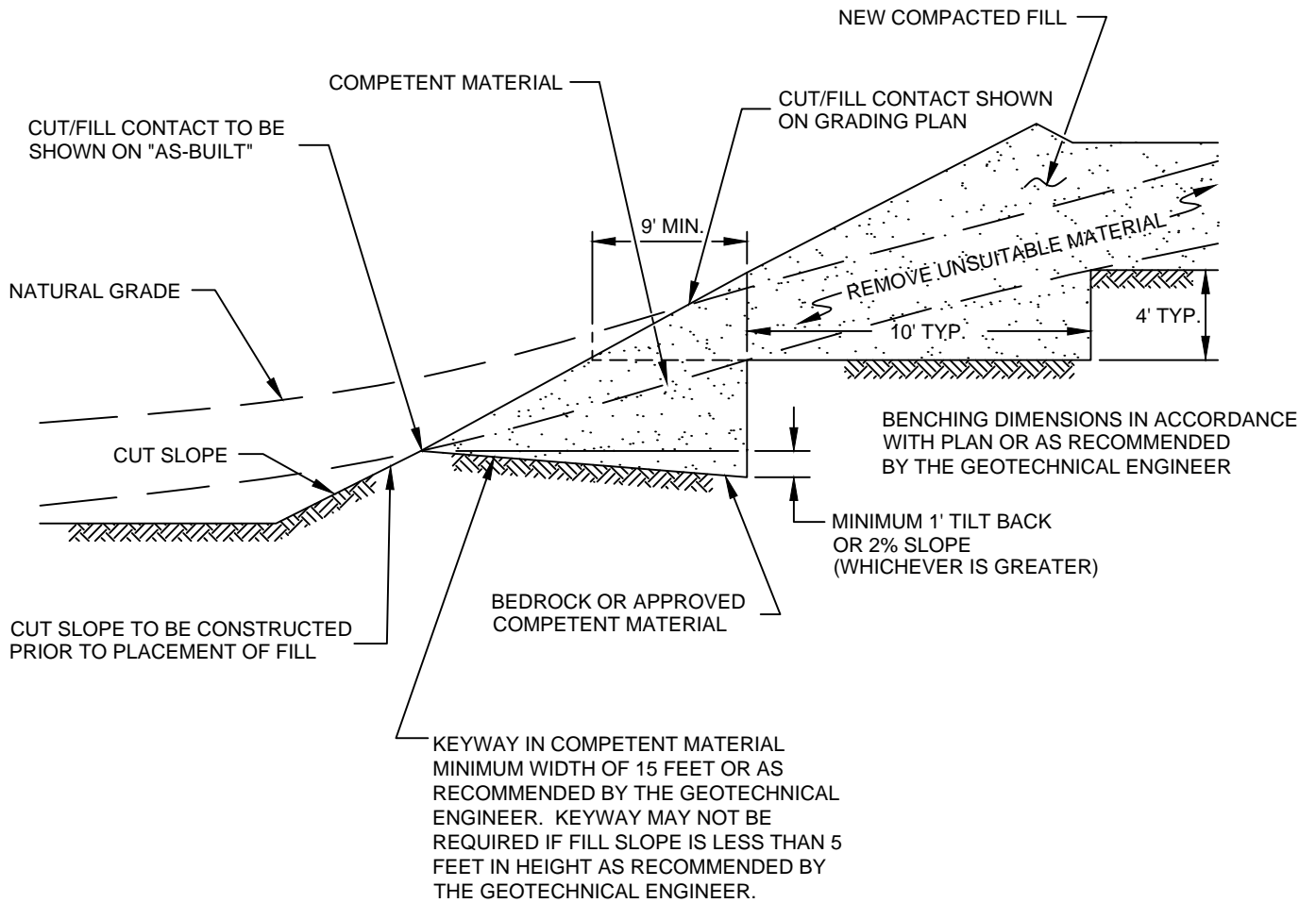

<b>FILL ABOVE CUT SLOPE DETAIL</b>	
<b>GRADING GUIDE SPECIFICATIONS</b>	
NOT TO SCALE	 <b>SOUTHERN CALIFORNIA GEOTECHNICAL</b>
DRAWN: JAS CHKD: GKM	
<b>PLATE D-2</b>	

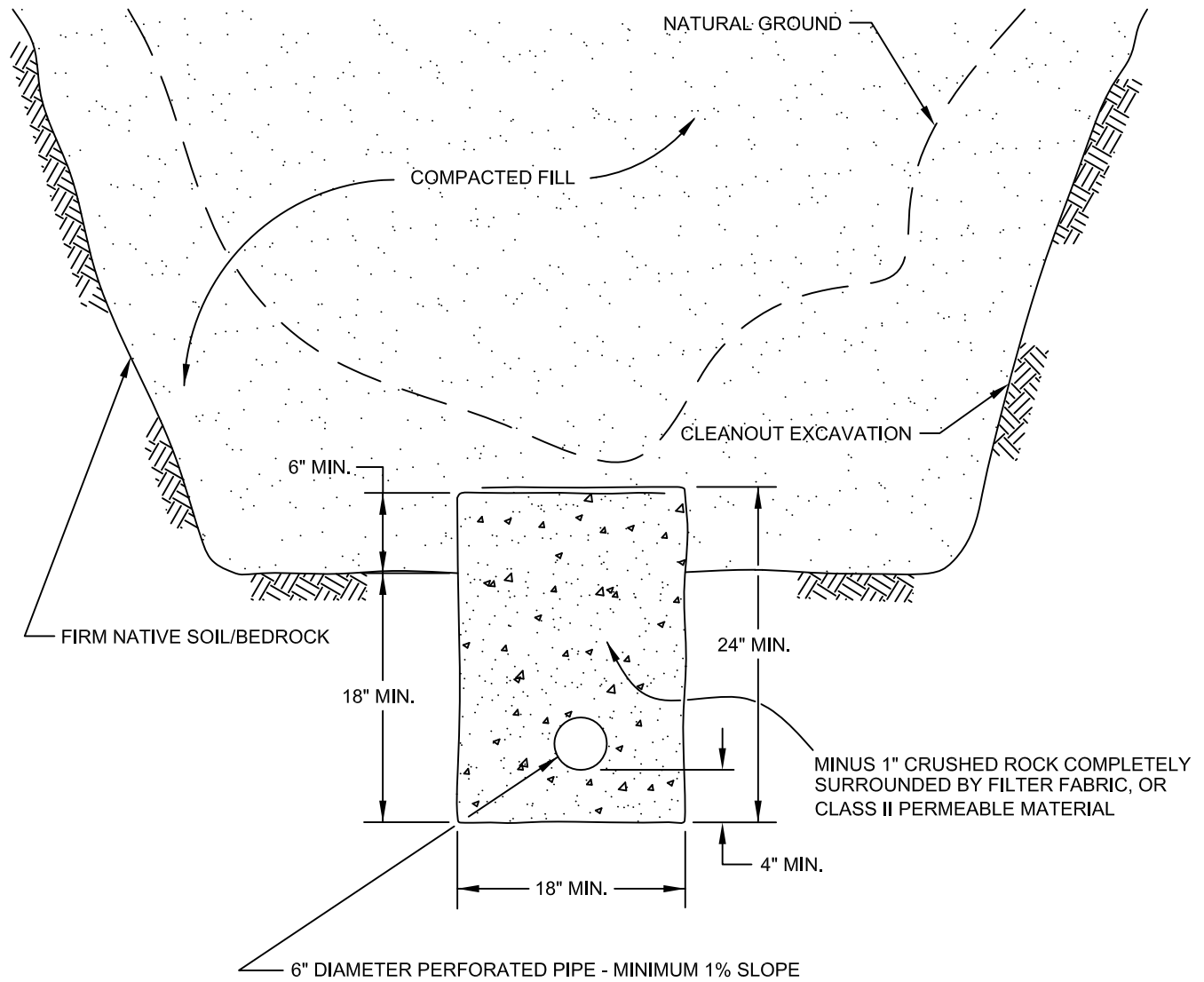

PIPE MATERIAL	DEPTH OF FILL OVER SUBDRAIN
ADS (CORRUGATED POLETHYLENE)	8
TRANSITE UNDERDRAIN	20
PVC OR ABS: SDR 35	35
SDR 21	100

**SCHEMATIC ONLY  
NOT TO SCALE**

<b>CANYON SUBDRAIN DETAIL</b>	
<b>GRADING GUIDE SPECIFICATIONS</b>	
NOT TO SCALE	 <b>SOUTHERN CALIFORNIA GEOTECHNICAL</b>
DRAWN: JAS CHKD: GKM	
<b>PLATE D-3</b>	

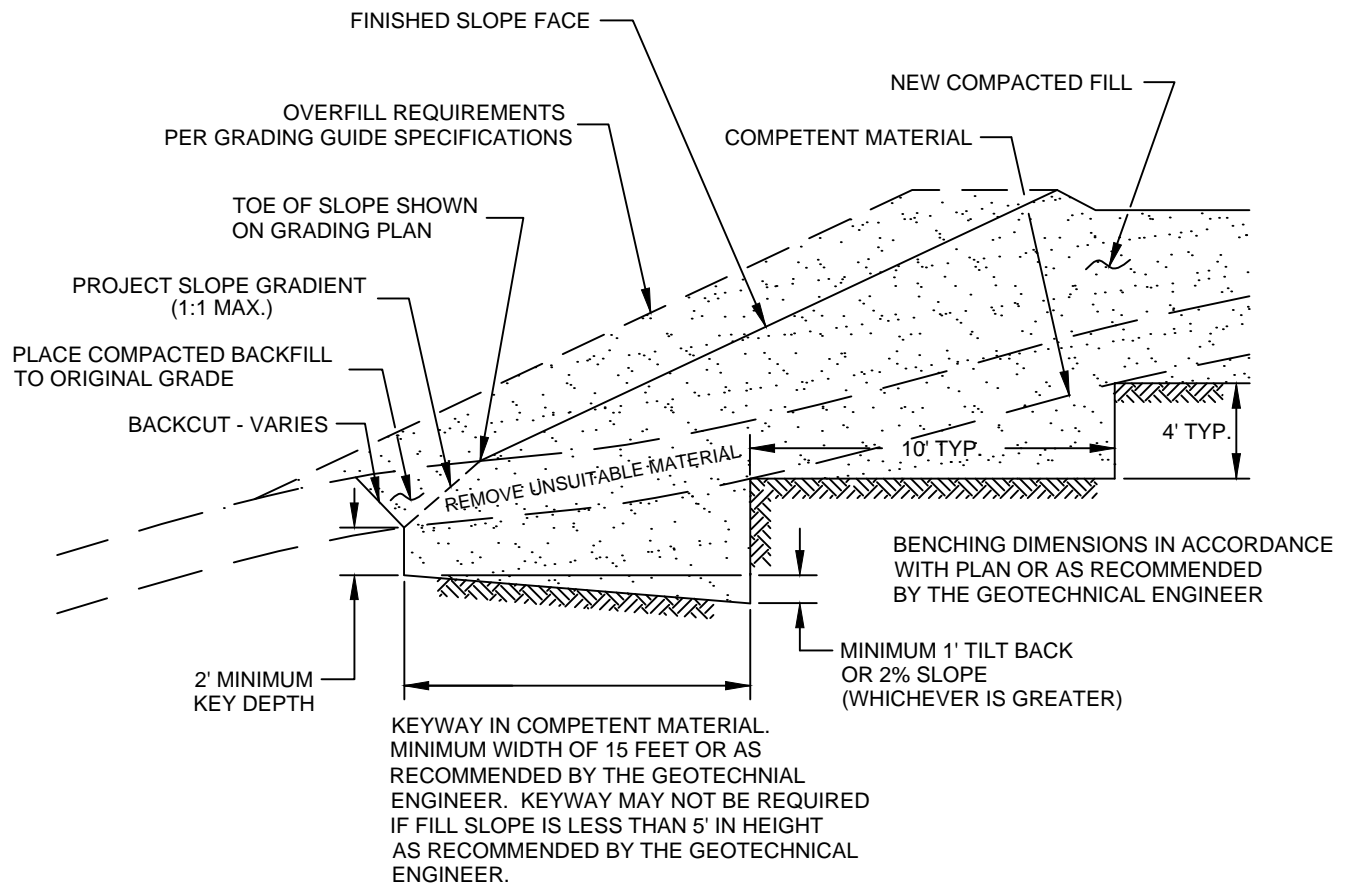

NOTE:  
 BENCHING SHALL BE REQUIRED  
 WHEN NATURAL SLOPES ARE  
 EQUAL TO OR STEEPER THAN 5:1  
 OR WHEN RECOMMENDED BY  
 THE GEOTECHNICAL ENGINEER.

<b>FILL ABOVE NATURAL SLOPE DETAIL</b>	
<b>GRADING GUIDE SPECIFICATIONS</b>	
NOT TO SCALE	 <b>SOUTHERN CALIFORNIA GEOTECHNICAL</b>
DRAWN: JAS CHKD: GKM	
<b>PLATE D-4</b>	

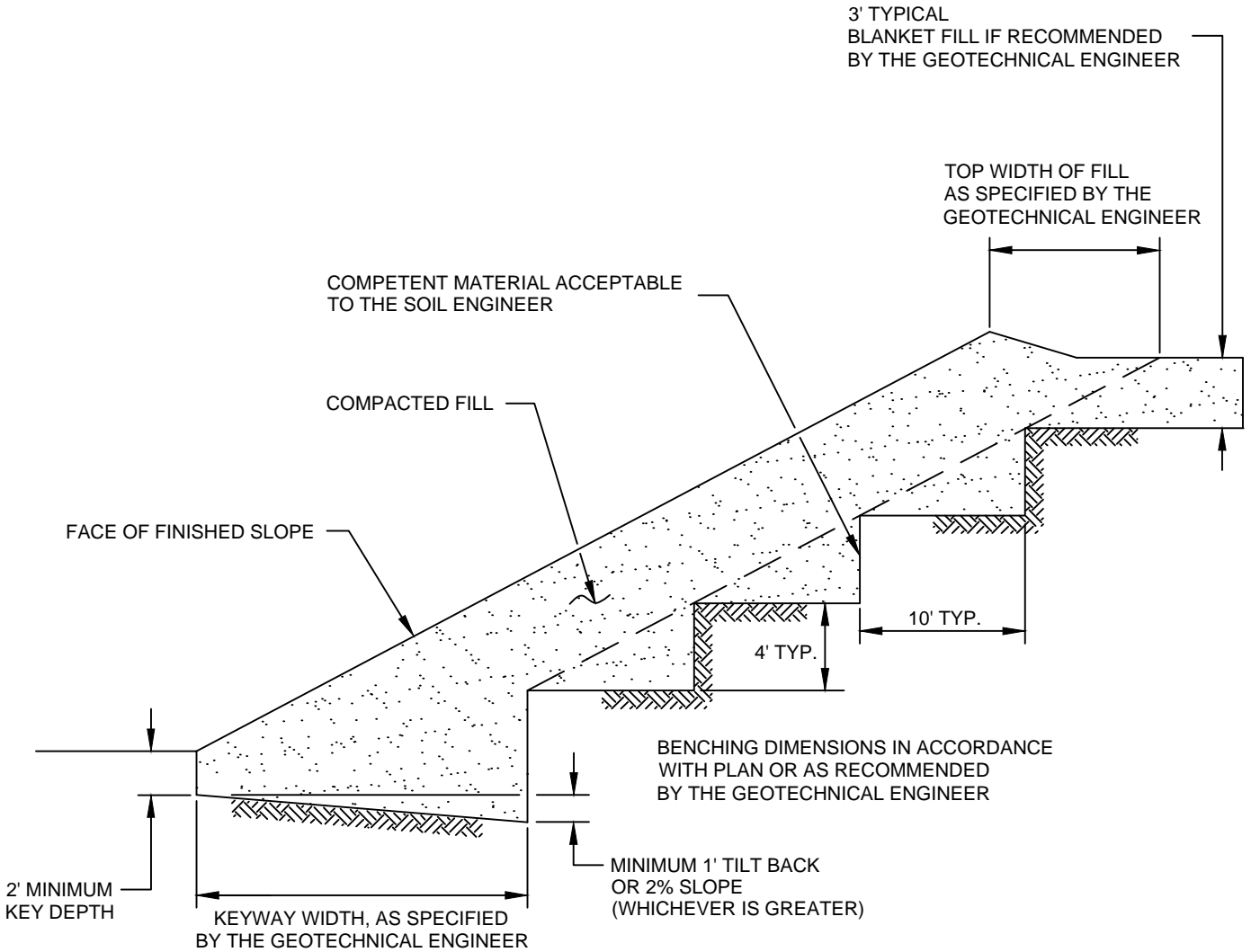

<b>STABILIZATION FILL DETAIL</b>	
GRADING GUIDE SPECIFICATIONS	
NOT TO SCALE	 <b>SOUTHERN CALIFORNIA GEOTECHNICAL</b>
DRAWN: JAS CHKD: GKM	
<b>PLATE D-5</b>	



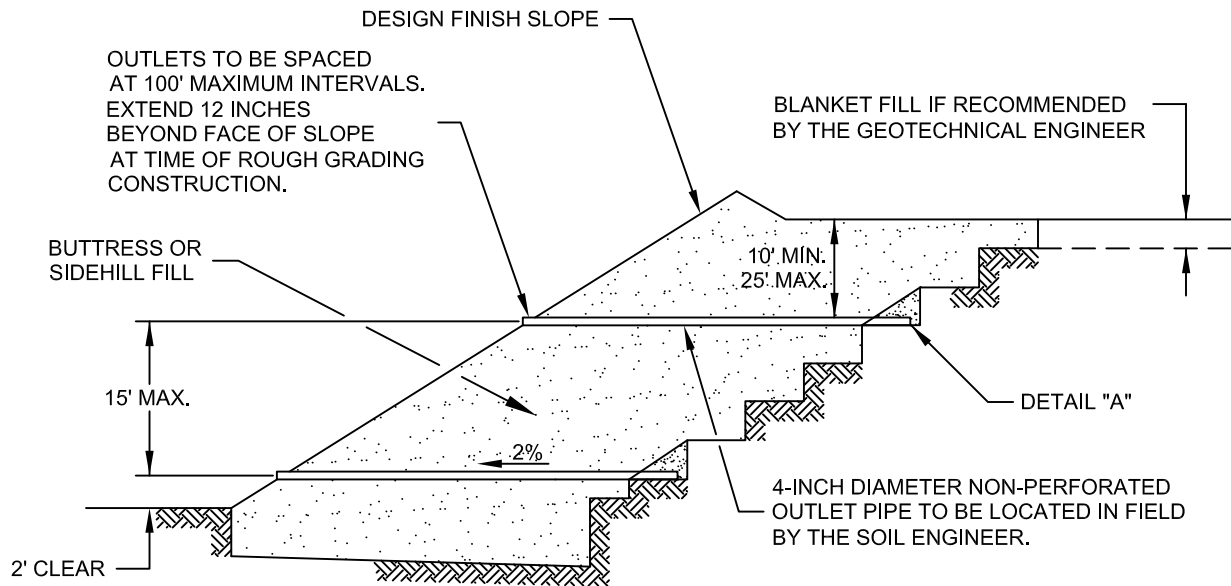

"FILTER MATERIAL" TO MEET FOLLOWING SPECIFICATION OR APPROVED EQUIVALENT: (CONFORMS TO EMA STD. PLAN 323)

SIEVE SIZE	PERCENTAGE PASSING
1"	100
3/4"	90-100
3/8"	40-100
NO. 4	25-40
NO. 8	18-33
NO. 30	5-15
NO. 50	0-7
NO. 200	0-3

"GRAVEL" TO MEET FOLLOWING SPECIFICATION OR APPROVED EQUIVALENT:

SIEVE SIZE	MAXIMUM PERCENTAGE PASSING
1 1/2"	100
NO. 4	50
NO. 200	8
SAND EQUIVALENT = MINIMUM OF 50	

OUTLET PIPE TO BE CONNECTED TO SUBDRAIN PIPE WITH TEE OR ELBOW

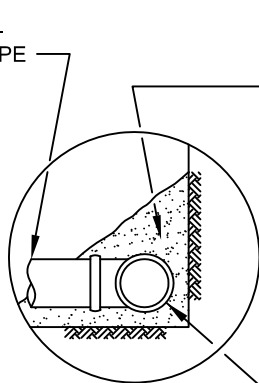

DETAIL "A"

FILTER MATERIAL - MINIMUM OF FIVE CUBIC FEET PER FOOT OF PIPE. SEE ABOVE FOR FILTER MATERIAL SPECIFICATION.

ALTERNATIVE: IN LIEU OF FILTER MATERIAL FIVE CUBIC FEET OF GRAVEL PER FOOT OF PIPE MAY BE ENCASED IN FILTER FABRIC. SEE ABOVE FOR GRAVEL SPECIFICATION.

FILTER FABRIC SHALL BE MIRAFI 140 OR EQUIVALENT. FILTER FABRIC SHALL BE LAPPED A MINIMUM OF 12 INCHES ON ALL JOINTS.

MINIMUM 4-INCH DIAMETER PVC SCH 40 OR ABS CLASS SDR 35 WITH A CRUSHING STRENGTH OF AT LEAST 1,000 POUNDS, WITH A MINIMUM OF 8 UNIFORMLY SPACED PERFORATIONS PER FOOT OF PIPE INSTALLED WITH PERFORATIONS ON BOTTOM OF PIPE. PROVIDE CAP AT UPSTREAM END OF PIPE. SLOPE AT 2 PERCENT TO OUTLET PIPE.

NOTES:

1. TRENCH FOR OUTLET PIPES TO BE BACKFILLED WITH ON-SITE SOIL.

SLOPE FILL SUBDRAINS	
GRADING GUIDE SPECIFICATIONS	
NOT TO SCALE	 <b>SOUTHERN CALIFORNIA GEOTECHNICAL</b>
DRAWN: JAS CHKD: GKM	
PLATE D-6	

MINIMUM ONE FOOT THICK LAYER OF LOW PERMEABILITY SOIL IF NOT COVERED WITH AN IMPERMEABLE SURFACE

MINIMUM ONE FOOT WIDE LAYER OF FREE DRAINING MATERIAL (LESS THAN 5% PASSING THE #200 SIEVE) OR PROPERLY INSTALLED PREFABRICATED DRAINAGE COMPOSITE (MiraDRAIN 6000 OR APPROVED EQUIVALENT).

FILTER MATERIAL - MINIMUM OF TWO CUBIC FEET PER FOOT OF PIPE. SEE BELOW FOR FILTER MATERIAL SPECIFICATION.

ALTERNATIVE: IN LIEU OF FILTER MATERIAL TWO CUBIC FEET OF GRAVEL PER FOOT OF PIPE MAY BE ENCASED IN FILTER FABRIC. SEE BELOW FOR GRAVEL SPECIFICATION.

FILTER FABRIC SHALL BE MIRAFI 140 OR EQUIVALENT. FILTER FABRIC SHALL BE LAPPED A MINIMUM OF 6 INCHES ON ALL JOINTS.

MINIMUM 4-INCH DIAMETER PVC SCH 40 OR ABS CLASS SDR 35 WITH A CRUSHING STRENGTH OF AT LEAST 1,000 POUNDS, WITH A MINIMUM OF 8 UNIFORMLY SPACED PERFORATIONS PER FOOT OF PIPE INSTALLED WITH PERFORATIONS ON BOTTOM OF PIPE. PROVIDE CAP AT UPSTREAM END OF PIPE. SLOPE AT 2 PERCENT TO OUTLET PIPE.

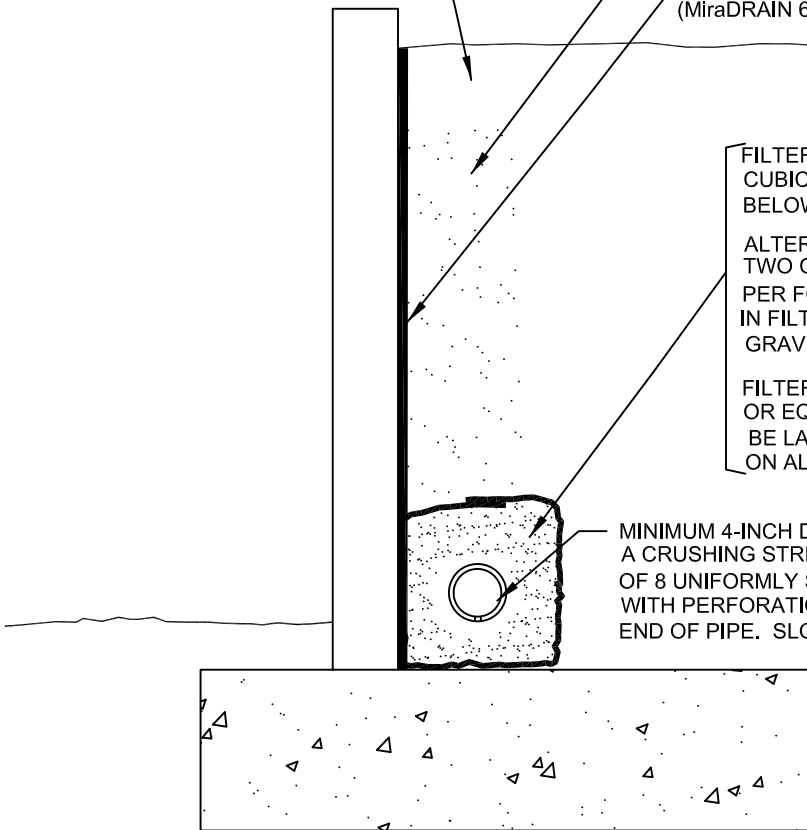

"FILTER MATERIAL" TO MEET FOLLOWING SPECIFICATION OR APPROVED EQUIVALENT: (CONFORMS TO EMA STD. PLAN 323)

SIEVE SIZE	PERCENTAGE PASSING
1"	100
3/4"	90-100
3/8"	40-100
NO. 4	25-40
NO. 8	18-33
NO. 30	5-15
NO. 50	0-7
NO. 200	0-3

"GRAVEL" TO MEET FOLLOWING SPECIFICATION OR APPROVED EQUIVALENT:

SIEVE SIZE	MAXIMUM PERCENTAGE PASSING
1 1/2"	100
NO. 4	50
NO. 200	8
SAND EQUIVALENT = MINIMUM OF 50	

RETAINING WALL BACKDRAINS	
GRADING GUIDE SPECIFICATIONS	
NOT TO SCALE	 <b>SOUTHERN CALIFORNIA GEOTECHNICAL</b>
DRAWN: JAS CHKD: GKM	
PLATE D-7	

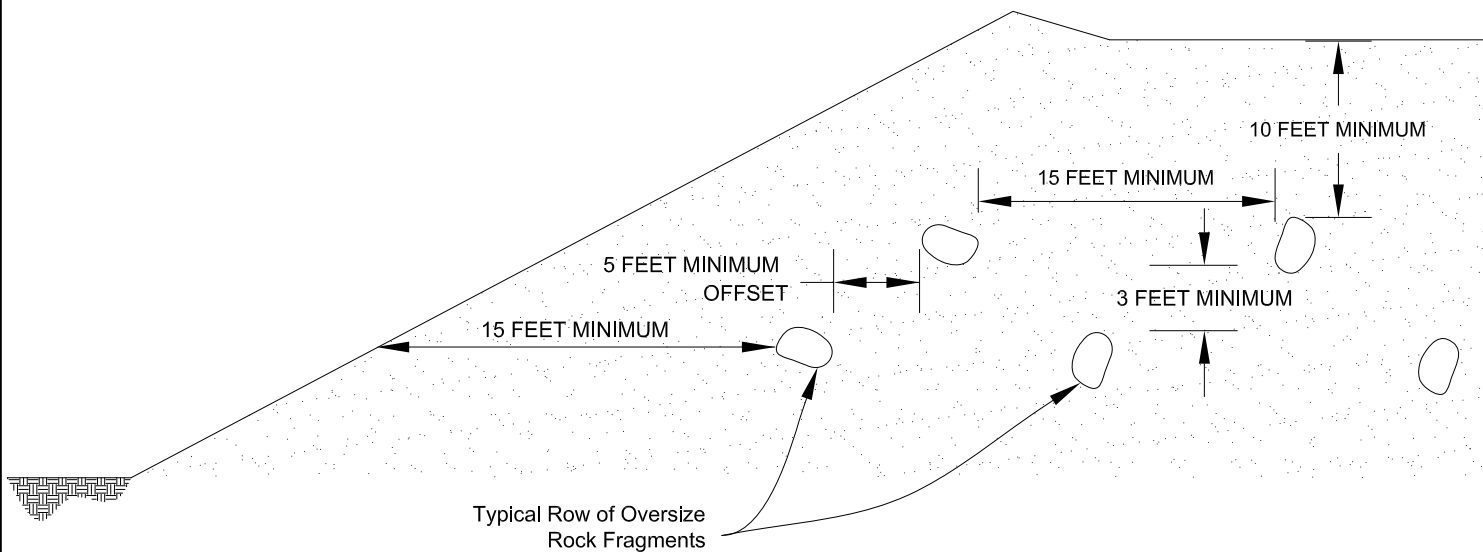

**Section View**

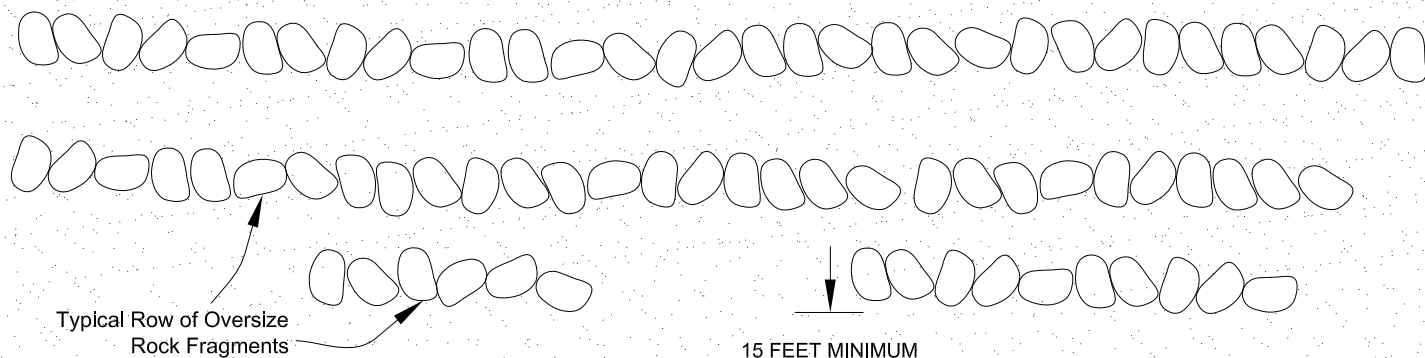

Fill Slope

**Plan View**

**PLACEMENT OF OVERSIZED MATERIAL  
GRADING GUIDE SPECIFICATIONS**

NOT TO SCALE

DRAWN: PM  
CHKD: GKM

PLATE D-8



**SOUTHERN  
CALIFORNIA  
GEOTECHNICAL**

# APPENDIX E



Latitude, Longitude: 33.835521, -117.228469



<b>Date</b>	2/3/2022, 4:34:53 PM
<b>Design Code Reference Document</b>	ASCE7-16
<b>Risk Category</b>	III
<b>Site Class</b>	D - Stiff Soil

Type	Value	Description
$S_S$	1.5	$MCE_R$ ground motion. (for 0.2 second period)
$S_1$	0.572	$MCE_R$ ground motion. (for 1.0s period)
$S_{MS}$	1.5	Site-modified spectral acceleration value
$S_{M1}$	null -See Section 11.4.8	Site-modified spectral acceleration value
$S_{DS}$	1	Numeric seismic design value at 0.2 second SA
$S_{D1}$	null -See Section 11.4.8	Numeric seismic design value at 1.0 second SA

Type	Value	Description
SDC	null -See Section 11.4.8	Seismic design category
$F_a$	1	Site amplification factor at 0.2 second
$F_v$	null -See Section 11.4.8	Site amplification factor at 1.0 second
PGA	0.5	$MCE_G$ peak ground acceleration
$F_{PGA}$	1.1	Site amplification factor at PGA
$PGA_M$	0.55	Site modified peak ground acceleration
$T_L$	8	Long-period transition period in seconds
$S_{sRT}$	1.53	Probabilistic risk-targeted ground motion. (0.2 second)
$S_{sUH}$	1.639	Factored uniform-hazard (2% probability of exceedance in 50 years) spectral acceleration
$S_{sD}$	1.5	Factored deterministic acceleration value. (0.2 second)
$S_{1RT}$	0.572	Probabilistic risk-targeted ground motion. (1.0 second)
$S_{1UH}$	0.627	Factored uniform-hazard (2% probability of exceedance in 50 years) spectral acceleration.
$S_{1D}$	0.6	Factored deterministic acceleration value. (1.0 second)
$PGA_d$	0.5	Factored deterministic acceleration value. (Peak Ground Acceleration)
$C_{RS}$	0.934	Mapped value of the risk coefficient at short periods
$C_{R1}$	0.912	Mapped value of the risk coefficient at a period of 1 s

SOURCE: SEAOC/OSHPD Seismic Design Maps Tool  
<https://seismicmaps.org/>



<b>SEISMIC DESIGN PARAMETERS - 2019 CBC</b>	
FIRST SINCLAIR LOGISTICS CENTER	
PERRIS, CALIFORNIA	
DRAWN: MD CHKD: RGT SCG PROJECT 22G122-1 <b>PLATE E-1</b>	 <b>SOUTHERN CALIFORNIA GEOTECHNICAL</b>



# Appendix 4: Historical Site Conditions

*Phase I Environmental Site Assessment or Other Information on Past Site Use*



## **Phase I Environmental Site Assessment**

100 Sinclair Street  
Perris, California 92571

February 24, 2022

First Industrial Realty Trust, Inc., First Industrial, L.P.  
First Industrial Acquisitions II, LLC and their Affiliates and Assigns  
One North Wacker Drive, Suite 4200  
Chicago, IL 60606

Project Number 22-01-015

Prepared by:



1938 Kellogg Avenue, Suite 116  
Carlsbad, CA 92008  
(760) 585-7070  
[www.weisenviro.com](http://www.weisenviro.com)



1938 Kellogg Avenue, Suite 116, Carlsbad, CA 92008  
(760) 585-7070  
www.weisenviro.com

February 24, 2022

Mike Reese  
First Industrial Realty Trust, Inc.  
One North Wacker Drive, Suite 4200  
Chicago, IL 60606

Subject: Phase I Environmental Site Assessment  
100 Sinclair Street  
Perris, California 92571  
Project Number 22-01-015

Dear Mr. Reese:

Weis Environmental, LLC has completed the contracted environmental consulting services for the above-referenced project. The services were performed in accordance with our proposal and agreement fully executed by all parties. The Phase I Environmental Site Assessment has been performed in accordance with American Society for Testing and Materials (ASTM) Standard Practice for Environmental Site Assessments: Phase I Environmental Site Assessment Process, ASTM Designation E1527-21 and Title 40 of the Code of Federal Regulations (40 CFR) Part 312. This assessment was also completed in accordance with the First Industrial Realty Trust Scope of Work for Phase I ESAs. We appreciate the opportunity to be of service to you on this project. Please contact us if you have any questions or comments regarding this report or if we can be of further assistance.

Sincerely,

Weis Environmental, LLC

A handwritten signature in black ink that reads "Daniel Weis". The signature is written in a cursive, flowing style.

Daniel Weis, R.E.H.S.  
Environmental Manager

# TABLE OF CONTENTS

1.0 INTRODUCTION .....	1
1.1 Purpose .....	1
1.2 Scope of the Assessment .....	1
1.3 Limitations and Exceptions .....	2
1.4 Special Terms and Conditions.....	3
1.5 Limiting Conditions and Deviations .....	3
1.6 Data Failure and Data Gaps .....	3
1.7 Reliance.....	3
2.0 SUBJECT PROPERTY DESCRIPTION .....	4
2.1 Location and Legal Description .....	4
2.2 Subject Property and Vicinity Characteristics .....	4
2.3 Current Use of the Subject Property .....	4
2.4 Description of Subject Property Improvements .....	4
2.5 Utilities.....	4
2.6 Description of Adjoining Properties .....	4
2.7 Summary Relative to Environmental Concerns .....	5
3.0 PHYSICAL SETTING .....	6
3.1 Topography .....	6
3.2 Hydrology .....	6
3.3 Geology .....	6
3.4 Hydrogeology.....	6
3.5 Oil and Gas Exploration.....	7
3.6 Summary Relative to Environmental Concerns .....	7
4.0 USER PROVIDED INFORMATION .....	8
4.1 Title Records .....	8
4.2 Environmental Liens .....	8
4.3 Activity and Use Limitations .....	8
4.4 Specialized or Actual Knowledge or Experience.....	8
4.5 Commonly Known or Reasonably Ascertainable Information .....	8
4.6 Valuation Reduction for Environmental Issues .....	8
4.7 Owner, Property Manager, and Occupant Information.....	9
4.8 Reason for Performing Phase I ESA .....	9
4.9 Proceedings Involving the Subject Property .....	9
4.10 Other Provided Documents .....	9
4.11 Summary Relative to Environmental Concerns .....	10
5.0 REGULATORY RECORDS REVIEW.....	11
5.1 Standard ASTM Regulatory Database Search .....	11
5.2 Non-ASTM Regulatory Database Search .....	14
5.3 Regulatory Agency File Reviews.....	15
5.4 Summary Relative to Environmental Concerns .....	16

6.0	HISTORICAL RESOURCE REVIEW .....	17
6.1	Aerial Photographs.....	17
6.2	Topographic Maps .....	18
6.3	City Directories .....	18
6.4	Other Historical Sources .....	18
6.5	Summary Relative to Environmental Concerns .....	19
7.0	SUBJECT PROPERTY RECONAISSANCE .....	20
7.1	Methodology and Limiting Conditions .....	20
7.2	Current General Subject Property and Vicinity Characteristics.....	20
7.3	Indications of Past Subject Property and Vicinity Uses.....	20
7.4	Subject Property-Specific Observations.....	20
7.5	Summary Relative to Environmental Concerns .....	22
8.0	INTERVIEWS .....	23
8.1	Subject Property Owner .....	23
8.2	Key Site Manager.....	23
8.3	Current Occupants.....	23
8.4	Local Government Official .....	23
8.5	Other Parties.....	23
8.6	Summary Relative to Environmental Concerns .....	23
9.0	ADDITIONAL SERVICES – NON-SCOPE ASTM CONSIDERATIONS.....	24
10.0	FINDINGS AND OPINIONS.....	25
11.0	CONCLUSIONS AND RECOMMENDATIONS .....	26
12.0	ENVIRONMENTAL PROFESSIONAL STATEMENT .....	27
13.0	ASSUMPTIONS.....	28
14.0	DEFINITIONS.....	29
15.0	REFERENCES .....	31
15.1	Documents, Plans and Reports.....	31
15.2	Personal Communications.....	31
15.3	Agencies Consulted.....	31

## FIGURES

- Figure 1 Vicinity Map
- Figure 2 Site Plan
- Figure 3 Topographic Map

## APPENDICES

- Appendix A User Provided Information
- Appendix B Regulatory Database Report
- Appendix C Regulatory Agency Records
- Appendix D Historical Resources
- Appendix E Photographs
- Appendix F Qualifications

## 1.0 INTRODUCTION

This report presents the methods and findings of a Phase I Environmental Site Assessment (ESA) of the subject property located at 100 Sinclair Street and identified by Riverside County Assessor's Parcel Number (APN) 303-080-015 in the City of Perris, Riverside County, California (Subject Property) performed in conformance with the contract/agreement for this assignment and the scope and limitations of ASTM Standard Practice E1527-21 and United States Environmental Protection Agency (EPA) Standards and Practices for All Appropriate Inquiries (AAI) as published in 40 Code of Federal Regulations (CFR) Part 312. EPA promulgated the AAI rule that became effective in November 2006. An acknowledgment is pending by the EPA that the ASTM E1527-21 practice is consistent with the requirements of AAI and may be used to comply with the provisions of the AAI rule. As such, it should be noted that this report also complies with the previously published ASTM E1527-13 standard and for the purposes of this report, any statement regarding compliance with ASTM E1527-21 is also an acknowledgment that the report complies with ASTM E1527-13 and the AAI rule. This assessment was also completed in accordance with the First Industrial Realty Trust Scope of Work for Phase I ESAs.

### 1.1 Purpose

The purpose of the ASTM E1527-21 practice (framework for this Phase I ESA) is to define good commercial and customary practice in the United States of America for conducting an ESA of a parcel of real estate with respect to the range of contaminants within the scope of the Comprehensive Environmental Response, Compensation and Liability Act (CERCLA) (Title 42 United States Code (U.S.C.) Section 9601)) and petroleum products. As such, this practice is intended to permit a user to satisfy one of the requirements to qualify for the innocent landowner, contiguous property owner, or bona fide prospective purchaser limitations on CERCLA liability (hereinafter, the "landowner liability protections," or "LLPs"): that is, the practice that constitutes all appropriate inquiries into the previous ownership and uses of the property consistent with good commercial and customary practice as defined at 42 U.S.C. Section 9601(35)(B).

In defining a standard of good commercial and customary practice for conducting this Phase I ESA of the Subject Property, the goal of the processes established by the ASTM E1527-21 practice is to identify, to the extent feasible, recognized environmental conditions. The term recognized environmental conditions is defined as the presence or likely presence of any hazardous substances or petroleum products in, on, or at a property: (1) due to any release to the environment; (2) under conditions indicative of a release to the environment; or (3) under conditions that pose a material threat of a future release to the environment. In addition, controlled recognized environmental conditions, historical recognized environmental conditions and/or de minimis conditions, if identified during the completion of the assessment, are discussed herein. Definitions of these terms and other key terminology relevant to the practice are included in Section 14.0 of this report.

### 1.2 Scope of the Assessment

In general terms, this Phase I ESA included the acquisition of readily available/accessible and practically reviewable regulatory records and historical information, a property reconnaissance, interviews, and preparation of this written report of findings. A more detailed description of the four primary components of the Phase I ESA is presented below.





**Records Review** - A review of Federal, State, Tribal and local standard ASTM and non-ASTM regulatory databases for a myriad of environmental identifiers including but not limited to properties with underground storage tanks (USTs), properties with leaking USTs, properties that have reported spills/releases that did not occur from a leaking UST, businesses that utilize hazardous materials and/or generate hazardous waste and hazardous waste disposal locations. The regulatory review may also include public records requests with one or more Federal, State, Tribal and/or local agencies. A review of historical sources is also completed to help ascertain previous land uses of the property in question and in the surrounding area.

**Subject Property Reconnaissance** - A property inspection and viewing of adjacent and surrounding properties for conditions that could be recognized environmental conditions.

**Interviews** - Interviews with present and past owners, operators and/or occupants of a property and local government officials.

**Reporting** - Evaluation of the information gathered during the completion of the Phase I ESA and the subsequent preparation of a written report.

### 1.3 Limitations and Exceptions

Concerns regarding liability under the Comprehensive Environmental Response, Compensation and Liability Act, 42 U.S.C. 9601 et seq. (CERCLA) and analogous State laws, have been a primary driver for Phase I ESA assignments in commercial real estate transactions. While the ASTM E1527-21 practice can be used in many contexts, a familiarity with CERCLA and its potential LLPs is critical in understanding and applying the ASTM E1527-21 practice. We advise consultation with legal counsel if further inquiry or information is desired.

AAI represents the minimum level of inquiry necessary to support the LLPs. However, it is important to understand that additional inquiry ultimately may be necessary or desirable for legal as well as business reasons depending upon the outcome of this inquiry and the particular risk tolerances of a given user. For example, additional inquiry may assist a user of a Phase I ESA in determining whether he or she would have continuing obligations in the event he or she acquires a given property and may also assist the user in defining the scope of future steps to be taken to satisfy such obligations. In addition, a user may be concerned about business environmental risks or non-scope ASTM considerations that do not fall within the definition of a recognized environmental condition. In addition, this assessment did not include subsurface or other invasive exploration, unless specifically documented herein. Users are also cautioned that Federal, State, Tribal and local laws may impose environmental assessment obligations that are beyond the scope of the ASTM E1527-21 practice.

The evaluation, opinion and conclusions presented herein are based solely on visual observations and regulatory, historical and personal knowledge related information that existed at the time our assessment was completed. The use of the gathered information is exclusively for the purposes outlined in this report and only for the Subject Property. Our firm can make no warranty, either express or implied, except that the services conducted were performed in accordance with generally accepted environmental assessment practices applicable at the time and location of the assessment and that the conclusions of the assessment have been based in part on professional judgment/experience, an interpretation of readily available data and the standard of care normally followed by similar professionals practicing in a similar locale and under similar circumstances. Any opinions presented cannot apply to Subject Property changes of which our firm is unaware and has not had the opportunity to evaluate. In addition, this report cannot feasibly include any evaluation of undocumented activities at the Subject Property or on adjacent or nearby properties. Lastly, a Phase I ESA meeting or exceeding



this practice and completed less than 180 days prior to the date of acquisition of a given property or (for transactions not involving an acquisition) the date of the intended transaction is presumed to be valid.

#### **1.4 Special Terms and Conditions**

This Phase I ESA was prepared in accordance with the terms and conditions of the contract/agreement for the work as executed between our firm and the client. There are no other special terms and conditions established between our firm and the client pertinent to the findings of this ESA or methodology used to complete this assessment. In addition, our firm has no final or other vested interest in the Subject Property or adjacent/surrounding properties, or in any entity that owns or occupies the Subject Property or adjacent/surrounding properties.

#### **1.5 Limiting Conditions and Deviations**

There were no significant limiting conditions that would inhibit our ability to identify recognized environmental conditions noted during the completion of this assessment. In addition, there were no deviations from the ASTM E1527-21 standard noted during the completion of this assessment. Any limiting conditions that are not considered to be ones that would inhibit our ability to identify recognized environmental conditions at the Subject Property are referenced in applicable sections of this report.

#### **1.6 Data Failure and Data Gaps**

No instances of data failure were encountered during the completion of this assessment. In addition, no data gaps of significance (i.e., those that would inhibit our ability to identify recognized environmental conditions) were identified during the completion of this assessment. Any data gaps that are not considered to be ones that would inhibit our ability to identify recognized environmental conditions at the Subject Property are referenced in applicable sections of this report.

#### **1.7 Reliance**

This report has been prepared for the exclusive use of First Industrial Realty Trust, Inc., First Industrial, LP and First Industrial Acquisitions II, LLC and their Affiliates and Assigns (User). This report may not be relied upon by any other person or entity without the written consent of both our firm and our client. The scope of services performed for this assessment may not be appropriate to satisfy the specific needs of other users, and any use or reuse of this document would be at the sole risk of said users. Any other party seeking liability protection under CERCLA must take independent action to accomplish its objective.



## 2.0 SUBJECT PROPERTY DESCRIPTION

### 2.1 Location and Legal Description

The Subject Property is a reported 13.66 acres and located to the north of West Rider Street, south of Morgan Street, east of Barrett and west of North Perris Boulevard at the physical address of 100 Sinclair Street. The Subject Property is further identified by Riverside County APN 303-080-015. A Vicinity Map is included as Figure 1. A Site Plan is included as Figure 2.

### 2.2 Subject Property and Vicinity Characteristics

The Subject Property is situated in an area consisting of commercial/light industrial land uses and vacant lots in the City of Perris. Additional details pertaining to the Subject Property and its adjoining properties are provided in the sections below.

### 2.3 Current Use of the Subject Property

The Subject Property is currently an unoccupied commercial/light-industrial property.

### 2.4 Description of Subject Property Improvements

The Subject Property is developed with a two-story light industrial building with a mezzanine level. The building is an estimated 150,000 square feet and was reportedly constructed in 2000. The structure appears to be of concrete masonry and corrugated steel construction and situated on a concrete slab-on-grade foundation. Other portions of the Subject Property consist of asphalt- and concrete-paved driveways and former operational areas to the north and south of the structure, asphalt parking areas to the east and southeast, a paved shipping/receiving area and an unpaved storage yard to the west, and minor landscaping. Access to the Subject Property is provided by Sinclair Street. Indicators of various utility systems are also present throughout the Subject Property.

### 2.5 Utilities

Utilities that are reported to be present at the Subject Property or provide service in the surrounding area are noted below along with their municipal provider where applicable.

Utility	Provider (Where Applicable)
Potable Water	Eastern Municipal Water District.
Sewage Maintenance	Eastern Municipal Water District.
Electrical	Southern California Edison.
Natural Gas	Southern California Gas.
Solid Waste Disposal	CR&R Waste Services – Perris.

### 2.6 Description of Adjoining Properties

Adjoining properties are defined as any real property or properties, the border of which is contiguous or partially contiguous with that of the subject property of a Phase I ESA, or that would be contiguous or partially contiguous with that of a subject property but for a street, road, or other public thoroughfare separating them. To the extent feasible, our firm performed a visual inspection of adjoining properties



from the Subject Property boundaries and along public right of ways. We did not encroach on to adjoining private property during the completion of this assessment. The following table identifies the adjoining property uses:

<b>Direction</b>	<b>Adjoining Property Use</b>
North	Vacant land (3562 North Perris Boulevard), then Morgan Street.
South	Recycling facility (200 Sinclair Street) and vacant land.
East	Vacant land (3562 North Perris Boulevard, then North Perris Boulevard.
West	Commercial/warehouse facility (3500 Indian Avenue).

## **2.7 Summary Relative to Environmental Concerns**

No recognized environmental conditions were noted in connection with the land use of the Subject Property and improvements at the Subject Property. In addition, the land uses of adjoining properties and properties in the vicinity of the Subject Property do not represent recognized environmental conditions to the Subject Property.



### 3.0 PHYSICAL SETTING

#### 3.1 Topography

The Subject Property is depicted on the United States Geological Survey (USGS) topographic map for the Perris, California 7.5-minute quadrangle. The Subject Property is shown on the map as being situated at an elevation of approximately 1,460 feet above mean sea level. The Subject Property and surrounding area appear to trend slightly to the east. There are no improvements or structures depicted on the Subject Property on the map. Surrounding roadways are depicted on the map. The Subject Property as depicted on a topographic map is included as Figure 3.

#### 3.2 Hydrology

The Subject Property is situated within the Perris North Hydrologic Area (HA) of the San Jacinto River Basin Hydrologic Unit. There are no known substantial hydrologic features at the Subject Property including major storm drain inlets or obvious drainages, channels, or surface waters. Due to the substantial amount of paving at the Subject Property, infiltration of precipitation to the Subject Property is likely relatively minor. Any excess water would appear to flow as surface runoff to the east to the adjoining vacant lot and surrounding areas of lower elevation. The Subject Property does not appear to receive significant drainage from off-site properties.

#### 3.3 Geology

General geologic information pertaining to the Subject Property is presented in the table below.

Geologic Consideration	Details
California Geomorphic Province	Peninsular Ranges.
Mapped Soils or Formation	Very old alluvial fan deposits.
Description of Soils or Formation	Slightly to moderately consolidated silts, sands, and gravel.
Distance/Direction to Mapped Faults	No known faults are present on the Subject Property. Segments of the San Jacinto Fault and Elsinore Fault are located approximately nine miles northeast and thirteen miles southwest of the Subject Property, respectively.

#### 3.4 Hydrogeology

General hydrogeologic information pertaining to the Subject Property is presented in the table below.

Hydrogeologic Consideration	Details
Groundwater Basin or Unit	Perris North Hydrologic Area.
Beneficial Uses	Municipal, industrial and agricultural.
Estimated Depth to Groundwater	Greater than 50 feet below the surface.
Estimated Flow of Groundwater	South to southeast.



Hydrogeologic Consideration	Details
Known Subject Property or Regional Groundwater Contamination Issues	None.

### 3.5 Oil and Gas Exploration

According to online resources provided by the California Department of Conservation, Geologic Energy Management Division (CalGEM), there are no oil, gas or geothermal wells located on the Subject Property or its adjacent properties.

### 3.6 Summary Relative to Environmental Concerns

No recognized environmental conditions were noted in connection with Subject Property physical setting considerations. In addition, physical setting considerations related to the adjoining properties and properties in the vicinity of the Subject Property do not represent recognized environmental conditions to the Subject Property.





## **4.0 USER PROVIDED INFORMATION**

A representative of the User of this report was interviewed during the completion of this assessment. The questions posed during the interview are defined by the ASTM E1527-21 practice. The User also provided our firm with any land title records and judicial records that may be available for the Subject Property as part of the required evaluation for environmental liens and activity and use limitations (AULs) in connection with the subject property of a Phase I ESA. As stated in the ASTM E1527-21 practice, it is the responsibility of the user of the report to provide any available records pertaining to environmental liens and AULs that may exist in connection with a given property. Any land title and judicial records provided to our firm are discussed below. If such information is not discussed in the sections below, it was not provided by the user of the report.

In addition to the contact information obtained, the user of the report was also asked if they are aware of other useful documents that may exist and if so whether copies can be provided to the environmental professional within reasonable time and cost constraints. A list of typical useful documents is included in Section 10.8.1 of the ASTM E1527-21 practice and include but are not limited to environmental assessment reports, compliance audits and permits, registrations for tank and other aboveground or underground systems, safety plans, spill prevention and other facility related plans and geological/geotechnical studies and environmental governmental agency notices and/or correspondence.

### **4.1 Title Records**

Title records were not provided to us for review. The User has reported completing a review of title for environmental liens and activity and use limitations. None were reported.

### **4.2 Environmental Liens**

The User is unaware of environmental liens in connection with the Subject Property.

### **4.3 Activity and Use Limitations**

The User is unaware of AULs in connection with the Subject Property.

### **4.4 Specialized or Actual Knowledge or Experience**

The User is unaware of specialized knowledge, actual knowledge or experience that is material to recognized environmental conditions in connection with the Subject Property other than that contained in prior assessment reports completed for the User's acquisition of the property. Those reports were provided and are summarized in this report.

### **4.5 Commonly Known or Reasonably Ascertainable Information**

The User is unaware of commonly known or reasonably ascertainable information within the local community that is material to recognized environmental conditions in connection with the Subject Property other than that contained in prior assessment reports completed for the User's acquisition of the property. Those reports were provided and are summarized in this report.

### **4.6 Valuation Reduction for Environmental Issues**



The User is unaware of information pertaining to an undervalued purchase price of the Subject Property relative to the estimated fair market value of the Subject Property due to the presence of contamination. However, the Subject Property is not for sale.

#### **4.7 Owner, Property Manager, and Occupant Information**

The Subject Property is currently owned and managed by First Industrial Realty Trust (owner since 2009). The Subject Property is unoccupied.

#### **4.8 Reason for Performing Phase I ESA**

The User has commissioned this Phase I ESA to evaluate Subject Property conditions with respect to the User's plans for redevelopment.

#### **4.9 Proceedings Involving the Subject Property**

The User is unaware of pending, threatened, or past litigation and administrative proceedings relevant to hazardous substances or petroleum products in, on, or from the Subject Property. The client is also unaware of notices from any governmental entity regarding any possible violation of environmental laws or possible liability relating to hazardous substances or petroleum products in connection with the Subject Property.

#### **4.10 Other Provided Documents**

The following prior environmental assessment reports were provided to us for review:

- LOR Geotechnical Group, Inc. 1995. Subsurface Soil Sampling and Testing, National RV, Inc., 3411 N Perris Boulevard, Perris, California. Prepared for: National RV, Inc. April 28, 1995.
- LOR Geotechnical Group, Inc. 2006. Phase I Environmental Site Assessment, National RV, Inc., 3411 North Perris Boulevard and 100 West Sinclair Street, Perris, California. Prepared for: National RV, Inc. October 15, 2006.
- Advantage Environmental Consultants, LLC 2007. Phase I Environmental Site Assessment, National RV, Inc., 3411 N. Perris Boulevard & 100 W. Sinclair Street, Perris, California 92571. Prepared for: First Industrial Realty Trust, Inc. and First Industrial, L.P. March 16, 2007.
- Advantage Environmental Consultants, LLC 2007. Phase II Environmental Site Assessment, National RV, Inc., 3411 N. Perris Boulevard & 100 W. Sinclair Street, Perris, California 92571. Prepared for: First Industrial Realty Trust, Inc. and First Industrial, L.P. June 5, 2007.

In 1995, LOR Geotechnical Group, Inc. collected five soil samples at the National RV facility located at 3411 North Perris Boulevard. This property is situated to the east of the Site across North Perris Boulevard. At the time of the assessment, the Subject Property was occupied by the same business as the adjacent property (National RV, Inc.). None of the soil samples were collected at the Site and no contaminants of concern were identified in soil samples obtained from the adjacent property.

In 2006, LOR Geotechnical Group, Inc. prepared a Phase I ESA on behalf of National RV, Inc. for the properties at 3411 North Perris Boulevard and 100 West Sinclair Street (Subject Property of our current Phase I ESA). The Phase I ESA was performed in general accordance with ASTM Standard E1527-05 and consisted of general reconnaissance of the subject properties and immediate vicinity, a



compilation, review and interpretation of published reports and data available from various private, public and regulatory agencies, a review of historical aerial photographs, topographic maps, and city directories, interviews with personnel familiar with Subject Property operations, and report preparation. At the time of the assessment, the study area was comprised of four legal parcels totaling a reported 50 acres. The 100 West Sinclair Street property at the time was 20 acres and consisted of two legal parcels and two buildings identified as Buildings #4 and #5. Since the 2006 assessment, the parcel containing Building #4 was sold by the client and readdressed as 200 West Sinclair Street (current recycling facility/business). At the time of the 2006 assessment, Building 5 was occupied by both National RV, Inc. (RV manufacturing company) and Weekend Warrior (trailer manufacturing facility). No recognized environmental conditions were noted in connection with the Subject Property at the time of the assessment. However, poor housekeeping was noted in the Weekend Warrior leased areas of the Subject Property and current southern adjoining property. Improved housekeeping practices were recommended.

In 2007, Advantage Environmental Consultants, LLC prepared a Phase I ESA in general accordance with ASTM Standard E1527-05 for the above referenced 50 acres that were assessed by LOR. The current and historical use of the properties as an industrial facility (RV and trailer manufacturing) was considered to be a recognized environmental condition. This conclusion was based on the length of time that industrial operations had occurred at the property, the nature of the operations at the properties (including the storage and use of hazardous materials), documented/former poor housekeeping at the Weekend Warrior subleased space and documented non-compliance with regulatory agencies pertaining to hazardous waste/materials management as indicated by levied violations and consent orders. Areas of concern identified at 100 W. Sinclair Street (Subject Property of our current Phase I ESA) included a Weekend Warrior overspray painting area, Weekend Warrior and National RV yard areas near a hazardous waste storage area (west of the existing Site building), a paint booth area and a clarifier near the southwest corner of the existing Site building. A Phase II ESA was recommended.

The Phase II was also completed in 2007 and consisted of the drilling of 12 soil borings using direct-push methods. Four of the 12 borings identified as B9, B10, B11 and B12 were drilled at the Subject Property at the following locations:

- B9 – Hazardous waste storage area
- B10 – Clarifier area
- B11 – Weekend Warrior yard (adjacent to hazardous waste storage)
- B12 – Weekend Warrior overspray area

Each of the borings were drilled to 20 feet with multiple soil samples collected at each location. A total of eight soil samples were selected for analysis at these locations with depths ranging from one to five feet in depth. None of the samples exhibited staining, odors or detections of undifferentiated volatile organic compounds (VOCs) when screened using a photoionization detector. Six of the soil samples were analyzed for petroleum hydrocarbons and VOCs, while two additional samples (overspray area) were analyzed for VOCs only. No contaminants of concern were identified in any of the soil samples collected at the Subject Property. Similar conditions (i.e. no detections of contaminants) were also documented on the adjoining property to the south and at the adjacent property to the east. No additional assessment was recommended.

#### **4.11 Summary Relative to Environmental Concerns**

No recognized environmental conditions were noted in connection with the user provided information.



## 5.0 REGULATORY RECORDS REVIEW

Our firm commissioned the preparation of a regulatory database report from Environmental Risk Information Services (ERIS) as part of the regulatory records review. ERIS searches a myriad of Federal, State, and local government environmental databases during the preparation of their deliverables. Certain databases are specifically required by the ASTM E1527-21 practice and are referenced as “standard ASTM regulatory databases.” Such databases are searched to at least the minimum search distance around a given property as defined in the practice. Other regulatory databases are also searched that are not specifically referenced in ASTM E1527-21. Such databases are referenced as “non-ASTM regulatory databases” and are searched as varying radii around a given property as selected by ERIS.

Descriptions of each database searched and the dates that the regulatory databases were last updated by the applicable agencies are included in the ERIS report. The extent of historical information varies with each database and current information is determined by what is publicly available to ERIS at the time of an updates. ERIS updates databases in accordance with ASTM E1527-21 which states that government information from nongovernmental sources may be considered current if the source updates the information at least every 90 days, or, for information that is updated less frequently than quarterly by the government agency, within 90 days of the date the government agency makes the information available to the public.

Our firm also reviewed unplottable sites listed in the database report by cross-referencing reasonably ascertainable information pertaining to such properties that may include facility names, street names, zip codes or other information. Unplottable sites are ones that cannot be formally mapped or geocoded due to various reasons, including limited geographic information. Any unplottable sites that we identify within the specified search radii have been evaluated as part of the preparation of this report. A copy of the regulatory database report is included in Appendix B.

### 5.1 Standard ASTM Regulatory Database Search

The tables below present the standard Federal, State, Tribal and local ASTM databases that were searched by ERIS including the search distances from the Subject Property. Below the tables are descriptions of any listings for the Subject Property that may appear in the databases. In addition, a discussion of adjoining properties or properties in the Subject Property vicinity that are listed in one or more regulatory databases that in our professional judgment and opinion have the potential to adversely impact the Subject Property due to current or former releases of hazardous substances and/or petroleum products that occurred at said properties is presented. This practice of discussing only properties of potential environmental concern to the Subject Property is noted in ASTM E1527-21 which states that the environmental professional may make statements applicable to multiple properties listed in regulatory databases that are not likely to have current or former releases of hazardous substances and/or petroleum products with the potential to migrate to a given subject property. Our professional judgment and opinions discussed herein are based on several factors including the nature of the regulatory database listings, distance of the off-site listed properties from the Subject Property, orientation of the listed properties relative to the Subject Property, interpreted direction of groundwater flow and/or regulatory case status information for the various properties as described in the databases.



The following Federal standard ASTM databases were searched:

Standard Environmental Record Source Name	ERIS Regulatory Database Identification	Search Distance From Subject Property (Miles)
National Priorities List (NPL) Site List	NPL – Proposed NPL – Superfund Record of Decision (ROD)	1.0
Delisted NPL Site List	Deleted NPL	0.5
Comprehensive Environmental Response, Compensation and Liability Information System (CERCLIS) List	CERCLIS - SEMS – SEMS Archive – ODI – IODI	0.5
CERCLIS List	CERCLIS LIENS – SEMS LIENS	Subject Property
CERCLIS No Further Remedial Action Planned (NFRAP) Site List	CERCLIS NFRAP	0.5
Resource Conservation and Recovery Act (RCRA) Corrective Action Sites (CORRACTS) Facilities List	RCRA CORRACTS – Department of Energy (DOE) Formerly Utilized Sites Remedial Action Program (FUSRAP)	1.0
RCRA Non-CORRACTS Treatment, Storage and Disposal (TSD) Facilities List	RCRA TSD	0.5
RCRA Generators List	RCRA LQG – RCRA SQG – RCRA VSQG – RCRA CESQG – RCRA NON-GEN – BULK TERMINAL – REFN – FEMA Underground Storage Tank (UST) – Facility Response Plan (FRP) – HIST GAS STATIONS	0.25
Institutional Control/Engineering Control Registries	FED ENG – FED INST – FED Brownfields – Land Use Control Information System (LUCIS) – RCRA Controls	0.5
Emergency Response Notification System (ERNS) List	ERNS – ERNS 1982 to 1986 – ERNS 1987 to 1989	Subject Property

**Subject Property** – The Subject Property is identified as National RV, Inc. on the RCRA LQG and RCRA SQG standard Federal ASTM regulatory databases. The business is referenced with EPA Handler IDs of CAR000104331 and CAL000219327 and with no reported violations. Listings identify generation of small and large quantities of hazardous waste including spent nonhalogenated solvents, ignitable wastes and methyl ethyl ketone. There are no references to chlorinated solvents in the database listings for the Site. The Subject Property is not listed on Federal databases indicative of releases of hazardous substances or petroleum products to the subsurface. These listings are not considered to be recognized environmental conditions in connection with the Subject Property.

**Adjoining Properties** – Wayfair, LLC (western adjoining property at 3500 Indian Avenue) is listed on the RCRA NON-GEN standard Federal ASTM regulatory database with no reported violations. This property is not listed on databases indicative of releases of hazardous substances or petroleum products to the subsurface and is not considered to be a recognized environmental condition to the Subject Property.



**Other Properties** – There are 10 listings on the standard Federal ASTM regulatory databases pertaining to multiple properties in the surrounding area including RCRA LQG (one listing) and RCRA NON-GEN (nine listings). None of these properties are considered a recognized environmental condition to the Subject Property. Our opinions regarding adjoining and nearby properties are based on the distance of the off-site listed properties from the Subject Property, orientation of the listed properties relative to the Subject Property, interpreted direction of groundwater flow and/or regulatory case status information for the various properties as described in the databases.

The following State, Tribal and local standard ASTM databases were searched:

Standard Environmental Record Sources Name	ERIS Regulatory Database Identification	Search Distance From Subject Property (Miles)
Equivalent NPL	RESPONSE	1.0
Equivalent CERCLIS	ENVIROSTOR – DELISTED ENVS – HWP – HHSS – SAM SAN DIEGO	0.5
Landfill and/or Solid Waste Disposal Site Lists	SWF/LF – LDS – SWAT – WMUD – SWRCB SWF – Construction and Demolition (C & D) DEBRIS RECY – CONTAINER RECY – RECYCLING – PROCESSORS	0.5
Leaking Storage Tank Lists	LUST – DELISTED LST – UST CLOSURE – CLEANUP SITES – INDIAN LUST – DELISTED ILST	0.5
Registered Storage Tank Lists	UST – AST – AST SWRCB – TANK OIL GAS – DELISTED TNK – CERS TANK – DELISTED CTNK – HIST TANK – UST SWEEPS – INDIAN UST – DELISTED IUUST – DELISTED COUNTY – LOP RIVERSIDE – UST RIVERSIDE	Subject Property and Adjoining Properties
Institutional Control/Engineering Control Registries	LUR – HLUR - DEED	Subject Property
Voluntary Cleanup Sites	VCP	0.5
Brownfield Sites	CALSITES	0.5

**Subject Property** – The Subject Property was identified as Avalon Shutters on the DELISTED COUNTY standard State ASTM regulatory database. The listing identifies that Avalon Shutters has been removed from County of Riverside databases due to being either inactive or operations deemed to be below reportable thresholds relative to hazardous materials and/or waste. No releases were reported and this listing is not considered to be a recognized environmental condition in connection with the Subject Property.

**Adjoining Properties** – RecycleWise at 200 Sinclair Street (south-adjoining) is listed on the State RECYCLING and PROCESSORS standard ASTM regulatory databases. These listings identify this business as a certified recycling facility under the State of California’s Beverage Container Recycling Program in operation since 2011. No releases have been reported and this property is not considered to be recognized environmental condition to the Subject Property.





**Other Properties** – There are six listings on the State, Tribal, and local standard ASTM regulatory databases pertaining to multiple properties in the surrounding area including ENVIROSTOR (one listing), LUST (one listing), HHSS (one listing), UST SWEEPS (one listing), HIST TANK (one listing), and LOP RIVERSIDE (one listing) databases. None of these properties are considered a recognized environmental condition to the Subject Property. Our opinions regarding adjoining and nearby properties are based on the distance of the off-site listed properties from the Subject Property, orientation of the listed properties relative to the Subject Property, interpreted direction of groundwater flow and/or regulatory case status information for the various properties as described in the databases.

## 5.2 Non-ASTM Regulatory Database Search

A myriad of non-ASTM regulatory databases was searched by ERIS as noted in the regulatory database report.

**Subject Property** – The Subject Property is listed on the following non-ASTM regulatory databases:

- FINDS/FRS database as National RV, Inc. and Avalon Shutters. These listings identify the Subject Property as a biennial hazardous waste reporter, motor home manufacturer, and wood, window, and door manufacturer.
- HZH RIVERSIDE database as Building Materials Distributors, Inc. This listing identifies that the Building Materials Distributors, Inc. had a business plan filed with the County of Riverside Department of Environmental Health.
- HAZNET database as Avalon Shutters, National RV, Inc., and Weekend Warrior Trailers, Inc. The listings reference EPA ID numbers CAL000348398, CAL000219327, CAL000320081, and CAR000104331. Listings identify that hazardous waste manifests were generated for the following materials: unspecified solvent mixtures, waste and mixed oil, organics, other inorganic solid waste, oxygenated solvents, oil/water separation sludge, unspecified organic liquid mixtures, and other organic solids.
- EMISSIONS database as Avalon Shutters and National RV, Inc. The listing references an EPA ID number of CAC002627822 with no other details provided. Listings identify that air emissions were monitored in 2004 through 2007 and 2010.
- CERS HAZ database as Building Materials Distributors, Inc. The database listing identifies minor violations related to the reporting, documentation, and storage area signage of hazardous materials stored at the property.

The above listings are not indicative of releases of hazardous substances or petroleum products to the subsurface and there are no references to chlorinated solvents in the databases. These listings are not considered to be recognized environmental conditions in connection with the Subject Property.

**Adjoining Properties** – RecycleWise at 200 Sinclair Street (south-adjoining) is listed on the FINDS/FRS non-ASTM regulatory database. This listing identifies RecycleWise as a scrap and waste materials facility with an associated EPA ID number (CAC003152234) and NPDES permit (CAZ446046). As stated previously, this property is not considered to be recognized environmental condition to the Subject Property.

**Other Properties** – There are eight listings on the non-ASTM regulatory databases pertaining to multiple properties in the surrounding area including SCH (one listing), MRDS (one listing), DELISTED HAZ (one listing), and EMISSIONS (six listings). None of these properties are considered



a recognized environmental condition to the Subject Property. Our opinions regarding adjoining and nearby properties are based on the distance of the off-site listed properties from the Subject Property, orientation of the listed properties relative to the Subject Property, interpreted direction of groundwater flow and/or regulatory case status information for the various properties as described in the databases.

### 5.3 Regulatory Agency File Reviews

If a property being assessed under a Phase I ESA or any of the adjoining properties are identified on one or more of the above referenced standard environmental record sources, pertinent regulatory files and/or records associated with such listings should be reviewed to assist the environmental professional in evaluating if recognized environmental conditions exist at a given subject property in connection with any listings. However, if in the environmental professional’s opinion, such a review is not warranted, file reviews need not be conducted if the environmental professional provides justification for not doing so.

Agency file reviews for the Subject Property completed during this assessment are noted below. No file reviews for adjoining properties or properties in the surrounding area were deemed warranted with the exception of research completed on the State Water Resources Control Board GeoTracker database regarding properties in the surrounding area of the Subject Property. The agency inquiries were performed by way of on-line searches/queries of published databases and/or direct inquiries with public records clerks at one or more agencies. Both James Wright and Samantha Weis of Weis Environmental conducted the agency file reviews during the completion of this assessment. Copies of regulatory agency records are included in Appendix C.

Regulatory Agency	Jurisdiction	Date of Inquiry or Request	Contact	Response or Information From Agency
United States EPA Envirofacts/ECHO/ TRIS	Federal	2/15/2022	Online <a href="https://enviro.epa.gov/">https://enviro.epa.gov/</a>  <a href="https://echo.epa.gov/facilities/facility-search">https://echo.epa.gov/facilities/facility-search</a>  <a href="https://www.epa.gov/toxics-release-inventory-tri-program">https://www.epa.gov/toxics-release-inventory-tri-program</a>	Records Identified
California DTSC	State	1/18/2022 and 2/15/2022	Online <a href="https://www.envirostor.dtsc.ca.gov/public">https://www.envirostor.dtsc.ca.gov/public</a>  <a href="https://hwts.dtsc.ca.gov/report_list.cfm">https://hwts.dtsc.ca.gov/report_list.cfm</a>  Public Records Clerk	Records Identified
State Water Resources Control Board/Regional Water Quality Control Board	State	1/18/2022 and 2/15/2022	Online <a href="https://geotracker.waterboards.ca.gov/">https://geotracker.waterboards.ca.gov/</a>  <a href="https://geotracker.waterboards.ca.gov/historical_ust_facilities">https://geotracker.waterboards.ca.gov/historical_ust_facilities</a>  Public Records Clerk	Records Identified
Riverside County	Local	1/18/2022	Public Records Clerks	No Records Identified



Regulatory Agency	Jurisdiction	Date of Inquiry or Request	Contact	Response or Information From Agency
City of Perris	Local	1/18/2022	Public Records Clerk	Records Identified

**United States EPA** – National RV, Inc. was identified in the EPA Envirofacts and ECHO databases. Records identified and associated EPA ID Nos. were consistent with information provided in the ERIS database report.

**California DTSC** - The DTSC maintains copies of hazardous waste manifests pertaining to wastes removed from the Subject Property between 2001 and 2015. Between zero and 26 manifests were generated annually at the Subject Property during this period associated with the EPA ID Nos. CAR000104331, CAL000320081, CAL000219327, and CAL000348398. All EPA IDs were identified as inactive. No chlorinated solvents are referenced as being part of Subject Property operations and no releases were reported. DTSC-provided information is consistent with the ERIS database report.

**State Water Resources Control Board/Regional Water Quality Control Board** – Records included various applications and Notices of Intent related to Subject Property industrial and construction stormwater permits.

**City of Perris** - Records included several building and spray booth permits (permit applications, structures, utilities, certificates of occupancy, plan reviews, etc.) pertaining to the Subject Property. No recognized environmental conditions were noted in the records.

**County of Riverside** – County files reference National RV, Weekend Warrior Inc., Avalon Shutters Inc. and Building Materials Distributors, Inc. as permitted entities for the Subject Property. The files contain various typical documents pertaining to hazardous waste and materials management including business plans, change of status reports, permits, hazardous materials/waste inventories and inspection reports. Administrative related violations were issued pertaining to permitting, employee training, business plan corrections and other typical administrative related formalities. The Weekend Warrior and Building Materials Distributors tenants both received notices of violation for operating without valid permits. These violations were subsequently cured. National RV also received violations pertaining to the storage and labeling of hazardous materials and waste storage containers with no references to spills or releases noted. Information included in the County files is consistent with information noted in the regulatory database report discussed previously in this report.

## 5.4 Summary Relative to Environmental Concerns

No recognized environmental conditions were noted in connection with the regulatory records searches. In addition, regulatory resources related to the adjoining properties and properties in the vicinity of the Subject Property do not represent recognized environmental conditions to the Subject Property.



## 6.0 HISTORICAL RESOURCE REVIEW

The objective of consulting historical sources is to develop a history of the previous uses of a property and surrounding area, in order to help identify the likelihood of past uses having led to recognized environmental conditions in connection with a given property. The goal of the historical research is to identify all obvious uses of a subject property from the present, back to the property’s first developed use, or back to 1940, whichever is earlier. The environmental professional exercises professional judgment in reviewing only as many of the standard historical sources referenced in ASTM E1527-21 that are deemed necessary, are reasonably ascertainable and are likely to be useful. Historical resources reviewed during the completion of this assessment are referenced below. Copies of the historical resources are included in Appendix D.

### 6.1 Aerial Photographs

We reviewed historical aerial photographs from the years 1938, 1953, 1958, 1962, 1966, 1970, 1976, 1985, 1997, 2002, 2004, 2005, 2006, 2010, 2012, 2014, 2016, 2018 and 2020 provided by ERIS. The table below presents the results of the photograph review.

Photograph Year	Subject Property Observations	Adjoining Property Observations
1938-1985	The Subject Property is used for agricultural purposes.	Adjoining and surrounding properties are utilized for agricultural purposes. Several small structures are present on the northern-adjointing property. A drainage pathway or culvert is visible south of the Subject Property. North Perris Boulevard is visible along the east side of the eastern-adjointing property.
1997	Similar to the prior photographs.	Adjointing property use is generally similar to the prior photographs. The northern-adjointing property appears to have been cleared and used for storage. Commercial/industrial development is visible to the east of the eastern-adjointing property.
2002-2006	The Subject Property appears similar to its current configuration.	The eastern- (vacant lot), northern- (vacant lot), and southern-adjointing (light industrial) properties appear similar to their current configurations.
2010	The Subject Property appears similar to its current configuration.	The western-adjointing property appears to be a vacant lot and no longer used for agricultural purposes. Other adjointing properties appear similar to previous photographs and current configurations.
2016-2020	The Subject Property appears similar to its current configuration.	The warehouse building is now present on the western-adjointing property. All adjointing properties appear similar to current configurations.

As stated above, the Subject Property has been previously used for agricultural purposes. During historical agricultural activities throughout the State of California, various pesticides and more specifically organochlorine pesticides were commonly applied during the normal course of agricultural



operations. Such compounds have since been banned from production and use in the United States. Based on the regulatory and historical research completed during the preparation of this assessment, no information has been revealed that would lead us to believe that an accidental spill or release of pesticide products has occurred at the Subject Property. In addition, the Subject Property has been developed with its current improvements following its previous residential and agricultural uses. It can be inferred that during development activities, shallow soils are disturbed and dispersed during grading and other activities, thereby potentially reducing concentrations of agricultural chemical residues (if present). As such, the potential presence of residual agricultural chemicals in Subject Property soils is not considered to be a recognized environmental condition in connection with the Subject Property.

## 6.2 Topographic Maps

Our firm reviewed topographic maps from the years 1901, 1942, 1953, 1967, 1973, 1978, 1979, and 2015 obtained by ERIS.

- The Subject Property and surrounding properties are not visible on the 1901 topographic map.
- In 1942, a small water feature (likely agricultural holding pond) is depicted in the central portion of the Subject Property. Several small structures are depicted on the northern-adjointing property. No other structures or other features are depicted on the Subject Property or adjoining properties.
- From 1953 until 1973, no structures or other features are depicted on the Subject Property. A small water feature (likely agricultural holding pond) is depicted on the southern-adjointing property, several small structures are depicted on the northern-adjointing property, and the Colorado River Aquaduct is depicted south of the Subject Property.
- The Subject Property and surrounding properties are not visible on the 1978 topographic map.
- Similar to prior years, in 1979 and 2015, no structures or other features are depicted on the Subject Property. Possible groundwater wells are depicted on the southern and northern adjoining properties. Structures are no longer depicted on the northern adjoining property on the 2015 topographic map.

None of the features identified on reviewed topographic maps are considered recognized environmental conditions to the Subject Property.

## 6.3 City Directories

Our firm reviewed city directories ranging in date from 1971 to 2020 provided by ERIS. The Subject Property is not listed prior to 2006-2007. In 2006-2007, Weekend Warrior is listed at the Subject Property. Avalon Shutters is listed at the Subject Property between 2012 and 2016. In 2016, Building Materials Distributors, Inc. is listed at the Subject Property. The southern-adjointing property (200 Sinclair Street) is listed as RecycleWise between 2012 and 2020. None of the listings are considered a recognized environmental condition to the Subject Property.

## 6.4 Other Historical Sources

Other historical sources are referenced in the ASTM E1527-21 practice as any source or sources other than the standard historical sources referenced in the practice that are credible to a reasonable person and that identify past uses of a subject property. This category includes, but is not limited to miscellaneous maps and directories, newspaper archives, internet sites, community organizations, local



libraries, historical societies, current owners or occupants of neighboring properties, or records in the files and/or personal knowledge of the property owner and/or occupants. No historical sources other than the standard sources described above were deemed necessary and useful to assist in identifying recognized environmental conditions.

## **6.5 Summary Relative to Environmental Concerns**

No recognized environmental conditions were noted in connection with the historical resources reviewed. In addition, historical resources related to the adjoining properties and properties in the vicinity of the Subject Property did not reveal recognized environmental conditions to the Subject Property.





## 7.0 SUBJECT PROPERTY RECONNAISSANCE

The objective of the reconnaissance is to obtain information indicating the likelihood of identifying recognized environmental conditions in connection with the Subject Property. The Subject Property visit for our assessment was completed on February 1, 2022 by James Wright of our firm. Mr. Wright was unaccompanied during the reconnaissance.

### 7.1 Methodology and Limiting Conditions

The Subject Property reconnaissance consisted of observing the Subject Property on foot via various transects and walking publicly accessible areas surrounding the Subject Property. No significant limiting conditions of the Subject Property inspection were noted. Select photographs of the Subject Property obtained during the Subject Property reconnaissance are included in Appendix E.

### 7.2 Current General Subject Property and Vicinity Characteristics

The Subject Property is situated in an area consisting of commercial/light industrial land uses and vacant lots in the City of Perris. The Subject Property is currently an unoccupied commercial/light-industrial property. The current use of the Subject Property and adjoining properties are not ones that are indicative of the use, treatment, storage disposal or generation of hazardous substances or petroleum products that may have impacted the Subject Property.

### 7.3 Indications of Past Subject Property and Vicinity Uses

There are no material differences between the current and past uses of the Subject Property, adjoining properties and the surrounding area Subject Property that were visually and/or physically observed during the Subject Property reconnaissance that pertain to recognized environmental conditions.

### 7.4 Subject Property-Specific Observations

We examined the Subject Property for the features and conditions noted in the table below.

Feature or Condition	Details
General Description of Structures	The Subject Property is developed with a two-story light industrial building with a mezzanine level. The building is an estimated 150,000 square feet and was reportedly constructed in 2000. The structure appears to be of concrete masonry and corrugated steel construction and situated on a concrete slab-on-grade foundation. Other portions of the Subject Property consist of asphalt- and concrete-paved driveways and former operational areas to the north and south of the structure, asphalt parking areas to the east and southeast, a paved shipping/receiving area and an unpaved storage yard to the west, and minor landscaping. Access to the Subject Property is provided by Sinclair Street. Indicators of various utility systems are also present throughout the Subject Property.



Feature or Condition	Details
Drains and Sumps	Typical interior floor drains are present in the restrooms and former maintenance rooms. Floor drains, reportedly leading to an underground clarifier, are present in the southwest building interior and the former spray booth adjacent to the southwest corner of the structure. Exterior floor drains are also present in the former employee break area adjacent to the eastern side of the structure. No staining, odors or other suspect conditions were noted.
Heating/Cooling Systems	Air-conditioning consists of conventional wall units adjacent to structure office areas.
Potable Water Supply	Eastern Municipal Water District.
Roads	North Perris Boulevard is located east of the Subject Property. The Subject Property is accessed via a driveway off of North Perris Boulevard at Sinclair Street.
Septic Systems / Sewage Disposal System	Eastern Municipal Water District.
Wastewater and Stormwater Discharges	None observed. Stormwater appears to flow generally east to a discharge pipe located at the eastern edge of the parking area to the adjoining vacant lot.
Wells	None observed.
Drums	None observed.
Electrical or Hydraulic Equipment Known to Contain PCBs or Likely to Contain PCBs	None observed.
Hazardous Substances and Petroleum Products in Connection with Identified Uses	None observed.
Hazardous Substance and Petroleum Products Not Necessarily in Connection with Identified Uses	None observed.
Odors	None noted.
Pits, Ponds or Lagoons	None observed.
Pools of Liquid	None observed.
Solid Waste (Including Fill Material)	None observed.
Stained Soil or Pavement	Minor asphalt staining consistent with typical automotive parking areas was observed. This is considered to be a de minimis condition.
Stains or Corrosion	None observed.
Chemical Storage Tanks	None observed.
Stressed Vegetation	None observed.
Unidentified Substance Containers	None observed.



## **7.5 Summary Relative to Environmental Concerns**

No recognized environmental conditions were noted in connection with the current use of the Subject Property during the Subject Property reconnaissance. In addition, no current uses of the adjoining properties or properties in the surrounding area that were visually and/or physically observed during the Subject Property reconnaissance were noted as recognized environmental conditions to the Subject Property.



## **8.0 INTERVIEWS**

### **8.1 Subject Property Owner**

The Subject Property is currently owned and managed by the User (owner since 2009). The User is unaware of environmental concerns in connection with the Subject Property. Information provided by the User has been incorporated into Section 4.0 of this report.

### **8.2 Key Site Manager**

The User is also considered to be the Key Site Manager. Please refer to Section 8.1 above.

### **8.3 Current Occupants**

The Subject Property is currently unoccupied.

### **8.4 Local Government Official**

During the preparation of this assessment, public records clerks from the City of Perris, State of California, and Riverside County were contacted by our firm regarding the Subject Property. Agency representatives indicated that public records requests should be conducted in order to obtain information known by the agencies regarding the Subject Property. Public records requests were completed by our firm as described in Section 5.3.

### **8.5 Other Parties**

Interviews with other persons were not conducted during the preparation of this assessment. As stated in the ASTM E1527-21 practice, interviews with past owners, operators and occupants of a subject property who are likely to have material information regarding the potential for contamination at a given property shall be conducted to the extent that they have been identified and that the information likely to be obtained is not duplicative of information already obtained from other sources. Interviews with persons with past association with the Subject Property were not deemed warranted during the completion of this assessment.

### **8.6 Summary Relative to Environmental Concerns**

No recognized environmental conditions were noted in connection with the interviews completed during the assessment.



## 9.0 ADDITIONAL SERVICES – NON-SCOPE ASTM CONSIDERATIONS

Several non-scope ASTM considerations are referenced in the ASTM E1527-21 practice that a user of a report may wish to evaluate. Listed considerations in the practice include asbestos-containing building materials, biological agents, cultural and historic resources, ecological resources, endangered species, health and safety, indoor air quality (unrelated to releases of hazardous substances or petroleum products into the environment), industrial hygiene, lead-based paint, lead in drinking water, mold, radon, regulatory compliance, and wetlands. No implication is intended by the practice as to the relative importance of inquiry into such non-scope considerations, and the list of considerations is not intended to be all-inclusive.

**Asbestos and Lead-Based Paint** – An asbestos and lead-based paint survey has been completed concurrently with this Phase I ESA. The results of the survey have been provided to the client under separate cover. No asbestos or lead was found at the Subject Property.

**Landmark/Historical/Cultural Significance Review** - Archeological/cultural and paleontological assessments of the Subject Property have been completed concurrently with this Phase I ESA. The results of the studies have been provided to the client under separate cover. No significant findings were reported.

**Lead in Drinking Water** - According to the most recent water quality report prepared by the City of Perris, the drinking water supplied to the area is in compliance with all Federal and State regulations.

**Mold Screening** – Minor water damage was observed in two areas: the mezzanine office area and Marvin office area adjoining the southern edge of the building. See Appendix E Photographs 22 and 26. Given the planned demolition and redevelopment of the Subject Property, the minor water damage does not warrant further investigation at this time.

**National Pollution Discharge Elimination System (NPDES)** – We are unaware of current NPDES related requirements that pertain to the Subject Property. Former Subject Property operations were subject to NPDES requirements pertaining to the general industrial and stormwater permits.

**Per- and Polyfluoroalkyl Substances (PFAS)** – There are no historical or current Subject Property or adjoining property uses that are indicative of scenarios where releases of such compounds have occurred.

**Pipelines** – Based on a review of the National Pipeline Mapping System. No pipelines used for the conveyance of oil, gas or other hazardous substances are present at the Subject Property.

**Radon Potential** - The Subject Property is located within United States EPA Radon Zone 2 which has predicted average indoor levels of radon between 2 and 4 picocuries per liter. Radon is not considered to be a concern at the Subject Property.

**Wellfield/Groundwater Protection Areas** – The Subject Property is not situated in a known wellfield/groundwater protection area.

**Wetlands and Threatened/Endangered Species** - A biological assessment of the Subject Property has been completed concurrently with this Phase I ESA. The results of the study have been provided to the client under separate cover. No wetlands were noted at the Subject Property and no significant biological findings were reported.

No other additional services were completed by our firm during the preparation of this assessment.



## **10.0 FINDINGS AND OPINIONS**

No features and/or conditions indicating the presence or likely presence of hazardous substances and/or petroleum products at the Subject Property that are considered to have the potential to adversely impact the Subject Property were identified during the completion of this assessment.





## 11.0 CONCLUSIONS AND RECOMMENDATIONS

We have performed a Phase I Environmental Site Assessment in conformance with the scope and limitations of ASTM International Practice E1527-21 of the Subject Property located at 100 Sinclair Street in the City of Perris, Riverside County, California (Riverside County APN 303-080-015). Any exceptions to, or deletions from, this practice are described in Section 1.5 of this report. This assessment has revealed no evidence of recognized environmental conditions, controlled recognized environmental conditions or historical recognized environmental conditions in connection with the Subject Property. Additional assessment at the Subject Property is not considered to be warranted at this time.



## 12.0 ENVIRONMENTAL PROFESSIONAL STATEMENT

I declare that, to the best of my professional knowledge and belief, I meet the definition of environmental professional as defined in Section 312.10 of 40 CFR. I have the specific qualifications based on education, training, and experience to assess a property of the nature, history, and setting of the Subject Property. I have developed and performed the all appropriate inquiries in conformance with the standards and practices set forth in 40 CFR Part 312. Qualifications of personnel involved with the completion of this report are included in Appendix F.

A handwritten signature in black ink that reads "Daniel Weis". The signature is written in a cursive style with a large initial "D" and "W".

Daniel Weis, R.E.H.S.  
Environmental Manager



## 13.0 ASSUMPTIONS

No Phase I ESA effort can eliminate uncertainty regarding the potential for recognized environmental conditions to exist in connection with a given property. Performance of the ASTM E1527-21 practice may reduce such uncertainty but in no way should the findings and report be misconstrued as insurance or a guarantee regarding the potential for recognized environmental conditions in connection with a given property. The ASTM E1527-21 practice recognizes reasonable limits of time and cost relative to the completion of a Phase I ESA.

During the completion of this ESA, our firm relied on certain information obtained from secondary sources, including but not limited to the user of the report, government agencies, historical research business entities, environmental databases, and interviews with one or more persons. The sources obtained and/or consulted are assumed to be reliable. However, our firm cannot warranty or guarantee that the information provided by these other sources is wholly accurate or complete. Our firm is not responsible for any misrepresentations or false statements that may be provided by others or the lack of pertinent/relevant information that should have been provided/disclosed by others and we assume no responsibility for any consequence as a result of such omissions or withheld information.

Accuracy and completeness of records varies among information sources, including from governmental agencies. As a result, there is a possibility that even with the proper application of the methodologies presented in ASTM E1527-21, conditions may exist that could not be identified within the scope of this assessment or which were not reasonably identifiable from the available information. In addition, any responses received from Federal, State, Tribal, and local regulatory agency secondary sources of information after the issuance of this report may change certain findings and conclusions of this report.

Estimations and opinions regarding the potential for off-site properties to adversely impact a given subject property is one of the key components of a Phase I ESA. In most cases, recent property-specific or adjacent-property specific measured groundwater data or other hydrogeological information is not reasonably ascertainable. In the absence of such data, reasonable assumptions regarding the depth and flow of groundwater are made based on various sources including comparisons to surface elevations, land topography and available hydrogeological on the State of California Geotracker database. In addition, estimations and opinions regarding potential impacts from off-site locations may be based on certain assumptions that a hazardous substance or petroleum product may not migrate laterally within unsaturated soil for a substantial distance and that contaminants that have reached saturated soil and groundwater may attenuate over time and/or may decrease in concentration relative to distance from its source. While any interpretations presented herein may be effective in reducing uncertainty regarding potential impacts to a subject property from off-site locations, in no way should the findings and report be misconstrued as insurance or a guarantee regarding the potential for such impacts to occur. Greater certainty regarding subsurface conditions at a given property can only be achieved by way of a subsurface sampling effort of one or more media.



## 14.0 DEFINITIONS

Definitions of key terminology relevant to the ASTM E1527-21 practice are presented below.

**Recognized Environmental Condition** - The presence or likely presence of any hazardous substances or petroleum products in, on, or at a property: (1) due to any release to the environment; (2) under conditions indicative of a release to the environment; or (3) under conditions that pose a material threat of a future release to the environment.

**Controlled Recognized Environmental Condition** - A recognized environmental condition resulting from a past release of hazardous substances or petroleum products that has been addressed to the satisfaction of the applicable regulatory authority (for example, as evidenced by the issuance of a no further action letter or equivalent, or meeting risk-based criteria established by regulatory authority), with hazardous substances or petroleum products allowed to remain in place subject to the implementation of required controls (for example, property use restrictions, activity and use limitations, institutional controls, or engineering controls).

**Data Failure** - A failure to achieve the historical research objectives as outlined in the ASTM E1527-21 practice even after reviewing the standard historical sources that are reasonably ascertainable and likely to be useful. Data failure is one type of data gap.

**Data Gap** - A lack of or inability to obtain information required by this practice despite good faith efforts by the environmental professional to gather such information. Data gaps may result from incompleteness in any of the activities required by the ASTM E1527-21 practice, including, but not limited to site reconnaissance (for example, an inability to conduct the site visit), and interviews (for example, an inability to interview the key site manager, regulatory officials, etc.). Data gaps are only considered to be significant if they affect the ability of the environmental professional to identify recognized environmental conditions.

**De Minimis Condition** - A condition that generally does not present a threat to human health or the environment and that generally would not be the subject of an enforcement action if brought to the attention of appropriate governmental agencies. Conditions determined to be de minimis conditions are not recognized environmental conditions nor controlled recognized environmental conditions.

**Environment** - (A) the navigable waters, the waters of the contiguous zone, and the ocean waters of which the natural resources are under the exclusive management authority of the United States under the Magnuson-Stevens Fishery Conservation and Management Act [16 U.S.C. §§ 1801 et seq.], and (B) any other surface water, groundwater, drinking water supply, land surface or subsurface strata, or ambient air within the United States or under the jurisdiction of the United States.

**Good Faith** - The absence of any intention to seek an unfair advantage or to defraud another party; an honest and sincere intention to fulfill one's obligations in the conduct or transaction concerned.

**Hazardous Substance** - Includes hazardous substances designated under section 311 of the Clean Water Act (CWA) or Section 102 of CERCLA, any toxic pollutant listed under Section 307(a) of the CWA, any waste that has been listed as a RCRA hazardous waste or possesses a RCRA hazardous waste characteristic, any substance that is identified as a hazardous pollutant under Section 112 of the Clean Air Act (CAA), and any imminently hazardous chemical that EPA has taken action pursuant to Section 7 of the Toxic Substances Control Act (TSCA).

**Historical Recognized Environmental Condition** - A past release of any hazardous substances or petroleum products that has been addressed to the satisfaction of the applicable regulatory authority or



meeting unrestricted use criteria established by a regulatory authority, without subjecting the property in question to any required controls (for example, property use restrictions, activity and use limitations, institutional controls, or engineering controls).

**Petroleum Exclusion** – While the definition of a CERCLA hazardous substance specifically excludes petroleum products and crude oil, the EPA has determined that the petroleum exclusion applies to petroleum products such as gasoline and other fuels containing lead, benzene or other hazardous substances that are normally added during the refining process. Notwithstanding the existence of the petroleum exclusion, petroleum products are included within the scope of the ASTM E1527-21 practice for multiple reasons. Petroleum products have historically been widely used at commercial properties. In addition, other federal and state laws may impose liability for releases or spills of petroleum products.

**Reasonably Ascertainable Information** - Information that is (1) publicly available, (2) obtainable from its source within reasonable time and cost constraints and (3) practically reviewable.

**Release or Threatened Release** - Spilling, leaking, pumping, pouring, emitting, emptying, discharging, injecting, escaping, leaching, dumping or disposing into the environment (including the abandonment or discarding of barrels, containers and other closed receptacles containing any hazardous substance, or pollutant or contaminant).



## 15.0 REFERENCES

Sources of information consulted during the completion of our Phase I ESA are noted in the sections below.

### 15.1 Documents, Plans and Reports

- All Appropriate Inquiry” as necessary to satisfy the defenses available under 42 U.S.C. §§ 9607(b)(3), 9607(r)(1), and 9607(q), relying on definitions provided at 42 U.S.C. §§ 9601(35)(B); and as further explained in 40 CFR §§ 312.1 – 312.31.
- ASTM International, "Standard Practice for Environmental Site Assessments: Phase I Environmental Site Assessment Process," ASTM Designation E 1527-21, 2021
- California Geological Survey, 2002, California Geomorphic Provinces Note 36, Electronic Copy, Revised December.
- California State Water Resources Control Board, Water Quality Control Plan for the Santa Ana River Basin (8), California, Published 2008.
- ERIS Database Report dated January 28, 2022.
- ERIS City Directory Report, Topographic Maps, and Historical Aerials Photographs dated January 28 and 31, 2022.
- USGS topographic map, Perris, California Quadrangle (2018).

### 15.2 Personal Communications

- Public Records Clerks – City of Perris, County of Riverside, State of California

### 15.3 Agencies Consulted

- California Department of Conservation, Geologic Energy Management Division (CalGEM)
- California Department of Toxic Substances Control
- California State Water Resources Control Board
- City of Perris
- County of Riverside
- United States EPA





**\*\*Figures and Appendices omitted from Phase 1 ESA Report for the Preliminary WQMP, will provided if requested\*\***

# Appendix 5: LID Infeasibility

*LID Technical Infeasibility Analysis*

***\*Section not applicable\****

# Appendix 6: BMP Design Details

*BMP Sizing, Design Details and other Supporting Documentation*

**Santa Ana Watershed - BMP Design Volume,  $V_{BMP}$**

(Rev. 10-2011)

Legend:

Required Entries

Calculated Cells

*(Note this worksheet shall **only** be used in conjunction with BMP designs from the **LID BMP Design Handbook**)*

Company Name **FMCivil**

Date **9/15/2022**

Designed by **Hector Paez**

Case No

Company Project Number/Name **22-004 - 100 W Sinclair Street**

**BMP Identification**

BMP NAME / ID **Bioretention Basin & Underground Chambers**

*Must match Name/ID used on BMP Design Calculation Sheet*

**Design Rainfall Depth**

85th Percentile, 24-hour Rainfall Depth,  
from the Isohyetal Map in Handbook Appendix E

$D_{85}$  = **0.65** inches

**Drainage Management Area Tabulation**

*Insert additional rows if needed to accommodate all DMAs draining to the BMP*

DMA Type/ID	DMA Area (square feet)	Post-Project Surface Type	Effective Imperivous Fraction, $I_f$	DMA Runoff Factor	DMA Areas x Runoff Factor	Design Storm Depth (in)	Design Capture Volume, $V_{BMP}$ (cubic feet)	Proposed Volume on Plans (cubic feet)
1	848338.1	Mixed Surface Types	0.941	0.79	672373			
	<b>848338.1</b>				<b>672373</b>	<b>0.65</b>	<b>36420.2</b>	<b>44587</b>

Notes:

Calculation for Mixed Surface Type 100 W Sinclair Street

DMA 1	Type	Fraction	Area	Area	Runoff Coefficient
	Landscaping	0.1	55789.9	5578.99	
	Roof	1	423223.99	423224	
	Concrete/Asphalt	1	369324.21	369324.2	0.940813
	Total		848338.10		

**100 W. Sinclair Street**

**Total Treatment Capacity Calculations for DMA 1**

Company Name: FMCivil Engineers

Designed by: Hector Paez

**Treatment Capacity of Bioretention Basin 1: Per RCFCID LID BMP Handbook**

6" max ponding

$$V\_BMP = A \text{ (ft}^2\text{)} * d\_E \text{ (ft)}$$

$$d\_E \text{ (ft)} = (0.3 * d\_s\text{(ft)} + 0.4 * 1\text{(ft)}) - (0.7\text{(ft}^2\text{)}/w\_t\text{(ft)} + 0.5 \text{ (ft)})$$

Depth of media:  $d\_s = 3'$

Width of basin:  $w\_t = 15.9'$

Basin Bottom Area:  $A = 3367.72 \text{ ft}^2$

$$d\_E = 1.76$$

$$V\_BMP = 5927.19 \text{ ft}^3$$

**Treatment Capacity of Bioretention Basin 2: Per RCFCID LID BMP Handbook**

6" max ponding

$$V\_BMP = A \text{ (ft}^2\text{)} * d\_E \text{ (ft)}$$

$$d\_E \text{ (ft)} = (0.3 * d\_s\text{(ft)} + 0.4 * 1\text{(ft)}) - (0.7\text{(ft}^2\text{)}/w\_t\text{(ft)} + 0.5 \text{ (ft)})$$

Depth of media:  $d\_s = 3'$

Width of basin:  $w\_t = 19.0'$

Basin Bottom Area:  $A = 3093.57 \text{ ft}^2$

$$d\_E = 1.76$$

$$V\_BMP = 5444.68 \text{ ft}^3$$

**Underground Chamber Capacity: Per Manufacturer (See Contech Specification Sheets in Appendix 6)**

$$V\_BMP = 33215 \text{ ft}^3$$

**Total Treatment Capacity for DMA 1: 44586.87 ft<sup>3</sup>**



# PROJECT SUMMARY

## CALCULATION DETAILS

- LOADING = HS20/HS25
- APPROX. LINEAR FOOTAGE = 522 LF

## STORAGE SUMMARY

- STORAGE VOLUME REQUIRED = N/A
- PIPE STORAGE VOLUME = 26,239 CF
- BACKFILL STORAGE VOLUME = 6,977 CF
- TOTAL STORAGE PROVIDED = 33,215 CF

## PIPE DETAILS

- DIAMETER = 96"
- CORRUGATION = 5x1
- GAGE = 16
- COATING = ALT2
- WALL TYPE = PERFORATED
- BARREL SPACING = 36"

## BACKFILL DETAILS

- WIDTH AT ENDS = 12"
- ABOVE PIPE = 0"
- WIDTH AT SIDES = 12"
- BELOW PIPE = 0"

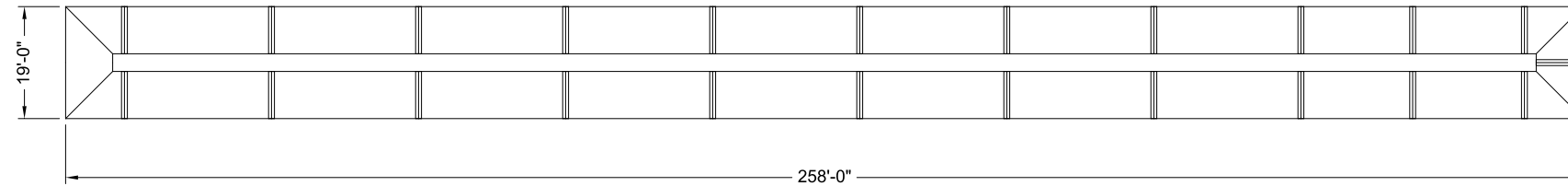

## NOTES

- ALL RISER AND STUB DIMENSIONS ARE TO CENTERLINE. ALL ELEVATIONS, DIMENSIONS, AND LOCATIONS OF RISERS AND INLETS, SHALL BE VERIFIED BY THE ENGINEER OF RECORD PRIOR TO RELEASING FOR FABRICATION.
- ALL FITTINGS AND REINFORCEMENT COMPLY WITH ASTM A998.
- ALL RISERS AND STUBS ARE 2<sup>2</sup>/<sub>3</sub>" x 1<sup>1</sup>/<sub>2</sub>" CORRUGATION AND 16 GAGE UNLESS OTHERWISE NOTED.
- RISERS TO BE FIELD TRIMMED TO GRADE.
- QUANTITY OF PIPE SHOWN DOES NOT PROVIDE EXTRA PIPE FOR CONNECTING THE SYSTEM TO EXISTING PIPE OR DRAINAGE STRUCTURES. OUR SYSTEM AS DETAILED PROVIDES NOMINAL INLET AND/OR OUTLET PIPE STUB FOR CONNECTION TO EXISTING DRAINAGE FACILITIES. IF ADDITIONAL PIPE IS NEEDED IT IS THE RESPONSIBILITY OF THE CONTRACTOR.
- BAND TYPE TO BE DETERMINED UPON FINAL DESIGN.
- THE PROJECT SUMMARY IS REFLECTIVE OF THE DYODS DESIGN, QUANTITIES ARE APPROX. AND SHOULD BE VERIFIED UPON FINAL DESIGN AND APPROVAL. FOR EXAMPLE, TOTAL EXCAVATION DOES NOT CONSIDER ALL VARIABLES SUCH AS SHORING AND ONLY ACCOUNTS FOR MATERIAL WITHIN THE ESTIMATED EXCAVATION FOOTPRINT.
- THESE DRAWINGS ARE FOR CONCEPTUAL PURPOSES AND DO NOT REFLECT ANY LOCAL PREFERENCES OR REGULATIONS. PLEASE CONTACT YOUR LOCAL CONTECH REP FOR MODIFICATIONS.

**ASSEMBLY**  
SCALE: 1" = 30'

C:\EXPORT\TEMPLATES\CMP\_16.DWG 10/18/2019 10:02 AM

The design and information shown on this drawing is provided as a service to the project owner, engineer and contractor by Contech Engineered Solutions LLC ("Contech"). Neither this drawing, nor any part thereof, may be used, reproduced or modified in any manner without the prior written consent of Contech. Failure to comply is done at the user's own risk and Contech expressly disclaims any liability or responsibility for such use.		
If discrepancies between the supplied information upon which the drawing is based and actual field conditions are encountered as site work progresses, these discrepancies must be reported to Contech immediately for re-evaluation of the design. Contech accepts no liability for designs based on missing, incomplete or inaccurate information supplied by others.		
DATE	REVISION DESCRIPTION	BY

**CONTECH**  
ENGINEERED SOLUTIONS LLC  
www.ContechES.com  
9025 Centre Pointe Dr., Suite 400, West Chester, OH 45069  
800-338-1122 513-645-7000 513-645-7993 FAX

**CONTECH**  
CMP DETENTION SYSTEMS  
CONTECH  
**DYODS**  
DRAWING

DYO21274 Sinclair St  
Under Ground Chamber System - Water Quality  
Perris, CA  
DETENTION SYSTEM

PROJECT No.: 13869	SEQ. No.: 21274	DATE: 9/14/2022
DESIGNED: DYO	DRAWN: DYO	
CHECKED: DYO	APPROVED: DYO	
SHEET NO.:		<b>1</b>

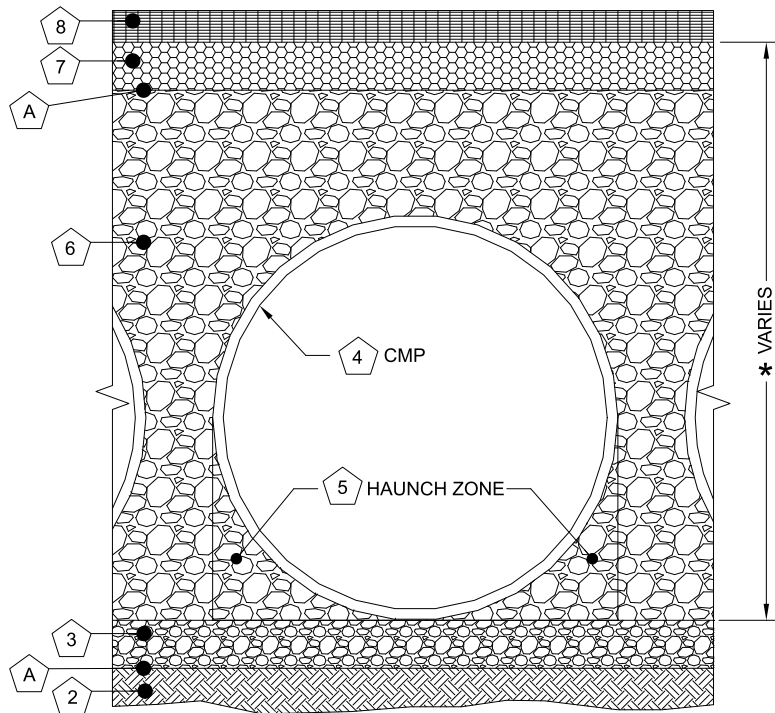

Infiltration Systems - CMP Infiltration & CMP Perforated Drainage Pipe			
Material Location	Description	Material Designation	Designation
8	Rigid or Flexible Pavement (if applicable)		
7	Road Base (if applicable)		
A	Geotextile Layer	Non-Woven Geotextile CONTECH C-40 or C-45	Engineer Decision for consideration to prevent soil migration into varying soil types. Wrap the trench only.
6	Backfill	Infiltration pipe systems have a pipe perforation sized of 3/8" diameter. An open graded, free draining stone, with a particle size of 1/2" - 2 1/2" diameter is recommended.	AASHTO M 145-A-1 or AASHTO M 43 - 3, 4 Material shall be worked into the pipe haunches by means of shovel-slicing, rodding, air-tamper, vibratory rod, or other effective methods. Compaction of all placed fill material is necessary and shall be considered adequate when no further yielding of the material is observed under the compactor, or under foot, and the Project Engineer or his representative is satisfied with the level of compaction"
3	Bedding Stone	Well graded granular bedding material w/maximum particle size of 3"	AASHTO M43 - 3,357,4,467, 5, 56, 57 For soil aggregates larger than 3/8" a dedicated bedding layer is not required for CMP. Pipe may be placed on the trench bottom comprised of native suitable well graded & granular material. For Arch pipes it is recommended to be shaped to a relatively flat bottom or fine-grade the foundation to a slight v-shape. Soil aggregates less than 3/8" and unsuitable material should be over-excavated and re-placed with a 4"-6" layer of well graded & granular stone per the material designation.
A	Geotextile Layer	None	None Contech does not recommend geotextiles be placed under the invert of infiltration systems due to the propensity for geotextiles to clog over time.

\* Note: The listed AASHTO designations are for gradation only. The stone must also be angular and clean.

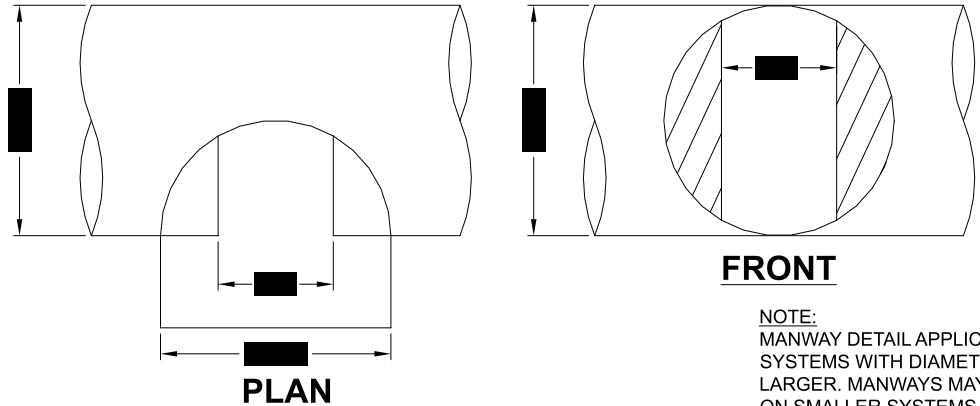

TYPICAL MANWAY DETAIL

NOTE: MANWAY DETAIL APPLICABLE FOR CMP SYSTEMS WITH DIAMETERS 48" AND LARGER. MANWAYS MAY BE REQUIRED ON SMALLER SYSTEMS DEPENDING ON ACTUAL SITE SPECIFIC CONDITIONS.

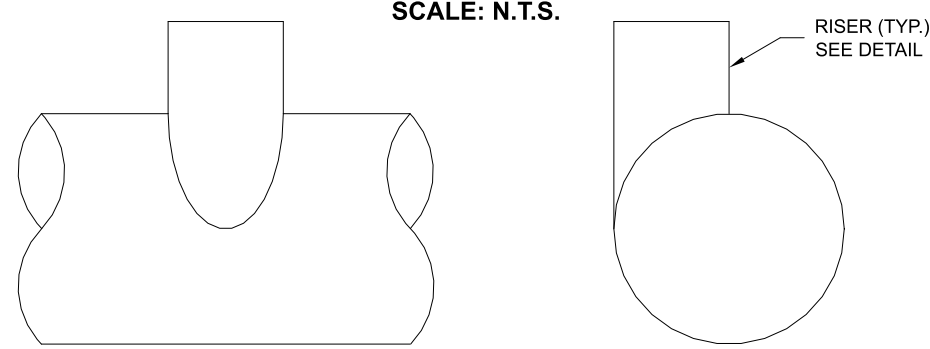

TYPICAL RISER DETAIL

NOTE: LADDERS ARE OPTIONAL AND ARE NOT REQUIRED FOR ALL SYSTEMS.

- 1 MINIMUM WIDTH DEPENDS ON SITE CONDITIONS AND ENGINEERING JUDGEMENT.
- 2 PRIOR TO PLACING THE BEDDING, THE FOUNDATION MUST BE CONSTRUCTED TO A UNIFORM AND STABLE GRADE. IN THE EVENT THAT UNSUITABLE FOUNDATION MATERIALS ARE ENCOUNTERED DURING EXCAVATION, THEY SHALL BE REMOVED AND BROUGHT BACK TO THE GRADE WITH A FILL MATERIAL AS APPROVED BY THE ENGINEER.
- 5 HAUNCH ZONE MATERIAL SHALL BE PLACED AND UNIFORMLY COMPACTED WITHOUT SOFT SPOTS.

**BACKFILL**  
MATERIAL SHALL BE PLACED IN 8"-10" MAXIMUM LIFTS. INADEQUATE COMPACTON CAN LEAD TO EXCESSIVE DEFLECTIONS WITHIN THE SYSTEM AND SETTLEMENT OF THE SOILS OVER THE SYSTEM. BACKFILL SHALL BE PLACED SUCH THAT THERE IS NO MORE THAN A TWO-LIFT DIFFERENTIAL BETWEEN THE SIDES OF ANY PIPE IN THE SYSTEM AT ALL TIMES DURING THE BACKFILL PROCESS. BACKFILL SHALL BE ADVANCED ALONG THE LENGTH OF THE SYSTEM AT THE SAME RATE TO AVOID DIFFERENTIAL LOADING ON ANY PIPES IN THE SYSTEM.

EQUIPMENT USED TO PLACE AND COMPACT THE BACKFILL SHALL BE OF A SIZE AND TYPE SO AS NOT TO DISTORT, DAMAGE, OR DISPLACE THE PIPE. ATTENTION MUST BE GIVEN TO PROVIDING ADEQUATE MINIMUM COVER FOR SUCH EQUIPMENT. MAINTAIN BALANCED LOADING ON ALL PIPES IN THE SYSTEM DURING ALL SUCH OPERATIONS.

OTHER ALTERNATE BACKFILL MATERIAL MAY BE ALLOWED DEPENDING ON SITE SPECIFIC CONDITIONS. REFER TO TYPICAL BACKFILL DETAIL FOR MATERIAL REQUIRED.

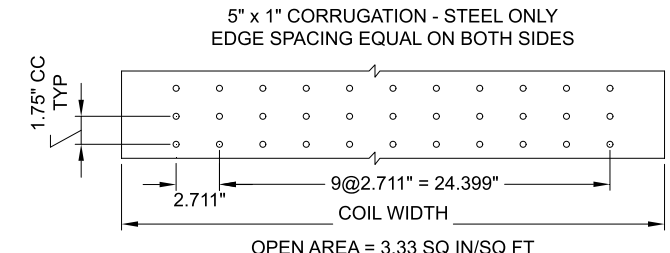
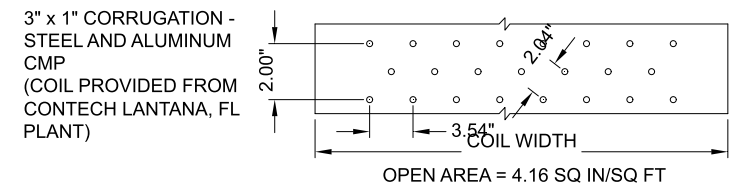
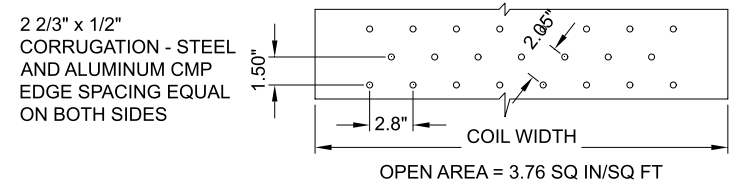

- NOTES:
- PERFORATIONS MEET AASHTO AND ASTM SPECIFICATIONS.
  - PERFORATION OPEN AREA PER SQUARE FOOT OF PIPE IS BASED ON THE NOMINAL DIAMETER AND LENGTH OF PIPE.
  - ALL DIMENSIONS ARE SUBJECT TO MANUFACTURING TOLERANCES.
  - ALL HOLES  $\varnothing$ 3/8".

TYPICAL PERFORATION DETAIL

SCALE: N.T.S.

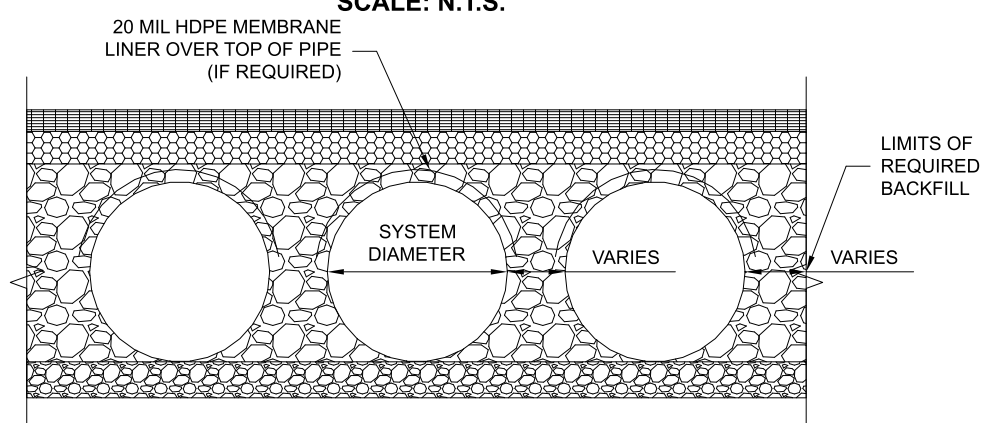

TYPICAL SECTION VIEW

LINER OVER ROWS  
SCALE: N.T.S.

NOTE: IF SALTING AGENTS FOR SNOW AND ICE REMOVAL ARE USED ON OR NEAR THE PROJECT, AN HDPE MEMBRANE LINER IS RECOMMENDED WITH THE SYSTEM. THE IMPERMEABLE LINER IS INTENDED TO HELP PROTECT THE SYSTEM FROM THE POTENTIAL ADVERSE EFFECTS THAT MAY RESULT FROM A CHANGE IN THE SURROUNDING ENVIRONMENT OVER A PERIOD OF TIME. PLEASE REFER TO THE CORRUGATED METAL PIPE DETENTION DESIGN GUIDE FOR ADDITIONAL INFORMATION.

C:\EXPORT\TEMPLATES\CMP\_V8.DWG 10/18/2019 10:02 AM

The design and information shown on this drawing is provided as a service to the project owner, engineer and contractor by Contech Engineered Solutions LLC ("Contech"). Neither this drawing, nor any part thereof, may be used, reproduced or modified in any manner without the prior written consent of Contech. Failure to comply is done at the user's own risk and Contech expressly disclaims any liability or responsibility for such use.

If discrepancies between the supplied information upon which the drawing is based and actual field conditions are encountered as site work progresses, these discrepancies must be reported to Contech immediately for re-evaluation of the design. Contech accepts no liability for designs based on missing, incomplete or inaccurate information supplied by others.

DATE	REVISION DESCRIPTION	BY

**CONTECH**  
ENGINEERED SOLUTIONS LLC  
www.ContechES.com  
9025 Centre Pointe Dr., Suite 400, West Chester, OH 45069  
800-338-1122 513-645-7000 513-645-7993 FAX

**CONTECH**  
CMP DETENTION SYSTEMS  
CONTECH  
DYODS  
DRAWING

DYO21274 Sinclair St  
Under Ground Chamber System - Water Quality  
Perris, CA  
DETENTION SYSTEM

PROJECT No.: 13869	SEQ. No.: 21274	DATE: 9/14/2022
DESIGNED: DYO	DRAWN: DYO	
CHECKED: DYO	APPROVED: DYO	
SHEET NO.:		1

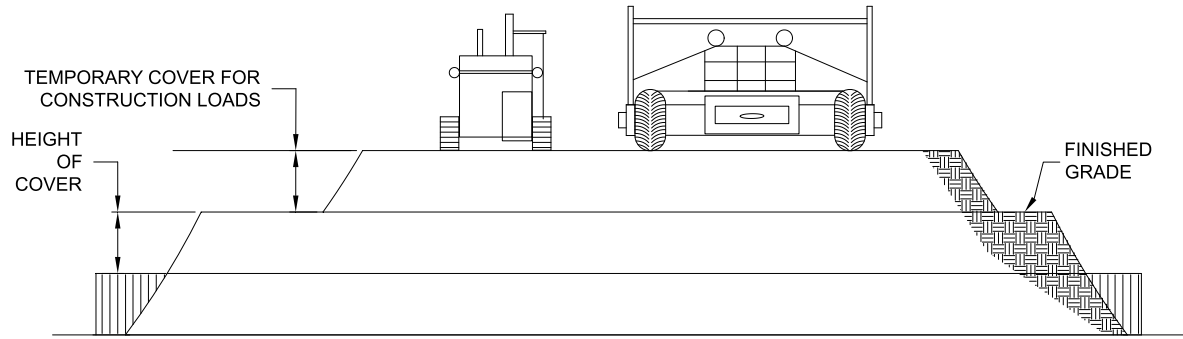

**CONSTRUCTION LOADS**

FOR TEMPORARY CONSTRUCTION VEHICLE LOADS, AN EXTRA AMOUNT OF COMPACTED COVER MAY BE REQUIRED OVER THE TOP OF THE PIPE. THE HEIGHT-OF-COVER SHALL MEET THE MINIMUM REQUIREMENTS SHOWN IN THE TABLE BELOW. THE USE OF HEAVY CONSTRUCTION EQUIPMENT NECESSITATES GREATER PROTECTION FOR THE PIPE THAN FINISHED GRADE COVER MINIMUMS FOR NORMAL HIGHWAY TRAFFIC.

PIPE SPAN, INCHES	AXLE LOADS (kips)			
	18-50	50-75	75-110	110-150
	MINIMUM COVER (FT)			
12-42	2.0	2.5	3.0	3.0
48-72	3.0	3.0	3.5	4.0
78-120	3.0	3.5	4.0	4.0
126-144	3.5	4.0	4.5	4.5

\*MINIMUM COVER MAY VARY, DEPENDING ON LOCAL CONDITIONS. THE CONTRACTOR MUST PROVIDE THE ADDITIONAL COVER REQUIRED TO AVOID DAMAGE TO THE PIPE. MINIMUM COVER IS MEASURED FROM THE TOP OF THE PIPE TO THE TOP OF THE MAINTAINED CONSTRUCTION ROADWAY SURFACE.

**CONSTRUCTION LOADING DIAGRAM**

SCALE: N.T.S.

**SPECIFICATION FOR DESIGNED DETENTION SYSTEM:**

**SCOPE**

THIS SPECIFICATION COVERS THE MANUFACTURE AND INSTALLATION OF THE DESIGNED DETENTION SYSTEM DETAILED IN THE PROJECT PLANS.

**MATERIAL**

THE MATERIAL SHALL CONFORM TO THE APPLICABLE REQUIREMENTS LISTED BELOW:

ALUMINIZED TYPE 2 STEEL COILS SHALL CONFORM TO THE REQUIREMENTS OF AASHTO M-274 OR ASTM A-92.

THE GALVANIZED STEEL COILS SHALL CONFORM TO THE REQUIREMENTS OF AASHTO M-218 OR ASTM A-929.

THE POLYMER COATED STEEL COILS SHALL CONFORM TO THE REQUIREMENTS OF AASHTO M-246 OR ASTM A-742.

THE ALUMINUM COILS SHALL CONFORM TO THE APPLICABLE OF AASHTO M-197 OR ASTM B-744.

**CONSTRUCTION LOADS**

CONSTRUCTION LOADS MAY BE HIGHER THAN FINAL LOADS. FOLLOW THE MANUFACTURER'S OR NCSA GUIDELINES.

**PIPE**

THE PIPE SHALL BE MANUFACTURED IN ACCORDANCE TO THE APPLICABLE REQUIREMENTS LISTED BELOW:

ALUMINIZED TYPE 2: AASHTO M-36 OR ASTM A-760

GALVANIZED: AASHTO M-36 OR ASTM A-760

POLYMER COATED: AASHTO M-245 OR ASTM A-762

ALUMINUM: AASHTO M-196 OR ASTM B-745

**HANDLING AND ASSEMBLY**

SHALL BE IN ACCORDANCE WITH NCSP'S (NATIONAL CORRUGATED STEEL ASSOCIATION) FOR ALUMINIZED TYPE 2, GALVANIZED OR POLYMER COATED STEEL. SHALL BE IN ACCORDANCE WITH THE MANUFACTURER'S RECOMMENDATIONS FOR ALUMINUM PIPE.

**INSTALLATION**

SHALL BE IN ACCORDANCE WITH AASHTO STANDARD SPECIFICATIONS FOR HIGHWAY BRIDGES, SECTION 26, DIVISION II DIVISION II OR ASTM A-798 (FOR ALUMINIZED TYPE 2, GALVANIZED OR POLYMER COATED STEEL) OR ASTM B-788 (FOR ALUMINUM PIPE) AND IN CONFORMANCE WITH THE PROJECT PLANS AND SPECIFICATIONS. IF THERE ARE ANY INCONSISTENCIES OR CONFLICTS THE CONTRACTOR SHOULD DISCUSS AND RESOLVE WITH THE SITE ENGINEER.

IT IS ALWAYS THE RESPONSIBILITY OF THE CONTRACTOR TO FOLLOW OSHA GUIDELINES FOR SAFE PRACTICES.

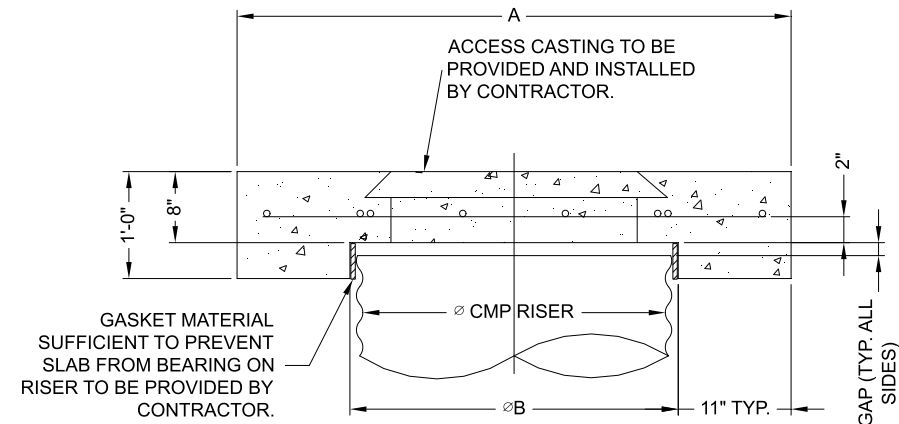

**SECTION VIEW**

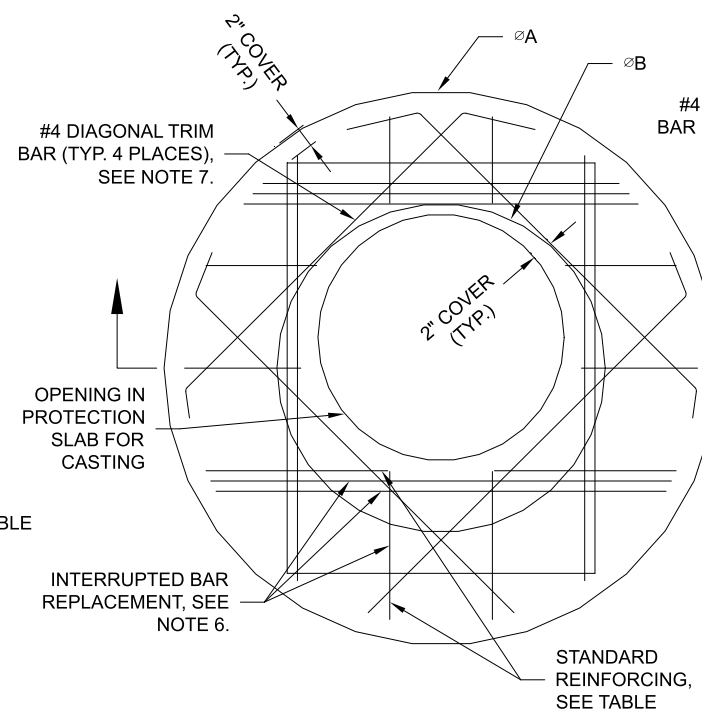

**ROUND OPTION PLAN VIEW**

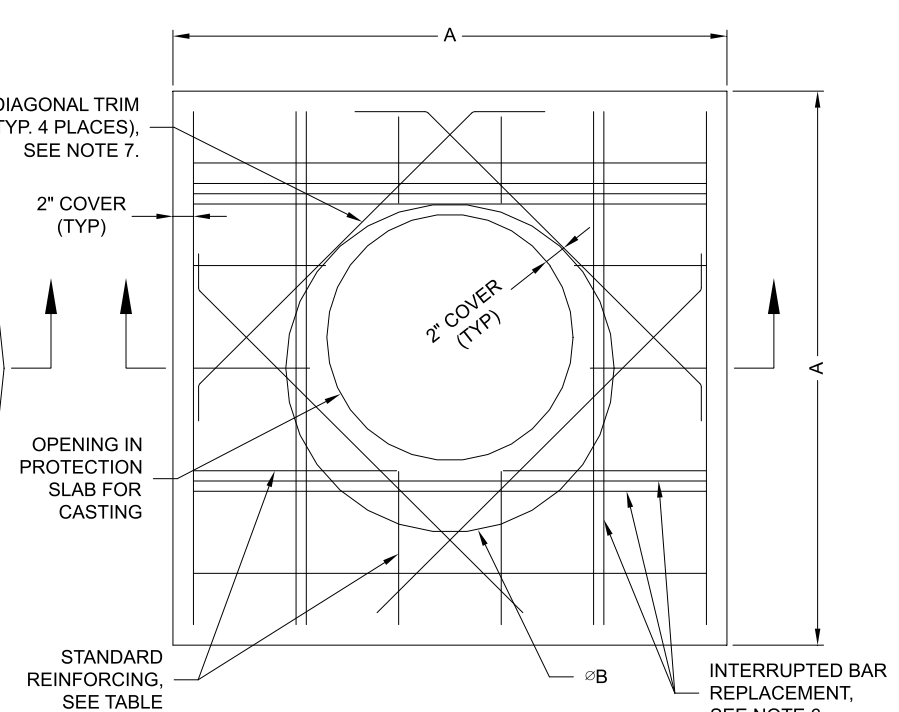

**SQUARE OPTION PLAN VIEW**

**NOTES:**

- DESIGN IN ACCORDANCE WITH AASHTO, 17th EDITION.
- DESIGN LOAD HS25.
- EARTH COVER = 1' MAX.
- CONCRETE STRENGTH = 3,500 psi
- REINFORCING STEEL = ASTM A615, GRADE 60.
- PROVIDE ADDITIONAL REINFORCING AROUND OPENINGS EQUAL TO THE BARS INTERRUPTED, HALF EACH SIDE. ADDITIONAL BARS TO BE IN THE SAME PLANE.
- TRIM OPENING WITH DIAGONAL #4 BARS, EXTEND BARS A MINIMUM OF 12" BEYOND OPENING, BEND BARS AS REQUIRED TO MAINTAIN BAR COVER.
- PROTECTION SLAB AND ALL MATERIALS TO BE PROVIDED AND INSTALLED BY CONTRACTOR.
- DETAIL DESIGN BY DELTA ENGINEERING, BINGHAMTON, NY.

**MANHOLE CAP DETAIL**

SCALE: N.T.S.

Ø CMP RISER	A	Ø B	REINFORCING	**BEARING PRESSURE (PSF)
24"	Ø 4' 4'X4'	26"	#5 @ 12" OCEW #5 @ 12" OCEW	2,410 1,780
30"	Ø 4'-6" 4'-6" X 4'-6"	32"	#5 @ 12" OCEW #5 @ 12" OCEW	2,120 1,530
36"	Ø 5' X 5'	38"	#5 @ 10" OCEW #5 @ 10" OCEW	1,890 1,350
42"	Ø 5'-6" X 5'-6"	44"	#5 @ 10" OCEW #5 @ 9" OCEW	1,720 1,210
48"	Ø 6' X 6'	50"	#5 @ 9" OCEW #5 @ 8" OCEW	1,600 1,100

\*\* ASSUMED SOIL BEARING CAPACITY

C:\EXPORT\TEMPLATES\CMP\_V8.DWG 10/18/2019 10:02 AM

**NOTE:**  
THESE DRAWINGS ARE FOR CONCEPTUAL PURPOSES AND DO NOT REFLECT ANY LOCAL PREFERENCES OR REGULATIONS. PLEASE CONTACT YOUR LOCAL CONTECH REP FOR MODIFICATIONS.

The design and information shown on this drawing is provided as a service to the project owner, engineer and contractor by Contech Engineered Solutions LLC ("Contech"). Neither this drawing, nor any part thereof, may be used, reproduced or modified in any manner without the prior written consent of Contech. Failure to comply is done at the user's own risk and Contech expressly disclaims any liability or responsibility for such use.

If discrepancies between the supplied information upon which the drawing is based and actual field conditions are encountered as site work progresses, these discrepancies must be reported to Contech immediately for re-evaluation of the design. Contech accepts no liability for designs based on missing, incomplete or inaccurate information supplied by others.

DATE	REVISION DESCRIPTION	BY

**CONTECH**  
ENGINEERED SOLUTIONS LLC  
www.ContechES.com  
9025 Centre Pointe Dr., Suite 400, West Chester, OH 45069  
800-338-1122 513-645-7000 513-645-7993 FAX

**CONTECH**  
CMP DETENTION SYSTEMS  
CONTECH  
DYODS  
DRAWING

DYO21274 Sinclair St  
Under Ground Chamber System - Water Quality  
Perris, CA  
DETENTION SYSTEM

PROJECT No.: 13869	SEQ. No.: 21274	DATE: 9/14/2022
DESIGNED: DYO	DRAWN: DYO	
CHECKED: DYO	APPROVED: DYO	
SHEET NO.:		1

## CMP DETENTION INSTALLATION GUIDE

PROPER INSTALLATION OF A FLEXIBLE UNDERGROUND DETENTION SYSTEM WILL ENSURE LONG-TERM PERFORMANCE. THE CONFIGURATION OF THESE SYSTEMS OFTEN REQUIRES SPECIAL CONSTRUCTION PRACTICES THAT DIFFER FROM CONVENTIONAL FLEXIBLE PIPE CONSTRUCTION. CONTECH ENGINEERED SOLUTIONS STRONGLY SUGGESTS SCHEDULING A PRE-CONSTRUCTION MEETING WITH YOUR LOCAL SALES ENGINEER TO DETERMINE IF ADDITIONAL MEASURES, NOT COVERED IN THIS GUIDE, ARE APPROPRIATE FOR YOUR SITE.

## FOUNDATION

CONSTRUCT A FOUNDATION THAT CAN SUPPORT THE DESIGN LOADING APPLIED BY THE PIPE AND ADJACENT BACKFILL WEIGHT AS WELL AS MAINTAIN ITS INTEGRITY DURING CONSTRUCTION.

IF SOFT OR UNSUITABLE SOILS ARE ENCOUNTERED, REMOVE THE POOR SOILS DOWN TO A SUITABLE DEPTH AND THEN BUILD UP TO THE APPROPRIATE ELEVATION WITH A COMPETENT BACKFILL MATERIAL. THE STRUCTURAL FILL MATERIAL GRADATION SHOULD NOT ALLOW THE MIGRATION OF FINES, WHICH CAN CAUSE SETTLEMENT OF THE DETENTION SYSTEM OR PAVEMENT ABOVE. IF THE STRUCTURAL FILL MATERIAL IS NOT COMPATIBLE WITH THE UNDERLYING SOILS AN ENGINEERING FABRIC SHOULD BE USED AS A SEPARATOR. IN SOME CASES, USING A STIFF REINFORCING GEOGRID REDUCES OVER EXCAVATION AND REPLACEMENT FILL QUANTITIES.

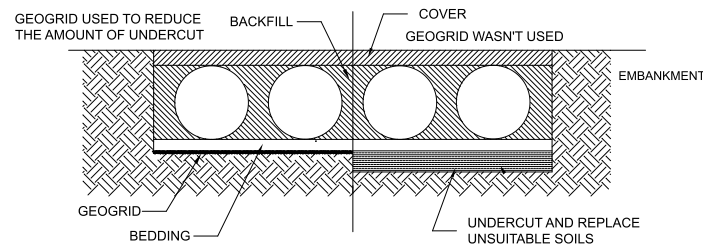

GRADE THE FOUNDATION SUBGRADE TO A UNIFORM OR SLIGHTLY SLOPING GRADE. IF THE SUBGRADE IS CLAY OR RELATIVELY NON-POROUS AND THE CONSTRUCTION SEQUENCE WILL LAST FOR AN EXTENDED PERIOD OF TIME, IT IS BEST TO SLOPE THE GRADE TO ONE END OF THE SYSTEM. THIS WILL ALLOW EXCESS WATER TO DRAIN QUICKLY, PREVENTING SATURATION OF THE SUBGRADE.

## GEOMEMBRANE BARRIER

A SITE'S RESISTIVITY MAY CHANGE OVER TIME WHEN VARIOUS TYPES OF SALTING AGENTS ARE USED, SUCH AS ROAD SALTS FOR DEICING AGENTS. IF SALTING AGENTS ARE USED ON OR NEAR THE PROJECT SITE, A GEOMEMBRANE BARRIER IS RECOMMENDED WITH THE SYSTEM. THE GEOMEMBRANE LINER IS INTENDED TO HELP PROTECT THE SYSTEM FROM THE POTENTIAL ADVERSE EFFECTS THAT MAY RESULT FROM THE USE OF SUCH AGENTS INCLUDING PREMATURE CORROSION AND REDUCED ACTUAL SERVICE LIFE.

THE PROJECT'S ENGINEER OF RECORD IS TO EVALUATE WHETHER SALTING AGENTS WILL BE USED ON OR NEAR THE PROJECT SITE, AND USE HIS/HER BEST JUDGEMENT TO DETERMINE IF ANY ADDITIONAL PROTECTIVE MEASURES ARE REQUIRED. BELOW IS A TYPICAL DETAIL SHOWING THE PLACEMENT OF A GEOMEMBRANE BARRIER FOR PROJECTS WHERE SALTING AGENTS ARE USED ON OR NEAR THE PROJECT SITE.

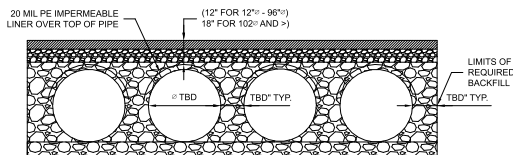

## IN-SITU TRENCH WALL

IF EXCAVATION IS REQUIRED, THE TRENCH WALL NEEDS TO BE CAPABLE OF SUPPORTING THE LOAD THAT THE PIPE SHEDS AS THE SYSTEM IS LOADED. IF SOILS ARE NOT CAPABLE OF SUPPORTING THESE LOADS, THE PIPE CAN DEFLECT. PERFORM A SIMPLE SOIL PRESSURE CHECK USING THE APPLIED LOADS TO DETERMINE THE LIMITS OF EXCAVATION BEYOND THE SPRING LINE OF THE OUTER MOST PIPES.

IN MOST CASES THE REQUIREMENTS FOR A SAFE WORK ENVIRONMENT AND PROPER BACKFILL PLACEMENT AND COMPACTION TAKE CARE OF THIS CONCERN.

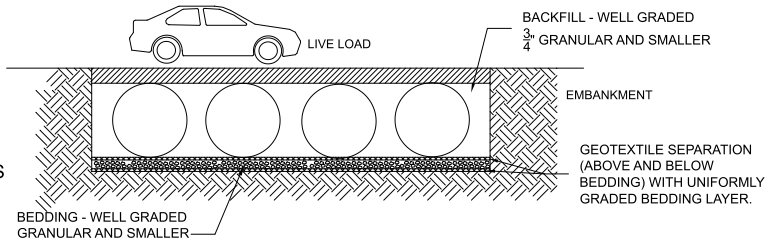

## BACKFILL PLACEMENT

MATERIAL SHALL BE WORKED INTO THE PIPE HAUNCHES BY MEANS OF SHOVEL-SLICING, RODDING, AIR TAMPER, VIBRATORY ROD, OR OTHER EFFECTIVE METHODS.

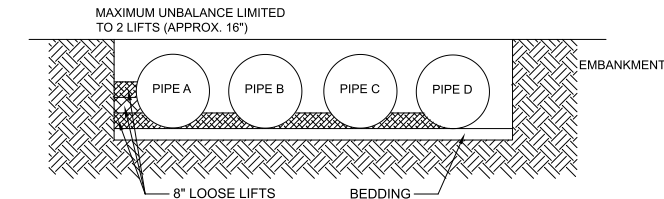

IF AASHTO T99 PROCEDURES ARE DETERMINED INFEASIBLE BY THE GEOTECHNICAL ENGINEER OF RECORD, COMPACTION IS CONSIDERED ADEQUATE WHEN NO FURTHER YIELDING OF THE MATERIAL IS OBSERVED UNDER THE COMPACTOR, OR UNDER FOOT, AND THE GEOTECHNICAL ENGINEER OF RECORD (OR REPRESENTATIVE THEREOF) IS SATISFIED WITH THE LEVEL OF COMPACTION.

FOR LARGE SYSTEMS, CONVEYOR SYSTEMS, BACKHOES WITH LONG REACHES OR DRAGLINES WITH STONE BUCKETS MAY BE USED TO PLACE BACKFILL. ONCE MINIMUM COVER FOR CONSTRUCTION LOADING ACROSS THE ENTIRE WIDTH OF THE SYSTEM IS REACHED, ADVANCE THE EQUIPMENT TO THE END OF THE RECENTLY PLACED FILL, AND BEGIN THE SEQUENCE AGAIN UNTIL THE SYSTEM IS COMPLETELY BACKFILLED. THIS TYPE OF CONSTRUCTION SEQUENCE PROVIDES ROOM FOR STOCKPILED BACKFILL DIRECTLY BEHIND THE BACKHOE, AS WELL AS THE MOVEMENT OF CONSTRUCTION TRAFFIC. MATERIAL STOCKPILES ON TOP OF THE BACKFILLED DETENTION SYSTEM SHOULD BE LIMITED TO 8- TO 10- FEET HIGH AND MUST PROVIDE BALANCED LOADING ACROSS ALL BARRELS. TO DETERMINE THE PROPER COVER OVER THE PIPES TO ALLOW THE MOVEMENT OF CONSTRUCTION EQUIPMENT SEE TABLE 1, OR CONTACT YOUR LOCAL CONTECH SALES ENGINEER.

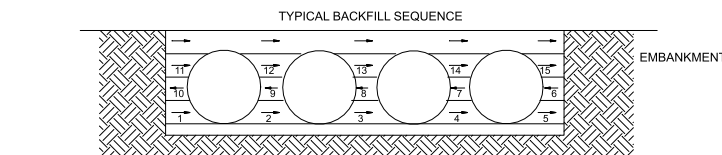

WHEN FLOWABLE FILL IS USED, YOU MUST PREVENT PIPE FLOATATION. TYPICALLY, SMALL LIFTS ARE PLACED BETWEEN THE PIPES AND THEN ALLOWED TO SET-UP PRIOR TO THE PLACEMENT OF THE NEXT LIFT. THE ALLOWABLE THICKNESS OF THE CLSM LIFT IS A FUNCTION OF A PROPER BALANCE BETWEEN THE UPLIFT FORCE OF THE CLSM, THE OPPOSING WEIGHT OF THE PIPE, AND THE EFFECT OF OTHER RESTRAINING MEASURES. THE PIPE CAN CARRY LIMITED FLUID PRESSURE WITHOUT PIPE DISTORTION OR DISPLACEMENT, WHICH ALSO AFFECTS THE CLSM LIFT THICKNESS. YOUR LOCAL CONTECH SALES ENGINEER CAN HELP DETERMINE THE PROPER LIFT THICKNESS.

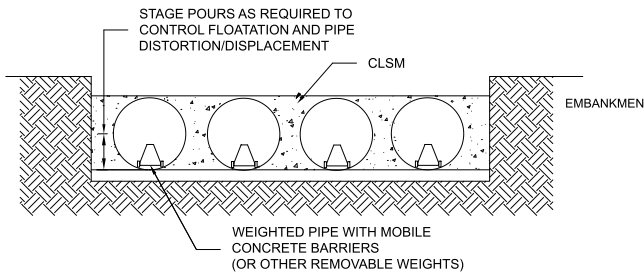

## CONSTRUCTION LOADING

TYPICALLY, THE MINIMUM COVER SPECIFIED FOR A PROJECT ASSUMES H-20 LIVE LOAD. BECAUSE CONSTRUCTION LOADS OFTEN EXCEED DESIGN LIVE LOADS, INCREASED TEMPORARY MINIMUM COVER REQUIREMENTS ARE NECESSARY. SINCE CONSTRUCTION EQUIPMENT VARIES FROM JOB TO JOB, IT IS BEST TO ADDRESS EQUIPMENT SPECIFIC MINIMUM COVER REQUIREMENTS WITH YOUR LOCAL CONTECH SALES ENGINEER DURING YOUR PRE-CONSTRUCTION MEETING.

## ADDITIONAL CONSIDERATIONS

BECAUSE MOST SYSTEMS ARE CONSTRUCTED BELOW-GRADE, RAINFALL CAN RAPIDLY FILL THE EXCAVATION; POTENTIALLY CAUSING FLOATATION AND MOVEMENT OF THE PREVIOUSLY PLACED PIPES. TO HELP MITIGATE POTENTIAL PROBLEMS, IT IS BEST TO START THE INSTALLATION AT THE DOWNSTREAM END WITH THE OUTLET ALREADY CONSTRUCTED TO ALLOW A ROUTE FOR THE WATER TO ESCAPE. TEMPORARY DIVERSION MEASURES MAY BE REQUIRED FOR HIGH FLOWS DUE TO THE RESTRICTED NATURE OF THE OUTLET PIPE.

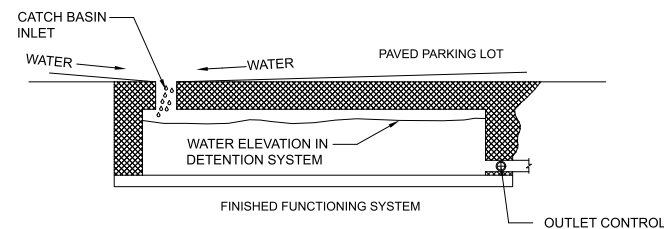

## CMP DETENTION SYSTEM INSPECTION AND MAINTENANCE

UNDERGROUND STORMWATER DETENTION AND INFILTRATION SYSTEMS MUST BE INSPECTED AND MAINTAINED AT REGULAR INTERVALS FOR PURPOSES OF PERFORMANCE AND LONGEVITY.

### INSPECTION

INSPECTION IS THE KEY TO EFFECTIVE MAINTENANCE OF CMP DETENTION SYSTEMS AND IS EASILY PERFORMED. CONTECH RECOMMENDS ONGOING, ANNUAL INSPECTIONS. SITES WITH HIGH TRASH LOAD OR SMALL OUTLET CONTROL ORIFICES MAY NEED MORE FREQUENT INSPECTIONS. THE RATE AT WHICH THE SYSTEM COLLECTS POLLUTANTS WILL DEPEND MORE ON SITE SPECIFIC ACTIVITIES RATHER THAN THE SIZE OR CONFIGURATION OF THE SYSTEM.

INSPECTIONS SHOULD BE PERFORMED MORE OFTEN IN EQUIPMENT WASHDOWN AREAS, IN CLIMATES WHERE SANDING AND/OR SALTING OPERATIONS TAKE PLACE, AND IN OTHER VARIOUS INSTANCES IN WHICH ONE WOULD EXPECT HIGHER ACCUMULATIONS OF SEDIMENT OR ABRASIVE/ CORROSIVE CONDITIONS. A RECORD OF EACH INSPECTION IS TO BE MAINTAINED FOR THE LIFE OF THE SYSTEM

### MAINTENANCE

CMP DETENTION SYSTEMS SHOULD BE CLEANED WHEN AN INSPECTION REVEALS ACCUMULATED SEDIMENT OR TRASH IS CLOGGING THE DISCHARGE ORIFICE.

ACCUMULATED SEDIMENT AND TRASH CAN TYPICALLY BE EVACUATED THROUGH THE MANHOLE OVER THE OUTLET ORIFICE. IF MAINTENANCE IS NOT PERFORMED AS RECOMMENDED, SEDIMENT AND TRASH MAY ACCUMULATE IN FRONT OF THE OUTLET ORIFICE. MANHOLE COVERS SHOULD BE SECURELY SEATED FOLLOWING CLEANING ACTIVITIES. CONTECH SUGGESTS THAT ALL SYSTEMS BE DESIGNED WITH AN ACCESS/INSPECTION MANHOLE SITUATED AT OR NEAR THE INLET AND THE OUTLET ORIFICE. SHOULD IT BE NECESSARY TO GET INSIDE THE SYSTEM TO PERFORM MAINTENANCE ACTIVITIES, ALL APPROPRIATE PRECAUTIONS REGARDING CONFINED SPACE ENTRY AND OSHA REGULATIONS SHOULD BE FOLLOWED.

ANNUAL INSPECTIONS ARE BEST PRACTICE FOR ALL UNDERGROUND SYSTEMS. DURING THIS INSPECTION, IF EVIDENCE OF SALTING/DE-ICING AGENTS IS OBSERVED WITHIN THE SYSTEM, IT IS BEST PRACTICE FOR THE SYSTEM TO BE RINSED, INCLUDING ABOVE THE SPRING LINE SOON AFTER THE SPRING THAW AS PART OF THE MAINTENANCE PROGRAM FOR THE SYSTEM.

MAINTAINING AN UNDERGROUND DETENTION OR INFILTRATION SYSTEM IS EASIEST WHEN THERE IS NO FLOW ENTERING THE SYSTEM. FOR THIS REASON, IT IS A GOOD IDEA TO SCHEDULE THE CLEANOUT DURING DRY WEATHER.

THE FOREGOING INSPECTION AND MAINTENANCE EFFORTS HELP ENSURE UNDERGROUND PIPE SYSTEMS USED FOR STORMWATER STORAGE CONTINUE TO FUNCTION AS INTENDED BY IDENTIFYING RECOMMENDED REGULAR INSPECTION AND MAINTENANCE PRACTICES. INSPECTION AND MAINTENANCE RELATED TO THE STRUCTURAL INTEGRITY OF THE PIPE OR THE SOUNDNESS OF PIPE JOINT CONNECTIONS IS BEYOND THE SCOPE OF THIS GUIDE.

C:\EXPORT\TEMPLATES\CMP\_V8.DWG 10/18/2019 10:02 AM

The design and information shown on this drawing is provided as a service to the project owner, engineer and contractor by Contech Engineered Solutions LLC ("Contech"). Neither this drawing, nor any part thereof, may be used, reproduced or modified in any manner without the prior written consent of Contech. Failure to comply is done at the user's own risk and Contech expressly disclaims any liability or responsibility for such use.

If discrepancies between the supplied information upon which the drawing is based and actual field conditions are encountered as site work progresses, these discrepancies must be reported to Contech immediately for re-evaluation of the design. Contech accepts no liability for designs based on missing, incomplete or inaccurate information supplied by others.

DATE	REVISION DESCRIPTION	BY

**CONTECH**  
ENGINEERED SOLUTIONS LLC  
www.ContechES.com

9025 Centre Pointe Dr., Suite 400, West Chester, OH 45069  
800-338-1122 513-645-7000 513-645-7993 FAX

**CONTECH**  
CMP DETENTION SYSTEMS

CONTECH  
**DYODS**  
DRAWING

DYO21274 Sinclair St  
Under Ground Chamber System - Water Quality  
Perris, CA  
DETENTION SYSTEM

PROJECT No.: 13869	SEQ. No.: 21274	DATE: 9/14/2022
DESIGNED: DYO	DRAWN: DYO	
CHECKED: DYO	APPROVED: DYO	
SHEET NO.:		<b>1</b>

# Appendix 7: Hydromodification

*Supporting Detail Relating to Hydrologic Conditions of Concern*



# 100 W Sinclair Street HCOC Applicability

Purple - Not Subject to HCOC  
Gold - Potentially Subject to HCOC

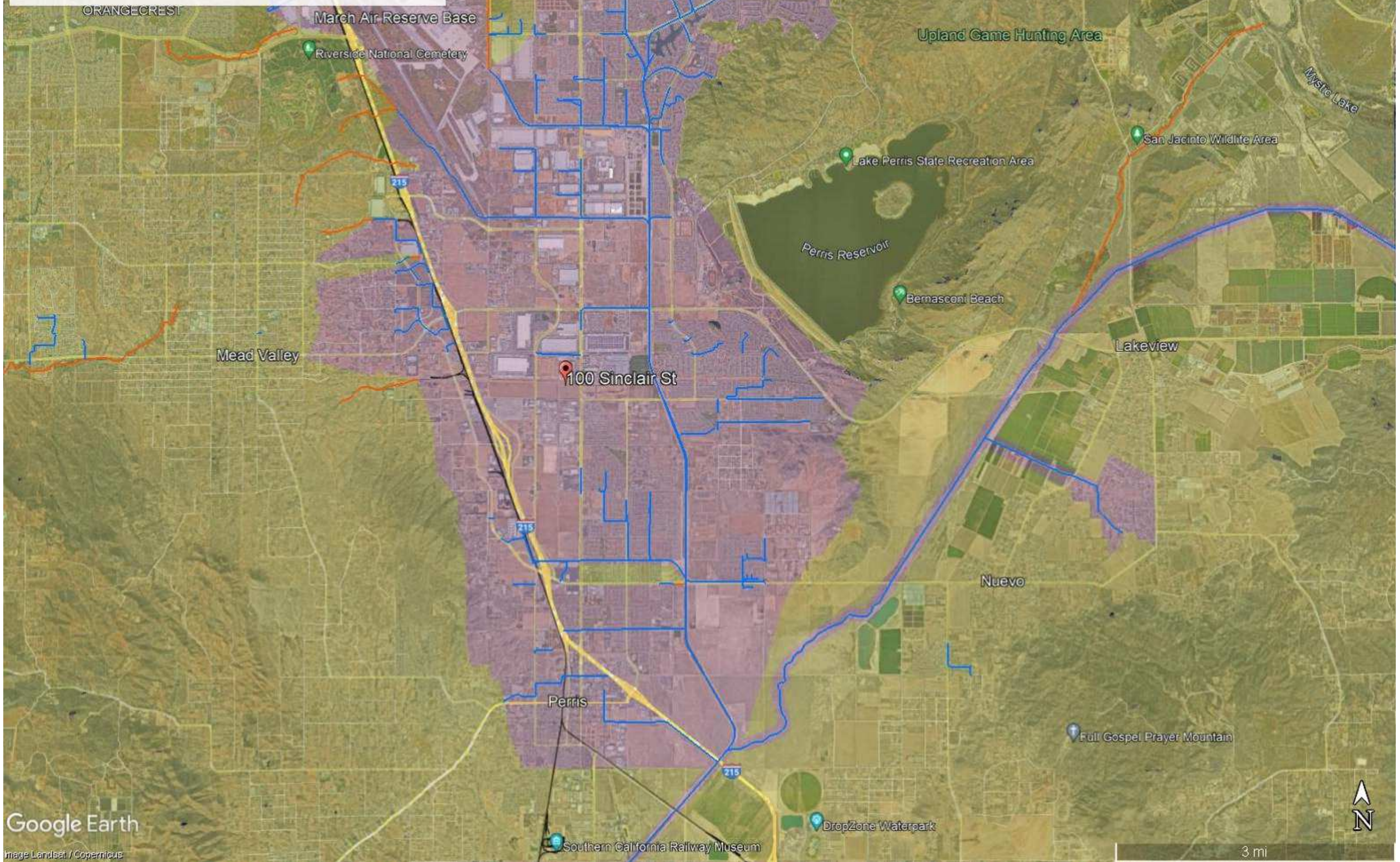



# Appendix 8: Source Control

*Pollutant Sources/Source Control Checklist*

STORMWATER POLLUTANT SOURCES/SOURCE CONTROL CHECKLIST

How to use this worksheet (also see instructions in Section G of the WQMP Template):

1. Review Column 1 and identify which of these potential sources of stormwater pollutants apply to your site. Check each box that applies.
2. Review Column 2 and incorporate all of the corresponding applicable BMPs in your WQMP Exhibit.
3. Review Columns 3 and 4 and incorporate all of the corresponding applicable permanent controls and operational BMPs in your WQMP. Use the format shown in Table G.1 on page 23 of this WQMP Template. Describe your specific BMPs in an accompanying narrative, and explain any special conditions or situations that required omitting BMPs or substituting alternative BMPs for those shown here.

1 IF THESE SOURCES WILL BE ON THE PROJECT SITE ...	... THEN YOUR WQMP SHOULD INCLUDE THESE SOURCE CONTROL BMPs, AS APPLICABLE		
1 Potential Sources of Runoff Pollutants	2 Permanent Controls—Show on WQMP Drawings	3 Permanent Controls—List in WQMP Table and Narrative	4 Operational BMPs—Include in WQMP Table and Narrative
<input checked="" type="checkbox"/> A. On-site storm drain inlets	<input checked="" type="checkbox"/> Locations of inlets.	<input checked="" type="checkbox"/> Mark all inlets with the words “Only Rain Down the Storm Drain” or similar. Catch Basin Markers may be available from the Riverside County Flood Control and Water Conservation District, call 951.955.1200 to verify.	<input checked="" type="checkbox"/> Maintain and periodically repaint or replace inlet markings. <input checked="" type="checkbox"/> Provide stormwater pollution prevention information to new site owners, lessees, or operators. <input checked="" type="checkbox"/> See applicable operational BMPs in Fact Sheet SC-44, “Drainage System Maintenance,” in the CASQA Stormwater Quality Handbooks at <a href="http://www.cabmphandbooks.com">www.cabmphandbooks.com</a> <input checked="" type="checkbox"/> Include the following in lease agreements: “Tenant shall not allow anyone to discharge anything to storm drains or to store or deposit materials so as to create a potential discharge to storm drains.”
<input type="checkbox"/> B. Interior floor drains and elevator shaft sump pumps		<input type="checkbox"/> State that interior floor drains and elevator shaft sump pumps will be plumbed to sanitary sewer.	<input type="checkbox"/> Inspect and maintain drains to prevent blockages and overflow.
<input type="checkbox"/> C. Interior parking garages		<input type="checkbox"/> State that parking garage floor drains will be plumbed to the sanitary sewer.	<input type="checkbox"/> Inspect and maintain drains to prevent blockages and overflow.

STORMWATER POLLUTANT SOURCES/SOURCE CONTROL CHECKLIST

IF THESE SOURCES WILL BE ON THE PROJECT SITE ...	... THEN YOUR WQMP SHOULD INCLUDE THESE SOURCE CONTROL BMPs, AS APPLICABLE		
1 Potential Sources of Runoff Pollutants	2 Permanent Controls—Show on WQMP Drawings	3 Permanent Controls—List in WQMP Table and Narrative	4 Operational BMPs—Include in WQMP Table and Narrative
<input type="checkbox"/> D1. Need for future indoor & structural pest control		<input type="checkbox"/> Note building design features that discourage entry of pests.	<input type="checkbox"/> Provide Integrated Pest Management information to owners, lessees, and operators.
<input checked="" type="checkbox"/> D2. Landscape/ Outdoor Pesticide Use	<input checked="" type="checkbox"/> Show locations of native trees or areas of shrubs and ground cover to be undisturbed and retained. <input checked="" type="checkbox"/> Show self-retaining landscape areas, if any. <input checked="" type="checkbox"/> Show stormwater treatment and hydrograph modification management BMPs. (See instructions in Chapter 3, Step 5 and guidance in Chapter 5.)	<input type="checkbox"/> State that final landscape plans will accomplish all of the following. <input type="checkbox"/> Preserve existing native trees, shrubs, and ground cover to the maximum extent possible. <input checked="" type="checkbox"/> Design landscaping to minimize irrigation and runoff, to promote surface infiltration where appropriate, and to minimize the use of fertilizers and pesticides that can contribute to stormwater pollution. <input checked="" type="checkbox"/> Where landscaped areas are used to retain or detain stormwater, specify plants that are tolerant of saturated soil conditions. <input checked="" type="checkbox"/> Consider using pest-resistant plants, especially adjacent to hardscape. <input checked="" type="checkbox"/> To insure successful establishment, select plants appropriate to site soils, slopes, climate, sun, wind, rain, land use, air movement, ecological consistency, and plant interactions.	<input checked="" type="checkbox"/> Maintain landscaping using minimum or no pesticides. <input checked="" type="checkbox"/> See applicable operational BMPs in “What you should know for....Landscape and Gardening” at <a href="http://rcfllood.org/stormwater/Error!">http://rcfllood.org/stormwater/Error!</a> Hyperlink reference not valid. <input checked="" type="checkbox"/> Provide IPM information to new owners, lessees and operators.

STORMWATER POLLUTANT SOURCES/SOURCE CONTROL CHECKLIST

... THEN YOUR WQMP SHOULD INCLUDE THESE SOURCE CONTROL BMPs, AS APPLICABLE			
1	2	3	4
Potential Sources of Runoff Pollutants	Permanent Controls—Show on WQMP Drawings	Permanent Controls—List in WQMP Table and Narrative	Operational BMPs—Include in WQMP Table and Narrative
<p><input type="checkbox"/> E. Pools, spas, ponds, decorative fountains, and other water features.</p>	<p><input type="checkbox"/> Show location of water feature and a sanitary sewer cleanout in an accessible area within 10 feet. (Exception: Public pools must be plumbed according to County Department of Environmental Health Guidelines.)</p>	<p>If the Co-Permittee requires pools to be plumbed to the sanitary sewer, place a note on the plans and state in the narrative that this connection will be made according to local requirements.</p>	<p><input type="checkbox"/> See applicable operational BMPs in "Guidelines for Maintaining Your Swimming Pool, Jacuzzi and Garden Fountain" at <a href="http://rcflood.org/stormwater/">http://rcflood.org/stormwater/</a></p>
<p><input type="checkbox"/> F. Food service</p>	<p><input type="checkbox"/> For restaurants, grocery stores, and other food service operations, show location (indoors or in a covered area outdoors) of a floor sink or other area for cleaning floor mats, containers, and equipment.</p> <p><input type="checkbox"/> On the drawing, show a note that this drain will be connected to a grease interceptor before discharging to the sanitary sewer.</p>	<p><input type="checkbox"/> Describe the location and features of the designated cleaning area.</p> <p><input type="checkbox"/> Describe the items to be cleaned in this facility and how it has been sized to insure that the largest items can be accommodated.</p>	<p><input type="checkbox"/> See the brochure, "The Food Service Industry Best Management Practices for: Restaurants, Grocery Stores, Delicatessens and Bakeries" at <a href="http://rcflood.org/stormwater/">http://rcflood.org/stormwater/</a></p> <p>Provide this brochure to new site owners, lessees, and operators.</p>
<p><input checked="" type="checkbox"/> G. Refuse areas</p>	<p><input checked="" type="checkbox"/> Show where site refuse and recycled materials will be handled and stored for pickup. See local municipal requirements for sizes and other details of refuse areas.</p> <p><input checked="" type="checkbox"/> If dumpsters or other receptacles are outdoors, show how the designated area will be covered, graded, and paved to prevent runoff and show locations of berms to prevent runoff from the area.</p> <p><input type="checkbox"/> Any drains from dumpsters, compactors, and tallow bin areas shall be connected to a grease removal device before discharge to sanitary sewer.</p>	<p><input checked="" type="checkbox"/> State how site refuse will be handled and provide supporting detail to what is shown on plans.</p> <p><input checked="" type="checkbox"/> State that signs will be posted on or near dumpsters with the words "Do not dump hazardous materials here" or similar.</p>	<p><input checked="" type="checkbox"/> State how the following will be implemented:</p> <p>Provide adequate number of receptacles. Inspect receptacles regularly; repair or replace leaky receptacles. Keep receptacles covered. Prohibit/prevent dumping of liquid or hazardous wastes. Post "no hazardous materials" signs. Inspect and pick up litter daily and clean up spills immediately. Keep spill control materials available on-site. See Fact Sheet SC-34, "Waste Handling and Disposal" in the CASQA Stormwater Quality Handbooks at <a href="http://www.cabmphandbooks.com">www.cabmphandbooks.com</a></p>

STORMWATER POLLUTANT SOURCES/SOURCE CONTROL CHECKLIST

<p>... THEN YOUR WQMP SHOULD INCLUDE THESE SOURCE CONTROL BMPs, AS APPLICABLE</p>			
<p>1 Potential Sources of Runoff Pollutants</p> <p><input checked="" type="checkbox"/> H. Industrial processes.</p>	<p>2 Permanent Controls—Show on WQMP Drawings</p> <p><input checked="" type="checkbox"/> Show process area.</p>	<p>3 Permanent Controls—List in WQMP Table and Narrative</p> <p><input checked="" type="checkbox"/> If industrial processes are to be located on site, state: “All process activities to be performed indoors. No processes to drain to exterior or to storm drain system.”</p>	<p>4 Operational BMPs—Include in WQMP Table and Narrative</p> <p><input checked="" type="checkbox"/> See Fact Sheet SC-10, “Non-Stormwater Discharges” in the CASQA Stormwater Quality Handbooks at <a href="http://www.cabmphandbooks.com">www.cabmphandbooks.com</a> See the brochure “Industrial &amp; Commercial Facilities Best Management Practices for: Industrial, Commercial Facilities” at <a href="http://rcflood.org/stormwater/">http://rcflood.org/stormwater/</a></p>

STORMWATER POLLUTANT SOURCES/SOURCE CONTROL CHECKLIST

IF THESE SOURCES WILL BE ON THE PROJECT SITE ...	... THEN YOUR WQMP SHOULD INCLUDE THESE SOURCE CONTROL BMPs, AS APPLICABLE
<p>1</p> <p>Potential Sources of Runoff Pollutants</p> <p><input type="checkbox"/> i. Outdoor storage of equipment or materials. (See rows J and K for source control measures for vehicle cleaning, repair, and maintenance.)</p>	<p>2</p> <p>Permanent Controls—Show on WQMP Drawings</p> <p><input type="checkbox"/> Show any outdoor storage areas, including how materials will be covered. Show how areas will be graded and bermed to prevent runoff or run-off from area.</p> <p><input type="checkbox"/> Storage of non-hazardous liquids shall be covered by a roof and/or drain to the sanitary sewer system, and be contained by berms, dikes, liners, or vaults.</p> <p><input type="checkbox"/> Storage of hazardous materials and wastes must be in compliance with the local hazardous materials ordinance and a Hazardous Materials Management Plan for the site.</p>
	<p>3</p> <p>Permanent Controls—List in WQMP Table and Narrative</p> <p>Include a detailed description of materials to be stored, storage areas, and structural features to prevent pollutants from entering storm drains.</p> <p>Where appropriate, reference documentation of compliance with the requirements of Hazardous Materials Programs for:</p> <ul style="list-style-type: none"> <li>▪ Hazardous Waste Generation</li> <li>▪ Hazardous Materials Release Response and Inventory</li> <li>▪ California Accidental Release (CalARP)</li> <li>▪ Aboveground Storage Tank</li> <li>▪ Uniform Fire Code Article 80 Section 103(b) &amp; (c) 1991</li> <li>▪ Underground Storage Tank</li> </ul> <p><a href="http://www.cchealth.org/groups/hazmat/">www.cchealth.org/groups/hazmat/</a></p>
	<p>4</p> <p>Operational BMPs—Include in WQMP Table and Narrative</p> <p><input type="checkbox"/> See the Fact Sheets SC-31, “Outdoor Liquid Container Storage” and SC-33, “Outdoor Storage of Raw Materials ” in the CASQA Stormwater Quality Handbooks at <a href="http://www.cabmphandbooks.com">www.cabmphandbooks.com</a></p>



STORMWATER POLLUTANT SOURCES/SOURCE CONTROL CHECKLIST

IF THESE SOURCES WILL BE ON THE PROJECT SITE ...	... THEN YOUR WQMP SHOULD INCLUDE THESE SOURCE CONTROL BMPs, AS APPLICABLE		
1 Potential Sources of Runoff Pollutants	2 Permanent Controls—Show on WQMP Drawings	3 Permanent Controls—List in WQMP Table and Narrative	4 Operational BMPs—Include in WQMP Table and Narrative
<p><input type="checkbox"/> J. Vehicle and Equipment Cleaning</p>	<p><input type="checkbox"/> Show on drawings as appropriate:</p> <p>(1) Commercial/industrial facilities having vehicle/equipment cleaning needs shall either provide a covered, bermed area for washing activities or discourage vehicle/equipment washing by removing hose bibs and installing signs prohibiting such uses.</p> <p>(2) Multi-dwelling complexes shall have a paved, bermed, and covered car wash area (unless car washing is prohibited on-site and hoses are provided with an automatic shut-off to discourage such use).</p> <p>(3) Washing areas for cars, vehicles, and equipment shall be paved, designed to prevent run-on to or runoff from the area, and plumbed to drain to the sanitary sewer.</p> <p>(4) Commercial car wash facilities shall be designed such that no runoff from the facility is discharged to the storm drain system. Wastewater from the facility shall discharge to the sanitary sewer, or a wastewater reclamation system shall be installed.</p>	<p><input type="checkbox"/> If a car wash area is not provided, describe any measures taken to discourage on-site car washing and explain how these will be enforced.</p>	<p>Describe operational measures to implement the following (if applicable):</p> <p><input type="checkbox"/> Washwater from vehicle and equipment washing operations shall not be discharged to the storm drain system. Refer to “Outdoor Cleaning Activities and Professional Mobile Service Providers” for many of the Potential Sources of Runoff Pollutants categories below. Brochure can be found at <a href="http://rcflood.org/stormwater/">http://rcflood.org/stormwater/</a></p> <p><input type="checkbox"/> Car dealerships and similar may rinse cars with water only.</p>

STORMWATER POLLUTANT SOURCES/SOURCE CONTROL CHECKLIST

IF THESE SOURCES WILL BE ON THE PROJECT SITE ...	... THEN YOUR WQMP SHOULD INCLUDE THESE SOURCE CONTROL BMPs, AS APPLICABLE		
1 Potential Sources of Runoff Pollutants	2 Permanent Controls—Show on WQMP Drawings	3 Permanent Controls—List in WQMP Table and Narrative	4 Operational BMPs—Include in WQMP Table and Narrative
<p><input type="checkbox"/> <b>K. Vehicle/Equipment Repair and Maintenance</b></p>	<p><input type="checkbox"/> Accommodate all vehicle equipment repair and maintenance indoors. Or designate an outdoor work area and design the area to prevent run-on and runoff of stormwater.</p> <p><input type="checkbox"/> Show secondary containment for exterior work areas where motor oil, brake fluid, gasoline, diesel fuel, radiator fluid, acid-containing batteries or other hazardous materials or hazardous wastes are used or stored. Drains shall not be installed within the secondary containment areas.</p> <p><input type="checkbox"/> Add a note on the plans that states either (1) there are no floor drains, or (2) floor drains are connected to wastewater pretreatment systems prior to discharge to the sanitary sewer and an industrial waste discharge permit will be obtained.</p>	<p><input type="checkbox"/> State that no vehicle repair or maintenance will be done outdoors, or else describe the required features of the outdoor work area.</p> <p><input type="checkbox"/> State that there are no floor drains or if there are floor drains, note the agency from which an industrial waste discharge permit will be obtained and that the design meets that agency's requirements.</p> <p><input type="checkbox"/> State that there are no tanks, containers or sinks to be used for parts cleaning or rinsing or, if there are, note the agency from which an industrial waste discharge permit will be obtained and that the design meets that agency's requirements.</p>	<p>Operational BMPs—Include in WQMP Table and Narrative</p> <p>In the Stormwater Control Plan, note that all of the following restrictions apply to use the site:</p> <p><input type="checkbox"/> No person shall dispose of, nor permit the disposal, directly or indirectly of vehicle fluids, hazardous materials, or rinsewater from parts cleaning into storm drains.</p> <p><input type="checkbox"/> No vehicle fluid removal shall be performed outside a building, nor on asphalt or ground surfaces, whether inside or outside a building, except in such a manner as to ensure that any spilled fluid will be in an area of secondary containment. Leaking vehicle fluids shall be contained or drained from the vehicle immediately.</p> <p><input type="checkbox"/> No person shall leave unattended drip parts or other open containers containing vehicle fluid, unless such containers are in use or in an area of secondary containment.</p> <p>Refer to “Automotive Maintenance &amp; Car Care Best Management Practices for Auto Body Shops, Auto Repair Shops, Car Dealerships, Gas Stations and Fleet Service Operations”. Brochure can be found at <a href="http://rcflood.org/stormwater/">http://rcflood.org/stormwater/</a></p> <p>Refer to Outdoor Cleaning Activities and Professional Mobile Service Providers for many of the Potential Sources of Runoff Pollutants categories below. Brochure can be found at <a href="http://rcflood.org/stormwater/">http://rcflood.org/stormwater/</a></p>

STORMWATER POLLUTANT SOURCES/SOURCE CONTROL CHECKLIST

IF THESE SOURCES WILL BE ON THE PROJECT SITE ...	... THEN YOUR WQMP SHOULD INCLUDE THESE SOURCE CONTROL BMPs, AS APPLICABLE		
1 Potential Sources of Runoff Pollutants	2 Permanent Controls—Show on WQMP Drawings	3 Permanent Controls—List in WQMP Table and Narrative	4 Operational BMPs—Include in WQMP Table and Narrative
<input type="checkbox"/> L. Fuel Dispensing Areas	<input type="checkbox"/> Fueling areas <sup>6</sup> shall have impermeable floors (i.e., portland cement concrete or equivalent smooth impervious surface) that are: a) graded at the minimum slope necessary to prevent ponding; and b) separated from the rest of the site by a grade break that prevents run-on of stormwater to the maximum extent practicable.  <input type="checkbox"/> Fueling areas shall be covered by a canopy that extends a minimum of ten feet in each direction from each pump. [Alternative: The fueling area must be covered and the cover's minimum dimensions must be equal to or greater than the area within the grade break or fuel dispensing area <sup>1</sup> .] The canopy [or cover] shall not drain onto the fueling area.		<input type="checkbox"/> The property owner shall dry sweep the fueling area routinely. <input type="checkbox"/> See the Fact Sheet SD-30, "Fueling Areas" in the CASQA Stormwater Quality Handbooks at <a href="http://www.cabmphandbooks.com">www.cabmphandbooks.com</a>

---

<sup>6</sup> The fueling area shall be defined as the area extending a minimum of 6.5 feet from the corner of each fuel dispenser or the length at which the hose and nozzle assembly may be operated plus a minimum of one foot, whichever is greater.

STORMWATER POLLUTANT SOURCES/SOURCE CONTROL CHECKLIST

IF THESE SOURCES WILL BE ON THE PROJECT SITE ...	... THEN YOUR WQMP SHOULD INCLUDE THESE SOURCE CONTROL BMPs, AS APPLICABLE		
1 Potential Sources of Runoff Pollutants	2 Permanent Controls—Show on WQMP Drawings	3 Permanent Controls—List in WQMP Table and Narrative	4 Operational BMPs—Include in WQMP Table and Narrative
<p><input checked="" type="checkbox"/> M. Loading Docks</p>	<p><input checked="" type="checkbox"/> Show a preliminary design for the loading dock area, including roofing and drainage. Loading docks shall be covered and/or graded to minimize run-on to and runoff from the loading area. Roof downspouts shall be positioned to direct stormwater away from the loading area. Water from loading dock areas shall be drained to the sanitary sewer, or diverted and collected for ultimate discharge to the sanitary sewer.</p> <p><input checked="" type="checkbox"/> Loading dock areas draining directly to the sanitary sewer shall be equipped with a spill control valve or equivalent device, which shall be kept closed during periods of operation.</p> <p><input checked="" type="checkbox"/> Provide a roof overhang over the loading area or install door skirts (cowling) at each bay that enclose the end of the trailer.</p>		<p><input checked="" type="checkbox"/> Move loaded and unloaded items indoors as soon as possible.</p> <p><input checked="" type="checkbox"/> See Fact Sheet SC-30, “Outdoor Loading and Unloading,” in the CASQA Stormwater Quality Handbooks at <a href="http://www.cabmphandbooks.com">www.cabmphandbooks.com</a></p>

STORMWATER POLLUTANT SOURCES/SOURCE CONTROL CHECKLIST

IF THESE SOURCES WILL BE ON THE PROJECT SITE ...	... THEN YOUR WQMP SHOULD INCLUDE THESE SOURCE CONTROL BMPs, AS APPLICABLE		
1 Potential Sources of Runoff Pollutants	2 Permanent Controls—Show on WQMP Drawings	3 Permanent Controls—List in WQMP Table and Narrative	4 Operational BMPs—Include in WQMP Table and Narrative
<input checked="" type="checkbox"/> N. Fire Sprinkler Test Water  <input type="checkbox"/> O. Miscellaneous Drain or Wash Water or Other Sources <input type="checkbox"/> Boiler drain lines <input checked="" type="checkbox"/> Condensate drain lines <input checked="" type="checkbox"/> Rooftop equipment <input type="checkbox"/> Drainage sumps <input checked="" type="checkbox"/> Roofing, gutters, and trim. <input type="checkbox"/> Other sources		<input checked="" type="checkbox"/> Provide a means to drain fire sprinkler test water to the sanitary sewer.  <input type="checkbox"/> Boiler drain lines shall be directly or indirectly connected to the sanitary sewer system and may not discharge to the storm drain system. Condensate drain lines may discharge to landscaped areas if the flow is small enough that runoff will not occur. Condensate drain lines may not discharge to the storm drain system. <input checked="" type="checkbox"/> Rooftop equipment with potential to produce pollutants shall be roofed and/or have secondary containment. <input type="checkbox"/> Any drainage sumps on-site shall feature a sediment sump to reduce the quantity of sediment in pumped water. <input checked="" type="checkbox"/> Avoid roofing, gutters, and trim made of copper or other unprotected metals that may leach into runoff. Include controls for other sources as specified by local reviewer.	<input checked="" type="checkbox"/> See the note in Fact Sheet SC-41, “Building and Grounds Maintenance,” in the CASQA Stormwater Quality Handbooks at <a href="http://www.cabmphandbooks.com">www.cabmphandbooks.com</a>

STORMWATER POLLUTANT SOURCES/SOURCE CONTROL CHECKLIST

IF THESE SOURCES WILL BE ON THE PROJECT SITE ...	... THEN YOUR WQMP SHOULD INCLUDE THESE SOURCE CONTROL BMPs, AS APPLICABLE		
1 Potential Sources of Runoff Pollutants	2 Permanent Controls—Show on WQMP Drawings	3 Permanent Controls—List in WQMP Table and Narrative	4 Operational BMPs—Include in WQMP Table and Narrative
<input checked="" type="checkbox"/> P. Plazas, sidewalks, and parking lots.			<input checked="" type="checkbox"/> Sweep plazas, sidewalks, and parking lots regularly to prevent accumulation of litter and debris. Collect debris from pressure washing to prevent entry into the storm drain system. Collect washwater containing any cleaning agent or degreaser and discharge to the sanitary sewer not to a storm drain.



# Appendix 9: O&M

*Operation and Maintenance Plan and Documentation of Finance, Maintenance and Recording Mechanisms*

***\*Section to be completed during the Final WQMP Submittal\****

# Appendix 10: Educational Materials

*BMP Fact Sheets, Maintenance Guidelines and Other End-User BMP Information*

# Spill Prevention, Control & Cleanup SC-11



## Objectives

- Cover
- Contain
- Educate
- Reduce/Minimize
- Product Substitution

## Description

Spills and leaks, if not properly controlled, can adversely impact the storm drain system and receiving waters. Due to the type of work or the materials involved, many activities that occur either at a municipal facility or as a part of municipal field programs have the potential for accidental spills and leaks. Proper spill response planning and preparation can enable municipal employees to effectively respond to problems when they occur and minimize the discharge of pollutants to the environment.

## Approach

- An effective spill response and control plan should include:
  - Spill/leak prevention measures;
  - Spill response procedures;
  - Spill cleanup procedures;
  - Reporting; and
  - Training
- A well thought out and implemented plan can prevent pollutants from entering the storm drainage system and can be used as a tool for training personnel to prevent and control future spills as well.

## Pollution Prevention

- Develop and implement a Spill Prevention Control and Response Plan. The plan should include:

## Targeted Constituents

Sediment	
Nutrients	☑
Trash	
Metals	☑
Bacteria	
Oil and Grease	☑
Organics	☑
Oxygen Demanding	☑



# **SC-11 Spill Prevention, Control & Cleanup**

---

- A description of the facility, the address, activities and materials involved
- Identification of key spill response personnel
- Identification of the potential spill areas or operations prone to spills/leaks
- Identification of which areas should be or are bermed to contain spills/leaks
- Facility map identifying the key locations of areas, activities, materials, structural BMPs, etc.
- Material handling procedures
- Spill response procedures including:
  - Assessment of the site and potential impacts
  - Containment of the material
  - Notification of the proper personnel and evacuation procedures
  - Clean up of the site
  - Disposal of the waste material and
  - Proper record keeping
- Product substitution – use less toxic materials (i.e. use water based paints instead of oil based paints)
- Recycle, reclaim, or reuse materials whenever possible. This will reduce the amount of materials that are brought into the facility or into the field.

## ***Suggested Protocols***

### ***Spill/Leak Prevention Measures***

- If possible, move material handling indoors, under cover, or away from storm drains or sensitive water bodies.
- Properly label all containers so that the contents are easily identifiable.
- Berm storage areas so that if a spill or leak occurs, the material is contained.
- Cover outside storage areas either with a permanent structure or with a seasonal one such as a tarp so that rain can not come into contact with the materials.
- Check containers (and any containment sumps) often for leaks and spills. Replace containers that are leaking, corroded, or otherwise deteriorating with containers in good condition. Collect all spilled liquids and properly dispose of them.

# Spill Prevention, Control & Cleanup SC-11

---

- Store, contain and transfer liquid materials in such a manner that if the container is ruptured or the contents spilled, they will not discharge, flow or be washed into the storm drainage system, surface waters, or groundwater.
- Place drip pans or absorbent materials beneath all mounted taps and at all potential drip and spill locations during the filling and unloading of containers. Any collected liquids or soiled absorbent materials should be reused/recycled or properly disposed of.
- For field programs, only transport the minimum amount of material needed for the daily activities and transfer materials between containers at a municipal yard where leaks and spill are easier to control.
- If paved, sweep and clean storage areas monthly, do not use water to hose down the area unless all of the water will be collected and disposed of properly.
- Install a spill control device (such as a tee section) in any catch basins that collect runoff from any storage areas if the materials stored are oil, gas, or other materials that separate from and float on water. This will allow for easier cleanup if a spill occurs.
- If necessary, protect catch basins while conducting field activities so that if a spill occurs, the material will be contained.

## ***Training***

- Educate employees about spill prevention, spill response and cleanup on a routine basis.
- Well-trained employees can reduce human errors that lead to accidental releases or spills:
  - The employees should have the tools and knowledge to immediately begin cleaning up a spill if one should occur.
  - Employees should be familiar with the Spill Prevention Control and Countermeasure Plan if one is available.
- Training of staff from all municipal departments should focus on recognizing and reporting potential or current spills/leaks and who they should contact.
- Employees responsible for aboveground storage tanks and liquid transfers for large bulk containers should be thoroughly familiar with the Spill Prevention Control and Countermeasure Plan and the plan should be readily available.

## ***Spill Response and Prevention***

- Identify key spill response personnel and train employees on who they are.
- Store and maintain appropriate spill cleanup materials in a clearly marked location near storage areas; and train employees to ensure familiarity with the site's spill control plan and/or proper spill cleanup procedures.
- Locate spill cleanup materials, such as absorbents, where they will be readily accessible (e.g. near storage and maintenance areas, on field trucks).

# **SC-11 Spill Prevention, Control & Cleanup**

---

- Follow the Spill Prevention Control and Countermeasure Plan if one is available.
- If a spill occurs, notify the key spill response personnel immediately. If the material is unknown or hazardous, the local fire department may also need to be contacted.
- If safe to do so, attempt to contain the material and block the nearby storm drains so that the area impacted is minimized. If the material is unknown or hazardous wait for properly trained personnel to contain the materials.
- Perform an assessment of the area where the spill occurred and the downstream area that it could impact. Relay this information to the key spill response and clean up personnel.

## *Spill Cleanup Procedures*

- Small non-hazardous spills
  - Use a rag, damp cloth or absorbent materials for general clean up of liquids
  - Use brooms or shovels for the general clean up of dry materials
  - If water is used, it must be collected and properly disposed of. The wash water can not be allowed to enter the storm drain.
  - Dispose of any waste materials properly
  - Clean or dispose of any equipment used to clean up the spill properly
- Large non-hazardous spills
  - Use absorbent materials for general clean up of liquids
  - Use brooms, shovels or street sweepers for the general clean up of dry materials
  - If water is used, it must be collected and properly disposed of. The wash water can not be allowed to enter the storm drain.
  - Dispose of any waste materials properly
  - Clean or dispose of any equipment used to clean up the spill properly
- For hazardous or very large spills, a private cleanup company or Hazmat team may need to be contacted to assess the situation and conduct the cleanup and disposal of the materials.
- Chemical cleanups of material can be achieved with the use of absorbents, gels, and foams. Remove the adsorbent materials promptly and dispose of according to regulations.
- If the spilled material is hazardous, then the used cleanup materials are also hazardous and must be sent to a certified laundry (rags) or disposed of as hazardous waste.

## *Reporting*

- Report any spills immediately to the identified key municipal spill response personnel.



# Spill Prevention, Control & Cleanup SC-11

---

- Report spills in accordance with applicable reporting laws. Spills that pose an immediate threat to human health or the environment must be reported immediately to the Office of Emergency Service (OES)
- Spills that pose an immediate threat to human health or the environment may also need to be reported within 24 hours to the Regional Water Quality Control Board.
- Federal regulations require that any oil spill into a water body or onto an adjoining shoreline be reported to the National Response Center (NRC) at 800-424-8802 (24 hour)
- After the spill has been contained and cleaned up, a detailed report about the incident should be generated and kept on file (see the section on Reporting below). The incident may also be used in briefing staff about proper procedures

## ***Other Considerations***

- State regulations exist for facilities with a storage capacity of 10,000 gallons or more of petroleum to prepare a Spill Prevention Control and Countermeasure Plan (SPCC) Plan (Health & Safety Code Chapter 6.67).
- State regulations also exist for storage of hazardous materials (Health & Safety Code Chapter 6.95), including the preparation of area and business plans for emergency response to the releases or threatened releases.
- Consider requiring smaller secondary containment areas (less than 200 sq. ft.) to be connected to the sanitary sewer, if permitted to do so, prohibiting any hard connections to the storm drain.

## **Requirements**

### ***Costs***

- Will vary depending on the size of the facility and the necessary controls.
- Prevention of leaks and spills is inexpensive. Treatment and/or disposal of wastes, contaminated soil and water is very expensive

### ***Maintenance***

- This BMP has no major administrative or staffing requirements. However, extra time is needed to properly handle and dispose of spills, which results in increased labor costs

## **Supplemental Information**

### ***Further Detail of the BMP***

#### ***Reporting***

Record keeping and internal reporting represent good operating practices because they can increase the efficiency of the response and containment of a spill. A good record keeping system helps the municipality minimize incident recurrence, correctly respond with appropriate containment and cleanup activities, and comply with legal requirements.

A record keeping and reporting system should be set up for documenting spills, leaks, and other discharges, including discharges of hazardous substances in reportable quantities. Incident records describe the quality and quantity of non-stormwater discharges to the storm drain.

# **SC-11 Spill Prevention, Control & Cleanup**

---

These records should contain the following information:

- Date and time of the incident
- Weather conditions
- Duration of the spill/leak/discharge
- Cause of the spill/leak/discharge
- Response procedures implemented
- Persons notified
- Environmental problems associated with the spill/leak/discharge

Separate record keeping systems should be established to document housekeeping and preventive maintenance inspections, and training activities. All housekeeping and preventive maintenance inspections should be documented. Inspection documentation should contain the following information:

- The date and time the inspection was performed
- Name of the inspector
- Items inspected
- Problems noted
- Corrective action required
- Date corrective action was taken

Other means to document and record inspection results are field notes, timed and dated photographs, videotapes, and drawings and maps.

## ***Examples***

The City of Palo Alto includes spill prevention and control as a major element of its highly effective program for municipal vehicle maintenance shops.

## **References and Resources**

King County Stormwater Pollution Control Manual - <http://dnr.metrokc.gov/wlr/dss/spcm.htm>

Orange County Stormwater Program

[http://www.ocwatersheds.com/stormwater/swp\\_introduction.asp](http://www.ocwatersheds.com/stormwater/swp_introduction.asp)

San Diego Stormwater Co-permittees Jurisdictional Urban Runoff Management Program (URMP)

<http://www.projectcleanwater.org/pdf/Model%20Program%20Municipal%20Facilities.pdf>

# Parking/Storage Area Maintenance SC-43



## Description

Parking lots and storage areas can contribute a number of substances, such as trash, suspended solids, hydrocarbons, oil and grease, and heavy metals that can enter receiving waters through stormwater runoff or non-stormwater discharges. The following protocols are intended to prevent or reduce the discharge of pollutants from parking/storage areas and include using good housekeeping practices, following appropriate cleaning BMPs, and training employees.

## Approach

### ***Pollution Prevention***

- Encourage alternative designs and maintenance strategies for impervious parking lots. (See New Development and Redevelopment BMP Handbook).
- Keep accurate maintenance logs to evaluate BMP implementation.

### ***Suggested Protocols***

#### *General*

- Keep the parking and storage areas clean and orderly. Remove debris in a timely fashion.
- Allow sheet runoff to flow into biofilters (vegetated strip and swale) and/or infiltration devices.
- Utilize sand filters or oleophilic collectors for oily waste in low concentrations.

## Objectives

- Cover
- Contain
- Educate
- Reduce/Minimize
- Product Substitution

## Targeted Constituents

Sediment	<input checked="" type="checkbox"/>
Nutrients	<input checked="" type="checkbox"/>
Trash	<input checked="" type="checkbox"/>
Metals	<input checked="" type="checkbox"/>
Bacteria	<input checked="" type="checkbox"/>
Oil and Grease	<input checked="" type="checkbox"/>
Organics	<input checked="" type="checkbox"/>
Oxygen Demanding	<input checked="" type="checkbox"/>



# **SC-43 Parking/Storage Area Maintenance**

---

- Arrange rooftop drains to prevent drainage directly onto paved surfaces.
- Design lot to include semi-permeable hardscape.

## *Controlling Litter*

- Post “No Littering” signs and enforce anti-litter laws.
- Provide an adequate number of litter receptacles.
- Clean out and cover litter receptacles frequently to prevent spillage.
- Provide trash receptacles in parking lots to discourage litter.
- Routinely sweep, shovel and dispose of litter in the trash.

## *Surface cleaning*

- Use dry cleaning methods (e.g. sweeping or vacuuming) to prevent the discharge of pollutants into the stormwater conveyance system.
- Establish frequency of public parking lot sweeping based on usage and field observations of waste accumulation.
- Sweep all parking lots at least once before the onset of the wet season.
- If water is used follow the procedures below:
  - Block the storm drain or contain runoff.
  - Wash water should be collected and pumped to the sanitary sewer or discharged to a pervious surface, do not allow wash water to enter storm drains.
  - Dispose of parking lot sweeping debris and dirt at a landfill.
- When cleaning heavy oily deposits:
  - Use absorbent materials on oily spots prior to sweeping or washing.
  - Dispose of used absorbents appropriately.

## *Surface Repair*

- Pre-heat, transfer or load hot bituminous material away from storm drain inlets.
- Apply concrete, asphalt, and seal coat during dry weather to prevent contamination from contacting stormwater runoff.
- Cover and seal nearby storm drain inlets (with waterproof material or mesh) and manholes before applying seal coat, slurry seal, etc., where applicable. Leave covers in place until job is complete and until all water from emulsified oil sealants has drained or evaporated. Clean any debris from these covered manholes and drains for proper disposal.

# **Parking/Storage Area Maintenance SC-43**

---

- Use only as much water as necessary for dust control, to avoid runoff.
- Catch drips from paving equipment that is not in use with pans or absorbent material placed under the machines. Dispose of collected material and absorbents properly.

## ***Inspection***

- Have designated personnel conduct inspections of the parking facilities and stormwater conveyance systems associated with them on a regular basis.
- Inspect cleaning equipment/sweepers for leaks on a regular basis.

## ***Training***

- Provide regular training to field employees and/or contractors regarding cleaning of paved areas and proper operation of equipment.
- Train employees and contractors in proper techniques for spill containment and cleanup.

## ***Spill Response and Prevention***

- Refer to SC-11, Spill Prevention, Control & Cleanup.
- Keep your Spill Prevention Control and countermeasure (SPCC) plan up-to-date, and implement accordingly.
- Have spill cleanup materials readily available and in a known location.
- Cleanup spills immediately and use dry methods if possible.
- Properly dispose of spill cleanup material.

## ***Other Considerations***

- Limitations related to sweeping activities at large parking facilities may include high equipment costs, the need for sweeper operator training, and the inability of current sweeper technology to remove oil and grease.

## **Requirements**

### ***Costs***

Cleaning/sweeping costs can be quite large, construction and maintenance of stormwater structural controls can be quite expensive as well.

### ***Maintenance***

- Sweep parking lot to minimize cleaning with water.
- Clean out oil/water/sand separators regularly, especially after heavy storms.
- Clean parking facilities on a regular basis to prevent accumulated wastes and pollutants from being discharged into conveyance systems during rainy conditions.

# **SC-43 Parking/Storage Area Maintenance**

---

## **Supplemental Information**

### ***Further Detail of the BMP***

#### ***Surface Repair***

Apply concrete, asphalt, and seal coat during dry weather to prevent contamination from contacting stormwater runoff. Where applicable, cover and seal nearby storm drain inlets (with waterproof material or mesh) and manholes before applying seal coat, slurry seal, etc. Leave covers in place until job is complete and until all water from emulsified oil sealants has drained or evaporated. Clean any debris from these covered manholes and drains for proper disposal. Use only as much water as necessary for dust control, to avoid runoff.

## **References and Resources**

<http://www.stormwatercenter.net/>

California's Nonpoint Source Program Plan <http://www.swrcb.ca.gov/nps/index.html>

Model Urban Runoff Program: A How-To Guide for Developing Urban Runoff Programs for Small Municipalities. Prepared by City of Monterey, City of Santa Cruz, California Coastal Commission, Monterey Bay National Marine Sanctuary, Association of Monterey Bay Area Governments, Woodward-Clyde, Central Coast Regional Water Quality Control Board. July 1998 (Revised February 2002 by the California Coastal Commission).

### **Orange County Stormwater Program**

[http://www.ocwatersheds.com/StormWater/swp\\_introduction.asp](http://www.ocwatersheds.com/StormWater/swp_introduction.asp)

Oregon Association of Clean Water Agencies. Oregon Municipal Stormwater Toolbox for Maintenance Practices. June 1998.

Pollution from Surface Cleaning Folder. 1996. Bay Area Stormwater Management Agencies Association (BASMAA) <http://www.basma.org>

San Diego Stormwater Co-permittees Jurisdictional Urban Runoff Management Program (URMP)

<http://www.projectcleanwater.org/pdf/Model%20Program%20Municipal%20Facilities.pdf>



## Description

Promote efficient and safe housekeeping practices (storage, use, and cleanup) when handling potentially harmful materials such as fertilizers, pesticides, cleaning solutions, paint products, automotive products, and swimming pool chemicals. Related information is provided in BMP fact sheets SC-11 Spill Prevention, Control & Cleanup and SC-34 Waste Handling & Disposal.

## Approach

### ***Pollution Prevention***

- Purchase only the amount of material that will be needed for foreseeable use. In most cases this will result in cost savings in both purchasing and disposal. See SC-61 Safer Alternative Products for additional information.
- Be aware of new products that may do the same job with less environmental risk and for less or the equivalent cost. Total cost must be used here; this includes purchase price, transportation costs, storage costs, use related costs, clean up costs and disposal costs.

### ***Suggested Protocols***

#### *General*

- Keep work sites clean and orderly. Remove debris in a timely fashion. Sweep the area.
- Dispose of wash water, sweepings, and sediments, properly.
- Recycle or dispose of fluids properly.
- Establish a daily checklist of office, yard and plant areas to confirm cleanliness and adherence to proper storage and security. Specific employees should be assigned specific inspection responsibilities and given the authority to remedy any problems found.
- Post waste disposal charts in appropriate locations detailing for each waste its hazardous nature (poison, corrosive, flammable), prohibitions on its disposal (dumpster, drain, sewer) and the recommended disposal method (recycle, sewer, burn, storage, landfill).
- Summarize the chosen BMPs applicable to your operation and post them in appropriate conspicuous places.

## Objectives

- Cover
- Contain
- Educate
- Reduce/Minimize
- Product Substitution

## Targeted Constituents

Sediment	<input checked="" type="checkbox"/>
Nutrients	<input checked="" type="checkbox"/>
Trash	<input checked="" type="checkbox"/>
Metals	<input checked="" type="checkbox"/>
Bacteria	<input checked="" type="checkbox"/>
Oil and Grease	<input checked="" type="checkbox"/>
Organics	<input checked="" type="checkbox"/>
Oxygen Demanding	<input checked="" type="checkbox"/>



- Require a signed checklist from every user of any hazardous material detailing amount taken, amount used, amount returned and disposal of spent material.
- Do a before audit of your site to establish baseline conditions and regular subsequent audits to note any changes and whether conditions are improving or deteriorating.
- Keep records of water, air and solid waste quantities and quality tests and their disposition.
- Maintain a mass balance of incoming, outgoing and on hand materials so you know when there are unknown losses that need to be tracked down and accounted for.
- Use and reward employee suggestions related to BMPs, hazards, pollution reduction, work place safety, cost reduction, alternative materials and procedures, recycling and disposal.
- Have, and review regularly, a contingency plan for spills, leaks, weather extremes etc. Make sure all employees know about it and what their role is so that it comes into force automatically.

### ***Training***

- Train all employees, management, office, yard, manufacturing, field and clerical in BMPs and pollution prevention and make them accountable.
- Train municipal employees who handle potentially harmful materials in good housekeeping practices.
- Train personnel who use pesticides in the proper use of the pesticides. The California Department of Pesticide Regulation license pesticide dealers, certify pesticide applicators and conduct onsite inspections.
- Train employees and contractors in proper techniques for spill containment and cleanup. The employee should have the tools and knowledge to immediately begin cleaning up a spill if one should occur.

### ***Spill Response and Prevention***

- Refer to SC-11, Spill Prevention, Control & Cleanup.
- Keep your Spill Prevention Control and Countermeasure (SPCC) plan up-to-date, and implement accordingly.
- Have spill cleanup materials readily available and in a known location.
- Cleanup spills immediately and use dry methods if possible.
- Properly dispose of spill cleanup material.

### ***Other Considerations***

- There are no major limitations to this best management practice.
- There are no regulatory requirements to this BMP. Existing regulations already require municipalities to properly store, use, and dispose of hazardous materials

## Requirements

### *Costs*

- Minimal cost associated with this BMP. Implementation of good housekeeping practices may result in cost savings as these procedures may reduce the need for more costly BMPs.

### *Maintenance*

- Ongoing maintenance required to keep a clean site. Level of effort is a function of site size and type of activities.

## Supplemental Information

### *Further Detail of the BMP*

- The California Integrated Waste Management Board's Recycling Hotline, 1-800-553-2962, provides information on household hazardous waste collection programs and facilities.

### *Examples*

There are a number of communities with effective programs. The most pro-active include Santa Clara County and the City of Palo Alto, the City and County of San Francisco, and the Municipality of Metropolitan Seattle (Metro).

## References and Resources

British Columbia Lake Stewardship Society. Best Management Practices to Protect Water Quality from Non-Point Source Pollution. March 2000.

<http://www.nalms.org/bclss/bmphome.html#bmp>

King County Stormwater Pollution Control Manual - <http://dnr.metrokc.gov/wlr/dss/spcm.htm>

Model Urban Runoff Program: A How-To Guide for Developing Urban Runoff Programs for Small Municipalities, Prepared by City of Monterey, City of Santa Cruz, California Coastal Commission, Monterey Bay National Marine Sanctuary, Association of Monterey Bay Area Governments, Woodward-Clyde, Central Coast Regional Water Quality Control Board. July, 1998, Revised by California Coastal Commission, February 2002.

Orange County Stormwater Program

[http://www.ocwatersheds.com/stormwater/swp\\_introduction.asp](http://www.ocwatersheds.com/stormwater/swp_introduction.asp)

San Mateo STOPPP - (<http://stoppp.tripod.com/bmp.html>)



## Objectives

- Contain
- Educate
- Reduce/Minimize
- Product Substitution

## Targeted Constituents

Sediment	<input checked="" type="checkbox"/>
Nutrients	<input checked="" type="checkbox"/>
Trash	<input checked="" type="checkbox"/>
Metals	
Bacteria	
Oil and Grease	
Organics	
Oxygen Demanding	<input checked="" type="checkbox"/>

## Description

Landscape maintenance activities include vegetation removal; herbicide and insecticide application; fertilizer application; watering; and other gardening and lawn care practices. Vegetation control typically involves a combination of chemical (herbicide) application and mechanical methods. All of these maintenance practices have the potential to contribute pollutants to the storm drain system. The major objectives of this BMP are to minimize the discharge of pesticides, herbicides and fertilizers to the storm drain system and receiving waters; prevent the disposal of landscape waste into the storm drain system by collecting and properly disposing of clippings and cuttings, and educating employees and the public.

## Approach

### ***Pollution Prevention***

- Implement an integrated pest management (IPM) program. IPM is a sustainable approach to managing pests by combining biological, cultural, physical, and chemical tools.
- Choose low water using flowers, trees, shrubs, and groundcover.
- Consider alternative landscaping techniques such as naturescaping and xeriscaping.
- Conduct appropriate maintenance (i.e. properly timed fertilizing, weeding, pest control, and pruning) to help preserve the landscapes water efficiency.



- Consider grass cycling (grass cycling is the natural recycling of grass by leaving the clippings on the lawn when mowing. Grass clippings decompose quickly and release valuable nutrients back into the lawn).

### ***Suggested Protocols***

#### *Mowing, Trimming, and Weeding*

- Whenever possible use mechanical methods of vegetation removal (e.g mowing with tractor-type or push mowers, hand cutting with gas or electric powered weed trimmers) rather than applying herbicides. Use hand weeding where practical.
- Avoid loosening the soil when conducting mechanical or manual weed control, this could lead to erosion. Use mulch or other erosion control measures when soils are exposed.
- Performing mowing at optimal times. Mowing should not be performed if significant rain events are predicted.
- Mulching mowers may be recommended for certain flat areas. Other techniques may be employed to minimize mowing such as selective vegetative planting using low maintenance grasses and shrubs.
- Collect lawn and garden clippings, pruning waste, tree trimmings, and weeds. Chip if necessary, and compost or dispose of at a landfill (see waste management section of this fact sheet).
- Place temporarily stockpiled material away from watercourses, and berm or cover stockpiles to prevent material releases to storm drains.

### ***Planting***

- Determine existing native vegetation features (location, species, size, function, importance) and consider the feasibility of protecting them. Consider elements such as their effect on drainage and erosion, hardiness, maintenance requirements, and possible conflicts between preserving vegetation and the resulting maintenance needs.
- Retain and/or plant selected native vegetation whose features are determined to be beneficial, where feasible. Native vegetation usually requires less maintenance (e.g., irrigation, fertilizer) than planting new vegetation.
- Consider using low water use groundcovers when planting or replanting.

### ***Waste Management***

- Compost leaves, sticks, or other collected vegetation or dispose of at a permitted landfill. Do not dispose of collected vegetation into waterways or storm drainage systems.
- Place temporarily stockpiled material away from watercourses and storm drain inlets, and berm or cover stockpiles to prevent material releases to the storm drain system.
- Reduce the use of high nitrogen fertilizers that produce excess growth requiring more frequent mowing or trimming.

- Avoid landscape wastes in and around storm drain inlets by either using bagging equipment or by manually picking up the material.

## ***Irrigation***

- Where practical, use automatic timers to minimize runoff.
- Use popup sprinkler heads in areas with a lot of activity or where there is a chance the pipes may be broken. Consider the use of mechanisms that reduce water flow to sprinkler heads if broken.
- Ensure that there is no runoff from the landscaped area(s) if re-claimed water is used for irrigation.
- If bailing of muddy water is required (e.g. when repairing a water line leak), do not put it in the storm drain; pour over landscaped areas.
- Irrigate slowly or pulse irrigate to prevent runoff and then only irrigate as much as is needed.
- Apply water at rates that do not exceed the infiltration rate of the soil.

## ***Fertilizer and Pesticide Management***

- Utilize a comprehensive management system that incorporates integrated pest management (IPM) techniques. There are many methods and types of IPM, including the following:
  - Mulching can be used to prevent weeds where turf is absent, fencing installed to keep rodents out, and netting used to keep birds and insects away from leaves and fruit.
  - Visible insects can be removed by hand (with gloves or tweezers) and placed in soapy water or vegetable oil. Alternatively, insects can be sprayed off the plant with water or in some cases vacuumed off of larger plants.
  - Store-bought traps, such as species-specific, pheromone-based traps or colored sticky cards, can be used.
  - Slugs can be trapped in small cups filled with beer that are set in the ground so the slugs can get in easily.
  - In cases where microscopic parasites, such as bacteria and fungi, are causing damage to plants, the affected plant material can be removed and disposed of (pruning equipment should be disinfected with bleach to prevent spreading the disease organism).
  - Small mammals and birds can be excluded using fences, netting, tree trunk guards.
  - Beneficial organisms, such as bats, birds, green lacewings, ladybugs, praying mantis, ground beetles, parasitic nematodes, trichogramma wasps, seed head weevils, and spiders that prey on detrimental pest species can be promoted.
- Follow all federal, state, and local laws and regulations governing the use, storage, and disposal of fertilizers and pesticides and training of applicators and pest control advisors.



- Use pesticides only if there is an actual pest problem (not on a regular preventative schedule).
- Do not use pesticides if rain is expected. Apply pesticides only when wind speeds are low (less than 5 mph).
- Do not mix or prepare pesticides for application near storm drains.
- Prepare the minimum amount of pesticide needed for the job and use the lowest rate that will effectively control the pest.
- Employ techniques to minimize off-target application (e.g. spray drift) of pesticides, including consideration of alternative application techniques.
- Fertilizers should be worked into the soil rather than dumped or broadcast onto the surface.
- Calibrate fertilizer and pesticide application equipment to avoid excessive application.
- Periodically test soils for determining proper fertilizer use.
- Sweep pavement and sidewalk if fertilizer is spilled on these surfaces before applying irrigation water.
- Purchase only the amount of pesticide that you can reasonably use in a given time period (month or year depending on the product).
- Triple rinse containers, and use rinse water as product. Dispose of unused pesticide as hazardous waste.
- Dispose of empty pesticide containers according to the instructions on the container label.

### *Inspection*

- Inspect irrigation system periodically to ensure that the right amount of water is being applied and that excessive runoff is not occurring. Minimize excess watering, and repair leaks in the irrigation system as soon as they are observed.
- Inspect pesticide/fertilizer equipment and transportation vehicles daily.

### *Training*

- Educate and train employees on use of pesticides and in pesticide application techniques to prevent pollution. Pesticide application must be under the supervision of a California qualified pesticide applicator.
- Train/encourage municipal maintenance crews to use IPM techniques for managing public green areas.
- Annually train employees within departments responsible for pesticide application on the appropriate portions of the agency's IPM Policy, SOPs, and BMPs, and the latest IPM techniques.

- Employees who are not authorized and trained to apply pesticides should be periodically (at least annually) informed that they cannot use over-the-counter pesticides in or around the workplace.
- Use a training log or similar method to document training.

### ***Spill Response and Prevention***

- Refer to SC-11, Spill Prevention, Control & Cleanup
- Have spill cleanup materials readily available and in a known location
- Cleanup spills immediately and use dry methods if possible.
- Properly dispose of spill cleanup material.

### ***Other Considerations***

- The Federal Pesticide, Fungicide, and Rodenticide Act and California Title 3, Division 6, Pesticides and Pest Control Operations place strict controls over pesticide application and handling and specify training, annual refresher, and testing requirements. The regulations generally cover: a list of approved pesticides and selected uses, updated regularly; general application information; equipment use and maintenance procedures; and record keeping. The California Department of Pesticide Regulations and the County Agricultural Commission coordinate and maintain the licensing and certification programs. All public agency employees who apply pesticides and herbicides in “agricultural use” areas such as parks, golf courses, rights-of-way and recreation areas should be properly certified in accordance with state regulations. Contracts for landscape maintenance should include similar requirements.
- All employees who handle pesticides should be familiar with the most recent material safety data sheet (MSDS) files.
- Municipalities do not have the authority to regulate the use of pesticides by school districts, however the California Healthy Schools Act of 2000 (AB 2260) has imposed requirements on California school districts regarding pesticide use in schools. Posting of notification prior to the application of pesticides is now required, and IPM is stated as the preferred approach to pest management in schools.

## **Requirements**

### ***Costs***

Additional training of municipal employees will be required to address IPM techniques and BMPs. IPM methods will likely increase labor cost for pest control which may be offset by lower chemical costs.

### ***Maintenance***

Not applicable

**Supplemental Information*****Further Detail of the BMP******Waste Management***

Composting is one of the better disposal alternatives if locally available. Most municipalities either have or are planning yard waste composting facilities as a means of reducing the amount of waste going to the landfill. Lawn clippings from municipal maintenance programs as well as private sources would probably be compatible with most composting facilities

***Contractors and Other Pesticide Users***

Municipal agencies should develop and implement a process to ensure that any contractor employed to conduct pest control and pesticide application on municipal property engages in pest control methods consistent with the IPM Policy adopted by the agency. Specifically, municipalities should require contractors to follow the agency's IPM policy, SOPs, and BMPs; provide evidence to the agency of having received training on current IPM techniques when feasible; provide documentation of pesticide use on agency property to the agency in a timely manner.

**References and Resources**

King County Stormwater Pollution Control Manual. Best Management Practices for Businesses. 1995. King County Surface Water Management. July. On-line: <http://dnr.metrokc.gov/wlr/dss/spcm.htm>

Los Angeles County Stormwater Quality Model Programs. Public Agency Activities [http://ladpw.org/wmd/npdes/model\\_links.cfm](http://ladpw.org/wmd/npdes/model_links.cfm)

Model Urban Runoff Program: A How-To Guide for Developing Urban Runoff Programs for Small Municipalities. Prepared by City of Monterey, City of Santa Cruz, California Coastal Commission, Monterey Bay National Marine Sanctuary, Association of Monterey Bay Area Governments, Woodward-Clyde, Central Coast Regional Water Quality Control Board. July. 1998.

**Orange County Stormwater Program**

[http://www.ocwatersheds.com/StormWater/swp\\_introduction.asp](http://www.ocwatersheds.com/StormWater/swp_introduction.asp)

Santa Clara Valley Urban Runoff Pollution Prevention Program. 1997 Urban Runoff Management Plan. September 1997, updated October 2000.

United States Environmental Protection Agency (USEPA). 2002. Pollution Prevention/Good Housekeeping for Municipal Operations Landscaping and Lawn Care. Office of Water. Office of Wastewater Management. On-line: [http://www.epa.gov/npdes/menuofbmps/poll\\_8.htm](http://www.epa.gov/npdes/menuofbmps/poll_8.htm)



Photo Credit: Geoff Brosseau

## Objectives

- Contain
- Educate
- Reduce/Minimize

## Description

As a consequence of its function, the stormwater conveyance system collects and transports urban runoff that may contain certain pollutants. Maintaining catch basins, stormwater inlets, and other stormwater conveyance structures on a regular basis will remove pollutants, prevent clogging of the downstream conveyance system, restore catch basins' sediment trapping capacity, and ensure the system functions properly hydraulically to avoid flooding.

## Approach

### ***Suggested Protocols***

#### *Catch Basins/Inlet Structures*

- Municipal staff should regularly inspect facilities to ensure the following:
  - Immediate repair of any deterioration threatening structural integrity.
  - Cleaning before the sump is 40% full. Catch basins should be cleaned as frequently as needed to meet this standard.
  - Stenciling of catch basins and inlets (see SC-75 Waste Handling and Disposal).
- Clean catch basins, storm drain inlets, and other conveyance structures in high pollutant load areas just before the wet season to remove sediments and debris accumulated during the summer.

## Targeted Constituents

Sediment	<input checked="" type="checkbox"/>
Nutrients	<input checked="" type="checkbox"/>
Trash	<input checked="" type="checkbox"/>
Metals	<input checked="" type="checkbox"/>
Bacteria	<input checked="" type="checkbox"/>
Oil and Grease	<input checked="" type="checkbox"/>
Organics	<input checked="" type="checkbox"/>
Oxygen Demanding	<input checked="" type="checkbox"/>



- Conduct inspections more frequently during the wet season for problem areas where sediment or trash accumulates more often. Clean and repair as needed.
- Keep accurate logs of the number of catch basins cleaned.
- Record the amount of waste collected.
- Store wastes collected from cleaning activities of the drainage system in appropriate containers or temporary storage sites in a manner that prevents discharge to the storm drain.
- Dewater the wastes with outflow into the sanitary sewer if permitted. Water should be treated with an appropriate filtering device prior to discharge to the sanitary sewer. If discharge to the sanitary sewer is not allowed, water should be pumped or vacuumed to a tank and properly disposed of. Do not dewater near a storm drain or stream.
- Except for small communities with relatively few catch basins that may be cleaned manually, most municipalities will require mechanical cleaners such as eductors, vacuums, or bucket loaders.

#### *Storm Drain Conveyance System*

- Locate reaches of storm drain with deposit problems and develop a flushing schedule that keeps the pipe clear of excessive buildup.
- Collect flushed effluent and pump to the sanitary sewer for treatment.

#### *Pump Stations*

- Clean all storm drain pump stations prior to the wet season to remove silt and trash.
- Do not allow discharge from cleaning a storm drain pump station or other facility to reach the storm drain system.
- Conduct quarterly routine maintenance at each pump station.
- Inspect, clean, and repair as necessary all outlet structures prior to the wet season.
- Sample collected sediments to determine if landfill disposal is possible, or illegal discharges in the watershed are occurring.

#### *Open Channel*

- Consider modification of storm channel characteristics to improve channel hydraulics, to increase pollutant removals, and to enhance channel/creek aesthetic and habitat value.
- Conduct channel modification/improvement in accordance with existing laws. Any person, government agency, or public utility proposing an activity that will change the natural (emphasis added) state of any river, stream, or lake in California, must enter into a stream or Lake Alteration Agreement with the Department of Fish and Game. The developer-applicant should also contact local governments (city, county, special districts), other state agencies

(SWRCB, RWQCB, Department of Forestry, Department of Water Resources), and Federal Corps of Engineers and USFWS

## *Illicit Connections and Discharges*

- During routine maintenance of conveyance system and drainage structures field staff should look for evidence of illegal discharges or illicit connections:
  - Is there evidence of spills such as paints, discoloring, etc.
  - Are there any odors associated with the drainage system
  - Record locations of apparent illegal discharges/illicit connections
  - Track flows back to potential dischargers and conduct aboveground inspections. This can be done through visual inspection of up gradient manholes or alternate techniques including zinc chloride smoke testing, fluorometric dye testing, physical inspection testing, or television camera inspection.
  - Once the origin of flow is established, require illicit discharger to eliminate the discharge.
- Stencil storm drains, where applicable, to prevent illegal disposal of pollutants. Storm drain inlets should have messages such as “Dump No Waste Drains to Stream” stenciled next to them to warn against ignorant or intentional dumping of pollutants into the storm drainage system.
- Refer to fact sheet SC-10 Non-Stormwater Discharges.

## *Illegal Dumping*

- Regularly inspect and clean up hot spots and other storm drainage areas where illegal dumping and disposal occurs.
- Establish a system for tracking incidents. The system should be designed to identify the following:
  - Illegal dumping hot spots
  - Types and quantities (in some cases) of wastes
  - Patterns in time of occurrence (time of day/night, month, or year)
  - Mode of dumping (abandoned containers, “midnight dumping” from moving vehicles, direct dumping of materials, accidents/spills)
  - Responsible parties
- Post “No Dumping” signs in problem areas with a phone number for reporting dumping and disposal. Signs should also indicate fines and penalties for illegal dumping.
- Refer to fact sheet SC-10 Non-Stormwater Discharges.



- The State Department of Fish and Game has a hotline for reporting violations called Cal TIP (1-800-952-5400). The phone number may be used to report any violation of a Fish and Game code (illegal dumping, poaching, etc.).
- The California Department of Toxic Substances Control's Waste Alert Hotline, 1-800-69TOXIC, can be used to report hazardous waste violations.

***Training***

- Train crews in proper maintenance activities, including record keeping and disposal.
- Only properly trained individuals are allowed to handle hazardous materials/wastes.
- Train municipal employees from all departments (public works, utilities, street cleaning, parks and recreation, industrial waste inspection, hazardous waste inspection, sewer maintenance) to recognize and report illegal dumping.
- Train municipal employees and educate businesses, contractors, and the general public in proper and consistent methods for disposal.
- Train municipal staff regarding non-stormwater discharges (See SC-10 Non-Stormwater Discharges).

***Spill Response and Prevention***

- Refer to SC-11, Prevention, Control & Cleanup
- Have spill cleanup materials readily available and in a known location.
- Cleanup spills immediately and use dry methods if possible.
- Properly dispose of spill cleanup material.

***Other Considerations***

- Cleanup activities may create a slight disturbance for local aquatic species. Access to items and material on private property may be limited. Trade-offs may exist between channel hydraulics and water quality/riparian habitat. If storm channels or basins are recognized as wetlands, many activities, including maintenance, may be subject to regulation and permitting.
- Storm drain flushing is most effective in small diameter pipes (36-inch diameter pipe or less, depending on water supply and sediment collection capacity). Other considerations associated with storm drain flushing may include the availability of a water source, finding a downstream area to collect sediments, liquid/sediment disposal, and disposal of flushed effluent to sanitary sewer may be prohibited in some areas.
- Regulations may include adoption of substantial penalties for illegal dumping and disposal.
- Municipal codes should include sections prohibiting the discharge of soil, debris, refuse, hazardous wastes, and other pollutants into the storm drain system.
- Private property access rights may be needed to track illegal discharges up gradient.

- Requirements of municipal ordinance authority for suspected source verification testing for illicit connections necessary for guaranteed rights of entry.

## Requirements

### **Costs**

- An aggressive catch basin cleaning program could require a significant capital and O&M budget. A careful study of cleaning effectiveness should be undertaken before increased cleaning is implemented. Catch basin cleaning costs are less expensive if vacuum street sweepers are available; cleaning catch basins manually can cost approximately twice as much as cleaning the basins with a vacuum attached to a sweeper.
- Methods used for illicit connection detection (smoke testing, dye testing, visual inspection, and flow monitoring) can be costly and time-consuming. Site-specific factors, such as the level of impervious area, the density and ages of buildings, and type of land use will determine the level of investigation necessary. Encouraging reporting of illicit discharges by employees can offset costs by saving expense on inspectors and directing resources more efficiently. Some programs have used funds available from “environmental fees” or special assessment districts to fund their illicit connection elimination programs.

### **Maintenance**

- Two-person teams may be required to clean catch basins with vector trucks.
- Identifying illicit discharges requires teams of at least two people (volunteers can be used), plus administrative personnel, depending on the complexity of the storm sewer system.
- Arrangements must be made for proper disposal of collected wastes.
- Requires technical staff to detect and investigate illegal dumping violations, and to coordinate public education.

## Supplemental Information

### **Further Detail of the BMP**

#### *Storm Drain flushing*

Sanitary sewer flushing is a common maintenance activity used to improve pipe hydraulics and to remove pollutants in sanitary sewer systems. The same principles that make sanitary sewer flushing effective can be used to flush storm drains. Flushing may be designed to hydraulically convey accumulated material to strategic locations, such as to an open channel, to another point where flushing will be initiated, or over to the sanitary sewer and on to the treatment facilities, thus preventing re-suspension and overflow of a portion of the solids during storm events. Flushing prevents “plug flow” discharges of concentrated pollutant loadings and sediments. The deposits can hinder the designed conveyance capacity of the storm drain system and potentially cause backwater conditions in severe cases of clogging.

Storm drain flushing usually takes place along segments of pipe with grades that are too flat to maintain adequate velocity to keep particles in suspension. An upstream manhole is selected to place an inflatable device that temporarily plugs the pipe. Further upstream, water is pumped into the line to create a flushing wave. When the upstream reach of pipe is sufficiently full to

# SC-74      Drainage System Maintenance

---

cause a flushing wave, the inflated device is rapidly deflated with the assistance of a vacuum pump, releasing the backed up water and resulting in the cleaning of the storm drain segment.

To further reduce the impacts of stormwater pollution, a second inflatable device, placed well downstream, may be used to re-collect the water after the force of the flushing wave has dissipated. A pump may then be used to transfer the water and accumulated material to the sanitary sewer for treatment. In some cases, an interceptor structure may be more practical or required to re-collect the flushed waters.

It has been found that cleansing efficiency of periodic flush waves is dependent upon flush volume, flush discharge rate, sewer slope, sewer length, sewer flow rate, sewer diameter, and population density. As a rule of thumb, the length of line to be flushed should not exceed 700 feet. At this maximum recommended length, the percent removal efficiency ranges between 65-75 percent for organics and 55-65 percent for dry weather grit/inorganic material. The percent removal efficiency drops rapidly beyond that. Water is commonly supplied by a water truck, but fire hydrants can also supply water. To make the best use of water, it is recommended that reclaimed water be used or that fire hydrant line flushing coincide with storm drain flushing.

## *Flow Management*

Flow management has been one of the principal motivations for designing urban stream corridors in the past. Such needs may or may not be compatible with the stormwater quality goals in the stream corridor.

Downstream flood peaks can be suppressed by reducing through flow velocity. This can be accomplished by reducing gradient with grade control structures or increasing roughness with boulders, dense vegetation, or complex banks forms. Reducing velocity correspondingly increases flood height, so all such measures have a natural association with floodplain open space. Flood elevations laterally adjacent to the stream can be lowered by increasing through flow velocity.

However, increasing velocity increases flooding downstream and inherently conflicts with channel stability and human safety. Where topography permits, another way to lower flood elevation is to lower the level of the floodway with drop structures into a large but subtly excavated bowl where flood flows we allowed to spread out.

## *Stream Corridor Planning*

Urban streams receive and convey stormwater flows from developed or developing watersheds. Planning of stream corridors thus interacts with urban stormwater management programs. If local programs are intended to control or protect downstream environments by managing flows delivered to the channels, then it is logical that such programs should be supplemented by management of the materials, forms, and uses of the downstream riparian corridor. Any proposal for steam alteration or management should be investigated for its potential flow and stability effects on upstream, downstream, and laterally adjacent areas. The timing and rate of flow from various tributaries can combine in complex ways to alter flood hazards. Each section of channel is unique, influenced by its own distribution of roughness elements, management activities, and stream responses.

Flexibility to adapt to stream features and behaviors as they evolve must be included in stream reclamation planning. The amenity and ecology of streams may be enhanced through the landscape design options of 1) corridor reservation, 2) bank treatment, 3) geomorphic restoration, and 4) grade control.

**Corridor reservation** - Reserving stream corridors and valleys to accommodate natural stream meandering, aggradation, degradation, and over bank flows allows streams to find their own form and generate less ongoing erosion. In California, open stream corridors in recent urban developments have produced recreational open space, irrigation of streamside plantings, and the aesthetic amenity of flowing water.

**Bank treatment** - The use of armoring, vegetative cover, and flow deflection may be used to influence a channel's form, stability, and biotic habitat. To prevent bank erosion, armoring can be done with rigid construction materials, such as concrete, masonry, wood planks and logs, riprap, and gabions. Concrete linings have been criticized because of their lack of provision of biotic habitat. In contrast, riprap and gabions make relatively porous and flexible linings. Boulders, placed in the bed reduce velocity and erosive power.

Riparian vegetation can stabilize the banks of streams that are at or near a condition of equilibrium. Binding networks of roots increase bank shear strength. During flood flows, resilient vegetation is forced into erosion-inhibiting mats. The roughness of vegetation leads to lower velocity, further reducing erosive effects. Structural flow deflection can protect banks from erosion or alter fish habitat. By concentrating flow, a deflector causes a pool to be scoured in the bed.

**Geomorphic restoration** – Restoration refers to alteration of disturbed streams so their form and behavior emulate those of undisturbed streams. Natural meanders are retained, with grading to gentle slopes on the inside of curves to allow point bars and riffle-pool sequences to develop. Trees are retained to provide scenic quality, biotic productivity, and roots for bank stabilization, supplemented by plantings where necessary.

A restorative approach can be successful where the stream is already approaching equilibrium. However, if upstream urbanization continues new flow regimes will be generated that could disrupt the equilibrium of the treated system.

**Grade Control** - A grade control structure is a level shelf of a permanent material, such as stone, masonry, or concrete, over which stream water flows. A grade control structure is called a sill, weir, or drop structure, depending on the relation of its invert elevation to upstream and downstream channels.

A sill is installed at the preexisting channel bed elevation to prevent upstream migration of nick points. It establishes a firm base level below which the upstream channel can not erode.

A weir or check dam is installed with invert above the preexisting bed elevation. A weir raises the local base level of the stream and causes aggradation upstream. The gradient, velocity, and erosive potential of the stream channel are reduced. A drop structure lowers the downstream invert below its preexisting elevation, reducing downstream gradient and velocity. Weirs and drop structure control erosion by dissipating energy and reducing slope velocity.

When carefully applied, grade control structures can be highly versatile in establishing human and environmental benefits in stabilized channels. To be successful, application of grade control structures should be guided by analysis of the stream system both upstream and downstream from the area to be reclaimed.

**Examples**

The California Department of Water Resources began the Urban Stream Restoration Program in 1985. The program provides grant funds to municipalities and community groups to implement stream restoration projects. The projects reduce damages from streambank and watershed instability and floods while restoring streams' aesthetic, recreational, and fish and wildlife values.

In Buena Vista Park, upper floodway slopes are gentle and grassed to achieve continuity of usable park land across the channel of small boulders at the base of the slopes.

The San Diego River is a large, vegetative lined channel, which was planted in a variety of species to support riparian wildlife while stabilizing the steep banks of the floodway.

**References and Resources**

Ferguson, B.K. 1991. Urban Stream Reclamation, p. 324-322, *Journal of Soil and Water Conservation*.

Los Angeles County Stormwater Quality. Public Agency Activities Model Program. On-line: [http://ladpw.org/wmd/npdes/public\\_TC.cfm](http://ladpw.org/wmd/npdes/public_TC.cfm)

Model Urban Runoff Program: A How-To Guide for Developing Urban Runoff Programs for Small Municipalities. Prepared by City of Monterey, City of Santa Cruz, California Coastal Commission, Monterey Bay National Marine Sanctuary, Association of Monterey Bay Area Governments, Woodward-Clyde, Central Coast Regional Water Quality Control Board. July, 1998.

Orange County Stormwater Program

[http://www.ocwatersheds.com/StormWater/swp\\_introduction.asp](http://www.ocwatersheds.com/StormWater/swp_introduction.asp)

Santa Clara Valley Urban Runoff Pollution Prevention Program. 1997 Urban Runoff Management Plan. September 1997, updated October 2000.

San Diego Stormwater Co-permittees Jurisdictional Urban Runoff Management Program (URMP) Municipal Activities Model Program Guidance. 2001. Project Clean Water. November.

United States Environmental Protection Agency (USEPA). 1999. Stormwater Management Fact Sheet Non-stormwater Discharges to Storm Sewers. EPA 832-F-99-022. Office of Water, Washington, D.C. September.

United States Environmental Protection Agency (USEPA). 1999. Stormwater O&M Fact Sheet Catch Basin Cleaning. EPA 832-F-99-011. Office of Water, Washington, D.C. September.

United States Environmental Protection Agency (USEPA). 2002. Pollution Prevention/Good Housekeeping for Municipal Operations Illegal Dumping Control. On line:  
[http://www.epa.gov/npdes/menuofbmps/poll\\_7.htm](http://www.epa.gov/npdes/menuofbmps/poll_7.htm)

United States Environmental Protection Agency (USEPA). 2002. Pollution Prevention/Good Housekeeping for Municipal Operations Storm Drain System Cleaning. On line:  
[http://www.epa.gov/npdes/menuofbmps/poll\\_16.htm](http://www.epa.gov/npdes/menuofbmps/poll_16.htm)



# Site Design & Landscape Planning SD-10



---

## Design Objectives

---

- Maximize Infiltration
  - Provide Retention
  - Slow Runoff
  - Minimize Impervious Land Coverage
  - Prohibit Dumping of Improper Materials
  - Contain Pollutants
  - Collect and Convey
- 

## Description

Each project site possesses unique topographic, hydrologic, and vegetative features, some of which are more suitable for development than others. Integrating and incorporating appropriate landscape planning methodologies into the project design is the most effective action that can be done to minimize surface and groundwater contamination from stormwater.

## Approach

Landscape planning should couple consideration of land suitability for urban uses with consideration of community goals and projected growth. Project plan designs should conserve natural areas to the extent possible, maximize natural water storage and infiltration opportunities, and protect slopes and channels.

## Suitable Applications

Appropriate applications include residential, commercial and industrial areas planned for development or redevelopment.

## Design Considerations

Design requirements for site design and landscapes planning should conform to applicable standards and specifications of agencies with jurisdiction and be consistent with applicable General Plan and Local Area Plan policies.



# SD-10 Site Design & Landscape Planning

---

## *Designing New Installations*

Begin the development of a plan for the landscape unit with attention to the following general principles:

- Formulate the plan on the basis of clearly articulated community goals. Carefully identify conflicts and choices between retaining and protecting desired resources and community growth.
- Map and assess land suitability for urban uses. Include the following landscape features in the assessment: wooded land, open unwooded land, steep slopes, erosion-prone soils, foundation suitability, soil suitability for waste disposal, aquifers, aquifer recharge areas, wetlands, floodplains, surface waters, agricultural lands, and various categories of urban land use. When appropriate, the assessment can highlight outstanding local or regional resources that the community determines should be protected (e.g., a scenic area, recreational area, threatened species habitat, farmland, fish run). Mapping and assessment should recognize not only these resources but also additional areas needed for their sustenance.

Project plan designs should conserve natural areas to the extent possible, maximize natural water storage and infiltration opportunities, and protect slopes and channels.

## *Conserve Natural Areas during Landscape Planning*

If applicable, the following items are required and must be implemented in the site layout during the subdivision design and approval process, consistent with applicable General Plan and Local Area Plan policies:

- Cluster development on least-sensitive portions of a site while leaving the remaining land in a natural undisturbed condition.
- Limit clearing and grading of native vegetation at a site to the minimum amount needed to build lots, allow access, and provide fire protection.
- Maximize trees and other vegetation at each site by planting additional vegetation, clustering tree areas, and promoting the use of native and/or drought tolerant plants.
- Promote natural vegetation by using parking lot islands and other landscaped areas.
- Preserve riparian areas and wetlands.

## *Maximize Natural Water Storage and Infiltration Opportunities Within the Landscape Unit*

- Promote the conservation of forest cover. Building on land that is already deforested affects basin hydrology to a lesser extent than converting forested land. Loss of forest cover reduces interception storage, detention in the organic forest floor layer, and water losses by evapotranspiration, resulting in large peak runoff increases and either their negative effects or the expense of countering them with structural solutions.
- Maintain natural storage reservoirs and drainage corridors, including depressions, areas of permeable soils, swales, and intermittent streams. Develop and implement policies and

# Site Design & Landscape Planning SD-10

---

regulations to discourage the clearing, filling, and channelization of these features. Utilize them in drainage networks in preference to pipes, culverts, and engineered ditches.

- Evaluating infiltration opportunities by referring to the stormwater management manual for the jurisdiction and pay particular attention to the selection criteria for avoiding groundwater contamination, poor soils, and hydrogeological conditions that cause these facilities to fail. If necessary, locate developments with large amounts of impervious surfaces or a potential to produce relatively contaminated runoff away from groundwater recharge areas.

## *Protection of Slopes and Channels during Landscape Design*

- Convey runoff safely from the tops of slopes.
- Avoid disturbing steep or unstable slopes.
- Avoid disturbing natural channels.
- Stabilize disturbed slopes as quickly as possible.
- Vegetate slopes with native or drought tolerant vegetation.
- Control and treat flows in landscaping and/or other controls prior to reaching existing natural drainage systems.
- Stabilize temporary and permanent channel crossings as quickly as possible, and ensure that increases in run-off velocity and frequency caused by the project do not erode the channel.
- Install energy dissipaters, such as riprap, at the outlets of new storm drains, culverts, conduits, or channels that enter unlined channels in accordance with applicable specifications to minimize erosion. Energy dissipaters shall be installed in such a way as to minimize impacts to receiving waters.
- Line on-site conveyance channels where appropriate, to reduce erosion caused by increased flow velocity due to increases in tributary impervious area. The first choice for linings should be grass or some other vegetative surface, since these materials not only reduce runoff velocities, but also provide water quality benefits from filtration and infiltration. If velocities in the channel are high enough to erode grass or other vegetative linings, riprap, concrete, soil cement, or geo-grid stabilization are other alternatives.
- Consider other design principles that are comparable and equally effective.

## ***Redeveloping Existing Installations***

Various jurisdictional stormwater management and mitigation plans (SUSMP, WQMP, etc.) define “redevelopment” in terms of amounts of additional impervious area, increases in gross floor area and/or exterior construction, and land disturbing activities with structural or impervious surfaces. The definition of “redevelopment” must be consulted to determine whether or not the requirements for new development apply to areas intended for redevelopment. If the definition applies, the steps outlined under “designing new installations” above should be followed.

# **SD-10 Site Design & Landscape Planning**

---

Redevelopment may present significant opportunity to add features which had not previously been implemented. Examples include incorporation of depressions, areas of permeable soils, and swales in newly redeveloped areas. While some site constraints may exist due to the status of already existing infrastructure, opportunities should not be missed to maximize infiltration, slow runoff, reduce impervious areas, disconnect directly connected impervious areas.

## **Other Resources**

A Manual for the Standard Urban Stormwater Mitigation Plan (SUSMP), Los Angeles County Department of Public Works, May 2002.

Stormwater Management Manual for Western Washington, Washington State Department of Ecology, August 2001.

Model Standard Urban Storm Water Mitigation Plan (SUSMP) for San Diego County, Port of San Diego, and Cities in San Diego County, February 14, 2002.

Model Water Quality Management Plan (WQMP) for County of Orange, Orange County Flood Control District, and the Incorporated Cities of Orange County, Draft February 2003.

Ventura Countywide Technical Guidance Manual for Stormwater Quality Control Measures, July 2002.



## Design Objectives

- Maximize Infiltration
- Provide Retention
- Slow Runoff
- Minimize Impervious Land Coverage
- Prohibit Dumping of Improper Materials
- Contain Pollutants
- Collect and Convey

## Description

Irrigation water provided to landscaped areas may result in excess irrigation water being conveyed into stormwater drainage systems.

## Approach

Project plan designs for development and redevelopment should include application methods of irrigation water that minimize runoff of excess irrigation water into the stormwater conveyance system.

## Suitable Applications

Appropriate applications include residential, commercial and industrial areas planned for development or redevelopment. (Detached residential single-family homes are typically excluded from this requirement.)

## Design Considerations

### ***Designing New Installations***

The following methods to reduce excessive irrigation runoff should be considered, and incorporated and implemented where determined applicable and feasible by the Permittee:

- Employ rain-triggered shutoff devices to prevent irrigation after precipitation.
- Design irrigation systems to each landscape area's specific water requirements.
- Include design featuring flow reducers or shutoff valves triggered by a pressure drop to control water loss in the event of broken sprinkler heads or lines.
- Implement landscape plans consistent with County or City water conservation resolutions, which may include provision of water sensors, programmable irrigation times (for short cycles), etc.



- Design timing and application methods of irrigation water to minimize the runoff of excess irrigation water into the storm water drainage system.
- Group plants with similar water requirements in order to reduce excess irrigation runoff and promote surface filtration. Choose plants with low irrigation requirements (for example, native or drought tolerant species). Consider design features such as:
  - Using mulches (such as wood chips or bar) in planter areas without ground cover to minimize sediment in runoff
  - Installing appropriate plant materials for the location, in accordance with amount of sunlight and climate, and use native plant materials where possible and/or as recommended by the landscape architect
  - Leaving a vegetative barrier along the property boundary and interior watercourses, to act as a pollutant filter, where appropriate and feasible
  - Choosing plants that minimize or eliminate the use of fertilizer or pesticides to sustain growth
- Employ other comparable, equally effective methods to reduce irrigation water runoff.

### ***Redeveloping Existing Installations***

Various jurisdictional stormwater management and mitigation plans (SUSMP, WQMP, etc.) define “redevelopment” in terms of amounts of additional impervious area, increases in gross floor area and/or exterior construction, and land disturbing activities with structural or impervious surfaces. The definition of “redevelopment” must be consulted to determine whether or not the requirements for new development apply to areas intended for redevelopment. If the definition applies, the steps outlined under “designing new installations” above should be followed.

### **Other Resources**

A Manual for the Standard Urban Stormwater Mitigation Plan (SUSMP), Los Angeles County Department of Public Works, May 2002.

Model Standard Urban Storm Water Mitigation Plan (SUSMP) for San Diego County, Port of San Diego, and Cities in San Diego County, February 14, 2002.

Model Water Quality Management Plan (WQMP) for County of Orange, Orange County Flood Control District, and the Incorporated Cities of Orange County, Draft February 2003.

Ventura Countywide Technical Guidance Manual for Stormwater Quality Control Measures, July 2002.





## Design Objectives

- Maximize Infiltration
- Provide Retention
- Slow Runoff
- Minimize Impervious Land Coverage
- Prohibit Dumping of Improper Materials
- Contain Pollutants
- Collect and Convey

## Description

Waste materials dumped into storm drain inlets can have severe impacts on receiving and ground waters. Posting notices regarding discharge prohibitions at storm drain inlets can prevent waste dumping. Storm drain signs and stencils are highly visible source controls that are typically placed directly adjacent to storm drain inlets.

## Approach

The stencil or affixed sign contains a brief statement that prohibits dumping of improper materials into the urban runoff conveyance system. Storm drain messages have become a popular method of alerting the public about the effects of and the prohibitions against waste disposal.

## Suitable Applications

Stencils and signs alert the public to the destination of pollutants discharged to the storm drain. Signs are appropriate in residential, commercial, and industrial areas, as well as any other area where contributions or dumping to storm drains is likely.

## Design Considerations

Storm drain message markers or placards are recommended at all storm drain inlets within the boundary of a development project. The marker should be placed in clear sight facing toward anyone approaching the inlet from either side. All storm drain inlet locations should be identified on the development site map.

## *Designing New Installations*

The following methods should be considered for inclusion in the project design and show on project plans:

- Provide stenciling or labeling of all storm drain inlets and catch basins, constructed or modified, within the project area with prohibitive language. Examples include “NO DUMPING



– DRAINS TO OCEAN” and/or other graphical icons to discourage illegal dumping.

- Post signs with prohibitive language and/or graphical icons, which prohibit illegal dumping at public access points along channels and creeks within the project area.

Note - Some local agencies have approved specific signage and/or storm drain message placards for use. Consult local agency stormwater staff to determine specific requirements for placard types and methods of application.

### ***Redeveloping Existing Installations***

Various jurisdictional stormwater management and mitigation plans (SUSMP, WQMP, etc.) define “redevelopment” in terms of amounts of additional impervious area, increases in gross floor area and/or exterior construction, and land disturbing activities with structural or impervious surfaces. If the project meets the definition of “redevelopment”, then the requirements stated under “designing new installations” above should be included in all project design plans.

### **Additional Information**

#### ***Maintenance Considerations***

- Legibility of markers and signs should be maintained. If required by the agency with jurisdiction over the project, the owner/operator or homeowner’s association should enter into a maintenance agreement with the agency or record a deed restriction upon the property title to maintain the legibility of placards or signs.

#### ***Placement***

- Signage on top of curbs tends to weather and fade.
- Signage on face of curbs tends to be worn by contact with vehicle tires and sweeper brooms.

### **Supplemental Information**

#### ***Examples***

- Most MS4 programs have storm drain signage programs. Some MS4 programs will provide stencils, or arrange for volunteers to stencil storm drains as part of their outreach program.

### **Other Resources**

A Manual for the Standard Urban Stormwater Mitigation Plan (SUSMP), Los Angeles County Department of Public Works, May 2002.

Model Standard Urban Storm Water Mitigation Plan (SUSMP) for San Diego County, Port of San Diego, and Cities in San Diego County, February 14, 2002.

Model Water Quality Management Plan (WQMP) for County of Orange, Orange County Flood Control District, and the Incorporated Cities of Orange County, Draft February 2003.

Ventura Countywide Technical Guidance Manual for Stormwater Quality Control Measures, July 2002.



## Design Objectives

- Maximize Infiltration
- Provide Retention
- Slow Runoff
- Minimize Impervious Land Coverage
- Prohibit Dumping of Improper Materials
- Contain Pollutants
- Collect and Convey

## Description

Several measures can be taken to prevent operations at maintenance bays and loading docks from contributing a variety of toxic compounds, oil and grease, heavy metals, nutrients, suspended solids, and other pollutants to the stormwater conveyance system.

## Approach

In designs for maintenance bays and loading docks, containment is encouraged. Preventative measures include overflow containment structures and dead-end sumps. However, in the case of loading docks from grocery stores and warehouse/distribution centers, engineered infiltration systems may be considered.

## Suitable Applications

Appropriate applications include commercial and industrial areas planned for development or redevelopment.

## Design Considerations

Design requirements for vehicle maintenance and repair are governed by Building and Fire Codes, and by current local agency ordinances, and zoning requirements. The design criteria described in this fact sheet are meant to enhance and be consistent with these code requirements.

## Designing New Installations

Designs of maintenance bays should consider the following:

- Repair/maintenance bays and vehicle parts with fluids should be indoors; or designed to preclude urban run-on and runoff.
- Repair/maintenance floor areas should be paved with Portland cement concrete (or equivalent smooth impervious surface).



- Repair/maintenance bays should be designed to capture all wash water leaks and spills. Provide impermeable berms, drop inlets, trench catch basins, or overflow containment structures around repair bays to prevent spilled materials and wash-down waters from entering the storm drain system. Connect drains to a sump for collection and disposal. Direct connection of the repair/maintenance bays to the storm drain system is prohibited. If required by local jurisdiction, obtain an Industrial Waste Discharge Permit.
- Other features may be comparable and equally effective.

The following designs of loading/unloading dock areas should be considered:

- Loading dock areas should be covered, or drainage should be designed to preclude urban run-on and runoff.
- Direct connections into storm drains from depressed loading docks (truck wells) are prohibited.
- Below-grade loading docks from grocery stores and warehouse/distribution centers of fresh food items should drain through water quality inlets, or to an engineered infiltration system, or an equally effective alternative. Pre-treatment may also be required.
- Other features may be comparable and equally effective.

### ***Redeveloping Existing Installations***

Various jurisdictional stormwater management and mitigation plans (SUSMP, WQMP, etc.) define “redevelopment” in terms of amounts of additional impervious area, increases in gross floor area and/or exterior construction, and land disturbing activities with structural or impervious surfaces. The definition of “redevelopment” must be consulted to determine whether or not the requirements for new development apply to areas intended for redevelopment. If the definition applies, the steps outlined under “designing new installations” above should be followed.

### **Additional Information**

Stormwater and non-stormwater will accumulate in containment areas and sumps with impervious surfaces. Contaminated accumulated water must be disposed of in accordance with applicable laws and cannot be discharged directly to the storm drain or sanitary sewer system without the appropriate permit.

### **Other Resources**

A Manual for the Standard Urban Stormwater Mitigation Plan (SUSMP), Los Angeles County Department of Public Works, May 2002.

Model Standard Urban Storm Water Mitigation Plan (SUSMP) for San Diego County, Port of San Diego, and Cities in San Diego County, February 14, 2002.

Model Water Quality Management Plan (WQMP) for County of Orange, Orange County Flood Control District, and the Incorporated Cities of Orange County, Draft February 2003.

Ventura Countywide Technical Guidance Manual for Stormwater Quality Control Measures, July 2002.



## Description

Trash storage areas are areas where a trash receptacle (s) are located for use as a repository for solid wastes. Stormwater runoff from areas where trash is stored or disposed of can be polluted. In addition, loose trash and debris can be easily transported by water or wind into nearby storm drain inlets, channels, and/or creeks. Waste handling operations that may be sources of stormwater pollution include dumpsters, litter control, and waste piles.

## Approach

This fact sheet contains details on the specific measures required to prevent or reduce pollutants in stormwater runoff associated with trash storage and handling. Preventative measures including enclosures, containment structures, and impervious pavements to mitigate spills, should be used to reduce the likelihood of contamination.

## Suitable Applications

Appropriate applications include residential, commercial and industrial areas planned for development or redevelopment. (Detached residential single-family homes are typically excluded from this requirement.)

## Design Considerations

Design requirements for waste handling areas are governed by Building and Fire Codes, and by current local agency ordinances and zoning requirements. The design criteria described in this fact sheet are meant to enhance and be consistent with these code and ordinance requirements. Hazardous waste should be handled in accordance with legal requirements established in Title 22, California Code of Regulation.

Wastes from commercial and industrial sites are typically hauled by either public or commercial carriers that may have design or access requirements for waste storage areas. The design criteria in this fact sheet are recommendations and are not intended to be in conflict with requirements established by the waste hauler. The waste hauler should be contacted prior to the design of your site trash collection areas. Conflicts or issues should be discussed with the local agency.

## *Designing New Installations*

Trash storage areas should be designed to consider the following structural or treatment control BMPs:

- Design trash container areas so that drainage from adjoining roofs and pavement is diverted around the area(s) to avoid run-on. This might include berming or grading the waste handling area to prevent run-on of stormwater.
- Make sure trash container areas are screened or walled to prevent off-site transport of trash.

## Design Objectives

- Maximize Infiltration
- Provide Retention
- Slow Runoff
- Minimize Impervious Land Coverage
- Prohibit Dumping of Improper Materials
- Contain Pollutants
- Collect and Convey



- Use lined bins or dumpsters to reduce leaking of liquid waste.
- Provide roofs, awnings, or attached lids on all trash containers to minimize direct precipitation and prevent rainfall from entering containers.
- Pave trash storage areas with an impervious surface to mitigate spills.
- Do not locate storm drains in immediate vicinity of the trash storage area.
- Post signs on all dumpsters informing users that hazardous materials are not to be disposed of therein.

### ***Redeveloping Existing Installations***

Various jurisdictional stormwater management and mitigation plans (SUSMP, WQMP, etc.) define “redevelopment” in terms of amounts of additional impervious area, increases in gross floor area and/or exterior construction, and land disturbing activities with structural or impervious surfaces. The definition of “redevelopment” must be consulted to determine whether or not the requirements for new development apply to areas intended for redevelopment. If the definition applies, the steps outlined under “designing new installations” above should be followed.

### **Additional Information**

#### ***Maintenance Considerations***

The integrity of structural elements that are subject to damage (i.e., screens, covers, and signs) must be maintained by the owner/operator. Maintenance agreements between the local agency and the owner/operator may be required. Some agencies will require maintenance deed restrictions to be recorded of the property title. If required by the local agency, maintenance agreements or deed restrictions must be executed by the owner/operator before improvement plans are approved.

### **Other Resources**

A Manual for the Standard Urban Stormwater Mitigation Plan (SUSMP), Los Angeles County Department of Public Works, May 2002.

Model Standard Urban Storm Water Mitigation Plan (SUSMP) for San Diego County, Port of San Diego, and Cities in San Diego County, February 14, 2002.

Model Water Quality Management Plan (WQMP) for County of Orange, Orange County Flood Control District, and the Incorporated Cities of Orange County, Draft February 2003.

Ventura Countywide Technical Guidance Manual for Stormwater Quality Control Measures, July 2002.



## Description

Drain inserts are manufactured filters or fabric placed in a drop inlet to remove sediment and debris. There are a multitude of inserts of various shapes and configurations, typically falling into one of three different groups: socks, boxes, and trays. The sock consists of a fabric, usually constructed of polypropylene. The fabric may be attached to a frame or the grate of the inlet holds the sock. Socks are meant for vertical (drop) inlets. Boxes are constructed of plastic or wire mesh. Typically a polypropylene “bag” is placed in the wire mesh box. The bag takes the form of the box. Most box products are one box; that is, the setting area and filtration through media occur in the same box. Some products consist of one or more trays or mesh grates. The trays may hold different types of media. Filtration media vary by manufacturer. Types include polypropylene, porous polymer, treated cellulose, and activated carbon.

## California Experience

The number of installations is unknown but likely exceeds a thousand. Some users have reported that these systems require considerable maintenance to prevent plugging and bypass.

## Advantages

- Does not require additional space as inserts as the drain inlets are already a component of the standard drainage systems.
- Easy access for inspection and maintenance.
- As there is no standing water, there is little concern for mosquito breeding.
- A relatively inexpensive retrofit option.

## Limitations

Performance is likely significantly less than treatment systems that are located at the end of the drainage system such as ponds and vaults. Usually not suitable for large areas or areas with trash or leaves than can plug the insert.

## Design and Sizing Guidelines

Refer to manufacturer’s guidelines. Drain inserts come any many configurations but can be placed into three general groups: socks, boxes, and trays. The sock consists of a fabric, usually constructed of polypropylene. The fabric may be attached to a frame or the grate of the inlet holds the sock. Socks are meant for vertical (drop) inlets. Boxes are constructed of plastic or wire mesh. Typically a polypropylene “bag” is placed in the wire mesh box. The bag takes the form of the box. Most box products are

## Design Considerations

- Use with other BMPs
- Fit and Seal Capacity within Inlet

## Targeted Constituents

- Sediment
- Nutrients
- Trash
- Metals
- Bacteria
- Oil and Grease
- Organics

### Removal Effectiveness

See New Development and Redevelopment Handbook-Section 5.



one box; that is, the setting area and filtration through media occurs in the same box. One manufacturer has a double-box. Stormwater enters the first box where setting occurs. The stormwater flows into the second box where the filter media is located. Some products consist of one or more trays or mesh grates. The trays can hold different types of media. Filtration media vary with the manufacturer: types include polypropylene, porous polymer, treated cellulose, and activated carbon.

### ***Construction/Inspection Considerations***

Be certain that installation is done in a manner that makes certain that the stormwater enters the unit and does not leak around the perimeter. Leakage between the frame of the insert and the frame of the drain inlet can easily occur with vertical (drop) inlets.

### **Performance**

Few products have performance data collected under field conditions.

### **Siting Criteria**

It is recommended that inserts be used only for retrofit situations or as pretreatment where other treatment BMPs presented in this section area used.

### **Additional Design Guidelines**

Follow guidelines provided by individual manufacturers.

### **Maintenance**

Likely require frequent maintenance, on the order of several times per year.

### **Cost**

- The initial cost of individual inserts ranges from less than \$100 to about \$2,000. The cost of using multiple units in curb inlet drains varies with the size of the inlet.
- The low cost of inserts may tend to favor the use of these systems over other, more effective treatment BMPs. However, the low cost of each unit may be offset by the number of units that are required, more frequent maintenance, and the shorter structural life (and therefore replacement).

### **References and Sources of Additional Information**

Hrachovec, R., and G. Minton, 2001, Field testing of a sock-type catch basin insert, Planet CPR, Seattle, Washington

Interagency Catch Basin Insert Committee, Evaluation of Commercially-Available Catch Basin Inserts for the Treatment of Stormwater Runoff from Developed Sites, 1995

Larry Walker Associates, June 1998, NDMP Inlet/In-Line Control Measure Study Report

Manufacturers literature

Santa Monica (City), Santa Monica Bay Municipal Stormwater/Urban Runoff Project - Evaluation of Potential Catch basin Retrofits, Woodward Clyde, September 24, 1998

Woodward Clyde, June 11, 1996, Parking Lot Monitoring Report, Santa Clara Valley Nonpoint Source Pollution Control Program.