

NOV 08 2023

DONNA HILLEGASS, Clerk
BY mandy hui
DEPUTY CLERK

NOTICE OF EXEMPTION

TO: X Office of Planning Research
P.O. Box 3044, Rm. 212
Sacramento, CA 95812

FROM: Olivehurst Public Utility District
1970 9th Ave
Olivehurst, CA 95961

or

X County Clerk, County of Yuba
915 8th Street
Marysville, CA 95901

SUBJECT: Filing of Notice of Exemption.

PROJECT TITLE/CASE NO.: Advanced Meter Integration at the OPUD Plumas Lake Water Treatment Plant

PROJECT LOCATION - SPECIFIC AND COMMUNITY: The Olivehurst Public Utility District (OPUD) is seeking environmental approval to install a 80' tall satellite communication tower to their existing Plumas Lake Water Treatment Facility located at 1074 Algodon Rd. (APN:016-040-114) in the unincorporated community of Olivehurst approximately 10 miles south of the City of Marysville.

DESCRIPTION OF NATURE, PURPOSE, AND BENEFICIARIES OF PROJECT:

The proposed project seeks to construct an 80' tall universal tower on a 6' x 8' concrete pad. Satellites would be placed on the tower in order to be able to have advanced meter infrastructure for meter readings or a two-way communication system to collect detailed metering information throughout OPUD's utility service district.

NAME OF PUBLIC AGENCY\CONTACT PERSON\TELEPHONE #: OPUD, Swarnjit Boyal, (530) 743-8132

NAME OF PERSON OR AGENCY CARRYING OUT PROJECT:

Olivehurst Public Utility District; contact: Swarnjit Boyal
1970 9th Ave
Olivehurst, CA 95961
(530) 682-0736

EXEMPT STATUS: (Check One)

- Ministerial (Sec. 21080(b)(1), 15268);
- Declared Emergency (Sec. 21080(b)(3), 15269(a));
- Emergency Project (Sec. 21080(b)(4), 15269(b)(c));
- Categorical (Sec. 15303 (d));
- Statutory (Sec. 21083 and 21087, 15260-15267);
- Other. Sec. 15182

REASONS WHY PROJECT IS EXEMPT: The project is exempt pursuant to Section 15303 of the California Environmental Quality Act (New Construction or Conversion of Small Structures).

POSTED 2023 FG-00035
11/8/2023 to 12.11.2023

11/11/2020
11/11/2020

11/11/2020

11/11/2020

11/11/2020

11/11/2020

11/11/2020

Section 15303 provides exemptions to for new small facilities and structures. The proposed tower is proposed to be constructed entirely on the existing OPUD Plumas Lake Water Treatment Plant and on a concrete pad that is 6'x 8' in size. The proposed tower is intended to improve satellite communications between all utility facilities located throughout the OPUD district.

CONTACT PERSON: Swarnjit Boyal

TELEPHONE NO.: 530-682-0736

SIGNATURE

TITLE

DATE RECEIVED FOR FILING

Swarnjit Boyal



Public Works Engineer

11/8/2023

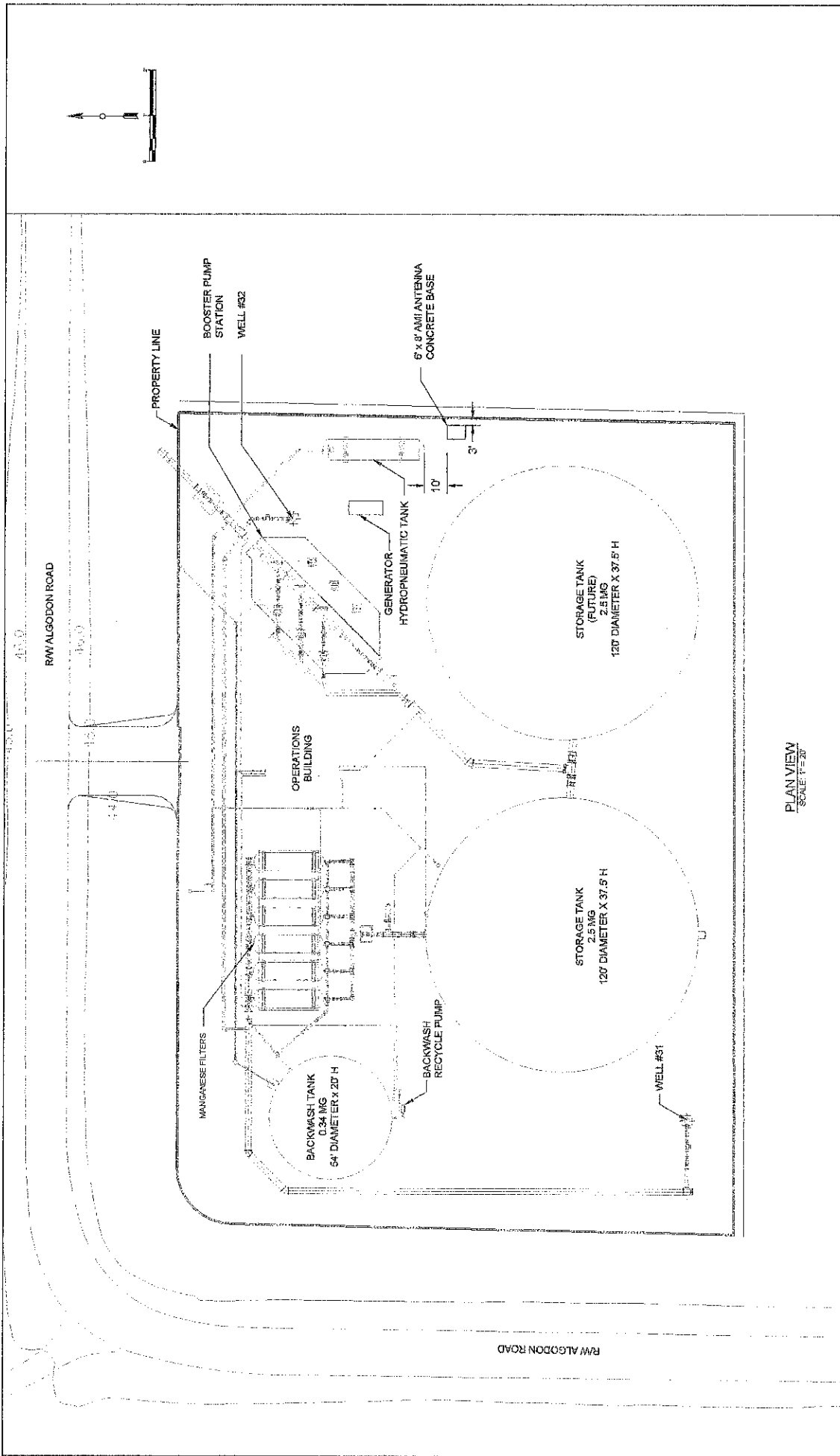

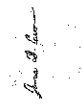
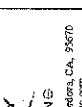

PLAN VIEW
SCALE: 1" = 20'

CONSULTANT: AFFINITY ENGINEERING 3493 Maricopa Court, Rancho Cordova, CA, 95670 www.affinityengineering.com	 	NO.	REVISION DESCRIPTION	BY	DATE	CLIENT:  Olivesthirst Public Utility District 1570 9th Avenue Olivesthirst, CA 95661	PROJECT: PLUMAS LAKE WATER PLANT ADVANCED METERING INFRASTRUCTURE	SCALE: AS SHOWN ATTENTION LINE IS 2" AT FULL SIZE (SCALE ACCORDING TO)	SHEET TITLE: CIVIL	SHEET NAME: C3
								SHEET NUMBER: 1 of 1 7/5/23		

FREESTANDING ALUMINUM TOWER

MODEL #HD 12-80

TOTAL WEIGHT: 351 LBS.

WIND LOADING:
11.91 Sq. Ft.

Contact Universal Towers to confirm
geographical location of your tower and
all wind load implications

14-TOP

18-TAPR

18-STRT

22-TAPR

26-TAPR

30-TAPR

30-STRT

30-STRT

B-30

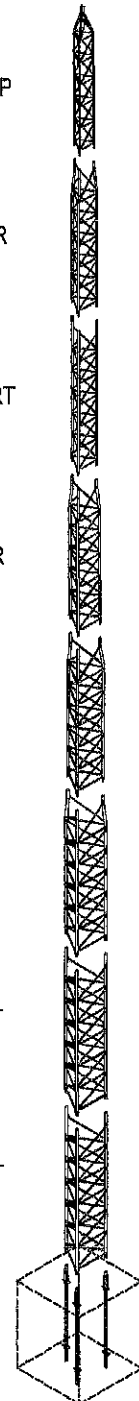
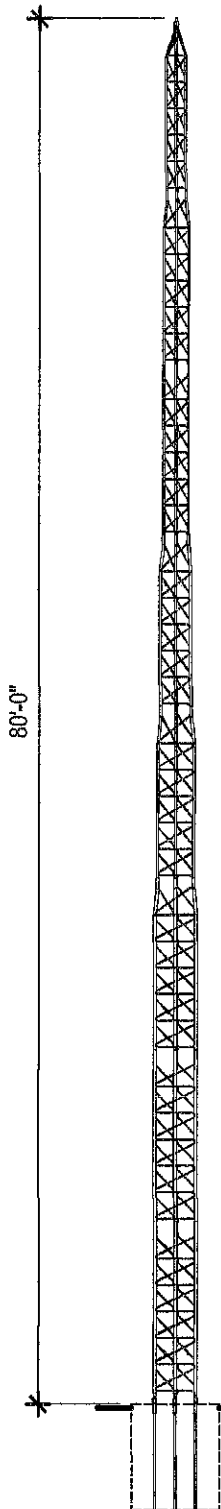

WARRANTY

UNIVERSAL TOWERS ARE WARRANTED AGAINST DEFECTIVE MATERIAL OR WORKMANSHIP AND ARE SUBJECT TO REPAIR OR TO MATERIAL REPLACEMENT ONLY IF FAILURE RESULTS FROM THESE FACTORS WITHIN ONE YEAR FROM PURCHASE BY USER. THIS WARRANTY DOES NOT EXTEND TO ANY OF OUR PRODUCTS WHICH HAVE BEEN SUBJECTED TO MISUSE, NEGLIGENCE, ACCIDENT, IMPROPER INSTALLATION OR APPLICATION, NOR SHALL IT EXTEND TO UNITS WHICH HAVE BEEN REPAIRED OR SUBSTANTIALLY ALTERED OUTSIDE OF OUR FACTORY. THIS WARRANTY IS IN LIEU OF ALL OTHER WARRANTIES EXPRESSED OR IMPLIED.

ELEVATION

SCALE: 3/32"=1'-0"

2

ISOMETRIC

SCALE: N.T.S.

1

ALUMINUM TOWER



UNIVERSAL TOWERS
A DIVISION OF
UNIVERSAL MANUFACTURING CORP.
43900 GROESBECK HWY.
CLINTON TOWNSHIP, MI 48036
PH: (586) 463-2560
FAX: (586) 463-2964

JOB NO.:

COMPONENT:

HD 12-80

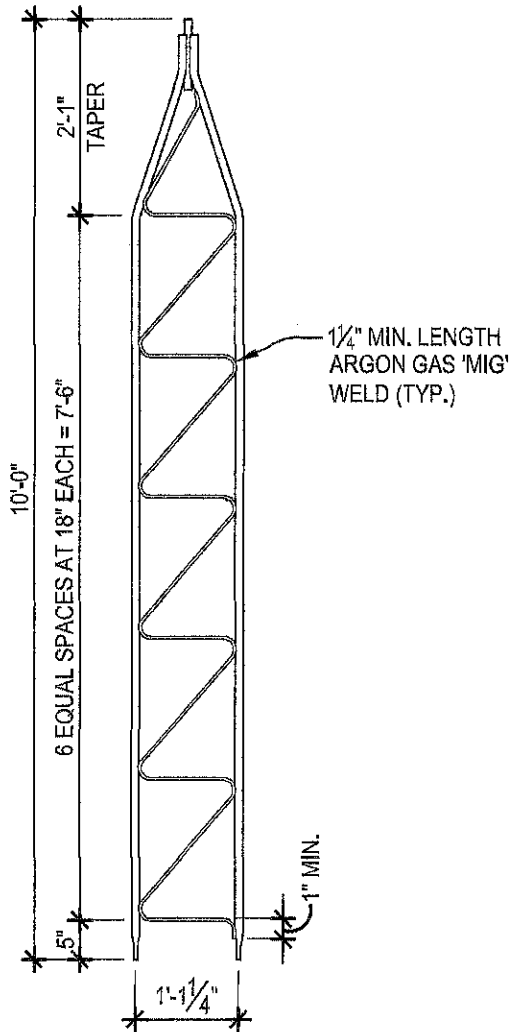

ELEVATION 2
SCALE: 1/2"=1'-0"

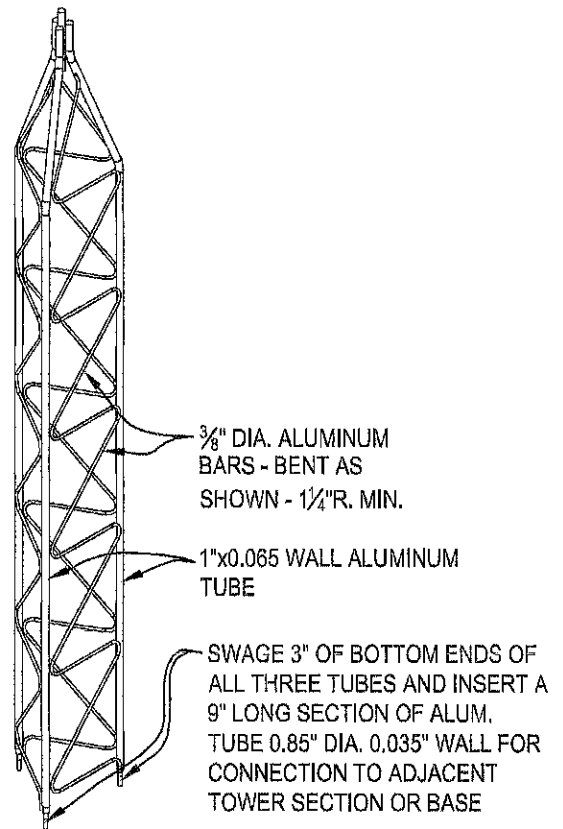

ISOMETRIC 3
SCALE: N.T.S.

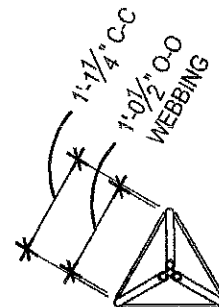

PLAN VIEW 1
SCALE: 1/2"=1'-0"

TOP SECTION



UNIVERSAL TOWERS
A DIVISION OF
UNIVERSAL MANUFACTURING CORP.
43900 GROESBECK HWY.
CLINTON TOWNSHIP, MI 48036
PH: (586) 463-2560
FAX: (586) 463-2964

JOB NO.:
COMPONENT:
14-TOP

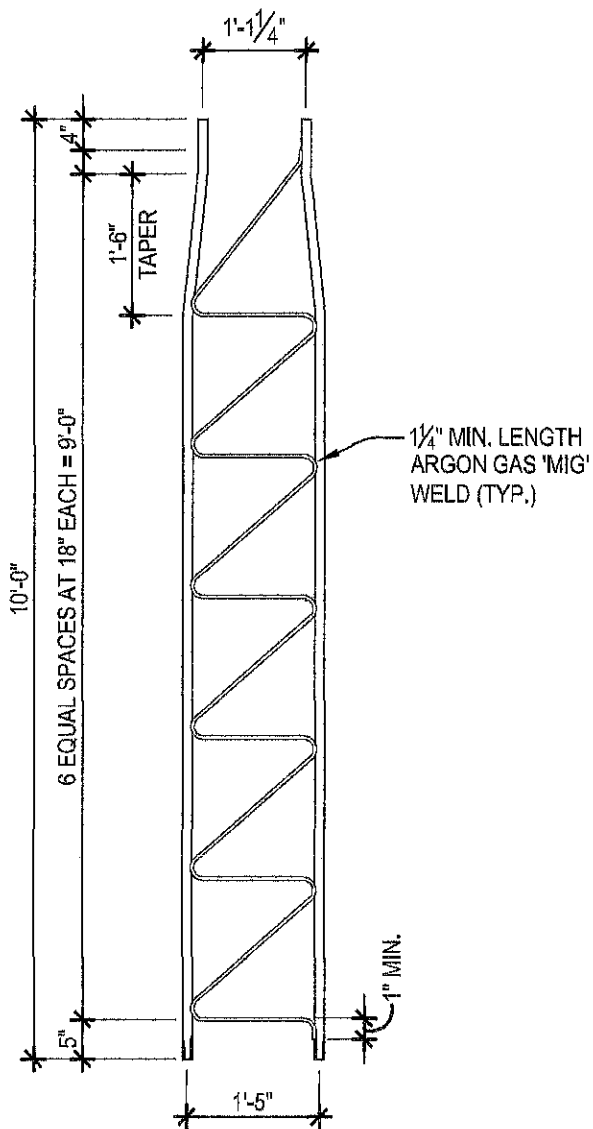

ELEVATION 2

SCALE: 1/2"=1'-0"

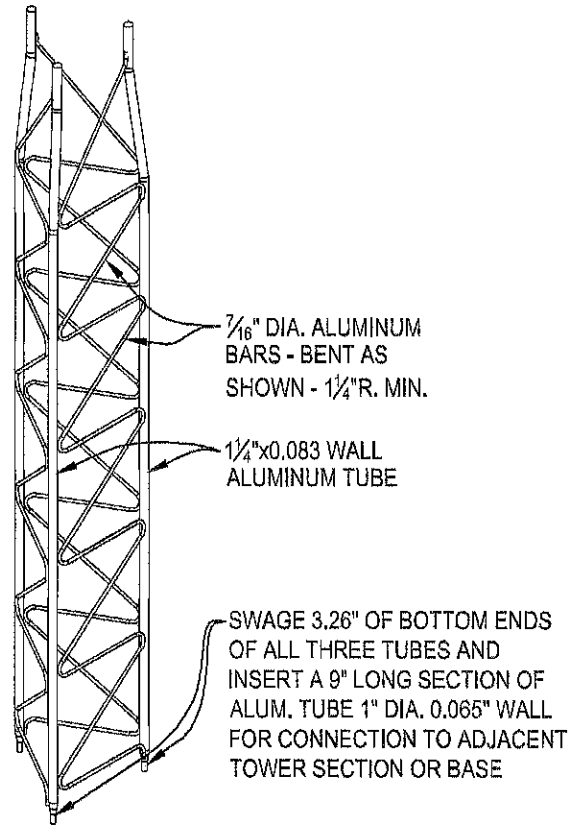

ISOMETRIC 3

SCALE: N.T.S.

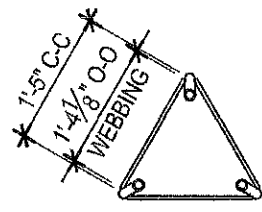

PLAN VIEW 1

SCALE: 1/2"=1'-0"

TAPERED SECTION

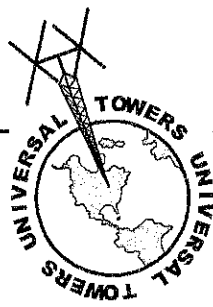

UNIVERSAL TOWERS
 A DIVISION OF
 UNIVERSAL MANUFACTURING CORP.
 43900 GROESBECK HWY.
 CLINTON TOWNSHIP, MI 48036
 PH: (586) 463-2560
 FAX: (586) 463-2964

JOB NO.:

COMPONENT:
18-TAPR

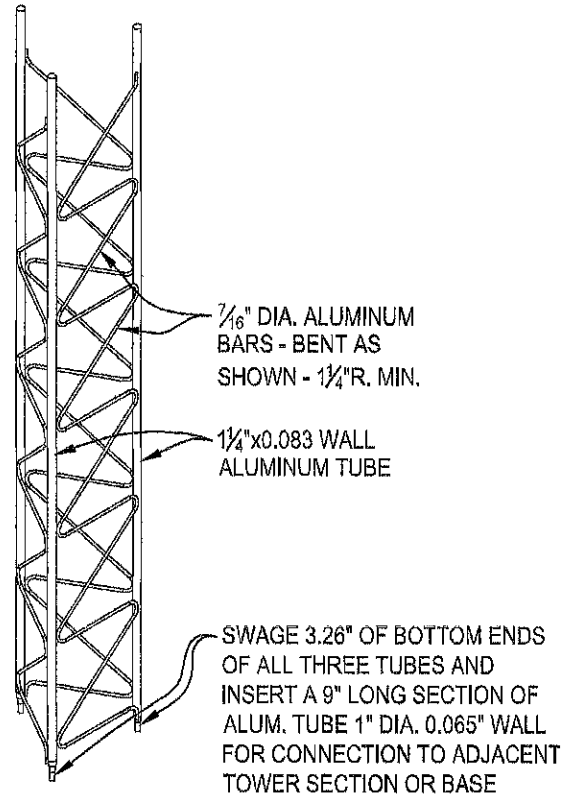
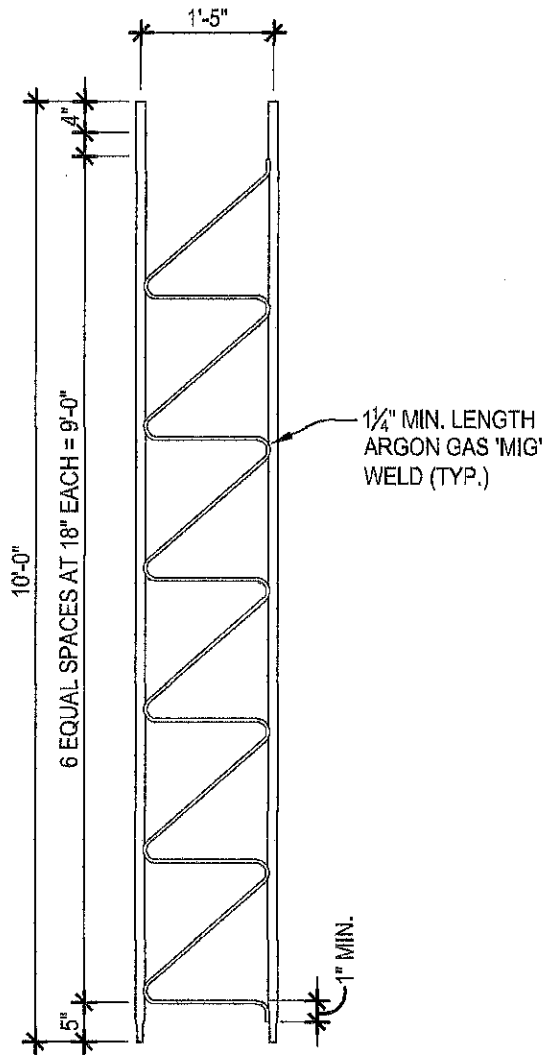

ISOMETRIC 3
SCALE: N.T.S.

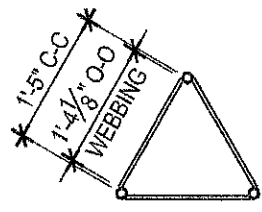

ELEVATION 2
SCALE: 1/2"=1'-0"

PLAN VIEW 1
SCALE: 1/2"=1'-0"

STRAIGHT SECTION



UNIVERSAL TOWERS
A DIVISION OF
UNIVERSAL MANUFACTURING CORP.
43900 CROSBECK HWY.
CLINTON TOWNSHIP, MI 48036
PH: (586) 463-2560
FAX: (586) 463-2964

JOB NO.:
COMPONENT:
18-STRT

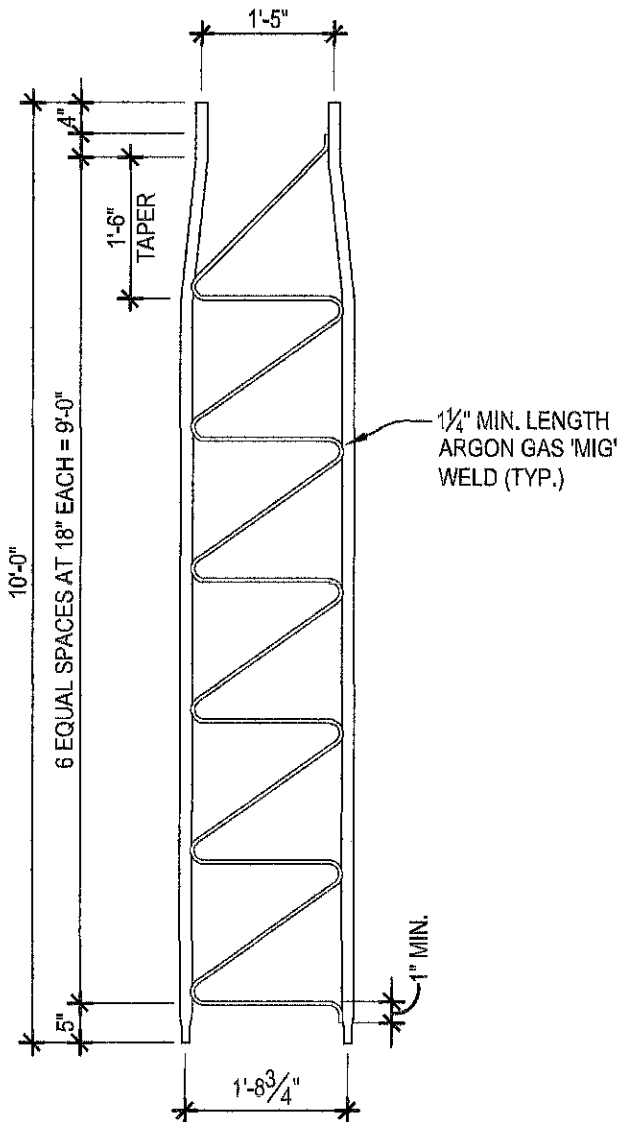

ELEVATION 2

SCALE: 1/2"=1'-0"

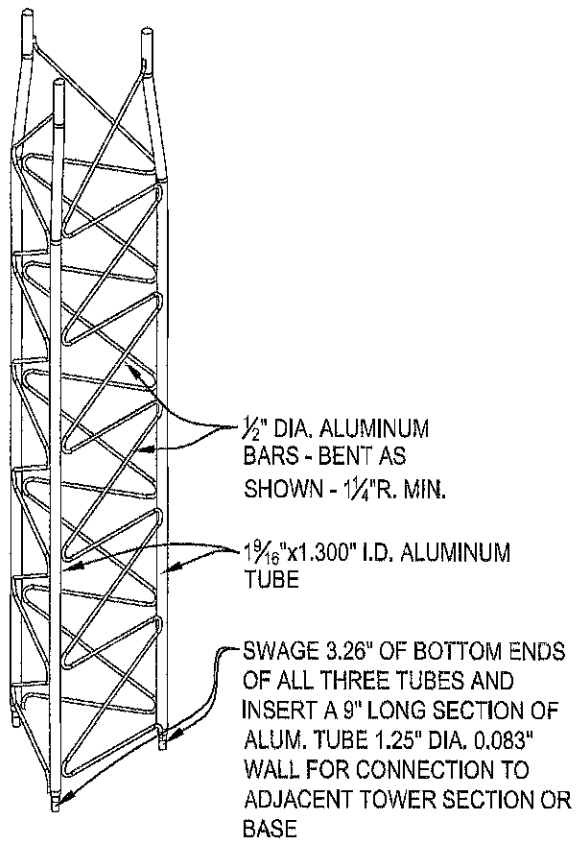

ISOMETRIC 3

SCALE: N.T.S.

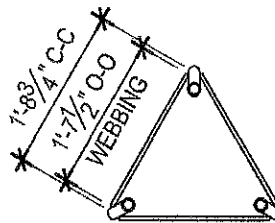

PLAN VIEW 1

SCALE: 1/2"=1'-0"

TAPERED SECTION



UNIVERSAL TOWERS
 A DIVISION OF
 UNIVERSAL MANUFACTURING CORP.
 43900 GROESBECK HWY.
 CLINTON TOWNSHIP, MI 48036
 PH: (586) 463-2560
 FAX: (586) 463-2964

JOB NO.:

COMPONENT:
22-TAPR

Bof12

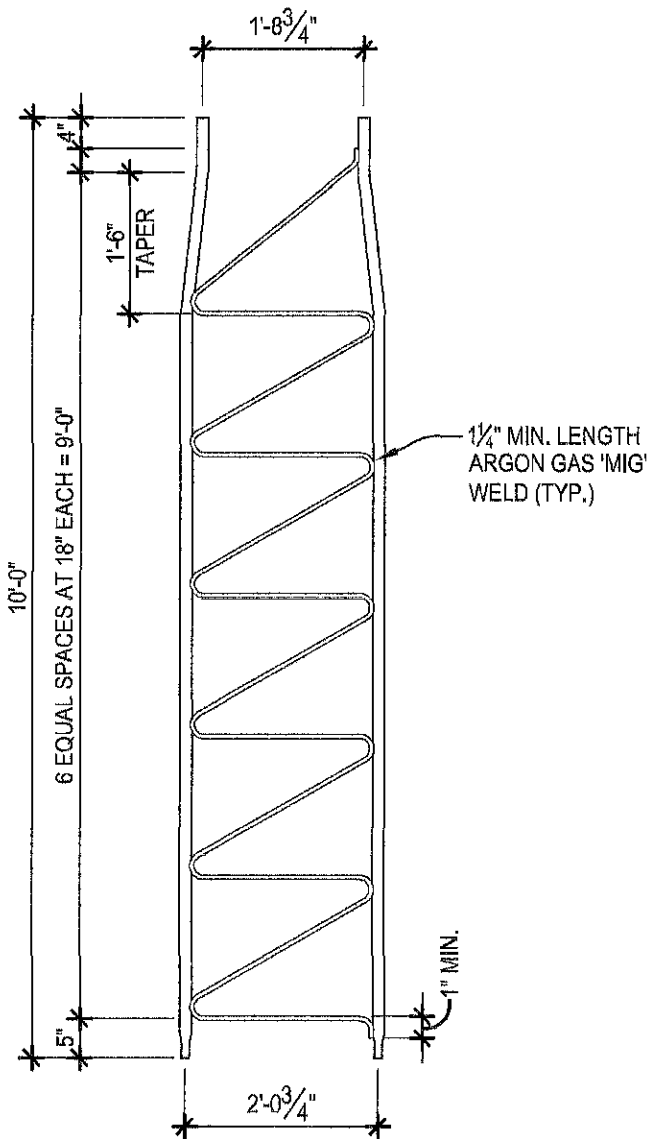

ELEVATION 2

SCALE: 1/2"=1'-0"

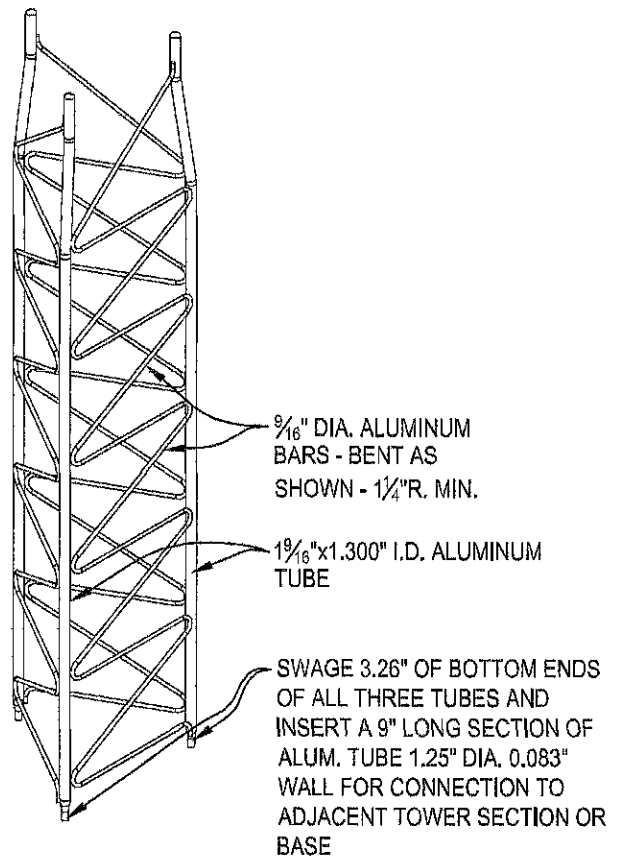

ISOMETRIC 3

SCALE: N.T.S.

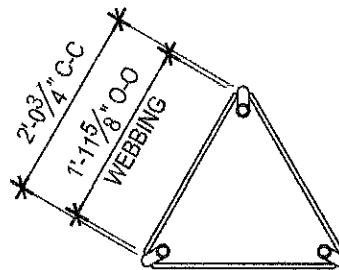

PLAN VIEW 1

SCALE: 1/2"=1'-0"

TAPERED SECTION



UNIVERSAL TOWERS
 A DIVISION OF
 UNIVERSAL MANUFACTURING CORP.
 43500 GROESBECK HWY.
 CLINTON TOWNSHIP, MI 48036
 PH: (586) 463-2560
 FAX: (586) 463-2964

JOB NO.:

COMPONENT:
 26-TAPR

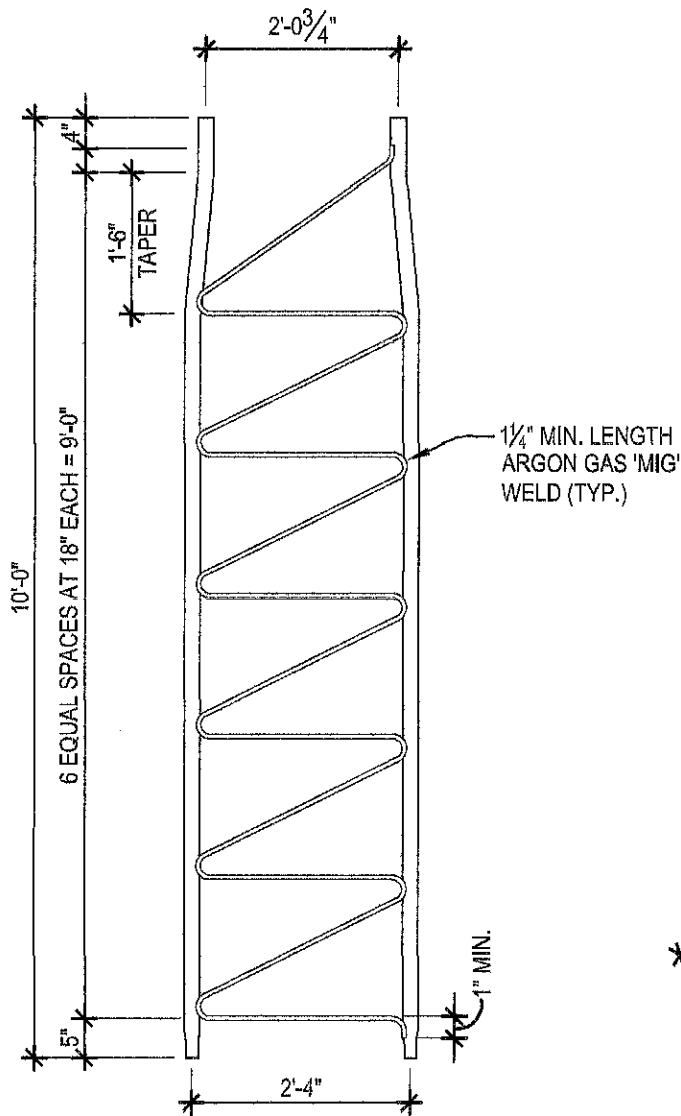

ELEVATION 2
SCALE: 1/2"=1'-0"

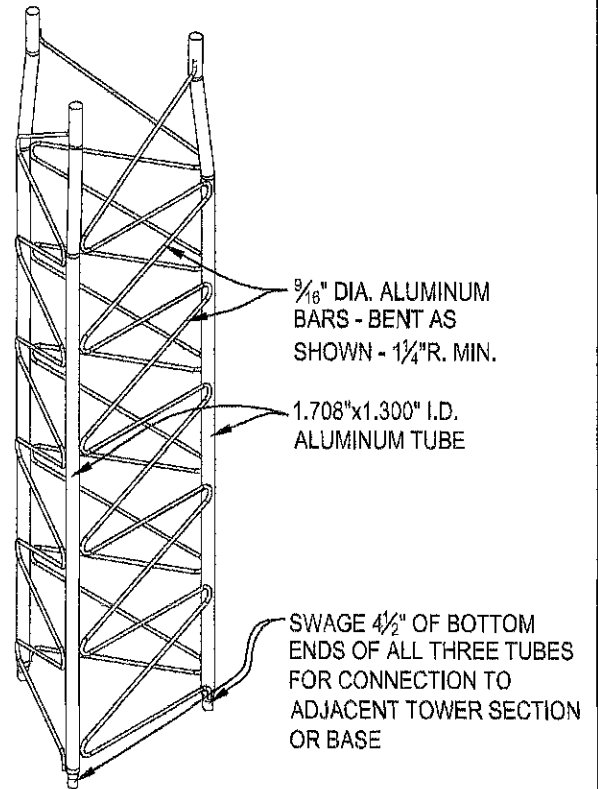

ISOMETRIC 3
SCALE: N.T.S.

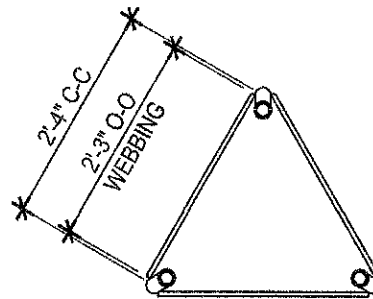

PLAN VIEW 1
SCALE: 1/2"=1'-0"

TAPERED SECTION



UNIVERSAL TOWERS
A DIVISION OF
UNIVERSAL MANUFACTURING CORP.
43900 GROESBECK HWY.
CLINTON TOWNSHIP, MI 48036
PH: (586) 463-2560
FAX: (586) 463-2964

JOB NO.:

COMPONENT:
30-TAPR

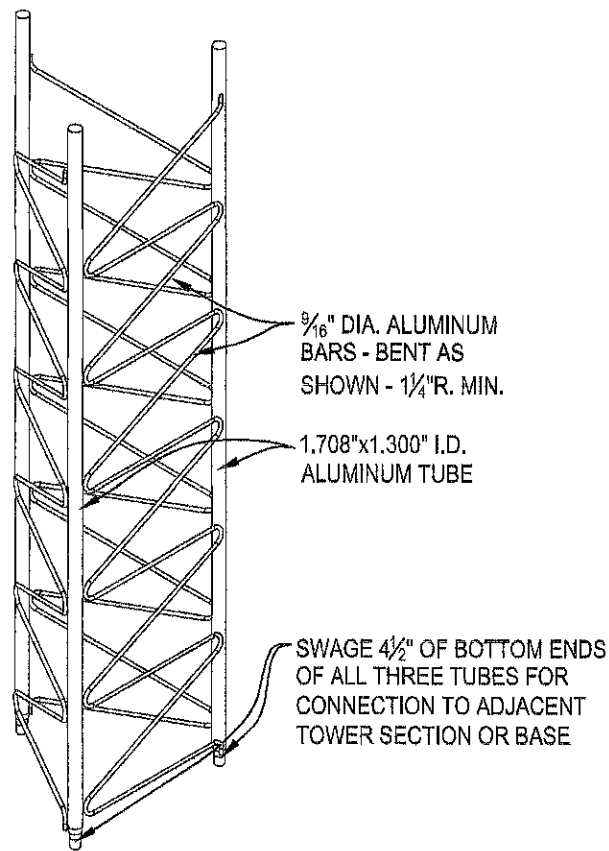
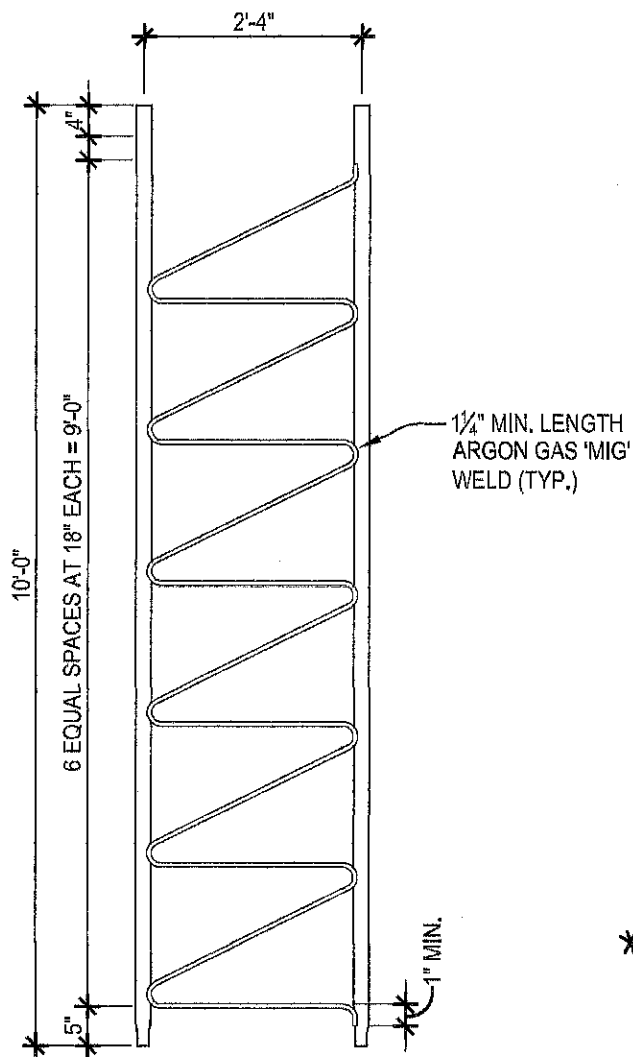

ISOMETRIC

SCALE: N.T.S.

3

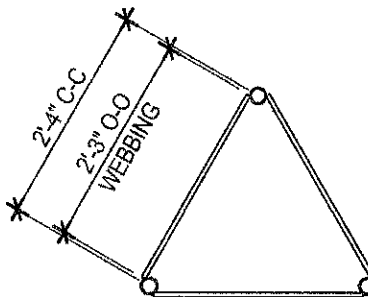

ELEVATION

SCALE: 1/2"=1'-0"

2

PLAN VIEW

SCALE: 1/2"=1'-0"

1

STRAIGHT SECTION



UNIVERSAL TOWERS
A DIVISION OF
UNIVERSAL MANUFACTURING CORP.
43900 GROESBECK HWY.
CLINTON TOWNSHIP, MI 48036
PH: (586) 463-2560
FAX: (586) 463-2964

JOB NO.:

COMPONENT:

30-STRT

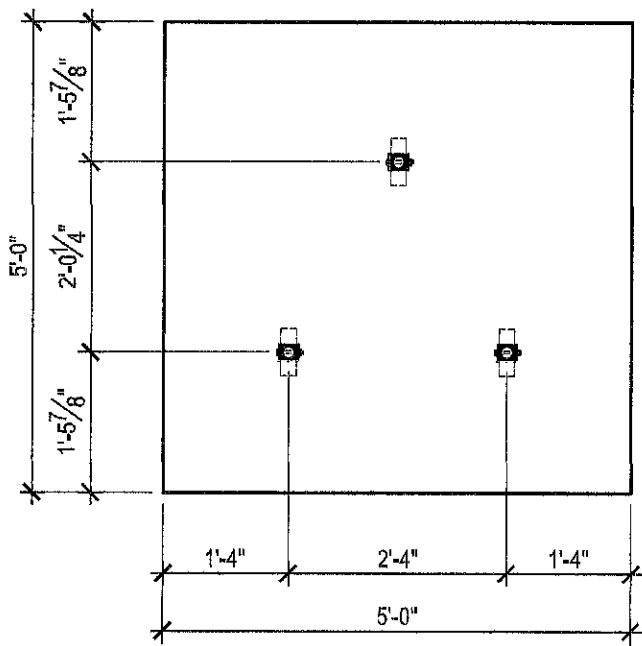

PLAN VIEW

SCALE: 1/2"=1'-0"

1

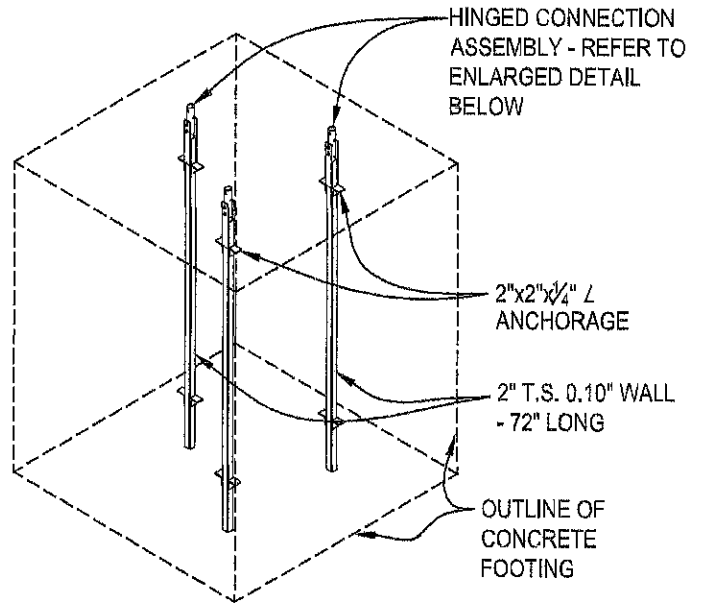

ISOMETRIC

SCALE: N.T.S.

3

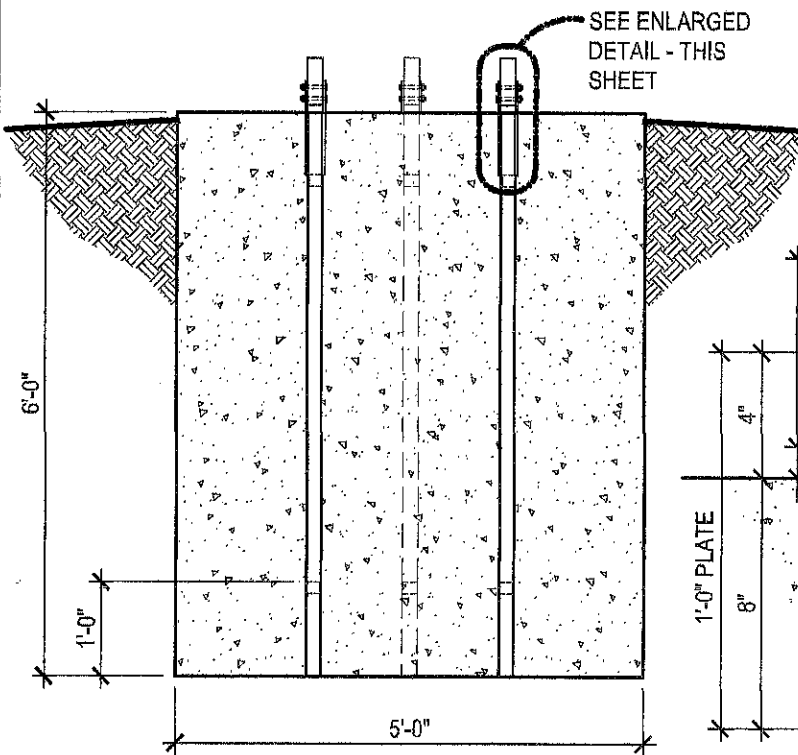

ELEVATION

SCALE: 1/2"=1'-0"

2

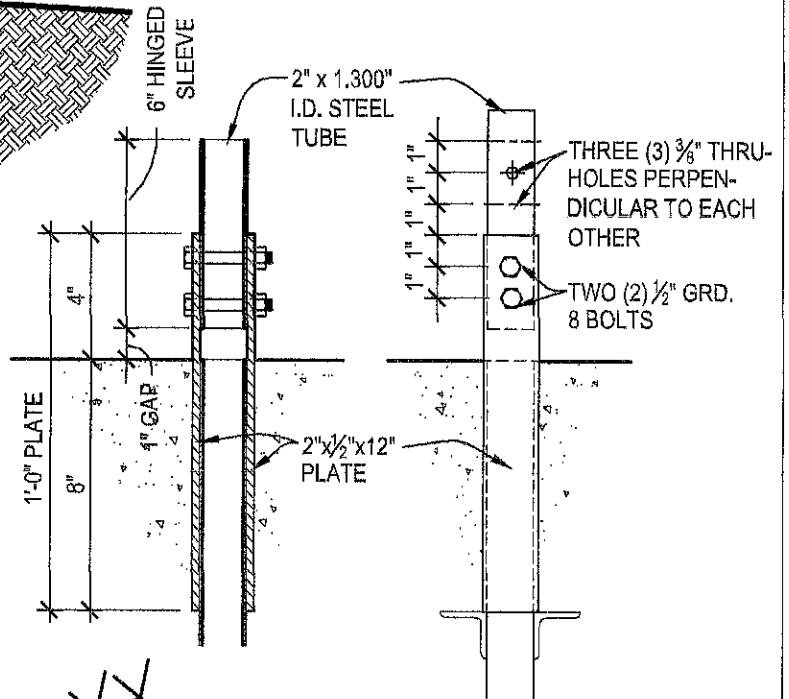

NOTE: FOUNDATIONS ARE DESIGNED FOR FIRM BEARING SOIL.

BASE FOOTING



UNIVERSAL TOWERS
 A DIVISION OF
 UNIVERSAL MANUFACTURING CORP.
 45900 GROESBECK HWY.
 CLINTON TOWNSHIP, MI 48036
 PH: (586) 463-2560
 FAX: (586) 463-2964

JOB NO.:

COMPONENT:

B-30



State of California - Department of Fish and Wildlife
2023 ENVIRONMENTAL DOCUMENT FILING FEE
CASH RECEIPT
 DFW 753.5a (REV. 01/01/23) Previously DFG 753.5a

Corrected receipt

RECEIPT NUMBER: 58 - 11082023 - 35
STATE CLEARINGHOUSE NUMBER (If applicable)

SEE INSTRUCTIONS ON REVERSE. TYPE OR PRINT CLEARLY.

LEAD AGENCY OLIVEHURST PUBLIC UTILITY DIST	LEAD AGENCY EMAIL	DATE 11/08/2023
COUNTY/STATE AGENCY OF FILING YUBA	DOCUMENT NUMBER 2023FG-00035	

PROJECT TITLE
 ADVANCED METER INTEGRATION AT THE OPUD PLUMAS LAKE WATER TREATMENT PLANT

PROJECT APPLICANT NAME OLIVEHURST PUBLIC UTILITY DIST	PROJECT APPLICANT EMAIL	PHONE NUMBER (530) 682-0736
PROJECT APPLICANT ADDRESS 1970 9TH AVE	CITY OLIVEHURST	STATE CA
		ZIP CODE 95961

PROJECT APPLICANT (Check appropriate box)

Local Public Agency
 School District
 Other Special District
 State Agency
 Private Entity

CHECK APPLICABLE FEES:

- Environmental Impact Report (EIR) \$3,839.25 \$ _____
- Mitigated/Negative Declaration (MND)(ND) \$2,764.00 \$ _____
- Certified Regulatory Program (CRP) document - payment due directly to CDFW \$1,305.25 \$ _____
- Exempt from fee
 - Notice of Exemption (attach)
 - CDFW No Effect Determination (attach)
- Fee previously paid (attach previously issued cash receipt copy)

- Water Right Application or Petition Fee (State Water Resources Control Board only) \$850.00 \$ _____
- County documentary handling fee \$ _____ \$50.00
- Other 0.00 \$ _____

PAYMENT METHOD:

- Cash
 Credit
 Check
 Other
 TOTAL RECEIVED \$ _____ \$50.00

SIGNATURE X	AGENCY OF FILING PRINTED NAME AND TITLE Nelida Williams Deputy
----------------	---



State of California - Department of Fish and Wildlife
2023 ENVIRONMENTAL DOCUMENT FILING FEE
CASH RECEIPT
 DFW 753.5a (REV. 01/01/23) Previously DFG 753.5a

NOTICE

Each project applicant shall remit to the county clerk the environmental filing fee before or at the time of filing a Notice of Determination (Pub. Resources Code, § 21152; Fish & G. Code, § 711.4, subdivision (d); Cal. Code Regs., tit. 14, § 753.5). Without the appropriate fee, statutory or categorical exemption, or a valid No Effect Determination issued by the California Department of Fish and Wildlife (CDFW), the Notice of Determination is not operative, vested, or final, and shall not be accepted by the county clerk.

COUNTY DOCUMENTARY HANDLING FEE

The county clerk may charge a documentary handling fee of fifty dollars (\$50) per filing in addition to the environmental filing fee (Fish & G. Code, § 711.4, subd. (e); Cal. Code Regs., tit. 14, § 753.5, subd. (g)(1)). A county board of supervisors shall have the authority to increase or decrease the fee or charge, that is otherwise authorized to be levied by another provision of law, in the amount reasonably necessary to recover the cost of providing any product or service or the cost of enforcing any regulation for which the fee or charge is levied (Gov. Code, § 54985, subd. (a)).

COLLECTION PROCEDURES FOR COUNTY GOVERNMENTS

Filing Notice of Determination (NOD):

- Collect environmental filing fee or copy of previously issued cash receipt. *(Do not collect fee if project applicant presents a No Effect Determination signed by CDFW. An additional fee is required for each separate environmental document. An addendum is not considered a separate environmental document. Checks should be made payable to the county.)*
- Issue cash receipt to project applicant.
- Attach copy of cash receipt and, if applicable, previously issued cash receipt, to NOD.
- Mail filing fees for **CRP** document to CDFW prior to filing the NOD or equivalent final approval (Cal. Code Regs. Tit. 14, § 753.5 (b)(5)). The CRP should request receipt from CDFW to show proof of payment for filing the NOD or equivalent approval. Please mail payment to address below made attention to the Cash Receipts Unit of the Accounting Services Branch.

If the project applicant presents a **No Effect Determination** signed by CDFW, also:

- Attach No Effect Determination to NOD *(no environmental filing fee is due)*.

Filing Notice of Exemption (NOE) *(Statutorily or categorically exempt project (Cal. Code Regs., tit. 14, §§ 15260-15285, 15300-15333))*

- Issue cash receipt to project applicant.
- Attach copy of cash receipt to NOE *(no environmental filing fee is due)*.

Within 30 days after the end of each month in which the environmental filing fees are collected, each county shall summarize and record the amount collected on the monthly State of California Form No. CA25 (TC31) and remit the amount collected to the State Treasurer. Identify the remittance on Form No. CA25 as "Environmental Document Filing Fees" per Fish and Game Code section 711.4.

The county clerk shall mail the following documents to CDFW on a monthly basis:

- ✓ A photocopy of the monthly State of California Form No. CA25 (TC31)
- ✓ CDFW/ASB copies of all cash receipts (including all voided receipts)
- ✓ A copy of all CDFW No Effect Determinations filed in lieu of fee payment
- ✓ A copy of all NODs filed with the county during the preceding month
- ✓ A list of the name, address and telephone number of all project applicants for which an NOD has been filed. If this information is contained on the cash receipt filed with CDFW under California Code of Regulations, title 14, section 753.5, subdivision (e)(6), no additional information is required.

DOCUMENT RETENTION

The county shall retain two copies of the cash receipt (for lead agency and county clerk) and a copy of all documents described above for at least 12 months.

RECEIPT NUMBER

- # The first two digits automatically populate by making the appropriate selection in the County/State Agency of Filing drop down menu.
- # The next eight digits automatically populate when a date is entered.
- # The last three digits correspond with the sequential order of issuance for each calendar year. For example, the first receipt number issued on January 1 should end in 001. If a county issued 252 receipts for the year ending on December 31, the last receipt number should end in 252. CDFW recommends that counties and state agencies 1) save a local copy of this form, and 2) track receipt numbers on a spreadsheet tabbed by month to ensure accuracy.

DO NOT COMBINE THE ENVIRONMENTAL FEES WITH THE STATE SHARE OF FISH AND WILDLIFE FEES.

Mail to:
 California Department of Fish and Wildlife
 Accounting Services Branch
 P.O. Box 944209
 Sacramento, California 94244-2090



State of California - Department of Fish and Wildlife
2023 ENVIRONMENTAL DOCUMENT FILING FEE
CASH RECEIPT
 DFW 753.5a (REV. 01/01/23) Previously DFG 753.5a

Corrected receipt

RECEIPT NUMBER: 58 - 11082023 - 35
STATE CLEARINGHOUSE NUMBER (if applicable)

SEE INSTRUCTIONS ON REVERSE. TYPE OR PRINT CLEARLY.

LEAD AGENCY OLIVEHURST PUBLIC UTILITY DIST	LEAD AGENCY EMAIL	DATE 11/08/2023
COUNTY/STATE AGENCY OF FILING YUBA	DOCUMENT NUMBER 2023FG-00035	

PROJECT TITLE
 ADVANCED METER INTEGRATION AT THE OPUD PLUMAS LAKE WATER TREATMENT PLANT

PROJECT APPLICANT NAME OLIVEHURST PUBLIC UTILITY DIST	PROJECT APPLICANT EMAIL	PHONE NUMBER (530) 682-0736
PROJECT APPLICANT ADDRESS 1970 9TH AVE	CITY OLIVEHURST	STATE CA
		ZIP CODE 95961

PROJECT APPLICANT (Check appropriate box)

Local Public Agency
 School District
 Other Special District
 State Agency
 Private Entity

CHECK APPLICABLE FEES:

- Environmental Impact Report (EIR) \$3,839.25 \$ _____
- Mitigated/Negative Declaration (MND)(ND) \$2,764.00 \$ _____
- Certified Regulatory Program (CRP) document - payment due directly to CDFW \$1,305.25 \$ _____

- Exempt from fee
 - Notice of Exemption (attach)
 - CDFW No Effect Determination (attach)
- Fee previously paid (attach previously issued cash receipt copy)

- Water Right Application or Petition Fee (State Water Resources Control Board only) \$850.00 \$ _____
- County documentary handling fee \$ _____ \$50.00
- Other 0.00 \$ _____

PAYMENT METHOD:

- Cash
 Credit
 Check
 Other
 TOTAL RECEIVED \$ _____ \$50.00

SIGNATURE X	AGENCY OF FILING PRINTED NAME AND TITLE Nelida Williams Deputy
-----------------------	---



State of California - Department of Fish and Wildlife
2023 ENVIRONMENTAL DOCUMENT FILING FEE
CASH RECEIPT
 DFW 753.5a (REV. 01/01/23) Previously DFG 753.5a

NOTICE

Each project applicant shall remit to the county clerk the environmental filing fee before or at the time of filing a Notice of Determination (Pub. Resources Code, § 21152; Fish & G. Code, § 711.4, subdivision (d); Cal. Code Regs., tit. 14, § 753.5). Without the appropriate fee, statutory or categorical exemption, or a valid No Effect Determination issued by the California Department of Fish and Wildlife (CDFW), the Notice of Determination is not operative, vested, or final, and shall not be accepted by the county clerk.

COUNTY DOCUMENTARY HANDLING FEE

The county clerk may charge a documentary handling fee of fifty dollars (\$50) per filing in addition to the environmental filing fee (Fish & G. Code, § 711.4, subd. (e); Cal. Code Regs., tit. 14, § 753.5, subd. (g)(1)). A county board of supervisors shall have the authority to increase or decrease the fee or charge, that is otherwise authorized to be levied by another provision of law, in the amount reasonably necessary to recover the cost of providing any product or service or the cost of enforcing any regulation for which the fee or charge is levied (Gov. Code, § 54985, subd. (a)).

COLLECTION PROCEDURES FOR COUNTY GOVERNMENTS

Filing Notice of Determination (NOD):

- Collect environmental filing fee or copy of previously issued cash receipt. *(Do not collect fee if project applicant presents a No Effect Determination signed by CDFW. An additional fee is required for each separate environmental document. An addendum is not considered a separate environmental document. Checks should be made payable to the county.)*
- Issue cash receipt to project applicant.
- Attach copy of cash receipt and, if applicable, previously issued cash receipt, to NOD.
- Mail filing fees for **CRP** document to CDFW prior to filing the NOD or equivalent final approval (Cal. Code Regs. Tit. 14, § 753.5 (b)(5)). The CRP should request receipt from CDFW to show proof of payment for filing the NOD or equivalent approval. Please mail payment to address below made attention to the Cash Receipts Unit of the Accounting Services Branch.

If the project applicant presents a **No Effect Determination** signed by CDFW, also:

- Attach No Effect Determination to NOD *(no environmental filing fee is due)*.

Filing Notice of Exemption (NOE) (Statutorily or categorically exempt project (Cal. Code Regs., tit. 14, §§ 15260-15285, 15300-15333))

- Issue cash receipt to project applicant.
- Attach copy of cash receipt to NOE *(no environmental filing fee is due)*.

Within **30 days after the end of each month in which the environmental filing fees are collected**, each county shall summarize and record the amount collected on the monthly State of California Form No. CA25 (TC31) and remit the amount collected to the State Treasurer. Identify the remittance on Form No. CA25 as "Environmental Document Filing Fees" per Fish and Game Code section 711.4.

The county clerk shall mail the following documents to CDFW on a monthly basis:

- ✓ A photocopy of the monthly State of California Form No. CA25 (TC31)
- ✓ CDFW/ASB copies of all cash receipts (including all voided receipts)
- ✓ A copy of all CDFW No Effect Determinations filed in lieu of fee payment
- ✓ A copy of all NODs filed with the county during the preceding month
- ✓ A list of the name, address and telephone number of all project applicants for which an NOD has been filed. If this information is contained on the cash receipt filed with CDFW under California Code of Regulations, title 14, section 753.5, subdivision (e)(6), no additional information is required.

DOCUMENT RETENTION

The county shall retain two copies of the cash receipt (for lead agency and county clerk) and a copy of all documents described above for at least 12 months.

RECEIPT NUMBER

- # The first two digits automatically populate by making the appropriate selection in the County/State Agency of Filing drop down menu.
- # The next eight digits automatically populate when a date is entered.
- # The last three digits correspond with the sequential order of issuance for each calendar year. For example, the first receipt number issued on January 1 should end in 001. If a county issued 252 receipts for the year ending on December 31, the last receipt number should end in 252. CDFW recommends that counties and state agencies 1) save a local copy of this form, and 2) track receipt numbers on a spreadsheet tabbed by month to ensure accuracy.

DO NOT COMBINE THE ENVIRONMENTAL FEES WITH THE STATE SHARE OF FISH AND WILDLIFE FEES.

Mail to:

California Department of Fish and Wildlife
 Accounting Services Branch
 P.O. Box 944209
 Sacramento, California 94244-2090



State of California - Department of Fish and Wildlife
2023 ENVIRONMENTAL DOCUMENT FILING FEE
CASH RECEIPT
 DFW 753.5a (REV. 01/01/23) Previously DFG 753.5a

corrected receipt

RECEIPT NUMBER: 58 - 11082023 - 35
STATE CLEARINGHOUSE NUMBER (If applicable)

SEE INSTRUCTIONS ON REVERSE. TYPE OR PRINT CLEARLY.

LEAD AGENCY OLIVEHURST PUBLIC UTILITY DIST	LEAD AGENCY EMAIL	DATE 11/08/2023
COUNTY/STATE AGENCY OF FILING YUBA	DOCUMENT NUMBER 2023FG-00035	

PROJECT TITLE
 ADVANCED METER INTEGRATION AT THE OPUD PLUMAS LAKE WATER TREATMENT PLANT

PROJECT APPLICANT NAME OLIVEHURST PUBLIC UTILITY DIST	PROJECT APPLICANT EMAIL	PHONE NUMBER (530) 682-0736
PROJECT APPLICANT ADDRESS 1970 9TH AVE	CITY OLIVEHURST	STATE CA
		ZIP CODE 95961

PROJECT APPLICANT (Check appropriate box)

- Local Public Agency
 School District
 Other Special District
 State Agency
 Private Entity

CHECK APPLICABLE FEES:

- | | | |
|---|------------|----------|
| <input type="checkbox"/> Environmental Impact Report (EIR) | \$3,839.25 | \$ _____ |
| <input type="checkbox"/> Mitigated/Negative Declaration (MND)(ND) | \$2,764.00 | \$ _____ |
| <input type="checkbox"/> Certified Regulatory Program (CRP) document - payment due directly to CDFW | \$1,305.25 | \$ _____ |

- Exempt from fee
 Notice of Exemption (attach)
 CDFW No Effect Determination (attach)
 Fee previously paid (attach previously issued cash receipt copy)

- | | | |
|---|----------|------------------|
| <input type="checkbox"/> Water Right Application or Petition Fee (State Water Resources Control Board only) | \$850.00 | \$ _____ |
| <input checked="" type="checkbox"/> County documentary handling fee | | \$ _____ \$50.00 |
| <input type="checkbox"/> Other 0.00 | | \$ _____ |

PAYMENT METHOD:

- Cash Credit Check Other
 TOTAL RECEIVED \$ _____ \$50.00

SIGNATURE X	AGENCY OF FILING PRINTED NAME AND TITLE Nelida Williams Deputy
-----------------------	---



State of California - Department of Fish and Wildlife
2023 ENVIRONMENTAL DOCUMENT FILING FEE
CASH RECEIPT
 DFW 753.5a (REV. 01/01/23) Previously DFG 753.5a

NOTICE

Each project applicant shall remit to the county clerk the environmental filing fee before or at the time of filing a Notice of Determination (Pub. Resources Code, § 21152; Fish & G. Code, § 711.4, subdivision (d); Cal. Code Regs., tit. 14, § 753.5). Without the appropriate fee, statutory or categorical exemption, or a valid No Effect Determination issued by the California Department of Fish and Wildlife (CDFW), the Notice of Determination is not operative, vested, or final, and shall not be accepted by the county clerk.

COUNTY DOCUMENTARY HANDLING FEE

The county clerk may charge a documentary handling fee of fifty dollars (\$50) per filing in addition to the environmental filing fee (Fish & G. Code, § 711.4, subd. (e); Cal. Code Regs., tit. 14, § 753.5, subd. (g)(1)). A county board of supervisors shall have the authority to increase or decrease the fee or charge, that is otherwise authorized to be levied by another provision of law, in the amount reasonably necessary to recover the cost of providing any product or service or the cost of enforcing any regulation for which the fee or charge is levied (Gov. Code, § 54985, subd. (a)).

COLLECTION PROCEDURES FOR COUNTY GOVERNMENTS

Filing Notice of Determination (NOD):

- Collect environmental filing fee or copy of previously issued cash receipt. *(Do not collect fee if project applicant presents a No Effect Determination signed by CDFW. An additional fee is required for each separate environmental document. An addendum is not considered a separate environmental document. Checks should be made payable to the county.)*
- Issue cash receipt to project applicant.
- Attach copy of cash receipt and, if applicable, previously issued cash receipt, to NOD.
- Mail filing fees for **CRP** document to CDFW prior to filing the NOD or equivalent final approval (Cal. Code Regs. Tit. 14, § 753.5 (b)(5)). The CRP should request receipt from CDFW to show proof of payment for filing the NOD or equivalent approval. Please mail payment to address below made attention to the Cash Receipts Unit of the Accounting Services Branch.

If the project applicant presents a **No Effect Determination** signed by CDFW, also:

- Attach No Effect Determination to NOD *(no environmental filing fee is due)*.

Filing Notice of Exemption (NOE) (Statutorily or categorically exempt project (Cal. Code Regs., tit. 14, §§ 15260-15285, 15300-15333))

- Issue cash receipt to project applicant.
- Attach copy of cash receipt to NOE *(no environmental filing fee is due)*.

Within **30 days after the end of each month in which the environmental filing fees are collected**, each county shall summarize and record the amount collected on the monthly State of California Form No. CA25 (TC31) and remit the amount collected to the State Treasurer. Identify the remittance on Form No. CA25 as "Environmental Document Filing Fees" per Fish and Game Code section 711.4.

The county clerk shall mail the following documents to CDFW on a monthly basis:

- ✓ A photocopy of the monthly State of California Form No. CA25 (TC31)
- ✓ CDFW/ASB copies of all cash receipts (including all voided receipts)
- ✓ A copy of all CDFW No Effect Determinations filed in lieu of fee payment
- ✓ A copy of all NODs filed with the county during the preceding month
- ✓ A list of the name, address and telephone number of all project applicants for which an NOD has been filed. If this information is contained on the cash receipt filed with CDFW under California Code of Regulations, title 14, section 753.5, subdivision (e)(6), no additional information is required.

DOCUMENT RETENTION

The county shall retain two copies of the cash receipt (for lead agency and county clerk) and a copy of all documents described above for at least 12 months.

RECEIPT NUMBER

- # The first two digits automatically populate by making the appropriate selection in the County/State Agency of Filing drop down menu.
- # The next eight digits automatically populate when a date is entered.
- # The last three digits correspond with the sequential order of issuance for each calendar year. For example, the first receipt number issued on January 1 should end in 001. If a county issued 252 receipts for the year ending on December 31, the last receipt number should end in 252. CDFW recommends that counties and state agencies 1) save a local copy of this form, and 2) track receipt numbers on a spreadsheet tabbed by month to ensure accuracy.

DO NOT COMBINE THE ENVIRONMENTAL FEES WITH THE STATE SHARE OF FISH AND WILDLIFE FEES.

Mail to:

California Department of Fish and Wildlife
 Accounting Services Branch
 P.O. Box 944209
 Sacramento, California 94244-2090



State of California - Department of Fish and Wildlife
2023 ENVIRONMENTAL DOCUMENT FILING FEE
CASH RECEIPT
 DFW 753.5a (REV. 01/01/23) Previously DFG 753.5a

RECEIPT NUMBER:
 58 - 11082023 - 35
 STATE CLEARINGHOUSE NUMBER (If applicable)

SEE INSTRUCTIONS ON REVERSE. TYPE OR PRINT CLEARLY.

LEAD AGENCY OLIVEHURST PUBLIC UTILITY DIST	LEAD AGENCY EMAIL	DATE 11/08/2023
COUNTY/STATE AGENCY OF FILING YUBA	DOCUMENT NUMBER 2023FG-00035	

PROJECT TITLE
 ADVANCED METER INTEGRATION AT THE OPUD PLUMAS LAKE WATER

PROJECT APPLICANT NAME OLIVEHURST PUBLIC UTILITY DIST	PROJECT APPLICANT EMAIL	PHONE NUMBER
PROJECT APPLICANT ADDRESS 1970 9TH AVE	CITY OLIVEHURST	STATE CA
		ZIP CODE 95961

PROJECT APPLICANT (Check appropriate box)

- Local Public Agency
 School District
 Other Special District
 State Agency
 Private Entity

CHECK APPLICABLE FEES:

- Environmental Impact Report (EIR) \$3,839.25 \$ _____
 Mitigated/Negative Declaration (MND)(ND) \$2,764.00 \$ _____
 Certified Regulatory Program (CRP) document - payment due directly to CDFW \$1,305.25 \$ _____

- Exempt from fee
 Notice of Exemption (attach)
 CDFW No Effect Determination (attach)
 Fee previously paid (attach previously issued cash receipt copy)

- Water Right Application or Petition Fee (State Water Resources Control Board only) \$850.00 \$ _____
 County documentary handling fee \$ _____ \$50.00
 Other 0.00 \$ _____

PAYMENT METHOD:

- Cash
 Credit
 Check
 Other
 TOTAL RECEIVED \$ _____ \$50.00

SIGNATURE X Mandy Luis	AGENCY OF FILING PRINTED NAME AND TITLE Mandy Luis Deputy
---------------------------	--



State of California - Department of Fish and Wildlife
2023 ENVIRONMENTAL DOCUMENT FILING FEE
CASH RECEIPT
 DFW 753.5a (REV. 01/01/23) Previously DFG 753.5a

NOTICE

Each project applicant shall remit to the county clerk the environmental filing fee before or at the time of filing a Notice of Determination (Pub. Resources Code, § 21152; Fish & G. Code, § 711.4, subdivision (d); Cal. Code Regs., tit. 14, § 753.5). Without the appropriate fee, statutory or categorical exemption, or a valid No Effect Determination issued by the California Department of Fish and Wildlife (CDFW), the Notice of Determination is not operative, vested, or final, and shall not be accepted by the county clerk.

COUNTY DOCUMENTARY HANDLING FEE

The county clerk may charge a documentary handling fee of fifty dollars (\$50) per filing in addition to the environmental filing fee (Fish & G. Code, § 711.4, subd. (e); Cal. Code Regs., tit. 14, § 753.5, subd. (g)(1)). A county board of supervisors shall have the authority to increase or decrease the fee or charge, that is otherwise authorized to be levied by another provision of law, in the amount reasonably necessary to recover the cost of providing any product or service or the cost of enforcing any regulation for which the fee or charge is levied (Gov. Code, § 54985, subd. (a)).

COLLECTION PROCEDURES FOR COUNTY GOVERNMENTS

Filing Notice of Determination (NOD):

- Collect environmental filing fee or copy of previously issued cash receipt. *(Do not collect fee if project applicant presents a No Effect Determination signed by CDFW. An additional fee is required for each separate environmental document. An addendum is not considered a separate environmental document. Checks should be made payable to the county.)*
- Issue cash receipt to project applicant.
- Attach copy of cash receipt and, if applicable, previously issued cash receipt, to NOD.
- Mail filing fees for **CRP** document to CDFW prior to filing the NOD or equivalent final approval (Cal. Code Regs. Tit. 14, § 753.5 (b)(5)). The CRP should request receipt from CDFW to show proof of payment for filing the NOD or equivalent approval. Please mail payment to address below made attention to the Cash Receipts Unit of the Accounting Services Branch.

If the project applicant presents a **No Effect Determination** signed by CDFW, also:

- Attach No Effect Determination to NOD *(no environmental filing fee is due)*.

Filing Notice of Exemption (NOE) *(Statutorily or categorically exempt project (Cal. Code Regs., tit. 14, §§ 15260-15285, 15300-15333))*

- Issue cash receipt to project applicant.
- Attach copy of cash receipt to NOE *(no environmental filing fee is due)*.

Within 30 days after the end of each month in which the environmental filing fees are collected, each county shall summarize and record the amount collected on the monthly State of California Form No. CA25 (TC31) and remit the amount collected to the State Treasurer. Identify the remittance on Form No. CA25 as "Environmental Document Filing Fees" per Fish and Game Code section 711.4.

The county clerk shall mail the following documents to CDFW on a monthly basis:

- ✓ A photocopy of the monthly State of California Form No. CA25 (TC31)
- ✓ CDFW/ASB copies of all cash receipts (including all voided receipts)
- ✓ A copy of all CDFW No Effect Determinations filed in lieu of fee payment
- ✓ A copy of all NODs filed with the county during the preceding month
- ✓ A list of the name, address and telephone number of all project applicants for which an NOD has been filed. If this information is contained on the cash receipt filed with CDFW under California Code of Regulations, title 14, section 753.5, subdivision (e)(6), no additional information is required.

DOCUMENT RETENTION

The county shall retain two copies of the cash receipt (for lead agency and county clerk) and a copy of all documents described above for at least 12 months.

RECEIPT NUMBER

- # The first two digits automatically populate by making the appropriate selection in the County/State Agency of Filing drop down menu.
- # The next eight digits automatically populate when a date is entered.
- # The last three digits correspond with the sequential order of issuance for each calendar year. For example, the first receipt number issued on January 1 should end in 001. If a county issued 252 receipts for the year ending on December 31, the last receipt number should end in 252. CDFW recommends that counties and state agencies 1) save a local copy of this form, and 2) track receipt numbers on a spreadsheet tabbed by month to ensure accuracy.

DO NOT COMBINE THE ENVIRONMENTAL FEES WITH THE STATE SHARE OF FISH AND WILDLIFE FEES.

Mail to:

California Department of Fish and Wildlife
 Accounting Services Branch
 P.O. Box 944209
 Sacramento, California 94244-2090