

Project Specific Water Quality Management Plan

A Template for Projects located within the **Santa Ana Watershed** Region of Riverside County

Project Title: The Ridge - Idyllwild Guest Ranch

Development No: APN 568-070-006, 568-070-007, 568-070-021

Design Review/Case No: CUP 210121

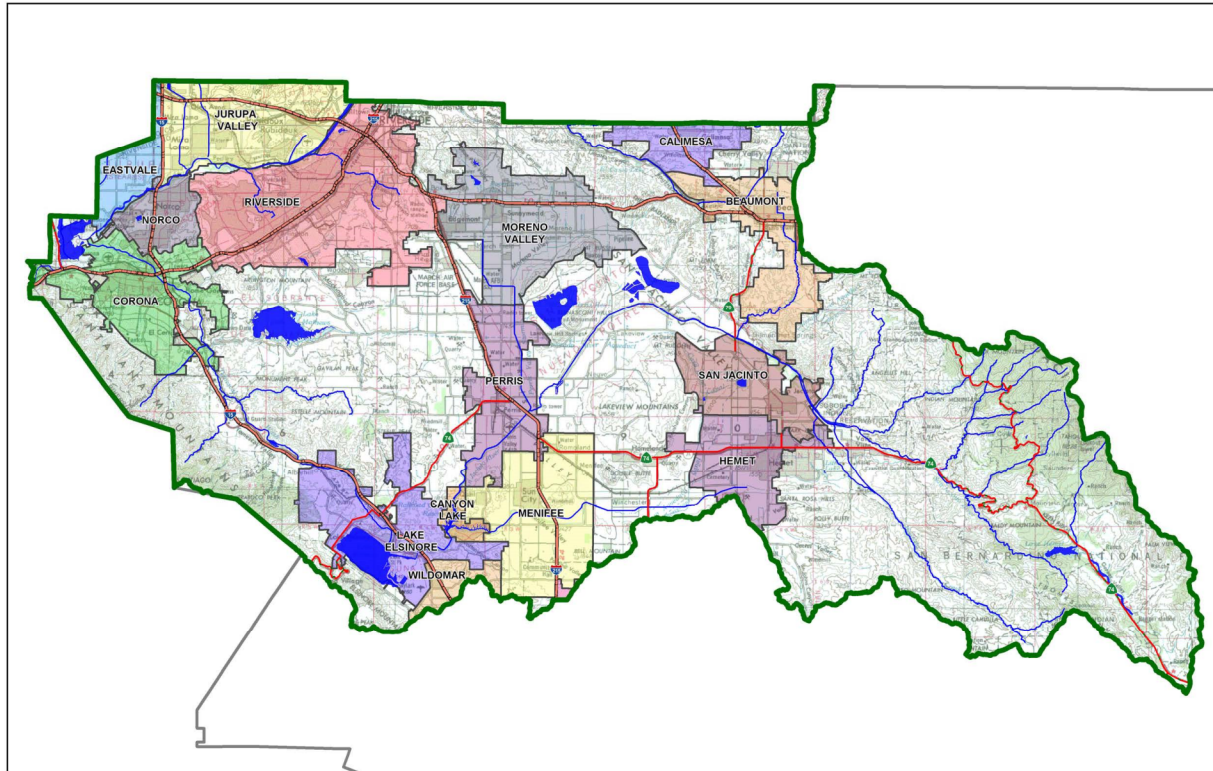

- Preliminary
- Final

Original Date Prepared: 07/19/2021

Revision Date(s): November 7, 2022, November 21, 2022,
May 26, 2023

Prepared for Compliance with
Regional Board Order No. R8-2010-0033

Template revised June 30, 2016

Contact Information:

Prepared for:

Caroline Legrand
The Ridge
8407 Wyndham Road
Los Angeles, CA 90046
(310) 666-3623

Prepared by:

Joseph L. Castaneda, P.E.
JLC Engineering and Consulting, Inc.
41660 Ivy Street, Suite A
Murrieta, CA 92562
(951) 304-9552

**RIVERSIDE COUNTY
TRANSPORTATION DEPT
WQMP
PRELIMINARY
APPROVAL**

Date: 6/13/2023 By: RTebben

A Brief Introduction

This Project-Specific WQMP Template for the **Santa Ana Region** has been prepared to help guide you in documenting compliance for your project. Because this document has been designed to specifically document compliance, you will need to utilize the WQMP Guidance Document as your “how-to” manual to help guide you through this process. Both the Template and Guidance Document go hand-in-hand, and will help facilitate a well prepared Project-Specific WQMP. Below is a flowchart for the layout of this Template that will provide the steps required to document compliance.

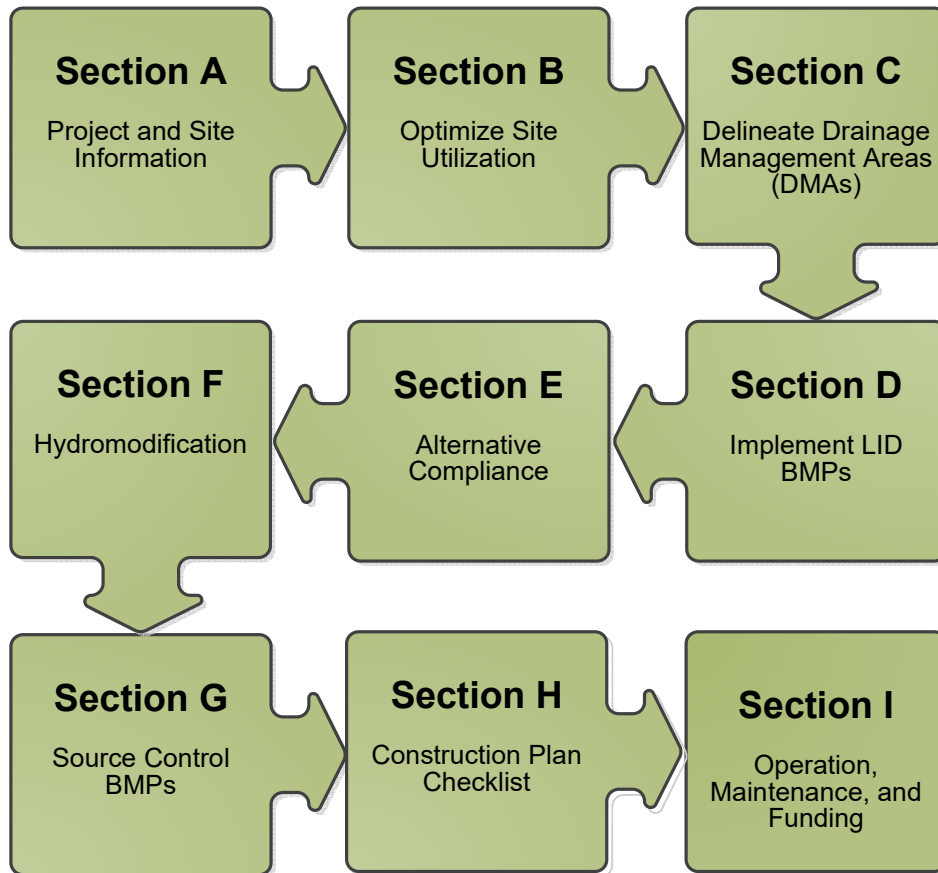

OWNER'S CERTIFICATION

This Project-Specific Water Quality Management Plan (WQMP) has been prepared for The Ridge by JLC Engineering for The Ridge – Idyllwild Guest Ranch project.

This WQMP is intended to comply with the requirements of Riverside County for Ordinance No. 14.12.316 which includes the requirement for the preparation and implementation of a Project-Specific WQMP.

The undersigned, while owning the property/project described in the preceding paragraph, shall be responsible for the implementation and funding of this WQMP and will ensure that this WQMP is amended as appropriate to reflect up-to-date conditions on the site. In addition, the property owner accepts responsibility for interim operation and maintenance of Stormwater BMPs until such time as this responsibility is formally transferred to a subsequent owner. This WQMP will be reviewed with the facility operator, facility supervisors, employees, tenants, maintenance and service contractors, or any other party (or parties) having responsibility for implementing portions of this WQMP. At least one copy of this WQMP will be maintained at the project site or project office in perpetuity. The undersigned is authorized to certify and to approve implementation of this WQMP. The undersigned is aware that implementation of this WQMP is enforceable under Riverside County Water Quality Ordinance Municipal Code Section 14.12.316.

"I, the undersigned, certify under penalty of law that the provisions of this WQMP have been reviewed and accepted and that the WQMP will be transferred to future successors in interest."

Owner's Signature

Date

Owner's Printed Name

Owner's Title/Position

PREPARER'S CERTIFICATION

"The selection, sizing and design of stormwater treatment and other stormwater quality and quantity control measures in this plan meet the requirements of Regional Water Quality Control Board Order No. **R8-2010-0033** and any subsequent amendments thereto."



Preparer's Signature

5/26/2023

Date

Joseph L. Castaneda

Preparer's Printed Name

P.E./Project Manager

Preparer's Title/Position

Preparer's Licensure:



Table of Contents

Section A: Project and Site Information.....	6
A.1 Maps and Site Plans.....	6
A.2 Identify Receiving Waters.....	7
A.3 Additional Permits/Approvals required for the Project:	7
Section B: Optimize Site Utilization (LID Principles)	9
Section C: Delineate Drainage Management Areas (DMAs).....	11
Section D: Implement LID BMPs	13
D.1 Infiltration Applicability	13
D.2 Harvest and Use Assessment.....	14
D.3 Bioretention and Biotreatment Assessment	16
D.4 Feasibility Assessment Summaries	17
D.5 LID BMP Sizing	18
Section E: Alternative Compliance (LID Waiver Program)	19
E.1 Identify Pollutants of Concern	20
E.2 Stormwater Credits	21
E.3 Sizing Criteria.....	21
E.4 Treatment Control BMP Selection	22
Section F: Hydromodification	23
F.1 Hydrologic Conditions of Concern (HCOC) Analysis.....	23
F.2 HCOC Mitigation.....	24
Section G: Source Control BMPs.....	25
Section H: Construction Plan Checklist	28
Section I: Operation, Maintenance and Funding.....	29

List of Tables

Table A.1 Identification of Receiving Waters.....	7
Table A.2 Other Applicable Permits.....	7
Table C.1 DMA Classifications.....	11
Table C.2 Type 'A', Self-Treating Areas.....	11
Table C.3 Type 'B', Self-Retaining Areas.....	11
Table C.4 Type 'C', Areas that Drain to Self-Retaining Areas.....	12
Table C.5 Type 'D', Areas Draining to BMPs.....	12
Table D.1 Infiltration Feasibility.....	13
Table D.2 LID Prioritization Summary Matrix.....	17
Table D.3 DCV Calculations for LID BMPs.....	18
Table E.1 Potential Pollutants by Land Use Type.....	20
Table E.2 Water Quality Credits.....	21
Table E.3 Treatment Control BMP Sizing.....	21
Table E.4 Treatment Control BMP Selection.....	22
Table F.1 Hydrologic Conditions of Concern Summary.....	23
Table G.1 Permanent and Operational Source Control Measures.....	25
Table H.1 Construction Plan Cross-reference.....	28

List of Appendices

Appendix 1: Maps and Site Plans.....	30
Appendix 2: Construction Plans.....	31
Appendix 3: Soils Information.....	32
Appendix 4: Historical Site Conditions.....	33
Appendix 5: LID Infeasibility.....	34
Appendix 6: BMP Design Details.....	35
Appendix 7: Hydromodification.....	36
Appendix 8: Source Control.....	37
Appendix 9: O&M.....	38
Appendix 10: Educational Materials.....	- 6 -

Section A: Project and Site Information

PROJECT INFORMATION	
Type of Project:	Wellness Camp
Planning Area:	N/A
Community Name:	Idyllwild
Development Name:	The Ridge – Wellness Camp
PROJECT LOCATION	
Latitude & Longitude (DMS): 33°40'29.1"N 116°40'37.2"W	
Project Watershed and Sub-Watershed: San Jacinto Valley Hydrological Unit, Hemet Lake Hydrological Subarea	
Gross Acres: 37.37 Acres	
APN(s): 568-170-021, 568-170-006, 568-170-007	
Map Book and Page No.: Map Book 568, Page 7	
PROJECT CHARACTERISTICS	
Proposed or Potential Land Use(s)	N-A (Natural Assets)
Proposed or Potential SIC Code(s)	7041
Area of Impervious Project Footprint (SF)	161,370.4 SF
Total Area of <u>proposed</u> Impervious Surfaces within the Project Footprint (SF)/or Replacement	161,370.4 SF
Does the project consist of offsite road improvements?	<input type="checkbox"/> Y <input checked="" type="checkbox"/> N
Does the project propose to construct unpaved roads?	<input type="checkbox"/> Y <input checked="" type="checkbox"/> N
Is the project part of a larger common plan of development (phased project)?	<input type="checkbox"/> Y <input checked="" type="checkbox"/> N
EXISTING SITE CHARACTERISTICS	
Total area of <u>existing</u> Impervious Surfaces within the Project limits Footprint (SF)	0
Is the project located within any MSHCP Criteria Cell?	<input type="checkbox"/> Y <input checked="" type="checkbox"/> N
If so, identify the Cell number:	N/A
Are there any natural hydrologic features on the project site?	<input checked="" type="checkbox"/> Y <input type="checkbox"/> N
<i>Project is adjacent to the Hurkey Creek, a watershed area that is approximately 7,000 acres in size.</i>	
Is a Geotechnical Report attached?	<input checked="" type="checkbox"/> Y <input type="checkbox"/> N
If no Geotech. Report, list the NRCS soils type(s) present on the site (A, B, C and/or D)	A
What is the Water Quality Design Storm Depth for the project?	0.9"

Project Narrative

The water quality for this project is composed of three areas labeled as DMA 1, DMA 2 and DMA 4 which all drain into Bioretention Basin 1 for water treatment. Bioretention Basin 1 will provide storage volume for the water quality design capture volume and it will provide storage volume for increased runoff produced from the post development of the project site.

A.1 Maps and Site Plans

When completing your Project-Specific WQMP, include a map of the local vicinity and existing site. In addition, include all grading, drainage, landscape/plant palette and other pertinent construction plans in Appendix 2. At a **minimum**, your WQMP Site Plan should include the following:

- Drainage Management Areas
- Proposed Structural BMPs
- Drainage Path
- Drainage Infrastructure, Inlets, Overflows
- Source Control BMPs
- Buildings, Roof Lines, Downspouts
- Impervious Surfaces
- Standard Labeling
- BMP Locations (Lat/Long)

Use your discretion on whether or not you may need to create multiple sheets or can appropriately accommodate these features on one or two sheets. Keep in mind that the Co-Permittee plan reviewer must be able to easily analyze your project utilizing this template and its associated site plans and maps.

A.2 Identify Receiving Waters

Using Table A.1 below, list in order of upstream to downstream, the receiving waters that the project site is tributary to. Continue to fill each row with the Receiving Water’s 303(d) listed impairments (if any), designated beneficial uses, and proximity, if any, to a RARE beneficial use. Include a map of the receiving waters in Appendix 1.

Table A.1 Identification of Receiving Waters

Receiving Waters	EPA Approved 303(d) List Impairments	Designated Beneficial Uses	Proximity to RARE Beneficial Use
Hurkey Creek	N/A	MUN, AGR, GWR, REC-1, REC-2, WARM, WILD	Not a RARE designated water body
Lake Hemet	N/A	MUN, AGR, GWR, POW, REC-1, REC-2, WARM, COLD, WILD, SPWN	Not a RARE designated water body
San Jacinto River	Escherichia coli, Fecal Coliform, Nitrate, Dissolved Oxygen, Toxicity, Turbidity	AGR, GWR, REC-1, REC-2, WARM, WILD	Not a RARE designated water body
Canyon Lake	Nutrients	MUN, AGR, GWR, REC-1, REC-2, WARM, WILD	Not a RARE designated water body
San Jacinto River	Escherichia coli, Fecal Coliform, Nitrate, Dissolved Oxygen, Toxicity, Turbidity	MUN, AGR, GWR, REC-1, REC-2, WARM, WILD	Not a RARE designated water body
Lake Elsinore	DDT, Nutrients, Organic Enrichment/Low Dissolved Oxygen, PCBs, Toxicity	REC-1, REC-2, WARM, WILD	Not a RARE designated water body

A.3 Additional Permits/Approvals required for the Project:

Table A.2 Other Applicable Permits

Agency	Permit Required	
State Department of Fish and Game, 1602 Streambed Alteration Agreement	<input type="checkbox"/> Y	<input checked="" type="checkbox"/> N
State Water Resources Control Board, Clean Water Act (CWA) Section 401 Water Quality Cert.	<input type="checkbox"/> Y	<input checked="" type="checkbox"/> N
US Army Corps of Engineers, CWA Section 404 Permit	<input type="checkbox"/> Y	<input checked="" type="checkbox"/> N
US Fish and Wildlife, Endangered Species Act Section 7 Biological Opinion	<input type="checkbox"/> Y	<input checked="" type="checkbox"/> N
Statewide Construction General Permit Coverage	<input checked="" type="checkbox"/> Y	<input type="checkbox"/> N
Statewide Industrial General Permit Coverage	<input type="checkbox"/> Y	<input checked="" type="checkbox"/> N
Western Riverside MSHCP Consistency Approval (e.g., JPR, DBESP)	<input type="checkbox"/> Y	<input checked="" type="checkbox"/> N
Other (please list in the space below as required)	<input type="checkbox"/> Y	<input type="checkbox"/> N

If yes is answered to any of the questions above, the Co-Permittee may require proof of approval/coverage from those agencies as applicable including documentation of any associated requirements that may affect this Project-Specific WQMP.

Section B: Optimize Site Utilization (LID Principles)

Review of the information collected in Section 'A' will aid in identifying the principal constraints on site design and selection of LID BMPs as well as opportunities to reduce imperviousness and incorporate LID Principles into the site and landscape design. For example, **constraints** might include impermeable soils, high groundwater, groundwater pollution or contaminated soils, steep slopes, geotechnical instability, high-intensity land use, heavy pedestrian or vehicular traffic, utility locations or safety concerns. **Opportunities** might include existing natural areas, low areas, oddly configured or otherwise unbuildable parcels, easements and landscape amenities including open space and buffers (which can double as locations for bioretention BMPs), and differences in elevation (which can provide hydraulic head). Prepare a brief narrative for each of the site optimization strategies described below. This narrative will help you as you proceed with your LID design and explain your design decisions to others.

The 2010 Santa Ana MS4 Permit further requires that LID Retention BMPs (Infiltration Only or Harvest and Use) be used unless it can be shown that those BMPs are infeasible. Therefore, it is important that your narrative identify and justify if there are any constraints that would prevent the use of those categories of LID BMPs. Similarly, you should also note opportunities that exist which will be utilized during project design. Upon completion of identifying Constraints and Opportunities, include these on your WQMP Site plan in Appendix 1.

Consideration of "highest and best use" of the discharge should also be considered. For example, Lake Elsinore is evaporating faster than runoff from natural precipitation can recharge it. Requiring infiltration of 85% of runoff events for projects tributary to Lake Elsinore would only exacerbate current water quality problems associated with Pollutant concentration due to lake water evaporation. In cases where rainfall events have low potential to recharge Lake Elsinore (i.e. no hydraulic connection between groundwater to Lake Elsinore, or other factors), requiring infiltration of Urban Runoff from projects is counterproductive to the overall watershed goals. Project proponents, in these cases, would be allowed to discharge Urban Runoff, provided they used equally effective filtration-based BMPs.

Site Optimization

The following questions are based upon Section 3.2 of the WQMP Guidance Document. Review of the WQMP Guidance Document will help you determine how best to optimize your site and subsequently identify opportunities and/or constraints, and document compliance.

Did you identify and preserve existing drainage patterns? If so, how? If not, why?

Yes, the existing site maintained the drainage patterns which flow from the north to south. The development plan prepared by the project team developed a site plan that would minimize disturbance to the project site area by salvaging existing trees and the natural terrain. Any disturbance to the drainage patterns were a result of meeting County of Riverside design criteria required for structural integrity of the buildings or providing structural drive aisle for public safety and the use of County Fire Services

Did you identify and protect existing vegetation? If so, how? If not, why?

Yes, to project design was designed to maintain and protect the existing trees and natural landscape to the maximum extent practicable. Any disturbance to the natural vegetation were a result of meeting County of Riverside design criteria required for structural integrity of the buildings or providing structural drive aisle for public safety and the use of County Fire Services

Did you identify and preserve natural infiltration capacity? If so, how? If not, why?

Yes, the natural infiltration of the project site has been maintained to the maximum extent practicable. However, natural infiltration will be disturbed in areas that require compaction to meet County of Riverside design criteria required for structural integrity of the buildings or providing structural drive aisle for public safety. It should be noted that the project will not be able to implement infiltration type BMPs due to the high ground water table based on the geotechnical report.

Did you identify and minimize impervious area? If so, how? If not, why?

Yes, impervious area is limited to the maximum extent practicable. Areas what have been converted to impervious areas are required to meet County of Riverside design criteria required for structural integrity of the buildings or providing structural drive aisle for public safety.

Did you identify and disperse runoff to adjacent pervious areas? If so, how? If not, why?

Yes, runoff from roofs and impervious areas will be directed into the adjacent landscaping prior to collection in storm drains. Moreover, the runoff will be conveyed into landscape BMPs to further promote evaporation and transpiration of the runoff.

Section C: Delineate Drainage Management Areas (DMAs)

Utilizing the procedure in Section 3.3 of the WQMP Guidance Document which discusses the methods of delineating and mapping your project site into individual DMAs, complete Table C.1 below to appropriately categorize the types of classification (e.g., Type A, Type B, etc.) per DMA for your project site. Upon completion of this table, this information will then be used to populate and tabulate the corresponding tables for their respective DMA classifications.

Table C.1 DMA Classifications

DMA Name or ID	Surface Type(s) ¹²	Area (Sq. Ft.)	DMA Type
DMA 1	ROOF, ROAD, SIDEWALK & NATURAL	310,582.8 SF	D
DMA 2	ROOF, ROAD, SIDEWALK & NATURAL	221,720.4 SF	D
DMA 4	NATURAL	29,342.5 SF	D

¹Reference Table 2-1 in the WQMP Guidance Document to populate this column

²If multi-surface provide back-up

Table C.2 Type 'A', Self-Treating Areas

DMA Name or ID	Area (Sq. Ft.)	Stabilization Type	Irrigation Type (if any)

Table C.3 Type 'B', Self-Retaining Areas

Self-Retaining Area				Type 'C' DMAs that are draining to the Self-Retaining Area		
DMA Name/ ID	Post-project surface type	Area (square feet)	Storm Depth (inches)	DMA Name / ID	[C] from Table C.4 = [C]	Required Retention Depth (inches)
		[A]	[B]			[D]

$$[D] = [B] + \frac{[B] \cdot [C]}{[A]}$$

Table C.4 Type 'C', Areas that Drain to Self-Retaining Areas

DMA					Receiving Self-Retaining DMA		
DMA Name/ ID	Area (square feet)	Post-project surface type	Impervious fraction	Product	DMA name /ID	Area (square feet)	Ratio
	[A]		[B]			[C] = [A] x [B]	[D]

Table C.5 Type 'D', Areas Draining to BMPs

DMA Name or ID	BMP Name or ID
DMA 1	Basin 1
DMA 2	Basin 1
DMA 4	Basin 1

Note: More than one drainage management area can drain to a single LID BMP, however, one drainage management area may not drain to more than one BMP.

Section D: Implement LID BMPs

D.1 Infiltration Applicability

Is there an approved downstream ‘Highest and Best Use’ for stormwater runoff (see discussion in Chapter 2.4.4 of the WQMP Guidance Document for further details)? Y N

If yes has been checked, Infiltration BMPs shall not be used for the site; proceed to section D.3

If no, continue working through this section to implement your LID BMPs. It is recommended that you contact your Co-Permittee to verify whether or not your project discharges to an approved downstream ‘Highest and Best Use’ feature.

Geotechnical Report

A Geotechnical Report or Phase I Environmental Site Assessment may be required by the Copermitee to confirm present and past site characteristics that may affect the use of Infiltration BMPs. In addition, the Co-Permittee, at their discretion, may not require a geotechnical report for small projects as described in Chapter 2 of the WQMP Guidance Document. If a geotechnical report has been prepared, include it in Appendix 3. In addition, if a Phase I Environmental Site Assessment has been prepared, include it in Appendix 4.

Is this project classified as a small project consistent with the requirements of Chapter 2 of the WQMP Guidance Document? Y N

Infiltration Feasibility

Table D.1 below is meant to provide a simple means of assessing which DMAs on your site support Infiltration BMPs and is discussed in the WQMP Guidance Document in Chapter 2.4.5. Check the appropriate box for each question and then list affected DMAs as applicable. If additional space is needed, add a row below the corresponding answer.

Table D.1 Infiltration Feasibility

Does the project site...	YES	NO
...have any DMAs with a seasonal high groundwater mark shallower than 10 feet? If Yes, list affected DMAs: DMA 1, DMA 2	X	
...have any DMAs located within 100 feet of a water supply well? If Yes, list affected DMAs:		X
...have any areas identified by the geotechnical report as posing a public safety risk where infiltration of stormwater could have a negative impact? If Yes, list affected DMAs:		X
...have measured in-situ infiltration rates of less than 1.6 inches / hour? If Yes, list affected DMAs:		X
...have significant cut and/or fill conditions that would preclude in-situ testing of infiltration rates at the final infiltration surface? If Yes, list affected DMAs:		X
...geotechnical report identify other site-specific factors that would preclude effective and safe infiltration? Describe here: The project is subject to liquefaction	X	

If you answered “Yes” to any of the questions above for any DMA, Infiltration BMPs should not be used for those DMAs and you should proceed to the assessment for Harvest and Use below.

D.2 Harvest and Use Assessment

Please check what applies:

- Reclaimed water will be used for the non-potable water demands for the project.
- Downstream water rights may be impacted by Harvest and Use as approved by the Regional Board (verify with the Copermittee).
- The Design Capture Volume will be addressed using Infiltration Only BMPs. In such a case, Harvest and Use BMPs are still encouraged, but it would not be required if the Design Capture Volume will be infiltrated or evapotranspired.

If any of the above boxes have been checked, Harvest and Use BMPs need not be assessed for the site. If none of the above criteria applies, follow the steps below to assess the feasibility of irrigation use, toilet use and other non-potable uses (e.g., industrial use).

Project has implemented a self-retaining area to maximize infiltration. Additionally, project will not implement harvest and use since the project does not want to adversely impact water storage to Lake Hemet which is a reservoir that impounds runoff for domestic consumption.

Irrigation Use Feasibility

Complete the following steps to determine the feasibility of harvesting stormwater runoff for Irrigation Use BMPs on your site:

Step 1: Identify the total area of irrigated landscape on the site, and the type of landscaping used.

Total Area of Irrigated Landscape: N/A

Type of Landscaping (Conservation Design or Active Turf): N/A

Step 2: Identify the planned total of all impervious areas on the proposed project from which runoff might be feasibly captured and stored for irrigation use. Depending on the configuration of buildings and other impervious areas on the site, you may consider the site as a whole, or parts of the site, to evaluate reasonable scenarios for capturing and storing runoff and directing the stored runoff to the potential use(s) identified in Step 1 above.

Total Area of Impervious Surfaces: 0 acres

Step 3: Cross reference the Design Storm depth for the project site (see Exhibit A of the WQMP Guidance Document) with the left column of Table 2-3 in Chapter 2 to determine the minimum area of Effective Irrigated Area per Tributary Impervious Area (EIATIA).

Enter your EIATIA factor: N/A

Step 4: Multiply the unit value obtained from Step 3 by the total of impervious areas from Step 2 to develop the minimum irrigated area that would be required.

Minimum required irrigated area: N/A

Step 5: Determine if harvesting stormwater runoff for irrigation use is feasible for the project by comparing the total area of irrigated landscape (Step 1) to the minimum required irrigated area (Step 4).

Minimum required irrigated area (Step 4)	Available Irrigated Landscape (Step 1)
N/A	N/A

Toilet Use Feasibility

Complete the following steps to determine the feasibility of harvesting stormwater runoff for toilet flushing uses on your site:

Step 1: Identify the projected total number of daily toilet users during the wet season, and account for any periodic shut downs or other lapses in occupancy:

Projected Number of Daily Toilet Users: N/A

Project Type: N/A

Step 2: Identify the planned total of all impervious areas on the proposed project from which runoff might be feasibly captured and stored for toilet use. Depending on the configuration of buildings and other impervious areas on the site, you may consider the site as a whole, or parts of the site, to evaluate reasonable scenarios for capturing and storing runoff and directing the stored runoff to the potential use(s) identified in Step 1 above.

Total Area of Impervious Surfaces: 0 acres

Step 3: Enter the Design Storm depth for the project site (see Exhibit A) into the left column of Table 2-2 in Chapter 2 to determine the minimum number of toilet users per tributary impervious acre (TUTIA).

Enter your TUTIA factor: N/A

Step 4: Multiply the unit value obtained from Step 3 by the total of impervious areas from Step 2 to develop the minimum number of toilet users that would be required.

Minimum number of toilet users: N/A

Step 5: Determine if harvesting stormwater runoff for toilet flushing use is feasible for the project by comparing the Number of Daily Toilet Users (Step 1) to the minimum required number of toilet users (Step 4).

Minimum required Toilet Users (Step 4)	Projected number of toilet users (Step 1)
N/A	N/A

Other Non-Potable Use Feasibility

Are there other non-potable uses for stormwater runoff on the site (e.g. industrial use)? See Chapter 2 of the Guidance for further information. If yes, describe below. If no, write N/A.

N/A

Step 1: Identify the projected average daily non-potable demand, in gallons per day, during the wet season and accounting for any periodic shut downs or other lapses in occupancy or operation.

Average Daily Demand: Projected Average Daily Use (gpd)

Step 2: Identify the planned total of all impervious areas on the proposed project from which runoff might be feasibly captured and stored for the identified non-potable use. Depending on the configuration of buildings and other impervious areas on the site, you may consider the site as a whole, or parts of the site, to evaluate reasonable scenarios for capturing and storing runoff and directing the stored runoff to the potential use(s) identified in Step 1 above.

Total Area of Impervious Surfaces: Insert Area (Acres)

Step 3: Enter the Design Storm depth for the project site (see Exhibit A) into the left column of Table 2-4 in Chapter 2 to determine the minimum demand for non-potable uses per tributary impervious acre.

Enter the factor from Table 2-4: Enter Value

Step 4: Multiply the unit value obtained from Step 3 by the total of impervious areas from Step 2 to develop the minimum number of gallons per day of non-potable use that would be required.

Minimum required use: Minimum use required (gpd)

Step 5: Determine if harvesting stormwater runoff for other non-potable use is feasible for the project by comparing the projected average daily use (Step 1) to the minimum required non-potable use (Step 4).

Minimum required non-potable use (Step 4)	Projected average daily use (Step 1)
Minimum use required (gpd)	Projected Average Daily Use (gpd)

If Irrigation, Toilet and Other Use feasibility anticipated demands are less than the applicable minimum values, Harvest and Use BMPs are not required and you should proceed to utilize LID Bioretention and Biotreatment per Section 3.4.2 of the WQMP Guidance Document.

D.3 Bioretention and Biotreatment Assessment

Other LID Bioretention and Biotreatment BMPs as described in Chapter 2.4.7 of the WQMP Guidance Document are feasible on nearly all development sites with sufficient advance planning.

Select one of the following:

- LID Bioretention/Biotreatment BMPs will be used for some or all DMAs of the project as noted below in Section D.4 (note the requirements of Section 3.4.2 in the WQMP Guidance Document).
- A site-specific analysis demonstrating the technical infeasibility of all LID BMPs has been performed and is included in Appendix 5. If you plan to submit an analysis demonstrating the technical infeasibility of LID BMPs, request a pre-submittal meeting with the Copermittee to discuss this option. Proceed to Section E to document your alternative compliance measures.

D.4 Feasibility Assessment Summaries

From the Infiltration, Harvest and Use, Bioretention and Biotreatment Sections above, complete Table D.2 below to summarize which LID BMPs are technically feasible, and which are not, based upon the established hierarchy.

Table D.2 LID Prioritization Summary Matrix

DMA Name/ID	LID BMP Hierarchy				No LID (Alternative Compliance)
	1. Infiltration	2. Harvest and use	3. Bioretention	4. Biotreatment	
1	<input type="checkbox"/>	<input type="checkbox"/>	<input checked="" type="checkbox"/>	<input type="checkbox"/>	<input type="checkbox"/>
2	<input type="checkbox"/>	<input type="checkbox"/>	<input checked="" type="checkbox"/>	<input type="checkbox"/>	<input type="checkbox"/>
4	<input type="checkbox"/>	<input type="checkbox"/>	<input checked="" type="checkbox"/>	<input type="checkbox"/>	<input type="checkbox"/>
	<input type="checkbox"/>	<input type="checkbox"/>	<input type="checkbox"/>	<input type="checkbox"/>	<input type="checkbox"/>
	<input type="checkbox"/>	<input type="checkbox"/>	<input type="checkbox"/>	<input type="checkbox"/>	<input type="checkbox"/>
	<input type="checkbox"/>	<input type="checkbox"/>	<input type="checkbox"/>	<input type="checkbox"/>	<input type="checkbox"/>

For those DMAs where LID BMPs are not feasible, provide a brief narrative below summarizing why they are not feasible, include your technical infeasibility criteria in Appendix 5, and proceed to Section E below to document Alternative Compliance measures for those DMAs. Recall that each proposed DMA must pass through the LID BMP hierarchy before alternative compliance measures may be considered.

Project was able to implement LID BMPs for the project area. DMA's 1, 2 and 4 are all treated at Bioretention Basin 1.

D.5 LID BMP Sizing

Each LID BMP must be designed to ensure that the Design Capture Volume will be addressed by the selected BMPs. First, calculate the Design Capture Volume for each LID BMP using the V_{BMP} worksheet in Appendix F of the LID BMP Design Handbook. Second, design the LID BMP to meet the required V_{BMP} using a method approved by the Copermittee. Utilize the worksheets found in the LID BMP Design Handbook or consult with your Copermittee to assist you in correctly sizing your LID BMPs. Complete Table D.3 below to document the Design Capture Volume and the Proposed Volume for each LID BMP. Provide the completed design procedure sheets for each LID BMP in Appendix 6. You may add additional rows to the table below as needed.

Table D.3 DCV Calculations for LID BMPs

DMA Type/ID	DMA Area (square feet)	Post-Project Surface Type	Effective Impervious Fraction, I_f	DMA Runoff Factor	DMA Areas x Runoff Factor	<i>Bioretention Basin 1</i>		
DMA	[A]		[B]	[C]	[A] x [C]			
DMA 1	29355	Roofs	1	0.89	26184.7	Design Storm Depth (in)	Design Capture Volume, V_{BMP} (cubic feet)	Proposed Volume on Plans (cubic feet)
DMA 1	47963	Concrete or Asphalt	1	0.89	42783			
DMA 1	233264.8	Natural (A Soil)	0.03	0.06	14588.7			
DMA 2	27879	Roofs	1	0.89	24868.1			
DMA 2	47855	Concrete or Asphalt	1	0.89	42686.7			
DMA 2	145986.4	Natural (A Soil)	0.03	0.06	9130.2			
DMA 4	29342.5	Natural (A Soil)	0.03	0.06	1835.1			
	$A_T = \Sigma[A]$ = 561645.7				$\Sigma =$ [D]=162076.5			

[B], [C] is obtained as described in Section 2.3.1 of the WQMP Guidance Document

[E] is obtained from Exhibit A in the WQMP Guidance Document

[G] is obtained from a design procedure sheet, such as in LID BMP Design Handbook and placed in Appendix 6

The total Bioretention Basin 1 design volume spreadsheet has been included in Appendix 6. Basin 1 has a WQ Volume = 12200 CF = 0.28 Ac-ft. For hydromodifications of the 10 year, 24 hr storm event, it contains a Mitigation Volume = 1.3 Ac-ft. Basin 1 has been adequately sized to hold both a WQ and Mitigation Volume as it has a Total Design Volume of 2.87 Ac-ft and a volume of 1.3 Ac-ft for mitigation.

Section E: Alternative Compliance (LID Waiver Program)

LID BMPs are expected to be feasible on virtually all projects. Where LID BMPs have been demonstrated to be infeasible as documented in Section D, other Treatment Control BMPs must be used (subject to LID waiver approval by the Copermittee). Check one of the following Boxes:

LID Principles and LID BMPs have been incorporated into the site design to fully address all Drainage Management Areas. No alternative compliance measures are required for this project and thus this Section is not required to be completed.

- Or -

The following Drainage Management Areas are unable to be addressed using LID BMPs. A site-specific analysis demonstrating technical infeasibility of LID BMPs has been approved by the Co-Permittee and included in Appendix 5. Additionally, no downstream regional and/or sub-regional LID BMPs exist or are available for use by the project. The following alternative compliance measures on the following pages are being implemented to ensure that any pollutant loads expected to be discharged by not incorporating LID BMPs, are fully mitigated.

List DMAs here.

E.1 Identify Pollutants of Concern

Utilizing Table A.1 from Section A above which noted your project's receiving waters and their associated EPA approved 303(d) listed impairments, cross reference this information with that of your selected Priority Development Project Category in Table E.1 below. If the identified General Pollutant Categories are the same as those listed for your receiving waters, then these will be your Pollutants of Concern and the appropriate box or boxes will be checked on the last row. The purpose of this is to document compliance and to help you appropriately plan for mitigating your Pollutants of Concern in lieu of implementing LID BMPs.

Table E.1 Potential Pollutants by Land Use Type

Priority Development Project Categories and/or Project Features (check those that apply)	General Pollutant Categories							
	Bacterial Indicators	Metals	Nutrients	Pesticides	Toxic Organic Compounds	Sediments	Trash & Debris	Oil & Grease
<input type="checkbox"/> Detached Residential Development	P	N	P	P	N	P	P	P
<input type="checkbox"/> Attached Residential Development	P	N	P	P	N	P	P	P ⁽²⁾
<input type="checkbox"/> Commercial/Industrial Development	P ⁽³⁾	P	P ⁽¹⁾	P ⁽¹⁾	P ⁽⁵⁾	P ⁽¹⁾	P	P
<input type="checkbox"/> Automotive Repair Shops	N	P	N	N	P ^(4, 5)	N	P	P
<input type="checkbox"/> Restaurants (>5,000 ft ²)	P	N	N	N	N	N	P	P
<input type="checkbox"/> Hillside Development (>5,000 ft ²)	P	N	P	P	N	P	P	P
<input type="checkbox"/> Parking Lots (>5,000 ft ²)	P ⁽⁶⁾	P	P ⁽¹⁾	P ⁽¹⁾	P ⁽⁴⁾	P ⁽¹⁾	P	P
<input type="checkbox"/> Retail Gasoline Outlets	N	P	N	N	P	N	P	P
Project Priority Pollutant(s) of Concern	<input type="checkbox"/>	<input type="checkbox"/>	<input type="checkbox"/>	<input type="checkbox"/>	<input type="checkbox"/>	<input type="checkbox"/>	<input type="checkbox"/>	<input type="checkbox"/>

P = Potential

N = Not Potential

⁽¹⁾ A potential Pollutant if non-native landscaping exists or is proposed onsite; otherwise not expected

⁽²⁾ A potential Pollutant if the project includes uncovered parking areas; otherwise not expected

⁽³⁾ A potential Pollutant is land use involving animal waste

⁽⁴⁾ Specifically petroleum hydrocarbons

⁽⁵⁾ Specifically solvents

⁽⁶⁾ Bacterial indicators are routinely detected in pavement runoff

E.2 Stormwater Credits

Projects that cannot implement LID BMPs but nevertheless implement smart growth principles are potentially eligible for Stormwater Credits. Utilize Table 3-8 within the WQMP Guidance Document to identify your Project Category and its associated Water Quality Credit. If not applicable, write N/A.

Table E.2 Water Quality Credits

Qualifying Project Categories	Credit Percentage ²
<i>Total Credit Percentage¹</i>	

¹Cannot Exceed 50%

²Obtain corresponding data from Table 3-8 in the WQMP Guidance Document

E.3 Sizing Criteria

After you appropriately considered Stormwater Credits for your project, utilize Table E.3 below to appropriately size them to the DCV, or Design Flow Rate, as applicable. Please reference Chapter 3.5.2 of the WQMP Guidance Document for further information.

Table E.3 Treatment Control BMP Sizing

DMA Type/ID	DMA Area (square feet)	Post-Project Surface Type	Effective Impervious Fraction, I _r	DMA Runoff Factor	DMA Area x Runoff Factor	Enter BMP Name / Identifier Here			
	[A]		[B]	[C]	[A] x [C]				
						Design Storm Depth (in)	Minimum Design Capture Volume or Design Flow Rate (cubic feet or cfs)	Total Storm Water Credit % Reduction	Proposed Volume or Flow on Plans (cubic feet or cfs)
	$A_T = \sum[A]$			$\Sigma = [D]$	[E]	$[F] = \frac{[D] \times [E]}{[G]}$	$[F] \times (1-[H])$	[I]	

[B], [C] is obtained as described in Section 2.3.1 from the WQMP Guidance Document

[E] is for Flow-Based Treatment Control BMPs [E] = .2, for Volume-Based Control Treatment BMPs, [E] obtained from Exhibit A in the WQMP Guidance Document

[G] is for Flow-Based Treatment Control BMPs [G] = 43,560, for Volume-Based Control Treatment BMPs, [G] = 12

[H] is from the Total Credit Percentage as Calculated from Table E.2 above

[I] as obtained from a design procedure sheet from the BMP manufacturer and should be included in Appendix 6

E.4 Treatment Control BMP Selection

Treatment Control BMPs typically provide proprietary treatment mechanisms to treat potential pollutants in runoff, but do not sustain significant biological processes. Treatment Control BMPs must have a removal efficiency of a medium or high effectiveness as quantified below:

- **High:** equal to or greater than 80% removal efficiency
- **Medium:** between 40% and 80% removal efficiency

Such removal efficiency documentation (e.g., studies, reports, etc.) as further discussed in Chapter 3.5.2 of the WQMP Guidance Document, must be included in Appendix 6. In addition, ensure that proposed Treatment Control BMPs are properly identified on the WQMP Site Plan in Appendix 1.

Table E.4 Treatment Control BMP Selection

Selected Treatment Control BMP Name or ID ¹	Priority Pollutant(s) of Concern to Mitigate ²	Removal Efficiency Percentage ³

¹ Treatment Control BMPs must not be constructed within Receiving Waters. In addition, a proposed Treatment Control BMP may be listed more than once if they possess more than one qualifying pollutant removal efficiency.

² Cross Reference Table E.1 above to populate this column.

³ As documented in a Co-Permittee Approved Study and provided in Appendix 6.

Section F: Hydromodification

F.1 Hydrologic Conditions of Concern (HCOC) Analysis

Once you have determined that the LID design is adequate to address water quality requirements, you will need to assess if the proposed LID Design may still create a HCOC. Review Chapters 2 and 3 (including Figure 3-7) of the WQMP Guidance Document to determine if your project must mitigate for Hydromodification impacts. If your project meets one of the following criteria which will be indicated by the check boxes below, you do not need to address Hydromodification at this time. However, if the project does not qualify for Exemptions 1, 2 or 3, then additional measures must be added to the design to comply with HCOC criteria. This is discussed in further detail below in Section F.2.

HCOC EXEMPTION 1: The Priority Development Project disturbs less than one acre. The Copermitttee has the discretion to require a Project-Specific WQMP to address HCOCs on projects less than one acre on a case by case basis. The disturbed area calculation should include all disturbances associated with larger common plans of development.

Does the project qualify for this HCOC Exemption? Y N

If Yes, HCOC criteria do not apply.

HCOC EXEMPTION 2: The volume and time of concentration¹ of storm water runoff for the post-development condition is not significantly different from the pre-development condition for a 2-year return frequency storm (a difference of 5% or less is considered insignificant) using one of the following methods to calculate:

- Riverside County Hydrology Manual
- Technical Release 55 (TR-55): Urban Hydrology for Small Watersheds (NRCS 1986), or derivatives thereof, such as the Santa Barbara Urban Hydrograph Method
- Other methods acceptable to the Co-Permittee

Does the project qualify for this HCOC Exemption? Y N

If Yes, report results in Table F.1 below and provide your substantiated hydrologic analysis in Appendix 7.

Table F.1 Hydrologic Conditions of Concern Summary

	2 year – 24 hour		
	Pre-condition	Post-condition	% Difference
Time of Concentration	INSERT VALUE	INSERT VALUE	INSERT VALUE
Volume (Cubic Feet)	INSERT VALUE	INSERT VALUE	INSERT VALUE

¹ Time of concentration is defined as the time after the beginning of the rainfall when all portions of the drainage basin are contributing to flow at the outlet.

HCOC EXEMPTION 3: All downstream conveyance channels to an adequate sump (for example, Prado Dam, Lake Elsinore, Canyon Lake, Santa Ana River, or other lake, reservoir or naturally erosion resistant feature) that will receive runoff from the project are engineered and regularly maintained to ensure design flow capacity; no sensitive stream habitat areas will be adversely affected; or are not identified on the Co-Permittees Hydromodification Susceptibility Maps.

Does the project qualify for this HCOC Exemption? Y N

If Yes, HCOC criteria do not apply and note below which adequate sump applies to this HCOC qualifier:

INSERT TEXT HERE

F.2 HCOC Mitigation

If none of the above HCOC Exemption Criteria are applicable, HCOC criteria is considered mitigated if they meet one of the following conditions:

- a. Additional LID BMPS are implemented onsite or offsite to mitigate potential erosion or habitat impacts as a result of HCOCs. This can be conducted by an evaluation of site-specific conditions utilizing accepted professional methodologies published by entities such as the California Stormwater Quality Association (CASQA), the Southern California Coastal Water Research Project (SCCRWP), or other Co-Permittee approved methodologies for site-specific HCOC analysis.
- b. The project is developed consistent with an approved Watershed Action Plan that addresses HCOC in Receiving Waters.
- c. Mimicking the pre-development hydrograph with the post-development hydrograph, for a 2-year return frequency storm. Generally, the hydrologic conditions of concern are not significant, if the post-development hydrograph is no more than 10% greater than pre-development hydrograph. In cases where excess volume cannot be infiltrated or captured and reused, discharge from the site must be limited to a flow rate no greater than 110% of the pre-development 2-year peak flow.

Be sure to include all pertinent documentation used in your analysis of the items a, b or c in Appendix 7.

Basin 1 has been designed to mitigate the post-project increased peak flow rate to be equal to the pre-project flow rate. Calculations have been included in Appendix 7.

Section G: Source Control BMPs

Source control BMPs include permanent, structural features that may be required in your project plans — such as roofs over and berms around trash and recycling areas — and Operational BMPs, such as regular sweeping and “housekeeping”, that must be implemented by the site’s occupant or user. The MEP standard typically requires both types of BMPs. In general, Operational BMPs cannot be substituted for a feasible and effective permanent BMP. Using the Pollutant Sources/Source Control Checklist in Appendix 8, review the following procedure to specify Source Control BMPs for your site:

1. **Identify Pollutant Sources:** Review Column 1 in the Pollutant Sources/Source Control Checklist. Check off the potential sources of Pollutants that apply to your site.
2. **Note Locations on Project-Specific WQMP Exhibit:** Note the corresponding requirements listed in Column 2 of the Pollutant Sources/Source Control Checklist. Show the location of each Pollutant source and each permanent Source Control BMP in your Project-Specific WQMP Exhibit located in Appendix 1.
3. **Prepare a Table and Narrative:** Check off the corresponding requirements listed in Column 3 in the Pollutant Sources/Source Control Checklist. In the left column of Table G.1 below, list each potential source of runoff Pollutants on your site (from those that you checked in the Pollutant Sources/Source Control Checklist). In the middle column, list the corresponding permanent, Structural Source Control BMPs (from Columns 2 and 3 of the Pollutant Sources/Source Control Checklist) used to prevent Pollutants from entering runoff. **Add additional narrative** in this column that explains any special features, materials or methods of construction that will be used to implement these permanent, Structural Source Control BMPs.
4. **Identify Operational Source Control BMPs:** To complete your table, refer once again to the Pollutant Sources/Source Control Checklist. List in the right column of your table the Operational BMPs that should be implemented as long as the anticipated activities continue at the site. Copermittee stormwater ordinances require that applicable Source Control BMPs be implemented; the same BMPs may also be required as a condition of a use permit or other revocable Discretionary Approval for use of the site.

Table G.1 Permanent and Operational Source Control Measures

Potential Sources of Runoff pollutants	Permanent Structural Source Control BMPs	Operational Source Control BMPs
On-site storm drain inlets	Mark all inlets with the words “Only Rain Down the Storm Drain” or similar. Catch Basin Markers may be available from the Riverside County Flood Control and Water Conservation District, call 951.955.1200 to verify.	Maintain and periodically repaint or replace inlet markings. Provide stormwater pollution prevention information to new site owners, lessees, or operators. See applicable operational BMPs in Fact Sheet SC-44, “Drainage System Maintenance,” in the CASQA Stormwater Quality Handbooks at www.cabmphandbooks.com

Need for future indoor & structural pest control	Note building design features that discourage entry of pests.	Provide Integrated Pest Management information to owners, lessees, and operators.
Landscape/ Outdoor Pesticide Use	<p>State that final landscape plans will accomplish all of the following.</p> <p>Preserve existing native trees, shrubs, and ground cover to the maximum extent possible. Design landscaping to minimize irrigation and runoff, to promote surface infiltration where appropriate, and to minimize the use of fertilizers and pesticides that can contribute to stormwater pollution</p> <p>Where landscaped areas are used to retain or detain stormwater, specify plants that are tolerant of saturated soil conditions</p> <p>Consider using pest-resistant plants, especially adjacent to hardscape.</p> <p>To insure successful establishment, select plants appropriate to site soils, slopes, climate, sun, wind, rain, land use, air movement, ecological consistency, and plant interactions.</p>	<p>Maintain landscaping using minimum or no pesticides. See applicable operational BMPs in “What you should know for.....Landscape and Gardening” at http://rcflood.org/stormwater/Error! Hyperlink reference not valid.</p> <p>Provide IPM information to new owners, lessees and operators</p>
Pools, spas, ponds, decorative fountains, and other water features.	If the Co-Permittee requires pools to be plumbed to the sanitary sewer, place a note on the plans and state in the narrative that this connection will be made according to local requirements.	See applicable operational BMPs in “Guidelines for Maintaining Your Swimming Pool, Jacuzzi and Garden Fountain” at http://rcflood.org/stormwater/
Food service	Describe the location and features of the designated cleaning area. Describe the items to be cleaned in this facility and how it has been sized to insure that the largest	See the brochure, “The Food Service Industry Best Management Practices for: Restaurants, Grocery Stores, Delicatessens and Bakeries” at http://rcflood.org/stormwater/ Provide this brochure to new site owners, lessees, and operators.

	items can be accommodated.	
Refuse areas	<p>State how site refuse will be handled and provide supporting detail to what is shown on plans.</p> <p>State that signs will be posted on or near dumpsters with the words “Do not dump hazardous materials here” or similar.</p>	<p>State how the following will be implemented:</p> <p>Provide adequate number of receptacles. Inspect receptacles regularly; repair or replace leaky receptacles. Keep receptacles covered. Prohibit/prevent dumping of liquid or hazardous wastes. Post “no hazardous materials” signs. Inspect and pick up litter daily and clean up spills immediately. Keep spill control materials available on-site. See Fact Sheet SC-34, “Waste Handling and Disposal” in the CASQA Stormwater Quality Handbooks at www.cabmphandbooks.com</p>
Fire Sprinkler Test Water	Provide a means to drain fire sprinkler test water to the sanitary sewer.	See the note in Fact Sheet SC-41, “Building and Grounds Maintenance,” in the CASQA Stormwater Quality Handbooks at www.cabmphandbooks.com
Condensate drain lines	<p>Condensate drain lines may discharge to landscaped areas if the flow is small enough that runoff will not occur.</p> <p>Condensate drain lines may not discharge to the storm drain system.</p>	
Roofing, gutters, and trim.	Avoid roofing, gutters, and trim made of copper or other unprotected metals that may leach into runoff.	

Section H: Construction Plan Checklist

Populate Table H.1 below to assist the plan checker in an expeditious review of your project. The first two columns will contain information that was prepared in previous steps, while the last column will be populated with the corresponding plan sheets. This table is to be completed with the submittal of your final Project-Specific WQMP.

Table H.1 Construction Plan Cross-reference

BMP No. or ID	BMP Identifier and Description	Corresponding Plan Sheet(s)	BMP Location (Lat/Long)

Note that the updated table — or Construction Plan WQMP Checklist — is **only a reference tool** to facilitate an easy comparison of the construction plans to your Project-Specific WQMP. Co-Permittee staff can advise you regarding the process required to propose changes to the approved Project-Specific WQMP.

The WQMP is preliminary and does not have any construction drawing prepared at this time. Section H will be completed during final engineering.

Section I: Operation, Maintenance and Funding

The Copermittee will periodically verify that Stormwater BMPs on your site are maintained and continue to operate as designed. To make this possible, your Copermittee will require that you include in Appendix 9 of this Project-Specific WQMP:

1. A means to finance and implement facility maintenance in perpetuity, including replacement cost.
2. Acceptance of responsibility for maintenance from the time the BMPs are constructed until responsibility for operation and maintenance is legally transferred. A warranty covering a period following construction may also be required.
3. An outline of general maintenance requirements for the Stormwater BMPs you have selected.
4. Figures delineating and designating pervious and impervious areas, location, and type of Stormwater BMP, and tables of pervious and impervious areas served by each facility. Geo-locating the BMPs using a coordinate system of latitude and longitude is recommended to help facilitate a future statewide database system.
5. A separate list and location of self-retaining areas or areas addressed by LID Principles that do not require specialized O&M or inspections but will require typical landscape maintenance as noted in Chapter 5, pages 85-86, in the WQMP Guidance. Include a brief description of typical landscape maintenance for these areas.

Your local Co-Permittee will also require that you prepare and submit a detailed Stormwater BMP Operation and Maintenance Plan that sets forth a maintenance schedule for each of the Stormwater BMPs built on your site. An agreement assigning responsibility for maintenance and providing for inspections and certification may also be required.

Details of these requirements and instructions for preparing a Stormwater BMP Operation and Maintenance Plan are in Chapter 5 of the WQMP Guidance Document.

Maintenance Mechanism: Insert text here.

Will the proposed BMPs be maintained by a Home Owners' Association (HOA) or Property Owners Association (POA)?

Y N

Include your Operation and Maintenance Plan and Maintenance Mechanism in Appendix 9. Additionally, include all pertinent forms of educational materials for those personnel that will be maintaining the proposed BMPs within this Project-Specific WQMP in Appendix 10.

An O&M Manual will be prepared during final engineering once the final design is prepared.

Appendix 1: Maps and Site Plans

Location Map, WQMP Site Plan and Receiving Waters Map

Drawing Name: O:\302.01.21\Engineering\Hydrology_Plan\Exhibits\FIGURE-1-VICINITY-MAP.dwg
Last Opened: Jul 16, 2021 - 11:16am by stanner



VICINITY MAP





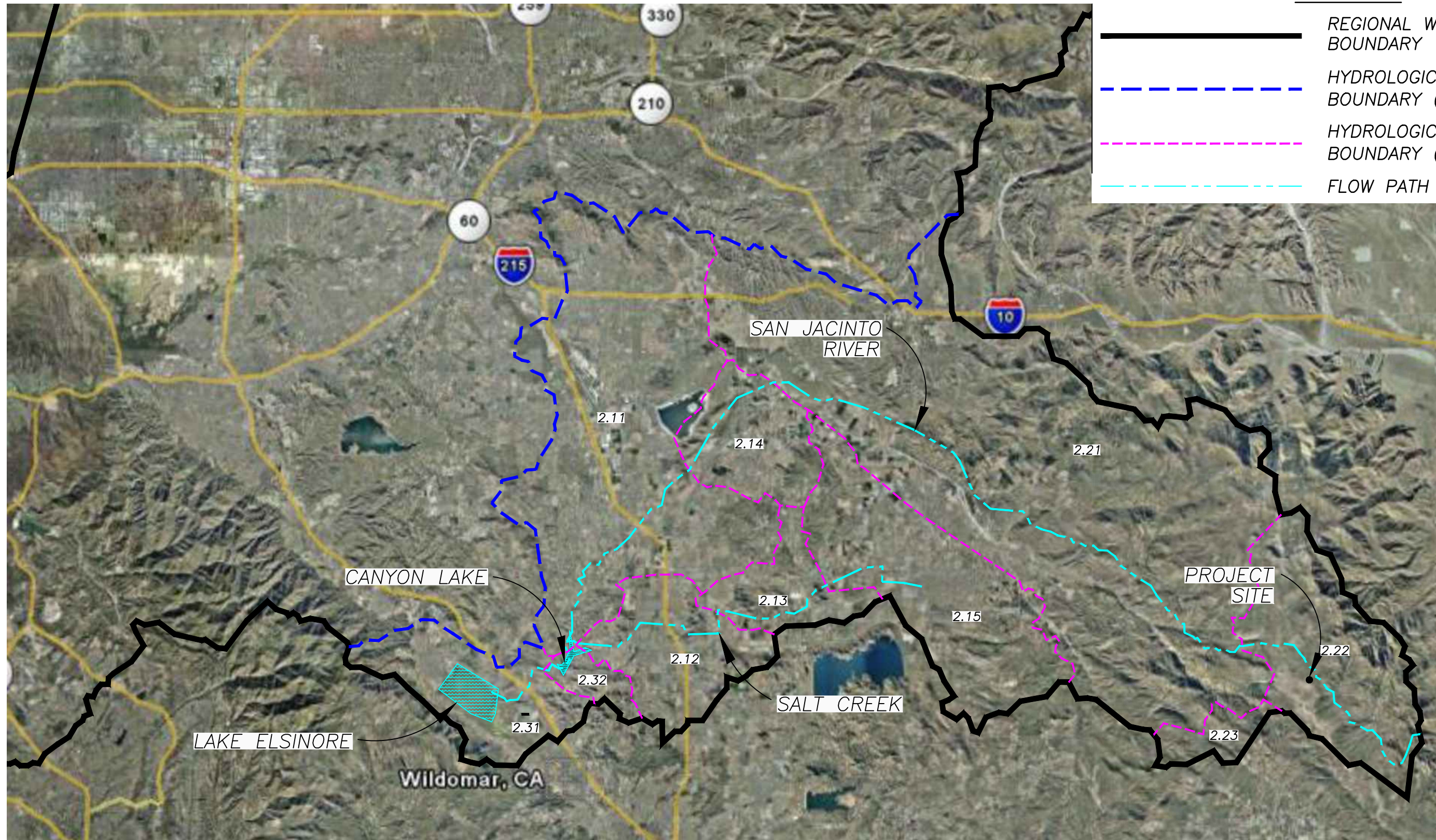

41660 IVY STREET, SUITE A
MURRIETA, CA 92562
PH. 951.304.9552 FAX 951.304.3568

FIGURE 1

Drawing Name: O:\302.01.21\Engineering\WQMP\Appendix 1 - Maps & Site Plan\Figure 2 - Receiving Waters Map.dwg
Last Opened: Jul 16, 2021 - 2:24pm by stanner



LEGEND

-  REGIONAL WATERSHED BOUNDARY
-  HYDROLOGICAL UNIT BOUNDARY (HU)
-  HYDROLOGICAL SUBAREA BOUNDARY (SA)
-  FLOW PATH

**THE RIDGE - RECEIVING WATERS MAP
SAN JACINTO WATERSHED**



JLC Engineering & Consulting, Inc.
41660 IVY STREET, SUITE A
MURRIETA, CA 92562
PH. 951.304.9552 FAX 951.304.3568

FIGURE 2

PRELIMINARY CONDITIONAL USE PERMIT 21-1021

COUNTY OF RIVERSIDE, STATE OF CALIFORNIA

WQMP SITE PLAN

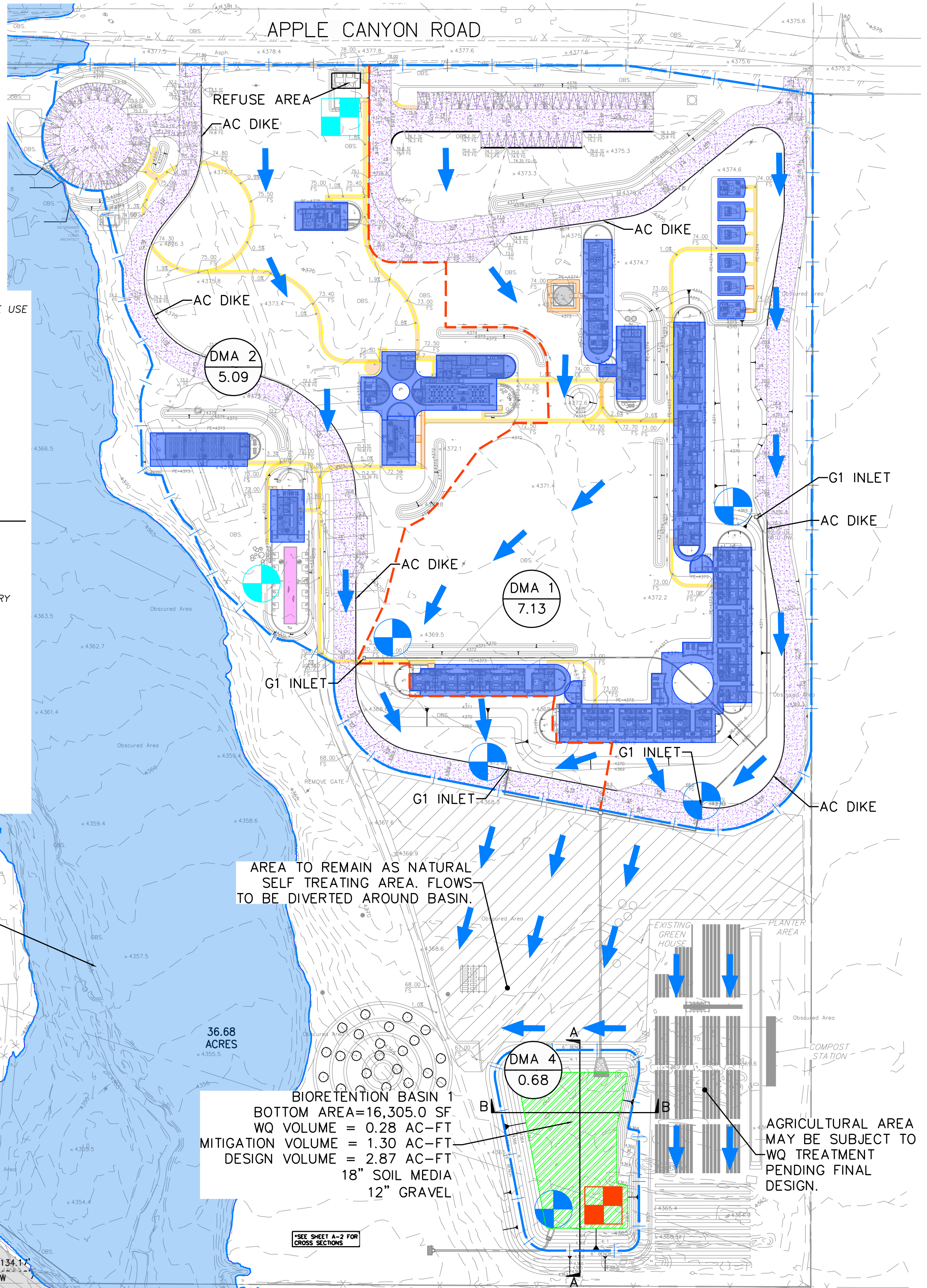

SOURCE CONTROL BMPS:

- SC-A: STORM DRAIN INLETS
- SC-D2: LANDSCAPE/OUTDOOR PESTICIDE USE
- SC-E: POOLS
- SC-G: REFUSE AREAS

LEGEND:

- SUB AREA ACRES
- WATERSHED SUB-BOUNDARY
- WATERSHED BOUNDARY
- FLOW ARROW
- BASIN
- POOL
- DRIVE AISLE
- ROOF
- PEDESTRIAN PATH

AREA TO REMAIN AS NATURAL SELF TREATING AREA. FLOWS TO BE DIVERTED AROUND BASIN.

BIORETENTION BASIN 1
 BOTTOM AREA=16,305.0 SF
 WQ VOLUME = 0.28 AC-FT
 MITIGATION VOLUME = 1.30 AC-FT
 DESIGN VOLUME = 2.87 AC-FT
 18" SOIL MEDIA
 12" GRAVEL

AGRICULTURAL AREA MAY BE SUBJECT TO WQ TREATMENT PENDING FINAL DESIGN.

NOTE:

1. WQ VOLUME = 12,200 CF = 0.28 AC-FT
2. AREA WILL NOT DRAIN INTO BIORETENTION BASIN 1. AREA TO REMAIN NATURAL SELF TREATING AREA FLOWS TO BE DIVERTED AROUND BASIN.

DMA AREA SUMMARY TABLE

DMA	ROOF TOP AREA (SF)	SIDEWALK (SF)	ROAD	NATURAL (SOIL A)	TOTAL IMPERVIOUS AREA (AC)	TOTAL AREA (AC)	IMPERVIOUS PERCENT
1	29,355.00	1,999.00	45,864.00	5.36	1.77	7.13	0.25%
2	27,879.00	17,159.00	30,696.00	3.35	1.74	5.09	0.34%
4	0.00	0.00	0.00	0.00	0.00	0.68	0.00%

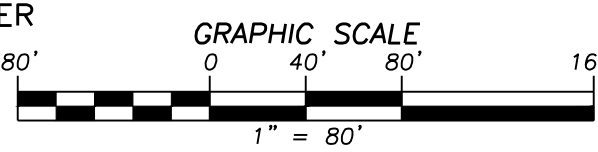
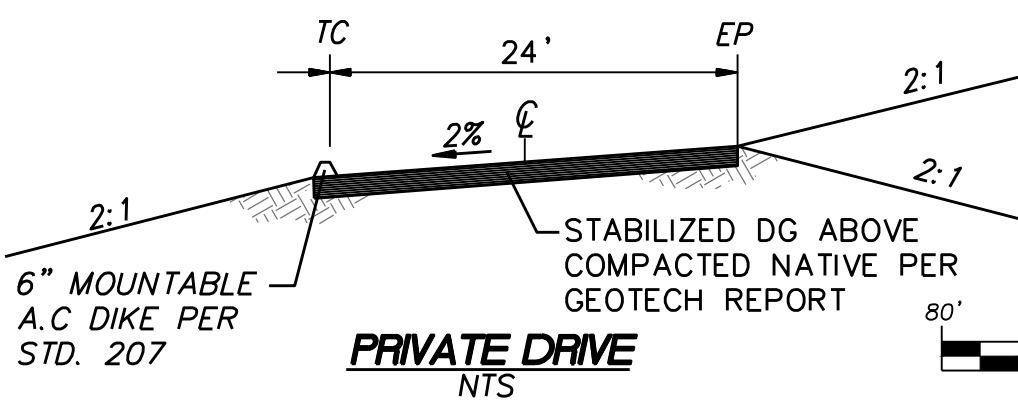

JLC Engineering & Consulting, Inc.
 41660 IVY STREET, SUITE A
 MURRIETA, CA 92562
 PH. 951.304.9552 FAX 951.304.3568

EXHIBIT "A-1"
CUP NO. 21-1021
WQMP SITE PLAN

PRELIMINARY CONDITIONAL USE PERMIT 21-1021

COUNTY OF RIVERSIDE, STATE OF CALIFORNIA

WQMP SITE PLAN

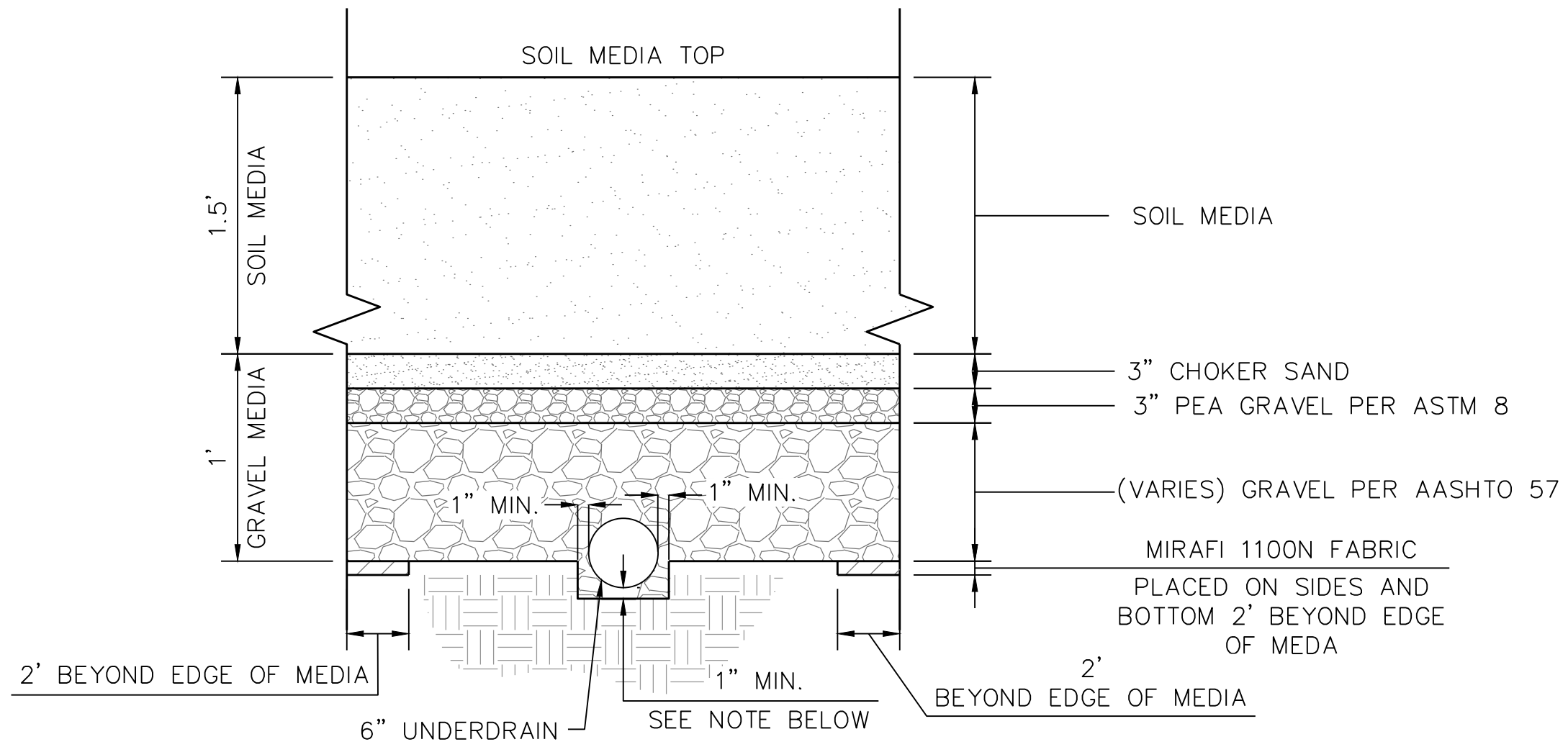

TYPICAL BIOFILTRATION BASIN** MEDIA DETAIL

SCALE: N.T.S.

NOTE: ENSURE 6" UNDERDRAINS HAVE 1" MINIMUM OF GRAVEL SURROUNDING ALL SIDES.

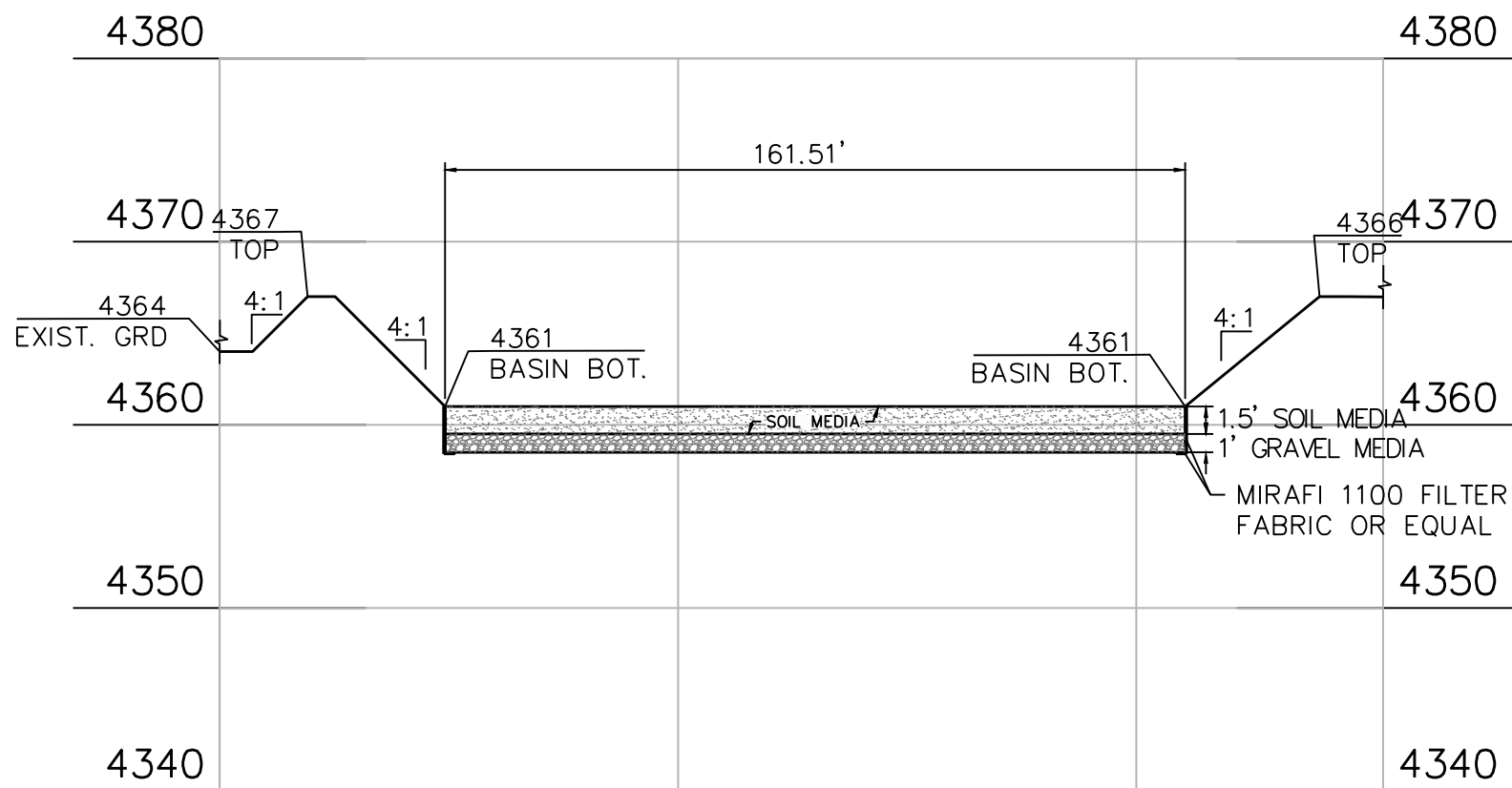

SECTION A

SCALE HORZ.: 1"=40'
VERT.: 1"=10'

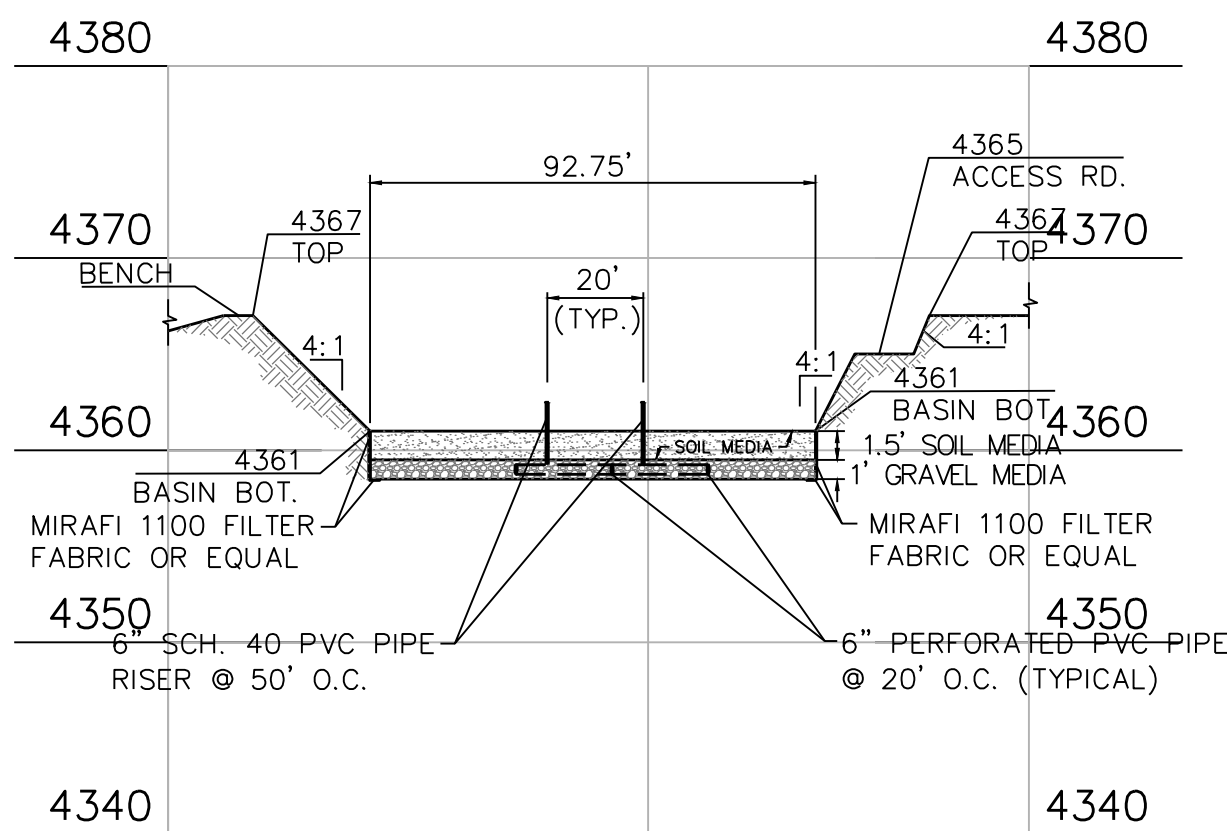

SECTION B

SCALE HORZ.: 1"=40'
VERT.: 1"=10'

EXHIBIT "A-2"

CUP NO. 21-1021

WQMP SITE PLAN



41660 IVY STREET, SUITE A
MURRIETA, CA 92562
PH. 951.304.9552 FAX 951.304.3568

Appendix 2: Construction Plans

Grading and Drainage Plans

Construction Plans will be provided during final engineering

Appendix 3: Soils Information

Geotechnical Study and Other Infiltration Testing Data

PLANNING LEVEL GEOTECHNICAL ASSESSMENT

*THE RIDGE WELLNESS CENTER
APPROXIMATE 36-ACRE PARCEL, ASSESSOR PARCEL NUMBER 568-070-021
LAKE HEMET AREA, RIVERSIDE COUNTY, CALIFORNIA*

MS. CAROLINE LEGRAND

*JULY 29, 2022
J.N. 20-227*

ENGINEERS + GEOLOGISTS + ENVIRONMENTAL SCIENTISTS

July 29, 2022
J.N. 20-227

MS. CAROLINE LEGRAND
8407 Wyndham Road
Los Angeles, California 90046

Subject: Planning Level Geotechnical Assessment: *The Ridge Wellness Center*, Approximate 36-acre Parcel, Assessor Parcel Number 568-070-021, Lake Hemet Area, Riverside County, California

Dear Ms. Legrand:

We are submitting our planning level geotechnical assessment report for the subject property located on Apple Canyon Road in the Lake Hemet area of Riverside County. Our work was performed in accordance with the scope of work outlined in our Proposal No. 20-227P, dated June 9, 2020, and supplemental proposal dated April 21, 2021. This report presents the results of our field investigation, laboratory testing, and our engineering judgment, opinions, conclusions, and recommendations about geotechnical design aspects of the proposed development.

It has been a pleasure to be of service to you on this project. Should you have any questions regarding the contents of this report or should you require additional information, please do not hesitate to contact us.

Respectfully submitted,

PETRA GEOSCIENCES, INC.



Alan Pace
Vice President

TABLE OF CONTENTS

	<u>Page</u>
INTRODUCTION	1
SITE LOCATION AND DESCRIPTION	1
PROPOSED CONSTRUCTION AND GRADING	2
REQUIRED ZONES OF INVESTIGATION	3
SUBSURFACE EXPLORATION.....	4
LABORATORY TESTING	5
Monitoring Well.....	6
PRELIMINARY INFILTRATION RATES.....	6
Shallow Infiltration Test Results.....	6
FINDINGS	7
Regional Geology.....	7
Local Geology and Subsurface Conditions	7
Groundwater.....	8
Flooding	9
Faulting	10
Seismically-Induced Flooding.....	10
Earthquake Loads.....	10
Discussion - General	13
Liquefaction and Seismically-Induced Settlement.....	14
Site-Specific Liquefaction Analysis.....	14
Analyses Using CPT Sounding Results	16
Analysis Results and Assessment of Liquefaction Effects.....	16
Soil Strength Loss	17
Surface Manifestation of Liquefaction.....	18
CONCLUSIONS AND RECOMMENDATIONS	20
General.....	20
Grading Plan Review	20
Effect of Proposed Grading on Adjacent Properties	20
Ground Improvement Program	20
Earthwork Recommendations	21
Earthwork Specifications	21
Site Clearing.....	21
Ground Preparation – Buildings and Structure Areas	22
Ground Preparation – Roadways and Flatwork not in Ground Improved Areas.....	22
Excavation Characteristics	23
Suitability of Site Soils as Fill.....	23
Fill Placement and Testing	23
Temporary Excavations.....	23
Slope Construction.....	24
Fill Slopes	24
Cut Slopes	24
Shrinkage and Subsidence.....	24
Oversize Material	24
Geotechnical Observations.....	25
PRELIMINARY FOUNDATION DESIGN GUIDELINES.....	25
Allowable Bearing Capacity, Estimated Settlement and Lateral Resistance	25
Allowable Soil Bearing Capacities.....	25
Static Settlement.....	26

TABLE OF CONTENTS

	<u>Page</u>
Dynamic (Seismically-Induced) Settlement.....	26
Lateral Resistance	26
Preliminary Guidelines for Footings and Slabs on-Grade Design and Construction	26
Conventional Slab-on-Grade System	27
Posts or Pole Foundations	29
Footing Observations	31
General Corrosivity Screening.....	31
Retaining Walls.....	32
Allowable Bearing Values	32
Active and At-Rest Earth Pressures	33
Earthquake Loads Retaining Walls	34
Subdrainage.....	34
Waterproofing	34
Wall Backfill	34
Geotechnical Observation and Testing.....	35
Masonry Block Walls	35
Exterior Concrete Flatwork.....	36
Subgrade Preparation	36
Drainage.....	36
Thickness and Joint Spacing	37
Reinforcement.....	37
Edge Beams (Optional).....	37
Tree Wells	38
Utility Trench Backfill	38
Site Drainage.....	38
Bottomless Trench Drains.....	39
Swimming Pool and Spa.....	39
Allowable Bearing and Settlement.....	39
Lateral Earth Pressures.....	40
Stability of Temporary Excavation	40
Temporary Access Ramps.....	40
Pool Bottom	40
Pool Decking.....	40
Plumbing Fixtures	40
Preliminary Pavement Design.....	41
EVALUATION LIMITATIONS.....	41
Direct Shear.....	54

FIGURES (Included is Body of Report)

FIGURE 1 – SITE LOCATION MAP

FIGURE 2 – STATE OF CALIFORNIA EARTHQUAKE ZONES OF REQUIRED INVESTIGATION

FIGURE 3 – RIVERSIDE COUNTY LIQUEFACTION SUSCEPTIBILITY MAP

FIGURE 4 – SEISMICALLY INDUCED SETTLEMENT

FIGURE 5 – LATERAL SPREADING ESTIMATES

ATTACHMENTS

LITERATURE REVIEWED

FIGURES RW-1 through RW-3 – RETAINING WALL DETAILS

APPENDIX A-1 – BORING LOGS / CPT SOUNDING LOGS

APPENDIX A-2 – GEOPHYSICISTS REFLECTION LINE REPORT

APPENDIX B-1 – LABORATORY TEST PROCEDURES / LABORATORY DATA SUMMARY

APPENDIX B-2 – LABORATORY TEST RESULTS – WATER SAMPLES FROM MW-1

APPENDIX C – PUMP TEST RESULTS MW-1

APPENDIX D – PERCOLATION TEST SUMMARY

APPENDIX E – SEISMIC DESIGN PARAMETERS

APPENDIX F – LIQUEFACTION ANALYSIS

PLATE 1 – GEOTECHNICAL MAP

PLANNING LEVEL GEOTECHNICAL ASSESSMENT
THE RIDGE WELLNESS CENTER
APPROXIMATELY 36 ACRE PARCEL, ASSESSOR PARCEL NUMBER 568-070-021
LAKE HEMET AREA, RIVERSIDE COUNTY, CALIFORNIA

INTRODUCTION

Petra Geosciences, Inc. (Petra) is presenting herein the results of our planning level geotechnical assessment of the subject property. The purposes of this assessment were to determine the nature of subsurface soils and evaluate their in-place characteristics, to provide planning level geotechnical recommendations with respect to site clearing and grading, and for the design and construction of building foundations.

SITE LOCATION AND DESCRIPTION

The subject site is a vacant, rectangular-shaped lot, approximately 36-acre parcel. It is located south of Apple Canyon Road, in the Lake Hemet area of Riverside County. The site is bounded by Apple Canyon Road on the north and by vacant land to the east and southeast. It is transected along the southwesterly side by State Highway 74, with a small portion of the parcel located southwesterly of that highway at the intersection with Lake Hemet Drive. On the western side is additional vacant property ascending uphill from the subject site. Several horse corals and other ancillary structures were observed onsite. A wide drainage feature transects the site in the middle, flowing from north to south, that empties into Lake Hemet. The location of the site is shown on Figure 1, below.

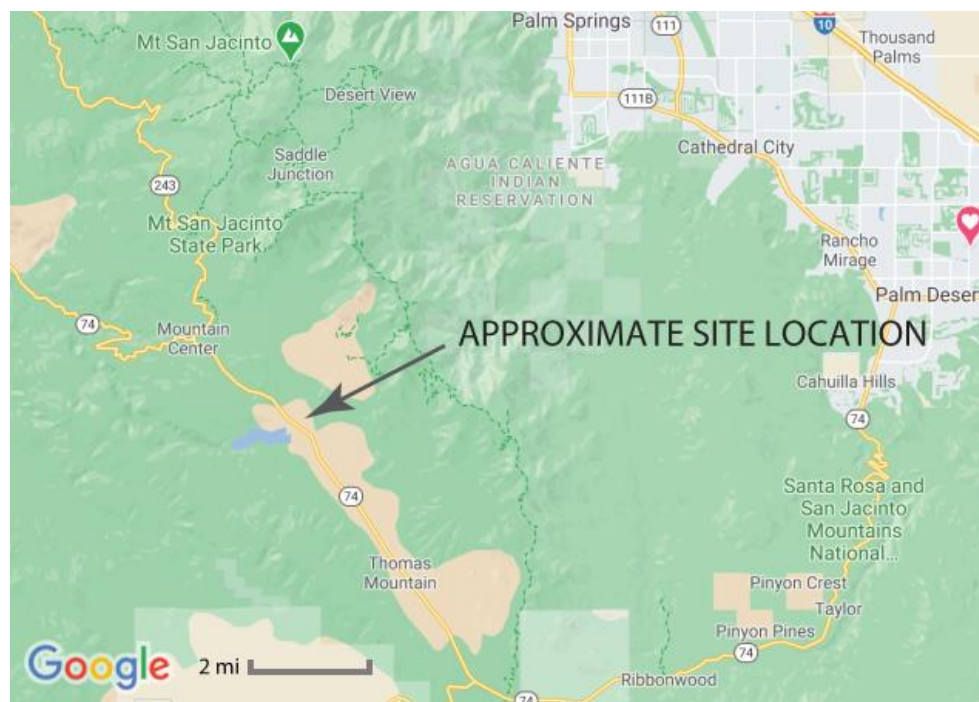

Figure 1 – Site Location Map

Topographically, site elevations range from a low of approximately 4,349 feet above mean sea level (msl) near the middle of the southern boundary to a high of 4,407 feet above msl along the middle of the western boundary, with overall relief on the order of 58 feet. The majority of the parcel, located on the eastern side of the main drainage, slopes very gently at an approximate 1 percent gradient from the northern property boundary to the southern property boundary.

PROPOSED CONSTRUCTION AND GRADING

Based on our review of the site plan prepared by MCE/ Assaro, dated July 1, 2022, development of the site is planned as a camp/resort area, with lodging facilities, a kitchen, welcome/receiving and administration building, storage, various activity buildings, tent structures, and other site improvements. We understand that the proposed new buildings will be wooden structures primarily with concrete floor slabs on grade. However, one or two buildings may be wood-frame on raised-floor supported by concrete pier foundations. Associated site improvements consist of retaining walls up to approximately 6 feet high, access drives and parking stalls, a swimming pool and restroom building, activity areas, exterior concrete walkways and patios, fence/screen walls, courtyards, planter areas, greenhouses, and landscaping. Other proposed improvements include stormwater management systems and above-ground domestic water tanks. Sewage will be managed through various onsite treatment systems. Additionally, a transformer pad and switchgear may be needed.

A grading plan is currently under development but, as of yet, has not been completed. However, we understand that site grading will consist generally of cuts and fills generally less than 5 feet. However, there may be a few select areas along the creek that may have fill on the order of 10 to 12 feet. It should be noted, however, that the ultimate fill thicknesses throughout the site will be greater due to the required remedial grading (i.e., removal and recompaction of existing unsuitable surficial soils, etc.) as recommended in subsequent sections of this report.

Preliminary recommendations for site grading and for the design and construction of building foundations are presented in the “Conclusions and Recommendations” section of this report. These preliminary recommendations are based on assumptions on the design grades (as noted above) and from our understanding of the proposed construction.

REQUIRED ZONES OF INVESTIGATION

The site is located in an area identified by the County of Riverside (County) and State of California (State) with active faulting requiring site specific investigation of the property prior to any development. The fault investigation for The Ridge has been completed (Petra,2020) and a building restriction zone identified. The fault investigation report has been reviewed and approved by the County. The site is not located within a designed Liquefaction Hazard Zone, or Landslide Hazard Zone, by the State of California. The location of the site regarding Fault Hazard zones is shown below on Figure 2.

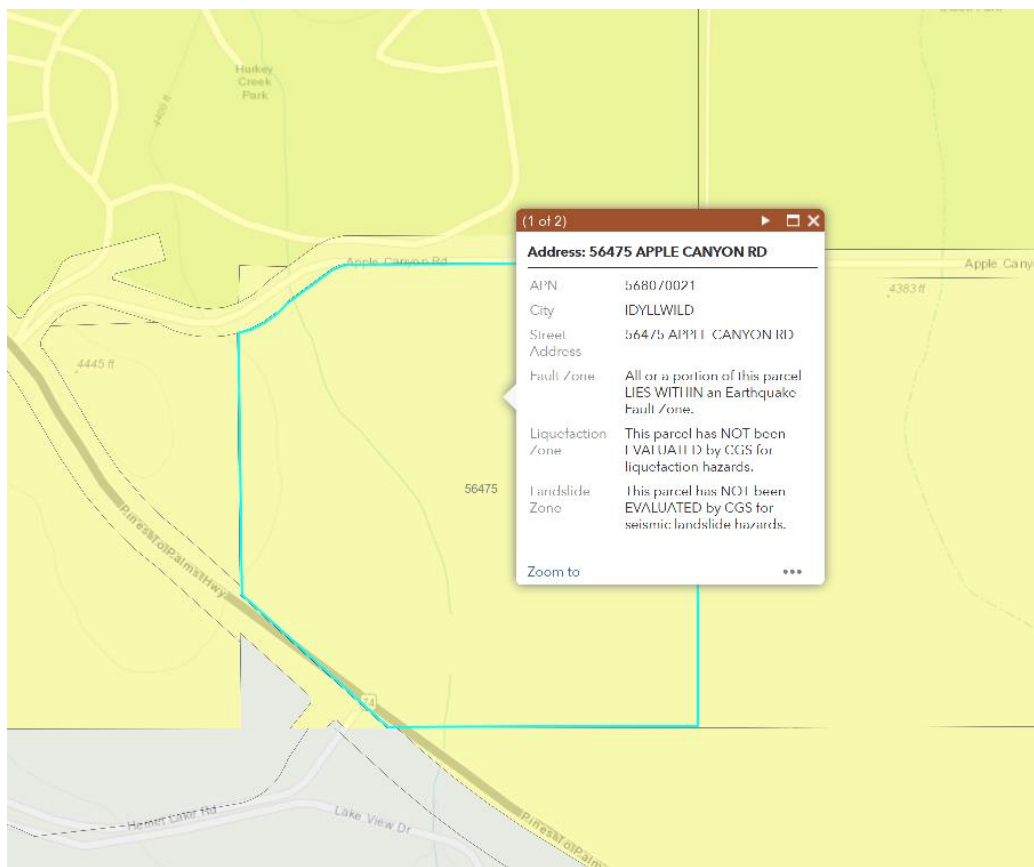

Figure 2 – State of California Earthquake Zones of Required Investigation

The County of Riverside also has not mapped the subject property area as susceptible to liquefaction hazards. The site location in relation to that mapping is shown below. There appears to be a mismatch between the area's shown by the County as potentially liquefiable, and the general underlying geology.



Figure 3 – Riverside County Liquefaction Susceptibility Map

Although though not mapped as susceptible to liquefaction, due to anticipated site conditions Petra conducted subsurface exploration during this current assessment to evaluate the site susceptibility to liquefaction.

SUBSURFACE EXPLORATION

Our subsurface exploration was performed in several stages. Previous exploration for our fault study included a seismic reflection line (Petra 2020) [See Appendix A2]. For the current exploration reported herein, percolation testing within two test pits were conducted on August 17, 2020. Further exploration by excavation of additional test pits occurred on May 7, 2021. On June 7, 2021, and on August 31, 2021 hollow stem auger drilling was conducted. CPT soundings were conducted on June 16, 2021, and August 30, 2021. The following summarizes the scope of each type of exploration method.

- Excavation and logging of a total of seven test pits. Six test pits were used to assess percolation rates at depths ranging from 2.5 to 3.2 feet.
- Conducted six dual-ring infiltrometer percolation tests to observe infiltration characteristics of subsurface materials that will be utilized in design of the infiltration system, and to determine if subsurface sewage disposal systems were feasible.
- Drilling and sampling of seven borings (B-1 through B-7) to depths ranging from 21.5 to 51 feet below the existing ground surface (bgs). All of the borings were drilled utilizing a truck-mounted, hollow-stem auger drill rig.

- Drill and install one groundwater monitoring well (MW-1) in the northeastern portion of the subject property at a depth of 40.5 feet bgs.
- Advanced seventeen Cone Penetrometer Test (CPT) soundings to depths ranging from 8 to 40 feet.

Earth materials encountered in each of the exploratory borings were field classified and logged in accordance with Unified Soil Classification System procedures. In addition, our subsurface exploration included the collection of bulk samples and relatively undisturbed samples of the subsurface soils for laboratory testing purposes. Bulk samples consisted of selected earth materials obtained at various depth intervals from selected borings. Relatively undisturbed samples were collected using a 3-inch, outside-diameter, modified California split-spoon soil sampler lined with 1-inch high brass rings. The modified sampler was driven with successive 30-inch drops of a hydraulically operated 140-pound automatic trip hammer. Blow counts for each 6-inch driving increment were recorded on the field logs. The number of blows required to drive the standard split-spoon sampler for the last 12 of the 18 inches was identified as the uncorrected standard penetration resistance (N). The central portions of the driven core samples were placed in sealed containers and transported to our laboratory for testing. The approximate locations of the exploratory borings are shown on the attached geotechnical map (Plate 1), and descriptive exploration logs are presented in Appendix A1.

In addition to the above sampling method, Standard Penetration Tests (SPT's) were also performed at selected depth intervals in accordance with the American Society for Testing Materials (ASTM) Standard Procedure D 1586. This method consists of mechanically driving an unlined standard split-barrel sampler 18 inches into the soil with successive 30-inch drops of the 140-pound automatic trip hammer. Blow counts for each 6-inch driving increment were recorded on the exploration logs. Disturbed soil samples from the unlined standard split-spoon (SPT) sampler were placed in plastic bags and transported to our laboratory for testing.

LABORATORY TESTING

To evaluate the engineering properties of site soils, several laboratory tests were performed on selected samples considered representative of those encountered. Laboratory tests included the determination of maximum dry density and optimum moisture content, grain-size analysis, soluble sulfate and chloride contents, pH, resistivity, collapse testing, and shear strength analysis. A description of laboratory test criteria is given in Appendix B1. Laboratory test data are summarized in Appendix B1 and on the Exploration Logs in Appendix A1. An evaluation of the data is reflected throughout the "Conclusions and Recommendations" section of this report.

Monitoring Well

A monitoring well was installed onsite to determine groundwater levels for the use in the liquefaction studies. A pump test was conducted on the water to determine flow rates and pore pressures and recovery rates for the in-situ soils. As part of these studies a water quality sample was collected for potential use in liquefaction mitigation strategies. The results are report in Appendix B-2. The pump test description and results are discussed and shown in Appendix C.

PRELIMINARY INFILTRATION RATES

Shallow Infiltration Test Results

Two dual ring infiltrometer tests (DRI) were performed on August 17, 2020 within the northeastern portion of the subject property (DR-1 and DR-2). Four additional DRI test were performed on July 2, 2021 along the eastern portion of the subject site (TP/P-1, TP/P-2, TP/P-3, and TP/P-4). Test depths ranged from 2.5 to 3.2 feet below the ground surface (bgs).

Testing was conducted using a dual-ring infiltrometer in accordance with ASTM Test Method D3385-09 and the soils encountered were predominantly moist, loose silty fine-grain sands with some medium-grain sand. The un-factored test results are summarized in Table 1 and Appendix D contains the field test data calculations.

TABLE 1

Test No.	Approximate Test Location (see Figure 2)	Test Zone Depth	Infiltration Rate, I_t⁽¹⁾ (in./hr.)
DR-1	Near N.E. Site Boundary	2.5'	25
DR-2	Central Area of N. Site Boundary	5'	29
TP/P-1	Central Portion Near E. Site Boundary	2' 11"	3
TP/P-2	SE Portion of Site	3' 2"	2
TP/P-3	SE Portion of Site	3' 2"	1
TP/P-4	SE Portion of Site	2' 8"	Too rapid to measure

(1) No Factor of Safety Applied

FINDINGS

Regional Geology

Geologically, the site lies within an elongated valley in the San Jacinto Mountains of southern California. The San Jacinto Mountain range is a [fault block](#) of granitic rocks squeezed between the San Jacinto fault on the west and the San Andreas fault system on the east. The [fault scarp](#) on the northern and eastern side is one of the most abrupt in North America, going from sea level to 10,000 feet in a few miles. The height and steepness of the range points out that the San Jacinto fault and San Andreas fault are very active and capable of producing major earthquakes (in excess of magnitude 7). The last massive quake struck the southern segment of the San Andreas-San Jacinto fault complex more than 200 years ago.

Local Geology and Subsurface Conditions

Young alluvial soils underlie the subject site. The soils are fine to coarse grained. Below the alluvium are Cretaceous-age granitic rocks mapped as Quartz Diorite to Granodiorite (Dibblee 2008). This subsurface profile was generally confirmed during the site-specific assessment recently conducted by our firm.

Alluvium

In general, the soil materials underlying the site as encountered in our borings were observed to consist of loose to very dense, light brown to brown, poorly graded sands, from dry to wet, with trace to few gravels. A few fine-grained soil layers (silt and clay) were noted primarily towards the bottom of the CPT-4 sounding.

Granitic Bedrock

Bedrock was encountered at depth of 8 to 40 feet. Bedrock consisted of granitic rock that was weathered in the upper zone where first encountered and penetrated by the drilling equipment. However, it became hard and less weathered rapidly with depth. The bedrock was generally yellowish brown, and fine to coarse grained. Bedrock depths were observed in our borings or interpreted from the CPT soundings as shown in Table 3 below. Interpreted approximate bedrock depth contours are depicted on Plate 1.

TABLE 2A

Bedrock Depths Directly Observed in Borings

Boring or CPT ID	Depth to Bedrock (ft)
B-1	37
B-3	40
B-6	31
MW-1	36

TABLE 2B
Bedrock Depth Interpreted from CPT Soundings

Boring or CPT ID	Depth to Bedrock (ft)
CPT-1	35
CPT-2	39
CPT-3	40
CPT-4	28
CPT-5	26
CPT-6	35
CPT-7	36
CPT-8	17
CPT-9	23
CPT-10	32
CPT-11	21
CPT-12	8
CPT-13	22
CPT-14	22
CPT-15	39
CPT-16	39
CPT-17	36

Note: CPT depths are interpreted based on rapid refusal of tip.

Groundwater

Free ground water was encountered in our borings during our field exploration. Groundwater was found shallower than 10 feet below the existing ground surface. Groundwater levels were also established based on the pore pressure dissipation tests in several of the CPT soundings. Fluctuations in the level of ground water can occur due to seasonal climatic variations, changes in the land use and other factors. Groundwater levels observed during this investigation are shown in Table 4 below.

TABLE 3A
Groundwater Levels Observed in Borings

Boring ID	Groundwater Depth (ft)
B-1	12.5
B-2	9.8
B-3	8.7
B-4	10.4
B-5	10.8
B-6	11.0
B-7	12.5
MW-1	11.0

TABLE 3B
Groundwater Levels Established from PPD⁽¹⁾ Tests in CPT Soundings

CPT ID	Groundwater Depth (ft)
CPT-1	7.6
CPT-2	9.9
CPT-3	9.7
CPT-4	11.0

Note: ⁽¹⁾ Pore pressure dissipation. PPD tests were attempted in later CPT soundings; however, the data was judged to be suspect.

Flooding

The site and vicinity are located within FEMA National Flood Hazard Layer FIRMette No.06065C0065G (dated August 28, 2008). The subject site is depicted within Zone D, defined as “An area of undetermined flood hazard.”

The California Department of Water Resources - Division of Dam Safety, Dam Breach Inundation Map Web Publisher (DDS, 2021), lists the downstream hazard of flooding from the Hemet Lake as “extremely high.” The subject property is located up-gradient from the lake and not affected by a potential dam breach.

Faulting

An active fault, identified as the Hot Springs Fault (Anza) segment of the San Jacinto Fault zone crosses through the subject property. Specific information is provided in Petra's fault investigation reports (Petra 2020, 2021). The location of the fault and Earthquake Hazard Zone is provided on the Geologic Map, Plate 1.

It should be noted that according to the USGS Unified Hazard Tool website and/or 2010 CGS Fault Activity Map of California, the San Jacinto Fault zone, a portion of which transects the southern subject property, would probably generate the most severe site ground motions and, therefore, is the majority contributor to the deterministic minimum component of the ground motion models. This fault is capable of producing Magnitudes up to MW 8.1. The subject site is located at a distance of less than 6.25 miles (10 km) from the surface projection of this fault system, which is capable of producing magnitude 6 or larger events with a slip rate along the fault greater than 0.04 inch per year. As such, the site should be considered as a **Near-Fault Site** in accordance with ASCE 7-16, Section 11.4.1.

Seismically-Induced Flooding

The types of seismically induced flooding which may be considered as potential hazards to a particular site normally includes flooding due to a tsunami (seismic sea wave), a seiche, or failure of a major reservoir or other water retention structure upstream of the site. Since the site lies more than 80 kilometers (50 miles) inland from the Pacific Ocean at a minimum elevation of approximately 4,349 feet above sea level and does not lie in close proximity to an enclosed body of water or downstream of a major reservoir or other retention structure, the probability of flooding from a tsunami, seiche or dam-break is considered to be very low.

Earthquake Loads

Earthquake loads on earthen structures and buildings are a function of ground acceleration which may be determined from the site-specific ground motion analysis. Alternatively, a design response spectrum can be developed for certain sites based on the code guidelines. To provide the design team with the parameters necessary to construct the design acceleration response spectrum for this project, we used two computer applications. Specifically, the first computer application, which was jointly developed by Structural Engineering Association of California (SEAOC) and California's Office of Statewide Health Planning and Development (OSHPD), the SEA/OSHPD Seismic Design Maps Tool website, <https://seismicmaps.org>, is used to calculate the ground motion parameters (see Appendix D). The second computer application, the United States Geological Survey (USGS) Unified Hazard Tool website,

<https://earthquake.usgs.gov/hazards/interactive/>, is used to estimate the earthquake magnitude and the distance to surface projection of the fault (also see Appendix D).

To run the above computer applications, site latitude and longitude, seismic risk category and knowledge of site class are required. The site class definition depends on the direct measurement and the ASCE 7-16 recommended procedure for calculating average small-strain shear wave velocity, V_{s30} , within the upper 30 meters (approximately 100 feet) of site soils.

A seismic risk category of II was assigned to the proposed building in accordance with 2019 CBC, Table 1604.5. No shear wave velocity measurement was performed at the site, however, the subsurface materials at the site appears to exhibit the characteristics of stiff soils condition for Site Class D designation. Therefore, an average shear wave velocity of 600 to 1,200 feet per second for the upper 100 feet was assigned to the site based on engineering judgment and geophysical experience. As such, in accordance with ASCE 7-16, Table 20.3-1, Site Class D (D as per SEA/OSHPD software) has been assigned to the subject site.

The following table, Table 4, provides parameters required to construct the seismic response coefficient, C_s , curve based on ASCE 7-16, Article 12.8 guidelines.

~Remainder of Page Intentionally Left Blank~

TABLE 4
Seismic Design Parameters

Ground Motion Parameters	Specific Reference	Parameter Value	Unit
Site Latitude (North)	-	33.674	°
Site Longitude (West)	-	-116.667	°
Site Class Definition	Section 1613.2.2 ⁽¹⁾ , Chapter 20 ⁽²⁾	D ⁽⁴⁾	-
Assumed Seismic Risk Category	Table 1604.5 ⁽¹⁾	II	-
M _w - Earthquake Magnitude	USGS Unified Hazard Tool ⁽³⁾	7.79 ⁽³⁾	-
R – Distance to Surface Projection of Fault	USGS Unified Hazard Tool ⁽³⁾	7.34 ⁽³⁾	km
S _s - Mapped Spectral Response Acceleration Short Period (0.2 second)	Figure 1613.2.1(1) ⁽¹⁾	1.641 ⁽⁴⁾	g
S ₁ - Mapped Spectral Response Acceleration Long Period (1.0 second)	Figure 1613.2.1(2) ⁽¹⁾	0.639 ⁽⁴⁾	g
F _a – Short Period (0.2 second) Site Coefficient	Table 1613.2.3(1) ⁽¹⁾	1.0 ⁽⁴⁾	-
F _v – Long Period (1.0 second) Site Coefficient	Table 1613.2.3(2) ⁽¹⁾	Null ⁽⁴⁾	-
S _{MS} – MCE _R Spectral Response Acceleration Parameter Adjusted for Site Class Effect (0.2 second)	Equation 16-36 ⁽¹⁾	1.641 ⁽⁴⁾	g
S _{M1} - MCE _R Spectral Response Acceleration Parameter Adjusted for Site Class Effect (1.0 second)	Equation 16-37 ⁽¹⁾	Null ⁽⁴⁾	g
S _{DS} - Design Spectral Response Acceleration at 0.2-s	Equation 16-38 ⁽¹⁾	1.094 ⁽⁴⁾	g
S _{D1} - Design Spectral Response Acceleration at 1-s	Equation 16-39 ⁽¹⁾	Null ⁽⁴⁾	g
T _o = 0.2 S _{D1} / S _{DS}	Section 11.4.6 ⁽²⁾	Null	s
T _s = S _{D1} / S _{DS}	Section 11.4.6 ⁽²⁾	Null	s
T _L - Long Period Transition Period	Figure 22-14 ⁽²⁾	8 ⁽⁴⁾	s
PGA - Peak Ground Acceleration at MCE _G ^(*)	Figure 22-9 ⁽²⁾	0.695	g
F _{PGA} - Site Coefficient Adjusted for Site Class Effect ⁽²⁾	Table 11.8-1 ⁽²⁾	1.1 ⁽⁴⁾	-
PGA _M –Peak Ground Acceleration ⁽²⁾ Adjusted for Site Class Effect	Equation 11.8-1 ⁽²⁾	0.765 ⁽⁴⁾	g
Design PGA ≈ (2/3 PGA _M) ^(†)	Similar to Eqs. 16-38 & 16-39 ⁽²⁾	0.51	g
Design PGA ≈ (0.4 S _{DS}) – Short Retaining Walls ^(‡)	Equation 11.4-5 ⁽²⁾	0.438	g
C _{RS} - Short Period Risk Coefficient	Figure 22-18A ⁽²⁾	0.908 ⁽⁴⁾	-
C _{R1} - Long Period Risk Coefficient	Figure 22-19A ⁽²⁾	0.89 ⁽⁴⁾	-
SDC - Seismic Design Category ^(§)	Section 1613.2.5 ⁽¹⁾	Null ⁽⁴⁾	-

References:

- ⁽¹⁾ California Building Code (CBC), 2019, California Code of Regulations, Title 24, Part 2, Volume I and II.
- ⁽²⁾ American Society of Civil Engineers/Structural Engineering Institute (ASCE/SEI), 2016, Minimum Design Loads and Associated Criteria for Buildings and Other Structures, Standards 7-16.
- ⁽³⁾ USGS Unified Hazard Tool - <https://earthquake.usgs.gov/hazards/interactive/>
- ⁽⁴⁾ SEI/OSHDP Seismic Design Map Application – <https://seismicmaps.org>

Related References:

Federal Emergency Management Agency (FEMA), 2015, NEHERP (National Earthquake Hazards Reduction Program) Recommended Seismic Provision for New Building and Other Structures (FEMA P-1050).

Notes:

- * PGA Calculated at the MCE return period of 2475 years (2 percent chance of exceedance in 50 years).
- † PGA Calculated at the Design Level of 2/3 of MCE; approximately equivalent to a return period of 475 years (10 percent chance of exceedance in 50 years).
- ‡ PGA Calculated for short, stubby retaining walls with an infinitesimal (zero) fundamental period.
- § The designation provided herein may be superseded by the structural engineer in accordance with Section 1613.2.5.1, if applicable.

Discussion - General

Owing to the characteristics of the subsurface soils, as defined by Site Class D-Stiff Soil designation, and proximity of the site to the sources of major ground shaking, the site is expected to experience strong ground shaking during its anticipated life span. Under these circumstances, where the code-specified design response spectrum may not adequately characterize site response, the 2019 CBC typically requires a site-specific seismic response analysis to be performed. This requirement is signified/identified by the “null” values that are output using SEA/OSHPD software in determination of short period, but mostly, in determination of long period seismic parameters (see Table 4).

For conditions where a “null” value is reported for the site, a variety of design approaches are permitted by 2019 CBC and ASCE 7-16 in lieu of a site-specific seismic hazard analysis. For any specific site, these alternative design approaches, which include Equivalent Lateral Force (ELF) procedure, Modal Response Spectrum Analysis (MRSA) procedure, Linear Response History Analysis (LRHA) procedure and Simplified Design procedure, among other methods, are expected to provide results that may or may not be more economical than those that are obtained if a site-specific seismic hazards analysis is performed. These design approaches and their limitations should be evaluated by the project structural engineer.

Discussion – Seismic Design Category

Please note that the Seismic Design Category, SDC, is also designated as “null” in Table 4. For condition where the mapped spectral response acceleration parameter at 1 – second period, S_1 , is less than 0.75, the 2019 CBC, Section 1613.2.5.1 allows that seismic design category to be determined from Table 1613.2.5(1) alone provided that all four requirements concerning fundamental period of structure, story drift, seismic response coefficient, and relative rigidity of the diaphragms are met. Our interpretation of ASCE 7-16 is that for conditions where one or more of these four conditions are not met, seismic design category should be assigned based on: 1) 2019 CBC, Table 1613.2.5(1), 2) structure’s risk category and 3) the value of S_{DS} , at the discretion of the project structural engineer.

Discussion – Equivalent Lateral Force Method

Should the Equivalent Lateral Force (ELF) method be used for seismic design of structural elements, the value of Constant Velocity Domain Transition Period, T_s , is estimated to be 0.66 seconds and the value of Long Period Transition Period, T_L , is provided in Table 4 for construction of Seismic Response Coefficient – Period ($C_s - T$) curve that is used in the ELF procedure.

As stated herein, the subject site is considered to be within a Site Class D-Stiff Soil. A site-specific ground motion hazard analysis is not required for structures on Site Class D-Stiff Soil with $S_1 \geq 0.2$ provided that the Seismic Response Coefficient, C_s , is determined in accordance with ASCE 7-16, Article 12.8 and structural design is performed in accordance with Equivalent Lateral Force (ELF) procedure.

Liquefaction and Seismically-Induced Settlement

Assessment of liquefaction potential for a particular site requires knowledge of a number of regional as well as site-specific parameters, including the estimated design earthquake magnitude, the distance to the assumed causative fault and the associated probable peak horizontal ground acceleration at the site, subsurface stratigraphy and soil characteristics and groundwater elevation. Parameters such as distance to causative faults and estimated probable peak horizontal ground acceleration can readily be determined using published references, or by utilizing a commercially available computer program specifically designed to perform a probabilistic analysis. Stratigraphy and soil characteristics can only be accurately determined by means of a site-specific subsurface evaluation combined with appropriate laboratory analysis of representative samples of onsite soils.

Liquefaction occurs when dynamic loading of a saturated sand or silt causes pore-water pressures to increase to levels where grain-to-grain contact is lost, and material temporarily behaves as a viscous fluid. Liquefaction can cause settlement of the ground surface, settlement and tilting of engineered structures, flotation of buoyant buried structures and fissuring of the ground surface. A common manifestation of liquefaction is the formation of sand boils – short-lived fountains of soil and water that emerge from fissures or vents and leave freshly deposited conical mounds of sand or silt on the ground surface.

Riverside County identifies the subject property within a zone of liquefaction potential (County of Riverside Mapping Portal, 2021). In view of the depth to groundwater and unconsolidated to consolidated young alluvium encountered during our field exploration, the potential for manifestation of liquefaction induced features and dynamic settlement is anticipated to be high.

Site-Specific Liquefaction Analysis

In April 1991, the State of California enacted the Seismic Hazards Mapping Act (Public Resources Code, Division 2, Chapters 7-8). The purpose of the Act is to protect the public safety from the effects of strong ground shaking, liquefaction, landslides, or other ground failure. The Act defines mitigation as “... *those measures that are consistent with established practice and reduce seismic risk to acceptable levels.*” Acceptable level of risk is defined as “*that level that provides reasonable protection of the public safety,*

though it does not necessarily ensure continued structural integrity and functionality of the project [California Code of Regulations; Section 3721 (a)].” In the context of that Act, mitigation of the potential liquefaction hazards at this site to appropriate levels of risk can be accomplished through appropriate foundation and/or subsurface improvement design.

Based on site exploration, this site is considered susceptible to seismic liquefaction. This is due primarily to the documented presence of unconsolidated granular (sandy) soils in the area, the shallow groundwater conditions, and to the proximity of seismic sources. For this reason, a site-specific liquefaction analysis was performed as part of this evaluation.

Assessment of liquefaction potential for a particular site requires knowledge of a number of regional as well as site-specific parameters, including the estimated design earthquake magnitude, and the associated probable peak horizontal ground acceleration at the site, subsurface stratigraphy and soil characteristics. Parameters such as estimated probable peak horizontal ground acceleration can readily be determined using published references, or by utilizing a commercially available computer program specifically designed to perform a probabilistic analysis. On the other hand, stratigraphy and soil characteristics can only be accurately determined by means of a site-specific subsurface evaluation combined with appropriate laboratory analysis of representative samples of onsite soils.

Propagating earthquake waves induce shearing stresses and strains in soil materials during strong ground shaking. This process rearranges the structure of granular soils such that there is an increase in density, with a corresponding decrease in volume, which results in vertical settlement. Dynamic settlement has been well documented in wet, sandy deposits undergoing liquefaction (see Tokimatsu and Seed, 1987) and in relatively dry sediments as well (Stewart et al, 1996). Specific methods to analyze potential wet and dry dynamic settlement are reported in Tokimatsu and Seed (1987), and specifically dry settlement in Pradel (1998) and Stewart et al. (2001; 2002) respectively. Most of the referenced papers focus on the seismic effects on dry, clean sands of a uniform grain size, though several reports extend the literature to fine-grained soils (Stewart et al., 2001 & 2002). State guidelines for evaluating dynamic settlement are provided in the California Geological Survey Special Publication 117A (CGS, 2008).

As noted previously herein, groundwater was observed to be at depths of 7.6 to 12.5 feet at the time of field assessment. We have used a conservative value of 7 feet for our liquefaction analysis.

Analyses Using CPT Sounding Results

Six CPT soundings at the site were used in the liquefaction analysis. Our analysis using the CPT data provides *continuous* penetration resistance data rather than borehole data using SPT sampling that must be averaged over discrete sampling increments (e.g., 5 or 10 feet). A variety of computer programs are available that were developed specifically for liquefaction and seismic settlement analyses. For purposes of this study, we selected the commercially available software program CLiq Version 1.7.6.34 (GeoLogismiki, 2014) that implements updated versions of the NCEER procedure as recommended by Dr. Peter Robertson (2010), or that of Professors Idriss and Boulanger (2008, 2014). The procedures were based on the methods originally recommended by Seed and Idriss (1982). Calculations using CPT data are provided in Appendix F.

Analysis Results and Assessment of Liquefaction Effects

Section 1803.5.12.3 of the 2019 CBC requires the “assessment of potential consequences of liquefaction and soil strength loss, including, but not limited to” the following items, which we will discuss in the order that they appear in the code.

2019 CBC Section 1803.5.12.3 – 3.1 – Estimation of total and differential settlement;

Analyses with historic high groundwater estimated at 7 feet below the ground surface indicated that the major potentially liquefiable zones are from approximately 7 to 35 feet below the ground surface in CPT-1 through CPT-17. A factor of safety of 1.3 was used in our analysis in accordance with the procedures of CGS publication SP117A.

To determine the estimated seismically induced settlement from the CPT soundings we used the Robertson (2009) modifications to the NCEER procedure to estimate the free field settlement. Tabulated results of the estimated settlement for this analysis method are provided in Appendix F of this report and are shown in Figure 4 below. The results of the other methods are shown on the summary comparison plot printouts. Please note, total seismic settlement is based on the depth of our evaluation at each location. Our analysis also included the potential settlement of any dry sand above the water table.

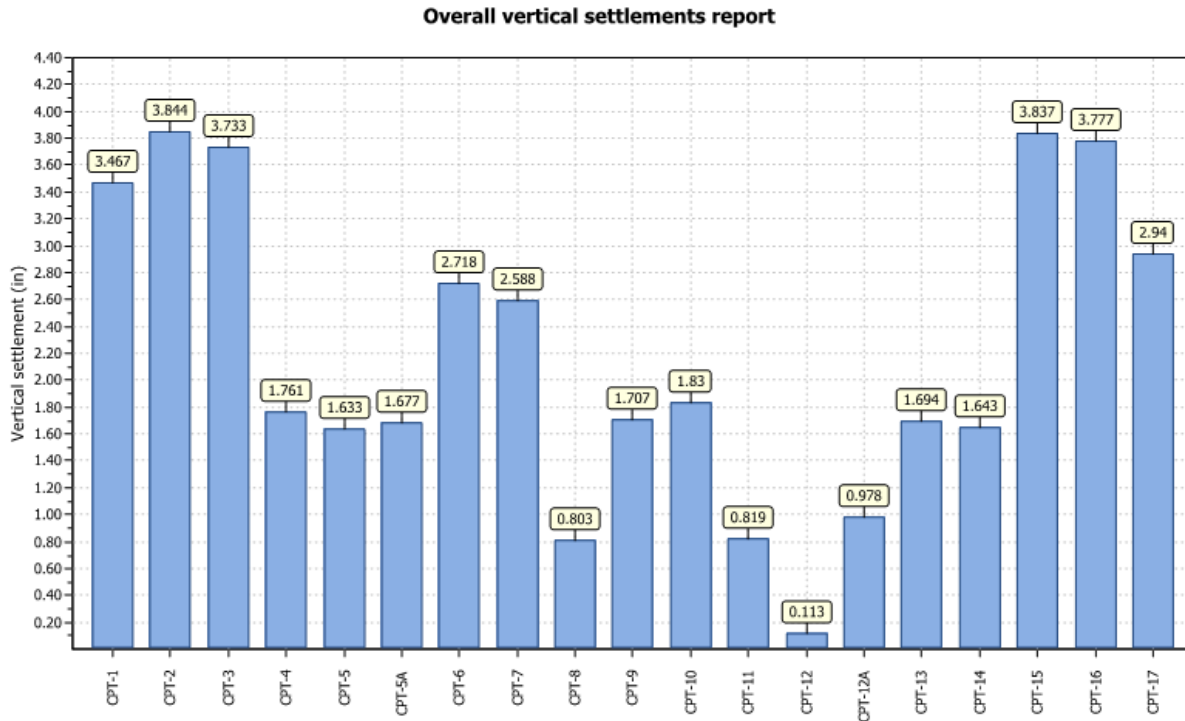

Figure 4 - Seismically Induced Settlement

Based on our calculations, total seismically induced settlement at the six CPT locations is considered excessive in accordance with guidelines provided in the California Geotechnical Survey Special Publication 117A (CGA, 2008). As noted from the figure above, differential settlements of up to 4 inches may be experienced within the footprint of the area to be developed. This is generally beyond the levels typically expected to be tolerated by conventional shallow slab-on-grade foundations.

The minimum goal of liquefaction mitigation should be to provide a foundation system that can withstand the expected movement without causing such structural damage so as to pose a life-safety hazard (such as structural collapse from excessive drift). A mitigation strategy by ground improvement is discussed in a later section of this report.

Soil Strength Loss

The results of our analysis show that subsurface soils are subject to significant strength loss during a strong seismic event. The fine-grained soils at the site are prone to cyclical softening and strength loss in addition to the classical strength loss of the sandy soils. As a result, the post-liquefaction bearing capacity for shallow foundation elements will be significantly reduced from the static condition. Mitigation measures are outlined in the Ground Modifications section of this report.

Surface Manifestation of Liquefaction

Based on the method outlined by Ishihara (1985) and considering the depth of the shallow liquefiable layers identified by the results of CPT soundings (approximately 7 to 30 feet below the existing ground surface), the overall depth of underlying liquefiable layers, the thickness of the non-liquefiable layers above the upper liquefiable zone are not sufficient to prevent significant surface manifestation of liquefaction. Additional distress to structures located at the surface is likely to occur beyond that which may be imposed by ground surface settlement. Therefore mitigation measures should be undertaken to alleviate the distress from surface manifestation of liquefaction. Liquefaction mitigation measure are discussed in a later section of this report.

2019 CBC Section 1803.5.12.3 – 3.2 – Lateral soil movement;

Lateral spreading is the movement of the ground surface down a gentle slope or toward an open free face during a seismic event that causes soil liquefaction. Therefore, given the depths and thicknesses of the liquefiable layers identified and the gently sloping ground surface we can conclude that lateral spreading is an issue likely to occur at this site.

In accordance with California Geological Survey (CGS) requirements, we performed an additional analysis to determine if lateral spreading is likely to accompany earthquake-induced liquefaction at the site. Amounts of calculated lateral spreading is provided below in Figure 5. As can be seen from the estimates on the figure, the range of lateral spreading varied from 0 to 52 inches across the site. The amount of lateral spreading estimated is beyond that typically tolerable for slab-on-grade construction. Mitigation measures will be discussed in a later section of this report.

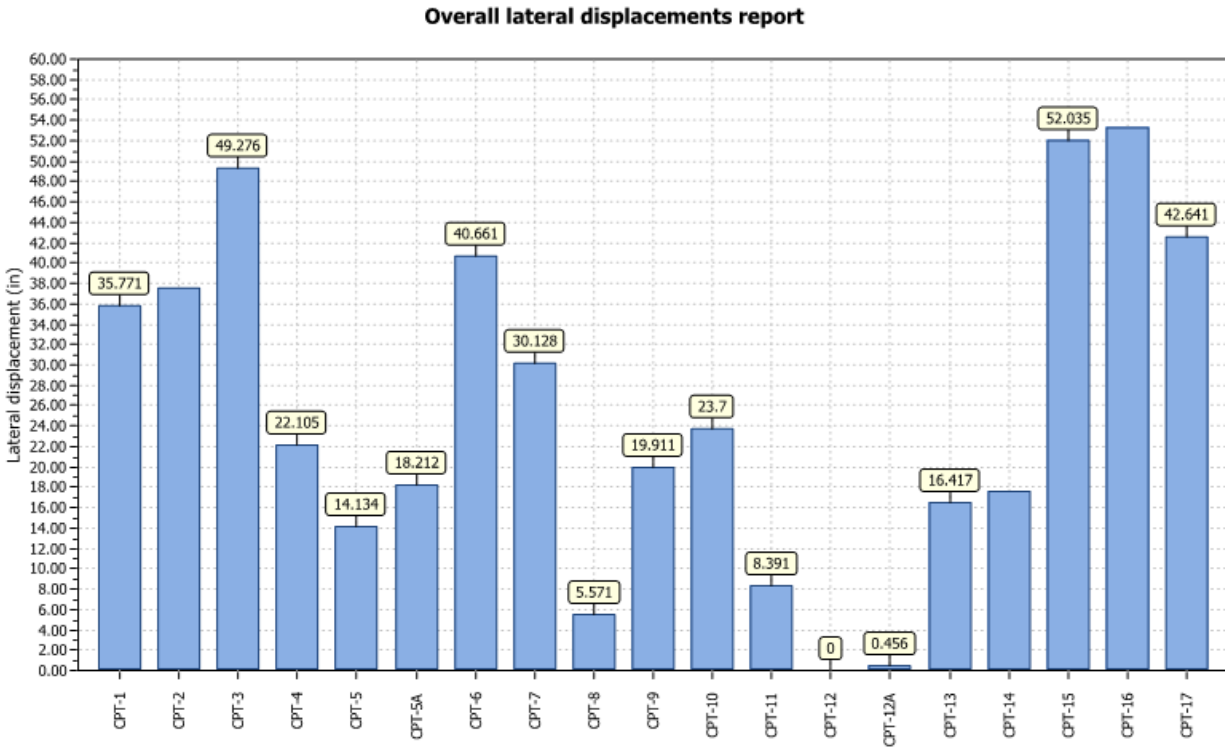

Figure 5 – Lateral Spreading Estimates

2019 CBC Section 1803.5.12.3 – 3.3 – Lateral soil loads on foundations;

Basement structures are not planned for this site; therefore, lateral load effects on basement foundations are not applicable.

2019 CBC Section 1803.5.12.3 – 3.4 – Reduction in foundation soil-bearing capacity and lateral soil reaction;

Without corrective grading and/or ground improvement the site would have a reduce or non-existent bearing capacity. Recommendations presented later on for a ground improvement program to mitigate these effects.

2019 CBC Section 1803.5.12.3 – 3.4 – Soil downdrag and reduction in axial and lateral soil reaction for pile foundations;

Pile foundations are not proposed as foundations for the proposed structures; therefore, soil downdrag and reduction in axial and lateral soil reaction for pile foundations will not be applicable.

2019 CBC Section 1803.5.12.3 – 3.5 – Increases in soil lateral pressures on retaining walls;

Rough grading and/or retaining wall plans are not available at this time. Increase in soil lateral pressures on retaining walls over a height of 6 feet is recommended. This is discussed later in this report.

2019 CBC Section 1803.5.12.3 – 3.6 – Flotation of buried structures;

Structures that enclose a void space such as pipelines, manholes, or buried vaults may be subject to buoyant forces if they are located below $7\pm$ feet from the ground surface where we noted that liquefaction was likely to occur for this site. Such structures may need to be anchored if they are not located within areas mitigated by remedial grading or ground improvements.

CONCLUSIONS AND RECOMMENDATIONS

General

From a soils engineering and engineering geologic standpoint, the subject property is considered suitable for the proposed construction provided the following conclusions and recommendations are incorporated into the design criteria and project specifications.

Grading Plan Review

The following recommendations are based on a review of the architectural site plan prepared by MCE/ and Assaro Architects dated July 1, 2022. As such, the recommendations provided in this report should be considered tentative until a finalized grading plan is available and reviewed by the project geotechnical consultant. Depending on the results of the grading plan review, revised and/or additional recommendations should be prepared by the geotechnical consultant as deemed appropriate.

Effect of Proposed Grading on Adjacent Properties

Provided that proposed grades are as anticipated in this report, it is our opinion that the proposed grading and construction will not adversely affect the stability of adjoining properties in an adverse manner provided grading and construction are performed in accordance with current standards of practice, all applicable grading ordinances and the recommendations presented in this report. However, if the final grades adjacent to the property lines are lowered or raised, it should be brought to the attention of the project geotechnical consultant in order to evaluate the potential effects of the grade changes on adjacent properties or rights-of-way.

Ground Improvement Program

Since the site is subject to significant distress from the liquefiable soils under an earthquake mitigation measures are recommended to improve the ground and alleviate the distress potential. A mitigation program should be undertaken by a specialty geotechnical contractor with extensive knowledge and experience in ground improvement. For this site we recommend that such a program would most likely consist of deep

dynamic compaction to densify the soils below the site to a level where more conventional foundations may be used. Deep dynamic compaction generally consists of the use of a large crane which drops a large dead weight from a great height onto the ground surface. The large energy developed from such a weight drop can densify the ground sometimes as deep as 30 feet or so. The weight drops would be done in an overlapping pattern in the general footprint area of the planned structures. The specialty contractor should be responsible for developing the drop grid pattern and providing a shop drawing for the engineers review prior to implementation. The following criteria should be used for the design and implementation of such a program.

- The densification pattern should be extended beyond the edge of the building footprints laterally to the extent of approximately 1/3 to 1/2 of the depth of the improvement.
- The ground improvement should be conducted in such a way as to reduce impacts on the nearby trees.
- The ground improvement program should target the following design criteria for the amount of settlement and lateral spreading that would remain as potentially possible after an earthquake.
 - For a 20 percent chance in 50 years earthquake, the differential settlement should be reduced to less than 1 inch in a span of 40 feet. The lateral spreading should be reduced to less than 6 inches.
 - For a 2 percent chance in 50 years earthquake, the ground should be improved to reduce the settlement to less than 4 inches total, with a differential of less than 2 inches in 40 feet. The lateral spreading should be reduced to less than 18 inches.
- The level of ground improvement achieved should be evaluated by the use of CPT's conducted after the deep dynamic compaction.

Earthwork Recommendations

Earthwork Specifications

All earthwork and grading should be performed in accordance with the applicable requirements of County of Riverside, in compliance with all applicable provisions of the 2019 California Building Code (CBC) and in accordance with the following recommendations prepared by this firm.

Site Clearing

Clearing operations should include the removal of all vegetation and any existing structural features where found within planned building envelopes. Large shrubs or trees, when removed, should be grubbed out to include their stumps and major root systems.

Should any unusual conditions or subsurface structures be encountered during demolition operations or during grading that are not described or anticipated herein, these conditions should be brought to the immediate attention of the project geotechnical consultant for corrective recommendations.

Ground Preparation – Buildings and Structure Areas

The ground improvement will cause significant disturbance to the near surface soils in the footprints of the improvement areas. Therefore, in order to mitigate possible distress to the proposed building footings and floor slabs and exterior improvements it is recommended that all unsuitable surficial materials be removed down to competent densified sand deposits and then replaced as properly compacted fill. This may be accomplished by over-excavating the ground surface to a depth of at least 5 to 10 feet below existing grades or at least 24 inches below the bottoms of the proposed footings, whichever is deeper, and then reprocessing the next underlying 6 inches in place. That is, prior to replacing the excavated materials as compacted fill, the exposed bottom surface should be scarified to a depth of at least 6 inches, watered as necessary to achieve slightly above optimum moisture conditions, and then recompacted in-place to a minimum relative compaction of 90 percent. In order to provide adequate support for sidewalks, patios, and similar improvements, overexcavation and recompaction of the existing ground surface should essentially include building envelopes and concrete flatwork that are sensitive to settlement.

It should be noted that the DDC likely would cause a cratering pattern in the near surface soils. The ground in this pattern of improvement would also typically include significant volume loss due to the densification. Therefore to achieve the design grades fill may be necessary to achieve the design grades beyond that typically done general removal and recompaction efforts if ground improvement was not done.

Ground Preparation – Roadways and Flatwork not in Ground Improved Areas

For proposed roadways, the existing ground surfaces should be over-excavated to a minimum depth of 12 inches below the existing ground surface or 2 feet below the proposed subgrade elevations, whichever is deeper. After completion of over-excavation, the areas should be scarified to a minimum depth of 6 inches, moisture-conditioned, and recompacted to a minimum 95 percent relative compaction. The excavated materials may be replaced as properly compacted fill. The horizontal limits of over-excavation should extend to a minimum horizontal distance of 12 inches beyond the perimeter of the proposed improvements.

All fills should be placed in 6- to 8-inch-thick lifts, watered or air dried as necessary to achieve slightly above-optimum moisture conditions, and then compacted to a minimum relative compaction of 95 percent per ASTM D 1557. The laboratory maximum dry density and optimum moisture content for each change in soil type should be determined in accordance with Test Method ASTM D 1557.

Excavation Characteristics

The existing site soils are expected to be readily excavated with conventional earthmoving equipment. Very loose and dry to slightly moist, silty sandy and gravelly sandy soils are anticipated to be encountered within near surface soils across the site. If oversized rocks (i.e., 12-inches in one dimension or greater) are encountered they should either be stockpiled for use in landscaping, disposed of offsite, or properly buried within the planned deeper fills or ground improvement craters in an approved engineered fashion, a minimum of 10 feet below finish pad grades.

Suitability of Site Soils as Fill

Site soils are suitable for use in engineered fills provided they are clean from organics and/or debris.

Fill Placement and Testing

New engineered fills should be placed in lifts not exceeding 6 inches in thickness, watered or air dried as necessary to achieve near optimum moisture conditions, and then compacted in place to a minimum relative compaction of 90 percent. Each fill lift should be treated in a similar manner. Subsequent lifts should not be placed until the preceding lift has been tested by the project geotechnical consultant to document that the required 90 percent relative compaction has been achieved. The laboratory maximum dry density and optimum moisture content for each change in soil type should be determined in accordance with Test Method ASTM D 1557.

Imported soils, if any, should consist of clean granular materials exhibiting a Very Low expansion potential (Expansion Index less than 20). Soils to be imported should be observed and, if deemed necessary, tested by the project geotechnical consultant prior to importation to determine whether the material meets project specifications.

Temporary Excavations

Temporary excavations up to a depth of 10 feet below existing grades may be required to accommodate the recommended over-excavation. Based on the physical properties of onsite soils, temporary excavation slopes which are constructed exceeding 4 feet in height, should be cut back to an inclination of 1:1 (h:v) or flatter for the duration of the over-excavation of unsuitable soil material and replacement as compacted fill, as well as placement of underground utilities. However, the temporary excavations should be observed by a representative of the project geotechnical consultant for evidence of potential instability. Depending on the results of these observations, revised slope configurations may be necessary. Other factors which should be considered with respect to the stability of the temporary slopes include construction traffic and/or storage

of materials on or near the tops of slopes, construction scheduling, presence of nearby walls or structures on adjacent properties and weather conditions at the time of construction. Applicable requirements of the California Construction and General Industry Safety Orders, the Occupational Safety and Health act of 1970 and the Construction Safety Act should also be followed.

Slope Construction

Fill Slopes

For fill slopes exceeding 5 feet in height, a fill key excavated a depth of 2 feet or more into competent alluvial deposits is recommended at the base of the fill slope. The width of the fill key should be equal to one-half the slope height or 15 feet, whichever is greater. To obtain proper compaction to the face of fill slopes, low-height fill slopes should be overfilled during construction and then trimmed-back to the compacted inner core.

Cut Slopes

Observations during grading of individual cut slopes by the project engineering geologist to document favorable geologic structure or soil conditions of the exposed conditions is recommended. Where cohesionless sandy soil materials are observed, the cut slopes in question may require stabilization by means of a compacted stabilization fill.

Shrinkage and Subsidence

An average shrinkage on the order of about 15 to 20 percent may occur when excavated onsite soils are replaced (removed and recompacted) as properly compacted fill. A subsidence estimated of approximately 0.2 may also be expected when exposed bottom surfaces in removal areas are scarified and re-compacted as recommended herein. The above estimates of shrinkage and subsidence are intended as an aid for project planners in determining the earthwork quantities. However, these estimates should be used with some caution since they are not absolute values.

Oversize Material

Based upon our field observations and subsurface conditions encountered in our borings, oversize rock fragments were not visible on the surface and were not encountered in our shallow test pits.

However, if encountered, oversize material defined as rock, or other irreducible material with a maximum dimension greater than 12 inches in diameter, shall be taken offsite or placed in accordance with the

recommendations of the Geotechnical Consultant in areas designated as suitable for rock disposal (typical details for Rock Disposal are given on Plate SG-4, Appendix D).

Rock fragments less than 12 inches in diameter may be utilized in the fill provided, they are not nested or placed in concentrated pockets, they are surrounded by compacted fine-grained soil material and the distribution of rocks is approved by the Geotechnical Consultant.

Geotechnical Observations

Exposed bottom surfaces in each removal area should be observed by the project geotechnical consultant prior to placing fill. No fills should be placed without prior approval from the geotechnical consultant. The project geotechnical consultant should also be present on site during grading operations to observe proper placement and compaction of fill, as well as to document compliance with the recommendations presented herein.

PRELIMINARY FOUNDATION DESIGN GUIDELINES

Allowable Bearing Capacity, Estimated Settlement and Lateral Resistance

Based on Petra evaluation of the engineering characteristics of the site soils, we have provided recommendations for a conventional shallow foundation system. Other foundation system options, such as post-tensioned, can be provided upon request.

Allowable Soil Bearing Capacities

Pad Footings

An allowable soil bearing capacity of 1,500 pounds per square foot may be utilized for design of isolated 24-inch-square footings founded at a minimum depth of 12 inches below the lowest adjacent final grade for pad footings that are not a part of the slab system and are used for support of such features as roof overhang, second-story decks, patio covers, etc. This value may be increased by 20 percent for each additional foot of depth and by 10 percent for each additional foot of width, to a maximum value of 2,500 pounds per square foot. The recommended allowable bearing value includes both dead and live loads and may be increased by one-third for short duration wind and seismic forces.

Continuous Footings

An allowable soil bearing capacity of 1,500 pounds per square foot may be utilized for design of continuous footings founded at a minimum depth of 12 inches below the lowest adjacent final grade. This value may be increased by 20 percent for each additional foot of depth and by 10 percent for each additional foot of

width, to a maximum value of 2,500 pounds per square foot. The recommended allowable bearing value includes both dead and live loads and may be increased by one-third for short duration wind and seismic forces.

Static Settlement

Under the above recommended bearing values, total static settlements due to new building loads are expected to be less than 1 of an inch, and differential settlement between adjacent footings is expected to be less than 1/2 of an inch over a span of 40 feet. The majority of the anticipated settlement is expected to take place during construction as building loads are applied.

Dynamic (Seismically-Induced) Settlement

As stated previously in this report, the maximum differential settlement is estimated to be approximately one inch over a horizontal span of approximately 40 feet, with a corresponding equivalent angular distortion ratio of approximately 1:480 for a moderate earthquake. For a large earthquake the differential settlement should be less than 2 inches in 40 feet for an angular distortion ratio of 1:240. The project structural engineer should determine whether the static and dynamic settlement estimates provided herein should be considered additive for purposes of their structural design.

Lateral Resistance

A passive earth pressure of 300 pounds per square foot, per foot of depth, to a maximum value of 3,000 pounds per square foot, may be used to determine lateral bearing resistance for footings. In addition, a coefficient of friction of 0.35 times the dead load forces may be used between concrete and the supporting soils to determine lateral sliding resistance. The above values may be increased by one-third when designing for short duration wind or seismic forces. The above values are based on footings placed directly against compacted fill to be compacted to at least 90 percent of maximum dry density. The upper foot of passive soil resistance should be neglected where soil adjacent to the footing is not covered and protected by a concrete slab or pavement. The above values given for coefficient of friction and passive soil resistance are allowable values with a factor of safety of 1.5 and the designer may choose an appropriate factor of safety based on the loadings.

Preliminary Guidelines for Footings and Slabs on-Grade Design and Construction

The results of our laboratory tests performed on representative samples of near-surface soils within the subject site during our evaluation indicate that these materials predominantly exhibit expansion indices that are less than 20. As indicated in Section 1803.5.3 of 2019 California Building Code (2019 CBC), these

soils are considered non-expansive and, as such, the design of slabs on-grade is considered to be exempt from the procedures outlined in Sections 1808.6.2 of the 2019 CBC and may be performed using any method deemed rational and appropriate by the project structural engineer. However, the following minimum recommendations are presented herein for conditions where the project design team may require geotechnical engineering guidelines for design and construction of footings and slabs on-grade the project site.

The design and construction guidelines that follow are based on the above soil conditions and may be considered for reducing the effects of variability in fabric, composition and, therefore, the detrimental behavior of the site soils such as excessive short- and long-term total and differential heave or settlement. These guidelines have been developed on the basis of the previous experience of this firm on projects with similar soil conditions. Although construction performed in accordance with these guidelines has been found to reduce post-construction movement and/or distress, they generally do not positively eliminate all potential effects of variability in soils characteristics and future heave or settlement.

It should also be noted that the suggestions for dimension and reinforcement provided herein are performance-based and intended only as preliminary guidelines to achieve adequate performance under the anticipated soil conditions. However, they should not be construed as replacement for structural engineering analyses, experience, and judgment. The project structural engineer, architect and/or civil engineer should make appropriate adjustments to slab and footing dimensions, and reinforcement type, size and spacing to account for internal concrete forces (e.g., thermal, shrinkage and expansion) as well as external forces (e.g., applied loads) as deemed necessary. Consideration should also be given to minimum design criteria as dictated by local building code requirements.

Conventional Slab-on-Grade System

Given the expansion index of less than 20, as generally exhibited by onsite soils, we recommend that footings and floor slabs be designed and constructed in accordance with the following minimum criteria.

Footings

1. Exterior continuous footings supporting one- and two-story structures should be founded at a minimum depth of 12 inches below the lowest adjacent final grade, respectively. Interior continuous footings may be founded at a minimum depth of 10 inches below the top of the adjacent finish floor slabs.

2. In accordance with Table 1809.7 of 2019 CBC for light-frame construction, and regarding the earthquake potential, all continuous footings should have minimum widths of 12 inches for one- and two-story construction. We recommend all continuous footings should be reinforced with a minimum of four No. 4 bars, two top and two bottom.
3. A minimum 12-inch-wide grade beam founded at the same depth as adjacent footings should be provided across garage entrances or similar openings (such as large doors or bay windows). The grade beam should be reinforced with a similar manner as provided above.
4. Interior isolated pad footings, if required, should be a minimum of 24 inches square and founded at a minimum depth of 12 inches below the bottoms of the adjacent floor slabs for one- and two-story buildings. Pad footings should be reinforced with No. 4 bars spaced a maximum of 18 inches on centers, both ways, placed near the bottoms of the footings.
5. Exterior isolated pad footings intended for support of roof overhangs such as second-story decks, patio covers, and similar construction should be a minimum of 24 inches square and founded at a minimum depth of 18 inches below the lowest adjacent final grade. The pad footings should be reinforced with No. 4 bars spaced a maximum of 18 inches on centers, both ways, placed near the bottoms of the footings. Exterior isolated pad footings may need to be connected to adjacent pad and/or continuous footings via tie beams at the discretion of the project structural engineer.
6. The minimum footing dimensions and reinforcement recommended herein may be modified (increased or decreased subject to the constraints of Chapter 18 of the 2019 CBC) by the structural engineer responsible for foundation design based on his/her calculations, engineering experience and judgment.

Building Floor Slabs

1. Concrete floor slabs should be a minimum 4 inches thick and reinforced with No. 4 bars spaced a maximum of 18 inches on centers, both ways. All slab reinforcement should be supported on concrete chairs or brick to ensure the desired placement near mid-depth.

Slab dimension, reinforcement type, size and spacing need to account for internal concrete forces (e.g., thermal, shrinkage and expansion) as well as external forces (e.g., applied loads), as deemed necessary.

2. Living area concrete floor slabs and areas to receive moisture sensitive floor covering should be underlain with a moisture vapor retarder consisting of a minimum 10-mil-thick polyethylene or polyolefin membrane that meets the minimum requirements of ASTM E96 and ASTM E1745 for vapor retarders (such as Husky Yellow Guard®, Stego® Wrap, or equivalent). All laps within the membrane should be sealed, and at least 2 inches of clean sand should be placed over the membrane to promote uniform curing of the concrete. To reduce the potential for punctures, the membrane should be placed on a pad surface that has been graded smooth without any sharp protrusions. If a smooth surface cannot be achieved by grading, consideration should be given to lowering the pad finished grade an additional inch and then placing a 1-inch-thick leveling course of sand across the pad surface prior to the placement of the membrane.

At the present time, some slab designers, geotechnical professionals, and concrete experts view the sand layer below the slab (blotting sand) as a place for entrapment of excess moisture that could adversely impact moisture-sensitive floor coverings. As a preventive measure, the potential for moisture intrusion into the concrete slab could be reduced if the concrete is placed

directly on the vapor retarder. However, if this sand layer is omitted, appropriate curing methods must be implemented to ensure that the concrete slab cures uniformly. A qualified materials engineer with experience in slab design and construction should provide recommendations for alternative methods of curing and supervise the construction process to ensure uniform slab curing. Additional steps would also need to be taken to prevent puncturing of the vapor retarder during concrete placement.

3. Garage floor slabs should be a minimum 4 inches thick and reinforced in a similar manner as living area floor slabs. Garage slabs should also be poured separately from adjacent wall footings with a positive separation maintained using ¾-inch-minimum felt expansion joint material. To control the propagation of shrinkage cracks, garage floor slabs should be quartered with weakened plane joints. Consideration should be given to placement of a moisture vapor retarder below the garage slab, similar to that provided in Item 2 above, should the garage slab be overlain with moisture sensitive floor covering.
4. Presaturation of the subgrade below floor slabs will not be required; however, prior to placing concrete, the subgrade below all dwelling and garage floor slab areas should be thoroughly moistened to achieve a moisture content that is at least equal to or slightly greater than optimum moisture content. This moisture content should penetrate to a minimum depth of 12 inches below the bottoms of the slabs.

The minimum dimensions and reinforcement recommended herein for building floor slabs may be modified (increased or decreased subject to the constraints of Chapter 18 of the 2019 CBC) by the structural engineer responsible for foundation design based on his/her calculations, engineering experience and judgment.

Posts or Pole Foundations

Ancillary improvements such as lights, fences, pole for sports, or some light structures etc. may be mounted on posts or poles.

CIDH Design

Cast-in-drilled-hole (CIDH) concrete piers may be required for light poles, signs, posts, and utility poles. Shallow piers are usually designed based on rigid body mechanics. Piers or piles generally act as rigid bodies when the length to width ratio is less than 10. Equations for lateral resistance design are given in 2019 CBC section 1807.3. The code limits the use of these equations to piers that are less than 12 feet in length. If piers deeper than 12 feet are required, we can provide supplemental recommendations as needed.

A minimum diameter of 24 inches is recommended for such piers. The 24-inch-diameter is recommended to allow in-hole observations by the project engineering geologist and to allow proper cleanout by the contractor. Pier depth and spacing should be determined by the project structural engineer based on total loads and lateral loading. However, minimum clear spacing between piers should be two pier diameters,

sidewall to sidewall. Reinforcement for piers should be determined by the project structural engineer with regard to strengthening the concrete to resist lateral forces.

For concrete piers founded in existing alluvial or fill soils, the following design values may tentatively be used:

- End Bearing: An end bearing pressure of 500 pounds per square foot (psf) may be assumed for the bottom of the piers. End bearing capacity and skin friction may be combined to determine allowable pier capacities provided the minimum caisson diameter is 24 inches.
- Adhesion: An adhesion value of 100 psf may be assumed for skin frictional resistance at the interface between the concrete pier and the surrounding soils.
- Passive Pressure: A variable passive resistance of 150 pounds per square foot, per foot of depth, may be used for design purposes. The maximum total passive pressure should not exceed a value of 2,000 psf at any depth. This includes a safety factor of 1.5.
- Point of Fixity: The point of fixity for the caissons should be determined by the project structural engineer. It should be noted that caissons that have a slenderness ratio less than 10 (length divided by diameter) may tend to act in a rigid manner; therefore, a point of fixity may not be an accurate model of pier performance.
- Uplift: Caissons may be considered to resist uplift forces equal to the skin friction between the concrete pier and the surrounding fill as described above. Allowable uplift capacity should not exceed 90 percent of the allowable downward capacity.

Additional Design and Construction Recommendations for CIDH Piers and Piles

Recommendations concerning the construction of cast-in-place concrete caisson are outlined below. CIDH piles should be constructed in accordance with Section 49 of the Caltrans Standard Specifications, and the following recommendations.

1. Caisson drilling should be conducted under the continuous observation of the project geotechnical engineer. Caisson excavations should not remain open overnight.
2. With groundwater detected as shallow as 7 feet from the CPT data, below the ground surface, caving can be expected. Thus, casing or the use of drilling mud may be necessary during construction.
3. Prior to rebar cage and concrete installation, the shaft walls and base should be observed for anomalies, unexpected soft soil conditions, or caving.
4. The bottom of the drilled shafts should be cleared of all loose soil material prior to the concrete pour.
5. Concrete should not be allowed to free fall more than 4 feet and should not be allowed to hit the sidewalls of the excavation. For this reason, it is recommended that the concrete be placed using a tremie pipe. The tremie pipe should be submerged a minimum of 4 feet during concrete placement.

6. The rebar cage must be prevented from buckling during the concrete pour.
7. The volume of concrete should be checked to ensure voids did not result during extraction of any casing. Pulling of casing with insufficient concrete inside should be restricted.
8. If groundwater has entered the shaft, concrete must be tremied into place with an adequate head to displace water or slurry. Tremie pipe should be watertight and should be fitted with a valve at the lower end.
9. Piles should be checked for alignment and plumbness. The amount of acceptable horizontal misalignment of a CIDH pile is approximately 2 to 3 inches from the exact location and it is usually acceptable for the pile to be out of plumb 1 percent of the depth of the pile.

Footing Observations

Foundation footing trenches should be observed by the project geotechnical consultant to document into competent bearing-soils. The foundation excavations should be observed prior to the placement of forms, reinforcement, or concrete. The excavations should be trimmed neat, level, and square. Prior to placing concrete, all loose, sloughed, or softened soils and/or construction debris should be removed. Excavated soils derived from footing and utility trench excavations should not be placed in slab-on-grade areas unless the soils are compacted to a relative compaction of 90 percent or more.

General Corrosivity Screening

As a screening level study, very limited chemical and electrical tests were performed on several samples considered representative of the onsite soils to identify potential corrosive characteristics of these soils. The common indicators associated with soil corrosivity include water-soluble sulfate and chloride levels, pH (a measure of acidity), and minimum electrical resistivity. Test results are presented in Table 7 below.

It should be noted that Petra does not practice corrosion engineering; therefore, the test results, opinion and engineering judgment provided herein should be considered as general guidelines only. Additional analyses would be warranted, especially, for cases where buried metallic building materials (such as copper and cast or ductile iron pipes) in contact with site soils are planned for the project.

In many cases, the project geotechnical engineer may not be informed of these choices. Therefore, for conditions where such elements are considered, we recommend that other, relevant project design professionals (e.g., the architect, landscape architect, civil and/or structural engineer) also consider recommending a qualified corrosion engineer to conduct additional sampling and testing of near-surface soils during the final stages of site grading to provide a complete assessment of

soil corrosivity. Recommendations to mitigate the detrimental effects of corrosive soils on buried metallic and other building materials that may be exposed to corrosive soils should be provided by the corrosion engineer as deemed appropriate.

In general, a soil’s water-soluble sulfate levels and pH relate to the potential for concrete degradation; water-soluble chlorides in soils impact ferrous metals embedded or encased in concrete, e.g., reinforcing steel; and electrical resistivity is a measure of a soil’s corrosion potential to a variety of buried metals used in the building industry, such as copper tubing and cast or ductile iron pipes. Table 5, below, presents test results. with an interpretation of current code indicators and guidelines that are commonly used in this industry. The table includes the classifications of the soils as they relate to the various tests, as well as a general recommendation for possible mitigation measures in view of the potential adverse impact on various components of the proposed structures in direct contact with site soils. The guidelines provided herein should be evaluated and confirmed, or modified, in their entirety by the project structural engineer, corrosion engineer and/or the contractor responsible for concrete placement for structural concrete used in exterior and interior footings, interior slabs on-ground, garage slabs, wall foundations and concrete exposed to weather such as driveways, patios, porches, walkways, ramps, steps, curbs, etc.

TABLE 5
Soil Corrosivity Screening Results

Test	Test Results	Classification	General Recommendations
Soluble Sulfates (Cal 417)	0.0006 percent	S0 ⁽¹⁾	Type II cement; min. $f'_c = 2,500$ psi; no water/cement ratio restrictions
pH (Cal 643)	7.75	Slightly Alkaline	No special recommendations
Soluble Chloride (Cal 422)	227.7 ppm	C1 ⁽²⁾	Residence: No special recommendations, minimum concrete cover on reinforcement
Resistivity (Cal 643)	10,000 ohm-cm	Mildly Corrosive ⁽³⁾	Protective wrapping/coating of buried pipes; corrosion resistant materials

Notes:

1. ACI 318-14, Section 19.3
2. ACI 318-14, Section 19.3
3. Pierre R. Roberge, “Handbook of Corrosion Engineering”

Retaining Walls

Allowable Bearing Values

Proposed retaining walls should be supported on spread footings using the design criteria recommended previously for building footings; however, when calculating passive resistance, the passive earth pressure

should be reduced to 150 pounds per square foot, per foot of depth, to a maximum value of 1,500 pounds per square foot.

Active and At-Rest Earth Pressures

1. On-Site Soils Used for Backfill

On-site earth materials are considered to have a moderate expansion potential and are not recommended for use as backfill. However, if these materials are used as backfill, active earth pressures equivalent to fluids having densities of 35 and 60 pounds per cubic foot should be used for design of cantilevered walls retaining a level backfill and ascending 2:1 backfill, respectively. For walls that are restrained at the top, at-rest earth pressures of 55 and 85 pounds per cubic foot (equivalent fluid pressures) should be used. The above values are for retaining walls that have been supplied with a proper subdrain system (see Figure RW-1). All walls should be designed to support any adjacent structural surcharge loads imposed by other nearby walls or footings in addition to the active and at-rest earth pressures.

2. Imported Sand, Pea Gravel, or Rock Used for Wall Backfill

Imported clean sand exhibiting a sand equivalent value (SE) of 30 or greater, pea gravel, or crushed rock may be used for wall backfill to reduce the lateral earth pressures provided these granular backfill materials extend behind the walls to a minimum horizontal distance equal to one-half the wall height. In addition, the sand, pea gravel, or rock backfill materials should extend behind the walls to a minimum horizontal distance of 2 feet at the base of the wall or to a horizontal distance equal to the heel width of the footing, whichever is greater (see Figures RW-2 and RW-3). For the above conditions, cantilevered walls retaining a level backfill and ascending 2:1 backfill may be designed to resist active earth pressures equivalent to fluids having densities of 30 and 41 pounds per cubic foot, respectively. For walls that are restrained at the top, at-rest earth pressures equivalent to fluids having densities of 45 and 62 pounds per cubic foot are recommended for design of restrained walls supporting a level backfill and ascending 2:1 backfill, respectively. These values are also for retaining walls supplied with a proper subdrain system.

Furthermore, as with existing soil backfill, the walls should be designed to support any adjacent structural surcharge loads imposed by other nearby walls or footings in addition to the recommended active and at-rest earth pressures. All structural calculations and details should be provided to this firm for verification purposes prior to grading and construction phases.

Earthquake Loads Retaining Walls

Note 1 of Section 1803.5.12 of the 2019 CBC indicates that the dynamic seismic lateral earth pressures on foundation walls and retaining walls supporting more than 6 feet of backfill height due to design earthquake ground motions be determined. It is unlikely that any wall retaining 6 or more feet of backfill will be constructed onsite. Accordingly, dynamic seismic lateral earth pressures are not considered necessary for this project.

Subdrainage

Perforated pipe and gravel subdrains should be installed behind all retaining walls to prevent entrapment of water in the backfill (see Figures RW-1 through RW-3). Perforated pipe should consist of 4-inch-minimum diameter PVC Schedule 40, or SDR-35, with the perforations laid down. The pipe should be encased in a 1-foot-wide column of ¾-inch to 1½-inch open-graded gravel. If on-site soils are used as backfill, the open-graded gravel should extend above the wall footings to a minimum height equal to one-third the wall height or to a minimum height of 1.5 feet above the footing, whichever is greater. If imported sand, pea gravel, or crushed rock is used as backfill, subdrain details shown on Figures RW-2 and RW-3 should be utilized. The open-graded gravel should be completely wrapped in filter fabric consisting of Mirafi 140N or equivalent. Solid outlet pipes should be connected to the subdrains and then routed to a suitable area for discharge of accumulated water.

If a limited area exists behind the walls for installation of a pipe and gravel subdrain, a geotextile drain mat such as Mirafi Miradrain, or equivalent, can be used in lieu of drainage gravel. The drain mat should extend the full height and lengths of the walls and the filter fabric side of the drain mat should be placed up against the backcut. The perforated pipe drain line placed at the bottom of the drain mat should consist of 4-inch minimum diameter PVC Schedule 40 or SDR-35. The filter fabric on the drain mat should be peeled back and then wrapped around the drain line.

Waterproofing

The portions of retaining walls supporting backfill should be coated with an approved waterproofing compound or covered with a similar material to inhibit infiltration of moisture through the walls.

Wall Backfill

Where the onsite soils materials or imported sand (with a Sand Equivalent of 30 or greater) are used as backfill behind the proposed retaining walls, the backfill materials should be placed in approximately 6- to 8-inch-thick maximum lifts, watered as necessary to achieve above optimum moisture conditions, and then

mechanically compacted in place to a minimum relative compaction of 90 percent. Flooding or jetting of the backfill materials should be avoided. A representative of the project geotechnical consultant should observe the backfill procedures and test the wall backfill to verify adequate compaction.

If imported pea gravel or rock is used for backfill, the gravel should be placed in approximately 2- to 3-foot-thick lifts, thoroughly wetted but not flooded, and then mechanically tamped or vibrated into place. A representative of the project geotechnical consultant should observe the backfill procedures and probe the backfill to determine that an adequate degree of compaction is achieved.

To reduce the potential for the direct infiltration of surface water into the backfill, imported sand, gravel, or rock backfill should be capped with at least 12 inches of on-site soil. Filter fabric such as Mirafi 140N or equivalent, should be placed between the soil and the imported gravel or rock to prevent fines from penetrating into the backfill.

Geotechnical Observation and Testing

All grading and construction phases associated with retaining wall construction, including backcut excavations, footing trenches, installation of the subdrainage systems, and placement of backfill should be observed and tested by a representative of the project geotechnical consultant.

Masonry Block Walls

Footings for free-standing masonry block walls and other rigid structures should be designed and reinforced utilizing the criteria recommended for conventional building foundations. Where existing surface soils are not removed and re-compacted as recommended herein, the footings should be extended through these loose surface soils and founded in underlying competent materials. Positive separations in walls should also be provided at corners and at horizontal spacing of approximately 25 feet to permit relative movement. The separations should be provided in the blocks and not extend through the footings. The footings should be poured monolithically with continuous rebars to serve as effective “grade beams” below the walls.

Where remedial grading cannot be performed due to site constraints, a reduced bearing value of 1,200 pounds per square foot should be used for 12-inch-wide continuous footings founded at a minimum depth of 12 inches below the lowest adjacent final grade. No increase in bearing value may be used for wider or deeper footings for this condition. The recommended allowable bearing value includes both dead and live loads, and may be increased by one-third for short duration wind and seismic forces. In addition, a reduced passive earth pressure of 175 pounds per square foot per foot of depth, to a maximum value of 1,750 pounds per square foot, should be used to resist lateral loads. A coefficient of friction of 0.3 times the dead load

forces may still be used between concrete and the supporting soils to determine lateral sliding resistance. An increase of one-third of the above values may also be used when designing for short duration wind or seismic forces.

Exterior Concrete Flatwork

Subgrade Preparation

Compaction

To reduce the potential for distress to concrete flatwork, the subgrade soils below concrete flatwork areas to a minimum depth of 12 inches (or deeper, as either prescribed elsewhere in this report or determined in the field) should be moisture conditioned to at least equal to, or slightly greater than, the optimum moisture content and then compacted to a minimum relative compaction of 90 percent. Where concrete public roads, concrete segments of roads and/or concrete access driveways are proposed, the upper 6 inches of subgrade soil should be compacted to a minimum 95 percent relative compaction.

Pre-Moistening

As a further measure to reduce the potential for concrete flatwork cracking, subgrade soils should be thoroughly moistened prior to placing concrete. The moisture content of the soils should be at least the optimum moisture content to a minimum depth of 12 inches into the subgrade. Flooding or ponding of the subgrade is not considered feasible to achieve the above moisture conditions since this method would likely require construction of numerous earth berms to contain the water. Therefore, moisture conditioning should be achieved with sprinklers, or a light spray applied to the subgrade over a period of few to several days just prior to pouring concrete. Pre-watering of the soils is intended to promote uniform curing of the concrete, reduce the development of shrinkage cracks and reduce the potential for differential expansion pressure on freshly poured flatwork. A representative of the project geotechnical consultant should observe and verify the density and moisture content of the soils, and the depth of moisture penetration prior to pouring concrete.

Drainage

Drainage from patios and other flatwork areas should be directed to local area drains and/or graded earth swales designed to carry runoff water to the adjacent streets or other approved drainage structures. The concrete flatwork should be sloped at a minimum gradient of one percent, or as prescribed by project civil engineer or local codes, away from building foundations, retaining walls, masonry garden walls and slope areas.

Thickness and Joint Spacing

To reduce the potential of unsightly cracking, concrete walkways, patio-type slabs, large decorative slabs and concrete sub-slabs to be covered with decorative pavers should be at least 4 inches thick and provided with construction joints or expansion joints every 6 feet or less. Private driveways that will be designed for the use of passenger cars for access to private garages should also be at least 4 inches thick and provided with construction joints or expansion joints every 10 feet or less. Concrete pavement that will be designed based on an unlimited number of applications of an 18-kip single-axle load in public access areas, segments of road that will be paved with concrete (such as bus stops and cross-walks) or access roads that will be subject to heavy truck loadings should have a minimum thickness of 5 inches and be provided with control joints spaced at maximum 10-foot intervals. A modulus of subgrade reaction of 125 pounds per cubic foot may be used for design of the public and access roads.

Reinforcement

All concrete flatwork having their largest plan-view panel dimension exceeding 10 feet should be reinforced with a minimum of No. 3 bars spaced 24 inches on centers, both ways. Alternatively, the slab reinforcement may consist of welded wire mesh of the sheet type (not rolled) with 6x6/W1.4xW1.4 designation in accordance with the Wire Reinforcement Institute (WRI). The reinforcement should be properly positioned near the middle of the slabs.

The reinforcement recommendations provided herein are intended as guidelines to achieve adequate performance for anticipated soil conditions. The project architect, civil and/or structural engineer should make appropriate adjustments in reinforcement type, size and spacing to account for concrete internal (e.g., shrinkage and thermal) and external (e.g., applied loads) forces as deemed necessary.

Edge Beams (Optional)

Where the outer edges of concrete flatwork are to be bordered by landscaping, it is recommended that consideration be given to the use of edge beams (thickened edges) to prevent excessive infiltration and accumulation of water under the slabs. Edge beams, if used, should be 6 to 8 inches wide, extend 8 inches below the tops of the finish slab surfaces. Edge beams are not mandatory; however, their inclusion in flatwork construction adjacent to landscaped areas is intended to reduce the potential for vertical and horizontal movement and subsequent cracking of the flatwork related to uplift forces that can develop in expansive soils.

Tree Wells

Tree wells are not recommended in concrete flatwork areas since they introduce excessive water into the subgrade soils and allow root invasion, both of which can cause heaving and cracking of the flatwork.

Utility Trench Backfill

All utility trench backfill should be compacted to a minimum relative compaction of 90 percent. Onsite earth materials cannot be densified adequately by flooding and jetting techniques. Therefore, trench backfill should be placed in lifts no greater than 6 inches in thickness, watered or air-dried as necessary to achieve near optimum moisture conditions, and mechanically compacted in place to a minimum relative compaction of 90 percent. A representative of the project geotechnical consultant should probe and test the trench backfills to document that adequate compaction has been achieved.

As an alternative for shallow trenches where pipe or utility lines may be damaged by mechanical compaction equipment, such as under building floor slabs, imported clean sand having a sand equivalent (SE) value of 30 or greater may be utilized. The sand backfill materials should be watered to achieve near optimum moisture conditions and then tamped into place. No specific relative compaction will be required; however, observation, probing, and if deemed necessary, testing should be performed by a representative of the project geotechnical consultant to verify an adequate degree of compaction.

If clean, imported sand is to be used for backfill of exterior utility trenches, it is recommended that the upper 12 inches of trench backfill materials consist of properly compacted onsite soil materials. This is to mitigate infiltration of irrigation and rainwater into granular trench backfill materials.

Where an interior or exterior utility trench is proposed parallel to a building footing, the bottom of the trench should not be located below a 1:1 plane projected downward from the outside bottom edge of the adjacent footing. Where this condition exists, the adjacent footing should be deepened such that the bottom of the utility trench is located above the 1:1 projection. Where utility trenches cross under a building footing, these trenches should be backfilled with on-site soils at the point where the trench crosses under the footing to reduce the potential for water to migrate under the floor slabs.

Site Drainage

Positive surface drainage systems consisting of a combination of sloped concrete flatwork/asphalt pavement, sheet flow gradients, swales and surface area drains (where needed) should be provided around the building and within the planter areas to collect and direct all surface waters to an appropriate drainage

facility as determined by the project civil engineer. The ground surfaces of planter and landscape areas that are located within 10 feet of building foundations should be sloped at a minimum gradient of 5 percent away from the foundations and towards the nearest area drains. The ground surfaces of planter and landscape areas that are located more than 10 feet away from building foundations may be sloped at a minimum gradient of 2 percent away from the foundations and towards the nearest area drains.

Concrete flatwork surfaces that are located within 10 feet of building foundations should be inclined at a minimum gradient of 2 percent away from the building foundations and towards the nearest area drains. Concrete flatwork surfaces that are located more than 10 feet away from building foundations may be sloped at a minimum gradient of 1 percent away from the foundations and towards the nearest area drains. Surface waters should not be allowed to collect or pond against building foundations and within the level areas of the site. All drainage devices should be properly maintained throughout the lifetime of the development. Future changes to site improvements, or planting and watering practices, should not be allowed to cause over-saturation of site soils adjacent to the structures.

Bottomless Trench Drains

When gravel filled bottomless infiltration systems are constructed near foundations, a potential exists for oversaturation of the foundation soils which conflicts with the intended purpose of onsite drainage facilities. In addition, it has been our experience that a leading cause of distress to buildings and foundations is due to poor management of water next to building foundations. Petra recommends a setback of at least 15 feet between any infiltration system and building foundations. If this setback distance cannot be maintained, then a modified foundation system may be required to alleviate any distress that could be caused by infiltration of water near the footing. A modified foundation system could consist of constructing deepened footings within 15 feet of the infiltration system and installing extra reinforcement. Design of a modified foundation system is referred to the project structural engineer.

Swimming Pool and Spa

Allowable Bearing and Settlement

Based on the currently proposed pool location, the pool may be designed as a conventional pool shell founded on improved ground. Any loose sand below the pool shell should be removed and replaced with engineered fill. Therefore, the pool shell may be designed using an allowable bearing value of 1,500 pounds per square foot. A potential for seismic differential settlement on the order of one inch to occur across the pool/spa shells should be considered in the design.

Lateral Earth Pressures

The pool walls should be designed assuming that an earth pressure equivalent to a fluid having a density of 90 pounds per cubic foot is acting on the outer surface of the pool walls. For this long-term condition, the walls should be designed using a lateral earth pressure of $62.4H$ pounds per square foot (where “H” equals the vertical depth in feet below the ground surface) that is acting on the inner surface of the pool walls. Pool walls should also be designed to resist lateral surcharge pressures imposed by any adjacent footings or structures in addition to the above lateral earth pressures.

Stability of Temporary Excavation

The pool excavation is expected to expose compacted fill. Based on the anticipated physical characteristics of these materials, the pool excavation sidewalls may be cut at 4 foot vertical with sloping sidewalls above per the previous recommendations for temporary excavation stability. Therefore, the temporary excavation sidewalls should be sloped at a slope ratio of 2:1 (horizontal to vertical) or flatter before forming of the pool walls.

Temporary Access Ramps

It is essential that all backfill placed within temporary access ramps extending into the pool excavation be properly compacted and tested. This will reduce the potential for excessive settlement of the backfill and subsequent damage to pool decking or other structures placed on the backfill.

Pool Bottom

It is expected that the swimming pool bottom will rest entirely on medium dense to dense dune sand deposits. Therefore, care should be taken while excavating these structures to prevent disturbance of subgrade soils exposed at grade in the pool bottom.

Pool Decking

Pool decking should be constructed in accordance with the recommendations presented in the “Exterior Concrete Flatwork” section of this report.

Plumbing Fixtures

Leakage from the swimming pool or from any of the appurtenant plumbing could create adverse saturated conditions of the surrounding subgrade soils. Localized areas of oversaturation can lead to differential expansion (heave) of the subgrade soils and subsequent raising and shifting of concrete flatwork. Therefore, it is essential that all plumbing and pool fixtures be absolutely leak-free. For similar reasons, drainage from

pool deck areas should be directed to local area drains and/or graded earth swales designed to carry runoff water to a suitable discharge point.

Preliminary Pavement Design

Onsite soil is highly granular and R-values of future access road subgrades following site grading are expected to be over 50. The access roadway is expected to be classified as 'Local' and associated Traffic Indices (TI) are expected to be 5. A tentative structural pavement section for the roadway is 3 inches of asphalt over 4 inches of base material. Final pavement design should be performed at the completion of rough grading with final R-value testing.

Subgrade soils immediately below the aggregate base, to a minimum depth of 12 inches, should be compacted to a minimum relative compaction of 95 percent based on ASTM D1557. Final subgrade compaction should be performed prior to placing base materials and after utility-trench backfills have been compacted and tested.

The base materials should meet the specifications for Crushed Aggregate Base, Crushed Miscellaneous Base or Processed Miscellaneous Base as defined in Section 200-2 of the current edition of the Standard Specifications for Public Works Construction (Greenbook). The base course should be compacted to 95 percent or more of the maximum dry density as evaluated by ASTM D1557. Asphaltic concrete materials and construction should conform to Section 203 of the Greenbook or by County of Riverside specifications.

EVALUATION LIMITATIONS

This report is based on the proposed project and geotechnical data as described herein. The materials encountered on the project site, described in other literature, and utilized in our laboratory assessment are believed representative of the project area, and the conclusions and recommendations contained in this report are presented on that basis. However, soil materials can vary in characteristics between points of exploration, both laterally and vertically, and those variations could affect the conclusions and recommendations contained herein. As such, observation and testing by a geotechnical consultant during the grading and construction phases of the project are essential to confirming the basis of this report. Without this confirmation, this report is to be considered incomplete and this firm and the undersigned professionals assume no responsibility for its use.

This report has been prepared consistent with that level of care being provided by other professionals providing similar services at the same locale and time period. The contents of this report are professional

opinions and as such, are not to be considered a guarantee or warranty. This report should be reviewed and updated after a period of one year or if the project concept changes from that described herein.

The information contained herein has not been prepared for use by parties or projects other than those named or described herein. This report may not contain sufficient information for other parties or other purposes. In addition, this report should be reviewed and updated after a period of one year, or sooner if the site ownership or project concept changes from that described herein.

This opportunity to be of service is sincerely appreciated. Please call if you have any questions pertaining to this report.

Respectfully submitted,

PETRA GEOSCIENCES, INC.



8/1/22

J. Montgomery Schultz
Associate Engineer
GE 2941

JMS/AP/lv

W:\2020-2025\2020\200\20-227\Reports\20-227 110 Geotechnical Investigation.docx

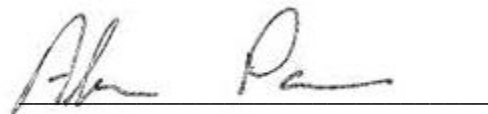

Alan Pace
Senior Associate Geologist
CEG 1952



LITERATURE REVIEWED

- American Concrete Institute, 2014, Building Code Requirements for Structural Concrete (ACI 318-14) and Commentary, Committee 318.
- American Society of Civil Engineers (ASCE/SEI), 2016, Minimum Design Load for Buildings and Other Structures, Standards 7-16.
- Bedrossian, T.L., Hayhurst, C.A., and Roffers, P.D., 2010, Geologic Compilation of Quaternary Surficial Deposits in Southern California, San Bernardino 30' x 60' Quadrangle, CGS Special Report 217, Plate 13, July.
- California Building Code (CBC), 2019, California Code of Regulations, Title 24, Part 2, Volume I and II.
- California Department of Water Resources, 2021, Water Data Library, <http://www.water.ca.gov/waterdatalibrary/>.
- _____, Division of Dam Safety (DDS), 2021, Dam Breach Inundation Map Web Publisher, <https://fmds.water.ca.gov/maps/damim/>
- California Geological Survey, 2010, 'Fault Activity Map of California, Geologic Data Map No. 6, <http://maps.conservation.ca.gov/cgs/fam/>.
- California Geological Survey, 2018, Earthquake Fault Zones, A Guide for Government Agencies, Property Owners/Developers, and Geoscience Practitioners for Assessing Fault Rupture Hazards in California, Special Publication 42.
- Caltrans, 2003, Bridge Design Specifications, Section 8 – Reinforced Concrete, dated September.
- Cao, T., et al., 2003, Revised 2002 California Probabilistic Seismic Hazard Maps, June 2003: California Geological Survey.
- Dibble, T.W., Jr., 1982, Geologic Map of the Idyllwild (15-Munite) Quadrangle, California, South Coast Geological Society, Geologic Map SCGS-5.
- Federal Emergency Management Agency (FEMA), 2009, NEHERP (National Earthquake Hazards Reduction Program) Recommended Seismic Provision for New Building and Other Structures (FEMA P-750).
- _____, 2008, National Flood Hazard Layer FIRMette, Panel 06065C2170G, dated August 28.
- Hart, E.W., and Bryant, W.A., 1997, Fault-Rupture Hazard Zones in California, Alquist-Priolo Earthquake Fault Zoning Act: California Division of Mines and Geology, Special Publication 42 (Supplements 1 and 2 added 1999, and Supplement 3 added 2003).
- Ishihara, K., 1985, Stability of Natural Deposits During Earthquakes, 11th International Conference on Soil Mechanics and Foundation Engineering, Proceedings, San Francisco, Vol. 1., pp. 321-376.
- Pradel, D., 1998, Procedure to Evaluate Earthquake-Induced Settlements in Dry Sandy Soils: *in Journal of Geotechnical and Geoenvironmental Engineering*: Vol. 124, No. 4.
- Petra Geoscience, Inc., 2020, Report of Active Faulting, The Ridge Wellness Center, Approximately 36-acre Parcel, Assessor Parcel Number 568-070-021, Lake Hemet Area, Riverside County, California; J.N. 20-227, dated October 12.
- _____, 2021, Response to Comment by Riverside County Geologist, County Geologic Report 210001, Report of Active Faulting, The Ridge Wellness Center, Approximately 36-acre Parcel, Assessor Parcel Number 568-070-021, Lake Hemet Area, Riverside County, California; J.N. 20-227, dated January 19.

LITERATURE REVIEWED

SEAOC & OSHPD Seismic Design Maps Web Application – <https://seismicmaps.org/>

Seed, R.B. et. al., 2003, Recent Advances in Soil Liquefaction Engineering: A Unified and Consistent Framework, Earthquake Engineering Research Center; Report No. EERC 2003-06; 26th Annual ASCE Los Angeles Section Spring Seminar, Keynote Presentation, H.M.S. Queen Mary, Long Beach, California, April 30.

Southern California Earthquake Center (SCEC, 1998), Seismic Hazards in Southern California: Probable Earthquakes, 1994 to 2024: by Working Group on California Earthquake Probabilities.

Southern California Earthquake Center (SCEC, 1999, Revised 2008), Recommended Procedures for Implementation of DMG Special Publication 117, Guidelines for Analyzing and Mitigating Liquefaction Hazards in California: organized through the Southern California Earthquake Center, University of Southern California.

Standard Specifications for Public Works Construction (Greenbook), 2009, BNI Publishers.

Tokimatsu, K.; Seed, H.B.; 1987; Evaluation of settlements in sands due to earthquake shaking; Journal of Geotechnical Engineering: Vol. 113, No. 8, p. 861-879.

United States Geologic Survey (U.S.G.S.), 1996a, Probabilistic Seismic Hazard Assessment for the State of California, Open-File Report 96-706.

_____, 1996b, National Seismic-Hazards Maps, Open-File Report 96-532.

_____, 2002, Documentations for the 2002 Update of the National Seismic Hazard Maps, Open-File Report 02-20.

_____, 2007, Preliminary Documentation for the 2007 Update of the United States National Seismic Hazard Maps, Seismic Hazards Mapping Project, Open-File Report 2007-June Draft.

_____, 2011, Earthquake Ground Motion Parameters, Version 5.1.0, utilizing ASCE 7 Standard Analysis Option, dated February 10.

_____, 2021, Unified Hazard Tool Calculator, [Unified Hazard Tool \(usgs.gov\)](https://www.usgs.gov/hazard-tool)

Wire Reinforcement Institute (WRI), 1996, Design of Slabs on Ground.

Youd, T.L., Hansen, C.M., Bartlett, S.F., 2002, Revised Multilinear Regression Equations for Prediction of Lateral Spread Displacement, Journal of Geotechnical and Geoenvironmental Engineering, December 2002, Vol. 128, No. 12.

.

FIGURES

NATIVE SOIL BACKFILL

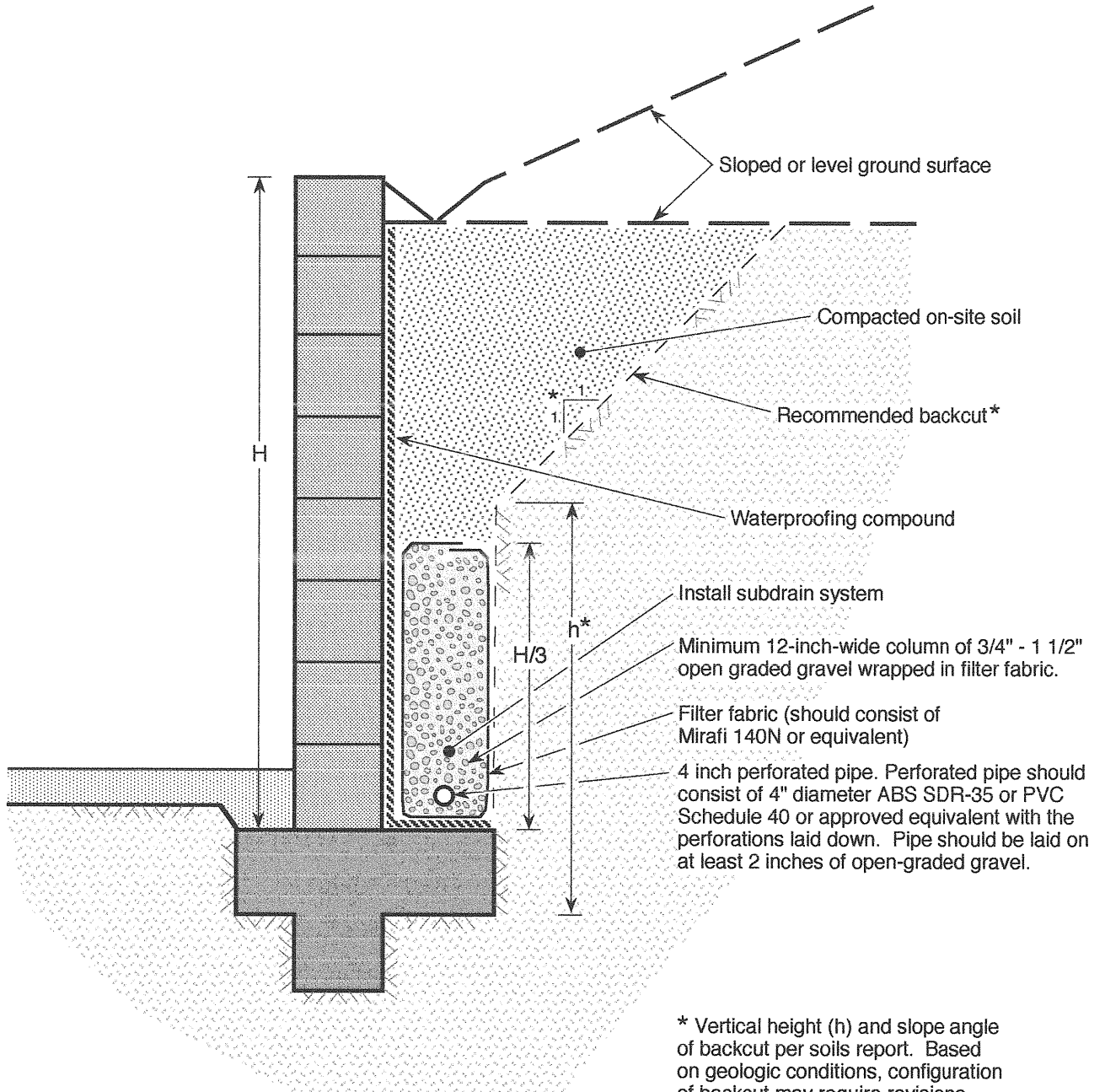

* Vertical height (h) and slope angle of backcut per soils report. Based on geologic conditions, configuration of backcut may require revisions (i.e. reduced vertical height, revised slope angle, etc.)

IMPORTED SAND BACKFILL

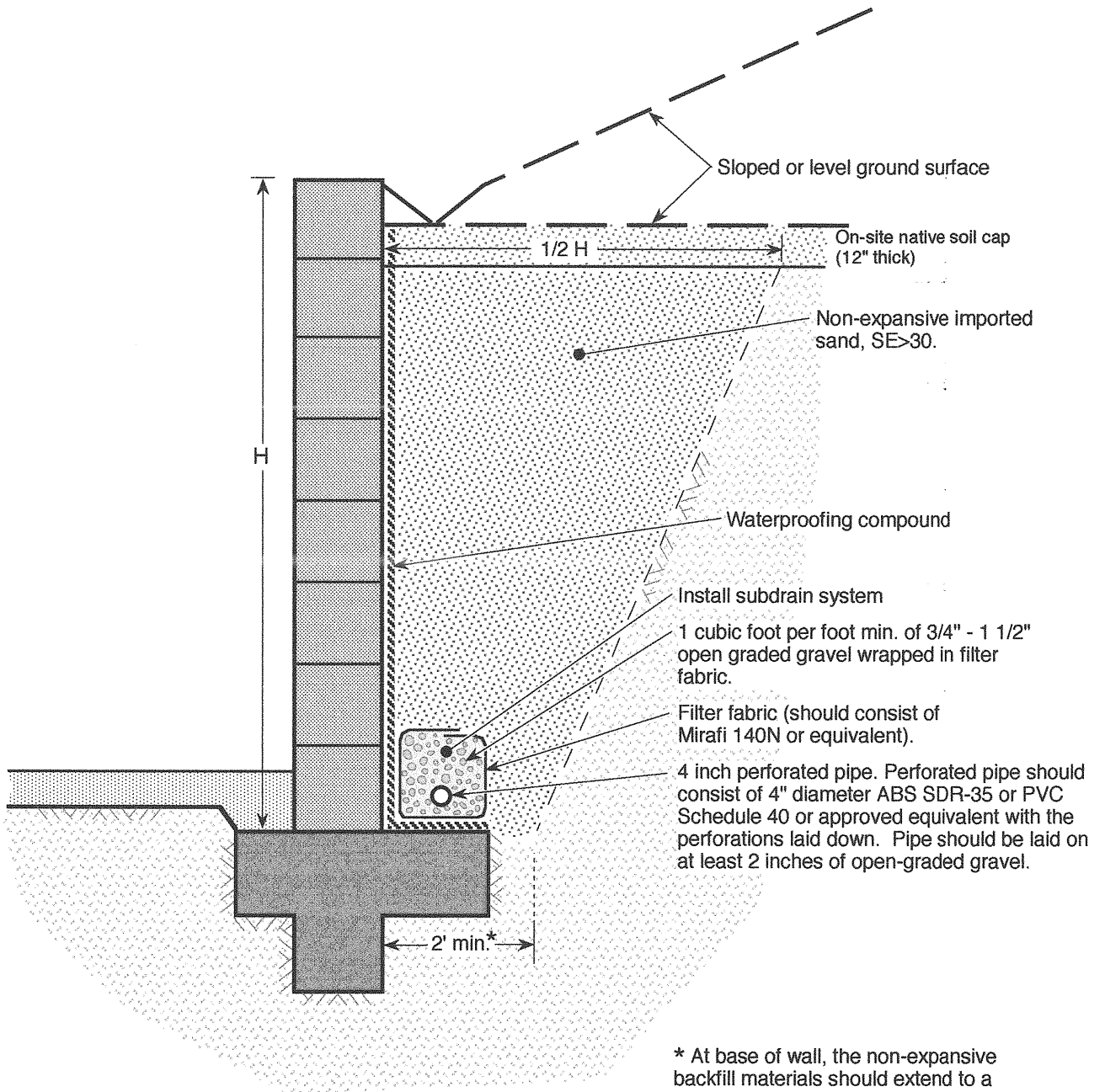

* At base of wall, the non-expansive backfill materials should extend to a min. distance of 2' or to a horizontal distance equal to the heel width of the footing, whichever is greater.

IMPORTED GRAVEL OR CRUSHED ROCK BACKFILL

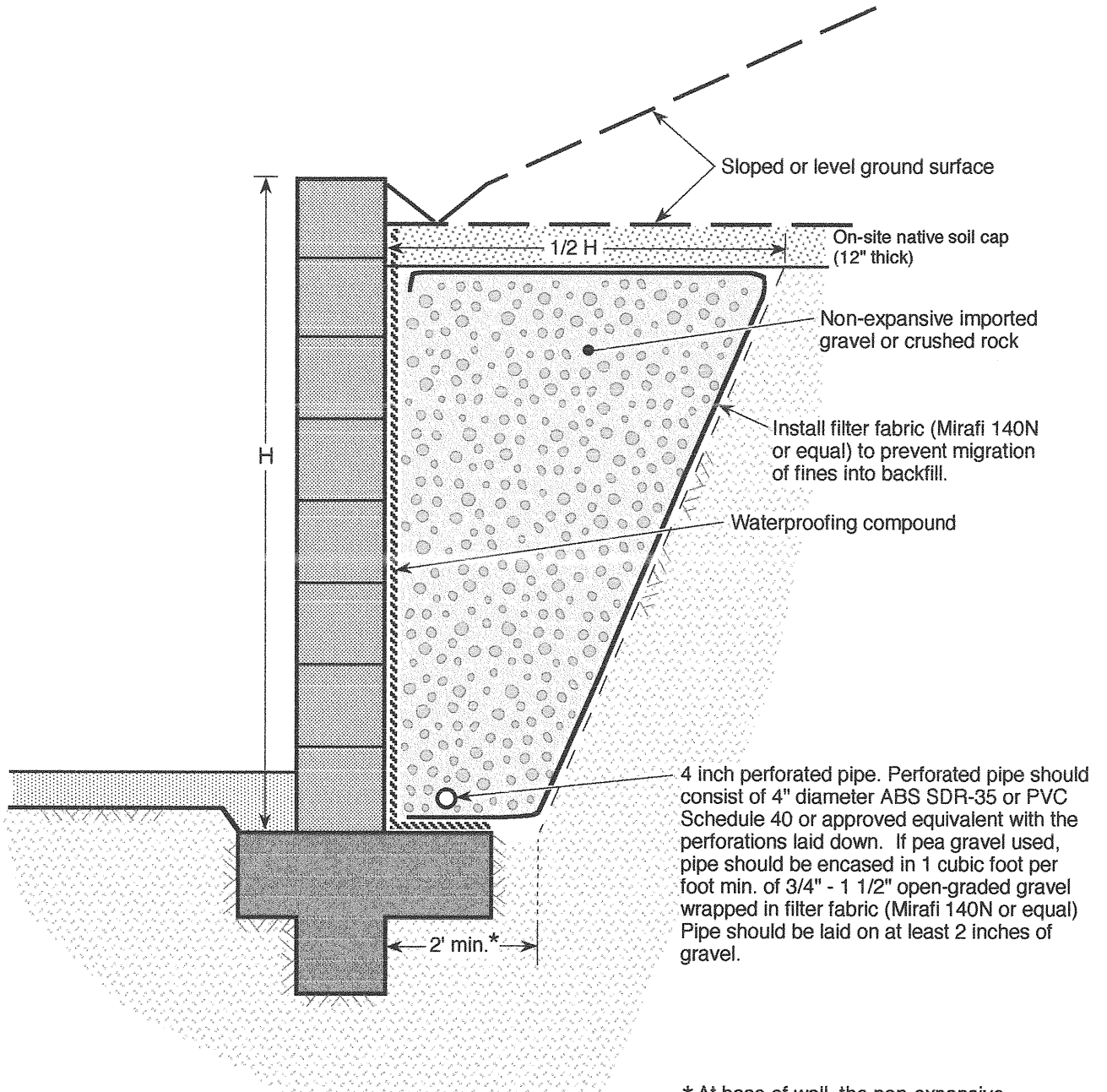

* At base of wall, the non-expansive backfill materials should extend to a min. distance of 2' or to a horizontal distance equal to the heel width of the footing, whichever is greater.



PETRA

**RETAINING WALL BACKFILL
AND SUBDRAIN DETAILS**

FIGURE RW-3

APPENDIX A-1

EXPLORATION (BORING) LOGS

CPT SOUNDING LOGS

Soil Classification



4 Moisture Content
Dry
Slightly Moist
Moist
Very Moist
Wet (Saturated)

Modifiers	
Trace	< 1 %
Few	1 - 5 %
Some	5 - 12 %
Numerous	12 - 20 %

Soil Classification Should Include:
PREFERRED ORDER
1. Group Name
2. Group Symbol
3. Color
4. Moisture Content
5. Relative Density / Consistency
6. Grain Size Range
7. Structure
8. Odor
9. Additional comments indicating soil characteristics which might affect engineering properties

6 Grain Size			
Description	Sieve Size	Grain Size	Approximate Size
Boulders	>12"	>12"	Larger than basketball-sized
Cobbles	3 - 12"	3 - 12"	Fist-sized to basketball-sized
Gravel	coarse	3/4 - 3"	Thumb-sized to fist-sized
	fine	#4 - 3/4"	Pea-sized to thumb-sized
Sand	coarse	#10 - #4	Rock salt-sized to pea-sized
	medium	#40 - #10	Sugar-sized to rock salt-sized
	fine	#200 - #40	Flour-sized to sugar-sized to
Fines	Passing #200	<0.0029"	Flour-sized and smaller

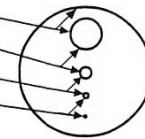

1 2 Unified Soil Classification System				
Coarse-grained Soils > 1/2 of materials is larger than #200 sieve	GRAVELS more than half of coarse fraction is larger than #4 sieve	Clean Gravels (less than 5% fines)	GW Well-graded gravels, gravel-sand mixtures, little or no fines	
		Gravels with fines	GP Poorly-graded gravels, gravel-sand mixtures, little or no fines	
	SANDS more than half of coarse fraction is smaller than #4 sieve	Clean Sands (less than 5% fines)	GM Silty Gravels, poorly-graded gravel-sand-silt mixtures	
		Sands with fines	GC Clayey Gravels, poorly-graded gravel-sand-clay mixtures	
	Fine-grained Soils > 1/2 of materials is smaller than #200 sieve The No. 200 U.S. Standard Sieve is about the smallest particle visible to the naked eye	SILTS & CLAYS Liquid Limit Less Than 50		SW Well-graded sands, gravelly sands, little or no fines
				SP Poorly-graded sands, gravelly sands, little or no fines
		SILTS & CLAYS Liquid Limit Greater Than 50		SM Silty Sands, poorly-graded sand-gravel-silt mixtures
				SC Clayey Sands, poorly-graded sand-gravel-clay mixtures
				ML Inorganic silts & very fine sands, silty or clayey fine sands, clayey silts with slight plasticity
				CL Inorganic clays of low to medium plasticity, gravelly clays, sandy clays, silty clays, lean clays
			OL Organic silty & clays of low plasticity	
			MH Inorganic silts, micaceous or diatomaceous fine sand or silt	
Highly Organic Soils		CH Inorganic clays of high plasticity, fat clays		
		OH Organic silts and clays of medium-to-high plasticity		
		PT Peat, humus swamp soils with high organic content		

5 Consistency - Fine Grained Soils			
Apparent Density	SPT (# blows/foot)	Modified CA Sampler (# blows/foot)	Field Test
Very Soft	<2	<3	Easily penetrated by thumb; exudes between thumb and fingers when squeezed in hand
Soft	2-4	3-6	Easily penetrated one inch by thumb; molded by light finger pressure
Firm	5-8	7-12	Penetrated over 1/2 inch by thumb with moderate effort; molded by strong finger pressure
Stiff	9-15	13-25	Indented about 1/2 inch by thumb but penetrated only with great effort
Very Stiff	16-30	26-50	Readily indented by thumbnail
Hard	>30	>50	Indented with difficulty by thumbnail

5 Relative Density - Coarse Grained Soils			
Apparent Density	SPT (# blows/foot)	Modified CA Sampler (# blows/foot)	Field Test
Very Loose	<4	<5	Easily penetrated with 1/2-inch reinforcing rod pushed by hand
Loose	4-10	5-12	Easily penetrated with 1/2-inch reinforcing rod pushed by hand
Medium Dense	11-30	13-35	Easily penetrated 1-foot with 1/2-inch reinforcing rod driven with a 5-lb hammer
Dense	31-50	36-60	Difficult to penetrated 1-foot with 1/2-inch reinforcing rod driven with a 5-lb hammer
Very Dense	>50	>60	Penetrated only a few inches with 1/2-inch reinforcing rod driven with a 5-lb hammer

TEST PIT LOG

Project: Wellness Center			Boring No.: B-1						
Location: Lake Hemet			Elevation: ±4382'						
Job No.: 20-227		Client:		Date: 6/7/2021					
Drill Method: 8" Hollow Stem Auger		Driving Weight: 140lbs/30"		Logged By: KTM					
Depth (Feet)	Lithology	Material Description	W A T E R	Samples		Laboratory Tests			
				Blows per 6 in.	C o r e	B u l k	Moisture Content (%)	Dry Density (pcf)	Other Lab Tests
0		ALLUVIUM (Qal) Silty Clay (ML): Brown, slightly moist, firm, fine-grained sand.		8 13 14	█		4.6	114.5	MAX, EI, AT, HYD, S04, CL, RES, pH
5		Sand (SP): Gray, moist, medium-dense, fine- to medium-grained sand, trace gravel up to 1/4" in diameter. Becomes off-white, fine- to medium-grained.		8 8 10	█		3.1	106.7	200
				8 10 20	█		2.5	108.2	
10		Silty Sand (SM): Gray, wet, medium-dense, medium- to coarse-grained. @12.5' Groundwater encountered.	▽	11 15 18	█		14.5	111.0	MA
15		Same as above.		4 10 15	█		14.4	117.2	200
20		Same as above.		4 9 9	█				200
25		No recovery (likely rock encountered).		36 50/5"	█				
30		Sand with Silt & Gravel (SP-SM): Gray, wet, medium-dense, fine- to medium-grained.		7 9 11	█				MA
35		Silty Sand (SM): Grayish-brown, wet, medium-dense to dense, fine- to		7	█				

TEST PIT LOG

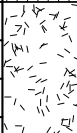
Project: Wellness Center				Boring No.: B-1					
Location: Lake Hemet				Elevation: ±4382'					
Job No.: 20-227		Client:		Date: 6/7/2021					
Drill Method: 8" Hollow Stem Auger		Driving Weight: 140lbs/30"		Logged By: KTM					
Depth (Feet)	Lithology	Material Description	W A T E R	Samples			Laboratory Tests		
				Blows per 6 in.	C o r e	B u l k	Moisture Content (%)	Dry Density (pcf)	Other Lab Tests
		medium-grained.		16			11.2	125.5	200
		BEDROCK - Granitics (Kgr) Off-white, coarse-grained, very hard, slightly weathered, Drill begins to struggle.		26					
40		Total Depth= 40'5" Groundwater @ 12.5' Boring backfilled with cuttings.							
45									
50									
55									
60									
65									
70									

TEST PIT LOG

Project: Wellness Center				Boring No.: B-2					
Location: Lake Hemet				Elevation: ±4381'					
Job No.: 20-227		Client:		Date: 6/7/2021					
Drill Method: 8" Hollow Stem Auger		Driving Weight: 140lbs/30"		Logged By: KTM					
Depth (Feet)	Lithology	Material Description	W A T E R	Samples		Laboratory Tests			
				Blows per 6 in.	C o r e	B u l k	Moisture Content (%)	Dry Density (pcf)	Other Lab Tests
0		ALLUVIUM (Qal) Sandy Silt (ML): Brown, moist, firm, fine-grained.							
		Silty Sand (SM): Grayish-brown, wet, medium-dense, fine- to medium-grained, (Sample was possibly wet from previous boring carry over).		11 13 15	█		7.1	118.9	CON
5		Silty Sand (SM): Brown, moist, medium-dense, fine- to coarse-grained.		10 12 17	█		4.7	115.2	MA
		Becomes fine- to coarse-grained, dark gray and wet.		10 12 17	█		17.0	114.9	DSU
10		@9'8" Groundwater encountered. Becomes off-white and coarse-grained. Silty Sand (SM): Dark gray, wet, medium-dense, fine-grained.	▽	7 10 16	█		14.9	115.8	
15		Sand (SP): Gray, wet, medium-dense, medium- to coarse-grained.		7 12 12	█		12.2	110.9	
20		Same as above.		13 30 32	█		14.8	122.3	
25		Total Depth= 25' Reusal due to heaving sands clogging auger Groundwater @ 9'8" Boring backfilled with cuttings.							
30									
35									

TEST PIT LOG

Project: Wellness Center				Boring No.: B-3					
Location: Lake Hemet				Elevation: ±4377'					
Job No.: 20-227		Client:		Date: 6/7/2021					
Drill Method: 8" Hollow Stem Auger		Driving Weight: 140lbs/30"		Logged By: KTM					
Depth (Feet)	Lith-ology	Material Description	W A T E R	Samples			Laboratory Tests		
				Blows per 6 in.	C o r e	B u l k	Moisture Content (%)	Dry Density (pcf)	Other Lab Tests
0		ALLUVIUM (Qal) Sandy Silt (ML): Brown, slightly moist, firm, fine-grained sand.							
10		Silty Sand (SM): Dark brown, moist, medium-dense, fine- to medium-grained.		10 13 13	█		7.7	120.9	
5		Sand (SP): Grayish-brown, very moist, medium-dense, medium- to coarse-grained, trace gravel up to 1" in diameter = 1%.		6 9 10	█		10.5	107.6	
10		@8'8" Groundwater encountered. Becomes gray with orange oxidation staining, medium-grained.	▽	10 11 17	█		15.1	112.8	
15		Becomes dark gray to black.		9 10 9	█		21.7	105.8	
20		Becomes grayish-brown and medium to coarse-grained. @16' Drill struggles for approximately 1' and then proceeds as normal.		4 8 14	█		12.8	118.5	
25		Becomes fine- to coarse-grained.		7 13 18	█		13.6	117.5	
30		Becomes fine- to medium-grained, micaceous.		10 17 22	█		17.1	115.6	
35		Becomes fine- to coarse-grained.		11 16 24	█		15.7	118.2	
35		Silty Sand (SM): Dark yellowish-brown, wet, medium-dense, fine- to coarse-		7	█				

TEST PIT LOG

Project: Wellness Center				Boring No.: B-3					
Location: Lake Hemet				Elevation: ±4377'					
Job No.: 20-227		Client:		Date: 6/7/2021					
Drill Method: 8" Hollow Stem Auger		Driving Weight: 140lbs/30"		Logged By: KTM					
Depth (Feet)	Lith-ology	Material Description	W A T E R	Samples		Laboratory Tests			
				Blows per 6 in.	C o r e	B u l k	Moisture Content (%)	Dry Density (pcf)	Other Lab Tests
	[Dotted pattern]	grained.		12 10	■		16.4	114.1	
40	[Cross-hatched pattern]	BEDROCK - Granitics (Kgr) Granite: Yellowish-brown, fine- to coarse-grained, hard, highly weathered. Drill begins to struggle.		22 50/4"	■		9.6	132.4	
45	[Cross-hatched pattern]	Same as above.		50/4"	■		11.1	129.4	
50	[Cross-hatched pattern]	Becomes slightly weathered.		50/5"	■		18.4	115.5	
55		Total Depth= 51' Refusal due to hard bedrock Ground water @ 8'8" Boring backfilled with cuttings.							
60									
65									
70									

TEST PIT LOG

Project: Wellness Center				Boring No.: B-4					
Location: Lake Hemet				Elevation: ±4382'					
Job No.: 20-227		Client:		Date: 6/7/2021					
Drill Method: 8" Hollow Stem Auger		Driving Weight: 140lbs/30"		Logged By: KTM					
Depth (Feet)	Lithology	Material Description	W A T E R	Samples			Laboratory Tests		
				Blows per 6 in.	C o r e	B u l k	Moisture Content (%)	Dry Density (pcf)	Other Lab Tests
0		ALLUVIUM (Qal) Sand (SP): Gray, dry, loose, fine- to coarse-grained. Becomes brown and moist. Becomes grayish-brown.		7 7 8	█		4.5	107.5	
5		Becomes yellowish-gray, medium- to coarse-grained.		8 12 16	█		6.2	107.1	
		<u>Silty Sand (SM):</u> Dark grayish-brown, very moist, medium-dense, fine-grained.		8 11 14	█		17.9	108.6	
10		<u>Sand (SP):</u> Brown, wet, medium-dense, fine- to medium-grained. @10'4" Groundwater encountered.	▽	7 14 16	█		15.2	116.3	
15		Becomes dark gray.		10 25 36	█		16.5	114.1	
20		<u>Silty Sand (SM):</u> Brown, wet, medium-dense.		4 10 30	█		15.5	117.8	
		Total Depth= 21.5' Groundwater @ 10'4" Boring backfilled with cuttings.							
25									
30									
35									

TEST PIT LOG

Project: Wellness Center				Boring No.: B-5					
Location: Lake Hemet				Elevation: ±4393'					
Job No.: 20-227		Client:		Date: 6/7/2021					
Drill Method: 8" Hollow Stem Auger		Driving Weight: 140lbs/30"		Logged By: KTM					
Depth (Feet)	Lithology	Material Description	W A T E R	Samples			Laboratory Tests		
				Blows per 6 in.	C o r e	B u l k	Moisture Content (%)	Dry Density (pcf)	Other Lab Tests
0		ALLUVIUM (Qal) Sand (SP): Brown, dry, medium-dense, fine-grained. Becomes wet.							
5		Becomes fine-grained & micaceous. Becomes off-white & coarse-grained. Becomes grayish-brown.							
10		Becomes wet with trace gravel up to 2" in diameter =2%. @10'9" Groundwater encountered.	▽						
15		Beomes medium- to coarse-grained. @16' Drill begins to chatter and struggle.							
20		@19' Drill continues as normal. Becomes medium-dense to dense.							
25		Total Depth= 21.5' Groundwater encountered @ 10'9" Boring backfilled with cuttings.							
30									
35									

TEST PIT LOG

Project: Wellness Center				Boring No.: B-6					
Location: Lake Hemet				Elevation: ±4373'					
Job No.: 20-227		Client:		Date: 8/31/2021					
Drill Method: 8" Hollow Stem Auger		Driving Weight: 140lbs/30"		Logged By: KTM					
Depth (Feet)	Lithology	Material Description	W A T E R	Samples			Laboratory Tests		
				Blows per 6 in.	C o r e	B u l k	Moisture Content (%)	Dry Density (pcf)	Other Lab Tests
0		ALLUVIUM (Qal) <u>Silty Sand (SM)</u> : Brown, dry to slightly moist, loose, fine- to medium-grained sand.							
5		<u>Sand with Silt (SP-SM)</u> : Grayish-brown, slightly moist, medium-dense, fine- to medium-grained sand.		5 6 10					DSU
5		<u>Sand (SP)</u> : Pinkish-gray, dry, medium-dense, fine- to coarse-grained.		7 8 12		2.3	104.8		
10		<u>Sand with Silt (SP-SM)</u> : Dark yellowish-brown, moist, medium-dense, fine- to medium-grained.		10 12 14		4.2	107.2		
10		<u>Silty Sand (SM)</u> : Gray, wet, medium-dense, fine- to coarse-grained.	▽	7 12 16		15.5	114.1		
15		<u>Sand with Silt (SP-SM)</u> : Grayish-brown, wet, medium-dense, fine- to coarse-grained, trace angular gravel up to 3/4" in diameter.		13 18 21		14.6	115.7		
20		<u>Sand (SP)</u> : Dark gray, wet, medium-dense, medium-grained.		7 12 12					
25		<u>Sand with Silt (SP-SM)</u> : Gray, wet, medium-dense, fine- to coarse-grained.		10 14 25		22.0	105.6		
30		@29' drill begins to struggle.							
30		BEDROCK - Granitics (Kgr) Off-white & black, moist, fine- to coarse-grained, moderately hard, .		15 33 33					
35		Becomes off-white and very hard.		33					

TEST PIT LOG

Project: Wellness Center				Boring No.: B-6					
Location: Lake Hemet				Elevation: ±4373'					
Job No.: 20-227		Client:		Date: 8/31/2021					
Drill Method 8" Hollow Stem Auger		Driving Weight: 140lbs/30"		Logged By: KTM					
Depth (Feet)	Lithology	Material Description	W A T E R	Samples			Laboratory Tests		
				Blows per 6 in.	C o r e	B u l k	Moisture Content (%)	Dry Density (pcf)	Other Lab Tests
<div style="text-align: center;">40</div> <div style="text-align: center;">45</div> <div style="text-align: center;">50</div> <div style="text-align: center;">55</div> <div style="text-align: center;">60</div> <div style="text-align: center;">65</div> <div style="text-align: center;">70</div>		Total Depth= 36' Refusal due to hard bedrock Groundwater @ 11' Boring backfilled with cuttings.	50/5"	█		9.9	123.7		

TEST PIT LOG

Project: Wellness Center				Boring No.: B-7					
Location: Lake Hemet				Elevation: ±4373'					
Job No.: 20-227		Client:		Date: 8/31/2022					
Drill Method 8" Hollow Stem Auger		Driving Weight: 140lbs/30"		Logged By: KTM					
Depth (Feet)	Lithology	Material Description	W A T E R	Samples			Laboratory Tests		
				Blows per 6 in.	C o r e	B u l k	Moisture Content (%)	Dry Density (pcf)	Other Lab Tests
0		ALLUVIUM (Qal) <u>Silty Sand (SM)</u> : Grayish-brown, slightly moist, medium-dense, fine-grained sand, trace medium-grained sand, trace gravel up to 1" in diameter.							
		Same as above.		8 12 10	█		2.9	104.0	
5		Same as above.		7 11 17	█		3.4	106.1	
		<u>Sand with Silt (SP-SM)</u> : Gray, moist, medium-dense, fine- to coarse-grained.		6 12 20	█		4.4	117.9	
10		Becomes black & gray with trace gravel up to 3/4" in diameter.		15 25 20	█		9.8	122.3	
		<u>Sand with Silt (SP-SM)</u> : Grayish-brown, wet, medium-dense, fine- to coarse-grained sand.					9.8	117.6	
		Total Depth= 16.5' Groundwater @ 12.5' Boring backfilled with cuttings.	▽						
20									
25									
30									
35									

TEST PIT LOG

Project: Wellness Center				Boring No.: MW-1				
Location: Lake Hemet				Elevation: ±4376'				
Job No.: 20-227		Client:		Date: 8/31/2022				
Drill Method: 8" Hollow Stem Auger		Driving Weight: 140lbs/30"		Logged By: KTM				
Depth (Feet)	Lith-ology	Material Description	W A T E R	Samples		Laboratory Tests		
				Blows per 6 in.	C o r e	B u l k	Moisture Content (%)	Dry Density (pcf)
0		ALLUVIUM (Qal) Silty Sand (SM): Brown, dry to slightly moist, loose, fine- to medium-grained.						
5		Sand (SP): Grayish-brown, moist, medium-dense, fine- to coarse-grained.		6 7 9	█		3.4	108.0
10			▽	12 16 16	█		5.4	108.5 HYD
15		Sand with Silt (SP-SM): Gray, wet, medium-dense, fine- to coarse-grained.		3 6 5	█			HYD
20		Same as above.		5 9 12	█			HYD
25		Same as above.		7 8 12	█			HYD
30		Same as above.		18 12 20	█			HYD
35				25	█			

TEST PIT LOG

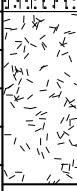
Project: Wellness Center				Boring No.: MW-1					
Location: Lake Hemet				Elevation: ±4376'					
Job No.: 20-227		Client:		Date: 8/31/2022					
Drill Method: 8" Hollow Stem Auger		Driving Weight: 140lbs/30"		Logged By: KTM					
Depth (Feet)	Lithology	Material Description	W A T E R	Samples			Laboratory Tests		
				Blows per 6 in.	C o r e	B u l k	Moisture Content (%)	Dry Density (pcf)	Other Lab Tests
		BEDROCK - Granitics (Kgr) Off-white to yellowish-brown, moist, fine-grained, , hard, moderately weathered. Becomes very hard.		50/5"	■				HYD
40		Total Depth= 40.5' Groundwater encountered @ 11' After the completion of drilling, the borehole was converted into a monitoring well with the following construction: 38.5 feet of 2"-diameter PVC casing was installed; solid from 0 to 28.5 feet and 2-mm slotted from 28.5 to 38.5 feet. The annulus space consisted of sand (#50) to 8 feet bgs; bentonite to 1.5 feet bgs; capped with concrete to surface Well casing covered with a locking cap		50/5"	■				
45									
50									
55									
60									
65									
70									

TEST PIT LOG

Project: Wellness Center				Boring No.: TP-1					
Location: Lake Hemet				Elevation: ±4383'					
Job No.: 20-227		Client:		Date: 5/7/2021					
Drill Method: Backhoe		Driving Weight: Not Applicable		Logged By: KTM					
Depth (Feet)	Lithology	Material Description	W A T E R	Samples			Laboratory Tests		
				Blows per 6 in.	C o r e	B u l k	Moisture Content (%)	Dry Density (pcf)	Other Lab Tests
0	[Pattern]	TOPSOIL Silty Sand (SM): Brown, dry, fine-grained, few rootlets. ALLUVIUM (Qal) Silty Sand (SM): Brown, moist, loose, fine-grained, with trace medium-grained sand. Total Depth= 2'11" No groundwater encountered Dual ring infiltration test ran on bottom of test pit.							
5									
10									
15									
20									
25									
30									
35									

TEST PIT LOG

Project: Wellness Center				Boring No.: TP-2					
Location: Lake Hemet				Elevation: ±4381'					
Job No.: 20-227		Client:		Date: 5/7/2021					
Drill Method: Backhoe		Driving Weight: Not Applicable		Logged By: KTM					
Depth (Feet)	Lithology	Material Description	W A T E R	Samples			Laboratory Tests		
				Blows per 6 in.	C o r e	B u l k	Moisture Content (%)	Dry Density (pcf)	Other Lab Tests
0	[Pattern]	TOPSOIL Silty Sand (SM): Brown, dry, fine-grained, few rootlets. ALLUVIUM (Qal) Silty Sand (SM): Brown, moist, loose, fine-grained, with trace medium-grained sand. Total Depth= 3'2" No groundwater encountered Dual ring infiltration test ran on bottom of test pit.							
5									
10									
15									
20									
25									
30									
35									

TEST PIT LOG

Project: Wellness Center				Boring No.: TP-3					
Location: Lake Hemet				Elevation: ±4,368'					
Job No.: 20-227		Client:		Date: 5/7/2021					
Drill Method: Backhoe		Driving Weight: Not Applicable		Logged By: KTM					
Depth (Feet)	Lithology	Material Description	W A T E R	Samples			Laboratory Tests		
				Blows per 6 in.	C o r e	B u l k	Moisture Content (%)	Dry Density (pcf)	Other Lab Tests
0	[Pattern]	TOPSOIL Silty Sand (SM): Brown, dry, fine-grained, few rootlets. ALLUVIUM (Qal) Silty Sand (SM): Brown, moist, loose, fine-grained, with trace medium-grained sand. Total Depth= 3'2" No groundwater encountered Dual ring infiltration test ran on bottom of test pit.							
5									
10									
15									
20									
25									
30									
35									

TEST PIT LOG

Project: Wellness Center				Boring No.: TP-4					
Location: Lake Hemet				Elevation: ±4,379'					
Job No.: 20-227		Client:		Date: 5/7/2021					
Drill Method: Backhoe		Driving Weight: Not Applicable		Logged By: KTM					
Depth (Feet)	Lithology	Material Description	W A T E R	Samples			Laboratory Tests		
				Blows per 6 in.	C o r e	B u l k	Moisture Content (%)	Dry Density (pcf)	Other Lab Tests
0	[Dotted Pattern]	TOPSOIL Silty Sand (SM): Brown, dry, fine-grained, few rootlets. ALLUVIUM (Qal) Sand (SP): Brown, moist, loose, fine- to medium-grained, with trace medium-grained sand. Total Depth= 2'8" No groundwater encountered Dual ring infiltration test ran on bottom of test pit.							
5									
10									
15									
20									
25									
30									
35									

TEST PIT LOG

Project: Wellness Center				Boring No.: TP-5					
Location: Lake Hemet				Elevation: ±4,383'					
Job No.: 20-227		Client:		Date: 5/7/2021					
Drill Method: Backhoe		Driving Weight: Not Applicable		Logged By: KTM					
Depth (Feet)	Lithology	Material Description	W A T E R	Samples			Laboratory Tests		
				Blows per 6 in.	C o r e	B u l k	Moisture Content (%)	Dry Density (pcf)	Other Lab Tests
0	●●●●	TOPSOIL Silty Sand (SM): Brown, dry, fine-grained, few rootlets. ALLUVIUM (Qal) Sand (SP): Grayish-brown, moist, loose, fine- to coarse-grained. Total Depth= 2'5" No groundwater encountered.							
5									
10									
15									
20									
25									
30									
35									

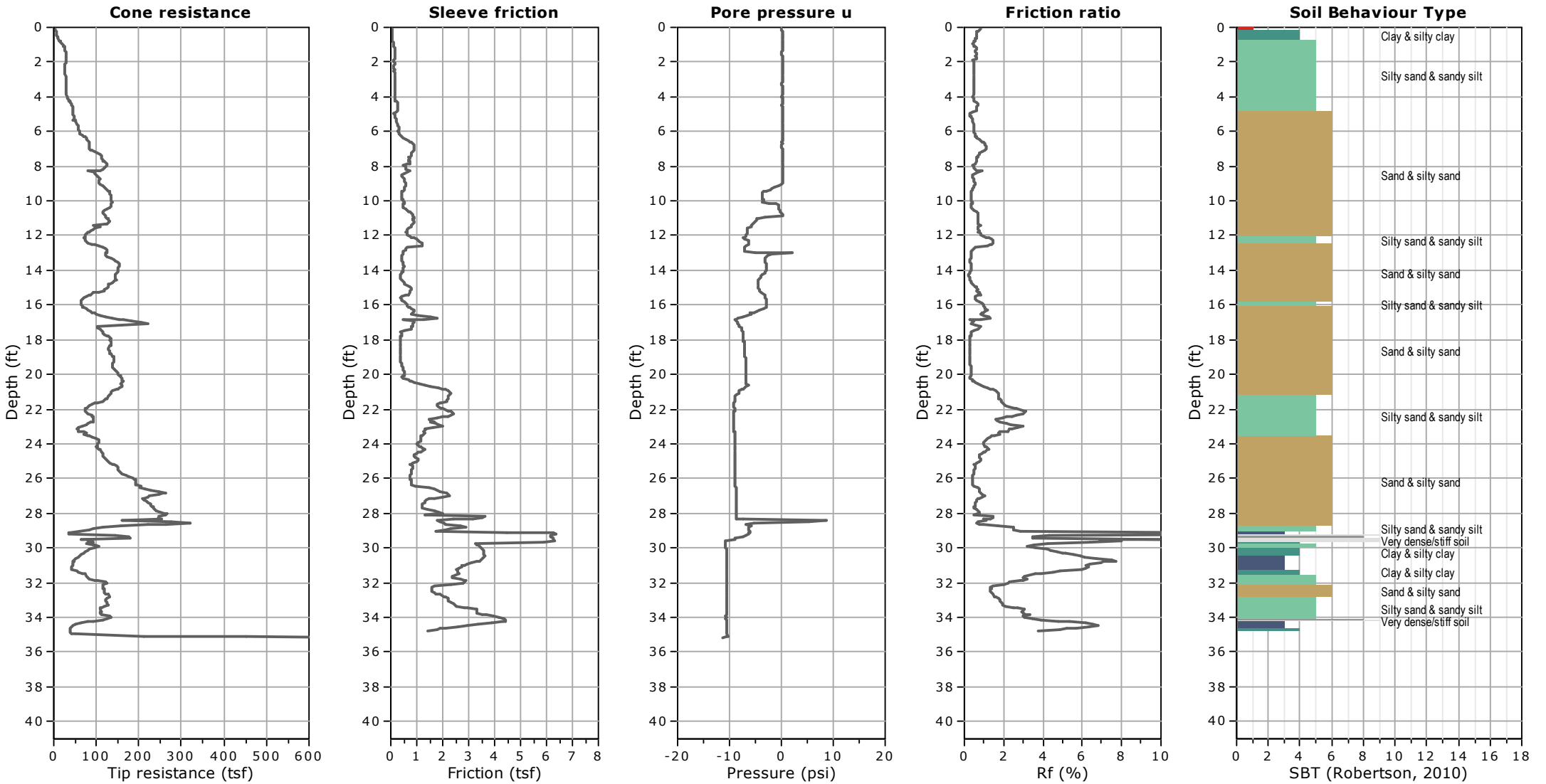

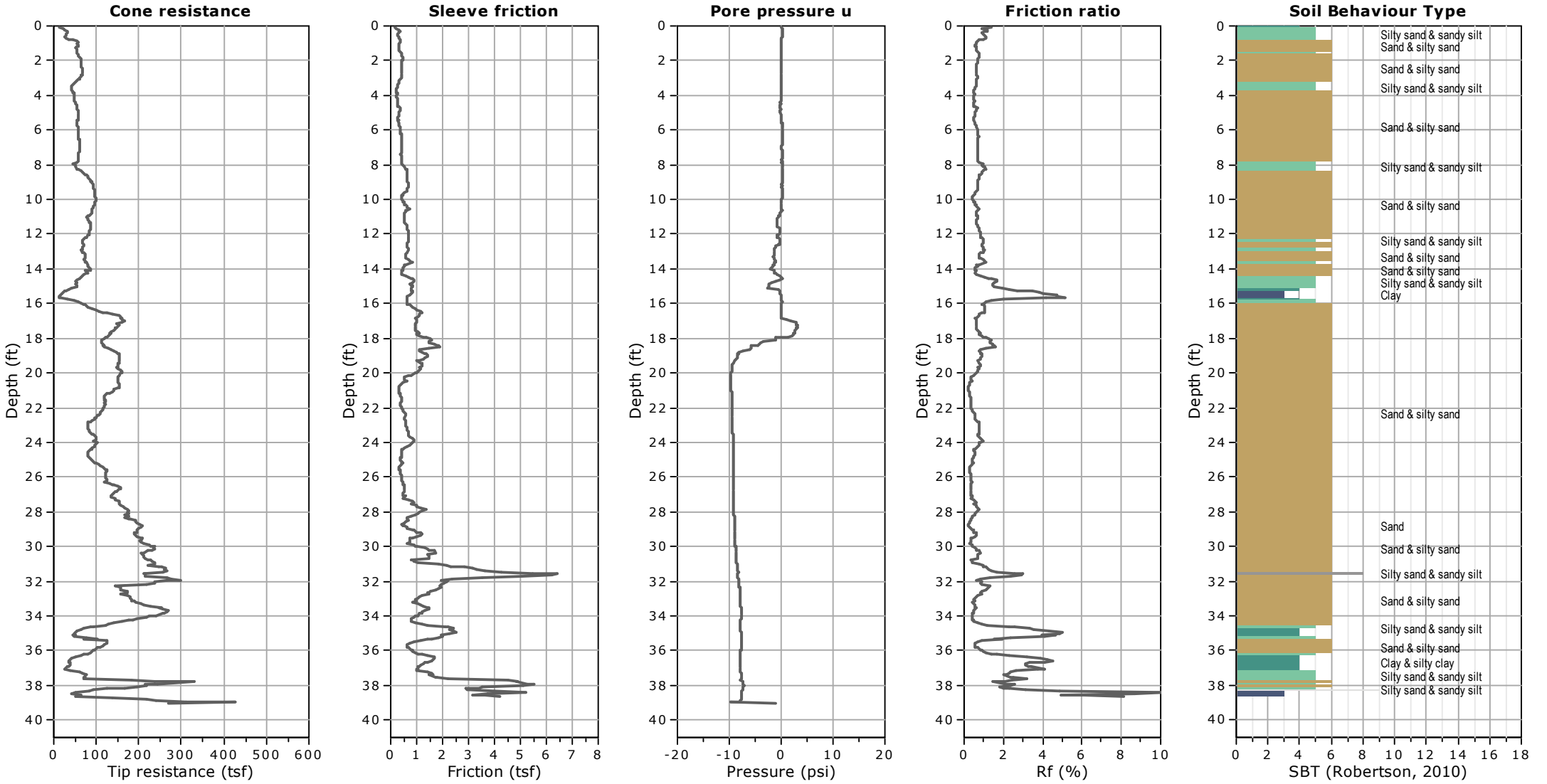

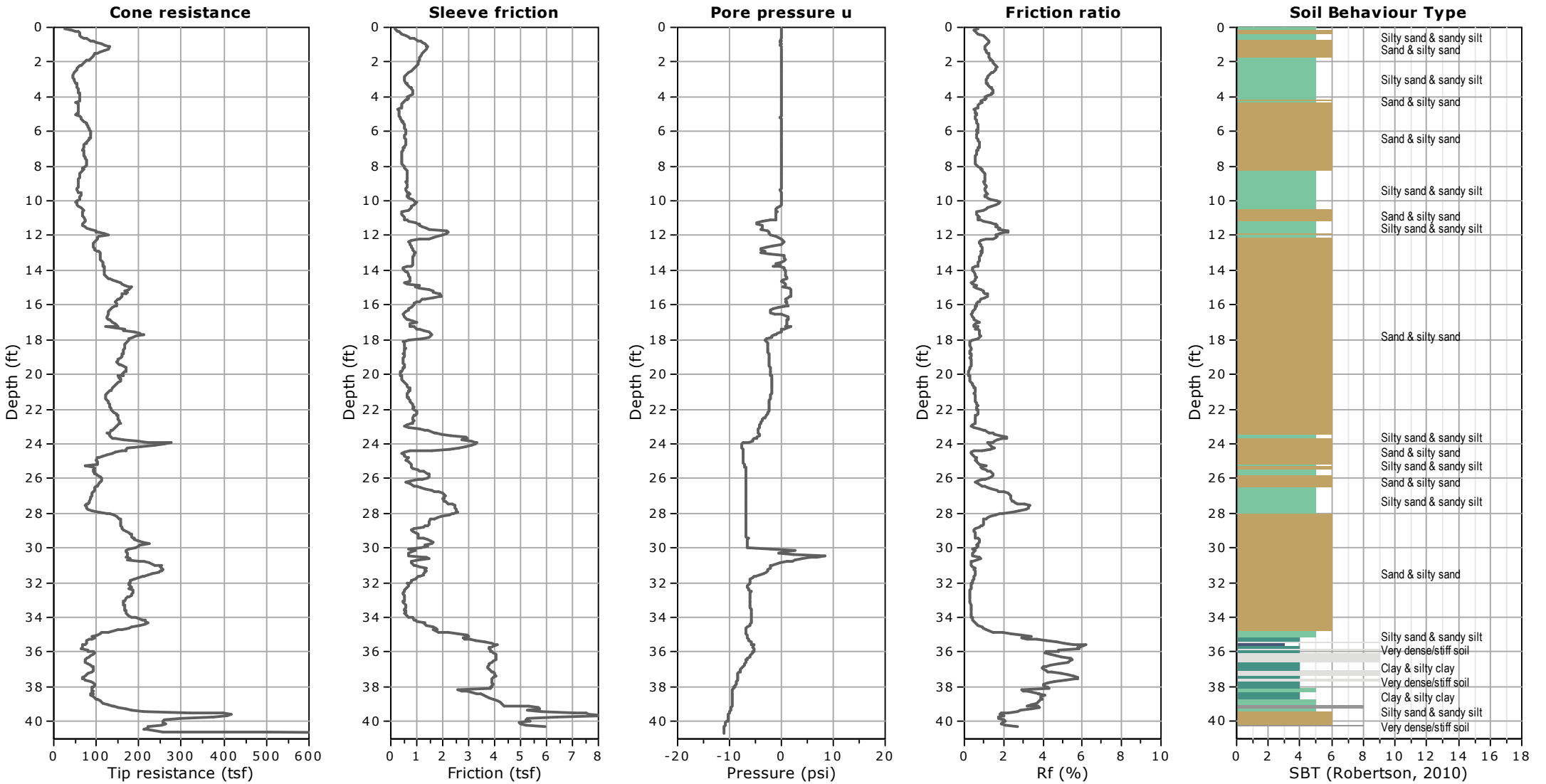

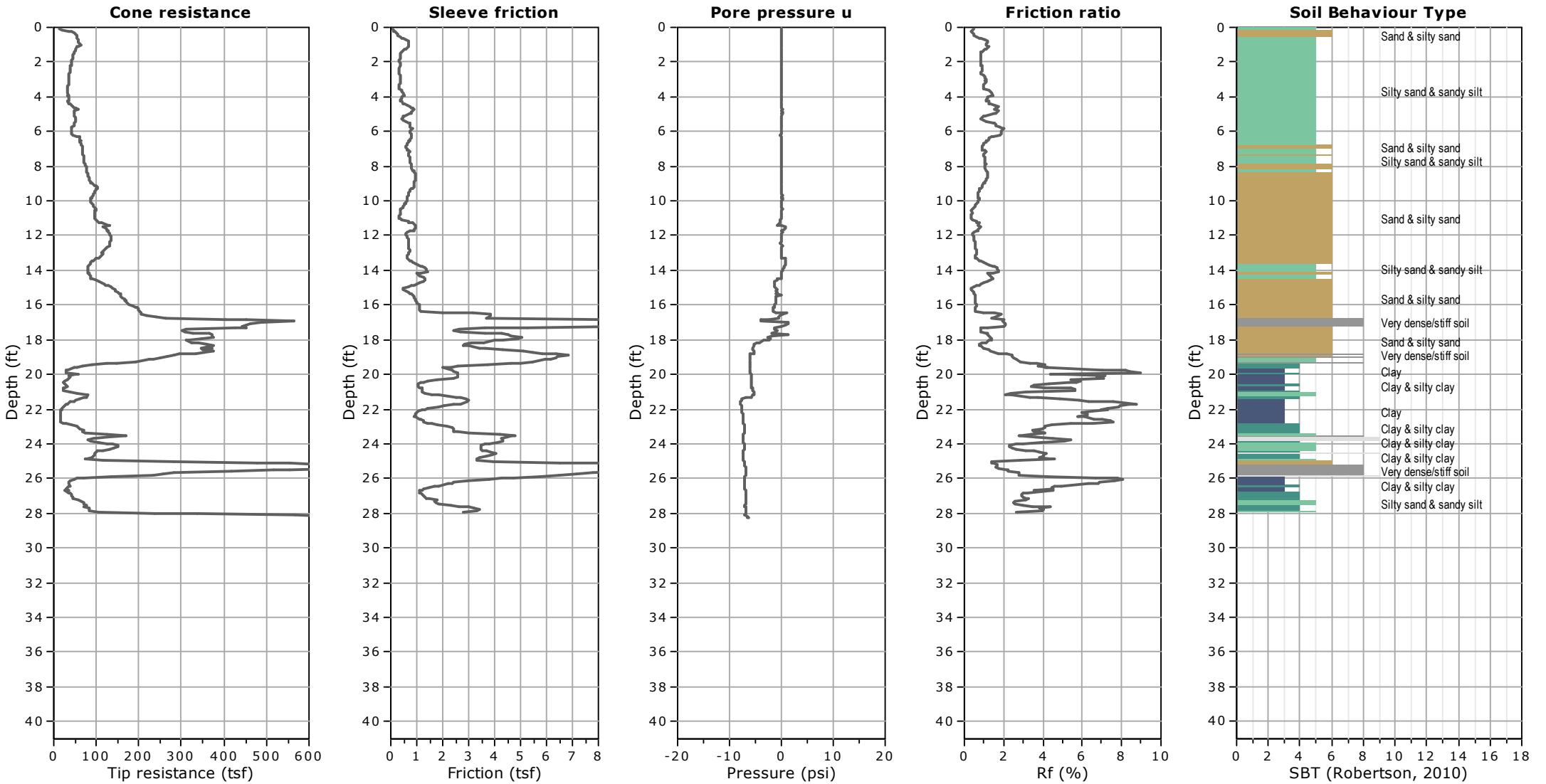

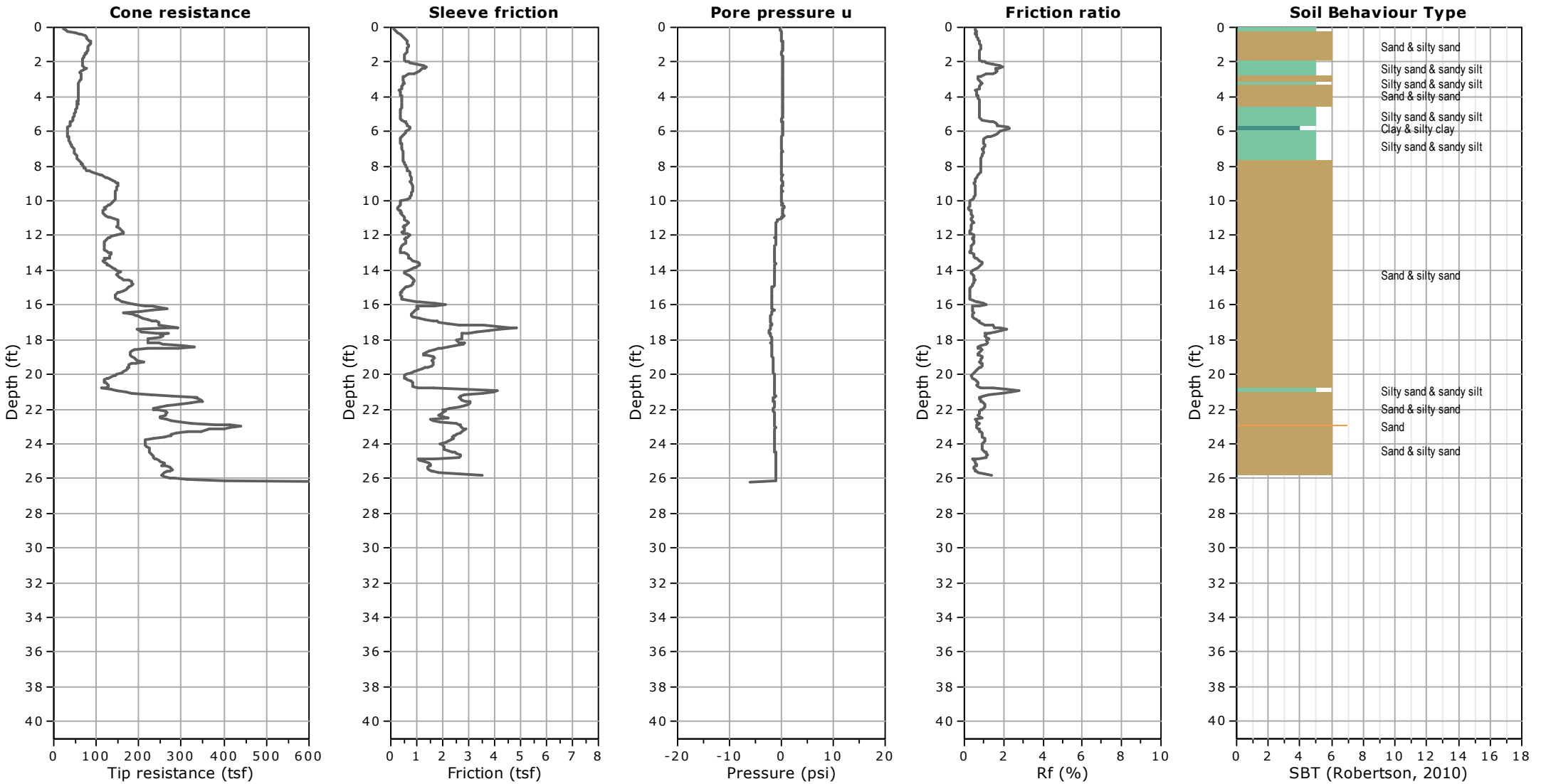

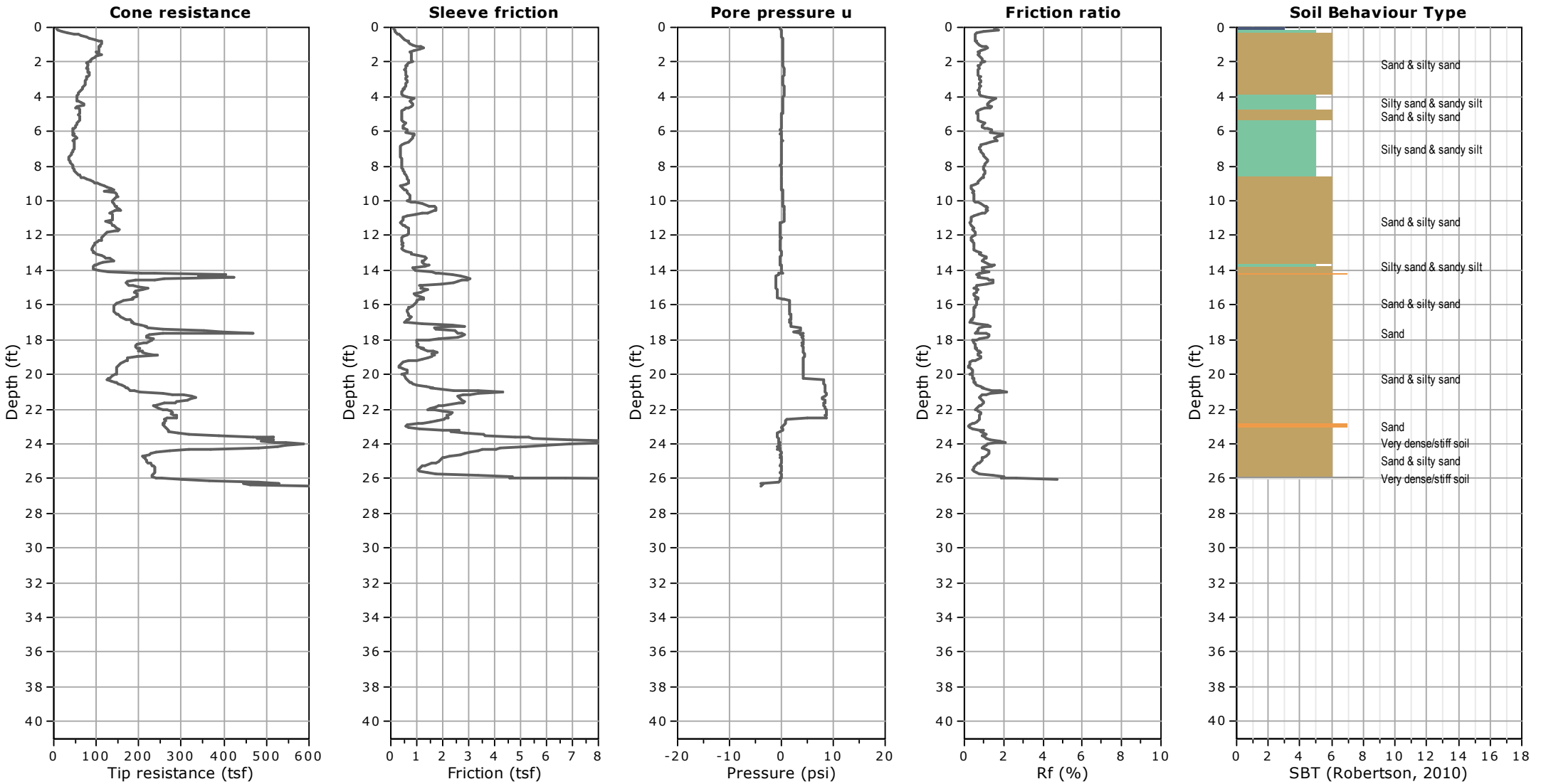

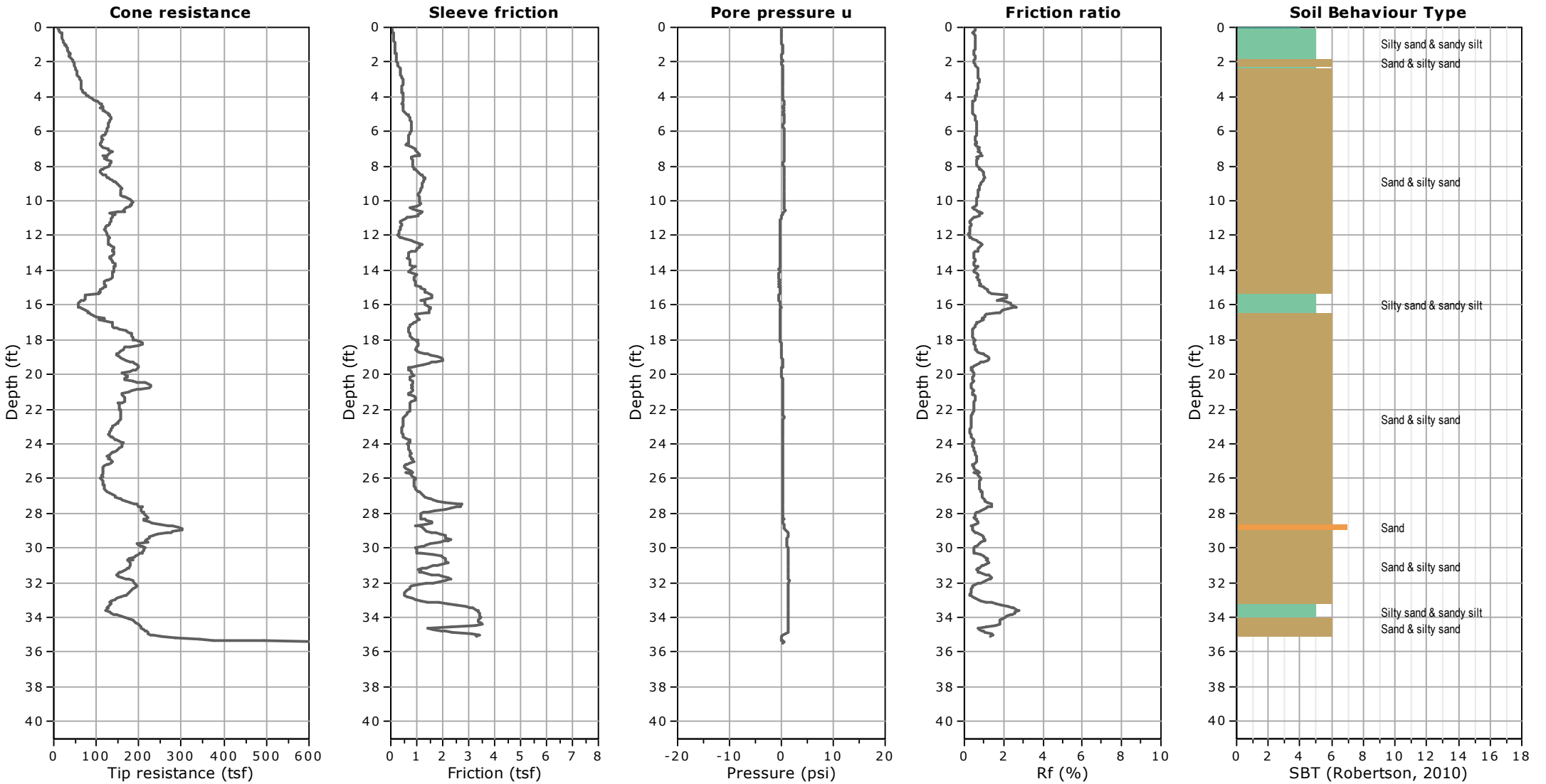

TEST ID: CPT-1

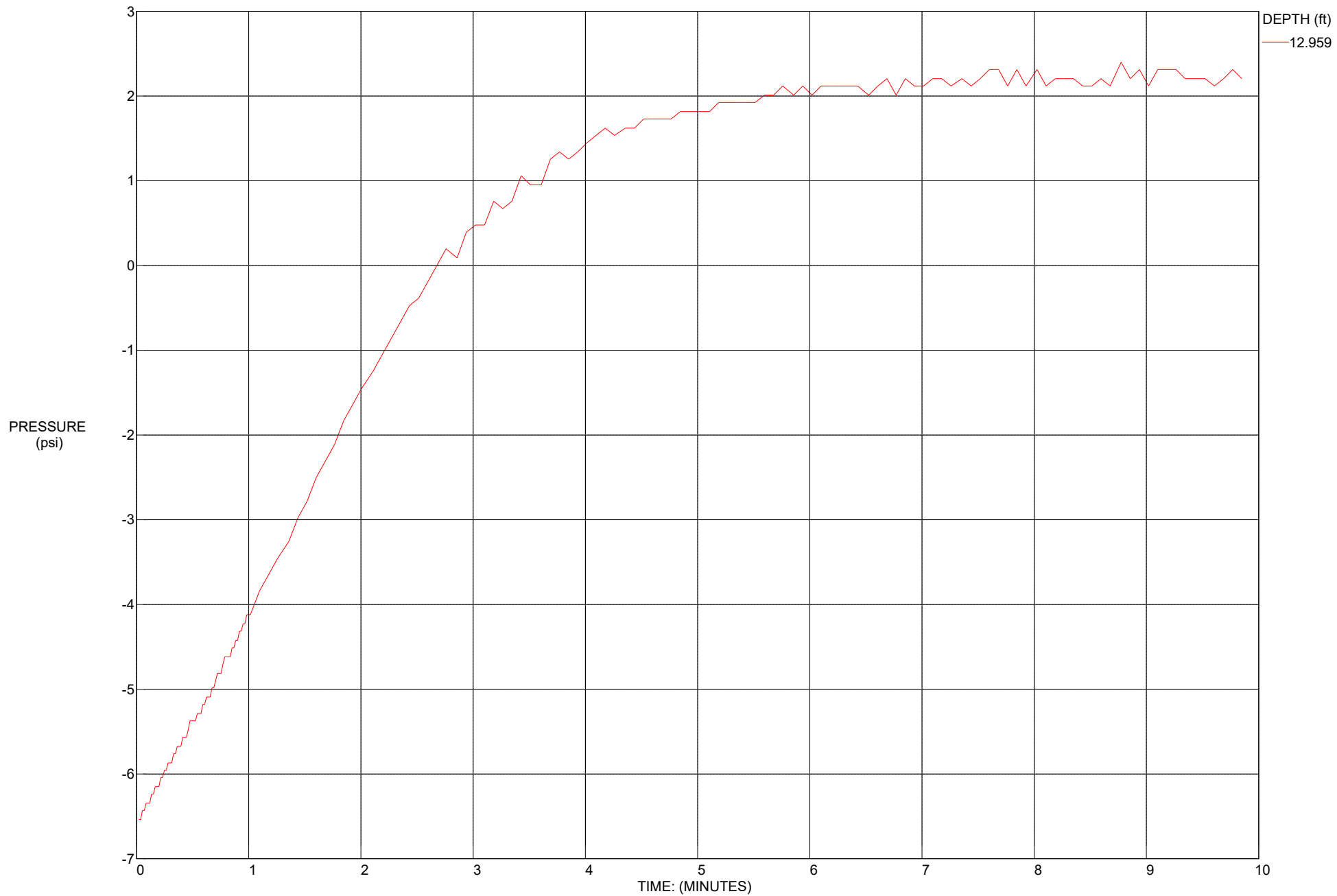

TEST ID: CPT-1

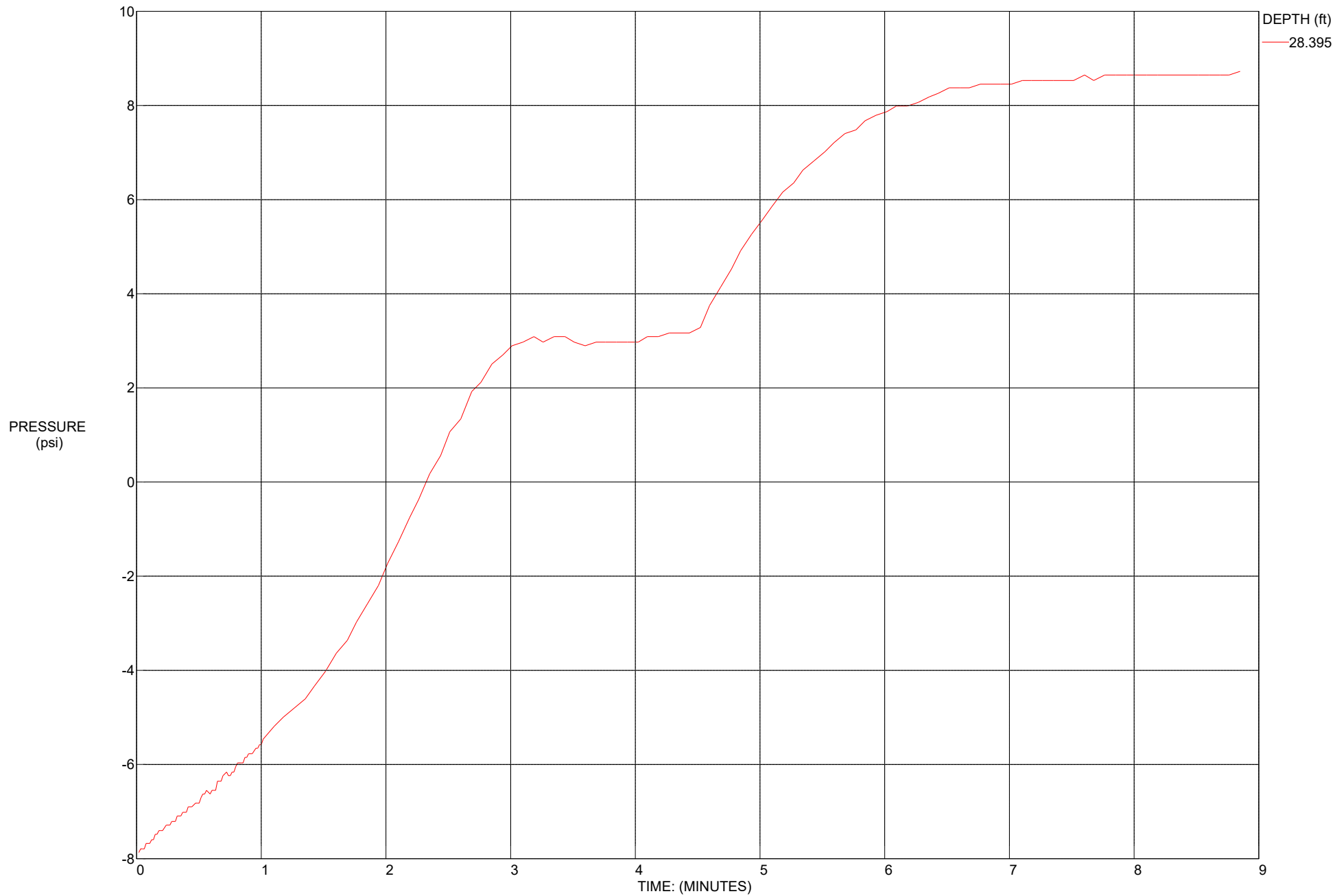

TEST ID: CPT-2

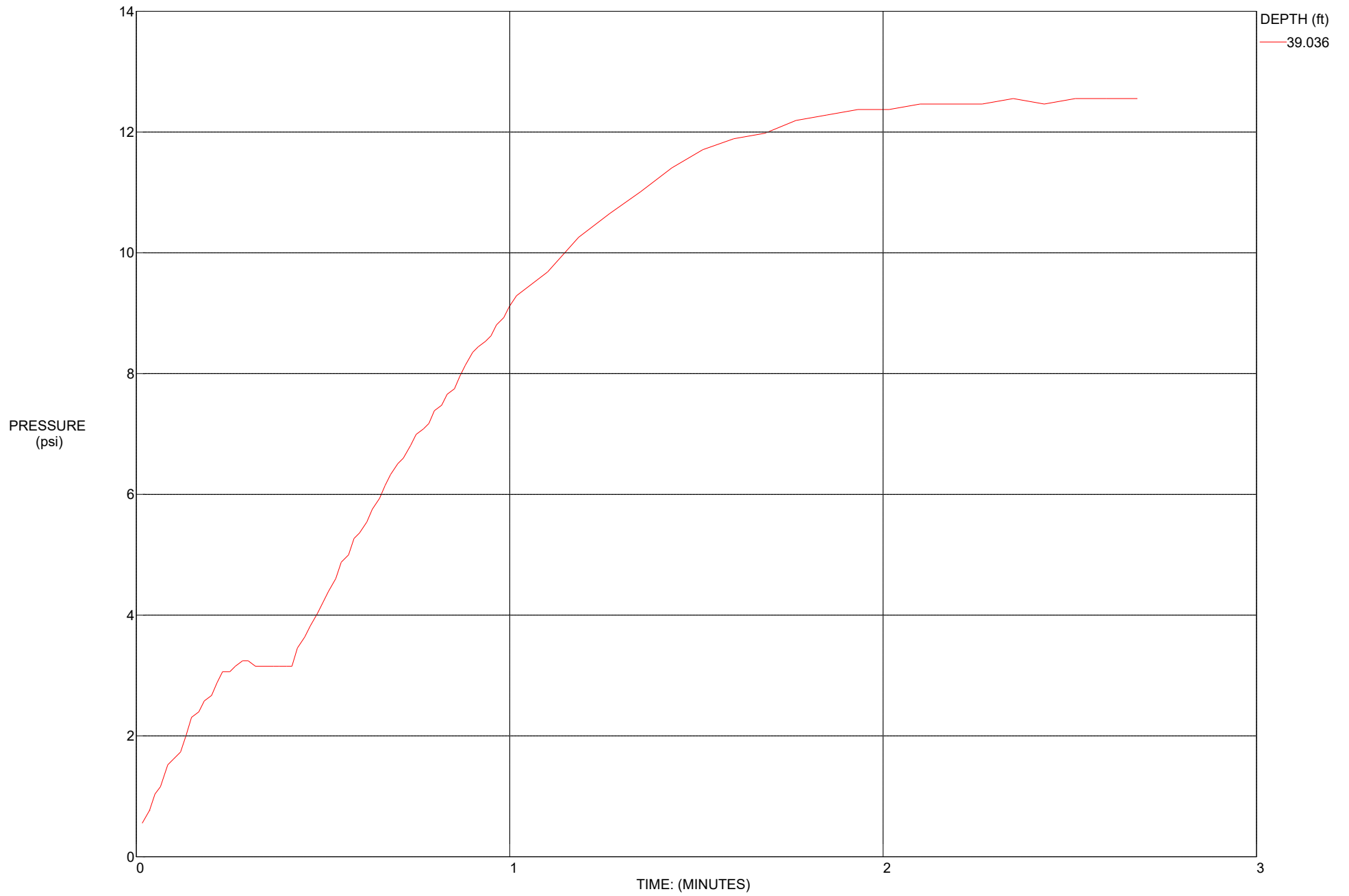

TEST ID: CPT-3

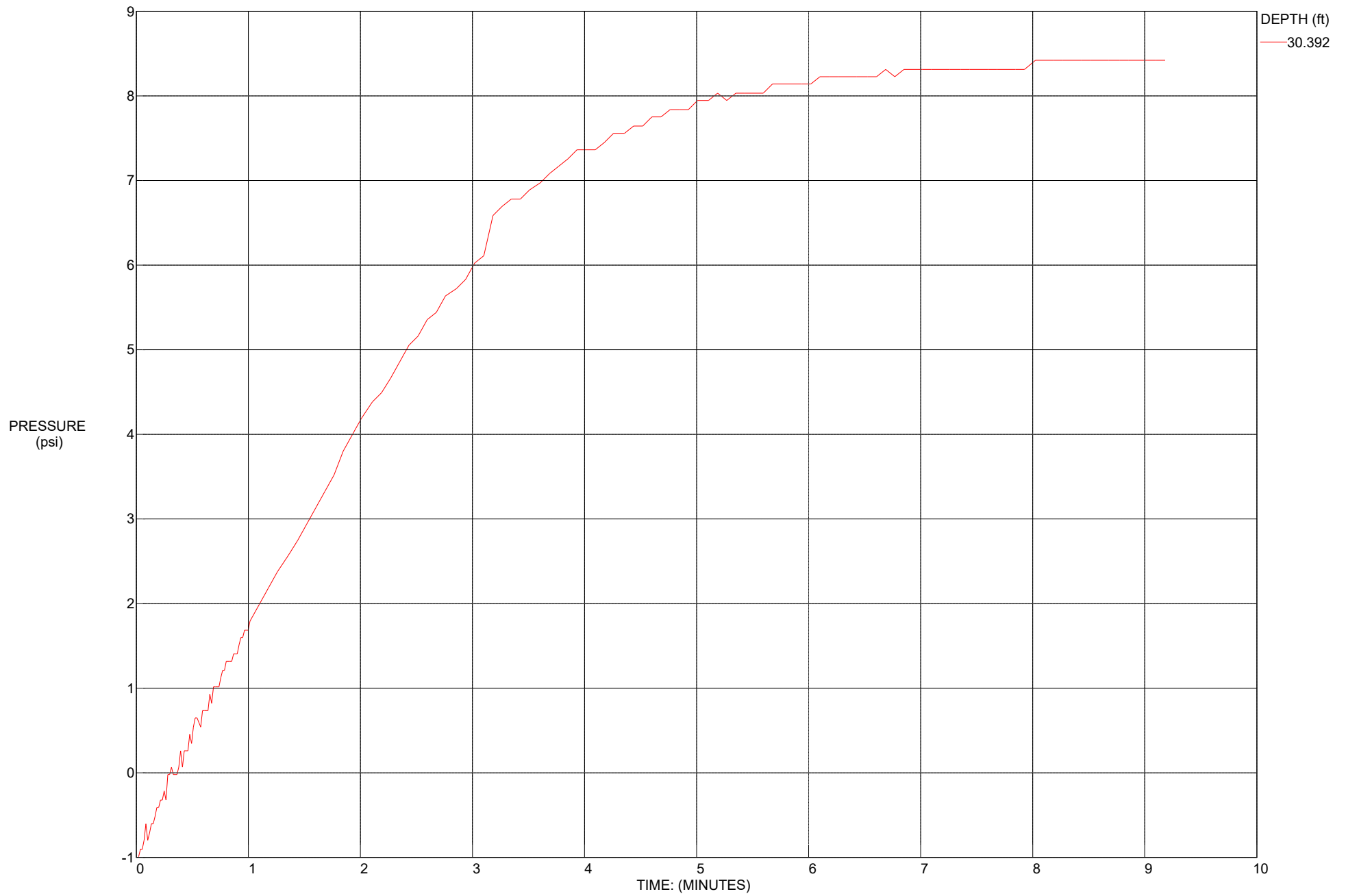

TEST ID: CPT-4

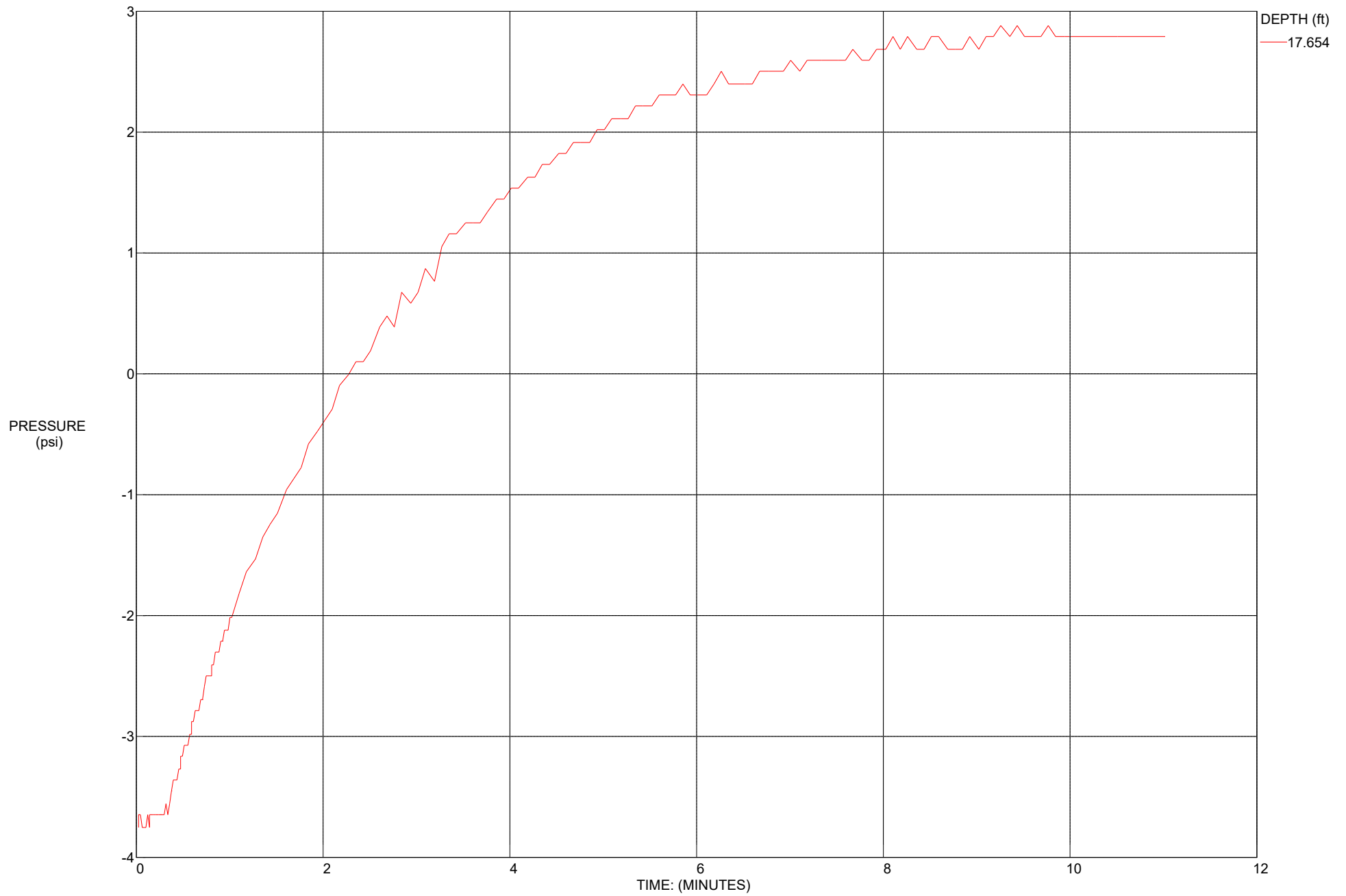

Petra Geosciences
 Apple Canyon
 Lake Hemit, CA

CPT Shear Wave Measurements

Location	Tip Depth (ft)	Geophone Depth (ft)	Travel Distance (ft)	S-Wave Arrival (msec)	S-Wave Velocity from Surface (ft/sec)	Interval S-Wave Velocity (ft/sec)
CPT-3	5.02	4.02	4.49	5.68	790	
	10.01	9.01	9.23	12.20	757	727
	15.09	14.09	14.23	20.12	707	632
	20.11	19.11	19.21	26.98	712	726
	25.16	24.16	24.24	34.04	712	712
	30.09	29.09	29.16	40.04	728	819
	35.04	34.04	34.10	46.24	737	797
	40.06	39.06	39.11	50.84	769	1090

Shear Wave Source Offset - 2 ft

S-Wave Velocity from Surface = Travel Distance/S-Wave Arrival
 Interval S-Wave Velocity = (Travel Dist2-Travel Dist1)/(Time2-Time1)

□□□□□ □□ □□□□□□□□**S**

□□ □□□□□□□□□□□

□□ **S**□**MM**□□□ □□ □□□□□ □ □□□

□□ □□□□□ □□□□□**M**□□□ □ □□□□□□□□□□**S**

□□ □□□□ □□□□□□□□□□□ □□**S**□ □□□□ □ □□□□□□□□□□□□□□□□

□□□□□□□□

- CPT Plots
- CPT Classification/Soil Behavior Chart
- Summary of Shear Wave Velocities
- CPT Data Files (sent via email)

SUMMARY

1

1.0 Introduction

1.1 Background

This report presents the results of a Cone Penetration Test (CPT) program carried out for the Apple Canyon Lake Hemet project located in Lake Hemet, California. The work was performed by Kehoe Testing & Engineering (KTE) on August 30, 2021. The scope of work was performed as directed by Petra Geosciences, Inc. personnel.

1.2 Summary

The fieldwork consisted of performing CPT soundings at 12 locations to determine the soil lithology. A summary is provided in Table 1.

Location	Depth (ft)	Result
1	35	Refusal
2	17	Refusal
3	23	Refusal
4	31	Refusal
5	20	Refusal
6	7	Refusal
7	8	Refusal
8	22	Refusal
9	22	Refusal
10	38	Refusal
11	39	Refusal
12	36	Refusal

Table 1. Summary of CPT Soundings

1.3 Methodology

The CPT soundings were carried out by KTE using an integrated electronic cone system manufactured by Vertek. The CPT soundings were performed in accordance with ASTM standards (D5778). The cone penetrometers were pushed using a 30-ton CPT rig. The cone used during the program was a 15 cm² cone with a cone net area ratio of 0.83. The following parameters were recorded at approximately 2.5 cm depth intervals:

- Cone Resistance (qc)
- Sleeve Friction (fs)
- Dynamic Pore Pressure (u)
- Inclination
- Penetration Speed

At location CPT-7, shear wave measurements were obtained at approximately 5-foot intervals. The shear wave is generated using an air-actuated hammer, which is located inside the front jack of the CPT rig. The cone has a triaxial geophone, which recorded the shear wave signal generated by the air hammer.

The above parameters were recorded and viewed in real time using a laptop computer. Data is stored at the KTE office for up to 2 years for future analysis and reference. A complete set of baseline readings was taken prior to each sounding to determine temperature shifts and any zero load offsets. Monitoring base line readings ensures that the cone electronics are operating properly.

□□ □□□□ □□□□□□□□□□ □ □□S□ □□□□ □ □□□□□□□□□□□□ □

The Cone Penetration Test data is presented in graphical form in the attached Appendix. These plots were generated using the CPeT-IT program. Penetration depths are referenced to ground surface. The soil behavior type on the CPT plots is derived from the attached CPT SBT plot (Robertson, "Interpretation of Cone Penetration Test...", 2009) and presents major soil lithologic changes. The stratigraphic interpretation is based on relationships between cone resistance (qc), sleeve friction (fs), and penetration pore pressure (u). The friction ratio (Rf), which is sleeve friction divided by cone resistance, is a calculated parameter that is used along with cone resistance to infer soil behavior type. Generally, cohesive soils (clays) have high friction ratios, low cone resistance and generate excess pore water pressures. Cohesionless soils (sands) have lower friction ratios, high cone bearing and generate little (or negative) excess pore water pressures.

The CPT data files have also been provided. These files can be imported in CPeT-IT (software by GeoLogismiki) and other programs to calculate various geotechnical parameters.

It should be noted that it is not always possible to clearly identify a soil type based on qc, fs and u. In these situations, experience, judgement and an assessment of the pore pressure data should be used to infer the soil behavior type.

If you have any questions regarding this information, please do not hesitate to call our office at (714) 901-7270.

Sincerely,

KEHOE TESTING & ENGINEERING



Steven P. Kehoe
President

□□□□□□□

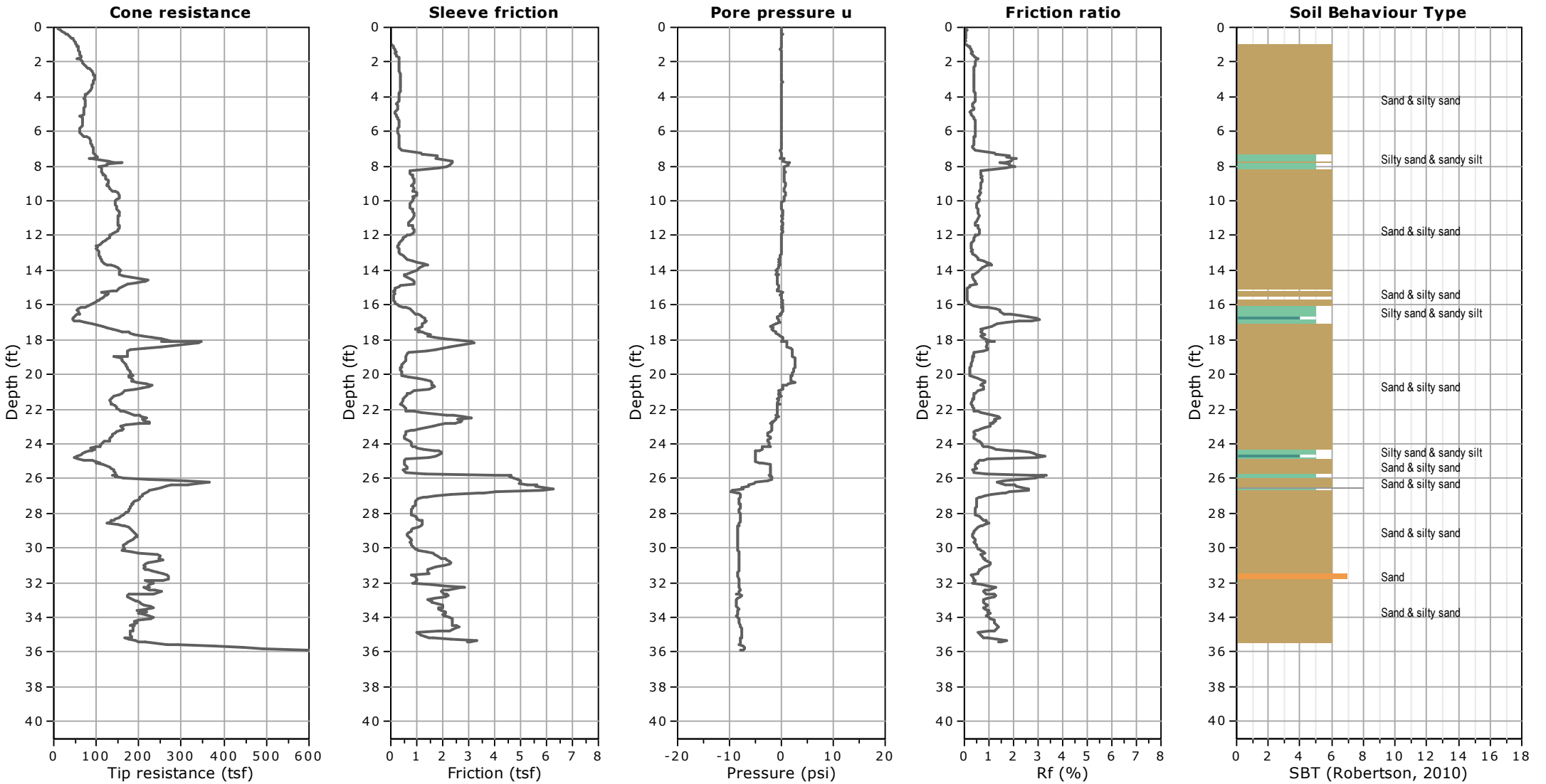

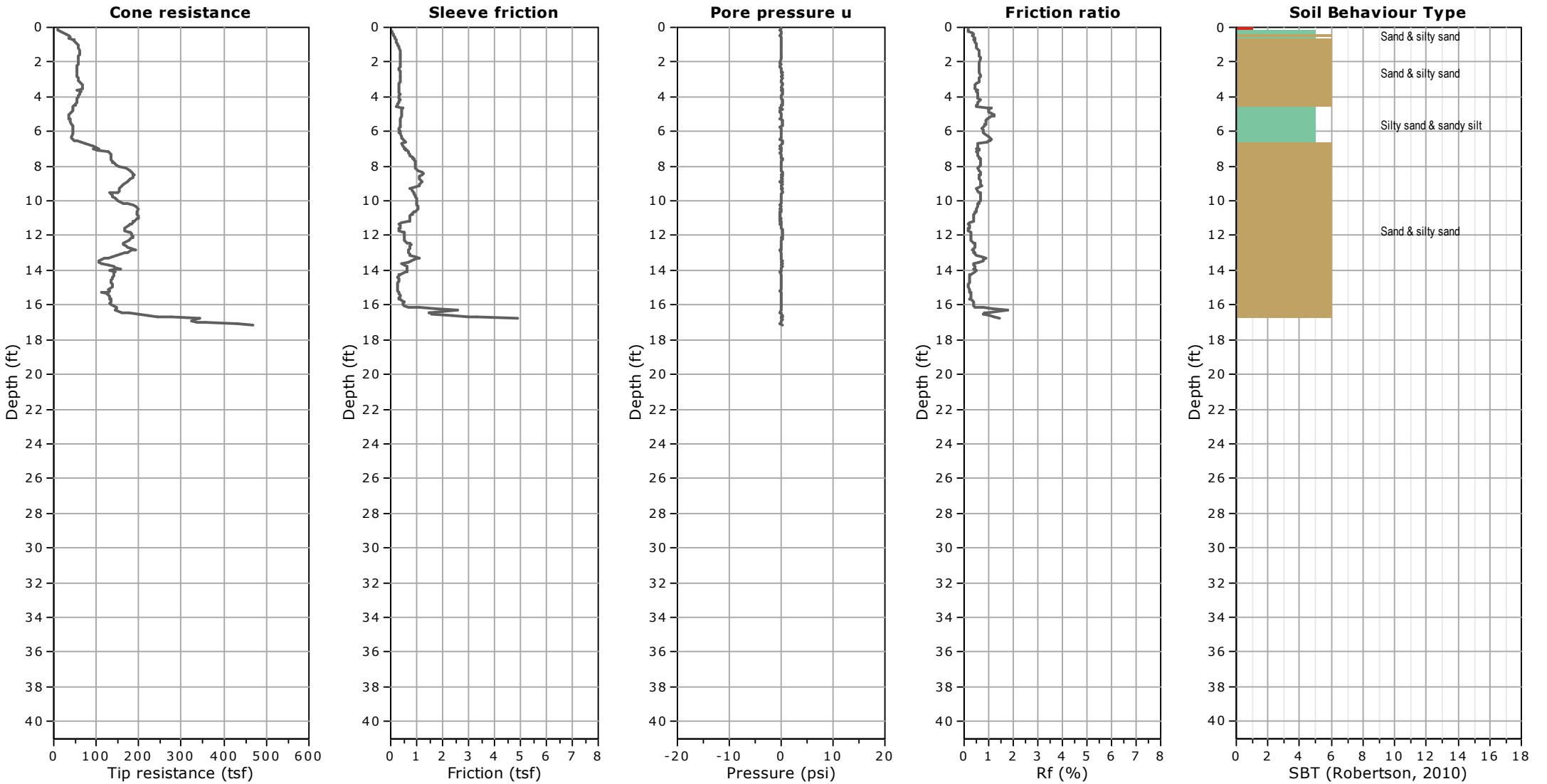

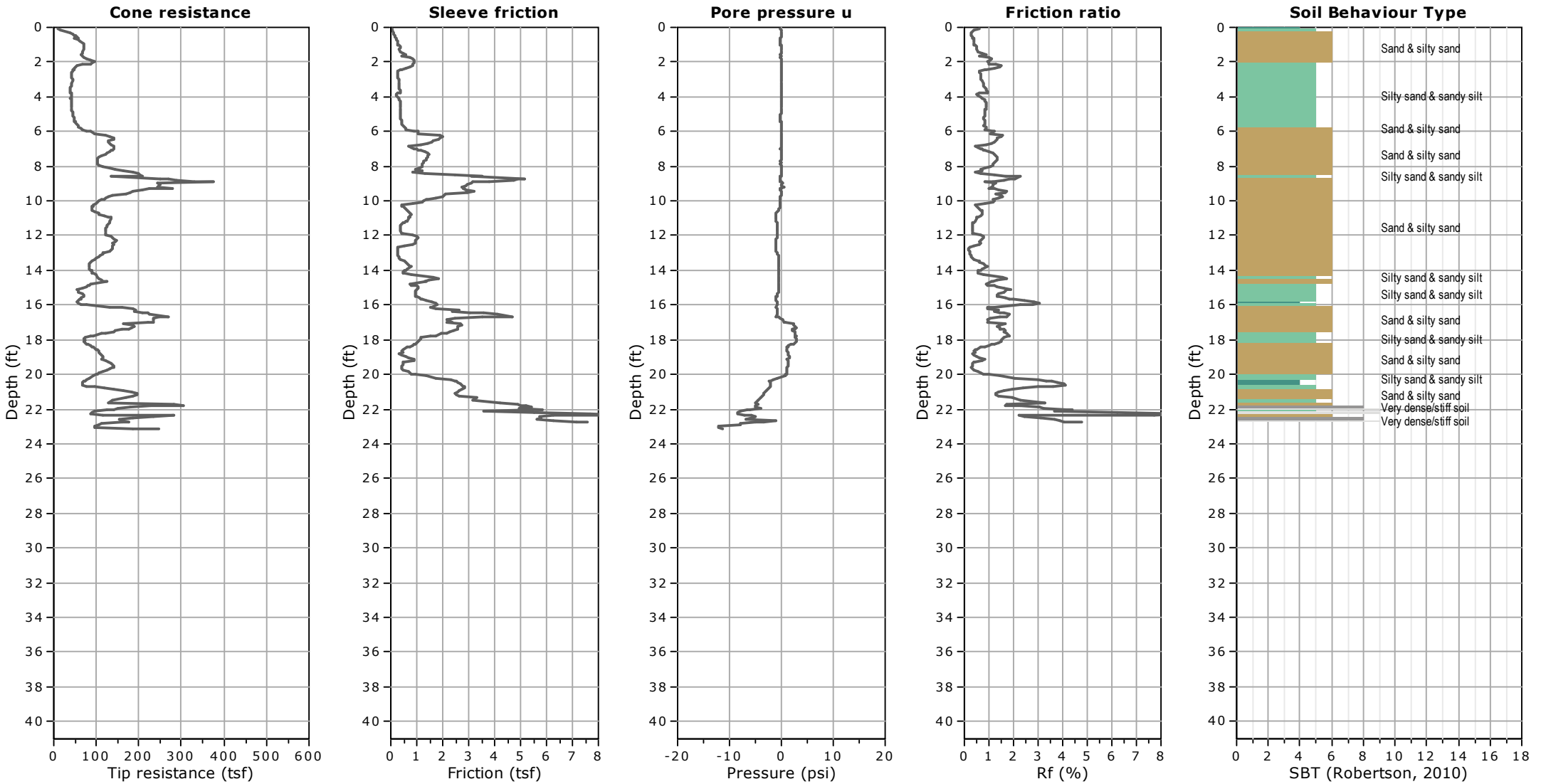

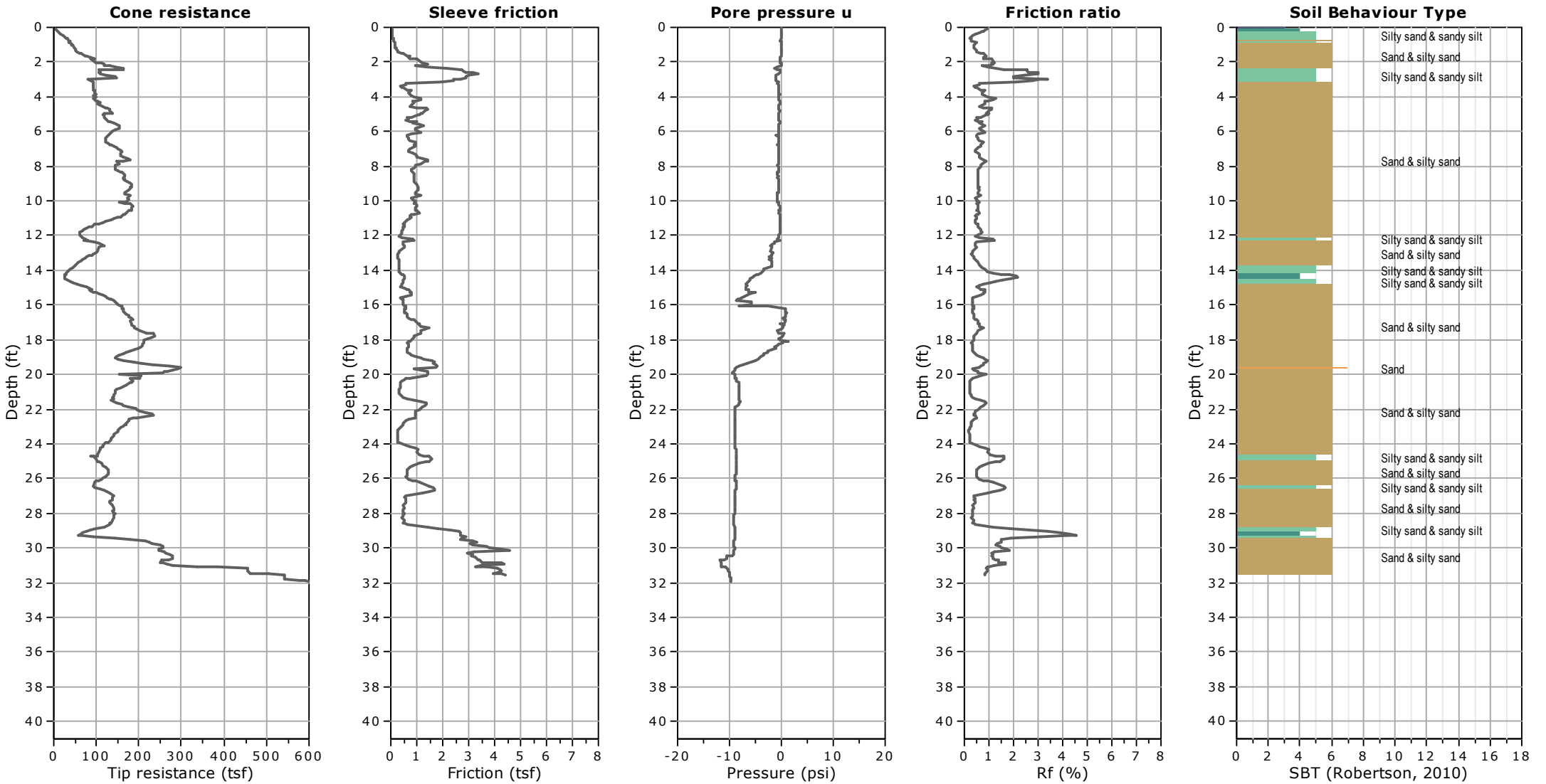

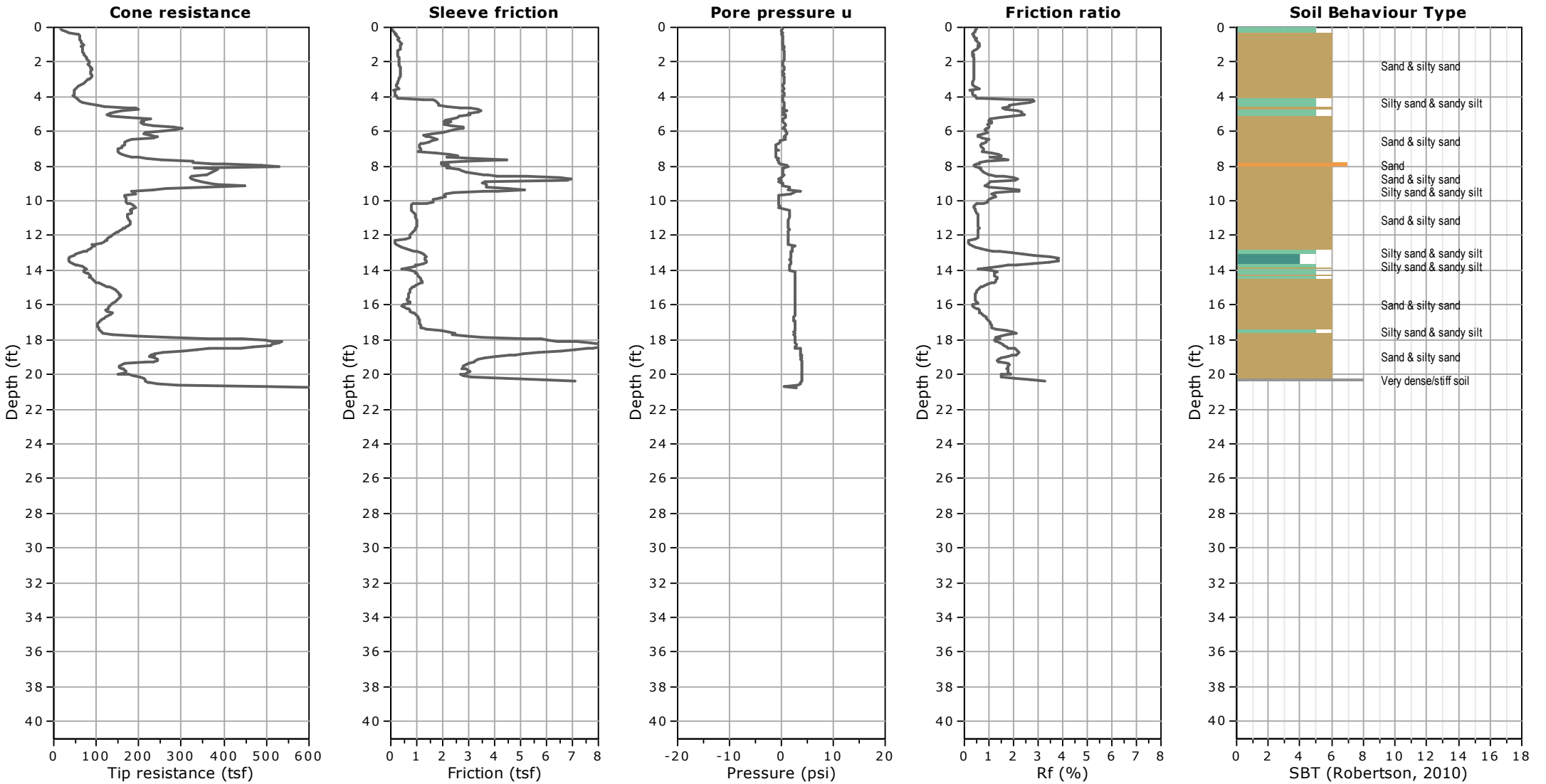

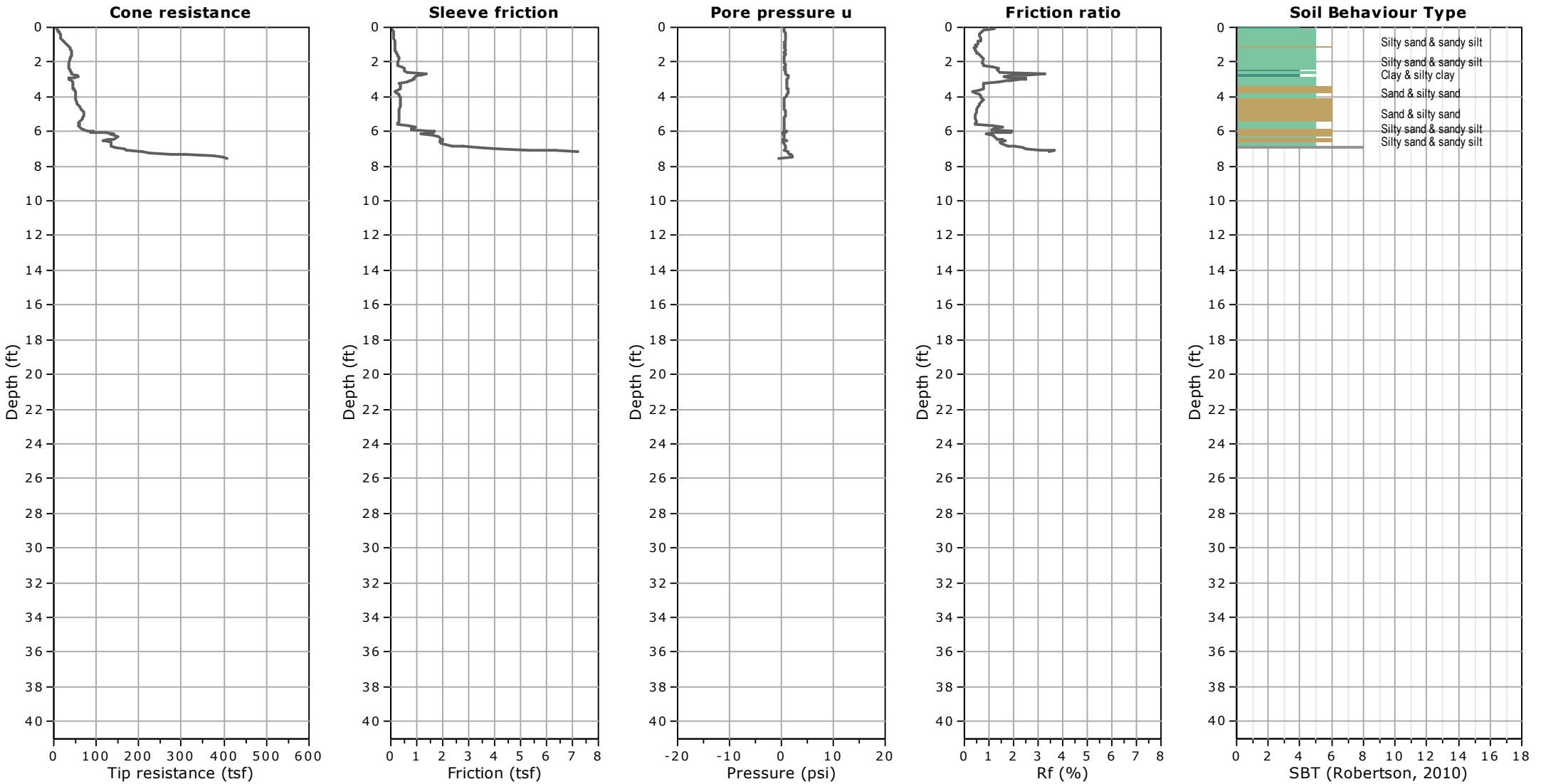

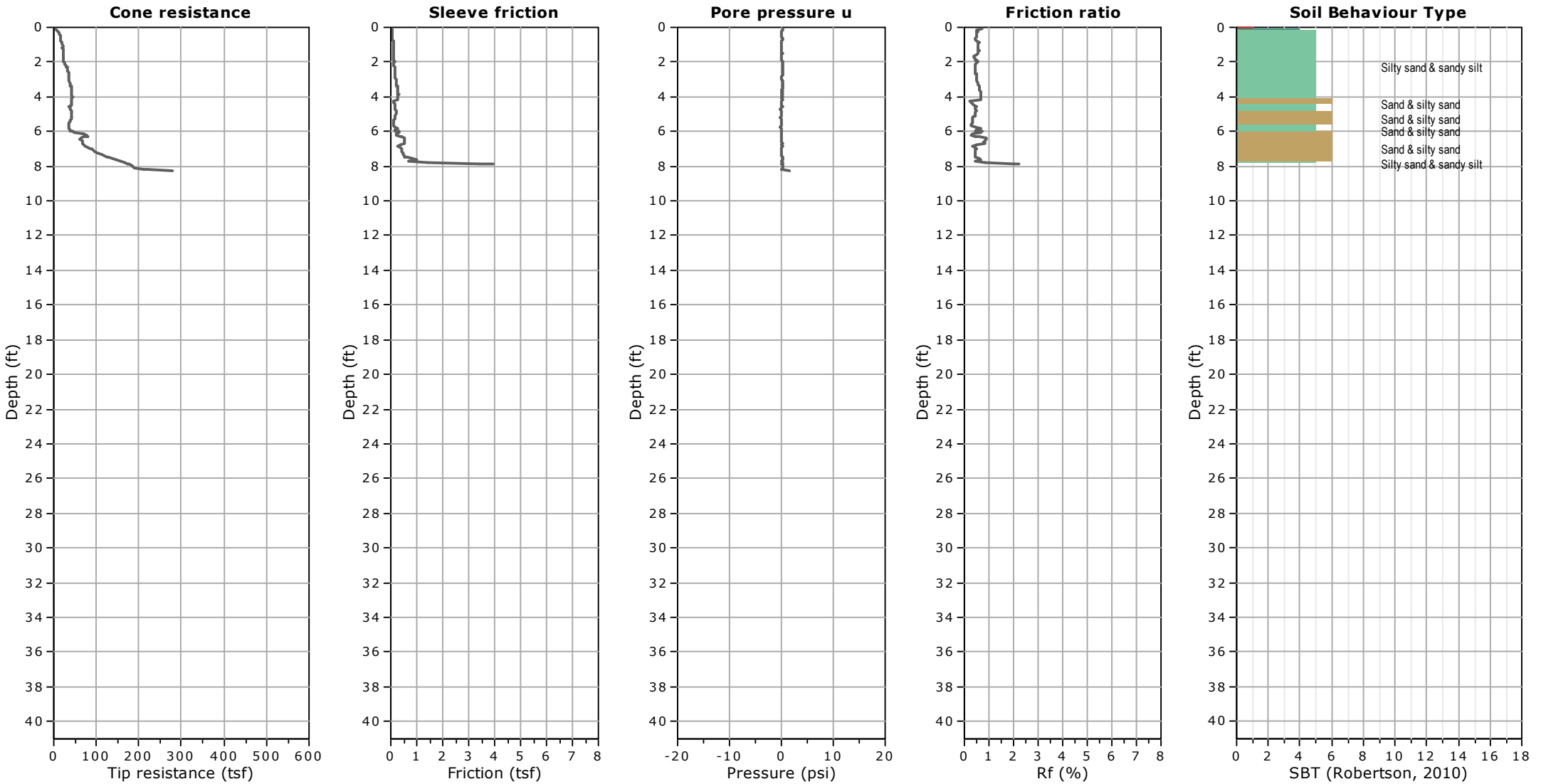

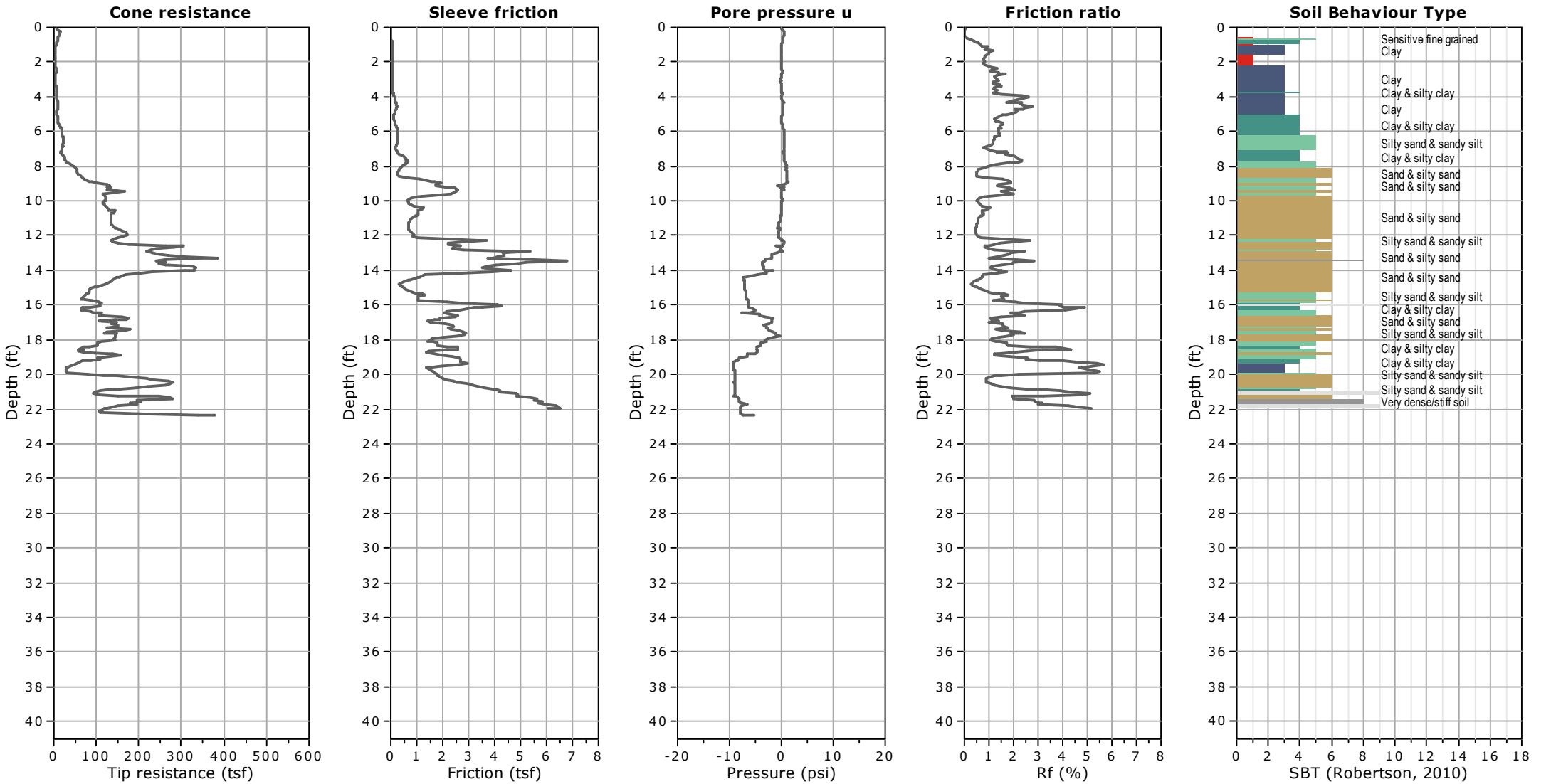

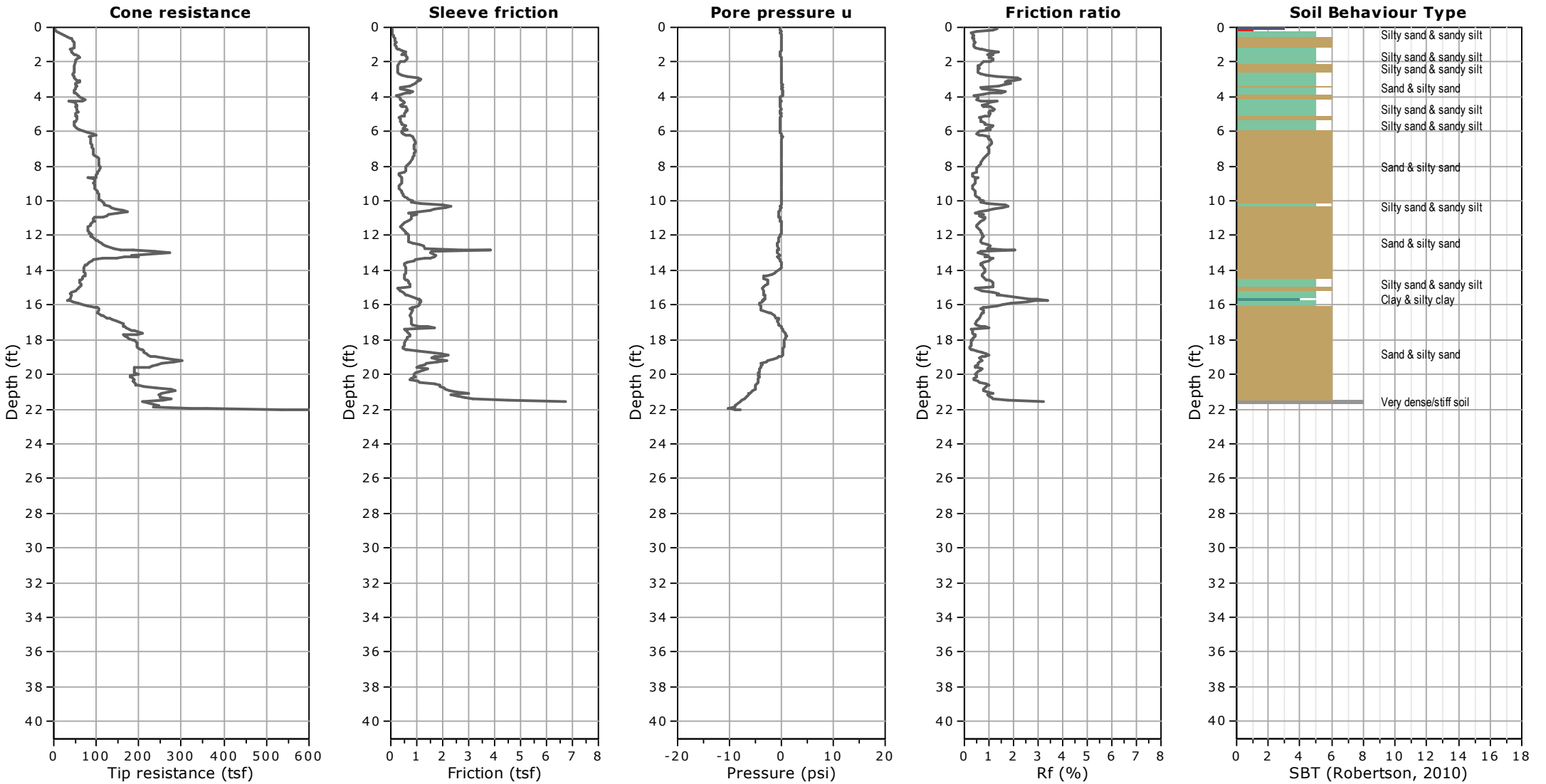

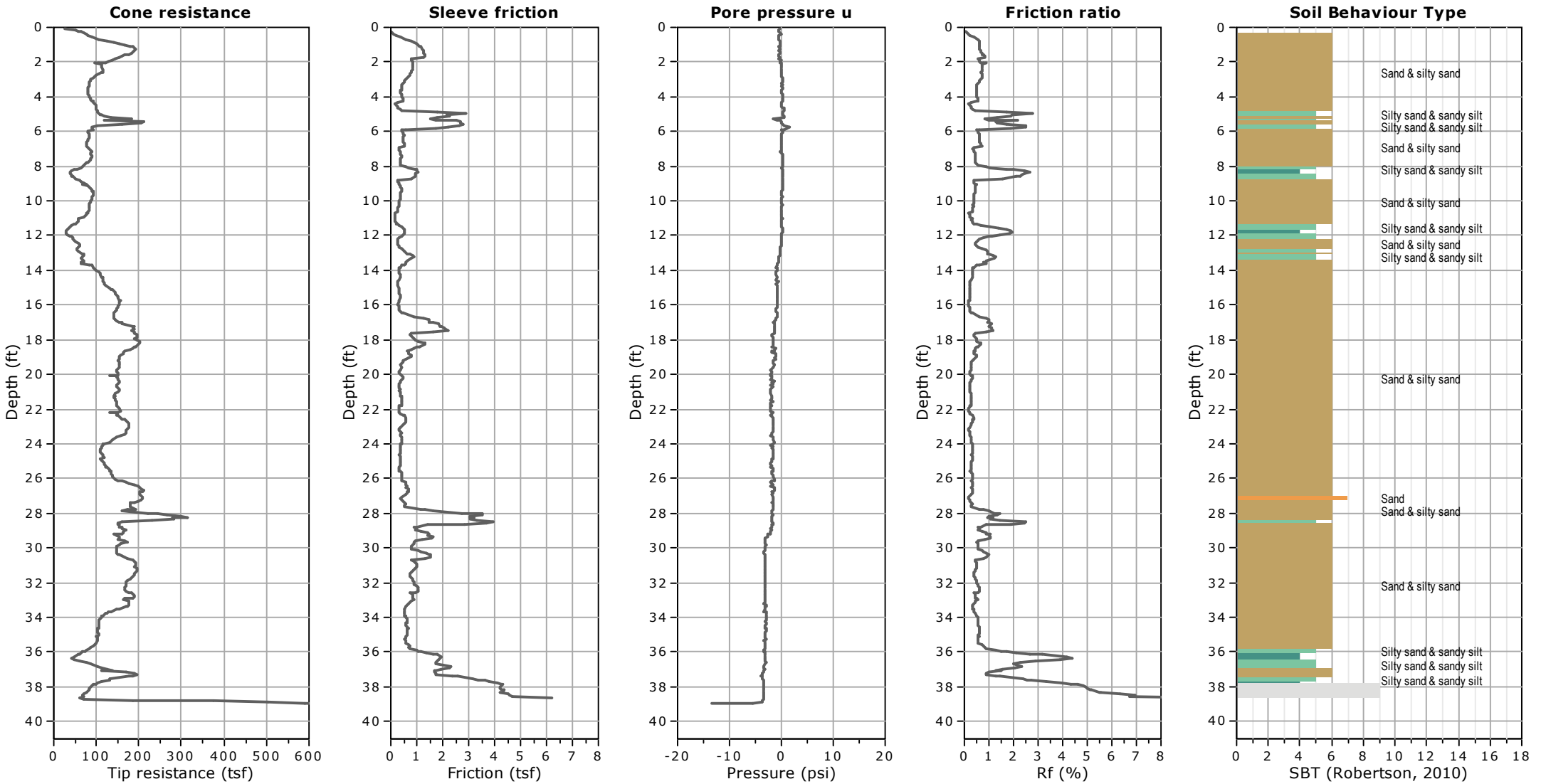

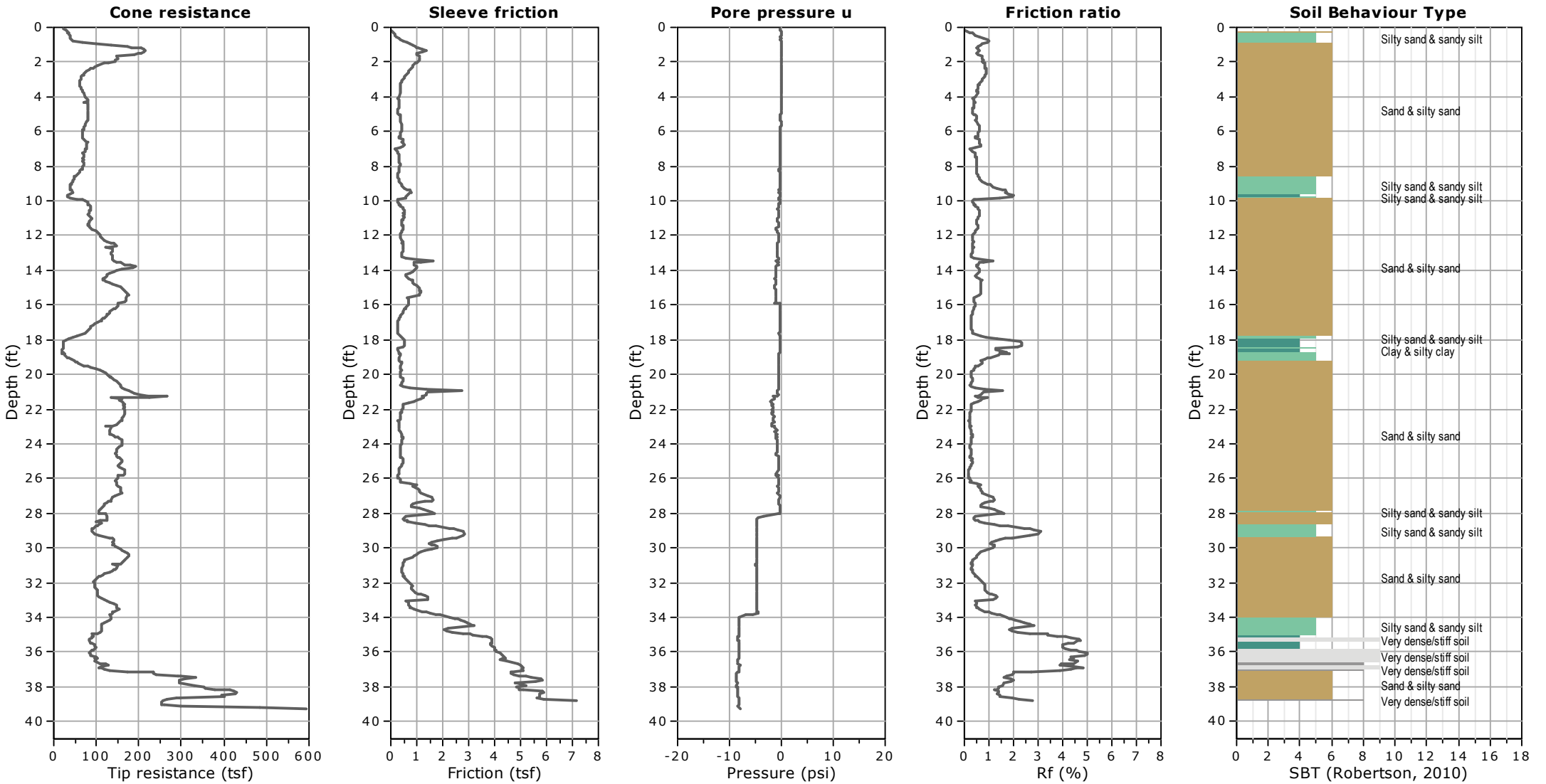

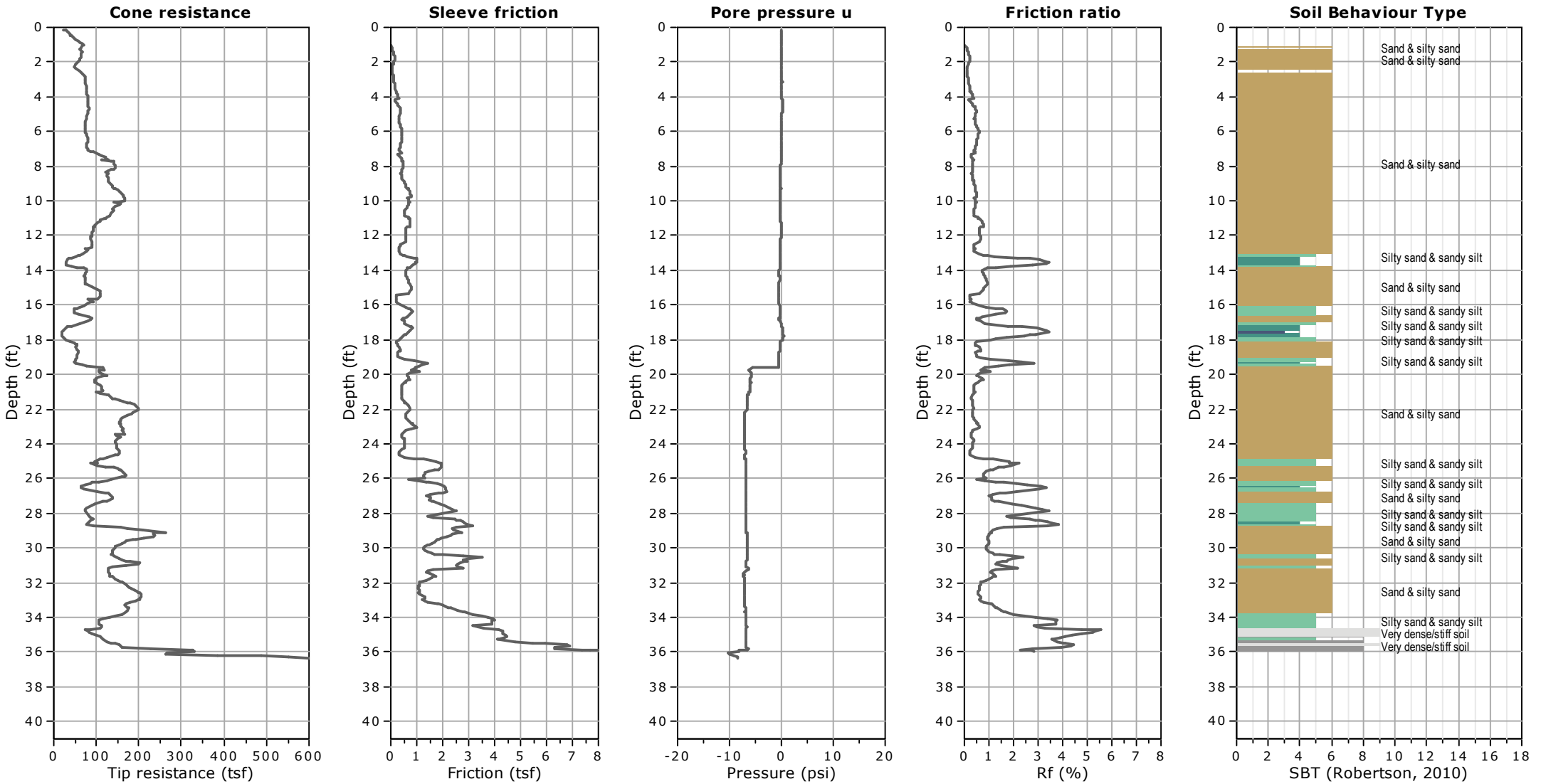



Kehoe Testing & Engineering

714-901-7270

steve@kehoetesting.com

www.kehoetesting.com

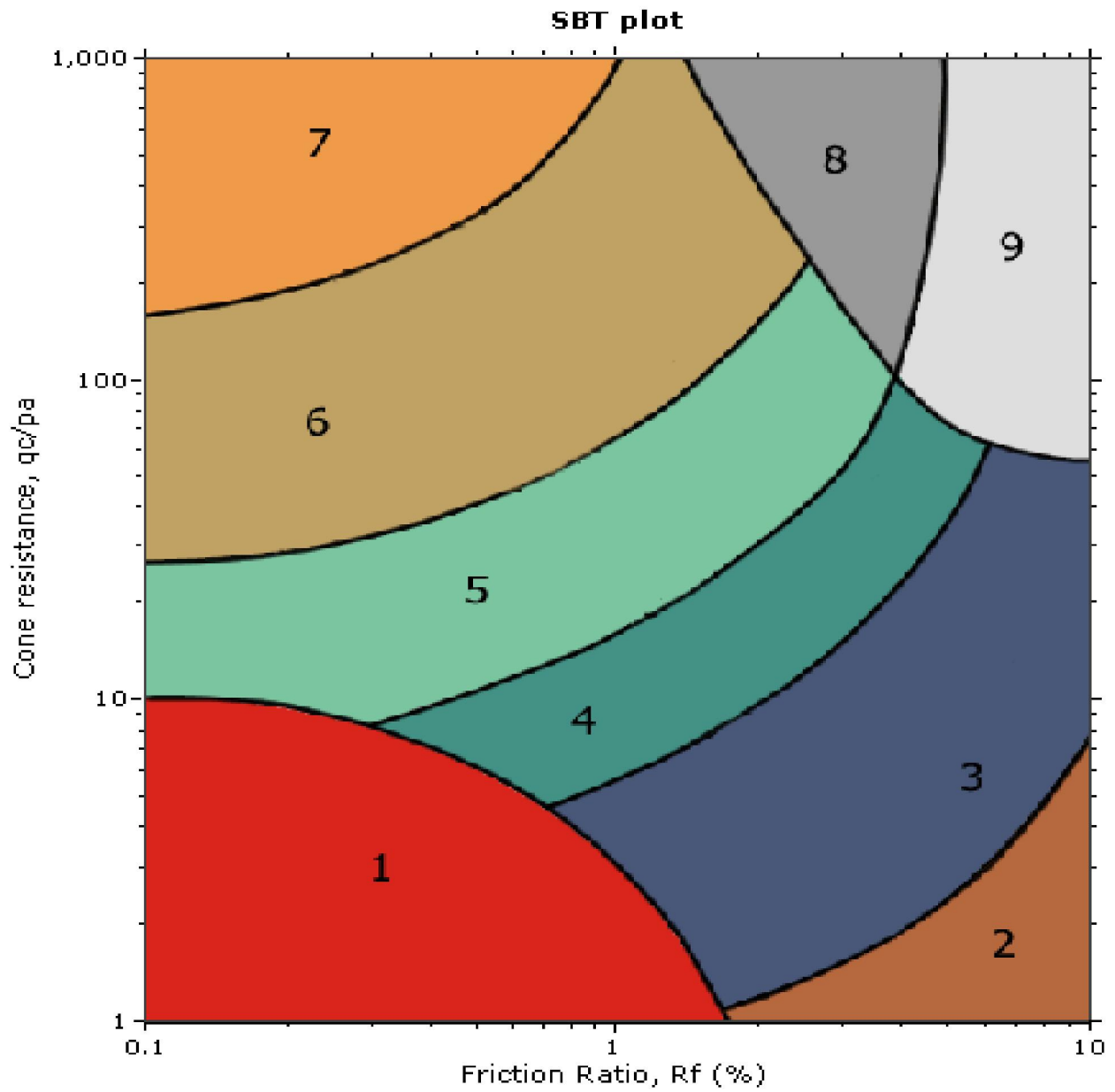

SBT legend

- | | | |
|---------------------------|------------------------------|-----------------------------------|
| 1. Sensitive fine grained | 4. Clayey silt to silty clay | 7. Gravely sand to sand |
| 2. Organic material | 5. Silty sand to sandy silt | 8. Very stiff sand to clayey sand |
| 3. Clay to silty clay | 6. Clean sand to silty sand | 9. Very stiff fine grained |

Petra Geosciences
Apple Canyon
Lake Hemet, CA

CPT Shear Wave Measurements

Location	Tip Depth (ft)	Geophone Depth (ft)	Travel Distance (ft)	S-Wave Arrival (msec)	S-Wave Velocity from Surface (ft/sec)	Interval S-Wave Velocity (ft/sec)
CPT-7	5.09	4.09	4.55	6.84	666	
	10.01	9.01	9.23	13.26	696	728
	15.12	14.12	14.26	20.42	698	703
	20.37	19.37	19.47	29.20	667	594
	25.13	24.13	24.21	34.68	698	865
	30.05	29.05	29.12	41.44	703	726
	35.20	34.20	34.26	46.76	733	966

Shear Wave Source Offset - 2 ft

S-Wave Velocity from Surface = Travel Distance/S-Wave Arrival
Interval S-Wave Velocity = (Travel Dist2-Travel Dist1)/(Time2-Time1)

TEST ID: CPT-7

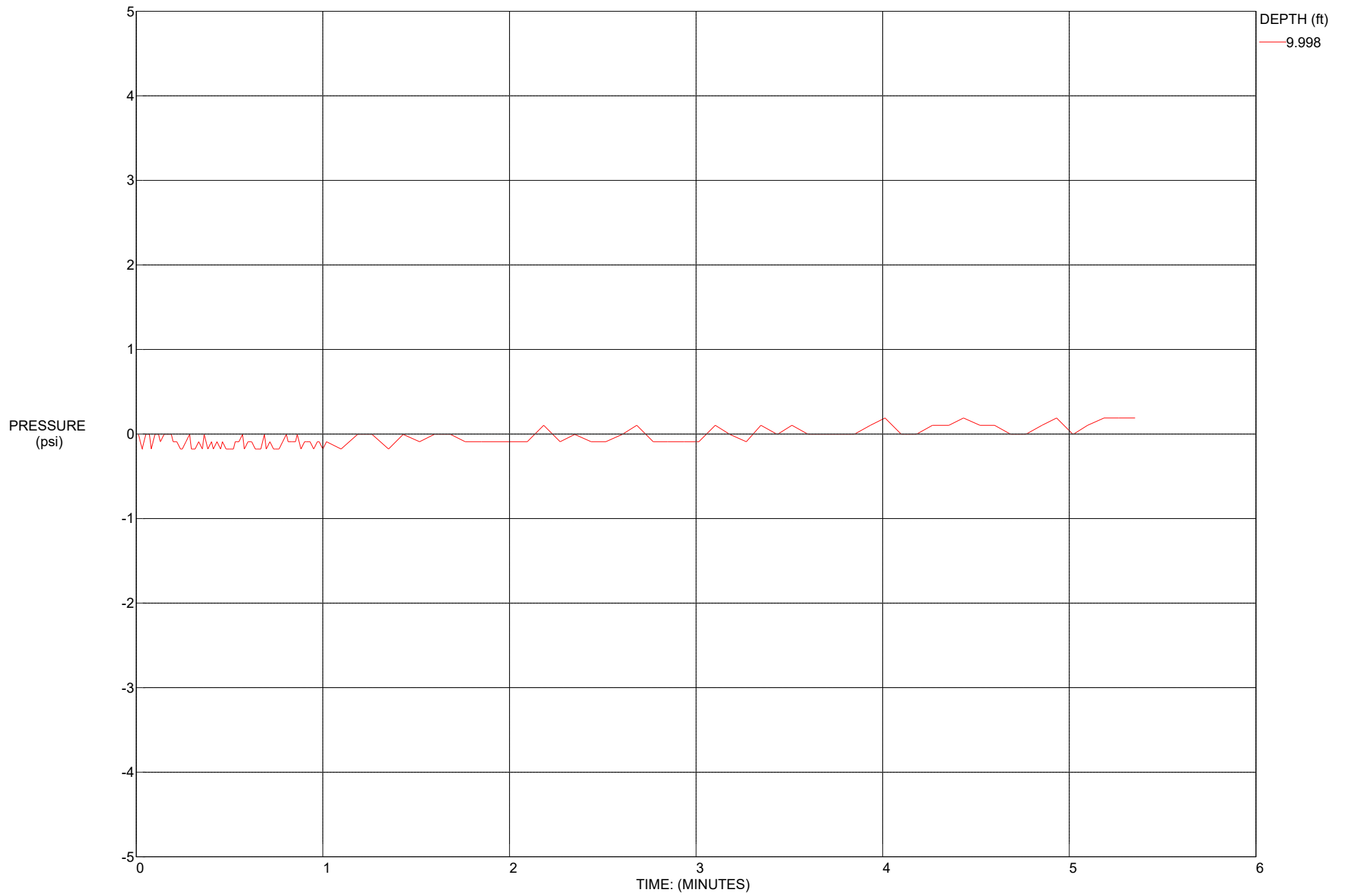

TEST ID: CPT-7

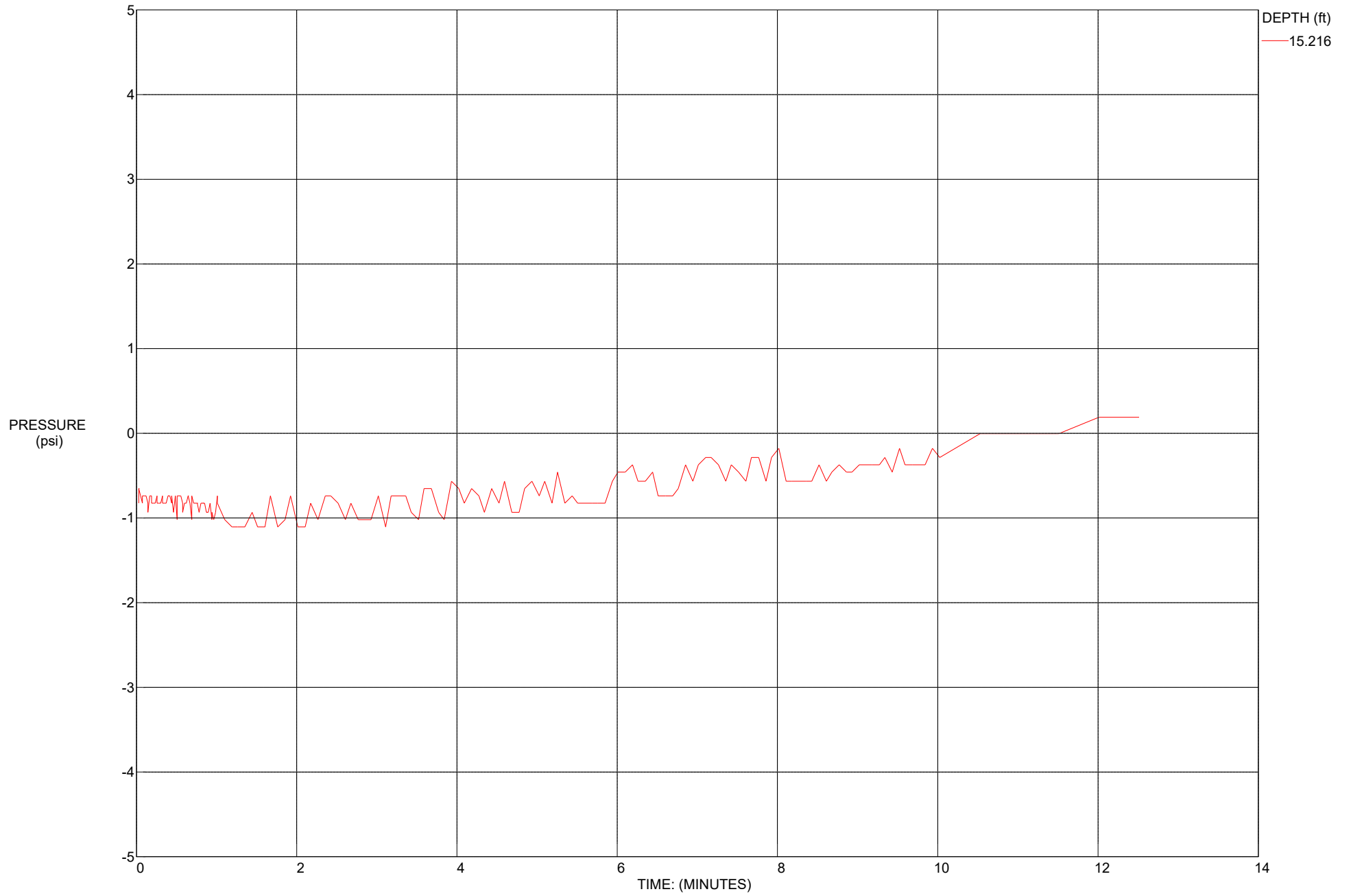

TEST ID: CPT-7

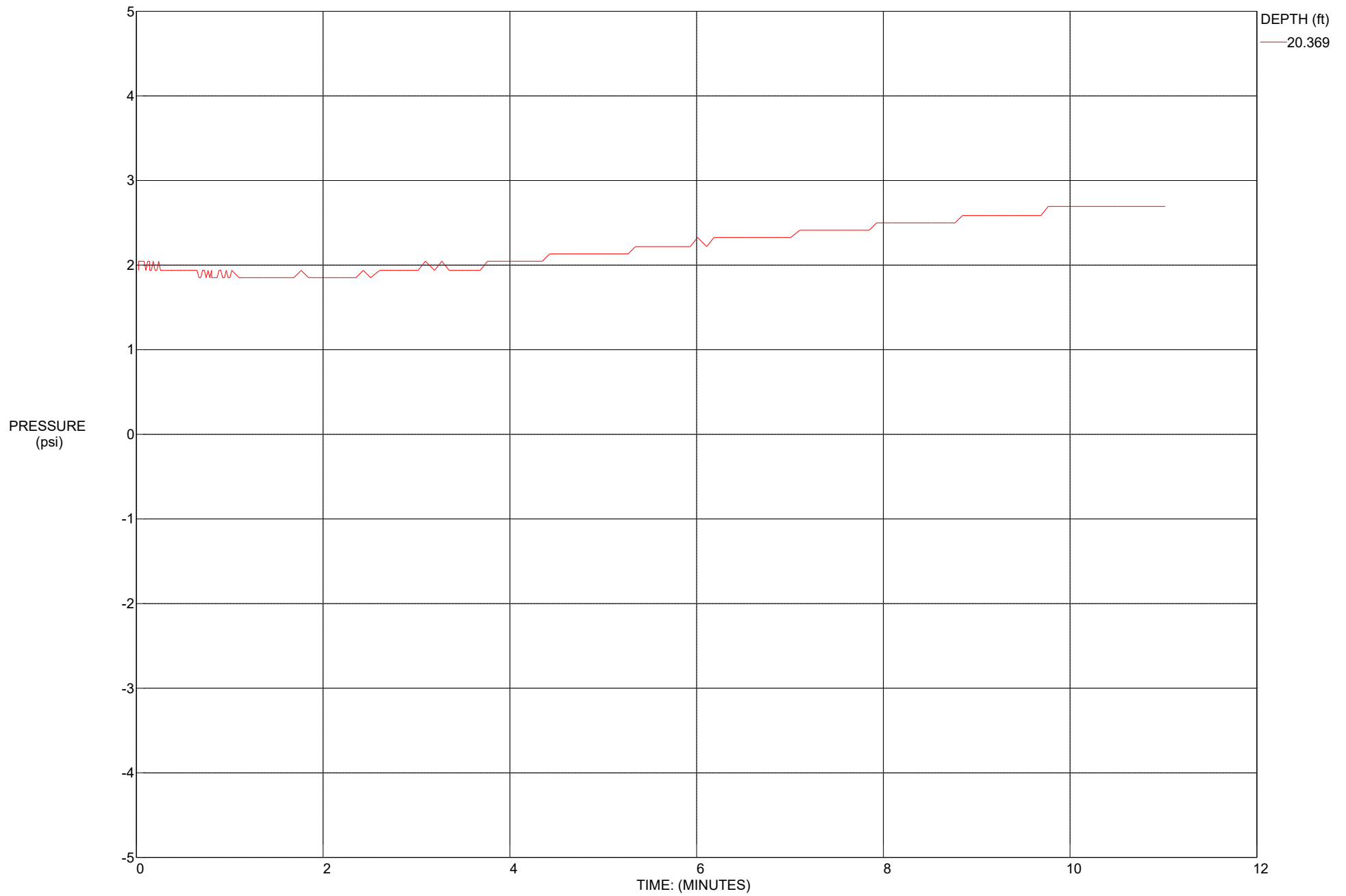

TEST ID: CPT-7

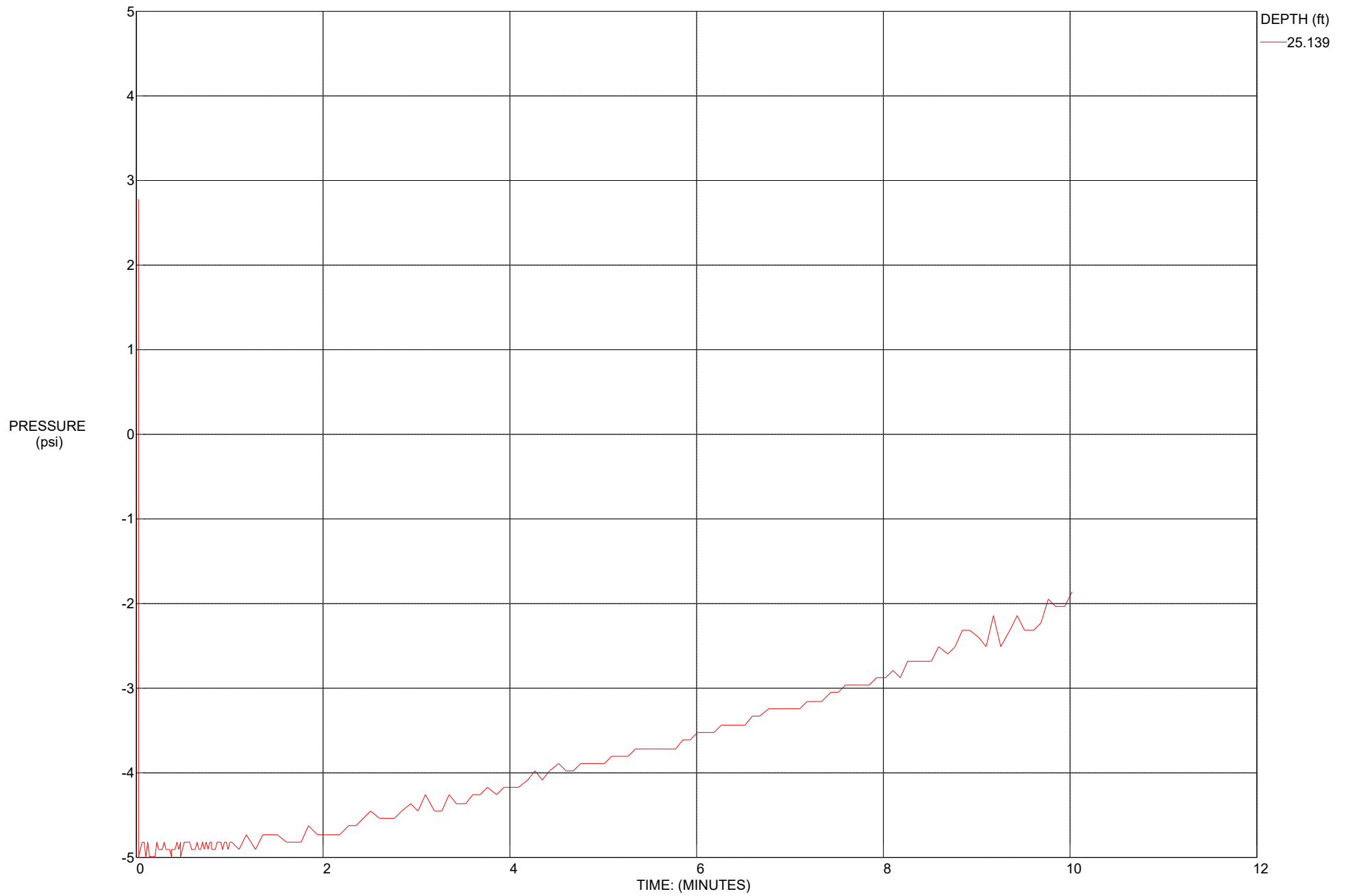

TEST ID: CPT-10

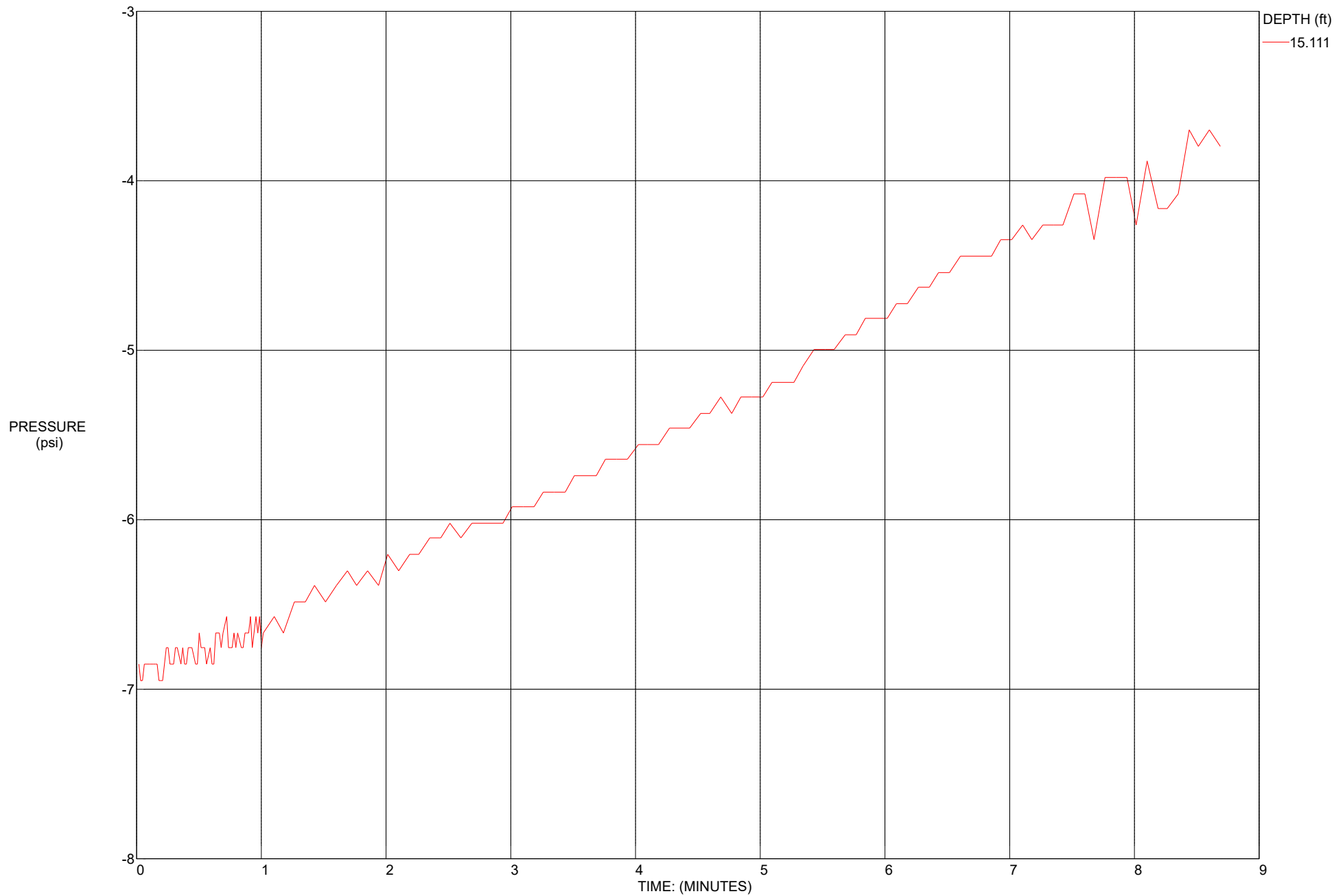

TEST ID: CPT-8

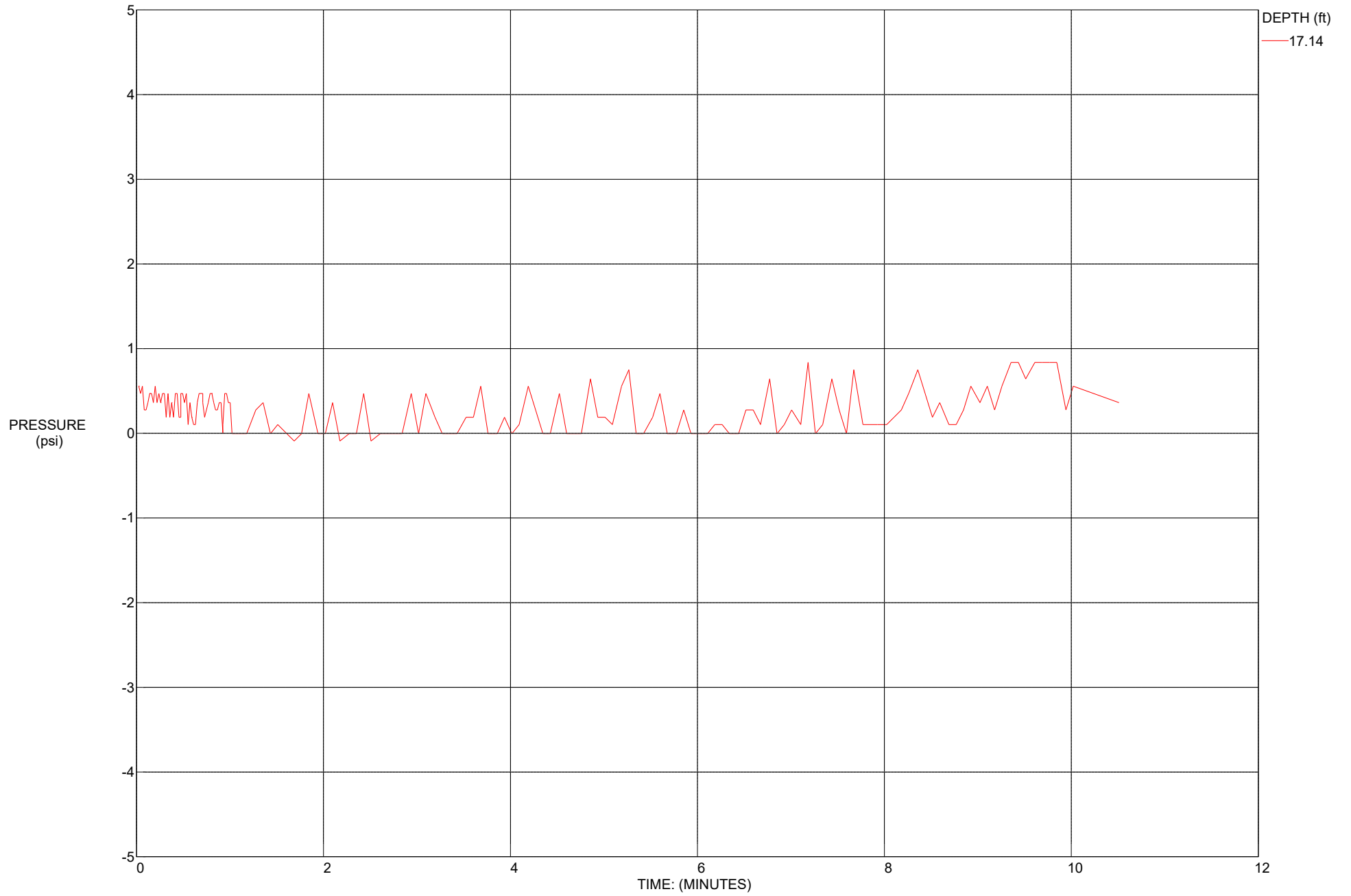

TEST ID: CPT-10

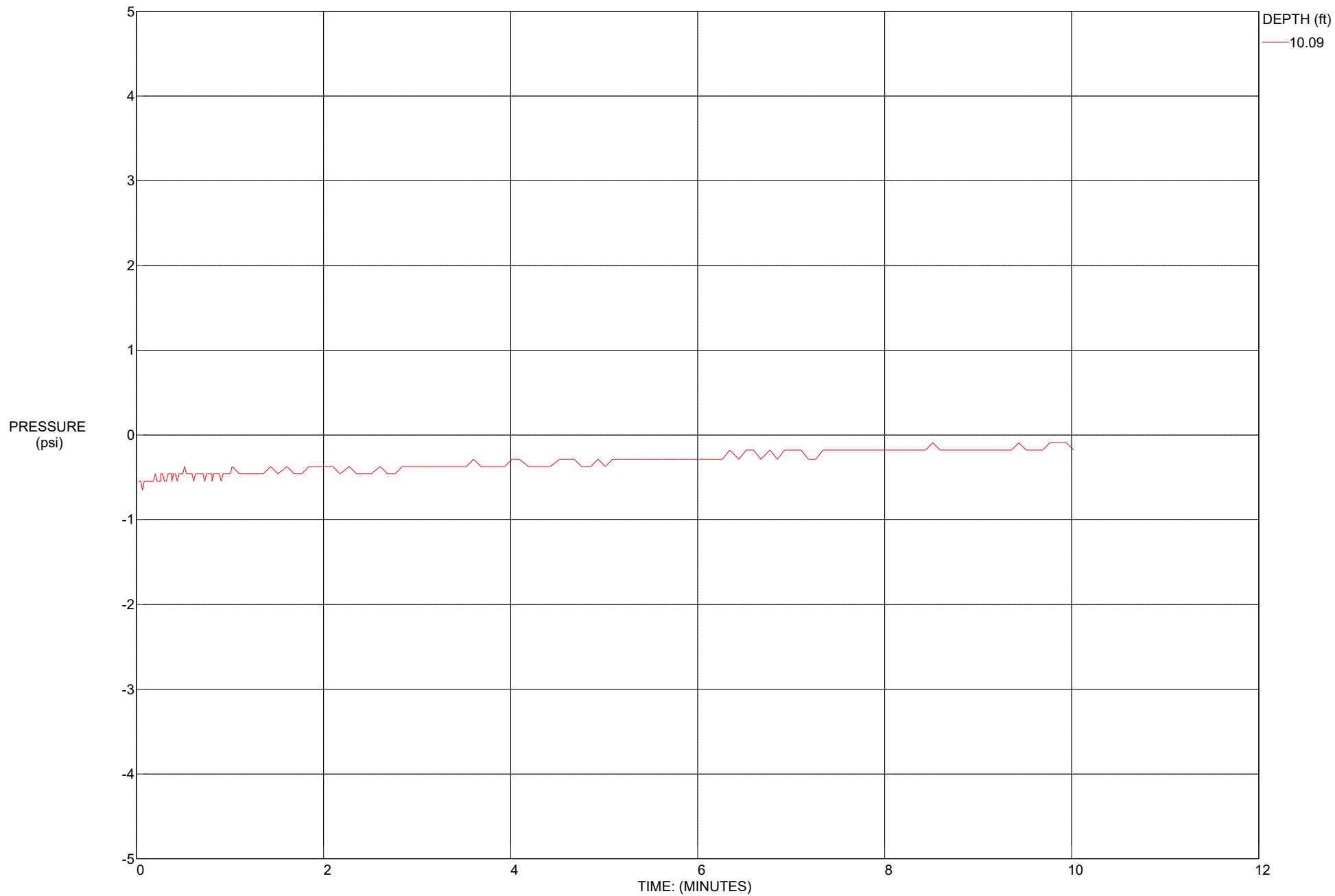

TEST ID: CPT-13

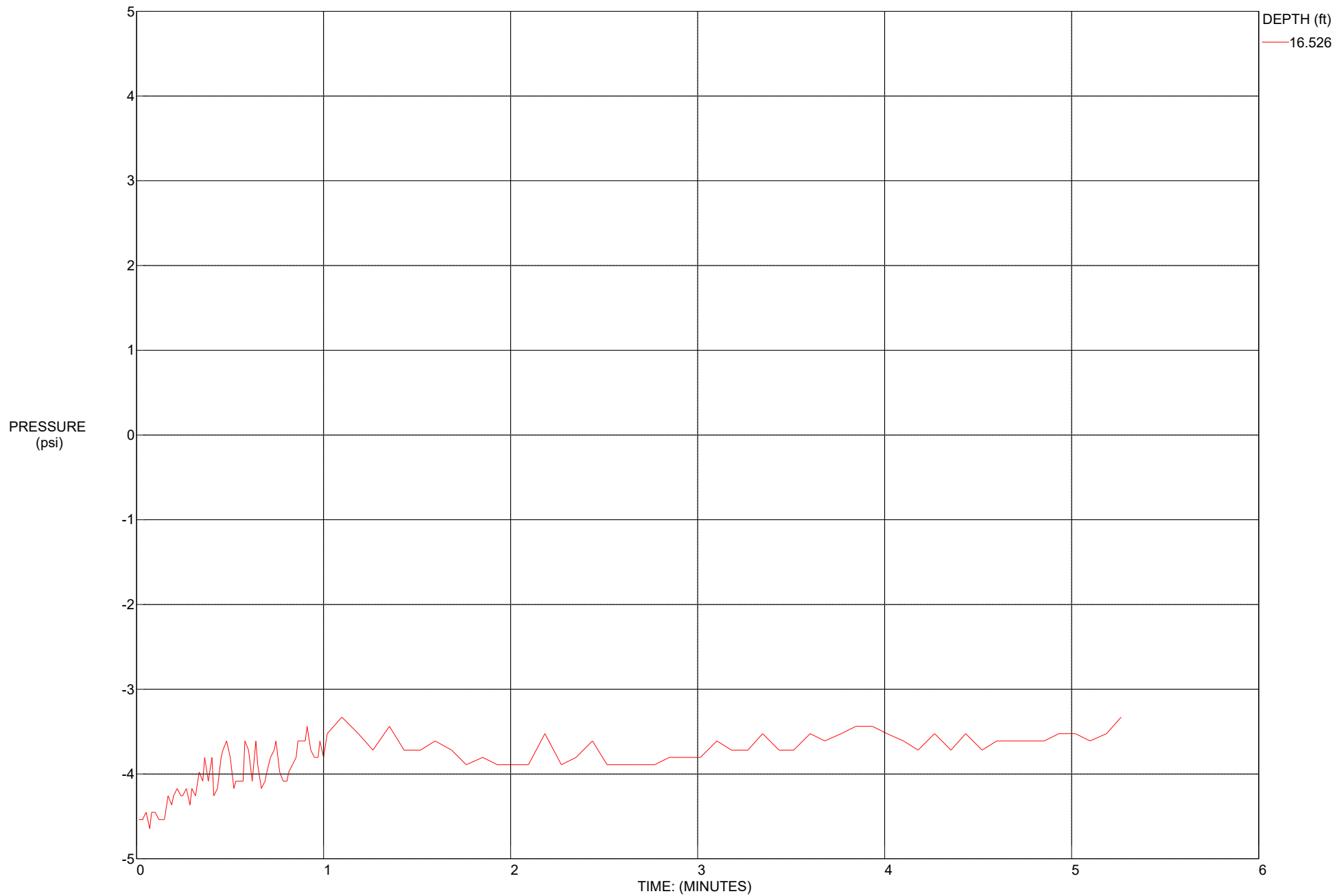

TEST ID: CPT-15

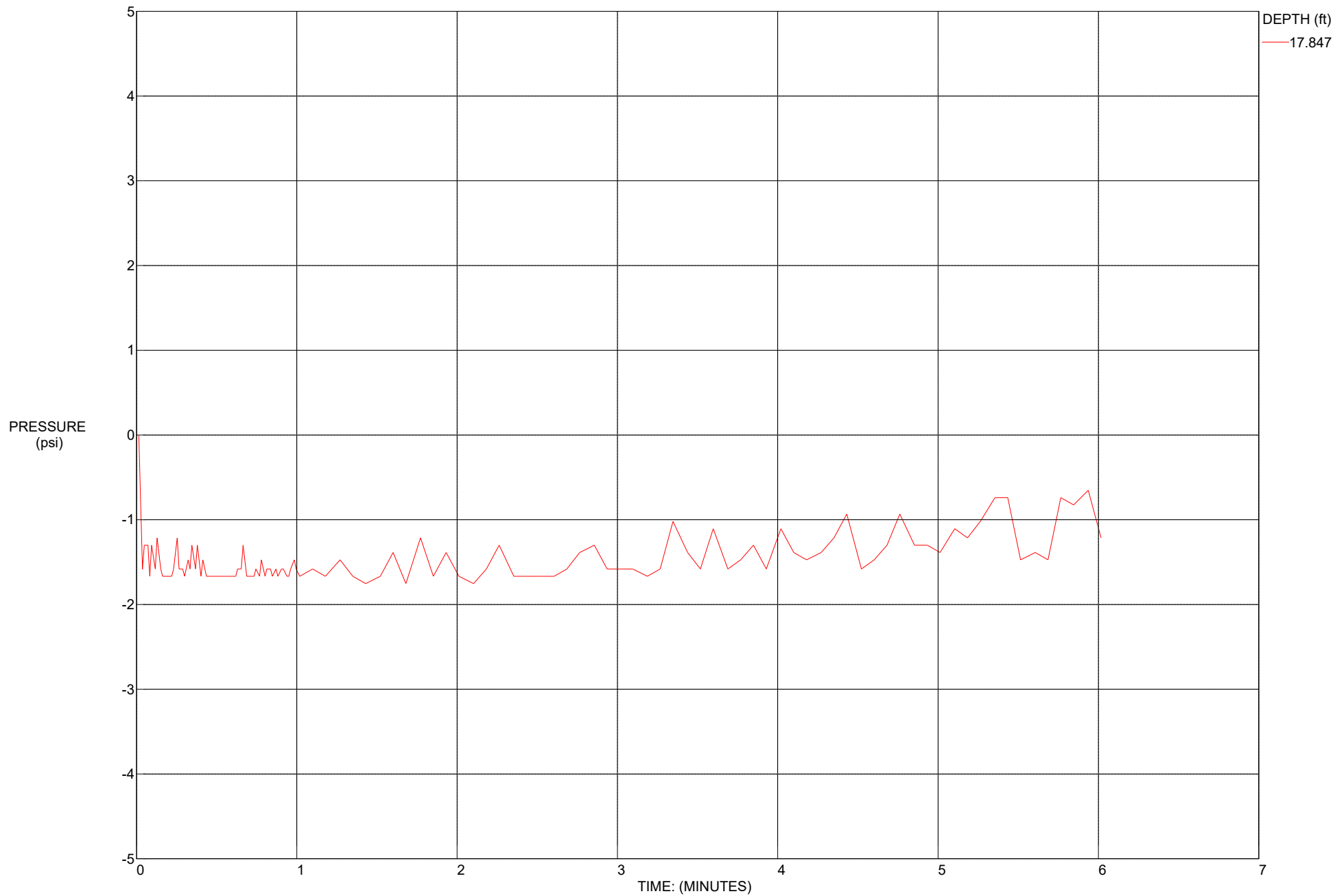

APPENDIX A-2

GEOPHYSICISTS REFLECTION LINE REPORT



ATLAS

□ □ □ □ □ **S** □ □ □ □ **S** □ □ □ □ □

□ □ □ □ □ **M** □ □ □ □ □ **SS** □ □ □ □ □ □ □ □ □ □ **S** □ □ □ □ □

Lake Hemet, California

□ □ □ □ □ □ □ □ □ □ □ □
Petra, Inc.
42-240 Green Way, Suite E
Palm Desert, CA 92211

□ □ □ □ □ □ □ □ □ □ □ □
Atlas Technical Consultants, LLC
6280 Riverdale Street
San Diego, CA 92120

□ □ □ □ □ □ **r** □ □ □ □ □ □ □ □



00 000000000000

In accordance with your authorization, Atlas Technical Consultants (Atlas) has performed a geophysical study pertaining to the proposed Lake Hemet Wellness Center located in Lake Hemet, California (Figure 1). Specifically, our study included evaluating the presence of faulting at a portion of the project site through the collection of seismic reflection data. The field work was conducted on August 17 through 20, 2020. This data report presents our survey methodology, equipment used, analysis, and results.

00 S0000 00 S00000S

Our scope of services included:

- Review of background project information, including maps, provided by your office.
- Conducting a seismic reflection line across a portion of the project site.
- Compiling and analyzing the data collected.
- Preparing this illustrated data report presenting our findings and conclusions.

00 S000 000 0000000 00S0000000

The project site is located to the northeast of the Lake Hemet reservoir and is in between Apple Canyon Road and Highway 74 (Figure 1). The study area, which was selected by your office, included a portion of the property. Specifically, the seismic traverse crossed the study area southwest to northeast, roughly perpendicular to possible faulting in the area (Figure 2). The study area is relatively flat, and vegetation includes scattered brush and trees, and annual grass. Overhead electric lines are located just to the west of the seismic traverse. Figures 2 and 3 depict the general site conditions in the study area.

Based on our discussions with you, it is our understanding that faulting has been mapped in or near the study area. It is also our understanding that your office is conducting a fault hazard evaluation for the proposed development.

00 000000S0000 M00000 000 00000000000S

Our evaluation included the assessing the presence of faulting at the project site through the collection of seismic reflection data. The seismic reflection method uses body waves which are generated, typically at the surface, and then recorded using an array of vertical component geophones (receivers). When the propagating wave encounters a change in acoustic impedance (impedance is equal to the product of a materials density and velocity) some of the wave energy is reflected back to the surface and detected by the geophones and recorded with a data logging instrument (seismograph). During the acquisition of seismic reflection data, the seismic waves recorded from each geophone are gathered into groups that have a common source point (source record). The individual traces within the source records are subsequently regrouped into gathers

that have the midpoint between their source and receiver locations in common (termed common-midpoint [CMP] or common-depth-point [CDP] gathers). The differences in times of arrivals at variable source points to geophone distances along reflection paths are termed “moveout” and are hyperbolic (if reflecting geologic strata dips and source-receiver offsets distances are not too large). Moveout depends upon velocity, dip (to a lesser extent), and offset distance and decreases with increased reflection time.

Once the seismic traces have been grouped (sorted) into CDP gathers, analyses of the moveout of reflections within the dataset provides velocities that are used to flatten the hyperbolic moveout on adjacent traces to a common two-way travel time (time it takes seismic energy to travel from a point on the surface to a reflector and back to the same point on the surface). These correction velocities consider the approximate root-mean-square (rms) velocities of all the overlying layers, and the moveout correction is termed normal moveout or NMO. Corrected traces can be summed horizontally, or CDP stacked, to attenuate random effects and non-primary reflection NMO from other wave types (e.g., multiple reflections, surface waves, refractions, diffractions, etc.), and to increase the signal-to-noise (S/N) ratio. The amount of horizontal summing, or CDP fold, is dependent upon the number of seismograph channels (i.e., number of geophones), and the location and number of source points. Each CDP gather then becomes one stacked trace with reflected energy at two-way travel time. A seismic reflection section consists of stacked CDP gathers along the length of the line.

Signals can be enhanced through vertical stacking, which involves repeated source impacts at the same point into the same set of geophones. For each source point the stacked data are recorded into the same seismic data file and theoretically the seismic signal arrives at the same time from each impact, and thus is enhanced, while noise is random and tends to be reduced or canceled.

The quality of seismic data can be adversely affected by spurious vibrations from nearby vehicular or aircraft traffic, machinery, or wind. If the seismic noise sources are sporadic, acquisition can be timed to when the noise is at a minimum. Under conditions of constant noise, the number of stacks can be increased, or at last resort filtering can be applied.

The seismic reflection data for our study were acquired along a linear geophone spread. Five Geometrics Geode signal-enhancement seismographs and 120 40-Hz vertical component geophones spaced 8 feet apart were used. Shots were conducted between each geophone pair along the array and off the ends of the geophone spread. A 20-pound sledgehammer and aluminum impact plate were used as a seismic source (shot).

After initial in-field testing, data were independently acquired five times at each source point. Only data of high quality were vertically stacked (i.e., the records at each source point were stacked together) during processing although for most source points that included each record. Each geophone location and elevation along the line were recorded. The overall quality of the reflection seismic data collected is considered good to excellent.



The collected reflection seismic data were processed by Columbia Geophysical, LLC, Englewood, Colorado. Columbia Geophysical's UNIX workstation-based ProMAX reflection seismic software package was used to process the data and offered the opportunity to perform extensive testing in a short period of time.

The seismic data processing sequence applied is as follows (** = testing steps):

1. Format conversion from SEG2 to SEG-Y
2. Geometry definition and application
3. Trace editing
4. ***Spectral analysis and filter analysis to determine frequency range*
5. ***First break picking and refraction statics calculation*
6. Statics calculations: datum = 0 feet, velocity = 4,200 ft/sec
7. Gain recovery and spherical divergence correction
8. ***Deconvolution (testing)*
9. Surface consistent spiking deconvolution
10. Zero phase spectral whitening: 6-10-130-150 Hz range
11. Long gate trace balance
12. Common-Depth-Point (CDP) sort
13. Interactive velocity analysis
14. ***First break mute analysis*
15. Preliminary brute stack with datum statics and mutes
16. Surface consistent residual autostatics
17. Interactive velocity analysis with autostatics applied
18. Q.C. of shot records and CDP gathers
19. Normal moveout (NMO) corrections
20. ***Final first break mute analysis*
21. Final mute application
22. CDP stack
23. ***Spectral analysis and filter testing on unfiltered final stack*
24. Bandpass filter application (20-30-150-200 Hz), 0 to 500 milliseconds (ms)
25. FX noise attenuation
26. Time variant scaling
27. SEG-Y digital output.

Spectral analyses and filter tests are conducted upon individual records in order to determine the quality of the data, the amount of information present, and to design a preliminary data processing flow. Elevation statics are used to determine surface consistent residual statics that are applied after interactive velocity analysis. Statics are corrections applied to seismic data to compensate for the effects of variations in elevation, weathering thickness, weathering velocity and reference to a datum. The objective is to determine the reflection arrival times which would have been observed if all measurements had been made on a (usually) flat plane with no weathering or low velocity material present. Surface consistent means that the statics take into account time delays from both source and geophone locations.

Normal moveout (NMO) is described as the variation of reflection arrival time because of different source point to geophone distances. To determine the NMO correction, velocity analyses of the CDP gathers are conducted by stacking several velocities and choosing those velocities where

the coherency of the NMO for selected reflectors is maximized. These velocities are further refined via narrow and/or full-line CDP gather panel analyses to arrive at the final stacking velocities along the lines. The first-break mute excludes traces that are dominated by refraction arrivals or contain frequencies after NMO correction that are appreciably lower than the other surrounding traces.

In filter testing, narrow bandpass filters were applied to the data to determine the optimum frequency filtering interval(s) that can be used on the data to enhance any possible reflections and reduce noise. For the processing flow used in this project (and typically for most seismic data processing), the data are bandpass filtered after CDP stacking.

SEISMIC DATA

As previously discussed, the purpose of our geophysical study was to assess the presence of faulting within the study area through the collection of seismic reflection data. The reflection results are presented in Figure 4 as a model comprised of continuous and discontinuous reflectors (orange and black bands). Please note that the reflection profile vertical scale is two-way travel time (TWTT) in milliseconds (ms) and that absent specific subsurface velocity information, an accurate depth scale is not provided. For rough estimating purposes only, the two-way travel time multiplied by two approximates the near surface depth in feet. This multiplier increases with depth and increased velocity. It should also be noted that the data near the beginning and the end of the section is generally incoherent because the CDP fold is low near the ends of the line. Consequently, interpretations of the sections near the ends of lines are questionable or not possible.

As illustrated in Figure 4, a very strong reflector is present at approximately 45ms (TWTT). This reflector is continuous across the profile and likely represents the contact with or within the granitic rock. Based on our discussions with you, it is understanding that the site is likely underlain by massive alluvial soils over granitic rock, with varied degrees of weathering. The depth to this bright reflector is on the order of 90 feet, which would suggest that the alluvium is 90 feet thick if the reflector represents the top of the granitic rock. As part of our evaluation we conducted some limited refraction analyses on the collected data and found that there is a substantial increase in P-wave velocity from 5,000 to 7,000 feet per second at 35 to 40 feet below the ground surface. These velocities are typical of weathered granitic bedrock. Consequently, the strong reflector, observed at 45ms likely represents a transition from weathered to non, or slightly, weathered rock rather than the top of the rock.

Based on our results, two possible somewhat subtle fault splays are observed in the data, and are shown in blue on Figure 4. These two features appear to disrupt the granitic rock. The surface projection of these features are shown on Figure 2 as the limits of a possible fault zone.

It should be noted that the picking, or tracing, of reflectors and faulting in high resolution data may be considered a combination of art and science and it is possible that other geophysicists or



geologists might trace features differently along some portions of the line, although the general nature of the subsurface interpretation of the seismic data will not appreciably change.

□□ □M□□□□□□□S

The field evaluation and geophysical analyses presented in this report have been conducted in general accordance with current practice and the standard of care exercised by consultants performing similar tasks in the project area. No warranty, express or implied, is made regarding the conclusions, recommendations, and opinions presented in this report. There is no evaluation detailed enough to reveal every subsurface condition. Variations may exist and conditions not observed or described in this report may be present. Uncertainties relative to subsurface conditions can be reduced through additional subsurface exploration. Additional subsurface surveying will be performed upon request.

This document is intended to be used only in its entirety. No portion of the document, by itself, is designed to completely represent any aspect of the project described herein. Atlas should be contacted if the reader requires additional information or has questions regarding the content, interpretations presented, or completeness of this document. This report is intended exclusively for use by the client. Any use or reuse of the findings, conclusions, and/or recommendations of this report by parties other than the client is undertaken at said parties' sole risk.

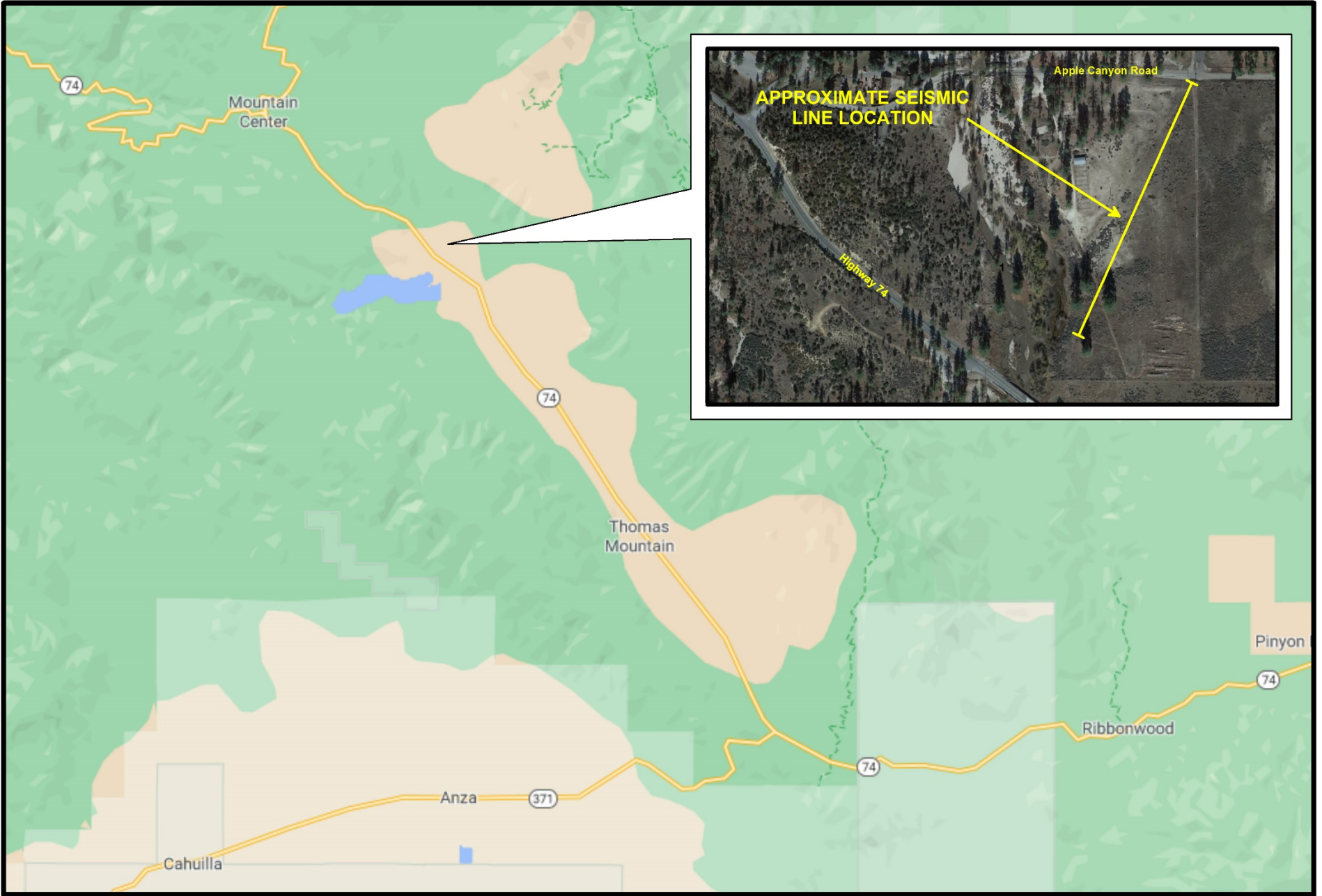

SITE LOCATION MAP



Lake Hemet Wellness Center
Lake Hemet, California

Project No.: 120361SWG

Date: 10/20



Figure 1

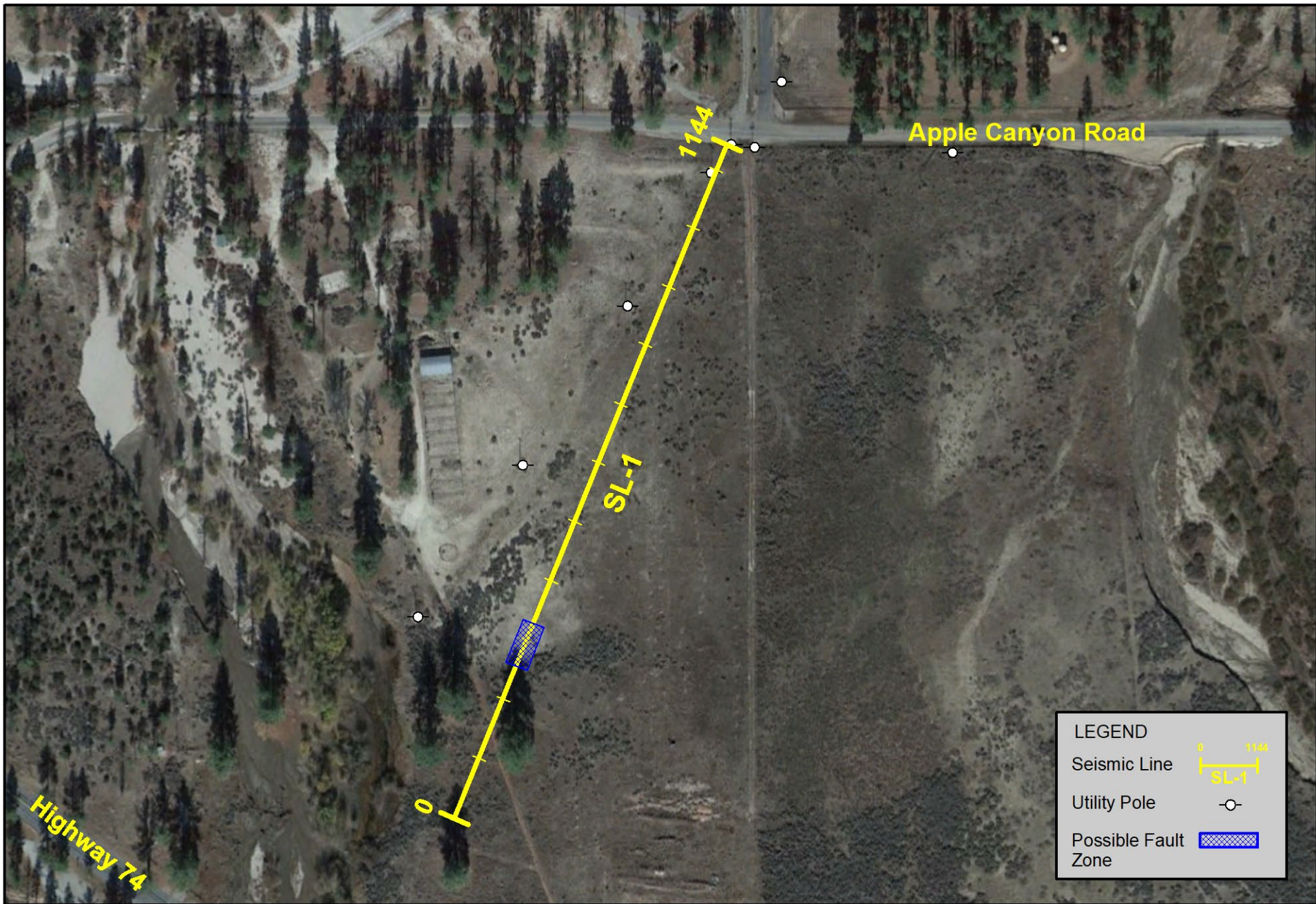

LEGEND

- Seismic Line
- Utility Pole
- Possible Fault Zone

**LINE LOCATION
MAP**



Lake Hemet Wellness Center
Lake Hemet, California

Project No.: 120361SWG

Date: 10/20



Figure 2

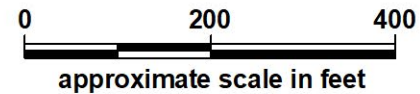

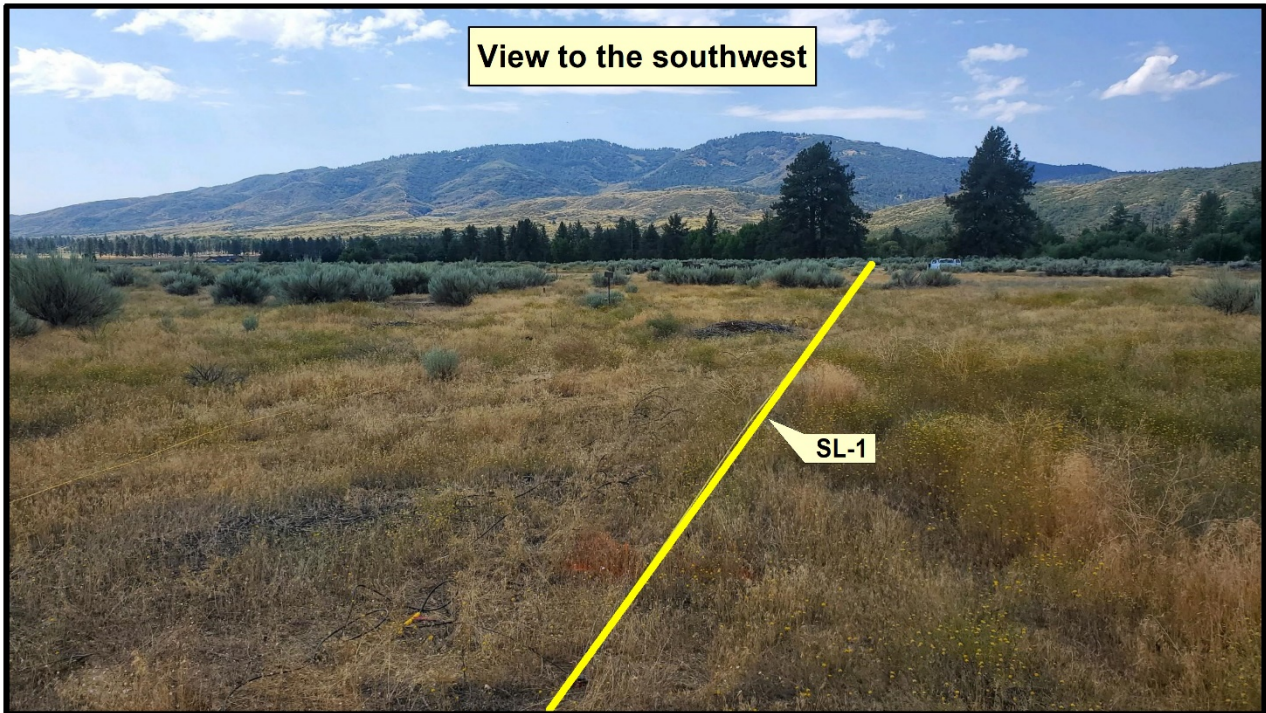
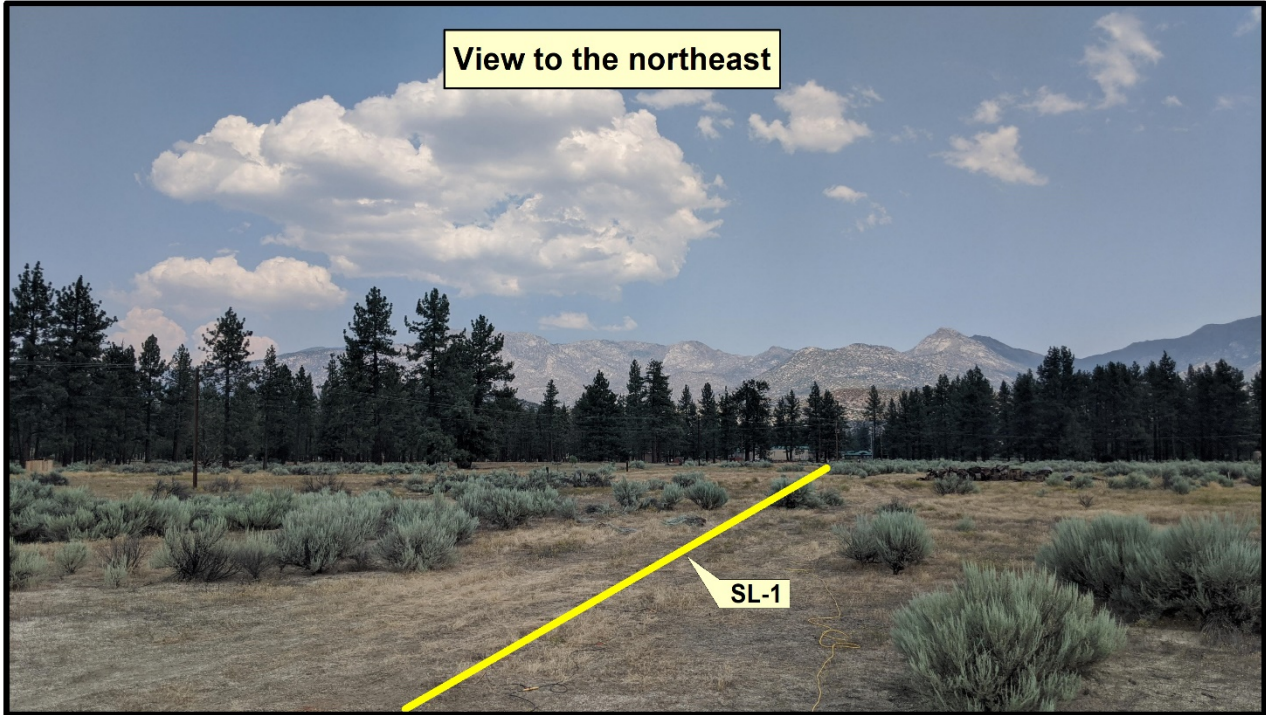

SITE PHOTOGRAPHS

Lake Hemet Wellness Center
Lake Hemet, California

Project No.: 120361SWG

Date: 10/20



Figure 3

NORTHEAST →

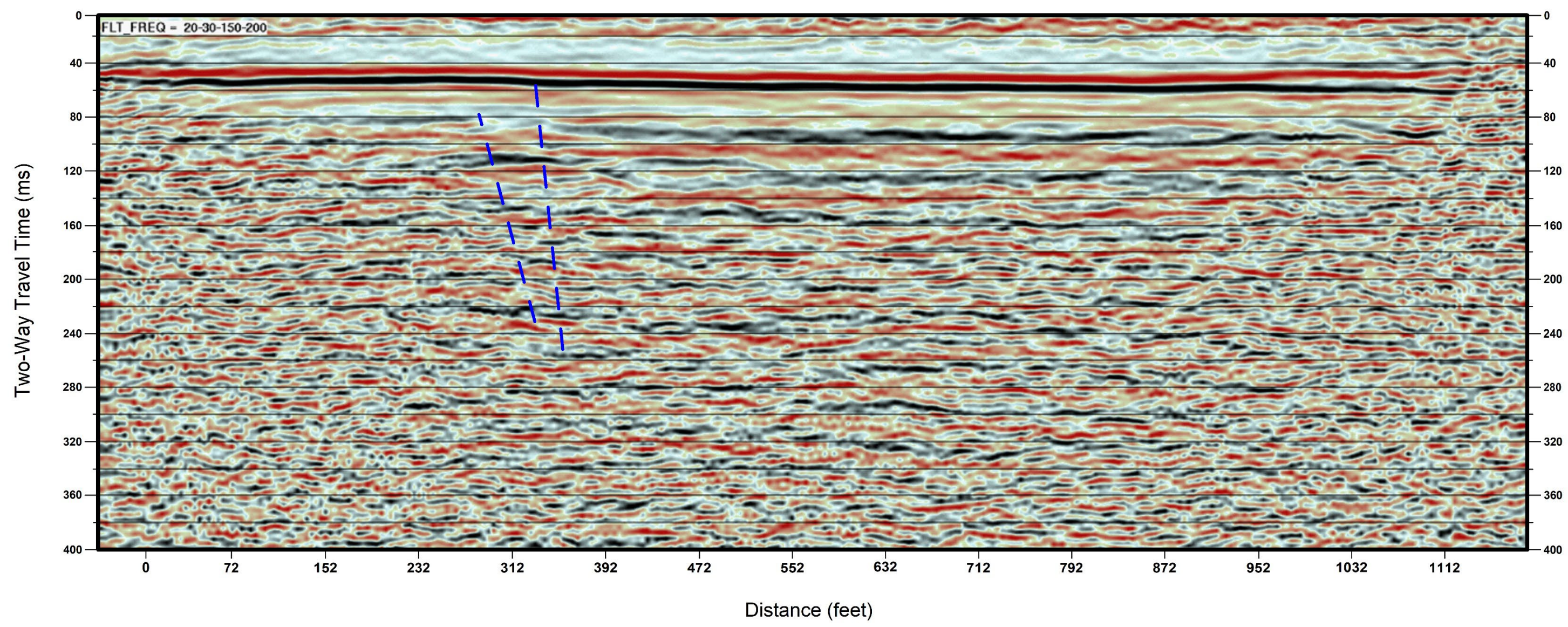

Legend

Possible Fault — — —

APPENDIX B-1

LABORATORY TEST PROCEDURES

LABORATORY DATA SUMMARY

LABORATORY TEST PROCEDURES

Soil Classification

Soil materials encountered within the property were classified and described in accordance with the Unified Soil Classification System and in general accordance with the current version of Test Method ASTM D 2488. The assigned group symbols are presented in the exploration logs, Appendix A.

Moisture Content and In Situ Moisture Content and Dry Unit Weight

Moisture content of selected bulk samples and in-place moisture content and dry unit weight of selected, relatively undisturbed soil samples were determined in accordance with the current version of the Test Method ASTM D 2435 and Test Method ASTM D 2216, respectively. Test data are presented on the exploration logs, Appendix A.

Laboratory Maximum Dry Unit Weight and Optimum Moisture Content

The maximum dry unit weight and optimum moisture content of the on-site soils were determined for a selected bulk sample in accordance with current version of Method A of ASTM D 1557. The results of these tests are presented on Plate B-1 and B-2.

Corrosivity Screening

Chemical and electrical analyses were performed on a selected bulk sample of onsite soils to determine their soluble sulfate content, chloride content, pH (acidity), and minimum electrical resistivity. These tests were performed in accordance with the current versions of California Test Method Nos. CTM 417, CTM 422 and CTM 643, respectively. The results of these tests are included on Plate B-1.

Grain Size Distribution

A grain size analysis was performed on a selected bulk sample of onsite soils in accordance with the current versions of Test Method ASTM D 136 and/or Test Method ASTM D 422. The test result is graphically presented on Plate B-3 through B-12.

Expansion Index

Expansion index tests were performed on selected bulk samples of the on-site soils in accordance with the latest version of Test Method ASTM D4829. The test results are presented on Plate B-1.

Percent Passing No. 200 Sieve

Selected samples were run through a number 200 sieve in general accordance with the latest version of Test Method ASTM D 1140. The results of these tests are included on Plate B-1.

Direct Shear

The Coulomb shear strength parameters, i.e., angle of internal friction and cohesion, were determined for selected, relatively undisturbed and/or reconstituted-bulk samples of onsite soil. This test was performed in general accordance with the latest version of Test Method ASTM D 3080. Three specimens were prepared for each test. The test specimens were inundated and then sheared under various normal loads at a constant strain rate of 0.005 inch per minute. The results of the direct shear test are graphically presented on Plates B-13 and 14.

Consolidation

Volume change (settlement or heave) characteristics of select undisturbed soils were determined by one-dimensional consolidation tests. These tests were performed in general accordance with the latest version of the Test Method ASTM D 2435. Additionally, heave or hydro-consolidation tests were performed in general accordance with the latest version of Test Method ASTM D 4546, or ASTM D 5333 respectively. Axial loads were applied in several increments to laterally restrained 1-inch-high samples. The resulting deformations were recorded at selected time intervals. The test samples were inundated at the approximate in-situ and/or anticipated design overburden pressure in order to evaluate the effect of an increase in moisture content, e.g., hydro-consolidation potential or heave. Results of these tests are graphically presented on Plates B-15.

LABORATORY DATA SUMMARY*														
Boring Number	Sample Depth (ft.)	Soil Description ¹	Compaction ³		Expansion ⁴		Atterberg Limits ⁵			Corrosivity Screening				Percent Passing No. 200 Sieve ⁹
			Maximum Dry Unit Weight (pcf)	Optimum Moisture (%)	Index	Potential	LL	PL	PI	Soluble Sulfate Content ⁶ (%)	Chloride Content ⁷ (ppm)	pH ⁸ (Acidity)	Minimum Resistivity ⁸ (Ohm-cm)	
B-1	0-5.0	Silty fine to coarse Sand with trace Clay (SM)	129.2	8.4	0	Very Low	-	-	-	0.0006	277.5	7.75	10000	-
B-1	5	-	-	-	-	-	-	-	-	-	-	-	-	20.7
B-1	15	-	-	-	-	-	-	-	-	-	-	-	-	7.2
B-1	20	-	-	-	-	-	-	-	-	-	-	-	-	36.2
B-1	35	-	-	-	-	-	-	-	-	-	-	-	-	1.7

*Note: Laboratory data pertaining to in-place soil moisture content and dry density are provided on the exploration logs included in Appendix A of this report.

Test Procedures: ¹ Per Test Method ASTM D 2488 ⁶ Per California Test Method CTM 417
³ Per Test Method ASTM D 1557 ⁷ Per California Test Method CTM 422
⁴ Per Test Method ASTM D 4829 ⁸ Per California Test Method CTM 643
⁵ Per Test Method ASTM D 4318 ⁹ Per Test Method ASTM D 1140

COMPACTION TEST REPORT

Project No.: 20-227

Date: 6/15/2021

Project: The Ridge Wellness Center

Client: Caroline Legrand

Source of Sample: Phase 110 **Depth:** 0-5'

Sample Number: B-1

Remarks:

MATERIAL DESCRIPTION

Description: Dark Gray, Silty fine to coarse Sand with trace Clay

Classifications -

USCS: SM

AASHTO:

Nat. Moist. =

Sp.G. =

Liquid Limit =

Plasticity Index =

% < No.200 = 25.9 %

TEST RESULTS

Maximum dry density = 129.2 pcf

Optimum moisture = 8.4 %

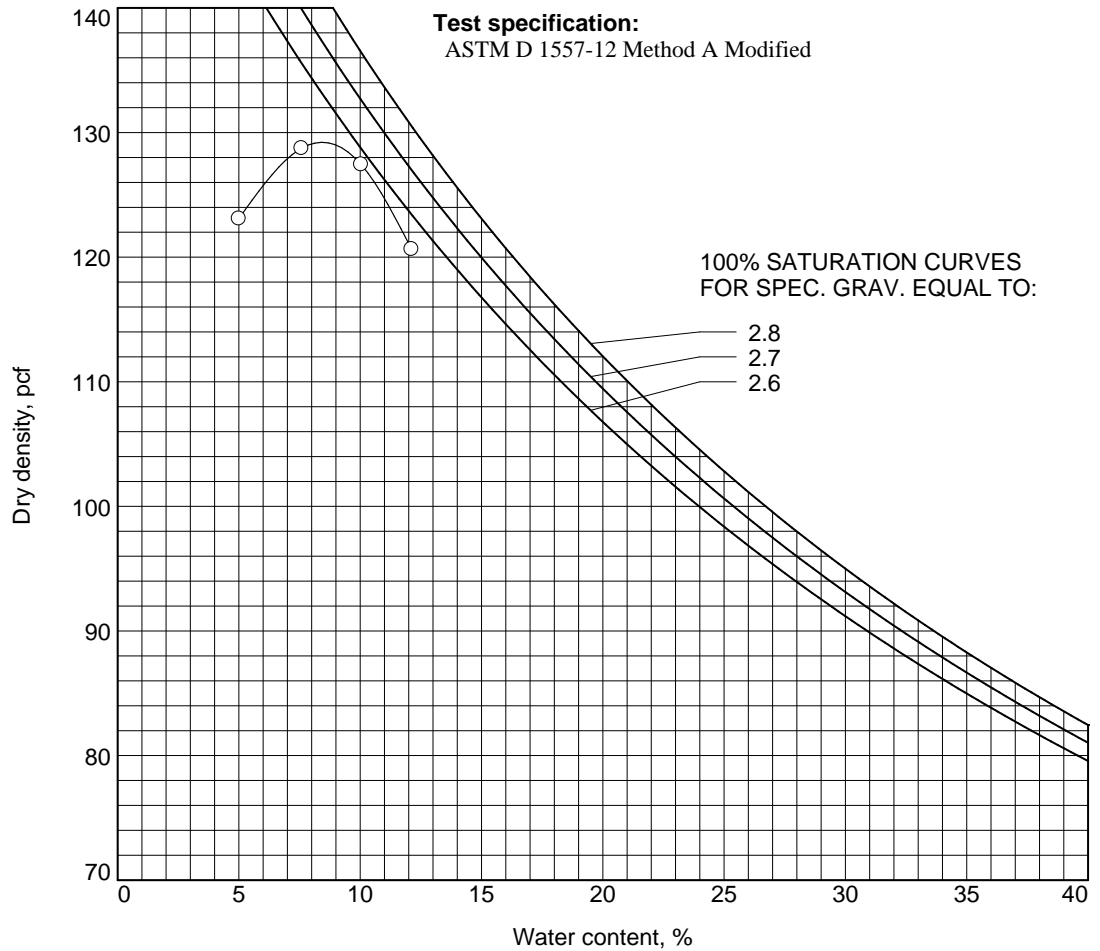

Laboratory:
1251 West Pomona Road, Unit #103, Corona, Ca 92882 Phone #. 714.549.8921

Particle Size Distribution Report

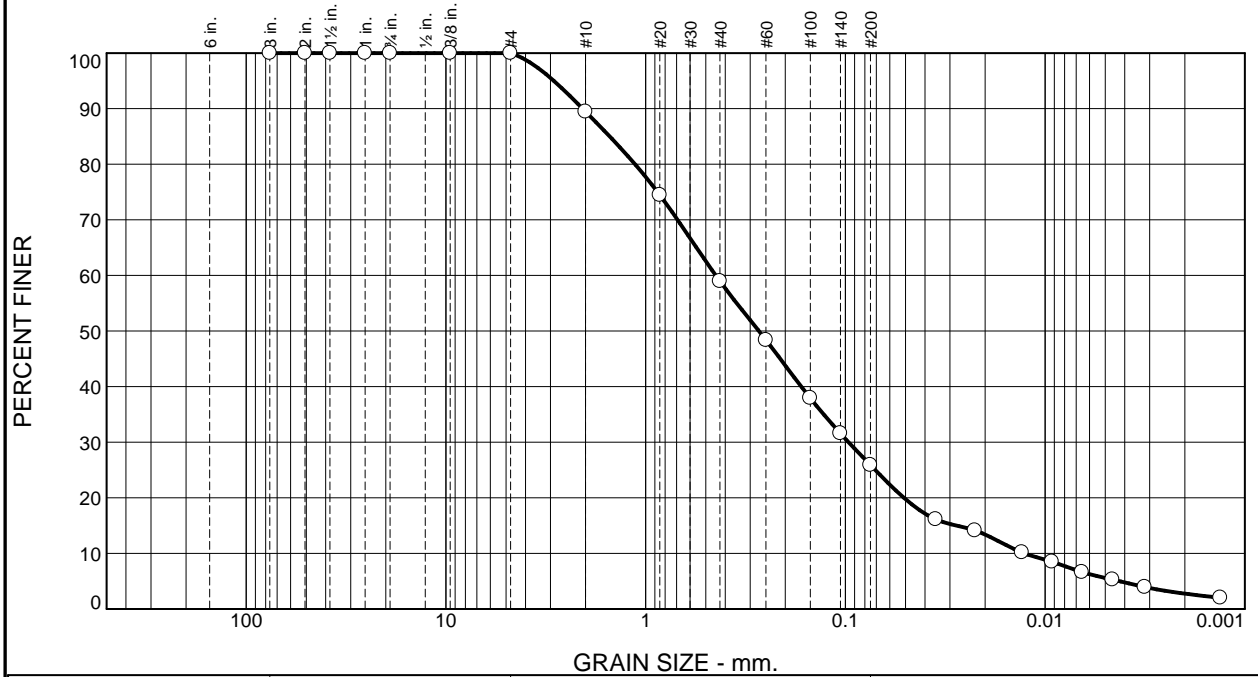

% +3"	% Gravel		% Sand			% Fines	
	Coarse	Fine	Coarse	Medium	Fine	Silt	Clay
0.0	0.0	0.0	10.5	30.5	33.1	20.3	5.6

TEST RESULTS			
Opening Size	Percent Finer	Spec.* (Percent)	Pass? (X=Fail)
3	100.0		
2	100.0		
1.5	100.0		
1	100.0		
.75	100.0		
.375	100.0		
#4	100.0		
#10	89.5		
#20	74.5		
#40	59.0		
#60	48.4		
#100	37.9		
#140	31.6		
#200	25.9		
0.0354 mm.	16.1		
0.0225 mm.	14.1		
0.0131 mm.	10.2		
0.0092 mm.	8.5		
0.0065 mm.	6.6		
0.0046 mm.	5.3		
0.0032 mm.	3.9		
0.0013 mm.	2.0		

* (no specification provided)

Material Description

Dark Gray, Silty fine to coarse Sand with trace Clay

Atterberg Limits (ASTM D 4318)

PL= _____ LL= _____ PI= _____

Classification

USCS (D 2487)= SM AASHTO (M 145)= _____

Coefficients

D₉₀= 2.0702 D₈₅= 1.5142 D₆₀= 0.4459
 D₅₀= 0.2714 D₃₀= 0.0965 D₁₅= 0.0278
 D₁₀= 0.0127 C_u= 35.10 C_c= 1.64

Remarks

Date Received: _____ Date Tested: _____

Tested By: _____

Checked By: _____

Title: _____

Laboratory: 1251 West Pomona Road, Unit #103, Corona, Ca 92882 Phone #: 714.549.8921

Source of Sample: Phase 110 Depth: 0-5' Date Sampled: 6/17/2021
 Sample Number: B-1



Client: Caroline Legrand
 Project: The Ridge Wellness Center

Project No: 20-227 PLATE B-3

Particle Size Distribution Report

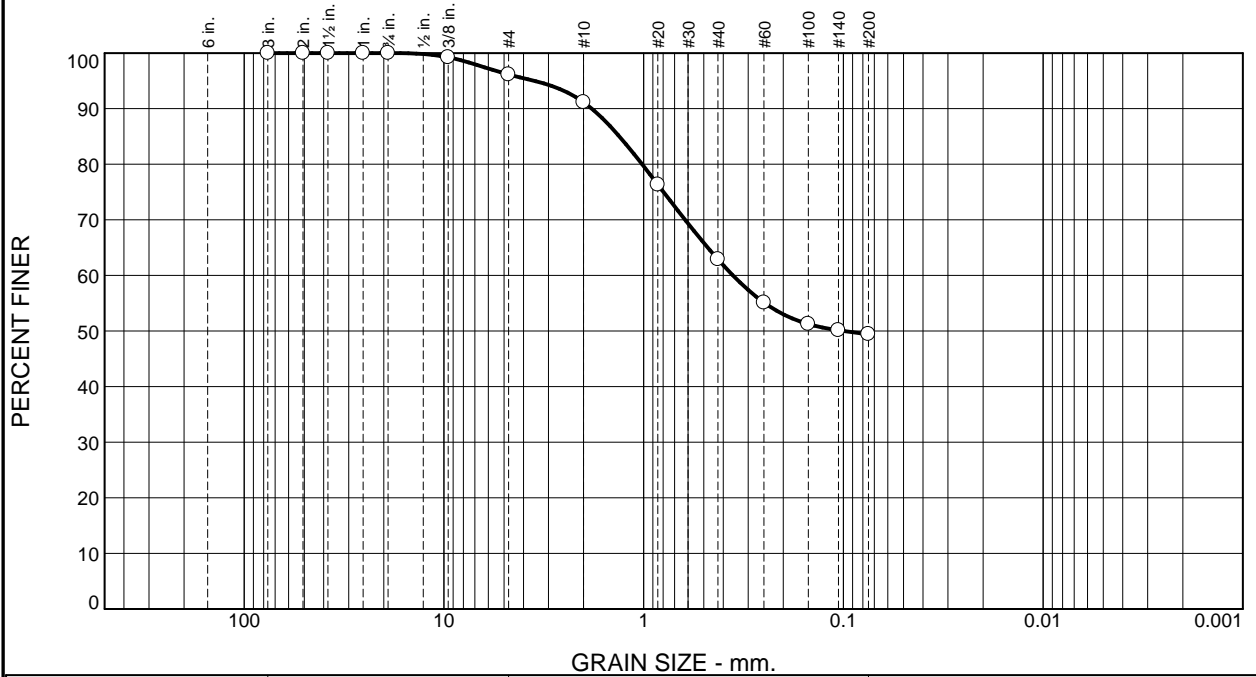

% +3"	% Gravel		% Sand			% Fines	
	Coarse	Fine	Coarse	Medium	Fine	Silt	Clay
0.0	0.0	3.9	4.9	28.3	13.5	49.4	

TEST RESULTS			
Opening Size	Percent Finer	Spec.* (Percent)	Pass? (X=Fail)
3	100.0		
2	100.0		
1.5	100.0		
1	100.0		
.75	100.0		
.375	99.2		
#4	96.1		
#10	91.2		
#20	76.3		
#40	62.9		
#60	55.1		
#100	51.3		
#140	50.1		
#200	49.4		

Material Description

Brown, Silty fine to coarse Sand with trace Gravel

Atterberg Limits (ASTM D 4318)

PL= _____ LL= _____ PI= _____

Classification

USCS (D 2487)= SM AASHTO (M 145)= _____

Coefficients

D₉₀= 1.8180 D₈₅= 1.3238 D₆₀= 0.3574
D₅₀= 0.0998 D₃₀= _____ D₁₅= _____
D₁₀= _____ C_u= _____ C_c= _____

Remarks

Date Received: _____ Date Tested: _____

Tested By: _____

Checked By: _____

Title: _____

* (no specification provided)

Source of Sample: Phase 110 Depth: 10 Date Sampled: 06/22/2021
Sample Number: B-1

Laboratory: 1251 West Pomona Road, Unit #103, Corona, Ca 92882 Phone #: 714.549.8921



Client: Caroline Legrand
Project: The Ridge Wellness Center

Project No: 20-227

PLATE B-4

Particle Size Distribution Report

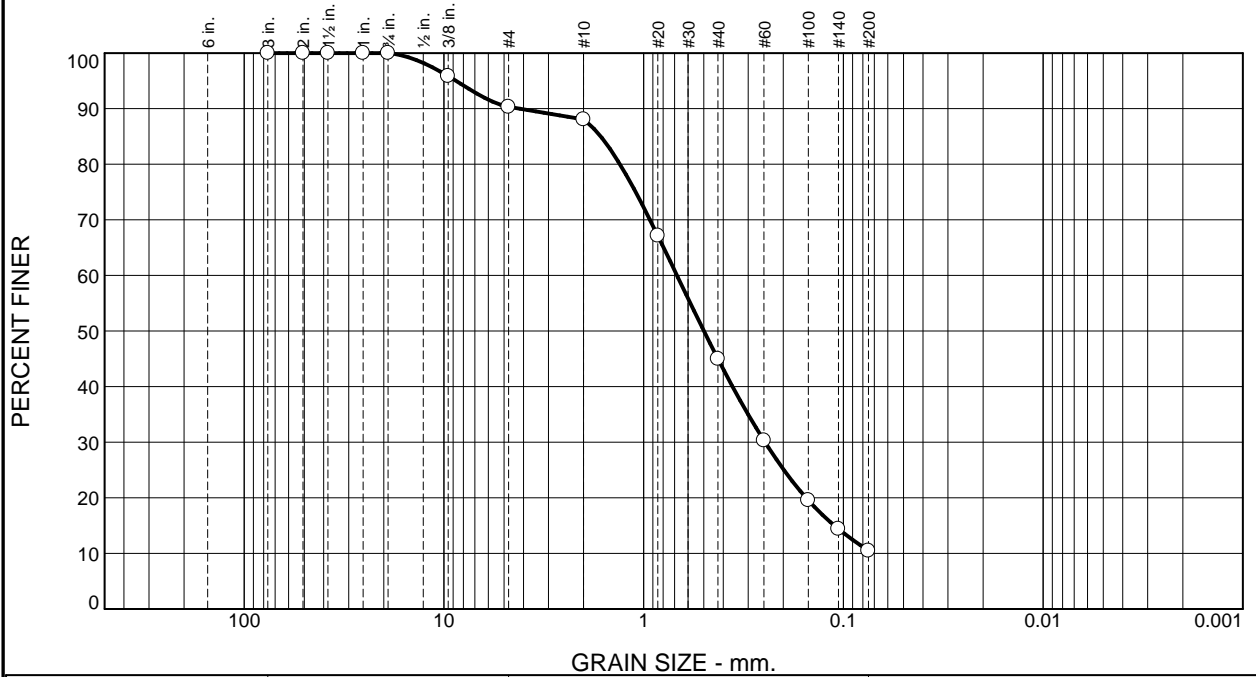

% +3"	% Gravel		% Sand			% Fines	
	Coarse	Fine	Coarse	Medium	Fine	Silt	Clay
0.0	0.0	9.7	2.2	43.1	34.5	10.5	

TEST RESULTS			
Opening Size	Percent Finer	Spec.* (Percent)	Pass? (X=Fail)
3	100.0		
2	100.0		
1.5	100.0		
1	100.0		
.75	100.0		
.375	95.9		
#4	90.3		
#10	88.1		
#20	67.1		
#40	45.0		
#60	30.3		
#100	19.6		
#140	14.4		
#200	10.5		

Material Description

Light Brown, fine to coarse Sand with Silt and fine Gravel

Atterberg Limits (ASTM D 4318)

PL= _____ LL= _____ PI= _____

Classification

USCS (D 2487)= SP AASHTO (M 145)= _____

Coefficients

D₉₀= 4.2018 D₈₅= 1.6414 D₆₀= 0.6814
D₅₀= 0.4995 D₃₀= 0.2470 D₁₅= 0.1110
D₁₀= _____ C_u= _____ C_c= _____

Remarks

Date Received: _____ Date Tested: _____

Tested By: _____

Checked By: _____

Title: _____

* (no specification provided)

Source of Sample: Phase 110 Depth: 30 Date Sampled: 06/22/2021
Sample Number: B-1

Laboratory: 1251 West Pomona Road, Unit #103, Corona, Ca 92882 Phone #: 714.549.8921



Client: Caroline Legrand
Project: The Ridge Wellness Center

Project No: 20-227

PLATE B-5

Particle Size Distribution Report

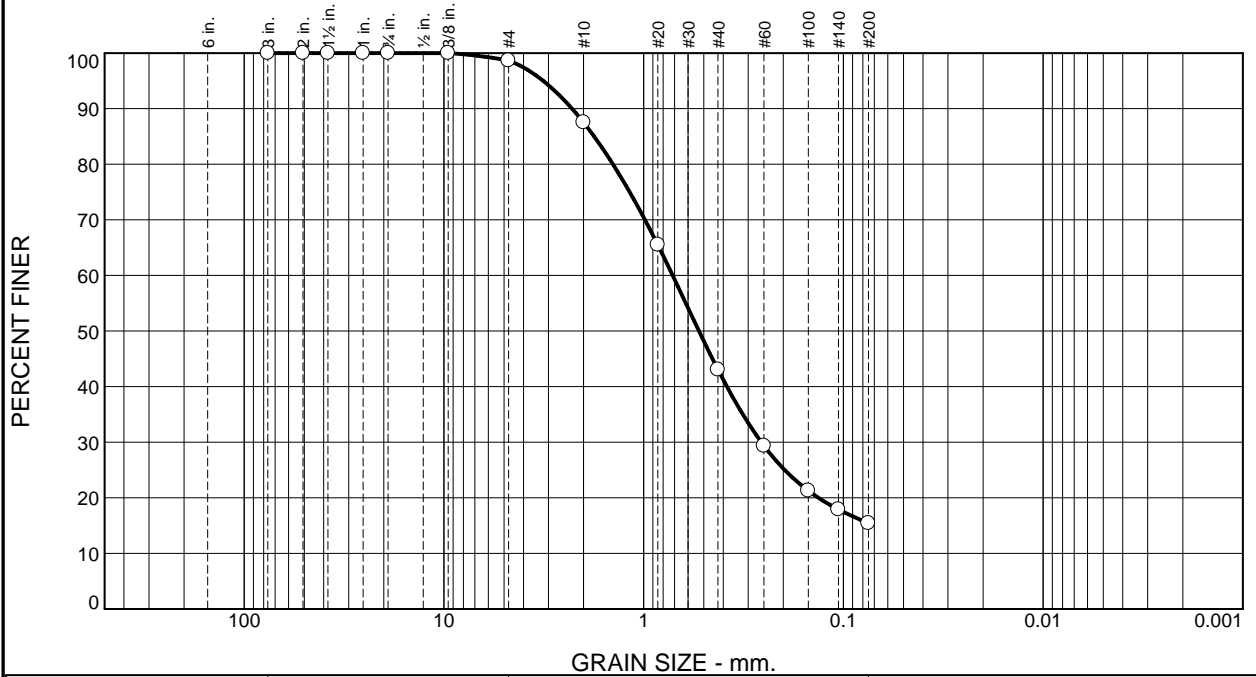

% +3"	% Gravel		% Sand			% Fines	
	Coarse	Fine	Coarse	Medium	Fine	Silt	Clay
0.0	0.0	1.3	11.2	44.4	27.7	15.4	

TEST RESULTS			
Opening Size	Percent Finer	Spec.* (Percent)	Pass? (X=Fail)
3	100.0		
2	100.0		
1.5	100.0		
1	100.0		
.75	100.0		
.375	100.0		
#4	98.7		
#10	87.5		
#20	65.5		
#40	43.1		
#60	29.3		
#100	21.3		
#140	17.9		
#200	15.4		

Material Description

Brown Silty fine to coarse Sand

Atterberg Limits (ASTM D 4318)

PL= _____ LL= _____ PI= _____

Classification

USCS (D 2487)= SM AASHTO (M 145)= _____

Coefficients

D₉₀= 2.2836 D₈₅= 1.7697 D₆₀= 0.7162
D₅₀= 0.5291 D₃₀= 0.2579 D₁₅= _____
D₁₀= _____ C_u= _____ C_c= _____

Remarks

Date Received: _____ Date Tested: _____

Tested By: _____

Checked By: _____

Title: _____

* (no specification provided)

Source of Sample: Phase 110 Depth: 5 Date Sampled: 06/22/2021
Sample Number: B-2

Laboratory: 1251 West Pomona Road, Unit #103, Corona, Ca 92882 Phone #: 714.549.8921



Client: Caroline Legrand
Project: The Ridge Wellness Center

Project No: 20-227

PLATE B-6

Laboratory: 1251 West Pomona Road, Unit #103, Corona, Ca 92882 Phone #: 714.549.8921

Particle Size Distribution Report

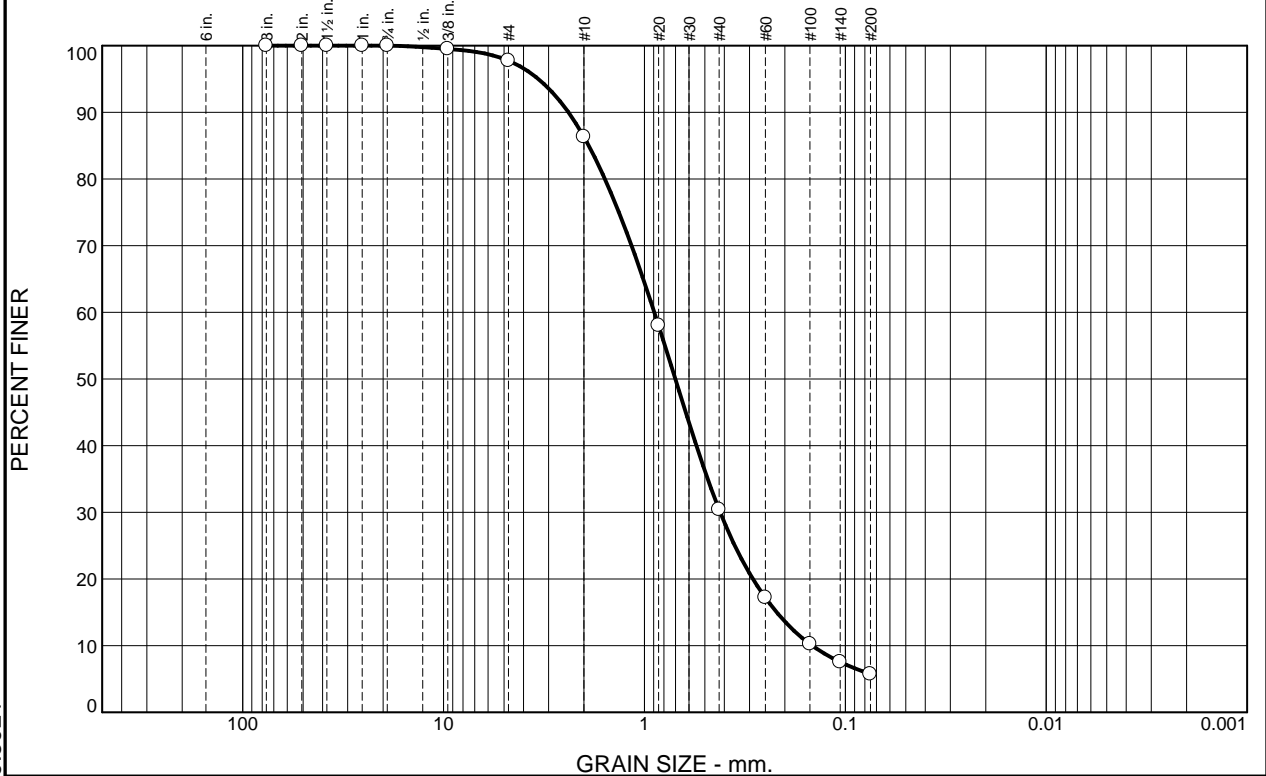

% +3"	% Gravel		% Sand			% Fines	
	Coarse	Fine	Coarse	Medium	Fine	Silt	Clay
0.0	0.0	0.0	11.7	57.2	25.2	5.9	

SIEVE SIZE	PERCENT FINER	SPEC.* PERCENT	PASS? (X=NO)
3	100.0		
2	100.0		
1.5	100.0		
1	100.0		
.75	100.0		
.375	99.5		
#4	97.7		
#10	86.3		
#20	58.0		
#40	30.4		
#60	17.2		
#100	10.2		
#140	7.5		
#200	5.7		

Material Description

Brown fine to coarse Sand with trace Silt

Atterberg Limits
 PL= LL= PI=

Coefficients
 D₉₀= 2.1516 D₈₅= 1.7592 D₆₀= 0.8631
 D₅₀= 0.6827 D₃₀= 0.4112 D₁₅= 0.2148
 D₁₀= 0.1427 C_u= 6.05 C_c= 1.37

Classification
 USCS= SP AASHTO=

Remarks

* (no specification provided)

Source of Sample: L-21-306 (100) **Depth:** 10 **Date:** 09/21/2021
Sample Number: MW-1



Client: Caroline Legrand
Project: The Ridge Wellness Center
Project No: 20-227

Figure B-7

Tested By: SB

Particle Size Distribution Report

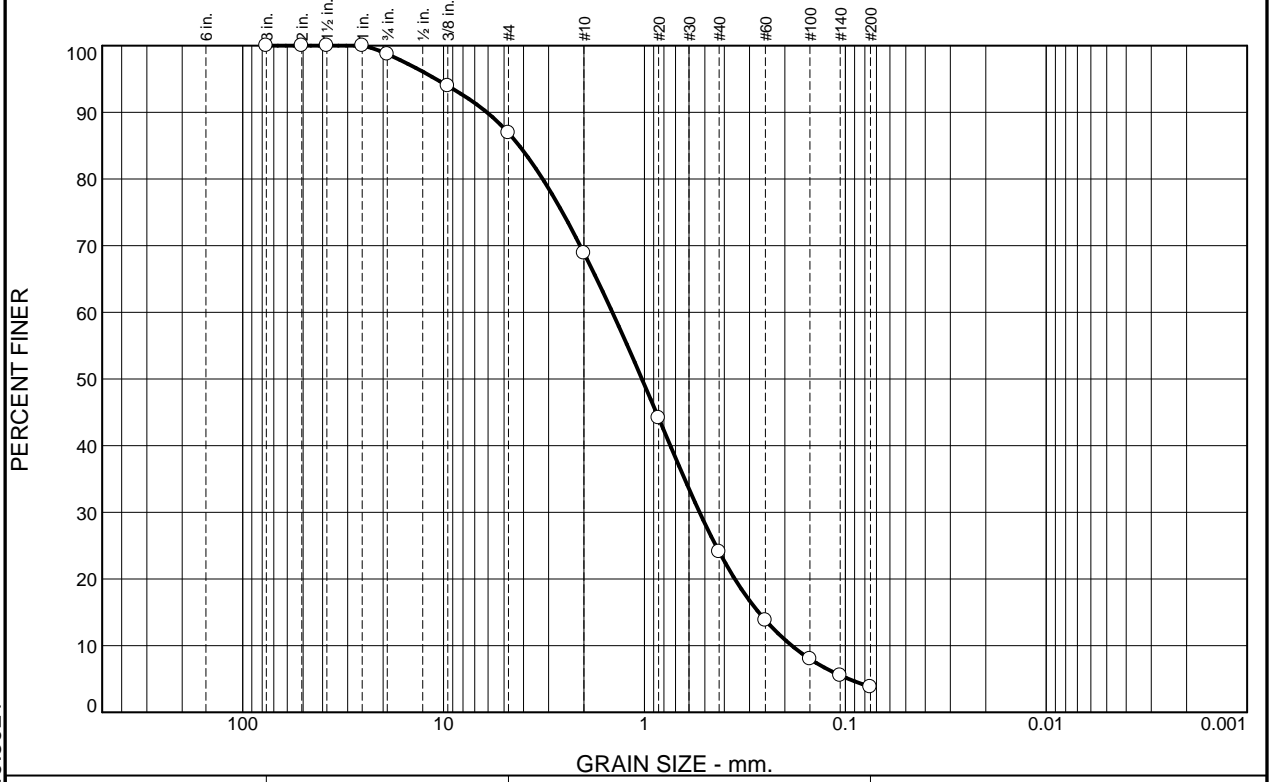

% +3"	% Gravel		% Sand			% Fines	
	Coarse	Fine	Coarse	Medium	Fine	Silt	Clay
0.0	0.0	0.0	20.7	51.6	23.3	4.4	

SIEVE SIZE	PERCENT FINER	SPEC.* PERCENT	PASS? (X=NO)
3	100.0		
2	100.0		
1.5	100.0		
1	100.0		
.75	98.7		
.375	94.0		
#4	86.9		
#10	68.9		
#20	44.2		
#40	24.1		
#60	13.8		
#100	8.0		
#140	5.5		
#200	3.8		

Material Description

Brown fine to coarse Sand with trace Silt

Atterberg Limits

PL= LL= PI=

Coefficients

D₉₀= 2.8558 D₈₅= 2.4035 D₆₀= 1.1097
D₅₀= 0.8304 D₃₀= 0.4598 D₁₅= 0.2368
D₁₀= 0.1620 C_u= 6.85 C_c= 1.18

Classification

USCS= SW AASHTO=

Remarks

* (no specification provided)

Source of Sample: L-21-306 (100)
Sample Number: MW-1

Depth: 15

Date: 09/20/2021

Laboratory: 1251 West Pomona Road, Unit #103, Corona, Ca 92882 Phone #: 714.549.8921



Client: Caroline Legrand
Project: The Ridge Wellness Center

Project No: 20-227

Figure B-8

Tested By: SB

Laboratory: 1251 West Pomona Road, Unit #103, Corona, Ca 92882 Phone #: 714.549.8921

Particle Size Distribution Report

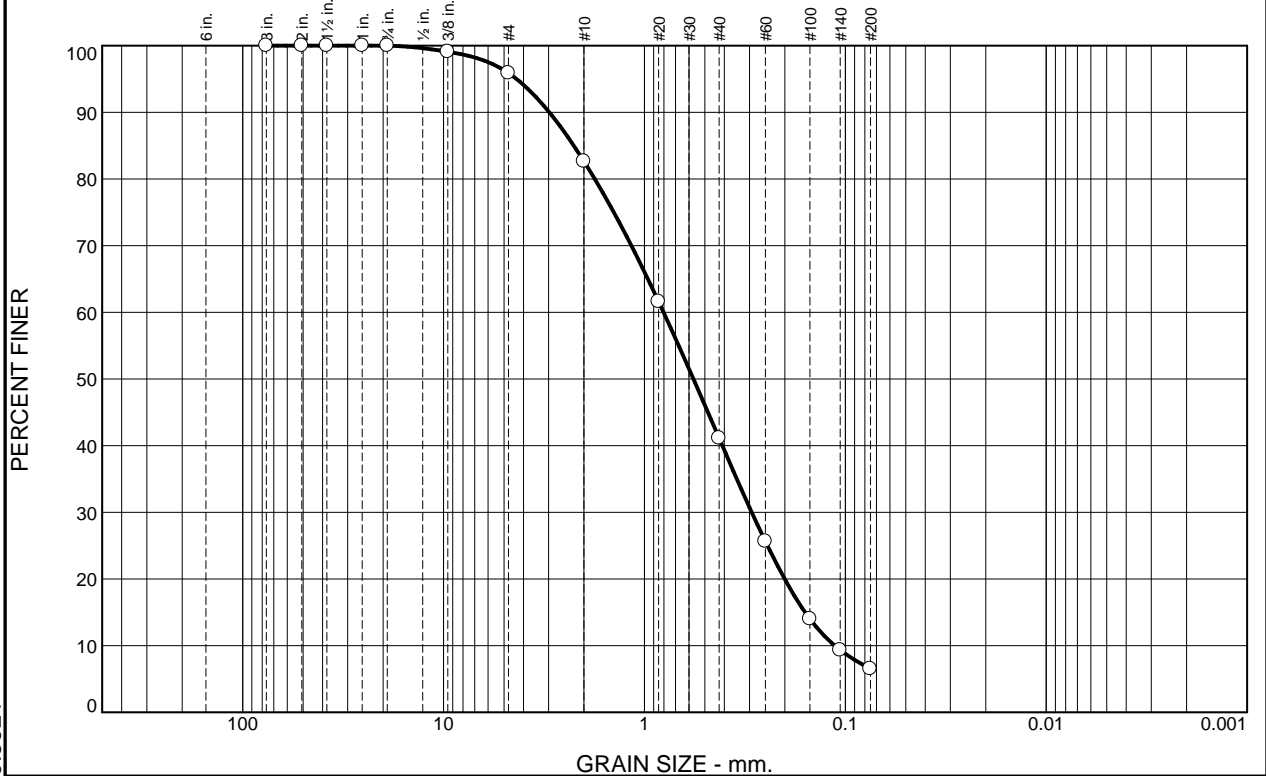

% +3"	% Gravel		% Sand			% Fines	
	Coarse	Fine	Coarse	Medium	Fine	Silt	Clay
0.0	0.0	0.0	13.8	43.3	36.1	6.8	

SIEVE SIZE	PERCENT FINER	SPEC.* PERCENT	PASS? (X=NO)
3	100.0		
2	100.0		
1.5	100.0		
1	100.0		
.75	100.0		
.375	99.1		
#4	95.9		
#10	82.6		
#20	61.6		
#40	41.1		
#60	25.6		
#100	14.0		
#140	9.3		
#200	6.5		

Material Description

Brown fine to coarse Sand with trace Silt

Atterberg Limits
 PL= LL= PI=

Coefficients
 D₉₀= 2.3850 D₈₅= 1.8980 D₆₀= 0.7361
 D₅₀= 0.5323 D₃₀= 0.2800 D₁₅= 0.1534
 D₁₀= 0.1087 C_u= 6.77 C_c= 0.98

Classification
 USCS= AASHTO=

Remarks

* (no specification provided)

Source of Sample: L-21-306 (100) **Depth:** 20 **Date:** 09/20/2021
Sample Number: MW-1



Client: Caroline Legrand
Project: The Ridge Wellness Center
Project No: 20-227

Figure B-9

Tested By: SB

Particle Size Distribution Report

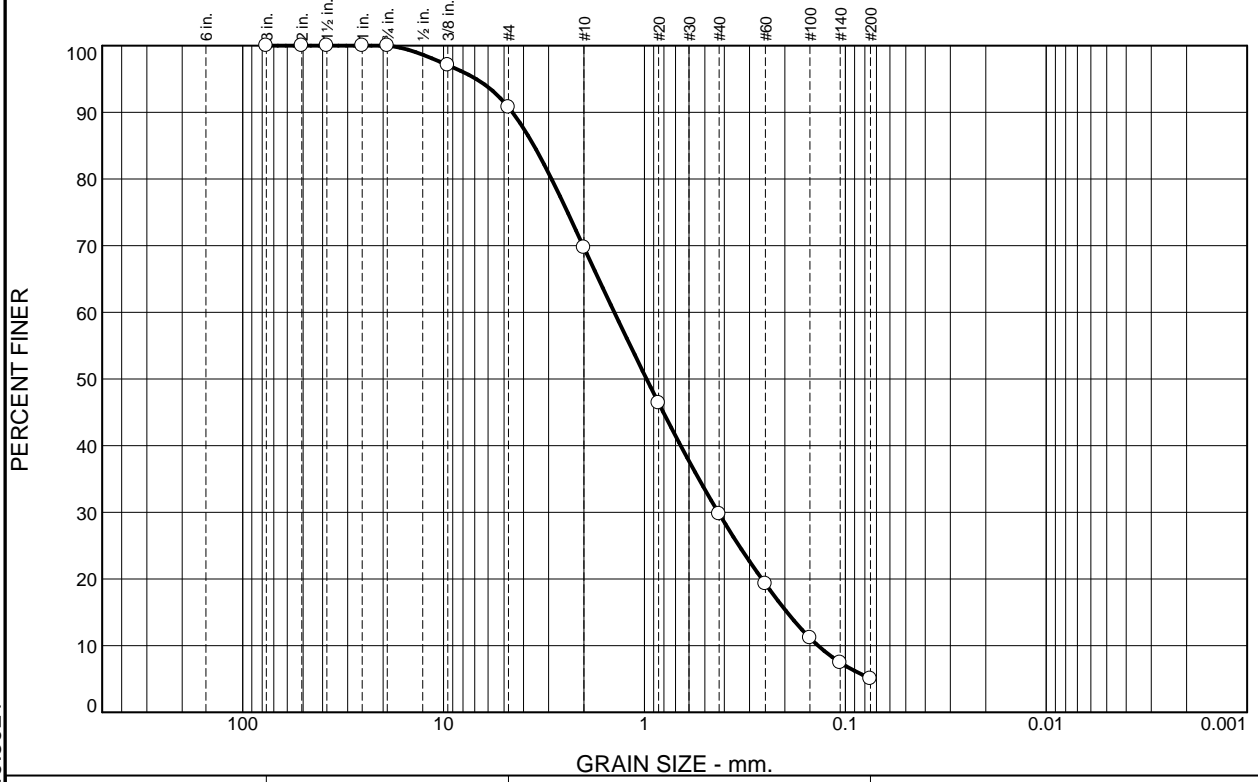

% +3"	% Gravel		% Sand			% Fines	
	Coarse	Fine	Coarse	Medium	Fine	Silt	Clay
0.0	0.0	9.2	21.1	39.9	24.7	5.1	

SIEVE SIZE	PERCENT FINER	SPEC.* PERCENT	PASS? (X=NO)
3	100.0		
2	100.0		
1.5	100.0		
1	100.0		
.75	100.0		
.375	97.1		
#4	90.8		
#10	69.7		
#20	46.4		
#40	29.8		
#60	19.3		
#100	11.1		
#140	7.5		
#200	5.1		

Material Description

Yellowish brown fine to coarse Sand with Silt

Atterberg Limits

PL= LL= PI=

Coefficients

D₉₀= 4.5362 D₈₅= 3.5493 D₆₀= 1.4125
 D₅₀= 0.9753 D₃₀= 0.4295 D₁₅= 0.1950
 D₁₀= 0.1367 C_u= 10.33 C_c= 0.96

Classification

USCS= AASHTO=

Remarks

* (no specification provided)

Source of Sample: L-21-306 (100)
 Sample Number: MW-1

Depth: 25

Date: 09/20/2021

Laboratory: 1251 West Pomona Road, Unit #103, Corona, Ca 92882 Phone #: 714.549.8921



Client: Caroline Legrand
 Project: The Ridge Wellness Center

Project No: 20-227

Figure B-10

Tested By: SB

Particle Size Distribution Report

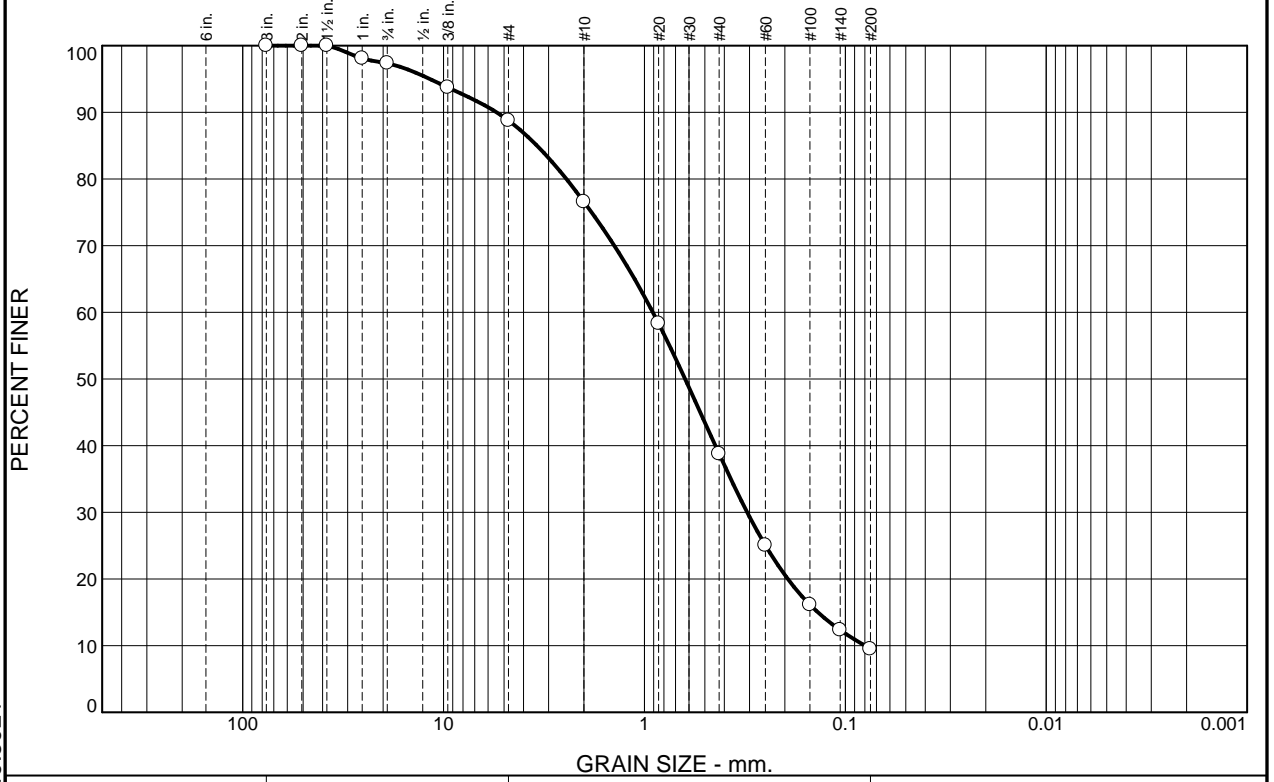

% +3"	% Gravel		% Sand			% Fines	
	Coarse	Fine	Coarse	Medium	Fine	Silt	Clay
0.0	2.7	8.5	12.2	37.8	29.3	9.5	

SIEVE SIZE	PERCENT FINER	SPEC.* PERCENT	PASS? (X=NO)
3	100.0		
2	100.0		
1.5	100.0		
1	98.1		
.75	97.3		
.375	93.7		
#4	88.8		
#10	76.6		
#20	58.3		
#40	38.8		
#60	25.0		
#100	16.1		
#140	12.3		
#200	9.5		

Material Description

brown Silty fine to coarse Sand

Atterberg Limits

PL= LL= PI=

Coefficients

D₉₀= 5.4473 D₈₅= 3.4278 D₆₀= 0.9076
 D₅₀= 0.6272 D₃₀= 0.3078 D₁₅= 0.1370
 D₁₀= 0.0800 C_u= 11.34 C_c= 1.30

Classification

USCS= AASHTO=

Remarks

* (no specification provided)

Source of Sample: L-21-306 (100)
 Sample Number: MW-1

Depth: 30

Date: 09/20/2021

Laboratory: 1251 West Pomona Road, Unit #103, Corona, Ca 92882 Phone #: 714.549.8921



Client: Caroline Legrand
 Project: The Ridge Wellness Center

Project No: 20-227

Figure B-11

Tested By: SB

Particle Size Distribution Report

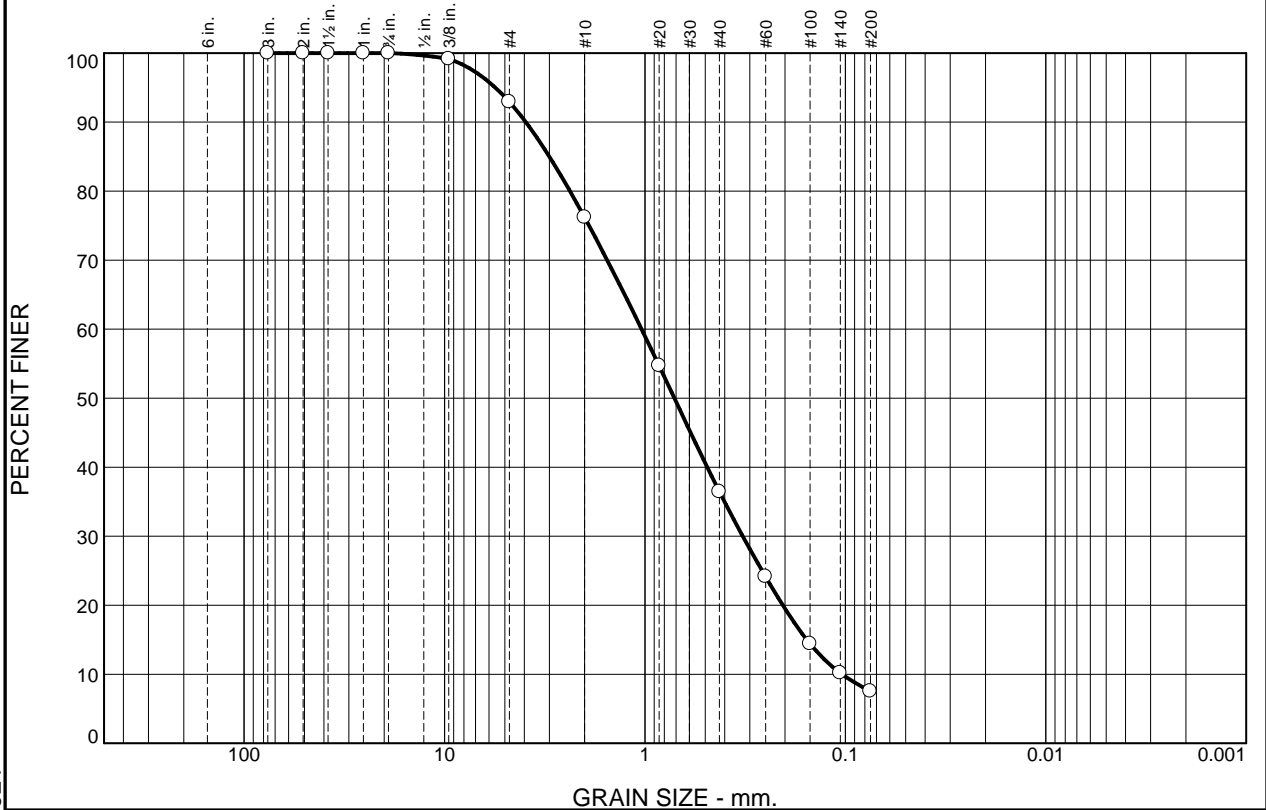

% +3"	% Gravel		% Sand			% Fines	
	Coarse	Fine	Coarse	Medium	Fine	Silt	Clay
0.0	0.0	7.1	16.7	39.8	28.9	7.5	

SIEVE SIZE	PERCENT FINER	SPEC.* PERCENT	PASS? (X=NO)
3	100.0		
2	100.0		
1.5	100.0		
1	100.0		
.75	100.0		
.375	99.2		
#4	92.9		
#10	76.2		
#20	54.7		
#40	36.4		
#60	24.1		
#100	14.4		
#140	10.2		
#200	7.5		

Material Description

Brown, fine to coarse Sand with Silt

Atterberg Limits
 PL= LL= PI=

Coefficients
 D₉₀= 3.9299 D₈₅= 2.9986 D₆₀= 1.0393
 D₅₀= 0.7130 D₃₀= 0.3250 D₁₅= 0.1558
 D₁₀= 0.1038 C_u= 10.01 C_c= 0.98

Classification
 USCS= AASHTO=

Remarks

* (no specification provided)

Source of Sample: L-21-306 (100)
Sample Number: MW-1

Depth: 35

Date: 9/22/2021

Laboratory: 1251 West Pomona Road, Unit #103, Corona, Ca 92882 Phone #: 714.549.8921



Client: Caroline Legrand
Project: The Ridge Wellness Center

Project No: 20-227

Figure B-12

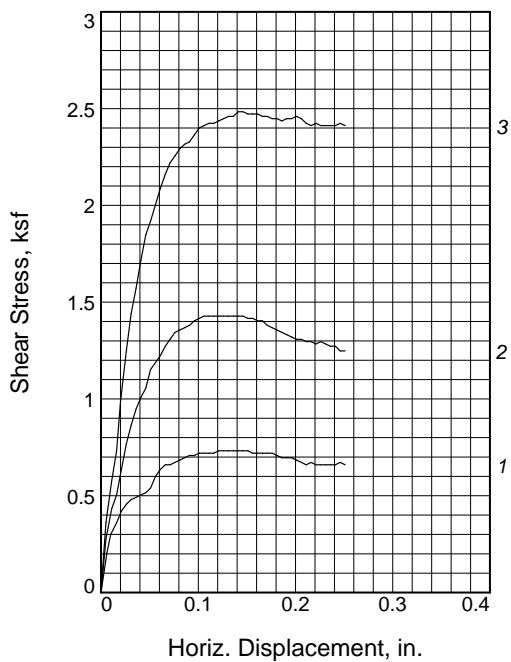
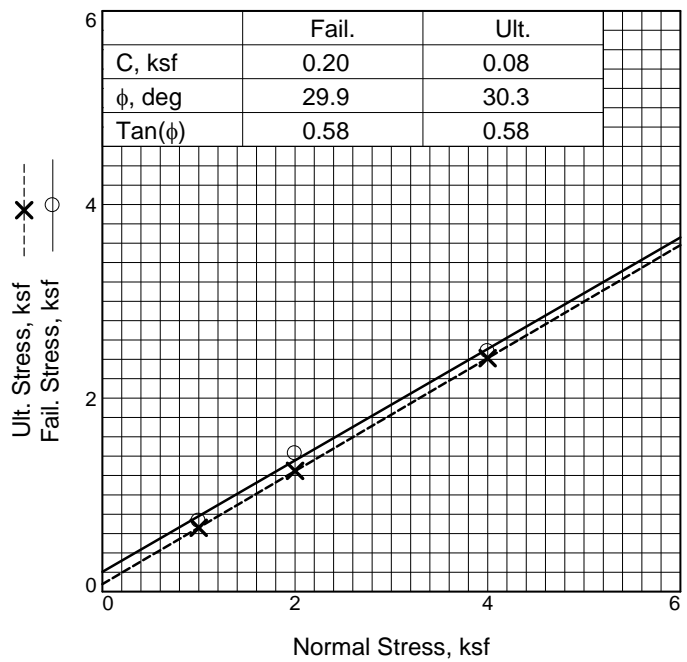
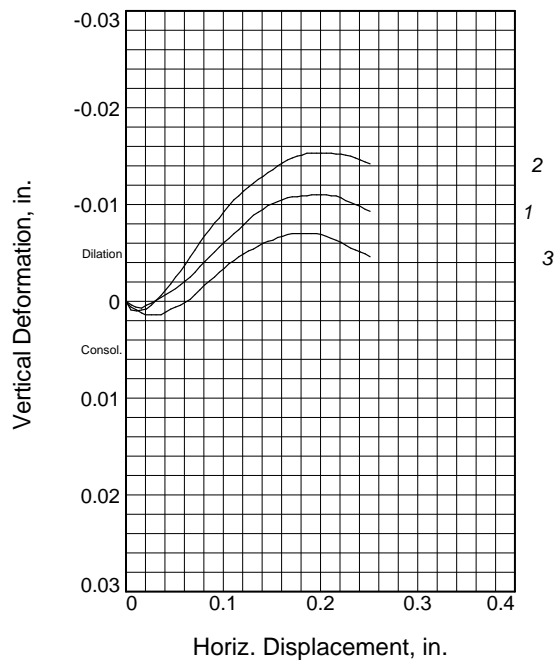

Sample No.	1	2	3	
Initial	Water Content, %	4.7	4.7	4.7
	Dry Density, pcf	110.3	123.1	113.7
	Saturation, %	25.2	36.6	27.7
	Void Ratio	0.4998	0.3439	0.4545
	Diameter, in.	2.42	2.42	2.42
	Height, in.	0.98	0.97	0.99
At Test	Water Content, %	18.8	13.0	17.1
	Dry Density, pcf	110.3	123.1	113.7
	Saturation, %	99.7	99.8	99.5
	Void Ratio	0.4998	0.3439	0.4545
	Diameter, in.	2.42	2.42	2.42
	Height, in.	0.98	0.97	0.99
Normal Stress, ksf	1.00	2.00	4.00	
Fail. Stress, ksf	0.73	1.43	2.48	
Displacement, in.	0.15	0.15	0.14	
Ult. Stress, ksf	0.66	1.25	2.41	
Displacement, in.	0.25	0.25	0.25	
Strain rate, in./min.	0.040	0.040	0.040	

Sample Type:

Description: Brown Silty fine to coarse Sand

Assumed Specific Gravity= 2.65

Remarks:

PLATE B-13

Client: Caroline Legrand

Project: The Ridge Wellness Center

Source of Sample: Phase 110

Depth: 5

Sample Number: B-2

Proj. No.: 20-227

Date Sampled: 06/22/2021



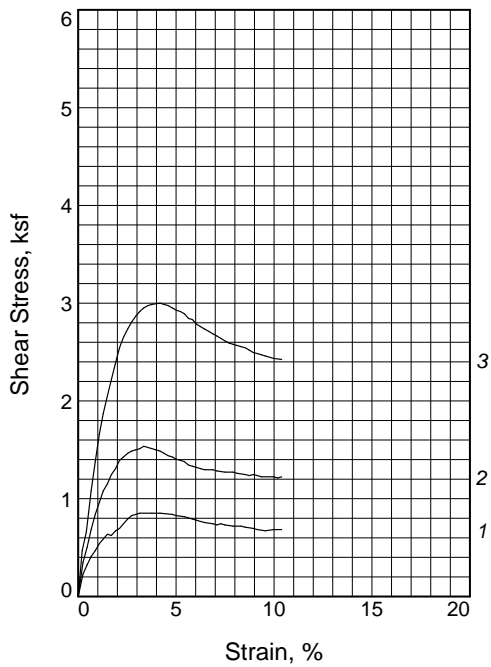
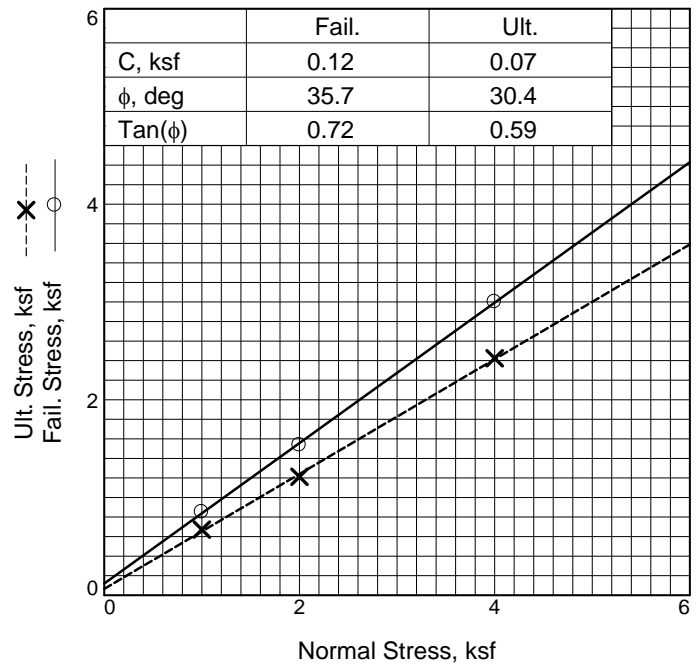
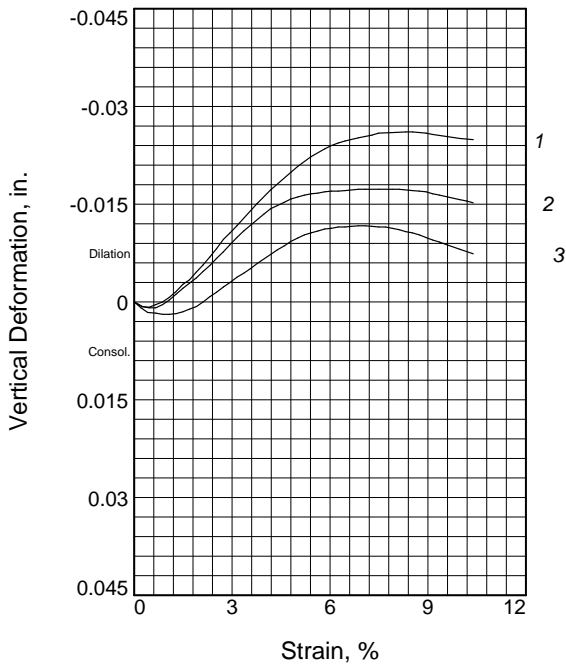

Sample No.		1	2	3
Initial	Water Content, %	3.4	3.4	3.4
	Dry Density, pcf	110.0	105.1	99.6
	Saturation, %	17.8	15.6	13.5
	Void Ratio	0.5033	0.5738	0.6618
	Diameter, in.	2.42	2.42	2.42
	Height, in.	0.97	0.97	0.97
At Test	Water Content, %	18.5	20.8	22.7
	Dry Density, pcf	110.9	106.7	103.2
	Saturation, %	99.6	99.9	99.7
	Void Ratio	0.4912	0.5512	0.6035
	Diameter, in.	2.42	2.42	2.42
	Height, in.	0.97	0.96	0.93
Normal Stress, ksf		1.00	2.00	4.00
Fail. Stress, ksf		0.85	1.54	3.00
Strain, %		3.8	3.4	4.2
Ult. Stress, ksf		0.67	1.21	2.42
Strain, %		9.6	10.2	10.4
Strain rate, in./min.		0.040	0.040	0.040

Sample Type: Undisturbed
Description: Grayish Brown, fine to coarse Sand with Silt
Specific Gravity= 2.65
Remarks:

Client: Caroline Legrand
Project: The Ridge Wellness Center
Source of Sample: L-21-306 (100) **Depth:** 5
Sample Number: B-7
Proj. No.: 20-227 **Date Sampled:** 9/22/2021

Figure B-14



COLLAPSE TEST REPORT

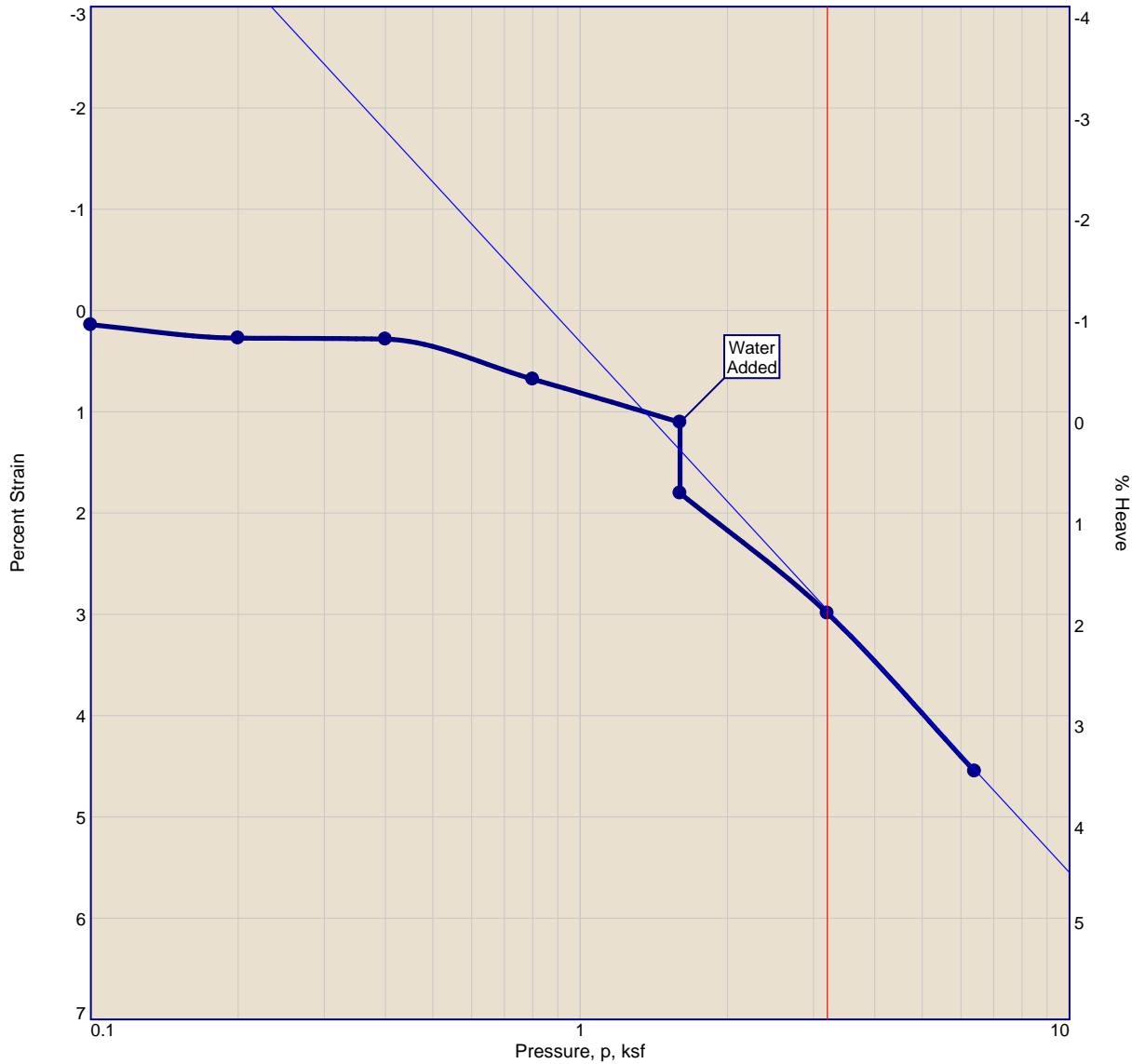

SUMMARY OF TEST RESULTS

	DRY DENSITY (pcf)	MOISTURE CONTENT, (%)	SATURATION (%)	VOID RATIO	SPECIFIC GRAVITY	OVERBURDEN (ksf)	P _C (ksf)	C _C	SWELL PRESS. (ksf)
INITIAL	118.9	7.1	45.4	0.412	2.65	0.31	3.3	0.07	
FINAL		15.3	100.0	0.348					

Source of Sample: Phase 110 **Depth:** 2.5 **Sample Number:** B-2
Material Description: Brown Silty fine to coarse Sand

USCS: SM **AASHTO:**

Remarks:

Laboratory:

1251 West Pomona Road, Unit #103, Corona, Ca 92882 Phone #: 714.549.8921



Client: Caroline Legrand
Project: The Ridge Wellness Center

Project No.: 20-227

PLATE B-15

APPENDIX B-2

LABORATORY TEST RESULTS – WATER SAMPLES FROM MW-1



Orange Coast Analytical, Inc.

3002 Dow, Suite 532, Tustin, CA 92780 (714) 832-0064 Fax (714) 832-0067
4620 E. Elwood, Suite 4, Phoenix, AZ 85040 (480) 736-0960 Fax (480) 736-0970

LABORATORY REPORT FORM

ORANGE COAST ANALYTICAL, INC.

3002 Dow Suite 532 Tustin, CA 92780

(714) 832-0064

Laboratory Certification (ELAP) No.:2576

Expiration Date: 2023

Los Angeles County Sanitation District Lab ID# 10206

Laboratory Director's Name:

Mark Noorani

Client: Petra Geosciences, Inc.

Laboratory Reference: PTE 26382

Project Name: The Ridge Wellness Center

Project Number: 20-227

Date Received: 9/23/2021

Date Reported: 10/5/2021

Chain of Custody Received:

Analytical Method: 300.0, 120.1, 353.2,

Mark Noorani, Laboratory Director

Mr. Kurtis Morenz
Petra Geosciences, Inc.
3786 Airway Ave Suite K
Costa Mesa, CA, 92626

Lab Reference #: PTE 26382
Project Name: The Ridge Wellness Center
Project #: 20-227

Case Narrative

Sample Receipt:

All samples on the Chain of Custody were received by OCA at 6°C, on ice.

Holding Times:

All samples were analyzed within required holding times unless otherwise noted in the data qualifier section of the report.

Analytical Methods:

Sample analysis was performed following the analytical methods listed on the cover page.

Data Qualifiers:

Within this report, data qualifiers may have been assigned to clarify deviations in common laboratory procedures or any divergence from laboratory QA/QC criteria. If a data qualifier has been used, it will appear in the back of the report along with its description. All method QA/QC criteria have been met unless otherwise noted in the data qualifier section.

Definition of Terms:

The definitions of common terms and acronyms used in the report have been placed at the back of the report to assist data users.

Comments:

None

Mr. Kurtis Morenz
Petra Geosciences, Inc.
3786 Airway Ave Suite K
Costa Mesa, CA, 92626

Lab Reference #: PTE 26382
Project Name: The Ridge Wellness Center
Project #: 20-227

Client Sample Summary

Client Sample ID	Lab Sample Number	Date Received	Date Sampled	Matrix
1A	26382-001	9/23/2021	9/23/2021	Water
2A	26382-002	9/23/2021	9/23/2021	Water
3A	26382-003	9/23/2021	9/23/2021	Water

Mr. Kurtis Morenz
 Petra Geosciences, Inc.
 3786 Airway Ave Suite K
 Costa Mesa, CA, 92626

Lab Reference #: PTE 26382
 Project Name: The Ridge Wellness Center
 Project #: 20-227

Inorganics

Client Sample ID	Lab Sample Number	Date Received	Date Sampled	Matrix				
1A	26382-001	9/23/2021 11:31	9/23/2021 8:40	Water				
<u>ANALYTE</u>	<u>EPA Method</u>	<u>Result</u>	<u>Units</u>	<u>Date Extracted</u>	<u>Date Analyzed</u>	<u>Qual</u>	<u>DF</u>	
Nitrite as N	353.2	<0.10	mg/L	09/24/21 14:00	09/24/21 14:51	--	1	
2A	26382-002	9/23/2021 11:31	9/23/2021 8:41	Water				
<u>ANALYTE</u>	<u>EPA Method</u>	<u>Result</u>	<u>Units</u>	<u>Date Extracted</u>	<u>Date Analyzed</u>	<u>Qual</u>	<u>DF</u>	
Nitrate as N	353.2	<0.10	mg/L	09/24/21 14:00	09/24/21 17:12	--	1	
3A	26382-003	9/23/2021 11:31	9/23/2021 8:42	Water				
<u>ANALYTE</u>	<u>EPA Method</u>	<u>Result</u>	<u>Units</u>	<u>Date Extracted</u>	<u>Date Analyzed</u>	<u>Qual</u>	<u>DF</u>	
Chloride	300.0	10	mg/L	09/27/21 10:00	09/27/21 14:02	D1,	5	
Conductivity	120.1	170	µmhos/cm	09/23/21 12:15	09/23/21 12:15	--	1	
Sulfate	300.0	3.7	mg/L	10/01/21 10:00	10/01/21 15:36	--	1	
Method Blank				Water				
<u>MB ID</u>	<u>ANALYTE</u>	<u>EPA Method</u>	<u>Result</u>	<u>Units</u>	<u>Date Extracted</u>	<u>Date Analyzed</u>	<u>Qual</u>	<u>DF</u>
MBRL0927211	Chloride	300.0	<0.50	mg/L	09/27/21 10:00	09/27/21 12:53	--	1
MBHC0924211	Nitrate as N	353.2	<0.10	mg/L	09/24/21 14:00	09/24/21 14:33	--	1
MBHC0924211	Nitrite as N	353.2	<0.10	mg/L	09/24/21 14:00	09/24/21 14:33	--	1
MBRL1001212	Sulfate	300.0	<0.20	mg/L	10/01/21 10:00	10/01/21 13:57	--	1

**QA/QC Report
for Inorganics**

Reference #: PTE 26382

Reporting units: ppm

Matrix Spike (MS) / Matrix Spike Duplicate (MSD)

Analyte	Date of Extraction	MS Date of Analysis	MSD Date of Analysis	Laboratory Sample #	R1	SPC CONC	MS	MSD	%MS	%MSD	RPD	ACP %MS	ACP RPD	Qual
Chloride	9/27/2021 10:00	9/27/2021 14:15	9/27/2021 14:28	26382-003	10.0	12.5	22.7	22.8	102	102	0	90-110	20	--
Nitrate as N	9/24/2021 14:00	9/24/2021 17:12	9/24/2021 17:12	26382-001	0.0710	2.50	2.71	2.43	106	94	11	90-110	20	--
Nitrite as N	9/24/2021 14:00	9/24/2021 16:49	9/24/2021 16:50	26382-001	0.00	2.50	3.13	2.79	125	112	11	90-110	20	M1,
Sulfate	10/1/2021 10:00	10/1/2021 16:34	10/1/2021 16:47	26382-003	3.70	5.00	8.39	8.49	94	96	1	90-110	20	--

Laboratory Control Spike (LCS) / Laboratory Control Spike Duplicate (LCSD)

Analyte	Date of Extraction	LCS Date of Analysis	LCSD Date of Analysis	Laboratory Sample #	SPC CONC	LCS	LCSD	%LCS	% LCSD	RPD	ACP %LCS	ACP RPD	Qual
Chloride	9/27/2021 10:00	9/27/2021 13:06	9/27/2021 13:19	RL0927211	2.50	2.50	2.60	100	104	4	90-110	20	--
Nitrate as N	9/24/2021 14:00	9/24/2021 17:12	9/24/2021 17:12	HC0924211	2.50	2.21	2.33	88	93	5	90-110	20	L2,
Nitrite as N	9/24/2021 16:46	9/24/2021 16:46	9/24/2021 16:47	HC0924211	2.50	2.66	2.86	106	114	7	90-110	20	L1,
Sulfate	10/1/2021 10:00	10/1/2021 14:11	10/1/2021 14:24	RL1001212	2.50	2.39	2.42	96	97	1	90-110	20	--

Data Qualifier Definitions

Qualifier

D1 = Sample required dilution due to matrix.

L1 = The associated blank spike recovery was above laboratory acceptance limits.

HC0924211	353.2	Nitrite as N	LCSD
-----------	-------	--------------	------

L2 = The associated blank spike recovery was below laboratory acceptance limits.

HC0924211	353.2	Nitrate as N	LCS
-----------	-------	--------------	-----

M1 = Matrix spike recovery was high, the associated blank spike recovery was acceptable.

26382-001	353.2	Nitrite as N	MS/MSD
-----------	-------	--------------	--------

Definition of terms:

R1	Result of unspiked laboratory sample used for matrix spike determination.
SP CONC (or Spike Conc.)	Spike concentration added to sample or blank
MS	Matrix Spike sample result
MSD	Matrix Spike Duplicate sample result
%MS	Percent recovery of MS: $\{(MS-R1) / SP\ CONC\} \times 100$
%MSD	Percent recovery of MSD: $\{(MSD-R1) / SP\ CONC\} \times 100$
RPD (for MS/MSD)	Relative Percent Difference: $\{(MS-MSD) / (MS+MSD)\} \times 100 \times 2$
LCS	Laboratory Control Sample result
LCSD	Laboratory Control Sample Duplicate result
%LCS	Percent recovery of LCS: $\{(LCS) / SP\ CONC\} \times 100$
%LCSD	Percent recovery of LCSD: $\{(LCSD) / SP\ CONC\} \times 100$
RPD (for LCS/LCSD)	Relative Percent Difference: $\{(LCS-LCSD) / (LCS+LCSD)\} \times 100 \times 2$
ACP %LCS	Acceptable percent recovery range for Laboratory Control Samples.
ACP %MS	Acceptable percent recovery range for Matrix Spike samples
ACP RPD	Acceptable Relative Percent Difference
D	Detectable, result must be greater than zero
Qual	A checked box indicates a data qualifier was utilized and/or required for this analyte see attached explanation.
ND	Analyte Not Detected

Analysis Request and Chain of Custody Record

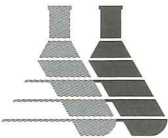

ORANGE COAST ANALYTICAL, INC. www.ocalab.com

3002 Dow, Suite 532
Tustin, CA 92780
(714) 832-0064 Fax (714) 832-0067

4620 E. Elwood, Suite 4
Phoenix, AZ 85040
(480) 736-0960 Fax (480) 736-0970

Lab Job No: 26382
Page _____ of _____

REQUIRED TURN AROUND TIME: Standard: _____
72 Hours: _____ 48 Hours: _____ 24 Hours: _____

CUSTOMER INFORMATION		PROJECT INFORMATION					ANALYSIS REQUEST / PRESERVATIVE										REMARKS/PRECAUTIONS				
COMPANY: <i>Petra Geosciences, Inc.</i>		PROJECT NAME: <i>The Ridge Wellness Center</i>					<i>Nitrate</i>	<i>Nitrite</i>	<i>Cl</i>	<i>SO4</i>	<i>Conductivity</i>										
SEND REPORT TO: <i>kmorenz@p - Kurtis Morenz</i>		NUMBER: <i>20-227</i>																			
EMAIL: <i>kmorenz@petra-inc.com</i>		ADDRESS: <i>Lake Hemet</i>																			
ADDRESS: <i>386 Airway Ave., suite K Costa Mesa, CA 92626</i>		P.O. #: <i>21-1136</i>																			
PHONE: <i>714-951-6194</i> FAX:		SAMPLED BY: <i>Kurtis Morenz</i>																			
SAMPLE ID	NO. OF CONTAINERS	SAMPLE DATE	SAMPLE TIME	SAMPLE MATRIX	CONTAINER TYPE																
<i>1A</i>	<i>1</i>	<i>9/23/21</i>	<i>8:40</i>	<i>H₂O</i>	<i>HDPE</i>	/															
<i>2A</i>	<i>1</i>	<i>9/23/21</i>	<i>8:41</i>	<i>H₂O</i>	<i>HDPE</i>	/															
<i>3A</i>	<i>1</i>	<i>9/23/21</i>	<i>8:42</i>	<i>H₂O</i>	<i>HDPE</i>			<i>/</i>	<i>/</i>	<i>/</i>											
Total No. of Samples: <i>3</i>		Method of Shipment:					Preservative: 1 = Ice 2 = HCl 3 = HNO ₃ 4 = H ₂ SO ₄ 5 = NaOH 6 = Other														
Relinquished By: <i>Ki [signature]</i>	Date/Time: <i>9/23/21 11:31 AM</i>	Received By:				Date/Time:	Sample Matrix: GW - Groundwater DW - Drinking Water WW - Wastewater W - Water SW - Stormwater SS - Soil/Solid OT - Other														
Relinquished By:	Date/Time:	Received By:				Date/Time:	Sample Integrity: Intact: _____ On Ice <input checked="" type="radio"/> Yes <input type="radio"/> No <i>6+0 = 6.0 °C IR #3</i>														
Relinquished By:	Date/Time:	Received For Lab By: <i>Mark [signature]</i>				Date/Time: <i>9-23-21 1131</i>															

By signing above, client acknowledges responsibility for payment of all services requested on this chain of custody form and any additional services provided in support of this project. Payment is due within 30 days of invoice date unless otherwise agreed upon, in writing, with Orange Coast Analytical, Inc. All samples remain the property of the client. A disposal fee may be imposed if client fails to pickup sample.

Sample Receipt Report

Laboratory Reference PTE 26382

Logged in by HC

Received: 09/23/21 11:31 Company Name: Petra Geosciences, Inc.
Method of Shipment: Hand Delivered Project Manager: Mr. Kurtis Morenz
Shipping Container: Cooler Project Name: The Ridge Wellness Center
Shipping Containers: 1 Project #: 20-227

Sample Quantity

3 Water

Chain of Custody	Complete <input checked="" type="checkbox"/>	Incomplete <input type="checkbox"/>	None <input type="checkbox"/>
Samples On Ice	Yes, Wet <input checked="" type="checkbox"/>	Yes, Blue <input type="checkbox"/>	No <input type="checkbox"/>
Observed Temp. (°C): <u>6</u>	Thermometer ID: <u>IR#3</u>	Adjusted Temp.: <u>6+0=6</u>	
Shipping Intact	Yes <input checked="" type="checkbox"/>	N/A <input type="checkbox"/>	No <input type="checkbox"/>
Shipping Custody Seals Intact	Yes <input type="checkbox"/>	N/A <input checked="" type="checkbox"/>	No <input type="checkbox"/>
Samples Intact	Yes <input checked="" type="checkbox"/>		No <input type="checkbox"/>
Sample Custody Seals Intact	Yes <input type="checkbox"/>	N/A <input checked="" type="checkbox"/>	No <input type="checkbox"/>
Custody Seals Signed & Dated	Yes <input type="checkbox"/>	N/A <input checked="" type="checkbox"/>	No <input type="checkbox"/>
Proper Test Containers	Yes <input checked="" type="checkbox"/>		No <input type="checkbox"/>
Proper Test Preservations	Yes <input checked="" type="checkbox"/>		No <input type="checkbox"/>
Samples Within Hold Times	Yes <input checked="" type="checkbox"/>		No <input type="checkbox"/>
VOAs Have Zero Headspace	Yes <input type="checkbox"/>	N/A <input checked="" type="checkbox"/>	No <input type="checkbox"/>
Sample Labels	Complete <input checked="" type="checkbox"/>	Incomplete <input type="checkbox"/>	None <input type="checkbox"/>
Sample Information Matches COC	Yes <input checked="" type="checkbox"/>	N/A <input type="checkbox"/>	No <input type="checkbox"/>

Notes

Client Notified _____ By _____ On _____

APPENDIX C

PUMP TEST RESULTS MW-1

APPENDIX C

Monitoring Well MW-1 Installation Data and Pump Test

Pump Specifications

Proactive Super Twister 12v Groundwater Pump (up to 85 feet) using 100 feet of ½” clear vinyl tubing.

Table C-1

Pumping Depth in Feet DTW (Depth to Water)	Gallons per Minute At 12.5 Volts at the Source
3	4.0
10	3.50
20	3.00
30	2.90
40	2.75
50	2.40
60	2.00
70	1.50
80	1.00
85	0.60

Well Specifications

TD = 40.5 feet

Groundwater= 11 feet

Installation Notes

An 8-inch diameter hollow stem auger was used to install 30 feet of solid 2-inch PVC pipe, and 10 feet of 2-inch screened PVC pipe.

During removal of hollow-stem augers, the well pipe pulled up approximately 1.5 feet. As well, the surrounding sand caved to a depth of 20 feet. Total depth of the pipe came to 38.5 feet.

From there, sand (#50) was added to a depth of 8 feet.

6.5 feet of bentonite was brought to within 1.5 feet of the surface.

The upper 1.5 feet was capped with concrete.

Pipe was then capped.

Pump Test Notes

Pumped on September 20, 2021.

Pump was placed 30 feet deep and ran for two and one-half hours.

Table C-2

Start Time	End Time	Time Interval (minutes)	Elapsed Time (minutes)	Depth to Water (ft) @ Start	Depth to Water (ft) @ End
8:05	8:35	30	30	11.1	15.5
8:35	9:05	30	60	15.5	17.2
9:05	9:35	30	90	17.2	17.2
9:35	10:05	30	120	17.2	17.2
10:05	10:35	30	150	17.2	17.2
10:35	11:05	30	180	17.2	17.2
11:05	11:35	30	210	17.2	17.2
11:35	11:50	15	225	17.2	11.1

After 1 hour, the depth stabilized at 17.2 feet and would not progress.

On September 23, 2021, the geologist returned to collect the water samples from the well.

Samples were immediately taken to Orange Coast Analytical, Inc.

Rebound Tested

Start Time	End Time	Time Interval (minutes)	Elapsed Time (minutes)	Depth to Water (ft) @ Start	Depth to Water (ft) @ End
11:35	11:50	15	225	17.2	11.1

Speed Test

Filling a 5-gallon bucket took 1 minute, 46 seconds (2.8 gal./minute)

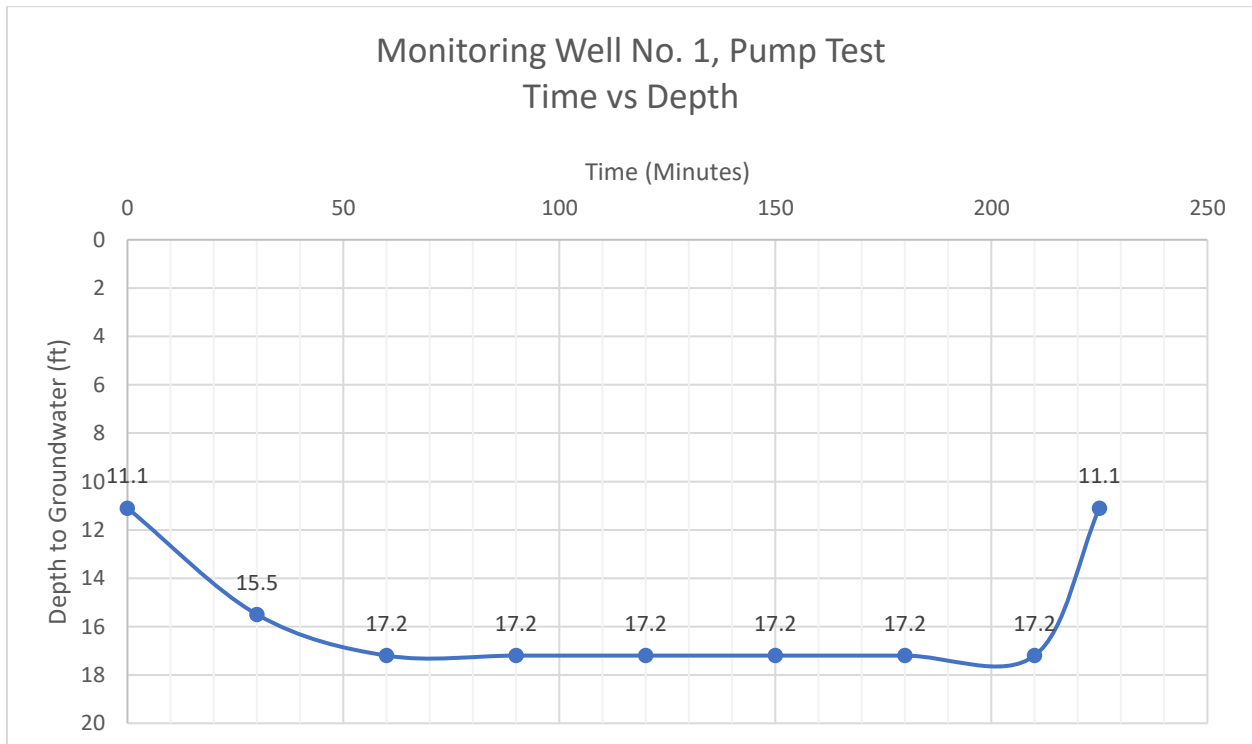

APPENDIX D

PERCOLATION TEST SUMMARY

Infiltration Test DRI-1

Double-Ring Infiltrometer Test, ASTM D3385-09

Time (m)	Δ Time (m)	Elapsed Time (m)	Inner Ring (cm)	Volume Inner (cm ³)	Rate Inner (cm/h)
11:16	15		58.0	9012.4	52.0
11:31		15	7.0		
11:48	5		59.4	6626.8	114.8
11:53		20	21.9		
12:01	5		59.0	5160.1	89.4
12:06		25	29.8		
12:06	5		29.8	3675.7	63.7
12:11		30	9.0		

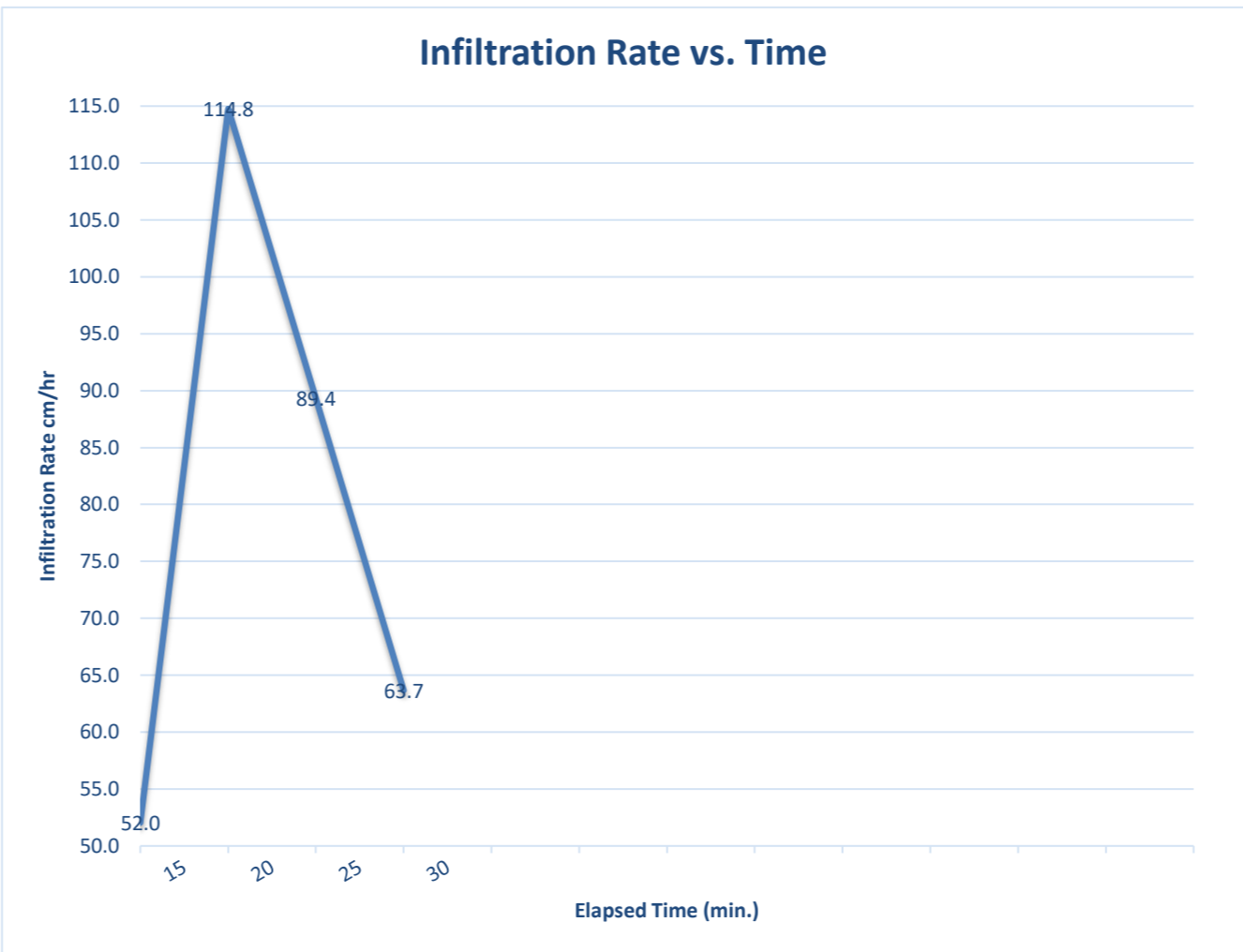

Area of Inner Ring (cm²)
 692.8

Area of Annular Space (cm²)
 2120.5

Infiltration Rate **64 cm/hr**
2E-02 cm/sec
25 in/hr
375 gal/day/ft²



Lake Hemet Wellness Center
 JN 20-227
 Tested by L. Holmes, August 18, 2020

Infiltration Test DRI-2
 Double-Ring Infiltrometer Test, ASTM D3385-09

Time (m)	Δ Time (m)	Elapsed Time (m)	Inner Ring (cm)	Volume Inner (cm ³)	Rate Inner (cm/h)
9:36	5		59.0	5124.7	88.8
9:41		5	30.0		
9:44	5		57.6	4382.5	75.9
9:49		10	32.8		
9:53	5		58.9	3993.7	69.2
9:58		15	36.3		
10:01	5		59.0	4329.5	75.0
10:06		20	34.5		
10:09	5		57.4	4612.3	79.9
10:14		25	31.3		
10:15	5		31.3	4205.8	72.8
10:20		30	7.5		

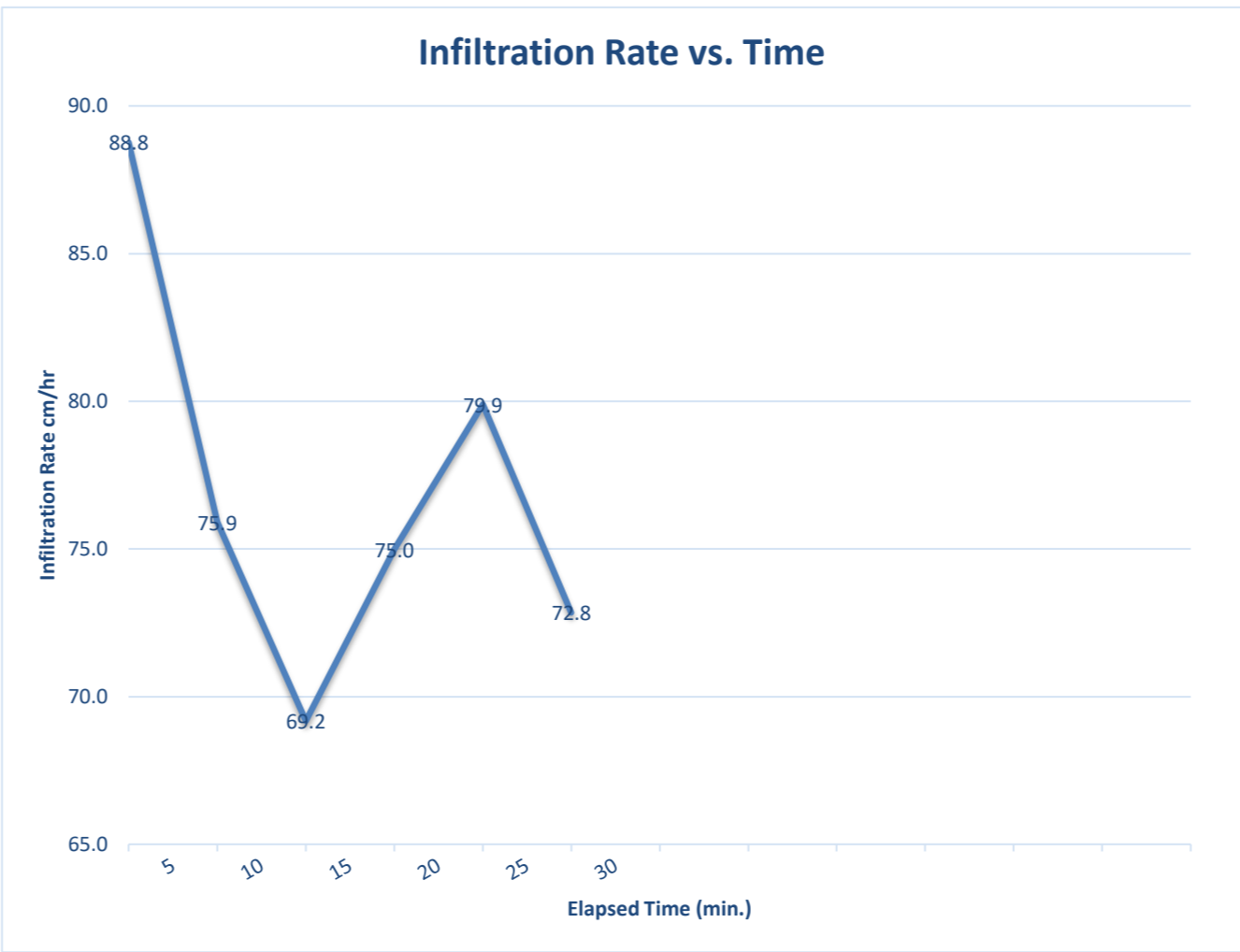

Area of Inner Ring (cm²)
 692.8

Area of Annular Space (cm²)
 2120.5

Infiltration Rate **73** cm/hr
 2.0E-02 cm/sec
 29 in/hr
 430 gal/day/ft²



Infiltration Test P-1
Double-Ring Infiltrometer Test, ASTM D3385-09

Time (m)	Δ Time (m)	Elapsed Time (m)	Inner Ring (cm)	Volume Inner (cm ³)	Rate Inner (cm/h)
9:47			10.2		
9:57	10	10	0.9	1638.3	14.2
10:00			6.7		
10:10	10	20	1.3	964.9	8.4
10:13			10.2		
10:23	10	30	5.08	904.8	7.8
10:27			12.7		
10:37	10	40	7.37	941.9	8.2
10:42			11.43		
10:52	10	50	6.4	897.7	7.8
10:56			12.7		
11:06	10	60	7.6	897.7	7.8

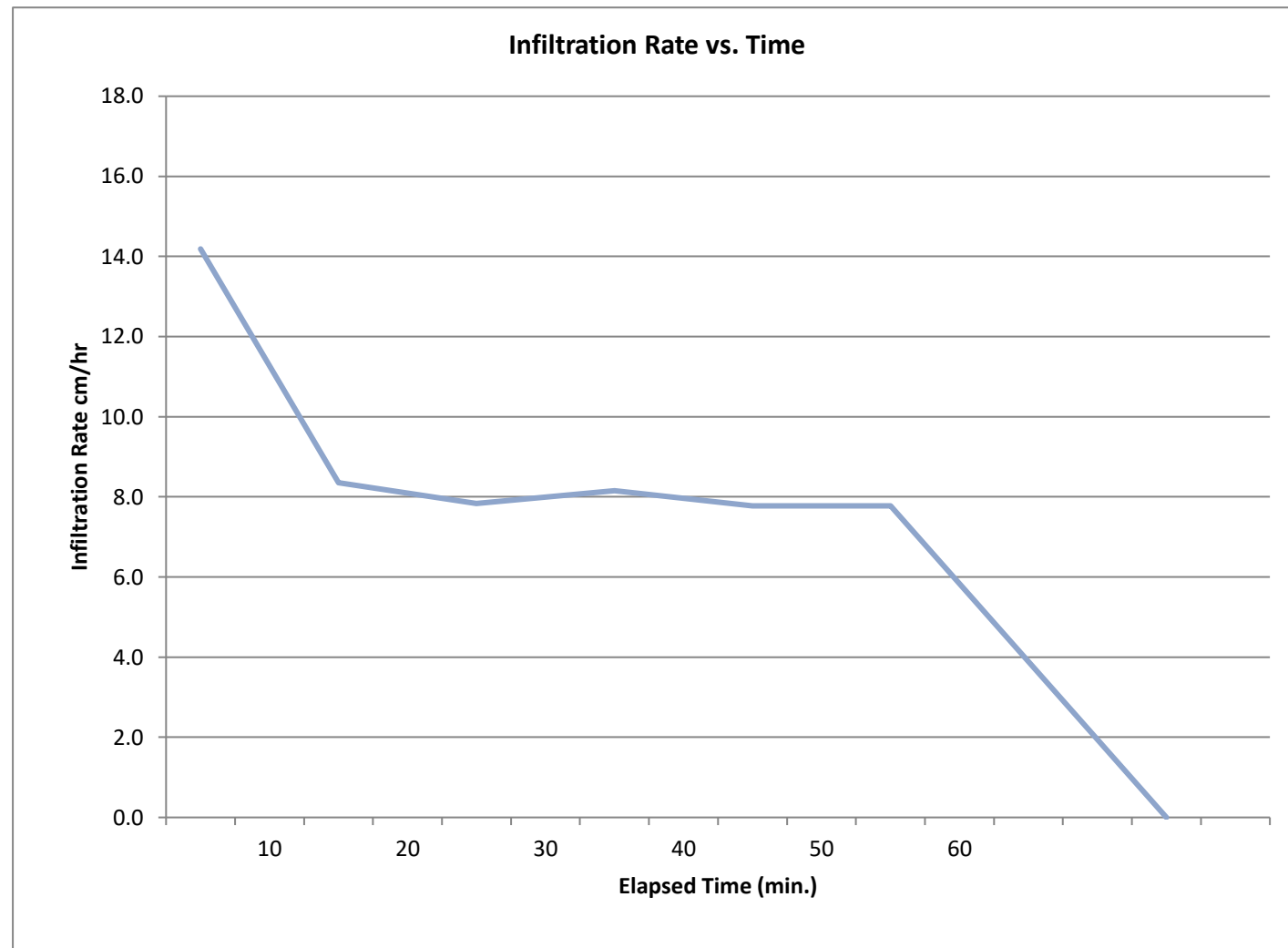

Area of Inner Ring (cm²)
692.8

Infiltration Rate

Area of Annular Space (cm²)
2120.5

Tested by KTM, 5-7-2021

8 cm/hr
0.002 cm/sec
3 in/hr
46 gal/day/ft²

Infiltration Test P-2
Double-Ring Infiltrometer Test, ASTM D3385-09

Time (m)	Δ Time (m)	Elapsed Time (m)	Inner Ring (cm)	Volume Inner (cm ³)	Rate Inner (cm/h)
11:13			13.0		
11:23	10	10	7.8	927.8	8.0
11:26			15.0		
11:36	10	20	10.5	788.1	6.8
11:40			14.6		
11:50	10	30	10.29	761.6	6.6
11:55			13.3		
12:05	10	40	9.7	636.2	5.5
12:08			14		
12:18	10	50	10.8	565.5	4.9
12:22			14.2		
12:16	10	60	11.0	565.5	4.9

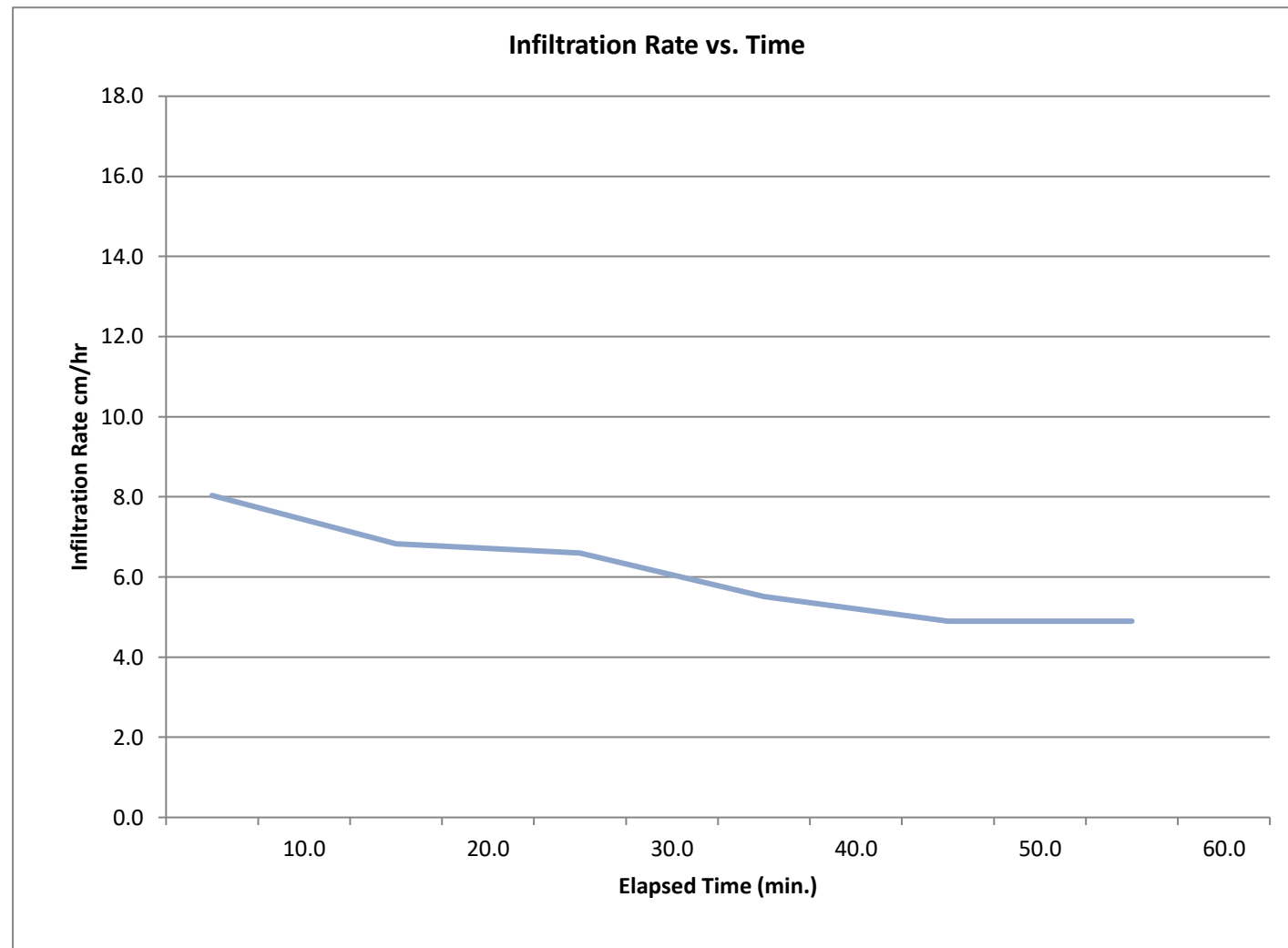

Area of Inner Ring (cm²)
692.8

Infiltration Rate

Area of Annular Space (cm²)
2120.5

Tested by KTM, 5-7-2021

- 5 cm/hr
- 1E-03 cm/sec
- 2 in/hr
- 29 gal/day/ft²

Infiltration Test P-3
 Double-Ring Infiltrometer Test, ASTM D3385-09

Time (m)	Δ Time (m)	Elapsed Time (m)	Inner Ring (cm)	Volume Inner (cm ³)	Rate Inner (cm/h)
12:44			14.7		
12:54	10	10	12.3	424.1	3.7
13:11			20.3		
13:21	10	20	17.0	583.2	5.1
13:24			15.1		
13:34	10	30	12.7	424.1	3.7
13:37			16.5		
13:47	10	40	13	620.3	5.4
13:52			14.7		
14:02	10	50	12.4	406.4	3.5
14:05			15.0		
14:15	10	60	12.7	406.4	3.5

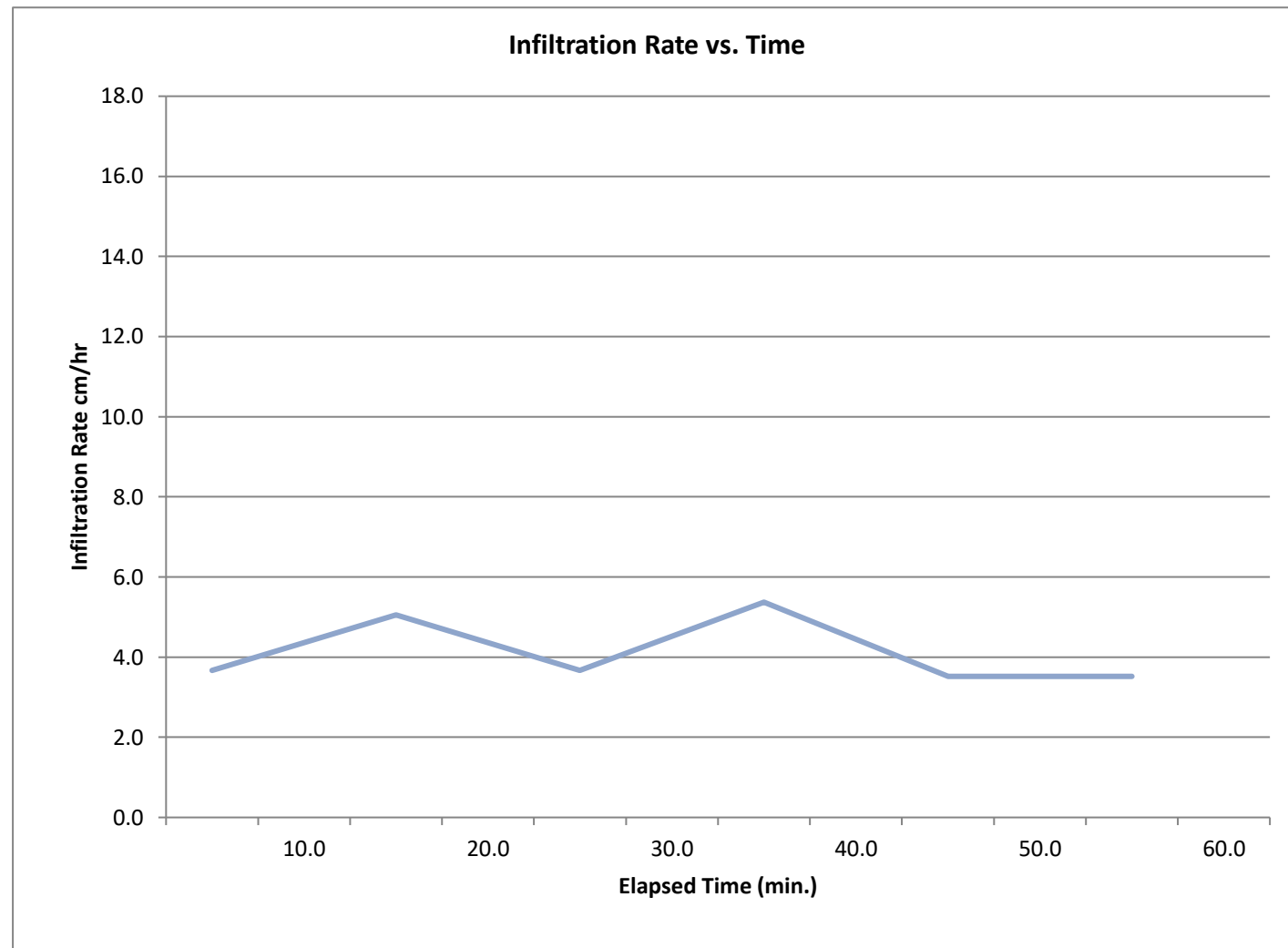

Area of Inner Ring (cm²)
692.8

Infiltration Rate

Area of Annular Space (cm²)
2120.5

Tested by KTM, 5-7-2021

- 4 cm/hr
- 1E-03 cm/sec
- 1 in/hr
- 21 gal/day/ft²

APPENDIX E

SEISMIC DESIGN PARAMETERS

SITE CLASSIFICATION DETERMINATION BASED ON N-SPT FOR SEISMIC DESIGN

Per Table 20.3-1 and Section 20.4.2 of ASCE 7-16

J.N: **20-227**

Project: **The Ridge**

Date: **7/2/2021**

Boring: **B-3**

Total Depth of Boring: **51** feet

SPT Test Interval: every **5** feet

Layer No. (i)	Depth to Soil/Rock Layer		Layer Thickness (d _i)	$\sum_{i=1}^n d_i$	Mod. Cal. Sampler Blow Counts ¹	Equivalent N-SPT ² (N _i)	N-SPT ³ (N _i)	$\sum_{i=1}^n \frac{d_i}{N_i}$
	Top	Bottom						
	ft	ft	ft	ft	blows/ft	blows/ft	blows/ft	
1	0	5	5	5.0	26	17		0.29
2	5	8	3	8.0	19	12		0.54
3	8	11	3	11.0	28	18		0.71
4	11	15	4	15.0	19	12		1.04
5	15	20	5	20.0	22	14		1.40
6	20	25	5	25.0	31	20		1.65
7	25	30	5	30.0	39	25		1.85
8	30	35	5	35.0	40	26		2.04
9	35	40	5	40.0	22	14		2.40
10	40	45	5	45.0	Refusal	100		2.45
11	45	50	5	50.0	Refusal	100		2.50
12	50	100	50	100.0	Refusal	100		3.00
13	0	0	0	0.0		0		0.00
14	0	0	0	0.0		0		0.00
15	0	0	0	0.0		0		0.00



Average Field Standard Penetration Resistance (blows/ft)	Site Classification Per Table 20.3-1
$\bar{N} = \frac{\sum_{i=1}^n d_i}{\sum_{i=1}^n \frac{d_i}{N_i}} = 33$	D

- 1 Modified California sampler blow counts as directly measured in the field without corrections.
- 2 Equivalent SPT blow counts are calculated from field measured Modified California sampler blow counts using the standard Burmister formula (Burmister, 1948).
Eq. N-SPT = 0.651 x (Mod. Cal. Sampler Blow Counts)
- 3 Standard penetration resistance (ASTM D1586) not to exceed 100 blows /ft (305 blows /m) as directly measured in the field without corrections. When Refusal is met for a rock layer, this value shall be taken as 100 blows /ft (305 blows /m).



The Ridge

Latitude, Longitude: 33.674, -116.677

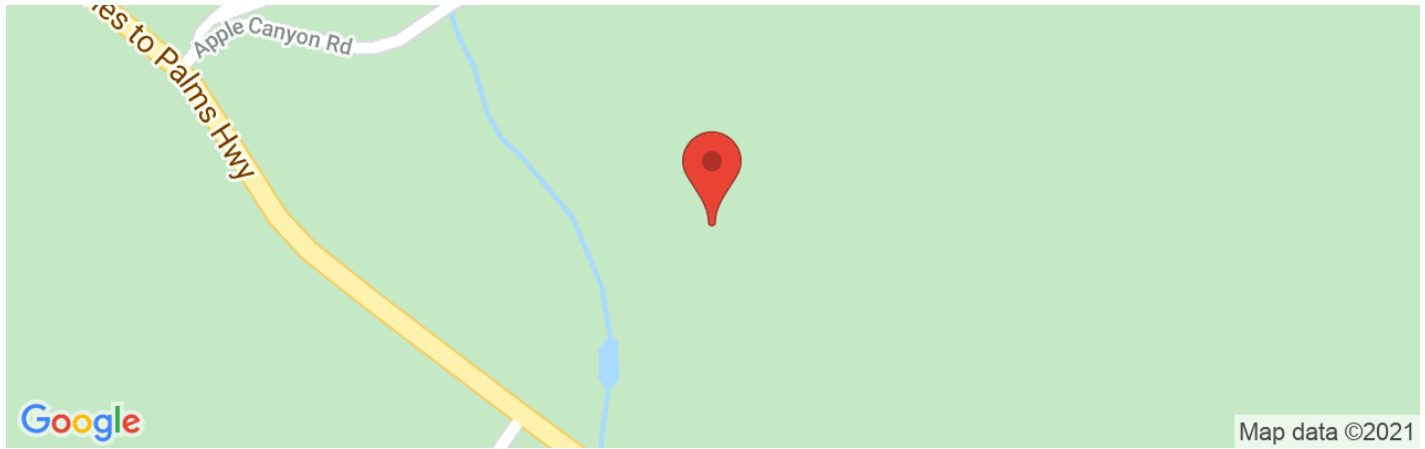

Date	7/2/2021, 2:21:22 PM
Design Code Reference Document	ASCE7-16
Risk Category	II
Site Class	D - Stiff Soil

Type	Value	Description
S _S	1.641	MCE _R ground motion. (for 0.2 second period)
S ₁	0.639	MCE _R ground motion. (for 1.0s period)
S _{MS}	1.641	Site-modified spectral acceleration value
S _{M1}	null -See Section 11.4.8	Site-modified spectral acceleration value
S _{DS}	1.094	Numeric seismic design value at 0.2 second SA
S _{D1}	null -See Section 11.4.8	Numeric seismic design value at 1.0 second SA

Type	Value	Description
SDC	null -See Section 11.4.8	Seismic design category
F _a	1	Site amplification factor at 0.2 second
F _v	null -See Section 11.4.8	Site amplification factor at 1.0 second
PGA	0.695	MCE _G peak ground acceleration
F _{PGA}	1.1	Site amplification factor at PGA
PGA _M	0.765	Site modified peak ground acceleration
T _L	8	Long-period transition period in seconds
S _{sRT}	1.994	Probabilistic risk-targeted ground motion. (0.2 second)
S _{sUH}	2.196	Factored uniform-hazard (2% probability of exceedance in 50 years) spectral acceleration
S _{sD}	1.641	Factored deterministic acceleration value. (0.2 second)
S _{1RT}	0.757	Probabilistic risk-targeted ground motion. (1.0 second)
S _{1UH}	0.85	Factored uniform-hazard (2% probability of exceedance in 50 years) spectral acceleration.
S _{1D}	0.639	Factored deterministic acceleration value. (1.0 second)
PGA _d	0.695	Factored deterministic acceleration value. (Peak Ground Acceleration)
C _{RS}	0.908	Mapped value of the risk coefficient at short periods
C _{R1}	0.89	Mapped value of the risk coefficient at a period of 1 s

DISCLAIMER

While the information presented on this website is believed to be correct, [SEAC / OSHPD](#) and its sponsors and contributors assume no responsibility or liability for its accuracy. The material presented in this web application should not be used or relied upon for any specific application without competent examination and verification of its accuracy, suitability and applicability by engineers or other licensed professionals. SEAC / OSHPD do not intend that the use of this information replace the sound judgment of such competent professionals, having experience and knowledge in the field of practice, nor to substitute for the standard of care required of such professionals in interpreting and applying the results of the seismic data provided by this website. Users of the information from this website assume all liability arising from such use. Use of the output of this website does not imply approval by the governing building code bodies responsible for building code approval and interpretation for the building site described by latitude/longitude location in the search results of this website.

U.S. Geological Survey - Earthquake Hazards Program

Unified Hazard Tool

- Please do not use this tool to obtain ground motion parameter values for the design code reference documents covered by the [U.S. Seismic Design Maps web tools](#) (e.g., the International Building Code and the ASCE 7 or 41 Standard). The values returned by the two applications are not identical.

^ Input

Edition

Dynamic: Conterminous U.S. 2014 (update) (v...

Spectral Period

Peak Ground Acceleration

Latitude

Decimal degrees

33.674

Time Horizon

Return period in years

2475

Longitude

Decimal degrees, negative values for western longitudes

-116.677

Site Class

259 m/s (Site class D)

^ Hazard Curve

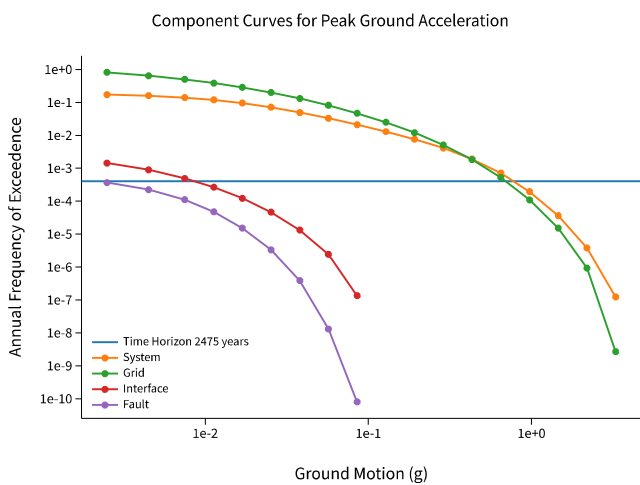
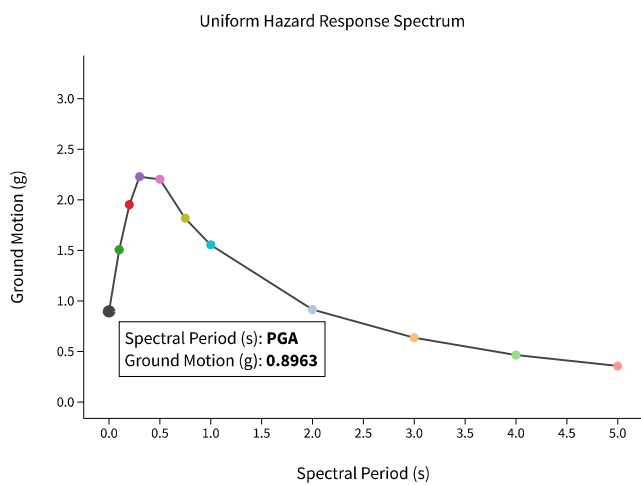
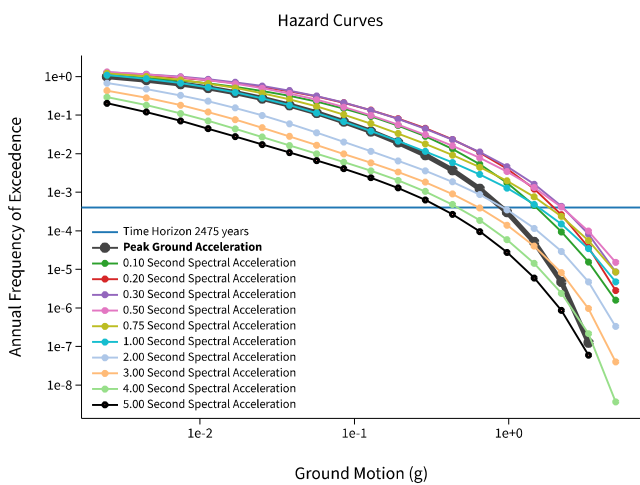

[View Raw Data](#)

^ Deaggregation

Component

Total

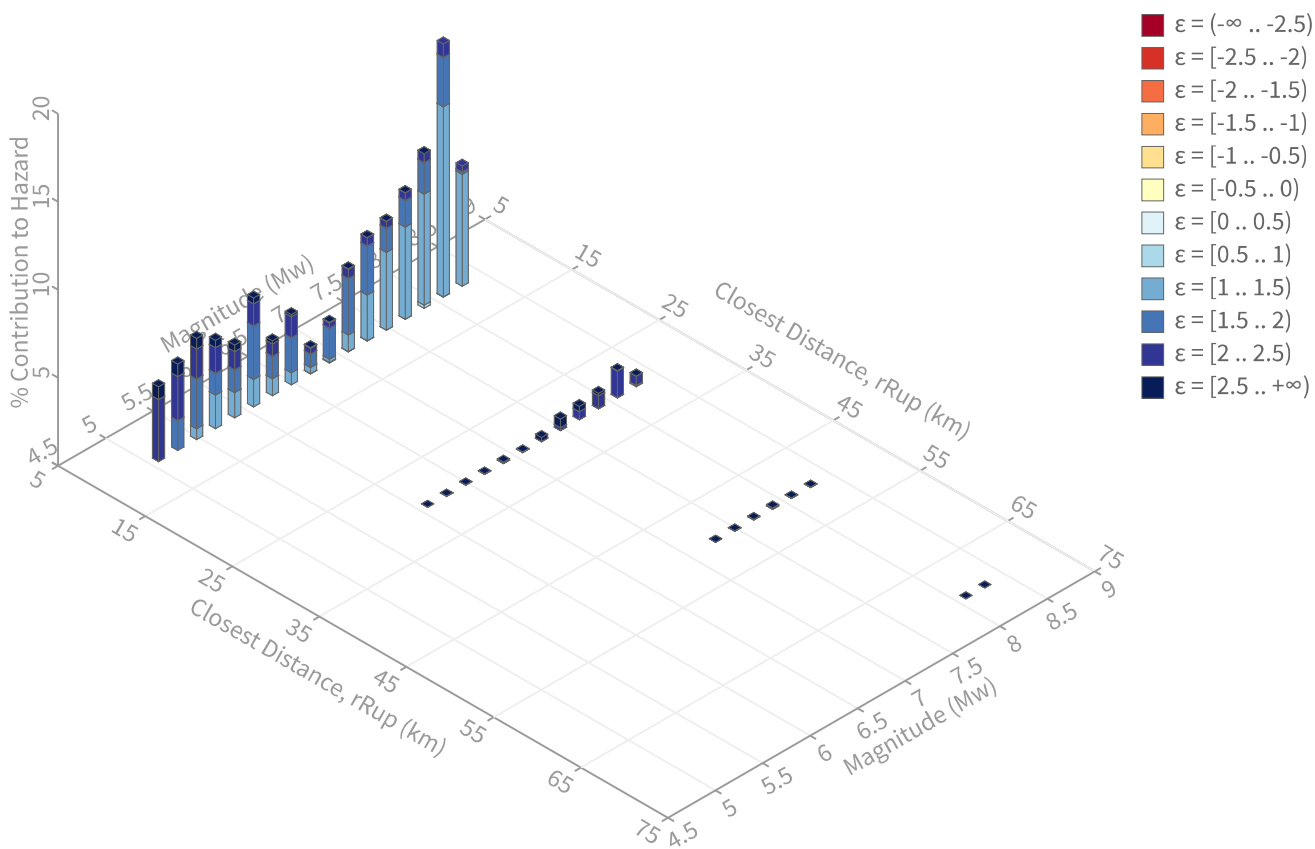

Summary statistics for, Deaggregation: Total

Deaggregation targets

Return period: 2475 yrs
Exceedance rate: 0.0004040404 yr⁻¹
PGA ground motion: 0.89631882 g

Totals

Binned: 100 %
Residual: 0 %
Trace: 0.04 %

Mode (largest m-r bin)

m: 8.1
r: 7.36 km
 ϵ_0 : 1.31 σ
Contribution: 14.39 %

Discretization

r: min = 0.0, max = 1000.0, Δ = 20.0 km
m: min = 4.4, max = 9.4, Δ = 0.2
 ϵ : min = -3.0, max = 3.0, Δ = 0.5 σ

Recovered targets

Return period: 3202.5687 yrs
Exceedance rate: 0.00031224935 yr⁻¹

Mean (over all sources)

m: 7
r: 8.67 km
 ϵ_0 : 1.66 σ

Mode (largest m-r- ϵ_0 bin)

m: 8.1
r: 7.36 km
 ϵ_0 : 1.19 σ
Contribution: 10.8 %

Epsilon keys

ϵ_0 : [- ∞ .. -2.5)
 ϵ_1 : [-2.5 .. -2.0)
 ϵ_2 : [-2.0 .. -1.5)
 ϵ_3 : [-1.5 .. -1.0)
 ϵ_4 : [-1.0 .. -0.5)
 ϵ_5 : [-0.5 .. 0.0)
 ϵ_6 : [0.0 .. 0.5)
 ϵ_7 : [0.5 .. 1.0)
 ϵ_8 : [1.0 .. 1.5)
 ϵ_9 : [1.5 .. 2.0)
 ϵ_{10} : [2.0 .. 2.5)
 ϵ_{11} : [2.5 .. + ∞]

Deaggregation Contributors

Source Set	Source	Type	r	m	ϵ_0	lon	lat	az	%
UC33brAvg_FM31		System							31.27
	San Jacinto (Anza) rev [2]		7.34	7.79	1.40	116.721°W	33.619°N	213.82	25.88
	San Jacinto (Anza) rev [3]		7.46	6.97	1.70	116.713°W	33.614°N	206.40	2.60
	San Andreas (San Gorgonio Pass-Garnet Hill) [4]		28.06	7.92	2.32	116.568°W	33.909°N	21.09	1.72
UC33brAvg_FM32		System							31.12
	San Jacinto (Anza) rev [2]		7.34	7.79	1.40	116.721°W	33.619°N	213.82	25.85
	San Jacinto (Anza) rev [3]		7.46	6.98	1.70	116.713°W	33.614°N	206.40	2.52
	San Andreas (San Gorgonio Pass-Garnet Hill) [4]		28.06	7.92	2.32	116.568°W	33.909°N	21.09	1.72
UC33brAvg_FM31 (opt)		Grid							18.81
	PointSourceFinite: -116.677, 33.705		6.22	5.65	1.73	116.677°W	33.705°N	0.00	5.39
	PointSourceFinite: -116.677, 33.705		6.22	5.65	1.73	116.677°W	33.705°N	0.00	5.38
	PointSourceFinite: -116.677, 33.741		8.26	5.93	1.96	116.677°W	33.741°N	0.00	1.30
	PointSourceFinite: -116.677, 33.741		8.26	5.93	1.96	116.677°W	33.741°N	0.00	1.29
UC33brAvg_FM32 (opt)		Grid							18.80
	PointSourceFinite: -116.677, 33.705		6.22	5.65	1.73	116.677°W	33.705°N	0.00	5.38
	PointSourceFinite: -116.677, 33.705		6.22	5.65	1.73	116.677°W	33.705°N	0.00	5.38
	PointSourceFinite: -116.677, 33.741		8.26	5.93	1.96	116.677°W	33.741°N	0.00	1.29
	PointSourceFinite: -116.677, 33.741		8.26	5.93	1.96	116.677°W	33.741°N	0.00	1.29

APPENDIX F

LIQUEFACTION ANALYSIS

Project title : Petra Geosciences / Apple Canyon

Location : Lake Hemet, CA

Overall Liquefaction Potential Index report

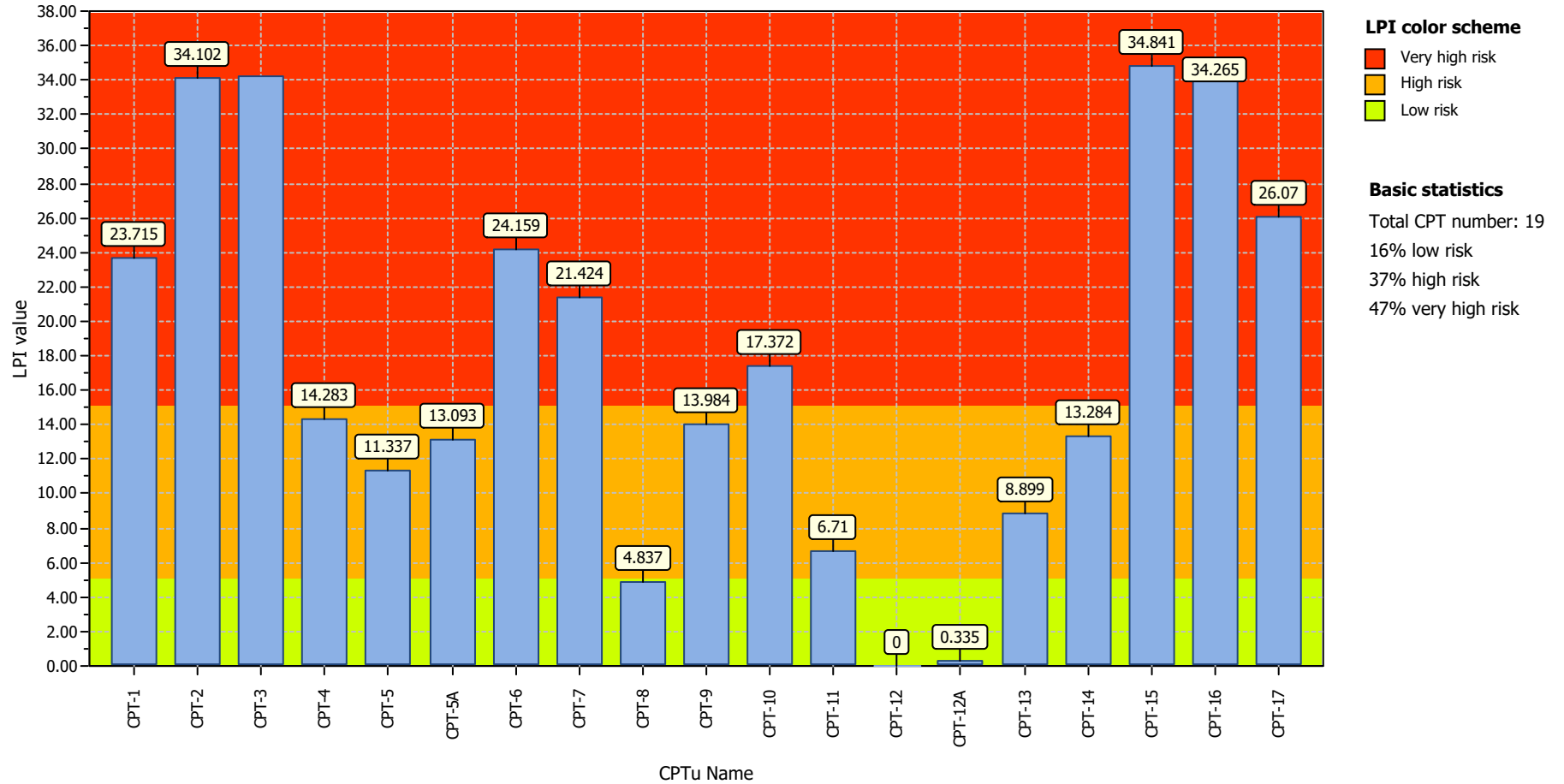

Project title : Petra Geosciences / Apple Canyon

Location : Lake Hemet, CA

Overall Liquefaction Severity Number report

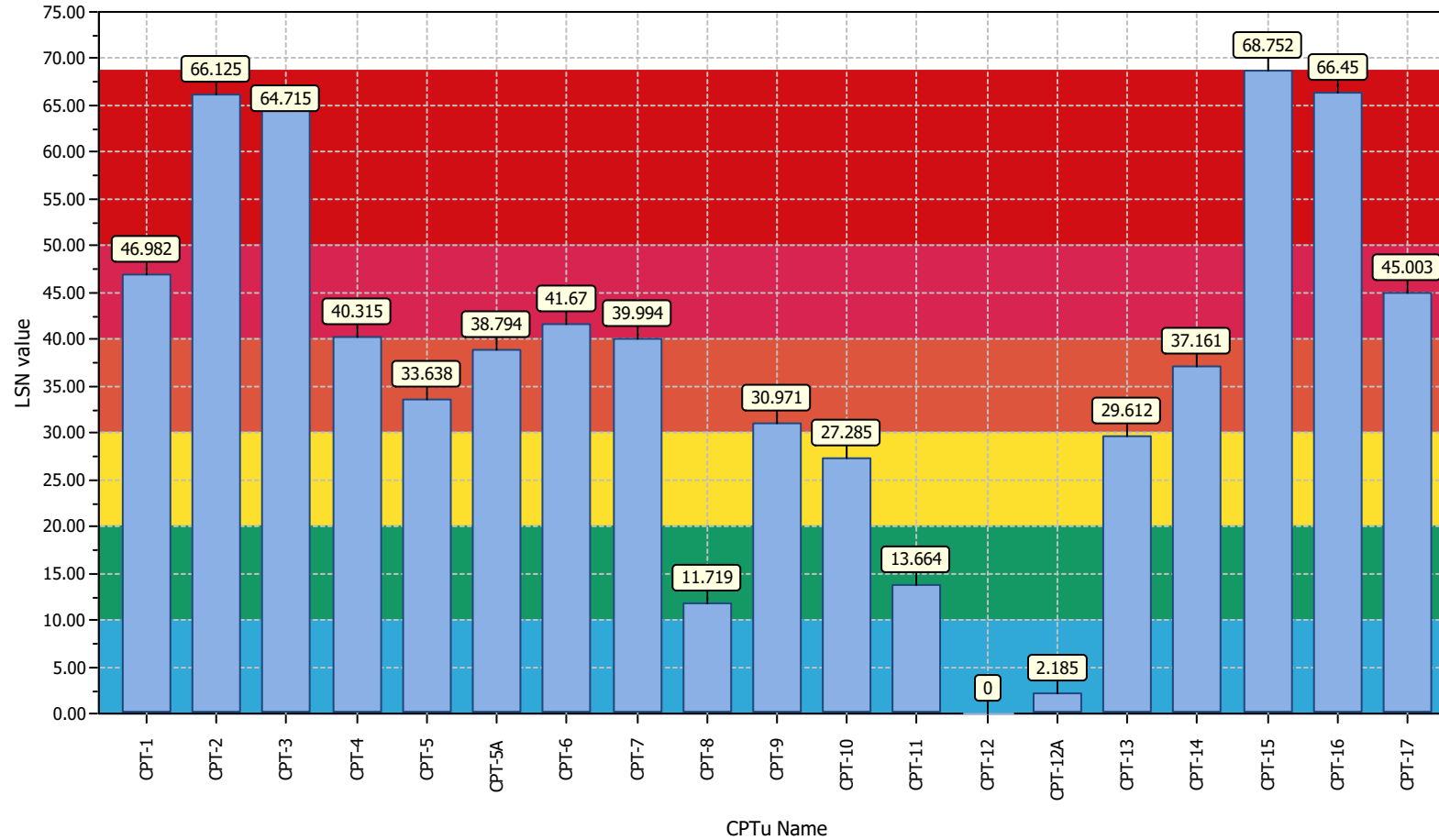

LSN color scheme

- Severe damage
- Major expression of liquefaction
- Moderate to severe exp. of liquefaction
- Moderate expression of liquefaction
- Minor expression of liquefaction
- Little to no expression of liquefaction

Basic statistics

- Total CPT number: 19
- 11% little liquefaction
- 11% minor liquefaction
- 11% moderate liquefaction
- 26% moderate to major liquefaction
- 21% major liquefaction
- 21% severe liquefaction

Project title : Petra Geosciences / Apple Canyon

Location : Lake Hemet, CA

Overall lateral displacements report

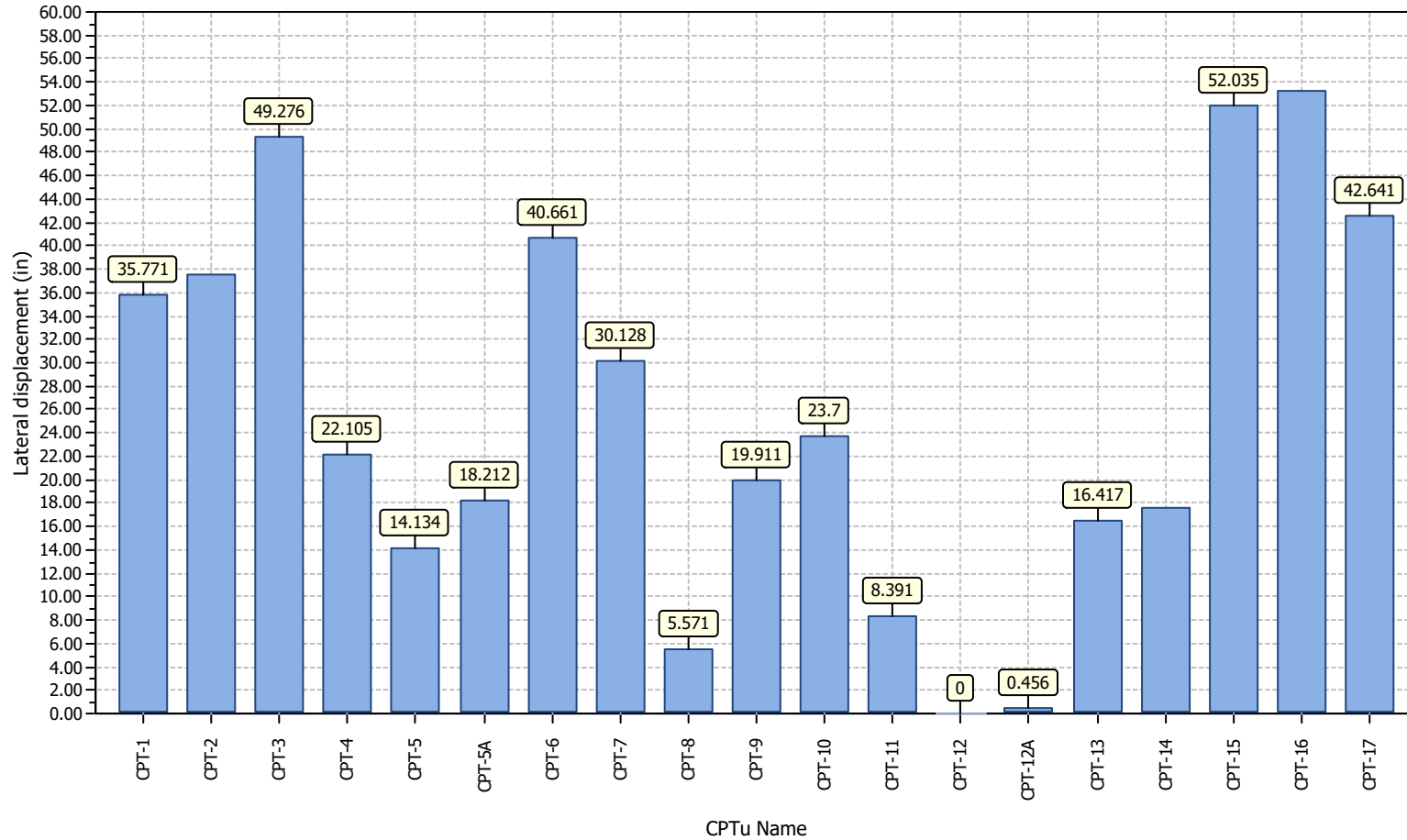

Project title : Petra Geosciences / Apple Canyon

Location : Lake Hemet, CA

Overall Probability for Liquefaction report

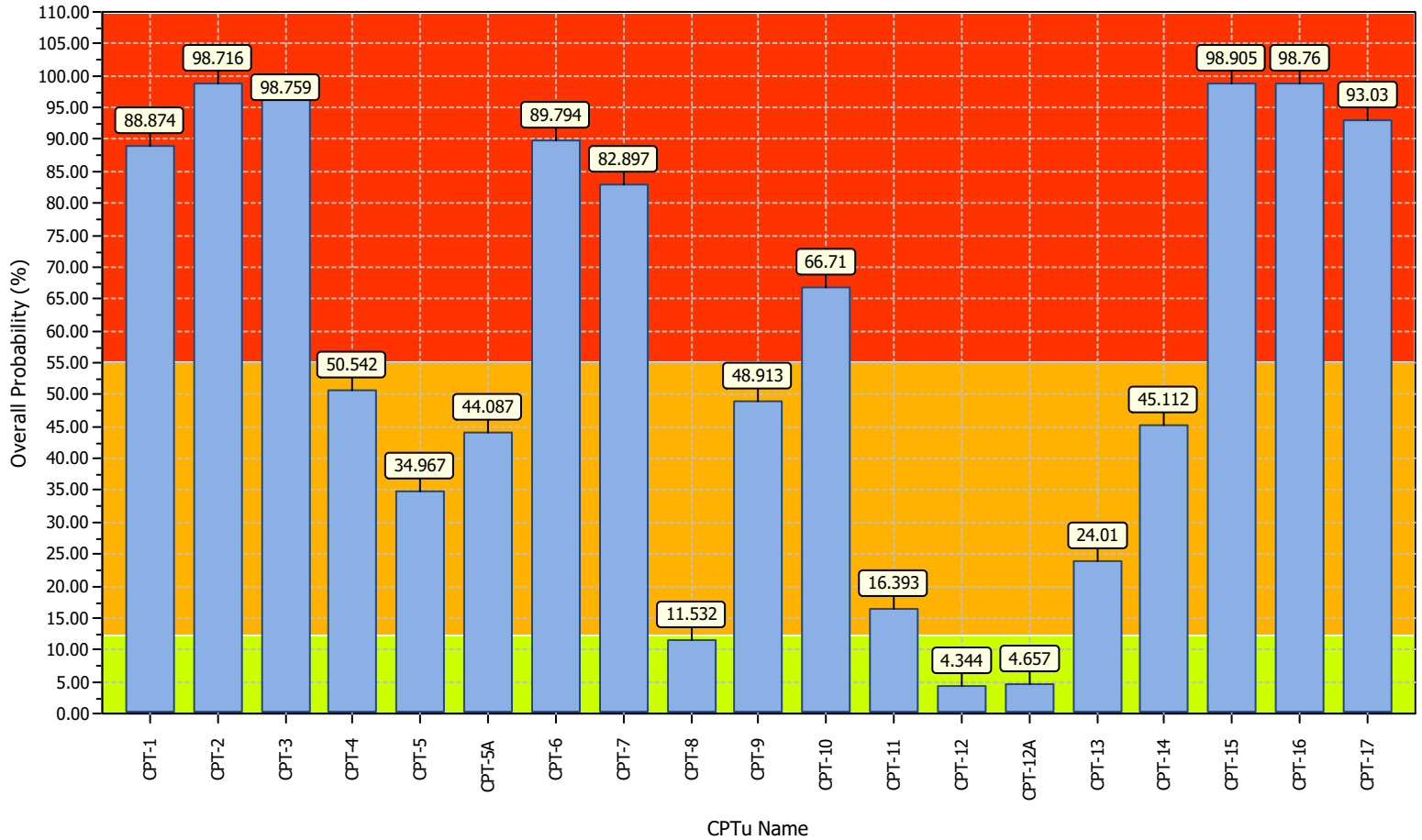

Probability color scheme

- Very High Probability
- High Probability
- Low Probability

Basic statistics

Total CPT number: 19
16% low probability
37% high probability
47% very high probability

Project title : Petra Geosciences / Apple Canyon

Location : Lake Hemet, CA

Overall vertical settlements report

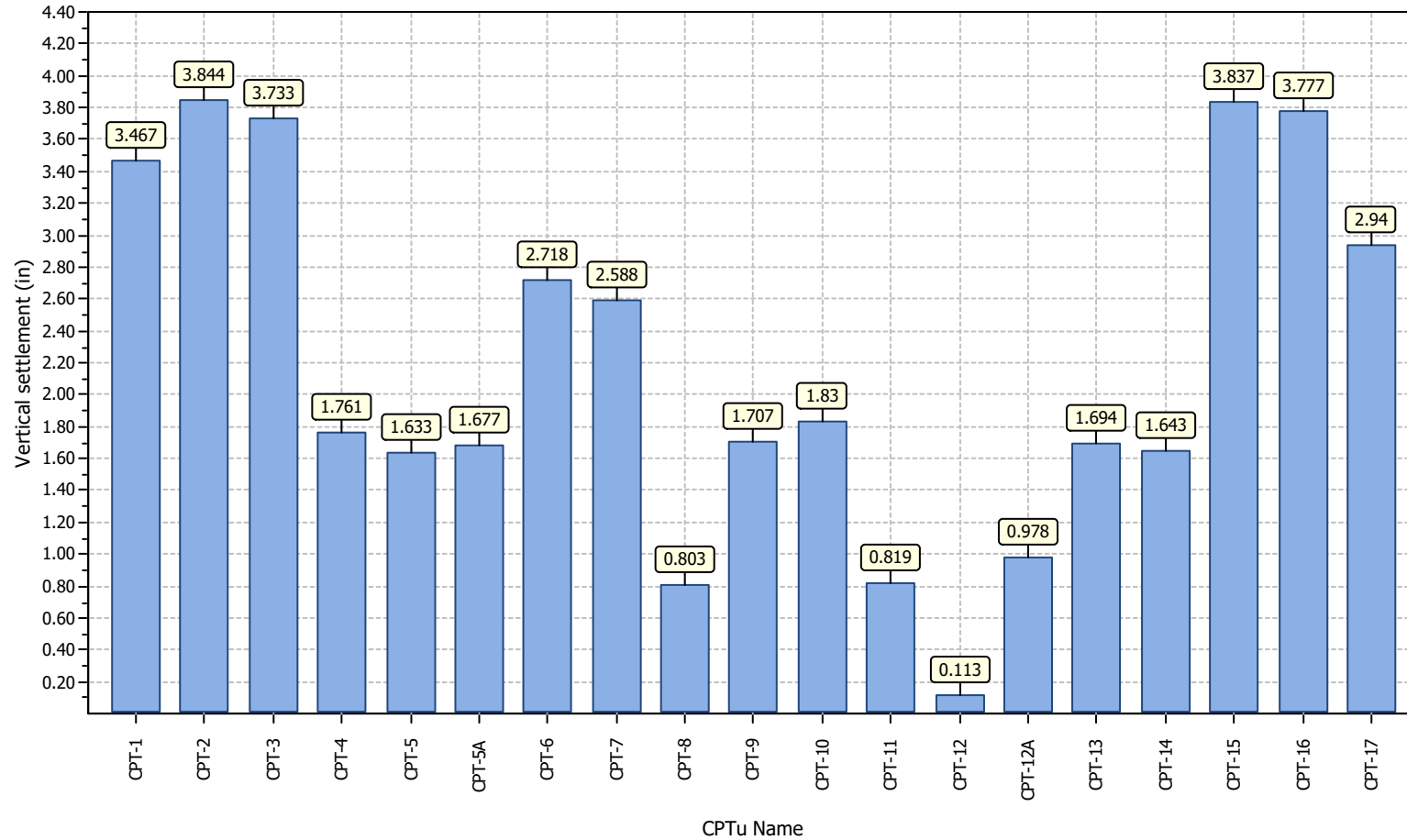

PGA Based Parametric Analysis

Settlements vs PGA

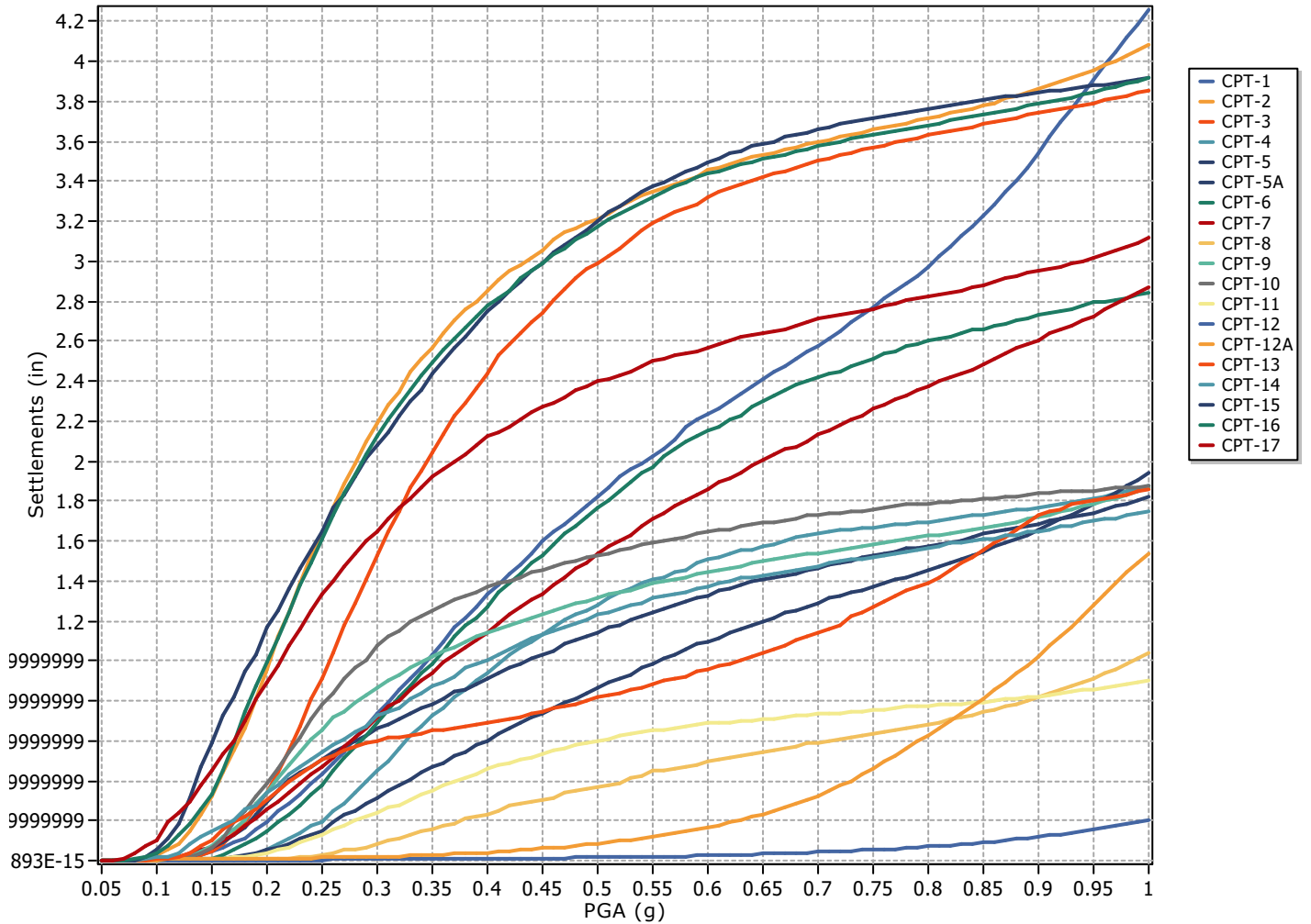

:: CPT main liquefaction parameters details ::

CPT Name	Assesment method	Earthquake Mag.	GWT in situ (ft)	GWT earthq. (ft)
CPT-1	NCEER (1998)	8.10	7.60	7.00
CPT-2	NCEER (1998)	8.10	9.90	7.00
CPT-3	NCEER (1998)	8.10	9.70	7.00
CPT-4	NCEER (1998)	8.10	11.00	7.00
CPT-5	NCEER (1998)	8.10	10.50	7.00
CPT-5A	NCEER (1998)	8.10	10.50	7.00
CPT-6	NCEER (1998)	8.10	10.50	7.00
CPT-7	NCEER (1998)	8.10	11.00	7.00
CPT-8	NCEER (1998)	8.10	11.00	7.00
CPT-9	NCEER (1998)	8.10	12.50	7.00
CPT-10	NCEER (1998)	8.10	10.50	7.00
CPT-11	NCEER (1998)	8.10	11.00	7.00
CPT-12	NCEER (1998)	8.10	12.00	7.00
CPT-12A	NCEER (1998)	8.10	12.00	7.00
CPT-13	NCEER (1998)	8.10	12.00	7.00



PGA Based Parametric Analysis

CPT-14	NCEER (1998)	8.10	9.50	7.00
CPT-15	NCEER (1998)	8.10	9.00	7.00
CPT-16	NCEER (1998)	8.10	9.80	7.00
CPT-17	NCEER (1998)	8.10	12.50	7.00

PGA Based Parametric Analysis

Lateral Displacements vs PGA

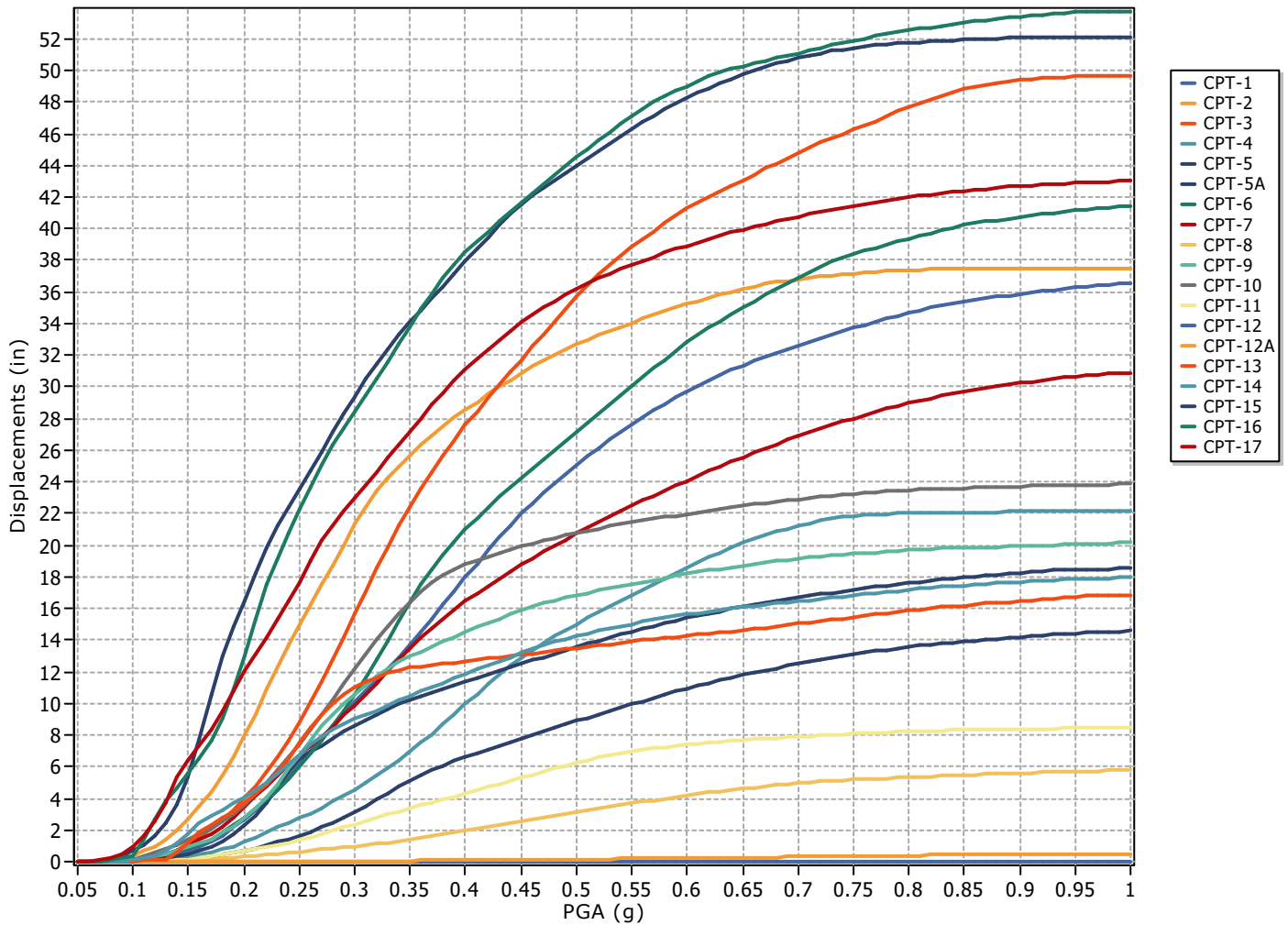

:: CPT main liquefaction parameters details ::

CPT Name	Assesment method	Earthquake Mag.	GWT in situ (ft)	GWT earthq. (ft)
CPT-1	NCEER (1998)	8.10	7.60	7.00
CPT-2	NCEER (1998)	8.10	9.90	7.00
CPT-3	NCEER (1998)	8.10	9.70	7.00
CPT-4	NCEER (1998)	8.10	11.00	7.00
CPT-5	NCEER (1998)	8.10	10.50	7.00
CPT-5A	NCEER (1998)	8.10	10.50	7.00
CPT-6	NCEER (1998)	8.10	10.50	7.00
CPT-7	NCEER (1998)	8.10	11.00	7.00
CPT-8	NCEER (1998)	8.10	11.00	7.00
CPT-9	NCEER (1998)	8.10	12.50	7.00
CPT-10	NCEER (1998)	8.10	10.50	7.00
CPT-11	NCEER (1998)	8.10	11.00	7.00
CPT-12	NCEER (1998)	8.10	12.00	7.00
CPT-12A	NCEER (1998)	8.10	12.00	7.00
CPT-13	NCEER (1998)	8.10	12.00	7.00



PGA Based Parametric Analysis

CPT-14	NCEER (1998)	8.10	9.50	7.00
CPT-15	NCEER (1998)	8.10	9.00	7.00
CPT-16	NCEER (1998)	8.10	9.80	7.00
CPT-17	NCEER (1998)	8.10	12.50	7.00

PGA Based Parametric Analysis

Liquefaction Severity Number vs PGA

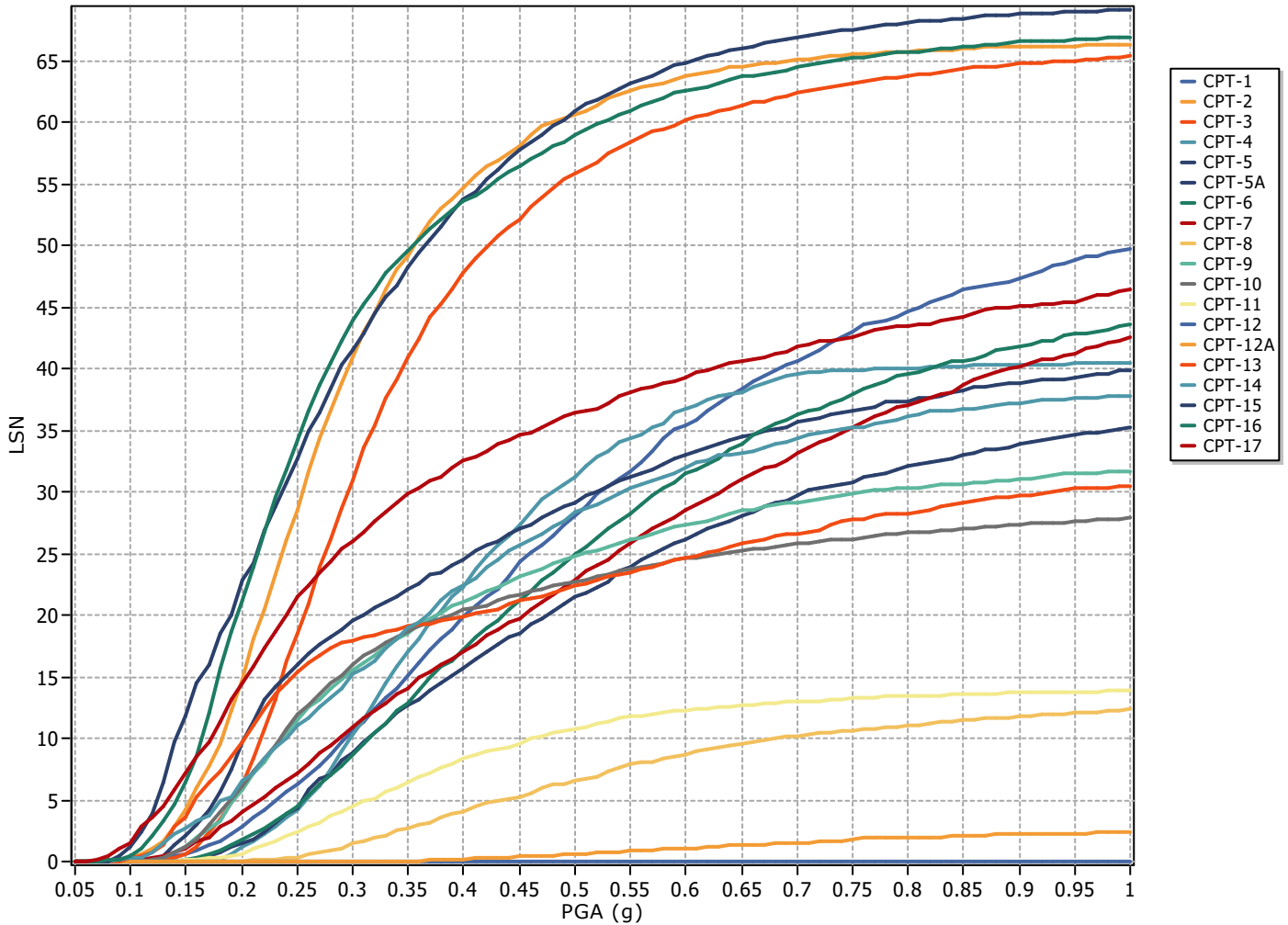

:: CPT main liquefaction parameters details ::

CPT Name	Assesment method	Earthquake Mag.	GWT in situ (ft)	GWT earthq. (ft)
CPT-1	NCEER (1998)	8.10	7.60	7.00
CPT-2	NCEER (1998)	8.10	9.90	7.00
CPT-3	NCEER (1998)	8.10	9.70	7.00
CPT-4	NCEER (1998)	8.10	11.00	7.00
CPT-5	NCEER (1998)	8.10	10.50	7.00
CPT-5A	NCEER (1998)	8.10	10.50	7.00
CPT-6	NCEER (1998)	8.10	10.50	7.00
CPT-7	NCEER (1998)	8.10	11.00	7.00
CPT-8	NCEER (1998)	8.10	11.00	7.00
CPT-9	NCEER (1998)	8.10	12.50	7.00
CPT-10	NCEER (1998)	8.10	10.50	7.00
CPT-11	NCEER (1998)	8.10	11.00	7.00
CPT-12	NCEER (1998)	8.10	12.00	7.00
CPT-12A	NCEER (1998)	8.10	12.00	7.00
CPT-13	NCEER (1998)	8.10	12.00	7.00



PGA Based Parametric Analysis

CPT-14	NCEER (1998)	8.10	9.50	7.00
CPT-15	NCEER (1998)	8.10	9.00	7.00
CPT-16	NCEER (1998)	8.10	9.80	7.00
CPT-17	NCEER (1998)	8.10	12.50	7.00

TABLE OF CONTENTS

CPT-1 results	
Summary data report	1
Transition layer algorithm summary report	8
Vertical settlements summary report	9
Lateral displacements summary report	10
CPT-2 results	
Summary data report	13
Transition layer algorithm summary report	20
Vertical settlements summary report	21
Lateral displacements summary report	22
CPT-3 results	
Summary data report	25
Transition layer algorithm summary report	32
Vertical settlements summary report	33
Lateral displacements summary report	34
CPT-4 results	
Summary data report	37
Transition layer algorithm summary report	44
Vertical settlements summary report	45
Lateral displacements summary report	46
CPT-5 results	
Summary data report	49
Transition layer algorithm summary report	56
Vertical settlements summary report	57
Lateral displacements summary report	58
CPT-5A results	
Summary data report	61
Transition layer algorithm summary report	68
Vertical settlements summary report	69
Lateral displacements summary report	70
CPT-6 results	
Summary data report	73
Transition layer algorithm summary report	80
Vertical settlements summary report	81
Lateral displacements summary report	82
CPT-7 results	
Summary data report	85
Transition layer algorithm summary report	92
Vertical settlements summary report	93
Lateral displacements summary report	94
CPT-8 results	
Summary data report	97
Transition layer algorithm summary report	104
Vertical settlements summary report	105
Lateral displacements summary report	106
CPT-9 results	
Summary data report	109
Transition layer algorithm summary report	116
Vertical settlements summary report	117
Lateral displacements summary report	118
CPT-10 results	
Summary data report	121

Transition layer algorithm summary report	128
Vertical settlements summary report	129
Lateral displacements summary report	130
CPT-11 results	
Summary data report	133
Transition layer algorithm summary report	140
Vertical settlements summary report	141
Lateral displacements summary report	142
CPT-12 results	
Summary data report	145
Transition layer algorithm summary report	152
Vertical settlements summary report	153
Lateral displacements summary report	154
CPT-12A results	
Summary data report	157
Transition layer algorithm summary report	164
Vertical settlements summary report	165
Lateral displacements summary report	166
CPT-13 results	
Summary data report	169
Transition layer algorithm summary report	176
Vertical settlements summary report	177
Lateral displacements summary report	178
CPT-14 results	
Summary data report	181
Transition layer algorithm summary report	188
Vertical settlements summary report	189
Lateral displacements summary report	190
CPT-15 results	
Summary data report	193
Transition layer algorithm summary report	200
Vertical settlements summary report	201
Lateral displacements summary report	202
CPT-16 results	
Summary data report	205
Transition layer algorithm summary report	212
Vertical settlements summary report	213
Lateral displacements summary report	214
CPT-17 results	
Summary data report	217
Transition layer algorithm summary report	224
Vertical settlements summary report	225
Lateral displacements summary report	226

LIQUEFACTION ANALYSIS REPORT

Project title : Petra Geosciences / Apple Canyon

Location : Lake Hemet, CA

CPT file : CPT-1

Input parameters and analysis data

Analysis method:	NCEER (1998)	G.W.T. (in-situ):	7.60 ft	Use fill:	No	Clay like behavior applied:	Sands only
Fines correction method:	NCEER (1998)	G.W.T. (earthq.):	7.00 ft	Fill height:	N/A	Limit depth applied:	No
Points to test:	Based on Ic value	Average results interval:	3	Fill weight:	N/A	Limit depth:	N/A
Earthquake magnitude M_w :	8.10	Ic cut-off value:	2.60	Trans. detect. applied:	Yes	MSF method:	Method based
Peak ground acceleration:	0.89	Unit weight calculation:	Based on SBT	K_o applied:	Yes		

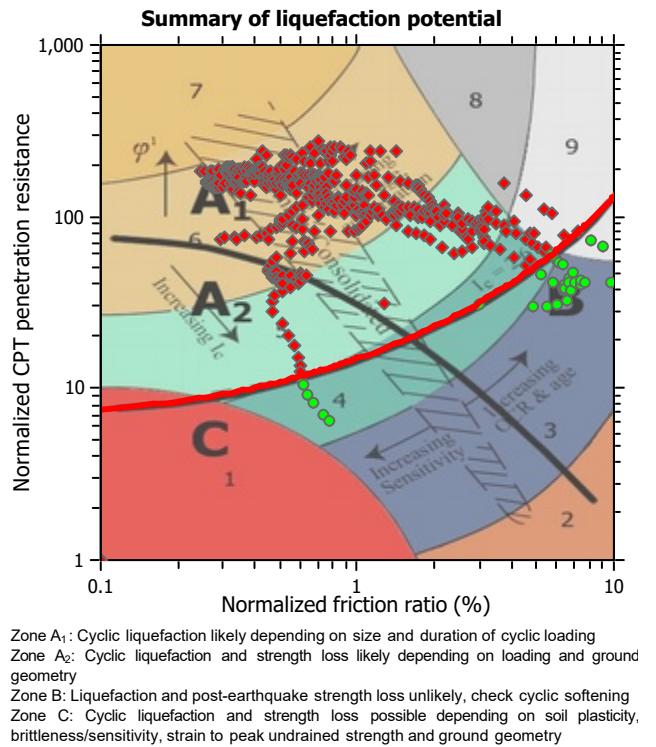
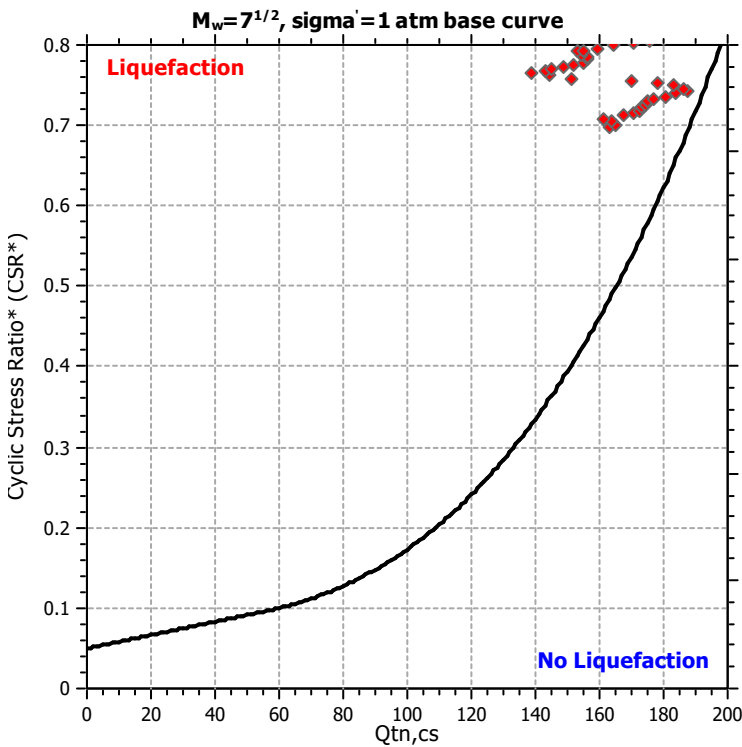
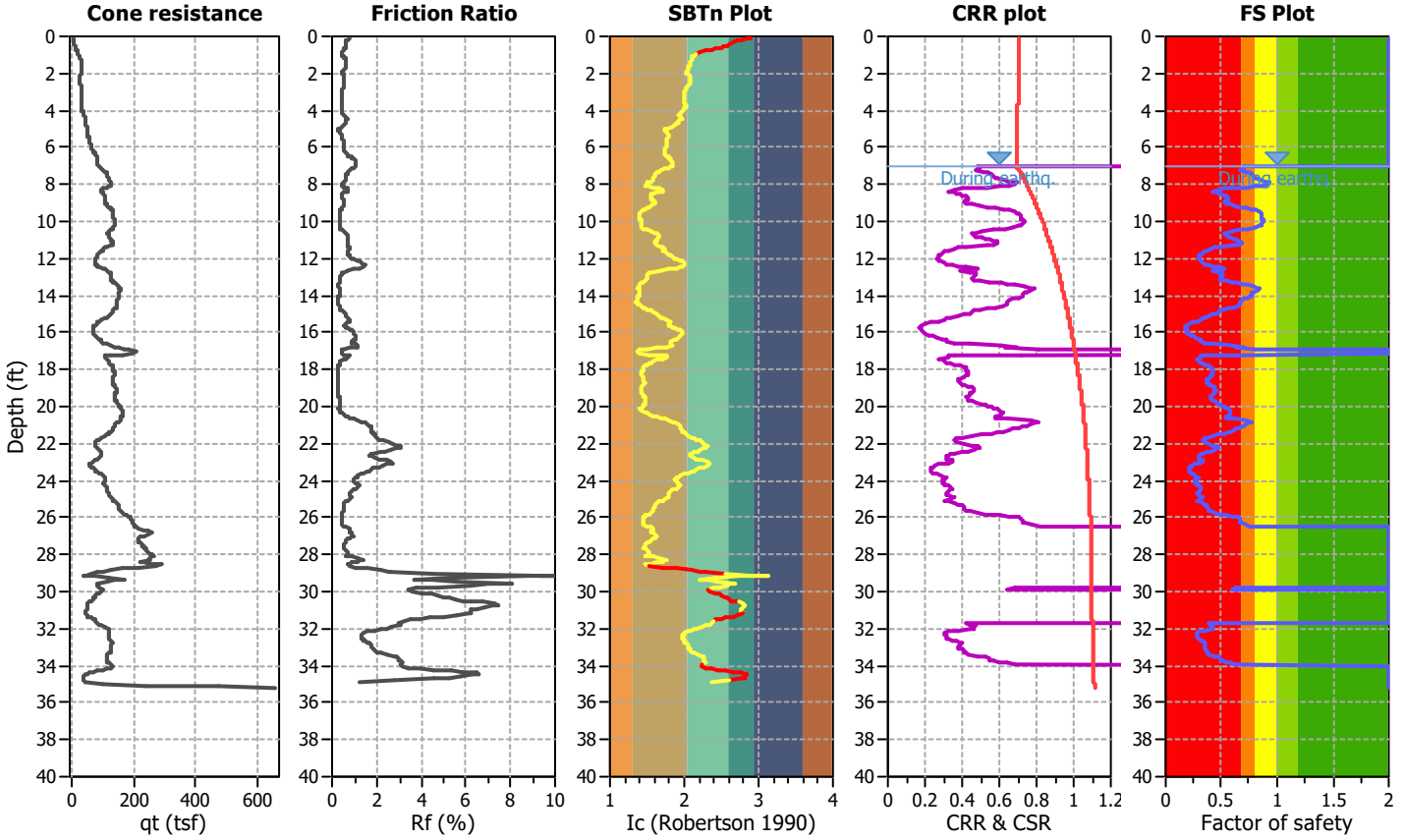

CPT basic interpretation plots

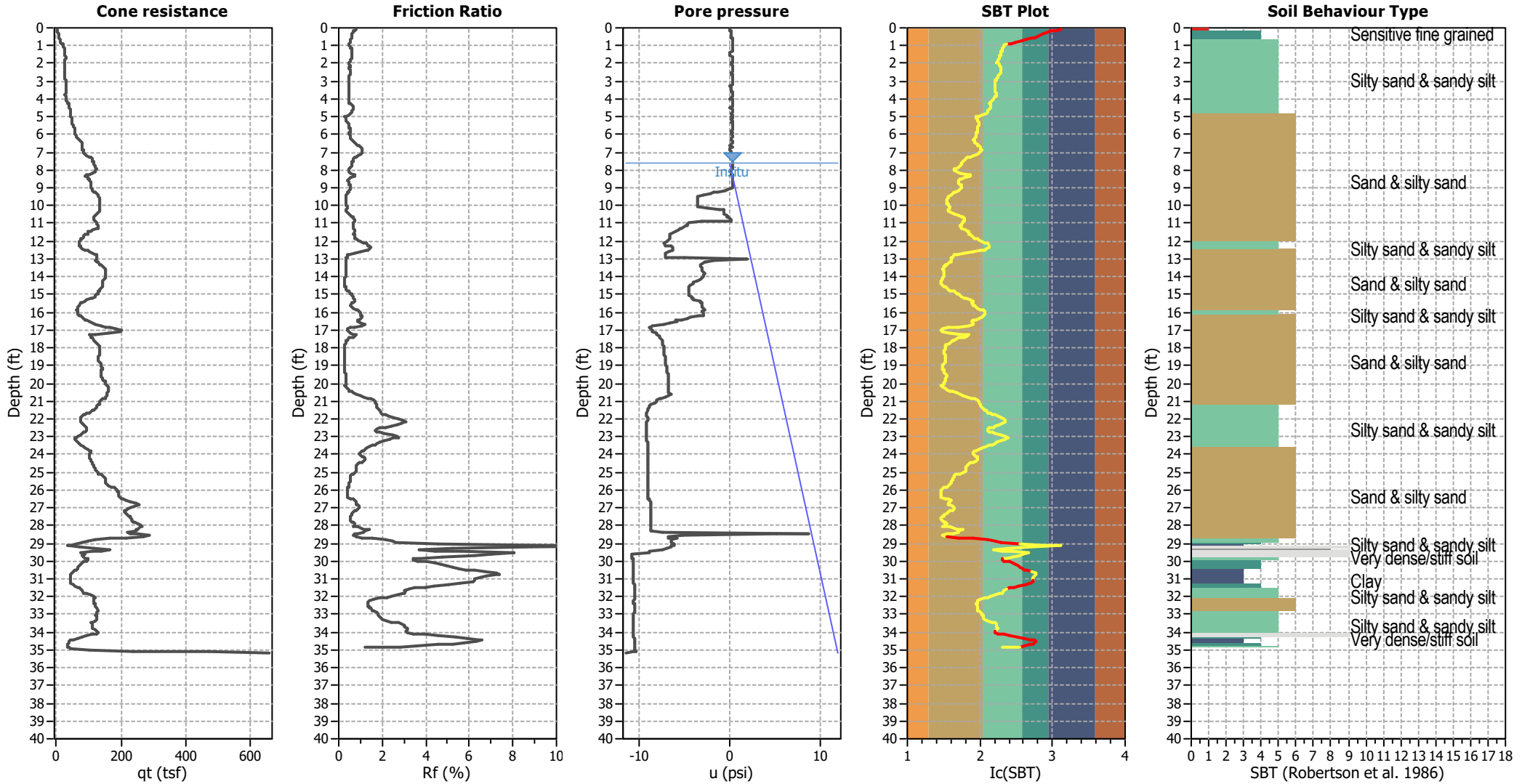

Input parameters and analysis data

Analysis method:	NCEER (1998)	Depth to water table (erthq.):	7.00 ft	Fill weight:	N/A
Fines correction method:	NCEER (1998)	Average results interval:	3	Transition detect. applied:	Yes
Points to test:	Based on Ic value	Ic cut-off value:	2.60	K ₀ applied:	Yes
Earthquake magnitude M _w :	8.10	Unit weight calculation:	Based on SBT	Clay like behavior applied:	Sands only
Peak ground acceleration:	0.89	Use fill:	No	Limit depth applied:	No
Depth to water table (insitu):	7.60 ft	Fill height:	N/A	Limit depth:	N/A

SBT legend

1. Sensitive fine grained	4. Clayey silt to silty	7. Gravely sand to sand
2. Organic material	5. Silty sand to sandy silt	8. Very stiff sand to
3. Clay to silty clay	6. Clean sand to silty sand	9. Very stiff fine grained

CPT basic interpretation plots (normalized)

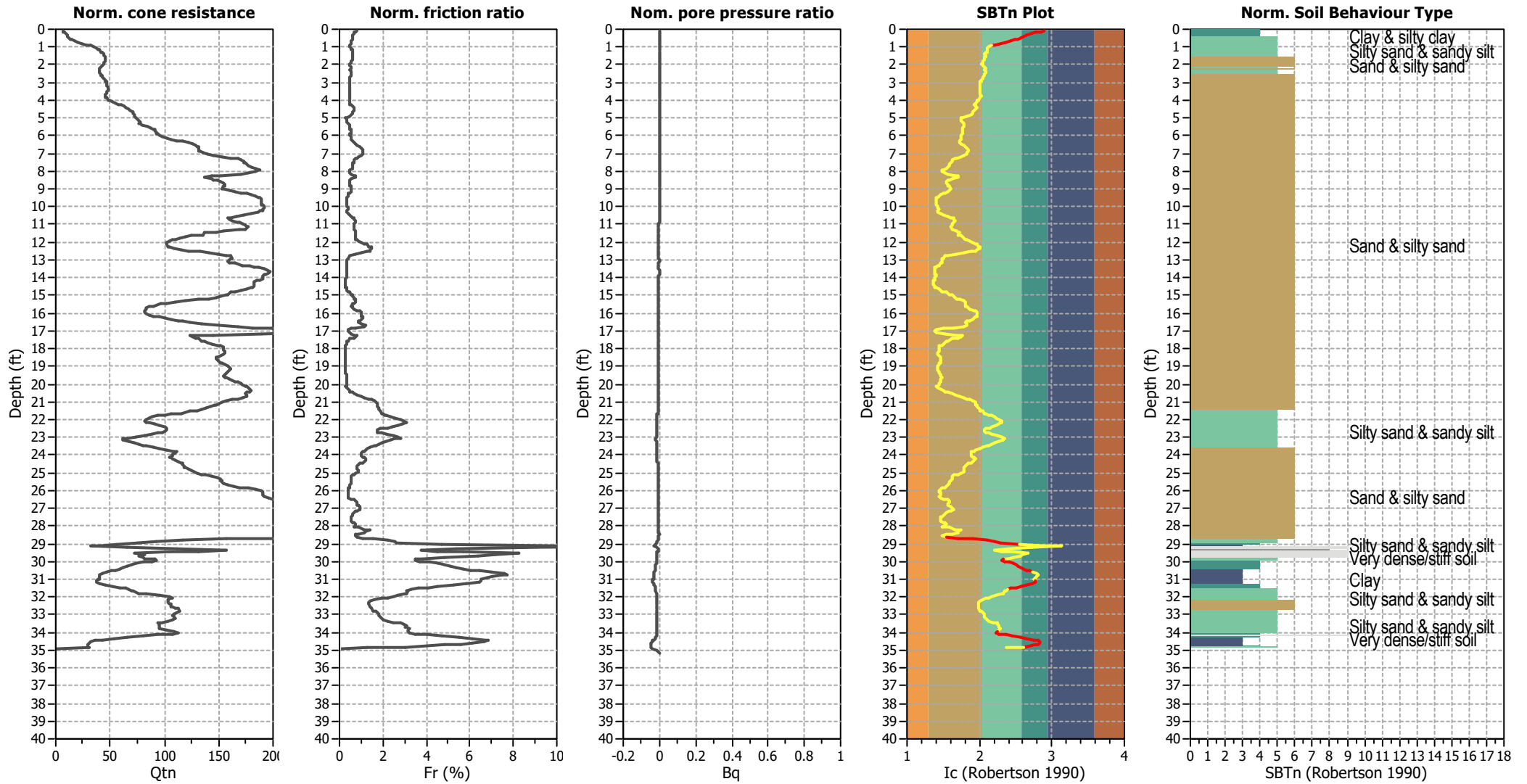

Input parameters and analysis data

Analysis method:	NCEER (1998)	Depth to water table (earthq.):	7.00 ft	Fill weight:	N/A
Fines correction method:	NCEER (1998)	Average results interval:	3	Transition detect. applied:	Yes
Points to test:	Based on Ic value	Ic cut-off value:	2.60	K ₀ applied:	Yes
Earthquake magnitude M _w :	8.10	Unit weight calculation:	Based on SBT	Clay like behavior applied:	Sands only
Peak ground acceleration:	0.89	Use fill:	No	Limit depth applied:	No
Depth to water table (insitu):	7.60 ft	Fill height:	N/A	Limit depth:	N/A

SBTn legend

1. Sensitive fine grained	4. Clayey silt to silty	7. Gravely sand to sand
2. Organic material	5. Silty sand to sandy silt	8. Very stiff sand to
3. Clay to silty clay	6. Clean sand to silty sand	9. Very stiff fine grained

Liquefaction analysis overall plots (intermediate results)

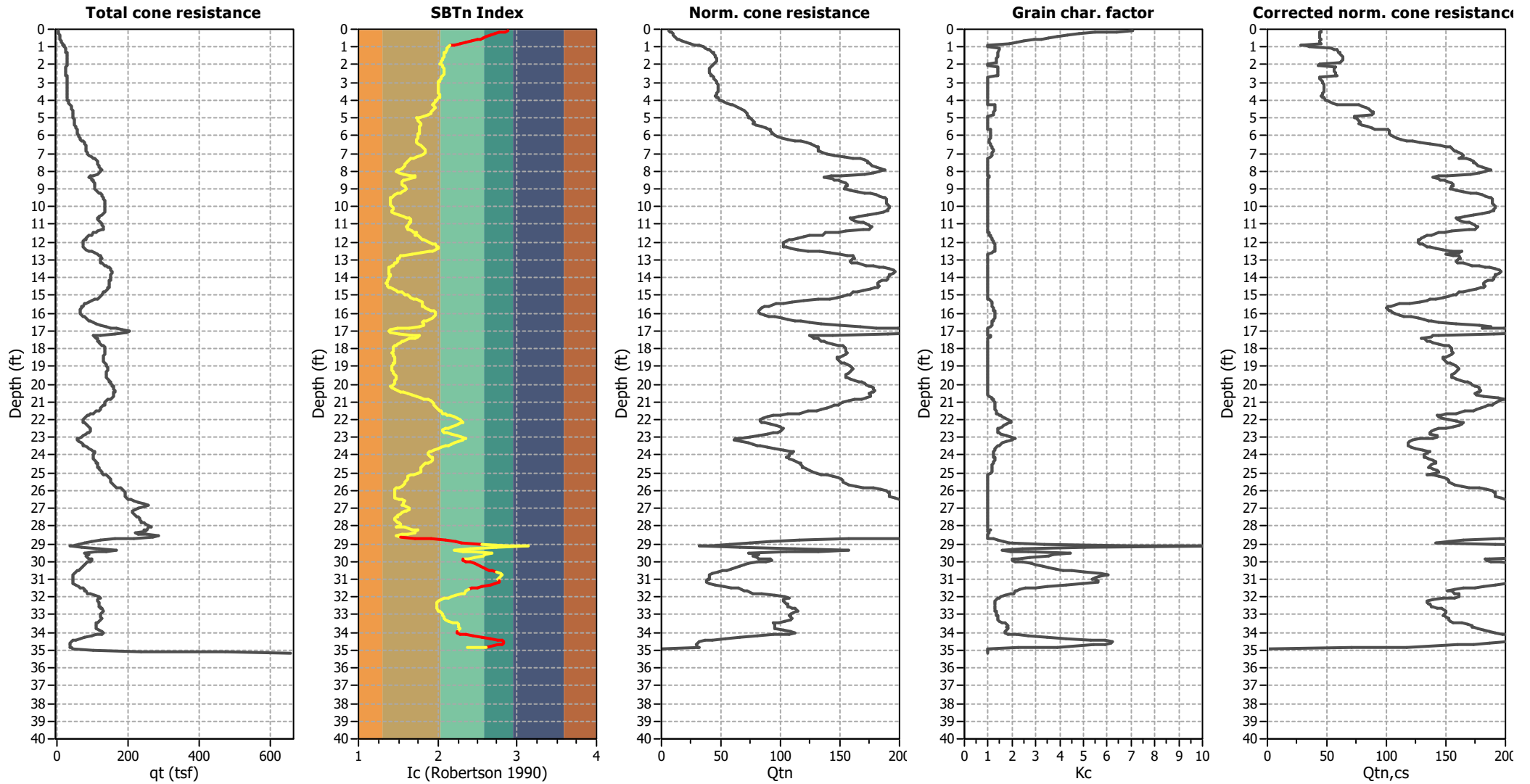

Input parameters and analysis data

Analysis method:	NCEER (1998)	Depth to water table (earthq.):	7.00 ft	Fill weight:	N/A
Fines correction method:	NCEER (1998)	Average results interval:	3	Transition detect. applied:	Yes
Points to test:	Based on Ic value	Ic cut-off value:	2.60	K _o applied:	Yes
Earthquake magnitude M _w :	8.10	Unit weight calculation:	Based on SBT	Clay like behavior applied:	Sands only
Peak ground acceleration:	0.89	Use fill:	No	Limit depth applied:	No
Depth to water table (insitu):	7.60 ft	Fill height:	N/A	Limit depth:	N/A

Liquefaction analysis overall plots

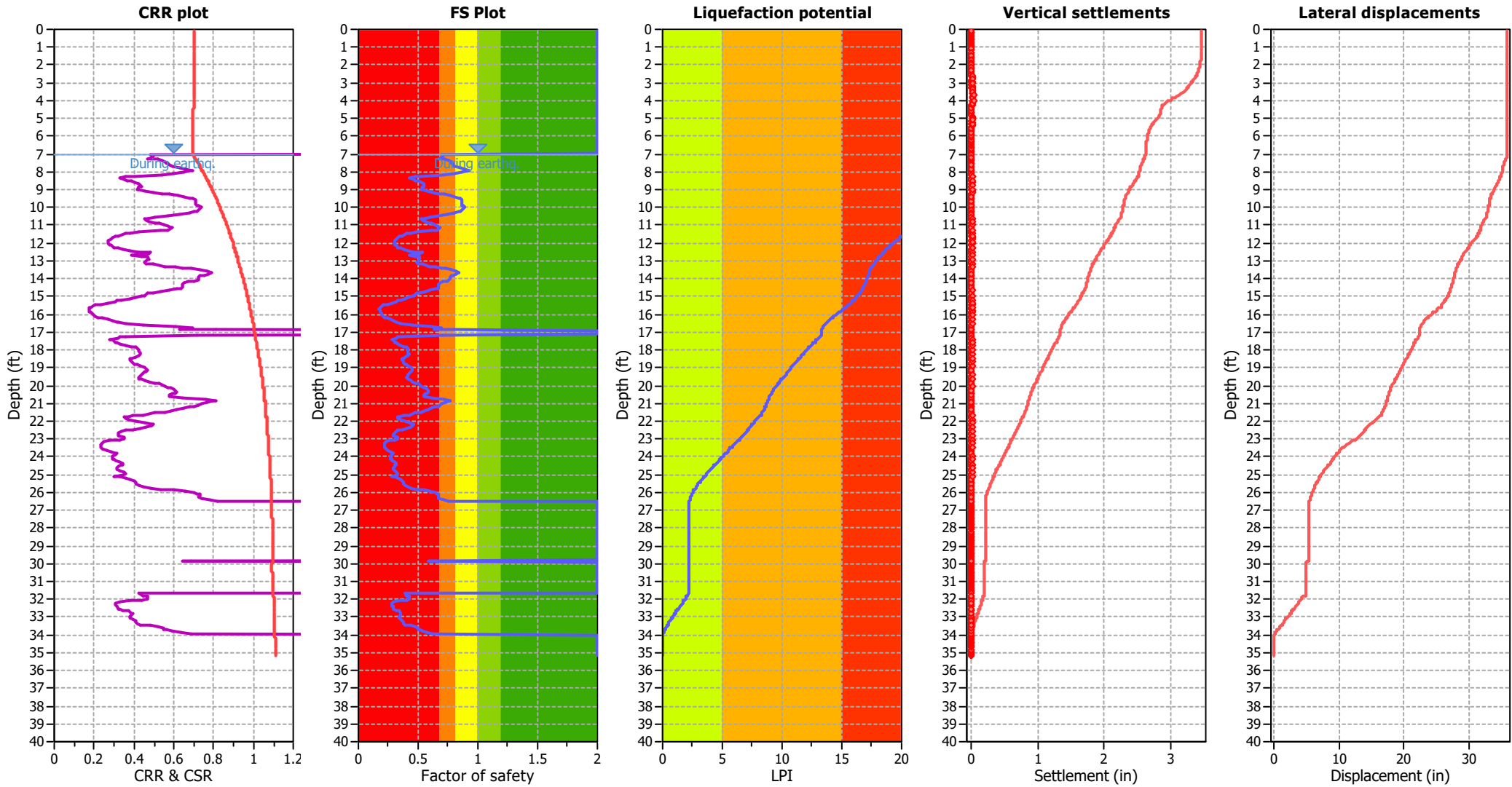

Input parameters and analysis data

Analysis method:	NCEER (1998)	Depth to water table (earthq.):	7.00 ft	Fill weight:	N/A
Fines correction method:	NCEER (1998)	Average results interval:	3	Transition detect. applied:	Yes
Points to test:	Based on Ic value	Ic cut-off value:	2.60	K ₀ applied:	Yes
Earthquake magnitude M _w :	8.10	Unit weight calculation:	Based on SBT	Clay like behavior applied:	Sands only
Peak ground acceleration:	0.89	Use fill:	No	Limit depth applied:	No
Depth to water table (insitu):	7.60 ft	Fill height:	N/A	Limit depth:	N/A

F.S. color scheme

- Almost certain it will liquefy
- Very likely to liquefy
- Liquefaction and no liq. are equally likely
- Unlike to liquefy
- Almost certain it will not liquefy

LPI color scheme

- Very high risk
- High risk
- Low risk

Liquefaction analysis summary plots

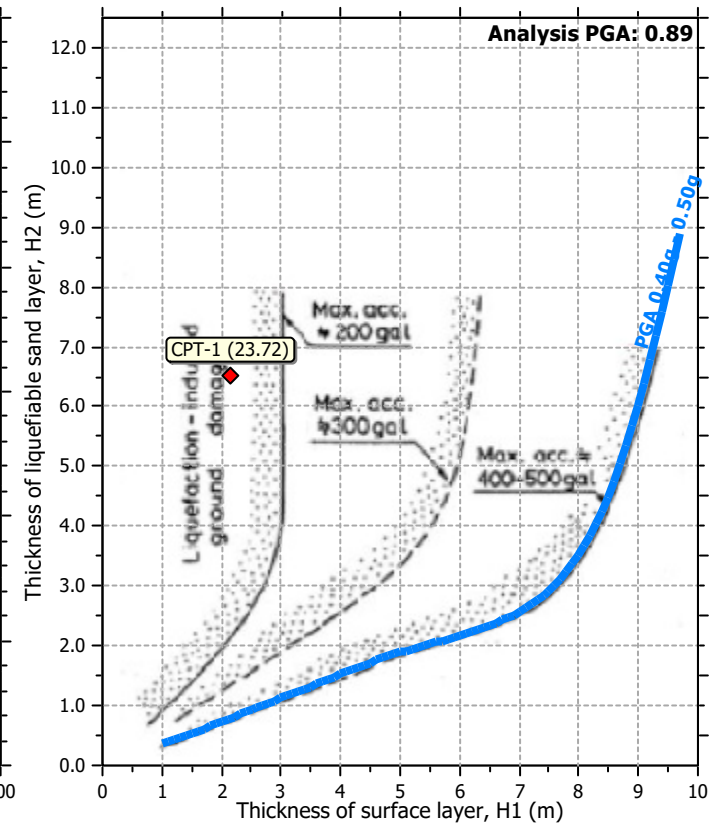
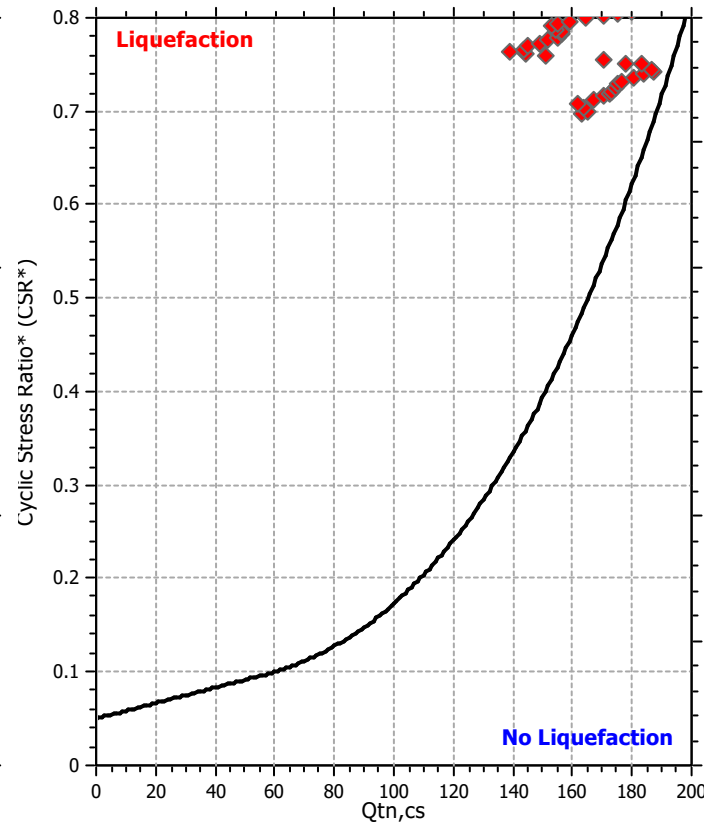
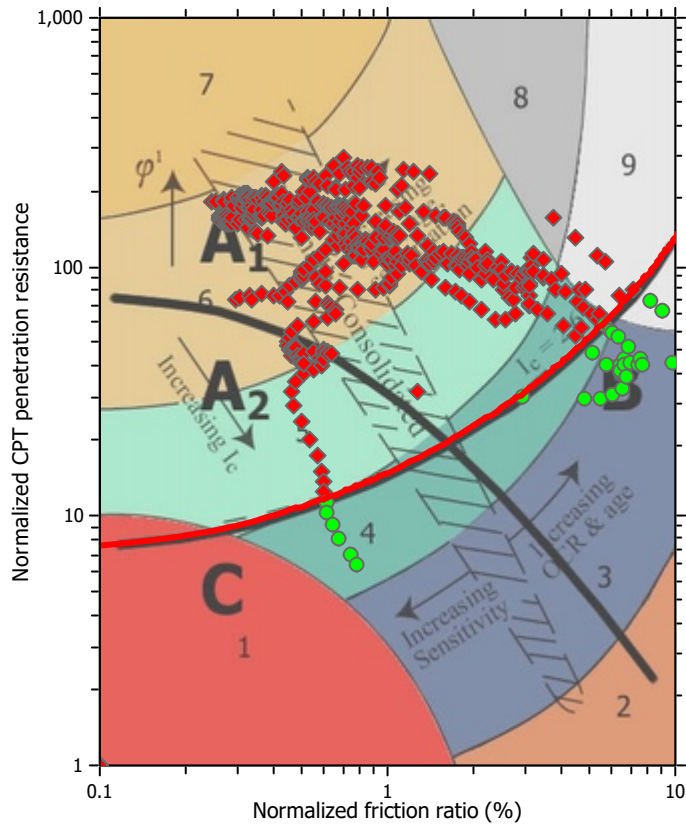

Input parameters and analysis data

Analysis method:	NCEER (1998)	Depth to water table (earthq.):	7.00 ft	Fill weight:	N/A
Fines correction method:	NCEER (1998)	Average results interval:	3	Transition detect. applied:	Yes
Points to test:	Based on Ic value	Ic cut-off value:	2.60	K_v applied:	Yes
Earthquake magnitude M_w :	8.10	Unit weight calculation:	Based on SBT	Clay like behavior applied:	Sands only
Peak ground acceleration:	0.89	Use fill:	No	Limit depth applied:	No
Depth to water table (insitu):	7.60 ft	Fill height:	N/A	Limit depth:	N/A

Check for strength loss plots (Robertson (2010))

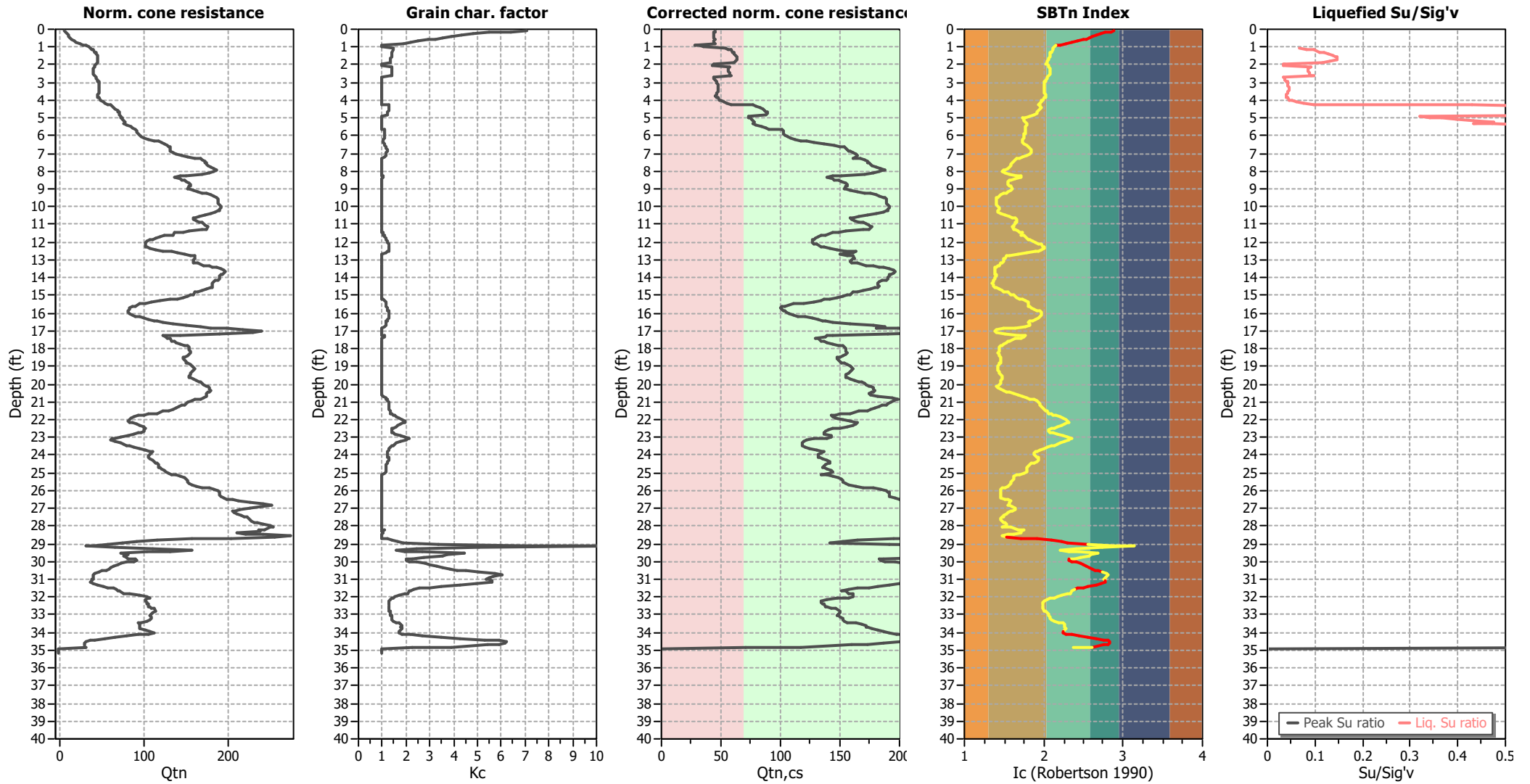

Input parameters and analysis data

Analysis method:	NCEER (1998)	Depth to water table (erthq.):	7.00 ft	Fill weight:	N/A
Fines correction method:	NCEER (1998)	Average results interval:	3	Transition detect. applied:	Yes
Points to test:	Based on Ic value	Ic cut-off value:	2.60	K _o applied:	Yes
Earthquake magnitude M _w :	8.10	Unit weight calculation:	Based on SBT	Clay like behavior applied:	Sands only
Peak ground acceleration:	0.89	Use fill:	No	Limit depth applied:	No
Depth to water table (insitu):	7.60 ft	Fill height:	N/A	Limit depth:	N/A

TRANSITION LAYER DETECTION ALGORITHM REPORT

Summary Details & Plots

Short description

The software will delete data when the cone is in transition from either clay to sand or vice-versa. To do this the software requires a range of I_c values over which the transition will be defined (typically somewhere between $1.80 < I_c < 3.0$) and a rate of change of I_c . Transitions typically occur when the rate of change of I_c is fast (i.e. ΔI_c is small).

The SBT_n plot below, displays in red the detected transition layers based on the parameters listed below the graphs.

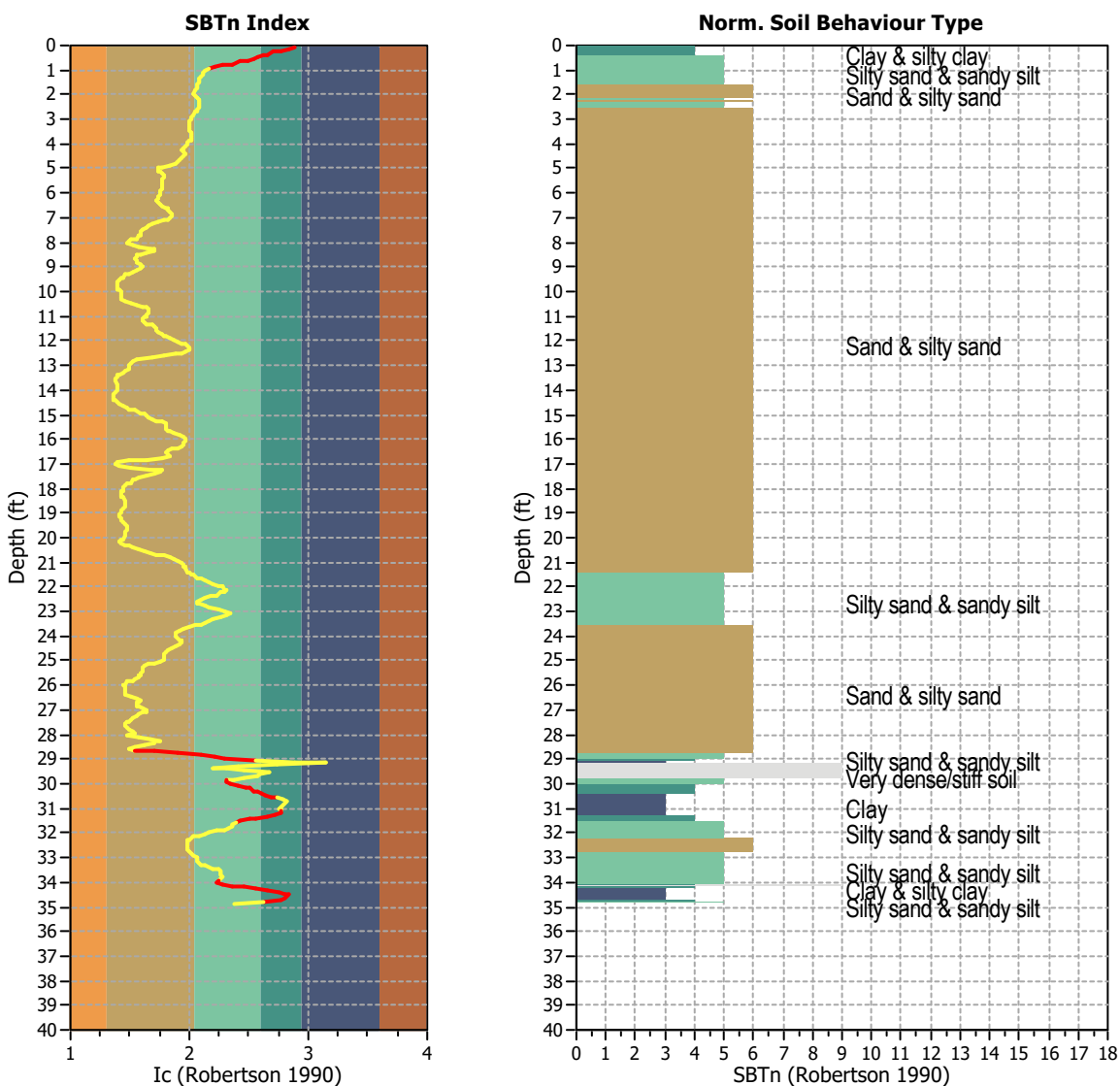

Transition layer algorithm properties

I_c minimum check value: 1.70
 I_c maximum check value: 3.00
 I_c change ratio value: 0.0250
 Minimum number of points in layer: 4

General statistics

Total points in CPT file: 536
 Total points excluded: 56
 Exclusion percentage: 10.45%
 Number of layers detected: 6

Estimation of post-earthquake settlements

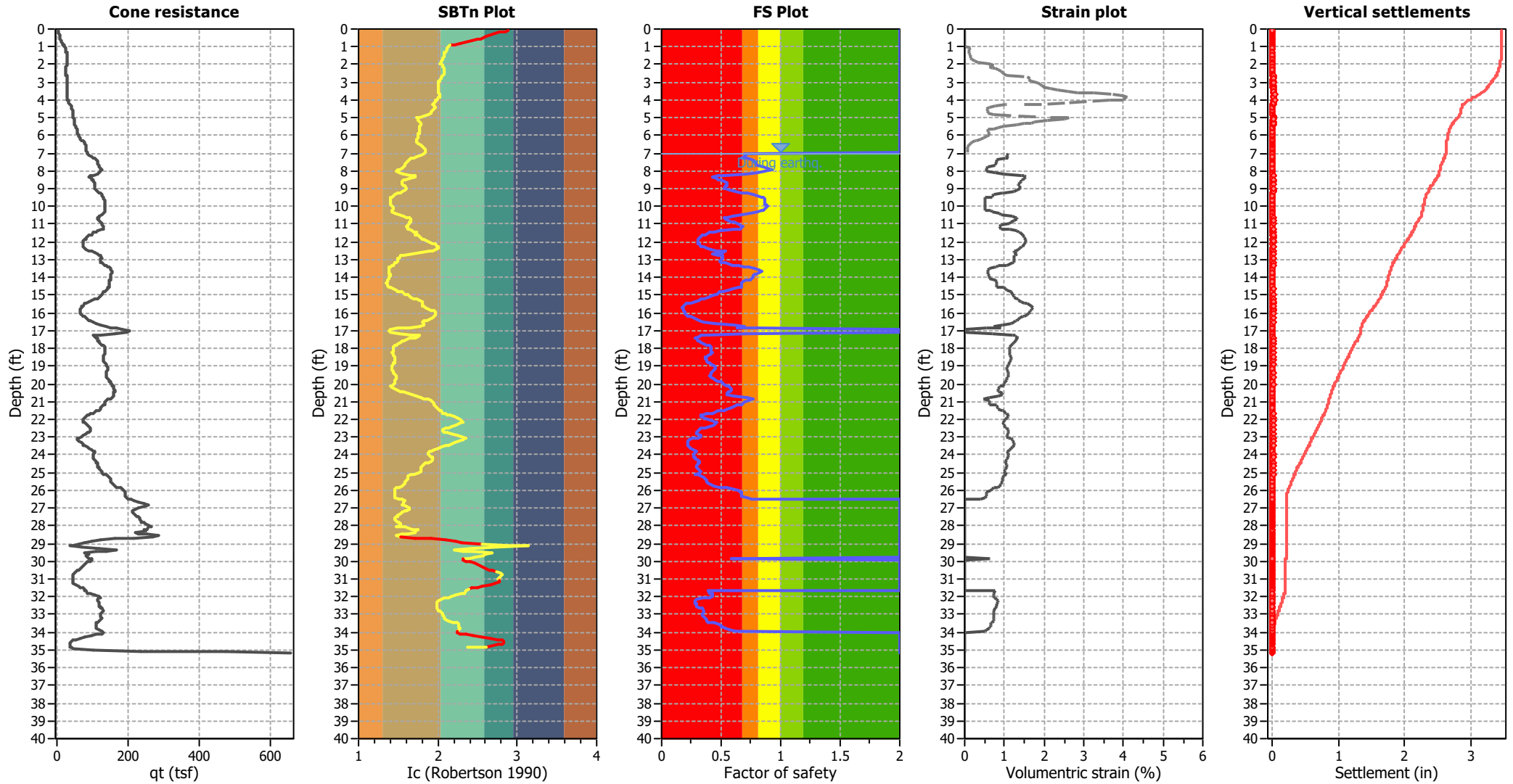

Abbreviations

- q_c: Total cone resistance (cone resistance q_c corrected for pore water effects)
- I_c: Soil Behaviour Type Index
- FS: Calculated Factor of Safety against liquefaction
- Volumetric strain: Post-liquefaction volumetric strain

Estimation of post-earthquake lateral Displacements

Geometric parameters: Gently sloping ground without free face (Slope 1.00 %)

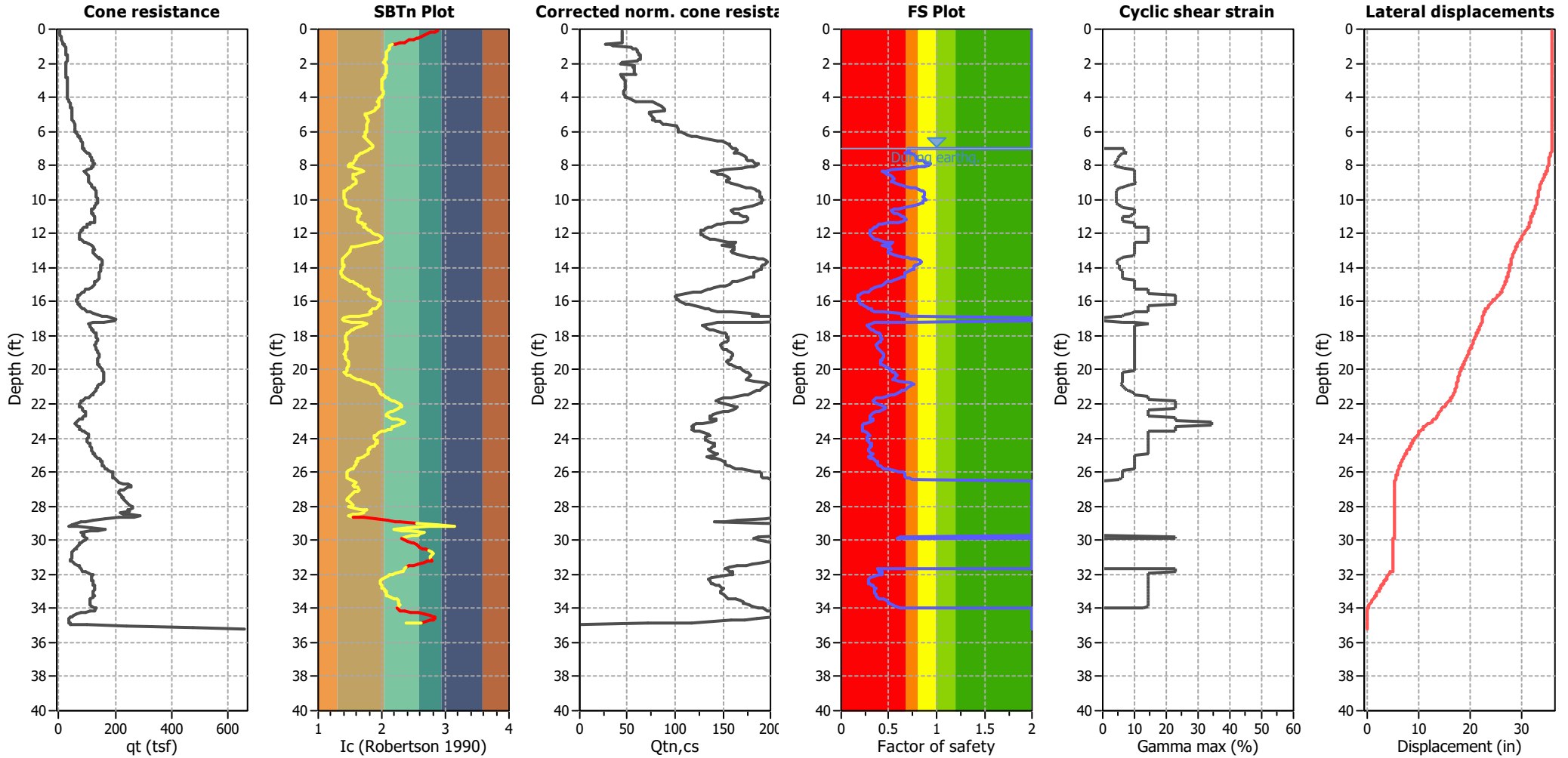

Abbreviations

q_t: Total cone resistance (cone resistance q_c corrected for pore water effects)
 I_c: Soil Behaviour Type Index
 Q_{tn,cs}: Equivalent clean sand normalized CPT total cone resistance

F.S.: Factor of safety
 γ_{max}: Maximum cyclic shear strain
 LDI: Lateral displacement index

Surface condition



Aging Calculation Estimation

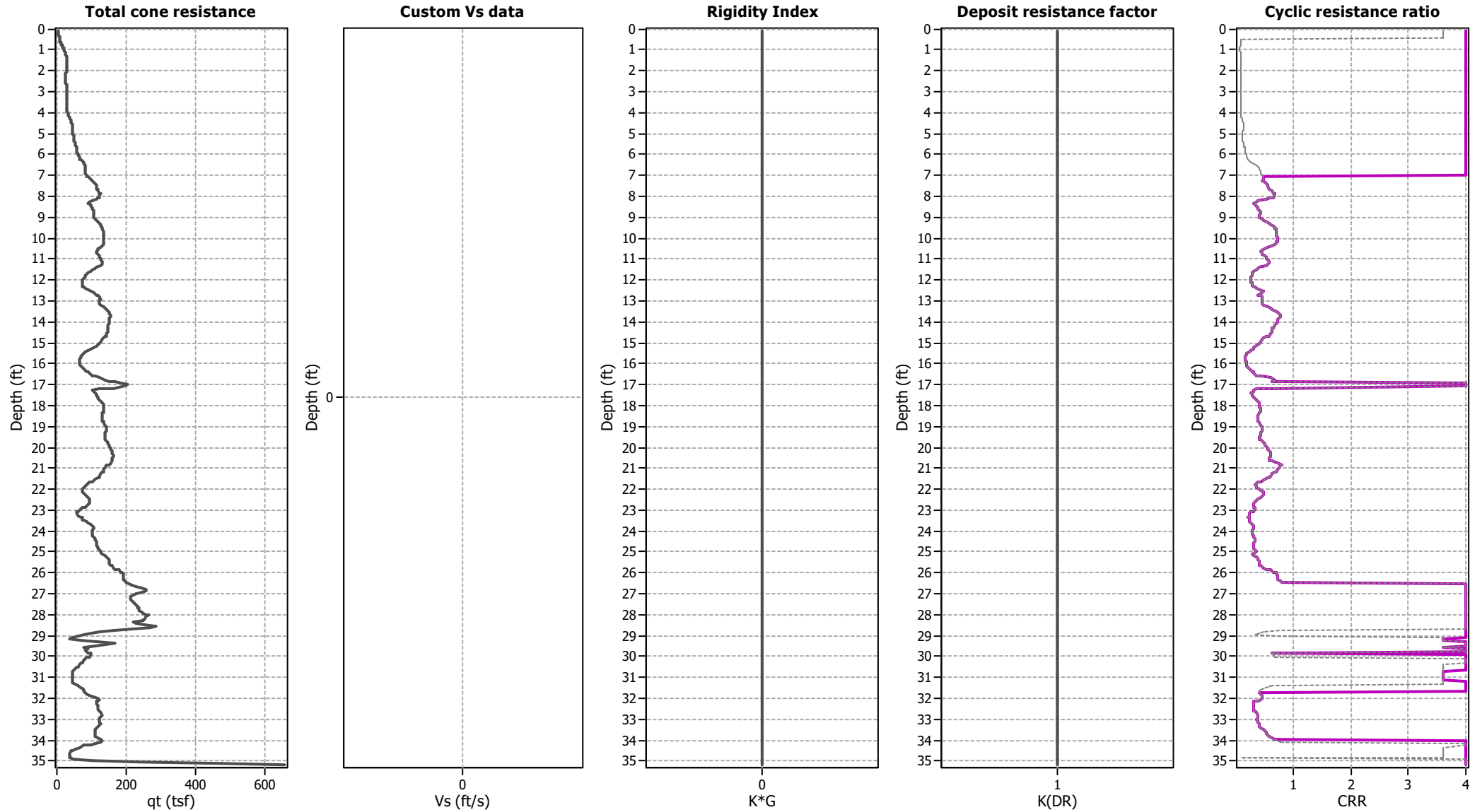

Ejecta Severity Estimation

Corrected norm. cone resista

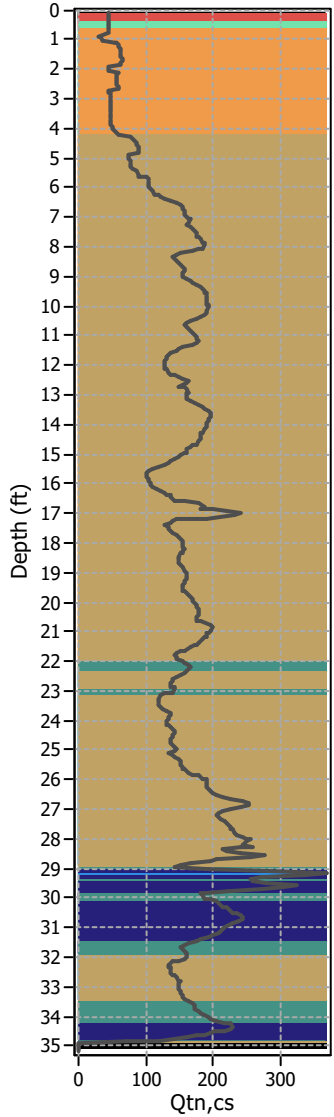

SBTn Index Plot

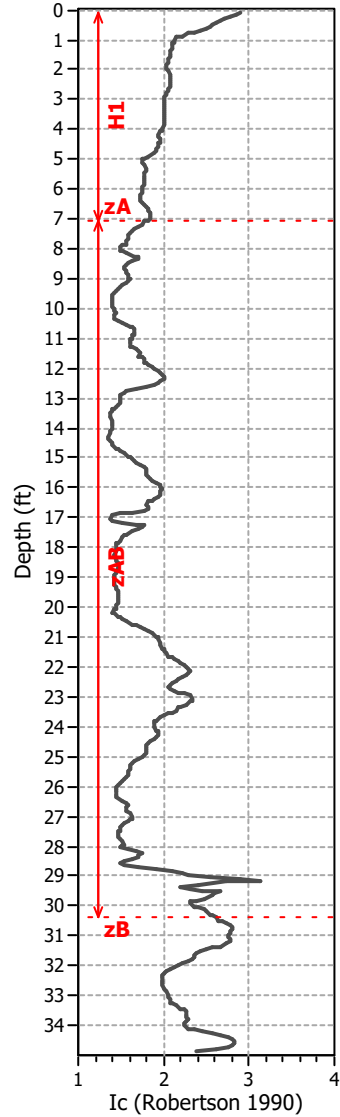

FS plot

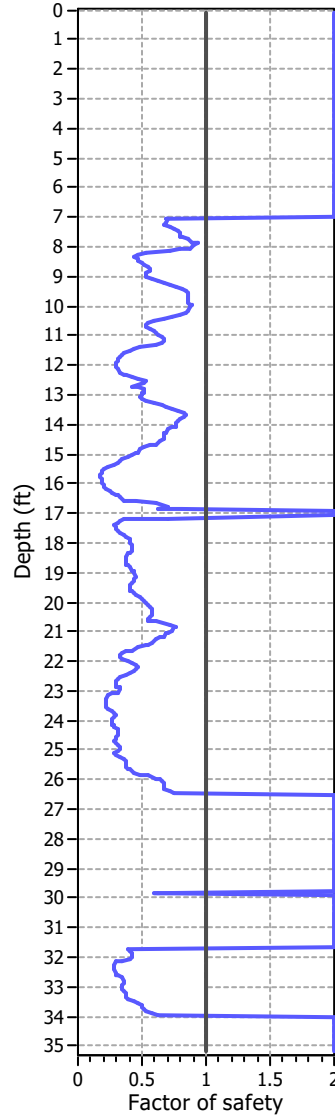

Stresses vs Depth

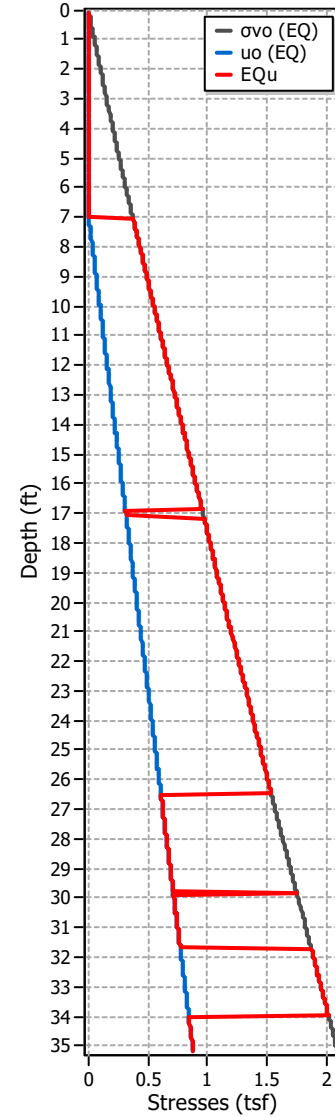

Excess Head

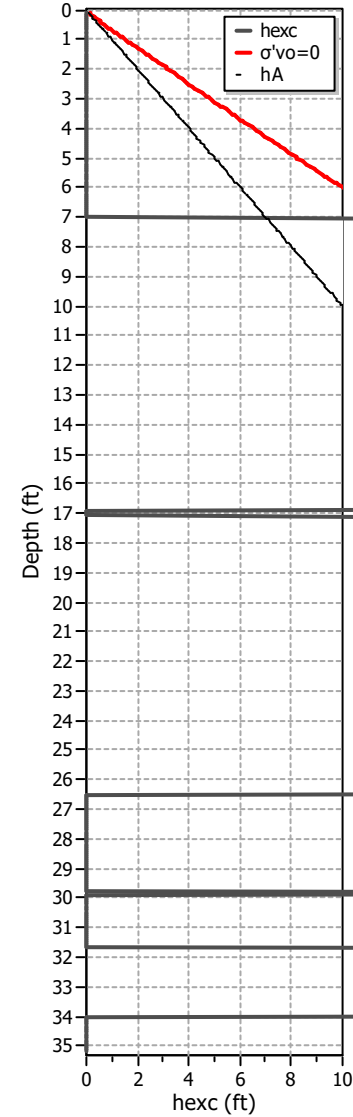

Liq. ejecta demand

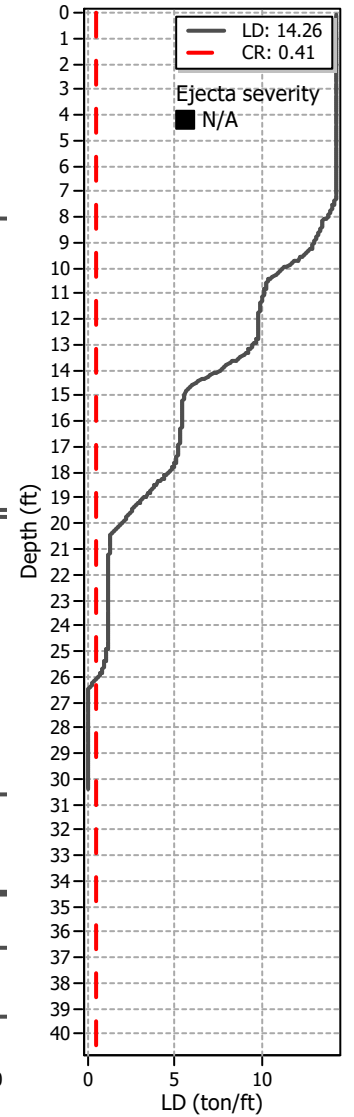

LIQUEFACTION ANALYSIS REPORT

Project title : Petra Geosciences / Apple Canyon

Location : Lake Hemet, CA

CPT file : CPT-2

Input parameters and analysis data

Analysis method:	NCEER (1998)	G.W.T. (in-situ):	9.90 ft	Use fill:	No	Clay like behavior applied:	Sands only
Fines correction method:	NCEER (1998)	G.W.T. (earthq.):	7.00 ft	Fill height:	N/A	Limit depth applied:	No
Points to test:	Based on Ic value	Average results interval:	3	Fill weight:	N/A	Limit depth:	N/A
Earthquake magnitude M_w :	8.10	Ic cut-off value:	2.60	Trans. detect. applied:	Yes	MSF method:	Method based
Peak ground acceleration:	0.89	Unit weight calculation:	Based on SBT	K_o applied:	Yes		

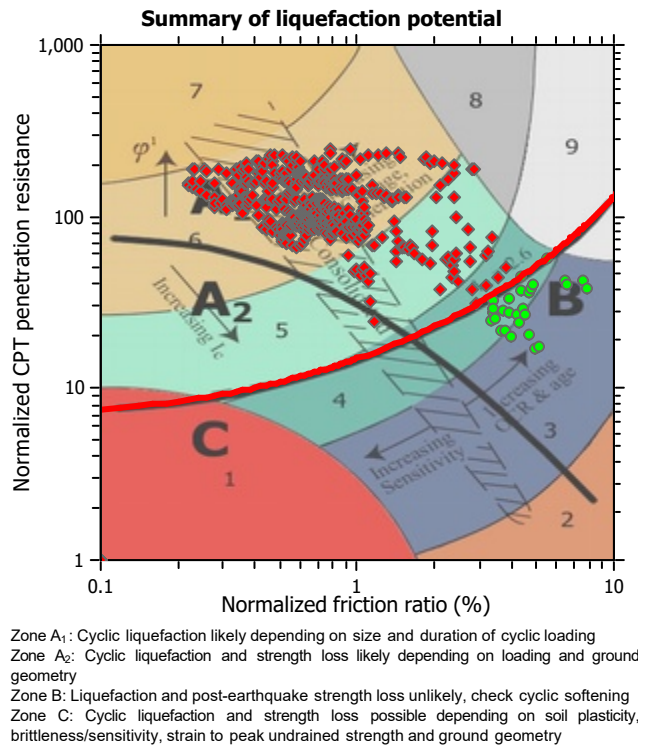
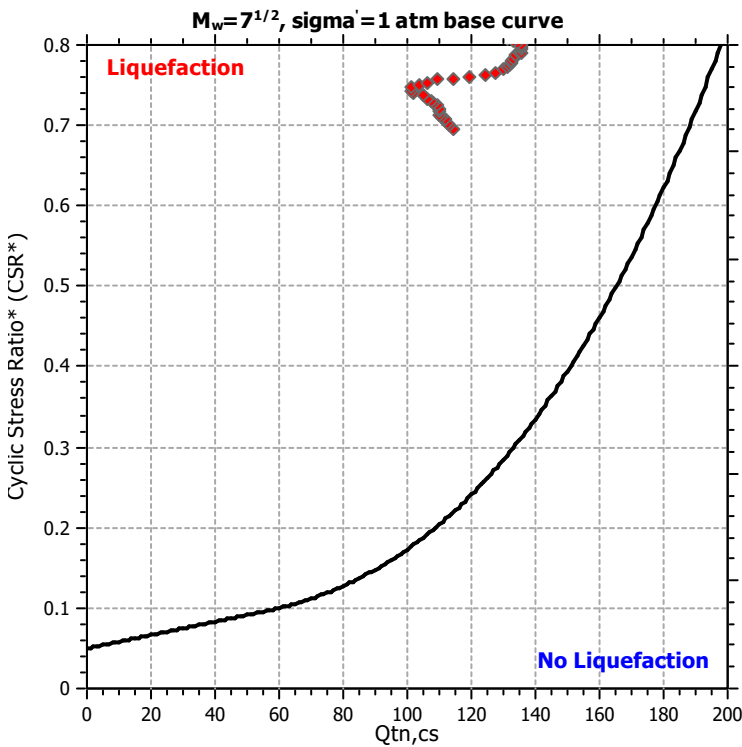
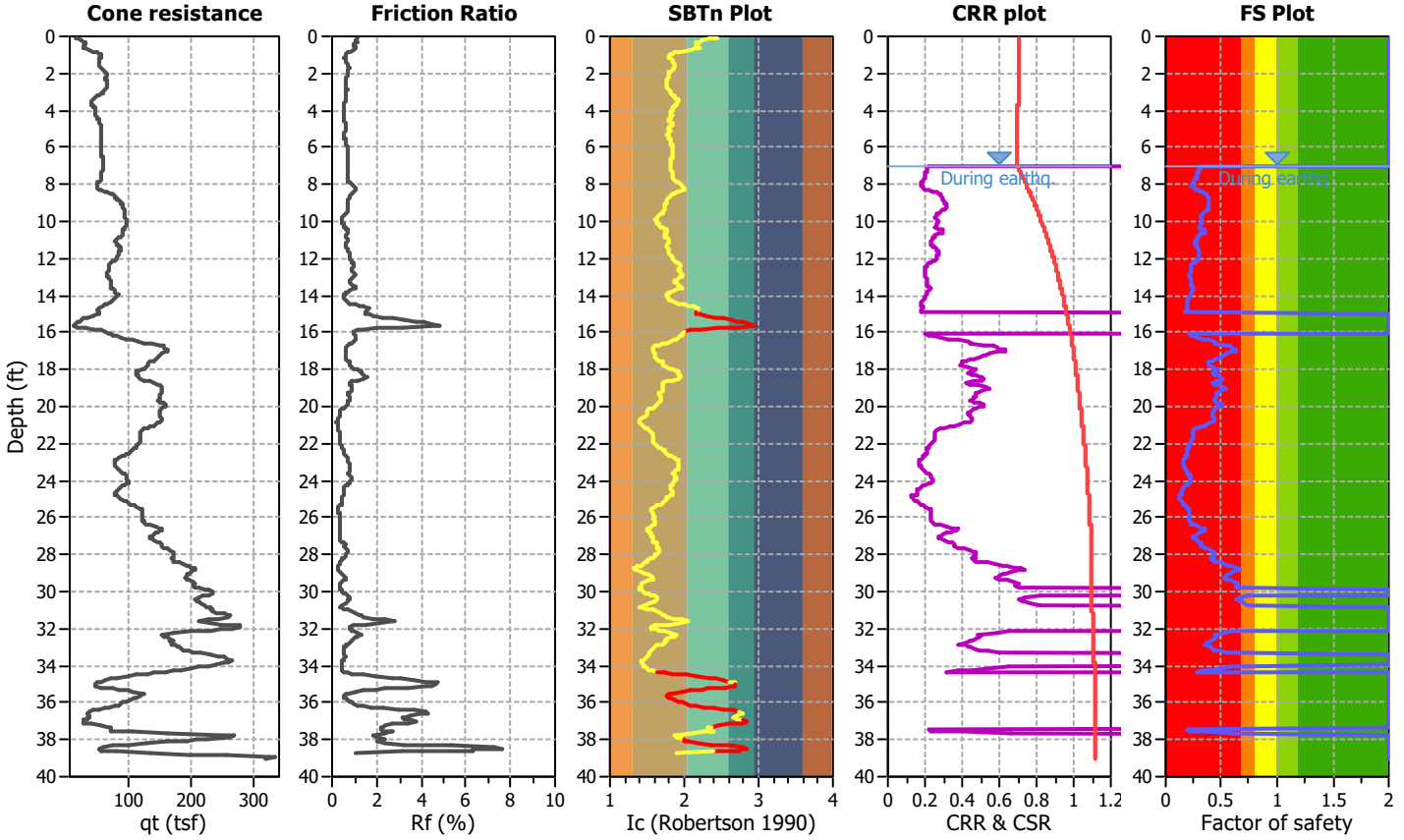

CPT basic interpretation plots

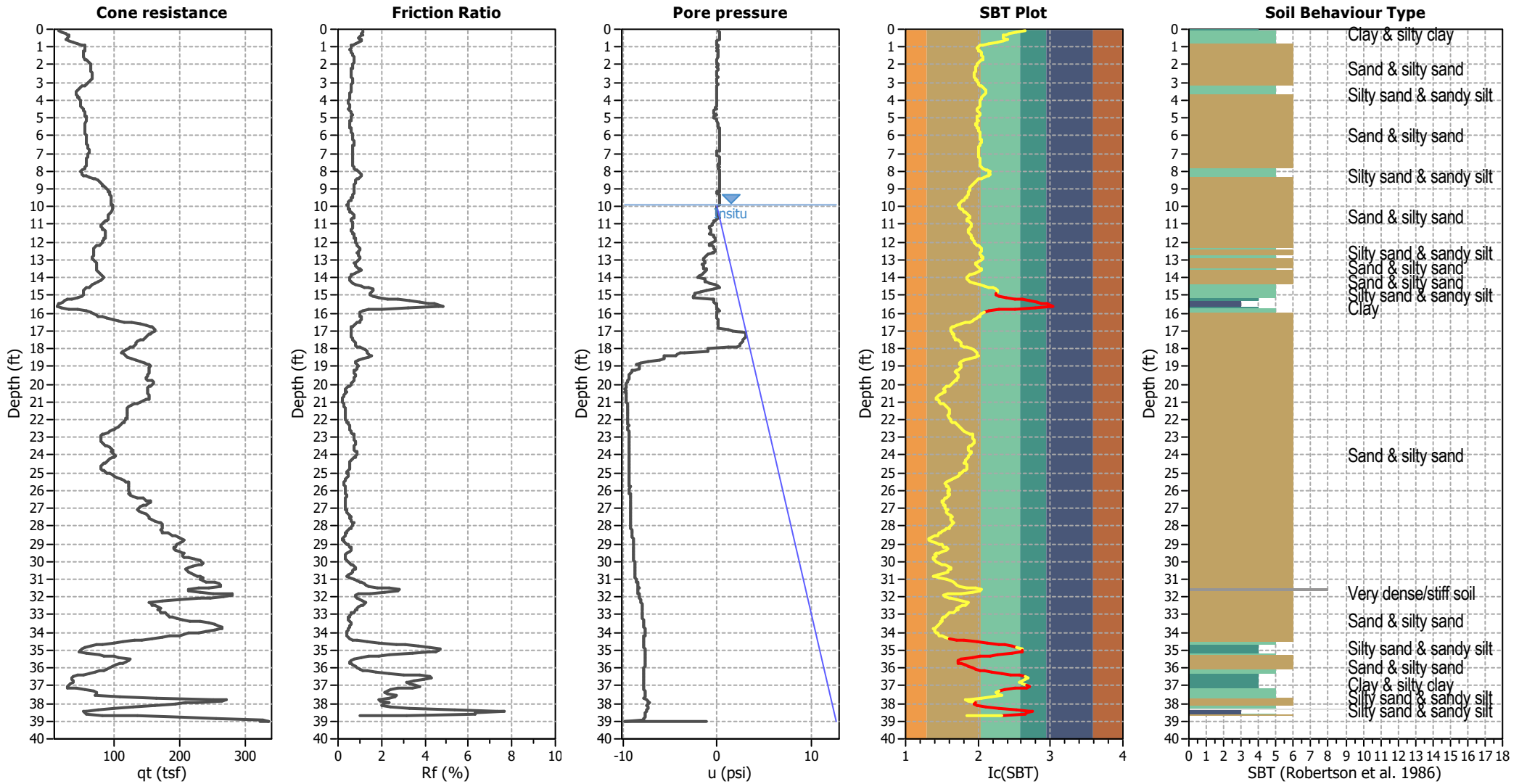

Input parameters and analysis data

Analysis method:	NCEER (1998)	Depth to water table (erthq.):	7.00 ft	Fill weight:	N/A
Fines correction method:	NCEER (1998)	Average results interval:	3	Transition detect. applied:	Yes
Points to test:	Based on Ic value	Ic cut-off value:	2.60	K _o applied:	Yes
Earthquake magnitude M _w :	8.10	Unit weight calculation:	Based on SBT	Clay like behavior applied:	Sands only
Peak ground acceleration:	0.89	Use fill:	No	Limit depth applied:	No
Depth to water table (insitu):	9.90 ft	Fill height:	N/A	Limit depth:	N/A

SBT legend

1. Sensitive fine grained	4. Clayey silt to silty	7. Gravely sand to sand
2. Organic material	5. Silty sand to sandy silt	8. Very stiff sand to
3. Clay to silty clay	6. Clean sand to silty sand	9. Very stiff fine grained

CPT basic interpretation plots (normalized)

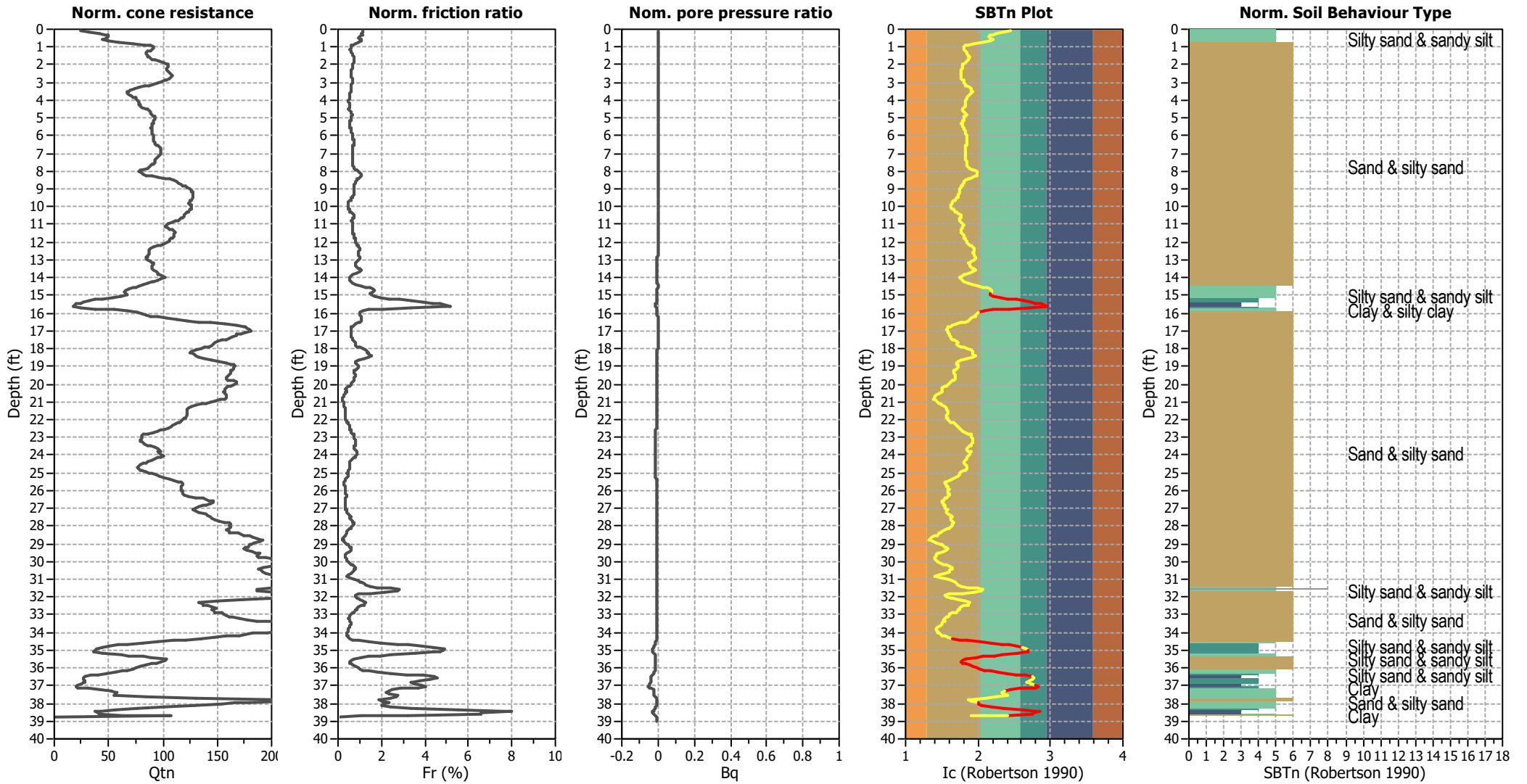

Input parameters and analysis data

Analysis method:	NCEER (1998)	Depth to water table (erthq.):	7.00 ft	Fill weight:	N/A
Fines correction method:	NCEER (1998)	Average results interval:	3	Transition detect. applied:	Yes
Points to test:	Based on Ic value	Ic cut-off value:	2.60	K _o applied:	Yes
Earthquake magnitude M _w :	8.10	Unit weight calculation:	Based on SBT	Clay like behavior applied:	Sands only
Peak ground acceleration:	0.89	Use fill:	No	Limit depth applied:	No
Depth to water table (insitu):	9.90 ft	Fill height:	N/A	Limit depth:	N/A

SBTn legend

1. Sensitive fine grained	4. Clayey silt to silty	7. Gravely sand to sand
2. Organic material	5. Silty sand to sandy silt	8. Very stiff sand to
3. Clay to silty clay	6. Clean sand to silty sand	9. Very stiff fine grained

Liquefaction analysis overall plots (intermediate results)

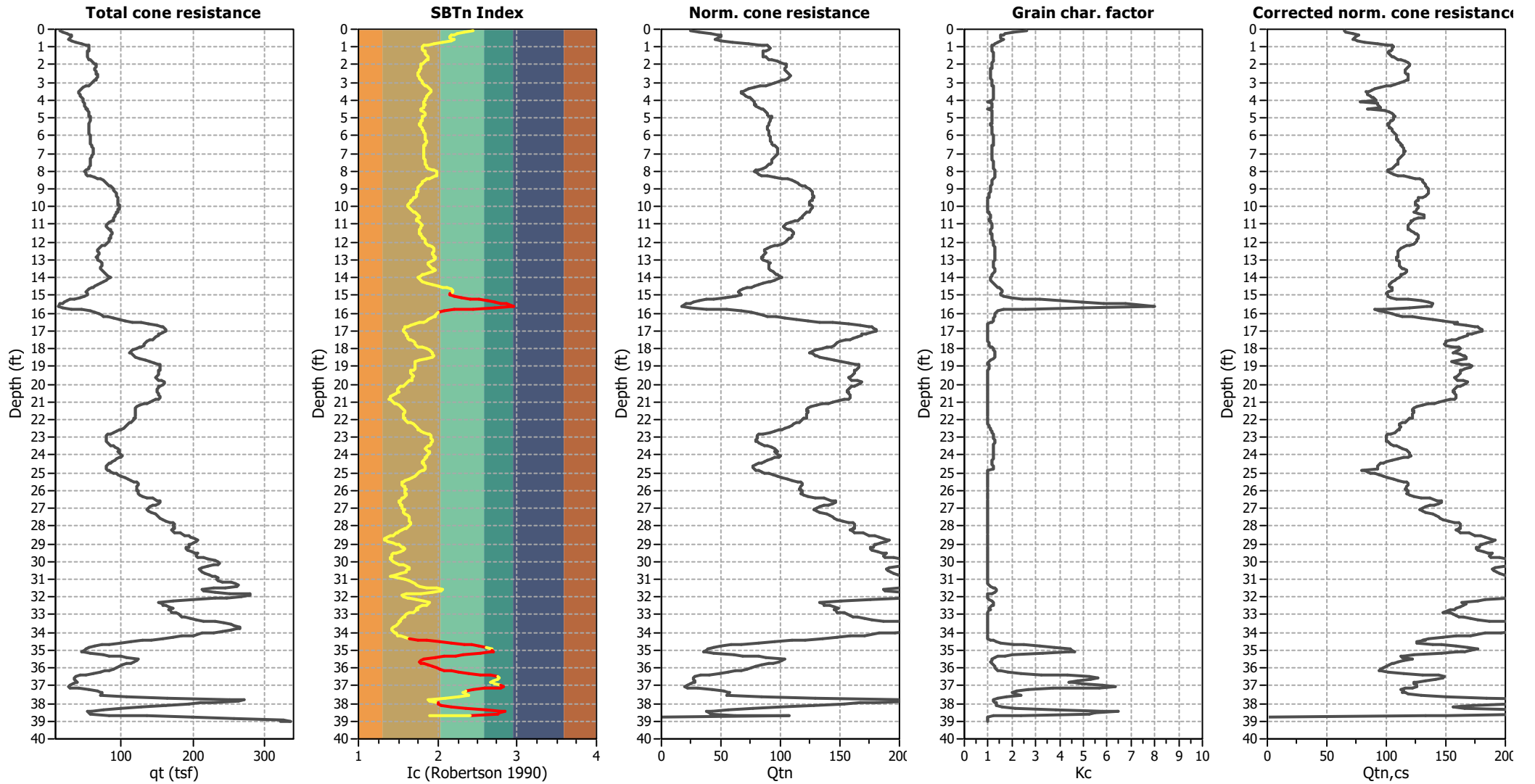

Input parameters and analysis data

Analysis method:	NCEER (1998)	Depth to water table (erthq.):	7.00 ft	Fill weight:	N/A
Fines correction method:	NCEER (1998)	Average results interval:	3	Transition detect. applied:	Yes
Points to test:	Based on Ic value	Ic cut-off value:	2.60	K _o applied:	Yes
Earthquake magnitude M _w :	8.10	Unit weight calculation:	Based on SBT	Clay like behavior applied:	Sands only
Peak ground acceleration:	0.89	Use fill:	No	Limit depth applied:	No
Depth to water table (insitu):	9.90 ft	Fill height:	N/A	Limit depth:	N/A

Liquefaction analysis overall plots

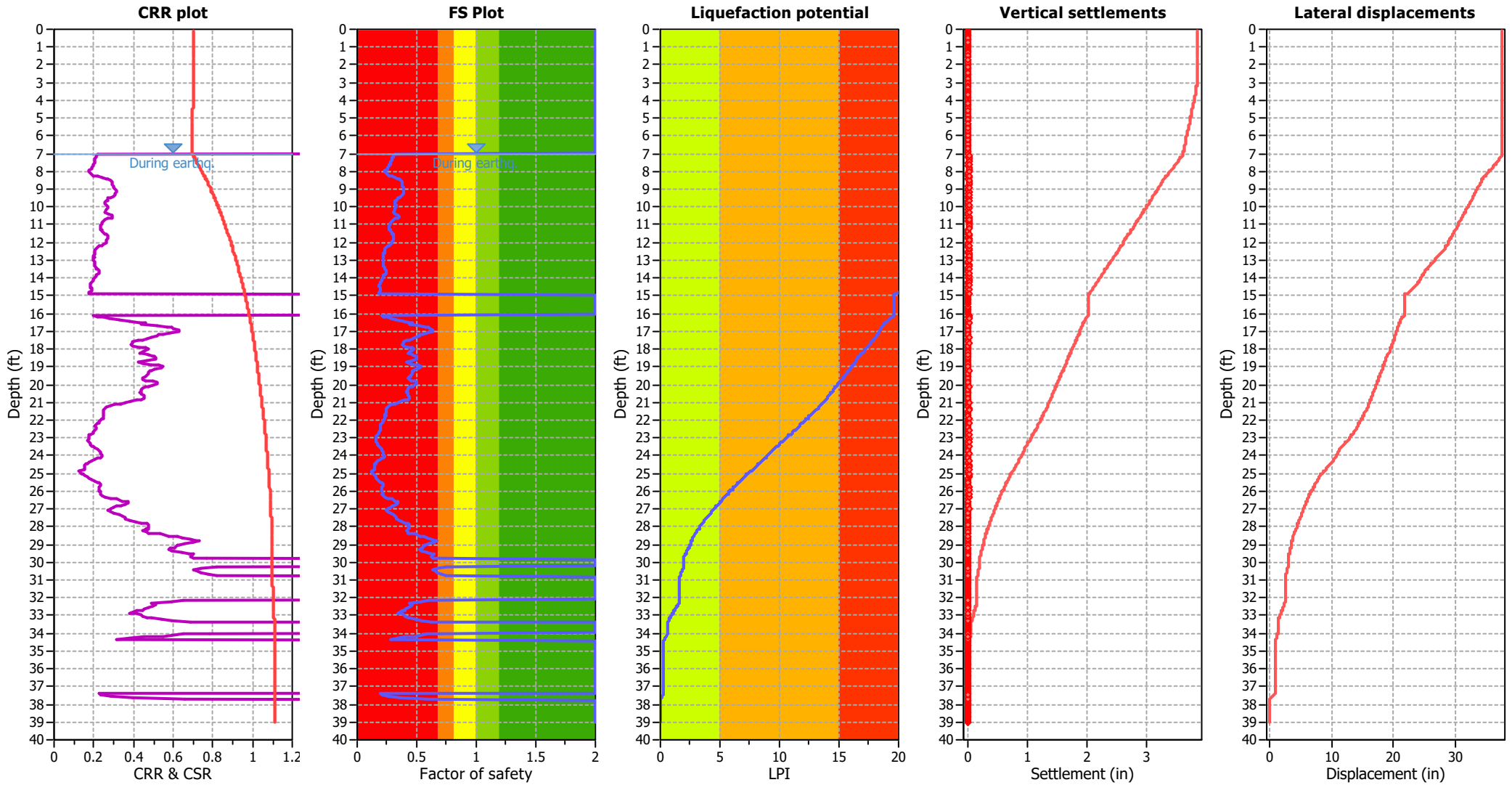

Input parameters and analysis data

Analysis method:	NCEER (1998)	Depth to water table (earthq.):	7.00 ft	Fill weight:	N/A
Fines correction method:	NCEER (1998)	Average results interval:	3	Transition detect. applied:	Yes
Points to test:	Based on Ic value	Ic cut-off value:	2.60	K_0 applied:	Yes
Earthquake magnitude M_w :	8.10	Unit weight calculation:	Based on SBT	Clay like behavior applied:	Sands only
Peak ground acceleration:	0.89	Use fill:	No	Limit depth applied:	No
Depth to water table (insitu):	9.90 ft	Fill height:	N/A	Limit depth:	N/A

F.S. color scheme

- Almost certain it will liquefy
- Very likely to liquefy
- Liquefaction and no liq. are equally likely
- Unlike to liquefy
- Almost certain it will not liquefy

LPI color scheme

- Very high risk
- High risk
- Low risk

Liquefaction analysis summary plots

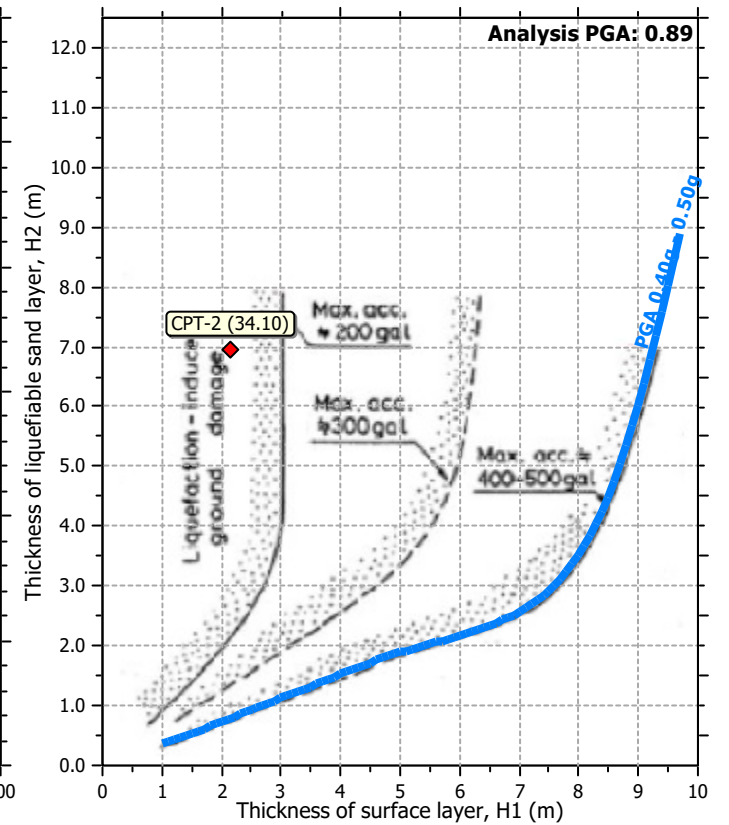
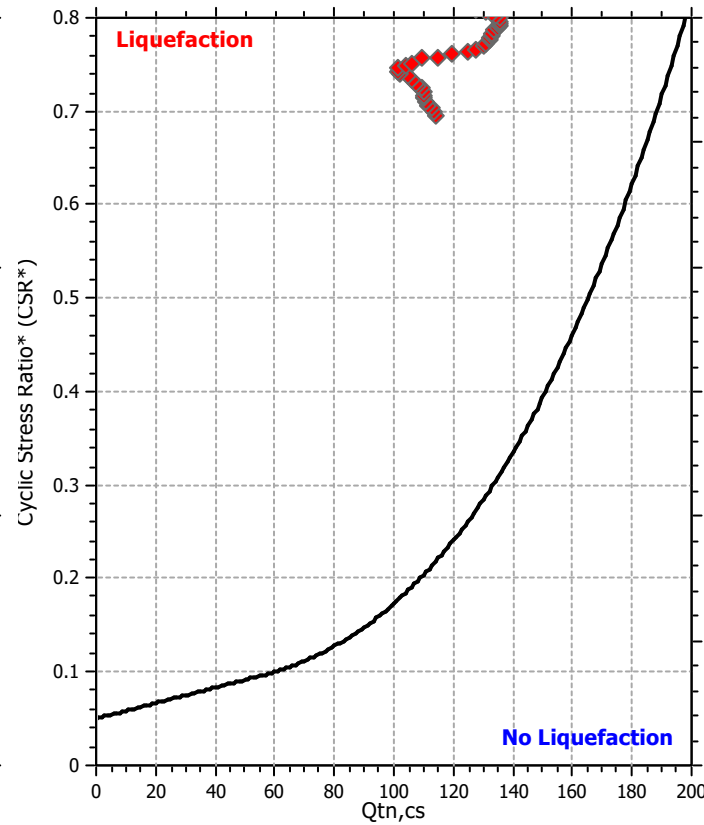
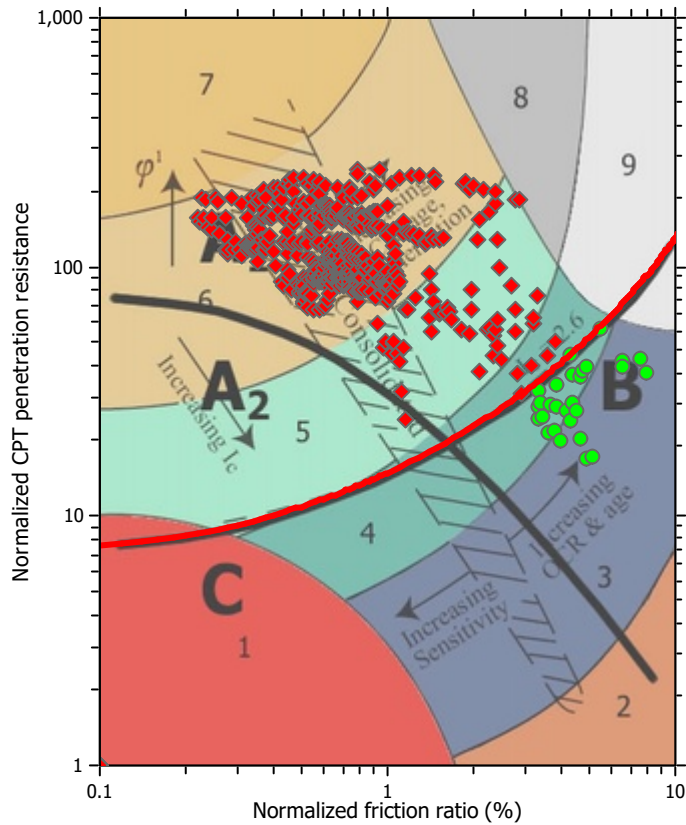

Input parameters and analysis data

Analysis method:	NCEER (1998)	Depth to water table (earthq.):	7.00 ft	Fill weight:	N/A
Fines correction method:	NCEER (1998)	Average results interval:	3	Transition detect. applied:	Yes
Points to test:	Based on Ic value	Ic cut-off value:	2.60	K _o applied:	Yes
Earthquake magnitude M _w :	8.10	Unit weight calculation:	Based on SBT	Clay like behavior applied:	Sands only
Peak ground acceleration:	0.89	Use fill:	No	Limit depth applied:	No
Depth to water table (insitu):	9.90 ft	Fill height:	N/A	Limit depth:	N/A

Check for strength loss plots (Robertson (2010))

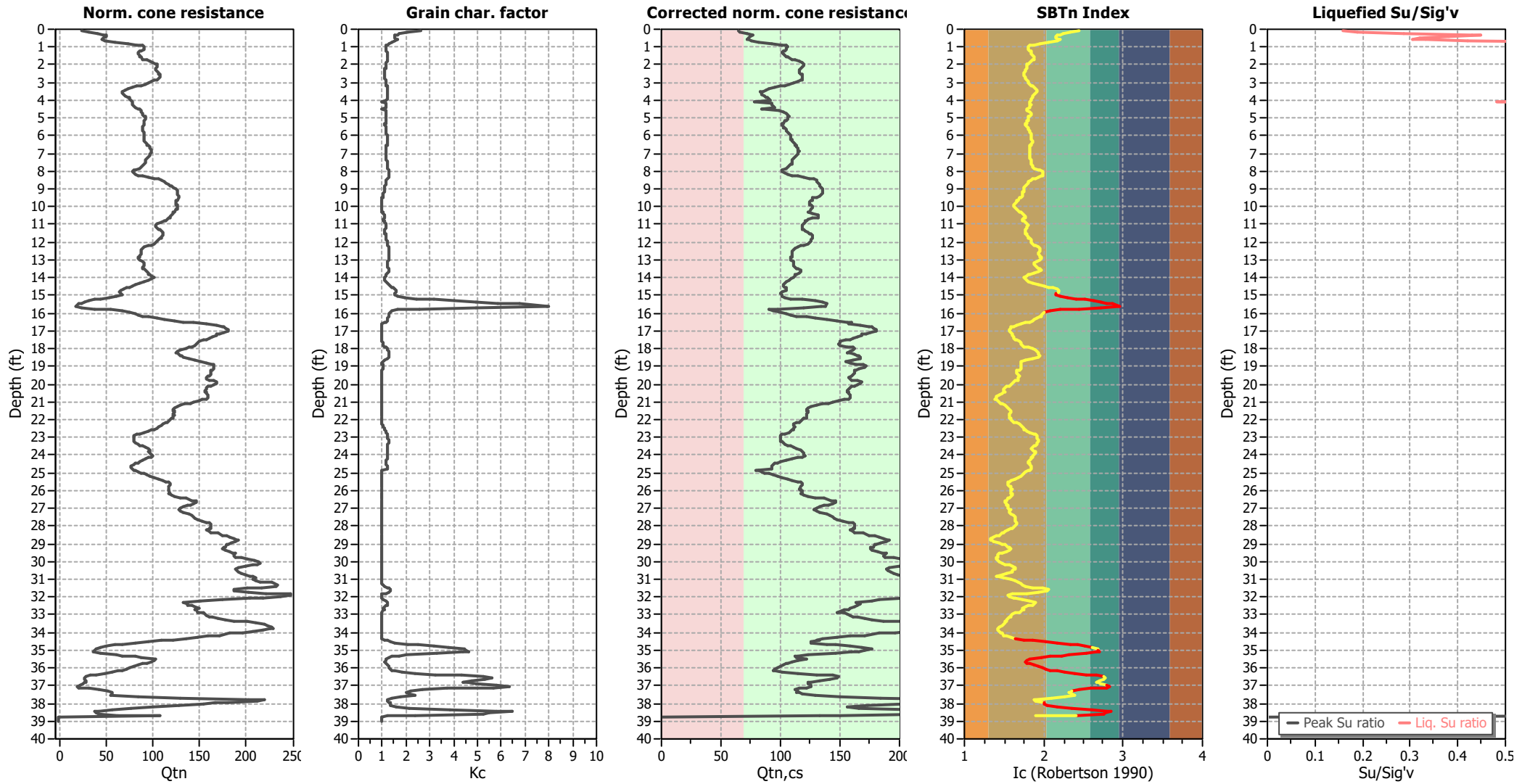

Input parameters and analysis data

Analysis method:	NCEER (1998)	Depth to water table (earthq.):	7.00 ft	Fill weight:	N/A
Fines correction method:	NCEER (1998)	Average results interval:	3	Transition detect. applied:	Yes
Points to test:	Based on Ic value	Ic cut-off value:	2.60	K _o applied:	Yes
Earthquake magnitude M _w :	8.10	Unit weight calculation:	Based on SBT	Clay like behavior applied:	Sands only
Peak ground acceleration:	0.89	Use fill:	No	Limit depth applied:	No
Depth to water table (insitu):	9.90 ft	Fill height:	N/A	Limit depth:	N/A

TRANSITION LAYER DETECTION ALGORITHM REPORT

Summary Details & Plots

Short description

The software will delete data when the cone is in transition from either clay to sand or vice-versa. To do this the software requires a range of I_c values over which the transition will be defined (typically somewhere between $1.80 < I_c < 3.0$) and a rate of change of I_c . Transitions typically occur when the rate of change of I_c is fast (i.e. ΔI_c is small).

The SBT_n plot below, displays in red the detected transition layers based on the parameters listed below the graphs.

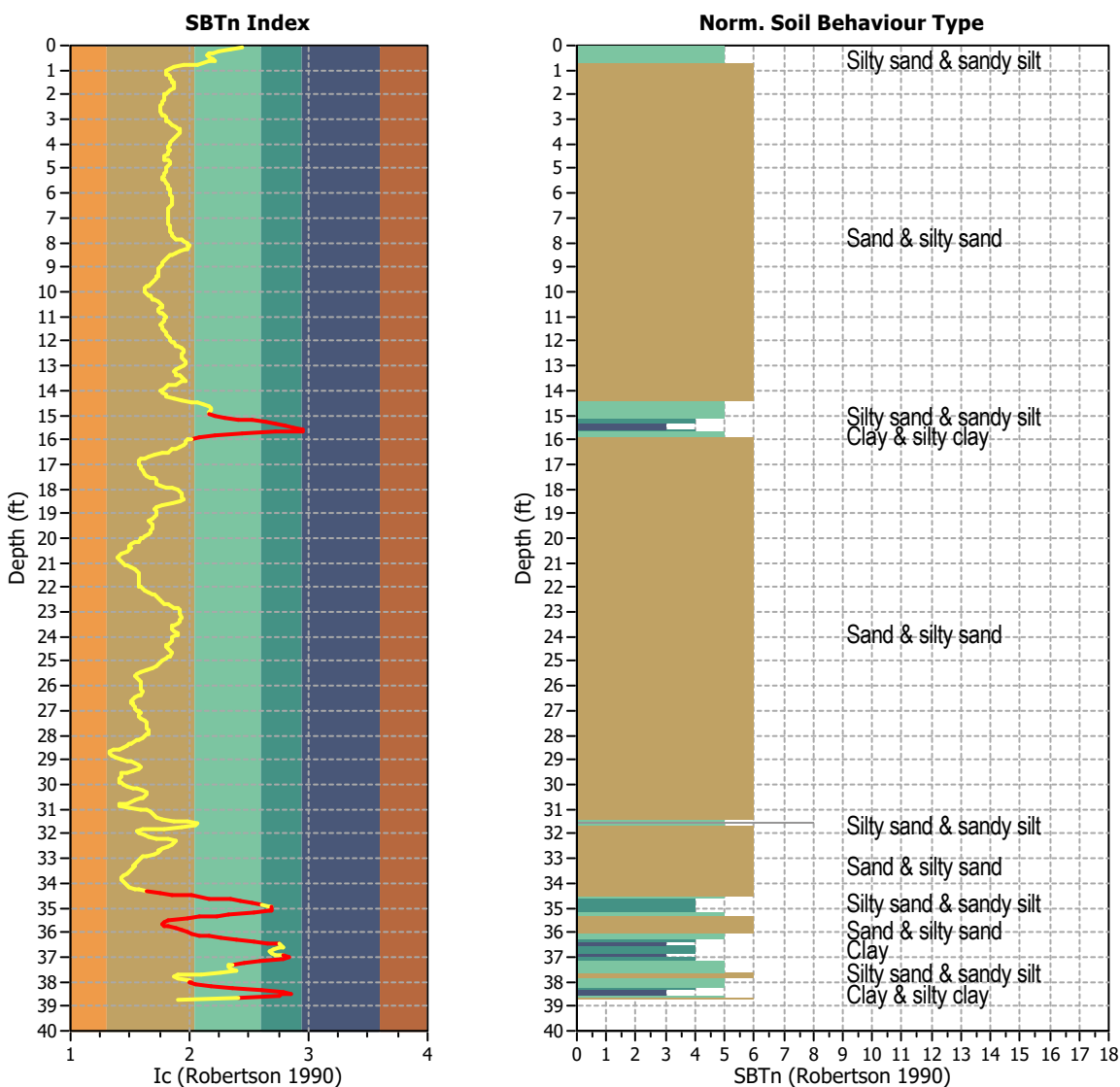

Transition layer algorithm properties		General statistics	
I_c minimum check value:	1.70	Total points in CPT file:	595
I_c maximum check value:	3.00	Total points excluded:	68
I_c change ratio value:	0.0250	Exclusion percentage:	11.43%
Minimum number of points in layer:	4	Number of layers detected:	8

Estimation of post-earthquake settlements

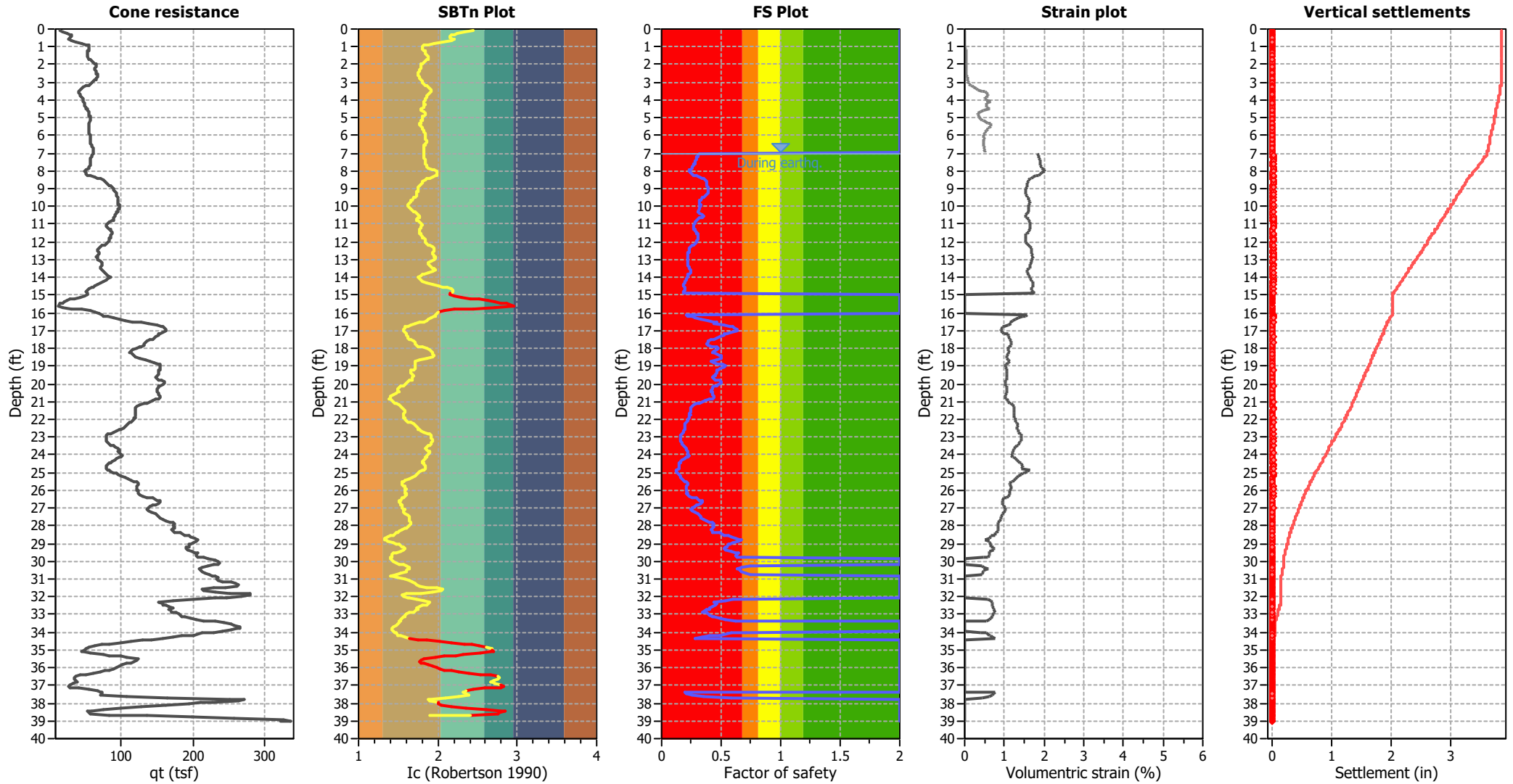

Abbreviations

- q_c: Total cone resistance (cone resistance q_c corrected for pore water effects)
- I_c: Soil Behaviour Type Index
- FS: Calculated Factor of Safety against liquefaction
- Volumetric strain: Post-liquefaction volumetric strain

Estimation of post-earthquake lateral Displacements

Geometric parameters: Gently sloping ground without free face (Slope 0.70 %)

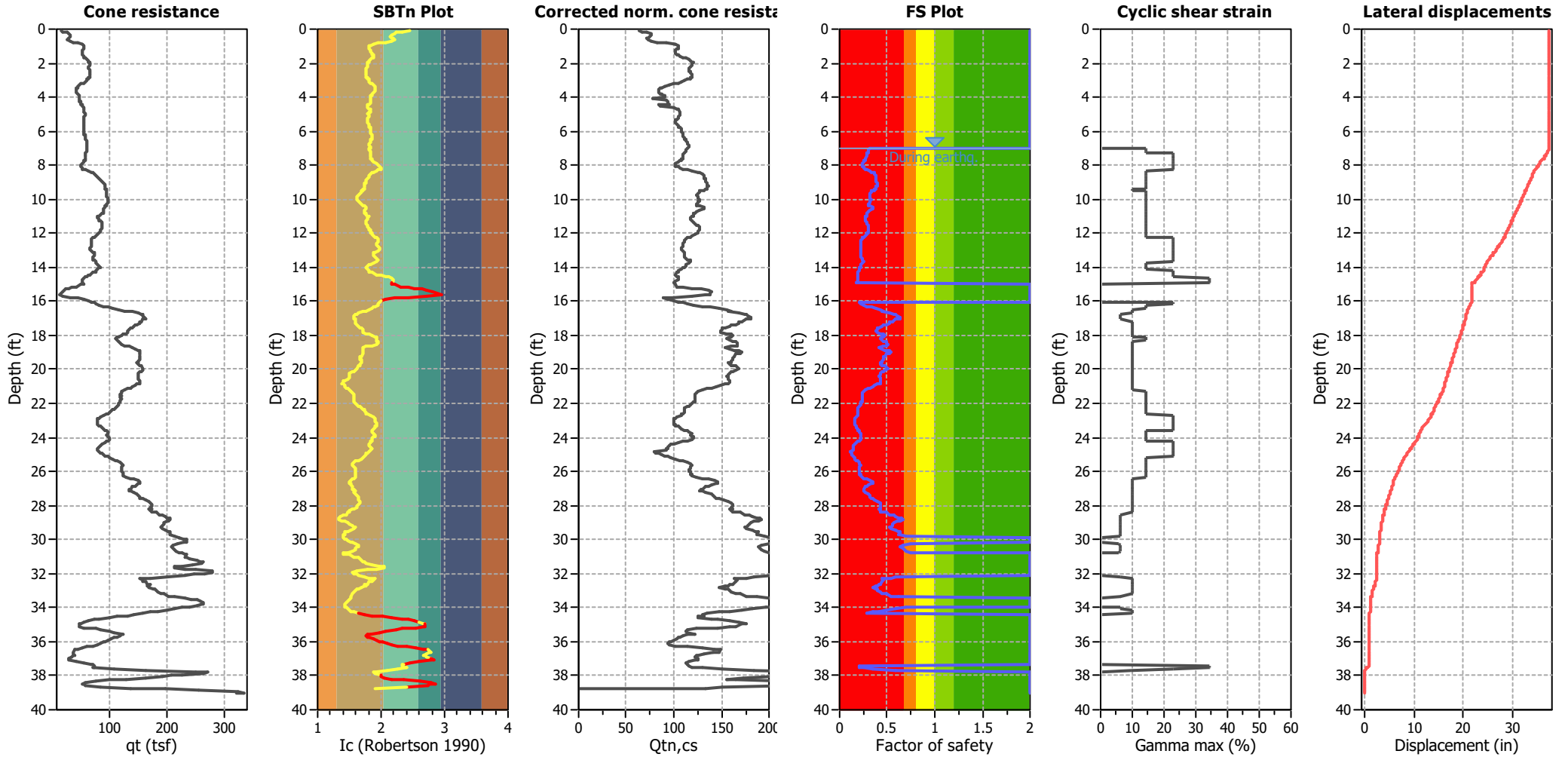

Abbreviations

qt: Total cone resistance (cone resistance q_c corrected for pore water effects)
 Ic: Soil Behaviour Type Index
 $Q_{tn,cs}$: Equivalent clean sand normalized CPT total cone resistance

F.S.: Factor of safety
 γ_{max} : Maximum cyclic shear strain
 LDI: Lateral displacement index

Surface condition



Aging Calculation Estimation

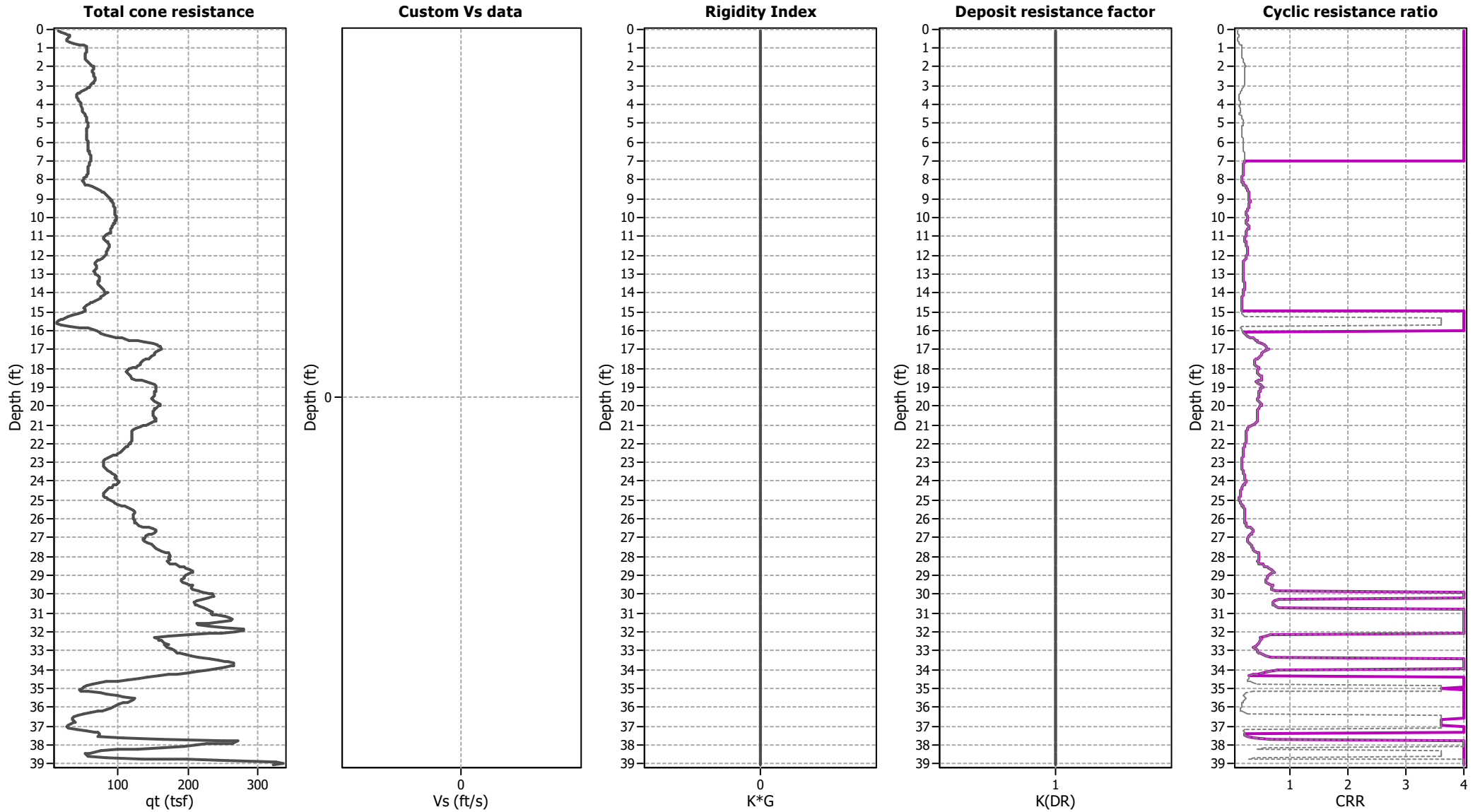

Ejecta Severity Estimation

Corrected norm. cone resista

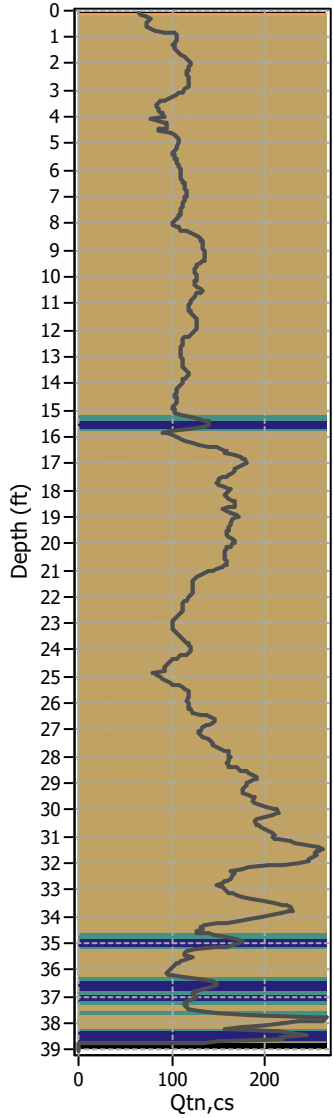

SBTn Index Plot

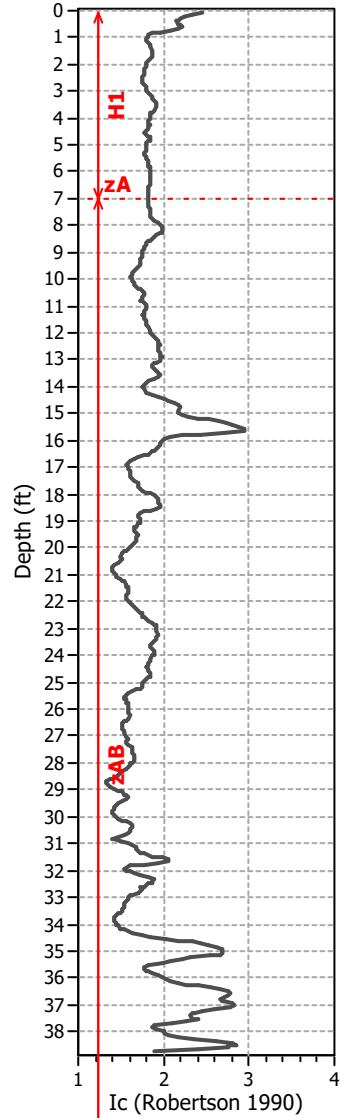

FS plot

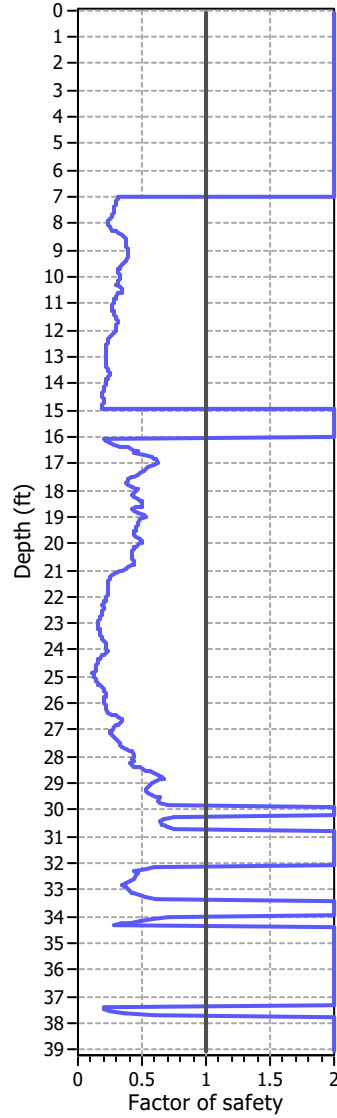

Stresses vs Depth

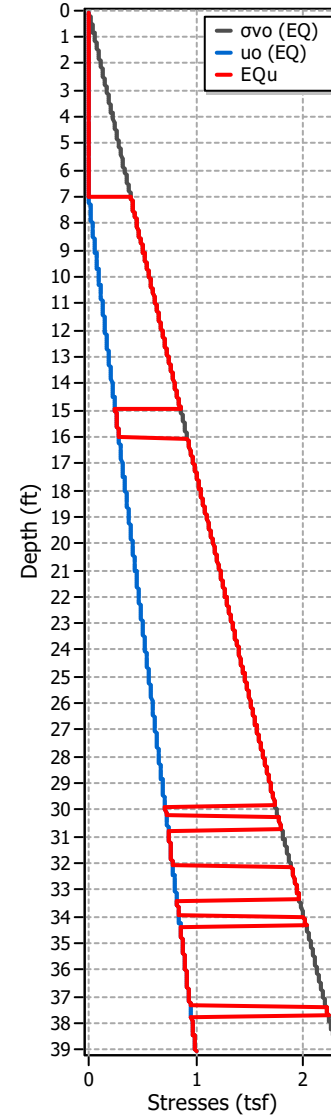

Excess Head

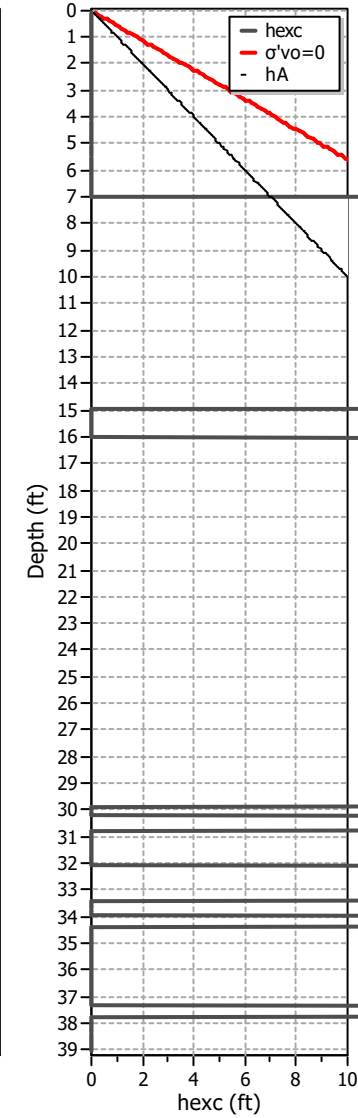

Liq. ejecta demand

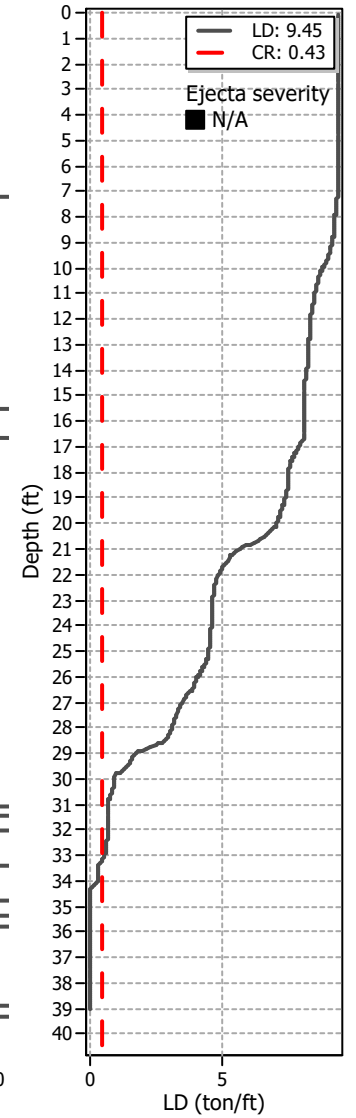

LIQUEFACTION ANALYSIS REPORT

Project title : Petra Geosciences / Apple Canyon

Location : Lake Hemet, CA

CPT file : CPT-3

Input parameters and analysis data

Analysis method:	NCEER (1998)	G.W.T. (in-situ):	9.70 ft	Use fill:	No	Clay like behavior applied:	Sands only
Fines correction method:	NCEER (1998)	G.W.T. (earthq.):	7.00 ft	Fill height:	N/A	Limit depth applied:	No
Points to test:	Based on Ic value	Average results interval:	3	Fill weight:	N/A	Limit depth:	N/A
Earthquake magnitude M_w :	8.10	Ic cut-off value:	2.60	Trans. detect. applied:	Yes	MSF method:	Method based
Peak ground acceleration:	0.89	Unit weight calculation:	Based on SBT	K_o applied:	Yes		

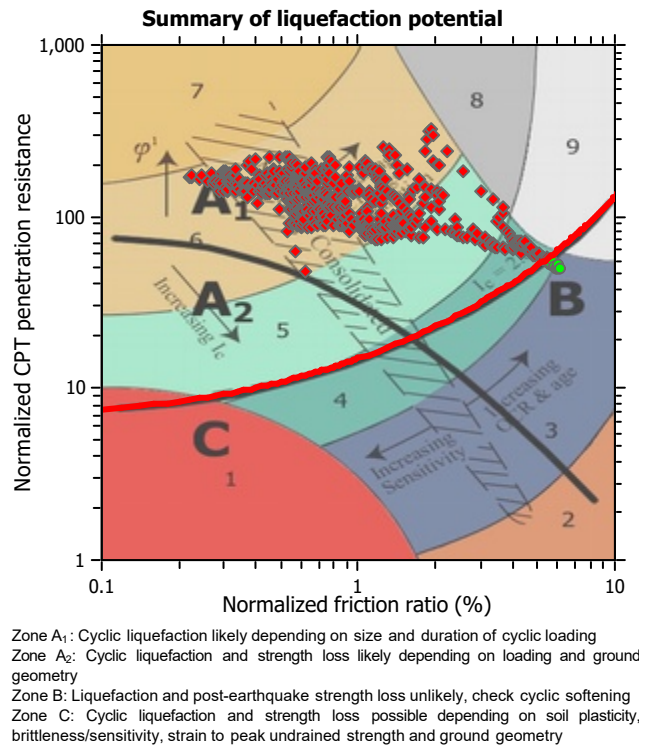
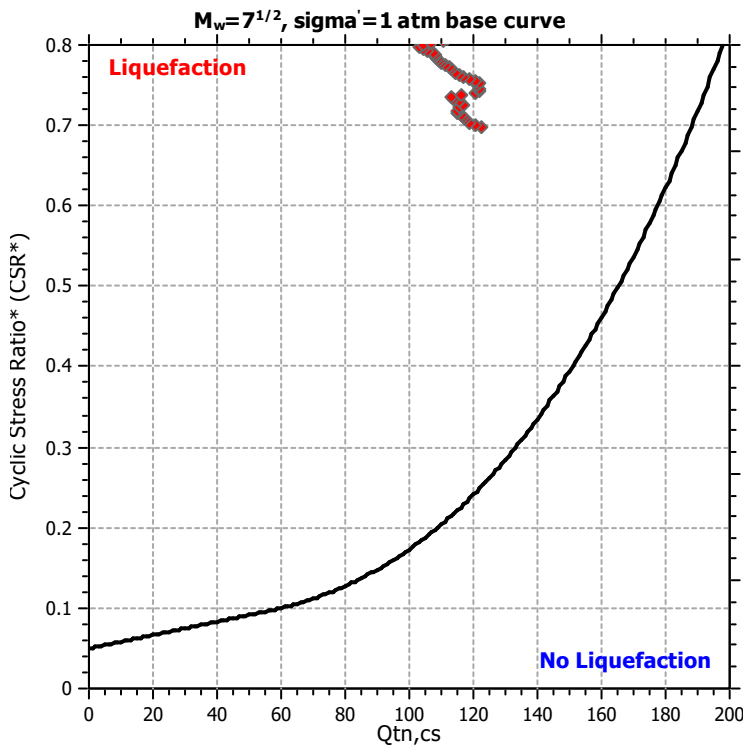
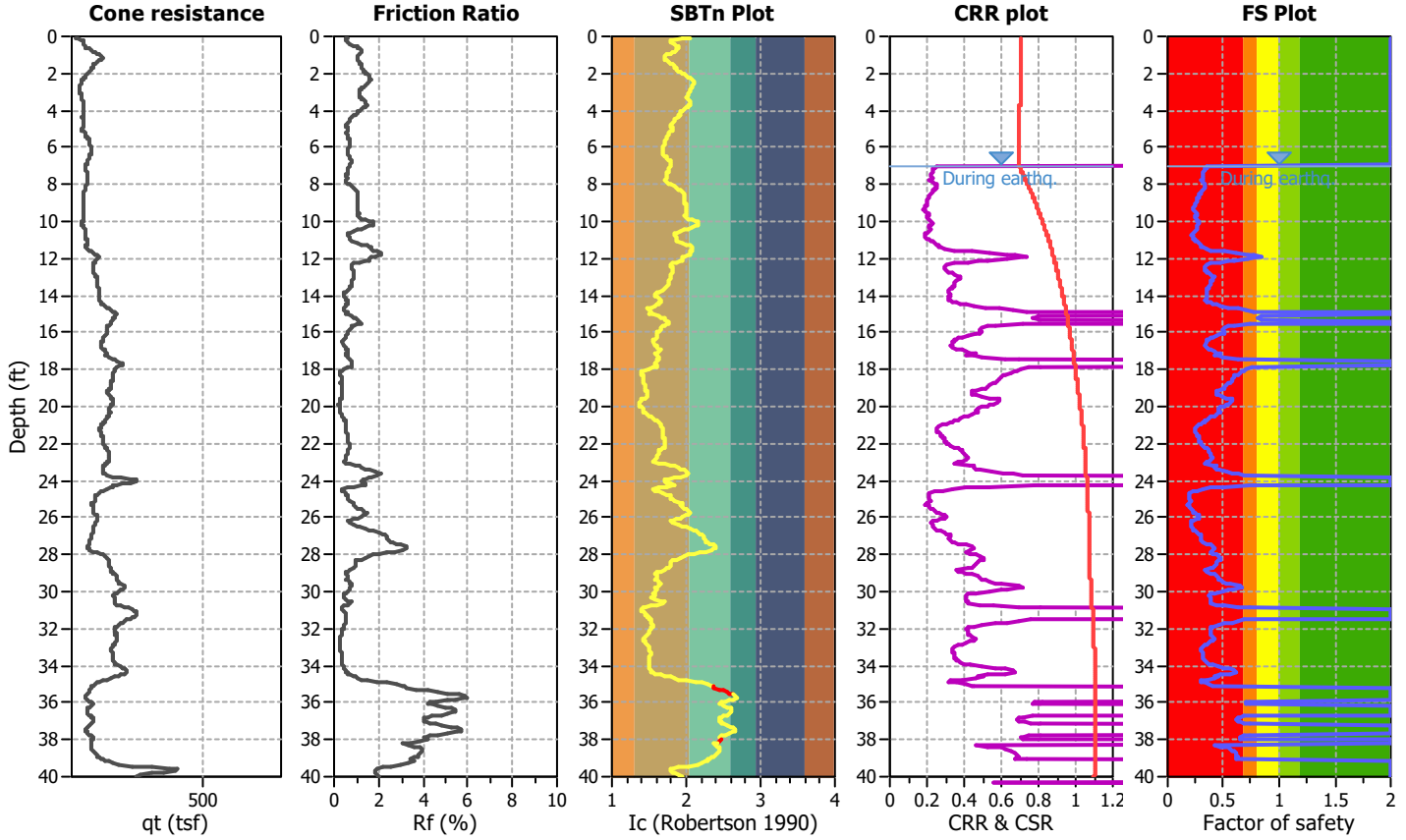

CPT basic interpretation plots

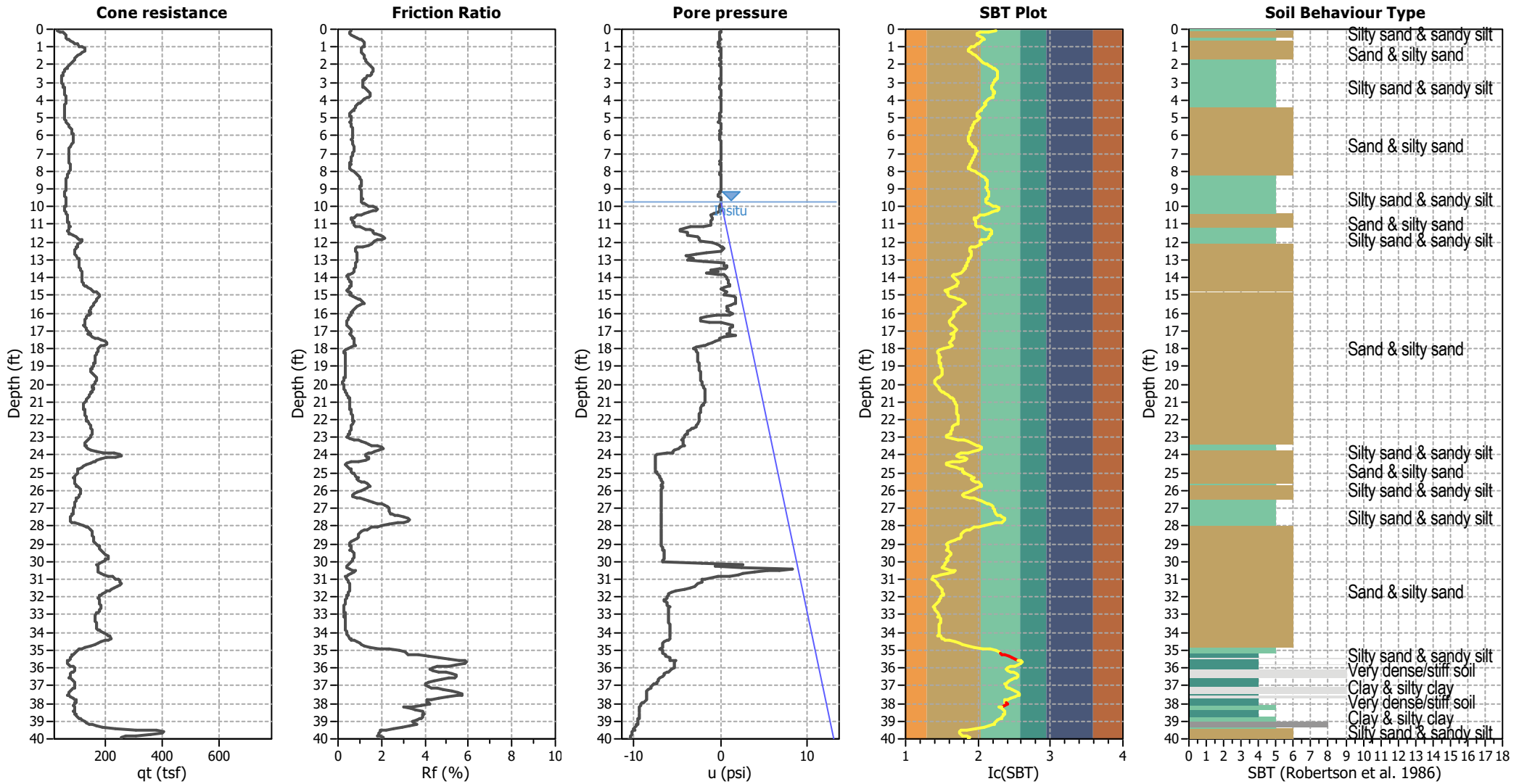

Input parameters and analysis data

Analysis method:	NCEER (1998)	Depth to water table (earthq.):	7.00 ft	Fill weight:	N/A
Fines correction method:	NCEER (1998)	Average results interval:	3	Transition detect. applied:	Yes
Points to test:	Based on Ic value	Ic cut-off value:	2.60	K _o applied:	Yes
Earthquake magnitude M _w :	8.10	Unit weight calculation:	Based on SBT	Clay like behavior applied:	Sands only
Peak ground acceleration:	0.89	Use fill:	No	Limit depth applied:	No
Depth to water table (insitu):	9.70 ft	Fill height:	N/A	Limit depth:	N/A

SBT legend

1. Sensitive fine grained	4. Clayey silt to silty	7. Gravely sand to sand
2. Organic material	5. Silty sand to sandy silt	8. Very stiff sand to
3. Clay to silty clay	6. Clean sand to silty sand	9. Very stiff fine grained

CPT basic interpretation plots (normalized)

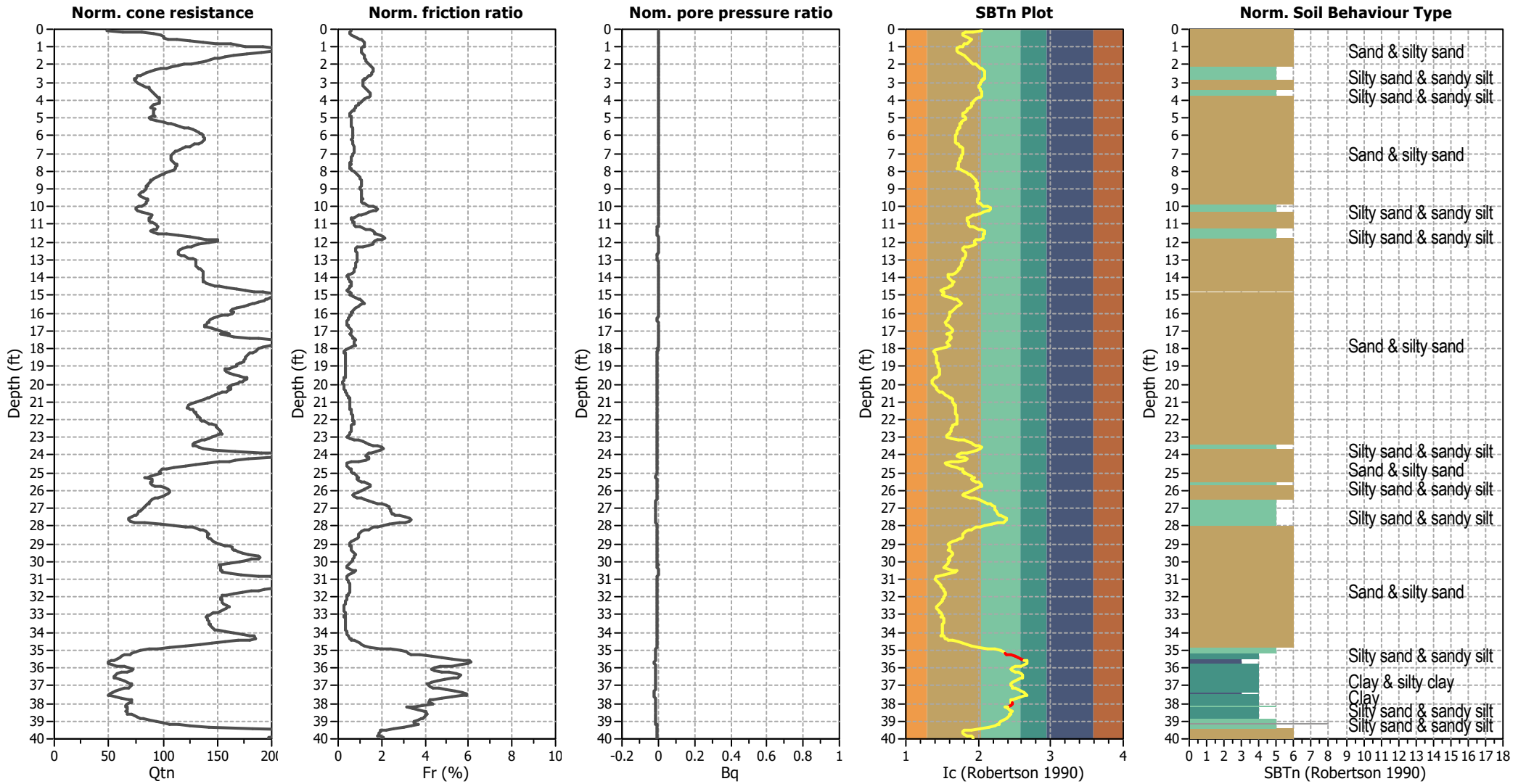

Input parameters and analysis data

Analysis method:	NCEER (1998)	Depth to water table (erthq.):	7.00 ft	Fill weight:	N/A
Fines correction method:	NCEER (1998)	Average results interval:	3	Transition detect. applied:	Yes
Points to test:	Based on Ic value	Ic cut-off value:	2.60	K ₀ applied:	Yes
Earthquake magnitude M _w :	8.10	Unit weight calculation:	Based on SBT	Clay like behavior applied:	Sands only
Peak ground acceleration:	0.89	Use fill:	No	Limit depth applied:	No
Depth to water table (insitu):	9.70 ft	Fill height:	N/A	Limit depth:	N/A

SBTn legend

1. Sensitive fine grained	4. Clayey silt to silty	7. Gravely sand to sand
2. Organic material	5. Silty sand to sandy silt	8. Very stiff sand to
3. Clay to silty clay	6. Clean sand to silty sand	9. Very stiff fine grained

Liquefaction analysis overall plots (intermediate results)

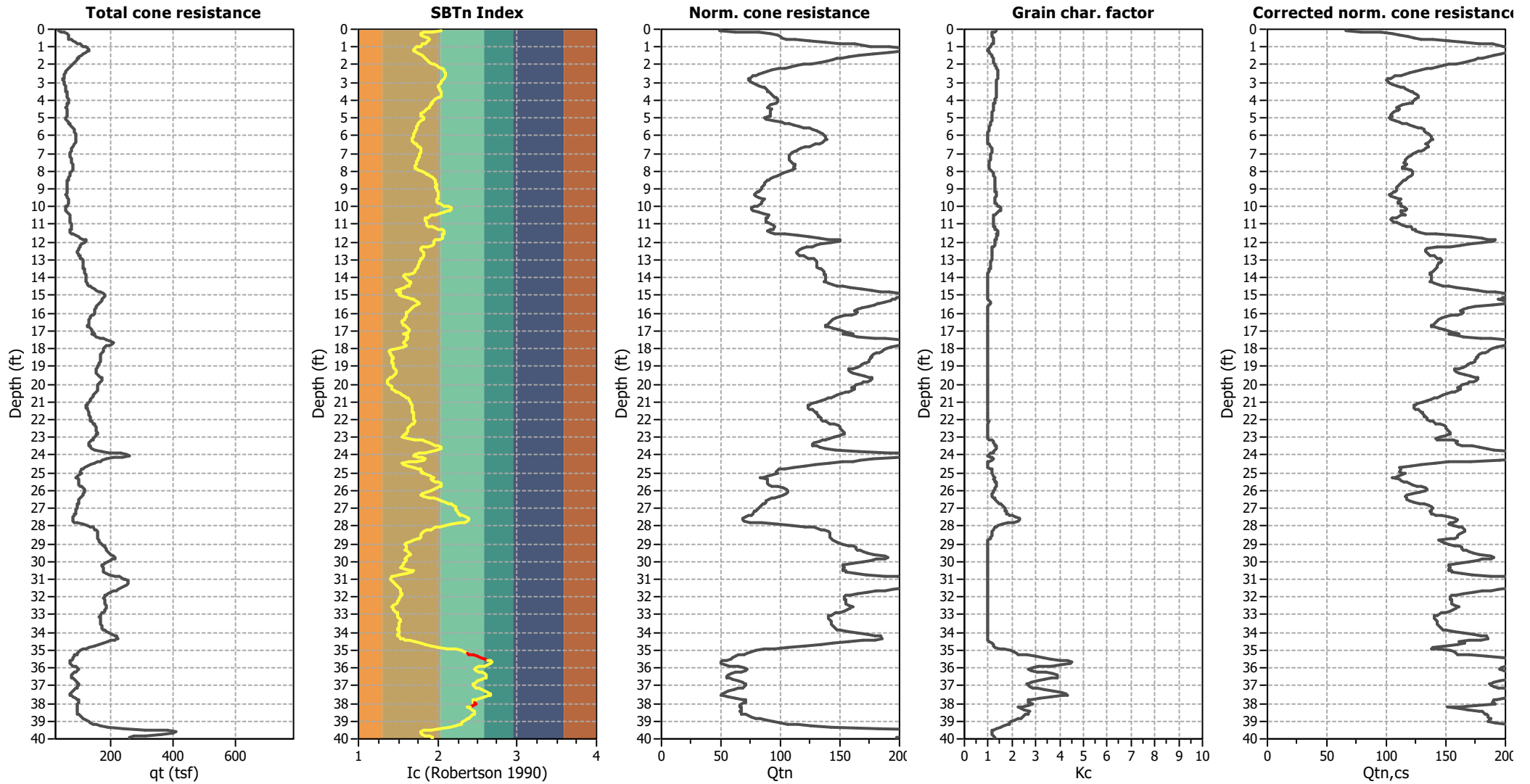

Input parameters and analysis data

Analysis method:	NCEER (1998)	Depth to water table (earthq.):	7.00 ft	Fill weight:	N/A
Fines correction method:	NCEER (1998)	Average results interval:	3	Transition detect. applied:	Yes
Points to test:	Based on Ic value	Ic cut-off value:	2.60	K _o applied:	Yes
Earthquake magnitude M _w :	8.10	Unit weight calculation:	Based on SBT	Clay like behavior applied:	Sands only
Peak ground acceleration:	0.89	Use fill:	No	Limit depth applied:	No
Depth to water table (insitu):	9.70 ft	Fill height:	N/A	Limit depth:	N/A

Liquefaction analysis overall plots

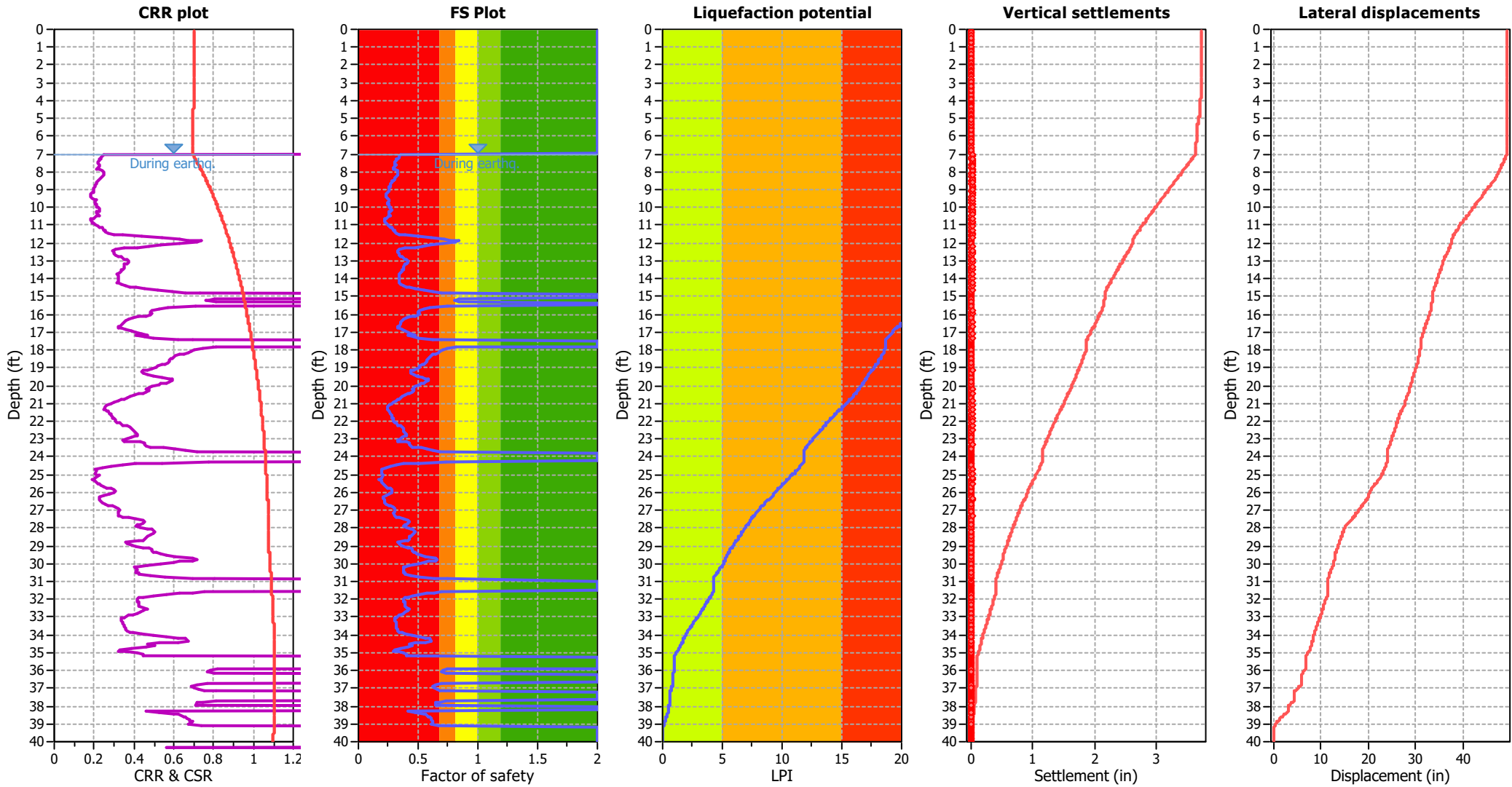

Input parameters and analysis data

Analysis method:	NCEER (1998)	Depth to water table (earthq.):	7.00 ft	Fill weight:	N/A
Fines correction method:	NCEER (1998)	Average results interval:	3	Transition detect. applied:	Yes
Points to test:	Based on Ic value	Ic cut-off value:	2.60	K_0 applied:	Yes
Earthquake magnitude M_w :	8.10	Unit weight calculation:	Based on SBT	Clay like behavior applied:	Sands only
Peak ground acceleration:	0.89	Use fill:	No	Limit depth applied:	No
Depth to water table (insitu):	9.70 ft	Fill height:	N/A	Limit depth:	N/A

F.S. color scheme

- Almost certain it will liquefy
- Very likely to liquefy
- Liquefaction and no liq. are equally likely
- Unlike to liquefy
- Almost certain it will not liquefy

LPI color scheme

- Very high risk
- High risk
- Low risk

Liquefaction analysis summary plots

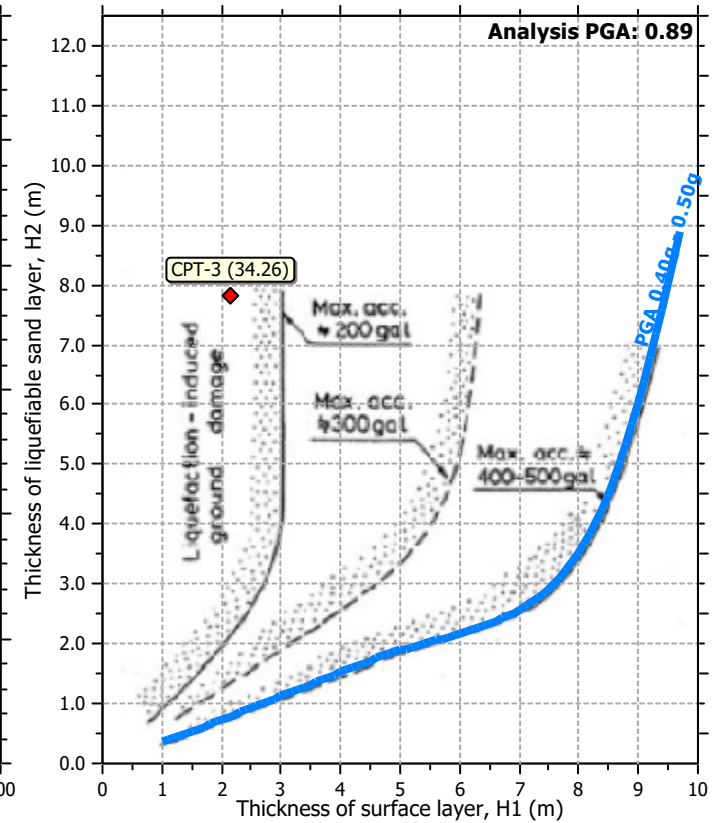
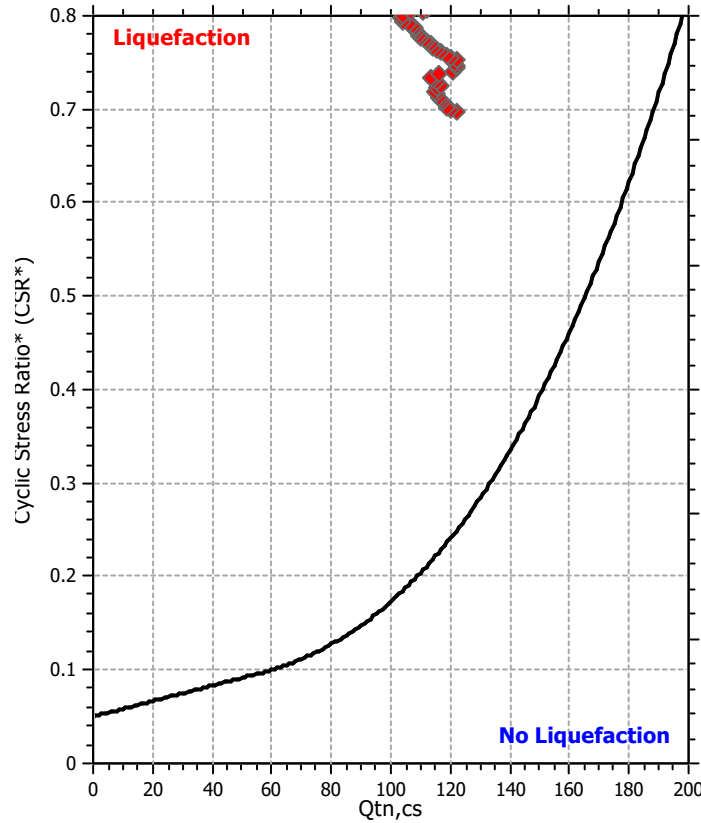
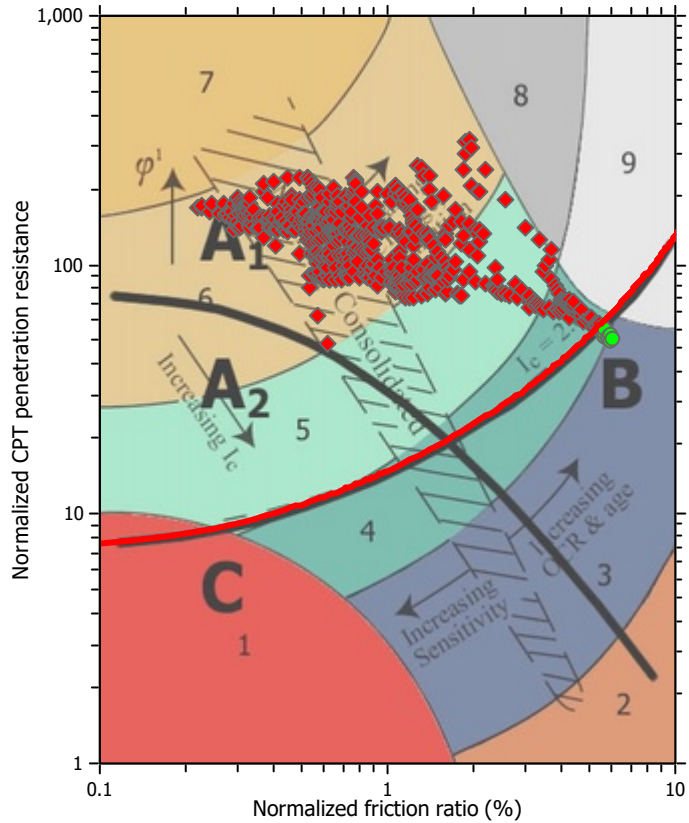

Input parameters and analysis data

Analysis method:	NCEER (1998)	Depth to water table (earthq.):	7.00 ft	Fill weight:	N/A
Fines correction method:	NCEER (1998)	Average results interval:	3	Transition detect. applied:	Yes
Points to test:	Based on Ic value	Ic cut-off value:	2.60	K_v applied:	Yes
Earthquake magnitude M_w :	8.10	Unit weight calculation:	Based on SBT	Clay like behavior applied:	Sands only
Peak ground acceleration:	0.89	Use fill:	No	Limit depth applied:	No
Depth to water table (insitu):	9.70 ft	Fill height:	N/A	Limit depth:	N/A

Check for strength loss plots (Robertson (2010))

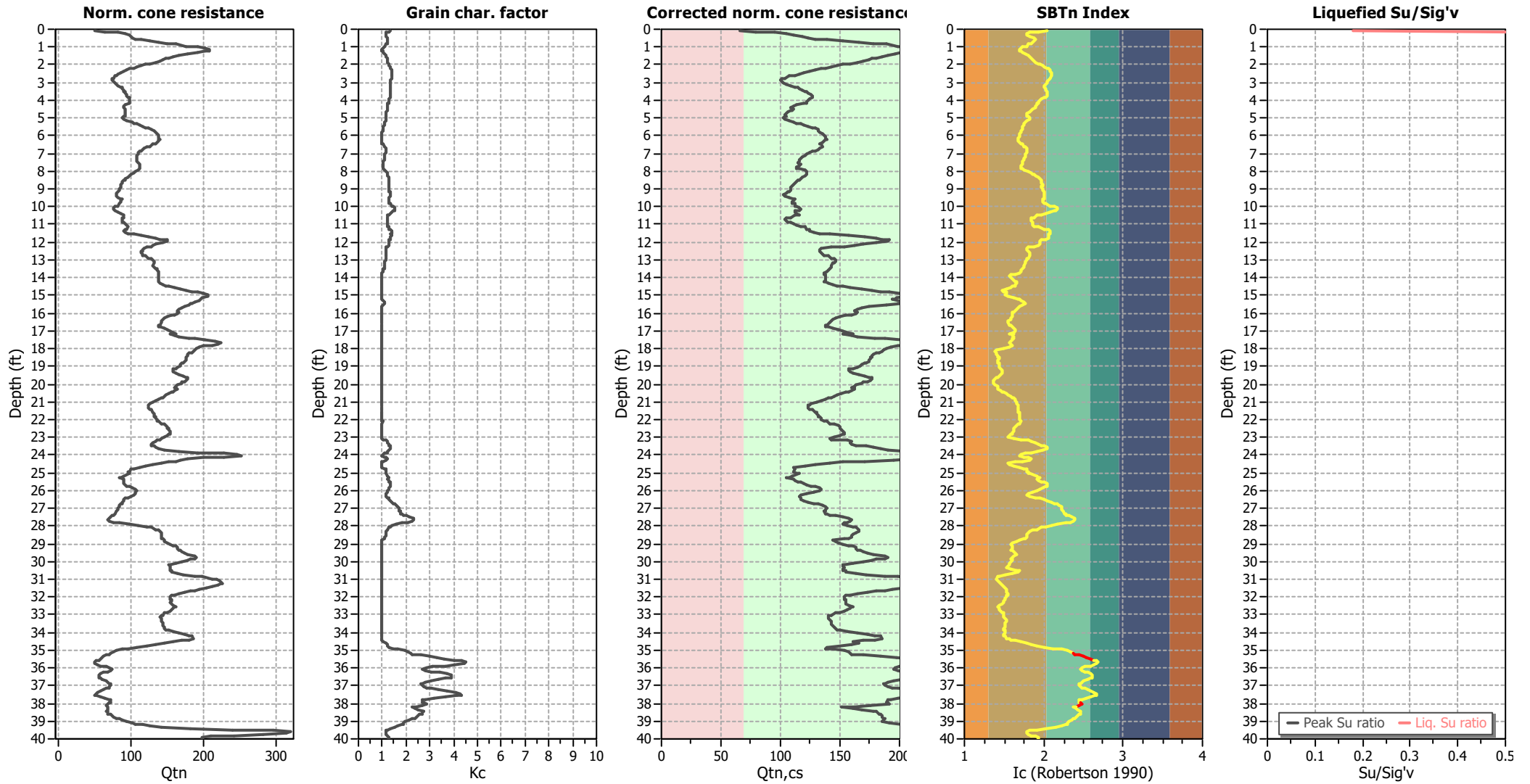

Input parameters and analysis data

Analysis method:	NCEER (1998)	Depth to water table (earthq.):	7.00 ft	Fill weight:	N/A
Fines correction method:	NCEER (1998)	Average results interval:	3	Transition detect. applied:	Yes
Points to test:	Based on Ic value	Ic cut-off value:	2.60	K _o applied:	Yes
Earthquake magnitude M _w :	8.10	Unit weight calculation:	Based on SBT	Clay like behavior applied:	Sands only
Peak ground acceleration:	0.89	Use fill:	No	Limit depth applied:	No
Depth to water table (insitu):	9.70 ft	Fill height:	N/A	Limit depth:	N/A

TRANSITION LAYER DETECTION ALGORITHM REPORT

Summary Details & Plots

Short description

The software will delete data when the cone is in transition from either clay to sand or vice-versa. To do this the software requires a range of I_c values over which the transition will be defined (typically somewhere between $1.80 < I_c < 3.0$) and a rate of change of I_c . Transitions typically occur when the rate of change of I_c is fast (i.e. ΔI_c is small).

The SBT_n plot below, displays in red the detected transition layers based on the parameters listed below the graphs.

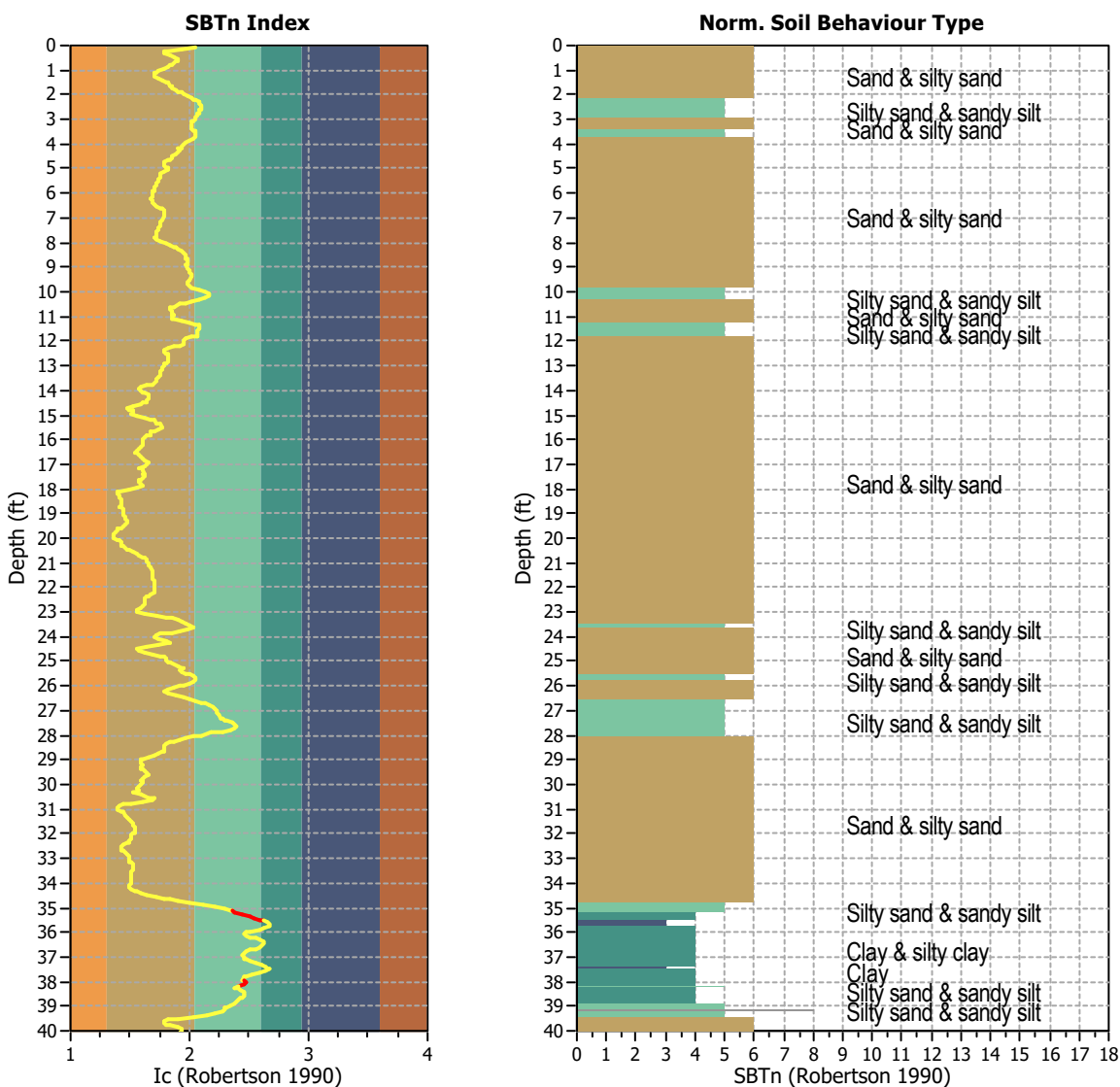

Transition layer algorithm properties

I_c minimum check value: 1.70
 I_c maximum check value: 3.00
 I_c change ratio value: 0.0250
 Minimum number of points in layer: 4

General statistics

Total points in CPT file: 618
 Total points excluded: 11
 Exclusion percentage: 1.78%
 Number of layers detected: 2

Estimation of post-earthquake settlements

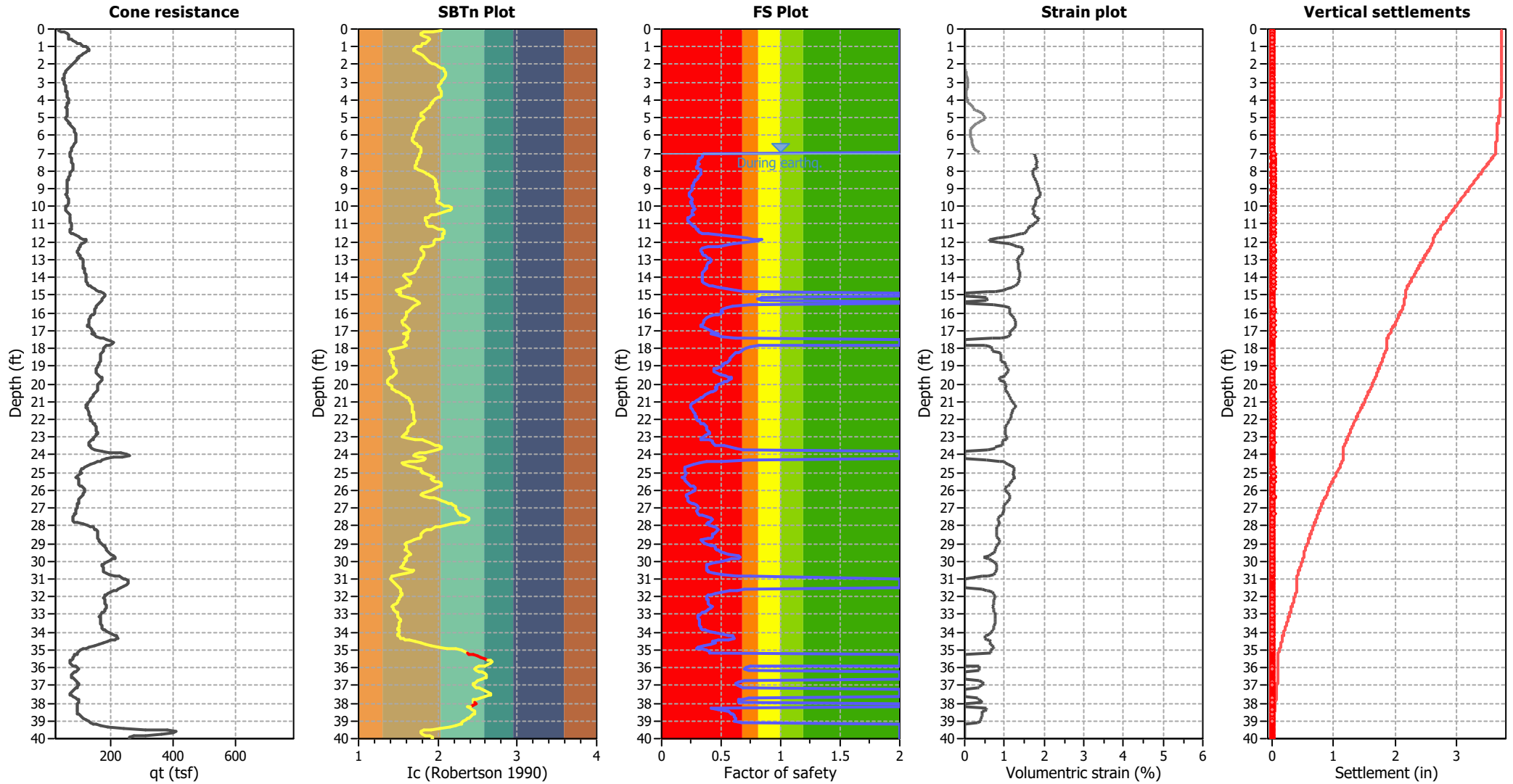

Abbreviations

- q_c: Total cone resistance (cone resistance q_c corrected for pore water effects)
- I_c: Soil Behaviour Type Index
- FS: Calculated Factor of Safety against liquefaction
- Volumetric strain: Post-liquefaction volumetric strain

Estimation of post-earthquake lateral Displacements

Geometric parameters: Gently sloping ground without free face (Slope 0.85 %)

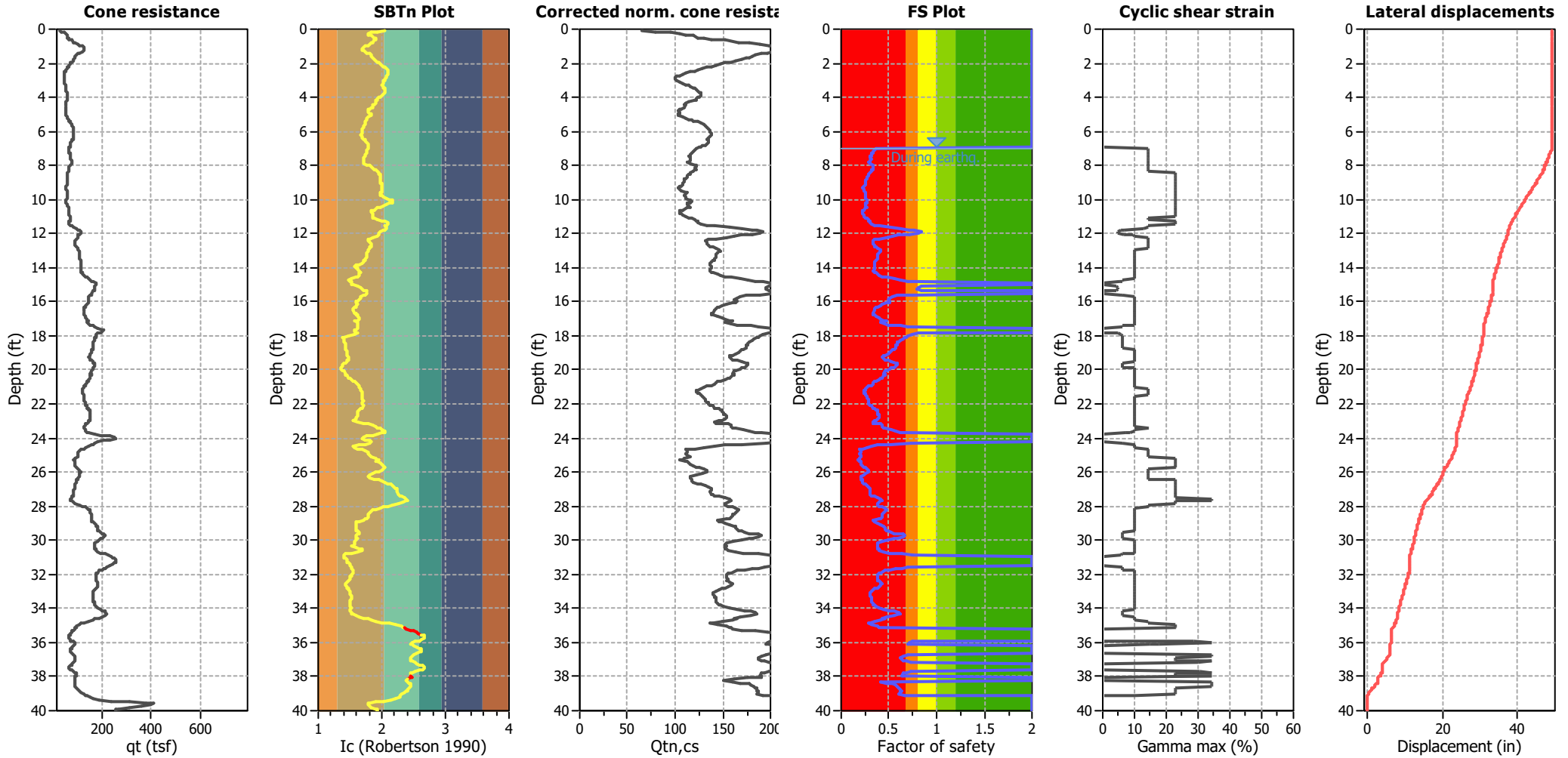

Abbreviations

q_t: Total cone resistance (cone resistance q_c corrected for pore water effects)
 I_c: Soil Behaviour Type Index
 Q_{tn,cs}: Equivalent clean sand normalized CPT total cone resistance

F.S.: Factor of safety
 γ_{max}: Maximum cyclic shear strain
 LDI: Lateral displacement index

Surface condition



Aging Calculation Estimation

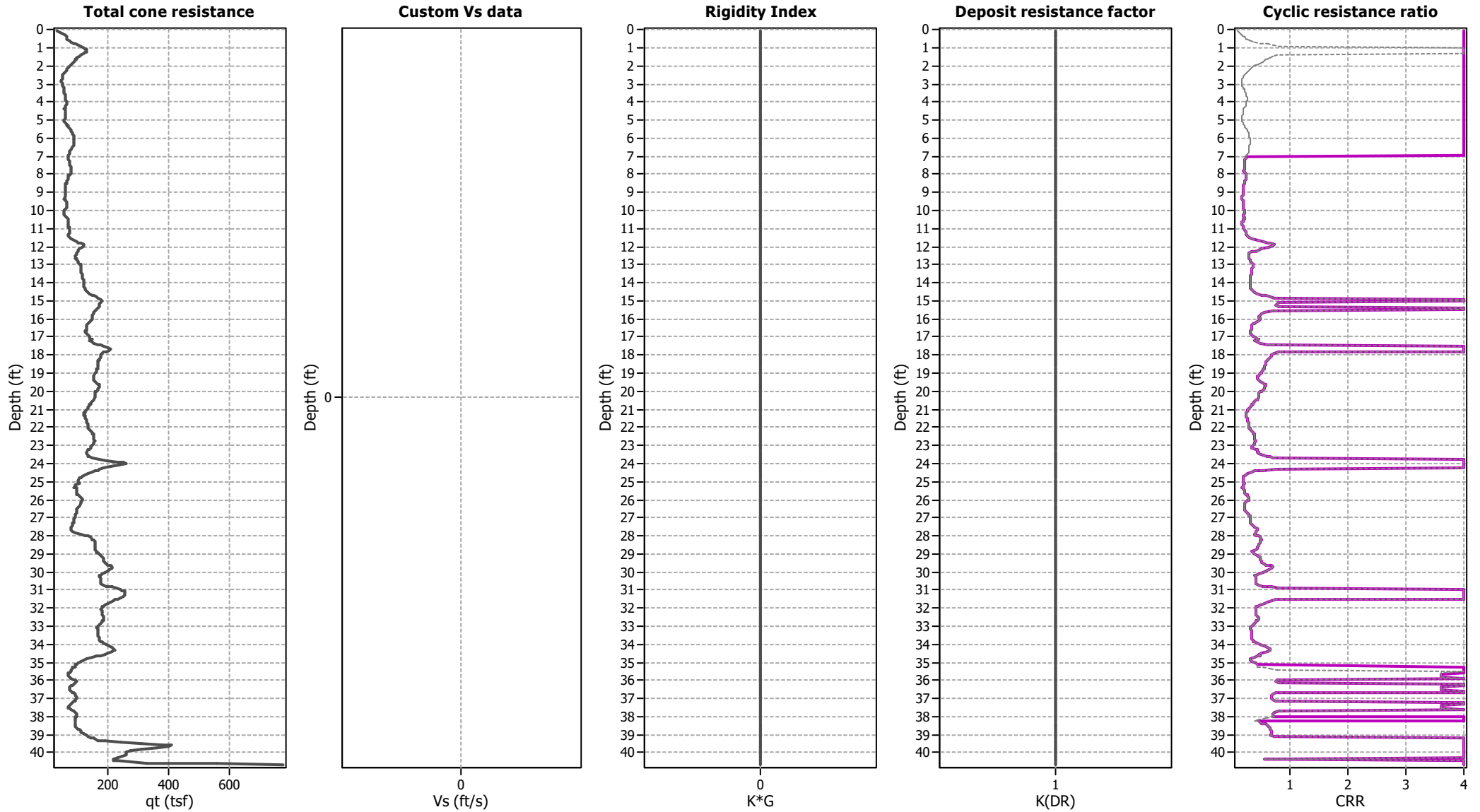

Ejecta Severity Estimation

Corrected norm. cone resista

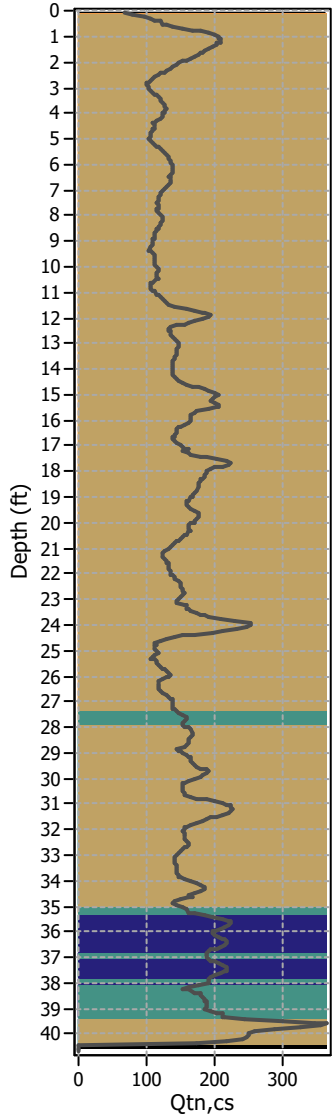

SBTn Index Plot

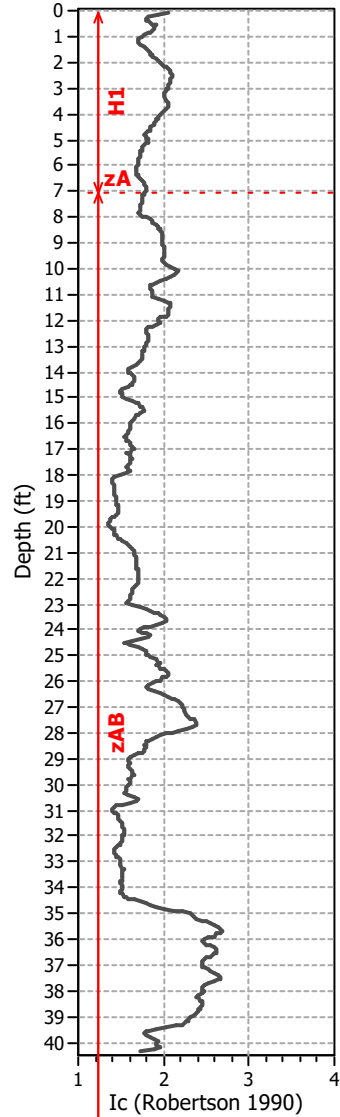

FS plot

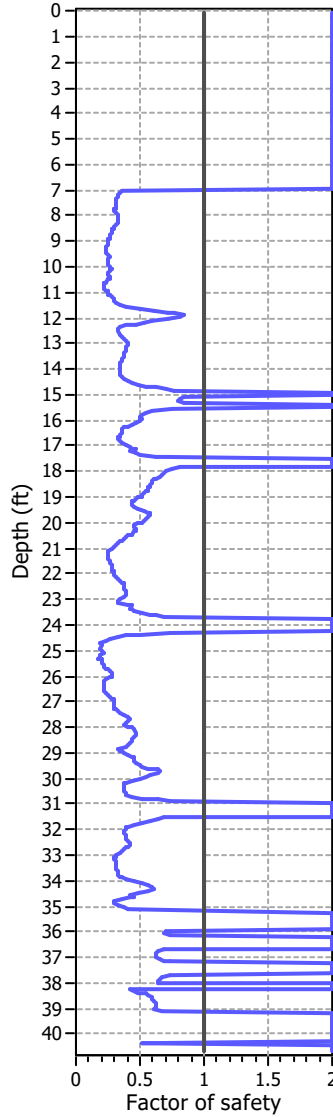

Stresses vs Depth

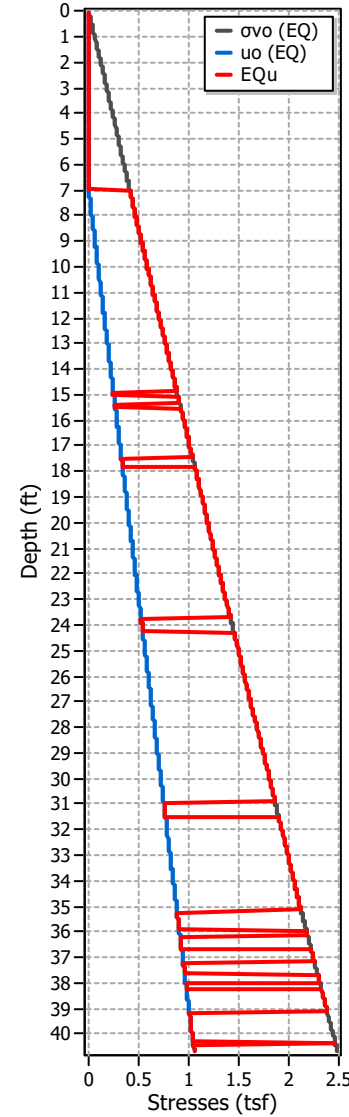

Excess Head

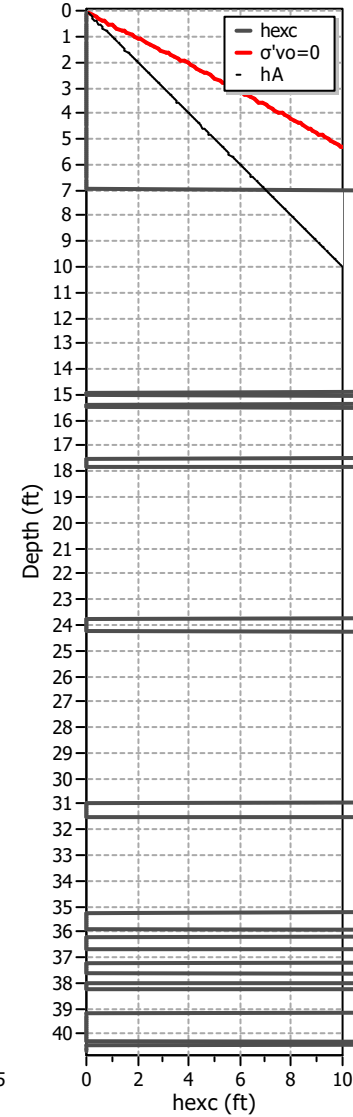

Liq. ejecta demand

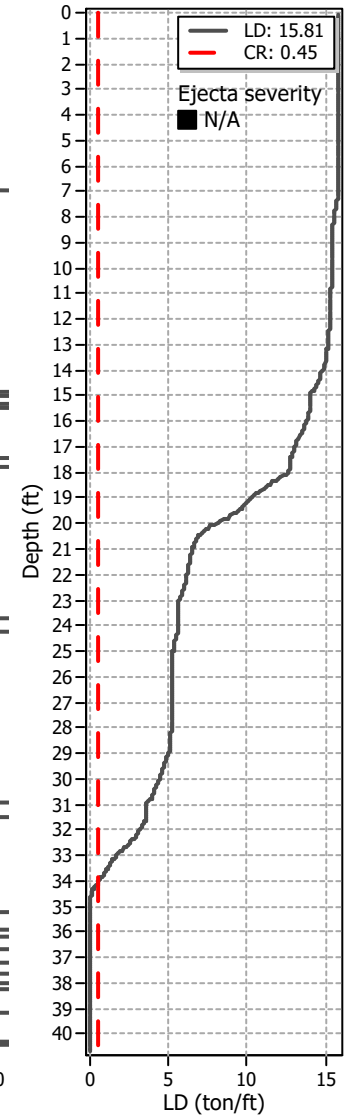

LIQUEFACTION ANALYSIS REPORT

Project title : Petra Geosciences / Apple Canyon

Location : Lake Hemet, CA

CPT file : CPT-4

Input parameters and analysis data

Analysis method:	NCEER (1998)	G.W.T. (in-situ):	11.00 ft	Use fill:	No	Clay like behavior applied:	Sands only
Fines correction method:	NCEER (1998)	G.W.T. (earthq.):	7.00 ft	Fill height:	N/A	Limit depth applied:	No
Points to test:	Based on Ic value	Average results interval:	3	Fill weight:	N/A	Limit depth:	N/A
Earthquake magnitude M_w :	8.10	Ic cut-off value:	2.60	Trans. detect. applied:	Yes	MSF method:	Method based
Peak ground acceleration:	0.89	Unit weight calculation:	Based on SBT	K_o applied:	Yes		

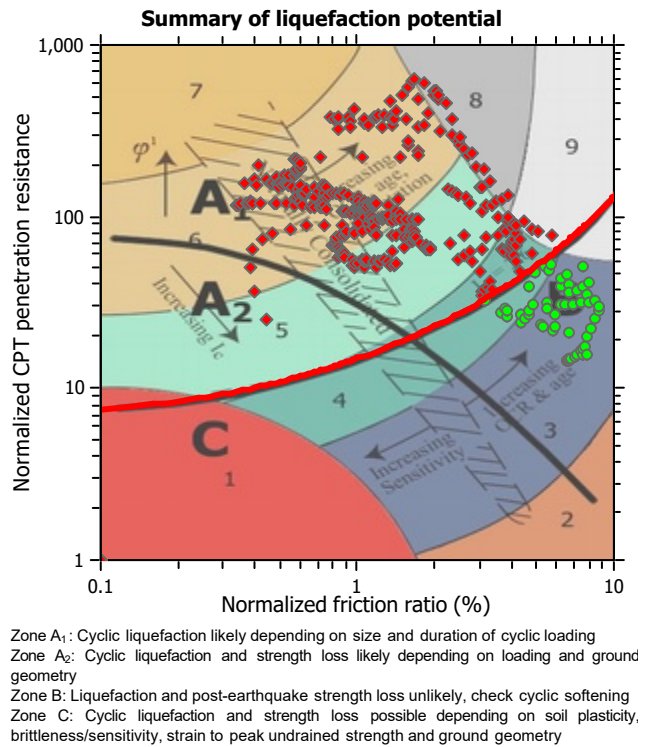
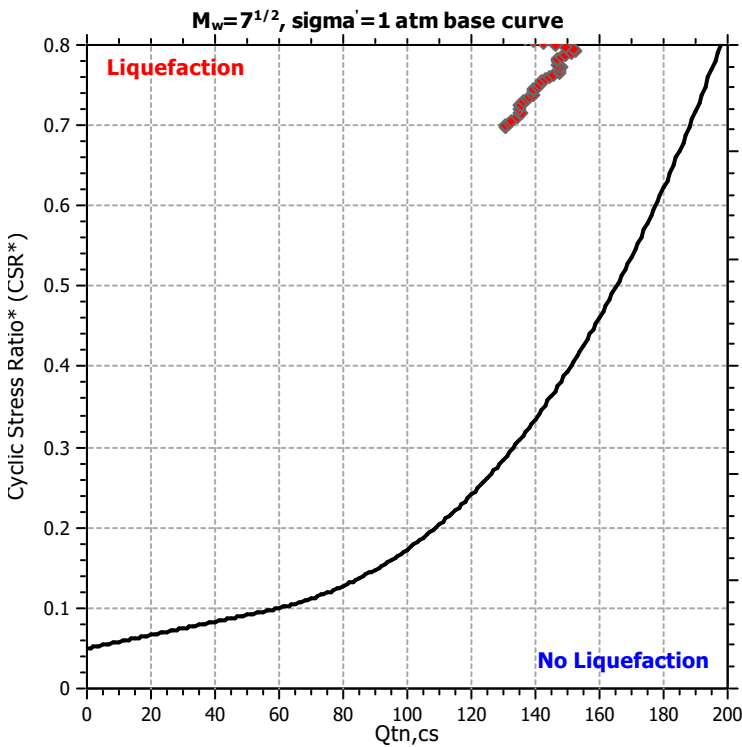
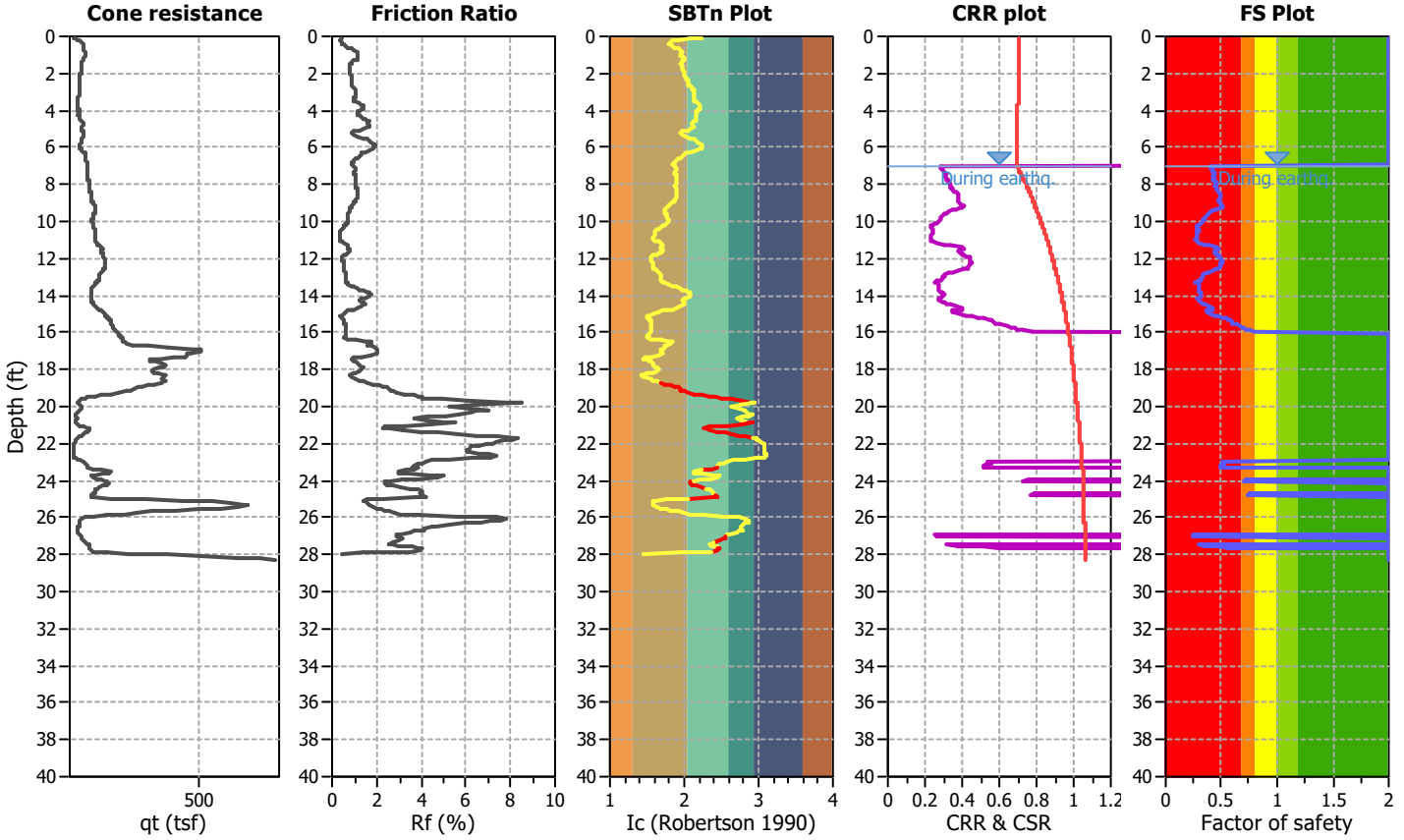

CPT basic interpretation plots

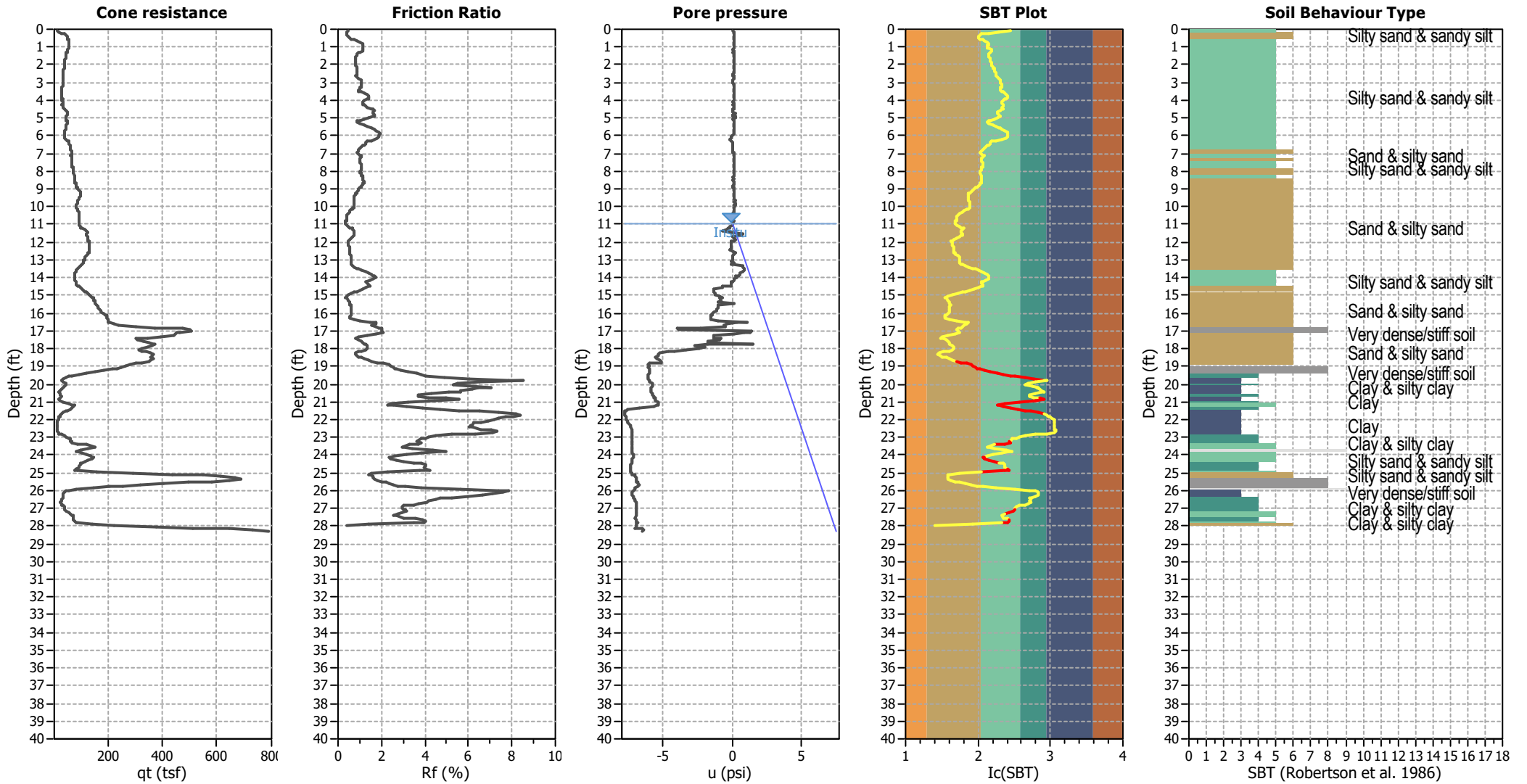

Input parameters and analysis data

Analysis method:	NCEER (1998)	Depth to water table (erthq.):	7.00 ft	Fill weight:	N/A
Fines correction method:	NCEER (1998)	Average results interval:	3	Transition detect. applied:	Yes
Points to test:	Based on Ic value	Ic cut-off value:	2.60	K _o applied:	Yes
Earthquake magnitude M _w :	8.10	Unit weight calculation:	Based on SBT	Clay like behavior applied:	Sands only
Peak ground acceleration:	0.89	Use fill:	No	Limit depth applied:	No
Depth to water table (insitu):	11.00 ft	Fill height:	N/A	Limit depth:	N/A

SBT legend

1. Sensitive fine grained	4. Clayey silt to silty	7. Gravely sand to sand
2. Organic material	5. Silty sand to sandy silt	8. Very stiff sand to
3. Clay to silty clay	6. Clean sand to silty sand	9. Very stiff fine grained

CPT basic interpretation plots (normalized)

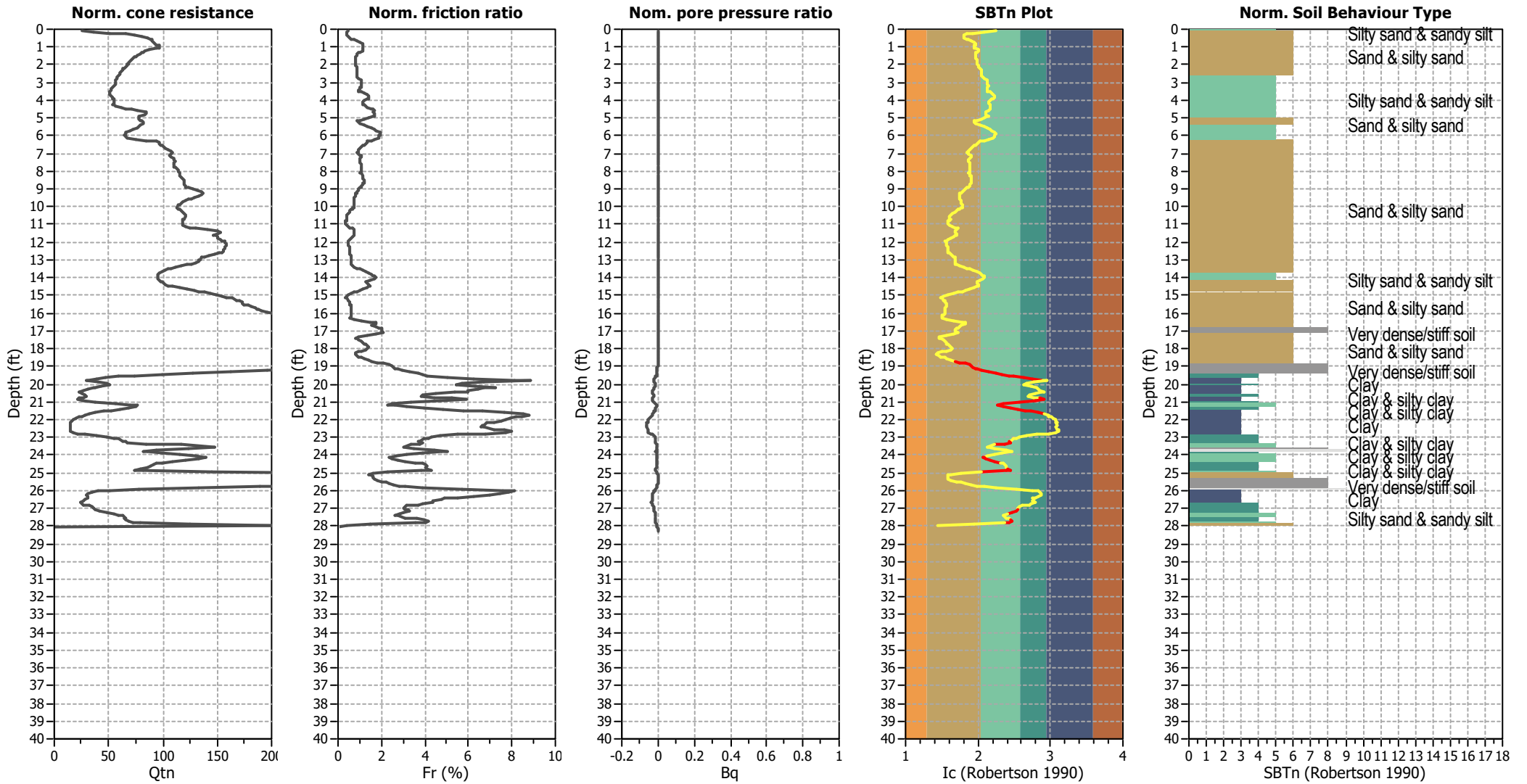

Input parameters and analysis data

Analysis method:	NCEER (1998)	Depth to water table (erthq.):	7.00 ft	Fill weight:	N/A
Fines correction method:	NCEER (1998)	Average results interval:	3	Transition detect. applied:	Yes
Points to test:	Based on Ic value	Ic cut-off value:	2.60	K ₀ applied:	Yes
Earthquake magnitude M _w :	8.10	Unit weight calculation:	Based on SBT	Clay like behavior applied:	Sands only
Peak ground acceleration:	0.89	Use fill:	No	Limit depth applied:	No
Depth to water table (insitu):	11.00 ft	Fill height:	N/A	Limit depth:	N/A

SBTn legend

1. Sensitive fine grained	4. Clayey silt to silty	7. Gravely sand to sand
2. Organic material	5. Silty sand to sandy silt	8. Very stiff sand to
3. Clay to silty clay	6. Clean sand to silty sand	9. Very stiff fine grained

Liquefaction analysis overall plots (intermediate results)

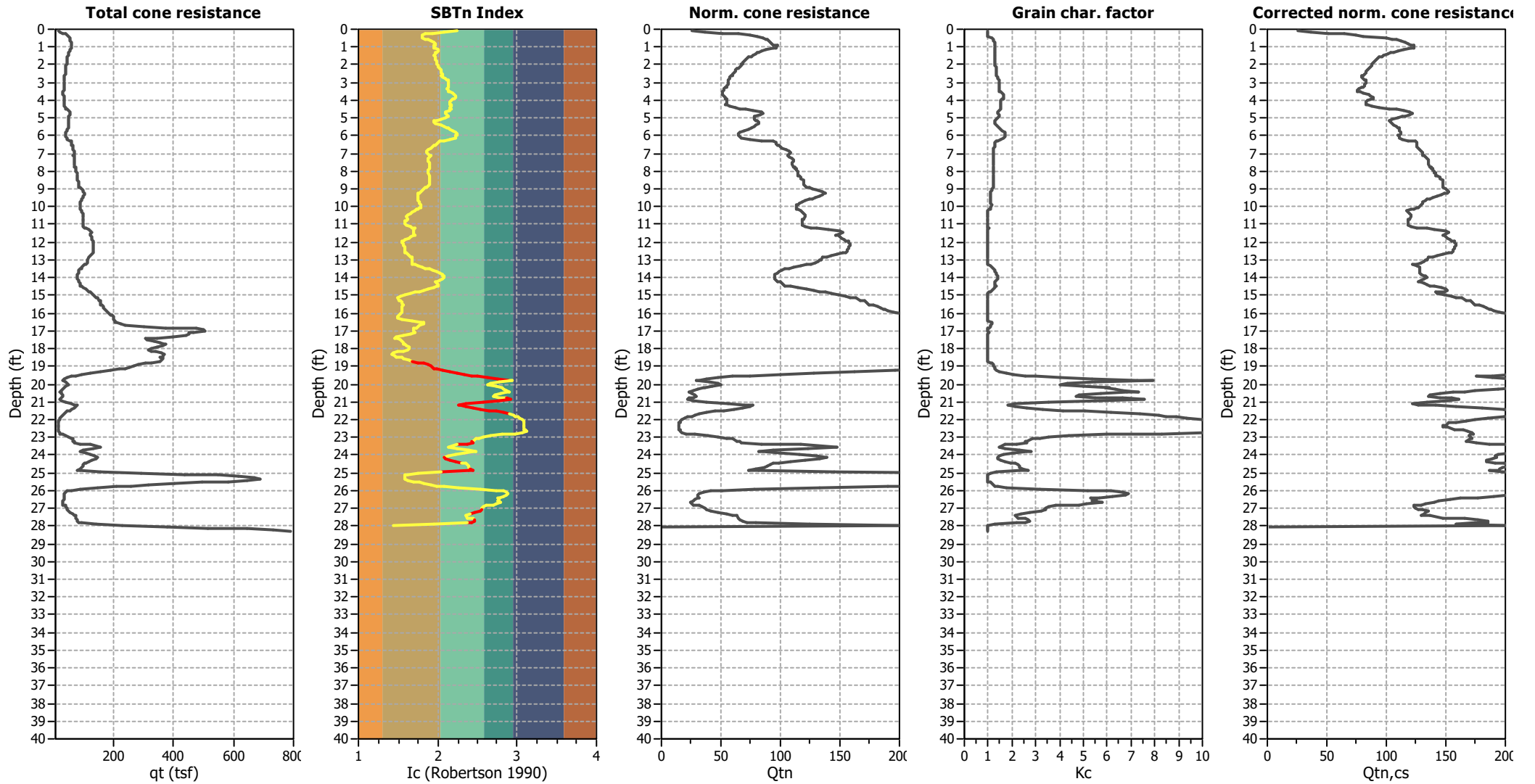

Input parameters and analysis data

Analysis method:	NCEER (1998)	Depth to water table (earthq.):	7.00 ft	Fill weight:	N/A
Fines correction method:	NCEER (1998)	Average results interval:	3	Transition detect. applied:	Yes
Points to test:	Based on Ic value	Ic cut-off value:	2.60	K _o applied:	Yes
Earthquake magnitude M _w :	8.10	Unit weight calculation:	Based on SBT	Clay like behavior applied:	Sands only
Peak ground acceleration:	0.89	Use fill:	No	Limit depth applied:	No
Depth to water table (insitu):	11.00 ft	Fill height:	N/A	Limit depth:	N/A

Liquefaction analysis overall plots

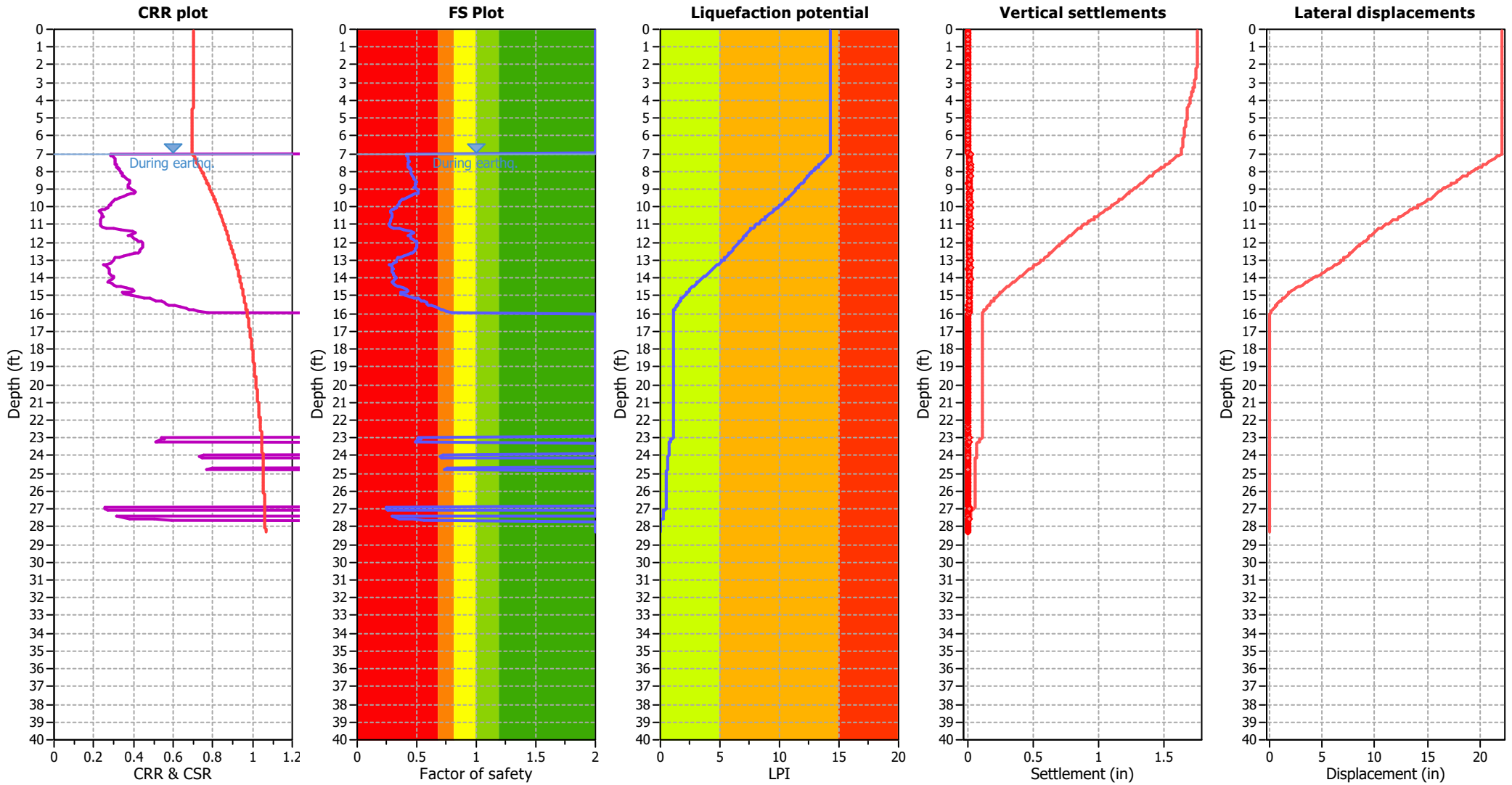

Input parameters and analysis data

Analysis method:	NCEER (1998)	Depth to water table (earthq.):	7.00 ft	Fill weight:	N/A
Fines correction method:	NCEER (1998)	Average results interval:	3	Transition detect. applied:	Yes
Points to test:	Based on Ic value	Ic cut-off value:	2.60	K_0 applied:	Yes
Earthquake magnitude M_w :	8.10	Unit weight calculation:	Based on SBT	Clay like behavior applied:	Sands only
Peak ground acceleration:	0.89	Use fill:	No	Limit depth applied:	No
Depth to water table (insitu):	11.00 ft	Fill height:	N/A	Limit depth:	N/A

F.S. color scheme

- Almost certain it will liquefy
- Very likely to liquefy
- Liquefaction and no liq. are equally likely
- Unlike to liquefy
- Almost certain it will not liquefy

LPI color scheme

- Very high risk
- High risk
- Low risk

Liquefaction analysis summary plots

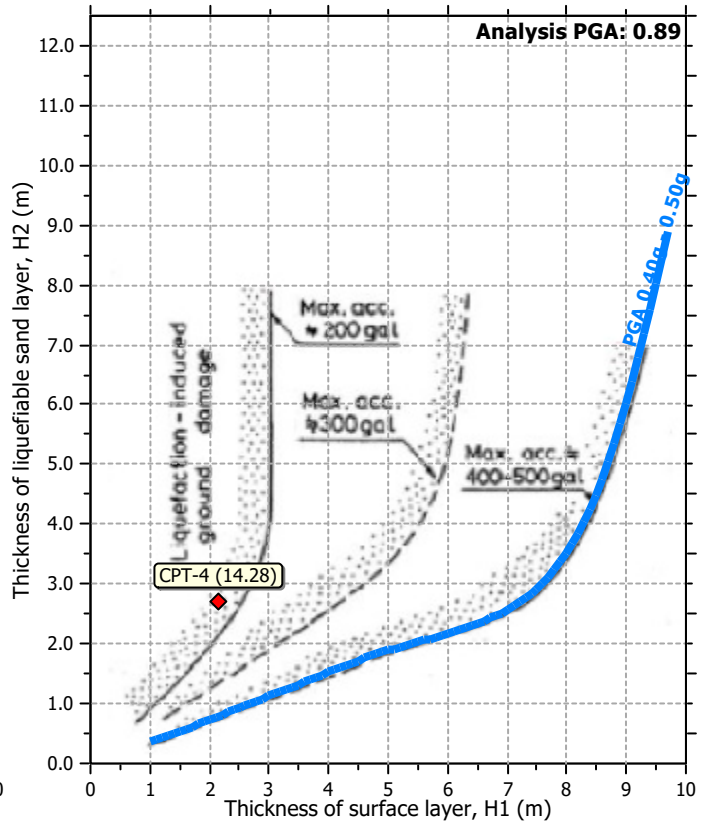
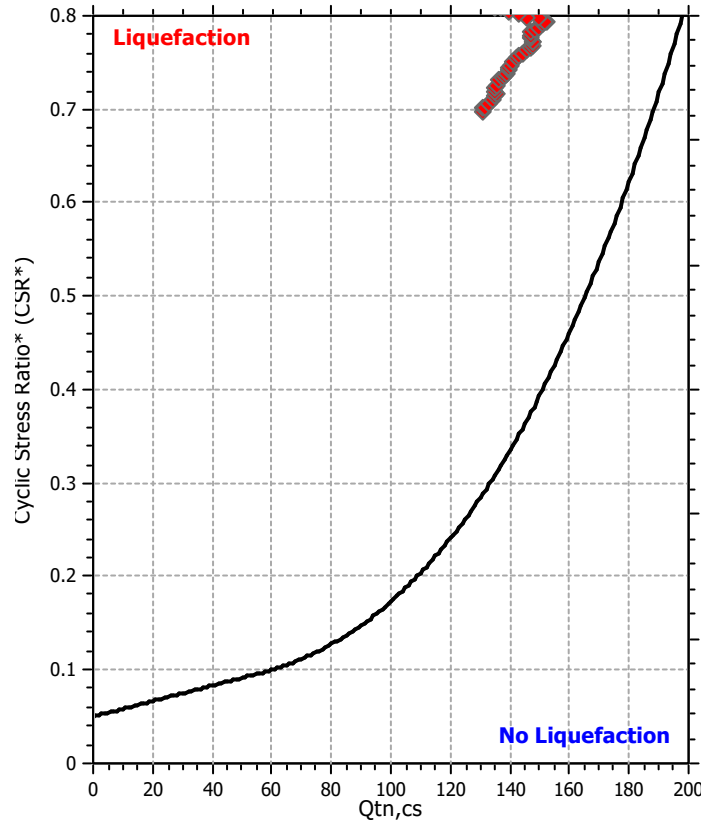
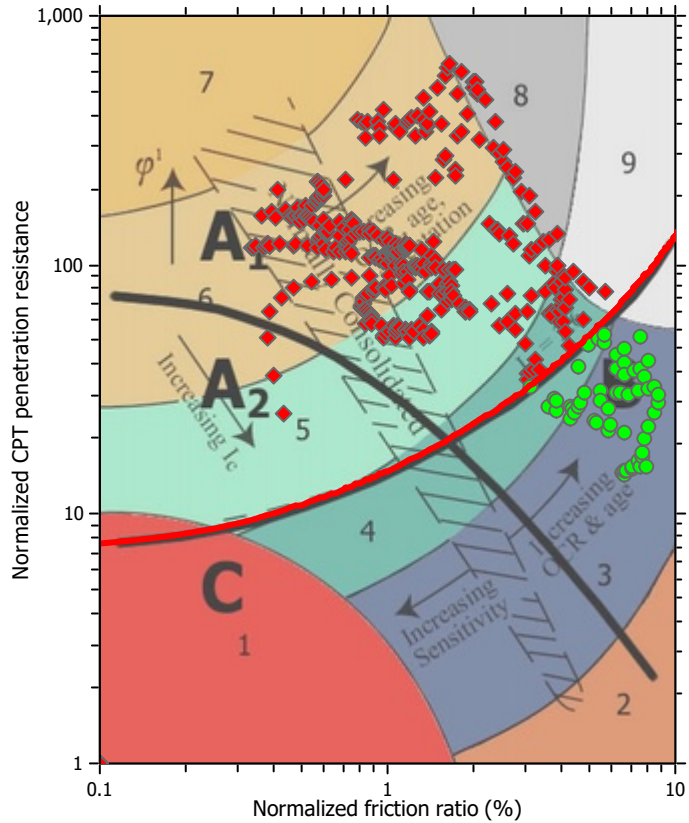

Input parameters and analysis data

Analysis method:	NCEER (1998)	Depth to water table (erthq.):	7.00 ft	Fill weight:	N/A
Fines correction method:	NCEER (1998)	Average results interval:	3	Transition detect. applied:	Yes
Points to test:	Based on Ic value	Ic cut-off value:	2.60	K _o applied:	Yes
Earthquake magnitude M _w :	8.10	Unit weight calculation:	Based on SBT	Clay like behavior applied:	Sands only
Peak ground acceleration:	0.89	Use fill:	No	Limit depth applied:	No
Depth to water table (insitu):	11.00 ft	Fill height:	N/A	Limit depth:	N/A

Check for strength loss plots (Robertson (2010))

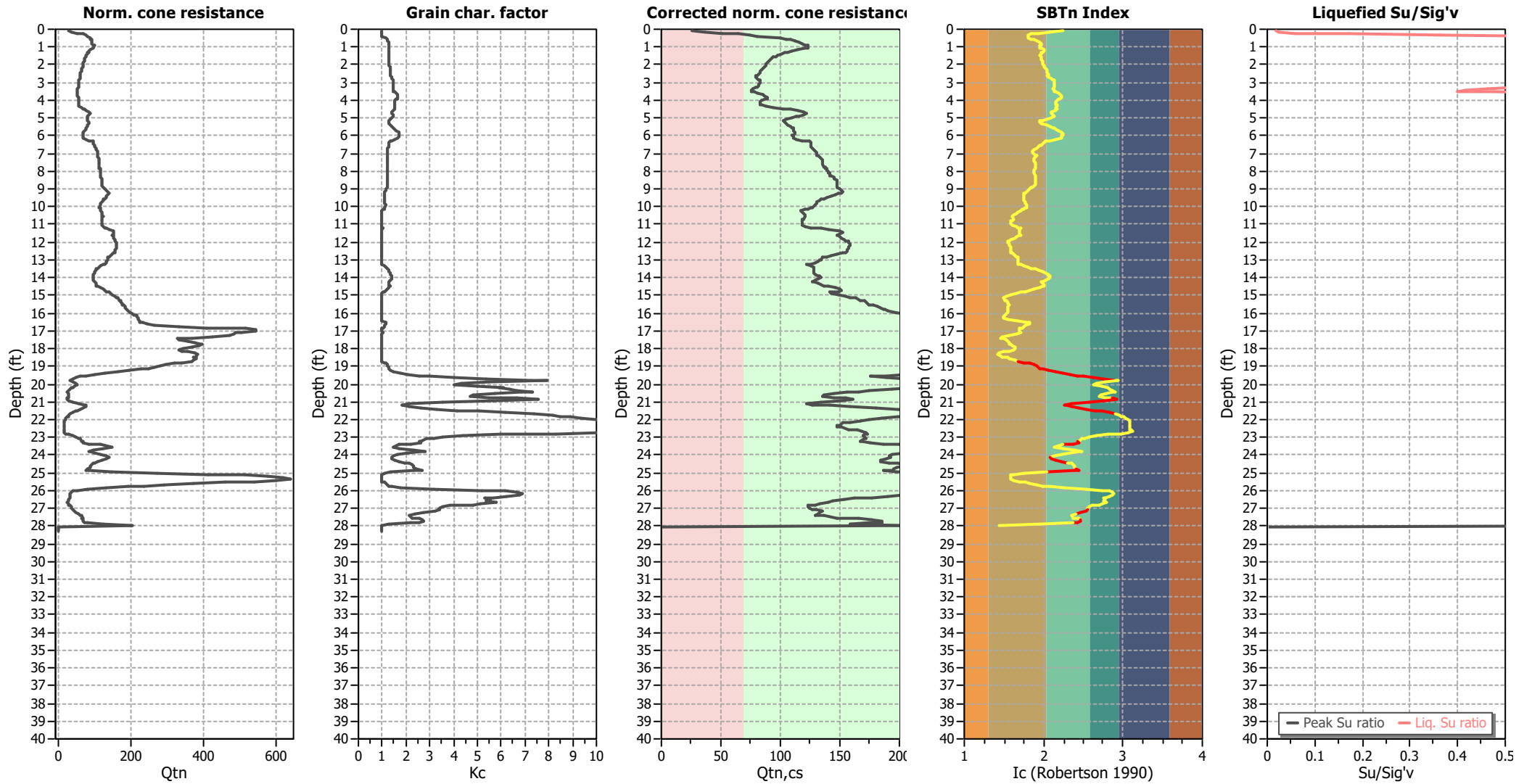

Input parameters and analysis data

Analysis method:	NCEER (1998)	Depth to water table (earthq.):	7.00 ft	Fill weight:	N/A
Fines correction method:	NCEER (1998)	Average results interval:	3	Transition detect. applied:	Yes
Points to test:	Based on Ic value	Ic cut-off value:	2.60	K _o applied:	Yes
Earthquake magnitude M _w :	8.10	Unit weight calculation:	Based on SBT	Clay like behavior applied:	Sands only
Peak ground acceleration:	0.89	Use fill:	No	Limit depth applied:	No
Depth to water table (insitu):	11.00 ft	Fill height:	N/A	Limit depth:	N/A

TRANSITION LAYER DETECTION ALGORITHM REPORT

Summary Details & Plots

Short description

The software will delete data when the cone is in transition from either clay to sand or vice-versa. To do this the software requires a range of I_c values over which the transition will be defined (typically somewhere between $1.80 < I_c < 3.0$) and a rate of change of I_c . Transitions typically occur when the rate of change of I_c is fast (i.e. ΔI_c is small).

The SBT_n plot below, displays in red the detected transition layers based on the parameters listed below the graphs.

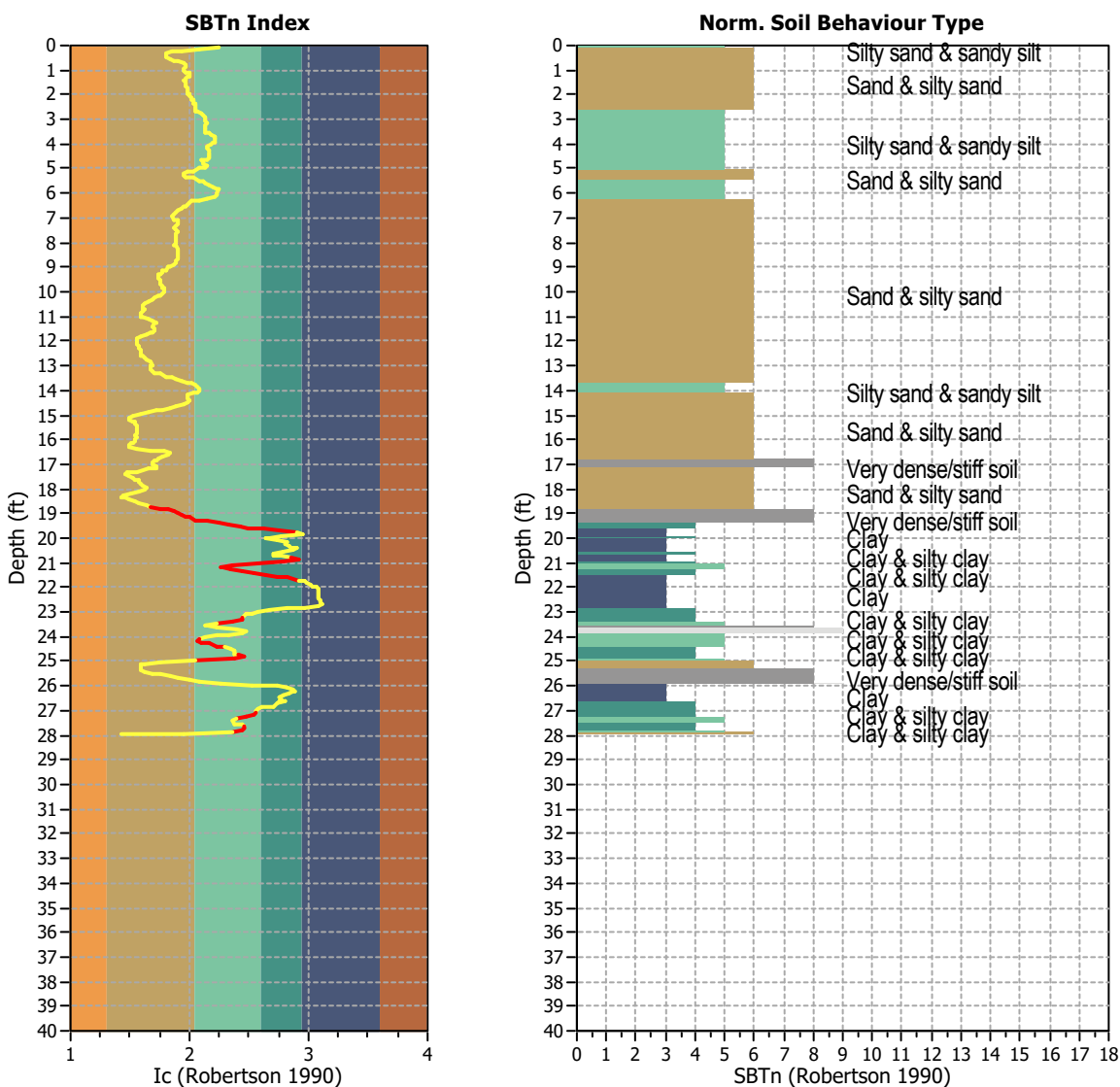

Transition layer algorithm properties

I_c minimum check value: 1.70
 I_c maximum check value: 3.00
 I_c change ratio value: 0.0250
 Minimum number of points in layer: 4

General statistics

Total points in CPT file: 431
 Total points excluded: 54
 Exclusion percentage: 12.53%
 Number of layers detected: 8

Estimation of post-earthquake settlements

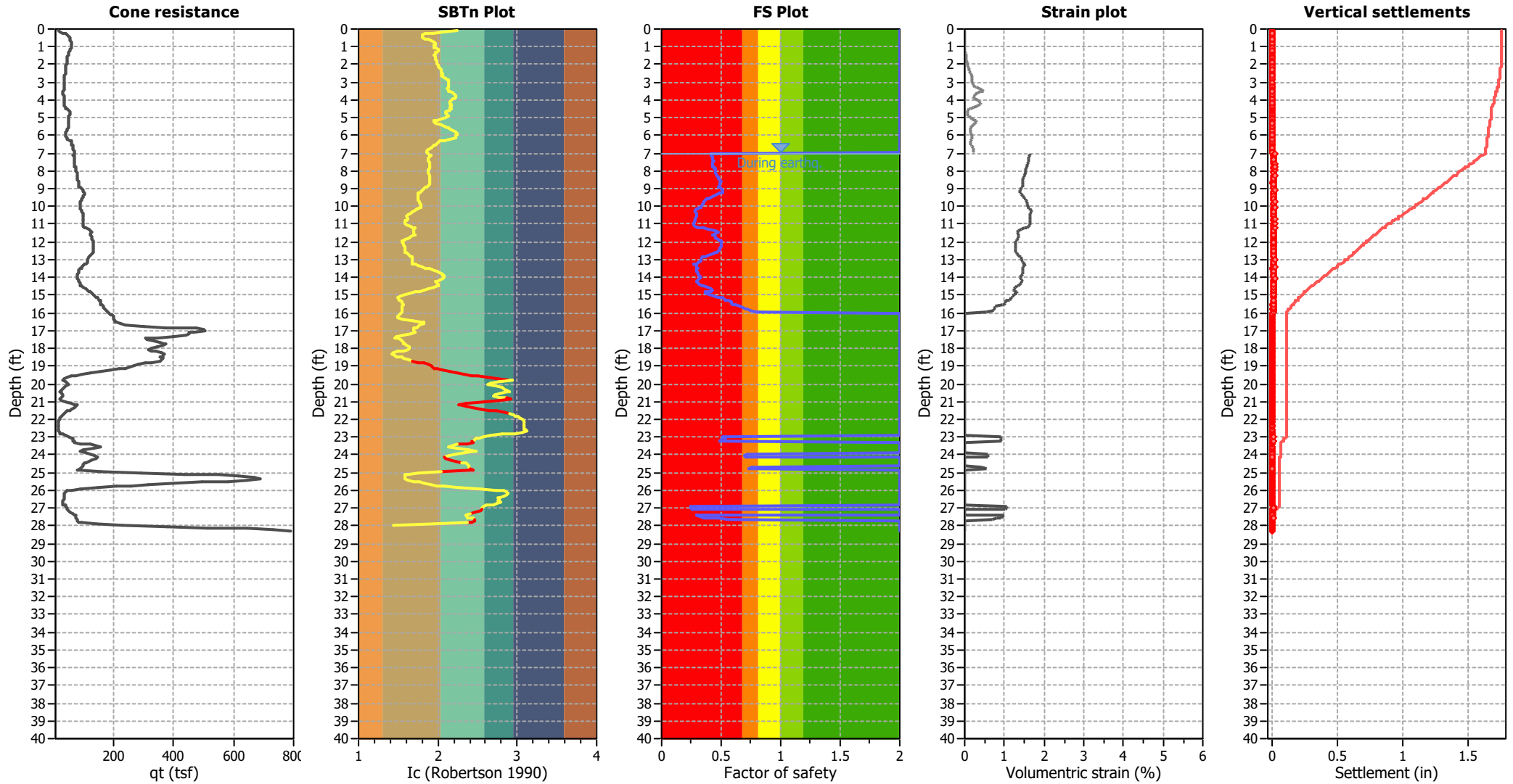

Abbreviations

- q_c: Total cone resistance (cone resistance q_c corrected for pore water effects)
- I_c: Soil Behaviour Type Index
- FS: Calculated Factor of Safety against liquefaction
- Volumetric strain: Post-liquefaction volumetric strain

Estimation of post-earthquake lateral Displacements

Geometric parameters: Level ground (or gently sloping) with free face (L: 40.00 ft - H: 8.00 ft)

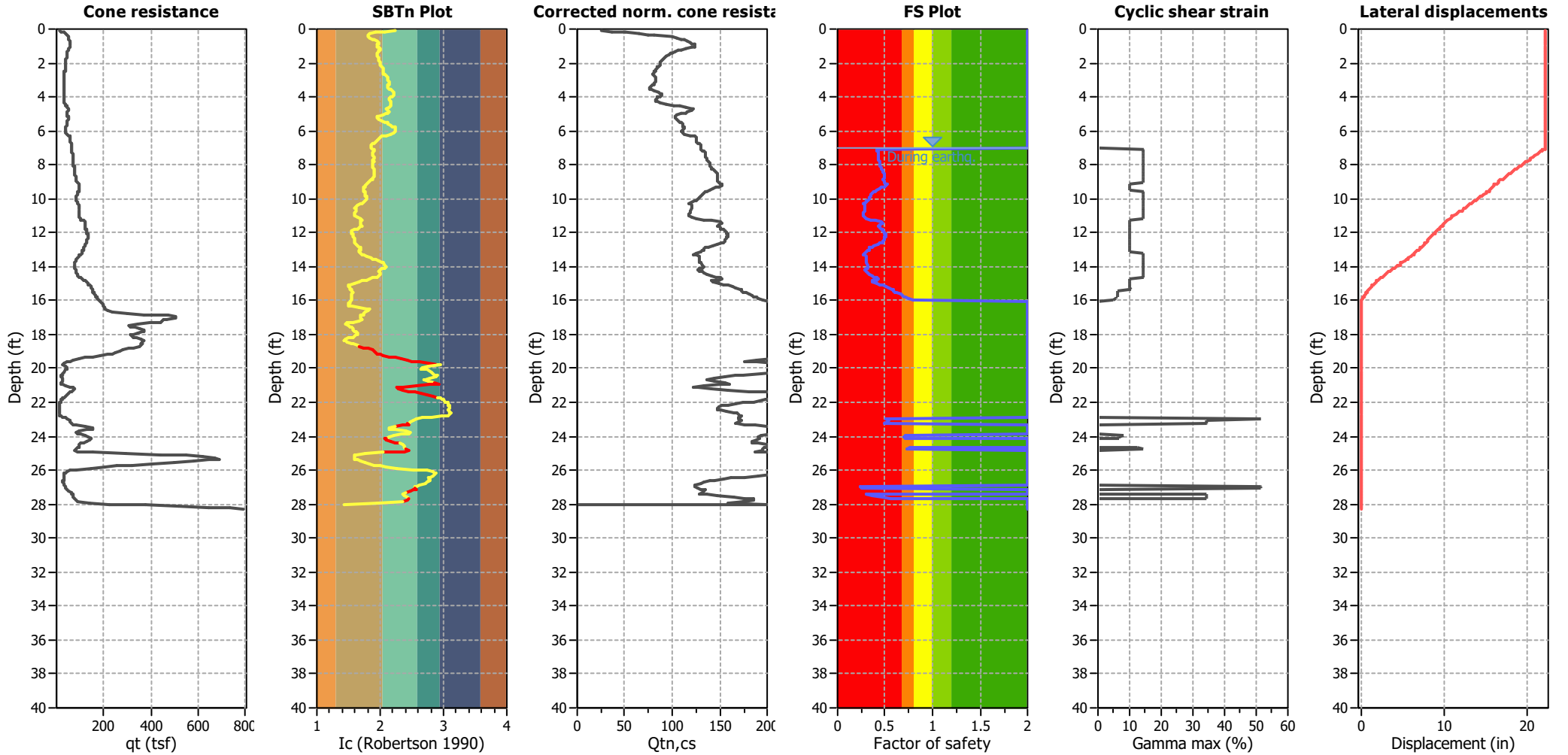

Abbreviations

q_t: Total cone resistance (cone resistance q_c corrected for pore water effects)
 I_c: Soil Behaviour Type Index
 Q_{tn,cs}: Equivalent clean sand normalized CPT total cone resistance

F.S.: Factor of safety
 γ_{max}: Maximum cyclic shear strain
 LDI: Lateral displacement index

Surface condition

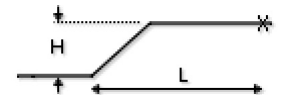

Aging Calculation Estimation

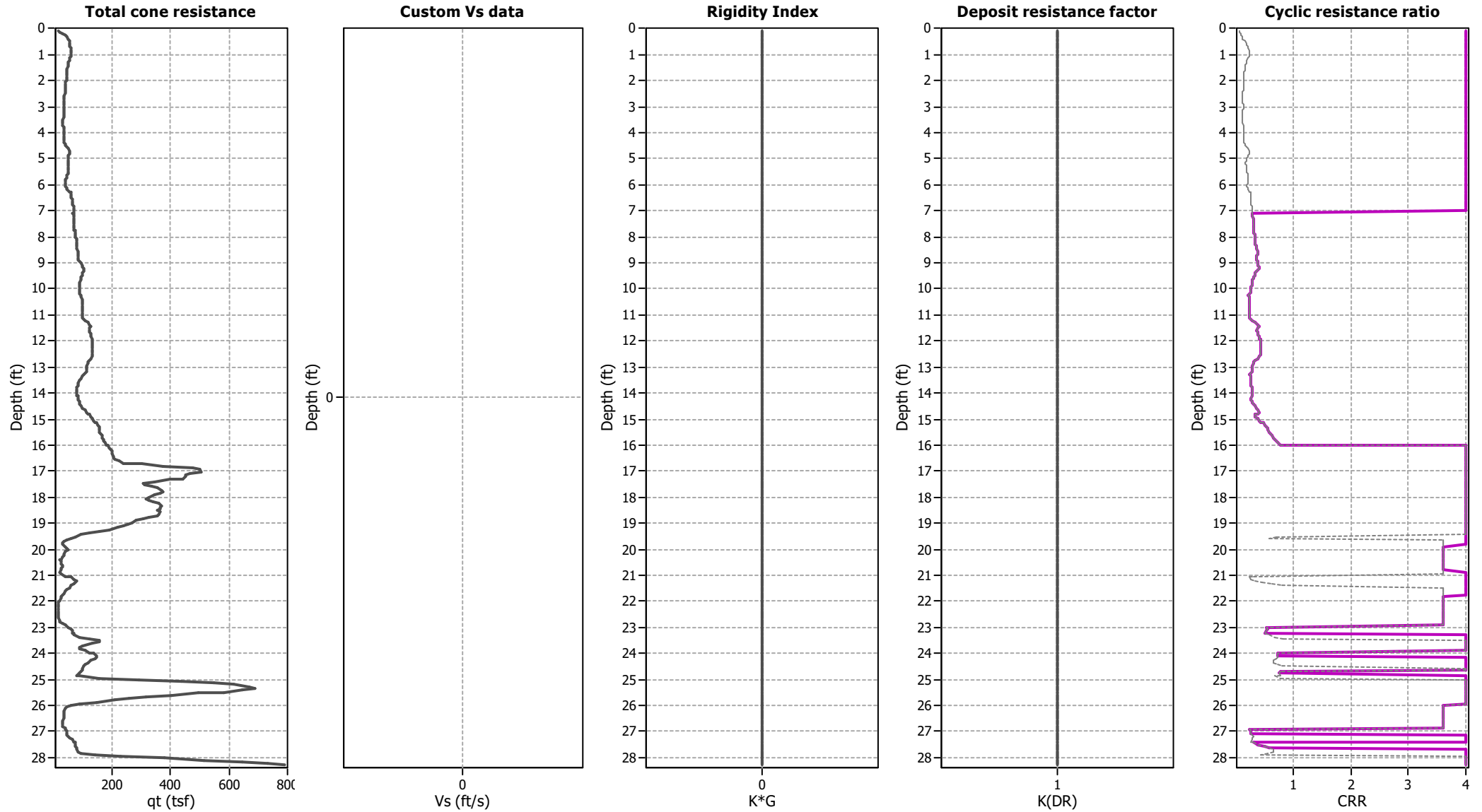

Ejecta Severity Estimation

Corrected norm. cone resista

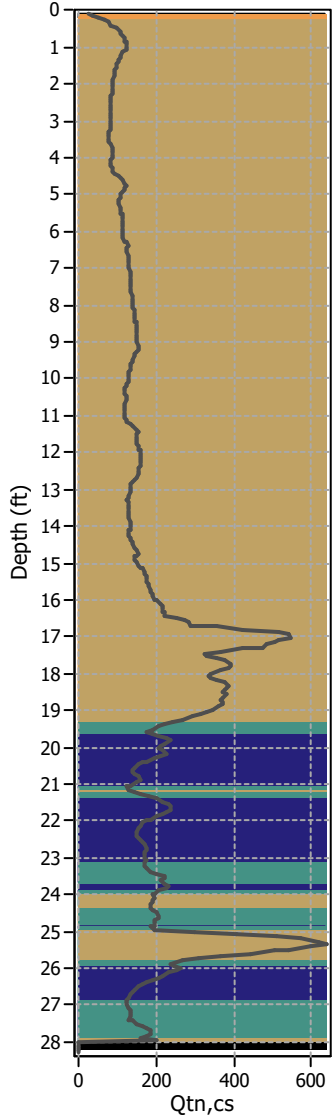

SBTn Index Plot

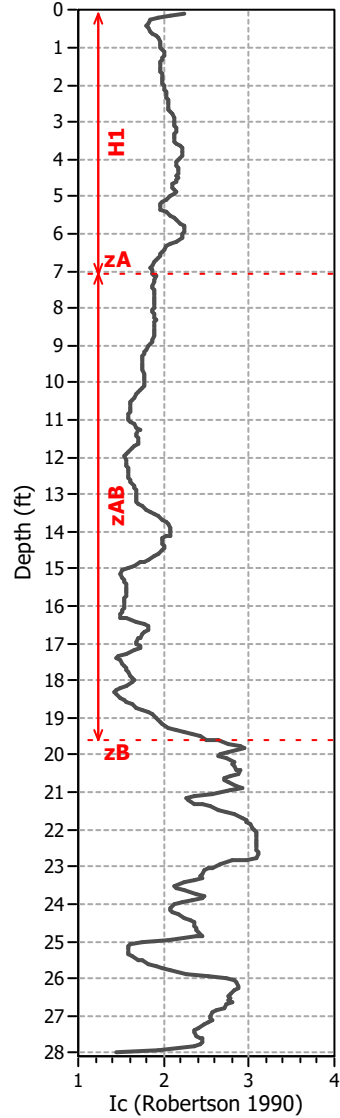

FS plot

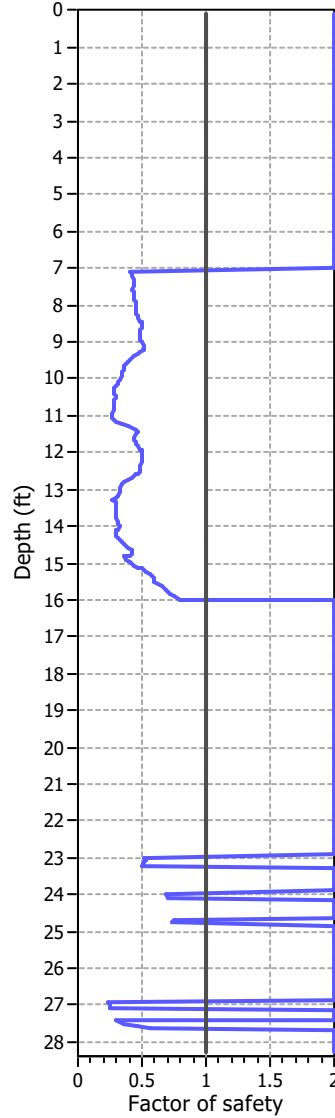

Stresses vs Depth

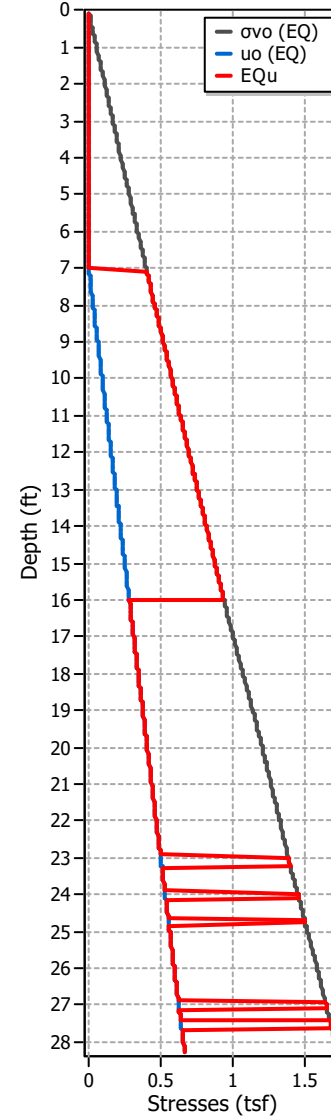

Excess Head

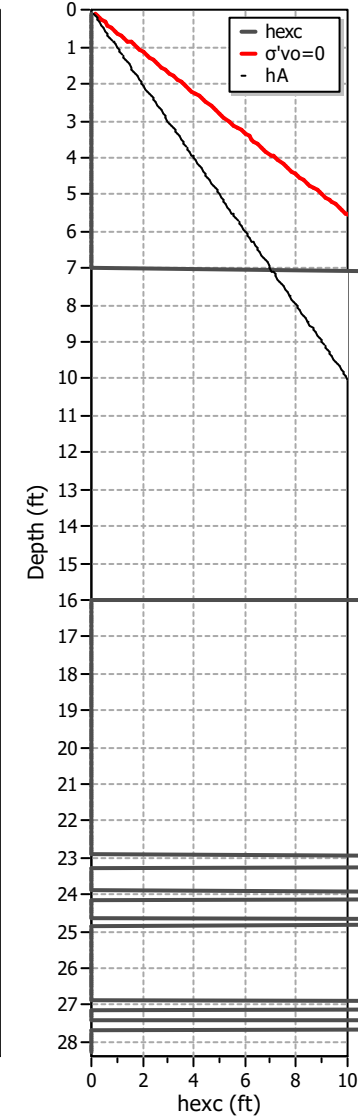

Liq. ejecta demand

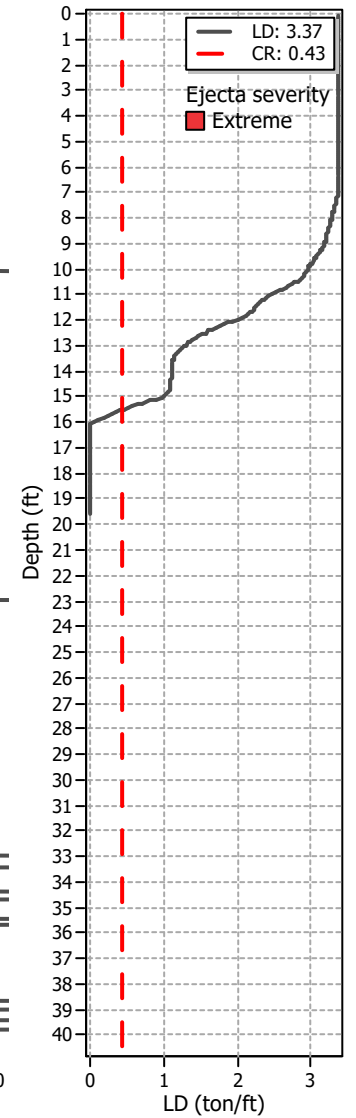

LIQUEFACTION ANALYSIS REPORT

Project title : Petra Geosciences / Apple Canyon

Location : Lake Hemet, CA

CPT file : CPT-5

Input parameters and analysis data

Analysis method:	NCEER (1998)	G.W.T. (in-situ):	10.50 ft	Use fill:	No	Clay like behavior applied:	Sands only
Fines correction method:	NCEER (1998)	G.W.T. (earthq.):	7.00 ft	Fill height:	N/A	Limit depth applied:	No
Points to test:	Based on Ic value	Average results interval:	3	Fill weight:	N/A	Limit depth:	N/A
Earthquake magnitude M_w :	8.10	Ic cut-off value:	2.60	Trans. detect. applied:	Yes	MSF method:	Method based
Peak ground acceleration:	0.89	Unit weight calculation:	Based on SBT	K_o applied:	Yes		

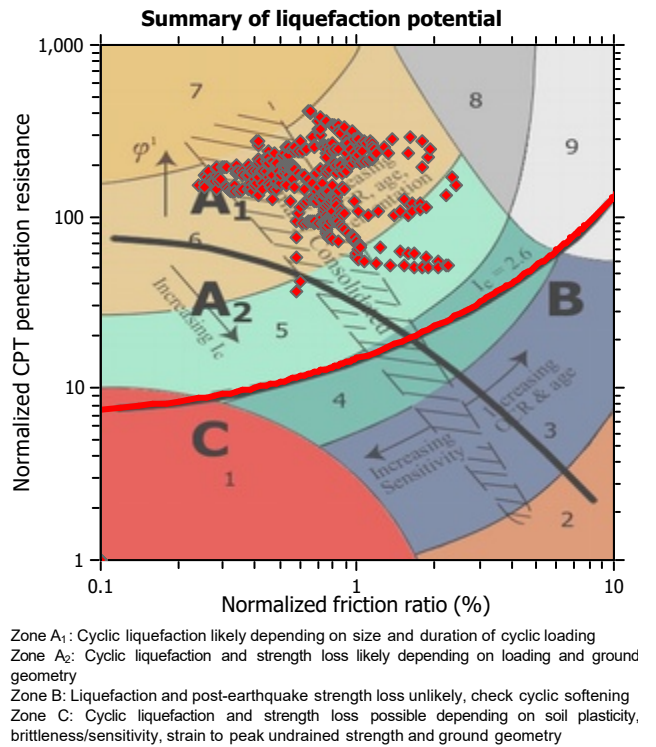
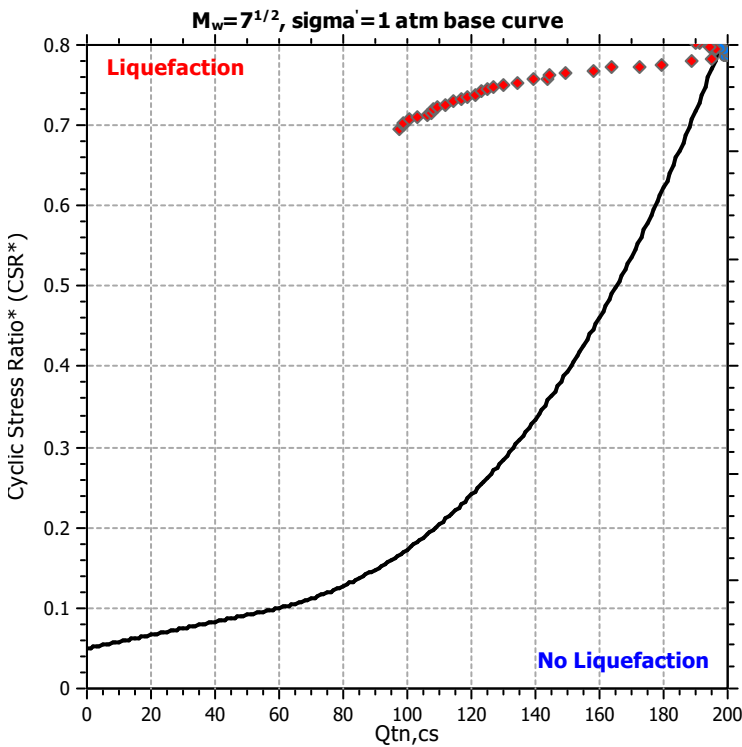
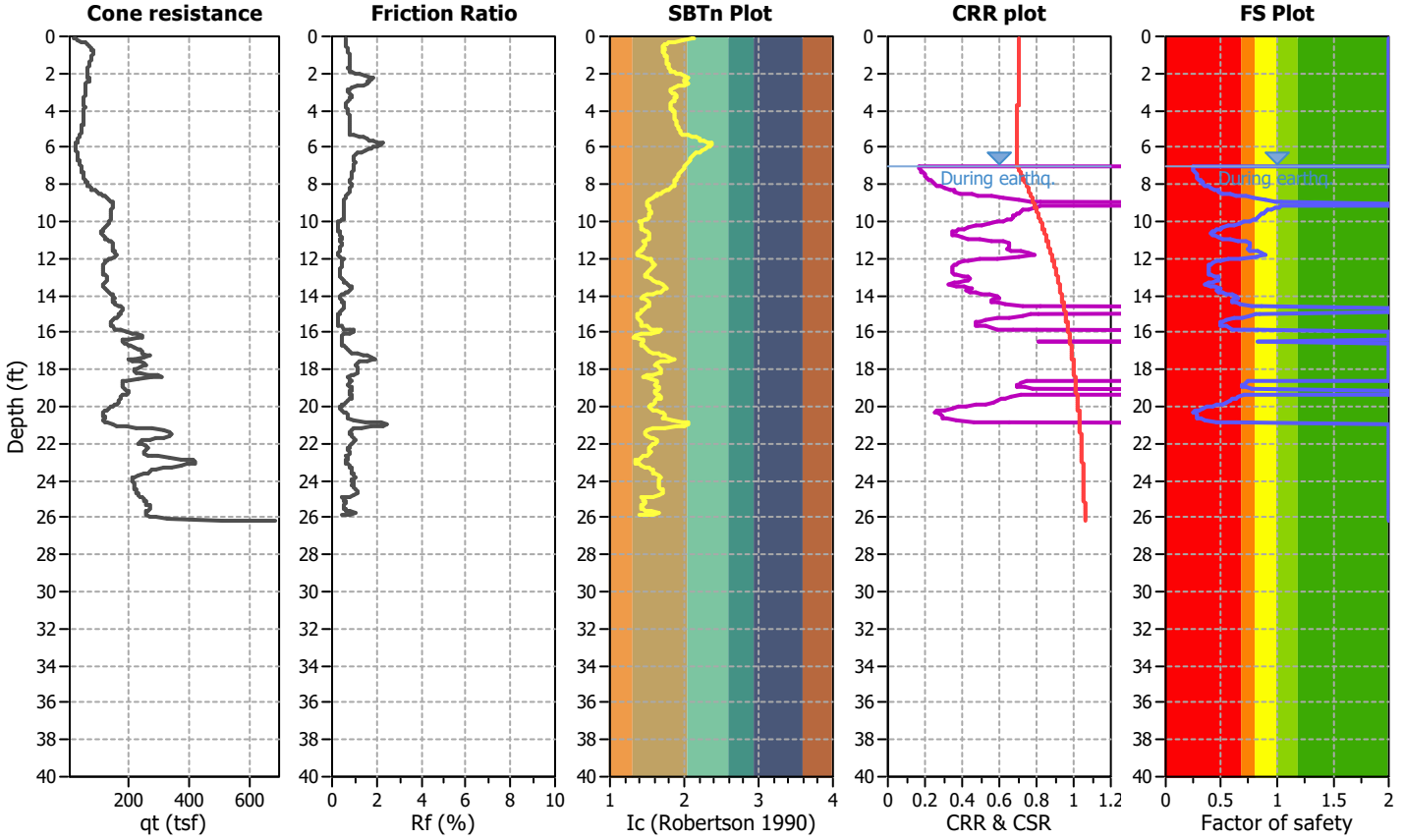

CPT basic interpretation plots

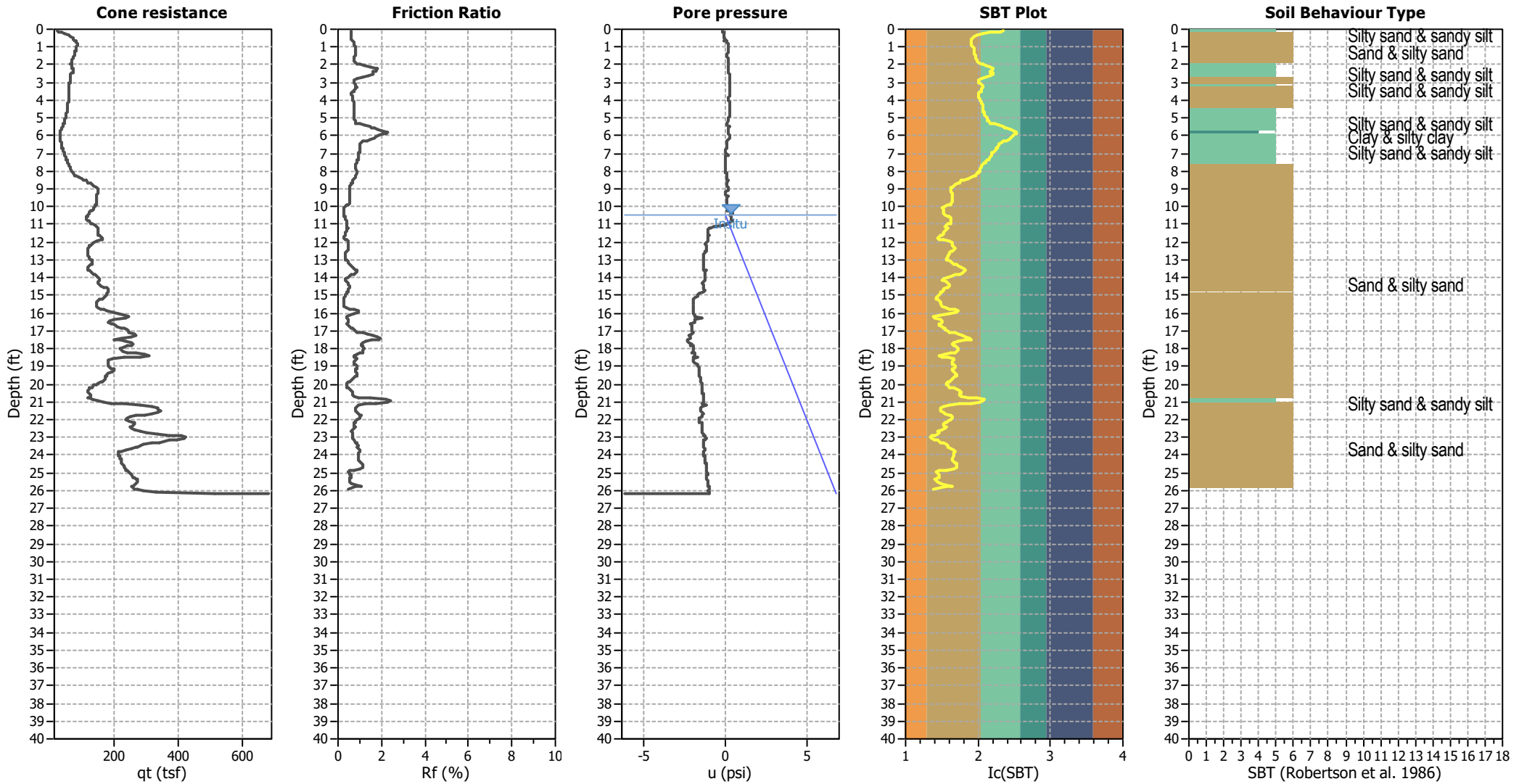

Input parameters and analysis data

Analysis method:	NCEER (1998)	Depth to water table (earthq.):	7.00 ft	Fill weight:	N/A
Fines correction method:	NCEER (1998)	Average results interval:	3	Transition detect. applied:	Yes
Points to test:	Based on Ic value	Ic cut-off value:	2.60	K ₀ applied:	Yes
Earthquake magnitude M _w :	8.10	Unit weight calculation:	Based on SBT	Clay like behavior applied:	Sands only
Peak ground acceleration:	0.89	Use fill:	No	Limit depth applied:	No
Depth to water table (insitu):	10.50 ft	Fill height:	N/A	Limit depth:	N/A

SBT legend

1. Sensitive fine grained	4. Clayey silt to silty	7. Gravely sand to sand
2. Organic material	5. Silty sand to sandy silt	8. Very stiff sand to
3. Clay to silty clay	6. Clean sand to silty sand	9. Very stiff fine grained

CPT basic interpretation plots (normalized)

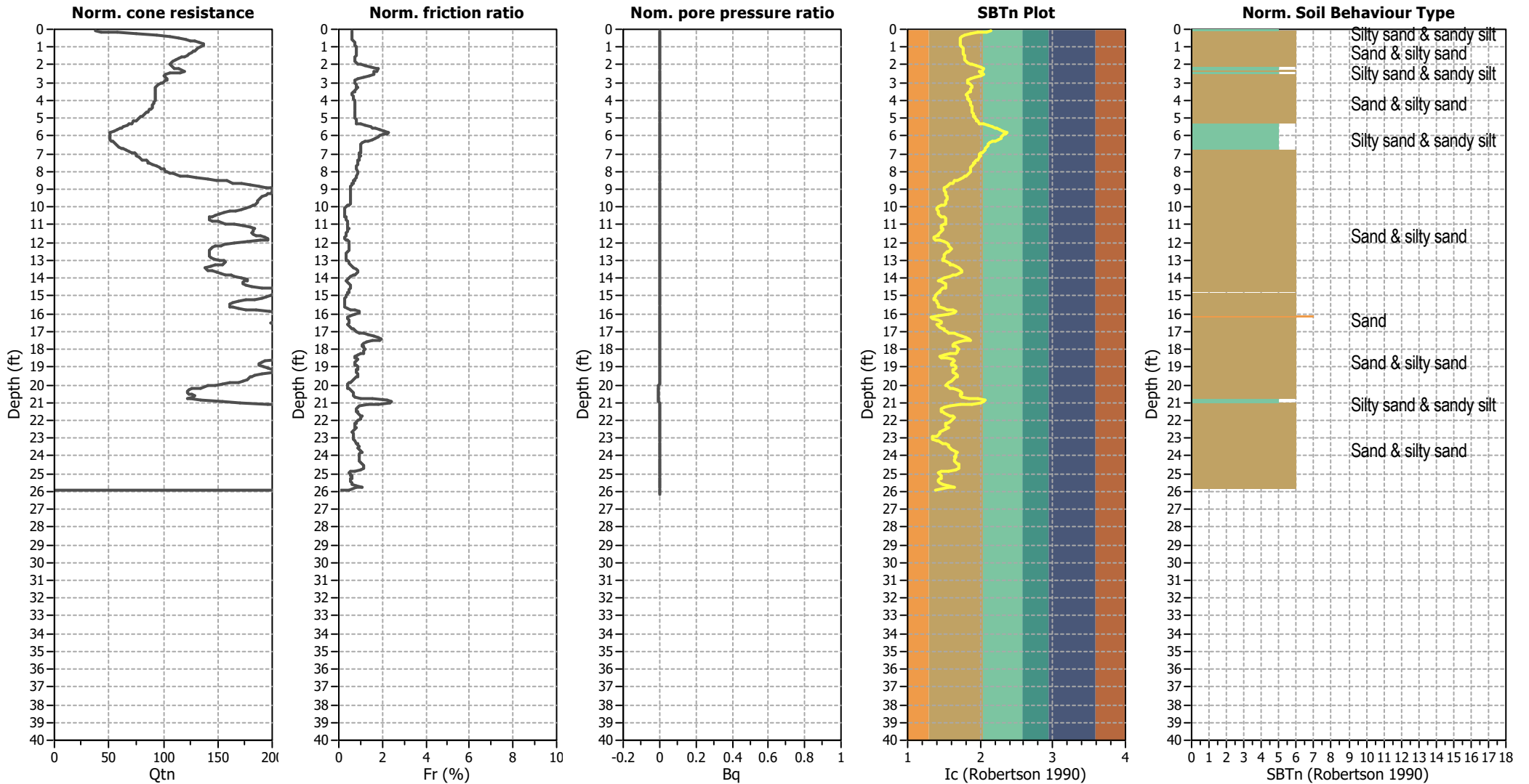

Input parameters and analysis data

Analysis method:	NCEER (1998)	Depth to water table (earthq.):	7.00 ft	Fill weight:	N/A
Fines correction method:	NCEER (1998)	Average results interval:	3	Transition detect. applied:	Yes
Points to test:	Based on Ic value	Ic cut-off value:	2.60	K ₀ applied:	Yes
Earthquake magnitude M _w :	8.10	Unit weight calculation:	Based on SBT	Clay like behavior applied:	Sands only
Peak ground acceleration:	0.89	Use fill:	No	Limit depth applied:	No
Depth to water table (insitu):	10.50 ft	Fill height:	N/A	Limit depth:	N/A

SBTn legend

1. Sensitive fine grained	4. Clayey silt to silty	7. Gravely sand to sand
2. Organic material	5. Silty sand to sandy silt	8. Very stiff sand to
3. Clay to silty clay	6. Clean sand to silty sand	9. Very stiff fine grained

Liquefaction analysis overall plots (intermediate results)

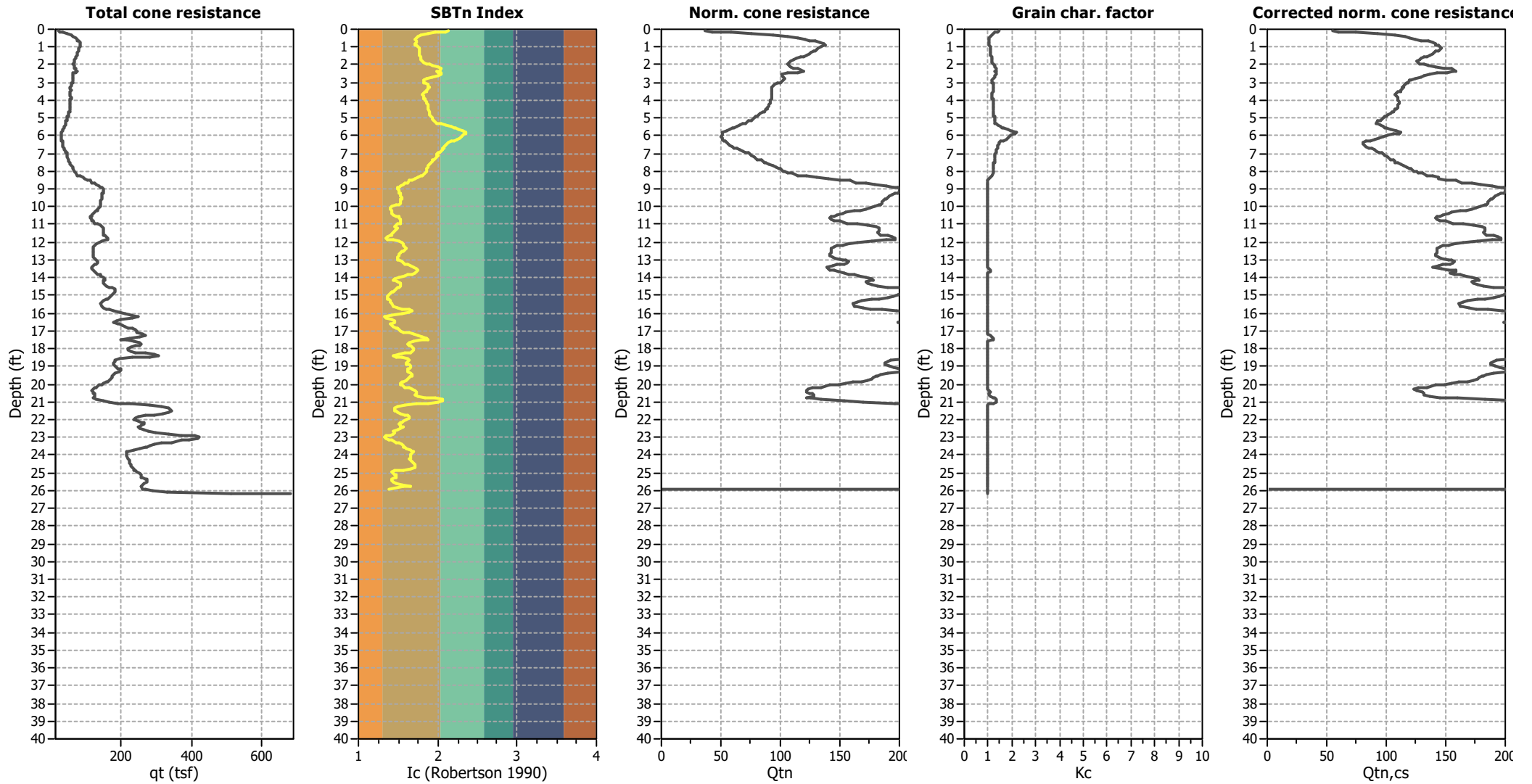

Input parameters and analysis data

Analysis method:	NCEER (1998)	Depth to water table (earthq.):	7.00 ft	Fill weight:	N/A
Fines correction method:	NCEER (1998)	Average results interval:	3	Transition detect. applied:	Yes
Points to test:	Based on Ic value	Ic cut-off value:	2.60	K _o applied:	Yes
Earthquake magnitude M _w :	8.10	Unit weight calculation:	Based on SBT	Clay like behavior applied:	Sands only
Peak ground acceleration:	0.89	Use fill:	No	Limit depth applied:	No
Depth to water table (insitu):	10.50 ft	Fill height:	N/A	Limit depth:	N/A

Liquefaction analysis overall plots

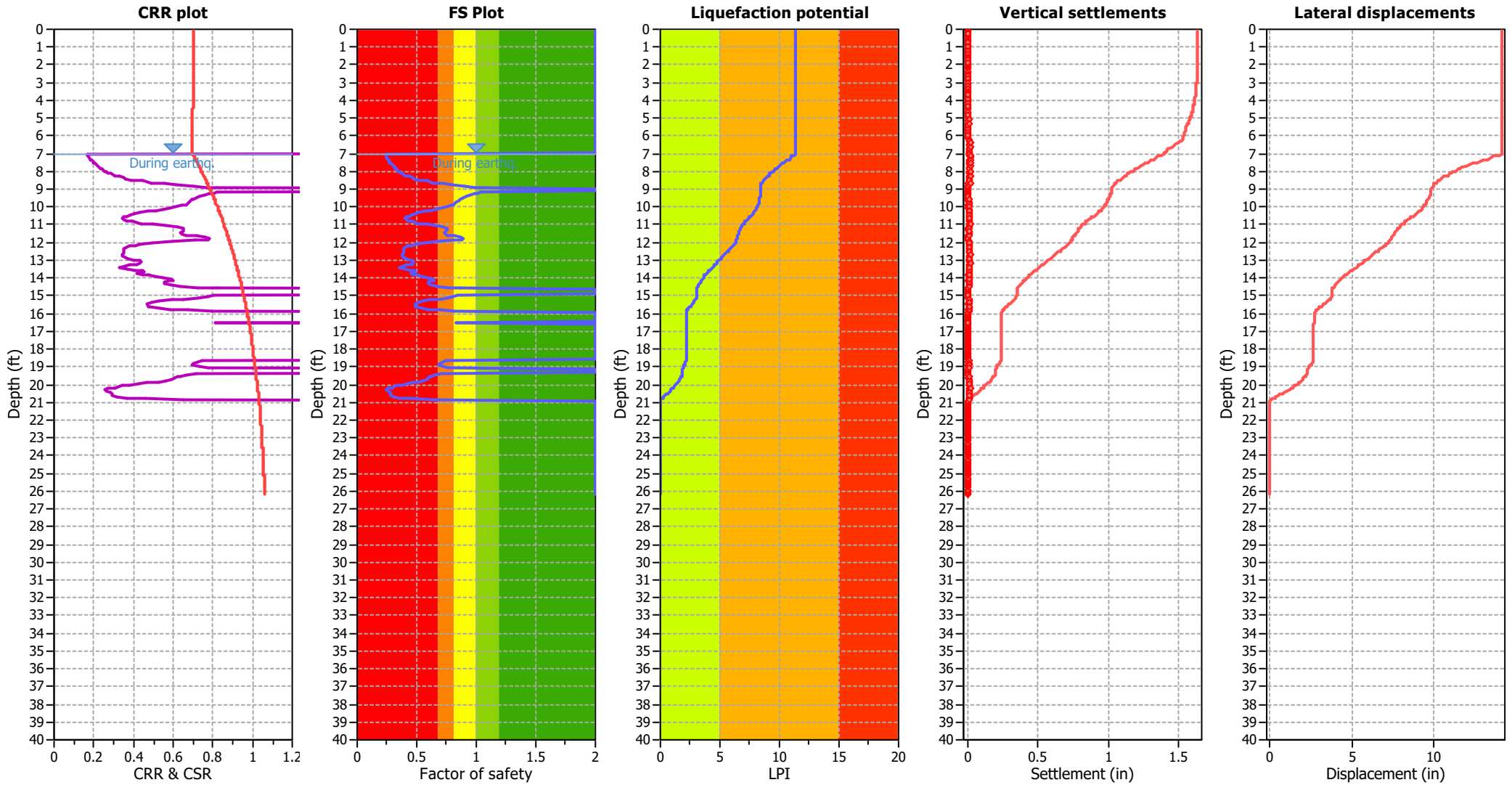

Input parameters and analysis data

Analysis method:	NCEER (1998)	Depth to water table (earthq.):	7.00 ft	Fill weight:	N/A
Fines correction method:	NCEER (1998)	Average results interval:	3	Transition detect. applied:	Yes
Points to test:	Based on Ic value	Ic cut-off value:	2.60	K_0 applied:	Yes
Earthquake magnitude M_w :	8.10	Unit weight calculation:	Based on SBT	Clay like behavior applied:	Sands only
Peak ground acceleration:	0.89	Use fill:	No	Limit depth applied:	No
Depth to water table (insitu):	10.50 ft	Fill height:	N/A	Limit depth:	N/A

F.S. color scheme

- Almost certain it will liquefy
- Very likely to liquefy
- Liquefaction and no liq. are equally likely
- Unlike to liquefy
- Almost certain it will not liquefy

LPI color scheme

- Very high risk
- High risk
- Low risk

Liquefaction analysis summary plots

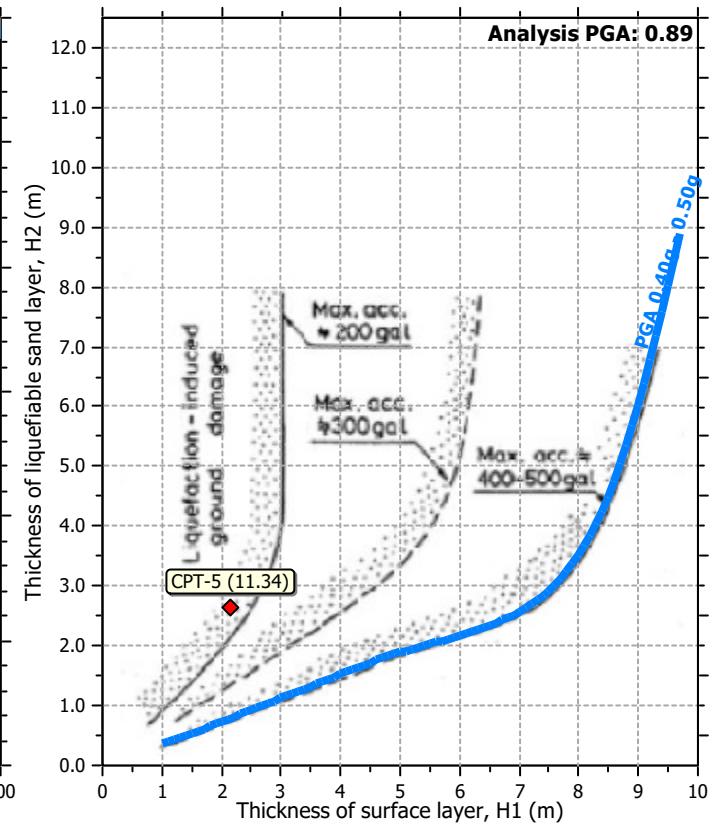
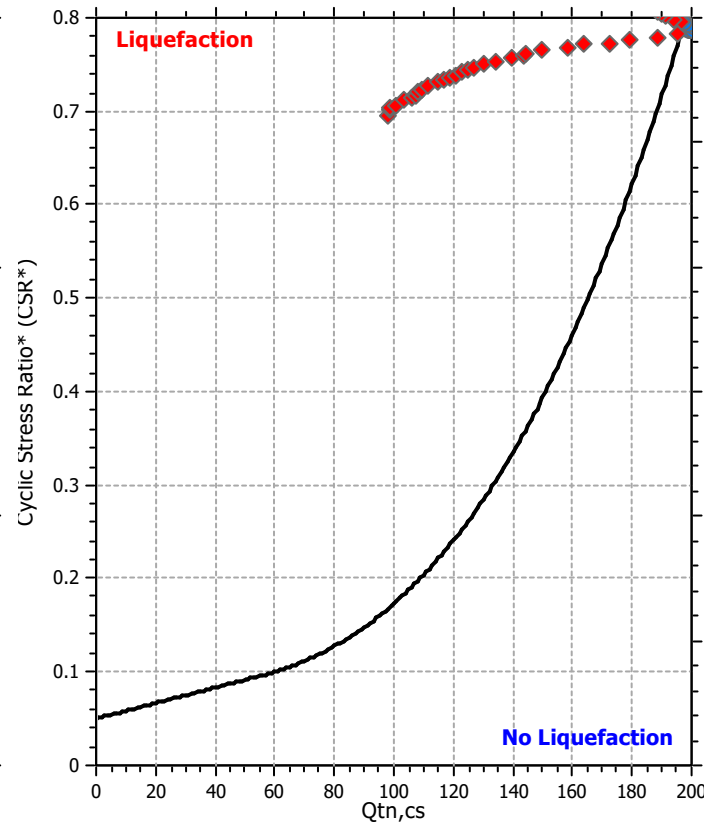
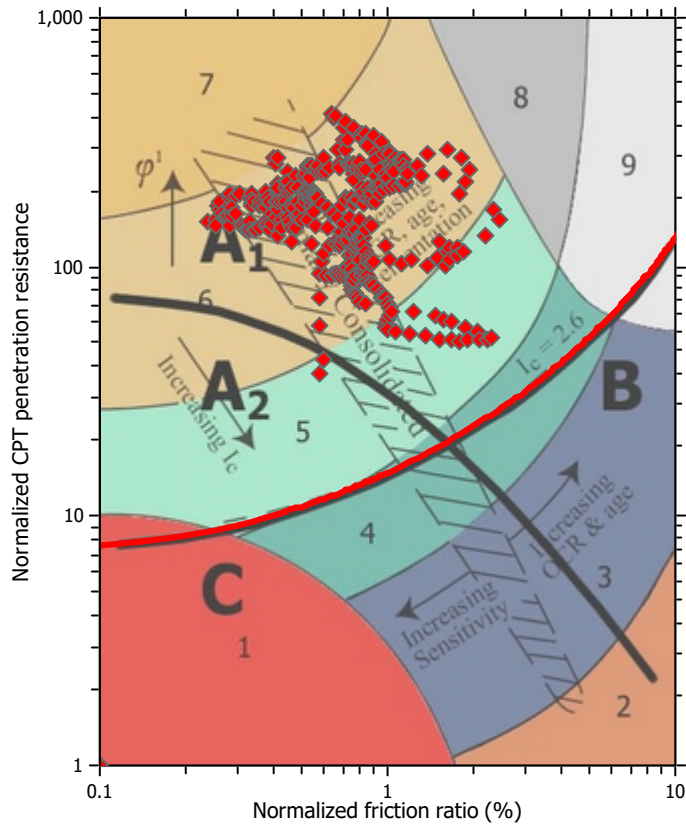

Input parameters and analysis data

Analysis method:	NCEER (1998)	Depth to water table (earthq.):	7.00 ft	Fill weight:	N/A
Fines correction method:	NCEER (1998)	Average results interval:	3	Transition detect. applied:	Yes
Points to test:	Based on I_c value	I_c cut-off value:	2.60	K_o applied:	Yes
Earthquake magnitude M_w :	8.10	Unit weight calculation:	Based on SBT	Clay like behavior applied:	Sands only
Peak ground acceleration:	0.89	Use fill:	No	Limit depth applied:	No
Depth to water table (insitu):	10.50 ft	Fill height:	N/A	Limit depth:	N/A

Check for strength loss plots (Robertson (2010))

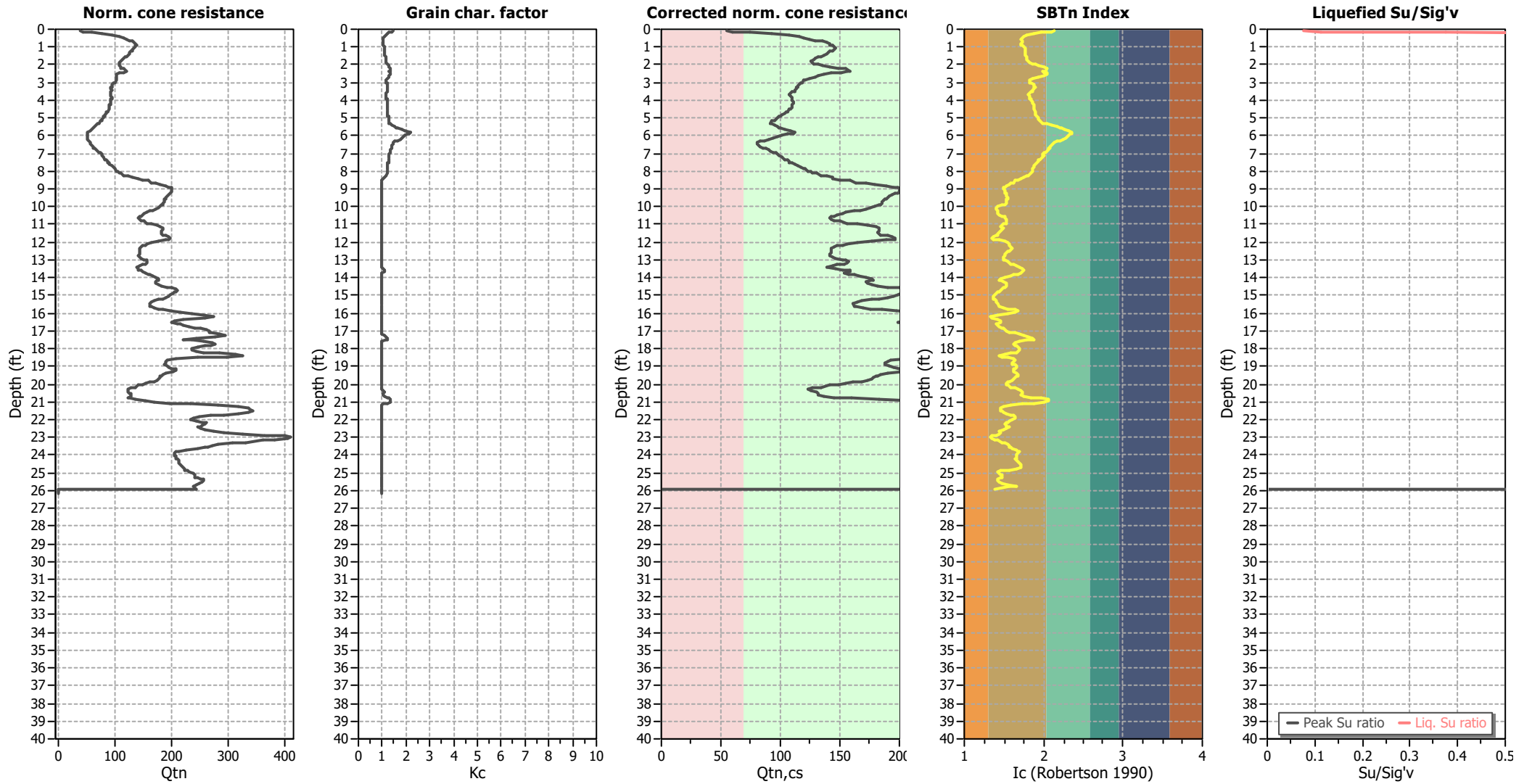

Input parameters and analysis data

Analysis method:	NCEER (1998)	Depth to water table (earthq.):	7.00 ft	Fill weight:	N/A
Fines correction method:	NCEER (1998)	Average results interval:	3	Transition detect. applied:	Yes
Points to test:	Based on Ic value	Ic cut-off value:	2.60	K _o applied:	Yes
Earthquake magnitude M _w :	8.10	Unit weight calculation:	Based on SBT	Clay like behavior applied:	Sands only
Peak ground acceleration:	0.89	Use fill:	No	Limit depth applied:	No
Depth to water table (insitu):	10.50 ft	Fill height:	N/A	Limit depth:	N/A

TRANSITION LAYER DETECTION ALGORITHM REPORT

Summary Details & Plots

Short description

The software will delete data when the cone is in transition from either clay to sand or vice-versa. To do this the software requires a range of I_c values over which the transition will be defined (typically somewhere between $1.80 < I_c < 3.0$) and a rate of change of I_c . Transitions typically occur when the rate of change of I_c is fast (i.e. ΔI_c is small).

The SBT_n plot below, displays in red the detected transition layers based on the parameters listed below the graphs.

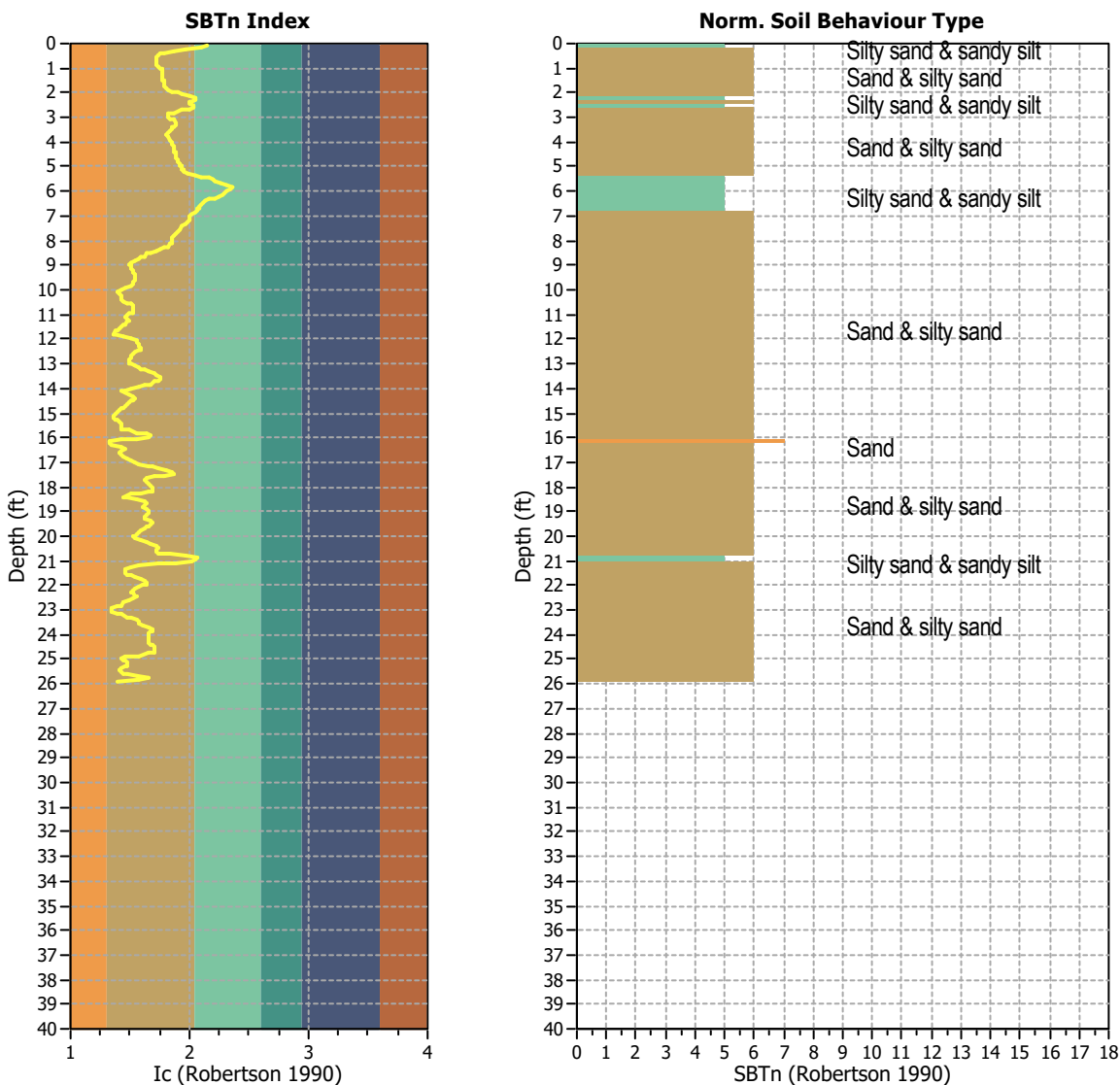

Transition layer algorithm properties

I_c minimum check value: 1.70
 I_c maximum check value: 3.00
 I_c change ratio value: 0.0250
 Minimum number of points in layer: 4

General statistics

Total points in CPT file: 399
 Total points excluded: 0
 Exclusion percentage: 0.00%
 Number of layers detected: 0

Estimation of post-earthquake settlements

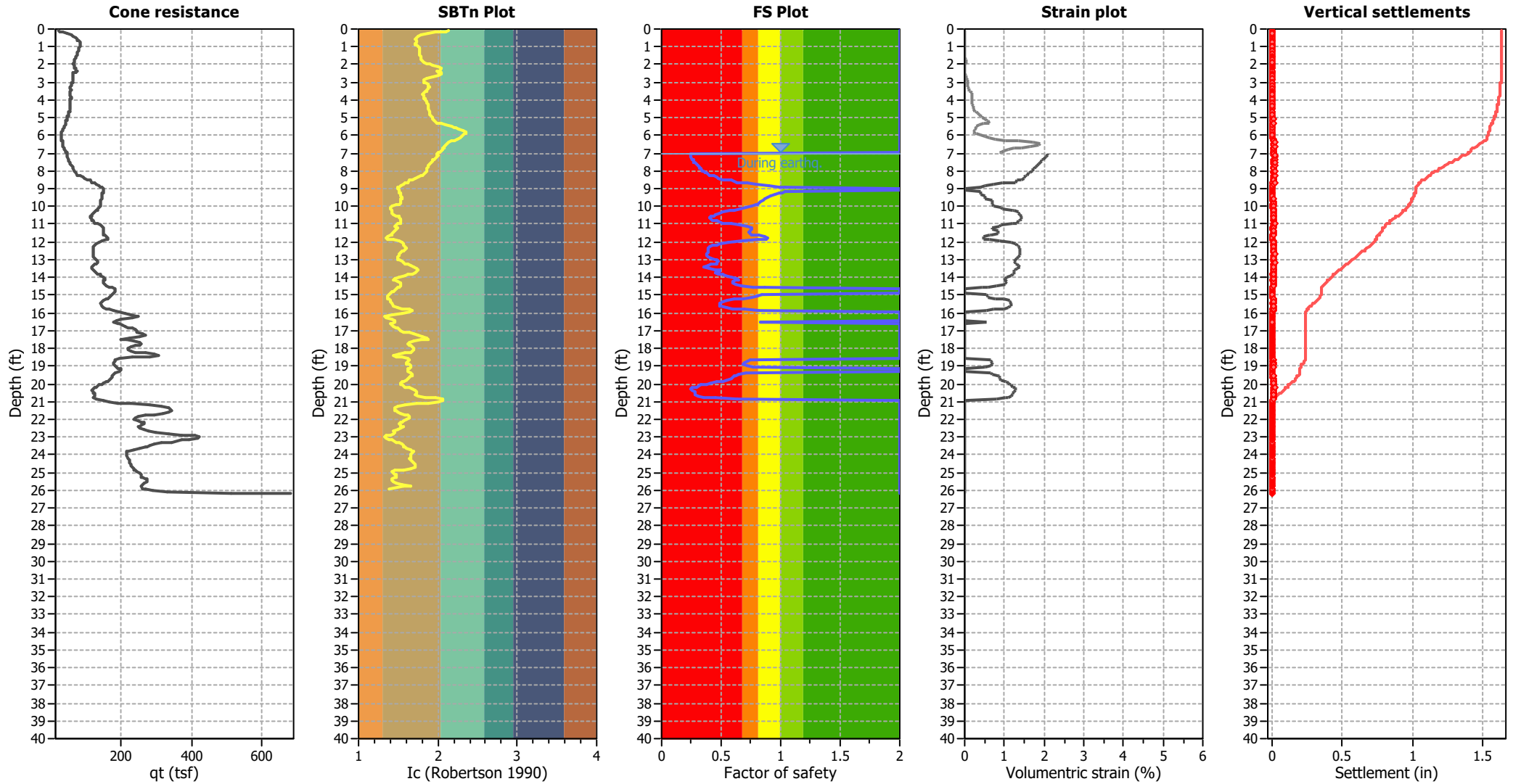

Abbreviations

- q_c: Total cone resistance (cone resistance q_c corrected for pore water effects)
- I_c: Soil Behaviour Type Index
- FS: Calculated Factor of Safety against liquefaction
- Volumetric strain: Post-liquefaction volumetric strain

Estimation of post-earthquake lateral Displacements

Geometric parameters: Gently sloping ground without free face (Slope 1.00 %)

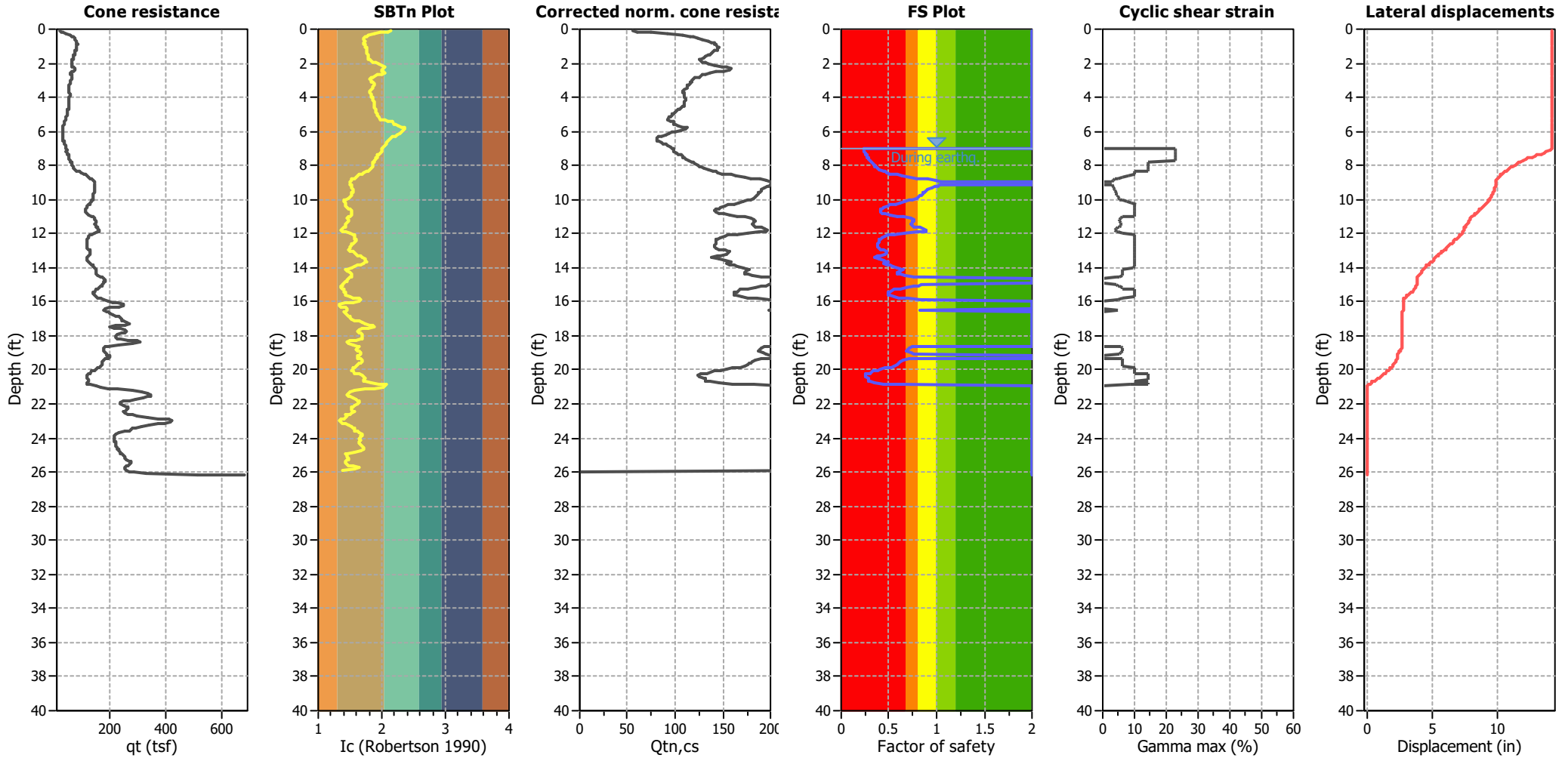

Abbreviations

q_t: Total cone resistance (cone resistance q_c corrected for pore water effects)
 I_c: Soil Behaviour Type Index
 Q_{tn,cs}: Equivalent clean sand normalized CPT total cone resistance

F.S.: Factor of safety
 γ_{max}: Maximum cyclic shear strain
 LDI: Lateral displacement index

Surface condition



Aging Calculation Estimation

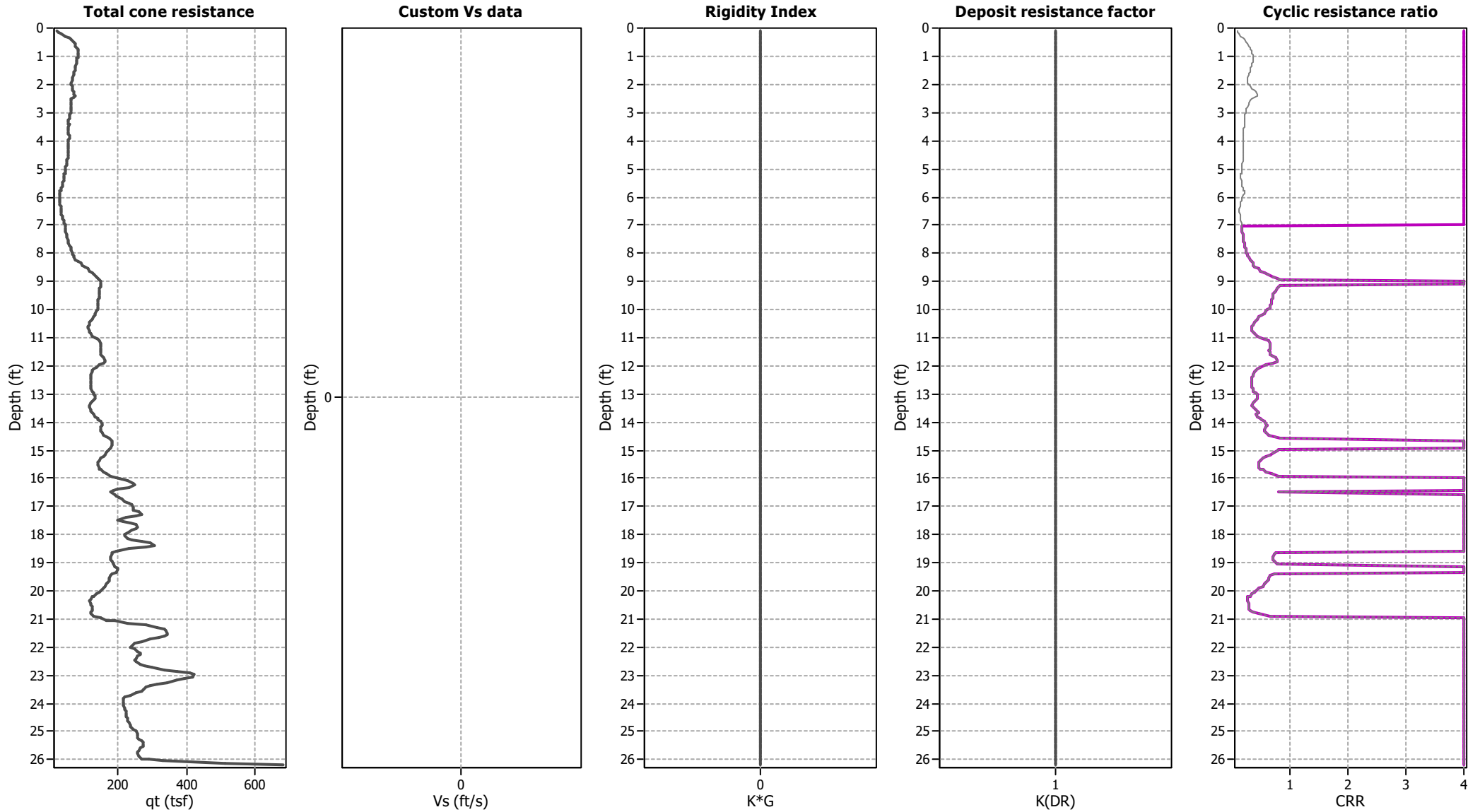

Ejecta Severity Estimation

Corrected norm. cone resista

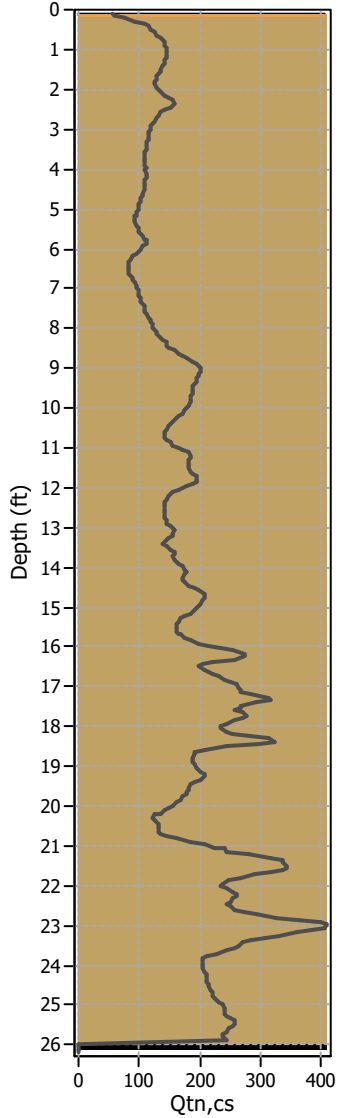

SBTn Index Plot

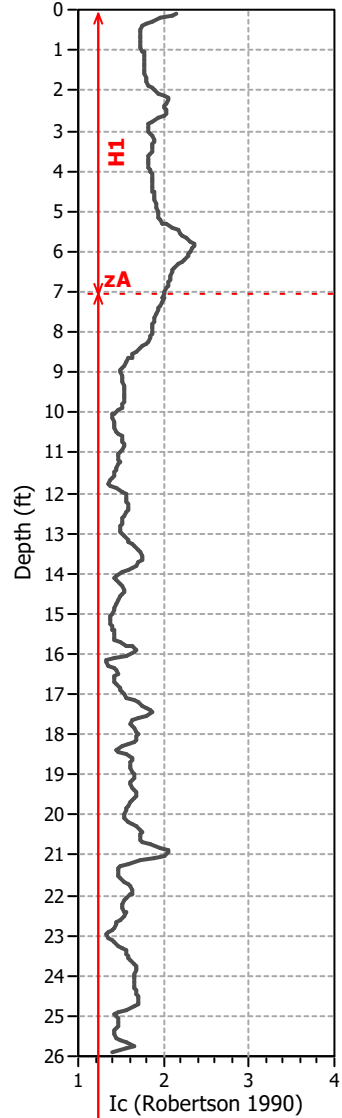

FS plot

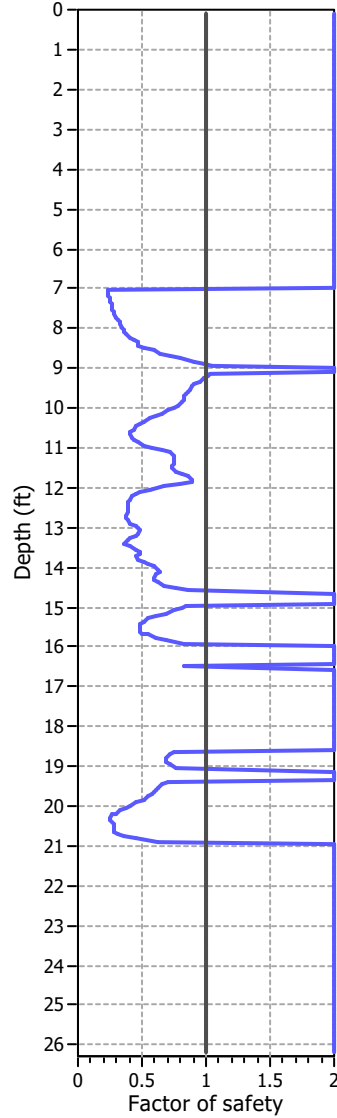

Stresses vs Depth

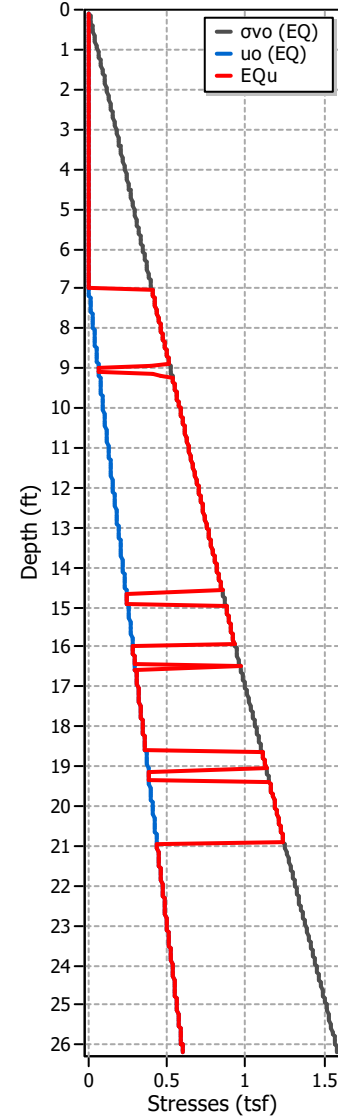

Excess Head

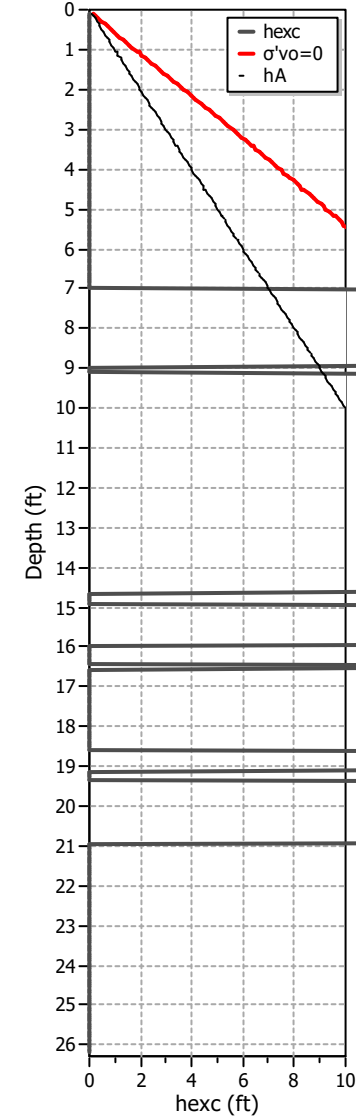

Liq. ejecta demand

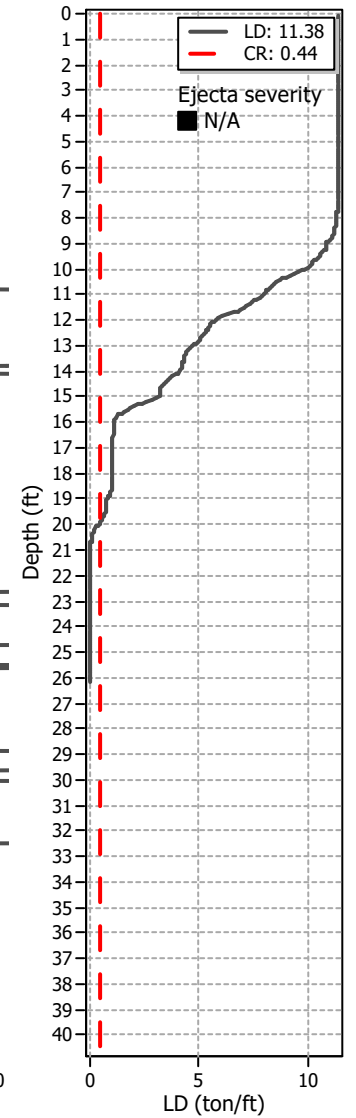

LIQUEFACTION ANALYSIS REPORT

Project title : Petra Geosciences / Apple Canyon

Location : Lake Hemet, CA

CPT file : CPT-5A

Input parameters and analysis data

Analysis method:	NCEER (1998)	G.W.T. (in-situ):	10.50 ft	Use fill:	No	Clay like behavior applied:	Sands only
Fines correction method:	NCEER (1998)	G.W.T. (earthq.):	7.00 ft	Fill height:	N/A	Limit depth applied:	No
Points to test:	Based on Ic value	Average results interval:	3	Fill weight:	N/A	Limit depth:	N/A
Earthquake magnitude M_w :	8.10	Ic cut-off value:	2.60	Trans. detect. applied:	Yes	MSF method:	Method based
Peak ground acceleration:	0.89	Unit weight calculation:	Based on SBT	K_o applied:	Yes		

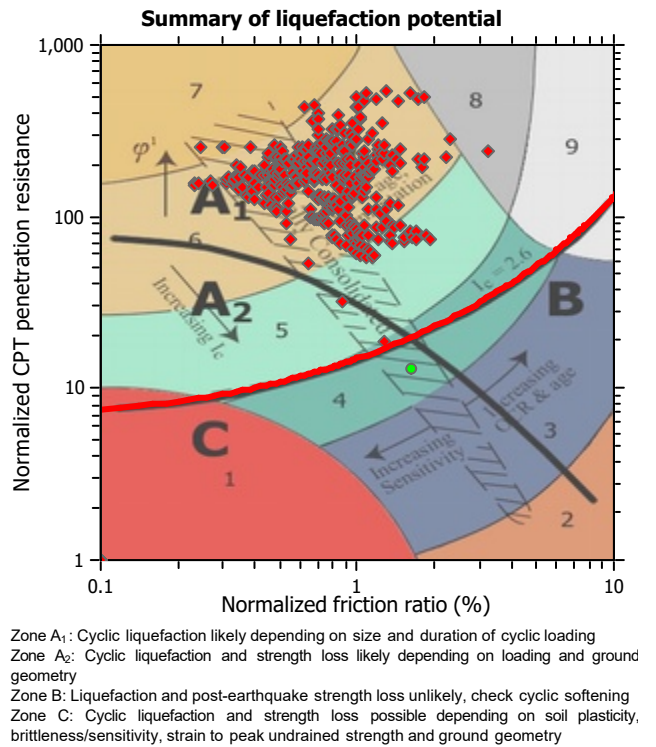
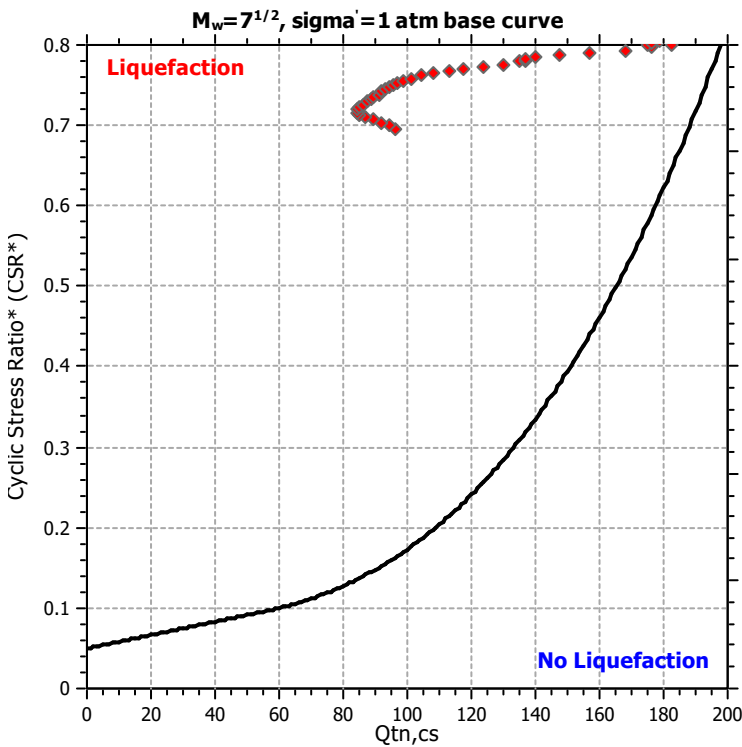
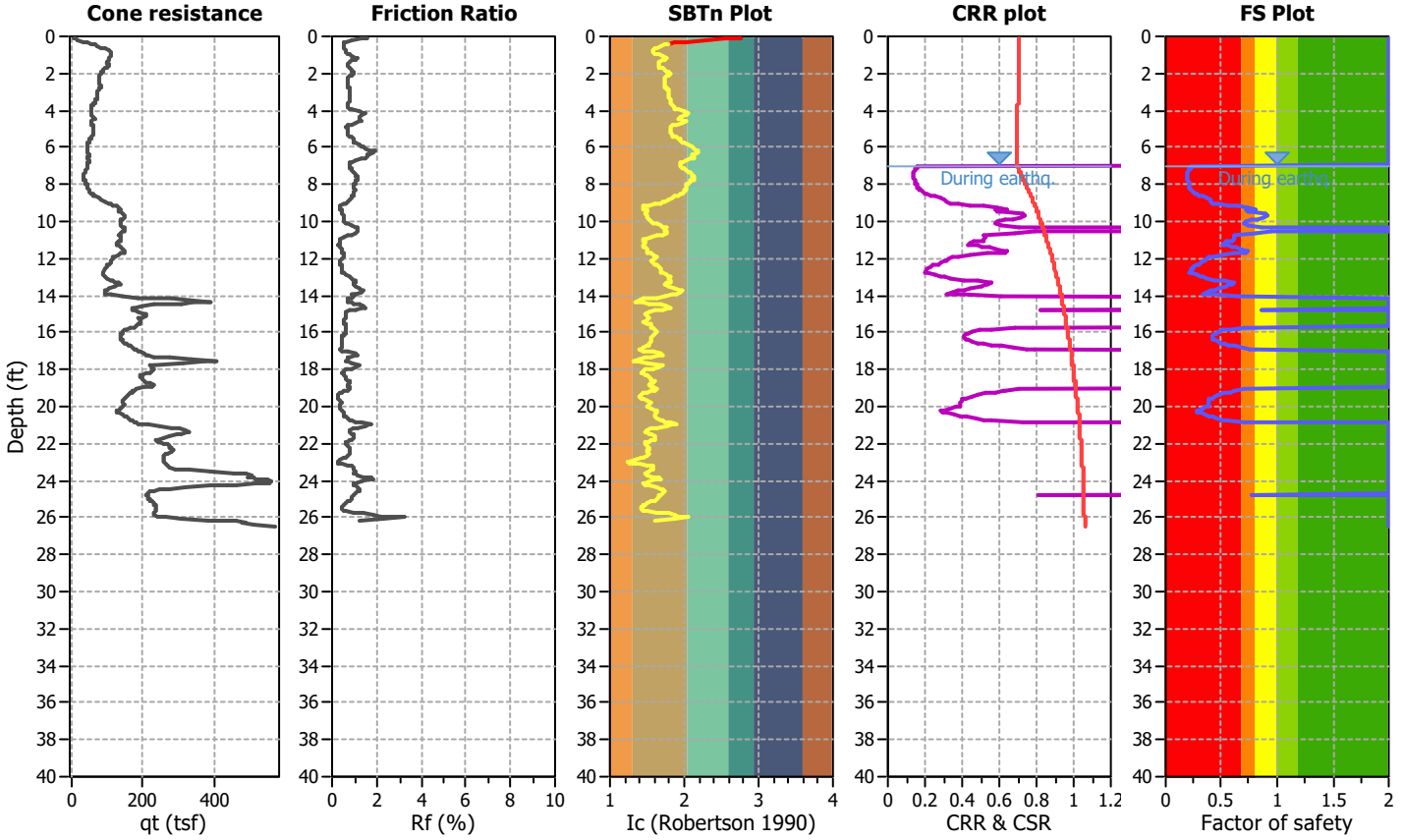

CPT basic interpretation plots

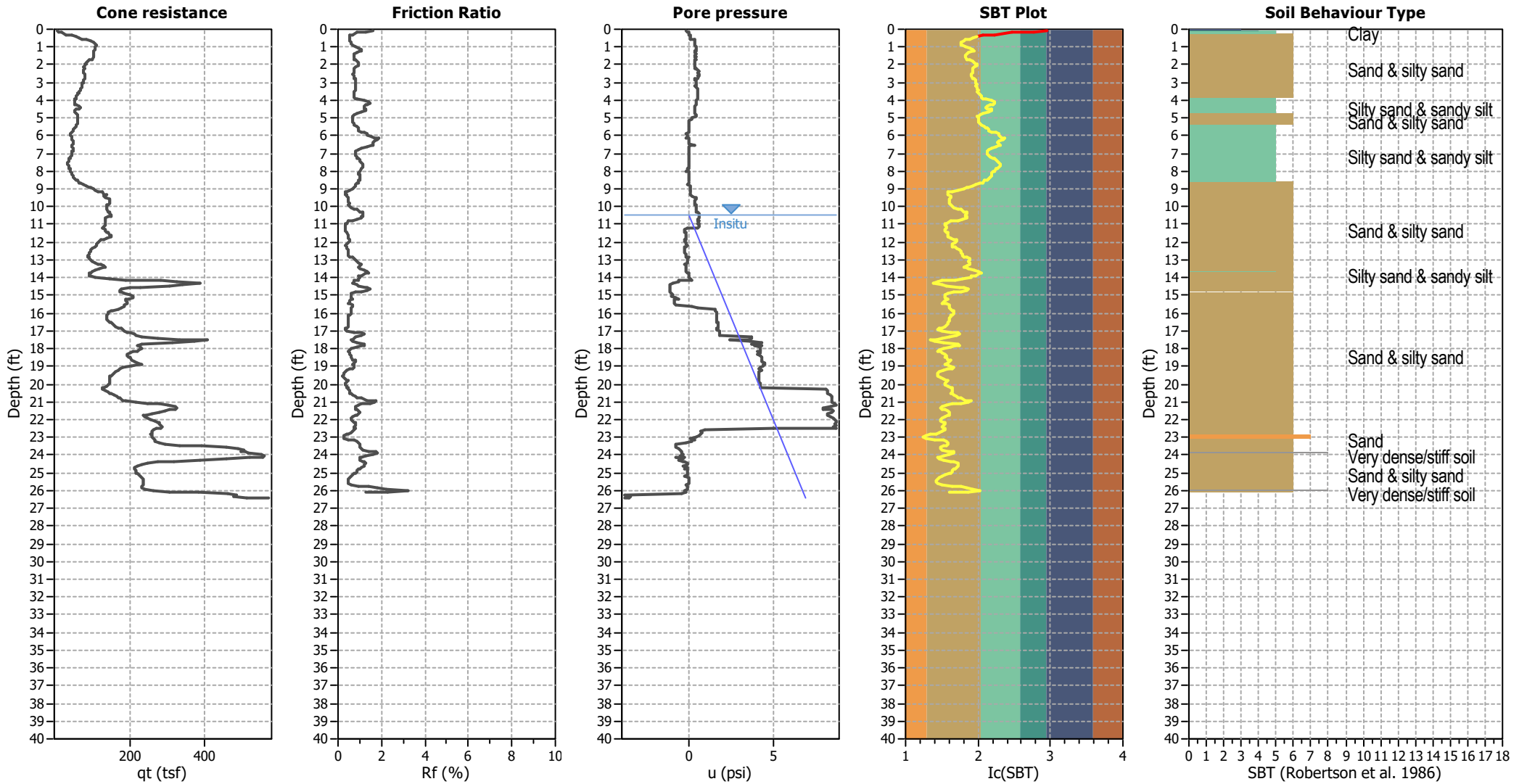

Input parameters and analysis data

Analysis method:	NCEER (1998)	Depth to water table (erthq.):	7.00 ft	Fill weight:	N/A
Fines correction method:	NCEER (1998)	Average results interval:	3	Transition detect. applied:	Yes
Points to test:	Based on Ic value	Ic cut-off value:	2.60	K_0 applied:	Yes
Earthquake magnitude M_w :	8.10	Unit weight calculation:	Based on SBT	Clay like behavior applied:	Sands only
Peak ground acceleration:	0.89	Use fill:	No	Limit depth applied:	No
Depth to water table (insitu):	10.50 ft	Fill height:	N/A	Limit depth:	N/A

SBT legend

1. Sensitive fine grained	4. Clayey silt to silty	7. Gravely sand to sand
2. Organic material	5. Silty sand to sandy silt	8. Very stiff sand to
3. Clay to silty clay	6. Clean sand to silty sand	9. Very stiff fine grained

CPT basic interpretation plots (normalized)

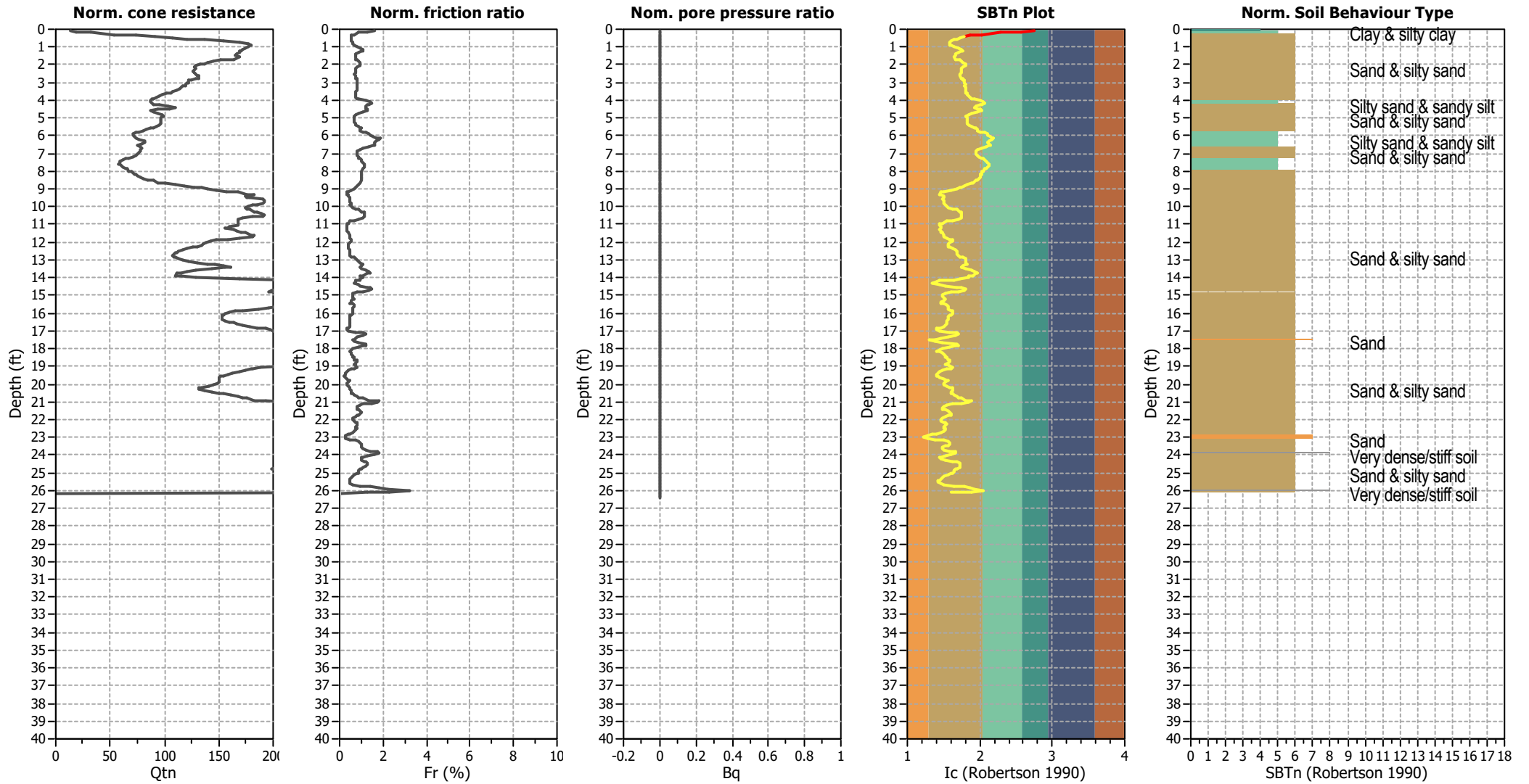

Input parameters and analysis data

Analysis method:	NCEER (1998)	Depth to water table (erthq.):	7.00 ft	Fill weight:	N/A
Fines correction method:	NCEER (1998)	Average results interval:	3	Transition detect. applied:	Yes
Points to test:	Based on Ic value	Ic cut-off value:	2.60	K ₀ applied:	Yes
Earthquake magnitude M _w :	8.10	Unit weight calculation:	Based on SBT	Clay like behavior applied:	Sands only
Peak ground acceleration:	0.89	Use fill:	No	Limit depth applied:	No
Depth to water table (insitu):	10.50 ft	Fill height:	N/A	Limit depth:	N/A

SBTn legend

1. Sensitive fine grained	4. Clayey silt to silty	7. Gravely sand to sand
2. Organic material	5. Silty sand to sandy silt	8. Very stiff sand to
3. Clay to silty clay	6. Clean sand to silty sand	9. Very stiff fine grained

Liquefaction analysis overall plots (intermediate results)

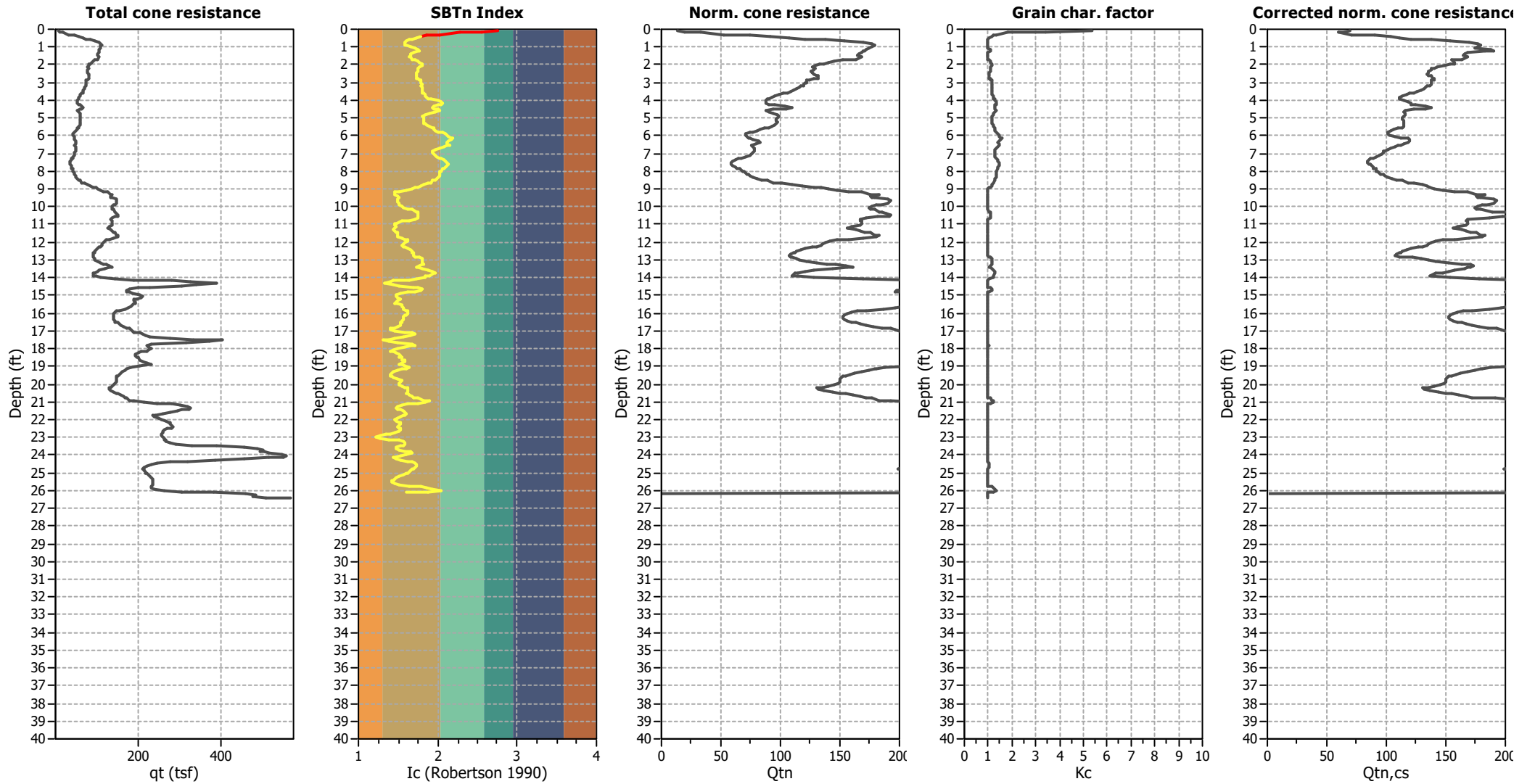

Input parameters and analysis data

Analysis method:	NCEER (1998)	Depth to water table (earthq.):	7.00 ft	Fill weight:	N/A
Fines correction method:	NCEER (1998)	Average results interval:	3	Transition detect. applied:	Yes
Points to test:	Based on Ic value	Ic cut-off value:	2.60	K _o applied:	Yes
Earthquake magnitude M _w :	8.10	Unit weight calculation:	Based on SBT	Clay like behavior applied:	Sands only
Peak ground acceleration:	0.89	Use fill:	No	Limit depth applied:	No
Depth to water table (insitu):	10.50 ft	Fill height:	N/A	Limit depth:	N/A

Liquefaction analysis overall plots

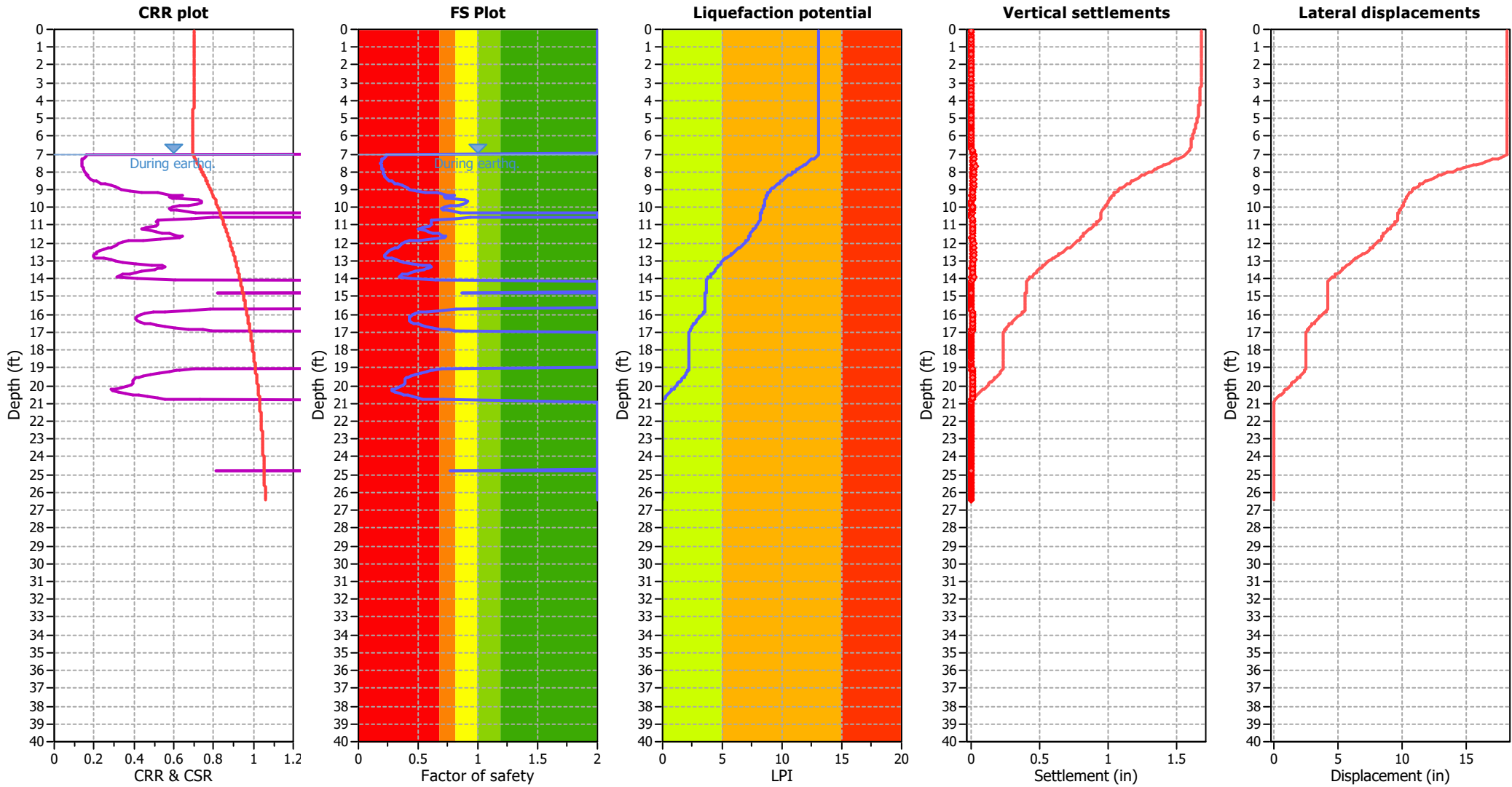

Input parameters and analysis data

Analysis method:	NCEER (1998)	Depth to water table (earthq.):	7.00 ft	Fill weight:	N/A
Fines correction method:	NCEER (1998)	Average results interval:	3	Transition detect. applied:	Yes
Points to test:	Based on Ic value	Ic cut-off value:	2.60	K_0 applied:	Yes
Earthquake magnitude M_w :	8.10	Unit weight calculation:	Based on SBT	Clay like behavior applied:	Sands only
Peak ground acceleration:	0.89	Use fill:	No	Limit depth applied:	No
Depth to water table (insitu):	10.50 ft	Fill height:	N/A	Limit depth:	N/A

F.S. color scheme

- Almost certain it will liquefy
- Very likely to liquefy
- Liquefaction and no liq. are equally likely
- Unlike to liquefy
- Almost certain it will not liquefy

LPI color scheme

- Very high risk
- High risk
- Low risk

Liquefaction analysis summary plots

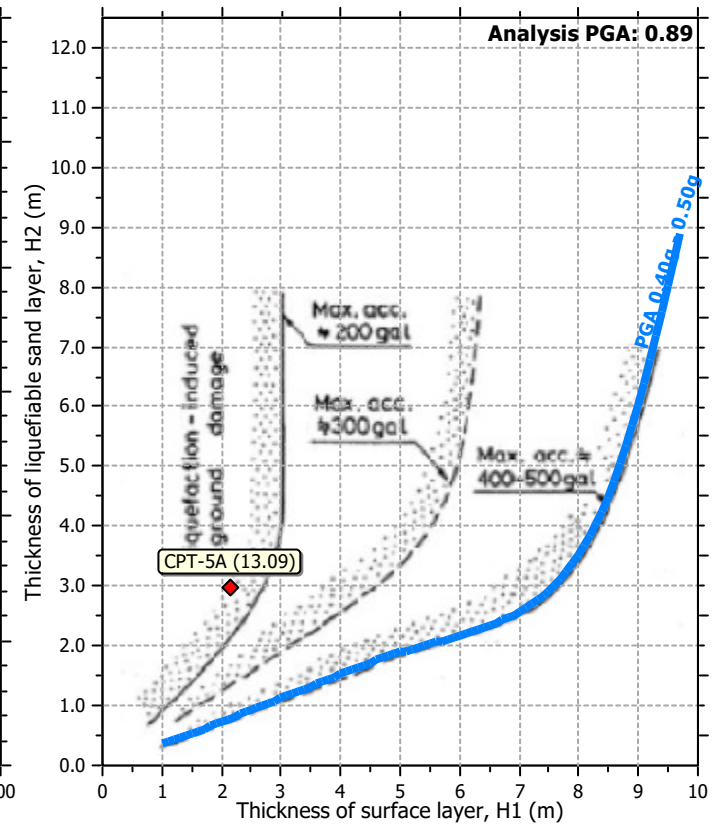
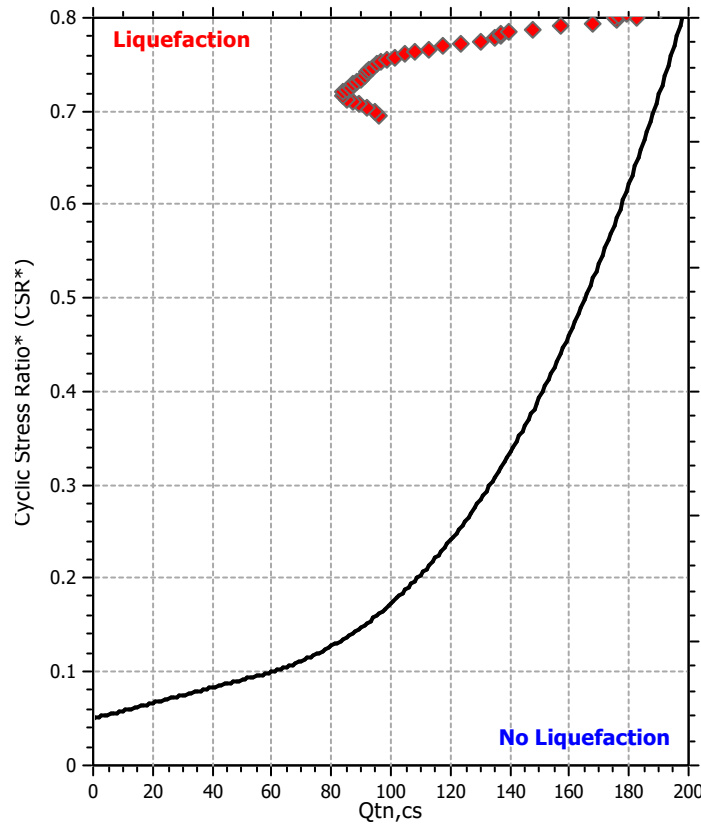
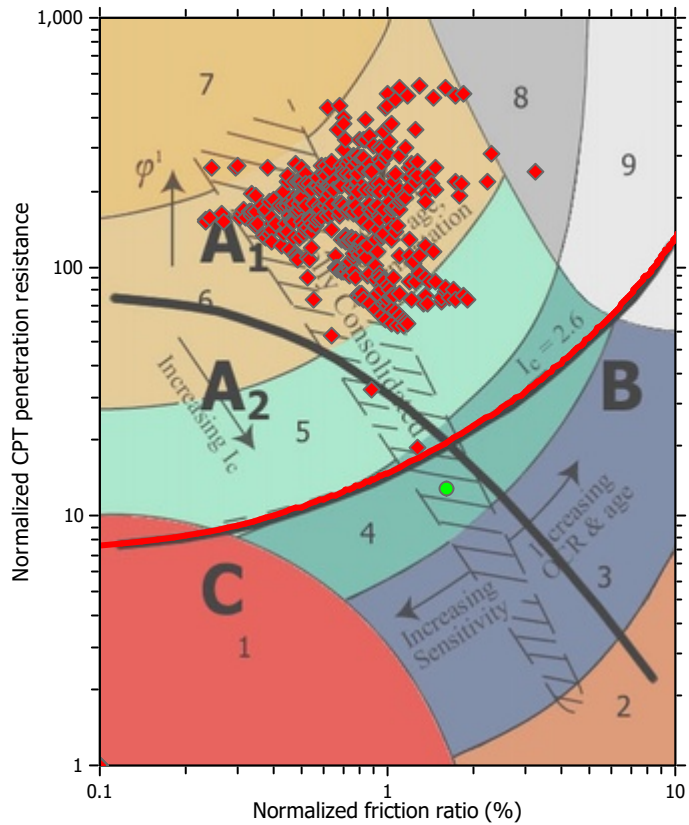

Input parameters and analysis data

Analysis method:	NCEER (1998)	Depth to water table (earthq.):	7.00 ft	Fill weight:	N/A
Fines correction method:	NCEER (1998)	Average results interval:	3	Transition detect. applied:	Yes
Points to test:	Based on I_c value	I_c cut-off value:	2.60	K_o applied:	Yes
Earthquake magnitude M_w :	8.10	Unit weight calculation:	Based on SBT	Clay like behavior applied:	Sands only
Peak ground acceleration:	0.89	Use fill:	No	Limit depth applied:	No
Depth to water table (insitu):	10.50 ft	Fill height:	N/A	Limit depth:	N/A

Check for strength loss plots (Robertson (2010))

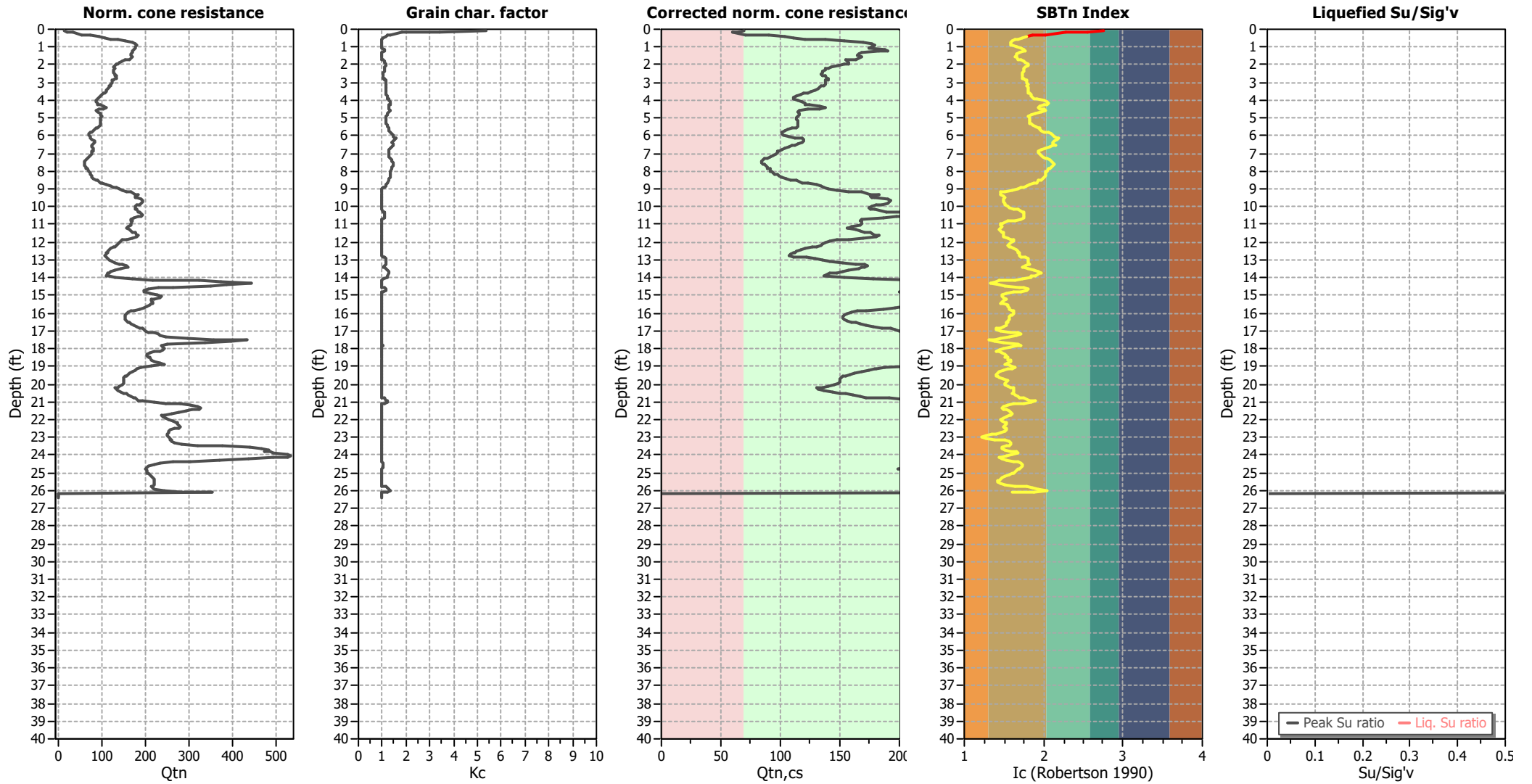

Input parameters and analysis data

Analysis method:	NCEER (1998)	Depth to water table (earthq.):	7.00 ft	Fill weight:	N/A
Fines correction method:	NCEER (1998)	Average results interval:	3	Transition detect. applied:	Yes
Points to test:	Based on Ic value	Ic cut-off value:	2.60	K _o applied:	Yes
Earthquake magnitude M _w :	8.10	Unit weight calculation:	Based on SBT	Clay like behavior applied:	Sands only
Peak ground acceleration:	0.89	Use fill:	No	Limit depth applied:	No
Depth to water table (insitu):	10.50 ft	Fill height:	N/A	Limit depth:	N/A

TRANSITION LAYER DETECTION ALGORITHM REPORT

Summary Details & Plots

Short description

The software will delete data when the cone is in transition from either clay to sand or vice-versa. To do this the software requires a range of I_c values over which the transition will be defined (typically somewhere between $1.80 < I_c < 3.0$) and a rate of change of I_c . Transitions typically occur when the rate of change of I_c is fast (i.e. ΔI_c is small).

The SBT_n plot below, displays in red the detected transition layers based on the parameters listed below the graphs.

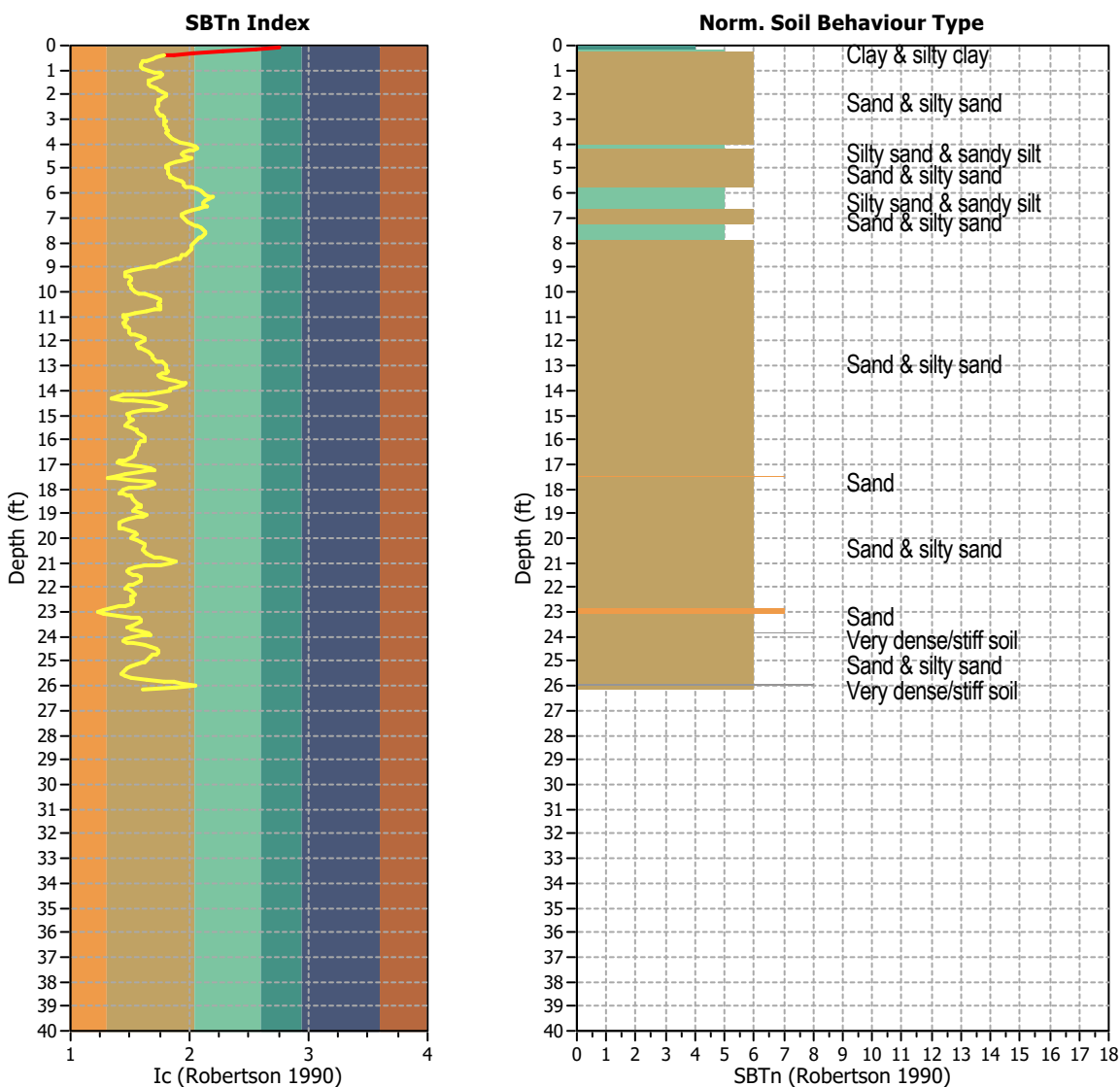

Transition layer algorithm properties

I_c minimum check value: 1.70
 I_c maximum check value: 3.00
 I_c change ratio value: 0.0250
 Minimum number of points in layer: 4

General statistics

Total points in CPT file: 403
 Total points excluded: 7
 Exclusion percentage: 1.74%
 Number of layers detected: 1

Estimation of post-earthquake settlements

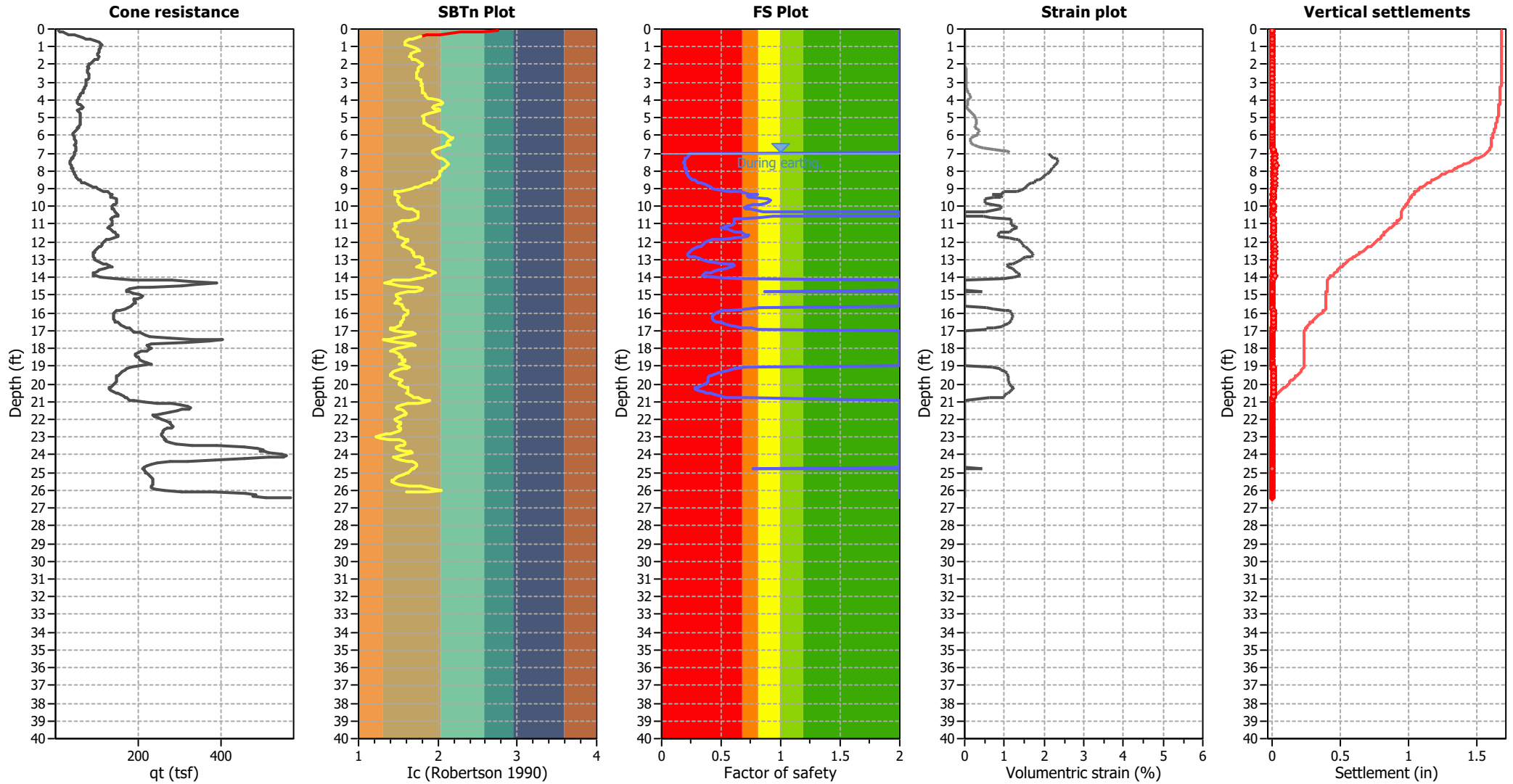

Abbreviations

- q_c: Total cone resistance (cone resistance q_c corrected for pore water effects)
- I_c: Soil Behaviour Type Index
- FS: Calculated Factor of Safety against liquefaction
- Volumetric strain: Post-liquefaction volumetric strain

Estimation of post-earthquake lateral Displacements

Geometric parameters: Gently sloping ground without free face (Slope 1.00 %)

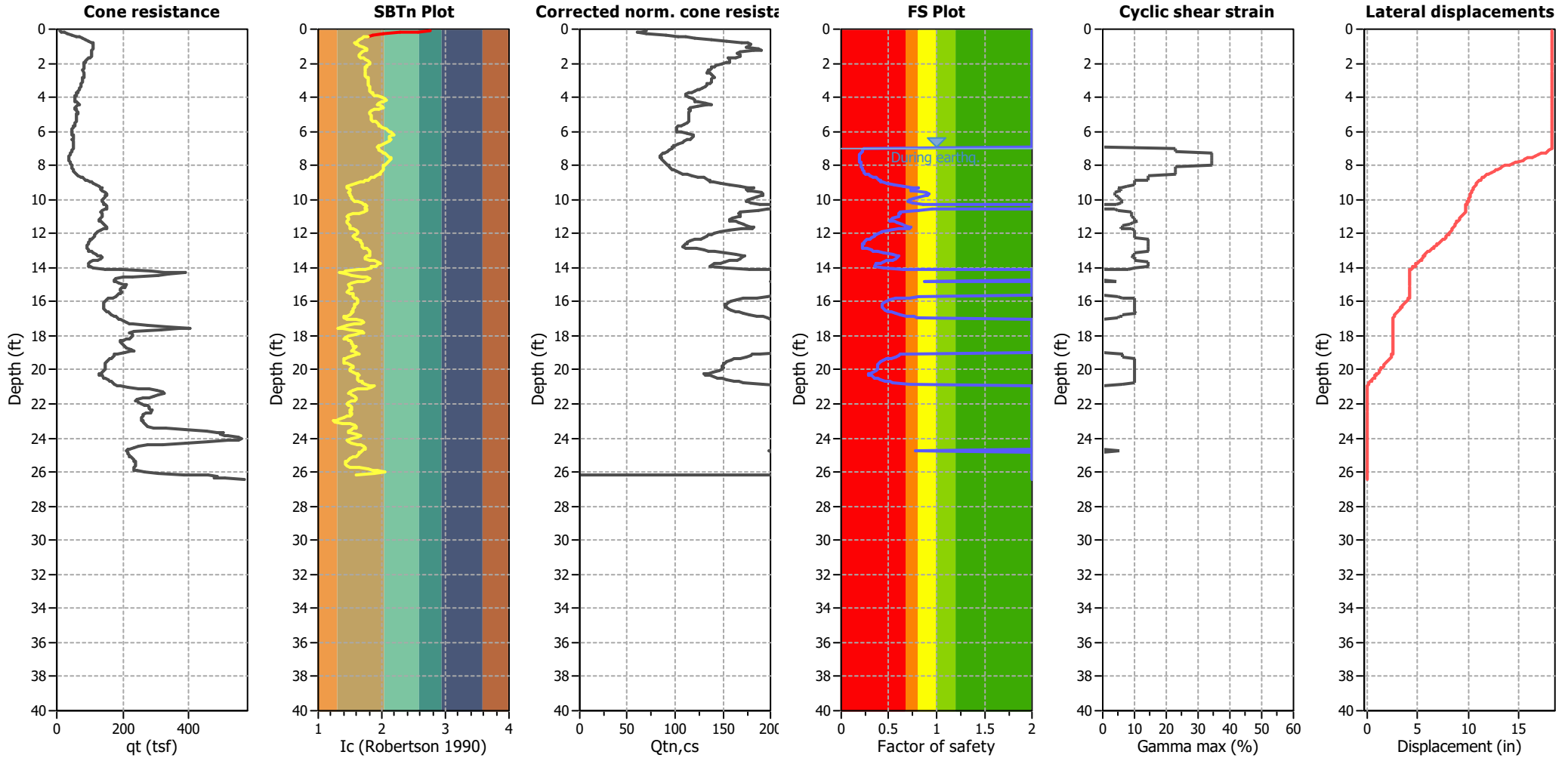

Abbreviations

q_t: Total cone resistance (cone resistance q_c corrected for pore water effects)
 I_c: Soil Behaviour Type Index
 Q_{tn,cs}: Equivalent clean sand normalized CPT total cone resistance

F.S.: Factor of safety
 γ_{max}: Maximum cyclic shear strain
 LDI: Lateral displacement index

Surface condition



Aging Calculation Estimation

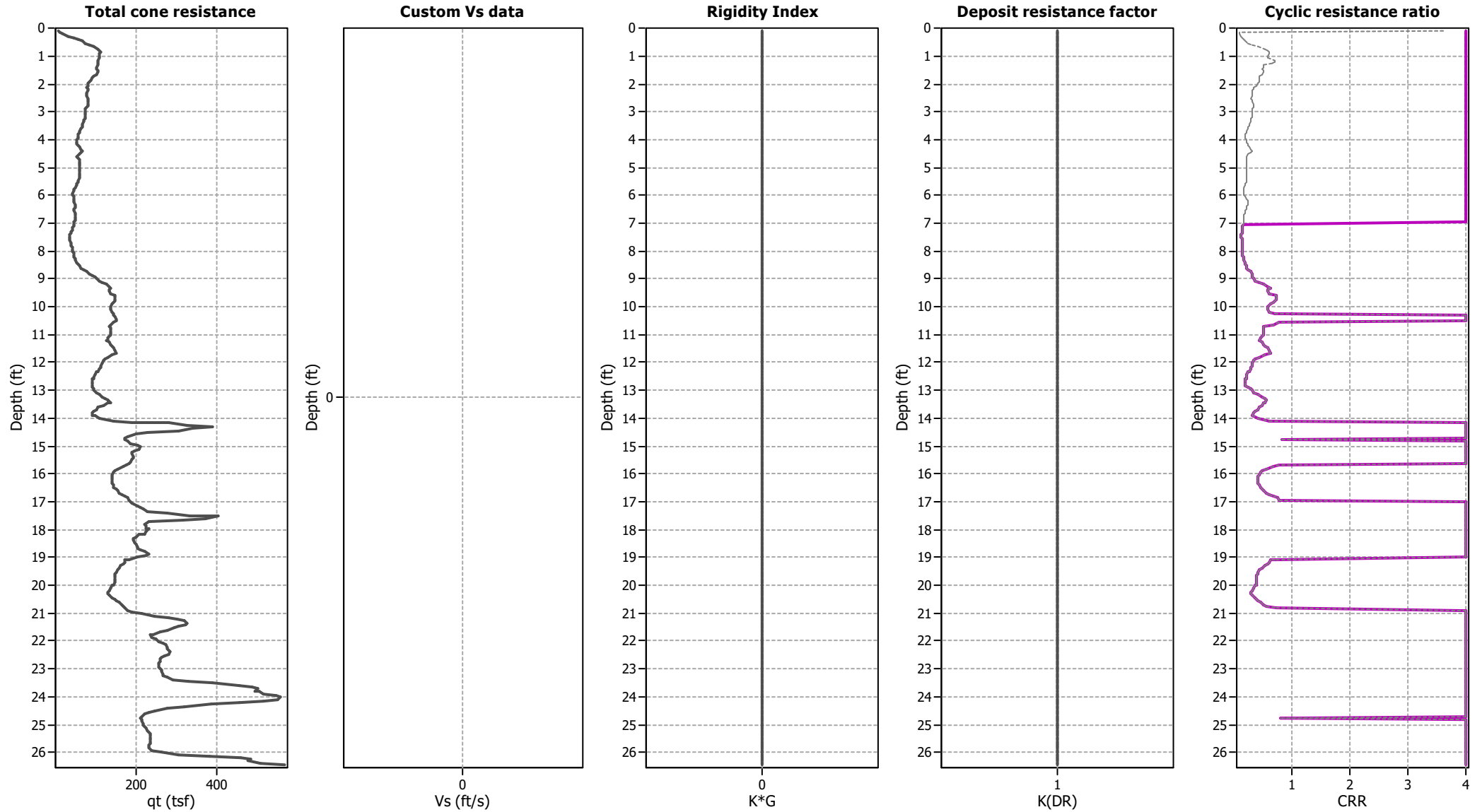

Ejecta Severity Estimation

Corrected norm. cone resista

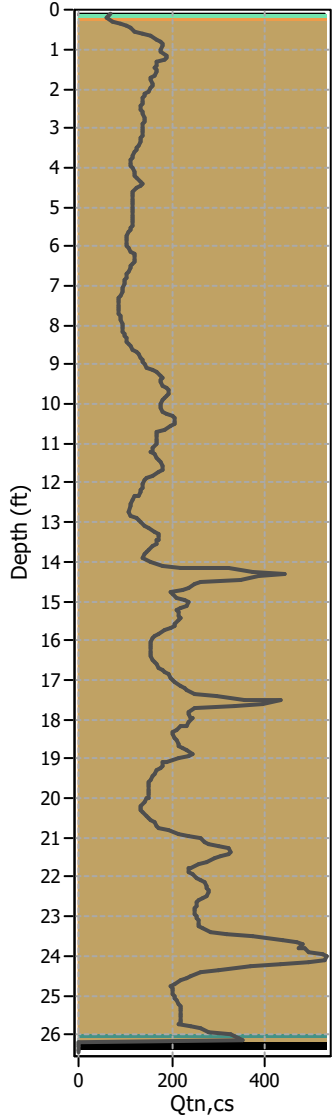

SBTn Index Plot

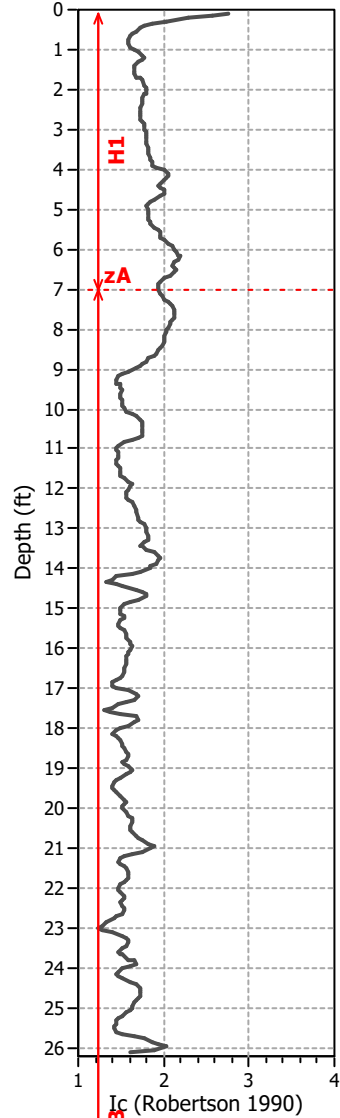

FS plot

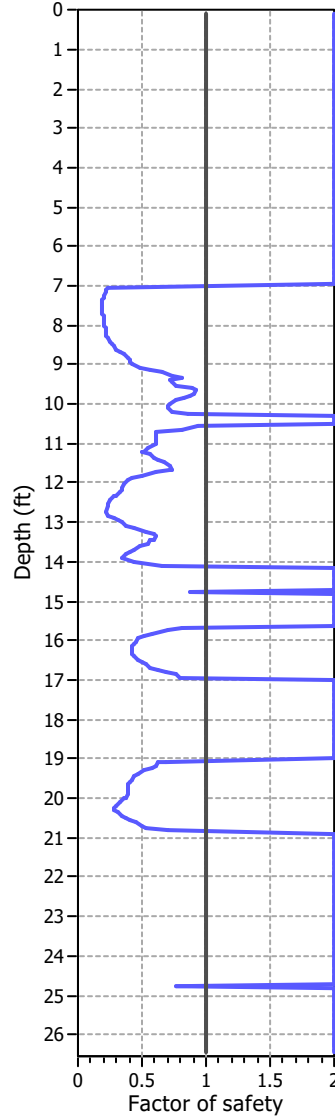

Stresses vs Depth

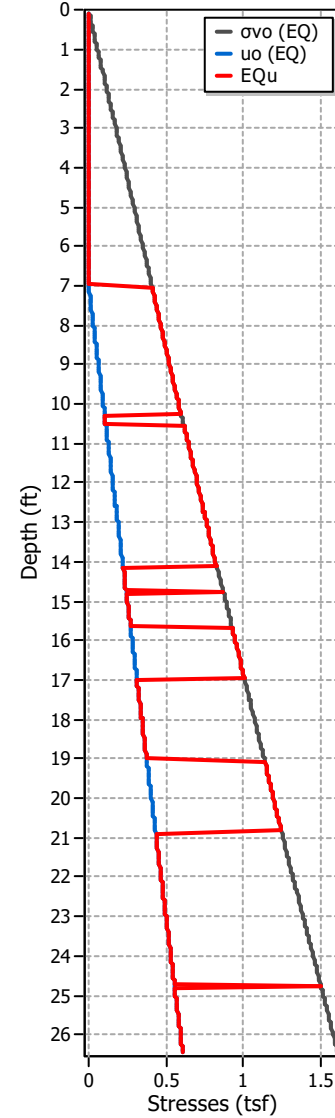

Excess Head

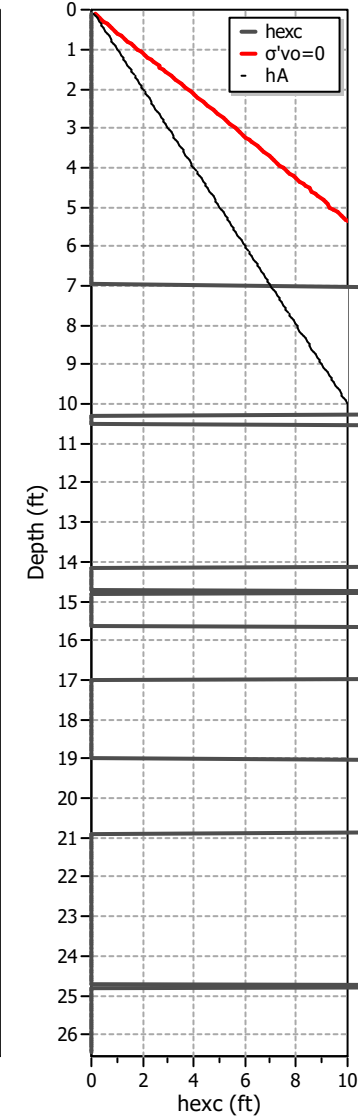

Liq. ejecta demand

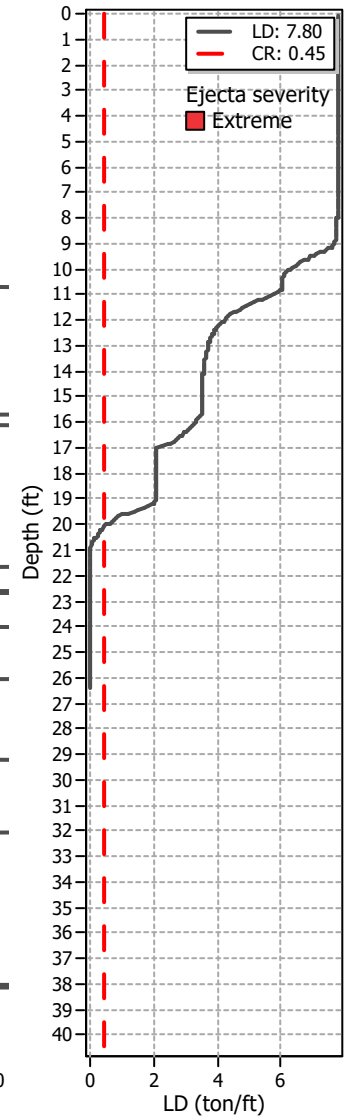

LIQUEFACTION ANALYSIS REPORT

Project title : Petra Geosciences / Apple Canyon

Location : Lake Hemet, CA

CPT file : CPT-6

Input parameters and analysis data

Analysis method:	NCEER (1998)	G.W.T. (in-situ):	10.50 ft	Use fill:	No	Clay like behavior applied:	Sands only
Fines correction method:	NCEER (1998)	G.W.T. (earthq.):	7.00 ft	Fill height:	N/A	Limit depth applied:	No
Points to test:	Based on Ic value	Average results interval:	3	Fill weight:	N/A	Limit depth:	N/A
Earthquake magnitude M_w :	8.10	Ic cut-off value:	2.60	Trans. detect. applied:	Yes	MSF method:	Method based
Peak ground acceleration:	0.89	Unit weight calculation:	Based on SBT	K_o applied:	Yes		

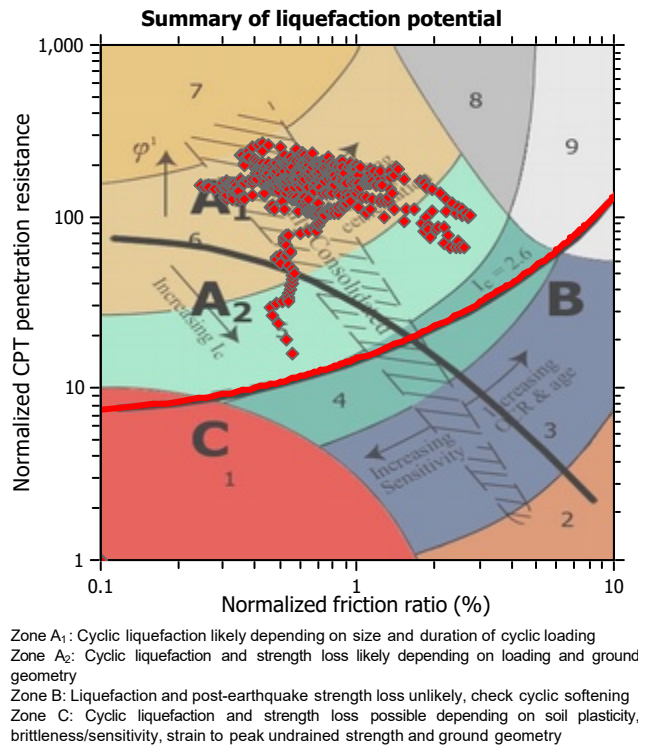
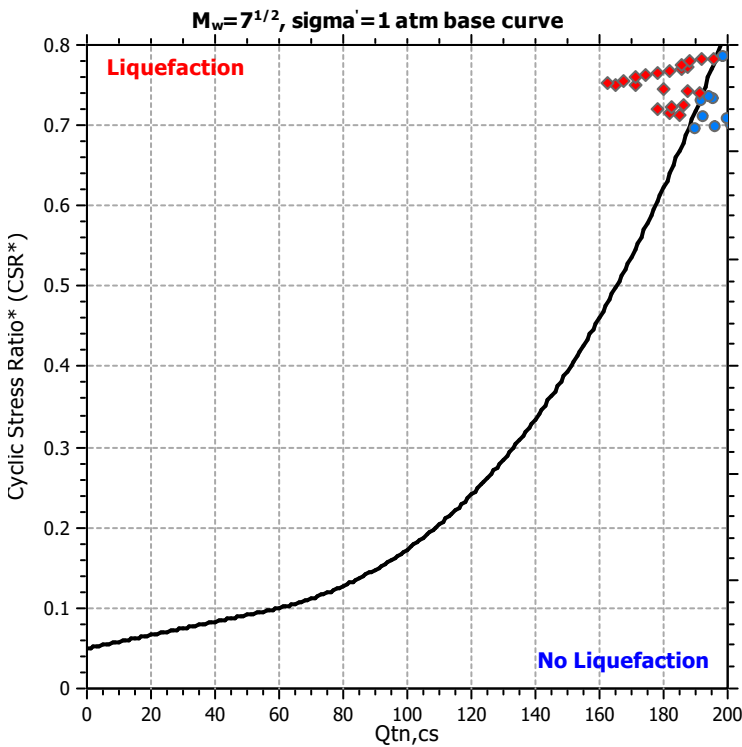
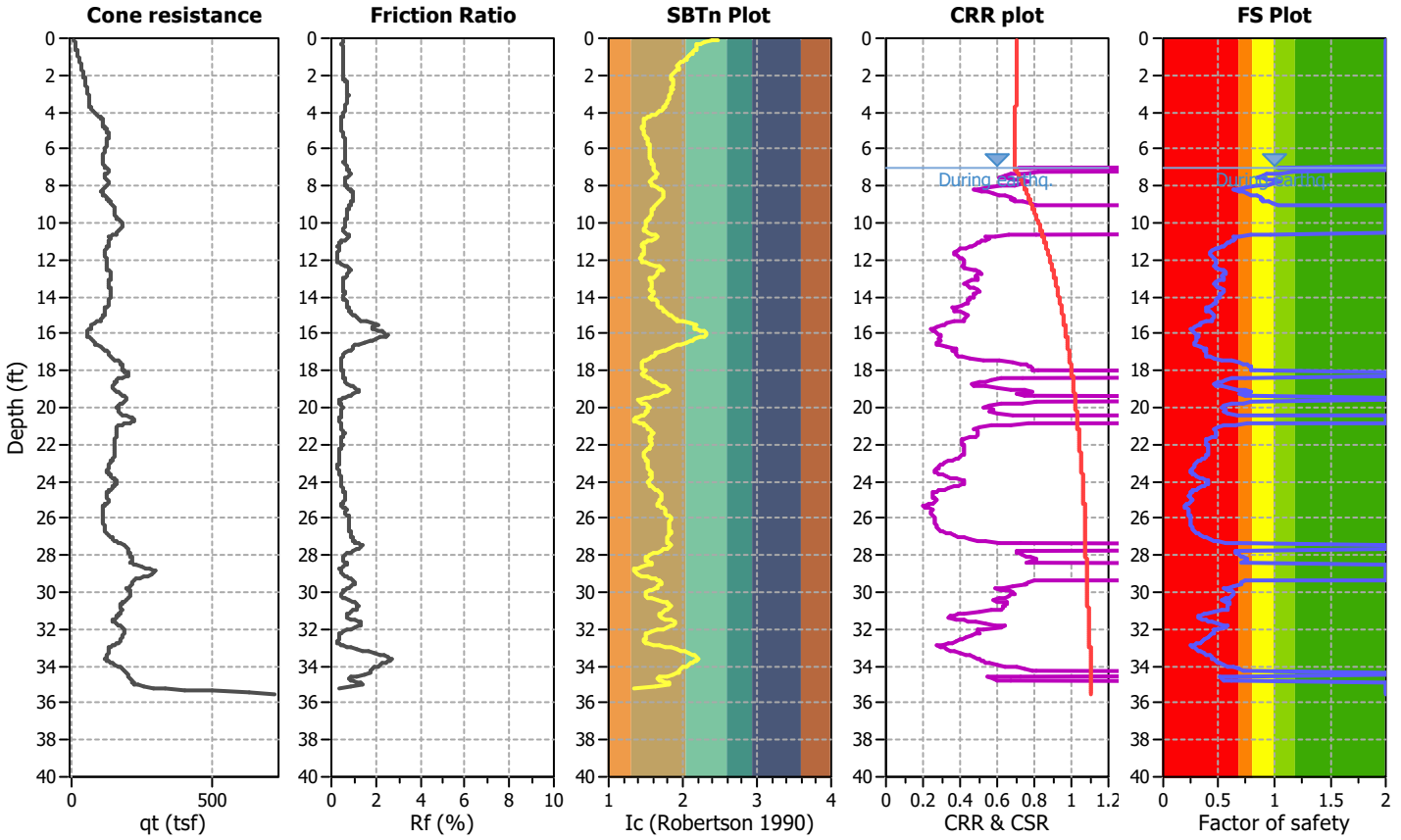

CPT basic interpretation plots

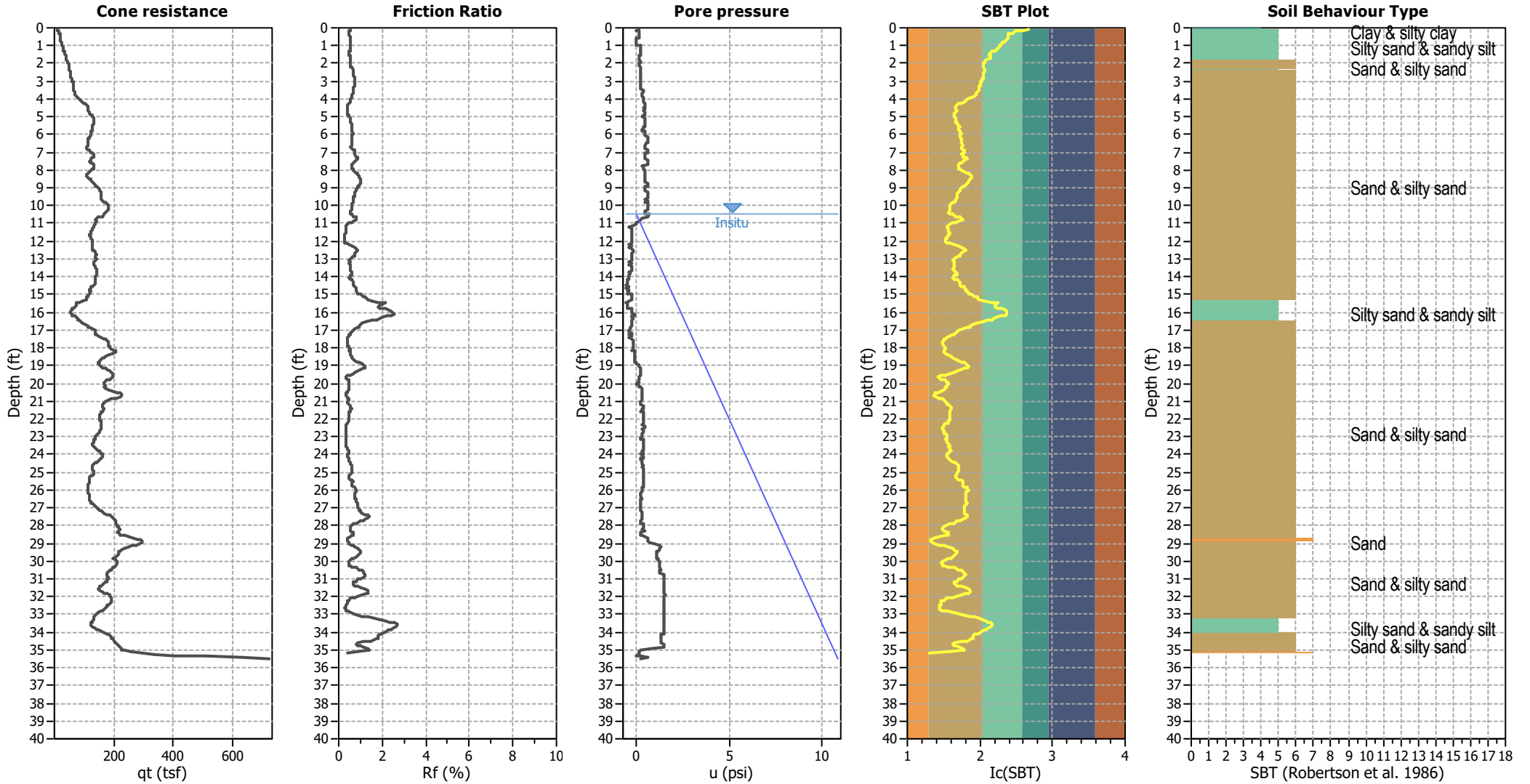

Input parameters and analysis data

Analysis method:	NCEER (1998)	Depth to water table (earthq.):	7.00 ft	Fill weight:	N/A
Fines correction method:	NCEER (1998)	Average results interval:	3	Transition detect. applied:	Yes
Points to test:	Based on Ic value	Ic cut-off value:	2.60	K _o applied:	Yes
Earthquake magnitude M _w :	8.10	Unit weight calculation:	Based on SBT	Clay like behavior applied:	Sands only
Peak ground acceleration:	0.89	Use fill:	No	Limit depth applied:	No
Depth to water table (insitu):	10.50 ft	Fill height:	N/A	Limit depth:	N/A

SBT legend

1. Sensitive fine grained	4. Clayey silt to silty	7. Gravely sand to sand
2. Organic material	5. Silty sand to sandy silt	8. Very stiff sand to
3. Clay to silty clay	6. Clean sand to silty sand	9. Very stiff fine grained

CPT basic interpretation plots (normalized)

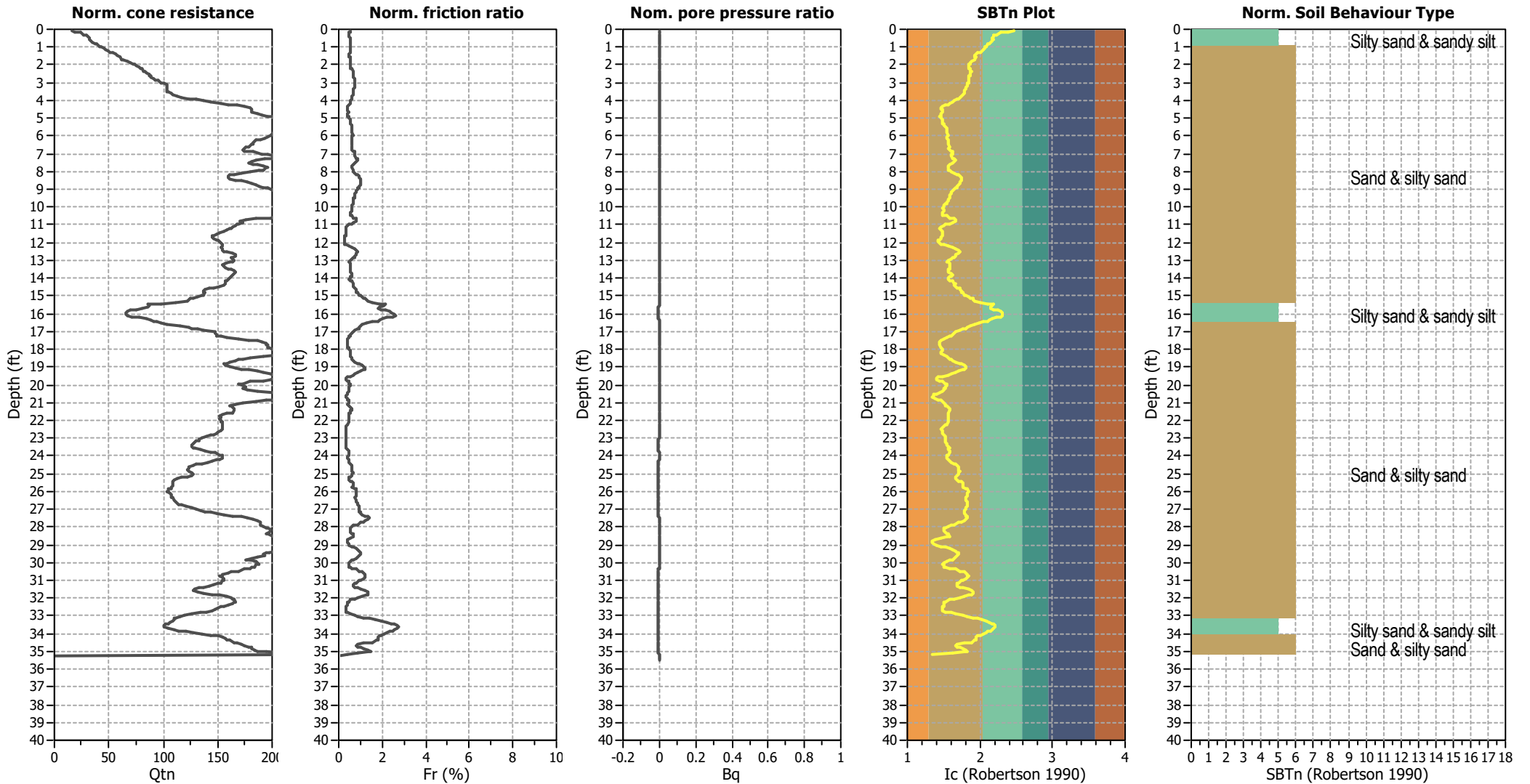

Input parameters and analysis data

Analysis method:	NCEER (1998)	Depth to water table (erthq.):	7.00 ft	Fill weight:	N/A
Fines correction method:	NCEER (1998)	Average results interval:	3	Transition detect. applied:	Yes
Points to test:	Based on Ic value	Ic cut-off value:	2.60	K ₀ applied:	Yes
Earthquake magnitude M _w :	8.10	Unit weight calculation:	Based on SBT	Clay like behavior applied:	Sands only
Peak ground acceleration:	0.89	Use fill:	No	Limit depth applied:	No
Depth to water table (insitu):	10.50 ft	Fill height:	N/A	Limit depth:	N/A

SBTn legend

1. Sensitive fine grained	4. Clayey silt to silty	7. Gravely sand to sand
2. Organic material	5. Silty sand to sandy silt	8. Very stiff sand to
3. Clay to silty clay	6. Clean sand to silty sand	9. Very stiff fine grained

Liquefaction analysis overall plots (intermediate results)

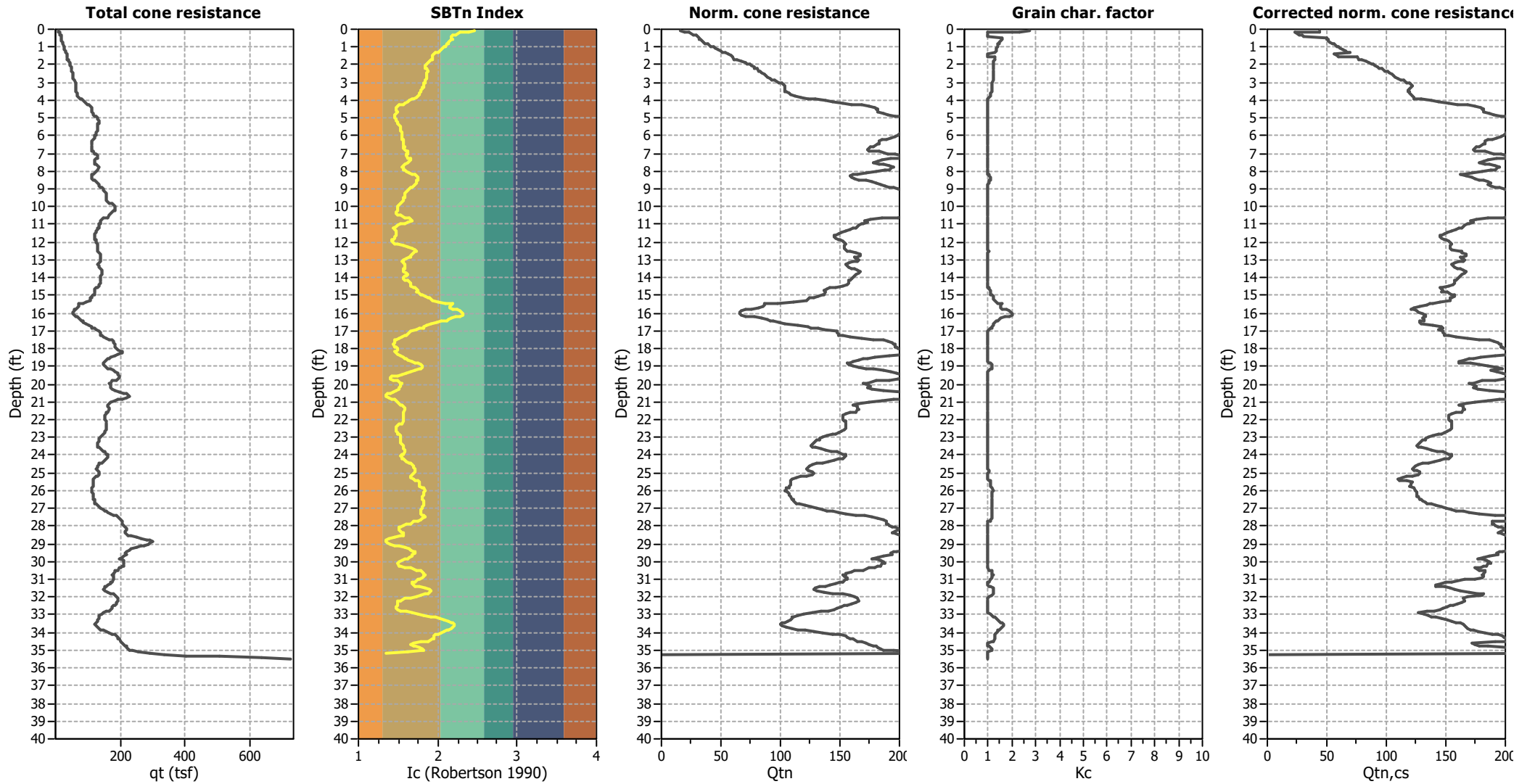

Input parameters and analysis data

Analysis method:	NCEER (1998)	Depth to water table (earthq.):	7.00 ft	Fill weight:	N/A
Fines correction method:	NCEER (1998)	Average results interval:	3	Transition detect. applied:	Yes
Points to test:	Based on Ic value	Ic cut-off value:	2.60	K _o applied:	Yes
Earthquake magnitude M _w :	8.10	Unit weight calculation:	Based on SBT	Clay like behavior applied:	Sands only
Peak ground acceleration:	0.89	Use fill:	No	Limit depth applied:	No
Depth to water table (insitu):	10.50 ft	Fill height:	N/A	Limit depth:	N/A

Liquefaction analysis overall plots

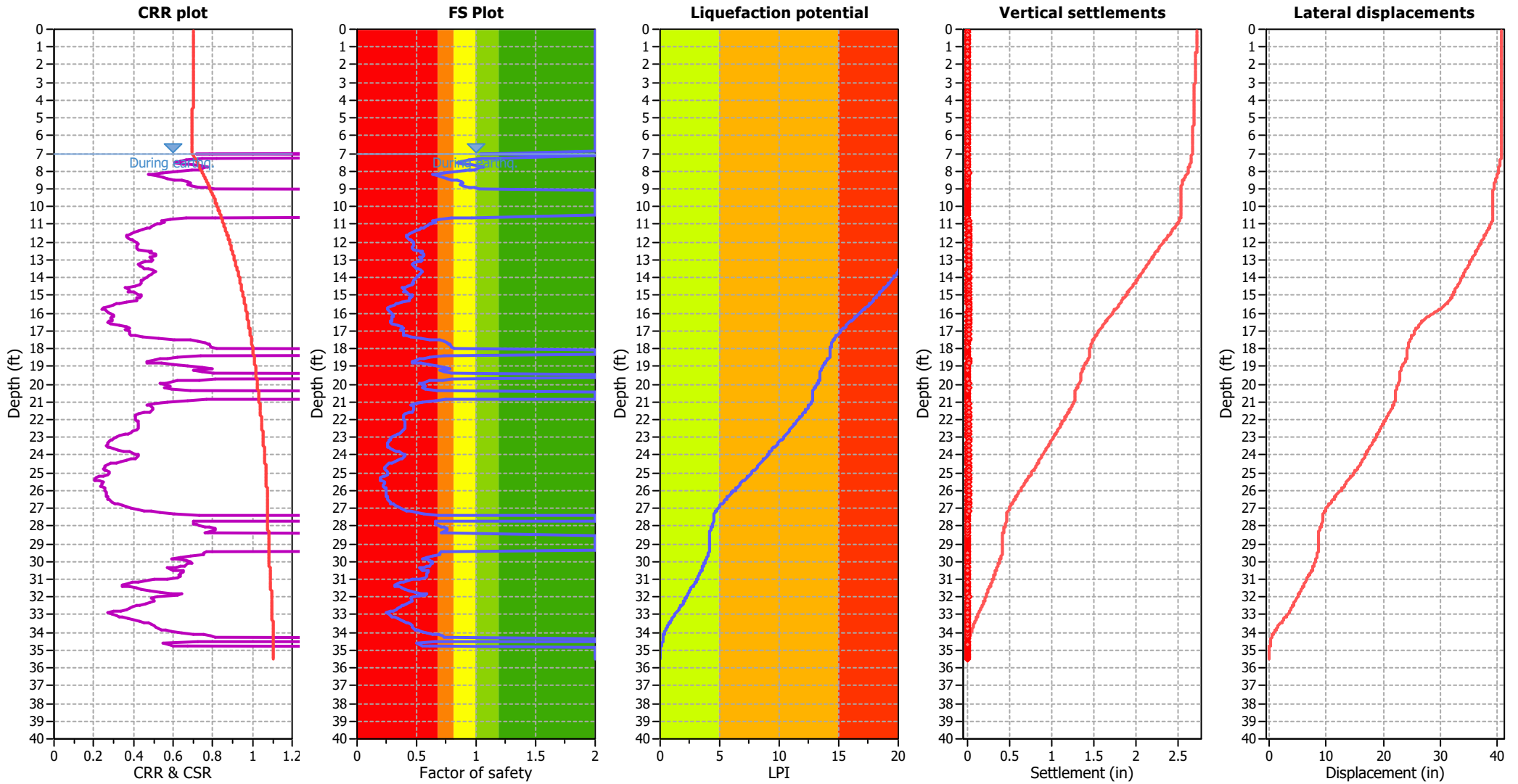

Input parameters and analysis data

Analysis method:	NCEER (1998)	Depth to water table (earthq.):	7.00 ft	Fill weight:	N/A
Fines correction method:	NCEER (1998)	Average results interval:	3	Transition detect. applied:	Yes
Points to test:	Based on Ic value	Ic cut-off value:	2.60	K_0 applied:	Yes
Earthquake magnitude M_w :	8.10	Unit weight calculation:	Based on SBT	Clay like behavior applied:	Sands only
Peak ground acceleration:	0.89	Use fill:	No	Limit depth applied:	No
Depth to water table (insitu):	10.50 ft	Fill height:	N/A	Limit depth:	N/A

F.S. color scheme

- Almost certain it will liquefy
- Very likely to liquefy
- Liquefaction and no liq. are equally likely
- Unlike to liquefy
- Almost certain it will not liquefy

LPI color scheme

- Very high risk
- High risk
- Low risk

Liquefaction analysis summary plots

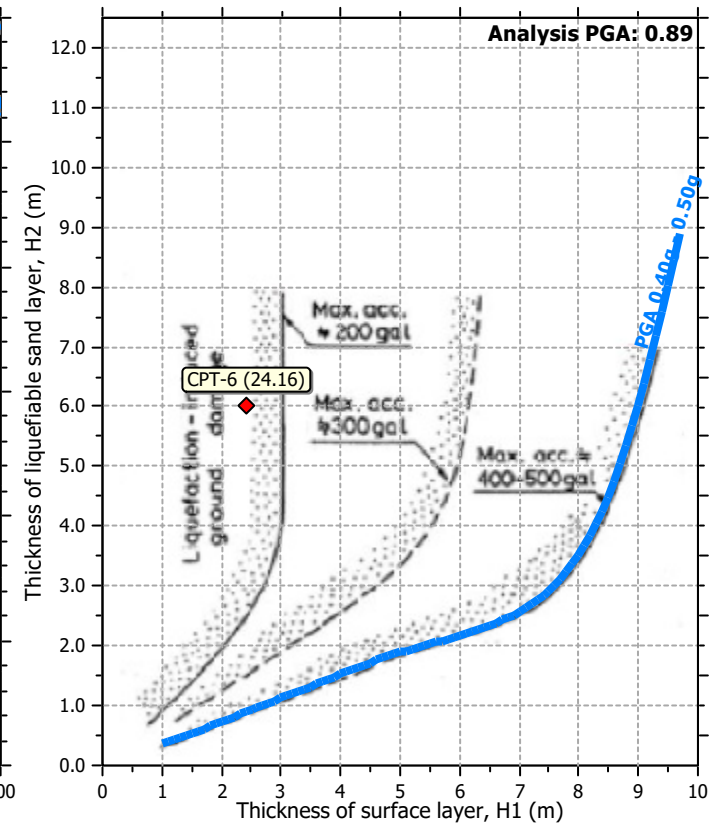
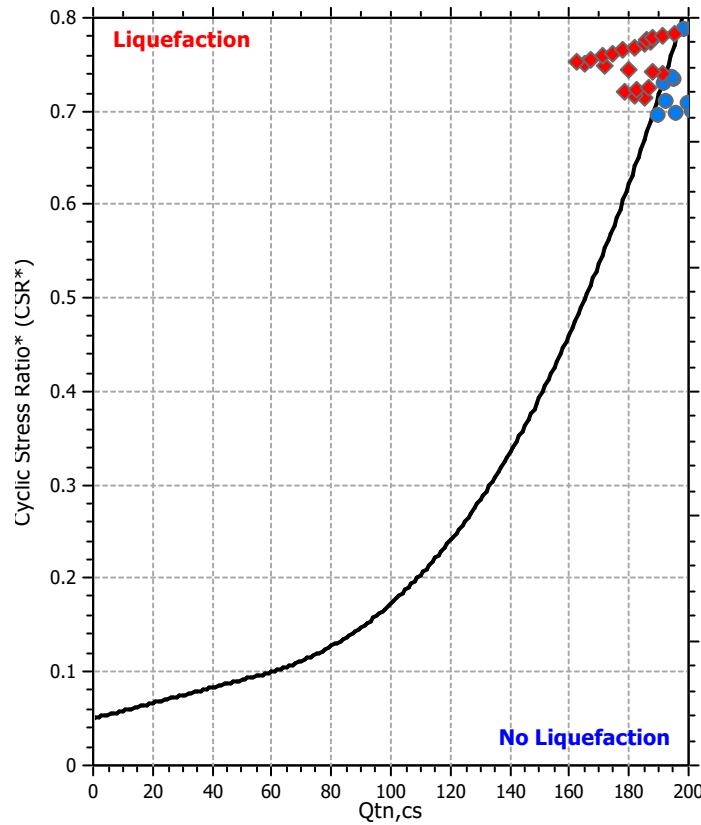
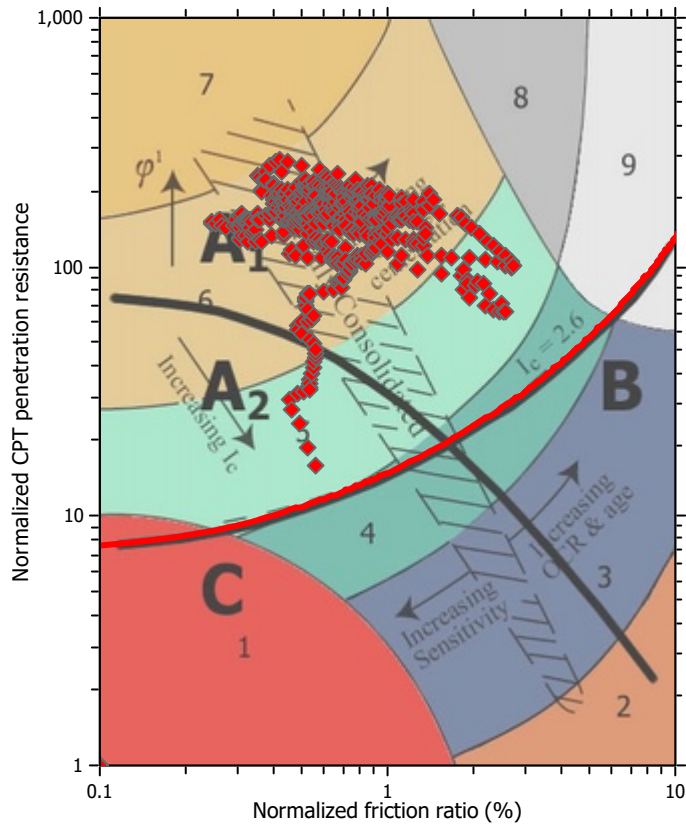

Input parameters and analysis data

Analysis method:	NCEER (1998)	Depth to water table (earthq.):	7.00 ft	Fill weight:	N/A
Fines correction method:	NCEER (1998)	Average results interval:	3	Transition detect. applied:	Yes
Points to test:	Based on Ic value	Ic cut-off value:	2.60	K _v applied:	Yes
Earthquake magnitude M _w :	8.10	Unit weight calculation:	Based on SBT	Clay like behavior applied:	Sands only
Peak ground acceleration:	0.89	Use fill:	No	Limit depth applied:	No
Depth to water table (insitu):	10.50 ft	Fill height:	N/A	Limit depth:	N/A

Check for strength loss plots (Robertson (2010))

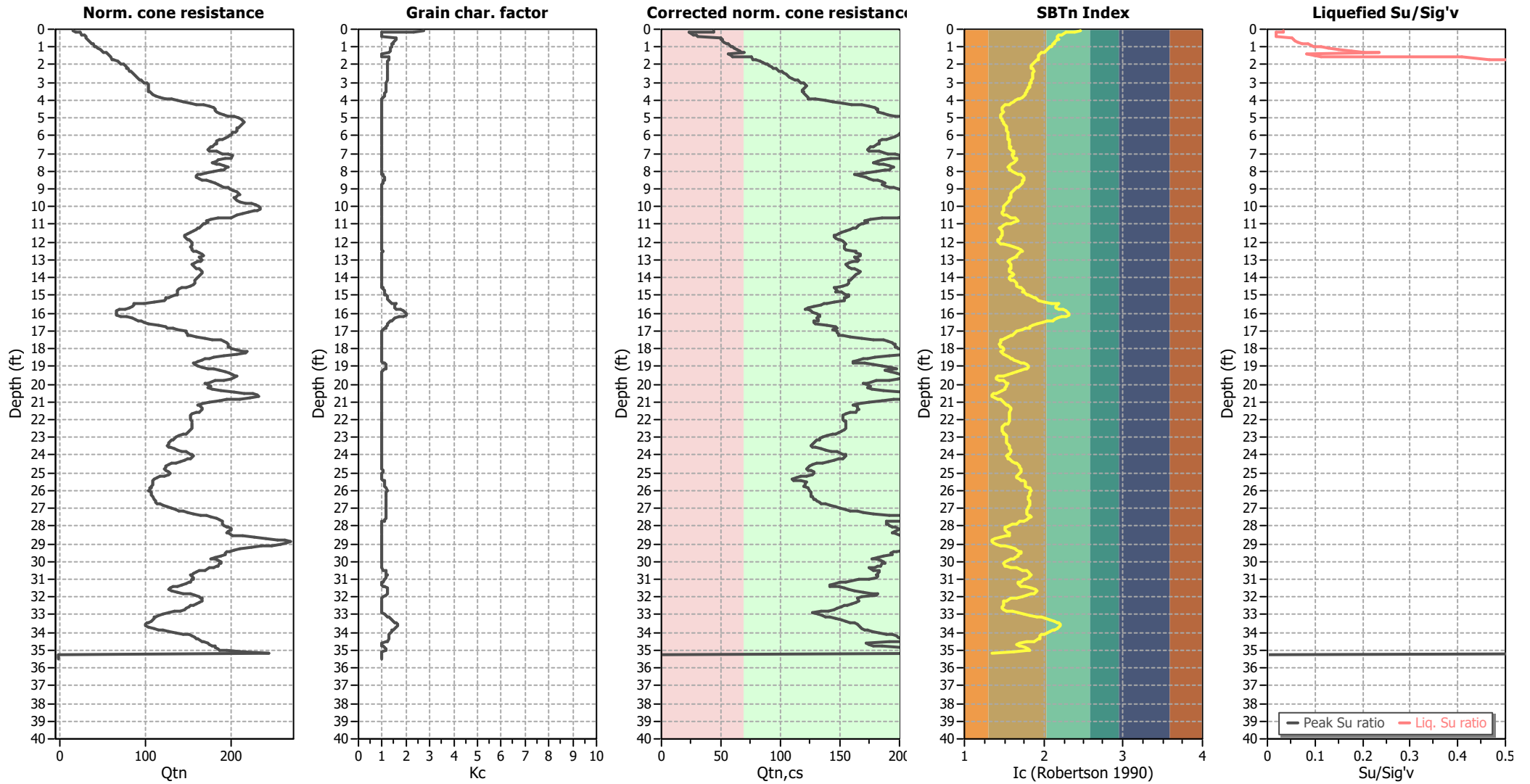

Input parameters and analysis data

Analysis method:	NCEER (1998)	Depth to water table (earthq.):	7.00 ft	Fill weight:	N/A
Fines correction method:	NCEER (1998)	Average results interval:	3	Transition detect. applied:	Yes
Points to test:	Based on Ic value	Ic cut-off value:	2.60	K _o applied:	Yes
Earthquake magnitude M _w :	8.10	Unit weight calculation:	Based on SBT	Clay like behavior applied:	Sands only
Peak ground acceleration:	0.89	Use fill:	No	Limit depth applied:	No
Depth to water table (insitu):	10.50 ft	Fill height:	N/A	Limit depth:	N/A

TRANSITION LAYER DETECTION ALGORITHM REPORT

Summary Details & Plots

Short description

The software will delete data when the cone is in transition from either clay to sand or vice-versa. To do this the software requires a range of I_c values over which the transition will be defined (typically somewhere between $1.80 < I_c < 3.0$) and a rate of change of I_c . Transitions typically occur when the rate of change of I_c is fast (i.e. ΔI_c is small).

The SBT_n plot below, displays in red the detected transition layers based on the parameters listed below the graphs.

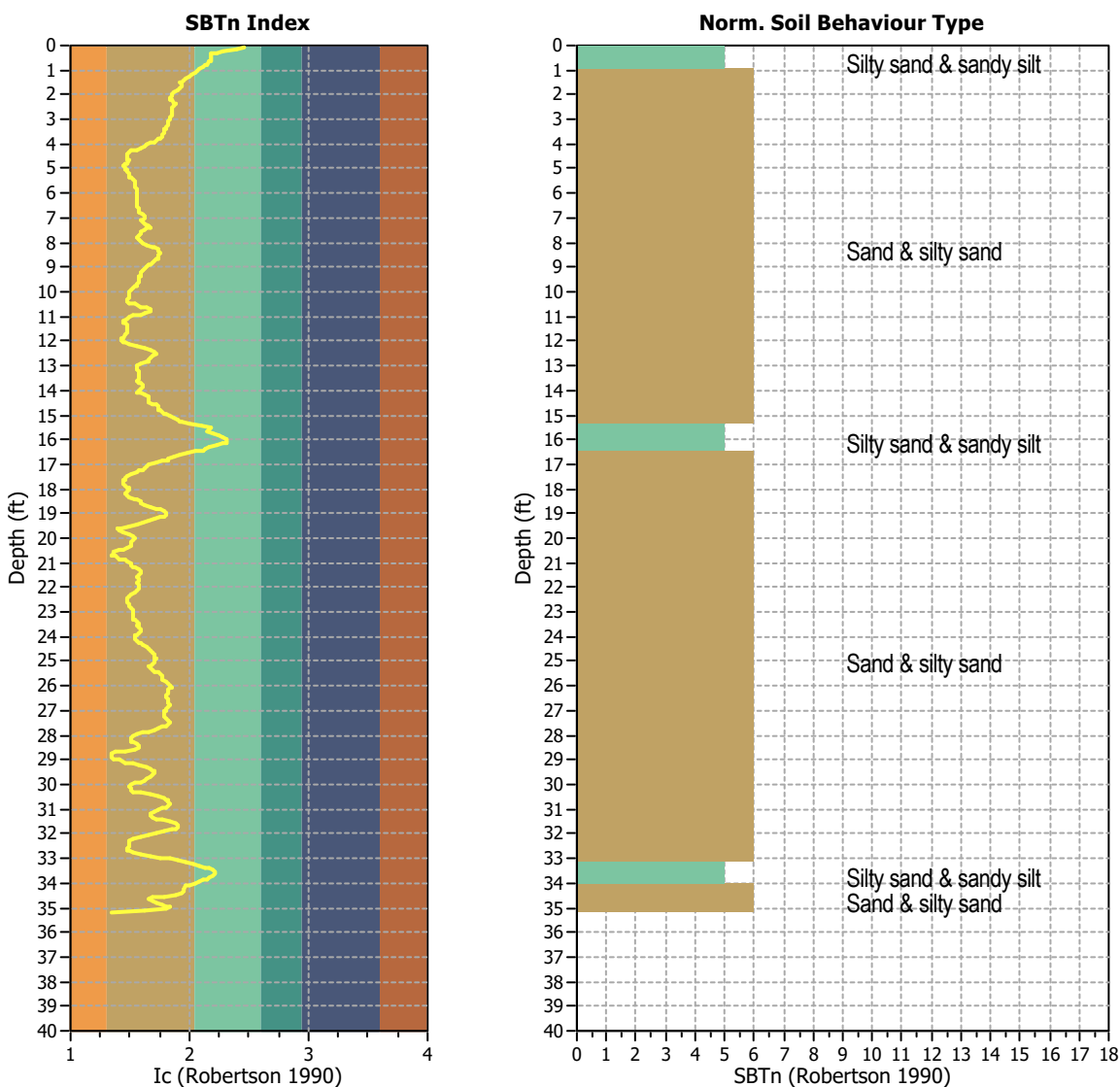

Transition layer algorithm properties		General statistics	
I_c minimum check value:	1.70	Total points in CPT file:	541
I_c maximum check value:	3.00	Total points excluded:	0
I_c change ratio value:	0.0250	Exclusion percentage:	0.00%
Minimum number of points in layer:	4	Number of layers detected:	0

Estimation of post-earthquake settlements

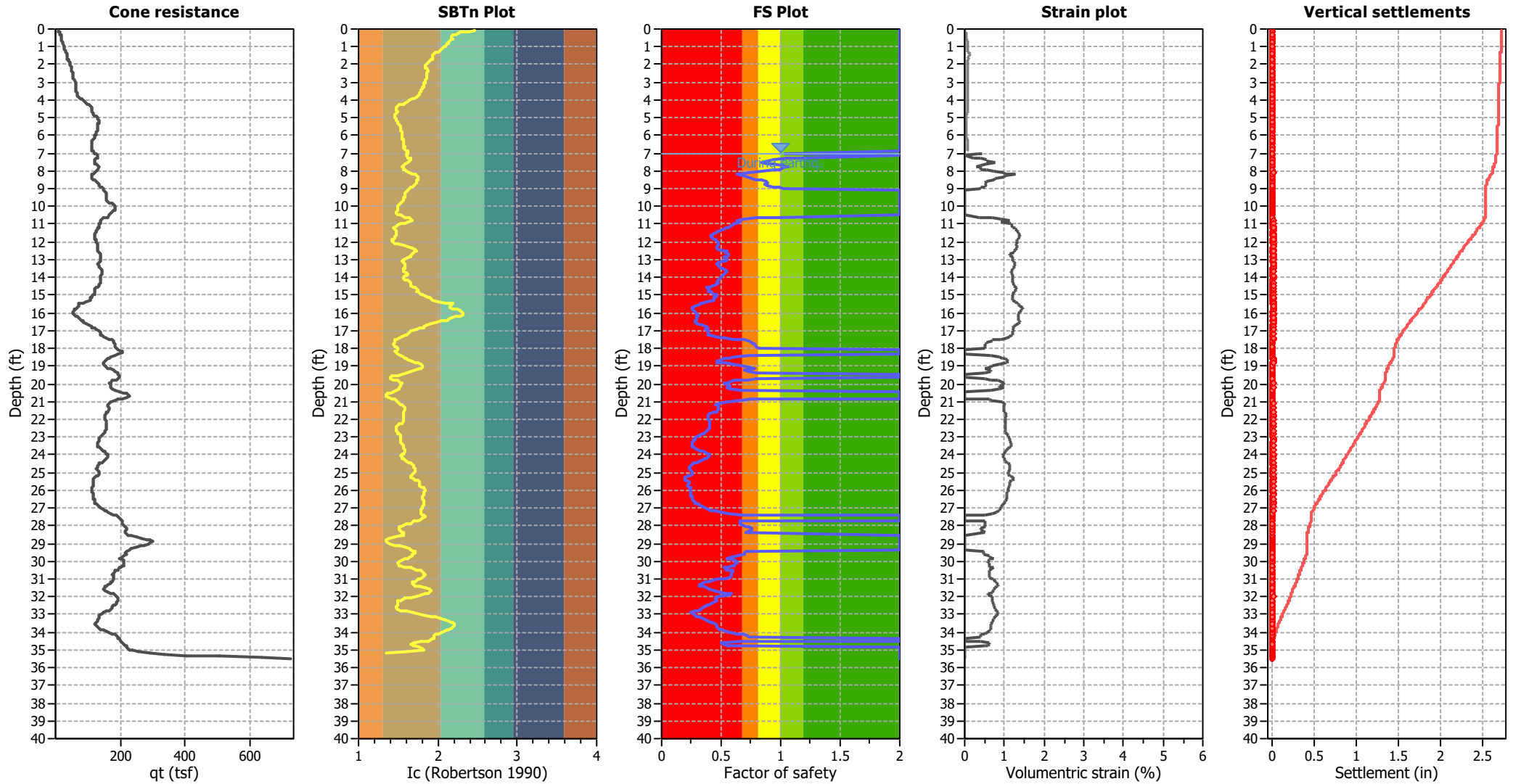

Abbreviations

- q_c: Total cone resistance (cone resistance q_c corrected for pore water effects)
- I_c: Soil Behaviour Type Index
- FS: Calculated Factor of Safety against liquefaction
- Volumetric strain: Post-liquefaction volumetric strain

Estimation of post-earthquake lateral Displacements

Geometric parameters: Gently sloping ground without free face (Slope 1.20 %)

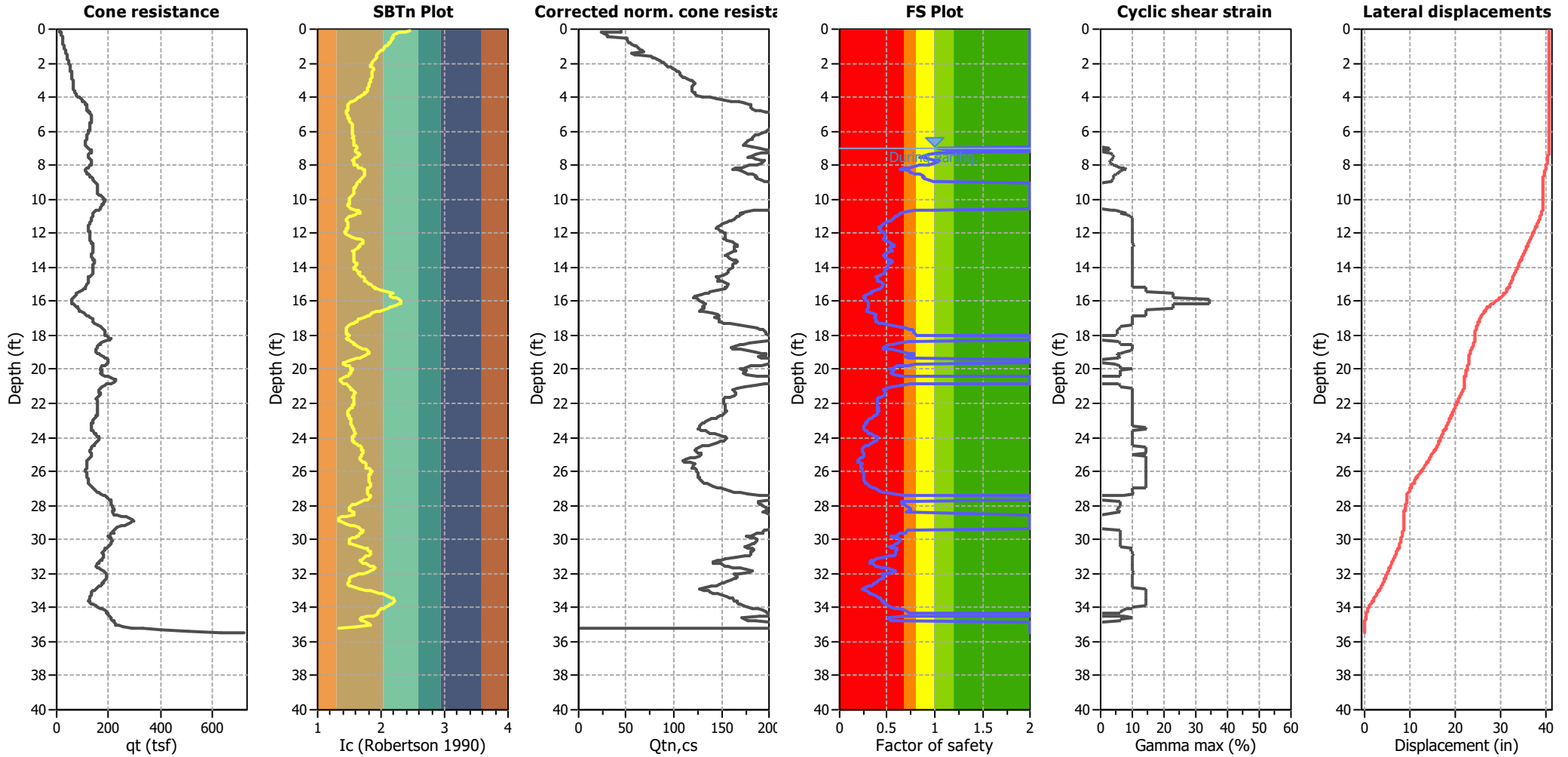

Abbreviations

qt: Total cone resistance (cone resistance q_c corrected for pore water effects)
 Ic: Soil Behaviour Type Index
 $Q_{tn,cs}$: Equivalent clean sand normalized CPT total cone resistance

F.S.: Factor of safety
 γ_{max} : Maximum cyclic shear strain
 LDI: Lateral displacement index

Surface condition

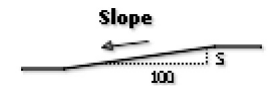

Aging Calculation Estimation

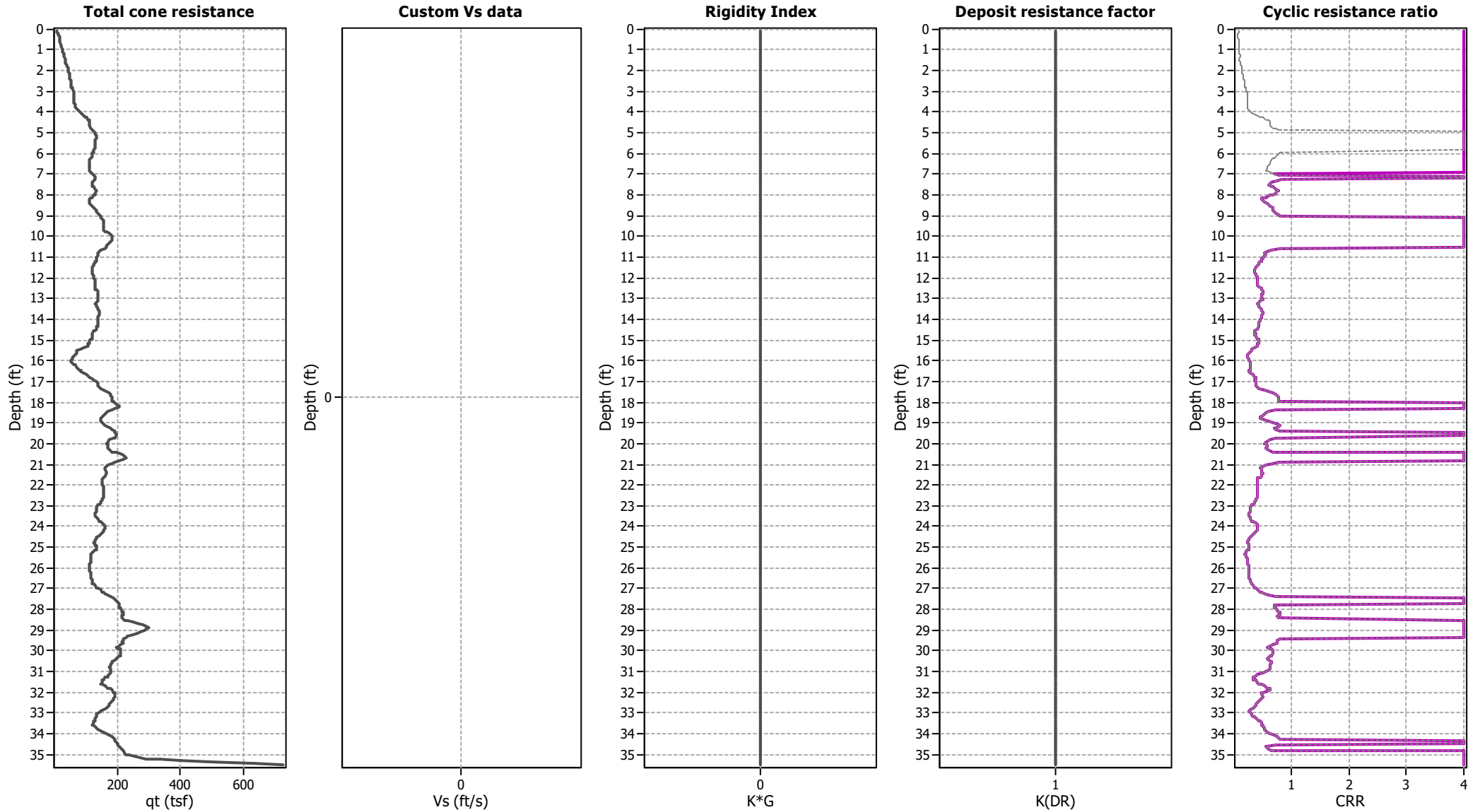

Ejecta Severity Estimation

Corrected norm. cone resista

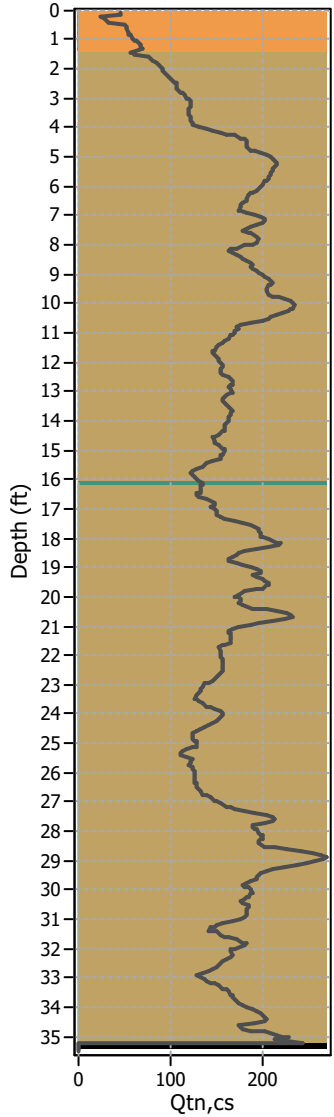

SBTn Index Plot

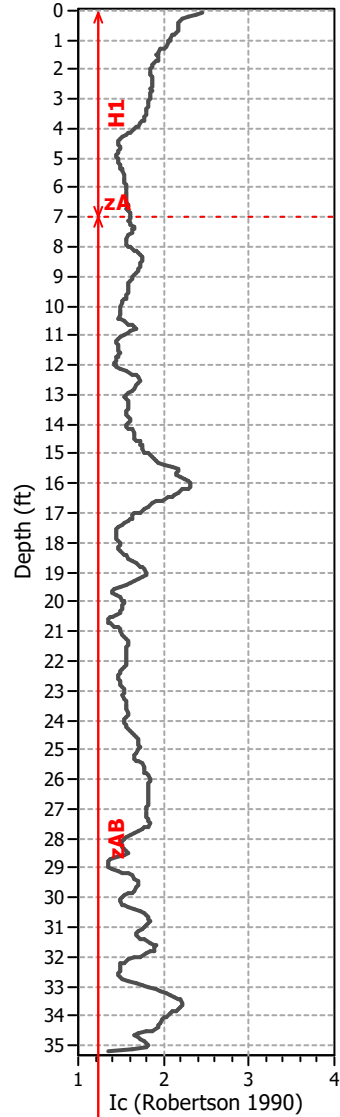

FS plot

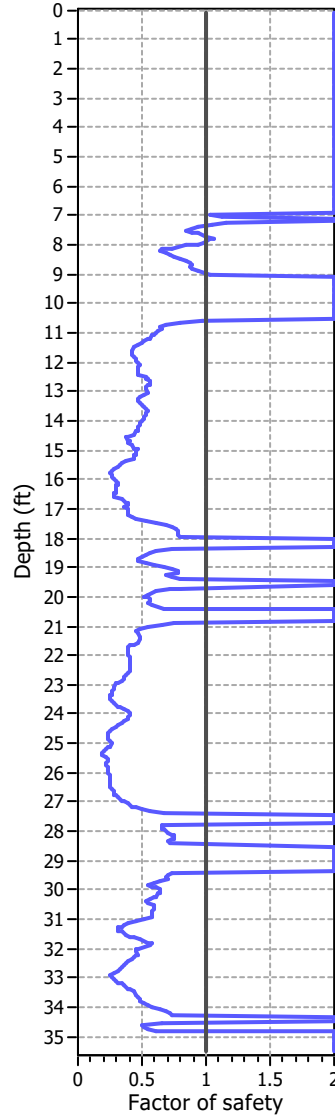

Stresses vs Depth

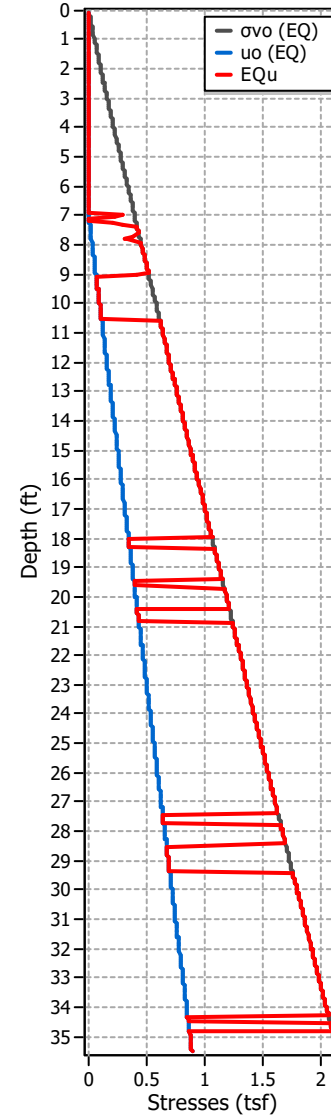

Excess Head

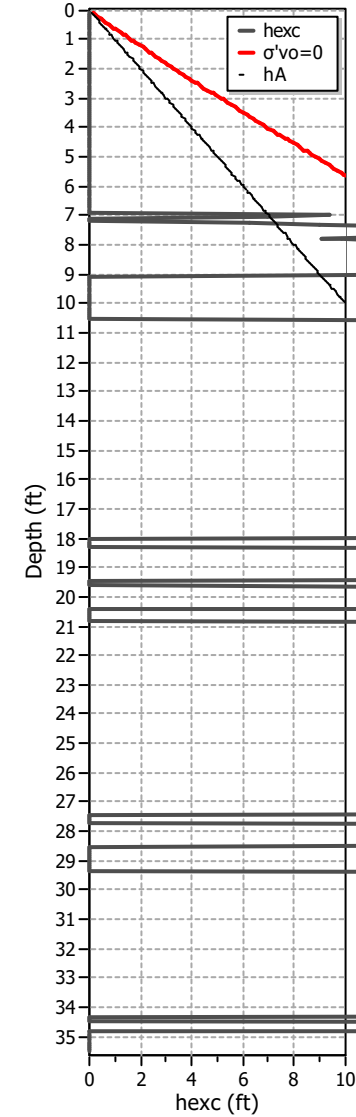

Liq. ejecta demand

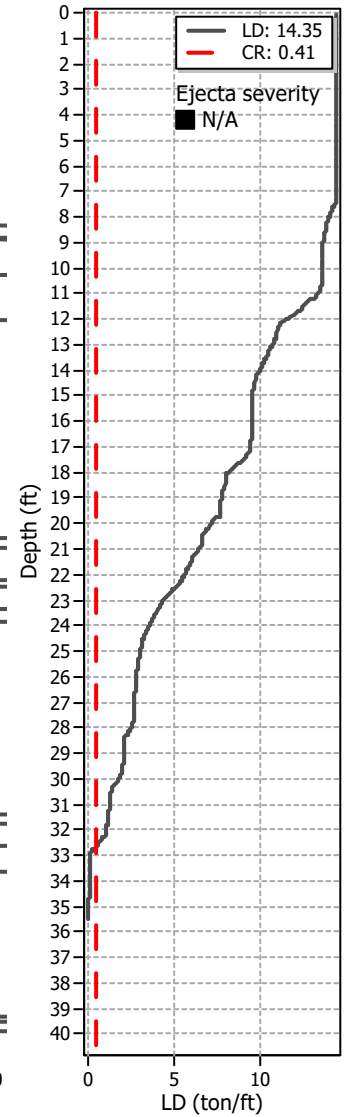

LIQUEFACTION ANALYSIS REPORT

Project title : Petra Geosciences / Apple Canyon

Location : Lake Hemet, CA

CPT file : CPT-7

Input parameters and analysis data

Analysis method:	NCEER (1998)	G.W.T. (in-situ):	11.00 ft	Use fill:	No	Clay like behavior applied:	Sands only
Fines correction method:	NCEER (1998)	G.W.T. (earthq.):	7.00 ft	Fill height:	N/A	Limit depth applied:	No
Points to test:	Based on Ic value	Average results interval:	3	Fill weight:	N/A	Limit depth:	N/A
Earthquake magnitude M_w :	8.10	Ic cut-off value:	2.60	Trans. detect. applied:	Yes	MSF method:	Method based
Peak ground acceleration:	0.89	Unit weight calculation:	Based on SBT	K_o applied:	Yes		

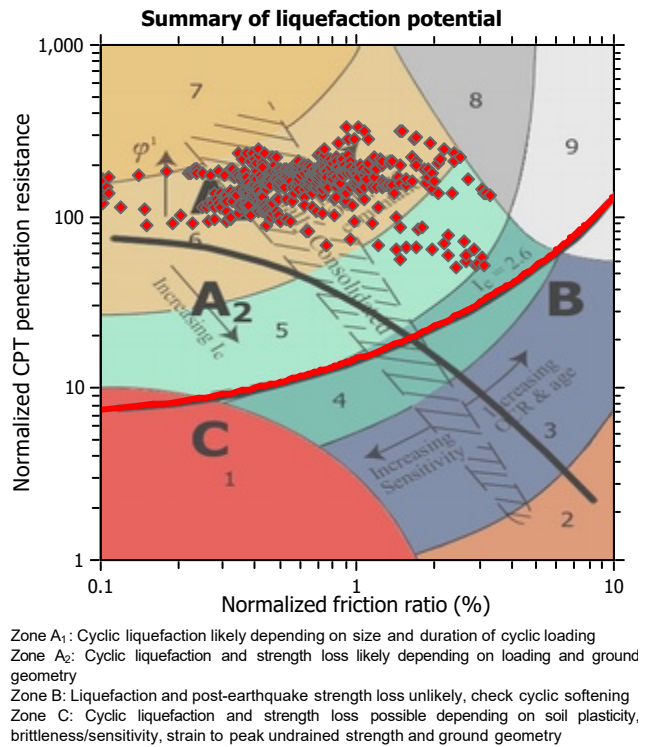
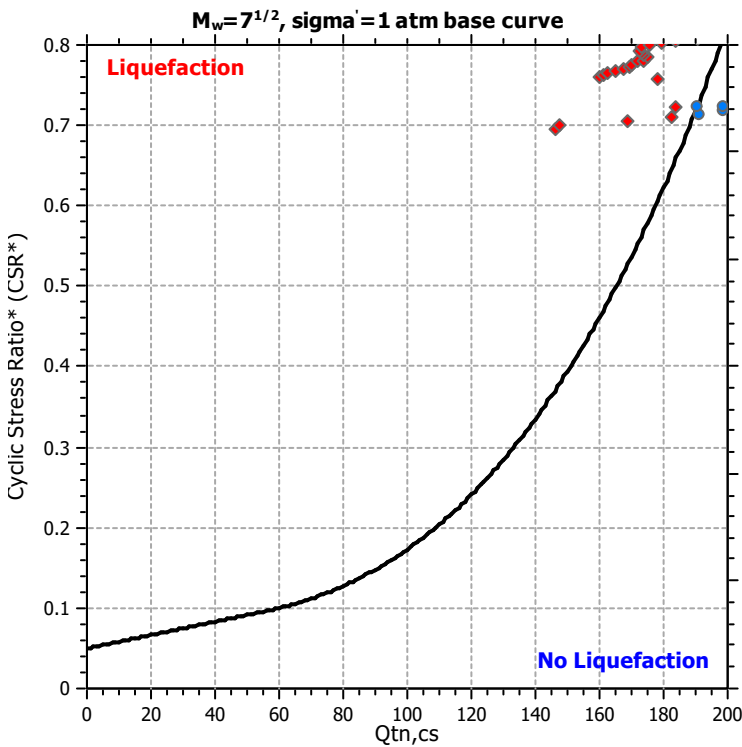
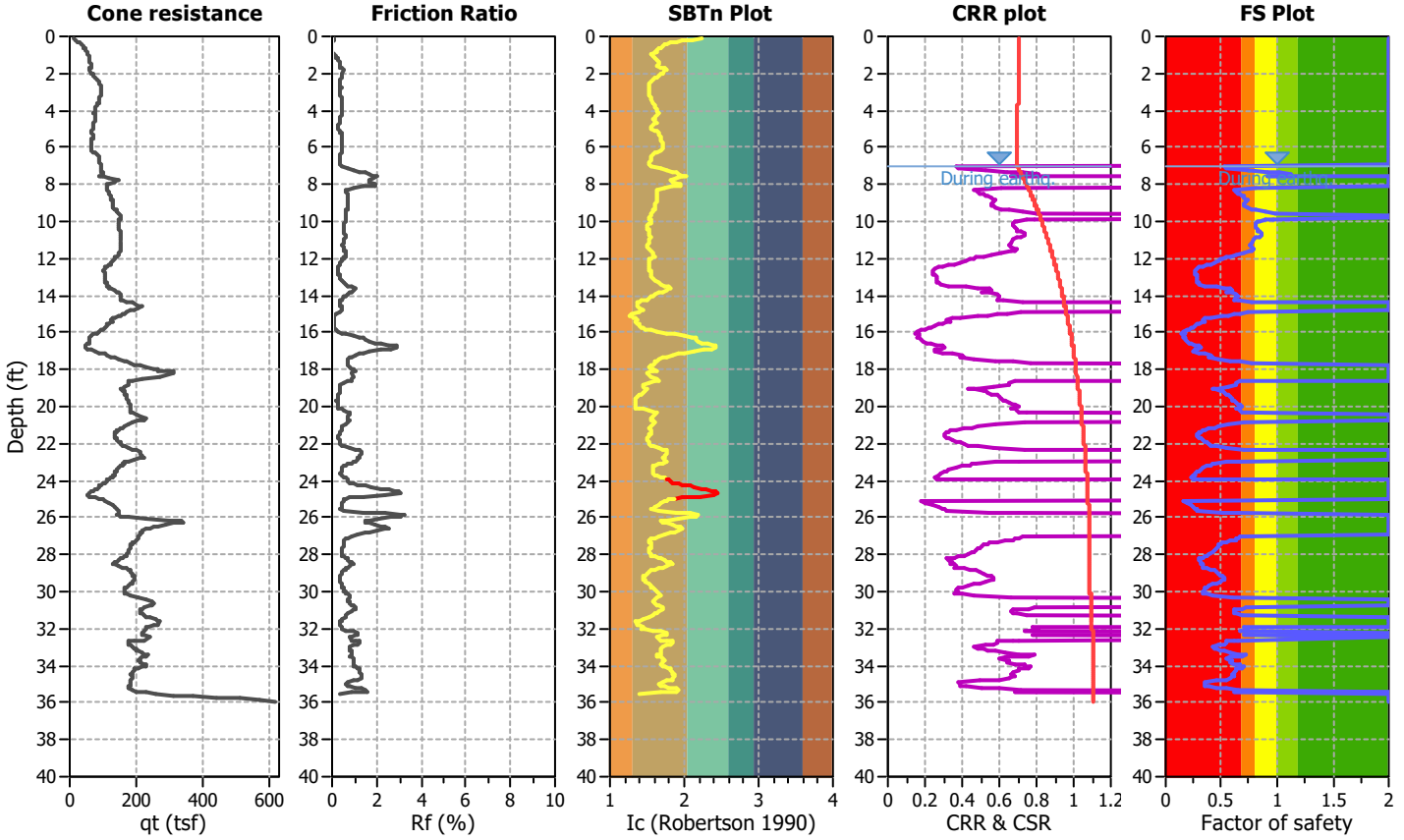

CPT basic interpretation plots

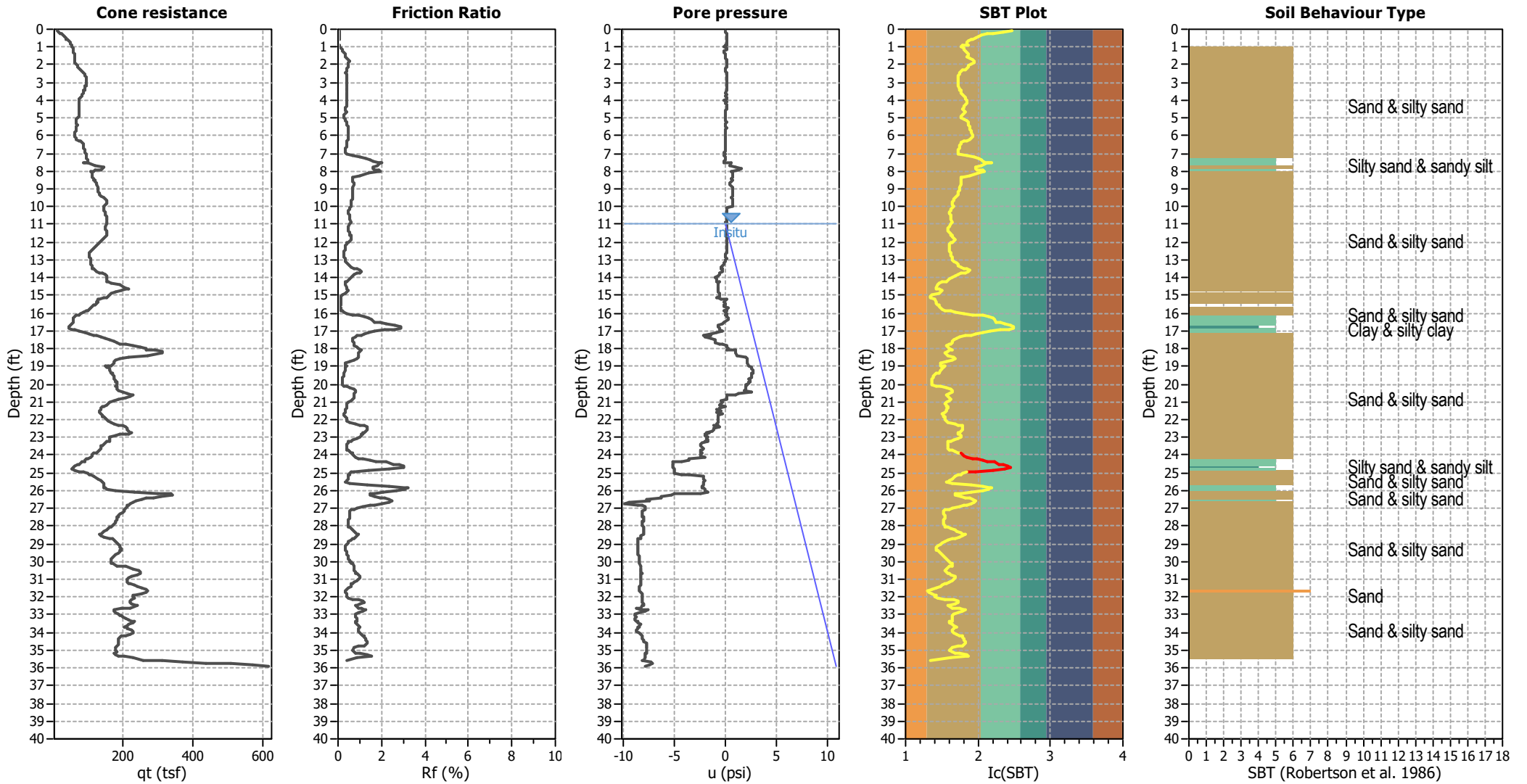

Input parameters and analysis data

Analysis method:	NCEER (1998)	Depth to water table (earthq.):	7.00 ft	Fill weight:	N/A
Fines correction method:	NCEER (1998)	Average results interval:	3	Transition detect. applied:	Yes
Points to test:	Based on Ic value	Ic cut-off value:	2.60	K _o applied:	Yes
Earthquake magnitude M _w :	8.10	Unit weight calculation:	Based on SBT	Clay like behavior applied:	Sands only
Peak ground acceleration:	0.89	Use fill:	No	Limit depth applied:	No
Depth to water table (insitu):	11.00 ft	Fill height:	N/A	Limit depth:	N/A

SBT legend

1. Sensitive fine grained	4. Clayey silt to silty	7. Gravely sand to sand
2. Organic material	5. Silty sand to sandy silt	8. Very stiff sand to
3. Clay to silty clay	6. Clean sand to silty sand	9. Very stiff fine grained

CPT basic interpretation plots (normalized)

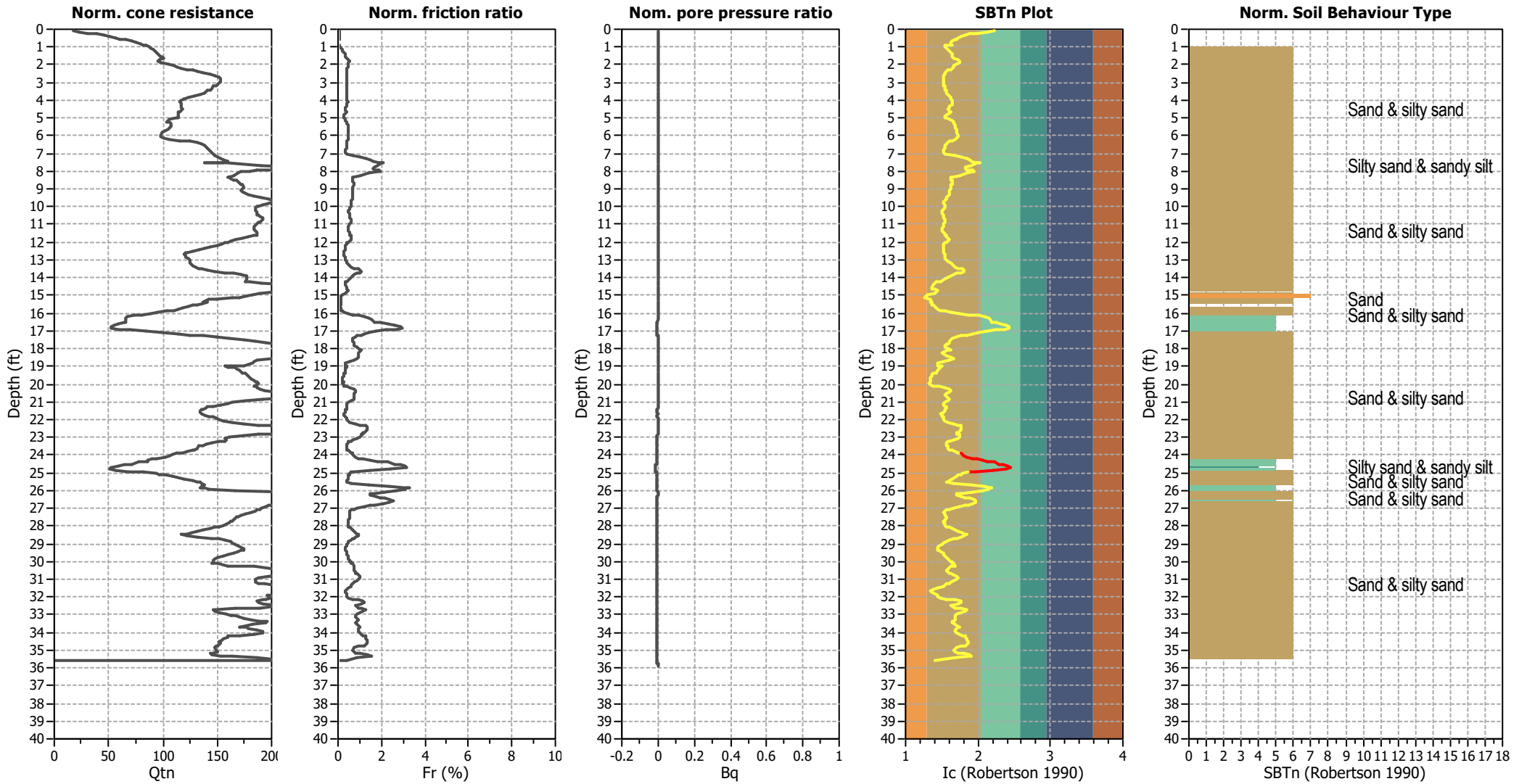

Input parameters and analysis data

Analysis method:	NCEER (1998)	Depth to water table (erthq.):	7.00 ft	Fill weight:	N/A
Fines correction method:	NCEER (1998)	Average results interval:	3	Transition detect. applied:	Yes
Points to test:	Based on Ic value	Ic cut-off value:	2.60	K _o applied:	Yes
Earthquake magnitude M _w :	8.10	Unit weight calculation:	Based on SBT	Clay like behavior applied:	Sands only
Peak ground acceleration:	0.89	Use fill:	No	Limit depth applied:	No
Depth to water table (insitu):	11.00 ft	Fill height:	N/A	Limit depth:	N/A

SBTn legend

1. Sensitive fine grained	4. Clayey silt to silty	7. Gravely sand to sand
2. Organic material	5. Silty sand to sandy silt	8. Very stiff sand to
3. Clay to silty clay	6. Clean sand to silty sand	9. Very stiff fine grained

Liquefaction analysis overall plots (intermediate results)

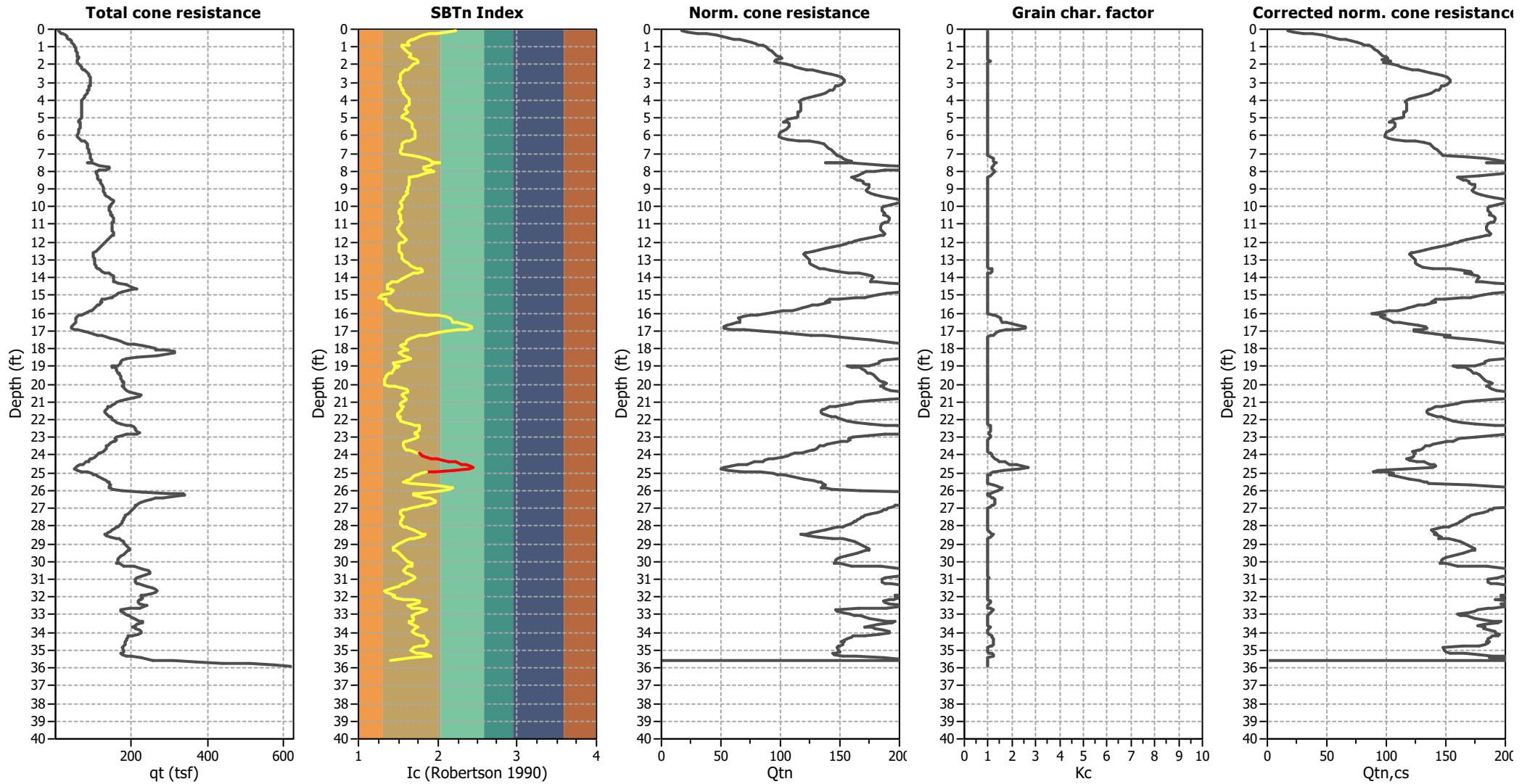

Input parameters and analysis data

Analysis method:	NCEER (1998)	Depth to water table (earthq.):	7.00 ft	Fill weight:	N/A
Fines correction method:	NCEER (1998)	Average results interval:	3	Transition detect. applied:	Yes
Points to test:	Based on Ic value	Ic cut-off value:	2.60	K _o applied:	Yes
Earthquake magnitude M _w :	8.10	Unit weight calculation:	Based on SBT	Clay like behavior applied:	Sands only
Peak ground acceleration:	0.89	Use fill:	No	Limit depth applied:	No
Depth to water table (insitu):	11.00 ft	Fill height:	N/A	Limit depth:	N/A

Liquefaction analysis overall plots

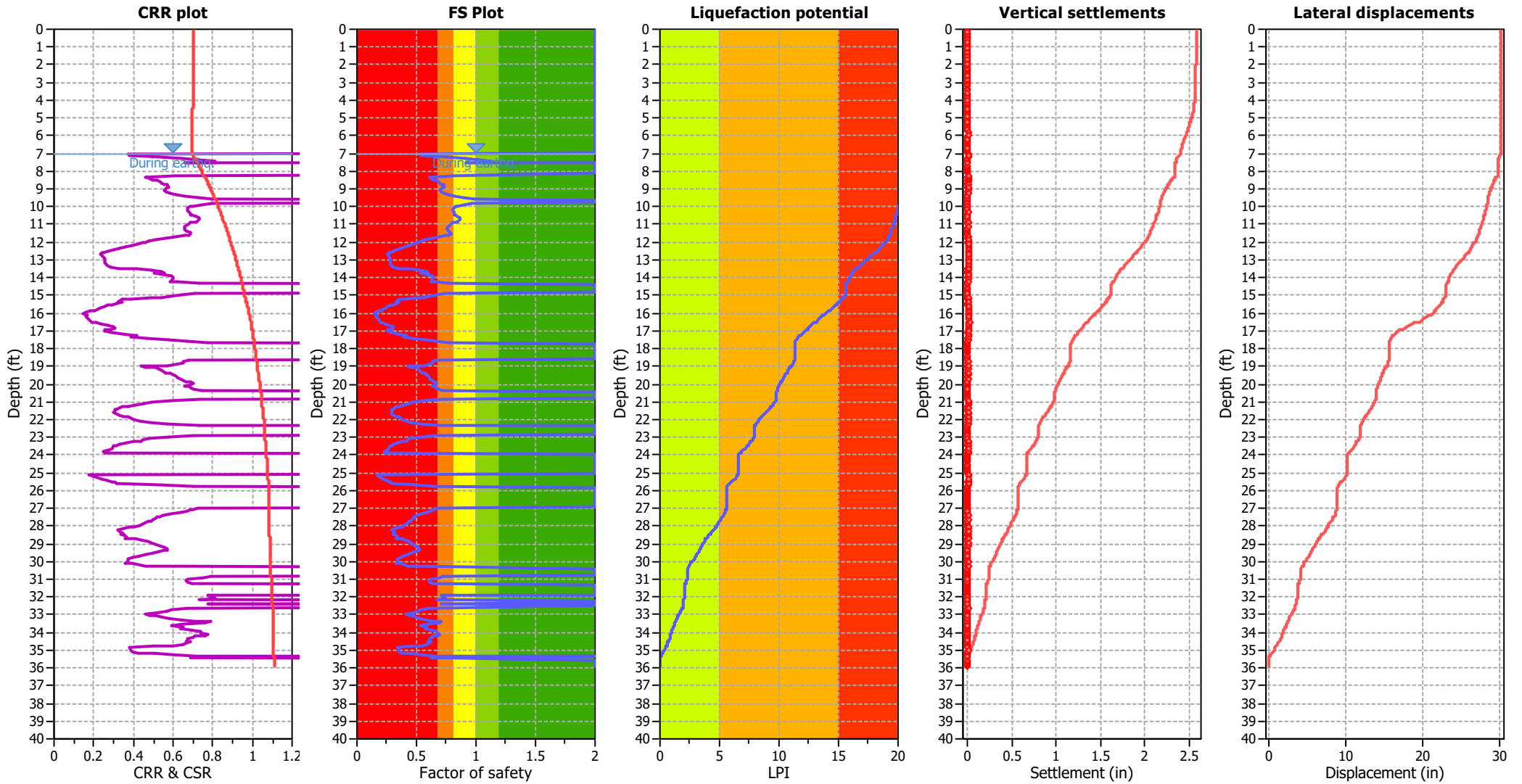

Input parameters and analysis data

Analysis method:	NCEER (1998)	Depth to water table (earthq.):	7.00 ft	Fill weight:	N/A
Fines correction method:	NCEER (1998)	Average results interval:	3	Transition detect. applied:	Yes
Points to test:	Based on Ic value	Ic cut-off value:	2.60	K_0 applied:	Yes
Earthquake magnitude M_w :	8.10	Unit weight calculation:	Based on SBT	Clay like behavior applied:	Sands only
Peak ground acceleration:	0.89	Use fill:	No	Limit depth applied:	No
Depth to water table (insitu):	11.00 ft	Fill height:	N/A	Limit depth:	N/A

F.S. color scheme

- Almost certain it will liquefy
- Very likely to liquefy
- Liquefaction and no liq. are equally likely
- Unlike to liquefy
- Almost certain it will not liquefy

LPI color scheme

- Very high risk
- High risk
- Low risk

Liquefaction analysis summary plots

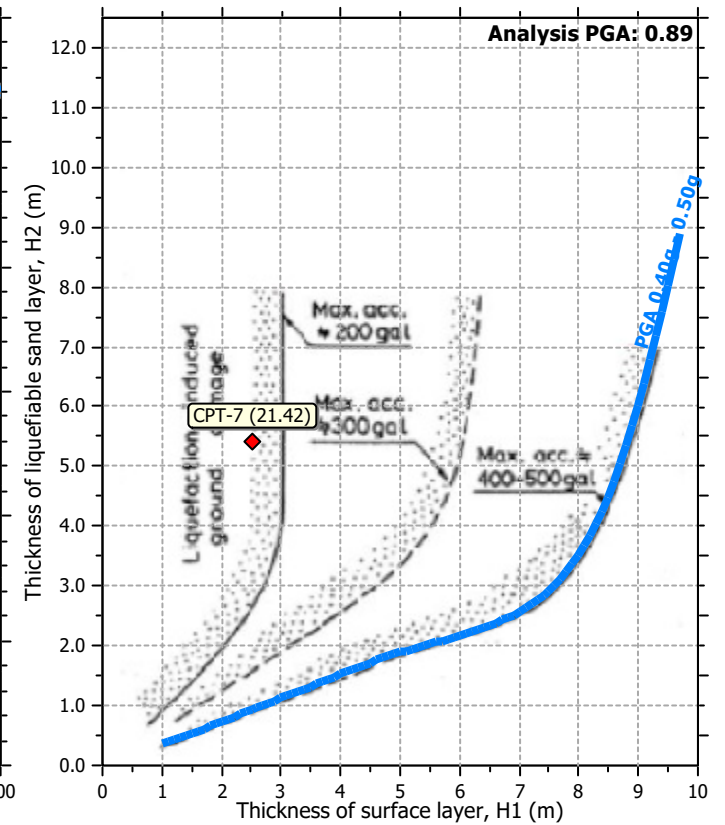
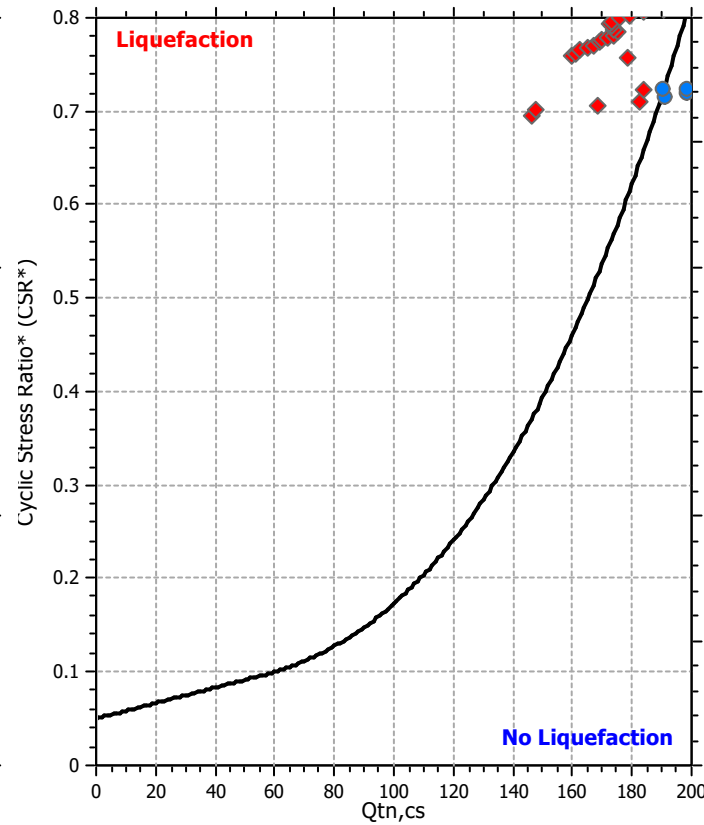
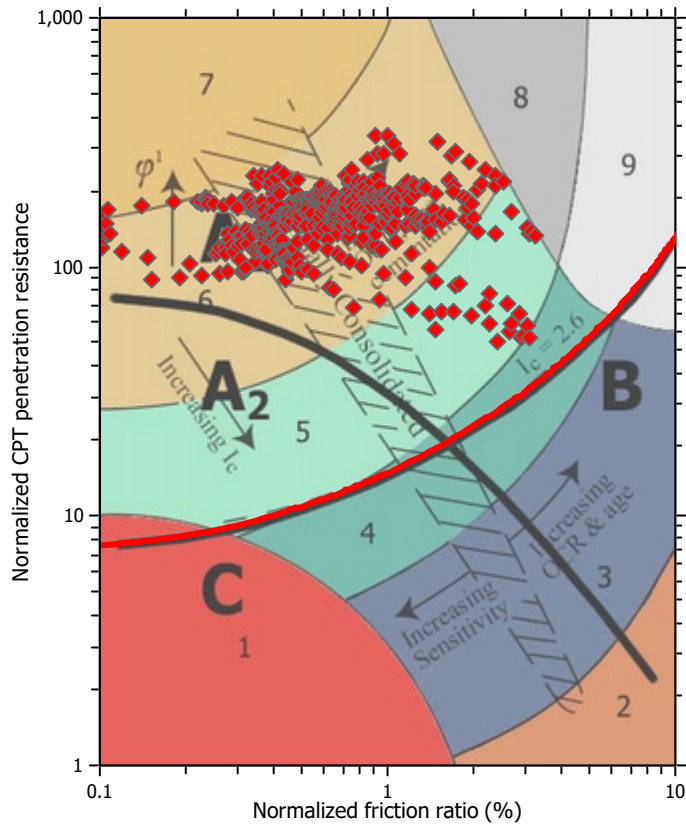

Input parameters and analysis data

Analysis method:	NCEER (1998)	Depth to water table (earthq.):	7.00 ft	Fill weight:	N/A
Fines correction method:	NCEER (1998)	Average results interval:	3	Transition detect. applied:	Yes
Points to test:	Based on Ic value	Ic cut-off value:	2.60	K _o applied:	Yes
Earthquake magnitude M _w :	8.10	Unit weight calculation:	Based on SBT	Clay like behavior applied:	Sands only
Peak ground acceleration:	0.89	Use fill:	No	Limit depth applied:	No
Depth to water table (insitu):	11.00 ft	Fill height:	N/A	Limit depth:	N/A

Check for strength loss plots (Robertson (2010))

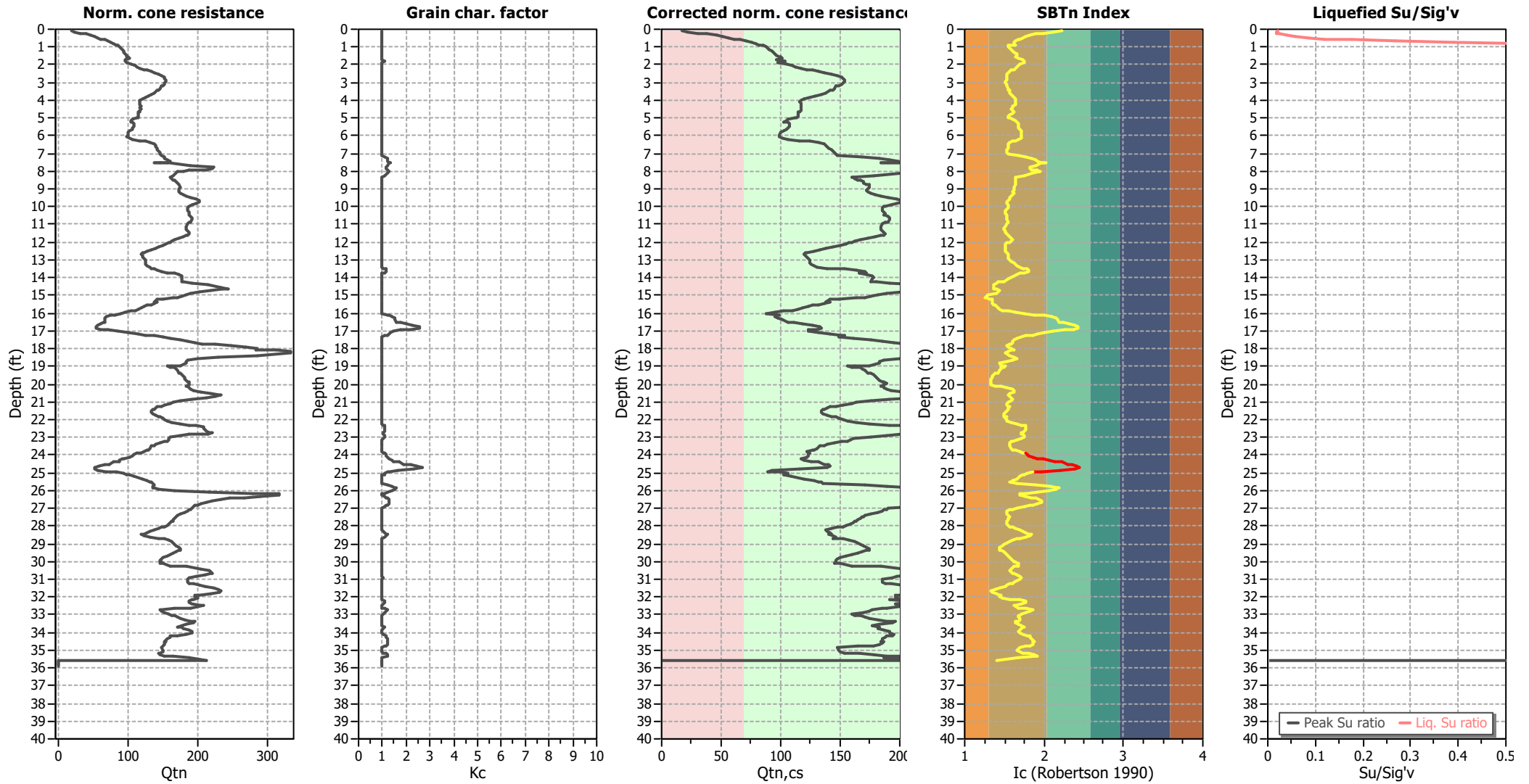

Input parameters and analysis data

Analysis method:	NCEER (1998)	Depth to water table (earthq.):	7.00 ft	Fill weight:	N/A
Fines correction method:	NCEER (1998)	Average results interval:	3	Transition detect. applied:	Yes
Points to test:	Based on Ic value	Ic cut-off value:	2.60	K _o applied:	Yes
Earthquake magnitude M _w :	8.10	Unit weight calculation:	Based on SBT	Clay like behavior applied:	Sands only
Peak ground acceleration:	0.89	Use fill:	No	Limit depth applied:	No
Depth to water table (insitu):	11.00 ft	Fill height:	N/A	Limit depth:	N/A

TRANSITION LAYER DETECTION ALGORITHM REPORT

Summary Details & Plots

Short description

The software will delete data when the cone is in transition from either clay to sand or vice-versa. To do this the software requires a range of I_c values over which the transition will be defined (typically somewhere between $1.80 < I_c < 3.0$) and a rate of change of I_c . Transitions typically occur when the rate of change of I_c is fast (i.e. ΔI_c is small).

The SBT_n plot below, displays in red the detected transition layers based on the parameters listed below the graphs.

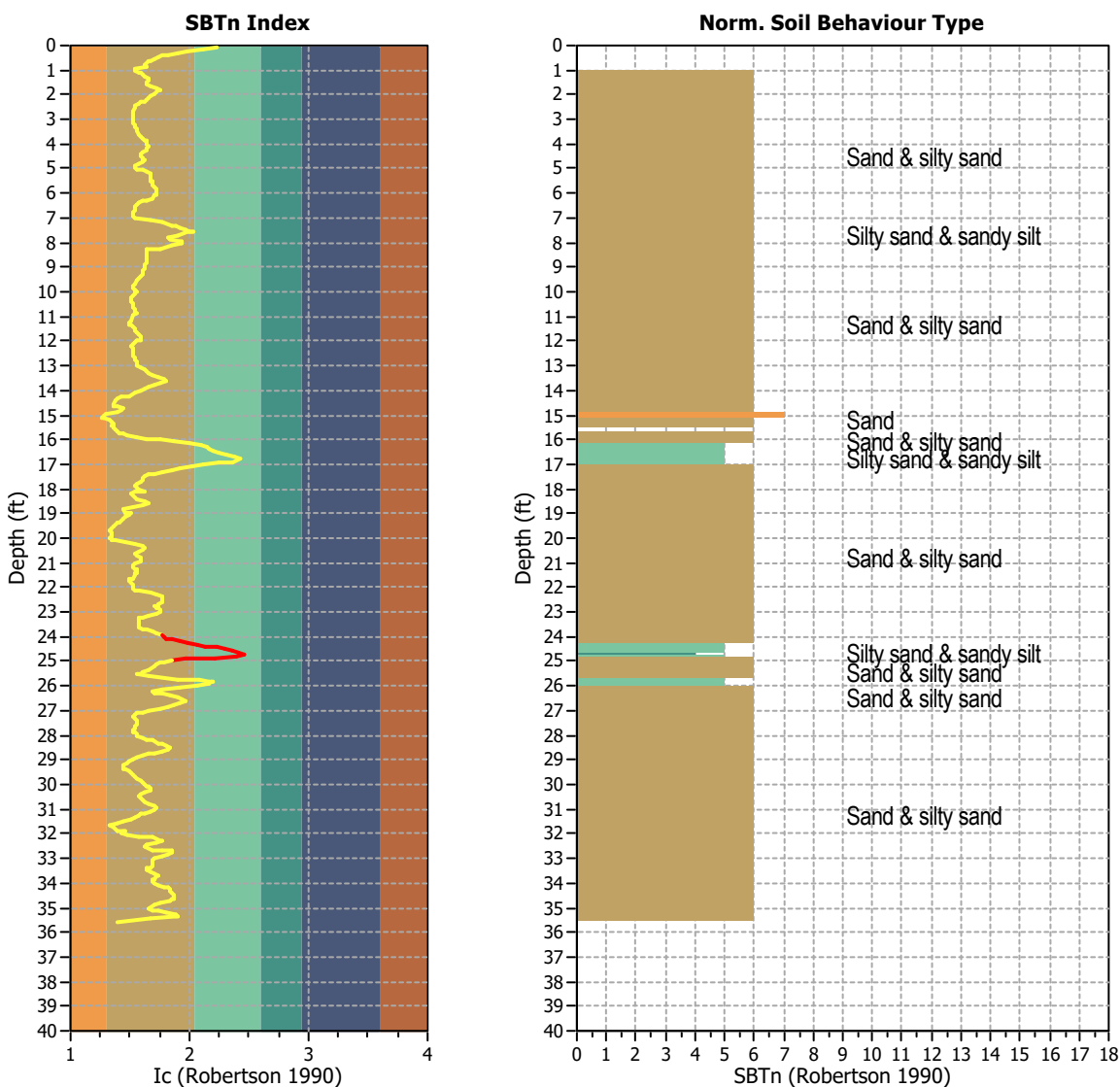

Transition layer algorithm properties		General statistics	
I_c minimum check value:	1.70	Total points in CPT file:	514
I_c maximum check value:	3.00	Total points excluded:	18
I_c change ratio value:	0.0250	Exclusion percentage:	3.50%
Minimum number of points in layer:	4	Number of layers detected:	2

Estimation of post-earthquake settlements

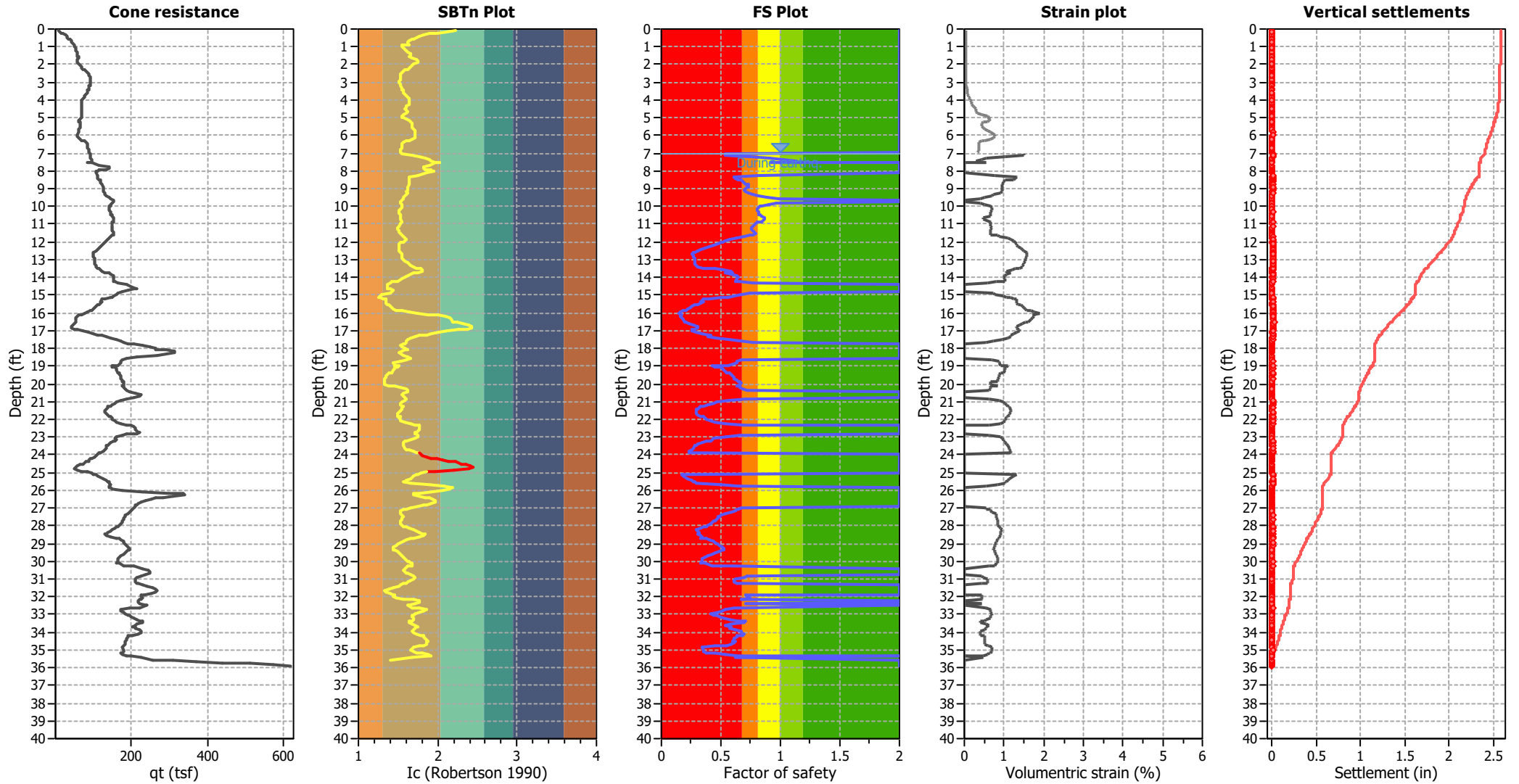

Abbreviations

- q_c: Total cone resistance (cone resistance q_c corrected for pore water effects)
- I_c: Soil Behaviour Type Index
- FS: Calculated Factor of Safety against liquefaction
- Volumetric strain: Post-liquefaction volumetric strain

Estimation of post-earthquake lateral Displacements

Geometric parameters: Gently sloping ground without free face (Slope 1.00 %)

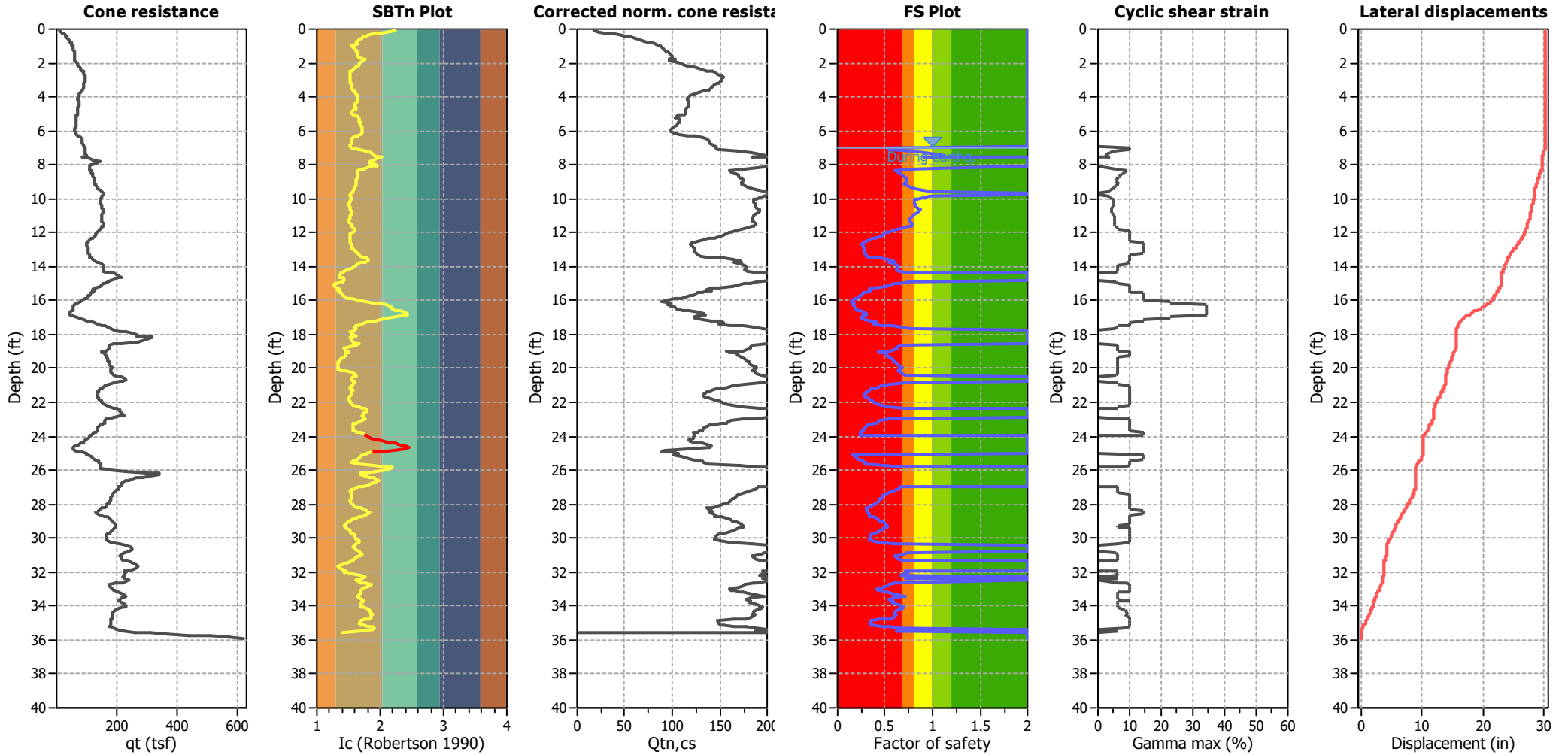

Abbreviations

q_t: Total cone resistance (cone resistance q_c corrected for pore water effects)
 I_c: Soil Behaviour Type Index
 Q_{tn,cs}: Equivalent clean sand normalized CPT total cone resistance

F.S.: Factor of safety
 γ_{max}: Maximum cyclic shear strain
 LDI: Lateral displacement index

Surface condition

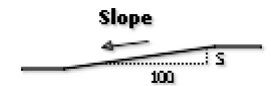

Aging Calculation Estimation

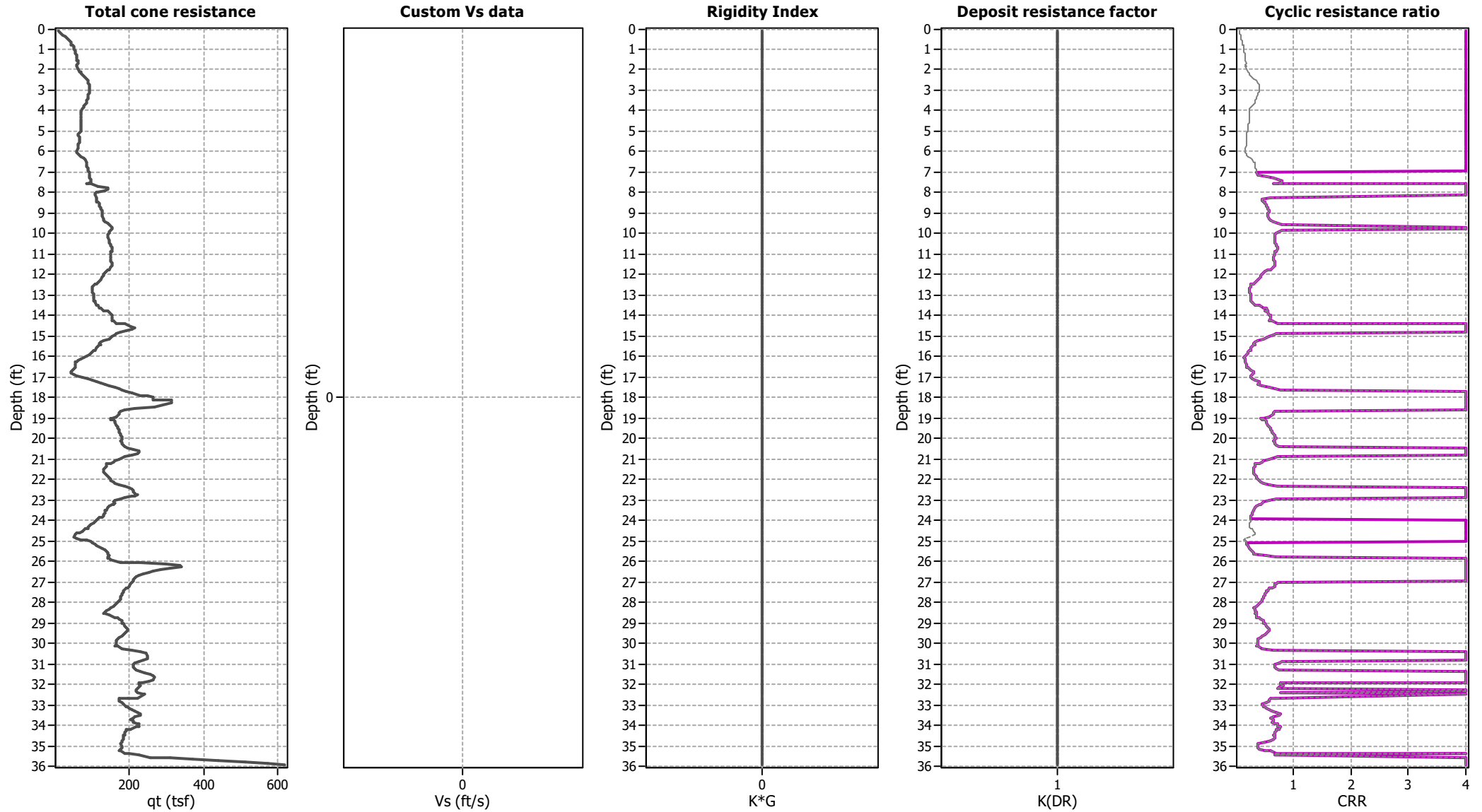

Ejecta Severity Estimation

Corrected norm. cone resista

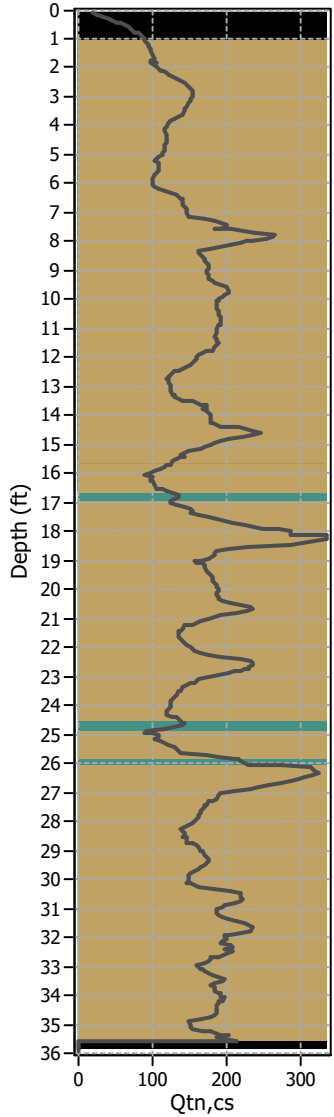

SBTn Index Plot

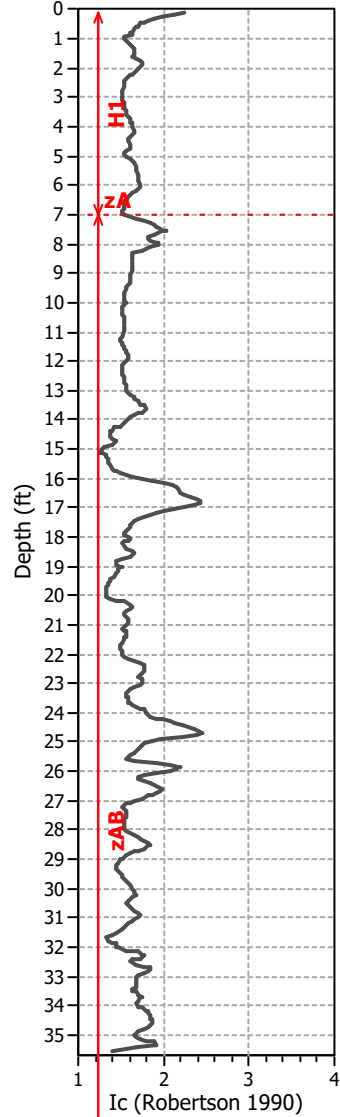

FS plot

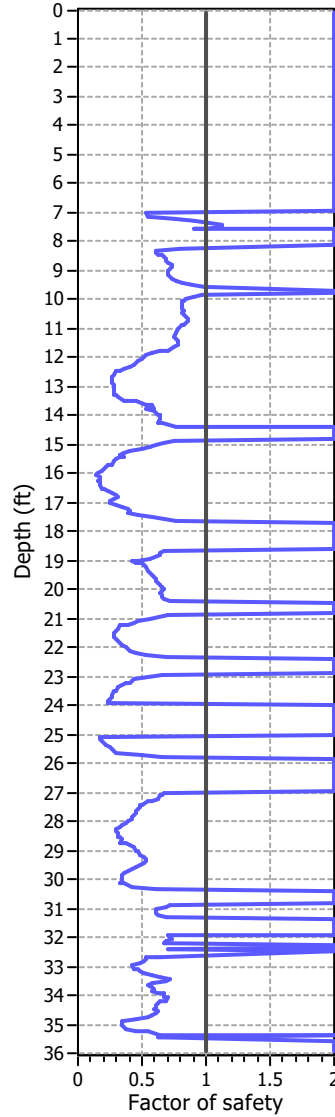

Stresses vs Depth

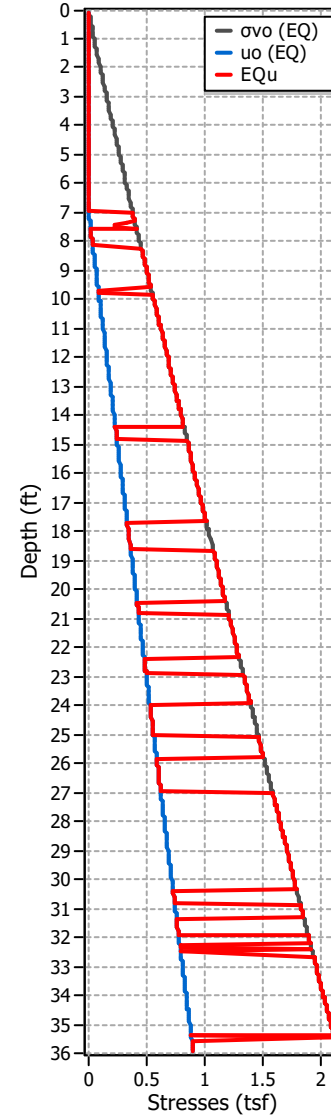

Excess Head

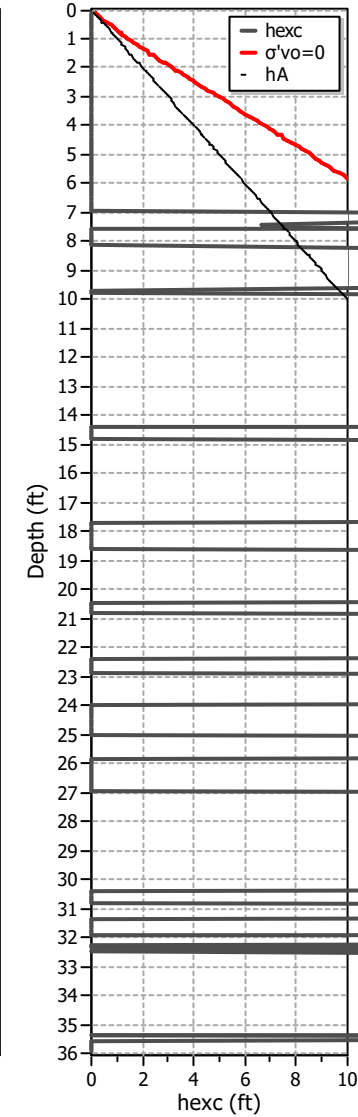

Liq. ejecta demand

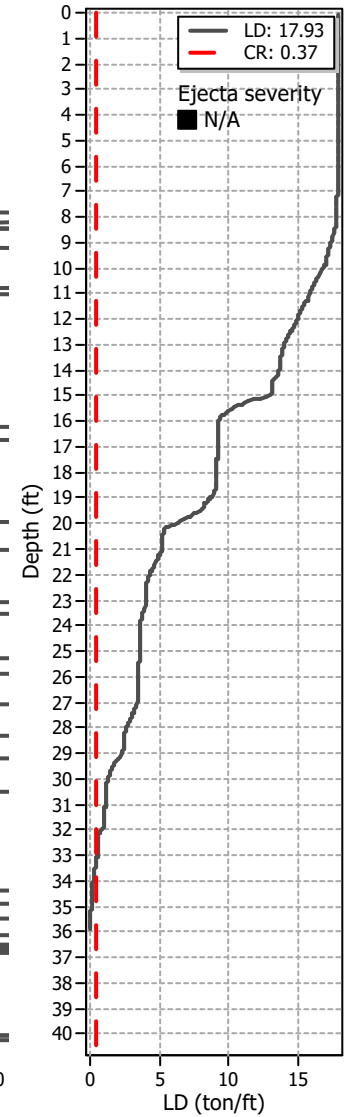

LIQUEFACTION ANALYSIS REPORT

Project title : Petra Geosciences / Apple Canyon

Location : Lake Hemet, CA

CPT file : CPT-8

Input parameters and analysis data

Analysis method:	NCEER (1998)	G.W.T. (in-situ):	11.00 ft	Use fill:	No	Clay like behavior applied:	Sands only
Fines correction method:	NCEER (1998)	G.W.T. (earthq.):	7.00 ft	Fill height:	N/A	Limit depth applied:	No
Points to test:	Based on Ic value	Average results interval:	3	Fill weight:	N/A	Limit depth:	N/A
Earthquake magnitude M_w :	8.10	Ic cut-off value:	2.60	Trans. detect. applied:	Yes	MSF method:	Method based
Peak ground acceleration:	0.89	Unit weight calculation:	Based on SBT	K_o applied:	Yes		

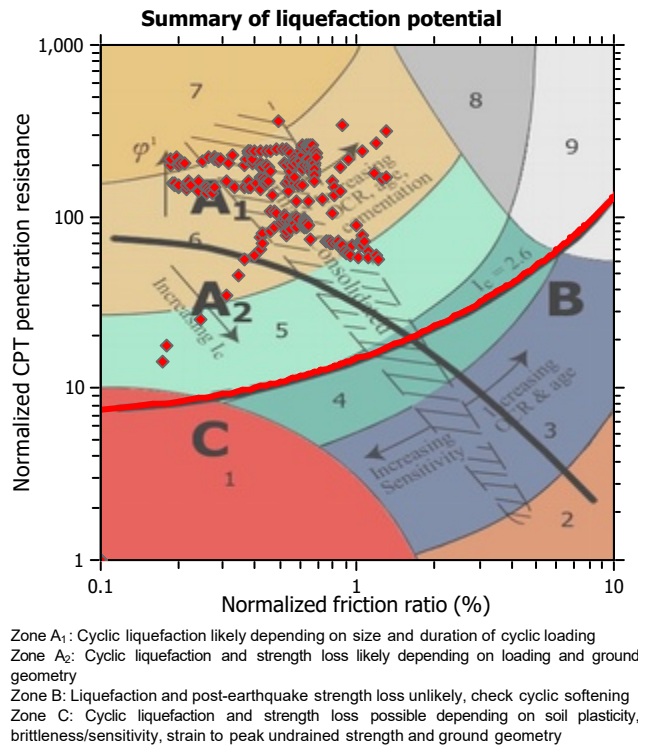
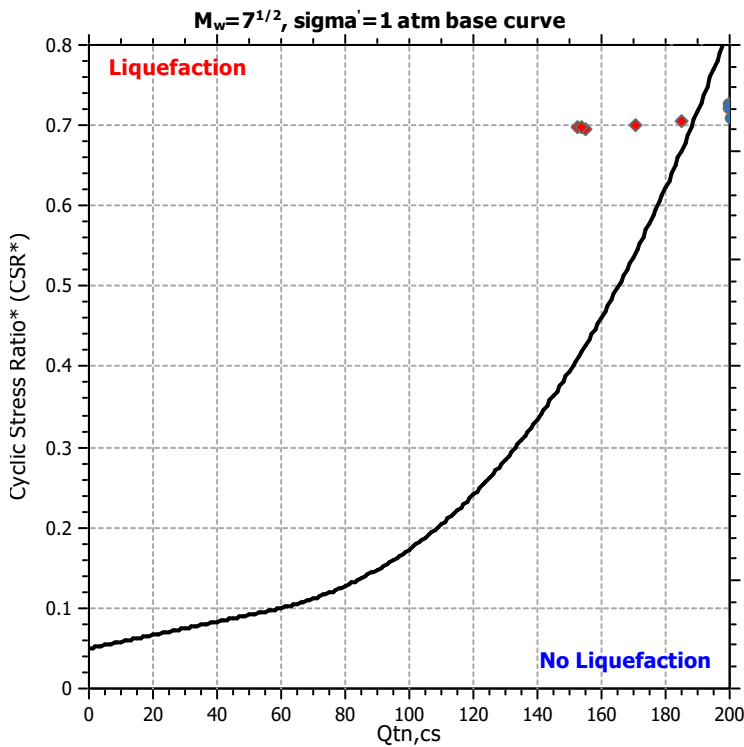
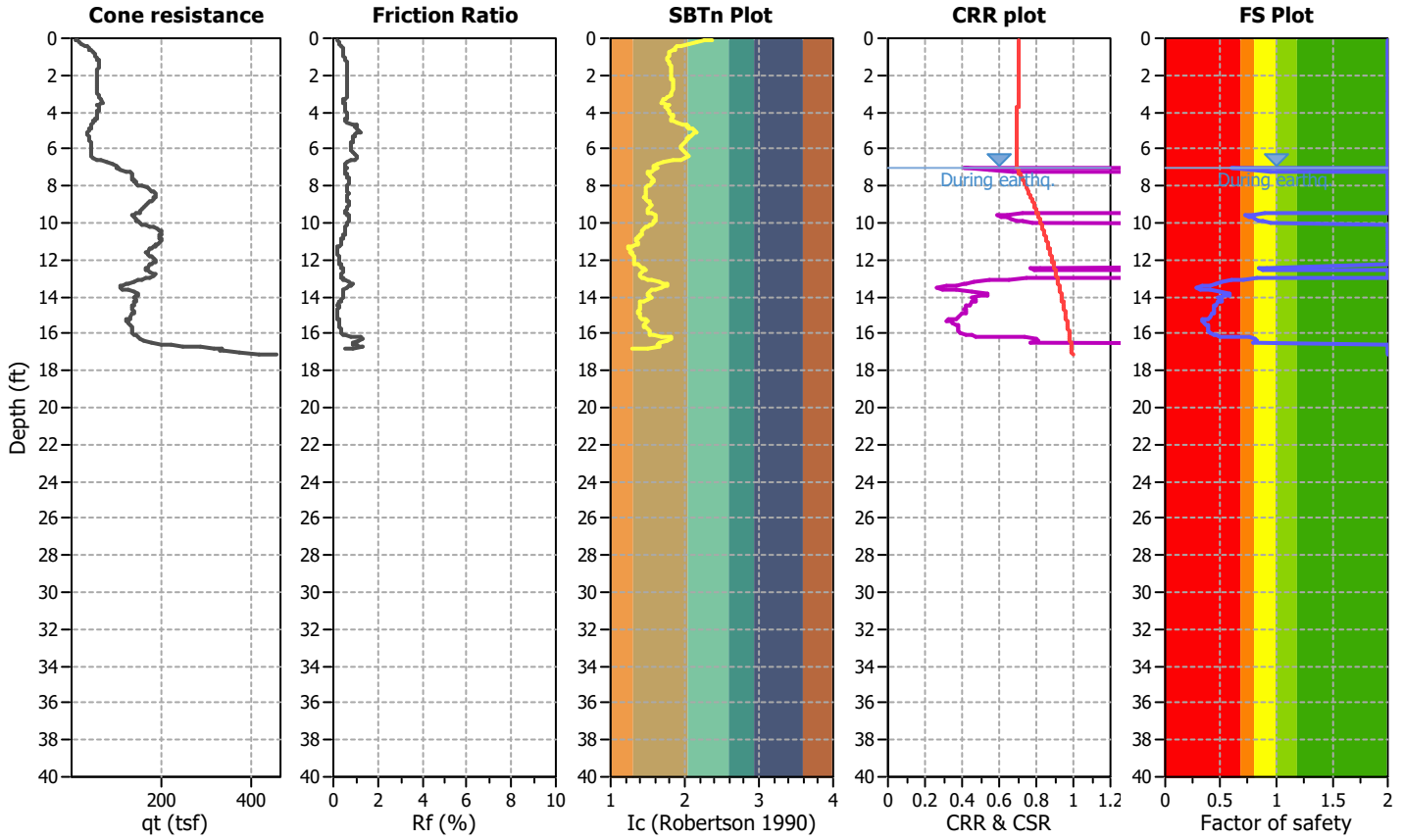

CPT basic interpretation plots

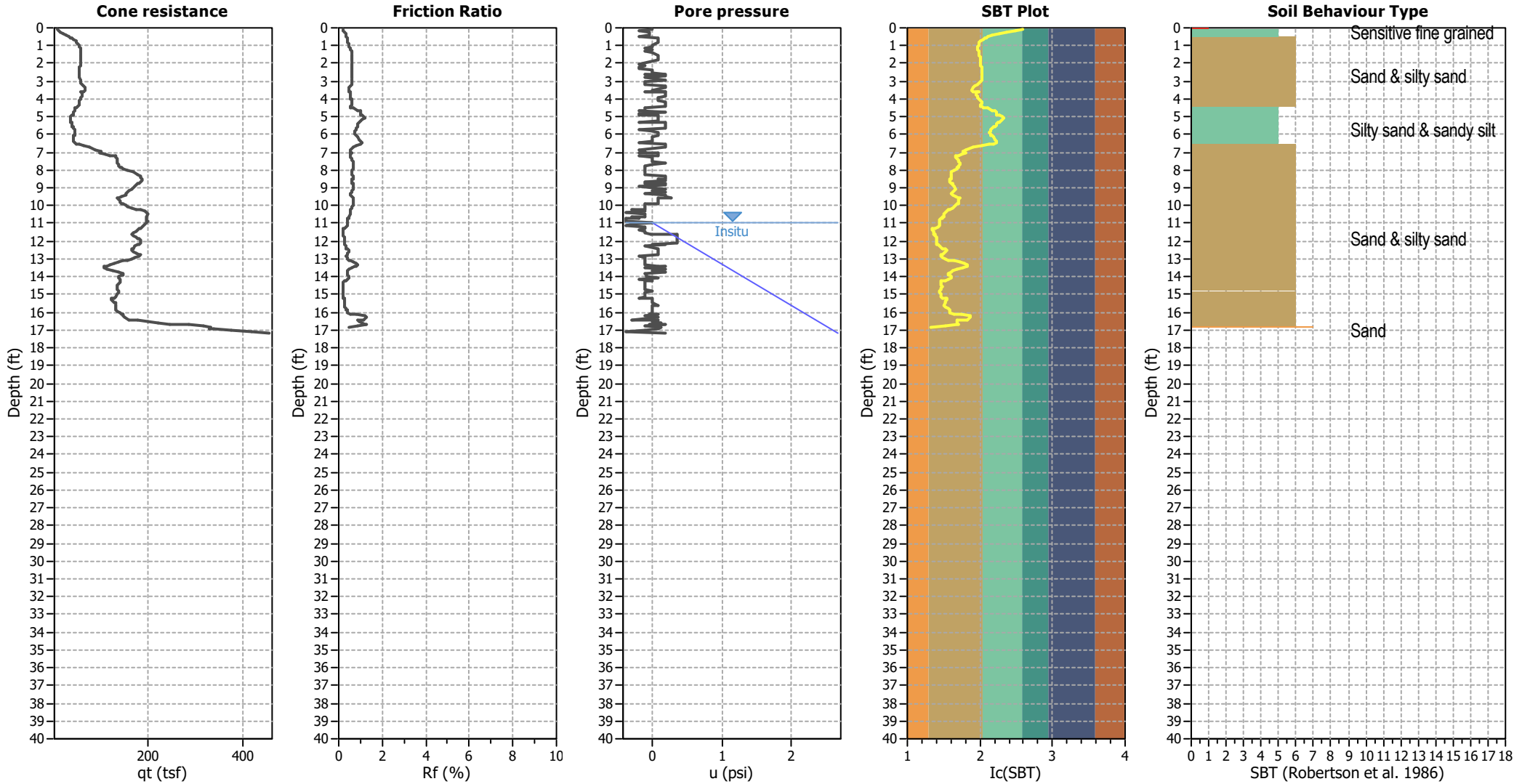

Input parameters and analysis data

Analysis method:	NCEER (1998)	Depth to water table (earthq.):	7.00 ft	Fill weight:	N/A
Fines correction method:	NCEER (1998)	Average results interval:	3	Transition detect. applied:	Yes
Points to test:	Based on Ic value	Ic cut-off value:	2.60	K _o applied:	Yes
Earthquake magnitude M _w :	8.10	Unit weight calculation:	Based on SBT	Clay like behavior applied:	Sands only
Peak ground acceleration:	0.89	Use fill:	No	Limit depth applied:	No
Depth to water table (insitu):	11.00 ft	Fill height:	N/A	Limit depth:	N/A

SBT legend

1. Sensitive fine grained	4. Clayey silt to silty	7. Gravely sand to sand
2. Organic material	5. Silty sand to sandy silt	8. Very stiff sand to
3. Clay to silty clay	6. Clean sand to silty sand	9. Very stiff fine grained

CPT basic interpretation plots (normalized)

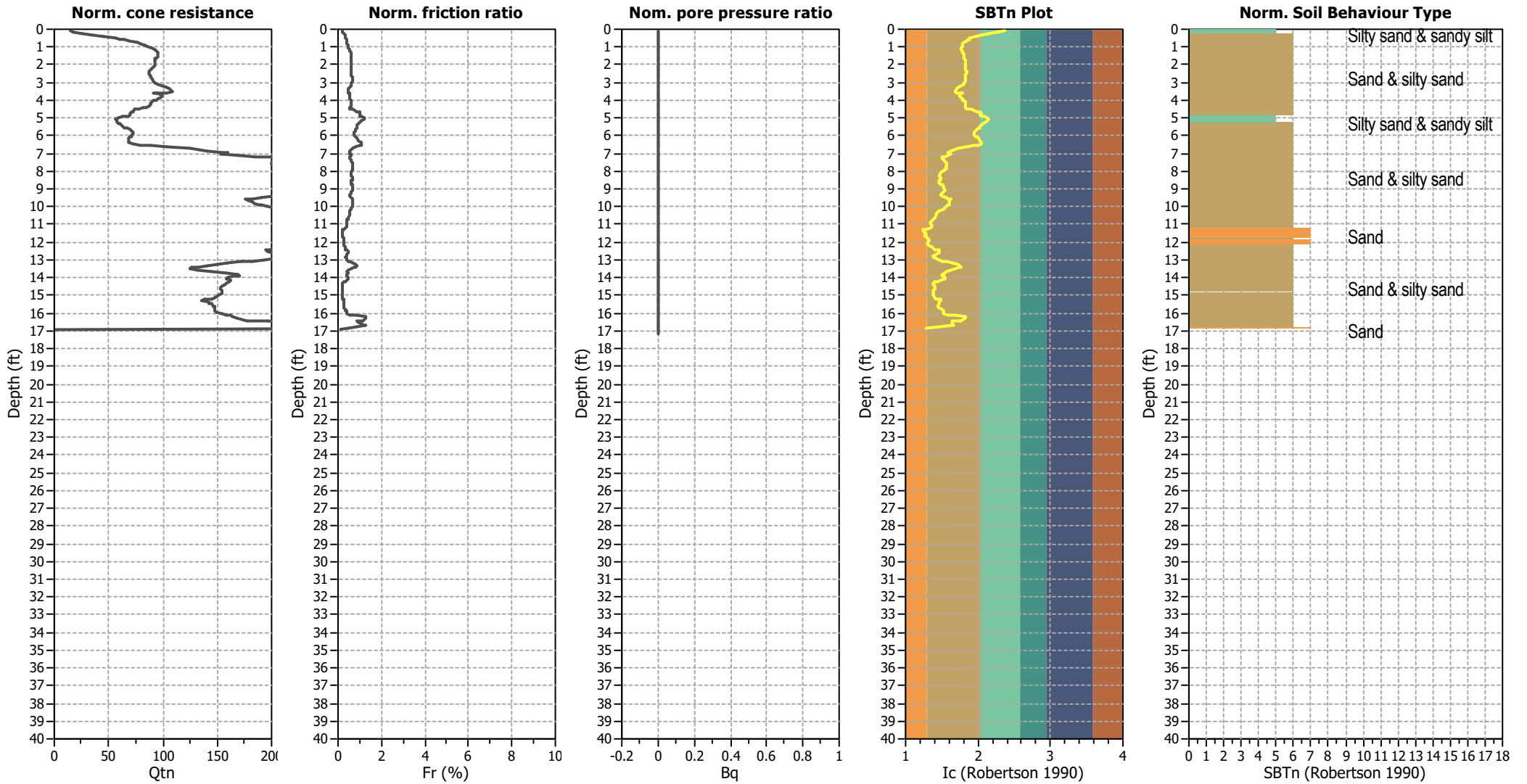

Input parameters and analysis data

Analysis method:	NCEER (1998)	Depth to water table (erthq.):	7.00 ft	Fill weight:	N/A
Fines correction method:	NCEER (1998)	Average results interval:	3	Transition detect. applied:	Yes
Points to test:	Based on Ic value	Ic cut-off value:	2.60	K _o applied:	Yes
Earthquake magnitude M _w :	8.10	Unit weight calculation:	Based on SBT	Clay like behavior applied:	Sands only
Peak ground acceleration:	0.89	Use fill:	No	Limit depth applied:	No
Depth to water table (insitu):	11.00 ft	Fill height:	N/A	Limit depth:	N/A

SBTn legend

1. Sensitive fine grained	4. Clayey silt to silty	7. Gravely sand to sand
2. Organic material	5. Silty sand to sandy silt	8. Very stiff sand to
3. Clay to silty clay	6. Clean sand to silty sand	9. Very stiff fine grained

Liquefaction analysis overall plots (intermediate results)

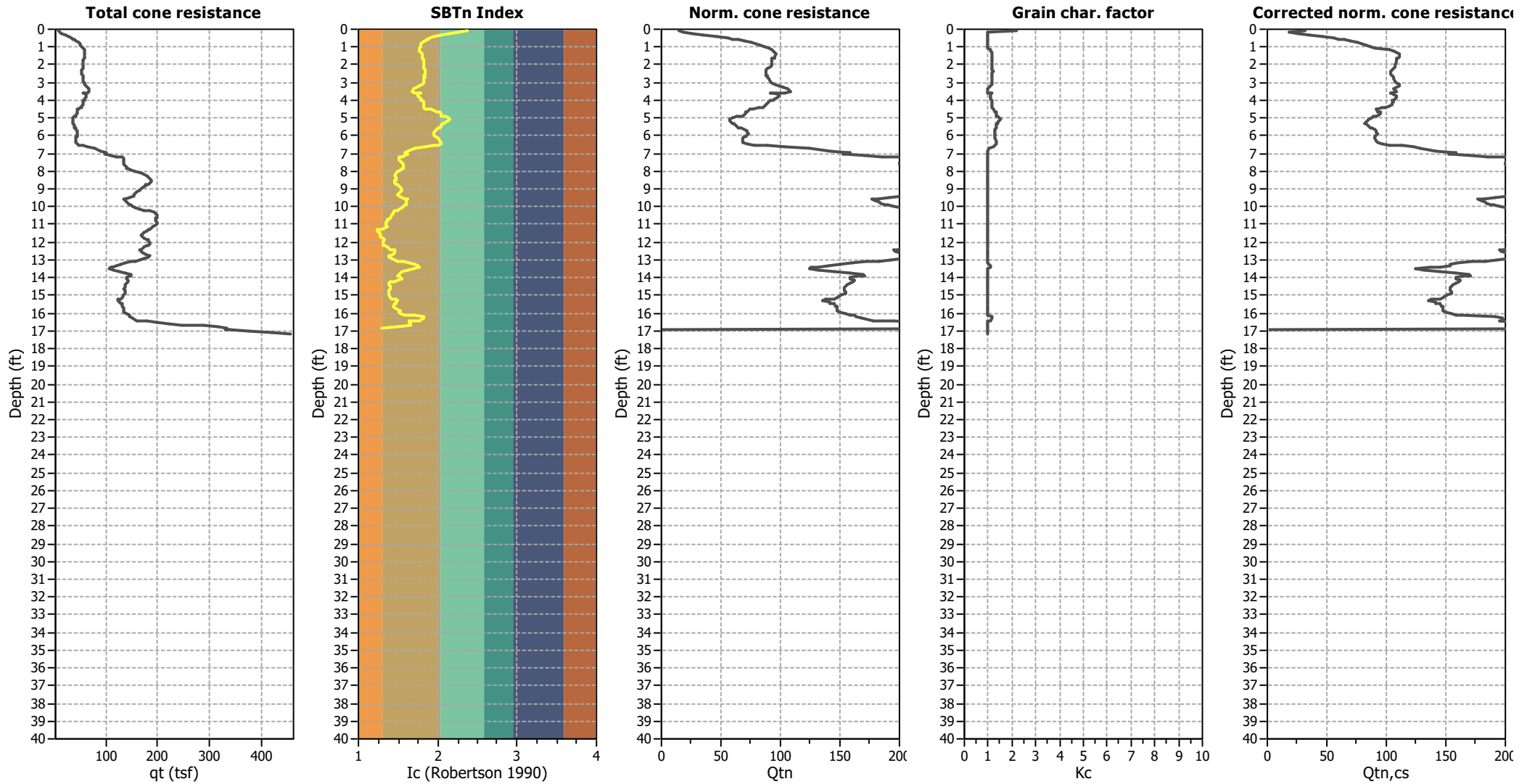

Input parameters and analysis data

Analysis method:	NCEER (1998)	Depth to water table (earthq.):	7.00 ft	Fill weight:	N/A
Fines correction method:	NCEER (1998)	Average results interval:	3	Transition detect. applied:	Yes
Points to test:	Based on Ic value	Ic cut-off value:	2.60	K _{cs} applied:	Yes
Earthquake magnitude M _w :	8.10	Unit weight calculation:	Based on SBT	Clay like behavior applied:	Sands only
Peak ground acceleration:	0.89	Use fill:	No	Limit depth applied:	No
Depth to water table (insitu):	11.00 ft	Fill height:	N/A	Limit depth:	N/A

Liquefaction analysis overall plots

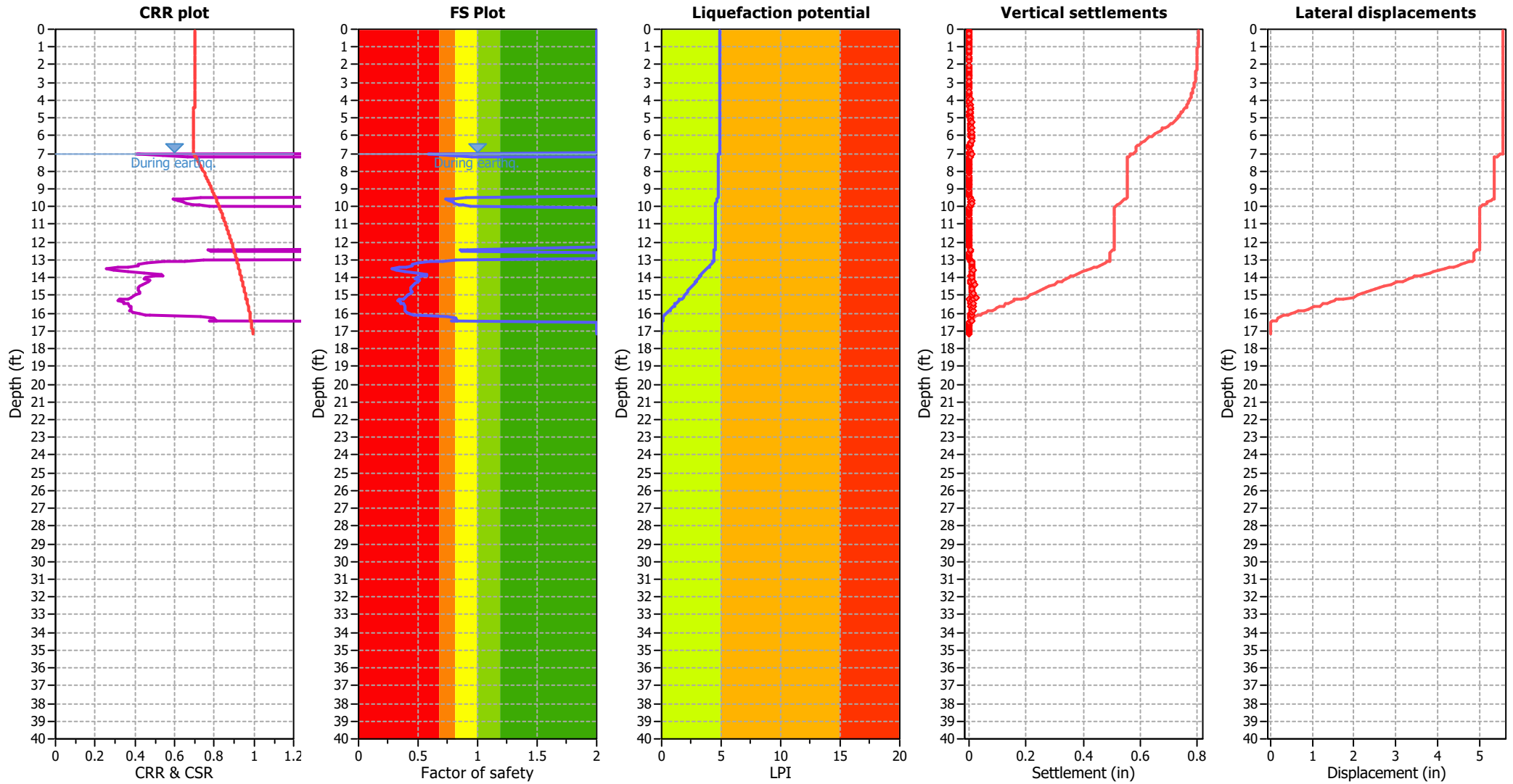

Input parameters and analysis data

Analysis method:	NCEER (1998)	Depth to water table (earthq.):	7.00 ft	Fill weight:	N/A
Fines correction method:	NCEER (1998)	Average results interval:	3	Transition detect. applied:	Yes
Points to test:	Based on Ic value	Ic cut-off value:	2.60	K_0 applied:	Yes
Earthquake magnitude M_w :	8.10	Unit weight calculation:	Based on SBT	Clay like behavior applied:	Sands only
Peak ground acceleration:	0.89	Use fill:	No	Limit depth applied:	No
Depth to water table (insitu):	11.00 ft	Fill height:	N/A	Limit depth:	N/A

F.S. color scheme

- Almost certain it will liquefy
- Very likely to liquefy
- Liquefaction and no liq. are equally likely
- Unlike to liquefy
- Almost certain it will not liquefy

LPI color scheme

- Very high risk
- High risk
- Low risk

Liquefaction analysis summary plots

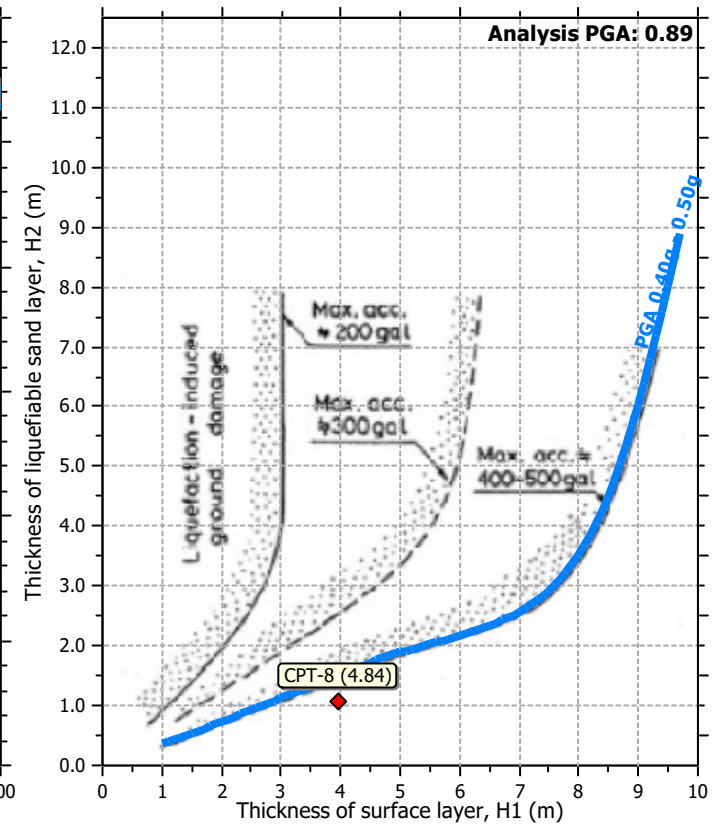
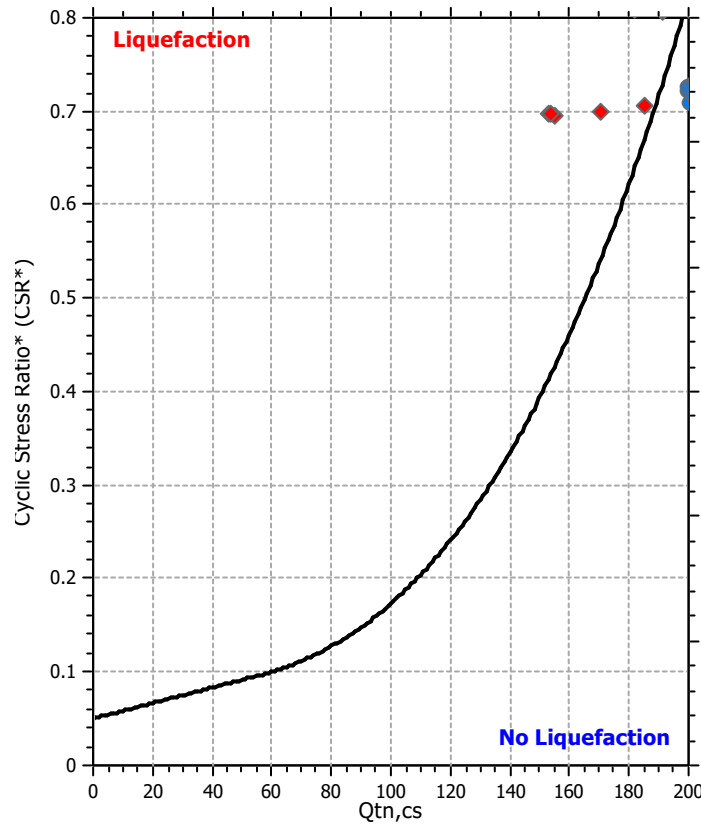
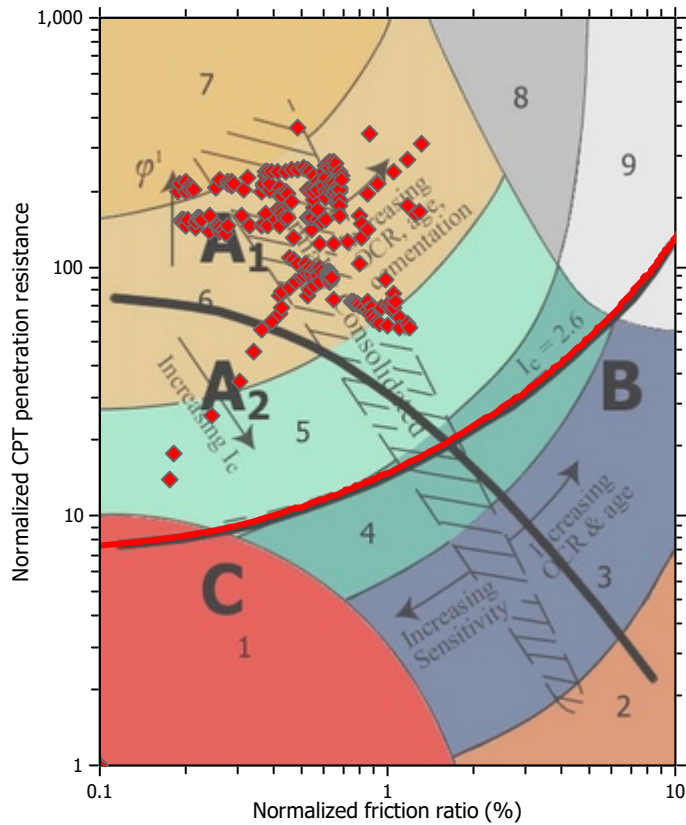

Input parameters and analysis data

Analysis method:	NCEER (1998)	Depth to water table (earthq.):	7.00 ft	Fill weight:	N/A
Fines correction method:	NCEER (1998)	Average results interval:	3	Transition detect. applied:	Yes
Points to test:	Based on Ic value	Ic cut-off value:	2.60	K_v applied:	Yes
Earthquake magnitude M_w :	8.10	Unit weight calculation:	Based on SBT	Clay like behavior applied:	Sands only
Peak ground acceleration:	0.89	Use fill:	No	Limit depth applied:	No
Depth to water table (insitu):	11.00 ft	Fill height:	N/A	Limit depth:	N/A

Check for strength loss plots (Robertson (2010))

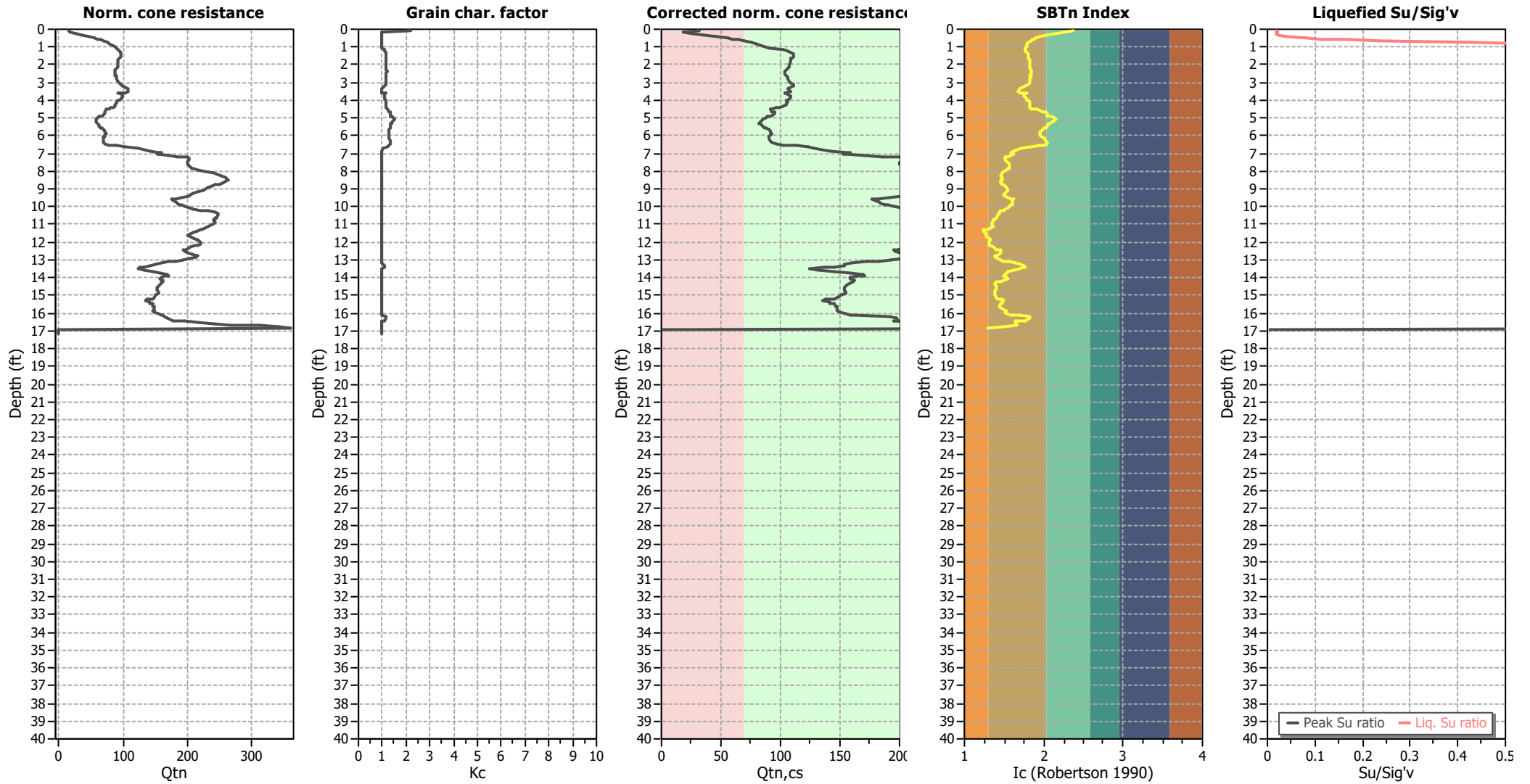

Input parameters and analysis data

Analysis method:	NCEER (1998)	Depth to water table (earthq.):	7.00 ft	Fill weight:	N/A
Fines correction method:	NCEER (1998)	Average results interval:	3	Transition detect. applied:	Yes
Points to test:	Based on Ic value	Ic cut-off value:	2.60	K _o applied:	Yes
Earthquake magnitude M _w :	8.10	Unit weight calculation:	Based on SBT	Clay like behavior applied:	Sands only
Peak ground acceleration:	0.89	Use fill:	No	Limit depth applied:	No
Depth to water table (insitu):	11.00 ft	Fill height:	N/A	Limit depth:	N/A

TRANSITION LAYER DETECTION ALGORITHM REPORT

Summary Details & Plots

Short description

The software will delete data when the cone is in transition from either clay to sand or vice-versa. To do this the software requires a range of I_c values over which the transition will be defined (typically somewhere between $1.80 < I_c < 3.0$) and a rate of change of I_c . Transitions typically occur when the rate of change of I_c is fast (i.e. ΔI_c is small).

The SBT_n plot below, displays in red the detected transition layers based on the parameters listed below the graphs.

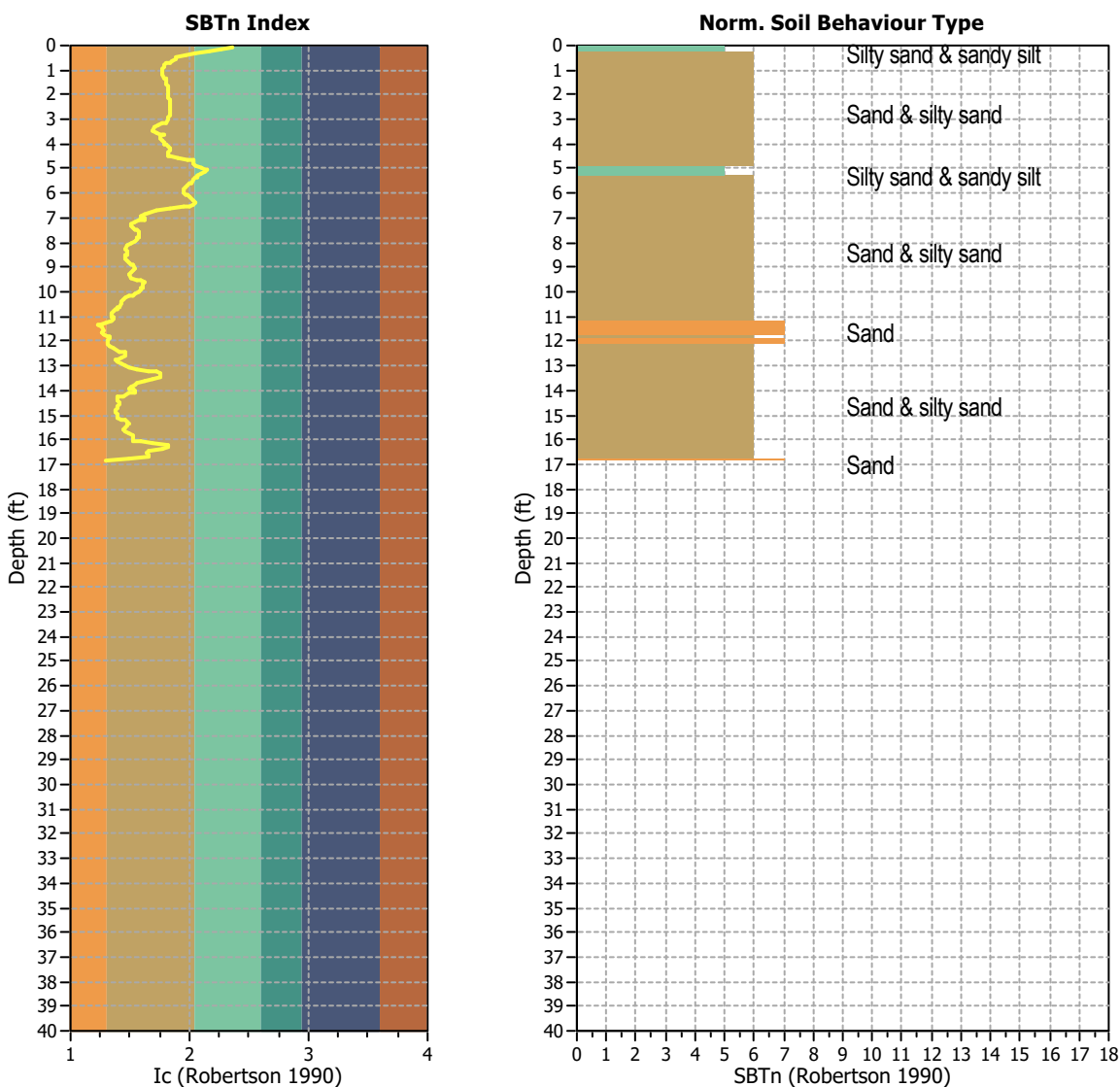

Transition layer algorithm properties

I_c minimum check value: 1.70
 I_c maximum check value: 3.00
 I_c change ratio value: 0.0250
 Minimum number of points in layer: 4

General statistics

Total points in CPT file: 243
 Total points excluded: 0
 Exclusion percentage: 0.00%
 Number of layers detected: 0

Estimation of post-earthquake settlements

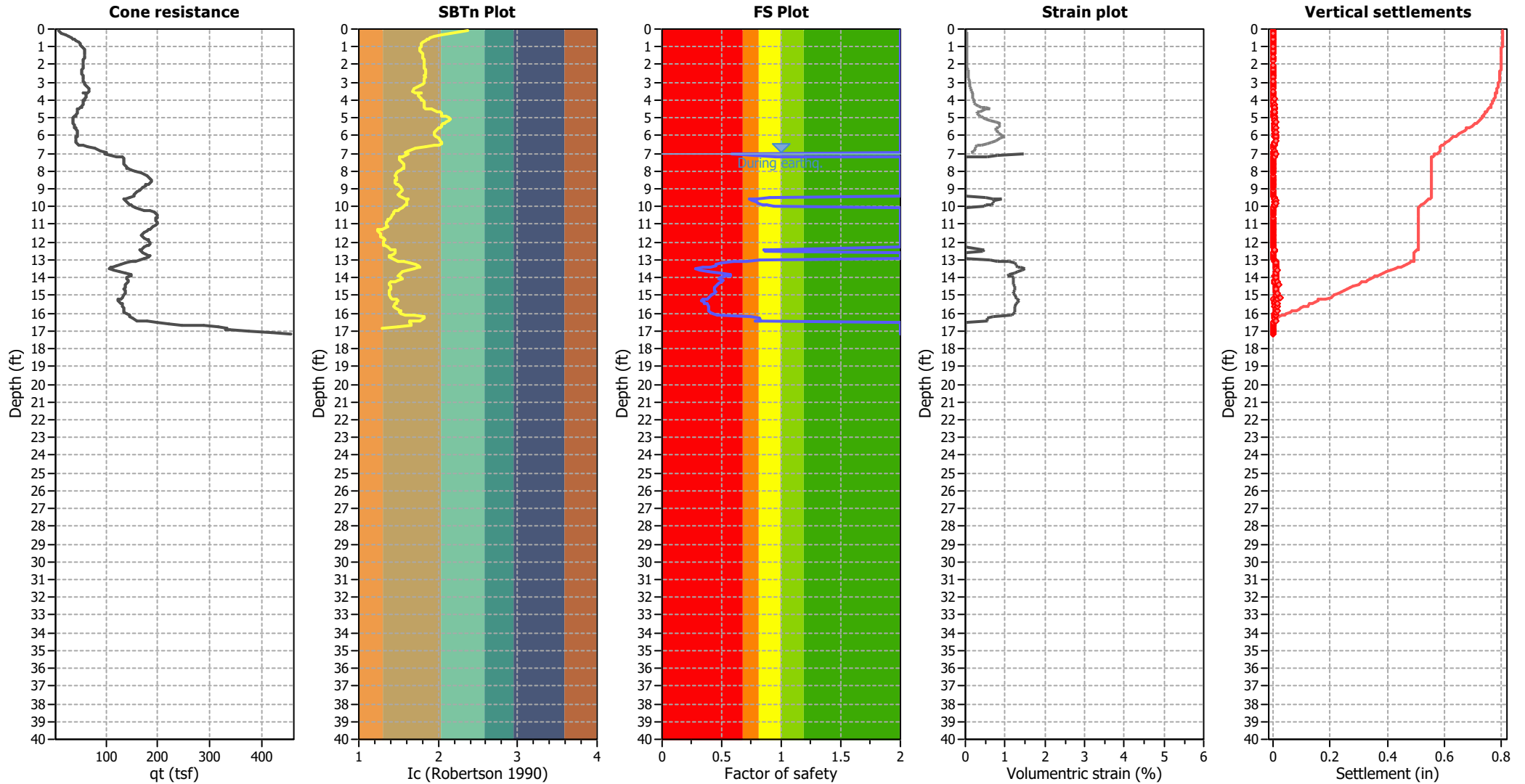

Abbreviations

- q_c: Total cone resistance (cone resistance q_c corrected for pore water effects)
- I_c: Soil Behaviour Type Index
- FS: Calculated Factor of Safety against liquefaction
- Volumetric strain: Post-liquefaction volumetric strain

Estimation of post-earthquake lateral Displacements

Geometric parameters: Gently sloping ground without free face (Slope 1.00 %)

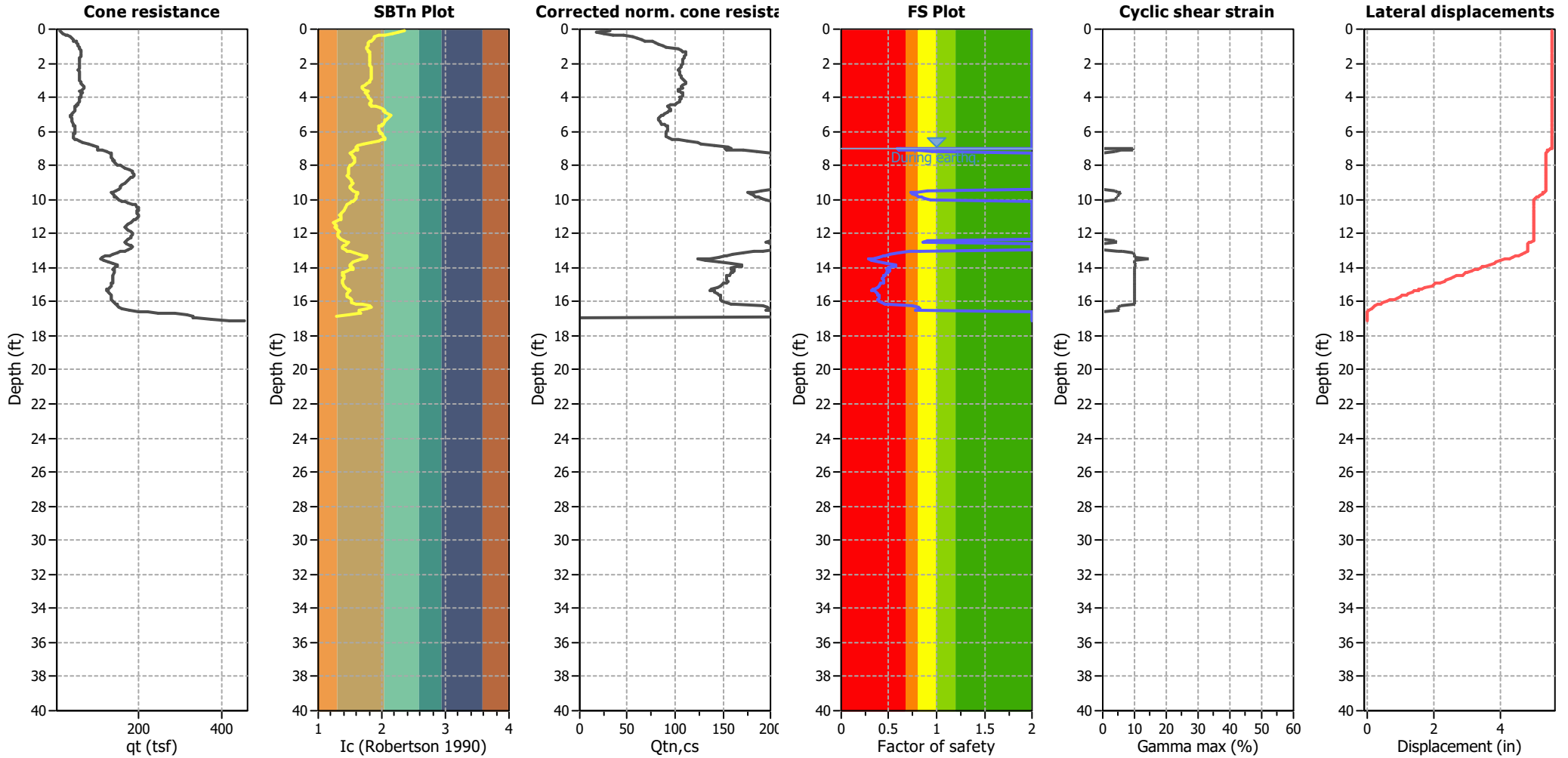

Abbreviations

q_t: Total cone resistance (cone resistance q_c corrected for pore water effects)
 I_c: Soil Behaviour Type Index
 Q_{tn,cs}: Equivalent clean sand normalized CPT total cone resistance

F.S.: Factor of safety
 γ_{max}: Maximum cyclic shear strain
 LDI: Lateral displacement index

Surface condition

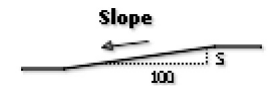

Aging Calculation Estimation

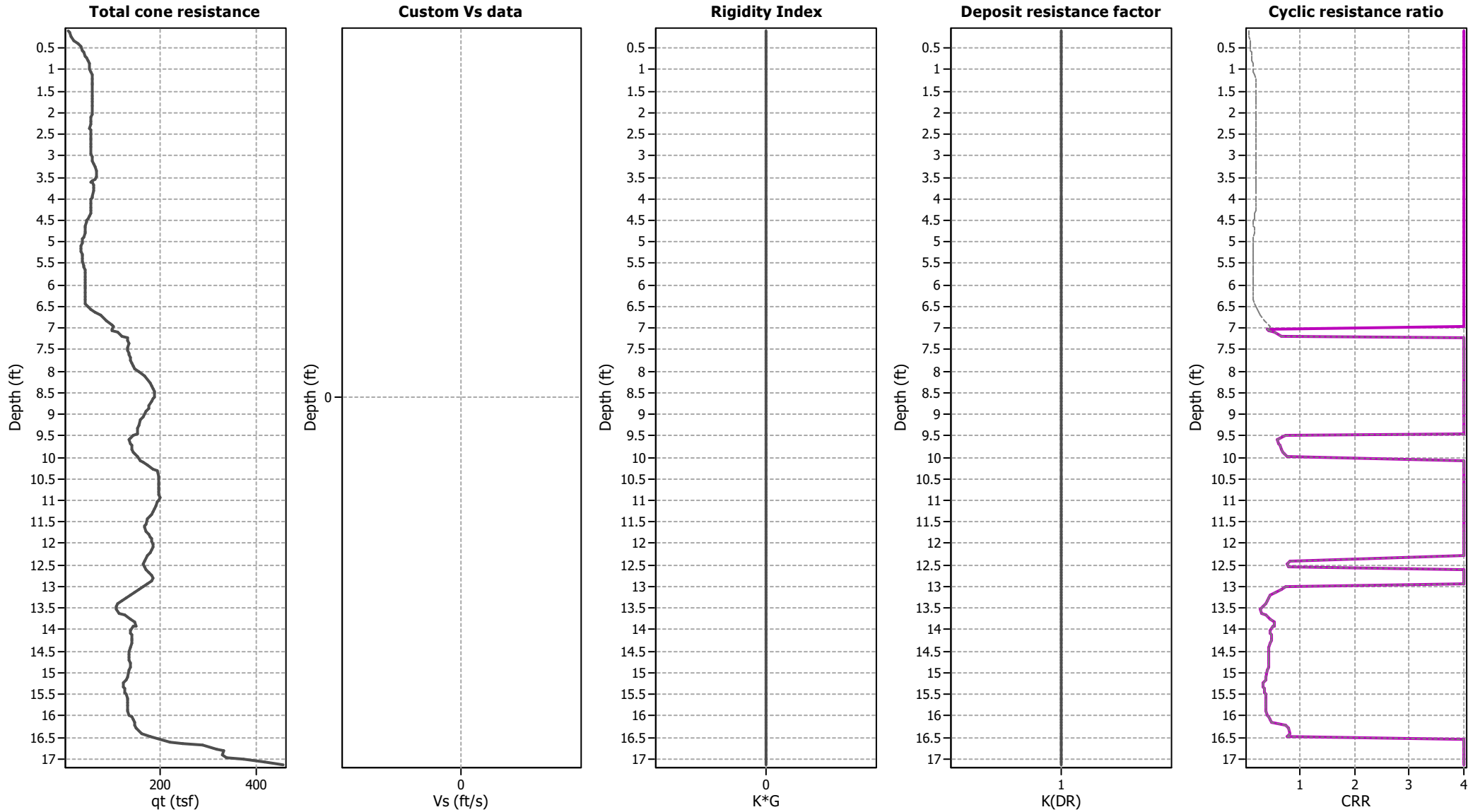

Ejecta Severity Estimation

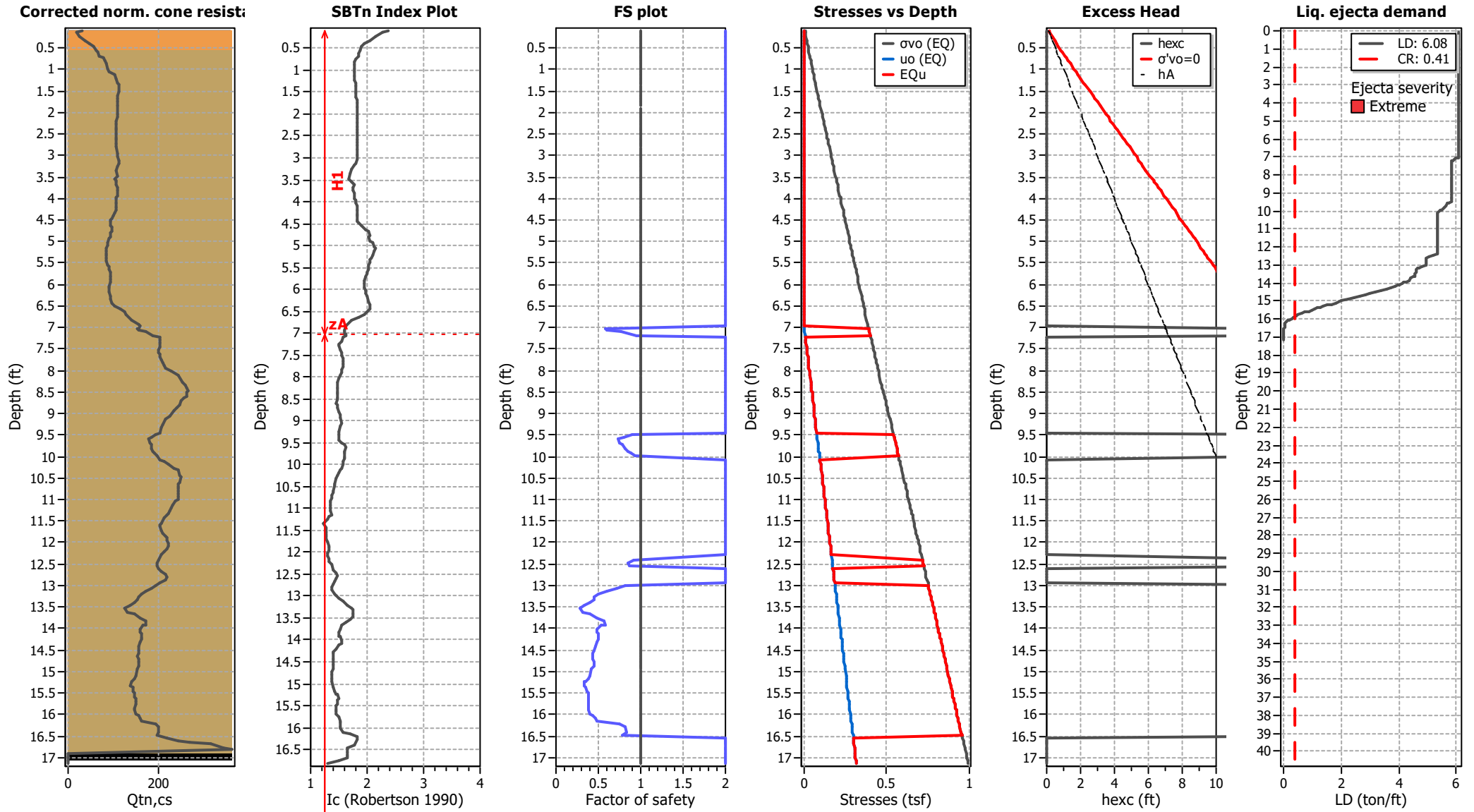

LIQUEFACTION ANALYSIS REPORT

Project title : Petra Geosciences / Apple Canyon

Location : Lake Hemet, CA

CPT file : CPT-9

Input parameters and analysis data

Analysis method:	NCEER (1998)	G.W.T. (in-situ):	12.50 ft	Use fill:	No	Clay like behavior applied:	Sands only
Fines correction method:	NCEER (1998)	G.W.T. (earthq.):	7.00 ft	Fill height:	N/A	Limit depth applied:	No
Points to test:	Based on Ic value	Average results interval:	3	Fill weight:	N/A	Limit depth:	N/A
Earthquake magnitude M_w :	8.10	Ic cut-off value:	2.60	Trans. detect. applied:	Yes	MSF method:	Method based
Peak ground acceleration:	0.89	Unit weight calculation:	Based on SBT	K_o applied:	Yes		

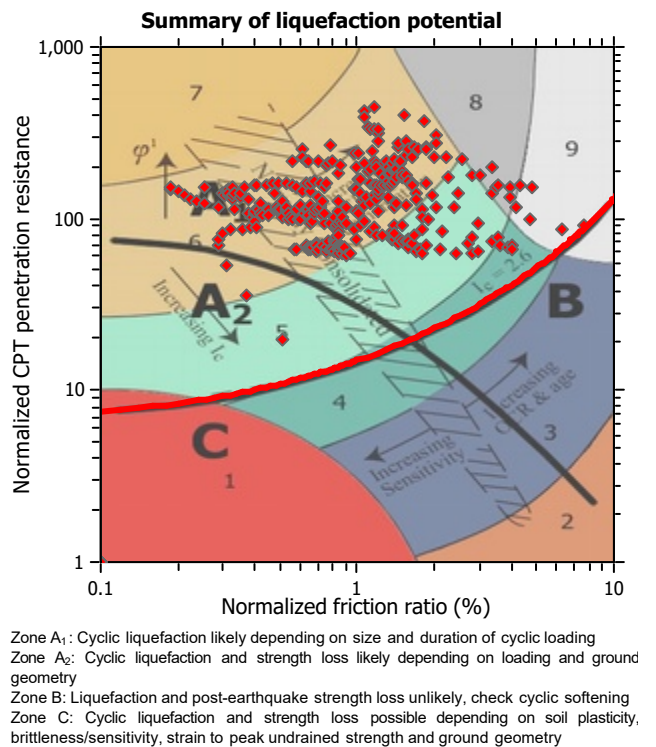
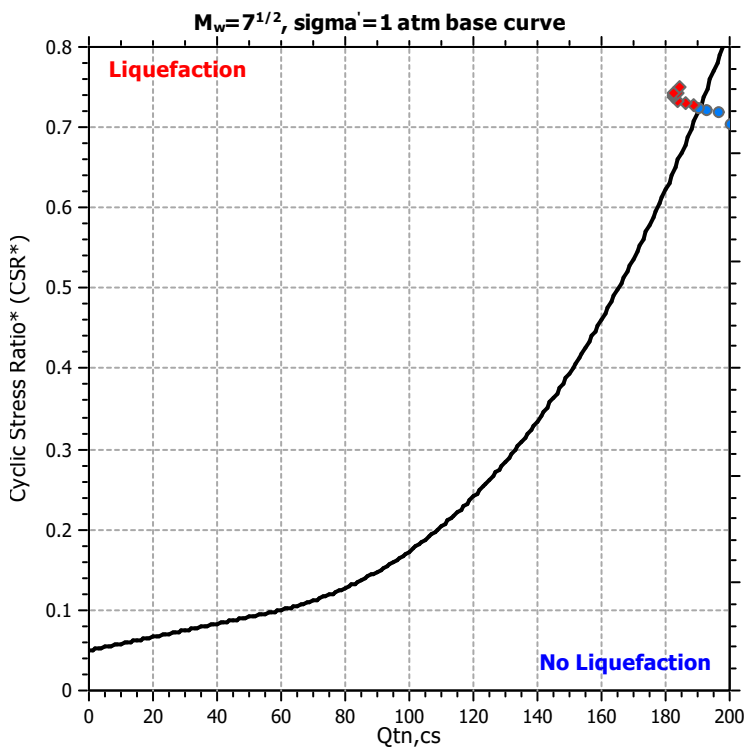
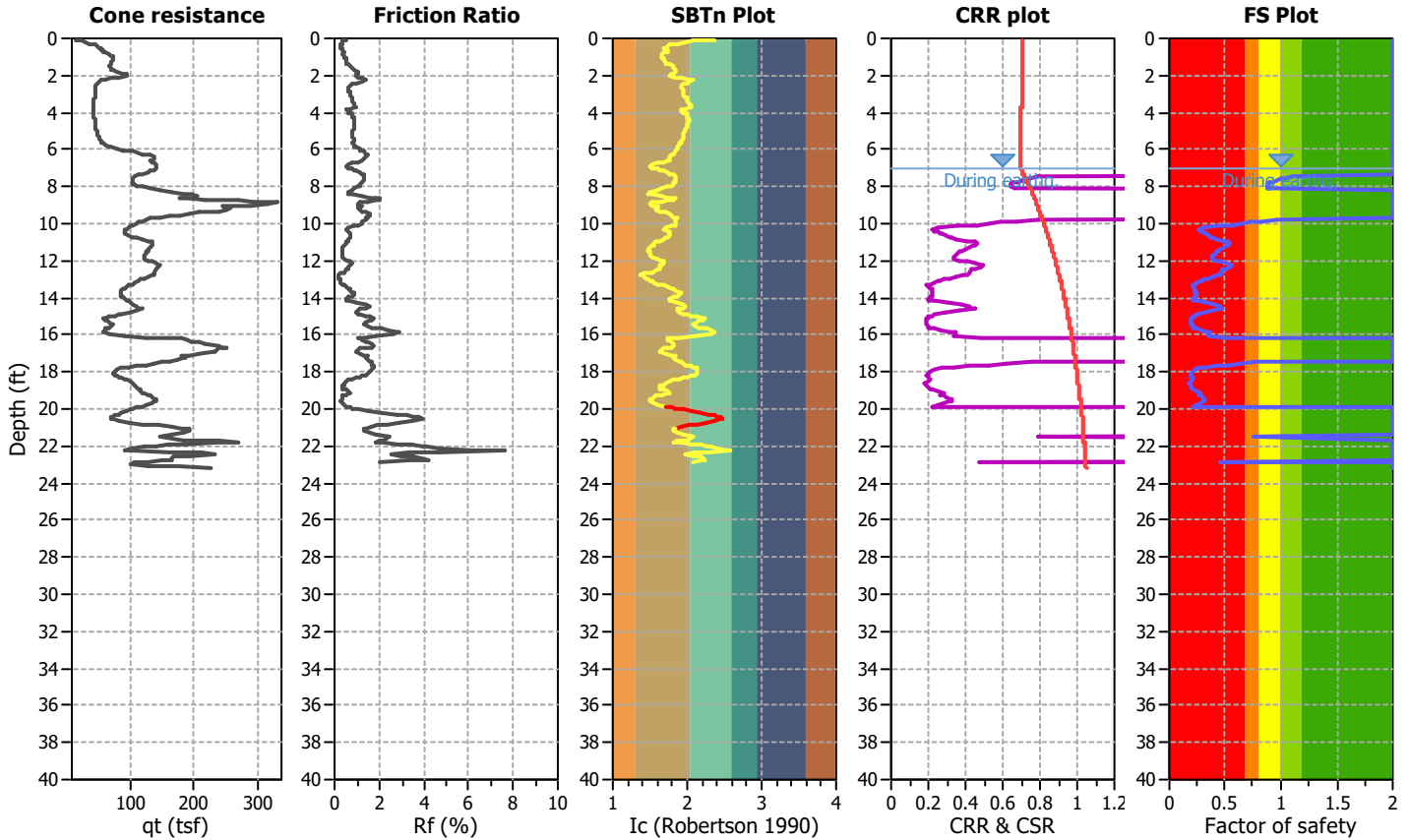

CPT basic interpretation plots

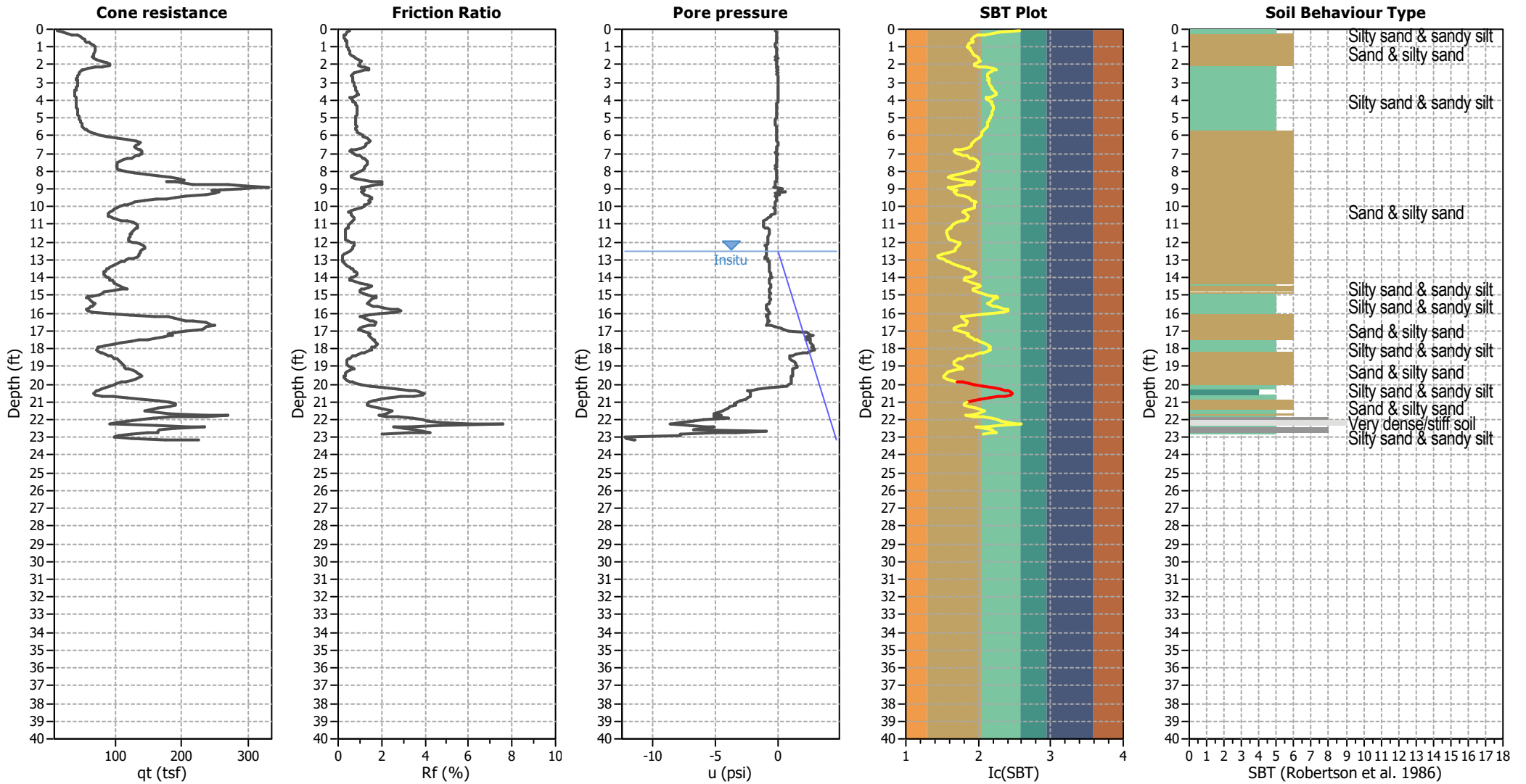

Input parameters and analysis data

Analysis method:	NCEER (1998)	Depth to water table (erthq.):	7.00 ft	Fill weight:	N/A
Fines correction method:	NCEER (1998)	Average results interval:	3	Transition detect. applied:	Yes
Points to test:	Based on Ic value	Ic cut-off value:	2.60	K ₀ applied:	Yes
Earthquake magnitude M _w :	8.10	Unit weight calculation:	Based on SBT	Clay like behavior applied:	Sands only
Peak ground acceleration:	0.89	Use fill:	No	Limit depth applied:	No
Depth to water table (insitu):	12.50 ft	Fill height:	N/A	Limit depth:	N/A

SBT legend

1. Sensitive fine grained	4. Clayey silt to silty	7. Gravely sand to sand
2. Organic material	5. Silty sand to sandy silt	8. Very stiff sand to
3. Clay to silty clay	6. Clean sand to silty sand	9. Very stiff fine grained

CPT basic interpretation plots (normalized)

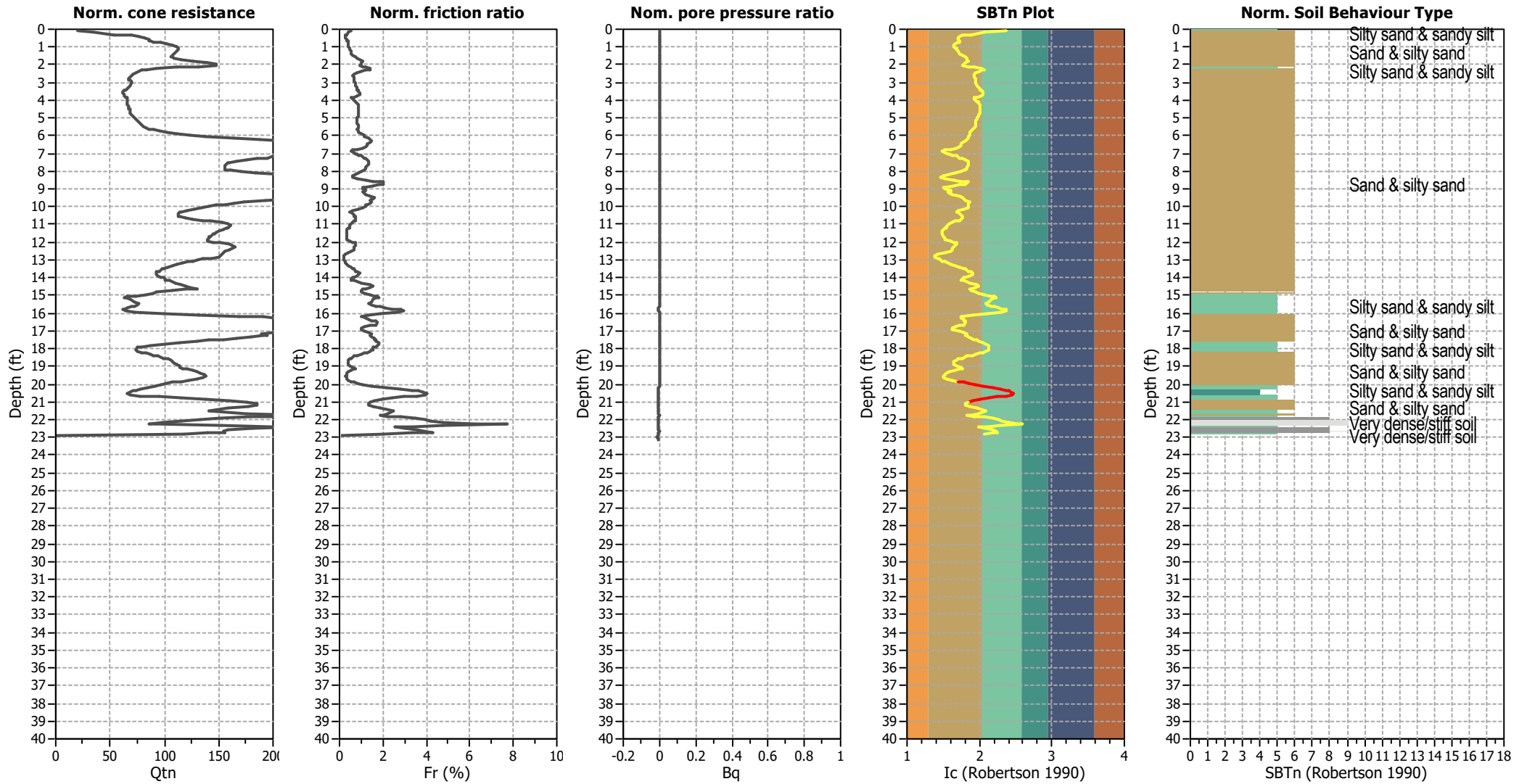

Input parameters and analysis data

Analysis method:	NCEER (1998)	Depth to water table (erthq.):	7.00 ft	Fill weight:	N/A
Fines correction method:	NCEER (1998)	Average results interval:	3	Transition detect. applied:	Yes
Points to test:	Based on Ic value	Ic cut-off value:	2.60	K ₀ applied:	Yes
Earthquake magnitude M _w :	8.10	Unit weight calculation:	Based on SBT	Clay like behavior applied:	Sands only
Peak ground acceleration:	0.89	Use fill:	No	Limit depth applied:	No
Depth to water table (insitu):	12.50 ft	Fill height:	N/A	Limit depth:	N/A

SBTn legend

1. Sensitive fine grained	4. Clayey silt to silty	7. Gravely sand to sand
2. Organic material	5. Silty sand to sandy silt	8. Very stiff sand to
3. Clay to silty clay	6. Clean sand to silty sand	9. Very stiff fine grained

Liquefaction analysis overall plots (intermediate results)

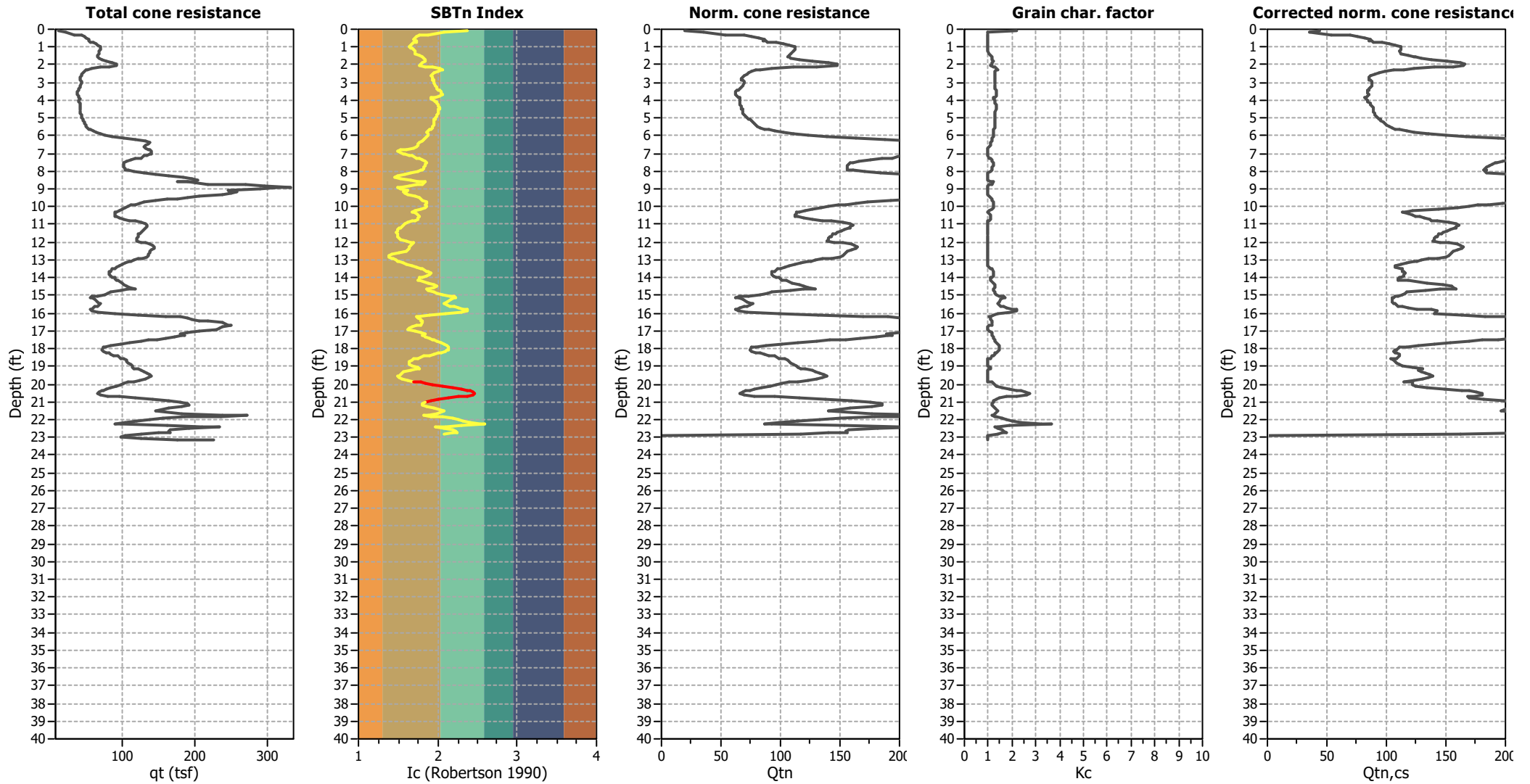

Input parameters and analysis data

Analysis method:	NCEER (1998)	Depth to water table (erthq.):	7.00 ft	Fill weight:	N/A
Fines correction method:	NCEER (1998)	Average results interval:	3	Transition detect. applied:	Yes
Points to test:	Based on Ic value	Ic cut-off value:	2.60	K _o applied:	Yes
Earthquake magnitude M _w :	8.10	Unit weight calculation:	Based on SBT	Clay like behavior applied:	Sands only
Peak ground acceleration:	0.89	Use fill:	No	Limit depth applied:	No
Depth to water table (insitu):	12.50 ft	Fill height:	N/A	Limit depth:	N/A

Liquefaction analysis overall plots

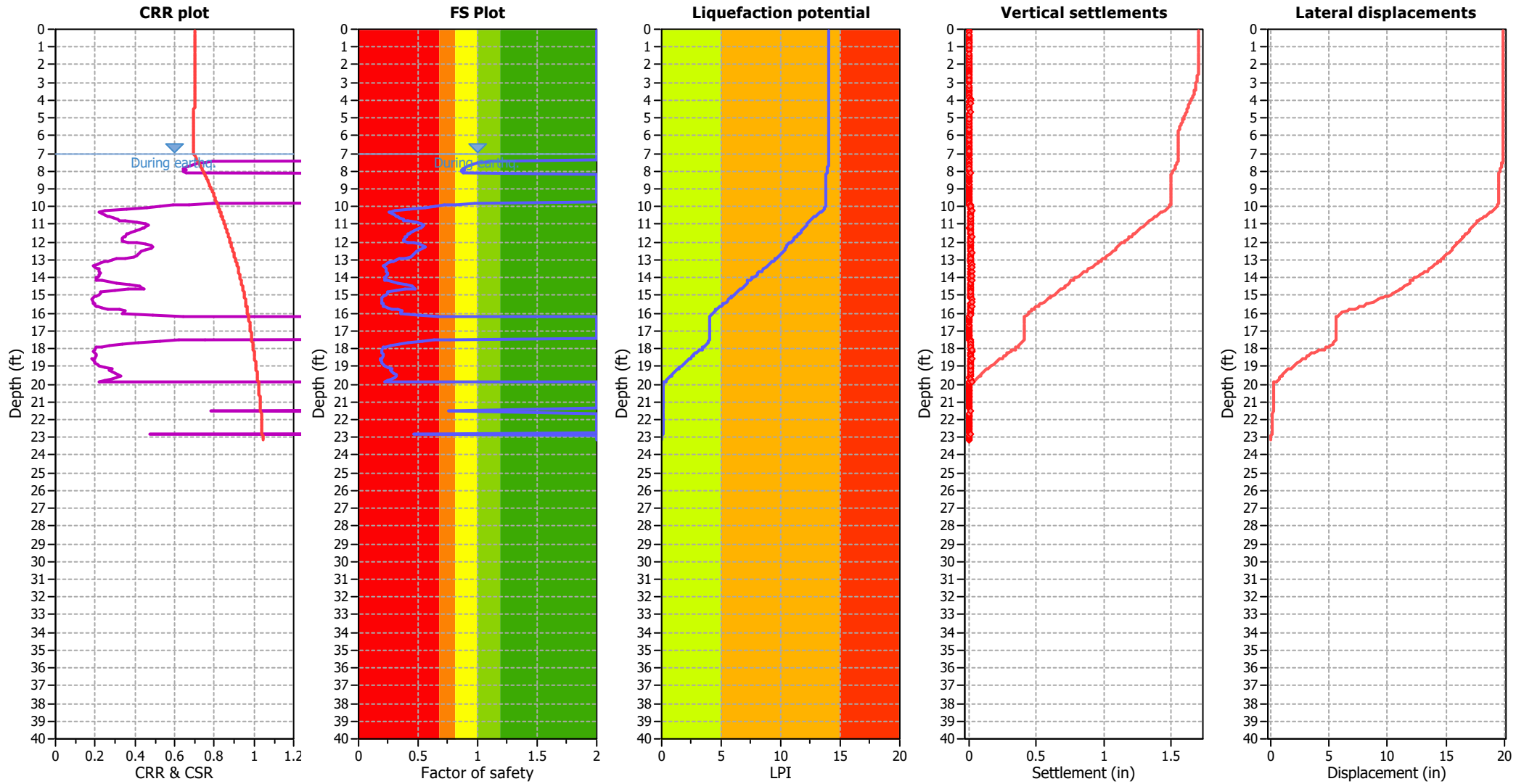

Input parameters and analysis data

Analysis method:	NCEER (1998)	Depth to water table (earthq.):	7.00 ft	Fill weight:	N/A
Fines correction method:	NCEER (1998)	Average results interval:	3	Transition detect. applied:	Yes
Points to test:	Based on Ic value	Ic cut-off value:	2.60	K _o applied:	Yes
Earthquake magnitude M _w :	8.10	Unit weight calculation:	Based on SBT	Clay like behavior applied:	Sands only
Peak ground acceleration:	0.89	Use fill:	No	Limit depth applied:	No
Depth to water table (insitu):	12.50 ft	Fill height:	N/A	Limit depth:	N/A

F.S. color scheme

- Almost certain it will liquefy
- Very likely to liquefy
- Liquefaction and no liq. are equally likely
- Unlike to liquefy
- Almost certain it will not liquefy

LPI color scheme

- Very high risk
- High risk
- Low risk

Liquefaction analysis summary plots

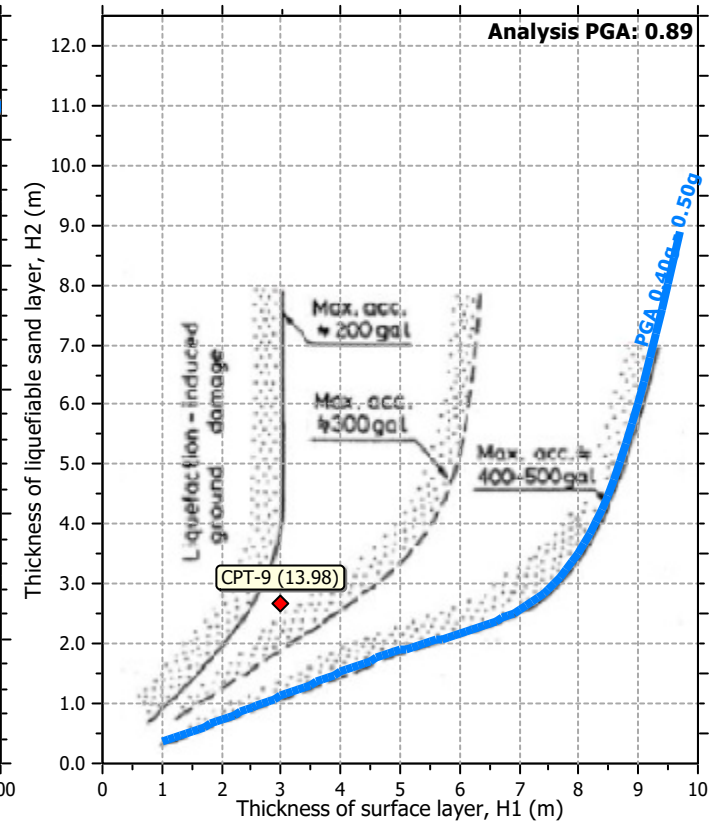
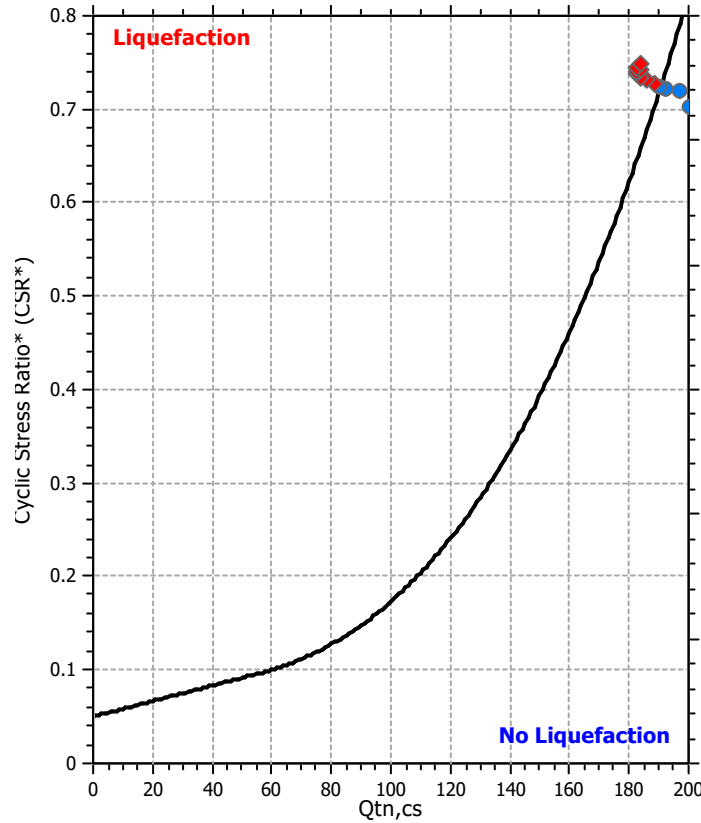
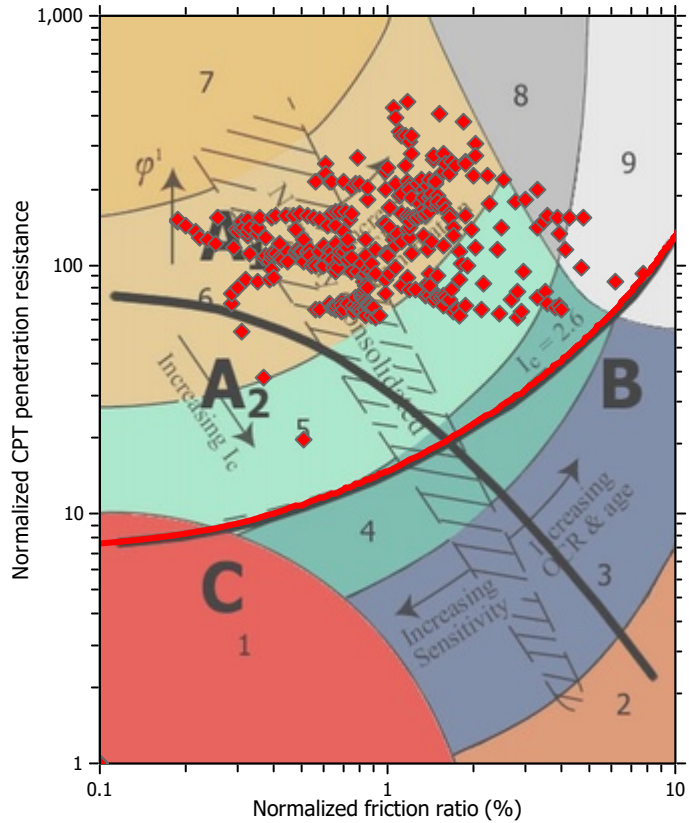

Input parameters and analysis data

Analysis method:	NCEER (1998)	Depth to water table (earthq.):	7.00 ft	Fill weight:	N/A
Fines correction method:	NCEER (1998)	Average results interval:	3	Transition detect. applied:	Yes
Points to test:	Based on Ic value	Ic cut-off value:	2.60	K_v applied:	Yes
Earthquake magnitude M_w :	8.10	Unit weight calculation:	Based on SBT	Clay like behavior applied:	Sands only
Peak ground acceleration:	0.89	Use fill:	No	Limit depth applied:	No
Depth to water table (insitu):	12.50 ft	Fill height:	N/A	Limit depth:	N/A

Check for strength loss plots (Robertson (2010))

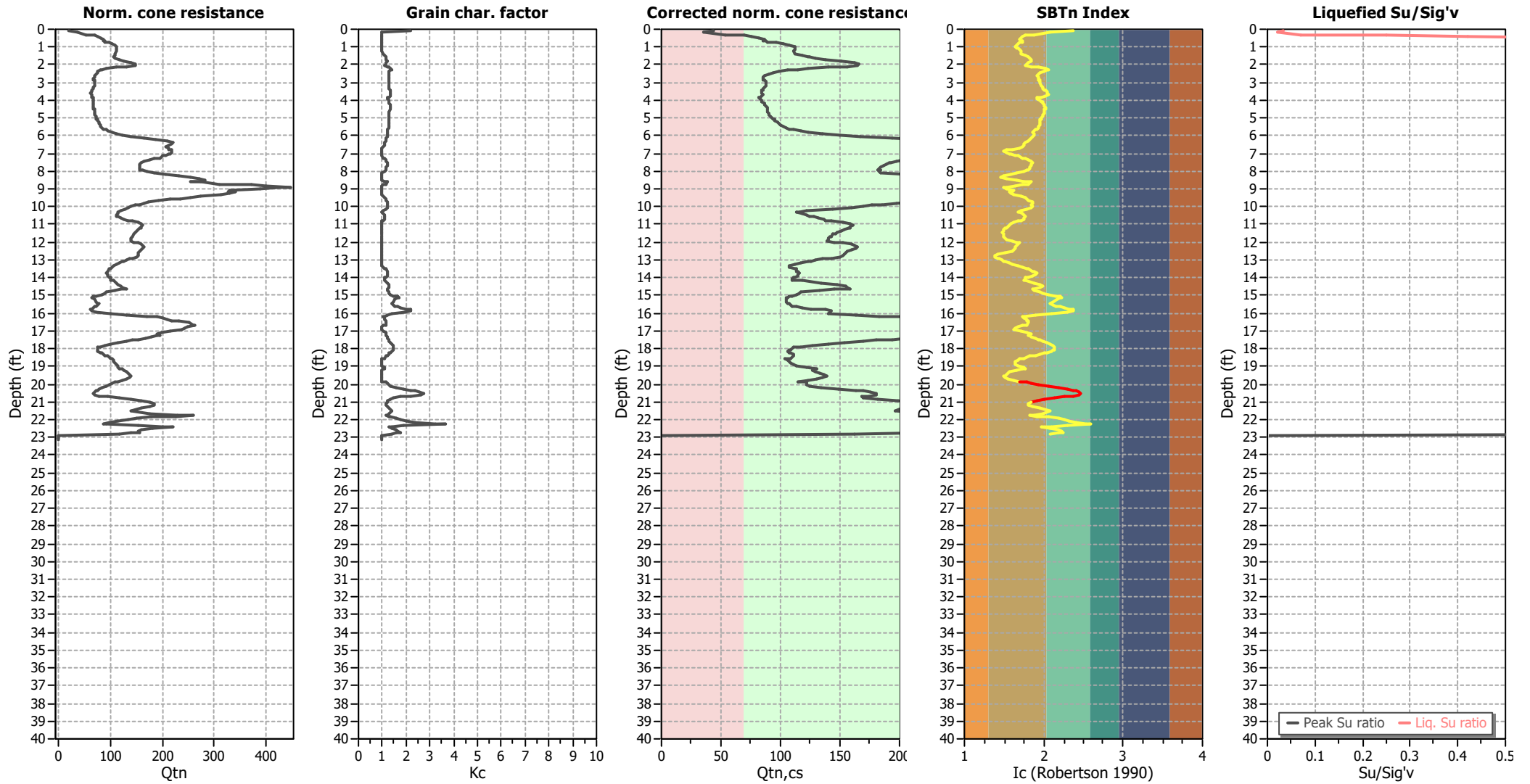

Input parameters and analysis data

Analysis method:	NCEER (1998)	Depth to water table (earthq.):	7.00 ft	Fill weight:	N/A
Fines correction method:	NCEER (1998)	Average results interval:	3	Transition detect. applied:	Yes
Points to test:	Based on Ic value	Ic cut-off value:	2.60	K _o applied:	Yes
Earthquake magnitude M _w :	8.10	Unit weight calculation:	Based on SBT	Clay like behavior applied:	Sands only
Peak ground acceleration:	0.89	Use fill:	No	Limit depth applied:	No
Depth to water table (insitu):	12.50 ft	Fill height:	N/A	Limit depth:	N/A

TRANSITION LAYER DETECTION ALGORITHM REPORT

Summary Details & Plots

Short description

The software will delete data when the cone is in transition from either clay to sand or vice-versa. To do this the software requires a range of I_c values over which the transition will be defined (typically somewhere between $1.80 < I_c < 3.0$) and a rate of change of I_c . Transitions typically occur when the rate of change of I_c is fast (i.e. ΔI_c is small).

The SBT_n plot below, displays in red the detected transition layers based on the parameters listed below the graphs.

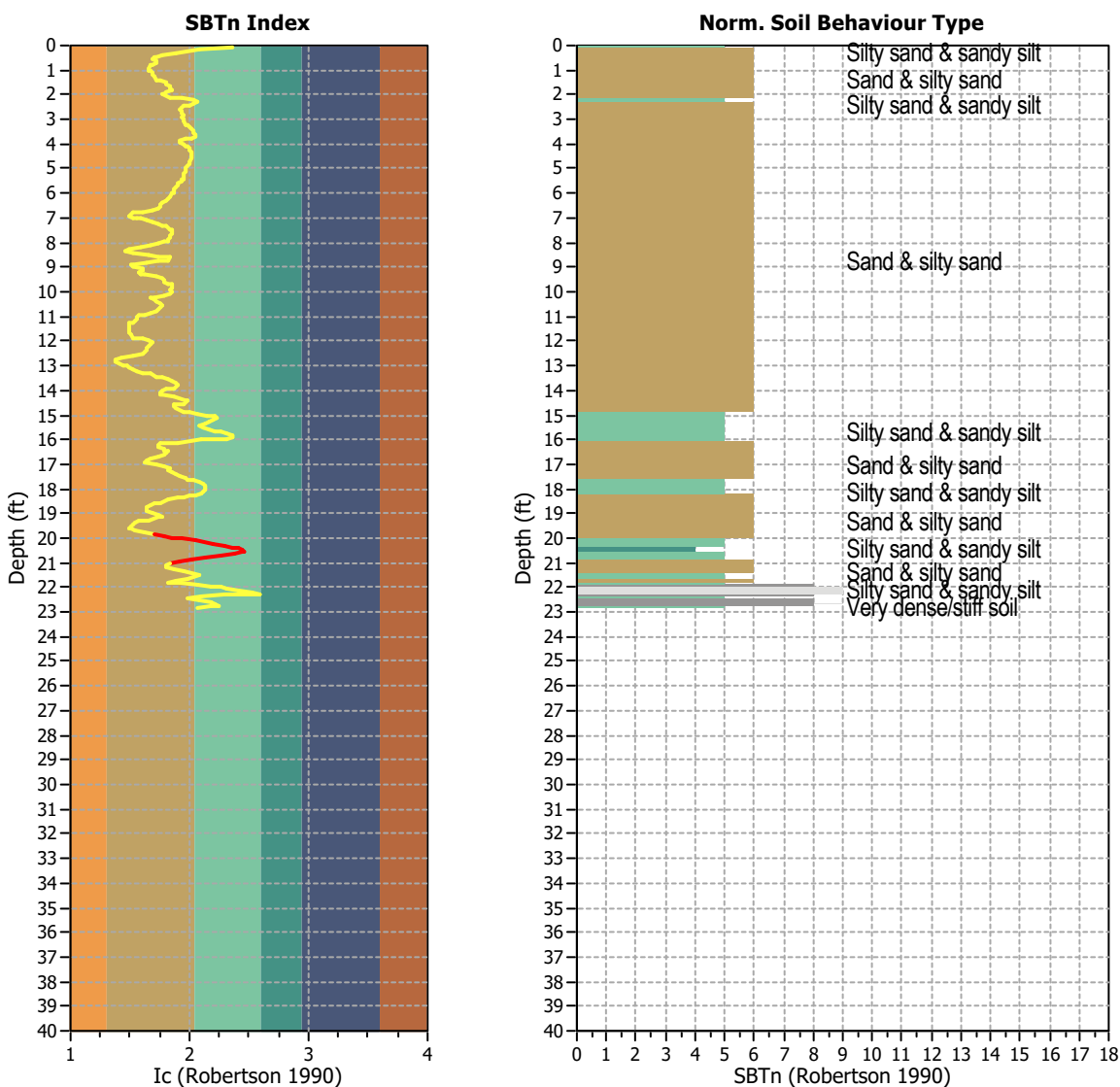

Transition layer algorithm properties

I_c minimum check value: 1.70
 I_c maximum check value: 3.00
 I_c change ratio value: 0.0250
 Minimum number of points in layer: 4

General statistics

Total points in CPT file: 335
 Total points excluded: 18
 Exclusion percentage: 5.37%
 Number of layers detected: 2

Estimation of post-earthquake settlements

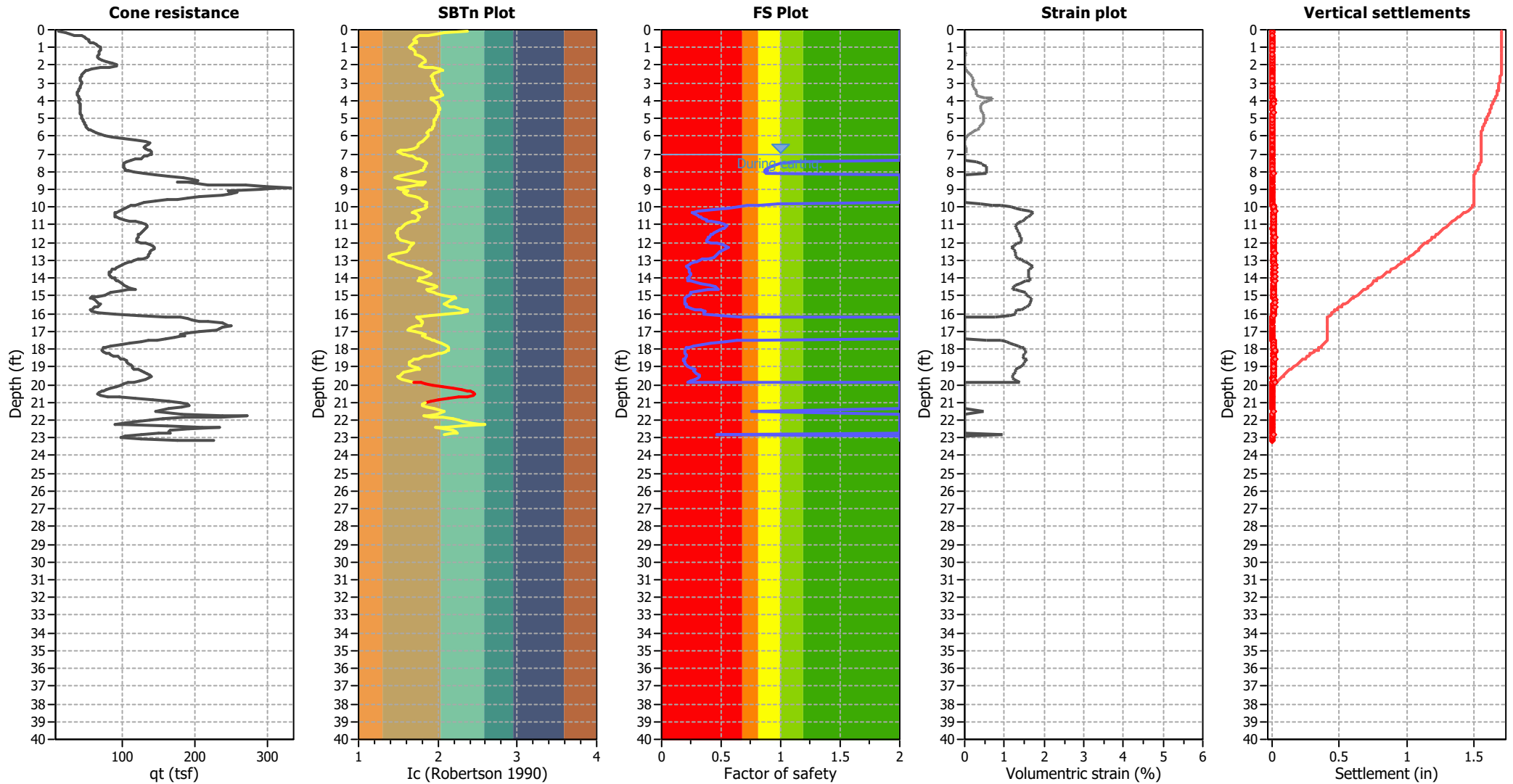

Abbreviations

- q_c: Total cone resistance (cone resistance q_c corrected for pore water effects)
- I_c: Soil Behaviour Type Index
- FS: Calculated Factor of Safety against liquefaction
- Volumetric strain: Post-liquefaction volumetric strain

Estimation of post-earthquake lateral Displacements

Geometric parameters: Gently sloping ground without free face (Slope 1.00 %)

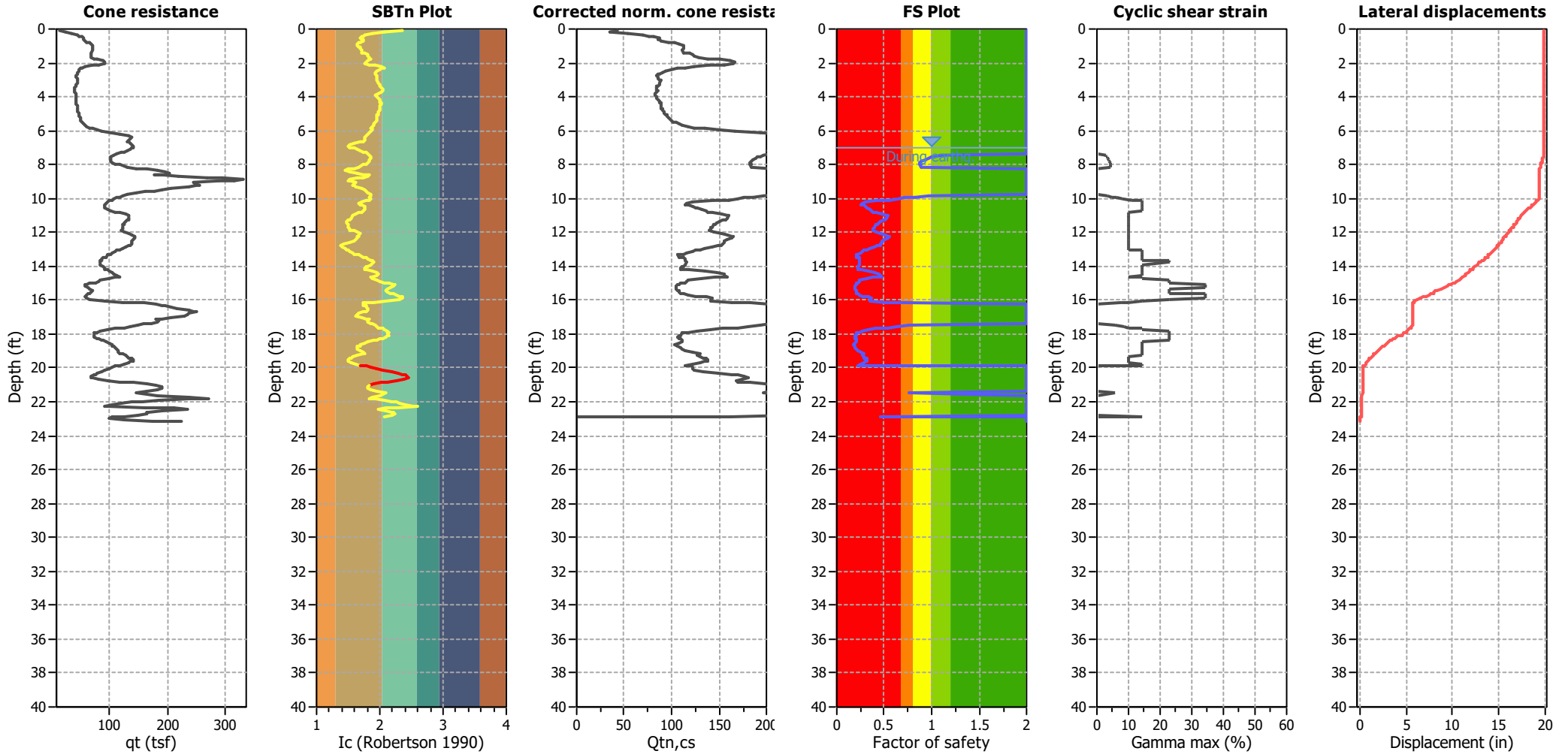

Abbreviations

q_t: Total cone resistance (cone resistance q_c corrected for pore water effects)
 I_c: Soil Behaviour Type Index
 Q_{tn,cs}: Equivalent clean sand normalized CPT total cone resistance

F.S.: Factor of safety
 γ_{max}: Maximum cyclic shear strain
 LDI: Lateral displacement index

Surface condition

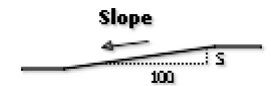

Aging Calculation Estimation

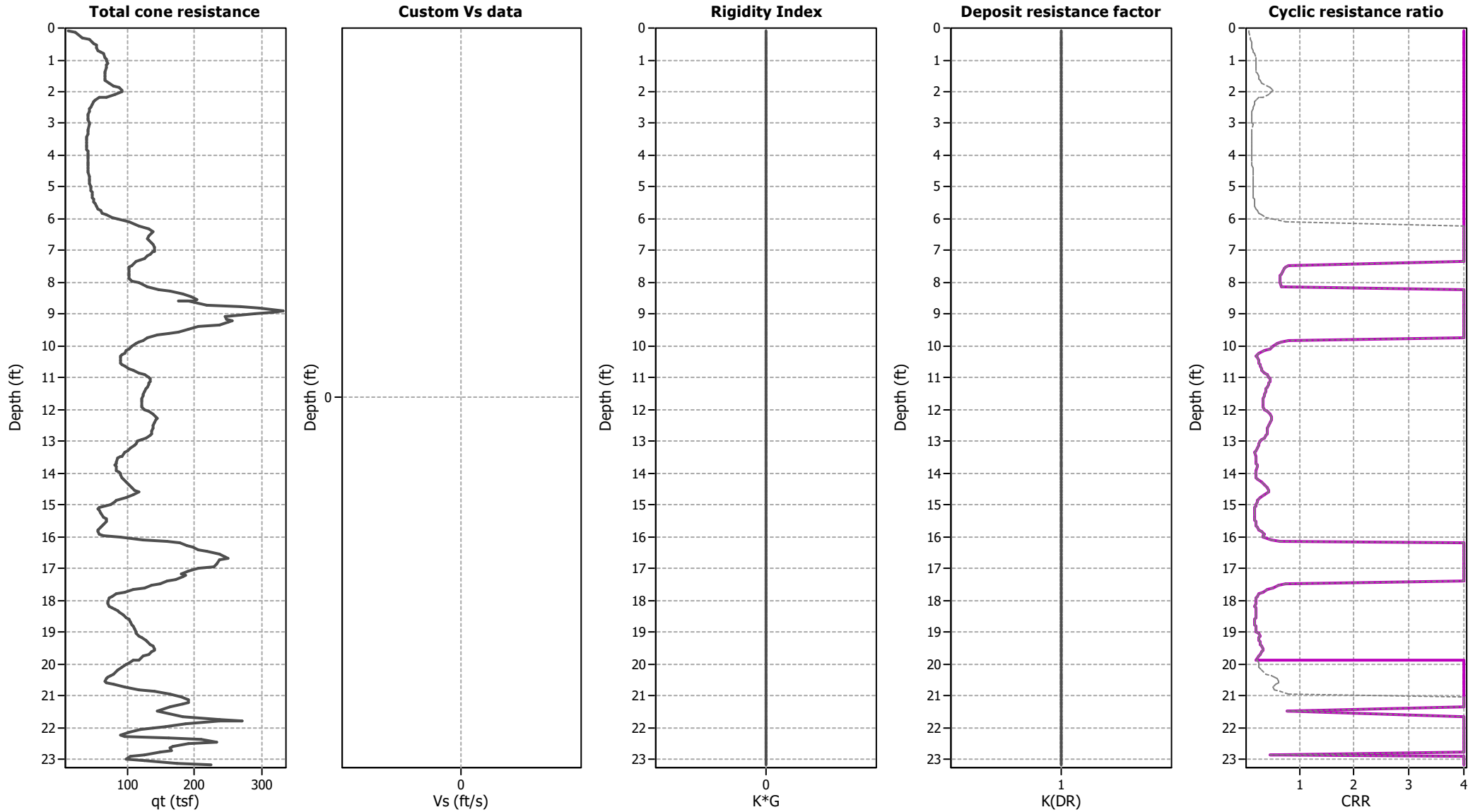

Ejecta Severity Estimation

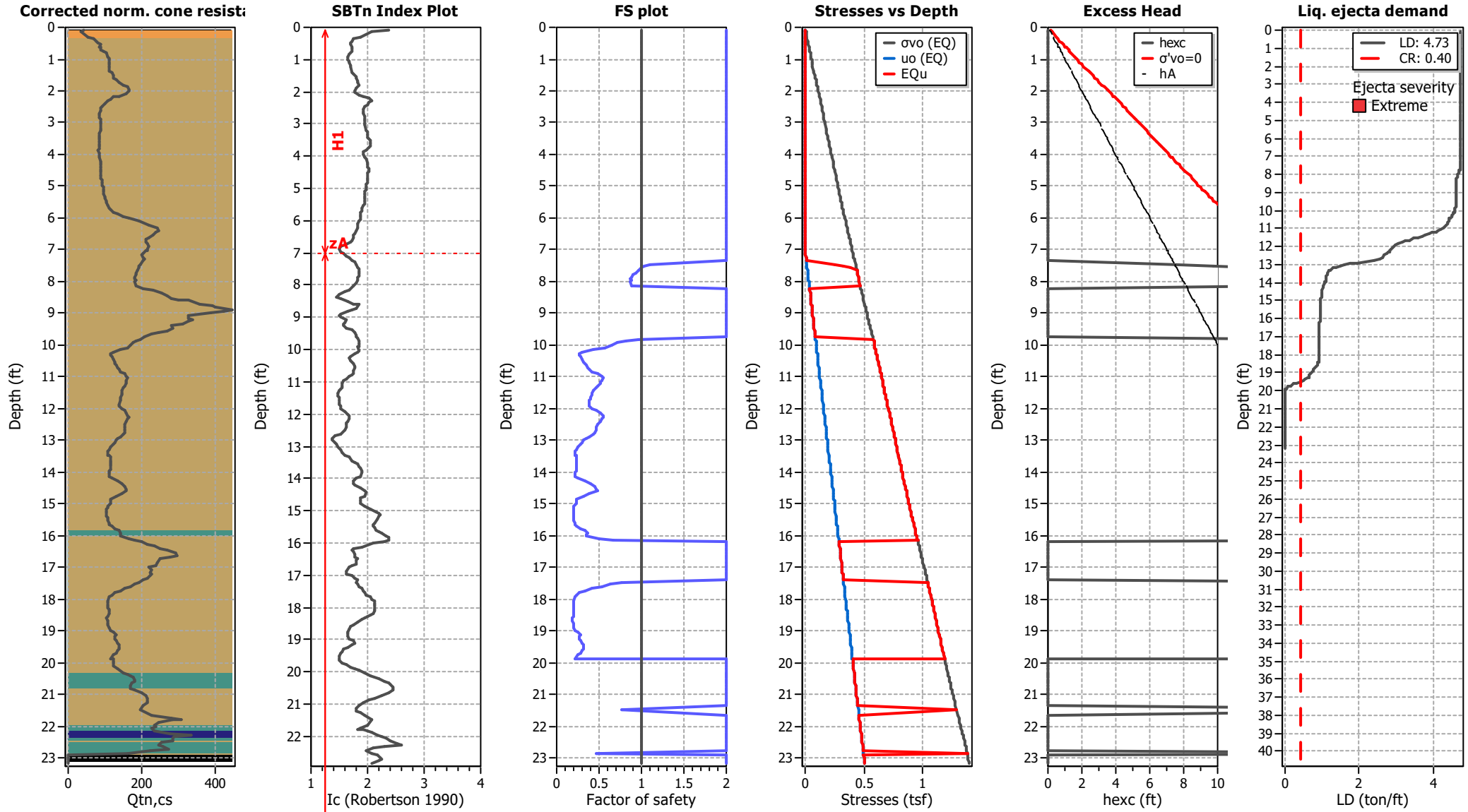

LIQUEFACTION ANALYSIS REPORT

Project title : Petra Geosciences / Apple Canyon

Location : Lake Hemet, CA

CPT file : CPT-10

Input parameters and analysis data

Analysis method:	NCEER (1998)	G.W.T. (in-situ):	10.50 ft	Use fill:	No	Clay like behavior applied:	Sands only
Fines correction method:	NCEER (1998)	G.W.T. (earthq.):	7.00 ft	Fill height:	N/A	Limit depth applied:	No
Points to test:	Based on Ic value	Average results interval:	3	Fill weight:	N/A	Limit depth:	N/A
Earthquake magnitude M_w :	8.10	Ic cut-off value:	2.60	Trans. detect. applied:	Yes	MSF method:	Method based
Peak ground acceleration:	0.89	Unit weight calculation:	Based on SBT	K_o applied:	Yes		

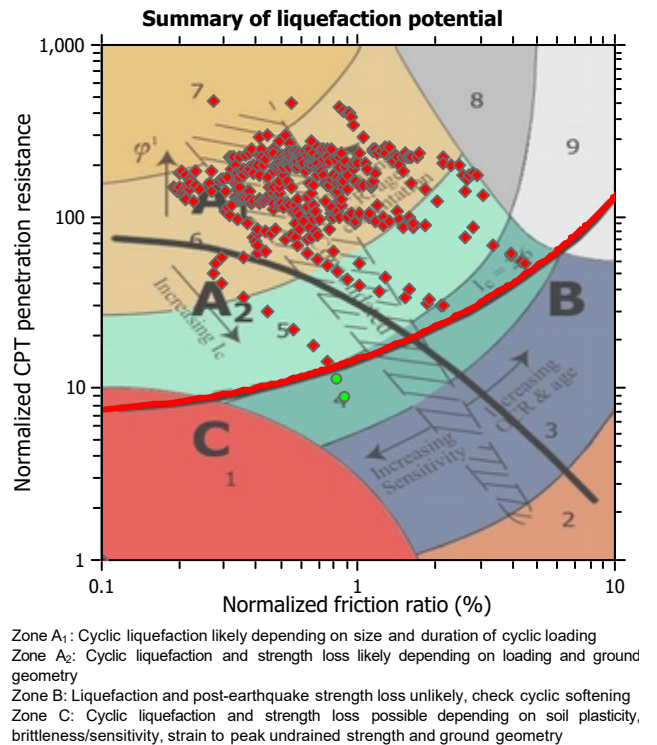
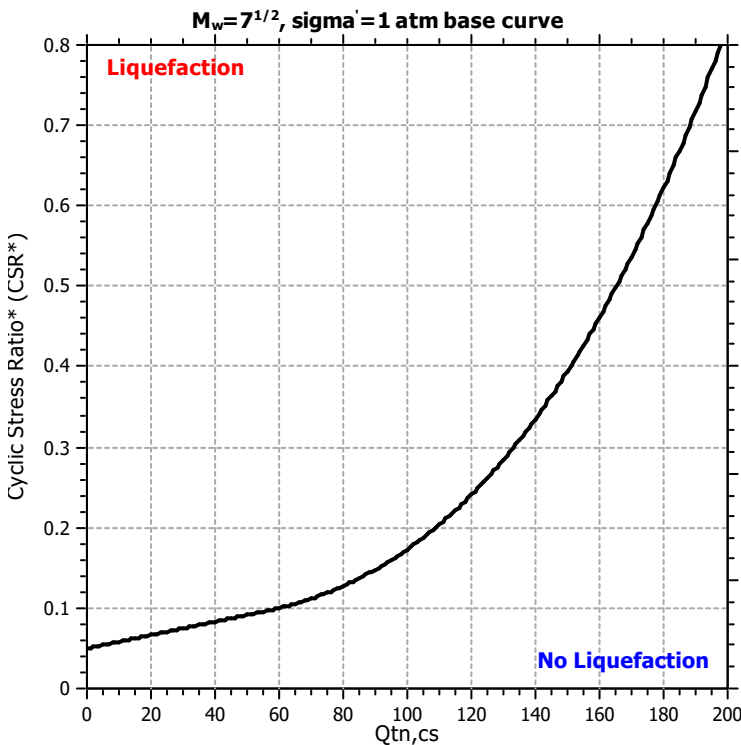
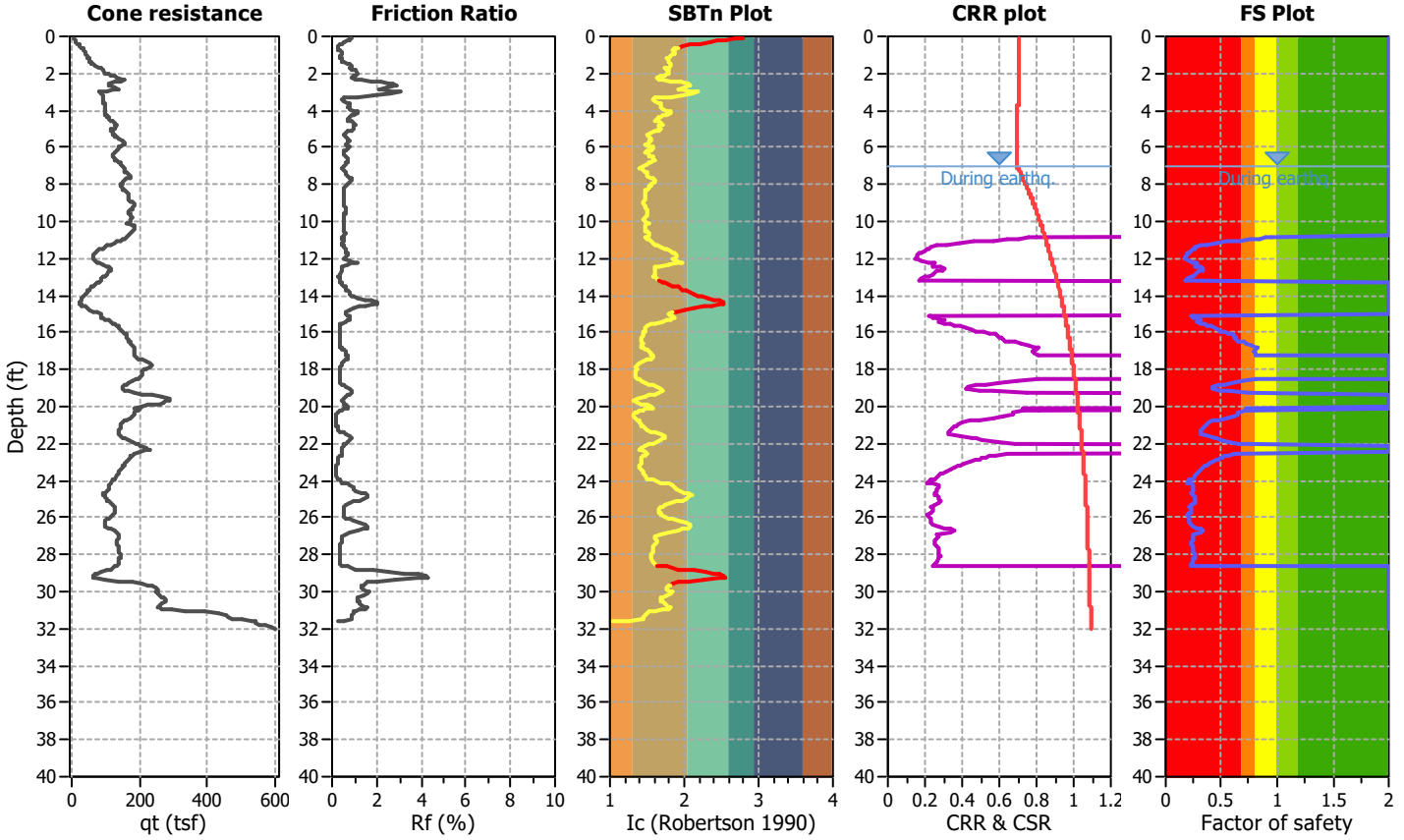

CPT basic interpretation plots

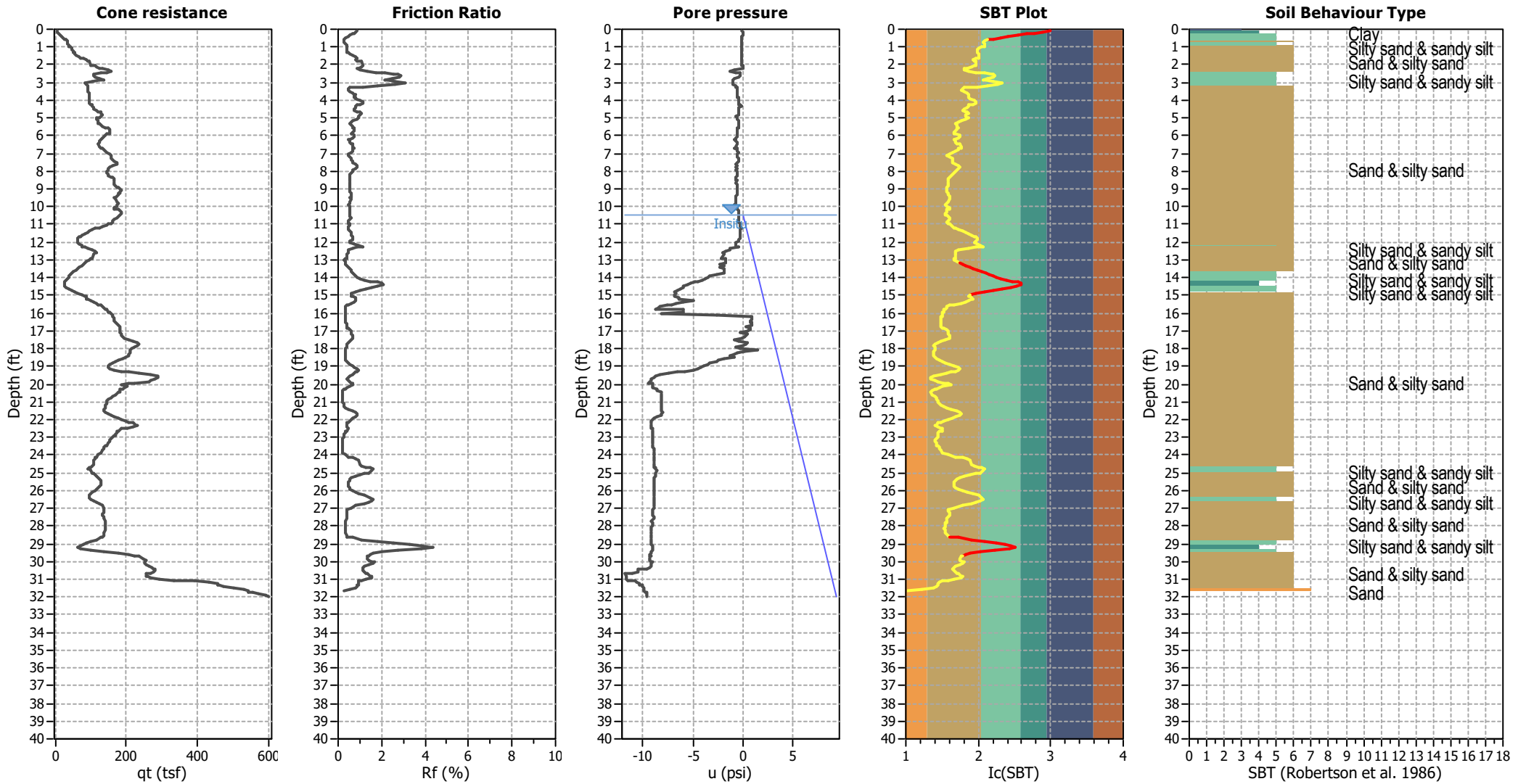

Input parameters and analysis data

Analysis method:	NCEER (1998)	Depth to water table (erthq.):	7.00 ft	Fill weight:	N/A
Fines correction method:	NCEER (1998)	Average results interval:	3	Transition detect. applied:	Yes
Points to test:	Based on Ic value	Ic cut-off value:	2.60	K _o applied:	Yes
Earthquake magnitude M _w :	8.10	Unit weight calculation:	Based on SBT	Clay like behavior applied:	Sands only
Peak ground acceleration:	0.89	Use fill:	No	Limit depth applied:	No
Depth to water table (insitu):	10.50 ft	Fill height:	N/A	Limit depth:	N/A

SBT legend

1. Sensitive fine grained	4. Clayey silt to silty	7. Gravely sand to sand
2. Organic material	5. Silty sand to sandy silt	8. Very stiff sand to
3. Clay to silty clay	6. Clean sand to silty sand	9. Very stiff fine grained

CPT basic interpretation plots (normalized)

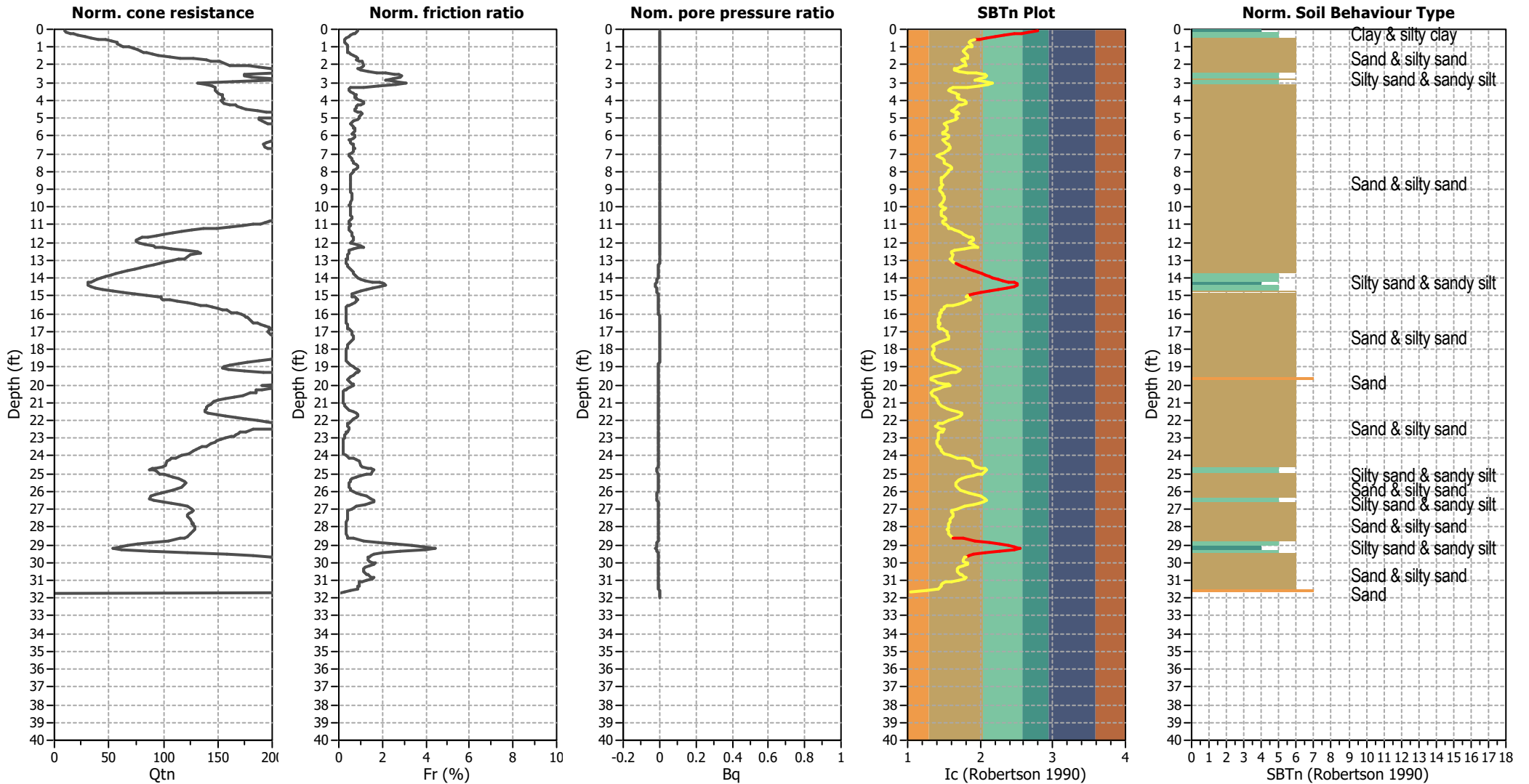

Input parameters and analysis data

Analysis method:	NCEER (1998)	Depth to water table (earthq.):	7.00 ft	Fill weight:	N/A
Fines correction method:	NCEER (1998)	Average results interval:	3	Transition detect. applied:	Yes
Points to test:	Based on Ic value	Ic cut-off value:	2.60	K ₀ applied:	Yes
Earthquake magnitude M _w :	8.10	Unit weight calculation:	Based on SBT	Clay like behavior applied:	Sands only
Peak ground acceleration:	0.89	Use fill:	No	Limit depth applied:	No
Depth to water table (insitu):	10.50 ft	Fill height:	N/A	Limit depth:	N/A

SBTn legend

1. Sensitive fine grained	4. Clayey silt to silty	7. Gravely sand to sand
2. Organic material	5. Silty sand to sandy silt	8. Very stiff sand to
3. Clay to silty clay	6. Clean sand to silty sand	9. Very stiff fine grained

Liquefaction analysis overall plots (intermediate results)

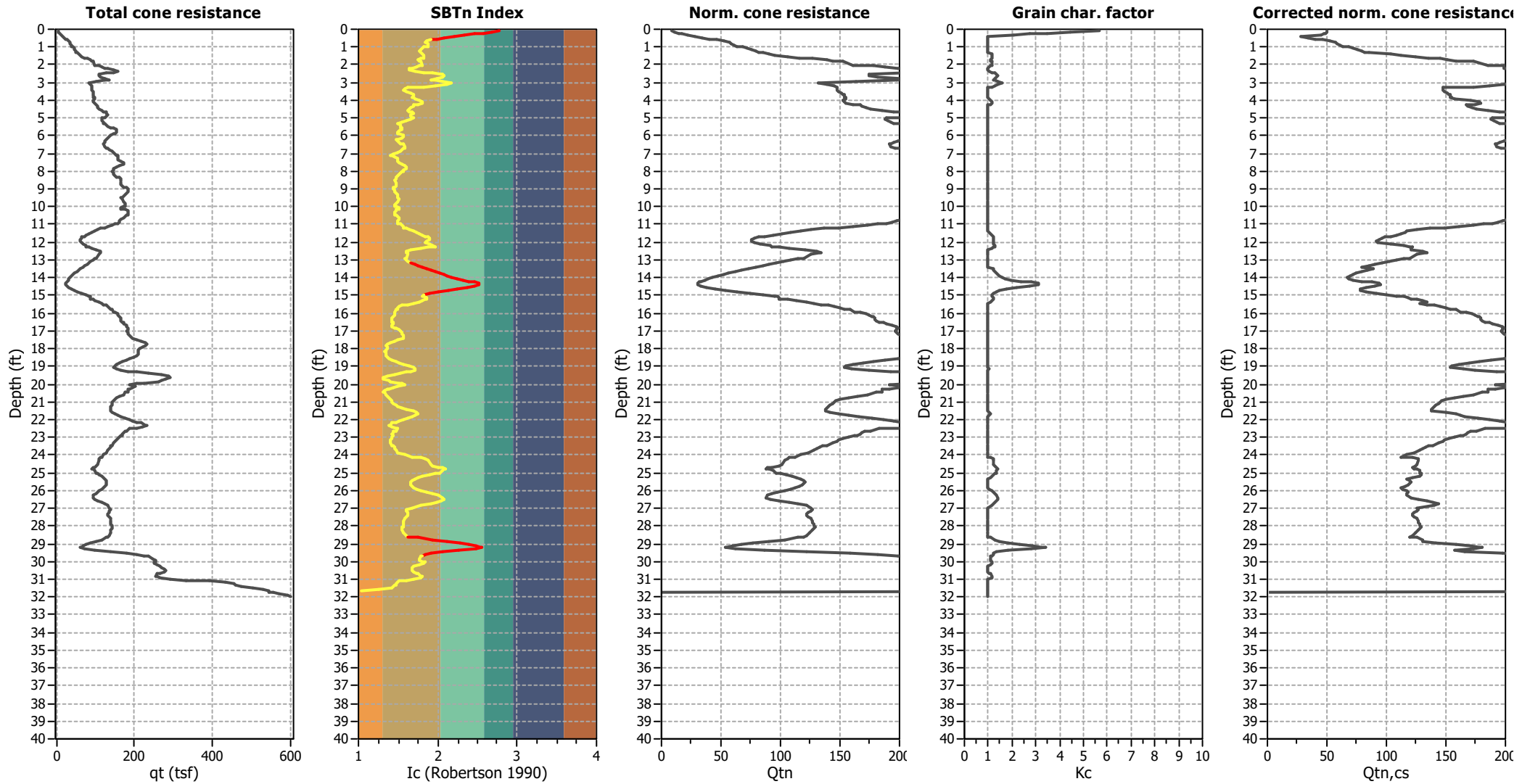

Input parameters and analysis data

Analysis method:	NCEER (1998)	Depth to water table (earthq.):	7.00 ft	Fill weight:	N/A
Fines correction method:	NCEER (1998)	Average results interval:	3	Transition detect. applied:	Yes
Points to test:	Based on Ic value	Ic cut-off value:	2.60	K _o applied:	Yes
Earthquake magnitude M _w :	8.10	Unit weight calculation:	Based on SBT	Clay like behavior applied:	Sands only
Peak ground acceleration:	0.89	Use fill:	No	Limit depth applied:	No
Depth to water table (insitu):	10.50 ft	Fill height:	N/A	Limit depth:	N/A

Liquefaction analysis overall plots

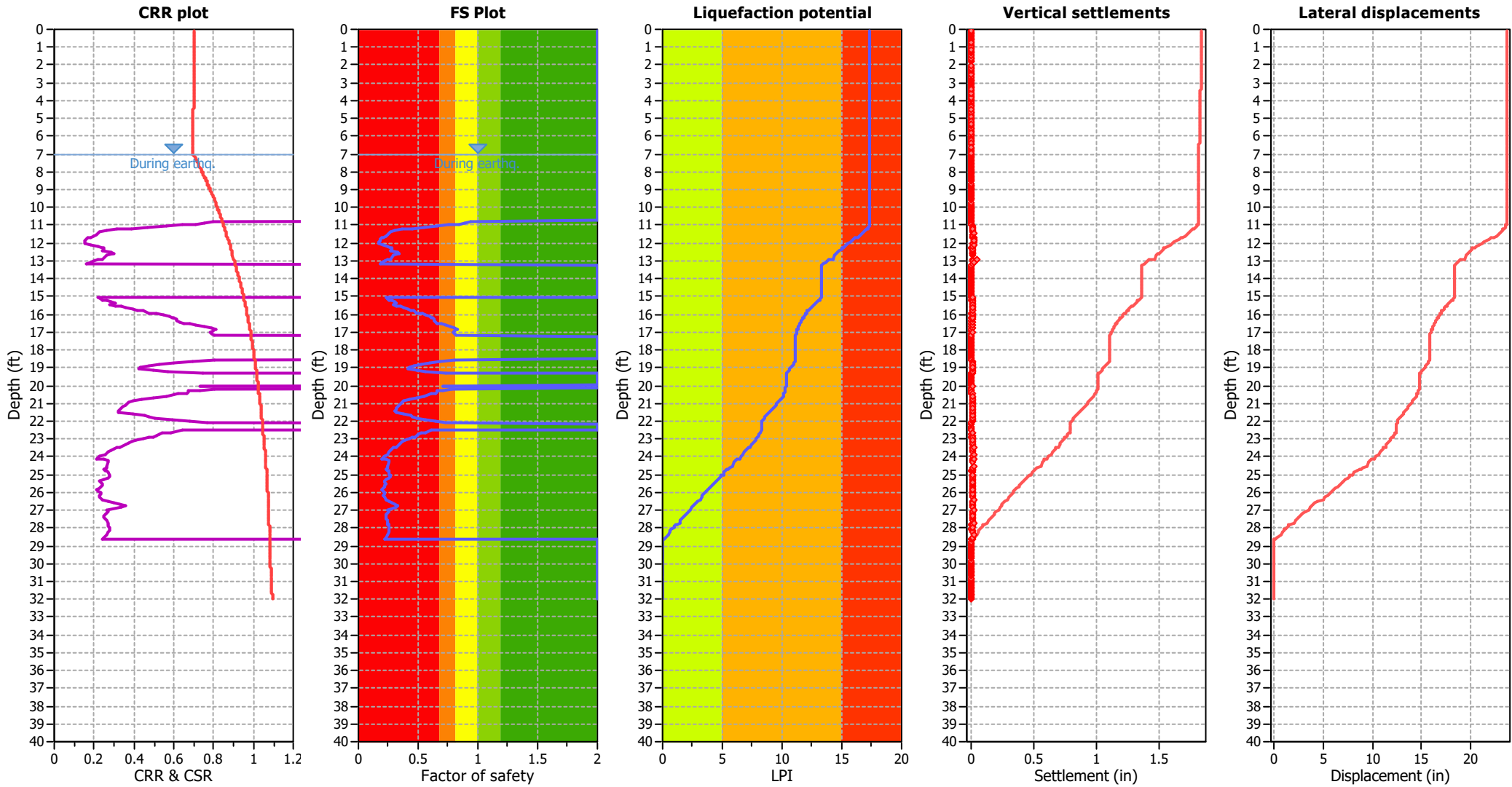

Input parameters and analysis data

Analysis method:	NCEER (1998)	Depth to water table (earthq.):	7.00 ft	Fill weight:	N/A
Fines correction method:	NCEER (1998)	Average results interval:	3	Transition detect. applied:	Yes
Points to test:	Based on Ic value	Ic cut-off value:	2.60	K_0 applied:	Yes
Earthquake magnitude M_w :	8.10	Unit weight calculation:	Based on SBT	Clay like behavior applied:	Sands only
Peak ground acceleration:	0.89	Use fill:	No	Limit depth applied:	No
Depth to water table (insitu):	10.50 ft	Fill height:	N/A	Limit depth:	N/A

F.S. color scheme

- Almost certain it will liquefy
- Very likely to liquefy
- Liquefaction and no liq. are equally likely
- Unlike to liquefy
- Almost certain it will not liquefy

LPI color scheme

- Very high risk
- High risk
- Low risk

Liquefaction analysis summary plots

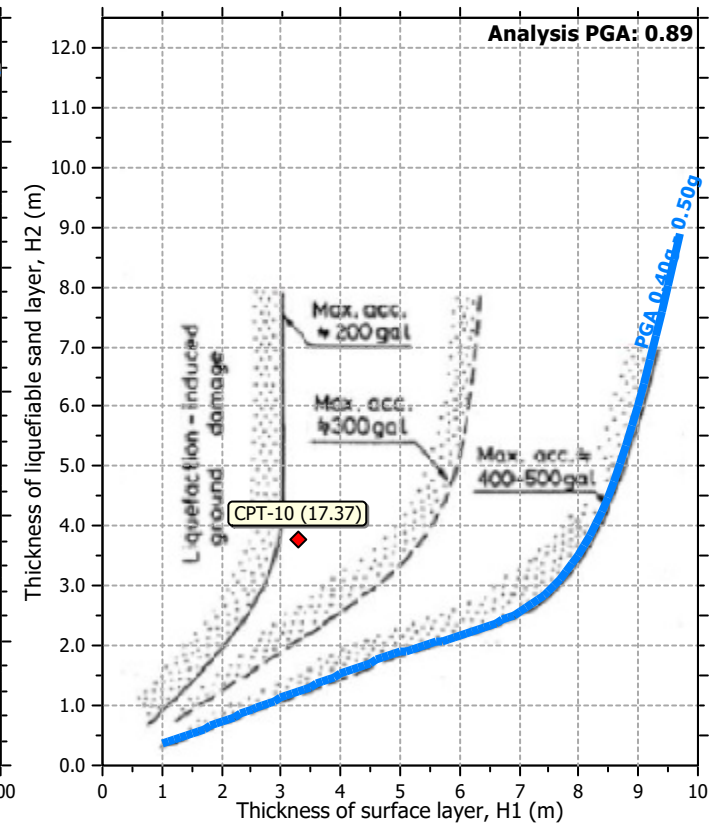
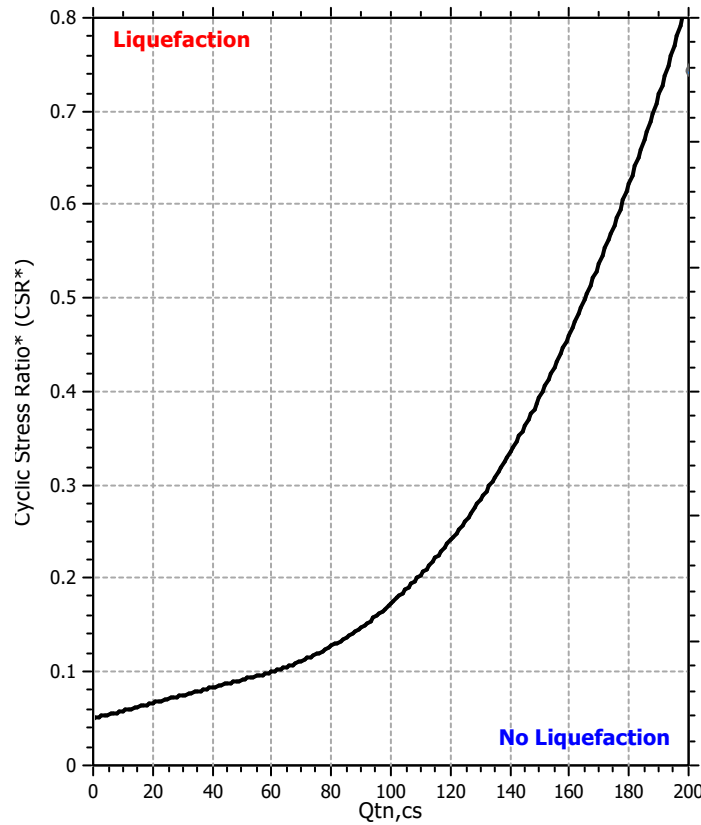
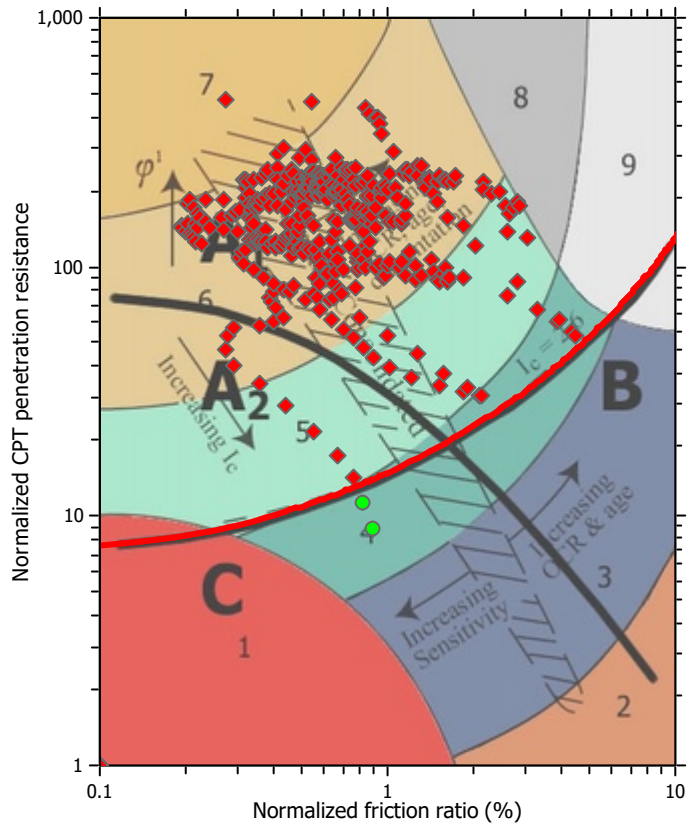

Input parameters and analysis data

Analysis method:	NCEER (1998)	Depth to water table (earthq.):	7.00 ft	Fill weight:	N/A
Fines correction method:	NCEER (1998)	Average results interval:	3	Transition detect. applied:	Yes
Points to test:	Based on Ic value	Ic cut-off value:	2.60	K ₀ applied:	Yes
Earthquake magnitude M _w :	8.10	Unit weight calculation:	Based on SBT	Clay like behavior applied:	Sands only
Peak ground acceleration:	0.89	Use fill:	No	Limit depth applied:	No
Depth to water table (insitu):	10.50 ft	Fill height:	N/A	Limit depth:	N/A

Check for strength loss plots (Robertson (2010))

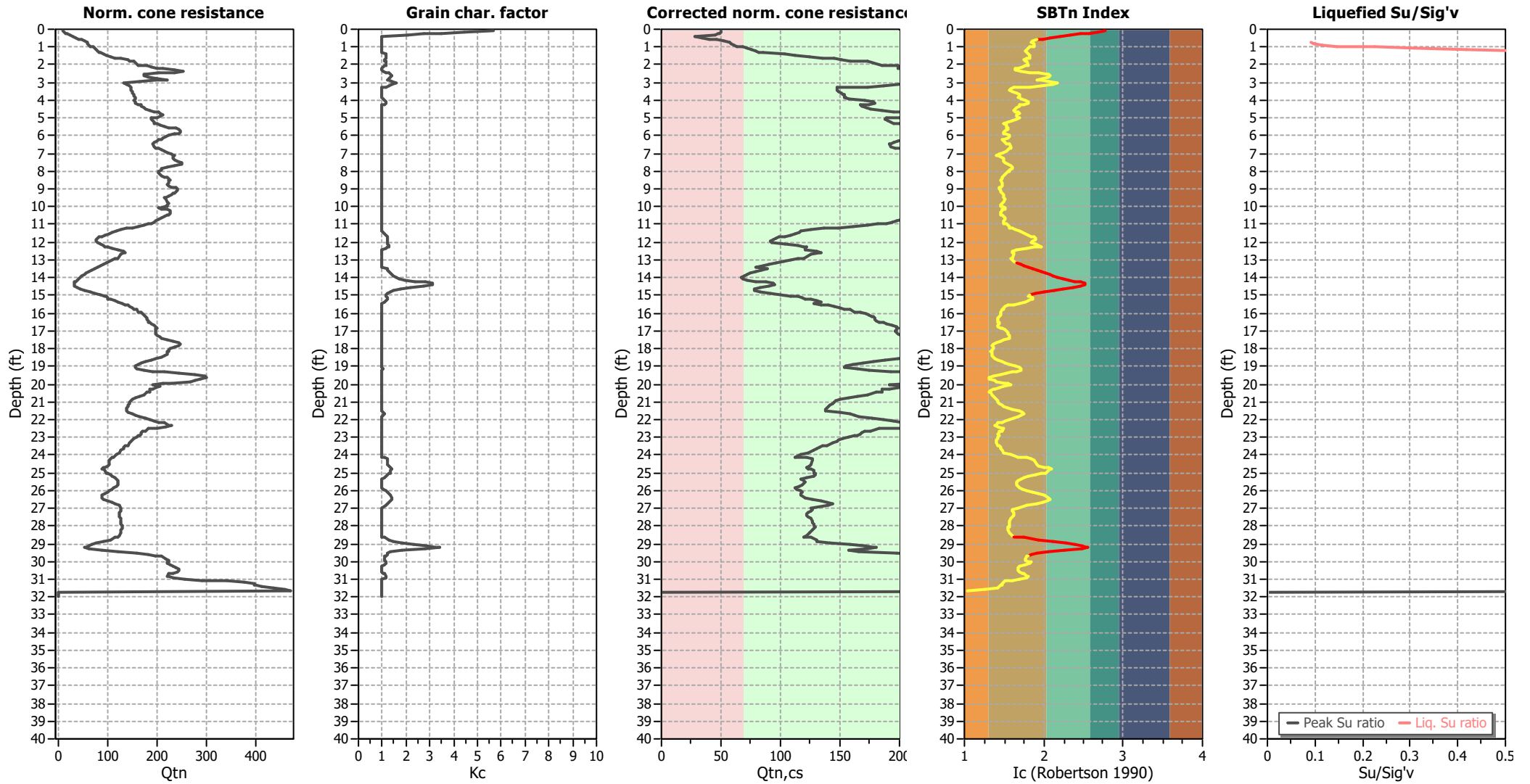

Input parameters and analysis data

Analysis method:	NCEER (1998)	Depth to water table (earthq.):	7.00 ft	Fill weight:	N/A
Fines correction method:	NCEER (1998)	Average results interval:	3	Transition detect. applied:	Yes
Points to test:	Based on Ic value	Ic cut-off value:	2.60	K _o applied:	Yes
Earthquake magnitude M _w :	8.10	Unit weight calculation:	Based on SBT	Clay like behavior applied:	Sands only
Peak ground acceleration:	0.89	Use fill:	No	Limit depth applied:	No
Depth to water table (insitu):	10.50 ft	Fill height:	N/A	Limit depth:	N/A

TRANSITION LAYER DETECTION ALGORITHM REPORT

Summary Details & Plots

Short description

The software will delete data when the cone is in transition from either clay to sand or vice-versa. To do this the software requires a range of I_c values over which the transition will be defined (typically somewhere between $1.80 < I_c < 3.0$) and a rate of change of I_c . Transitions typically occur when the rate of change of I_c is fast (i.e. ΔI_c is small).

The SBT_n plot below, displays in red the detected transition layers based on the parameters listed below the graphs.

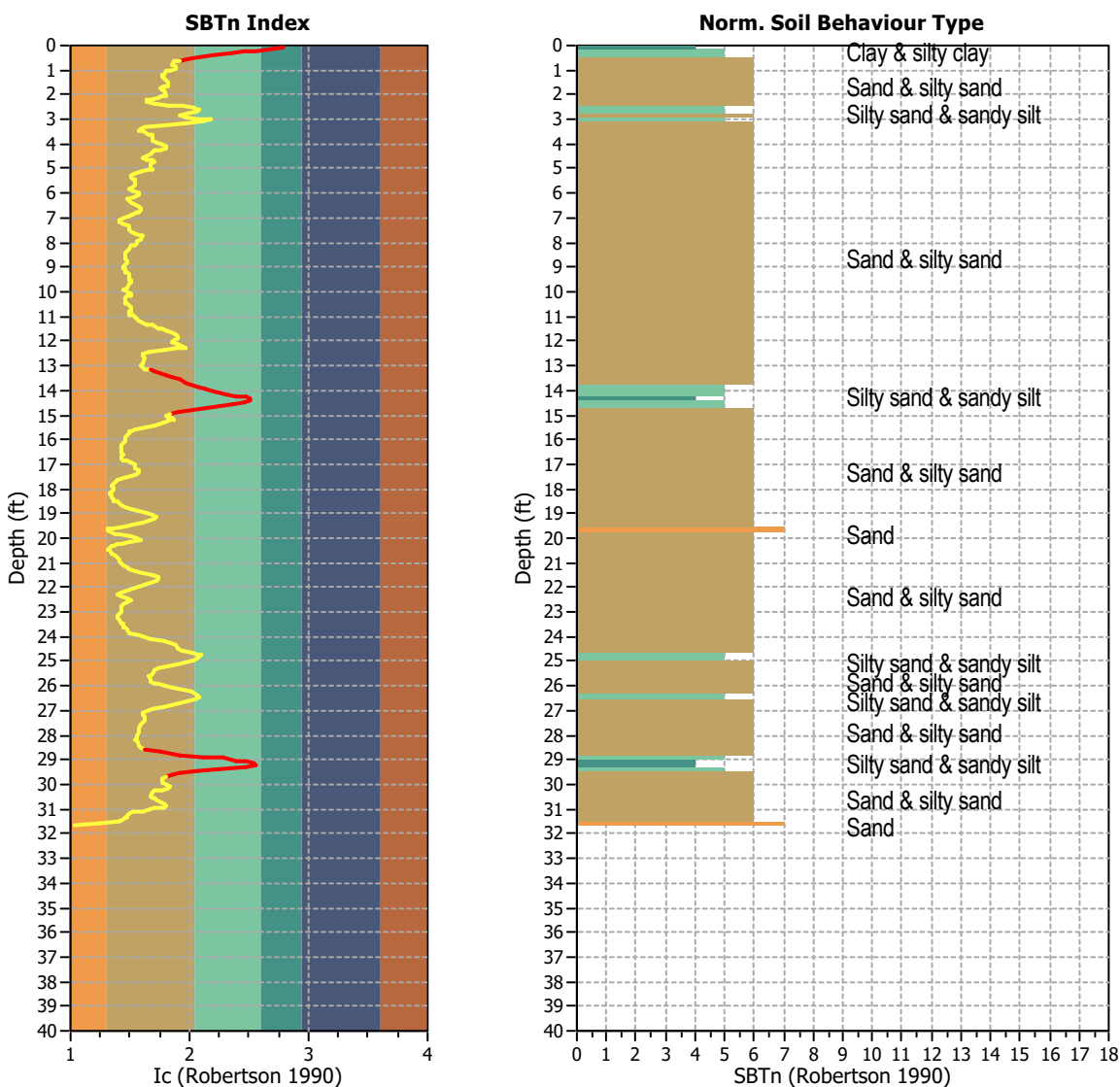

Transition layer algorithm properties

I_c minimum check value: 1.70
 I_c maximum check value: 3.00
 I_c change ratio value: 0.0250
 Minimum number of points in layer: 4

General statistics

Total points in CPT file: 443
 Total points excluded: 49
 Exclusion percentage: 11.06%
 Number of layers detected: 5

Estimation of post-earthquake settlements

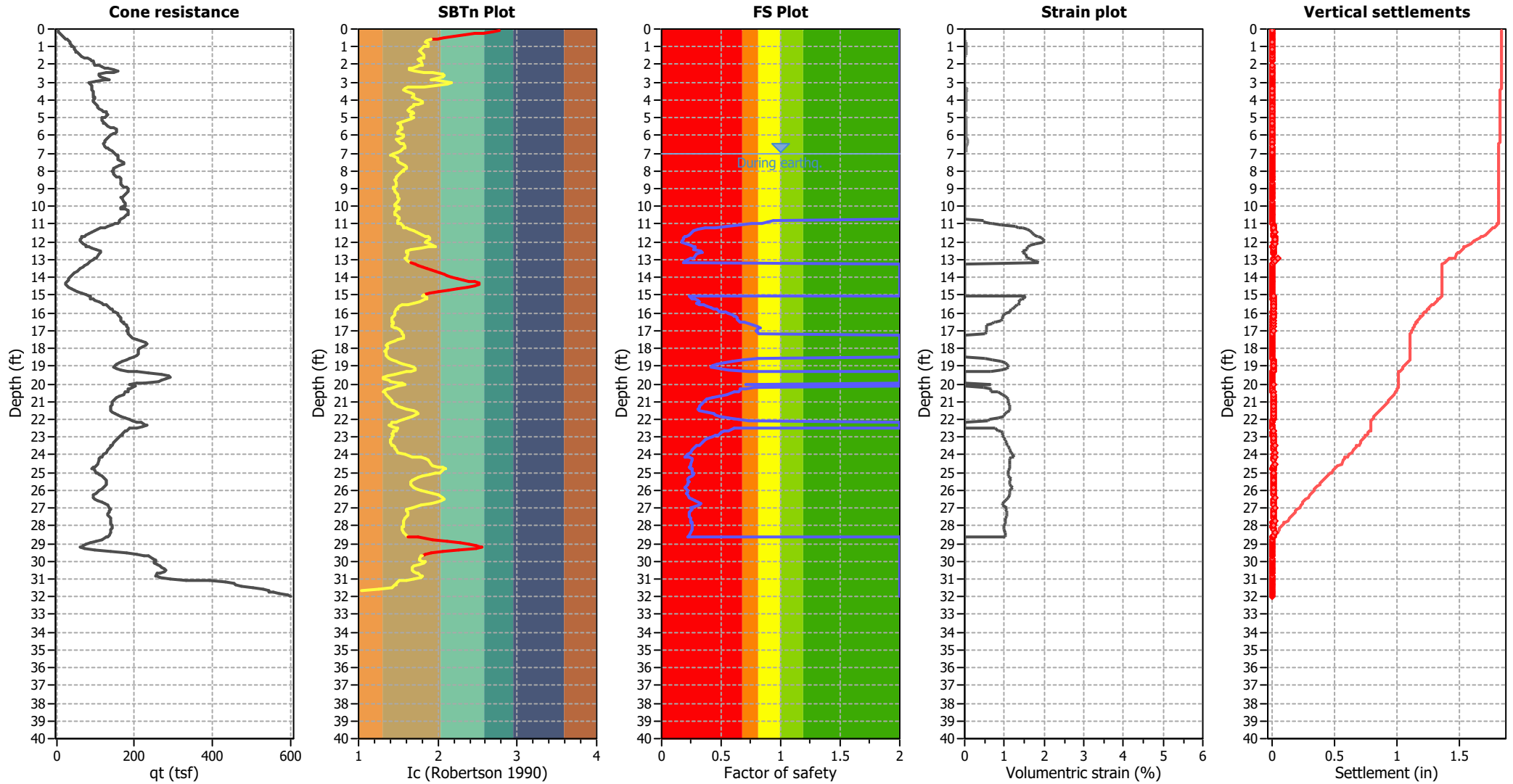

Abbreviations

- q_c: Total cone resistance (cone resistance q_c corrected for pore water effects)
- I_c: Soil Behaviour Type Index
- FS: Calculated Factor of Safety against liquefaction
- Volumetric strain: Post-liquefaction volumetric strain

Estimation of post-earthquake lateral Displacements

Geometric parameters: Gently sloping ground without free face (Slope 1.00 %)

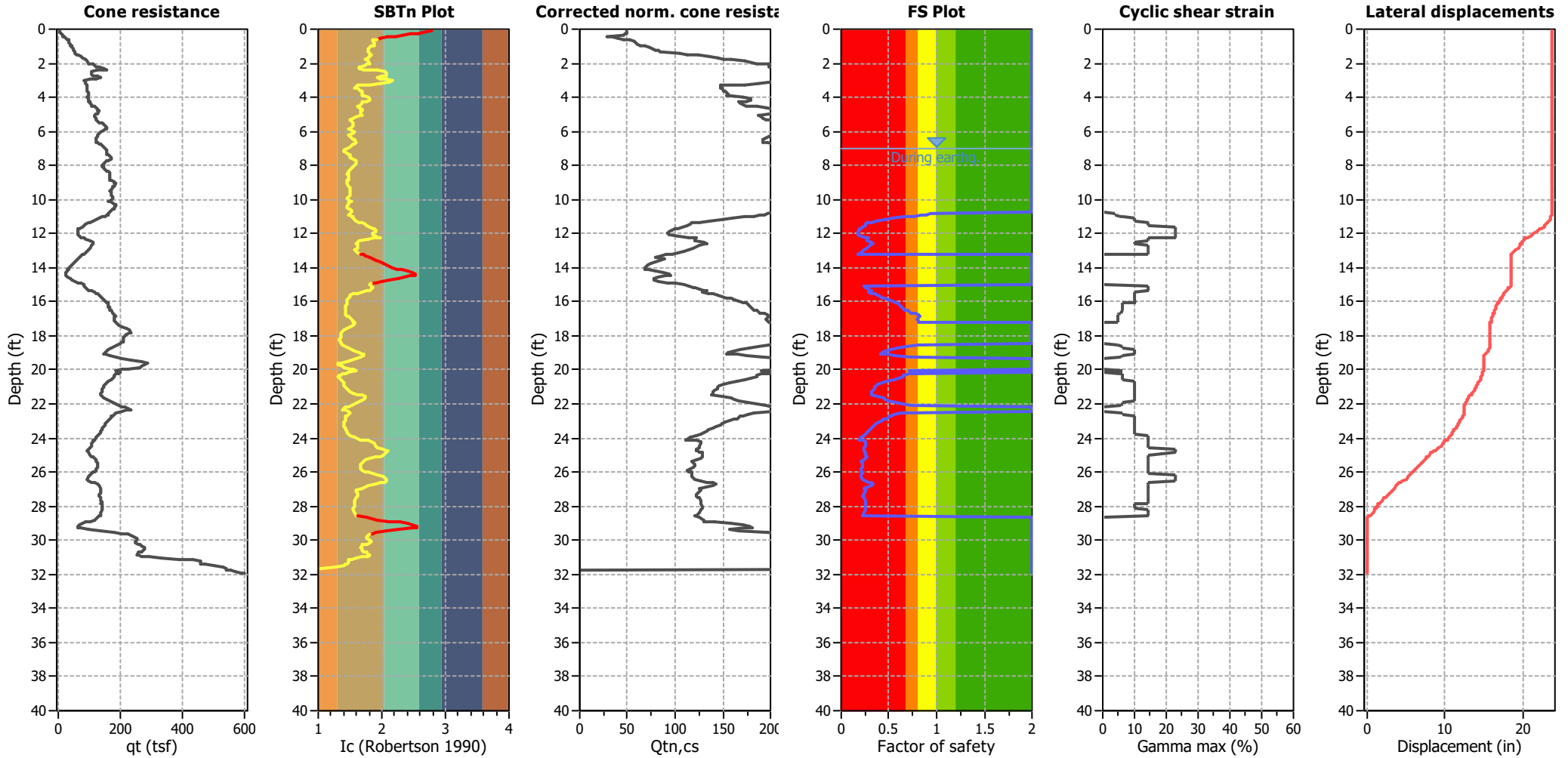

Abbreviations

q_t: Total cone resistance (cone resistance q_c corrected for pore water effects)
 I_c: Soil Behaviour Type Index
 Q_{tn,cs}: Equivalent clean sand normalized CPT total cone resistance

F.S.: Factor of safety
 γ_{max}: Maximum cyclic shear strain
 LDI: Lateral displacement index

Surface condition



Aging Calculation Estimation

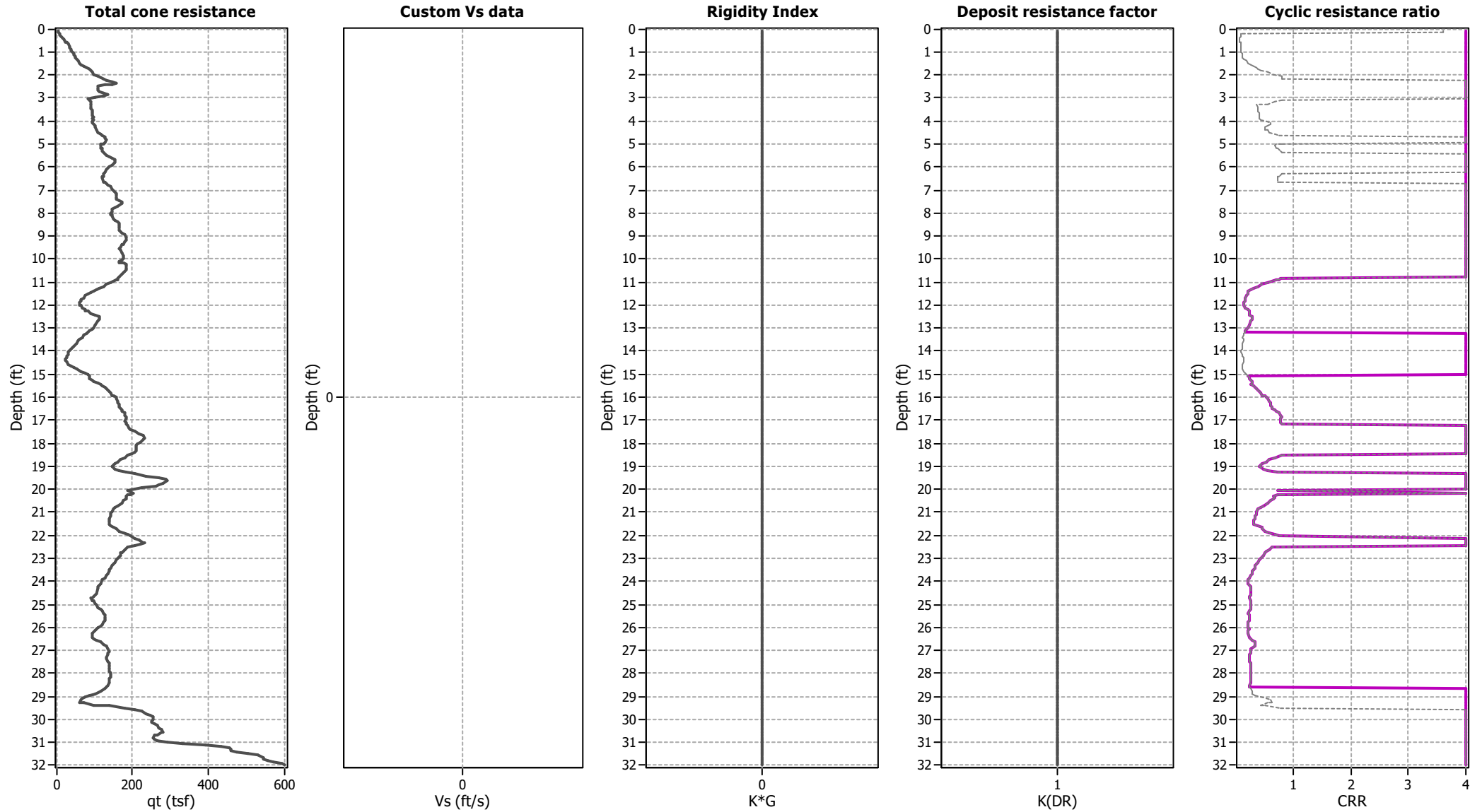

Ejecta Severity Estimation

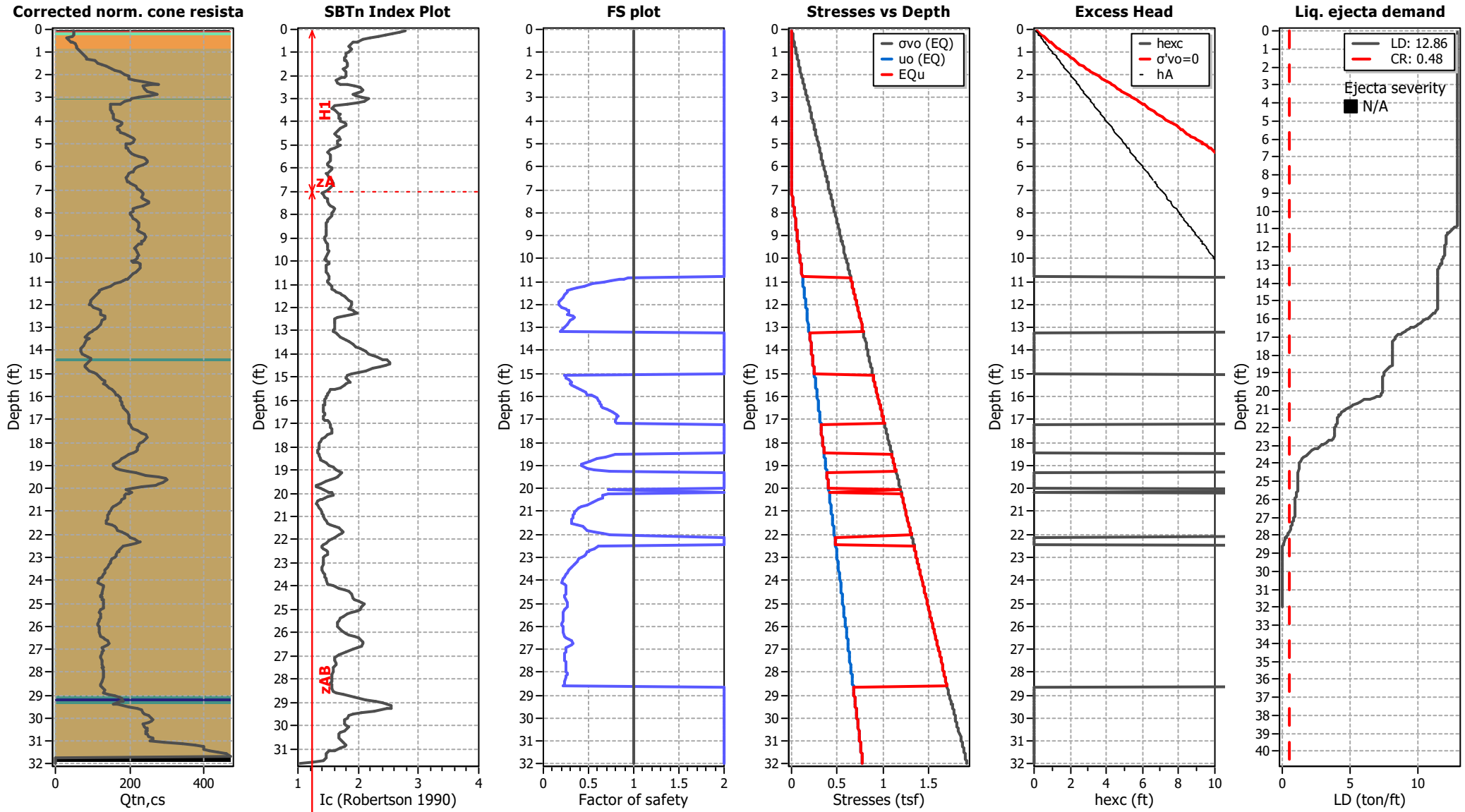

LIQUEFACTION ANALYSIS REPORT

Project title : Petra Geosciences / Apple Canyon

Location : Lake Hemet, CA

CPT file : CPT-11

Input parameters and analysis data

Analysis method:	NCEER (1998)	G.W.T. (in-situ):	11.00 ft	Use fill:	No	Clay like behavior applied:	Sands only
Fines correction method:	NCEER (1998)	G.W.T. (earthq.):	7.00 ft	Fill height:	N/A	Limit depth applied:	No
Points to test:	Based on Ic value	Average results interval:	3	Fill weight:	N/A	Limit depth:	N/A
Earthquake magnitude M_w :	8.10	Ic cut-off value:	2.60	Trans. detect. applied:	Yes	MSF method:	Method based
Peak ground acceleration:	0.89	Unit weight calculation:	Based on SBT	K_o applied:	Yes		

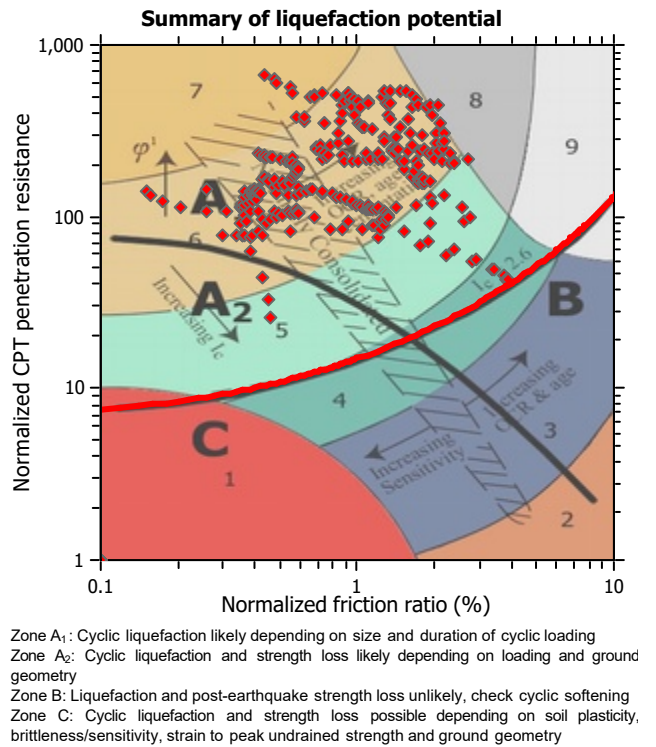
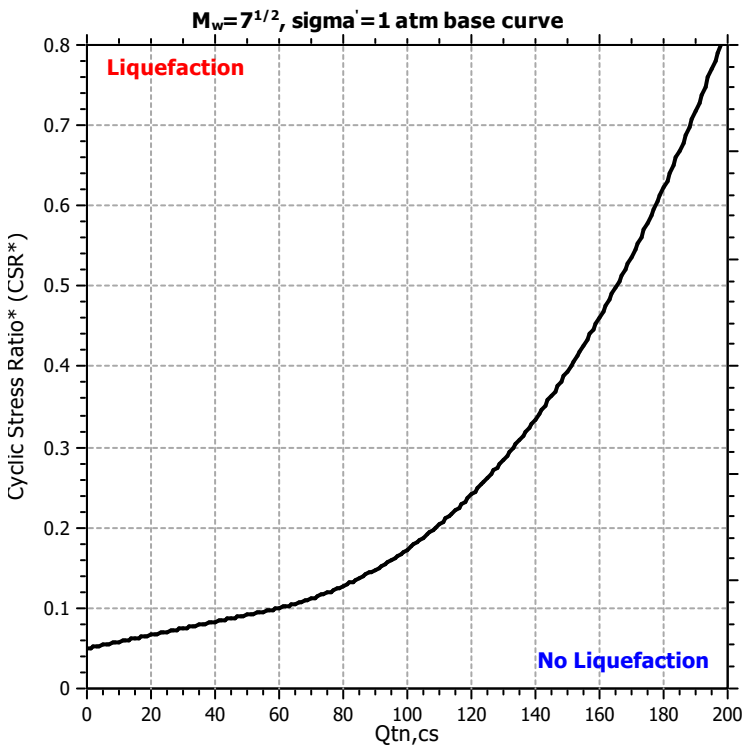
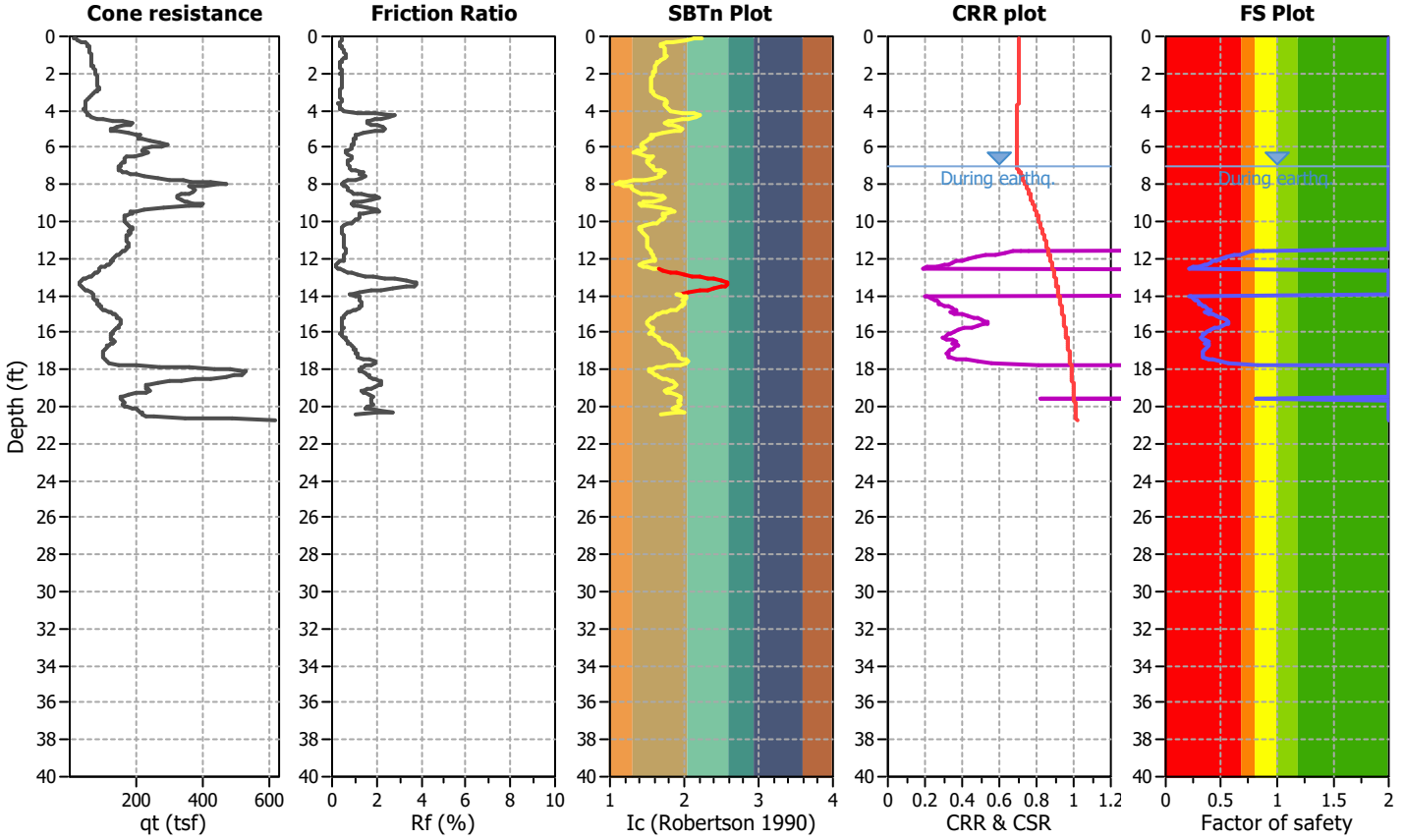

CPT basic interpretation plots

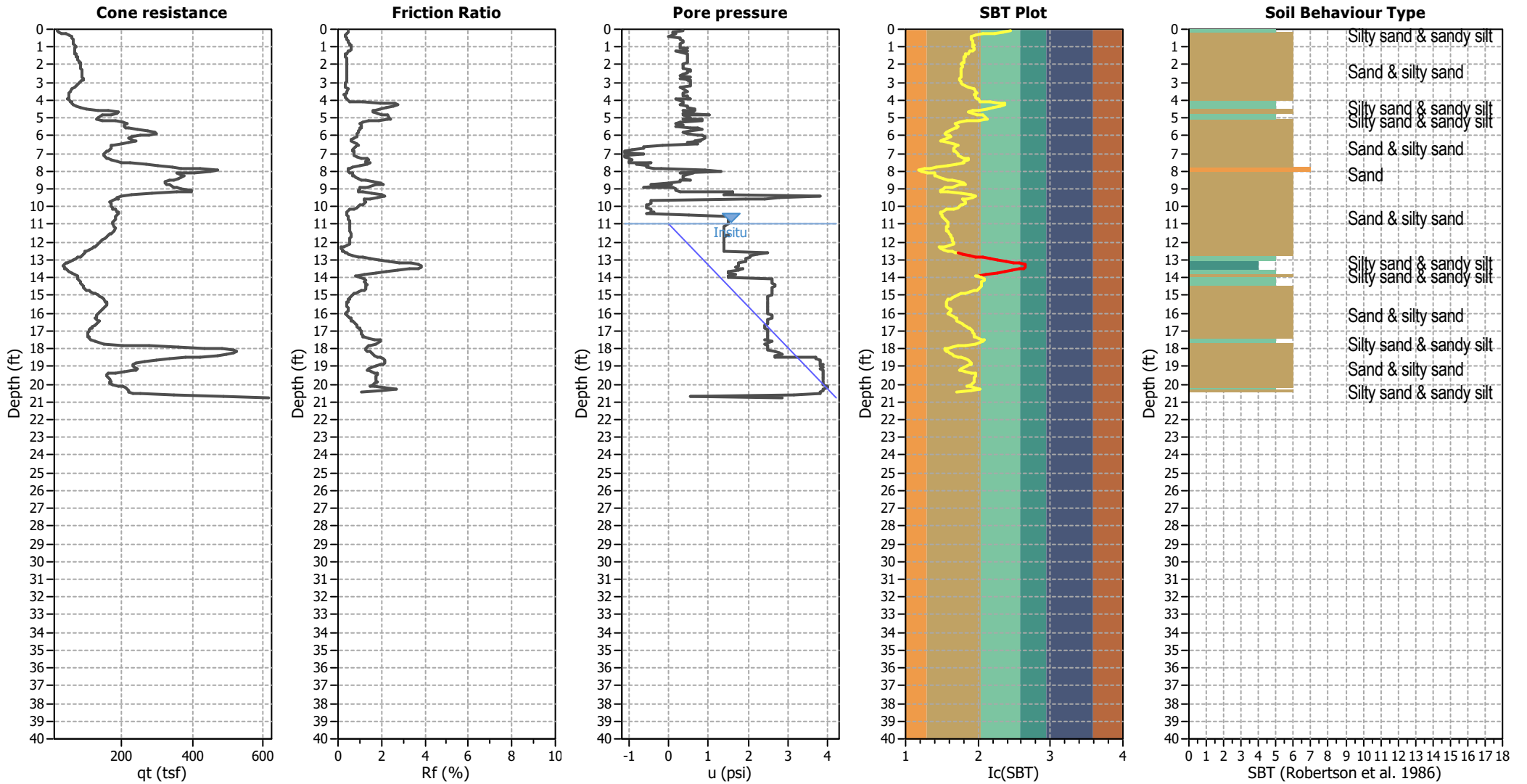

Input parameters and analysis data

Analysis method:	NCEER (1998)	Depth to water table (earthq.):	7.00 ft	Fill weight:	N/A
Fines correction method:	NCEER (1998)	Average results interval:	3	Transition detect. applied:	Yes
Points to test:	Based on Ic value	Ic cut-off value:	2.60	K _o applied:	Yes
Earthquake magnitude M _w :	8.10	Unit weight calculation:	Based on SBT	Clay like behavior applied:	Sands only
Peak ground acceleration:	0.89	Use fill:	No	Limit depth applied:	No
Depth to water table (insitu):	11.00 ft	Fill height:	N/A	Limit depth:	N/A

SBT legend

1. Sensitive fine grained	4. Clayey silt to silty	7. Gravely sand to sand
2. Organic material	5. Silty sand to sandy silt	8. Very stiff sand to
3. Clay to silty clay	6. Clean sand to silty sand	9. Very stiff fine grained

CPT basic interpretation plots (normalized)

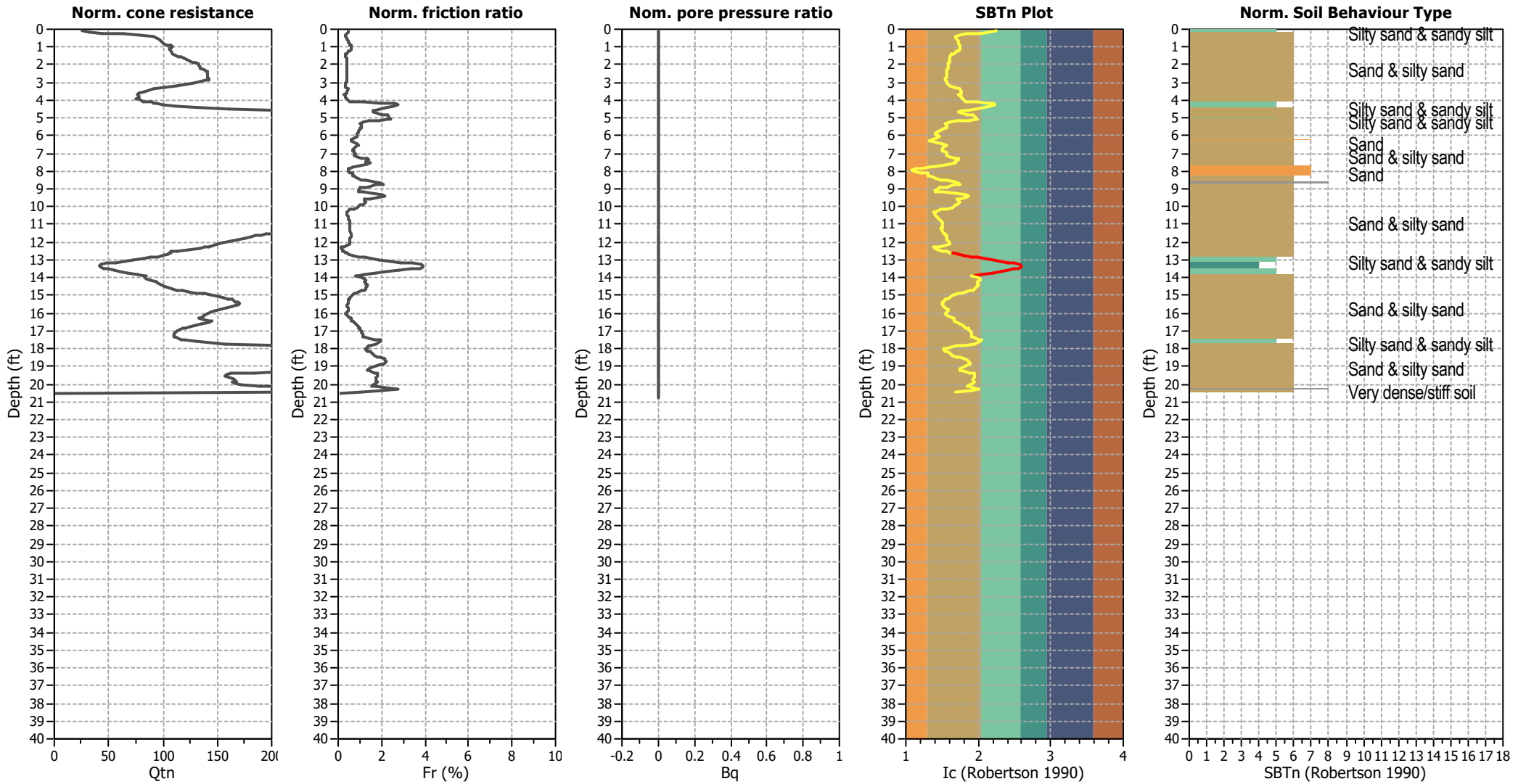

Input parameters and analysis data

Analysis method:	NCEER (1998)	Depth to water table (erthq.):	7.00 ft	Fill weight:	N/A
Fines correction method:	NCEER (1998)	Average results interval:	3	Transition detect. applied:	Yes
Points to test:	Based on Ic value	Ic cut-off value:	2.60	K _o applied:	Yes
Earthquake magnitude M _w :	8.10	Unit weight calculation:	Based on SBT	Clay like behavior applied:	Sands only
Peak ground acceleration:	0.89	Use fill:	No	Limit depth applied:	No
Depth to water table (insitu):	11.00 ft	Fill height:	N/A	Limit depth:	N/A

SBTn legend

1. Sensitive fine grained	4. Clayey silt to silty	7. Gravely sand to sand
2. Organic material	5. Silty sand to sandy silt	8. Very stiff sand to
3. Clay to silty clay	6. Clean sand to silty sand	9. Very stiff fine grained

Liquefaction analysis overall plots (intermediate results)

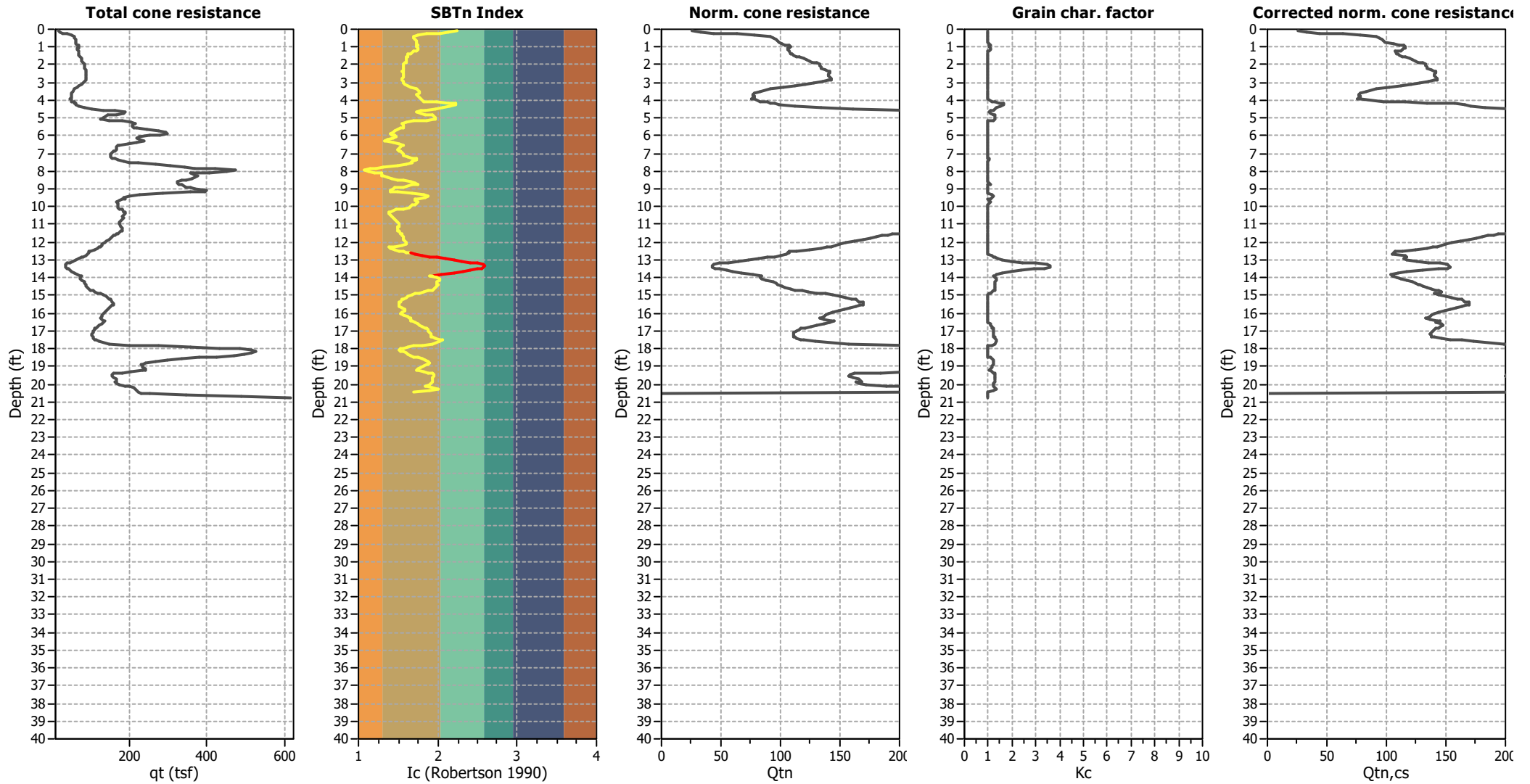

Input parameters and analysis data

Analysis method:	NCEER (1998)	Depth to water table (earthq.):	7.00 ft	Fill weight:	N/A
Fines correction method:	NCEER (1998)	Average results interval:	3	Transition detect. applied:	Yes
Points to test:	Based on Ic value	Ic cut-off value:	2.60	K _o applied:	Yes
Earthquake magnitude M _w :	8.10	Unit weight calculation:	Based on SBT	Clay like behavior applied:	Sands only
Peak ground acceleration:	0.89	Use fill:	No	Limit depth applied:	No
Depth to water table (insitu):	11.00 ft	Fill height:	N/A	Limit depth:	N/A

Liquefaction analysis overall plots

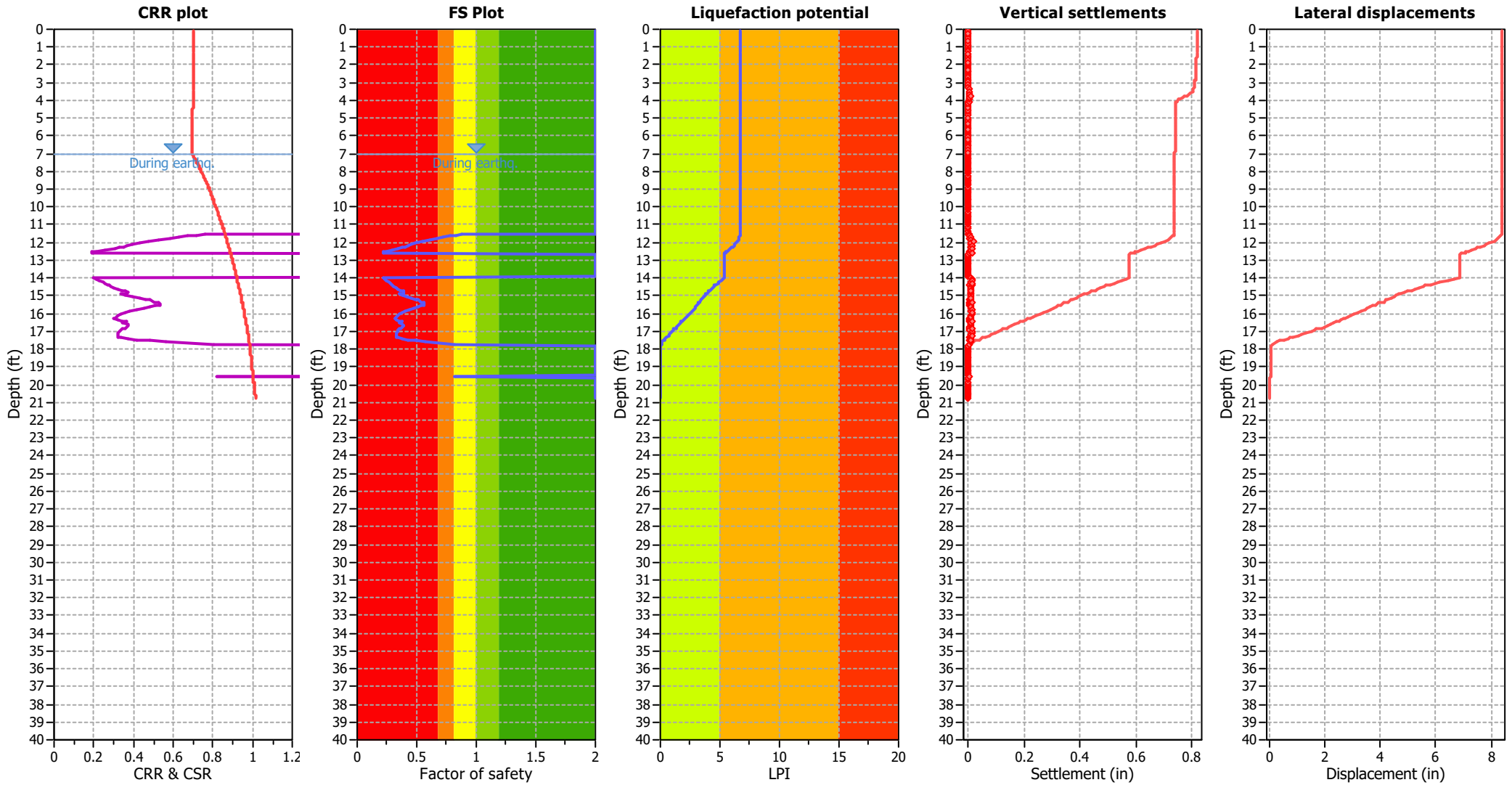

Input parameters and analysis data

Analysis method:	NCEER (1998)	Depth to water table (earthq.):	7.00 ft	Fill weight:	N/A
Fines correction method:	NCEER (1998)	Average results interval:	3	Transition detect. applied:	Yes
Points to test:	Based on Ic value	Ic cut-off value:	2.60	K_0 applied:	Yes
Earthquake magnitude M_w :	8.10	Unit weight calculation:	Based on SBT	Clay like behavior applied:	Sands only
Peak ground acceleration:	0.89	Use fill:	No	Limit depth applied:	No
Depth to water table (insitu):	11.00 ft	Fill height:	N/A	Limit depth:	N/A

F.S. color scheme

- Almost certain it will liquefy
- Very likely to liquefy
- Liquefaction and no liq. are equally likely
- Unlike to liquefy
- Almost certain it will not liquefy

LPI color scheme

- Very high risk
- High risk
- Low risk

Liquefaction analysis summary plots

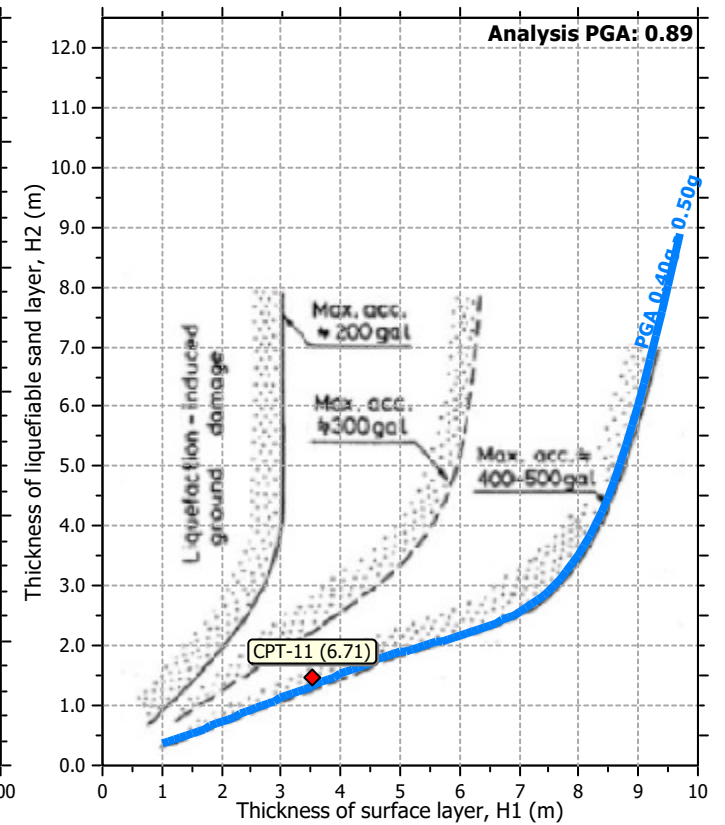
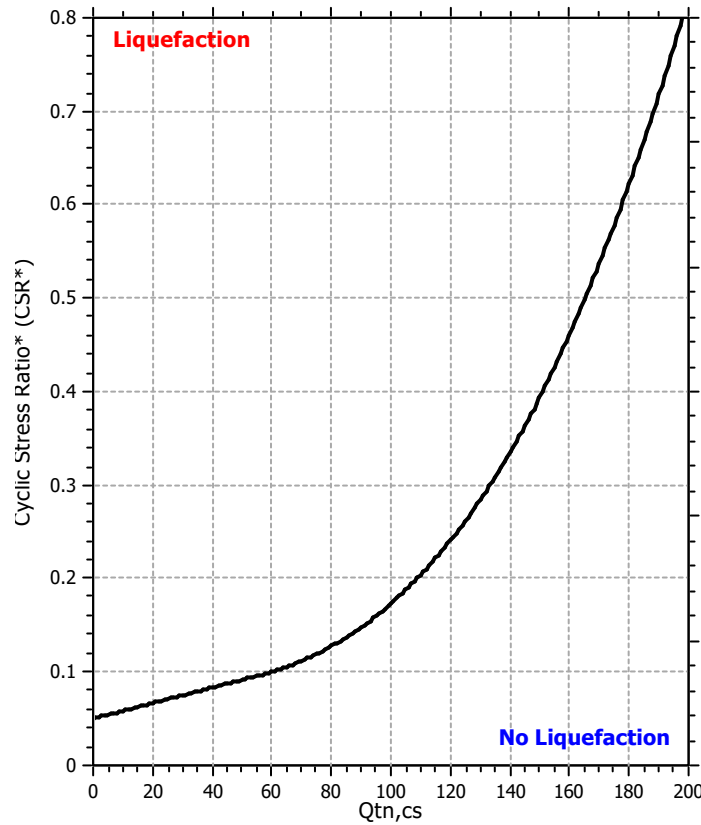
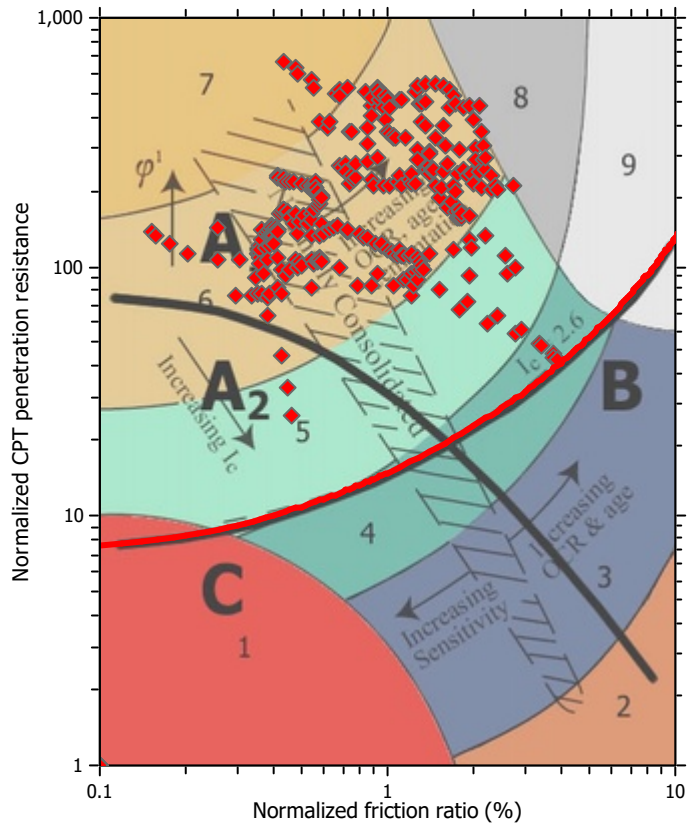

Input parameters and analysis data

Analysis method:	NCEER (1998)	Depth to water table (earthq.):	7.00 ft	Fill weight:	N/A
Fines correction method:	NCEER (1998)	Average results interval:	3	Transition detect. applied:	Yes
Points to test:	Based on I_c value	I_c cut-off value:	2.60	K_o applied:	Yes
Earthquake magnitude M_w :	8.10	Unit weight calculation:	Based on SBT	Clay like behavior applied:	Sands only
Peak ground acceleration:	0.89	Use fill:	No	Limit depth applied:	No
Depth to water table (insitu):	11.00 ft	Fill height:	N/A	Limit depth:	N/A

Check for strength loss plots (Robertson (2010))

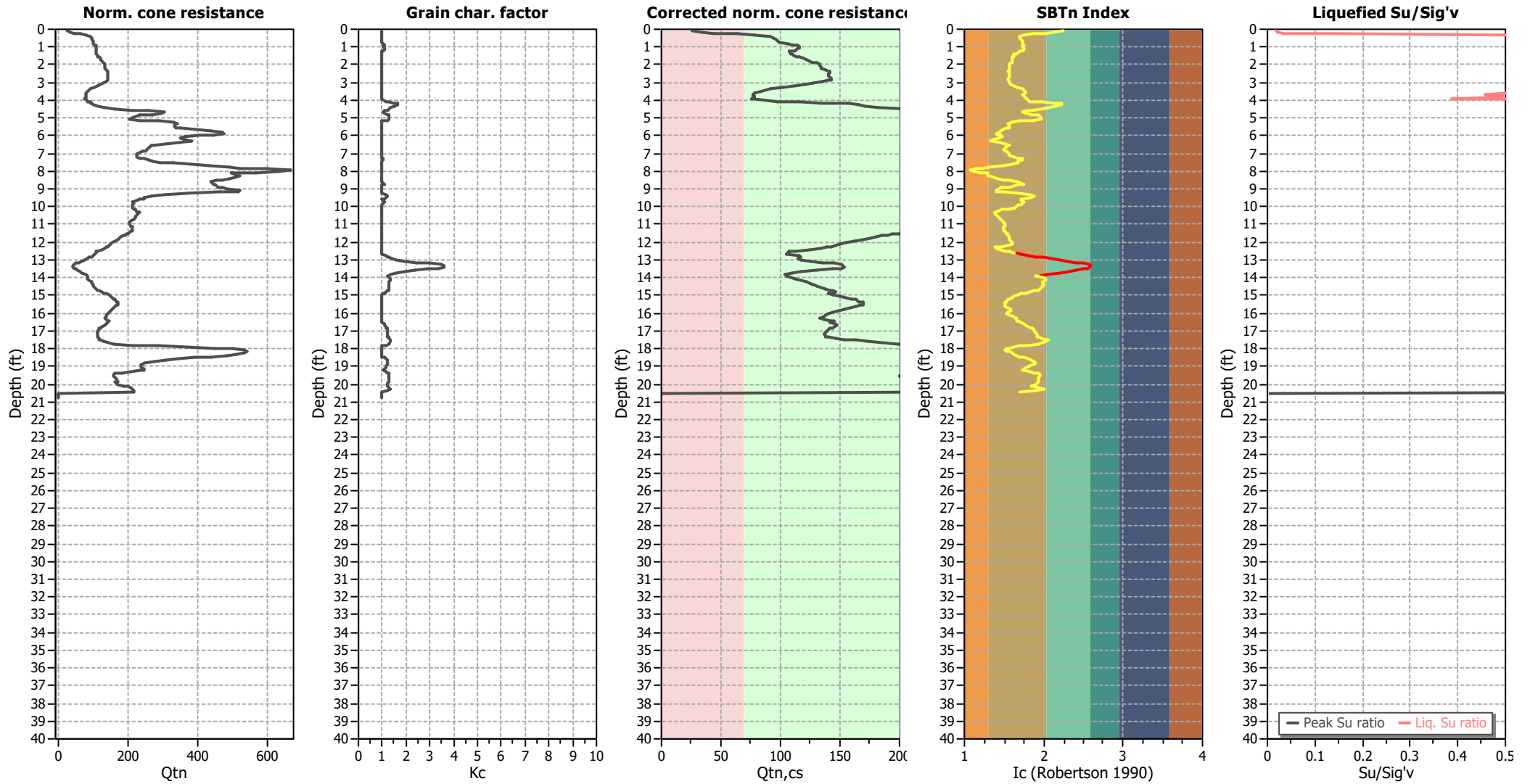

Input parameters and analysis data

Analysis method:	NCEER (1998)	Depth to water table (erthq.):	7.00 ft	Fill weight:	N/A
Fines correction method:	NCEER (1998)	Average results interval:	3	Transition detect. applied:	Yes
Points to test:	Based on Ic value	Ic cut-off value:	2.60	K _o applied:	Yes
Earthquake magnitude M _w :	8.10	Unit weight calculation:	Based on SBT	Clay like behavior applied:	Sands only
Peak ground acceleration:	0.89	Use fill:	No	Limit depth applied:	No
Depth to water table (insitu):	11.00 ft	Fill height:	N/A	Limit depth:	N/A

TRANSITION LAYER DETECTION ALGORITHM REPORT

Summary Details & Plots

Short description

The software will delete data when the cone is in transition from either clay to sand or vice-versa. To do this the software requires a range of I_c values over which the transition will be defined (typically somewhere between $1.80 < I_c < 3.0$) and a rate of change of I_c . Transitions typically occur when the rate of change of I_c is fast (i.e. ΔI_c is small).

The SBT_n plot below, displays in red the detected transition layers based on the parameters listed below the graphs.

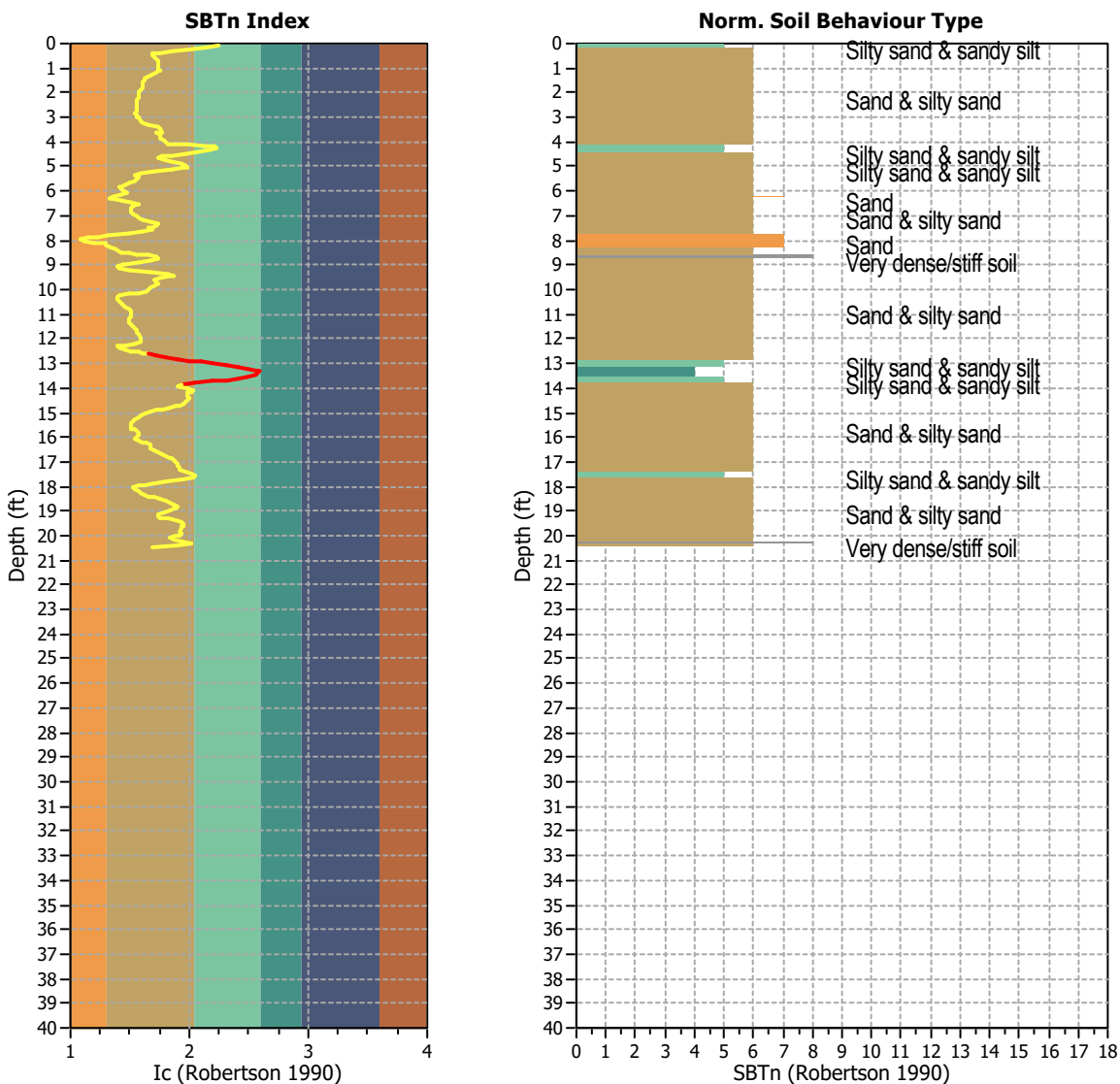

Transition layer algorithm properties

I_c minimum check value: 1.70
 I_c maximum check value: 3.00
 I_c change ratio value: 0.0250
 Minimum number of points in layer: 4

General statistics

Total points in CPT file: 311
 Total points excluded: 20
 Exclusion percentage: 6.43%
 Number of layers detected: 2

Estimation of post-earthquake settlements

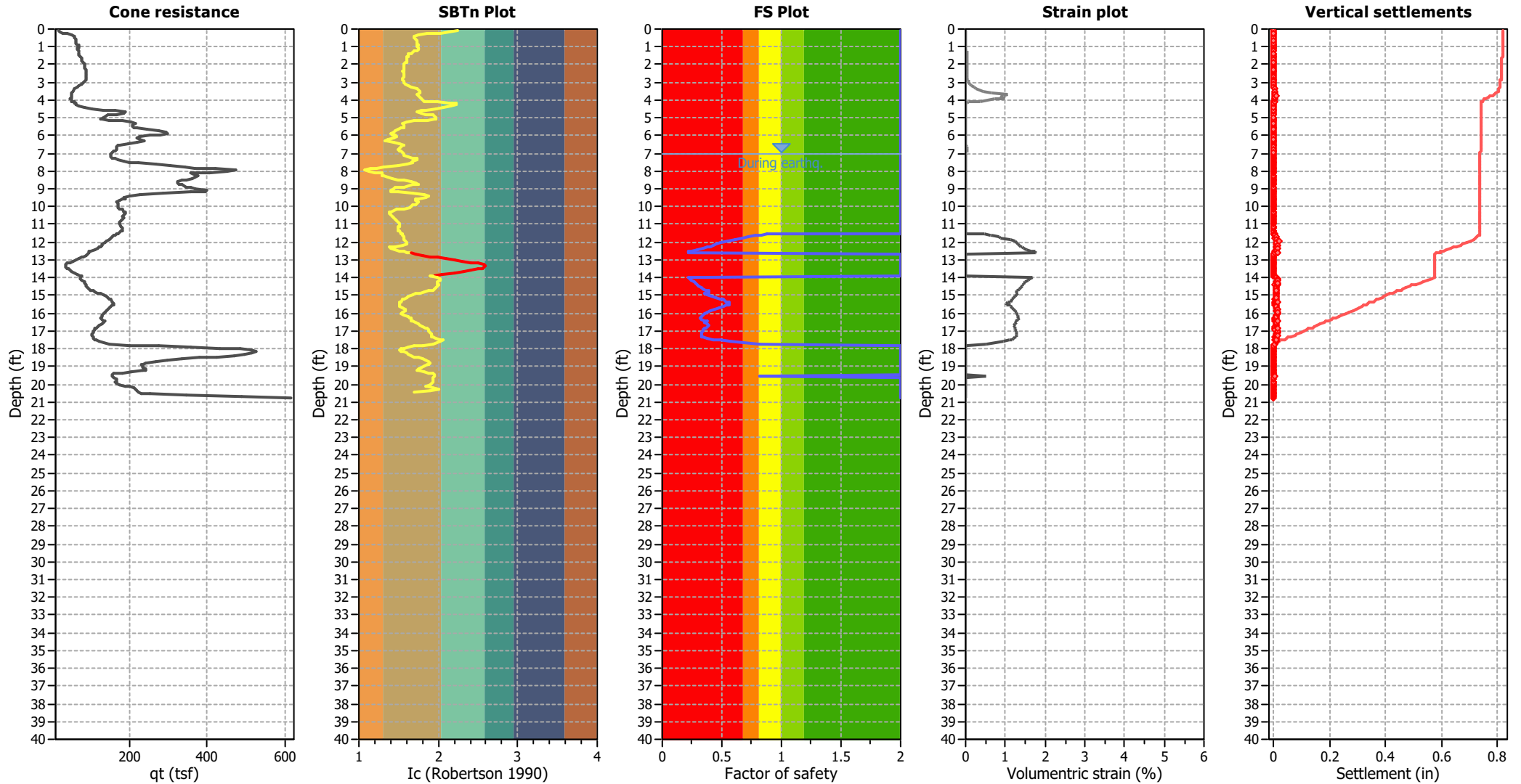

Abbreviations

- q_c: Total cone resistance (cone resistance q_c corrected for pore water effects)
- I_c: Soil Behaviour Type Index
- FS: Calculated Factor of Safety against liquefaction
- Volumetric strain: Post-liquefaction volumetric strain

Estimation of post-earthquake lateral Displacements

Geometric parameters: Gently sloping ground without free face (Slope 1.00 %)

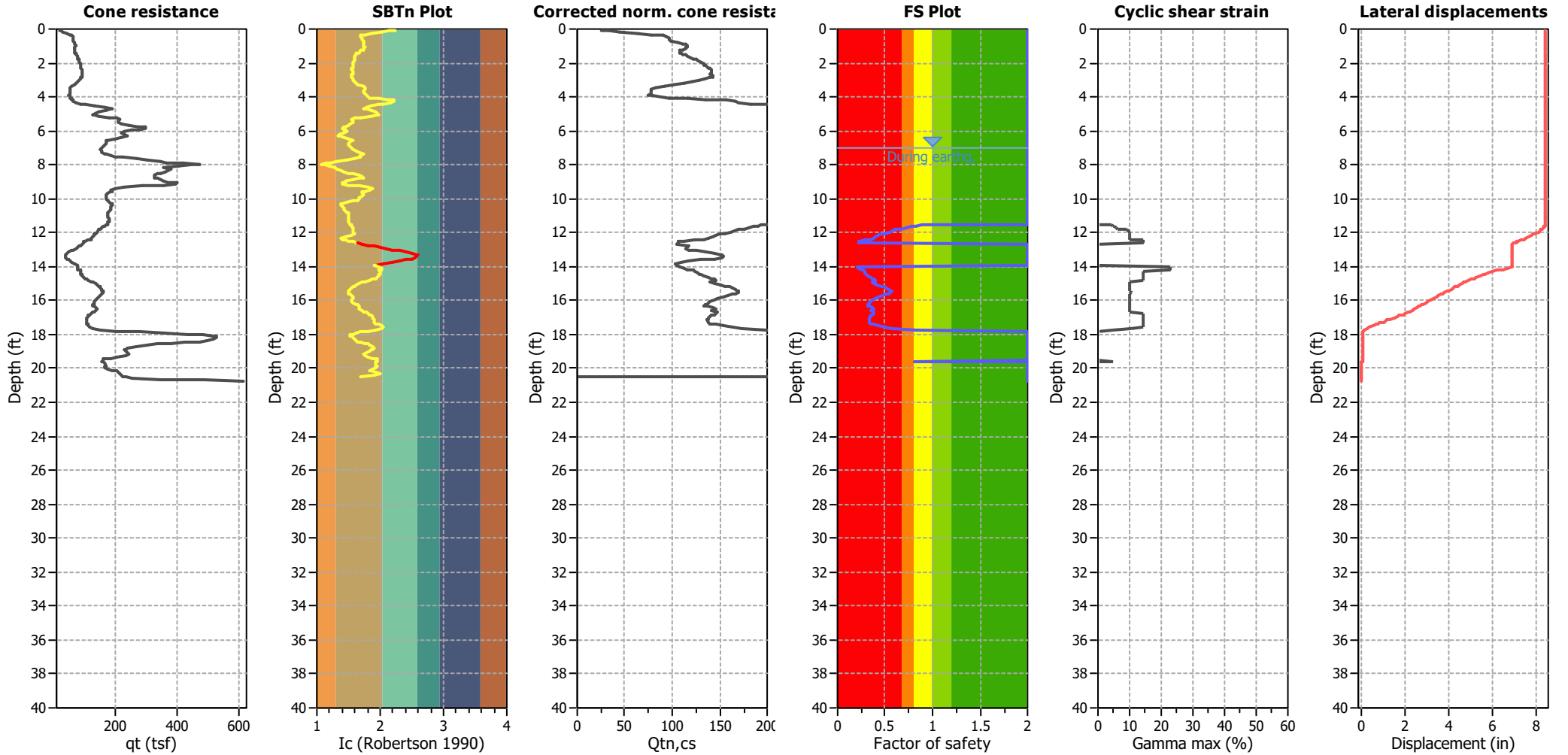

Abbreviations

q_t: Total cone resistance (cone resistance q_c corrected for pore water effects)
 I_c: Soil Behaviour Type Index
 Q_{tn,cs}: Equivalent clean sand normalized CPT total cone resistance

F.S.: Factor of safety
 γ_{max}: Maximum cyclic shear strain
 LDI: Lateral displacement index

Surface condition



Aging Calculation Estimation

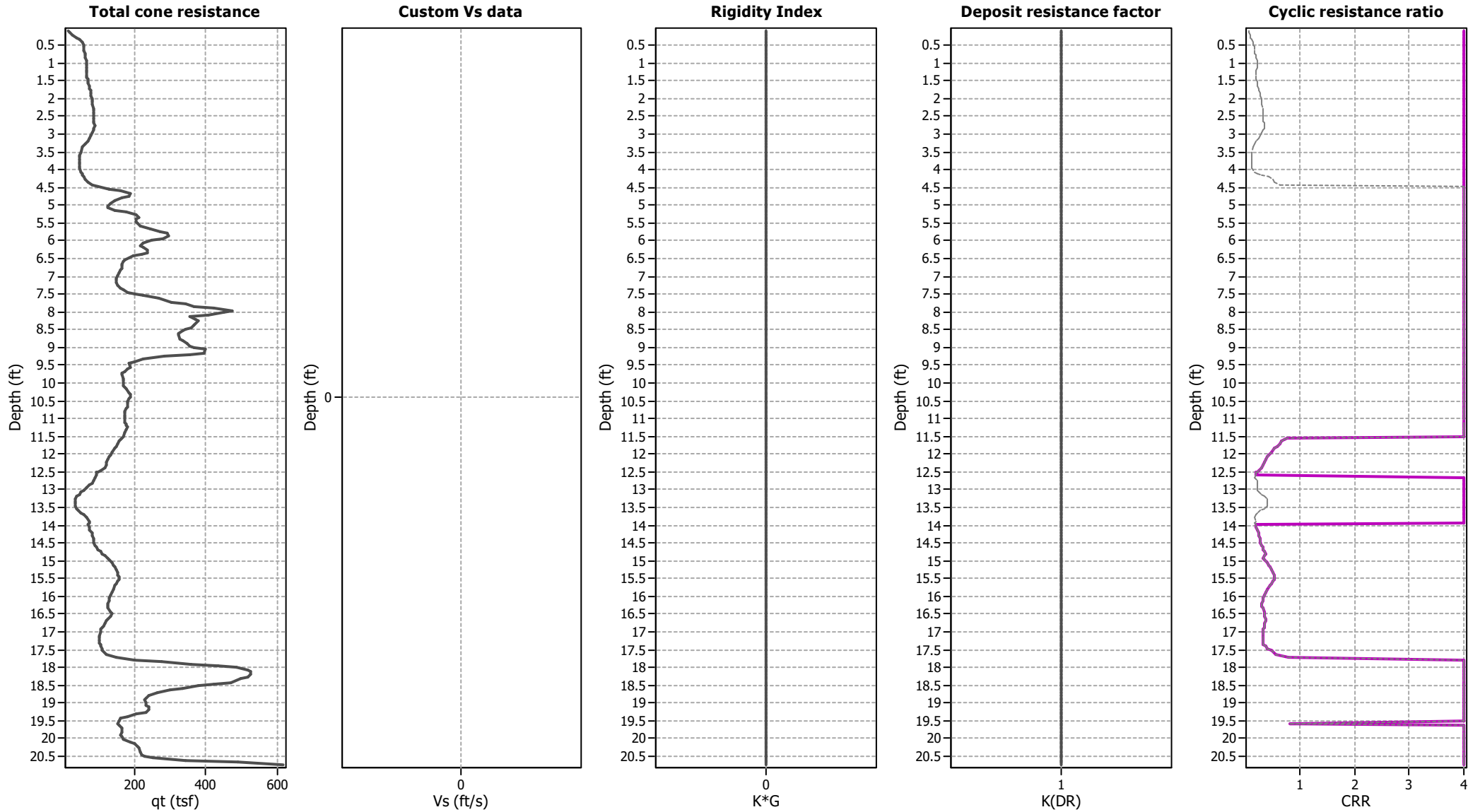

Ejecta Severity Estimation

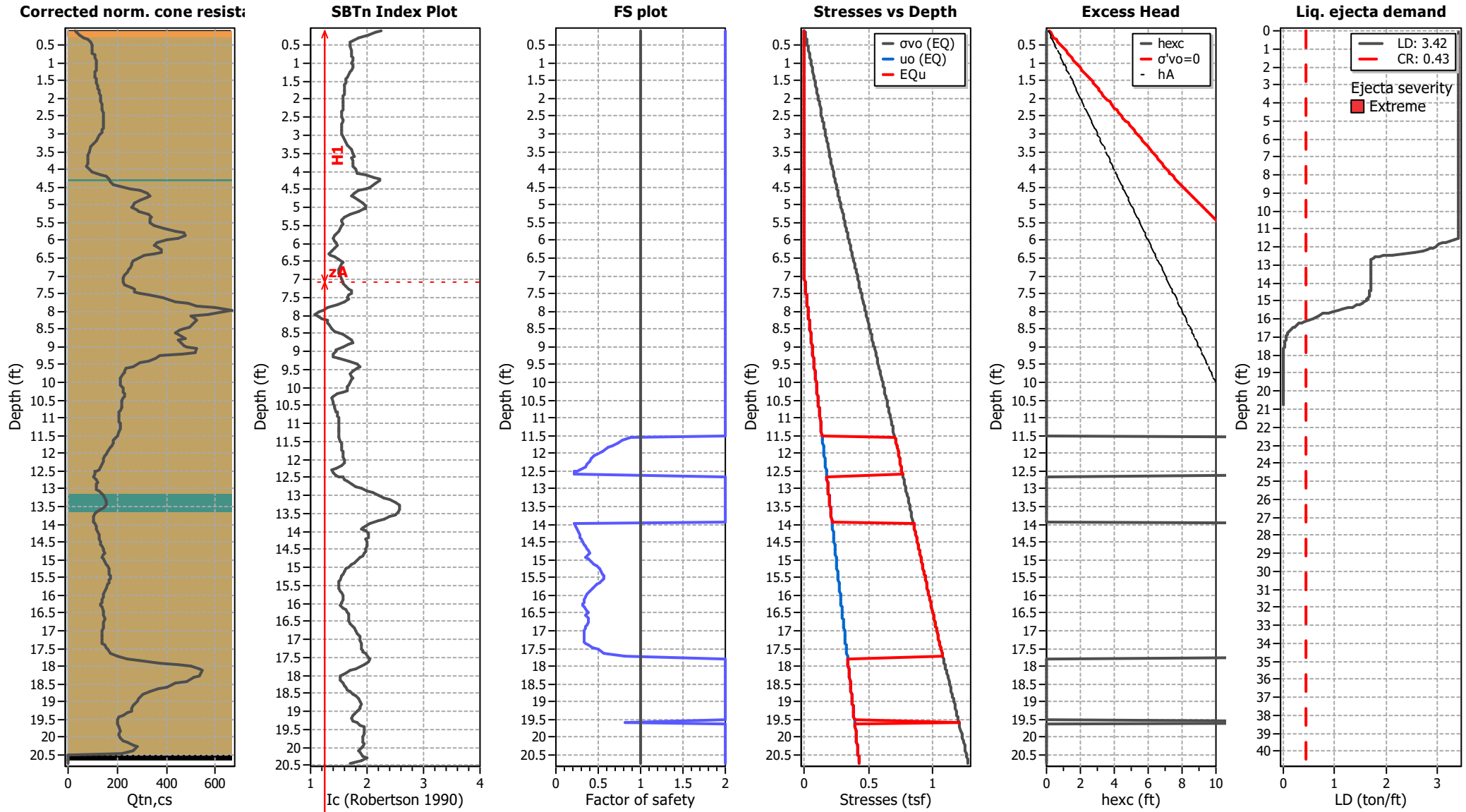

LIQUEFACTION ANALYSIS REPORT

Project title : Petra Geosciences / Apple Canyon

Location : Lake Hemet, CA

CPT file : CPT-12

Input parameters and analysis data

Analysis method:	NCEER (1998)	G.W.T. (in-situ):	12.00 ft	Use fill:	No	Clay like behavior applied:	Sands only
Fines correction method:	NCEER (1998)	G.W.T. (earthq.):	7.00 ft	Fill height:	N/A	Limit depth applied:	No
Points to test:	Based on Ic value	Average results interval:	3	Fill weight:	N/A	Limit depth:	N/A
Earthquake magnitude M_w :	8.10	Ic cut-off value:	2.60	Trans. detect. applied:	Yes	MSF method:	Method based
Peak ground acceleration:	0.89	Unit weight calculation:	Based on SBT	K_o applied:	Yes		

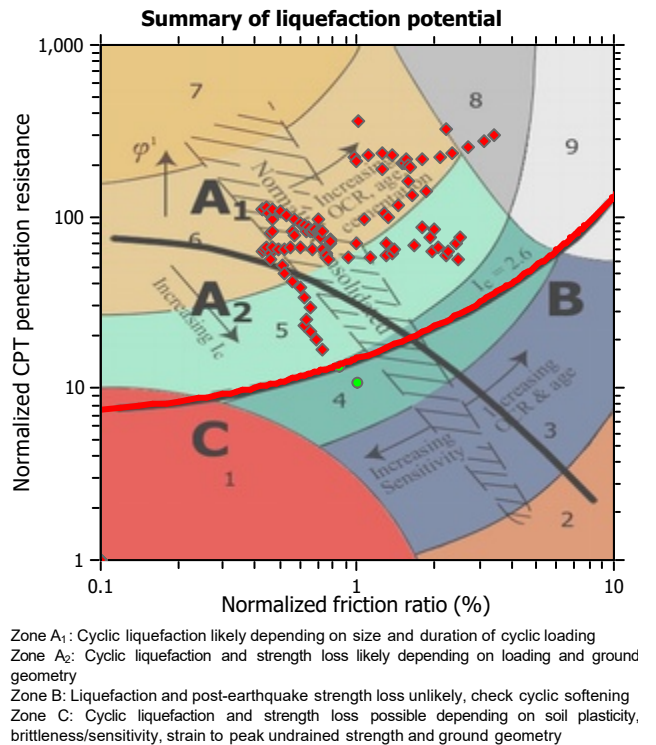
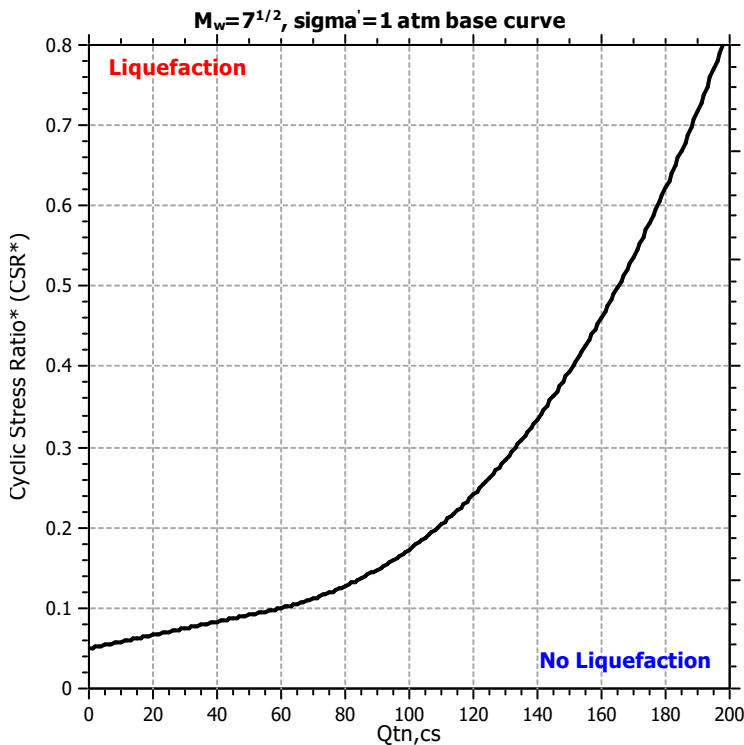
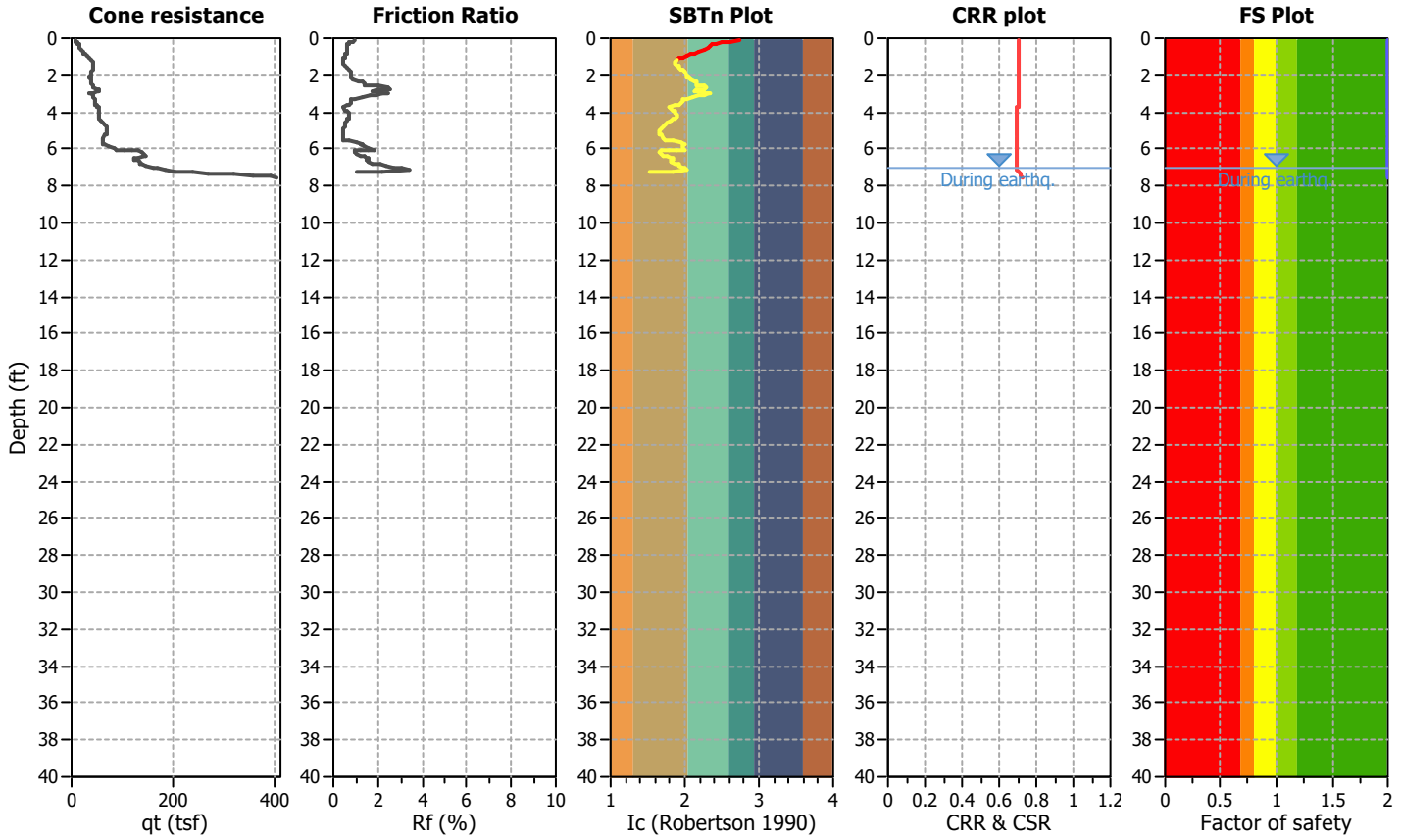

CPT basic interpretation plots

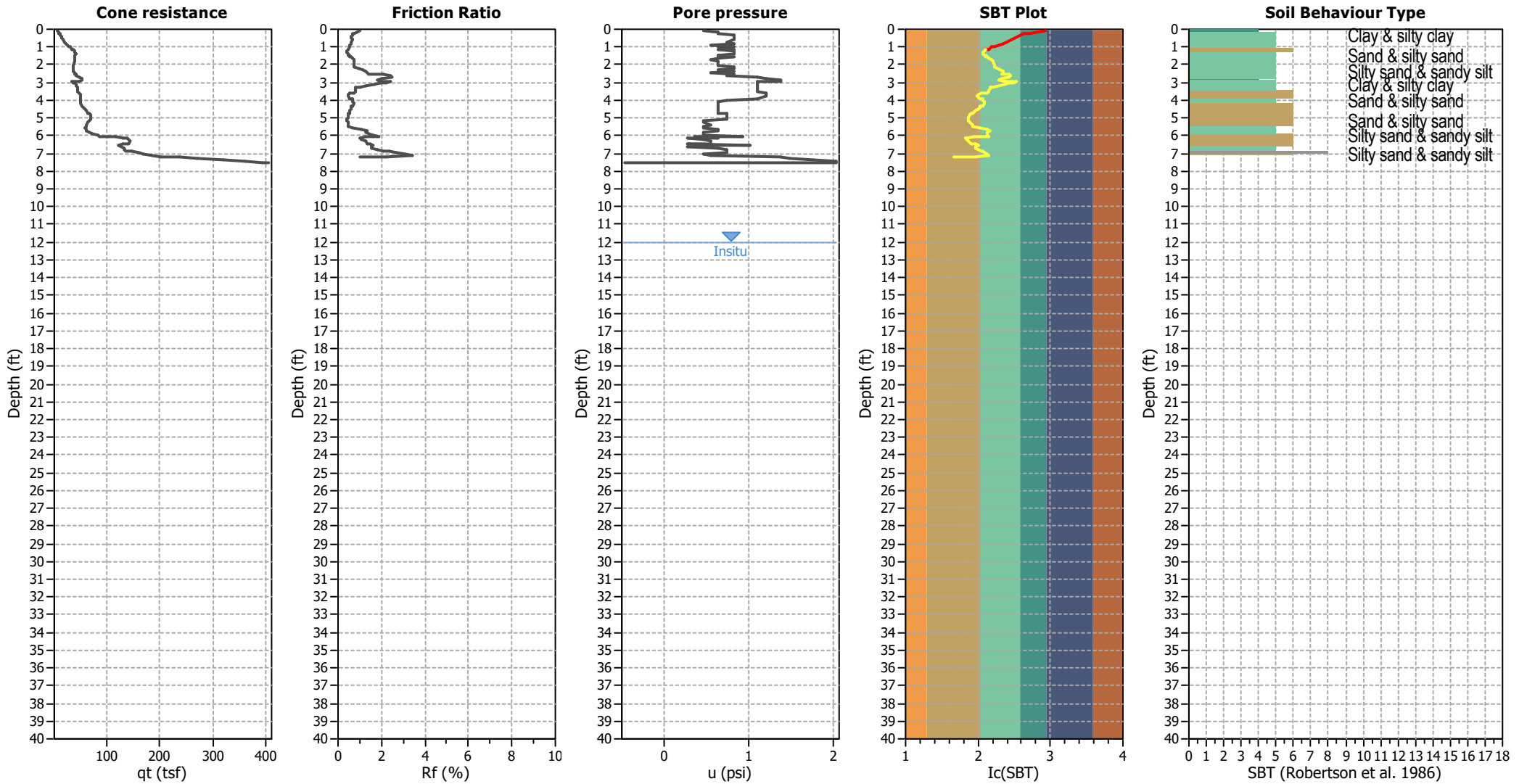

Input parameters and analysis data

Analysis method:	NCEER (1998)	Depth to water table (earthq.):	7.00 ft	Fill weight:	N/A
Fines correction method:	NCEER (1998)	Average results interval:	3	Transition detect. applied:	Yes
Points to test:	Based on Ic value	Ic cut-off value:	2.60	K ₀ applied:	Yes
Earthquake magnitude M _w :	8.10	Unit weight calculation:	Based on SBT	Clay like behavior applied:	Sands only
Peak ground acceleration:	0.89	Use fill:	No	Limit depth applied:	No
Depth to water table (insitu):	12.00 ft	Fill height:	N/A	Limit depth:	N/A

SBT legend

1. Sensitive fine grained	4. Clayey silt to silty	7. Gravely sand to sand
2. Organic material	5. Silty sand to sandy silt	8. Very stiff sand to
3. Clay to silty clay	6. Clean sand to silty sand	9. Very stiff fine grained

CPT basic interpretation plots (normalized)

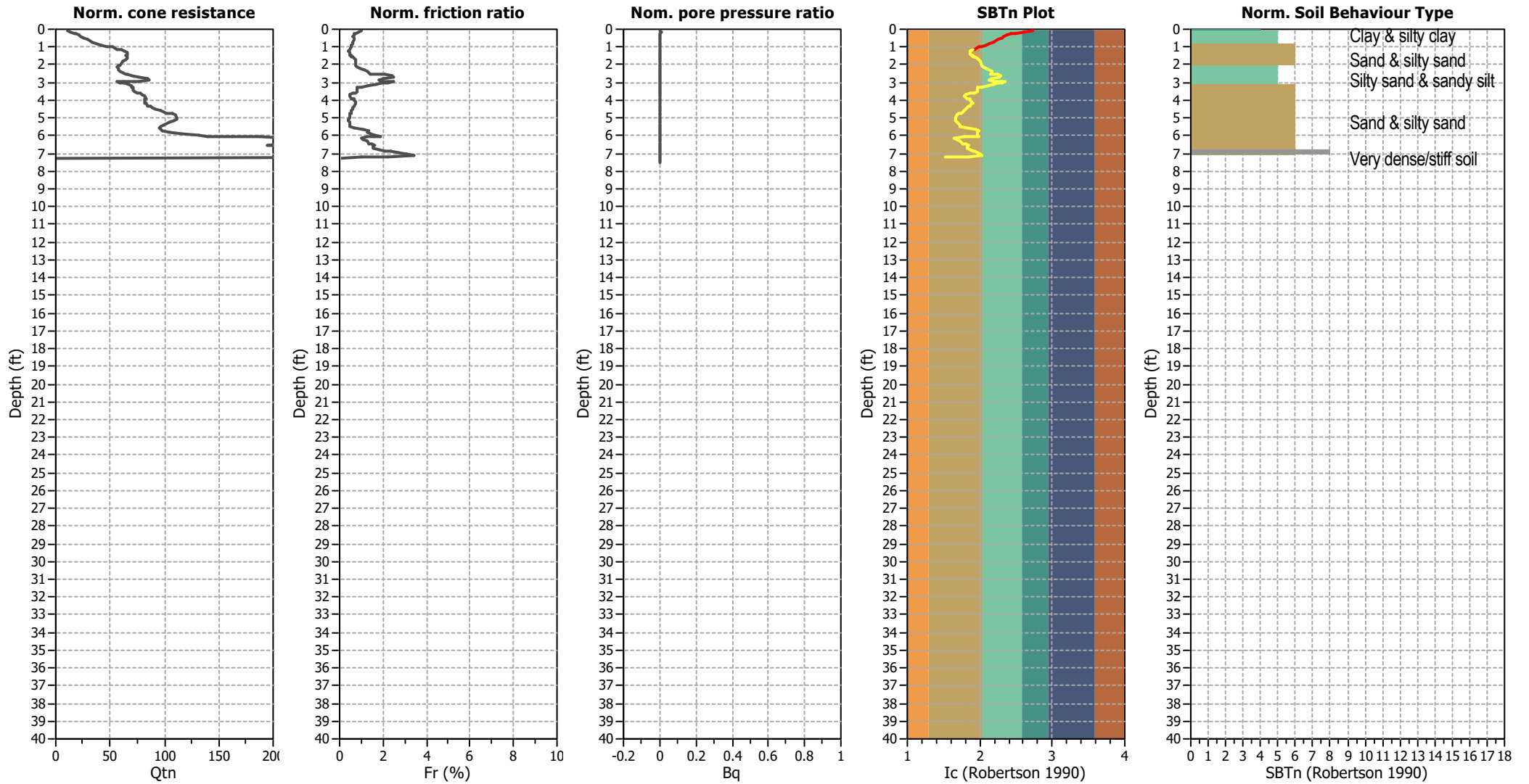

Input parameters and analysis data

Analysis method:	NCEER (1998)	Depth to water table (erthq.):	7.00 ft	Fill weight:	N/A
Fines correction method:	NCEER (1998)	Average results interval:	3	Transition detect. applied:	Yes
Points to test:	Based on Ic value	Ic cut-off value:	2.60	K ₀ applied:	Yes
Earthquake magnitude M _w :	8.10	Unit weight calculation:	Based on SBT	Clay like behavior applied:	Sands only
Peak ground acceleration:	0.89	Use fill:	No	Limit depth applied:	No
Depth to water table (insitu):	12.00 ft	Fill height:	N/A	Limit depth:	N/A

SBTn legend

1. Sensitive fine grained	4. Clayey silt to silty	7. Gravely sand to sand
2. Organic material	5. Silty sand to sandy silt	8. Very stiff sand to
3. Clay to silty clay	6. Clean sand to silty sand	9. Very stiff fine grained

Liquefaction analysis overall plots (intermediate results)

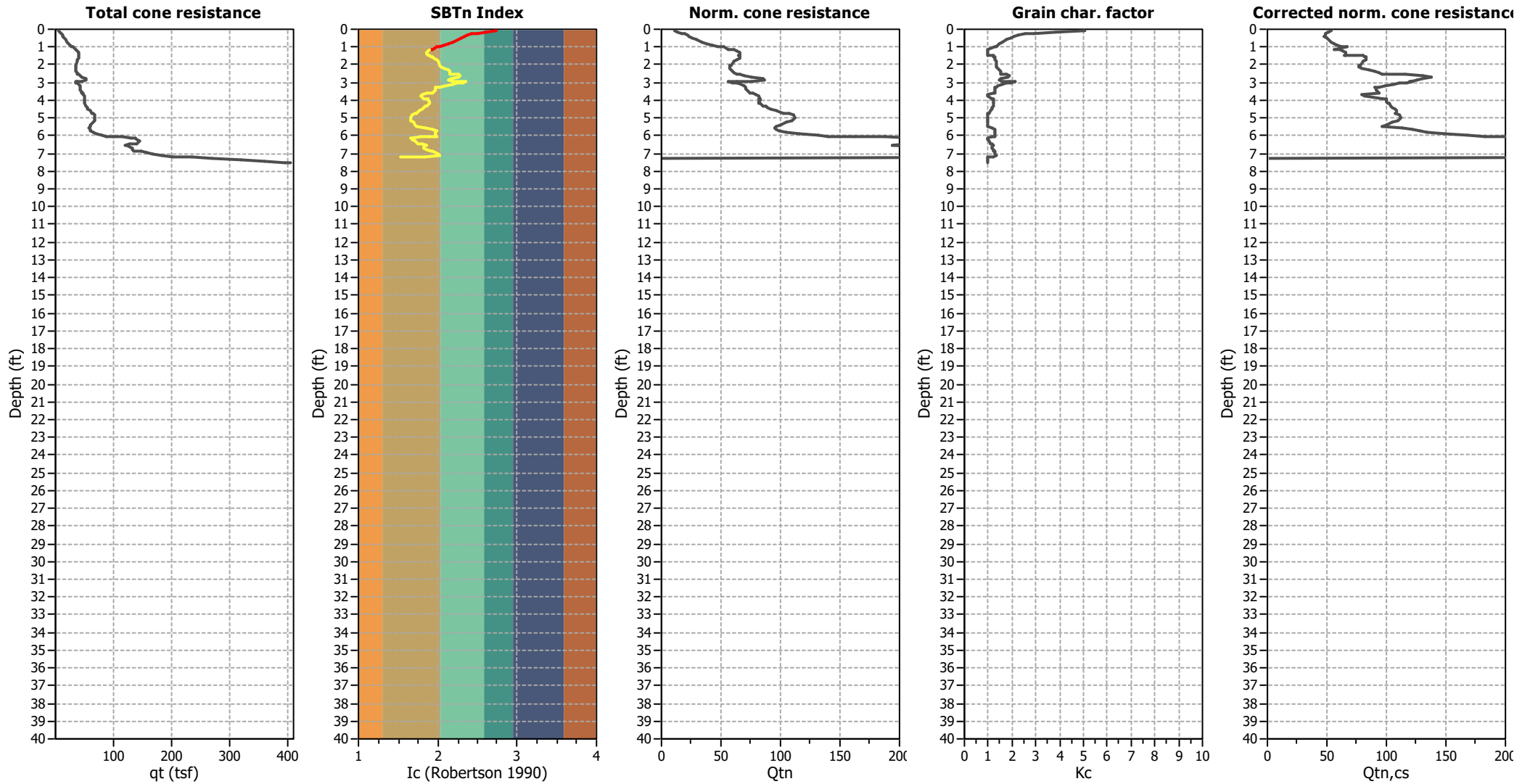

Input parameters and analysis data

Analysis method:	NCEER (1998)	Depth to water table (erthq.):	7.00 ft	Fill weight:	N/A
Fines correction method:	NCEER (1998)	Average results interval:	3	Transition detect. applied:	Yes
Points to test:	Based on Ic value	Ic cut-off value:	2.60	K _o applied:	Yes
Earthquake magnitude M _w :	8.10	Unit weight calculation:	Based on SBT	Clay like behavior applied:	Sands only
Peak ground acceleration:	0.89	Use fill:	No	Limit depth applied:	No
Depth to water table (insitu):	12.00 ft	Fill height:	N/A	Limit depth:	N/A

Liquefaction analysis overall plots

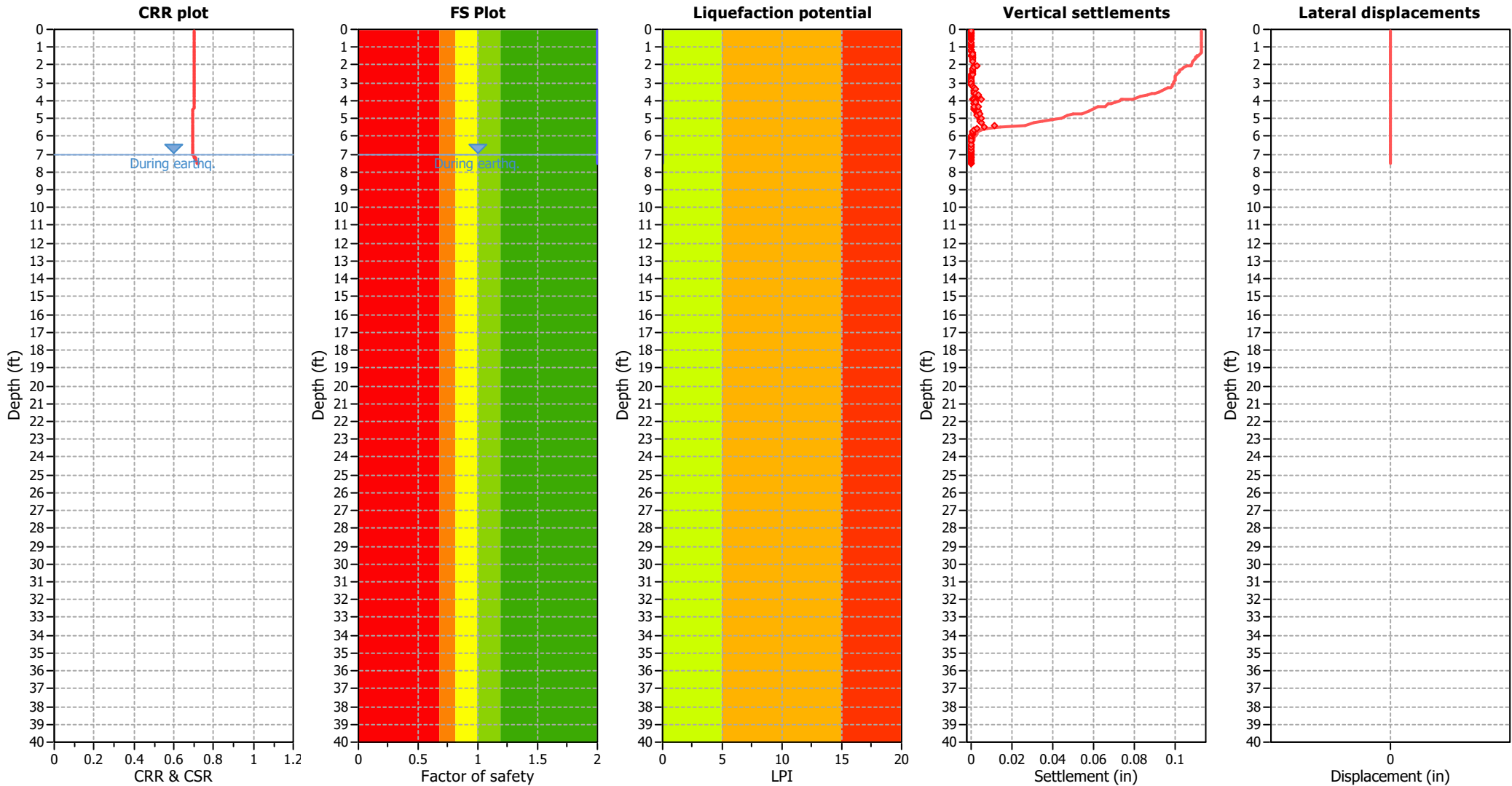

Input parameters and analysis data

Analysis method:	NCEER (1998)	Depth to water table (earthq.):	7.00 ft	Fill weight:	N/A
Fines correction method:	NCEER (1998)	Average results interval:	3	Transition detect. applied:	Yes
Points to test:	Based on Ic value	Ic cut-off value:	2.60	K _o applied:	Yes
Earthquake magnitude M _w :	8.10	Unit weight calculation:	Based on SBT	Clay like behavior applied:	Sands only
Peak ground acceleration:	0.89	Use fill:	No	Limit depth applied:	No
Depth to water table (insitu):	12.00 ft	Fill height:	N/A	Limit depth:	N/A

F.S. color scheme

- Almost certain it will liquefy
- Very likely to liquefy
- Liquefaction and no liq. are equally likely
- Unlike to liquefy
- Almost certain it will not liquefy

LPI color scheme

- Very high risk
- High risk
- Low risk

Liquefaction analysis summary plots

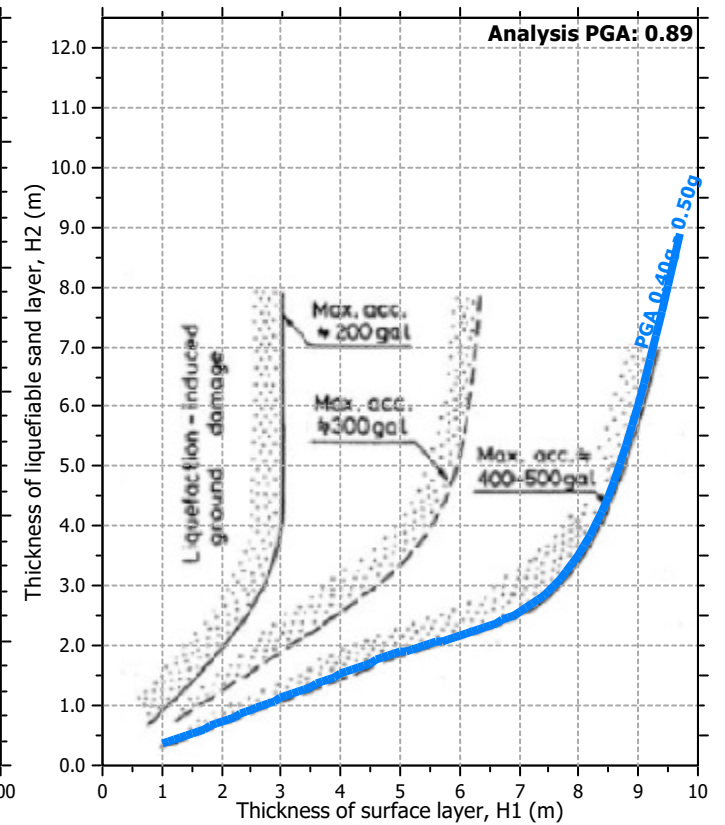
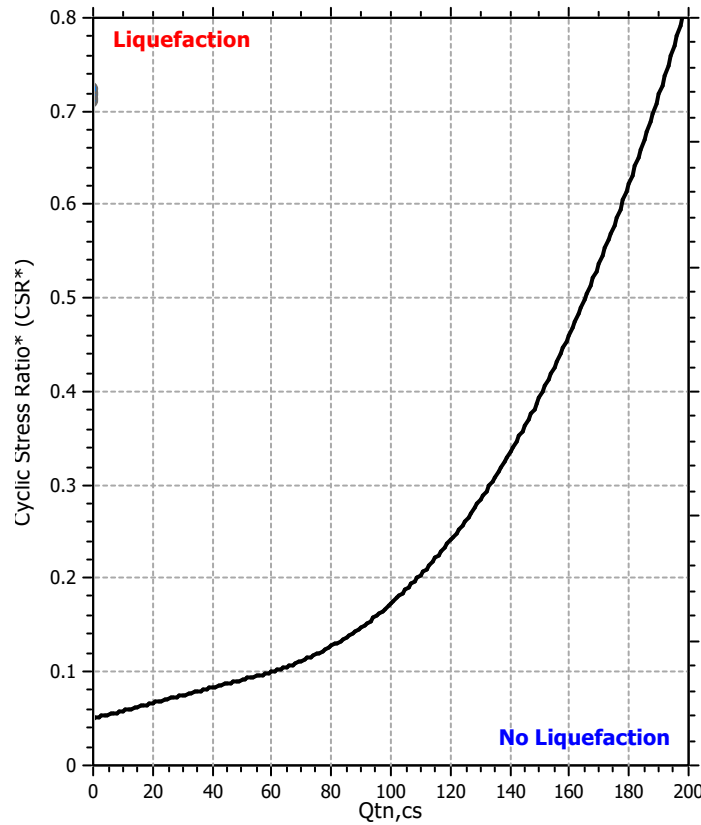
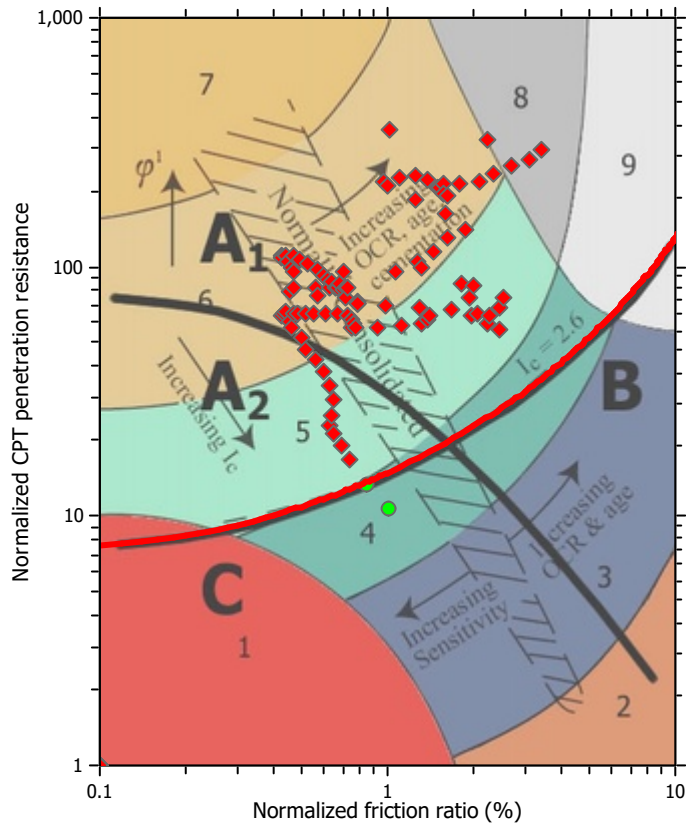

Input parameters and analysis data

Analysis method:	NCEER (1998)	Depth to water table (erthq.):	7.00 ft	Fill weight:	N/A
Fines correction method:	NCEER (1998)	Average results interval:	3	Transition detect. applied:	Yes
Points to test:	Based on I_c value	I_c cut-off value:	2.60	K_o applied:	Yes
Earthquake magnitude M_w :	8.10	Unit weight calculation:	Based on SBT	Clay like behavior applied:	Sands only
Peak ground acceleration:	0.89	Use fill:	No	Limit depth applied:	No
Depth to water table (insitu):	12.00 ft	Fill height:	N/A	Limit depth:	N/A

Check for strength loss plots (Robertson (2010))

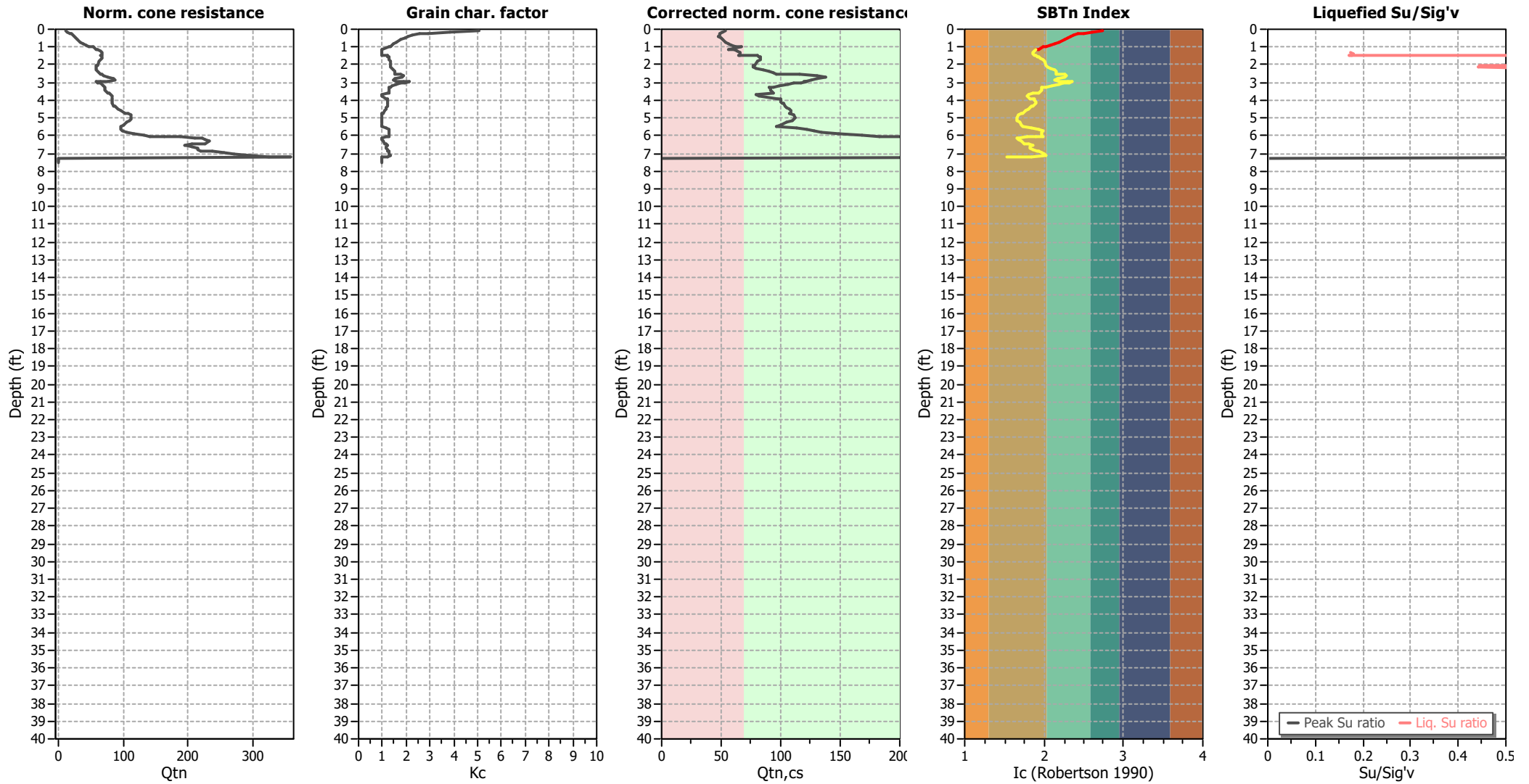

Input parameters and analysis data

Analysis method:	NCEER (1998)	Depth to water table (earthq.):	7.00 ft	Fill weight:	N/A
Fines correction method:	NCEER (1998)	Average results interval:	3	Transition detect. applied:	Yes
Points to test:	Based on Ic value	Ic cut-off value:	2.60	K _o applied:	Yes
Earthquake magnitude M _w :	8.10	Unit weight calculation:	Based on SBT	Clay like behavior applied:	Sands only
Peak ground acceleration:	0.89	Use fill:	No	Limit depth applied:	No
Depth to water table (insitu):	12.00 ft	Fill height:	N/A	Limit depth:	N/A

TRANSITION LAYER DETECTION ALGORITHM REPORT

Summary Details & Plots

Short description

The software will delete data when the cone is in transition from either clay to sand or vice-versa. To do this the software requires a range of I_c values over which the transition will be defined (typically somewhere between $1.80 < I_c < 3.0$) and a rate of change of I_c . Transitions typically occur when the rate of change of I_c is fast (i.e. ΔI_c is small).

The SBT_n plot below, displays in red the detected transition layers based on the parameters listed below the graphs.

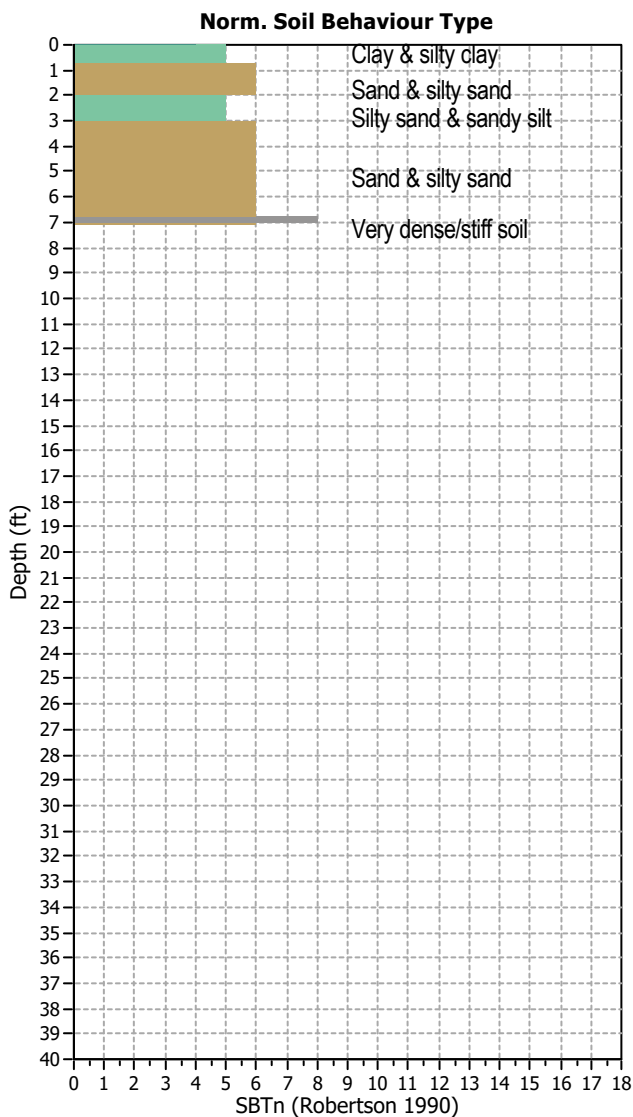
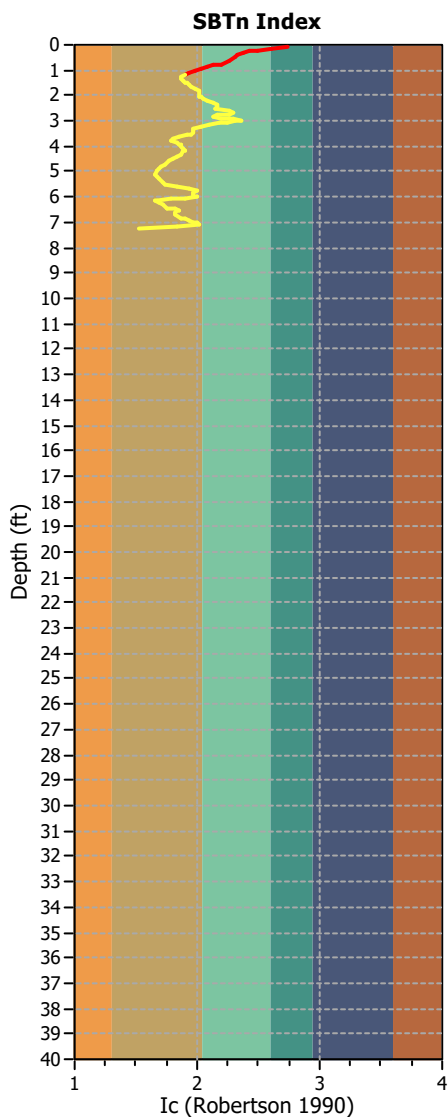

Transition layer algorithm properties

I_c minimum check value: 1.70
 I_c maximum check value: 3.00
 I_c change ratio value: 0.0250
 Minimum number of points in layer: 4

General statistics

Total points in CPT file: 108
 Total points excluded: 16
 Exclusion percentage: 14.81%
 Number of layers detected: 1

Estimation of post-earthquake settlements

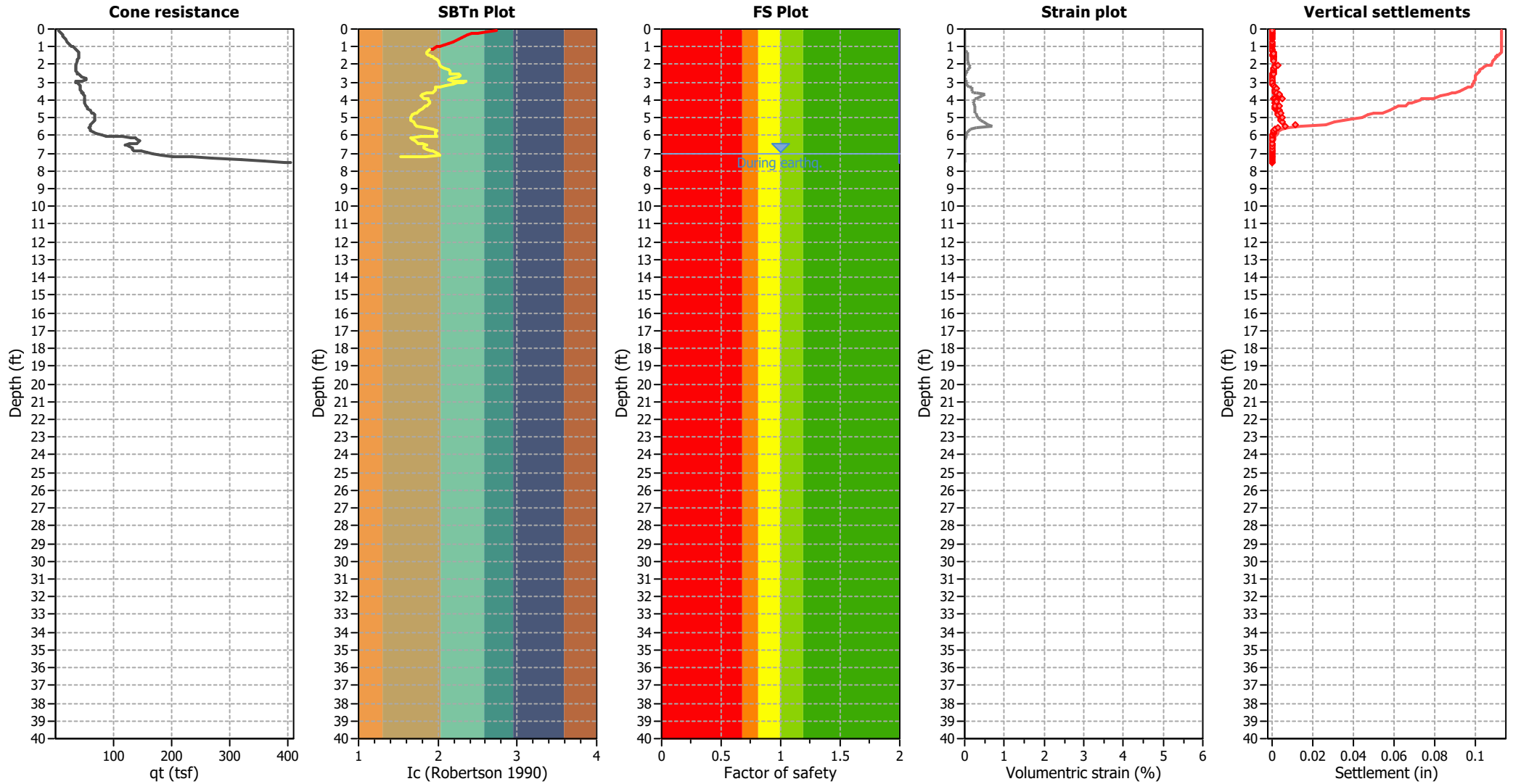

Abbreviations

- q_c: Total cone resistance (cone resistance q_c corrected for pore water effects)
- I_c: Soil Behaviour Type Index
- FS: Calculated Factor of Safety against liquefaction
- Volumetric strain: Post-liquefaction volumetric strain

Estimation of post-earthquake lateral Displacements

Geometric parameters: Gently sloping ground without free face (Slope 1.00 %)

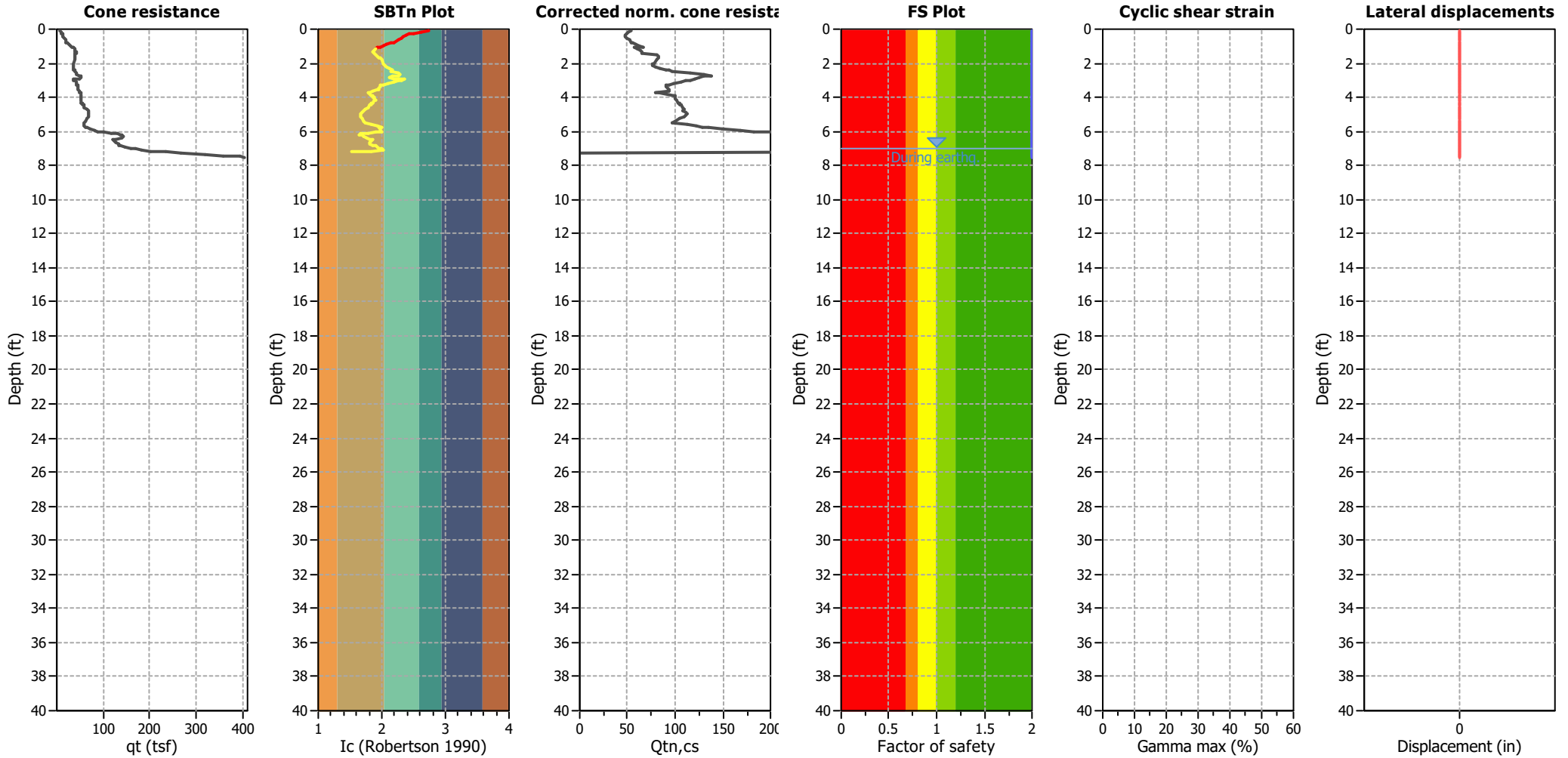

Abbreviations

q_t: Total cone resistance (cone resistance q_c corrected for pore water effects)
 I_c: Soil Behaviour Type Index
 Q_{tn,cs}: Equivalent clean sand normalized CPT total cone resistance

F.S.: Factor of safety
 γ_{max}: Maximum cyclic shear strain
 LDI: Lateral displacement index

Surface condition

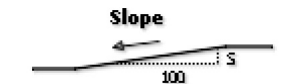

Aging Calculation Estimation

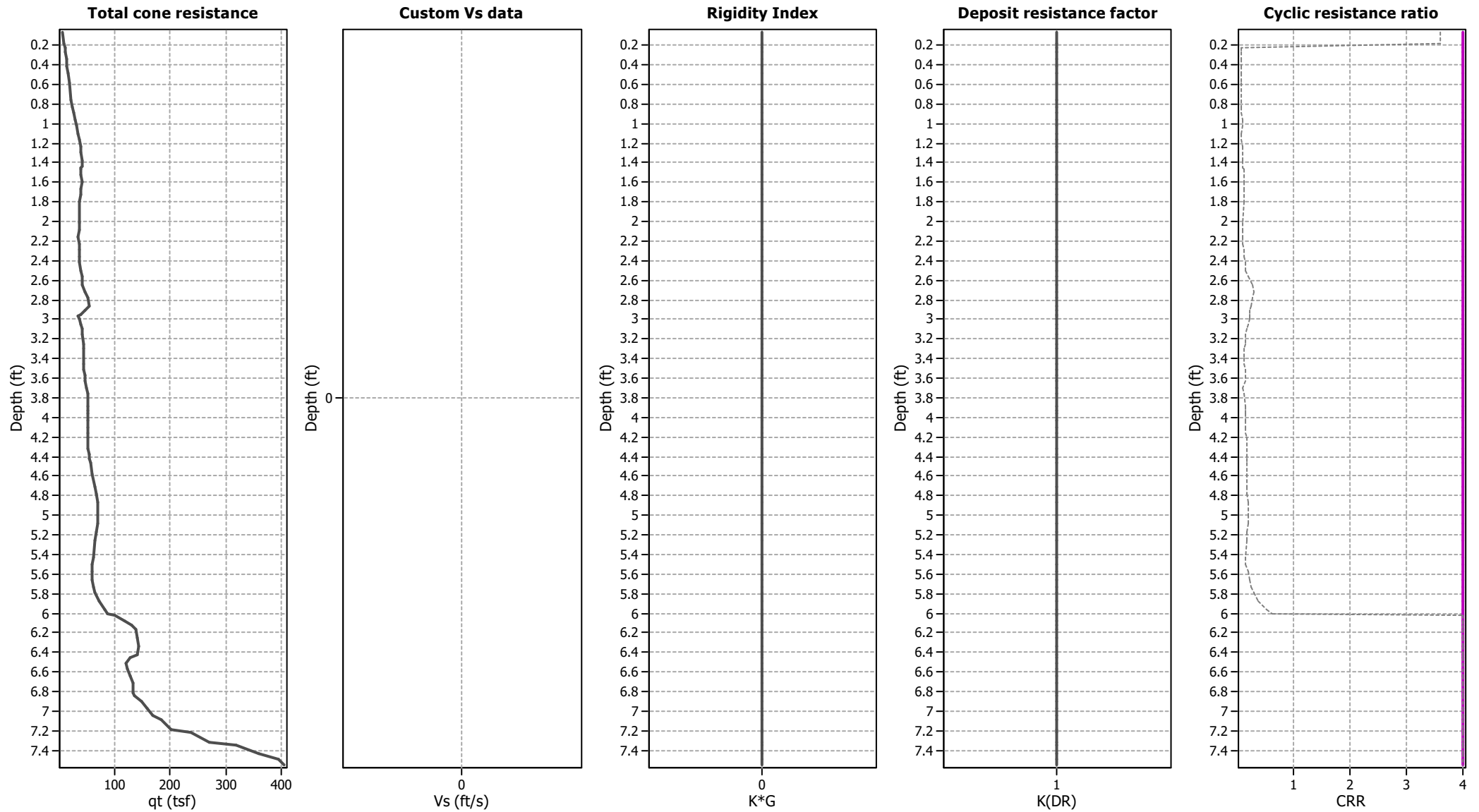

Ejecta Severity Estimation

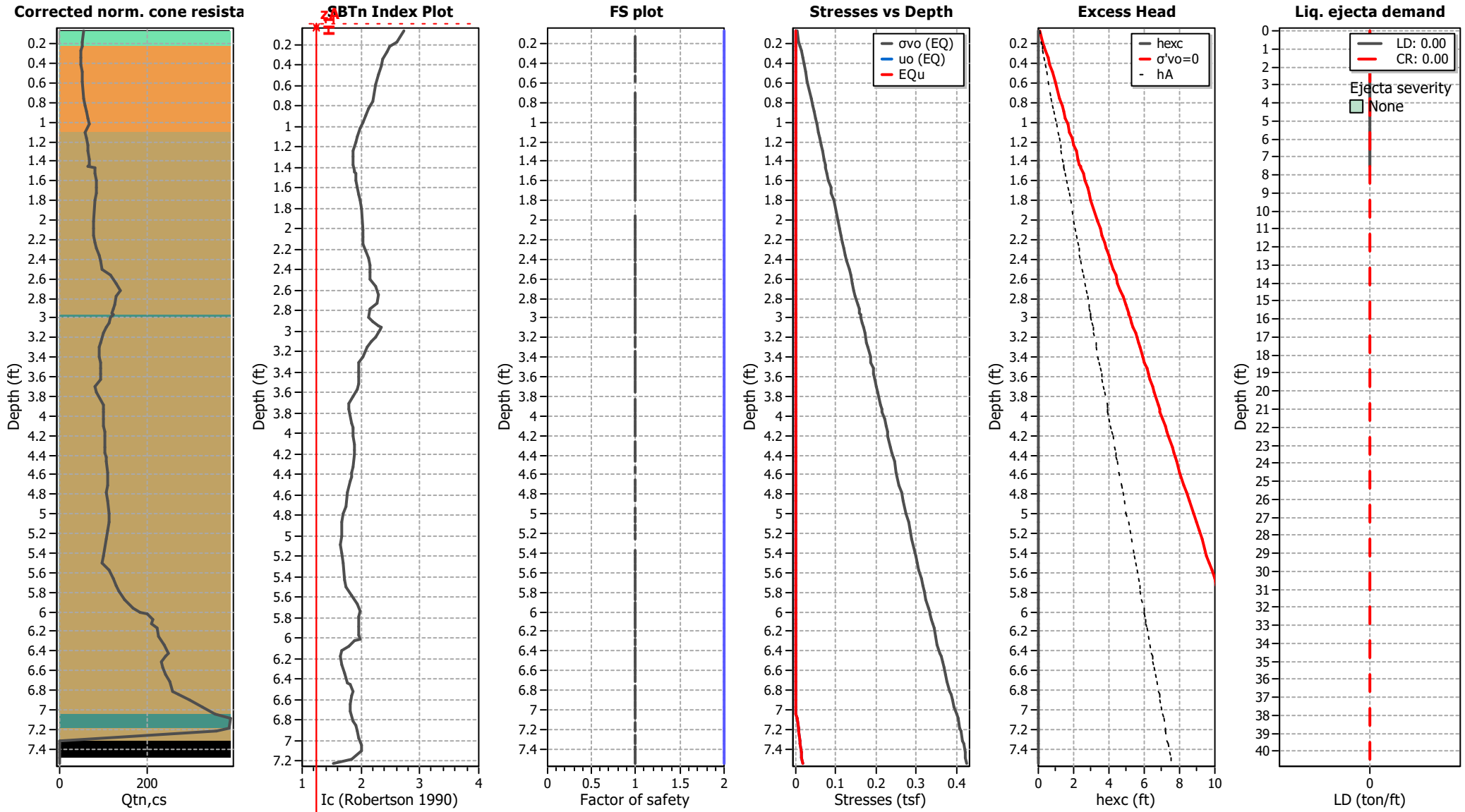

LIQUEFACTION ANALYSIS REPORT

Project title : Petra Geosciences / Apple Canyon

Location : Lake Hemet, CA

CPT file : CPT-12A

Input parameters and analysis data

Analysis method:	NCEER (1998)	G.W.T. (in-situ):	12.00 ft	Use fill:	No	Clay like behavior applied:	Sands only
Fines correction method:	NCEER (1998)	G.W.T. (earthq.):	7.00 ft	Fill height:	N/A	Limit depth applied:	No
Points to test:	Based on Ic value	Average results interval:	3	Fill weight:	N/A	Limit depth:	N/A
Earthquake magnitude M_w :	8.10	Ic cut-off value:	2.60	Trans. detect. applied:	Yes	MSF method:	Method based
Peak ground acceleration:	0.89	Unit weight calculation:	Based on SBT	K_o applied:	Yes		

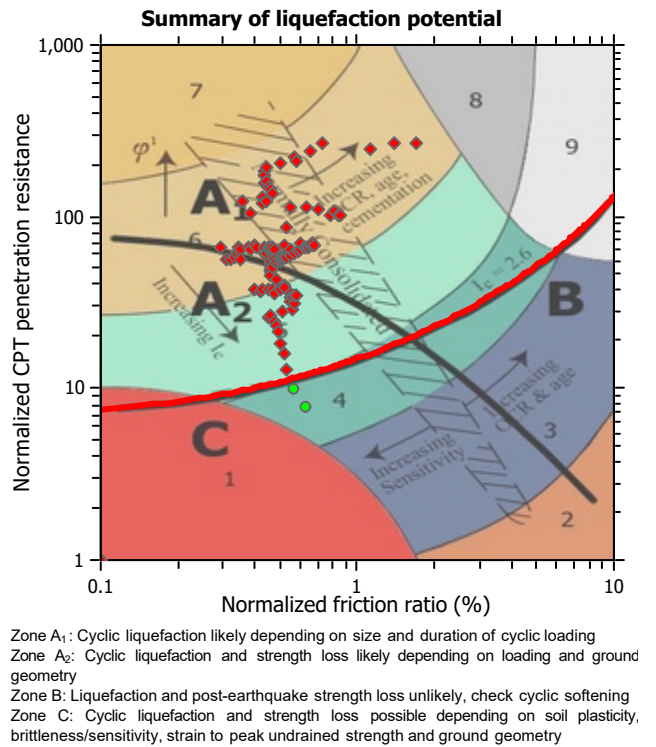
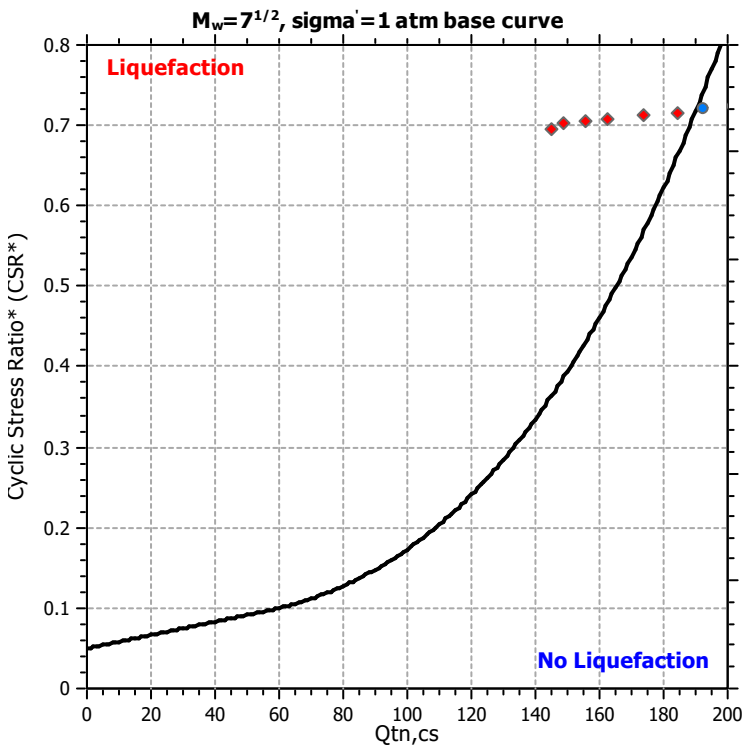
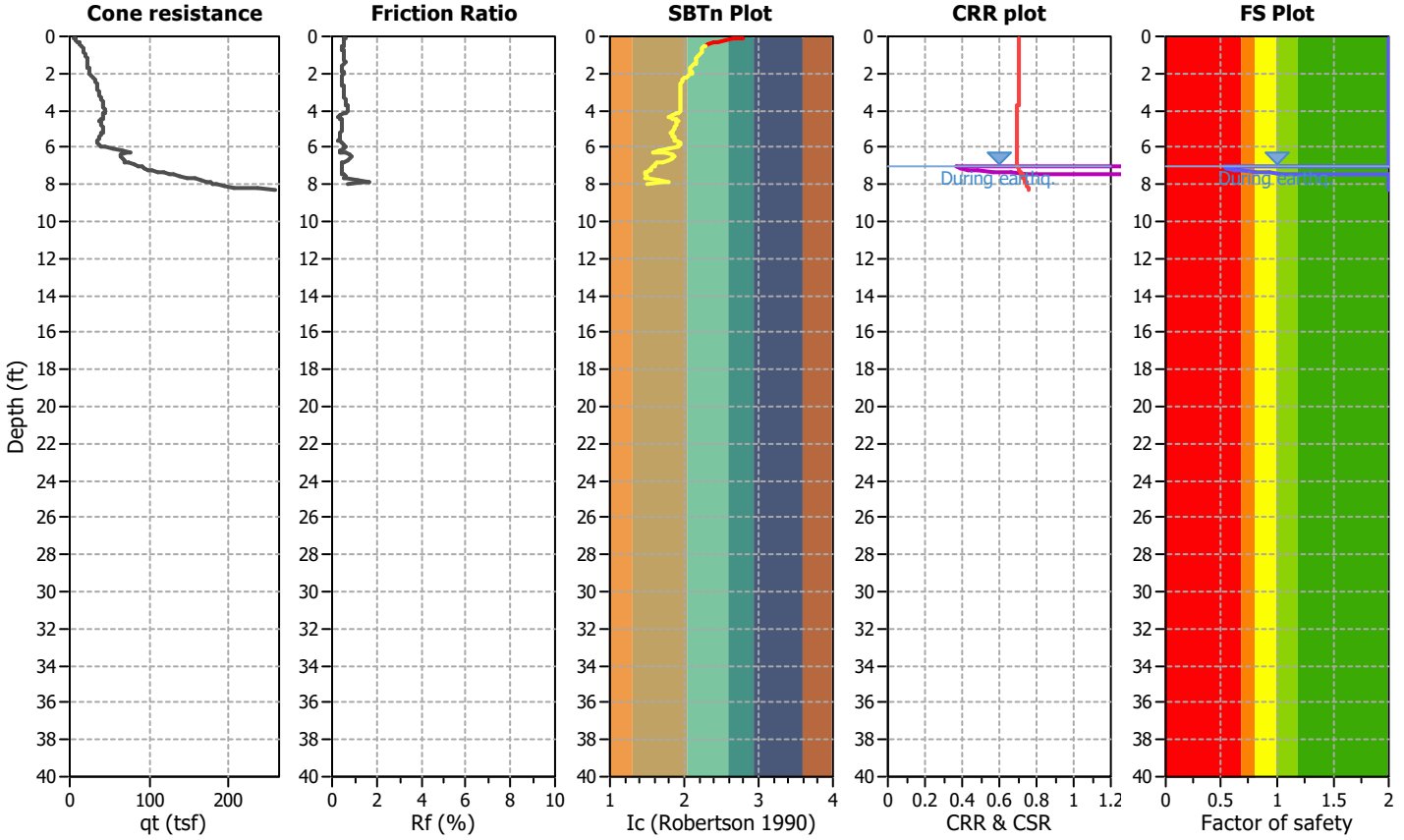

CPT basic interpretation plots

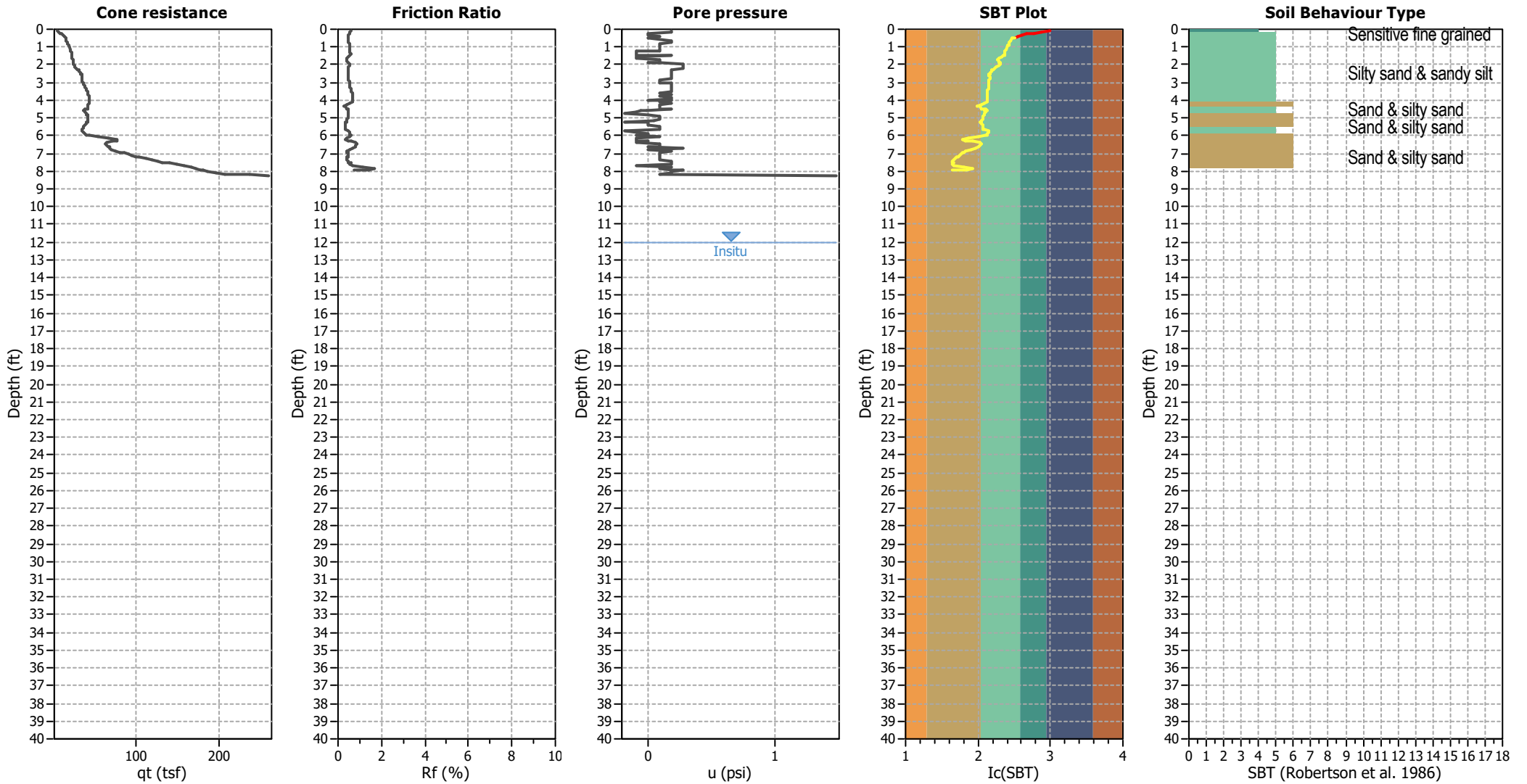

Input parameters and analysis data

Analysis method:	NCEER (1998)	Depth to water table (earthq.):	7.00 ft	Fill weight:	N/A
Fines correction method:	NCEER (1998)	Average results interval:	3	Transition detect. applied:	Yes
Points to test:	Based on Ic value	Ic cut-off value:	2.60	K _o applied:	Yes
Earthquake magnitude M _w :	8.10	Unit weight calculation:	Based on SBT	Clay like behavior applied:	Sands only
Peak ground acceleration:	0.89	Use fill:	No	Limit depth applied:	No
Depth to water table (insitu):	12.00 ft	Fill height:	N/A	Limit depth:	N/A

SBT legend

1. Sensitive fine grained	4. Clayey silt to silty	7. Gravelly sand to sand
2. Organic material	5. Silty sand to sandy silt	8. Very stiff sand to
3. Clay to silty clay	6. Clean sand to silty sand	9. Very stiff fine grained

CPT basic interpretation plots (normalized)

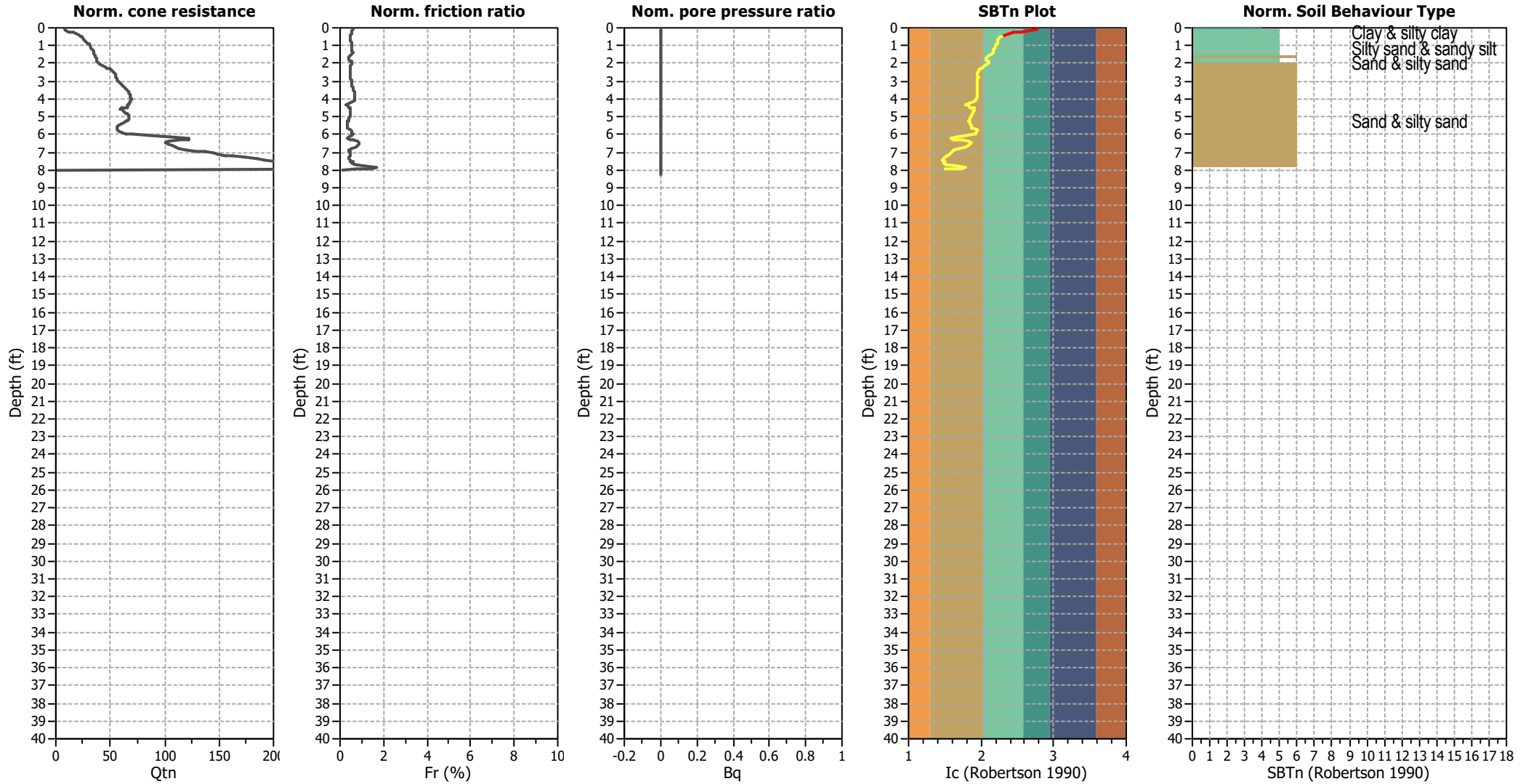

Input parameters and analysis data

Analysis method:	NCEER (1998)	Depth to water table (erthq.):	7.00 ft	Fill weight:	N/A
Fines correction method:	NCEER (1998)	Average results interval:	3	Transition detect. applied:	Yes
Points to test:	Based on Ic value	Ic cut-off value:	2.60	K ₀ applied:	Yes
Earthquake magnitude M _w :	8.10	Unit weight calculation:	Based on SBT	Clay like behavior applied:	Sands only
Peak ground acceleration:	0.89	Use fill:	No	Limit depth applied:	No
Depth to water table (insitu):	12.00 ft	Fill height:	N/A	Limit depth:	N/A

SBTn legend

1. Sensitive fine grained	4. Clayey silt to silty	7. Gravely sand to sand
2. Organic material	5. Silty sand to sandy silt	8. Very stiff sand to
3. Clay to silty clay	6. Clean sand to silty sand	9. Very stiff fine grained

Liquefaction analysis overall plots (intermediate results)

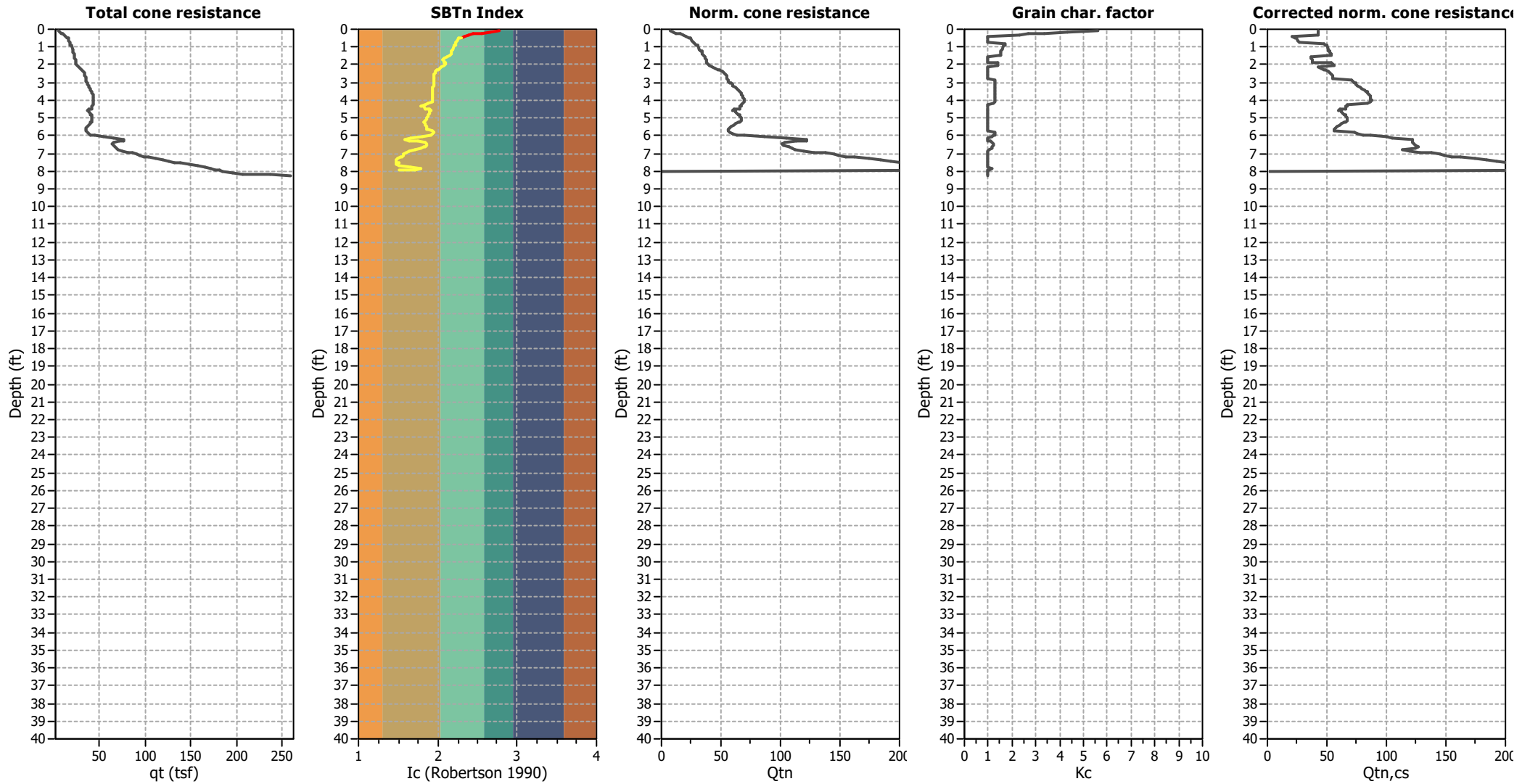

Input parameters and analysis data

Analysis method:	NCEER (1998)	Depth to water table (earthq.):	7.00 ft	Fill weight:	N/A
Fines correction method:	NCEER (1998)	Average results interval:	3	Transition detect. applied:	Yes
Points to test:	Based on Ic value	Ic cut-off value:	2.60	K _o applied:	Yes
Earthquake magnitude M _w :	8.10	Unit weight calculation:	Based on SBT	Clay like behavior applied:	Sands only
Peak ground acceleration:	0.89	Use fill:	No	Limit depth applied:	No
Depth to water table (insitu):	12.00 ft	Fill height:	N/A	Limit depth:	N/A

Liquefaction analysis overall plots

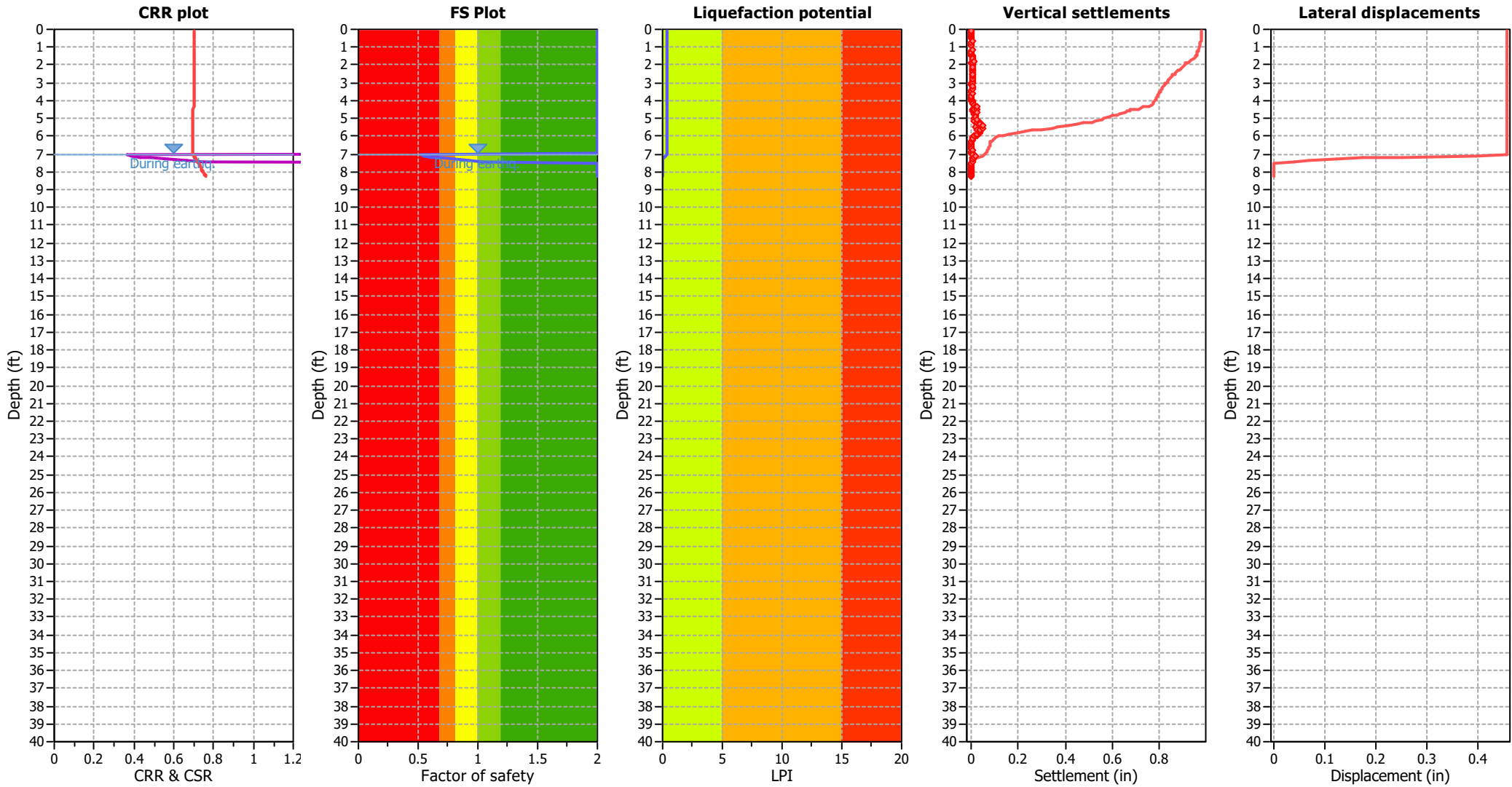

Input parameters and analysis data

Analysis method:	NCEER (1998)	Depth to water table (earthq.):	7.00 ft	Fill weight:	N/A
Fines correction method:	NCEER (1998)	Average results interval:	3	Transition detect. applied:	Yes
Points to test:	Based on Ic value	Ic cut-off value:	2.60	K _o applied:	Yes
Earthquake magnitude M _w :	8.10	Unit weight calculation:	Based on SBT	Clay like behavior applied:	Sands only
Peak ground acceleration:	0.89	Use fill:	No	Limit depth applied:	No
Depth to water table (insitu):	12.00 ft	Fill height:	N/A	Limit depth:	N/A

F.S. color scheme

- Almost certain it will liquefy
- Very likely to liquefy
- Liquefaction and no liq. are equally likely
- Unlike to liquefy
- Almost certain it will not liquefy

LPI color scheme

- Very high risk
- High risk
- Low risk

Liquefaction analysis summary plots

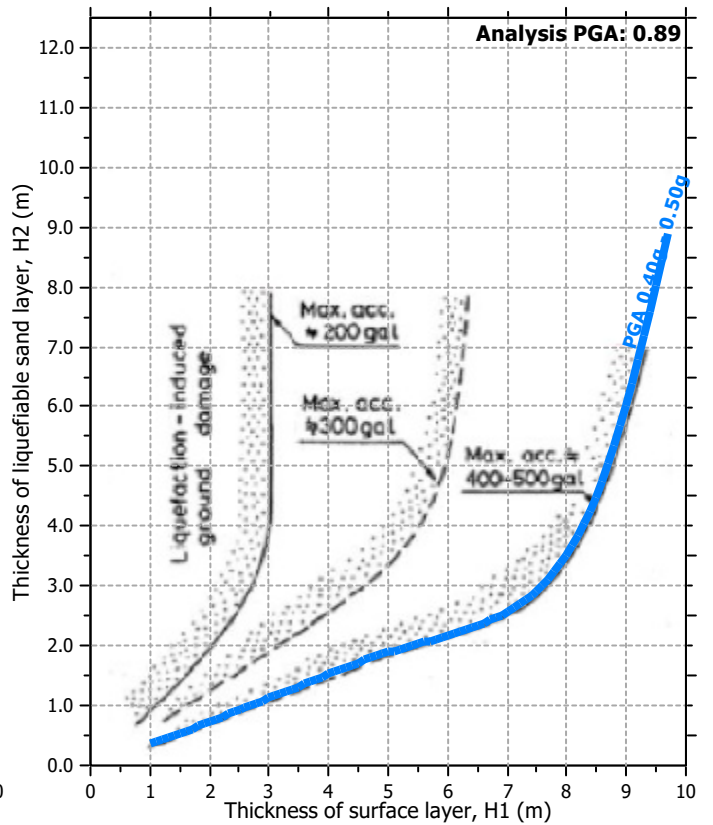
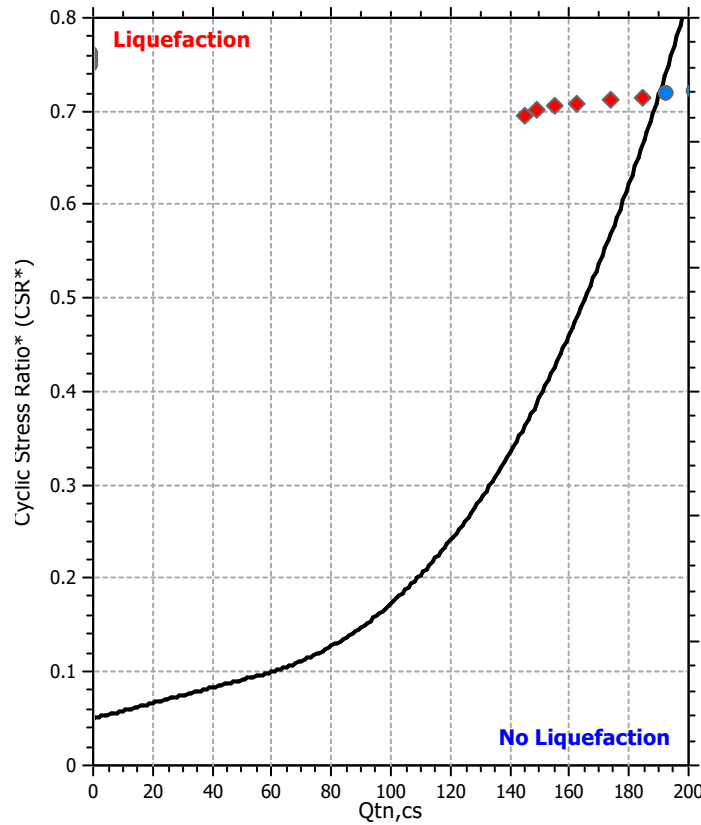
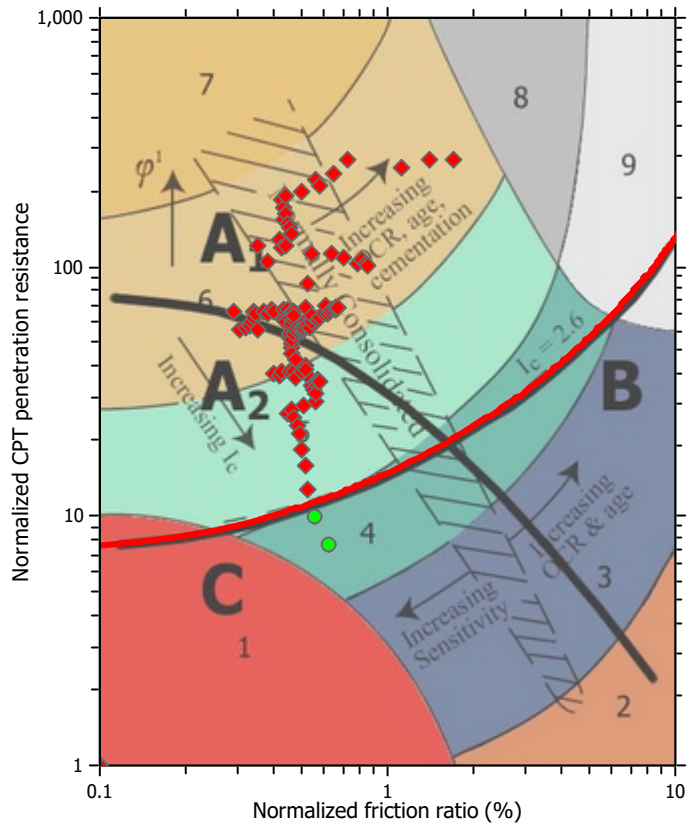

Input parameters and analysis data

Analysis method:	NCEER (1998)	Depth to water table (earthq.):	7.00 ft	Fill weight:	N/A
Fines correction method:	NCEER (1998)	Average results interval:	3	Transition detect. applied:	Yes
Points to test:	Based on Ic value	Ic cut-off value:	2.60	K_0 applied:	Yes
Earthquake magnitude M_w :	8.10	Unit weight calculation:	Based on SBT	Clay like behavior applied:	Sands only
Peak ground acceleration:	0.89	Use fill:	No	Limit depth applied:	No
Depth to water table (insitu):	12.00 ft	Fill height:	N/A	Limit depth:	N/A

Check for strength loss plots (Robertson (2010))

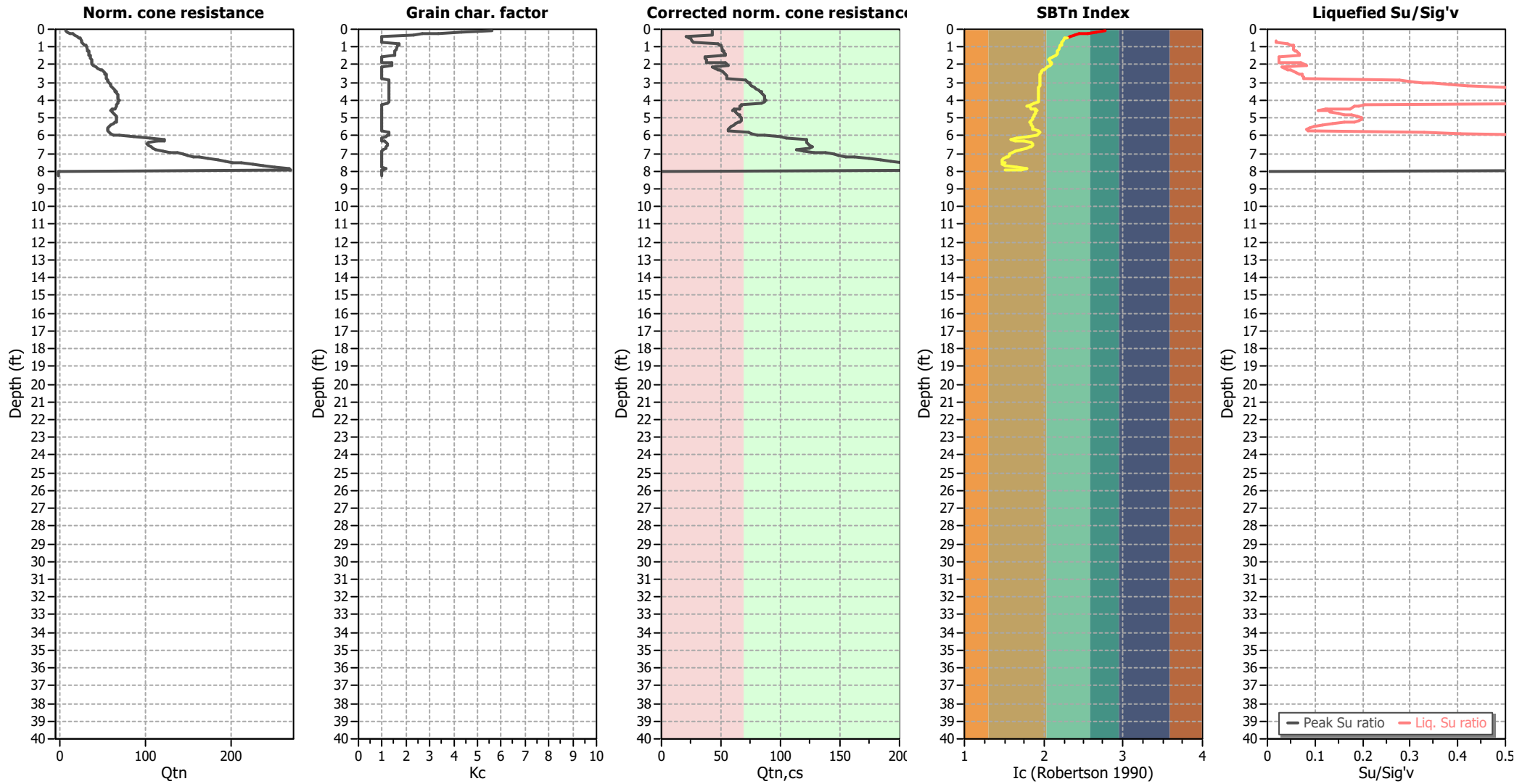

Input parameters and analysis data

Analysis method:	NCEER (1998)	Depth to water table (erthq.):	7.00 ft	Fill weight:	N/A
Fines correction method:	NCEER (1998)	Average results interval:	3	Transition detect. applied:	Yes
Points to test:	Based on Ic value	Ic cut-off value:	2.60	K _o applied:	Yes
Earthquake magnitude M _w :	8.10	Unit weight calculation:	Based on SBT	Clay like behavior applied:	Sands only
Peak ground acceleration:	0.89	Use fill:	No	Limit depth applied:	No
Depth to water table (insitu):	12.00 ft	Fill height:	N/A	Limit depth:	N/A

TRANSITION LAYER DETECTION ALGORITHM REPORT

Summary Details & Plots

Short description

The software will delete data when the cone is in transition from either clay to sand or vice-versa. To do this the software requires a range of I_c values over which the transition will be defined (typically somewhere between $1.80 < I_c < 3.0$) and a rate of change of I_c . Transitions typically occur when the rate of change of I_c is fast (i.e. ΔI_c is small).

The SBT_n plot below, displays in red the detected transition layers based on the parameters listed below the graphs.

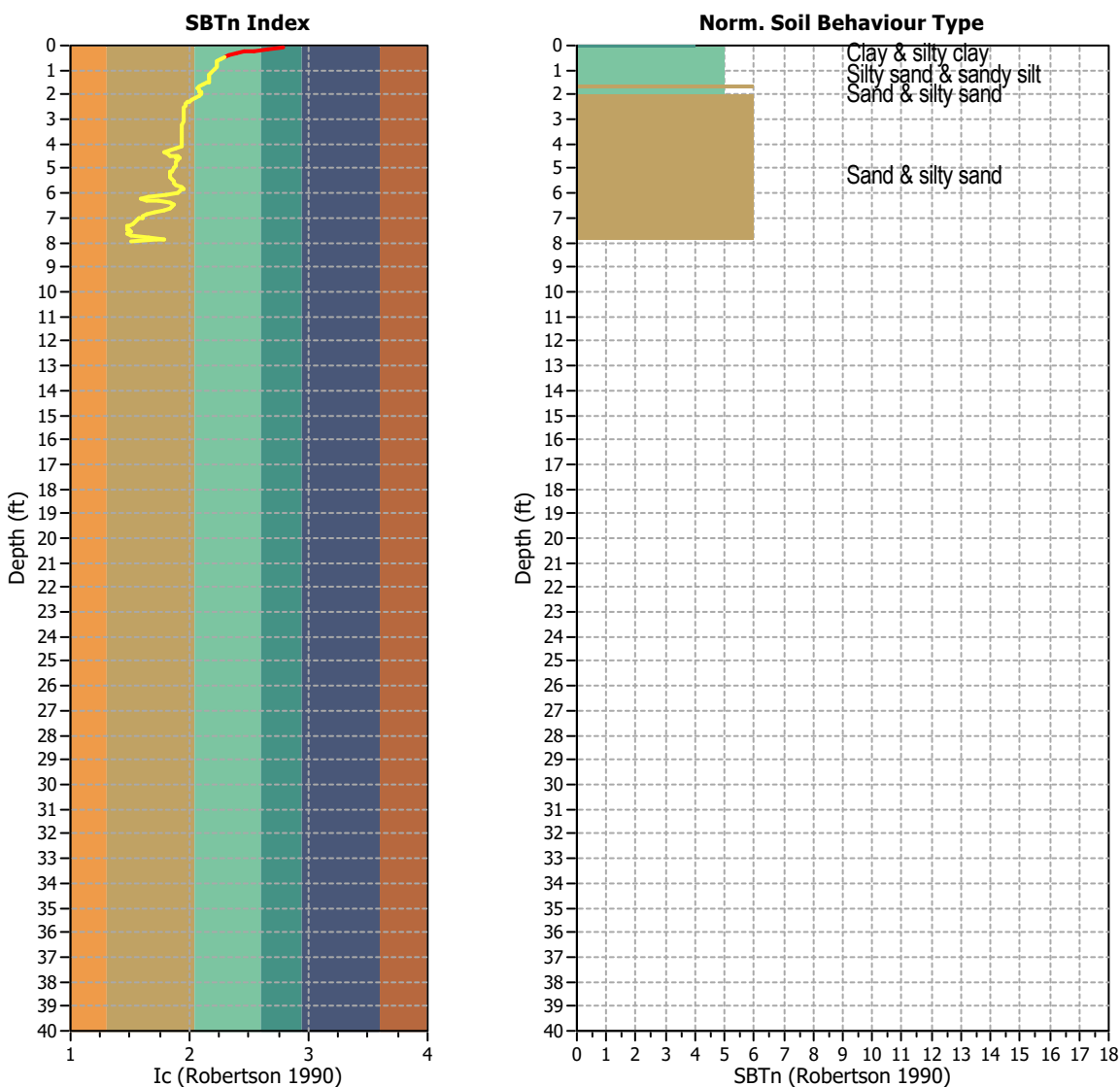

Transition layer algorithm properties

I_c minimum check value: 1.70
 I_c maximum check value: 3.00
 I_c change ratio value: 0.0250
 Minimum number of points in layer: 4

General statistics

Total points in CPT file: 124
 Total points excluded: 8
 Exclusion percentage: 6.45%
 Number of layers detected: 1

Estimation of post-earthquake settlements

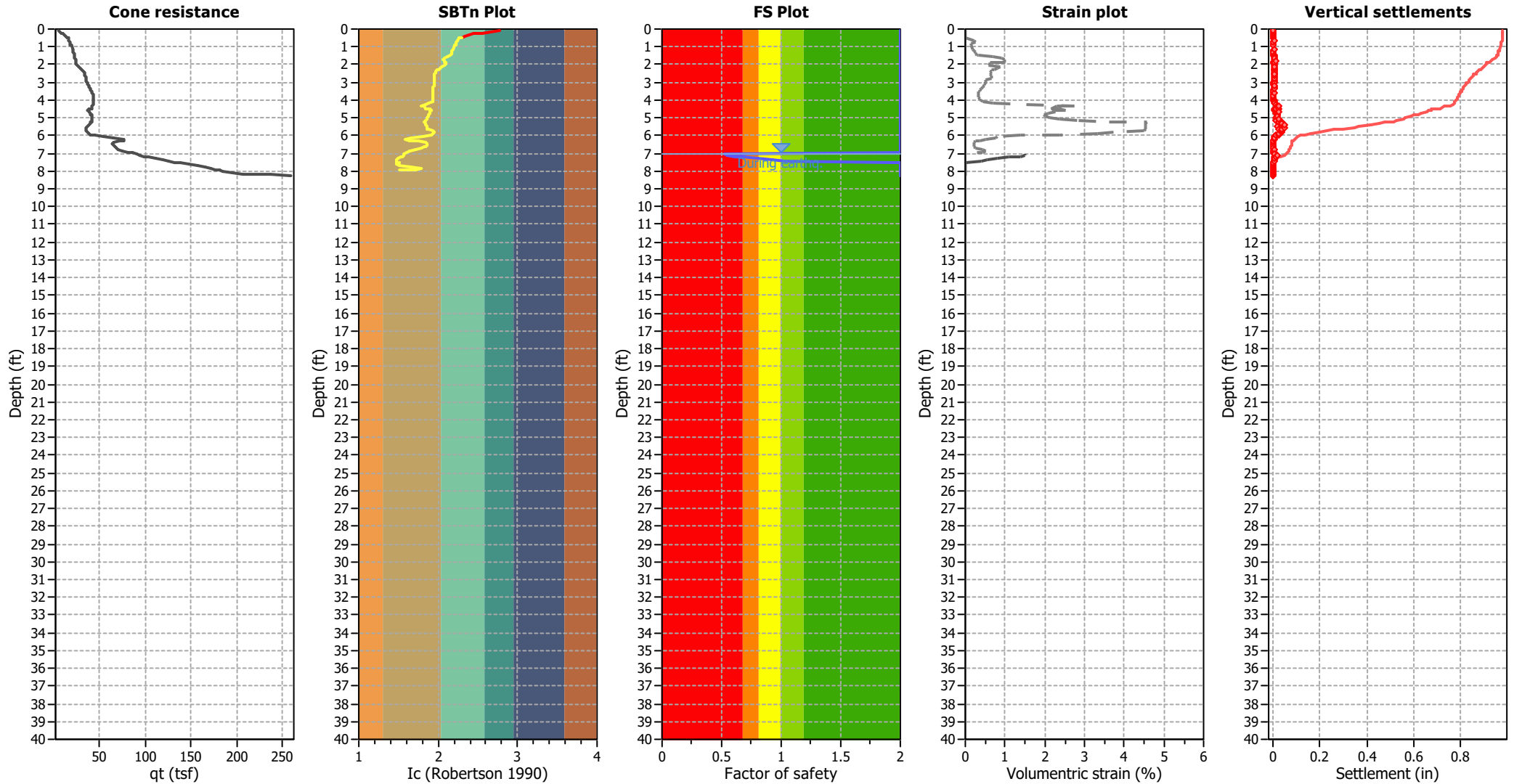

Abbreviations

- q_c: Total cone resistance (cone resistance q_c corrected for pore water effects)
- I_c: Soil Behaviour Type Index
- FS: Calculated Factor of Safety against liquefaction
- Volumetric strain: Post-liquefaction volumetric strain

Estimation of post-earthquake lateral Displacements

Geometric parameters: Gently sloping ground without free face (Slope 1.00 %)

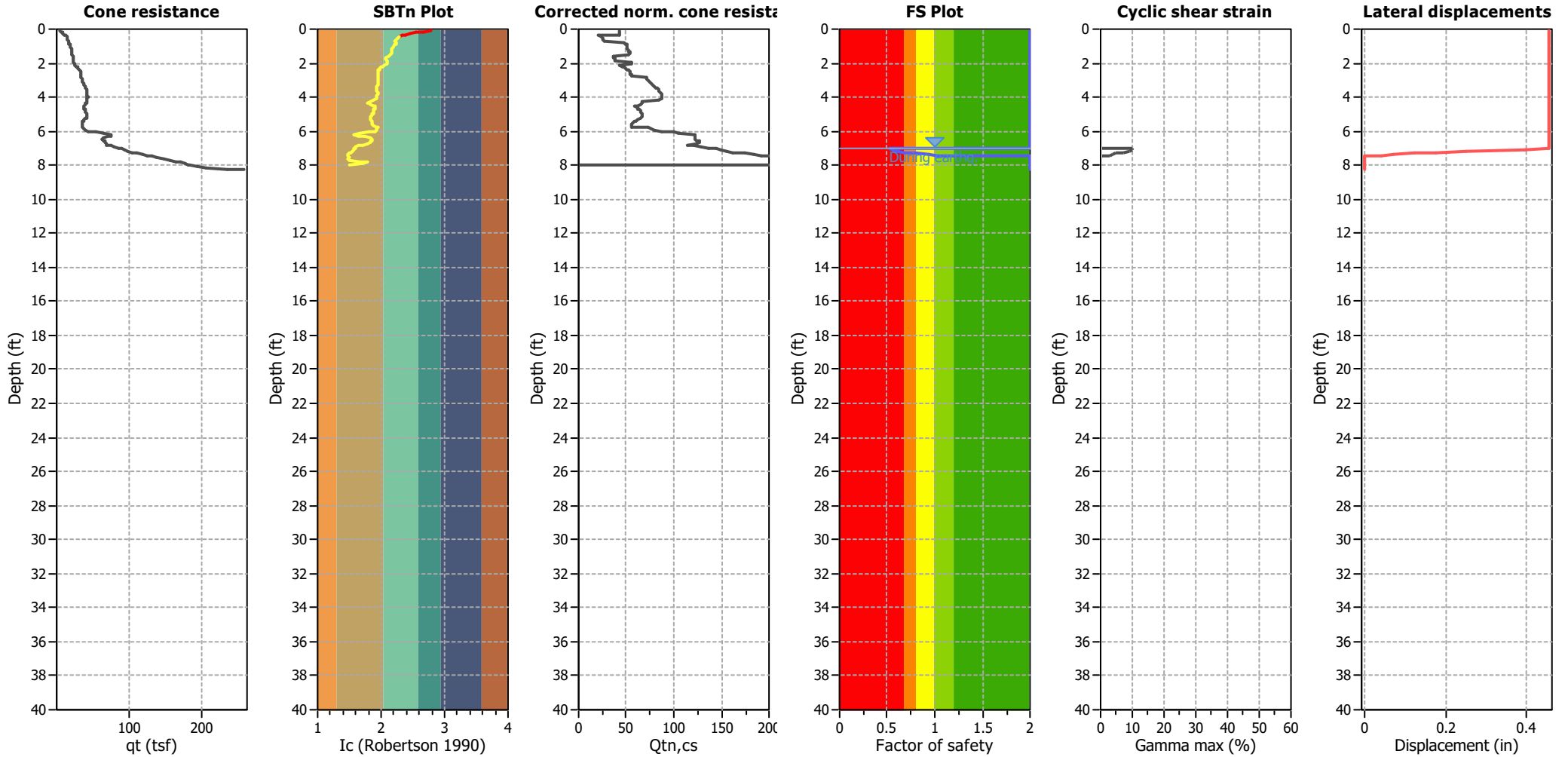

Abbreviations

q_t: Total cone resistance (cone resistance q_c corrected for pore water effects)
 I_c: Soil Behaviour Type Index
 Q_{tn,cs}: Equivalent clean sand normalized CPT total cone resistance

F.S.: Factor of safety
 γ_{max}: Maximum cyclic shear strain
 LDI: Lateral displacement index

Surface condition



Aging Calculation Estimation

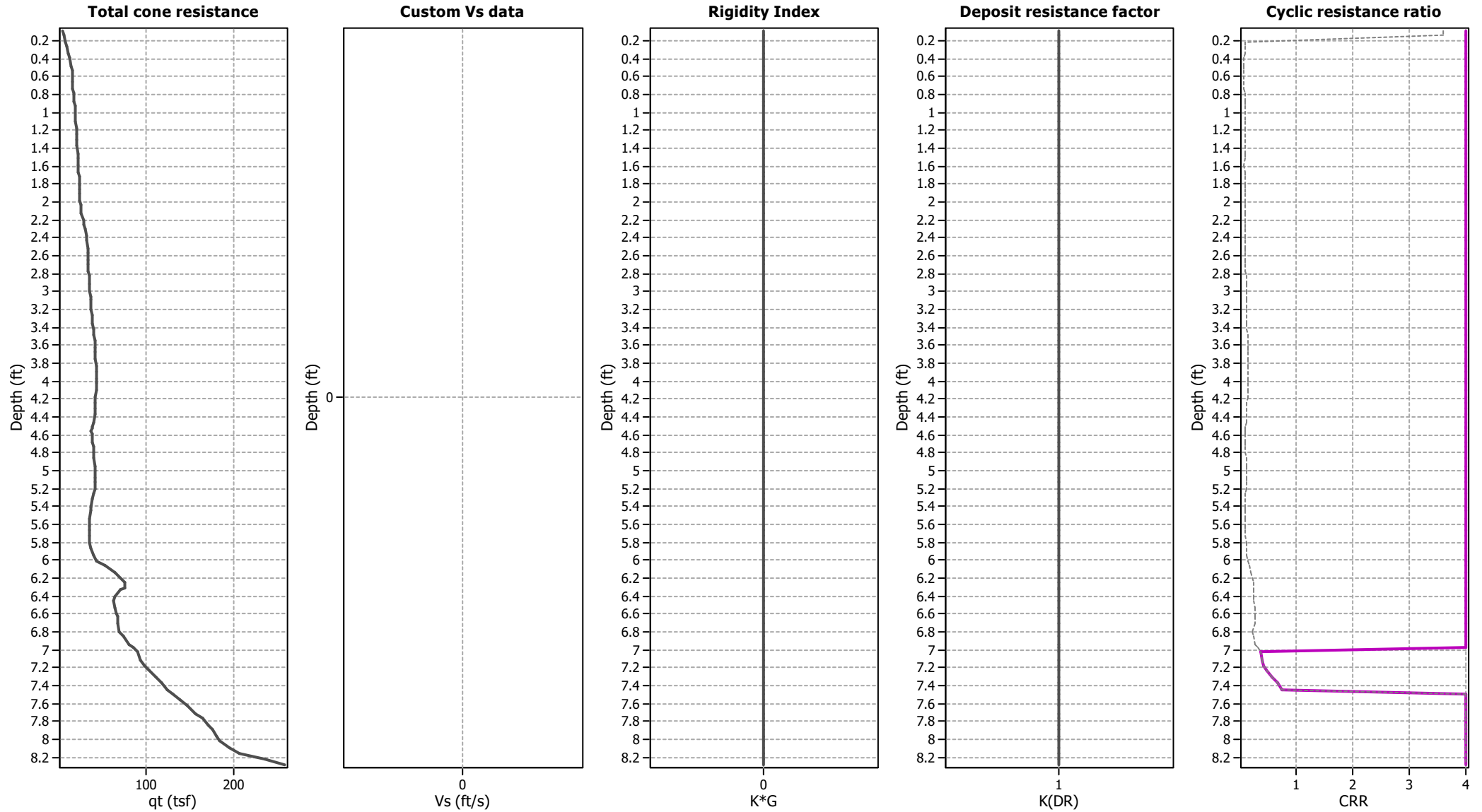

Ejecta Severity Estimation

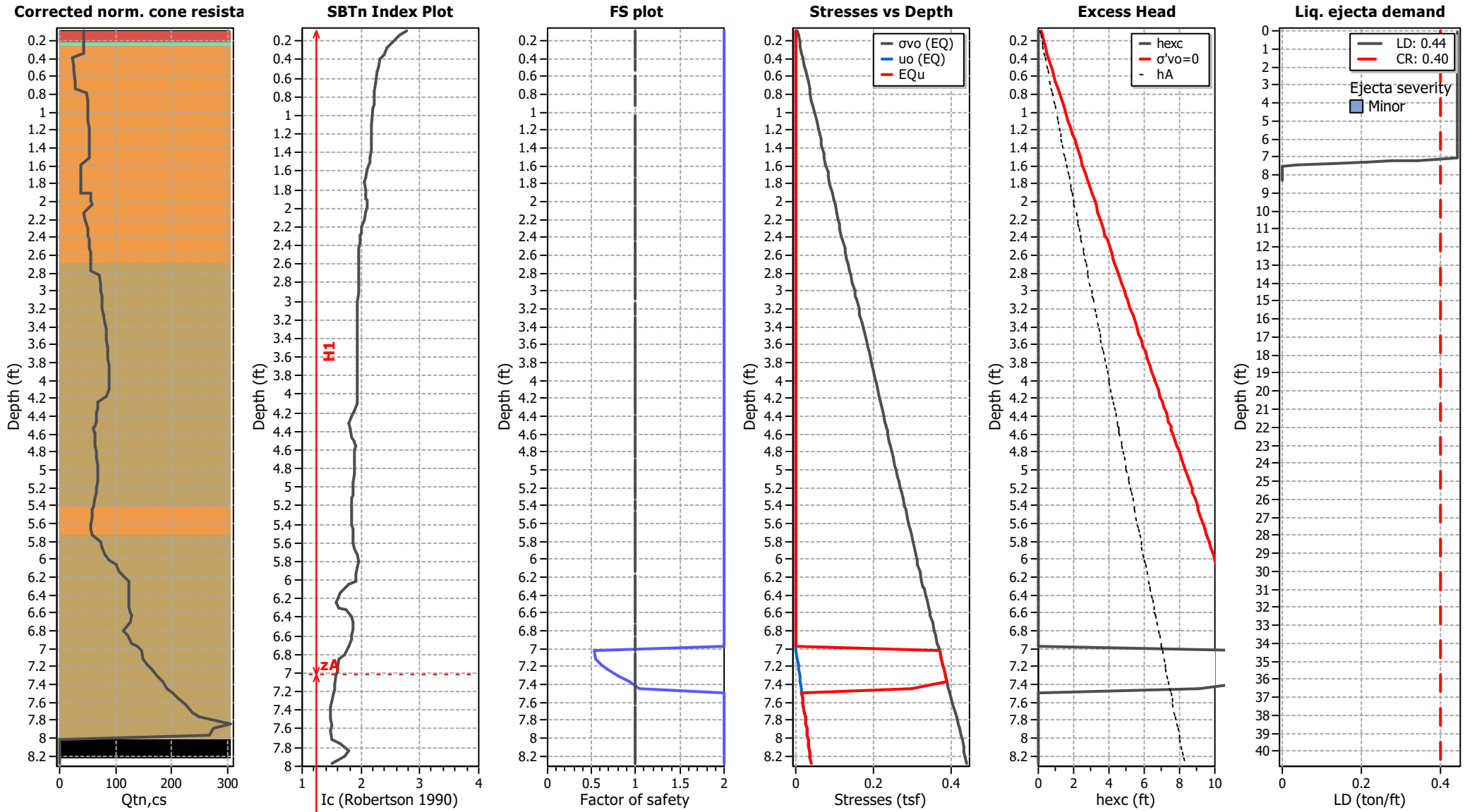

LIQUEFACTION ANALYSIS REPORT

Project title : Petra Geosciences / Apple Canyon

Location : Lake Hemet, CA

CPT file : CPT-13

Input parameters and analysis data

Analysis method:	NCEER (1998)	G.W.T. (in-situ):	12.00 ft	Use fill:	No	Clay like behavior applied:	Sands only
Fines correction method:	NCEER (1998)	G.W.T. (earthq.):	7.00 ft	Fill height:	N/A	Limit depth applied:	No
Points to test:	Based on Ic value	Average results interval:	3	Fill weight:	N/A	Limit depth:	N/A
Earthquake magnitude M_w :	8.10	Ic cut-off value:	2.60	Trans. detect. applied:	Yes	MSF method:	Method based
Peak ground acceleration:	0.89	Unit weight calculation:	Based on SBT	K_o applied:	Yes		

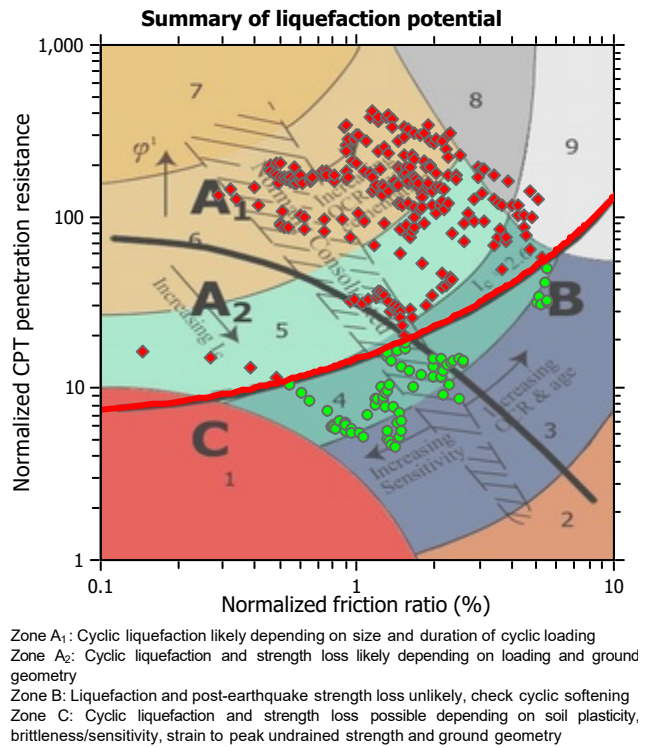
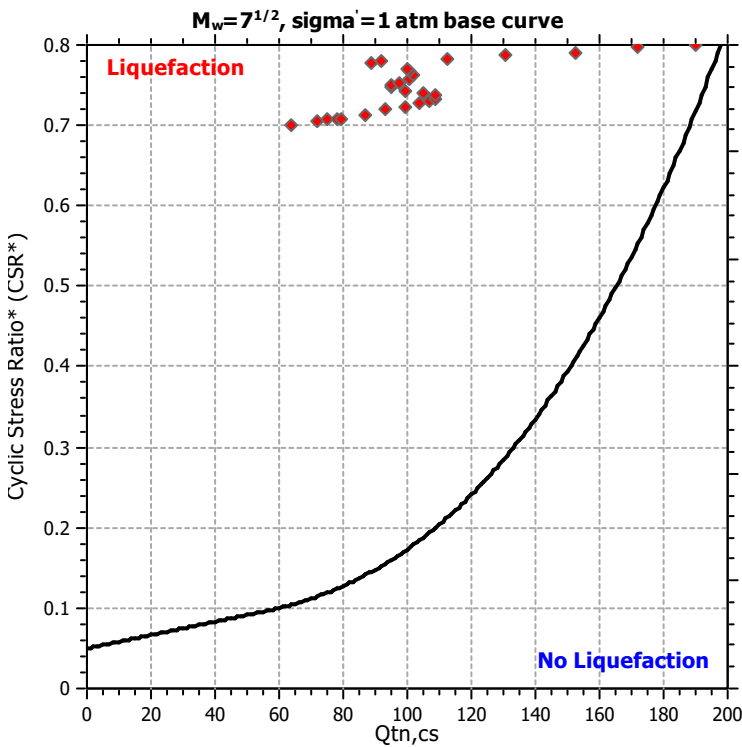
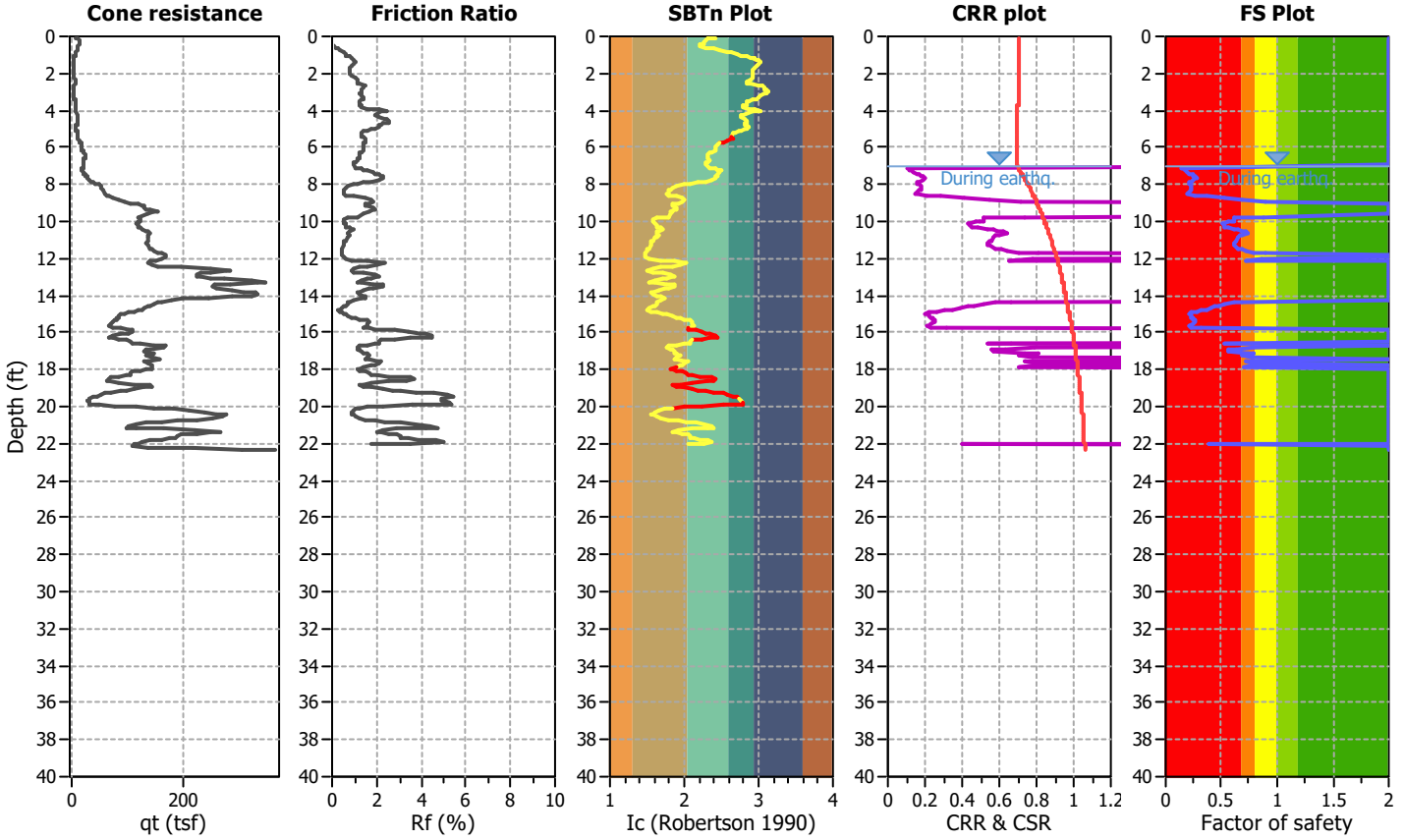

CPT basic interpretation plots

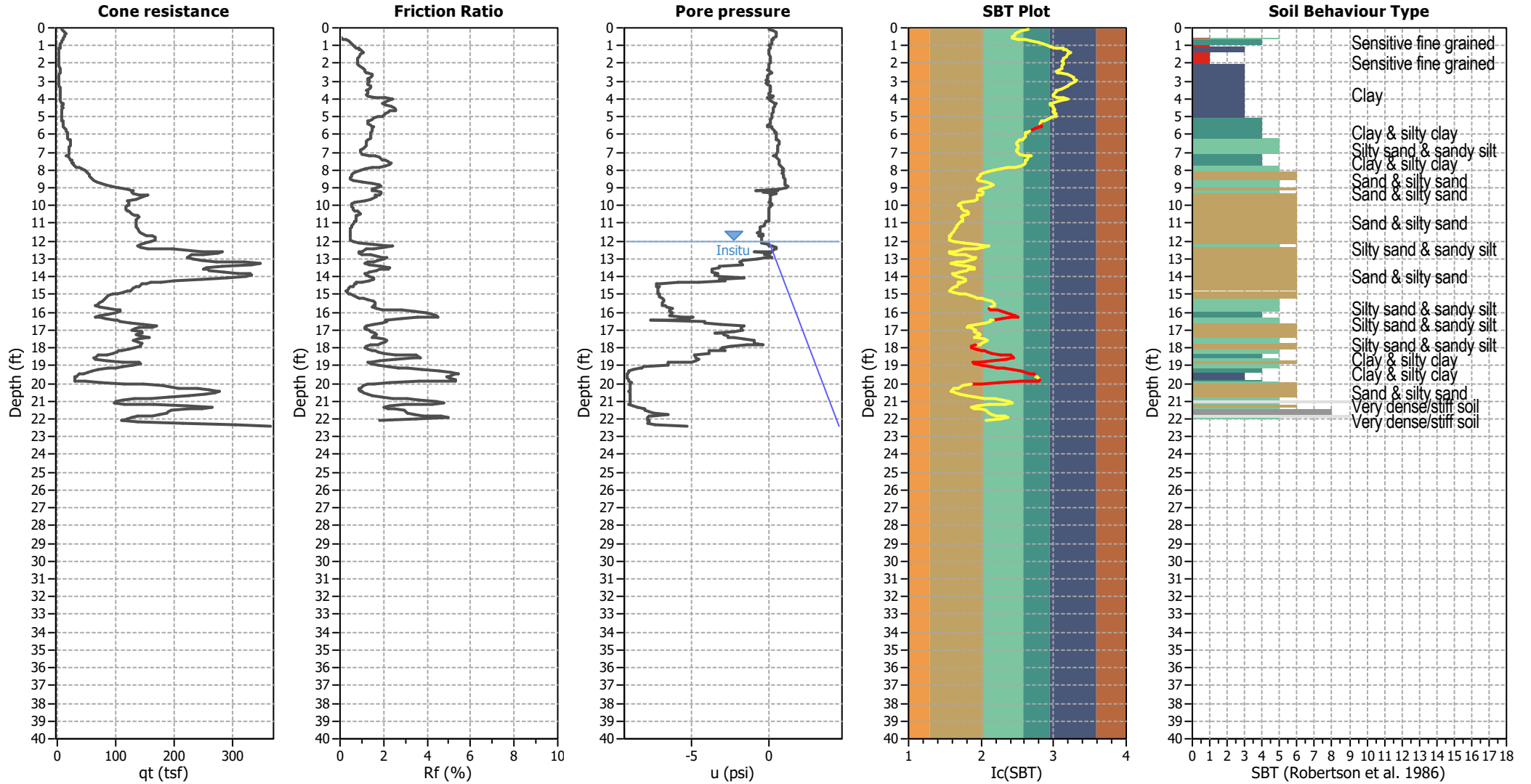

Input parameters and analysis data

Analysis method:	NCEER (1998)	Depth to water table (earthq.):	7.00 ft	Fill weight:	N/A
Fines correction method:	NCEER (1998)	Average results interval:	3	Transition detect. applied:	Yes
Points to test:	Based on Ic value	Ic cut-off value:	2.60	K _o applied:	Yes
Earthquake magnitude M _w :	8.10	Unit weight calculation:	Based on SBT	Clay like behavior applied:	Sands only
Peak ground acceleration:	0.89	Use fill:	No	Limit depth applied:	No
Depth to water table (insitu):	12.00 ft	Fill height:	N/A	Limit depth:	N/A

SBT legend

1. Sensitive fine grained	4. Clayey silt to silty	7. Gravely sand to sand
2. Organic material	5. Silty sand to sandy silt	8. Very stiff sand to
3. Clay to silty clay	6. Clean sand to silty sand	9. Very stiff fine grained

CPT basic interpretation plots (normalized)

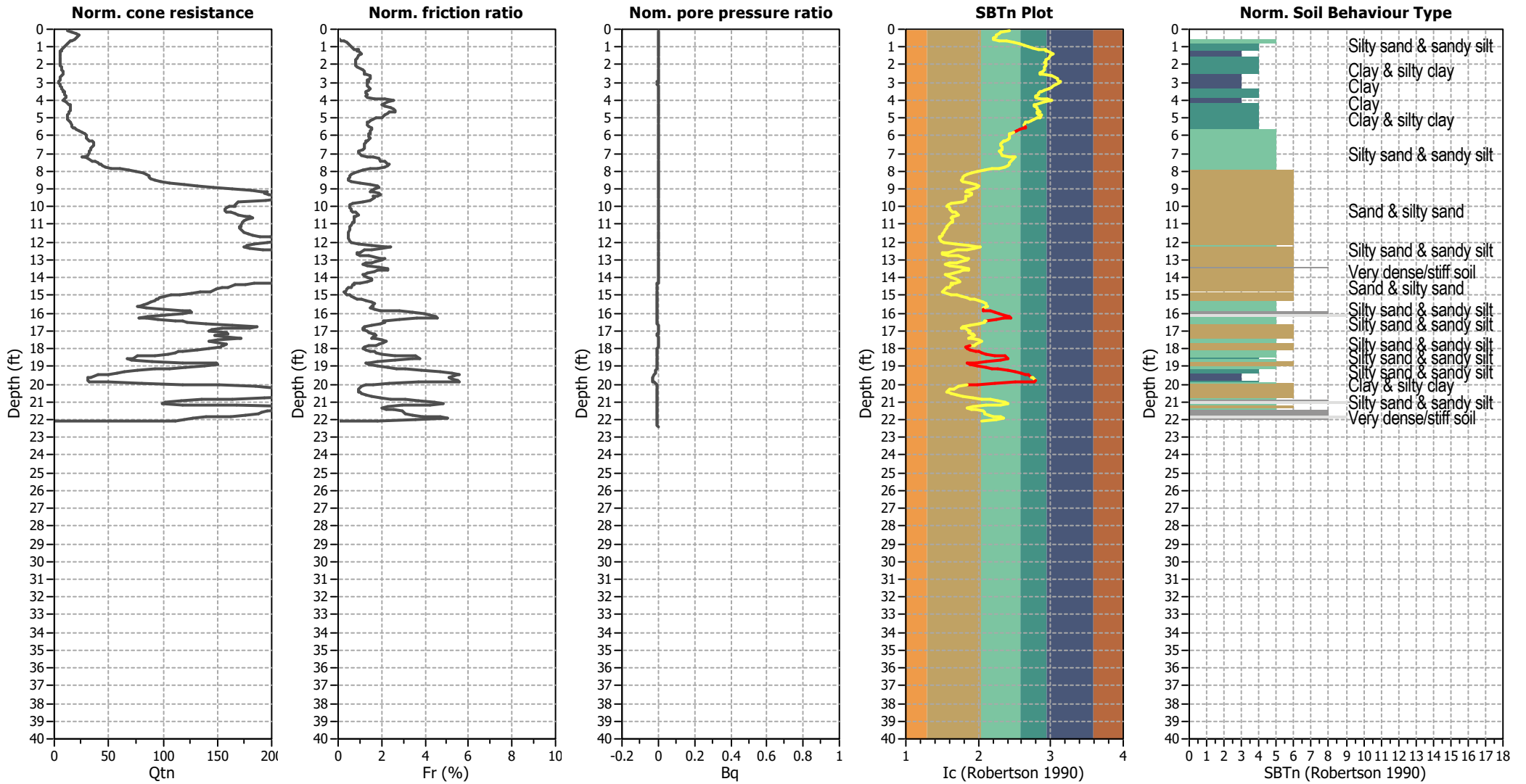

Input parameters and analysis data

Analysis method:	NCEER (1998)	Depth to water table (erthq.):	7.00 ft	Fill weight:	N/A
Fines correction method:	NCEER (1998)	Average results interval:	3	Transition detect. applied:	Yes
Points to test:	Based on Ic value	Ic cut-off value:	2.60	K ₀ applied:	Yes
Earthquake magnitude M _w :	8.10	Unit weight calculation:	Based on SBT	Clay like behavior applied:	Sands only
Peak ground acceleration:	0.89	Use fill:	No	Limit depth applied:	No
Depth to water table (insitu):	12.00 ft	Fill height:	N/A	Limit depth:	N/A

SBTn legend

1. Sensitive fine grained	4. Clayey silt to silty	7. Gravely sand to sand
2. Organic material	5. Silty sand to sandy silt	8. Very stiff sand to
3. Clay to silty clay	6. Clean sand to silty sand	9. Very stiff fine grained

Liquefaction analysis overall plots (intermediate results)

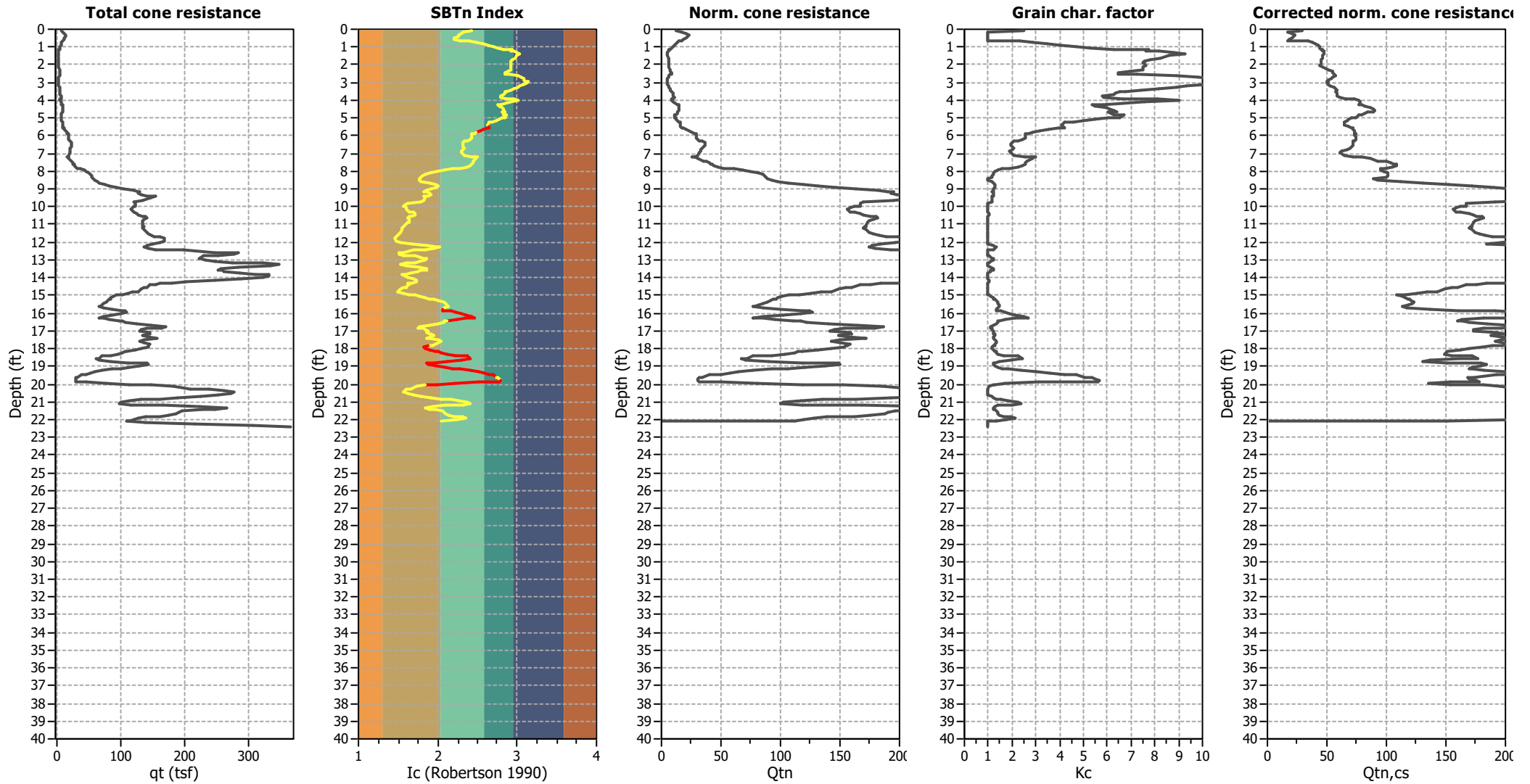

Input parameters and analysis data

Analysis method:	NCEER (1998)	Depth to water table (earthq.):	7.00 ft	Fill weight:	N/A
Fines correction method:	NCEER (1998)	Average results interval:	3	Transition detect. applied:	Yes
Points to test:	Based on Ic value	Ic cut-off value:	2.60	K _o applied:	Yes
Earthquake magnitude M _w :	8.10	Unit weight calculation:	Based on SBT	Clay like behavior applied:	Sands only
Peak ground acceleration:	0.89	Use fill:	No	Limit depth applied:	No
Depth to water table (insitu):	12.00 ft	Fill height:	N/A	Limit depth:	N/A

Liquefaction analysis overall plots

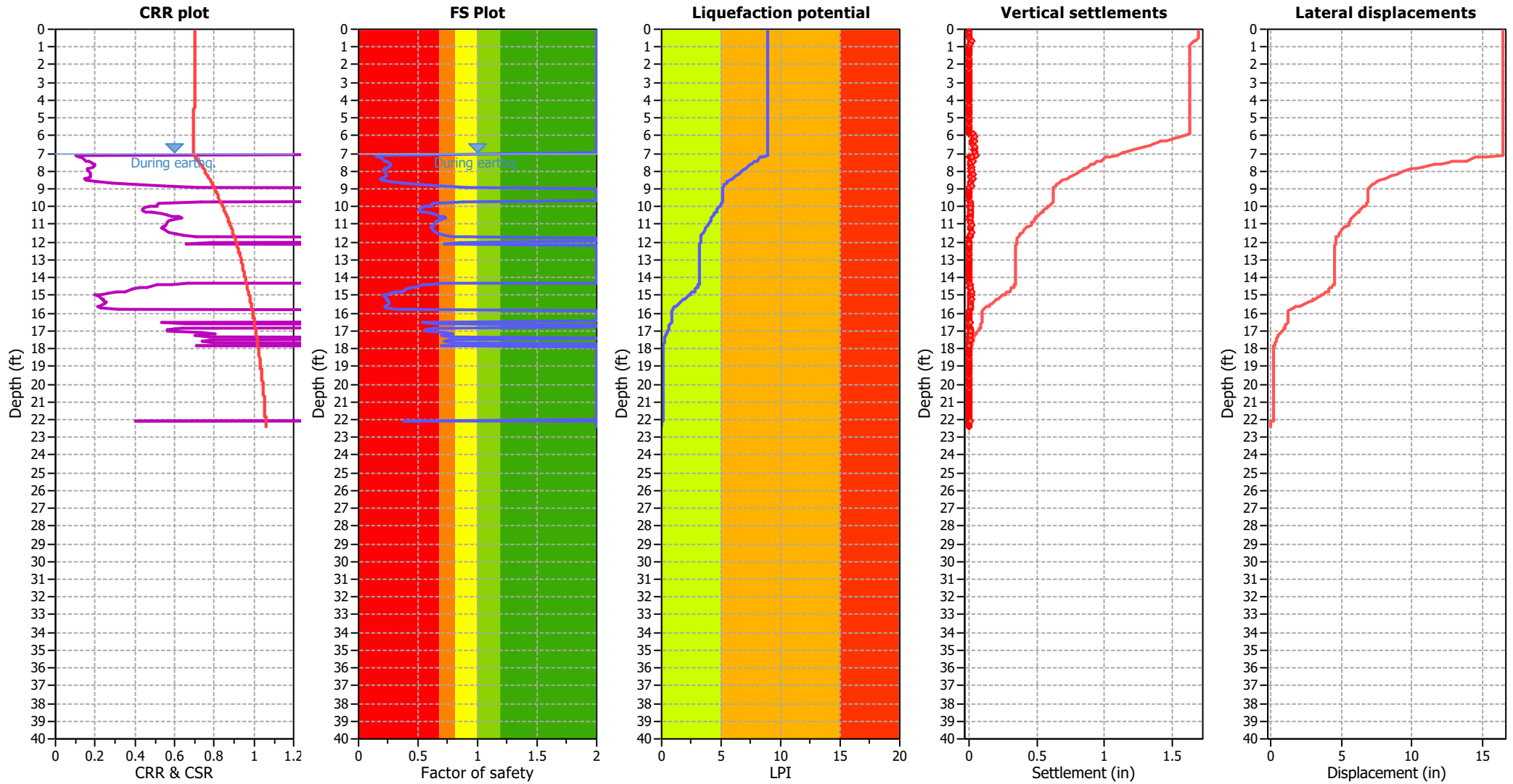

Input parameters and analysis data

Analysis method:	NCEER (1998)	Depth to water table (earthq.):	7.00 ft	Fill weight:	N/A
Fines correction method:	NCEER (1998)	Average results interval:	3	Transition detect. applied:	Yes
Points to test:	Based on Ic value	Ic cut-off value:	2.60	K_0 applied:	Yes
Earthquake magnitude M_w :	8.10	Unit weight calculation:	Based on SBT	Clay like behavior applied:	Sands only
Peak ground acceleration:	0.89	Use fill:	No	Limit depth applied:	No
Depth to water table (insitu):	12.00 ft	Fill height:	N/A	Limit depth:	N/A

F.S. color scheme

- Almost certain it will liquefy
- Very likely to liquefy
- Liquefaction and no liq. are equally likely
- Unlike to liquefy
- Almost certain it will not liquefy

LPI color scheme

- Very high risk
- High risk
- Low risk

Liquefaction analysis summary plots

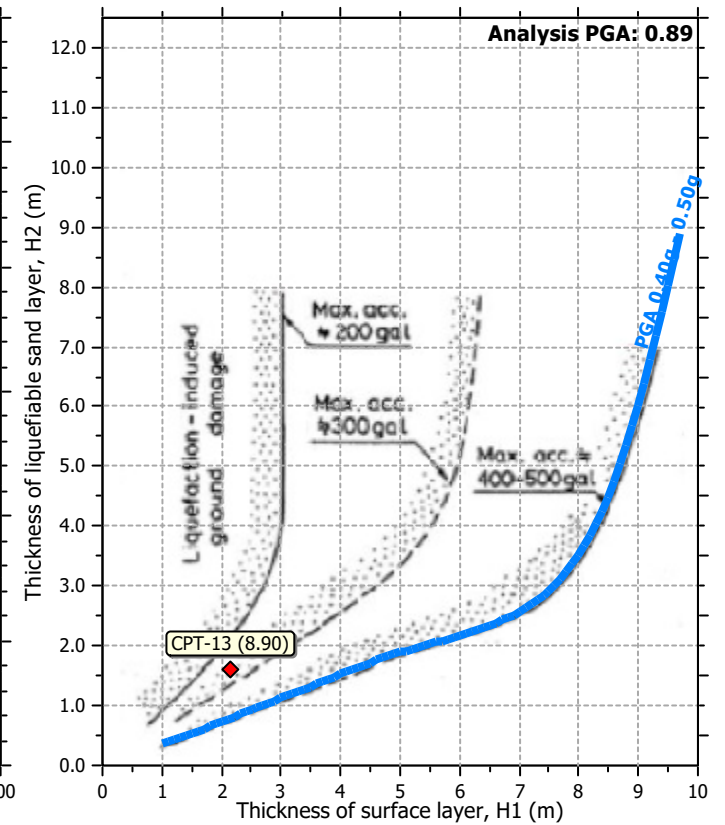
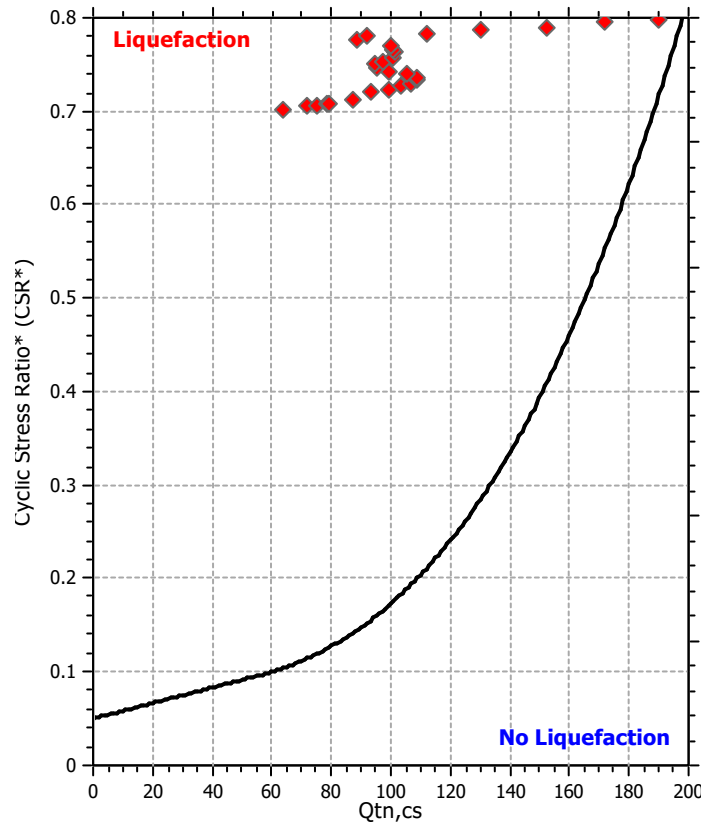
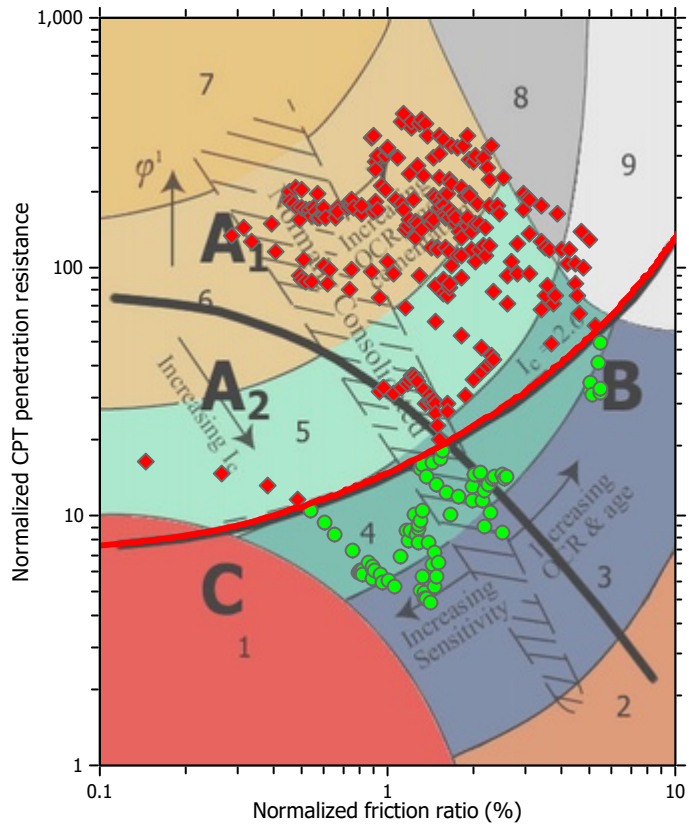

Input parameters and analysis data

Analysis method:	NCEER (1998)	Depth to water table (earthq.):	7.00 ft	Fill weight:	N/A
Fines correction method:	NCEER (1998)	Average results interval:	3	Transition detect. applied:	Yes
Points to test:	Based on Ic value	Ic cut-off value:	2.60	K_v applied:	Yes
Earthquake magnitude M_w :	8.10	Unit weight calculation:	Based on SBT	Clay like behavior applied:	Sands only
Peak ground acceleration:	0.89	Use fill:	No	Limit depth applied:	No
Depth to water table (insitu):	12.00 ft	Fill height:	N/A	Limit depth:	N/A

Check for strength loss plots (Robertson (2010))

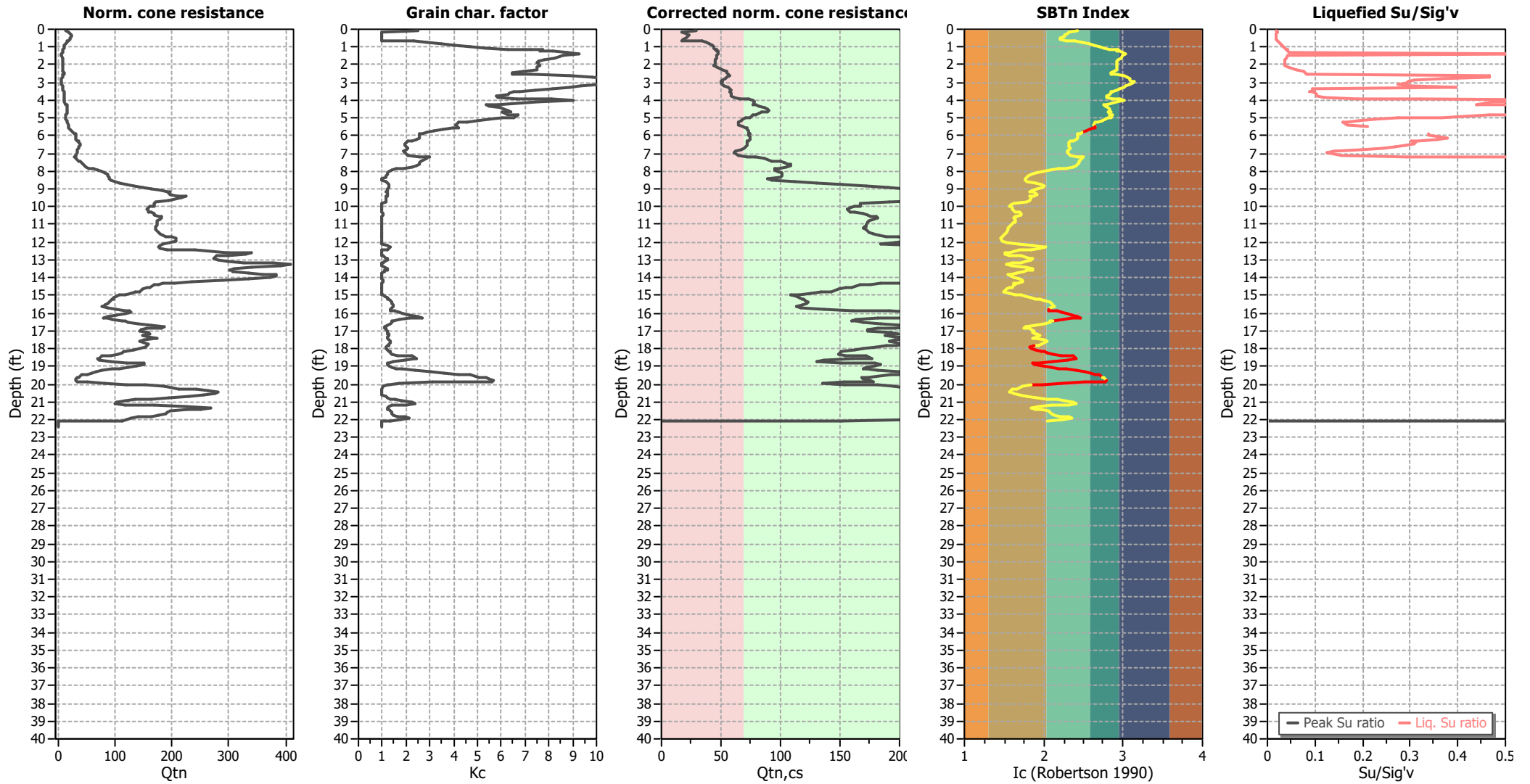

Input parameters and analysis data

Analysis method:	NCEER (1998)	Depth to water table (erthq.):	7.00 ft	Fill weight:	N/A
Fines correction method:	NCEER (1998)	Average results interval:	3	Transition detect. applied:	Yes
Points to test:	Based on Ic value	Ic cut-off value:	2.60	K _o applied:	Yes
Earthquake magnitude M _w :	8.10	Unit weight calculation:	Based on SBT	Clay like behavior applied:	Sands only
Peak ground acceleration:	0.89	Use fill:	No	Limit depth applied:	No
Depth to water table (insitu):	12.00 ft	Fill height:	N/A	Limit depth:	N/A

TRANSITION LAYER DETECTION ALGORITHM REPORT

Summary Details & Plots

Short description

The software will delete data when the cone is in transition from either clay to sand or vice-versa. To do this the software requires a range of I_c values over which the transition will be defined (typically somewhere between $1.80 < I_c < 3.0$) and a rate of change of I_c . Transitions typically occur when the rate of change of I_c is fast (i.e. ΔI_c is small).

The SBT_n plot below, displays in red the detected transition layers based on the parameters listed below the graphs.

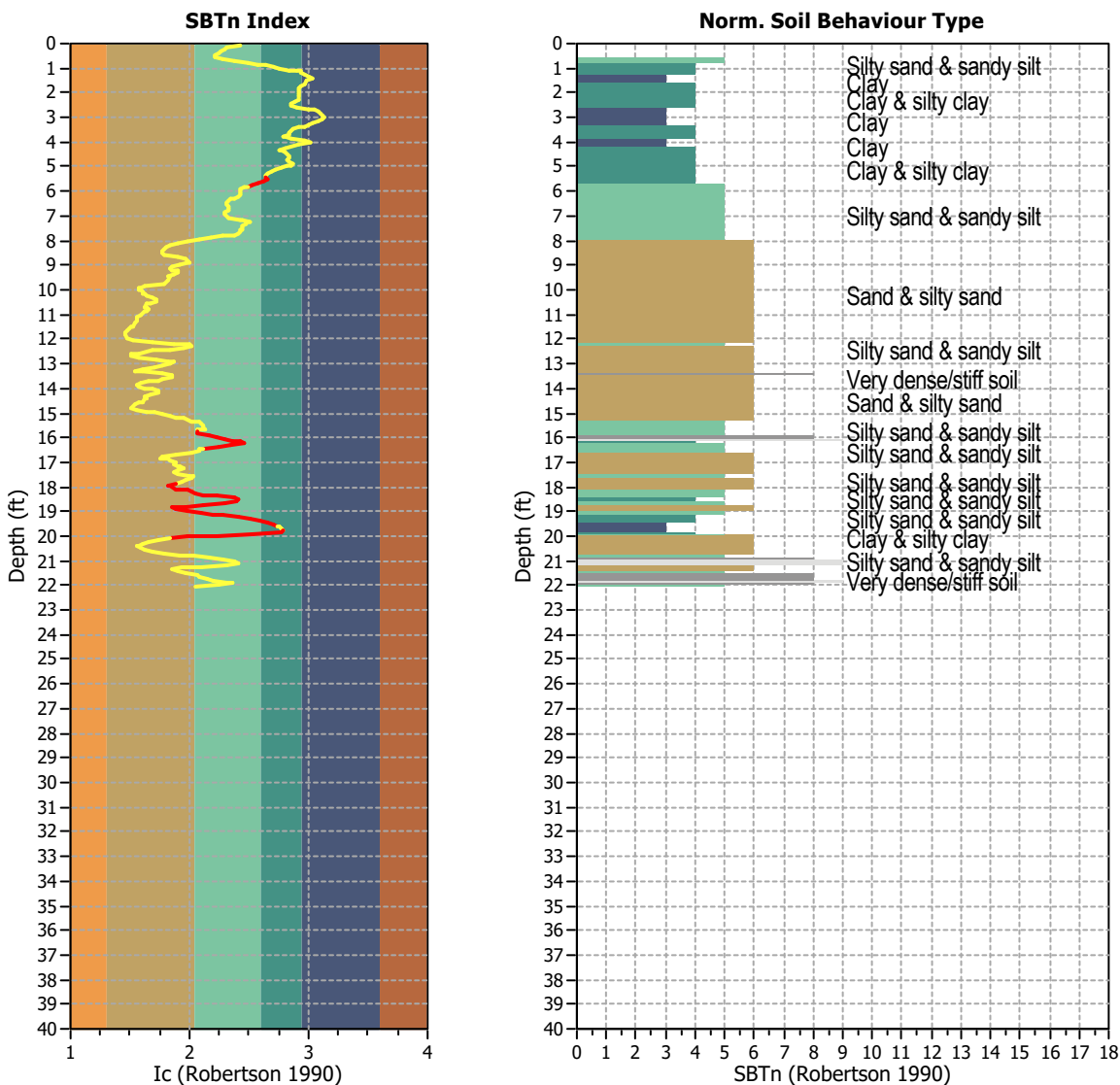

Transition layer algorithm properties

I_c minimum check value: 1.70
 I_c maximum check value: 3.00
 I_c change ratio value: 0.0250
 Minimum number of points in layer: 4

General statistics

Total points in CPT file: 326
 Total points excluded: 53
 Exclusion percentage: 16.26%
 Number of layers detected: 7

Estimation of post-earthquake settlements

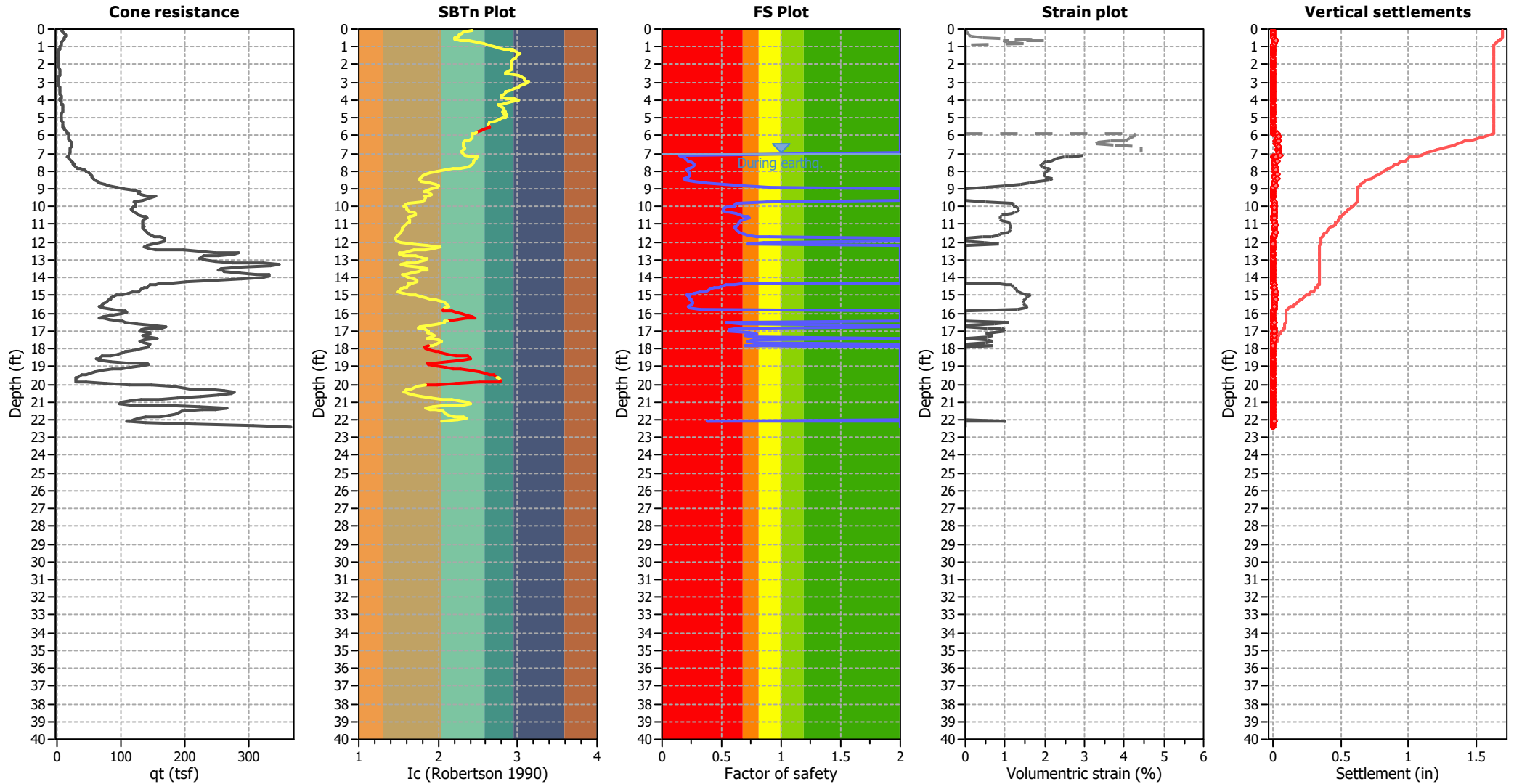

Abbreviations

- q_c: Total cone resistance (cone resistance q_c corrected for pore water effects)
- I_c: Soil Behaviour Type Index
- FS: Calculated Factor of Safety against liquefaction
- Volumetric strain: Post-liquefaction volumetric strain

Estimation of post-earthquake lateral Displacements

Geometric parameters: Gently sloping ground without free face (Slope 1.00 %)

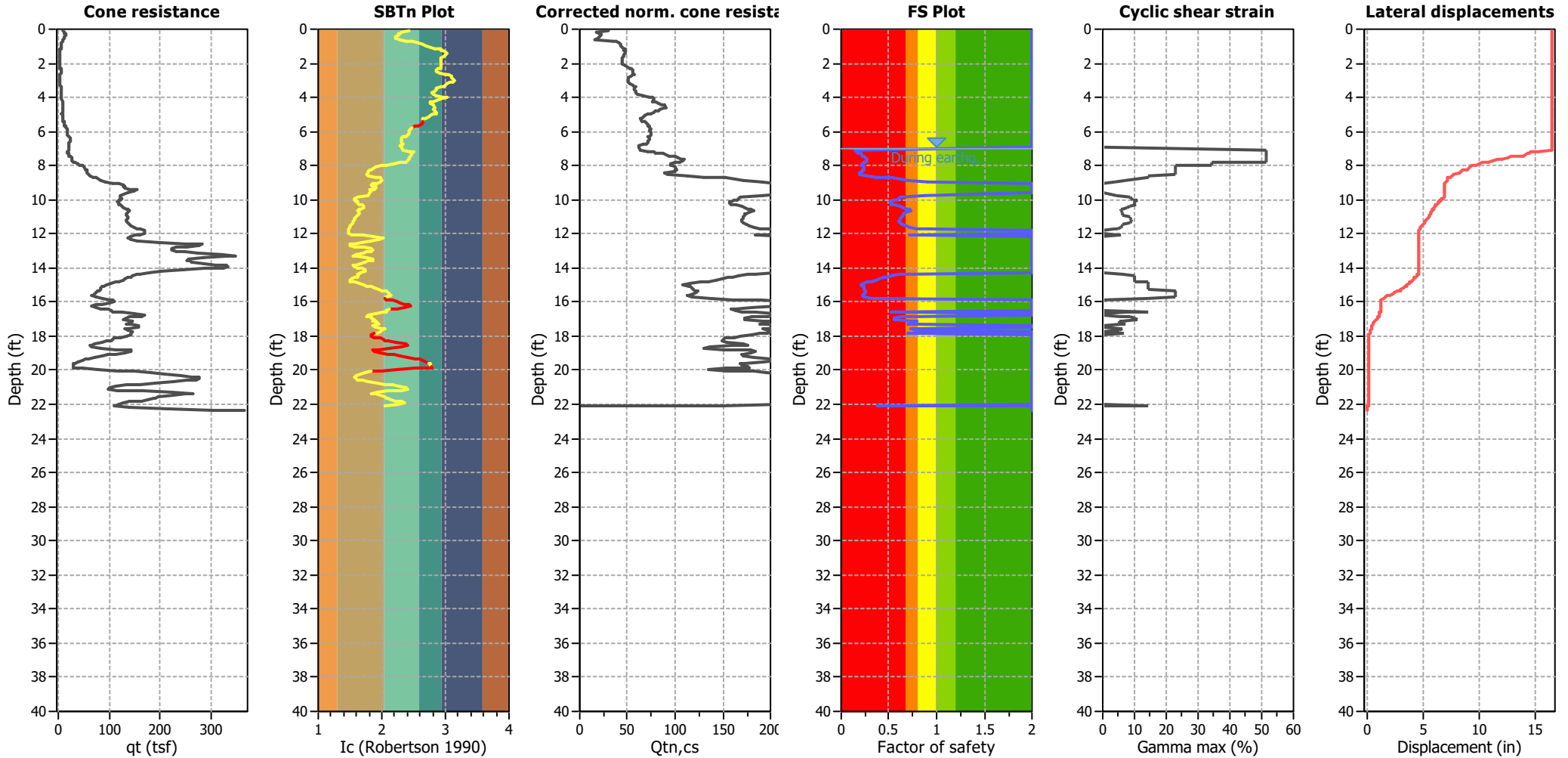

Abbreviations

qt: Total cone resistance (cone resistance q_c corrected for pore water effects)
 Ic: Soil Behaviour Type Index
 $Q_{tn,cs}$: Equivalent clean sand normalized CPT total cone resistance

F.S.: Factor of safety
 γ_{max} : Maximum cyclic shear strain
 LDI: Lateral displacement index

Surface condition



Aging Calculation Estimation

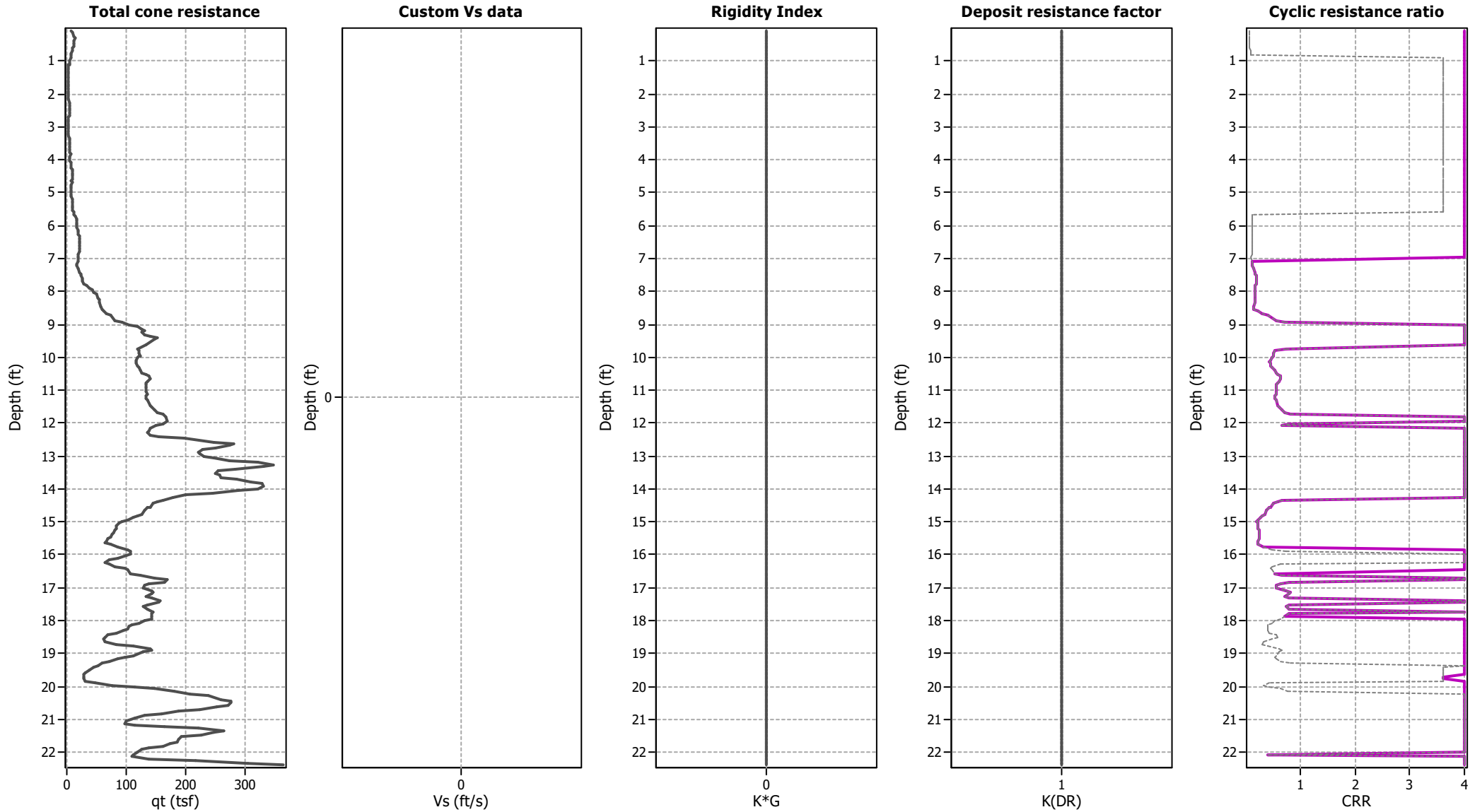

Ejecta Severity Estimation

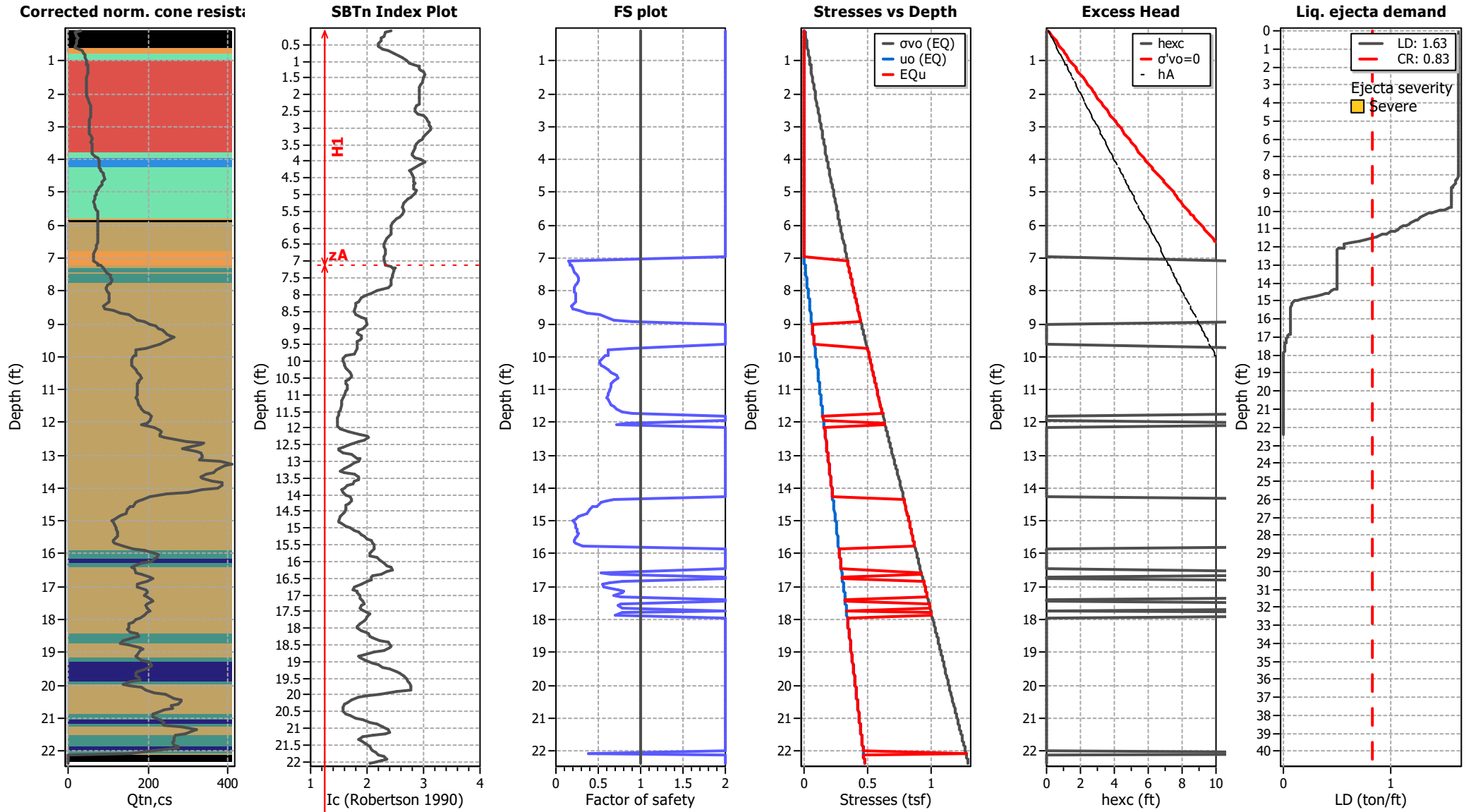

LIQUEFACTION ANALYSIS REPORT

Project title : Petra Geosciences / Apple Canyon

Location : Lake Hemet, CA

CPT file : CPT-14

Input parameters and analysis data

Analysis method:	NCEER (1998)	G.W.T. (in-situ):	9.50 ft	Use fill:	No	Clay like behavior applied:	Sands only
Fines correction method:	NCEER (1998)	G.W.T. (earthq.):	7.00 ft	Fill height:	N/A	Limit depth applied:	No
Points to test:	Based on Ic value	Average results interval:	3	Fill weight:	N/A	Limit depth:	N/A
Earthquake magnitude M_w :	8.10	Ic cut-off value:	2.60	Trans. detect. applied:	Yes	MSF method:	Method based
Peak ground acceleration:	0.89	Unit weight calculation:	Based on SBT	K_o applied:	Yes		

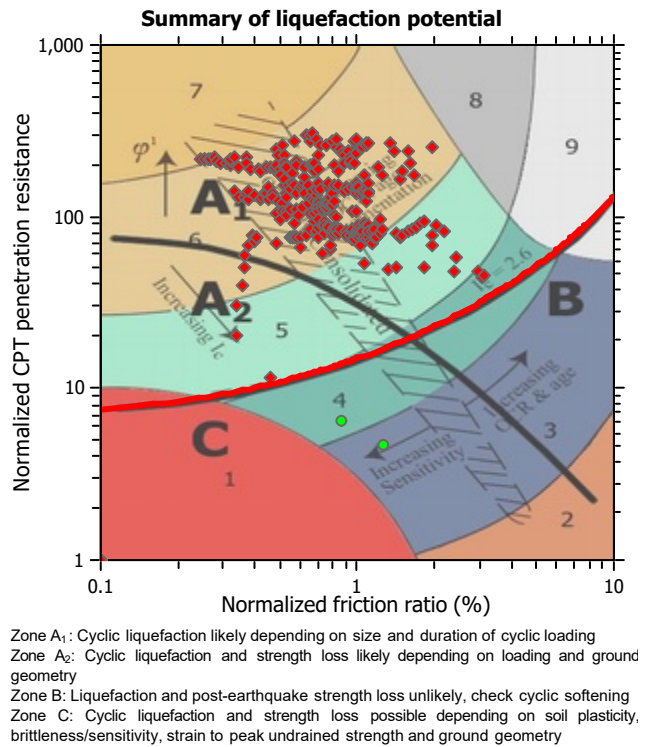
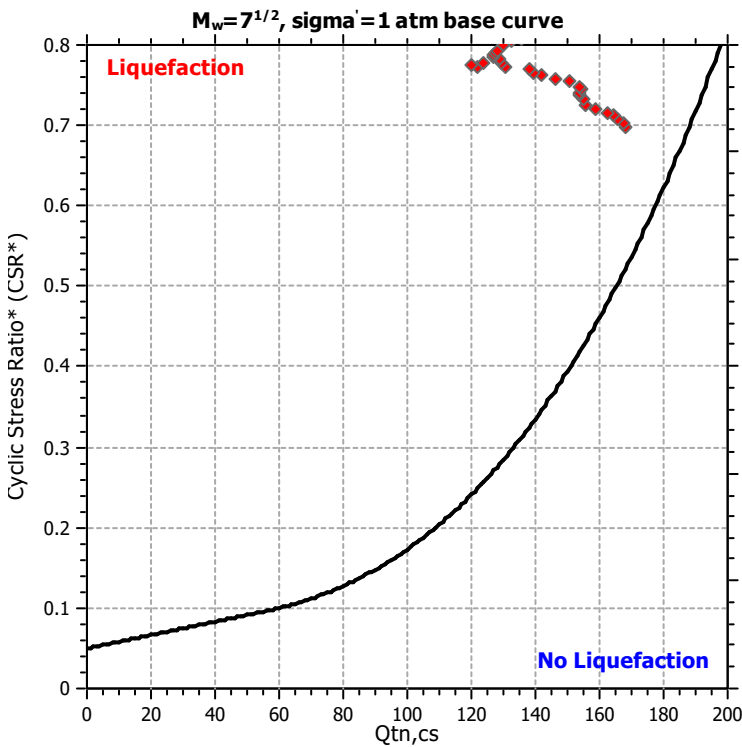
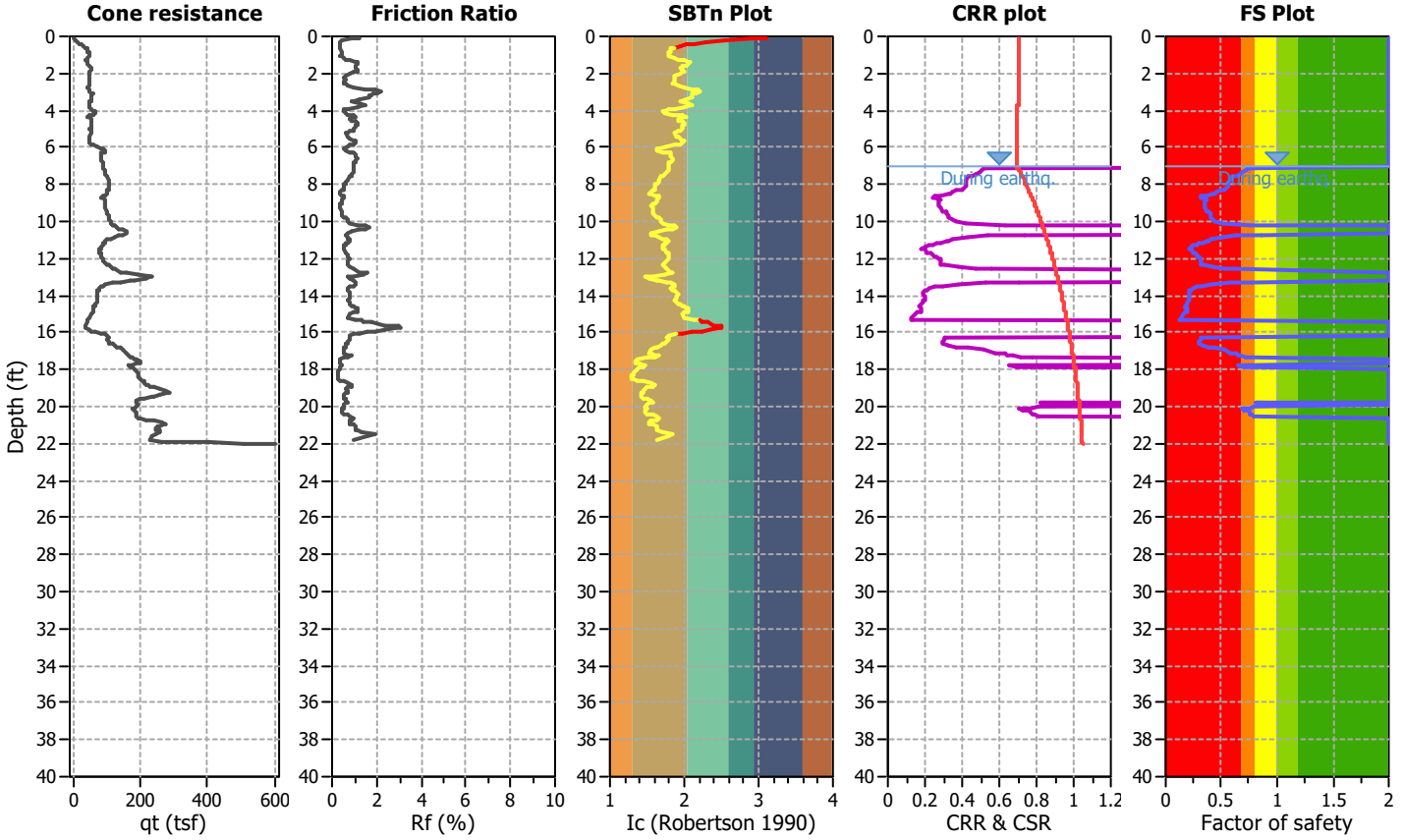

CPT basic interpretation plots

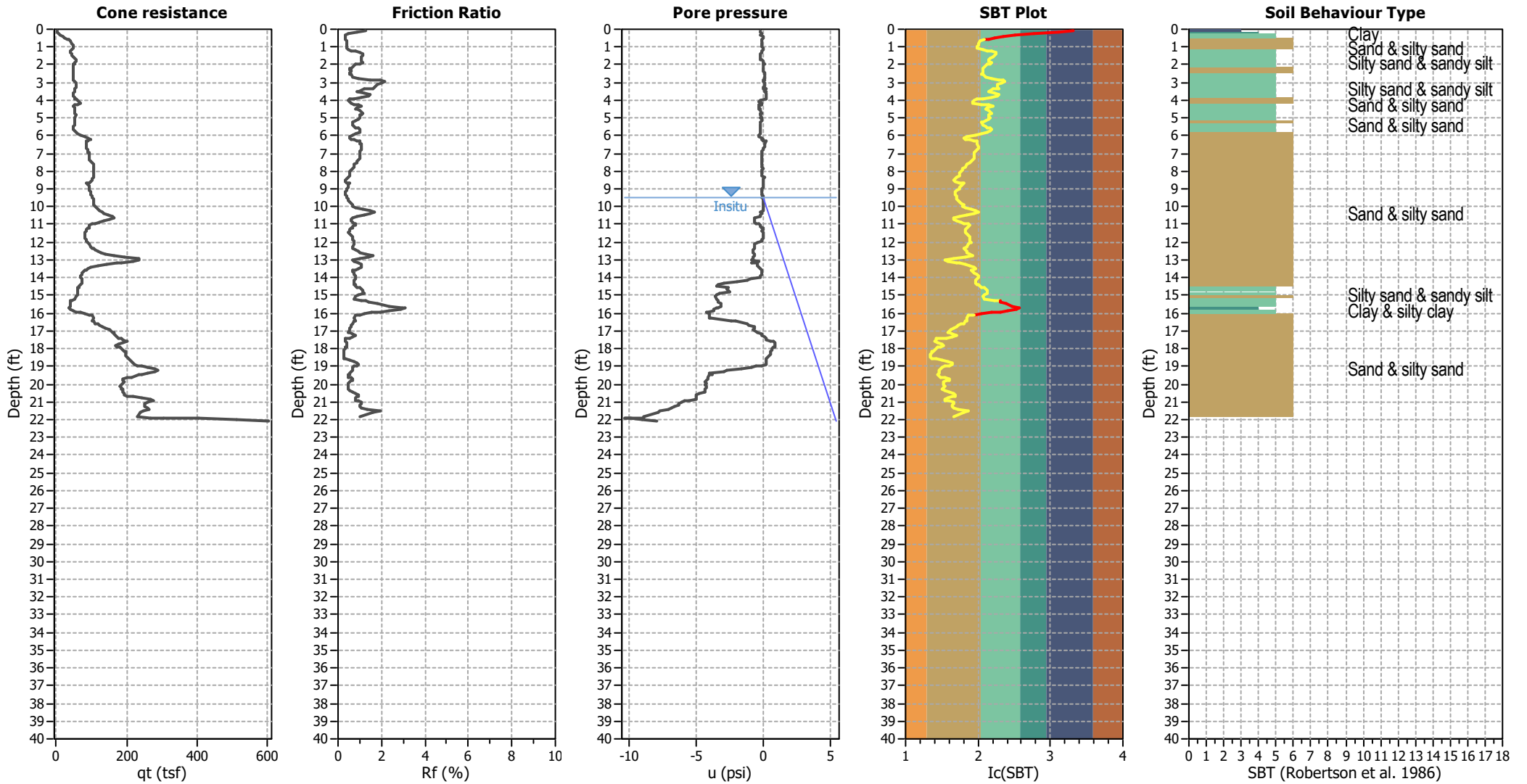

Input parameters and analysis data

Analysis method:	NCEER (1998)	Depth to water table (earthq.):	7.00 ft	Fill weight:	N/A
Fines correction method:	NCEER (1998)	Average results interval:	3	Transition detect. applied:	Yes
Points to test:	Based on Ic value	Ic cut-off value:	2.60	K ₀ applied:	Yes
Earthquake magnitude M _w :	8.10	Unit weight calculation:	Based on SBT	Clay like behavior applied:	Sands only
Peak ground acceleration:	0.89	Use fill:	No	Limit depth applied:	No
Depth to water table (insitu):	9.50 ft	Fill height:	N/A	Limit depth:	N/A

SBT legend

1. Sensitive fine grained	4. Clayey silt to silty	7. Gravely sand to sand
2. Organic material	5. Silty sand to sandy silt	8. Very stiff sand to
3. Clay to silty clay	6. Clean sand to silty sand	9. Very stiff fine grained

CPT basic interpretation plots (normalized)

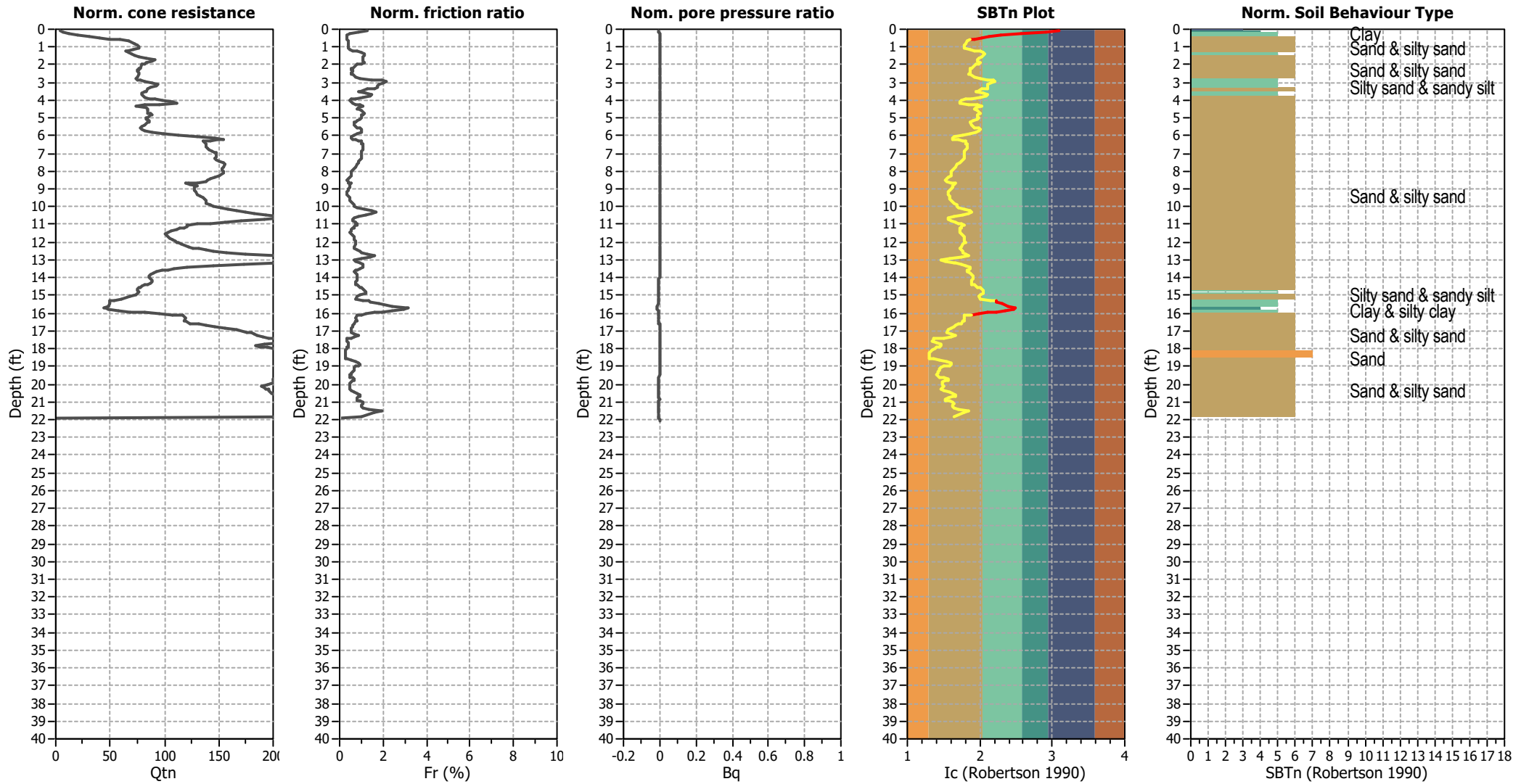

Input parameters and analysis data

Analysis method:	NCEER (1998)	Depth to water table (erthq.):	7.00 ft	Fill weight:	N/A
Fines correction method:	NCEER (1998)	Average results interval:	3	Transition detect. applied:	Yes
Points to test:	Based on Ic value	Ic cut-off value:	2.60	K ₀ applied:	Yes
Earthquake magnitude M _w :	8.10	Unit weight calculation:	Based on SBT	Clay like behavior applied:	Sands only
Peak ground acceleration:	0.89	Use fill:	No	Limit depth applied:	No
Depth to water table (insitu):	9.50 ft	Fill height:	N/A	Limit depth:	N/A

SBTn legend

1. Sensitive fine grained	4. Clayey silt to silty	7. Gravely sand to sand
2. Organic material	5. Silty sand to sandy silt	8. Very stiff sand to
3. Clay to silty clay	6. Clean sand to silty sand	9. Very stiff fine grained

Liquefaction analysis overall plots (intermediate results)

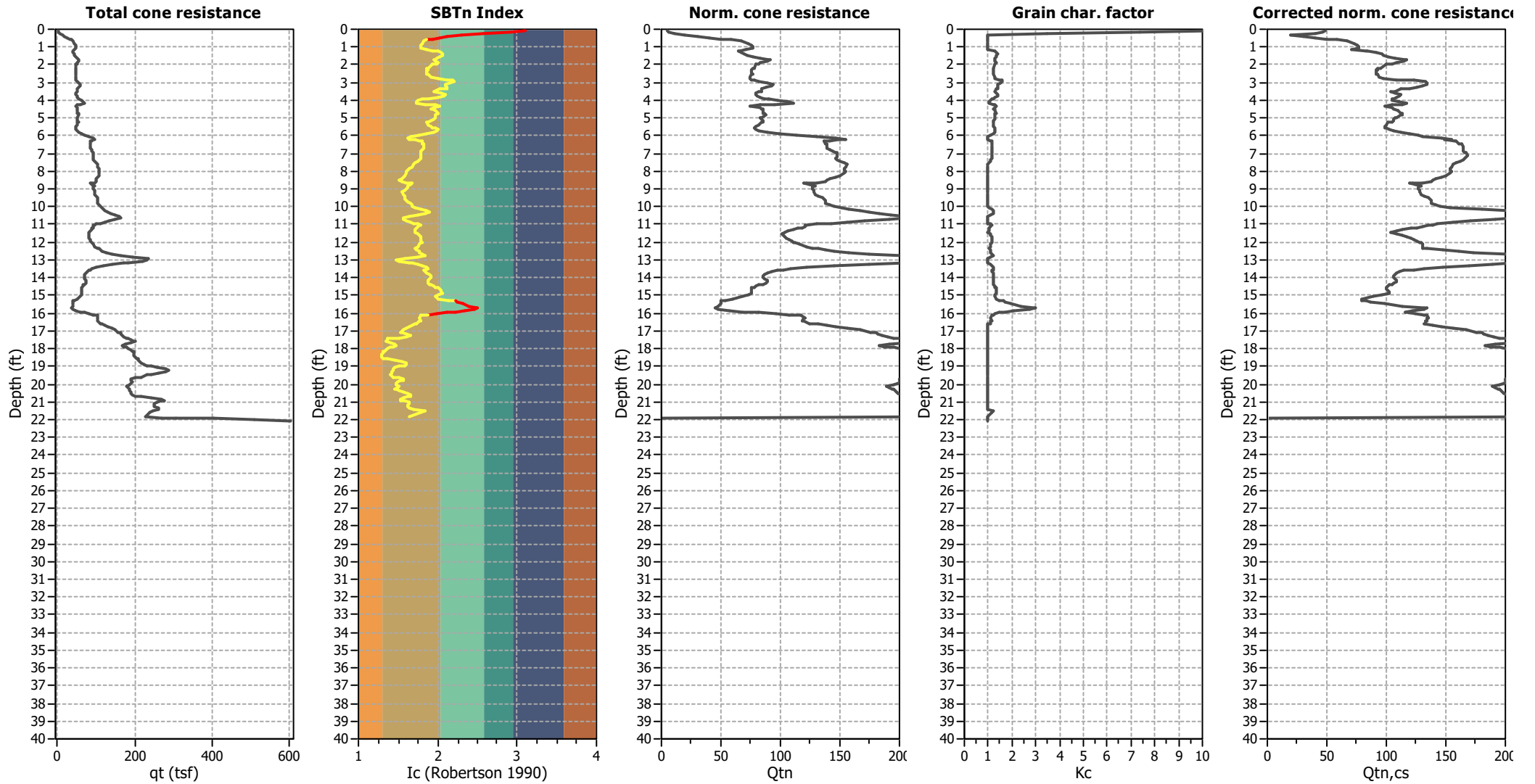

Input parameters and analysis data

Analysis method:	NCEER (1998)	Depth to water table (earthq.):	7.00 ft	Fill weight:	N/A
Fines correction method:	NCEER (1998)	Average results interval:	3	Transition detect. applied:	Yes
Points to test:	Based on Ic value	Ic cut-off value:	2.60	K _o applied:	Yes
Earthquake magnitude M _w :	8.10	Unit weight calculation:	Based on SBT	Clay like behavior applied:	Sands only
Peak ground acceleration:	0.89	Use fill:	No	Limit depth applied:	No
Depth to water table (insitu):	9.50 ft	Fill height:	N/A	Limit depth:	N/A

Liquefaction analysis overall plots

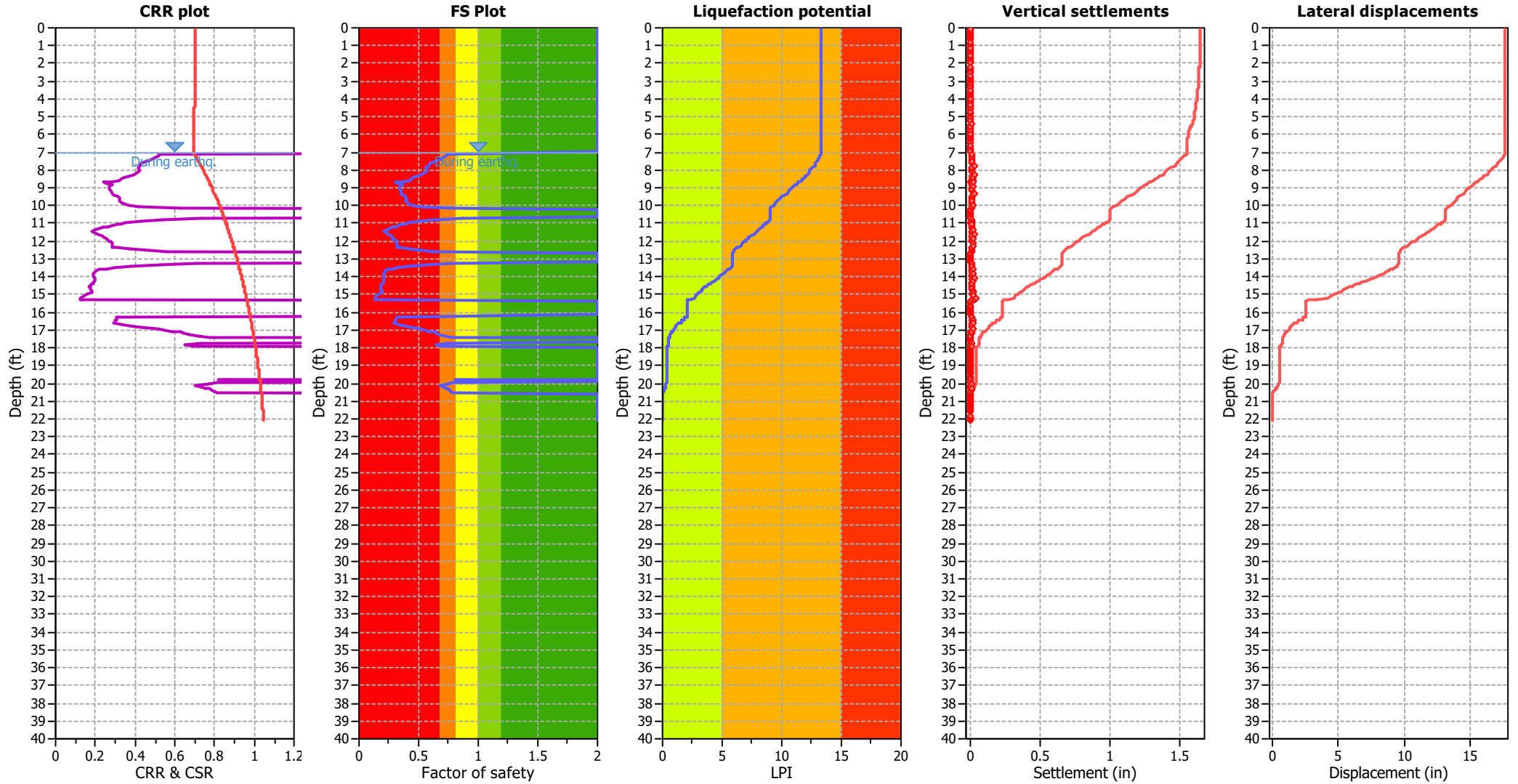

Input parameters and analysis data

Analysis method:	NCEER (1998)	Depth to water table (earthq.):	7.00 ft	Fill weight:	N/A
Fines correction method:	NCEER (1998)	Average results interval:	3	Transition detect. applied:	Yes
Points to test:	Based on Ic value	Ic cut-off value:	2.60	K_0 applied:	Yes
Earthquake magnitude M_w :	8.10	Unit weight calculation:	Based on SBT	Clay like behavior applied:	Sands only
Peak ground acceleration:	0.89	Use fill:	No	Limit depth applied:	No
Depth to water table (insitu):	9.50 ft	Fill height:	N/A	Limit depth:	N/A

F.S. color scheme

- Almost certain it will liquefy
- Very likely to liquefy
- Liquefaction and no liq. are equally likely
- Unlike to liquefy
- Almost certain it will not liquefy

LPI color scheme

- Very high risk
- High risk
- Low risk

Liquefaction analysis summary plots

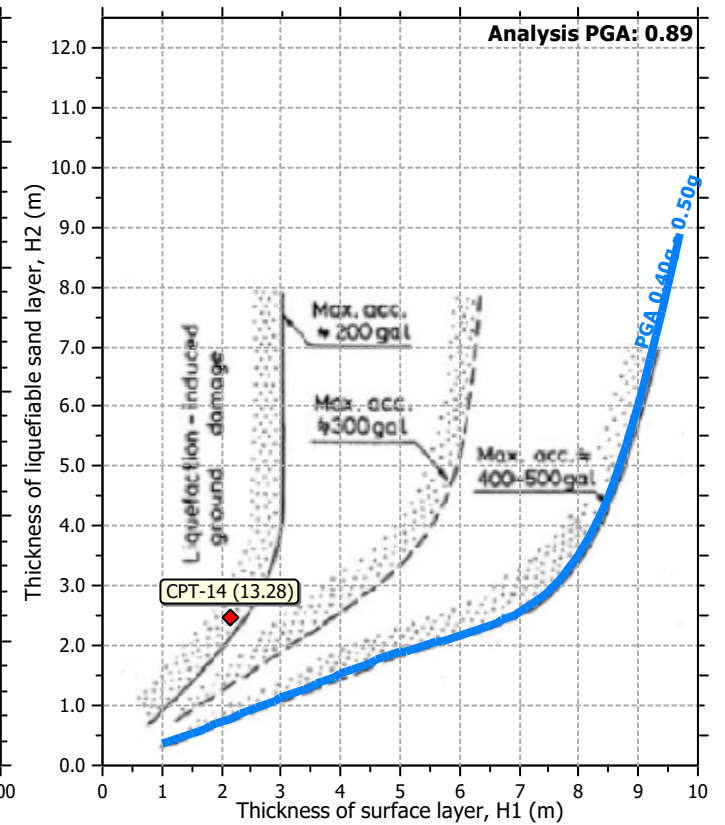
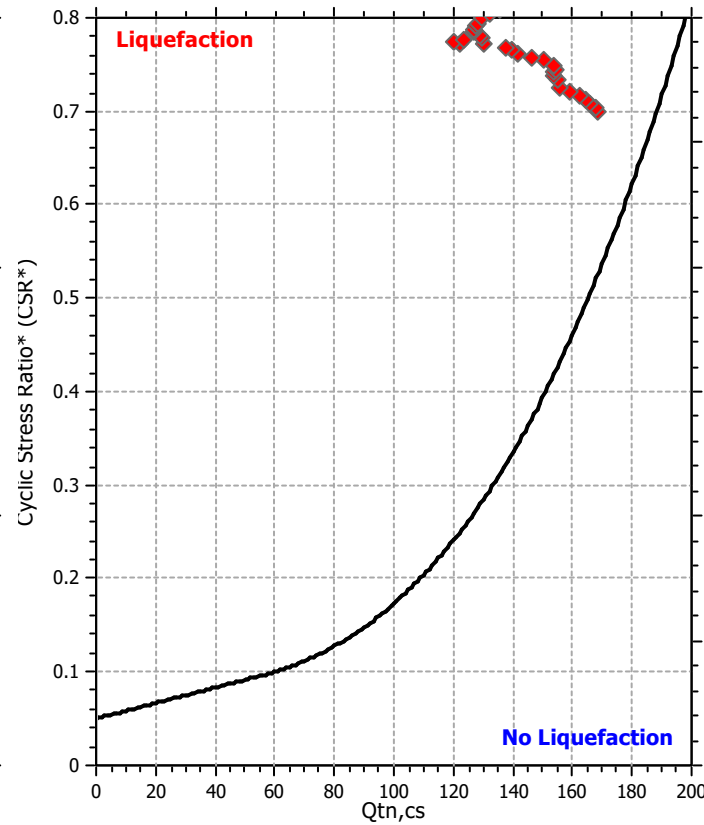
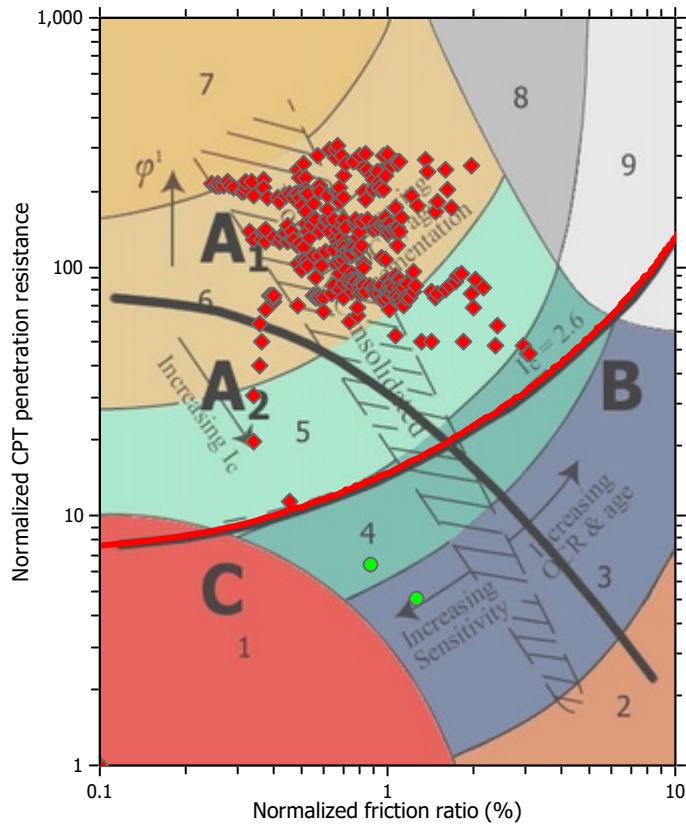

Input parameters and analysis data

Analysis method:	NCEER (1998)	Depth to water table (earthq.):	7.00 ft	Fill weight:	N/A
Fines correction method:	NCEER (1998)	Average results interval:	3	Transition detect. applied:	Yes
Points to test:	Based on I_c value	I_c cut-off value:	2.60	K_o applied:	Yes
Earthquake magnitude M_w :	8.10	Unit weight calculation:	Based on SBT	Clay like behavior applied:	Sands only
Peak ground acceleration:	0.89	Use fill:	No	Limit depth applied:	No
Depth to water table (insitu):	9.50 ft	Fill height:	N/A	Limit depth:	N/A

Check for strength loss plots (Robertson (2010))

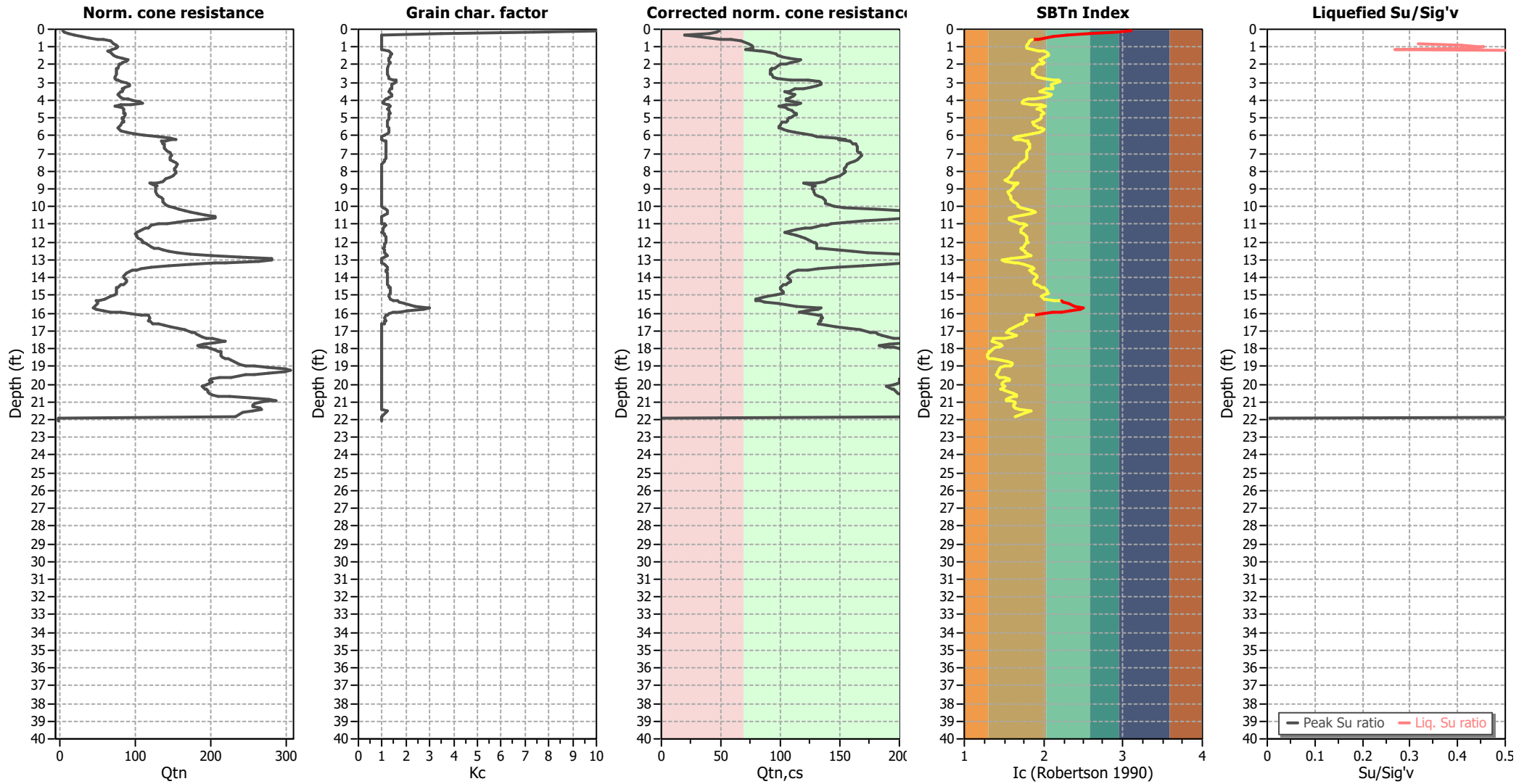

Input parameters and analysis data

Analysis method:	NCEER (1998)	Depth to water table (earthq.):	7.00 ft	Fill weight:	N/A
Fines correction method:	NCEER (1998)	Average results interval:	3	Transition detect. applied:	Yes
Points to test:	Based on Ic value	Ic cut-off value:	2.60	K _o applied:	Yes
Earthquake magnitude M _w :	8.10	Unit weight calculation:	Based on SBT	Clay like behavior applied:	Sands only
Peak ground acceleration:	0.89	Use fill:	No	Limit depth applied:	No
Depth to water table (insitu):	9.50 ft	Fill height:	N/A	Limit depth:	N/A

TRANSITION LAYER DETECTION ALGORITHM REPORT

Summary Details & Plots

Short description

The software will delete data when the cone is in transition from either clay to sand or vice-versa. To do this the software requires a range of I_c values over which the transition will be defined (typically somewhere between $1.80 < I_c < 3.0$) and a rate of change of I_c . Transitions typically occur when the rate of change of I_c is fast (i.e. ΔI_c is small).

The SBT_n plot below, displays in red the detected transition layers based on the parameters listed below the graphs.

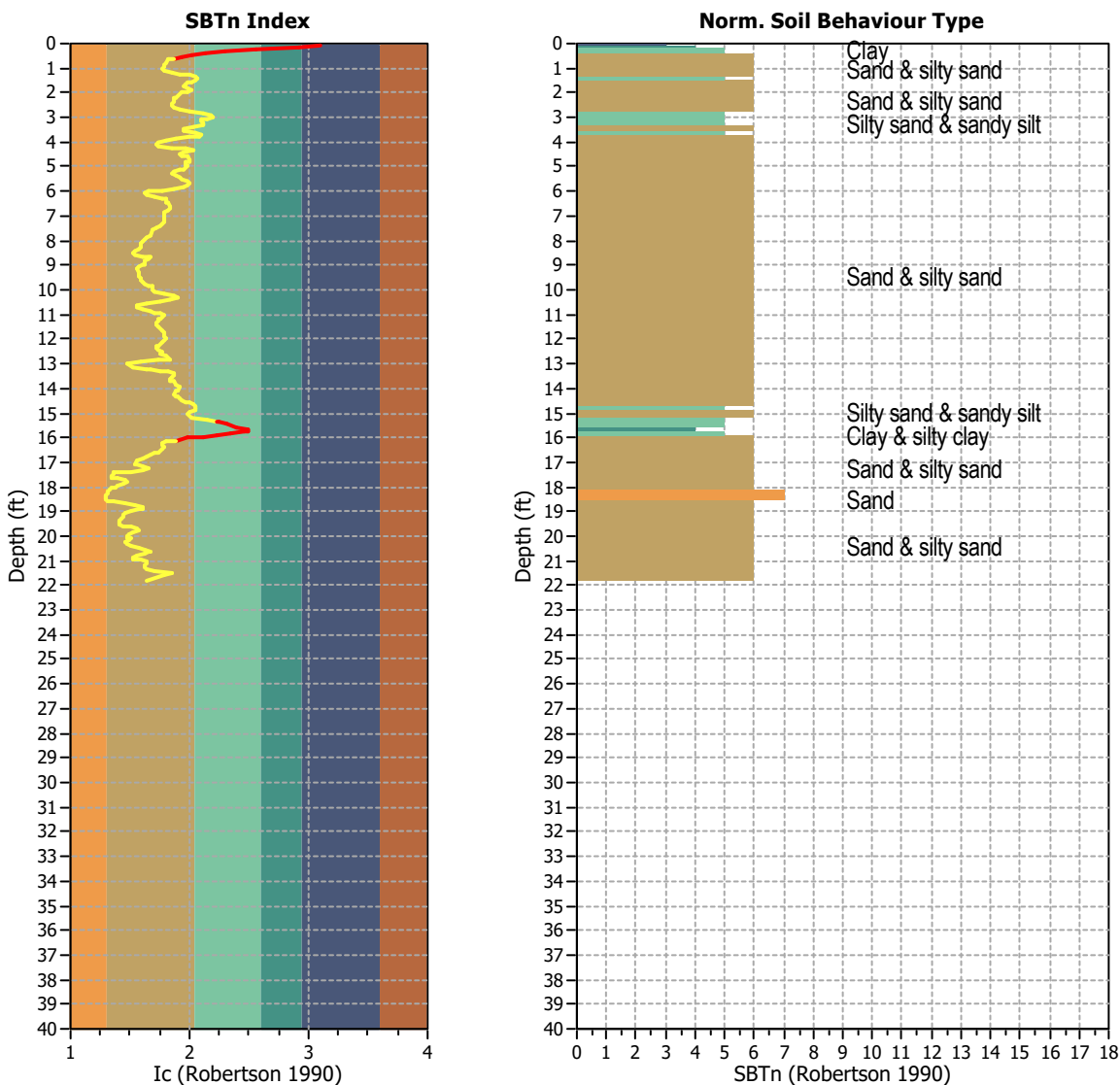

Transition layer algorithm properties

I_c minimum check value: 1.70
 I_c maximum check value: 3.00
 I_c change ratio value: 0.0250
 Minimum number of points in layer: 4

General statistics

Total points in CPT file: 304
 Total points excluded: 20
 Exclusion percentage: 6.58%
 Number of layers detected: 3

Estimation of post-earthquake settlements

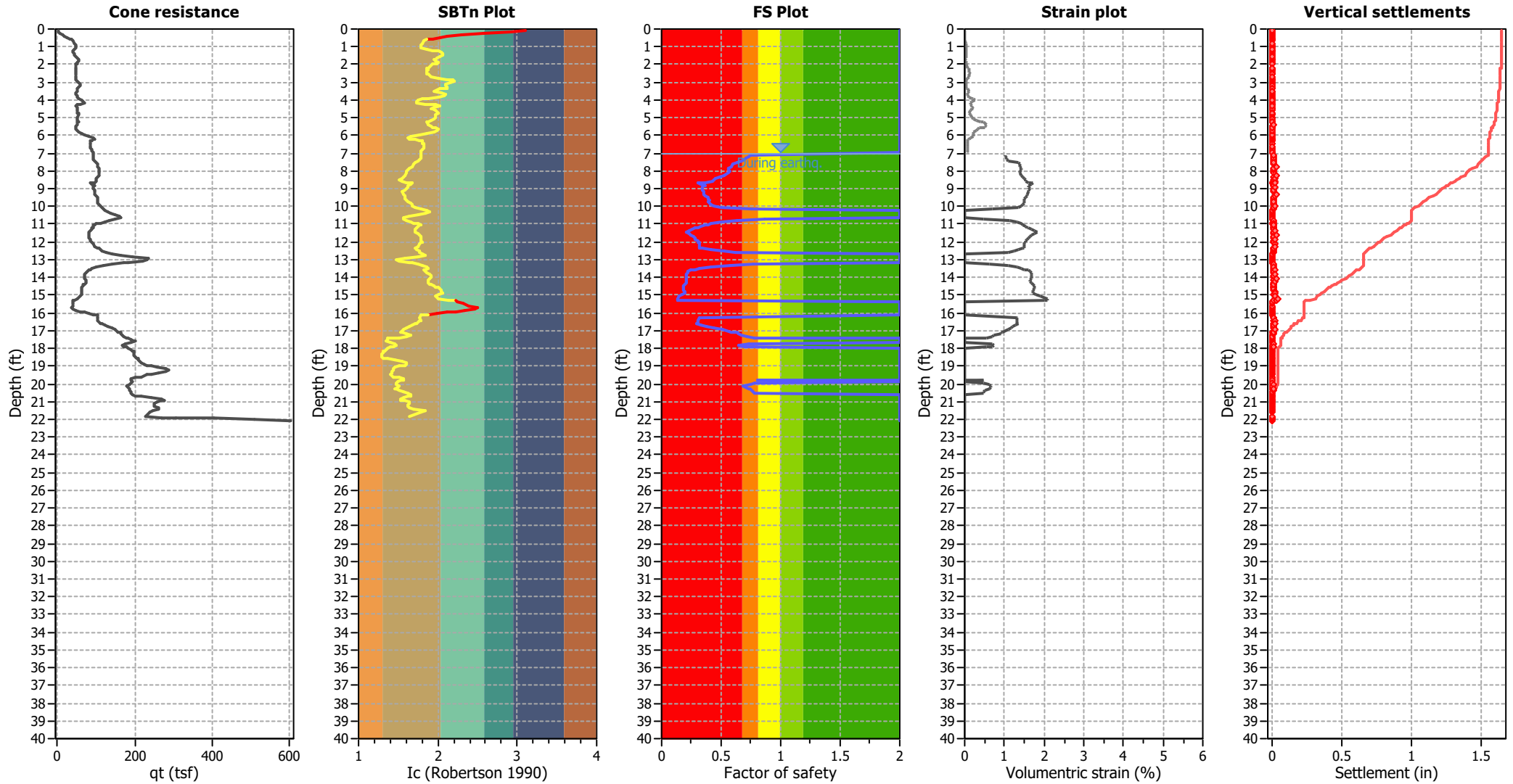

Abbreviations

- q_c: Total cone resistance (cone resistance q_c corrected for pore water effects)
- I_c: Soil Behaviour Type Index
- FS: Calculated Factor of Safety against liquefaction
- Volumetric strain: Post-liquefaction volumetric strain

Estimation of post-earthquake lateral Displacements

Geometric parameters: Gently sloping ground without free face (Slope 1.00 %)

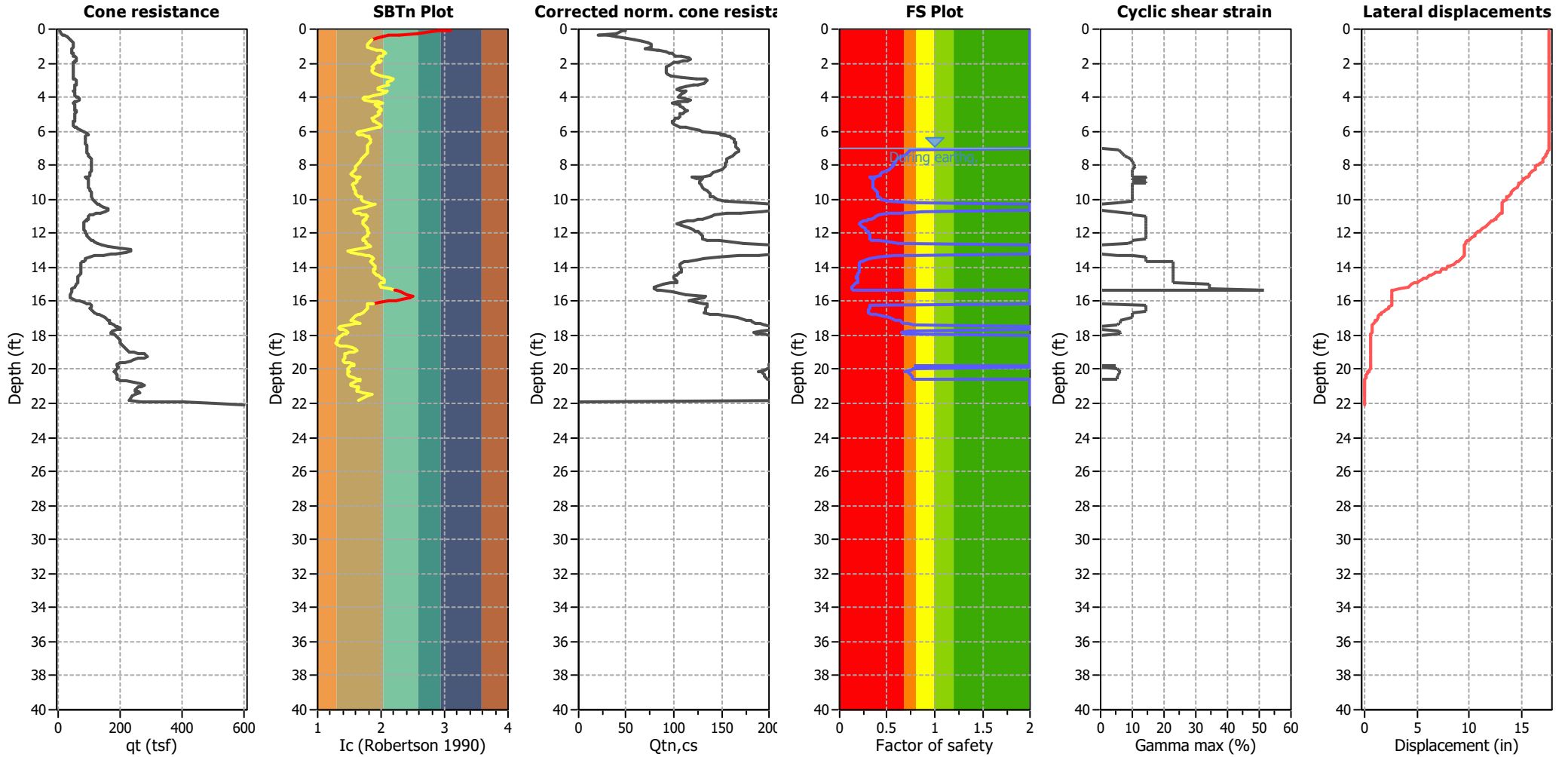

Abbreviations

qt: Total cone resistance (cone resistance q_c corrected for pore water effects)
 Ic: Soil Behaviour Type Index
 $Q_{tn,cs}$: Equivalent clean sand normalized CPT total cone resistance

F.S.: Factor of safety
 γ_{max} : Maximum cyclic shear strain
 LDI: Lateral displacement index

Surface condition

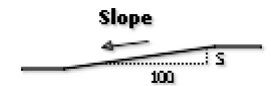

Aging Calculation Estimation

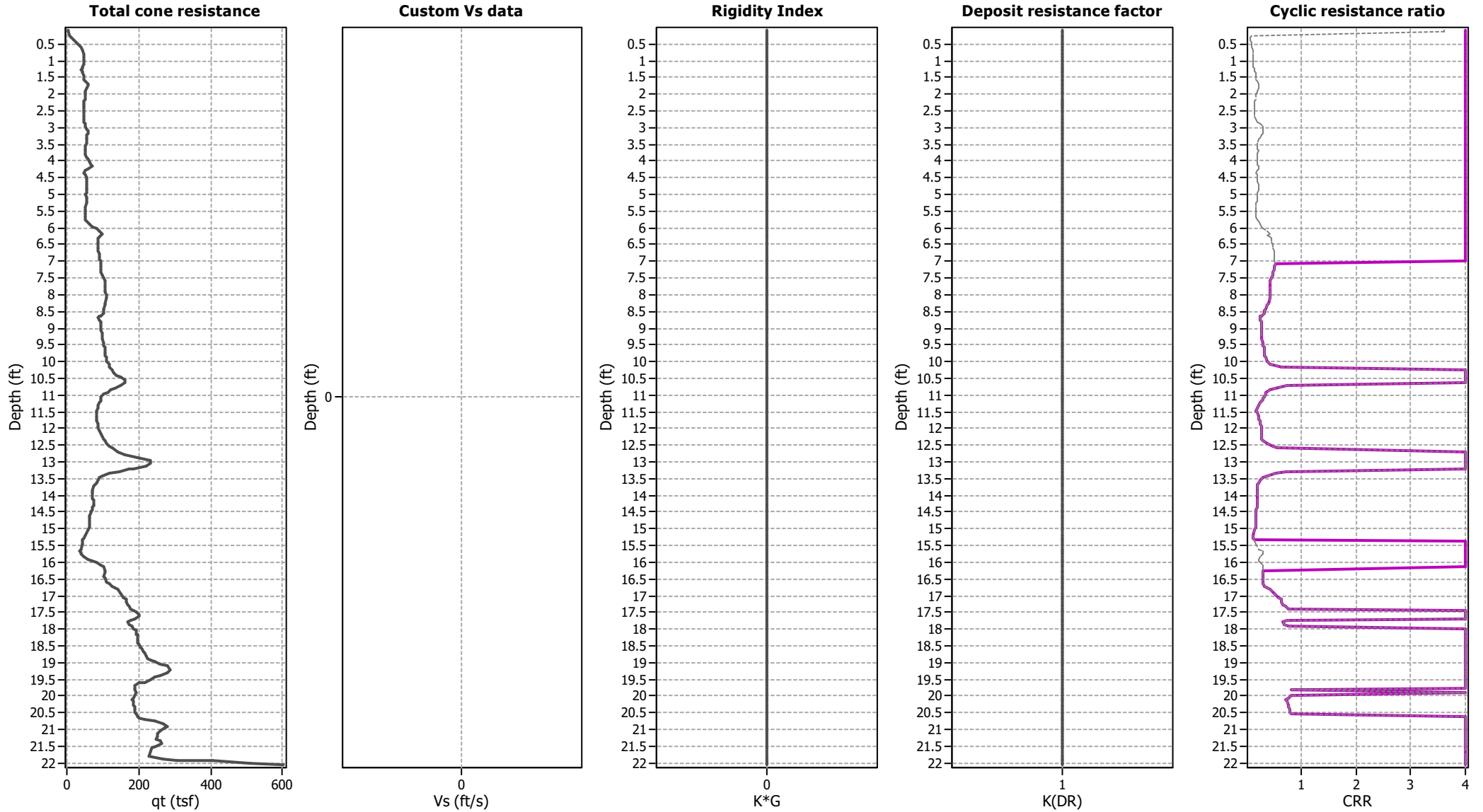

Ejecta Severity Estimation

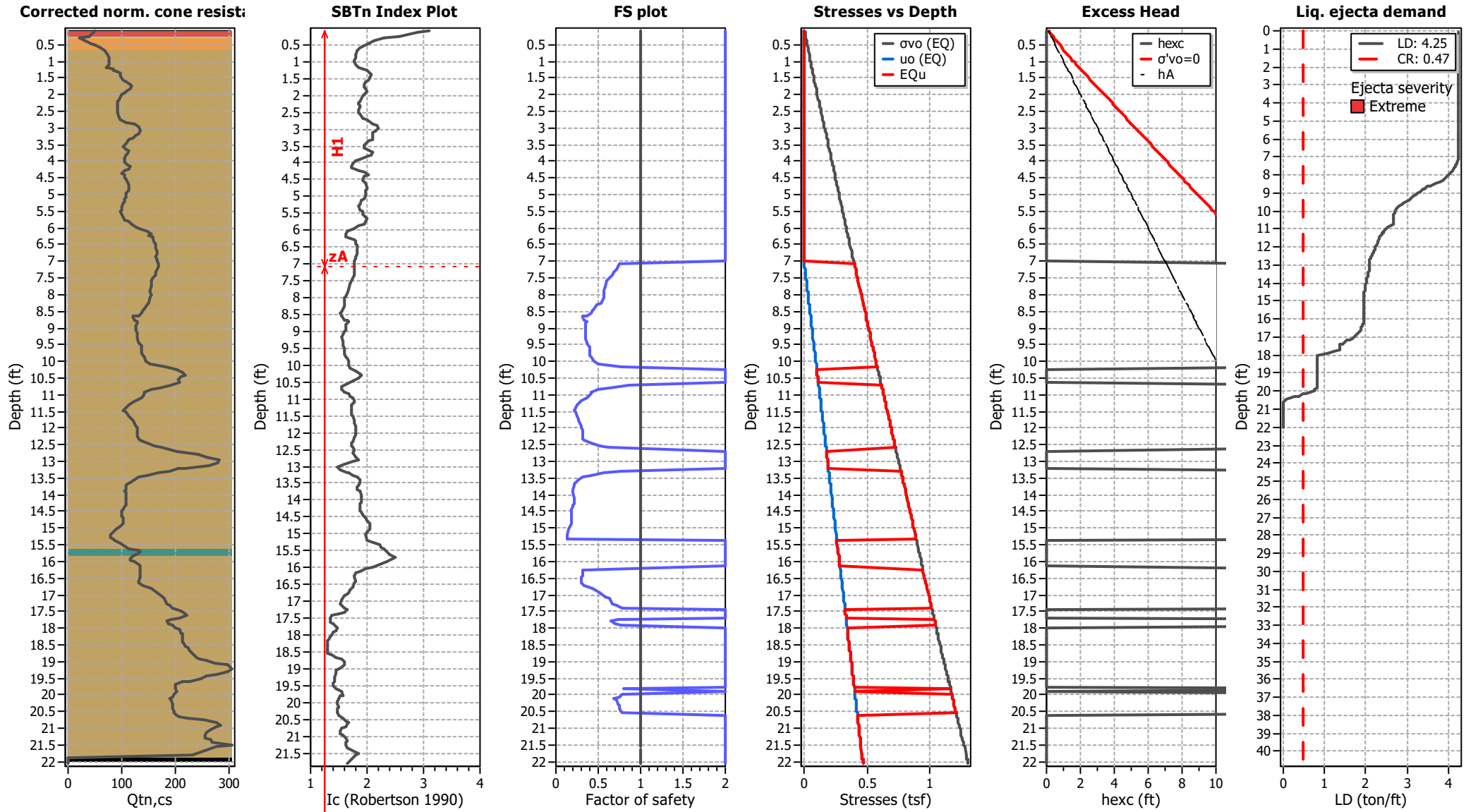

LIQUEFACTION ANALYSIS REPORT

Project title : Petra Geosciences / Apple Canyon

Location : Lake Hemet, CA

CPT file : CPT-15

Input parameters and analysis data

Analysis method:	NCEER (1998)	G.W.T. (in-situ):	9.00 ft	Use fill:	No	Clay like behavior applied:	Sands only
Fines correction method:	NCEER (1998)	G.W.T. (earthq.):	7.00 ft	Fill height:	N/A	Limit depth applied:	No
Points to test:	Based on Ic value	Average results interval:	3	Fill weight:	N/A	Limit depth:	N/A
Earthquake magnitude M_w :	8.10	Ic cut-off value:	2.60	Trans. detect. applied:	Yes	MSF method:	Method based
Peak ground acceleration:	0.89	Unit weight calculation:	Based on SBT	K_o applied:	Yes		

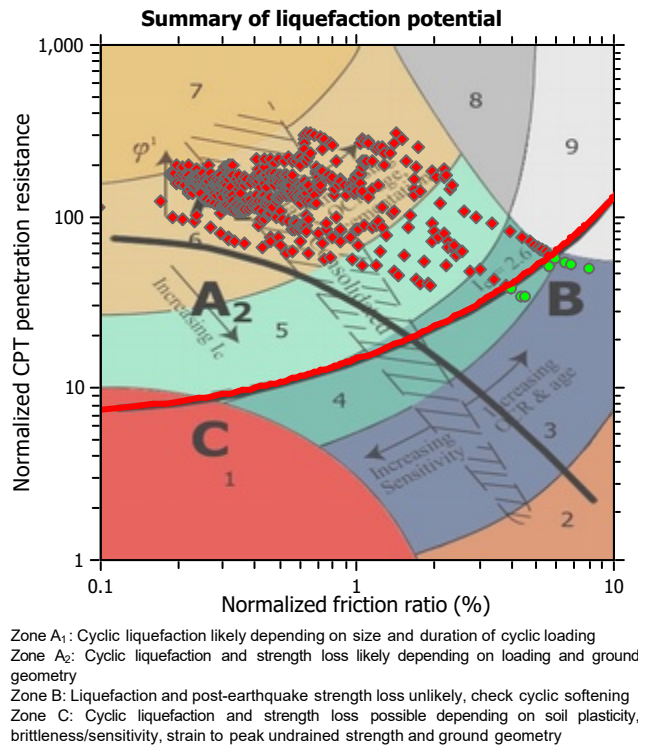
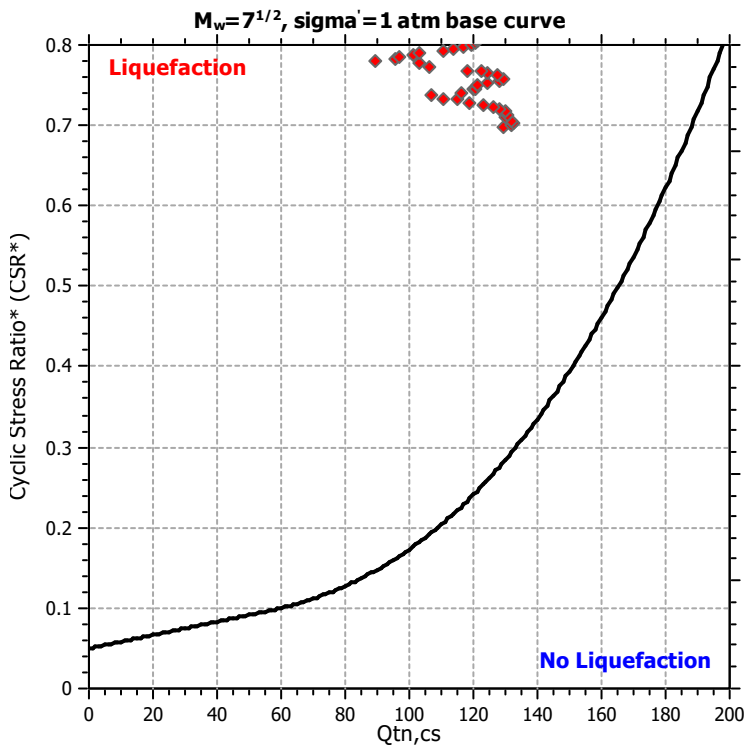
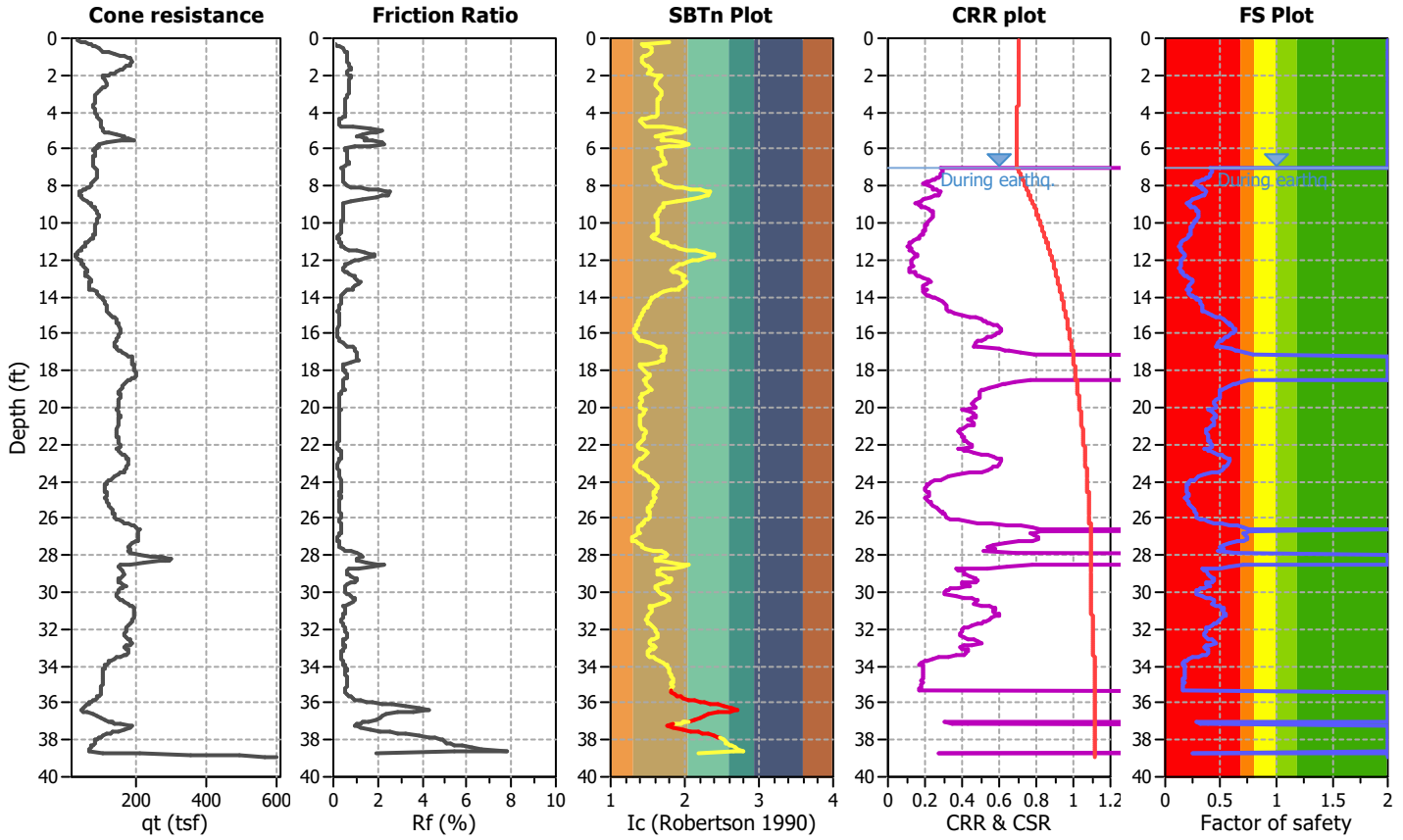

CPT basic interpretation plots

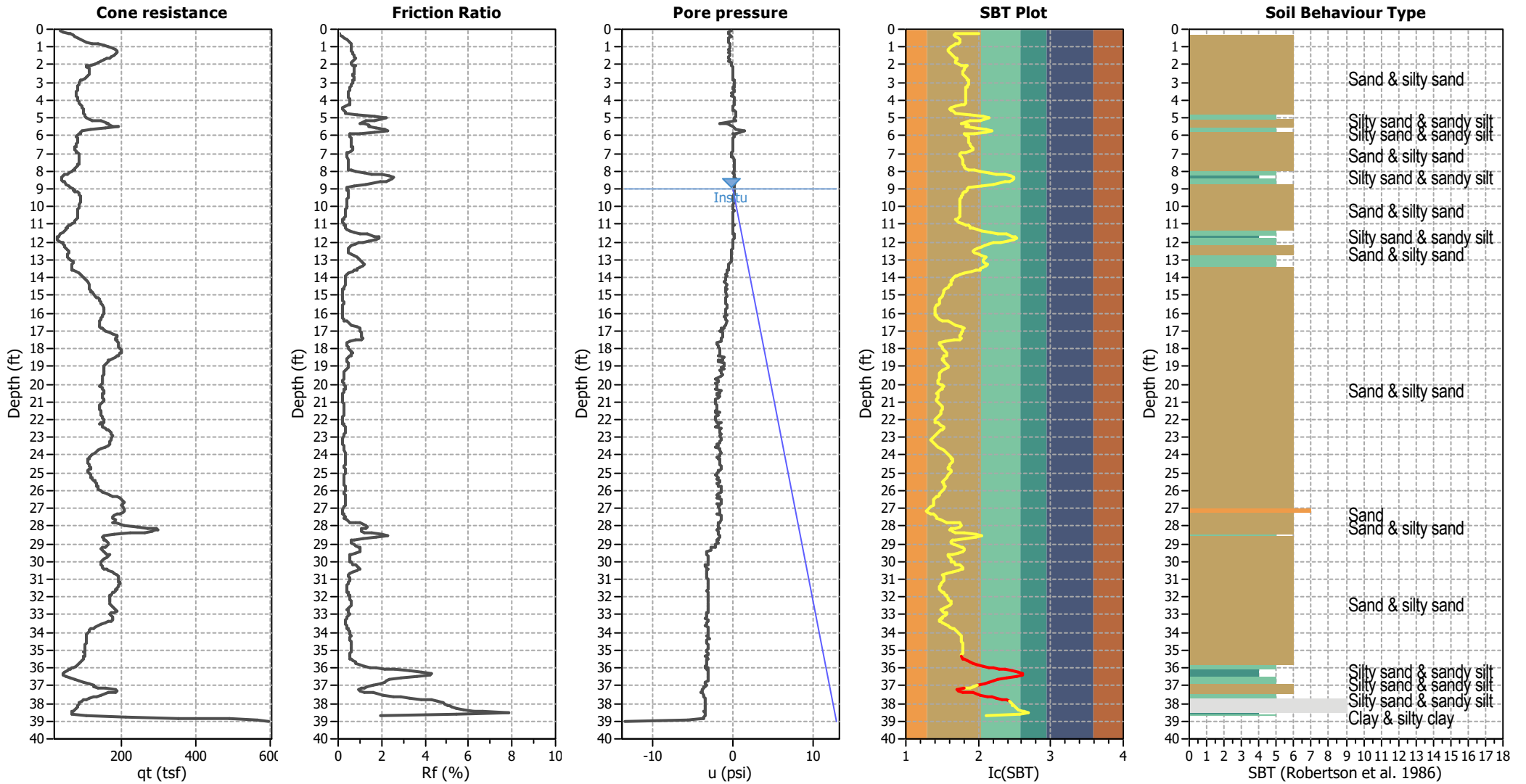

Input parameters and analysis data

Analysis method:	NCEER (1998)	Depth to water table (earthq.):	7.00 ft	Fill weight:	N/A
Fines correction method:	NCEER (1998)	Average results interval:	3	Transition detect. applied:	Yes
Points to test:	Based on Ic value	Ic cut-off value:	2.60	K ₀ applied:	Yes
Earthquake magnitude M _w :	8.10	Unit weight calculation:	Based on SBT	Clay like behavior applied:	Sands only
Peak ground acceleration:	0.89	Use fill:	No	Limit depth applied:	No
Depth to water table (insitu):	9.00 ft	Fill height:	N/A	Limit depth:	N/A

SBT legend

1. Sensitive fine grained	4. Clayey silt to silty	7. Gravely sand to sand
2. Organic material	5. Silty sand to sandy silt	8. Very stiff sand to
3. Clay to silty clay	6. Clean sand to silty sand	9. Very stiff fine grained

CPT basic interpretation plots (normalized)

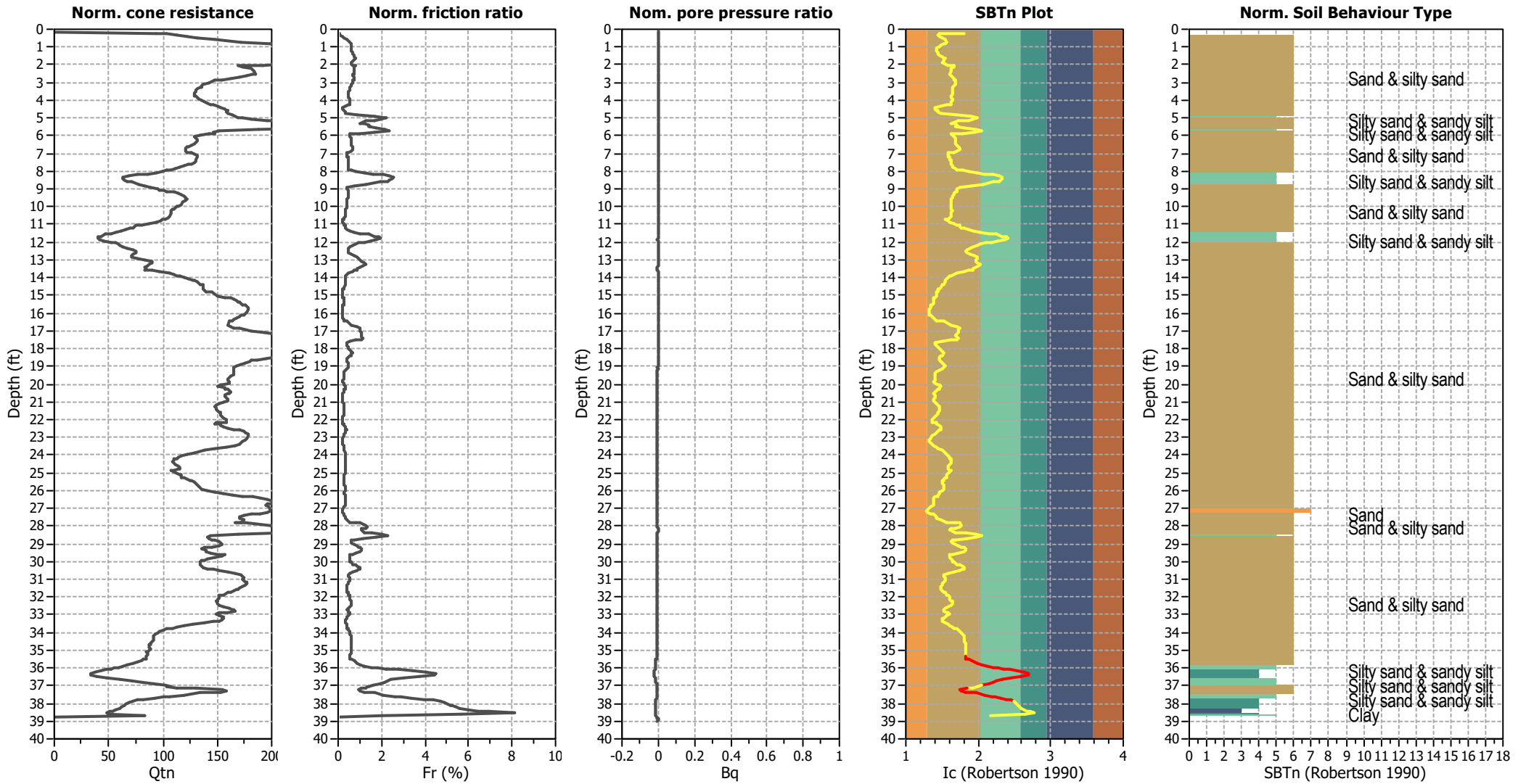

Input parameters and analysis data

Analysis method:	NCEER (1998)	Depth to water table (erthq.):	7.00 ft	Fill weight:	N/A
Fines correction method:	NCEER (1998)	Average results interval:	3	Transition detect. applied:	Yes
Points to test:	Based on Ic value	Ic cut-off value:	2.60	K ₀ applied:	Yes
Earthquake magnitude M _w :	8.10	Unit weight calculation:	Based on SBT	Clay like behavior applied:	Sands only
Peak ground acceleration:	0.89	Use fill:	No	Limit depth applied:	No
Depth to water table (insitu):	9.00 ft	Fill height:	N/A	Limit depth:	N/A

SBTn legend

1. Sensitive fine grained	4. Clayey silt to silty	7. Gravely sand to sand
2. Organic material	5. Silty sand to sandy silt	8. Very stiff sand to
3. Clay to silty clay	6. Clean sand to silty sand	9. Very stiff fine grained

Liquefaction analysis overall plots (intermediate results)

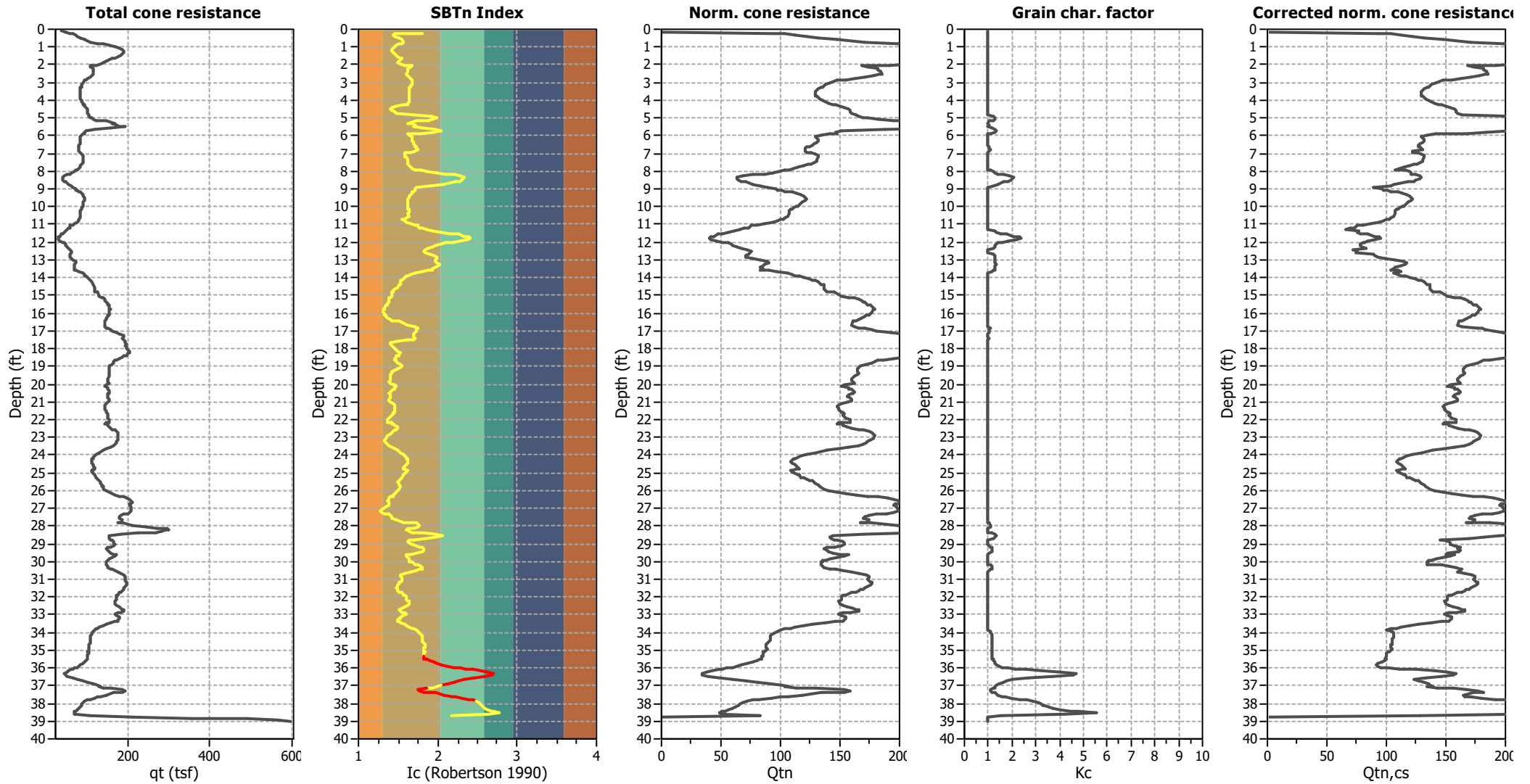

Input parameters and analysis data

Analysis method:	NCEER (1998)	Depth to water table (earthq.):	7.00 ft	Fill weight:	N/A
Fines correction method:	NCEER (1998)	Average results interval:	3	Transition detect. applied:	Yes
Points to test:	Based on Ic value	Ic cut-off value:	2.60	K _o applied:	Yes
Earthquake magnitude M _w :	8.10	Unit weight calculation:	Based on SBT	Clay like behavior applied:	Sands only
Peak ground acceleration:	0.89	Use fill:	No	Limit depth applied:	No
Depth to water table (insitu):	9.00 ft	Fill height:	N/A	Limit depth:	N/A

Liquefaction analysis overall plots

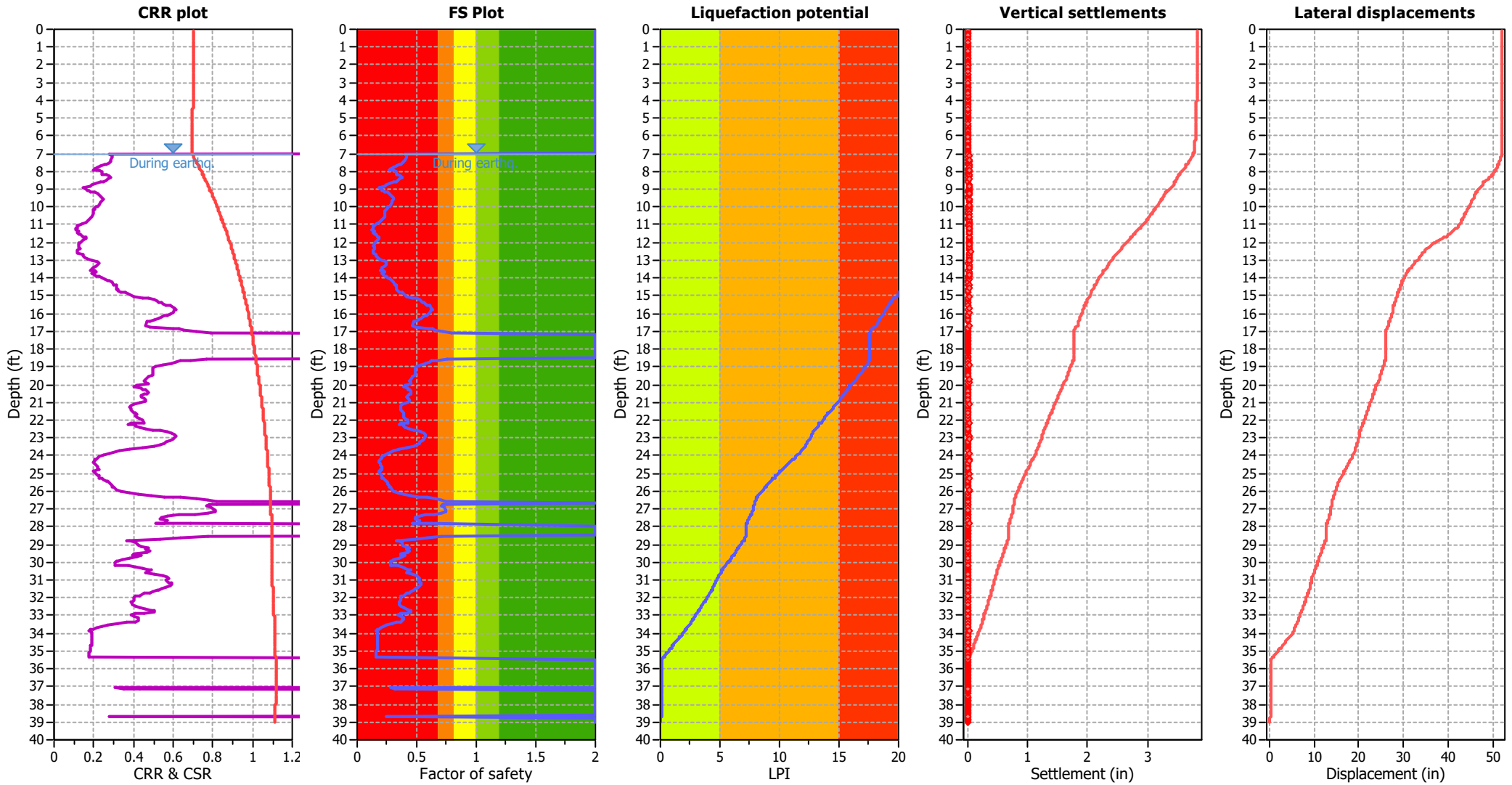

Input parameters and analysis data

Analysis method:	NCEER (1998)	Depth to water table (earthq.):	7.00 ft	Fill weight:	N/A
Fines correction method:	NCEER (1998)	Average results interval:	3	Transition detect. applied:	Yes
Points to test:	Based on Ic value	Ic cut-off value:	2.60	K_0 applied:	Yes
Earthquake magnitude M_w :	8.10	Unit weight calculation:	Based on SBT	Clay like behavior applied:	Sands only
Peak ground acceleration:	0.89	Use fill:	No	Limit depth applied:	No
Depth to water table (insitu):	9.00 ft	Fill height:	N/A	Limit depth:	N/A

F.S. color scheme

- Almost certain it will liquefy
- Very likely to liquefy
- Liquefaction and no liq. are equally likely
- Unlike to liquefy
- Almost certain it will not liquefy

LPI color scheme

- Very high risk
- High risk
- Low risk

Liquefaction analysis summary plots

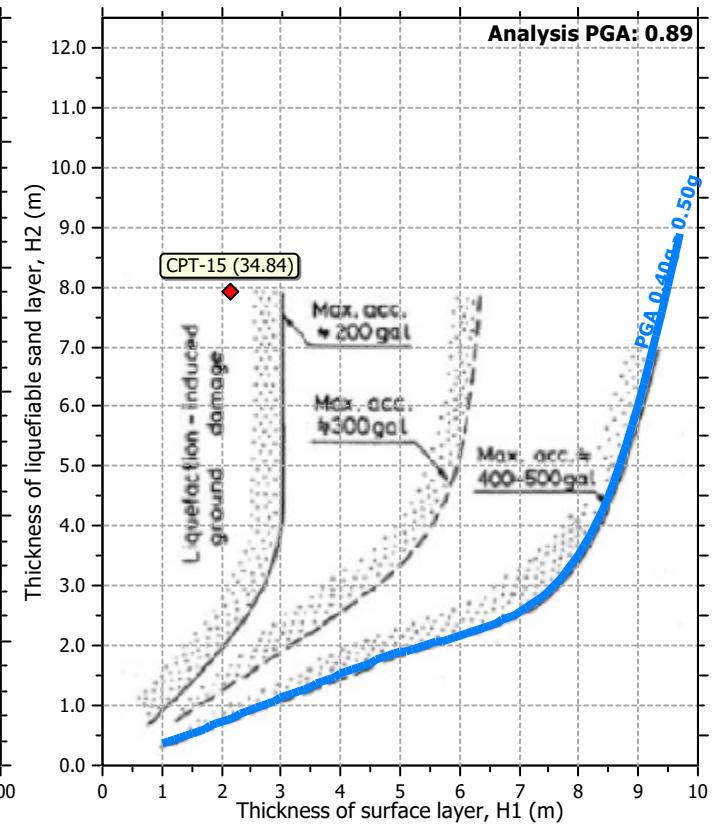
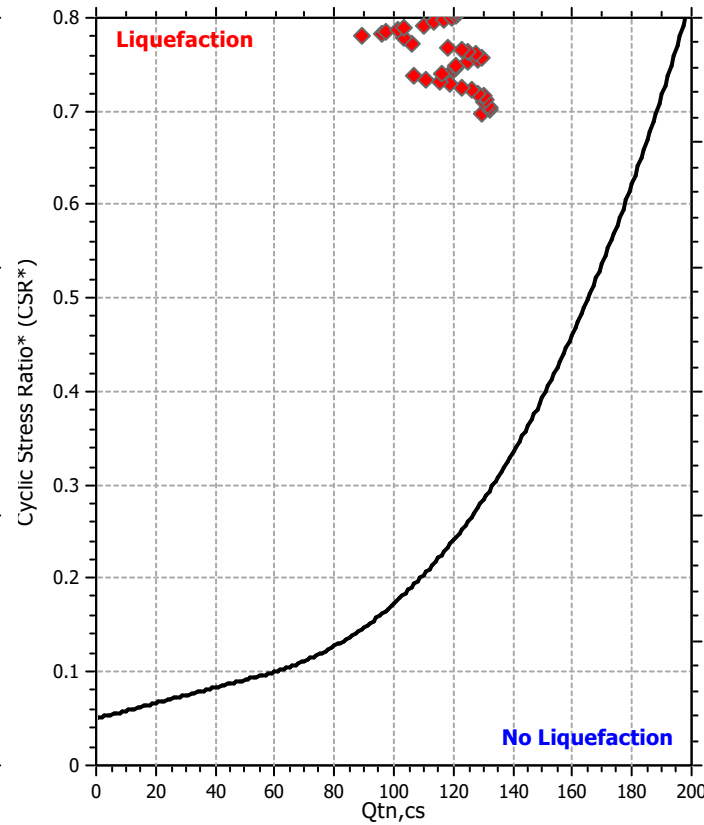
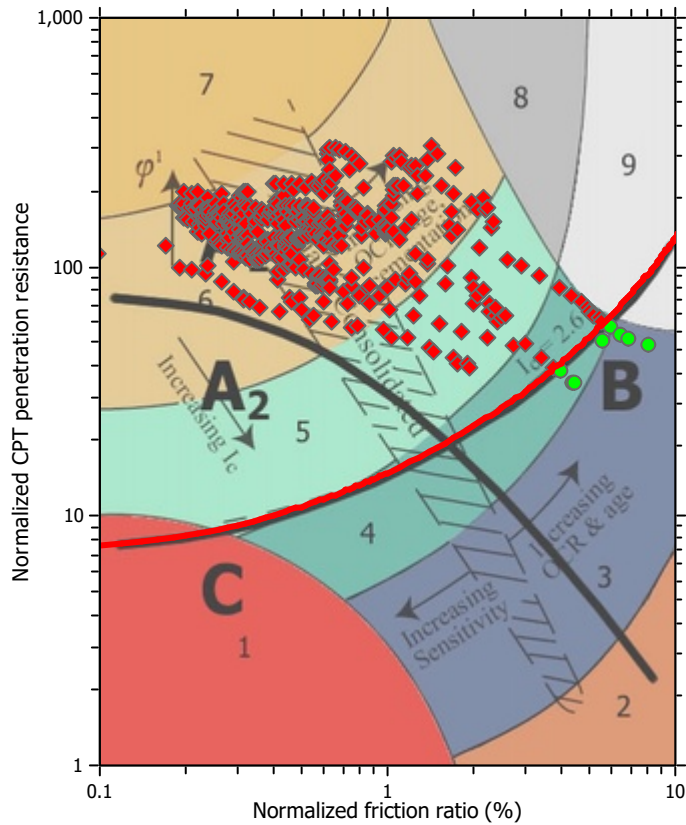

Input parameters and analysis data

Analysis method:	NCEER (1998)	Depth to water table (earthq.):	7.00 ft	Fill weight:	N/A
Fines correction method:	NCEER (1998)	Average results interval:	3	Transition detect. applied:	Yes
Points to test:	Based on I_c value	I_c cut-off value:	2.60	K_v applied:	Yes
Earthquake magnitude M_w :	8.10	Unit weight calculation:	Based on SBT	Clay like behavior applied:	Sands only
Peak ground acceleration:	0.89	Use fill:	No	Limit depth applied:	No
Depth to water table (insitu):	9.00 ft	Fill height:	N/A	Limit depth:	N/A

Check for strength loss plots (Robertson (2010))

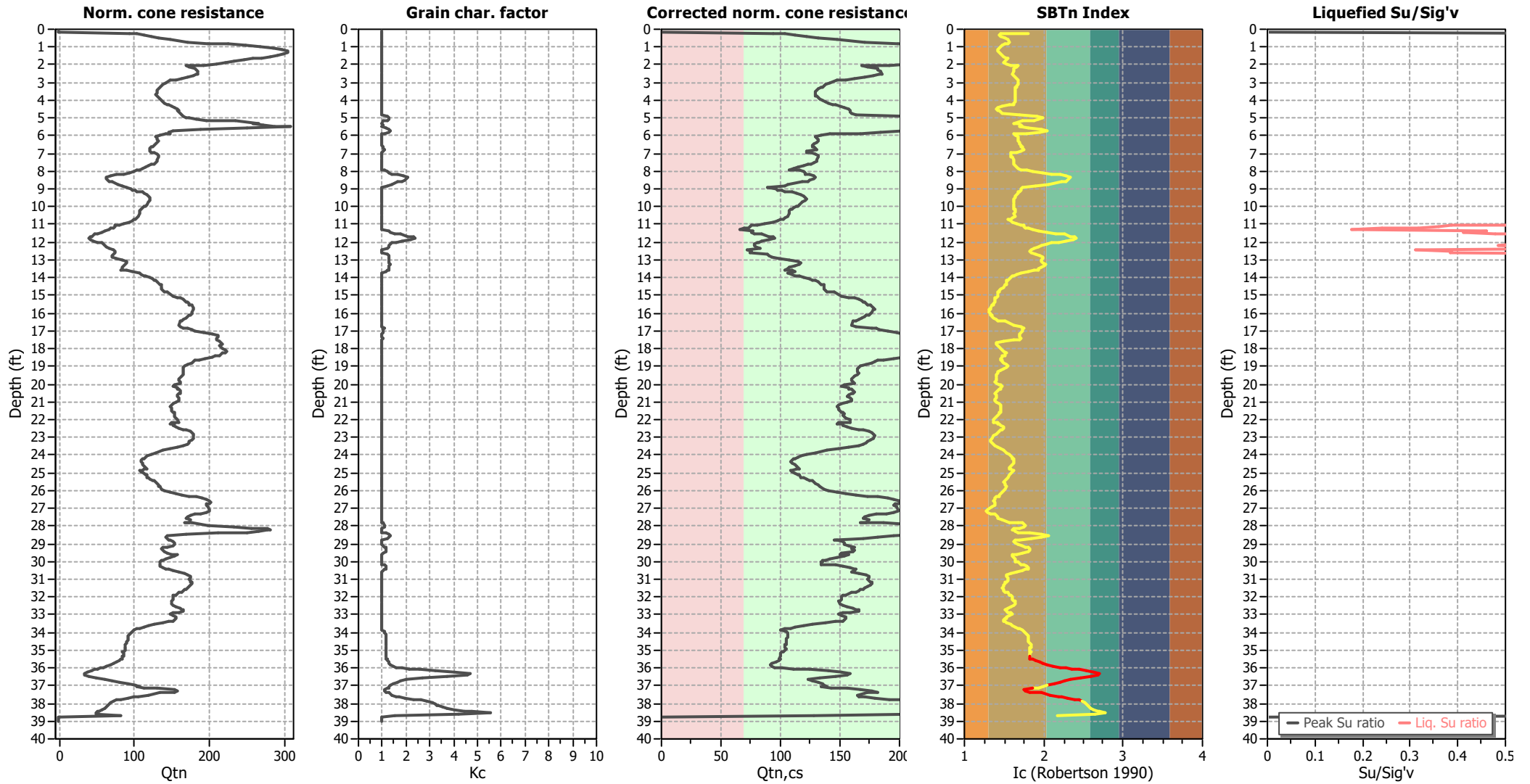

Input parameters and analysis data

Analysis method:	NCEER (1998)	Depth to water table (earthq.):	7.00 ft	Fill weight:	N/A
Fines correction method:	NCEER (1998)	Average results interval:	3	Transition detect. applied:	Yes
Points to test:	Based on Ic value	Ic cut-off value:	2.60	K _o applied:	Yes
Earthquake magnitude M _w :	8.10	Unit weight calculation:	Based on SBT	Clay like behavior applied:	Sands only
Peak ground acceleration:	0.89	Use fill:	No	Limit depth applied:	No
Depth to water table (insitu):	9.00 ft	Fill height:	N/A	Limit depth:	N/A

TRANSITION LAYER DETECTION ALGORITHM REPORT

Summary Details & Plots

Short description

The software will delete data when the cone is in transition from either clay to sand or vice-versa. To do this the software requires a range of I_c values over which the transition will be defined (typically somewhere between $1.80 < I_c < 3.0$) and a rate of change of I_c . Transitions typically occur when the rate of change of I_c is fast (i.e. ΔI_c is small).

The SBT_n plot below, displays in red the detected transition layers based on the parameters listed below the graphs.

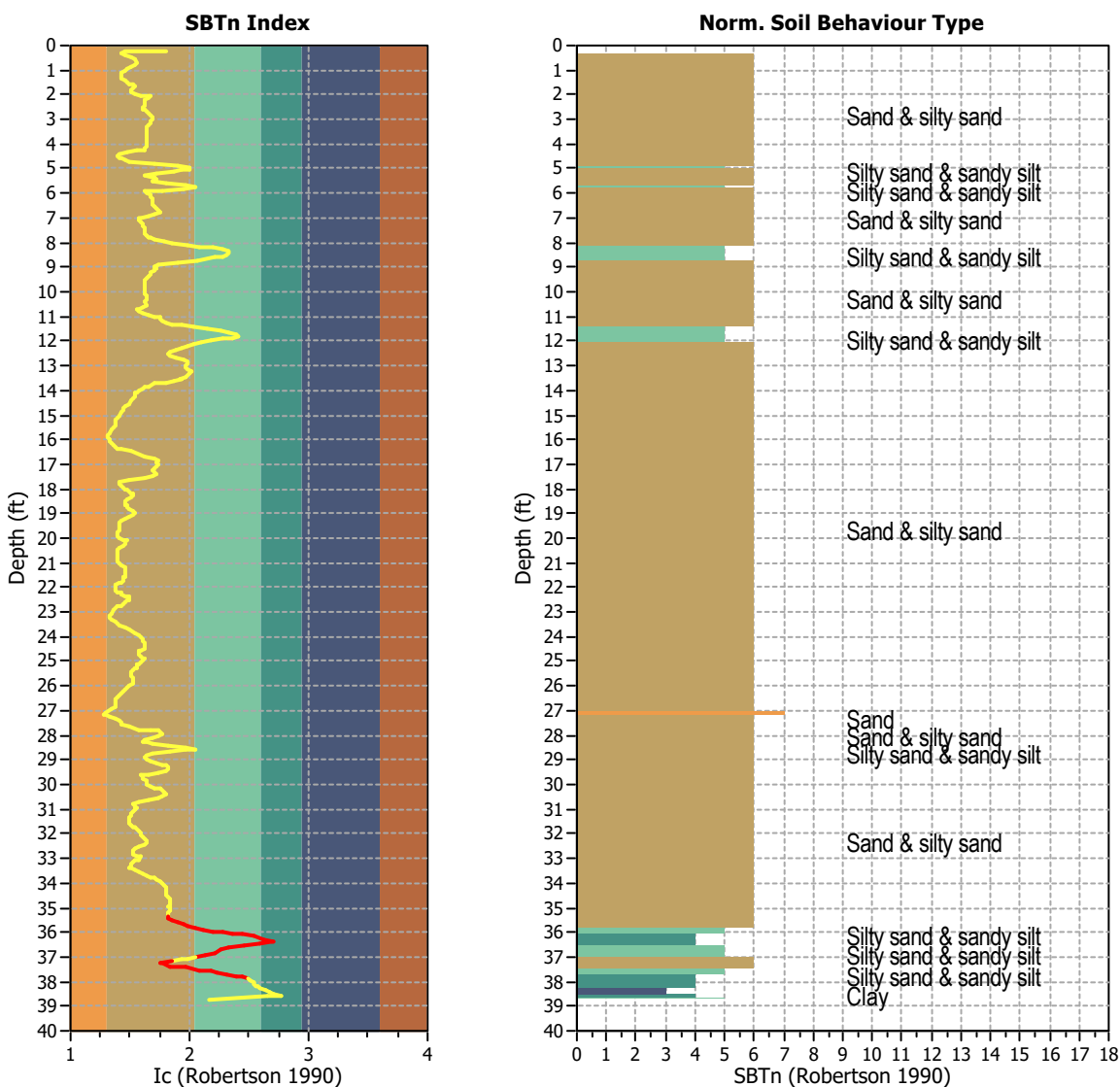

Transition layer algorithm properties		General statistics	
I_c minimum check value:	1.70	Total points in CPT file:	557
I_c maximum check value:	3.00	Total points excluded:	35
I_c change ratio value:	0.0250	Exclusion percentage:	6.28%
Minimum number of points in layer:	4	Number of layers detected:	3

Estimation of post-earthquake settlements

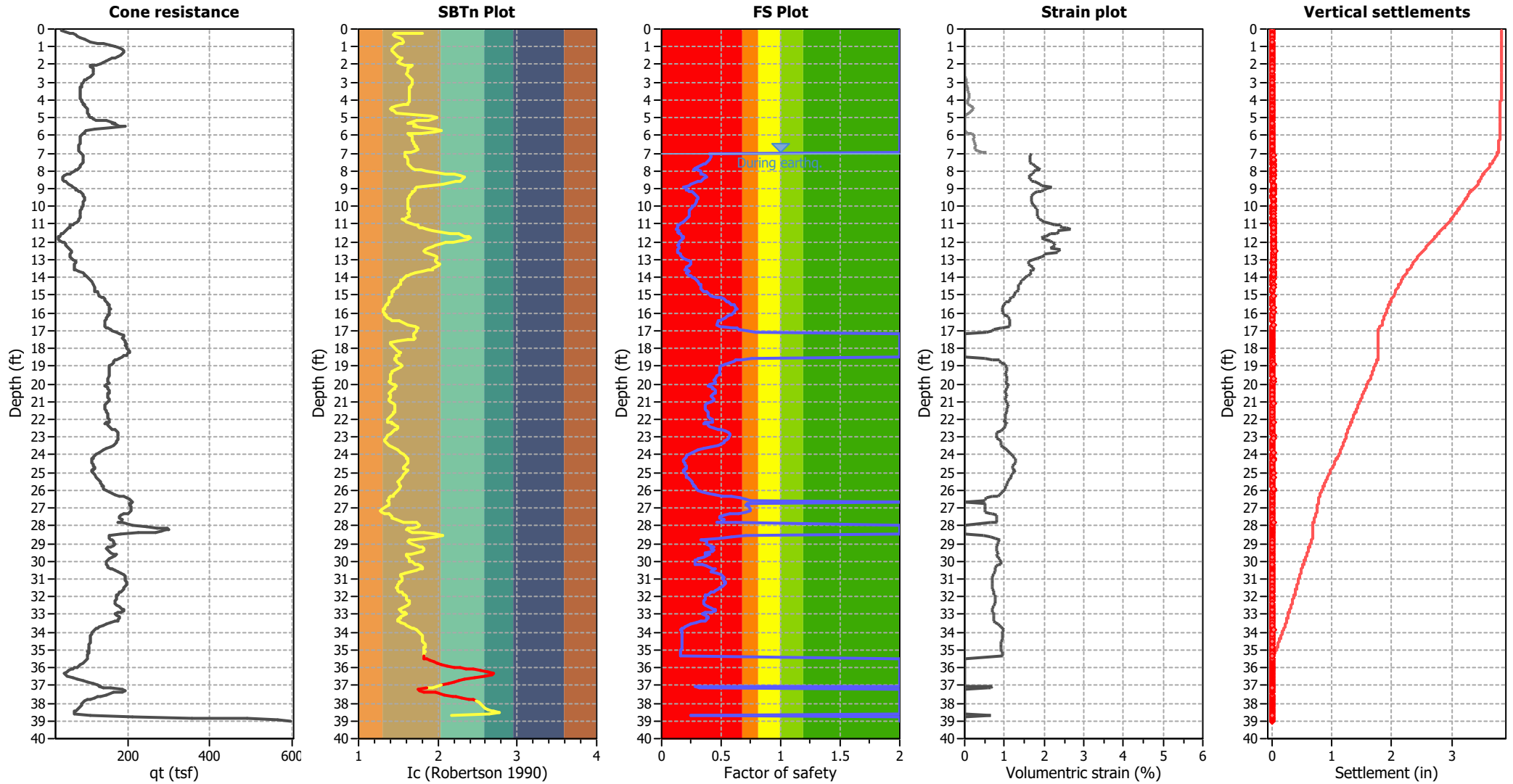

Abbreviations

- q_c: Total cone resistance (cone resistance q_c corrected for pore water effects)
- I_c: Soil Behaviour Type Index
- FS: Calculated Factor of Safety against liquefaction
- Volumetric strain: Post-liquefaction volumetric strain

Estimation of post-earthquake lateral Displacements

Geometric parameters: Gently sloping ground without free face (Slope 1.00 %)

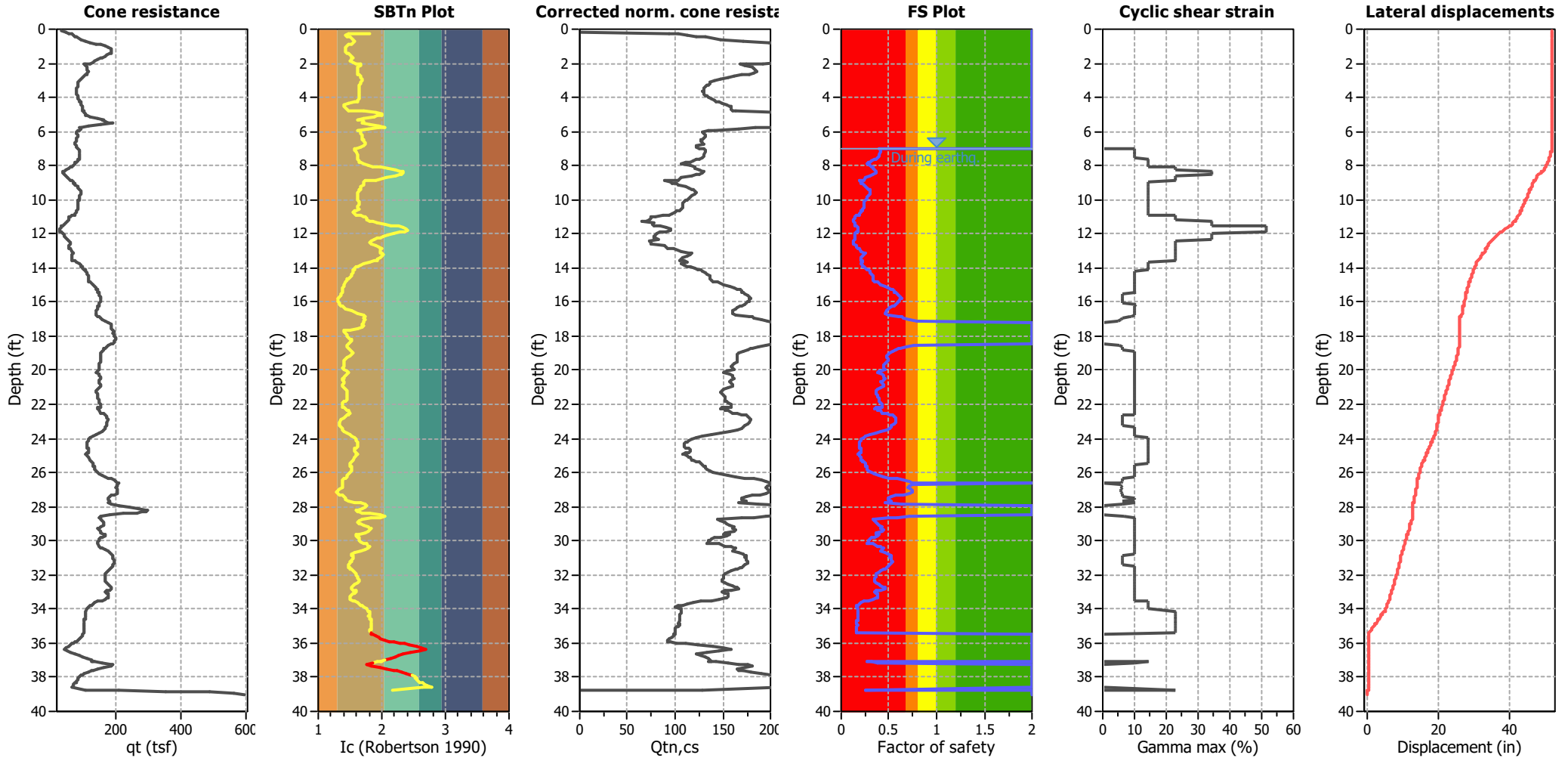

Abbreviations

q_t: Total cone resistance (cone resistance q_c corrected for pore water effects)
 I_c: Soil Behaviour Type Index
 Q_{tn,cs}: Equivalent clean sand normalized CPT total cone resistance

F.S.: Factor of safety
 γ_{max}: Maximum cyclic shear strain
 LDI: Lateral displacement index

Surface condition



Aging Calculation Estimation

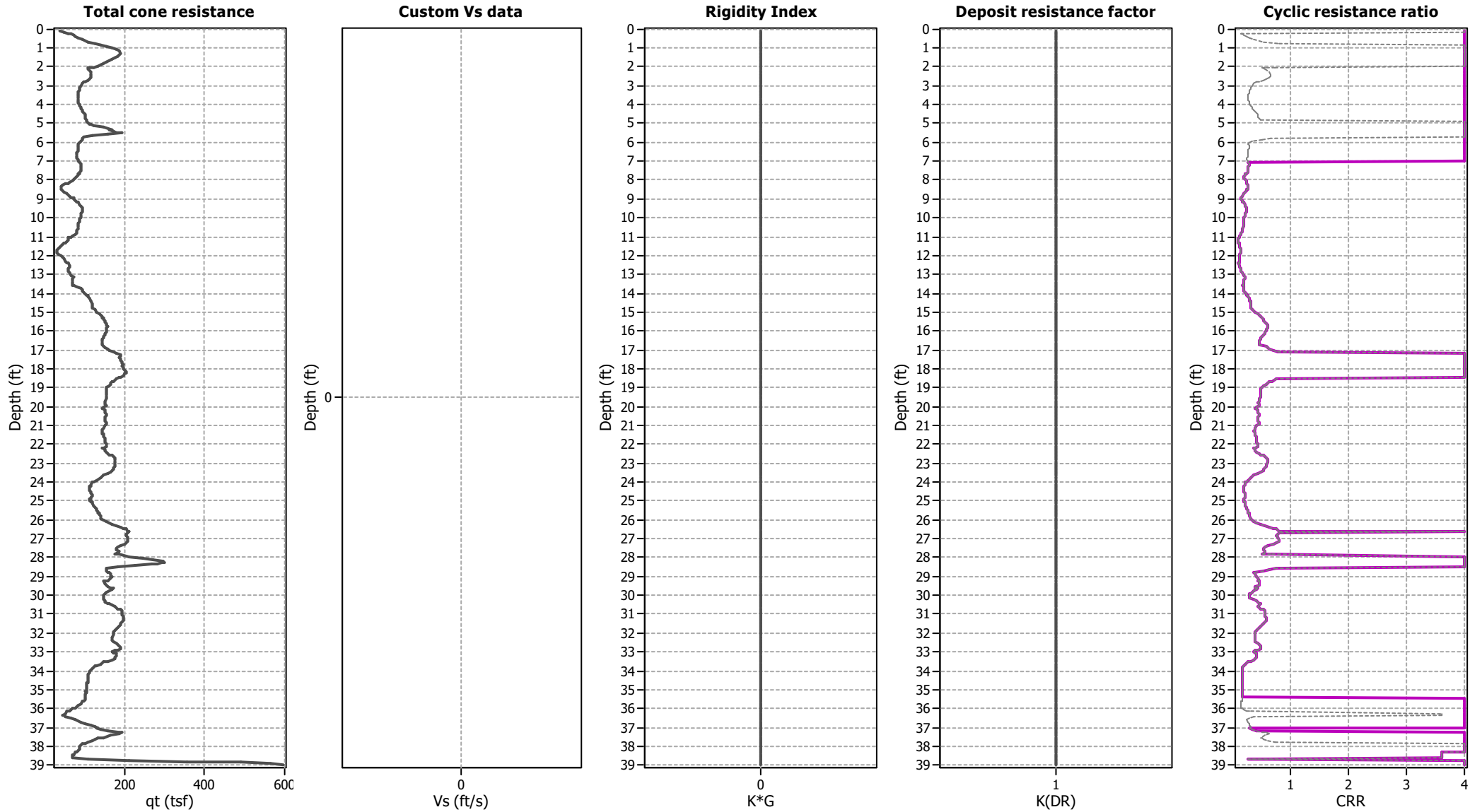

Ejecta Severity Estimation

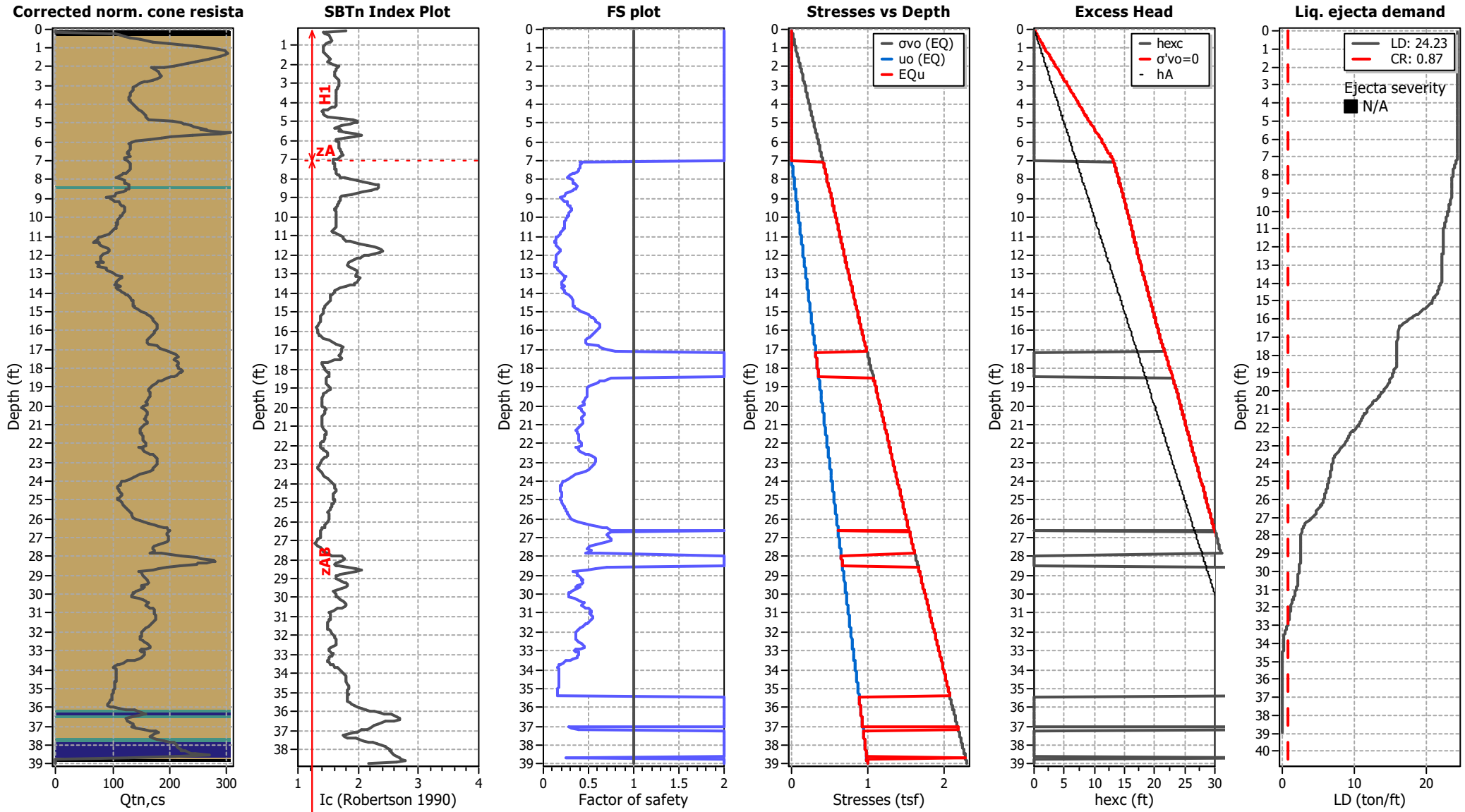

LIQUEFACTION ANALYSIS REPORT

Project title : Petra Geosciences / Apple Canyon

Location : Lake Hemet, CA

CPT file : CPT-16

Input parameters and analysis data

Analysis method:	NCEER (1998)	G.W.T. (in-situ):	9.80 ft	Use fill:	No	Clay like behavior applied:	Sands only
Fines correction method:	NCEER (1998)	G.W.T. (earthq.):	7.00 ft	Fill height:	N/A	Limit depth applied:	No
Points to test:	Based on Ic value	Average results interval:	3	Fill weight:	N/A	Limit depth:	N/A
Earthquake magnitude M_w :	8.10	Ic cut-off value:	2.60	Trans. detect. applied:	Yes	MSF method:	Method based
Peak ground acceleration:	0.89	Unit weight calculation:	Based on SBT	K_o applied:	Yes		

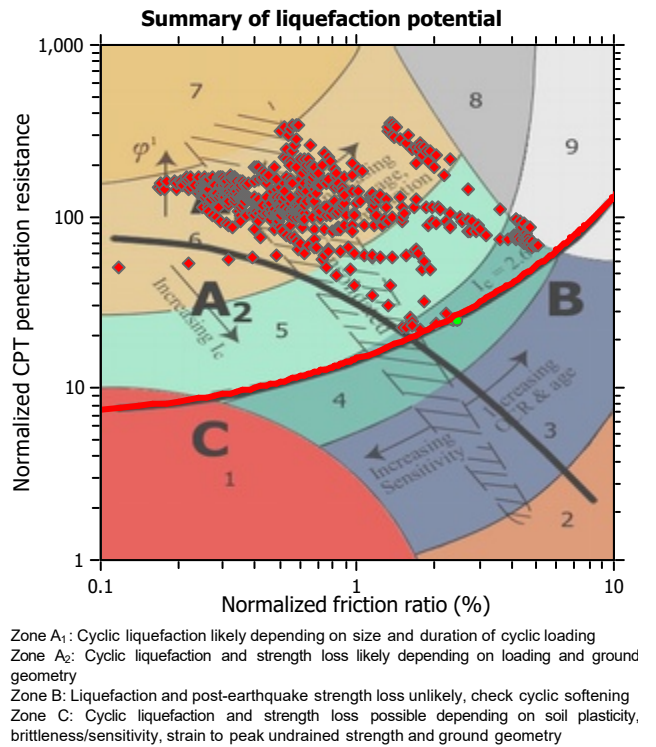
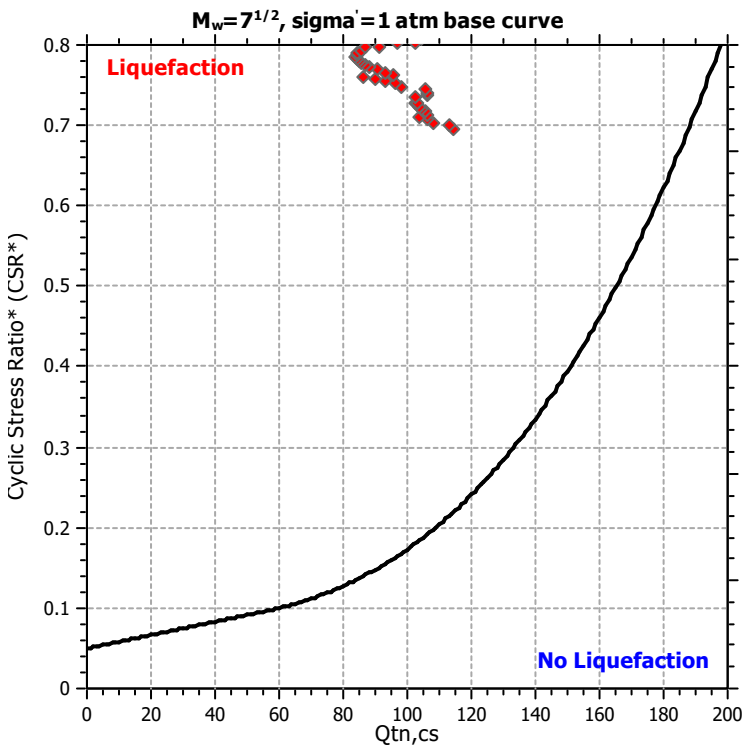
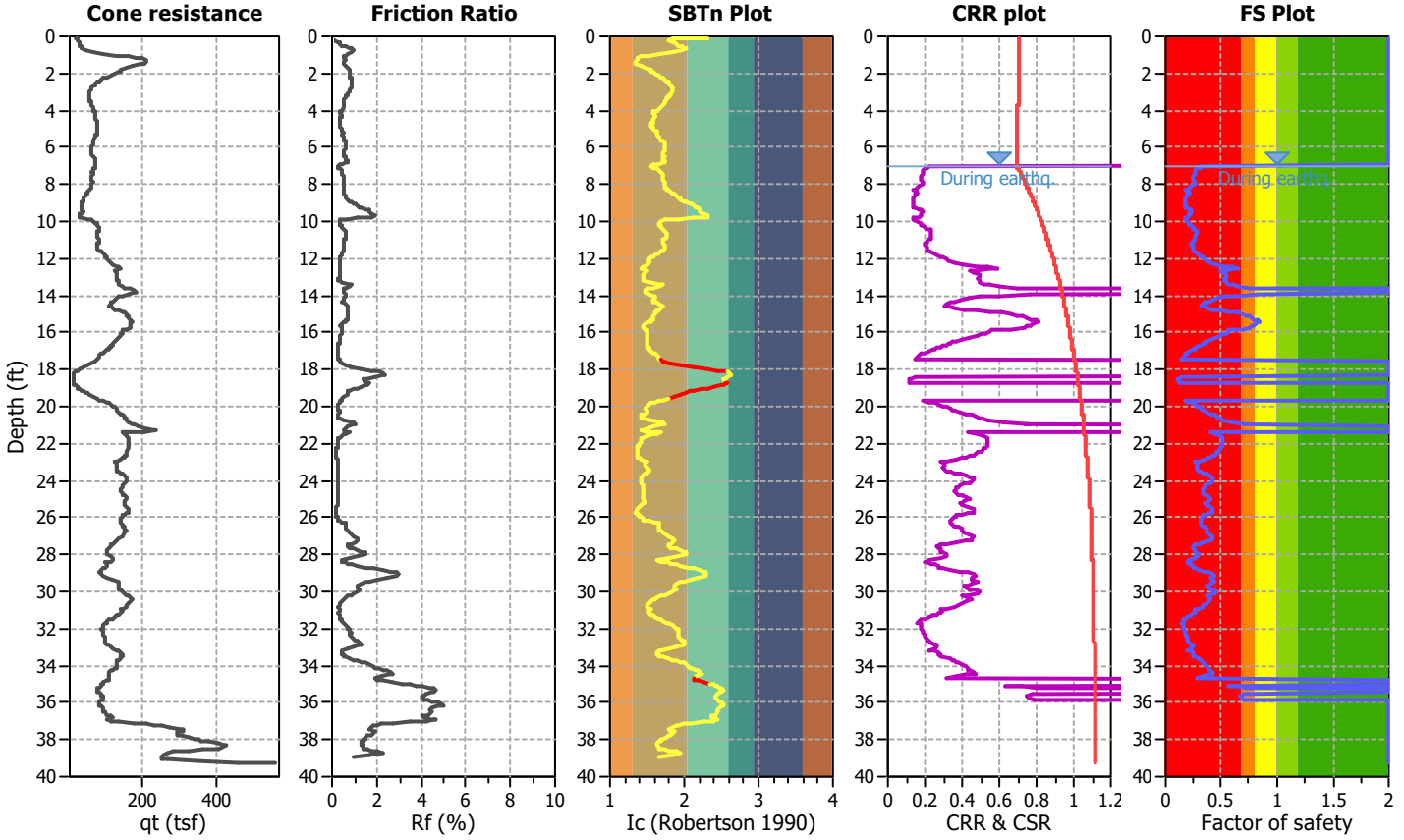

CPT basic interpretation plots

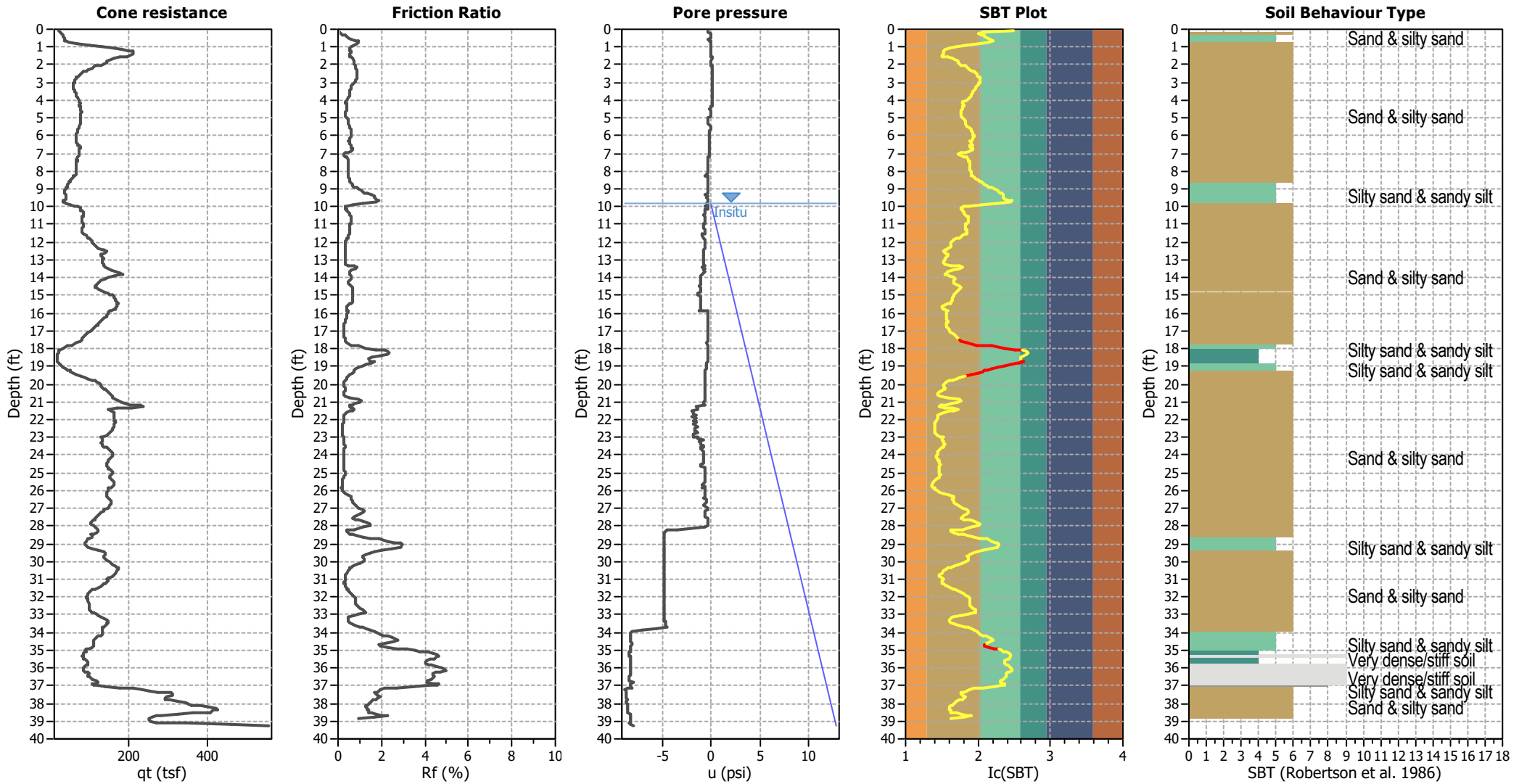

Input parameters and analysis data

Analysis method:	NCEER (1998)	Depth to water table (earthq.):	7.00 ft	Fill weight:	N/A
Fines correction method:	NCEER (1998)	Average results interval:	3	Transition detect. applied:	Yes
Points to test:	Based on Ic value	Ic cut-off value:	2.60	K _o applied:	Yes
Earthquake magnitude M _w :	8.10	Unit weight calculation:	Based on SBT	Clay like behavior applied:	Sands only
Peak ground acceleration:	0.89	Use fill:	No	Limit depth applied:	No
Depth to water table (insitu):	9.80 ft	Fill height:	N/A	Limit depth:	N/A

SBT legend

1. Sensitive fine grained	4. Clayey silt to silty	7. Gravely sand to sand
2. Organic material	5. Silty sand to sandy silt	8. Very stiff sand to
3. Clay to silty clay	6. Clean sand to silty sand	9. Very stiff fine grained

CPT basic interpretation plots (normalized)

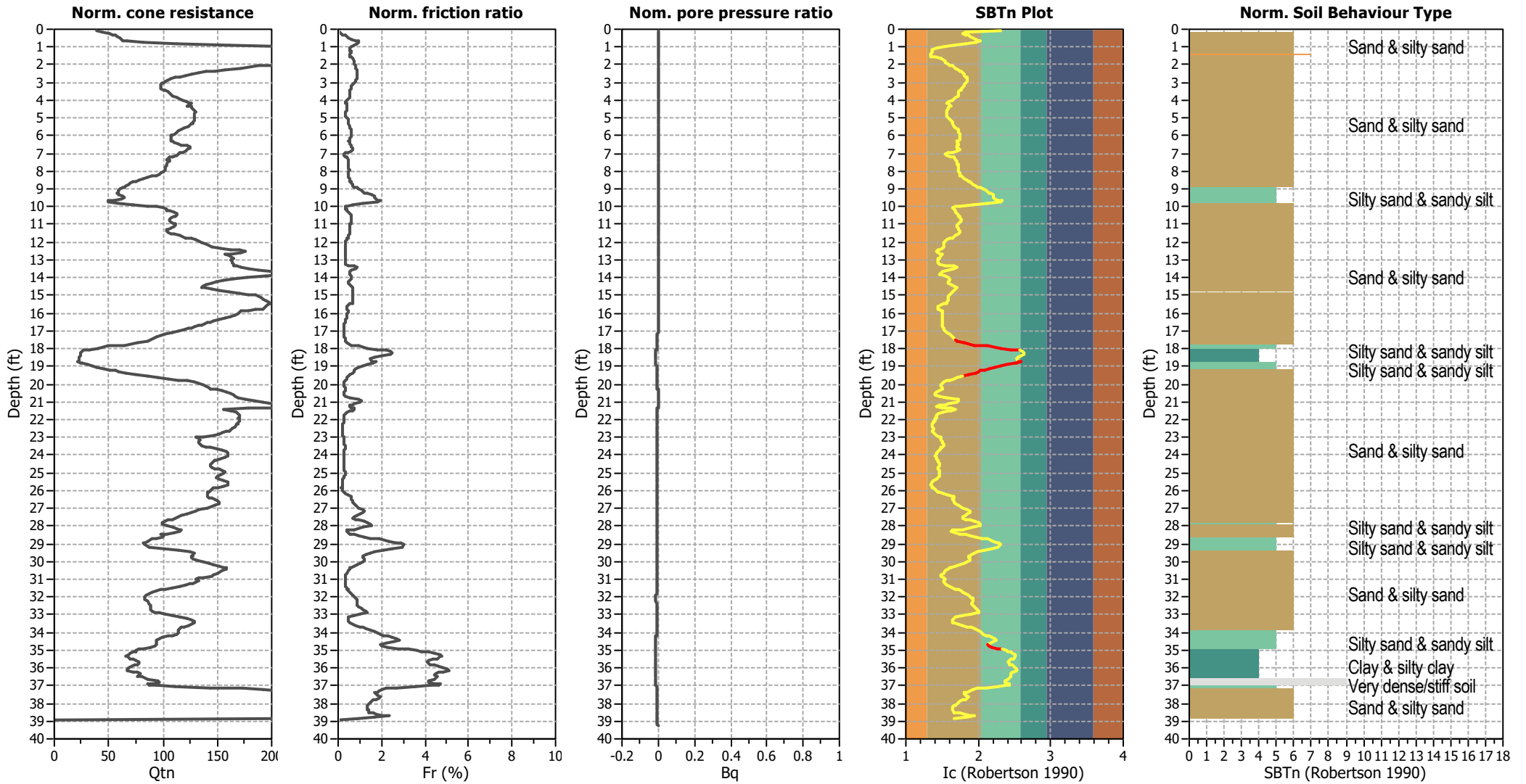

Input parameters and analysis data

Analysis method:	NCEER (1998)	Depth to water table (earthq.):	7.00 ft	Fill weight:	N/A
Fines correction method:	NCEER (1998)	Average results interval:	3	Transition detect. applied:	Yes
Points to test:	Based on Ic value	Ic cut-off value:	2.60	K _o applied:	Yes
Earthquake magnitude M _w :	8.10	Unit weight calculation:	Based on SBT	Clay like behavior applied:	Sands only
Peak ground acceleration:	0.89	Use fill:	No	Limit depth applied:	No
Depth to water table (insitu):	9.80 ft	Fill height:	N/A	Limit depth:	N/A

SBTn legend

1. Sensitive fine grained	4. Clayey silt to silty	7. Gravely sand to sand
2. Organic material	5. Silty sand to sandy silt	8. Very stiff sand to
3. Clay to silty clay	6. Clean sand to silty sand	9. Very stiff fine grained

Liquefaction analysis overall plots (intermediate results)

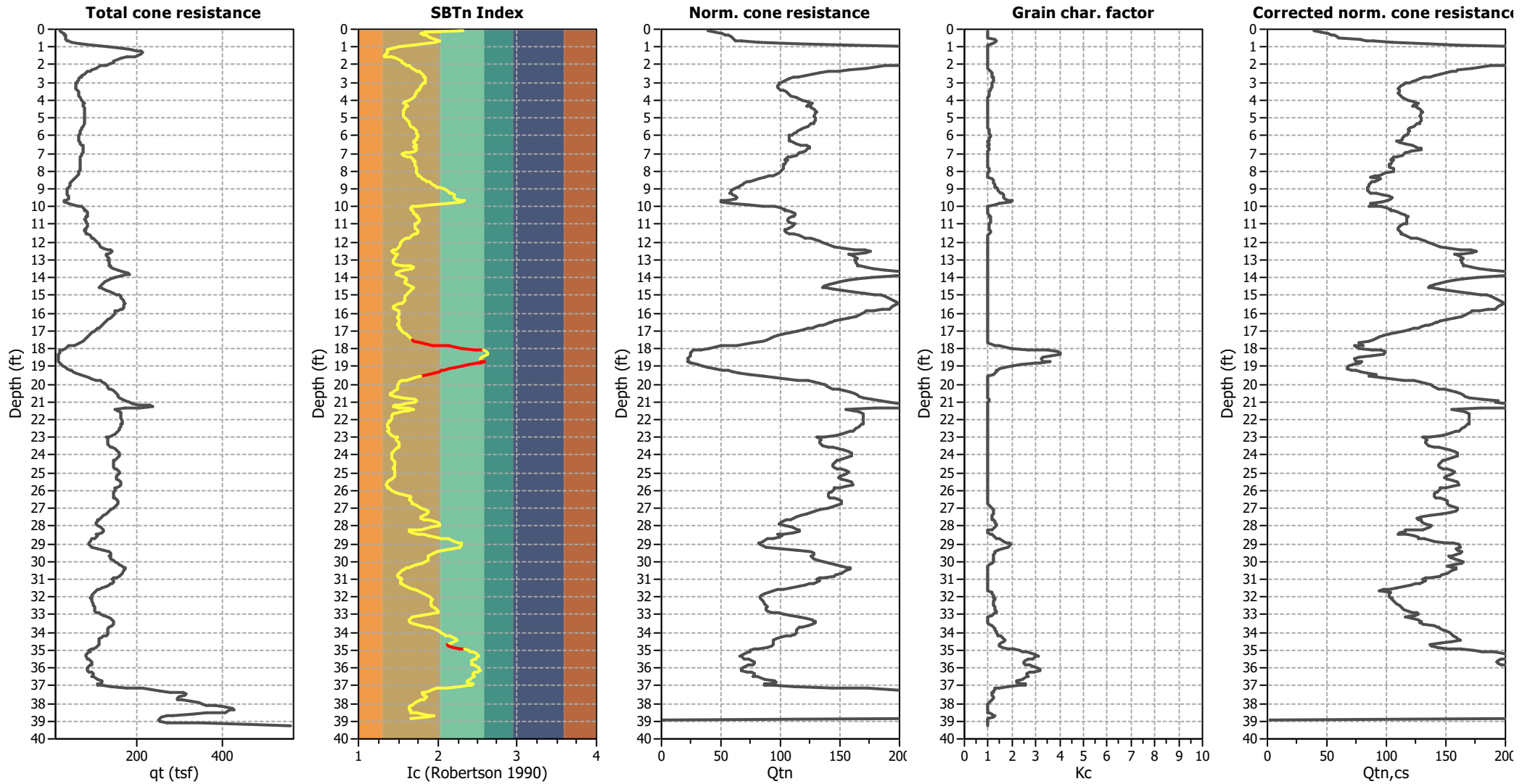

Input parameters and analysis data

Analysis method:	NCEER (1998)	Depth to water table (earthq.):	7.00 ft	Fill weight:	N/A
Fines correction method:	NCEER (1998)	Average results interval:	3	Transition detect. applied:	Yes
Points to test:	Based on Ic value	Ic cut-off value:	2.60	K _o applied:	Yes
Earthquake magnitude M _w :	8.10	Unit weight calculation:	Based on SBT	Clay like behavior applied:	Sands only
Peak ground acceleration:	0.89	Use fill:	No	Limit depth applied:	No
Depth to water table (insitu):	9.80 ft	Fill height:	N/A	Limit depth:	N/A

Liquefaction analysis overall plots

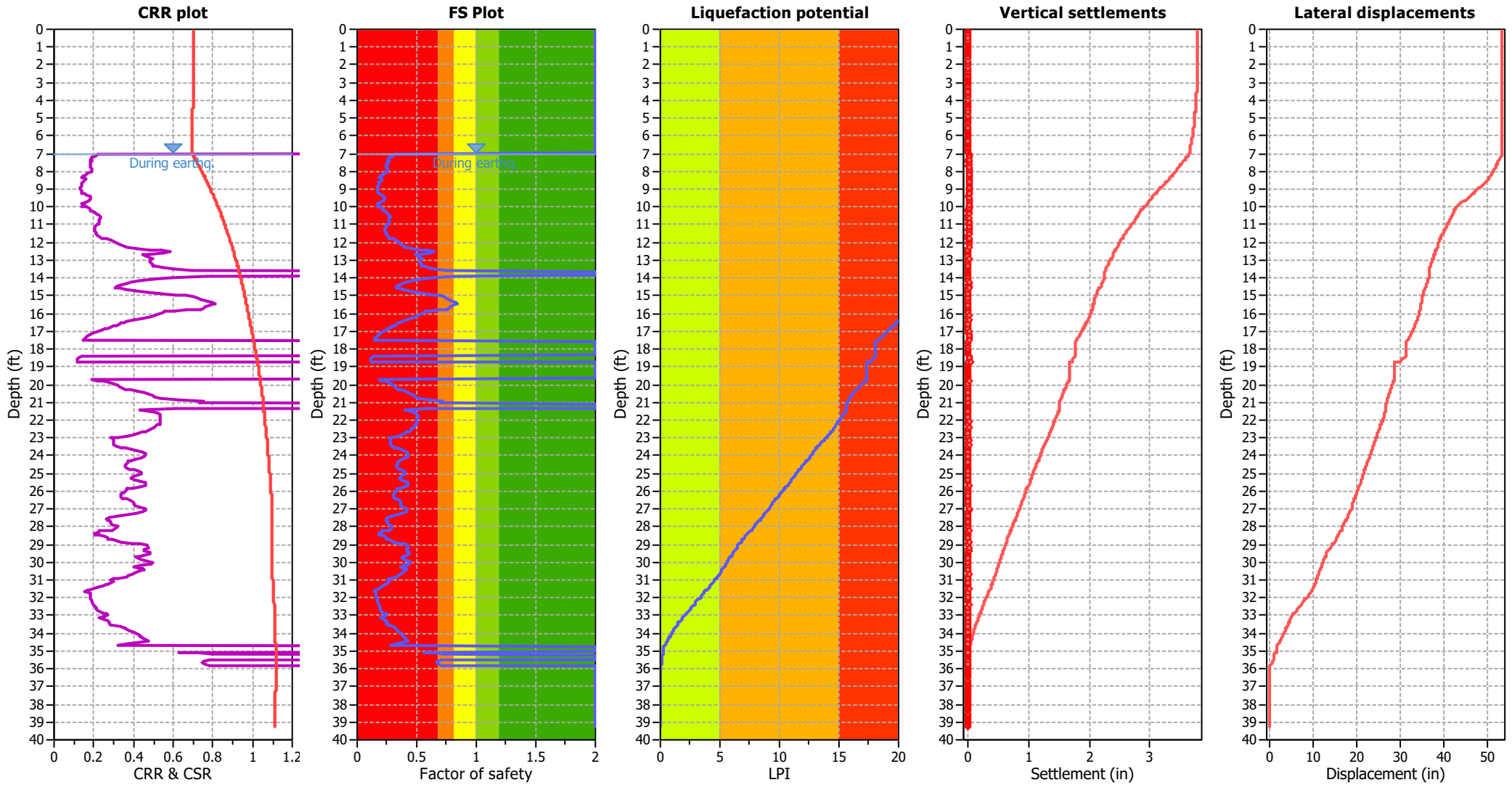

Input parameters and analysis data

Analysis method:	NCEER (1998)	Depth to water table (earthq.):	7.00 ft	Fill weight:	N/A
Fines correction method:	NCEER (1998)	Average results interval:	3	Transition detect. applied:	Yes
Points to test:	Based on Ic value	Ic cut-off value:	2.60	K_0 applied:	Yes
Earthquake magnitude M_w :	8.10	Unit weight calculation:	Based on SBT	Clay like behavior applied:	Sands only
Peak ground acceleration:	0.89	Use fill:	No	Limit depth applied:	No
Depth to water table (insitu):	9.80 ft	Fill height:	N/A	Limit depth:	N/A

F.S. color scheme

- Almost certain it will liquefy
- Very likely to liquefy
- Liquefaction and no liq. are equally likely
- Unlike to liquefy
- Almost certain it will not liquefy

LPI color scheme

- Very high risk
- High risk
- Low risk

Liquefaction analysis summary plots

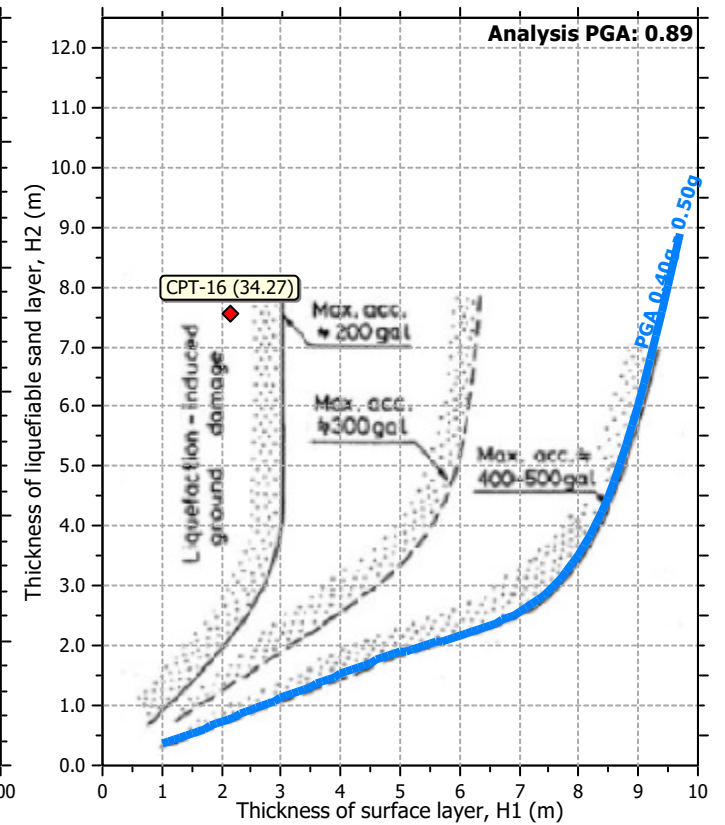
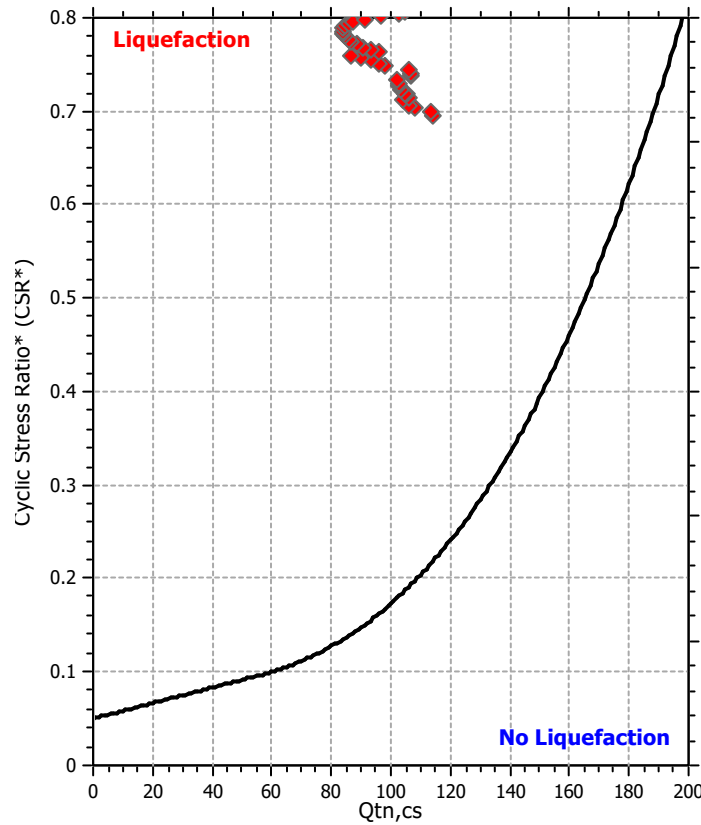
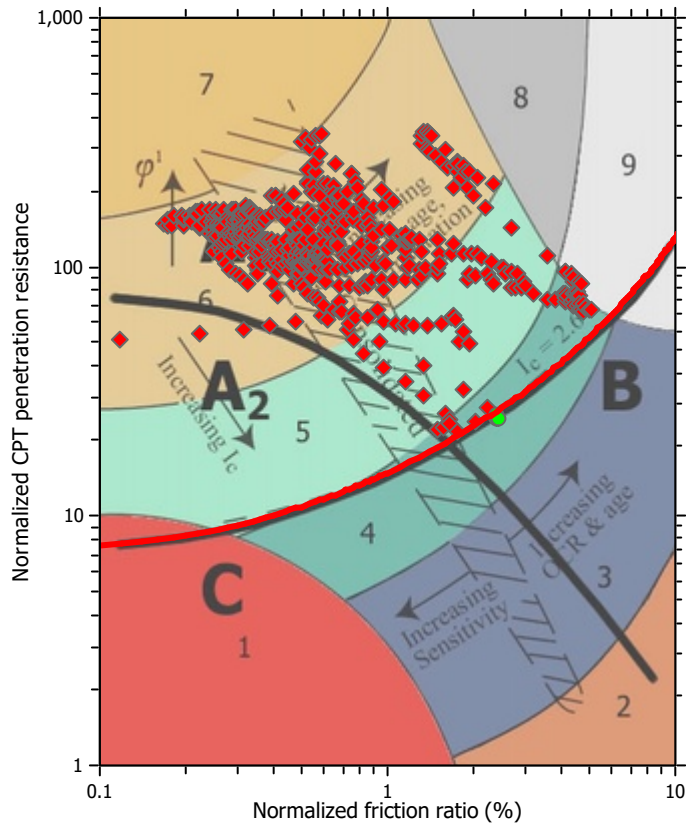

Input parameters and analysis data

Analysis method:	NCEER (1998)	Depth to water table (earthq.):	7.00 ft	Fill weight:	N/A
Fines correction method:	NCEER (1998)	Average results interval:	3	Transition detect. applied:	Yes
Points to test:	Based on Ic value	Ic cut-off value:	2.60	K_v applied:	Yes
Earthquake magnitude M_w :	8.10	Unit weight calculation:	Based on SBT	Clay like behavior applied:	Sands only
Peak ground acceleration:	0.89	Use fill:	No	Limit depth applied:	No
Depth to water table (insitu):	9.80 ft	Fill height:	N/A	Limit depth:	N/A

Check for strength loss plots (Robertson (2010))

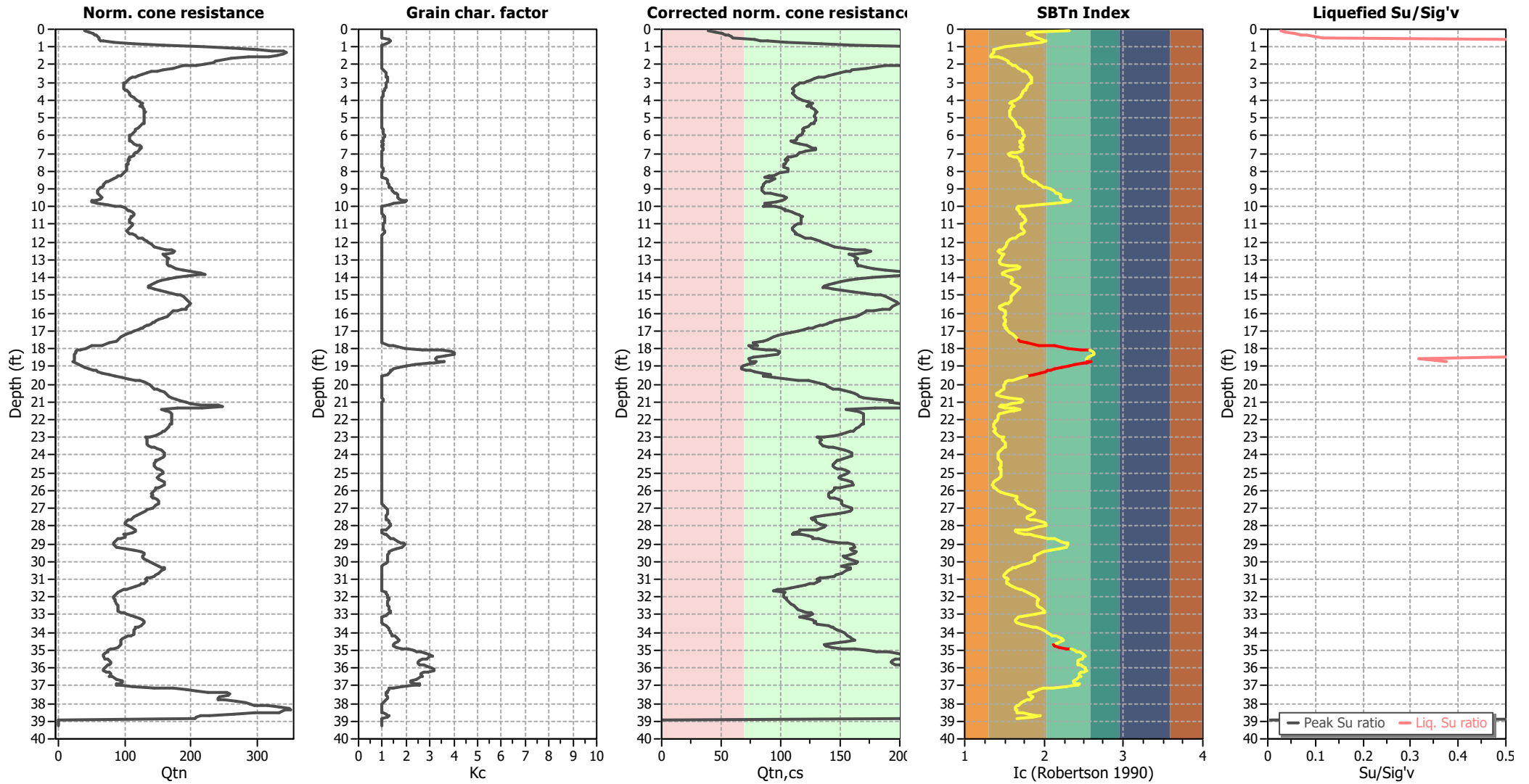

Input parameters and analysis data

Analysis method:	NCEER (1998)	Depth to water table (earthq.):	7.00 ft	Fill weight:	N/A
Fines correction method:	NCEER (1998)	Average results interval:	3	Transition detect. applied:	Yes
Points to test:	Based on Ic value	Ic cut-off value:	2.60	K _o applied:	Yes
Earthquake magnitude M _w :	8.10	Unit weight calculation:	Based on SBT	Clay like behavior applied:	Sands only
Peak ground acceleration:	0.89	Use fill:	No	Limit depth applied:	No
Depth to water table (insitu):	9.80 ft	Fill height:	N/A	Limit depth:	N/A

TRANSITION LAYER DETECTION ALGORITHM REPORT

Summary Details & Plots

Short description

The software will delete data when the cone is in transition from either clay to sand or vice-versa. To do this the software requires a range of I_c values over which the transition will be defined (typically somewhere between $1.80 < I_c < 3.0$) and a rate of change of I_c . Transitions typically occur when the rate of change of I_c is fast (i.e. ΔI_c is small).

The SBT_n plot below, displays in red the detected transition layers based on the parameters listed below the graphs.

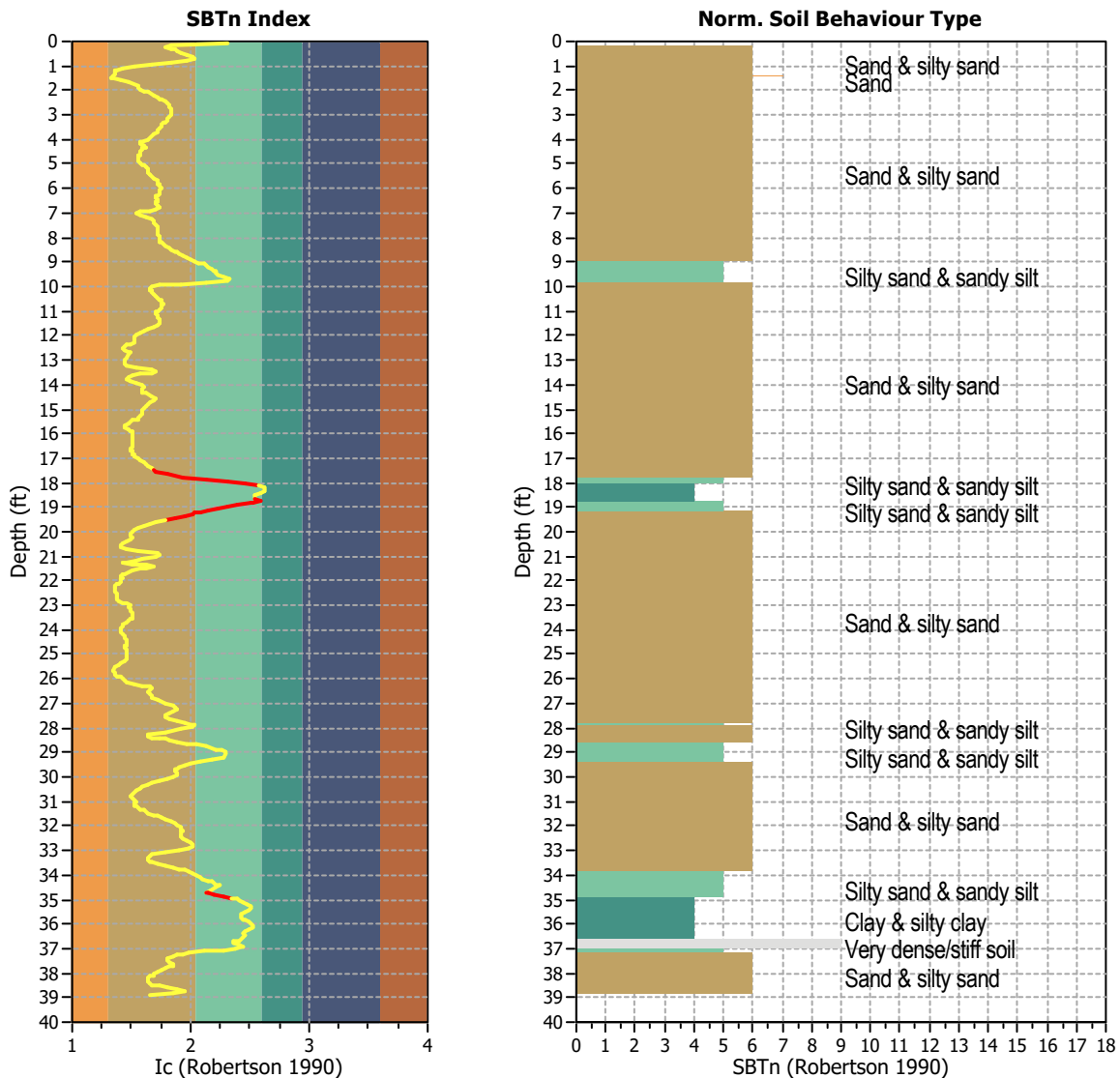

Transition layer algorithm properties

I_c minimum check value: 1.70
 I_c maximum check value: 3.00
 I_c change ratio value: 0.0250
 Minimum number of points in layer: 4

General statistics

Total points in CPT file: 563
 Total points excluded: 27
 Exclusion percentage: 4.80%
 Number of layers detected: 3

Estimation of post-earthquake settlements

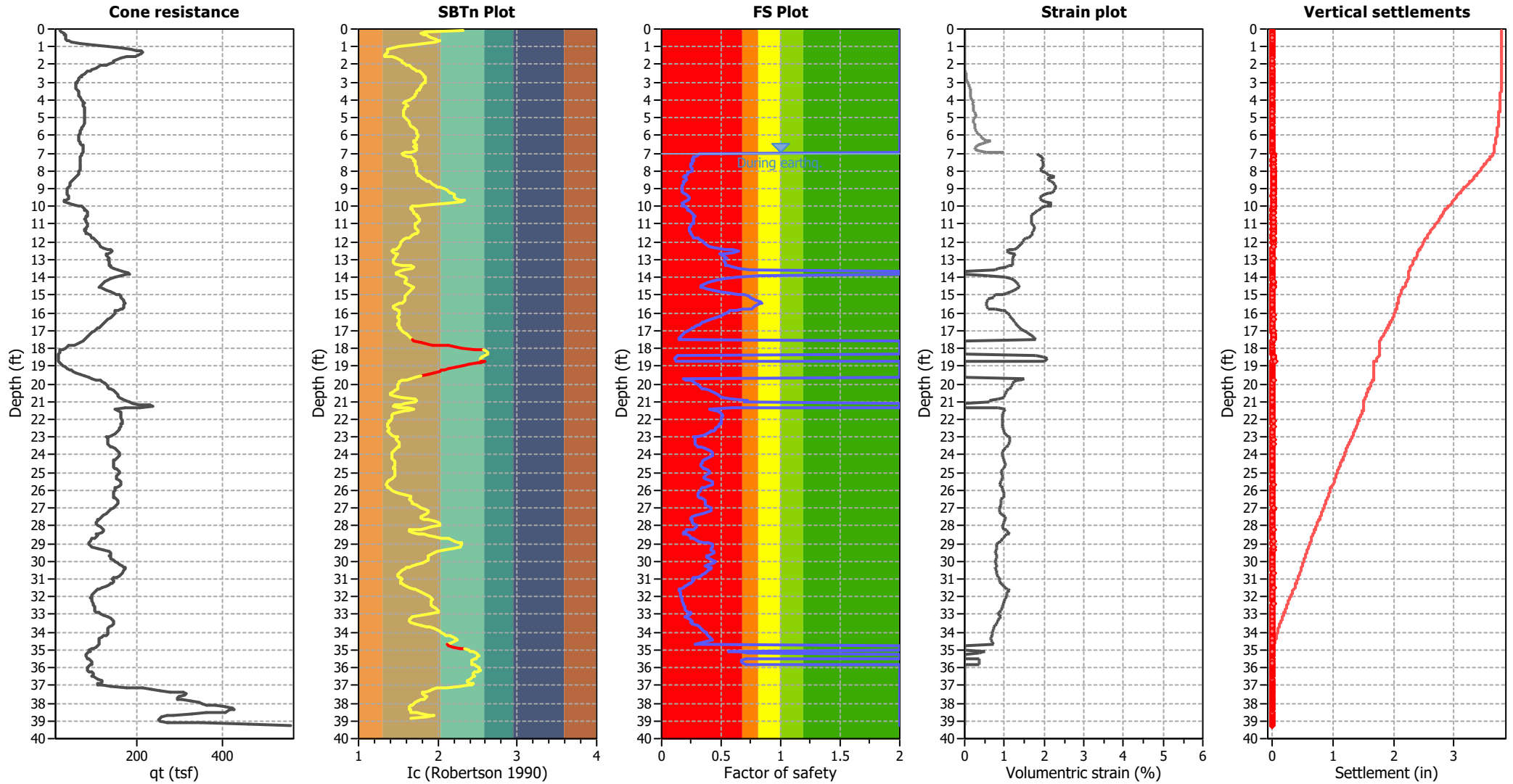

Abbreviations

- q_c: Total cone resistance (cone resistance q_c corrected for pore water effects)
- I_c: Soil Behaviour Type Index
- FS: Calculated Factor of Safety against liquefaction
- Volumetric strain: Post-liquefaction volumetric strain

Estimation of post-earthquake lateral Displacements

Geometric parameters: Gently sloping ground without free face (Slope 1.00 %)

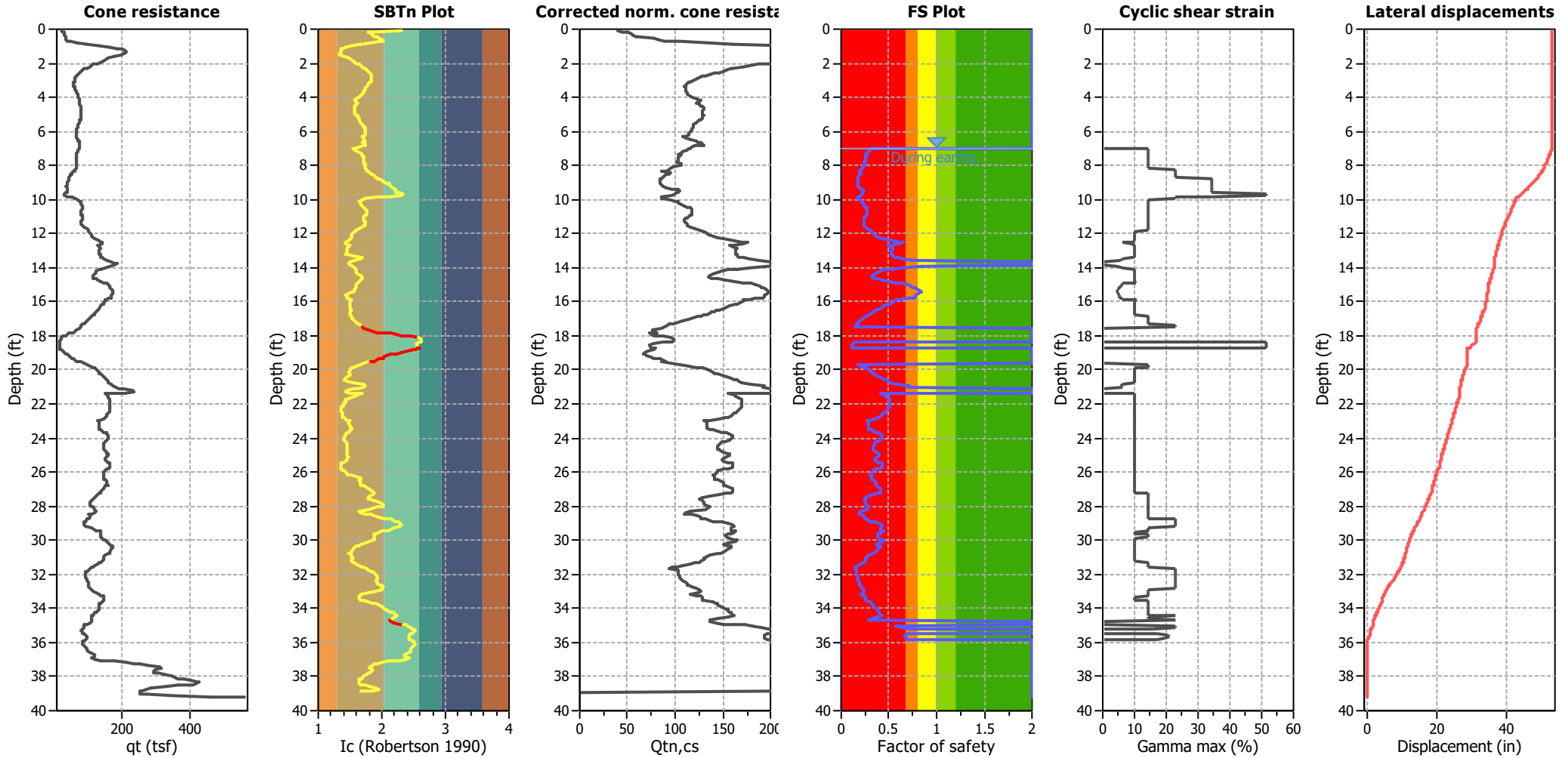

Abbreviations

q_t: Total cone resistance (cone resistance q_c corrected for pore water effects)
 I_c: Soil Behaviour Type Index
 Q_{tn,cs}: Equivalent clean sand normalized CPT total cone resistance

F.S.: Factor of safety
 γ_{max}: Maximum cyclic shear strain
 LDI: Lateral displacement index

Surface condition



Aging Calculation Estimation

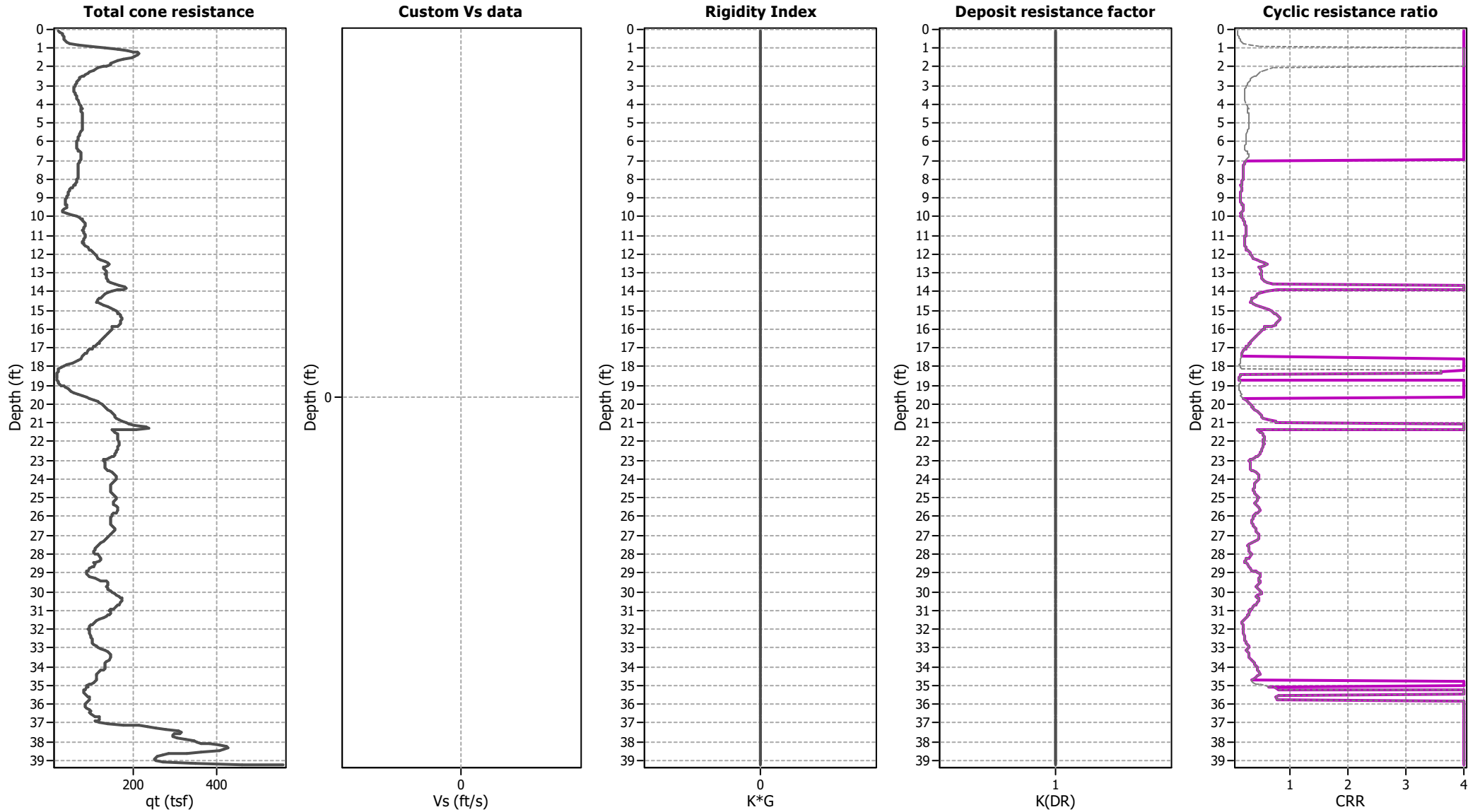

Ejecta Severity Estimation

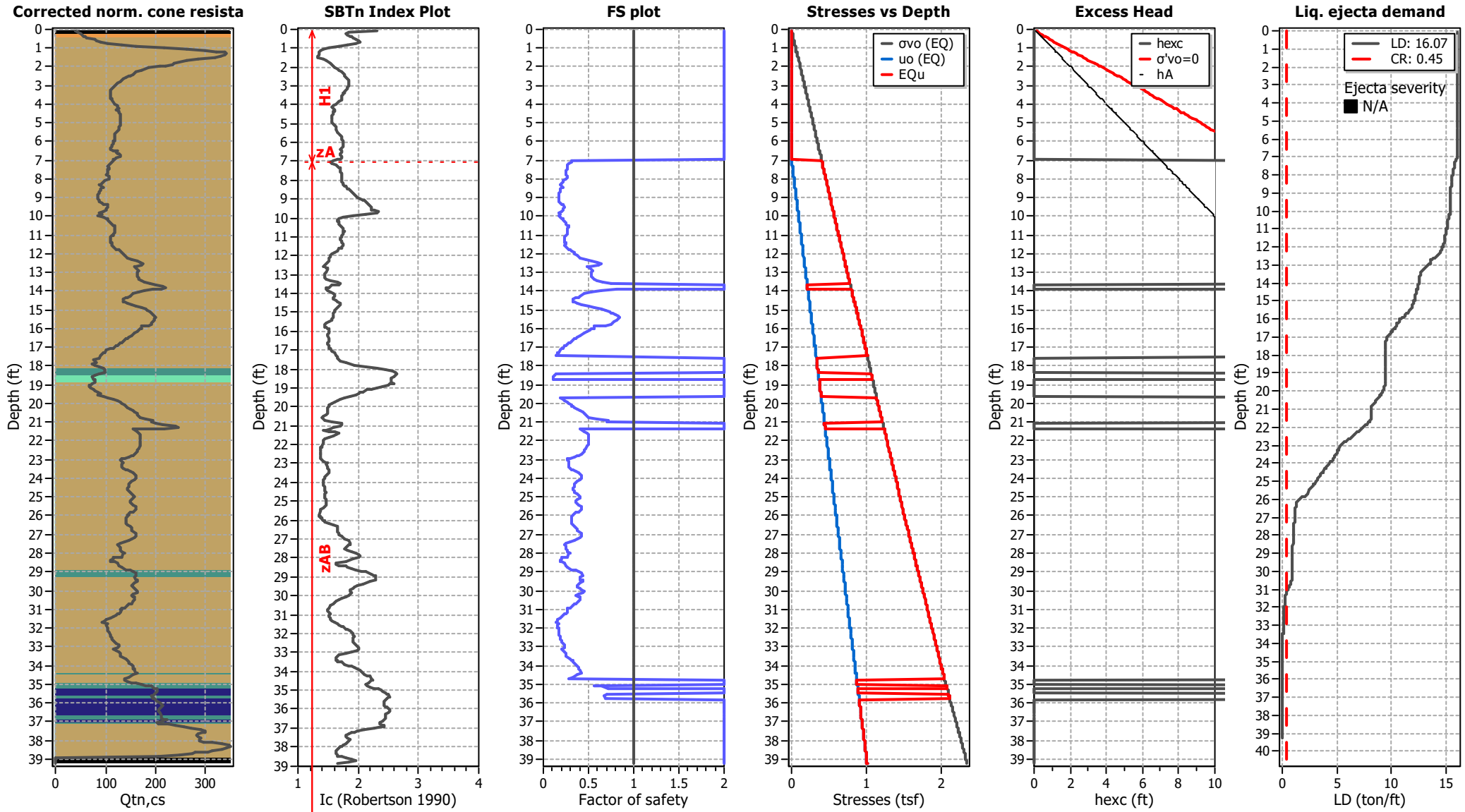

LIQUEFACTION ANALYSIS REPORT

Project title : Petra Geosciences / Apple Canyon

Location : Lake Hemet, CA

CPT file : CPT-17

Input parameters and analysis data

Analysis method:	NCEER (1998)	G.W.T. (in-situ):	12.50 ft	Use fill:	No	Clay like behavior applied:	Sands only
Fines correction method:	NCEER (1998)	G.W.T. (earthq.):	7.00 ft	Fill height:	N/A	Limit depth applied:	No
Points to test:	Based on Ic value	Average results interval:	3	Fill weight:	N/A	Limit depth:	N/A
Earthquake magnitude M_w :	8.10	Ic cut-off value:	2.60	Trans. detect. applied:	Yes	MSF method:	Method based
Peak ground acceleration:	0.89	Unit weight calculation:	Based on SBT	K_o applied:	Yes		

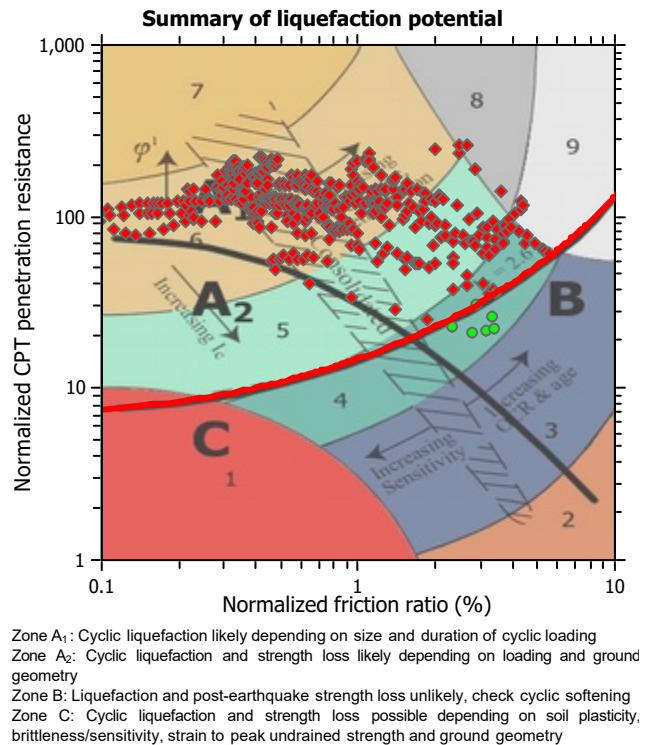
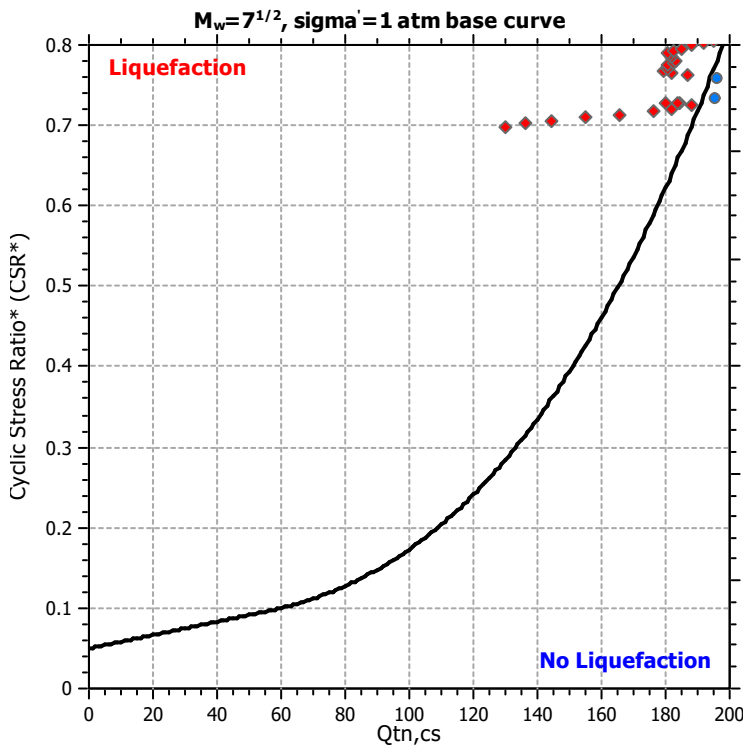
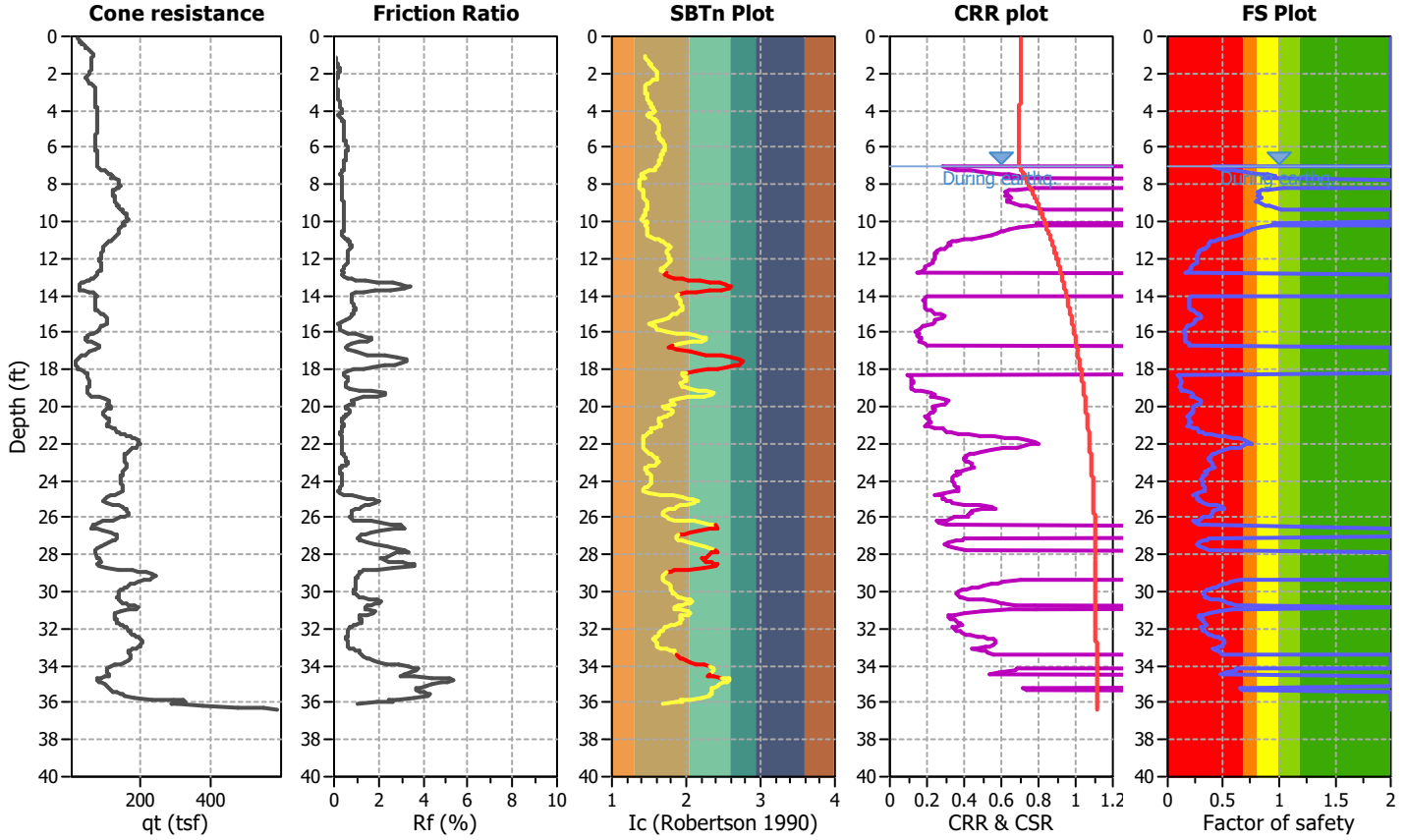

CPT basic interpretation plots

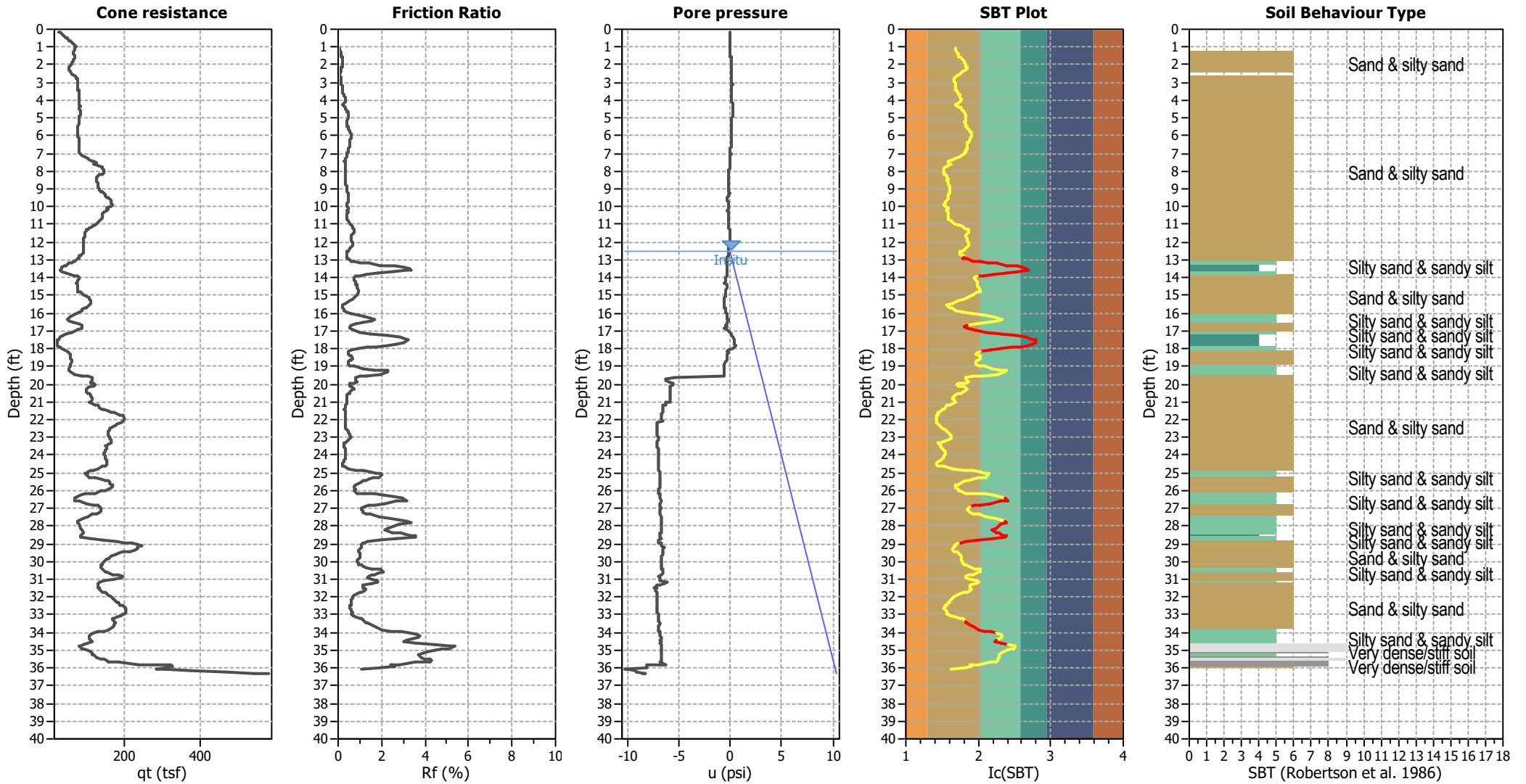

Input parameters and analysis data

Analysis method:	NCEER (1998)	Depth to water table (earthq.):	7.00 ft	Fill weight:	N/A
Fines correction method:	NCEER (1998)	Average results interval:	3	Transition detect. applied:	Yes
Points to test:	Based on Ic value	Ic cut-off value:	2.60	K ₀ applied:	Yes
Earthquake magnitude M _w :	8.10	Unit weight calculation:	Based on SBT	Clay like behavior applied:	Sands only
Peak ground acceleration:	0.89	Use fill:	No	Limit depth applied:	No
Depth to water table (insitu):	12.50 ft	Fill height:	N/A	Limit depth:	N/A

SBT legend

1. Sensitive fine grained	4. Clayey silt to silty	7. Gravely sand to sand
2. Organic material	5. Silty sand to sandy silt	8. Very stiff sand to
3. Clay to silty clay	6. Clean sand to silty sand	9. Very stiff fine grained

CPT basic interpretation plots (normalized)

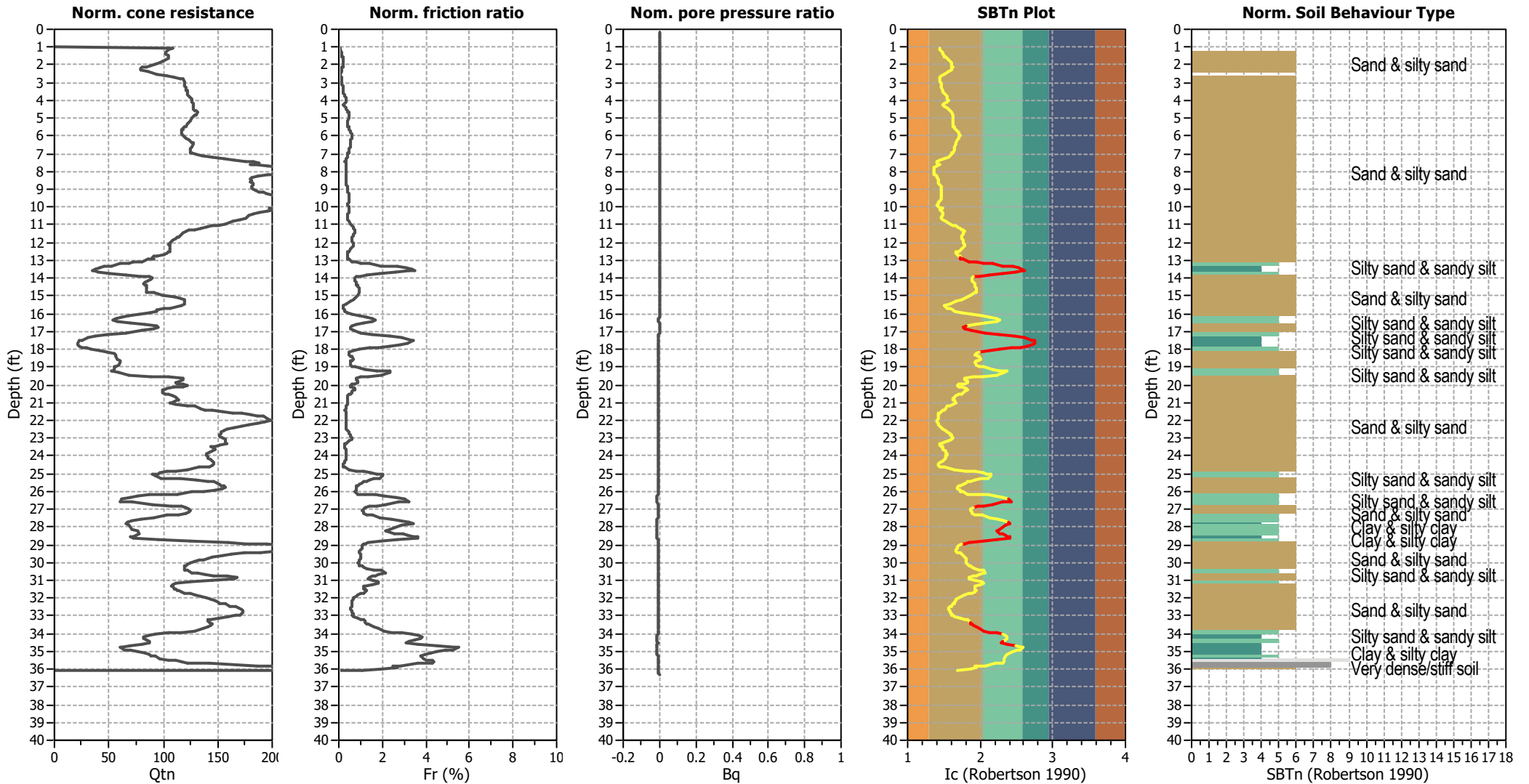

Input parameters and analysis data

Analysis method:	NCEER (1998)	Depth to water table (earthq.):	7.00 ft	Fill weight:	N/A
Fines correction method:	NCEER (1998)	Average results interval:	3	Transition detect. applied:	Yes
Points to test:	Based on Ic value	Ic cut-off value:	2.60	K ₀ applied:	Yes
Earthquake magnitude M _w :	8.10	Unit weight calculation:	Based on SBT	Clay like behavior applied:	Sands only
Peak ground acceleration:	0.89	Use fill:	No	Limit depth applied:	No
Depth to water table (insitu):	12.50 ft	Fill height:	N/A	Limit depth:	N/A

SBTn legend

1. Sensitive fine grained	4. Clayey silt to silty	7. Gravely sand to sand
2. Organic material	5. Silty sand to sandy silt	8. Very stiff sand to
3. Clay to silty clay	6. Clean sand to silty sand	9. Very stiff fine grained

Liquefaction analysis overall plots (intermediate results)

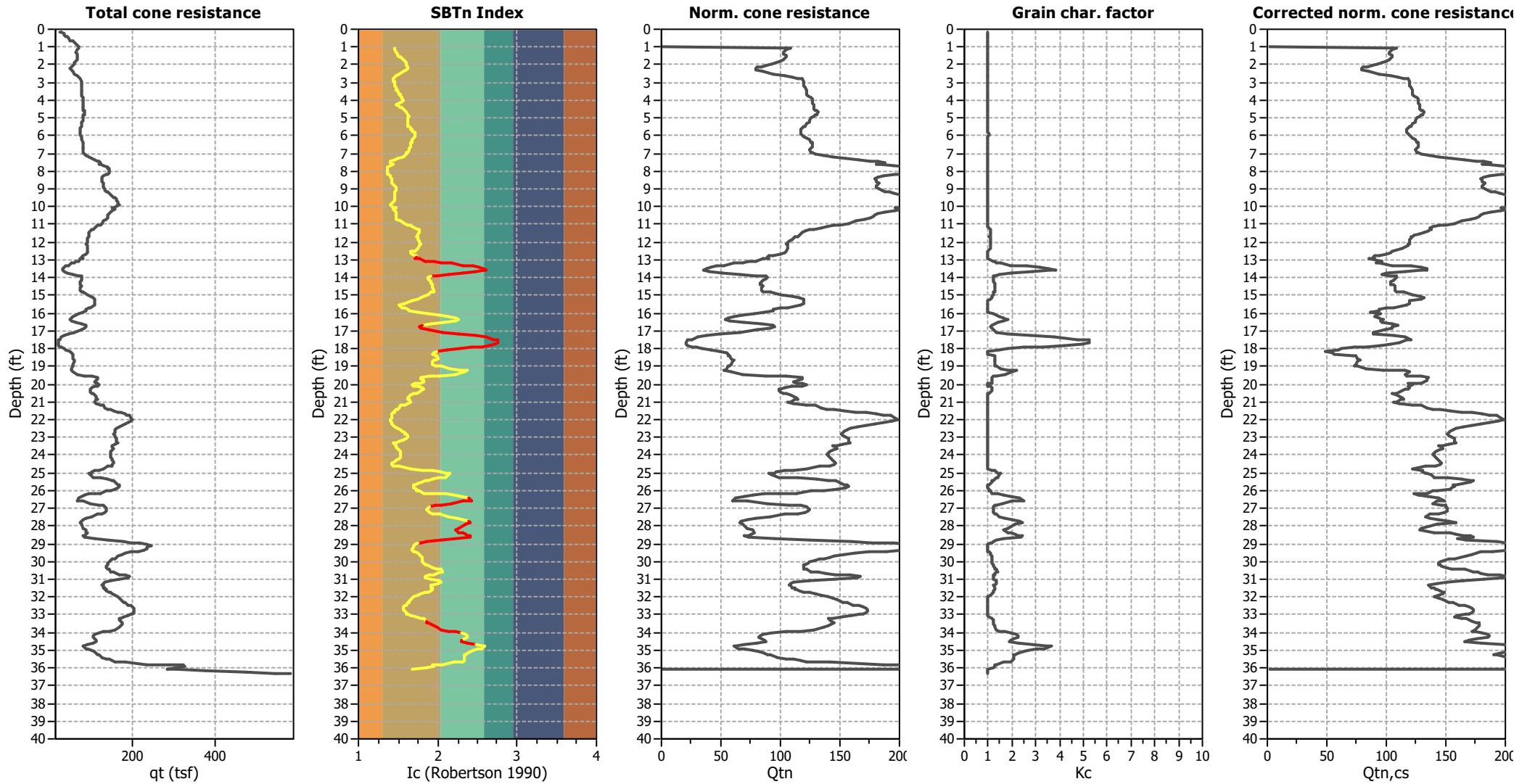

Input parameters and analysis data

Analysis method:	NCEER (1998)	Depth to water table (earthq.):	7.00 ft	Fill weight:	N/A
Fines correction method:	NCEER (1998)	Average results interval:	3	Transition detect. applied:	Yes
Points to test:	Based on Ic value	Ic cut-off value:	2.60	K _{cs} applied:	Yes
Earthquake magnitude M _w :	8.10	Unit weight calculation:	Based on SBT	Clay like behavior applied:	Sands only
Peak ground acceleration:	0.89	Use fill:	No	Limit depth applied:	No
Depth to water table (insitu):	12.50 ft	Fill height:	N/A	Limit depth:	N/A

Liquefaction analysis overall plots

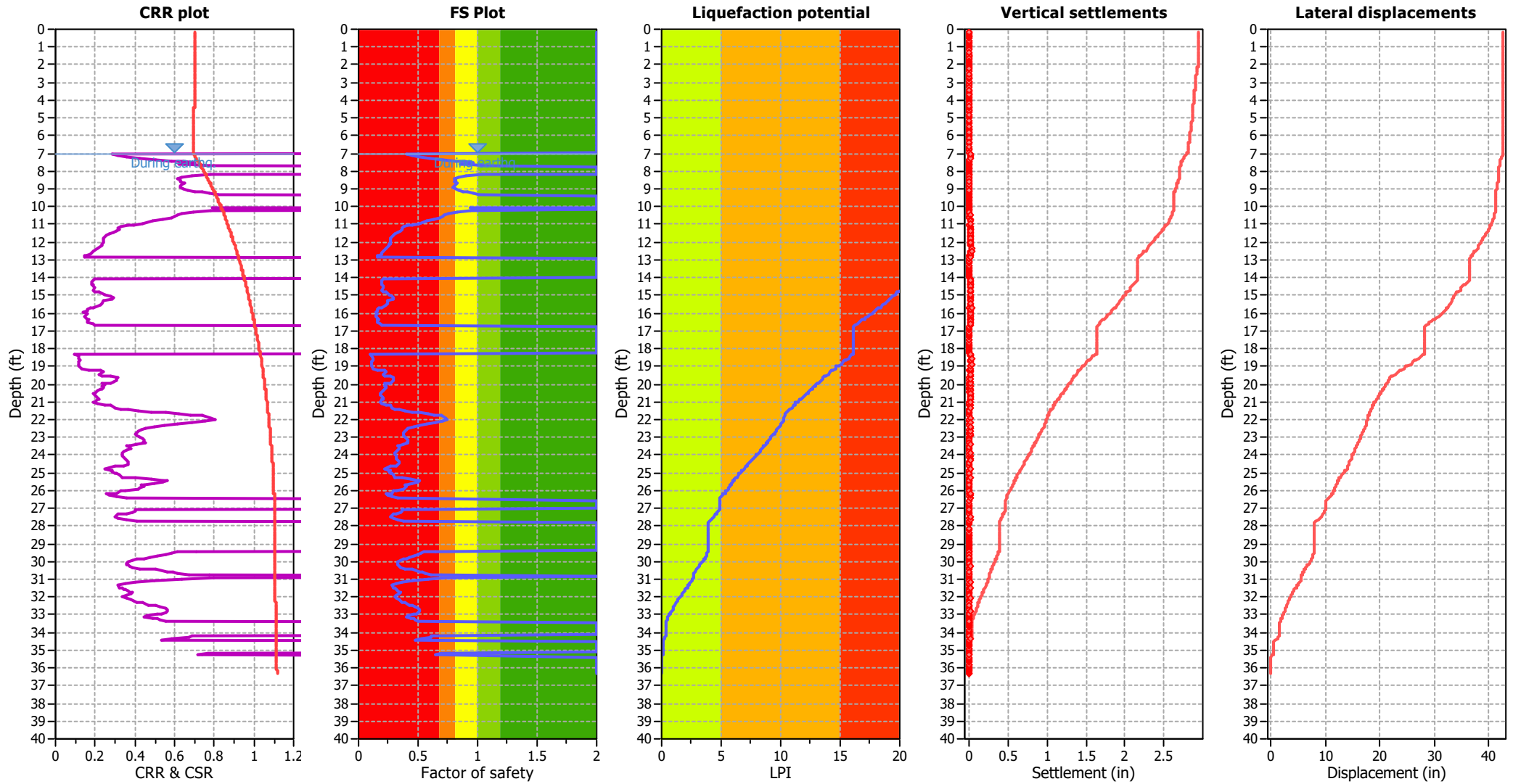

Input parameters and analysis data

Analysis method:	NCEER (1998)	Depth to water table (earthq.):	7.00 ft	Fill weight:	N/A
Fines correction method:	NCEER (1998)	Average results interval:	3	Transition detect. applied:	Yes
Points to test:	Based on Ic value	Ic cut-off value:	2.60	K_0 applied:	Yes
Earthquake magnitude M_w :	8.10	Unit weight calculation:	Based on SBT	Clay like behavior applied:	Sands only
Peak ground acceleration:	0.89	Use fill:	No	Limit depth applied:	No
Depth to water table (insitu):	12.50 ft	Fill height:	N/A	Limit depth:	N/A

F.S. color scheme

- Almost certain it will liquefy
- Very likely to liquefy
- Liquefaction and no liq. are equally likely
- Unlike to liquefy
- Almost certain it will not liquefy

LPI color scheme

- Very high risk
- High risk
- Low risk

Liquefaction analysis summary plots

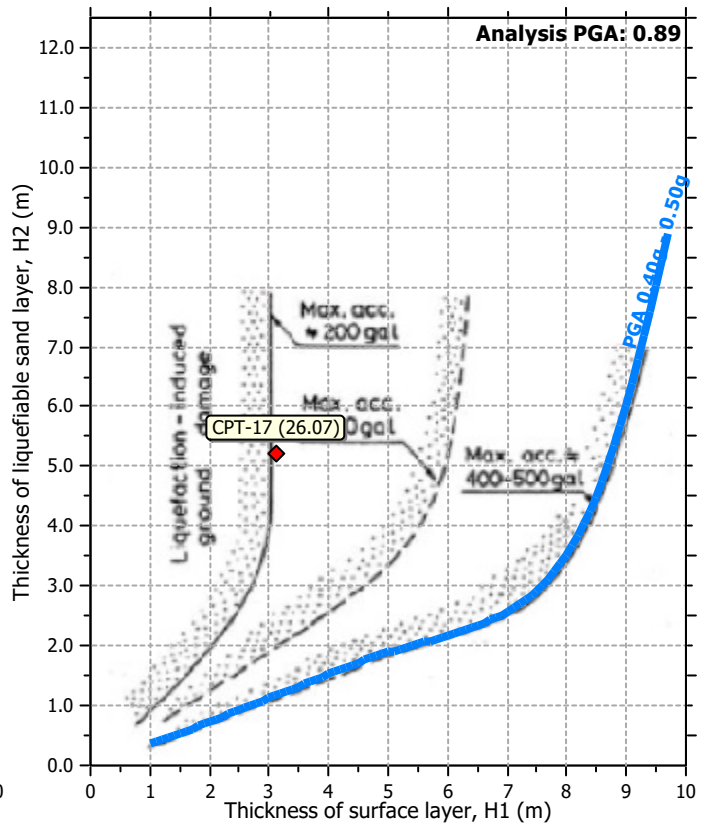
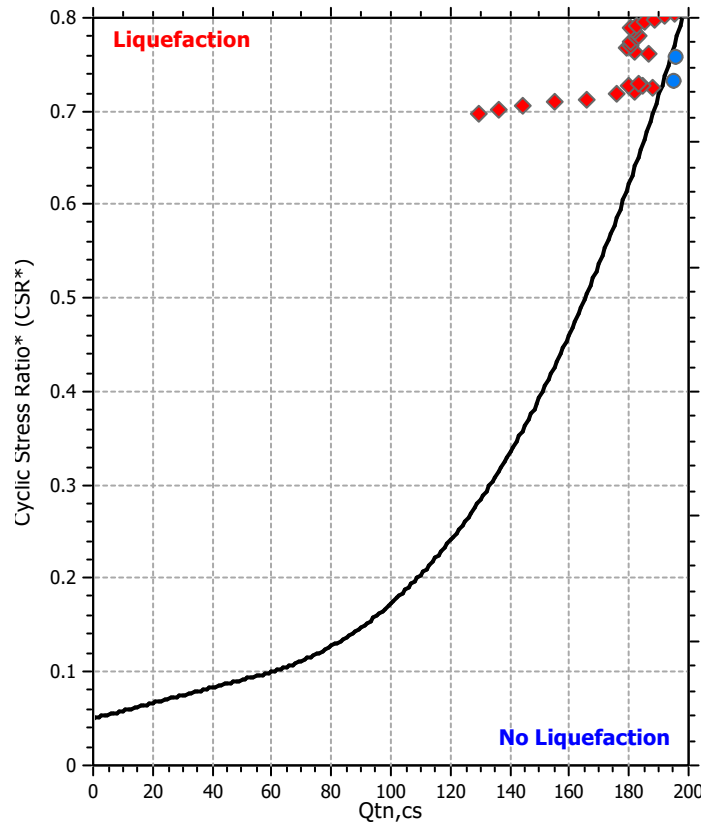
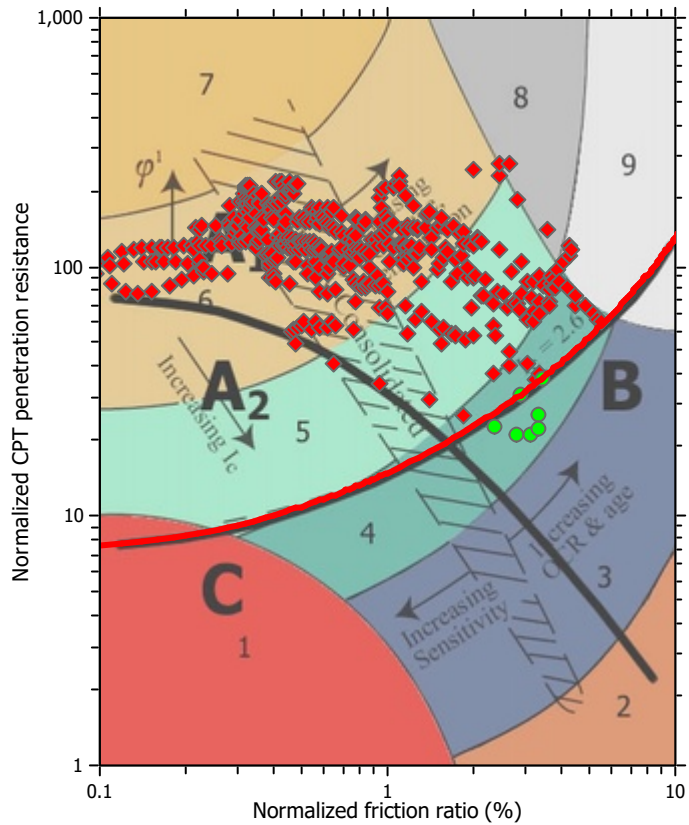

Input parameters and analysis data

Analysis method:	NCEER (1998)	Depth to water table (earthq.):	7.00 ft	Fill weight:	N/A
Fines correction method:	NCEER (1998)	Average results interval:	3	Transition detect. applied:	Yes
Points to test:	Based on Ic value	Ic cut-off value:	2.60	K ₀ applied:	Yes
Earthquake magnitude M _w :	8.10	Unit weight calculation:	Based on SBT	Clay like behavior applied:	Sands only
Peak ground acceleration:	0.89	Use fill:	No	Limit depth applied:	No
Depth to water table (insitu):	12.50 ft	Fill height:	N/A	Limit depth:	N/A

Check for strength loss plots (Robertson (2010))

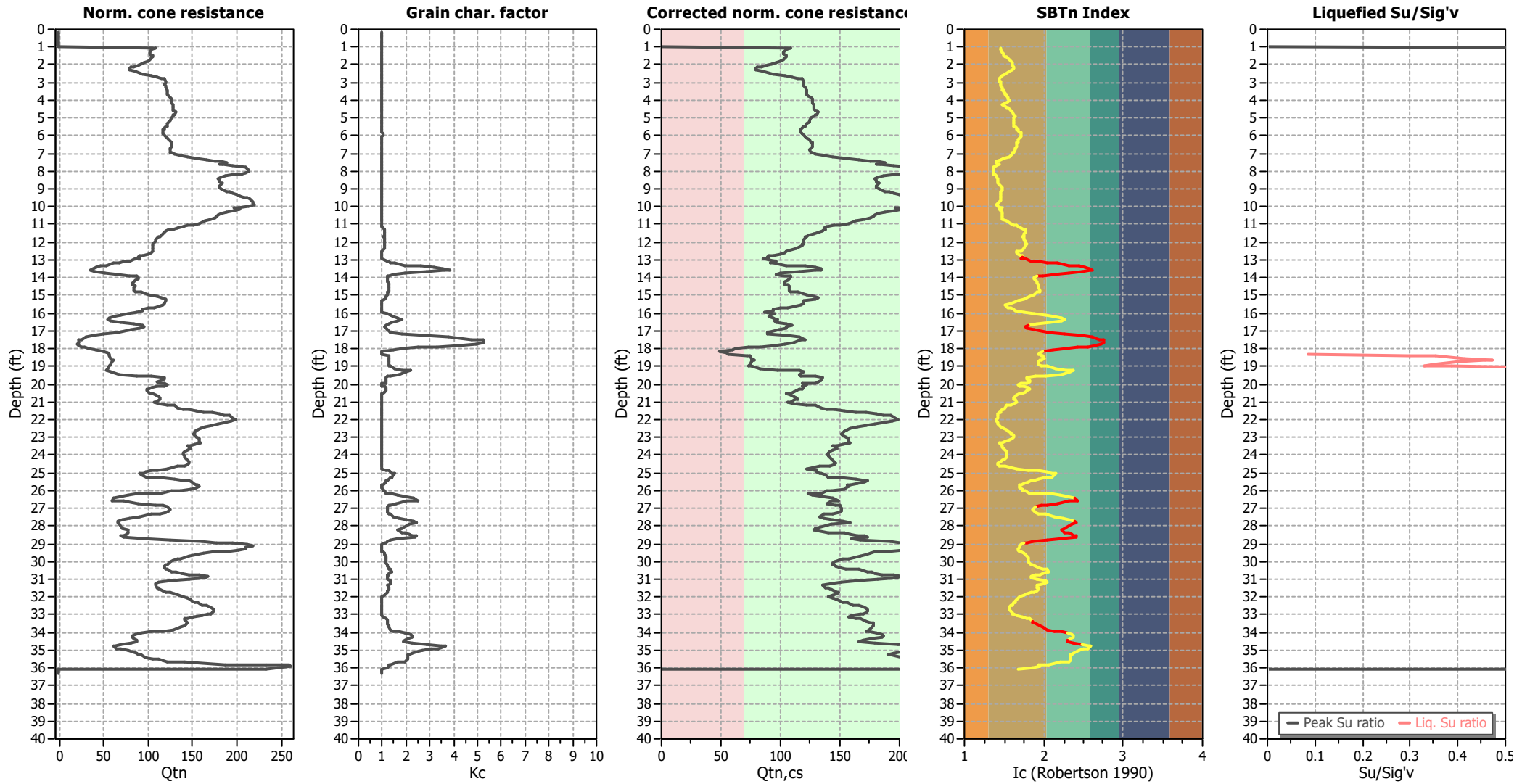

Input parameters and analysis data

Analysis method:	NCEER (1998)	Depth to water table (earthq.):	7.00 ft	Fill weight:	N/A
Fines correction method:	NCEER (1998)	Average results interval:	3	Transition detect. applied:	Yes
Points to test:	Based on Ic value	Ic cut-off value:	2.60	K _o applied:	Yes
Earthquake magnitude M _w :	8.10	Unit weight calculation:	Based on SBT	Clay like behavior applied:	Sands only
Peak ground acceleration:	0.89	Use fill:	No	Limit depth applied:	No
Depth to water table (insitu):	12.50 ft	Fill height:	N/A	Limit depth:	N/A

TRANSITION LAYER DETECTION ALGORITHM REPORT

Summary Details & Plots

Short description

The software will delete data when the cone is in transition from either clay to sand or vice-versa. To do this the software requires a range of I_c values over which the transition will be defined (typically somewhere between $1.80 < I_c < 3.0$) and a rate of change of I_c . Transitions typically occur when the rate of change of I_c is fast (i.e. ΔI_c is small).

The SBT_n plot below, displays in red the detected transition layers based on the parameters listed below the graphs.

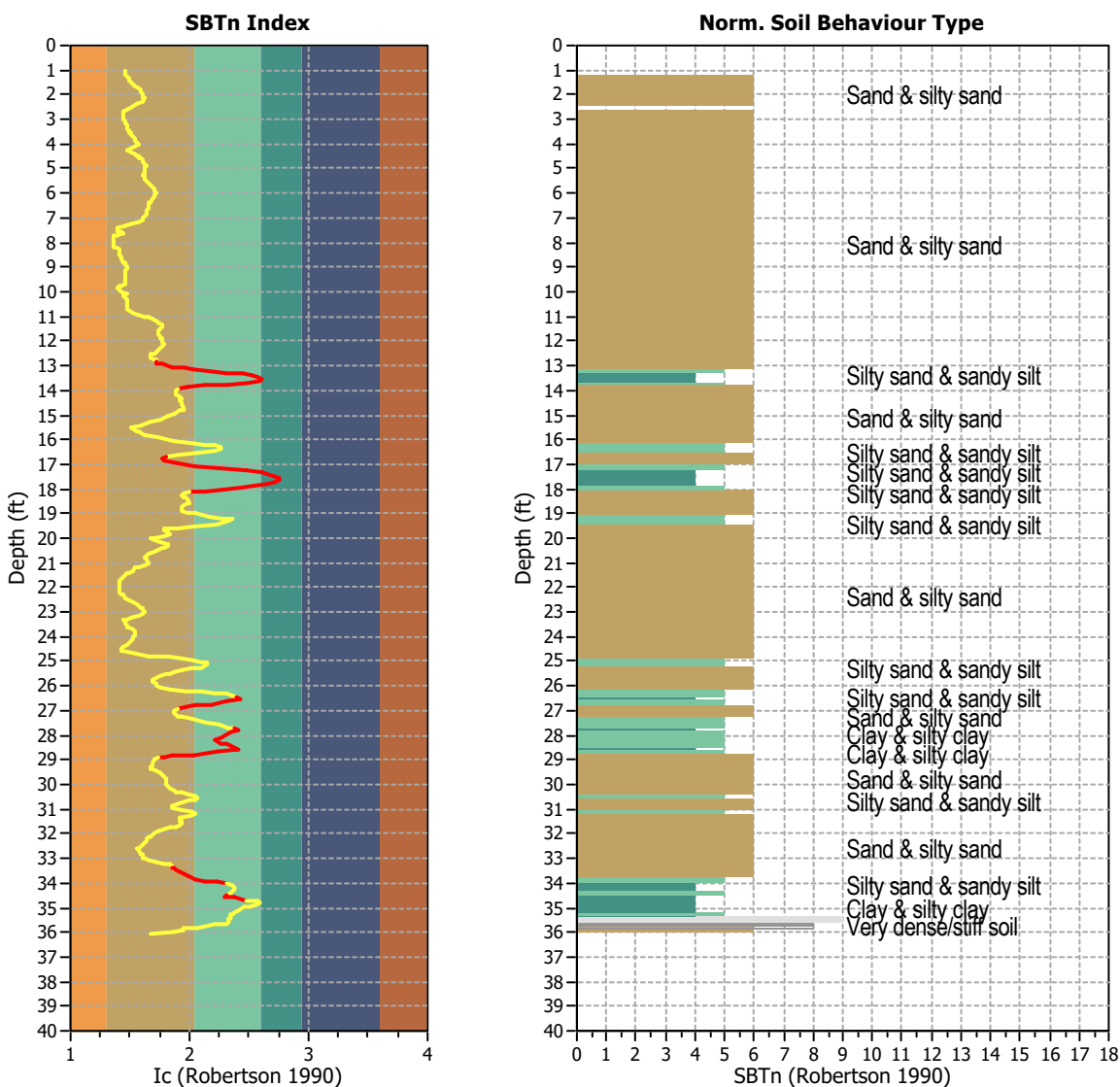

Transition layer algorithm properties

I_c minimum check value: 1.70
 I_c maximum check value: 3.00
 I_c change ratio value: 0.0250
 Minimum number of points in layer: 4

General statistics

Total points in CPT file: 509
 Total points excluded: 75
 Exclusion percentage: 14.73%
 Number of layers detected: 10

Estimation of post-earthquake settlements

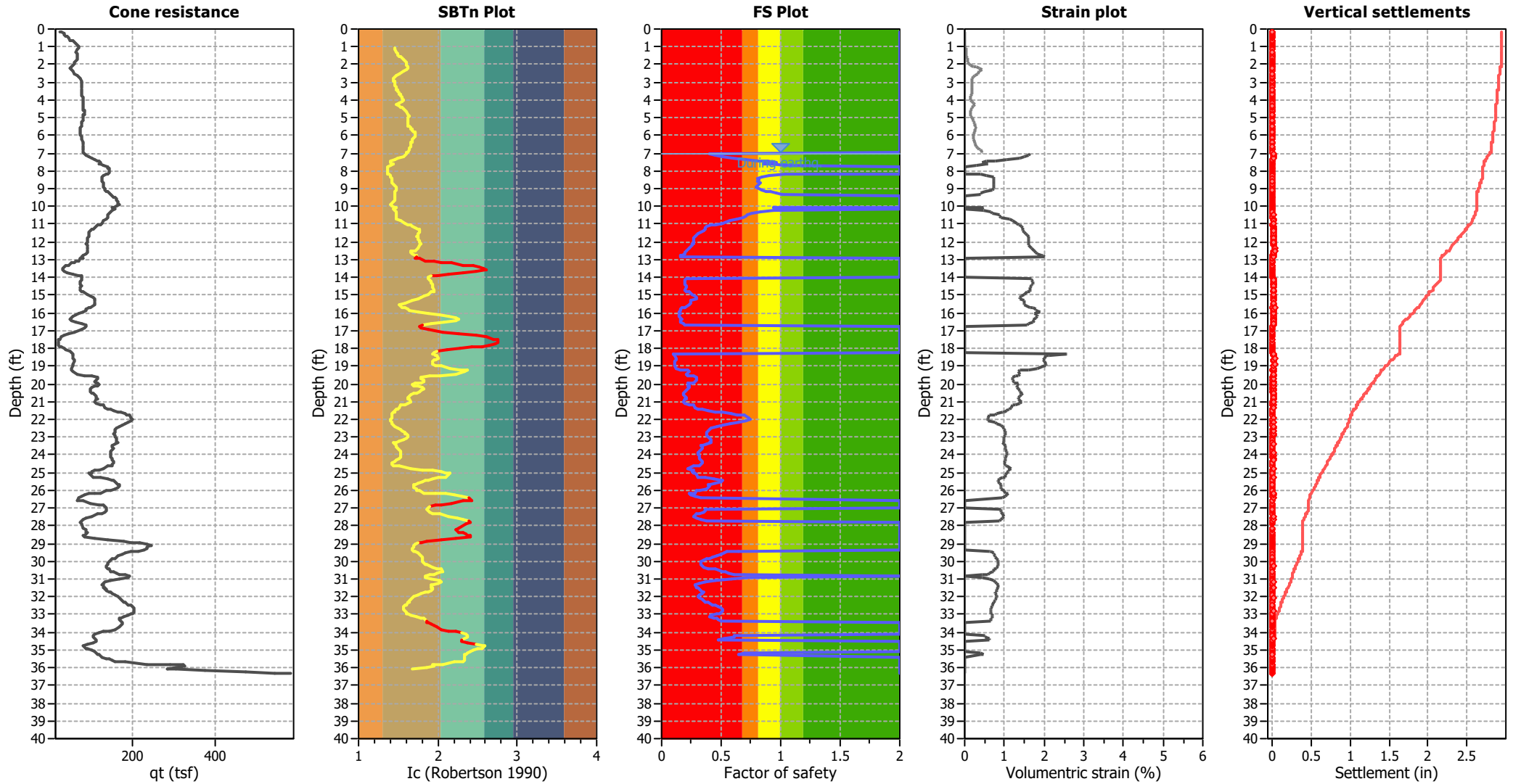

Abbreviations

- q_c: Total cone resistance (cone resistance q_c corrected for pore water effects)
- I_c: Soil Behaviour Type Index
- FS: Calculated Factor of Safety against liquefaction
- Volumetric strain: Post-liquefaction volumetric strain

Estimation of post-earthquake lateral Displacements

Geometric parameters: Gently sloping ground without free face (Slope 1.00 %)

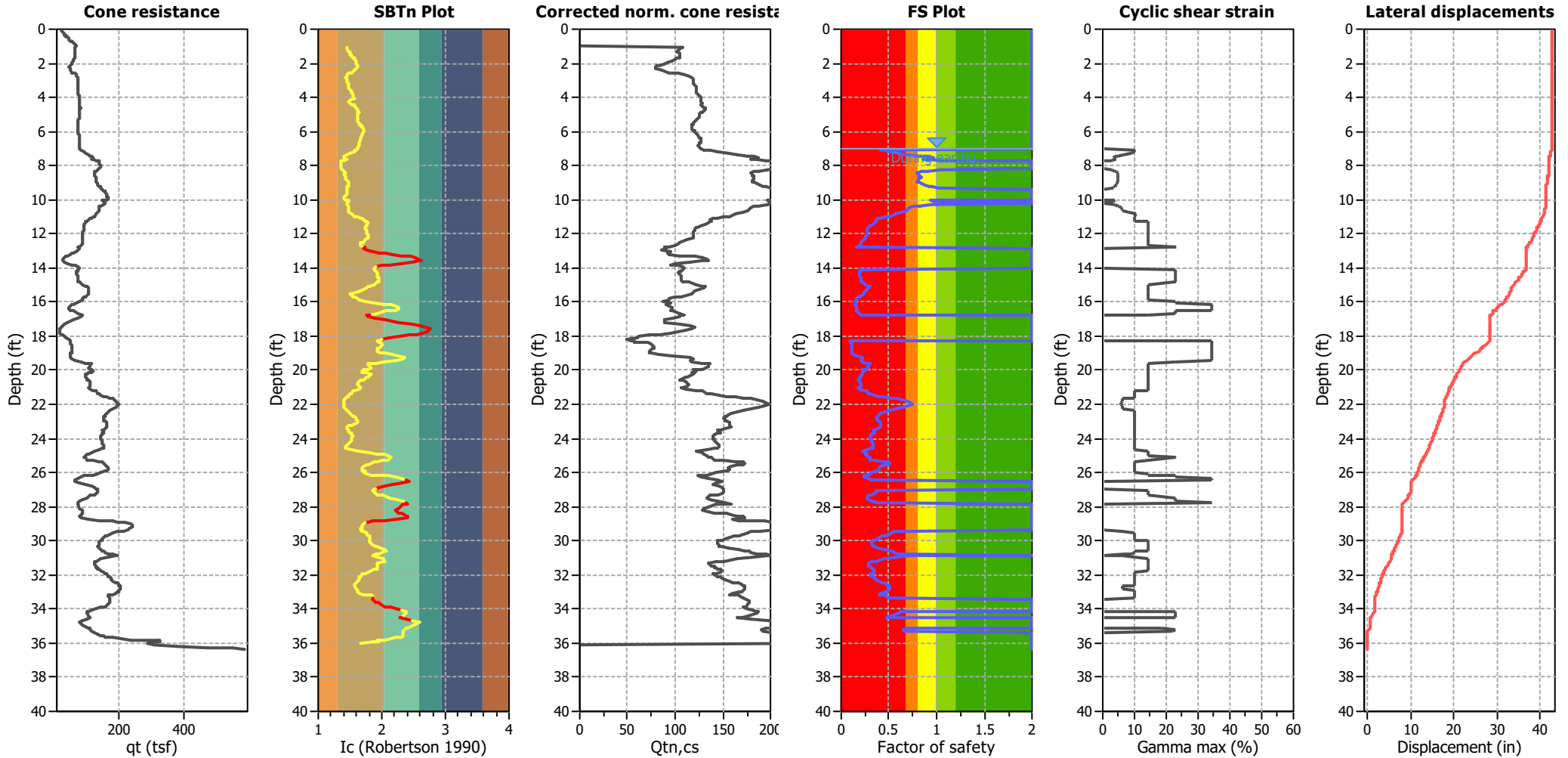

Abbreviations

qt: Total cone resistance (cone resistance q_c corrected for pore water effects)
 Ic: Soil Behaviour Type Index
 $Q_{tn,cs}$: Equivalent clean sand normalized CPT total cone resistance

F.S.: Factor of safety
 γ_{max} : Maximum cyclic shear strain
 LDI: Lateral displacement index

Surface condition



Aging Calculation Estimation

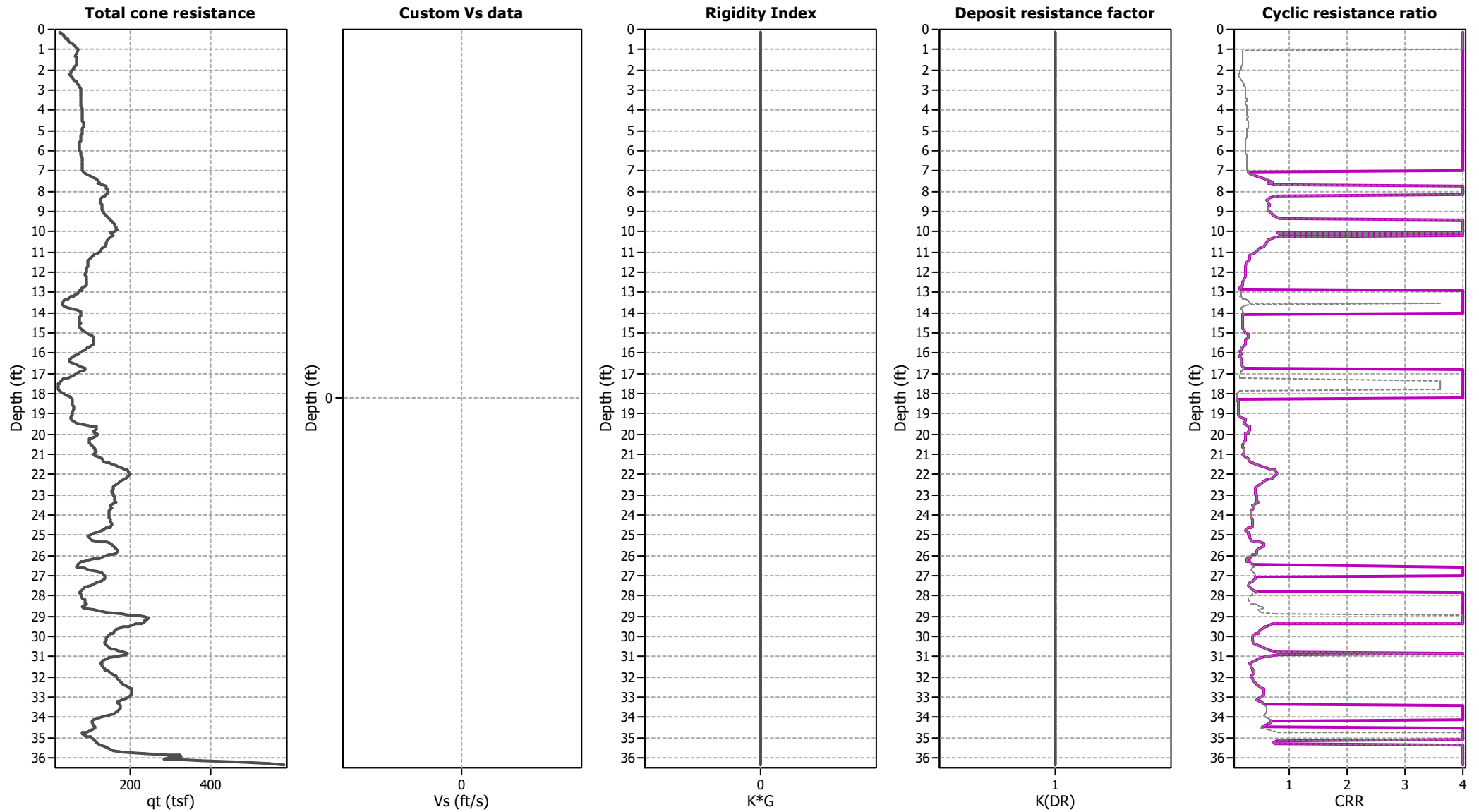

Ejecta Severity Estimation

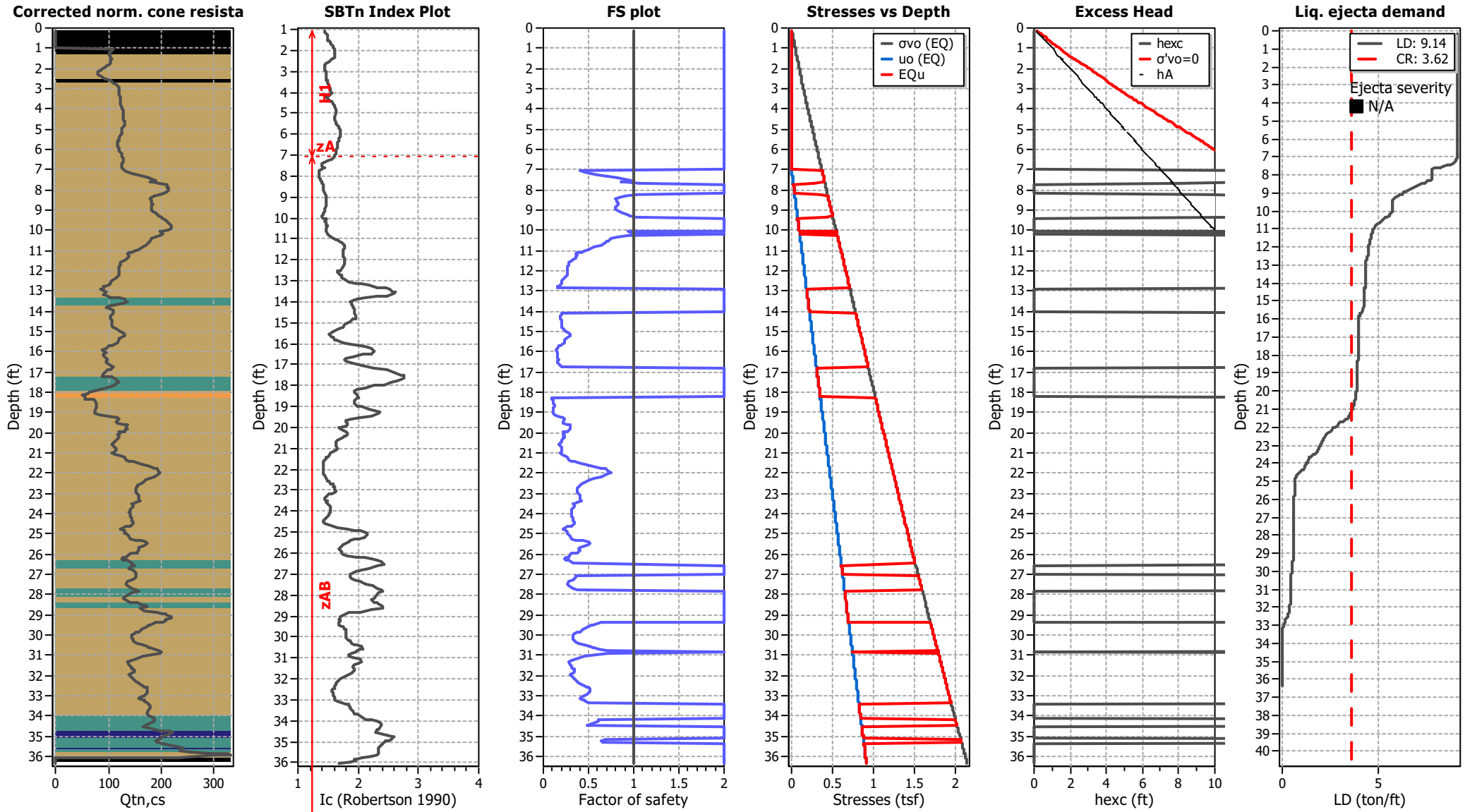

Procedure for the evaluation of soil liquefaction resistance, NCEER (1998)

Calculation of soil resistance against liquefaction is performed according to the Robertson & Wride (1998) procedure. The procedure used in the software, slightly differs from the one originally published in NCEER-97-0022 (Proceedings of the NCEER Workshop on Evaluation of Liquefaction Resistance of Soils). The revised procedure is presented below in the form of a flowchart¹:

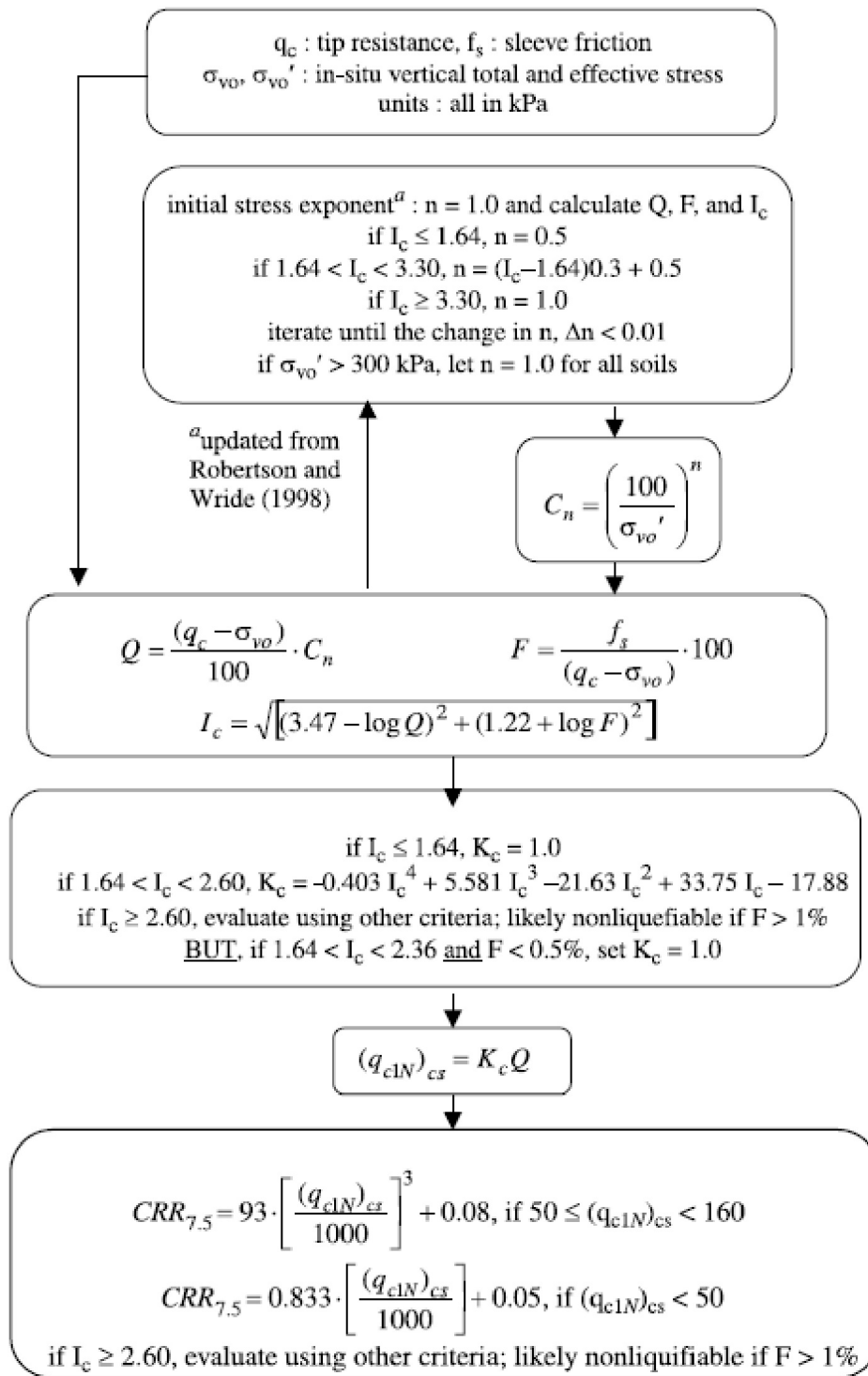

¹ "Estimating liquefaction-induced ground settlements from CPT for level ground", G. Zhang, P.K. Robertson, and R.W.I. Brachman

Procedure for the evaluation of soil liquefaction resistance (all soils), Robertson (2010)

Calculation of soil resistance against liquefaction is performed according to the Robertson & Wride (1998) procedure. This procedure used in the software, slightly differs from the one originally published in NCEER-97-0022 (Proceedings of the NCEER Workshop on Evaluation of Liquefaction Resistance of Soils). The revised procedure is presented below in the form of a flowchart¹:

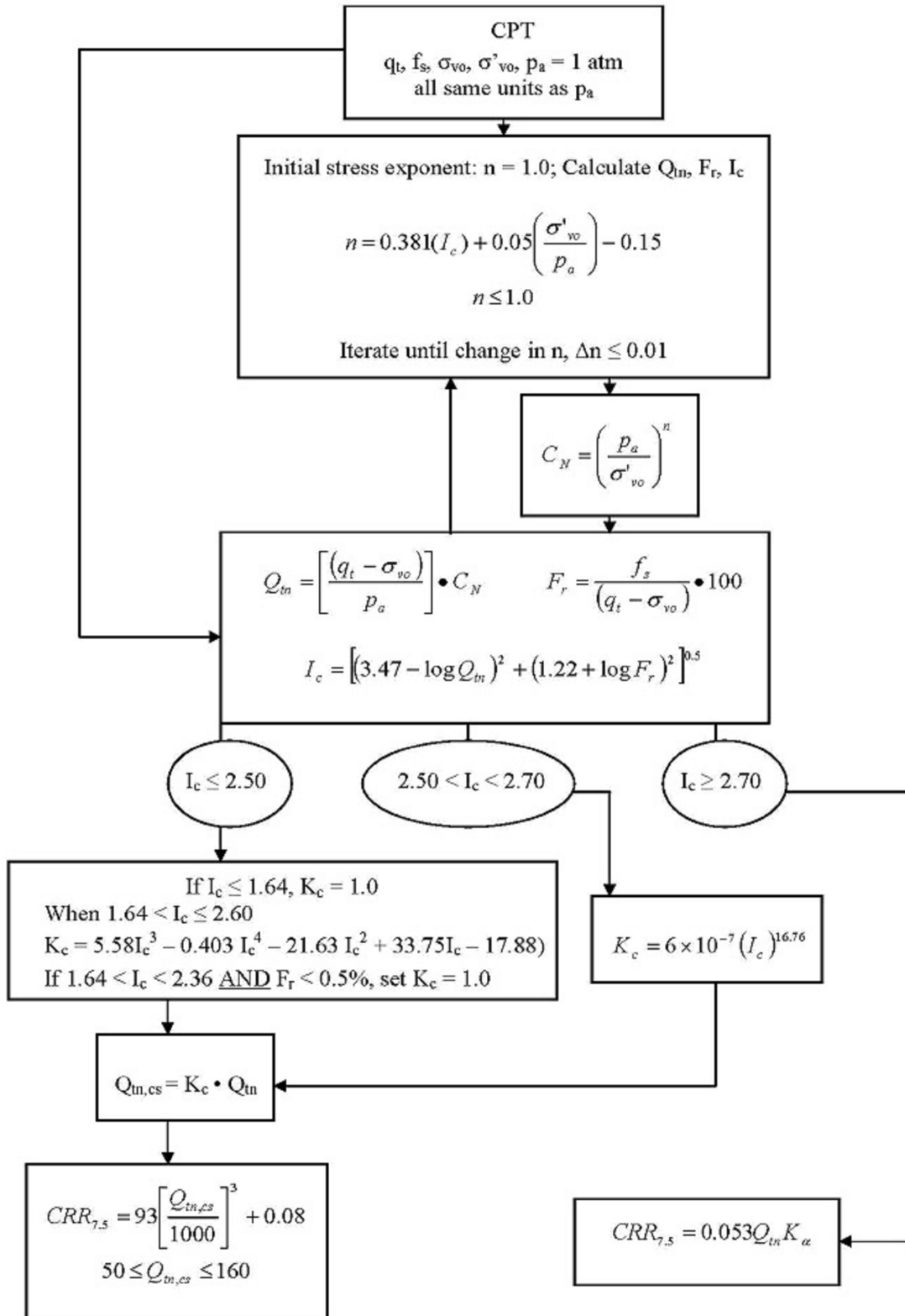

¹ P.K. Robertson, 2009. "Performance based earthquake design using the CPT", Keynote Lecture, International Conference on Performance-based Design in Earthquake Geotechnical Engineering – from case history to practice, IS-Tokyo, June 2009

Procedure for the evaluation of soil liquefaction resistance, Idriss & Boulanger (2008)

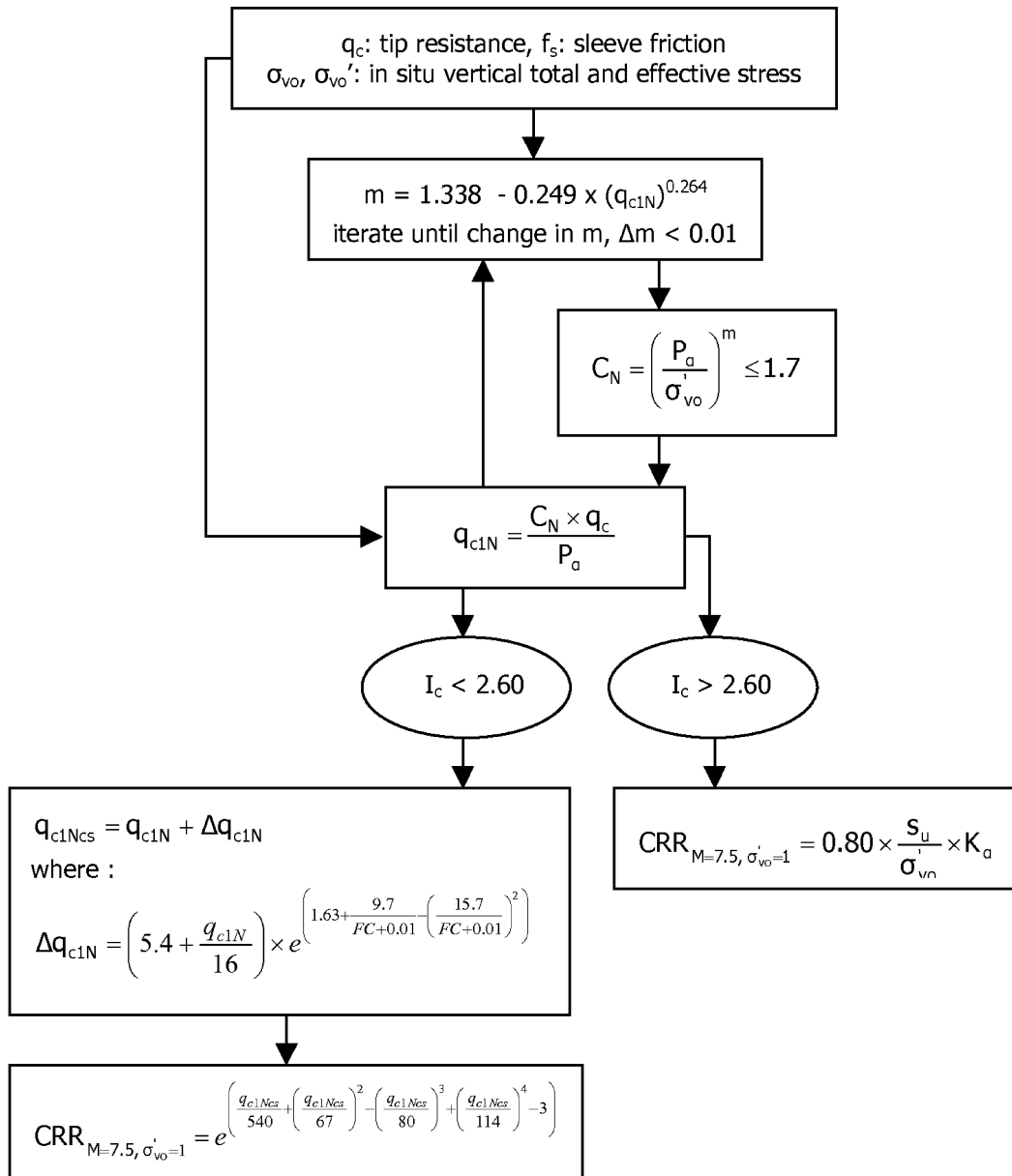

Procedure for the evaluation of soil liquefaction resistance (sandy soils), Moss et al. (2006)

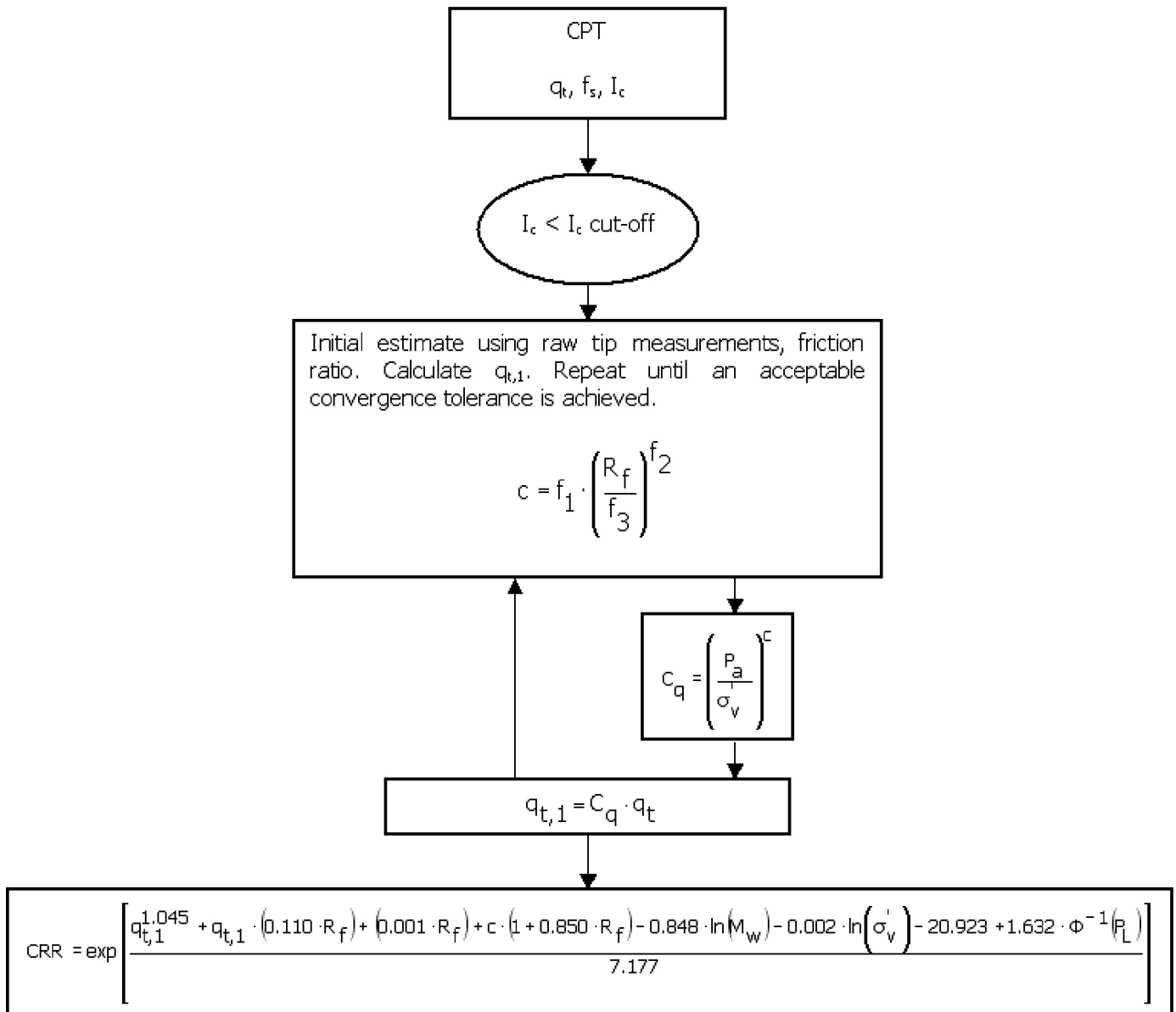

Procedure for the evaluation of soil liquefaction resistance, Boulanger & Idriss(2014)

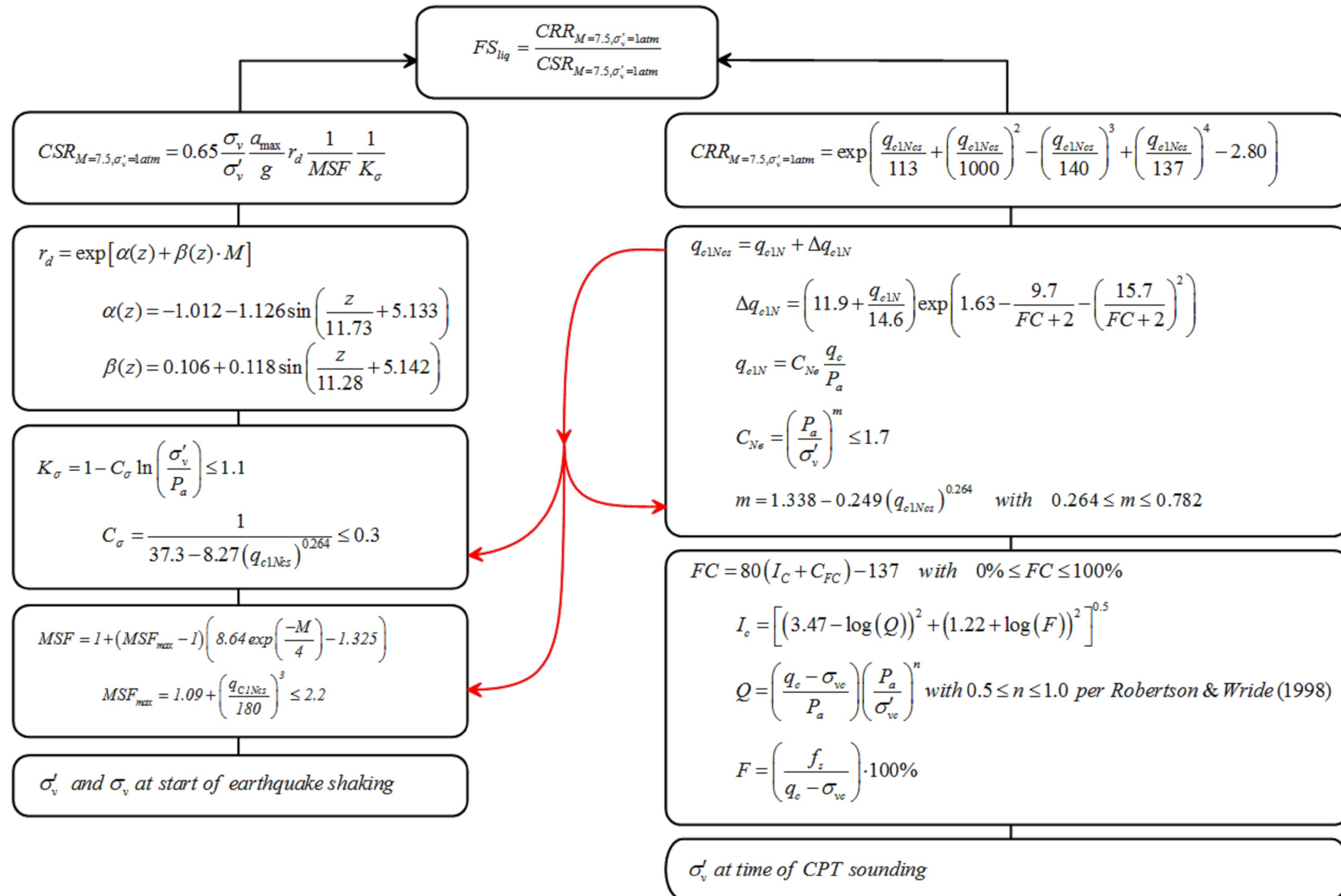

Procedure for the evaluation of liquefaction-induced lateral spreading displacements

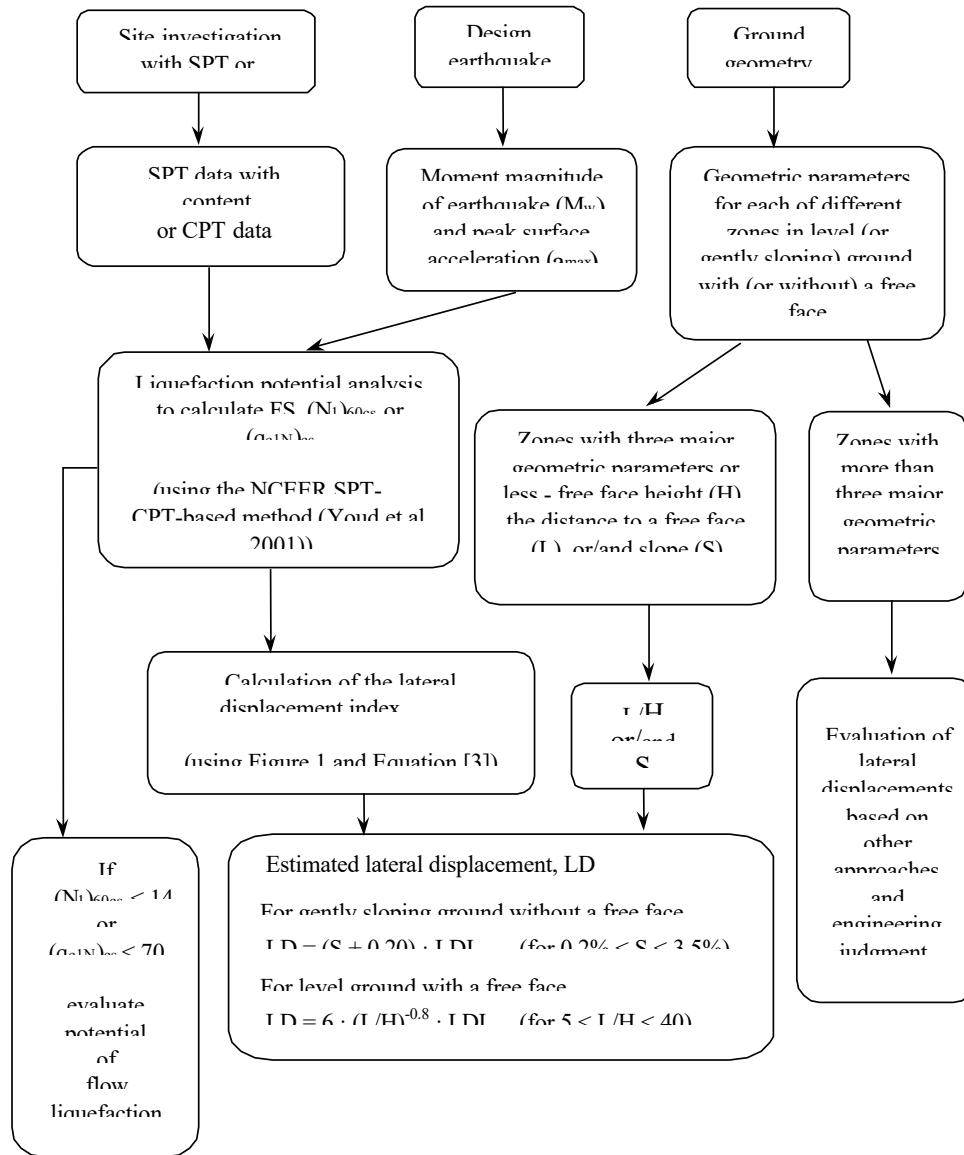

¹ Flow chart illustrating major steps in estimating liquefaction-induced lateral spreading displacements using the proposed approach

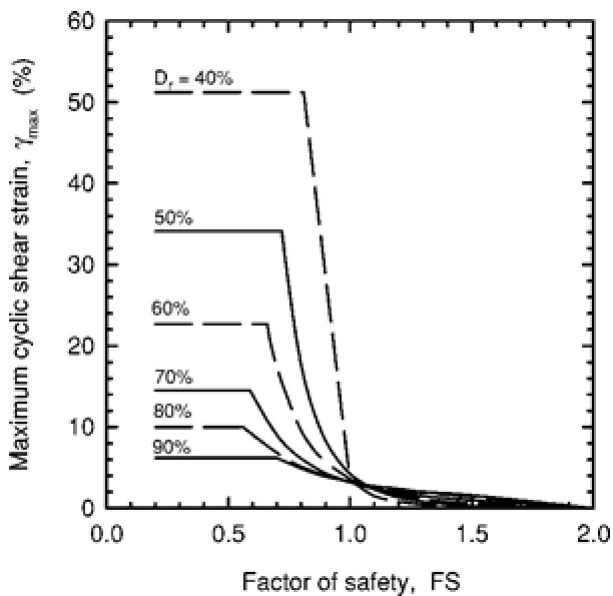

¹ Figure 1

$$LDI = \int_0^{Z_{max}} \gamma_{max} dz$$

¹ Equation [3]

¹ "Estimating liquefaction-induced ground settlements from CPT for level ground", G. Zhang, P.K. Robertson, and R.W.I. Brachman

Procedure for the estimation of seismic induced settlements in dry sands

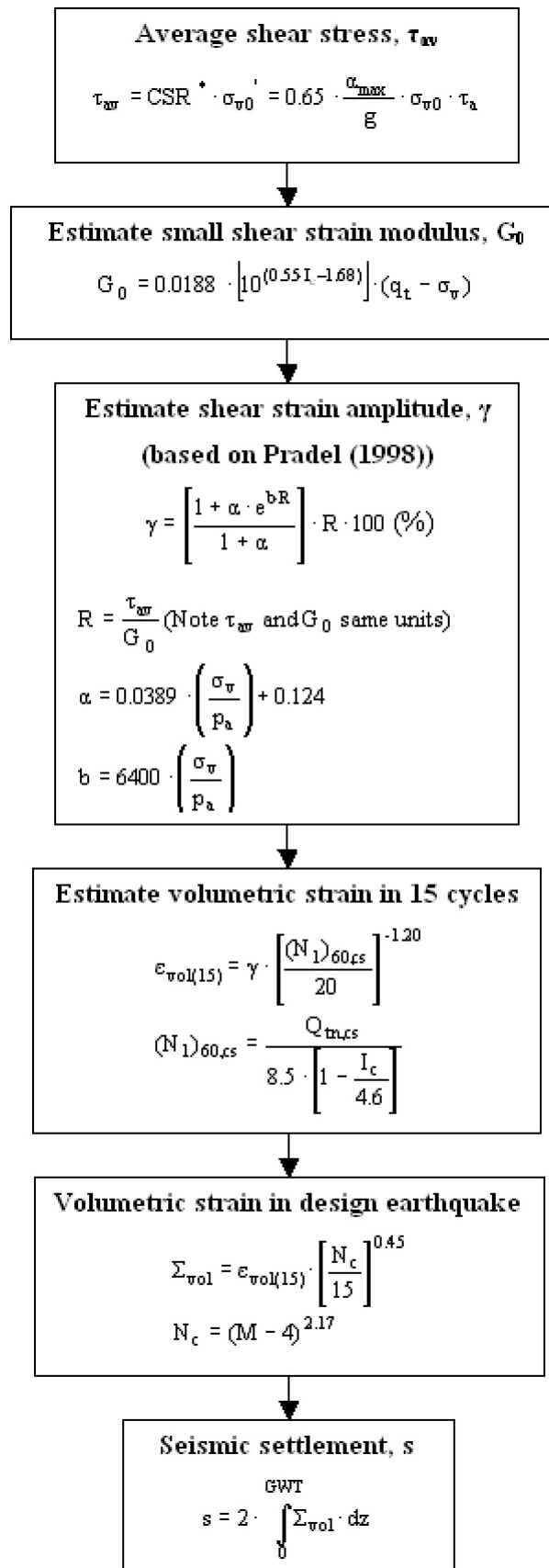

Robertson, P.K. and Lisheng, S., 2010, "Estimation of seismic compression in dry soils using the CPT" FIFTH INTERNATIONAL CONFERENCE ON RECENT ADVANCES IN GEOTECHNICAL EARTHQUAKE ENGINEERING AND SOIL DYNAMICS, Symposium in honor of professor I. M. Idriss, San Diego, CA

Liquefaction Potential Index (LPI) calculation procedure

Calculation of the Liquefaction Potential Index (LPI) is used to interpret the liquefaction assessment calculations in terms of severity over depth. The calculation procedure is based on the methodology developed by Iwasaki (1982) and is adopted by AFPS.

To estimate the severity of liquefaction extent at a given site, LPI is calculated based on the following equation:

$$\mathbf{LPI} = \int_0^{20} (10 - 0,5z) \times F_L \times d_z$$

where:

$F_L = 1 - F.S.$ when F.S. less than 1

$F_L = 0$ when F.S. greater than 1

z depth of measurement in meters

Values of LPI range between zero (0) when no test point is characterized as liquefiable and 100 when all points are characterized as susceptible to liquefaction. Iwasaki proposed four (4) discrete categories based on the numeric value of LPI:

- LPI = 0 : Liquefaction risk is very low
- $0 < LPI \leq 5$: Liquefaction risk is low
- $5 < LPI \leq 15$: Liquefaction risk is high
- LPI > 15 : Liquefaction risk is very high

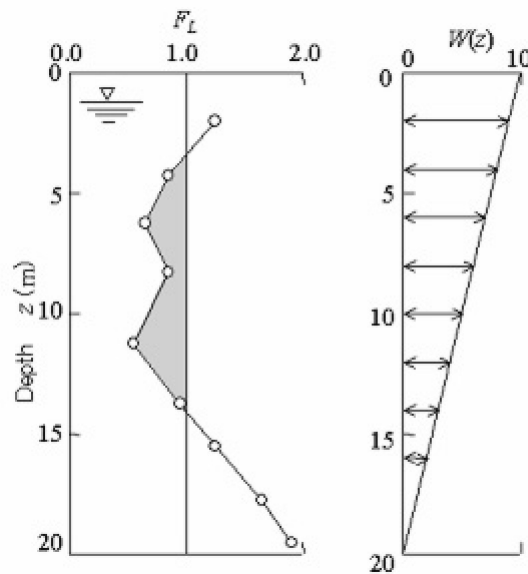

Graphical presentation of the LPI calculation procedure

Shear-Induced Building Settlement (Ds) calculation procedure

The shear-induced building settlement (Ds) due to liquefaction below the building can be estimated using the relationship developed by Bray and Macedo (2017):

$$\begin{aligned} \ln(Ds) = & c1 + c2 * LBS + 0.58 * \ln\left(\tanh\left(\frac{HL}{6}\right)\right) + \\ & 4.59 * \ln(Q) - 0.42 * \ln(Q)^2 - 0.02 * B + \\ & 0.84 * \ln(CAVdp) + 0.41 * \ln(Sa1) + \varepsilon \end{aligned}$$

where Ds is in the units of mm, c1= -8.35 and c2= 0.072 for LBS ≤ 16, and c1= -7.48 and c2= 0.014 otherwise. Q is the building contact pressure in units of kPa, HL is the cumulative thickness of the liquefiable layers in the units of m, B is the building width in the units of m, CAVdp is a standardized version of the cumulative absolute velocity in the units of g-s, Sa1 is 5%-damped pseudo-acceleration response spectral value at a period of 1 s in the units of g, and ε is a normal random variable with zero mean and 0.50 standard deviation in Ln units. The liquefaction-induced building settlement index (LBS) is:

$$LBS = \sum W * \frac{\varepsilon_{shear}}{z} dz$$

where z (m) is the depth measured from the ground surface > 0, w is a foundation-weighting factor wherein W = 0.0 for z less than Df, which is the embedment depth of the foundation, and W = 1.0 otherwise. The shear strain parameter (ε_{shear}) is the liquefaction-induced free-field shear strain (in %) estimated using Zhang et al. (2004). It is calculated based on the estimated Dr of the liquefied soil layer and the calculated safety factor against liquefaction triggering (FSL).

References

- Lunne, T., Robertson, P.K., and Powell, J.J.M 1997. Cone penetration testing in geotechnical practice, E & FN Spon Routledge, 352 p, ISBN 0-7514-0393-8.
- Boulanger, R.W. and Idriss, I. M., 2007. Evaluation of Cyclic Softening in Silts and Clays. ASCE Journal of Geotechnical and Geoenvironmental Engineering June, Vol. 133, No. 6 pp 641-652
- Boulanger, R.W. and Idriss, I. M., 2014. CPT AND SPT BASED LIQUEFACTION TRIGGERING PROCEDURES. DEPARTMENT OF CIVIL & ENVIRONMENTAL ENGINEERING COLLEGE OF ENGINEERING UNIVERSITY OF CALIFORNIA AT DAVIS
- Robertson, P.K. and Cabal, K.L., 2007, Guide to Cone Penetration Testing for Geotechnical Engineering. Available at no cost at <http://www.geologismiki.gr/>
- Robertson, P.K. 1990. Soil classification using the cone penetration test. Canadian Geotechnical Journal, 27 (1), 151-8.
- Robertson, P.K. and Wride, C.E., 1998. Cyclic Liquefaction and its Evaluation based on the CPT Canadian Geotechnical Journal, 1998, Vol. 35, August.
- Youd, T.L., Idriss, I.M., Andrus, R.D., Arango, I., Castro, G., Christian, J.T., Dobry, R., Finn, W.D.L., Harder, L.F., Hynes, M.E., Ishihara, K., Koester, J., Liao, S., Marcuson III, W.F., Martin, G.R., Mitchell, J.K., Moriwaki, Y., Power, M.S., Robertson, P.K., Seed, R., and Stokoe, K.H., Liquefaction Resistance of Soils: Summary Report from the 1996 NCEER and 1998 NCEER/NSF Workshop on Evaluation of Liquefaction Resistance of Soils, ASCE, Journal of Geotechnical & Geoenvironmental Engineering, Vol. 127, October, pp 817-833
- Zhang, G., Robertson. P.K., Brachman, R., 2002, Estimating Liquefaction Induced Ground Settlements from the CPT, Canadian Geotechnical Journal, 39: pp 1168-1180
- Zhang, G., Robertson. P.K., Brachman, R., 2004, Estimating Liquefaction Induced Lateral Displacements using the SPT and CPT, ASCE, Journal of Geotechnical & Geoenvironmental Engineering, Vol. 130, No. 8, 861-871
- Pradel, D., 1998, Procedure to Evaluate Earthquake-Induced Settlements in Dry Sandy Soils, ASCE, Journal of Geotechnical & Geoenvironmental Engineering, Vol. 124, No. 4, 364-368
- Iwasaki, T., 1986, Soil liquefaction studies in Japan: state-of-the-art, Soil Dynamics and Earthquake Engineering, Vol. 5, No. 1, 2-70
- Papathanassiou G., 2008, LPI-based approach for calibrating the severity of liquefaction-induced failures and for assessing the probability of liquefaction surface evidence, Eng. Geol. 96:94–104
- P.K. Robertson, 2009, Interpretation of Cone Penetration Tests - a unified approach., Canadian Geotechnical Journal, Vol. 46, No. 11, pp 1337-1355
- P.K. Robertson, 2009. "Performance based earthquake design using the CPT", Keynote Lecture, International Conference on Performance-based Design in Earthquake Geotechnical Engineering - from case history to practice, IS-Tokyo, June 2009
- Robertson, P.K. and Lisheng, S., 2010, "Estimation of seismic compression in dry soils using the CPT" FIFTH INTERNATIONAL CONFERENCE ON RECENT ADVANCES IN GEOTECHNICAL EARTHQUAKE ENGINEERING AND SOIL DYNAMICS, *Symposium in honor of professor I. M. Idriss*, SAN diego, CA
- R. E. S. Moss, R. B. Seed, R. E. Kayen, J. P. Stewart, A. Der Kiureghian, K. O. Cetin, CPT-Based Probabilistic and Deterministic Assessment of In Situ Seismic Soil Liquefaction Potential, Journal of Geotechnical and Geoenvironmental Engineering, Vol. 132, No. 8, August 1, 2006
- I. M. Idriss and R. W. Boulanger, 2008. Soil liquefaction during earthquakes, Earthquake Engineering Research Institute MNO-12
- Jonathan D. Bray & Jorge Macedo, Department of Civil & Environmental Engineering, Univ. of California, Berkeley, CA, USA, Simplified procedure for estimating liquefaction-induced building settlement, *Proceedings of the 19th International Conference on Soil Mechanics and Geotechnical Engineering, Seoul 201*

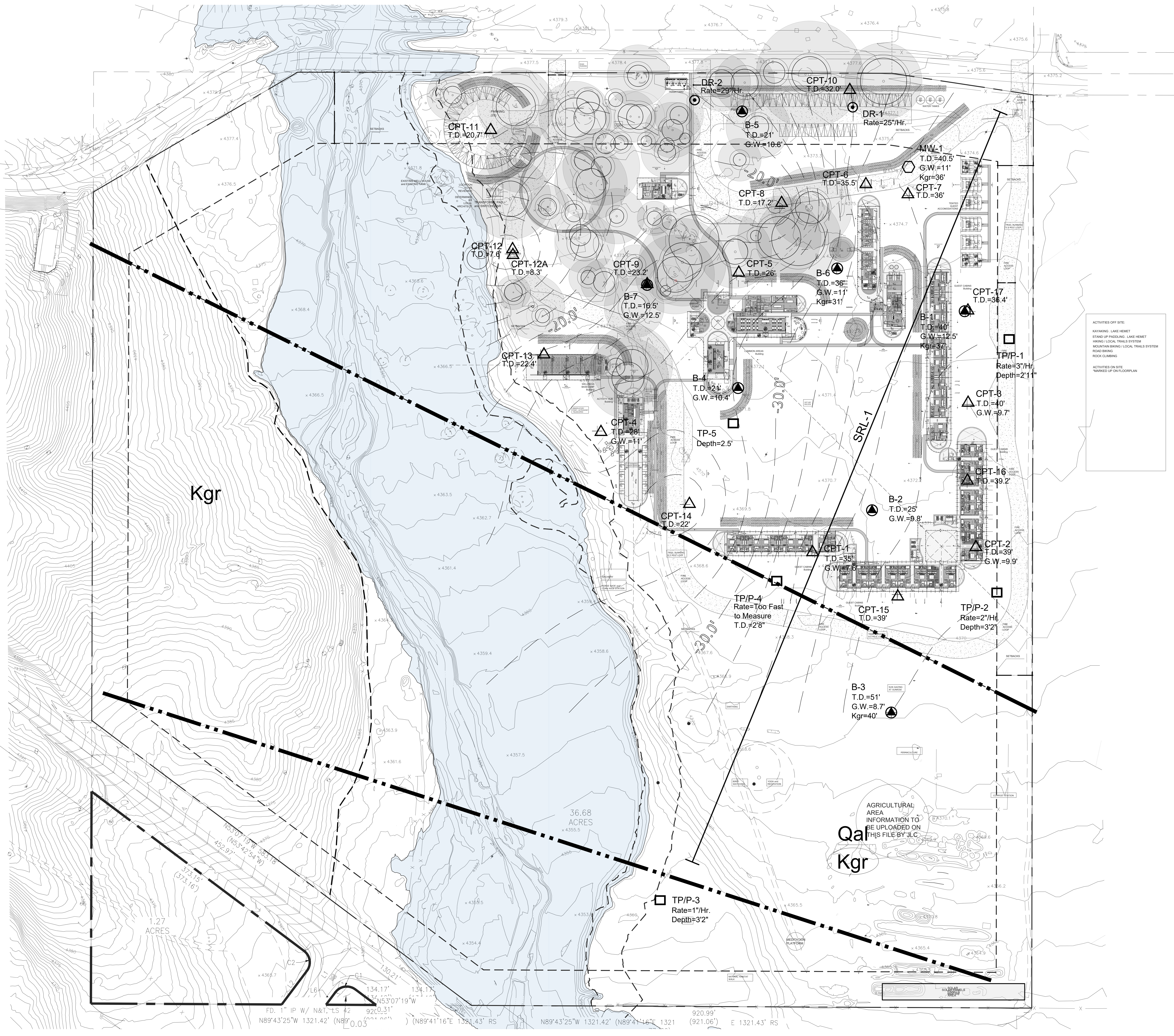

LEGEND	
B-1	Hollow Stem Auger (Petra, 2021)
TP/P-1	Backhoe Test Pit/Dual Ring Infiltrometer Test (Petra, 2021)
CPT-1	Cone Penetration Test (Petra, 2021)
DR-1	Dual Ring Infiltrometer (Petra, 2020)
MW-1	Monitoring Wells (Petra, 2021)
T.D.	Total Depth
G.W.	Ground Water
— —	Seismic Reflection Line
Qal	Alluvium
Kgr	Granitic Bedrock-Circled where buried
- - -	Geotechnical Contact
- - -	Bedrock Contours

Reference List of Base CAD files used provided by:
MCE, the design Architect.
received 7-20-2022

220720 TR.SD-Masterplan Ground Floor.dwg

ACTIVITIES OFF SITE:
KAYAKING, LAKE HEMET
STAND UP PADDLING, LAKE HEMET
HIKING, LOCAL TRAILS SYSTEM
MOUNTAIN BIKING, LOCAL TRAILS SYSTEM
ROAD BIKING
ROCK CLIMBING

ACTIVITIES ON SITE:
*MARKED UP ON FLOORPLAN

PETRA GEOSCIENCES, INC. 3186 Airway Avenue, Suite K Costa Mesa, California 92626 PHONE: (714) 549-8921 COSTA MESA TEMECULA VALENCIA PALM DESERT CORONA		
GEOTECHNICAL MAP		
The Ridge County of Riverside, CALIFORNIA		
DATE: July 2022	J.N: 20-227	PLATE 1

THE RIDGE PROJECT

SCHMATIC DESIGN PROJECT PHASE

JULY 1st 2022 DATE

MASTERPLAN GROUND FLOOR LEVEL PLAN NAME

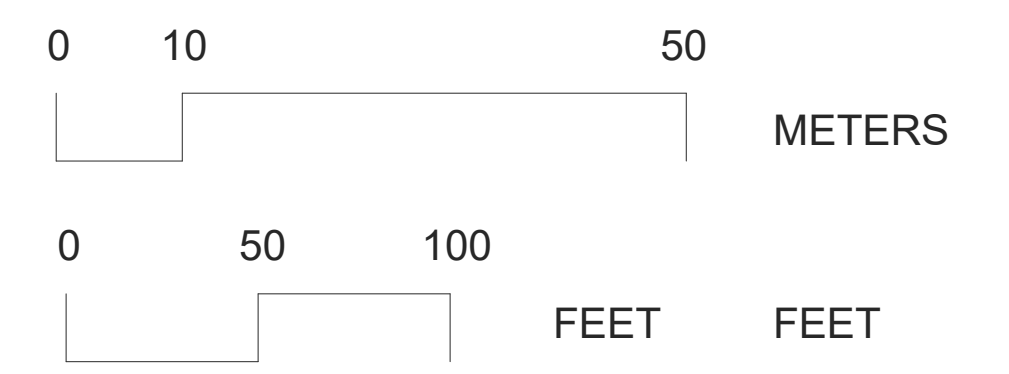

FD, 1" IP W/ N&T, LS 42
 N89°43'25"W 1321.42' (N89°0.03'
 N53°07'19"W 134.17'
 N53°07'19"W 134.11'
 N89°41'16"E 1321.43' RS
 N89°43'25"W 1321.42' (N89°41'16"E 1321
 920.99' (921.06') E 1321.43' RS

Appendix 4: Historical Site Conditions

Phase I Environmental Site Assessment or Other Information on Past Site Use

Appendix 5: LID Infeasibility

LID Technical Infeasibility Analysis

Project has implemented LID BMPs ; as a result, infeasibility analysis was not required..

Santa Ana Watershed - BMP Design Volume, V_{BMP}

(Rev. 10-2011)

Legend:



Required Entries

Calculated Cells

*(Note this worksheet shall **only** be used in conjunction with BMP designs from the **LID BMP Design Handbook**)*

Company Name **JLC Engineering and Consulting, Inc.**

Date **11/19/2022**

Designed by **SMT**

Case No

Company Project Number/Name

302.01.21

BMP Identification

BMP NAME / ID **Bioretention Basin 2**

Must match Name/ID used on BMP Design Calculation Sheet

Design Rainfall Depth

85th Percentile, 24-hour Rainfall Depth,
from the Isohyetal Map in Handbook Appendix E

$D_{85} =$ **0.90** inches

Drainage Management Area Tabulation

Insert additional rows if needed to accommodate all DMAs draining to the BMP

DMA Type/ID	DMA Area (square feet)	Post-Project Surface Type	Effective Imperivous Fraction, I_f	DMA Runoff Factor	DMA Areas x Runoff Factor	Design Storm Depth (in)	Design Capture Volume, V_{BMP} (cubic feet)	Proposed Volume on Plans (cubic feet)
DMA 1	29355	Roofs	1	0.89	26184.7	0.90	12155.7	12200
DMA 1	47963	Concrete or Asphalt	1	0.89	42783			
DMA 1	233264.8	Natural (A Soil)	0.03	0.06	14588.7			
DMA 4	29342.5	Natural (A Soil)	0.03	0.06	1835.1			
DMA 2	47855	Concrete or Asphalt	1	0.89	42686.7			
DMA 2	27879	Roofs	1	0.89	24868.1			
DMA 2	145986.4	Natural (A Soil)	0.03	0.06	9130.2			
561645.7		Total			162076.5	0.90	12155.7	12200

Notes:

Bioretention Facility - Design Procedure		BMP ID BMP 2	Legend:	Required Entries
				Calculated Cells
Company Name:	JLC Engineering & Consulting		Date:	
Designed by:	SMT		County/City Case No.:	
Design Volume				
Enter the area tributary to this feature			$A_T =$	12.9 acres
Enter V_{BMP} determined from Section 2.1 of this Handbook			$V_{BMP} =$	12,200 ft ³
Type of Bioretention Facility Design				
<input type="radio"/> Side slopes required (parallel to parking spaces or adjacent to walkways) <input checked="" type="radio"/> No side slopes required (perpendicular to parking space or Planter Boxes)				
Bioretention Facility Surface Area				
Depth of Soil Filter Media Layer			$d_S =$	1.5 ft
Top Width of Bioretention Facility, excluding curb			$w_T =$	20.0 ft
Total Effective Depth, d_E				
$d_E = [(0.3) \times d_S + (0.4) \times 1] + 0.5$			$d_E =$	1.35 ft
Minimum Surface Area, A_m				
$A_M (ft^2) = \frac{V_{BMP} (ft^3)}{d_E (ft)}$			$A_M =$	9,038 ft ²
Proposed Surface Area			$A =$	16,304 ft ²
Minimum Required Length of Bioretention Facility, L			$L =$	451.9 ft
Bioretention Facility Properties				
Side Slopes in Bioretention Facility			$z =$	4 :1
Diameter of Underdrain				6 inches
Longitudinal Slope of Site (3% maximum)				0.005 %
6" Check Dam Spacing				0 feet
Describe Vegetation:			Other	
Notes: BASIN TO BE PLANTED WITH CALIFORNIA NATIVE PLANS THAT ARE NATURAL TO SURROUNDING AREA.				

THE RIDGE - BASIN 1 VOLUME CALCULATION

Contour Elevation	Contour Area (sf)	Contour Area (ac)	Average Area (ac)	Incremental Volume (ac-ft) (ac-ft)	Total Basin Volume (ac-ft)
4362.0	16304.60	0.374		0	RESERVED FOR WQ UP TO 4362.5
			0.386		
4362.5	17299.05	0.397			0
			0.409		
4363.0	18293.50	0.420		0.409	0.41
			0.444		
4364.0	20359.2	0.467		0.444	0.85
			0.492		
4365.0	22504.40	0.517		0.492	1.34
			0.542		
4366.0	24728.4	0.568		0.542	1.89
			0.594		
4367.0	27031.26	0.621		0.594	2.48
			0.647		
4367	29342.5	0.674		0.647	3.13

WATER QUALITY VOLUME FOR DMA 1, 2 & DMA 4=12,200, REQUIRES BOTTOM AREA OF 9,038 SF.
 BASIN 2 BOTTOM AREA IS 16,304.6 BASED ON GRADING PLAN
 MITIGATION VOLUME = 1.3 AC-FT. PONDS AT 4365.0 FT

Appendix 6: BMP Design Details

BMP Sizing, Design Details and other Supporting Documentation

Appendix 7: Hydromodification

Supporting Detail Relating to Hydrologic Conditions of Concern

Basin 1 is designed to mitigate the increase in runoff from the 10-year, 24-hour storm and mitigate for hydromodifications.

The following are results from the unit hydrograph analysis of the 10-year, 24-hour storm event:

Area A	Area (ac)	10-Year, 24-Hour, Q (CFS)
Pre-Project	12.23	1.4
Post-Project	12.23	3.0
Delta	0	+1.6

The following were taken from the post-project unit hydrograph:

Time (hours+minutes)	Volume (acre-feet)	Flow rate (ft³/s)
8+40	0.4	1.4
16+05	1.7	1.4

The peak flow rate from the pre-project condition is 1.4 CFS. Before time 8+40 and after time 16+05 the flow rate is below 1.4 CFS for the post-project condition. The volume difference between these two times is 1.4 acre-feet (1.9-0.5=1.3).

Basin 1 has a mitigation storage volume of 3.1 acre-feet which exceeds the required volume of 1.4 acre-feet.

Unit Hydrograph Analysis

Copyright (c) CIVILCADD/CIVILDESIGN, 1989 - 2014, Version 9.0
Study date 02/16/23 File: ara2410.out

+++++

Riverside County Synthetic Unit Hydrology Method
RCFC & WCD Manual date - April 1978

Program License Serial Number 6279

English (in-lb) Input Units Used
English Rainfall Data (Inches) Input Values Used

English Units used in output format

302.01.21
AREA A
10 YR STORM
POST PROJECT

Drainage Area = 12.23(Ac.) = 0.019 Sq. Mi.
Drainage Area for Depth-Area Areal Adjustment = 12.23(Ac.) = 0.019
Sq. Mi.
Length along longest watercourse = 1105.90(Ft.)
Length along longest watercourse measured to centroid = 610.60(Ft.)
Length along longest watercourse = 0.209 Mi.
Length along longest watercourse measured to centroid = 0.116 Mi.
Difference in elevation = 9.50(Ft.)
Slope along watercourse = 45.3567 Ft./Mi.
Average Manning's 'N' = 0.025
Lag time = 0.071 Hr.
Lag time = 4.24 Min.
25% of lag time = 1.06 Min.
40% of lag time = 1.70 Min.
Unit time = 5.00 Min.
Duration of storm = 24 Hour(s)
User Entered Base Flow = 0.00(CFS)

2 YEAR Area rainfall data:

Area(Ac.) [1]	Rainfall(In) [2]	Weighting[1*2]
12.23	2.79	34.12

100 YEAR Area rainfall data:

Area(Ac.) [1]	Rainfall(In) [2]	Weighting[1*2]
12.23	7.72	94.42

STORM EVENT (YEAR) = 10.00
 Area Averaged 2-Year Rainfall = 2.790 (In)
 Area Averaged 100-Year Rainfall = 7.720 (In)

Point rain (area averaged) = 4.818 (In)
 Areal adjustment factor = 100.00 %
 Adjusted average point rain = 4.818 (In)

Sub-Area Data:

Area (Ac.)	Runoff Index	Impervious %
12.230	33.60	0.350
Total Area Entered = 12.23 (Ac.)		

RI	RI	Infil. Rate	Impervious	Adj. Infil. Rate	Area%	F
AMC2	AMC-2	(In/Hr)	(Dec.%)	(In/Hr)	(Dec.)	(In/Hr)
33.6	33.6	0.728	0.350	0.498	1.000	0.498
						Sum (F) = 0.498

Area averaged mean soil loss (F) (In/Hr) = 0.498
 Minimum soil loss rate ((In/Hr)) = 0.249
 (for 24 hour storm duration)
 Soil loss rate (decimal) = 0.620

Unit Hydrograph
 MOUNTAIN S-Curve

Unit Hydrograph Data

Unit time period (hrs)	Time % of lag	Distribution Graph %	Unit Hydrograph (CFS)
1	0.083	117.878	27.331
2	0.167	235.755	38.091
3	0.250	353.633	12.913
4	0.333	471.511	6.898
5	0.417	589.388	4.601
6	0.500	707.266	3.392
7	0.583	825.144	2.550
8	0.667	943.021	2.137
9	0.750	1060.899	2.087
		Sum = 100.000	Sum= 12.326

The following loss rate calculations reflect use of the minimum calculated loss rate subtracted from the Storm Rain to produce the maximum Effective Rain value

Unit Time (Hr.)	Pattern Percent	Storm Rain (In/Hr)	Loss rate (In./Hr)		Effective (In/Hr)
			Max	Low	
1	0.08	0.07	(0.884)	0.024	0.015
2	0.17	0.07	(0.880)	0.024	0.015
3	0.25	0.07	(0.877)	0.024	0.015
4	0.33	0.10	(0.873)	0.036	0.022
5	0.42	0.10	(0.870)	0.036	0.022
6	0.50	0.10	(0.867)	0.036	0.022
7	0.58	0.10	(0.863)	0.036	0.022
8	0.67	0.10	(0.860)	0.036	0.022
9	0.75	0.10	(0.856)	0.036	0.022
10	0.83	0.13	(0.853)	0.048	0.029

11	0.92	0.13	0.077	(0.850)	0.048	0.029
12	1.00	0.13	0.077	(0.846)	0.048	0.029
13	1.08	0.10	0.058	(0.843)	0.036	0.022
14	1.17	0.10	0.058	(0.840)	0.036	0.022
15	1.25	0.10	0.058	(0.836)	0.036	0.022
16	1.33	0.10	0.058	(0.833)	0.036	0.022
17	1.42	0.10	0.058	(0.830)	0.036	0.022
18	1.50	0.10	0.058	(0.826)	0.036	0.022
19	1.58	0.10	0.058	(0.823)	0.036	0.022
20	1.67	0.10	0.058	(0.820)	0.036	0.022
21	1.75	0.10	0.058	(0.816)	0.036	0.022
22	1.83	0.13	0.077	(0.813)	0.048	0.029
23	1.92	0.13	0.077	(0.810)	0.048	0.029
24	2.00	0.13	0.077	(0.807)	0.048	0.029
25	2.08	0.13	0.077	(0.803)	0.048	0.029
26	2.17	0.13	0.077	(0.800)	0.048	0.029
27	2.25	0.13	0.077	(0.797)	0.048	0.029
28	2.33	0.13	0.077	(0.794)	0.048	0.029
29	2.42	0.13	0.077	(0.790)	0.048	0.029
30	2.50	0.13	0.077	(0.787)	0.048	0.029
31	2.58	0.17	0.096	(0.784)	0.060	0.037
32	2.67	0.17	0.096	(0.781)	0.060	0.037
33	2.75	0.17	0.096	(0.778)	0.060	0.037
34	2.83	0.17	0.096	(0.774)	0.060	0.037
35	2.92	0.17	0.096	(0.771)	0.060	0.037
36	3.00	0.17	0.096	(0.768)	0.060	0.037
37	3.08	0.17	0.096	(0.765)	0.060	0.037
38	3.17	0.17	0.096	(0.762)	0.060	0.037
39	3.25	0.17	0.096	(0.758)	0.060	0.037
40	3.33	0.17	0.096	(0.755)	0.060	0.037
41	3.42	0.17	0.096	(0.752)	0.060	0.037
42	3.50	0.17	0.096	(0.749)	0.060	0.037
43	3.58	0.17	0.096	(0.746)	0.060	0.037
44	3.67	0.17	0.096	(0.743)	0.060	0.037
45	3.75	0.17	0.096	(0.740)	0.060	0.037
46	3.83	0.20	0.116	(0.736)	0.072	0.044
47	3.92	0.20	0.116	(0.733)	0.072	0.044
48	4.00	0.20	0.116	(0.730)	0.072	0.044
49	4.08	0.20	0.116	(0.727)	0.072	0.044
50	4.17	0.20	0.116	(0.724)	0.072	0.044
51	4.25	0.20	0.116	(0.721)	0.072	0.044
52	4.33	0.23	0.135	(0.718)	0.084	0.051
53	4.42	0.23	0.135	(0.715)	0.084	0.051
54	4.50	0.23	0.135	(0.712)	0.084	0.051
55	4.58	0.23	0.135	(0.709)	0.084	0.051
56	4.67	0.23	0.135	(0.706)	0.084	0.051
57	4.75	0.23	0.135	(0.703)	0.084	0.051
58	4.83	0.27	0.154	(0.700)	0.096	0.059
59	4.92	0.27	0.154	(0.697)	0.096	0.059
60	5.00	0.27	0.154	(0.694)	0.096	0.059
61	5.08	0.20	0.116	(0.691)	0.072	0.044
62	5.17	0.20	0.116	(0.688)	0.072	0.044
63	5.25	0.20	0.116	(0.685)	0.072	0.044
64	5.33	0.23	0.135	(0.682)	0.084	0.051
65	5.42	0.23	0.135	(0.679)	0.084	0.051
66	5.50	0.23	0.135	(0.676)	0.084	0.051
67	5.58	0.27	0.154	(0.673)	0.096	0.059
68	5.67	0.27	0.154	(0.670)	0.096	0.059
69	5.75	0.27	0.154	(0.667)	0.096	0.059
70	5.83	0.27	0.154	(0.664)	0.096	0.059

71	5.92	0.27	0.154	(0.661)	0.096	0.059
72	6.00	0.27	0.154	(0.658)	0.096	0.059
73	6.08	0.30	0.173	(0.655)	0.108	0.066
74	6.17	0.30	0.173	(0.652)	0.108	0.066
75	6.25	0.30	0.173	(0.649)	0.108	0.066
76	6.33	0.30	0.173	(0.646)	0.108	0.066
77	6.42	0.30	0.173	(0.643)	0.108	0.066
78	6.50	0.30	0.173	(0.640)	0.108	0.066
79	6.58	0.33	0.193	(0.638)	0.119	0.073
80	6.67	0.33	0.193	(0.635)	0.119	0.073
81	6.75	0.33	0.193	(0.632)	0.119	0.073
82	6.83	0.33	0.193	(0.629)	0.119	0.073
83	6.92	0.33	0.193	(0.626)	0.119	0.073
84	7.00	0.33	0.193	(0.623)	0.119	0.073
85	7.08	0.33	0.193	(0.620)	0.119	0.073
86	7.17	0.33	0.193	(0.618)	0.119	0.073
87	7.25	0.33	0.193	(0.615)	0.119	0.073
88	7.33	0.37	0.212	(0.612)	0.131	0.081
89	7.42	0.37	0.212	(0.609)	0.131	0.081
90	7.50	0.37	0.212	(0.606)	0.131	0.081
91	7.58	0.40	0.231	(0.604)	0.143	0.088
92	7.67	0.40	0.231	(0.601)	0.143	0.088
93	7.75	0.40	0.231	(0.598)	0.143	0.088
94	7.83	0.43	0.251	(0.595)	0.155	0.095
95	7.92	0.43	0.251	(0.593)	0.155	0.095
96	8.00	0.43	0.251	(0.590)	0.155	0.095
97	8.08	0.50	0.289	(0.587)	0.179	0.110
98	8.17	0.50	0.289	(0.584)	0.179	0.110
99	8.25	0.50	0.289	(0.582)	0.179	0.110
100	8.33	0.50	0.289	(0.579)	0.179	0.110
101	8.42	0.50	0.289	(0.576)	0.179	0.110
102	8.50	0.50	0.289	(0.574)	0.179	0.110
103	8.58	0.53	0.308	(0.571)	0.191	0.117
104	8.67	0.53	0.308	(0.568)	0.191	0.117
105	8.75	0.53	0.308	(0.565)	0.191	0.117
106	8.83	0.57	0.328	(0.563)	0.203	0.125
107	8.92	0.57	0.328	(0.560)	0.203	0.125
108	9.00	0.57	0.328	(0.557)	0.203	0.125
109	9.08	0.63	0.366	(0.555)	0.227	0.139
110	9.17	0.63	0.366	(0.552)	0.227	0.139
111	9.25	0.63	0.366	(0.550)	0.227	0.139
112	9.33	0.67	0.385	(0.547)	0.239	0.146
113	9.42	0.67	0.385	(0.544)	0.239	0.146
114	9.50	0.67	0.385	(0.542)	0.239	0.146
115	9.58	0.70	0.405	(0.539)	0.251	0.154
116	9.67	0.70	0.405	(0.537)	0.251	0.154
117	9.75	0.70	0.405	(0.534)	0.251	0.154
118	9.83	0.73	0.424	(0.531)	0.263	0.161
119	9.92	0.73	0.424	(0.529)	0.263	0.161
120	10.00	0.73	0.424	(0.526)	0.263	0.161
121	10.08	0.50	0.289	(0.524)	0.179	0.110
122	10.17	0.50	0.289	(0.521)	0.179	0.110
123	10.25	0.50	0.289	(0.519)	0.179	0.110
124	10.33	0.50	0.289	(0.516)	0.179	0.110
125	10.42	0.50	0.289	(0.514)	0.179	0.110
126	10.50	0.50	0.289	(0.511)	0.179	0.110
127	10.58	0.67	0.385	(0.509)	0.239	0.146
128	10.67	0.67	0.385	(0.506)	0.239	0.146
129	10.75	0.67	0.385	(0.504)	0.239	0.146
130	10.83	0.67	0.385	(0.501)	0.239	0.146

131	10.92	0.67	0.385	(0.499)	0.239	0.146
132	11.00	0.67	0.385	(0.496)	0.239	0.146
133	11.08	0.63	0.366	(0.494)	0.227	0.139
134	11.17	0.63	0.366	(0.491)	0.227	0.139
135	11.25	0.63	0.366	(0.489)	0.227	0.139
136	11.33	0.63	0.366	(0.487)	0.227	0.139
137	11.42	0.63	0.366	(0.484)	0.227	0.139
138	11.50	0.63	0.366	(0.482)	0.227	0.139
139	11.58	0.57	0.328	(0.479)	0.203	0.125
140	11.67	0.57	0.328	(0.477)	0.203	0.125
141	11.75	0.57	0.328	(0.475)	0.203	0.125
142	11.83	0.60	0.347	(0.472)	0.215	0.132
143	11.92	0.60	0.347	(0.470)	0.215	0.132
144	12.00	0.60	0.347	(0.468)	0.215	0.132
145	12.08	0.83	0.482	(0.465)	0.299	0.183
146	12.17	0.83	0.482	(0.463)	0.299	0.183
147	12.25	0.83	0.482	(0.461)	0.299	0.183
148	12.33	0.87	0.501	(0.458)	0.311	0.190
149	12.42	0.87	0.501	(0.456)	0.311	0.190
150	12.50	0.87	0.501	(0.454)	0.311	0.190
151	12.58	0.93	0.540	(0.451)	0.335	0.205
152	12.67	0.93	0.540	(0.449)	0.335	0.205
153	12.75	0.93	0.540	(0.447)	0.335	0.205
154	12.83	0.97	0.559	(0.445)	0.347	0.212
155	12.92	0.97	0.559	(0.442)	0.347	0.212
156	13.00	0.97	0.559	(0.440)	0.347	0.212
157	13.08	1.13	0.655	(0.438)	0.406	0.249
158	13.17	1.13	0.655	(0.436)	0.406	0.249
159	13.25	1.13	0.655	(0.433)	0.406	0.249
160	13.33	1.13	0.655	(0.431)	0.406	0.249
161	13.42	1.13	0.655	(0.429)	0.406	0.249
162	13.50	1.13	0.655	(0.427)	0.406	0.249
163	13.58	0.77	0.443	(0.425)	0.275	0.168
164	13.67	0.77	0.443	(0.423)	0.275	0.168
165	13.75	0.77	0.443	(0.420)	0.275	0.168
166	13.83	0.77	0.443	(0.418)	0.275	0.168
167	13.92	0.77	0.443	(0.416)	0.275	0.168
168	14.00	0.77	0.443	(0.414)	0.275	0.168
169	14.08	0.90	0.520	(0.412)	0.323	0.198
170	14.17	0.90	0.520	(0.410)	0.323	0.198
171	14.25	0.90	0.520	(0.408)	0.323	0.198
172	14.33	0.87	0.501	(0.406)	0.311	0.190
173	14.42	0.87	0.501	(0.404)	0.311	0.190
174	14.50	0.87	0.501	(0.401)	0.311	0.190
175	14.58	0.87	0.501	(0.399)	0.311	0.190
176	14.67	0.87	0.501	(0.397)	0.311	0.190
177	14.75	0.87	0.501	(0.395)	0.311	0.190
178	14.83	0.83	0.482	(0.393)	0.299	0.183
179	14.92	0.83	0.482	(0.391)	0.299	0.183
180	15.00	0.83	0.482	(0.389)	0.299	0.183
181	15.08	0.80	0.463	(0.387)	0.287	0.176
182	15.17	0.80	0.463	(0.385)	0.287	0.176
183	15.25	0.80	0.463	(0.383)	0.287	0.176
184	15.33	0.77	0.443	(0.381)	0.275	0.168
185	15.42	0.77	0.443	(0.379)	0.275	0.168
186	15.50	0.77	0.443	(0.377)	0.275	0.168
187	15.58	0.63	0.366	(0.376)	0.227	0.139
188	15.67	0.63	0.366	(0.374)	0.227	0.139
189	15.75	0.63	0.366	(0.372)	0.227	0.139
190	15.83	0.63	0.366	(0.370)	0.227	0.139

191	15.92	0.63	0.366	(0.368)	0.227	0.139
192	16.00	0.63	0.366	(0.366)	0.227	0.139
193	16.08	0.13	0.077	(0.364)	0.048	0.029
194	16.17	0.13	0.077	(0.362)	0.048	0.029
195	16.25	0.13	0.077	(0.360)	0.048	0.029
196	16.33	0.13	0.077	(0.359)	0.048	0.029
197	16.42	0.13	0.077	(0.357)	0.048	0.029
198	16.50	0.13	0.077	(0.355)	0.048	0.029
199	16.58	0.10	0.058	(0.353)	0.036	0.022
200	16.67	0.10	0.058	(0.351)	0.036	0.022
201	16.75	0.10	0.058	(0.350)	0.036	0.022
202	16.83	0.10	0.058	(0.348)	0.036	0.022
203	16.92	0.10	0.058	(0.346)	0.036	0.022
204	17.00	0.10	0.058	(0.344)	0.036	0.022
205	17.08	0.17	0.096	(0.343)	0.060	0.037
206	17.17	0.17	0.096	(0.341)	0.060	0.037
207	17.25	0.17	0.096	(0.339)	0.060	0.037
208	17.33	0.17	0.096	(0.337)	0.060	0.037
209	17.42	0.17	0.096	(0.336)	0.060	0.037
210	17.50	0.17	0.096	(0.334)	0.060	0.037
211	17.58	0.17	0.096	(0.332)	0.060	0.037
212	17.67	0.17	0.096	(0.331)	0.060	0.037
213	17.75	0.17	0.096	(0.329)	0.060	0.037
214	17.83	0.13	0.077	(0.327)	0.048	0.029
215	17.92	0.13	0.077	(0.326)	0.048	0.029
216	18.00	0.13	0.077	(0.324)	0.048	0.029
217	18.08	0.13	0.077	(0.323)	0.048	0.029
218	18.17	0.13	0.077	(0.321)	0.048	0.029
219	18.25	0.13	0.077	(0.319)	0.048	0.029
220	18.33	0.13	0.077	(0.318)	0.048	0.029
221	18.42	0.13	0.077	(0.316)	0.048	0.029
222	18.50	0.13	0.077	(0.315)	0.048	0.029
223	18.58	0.10	0.058	(0.313)	0.036	0.022
224	18.67	0.10	0.058	(0.312)	0.036	0.022
225	18.75	0.10	0.058	(0.310)	0.036	0.022
226	18.83	0.07	0.039	(0.309)	0.024	0.015
227	18.92	0.07	0.039	(0.307)	0.024	0.015
228	19.00	0.07	0.039	(0.306)	0.024	0.015
229	19.08	0.10	0.058	(0.304)	0.036	0.022
230	19.17	0.10	0.058	(0.303)	0.036	0.022
231	19.25	0.10	0.058	(0.302)	0.036	0.022
232	19.33	0.13	0.077	(0.300)	0.048	0.029
233	19.42	0.13	0.077	(0.299)	0.048	0.029
234	19.50	0.13	0.077	(0.297)	0.048	0.029
235	19.58	0.10	0.058	(0.296)	0.036	0.022
236	19.67	0.10	0.058	(0.295)	0.036	0.022
237	19.75	0.10	0.058	(0.293)	0.036	0.022
238	19.83	0.07	0.039	(0.292)	0.024	0.015
239	19.92	0.07	0.039	(0.291)	0.024	0.015
240	20.00	0.07	0.039	(0.289)	0.024	0.015
241	20.08	0.10	0.058	(0.288)	0.036	0.022
242	20.17	0.10	0.058	(0.287)	0.036	0.022
243	20.25	0.10	0.058	(0.286)	0.036	0.022
244	20.33	0.10	0.058	(0.284)	0.036	0.022
245	20.42	0.10	0.058	(0.283)	0.036	0.022
246	20.50	0.10	0.058	(0.282)	0.036	0.022
247	20.58	0.10	0.058	(0.281)	0.036	0.022
248	20.67	0.10	0.058	(0.280)	0.036	0.022
249	20.75	0.10	0.058	(0.278)	0.036	0.022
250	20.83	0.07	0.039	(0.277)	0.024	0.015

251	20.92	0.07	0.039	(0.276)	0.024	0.015
252	21.00	0.07	0.039	(0.275)	0.024	0.015
253	21.08	0.10	0.058	(0.274)	0.036	0.022
254	21.17	0.10	0.058	(0.273)	0.036	0.022
255	21.25	0.10	0.058	(0.272)	0.036	0.022
256	21.33	0.07	0.039	(0.271)	0.024	0.015
257	21.42	0.07	0.039	(0.270)	0.024	0.015
258	21.50	0.07	0.039	(0.269)	0.024	0.015
259	21.58	0.10	0.058	(0.268)	0.036	0.022
260	21.67	0.10	0.058	(0.267)	0.036	0.022
261	21.75	0.10	0.058	(0.266)	0.036	0.022
262	21.83	0.07	0.039	(0.265)	0.024	0.015
263	21.92	0.07	0.039	(0.264)	0.024	0.015
264	22.00	0.07	0.039	(0.263)	0.024	0.015
265	22.08	0.10	0.058	(0.262)	0.036	0.022
266	22.17	0.10	0.058	(0.261)	0.036	0.022
267	22.25	0.10	0.058	(0.261)	0.036	0.022
268	22.33	0.07	0.039	(0.260)	0.024	0.015
269	22.42	0.07	0.039	(0.259)	0.024	0.015
270	22.50	0.07	0.039	(0.258)	0.024	0.015
271	22.58	0.07	0.039	(0.257)	0.024	0.015
272	22.67	0.07	0.039	(0.257)	0.024	0.015
273	22.75	0.07	0.039	(0.256)	0.024	0.015
274	22.83	0.07	0.039	(0.255)	0.024	0.015
275	22.92	0.07	0.039	(0.255)	0.024	0.015
276	23.00	0.07	0.039	(0.254)	0.024	0.015
277	23.08	0.07	0.039	(0.254)	0.024	0.015
278	23.17	0.07	0.039	(0.253)	0.024	0.015
279	23.25	0.07	0.039	(0.252)	0.024	0.015
280	23.33	0.07	0.039	(0.252)	0.024	0.015
281	23.42	0.07	0.039	(0.251)	0.024	0.015
282	23.50	0.07	0.039	(0.251)	0.024	0.015
283	23.58	0.07	0.039	(0.251)	0.024	0.015
284	23.67	0.07	0.039	(0.250)	0.024	0.015
285	23.75	0.07	0.039	(0.250)	0.024	0.015
286	23.83	0.07	0.039	(0.250)	0.024	0.015
287	23.92	0.07	0.039	(0.249)	0.024	0.015
288	24.00	0.07	0.039	(0.249)	0.024	0.015

(Loss Rate Not Used)

Sum = 100.0 Sum = 22.0

Flood volume = Effective rainfall 1.83(In)
times area 12.2(Ac.) / [(In)/(Ft.)] = 1.9(Ac.Ft)

Total soil loss = 2.99(In)
Total soil loss = 3.044(Ac.Ft)
Total rainfall = 4.82(In)
Flood volume = 81282.1 Cubic Feet
Total soil loss = 132618.2 Cubic Feet

Peak flow rate of this hydrograph = 3.040(CFS)

+++++

24 - H O U R S T O R M
R u n o f f H y d r o g r a p h

Hydrograph in 5 Minute intervals ((CFS))

Time(h+m)	Volume Ac.Ft	Q(CFS)	0	2.5	5.0	7.5	10.0
0+ 5	0.0003	0.05	Q				

0+10	0.0012	0.12	Q
0+15	0.0021	0.14	Q
0+20	0.0034	0.18	Q
0+25	0.0049	0.22	Q
0+30	0.0065	0.24	Q
0+35	0.0083	0.25	Q
0+40	0.0100	0.26	VQ
0+45	0.0119	0.26	VQ
0+50	0.0139	0.29	VQ
0+55	0.0161	0.33	VQ
1+ 0	0.0185	0.34	VQ
1+ 5	0.0207	0.32	VQ
1+10	0.0227	0.29	VQ
1+15	0.0247	0.28	VQ
1+20	0.0266	0.28	VQ
1+25	0.0285	0.28	VQ
1+30	0.0304	0.28	VQ
1+35	0.0323	0.27	VQ
1+40	0.0342	0.27	VQ
1+45	0.0361	0.27	VQ
1+50	0.0381	0.30	VQ
1+55	0.0404	0.33	VQ
2+ 0	0.0427	0.34	VQ
2+ 5	0.0451	0.35	VQ
2+10	0.0476	0.35	Q
2+15	0.0500	0.36	Q
2+20	0.0525	0.36	Q
2+25	0.0549	0.36	Q
2+30	0.0574	0.36	Q
2+35	0.0601	0.39	Q
2+40	0.0630	0.42	Q
2+45	0.0660	0.43	Q
2+50	0.0690	0.44	Q
2+55	0.0720	0.44	Q
3+ 0	0.0751	0.45	Q
3+ 5	0.0782	0.45	Q
3+10	0.0813	0.45	Q
3+15	0.0844	0.45	Q
3+20	0.0875	0.45	Q
3+25	0.0906	0.45	Q
3+30	0.0937	0.45	QV
3+35	0.0968	0.45	QV
3+40	0.0999	0.45	QV
3+45	0.1030	0.45	QV
3+50	0.1063	0.48	QV
3+55	0.1098	0.51	Q
4+ 0	0.1134	0.52	Q
4+ 5	0.1171	0.53	Q
4+10	0.1207	0.53	Q
4+15	0.1244	0.54	Q
4+20	0.1283	0.56	Q
4+25	0.1324	0.60	Q
4+30	0.1366	0.61	Q
4+35	0.1409	0.62	QV
4+40	0.1452	0.62	QV
4+45	0.1495	0.63	QV
4+50	0.1540	0.65	QV
4+55	0.1588	0.69	QV
5+ 0	0.1636	0.70	QV
5+ 5	0.1681	0.66	QV

5+10	0.1722	0.60	QV			
5+15	0.1762	0.57	QV			
5+20	0.1803	0.59	QV			
5+25	0.1845	0.62	QV			
5+30	0.1888	0.62	Q V			
5+35	0.1933	0.65	Q V			
5+40	0.1980	0.69	Q V			
5+45	0.2028	0.70	Q V			
5+50	0.2077	0.71	Q V			
5+55	0.2126	0.71	Q V			
6+ 0	0.2175	0.72	Q V			
6+ 5	0.2226	0.74	Q V			
6+10	0.2280	0.78	QV			
6+15	0.2335	0.79	Q V			
6+20	0.2390	0.80	Q V			
6+25	0.2445	0.80	Q V			
6+30	0.2501	0.81	Q V			
6+35	0.2558	0.83	Q V			
6+40	0.2618	0.87	Q V			
6+45	0.2679	0.88	Q V			
6+50	0.2740	0.89	Q V			
6+55	0.2802	0.89	Q V			
7+ 0	0.2863	0.90	Q V			
7+ 5	0.2925	0.90	Q V			
7+10	0.2987	0.90	Q V			
7+15	0.3050	0.90	Q V			
7+20	0.3114	0.93	Q V			
7+25	0.3180	0.96	Q V			
7+30	0.3247	0.97	Q V			
7+35	0.3316	1.00	Q V			
7+40	0.3388	1.04	Q V			
7+45	0.3461	1.06	Q V			
7+50	0.3536	1.09	Q V			
7+55	0.3614	1.13	Q V			
8+ 0	0.3693	1.15	Q V			
8+ 5	0.3776	1.21	Q V			
8+10	0.3864	1.28	Q V			
8+15	0.3955	1.31	Q V			
8+20	0.4046	1.32	Q V			
8+25	0.4138	1.33	Q V			
8+30	0.4230	1.34	Q V			
8+35	0.4325	1.37	Q V			
8+40	0.4422	1.41	Q V			
8+45	0.4520	1.43	Q V			
8+50	0.4620	1.46	Q V			
8+55	0.4723	1.49	Q V			
9+ 0	0.4827	1.51	Q V			
9+ 5	0.4935	1.57	Q V			
9+10	0.5048	1.64	Q V			
9+15	0.5163	1.67	Q V			
9+20	0.5281	1.71	Q V			
9+25	0.5402	1.75	Q V			
9+30	0.5524	1.77	Q V			
9+35	0.5649	1.81	Q V			
9+40	0.5776	1.85	Q V			
9+45	0.5905	1.87	Q V			
9+50	0.6036	1.90	Q V			
9+55	0.6170	1.94	Q V			
10+ 0	0.6305	1.96	Q V			
10+ 5	0.6429	1.80	Q V			

10+10	0.6537	1.56	Q	V			
10+15	0.6639	1.49	Q	V			
10+20	0.6738	1.44	Q	V			
10+25	0.6836	1.42	Q	V			
10+30	0.6932	1.40	Q	V			
10+35	0.7036	1.50	Q	V			
10+40	0.7150	1.66	Q	V			
10+45	0.7268	1.71	Q	V			
10+50	0.7388	1.74	Q	V			
10+55	0.7509	1.76	Q	V			
11+ 0	0.7631	1.78	Q	V			
11+ 5	0.7753	1.76	Q	V			
11+10	0.7872	1.74	Q	V			
11+15	0.7992	1.74	Q	V			
11+20	0.8111	1.73	Q	V			
11+25	0.8230	1.73	Q	V			
11+30	0.8349	1.72	Q	V			
11+35	0.8464	1.67	Q	V			
11+40	0.8574	1.60	Q	V			
11+45	0.8682	1.57	Q	V			
11+50	0.8791	1.59	Q	V			
11+55	0.8903	1.61	Q	V			
12+ 0	0.9014	1.62	Q	V			
12+ 5	0.9137	1.79	Q	V			
12+10	0.9278	2.03	Q	V			
12+15	0.9423	2.11	Q	V			
12+20	0.9574	2.19	Q	V			
12+25	0.9729	2.25	Q	V			
12+30	0.9886	2.29	Q	V			
12+35	1.0048	2.36	Q	V			
12+40	1.0217	2.44	Q	V			
12+45	1.0388	2.48	Q	V			
12+50	1.0562	2.52	Q	V			
12+55	1.0738	2.57	Q	V			
13+ 0	1.0917	2.59	Q	V			
13+ 5	1.1104	2.72	Q	V			
13+10	1.1304	2.90	Q	V			
13+15	1.1508	2.97	Q	V			
13+20	1.1715	3.00	Q	V			
13+25	1.1923	3.02	Q	V			
13+30	1.2132	3.04	Q	V			
13+35	1.2324	2.78	Q	V			
13+40	1.2490	2.41	Q	V			
13+45	1.2648	2.29	Q	V			
13+50	1.2801	2.22	Q	V			
13+55	1.2951	2.18	Q	V			
14+ 0	1.3099	2.14	Q	V			
14+ 5	1.3251	2.22	Q	V			
14+10	1.3412	2.33	Q	V			
14+15	1.3575	2.36	Q	V			
14+20	1.3737	2.36	Q	V			
14+25	1.3899	2.34	Q	V			
14+30	1.4060	2.34	Q	V			
14+35	1.4222	2.35	Q	V			
14+40	1.4383	2.35	Q	V			
14+45	1.4546	2.35	Q	V			
14+50	1.4706	2.33	Q	V			
14+55	1.4864	2.29	Q	V			
15+ 0	1.5020	2.28	Q	V			
15+ 5	1.5175	2.25	Q	V			

15+10	1.5327	2.21		Q		V
15+15	1.5478	2.19		Q		V
15+20	1.5627	2.16		Q		V
15+25	1.5773	2.12		Q		V
15+30	1.5918	2.10		Q		V
15+35	1.6055	2.00		Q		V
15+40	1.6183	1.85		Q		V
15+45	1.6307	1.80		Q		V
15+50	1.6429	1.77		Q		V
15+55	1.6550	1.75		Q		V
16+ 0	1.6670	1.74		Q		V
16+ 5	1.6763	1.36		Q		V
16+10	1.6821	0.84		Q		V
16+15	1.6866	0.65		Q		V
16+20	1.6905	0.56		Q		V
16+25	1.6939	0.50		Q		V
16+30	1.6970	0.45		Q		V
16+35	1.6997	0.39		Q		V
16+40	1.7020	0.33		Q		V
16+45	1.7040	0.29		Q		V
16+50	1.7060	0.28		Q		V
16+55	1.7079	0.28		Q		V
17+ 0	1.7098	0.28		Q		V
17+ 5	1.7120	0.32		Q		V
17+10	1.7147	0.39		Q		V
17+15	1.7176	0.41		Q		V
17+20	1.7205	0.42		Q		V
17+25	1.7235	0.43		Q		V
17+30	1.7265	0.44		Q		V
17+35	1.7296	0.44		Q		V
17+40	1.7327	0.45		Q		V
17+45	1.7358	0.45		Q		V
17+50	1.7387	0.43		Q		V
17+55	1.7414	0.39		Q		V
18+ 0	1.7440	0.38		Q		V
18+ 5	1.7466	0.37		Q		V
18+10	1.7492	0.37		Q		V
18+15	1.7517	0.37		Q		V
18+20	1.7542	0.37		Q		V
18+25	1.7567	0.36		Q		V
18+30	1.7592	0.36		Q		V
18+35	1.7615	0.34		Q		V
18+40	1.7636	0.30		Q		V
18+45	1.7656	0.29		Q		V
18+50	1.7674	0.26		Q		V
18+55	1.7689	0.22		Q		V
19+ 0	1.7703	0.21		Q		V
19+ 5	1.7719	0.22		Q		V
19+10	1.7736	0.25		Q		V
19+15	1.7754	0.26		Q		V
19+20	1.7773	0.29		Q		V
19+25	1.7796	0.32		Q		V
19+30	1.7819	0.34		Q		V
19+35	1.7841	0.32		Q		V
19+40	1.7861	0.29		Q		V
19+45	1.7880	0.28		Q		V
19+50	1.7898	0.26		Q		V
19+55	1.7913	0.22		Q		V
20+ 0	1.7927	0.21		Q		V
20+ 5	1.7943	0.22		Q		V

20+10	1.7960	0.25	Q	V
20+15	1.7978	0.26	Q	V
20+20	1.7996	0.26	Q	V
20+25	1.8014	0.26	Q	V
20+30	1.8032	0.26	Q	V
20+35	1.8050	0.27	Q	V
20+40	1.8069	0.27	Q	V
20+45	1.8088	0.27	Q	V
20+50	1.8104	0.25	Q	V
20+55	1.8119	0.21	Q	V
21+ 0	1.8133	0.20	Q	V
21+ 5	1.8148	0.22	Q	V
21+10	1.8165	0.25	Q	V
21+15	1.8183	0.26	Q	V
21+20	1.8199	0.24	Q	V
21+25	1.8213	0.20	Q	V
21+30	1.8227	0.19	Q	V
21+35	1.8241	0.21	Q	V
21+40	1.8258	0.25	Q	V
21+45	1.8276	0.26	Q	V
21+50	1.8292	0.24	Q	V
21+55	1.8306	0.20	Q	V
22+ 0	1.8320	0.19	Q	V
22+ 5	1.8335	0.21	Q	V
22+10	1.8352	0.25	Q	V
22+15	1.8369	0.26	Q	V
22+20	1.8386	0.24	Q	V
22+25	1.8400	0.20	Q	V
22+30	1.8413	0.19	Q	V
22+35	1.8426	0.19	Q	V
22+40	1.8439	0.19	Q	V
22+45	1.8452	0.19	Q	V
22+50	1.8465	0.18	Q	V
22+55	1.8477	0.18	Q	V
23+ 0	1.8490	0.18	Q	V
23+ 5	1.8502	0.18	Q	V
23+10	1.8515	0.18	Q	V
23+15	1.8527	0.18	Q	V
23+20	1.8540	0.18	Q	V
23+25	1.8552	0.18	Q	V
23+30	1.8564	0.18	Q	V
23+35	1.8577	0.18	Q	V
23+40	1.8589	0.18	Q	V
23+45	1.8602	0.18	Q	V
23+50	1.8614	0.18	Q	V
23+55	1.8627	0.18	Q	V
24+ 0	1.8639	0.18	Q	V
24+ 5	1.8648	0.13	Q	V
24+10	1.8652	0.06	Q	V
24+15	1.8655	0.04	Q	V
24+20	1.8657	0.03	Q	V
24+25	1.8658	0.02	Q	V
24+30	1.8659	0.01	Q	V
24+35	1.8660	0.01	Q	V
24+40	1.8660	0.00	Q	V

Unit Hydrograph Analysis

Copyright (c) CIVILCADD/CIVILDESIGN, 1989 - 2014, Version 9.0
Study date 02/16/23 File: ara2410.out

+++++

Riverside County Synthetic Unit Hydrology Method
RCFC & WCD Manual date - April 1978

Program License Serial Number 6279

English (in-lb) Input Units Used
English Rainfall Data (Inches) Input Values Used

English Units used in output format

302.01.21
AREA A
10 YR STORM
PRE PROJECT

Drainage Area = 12.23(Ac.) = 0.019 Sq. Mi.
Drainage Area for Depth-Area Areal Adjustment = 12.23(Ac.) = 0.019
Sq. Mi.
Length along longest watercourse = 1105.90(Ft.)
Length along longest watercourse measured to centroid = 610.60(Ft.)
Length along longest watercourse = 0.209 Mi.
Length along longest watercourse measured to centroid = 0.116 Mi.
Difference in elevation = 9.50(Ft.)
Slope along watercourse = 45.3567 Ft./Mi.
Average Manning's 'N' = 0.040
Lag time = 0.113 Hr.
Lag time = 6.79 Min.
25% of lag time = 1.70 Min.
40% of lag time = 2.71 Min.
Unit time = 5.00 Min.
Duration of storm = 24 Hour(s)
User Entered Base Flow = 0.00(CFS)

2 YEAR Area rainfall data:

Area(Ac.) [1]	Rainfall(In) [2]	Weighting[1*2]
12.23	2.79	34.12

100 YEAR Area rainfall data:

Area(Ac.) [1]	Rainfall(In) [2]	Weighting[1*2]
12.23	7.72	94.42

STORM EVENT (YEAR) = 10.00
 Area Averaged 2-Year Rainfall = 2.790 (In)
 Area Averaged 100-Year Rainfall = 7.720 (In)

Point rain (area averaged) = 4.818 (In)
 Areal adjustment factor = 100.00 %
 Adjusted average point rain = 4.818 (In)

Sub-Area Data:

Area (Ac.)	Runoff Index	Impervious %
12.230	46.00	0.000
Total Area Entered = 12.23 (Ac.)		

RI	RI	Infil. Rate	Impervious	Adj. Infil. Rate	Area%	F
AMC2	AMC-2	(In/Hr)	(Dec.%)	(In/Hr)	(Dec.)	(In/Hr)
46.0	46.0	0.611	0.000	0.611	1.000	0.611
						Sum (F) = 0.611

Area averaged mean soil loss (F) (In/Hr) = 0.611
 Minimum soil loss rate ((In/Hr)) = 0.306
 (for 24 hour storm duration)
 Soil loss rate (decimal) = 0.900

 U n i t H y d r o g r a p h
 MOUNTAIN S-Curve

Unit Hydrograph Data

Unit time period (hrs)	Time % of lag	Distribution Graph %	Unit Hydrograph (CFS)
1	0.083	73.674	15.042
2	0.167	147.347	36.939
3	0.250	221.021	14.894
4	0.333	294.694	8.503
5	0.417	368.368	5.644
6	0.500	442.041	3.929
7	0.583	515.715	3.090
8	0.667	589.388	2.520
9	0.750	663.062	2.116
10	0.833	736.736	1.784
11	0.917	810.409	1.461
12	1.000	884.083	1.329
13	1.083	957.756	1.326
14	1.167	1031.430	1.423
		Sum = 100.000	Sum= 12.326

The following loss rate calculations reflect use of the minimum calculated loss rate subtracted from the Storm Rain to produce the maximum Effective Rain value

Unit Time (Hr.)	Pattern Percent	Storm Rain (In/Hr)	Loss rate (In./Hr) Max Low	Effective (In/Hr)
1	0.08	0.039	(1.083)	0.035
2	0.17	0.039	(1.079)	0.035
3	0.25	0.039	(1.075)	0.035
4	0.33	0.058	(1.071)	0.052
5	0.42	0.058	(1.067)	0.052

6	0.50	0.10	0.058	(1.063)	0.052	0.006
7	0.58	0.10	0.058	(1.058)	0.052	0.006
8	0.67	0.10	0.058	(1.054)	0.052	0.006
9	0.75	0.10	0.058	(1.050)	0.052	0.006
10	0.83	0.13	0.077	(1.046)	0.069	0.008
11	0.92	0.13	0.077	(1.042)	0.069	0.008
12	1.00	0.13	0.077	(1.038)	0.069	0.008
13	1.08	0.10	0.058	(1.034)	0.052	0.006
14	1.17	0.10	0.058	(1.030)	0.052	0.006
15	1.25	0.10	0.058	(1.026)	0.052	0.006
16	1.33	0.10	0.058	(1.021)	0.052	0.006
17	1.42	0.10	0.058	(1.017)	0.052	0.006
18	1.50	0.10	0.058	(1.013)	0.052	0.006
19	1.58	0.10	0.058	(1.009)	0.052	0.006
20	1.67	0.10	0.058	(1.005)	0.052	0.006
21	1.75	0.10	0.058	(1.001)	0.052	0.006
22	1.83	0.13	0.077	(0.997)	0.069	0.008
23	1.92	0.13	0.077	(0.993)	0.069	0.008
24	2.00	0.13	0.077	(0.989)	0.069	0.008
25	2.08	0.13	0.077	(0.985)	0.069	0.008
26	2.17	0.13	0.077	(0.981)	0.069	0.008
27	2.25	0.13	0.077	(0.977)	0.069	0.008
28	2.33	0.13	0.077	(0.973)	0.069	0.008
29	2.42	0.13	0.077	(0.969)	0.069	0.008
30	2.50	0.13	0.077	(0.965)	0.069	0.008
31	2.58	0.17	0.096	(0.961)	0.087	0.010
32	2.67	0.17	0.096	(0.957)	0.087	0.010
33	2.75	0.17	0.096	(0.953)	0.087	0.010
34	2.83	0.17	0.096	(0.950)	0.087	0.010
35	2.92	0.17	0.096	(0.946)	0.087	0.010
36	3.00	0.17	0.096	(0.942)	0.087	0.010
37	3.08	0.17	0.096	(0.938)	0.087	0.010
38	3.17	0.17	0.096	(0.934)	0.087	0.010
39	3.25	0.17	0.096	(0.930)	0.087	0.010
40	3.33	0.17	0.096	(0.926)	0.087	0.010
41	3.42	0.17	0.096	(0.922)	0.087	0.010
42	3.50	0.17	0.096	(0.918)	0.087	0.010
43	3.58	0.17	0.096	(0.915)	0.087	0.010
44	3.67	0.17	0.096	(0.911)	0.087	0.010
45	3.75	0.17	0.096	(0.907)	0.087	0.010
46	3.83	0.20	0.116	(0.903)	0.104	0.012
47	3.92	0.20	0.116	(0.899)	0.104	0.012
48	4.00	0.20	0.116	(0.895)	0.104	0.012
49	4.08	0.20	0.116	(0.892)	0.104	0.012
50	4.17	0.20	0.116	(0.888)	0.104	0.012
51	4.25	0.20	0.116	(0.884)	0.104	0.012
52	4.33	0.23	0.135	(0.880)	0.121	0.013
53	4.42	0.23	0.135	(0.877)	0.121	0.013
54	4.50	0.23	0.135	(0.873)	0.121	0.013
55	4.58	0.23	0.135	(0.869)	0.121	0.013
56	4.67	0.23	0.135	(0.865)	0.121	0.013
57	4.75	0.23	0.135	(0.862)	0.121	0.013
58	4.83	0.27	0.154	(0.858)	0.139	0.015
59	4.92	0.27	0.154	(0.854)	0.139	0.015
60	5.00	0.27	0.154	(0.850)	0.139	0.015
61	5.08	0.20	0.116	(0.847)	0.104	0.012
62	5.17	0.20	0.116	(0.843)	0.104	0.012
63	5.25	0.20	0.116	(0.839)	0.104	0.012
64	5.33	0.23	0.135	(0.836)	0.121	0.013
65	5.42	0.23	0.135	(0.832)	0.121	0.013

66	5.50	0.23	0.135	(0.828)	0.121	0.013
67	5.58	0.27	0.154	(0.825)	0.139	0.015
68	5.67	0.27	0.154	(0.821)	0.139	0.015
69	5.75	0.27	0.154	(0.818)	0.139	0.015
70	5.83	0.27	0.154	(0.814)	0.139	0.015
71	5.92	0.27	0.154	(0.810)	0.139	0.015
72	6.00	0.27	0.154	(0.807)	0.139	0.015
73	6.08	0.30	0.173	(0.803)	0.156	0.017
74	6.17	0.30	0.173	(0.800)	0.156	0.017
75	6.25	0.30	0.173	(0.796)	0.156	0.017
76	6.33	0.30	0.173	(0.792)	0.156	0.017
77	6.42	0.30	0.173	(0.789)	0.156	0.017
78	6.50	0.30	0.173	(0.785)	0.156	0.017
79	6.58	0.33	0.193	(0.782)	0.173	0.019
80	6.67	0.33	0.193	(0.778)	0.173	0.019
81	6.75	0.33	0.193	(0.775)	0.173	0.019
82	6.83	0.33	0.193	(0.771)	0.173	0.019
83	6.92	0.33	0.193	(0.768)	0.173	0.019
84	7.00	0.33	0.193	(0.764)	0.173	0.019
85	7.08	0.33	0.193	(0.761)	0.173	0.019
86	7.17	0.33	0.193	(0.757)	0.173	0.019
87	7.25	0.33	0.193	(0.754)	0.173	0.019
88	7.33	0.37	0.212	(0.751)	0.191	0.021
89	7.42	0.37	0.212	(0.747)	0.191	0.021
90	7.50	0.37	0.212	(0.744)	0.191	0.021
91	7.58	0.40	0.231	(0.740)	0.208	0.023
92	7.67	0.40	0.231	(0.737)	0.208	0.023
93	7.75	0.40	0.231	(0.733)	0.208	0.023
94	7.83	0.43	0.251	(0.730)	0.225	0.025
95	7.92	0.43	0.251	(0.727)	0.225	0.025
96	8.00	0.43	0.251	(0.723)	0.225	0.025
97	8.08	0.50	0.289	(0.720)	0.260	0.029
98	8.17	0.50	0.289	(0.717)	0.260	0.029
99	8.25	0.50	0.289	(0.713)	0.260	0.029
100	8.33	0.50	0.289	(0.710)	0.260	0.029
101	8.42	0.50	0.289	(0.707)	0.260	0.029
102	8.50	0.50	0.289	(0.703)	0.260	0.029
103	8.58	0.53	0.308	(0.700)	0.278	0.031
104	8.67	0.53	0.308	(0.697)	0.278	0.031
105	8.75	0.53	0.308	(0.693)	0.278	0.031
106	8.83	0.57	0.328	(0.690)	0.295	0.033
107	8.92	0.57	0.328	(0.687)	0.295	0.033
108	9.00	0.57	0.328	(0.684)	0.295	0.033
109	9.08	0.63	0.366	(0.680)	0.330	0.037
110	9.17	0.63	0.366	(0.677)	0.330	0.037
111	9.25	0.63	0.366	(0.674)	0.330	0.037
112	9.33	0.67	0.385	(0.671)	0.347	0.039
113	9.42	0.67	0.385	(0.668)	0.347	0.039
114	9.50	0.67	0.385	(0.664)	0.347	0.039
115	9.58	0.70	0.405	(0.661)	0.364	0.040
116	9.67	0.70	0.405	(0.658)	0.364	0.040
117	9.75	0.70	0.405	(0.655)	0.364	0.040
118	9.83	0.73	0.424	(0.652)	0.382	0.042
119	9.92	0.73	0.424	(0.649)	0.382	0.042
120	10.00	0.73	0.424	(0.645)	0.382	0.042
121	10.08	0.50	0.289	(0.642)	0.260	0.029
122	10.17	0.50	0.289	(0.639)	0.260	0.029
123	10.25	0.50	0.289	(0.636)	0.260	0.029
124	10.33	0.50	0.289	(0.633)	0.260	0.029
125	10.42	0.50	0.289	(0.630)	0.260	0.029

126	10.50	0.50	0.289	(0.627)	0.260	0.029
127	10.58	0.67	0.385	(0.624)	0.347	0.039
128	10.67	0.67	0.385	(0.621)	0.347	0.039
129	10.75	0.67	0.385	(0.618)	0.347	0.039
130	10.83	0.67	0.385	(0.615)	0.347	0.039
131	10.92	0.67	0.385	(0.612)	0.347	0.039
132	11.00	0.67	0.385	(0.609)	0.347	0.039
133	11.08	0.63	0.366	(0.606)	0.330	0.037
134	11.17	0.63	0.366	(0.603)	0.330	0.037
135	11.25	0.63	0.366	(0.600)	0.330	0.037
136	11.33	0.63	0.366	(0.597)	0.330	0.037
137	11.42	0.63	0.366	(0.594)	0.330	0.037
138	11.50	0.63	0.366	(0.591)	0.330	0.037
139	11.58	0.57	0.328	(0.588)	0.295	0.033
140	11.67	0.57	0.328	(0.585)	0.295	0.033
141	11.75	0.57	0.328	(0.582)	0.295	0.033
142	11.83	0.60	0.347	(0.579)	0.312	0.035
143	11.92	0.60	0.347	(0.576)	0.312	0.035
144	12.00	0.60	0.347	(0.573)	0.312	0.035
145	12.08	0.83	0.482	(0.571)	0.434	0.048
146	12.17	0.83	0.482	(0.568)	0.434	0.048
147	12.25	0.83	0.482	(0.565)	0.434	0.048
148	12.33	0.87	0.501	(0.562)	0.451	0.050
149	12.42	0.87	0.501	(0.559)	0.451	0.050
150	12.50	0.87	0.501	(0.556)	0.451	0.050
151	12.58	0.93	0.540	(0.554)	0.486	0.054
152	12.67	0.93	0.540	(0.551)	0.486	0.054
153	12.75	0.93	0.540	(0.548)	0.486	0.054
154	12.83	0.97	0.559	(0.545)	0.503	0.056
155	12.92	0.97	0.559	(0.542)	0.503	0.056
156	13.00	0.97	0.559	(0.540)	0.503	0.056
157	13.08	1.13	0.655	0.537 (0.590)		0.118
158	13.17	1.13	0.655	0.534 (0.590)		0.121
159	13.25	1.13	0.655	0.532 (0.590)		0.124
160	13.33	1.13	0.655	0.529 (0.590)		0.126
161	13.42	1.13	0.655	0.526 (0.590)		0.129
162	13.50	1.13	0.655	0.524 (0.590)		0.132
163	13.58	0.77	0.443	(0.521)	0.399	0.044
164	13.67	0.77	0.443	(0.518)	0.399	0.044
165	13.75	0.77	0.443	(0.516)	0.399	0.044
166	13.83	0.77	0.443	(0.513)	0.399	0.044
167	13.92	0.77	0.443	(0.510)	0.399	0.044
168	14.00	0.77	0.443	(0.508)	0.399	0.044
169	14.08	0.90	0.520	(0.505)	0.468	0.052
170	14.17	0.90	0.520	(0.503)	0.468	0.052
171	14.25	0.90	0.520	(0.500)	0.468	0.052
172	14.33	0.87	0.501	(0.497)	0.451	0.050
173	14.42	0.87	0.501	(0.495)	0.451	0.050
174	14.50	0.87	0.501	(0.492)	0.451	0.050
175	14.58	0.87	0.501	(0.490)	0.451	0.050
176	14.67	0.87	0.501	(0.487)	0.451	0.050
177	14.75	0.87	0.501	(0.485)	0.451	0.050
178	14.83	0.83	0.482	(0.482)	0.434	0.048
179	14.92	0.83	0.482	(0.480)	0.434	0.048
180	15.00	0.83	0.482	(0.477)	0.434	0.048
181	15.08	0.80	0.463	(0.475)	0.416	0.046
182	15.17	0.80	0.463	(0.472)	0.416	0.046
183	15.25	0.80	0.463	(0.470)	0.416	0.046
184	15.33	0.77	0.443	(0.468)	0.399	0.044
185	15.42	0.77	0.443	(0.465)	0.399	0.044

186	15.50	0.77	0.443	(0.463)	0.399	0.044
187	15.58	0.63	0.366	(0.460)	0.330	0.037
188	15.67	0.63	0.366	(0.458)	0.330	0.037
189	15.75	0.63	0.366	(0.456)	0.330	0.037
190	15.83	0.63	0.366	(0.453)	0.330	0.037
191	15.92	0.63	0.366	(0.451)	0.330	0.037
192	16.00	0.63	0.366	(0.449)	0.330	0.037
193	16.08	0.13	0.077	(0.447)	0.069	0.008
194	16.17	0.13	0.077	(0.444)	0.069	0.008
195	16.25	0.13	0.077	(0.442)	0.069	0.008
196	16.33	0.13	0.077	(0.440)	0.069	0.008
197	16.42	0.13	0.077	(0.437)	0.069	0.008
198	16.50	0.13	0.077	(0.435)	0.069	0.008
199	16.58	0.10	0.058	(0.433)	0.052	0.006
200	16.67	0.10	0.058	(0.431)	0.052	0.006
201	16.75	0.10	0.058	(0.429)	0.052	0.006
202	16.83	0.10	0.058	(0.426)	0.052	0.006
203	16.92	0.10	0.058	(0.424)	0.052	0.006
204	17.00	0.10	0.058	(0.422)	0.052	0.006
205	17.08	0.17	0.096	(0.420)	0.087	0.010
206	17.17	0.17	0.096	(0.418)	0.087	0.010
207	17.25	0.17	0.096	(0.416)	0.087	0.010
208	17.33	0.17	0.096	(0.414)	0.087	0.010
209	17.42	0.17	0.096	(0.412)	0.087	0.010
210	17.50	0.17	0.096	(0.410)	0.087	0.010
211	17.58	0.17	0.096	(0.408)	0.087	0.010
212	17.67	0.17	0.096	(0.406)	0.087	0.010
213	17.75	0.17	0.096	(0.404)	0.087	0.010
214	17.83	0.13	0.077	(0.402)	0.069	0.008
215	17.92	0.13	0.077	(0.400)	0.069	0.008
216	18.00	0.13	0.077	(0.398)	0.069	0.008
217	18.08	0.13	0.077	(0.396)	0.069	0.008
218	18.17	0.13	0.077	(0.394)	0.069	0.008
219	18.25	0.13	0.077	(0.392)	0.069	0.008
220	18.33	0.13	0.077	(0.390)	0.069	0.008
221	18.42	0.13	0.077	(0.388)	0.069	0.008
222	18.50	0.13	0.077	(0.386)	0.069	0.008
223	18.58	0.10	0.058	(0.384)	0.052	0.006
224	18.67	0.10	0.058	(0.382)	0.052	0.006
225	18.75	0.10	0.058	(0.380)	0.052	0.006
226	18.83	0.07	0.039	(0.379)	0.035	0.004
227	18.92	0.07	0.039	(0.377)	0.035	0.004
228	19.00	0.07	0.039	(0.375)	0.035	0.004
229	19.08	0.10	0.058	(0.373)	0.052	0.006
230	19.17	0.10	0.058	(0.372)	0.052	0.006
231	19.25	0.10	0.058	(0.370)	0.052	0.006
232	19.33	0.13	0.077	(0.368)	0.069	0.008
233	19.42	0.13	0.077	(0.366)	0.069	0.008
234	19.50	0.13	0.077	(0.365)	0.069	0.008
235	19.58	0.10	0.058	(0.363)	0.052	0.006
236	19.67	0.10	0.058	(0.361)	0.052	0.006
237	19.75	0.10	0.058	(0.360)	0.052	0.006
238	19.83	0.07	0.039	(0.358)	0.035	0.004
239	19.92	0.07	0.039	(0.356)	0.035	0.004
240	20.00	0.07	0.039	(0.355)	0.035	0.004
241	20.08	0.10	0.058	(0.353)	0.052	0.006
242	20.17	0.10	0.058	(0.352)	0.052	0.006
243	20.25	0.10	0.058	(0.350)	0.052	0.006
244	20.33	0.10	0.058	(0.349)	0.052	0.006
245	20.42	0.10	0.058	(0.347)	0.052	0.006

246	20.50	0.10	0.058	(0.346)	0.052	0.006
247	20.58	0.10	0.058	(0.344)	0.052	0.006
248	20.67	0.10	0.058	(0.343)	0.052	0.006
249	20.75	0.10	0.058	(0.341)	0.052	0.006
250	20.83	0.07	0.039	(0.340)	0.035	0.004
251	20.92	0.07	0.039	(0.339)	0.035	0.004
252	21.00	0.07	0.039	(0.337)	0.035	0.004
253	21.08	0.10	0.058	(0.336)	0.052	0.006
254	21.17	0.10	0.058	(0.335)	0.052	0.006
255	21.25	0.10	0.058	(0.333)	0.052	0.006
256	21.33	0.07	0.039	(0.332)	0.035	0.004
257	21.42	0.07	0.039	(0.331)	0.035	0.004
258	21.50	0.07	0.039	(0.330)	0.035	0.004
259	21.58	0.10	0.058	(0.328)	0.052	0.006
260	21.67	0.10	0.058	(0.327)	0.052	0.006
261	21.75	0.10	0.058	(0.326)	0.052	0.006
262	21.83	0.07	0.039	(0.325)	0.035	0.004
263	21.92	0.07	0.039	(0.324)	0.035	0.004
264	22.00	0.07	0.039	(0.323)	0.035	0.004
265	22.08	0.10	0.058	(0.322)	0.052	0.006
266	22.17	0.10	0.058	(0.321)	0.052	0.006
267	22.25	0.10	0.058	(0.320)	0.052	0.006
268	22.33	0.07	0.039	(0.319)	0.035	0.004
269	22.42	0.07	0.039	(0.318)	0.035	0.004
270	22.50	0.07	0.039	(0.317)	0.035	0.004
271	22.58	0.07	0.039	(0.316)	0.035	0.004
272	22.67	0.07	0.039	(0.315)	0.035	0.004
273	22.75	0.07	0.039	(0.314)	0.035	0.004
274	22.83	0.07	0.039	(0.313)	0.035	0.004
275	22.92	0.07	0.039	(0.312)	0.035	0.004
276	23.00	0.07	0.039	(0.312)	0.035	0.004
277	23.08	0.07	0.039	(0.311)	0.035	0.004
278	23.17	0.07	0.039	(0.310)	0.035	0.004
279	23.25	0.07	0.039	(0.310)	0.035	0.004
280	23.33	0.07	0.039	(0.309)	0.035	0.004
281	23.42	0.07	0.039	(0.308)	0.035	0.004
282	23.50	0.07	0.039	(0.308)	0.035	0.004
283	23.58	0.07	0.039	(0.307)	0.035	0.004
284	23.67	0.07	0.039	(0.307)	0.035	0.004
285	23.75	0.07	0.039	(0.306)	0.035	0.004
286	23.83	0.07	0.039	(0.306)	0.035	0.004
287	23.92	0.07	0.039	(0.306)	0.035	0.004
288	24.00	0.07	0.039	(0.306)	0.035	0.004

(Loss Rate Not Used)

Sum = 100.0 Sum = 6.1

Flood volume = Effective rainfall 0.51 (In)
times area 12.2 (Ac.) / [(In) / (Ft.)] = 0.5 (Ac.Ft)
Total soil loss = 4.31 (In)
Total soil loss = 4.389 (Ac.Ft)
Total rainfall = 4.82 (In)
Flood volume = 22710.9 Cubic Feet
Total soil loss = 191189.4 Cubic Feet

Peak flow rate of this hydrograph = 1.436 (CFS)

+++++

24 - H O U R S T O R M
R u n o f f H y d r o g r a p h

Hydrograph in 5 Minute intervals ((CFS))

Time(h+m)	Volume	Ac.Ft	Q(CFS)	0	2.5	5.0	7.5	10.0
0+ 5	0.0000		0.01	Q				
0+10	0.0002		0.02	Q				
0+15	0.0004		0.03	Q				
0+20	0.0007		0.04	Q				
0+25	0.0011		0.05	Q				
0+30	0.0014		0.06	Q				
0+35	0.0019		0.06	Q				
0+40	0.0023		0.06	Q				
0+45	0.0027		0.06	Q				
0+50	0.0032		0.07	Q				
0+55	0.0038		0.08	Q				
1+ 0	0.0043		0.08	Q				
1+ 5	0.0049		0.08	Q				
1+10	0.0054		0.08	Q				
1+15	0.0060		0.07	Q				
1+20	0.0065		0.07	Q				
1+25	0.0070		0.07	Q				
1+30	0.0075		0.07	Q				
1+35	0.0080		0.07	Q				
1+40	0.0085		0.07	Q				
1+45	0.0090		0.07	Q				
1+50	0.0095		0.08	Q				
1+55	0.0101		0.08	Q				
2+ 0	0.0107		0.09	Q				
2+ 5	0.0113		0.09	Q				
2+10	0.0119		0.09	Q				
2+15	0.0126		0.09	Q				
2+20	0.0132		0.09	QV				
2+25	0.0138		0.09	QV				
2+30	0.0145		0.09	QV				
2+35	0.0151		0.10	QV				
2+40	0.0159		0.11	QV				
2+45	0.0166		0.11	QV				
2+50	0.0174		0.11	QV				
2+55	0.0182		0.11	QV				
3+ 0	0.0190		0.12	QV				
3+ 5	0.0198		0.12	QV				
3+10	0.0206		0.12	QV				
3+15	0.0214		0.12	QV				
3+20	0.0222		0.12	QV				
3+25	0.0230		0.12	QV				
3+30	0.0238		0.12	QV				
3+35	0.0247		0.12	QV				
3+40	0.0255		0.12	QV				
3+45	0.0263		0.12	Q V				
3+50	0.0271		0.12	Q V				
3+55	0.0280		0.13	Q V				
4+ 0	0.0290		0.13	Q V				
4+ 5	0.0299		0.14	Q V				
4+10	0.0309		0.14	Q V				
4+15	0.0318		0.14	Q V				
4+20	0.0328		0.14	Q V				
4+25	0.0339		0.15	Q V				
4+30	0.0349		0.16	Q V				
4+35	0.0360		0.16	Q V				
4+40	0.0371		0.16	Q V				

4+45	0.0383	0.16	Q	V
4+50	0.0394	0.17	Q	V
4+55	0.0406	0.18	Q	V
5+ 0	0.0419	0.18	Q	V
5+ 5	0.0431	0.18	Q	V
5+10	0.0442	0.16	Q	V
5+15	0.0452	0.15	Q	V
5+20	0.0463	0.15	Q	V
5+25	0.0474	0.16	Q	V
5+30	0.0485	0.16	Q	V
5+35	0.0497	0.17	Q	V
5+40	0.0509	0.18	Q	V
5+45	0.0522	0.18	Q	V
5+50	0.0534	0.18	Q	V
5+55	0.0547	0.19	Q	V
6+ 0	0.0560	0.19	Q	V
6+ 5	0.0573	0.19	Q	V
6+10	0.0587	0.20	Q	V
6+15	0.0601	0.20	Q	V
6+20	0.0615	0.21	Q	V
6+25	0.0629	0.21	Q	V
6+30	0.0644	0.21	Q	V
6+35	0.0659	0.21	Q	V
6+40	0.0674	0.22	Q	V
6+45	0.0690	0.23	Q	V
6+50	0.0706	0.23	Q	V
6+55	0.0722	0.23	Q	V
7+ 0	0.0738	0.23	Q	V
7+ 5	0.0754	0.23	Q	V
7+10	0.0770	0.24	Q	V
7+15	0.0786	0.24	Q	V
7+20	0.0803	0.24	Q	V
7+25	0.0820	0.25	Q	V
7+30	0.0837	0.25	Q	V
7+35	0.0855	0.26	Q	V
7+40	0.0874	0.27	Q	V
7+45	0.0893	0.27	Q	V
7+50	0.0912	0.28	Q	V
7+55	0.0932	0.29	Q	V
8+ 0	0.0952	0.30	Q	V
8+ 5	0.0973	0.31	Q	V
8+10	0.0996	0.33	Q	V
8+15	0.1019	0.33	Q	V
8+20	0.1042	0.34	Q	V
8+25	0.1066	0.34	Q	V
8+30	0.1090	0.35	Q	V
8+35	0.1114	0.35	Q	V
8+40	0.1139	0.36	Q	V
8+45	0.1165	0.37	Q	V
8+50	0.1190	0.38	Q	V
8+55	0.1217	0.39	Q	V
9+ 0	0.1244	0.39	Q	V
9+ 5	0.1272	0.40	Q	V
9+10	0.1301	0.42	Q	V
9+15	0.1330	0.43	Q	V
9+20	0.1361	0.44	Q	V
9+25	0.1392	0.45	Q	V
9+30	0.1423	0.46	Q	V
9+35	0.1455	0.47	Q	V
9+40	0.1488	0.48	Q	V

9+45	0.1522	0.48	Q	V					
9+50	0.1555	0.49	Q	V					
9+55	0.1590	0.50	Q	V					
10+ 0	0.1625	0.51	Q	V					
10+ 5	0.1659	0.49	Q	V					
10+10	0.1688	0.43	Q	V					
10+15	0.1716	0.41	Q	V					
10+20	0.1743	0.39	Q	V					
10+25	0.1770	0.38	Q	V					
10+30	0.1796	0.38	Q	V					
10+35	0.1823	0.39	Q	V					
10+40	0.1853	0.43	Q	V					
10+45	0.1883	0.45	Q	V					
10+50	0.1915	0.45	Q	V					
10+55	0.1946	0.46	Q	V					
11+ 0	0.1978	0.46	Q	V					
11+ 5	0.2010	0.46	Q	V					
11+10	0.2041	0.45	Q	V					
11+15	0.2072	0.45	Q	V					
11+20	0.2103	0.45	Q	V					
11+25	0.2134	0.45	Q	V					
11+30	0.2165	0.45	Q	V					
11+35	0.2196	0.45	Q	V					
11+40	0.2226	0.43	Q	V					
11+45	0.2255	0.42	Q	V					
11+50	0.2284	0.42	Q	V					
11+55	0.2313	0.43	Q	V					
12+ 0	0.2342	0.43	Q	V					
12+ 5	0.2374	0.45	Q	V					
12+10	0.2409	0.51	Q	V					
12+15	0.2446	0.54	Q	V					
12+20	0.2484	0.56	Q	V					
12+25	0.2524	0.57	Q	V					
12+30	0.2564	0.58	Q	V					
12+35	0.2605	0.60	Q	V					
12+40	0.2648	0.62	Q	V					
12+45	0.2692	0.63	Q	V					
12+50	0.2736	0.64	Q	V					
12+55	0.2782	0.66	Q	V					
13+ 0	0.2828	0.67	Q	V					
13+ 5	0.2882	0.79	Q	V					
13+10	0.2957	1.08	Q	V					
13+15	0.3041	1.22	Q	V					
13+20	0.3131	1.31	Q	V					
13+25	0.3226	1.38	Q	V					
13+30	0.3325	1.44	Q	V					
13+35	0.3416	1.32	Q	V					
13+40	0.3482	0.96	Q	V					
13+45	0.3538	0.82	Q	V					
13+50	0.3590	0.75	Q	V					
13+55	0.3638	0.70	Q	V					
14+ 0	0.3685	0.68	Q	V					
14+ 5	0.3731	0.67	Q	V					
14+10	0.3778	0.69	Q	V					
14+15	0.3825	0.68	Q	V					
14+20	0.3872	0.67	Q	V					
14+25	0.3917	0.65	Q	V					
14+30	0.3961	0.64	Q	V					
14+35	0.4004	0.63	Q	V					
14+40	0.4046	0.61	Q	V					

14+45	0.4089	0.61	Q			V
14+50	0.4131	0.61	Q			V
14+55	0.4172	0.60	Q			V
15+ 0	0.4214	0.60	Q			V
15+ 5	0.4255	0.60	Q			V
15+10	0.4295	0.59	Q			V
15+15	0.4335	0.58	Q			V
15+20	0.4375	0.58	Q			V
15+25	0.4414	0.56	Q			V
15+30	0.4453	0.56	Q			V
15+35	0.4490	0.54	Q			V
15+40	0.4525	0.50	Q			V
15+45	0.4558	0.49	Q			V
15+50	0.4591	0.48	Q			V
15+55	0.4624	0.47	Q			V
16+ 0	0.4656	0.47	Q			V
16+ 5	0.4684	0.41	Q			V
16+10	0.4703	0.28	Q			V
16+15	0.4719	0.22	Q			V
16+20	0.4732	0.19	Q			V
16+25	0.4743	0.17	Q			V
16+30	0.4754	0.15	Q			V
16+35	0.4763	0.14	Q			V
16+40	0.4771	0.12	Q			V
16+45	0.4778	0.11	Q			V
16+50	0.4785	0.10	Q			V
16+55	0.4791	0.09	Q			V
17+ 0	0.4797	0.08	Q			V
17+ 5	0.4803	0.09	Q			V
17+10	0.4810	0.10	Q			V
17+15	0.4817	0.10	Q			V
17+20	0.4824	0.11	Q			V
17+25	0.4832	0.11	Q			V
17+30	0.4840	0.11	Q			V
17+35	0.4847	0.11	Q			V
17+40	0.4855	0.11	Q			V
17+45	0.4863	0.12	Q			V
17+50	0.4871	0.11	Q			V
17+55	0.4878	0.10	Q			V
18+ 0	0.4885	0.10	Q			V
18+ 5	0.4892	0.10	Q			V
18+10	0.4899	0.10	Q			V
18+15	0.4906	0.10	Q			V
18+20	0.4913	0.10	Q			V
18+25	0.4919	0.10	Q			V
18+30	0.4926	0.10	Q			V
18+35	0.4932	0.09	Q			V
18+40	0.4938	0.08	Q			V
18+45	0.4944	0.08	Q			V
18+50	0.4949	0.07	Q			V
18+55	0.4953	0.06	Q			V
19+ 0	0.4957	0.06	Q			V
19+ 5	0.4961	0.06	Q			V
19+10	0.4966	0.07	Q			V
19+15	0.4971	0.07	Q			V
19+20	0.4976	0.07	Q			V
19+25	0.4981	0.08	Q			V
19+30	0.4987	0.09	Q			V
19+35	0.4993	0.08	Q			V
19+40	0.4998	0.08	Q			V

19+45	0.5003	0.07	Q	V
19+50	0.5008	0.07	Q	V
19+55	0.5012	0.06	Q	V
20+ 0	0.5016	0.06	Q	V
20+ 5	0.5020	0.06	Q	V
20+10	0.5025	0.07	Q	V
20+15	0.5029	0.07	Q	V
20+20	0.5034	0.07	Q	V
20+25	0.5039	0.07	Q	V
20+30	0.5044	0.07	Q	V
20+35	0.5049	0.07	Q	V
20+40	0.5054	0.07	Q	V
20+45	0.5058	0.07	Q	V
20+50	0.5063	0.07	Q	V
20+55	0.5067	0.06	Q	V
21+ 0	0.5071	0.05	Q	V
21+ 5	0.5075	0.06	Q	V
21+10	0.5079	0.06	Q	V
21+15	0.5084	0.07	Q	V
21+20	0.5088	0.06	Q	V
21+25	0.5092	0.06	Q	V
21+30	0.5096	0.05	Q	V
21+35	0.5100	0.06	Q	V
21+40	0.5104	0.06	Q	V
21+45	0.5108	0.07	Q	V
21+50	0.5113	0.06	Q	V
21+55	0.5117	0.06	Q	V
22+ 0	0.5120	0.05	Q	V
22+ 5	0.5124	0.06	Q	V
22+10	0.5128	0.06	Q	V
22+15	0.5133	0.07	Q	V
22+20	0.5137	0.06	Q	V
22+25	0.5141	0.06	Q	V
22+30	0.5145	0.05	Q	V
22+35	0.5148	0.05	Q	V
22+40	0.5152	0.05	Q	V
22+45	0.5155	0.05	Q	V
22+50	0.5159	0.05	Q	V
22+55	0.5162	0.05	Q	V
23+ 0	0.5165	0.05	Q	V
23+ 5	0.5169	0.05	Q	V
23+10	0.5172	0.05	Q	V
23+15	0.5175	0.05	Q	V
23+20	0.5179	0.05	Q	V
23+25	0.5182	0.05	Q	V
23+30	0.5185	0.05	Q	V
23+35	0.5189	0.05	Q	V
23+40	0.5192	0.05	Q	V
23+45	0.5195	0.05	Q	V
23+50	0.5198	0.05	Q	V
23+55	0.5202	0.05	Q	V
24+ 0	0.5205	0.05	Q	V
24+ 5	0.5208	0.04	Q	V
24+10	0.5209	0.02	Q	V
24+15	0.5210	0.02	Q	V
24+20	0.5211	0.01	Q	V
24+25	0.5212	0.01	Q	V
24+30	0.5212	0.01	Q	V
24+35	0.5213	0.01	Q	V
24+40	0.5213	0.00	Q	V

24+45	0.5213	0.00	Q				V
24+50	0.5213	0.00	Q				V
24+55	0.5214	0.00	Q				V
25+ 0	0.5214	0.00	Q				V
25+ 5	0.5214	0.00	Q				V

THE RIDGE - BASIN 1 VOLUME CALCULATION

Contour Elevation	Contour Area (sf)	Contour Area (ac)	Average Area (ac)	Incremental Volume (ac-ft) (ac-ft)	Total Basin Volume (ac-ft)
4362.0	16304.60	0.374		0	RESERVED FOR WQ UP TO 4362.5
			0.386		
4362.5	17299.05	0.397			0
			0.409		
4363.0	18293.50	0.420		0.409	0.41
			0.444		
4364.0	20359.2	0.467		0.444	0.85
			0.492		
4365.0	22504.40	0.517		0.492	1.34
			0.542		
4366.0	24728.4	0.568		0.542	1.89
			0.594		
4367.0	27031.26	0.621		0.594	2.48
			0.647		
4367	29342.5	0.674		0.647	3.13

WATER QUALITY VOLUME FOR DMA 1, 2 & DMA 4=12,200, REQUIRES BOTTOM AREA OF 9,038 SF.
 BASIN 2 BOTTOM AREA IS 16,304.6 BASED ON GRADING PLAN
 MITIGATION VOLUME = 1.3 AC-FT. PONDS AT 4365.0 FT

Appendix 8: Source Control

Pollutant Sources/Source Control Checklist

STORMWATER POLLUTANT SOURCES/SOURCE CONTROL CHECKLIST

How to use this worksheet (also see instructions in Section G of the WQMP Template):

1. Review Column 1 and identify which of these potential sources of stormwater pollutants apply to your site. Check each box that applies.
2. Review Column 2 and incorporate all of the corresponding applicable BMPs in your WQMP Exhibit.
3. Review Columns 3 and 4 and incorporate all of the corresponding applicable permanent controls and operational BMPs in your WQMP. Use the format shown in Table G.1 on page 23 of this WQMP Template. Describe your specific BMPs in an accompanying narrative, and explain any special conditions or situations that required omitting BMPs or substituting alternative BMPs for those shown here.

IF THESE SOURCES WILL BE ON THE PROJECT SITE THEN YOUR WQMP SHOULD INCLUDE THESE SOURCE CONTROL BMPs, AS APPLICABLE		
1 Potential Sources of Runoff Pollutants	2 Permanent Controls—Show on WQMP Drawings	3 Permanent Controls—List in WQMP Table and Narrative	4 Operational BMPs—Include in WQMP Table and Narrative
<input checked="" type="checkbox"/> A. On-site storm drain inlets	<input checked="" type="checkbox"/> Locations of inlets.	<input checked="" type="checkbox"/> Mark all inlets with the words “Only Rain Down the Storm Drain” or similar. Catch Basin Markers may be available from the Riverside County Flood Control and Water Conservation District, call 951.955.1200 to verify.	<input checked="" type="checkbox"/> Maintain and periodically repaint or replace inlet markings. <input checked="" type="checkbox"/> Provide stormwater pollution prevention information to new site owners, lessees, or operators. <input checked="" type="checkbox"/> See applicable operational BMPs in Fact Sheet SC-44, “Drainage System Maintenance,” in the CASQA Stormwater Quality Handbooks at www.cabmphandbooks.com <input type="checkbox"/> Include the following in lease agreements: “Tenant shall not allow anyone to discharge anything to storm drains or to store or deposit materials so as to create a potential discharge to storm drains.”
<input type="checkbox"/> B. Interior floor drains and elevator shaft sump pumps		<input type="checkbox"/> State that interior floor drains and elevator shaft sump pumps will be plumbed to sanitary sewer.	<input type="checkbox"/> Inspect and maintain drains to prevent blockages and overflow.
<input type="checkbox"/> C. Interior parking garages		<input type="checkbox"/> State that parking garage floor drains will be plumbed to the sanitary sewer.	<input type="checkbox"/> Inspect and maintain drains to prevent blockages and overflow.

STORMWATER POLLUTANT SOURCES/SOURCE CONTROL CHECKLIST

IF THESE SOURCES WILL BE ON THE PROJECT SITE THEN YOUR WQMP SHOULD INCLUDE THESE SOURCE CONTROL BMPs, AS APPLICABLE		
1 Potential Sources of Runoff Pollutants	2 Permanent Controls—Show on WQMP Drawings	3 Permanent Controls—List in WQMP Table and Narrative	4 Operational BMPs—Include in WQMP Table and Narrative
<input checked="" type="checkbox"/> D1. Need for future indoor & structural pest control		<input checked="" type="checkbox"/> Note building design features that discourage entry of pests.	<input checked="" type="checkbox"/> Provide Integrated Pest Management information to owners, lessees, and operators.
<input checked="" type="checkbox"/> D2. Landscape/ Outdoor Pesticide Use	<input checked="" type="checkbox"/> Show locations of native trees or areas of shrubs and ground cover to be undisturbed and retained. <input checked="" type="checkbox"/> Show self-retaining landscape areas, if any. <input checked="" type="checkbox"/> Show stormwater treatment and hydrograph modification management BMPs. (See instructions in Chapter 3, Step 5 and guidance in Chapter 5.)	<p>State that final landscape plans will accomplish all of the following.</p> <input checked="" type="checkbox"/> Preserve existing native trees, shrubs, and ground cover to the maximum extent possible. <input checked="" type="checkbox"/> Design landscaping to minimize irrigation and runoff, to promote surface infiltration where appropriate, and to minimize the use of fertilizers and pesticides that can contribute to stormwater pollution. <input checked="" type="checkbox"/> Where landscaped areas are used to retain or detain stormwater, specify plants that are tolerant of saturated soil conditions. <input checked="" type="checkbox"/> Consider using pest-resistant plants, especially adjacent to hardscape. <p>To insure successful establishment, select plants appropriate to site soils, slopes, climate, sun, wind, rain, land use, air movement, ecological consistency, and plant interactions.</p>	<input checked="" type="checkbox"/> Maintain landscaping using minimum or no pesticides. <input checked="" type="checkbox"/> See applicable operational BMPs in “What you should know for.....Landscape and Gardening” at http://rcflood.org/stormwater/Error! <small>Hyperlink reference not valid.</small> <input checked="" type="checkbox"/> Provide IPM information to new owners, lessees and operators.

STORMWATER POLLUTANT SOURCES/SOURCE CONTROL CHECKLIST

IF THESE SOURCES WILL BE ON THE PROJECT SITE THEN YOUR WQMP SHOULD INCLUDE THESE SOURCE CONTROL BMPs, AS APPLICABLE		
1 Potential Sources of Runoff Pollutants	2 Permanent Controls—Show on WQMP Drawings	3 Permanent Controls—List in WQMP Table and Narrative	4 Operational BMPs—Include in WQMP Table and Narrative
<input checked="" type="checkbox"/> E. Pools, spas, ponds, decorative fountains, and other water features.	<input type="checkbox"/> Show location of water feature and a sanitary sewer cleanout in an accessible area within 10 feet. (Exception: Public pools must be plumbed according to County Department of Environmental Health Guidelines.)	If the Co-Permittee requires pools to be plumbed to the sanitary sewer, place a note on the plans and state in the narrative that this connection will be made according to local requirements.	<input checked="" type="checkbox"/> See applicable operational BMPs in "Guidelines for Maintaining Your Swimming Pool, Jacuzzi and Garden Fountain" at http://rcflood.org/stormwater/
<input checked="" type="checkbox"/> F. Food service	<input checked="" type="checkbox"/> For restaurants, grocery stores, and other food service operations, show location (indoors or in a covered area outdoors) of a floor sink or other area for cleaning floor mats, containers, and equipment. <input checked="" type="checkbox"/> On the drawing, show a note that this drain will be connected to a grease interceptor before discharging to the sanitary sewer.	<input checked="" type="checkbox"/> Describe the location and features of the designated cleaning area. <input checked="" type="checkbox"/> Describe the items to be cleaned in this facility and how it has been sized to insure that the largest items can be accommodated.	<input checked="" type="checkbox"/> See the brochure, "The Food Service Industry Best Management Practices for: Restaurants, Grocery Stores, Delicatessens and Bakeries" at http://rcflood.org/stormwater/ Provide this brochure to new site owners, lessees, and operators.
<input checked="" type="checkbox"/> G. Refuse areas	<input checked="" type="checkbox"/> Show where site refuse and recycled materials will be handled and stored for pickup. See local municipal requirements for sizes and other details of refuse areas. <input checked="" type="checkbox"/> If dumpsters or other receptacles are outdoors, show how the designated area will be covered, graded, and paved to prevent run-on and show locations of berms to prevent runoff from the area. <input checked="" type="checkbox"/> Any drains from dumpsters, compactors, and tallow bin areas shall be connected to a grease removal device before discharge to sanitary sewer.	<input checked="" type="checkbox"/> State how site refuse will be handled and provide supporting detail to what is shown on plans. <input checked="" type="checkbox"/> State that signs will be posted on or near dumpsters with the words "Do not dump hazardous materials here" or similar.	<input checked="" type="checkbox"/> State how the following will be implemented: Provide adequate number of receptacles. Inspect receptacles regularly; repair or replace leaky receptacles. Keep receptacles covered. Prohibit/prevent dumping of liquid or hazardous wastes. Post "no hazardous materials" signs. Inspect and pick up litter daily and clean up spills immediately. Keep spill control materials available on-site. See Fact Sheet SC-34, "Waste Handling and Disposal" in the CASQA Stormwater Quality Handbooks at www.cabmphandbooks.com

STORMWATER POLLUTANT SOURCES/SOURCE CONTROL CHECKLIST

IF THESE SOURCES WILL BE ON THE PROJECT SITE THEN YOUR WQMP SHOULD INCLUDE THESE SOURCE CONTROL BMPs, AS APPLICABLE		
1 Potential Sources of Runoff Pollutants	2 Permanent Controls—Show on WQMP Drawings	3 Permanent Controls—List in WQMP Table and Narrative	4 Operational BMPs—Include in WQMP Table and Narrative
<input type="checkbox"/> H. Industrial processes.	<input type="checkbox"/> Show process area.	<input type="checkbox"/> If industrial processes are to be located on site, state: “All process activities to be performed indoors. No processes to drain to exterior or to storm drain system.”	<input type="checkbox"/> See Fact Sheet SC-10, “Non-Stormwater Discharges” in the CASQA Stormwater Quality Handbooks at www.cabmphandbooks.com See the brochure “Industrial & Commercial Facilities Best Management Practices for: Industrial, Commercial Facilities” at http://rcflood.org/stormwater/

STORMWATER POLLUTANT SOURCES/SOURCE CONTROL CHECKLIST

IF THESE SOURCES WILL BE ON THE PROJECT SITE THEN YOUR WQMP SHOULD INCLUDE THESE SOURCE CONTROL BMPs, AS APPLICABLE		
1 Potential Sources of Runoff Pollutants	2 Permanent Controls—Show on WQMP Drawings	3 Permanent Controls—List in WQMP Table and Narrative	4 Operational BMPs—Include in WQMP Table and Narrative
<input type="checkbox"/> I. Outdoor storage of equipment or materials. (See rows J and K for source control measures for vehicle cleaning, repair, and maintenance.)	<input type="checkbox"/> Show any outdoor storage areas, including how materials will be covered. Show how areas will be graded and bermed to prevent run-on or run-off from area. <input type="checkbox"/> Storage of non-hazardous liquids shall be covered by a roof and/or drain to the sanitary sewer system, and be contained by berms, dikes, liners, or vaults. <input type="checkbox"/> Storage of hazardous materials and wastes must be in compliance with the local hazardous materials ordinance and a Hazardous Materials Management Plan for the site.	<p>Include a detailed description of materials to be stored, storage areas, and structural features to prevent pollutants from entering storm drains.</p> <p>Where appropriate, reference documentation of compliance with the requirements of Hazardous Materials Programs for:</p> <ul style="list-style-type: none"> ▪ Hazardous Waste Generation ▪ Hazardous Materials Release Response and Inventory ▪ California Accidental Release (CalARP) ▪ Aboveground Storage Tank ▪ Uniform Fire Code Article 80 Section 103(b) & (c) 1991 ▪ Underground Storage Tank <p>www.cchealth.org/groups/hazmat/</p>	<input type="checkbox"/> See the Fact Sheets SC-31, “Outdoor Liquid Container Storage” and SC-33, “Outdoor Storage of Raw Materials ” in the CASQA Stormwater Quality Handbooks at www.cabmphandbooks.com

STORMWATER POLLUTANT SOURCES/SOURCE CONTROL CHECKLIST

IF THESE SOURCES WILL BE ON THE PROJECT SITE THEN YOUR WQMP SHOULD INCLUDE THESE SOURCE CONTROL BMPs, AS APPLICABLE		
1 Potential Sources of Runoff Pollutants	2 Permanent Controls—Show on WQMP Drawings	3 Permanent Controls—List in WQMP Table and Narrative	4 Operational BMPs—Include in WQMP Table and Narrative
<input type="checkbox"/> J. Vehicle and Equipment Cleaning	<input type="checkbox"/> Show on drawings as appropriate: (1) Commercial/industrial facilities having vehicle/equipment cleaning needs shall either provide a covered, bermed area for washing activities or discourage vehicle/equipment washing by removing hose bibs and installing signs prohibiting such uses. (2) Multi-dwelling complexes shall have a paved, bermed, and covered car wash area (unless car washing is prohibited on-site and hoses are provided with an automatic shut-off to discourage such use). (3) Washing areas for cars, vehicles, and equipment shall be paved, designed to prevent run-on to or runoff from the area, and plumbed to drain to the sanitary sewer. (4) Commercial car wash facilities shall be designed such that no runoff from the facility is discharged to the storm drain system. Wastewater from the facility shall discharge to the sanitary sewer, or a wastewater reclamation system shall be installed.	<input type="checkbox"/> If a car wash area is not provided, describe any measures taken to discourage on-site car washing and explain how these will be enforced.	Describe operational measures to implement the following (if applicable): <input type="checkbox"/> Washwater from vehicle and equipment washing operations shall not be discharged to the storm drain system. Refer to “Outdoor Cleaning Activities and Professional Mobile Service Providers” for many of the Potential Sources of Runoff Pollutants categories below. Brochure can be found at http://rcflood.org/stormwater/ <input type="checkbox"/> Car dealerships and similar may rinse cars with water only.

STORMWATER POLLUTANT SOURCES/SOURCE CONTROL CHECKLIST

IF THESE SOURCES WILL BE ON THE PROJECT SITE THEN YOUR WQMP SHOULD INCLUDE THESE SOURCE CONTROL BMPs, AS APPLICABLE		
1 Potential Sources of Runoff Pollutants	2 Permanent Controls—Show on WQMP Drawings	3 Permanent Controls—List in WQMP Table and Narrative	4 Operational BMPs—Include in WQMP Table and Narrative
<p><input type="checkbox"/> K. Vehicle/Equipment Repair and Maintenance</p>	<p><input type="checkbox"/> Accommodate all vehicle equipment repair and maintenance indoors. Or designate an outdoor work area and design the area to prevent run-on and runoff of stormwater.</p> <p><input type="checkbox"/> Show secondary containment for exterior work areas where motor oil, brake fluid, gasoline, diesel fuel, radiator fluid, acid-containing batteries or other hazardous materials or hazardous wastes are used or stored. Drains shall not be installed within the secondary containment areas.</p> <p><input type="checkbox"/> Add a note on the plans that states either (1) there are no floor drains, or (2) floor drains are connected to wastewater pretreatment systems prior to discharge to the sanitary sewer and an industrial waste discharge permit will be obtained.</p>	<p><input type="checkbox"/> State that no vehicle repair or maintenance will be done outdoors, or else describe the required features of the outdoor work area.</p> <p><input type="checkbox"/> State that there are no floor drains or if there are floor drains, note the agency from which an industrial waste discharge permit will be obtained and that the design meets that agency’s requirements.</p> <p><input type="checkbox"/> State that there are no tanks, containers or sinks to be used for parts cleaning or rinsing or, if there are, note the agency from which an industrial waste discharge permit will be obtained and that the design meets that agency’s requirements.</p>	<p>In the Stormwater Control Plan, note that all of the following restrictions apply to use the site:</p> <p><input type="checkbox"/> No person shall dispose of, nor permit the disposal, directly or indirectly of vehicle fluids, hazardous materials, or rinsewater from parts cleaning into storm drains.</p> <p><input type="checkbox"/> No vehicle fluid removal shall be performed outside a building, nor on asphalt or ground surfaces, whether inside or outside a building, except in such a manner as to ensure that any spilled fluid will be in an area of secondary containment. Leaking vehicle fluids shall be contained or drained from the vehicle immediately.</p> <p><input type="checkbox"/> No person shall leave unattended drip parts or other open containers containing vehicle fluid, unless such containers are in use or in an area of secondary containment.</p> <p>Refer to “Automotive Maintenance & Car Care Best Management Practices for Auto Body Shops, Auto Repair Shops, Car Dealerships, Gas Stations and Fleet Service Operations”. Brochure can be found at http://rcflood.org/stormwater/</p> <p>Refer to Outdoor Cleaning Activities and Professional Mobile Service Providers for many of the Potential Sources of Runoff Pollutants categories below. Brochure can be found at http://rcflood.org/stormwater/</p>

STORMWATER POLLUTANT SOURCES/SOURCE CONTROL CHECKLIST

IF THESE SOURCES WILL BE ON THE PROJECT SITE THEN YOUR WQMP SHOULD INCLUDE THESE SOURCE CONTROL BMPs, AS APPLICABLE		
1 Potential Sources of Runoff Pollutants	2 Permanent Controls—Show on WQMP Drawings	3 Permanent Controls—List in WQMP Table and Narrative	4 Operational BMPs—Include in WQMP Table and Narrative
<input type="checkbox"/> L. Fuel Dispensing Areas	<input type="checkbox"/> Fueling areas ⁶ shall have impermeable floors (i.e., portland cement concrete or equivalent smooth impervious surface) that are: a) graded at the minimum slope necessary to prevent ponding; and b) separated from the rest of the site by a grade break that prevents run-on of stormwater to the maximum extent practicable. <input type="checkbox"/> Fueling areas shall be covered by a canopy that extends a minimum of ten feet in each direction from each pump. [Alternative: The fueling area must be covered and the cover's minimum dimensions must be equal to or greater than the area within the grade break or fuel dispensing area ¹ .] The canopy [or cover] shall not drain onto the fueling area.		<input type="checkbox"/> The property owner shall dry sweep the fueling area routinely. <input type="checkbox"/> See the Fact Sheet SD-30 , “Fueling Areas” in the CASQA Stormwater Quality Handbooks at www.cabmphandbooks.com

⁶ The fueling area shall be defined as the area extending a minimum of 6.5 feet from the corner of each fuel dispenser or the length at which the hose and nozzle assembly may be operated plus a minimum of one foot, whichever is greater.

STORMWATER POLLUTANT SOURCES/SOURCE CONTROL CHECKLIST

IF THESE SOURCES WILL BE ON THE PROJECT SITE THEN YOUR WQMP SHOULD INCLUDE THESE SOURCE CONTROL BMPs, AS APPLICABLE		
1 Potential Sources of Runoff Pollutants	2 Permanent Controls—Show on WQMP Drawings	3 Permanent Controls—List in WQMP Table and Narrative	4 Operational BMPs—Include in WQMP Table and Narrative
<input type="checkbox"/> M. Loading Docks	<input type="checkbox"/> Show a preliminary design for the loading dock area, including roofing and drainage. Loading docks shall be covered and/or graded to minimize run-on to and runoff from the loading area. Roof downspouts shall be positioned to direct stormwater away from the loading area. Water from loading dock areas shall be drained to the sanitary sewer, or diverted and collected for ultimate discharge to the sanitary sewer. <input type="checkbox"/> Loading dock areas draining directly to the sanitary sewer shall be equipped with a spill control valve or equivalent device, which shall be kept closed during periods of operation. <input type="checkbox"/> Provide a roof overhang over the loading area or install door skirts (cowling) at each bay that enclose the end of the trailer.		<input type="checkbox"/> Move loaded and unloaded items indoors as soon as possible. <input type="checkbox"/> See Fact Sheet SC-30, “Outdoor Loading and Unloading,” in the CASQA Stormwater Quality Handbooks at www.cabmphandbooks.com

STORMWATER POLLUTANT SOURCES/SOURCE CONTROL CHECKLIST

IF THESE SOURCES WILL BE ON THE PROJECT SITE THEN YOUR WQMP SHOULD INCLUDE THESE SOURCE CONTROL BMPs, AS APPLICABLE		
1 Potential Sources of Runoff Pollutants	2 Permanent Controls—Show on WQMP Drawings	3 Permanent Controls—List in WQMP Table and Narrative	4 Operational BMPs—Include in WQMP Table and Narrative
<input checked="" type="checkbox"/> N. Fire Sprinkler Test Water		<input checked="" type="checkbox"/> Provide a means to drain fire sprinkler test water to the sanitary sewer.	<input checked="" type="checkbox"/> See the note in Fact Sheet SC-41, “Building and Grounds Maintenance,” in the CASQA Stormwater Quality Handbooks at www.cabmphandbooks.com
<p>O. Miscellaneous Drain or Wash Water or Other Sources</p> <input type="checkbox"/> Boiler drain lines <input checked="" type="checkbox"/> Condensate drain lines <input type="checkbox"/> Rooftop equipment <input type="checkbox"/> Drainage sumps <input checked="" type="checkbox"/> Roofing, gutters, and trim. <input type="checkbox"/> Other sources		<input type="checkbox"/> Boiler drain lines shall be directly or indirectly connected to the sanitary sewer system and may not discharge to the storm drain system. <input checked="" type="checkbox"/> Condensate drain lines may discharge to landscaped areas if the flow is small enough that runoff will not occur. Condensate drain lines may not discharge to the storm drain system. <input type="checkbox"/> Rooftop equipment with potential to produce pollutants shall be roofed and/or have secondary containment. <input type="checkbox"/> Any drainage sumps on-site shall feature a sediment sump to reduce the quantity of sediment in pumped water. <input checked="" type="checkbox"/> Avoid roofing, gutters, and trim made of copper or other unprotected metals that may leach into runoff. Include controls for other sources as specified by local reviewer.	

STORMWATER POLLUTANT SOURCES/SOURCE CONTROL CHECKLIST

IF THESE SOURCES WILL BE ON THE PROJECT SITE THEN YOUR WQMP SHOULD INCLUDE THESE SOURCE CONTROL BMPs, AS APPLICABLE		
1 Potential Sources of Runoff Pollutants	2 Permanent Controls—Show on WQMP Drawings	3 Permanent Controls—List in WQMP Table and Narrative	4 Operational BMPs—Include in WQMP Table and Narrative
<input checked="" type="checkbox"/> P. Plazas, sidewalks, and parking lots.			<input checked="" type="checkbox"/> Sweep plazas, sidewalks, and parking lots regularly to prevent accumulation of litter and debris. Collect debris from pressure washing to prevent entry into the storm drain system. Collect washwater containing any cleaning agent or degreaser and discharge to the sanitary sewer not to a storm drain.

Appendix 9: O&M

Operation and Maintenance Plan and Documentation of Finance, Maintenance and Recording Mechanisms

O&M will be prepared during final engineering.

Appendix 10: Educational Materials

BMP Fact Sheets, Maintenance Guidelines and Other End-User BMP Information

Educational Material will be provided during final engineering.