

Appendix B2
Updated Biological Resources Records Search

MASTER CASE No. 20-073
INITIAL STUDY

December 23, 2021

JN 181745

MONTE VISTA ASSETS, INC.

Attn: *Steve Landis, President*
8628 Hillside Road
Alta Loma, CA 91701

SUBJECT: Results of an Updated Records Search for the Fontana 47 Project – City of Fontana, San Bernardino County, California

Dear Mr. Landis:

Michael Baker International (Michael Baker) is pleased to submit this report to Monte Vista Assets, Inc. documenting the results of an updated records search for the proposed Fontana 47 Project (project or project site) located in the City of Fontana, San Bernardino County, California. The *Results of a Habitat Assessment for the Fontana 47 Project – City of Fontana, San Bernardino County, California* (Habitat Assessment), prepared by Michael Baker and dated January 22, 2021, previously evaluated potential biological resources impacts associated with the proposed project (refer to Attachment A, *2021 Habitat Assessment*). Since then, the project description has slightly changed as described below.

As an update to the Habitat Assessment, Michael Baker conducted an updated records search to identify any special-status¹ plant and wildlife species that were not previously identified in the Habitat Assessment and evaluate potential project impacts on such species. Specifically, the updated literature review included records searches in the following databases: the California Department of Fish and Wildlife (CDFW) California Natural Diversity Database (CNDDDB) RareFind 5 (CDFW 2021a), the CNDDDB Biogeographic Information and Observation System (BIOS; CDFW 2021b), and the California Native Plant Society (CNPS) Online Inventory of Rare and Endangered Plants of California (Online Inventory; CNPS 2021).

Revised Project Description

The project site is approximately 12 acres located on the west side of Catawba Avenue at the terminus of Hibiscus Street, and on the east side of Poplar Street. The revised project proposes to develop fifty-three (53) single-family residential units with associated road, utility, and water quality management improvements (refer to Attachment B, *Revised Site Plan*).

¹ As used in this report, “special-status” refers to plant and wildlife species that are federally-/State-listed, proposed, or candidates; plant species that have been designated a California Rare Plant Rank species by the California Native Plant Society; wildlife species that are designated by the California Department of Fish and Wildlife as Fully Protected, Species of Special Concern, or Watch List species; and State/locally rare vegetation communities.

Updated Records Search Results

The CNDDDB and CNPS Online Inventory were queried for reported locations of special-status plant and wildlife species as well as special-status natural vegetation communities in the USGS *Cucamonga Peak, Devore, Fontana, and Guasti, California* 7.5-minute quadrangles. The literature search identified fifty-five (55) special-status plant species and seventy-five (75) special-status wildlife species as occurring within the USGS *Cucamonga Peak, Devore, Fontana, and Guasti, California* 7.5-minute quadrangles. In addition, five (5) special-status vegetation communities were identified. Special-status biological resources identified during the literature review as having the potential to occur within the vicinity of the project site are presented in Attachment C, *Updated Records Search*. Special-status plant and wildlife species were evaluated for their potential to occur within the project site based on habitat requirements, availability and quality of suitable habitat, and known distributions.

Special-Status Plants

Based on the updated records search, fifty-five (55) special-status plant species have been recorded in the USGS *Cucamonga Peak, Devore, Fontana, and Guasti, California* 7.5-minute quadrangles by the CNDDDB and CNPS Online Inventory (refer to Attachment C). In comparison, the Habitat Assessment (prepared in January 2021) identified fifty-seven (57) special-status plant species in the same four USGS quadrangles. No new special-status plant species were identified in the updated records search. As stated in the Habitat Assessment, no special-status plant species were observed during the field survey conducted in December 2020. Based on the results of the Habitat Assessment, updated records search, and a review of specific habitat preferences, occurrence records, known distributions, and elevation ranges, the special-status plant species identified by the CNDDDB and CNPS databases are not expected to occur within the project site.

Special-Status Wildlife

The updated records search identified seventy-five (75) special-status wildlife species recorded in the USGS *Cucamonga Peak, Devore, Fontana, and Guasti, California* 7.5-minute quadrangles by the CNDDDB (refer to Attachment C). Compared to the records search conducted for the Habitat Assessment (prepared in January 2021), fifteen (15) new special-status wildlife species were identified in the updated records search of the same four USGS quadrangles. The new special-status wildlife species identified in the updated records search include great egret (*Ardea alba*), great blue heron (*Ardea herodias*), San Gabriel slender salamander (*Batrachoseps gabrieli*), Costa's hummingbird (*Calypte costae*), greenest tiger beetle (*Cicindela tranquebarica viridissima*), San Bernardino ringneck snake (*Diadophis punctatus modestus*), Dulzura kangaroo rat (*Dipodomys simulans*), snowy egret (*Egretta thula*), merlin (*Falco columbarius*), white cuckoo bee (*Neolarra alba*), black-crowned night heron (*Nycticorax nycticorax*), vermilion flycatcher (*Pyrocephalus rubinus*), rufous hummingbird (*Selasphorus rufus*), Lawrence's goldfinch (*Spinus lawrencei*), and Brewer's sparrow (*Spizella breweri*). As detailed in the Habitat Assessment, the project site is primarily comprised of residential development and disturbed habitat characterized by heavily disturbed/compacted soils. Additionally, the routine weed abatement within the project site and surrounding residential land uses have reduced the potential for the project site to provide suitable habitat for special-status wildlife species. Based on the results of the field survey conducted in December 2020 and a review of specific habitat preferences, occurrence records, known distributions, and elevation ranges, it was determined that none of the fifteen (15) additional special-status wildlife species identified in the CNDDDB database are expected to occur within the project site.

Special-Status Vegetation Communities

Similar to the Habitat Assessment, the updated records search identified the same five (5) special-status vegetation communities reported in the USGS *Cucamonga Peak, Devore, Fontana, and Guasti, California* 7.5-minute quadrangles by the CNDDDB: California Walnut Woodland, Coastal and Valley Freshwater Marsh, Riversidian Alluvial Fan Sage Scrub, Southern Riparian Forest, and Southern Sycamore Alder Riparian Woodland. As stated in the Habitat Assessment, the project site is comprised of residential development and disturbed habitat that is subject to routine weed abatement, resulting in heavily disturbed and compacted surface soils which reduces the likelihood of a special-status vegetation community from establishing. As such, no special-status vegetation communities were observed within the project site during the field survey conducted in December 2020. No changes are anticipated to these findings.

Conclusions and Recommendations

Based on the updated records search, no additional special-status plant or wildlife species are expected to occur within the project site not previously identified in the Habitat Assessment. The revised project would result in similar impacts as the original project description analyzed in the Habitat Assessment. Pre-construction nesting bird clearance surveys and burrowing owl clearance surveys would similarly be required for the revised project as detailed in the Habitat Assessment.

Please do not hesitate to contact me at (949) 246-7004 or tommillington@mbakerintl.com or Frances Yau at (949) 330-4105 or frances.yau@mbakerintl.com should you have any questions or require further information.

Sincerely,



Tom Millington
Senior Biologist
Natural Resources and Regulatory Permitting



Frances Yau
Biologist
Natural Resources and Regulatory Permitting

Attachments:

- A. *2021 Habitat Assessment*
- B. *Revised Site Plan*
- C. *Updated Records Searches*
- D. *References*

Attachment A

2021 Habitat Assessment

January 22, 2021

JN 181745

MONTE VISTA ASSETS, INC.

Attn: *Steve Landis, President*
8628 Hillside Road
Alta Loma, CA 91701

SUBJECT: Results of a Habitat Assessment for the Fontana 47 Project – City of Fontana, San Bernardino County, California

Dear Mr. Landis:

Michael Baker International (Michael Baker) is pleased to submit this report to Monte Vista Assets, Inc. documenting the results of a habitat assessment for the proposed Fontana 47 Project (project or project site) located in the City of Fontana, San Bernardino County, California. Michael Baker conducted a thorough literature review and a field survey to reconfirm existing site conditions and assess the potential for special-status¹ plant and wildlife species that have been documented or that are likely to occur on or within the immediate vicinity of the project site. Specifically, this report provides a detailed assessment of the suitability of the on-site habitat to support special-status plant and wildlife species that were identified in the California Department of Fish and Wildlife (CDFW) California Natural Diversity Database (CNDDDB) RareFind 5 (CDFW 2020a), the CNDDDB Biogeographic Information and Observation System (BIOS; CDFW 2020b), the California Native Plant Society (CNPS) Online Inventory of Rare and Endangered Plants of California (Online Inventory; CNPS 2020), and other databases as potentially occurring in the vicinity of the project site.

Project Location

The project site is generally located north of the Interstate 10, east of Interstate 15, south of State Route 210, and west of Interstate 215 in the City of Fontana, San Bernardino County, California. The project site is depicted in Section 13 of Township 1 South, Range 6 West, on the United States Geological Survey's (USGS) *Fontana, California* 7.5-minute quadrangle. Specifically, the project site is approximately 12.8 acres located to the north of Randall Avenue, to the east of Poplar Avenue, to the south of Merrill Avenue, and to the west of Catawba Avenue.

Project Description

The project consists of two main components: 1) land use and zoning changes over approximately 12 acres, and 2) tentative tract map and design review for the construction of 47 single- family dwellings on

¹ As used in this report, "special-status" refers to plant and wildlife species that are federally-/State-listed, proposed, or candidates; plant species that have been designated a California Rare Plant Rank species by the California Native Plant Society; wildlife species that are designated by the California Department of Fish and Wildlife as Fully Protected, Species of Special Concern, or Watch List species; and State/locally rare vegetation communities.

approximately 9 acres. The proposed project requires a number of entitlements from the City of Fontana, including:

- General Plan Amendment No. 20-015 – request to change the land use from R-SF to R-M;
- Zone Change No. 20-015 – request to change the zone from R-1 to R-2;
- Tentative Tract Map No. 20358 (TTM20-006) request to subdivide 9 gross acres into 47 single-family residential lots with private internal streets, street lighting, sewer, water, and perimeter block wall; and
- Design Review No. 20-028 – request to approve the architectural design and layout of the proposed housing product.

The project site is approximately 12 acres located on the west side of Catawba Avenue at the terminus of Hibiscus Street, and on the east side of Poplar Street. The project proposes to develop forty-seven (47) single family residential units with associated road, utility, and water quality management improvements (refer to Attachment B, *Site Plan*). At the City’s request, additional parcels have been included into the scope of the proposed General Plan Amendment and Zone Change. These parcels would undergo the aforementioned changes but would not be developed into residential units as part of this project.

Methodology

Literature Review

Michael Baker conducted thorough literature reviews and records searches to determine which special-status biological resources have the potential to occur on or within the general vicinity of the project site. Previous special-status plant and wildlife species occurrence records within the USGS *Cucamonga Peak, Devore, Fontana, and Guasti, California* 7.5-minute quadrangles were determined through a query of the CNDDDB (CDFW 2020a), BIOS (CDFW 2020b), CNPS Online Inventory (CNPS 2020), and the Calflora Database (Calflora 2020). Current conservation status of species was verified through lists and resources provided by the CDFW, specifically the *Special Animals List* (CNDDDB 2020c), *State and Federally Listed Endangered and Threatened Animals of California* (CNDDDB 2020d), *Special Vascular Plants, Bryophytes, and Lichens List* (CNDDDB 2020e), and *State and Federally Listed Endangered, Threatened, and Rare Plants of California* (CNDDDB 2020f). In addition, Michael Baker reviewed previously prepared reports, survey results, and literature, as available, detailing the biological resources previously observed on or within the vicinity of the project site to gain an understanding of existing site conditions, confirm previous species observations, and note the extent of any disturbances that have occurred within the project site that would otherwise limit the distribution of special-status biological resources. Standard field guides and texts were reviewed for specific habitat requirements of special-status species, as well as the following resources:

- City of Fontana General Plan Update (City of Fontana, 2017);
- Google Earth Pro Historical Aerial Imagery from 1994 to 2020 (Google, Inc. 2020);
- San Bernardino County General Plan (County of San Bernardino, 2007);
- Species Accounts provided by Birds of North America (The Cornell Lab of Ornithology 2020);
- *Staff Report on Burrowing Owl Mitigation* (CDFW, 2012);

- United States Department of Agriculture, Natural Resource Conservation Service’s (USDA) *Custom Soil Resource Report for San Bernardino County Southwestern Part, California*, (USDA 2020); and
- USFWS Critical Habitat Mapper and Environmental Conservation Online System (USFWS 2020b).

Habitat Assessment/Field Survey

Michael Baker biologists Ashley Spencer and Tom Millington conducted a habitat assessment/field survey on December 29, 2020 to confirm existing site conditions within the project site. Vegetation communities occurring within the project site were mapped on an aerial photograph and classified in accordance with the vegetation descriptions provided in *A Manual of California Vegetation* (MCV; Sawyer et al. 2009) and cross referenced with the *Preliminary Descriptions of the Terrestrial Natural Communities of California* (Holland 1986) for the purposes of evaluating the presence or absence of special-status vegetation communities identified in the CNDDDB records search, which uses the Holland vegetation system. In addition, site characteristics such as soil condition, topography, hydrology, anthropogenic disturbances, indicator species, condition of on-site vegetation communities, and the presence of potentially regulated jurisdictional features were noted. Michael Baker used Geographic Information Systems (GIS) ArcView software to digitize the mapped vegetation communities and then transferred these data onto an aerial photograph to further document existing conditions and quantify the acreage of each vegetation community. Refer to Table 1 below for a summary of the survey dates, timing, surveyors, and weather conditions.

Table 1: Survey Dates, Timing, Surveyors, and Weather Conditions

Date	Time (start / finish)	Surveyors	Weather Conditions	
			Temperature (°F) (start / finish)	Average Wind Speed (mph)
December 29, 2020	0900 / 1000	Ashley Spencer Tom Millington	56 sunny / 58 sunny	4 – 5

All plant and wildlife species observed, as well as dominant plant species within each vegetation community, were recorded. Plant species observed during the habitat assessment were identified by visual characteristics and morphology in the field while unusual and less familiar plant species were photographed and identified later using taxonomic guides. Plant nomenclature used in this report follows the *Jepson Flora Project* (2018) and scientific names are provided immediately following common names of plant species (first reference only). Wildlife detections were made through aural and visual detection, as well as observation of sign including scat, trails, tracks, burrows, and nests. Field guides used to assist with identification of species during the habitat assessment included *The Sibley Guide to Birds* (Sibley 2014) for birds, *A Field Guide to Western Reptiles and Amphibians* (Stebbins 2003) for herpetofauna, *Bats of the United States and Canada* (Harvey et al. 2011) for bats, and *A Field Guide to Mammals of North America* (Reid 2006). Although common names of wildlife species are well standardized, scientific names are provided immediately following common names of wildlife species in this report (first reference only). To the extent possible, nomenclature of birds follows the most recent annual supplement of the American Ornithological Union’s *Checklist of North American Birds* (Chesser et al. 2019), nomenclature of amphibians and reptiles follows *Scientific and Standard English Names of Amphibians and Reptiles of*

North America North of Mexico, with Comments Regarding Confidence in Our Understanding (Crother 2017), and nomenclature for mammals follows the *Revised Checklist of North American Mammals North of Mexico* (Bradley et al. 2014).

Existing Site Conditions

According to the *Custom Soil Resource Report for San Bernardino County Southwestern Part, California* (USDA 2020), the project site is underlain by the following soil units: Tujunga loamy sand, 0 to 5 percent slopes (TuB) and Tujunga gravelly loamy sand, 0 to 9 percent slopes (TvC). The project site ranges in elevation from approximately 1,188 to 1,202 feet above mean sea level. After a review of Google Earth historic aerial imagery and results from the field survey, it was determined that the project site is comprised of existing residential development and disturbed habitat that is subject to routine weed abatement, resulting in heavily disturbed and compacted surface soils. As such, native vegetation communities do not occur within the project site; instead it is comprised of disturbed and developed land dominated by non-native and ornamental plant species. Residential land uses comprise the northeast and southeast corners of the project site. In addition, residential land uses comprise the western portion of the project site. Remnant greenhouse structures can be found in the eastern portion of the project site. Areas surrounding the project site primarily consist of residential land uses. Refer to Attachment C for representative photographs of the project site taken during the field survey.

Vegetation Communities and Land Cover Types

As previously stated, the project site consists of disturbed/developed land that is subject to routine weed abatement, resulting in heavily disturbed and compacted surface soils. As such, native vegetation communities do not occur within the project site; instead it is comprised of disturbed and developed land dominated by non-native and ornamental plant species. These land uses are depicted on Figure 1, *Vegetation Communities and Other Land Uses*, and described in further detail below. In addition, refer to the paragraphs below for descriptions of plant species observed within the project site during the field survey.

Ornamental

Approximately 0.20-acre of ornamental vegetation occurs within the central portion of the project site. China berry tree (*Melia azedarach*) dominates this area.

Disturbed Habitat

Disturbed habitat comprises approximately 8.87 acres of the project site. Disturbed areas within the project site do not comprise a natural plant community and instead consist of unpaved bare ground or areas that have been previously disked or tilled as part of routine weed abatement activities. Surface soils within these areas have been heavily disturbed/compacted as a result of anthropogenic disturbances and are either devoid of vegetation or support non-native, ruderal plant species. Plant species observed in the disturbed areas include crabgrass (*Digitaria sanguinalis*), telegraph weed (*Heterotheca grandiflora*), common Mediterranean grass (*Schismus barbatus*), coastal heron's bill (*Erodium cicutarium*), giant reed (*Arundo donax*), flax-leaved horseweed (*Erigeron bonariensis*), golden crownbeard (*Verbesina encelioides*), Russian thistle (*Salsola tragus*), and annual bursage (*Ambrosia acanthicarpa*). In addition, sparse individuals of Fremont cottonwood (*Populus fremontii*), California sycamore (*Platanus racemosa*), and

silver dollar gum (*Eucalyptus polyanthemos*) can be found within the eastern and southern portion of the project site.

Developed

Developed areas make up approximately 3.52 acres of the project site and consist of existing structures, land that have been constructed upon, or areas that have been physically altered to a degree that native vegetation is no longer supported. Developed areas within the project site consist of the remnant greenhouse structures, residential development within the northeast, southeast, and western portions of the project site, Orchid Avenue, and Catawba Avenue.

Wildlife

Natural vegetation communities provide foraging habitat, nesting/denning sites, and shelter from adverse weather or predation. This section provides a general discussion of common wildlife species that were detected by Michael Baker during the field survey or that are expected to occur based on existing site conditions. The discussion is to be used as a general reference and is limited by the season, time of day, and weather conditions in which the field survey was conducted. Refer to the paragraphs below for descriptions of wildlife species observed within the project site during the field survey.

Fish

No fish or hydrogeomorphic features (e.g., perennial creeks, ponds, lakes, reservoirs) with frequent sources of water that would support populations of fish were observed in the project site during the field survey. Therefore, no fish are expected to occur.

Amphibians

No amphibians or hydrogeomorphic features (e.g., perennial creeks, ponds, lakes, reservoirs) that would provide suitable breeding habitat for amphibians were observed within the project site. Due to routine weed abatement within the project site and extensive residential development in the project site and surrounding area, it is highly unlikely that the project site would support a robust population of native amphibian species. Therefore, no amphibian species are expected to occur.

Reptiles

No reptiles were observed within the project site during the field survey. Since the project site is primarily disturbed/developed, it is expected to provide suitable habitat for a limited number of reptilian species that are acclimated to edge or urban environments. Reptilian species that may be present within the project site include western side-blotched lizard (*Uta stansburiana elegans*), Great Basin fence lizard (*Sceloporus occidentalis longipes*), and San Diego alligator lizard (*Elgaria multicarinata webbii*).

Birds

The project site provides marginal foraging and nesting habitat for a variety of resident and migrant bird species that are adapted to a high degree of disturbance associated with the surrounding residential land uses. Fifteen (15) bird species were detected during the field survey, including northern flicker (*Colaptes auratus*), rock dove (*Columba livia*), American crow (*Corvus brachyrhynchos*), American kestrel (*Falco sparverius*), house finch (*Haemorhous mexicanus*), northern mockingbird (*Mimus polyglottos*), house

sparrow (*Passer domesticus*), black phoebe (*Sayornis nigricans*), lesser goldfinch (*Spinus psaltria*), Eurasian collared dove (*Streptopelia decaocto*), western meadowlark (*Sturnella neglecta*), common starling (*Sturnus vulgaris*), Cassin's kingbird (*Tyrannus vociferans*), mourning dove (*Zenaida macroura*), and white-crowned sparrow (*Zonotrichia leucophrys*).

Nesting birds are protected pursuant to the federal Migratory Bird Treaty Act (MBTA) of 1918 and the California Fish and Game Code (CFGC)². To maintain compliance with the MBTA and CFGC, clearance surveys are typically required prior to any ground disturbance or vegetation removal activities to avoid direct or indirect impacts to active bird nests and/or nesting birds. Consequently, if an active bird nest is destroyed or if project activities result in indirect impacts (e.g., nest abandonment, loss of reproductive effort) to nesting birds, it is considered "take" and is potentially punishable by fines and/or imprisonment. The project site provides marginal nesting habitat for year-round and seasonal avian residents as well as migrating songbirds that could occur in the area. Additionally, the project site provides nesting habitat for avian species that nest on the open ground (e.g., killdeer [*Charadrius vociferus*], western meadowlark). One (1) remnant nest was observed approximately 150 feet to the north of the project site within a eucalyptus tree; however, no remnant nests were observed within the project site. Further, no active nests or birds displaying nesting behavior were observed.

Mammals

The project site provides suitable habitat for a limited number of mammalian species adapted to living in edge or urban environments. However, the routine weed abatement and surrounding residential development limits the potential for mammalian species to occur. Domestic cat (*Felis catus*) was the only mammal species observed during the field survey. Other common mammalian species that may occur within the project site include coyote (*Canis latrans*), domestic dog (*Canis lupus familiaris*), opossum (*Didelphis virginiana*), raccoon (*Procyon lotor*), and desert cottontail (*Sylvilagus audubonii*).

Bats occur throughout most of southern California and may use the project site as foraging habitat; however, the project site is heavily disturbed and is surrounded by residential development. Common bat species that may forage within the project site include Mexican free-tailed bat (*Tadarida brasiliensis*) and big brown bat (*Eptesicus fuscus*). Mexican free-tailed bats prefer caves or manmade structures (i.e., bridges, abandoned buildings) near water for roosting while big brown bat prefers hollow tree snags/limbs, loose bark, or manmade structures (i.e., bridges, abandoned buildings, barns) for roosting; however, these features are not present within the project site.

Migratory Corridors and Linkages

Wildlife corridors and linkages are key features for wildlife movement between habitat patches. Wildlife corridors are generally defined as those areas that provide opportunities for individuals or local populations to conduct seasonal migrations, permanent dispersals, or daily commutes, while linkages generally refer to broader areas that provide movement opportunities for multiple keystone/focal species or allow for

² Section 3503 makes it unlawful to take, possess, or needlessly destroy the nest or eggs of any bird, except as otherwise provided by the CFGC or any regulation made pursuant thereto; Section 3503.5 makes it unlawful to take, possess, or destroy any birds in the orders Falconiformes or Strigiformes (birds-of-prey); and Section 3513 makes it unlawful to take or possess any migratory non-game bird except as provided by the rules and regulations adopted by the Secretary of the Interior under provisions of the MBTA, as amended (16 U.S.C. § 703 *et seq.*).

propagation of ecological processes (e.g., for movement of pollinators), often between areas of conserved land.

The project site is not located within any wildlife corridors, wilderness areas, wilderness study areas, or areas of critical environmental concern identified in the San Bernardino County Land Use Plan (County of San Bernardino, 2007). The project site is located within a heavily developed area of the City of Fontana and is surrounded by residential development and highly trafficked roadways (i.e., Merrill Avenue to the north, Fontana Avenue to the east, Randall Avenue to the south). The surrounding residential land uses have fragmented the connection between the project site and surrounding naturally occurring vegetation communities. The disturbed and developed landscape of the project site and absence of native vegetation for cover most likely precludes the movement of wildlife through the project site. Further, elevated noise levels, vehicle traffic, lighting, and human presence associated with the surrounding residential development and roadways, decrease the suitability of the project site to be used as a wildlife movement corridor or linkage.

State and Federal Jurisdictional Resources

There are three agencies that regulate activities within inland streams, wetlands, and riparian areas in California. The U.S. Army Corps of Engineers (Corps) Regulatory Branch regulates discharge of dredged or fill material into “waters of the U.S.” pursuant to Section 404 of the CWA and Section 10 of the Rivers and Harbors Act. Of the State agencies, the Regional Water Quality Control Board (Regional Board) regulates discharges to surface waters pursuant to Section 401 of the CWA and Section 13263 of the California Porter-Cologne Water Quality Control Act and the CDFW regulates alterations to streambed and associated vegetation communities under Section 1600 et seq. of the CFGC.

No jurisdictional drainage or wetland features were observed within the boundaries of the project site. Therefore, development of the project site would not result in impacts to Corps, Regional Board, or CDFW jurisdictional areas and regulatory approvals would not be required.

Special-Status Biological Resources

The CNDDDB and CNPS Online Inventory were queried for reported locations of special-status plant and wildlife species as well as special-status natural vegetation communities in the USGS *Cucamonga Peak, Devore, Fontana, and Guasti, California* 7.5-minute quadrangles. The field survey was conducted to assess the conditions of the habitat(s) within the boundaries of the project site to determine if the existing vegetation communities, at the time of the field survey, have the potential to provide suitable habitat(s) for special-status plant and wildlife species. Additionally, the potentials for special-status species to occur within the project site were determined based on the reported locations in the CNDDDB and CNPS Online Inventory and the following:

- **Present:** the species was observed or detected within the project site during the field survey.
- **High:** Occurrence records (within 20 years) indicate that the species has been known to occur on or within 1 mile of the project site and the site is within the normal expected range of this species. Intact, suitable habitat preferred by this species occurs within the project site and/or there is viable landscape connectivity to a local known extant population(s) or sighting(s).
- **Moderate:** Occurrence records (within 20 years) indicate that the species has been known to occur within 1 mile of the project site and the site is within the normal expected range of this

species. There is suitable habitat within the project site but the site is ecologically isolated from any local known extant populations or sightings.

- **Low:** Occurrence records (within 20 years) indicate that the species has been known to occur within 5 miles of the project site, but the site is outside of the normal expected range of the species and/or there is poor quality or marginal habitat within the project site.
- **Not Expected:** There are no occurrence records of the species occurring within 5 miles of the project site, there is no suitable habitat within the project site, and/or the project site is outside of the normal expected range for the species.

The literature search identified fifty-seven (57) special-status plant species and sixty-two (62) special-status wildlife species as occurring within the USGS *Cucamonga Peak, Devore, Fontana, and Guasti, California* 7.5-minute quadrangles. In addition, five (5) special-status vegetation communities were identified. Special-status plant and wildlife species were evaluated for their potential to occur within the project site based on habitat requirements, availability and quality of suitable habitat, and known distributions. Special-status biological resources identified during the literature review as having the potential to occur within the vicinity of the project site are presented in *Table D-1: Potentially Occurring Special-Status Biological Resources*, provided in Attachment D.

Special-Status Plants

Fifty-seven (57) special-status plant species have been recorded in the USGS *Cucamonga Peak, Devore, Fontana, and Guasti, California* 7.5-minute quadrangles by the CNDDDB and CNPS Online Inventory (refer to Attachment D). No special-status plant species were observed during the field survey. The project site is primarily comprised of residential development and disturbed habitat characterized by heavily disturbed/compacted soils. Additionally, the routine weed abatement within the project site and surrounding residential land uses have reduced the potential for the project site to provide suitable habitat for special-status plant species. Based on the results of the habitat assessment and a review specific habitat preferences, occurrence records, known distributions, and elevation ranges, it was determined that the special-status plant species identified by the CNDDDB and CNPS databases are not expected to occur within the project site.

Special-Status Wildlife

Sixty-two (62) special-status wildlife species have been recorded in the USGS *Cucamonga Peak, Devore, Fontana, and Guasti, California* 7.5-minute quadrangles by the CNDDDB (refer to Attachment D). No special-status wildlife species identified by the CNDDDB were observed within the project site during the field survey. Based on the results of the field survey and a review of specific habitat preferences, occurrence records, known distributions, and elevation ranges, it was determined that the project site has a low potential to support Cooper's hawk (*Accipiter cooperii*; a CDFW Watch List species), sharp-shinned hawk (*Accipiter striatus*; a CDFW Watch List species), and California horned lark (*Eremophila alpestris actia*; a CDFW Watch List species). All remaining special-status wildlife species identified by the CNDDDB database are not expected to occur within the project site.

Special-Status Vegetation Communities

Five (5) special-status vegetation communities have been reported in the USGS *Cucamonga Peak, Devore, Fontana, and Guasti, California* 7.5-minute quadrangles by the CNDDDB: California Walnut Woodland,

Coastal and Valley Freshwater Marsh, Riversidian Alluvial Fan Sage Scrub, Southern Riparian Forest, and Southern Sycamore Alder Riparian Woodland. The project site is comprised of residential development and disturbed habitat that is subject to routine weed abatement, resulting in heavily disturbed and compacted surface soils which reduces the likelihood of a special-status vegetation community from establishing. As such, no special-status vegetation communities were observed within the project site during the field survey.

Critical Habitat

Under the definition used by the Federal Endangered Species Act (FESA), “Critical Habitat” refers to specific areas within the geographical range of a species that were occupied at the time it was listed that contain the physical or biological features that are essential to the survival and eventual recovery of that species and that may require special management considerations or protection, regardless of whether the species is still extant in the area. Areas that were not known to be occupied at the time a species was listed can also be designated as Critical Habitat if they contain one or more of the physical or biological features that are essential to that species’ conservation and if the occupied areas are inadequate to ensure the species’ recovery. If a project may result in take or adverse modification to a species’ designated Critical Habitat and the project has a federal nexus, the project proponent may be required to provide suitable mitigation. Projects with a federal nexus include those that occur on federal lands, require federal permits (e.g., federal Clean Water Act [CWA] Section 404 permit), or receive any federal oversight or funding. If there is a federal nexus, then the federal agency that is responsible for providing funds or permits would be required to consult with the USFWS under the FESA. The project site is not located within any federally-designated Critical Habitat.

Conclusions and Recommendations

The project site is primarily comprised of residential development and disturbed habitat that is subject to routine weed abatement, resulting in heavily disturbed and compacted surface soils. As such, native vegetation communities do not occur within the project site; instead it is comprised of disturbed and developed land dominated by non-native and ornamental plant species.

No special-status plant species were observed during the field survey. The residential development and routine weed abatement within the project site and surrounding residential land uses have reduced the potential for the project site to provide suitable habitat for special-status plant species. Based on the results of the literature review and the field survey, Michael Baker determined that all remaining special-status plant species identified by the CNDDDB and CNPS databases are not expected to occur within the project site based on existing site conditions and a review of specific habitat preferences, occurrence records, known distributions, and elevation ranges.

No special-status wildlife species were observed within the project site during the field survey. Based on the results of the habitat assessment and a review of specific habitat preferences, occurrence records, known distributions, and elevation ranges, it was determined that the project site has a low potential to support Cooper’s hawk, sharp-shinned hawk, and California horned lark. All remaining special-status wildlife species identified by the CNDDDB database are not expected to occur within the project site.

The project site and surrounding vegetation communities provide suitable foraging and nesting habitat for a variety of year-round and seasonal avian residents as well as migrating songbirds that could occur in the area. Nesting birds are protected under the MBTA, the Bald and Golden Eagle Protection Act, and the

CFGC. If project-related activities are to be initiated during the nesting season (January 1st to August 31st), a pre-construction nesting bird clearance survey should be conducted by a qualified biologist no more than three (3) days prior to the start of any vegetation removal or ground disturbing activities. The survey should be conducted by a qualified biologist and cover all suitable nesting habitat within the project impact area, and areas within a biologically defensible buffer zone surrounding the project impact area. Further, if an active bird nest is found, the qualified biologist should identify the specific bird species and establish a “no-disturbance” buffer around the active nest to avoid potential direct and indirect impacts. It is further recommended that the qualified biologist periodically monitor any active bird nests to determine if project-related activities disturb the birds and if the “no disturbance” buffer should be increased. Once the young have fledged and left the nest, or the nest otherwise becomes inactive under natural conditions, project activities within the “no-disturbance” buffer may occur following an additional survey by the qualified biologist to search for any new nests in the restricted area.

Although no burrowing owls were observed during the field survey, a pre-construction burrowing owl clearance survey should be conducted by a qualified biologist to ensure that burrowing owls remain absent from the project site and impacts to burrowing owls do not occur. The pre-construction clearance surveys should be conducted no more than 30 days prior to any vegetation removal or ground disturbing activities and in accordance with the *Staff Report on Burrowing Owl Mitigation* (CDFW, 2012). Documentation of surveys and findings shall be submitted to the City of Fontana for review and file. If no burrowing owls or occupied burrows are detected, construction may begin. If an occupied burrow is found within the development footprint during pre-construction clearance surveys, a burrowing owl exclusion and mitigation plan would need to be prepared and submitted to CDFW for approval prior to initiating project activities.

Please do not hesitate to contact me at (949) 246-7004 or tommillington@mbakerintl.com or Ashley Spencer at (949) 472-3454 or ashley.spencer@mbakerintl.com should you have any questions or require further information.

Sincerely,



Tom Millington
Senior Biologist
Natural Resources and Regulatory Permitting



Ashley Spencer
Biologist
Natural Resources and Regulatory Permitting

Attachments:

- A. *Figure 1 – Vegetation Communities and Other Land Uses*
- B. *Site Plan*
- C. *Site Photographs*
- D. *Potentially Occurring Special-Status Biological Resources*
- E. *References*

Attachment A

Figure 1 – Vegetation Communities and Other Land Uses



Legend

- Project Site
- Ornamental (0.20 acre)
- Disturbed Habitat (8.87 acres)
- Developed (3.52 acres)
- Reference Point



0 50 100
Feet

1/6/2021 J:\NONTACA\F51_bkr.mbakercorp.com\HROOT\PDATA\181745\Work\Bld4_Figure\GIS\MXD\Fig 01_Vegetation Communities and Other Land Uses.mxd RP

Attachment B

Site Plan

GENERAL NOTES

- ALL WORK SHOWN HEREON SHALL BE DONE IN ACCORDANCE WITH THE CITY OF FONTANA STANDARDS AND SPECIFICATIONS, THE CONTRACT PROVISIONS, AND THE STANDARD SPECIFICATIONS FOR PUBLIC WORKS CONSTRUCTION ("GREEN BOOK"), CALIFORNIA BUILDING CODE, 2019 EDITION, AND THE CONTRACT DOCUMENTS AND CITY OF FONTANA ORDINANCE 1384.
- ALL WORK SHALL BE DONE IN ACCORDANCE WITH THE SOILS ENGINEER'S RECOMMENDATIONS AND CONTRACT SPECIFICATIONS, THE SOILS REPORT PREPARED BY Z S ENGINEERING, 113 TOMATO SPRINGS, IRVINE, CA 92618. PH: (949) 331-3232, JOB #200604, DATED AUGUST 14, 2020 AND ANY AMENDMENTS THERETO, ARE HEREBY MADE A PART HEREOF.
- PRIOR TO THE START OF GRADING, ALL EXISTING VEGETATION AND DEBRIS, INCLUDING EXISTING STRUCTURES, FOOTINGS, FOUNDATIONS, RUBBLE, TREES, AND ROOT SYSTEMS, SHALL BE REMOVED FROM THE SITE TO THE SATISFACTION OF THE SOILS ENGINEER.
- AFTER STRIPPING EXISTING DEBRIS, ANY EXISTING LOOSE FILL OR DISTURBED NATURAL SOILS SHALL BE EXCAVATED TO THE SATISFACTION OF THE SOILS ENGINEER.
- THE EXPOSED SOILS SHALL THEN BE INSPECTED BY THE SOILS ENGINEER, AND ANY ADDITIONAL OVER-EXCAVATION SHALL THEN BE MADE IN ACCORDANCE WITH THE SOILS ENGINEER'S RECOMMENDATION AND AS CONTAINED IN THE SOILS REPORT.
- THE EXPOSED SOILS SHOULD THEN BE SCARIFIED TO A MINIMUM DEPTH OF 6 INCHES, BROUGHT TO PROPER MOISTURE CONTENT AND COMPACTED TO AT LEAST 90% OF THE MAXIMUM DENSITY OBTAINABLE BY THE A.S.T.M. 0-1557-70 METHOD OF COMPACTION TO ATTAIN A DENSE AND UNYIELDING CONDITION.
- COMPACTION SHALL BE OBTAINED BY METHODS APPROVED BY THE SOILS ENGINEER.
- IF ANY UNKNOWN SUBSURFACE STRUCTURES ARE ENCOUNTERED DURING CONSTRUCTION, THEY SHALL BE IMMEDIATELY BROUGHT TO THE ATTENTION OF THE SOILS ENGINEER PRIOR TO PROCEEDING.
- DUST SHALL BE CONTROLLED BY WATERING THROUGHOUT THE GRADING AND CONSTRUCTION OPERATIONS.
- PROTECTIVE MEASURES SHALL BE TAKEN BY THE CONTRACTOR TO PROTECT ADJACENT PROPERTY AT ALL TIMES DURING CONSTRUCTION. PROTECTIVE MEASURES SHALL BE TAKEN BY THE CONTRACTOR TO PREVENT MUD, SILT OR DEBRIS FROM BEING CARRIED ONTO ADJACENT PROPERTY. ANY MUD OR DEBRIS ON PUBLIC PROPERTY SHALL BE REMOVED IMMEDIATELY.
- ALL GRADING AND FILLING OPERATIONS SHALL BE OBSERVED, INSPECTED AND TESTED BY A LICENSED SOILS ENGINEER, APPROVED BY THE OWNER, AND COMPACTION REPORTS PROVIDED FOR CITY APPROVAL.
- PRIOR TO THE START OF ANY BUILDING CONSTRUCTION, THE CONTRACTOR SHALL FURNISH THE ARCHITECT, OWNER AND THE CITY WITH THE CIVIL ENGINEER'S WRITTEN OPINION THAT APPROVED PLANS AND COMPACTION REPORTS FROM THE SOILS ENGINEER THAT THE PROPER COMPACTION AND PREPARATION HAS BEEN OBTAINED.
- NO GRADING SHALL COMMENCE WITHOUT OBTAINING GRADING PERMIT FROM THE BUILDING AND SAFETY DIVISION AND NOTIFYING GRADING INSPECTOR 24 HOURS PRIOR TO THE START OF WORK.
- PRIOR TO THE COMPLETION OF THIS CONTRACT, THE CONTRACTOR SHALL OBTAIN COMPACTION REPORTS FROM THE SOILS ENGINEER THAT THE PROPER SUBGRADE COMPACTION HAS BEEN OBTAINED, AND SHALL FURNISH SAID REPORTS TO THE CITY FOR APPROVAL.
- THE CONTRACTOR SHALL BE RESPONSIBLE TO REPORT DISCREPANCIES IN PLANS AND/OR FIELD CONDITIONS IMMEDIATELY TO THE DESIGN ENGINEER FOR RESOLUTIONS PRIOR TO CONSTRUCTION, AND SHALL BE RESPONSIBLE FOR DISCREPANCIES NOT SO REPORTED AND RESOLVED.
- ALL MANUFACTURED SLOPES ARE 2(H): 1(V) UNLESS OTHERWISE NOTED ON THE PLANS. NO SLOPES SHALL BE CONSTRUCTED STEEPER THAN 2 (H): 1 (V).
- SEE THE DIMENSION CONTROL PLAN FOR PRECISE HORIZONTAL CONTROL DATA, CURVE DATA, BEARINGS, DISTANCES, ETC.
- PRIOR TO THE COMPLETION OF THIS CONTRACT, THE CONTRACTOR SHALL OBTAIN THE CIVIL ENGINEER'S WRITTEN OPINION THAT THE PROPER SUBGRADE ELEVATIONS HAVE BEEN OBTAINED AND SHALL FURNISH SAID WRITTEN OPINION TO THE CITY APPROVAL.
- MINIMUM GRADES SHALL BE:
 - (A) CONCRETE STRUCTURES: " V" GUTTERS, CURB AND GUTTER, ETC. = 0.50X
 - (B) ASPHALT TURF GRADED SOILS, ETC. = 1.0X
 - (C) ON DIRT SWALE = 1.0X MIN.
- CONTRACTOR SHALL IMPLEMENT SAND BAG EROSION CONTROL MEASURES AS NECESSARY TO PROTECT THE GRADING OPERATIONS AND ADJACENT PROPERTY. EROSION CONTROL MEASURES TO BE IMPLEMENTED IN ACCORDANCE WITH CALIFORNIA BUILDING CODE, 2013 EDITION.
- ALL TRENCH BACKFILL TO BE CERTIFIED BY SOILS ENGINEER.
- HOURS OF OPERATION ARE 7:00 AM TO 4:00 PM, MONDAY THROUGH FRIDAY.
- A SEPARATE ENGINEERING DIVISION PERMIT SHALL BE REQUIRED FOR ANY IMPROVEMENTS WITHIN THE PUBLIC RIGHT OF WAY.
- SEPARATE PERMITS AND PLAN CHECK FROM THE CITY OF FONTANA BUILDING AND SAFETY DIVISION SHALL BE REQUIRED FOR ANY WALLS.
- IT SHALL BE THE CONTRACTOR'S RESPONSIBILITY TO VERIFY THE LOCATION OF ALL UTILITIES OR STRUCTURES ABOVE OR BELOW GROUND, SHOWN OR NOT SHOWN ON THESE PLANS. HE WILL BE HELD RESPONSIBLE FOR ALL DAMAGE TO ANY UTILITIES THAT RESULT FROM HIS OPERATIONS.
- STRICT ADHERENCE TO DUST CONTROL REQUIREMENTS SHALL BE ENFORCED AND ADJACENT STREETS ARE TO BE CLEANED DAILY OF ALL DIRT AND DEBRIS THAT IS A RESULT OF THIS OPERATION.
- REVISIONS TO THESE PLANS SHALL BE SUBMITTED TO THE BUILDING AND SAFETY DIVISION OF THE CITY OF FONTANA FOR HIS REVIEW AND APPROVAL.
- CONSTRUCTION MATERIAL AND EQUIPMENT SHALL NOT OCCUPY ANY PORTION OF THE PUBLIC RIGHT OF WAY, SUCH AS STREET, ALLEY OR PUBLIC SIDEWALK AT ANY TIME. TEMPORARY USE OF PUBLIC RIGHT OF WAY, WHENEVER REQUESTED, SHOULD BE REVIEWED AND APPROVED BY THE CITY ENGINEER.
- CITY APPROVAL OF THESE PLANS DOES NOT RELIEVE THE CONTRACTOR FROM RESPONSIBILITY FOR THE CORRECTION OF ERRORS AND OMISSIONS DISCOVERED DURING CONSTRUCTION. UPON REQUEST, THE REQUIRED PLAN REVISIONS SHALL BE PROMPTLY SUBMITTED TO THE CITY ENGINEER FOR APPROVAL.
- ALL GRADING SHALL CEASE WHEN WINDS EXCEED 25 MPH.
- "ROCK SIZES GREATER THAN 12 INCHES (305 mm) AND UP TO 24 INCHES (610 mm) IN MAXIMUM DIMENSION SHALL BE THREE FEET (914 mm) OR MORE BELOW GRADE, MEASURED VERTICALLY. ROCK SIZES GREATER THAN 24 INCHES (610 mm) IN MAXIMUM DIMENSION SHALL BE 10 FEET (3048mm) OR MORE BELOW GRADE, MEASURED VERTICALLY.
- THE SOILS/GEOTECHNICAL REPORT SHALL BE CONSIDERED PART OF THESE PLANS.
- NPOES BEST MANAGEMENT PRACTICES MUST BE MAINTAINED AND IMPLEMENTED. THE WQID IDENTIFICATION NUMBER IS 8 36C388617

NOTE:

- GRADING PLAN SHALL COMPLY WITH THE LATEST ADOPTED EDITION OF THE FOLLOWING CODES:
 - A. 2019 CALIFORNIA BUILDING CODE AND ITS APPENDICES AND STANDARDS
 - B. 2019 CALIFORNIA PLUMBING CODE AND ITS APPENDICES AND STANDARDS
 - C. CITY OF FONTANA ORDINANCES AND REGULATIONS
- PAD CERTIFICATION, COMPACTION REPORT AND ANY OTHER REQUIRED DOCUMENTS SHALL BE PROVIDED TO THE BUILDING INSPECTOR AT ROUGH GRADING INSPECTION.
- BUILDER SHALL PROVIDE THE BUILDING INSPECTOR WITH A FINAL PRECISE GRADING CERTIFICATE FROM THE ENGINEER OF RECORD PRIOR TO BUILDING'S FINAL INSPECTION.
- ALL OFFSITE IMPROVEMENTS ARE TO BE COMPLETED PER A SEPARATE PERMIT.

PRIVATE ENGINEER'S NOTICE TO CONTRACTOR:

THE EXISTENCE AND LOCATION OF ANY UNDERGROUND UTILITY PIPES, CONDUITS, OR STRUCTURES SHOWN ON THESE PLANS ARE OBTAINED BY A SEARCH OF THE AVAILABLE RECORDS TO THE BEST OF OUR KNOWLEDGE. THERE ARE NO EXISTING UTILITIES EXCEPT AS SHOWN ON THESE PLANS. THE CONTRACTOR IS REQUIRED TO TAKE DUE PRECAUTIONARY MEASURES TO PROTECT THE UTILITIES SHOWN ON THESE DRAWINGS. THE CONTRACTOR FURTHER ASSUMES ALL LIABILITY AND RESPONSIBILITY FOR THE UTILITY PIPES, CONDUITS, OR STRUCTURES SHOWN OR NOT SHOWN ON THESE DRAWINGS.

CONTRACTOR AGREES THAT HE SHALL ASSUME SOLE AND COMPLETE RESPONSIBILITY FOR JOB SITE CONDITIONS DURING COURSE OF CONSTRUCTION OF THIS PROJECT, INCLUDING SAFETY OF ALL PERSONS AND PROPERTY; THAT THIS REQUIREMENT SHALL APPLY CONTINUOUSLY AND NOT BE LIMITED TO NORMAL WORKING HOURS; AND THAT THE CONTRACTOR SHALL DEFEND, INDEMNIFY, AND HOLD THE CITY OF FONTANA, THE OWNER, AND THE ENGINEER HARMLESS FROM ANY AND ALL LIABILITY, REAL OR ALLEGED, IN CONNECTION WITH THE PERFORMANCE OF WORK ON THIS PROJECT, EXCEPTING FOR LIABILITY ARISING FROM THE SOLE NEGLIGENCE OF THE OWNER OR THE ENGINEER.

UNAUTHORIZED CHANGES & USES:

THE ENGINEER PREPARING THESE PLANS WILL NOT BE RESPONSIBLE FOR, OR LIABLE FOR, UNAUTHORIZED CHANGES TO OR USES OF THESE PLANS. ALL CHANGES TO THE PLANS MUST BE IN WRITING AND MUST BE APPROVED BY THE PREPARER OF THESE PLANS.

ROUGH AND PRECISE GRADING PLANS FOR TRACT 20358

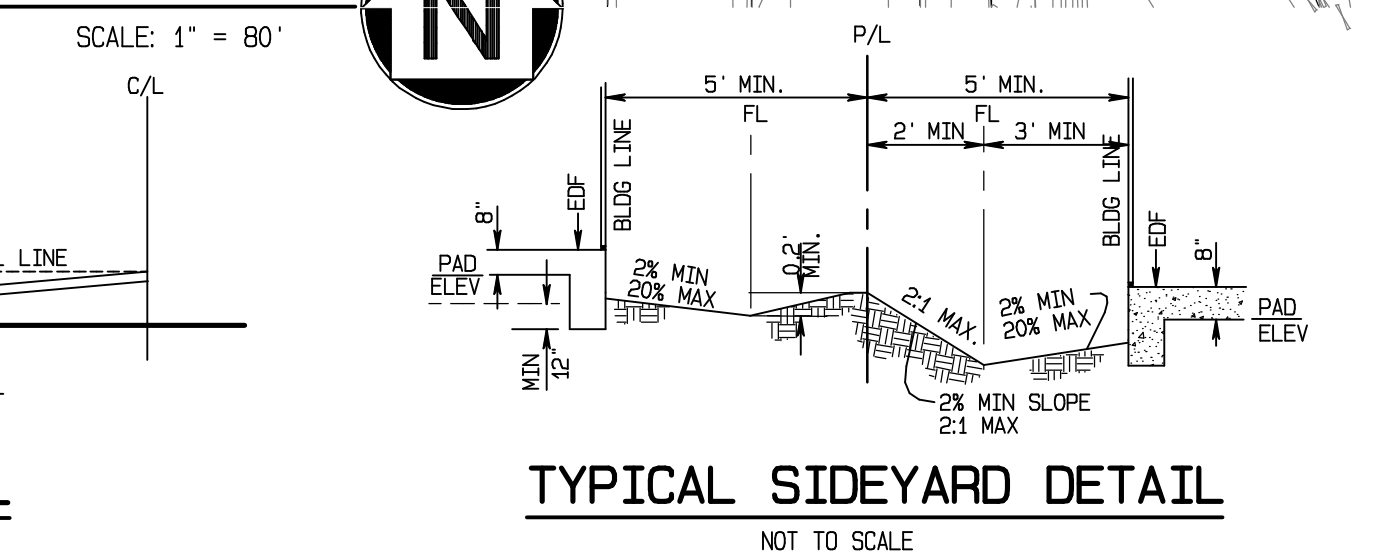
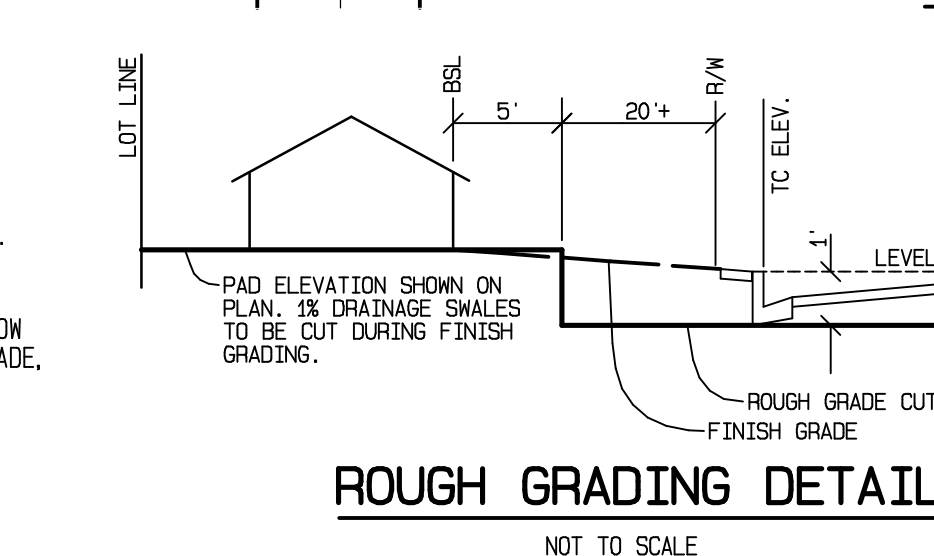
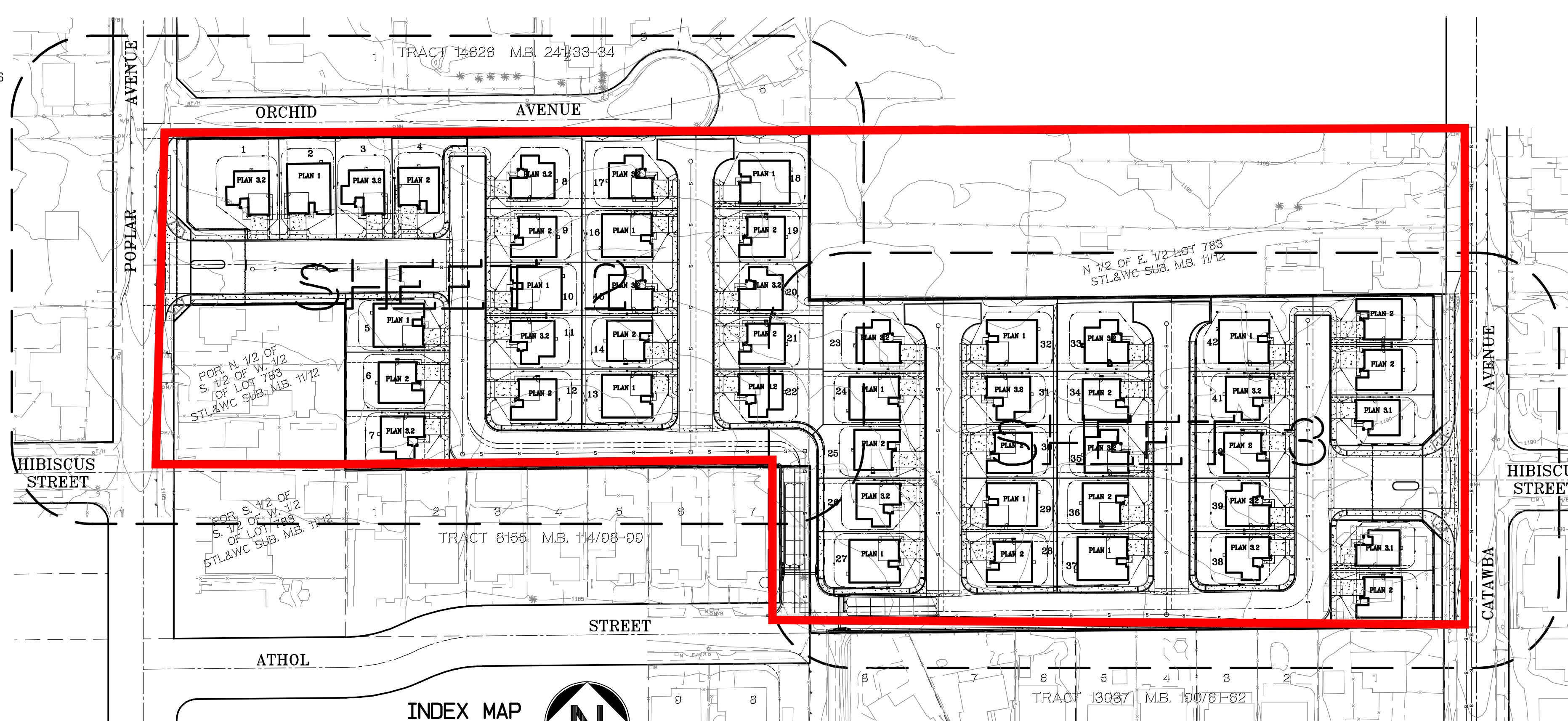

PLAN MATRIX

PLAN No.	FLOOR PLAN/SQUARE FEET	TOTAL NUMBER OF EACH PLAN	ELEVATION A	ELEVATION B	ELEVATION C
1	1,609	12	4	4	4
2	2,192	16	5	5	6
3, 1	2,008	2	6	6	5
3, 2	2,171	17			
TOTAL=		47	16	16	15

LEGAL DESCRIPTION

ALL THAT PORTION OF LOT 783, ACCORDING TO MAP SHOWING SUBDIVISION OF LANDS BELONGING TO THE SEMI-TROPIC LAND AND WATER COMPANY, IN THE CITY OF FONTANA, COUNTY OF SAN BERNARDINO, STATE OF CALIFORNIA, AS PER PLAT THEREOF RECORDED IN BOOK 11, PAGE 12 OF MAPS, IN THE OFFICE OF THE COUNTY RECORDER OF SAID COUNTY, DESCRIBED AS FOLLOWS:

- THE SOUTH ONE-HALF OF THE EAST ONE-HALF.
- THE SOUTH ONE-HALF OF THE NORTH ONE-HALF OF THE WEST ONE-HALF.
- THE NORTH ONE-HALF OF THE SOUTH ONE-HALF OF THE WEST ONE-HALF, EXCEPT THEREFROM THE WEST 200 FEET THEREOF.

AREAS AND DISTANCES COMPUTED TO STREET CENTERS.

HOUSE PLAN/ELEV/LOT AREA/STREET ADDRESS SCHEDULE

LOT NO.	FLOOR PLAN/SQUARE FEET	ELEVATION	LOT AREA/SQUARE FEET	STREET ADDRESS
1.	2,171 R	C	8,617	
2.	2,192 L	A	5,658	
3.	2,171 R	A	5,658	
4.	2,192 L	A	5,985	
5.	1,609 R	B	5,774	
6.	2,171 R	B	6,021	
7.	2,171 R	B	7,254	
8.	2,171 R	B	5,035	
9.	2,192 L	A	5,035	
10.	2,171 L	C	5,035	
11.	2,192 L	C	5,035	
12.	2,192 L	C	5,701	
13.	1,609 R	A	5,623	
14.	2,192 L	B	5,035	
15.	2,171 L	B	5,035	
16.	1,609 R	A	5,035	
17.	2,171 L	B	5,569	
18.	1,609 R	A	6,691	
19.	2,191 L	B	5,034	
20.	2,171 R	C	5,242	
21.	2,192 L	A	5,723	
22.	2,171 L	A	5,329	
23.	2,171 L	B	6,815	
24.	1,609 R	A	5,353	

HOUSE PLAN/ELEV/LOT AREA/STREET ADDRESS SCHEDULE

LOT NO.	FLOOR PLAN/SQUARE FEET	ELEVATION	LOT AREA/SQUARE FEET	STREET ADDRESS
25.	2,192 L	C	5,655	
26.	2,171 R	A	5,618	
27.	1,609 R	A	5,447	
28.	2,192 L	A	5,700	
29.	2,192 L	B	5,035	
30.	2,192 L	C	5,035	
31.	2,171 R	B	5,035	
32.	1,609 R	B	5,512	
33.	1,711	A	5,578	
34.	2,192 L	B	5,035	
35.	1,711	B	5,035	
36.	2,192 L	C	5,035	
37.	1,609 R	A	5,621	
38.	1,711	C	5,982	
39.	1,711	C	5,511	
40.	1,609 R	B	5,514	
41.	1,711 R	C	5,511	
42.	1,609 R	A	7,734	
43.	1,92	C	4,21	
44.	1,92	C	5,100	
45.	2,192 L	A	5,033	
46.	2,008 R	B	5,034	
47.	2,192 L	C	5,765	

RETAINING / FREESTANDING WALLS NOT A PART OF THIS PERMIT

CONSTRUCT PERIMETER MASONRY WALLS PER SEPARATE PERMIT.

SCOPE OF WORK

PROPOSED IS A 47 LOT SINGLE FAMILY RESIDENTIAL TRACT (IN FILL HOUSING) WITH PRIVATE STREETS, STREET LIGHTING, SEWER, WATER AND PERIMETER BLOCK WALL IMPROVEMENTS.

GENERAL NOTES

- ASSESSOR'S PARCEL No.: 0233-122-28, 29, 60, 63
- PROPERTY ADDRESS: 9092 CATAWBA AVENUE, FONTANA, CA 92335
- GROSS ACREAGE: 9.00 ACRES
- NET ACREAGE: 8.96 ACRES
- NUMBER OF LOTS: 47 LOTS
- PROJECT DENSITY: 5.25 LOTS/AC
- ZONING: R-2

EARTHWORK QUANTITIES

CUT YARDAGE: 0000 C.Y.
FILL YARDAGE: 0000 C.Y.

BLOCK WALL QUANTITIES

000 L.F.

NOTE:

WALL PLANS TO BE SUBMITTED UNDER SEPARATE PLAN CHECK NUMBER TO THE CITY OF FONTANA FOR REVIEW AND APPROVAL.

SOILS ENGINEER

Z S ENGINEERING
113 TOMATO SPRINGS
IRVINE, CA 92618
JOB NO. 200604
AUGUST 14, 2020
PHONE: (949) 331-3232

I REPRESENTING Z S ENGINEERING, INDICATE THAT RECOMMENDATIONS CONTAINED IN REPORTS PERTAINING TO SOIL ENGINEERING AND/OR ENGINEERING GEOLOGIC CONDITIONS HAVE BEEN COMPLIED WITH TO OUR SATISFACTION. THIS CONFIRMATION IS NOT TO BE CONSTRUED AS AN AUTHENTICATION OF ANY DIMENSIONS OR ELEVATIONS SHOWN ON THESE PLANS.

BY: ZAFAR AHMED GE #2720

DATE:

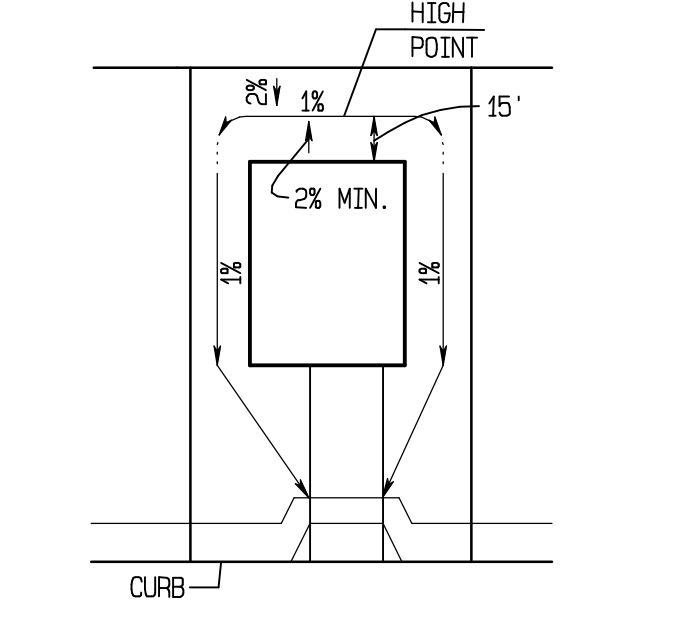

TYPICAL LOT DRAINAGE

NOT TO SCALE

1. RECORD OWNERS

- APN: 0233-122-28
NATHAN BOJORGUEZ
541 E. JAMIE AVENUE
LA HABRA, CA 90631
- APN: 0233-122-29
BASRO LLC
11801 S LAUSON AVENUE, #A
SANTA FE SPRINGS, CA 90670
- APN: 0233-122-60 AND 63
FERNANDO AND SUSANA MUFMAN FAMILY TRUST
30585 GANADO DRIVE
RANCHO PALOS VERDES, CA 90275

2. DEVELOPER

MONTEVISTA HOMES
8628 HILLSIDE ROAD
ALTA LOMA, CA 91701
ATTN: MR. STEVE LANDIS
PH: (951) 231-7206

3. ENGINEER

S.D. ENGINEERING AND ASSOCIATES
242 E. AIRPORT DRIVE, STE. 212
SAN BERNARDINO, CA 92408
ATTN: MR. SURESH DODDIAH
PH: (909) 215-3451

4. ASSESSORS PARCEL NO.:

0233-122-28, 29, 60, 63

5. ZONING

EXISTING: R-1
PROPOSED: R-2

AREA OF DISTURBANCE

47 RESIDENTIAL LOTS	6.05 ACRES
INTERIOR STREETS	2.91 ACRES
TOTAL AREA OF DISTURBANCE	8.96 ACRES

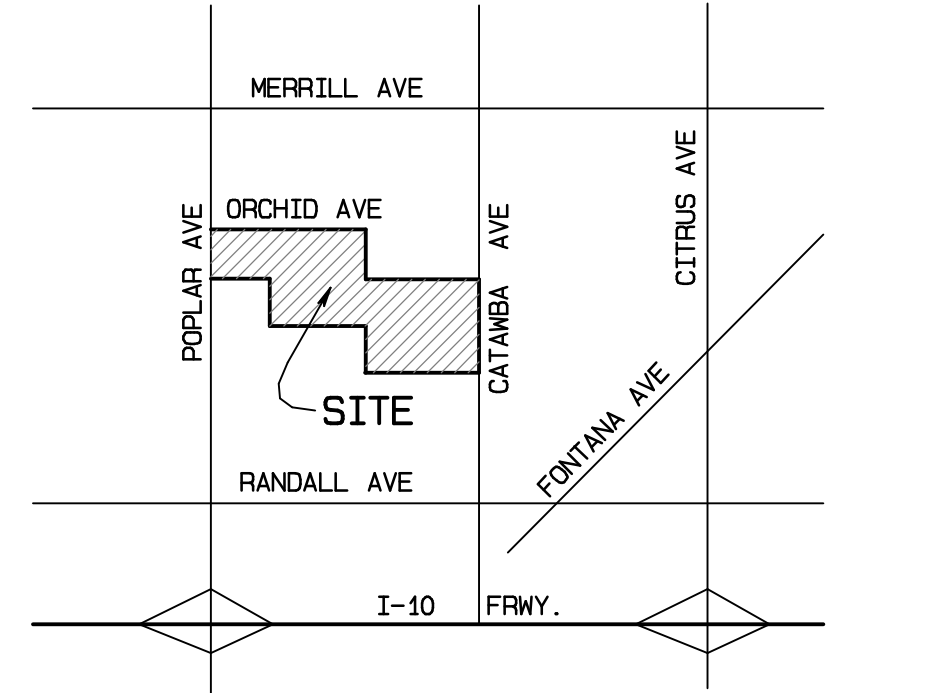

VICINITY MAP

NOT TO SCALE

SHEET INDEX

TITLE SHEET	SHEET 1
PRECISE GRADING PLAN	SHEET 2
PRECISE GRADING PLAN	SHEET 3

S.D. ENGINEERING AND ASSOCIATES
LAND PLANNING AND CIVIL ENGINEERING
242 E. AIRPORT DRIVE, SUITE 212 - SAN BERNARDINO, CA 92408
PHONE (909) 215-3451 EMAIL: SURESH@SDENGINEERING.NET

SURESH DODDIAH R.C.E. 36361 DATE



REV.	REVISION DESCRIPTION	DATE	ENGR.	CITY	DATE

SHOULD CONSTRUCTION OF THE REQUIRED IMPROVEMENTS NOT COMMENCE WITHIN TWO YEARS OF THE DATE OF APPROVAL SHOWN HEREON AND CARRIED FORTH IN A DILIGENT MANNER, THE CITY ENGINEER MAY REQUIRE REVISIONS TO THE PLANS TO BRING THEM INTO CONFORMANCE WITH CONDITIONS AND STANDARDS IN EFFECT.

BENCH MARK: BM #614
TOP OF FIRE HYDRANT AT THE NORTHWEST CORNER OF CATAWBA AVENUE AND HAWTHORNE STREET.
ELEVATION: 1152.53

CITY OF FONTANA, CALIFORNIA
ROUGH AND PRECISE GRADING PLANS

TRACT 20358
TITLE SHEET

SCALE: AS SHOWN
DATE: 8/19/2020
DRAWING NO. 1

APPROVED BY: CITY ENGINEER R.C.E. 51152 DATE: _____

Attachment C

Site Photographs



Photograph 1: Standing in the northwest portion of the project site, facing east.



Photograph 2: Standing in the western portion of the project site, facing east.



Photograph 3: Standing in the western portion of the project site, facing west.



Photograph 4: Standing in the southwest portion of the project site, facing north.



Photograph 5: Standing in the eastern portion of the project site, facing south.



Photograph 6: Standing in the eastern portion of the project site, facing west. The remnant greenhouse structures can be seen in the distance.



Photograph 7: Standing in the eastern portion of the project site, facing southwest.



Photograph 8: Standing adjacent to the southern boundary of the project site, facing northeast.

Attachment D

Potentially Occurring Special-Status Biological Resources

Table D-1: Potentially Occurring Special-Status Biological Resources

Scientific Name Common Name	Special-Status Rank*	Habitat Preferences and Distribution Affinities	Observed On-site	Potential to Occur
SPECIAL-STATUS WILDLIFE SPECIES				
<i>Accipiter cooperii</i> Cooper's hawk	WL G5 S4	Yearlong resident of California. Generally, found in forested areas up to 3,000 feet above mean sea level (amsl) in elevation, especially near edges and rivers. Prefers hardwood stands and mature forests, but can be found in urban and suburban areas where there are tall trees (25 to 50 feet high) for nesting. Prefers pines, oaks, Douglas-firs, beeches, spruces for nesting. Common in open areas during nesting season.	No	Low (Foraging): The project site provides marginal foraging habitat for this species. This species is not expected to nest within the project site due to the absence of tall, mature trees (25 to 50 feet high).
<i>Accipiter striatus</i> sharp-shinned hawk	WL G5 S4	Winter resident of southern California. Found in pine (<i>Pinus</i> spp.), fir (<i>Abies</i> spp.), and aspen (<i>Populus tremuloides</i>) forests. They can be found hunting in forest interior and edges from sea level to near alpine areas. Can also be found in rural, suburban and agricultural areas, where they often hunt at bird feeders.	No	Low (Foraging): The project site provides marginal foraging habitat for this species during the winter. This species does not breed in California.
<i>Agelaius tricolor</i> tricolored blackbird	ST SSC G2G3 S1S2	Range is limited to the coastal areas of the Pacific coast of North America, from Northern California to upper Baja California. Can be found in a wide variety of habitat including annual grasslands, wet and dry vernal pools and other seasonal wetlands, agricultural fields, cattle feedlots, and dairies. Occasionally forage in riparian scrub habitats along marsh borders. Basic habitat requirements for breeding include open accessible water, protected nesting substrate freshwater marsh dominated by cattails (<i>Typha</i> spp.), willows (<i>Salix</i> spp.), and bulrushes (<i>Schoenoplectus</i> spp.), and either flooded or thorny/spiny vegetation and suitable foraging space providing adequate insect prey.	No	Not Expected: Suitable nesting and foraging habitat consisting of annual grasslands, seasonal wetlands, freshwater marsh, and open accessible water are not present within the project site. Additionally, there are no occurrence records for this species within 5 miles of the project site (CNDDDB, 2020).
<i>Aimophila ruficeps canescens</i> southern California rufous-crowned sparrow	WL G5T3 S3	Yearlong resident that is typically found between 3,000 and 6,000 feet amsl. Breed in sparsely vegetated scrubland on hillsides and canyons. Prefers coastal sage scrub dominated by California sagebrush (<i>Artemisia californica</i>), but they can also be found breeding in coastal bluff scrub, low-growing serpentine chaparral, and along the edges of tall chaparral habitats.	No	Not Expected: Suitable coastal sage scrub, chaparral, and coastal bluff scrub habitats preferred by this species for foraging and nesting are not present within the project site. Additionally, there are no occurrence records for this species within 5 miles of the project site (CNDDDB, 2020).

Table D-1: Potentially Occurring Special-Status Biological Resources

Scientific Name Common Name	Special-Status Rank*	Habitat Preferences and Distribution Affinities	Observed On-site	Potential to Occur
<i>Anniella pulchra</i> northern California legless lizard	SSC G3 S3	Occurs from the southern edge of the San Joaquin River in northern Contra Costa County south to the Ventura County, south of which there is a wide area where the species of <i>Anniella</i> is or are unknown. Occurs in moist warm loose soil with plant cover. Moisture is essential. Occurs in sparsely vegetated areas of beach dunes, chaparral, pine-oak woodlands, desert scrub, sandy washes, and stream terraces with California sycamores (<i>Platanus racemosa</i>), Fremont cottonwoods (<i>Populus fremontii</i>), or oaks (<i>Quercus</i> spp.). Leaf litter under trees and bushes in sunny areas and dunes stabilized with bush lupine (<i>Lupinus</i> sp.) and mock heather (<i>Ericameria ericoides</i>) often indicate suitable habitat. Often can be found under surface objects such as rocks, boards, driftwood, and logs. Can also be found by gently raking leaf litter under bushes and trees. Sometimes found in suburban gardens in southern California.	No	Not Expected: Suitable beach dune, chaparral, pine-oak woodlands, desert scrub, sandy wash, and stream terrace habitats preferred by this species do not occur within the project site. The project site is comprised of residential development and disturbed habitat that is subject to routine weed abatement, resulting in heavily disturbed and compacted surface soils which likely precludes this species from occurring. Additionally, there are no occurrence records for this species within 5 miles of the project site (CNDDDB, 2020).
<i>Anniella stebbinsi</i> southern California legless lizard	SSC G3G4 S3S4	Locally abundant specimens are found in coastal sand dunes and a variety of interior habitats, including sandy washes and alluvial fans. A large protected population persists in the remnant of the once extensive El Segundo Dunes at Los Angeles International Airport.	No	Not Expected: Sandy wash and alluvial fan habitats preferred by this species are not present within the project site. The project site is comprised of residential development and disturbed habitat that is subject to routine weed abatement, resulting in heavily disturbed and compacted surface soils which likely precludes this species from occurring.
<i>Aquila chrysaetos</i> golden eagle	FP WL G5 S3	Yearlong resident of California. Occupies nearly all terrestrial habitats of the western states except densely forested areas. Favors secluded cliffs with overhanging ledges and large trees for nesting and cover. Hilly or mountainous country where takeoff and soaring are supported by updrafts is generally preferred to flat habitats. Deeply cut canyons rising to open mountain slopes and crags are ideal habitat.	No	Not Expected: This species is not expected to occur within the project site due to the lack of hilly and mountainous terrain preferred by this species for foraging and nesting. Additionally, there are no occurrence records for this species within 5 miles of the project site (CNDDDB, 2020).
<i>Arizona elegans occidentalis</i> California glossy snake	SSC G5T2 S2	Inhabits arid scrub, rocky washes, grasslands, and chaparral habitats. Appears to prefer microhabitats of open areas and areas with soil loose enough for easy burrowing.	No	Not Expected: Arid scrub, rocky washes, and grassland habitats preferred by this species are not present within the project site. The project site is comprised of residential development and disturbed habitat that is subject to routine weed abatement, resulting in heavily disturbed and compacted surface soils which likely precludes this species from occurring.

Table D-1: Potentially Occurring Special-Status Biological Resources

<i>Scientific Name</i> Common Name	Special-Status Rank*	Habitat Preferences and Distribution Affinities	Observed On-site	Potential to Occur
<i>Artemisospiza belli belli</i> Bell's sage sparrow	WL G5T2T3 S3	This species has a wide, but sparse distribution in western Riverside County, specifically within the "Riverside lowlands, San Jacinto Foothills, Santa Ana Mountains, and Desert Transition Bioregions. Yearlong resident on the coastal side of southern California mountains. Breeds in coastal sage scrub and chaparral habitats from February to August. They require semi-open habitats with evenly spaced shrubs one to two meters high. Occurs in chaparral dominated by fairly dense stands of chamise (<i>Adenostoma fasciculatum</i>).	No	Not Expected: The chaparral and coastal sage scrub habitats preferred by this species for foraging and nesting are not present within the project site. In addition, this species is possibly extirpated from the area (CNDDDB, 2020).
<i>Asio otus</i> long-eared owl	SSC G5 S3?	Nests in conifer, oak, riparian, pinyon-juniper, and desert woodlands that are either open or are adjacent to grasslands, meadows, or shrublands. Key habitat components are some dense cover for nesting and roosting, suitable nest platforms, and open foraging areas.	No	Not Expected: This species is not expected to occur within the project site due to the lack of dense woodland habitats preferred by this species for nesting and lack of open grasslands and meadows for foraging. Additionally, there are no occurrence records for this species within 5 miles of the project site (CNDDDB, 2020).
<i>Aspidoscelis hyperythra</i> orange-throated whiptail	WL G5 S2S3	Uncommon to fairly common over much of its range in Orange, Riverside, and San Diego counties. Also occurs in southwestern San Bernardino County near Colton. Semi-arid brushy areas typically with loose soil and rocks, including washes, streamsides, rocky hillsides, and coastal chaparral.	No	Not Expected: This species is not expected to occur within the project site due to the lack of washes, streamside, rocky hillside, and coastal chaparral habitats preferred by this species. The project site is comprised of residential development and disturbed habitat that is subject to routine weed abatement, resulting in heavily disturbed and compacted surface soils which likely precludes this species from occurring. Additionally, there are no occurrence records for this species within 5 miles of the project site (CNDDDB, 2020).

Table D-1: Potentially Occurring Special-Status Biological Resources

Scientific Name Common Name	Special-Status Rank*	Habitat Preferences and Distribution Affinities	Observed On-site	Potential to Occur
<i>Aspidoscelis tigris stejnegeri</i> coastal whiptail	SSC G5T5 S3	This subspecies is found in coastal southern California, mostly west of the Peninsular Ranges and south of the Transverse Ranges, and north into Ventura County. Ranges south into Baja California. Found in a variety of ecosystems, primarily hot and dry open areas with sparse vegetation in chaparral, woodland, and riparian areas. Associated with rocky areas with little vegetation or sunny microhabitats within shrub or grassland associations.	No	Not Expected: This species is not expected to occur within the project site due to the lack of chaparral, woodland, and riparian habitats preferred by this species. The project site is comprised of residential development and disturbed habitat that is subject to routine weed abatement, resulting in heavily disturbed and compacted surface soils which likely precludes this species from occurring. Additionally, there are no occurrence records for this species within 5 miles of the project site (CNDDDB, 2020).
<i>Athene cunicularia</i> burrowing owl	SSC G4 S3	Yearlong resident of California. Primarily a grassland species, but it persists and even thrives in some landscapes highly altered by human activity. Occurs in open, annual or perennial grasslands, deserts, and scrublands characterized by low-growing vegetation. The overriding characteristics of suitable habitat appear to be burrows for roosting and nesting and relatively short vegetation with only sparse shrubs and taller vegetation.	No	Not Expected: No burrowing owls or suitable burrows (>4 inches in diameter) capable of providing roosting and nesting opportunities were observed within the project site. The lack of suitable burrows, quality of surface soils within the project site, ongoing weed abatement, and the surrounding residential land uses likely preclude burrowing owls from occurring. In addition, the presence of telephone and light poles are expected to further decrease the likelihood that burrowing owls would occur within the project site as these features provide perching opportunities for larger raptors (e.g., red-tailed hawk [<i>Buteo jamaicensis</i>]) that are known to prey on burrowing owls.
<i>Bombus crotchii</i> Crotch bumble bee	SCE G3G4 S1S2	Found from coastal California east to the Sierra-Cascade crest and south into Mexico. Primarily occurs in California, including the Mediterranean region, Pacific coast, western desert, great valley, and adjacent foothills through most of southwestern California. Has also been recorded in Baja California, Baja California Sur, and in southwest Nevada. Inhabits open grassland and scrub habitats. Primarily nests underground. Food plant genera include <i>Antirrhinum</i> , <i>Phacelia</i> , <i>Clarkia</i> , <i>Dendromecon</i> , <i>Eschscholzia</i> , and <i>Eriogonum</i> .	No	Not Expected: This species is not expected to occur within the project site due to the ongoing weed abatement and lack of the preferred food plant genera.

Table D-1: Potentially Occurring Special-Status Biological Resources

<i>Scientific Name</i> Common Name	Special-Status Rank*	Habitat Preferences and Distribution Affinities	Observed On-site	Potential to Occur
<i>Buteo regalis</i> ferruginous hawk	WL G4 S3S4	Common winter resident of grasslands and agricultural areas in southwestern California. Frequents open grasslands, sagebrush flats, desert scrub, low foothills surrounding valleys, and fringes of pinyon-juniper habitats. This species does not breed in California.	No	Not Expected: Suitable open grasslands, sagebrush flats, desert scrub habitats preferred by this species for foraging are not present within the project site. Additionally, this species is not expected to nest within the project site because it does not breed in California and there are no occurrence records for this species within 5 miles of the project site (CNDDDB, 2020).
<i>Buteo swainsoni</i> Swainson's hawk	ST G5 S3	Summer migrant in southern California. Typical habitat is open desert, grassland, or cropland containing scattered, large trees or small groves. Breeds in stands with few trees in juniper-sage flats, riparian areas, and in oak savannah in the Central Valley. Forages in adjacent grassland or suitable grain or alfalfa fields or livestock pastures.	No	Not Expected: Suitable open desert, grassland, or cropland with scattered trees and groves preferred by this species for foraging and nesting are not present within the project site. Additionally, there are no occurrence records for this species within 5 miles of the project site (CNDDDB, 2020).
<i>Catostomus santaanae</i> Santa Ana sucker	FT G1 S1	Occur in the watersheds draining the San Gabriel and San Bernardino Mountains of southern California. Streams that Santa Ana Sucker inhabit are generally perennial streams with water ranging in depth from a few inches to several feet and with currents ranging from slight to swift.	No	Not Expected: Perennial streams preferred by this species are not present within the project site. Additionally, the project site is not located within Federally designated Critical Habitat for this species.
<i>Chaetodipus fallax fallax</i> northwestern San Diego pocket mouse	SSC G5T3T4 S3S4	Found terrestrially in a wide variety of temperate habitats ranging from chaparral and grasslands to scrub forests and deserts. Open habitat on the Pacific slope from southwestern San Bernardino County to northwestern Baja California. Habitat types include coastal sage scrub, sage scrub/grassland ecotones, and chaparral communities. Major habitat requirement is the presence of low growing vegetation or rocky outcroppings, as well as sandy soil to dig burrows.	No	Not Expected: Suitable coastal sage scrub/grassland and chaparral habitats with low growing vegetation and rocky outcroppings are not present within the project site. The project site is comprised of residential development and disturbed habitat that is subject to routine weed abatement, resulting in heavily disturbed and compacted surface soils which likely precludes this species from occurring.

Table D-1: Potentially Occurring Special-Status Biological Resources

Scientific Name Common Name	Special-Status Rank*	Habitat Preferences and Distribution Affinities	Observed On-site	Potential to Occur
<i>Chaetodipus fallax pallidus</i> pallid San Diego pocket mouse	SSC G5T34 S3S4	Common resident of sandy herbaceous areas, usually in association with rocks or coarse gravel in southwestern California. Occurs mainly in arid coastal and desert border areas. Habitats include coastal scrub, chamise-redshank chaparral, mixed chaparral, sagebrush, desert wash, desert scrub, desert succulent shrub, pinyon-juniper, and annual grassland.	No	Not Expected: Suitable coastal sage scrub, chamise-redshank chaparral, mixed chaparral, sagebrush, desert wash, desert scrub, desert succulent shrub, pinyon-juniper, and annual grassland habitats preferred by this species are not present within the project site. The project site is comprised of residential development and disturbed habitat that is subject to routine weed abatement, resulting in heavily disturbed and compacted surface soils which likely precludes this species from occurring.
<i>Circus hudsonius</i> northern harrier	SSC G5 S3	Yearlong resident of California. Frequents meadows, grasslands, open rangelands, desert sinks, fresh and saltwater emergent wetlands; seldom found in wooded area. In general, it prefers saltwater marshes, wet meadows, sloughs, and bogs for nesting and foraging. Nests on the ground in shrubby vegetation or patches of dense vegetation, usually at the marsh edge.	No	Not Expected: Preferred habitat consisting of saltwater marshes, wet meadows, sloughs, and bogs for nesting and foraging are not present within the project site. Additionally, there are no occurrence records for this species within 5 miles of the project site (CNDDDB, 2020).
<i>Coleonyx variegatus abbotti</i> San Diego banded gecko	SSC G5T3T4 S1S2	Found in southwestern California just inland from the Pacific coast, from Ventura County south into northwestern and central Baja California. Prefers granite or rocky outcrops in coastal scrub and chaparral habitats.	No	Not Expected: Coastal sage scrub and chaparral habitats preferred by this species are not present within the project site. The project site is comprised of residential development and disturbed habitat that is subject to routine weed abatement, resulting in heavily disturbed and compacted surface soils which likely precludes this species from occurring. Additionally, there are no occurrence records for this species within 5 miles of the project site (CNDDDB, 2020).
<i>Contopus cooperi</i> olive-sided flycatcher	SSC G4 S4	Uncommon to common, summer resident in a wide variety of forest and woodland habitats below 9,000 feet amsl throughout California exclusive of the deserts, the Central Valley, and other lowland valleys and basins. Preferred nesting habitats include mixed conifer, montane hardwood-conifer, Douglas fir (<i>Pseudotsuga menziesii</i>), redwood (<i>Sequoiadendron giganteum</i>), red fir (<i>Abies magnifica</i>), and lodgepole pine (<i>Pinus contorta</i>).	No	Not Expected: Forest and woodland habitats preferred by this species for nesting and foraging are not present within the project site. Additionally, there are no occurrence records for this species within 5 miles of the project site (CNDDDB, 2020).

Table D-1: Potentially Occurring Special-Status Biological Resources

Scientific Name Common Name	Special-Status Rank*	Habitat Preferences and Distribution Affinities	Observed On-site	Potential to Occur
<i>Crotalus ruber</i> red-diamond rattlesnake	SSC G4 S3	Found in southwestern California, from the Morongo Valley west to the coast and south along the peninsular ranges to mid Baja California. It can be found from the desert, through dense chaparral in the foothills (it avoids the mountains above around 4,000 feet amsl), to warm inland mesas and valleys, all the way to the cool ocean shore. It is most commonly associated with heavy brush with large rocks or boulders. Dense chaparral in the foothills, boulders associated coastal sage scrub, oak/pine woodlands, and desert slope scrub associations; however, chamise and red shank (<i>Adenostoma sparsifolium</i>) associations may offer better structural habitat for refuges and food resources for this species than other habitats.	No	Not Expected: Dense chaparral habitats with large rocks and boulders preferred by this species are not present within the project site. The project site is comprised of residential development and disturbed habitat that is subject to routine weed abatement, resulting in heavily disturbed and compacted surface soils which likely precludes this species from occurring. Additionally, there are no occurrence records for this species within 5 miles of the project site (CNDDDB, 2020).
<i>Dipodomys merriami parvus</i> San Bernardino kangaroo rat	FE SSC G5T1 S1	Primarily found in Riversidian alluvial fan sage scrub and sandy loam soils, alluvial fans and flood plains, and along washes with nearby sage scrub. May occur at lower densities in Riversidian upland sage scrub, chaparral and grassland in uplands and tributaries in proximity to Riversidian alluvial fan sage scrub habitats. Tend to avoid rocky substrates and prefer sandy loam substrates for digging of shallow burrows.	No	Not Expected: Suitable Riversidian alluvial fan sage scrub habitat with sandy soils preferred by this species for burrowing are not present within the project site. The quality of surface soils within the project site (e.g., heavily disturbed/compacted), ongoing weed abatement, and disconnection of the project site from natural fluvial processes likely precludes this species from occurring within the project site. Additionally, the project site is not located within Federally designated Critical Habitat for this species.
<i>Dipodomys nitratoides brevinasus</i> short-nosed kangaroo rat	SSC G3T1T2 S1S2	Occurs in the western, southern, and extreme southeastern side of the San Joaquin Valley, generally above the valley floor. Also occurs in Panoche Valley in eastern San Benito Valley, on the Carrizo Plain, in San Luis Obispo County, and the Cuyama Valley in San Luis Obispo and Santa Barbara counties. Generally associated with friable soils on flat or gently rolling terrain in grassland and desert-shrub vegetation (<i>Atriplex</i> sp. and <i>Ephedra californica</i>). In most of their range, they are found in lighter, friable soils such as sandy bottoms and banks of arroyos and other sandy areas.	No	Not Expected: Suitable grassland and desert-shrub habitats with friable soils are not present within the project site. The project site is comprised of residential development and disturbed habitat that is subject to routine weed abatement, resulting in heavily disturbed and compacted surface soils which likely precludes this species from occurring. Additionally, there are no occurrence records for this species within 5 miles of the project site (CNDDDB, 2020).

Table D-1: Potentially Occurring Special-Status Biological Resources

Scientific Name Common Name	Special-Status Rank*	Habitat Preferences and Distribution Affinities	Observed On-site	Potential to Occur
<i>Dipodomys stephensi</i> Stephens' kangaroo rat	FE ST G2 S2	Occur in arid and semi-arid habitats of open grassland or sparse shrublands with less than 50% protective cover. Require soft, well-drained substrate for building burrows and are typically found in areas with sandy soil in areas with <30 percent slope.	No	Not Expected: Suitable open grassland and sparse shrubland habitats with soft, sandy soils preferred by this species for burrowing are not present within the project site. The project site is comprised of residential development and disturbed habitat that is subject to routine weed abatement, resulting in heavily disturbed and compacted surface soils which likely precludes this species from occurring. Additionally, there are no occurrence records for this species within 5 miles of the project site (CNDDDB, 2020) and the project site is not located within Federally designated Critical Habitat for this species.
<i>Elanus leucurus</i> white-tailed kite	FP G5 S3S4	Yearlong resident along the coastal ranges and valleys of California. Occurs in low elevation, open grasslands, savannah-like habitats, agricultural areas, wetlands, and oak woodlands. Uses trees with dense canopies for cover. Important prey item is the California vole (<i>Microtus californicus</i>). Nests in tall (20 to 50 feet) coast live oaks (<i>Quercus agrifolia</i>).	No	Not Expected: Preferred open grassland, savannahs, agriculture, and oak woodland habitats preferred by this species for foraging and nesting are not present within the project site. Additionally, there are no occurrence records for this species within 5 miles of the project site (CNDDDB, 2020).
<i>Empidonax traillii</i> willow flycatcher	SE G5 S1S2	A rare summer resident of California with currently known breeding locations restricted primarily to the Sierra Nevada/Cascade region, near Buelton in Santa Barbara County; Prado Basin in Riverside County; and several locations in San Diego County. In California, the species is restricted to thickets of willows, whether along streams in broad valleys, in canyon bottoms, around mountain-side seepages, or at the margins of ponds and lakes.	No	Not Expected: Riparian habitat with thickets of willows that are adjacent to surface water preferred by this species for foraging and nesting are not present within the project site. Additionally, there are no occurrence records for this species within 5 miles of the project site (CNDDDB, 2020).
<i>Empidonax traillii eximus</i> southwestern willow flycatcher	FE SE G5T2 S1	Uncommon summer resident in southern California primarily found in lower elevation riparian habitats occurring along streams or in meadows. The structure of suitable breeding habitat typically consists of a dense mid-story and understory and can also include a dense canopy. Nest sites are generally located near surface water or saturated soils. The presence of surface water, swampy conditions, standing or flowing water under the riparian canopy are preferred.	No	Not Expected: Riparian habitats with thickets of willows that are adjacent to surface water preferred by this species for foraging and nesting are not present within the project site. Additionally, there are no occurrence records for this species within 5 miles of the project site (CNDDDB, 2020) and the project site is not located within Federally designated Critical Habitat for this species.

Table D-1: Potentially Occurring Special-Status Biological Resources

Scientific Name Common Name	Special-Status Rank*	Habitat Preferences and Distribution Affinities	Observed On-site	Potential to Occur
<i>Eremophila alpestris actia</i> California horned lark	WL G5T4Q S4	Yearlong resident of California. This subspecies is typically found in coastal regions. Breed in level or gently sloping shortgrass prairie, montane meadows, "bald" hills, open coastal plains, fallow grain fields, and alkali flats. Within southern California, California horned larks breed primarily in open fields, (short) grasslands, and rangelands. Nests on the open ground.	No	Low (Foraging and Nesting): The project site provides marginal foraging and nesting habitat for this species.
<i>Eumops perotis californicus</i> western mastiff bat	SSC G5T4 S3S4	Primarily a cliff-dwelling species, roost generally under exfoliating rock slabs. Roosts are generally high above the ground, usually allowing a clear vertical drop of at least 3 meters below the entrance for flight. In California, it is most frequently encountered in broad open areas. Its foraging habitat includes dry desert washes, flood plains, chaparral, oak woodland, open ponderosa pine forest, grassland, and agricultural areas.	No	Not Expected: Suitable open foraging habitat preferred by this species is not present within the project site. This species is not expected to roost within the project site due to the lack of exfoliating rock slabs.
<i>Falco mexicanus</i> prairie falcon	WL G5 S4	The prairie falcon is associated primarily with perennial grasslands, savannahs, rangeland, some agricultural fields during the winter season, and desert scrub areas, all typically dry environments of western North American where there are cliffs or bluffs for nest sites. The species requires sheltered cliff ledges for cover and nesting which may range in height from low rock outcrops of 30 feet to vertical, 400 feet high (or more) cliffs and typically overlook some treeless country for hunting. Open terrain is used for foraging.	No	Not Expected: Suitable perennial grassland, savannah, and desert scrub habitats preferred by this species for foraging are not present within the project site. Additionally, this species is not expected to nest within the project site due to the lack of sheltered cliffs. Further, there are no occurrence records for this species within 5 miles of the project site (CNDDDB, 2020).
<i>Gila orcuttii</i> arroyo chub	SSC G2 S2	Warm streams of the Los Angeles Plain, which are typically muddy torrents during the winter, and clear quiet brooks in the summer, possibly drying up in places. They are found both in slow-moving and fast-moving sections, but generally deeper than 16 inches.	No	Not Expected: Perennial streams preferred by this species are not present within the project site.
<i>Icteria virens</i> yellow-breasted chat	SSC G5 S3	Summer resident of California. Primarily found in tall, dense, relatively wide riparian woodlands and thickets of willows, vine tangles, and dense brush with well-developed understories. Breeding habitat within southern California primarily consists of dense, wide riparian woodlands and thickets of willows, vine tangles, and dense brush with well-developed understories. Nesting areas are associated with streams, swampy ground, and the borders of small ponds. It winters south the Central America. Found at elevations ranging from 820 to 2,625 feet amsl.	No	Not Expected: Riparian woodland habitats with thickets of willows and dense brush that are adjacent to surface water preferred by this species for foraging and nesting are not present within the project site. Additionally, there are no occurrence records for this species within 5 miles of the project site (CNDDDB, 2020).

Table D-1: Potentially Occurring Special-Status Biological Resources

Scientific Name Common Name	Special-Status Rank*	Habitat Preferences and Distribution Affinities	Observed On-site	Potential to Occur
<i>Lanius ludovicianus</i> loggerhead shrike	SSC G4 S4	Yearlong resident of California. Prefers open habitats with bare ground, scattered shrubs, and areas with low or sparse herbaceous cover including open-canopied valley foothill hardwood, riparian, pinyon-juniper desert riparian, creosote bush scrub, and Joshua tree woodland. Requires suitable perches including trees, posts, fences, utility lines, or other perches. Nests in branches up to 14 feet above the ground frequently in a shrub with thorns or with tangled branching habitats.	No	Not Expected: Suitable foraging and nesting habitat preferred by this species is not present within the project site. Further, there are no occurrence records for this species within 5 miles of the project site (CNDDDB, 2020).
<i>Larus californicus</i> California gull	WL G5 S4	Require isolated islands in rivers, reservoirs and natural lakes for nesting, where predations pressures from terrestrial mammals are diminished. Uses both fresh and saline aquatic habitats at variable elevations and degrees of aridity for nesting and for opportunistic foraging.	No	Not Expected: Suitable fresh/saline aquatic habitats used by this species for foraging and nesting are not present within the project site.
<i>Lasiurus xanthinus</i> western yellow bat	SSC G5 S3	Uncommon in California, known only in Los Angeles and San Bernardino Counties. Occurs in valley foothill riparian, desert riparian, desert wash, and palm oasis habitats. Prefers to roost and feed in, and near, palm oases and riparian habitats. Commonly found in the southwestern U.S. roosting in the skirt of dead fronds in both native and non-native palm trees.	No	Not Expected: This species is not expected to roost and forage within the project site due to the lack of palm oases and riparian habitats.
<i>Laterallus jamaicensis coturniculus</i> California black rail	ST FP G3G4T1 S1	Suitable habitat generally includes salt marshes, freshwater marshes, and wet meadows. Typical associated vegetation includes pickle weed (<i>Salicornia virginica</i>) in salt marshes and bulrushes in less saline habitats.	No	Not Expected: This species is not expected to nest and forage within the project site due to the lack of salt marsh, freshwater marsh, and wet meadow habitats. Additionally, there are no occurrence records for this species within 5 miles of the project site (CNDDDB, 2020).
<i>Lepus californicus bennettii</i> San Diego black-tailed jackrabbit	SSC G5T3T4 S3S4	Occupies many diverse habitats, but primarily is found in arid regions supporting short-grass habitats, agricultural fields, or sparse coastal scrub.	No	Not Expected: Suitable habitat preferred by this species is not present within the project site.
<i>Microtus californicus mohavensis</i> Mohave river vole	SSC G5T1 S1	Found in moist habitats including meadows, freshwater marshes and irrigated pastures in the vicinity of the Mojave River. Suitable habitat it associated with ponds and irrigation canals along with the Mojave River proper. Alfalfa (<i>Medicago sativa</i>) fields may also provide habitat.	No	Not Expected: The project site is outside of the known range of this species (habitats adjacent to the Mojave River). Additionally, there are no occurrence records for this species within 5 miles of the project site (CNDDDB, 2020).

Table D-1: Potentially Occurring Special-Status Biological Resources

Scientific Name Common Name	Special-Status Rank*	Habitat Preferences and Distribution Affinities	Observed On-site	Potential to Occur
<i>Neotoma lepida intermedia</i> San Diego desert woodrat	SSC G5T3T4 S3S4	Occurs in coastal scrub communities between San Luis Obispo and San Diego Counties. Found in a variety of shrub and desert habitats, primarily associated with rock outcroppings, boulders, cacti, or areas of dense undergrowth. Woodrats often are associated with cholla cactus which they use for water and dens or boulders and boulder piles. The most common natural habitats for records are chaparral, coastal sage scrub (including Riversidian sage scrub and Diegan coastal sage scrub) and grassland.	No	Not Expected: Suitable chaparral, coastal sage scrub, Riversidian sage scrub, and grassland habitats preferred by this species are not present within the project site. The project site is comprised of residential development and disturbed habitat that is subject to routine weed abatement, resulting in heavily disturbed and compacted surface soils which likely precludes this species from occurring.
<i>Nyctinomops femorosaccus</i> pocketed free-tailed bat	SSC G4 S3	Often found in pinyon-juniper woodlands, desert scrub, desert succulent shrub, desert riparian, desert wash, alkali desert scrub, Joshua tree (<i>Yucca brevifolia</i>) woodland, and palm oasis habitats. Prefers rocky desert areas with high cliffs or rock outcrops, which are used as roosting sites.	No	Not Expected: This species is not expected to roost and forage within the project site due to the lack of palm oasis and desert scrub and riparian habitats with high cliffs and rock outcrops.
<i>Oncorhynchus mykiss irideus</i> pop. 10 steelhead - southern California DPS	FE G5T1Q S1	Steelhead can survive in a wide range of temperature conditions. Species is found where dissolved oxygen concentration is at least 7 parts per million. In streams, deep low-velocity pools are important wintering habitats. Spawning habitat consists of gravel substrates free of excessive silt.	No	Not Expected: Perennial streams preferred by this species are not present within the project site.
<i>Onychomys torridus ramona</i> southern grasshopper mouse	SSC G5T3 S3	Common in arid desert habitats of the Mojave and southern Central Valley of California. Known elevation range is generally below 3,000 feet amsl. Little is known about habitat requirements; however, it is commonly found in scrub habitats with friable soils for digging in desert areas. It is believed that alkali desert scrub and desert scrub habitats are preferred, with somewhat lower densities expected in other desert habitats, including succulent shrub, wash, and riparian areas. Also occurs in coastal scrub, mixed chaparral, sagebrush, low sage, and bitterbrush habitats.	No	Not Expected: Desert scrub habitats with friable soils preferred by this species are not present within the project site. The project site is comprised of residential development and disturbed habitat that is subject to routine weed abatement, resulting in heavily disturbed and compacted surface soils which likely precludes this species from occurring. Additionally, there are no occurrence records for this species within 5 miles of the project site (CNDDDB, 2020).
<i>Ovis canadensis nelson</i> desert bighorn sheep	FP G4T4 S3	Preferred habitat is near mountainous terrain above the desert floor that is visually open, as well as steep and rocky. Most Mojave Desert mountain ranges satisfy these requirements well. Surface water is another element that is considered important to population health.	No	Not Expected: Mountainous terrain preferred by this species is not present within the project site.

Table D-1: Potentially Occurring Special-Status Biological Resources

Scientific Name Common Name	Special-Status Rank*	Habitat Preferences and Distribution Affinities	Observed On-site	Potential to Occur
<i>Pandion haliaetus</i> osprey	WL G5 S4	Winter resident of southern California. Associated strictly with large, fish-bearing waters, primarily in ponderosa pine through mixed conifer habitats. Uses large trees, snags, and dead-topped trees in open forest habitats for cover and nesting. Requires open, clear waters for foraging and uses rivers, lakes, reservoirs, bays, estuaries, and surf zones.	No	Not Expected: Mixed conifer habitats adjacent to a large water body preferred by this species for foraging and nesting are not present within the project site. Additionally, there are no occurrence records for this species within 5 miles of the project site (CNDDDB, 2020).
<i>Perognathus longimembris brevinasus</i> Los Angeles pocket mouse	SSC G5T1T2 S1S2	Occurs in lower elevation grasslands and coastal sage scrub communities in and around the Los Angeles Basin. Prefers open ground with fine sandy soils. May not dig extensive burrows, but instead will seek refuge under weeds and dead leaves instead.	No	Not Expected: Suitable grassland and coastal sage scrub habitats with fine sandy soils preferred by this species for burrowing are not present within the project site. The project site is comprised of residential development and disturbed habitat that is subject to routine weed abatement, resulting in heavily disturbed and compacted surface soils which likely precludes this species from occurring.
<i>Perognathus longimembris pacificus</i> Pacific pocket mouse	FE SSC G5T1 S1	One of sixteen currently recognized subspecies of little pocket mouse (<i>Perognathus longimembris</i>), which is a widespread species that is distributed throughout arid regions of the western U.S. extending into northern part of Baja California peninsula and west central Sonora, Mexico. Pacific pocket mouse is associated with fine grain, sandy substrates in coastal strand, coastal dunes, river alluvium and coastal sage scrub habitats within 2.5 miles of the ocean in southern California.	No	Not Expected: Suitable coastal dune, river alluvium, and coastal sage scrub habitats with fine sandy soils preferred by this species for burrowing are not present within the project site. The project site is comprised of residential development and disturbed habitat that is subject to routine weed abatement, resulting in heavily disturbed and compacted surface soils which likely precludes this species from occurring. Additionally, there are no occurrence records for this species within 5 miles of the project site (CNDDDB, 2020).
<i>Phalacrocorax auritus</i> double-crested cormorant	WL G5 S4	Yearlong resident of California. Prefers water less than 30 feet deep with rocky or gravel bottom. Rests in daytime and roosts overnight beside water on offshore rocks, islands, cliffs, dead branches of trees, wharfs, jetties, or even transmission lines. Occupies diverse aquatic habitats in all seasons. In California, most individuals are found nesting in coastal regions. Requires suitable places for daytime resting (e.g., rocks, sandbars, pilings). Forage in shallow water (< 30 feet deep).	No	Not Expected: Suitable aquatic habitats preferred by this species for foraging and nesting are not present within the project site. Additionally, there are no occurrence records for this species within 5 miles of the project site (CNDDDB, 2020).

Table D-1: Potentially Occurring Special-Status Biological Resources

Scientific Name Common Name	Special-Status Rank*	Habitat Preferences and Distribution Affinities	Observed On-site	Potential to Occur
<i>Phrynosoma blainvillii</i> coast horned lizard	SSC G3G4 S4	Occurs in a wide variety of vegetation types including coastal sage scrub, annual grassland, chaparral, oak woodland, riparian woodland and coniferous forest. Its elevational range extends up to 4,000 feet in the Sierra Nevada foothills and up to 6,000 feet in the mountains of southern California. In inland areas, this species is restricted to areas with pockets of open microhabitat, created by disturbance (e.g. fire, floods, unimproved roads, grazing lands, and fire breaks). The key elements of such habitats are loose, fine soils with a high sand fraction; an abundance of native ants or other insects; and open areas with limited overstory for basking and low, but relatively dense shrubs for refuge.	No	Not Expected: Loose, fine sandy soils preferred by this species are not present within the project site. The project site is comprised of residential development and disturbed habitat that is subject to routine weed abatement, resulting in heavily disturbed and compacted surface soils which likely precludes this species from occurring.
<i>Poliophtila californica californica</i> coastal California gnatcatcher	FT SSC G4G5T2Q S2	Yearlong resident of sage scrub habitats that are dominated by California sagebrush. This species generally occurs below 750 feet amsl in coastal regions and below 1,500 feet amsl inland. Ranges from the Ventura County, south to San Diego County and northern Baja California and it is less common in sage scrub with a high percentage of tall shrubs. Prefers habitat with more low-growing vegetation.	No	Not Expected: Suitable coastal sage scrub habitat dominated by California sagebrush are not present within the project site. Additionally, the project site is not located within Federally designated Critical Habitat for this species.
<i>Rana muscosa</i> southern mountain yellow-legged frog	FE SE WL G1 S1	The species inhabits ponds, lakes, and streams at moderate to high elevations. Usually associated with montane riparian habitats in lodgepole pine, yellow pine (<i>Pinus ponderosa</i>), sugar pine (<i>Pinus lambertiana</i>), white fir (<i>Abies concolor</i>), whitebark pine (<i>Pinus albicaulis</i>), and wet meadow vegetation types. Occupied alpine lakes usually have margins that are grassy or muddy and inhabit sandy or rocky shores at lower elevations. Streams utilized vary from rocky, high gradient streams with numerous pools, rapids, and small waterfalls to those with marshy edges and sod banks. Species seems to prefer streams of low gradient and slow or moderate flow with very small, shallow streams being less frequently used.	No	Not Expected: Montane riparian and wet meadow habitats preferred by this species are not present within the project site. Additionally, this species is possibly extirpated/ extirpated from the United States Geological Survey's (USGS) <i>Cucamonga Peak and Devore, California</i> 7.5-minute quadrangles (CNDDDB, 2020). Further, the project site is not located within Federally designated Critical Habitat for this species.
<i>Rhaphiomidas terminatus abdominalis</i> Delhi Sands flower-loving fly	FE G1T1 S1	Restricted to areas that include Delhi fine sand, an aeolian (wind-deposited) soil types. The highest density of this species has been found in habitat that includes a variety of plants including California buckwheat (<i>Eriogonum fasciculatum</i>), California croton (<i>Croton californicus</i>), deerweed (<i>Acmispon glaber</i>), and telegraph weed (<i>Heterotheca grandiflora</i>).	No	Not Expected: Delhi fine sand soils are not present within the project site.
<i>Rhinichthys osculus</i> ssp. 3 Santa Ana speckled dace	SSC G5T1 S1	Requires permanent flowing streams with summer water temperatures of 62 – 68 degrees Fahrenheit. Inhabits shallow cobble and gravel riffles and small streams that flow through steep, rocky canyons with chaparral covered walls.	No	Not Expected: Perennial streams preferred by this species are not present within the project site.

Table D-1: Potentially Occurring Special-Status Biological Resources

Scientific Name Common Name	Special-Status Rank*	Habitat Preferences and Distribution Affinities	Observed On-site	Potential to Occur
<i>Salvadora hexalepis virgulata</i> coast patch-nosed snake	SSC G5T4 S2S3	Occurs in brushy vegetation including coastal scrub and chaparral from the coast to the mountains. Takes refuge in existing small mammal burrows.	No	Not Expected: Coastal sage scrub and chaparral habitats preferred by this species are not present within the project site. The project site is comprised of residential development and disturbed habitat that is subject to routine weed abatement, resulting in heavily disturbed and compacted surface soils which likely precludes this species from occurring. Additionally, there are no occurrence records for this species within 5 miles of the project site (CNDDDB, 2020).
<i>Setophaga petechia</i> yellow warbler	SSC G5 S3S4	Present in California from April through September. Nests in riparian areas dominated by willows, cottonwoods, California sycamores, or alders (<i>Alnus</i> spp.) or in mature chaparral. May also use oaks, conifers, and urban areas near stream courses.	No	Not Expected: Riparian habitat dominated by willows, cottonwoods, alders, and/or California sycamores are not present within the project site. Additionally, there are no occurrence records for this species within 5 miles of the project site (CNDDDB, 2020).
<i>Spea hammondi</i> western spadefoot	SSC G3 S3	Prefers open areas with sandy or gravelly soils, in a variety of habitats including mixed woodlands, grasslands, coastal sage scrub, chaparral, sandy washes, lowlands, river floodplains, alluvial fans, playas, alkali flats, foothills, and mountains. Rain pools which do not contain American bullfrogs (<i>Lithobates catesbeianus</i>), predatory fish, or crayfish are necessary for breeding. Estivates in upland habitats adjacent to potential breeding sites in burrows approximating 3 feet in depth.	No	Not Expected: Suitable sandy and gravelly soils and habitats preferred by this species area not present within the project site. The project site is comprised of residential development and disturbed habitat that is subject to routine weed abatement, resulting in heavily disturbed and compacted surface soils which likely precludes this species from occurring. Additionally, there are no occurrence records for this species within 5 miles of the project site (CNDDDB, 2020).
<i>Strix occidentalis occidentalis</i> California spotted owl	SSC G3G4T2T3 S3	Yearlong resident that roosts and breeds in forests and woodlands with large, old growth trees and snags, dense canopies ($\geq 70\%$ canopy closure), multiple canopy layers, and downed woody debris. Species is considered a habitat specialist; large, old trees are the key component as they provide nest sites and cover from inclement weather and add structure to the forest canopy and woody debris to the forest floor.	No	Not Expected: Suitable old growth woodland forest habitats preferred by this species for foraging and nesting are not present within the project site. Additionally, there are no occurrence records for this species within 5 miles of the project site (CNDDDB, 2020).

Table D-1: Potentially Occurring Special-Status Biological Resources

Scientific Name Common Name	Special-Status Rank*	Habitat Preferences and Distribution Affinities	Observed On-site	Potential to Occur
<i>Taxidea taxus</i> American badger	SSC G5 S3	Occupies a wide variety of habitats including dry, open grassland, sagebrush, and woodland habitats. Require dry, friable, often sandy soil to dig burrows for cover, food storage, and giving birth. Occasionally found in riparian zones and open chaparral with less than 50% plant cover.	No	Not Expected: Suitable open grassland, sagebrush, and woodland habitats with sandy soils preferred by this species are not present within the project site. The project site is comprised of residential development and disturbed habitat that is subject to routine weed abatement, resulting in heavily disturbed and compacted surface soils which likely precludes this species from occurring. Additionally, there are no occurrence records for this species within 5 miles of the project site (CNDDDB, 2020).
<i>Thamnophis hammondi</i> two-striped garter snake	SSC G4 S3S4	Occurs in or near permanent fresh water, often along streams with rocky beds and riparian growth up to 7,000 feet amsl.	No	Not Expected: Permanent freshwater is not present within the project site. Additionally, there are no occurrence records for this species within 5 miles of the project site (CNDDDB, 2020).
<i>Vireo bellii pusillus</i> least Bell's vireo	FE SE SSC G5T2 S2	Summer resident in southern California. Breeding habitat generally consists of dense, low, shrubby vegetation in riparian areas, and mesquite brushlands, often near water in arid regions. Early successional cottonwood-willow riparian groves are preferred for nesting. The most critical structural component of nesting habitat in California is a dense shrub layer that is 2 to 10 feet (0.6 to 3.0 meters) above ground. The presence of water, including ponded surface water or moist soil conditions, may also be a key component for nesting habitat.	No	Not Expected: Riparian habitats with early successional cottonwood – willow groves that are adjacent to surface water preferred by this species for foraging and nesting are not present within the project site. Additionally, there are no occurrence records for this species within 5 miles of the project site (CNDDDB, 2020) and the project site is not located within Federally designated Critical Habitat for this species.
<i>Xanthocephalus xanthocephalus</i> yellow-headed blackbird	SSC G5 S3	Locally common yearlong resident in California. Occurs in freshwater emergent wetlands, and moist, open areas along croplands and mud flats of lacustrine habitats. Prefers to nest in dense wetland vegetation characterized by tules, cattails, or other similar plant species along the border of lakes and ponds.	No	Not Expected: Freshwater emergent wetland habitats preferred by this species for foraging and nesting are not present within the project site. Additionally, there are no occurrence records for this species within 5 miles of the project site (CNDDDB, 2020).
SPECIAL-STATUS PLANT SPECIES				
<i>Acanthoscyphus parishii</i> var. <i>parishii</i> Parish's oxytheca	4.2 G4?T3T4 S3S4	Annual herb. Habitats include sandy or shale chaparral. Found at elevations ranging from 3,750 to 6,748 feet amsl. Blooming period is June through August.	No	Not Expected: The project site is outside of the known elevation range for this species.

Table D-1: Potentially Occurring Special-Status Biological Resources

Scientific Name Common Name	Special-Status Rank*	Habitat Preferences and Distribution Affinities	Observed On-site	Potential to Occur
<i>Ambrosia monogyra</i> singlehorl burrobrush	2B.2 G5 S2	Perennial shrub. Found in sandy soils within chaparral and Sonoran Desert scrub habitat. Found at elevations ranging from 33 to 1,640 feet amsl. Blooming period is August through November.	No	Not Expected: The project site is comprised of residential development and disturbed habitat that is subject to routine weed abatement, resulting in heavily disturbed and compacted surface soils which likely precludes this species from occurring.
<i>Arctostaphylos glandulosa</i> ssp. <i>gabrielensis</i> San Gabriel manzanita	1B.2 G5T3 S3	Perennial evergreen shrub. Occurs on rocky soils within chaparral habitats. Occurs at elevations ranging from 1,952 to 4,921 feet amsl. Blooms during the month of March.	No	Not Expected: The project site is outside of the known elevation range for this species.
<i>Arenaria paludicola</i> marsh sandwort	FE SE 1B.1 G1 S1	Perennial stoloniferous herb. Found on sandy, openings within marshes and swamps (freshwater or brackish). Found at elevations ranging from 12 to 558 feet amsl. Blooming period is May through August.	No	Not Expected: The project site is outside of the known elevation range for this species.
<i>Asplenium vesperinum</i> western spleenwort	4.2 G4 S4	Perennial rhizomatous herb. Found on rocky soils within chaparral, cismontane woodland, and coastal scrub habitat. Found at elevations ranging from 591 to 3,281 feet amsl. Blooming period is February through June.	No	Not Expected: The project site is comprised of residential development and disturbed habitat that is subject to routine weed abatement, resulting in heavily disturbed and compacted surface soils which likely precludes this species from occurring.
<i>Berberis nevini</i> Nevin's barberry	FE SE 1B.1 G1 S1	Perennial evergreen shrub. Occurs on sandy or gravelly soils in chaparral, cismontane woodland, coastal scrub, and riparian scrub. Found at elevations ranging from 899 to 2,707 feet amsl. Blooming period is (February) March through June.	No	Not Expected: The project site is comprised of residential development and disturbed habitat that is subject to routine weed abatement, resulting in heavily disturbed and compacted surface soils which likely precludes this species from occurring.
<i>Calochortus catalinae</i> Catalina mariposa-lily	4.2 G3G4 S3S4	Perennial bulbiferous herb. Habitats include chaparral, cismontane woodland, coastal scrub, valley and foothill grassland. Found at elevations ranging from 49 to 2,297 feet amsl. Blooming period is (February) March to June.	No	Not Expected: The project site is comprised of residential development and disturbed habitat that is subject to routine weed abatement, resulting in heavily disturbed and compacted surface soils which likely precludes this species from occurring.
<i>Calochortus plummerae</i> Plummer's mariposa-lily	4.2 G4 S4	Perennial bulbiferous herb. Occurs on granitic and rocky soils within chaparral, cismontane woodland, coastal scrub, lower montane coniferous forest, and valley/foothill grassland. Grows in elevations ranging from 328 to 5,577 feet amsl. Blooming period is May through July.	No	Not Expected: The project site is comprised of residential development and disturbed habitat that is subject to routine weed abatement, resulting in heavily disturbed and compacted surface soils which likely precludes this species from occurring.

Table D-1: Potentially Occurring Special-Status Biological Resources

Scientific Name Common Name	Special-Status Rank*	Habitat Preferences and Distribution Affinities	Observed On-site	Potential to Occur
<i>Calochortus weedii</i> var. <i>intermedius</i> intermediate mariposa-lily	1B.2 G3G4T2 S2	Perennial bulbiferous herb. Found in chaparral, coastal scrub, and valley and foothill grasslands in rocky or calcareous soils. Found at elevations ranging from 344 to 2,805 feet amsl. Blooming period is from May to July.	No	Not Expected: The project site is comprised of residential development and disturbed habitat that is subject to routine weed abatement, resulting in heavily disturbed and compacted surface soils which likely precludes this species from occurring.
<i>Chloropyron maritimum</i> ssp. <i>maritimum</i> salt marsh bird's-beak	FE SE 1B.2 G4?T1 S1	Annual herb (hemiparasitic). Occurs on coastal dunes and marshes and swamps (coastal salt). Found at elevations ranging from 0 to 98 feet amsl. Blooming period is May through October (November).	No	Not Expected: The project site is outside of the known elevation range for this species.
<i>Chorizanthe parryi</i> var. <i>parryi</i> Parry's spineflower	1B.1 G3T2 S2	Annual herb. Occurs on sandy and/or rocky soils in chaparral, coastal sage scrub, and sandy openings within alluvial washes and margins. Found at elevations ranging from 951 to 3,773 feet amsl. Blooming period is April through June.	No	Not Expected: The project site is comprised of residential development and disturbed habitat that is subject to routine weed abatement, resulting in heavily disturbed and compacted surface soils which likely precludes this species from occurring.
<i>Chorizanthe xanti</i> var. <i>leucotheca</i> white-bracted spineflower	1B.2 G4T3 S3	Annual herb. Occurs on sandy or gravelly soils in coastal sage scrub (alluvial fans), Mojavean desert scrub, and pinyon and juniper woodland habitats. Found at elevations ranging from 984 to 3,937 feet amsl. Blooming period is April through June.	No	Not Expected: The project site is comprised of residential development and disturbed habitat that is subject to routine weed abatement, resulting in heavily disturbed and compacted surface soils which likely precludes this species from occurring.
<i>Cladium californicum</i> California sawgrass	2B.2 G4 S2	Perennial rhizomatous herb. Found in meadows and seeps, marshes and swamps (alkaline or freshwater). Found at elevations ranging from 197 to 5,249 feet amsl. Blooming period is June through September.	No	Not Expected: The project site is comprised of residential development and disturbed habitat that is subject to routine weed abatement, resulting in heavily disturbed and compacted surface soils which likely precludes this species from occurring.
<i>Claytonia peirsonii</i> ssp. <i>peirsonii</i> Peirson's spring beauty	1B.2 G2G3T2 S2	Perennial herb. Grows on scree within subalpine coniferous forest and upper montane coniferous forest habitats. Found at elevations ranging from 4,954 to 9,005 feet amsl. Blooming period is (March) May through June.	No	Not Expected: The project site is outside of the known elevation range for this species.
<i>Cryptantha incana</i> Tulare cryptantha	1B.3 G2 S2	Annual herb. Grows on gravelly or rocky soils within lower montane coniferous forest. Found at elevations ranging from 4,692 to 7,054 feet amsl. Blooming period is June through August.	No	Not Expected: The project site is outside of the known elevation range for this species.

Table D-1: Potentially Occurring Special-Status Biological Resources

Scientific Name Common Name	Special-Status Rank*	Habitat Preferences and Distribution Affinities	Observed On-site	Potential to Occur
<i>Deinandra paniculata</i> paniculate tarplant	4.2 G4 S4	Annual herb. Occurs in coastal scrub, vernal pools, and valley/foothill grassland habitats. Found at elevations ranging from 82 to 3,084 feet amsl. Blooming period is (March) April through November (December).	No	Not Expected: The project site is comprised of residential development and disturbed habitat that is subject to routine weed abatement, resulting in heavily disturbed and compacted surface soils which likely precludes this species from occurring.
<i>Diplacus johnstonii</i> Johnston's monkeyflower	4.3 G4 S4	Annual herb. Found in lower montane coniferous forest (scree, disturbed areas, rocky or gravelly, roadside). Found at elevations ranging from 3,198 to 9,580 feet amsl. Blooming period is (April) May through August.	No	Not Expected: The project site is outside of the known elevation range for this species.
<i>Dodecahema leptoceras</i> slender-horned spineflower	FE SE 1B.1 G1 S1	Annual herb. Occurs on flood deposited terraces and washes in chaparral, coastal scrub, and alluvial fan sage scrub habitats. Found at elevations ranging from 1,181 to 2,690 feet amsl. Blooming period is April through June.	No	Not Expected: The project site is comprised of residential development and disturbed habitat that is subject to routine weed abatement, resulting in heavily disturbed and compacted surface soils which likely precludes this species from occurring.
<i>Eriastrum densifolium</i> ssp. <i>sanctorum</i> Santa Ana River woollystar	FE SE 1B.1 G4T1 S1	Perennial herb. Grows on sandy or gravelly soils within chaparral and coastal scrub (alluvial fan) habitats. Found at elevations ranging from 298 to 2,001 feet amsl. Blooming period is April through September.	No	The project site is comprised of residential development and disturbed habitat that is subject to routine weed abatement, resulting in heavily disturbed and compacted surface soils which likely precludes this species from occurring.
<i>Eriogonum microthecum</i> var. <i>alpinum</i> alpine slender buckwheat	4.3 G5T3 S3	Perennial herb. Found in alpine dwarf scrub and Great Basin scrub, sometimes rocky or gravelly soils. Has an elevational range of 8,202 to 10,826 feet amsl. Blooming period is July to September.	No	Not Expected: The project site is outside of the known elevation range for this species.
<i>Eriogonum microthecum</i> var. <i>johnstonii</i> Johnston's buckwheat	1B.3 G5T2 S2	Perennial deciduous shrub. Grows on rocky soils in subalpine coniferous forest and upper montane coniferous forest habitat. Found at elevations ranging from 6,000 to 9,600 feet amsl. Blooming period is July through September.	No	Not Expected: The project site is outside of the known elevation range for this species.
<i>Eriogonum umbellatum</i> var. <i>minus</i> alpine sulphur-flowered buckwheat	4.3 G5T4 S4	Perennial herb. Occurs on gravelly soils within subalpine coniferous forest and upper montane coniferous forests. Found at elevations ranging from 5,906 to 10,066 feet amsl. Blooming period is June through September.	No	Not Expected: The project site is outside of the known elevation range for this species.
<i>Eriophyllum lanatum</i> var. <i>obovatum</i> Southern Sierra woolly sunflower	4.3 G5T4 S4	Perennial herb. Grows on sandy loam soils within lower montane coniferous forest and upper montane coniferous forest. Found at elevations ranging from 3,655 to 8,202 feet amsl. Blooming period is June through July.	No	Not Expected: The project site is outside of the known elevation range for this species.

Table D-1: Potentially Occurring Special-Status Biological Resources

Scientific Name Common Name	Special-Status Rank*	Habitat Preferences and Distribution Affinities	Observed On-site	Potential to Occur
<i>Fritillaria pinetorum</i> pine fritillary	4.3 G4 S4	Perennial bulbiferous herb. Associated with granitic and metamorphic soils within chaparral, lower montane coniferous forest, upper montane coniferous forest, subalpine coniferous forest, pinyon and juniper woodland. Found at elevations ranging from 5,692 to 10,826 feet amsl. Blooming period is May through July (September).	No	Not Expected: The project site is outside of the known elevation range for this species.
<i>Galium angustifolium</i> ssp. <i>gabrielense</i> San Antonio Canyon bedstraw	4.3 G5T3 S3	Perennial herb. Grows on granitic, sandy, or rocky soils within chaparral and lower montane coniferous forest. Found at elevations ranging from 3,937 to 8,694 feet amsl. Blooming period is April through August.	No	Not Expected: The project site is outside of the known elevation range for this species.
<i>Galium jepsonii</i> Jepson's bedstraw	4.3 G3 S3	Perennial rhizomatous herb. Grows on granitic, rocky, or gravelly soils within lower montane coniferous forest and upper montane coniferous forest habitats. Found at elevations ranging from 5,052 to 8,202 feet amsl. Blooming period is May through July.	No	Not Expected: The project site is outside of the known elevation range for this species.
<i>Galium johnstonii</i> Johnston's bedstraw	4.3 G4 S4	Perennial herb. Preferred habitats include chaparral, riparian woodland, lower montane coniferous forest, pinyon and juniper woodland. Found at elevations ranging from 4,003 to 7,546 feet amsl. Blooming period is June through July.	No	Not Expected: The project site is outside of the known elevation range for this species.
<i>Heuchera caespitosa</i> urn-flowered alumroot	4.3 G3 S3	Perennial rhizomatous herb. Grows on rocky soils within cismontane woodland, lower montane coniferous forest, riparian forest, and upper montane coniferous forest. Found at elevations ranging from 3,789 to 8,694 feet amsl. Blooming period is May through August.	No	Not Expected: The project site is outside of the known elevation range for this species.
<i>Horkelia cuneata</i> var. <i>puberula</i> mesa horkelia	1B.1 G4T1 S1	Perennial herb. Found on sandy or gravelly soils within chaparral, cismontane woodland, and coastal scrub habitats. Found at elevations ranging from 230 to 2,657 feet amsl. Blooming period is February through July (September).	No	Not Expected: The project site is comprised of residential development and disturbed habitat that is subject to routine weed abatement, resulting in heavily disturbed and compacted surface soils which likely precludes this species from occurring.
<i>Juglans californica</i> southern California black walnut	4.2 G4 S4	Perennial deciduous tree. Found in chaparral, cismontane woodland, coastal scrub, and riparian woodland habitats. Found at elevations ranging from 164 to 2,953 feet amsl. Blooming period is March through August.	No	Not Expected: This species was not observed onsite during the field survey.
<i>Juncus duranii</i> Duran's rush	4.3 G3 S3	Perennial rhizomatous herb. Habitats include lower and upper montane coniferous forests, meadows and seeps. Found at elevations ranging from 5,801 to 9,199 feet amsl. Blooming period is July through August.	No	Not Expected: The project site is outside of the known elevation range for this species.

Table D-1: Potentially Occurring Special-Status Biological Resources

Scientific Name Common Name	Special-Status Rank*	Habitat Preferences and Distribution Affinities	Observed On-site	Potential to Occur
<i>Lepechinia fragrans</i> fragrant pitcher sage	4.2 G3 S3	Perennial shrub. Occurs in chaparral habitats. Found at elevations ranging from 66 to 4,298 feet amsl. Blooming period is March through October.	No	Not Expected: The project site is comprised of residential development and disturbed habitat that is subject to routine weed abatement, resulting in heavily disturbed and compacted surface soils which likely precludes this species from occurring.
<i>Lepidium virginicum</i> var. <i>robinsonii</i> Robinson's pepper-grass	4.3 G5T3 S3	Annual herb. Dry soils on chaparral and coastal sage scrub. Found at elevations ranging from 66 to 4,396 feet amsl. Blooming period is January through July.	No	Not Expected: The project site is comprised of residential development and disturbed habitat that is subject to routine weed abatement, resulting in heavily disturbed and compacted surface soils which likely precludes this species from occurring.
<i>Lilium humboldtii</i> ssp. <i>ocellatum</i> ocellated Humboldt lily	4.2 G4T4? S4?	Perennial bulbiferous herb. Found in openings within chaparral, cismontane woodland, coastal scrub, lower montane coniferous forest, and riparian woodland habitats. Found at elevations ranging from 98 to 5,906 feet amsl. Blooming period is March through July (August).	No	Not Expected: The project site is comprised of residential development and disturbed habitat that is subject to routine weed abatement, resulting in heavily disturbed and compacted surface soils which likely precludes this species from occurring.
<i>Lilium parryi</i> lemon lily	1B.2 G3 S3	Perennial bulbiferous herb. Occurs on mesic soils within lower montane coniferous forest, meadows and seeps, riparian forest, and upper montane coniferous forest. Grows in elevation ranging from 4,003 to 9,006 feet amsl. Blooming period is July through August.	No	Not Expected: The project site is outside of the known elevation range for this species.
<i>Linanthus concinnus</i> San Gabriel linanthus	1B.2 G2 S2	Annual herb. Grows in rocky openings within chaparral, lower montane coniferous forest, and upper montane coniferous forest. Found at elevations ranging from 4,987 to 9,186 feet amsl. Blooming period is April through July.	No	Not Expected: The project site is outside of the known elevation range for this species.
<i>Lycium parishii</i> Parish's desert-thorn	2B.3 G3? S1	Perennial shrub. Grows in coastal scrub and Sonoran Desert scrub habitats. Found at elevations ranging from 443 to 3,281 feet amsl. Blooming period is March through April.	No	Not Expected: The project site is comprised of residential development and disturbed habitat that is subject to routine weed abatement, resulting in heavily disturbed and compacted surface soils which likely precludes this species from occurring.

Table D-1: Potentially Occurring Special-Status Biological Resources

<i>Scientific Name</i> Common Name	Special-Status Rank*	Habitat Preferences and Distribution Affinities	Observed On-site	Potential to Occur
<i>Malacothamnus parishii</i> Parish's bush-mallow	1A GXQ SX	Perennial deciduous shrub. Found in chaparral and coastal scrub habitats. Found at elevations ranging from 1,000 to 1,493 feet amsl. Blooming period is June through July.	No	Not Expected: The project site is comprised of residential development and disturbed habitat that is subject to routine weed abatement, resulting in heavily disturbed and compacted surface soils which likely precludes this species from occurring.
<i>Monardella australis ssp. jokerstii</i> Jokerst's monardella	1B.1 G4T1 S1	Perennial rhizomatous herb. Grows on steep scree or talus slopes between breccia and secondary alluvial benches along drainages and washes. Found in chaparral and lower montane coniferous forest habitat. Blooming period is July through September. Found at elevations ranging from 4,429 to 5,741 feet amsl.	No	Not Expected: The project site is outside of the known elevation range for this species.
<i>Monardella pringlei</i> Pringle's monardella	1A GX SX	Annual herb. Found on sandy soils within coastal scrub habitats. Found at elevations ranging from 984 to 1,312 feet amsl. Blooming period is May through June.	No	Not Expected: The project site is comprised of residential development and disturbed habitat that is subject to routine weed abatement, resulting in heavily disturbed and compacted surface soils which likely precludes this species from occurring.
<i>Monardella saxicola</i> rock monardella	4.2 G3 S3	Perennial rhizomatous herb. Grows on rocky (usually serpentinite) soils in closed-cone coniferous forest, chaparral, and lower montane coniferous forest habitats. Found at elevations ranging from 1,640 to 5,906 feet amsl. Blooming period is June through September.	No	Not Expected: The project site is outside of the known elevation range for this species.
<i>Muhlenbergia californica</i> California muhly	4.3 G4 S4	Perennial rhizomatous herb. Found in mesic areas, meadows, seeps, and streambanks within chaparral, coastal scrub, and lower montane coniferous forest. Found at elevations ranging from 328 to 6,562 feet amsl. Blooming period is June through September.	No	Not Expected: The project site is comprised of residential development and disturbed habitat that is subject to routine weed abatement, resulting in heavily disturbed and compacted surface soils which likely precludes this species from occurring.
<i>Muhlenbergia utilis</i> aparejo grass	2B.2 G4 S2S3	Perennial herb. Usually occurs in coastal sage scrub, creosote bush scrub, and wetland riparian habitats. Found at elevations ranging from 820 to 3,281 feet amsl. Blooming period is October through March.	No	Not Expected: The project site is comprised of residential development and disturbed habitat that is subject to routine weed abatement, resulting in heavily disturbed and compacted surface soils which likely precludes this species from occurring.

Table D-1: Potentially Occurring Special-Status Biological Resources

Scientific Name Common Name	Special-Status Rank*	Habitat Preferences and Distribution Affinities	Observed On-site	Potential to Occur
<i>Navarretia prostrata</i> prostrate vernal pool navarretia	1B.1 G2 S2	Annual herb. Blooms April through July. Occurs on mesic sites and on alkaline soils in coastal scrub, valley and foothill grassland, vernal pool, meadows, and seeps. Known elevations range from 5 to 4,055 feet amsl.	No	Not Expected: The project site is comprised of residential development and disturbed habitat that is subject to routine weed abatement, resulting in heavily disturbed and compacted surface soils which likely precludes this species from occurring.
<i>Opuntia basilaris</i> var. <i>brachyclada</i> short-joint beavertail	1B.2 G5T3 S3	Perennial stem succulent. Grows in chaparral, Joshua tree woodland, Mojavean desert scrub, and pinyon and juniper woodland habitats. Found at elevations ranging from 1,394 to 5,906 feet amsl. Blooming period is April through June.	No	Not Expected: The project site is outside of the known elevation range for this species.
<i>Oreonana vestita</i> woolly mountain-parsley	1B.3 G3 S3	Perennial herb. Associated with gravel and talus soils within lower montane coniferous forest, subalpine coniferous forest, and upper montane coniferous forest. Found at elevations ranging from 5,299 to 11,483 feet amsl. Blooming period is March through September.	No	Not Expected: The project site is outside of the known elevation range for this species.
<i>Phacelia mohavensis</i> Mojave phacelia	4.3 G4Q S4	Annual herb. Occurs on sandy or gravelly soils within cismontane woodland, lower montane coniferous forest, meadows and seeps, pinyon and juniper woodland. Found at elevations ranging from 4,593 to 8,202 feet amsl. Blooming period is April through August.	No	Not Expected: The project site is outside of the known elevation range for this species.
<i>Phacelia stellaris</i> Brand's star phacelia	1B.1 G1 S1	Annual herb. Found in coastal dunes and coastal scrub habitats. Found at elevations ranging from 3 to 1,312 feet amsl. Blooming period is March through June.	No	Not Expected: The project site is comprised of residential development and disturbed habitat that is subject to routine weed abatement, resulting in heavily disturbed and compacted surface soils which likely precludes this species from occurring.
<i>Pseudognaphalium leucocephalum</i> white rabbit-tobacco	2B.2 G4 S2	Perennial herb. Found on sandy and gravelly soils within chaparral, cismontane woodland, coastal scrub, and riparian woodland habitats. Found at elevations ranging from 0 to 6,890 feet amsl. Blooming period is August (July) through November (December).	No	Not Expected: The project site is comprised of residential development and disturbed habitat that is subject to routine weed abatement, resulting in heavily disturbed and compacted surface soils which likely precludes this species from occurring.
<i>Quercus durata</i> var. <i>gabrielensis</i> San Gabriel oak	4.2 G4T3 S3	Perennial evergreen shrub. Habitats include chaparral and cismontane woodland habitats. Found at elevations ranging from 1,476 to 3,281 feet amsl. Blooming period is April through May.	No	Not Expected: The project site is outside of the known elevation range for this species.

Table D-1: Potentially Occurring Special-Status Biological Resources

<i>Scientific Name</i> Common Name	Special-Status Rank*	Habitat Preferences and Distribution Affinities	Observed On-site	Potential to Occur
<i>Sagittaria sanfordii</i> Sandford's arrowhead	1B.2 G3 S3	Perennial rhizomatous herb (emergent). Blooms May through October (November). Found in standing or slow-moving freshwater ponds, marshes, and ditches. Known elevations range from 0 to 1,180 feet amsl.	No	Not Expected: The project site is outside of the known elevation range for this species.
<i>Senecio aphanactis</i> chaparral ragwort	2B.2 G3 S2	Annual herb. Grows on alkaline soils within chaparral, cismontane woodland, and coastal scrub habitats. Found at elevations ranging from 49 to 2,625 feet amsl. Blooming period is January through April (May).	No	Not Expected: The project site is comprised of residential development and disturbed habitat that is subject to routine weed abatement, resulting in heavily disturbed and compacted surface soils which likely precludes this species from occurring.
<i>Senecio astephanus</i> San Gabriel ragwort	4.3 G3 S3	Perennial herb. Occurs on rocky slopes within coastal bluff scrub and chaparral habitats. Found at elevations ranging from 1,312 to 4,921 feet amsl. Blooming period is May through July.	No	Not Expected: The project site is outside of the known elevation range for this species.
<i>Sphenopholis obtusata</i> prairie wedge grass	2B.2 G5 S2	Perennial herb. Occurs in cismontane woodland and meadows and seeps within mesic soils. Found at elevations ranging from 984 to 6,562 feet amsl. Blooming period is April through July.	No	Not Expected: The project site is comprised of residential development and disturbed habitat that is subject to routine weed abatement, resulting in heavily disturbed and compacted surface soils which likely precludes this species from occurring.
<i>Streptanthus bernardinus</i> Laguna Mountains jewelflower	4.3 G3G4 S3S4	Perennial herb. Occurs in chaparral and lower montane coniferous forest habitat. Found at elevations ranging from 2,198 to 8,202 feet amsl. Blooming period is May through August.	No	Not Expected: The project site is outside of the known elevation range for this species.
<i>Symphyotrichum defoliatum</i> San Bernardino aster	1B.2 G2 S2	Perennial rhizomatous herb. Occurs near ditches, streams, and springs within cismontane woodland, coastal scrub, lower montane coniferous forest, meadows, seeps, marshes, and valley/foothill grassland. Grows in elevations ranging from 0 to 6,700 feet amsl. Blooming period is July through November (December).	No	Not Expected: The project site is comprised of residential development and disturbed habitat that is subject to routine weed abatement, resulting in heavily disturbed and compacted surface soils which likely precludes this species from occurring.
<i>Viola pinetorum ssp. grisea</i> grey-leaved violet	1B.2 G4G5T3 S3	Perennial herb. Associated with upper montane coniferous forest, subalpine coniferous forest, meadows and seeps. Found at elevations ranging from 4,921 to 11,155 feet amsl. Blooming period is April through July.	No	Not Expected: The project site is outside of the known elevation range for this species.

Table D-1: Potentially Occurring Special-Status Biological Resources

Scientific Name Common Name	Special-Status Rank*	Habitat Preferences and Distribution Affinities	Observed On-site	Potential to Occur
SPECIAL-STATUS VEGETATION COMMUNITIES				
<u>CNDDDB/Holland (1986)</u> California Walnut Woodland <u>MCV (1995)</u> California Walnut Series <u>NVCS (2009)</u> <i>Juglans californica</i> Woodland Alliance	G3 S3.2	Found at elevations ranging from 490 to 2,952 feet amsl in riparian corridors, but most stands cover all hillslopes. Southern California black walnut is dominant or co-dominant in the tree canopy with white alder (<i>Alnus rhombifolia</i>), two petaled ash (<i>Fraxinus dipetala</i>), toyon (<i>Heteromeles arbutifolia</i>), coast live oak, valley oak (<i>Quercus lobata</i>), polished willow (<i>Salix laevigata</i>), arroyo willow (<i>Salix lasiolepis</i>), black elderberry (<i>Sambucus nigra</i>), and California bay (<i>Umbellularia californica</i>). Trees are less than 50 feet tall; canopy is open to continuous. Shrub layer is sparse to intermittent. Herbaceous layer is sparse or grassy.	No	Absent: This vegetation community does not occur within or adjacent to the project site.
<u>CNDDDB/Holland (1986)</u> Coastal and Valley Freshwater Marsh <u>MCV (1995)</u> Cattail Series, Bulrush-Cattail Series <u>NVCS (2009)</u> <i>Typha (angustifolia, latifolia)- (Schoenoplectus spp.)</i> Semipermanently Flooded Herbaceous Alliance, <i>Typha domingensis</i> Seasonally Flooded Temperate Herbaceous Alliance, <i>Typha latifolia</i> Seasonally Flooded Herbaceous Alliance	G5 S5	Occurs at elevations ranging from 0 to 1,148 feet amsl in semi-permanently flooded freshwater or brackish marshes with clayey or silty soils. Narrowleaf cattail (<i>Typha angustifolia</i>), southern cattail (<i>Typha domingensis</i>) or bulrush (<i>Typha latifolia</i>) is dominant or co-dominant in the herbaceous layer with creeping bentgrass (<i>Agrostis stolonifera</i>), pacific silverweed (<i>Argentina egedii</i>), <i>Cyperus</i> spp., desert saltgrass (<i>Distichlis spicata</i>), cocksbur grass (<i>Echinochloa crus-galli</i>), common spikerush (<i>Eleocharis macrostachya</i>), great horsetail (<i>Equisetum telmateia</i>), <i>Juncus</i> spp., least duckweed (<i>Lemna minuta</i>), broad leaved pepper grass (<i>Lepidium latifolium</i>), water parsley (<i>Oenanthe sarmentosa</i>), common knotweed (<i>Persicaria lapathifolia</i>), dotted smartweed (<i>Persicaria punctate</i>), common reed (<i>Phragmites australis</i>), Chairmaker's bulrush (<i>Schoenoplectus americanus</i>), California bulrush (<i>Schoenoplectus californicus</i>), <i>Typha ×glauca</i> and rough cocklebur (<i>Xanthium strumarium</i>). Emergent trees may be present at low cover, including <i>Salix</i> spp.	No	Absent: This vegetation community does not occur within or adjacent to the project site.

Table D-1: Potentially Occurring Special-Status Biological Resources

Scientific Name Common Name	Special-Status Rank*	Habitat Preferences and Distribution Affinities	Observed On-site	Potential to Occur
<u>CNDDB/Holland (1986)</u> Riversidian Alluvial Fan Sage Scrub <u>MCV (1995)</u> Scalebroom Series <u>NVCS (2009)</u> <i>Lepidospartum squamatum</i> Intermittently Flooded Shrubland Alliance	G3 S3	Found at elevations ranging from 164 to 4,922 feet amsl on intermittently or rarely flooded, low-gradient alluvial deposits along streams, washes, and fans. Scalebroom (<i>Lepidospartum squamatum</i>) is dominant, co-dominant, or conspicuous in the shrub canopy with burrobrush (<i>Ambrosia salsola</i>), California sagebrush, mule fat (<i>Baccharis salicifolia</i>), bladderpod (<i>Cleome isomeris</i>), California cholla (<i>Cylindropuntia californica</i>), brittlebush (<i>Encelia farinosa</i>), thick leaved yerba santa (<i>Eriodictyon crassifolium</i>), hairy yerba santa (<i>Eriodictyon trichocalyx</i>), California buckwheat, chaparral yucca (<i>Hesperoyucca whipplei</i>), deerweed, laurel sumac (<i>Malosma laurina</i>), prickly-pear cactus (<i>Opuntia littoralis</i>), lemonade berry (<i>Rhus integrifolia</i>), sugar bush (<i>Rhus ovata</i>), skunkbrush (<i>Rhus aromatica</i>), and poison oak (<i>Toxicodendron diversilobum</i>). Emergent trees or tall shrubs may be present at low cover, including mountain mahogany (<i>Cercocarpus betuloides</i>), southern California black walnut, California juniper (<i>Juniperus californica</i>), California sycamore, Fremont cottonwood, or black elderberry. Shrubs are less than 7 feet tall; canopy is open to continuous, and two tiered. Herbaceous is layer variable and may be grassy.	No	Absent: This vegetation community does not occur within or adjacent to the project site.
<u>CNDDB/Holland (1986)</u> Southern Riparian Forest <u>MCV (1995)</u> N/A <u>NVCS (2009)</u> N/A	N/A N/A	Riparian zones dominated by larger, mature trees consisting of various species of willows, cottonwoods, and sycamores.	No	Absent: This vegetation community does not occur within or adjacent to the project site.
<u>CNDDB/Holland (1986)</u> Southern Sycamore Alder Riparian Woodland <u>MCV (1995)</u> California Sycamore Series <u>NVCS (2009)</u> <i>Platanus racemosa</i> Woodland Alliance	G3 S3	Found at elevations ranging from sea level to 7,874 feet amsl in gullies, intermittent streams, springs, seeps, stream banks, and terraces adjacent to floodplains that are subject to high-intensity flooding. Soils are rocky or cobbly alluvium with permanent moisture at depth. California sycamore is a dominant or co-dominant in the tree canopy with white alder, southern California black walnut, Fremont cottonwood, coast live oak, valley oak, narrowleaf willow, Goodding's black willow (<i>Salix gooddingii</i>), polished willow, arroyo willow, yellow willow (<i>Salix lutea</i>), Peruvian pepper tree (<i>Schinus mole</i>), and California bay.	No	Absent: This vegetation community does not occur within or adjacent to the project site.

* U.S. Fish and Wildlife Service (USFWS)

- FE Endangered – any species which is in danger of extinction throughout all or a significant portion of its range.
- FT Threatened – any species which is likely to become an endangered species within the foreseeable future throughout all or a significant portion of its range.

California Department of Fish and Wildlife (CDFW)

- SE Endangered – any native species or subspecies of bird, mammal, fish, amphibian, reptile, or plant which is in serious danger of becoming extinct throughout all, or a significant portion, of its range due to one or more causes, including loss of habitat, change in habitat, overexploitation, predation, competition, or disease.
- SCE State Candidate for Listing as Endangered – the classification provided to a native species or subspecies of a bird, mammal, fish, amphibian, reptile, or plant that the Fish and Game Commission has formally noticed as being under review by the Department of Fish and Wildlife for addition to the list of endangered species, or a species for which the commission has published a notice of proposed regulation to add the species to the list of endangered species.
- ST Threatened – any native species or subspecies of bird, mammal, fish, amphibian, reptile, or plant that, although not presently threatened with extinction, is likely to become an endangered species in the foreseeable future in the absence of the special protection and management efforts required under the California Endangered Species Act.
- FP Fully Protected – any native species or subspecies of bird, mammal, fish, amphibian, or reptile that were determined by the State of California to be rare or face possible extinction.
- SSC Species of Special Concern – any species, subspecies, or distinct population of fish, amphibian, reptile, bird, or mammal native to California that currently satisfies one or more of the following criteria:
- is extirpated from California or, in the case of birds, in its primary seasonal or breeding role;
 - is listed as Federally-, but not State-, threatened or endangered; meets the State definition of threatened or endangered but has not formally been listed.
 - is experiencing, or formerly experienced, serious (noncyclical) population declines or range retractions (not reversed) that, if continued or resumed, could qualify it for State threatened or endangered status; or
 - has naturally small populations exhibiting high susceptibility to risk from any factor(s), that if realized, could lead to declines that would qualify it for State threatened or endangered status.
- WL Watch List - taxa that were previously designated as “Species of Special Concern” but no longer merit that status, or which do not yet meet SSC criteria, but for which there is concern and a need for additional information to clarify status.

California Native Plant Society (CNPS) California Rare Plant Rank

- 1A Presumed extirpated in California and either rare or extinct elsewhere.
- 1B Plants rare, threatened, or endangered in California and elsewhere.
- 2B Plants rare, threatened, or endangered in California but more common elsewhere.
- 4 Plants of limited distribution – Watch List.

Threat Ranks

- .1 Seriously threatened in California (over 80% of occurrences threatened/high degree any immediacy of threat).
- .2 Moderately threatened in California (20 to 80 percent of occurrences threatened/moderate degree and immediacy of threat).
- .3 Not very threatened in California (less than 20 percent of occurrences threatened/low degree and immediacy of threat or no current threats known).

NatureServe Conservation Status Rank

The Global Rank (G#) reflects the overall condition and imperilment of a species throughout its global range. The Intraspecific Taxon Rank (T#) reflects the global situation of just the subspecies or variety. The State Rank (S#) reflects the condition and imperilment of an element throughout its range within California. (G#Q) reflects that the element is very rare but there are taxonomic questions associated with it; the calculated G rank is qualified by adding a Q after the G#. Adding a ? to a rank expresses uncertainty about the rank.

- G1/T1 Critically Imperiled – At very high risk of extinction due to extreme rarity (often 5 or fewer populations), very steep declines, or other factors.
- G2/T2 Imperiled— At high risk of extinction due to very restricted range, very few populations (often 20 or fewer), steep declines, or other factors.
- G3/T3 Vulnerable— At moderate risk of extinction due to a restricted range, relatively few populations (often 80 or fewer), recent and widespread declines, or other factors.
- G4/T4 Apparently Secure— Uncommon but not rare; some cause for long-term concern due to declines or other factors.
- G5 Secure – Common; widespread and abundant.
- S1 Critically Imperiled – Critically imperiled in the state because of extreme rarity (often 5 or fewer occurrences) or because of some factor(s) such as very steep declines making it especially vulnerable to extirpation from the State.
- S2 Imperiled – Imperiled in the State because of rarity due to very restricted range, very few populations (often 20 or fewer), steep declines, or other factors making it very vulnerable to extirpation from the nation or State.
- S3 Vulnerable – Vulnerable in the State due to a restricted range, relatively few populations (often 80 or fewer), recent and widespread declines, or other factors making it vulnerable to extirpation.
- S4 Apparently Secure – Uncommon but not rare; some cause for long-term concern due to declines or other factors.

Attachment E

References

- Baldwin, B.G., D.H. Goldman, D.J. Keil, R. Patterson, T.J. Rosatti, and D.H. Wilken, eds. 2012. *The Jepson Manual: Vascular Plants of California, 2nd ed.* University of California Press, Berkeley.
- Bradley, D.R., Ammerman, L.K., Baker, R.J., Bradley, L.C., Cook, J.A., Dowler, R.C., Jones, C., Schmidly, D.J., Stangl Jr., F.B., Van Den Bussche, R.A., and B. Würsig. 2014. Revised Checklist of North American Mammals North of Mexico, 2014. Occasional Papers of the Museum of Texas Tech University. 327. 1-27.
- Calflora: Information on California plants for education, research and conservation. [web application]. 2020. Berkeley, California: The Calflora Database [a non-profit organization]. Accessed online at: <https://www.calflora.org/>.
- California Department of Fish and Wildlife (CDFW). 2019. California Natural Community List. November 8, 2019.
- California Department of Fish and Wildlife (CDFW). 2020a. RareFind 5, California Natural Diversity Data Base, California. Data base report on threatened, endangered, rare or otherwise sensitive species and communities for the USGS *Cucamonga Peak, Devore, Fontana, and Guasti, California 7.5-minute quadrangles*.
- California Department of Fish and Wildlife (CDFW). 2020b. Biogeographic Information and Observation System, California Natural Diversity Data Base, California. Data base report on threatened, endangered, rare or otherwise sensitive species and communities for the USGS *Cucamonga Peak, Devore, Fontana, and Guasti, California 7.5-minute quadrangles*.
- California Natural Diversity Database (CNDDDB). July 2020c. *Special Animals List*. California Department of Fish and Wildlife. Sacramento, CA.
- California Natural Diversity Database (CNDDDB). July 2020d. *State and Federally Listed Endangered and Threatened Animals of California*. California Department of Fish and Wildlife. Sacramento, CA.
- California Department of Fish and Wildlife, Natural Diversity Database. January 2020e. *Special Vascular Plants, Bryophytes, and Lichens List*. Quarterly publication. 140 pp.
- California Natural Diversity Database (CNDDDB). July 2020f. *State and Federally Listed Endangered, Threatened, and Rare Plants of California*. California Department of Fish and Wildlife. Sacramento, CA.
- California Native Plant Society, Rare Plant Program. 2020. Inventory of Rare and Endangered Plants of California (online edition, v8-03 0.39). Accessed online at: <http://www.rareplants.cnps.org/>.
- Chesser, R. T., K. J. Burns, C. Cicero, J. L. Dunn, A. W. Kratter, I. J. Lovette, P. C. Rasmussen, J. V. Remsen, Jr., D. F. Stotz, and K. Winker. 2019. Check-list of North American Birds (online). American Ornithological Society. Accessed online at: <http://checklist.aou.org/taxa>.
- City of Fontana. 2017. *Fontana Forward General Plan Update 2015-2035*.

- County of San Bernardino. 2007. *San Bernardino County General Plan Program*. Available online at the following link: <https://cms.sbcounty.gov/lus/Planning/GeneralPlan.aspx>.
- Crother, B. I. (ed.). 2017. Scientific and Standard English Names of Amphibians and Reptiles of North America North of Mexico, with Comments Regarding Confidence in Our Understanding pp. 1–102. SSAR Herpetological Circular 43.
- Google, Inc. 2020. Google Earth Pro Imagery Version 7.3.2.5776. Build date 07/21/2020. Aerial Image dated May 2, 2019.
- Hamilton, R.A. and D.R. Willick. 1996. *The Birds of Orange County, California: Status and Distribution*. Sea and Sage Press; Irvine, California.
- Harvey, M. J., J. S. Altenbach, and T.L. Best. 2011. *Bats of the United States and Canada*. John Hopkins University Press, Baltimore, Maryland.
- Holland, R. 1986. *Preliminary Descriptions of the Terrestrial Natural Communities of California*. California Department of Fish and Game, Sacramento.
- Jepson Flora Project (eds.). 2018. Jepson eFlora. Accessed online at: <http://ucjeps.berkeley.edu/eflora/>.
- Reid, F.A. 2006. *A Field Guide to Mammals of North America, Fourth Edition*. Houghton Mifflin Company, New York, New York.
- Sawyer, J.O., T. Keeler-Wolf, and J. Evens. 2009. *A Manual of California Vegetation (Second Edition)*. California Native Plant Society, Sacramento, California, USA.
- Sibley, D.A. 2014. *The Sibley Guide to Birds, Second Edition*. Alfred A. Knopf, Inc., New York, New York.
- Stebbins, R.C. 2003. *A Field Guide to Western Reptiles and Amphibians, Third Edition*. Houghton Mifflin Company, New York, New York.
- U.S. Department of Agriculture, Natural Resources Conservation Service. 2020. *Custom Soil Resource Report for San Bernardino County Southwestern Part, California*. Accessed online at: <http://websoilsurvey.nrcs.usda.gov/app/>.
- U.S. Fish and Wildlife Service (USFWS). 2020. ECOS Environmental Conservation Online System: Threatened and Endangered Species Active Critical Habitat Report. Accessed online at: <https://ecos.fws.gov/ecp/report/table/critical-habitat.html>.
- U.S. Geological Survey. 2020. *Cucamonga Peak, California 7.5-Minute Topographic Quadrangle Map*. 1966. Photorevised 1988.
- U.S. Geological Survey. 2020. *Devore, California 7.5-Minute Topographic Quadrangle Map*. 1966. Photorevised 1988.

U.S. Geological Survey. 2020. *Fontana, California* 7.5-Minute Topographic Quadrangle Map. 1967. Photorevised 1980.

U.S. Geological Survey. 2020. *Guasti, California* 7.5-Minute Topographic Quadrangle Map. 1966. Photorevised 1981.

Attachment B

Figure 1 – Revised Site Plan

IN THE CITY OF FONTANA, COUNTY OF SAN BERNARDINO, STATE OF CALIFORNIA
TENTATIVE TRACT NO. 20358

BEING A SUBDIVISION OF A PORTION OF LOT 783, ACCORDING TO MAP SHOWING SUBDIVISION OF LANDS BELONGING TO THE SEMI-TROPIC LAND AND WATER COMPANY, IN THE CITY OF FONTANA, COUNTY OF SAN BERNARDINO, STATE OF CALIFORNIA, AS PER MAP RECORDED IN BOOK 11 PAGE 12 OF MAPS, IN THE OFFICE OF THE RECORDER OF SAID COUNTY.

S D ENGINEERING AND ASSOCIATES

SEPTEMBER, 2021

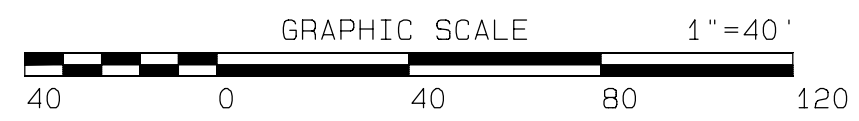
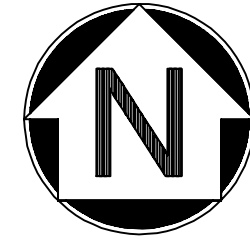

TRACT 14626 M.B. 241/33-34

APPLICANT/DEVELOPER

MONTEVISTA HOMES
 P.O. BOX 9559
 ALTA LOMA, CA 91701
 ATTN: MR. STEVE LANDIS
 PH: (951) 231-7206

PROPERTY ADDRESS

9092 CATAMBA AVENUE
 FONTANA, CA 92335

ENGINEER

S.D. ENGINEERING AND ASSOCIATES
 ATTN: MR. SURESH DODDIAH, P.E.
 242 E. AIRPORT DRIVE, STE. 212
 SAN BERNARDINO, CA. 92408
 PH: (909) 215-3451
 EMAIL: SURESH@SDENGINEERING.NET

UTILITY PROVIDERS

SEWER
 CITY OF FONTANA
 8353 STEPPA AVENUE
 FONTANA, CA 92335
 (909) 350-6632

WATER
 FONTANA WATER COMPANY
 4566 ARROW ROUTE
 FONTANA, CA 92335
 (909) 822-2201

ELECTRICITY
 SOUTHERN CALIFORNIA EDISON COMPANY
 300 N. PEPPER STREET
 RIALTO, CA 92376
 (909) 877-6233 -- UNDERGROUND
 (909) 875-5100 -- TRANSMISSION
 (213) 637-1233 -- PIPELINES

GENERAL NOTES

- ASSESSOR'S PARCEL NO.: 0233-122-60, 63, 28 and 29
- PROPERTY ADDRESS: 9092 CATAMBA AVENUE, FONTANA, CA 92336
- GROSS ACREAGE: 9.24 ACRES
- NET ACREAGE: 8.81 ACRES
- NUMBER OF PROPOSED LOTS: 53 LOTS
- PROJECT DENSITY: 8.0 UNITS/ACRE
- ZONING: EXISTING R1-6000
PROPOSED R-2 PRD
EXISTING RESIDENTIAL 6
- GENERAL PLAN DESIGNATION

SPECIAL NOTES

- ALL INTERIOR STREETS SHOWN ON THIS MAP ARE PRIVATE.
- ALL ON-SITE SEWER AND WATER LINES WILL BE MAINTAINED PRIVATELY.
- FRONT BUILDING SETBACKS SHOWN ARE FOR GARAGES.
- THERE IS NO C.F.D. REQUIREMENT. ALL LANDSCAPED AREAS, STREETS AND UTILITIES ARE MAINTAINED BY H.O.A.

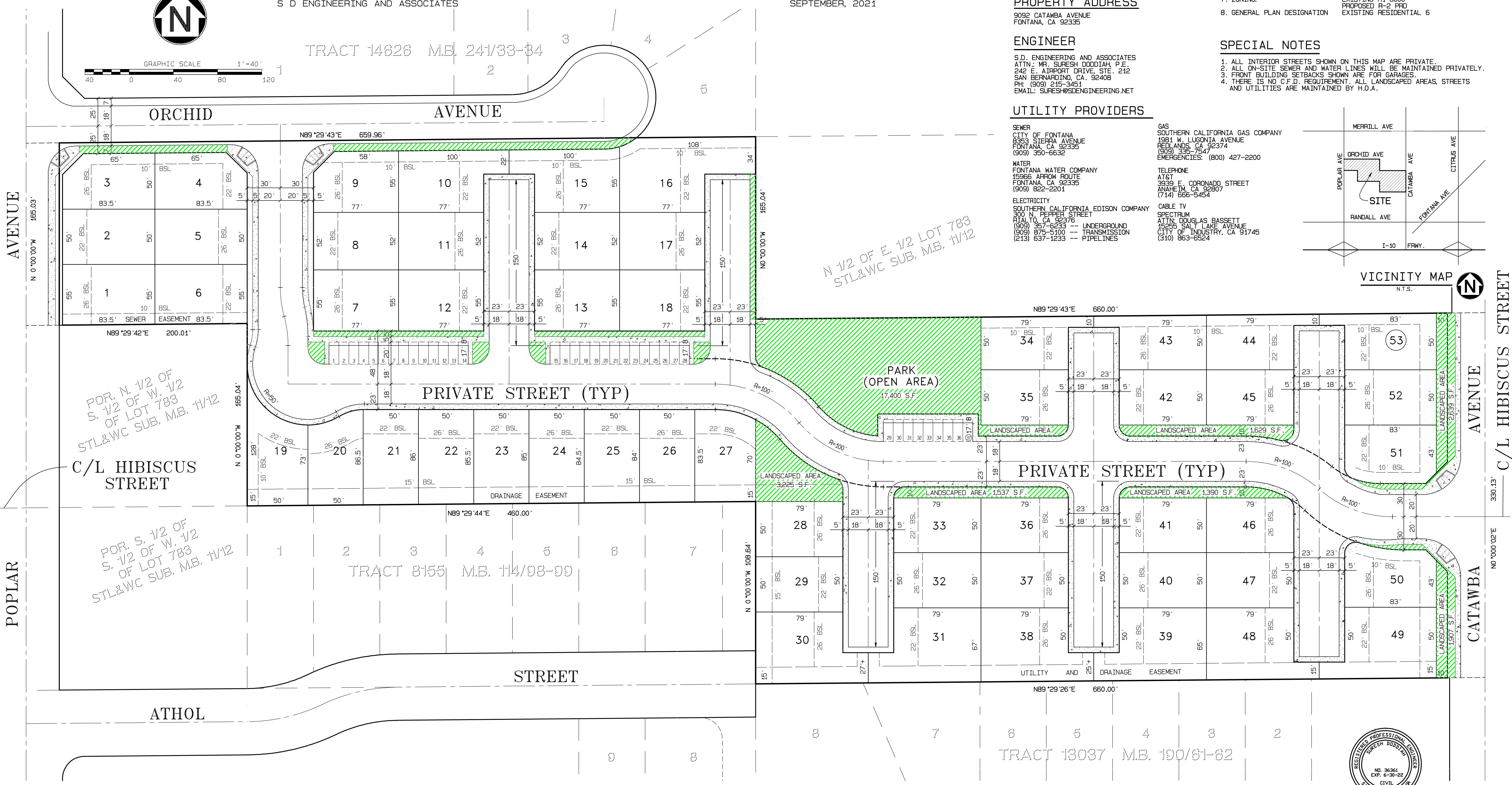

POR. N. 1/2 OF
 S. 1/2 OF W. 1/2
 OF LOT 783
 STL&WC SUB. M.B. 11/12

POR. S. 1/2 OF
 S. 1/2 OF W. 1/2
 OF LOT 783
 STL&WC SUB. M.B. 11/12

N 1/2 OF E. 1/2 LOT 783
 STL&WC SUB. M.B. 11/12

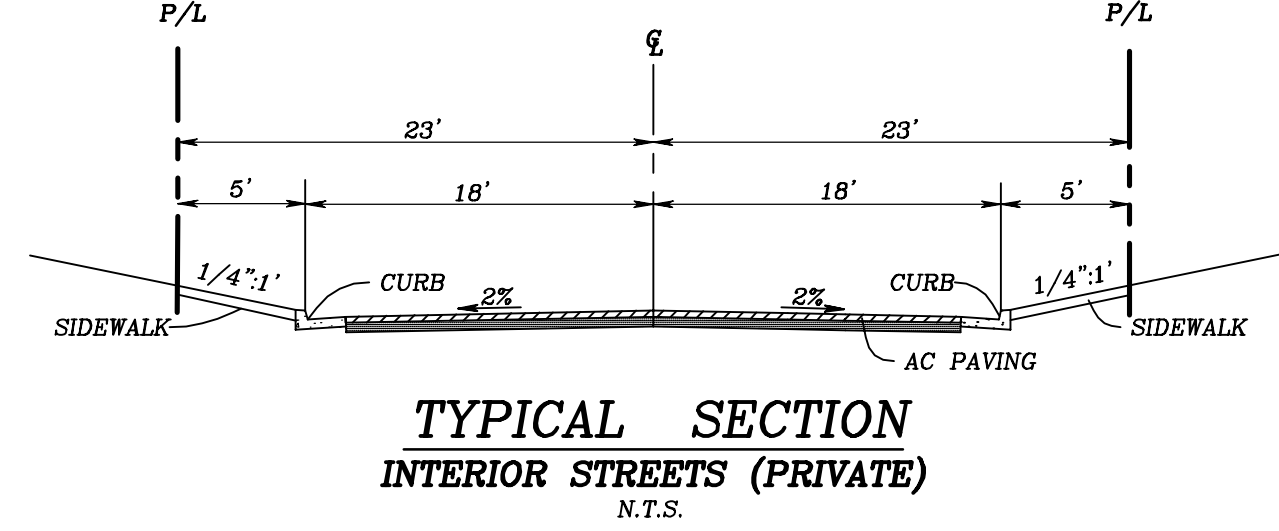
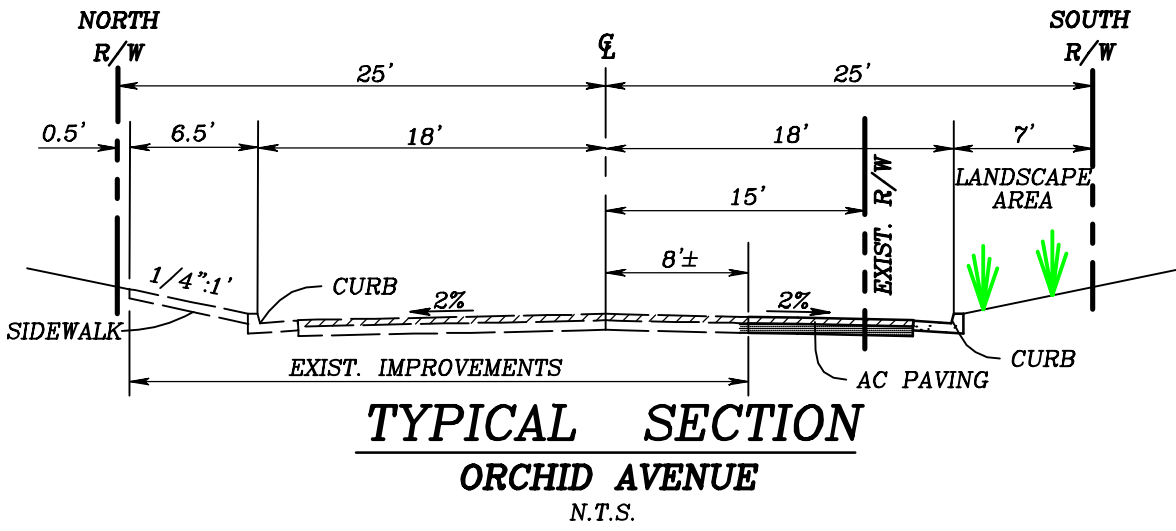
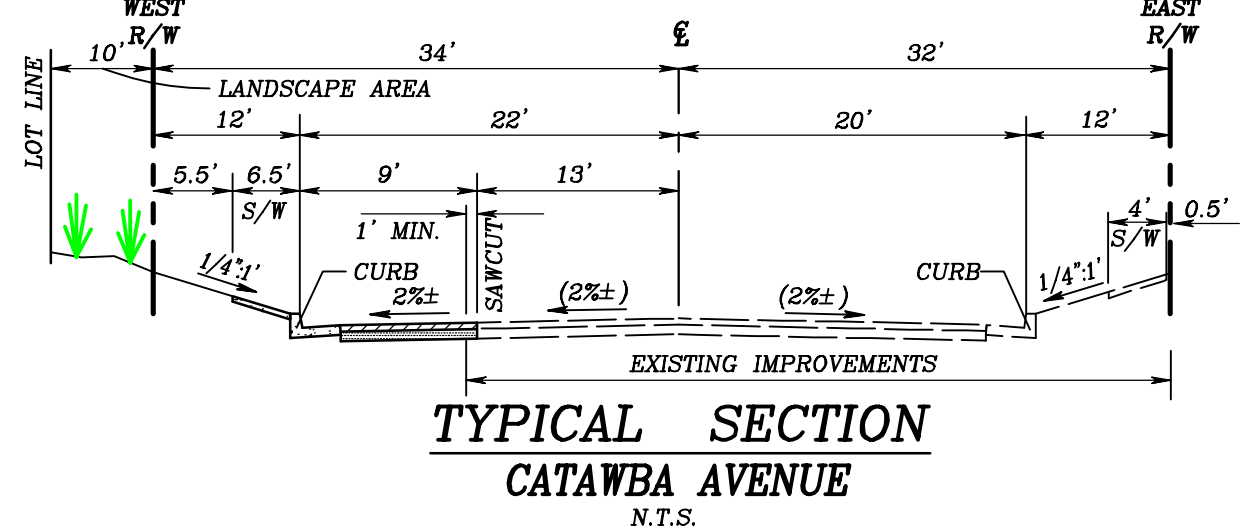
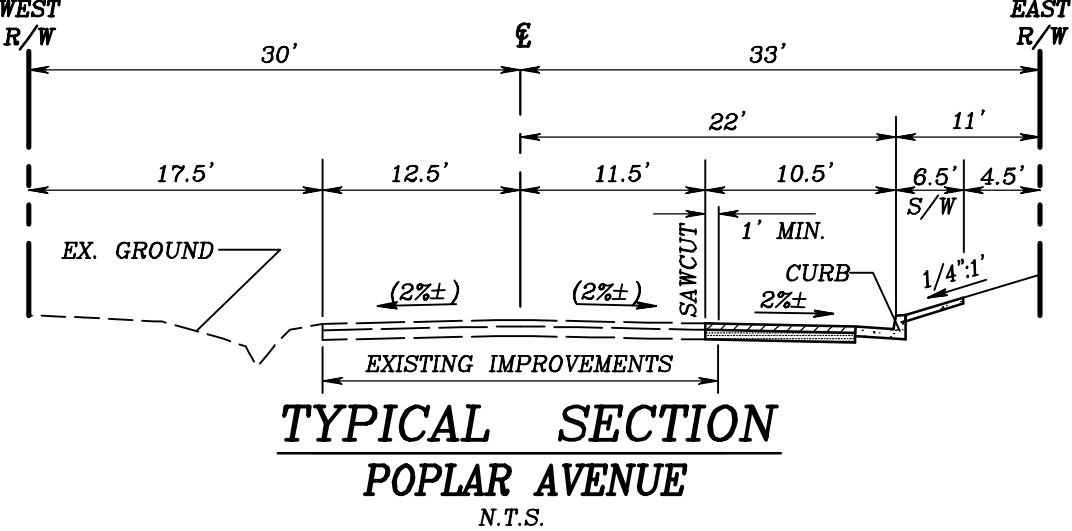

S. D. ENGINEERING AND ASSOCIATES
 LAND PLANNING AND CIVIL ENGINEERING
 242 E. AIRPORT DRIVE, STE. 212 - SAN BERNARDINO, CA 92408
 PHONE (909) 215-3451 EMAIL: suresh@sdengineering.net

SURESH DODDIAH R.C.E. NO. 36361
 DATE EXP. DATE: 06-30-22

Attachment C

Updated Records Searches

CNDDDB Quad Species List 65 records.

Element Type	Scientific Name	Common Name	Element Code	Federal Status	State Status	CDFW Status	CA Rare Plant Rank	Quad Code	Quad Name	Data Status	Taxonomic Sort
Animals - Amphibians	Batrachoseps gabrieli	San Gabriel slender salamander	AAAAD02110	None	None	-	-	3411724	DEVORE	Mapped	Animals - Amphibians - Plethodontidae - Batrachoseps gabrieli
Animals - Amphibians	Rana muscosa	southern mountain yellow-legged frog	AAABH01330	Endangered	Endangered	WL	-	3411724	DEVORE	Mapped	Animals - Amphibians - Ranidae - Rana muscosa
Animals - Birds	Accipiter cooperii	Cooper's hawk	ABNKC12040	None	None	WL	-	3411724	DEVORE	Unprocessed	Animals - Birds - Accipitridae - Accipiter cooperii
Animals - Birds	Aquila chrysaetos	golden eagle	ABNKC22010	None	None	FP , WL	-	3411724	DEVORE	Unprocessed	Animals - Birds - Accipitridae - Aquila chrysaetos
Animals - Birds	Buteo regalis	ferruginous hawk	ABNKC19120	None	None	WL	-	3411724	DEVORE	Unprocessed	Animals - Birds - Accipitridae - Buteo regalis
Animals - Birds	Circus hudsonius	northern harrier	ABNKC11011	None	None	SSC	-	3411724	DEVORE	Unprocessed	Animals - Birds - Accipitridae - Circus hudsonius
Animals - Birds	Elanus leucurus	white-tailed kite	ABNKC06010	None	None	FP	-	3411724	DEVORE	Unprocessed	Animals - Birds - Accipitridae - Elanus leucurus
Animals - Birds	Eremophila alpestris actia	California horned lark	ABPAT02011	None	None	WL	-	3411724	DEVORE	Unprocessed	Animals - Birds - Alaudidae - Eremophila alpestris actia
Animals - Birds	Ardea alba	great egret	ABNGA04040	None	None	-	-	3411724	DEVORE	Unprocessed	Animals - Birds - Ardeidae - Ardea alba
Animals - Birds	Ardea herodias	great blue heron	ABNGA04010	None	None	-	-	3411724	DEVORE	Unprocessed	Animals - Birds - Ardeidae - Ardea herodias
Animals - Birds	Falco mexicanus	prairie falcon	ABNKD06090	None	None	WL	-	3411724	DEVORE	Unprocessed	Animals - Birds - Falconidae - Falco mexicanus
Animals - Birds	Spinus lawrencei	Lawrence's goldfinch	ABPBY06100	None	None	-	-	3411724	DEVORE	Unprocessed	Animals - Birds - Fringillidae - Spinus lawrencei
Animals - Birds	Icteria virens	yellow-breasted chat	ABPBX24010	None	None	SSC	-	3411724	DEVORE	Unprocessed	Animals - Birds - Icteriidae - Icteria virens
Animals - Birds	Lanius ludovicianus	loggerhead shrike	ABPBR01030	None	None	SSC	-	3411724	DEVORE	Unprocessed	Animals - Birds - Laniidae - Lanius ludovicianus
Animals - Birds	Pandion haliaetus	osprey	ABNKC01010	None	None	WL	-	3411724	DEVORE	Unprocessed	Animals - Birds - Pandionidae - Pandion haliaetus
Animals - Birds	Setophaga petechia	yellow warbler	ABPBX03010	None	None	SSC	-	3411724	DEVORE	Unprocessed	Animals - Birds - Parulidae - Setophaga petechia
Animals - Birds	Aimophila ruficeps canescens	southern California rufous-crowned sparrow	ABPBX91091	None	None	WL	-	3411724	DEVORE	Unprocessed	Animals - Birds - Passerellidae - Aimophila ruficeps canescens
Animals - Birds	Artemisiospiza belli belli	Bell's sage sparrow	ABPBX97021	None	None	WL	-	3411724	DEVORE	Mapped and Unprocessed	Animals - Birds - Passerellidae - Artemisiospiza belli belli

Animals - Birds	<i>Polioptila californica californica</i>	coastal California gnatcatcher	ABPBJ08081	Threatened	None	SSC	-	3411724	DEVORE	Mapped and Unprocessed	Animals - Birds - Poliptilidae - <i>Polioptila californica californica</i>
Animals - Birds	<i>Athene cunicularia</i>	burrowing owl	ABNSB10010	None	None	SSC	-	3411724	DEVORE	Mapped and Unprocessed	Animals - Birds - Strigidae - <i>Athene cunicularia</i>
Animals - Birds	<i>Strix occidentalis occidentalis</i>	California Spotted Owl	ABNSB12013	None	None	SSC	-	3411724	DEVORE	Mapped	Animals - Birds - Strigidae - <i>Strix occidentalis occidentalis</i>
Animals - Birds	<i>Calypte costae</i>	Costa's hummingbird	ABNUC47020	None	None	-	-	3411724	DEVORE	Unprocessed	Animals - Birds - Trochilidae - <i>Calypte costae</i>
Animals - Birds	<i>Vireo bellii pusillus</i>	least Bell's vireo	ABPBW01114	Endangered	Endangered	-	-	3411724	DEVORE	Mapped and Unprocessed	Animals - Birds - Vireonidae - <i>Vireo bellii pusillus</i>
Animals - Fish	<i>Rhinichthys osculus</i> ssp. 8	Santa Ana speckled dace	AFCJB3705K	None	None	SSC	-	3411724	DEVORE	Mapped and Unprocessed	Animals - Fish - Cyprinidae - <i>Rhinichthys osculus</i> ssp. 8
Animals - Fish	<i>Oncorhynchus mykiss irideus</i> pop. 10	steelhead - southern California DPS	AFCHA0209J	Endangered	None	-	-	3411724	DEVORE	Unprocessed	Animals - Fish - Salmonidae - <i>Oncorhynchus mykiss irideus</i> pop. 10
Animals - Insects	<i>Bombus crotchii</i>	Crotch bumble bee	IIHYM24480	None	None	-	-	3411724	DEVORE	Mapped	Animals - Insects - Apidae - <i>Bombus crotchii</i>
Animals - Insects	<i>Neolarra alba</i>	white cuckoo bee	IIHYM81010	None	None	-	-	3411724	DEVORE	Mapped	Animals - Insects - Apidae - <i>Neolarra alba</i>
Animals - Mammals	<i>Microtus californicus mohavensis</i>	Mohave river vole	AMAFF11031	None	None	SSC	-	3411724	DEVORE	Unprocessed	Animals - Mammals - Cricetidae - <i>Microtus californicus mohavensis</i>
Animals - Mammals	<i>Neotoma lepida intermedia</i>	San Diego desert woodrat	AMAFF08041	None	None	SSC	-	3411724	DEVORE	Unprocessed	Animals - Mammals - Cricetidae - <i>Neotoma lepida intermedia</i>
Animals - Mammals	<i>Chaetodipus fallax fallax</i>	northwestern San Diego pocket mouse	AMAFD05031	None	None	SSC	-	3411724	DEVORE	Mapped and Unprocessed	Animals - Mammals - Heteromyidae - <i>Chaetodipus fallax fallax</i>
Animals - Mammals	<i>Chaetodipus fallax pallidus</i>	pallid San Diego pocket mouse	AMAFD05032	None	None	SSC	-	3411724	DEVORE	Mapped	Animals - Mammals - Heteromyidae - <i>Chaetodipus fallax pallidus</i>
Animals - Mammals	<i>Dipodomys merriami parvus</i>	San Bernardino kangaroo rat	AMAFD03143	Endangered	Candidate Endangered	SSC	-	3411724	DEVORE	Mapped and Unprocessed	Animals - Mammals - Heteromyidae - <i>Dipodomys merriami parvus</i>
Animals - Mammals	<i>Dipodomys simulans</i>	Dulzura kangaroo rat	AMAFD03170	None	None	-	-	3411724	DEVORE	Unprocessed	Animals - Mammals - Heteromyidae - <i>Dipodomys simulans</i>
Animals - Mammals	<i>Perognathus longimembris brevinasus</i>	Los Angeles pocket mouse	AMAFD01041	None	None	SSC	-	3411724	DEVORE	Mapped and Unprocessed	Animals - Mammals - Heteromyidae - <i>Perognathus longimembris brevinasus</i>

Animals - Mammals	<i>Lepus californicus bennettii</i>	San Diego black-tailed jackrabbit	AMAEB03051	None	None	SSC	-	3411724	DEVORE	Mapped and Unprocessed	Animals - Mammals - Leporidae - <i>Lepus californicus bennettii</i>
Animals - Mammals	<i>Nyctinomops femorosaccus</i>	pocketed free-tailed bat	AMACD04010	None	None	SSC	-	3411724	DEVORE	Mapped	Animals - Mammals - Molossidae - <i>Nyctinomops femorosaccus</i>
Animals - Mammals	<i>Taxidea taxus</i>	American badger	AMAJF04010	None	None	SSC	-	3411724	DEVORE	Unprocessed	Animals - Mammals - Mustelidae - <i>Taxidea taxus</i>
Animals - Reptiles	<i>Anniella stebbinsi</i>	Southern California legless lizard	ARACC01060	None	None	SSC	-	3411724	DEVORE	Mapped and Unprocessed	Animals - Reptiles - Anniellidae - <i>Anniella stebbinsi</i>
Animals - Reptiles	<i>Arizona elegans occidentalis</i>	California glossy snake	ARADB01017	None	None	SSC	-	3411724	DEVORE	Mapped and Unprocessed	Animals - Reptiles - Colubridae - <i>Arizona elegans occidentalis</i>
Animals - Reptiles	<i>Salvadora hexalepis virgultea</i>	coast patch-nosed snake	ARADB30033	None	None	SSC	-	3411724	DEVORE	Unprocessed	Animals - Reptiles - Colubridae - <i>Salvadora hexalepis virgultea</i>
Animals - Reptiles	<i>Phrynosoma blainvillii</i>	coast horned lizard	ARACF12100	None	None	SSC	-	3411724	DEVORE	Mapped and Unprocessed	Animals - Reptiles - Phrynosomatidae - <i>Phrynosoma blainvillii</i>
Animals - Reptiles	<i>Aspidoscelis tigris stejnegeri</i>	coastal whiptail	ARACJ02143	None	None	SSC	-	3411724	DEVORE	Unprocessed	Animals - Reptiles - Teiidae - <i>Aspidoscelis tigris stejnegeri</i>
Community - Terrestrial	Riversidian Alluvial Fan Sage Scrub	Riversidian Alluvial Fan Sage Scrub	CTT32720CA	None	None	-	-	3411724	DEVORE	Mapped	Community - Terrestrial - Riversidian Alluvial Fan Sage Scrub
Community - Terrestrial	Southern Riparian Forest	Southern Riparian Forest	CTT61300CA	None	None	-	-	3411724	DEVORE	Mapped	Community - Terrestrial - Southern Riparian Forest
Community - Terrestrial	Southern Sycamore Alder Riparian Woodland	Southern Sycamore Alder Riparian Woodland	CTT62400CA	None	None	-	-	3411724	DEVORE	Mapped	Community - Terrestrial - Southern Sycamore Alder Riparian Woodland
Plants - Vascular	<i>Ambrosia monogyra</i>	singlewhorl burrobrush	PDAST50010	None	None	-	2B.2	3411724	DEVORE	Mapped	Plants - Vascular - Asteraceae - <i>Ambrosia monogyra</i>
Plants - Vascular	<i>Senecio astephanus</i>	San Gabriel ragwort	PDAST8H090	None	None	-	4.3	3411724	DEVORE	Unprocessed	Plants - Vascular - Asteraceae - <i>Senecio astephanus</i>
Plants - Vascular	<i>Cryptantha incana</i>	Tulare cryptantha	PDBOR0A1D0	None	None	-	1B.3	3411724	DEVORE	Unprocessed	Plants - Vascular - Boraginaceae - <i>Cryptantha incana</i>
Plants - Vascular	<i>Streptanthus bernardinus</i>	Laguna Mountains jewelflower	PDBRA2G060	None	None	-	4.3	3411724	DEVORE	Mapped	Plants - Vascular - Brassicaceae - <i>Streptanthus bernardinus</i>
Plants - Vascular	<i>Opuntia basilaris</i> var. <i>brachyclada</i>	short-joint beavertail	PDCAC0D053	None	None	-	1B.2	3411724	DEVORE	Mapped	Plants - Vascular - Cactaceae - <i>Opuntia basilaris</i> var. <i>brachyclada</i>

Plants - Vascular	<i>Quercus durata</i> var. <i>gabrielensis</i>	San Gabriel oak	PDFAG050G2	None	None	-	4.2	3411724	DEVORE	Unprocessed	Plants - Vascular - Fagaceae - <i>Quercus durata</i> var. <i>gabrielensis</i>
Plants - Vascular	<i>Juglans californica</i>	southern California black walnut	PDJUG02020	None	None	-	4.2	3411724	DEVORE	Unprocessed	Plants - Vascular - Juglandaceae - <i>Juglans californica</i>
Plants - Vascular	<i>Monardella saxicola</i>	rock monardella	PDLAM180Q1	None	None	-	4.2	3411724	DEVORE	Unprocessed	Plants - Vascular - Lamiaceae - <i>Monardella saxicola</i>
Plants - Vascular	<i>Calochortus plummerae</i>	Plummer's mariposa-lily	PMLIL0D150	None	None	-	4.2	3411724	DEVORE	Mapped and Unprocessed	Plants - Vascular - Liliaceae - <i>Calochortus plummerae</i>
Plants - Vascular	<i>Lilium humboldtii</i> ssp. <i>ocellatum</i>	ocellated humboldt lily	PMLIL1A072	None	None	-	4.2	3411724	DEVORE	Unprocessed	Plants - Vascular - Liliaceae - <i>Lilium humboldtii</i> ssp. <i>ocellatum</i>
Plants - Vascular	<i>Lilium parryi</i>	lemon lily	PMLIL1A0J0	None	None	-	1B.2	3411724	DEVORE	Mapped	Plants - Vascular - Liliaceae - <i>Lilium parryi</i>
Plants - Vascular	<i>Malacothamnus parishii</i>	Parish's bush-mallow	PDMAL0Q0C0	None	None	-	1A	3411724	DEVORE	Mapped	Plants - Vascular - Malvaceae - <i>Malacothamnus parishii</i>
Plants - Vascular	<i>Eriastrum densifolium</i> ssp. <i>sanctorum</i>	Santa Ana River woollystar	PDPLM03035	Endangered	Endangered	-	1B.1	3411724	DEVORE	Mapped	Plants - Vascular - Polemoniaceae - <i>Eriastrum densifolium</i> ssp. <i>sanctorum</i>
Plants - Vascular	<i>Chorizanthe parryi</i> var. <i>parryi</i>	Parry's spineflower	PDPGN040J2	None	None	-	1B.1	3411724	DEVORE	Mapped and Unprocessed	Plants - Vascular - Polygonaceae - <i>Chorizanthe parryi</i> var. <i>parryi</i>
Plants - Vascular	<i>Chorizanthe xanti</i> var. <i>leucotheca</i>	white-bracted spineflower	PDPGN040Z1	None	None	-	1B.2	3411724	DEVORE	Mapped	Plants - Vascular - Polygonaceae - <i>Chorizanthe xanti</i> var. <i>leucotheca</i>
Plants - Vascular	<i>Dodecahema leptoceras</i>	slender-horned spineflower	PDPGN0V010	Endangered	Endangered	-	1B.1	3411724	DEVORE	Mapped and Unprocessed	Plants - Vascular - Polygonaceae - <i>Dodecahema leptoceras</i>
Plants - Vascular	<i>Horkelia cuneata</i> var. <i>puberula</i>	mesa horkelia	PDROS0W045	None	None	-	1B.1	3411724	DEVORE	Mapped	Plants - Vascular - Rosaceae - <i>Horkelia cuneata</i> var. <i>puberula</i>
Plants - Vascular	<i>Galium jepsonii</i>	Jepson's bedstraw	PDRUB0N130	None	None	-	4.3	3411724	DEVORE	Unprocessed	Plants - Vascular - Rubiaceae - <i>Galium jepsonii</i>
Plants - Vascular	<i>Galium johnstonii</i>	Johnston's bedstraw	PDRUB0N140	None	None	-	4.3	3411724	DEVORE	Unprocessed	Plants - Vascular - Rubiaceae - <i>Galium johnstonii</i>
Plants - Vascular	<i>Lycium parishii</i>	Parish's desert-thorn	PDSOL0G0D0	None	None	-	2B.3	3411724	DEVORE	Mapped	Plants - Vascular - Solanaceae - <i>Lycium parishii</i>

CNDDDB Quad Species List 79 records.

Element Type	Scientific Name	Common Name	Element Code	Federal Status	State Status	CDFW Status	CA Rare Plant Rank	Quad Code	Quad Name	Data Status	Taxonomic Sort
Animals - Amphibians	Batrachoseps gabrieli	San Gabriel slender salamander	AAAAD02110	None	None	-	-	3411725	CUCAMONGA PEAK	Mapped and Unprocessed	Animals - Amphibians - Plethodontidae - Batrachoseps gabrieli
Animals - Amphibians	Rana muscosa	southern mountain yellow-legged frog	AAABH01330	Endangered	Endangered	WL	-	3411725	CUCAMONGA PEAK	Mapped	Animals - Amphibians - Ranidae - Rana muscosa
Animals - Amphibians	Spea hammondii	western spadefoot	AAABF02020	None	None	SSC	-	3411725	CUCAMONGA PEAK	Mapped	Animals - Amphibians - Scaphiopodidae - Spea hammondii
Animals - Birds	Accipiter cooperii	Cooper's hawk	ABNKC12040	None	None	WL	-	3411725	CUCAMONGA PEAK	Unprocessed	Animals - Birds - Accipitridae - Accipiter cooperii
Animals - Birds	Circus hudsonius	northern harrier	ABNKC11011	None	None	SSC	-	3411725	CUCAMONGA PEAK	Unprocessed	Animals - Birds - Accipitridae - Circus hudsonius
Animals - Birds	Ardea alba	great egret	ABNGA04040	None	None	-	-	3411725	CUCAMONGA PEAK	Unprocessed	Animals - Birds - Ardeidae - Ardea alba
Animals - Birds	Ardea herodias	great blue heron	ABNGA04010	None	None	-	-	3411725	CUCAMONGA PEAK	Unprocessed	Animals - Birds - Ardeidae - Ardea herodias
Animals - Birds	Nycticorax nycticorax	black-crowned night heron	ABNGA11010	None	None	-	-	3411725	CUCAMONGA PEAK	Unprocessed	Animals - Birds - Ardeidae - Nycticorax nycticorax
Animals - Birds	Spinus lawrencei	Lawrence's goldfinch	ABPBY06100	None	None	-	-	3411725	CUCAMONGA PEAK	Unprocessed	Animals - Birds - Fringillidae - Spinus lawrencei
Animals - Birds	Xanthocephalus xanthocephalus	yellow-headed blackbird	ABPBXB3010	None	None	SSC	-	3411725	CUCAMONGA PEAK	Unprocessed	Animals - Birds - Icteridae - Xanthocephalus xanthocephalus
Animals - Birds	Lanius ludovicianus	loggerhead shrike	ABPBR01030	None	None	SSC	-	3411725	CUCAMONGA PEAK	Unprocessed	Animals - Birds - Laniidae - Lanius ludovicianus
Animals - Birds	Setophaga petechia	yellow warbler	ABPBX03010	None	None	SSC	-	3411725	CUCAMONGA PEAK	Unprocessed	Animals - Birds - Parulidae - Setophaga petechia
Animals - Birds	Aimophila ruficeps canescens	southern California rufous-crowned sparrow	ABPBX91091	None	None	WL	-	3411725	CUCAMONGA PEAK	Unprocessed	Animals - Birds - Passerellidae - Aimophila ruficeps canescens
Animals - Birds	Artemisospiza belli belli	Bell's sage sparrow	ABPBX97021	None	None	WL	-	3411725	CUCAMONGA PEAK	Unprocessed	Animals - Birds - Passerellidae - Artemisospiza belli belli
Animals - Birds	Spizella breweri	Brewer's sparrow	ABPBX94040	None	None	-	-	3411725	CUCAMONGA PEAK	Unprocessed	Animals - Birds - Passerellidae - Spizella breweri
Animals - Birds	Phalacrocorax auritus	double-crested cormorant	ABNFD01020	None	None	WL	-	3411725	CUCAMONGA PEAK	Unprocessed	Animals - Birds - Phalacrocoracidae - Phalacrocorax auritus
Animals - Birds	Polioptila californica californica	coastal California gnatcatcher	ABPBX08081	Threatened	None	SSC	-	3411725	CUCAMONGA PEAK	Mapped and Unprocessed	Animals - Birds - Poliopitidae - Polioptila californica californica
Animals - Birds	Asio otus	long-eared owl	ABNSB13010	None	None	SSC	-	3411725	CUCAMONGA PEAK	Unprocessed	Animals - Birds - Strigidae - Asio otus
Animals - Birds	Athene cunicularia	burrowing owl	ABNSB10010	None	None	SSC	-	3411725	CUCAMONGA PEAK	Unprocessed	Animals - Birds - Strigidae - Athene cunicularia

Animals - Birds	<i>Strix occidentalis occidentalis</i>	California Spotted Owl	ABNSB12013	None	None	SSC	-	3411725	CUCAMONGA PEAK	Mapped	Animals - Birds - Strigidae - <i>Strix occidentalis occidentalis</i>
Animals - Birds	<i>Calypte costae</i>	Costa's hummingbird	ABNUC47020	None	None	-	-	3411725	CUCAMONGA PEAK	Unprocessed	Animals - Birds - Trochilidae - <i>Calypte costae</i>
Animals - Birds	<i>Selasphorus rufus</i>	rufous hummingbird	ABNUC51020	None	None	-	-	3411725	CUCAMONGA PEAK	Unprocessed	Animals - Birds - Trochilidae - <i>Selasphorus rufus</i>
Animals - Birds	<i>Empidonax traillii</i>	willow flycatcher	ABPAE33040	None	Endangered	-	-	3411725	CUCAMONGA PEAK	Unprocessed	Animals - Birds - Tyrannidae - <i>Empidonax traillii</i>
Animals - Birds	<i>Empidonax traillii extimus</i>	southwestern willow flycatcher	ABPAE33043	Endangered	Endangered	-	-	3411725	CUCAMONGA PEAK	Unprocessed	Animals - Birds - Tyrannidae - <i>Empidonax traillii extimus</i>
Animals - Fish	<i>Oncorhynchus mykiss irideus</i> pop. 10	steelhead - southern California DPS	AFCHA0209J	Endangered	None	-	-	3411725	CUCAMONGA PEAK	Unprocessed	Animals - Fish - Salmonidae - <i>Oncorhynchus mykiss irideus</i> pop. 10
Animals - Insects	<i>Bombus crotchii</i>	Crotch bumble bee	IIHYM24480	None	None	-	-	3411725	CUCAMONGA PEAK	Mapped	Animals - Insects - Apidae - <i>Bombus crotchii</i>
Animals - Mammals	<i>Ovis canadensis nelsoni</i>	desert bighorn sheep	AMALE04013	None	None	FP	-	3411725	CUCAMONGA PEAK	Mapped and Unprocessed	Animals - Mammals - Bovidae - <i>Ovis canadensis nelsoni</i>
Animals - Mammals	<i>Neotoma lepida intermedia</i>	San Diego desert woodrat	AMAFF08041	None	None	SSC	-	3411725	CUCAMONGA PEAK	Mapped and Unprocessed	Animals - Mammals - Cricetidae - <i>Neotoma lepida intermedia</i>
Animals - Mammals	<i>Onychomys torridus ramona</i>	southern grasshopper mouse	AMAFF06022	None	None	SSC	-	3411725	CUCAMONGA PEAK	Unprocessed	Animals - Mammals - Cricetidae - <i>Onychomys torridus ramona</i>
Animals - Mammals	<i>Chaetodipus fallax fallax</i>	northwestern San Diego pocket mouse	AMAFD05031	None	None	SSC	-	3411725	CUCAMONGA PEAK	Mapped and Unprocessed	Animals - Mammals - Heteromyidae - <i>Chaetodipus fallax fallax</i>
Animals - Mammals	<i>Dipodomys merriami parvus</i>	San Bernardino kangaroo rat	AMAFD03143	Endangered	Candidate Endangered	SSC	-	3411725	CUCAMONGA PEAK	Mapped and Unprocessed	Animals - Mammals - Heteromyidae - <i>Dipodomys merriami parvus</i>
Animals - Mammals	<i>Dipodomys simulans</i>	Dulzura kangaroo rat	AMAFD03170	None	None	-	-	3411725	CUCAMONGA PEAK	Unprocessed	Animals - Mammals - Heteromyidae - <i>Dipodomys simulans</i>
Animals - Mammals	<i>Perognathus longimembris brevinasus</i>	Los Angeles pocket mouse	AMAFD01041	None	None	SSC	-	3411725	CUCAMONGA PEAK	Mapped and Unprocessed	Animals - Mammals - Heteromyidae - <i>Perognathus longimembris brevinasus</i>
Animals - Mammals	<i>Lepus californicus bennettii</i>	San Diego black-tailed jackrabbit	AMAEB03051	None	None	SSC	-	3411725	CUCAMONGA PEAK	Mapped and Unprocessed	Animals - Mammals - Leporidae - <i>Lepus californicus bennettii</i>
Animals - Mammals	<i>Eumops perotis californicus</i>	western mastiff bat	AMACD02011	None	None	SSC	-	3411725	CUCAMONGA PEAK	Mapped	Animals - Mammals - Molossidae - <i>Eumops perotis californicus</i>
Animals - Mammals	<i>Lasiurus xanthinus</i>	western yellow bat	AMACC05070	None	None	SSC	-	3411725	CUCAMONGA PEAK	Mapped	Animals - Mammals - Vespertilionidae - <i>Lasiurus xanthinus</i>
Animals - Reptiles	<i>Anniella stebbinsi</i>	Southern California legless lizard	ARACC01060	None	None	SSC	-	3411725	CUCAMONGA PEAK	Mapped	Animals - Reptiles - Anniellidae - <i>Anniella stebbinsi</i>

Animals - Reptiles	Arizona elegans occidentalis	California glossy snake	ARADB01017	None	None	SSC	-	3411725	CUCAMONGA PEAK	Mapped and Unprocessed	Animals - Reptiles - Colubridae - Arizona elegans occidentalis
Animals - Reptiles	Diadophis punctatus modestus	San Bernardino ringneck snake	ARADB10015	None	None	-	-	3411725	CUCAMONGA PEAK	Unprocessed	Animals - Reptiles - Colubridae - Diadophis punctatus modestus
Animals - Reptiles	Salvadora hexalepis virgultea	coast patch-nosed snake	ARADB30033	None	None	SSC	-	3411725	CUCAMONGA PEAK	Unprocessed	Animals - Reptiles - Colubridae - Salvadora hexalepis virgultea
Animals - Reptiles	Coleonyx variegatus abbotti	San Diego banded gecko	ARACD01031	None	None	SSC	-	3411725	CUCAMONGA PEAK	Unprocessed	Animals - Reptiles - Gekkonidae - Coleonyx variegatus abbotti
Animals - Reptiles	Thamnophis hammondi	two-striped gartersnake	ARADB36160	None	None	SSC	-	3411725	CUCAMONGA PEAK	Mapped	Animals - Reptiles - Natricidae - Thamnophis hammondi
Animals - Reptiles	Phrynosoma blainvillii	coast horned lizard	ARACF12100	None	None	SSC	-	3411725	CUCAMONGA PEAK	Mapped and Unprocessed	Animals - Reptiles - Phrynosomatidae - Phrynosoma blainvillii
Animals - Reptiles	Aspidoscelis hyperythra	orange-throated whiptail	ARACJ02060	None	None	WL	-	3411725	CUCAMONGA PEAK	Unprocessed	Animals - Reptiles - Teiidae - Aspidoscelis hyperythra
Animals - Reptiles	Aspidoscelis tigris stejnegeri	coastal whiptail	ARACJ02143	None	None	SSC	-	3411725	CUCAMONGA PEAK	Unprocessed	Animals - Reptiles - Teiidae - Aspidoscelis tigris stejnegeri
Community - Terrestrial	California Walnut Woodland	California Walnut Woodland	CTT71210CA	None	None	-	-	3411725	CUCAMONGA PEAK	Mapped	Community - Terrestrial - California Walnut Woodland
Community - Terrestrial	Coastal and Valley Freshwater Marsh	Coastal and Valley Freshwater Marsh	CTT52410CA	None	None	-	-	3411725	CUCAMONGA PEAK	Mapped	Community - Terrestrial - Coastal and Valley Freshwater Marsh
Community - Terrestrial	Riversidian Alluvial Fan Sage Scrub	Riversidian Alluvial Fan Sage Scrub	CTT32720CA	None	None	-	-	3411725	CUCAMONGA PEAK	Mapped	Community - Terrestrial - Riversidian Alluvial Fan Sage Scrub
Community - Terrestrial	Southern Sycamore Alder Riparian Woodland	Southern Sycamore Alder Riparian Woodland	CTT62400CA	None	None	-	-	3411725	CUCAMONGA PEAK	Mapped	Community - Terrestrial - Southern Sycamore Alder Riparian Woodland
Plants - Vascular	Sagittaria sanfordii	Sanford's arrowhead	PMALI040Q0	None	None	-	1B.2	3411725	CUCAMONGA PEAK	Mapped	Plants - Vascular - Alismataceae - Sagittaria sanfordii
Plants - Vascular	Oreonana vestita	wooly mountain-parsley	PDAP11G030	None	None	-	1B.3	3411725	CUCAMONGA PEAK	Mapped	Plants - Vascular - Apiaceae - Oreonana vestita
Plants - Vascular	Asplenium vespertinum	western spleenwort	PPASP021P0	None	None	-	4.2	3411725	CUCAMONGA PEAK	Unprocessed	Plants - Vascular - Aspleniaceae - Asplenium vespertinum
Plants - Vascular	Eriophyllum lanatum var. obovatum	southern Sierra woolly sunflower	PDAST3N05D	None	None	-	4.3	3411725	CUCAMONGA PEAK	Unprocessed	Plants - Vascular - Asteraceae - Eriophyllum lanatum var. obovatum
Plants - Vascular	Streptanthus bernardinus	Laguna Mountains jewelflower	PDBRA2G060	None	None	-	4.3	3411725	CUCAMONGA PEAK	Mapped and Unprocessed	Plants - Vascular - Brassicaceae - Streptanthus bernardinus
Plants - Vascular	Arctostaphylos glandulosa ssp. gabrielensis	San Gabriel manzanita	PDERI042P0	None	None	-	1B.2	3411725	CUCAMONGA PEAK	Mapped	Plants - Vascular - Ericaceae - Arctostaphylos glandulosa ssp. gabrielensis

Plants - Vascular	Phacelia mohavensis	Mojave phacelia	PDHYD0C310	None	None	-	4.3	3411725	CUCAMONGA PEAK	Unprocessed	Plants - Vascular - Hydrophyllaceae - Phacelia mohavensis
Plants - Vascular	Juglans californica	southern California black walnut	PDJUG02020	None	None	-	4.2	3411725	CUCAMONGA PEAK	Unprocessed	Plants - Vascular - Juglandaceae - Juglans californica
Plants - Vascular	Juncus duranii	Duran's rush	PMJUN013T0	None	None	-	4.3	3411725	CUCAMONGA PEAK	Unprocessed	Plants - Vascular - Juncaceae - Juncus duranii
Plants - Vascular	Lepechinia fragrans	fragrant pitcher sage	PDLAM0V030	None	None	-	4.2	3411725	CUCAMONGA PEAK	Unprocessed	Plants - Vascular - Lamiaceae - Lepechinia fragrans
Plants - Vascular	Monardella australis ssp. jokerstii	Jokerst's monardella	PDLAM18112	None	None	-	1B.1	3411725	CUCAMONGA PEAK	Mapped and Unprocessed	Plants - Vascular - Lamiaceae - Monardella australis ssp. jokerstii
Plants - Vascular	Calochortus plummerae	Plummer's mariposa-lily	PMLIL0D150	None	None	-	4.2	3411725	CUCAMONGA PEAK	Mapped and Unprocessed	Plants - Vascular - Liliaceae - Calochortus plummerae
Plants - Vascular	Calochortus weedii var. intermedius	intermediate mariposa-lily	PMLIL0D1J1	None	None	-	1B.2	3411725	CUCAMONGA PEAK	Mapped	Plants - Vascular - Liliaceae - Calochortus weedii var. intermedius
Plants - Vascular	Fritillaria pinetorum	pine fritillary	PMLIL0V0E0	None	None	-	4.3	3411725	CUCAMONGA PEAK	Unprocessed	Plants - Vascular - Liliaceae - Fritillaria pinetorum
Plants - Vascular	Lilium humboldtii ssp. ocellatum	ocellated humboldt lily	PMLIL1A072	None	None	-	4.2	3411725	CUCAMONGA PEAK	Unprocessed	Plants - Vascular - Liliaceae - Lilium humboldtii ssp. ocellatum
Plants - Vascular	Lilium parryi	lemon lily	PMLIL1A0J0	None	None	-	1B.2	3411725	CUCAMONGA PEAK	Mapped	Plants - Vascular - Liliaceae - Lilium parryi
Plants - Vascular	Claytonia peirsonii ssp. peirsonii	Peirson's spring beauty	PDPOR03121	None	None	-	1B.2	3411725	CUCAMONGA PEAK	Mapped	Plants - Vascular - Montiaceae - Claytonia peirsonii ssp. peirsonii
Plants - Vascular	Diplacus johnstonii	Johnston's monkeyflower	PDSCR1B1H0	None	None	-	4.3	3411725	CUCAMONGA PEAK	Unprocessed	Plants - Vascular - Phrymaceae - Diplacus johnstonii
Plants - Vascular	Muhlenbergia californica	California muhly	PMPOA480A0	None	None	-	4.3	3411725	CUCAMONGA PEAK	Unprocessed	Plants - Vascular - Poaceae - Muhlenbergia californica
Plants - Vascular	Linanthus concinnus	San Gabriel linanthus	PDPLM090D0	None	None	-	1B.2	3411725	CUCAMONGA PEAK	Mapped	Plants - Vascular - Polemoniaceae - Linanthus concinnus
Plants - Vascular	Chorizanthe parryi var. parryi	Parry's spineflower	PDPGN040J2	None	None	-	1B.1	3411725	CUCAMONGA PEAK	Mapped and Unprocessed	Plants - Vascular - Polygonaceae - Chorizanthe parryi var. parryi
Plants - Vascular	Eriogonum microthecum var. alpinum	alpine slender buckwheat	PDPGN083WA	None	None	-	4.3	3411725	CUCAMONGA PEAK	Unprocessed	Plants - Vascular - Polygonaceae - Eriogonum microthecum var. alpinum
Plants - Vascular	Eriogonum microthecum var. johnstonii	Johnston's buckwheat	PDPGN083W5	None	None	-	1B.3	3411725	CUCAMONGA PEAK	Mapped	Plants - Vascular - Polygonaceae - Eriogonum microthecum var. johnstonii
Plants - Vascular	Eriogonum umbellatum var. minus	alpine sulphur-flowered buckwheat	PDPGN086U7	None	None	-	4.3	3411725	CUCAMONGA PEAK	Unprocessed	Plants - Vascular - Polygonaceae - Eriogonum umbellatum var. minus
Plants - Vascular	Horkelia cuneata var. puberula	mesa horkelia	PDROS0W045	None	None	-	1B.1	3411725	CUCAMONGA PEAK	Mapped	Plants - Vascular - Rosaceae - Horkelia cuneata var. puberula

Plants - Vascular	<i>Galium angustifolium</i> ssp. <i>gabrielense</i>	San Antonio Canyon bedstraw	PDRUB0N044	None	None	-	4.3	3411725	CUCAMONGA PEAK	Unprocessed	Plants - Vascular - Rubiaceae - <i>Galium angustifolium</i> ssp. <i>gabrielense</i>
Plants - Vascular	<i>Galium jepsonii</i>	Jepson's bedstraw	PDRUB0N130	None	None	-	4.3	3411725	CUCAMONGA PEAK	Unprocessed	Plants - Vascular - Rubiaceae - <i>Galium jepsonii</i>
Plants - Vascular	<i>Galium johnstonii</i>	Johnston's bedstraw	PDRUB0N140	None	None	-	4.3	3411725	CUCAMONGA PEAK	Unprocessed	Plants - Vascular - Rubiaceae - <i>Galium johnstonii</i>
Plants - Vascular	<i>Heuchera caespitosa</i>	urn-flowered alumroot	PDSAX0E1C0	None	None	-	4.3	3411725	CUCAMONGA PEAK	Unprocessed	Plants - Vascular - Saxifragaceae - <i>Heuchera caespitosa</i>
Plants - Vascular	<i>Viola pinetorum</i> ssp. <i>grisea</i>	grey-leaved violet	PDVIO04431	None	None	-	1B.2	3411725	CUCAMONGA PEAK	Mapped	Plants - Vascular - Violaceae - <i>Viola pinetorum</i> ssp. <i>grisea</i>

CNDDB Quad Species List 47 records.

Element Type	Scientific Name	Common Name	Element Code	Federal Status	State Status	CDFW Status	CA Rare Plant Rank	Quad Code	Quad Name	Data Status	Taxonomic Sort
Animals - Birds	<i>Accipiter cooperii</i>	Cooper's hawk	ABNKC12040	None	None	WL	-	3411715	GUASTI	Unprocessed	Animals - Birds - Accipitridae - <i>Accipiter cooperii</i>
Animals - Birds	<i>Circus hudsonius</i>	northern harrier	ABNKC11011	None	None	SSC	-	3411715	GUASTI	Unprocessed	Animals - Birds - Accipitridae - <i>Circus hudsonius</i>
Animals - Birds	<i>Elanus leucurus</i>	white-tailed kite	ABNKC06010	None	None	FP	-	3411715	GUASTI	Unprocessed	Animals - Birds - Accipitridae - <i>Elanus leucurus</i>
Animals - Birds	<i>Eremophila alpestris actia</i>	California horned lark	ABPAT02011	None	None	WL	-	3411715	GUASTI	Unprocessed	Animals - Birds - Alaudidae - <i>Eremophila alpestris actia</i>
Animals - Birds	<i>Ardea alba</i>	great egret	ABNGA04040	None	None	-	-	3411715	GUASTI	Unprocessed	Animals - Birds - Ardeidae - <i>Ardea alba</i>
Animals - Birds	<i>Ardea herodias</i>	great blue heron	ABNGA04010	None	None	-	-	3411715	GUASTI	Unprocessed	Animals - Birds - Ardeidae - <i>Ardea herodias</i>
Animals - Birds	<i>Egretta thula</i>	snowy egret	ABNGA06030	None	None	-	-	3411715	GUASTI	Unprocessed	Animals - Birds - Ardeidae - <i>Egretta thula</i>
Animals - Birds	<i>Nycticorax nycticorax</i>	black-crowned night heron	ABNGA11010	None	None	-	-	3411715	GUASTI	Unprocessed	Animals - Birds - Ardeidae - <i>Nycticorax nycticorax</i>
Animals - Birds	<i>Agelaius tricolor</i>	tricolored blackbird	ABPBXB0020	None	Threatened	SSC	-	3411715	GUASTI	Mapped	Animals - Birds - Icteridae - <i>Agelaius tricolor</i>
Animals - Birds	<i>Lanius ludovicianus</i>	loggerhead shrike	ABPBR01030	None	None	SSC	-	3411715	GUASTI	Unprocessed	Animals - Birds - Laniidae - <i>Lanius ludovicianus</i>
Animals - Birds	<i>Larus californicus</i>	California gull	ABNNM03110	None	None	WL	-	3411715	GUASTI	Unprocessed	Animals - Birds - Laridae - <i>Larus californicus</i>
Animals - Birds	<i>Aimophila ruficeps canescens</i>	southern California rufous-crowned sparrow	ABPBX91091	None	None	WL	-	3411715	GUASTI	Unprocessed	Animals - Birds - Passerellidae - <i>Aimophila ruficeps canescens</i>
Animals - Birds	<i>Spizella breweri</i>	Brewer's sparrow	ABPBX94040	None	None	-	-	3411715	GUASTI	Unprocessed	Animals - Birds - Passerellidae - <i>Spizella breweri</i>
Animals - Birds	<i>Poliptila californica californica</i>	coastal California gnatcatcher	ABPBJ08081	Threatened	None	SSC	-	3411715	GUASTI	Mapped and Unprocessed	Animals - Birds - Polioptilidae - <i>Poliptila californica californica</i>
Animals - Birds	<i>Laterallus jamaicensis coturniculus</i>	California black rail	ABNME03041	None	Threatened	FP	-	3411715	GUASTI	Mapped	Animals - Birds - Rallidae - <i>Laterallus jamaicensis coturniculus</i>
Animals - Birds	<i>Athene cunicularia</i>	burrowing owl	ABNSB10010	None	None	SSC	-	3411715	GUASTI	Mapped and Unprocessed	Animals - Birds - Strigidae - <i>Athene cunicularia</i>
Animals - Birds	<i>Calypte costae</i>	Costa's hummingbird	ABNUC47020	None	None	-	-	3411715	GUASTI	Unprocessed	Animals - Birds - Trochilidae - <i>Calypte costae</i>
Animals - Birds	<i>Vireo bellii pusillus</i>	least Bell's vireo	ABPBW01114	Endangered	Endangered	-	-	3411715	GUASTI	Unprocessed	Animals - Birds - Vireonidae - <i>Vireo bellii pusillus</i>
Animals - Insects	<i>Bombus crotchii</i>	Crotch bumble bee	IIHYM24480	None	None	-	-	3411715	GUASTI	Mapped	Animals - Insects - Apidae - <i>Bombus crotchii</i>

Animals - Insects	Rhaphiomidas terminatus abdominalis	Delhi Sands flower-loving fly	IIDIP05021	Endangered	None	-	-	3411715	GUASTI	Mapped	Animals - Insects - Myridae - Rhaphiomidas terminatus abdominalis
Animals - Mammals	Neotoma lepida intermedia	San Diego desert woodrat	AMAFF08041	None	None	SSC	-	3411715	GUASTI	Mapped and Unprocessed	Animals - Mammals - Cricetidae - Neotoma lepida intermedia
Animals - Mammals	Chaetodipus fallax fallax	northwestern San Diego pocket mouse	AMAFD05031	None	None	SSC	-	3411715	GUASTI	Mapped and Unprocessed	Animals - Mammals - Heteromyidae - Chaetodipus fallax fallax
Animals - Mammals	Dipodomys merriami parvus	San Bernardino kangaroo rat	AMAFD03143	Endangered	Candidate Endangered	SSC	-	3411715	GUASTI	Mapped and Unprocessed	Animals - Mammals - Heteromyidae - Dipodomys merriami parvus
Animals - Mammals	Dipodomys nitratoides brevinasus	short-nosed kangaroo rat	AMAFD03153	None	None	SSC	-	3411715	GUASTI	Unprocessed	Animals - Mammals - Heteromyidae - Dipodomys nitratoides brevinasus
Animals - Mammals	Dipodomys simulans	Dulzura kangaroo rat	AMAFD03170	None	None	-	-	3411715	GUASTI	Unprocessed	Animals - Mammals - Heteromyidae - Dipodomys simulans
Animals - Mammals	Dipodomys stephensi	Stephens' kangaroo rat	AMAFD03100	Endangered	Threatened	-	-	3411715	GUASTI	Mapped	Animals - Mammals - Heteromyidae - Dipodomys stephensi
Animals - Mammals	Perognathus longimembris brevinasus	Los Angeles pocket mouse	AMAFD01041	None	None	SSC	-	3411715	GUASTI	Mapped and Unprocessed	Animals - Mammals - Heteromyidae - Perognathus longimembris brevinasus
Animals - Mammals	Lepus californicus bennettii	San Diego black-tailed jackrabbit	AMAEB03051	None	None	SSC	-	3411715	GUASTI	Unprocessed	Animals - Mammals - Leporidae - Lepus californicus bennettii
Animals - Mammals	Eumops perotis californicus	western mastiff bat	AMACD02011	None	None	SSC	-	3411715	GUASTI	Mapped and Unprocessed	Animals - Mammals - Molossidae - Eumops perotis californicus
Animals - Mammals	Lasiurus xanthinus	western yellow bat	AMACC05070	None	None	SSC	-	3411715	GUASTI	Mapped	Animals - Mammals - Vespertilionidae - Lasiurus xanthinus
Animals - Reptiles	Anniella stebbinsi	Southern California legless lizard	ARACC01060	None	None	SSC	-	3411715	GUASTI	Mapped	Animals - Reptiles - Anniellidae - Anniella stebbinsi
Animals - Reptiles	Arizona elegans occidentalis	California glossy snake	ARADB01017	None	None	SSC	-	3411715	GUASTI	Mapped	Animals - Reptiles - Colubridae - Arizona elegans occidentalis
Animals - Reptiles	Phrynosoma blainvillii	coast horned lizard	ARACF12100	None	None	SSC	-	3411715	GUASTI	Mapped and Unprocessed	Animals - Reptiles - Phrynosomatidae - Phrynosoma blainvillii
Animals - Reptiles	Aspidoscelis tigris stejnegeri	coastal whiptail	ARACJ02143	None	None	SSC	-	3411715	GUASTI	Unprocessed	Animals - Reptiles - Teiidae - Aspidoscelis tigris stejnegeri
Plants - Vascular	Deinandra paniculata	paniculate tarplant	PDAST4R0N0	None	None	-	4.2	3411715	GUASTI	Unprocessed	Plants - Vascular - Asteraceae - Deinandra paniculata

Plants - Vascular	<i>Pseudognaphalium leucocephalum</i>	white rabbit-tobacco	PDAST440C0	None	None	-	2B.2	3411715	GUASTI	Mapped	Plants - Vascular - Asteraceae - <i>Pseudognaphalium leucocephalum</i>
Plants - Vascular	<i>Symphotrichum defoliatum</i>	San Bernardino aster	PDASTE80C0	None	None	-	1B.2	3411715	GUASTI	Mapped	Plants - Vascular - Asteraceae - <i>Symphotrichum defoliatum</i>
Plants - Vascular	<i>Cladium californicum</i>	California saw-grass	PMCYP04010	None	None	-	2B.2	3411715	GUASTI	Mapped	Plants - Vascular - Cyperaceae - <i>Cladium californicum</i>
Plants - Vascular	<i>Phacelia stellaris</i>	Brand's star phacelia	PDHYD0C510	None	None	-	1B.1	3411715	GUASTI	Mapped	Plants - Vascular - Hydrophyllaceae - <i>Phacelia stellaris</i>
Plants - Vascular	<i>Juglans californica</i>	southern California black walnut	PDJUG02020	None	None	-	4.2	3411715	GUASTI	Unprocessed	Plants - Vascular - Juglandaceae - <i>Juglans californica</i>
Plants - Vascular	<i>Calochortus catalinae</i>	Catalina mariposa-lily	PMLIL0D080	None	None	-	4.2	3411715	GUASTI	Unprocessed	Plants - Vascular - Liliaceae - <i>Calochortus catalinae</i>
Plants - Vascular	<i>Calochortus plummerae</i>	Plummer's mariposa-lily	PMLIL0D150	None	None	-	4.2	3411715	GUASTI	Mapped	Plants - Vascular - Liliaceae - <i>Calochortus plummerae</i>
Plants - Vascular	<i>Muhlenbergia californica</i>	California muhly	PMPOA480A0	None	None	-	4.3	3411715	GUASTI	Mapped	Plants - Vascular - Poaceae - <i>Muhlenbergia californica</i>
Plants - Vascular	<i>Muhlenbergia utilis</i>	aparejo grass	PMPOA481X0	None	None	-	2B.2	3411715	GUASTI	Mapped	Plants - Vascular - Poaceae - <i>Muhlenbergia utilis</i>
Plants - Vascular	<i>Navarretia prostrata</i>	prostrate vernal pool navarretia	PDPLM0C0Q0	None	None	-	1B.2	3411715	GUASTI	Mapped	Plants - Vascular - Polemoniaceae - <i>Navarretia prostrata</i>
Plants - Vascular	<i>Chorizanthe parryi</i> var. <i>parryi</i>	Parry's spineflower	PDPGN040J2	None	None	-	1B.1	3411715	GUASTI	Mapped	Plants - Vascular - Polygonaceae - <i>Chorizanthe parryi</i> var. <i>parryi</i>
Plants - Vascular	<i>Horkelia cuneata</i> var. <i>puberula</i>	mesa horkelia	PDROS0W045	None	None	-	1B.1	3411715	GUASTI	Mapped	Plants - Vascular - Rosaceae - <i>Horkelia cuneata</i> var. <i>puberula</i>

CNDDDB Quad Species List 63 records.

Element Type	Scientific Name	Common Name	Element Code	Federal Status	State Status	CDFW Status	CA Rare Plant Rank	Quad Code	Quad Name	Data Status	Taxonomic Sort
Animals - Birds	<i>Accipiter cooperii</i>	Cooper's hawk	ABNKC12040	None	None	WL	-	3411714	FONTANA	Unprocessed	Animals - Birds - Accipitridae - Accipiter cooperii
Animals - Birds	<i>Accipiter striatus</i>	sharp-shinned hawk	ABNKC12020	None	None	WL	-	3411714	FONTANA	Unprocessed	Animals - Birds - Accipitridae - Accipiter striatus
Animals - Birds	<i>Aquila chrysaetos</i>	golden eagle	ABNKC22010	None	None	FP , WL	-	3411714	FONTANA	Unprocessed	Animals - Birds - Accipitridae - Aquila chrysaetos
Animals - Birds	<i>Buteo swainsoni</i>	Swainson's hawk	ABNKC19070	None	Threatened	-	-	3411714	FONTANA	Unprocessed	Animals - Birds - Accipitridae - Buteo swainsoni
Animals - Birds	<i>Circus hudsonius</i>	northern harrier	ABNKC11011	None	None	SSC	-	3411714	FONTANA	Unprocessed	Animals - Birds - Accipitridae - Circus hudsonius
Animals - Birds	<i>Elanus leucurus</i>	white-tailed kite	ABNKC06010	None	None	FP	-	3411714	FONTANA	Unprocessed	Animals - Birds - Accipitridae - Elanus leucurus
Animals - Birds	<i>Eremophila alpestris actia</i>	California horned lark	ABPAT02011	None	None	WL	-	3411714	FONTANA	Unprocessed	Animals - Birds - Alaudidae - Eremophila alpestris actia
Animals - Birds	<i>Ardea herodias</i>	great blue heron	ABNGA04010	None	None	-	-	3411714	FONTANA	Unprocessed	Animals - Birds - Ardeidae - Ardea herodias
Animals - Birds	<i>Falco columbarius</i>	merlin	ABNKD06030	None	None	WL	-	3411714	FONTANA	Unprocessed	Animals - Birds - Falconidae - Falco columbarius
Animals - Birds	<i>Spinus lawrencei</i>	Lawrence's goldfinch	ABPBY06100	None	None	-	-	3411714	FONTANA	Unprocessed	Animals - Birds - Fringillidae - Spinus lawrencei
Animals - Birds	<i>Agelaius tricolor</i>	tricolored blackbird	ABPBXB0020	None	Threatened	SSC	-	3411714	FONTANA	Mapped	Animals - Birds - Icteridae - Agelaius tricolor
Animals - Birds	<i>Icteria virens</i>	yellow-breasted chat	ABPBX24010	None	None	SSC	-	3411714	FONTANA	Unprocessed	Animals - Birds - Icteridae - Icteria virens
Animals - Birds	<i>Lanius ludovicianus</i>	loggerhead shrike	ABPBR01030	None	None	SSC	-	3411714	FONTANA	Unprocessed	Animals - Birds - Laniidae - Lanius ludovicianus
Animals - Birds	<i>Pandion haliaetus</i>	osprey	ABNKC01010	None	None	WL	-	3411714	FONTANA	Unprocessed	Animals - Birds - Pandionidae - Pandion haliaetus
Animals - Birds	<i>Setophaga petechia</i>	yellow warbler	ABPBX03010	None	None	SSC	-	3411714	FONTANA	Unprocessed	Animals - Birds - Parulidae - Setophaga petechia
Animals - Birds	<i>Aimophila ruficeps canescens</i>	southern California rufous-crowned sparrow	ABPBX91091	None	None	WL	-	3411714	FONTANA	Unprocessed	Animals - Birds - Passerellidae - Aimophila ruficeps canescens
Animals - Birds	<i>Artemisiospiza belli belli</i>	Bell's sage sparrow	ABPBX97021	None	None	WL	-	3411714	FONTANA	Unprocessed	Animals - Birds - Passerellidae - Artemisiospiza belli belli
Animals - Birds	<i>Polioptila californica californica</i>	coastal California gnatcatcher	ABPBJ08081	Threatened	None	SSC	-	3411714	FONTANA	Mapped and Unprocessed	Animals - Birds - Polioptilidae - Polioptila californica californica

Animals - Birds	Athene cunicularia	burrowing owl	ABNSB10010	None	None	SSC	-	3411714	FONTANA	Mapped and Unprocessed	Animals - Birds - Strigidae - Athene cunicularia
Animals - Birds	Calypte costae	Costa's hummingbird	ABNUC47020	None	None	-	-	3411714	FONTANA	Unprocessed	Animals - Birds - Trochilidae - Calypte costae
Animals - Birds	Contopus cooperi	olive-sided flycatcher	ABPAE32010	None	None	SSC	-	3411714	FONTANA	Unprocessed	Animals - Birds - Tyrannidae - Contopus cooperi
Animals - Birds	Empidonax traillii	willow flycatcher	ABPAE33040	None	Endangered	-	-	3411714	FONTANA	Unprocessed	Animals - Birds - Tyrannidae - Empidonax traillii
Animals - Birds	Pyrocephalus rubinus	vermillion flycatcher	ABPAE36010	None	None	SSC	-	3411714	FONTANA	Unprocessed	Animals - Birds - Tyrannidae - Pyrocephalus rubinus
Animals - Birds	Vireo bellii pusillus	least Bell's vireo	ABPBW01114	Endangered	Endangered	-	-	3411714	FONTANA	Mapped and Unprocessed	Animals - Birds - Vireonidae - Vireo bellii pusillus
Animals - Fish	Catostomus santaanae	Santa Ana sucker	AFCJC02190	Threatened	None	-	-	3411714	FONTANA	Mapped and Unprocessed	Animals - Fish - Catostomidae - Catostomus santaanae
Animals - Fish	Gila orcuttii	arroyo chub	AFCJB13120	None	None	SSC	-	3411714	FONTANA	Mapped and Unprocessed	Animals - Fish - Cyprinidae - Gila orcuttii
Animals - Fish	Oncorhynchus mykiss irideus pop. 10	steelhead - southern California DPS	AFCHA0209J	Endangered	None	-	-	3411714	FONTANA	Mapped	Animals - Fish - Salmonidae - Oncorhynchus mykiss irideus pop. 10
Animals - Insects	Bombus crotchii	Crotch bumble bee	IIHYM24480	None	None	-	-	3411714	FONTANA	Mapped	Animals - Insects - Apidae - Bombus crotchii
Animals - Insects	Neolarra alba	white cuckoo bee	IIHYM81010	None	None	-	-	3411714	FONTANA	Mapped	Animals - Insects - Apidae - Neolarra alba
Animals - Insects	Cicindela tranquebarica viridissima	greenest tiger beetle	IICOL02201	None	None	-	-	3411714	FONTANA	Mapped	Animals - Insects - Carabidae - Cicindela tranquebarica viridissima
Animals - Insects	Rhaphiomidas terminatus abdominalis	Delhi Sands flower-loving fly	IIDIP05021	Endangered	None	-	-	3411714	FONTANA	Mapped and Unprocessed	Animals - Insects - Mydidae - Rhaphiomidas terminatus abdominalis
Animals - Mammals	Chaetodipus fallax fallax	northwestern San Diego pocket mouse	AMAFD05031	None	None	SSC	-	3411714	FONTANA	Mapped and Unprocessed	Animals - Mammals - Heteromyidae - Chaetodipus fallax fallax
Animals - Mammals	Dipodomys merriami parvus	San Bernardino kangaroo rat	AMAFD03143	Endangered	Candidate Endangered	SSC	-	3411714	FONTANA	Mapped and Unprocessed	Animals - Mammals - Heteromyidae - Dipodomys merriami parvus
Animals - Mammals	Dipodomys simulans	Dulzura kangaroo rat	AMAFD03170	None	None	-	-	3411714	FONTANA	Unprocessed	Animals - Mammals - Heteromyidae - Dipodomys simulans
Animals - Mammals	Lepus californicus bennettii	San Diego black-tailed jackrabbit	AMAEB03051	None	None	SSC	-	3411714	FONTANA	Mapped and Unprocessed	Animals - Mammals - Leporidae - Lepus californicus bennettii

Animals - Mammals	<i>Eumops perotis californicus</i>	western mastiff bat	AMACD02011	None	None	SSC	-	3411714	FONTANA	Unprocessed	Animals - Mammals - Molossidae - <i>Eumops perotis californicus</i>
Animals - Mammals	<i>Nyctinomops femorosaccus</i>	pocketed free-tailed bat	AMACD04010	None	None	SSC	-	3411714	FONTANA	Mapped	Animals - Mammals - Molossidae - <i>Nyctinomops femorosaccus</i>
Animals - Mammals	<i>Taxidea taxus</i>	American badger	AMAJF04010	None	None	SSC	-	3411714	FONTANA	Unprocessed	Animals - Mammals - Mustelidae - <i>Taxidea taxus</i>
Animals - Mammals	<i>Lasiurus xanthinus</i>	western yellow bat	AMACC05070	None	None	SSC	-	3411714	FONTANA	Mapped and Unprocessed	Animals - Mammals - Vespertilionidae - <i>Lasiurus xanthinus</i>
Animals - Reptiles	<i>Anniella stebbinsi</i>	Southern California legless lizard	ARACC01060	None	None	SSC	-	3411714	FONTANA	Mapped and Unprocessed	Animals - Reptiles - Anniellidae - <i>Anniella stebbinsi</i>
Animals - Reptiles	<i>Arizona elegans occidentalis</i>	California glossy snake	ARADB01017	None	None	SSC	-	3411714	FONTANA	Mapped	Animals - Reptiles - Colubridae - <i>Arizona elegans occidentalis</i>
Animals - Reptiles	<i>Diadophis punctatus modestus</i>	San Bernardino ringneck snake	ARADB10015	None	None	-	-	3411714	FONTANA	Unprocessed	Animals - Reptiles - Colubridae - <i>Diadophis punctatus modestus</i>
Animals - Reptiles	<i>Coleonyx variegatus abbotti</i>	San Diego banded gecko	ARACD01031	None	None	SSC	-	3411714	FONTANA	Unprocessed	Animals - Reptiles - Gekkonidae - <i>Coleonyx variegatus abbotti</i>
Animals - Reptiles	<i>Phrynosoma blainvillii</i>	coast horned lizard	ARACF12100	None	None	SSC	-	3411714	FONTANA	Mapped and Unprocessed	Animals - Reptiles - Phrynosomatidae - <i>Phrynosoma blainvillii</i>
Animals - Reptiles	<i>Aspidoscelis hyperythra</i>	orange-throated whiptail	ARACJ02060	None	None	WL	-	3411714	FONTANA	Unprocessed	Animals - Reptiles - Teiidae - <i>Aspidoscelis hyperythra</i>
Animals - Reptiles	<i>Aspidoscelis tigris stejnegeri</i>	coastal whiptail	ARACJ02143	None	None	SSC	-	3411714	FONTANA	Unprocessed	Animals - Reptiles - Teiidae - <i>Aspidoscelis tigris stejnegeri</i>
Animals - Reptiles	<i>Crotalus ruber</i>	red-diamond rattlesnake	ARADE02090	None	None	SSC	-	3411714	FONTANA	Unprocessed	Animals - Reptiles - Viperidae - <i>Crotalus ruber</i>
Community - Terrestrial	Riversidian Alluvial Fan Sage Scrub	Riversidian Alluvial Fan Sage Scrub	CTT32720CA	None	None	-	-	3411714	FONTANA	Mapped	Community - Terrestrial - Riversidian Alluvial Fan Sage Scrub
Plants - Vascular	<i>Deinandra paniculata</i>	paniculate tarplant	PDAST4R0N0	None	None	-	4.2	3411714	FONTANA	Unprocessed	Plants - Vascular - Asteraceae - <i>Deinandra paniculata</i>
Plants - Vascular	<i>Senecio aphanactis</i>	chaparral ragwort	PDAST8H060	None	None	-	2B.2	3411714	FONTANA	Mapped	Plants - Vascular - Asteraceae - <i>Senecio aphanactis</i>
Plants - Vascular	<i>Symphotrichum defoliatum</i>	San Bernardino aster	PDASTE80C0	None	None	-	1B.2	3411714	FONTANA	Mapped	Plants - Vascular - Asteraceae - <i>Symphotrichum defoliatum</i>

Plants - Vascular	<i>Lepidium virginicum</i> var. <i>robinsonii</i>	Robinson's pepper-grass	PDBRA1M114	None	None	-	4.3	3411714	FONTANA	Mapped	Plants - Vascular - Brassicaceae - <i>Lepidium virginicum</i> var. <i>robinsonii</i>
Plants - Vascular	<i>Arenaria paludicola</i>	marsh sandwort	PDCAR040L0	Endangered	Endangered	-	1B.1	3411714	FONTANA	Mapped	Plants - Vascular - Caryophyllaceae - <i>Arenaria paludicola</i>
Plants - Vascular	<i>Juglans californica</i>	southern California black walnut	PDJUG02020	None	None	-	4.2	3411714	FONTANA	Unprocessed	Plants - Vascular - Juglandaceae - <i>Juglans californica</i>
Plants - Vascular	<i>Monardella pringlei</i>	Pringle's monardella	PDLAM180J0	None	None	-	1A	3411714	FONTANA	Mapped	Plants - Vascular - Lamiaceae - <i>Monardella pringlei</i>
Plants - Vascular	<i>Calochortus plummerae</i>	Plummer's mariposa-lily	PMLIL0D150	None	None	-	4.2	3411714	FONTANA	Mapped and Unprocessed	Plants - Vascular - Liliaceae - <i>Calochortus plummerae</i>
Plants - Vascular	<i>Malacothamnus parishii</i>	Parish's bush-mallow	PDMAL0Q0C0	None	None	-	1A	3411714	FONTANA	Mapped	Plants - Vascular - Malvaceae - <i>Malacothamnus parishii</i>
Plants - Vascular	<i>Chloropyron maritimum</i> ssp. <i>maritimum</i>	salt marsh bird's-beak	PDSCR0J0C2	Endangered	Endangered	-	1B.2	3411714	FONTANA	Mapped	Plants - Vascular - Orobanchaceae - <i>Chloropyron maritimum</i> ssp. <i>maritimum</i>
Plants - Vascular	<i>Sphenopholis obtusata</i>	prairie wedge grass	PMPOA5T030	None	None	-	2B.2	3411714	FONTANA	Mapped	Plants - Vascular - Poaceae - <i>Sphenopholis obtusata</i>
Plants - Vascular	<i>Eriastrum densifolium</i> ssp. <i>sanctorum</i>	Santa Ana River woollystar	PDPLM03035	Endangered	Endangered	-	1B.1	3411714	FONTANA	Mapped	Plants - Vascular - Polemoniaceae - <i>Eriastrum densifolium</i> ssp. <i>sanctorum</i>
Plants - Vascular	<i>Chorizanthe parryi</i> var. <i>parryi</i>	Parry's spineflower	PDPGN040J2	None	None	-	1B.1	3411714	FONTANA	Mapped	Plants - Vascular - Polygonaceae - <i>Chorizanthe parryi</i> var. <i>parryi</i>
Plants - Vascular	<i>Horkelia cuneata</i> var. <i>puberula</i>	mesa horkelia	PDROS0W045	None	None	-	1B.1	3411714	FONTANA	Mapped	Plants - Vascular - Rosaceae - <i>Horkelia cuneata</i> var. <i>puberula</i>
Plants - Vascular	<i>Lycium parishii</i>	Parish's desert-thorn	PDSOL0G0D0	None	None	-	2B.3	3411714	FONTANA	Mapped	Plants - Vascular - Solanaceae - <i>Lycium parishii</i>

Inventory of Rare and Endangered Plants of California



Search Results

55 matches found. Click on scientific name for details

Search Criteria: Quad is one of [3411725:3411724:3411714:3411715]

▲ SCIENTIFIC NAME	COMMON NAME	FAMILY	LIFEFORM	BLOOMING PERIOD	FED LIST	STATE LIST	GLOBAL RANK	STATE RANK	CA RARE PLANT RANK	PHOTO
Ambrosia monogyra	singlewhorl burrobrush	Asteraceae	perennial shrub	Aug-Nov	None	None	G5	S2	2B.2	No Photo Available
Arctostaphylos glandulosa ssp. gabrielensis	San Gabriel manzanita	Ericaceae	perennial evergreen shrub	Mar	None	None	G5T3	S3	1B.2	No Photo Available
Arenaria paludicola	marsh sandwort	Caryophyllaceae	perennial stoloniferous herb	May-Aug	FE	CE	G1	S1	1B.1	No Photo Available
Asplenium vespertinum	western spleenwort	Aspleniaceae	perennial rhizomatous herb	Feb-Jun	None	None	G4	S4	4.2	No Photo Available
Calochortus catalinae	Catalina mariposa lily	Liliaceae	perennial bulbiferous herb	(Feb)Mar-Jun	None	None	G3G4	S3S4	4.2	No Photo Available
Calochortus plummerae	Plummer's mariposa-lily	Liliaceae	perennial bulbiferous herb	May-Jul	None	None	G4	S4	4.2	No Photo Available
Calochortus weedii var. intermedius	intermediate mariposa-lily	Liliaceae	perennial bulbiferous herb	May-Jul	None	None	G3G4T2	S3	1B.2	No Photo Available
Chloropyron maritimum ssp. maritimum	salt marsh bird's-beak	Orobanchaceae	annual herb (hemiparasitic)	May-Oct(Nov)	FE	CE	G4?T1	S1	1B.2	No Photo Available
Chorizanthe parryi var. parryi	Parry's spineflower	Polygonaceae	annual herb	Apr-Jun	None	None	G3T2	S2	1B.1	No Photo Available
Chorizanthe xanti var. leucotheca	white-bracted spineflower	Polygonaceae	annual herb	Apr-Jun	None	None	G4T3	S3	1B.2	No Photo Available
Cladium californicum	California saw-grass	Cyperaceae	perennial rhizomatous herb	Jun-Sep	None	None	G4	S2	2B.2	No Photo Available
Claytonia peirsonii ssp. peirsonii	Peirson's spring beauty	Montiaceae	perennial herb	(Mar)May-Jun	None	None	G2G3T2	S2	1B.2	No Photo Available
Cryptantha incana	Tulare cryptantha	Boraginaceae	annual herb	Jun-Aug	None	None	G2	S2	1B.3	No Photo Available

<i>Deinandra paniculata</i>	paniculate tarplant	Asteraceae	annual herb	(Mar)Apr-Nov	None	None	G4	S4	4.2	No Photo Available
<i>Diplacus johnstonii</i>	Johnston's monkeyflower	Phrymaceae	annual herb	May-Aug	None	None	G4	S4	4.3	No Photo Available
<i>Dodecahema leptoceras</i>	slender-horned spineflower	Polygonaceae	annual herb	Apr-Jun	FE	CE	G1	S1	1B.1	No Photo Available
<i>Eriastrum densifolium</i> ssp. <i>sanctorum</i>	Santa Ana River woollystar	Polemoniaceae	perennial herb	Apr-Sep	FE	CE	G4T1	S1	1B.1	No Photo Available
<i>Eriogonum microthecum</i> var. <i>alpinum</i>	alpine slender buckwheat	Polygonaceae	perennial herb	Jul-Sep	None	None	G5T3	S3	4.3	No Photo Available
<i>Eriogonum microthecum</i> var. <i>johnstonii</i>	Johnston's buckwheat	Polygonaceae	perennial deciduous shrub	Jul-Sep	None	None	G5T2	S2	1B.3	No Photo Available
<i>Eriogonum umbellatum</i> var. <i>minus</i>	alpine sulfur-flowered buckwheat	Polygonaceae	perennial herb	Jun-Sep	None	None	G5T4	S4	4.3	No Photo Available
<i>Eriophyllum lanatum</i> var. <i>obovatum</i>	southern Sierra woolly sunflower	Asteraceae	perennial herb	Jun-Jul	None	None	G5T4	S4	4.3	No Photo Available
<i>Fritillaria pinetorum</i>	pine fritillary	Liliaceae	perennial bulbiferous herb	May-Jul(Sep)	None	None	G4	S4	4.3	No Photo Available
<i>Galium angustifolium</i> ssp. <i>gabrielense</i>	San Antonio Canyon bedstraw	Rubiaceae	perennial herb	Apr-Aug	None	None	G5T3	S3	4.3	No Photo Available
<i>Galium jepsonii</i>	Jepson's bedstraw	Rubiaceae	perennial rhizomatous herb	Jul-Aug	None	None	G3	S3	4.3	No Photo Available
<i>Galium johnstonii</i>	Johnston's bedstraw	Rubiaceae	perennial herb	Jun-Jul	None	None	G4	S4	4.3	No Photo Available
<i>Heuchera caespitosa</i>	urn-flowered alumroot	Saxifragaceae	perennial rhizomatous herb	May-Aug	None	None	G3	S3	4.3	No Photo Available
<i>Horkelia cuneata</i> var. <i>puberula</i>	mesa horkelia	Rosaceae	perennial herb	Feb-Jul(Sep)	None	None	G4T1	S1	1B.1	No Photo Available
<i>Juglans californica</i>	Southern California black walnut	Juglandaceae	perennial deciduous tree	Mar-Aug	None	None	G4	S4	4.2	No Photo Available
<i>Juncus duranii</i>	Duran's rush	Juncaceae	perennial rhizomatous	Jul-Aug	None	None	G3	S3	4.3	No Photo Available

			rhizomatous herb									No Photo Available
<i>Lepechinia fragrans</i>	fragrant pitcher sage	Lamiaceae	perennial shrub	Mar-Oct	None	None	G3	S3	4.2			No Photo Available
<i>Lepidium virginicum</i> var. <i>robinsonii</i>	Robinson's pepper-grass	Brassicaceae	annual herb	Jan-Jul	None	None	G5T3	S3	4.3			No Photo Available
<i>Lilium humboldtii</i> ssp. <i>ocellatum</i>	ocellated Humboldt lily	Liliaceae	perennial bulbiferous herb	Mar-Jul(Aug)	None	None	G4T4?	S4?	4.2			No Photo Available
<i>Lilium parryi</i>	lemon lily	Liliaceae	perennial bulbiferous herb	Jul-Aug	None	None	G3	S3	1B.2			No Photo Available
<i>Linanthus concinnus</i>	San Gabriel linanthus	Polemoniaceae	annual herb	Apr-Jul	None	None	G2	S2	1B.2			No Photo Available
<i>Lycium parishii</i>	Parish's desert-thorn	Solanaceae	perennial shrub	Mar-Apr	None	None	G4	S1	2B.3			No Photo Available
<i>Malacothamnus parishii</i>	Parish's bush-mallow	Malvaceae	perennial deciduous shrub	Jun-Jul	None	None	GXQ	SX	1A			© 2021 Keir Morse
<i>Monardella australis</i> ssp. <i>jokerstii</i>	Jokerst's monardella	Lamiaceae	perennial rhizomatous herb	Jul-Sep	None	None	G4T1?	S1?	1B.1			No Photo Available
<i>Monardella pringlei</i>	Pringle's monardella	Lamiaceae	annual herb	May-Jun	None	None	GX	SX	1A			No Photo Available
<i>Monardella saxicola</i>	rock monardella	Lamiaceae	perennial rhizomatous herb	Jun-Sep	None	None	G3	S3	4.2			No Photo Available
<i>Muhlenbergia californica</i>	California muhly	Poaceae	perennial rhizomatous herb	Jun-Sep	None	None	G4	S4	4.3			No Photo Available
<i>Muhlenbergia utilis</i>	aparejo grass	Poaceae	perennial rhizomatous herb	Mar-Oct	None	None	G4	S2S3	2B.2			No Photo Available
<i>Navarretia prostrata</i>	prostrate vernal pool navarretia	Polemoniaceae	annual herb	Apr-Jul	None	None	G2	S2	1B.2			No Photo Available
<i>Opuntia basilaris</i> var. <i>brachyclada</i>	short-joint beavertail	Cactaceae	perennial stem	Apr-Jun(Aug)	None	None	G5T3	S3	1B.2			No Photo Available
<i>Oreonana vestita</i>	woolly mountain-narslev	Apiaceae	perennial herb	Mar-Sep	None	None	G3	S3	1B.3			No Photo Available

Phacelia mohavensis	Mojave phacelia	Hydrophyllaceae	annual herb	Apr-Aug	None	None	G4Q	S4	4.3	No Photo Available
Phacelia stellaris	Brand's star phacelia	Hydrophyllaceae	annual herb	Mar-Jun	None	None	G1	S1	1B.1	No Photo Available
Pseudognaphalium leucocephalum	white rabbit-tobacco	Asteraceae	perennial herb	(Jul)Aug-Nov(Dec)	None	None	G4	S2	2B.2	No Photo Available
Quercus durata var. gabrielensis	San Gabriel oak	Fagaceae	perennial evergreen shrub	Apr-May	None	None	G4T3	S3	4.2	No Photo Available
Sagittaria sanfordii	Sanford's arrowhead	Alismataceae	perennial rhizomatous herb (emergent)	May-Oct(Nov)	None	None	G3	S3	1B.2	No Photo Available
Senecio aphanactis	chaparral ragwort	Asteraceae	annual herb	Jan-Apr(May)	None	None	G3	S2	2B.2	No Photo Available
Senecio astephanus	San Gabriel ragwort	Asteraceae	perennial herb	May-Jul	None	None	G3	S3	4.3	No Photo Available
Sphenopholis obtusata	prairie wedge grass	Poaceae	perennial herb	Apr-Jul	None	None	G5	S2	2B.2	No Photo Available
Streptanthus bernardinus	Laguna Mountains jewelflower	Brassicaceae	perennial herb	May-Aug	None	None	G3G4	S3S4	4.3	No Photo Available
Symphyotrichum defoliatum	San Bernardino aster	Asteraceae	perennial rhizomatous herb	Jul-Nov	None	None	G2	S2	1B.2	No Photo Available
Viola pinetorum ssp. grisea	grey-leaved violet	Violaceae	perennial herb	Apr-Jul	None	None	G4G5T3	S3	1B.2	No Photo Available

Showing 1 to 55 of 55 entries

Suggested Citation:

California Native Plant Society, Rare Plant Program. 2021. Inventory of Rare and Endangered Plants of California (online edition, v9-01 1.0). Website <https://www.rareplants.cnps.org> [accessed 20 December 2021].

CONTACT US

Send questions and comments to rareplants@cnps.org.

ABOUT THIS WEBSITE

[About the Inventory](#)
[Release Notes](#)
[Advanced Search](#)
[Glossary](#)

ABOUT CNPS

[About the Rare Plant Program](#)
[CNPS Home Page](#)
[About CNPS](#)
[Join CNPS](#)

CONTRIBUTORS

[The Calflora Database](#)
[The California Lichen Society](#)
[California Natural Diversity Database](#)
[The Jepson Flora Project](#)
[The Consortium of California Herbaria](#)

[CalPhotos](#)

Copyright © 2010-2021 [California Native Plant Society](#). All rights reserved.



Developed by
Rincon Consultants, Inc.

Attachment D

References

California Department of Fish and Wildlife (CDFW). 2021a. RareFind 5, California Natural Diversity Data Base, California. Data base report on threatened, endangered, rare or otherwise sensitive species and communities for the USGS *Cucamonga Peak, Devore, Fontana, and Guasti, California 7.5-minute quadrangles*.

California Department of Fish and Wildlife (CDFW). 2021b. Biogeographic Information and Observation System, California Natural Diversity Data Base, California. Data base report on threatened, endangered, rare or otherwise sensitive species and communities for the USGS *Cucamonga Peak, Devore, Fontana, and Guasti, California 7.5-minute quadrangles*.

California Native Plant Society, Rare Plant Program. 2021. Inventory of Rare and Endangered Plants of California (online edition, v8-03 0.39). Accessed online at: <http://www.rareplants.cnps.org/>.

Michael Baker International. 2021, January 22. *Results of a Habitat Assessment for the Fontana 47 Project – City of Fontana, San Bernardino County, California*.