

**PRELIMINARY
HYDROLOGY STUDY
FOR**

**Cotati Village Community
APN 046-286-021
APN 144-050-009
Cotati, CA 94931**

Prepared For:
116 Associated Investors, LLC
1101 Fifth Avenue, Suite 300
San Rafael, CA 94901

MFKessler
One Venture Ste, 130
Irvine, CA 92618
(949) 339-5330
Ali Monshizadeh P.E.

**Prepared: November 2021
Revised: December 2023**

TABLE OF CONTENTS

- I. VICINITY MAP

- II. SOILS AND RAINFALL INTENSITY MAPS

- III. DISCUSSION & CONCLUSION

- IV. 10 AND 100-YEAR HYDROLOGY CALCULATIONS – EXISTING AND DEVELOPED CONDITION

- V. HYDROLOGY MAP-EXISTING AND DEVELOPED CONDITIONS

- VI. AS-BUILTS AND REFERENCE DOCUMENTS

I. VICINITY MAP

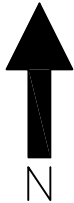
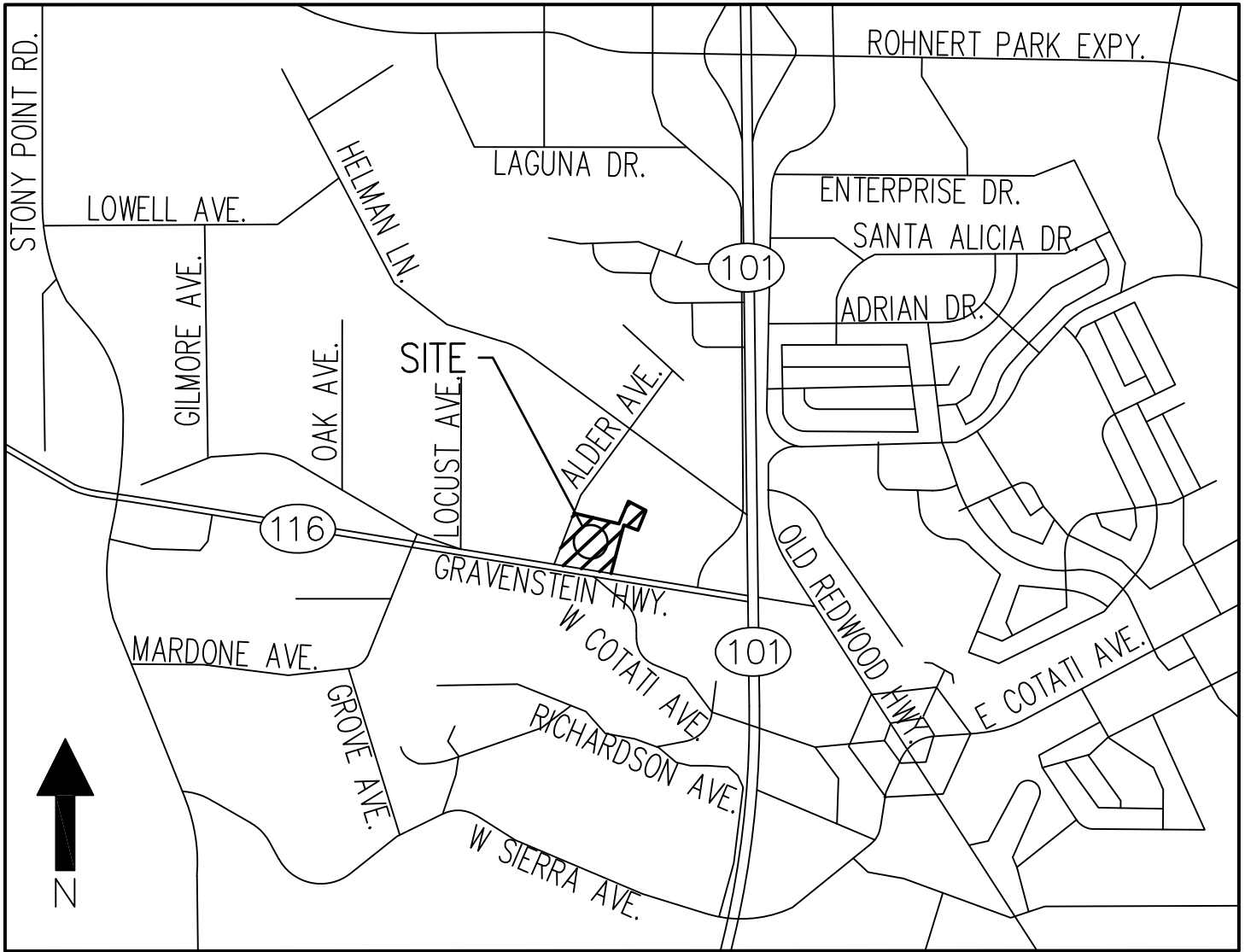

VICINITY MAP

N.T.S.

II. SOILS AND RAIN FALL INTENSITY MAPS

From Sonoma County Water Agency Flood Management Design Manual

Soil Type: C

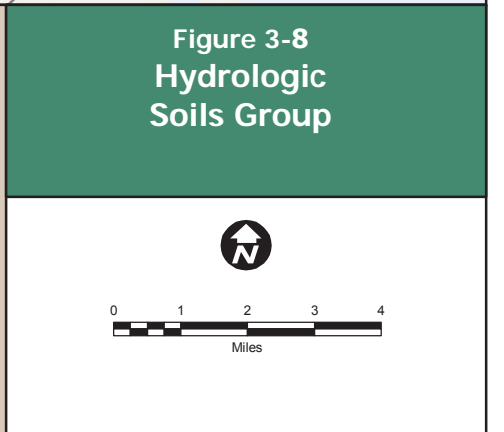
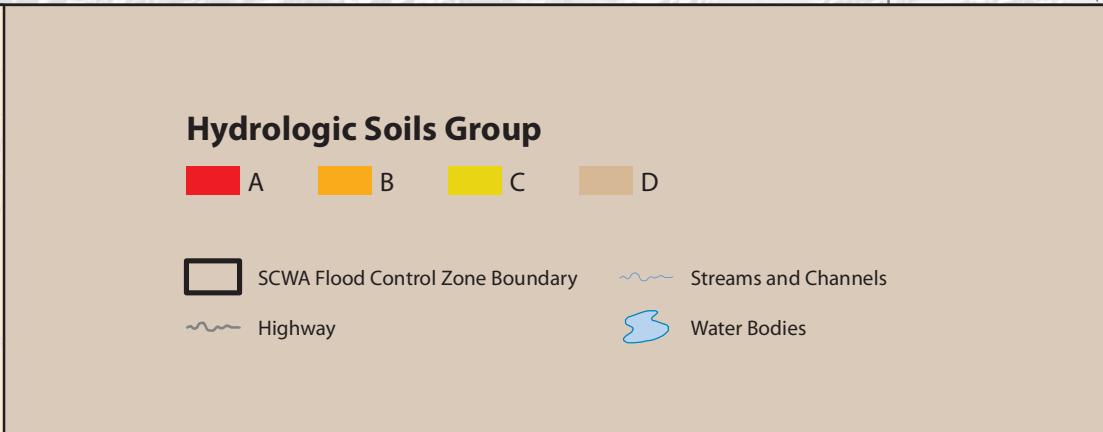
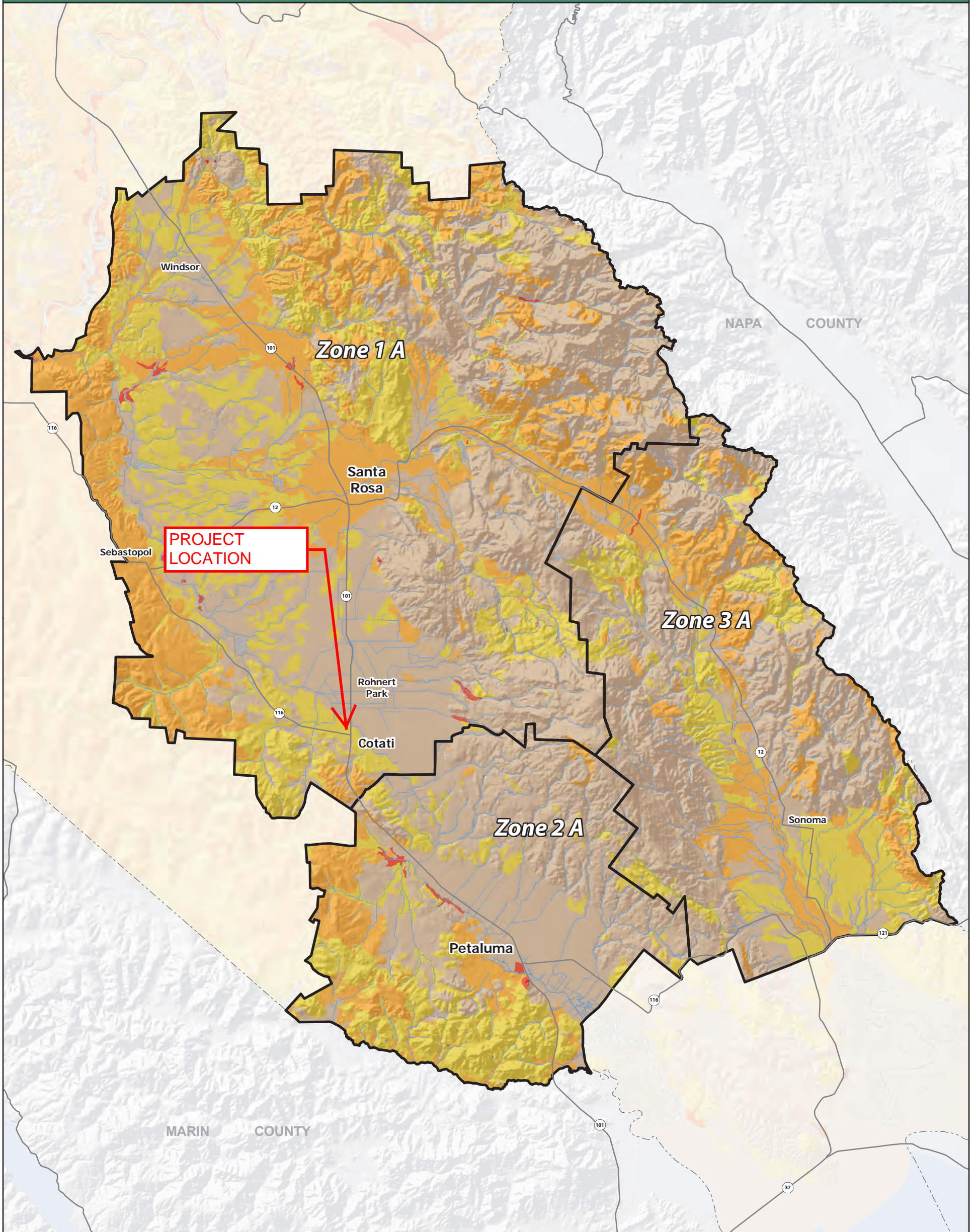

GENERAL SOIL MAP SONOMA COUNTY, CALIFORNIA

Scale 1:380,160
1 0 1 2 3 4 5 6 Miles

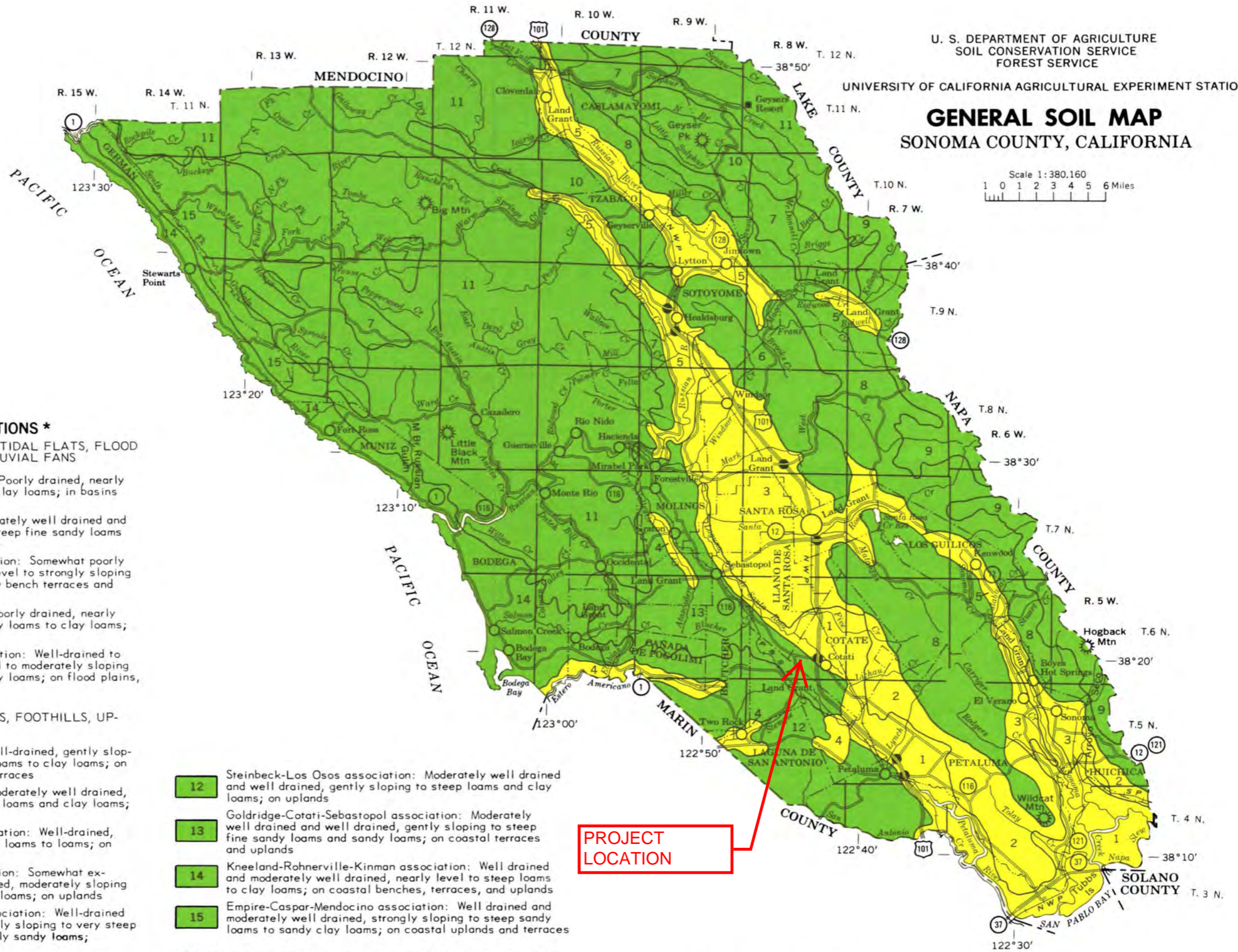

SOIL ASSOCIATIONS *

SOILS IN THE BASINS AND ON TIDAL FLATS, FLOOD PLAINS, TERRACES, AND ALLUVIAL FANS

- 1** Clear Lake-Reyes association: Poorly drained, nearly level to gently sloping clays to clay loams; in basins and on tidal flats
- 2** Haire-Diablo association: Moderately well drained and well drained, gently sloping to steep fine sandy loams to clays; on terraces and uplands
- 3** Huichica-Wright-Zamora association: Somewhat poorly drained to well-drained, nearly level to strongly sloping loams to silty clay loams; on low bench terraces and alluvial fans
- 4** Pajaro association: Somewhat poorly drained, nearly level to gently sloping fine sandy loams to clay loams; on low terraces and flood plains
- 5** Yolo-Cortina-Pleasanton association: Well-drained to excessively drained, nearly level to moderately sloping very gravelly sandy loams to clay loams; on flood plains, alluvial fans, and low terraces

SOILS OF THE HIGH TERRACES, FOOTHILLS, UPLANDS, AND MOUNTAINS

- 6** Spreckels-Felta association: Well-drained, gently sloping to very steep very gravelly loams to clay loams; on mountain foothills and on high terraces
- 7** Yorkville-Suther association: Moderately well drained, moderately sloping to very steep loams and clay loams; on uplands
- 8** Goulding-Toomes-Guenoc association: Well-drained, gently sloping to very steep clay loams to loams; on uplands
- 9** Kidd-Forward-Cohasset association: Somewhat excessively drained and well-drained, moderately sloping to very steep gravelly and stony loams; on uplands
- 10** Los Gatos-Henneke-Maymen association: Well-drained to excessively drained, moderately sloping to very steep loams, gravelly loams and gravelly sandy loams; on mountains
- 11** Hugo-Josephine-Laughlin association: Well-drained, gently sloping to very steep gravelly loams and loams; on mountains

- 12** Steinbeck-Los Osos association: Moderately well drained and well drained, gently sloping to steep loams and clay loams; on uplands
- 13** Goldridge-Cotati-Sebastopol association: Moderately well drained and well drained, gently sloping to steep fine sandy loams and sandy loams; on coastal terraces and uplands
- 14** Kneeland-Rohnerville-Kinman association: Well drained and moderately well drained, nearly level to steep loams to clay loams; on coastal benches, terraces, and uplands
- 15** Empire-Caspar-Mendocino association: Well drained and moderately well drained, strongly sloping to steep sandy loams to sandy clay loams; on coastal uplands and terraces

* Textures described in these soil associations are for the surface layer

PROJECT LOCATION

This map is for general planning. It shows only the major soils and does not contain sufficient detail for operational planning.

REFERENCE DOCUMENT A

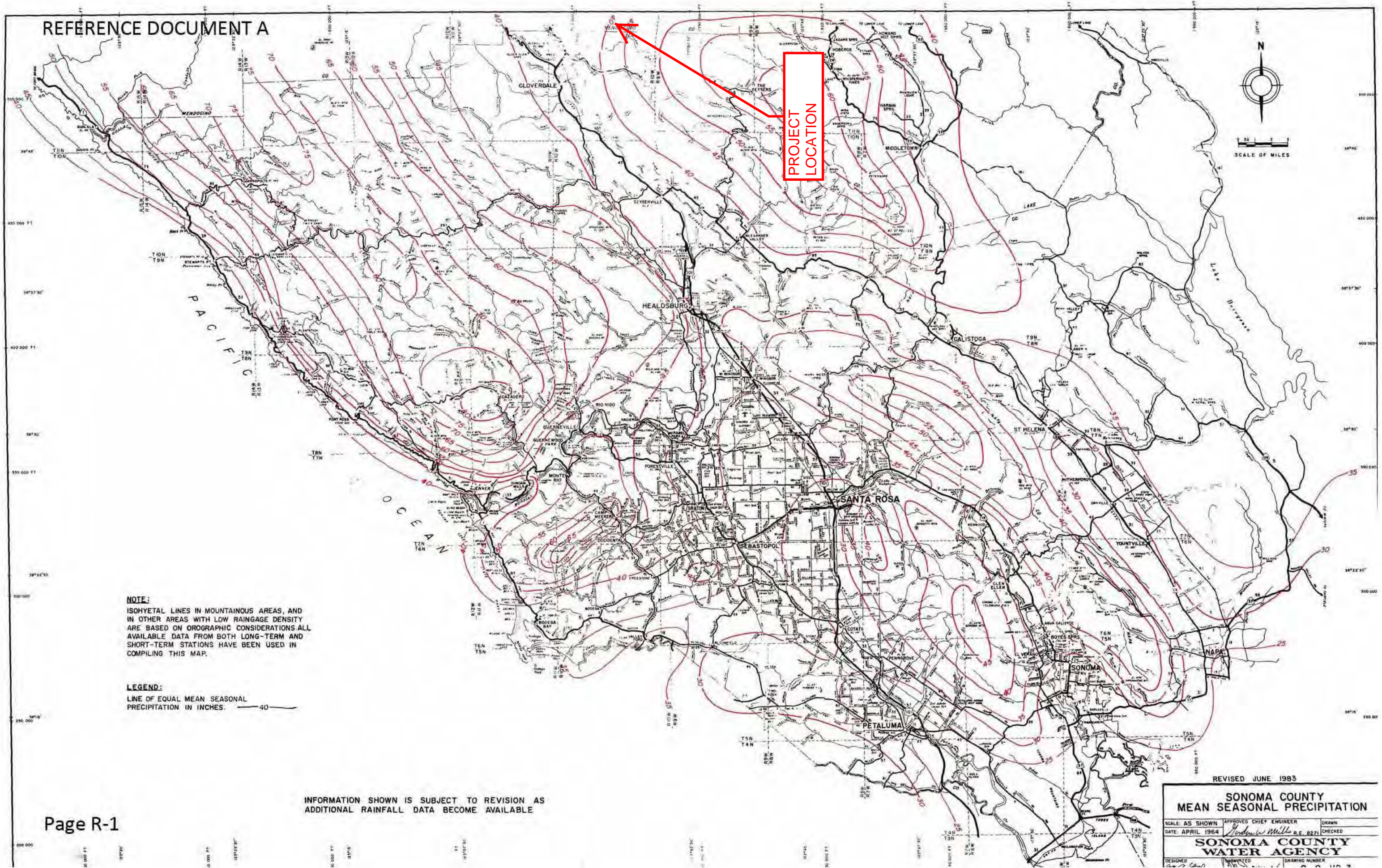

NOTE:
 ISOHYETAL LINES IN MOUNTAINOUS AREAS, AND IN OTHER AREAS WITH LOW RAINFALL DENSITY ARE BASED ON OROGRAPHIC CONSIDERATIONS. ALL AVAILABLE DATA FROM BOTH LONG-TERM AND SHORT-TERM STATIONS HAVE BEEN USED IN COMPILING THIS MAP.

LEGEND:
 LINE OF EQUAL MEAN SEASONAL PRECIPITATION IN INCHES. — 40 —

INFORMATION SHOWN IS SUBJECT TO REVISION AS ADDITIONAL RAINFALL DATA BECOME AVAILABLE

REVISED JUNE 1983

SONOMA COUNTY MEAN SEASONAL PRECIPITATION

SCALE: AS SHOWN	APPROVED CHIEF ENGINEER	DRAWN
DATE: APRIL 1964	<i>Richard Mills</i> R.E. 8271	CHECKED
SONOMA COUNTY WATER AGENCY		
DESIGNED	DRAWN	DRAWING NUMBER

Sonoma County Hazard Mitigation Plan

Figure 8.5
100-Year Flood Zone

Flood Zone Data

- 100-Year Zone
- Russian River
- Streams

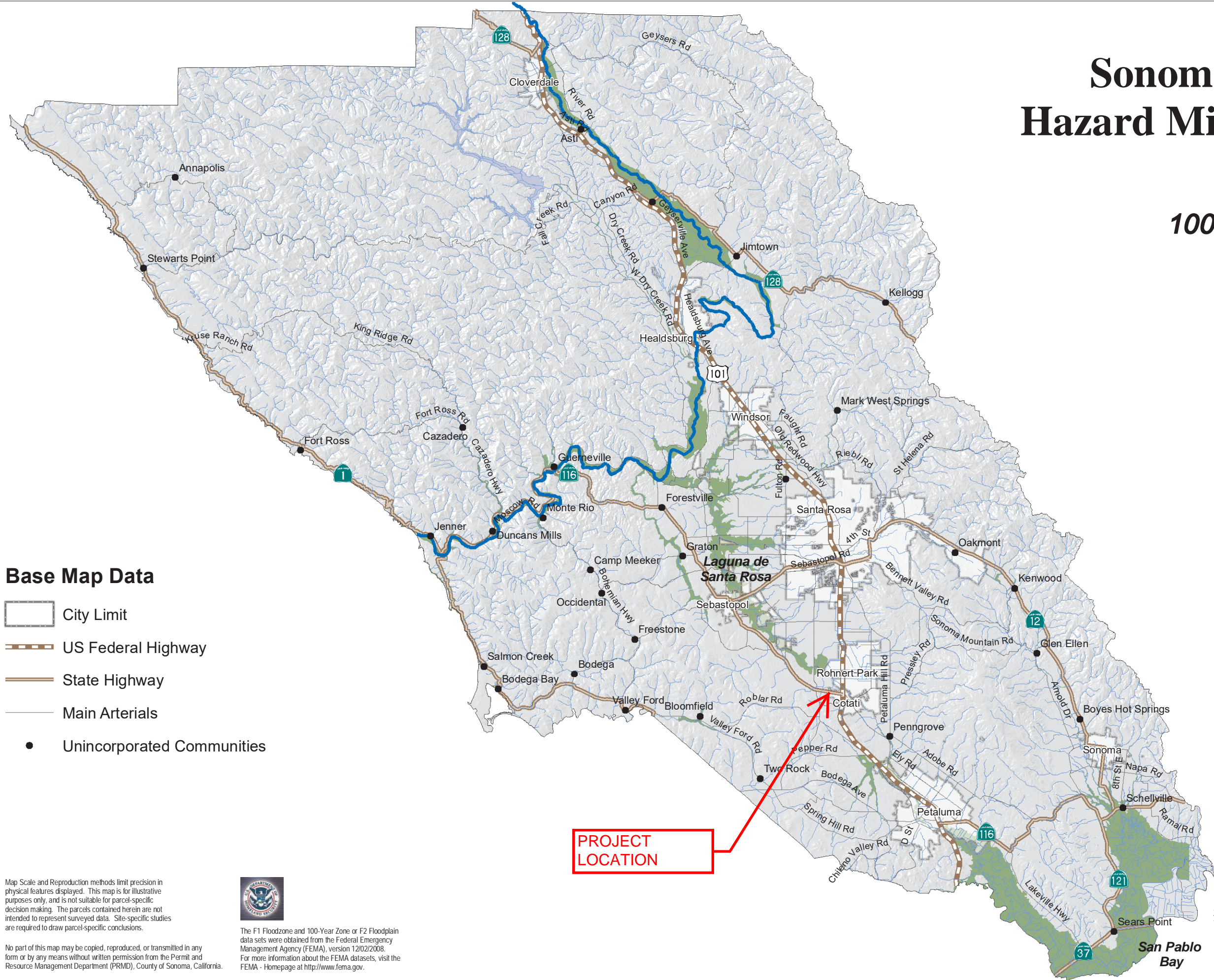

Base Map Data

- City Limit
- US Federal Highway
- State Highway
- Main Arterials
- Unincorporated Communities

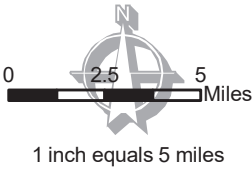

County of Sonoma

Permit and Resource Management Department
2550 Ventura Avenue, Santa Rosa, California 95403
707-565-1900 FAX 707-565-1103



Map Scale and Reproduction methods limit precision in physical features displayed. This map is for illustrative purposes only, and is not suitable for parcel-specific decision making. The parcels contained herein are not intended to represent surveyed data. Site-specific studies are required to draw parcel-specific conclusions.



The F1 Floodzone and 100-Year Zone or F2 Floodplain data sets were obtained from the Federal Emergency Management Agency (FEMA), version 12/02/2008. For more information about the FEMA datasets, visit the FEMA - Homepage at <http://www.fema.gov>.

No part of this map may be copied, reproduced, or transmitted in any form or by any means without written permission from the Permit and Resource Management Department (PRMD), County of Sonoma, California.



NOAA Atlas 14, Volume 6, Version 2
Location name: Cotati, California, USA*
Latitude: 38.3323°, Longitude: -122.7203°
Elevation: 106.17 ft**



* source: ESRI Maps
 ** source: USGS

POINT PRECIPITATION FREQUENCY ESTIMATES

Sanja Perica, Sarah Dietz, Sarah Heim, Lillian Hiner, Kazungu Maitaria, Deborah Martin, Sandra Pavlovic, Ishani Roy, Carl Tryppaluk, Dale Unruh, Fenglin Yan, Michael Yekta, Tan Zhao, Geoffrey Bonnin, Daniel Brewer, Li-Chuan Chen, Tye Parzybok, John Yarchoan

NOAA, National Weather Service, Silver Spring, Maryland

[PF_tabular](#) | [PF_graphical](#) | [Maps_&_aerials](#)

PF tabular

PDS-based point precipitation frequency estimates with 90% confidence intervals (in inches)¹										
Duration	Average recurrence interval (years)									
	1	2	5	10	25	50	100	200	500	1000
5-min	0.161 (0.144-0.183)	0.198 (0.176-0.225)	0.246 (0.218-0.281)	0.286 (0.251-0.330)	0.343 (0.289-0.411)	0.387 (0.318-0.476)	0.434 (0.346-0.548)	0.483 (0.373-0.631)	0.551 (0.406-0.756)	0.606 (0.429-0.866)
10-min	0.231 (0.206-0.263)	0.283 (0.252-0.322)	0.353 (0.312-0.402)	0.411 (0.360-0.473)	0.491 (0.414-0.589)	0.555 (0.457-0.682)	0.622 (0.497-0.786)	0.692 (0.535-0.904)	0.790 (0.582-1.08)	0.869 (0.615-1.24)
15-min	0.280 (0.249-0.318)	0.342 (0.304-0.389)	0.426 (0.378-0.486)	0.497 (0.436-0.572)	0.594 (0.501-0.712)	0.671 (0.552-0.825)	0.752 (0.601-0.951)	0.837 (0.647-1.09)	0.955 (0.704-1.31)	1.05 (0.744-1.50)
30-min	0.392 (0.349-0.445)	0.480 (0.426-0.545)	0.598 (0.529-0.682)	0.696 (0.610-0.801)	0.833 (0.702-0.998)	0.941 (0.774-1.16)	1.05 (0.841-1.33)	1.17 (0.906-1.53)	1.34 (0.986-1.84)	1.47 (1.04-2.10)
60-min	0.556 (0.495-0.631)	0.681 (0.605-0.774)	0.848 (0.751-0.967)	0.987 (0.866-1.14)	1.18 (0.995-1.42)	1.33 (1.10-1.64)	1.49 (1.19-1.89)	1.66 (1.29-2.17)	1.90 (1.40-2.60)	2.09 (1.48-2.98)
2-hr	0.838 (0.745-0.951)	1.02 (0.904-1.16)	1.25 (1.11-1.43)	1.45 (1.27-1.67)	1.71 (1.44-2.05)	1.92 (1.58-2.36)	2.13 (1.70-2.69)	2.35 (1.81-3.06)	2.64 (1.95-3.63)	2.88 (2.04-4.11)
3-hr	1.06 (0.943-1.20)	1.28 (1.14-1.46)	1.58 (1.40-1.80)	1.82 (1.59-2.09)	2.14 (1.80-2.56)	2.39 (1.96-2.93)	2.64 (2.11-3.34)	2.90 (2.24-3.79)	3.25 (2.40-4.46)	3.53 (2.50-5.04)
6-hr	1.57 (1.40-1.78)	1.91 (1.69-2.17)	2.34 (2.07-2.67)	2.69 (2.36-3.09)	3.15 (2.66-3.78)	3.51 (2.88-4.31)	3.86 (3.09-4.88)	4.23 (3.27-5.52)	4.72 (3.47-6.47)	5.09 (3.60-7.27)
12-hr	2.17 (1.93-2.46)	2.67 (2.37-3.03)	3.30 (2.92-3.77)	3.81 (3.34-4.39)	4.49 (3.78-5.38)	5.00 (4.11-6.14)	5.51 (4.40-6.97)	6.03 (4.66-7.88)	6.72 (4.95-9.22)	7.26 (5.13-10.4)
24-hr	2.92 (2.62-3.31)	3.64 (3.27-4.14)	4.57 (4.09-5.20)	5.30 (4.71-6.08)	6.27 (5.42-7.41)	7.00 (5.93-8.42)	7.72 (6.41-9.50)	8.45 (6.84-10.7)	9.43 (7.35-12.3)	10.2 (7.69-13.7)
2-day	3.88 (3.49-4.41)	4.87 (4.38-5.53)	6.11 (5.48-6.96)	7.10 (6.31-8.14)	8.38 (7.24-9.90)	9.34 (7.92-11.2)	10.3 (8.54-12.7)	11.2 (9.10-14.2)	12.5 (9.74-16.4)	13.4 (10.2-18.2)
3-day	4.48 (4.03-5.08)	5.63 (5.06-6.40)	7.07 (6.34-8.05)	8.20 (7.30-9.40)	9.68 (8.36-11.4)	10.8 (9.13-13.0)	11.8 (9.83-14.6)	12.9 (10.5-16.3)	14.3 (11.2-18.8)	15.4 (11.6-20.8)
4-day	4.98 (4.48-5.65)	6.28 (5.64-7.13)	7.89 (7.07-8.98)	9.14 (8.14-10.5)	10.8 (9.31-12.7)	12.0 (10.2-14.4)	13.2 (10.9-16.2)	14.3 (11.6-18.1)	15.9 (12.4-20.8)	17.0 (12.9-23.0)
7-day	6.02 (5.41-6.83)	7.62 (6.85-8.66)	9.60 (8.60-10.9)	11.1 (9.90-12.8)	13.1 (11.3-15.5)	14.5 (12.3-17.5)	15.9 (13.2-19.5)	17.3 (14.0-21.8)	19.0 (14.8-24.9)	20.3 (15.4-27.4)
10-day	6.87 (6.18-7.80)	8.73 (7.85-9.92)	11.0 (9.86-12.5)	12.7 (11.3-14.6)	15.0 (12.9-17.7)	16.5 (14.0-19.9)	18.1 (15.0-22.2)	19.6 (15.9-24.7)	21.5 (16.8-28.2)	22.9 (17.3-31.0)
20-day	9.11 (8.19-10.3)	11.7 (10.5-13.2)	14.7 (13.2-16.7)	17.0 (15.1-19.5)	19.8 (17.1-23.4)	21.8 (18.5-26.2)	23.7 (19.6-29.1)	25.5 (20.6-32.1)	27.8 (21.6-36.3)	29.4 (22.2-39.7)
30-day	11.1 (9.95-12.6)	14.2 (12.7-16.1)	17.8 (16.0-20.3)	20.5 (18.2-23.5)	23.8 (20.6-28.1)	26.1 (22.2-31.4)	28.3 (23.5-34.8)	30.3 (24.5-38.2)	32.9 (25.6-43.0)	34.7 (26.2-46.8)
45-day	13.6 (12.2-15.4)	17.3 (15.5-19.7)	21.7 (19.4-24.7)	24.8 (22.1-28.5)	28.7 (24.8-33.9)	31.3 (26.5-37.7)	33.7 (28.0-41.5)	36.0 (29.1-45.4)	38.8 (30.2-50.7)	40.7 (30.8-55.0)
60-day	16.1 (14.5-18.3)	20.5 (18.4-23.2)	25.4 (22.8-29.0)	29.0 (25.8-33.3)	33.4 (28.8-39.4)	36.3 (30.8-43.7)	39.0 (32.3-47.9)	41.4 (33.5-52.3)	44.4 (34.7-58.2)	46.5 (35.2-62.8)

¹ Precipitation frequency (PF) estimates in this table are based on frequency analysis of partial duration series (PDS). Numbers in parenthesis are PF estimates at lower and upper bounds of the 90% confidence interval. The probability that precipitation frequency estimates (for a given duration and average recurrence interval) will be greater than the upper bound (or less than the lower bound) is 5%. Estimates at upper bounds are not checked against probable maximum precipitation (PMP) estimates and may be higher than currently valid PMP values. Please refer to NOAA Atlas 14 document for more information.

PF graphical

PDS-based depth-duration-frequency (DDF) curves
 Latitude: 38.3323°, Longitude: -122.7203°

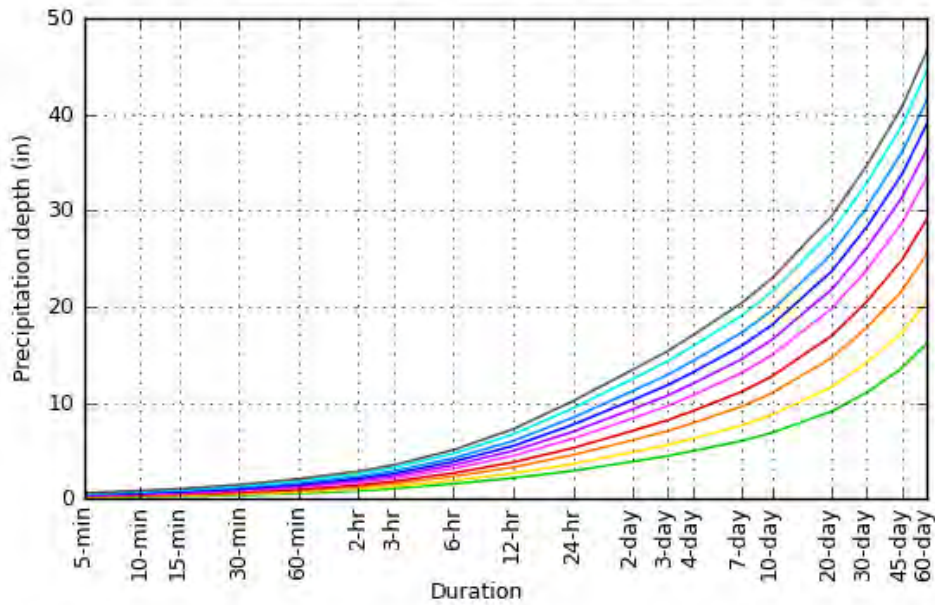

Average recurrence interval (years)
1
2
5
10
25
50
100
200
500
1000

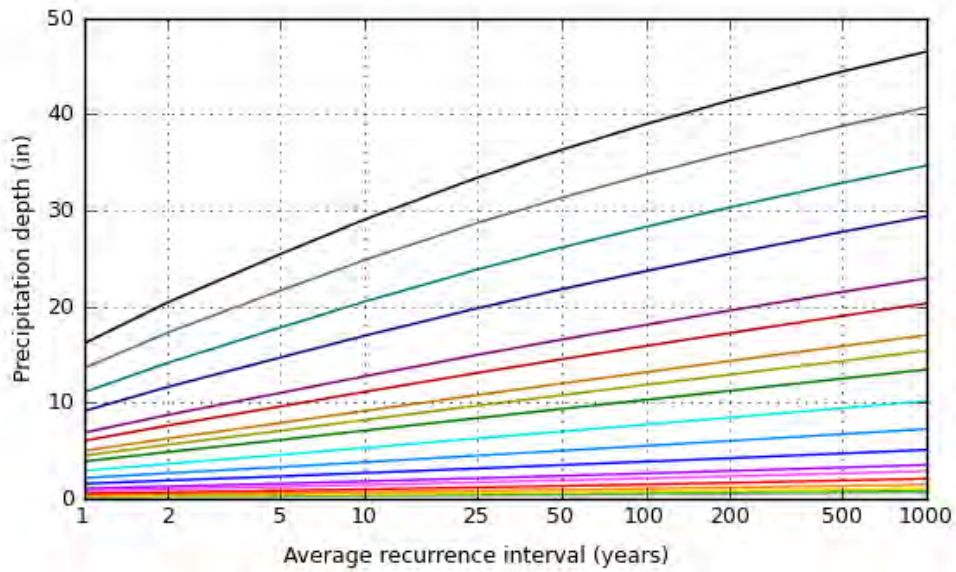

Duration
5-min
10-min
15-min
30-min
60-min
2-hr
3-hr
6-hr
12-hr
24-hr
2-day
3-day
4-day
7-day
10-day
20-day
30-day
45-day
60-day

[Back to Top](#)

Maps & aerials

Small scale terrain

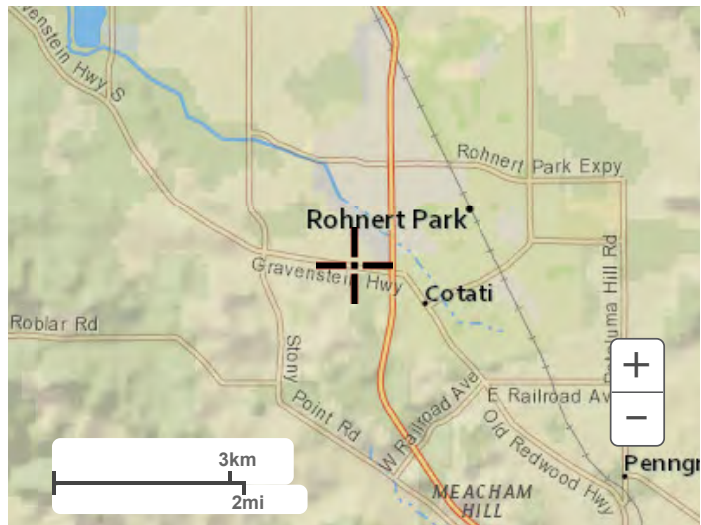

Large scale terrain



Large scale map



Large scale aerial



[Back to Top](#)

[US Department of Commerce](#)
[National Oceanic and Atmospheric Administration](#)
[National Weather Service](#)
[National Water Center](#)
1325 East West Highway
Silver Spring, MD 20910
Questions?: HDSC.Questions@noaa.gov

[Disclaimer](#)

NOTES TO USERS

This map is for use in administering the National Flood Insurance Program. It does not necessarily identify all areas subject to flooding, particularly from local drainage sources of small size. The community map repository should be consulted for possible updated or additional flood hazard information.

To obtain more detailed information in areas where **Base Flood Elevations (BFEs)** and/or **floodways** have been determined, users are encouraged to consult the Flood Profiles and Floodway Data and/or Summary of Stillwater Elevations tables contained within the Flood Insurance Study (FIS) report that accompanies this FIRM. Users should be aware that BFEs shown on the FIRM represent rounded whole-foot elevations. These BFEs are intended for flood insurance rating purposes only and should not be used as the sole source of flood elevation information. Accordingly, flood elevation data presented in the FIS report should be utilized in conjunction with the FIRM for purposes of construction and/or floodplain management.

Coastal Base Flood Elevations shown on this map apply only landward of 0.0 North American Vertical Datum of 1988 (NAVD 88). Users of this FIRM should be aware that coastal flood elevations are also provided in the Summary of Stillwater Elevations tables in the Flood Insurance Study report for this jurisdiction. Elevations shown in the Summary of Stillwater Elevations tables should be used for construction and/or floodplain management purposes when they are higher than the elevations shown on this FIRM.

Boundaries of the **floodways** were computed at cross sections and interpolated between cross sections. The floodways were based on hydraulic considerations with regard to requirements of the National Flood Insurance Program. Floodway widths and other pertinent floodway data are provided in the Flood Insurance Study report for this jurisdiction.

Certain areas not in Special Flood Hazard Areas may be protected by **flood control structures**. Refer to Section 2.4 "Flood Protection Measures" of the Flood Insurance Study report for information on flood control structures for this jurisdiction.

The **projection** used in the preparation of this map was California State Plane Zone II (FPSZONE 402). The **horizontal datum** was NAD 83, GRS80 spheroid. Differences in datum, spheroid, projection or UTM zones used in the production of FIRMs for adjacent jurisdictions may result in slight positional differences in map features across jurisdiction boundaries. These differences do not affect the accuracy of this FIRM.

Flood elevations on this map are referenced to the North American Vertical Datum of 1988. These flood elevations must be compared to structure and ground elevations referenced to the same vertical datum. For information regarding conversion between the National Geodetic Vertical Datum of 1929 and the North American Vertical Datum of 1988, visit the National Geodetic Survey website at <http://www.ngs.noaa.gov> or contact the National Geodetic Survey at the following address:

NGS Information Services
NOAA, N/INGS12
National Geodetic Survey
SSM-C-3, #9202
1315 East-West Highway
Silver Spring, Maryland 20910-3282
(301) 713-3242

To obtain current elevation, description, and/or location information for **bench marks** shown on this map, please contact the Information Services Branch of the National Geodetic Survey at (301) 713-3242, or visit its website at <http://www.ngs.noaa.gov>.

Base map information on this FIRM was derived from multiple sources. Data was provided in digital format by the County of Sonoma Information Systems Department, derived from 1:1,200, 1:2,400, and 1:4,800 scale digital orthophotos, dated April-May 2000. Information was provided by the City of Healdsburg Department of Public Works, derived from 1:600 scale digital orthophotos, dated March 3, 2007. Additional information was derived from 1:12,000 scale U.S. Geological Survey Digital Orthophoto Quadrangles, dated 2002.

This map reflects more detailed and up-to-date **stream channel configurations** than those shown on the previous FIRM for this jurisdiction. The floodplains and floodways that were transferred from the previous FIRM may have been adjusted to conform to these new stream channel configurations. As a result, the Flood Profiles and Floodway Data tables in the Flood Insurance Study Report (which contains authoritative hydraulic data) may reflect stream channel distances that differ from what is shown on this map.

Corporate limits shown on this map are based on the best data available at the time of publication. Because changes due to annexations or de-annexations may have occurred after this map was published, map users should contact appropriate community officials to verify current corporate limit locations.

Please refer to the separately printed **Map Index** for an overview map showing the layout of map panels; community map repository addresses; and a Listing of Communities table containing National Flood Insurance Program dates for each community as well as a listing of the panels on which each community is located.

Contact the **FEMA Map Service Center** at 1-800-358-9616 for information on available products associated with this FIRM. Available products may include previously issued Letters of Map Change, a Flood Insurance Study report, and/or digital versions of this map. The FEMA Map Service Center may also be reached by Fax at 1-800-358-9620 and its website at <http://msc.fema.gov>.

If you have **questions about this map** or questions concerning the National Flood Insurance Program in general, please call 1-877-FEMA MAP (1-877-336-2627) or visit the FEMA website at <http://www.fema.gov>.

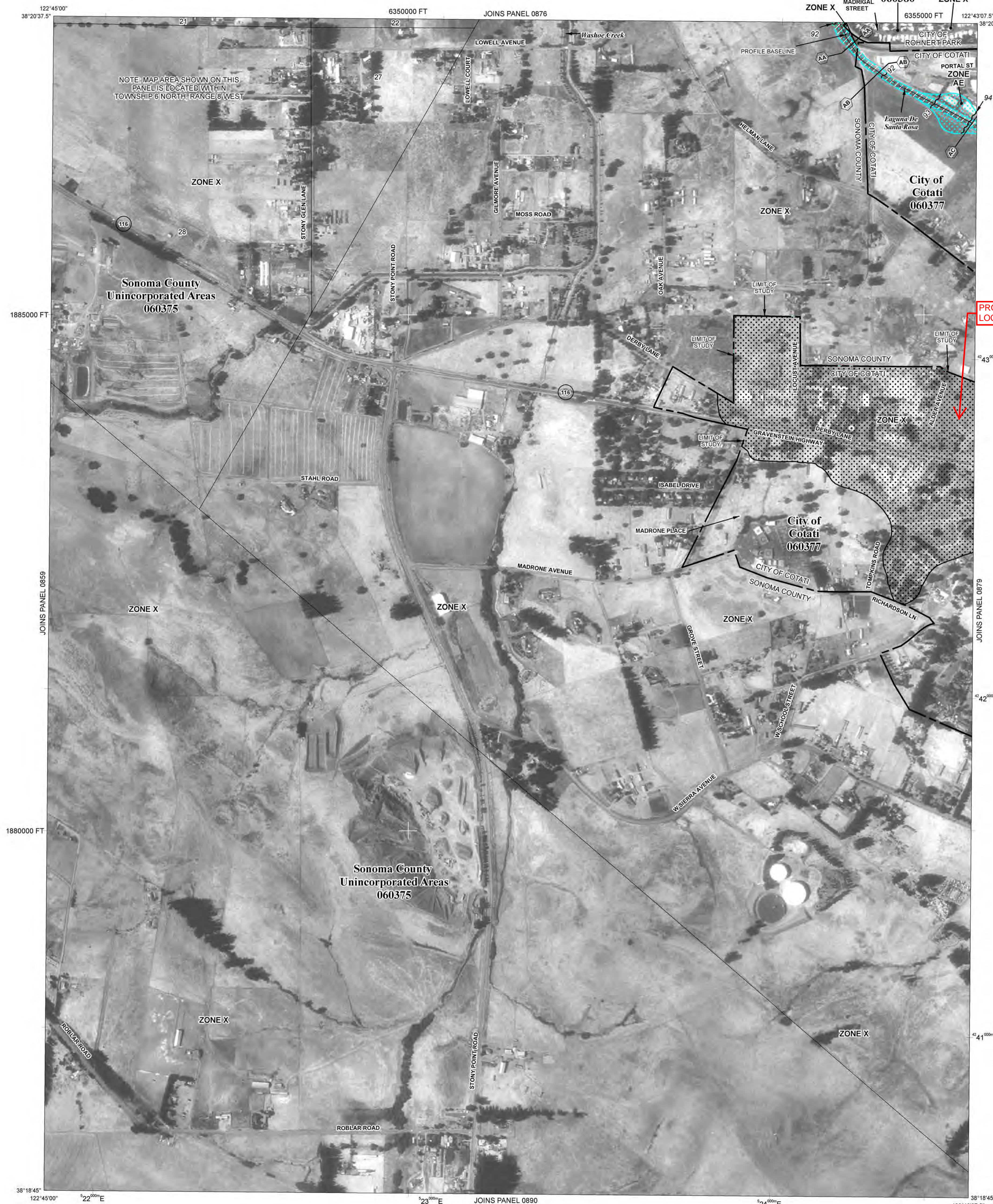

LEGEND

- SPECIAL FLOOD HAZARD AREAS SUBJECT TO INUNDATION BY THE 1% ANNUAL CHANCE FLOOD
- The 1% annual flood (100-year flood), also known as the base flood, is the flood that has a 1% chance of being equaled or exceeded in any given year. The Special Flood Hazard Area is the area subject to flooding by the 1% annual chance flood. Areas of Special Flood Hazard include Zones A, AE, AH, AO, AR, A99, V, and VE. The Base Flood Elevation is the water-surface elevation of the 1% annual chance flood.
- ZONE A** No Base Flood Elevations determined.
- ZONE AE** Base Flood Elevations determined.
- ZONE AH** Flood depths of 1 to 3 feet (usually areas of ponding); Base Flood Elevations determined.
- ZONE AO** Flood depths of 1 to 3 feet (usually sheet flow on sloping terrain); average depths determined. For areas of alluvial fan flooding, velocities also determined.
- ZONE AR** Special Flood Hazard Area formerly protected from the 1% annual chance flood by a flood control system that was subsequently destroyed. Zone AR indicates that the former flood control system is being restored to provide protection from the 1% annual chance or greater flood.
- ZONE A99** Area to be protected from 1% annual chance flood by a Federal flood protection system under construction; no Base Flood Elevations determined.
- ZONE V** Coastal flood zone with velocity hazard (wave action); no Base Flood Elevations determined.
- ZONE VE** Coastal flood zone with velocity hazard (wave action); Base Flood Elevations determined.
- FLOODWAY AREAS IN ZONE AE
- The floodway is the channel of a stream plus any adjacent floodplain areas that must be kept free of encroachment so that the 1% annual chance flood can be carried without substantial increases in flood heights.
- OTHER FLOOD AREAS**
- ZONE X** Areas of 0.2% annual chance flood; areas of 1% annual chance flood with average depths of less than 1 foot or with drainage areas less than 1 square mile; and areas protected by levees from 1% annual chance flood.
- OTHER AREAS**
- Areas determined to be outside the 0.2% annual chance floodplain.
- Areas in which flood hazards are undetermined, but possible.
- COASTAL BARRIER RESOURCES SYSTEM (CBRS) AREAS**
- OTHERWISE PROTECTED AREAS (OPAs)**
- CBRS areas and OPAs are normally located within or adjacent to Special Flood Hazard Areas.
- 1% annual chance floodplain boundary
- 0.2% annual chance floodplain boundary
- Floodway boundary
- Zone D boundary
- Zone D boundary
- CBRS and OPA boundary
- Boundary dividing Special Flood Hazard Area Zones and boundary dividing Special Flood Hazard Areas of different Base Flood Elevations, flood depths or flood velocities.
- Base Flood Elevation line and value; elevation in feet*
- Base Flood Elevation value where uniform within zone; elevation in feet*

* Referenced to the North American Vertical Datum of 1988

Cross section line

Transect line

87°07'45", 32°22'30"

76°N

600000 FT

1000-meter Universal Transverse Mercator grid values, zone 10

5000-foot grid ticks; California State Plane coordinate system, zone II (FPSZONE 0402), Lambert Conformal Conic projection

Bench mark (see explanation in Notes to Users section of this FIRM panel)

M1.5

River Mile

MAP REPOSITORY

Refer to listing of Map Repositories on Map Index

EFFECTIVE DATE OF COUNTY-WIDE FLOOD INSURANCE RATE MAP

December 2, 2008

EFFECTIVE DATE(S) OF REVISION(S) TO THIS PANEL

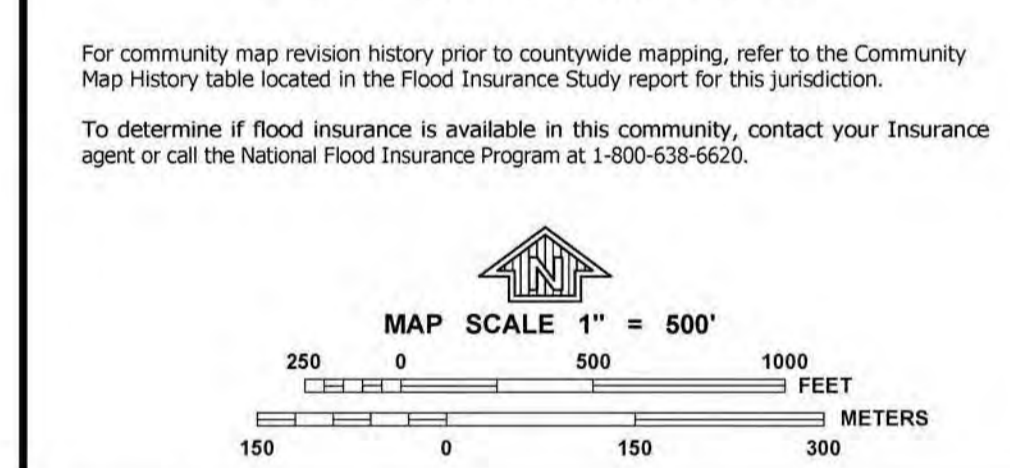

PANEL 0878E

FIRM

FLOOD INSURANCE RATE MAP

SONOMA COUNTY, CALIFORNIA AND INCORPORATED AREAS

PANEL 878 OF 1150
(SEE MAP INDEX FOR FIRM PANEL LAYOUT)

CONTAINS:

COMMUNITY	NUMBER	PANEL	SUFFIX
COTATI, CITY OF	060377	0878	E
ROHNERT PARK, CITY OF	060380	0878	E
SONOMA COUNTY	060375	0878	E

Notice to User: The Map Number shown below should be used when placing map orders. The Community Number shown above should be used on insurance applications for the subject community.

MAP NUMBER
06097C0878E

EFFECTIVE DATE
DECEMBER 2, 2008

Federal Emergency Management Agency

III. DISCUSSION & CONCLUSION

III. DISCUSSION

Introduction

The purpose of the attached analysis is to determine the existing and proposed storm water discharge flow for the project. The project is located on a vacant lot in the City of Cotati, CA. The project is bound by Gravenstein Highway to the south, Alder Avenue to the west, residential properties to the north and vacant lots to the east.

This hydrology report will calculate the 10-year and 100-year storm water runoff for this location. The hydraulics will be calculated for the last reach of storm drain pipe at this time.

Existing Conditions

The existing 7.53 acres site is 99% pervious and is currently a vacant lot consisting of miscellaneous trees and shrubs with one driveway approach. The site is relatively flat and drains to the north west. A relatively rectangular park located in the North east corner of the site will remain unchanged and is noted as Area X2 in this report.

Runoff is collected in a couple of drop inlets where it is conveyed to the private drainage swale located along the northerly boundary of the adjacent tract "Cotati Cottages." The proposed project site holds an easement for rights to drain to this private drainage swale.

The storm drain system located within Alder Ave starts upstream near the intersection of Gravenstein Hwy. A 30" RCP runs north-easterly where it transitions to a 36" RCP. Further downstream, the storm drain system transitions to 52" RCP where a 24" RCP connection from the private drainage swale merges from the east.

Project Description

The project proposes the construction of 3 multifamily buildings and 3 residential/retail buildings with 4 access points. Associated improvements will include a clubhouse with pool and gym, hardscape and landscape, bioretention swales, along with modifications to the private drainage swale.

The project proposes a storm drain system that will convey storm water offsite and will connect to the City storm drain system. The hydrology report demonstrates emergency ponding elevations in the event the storm drain system fails. It can be seen that there is well over 1' of protection between the overflow elevation and finished floor of all living spaces.

A previously reviewed and approved improvement plan for this subject parcel detailed a similar proposed storm drain system connecting to and modifying the existing drainage swale. See documents attached to this report.

Hydrology and Calculation Methodology

The hydrology study was performed utilizing Sonoma County Water Agency Flood Design Manual and City of Cotati Standards.

The hydraulics of the last reach of storm drain pipe calculated as follows.

Conclusion

The results from this hydrology and hydraulic analysis demonstrate the following:

- Per FEMA FIRM Map Number 06097C0878E Panel 878 of 1150, revised December 2, 2008, the subject site is in Zone X described as areas of 0.2% annual chance flood; areas of 1% foot or with drainage areas less than 1 square mile; and areas protected by levees from 1% annual chance flood. There is no established Base Flood Elevation (BFE) for this area. Proposed building finished floors (FF) will be set at least 1 foot higher than the closest safe outlet elevation. The overflow elevation is noted on the hydrology maps attached.
- The project Q10 and Q100 flows will increase for the developed portion of the site from existing to proposed as shown in the table below and in the hydrology maps attached.
- The detention basin/ swale will be modified to accommodate the additional flows including bioretention and storage.
- The 2002 Storm Drain Master Plan identifies the storm drain system in Alder Ave, and this project is within that subwatershed. The Master Plan does not identify the private drainage swale.
- The storm drain pipe is sized to handle the anticipated 100-yr flows.

A table of pre- and post-development flows can be seen in the table below:

Condition	Area	10-YR Flow (cfs)	100-YR Flow (cfs)
Pre-Developed Condition X1	6.74	2.84	4.27
Post-Developed Condition D1	6.74	5.37	8.10
Percent Change		+89.08%	+89.7%
Undisturbed Area X2	0.79	0.3	0.45

IV. 10 & 100-YEAR HYDROLOGY CALCULATIONS – EXISTING AND DEVELOPED CONDITIONS

	Acres	2yr	10yr	50yr	100yr
Existing Area X1					
Q=CIAK		1.76	2.55	3.44	3.85
Area (SF)	6.74	293752	293752	293752	293752
Pervious Area (SF)	6.68	290814	290814	290814	290814
Impervious Area (SF)	0.07	2938	2938	2938	2938
Intensity		0.68	0.99	1.33	1.49
T From Nomograph (min.)		25	25	25	25
Y (yr)		2	10	50	100
C (Ag and open space >2-6%)		0.38	0.38	0.38	0.38

	Acres	2yr	10yr	50yr	100yr
Existing Area X2					
Q=CIAK		0.21	0.30	0.40	0.45
Area (SF)	0.79	34332	34332	34332	34332
Pervious Area (SF)	0.78	33989	33989	33989	33989
Impervious Area (SF)	0.01	343	343	343	343
Intensity		0.68	0.99	1.33	1.49
T From Nomograph (min.)		15	15	15	15
Y (yr)		2	10	50	100
C (Ag and open space >2-6%)		0.38	0.38	0.38	0.38

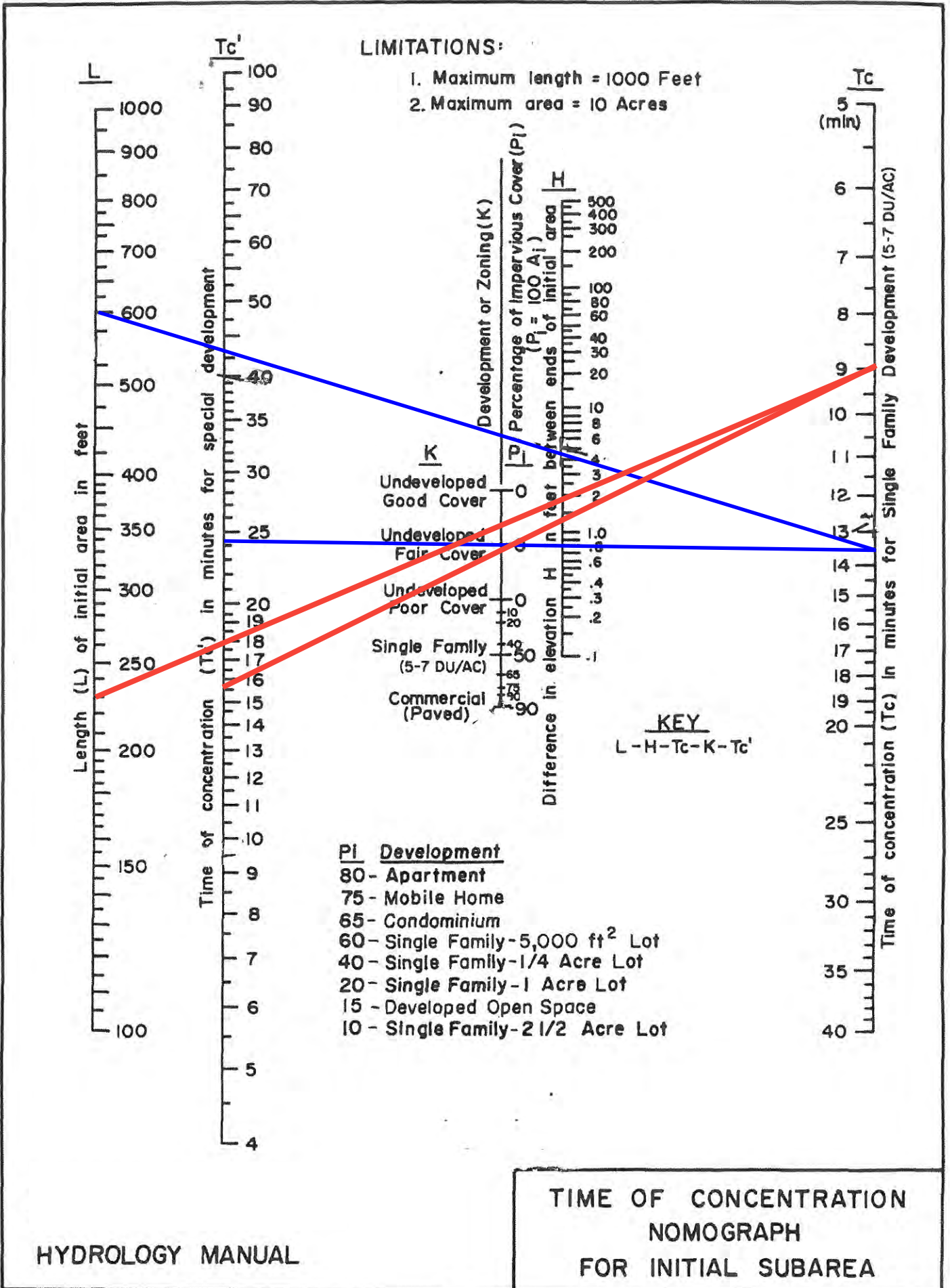

	Acres	2yr	10yr	50yr	100yr
Proposed Area D1					
Q=CIAK		3.38	4.90	6.60	7.39
Area (SF)	6.74	293752	293752	293752	293752
Pervious Area (SF)	1.96	85188	85188	85188	85188
Impervious Area (SF)	4.79	208564	208564	208564	208564
Intensity		0.68	0.99	1.33	1.49
T From Nomograph (min.)		15	15	15	15
Y (yr)		2	10	50	100
C (Med density Residential 0-2%)		0.73	0.73	0.73	0.73

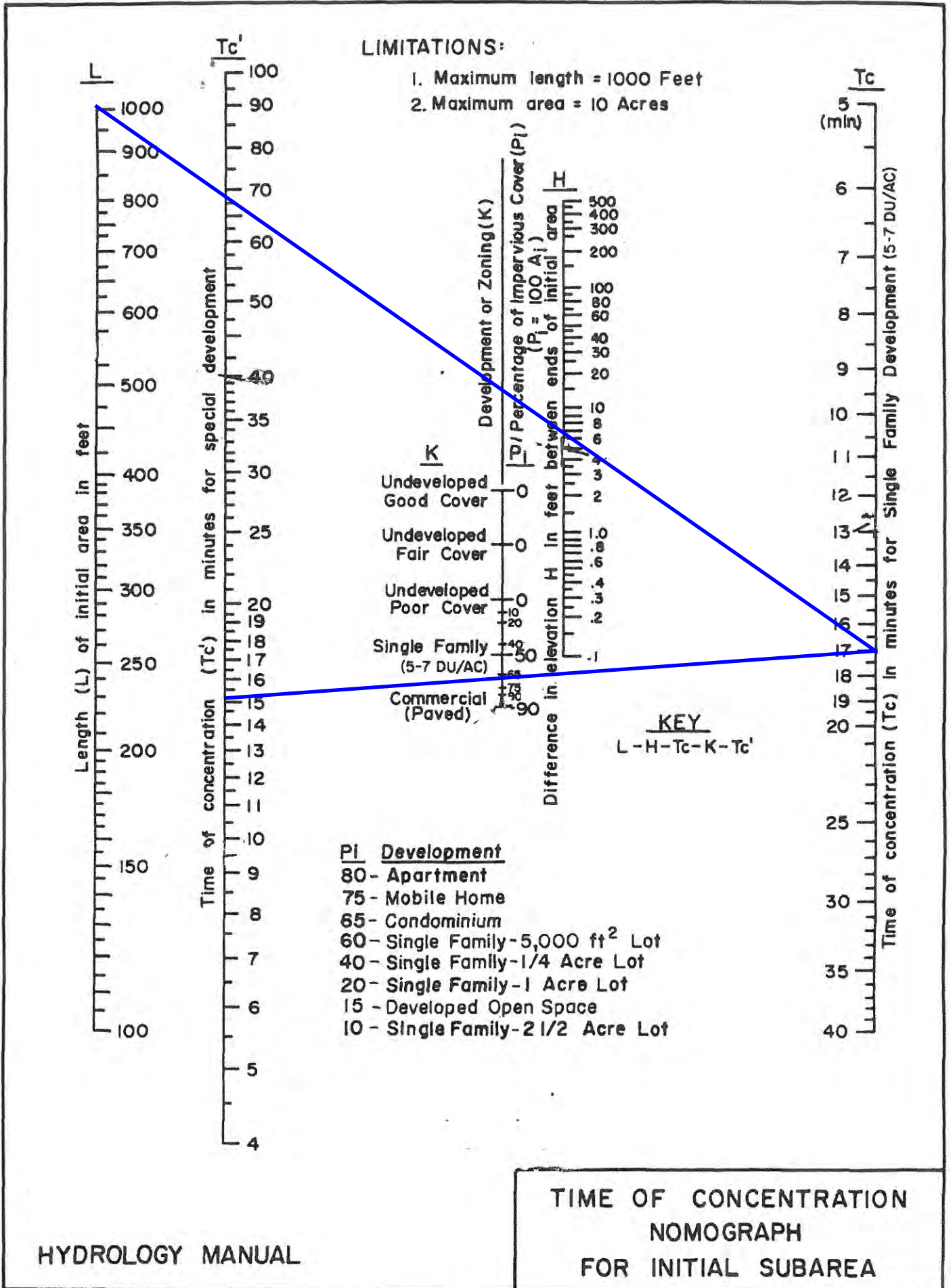

Channel Report

18 inch at 0.5% slope

Circular

Diameter (ft) = 1.50

Invert Elev (ft) = 100.00
Slope (%) = 0.50
N-Value = 0.012

Highlighted

Depth (ft) = 1.24
Q (cfs) = 8.100
Area (sqft) = 1.56
Velocity (ft/s) = 5.18
Wetted Perim (ft) = 3.43
Crit Depth, Yc (ft) = 1.11
Top Width (ft) = 1.13
EGL (ft) = 1.66

Calculations

Compute by: Known Q
Known Q (cfs) = 8.10

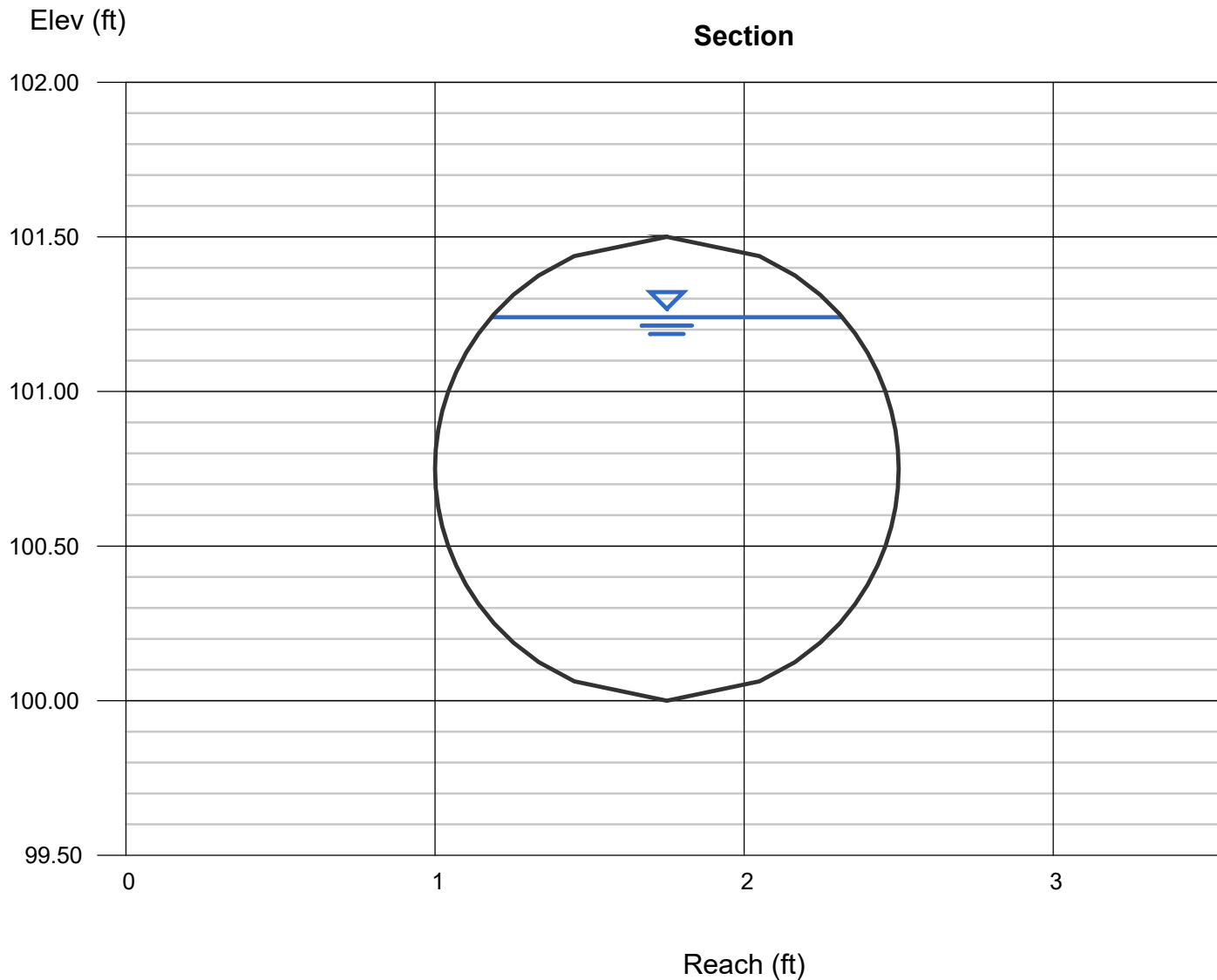

Channel Report

24 inch at 0.5% slope

Circular

Diameter (ft) = 2.00

Invert Elev (ft) = 100.00
Slope (%) = 0.50
N-Value = 0.012

Highlighted

Depth (ft) = 0.96
Q (cfs) = 8.100
Area (sqft) = 1.50
Velocity (ft/s) = 5.40
Wetted Perim (ft) = 3.07
Crit Depth, Yc (ft) = 1.01
Top Width (ft) = 2.00
EGL (ft) = 1.41

Calculations

Compute by: Known Q
Known Q (cfs) = 8.10

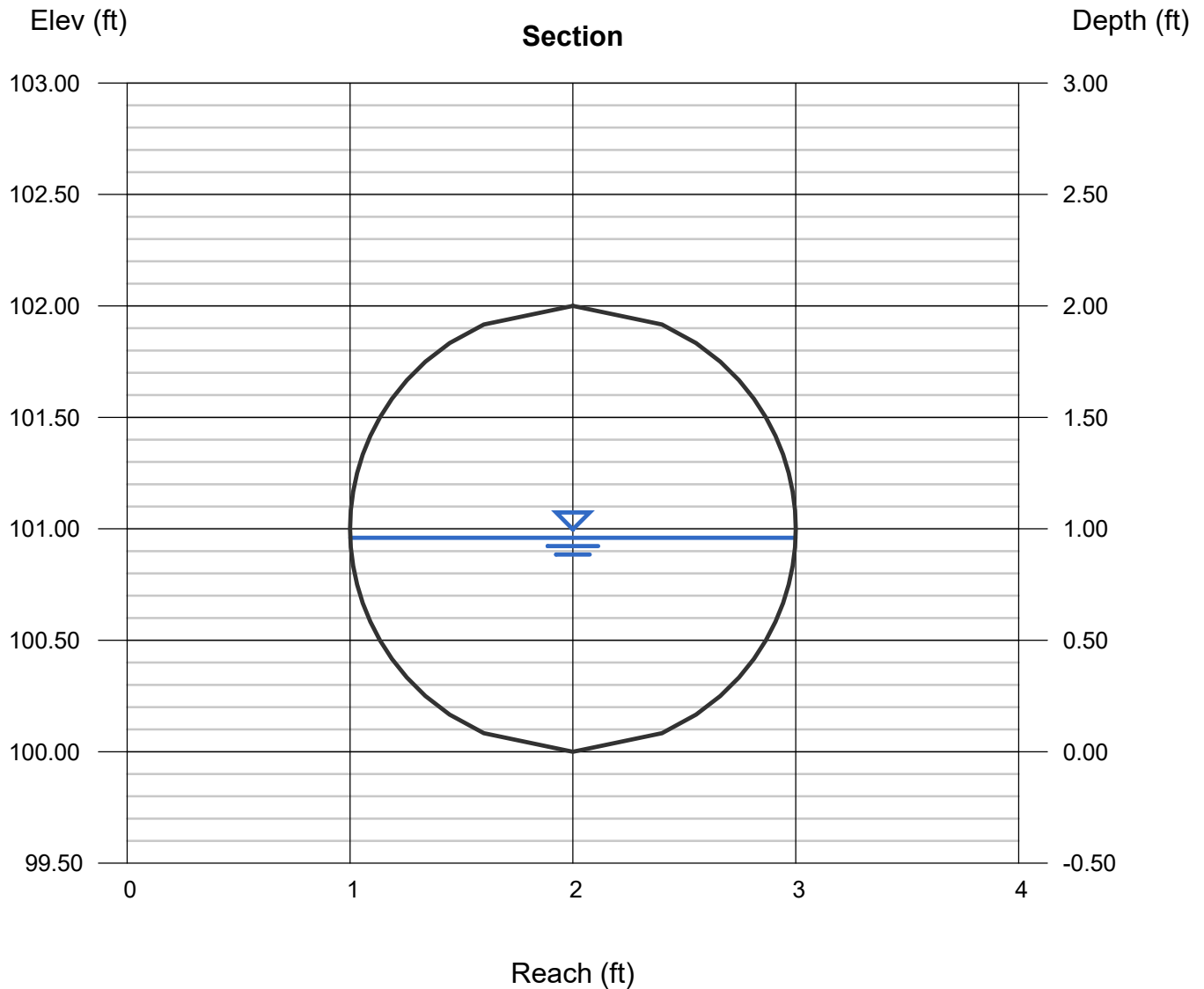

Storm Drain Capacity Full Depth Flow

$$Q=(1.486/n)AR^{2/3}S^{1/2}$$

Pipe Diameter (in)	s=0.5%				s=1.0%			
	4	6	8	12	4	6	8	12
S	0.005	0.005	0.005	0.005	0.010	0.010	0.010	0.010
N	0.012	0.012	0.012	0.012	0.012	0.012	0.012	0.012
A (sf)	0.09	0.20	0.35	0.79	0.09	0.20	0.35	0.79
R (ft)	0.08	0.13	0.17	0.25	0.08	0.13	0.17	0.25
Q (cfs)	0.15	0.43	0.93	2.73	0.21	0.61	1.31	3.86
V (fps)	1.67	2.19	2.65	3.47	2.36	3.10	3.75	4.91

Pipe Diameter (in)	s=1.5%				s=2.0%			
	4	6	8	12	4	6	8	12
S	0.015	0.015	0.015	0.015	0.020	0.020	0.020	0.020
N	0.012	0.012	0.012	0.012	0.012	0.012	0.012	0.012
A (sf)	0.09	0.20	0.35	0.79	0.09	0.20	0.35	0.79
R (ft)	0.08	0.13	0.17	0.25	0.08	0.13	0.17	0.25
Q (cfs)	0.25	0.74	1.60	4.72	0.29	0.86	1.85	5.46
V (fps)	2.89	3.79	4.59	6.02	3.34	4.38	5.30	6.95

NDS Area Drain Capacity

Per NDS Catalog

Size	Area Surface (in ²)	Capacity (cfs)
9x9 Atrium	31.5	0.09
9x9 Square	39.5	0.12
9x9 Ductile	35.7	0.10
9x9 Galvanized	65	0.19
12x12 Atrium	50.6	0.15
12x12 Square	50.76	0.15
12x12 Ductile	59.5	0.17
12x12 Galvanized	122.3	0.36
12x12 ADA	36.75	0.11
18x18 Atrium	89.4	0.26
18x18 Square	104	0.30
18x18 Cast Iron	100.63	0.29
18x18 Galvanized	291	0.85
24x24 Square	231.69	0.68
24x24 Cast Iron	187	0.55
24x24 Galvanized	332.06	0.97

V. HYDROLOGY MAP-EXISTING AND DEVELOPED CONDITIONS

DRAINAGE EXHIBIT DEVELOPED CONDITIONS

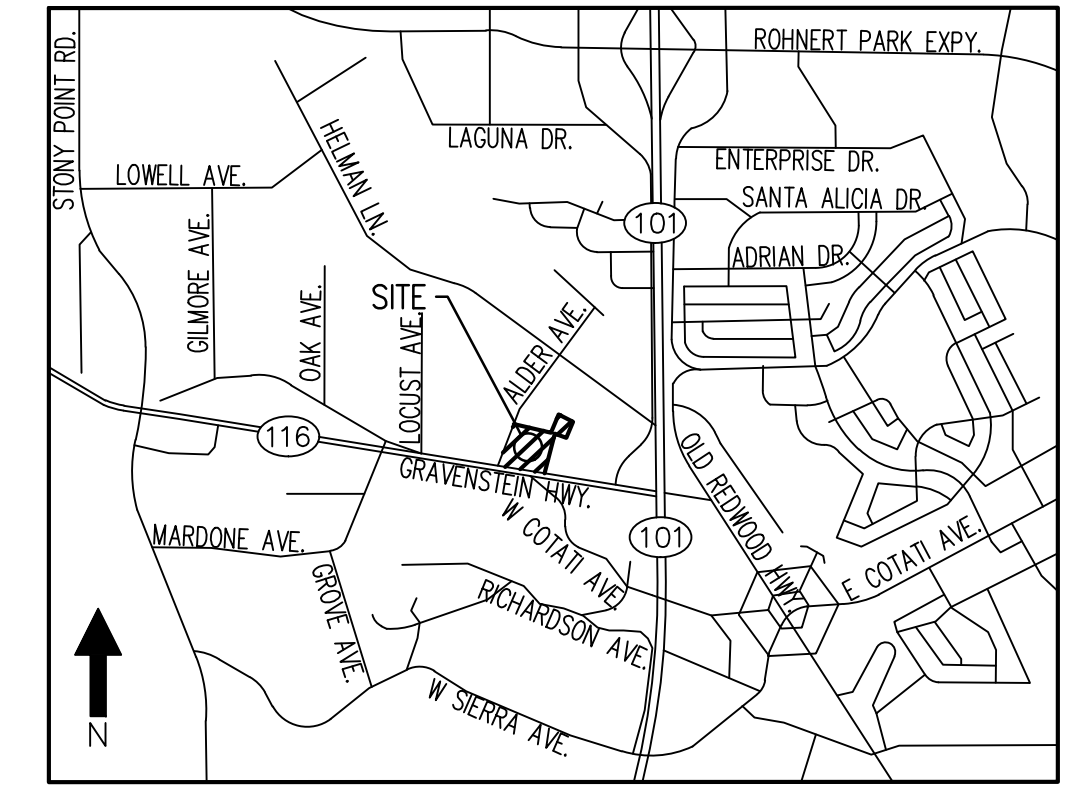

VICINITY MAP
N.T.S.

FLOOD NOTE:
PROJECT IS LOCATED IN ZONE X PER FEMA MAP# 06097C0878E. NO BASE FLOOD ELEVATION HAS BEEN ESTABLISHED FOR THE SUBJECT PROPERTY.

LEGEND:

- D1 SUB-AREA NUMBER
- 0.00 AC ACREAGE
- MAJOR-AREA BOUNDARY
- PROPERTY LINE
- SUB-AREA BOUNDARY
- FLOW PATH
- X NODE

OFFSITE FLOW NOTE:
THERE ARE NO OFFSITE FLOWS DISCHARGING THROUGH THE SITE IN EXISTING OR PROPOSED CONDITIONS.

SOIL TYPE: C

POST DEVELOPMENT:

D1	=	6.74 AC.
PERVIOUS AREA	=	1.96 AC. (29%)
IMPERVIOUS AREA	=	4.79 AC. (71%)
$Q_{100year}$	=	8.34 CFS
Q_{25year}	=	11.70 CFS

X2 (UNCHANGED)	=	0.79 AC.
PERVIOUS AREA	=	0.78 AC. (99%)
IMPERVIOUS AREA	=	0.01 AC. (1%)
$Q_{100year}$	=	0.30 CFS
Q_{25year}	=	0.45 CFS

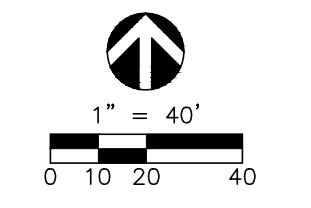
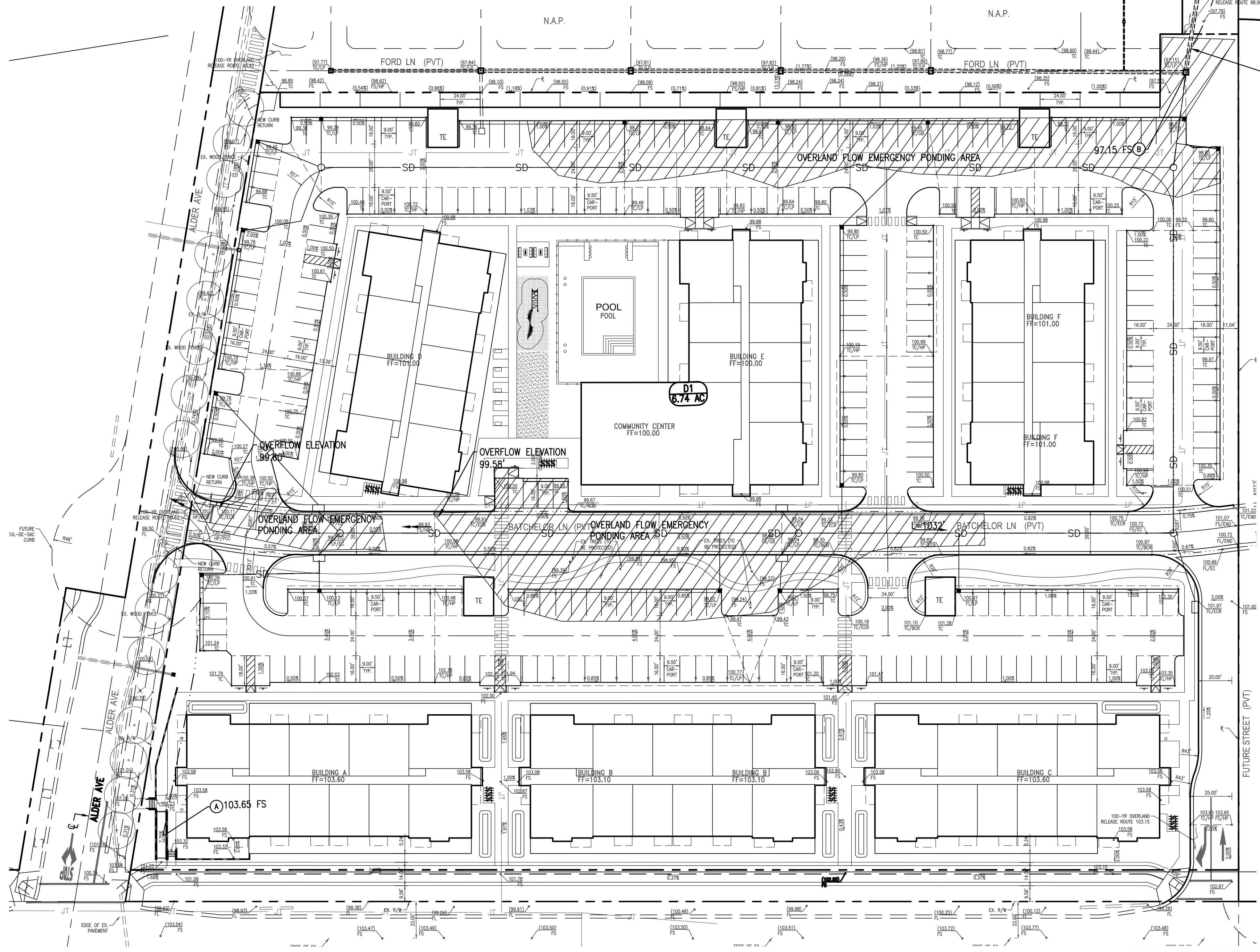

	PLAN PREPARED BY: MFKessler Civil Engineering, Land Planning, Surveying ONE VENTURE, SUITE 130 IRVINE, CA 92618 (949) 339-5330 MFKESSLER.COM	CITY OF COTATI DEVELOPED DRAINAGE EXHIBIT 8145 GRAVENSTEIN HWY COTATI, CA 94931	SHEET 1 OF 1
--	---	---	---------------------

VI. AS-BUILTS AND REFERENCE DOCUMENTS

Existing Drainage Facilities

The project drains to an existing swale, inlet structure and 24" storm drain pipe north of the site.

The developed 100 year flow from the existing site to the north has been calculated per the project's hydrology report to be 7.13 cfs. Excerpts from the approved report are attached herein.

The developed 100 year flow for the proposed site is 8.10 cfs.

The maximum flow into the swale, inlet, and 24" storm drain pipe is 15.23 cfs.

The attached capacity calculations demonstrate that the swale has a capacity of 28.55 cfs while maintaining a 1' freeboard, the 24" inlet has the capacity for 15.23 cfs while maintaining over 3' of freeboard, and the existing 24" storm drain pipe has a capacity of 34.65 cfs.

This demonstrates that the existing facilities have the adequate capacity to convey stormwater from the existing site.

Excerpts from approved Hydrology Report for Existing Site

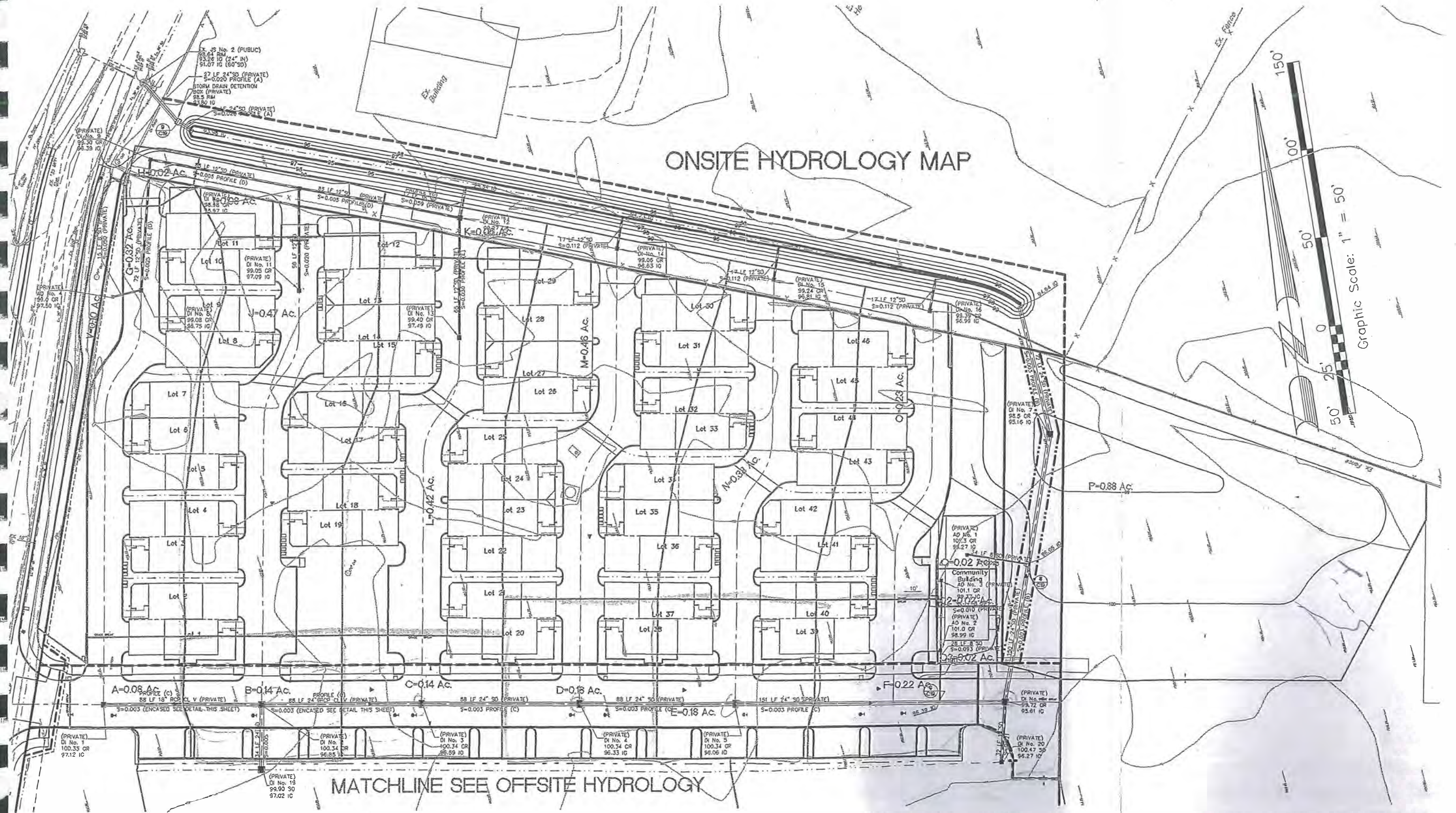

Hydroflow Storm Sewer Tabulation

→ SEE ELEVATION IN ANALYSIS -
 RETURN ELEVATION
 IN ANALYSIS -
 Page 1

Station		Len (ft)	Drng Area		Rnoff coeff (C)	Area x C		Tc		Rain (l) (in/hr)	Total flow (cfs)	Cap full (cfs)	Vel (ft/s)	Pipe		Invert Elev		HGL Elev		Grnd / Rim Elev		Line ID
Line	To Line		Incr (ac)	Total (ac)		Incr	Total	Inlet (min)	Syst (min)					Size (in)	Slope (%)	Up (ft)	Dn (ft)	Up (ft)	Dn (ft)	Up (ft)	Dn (ft)	
1	End	38.0	0.00	10.86	0.00	0.00	8.41	10.0	67.9	0.8	6.46	31.99	2.09	24	2.00	93.98	93.22	95.85	95.82	98.20	98.80	JS2-End Ditch
2	1	158.0	0.00	10.86	0.00	0.00	8.41	10.0	57.6	0.8	7.05	152.5	0.87	96	0.20	94.30	93.98	95.93	95.88	98.00	98.20	Begin ditch-FL12
3	2	93.0	0.00	9.39	0.00	0.00	7.21	10.0	50.6	0.9	6.46	153.2	0.93	96	0.20	94.49	94.30	95.98	95.94	98.50	98.00	FL12-FL14
4	3	92.0	0.00	8.93	0.00	0.00	6.82	10.0	43.5	1.0	6.62	149.9	1.07	96	0.20	94.67	94.49	96.06	96.00	99.00	98.50	FL14-FL15
5	4	88.0	0.00	8.55	0.00	0.00	6.50	10.0	36.5	1.1	6.92	153.3	1.21	96	0.20	94.85	94.67	96.17	96.08	99.00	99.00	FL15-FL16
6	5	45.0	0.00	8.32	0.00	0.00	6.30	10.0	32.8	1.1	7.09	151.5	1.30	96	0.20	94.94	94.85	96.25	96.20	99.50	99.00	FL16-OUTLET
7	6	72.0	0.88	8.32	0.35	0.31	6.30	10.0	32.4	1.1	7.13	12.50	3.40	24	0.31	95.16	94.94	96.37	96.27	98.50	99.50	OUTLET-DI7
8	7	72.0	0.00	7.44	0.00	0.00	5.99	10.0	32.1	1.1	6.83	12.50	3.34	24	0.31	95.38	95.16	96.56	96.47	100.00	98.50	DI 7-INT 1
9	8	78.0	0.22	7.40	0.85	0.19	5.97	10.0	31.7	1.1	6.85	12.28	3.18	24	0.29	95.61	95.38	96.84	96.75	99.72	100.00	INT 1-DI 6
10	9	38.0	0.00	4.93	0.00	0.00	3.76	10.0	31.4	1.2	4.34	12.17	1.78	24	0.29	95.72	95.61	97.12	97.11	100.10	99.72	DI 6-INT 2
11	10	114.0	0.18	4.89	0.85	0.15	3.75	10.0	30.5	1.2	4.39	12.35	2.06	24	0.30	96.06	95.72	97.22	97.17	100.34	100.10	INT 2-DI5
12	11	88.0	0.18	4.71	0.85	0.15	3.59	10.0	29.8	1.2	4.26	12.29	2.44	24	0.30	96.32	96.06	97.32	97.26	100.34	100.34	DI 5-4
13	12	88.0	0.14	2.54	0.85	0.12	1.95	10.0	28.5	1.2	2.36	12.29	1.47	24	0.30	96.59	96.33	97.51	97.49	100.34	100.34	DI 4-3
14	13	89.0	0.14	2.40	0.85	0.12	1.83	10.0	27.2	1.2	2.27	12.46	1.92	24	0.30	96.86	96.59	97.57	97.53	100.34	100.34	DI 3-2
15	14	36.0	0.08	2.18	0.80	0.06	1.64	10.0	12.4	1.9	3.07	5.80	3.09	18	0.31	96.96	96.85	97.77	97.69	101.50	100.34	DI 2-DI A7
16	9	32.0	0.21	2.25	0.90	0.19	2.03	10.0	16.0	1.6	3.32	7.43	1.93	18	0.50	95.77	95.61	97.13	97.11	100.66	99.72	DI 6-CB C4
17	16	54.0	0.20	0.20	0.90	0.18	0.18	10.0	10.0	2.1	0.38	4.57	0.31	15	0.50	96.04	95.77	97.22	97.22	100.66	100.66	CB C4-CB C3
18	16	148.0	0.52	1.84	0.90	0.47	1.66	10.0	14.6	1.7	2.84	7.43	2.23	18	0.50	96.51	95.77	97.34	97.22	101.52	100.66	CB C4-DI C2
19	18	54.0	0.52	0.52	0.90	0.47	0.47	10.0	10.0	2.1	0.98	4.57	1.09	15	0.50	96.78	96.51	97.54	97.53	101.52	101.52	DI C2-DI C1
20	18	166.0	0.40	0.80	0.90	0.36	0.72	10.0	11.4	2.0	1.41	7.43	2.10	18	0.50	97.34	96.51	97.80	97.53	104.00	101.52	DI C2-CB C2
21	20	50.0	0.40	0.40	0.90	0.36	0.36	10.0	10.0	2.1	0.75	4.57	1.50	15	0.50	97.59	97.34	98.04	98.02	104.00	104.00	CB C2-CB C1

Project File: 02059 (Cotati Cottages-10 Yr.)11-07-02.stm IDF File: Sonoma.IDF Total number of lines: 46 Run Date: 11-18-2002

NOTES: Intensity = 7.08 / (Inlet time + 0.10) ^ 0.53; Return period = 10 Yrs. ; Initial tailwater elevation = 95.82 (ft)

Hyd Flow Storm Sewer Tabulation

Station		Len (ft)	Drng Area		Rnoff coeff (C)	Area x C		Tc		Rain (l) (in/hr)	Total flow (cfs)	Cap full (cfs)	Vel (ft/s)	Pipe		Invert Elev		HGL Elev		Grnd / Rim Elev		Line ID
Line	To Line		Incr (ac)	Total (ac)		Incr	Total	Inlet (min)	Syst (min)					Size (in)	Slope (%)	Up (ft)	Dn (ft)	Up (ft)	Dn (ft)	Up (ft)	Dn (ft)	
1	End	38.0	0.00	10.86	0.00	0.00	8.41	10.0	50.4	1.3	10.71	31.99	3.41	24	2.00	93.98	93.22	101.74	101.65	98.20	98.80	JS2-End Ditch
2	1	158.0	0.00	10.86	0.00	0.00	8.41	10.0	43.2	1.4	11.63	152.5	0.23	96	0.20	94.30	93.98	101.82	101.82	98.00	98.20	Begin ditch-FL12
3	2	93.0	0.00	9.39	0.00	0.00	7.21	10.0	38.4	1.5	10.62	153.2	0.22	96	0.20	94.49	94.30	101.82	101.82	98.50	98.00	FL12-FL14
4	3	92.0	0.00	8.93	0.00	0.00	6.82	10.0	33.4	1.6	10.82	149.9	0.23	96	0.20	94.67	94.49	101.82	101.82	99.00	98.50	FL14-FL15
5	4	88.0	0.00	8.55	0.00	0.00	6.50	10.0	28.5	1.7	11.22	153.3	0.24	96	0.20	94.85	94.67	101.83	101.82	99.00	99.00	FL15-FL16
6	5	45.0	0.00	8.32	0.00	0.00	6.30	10.0	25.9	1.8	11.45	151.5	0.25	96	0.20	94.94	94.85	101.83	101.83	99.50	99.00	FL16-OUTLET
7	6	72.0	0.88	8.32	0.35	0.31	6.30	10.0	25.6	1.8	11.51	12.50	3.66	24	0.31	95.16	94.94	102.02	101.83	98.50	99.50	OUTLET-DI7
8	7	72.0	0.00	7.44	0.00	0.00	5.99	10.0	25.4	1.8	11.00	12.50	3.50	24	0.31	95.38	95.16	102.29	102.12	100.00	98.50	DI 7-INT 1
9	8	78.0	0.22	7.40	0.85	0.19	5.97	10.0	25.1	1.8	11.04	12.28	3.51	24	0.29	95.61	95.38	102.67	102.48	99.72	100.00	INT 1-DI 6
10	9	38.0	0.00	4.93	0.00	0.00	3.76	10.0	24.9	1.9	6.98	12.17	2.22	24	0.29	95.72	95.61	102.99	102.96	100.10	99.72	DI 6-INT 2
11	10	114.0	0.18	4.89	0.85	0.15	3.75	10.0	24.3	1.9	7.05	12.35	2.24	24	0.30	96.06	95.72	103.18	103.07	100.34	100.10	INT 2-DI5
12	11	88.0	0.18	4.71	0.85	0.15	3.59	10.0	23.8	1.9	6.84	12.29	2.18	24	0.30	96.32	96.06	103.30	103.22	100.34	100.34	DI 5-4
13	12	88.0	0.14	2.54	0.85	0.12	1.95	10.0	22.9	1.9	3.78	12.29	1.20	24	0.30	96.59	96.33	103.43	103.41	100.34	100.34	DI 4-3
14	13	89.0	0.14	2.40	0.85	0.12	1.83	10.0	22.0	2.0	3.63	12.46	1.16	24	0.30	96.86	96.59	103.47	103.45	100.34	100.34	DI 3-2
15	14	36.0	0.08	2.18	0.80	0.06	1.64	10.0	11.7	2.8	4.54	5.80	2.57	18	0.31	96.96	96.85	103.57	103.50	101.50	100.34	DI 2-DI A7
16	9	32.0	0.21	2.25	0.90	0.19	2.03	10.0	14.2	2.5	5.07	7.43	2.87	18	0.50	95.77	95.61	103.03	102.96	100.66	99.72	DI 6-CB C4
17	16	54.0	0.20	0.20	0.90	0.18	0.18	10.0	10.0	3.0	0.54	4.57	0.44	15	0.50	96.04	95.77	103.23	103.22	100.66	100.66	CB C4-CB C3
18	16	148.0	0.52	1.84	0.90	0.47	1.66	10.0	13.2	2.6	4.30	7.43	2.43	18	0.50	96.51	95.77	103.47	103.22	101.52	100.66	CB C4-DI C2
19	18	54.0	0.52	0.52	0.90	0.47	0.47	10.0	10.0	3.0	1.41	4.57	1.15	15	0.50	96.78	96.51	103.63	103.61	101.52	101.52	DI C2-DI C1
20	18	166.0	0.40	0.80	0.90	0.36	0.72	10.0	10.9	2.9	2.07	7.43	1.17	18	0.50	97.34	96.51	103.67	103.61	104.00	101.52	DI C2-CB C2
21	20	50.0	0.40	0.40	0.90	0.36	0.36	10.0	10.0	3.0	1.08	4.57	0.88	15	0.50	97.59	97.34	103.72	103.70	104.00	104.00	CB C2-CB C1

-2.0 = 99.83
101.83 101.83

Project File: 02059 (Cotati Cottages-100 Yr.)11-07-02.stm IDF File: Sonoma.IDF Total number of lines: 46 Run Date: 11-18-2002

NOTES: Intensity = 10.47 / (Inlet time + 0.20) ^ 0.54; Return period = 100 Yrs. ; Initial tailwater elevation = 101.65 (ft)

Inlet Report

Inlet Capacity

Drop Grate Inlet

Location	= Sag
Curb Length (ft)	= -0-
Throat Height (in)	= -0-
Grate Area (sqft)	= 3.00
Grate Width (ft)	= 2.00
Grate Length (ft)	= 2.00

Gutter

Slope, Sw (ft/ft)	= 2.000
Slope, Sx (ft/ft)	= 2.000
Local Depr (in)	= -0-
Gutter Width (ft)	= 4.00
Gutter Slope (%)	= -0-
Gutter n-value	= -0-

Calculations

Compute by:	Known Q
Q (cfs)	= 15.50

Highlighted

Q Total (cfs)	= 15.50
Q Capt (cfs)	= 15.50
Q Bypass (cfs)	= -0-
Depth at Inlet (in)	= 11.09
Efficiency (%)	= 100
Gutter Spread (ft)	= 4.92
Gutter Vel (ft/s)	= -0-
Bypass Spread (ft)	= -0-
Bypass Depth (in)	= -0-

All dimensions in feet

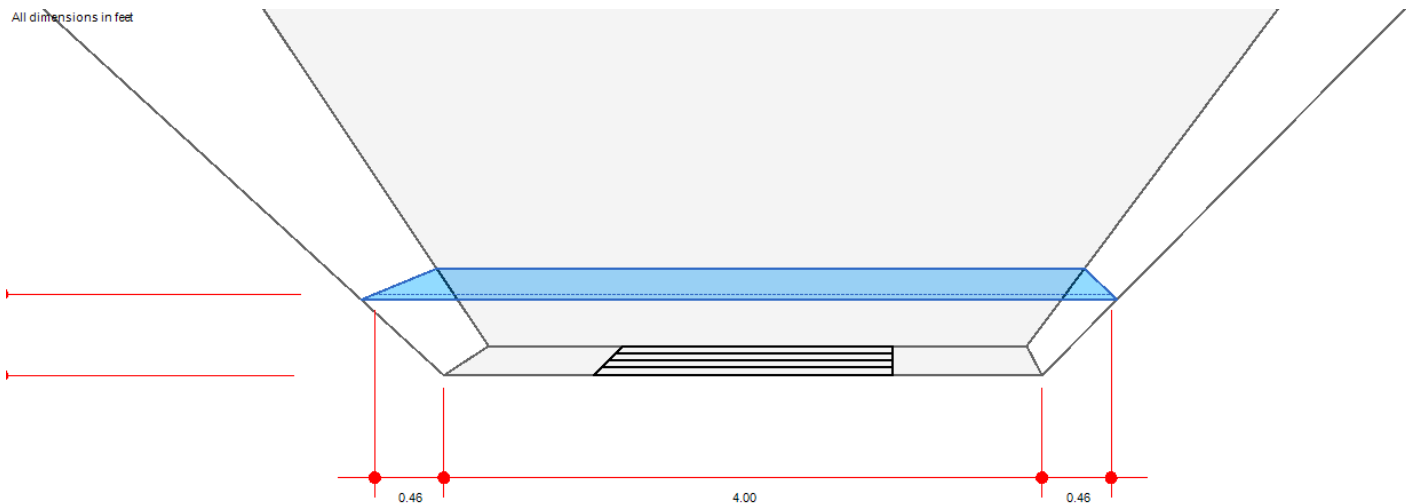

Channel Report

Pipe Capacity

Circular

Diameter (ft) = 2.00

Invert Elev (ft) = 100.00

Slope (%) = 2.00

N-Value = 0.012

Calculations

Compute by: Known Depth

Known Depth (ft) = 2.00

Highlighted

Depth (ft) = 2.00

Q (cfs) = 34.65

Area (sqft) = 3.14

Velocity (ft/s) = 11.03

Wetted Perim (ft) = 6.28

Crit Depth, Yc (ft) = 1.92

Top Width (ft) = 0.00

EGL (ft) = 3.89

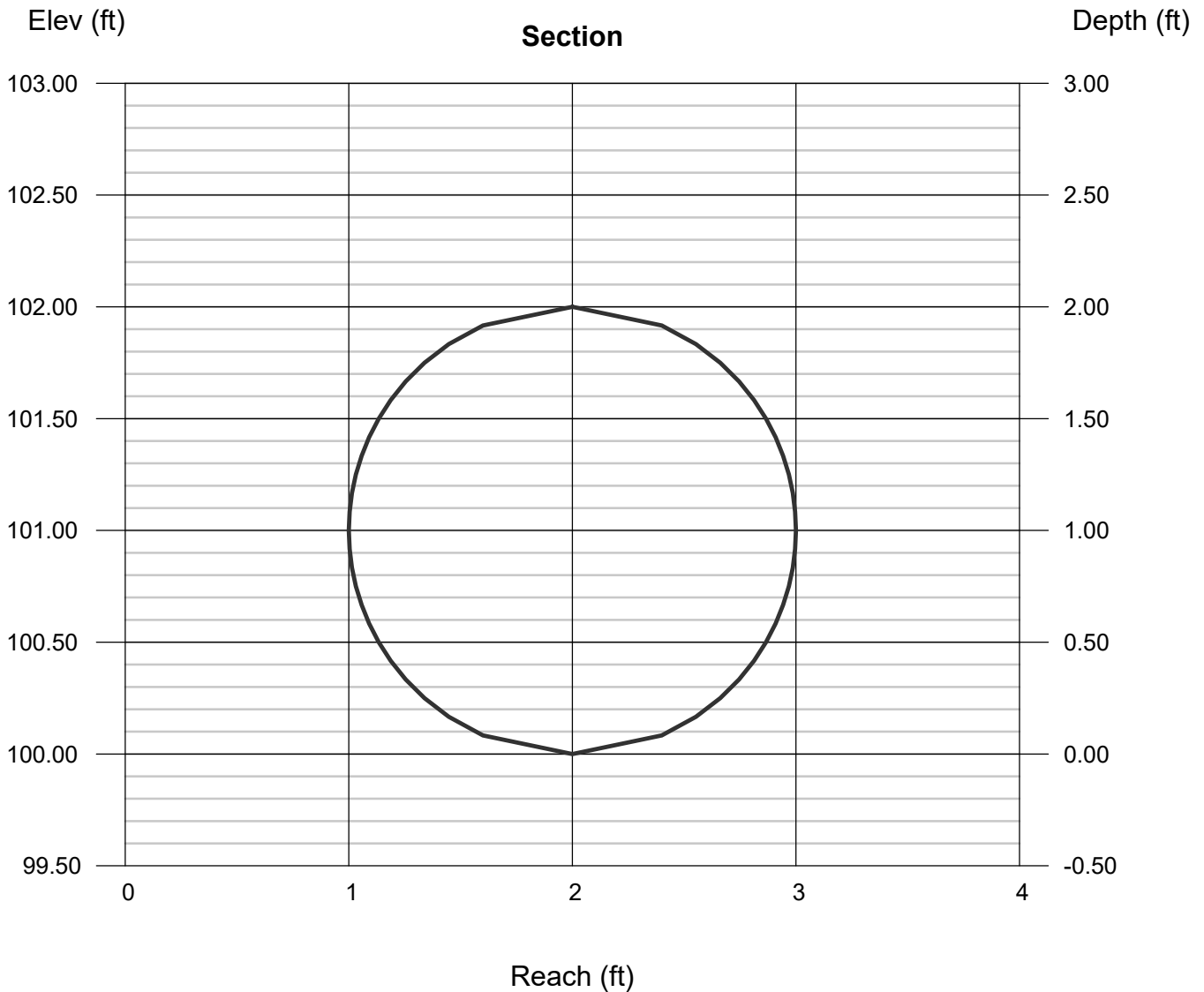

Channel Report

Swale Capacity

Trapezoidal

Bottom Width (ft) = 6.00
Side Slopes (z:1) = 2.00, 2.00
Total Depth (ft) = 4.00
Invert Elev (ft) = 100.00
Slope (%) = 0.50
N-Value = 0.200

Highlighted

Depth (ft) = 3.00
Q (cfs) = 28.55
Area (sqft) = 36.00
Velocity (ft/s) = 0.79
Wetted Perim (ft) = 19.42
Crit Depth, Y_c (ft) = 0.81
Top Width (ft) = 18.00
EGL (ft) = 3.01

Calculations

Compute by: Known Depth
Known Depth (ft) = 3.00

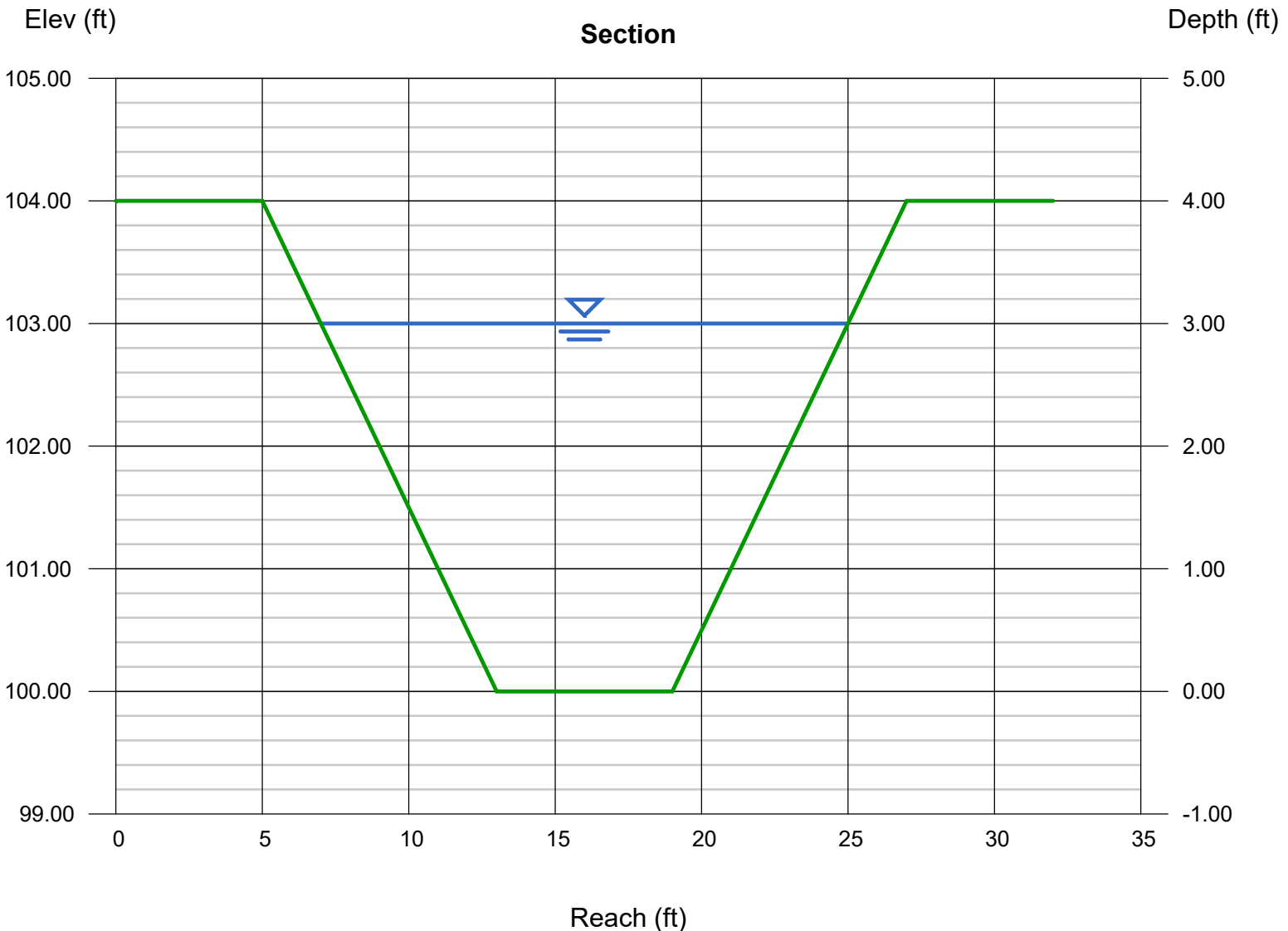

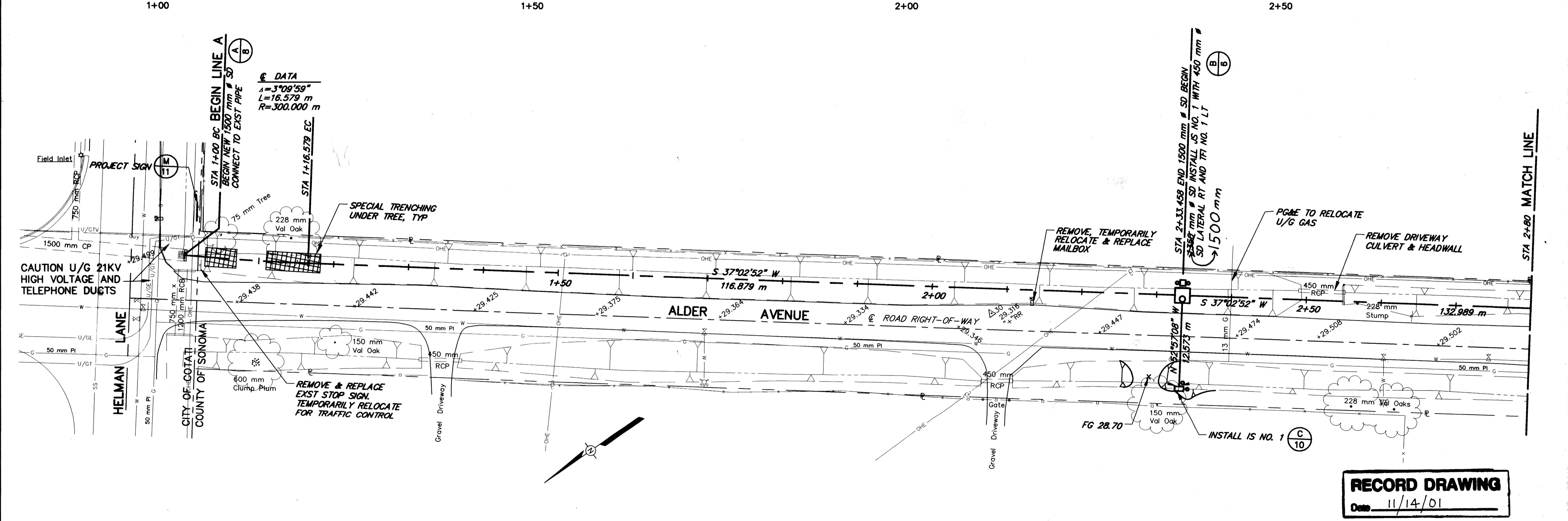
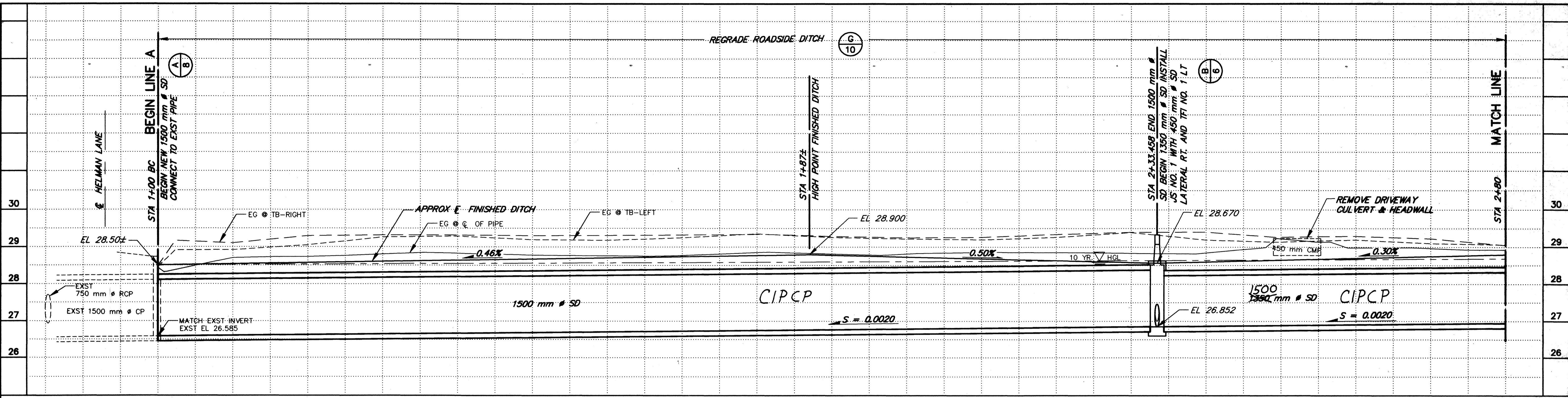

DATA
 $\Delta = 3^{\circ}09'59''$
 $L = 16.579 \text{ m}$
 $R = 300.000 \text{ m}$

RECORD DRAWING
 Date 11/14/01

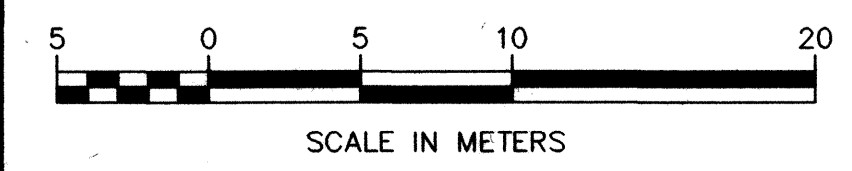

		SCALE: AS SHOWN DATE: 11 APRIL 2001 DRAWN: JLW/ADF CHECKED:	APPROVED DEPUTY CHIEF ENGINEER RCE 0046862 RCE 0046862 DESIGNED RCE 51532	LAGUNA MARK WEST - ZONE 1A COTATI SYSTEM B - LINE A PLAN & PROFILE - STA 1+00 TO STA 2+80 <small>FLOOD CONTROL\ZONE 1A\COTATI SYS B\1-4148-002_02</small> DRAWING NUMBER 1-4148/002 - 102.2	SHEET NO. 2 OF 11
NO.	DATE	REVISION	BY		

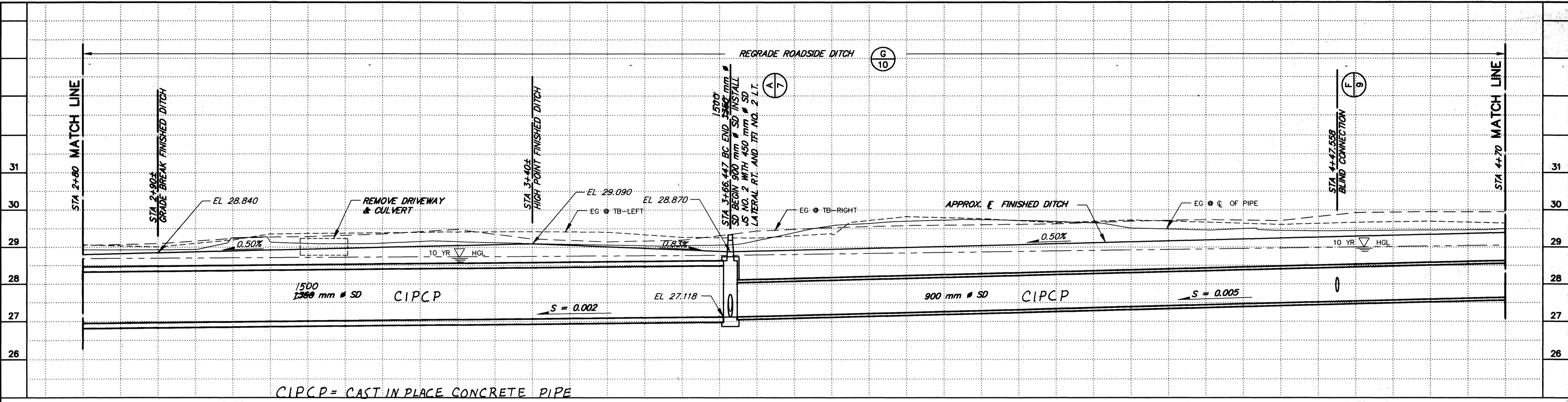

CIPCP = CAST IN PLACE CONCRETE PIPE

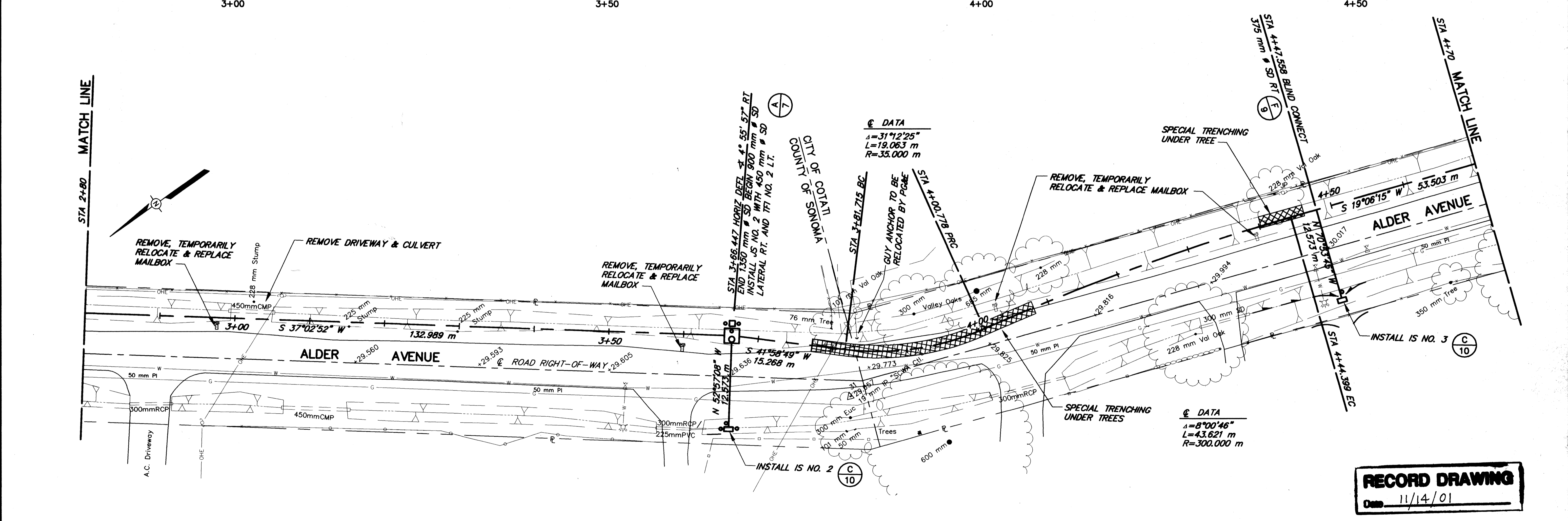

RECORD DRAWING
Date 11/14/01

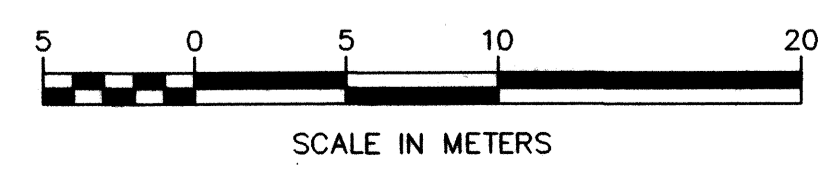

		SCALE: AS SHOWN DATE: 11 APRIL 2001 DRAWN: JLW/ADF CHECKED:	APPROVED DEPUTY CHIEF ENGINEER RCE 0046862 SUBMITTED RCE 0046862 DESIGNED RCE 51532 	LAGUNA MARK WEST - ZONE 1A COTATI SYSTEM B - LINE A PLAN & PROFILE - STA 2+80 TO STA 4+70 FLOOD CONTROL ZONE 1A/COTATI SYS B\1-4148-002_03 DRAWING NUMBER: 1-4148/002 - 102.3 SHEET NO. 3 OF 11
NO.	DATE	REVISION	BY	

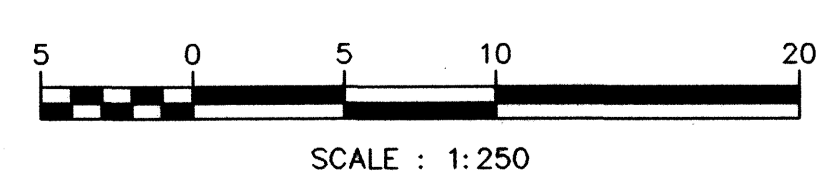
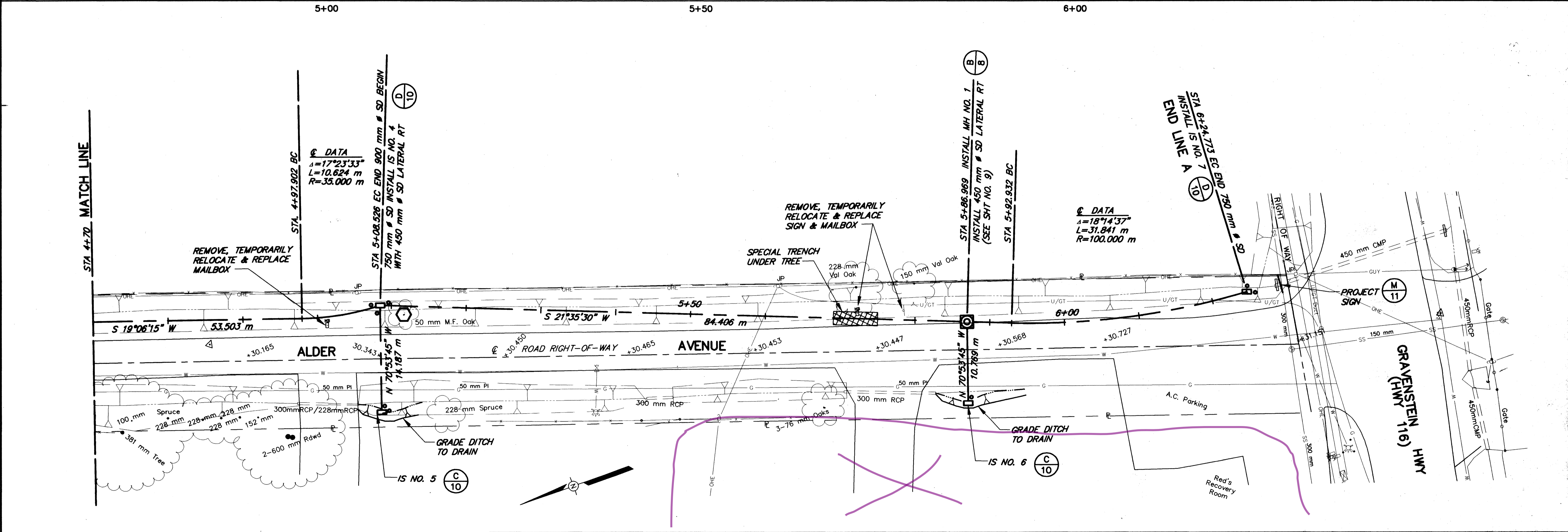
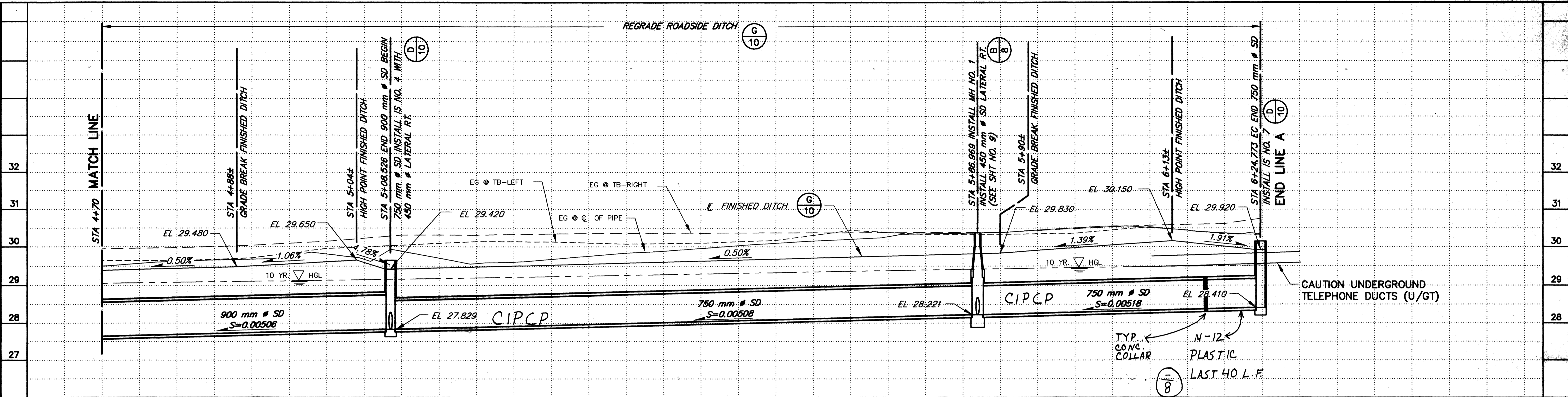

RECORD DRAWING
Date 11/14/01

NO.	DATE	REVISION	BY

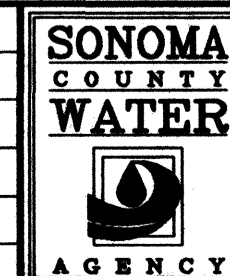

SCALE: AS SHOWN
DATE: 11 APRIL 2001
DRAWN: JLW/ADF
CHECKED: *[Signature]*

APPROVED DEPUTY CHIEF ENGINEER RCE 0046882
[Signature]
SUBMITTED RCE 0046882
DESIGNED RCE 51532
[Signature]

LAGUNA MARK WEST - ZONE 1A
COTATI SYSTEM B - LINE A
PLAN & PROFILE - STA 4+70 TO STA 6+24.773
DRAWING NUMBER 1-4148/002 - 102.4
SHEET NO. 4 OF 11

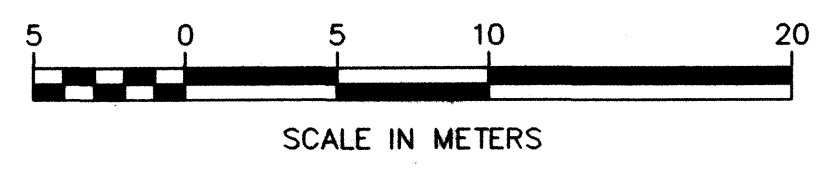
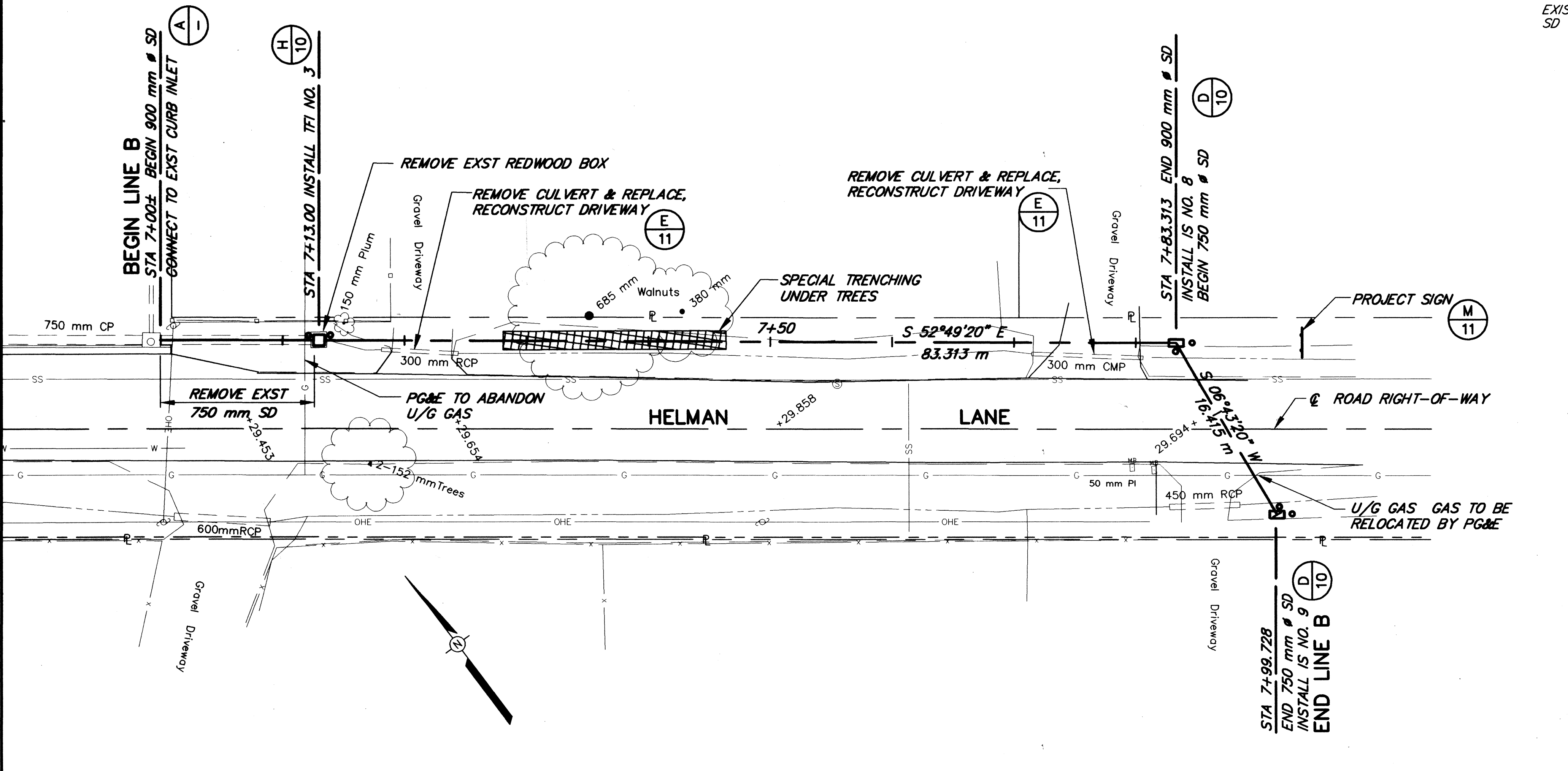
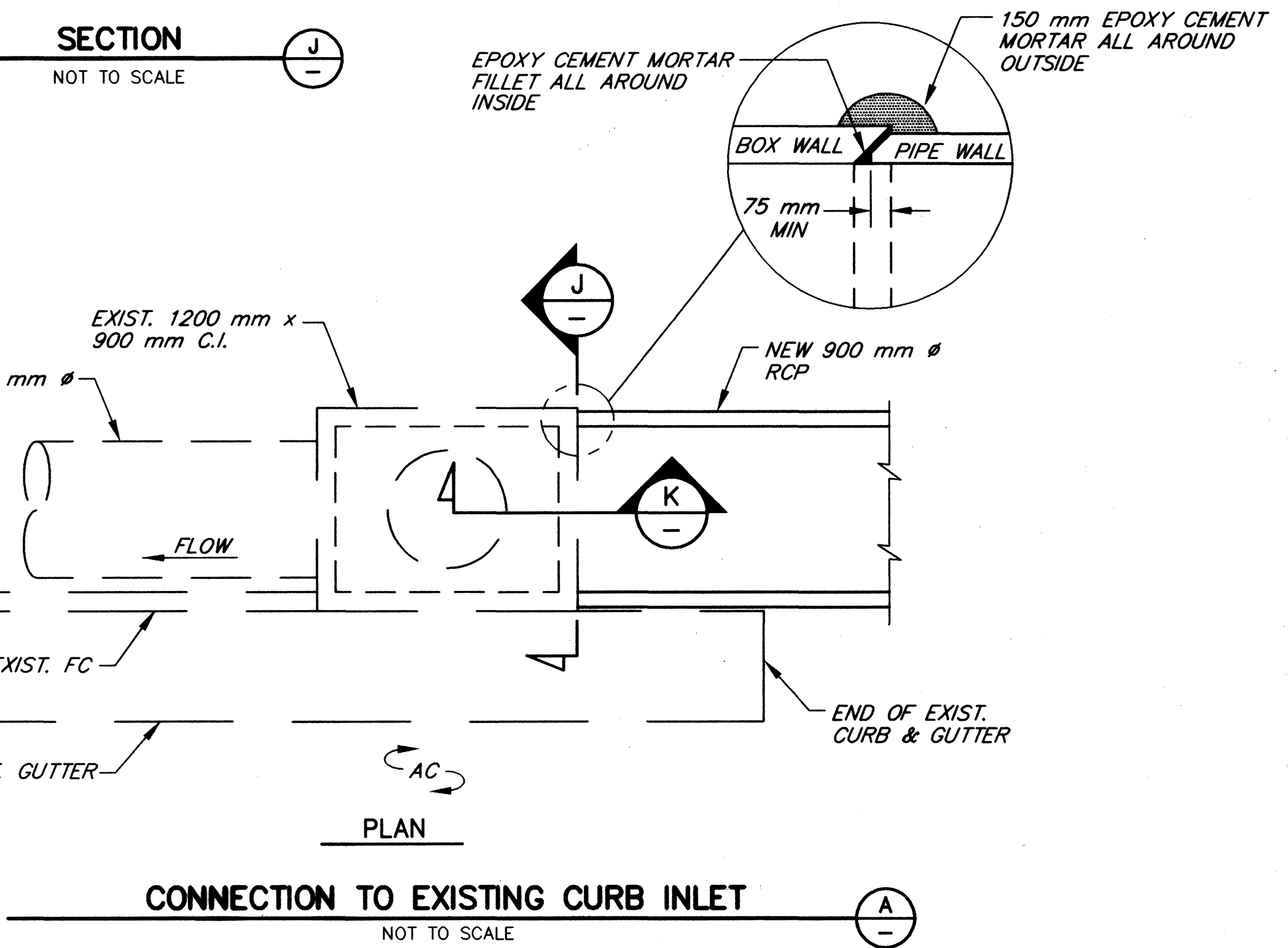
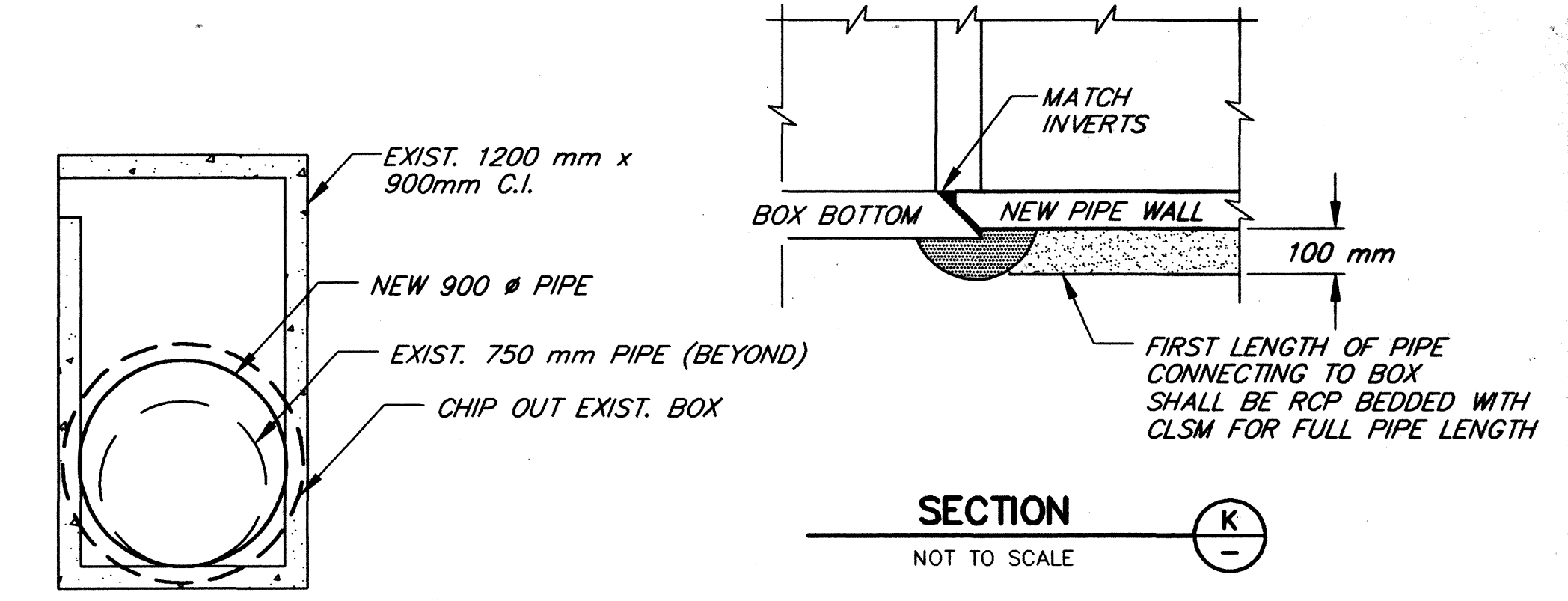
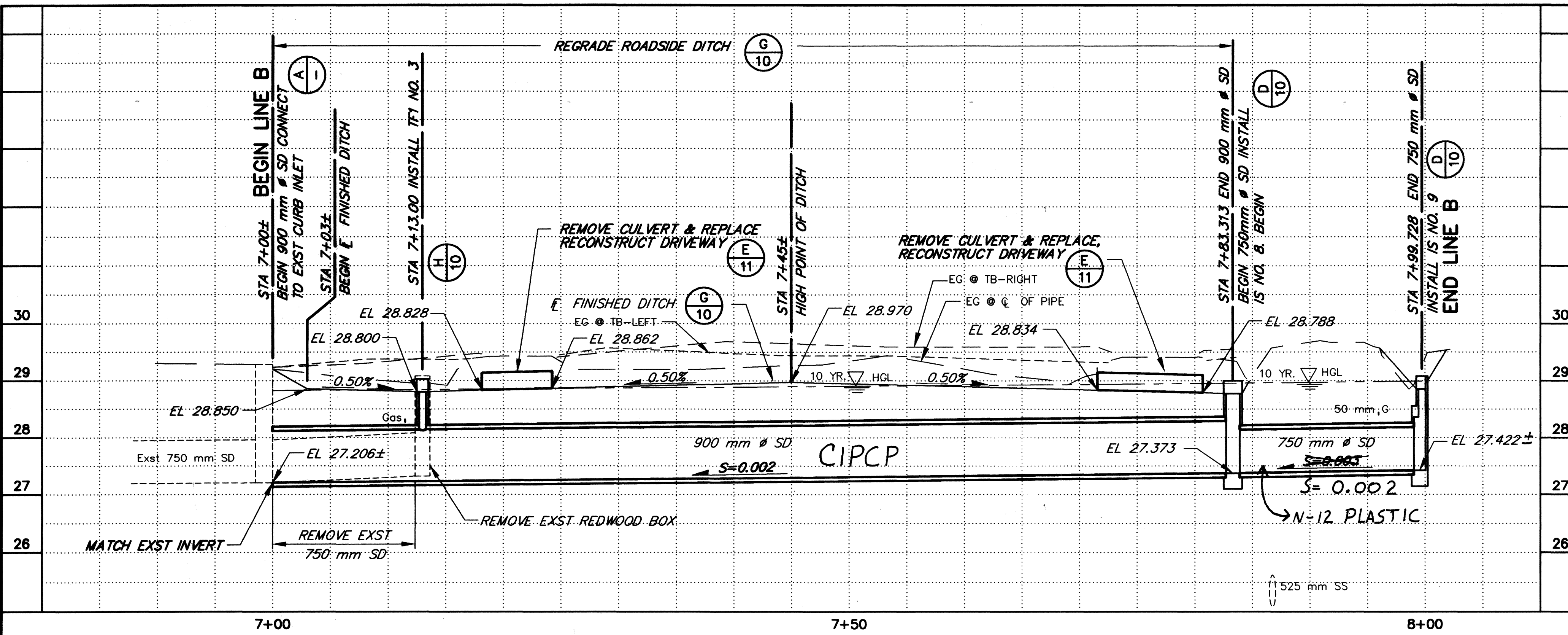

		SCALE: AS SHOWN DATE: 11 APRIL 2001 DRAWN: JLW/ADF CHECKED:	APPROVED DEPUTY CHIEF ENGINEER RCE 0046862 SUBMITTED RCE 0046862 DESIGNED RCE 51532 	LAGUNA MARK WEST - ZONE 1A COTATI SYSTEM B - LINE B PLAN & PROFILE - STA 7+00 TO STA 7+99.728 DRAWING NUMBER: 1-4148/002 - 102.5 SHEET NO. 5 OF 11
NO.	DATE	REVISION	BY	RECORD DRAWING Date: 11/14/01