

Stormwater Control Plan
For a Regulated Project
EKN Petaluma Hotel

September 26, 2023

Owner's Representative
Mike Jolly / EKN Development
Email: Mike@EKNDevGroup.com
Phone: 310-776-0621

prepared by:
N Consulting Engineers, Inc.
17780 Fitch, Suite 100
Irvine, CA 92614
Phone: 949-396-1161

Table of Contents

I.	Project Data	1
II.	Setting.....	1
II.A.	Project Location and Description	1
II.B.	Existing Site Features and Conditions	1
II.C.	Opportunities and Constraints for Stormwater Control.....	2
III.	Low Impact Development Design Strategies	2
III.A.	Optimization of Site Layout	2
III.A.1.	Limitation of development envelope	2
III.A.2.	Preservation of natural drainage features	2
III.A.3.	Setbacks from creeks, wetlands, and riparian habitats	2
III.A.4.	Minimization of imperviousness	2
III.A.5.	Use of drainage as a design element	2
III.B.	Use of Permeable Pavements.....	2
III.C.	Dispersal of Runoff to Pervious Areas.....	3
III.D.	Stormwater Control Measures	3
IV.	Documentation of Drainage Design	3
IV.A.	Descriptions of Each Drainage Management Area.....	3
IV.A.1.	Table of Drainage Management Areas	3
IV.A.2.	Drainage Management Area Descriptions	3
IV.B.	Tabulation and Sizing Calculations.....	3
IV.B.1.	Information Summary for Bioretention Facility Design	3
IV.B.2.	Self-Treating Areas	3
IV.B.3.	Self-Retaining Areas	3
IV.B.4.	Areas Draining to Self-Retaining Areas	3
IV.B.5.	Areas Draining to Bioretention Facilities	4
V.	Source Control Measures.....	5
V.A.	Site activities and potential sources of pollutants	5
V.B.	Source Control Table.....	5
V.C.	Features, Materials, and Methods of Construction of Source Control BMPs	5
VI.	Stormwater Facility Maintenance	6
VI.A.	Ownership and Responsibility for Maintenance in Perpetuity	6
VI.B.	Summary of Maintenance Requirements for Each Stormwater Facility.....	6
VII.	Construction Checklist	7
VIII.	Certifications	7

Tables

Table 1. Project Data	1
Table x. LID Facility Sizing Calculations.	4
Table x. Sources and Source Control Measures	5
Table x. Construction Plan C.3 Checklist	7

Figures

Location Map
Vicinity Map

Attachments

Stormwater Control Plan Exhibit
BMP Details

Appendices

This Stormwater Control Plan was prepared using the template dated July 11, 2014.

I. Project Data

Table 1. Project Data Form

Project Name/Number	EKN Petaluma Hotel
Application Submittal Date	2023-09-26
Project Location	2 Petaluma Blvd S, Petaluma, CA 94952
Project Phase No.	N/A
Project Type and Description	This project proposes a new 5-story building of 93 hotel rooms and 6,625sf of restaurant seating with a subterranean parking garage providing 58 parking spaces.
Total Project Site Area (acres)	0.33 acres
Total New and Replaced Impervious Surface Area	14,264 sf (0.33 ac)
Total Pre-Project Impervious Surface Area	0 sf (0 ac)
Total Post-Project Impervious Surface Area	14,264 sf (0.33 ac)

II. Setting

II.A. Project Location and Description

The project site is approximately 0.33 acres, located at 2 Petaluma Boulevard South, Petaluma, California. The proposed building consists of a one-story, ground-floor level housing retail/commercial and hotel support uses supporting four stories of hotel rooms and the rooftop terrace.

The proposed EKN Petaluma Hotel is a five-story building with a subterranean parking garage housing 58 parking spots and an occupiable rooftop which includes a garden, restaurant, bar, and event space. Six stories above grade and one down. 93 hotel rooms and 6,625 feet of restaurant seating. It is located at the southwest corner of Petaluma Blvd. South and B Street on a site that, until 2009, held a gas station. About three-quarters of the project area (all but the parcel directly adjacent to Bank of the West, to the south) is within the Petaluma Downtown Commercial District, a local district, and the National Register Commercial District.

II.B. Existing Site Features and Conditions

The project site is approximately 0.33 acres with elevation change across the site of roughly ± 2 ft to ± 3 ft, generally sloping from westerly to easterly direction. The existing site consists of undeveloped, pervious area. The property is surrounded by B Street to the northwesterly boundary, Petaluma Boulevard to the northeasterly boundary, hardware store to the southwesterly boundary, and a bank's parking lot to the southeasterly boundary. There is currently no existing storm drain system on the site. The existing stormwater runoff from the project area generally flows northeasterly on B Street and southeasterly on Petaluma Boulevard draining to a combination catch basin on Petaluma Boulevard at the southwesterly corner of intersection Petaluma Boulevard and C Street. Ultimately, the storm drain discharges to Petaluma River.

II.C. Opportunities and Constraints for Stormwater Control

The project site presents the following opportunities for stormwater controls:

1. Proprietary bioretention facilities (Modular Wetlands) will be incorporated on the roof of the development.
 - a. Designed to accept stormwater runoff from a minimum storm intensity of 0.2 in/hr per BASMAA requirements.
 - b. Stormwater runoff exceeding the 2-year event storm intensity of 0.5 in/hr will bypass the bioretention facility by overflowing and routed to the proposed off-site private detention facility.
2. Proprietary modular pavement support system (Silva Cells) designed as a detention facility will be incorporated underground along the frontage of the project site in public right-of-way.

The project site presents the following site constraints for stormwater controls:

1. Native soils encounter high groundwater and as a result infiltration is anticipated to be infeasible.
2. The proposed development is designed to occupy the property from lot line to lot line.

III. Low Impact Development Design Strategies

III.A. Optimization of Site Layout

All grading will match the adjoining street grades as close as possible, so slopes are minimized.

III.A.1. Limitation of development envelope

III.A.2. Preservation of natural drainage features

No natural drainage features are within the project area.

III.A.3. Setbacks from creeks, wetlands, and riparian habitats

No creeks, wetlands, or riparian habitats are within the project area.

III.A.4. Minimization of imperviousness

III.A.5. Use of drainage as a design element

III.B. Use of Permeable Pavements

Permeable pavements are not proposed for this project.

III.C. Dispersal of Runoff to Pervious Areas

III.D. Stormwater Control Measures

IV. Documentation of Drainage Design

IV.A. Descriptions of Each Drainage Management Area

IV.A.1. Table of Drainage Management Areas

DMA Name	Surface Type	Area (square feet)
1A	Roof	7,132
2A	Roof	6,074
3A	Patio	1,058
Total		14,264

IV.A.2. Drainage Management Area Descriptions

DMA 1A, totaling 7,132 square feet, drains northwesterly toward proprietary bioretention facility.

DMA 2A, totaling 6,074 square feet, drains northwesterly toward proprietary bioretention facility.

DMA 3A, totaling 1,058 square feet, drains northwesterly toward proprietary bioretention facility.

IV.B. Tabulation and Sizing Calculations

IV.B.1. Information Summary for Bioretention Facility Design

Total Project Area	14,264 sf
DMA 1A	7,132 sf
DMA 2A	6,074 sf
DMA 3A	1,058 sf

IV.B.2. Self-Treating Areas

N/A

IV.B.3. Self-Retaining Areas

N/A

IV.B.4. Areas Draining to Self-Retaining Areas

N/A

IV.B.5. Areas Draining to Bioretention Facilities

DMA Name	DMA Area (square feet)	Post-project surface type	DMA Runoff factor	DMA Area × runoff factor	Facility Name		
1A	7,132	Roof	1.0	7,132.0	Sizing factor	Minimum Facility Size	Proposed Facility Size
Total				7,132.0	0.04	286 sf	8x24*

* Proprietary Bioretention Facility is sized by the treatment flow

DMA Name	DMA Area (square feet)	Post-project surface type	DMA Runoff factor	DMA Area × runoff factor	Facility Name		
2A	6,074	Roof	1.0	6,074.0	Sizing factor	Minimum Facility Size	Proposed Facility Size
Total				6,074.0	0.04	243 sf	8x24*

* Proprietary Bioretention Facility is sized by the treatment flow

DMA Name	DMA Area (square feet)	Post-project surface type	DMA Runoff factor	DMA Area × runoff factor	Facility Name		
3A	1,058	Patio	1.0	1,058.0	Sizing factor	Minimum Facility Size	Proposed Facility Size
Total				1,058.0	0.04	43 sf	4x4*

* Proprietary Bioretention Facility is sized by the treatment flow

V. Source Control Measures

V.A. Site activities and potential sources of pollutants

Source Control Table below identifies and describes potential pollutant sources that will likely be present as part of this project. The table also includes the permanent source control BMP and operational source control BMP (that shall be implemented) to control the potential polluted surface runoff. These controls shall be implemented as long as the identified activities (sources) continue at the site.

During all phases of the development (mass grading and construction of the new hotel/restaurant and subterranean parking garage), sediment laden stormwater runoff shall not be permitted to leave the site.

V.B. Source Control Table

Potential source of runoff pollutants	Permanent source control BMPs	Operational source control BMPs
Roof	Proprietary Bioretention Facilities (Modular Wetland)	Encourage maintenance of bioretention following Maintenance Summary Sweep regularly to prevent accumulation of litter
Patio	Proprietary Bioretention Facility (Modular Wetland)	Encourage maintenance of bioretention following Maintenance Summary Sweep regularly to prevent accumulation of litter

V.C. Features, Materials, and Methods of Construction of Source Control BMPs

Appendix A. Stormwater Pollutant Sources/Source Controls Checklist

How to use this worksheet (also see instructions on page 3–6 of the *BASMAA Post-Construction Manual*):

1. Review Column 1 and identify which of these potential sources of stormwater pollutants apply to your site. Check each box that applies.
2. Review Column 2 and incorporate all of the corresponding applicable Structural Source Control BMPs in your Stormwater Control Plan drawings.
3. Review Columns 3 and 4 and incorporate all of the corresponding applicable Structural Source Control BMPs and Operational Source Control BMPs in a table in your Stormwater Control Plan. Use the format shown in Table 3-1 on page 3-6 of the *BASMAA Post-Construction Manual*. Describe your specific BMPs in an accompanying narrative, and explain any special conditions or situations that required omitting BMPs or substituting alternative BMPs.

IF THESE SOURCES WILL BE ON THE PROJECT SITE THEN YOUR STORMWATER CONTROL PLAN (SCP) SHOULD INCLUDE THESE SOURCE CONTROL BMPs		
1 Potential Sources of Runoff Pollutants	2 Structural Source Controls—Show on Stormwater Control Plan Drawings	3 Structural Source Controls—List in SCP Table and Narrative	4 Operational Source Control BMPs—Include in SCP Table and Narrative
<input checked="" type="checkbox"/> A. On-site storm drain inlets (unauthorized non-stormwater discharges and accidental spills or leaks)	<input checked="" type="checkbox"/> Locations of inlets.	<input checked="" type="checkbox"/> Mark all inlets with the words “No Dumping! Flows to Bay” or similar.	<input checked="" type="checkbox"/> Maintain and periodically repaint or replace inlet markings. <input checked="" type="checkbox"/> Provide stormwater pollution prevention information to new site owners, lessees, or operators. <input checked="" type="checkbox"/> See applicable operational BMPs in Fact Sheet SC-44, “Drainage System Maintenance,” in the CASQA Stormwater Quality Handbooks at www.casqa.org/resources/bmp-handbooks <input checked="" type="checkbox"/> Include the following in lease agreements: “Tenant shall not allow anyone to discharge anything to storm drains or to store or deposit materials so as to create a potential discharge to storm drains.”

IF THESE SOURCES WILL BE ON THE PROJECT SITE THEN YOUR STORMWATER CONTROL PLAN (SCP) SHOULD INCLUDE THESE SOURCE CONTROL BMPs		
1 Potential Sources of Runoff Pollutants	2 Structural Source Controls—Show on Stormwater Control Plan Drawings	3 Structural Source Controls—List in SCP Table and Narrative	4 Operational Source Control BMPs—Include in SCP Table and Narrative
<input type="checkbox"/> B. Interior floor drains and elevator shaft sump pumps	Show drains and pump locations	<input type="checkbox"/> State that interior floor drains and elevator shaft sump pumps will be plumbed to sanitary sewer.	<input type="checkbox"/> Inspect and maintain drains to prevent blockages and overflow.
<input checked="" type="checkbox"/> C. Interior parking garages	Show drain locations	<input checked="" type="checkbox"/> State that parking garage floor drains will be plumbed to the sanitary sewer.	<input checked="" type="checkbox"/> Inspect and maintain drains to prevent blockages and overflow.
<input type="checkbox"/> D1. Need for future indoor & structural pest control		<input type="checkbox"/> Note building design features that discourage entry of pests.	<input type="checkbox"/> Provide Integrated Pest Management information to owners, lessees, and operators.

IF THESE SOURCES WILL BE ON THE PROJECT SITE THEN YOUR STORMWATER CONTROL PLAN (SCP) SHOULD INCLUDE THESE SOURCE CONTROL BMPs		
1 Potential Sources of Runoff Pollutants	2 Structural Source Controls—Show on Stormwater Control Plan Drawings	3 Structural Source Controls—List in SCP Table and Narrative	4 Operational Source Control BMPs—Include in SCP Table and Narrative
<input checked="" type="checkbox"/> D2. Landscape/ Outdoor Pesticide Use/Building and Grounds Maintenance	<input type="checkbox"/> Show locations of native trees or areas of shrubs and ground cover to be undisturbed and retained. <input type="checkbox"/> Show self-retaining landscape areas, if any. <input checked="" type="checkbox"/> Show bioretention facilities. (See instructions in Chapter 4.)	<p>State that final landscape plans will accomplish all of the following.</p> <input type="checkbox"/> Preserve existing native trees, shrubs, and ground cover to the maximum extent possible. <input checked="" type="checkbox"/> Design landscaping to minimize irrigation and runoff, to promote surface infiltration where appropriate, and to minimize the use of fertilizers and pesticides that can contribute to stormwater pollution. <input checked="" type="checkbox"/> Where landscaped areas are used to retain or detain stormwater, specify plants that are tolerant of saturated soil conditions. <input checked="" type="checkbox"/> Consider using pest-resistant plants, especially adjacent to hardscape. <input checked="" type="checkbox"/> To insure successful establishment, select plants appropriate to site soils, slopes, climate, sun, wind, rain, land use, air movement, ecological consistency, and plant interactions.	<input checked="" type="checkbox"/> Maintain landscaping using minimum or no pesticides. <input checked="" type="checkbox"/> See applicable operational BMPs in Fact Sheet SC-41, “Building and Grounds Maintenance,” in the CASQA Stormwater Quality Handbooks at www.casqa.org/resources/bmp-handbooks <input checked="" type="checkbox"/> Provide IPM information to new owners, lessees and operators.

IF THESE SOURCES WILL BE ON THE PROJECT SITE THEN YOUR STORMWATER CONTROL PLAN (SCP) SHOULD INCLUDE THESE SOURCE CONTROL BMPs		
1 Potential Sources of Runoff Pollutants	2 Structural Source Controls—Show on Stormwater Control Plan Drawings	3 Structural Source Controls—List in SCP Table and Narrative	4 Operational Source Control BMPs—Include in SCP Table and Narrative
<input type="checkbox"/> E. Pools, spas, ponds, decorative fountains, and other water features.	<input type="checkbox"/> Show location of water feature and a sanitary sewer cleanout in an accessible area within 10 feet.	<input type="checkbox"/> If the local municipality requires pools to be plumbed to the sanitary sewer, place a note on the plans and state in the narrative that this connection will be made according to local requirements.	<input type="checkbox"/> See applicable operational BMPs in Fact Sheet SC-72, “Fountain and Pool Maintenance,” in the CASQA Stormwater Quality Handbooks at www.casqa.org/resources/bmp-handbooks The sanitary sewer operator must be notified and a clean out identified when pools are to be drained to the sanitary sewer.
<input checked="" type="checkbox"/> F. Food service	<input checked="" type="checkbox"/> For restaurants, grocery stores, and other food service operations, show location (indoors or in a covered area outdoors) of a floor sink or other area for cleaning floor mats, containers, and equipment. <input checked="" type="checkbox"/> On the drawing, show a note that this drain will be connected to a grease interceptor before discharging to the sanitary sewer.	<input checked="" type="checkbox"/> Describe the location and features of the designated cleaning area. <input checked="" type="checkbox"/> Describe the items to be cleaned in this facility and how it has been sized to insure that the largest items can be accommodated.	State maintenance schedule for grease interceptor

IF THESE SOURCES WILL BE ON THE PROJECT SITE THEN YOUR STORMWATER CONTROL PLAN (SCP) SHOULD INCLUDE THESE SOURCE CONTROL BMPs		
1 Potential Sources of Runoff Pollutants	2 Structural Source Controls—Show on Stormwater Control Plan Drawings	3 Structural Source Controls—List in SCP Table and Narrative	4 Operational Source Control BMPs—Include in SCP Table and Narrative
<input checked="" type="checkbox"/> G. Refuse areas	<input checked="" type="checkbox"/> Show where site refuse and recycled materials will be handled and stored for pickup. See local municipal requirements for sizes and other details of refuse areas. <input checked="" type="checkbox"/> If dumpsters or other receptacles are outdoors, show how the designated area will be covered, graded, and paved to prevent run-on and show locations of berms to prevent runoff from the area. <input checked="" type="checkbox"/> Any drains from dumpsters, compactors, and tallow bin areas shall be connected to a grease removal device before discharge to sanitary sewer.	<input checked="" type="checkbox"/> State how site refuse will be handled and provide supporting detail to what is shown on plans. <input checked="" type="checkbox"/> State that signs will be posted on or near dumpsters with the words “Do not dump hazardous materials here” or similar.	<input checked="" type="checkbox"/> State how the following will be implemented: Provide adequate number of receptacles. Inspect receptacles regularly; repair or replace leaky receptacles. Keep receptacles covered. Prohibit/prevent dumping of liquid or hazardous wastes. Post “no hazardous materials” signs. Inspect and pick up litter daily and clean up spills immediately. Keep spill control materials available on-site. See Fact Sheet SC-34, “Waste Handling and Disposal” in the CASQA Stormwater Quality Handbooks at www.casqa.org/resources/bmp-handbooks
<input type="checkbox"/> H. Industrial processes.	<input type="checkbox"/> Show process area.	<input type="checkbox"/> If industrial processes are to be located on site, state: “All process activities to be performed indoors. No processes to drain to exterior or to storm drain system.”	<input type="checkbox"/> See Fact Sheet SC-10, “Non-Stormwater Discharges” in the CASQA Stormwater Quality Handbooks at www.casqa.org/resources/bmp-handbooks

IF THESE SOURCES WILL BE ON THE PROJECT SITE THEN YOUR STORMWATER CONTROL PLAN (SCP) SHOULD INCLUDE THESE SOURCE CONTROL BMPs		
1 Potential Sources of Runoff Pollutants	2 Structural Source Controls—Show on Stormwater Control Plan Drawings	3 Structural Source Controls—List in SCP Table and Narrative	4 Operational Source Control BMPs—Include in SCP Table and Narrative
<input type="checkbox"/> I. Outdoor storage of equipment or materials. (See rows J and K for source control measures for vehicle cleaning, repair, and maintenance.)	<input type="checkbox"/> Show any outdoor storage areas, including how materials will be covered. Show how areas will be graded and bermed to prevent run-on or run-off from area. <input type="checkbox"/> Storage of non-hazardous liquids shall be covered by a roof and/or drain to the sanitary sewer system, and be contained by berms, dikes, liners, or vaults. <input type="checkbox"/> Storage of hazardous materials and wastes must be in compliance with the local hazardous materials ordinance and a Hazardous Materials Management Plan for the site.	<input type="checkbox"/> Include a detailed description of materials to be stored, storage areas, and structural features to prevent pollutants from entering storm drains. <input type="checkbox"/> Where appropriate, reference documentation of compliance with the requirements of programs for: <ul style="list-style-type: none"> ▪ Hazardous Waste Generation ▪ Hazardous Materials Release Response and Inventory ▪ California Accidental Release (CalARP) ▪ Aboveground Storage Tank ▪ Uniform Fire Code Article 80 Section 103(b) & (c) 1991 ▪ Underground Storage Tank 	<input type="checkbox"/> See the Fact Sheets SC-31, “Outdoor Liquid Container Storage” and SC-33, “Outdoor Storage of Raw Materials ” in the CASQA Stormwater Quality Handbooks at www.casqa.org/resources/bmp-handbooks

IF THESE SOURCES WILL BE ON THE PROJECT SITE THEN YOUR STORMWATER CONTROL PLAN (SCP) SHOULD INCLUDE THESE SOURCE CONTROL BMPs		
1 Potential Sources of Runoff Pollutants	2 Structural Source Controls—Show on Stormwater Control Plan Drawings	3 Structural Source Controls—List in SCP Table and Narrative	4 Operational Source Control BMPs—Include in SCP Table and Narrative
<input type="checkbox"/> J. Vehicle and Equipment Cleaning	<input type="checkbox"/> Show on drawings as appropriate: (1) Commercial/industrial facilities having vehicle/ equipment cleaning needs shall either provide a covered, bermed area for washing activities or discourage vehicle/equipment washing by removing hose bibs and installing signs prohibiting such uses. (2) Multi-dwelling complexes shall have a paved, bermed, and covered car wash area (unless car washing is prohibited on-site and hoses are provided with an automatic shut-off to discourage such use). (3) Washing areas for cars, vehicles, and equipment shall be paved, designed to prevent run-on to or runoff from the area, and plumbed to drain to the sanitary sewer. (4) Commercial car wash facilities shall be designed such that no runoff from the facility is discharged to the storm drain system. Wastewater from the facility shall discharge to the sanitary sewer, or a wastewater reclamation system shall be installed.	<input type="checkbox"/> If a car wash area is not provided, describe measures taken to discourage on-site car washing and explain how these will be enforced.	Describe operational measures to implement the following (if applicable): <input type="checkbox"/> Washwater from vehicle and equipment washing operations shall not be discharged to the storm drain system. <input type="checkbox"/> Car dealerships and similar may rinse cars with water only. See Fact Sheet SC-21, “Vehicle and Equipment Cleaning,” in the CASQA Stormwater Quality Handbooks at www.casqa.org/resources/bmp-handbooks

IF THESE SOURCES WILL BE ON THE PROJECT SITE THEN YOUR STORMWATER CONTROL PLAN (SCP) SHOULD INCLUDE THESE SOURCE CONTROL BMPs		
1 Potential Sources of Runoff Pollutants	2 Structural Source Controls—Show on Stormwater Control Plan Drawings	3 Structural Source Controls—List in SCP Table and Narrative	4 Operational Source Control BMPs—Include in SCP Table and Narrative
<input type="checkbox"/> K. Vehicle/Equipment Repair and Maintenance	<input type="checkbox"/> Accommodate all vehicle equipment repair and maintenance indoors. Or designate an outdoor work area and design the area to prevent run-on and runoff of stormwater. <input type="checkbox"/> Show secondary containment for exterior work areas where motor oil, brake fluid, gasoline, diesel fuel, radiator fluid, acid-containing batteries or other hazardous materials or hazardous wastes are used or stored. Drains shall not be installed within the secondary containment areas. <input type="checkbox"/> Add a note on the plans that states either (1) there are no floor drains, or (2) floor drains are connected to wastewater pretreatment systems prior to discharge to the sanitary sewer and an industrial waste discharge permit will be obtained.	<input type="checkbox"/> State that no vehicle repair or maintenance will be done outdoors, or else describe the required features of the outdoor work area. <input type="checkbox"/> State that there are no floor drains or if there are floor drains, note the agency from which an industrial waste discharge permit will be obtained and that the design meets that agency's requirements. <input type="checkbox"/> State that there are no tanks, containers or sinks to be used for parts cleaning or rinsing or, if there are, note the agency from which an industrial waste discharge permit will be obtained and that the design meets that agency's requirements.	<p>In the Stormwater Control Plan, note that all of the following restrictions apply to use the site:</p> <input type="checkbox"/> No person shall dispose of, nor permit the disposal, directly or indirectly of vehicle fluids, hazardous materials, or rinsewater from parts cleaning into storm drains. <input type="checkbox"/> No vehicle fluid removal shall be performed outside a building, nor on asphalt or ground surfaces, whether inside or outside a building, except in such a manner as to ensure that any spilled fluid will be in an area of secondary containment. Leaking vehicle fluids shall be contained or drained from the vehicle immediately. <input type="checkbox"/> No person shall leave unattended parts or other open containers containing vehicle fluid, unless such containers are in use or in an area of secondary containment.

IF THESE SOURCES WILL BE ON THE PROJECT SITE THEN YOUR STORMWATER CONTROL PLAN (SCP) SHOULD INCLUDE THESE SOURCE CONTROL BMPs		
1 Potential Sources of Runoff Pollutants	2 Structural Source Controls—Show on Stormwater Control Plan Drawings	3 Structural Source Controls—List in SCP Table and Narrative	4 Operational Source Control BMPs—Include in SCP Table and Narrative
<input type="checkbox"/> L. Fuel Dispensing Areas	<input type="checkbox"/> Fueling areas shall have impermeable floors (i.e., portland cement concrete or equivalent smooth impervious surface) that are: a) graded at the minimum slope necessary to prevent ponding; and b) separated from the rest of the site by a grade break that prevents run-on of stormwater to the maximum extent practicable. <input type="checkbox"/> Fueling areas shall be covered by a canopy that extends a minimum of ten feet in each direction from each pump. [Alternative: The fueling area must be covered and the cover's minimum dimensions must be equal to or greater than the area within the grade break or fuel dispensing area ¹ .] The canopy [or cover] shall not drain onto the fueling area.		<input type="checkbox"/> The property owner shall dry sweep the fueling area routinely. <input type="checkbox"/> See the Business Guide Sheet, “Automotive Service—Service Stations” in the CASQA Stormwater Quality Handbooks at www.casqa.org/resources/bmp-handbooks

IF THESE SOURCES WILL BE ON THE PROJECT SITE THEN YOUR STORMWATER CONTROL PLAN (SCP) SHOULD INCLUDE THESE SOURCE CONTROL BMPs		
1 Potential Sources of Runoff Pollutants	2 Structural Source Controls—Show on Stormwater Control Plan Drawings	3 Structural Source Controls—List in SCP Table and Narrative	4 Operational Source Control BMPs—Include in SCP Table and Narrative
<input type="checkbox"/> M. Loading Docks	<input type="checkbox"/> Show the loading dock area, including roofing and drainage. Loading docks shall be covered and/or graded to minimize run-on to and runoff from the loading area. Roof downspouts shall be positioned to direct stormwater away from the loading area. Water from loading dock areas shall be drained to the sanitary sewer, or diverted and collected for ultimate discharge to the sanitary sewer. <input type="checkbox"/> Loading dock areas draining directly to the sanitary sewer shall be equipped with a spill control valve or equivalent device, which shall be kept closed during periods of operation. <input type="checkbox"/> Provide a roof overhang over the loading area or install door skirts (cowling) at each bay that enclose the end of the trailer.		<input type="checkbox"/> Move loaded and unloaded items indoors as soon as possible. <input type="checkbox"/> See Fact Sheet SC-30, “Outdoor Loading and Unloading,” in the CASQA Stormwater Quality Handbooks at www.casqa.org/resources/bmp-handbooks
<input type="checkbox"/> N. Fire Sprinkler Test Water		<input type="checkbox"/> Provide a means to drain fire sprinkler test water to the sanitary sewer.	<input type="checkbox"/> See the note in Fact Sheet SC-41, “Building and Grounds Maintenance,” in the CASQA Stormwater Quality Handbooks at www.casqa.org/resources/bmp-handbooks

IF THESE SOURCES WILL BE ON THE PROJECT SITE THEN YOUR STORMWATER CONTROL PLAN (SCP) SHOULD INCLUDE THESE SOURCE CONTROL BMPs		
1 Potential Sources of Runoff Pollutants	2 Structural Source Controls—Show on Stormwater Control Plan Drawings	3 Structural Source Controls—List in SCP Table and Narrative	4 Operational Source Control BMPs—Include in SCP Table and Narrative
<p>O. Miscellaneous Drain or Wash Water or Other Sources</p> <ul style="list-style-type: none"> <input type="checkbox"/> Boiler drain lines <input type="checkbox"/> Condensate drain lines <input type="checkbox"/> Rooftop equipment <input type="checkbox"/> Drainage sumps <input checked="" type="checkbox"/> Roofing, gutters, and trim. <input type="checkbox"/> Other sources 	<p>Show drain lines and drainage sumps</p>	<ul style="list-style-type: none"> <input type="checkbox"/> Boiler drain lines shall be directly or indirectly connected to the sanitary sewer system and may not discharge to the storm drain system. <input type="checkbox"/> Condensate drain lines may discharge to landscaped areas if the flow is small enough that runoff will not occur. Condensate drain lines may not discharge to the storm drain system. <input type="checkbox"/> Rooftop equipment with potential to produce pollutants shall be roofed and/or have secondary containment. <input type="checkbox"/> Any drainage sumps on-site shall feature a sediment sump to reduce the quantity of sediment in pumped water. <input type="checkbox"/> Include controls for other sources as specified by local reviewer. 	<p>If architectural copper is used, implement the following BMPs for management of rinsewater during installation:</p> <ul style="list-style-type: none"> <input type="checkbox"/> If possible, purchase copper materials that have been pre-patinated at the factory. <input type="checkbox"/> If patination is done on-site, prevent rinse water from entering storm drains by discharging to landscaping or by collecting in a tank and hauling off-site. <input type="checkbox"/> Consider coating the copper materials with an impervious coating that prevents further corrosion and runoff. <p>Implement the following BMPs during routine maintenance:</p> <ul style="list-style-type: none"> <input type="checkbox"/> Prevent rinse water from entering storm drains by discharging to landscaping or by collecting in a tank and hauling off-site.
<ul style="list-style-type: none"> <input checked="" type="checkbox"/> P. Plazas, sidewalks, and parking lots. 	<p>Show extent of permeable paving materials</p>		<ul style="list-style-type: none"> <input checked="" type="checkbox"/> Sweep plazas, sidewalks, and parking lots regularly to prevent accumulation of litter and debris. Collect debris from pressure washing to prevent entry into the storm drain system. Collect washwater containing any cleaning agent or degreaser and discharge to the sanitary sewer not to a storm drain.

VI. Stormwater Facility Maintenance

VI.A. Ownership and Responsibility for Maintenance in Perpetuity

[Include (1) a commitment to execute any necessary agreements, and (2) a statement such as the following: “The applicant accepts responsibility for interim operation and maintenance of stormwater treatment and flow-control facilities until such time as this responsibility is formally transferred to a subsequent owner.”

VI.B. Summary of Maintenance Requirements for Each Stormwater Facility

Proprietary Bioretention Facility Maintenance Summary – Contech Modular Wetlands

Maintenance of Modular Wetlands devices include 5 simple steps with the use of a vacuum truck or can be cleaned by hand.

1. Remove Trash from the screening device.
2. Remove the sediment from the separation chamber.
3. Periodically replace the pretreatment cartridge filter media.
4. Replace the drain-down media.
5. Trim vegetation (if needed).

Proprietary Modular Pavement Support System Maintenance Summary – Silva Cells

Silva cell units require little to no maintenance. This summary will include the maintenance guidelines for the Silva Cell Frame and Tree opening provided within the Silva Cell Operations and Maintenance Manual.

For the frames (or base, posts, and deck) there is not any recommended frequency of inspection or routine maintenance. The only scenario when maintenance would be triggered would be if the facility shows signs of any damage from an external source whether that may be excessive loading from the surface, nearby construction, or similar activities. Each frame stack is independent of its adjacent frame stacks. Therefore, the compromise of one frame stack will not compromise the system of frame stacks. Any frame stack or part of the frame stack that is compromised are to be replaced with a new frame stack and/or part.

Tree openings are to be inspected in the spring, fall and after major storms. Inspections include checking for clogging, standing water, accumulation of sediment, debris, or trash. It is recommended to remove these items on an as needed basis.

Appendix B. Bioretention Facility Construction Inspection Checklist

Layout (to be confirmed prior to beginning excavation)

- Square footage of the facility meets or exceeds minimum shown in Stormwater Control Plan
- Site grading and grade breaks are consistent with the boundaries of the tributary Drainage Management Area(s) (DMAs) shown in the Stormwater Control Plan
- Inlet elevation of the facility is low enough to receive drainage from the entire tributary DMA
- Locations and elevations of overland flow or piping, including roof leaders, from impervious areas to the facility have been laid out and any conflicts resolved
- Rim elevation of the facility is laid out to be level all the way around, or elevations are consistent with a detailed cross-section showing location and height of interior dams
- Locations for vaults, utility boxes, and light standards have been identified so that they will not conflict with the facility
- Facility is protected as needed from construction-phase runoff and sediment

Excavation (to be confirmed prior to backfilling or pipe installation)

- Excavation conducted with materials and techniques to minimize compaction of soils within the facility area
- Excavation is to accurate area and depth
- Slopes or side walls protect from sloughing of native soils into the facility
- Moisture barrier, if specified, has been added to protect adjacent pavement or structures.
- Native soils at bottom of excavation are ripped or loosened to promote infiltration

Overflow or Surface Connection to Storm Drainage

(to be confirmed prior to backfilling with any materials)

- Overflow is at specified elevation
- No knockouts or side inlets are in overflow riser
- Overflow location selected to minimize surface flow velocity (near, but offset from, inlet recommended)
- Grating excludes mulch and litter (beehive or atrium-style grates with ¼" openings recommended)
- Overflow is connected to storm drain via appropriately sized piping

Underground connection to storm drain/outlet orifice

(to be confirmed prior to backfilling with any materials)

- Perforated pipe underdrain (PVC SDR 35 or approved equivalent) is installed with holes facing down
- Perforated pipe is connected to storm drain at specified elevation (typ. bottom of soil elevation)
- Cleanouts are in accessible locations and connected via sweep bends

Drain Rock/Subdrain (to be confirmed prior to installation of soil mix)

- Rock is installed as specified, 12" min. depth. Class 2 permeable, Caltrans specification 68-2.02F(3) recommended
- Rock is smoothed to a consistent top elevation. Depth and top elevation are as shown in plans
- Slopes or side walls protect from sloughing of native soils into the facility
- No filter fabric is placed between the subdrain and soil mix layers

Soil Mix

- Soil mix is as specified.
- Mix installed in lifts not exceeding 12"
- Mix is not compacted during installation but may be thoroughly wetted to encourage consolidation
- Mix is smoothed to a consistent top elevation. Depth of mix (18" min.) and top elevation are as shown in plans, accounting for depth of mulch to follow and required reservoir depth

Irrigation

- Irrigation system is installed so it can be controlled separately from other landscaped areas. Smart irrigation controllers and drip emitters are recommended and may be required by local code or ordinance.
- Spray heads, if any, are positioned to avoid direct spray into outlet structures

Planting

- Plants are installed consistent with approved planting plan, consistent with site water allowance
- Any trees and large shrubs are staked securely
- No fertilizer is added; compost tea may be used
- No native soil or clayey material are imported into the facility with plantings
- 1"-2" mulch may be applied following planting; mulch selected to avoid floating
- Final elevation of soil mix maintained following planting
- Curb openings are free of obstructions

Final Engineering Inspection

- Drainage Management Area(s) are free of construction sediment and landscaped areas are stabilized
- Inlets are installed to provide smooth entry of runoff from adjoining pavement, have sufficient reveal (drop from the adjoining pavement to the top of the mulch or soil mix, and are not blocked)
- Inflows from roof leaders and pipes are connected and operable
- Temporary flow diversions are removed
- Rock or other energy dissipation at piped or surface inlets is adequate
- Overflow outlets are configured to allow the facility to flood and fill to near rim before overflow
- Plantings are healthy and becoming established
- Irrigation is operable
- Facility drains rapidly; no surface ponding is evident
- Any accumulated construction debris, trash, or sediment is removed from facility
- Permanent signage is installed and is visible to site users and maintenance personnel

VII. Construction Checklist

Stormwater Control Plan Page #	Source Control or Treatment Control Measure	See Plan Sheet #s
	Proprietary Bioretention Facilities (Modular Wetland)	SWCP Plan
	Proprietary Modular Pavement Support System (Silva Cell)	SWCP Plan

VIII. Certifications

The preliminary design of stormwater treatment facilities and other stormwater pollution control measures in this plan are in accordance with the current edition of the BASMAA *Post-Construction Manual*.

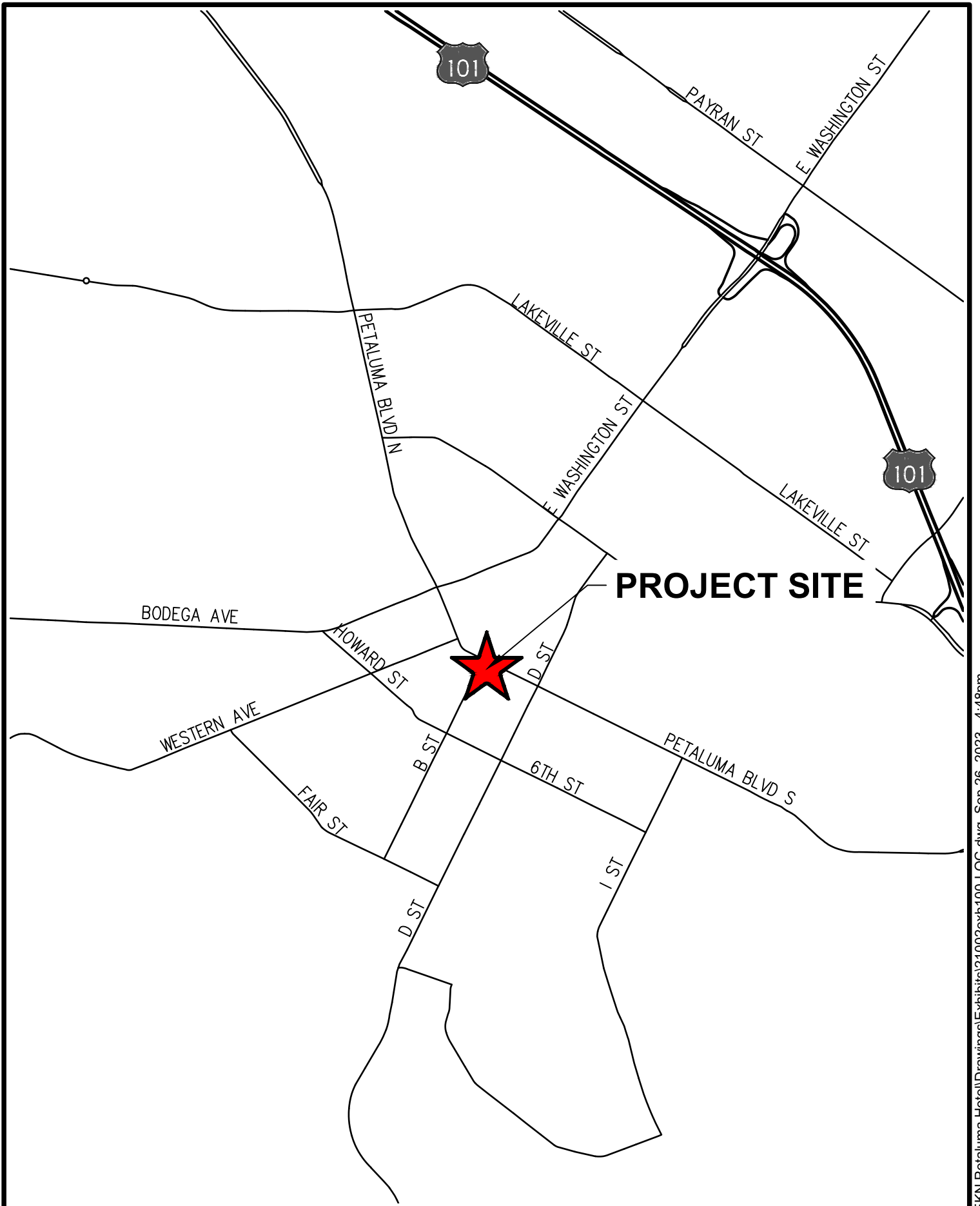

17780 FITCH
IRVINE, CA 92614
PHONE: 949.396.1161

LOCATION MAP

SCALE: 1" = 1500'
0 1500'



PROJECT SITE



17780 FITCH
IRVINE, CA 92614
PHONE: 949.396.1161

VICINITY MAP

SCALE: 1" = 200'
0  200'

NOT FOR CONSTRUCTION

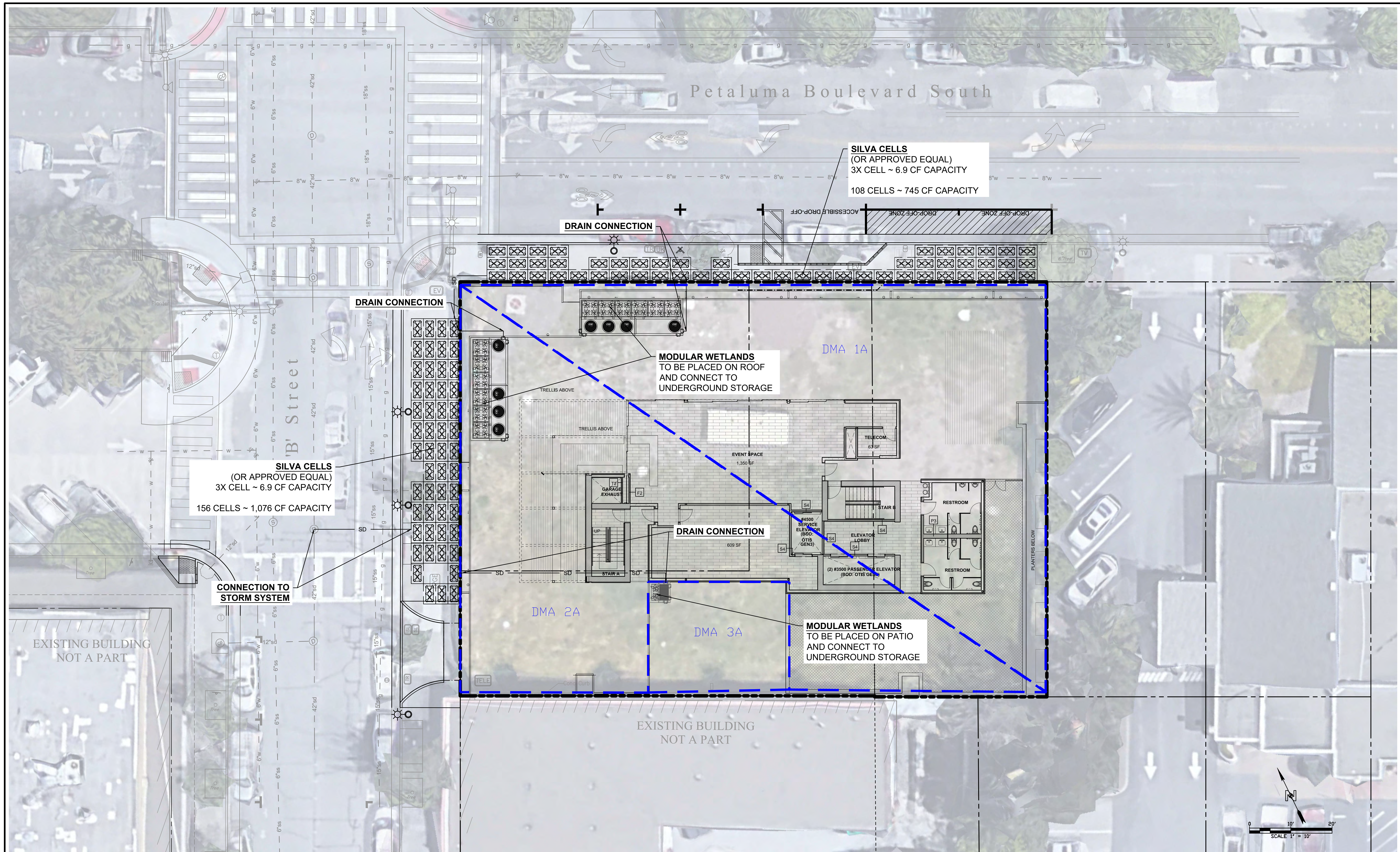

NO.	DATE	REVISION DESCRIPTION	BY	DATE

DIGALERT

 DIAL TOLL FREE
811
 AT LEAST TWO DAYS BEFORE YOU DIG
 UNDERGROUND SERVICE ALERT OF SOUTHERN CALIFORNIA

NOTICE TO CONTRACTOR:

- THE LOCATIONS OF EXISTING UTILITY INSTALLATIONS AS SHOWN ON THIS PLAN ARE APPROXIMATE. THERE MAY BE OTHER UNDERGROUND UTILITY INSTALLATIONS WITHIN THE PROJECT AREA THAT ARE NOT SHOWN.
- N CONSULTING ASSUMES NO RESPONSIBILITY FOR DAMAGES, LIABILITY OR COSTS RESULTING FROM CHANGES OR ALTERATIONS MADE TO THIS PLAN WITHOUT THE EXPRESSED WRITTEN CONSENT OF N CONSULTING.

SURVEYOR'S BENCHMARK:
 FOUND 3" BRASS DISK SET IN THE TOP OF A SANDSTONE WALL AT THE FOURTH STREET POST OFFICE, 0.3' ABOVE THE GROUND, STAMPED "12.045 JJ 107 1932", ELEVATION=15.20', NAVD88 DATUM (PER NGS DATASHEET). A CONVERSION FACTOR OF -2.795 SHOULD BE USED TO CONVERT NAVD88 ELEVATIONS TO NGVD29 ELEVATION.

BASIS OF BEARINGS:
 192 MAPS 26, SCR.

N CONSULTING ENGINEERS

 17780 Filch
 Irvine, CA 92614
 PHONE: 949.396.1161
 www.nconsulteng.com

ISSUE: ---
 PROJECT ADDRESS:
 2 PETALUMA BLVD
 PETALUMA, CA 94952
 CLIENT:
 EKN DEVELOPMENT GROUP
 220 NEWPORT CENTER DRIVE, SUITE 11-262
 NEWPORT BEACH, CA 92660

SITE:
EKN PETALUMA
 TITLE:
STORMWATER CONTROL PLAN
 DRAWN: S.S. SCALE AT D: 1" = 10' DATE: 9/26/2023 PROJECT NO: 21-002
 CHECKED: D.H.K. REV: --- COUNT: 1 OF 2 SHEETS SHEET: EXH110

C:\Users\Steven\OneDrive\Documents\Projects\2023\21-002\21-002\21-002\21-002.dwg Sep 26, 2023 - 5:38pm

NOT FOR CONSTRUCTION

SITE SPECIFIC DATA			
PROJECT NUMBER			
PROJECT NAME			
PROJECT LOCATION			
STRUCTURE ID			
TREATMENT REQUIRED			
FLOW BASED (CFS)			
0.052			
PEAK BYPASS REQUIRED (CFS) - IF APPLICABLE		OFFLINE	
PIPE DATA	I.E.	MATERIAL	DIAMETER
INLET PIPE 1			
INLET PIPE 2	N/A	N/A	N/A
OUTLET PIPE			
	PRETREATMENT	BIOFILTRATION	DISCHARGE
RIM ELEVATION			
SURFACE LOAD	PEDESTRIAN		
NOTES:			
* PRELIMINARY NOT FOR CONSTRUCTION			

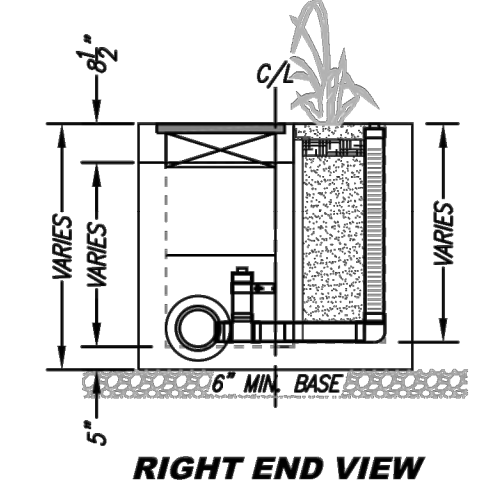
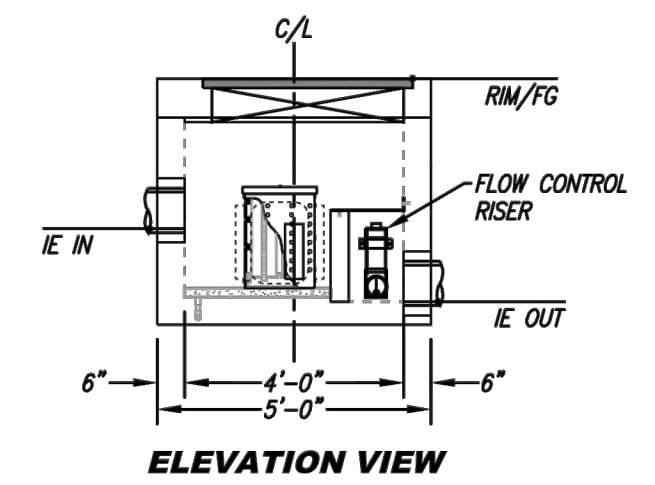
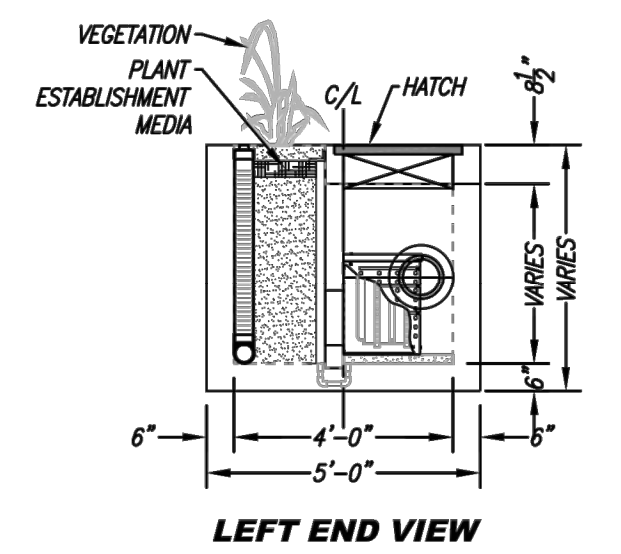
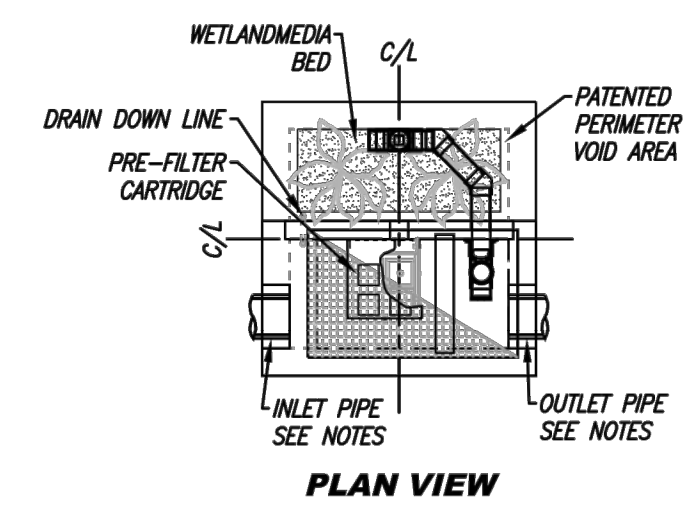

TREATMENT FLOW (CFS)	0.052
OPERATING HEAD (FT)	3.4
PRETREATMENT LOADING RATE (GPM/SF)	1.8
WETLAND MEDIA LOADING RATE (GPM/SF)	1.0

MWS-L-4-4-V
 STORMWATER BIOFILTRATION SYSTEM
 STANDARD DETAIL

- INSTALLATION NOTES**
- CONTRACTOR TO PROVIDE ALL LABOR, EQUIPMENT, MATERIALS AND INCIDENTALS REQUIRED TO OFFLOAD AND INSTALL THE SYSTEM AND APPURTENANCES IN ACCORDANCE WITH THIS DRAWING AND THE MANUFACTURER'S SPECIFICATIONS, UNLESS OTHERWISE STATED IN MANUFACTURER'S CONTRACT.
 - UNIT MUST BE INSTALLED ON LEVEL BASE. MANUFACTURER RECOMMENDS A MINIMUM 6" LEVEL ROCK BASE UNLESS SPECIFIED BY THE PROJECT ENGINEER. CONTRACTOR IS RESPONSIBLE FOR VERIFYING PROJECT ENGINEER'S RECOMMENDED BASE SPECIFICATIONS.
 - CONTRACTOR TO SUPPLY AND INSTALL ALL EXTERNAL CONNECTING PIPES. ALL PIPES MUST BE FLUSH WITH INSIDE SURFACE OF CONCRETE (PIPES CANNOT INTRUDE BEYOND FLUSH). INVERT OF OUTFLOW PIPE MUST BE FLUSH WITH DISCHARGE CHAMBER FLOOR. ALL PIPES SHALL BE SEALED WATER-TIGHT PER MANUFACTURER'S STANDARD CONNECTION DETAIL.
 - CONTRACTOR RESPONSIBLE FOR INSTALLATION OF ALL PIPES, RISERS, MANHOLES, AND HATCHES. CONTRACTOR TO USE GROUT AND/OR BRICKS TO MATCH COVERS WITH FINISHED SURFACE UNLESS SPECIFIED OTHERWISE.
 - VEGETATION SUPPLIED AND INSTALLED BY OTHERS. ALL UNITS WITH VEGETATION MUST HAVE DRIP OR SPRAY IRRIGATION SUPPLIED AND INSTALLED BY OTHERS.
 - CONTRACTOR RESPONSIBLE FOR CONTACTING CONTECH FOR ACTIVATION OF UNIT. MANUFACTURER'S WARRANTY IS VOID WITHOUT PROPER ACTIVATION BY A CONTECH REPRESENTATIVE.

- GENERAL NOTES**
- MANUFACTURER TO PROVIDE ALL MATERIALS UNLESS OTHERWISE NOTED.
 - ALL DIMENSIONS, ELEVATIONS, SPECIFICATIONS AND CAPACITIES ARE SUBJECT TO CHANGE. FOR PROJECT SPECIFIC DRAWINGS DETAILING EXACT DIMENSIONS, WEIGHTS AND ACCESSORIES PLEASE CONTACT CONTECH.

SITE SPECIFIC DATA			
PROJECT NUMBER			
PROJECT NAME			
PROJECT LOCATION			
STRUCTURE ID			
TREATMENT REQUIRED			
OPERATING HEAD (FT)			
PRETREATMENT LOADING RATE (GPM/SF)			
WETLAND MEDIA LOADING RATE (GPM/SF)			
PEAK BYPASS REQUIRED (CFS) - IF APPLICABLE		OFFLINE	
PIPE DATA	I.E.	MATERIAL	DIAMETER
INLET PIPE 1			
INLET PIPE 2			
OUTLET PIPE			
	PRETREATMENT	BIOFILTRATION	DISCHARGE
RIM ELEVATION			
SURFACE LOAD	PEDESTRIAN		
NOTES:			

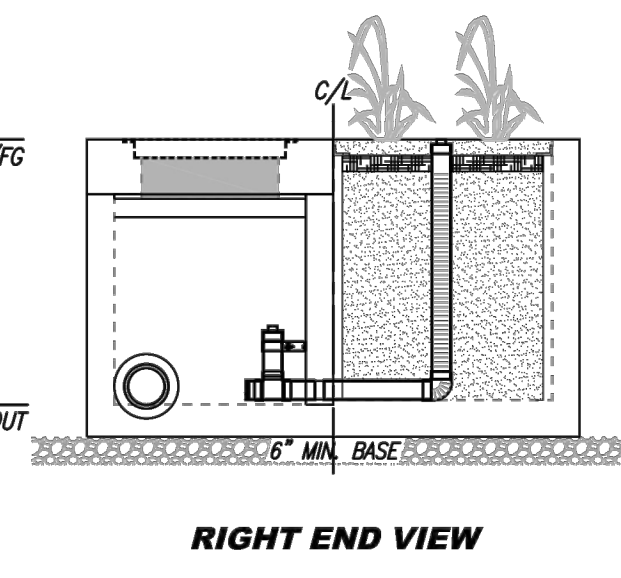
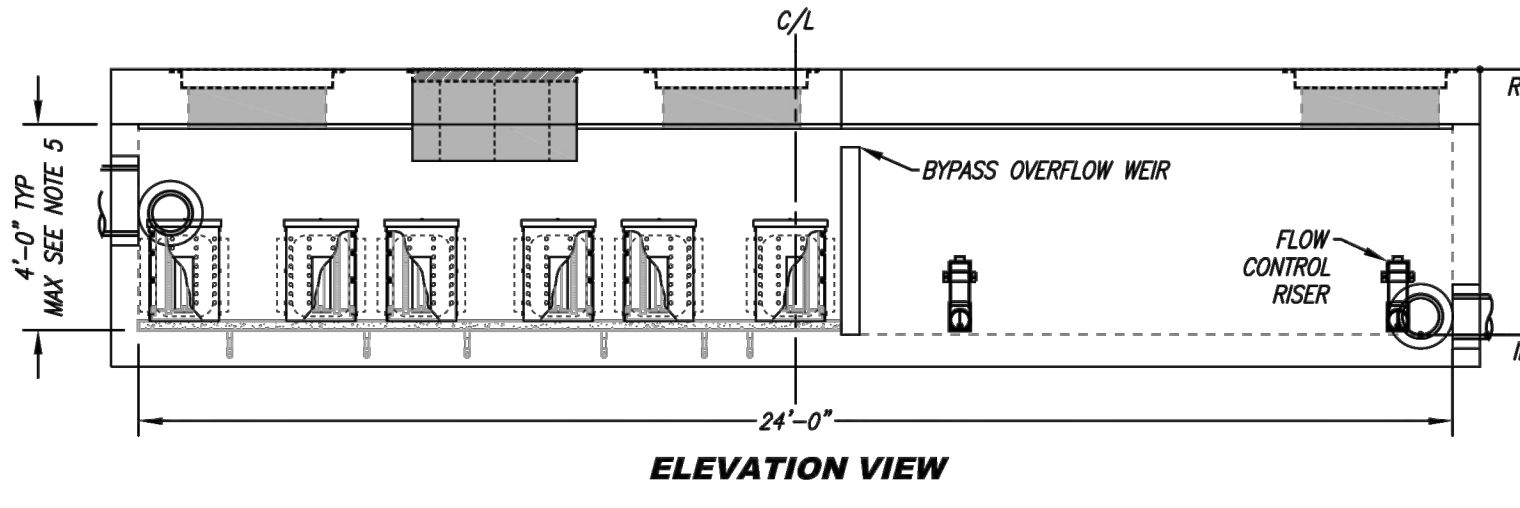
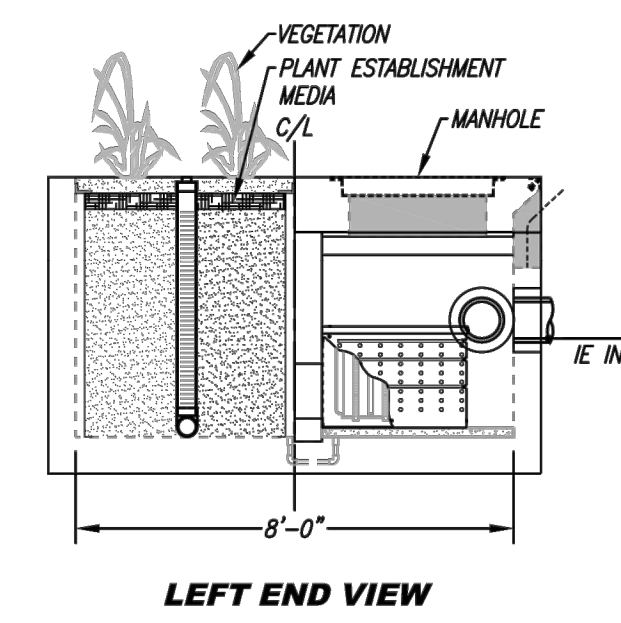
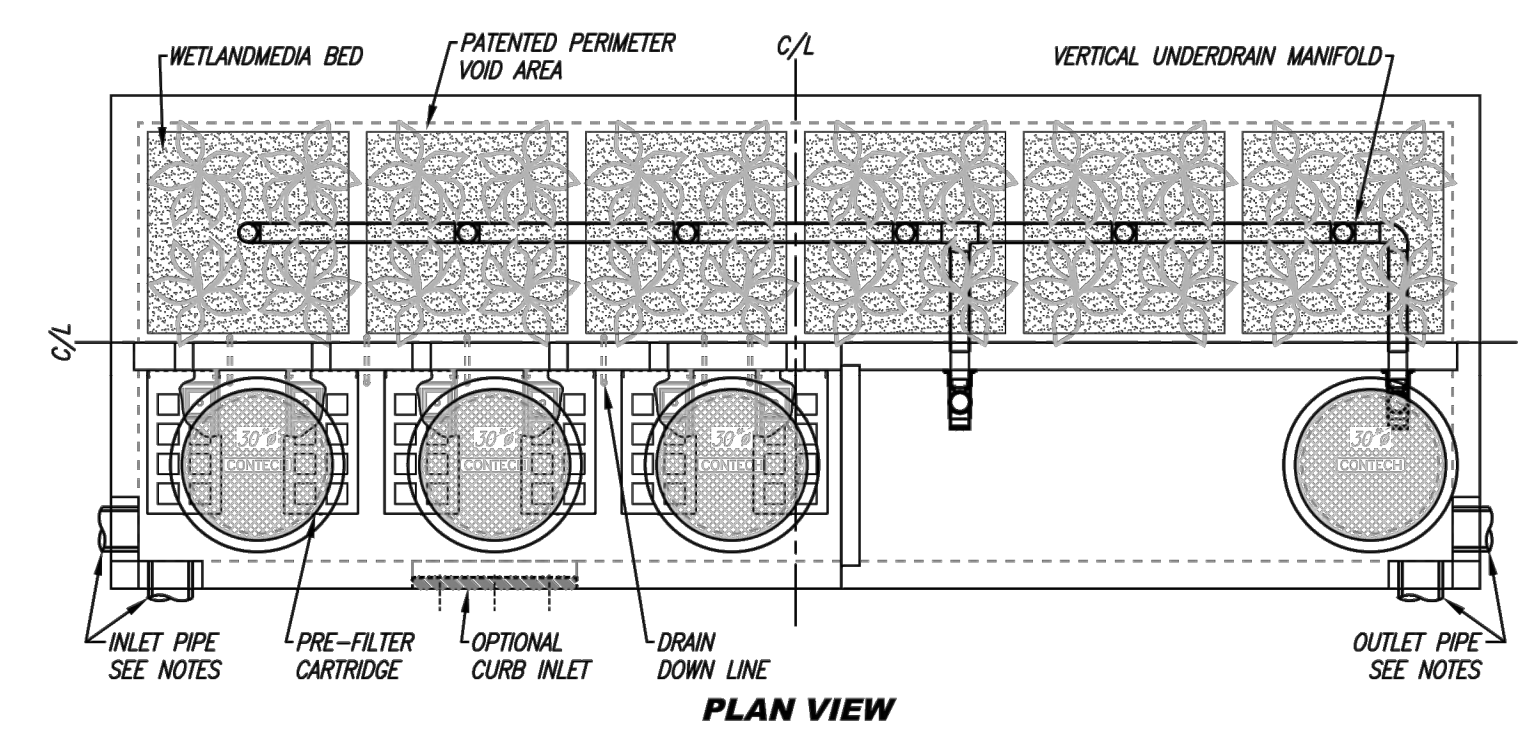

- INSTALLATION NOTES**
- CONTRACTOR TO PROVIDE ALL LABOR, EQUIPMENT, MATERIALS AND INCIDENTALS REQUIRED TO OFFLOAD AND INSTALL THE SYSTEM AND APPURTENANCES IN ACCORDANCE WITH THIS DRAWING AND THE MANUFACTURER'S SPECIFICATIONS, UNLESS OTHERWISE STATED IN MANUFACTURER'S CONTRACT.
 - UNIT MUST BE INSTALLED ON LEVEL BASE. MANUFACTURER RECOMMENDS A MINIMUM 6" LEVEL ROCK BASE UNLESS SPECIFIED BY THE PROJECT ENGINEER. CONTRACTOR IS RESPONSIBLE FOR VERIFYING PROJECT ENGINEER'S RECOMMENDED BASE SPECIFICATIONS.
 - CONTRACTOR TO SUPPLY AND INSTALL ALL EXTERNAL CONNECTING PIPES. ALL PIPES MUST BE FLUSH WITH INSIDE SURFACE OF CONCRETE (PIPES CANNOT INTRUDE BEYOND FLUSH). INVERT OF OUTFLOW PIPE MUST BE FLUSH WITH DISCHARGE CHAMBER FLOOR. ALL PIPES SHALL BE SEALED WATER-TIGHT PER MANUFACTURER'S STANDARD CONNECTION DETAIL.
 - CONTRACTOR RESPONSIBLE FOR CONTACTING CONTECH FOR ACTIVATION OF UNIT. MANUFACTURER'S WARRANTY IS VOID WITHOUT PROPER ACTIVATION BY A CONTECH REPRESENTATIVE.
 - VERTICAL HEIGHT VARIES BASED ON SITE SPECIFIC REQUIREMENTS.

MWS-L-8-24-V
 STORMWATER BIOFILTRATION SYSTEM
 STANDARD DETAIL

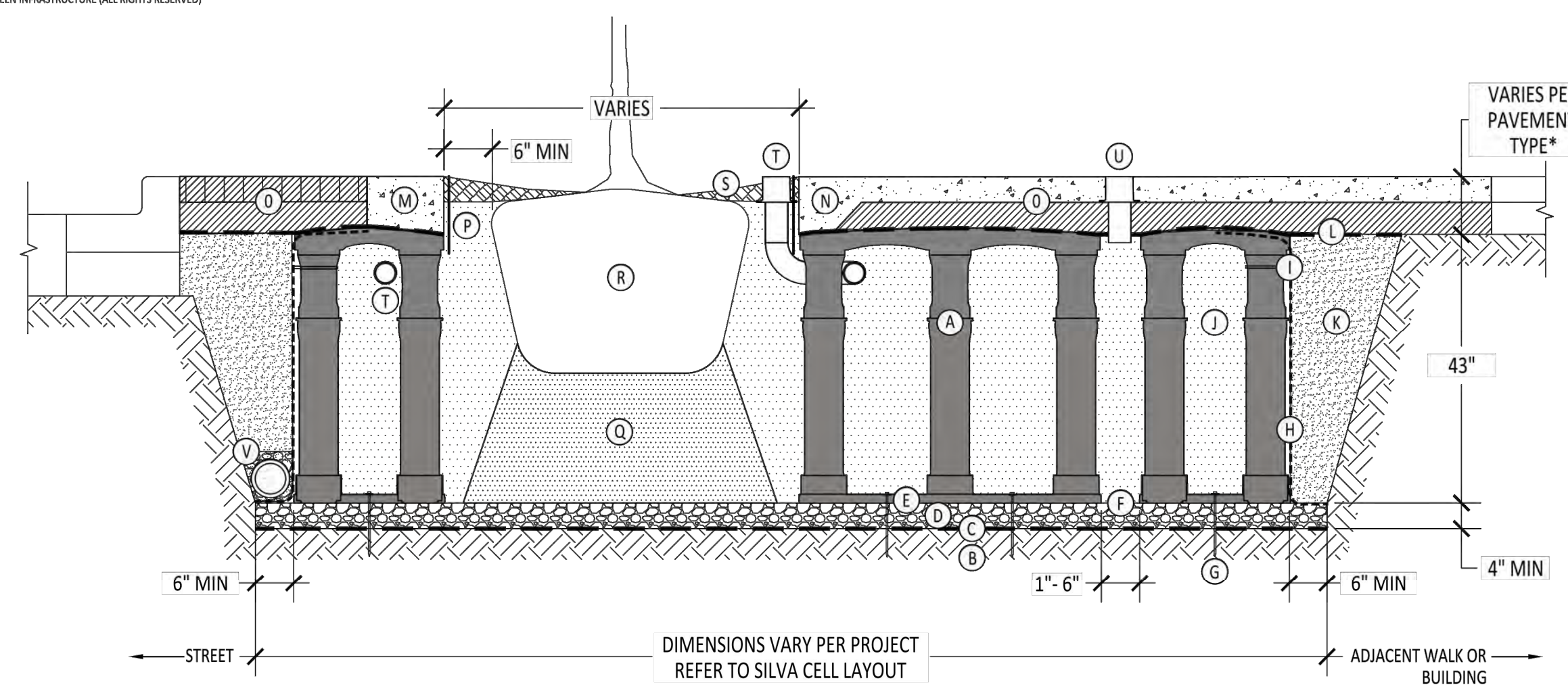

- SILVA CELL SYSTEM 3X**
NOT TO SCALE
- KEY PLAN**
- (A) SILVA CELL SYSTEM (DECK, BASE, AND POSTS)
 - (B) SUBGRADE, COMPACTED
 - (C) GEOTEXTILE FABRIC, PLACED ABOVE SUBGRADE
 - (D) 4" MIN AGGREGATE SUB BASE, COMPACTED TO 95% PROCTOR
 - (E) SILVA CELL BASE SLOPE, 10% MAX
 - (F) 1" TO 6" SPACING BETWEEN SILVA CELLS AT BASE
 - (G) ANCHORING SPIKES, CONTACT DEEPROOT FOR ALTERNATIVE
 - (H) GEOGRID, WRAPPED AROUND PERIMETER OF SYSTEM, WITH 6" TOE (OUTWARD FROM BASE) AND 12" EXCESS (OVER TOP OF DECK)
 - (I) CABLE TIE, ATTACHING GEOGRID TO SILVA CELL AT BASE OF UPPER LEG FLARE, AS NEEDED
 - (J) PLANTING SOIL, PER PROJECT SPECIFICATIONS, PLACED IN LIFTS AND WALK-IN COMPACTED TO 75-85% PROCTOR
 - (K) COMPACTED BACKFILL, PER PROJECT SPECIFICATIONS
 - (L) GEOTEXTILE FABRIC TO EDGE OF EXCAVATION
 - (M) RIBBON CURB AT TREE OPENING (TO BE USED WITH PAVERS OR ASPHALT)
 - (N) THICKENED EDGE AT TREE OPENING (TO BE USED WITH CONCRETE)
 - (O) PAVEMENT AND AGGREGATE BASE PER PROJECT *
 - (P) DEEPROOT ROOT BARRIER, 12" OR 18", DEPTH DETERMINED BY THICKNESS OF PAVEMENT SECTION, INSTALL DIRECTLY ADJACENT TO CONCRETE EDGE RESTRAINT
 - (Q) PLANTING SOIL BELOW ROOT BALL, COMPACTED WELL TO PREVENT SETTLING
 - (R) ROOT BALL
 - (S) TREE OPENING TREATMENT, PER PROJECT SPECIFICATIONS
 - (T) DEEPROOT WATER AND AIR VENT, ROOTBALL, WHEN REQUIRED
 - (U) DEEPROOT WATER AND AIR VENT, WHEN REQUIRED
 - (V) UNDERDRAIN SYSTEM, WHEN REQUIRED (LOCATION AND DETAILS BY OTHERS)
- NOTES**
- EXCAVATION SHALL BE DONE IN ACCORDANCE WITH ALL APPLICABLE HEALTH AND SAFETY REGULATIONS
 - INSTALLATION TO BE COMPLETED IN ACCORDANCE WITH MANUFACTURER'S SPECIFICATIONS
 - PROVIDE SUPPLEMENTAL IRRIGATION
 - DO NOT SCALE DRAWINGS
- *MINIMUM PAVEMENT PROFILE OPTIONS TO MEET H-20 LOADING**
- | | |
|---------------|-------------------------|
| PAVEMENT | + AGGREGATE BASE COURSE |
| 4" CONCRETE | + 4" AGGREGATE |
| 3" PAVEMENT | + 12" AGGREGATE |
| 4" ASPHALT | + 12" AGGREGATE |
| 2.6" PAVEMENT | + 5" CONCRETE |

DeepRoot Green Infrastructure
 www.deeproot.com
 T 415 781 9700
 F 415 781 0191

SILVA CELL SYSTEM 3X

NOT TO SCALE FEET

NO.	DATE	REVISION DESCRIPTION	BY	DATE

DIGALERT
 DIAL TOLL FREE
811
 AT LEAST TWO DAYS BEFORE YOU DIG
 UNDERGROUND SERVICE ALERT OF SOUTHERN CALIFORNIA

NOTICE TO CONTRACTOR:

- THE LOCATIONS OF EXISTING UTILITY INSTALLATIONS AS SHOWN ON THIS PLAN ARE APPROXIMATE. THERE MAY BE OTHER UNDERGROUND UTILITY INSTALLATIONS WITHIN THE PROJECT AREA THAT ARE NOT SHOWN.
- N CONSULTING ASSUMES NO RESPONSIBILITY FOR DAMAGES, LIABILITY OR COSTS RESULTING FROM CHANGES OR ALTERATIONS MADE TO THIS PLAN WITHOUT THE EXPRESSED WRITTEN CONSENT OF N CONSULTING.

SURVEYOR'S BENCHMARK:
FOUND 3" BRASS DISK SET IN THE TOP OF A SANDSTONE WALL AT THE FOURTH STREET POST OFFICE, 0.3' ABOVE THE GROUND, STAMPED "12.045 JJ 107 1932". ELEVATION=15.20', NAVD88 DATUM (PER NGS DATASHEET). A CONVERSION FACTOR OF -2.795 SHOULD BE USED TO CONVERT NAVD88 ELEVATIONS TO NGVD29 ELEVATION.

BASIS OF BEARINGS:
192 MAPS 26, SCR.

N CONSULTING ENGINEERS
 17780 Filch
 Irvine, CA 92614
 PHONE: 949.396.1161
 www.nconsulting.com

ISSUE: ---
PROJECT ADDRESS:
 2 PETALUMA BLVD
 PETALUMA, CA 94952
CLIENT:
 EKN DEVELOPMENT GROUP
 220 NEWPORT CENTER DRIVE, SUITE 11-262
 NEWPORT BEACH, CA 92660

SITE: EKN PETALUMA			
TITLE: BMP DETAILS			
DRAWN: S.S.	SCALE AT D: N.T.S.	DATE: 9/26/2023	PROJECT NO: 21-002
CHECKED: D.H.K.	REV: ---	COUNT: 2 OF 2 SHEETS	SHEET: EXH110

C:\Users\Steven.Solis\AppData\Local\Temp\AcPublish_2508421002exh110-BMPs.dwg Sep 26, 2023 - 5:39pm