

Project Specific Water Quality Management Plan (Preliminary)

For: **Brown Strauss Steel--Banning**

1431 and 1210 West Lincoln Street
Banning, CA 92220
APN 540-180-020, 022, & 026

DEVELOPMENT NO. DR 23-7008
DESIGN REVIEW NO. TBD

Prepared for:

Brown Strauss, Inc.
2495 Uravan Street
Aurora, CO 80011
Telephone: (310) 694-1001

Prepared by:

J.T. Stanton P.E.
Joseph E. Bonadiman & Associates, Inc.
234 North Arrowhead Avenue
San Bernardino, CA 92408
Telephone: (909) 885-3806

Original Date Prepared: March 2023

Revision Date(s): October 2023

OWNER'S CERTIFICATION

This project-specific Water Quality Management Plan (WQMP) has been prepared for:

Brown Strauss, Inc.
2495 Uravan Street
Aurora, CO 80011
Telephone: (310) 694-1001

This WQMP is intended to comply with the requirements of **The City of Banning** for **Brown Strauss Steel DR 23-7008**, which includes the requirement for the preparation and implementation of a project-specific WQMP.

The undersigned, while owning the property/project described in the preceding paragraph, shall be responsible for the implementation of this WQMP and will ensure that this WQMP is amended as appropriate to reflect up-to-date conditions on the site. This WQMP will be reviewed with the facility operator, facility supervisors, employees, tenants, maintenance and service contractors, or any other party (or parties) having responsibility for implementing portions of this WQMP. At least one copy of this WQMP will be maintained at the project site or project office in perpetuity.

The undersigned is authorized to certify and to approve implementation of this WQMP. The undersigned is aware that implementation of this WQMP is enforceable under **The City of Banning** Water Quality Ordinance (Municipal Code Section No. 1415 Sec.6).

If the undersigned transfers its interest in the subject property/project, the undersigned shall notify the successor in interest of its responsibility to implement this WQMP.

"I, the undersigned, certify under penalty of law that I am the owner of the property that is the subject of this WQMP, and that the provisions of this WQMP have been reviewed and accepted and that the WQMP will be transferred to future successors in interest."



Owner's Signature

Kris Farris

Owner's Printed Name

President & COO

Owner's Title/Position

11/9/2023

Date

2495 Uravan Street

Aurora, CO 80011

(310) 694-1001

ATTEST

Notary Signature

Printed Name

Title/Position

Date

THIS FORM SHALL BE NOTARIZED BEFORE ACCEPTANCE OF THE
FINAL PROJECT SPECIFIC WQMP

October 2023

Contents

| <u>SECTION</u> | <u>PAGE</u> |
|--|-------------|
| I. Project Description..... | 1 |
| II. Site Characterization | 4 |
| III. Pollutants of Concern..... | 6 |
| IV. Hydrologic Conditions of Concern | 7 |
| V. Best Management Practices..... | 8 |
| V.1 SITE DESIGN BMP CONCEPTS, LID/SITE DESIGN AND TREATMENT CONTROL BMPs..... | 8 |
| V.1.A SITE DESIGN BMP CONCEPTS AND LID/SITE DESIGN BMPs..... | 10 |
| V.1.B TREATMENT CONTROL BMPs | 17 |
| V.1.C MEASURABLE GOAL SUMMARY | 19 |
| V.2 SOURCE CONTROL BMPs | 20 |
| V.3 EQUIVALENT TREATMENT CONTROL BMP ALTERNATIVES | 23 |
| V.4 REGIONALLY-BASED BMPs | 23 |
| VI. Operation and Maintenance Responsibility for BMPs | 24 |
| VII. Funding | 26 |

TABLES

| | |
|--|----|
| TABLE 1. POLLUTANT OF CONCERN SUMMARY | 6 |
| TABLE 2. BMP SELECTION MATRIX BASED UPON POLLUTANT OF CONCERN REMOVAL EFFICIENCY | 9 |
| TABLE 3. IMPLEMENTATION OF SITE DESIGN BMP CONCEPTS | 11 |
| TABLE 4. LID/SITE DESIGN BMPs MEETING THE LID/SITE DESIGN MEASURABLE GOAL | 16 |
| TABLE 5: TREATMENT CONTROL BMP SUMMARY | 18 |
| TABLE 6: MEASURABLE GOAL SUMMARY | 19 |
| TABLE 7. SOURCE CONTROL BMPs | 20 |

APPENDICES

| | |
|---|--|
| A. CONDITIONS OF APPROVAL | |
| B. VICINITY MAP, WQMP SITE PLAN, AND RECEIVING WATERS MAP | |
| C. SUPPORTING DETAIL RELATED TO HYDROLOGIC CONDITIONS OF CONCERN (IF APPLICABLE) | |
| D. EDUCATIONAL MATERIALS | |
| E. SOILS REPORT (IF APPLICABLE) | |
| F. STRUCTURAL BMP AND/OR RETENTION FACILITY SIZING CALCULATIONS AND DESIGN DETAILS | |
| G. AGREEMENTS – CC&Rs, COVENANT AND AGREEMENTS, BMP MAINTENANCE AGREEMENTS AND/OR OTHER MECHANISMS FOR ENSURING ONGOING OPERATION, MAINTENANCE, FUNDING AND TRANSFER OF REQUIREMENTS FOR THIS PROJECT-SPECIFIC WQMP | |
| H. PHASE 1 ENVIRONMENTAL SITE ASSESSMENT – SUMMARY OF SITE REMEDIATION CONDUCTED AND USE RESTRICTIONS | |
| I. PROJECT-SPECIFIC WQMP SUMMARY DATA FORM | |

I. Project Description

Project Owner: Brown Strauss, Inc.
2495 Uravan Street
Aurora, CO 80011
(310) 694-1001

WQMP Preparer: J.T. Stanton P.E.
234 North Arrowhead Avenue
San Bernardino, CA 92408
(909) 885-3806

Project Site Address: **1431 and 1210 West Lincoln Street**
Banning, CA 92220

Planning Area/
Community Name/
Development Name: **Brown Strauss Steel--Banning**

APN Number(s): 540-180-020, 022, & 026

Latitude & Longitude: 33.922445, -116.891147

Receiving Water: Smith Creek

Project Site Size: 14.27 Acres

Standard Industrial Classification (SIC) Code: 5051

Formation of Home Owners' Association (HOA)
or Property Owners Association (POA): Y N

Additional Permits/Approvals required for the Project:

| AGENCY | Permit required |
|---|--|
| State Department of Fish and Wildlife, Fish and Game Code §1602 Streambed Alteration Agreement | Y <input type="checkbox"/> N <input checked="" type="checkbox"/> |
| State Water Resources Control Board, Clean Water Act (CWA) Section 401 Water Quality Certification | Y <input type="checkbox"/> N <input checked="" type="checkbox"/> |
| US Army Corps of Engineers, CWA Section 404 permit | Y <input type="checkbox"/> N <input checked="" type="checkbox"/> |
| US Fish and Wildlife, Endangered Species Act Section 7 biological opinion | Y <input type="checkbox"/> N <input checked="" type="checkbox"/> |
| Statewide Construction General Permit Coverage | Y <input checked="" type="checkbox"/> N <input type="checkbox"/> |
| Statewide Industrial General Permit Coverage | Y <input checked="" type="checkbox"/> N <input type="checkbox"/> |
| Other <i>(please list in the space below as required)</i> City of Banning Grading, Construction, & Encroachment Permits. | |

The existing project location is an empty vacant lot. The proposed project includes a new building, material storage yard, parking lot and landscaping on a vacant lot. The storm water runoff will be treated via vortex sporators and an underground infiltration system. The total area of the site is 621,431 s.f. /14.27 acres.

Appendix A of this project-specific WQMP includes a complete copy of the final Conditions of Approval. Appendix B of this project-specific WQMP includes:

- a. A Vicinity Map identifying the project site and surrounding planning areas in sufficient detail; and
- b. A Site Plan for the project. The Site Plan included as part of Appendix B depicts the following project features:
 - Location and identification of all structural BMPs, including Source Control, LID/Site Design and Treatment Control BMPs.
 - Landscaped areas.
 - Paved areas and intended uses (i.e., parking, outdoor work area, outdoor material storage area, sidewalks, patios, tennis courts, etc.).
 - Number and type of structures and intended uses (i.e., buildings, tenant spaces, dwelling units, community facilities such as pools, recreation facilities, tot lots, etc.).
 - Infrastructure (i.e., streets, storm drains, etc.) that will revert to public agency ownership and operation.
 - Location of existing and proposed public and private storm drainage facilities (i.e., storm drains, channels, basins, etc.), including catch basins and other inlets/outlet structures. Existing and proposed drainage facilities should be clearly differentiated.
 - Location(s) of Receiving Waters to which the project directly or indirectly discharges.
 - Location of points where onsite (or tributary offsite) flows exit the property/project site.
 - Delineation of proposed drainage area boundaries, including tributary offsite areas, for each location where flows exit the project site and existing site (where existing site flows are required to be addressed). Each tributary area should be clearly denoted.
 - Pre- and post-project topography.

Appendix I is a one page form that summarizes pertinent information relative to this project-specific WQMP.

II. Site Characterization

Land Use Designation or Zoning: **Industrial**

Current Property Use: **Vacant**

Proposed Property Use: **Steel Material Storage Yard**

Availability of Soils Report: Y N *Note: A soils report is required if infiltration BMPs are utilized. Attach report in Appendix E.*

Phase 1 Site Assessment: Y N *Note: If prepared, attached remediation summary and use restrictions in Appendix H.*

Receiving Waters for Urban Runoff from Site

| Receiving Waters | EPA Approved 303(d) List Impairments | Designated Beneficial Uses | Proximity to RARE Beneficial Use Designated Receiving Waters |
|--------------------------------|---|--|--|
| | | | |
| San Gorgonio River | N/A | MUN (Potential), AGR, GWR, REC I, REC II, COLD, WILD | N/A |
| Whitewater River | N/A | MUN, AGR, GWR, REC I, REC II, WARM (Intermittent), COLD, WILD, POW | N/A |
| Coachella Valley Storm Channel | DDT, Dieldrin, Indicator Bacteria, Nitrogen-ammonia, PCBs, Toxaphene, Toxicity (unknown) | FRSH, REC I, REC II, WARM, WILD, RARE | 49.00 Miles |
| Salton Sea | Arsenic, Chloride, Chlorpyrifos, DDT, Enterococcus, Low Dissolved Oxygen, Nitrogen-ammonia, Nutrients, Salinity, Toxicity | AQUA, IND (Potential), REC I, REC II, WARM, WILD, RARE | 68.94 Miles |

III. Pollutants of Concern

Table 1. Pollutant of Concern Summary

| Pollutant Category | Potential for Project and/or Existing Site | Causing Receiving Water Impairment | Additional Information and Comments |
|----------------------------|---|---|---|
| Bacteria/Virus | Yes | Yes | Potential source includes animal waste. Bacteria is common in parking lot runoff. |
| Heavy Metals | Yes | No | Potential source include brake pad and tire wear associated with driving. |
| Nutrients | Yes | Yes | Potential source include fertilizers and eroded soils. |
| Toxic Organic Compounds | Yes | Yes | Potential source include solvents and cleaning compounds. |
| Sediment/Turbidity | Yes | No | Potential source include eroded soils. |
| Trash & Debris | Yes | No | Potential source include paper, plastic, and aluminum materials. |
| Oil & Grease | Yes | No | Potential source include petroleum hydrocarbon products and motor products. |
| Other (specify pollutant): | N/A | N/A | N/A |
| Other (specify pollutant): | N/A | N/A | N/A |

IV. Hydrologic Conditions of Concern

Local Jurisdiction Requires On-Site Retention of Urban Runoff:

- Yes The project will be required to retain urban runoff onsite in conformance with local ordinance (See Table 6 of the WQMP Guidance document, "Local Land use Authorities Requiring Onsite Retention of Stormwater"). This section does not need to be completed; however, retention facility design details and sizing calculations must be included in Appendix F.
- No This section must be completed.

This Project meets the following condition:

- Condition A:** 1) Runoff from the Project is discharged directly to a publicly-owned, operated and maintained MS4 or engineered and maintained channel, 2) the discharge is in full compliance with local land use authority requirements for connections and discharges to the MS4 (including both quality and quantity requirements), 3) the discharge would not significantly impact stream habitat in proximate Receiving Waters, **and** 4) the discharge is authorized by the local land use authority.
- Condition B:** The project disturbs less than 1 acre and is not part of a larger common plan of development that exceeds 1 acre of disturbance. The disturbed area calculation must include all disturbances associated with larger plans of development.
- Condition C:** The project's runoff flow rate, volume, velocity and duration for the post-development condition do not exceed the pre-development condition for the 2-year, 24-hour and 10-year 24-hour rainfall events. This condition can be achieved by, where applicable, complying with the local land use authority's on-site retention ordinance, or minimizing impervious area on a site and incorporating other Site-Design BMP concepts and LID/Site Design BMPs that assure non-exceedance of pre-development conditions. This condition must be substantiated by hydrologic modeling methods acceptable to the local land use authority.
- None:** Refer to Section 3.4 of the Whitewater River Region WQMP Guidance document for additional requirements.

Supporting engineering studies, calculations, and reports are included in Appendix C.

| | 2 year – 24 hour | | 10 year – 24 hour | |
|---------------------|------------------|----------------|-------------------|----------------|
| | Precondition | Post-condition | Precondition | Post-condition |
| Discharge (cfs) | | | | |
| Velocity (fps) | | | | |
| Volume (cubic feet) | | | | |
| Duration (minutes) | | | | |

V. Best Management Practices

This project implements Best Management Practices (BMPs) to address the Pollutants of Concern that may potentially be generated from the use of the Project Site. These BMPs have been selected and implemented to comply with Section 3.5 of the WQMP Guidance document, and consist of Site Design BMP concepts, Source Control, LID/Site Design and, if/where necessary, Treatment Control BMPs as described herein.

V.1 SITE DESIGN BMP CONCEPTS, LID/SITE DESIGN AND TREATMENT CONTROL BMPs

Local Jurisdiction Requires On-Site Retention of Urban Runoff:

Yes The project will be required to retain Urban Runoff onsite in conformance with local ordinance (See Table 6 of the WQMP Guidance document, "Local Land use Authorities Requiring Onsite Retention of Stormwater). **The LID/Site Design measurable goal has thus been met (100%), and Sections V.1.A and V.1.B do not need to be completed;** however, retention facility design details and sizing calculations must be included in Appendix F, and '100%' should be entered into Column 3 of Table 6 below.

No Section V.1 must be completed.

This section of the Project-Specific WQMP documents the LID/Site Design BMPs and, if/where necessary, the Treatment Control BMPs that will be implemented on the project to meet the requirements detailed within Section 3.5.1 of the WQMP Guidance document. Section 3.5.1 includes requirements to implement Site Design Concepts and BMPs, and includes requirements to address Pollutants of Concern with BMPs. Further, sub-section 3.5.1.1 specifically requires that Pollutants of Concern be addressed with LID/Site Design BMPs to the extent feasible.

LID/Site Design BMPs are those BMPs listed within Table 2 below which promote retention and/or feature a natural treatment mechanism; off-site and regionally-based BMPs are also LID/Site Design BMPs, and therefore count towards the measurable goal, if they fit these criteria. This project incorporates LID/Site Design BMPs to fully address the Treatment Control BMP requirement where and to the extent feasible. If and where it has been acceptably demonstrated to the local land use authority that it is infeasible to fully meet this requirement with LID/Site Design BMPs, Section V.1.B (below) includes a description of the conventional Treatment Control BMPs that will be substituted to meet the same requirements.

In addressing Pollutants of Concern, BMPs are selected using Table 2 below.

Table 2. BMP Selection Matrix Based Upon Pollutant of Concern Removal Efficiency ⁽¹⁾

(Sources: Riverside County Flood Control & Water Conservation District Design Handbook for Low Impact Development Best Management Practices, dated September 2011, the Orange County Technical Guidance Document for Water Quality Management Plans, dated May 19, 2011, and the Caltrans Treatment BMP Technology Report, dated April 2010 and April 2008)

| Pollutant of Concern | Landscape Swale ^{2,3} | Landscape Strip ^{2,3} | Biofiltration (with underdrain) ^{2,3} | Extended Detention Basin ² | Sand Filter Basin ² | Infiltration Basin ² | Infiltration Trench ² | Permeable Pavement ² | Bioretention (w/o underdrain) ^{2,3} | Other BMPs Including Proprietary BMPs ^{4,6} |
|---|--------------------------------|--------------------------------|--|---------------------------------------|--------------------------------|---------------------------------|----------------------------------|---------------------------------|--|--|
| Sediment & Turbidity | M | M | H | M | H | H | H | H | H | Varies by Product ⁵ |
| Nutrients | L/M | L/M | M | L/M | L/M | H | H | H | H | |
| Toxic Organic Compounds | M/H | M/H | M/H | L | L/M | H | H | H | H | |
| Trash & Debris | L | L | H | H | H | H | H | L | H | |
| Bacteria & Viruses (also: Pathogens) | L | M | H | L | M | H | H | H | H | |
| Oil & Grease | M | M | H | M | H | H | H | H | H | |
| Heavy Metals | M | M/H | M/H | L/M | M | H | H | H | H | |
| <p>Abbreviations: L: Low removal efficiency M: Medium removal efficiency H: High removal efficiency</p> <p>Notes:</p> <ol style="list-style-type: none"> (1) Periodic performance assessment and updating of the guidance provided by this table may be necessary. (2) Expected performance when designed in accordance with the most current edition of the document, "Riverside County, Whitewater River Region Stormwater Quality Best Management Practice Design Handbook". (3) Performance dependent upon design which includes implementation of thick vegetative cover. Local water conservation and/or landscaping requirements should be considered; approval is based on the discretion of the local land use authority. (4) Includes proprietary stormwater treatment devices as listed in the CASQA Stormwater Best Management Practices Handbooks, other stormwater treatment BMPs not specifically listed in this WQMP (including proprietary filters, hydrodynamic separators, inserts, etc.), or newly developed/emerging stormwater treatment technologies. (5) Expected performance should be based on evaluation of unit processes provided by BMP and available testing data. Approval is based on the discretion of the local land use authority. (6) When used for primary treatment as opposed to pre-treatment, requires site-specific approval by the local land use authority. | | | | | | | | | | |

V.1.A SITE DESIGN BMP CONCEPTS AND LID/SITE DESIGN BMPs

This section documents the Site Design BMP concepts and LID/Site Design BMPs that will be implemented on this project to comply with the requirements detailed in Section 3.5.1 of the WQMP Guidance document.

- Table 3 herein documents the implementation of the Site Design BMP Concepts described in sub-sections 3.5.1.3 and 3.5.1.4.
 - Table 4 herein documents the extent to which this project has implemented the LID/Site Design goals described in sub-section 3.5.1.1.
-

Table 3. Implementation of Site Design BMP Concepts

| Design Concept | Technique | Specific BMP | Included | | | Brief Reason for BMPs Indicated as No or N/A |
|----------------------------------|---|---|-------------------------------------|--------------------------|-------------------------------------|---|
| | | | Yes | No | N/A | |
| <i>Site Design BMP Concept 1</i> | Minimize Urban Runoff, Minimize Impervious Footprint, and Conserve Natural Areas (See WQMP Section 3.5.1.3) | Conserve natural areas by concentrating or clustering development on the least environmentally sensitive portions of a site while leaving the remaining land in a natural, undisturbed condition. | <input type="checkbox"/> | <input type="checkbox"/> | <input checked="" type="checkbox"/> | |
| | | Conserve natural areas by incorporating the goals of the Multi-Species Habitat Conservation Plan or other natural resource plans. | <input type="checkbox"/> | <input type="checkbox"/> | <input checked="" type="checkbox"/> | |
| | | Preserve natural drainage features and natural depressional storage areas on the site. | <input type="checkbox"/> | <input type="checkbox"/> | <input checked="" type="checkbox"/> | |
| | | Maximize canopy interception and water conservation by preserving existing native trees and shrubs, and planting additional native or drought tolerant trees and large shrubs. | <input type="checkbox"/> | <input type="checkbox"/> | <input checked="" type="checkbox"/> | |
| | | Use natural drainage systems. | <input type="checkbox"/> | <input type="checkbox"/> | <input checked="" type="checkbox"/> | |
| | | Where applicable, incorporate Self-Treating Areas | <input checked="" type="checkbox"/> | <input type="checkbox"/> | <input type="checkbox"/> | Landscape area will be self treating. |
| | | Where applicable, incorporate Self-Retaining Areas | <input type="checkbox"/> | <input type="checkbox"/> | <input checked="" type="checkbox"/> | |
| | | Increase the building floor to area ratio (i.e., number of stories above or below ground). | <input type="checkbox"/> | <input type="checkbox"/> | <input checked="" type="checkbox"/> | |
| | | Construct streets, sidewalks and parking lot aisles to minimum widths necessary, provided that public safety and a walkable environment for pedestrians are not compromised. | <input checked="" type="checkbox"/> | <input type="checkbox"/> | <input type="checkbox"/> | Parking areas and side walk have been minimized to the extent possible. |
| | | Reduce widths of streets where off-street parking is available. | <input type="checkbox"/> | <input type="checkbox"/> | <input checked="" type="checkbox"/> | |
| | | Minimize the use of impervious surfaces, such as decorative concrete, in the landscape design. | <input checked="" type="checkbox"/> | <input type="checkbox"/> | <input type="checkbox"/> | Garvel used in material storage areas. |
| | | Other comparable and equally effective Site Design BMP concept(s) as approved by the local land use authority (Note: Additional narrative required to describe BMP and how it addresses site design concept). | <input type="checkbox"/> | <input type="checkbox"/> | <input checked="" type="checkbox"/> | |

Table 3. Site Design BMP Concepts (continued)

| Design Concept | Technique | Specific BMP | Included | | | Brief Reason for Each BMP Indicated as No or N/A | |
|---|--|--|-------------------------------------|--------------------------|-------------------------------------|--|--|
| | | | Yes | No | N/A | | |
| <i>Site Design BMP Concept 2</i> | Minimize Directly Connected Impervious Area (See WQMP Section 3.5.1.4) | Design residential and commercial sites to contain and infiltrate roof runoff, or direct roof runoff to landscaped swales or buffer areas. | <input type="checkbox"/> | <input type="checkbox"/> | <input checked="" type="checkbox"/> | | |
| | | Drain impervious sidewalks, walkways, trails, and patios into adjacent landscaping. | <input type="checkbox"/> | <input type="checkbox"/> | <input checked="" type="checkbox"/> | | |
| | | Incorporate landscaped buffer areas between sidewalks and streets. | <input type="checkbox"/> | <input type="checkbox"/> | <input checked="" type="checkbox"/> | | |
| | | Use natural or landscaped drainage swales in lieu of underground piping or imperviously lined swales. | <input type="checkbox"/> | <input type="checkbox"/> | <input checked="" type="checkbox"/> | | |
| | | Where soil conditions are suitable, use perforated pipe or gravel filtration pits for low flow infiltration. | <input checked="" type="checkbox"/> | <input type="checkbox"/> | <input type="checkbox"/> | An underground infiltration system consisting of perforated pipe will be used. | |
| | | Maximize the permeable area by constructing walkways, trails, patios, overflow parking, alleys, driveways, low-traffic streets, and other low-traffic areas with open-jointed paving materials or permeable surfaces such as pervious concrete, porous asphalt, unit pavers, and granular materials. | <input type="checkbox"/> | <input type="checkbox"/> | <input checked="" type="checkbox"/> | | |
| | | Use one or more of the following: | | | | | |
| | | Rural swale system: street sheet flows to landscaped swale or gravel shoulder, curbs used at street corners, and culverts used under driveways and street crossings. | <input type="checkbox"/> | <input type="checkbox"/> | <input checked="" type="checkbox"/> | | |
| | | Urban curb/swale system: street slopes to curb; periodic swale inlets drain to landscaped swale or biofilter. | <input type="checkbox"/> | <input type="checkbox"/> | <input checked="" type="checkbox"/> | | |
| | | Dual drainage system: first flush captured in street catch basins and discharged to adjacent vegetated swale or gravel shoulder; high flows connect directly to MS4s. | <input type="checkbox"/> | <input type="checkbox"/> | <input checked="" type="checkbox"/> | | |
| | | Other comparable and equally effective Site Design BMP concept(s) as approved by the local land use authority (Note: Additional narrative required to describe BMP and how it addresses site design concept). | <input type="checkbox"/> | <input type="checkbox"/> | <input checked="" type="checkbox"/> | | |
| | | Use one or more of the following for design of driveways and private residential parking areas: | | | | | |
| Design driveways with shared access, flared (single lane at street), or wheel strips (paving only under the tires). | <input type="checkbox"/> | <input type="checkbox"/> | <input checked="" type="checkbox"/> | | | | |

| Design Concept | Technique | Specific BMP | Included | | | Brief Reason for Each BMP Indicated as No or N/A |
|----------------|-----------|---|--------------------------|--------------------------|-------------------------------------|--|
| | | | Yes | No | N/A | |
| | | Uncovered temporary or guest parking on residential lots paved with a permeable surface, or designed to drain into landscaping. | <input type="checkbox"/> | <input type="checkbox"/> | <input checked="" type="checkbox"/> | |

Table 3. Site Design BMP Concepts (continued)

| Design Concept | Technique | Specific BMP | Included | | | Brief Reason for Each BMP Indicated as No or N/A | |
|---|--|---|-------------------------------------|--------------------------|-------------------------------------|--|--|
| | | | Yes | No | N/A | | |
| <i>Site Design BMP Concept 2 (cont'd)</i> | Minimize Directly Connected Impervious Area (See WQMP Section 3.5.1.4) | Other comparable and equally effective Site Design BMP concept(s) as approved by the local land use authority (Note: Additional narrative required to describe BMP and how it addresses site design concept). | <input type="checkbox"/> | <input type="checkbox"/> | <input checked="" type="checkbox"/> | | |
| | | Use one or more of the following for design of parking areas: | | | | | |
| | | Where landscaping is proposed in parking areas, incorporate parking area landscaping into the drainage design. | <input checked="" type="checkbox"/> | <input type="checkbox"/> | <input type="checkbox"/> | | |
| | | Overflow parking (parking stalls provided in excess of the Permittee's minimum parking requirements) may be constructed with permeable pavement. | <input type="checkbox"/> | <input type="checkbox"/> | <input checked="" type="checkbox"/> | | |
| | | Other comparable and equally effective Site Design BMP (or BMPs) as approved by the local land use authority (Note: Additional narrative required describing BMP and how it addresses site design concept). | <input type="checkbox"/> | <input type="checkbox"/> | <input checked="" type="checkbox"/> | | |

Project Site Design BMP Concepts:

DA-1, 2 & 3 area runoff will be routed via vortex separators to an underground stormwater retention basin sized to contain the WQMP volume and the developed condition hydrograph volumes for a 100-yr, 3-hr storm, 1.9698 ac ft (85,804 cu ft). Additional volume to buffer the difference between the existing condition and the developed condition hydrograph is also provide resulting in a total basin capacity of 2.9640 ac ft (129,110 cu ft). See project specific hydrology report for additional information.

Alternative Project Site Design BMP Concepts:

N/A

Table 4. LID/Site Design BMPs Meeting the LID/Site Design Measurable Goal

| <p>(1) DRAINAGE SUB-AREA ID OR NO.</p> | <p>(2) LID/SITE DESIGN BMP TYPE*</p> <p>(See Table 2)</p> | <p>(3) POTENTIAL POLLUTANTS OF CONCERN WITHIN DRAINAGE SUB-AREA</p> <p>(Refer to Table 1)</p> | <p>(4) POTENTIAL POLLUTANTS WITHIN SUB- AREA CAUSING RECEIVING WATER IMPAIRMENTS</p> <p>(Refer to Table 1)</p> | <p>(5) EFFECTIVENESS OF LID/SITE DESIGN BMP AT ADDRESSING IDENTIFIED POTENTIAL POLLUTANTS</p> <p>(U, L, M, H/M, H; see Table 2)</p> | <p>(6) BMP MEETS WHICH DESIGN CRITERIA?</p> <p>(Identify as V_{BMP} OR Q_{BMP})</p> | <p>(7) TOTAL AREA WITHIN DRAINAGE SUB-AREA</p> <p>(Nearest 0.1 acre)</p> |
|--|--|--|---|--|--|---|
| | | | | | | |
| | | | | | | |
| | | | | | | |
| | | | | | | |
| | | | | | | |
| | | | | | | |
| | | | | | | |
| | | | | | | |
| | | | | | | |
| | | | | | | |
| | | | | | | |
| | | | | | | |
| | | | | | | |
| | | | | | | |
| | | | | | | |
| | | | | | | |
| TOTAL PROJECT AREA TREATED WITH LID/SITE DESIGN BMPs (NEAREST 0.1 ACRE) | | | | | | |

* LID/Site Design BMPs listed in this table are those that completely address the 'Treatment Control BMP requirement' for their drainage sub-area.

Justification of infeasibility for sub-areas not addressed with LID/Site Design BMPs

V.1.B TREATMENT CONTROL BMPs

Conventional Treatment Control BMPs shall be implemented to address the project's Pollutants of Concern as required in WQMP Section 3.5.1 where, and to the extent that, Section V.1.A has demonstrated that it is infeasible to meet these requirements through implementation of LID/Site Design BMPs.

- The LID/Site Design BMPs described in Section V.1.A of this project-specific WQMP completely address the 'Treatment Control BMP requirement' for the entire project site (and where applicable, entire existing site) as required in Section 3.5.1.1 of the WQMP Guidance document. Supporting documentation for the sizing of these LID/Site Design BMPs is included in Appendix F. ***Section V.1.B does not need to be completed.**
 - The LID/Site Design BMPs described in Section V.1.A of this project-specific WQMP do **NOT** completely address the 'Treatment Control BMP requirement' for the entire project site (or where applicable, entire existing site) as required in Section 3.5.1.1 of the WQMP. ***Section V.1.B must be completed.**
-

The Treatment Control BMPs identified in this section are selected, sized and implemented to treat the design criteria of V_{BMP} and/or Q_{BMP} for all project (and if required, existing site) drainage sub-areas which were not fully addressed using LID/Site Design BMPs. Supporting documentation for the sizing of these Treatment Control BMPs is included in Appendix F.

Table 5: Treatment Control BMP Summary

| (1) DRAINAGE SUB-AREA ID OR NO. | (2) TREATMENT CONTROL BMP TYPE* (See Table 2) | (3) POTENTIAL POLLUTANTS OF CONCERN WITHIN DRAINAGE SUB-AREA (Refer to Table 1) | (4) POTENTIAL POLLUTANTS WITHIN SUB-AREA CAUSING RECEIVING WATER IMPAIRMENTS (Refer to Table 1) | (5) EFFECTIVENESS OF TREATMENT CONTROL BMP AT ADDRESSING IDENTIFIED POTENTIAL POLLUTANTS (U, L, M, H/M, H; see Table 2) | (6) BMP MEETS WHICH DESIGN CRITERIA? (Identify as V _{BMP} OR Q _{BMP}) | (7) TOTAL AREA WITHIN DRAINAGE SUB-AREA (Nearest 0.1 acre) |
|--|--|---|---|---|---|---|
| | | | | | | |
| | | | | | | |
| | | | | | | |
| | | | | | | |
| | | | | | | |
| | | | | | | |
| | TOTAL PROJECT AREA TREATED WITH TREATMENT CONTROL BMPs (NEAREST 0.1 ACRE) | | | | | |

V.1.C MEASURABLE GOAL SUMMARY

This section documents the extent to which this project has met the measurable goal described in WQMP Section 3.5.1.1 of addressing 100% of the project's 'Treatment Control BMP requirement' with LID/Site Design BMPs. Projects required to retain Urban Runoff onsite in conformance with local ordinance are considered to have met the measurable goal; for these instances, '100%' is entered into Column 3 of the Table.

Table 6: Measurable Goal Summary

| <p>(1) Total Area Treated with <u>LID/Site Design BMPs</u> (Last row of Table 4)</p> | <p>(2) Total Area Treated with <u>Treatment Control BMPs</u> (Last row of Table 5)</p> | <p>(3) % of Treatment Control BMP Requirement addressed with LID/Site Design BMPs</p> |
|--|--|---|
| <p>100%</p> | <p>N/A</p> | <p>100%</p> |

V.2 SOURCE CONTROL BMPs

This section identifies and describes the Source Control BMPs applicable and implemented on this project.

Table 7. Source Control BMPs

| BMP Name | Check One | | If not applicable, state brief reason |
|--|-------------------------------------|-------------------------------------|---------------------------------------|
| | Included | Not Applicable | |
| Non-Structural Source Control BMPs | | | |
| Education for Property Owners, Operators, Tenants, Occupants, or Employees | <input checked="" type="checkbox"/> | <input type="checkbox"/> | |
| Activity Restrictions | <input checked="" type="checkbox"/> | <input type="checkbox"/> | |
| Irrigation System and Landscape Maintenance | <input checked="" type="checkbox"/> | <input type="checkbox"/> | |
| Common Area Litter Control | <input checked="" type="checkbox"/> | <input type="checkbox"/> | |
| Street Sweeping Private Streets and Parking Lots | <input checked="" type="checkbox"/> | <input type="checkbox"/> | |
| Drainage Facility Inspection and Maintenance | <input checked="" type="checkbox"/> | <input type="checkbox"/> | |
| Structural Source Control BMPs | | | |
| Storm Drain Inlet Stenciling and Signage | <input checked="" type="checkbox"/> | <input type="checkbox"/> | |
| Landscape and Irrigation System Design | <input checked="" type="checkbox"/> | <input type="checkbox"/> | |
| Protect Slopes and Channels | <input checked="" type="checkbox"/> | <input type="checkbox"/> | |
| Provide Community Car Wash Racks | <input type="checkbox"/> | <input checked="" type="checkbox"/> | Project is a material yard. |
| Properly Design*: | | | |
| Fueling Areas | <input type="checkbox"/> | <input checked="" type="checkbox"/> | None proposed. |
| Air/Water Supply Area Drainage | <input type="checkbox"/> | <input checked="" type="checkbox"/> | None proposed. |
| Trash Storage Areas | <input type="checkbox"/> | <input checked="" type="checkbox"/> | None proposed. |
| Loading Docks | <input type="checkbox"/> | <input checked="" type="checkbox"/> | None proposed. |
| Maintenance Bays | <input type="checkbox"/> | <input checked="" type="checkbox"/> | None proposed. |
| Vehicle and Equipment Wash Areas | <input type="checkbox"/> | <input checked="" type="checkbox"/> | None proposed. |
| Outdoor Material Storage Areas | <input type="checkbox"/> | <input checked="" type="checkbox"/> | None proposed. |
| Outdoor Work Areas or Processing Areas | <input type="checkbox"/> | <input checked="" type="checkbox"/> | None proposed. |
| Provide Wash Water Controls for Food Preparation Areas | <input type="checkbox"/> | <input checked="" type="checkbox"/> | None proposed. |

*Details demonstrating proper design must be included in Appendix F.

Education of Property Owners, Operators, Tenants, Occupants, and Employees:

The property owner shall be familiar with the contents of this document and shall utilize the BMP materials in Appendix D which includes copies of the BMP educational materials (described in Section 3.5.2.1 of the WQMP Guidance document) that will be used in implementing this project-specific WQMP and training staff on an annual basis.

Activity Restrictions:

Pesticide application shall be performed by a CA licensed contractor. No vehicle washing or servicing permitted. No hosing of spilled materials or any other materials into storm drains, with dry cleanup methods practiced.

Storm Drain Inlet Stenciling/Placarding:

Owner shall apply and maintain “No Dumping-Drains to River” messages on all on-site storm drain inlets, with annual inspection/replacement for legibility.

Chamber Inspection/Maintenance:

Retention/infiltration chamber shall be routinely inspected and cleaned as needed.

Irrigation System & Landscape Maintenance:

Irrigation system shall be routinely checked for leaks and other deficiencies and repaired as necessary. Landscape shall be routinely inspected and kept free of trash and debris. All landscape maintenance waste shall be properly collected and disposed of to prevent discharge into storm drains.

Common Area Litter Control:

All open and common areas shall be routinely inspected and kept free of trash and debris.

Street Sweeping Private Streets & Parking Lots:

Driveway, drive aisles, and parking lot areas shall be routinely inspected, swept, and kept free of trash and debris.

Landscape & Irrigation System Design

Proposed commercial landscaping shall be native and drought-tolerant. Proposed commercial landscaping and associated irrigation systems shall be maintained in accordance with all applicable City of Banning landscaping ordinance(s) and requirements and the approved, original Landscape Design.

Protect Slopes & Channels

Proposed landscaped slopes along the northern and western edges of the project and the drainage swale along the eastern edge of the site shall be routinely inspected for sedimentation and erosion and repaired as necessary.

Trash Storage Areas

Trash and waste storage areas will be constructed per approved grading plans and include an impervious paved area and solid canopy style roof (if City dumpsters are utilized) for storage of the state compliant receptacles that are provided by the refuse service provider.

V.3 EQUIVALENT TREATMENT CONTROL BMP ALTERNATIVES

Not applicable – project proposes retention of urban runoff onsite in conformance with local City of Banning ordinance (per Table 6 of the WQMP Guidance document, “Local Land Use Authorities Requiring Onsite Retention of Storm Water”).

V.4 REGIONALLY-BASED BMPs

Not applicable.

VI. Operation and Maintenance Responsibility for BMPs

Appendix G of this project-specific WQMP includes copies of CC&Rs, Covenant and Agreements, BMP Maintenance Agreement and/or other mechanisms used to ensure the ongoing operation, maintenance, funding, transfer and implementation of the project-specific WQMP requirements.

Identification & Description of O&M for Applicable BMPs:

- Irrigation system & landscape maintenance: Irrigation system shall be routinely checked for leaks and other deficiencies and repaired as necessary. Landscape areas shall be routinely inspected and kept free of trash and debris.
- Common area litter control: All open and common areas shall be routinely inspected and kept free of trash and debris.
- Street sweeping private streets & parking lots: Driveway, drive aisles, loading dock areas, and parking lot areas shall be routinely inspected, swept, and kept free of trash and debris.
- Drainage facility inspection & maintenance: Proposed retention/infiltration chamber, gravity separator, on-site catch basins, and on-site storm drain lines on the site shall be routinely inspected and kept free of trash and debris.
- Protect slopes & channels: Proposed drainage swale along the eastern edge of the site and landscaped slopes along the northern and western edges of site shall be routinely inspected for sedimentation and erosion and repaired as necessary.
- Maintenance of Storm Drain Inlet stencils/placards: Proposed storm drain inlet stencils/placards shall be routinely inspected for legibility and replaced as necessary.
- Catch Basin Inlet Filters: Catch basin inlet filters shall be inspected after each major storm event and cleaned whenever the accumulation of floating debris and sediment exceeds 25% of the filter's capacity.
- Trash Storage Areas: Trash storage areas shall be inspected for damages and leaks, and repaired or replaced if needed.

BMP Start-Up Dates:

All BMP O&M described in this section shall begin immediately following construction.

Schedule of Frequency of O&M for Each BMP:

October 2023

1-24

All BMP O&M described in this section shall occur (at a minimum) weekly and before, during, and after storm events.

Identification of Parties Responsible for O&M:

All BMP O&M described in this section is the responsible of the following party:

Brown Strauss, Inc.
2495 Uravan Street
Aurora, CO 80011
Tel. (310) 694-1001

Self-Inspections & Record-Keeping Requirements for BMPs:

All BMP O&M described in this section is the responsible of the following party:

Brown Strauss, Inc.
2495 Uravan Street
Aurora, CO 80011
Tel. (310) 694-1001

Water Quality Monitoring:

Water quality monitoring is not required by the City of Banning at this time.

VII. Funding

The funding source for the operation and maintenance of all proposed BMPs is as follows:

Brown Strauss, Inc.
2495 Uravan Street
Aurora, CO 80011
Tel. (310) 694-1001

Appendix A

Conditions of Approval

Planning Commission Resolution _____

Dated _____

Appendix B

Vicinity Map, WQMP Site Plan, and Receiving Waters Map

EXHIBIT "C" - PROJECT RECEIVING WATERS

Figure 2. Whitewater River Region Receiving Waters Map

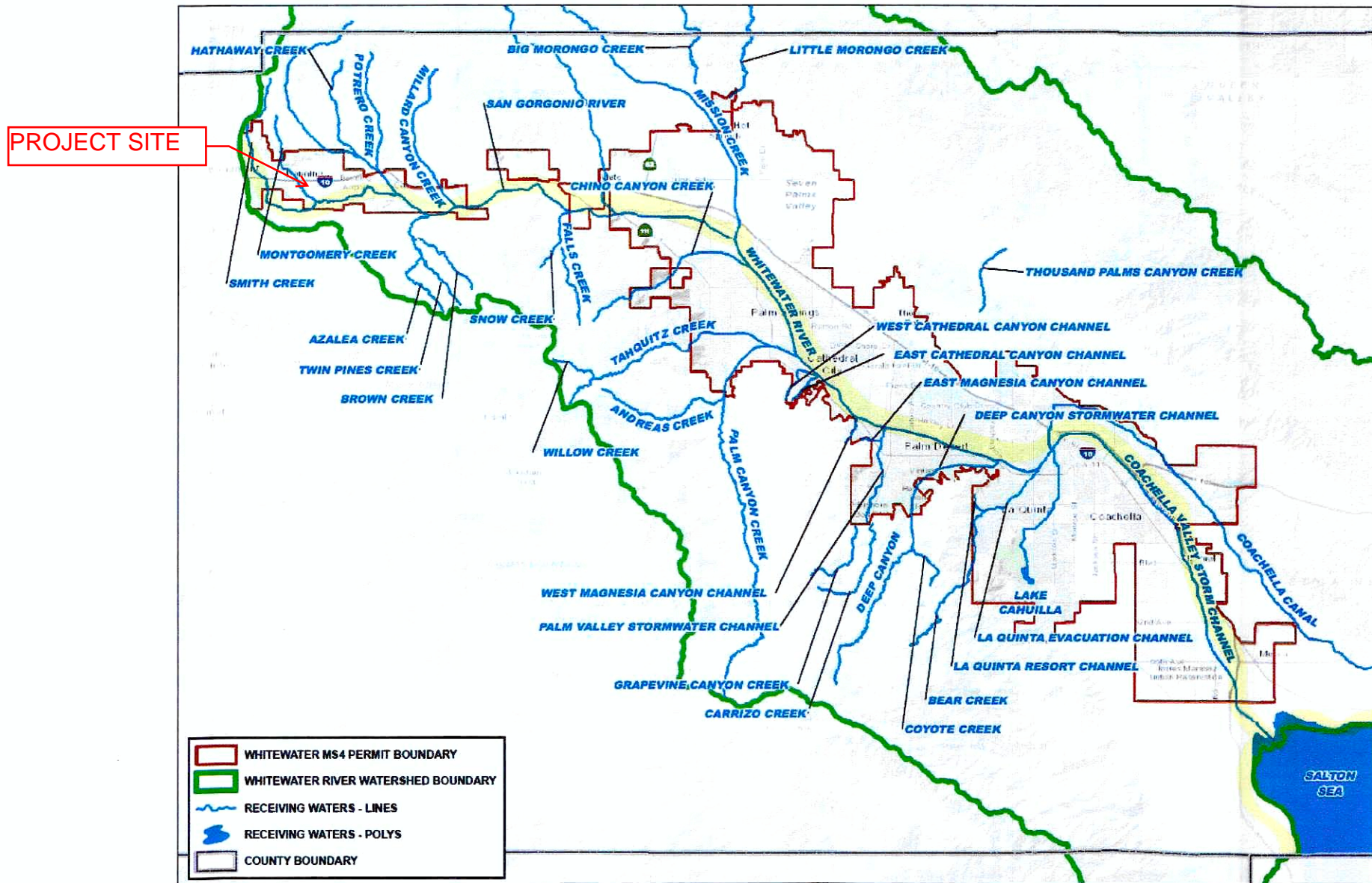

- LEGEND:**
- W.Q.M.P DRAINAGE AREA
 - PROPERTY LIMITS
 - FLOW LINE
 - PROPOSED LANDSCAPING AREAS
 - PROPOSED GRAVEL MATERIAL STORAGE AREAS
 - PROPOSED A/C PAVING AREAS
 - PROPOSED STRUCTURES



4" DIA
STORM DRAIN INLET MARKER
N.T.S.

OWNER INFORMATION:
BROWN STRAUSS, INC.
2495 URAVAN STREET
AURORA, CO 80011

CONTACT: KRIS FARRIS
PHONE: (310) 694-1001

- NON-STRUCTURAL SOURCE CONTROL BMPs:**
- ① IRRIGATION SYSTEM AND LANDSCAPE MAINTENANCE (SC-44) (SC-73)
 - ② VEHICLE FLUID LEAKAGE AND SPILL CLEAN-UP ON PAVEMENT
 - ③ STREET SWEEPING PRIVATE STREETS, LOADING DOCK AREAS, AND PARKING LOTS (SC-70)

- STRUCTURAL SOURCE CONTROL BMPs:**
- ① LANDSCAPE AND IRRIGATION SYSTEM DESIGN
 - ② PROTECT SLOPES AND CHANNELS
 - ③ STORM DRAIN INLET STENCILING AND SIGNAGE
NOTE: A METAL/ALUMINUM PLACARD SHALL BE INSTALLED WITH PAINTED STENCILLED MESSAGE STATING "NO DUMPING-DRAINS TO RIVER".

- PROPERLY DESIGN:**
- ① TRASH STORAGE AREAS (SD-32)
NOTE: TRASH ENCLOSURES SHALL BE COVERED WITH A SOLID ROOF.

- PROPOSED TREATMENT CONTROL BMPs:**
- ① VORTEX SEPARATOR (MP-51)
 - ② INFILTRATION BASIN (TC-11)

- W.Q.M.P. NOTES:**
- 1.) THIS IS NOT A CONSTRUCTION DOCUMENT. SEE APPROVED GRADING PLANS FOR BMP CONSTRUCTIONS DETAILS.

DA COVER INFORMATION:

| COVER TYPE: | QTY. |
|------------------|------------|
| ROOF | 46,454 SF |
| CONCRETE/ASPHALT | 415,612 SF |
| GRAVEL | 92,982 SF |
| LANDSCAPING | 66,383 SF |
| TOTAL | 621,431 SF |

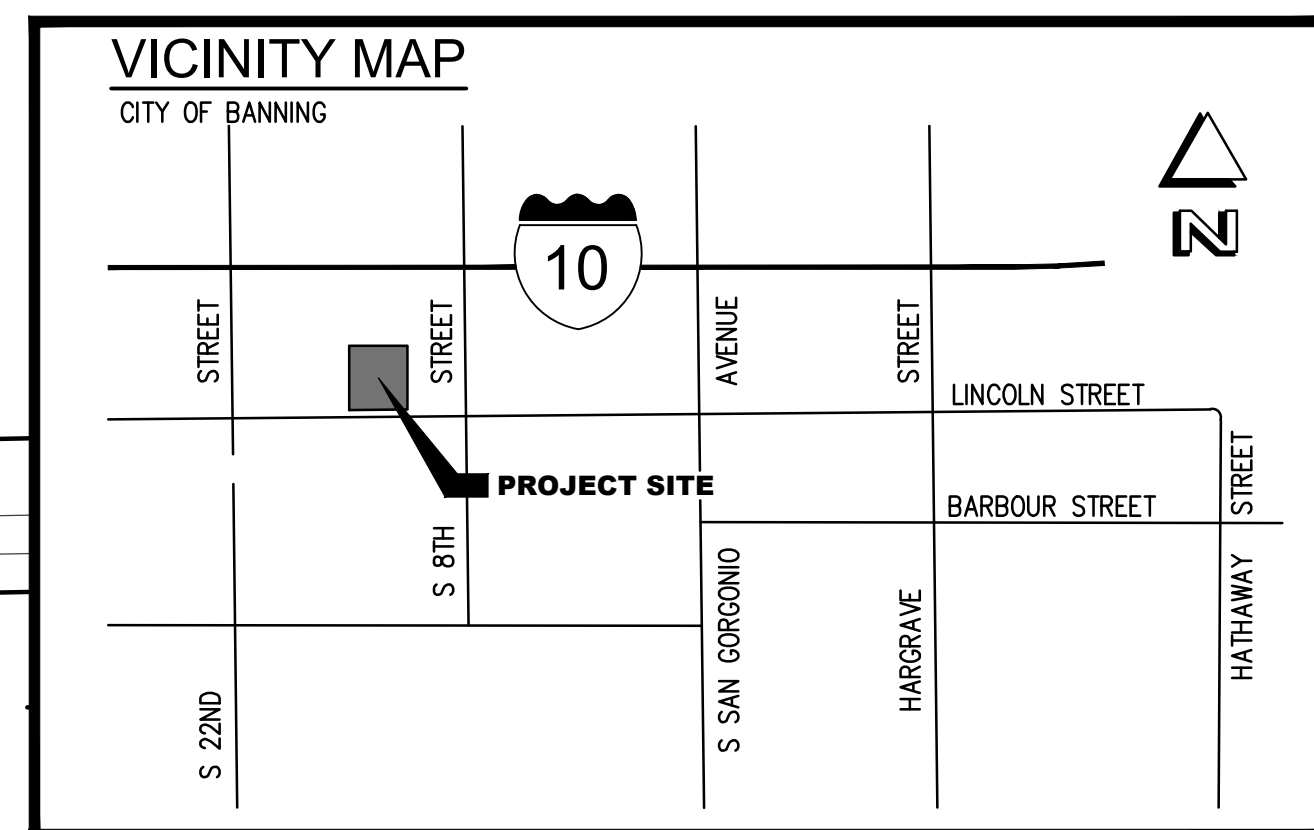
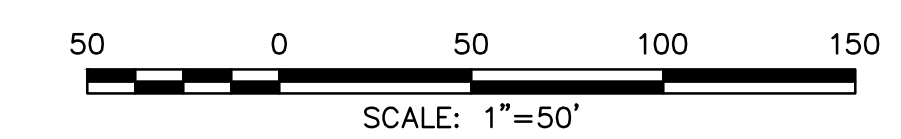
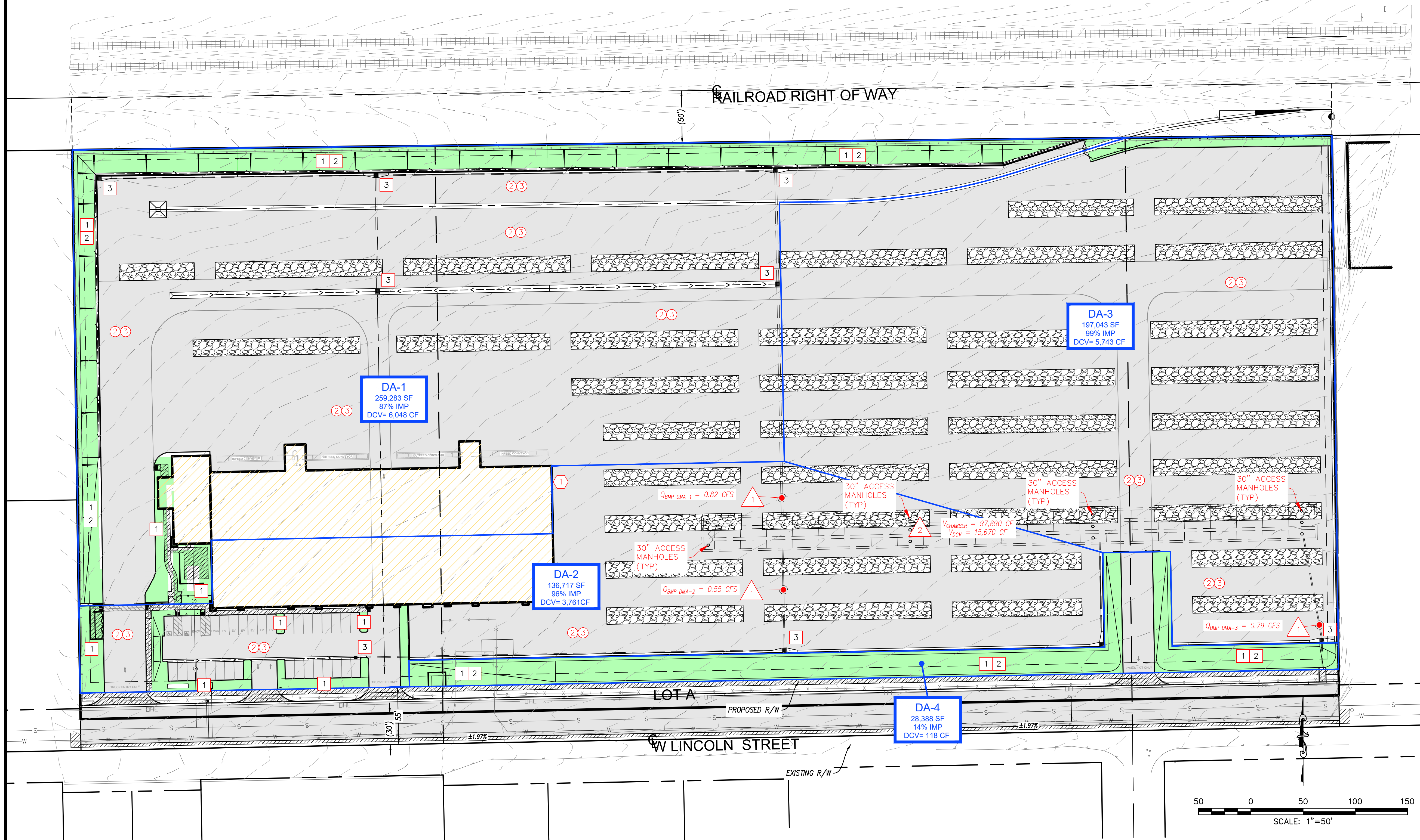

PRELIMINARY W.Q.M.P.
BROWN STRAUSS - BANNING
CITY OF BANNING, CA 92220
APN 540-180-020, 022, 026

BENADIMAN TEL: (909) 885-3806
JOSEPH E. BENADIMAN & ASSOCIATES, INC.
ENGINEERS • D.R. • SURVEYORS • PLANNERS

| | | |
|---|-----------------|---------------|
| PREPARED FOR: BROWN STRAUSS, INC. | SCALE: 1" = 50' | SHEET: 1 OF 1 |
| DRAWN BY: JTS | JOB NO: 225047 | |
| CHECKED BY: JTS | DATE: 09-07-23 | |
| DISREGARD PRINTS BEARING EARLIER REVISION DATES | | |

TENTATIVE PARCEL MAP No. 38659

BROWN STRAUSS - BANNING

IN THE CITY OF BANNING, CALIFORNIA

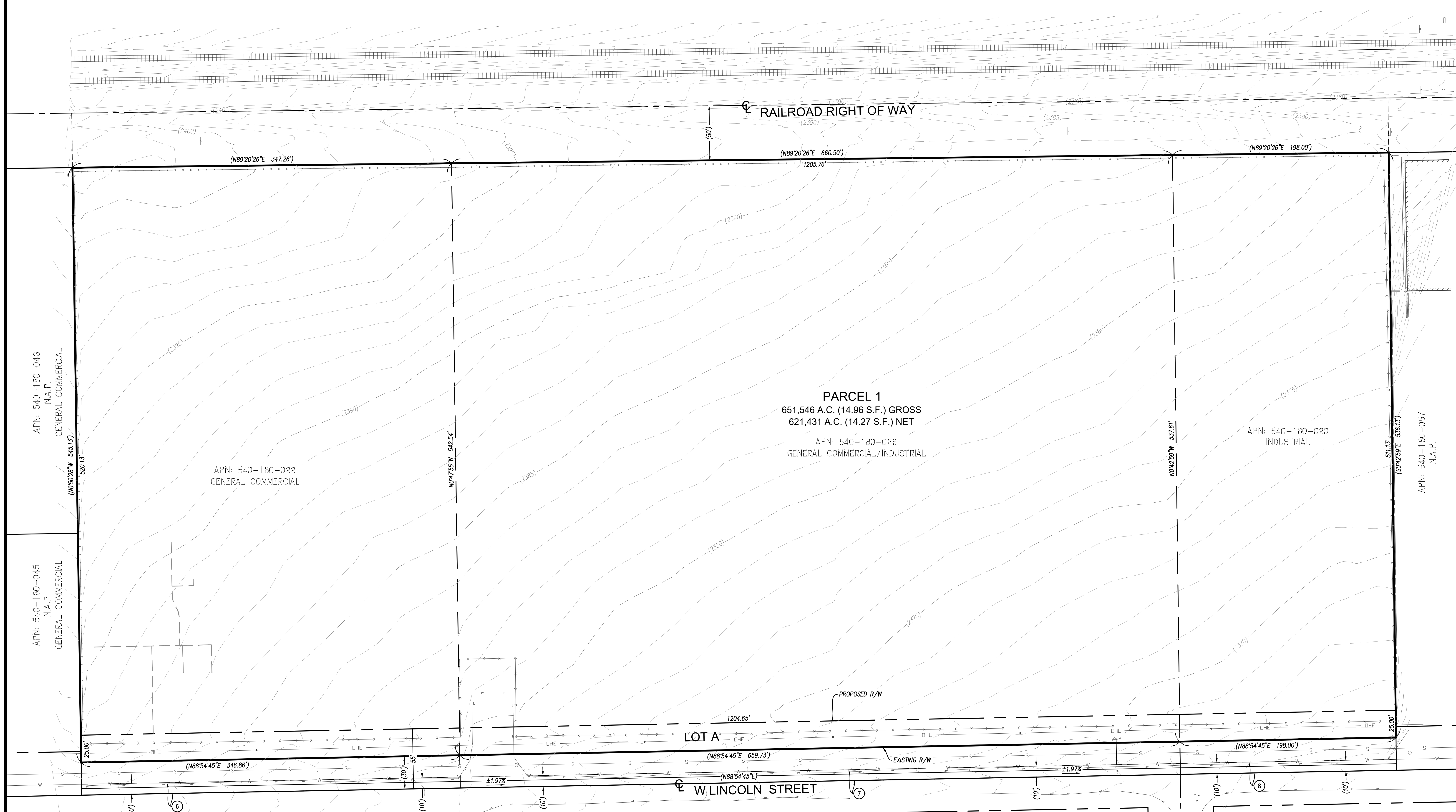

OWNER/DEVELOPER

BROWN STRAUSS, INC.
2495 URAVAN STREET
AURORA, CO 80011

CONTACT: KRIS FARRIS
PHONE: (310) 694-1001

EXHIBIT PREPARED BY

JOSEPH E. BONADIMAN & ASSOC, INC
234 N. SAN BERNARDINO, CA 92408
PHONE: (909) 885-3806
FAX: (909) 381-1721
ATTN: ED BONADIMAN
EMAIL: EDB@BONADIMAN.COM

SITE INFORMATION

PUBLIC ROADS:
W LINCOLN STREET: ARTERIAL HIGHWAY
ULTIMATE R/W: 110'

PARCELS:
ASSESSOR'S PARCEL NUMBER: 540-180-020, 022, & 026
EX PARCEL 1: 106,300 SF/2.44 AC
EX PARCEL 2: 356,505 SF/8.18 AC
EX PARCEL 3: 188,741 SF/4.33 AC
GROSS ACREAGE: 651,546 SF/14.96 AC
LOT A: 30,114 SF/0.69 AC
NET ACREAGE: 621,432 SF/14.27 AC

ZONING:
EXISTING ZONING: GENERAL COMMERCIAL & INDUSTRIAL
PROPOSED ZONING: INDUSTRIAL
EXISTING LAND USE CATEGORY: VACANT
PROPOSED LAND USE: STEEL YARD
FEMA DESIGNATION: UNSHADED ZONE X

LEGEND:

- ASPH ASPHALT SURFACE
 - BT BOTTOM OF TRENCH
 - C CENTER LINE
 - (E) EXISTING
 - EP EDGE OF PAVEMENT
 - FF FINISH FLOOR
 - FG FINISH GRADE
 - FL FLOWLINE
 - FS FINISHED SURFACE
 - GB GRADE BREAK
 - GW GUY WIRE
 - INV INVERT OF PIPE
 - MH MANHOLE
 - N/S NOT TO SCALE
 - P PROPERTY LINE
 - PP POWER POLE
 - SMH SEWER MANHOLE
 - TC TOP OF CURB
 - TF TOP OF FOOTING
 - TG TOP OF GRATE
 - TW TOP OF WALL
 - TY TYPICAL
 - UTL UTILITY
 - WI WROUGHT IRON
 - WV WATER VALVE
- EXISTING CONCRETE SURFACE
 - PROPOSED CONCRETE SURFACE
 - PROPOSED AC PAVEMENT
 - RIGHT OF WAY
 - PROPERTY LINE
 - CENTERLINE
 - EXISTING BLOCK WALL
 - FLOWLINE
 - FILL SLOPE
 - INDICATES DIRECTION OF FLOW
 - EXISTING CONTOUR (FEET)
 - PROPOSED CONTOUR (FEET)
 - PROPOSED BLOCK WALL

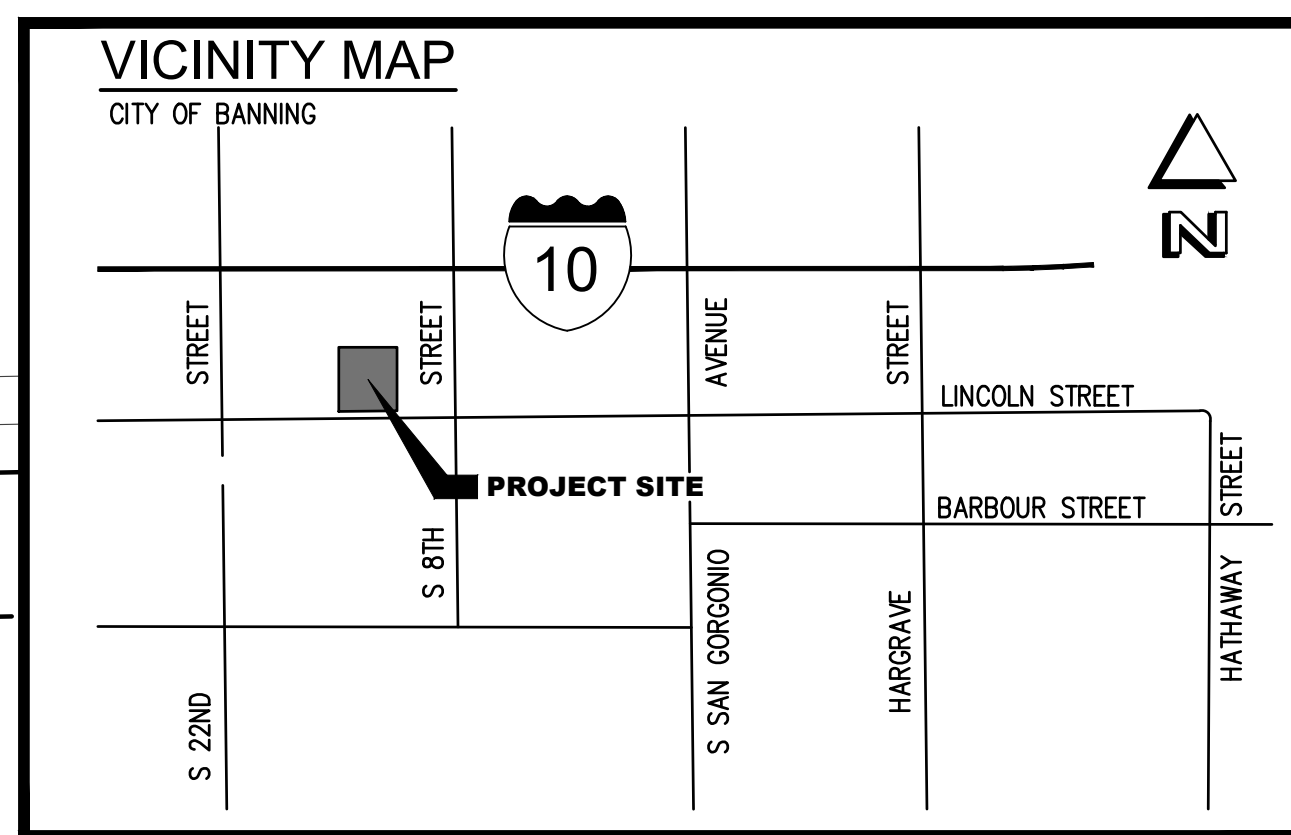

APN: 540-230-030
N.A.P.
BUSINESS PARK

APN: 540-230-029
N.A.P.
BUSINESS PARK

APN: 540-230-005
N.A.P.
BUSINESS PARK

APN: 540-230-032
N.A.P.
BUSINESS PARK

APN: 540-230-033
N.A.P.
BUSINESS PARK

APN: 540-230-019
N.A.P.
BUSINESS PARK

APN: 540-230-007
N.A.P.
BUSINESS PARK

APN: 540-230-014
N.A.P.

LEGAL DESCRIPTION
THE LAND REFERRED TO HEREIN BELOW IS SITUATED IN THE CITY OF BANNING, IN THE COUNTY OF RIVERSIDE, STATE OF CALIFORNIA, AND IS DESCRIBED AS FOLLOWS:

PARCEL 1: THE WESTERLY 188.00 FEET OF BLOCK 273 OF LANDS OF THE BANNING LAND COMPANY, IN THE CITY OF BANNING, COUNTY OF RIVERSIDE, STATE OF CALIFORNIA, AS PER MAP RECORDED IN BOOK 9, PAGE 44 OF MAPS, SAN BERNARDINO COUNTY RECORDS, EXCEPT THAT PORTION IN THE RIGHT OF WAY OF THE SOUTHERN PACIFIC RAILROAD COMPANY, ACQUIRED BY UNITED STATES CONGRESSIONAL GRANT.

PARCEL 2: BLOCK 274 OF LANDS OF THE BANNING LAND COMPANY, IN THE CITY OF BANNING, COUNTY OF RIVERSIDE, STATE OF CALIFORNIA, AS PER MAP RECORDED IN BOOK 9, PAGE 44 OF MAPS, SAN BERNARDINO COUNTY RECORDS, EXCEPT THAT PORTION IN THE RIGHT OF WAY OF THE SOUTHERN PACIFIC RAILROAD COMPANY, ACQUIRED BY UNITED STATES CONGRESSIONAL GRANT.

PARCEL 3: THE EAST ONE-HALF LOT OF 285 IN BANNING, AS SHOWN BY A CERTAIN MAP ENTITLED "AMENDED MAP OF BANNING LAND CO., AS PER MAP RECORDED IN BOOK 9, PAGE 44 OF MAPS, RECORDS OF SAN BERNARDINO, CALIFORNIA, EXCEPTING THEREFROM THAT PORTION IN THE RIGHT OF WAY ACQUIRED BY THE UNITED STATES CONGRESSIONAL GRANT.

APN: 540-180-020, 540-180-022, AND 540-180-026

EASEMENT NOTES
THE FOLLOWING ITEM WERE FOUND IN TITLE REPORT NO. 987-30095142-MAM DATED NOVEMBER 11, 2022 BY FIDELITY NATIONAL TITLE INSURANCE COMPANY:

1. PLOTTABLE ITEMS W/ (E)

2. COVENANTS, CONDITIONS, RESTRICTIONS AND EASEMENTS BUT OMITTING ANY COVENANTS OR RESTRICTIONS, AS SET FORTH IN THE DOCUMENT RECORDED IN BOOK 37, PAGE 234 DEED, THE EXACT LOCATION AND EXTENT OF SAID EASEMENT IS NOT DISCLOSED OF RECORD AND IS NOT PLOTTED HEREON.

3. EASEMENT(S) FOR THE PURPOSE(S) SHOWN BELOW AND RIGHTS INCIDENTAL THERETO AS RESERVED IN A DOCUMENT; RESERVED BY: BANNING LAND COMPANY; A CORPORATION AND BANNING WATER COMPANY PURPOSE: IMPROVE, EXPAND, CONSTRUCTION AND MAINTENANCE OF IRRIGATION DITCHES, PIPES OR FLUMES RECORDING DATE: MARCH 18, 1895 RECORDING NO: IN BOOK 31, PAGE 50 DEEDS THE EXACT LOCATION AND EXTENT OF SAID EASEMENT IS NOT DISCLOSED OF RECORD AND IS NOT PLOTTED.

4. AN EASEMENT FOR DITCHES, PIPES OR FLUMES PURPOSES TO BANNING LAND COMPANY AND BANNING WATER COMPANY; RECORDED FEBRUARY 19, 1899 IN BOOK 52, PAGE 175, DEEDS, THE EXACT LOCATION AND EXTENT OF SAID EASEMENT IS NOT DISCLOSED OF RECORD AND IS NOT PLOTTED HEREON.

5. AN EASEMENT FOR UTILITIES PURPOSES TO CITY OF BANNING, RECORDED MAY 12, 1958 AS INSTRUMENT NO. 34017, OFFICIAL RECORDS, EASEMENTS LIES WITHIN SURVEYED PROPERTY AND IS PLOTTED HEREON.

6. AN EASEMENT FOR TELEPHONE LINES, CONSISTING OF POLES, NECESSARY GUYS AND ANCHORS PURPOSES TO CITY OF BANNING, RECORDED MAY 12, 1958 AS INSTRUMENT NO. 34023, OFFICIAL RECORDS, EASEMENT LIES WITHIN SURVEYED PROPERTY AND IS PLOTTED HEREON.

7. AN EASEMENT FOR PIPE LINES AND CONDUITS PURPOSES TO THE CITY OF BANNING, RECORDED JULY 7, 1958 AS INSTRUMENT NO. 48052, OFFICIAL RECORDS, EASEMENTS AFFECTS SUBJECT PROPERTY AND IS PLOTTED HEREON.

BASIS OF BEARINGS
THE BASIS OF BEARINGS USED ON THIS SURVEY IS THE CENTERLINE OF WEST LINCOLN STREET BEARING NORTH 88°54'45" EAST AS SHOWN ON RECORD OF SURVEY BOOK 112 PAGE 60 RECORDS OF SAID COUNTY.

LIST OF ENCROACHMENTS
NONE TO STATE

BENCHMARK INFORMATION
BENCHMARK NO. H1311
DESCRIPTION: IN BANNING, AT THE CROSSING OF THE SOUTHERN PACIFIC RAILROAD AND 8TH STREET, IN THE NORTHEAST END OF THE ABUTMENT OF A RAILROAD BRIDGE.
ELEVATION: 2,364.82 FEET (NAVD88)

UTILITIES:
WATER, SEWER, & TRASH: CITY OF BANNING (951) 922-3185
ELECTRICITY: BANNING ELECTRIC UTILITY (951) 922-3185
GAS: THE GAS COMPANY (800) 427-2200

FLOOD ZONE NOTE:
PROPERTY IS LOCATED WITHIN UNSHADED FEMA ZONE X: "AREAS DETERMINED TO BE OUTSIDE THE 0.2% ANNUAL CHANCE FLOODPLAIN."
PER FIRM NO. 06065C0817G EFFECTIVE DATE: AUGUST 28, 2008

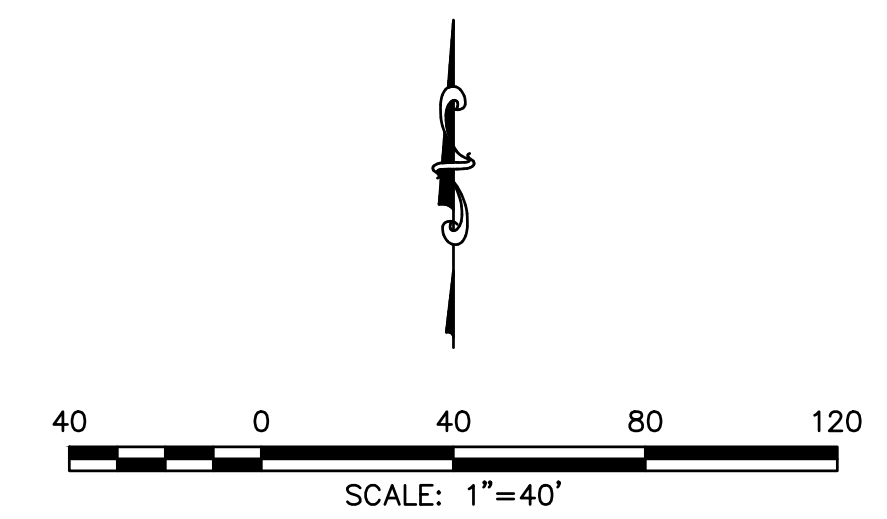

BONADIMAN ENGINEERS - C.T.S. - SURVEYING - PLANNING
JOSEPH E. BONADIMAN & ASSOCIATES, INC.
234 NORTH ARROWHEAD AVE
SAN BERNARDINO, CA 92408
TEL: (909) 885-3806
FAX: (909) 381-1721
WWW.BONADIMAN.COM

TENTATIVE PARCEL MAP No. 38659
BROWN STRAUSS STEEL
CITY OF BANNING, CA 92220
APN 540-180-020, 022, 026

| REVISIONS | | | | |
|-----------|-------------|----|----------|------|
| NO | DESCRIPTION | BY | APPROVED | DATE |
| | | | | |
| | | | | |
| | | | | |

PREPARED FOR: BREMCO CONSTRUCTION
DRAWN BY: JTS SCALE: 1" = 60'
CHECKED BY: JTS JOB NO: 225047 SHEET: 1 OF 3
DISREGARD PRINTS BEARING EARLIER REVISION DATES: 11-08-23

PRELIMINARY SITE/GRADING PLAN

BROWN STRAUSS - BANNING

IN THE CITY OF BANNING, CALIFORNIA

OWNER/DEVELOPER
 BROWN STRAUSS, INC.
 2495 URAVAN STREET
 AURORA, CO 80011
 CONTACT: KRIS FARRIS
 PHONE: (310) 694-1001

ENGINEER
 JOSEPH E. BONADIMAN & ASSOCIATES, INC.
 234 N. ARROWHEAD
 SAN BERNARDINO, CA 92408
 TEL: (909) 885-3806
 FAX: (909) 381-1721

ARCHITECT
 VERTREES A&E
 532 E. LAMBERT ROAD
 BREA, CA 92821
 (714) 255-9645

UTILITIES:
 WATER, SEWER, & TRASH: CITY OF BANNING (951) 922-3185
 ELECTRICITY: BANNING ELECTRIC UTILITY (951) 922-3185
 GAS: THE GAS COMPANY (800) 427-2200

SITE INFORMATION

PUBLIC ROADS:
 W. LINCOLN STREET: ULTIMATE R/W: 110'
 ARTERIAL HIGHWAY 110'

PARCELS:
 ASSESSOR'S PARCEL NUMBER: 540-180-020, 022, & 026
 EX PARCEL 1: 106,300 SF/2.44 AC
 EX PARCEL 2: 356,505 SF/8.18 AC
 EX PARCEL 3: 188,741 SF/4.33 AC
 GROSS ACREAGE: 651,546 SF/14.96 AC
 LOT A: 30,114 SF/0.69 AC
 NET ACREAGE: 621,431 SF/14.27 AC

ZONING:
 EXISTING ZONING: GENERAL COMMERCIAL & INDUSTRIAL
 PROPOSED ZONING: INDUSTRIAL
 EXISTING LAND USE CATEGORY: VACANT
 PROPOSED LAND USE: STEEL YARD
 FEMA DESIGNATION: UNSHADED ZONE X

SOURCE OF TOPOGRAPHY:

MAPPING OF EXISTING CONDITIONS WERE ESTABLISHED BY 1-FOOT CONTOUR INTERVALS, PROVIDED BY ANACAL ENGINEERING COMPANY PER ALTA SURVEY DATED NOVEMBER 30, 2022.

CONSTRUCTION NOTES

- CONTRACTOR SHALL CONTACT THE INSPECTION DIVISION OF THE PUBLIC WORKS DEPARTMENT AT LEAST 48 HOURS PRIOR TO STARTING WORK ON THE PROJECT.
- A PRE-CONSTRUCTION CONFERENCE SHALL BE HELD WITH THE CITY ENGINEER OR HIS DESIGNATED REPRESENTATIVE PRIOR TO BEGINNING CONSTRUCTION. THIS MEETING SHALL BE SCHEDULED WITH THE DEPARTMENT OF PUBLIC WORKS AT THE TIME THE NOTIFICATION OF WORK COMMENCEMENT IS GIVEN.

DRAINAGE NOTES

REFER TO THE PRELIMINARY HYDROLOGY & HYDRAULICS REPORT PREPARED BY JOSEPH E. BONADIMAN & ASSOCIATES, INC. (FEBRUARY 2023) FOR LOCATION OF OFFSITE AND ONSITE DRAINAGE AREAS, PRELIMINARY SIZING OF DRAINAGE FACILITIES, AND AN OVERLAY OF THE PROJECT SITE ON APPLICABLE FEMA FLOOD MAP(S).

OWNER STATEMENT

"I, AM THE OWNER OF THE PROPERTY AFFECTED BY THIS SITE PLAN. PRIOR TO REQUESTING A CERTIFICATE OF OCCUPANCY, I WILL SUBMIT A NOTARIZED STATEMENT AS FOLLOWS: I CERTIFY THAT THE SITE IMPROVEMENTS ARE COMPLETE AND IN ACCORDANCE WITH THE APPROVED PLANS AND SPECIFICATIONS. THIS CERTIFICATION WILL BE BASED ON OBSERVATIONS OF AND SUPERVISION OF CONSTRUCTION BY MY REPRESENTATIVE OR ME. I UNDERSTAND THAT THE CERTIFICATE OF OCCUPANCY WILL NOT BE APPROVED UNTIL THIS CERTIFICATION HAS BEEN MADE."

LEGAL DESCRIPTION

THE LAND REFERRED TO HEREIN BELOW IS SITUATED IN THE CITY OF BANNING, IN THE COUNTY OF RIVERSIDE, STATE OF CALIFORNIA, AND IS DESCRIBED AS FOLLOWS:

- PARCEL 1: THE WESTERLY 188.00 FEET OF BLOCK 273 OF LANDS OF THE BANNING LAND COMPANY, IN THE CITY OF BANNING, COUNTY OF RIVERSIDE, STATE OF CALIFORNIA, AS PER MAP RECORDED IN BOOK 9, PAGE 44 OF MAPS, SAN BERNARDINO COUNTY RECORDS, EXCEPT THAT PORTION IN THE RIGHT OF WAY OF THE SOUTHERN PACIFIC RAILROAD COMPANY, ACQUIRED BY UNITED STATES CONGRESSIONAL GRANT.
- PARCEL 2: BLOCK 274 OF LANDS OF THE BANNING LAND COMPANY, IN THE CITY OF BANNING, COUNTY OF RIVERSIDE, STATE OF CALIFORNIA, AS PER MAP RECORDED IN BOOK 9, PAGE 44 OF MAPS, SAN BERNARDINO COUNTY RECORDS, EXCEPT THAT PORTION IN THE RIGHT OF WAY OF THE SOUTHERN PACIFIC RAILROAD COMPANY, ACQUIRED BY UNITED STATES CONGRESSIONAL GRANT.
- PARCEL 3: THE EAST ONE-HALF LOT OF 285 IN BANNING, AS SHOWN BY A CERTAIN MAP ENTITLED "AMENDED MAP OF BANNING LAND CO., AS PER MAP RECORDED IN BOOK 9, PAGE 44 OF MAPS, RECORDS OF SAN BERNARDINO, CALIFORNIA, EXCEPT THEREFROM THAT PORTION IN THE RIGHT OF WAY ACCQUIRED BY THE UNITED STATES CONGRESSIONAL GRANT.
- APN: 540-180-020, 540-180-022, AND 540-180-026

PROJECT AREAS:

| | |
|-------------------|---------------------|
| GROSS AREA: | 687,683 SF/15.79 AC |
| NET AREA: | 621,431 SF/14.27 AC |
| DISTURBANCE AREA: | 687,683 SF/15.79 AC |
| BUILDING AREA: | 46,454 SF/1.07 AC |
| WAREHOUSE: | 43,510 SF |
| OFFICE: | 3,452 SF |
| CONCRETE/ASPHALT: | 419,539 SF/9.63 AC |
| GRAVEL: | 92,982 SF/2.13 AC |
| LANDSCAPING: | 62,456 SF/1.44 AC |
| TOTAL: | 621,431 SF/14.27 AC |

FLOOD ZONE NOTE:

PROPERTY IS LOCATED WITHIN UNSHADED FEMA ZONE X. "AREAS DETERMINED TO BE OUTSIDE THE 0.2% ANNUAL CHANCE FLOODPLAIN."
 PER FIRM NO. 06065C0817G EFFECTIVE DATE: AUGUST 28, 2008

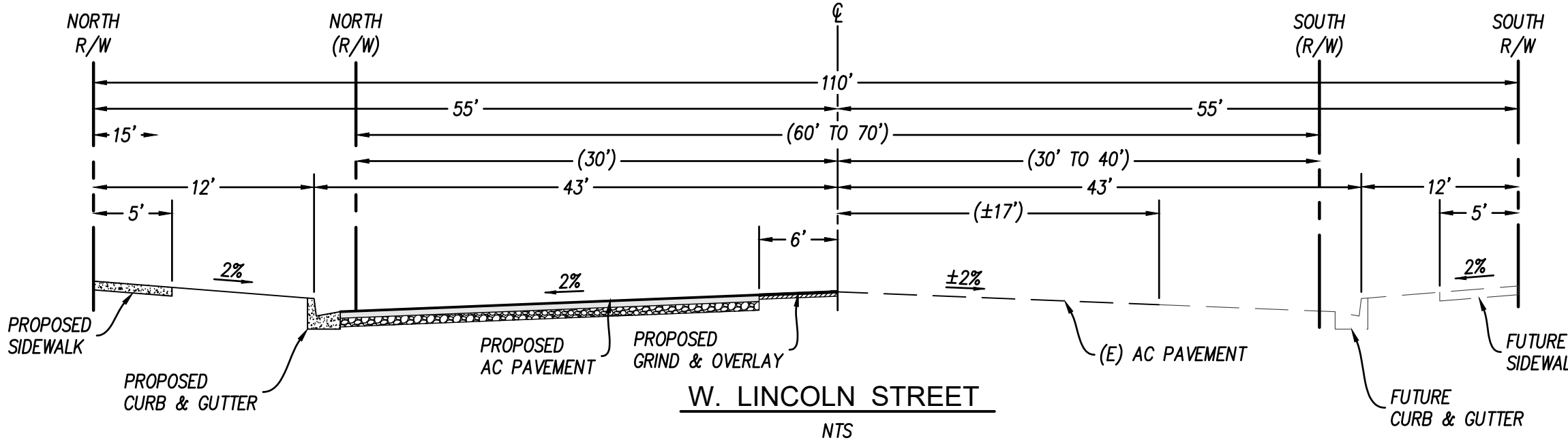

SECTION A

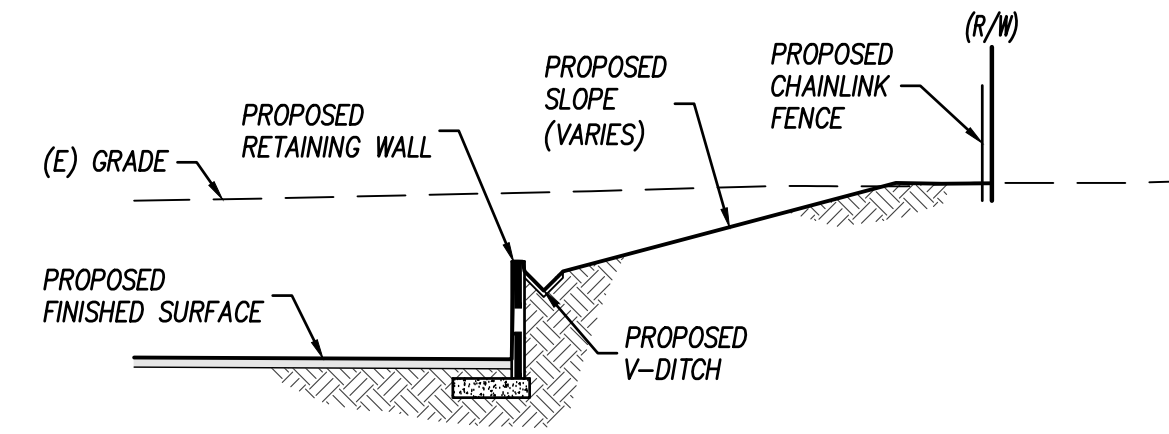

SECTION B

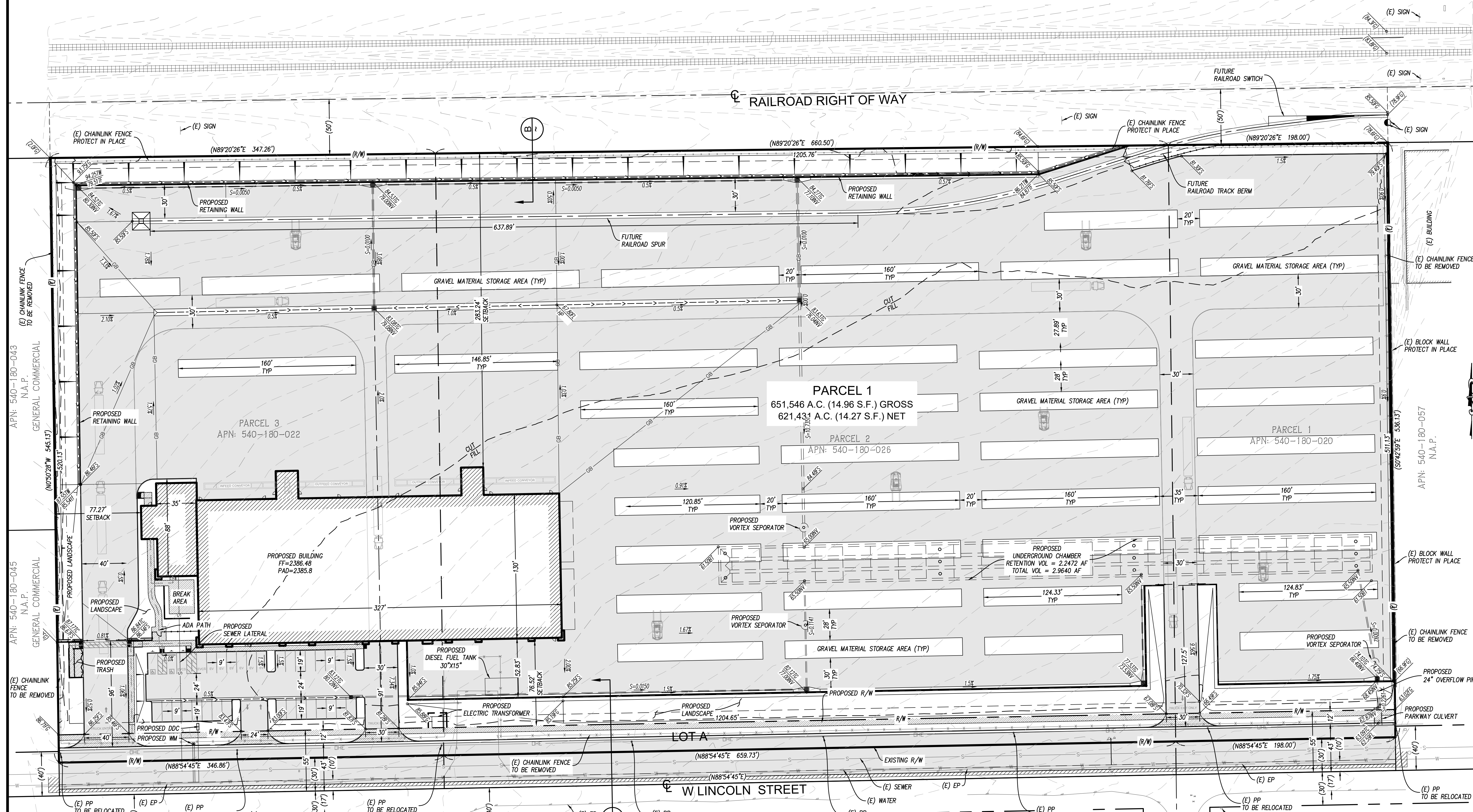

LEGEND:

| | |
|--|-----------------------------------|
| ASPH ASPHALT SURFACE BY BOTTOM OF TRENCH | EXISTING CONCRETE SURFACE |
| FF FINISH FLOOR | PROPOSED CONCRETE SURFACE |
| FL FINISH GRADE | (E) EXISTING |
| FL FINISH GRADE | PROPOSED AC PAVEMENT |
| FS FINISH SURFACE | RIGHT OF WAY |
| GS GRADE BREAK | PROPERTY LINE |
| GW GUY WIRE | CENTERLINE |
| INV INVERT OF PIPE | EXISTING BLOCK WALL |
| MH MANHOLE | EXISTING BLOCK WALL |
| NTS NOT TO SCALE | (E) CHAINLINK FENCE TO BE REMOVED |
| P PROPERTY LINE | (E) BLOCK WALL TO BE REMOVED |
| PP POWER POLE | (E) CHAINLINK FENCE TO BE REMOVED |
| SMH SEWER MANHOLE | (E) BLOCK WALL TO BE REMOVED |
| TC TOP OF CURB | (E) CHAINLINK FENCE TO BE REMOVED |
| TF TOP OF FOOTING | (E) BLOCK WALL TO BE REMOVED |
| TG TOP OF GRATE | (E) CHAINLINK FENCE TO BE REMOVED |
| TW TOP OF WALL | (E) BLOCK WALL TO BE REMOVED |
| TY TYPICAL | (E) CHAINLINK FENCE TO BE REMOVED |
| UL UTIL UTILITY | (E) BLOCK WALL TO BE REMOVED |
| W WROUGHT IRON | (E) CHAINLINK FENCE TO BE REMOVED |
| WV WATER VALVE | (E) BLOCK WALL TO BE REMOVED |

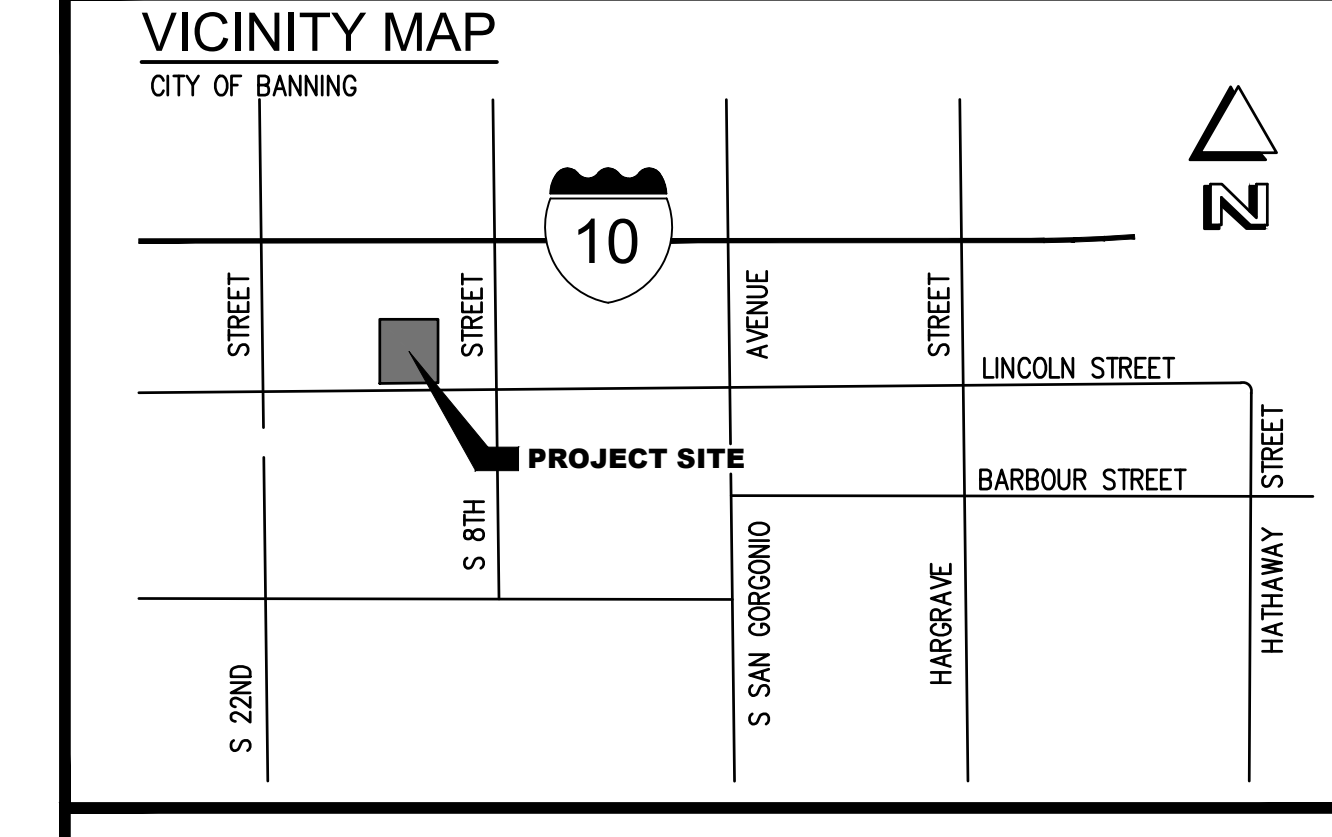
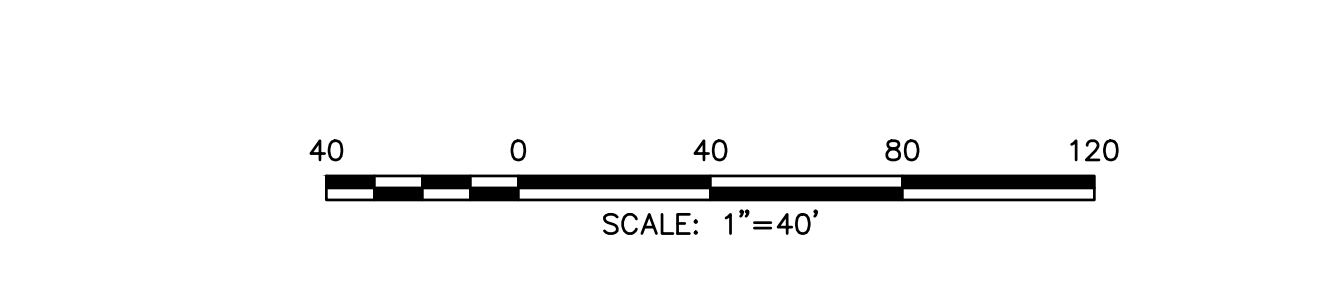

BONADIMAN TEL: (909) 885-3806
 JOSEPH E. BONADIMAN & ASSOCIATES, INC. 234 NORTH ARROWHEAD AVE
 ENGINEERS - C.T.S. - SURVEYING - PLANNING SAN BERNARDINO, CA 92408
 FAX: (909) 381-1721
 www.bonadiman.com

PRELIMINARY SITE/GRADING PLAN
 BROWN STRAUSS STEEL
 CITY OF BANNING, CA 92220
 APN 540-180-020, 022, 026

REVISIONS

| NO | DESCRIPTION | BY | APPROVED | DATE |
|----|-------------|----|----------|------|
| | | | | |
| | | | | |
| | | | | |
| | | | | |

PREPARED FOR: BREMCO CONSTRUCTION
 DRAWN BY: JTS SCALE: 1"=40'
 CHECKED BY: JTS JOB NO: 225047 SHEET: 2 OF 3
 DISREGARD PRINTS BEARING EARLIER REVISION DATES 11-08-23

PRELIMINARY CUT/FILL MAP

BROWN STRAUSS - BANNING

IN THE CITY OF BANNING, CALIFORNIA

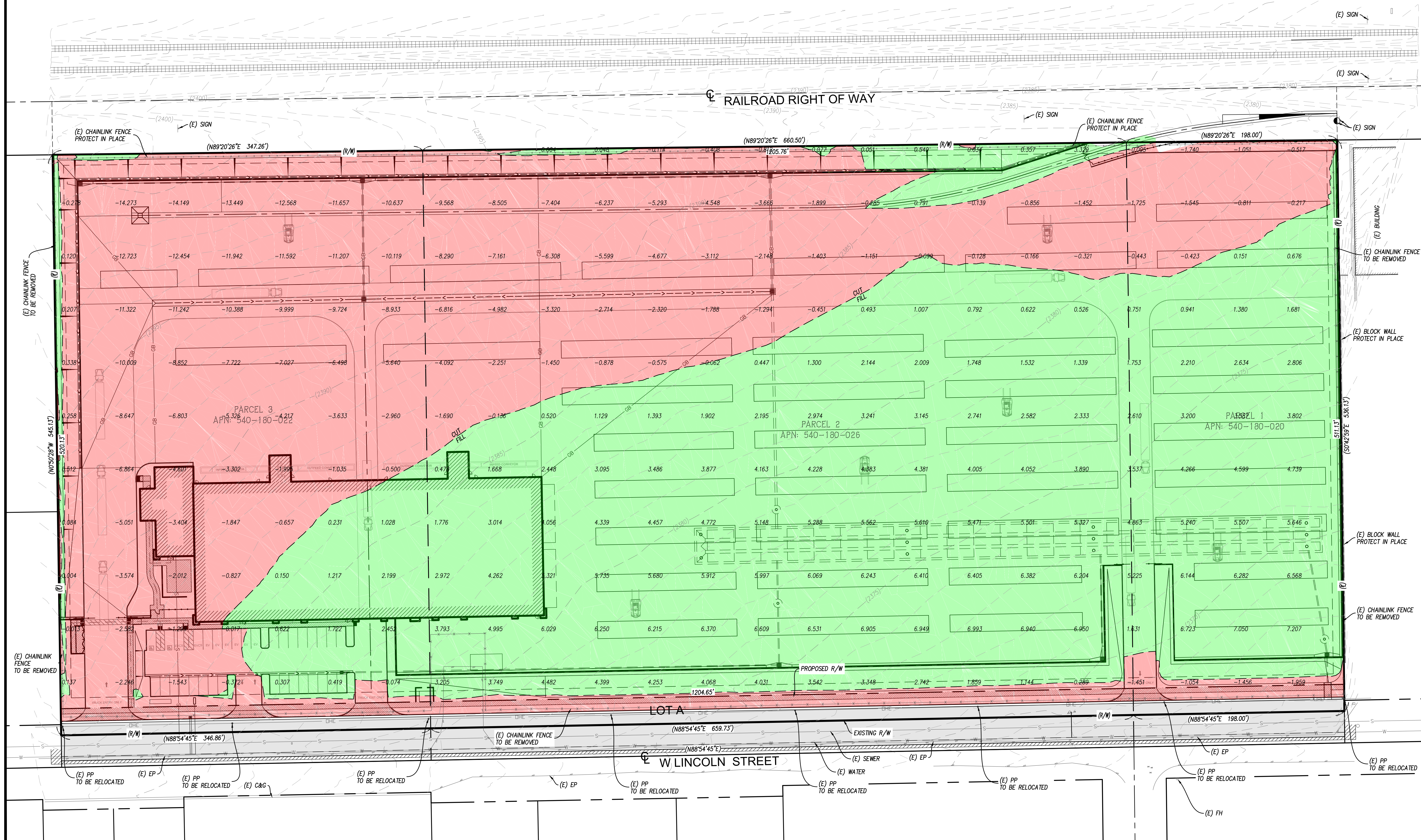

EARTHWORK ESTIMATE QUANTITIES:

CONSTRUCTION MAY VARY.
 CUT 47,965 CUBIC YARDS
 FILL 45,717 CUBIC YARDS

EARTH WORK QUANTITIES NOTE: THE ABOVE LISTED QUANTITIES REFLECT THE ENGINEER'S ESTIMATE OF THE RAW VOLUMES OF MATERIAL CUT AND FILLED. THESE QUANTITIES ARE FOR ESTIMATING AND BONDING PURPOSE ONLY. THE CONTRACTOR IS RESPONSIBLE FOR COMPUTING HIS OWN QUANTITIES FOR CONTRACT PURPOSES.

| Elevations Table | | | |
|------------------|-------------------|-------------------|-------|
| Number | Minimum Elevation | Maximum Elevation | Color |
| 1 | -15.9515 | 0.0000 | |
| 2 | 0.0000 | 7.7000 | |

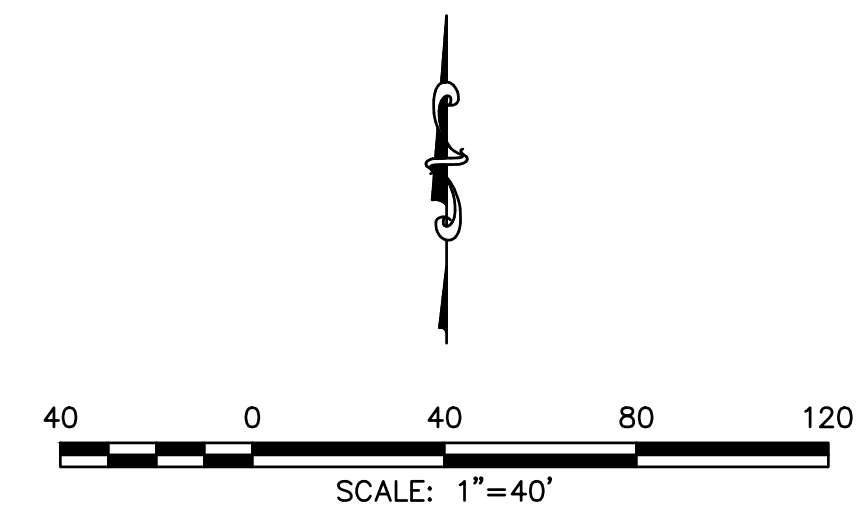

TEL: (909) 885-3806
 234 NORTH ARROWHEAD AVE
 SAN BERNARDINO, CA 92408
 FAX: (909) 381-1221
 www.bonadiman.com

PRELIMINARY CUT/FILL MAP
 BROWN STRAUSS STEEL
 CITY OF BANNING, CA 92220
 APN 540-180-020, 022, 026

| REVISIONS | | | | |
|-----------|-------------|----|----------|------|
| NO | DESCRIPTION | BY | APPROVED | DATE |
| | | | | |
| | | | | |

PREPARED FOR: BREMCO CONSTRUCTION
 DRAWN BY: JTS SCALE: 1" = 40'
 CHECKED BY: JTS JOB NO: 225047 SHEET: 3 OF 3
 DISREGARD PRINTS BEARING EARLIER REVISION DATES 11-08-23

DESIGN INFORMATION
 MATERIAL FINISH = ALZD TYPE II
 PIPE GAUGE = 16
 PERFORATED = YES
 DIAMETER = 36"
 LOADING = H20/H25
 SYSTEM INV = ---

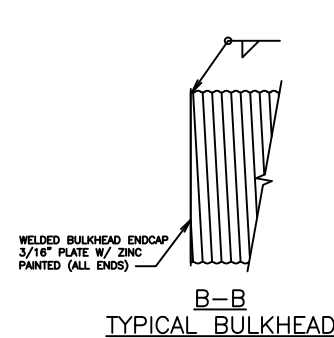
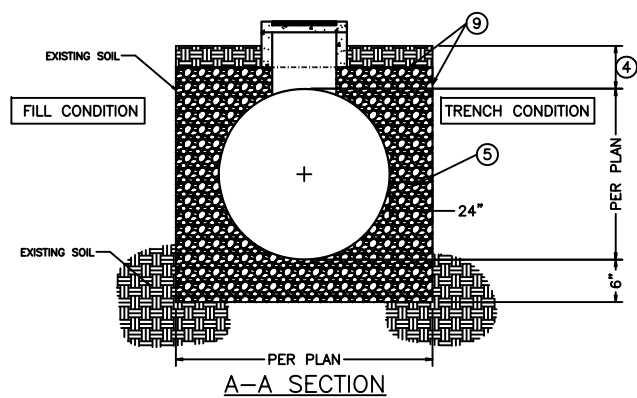
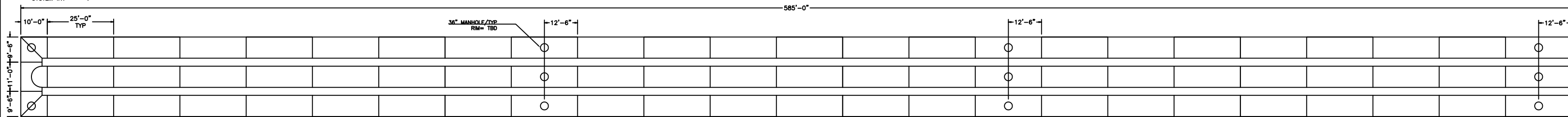

- NOTES:
- RIGID OR FLEXIBLE PAVEMENT.
 - GRANULAR ROAD BASE.
 - NORMAL ROADWAY EMBANKMENT FILL PLACED IN 8" LIFTS AND COMPACTED TO MIN. 90% STANDARD DENSITY PER AASHTO T-99.
 - 12" MIN. FOR DIAMETERS THROUGH 96", 18" MIN. FOR DIAMETERS FROM 102" AND UP. MEASURE FROM TOP OF PIPE TO BOTTOM OF FLEXIBLE PAVEMENT OR TOP OF PIPE TO TOP OF RIGID PAVEMENT.
 - FREE DRAINING ANGULAR WASHED STONE 3/4" - 2" AROUND PIPE ENVELOPE AS SHOWN OR OTHERWISE NOTED.
 - 5 x 1" CSP GAGE PER AASHTO SECTION 12.
 - NOT USED
 - LISTED SPACING CHART IS FOR MULTIPLE PIPE INSTALLATION. FOR SINGLE RUN, THE TRENCH REQUIRES ONLY THE BOTTOM WIDTH OF THE PIPE'S SPAN, PLUS ROOM FOR COMPACTION EQUIPMENT.

| SPACING CHART PER AISI AND NCSIPA GUIDELINES | |
|--|------------------|
| DIAMETER | REQUIRED SPACING |
| UP TO 24" | 12" |
| 24" - 72" | 1/2 PIPE DIA. |
| 72" AND UP | 36" |

- 4 oz. NON WOVEN GEOTEXTILE FABRIC.
- RELATIVELY LOOSE GRANULAR BEDDING ROUGHLY SHAPED TO FIT BOTTOM OF PIPE, 4" TO 6" IN DEPTH. (#57 OR #6 OR OTHER SUITABLE GRANULAR).

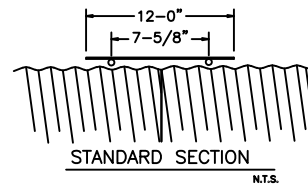
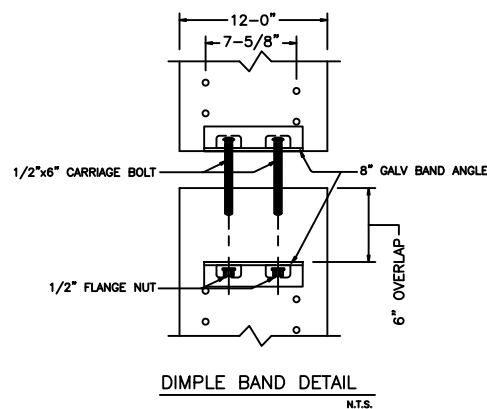
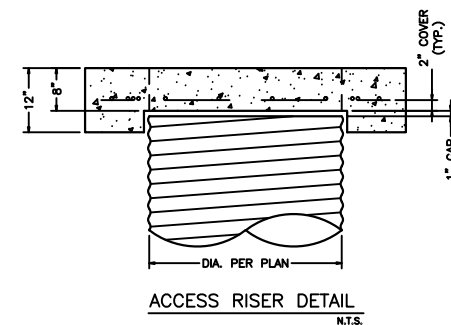
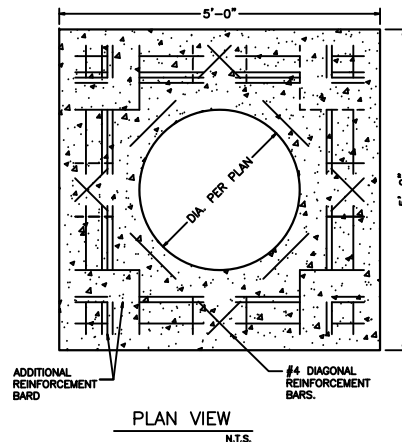

- GENERAL NOTES:
- BANDS ARE FURNISHED AS FOLLOWS:
 12" THRU 48" - 1-PIECE
 54" THRU 96" - 2-PIECE
 102" THRU 144" - 3-PIECE
 - GALV BAND ANGLES ARE ATTACHED WITH SPOT WELDS, RIVETS OR HAND WELDED.
 - DIMENSIONS ARE SUBJECT TO MANUFACTURING TOLERANCES.
 - DIMPLE BANDS FOR ARCHED PIPE ARE THE SAME AS FOR EQUIVALENT ROUND PIPE DIAMETER.

South Bay Foundry SBF 1251
 36" MANHOLE FRAME AND COVER WITH DRAIN

SECTION A-A

SET WEIGHT
 FRAME 257 LB
 COVER 344 LB
 TOTAL 601 LB

APPROVED

BY: _____
 TITLE: _____
 AGENCY: _____
 DATE: _____

PACIFIC CORRUGATED PIPE CO.
 13680 SLOVER AVENUE FONTANA, CA 92337
 800.338.5858 * 909.829.4235
 Fx: 909.829.8035
 SOCAL@PCPIPE.COM

NOTE:
 THE SUITABILITY OF THE INFORMATION PRESENTED FOR USE ON ANY PARTICULAR PROJECT SHOULD BE DETERMINED BY THE ENGINEER RESPONSIBLE FOR THE DESIGN.

PROJECT NAME: BANNING

PROJECT #: _____

DRAWN BY: C.CLARK

SCALE: AS NOTED

DATE: 11/06/23

SHEET NO: 1 OF 1

DATE: _____ SIGNATURE: _____

DATE: _____

DESCRIPTION: BROWN STRAUSS STEEL

Appendix C

Supporting Detail Related to Hydrologic Conditions of Concern

The project is required to retain and treat the stormwater runoff hydrograph volume for a 100 year, 3 hour duration event in the post-development condition, via storage in the proposed on-site retention/infiltration basin, per City Ordinance #1415. See Appendix F calculations.

Appendix D

Educational Materials



A Citizen's Guide to Understanding Stormwater



EPA 833-B-03-002
United States Environmental Protection Agency

January 2003

Revised Edition of "When It Rains It Drains"
Process Change File Revised Figure



After the Storm

For more information contact:
www.epa.gov/nps
or visit
www.epa.gov/nps/stormwater



What is stormwater runoff?



Stormwater runoff occurs when precipitation from rain or snowmelt flows over the ground. Impervious surfaces like driveways, sidewalks, and streets prevent stormwater from naturally soaking into the ground.

Why is stormwater runoff a problem?



Stormwater can pick up debris, chemicals, dirt, and other pollutants and flow into a storm sewer system or directly to a lake, stream, river, wetland, or coastal water. Anything that enters a storm sewer system is discharged untreated into the waterbodies we use for swimming, fishing, and providing drinking water.

The effects of pollution

Polluted stormwater runoff can have many adverse effects on plants, fish, animals, and people.

- ◆ Sediment can cloud the water and make it difficult or impossible for aquatic plants to grow. Sediment also can destroy aquatic habitats.
- ◆ Excess nutrients can cause algae blooms. When algae die, they sink to the bottom and decompose in a process that removes oxygen from the water. Fish and other aquatic organisms can't exist in water with low dissolved oxygen levels.
- ◆ Bacteria and other pathogens can wash into swimming areas and create health hazards, often making beach closures necessary.
- ◆ Debris—plastic bags, six-pack rings, bottles, and cigarette butts—washed into waterbodies can choke, suffocate, or disable aquatic life like ducks, fish, turtles, and birds.
- ◆ Household hazardous wastes like insecticides, pesticides, paint, solvents, used motor oil, and other auto fluids can poison aquatic life. Land animals and people can become sick or die from eating diseased fish and shellfish or ingesting polluted water.



◆ Polluted stormwater often affects drinking water sources. This, in turn, can affect human health and increase drinking water treatment costs.

Stormwater Pollution Solutions

Residential



Recycle or properly dispose of household products that contain chemicals, such as insecticides, pesticides, paint, solvents, and used motor oil and other auto fluids. Don't pour them onto the ground or into storm drains.

Lawn care

Excess fertilizers and pesticides applied to lawns and gardens wash off and pollute streams. In addition, yard clippings and leaves can wash into storm drains and contribute nutrients and organic matter to streams.



- ◆ Don't overwater your lawn. Consider using a soaker hose instead of a sprinkler.
- ◆ Use pesticides and fertilizers sparingly. When use is necessary, use these chemicals in the recommended amounts. Use organic mulch or safer pest control methods whenever possible.
- ◆ Compost or mulch yard waste. Don't leave it in the street or sweep it into storm drains or streams.
- ◆ Cover piles of dirt or mulch being used in landscaping projects.

Septic systems

Leaking and poorly maintained septic systems release nutrients and pathogens (bacteria and viruses) that can be picked up by stormwater and discharged into nearby waterbodies. Pathogens can cause public health problems and environmental concerns.



- ◆ Inspect your system every 3 years and pump your tank as necessary (every 3 to 5 years).
- ◆ Don't dispose of household hazardous waste in sinks or toilets.

Auto care

Washing your car and degreasing auto parts at home can send detergents and other contaminants through the storm sewer system. Dumping automotive fluids into storm drains has the same result as dumping the materials directly into a waterbody.



- ◆ Use a commercial car wash that treats or recycles its wastewater, or wash your car on your yard so the water infiltrates into the ground.
- ◆ Repair leaks and dispose of used auto fluids and batteries at designated drop-off or recycling locations.

Pet waste

Pet waste can be a major source of bacteria and excess nutrients in local waters.



- ◆ When walking your pet, remember to pick up the waste and dispose of it properly. Flushing pet waste is the best disposal method. Leaving pet waste on the ground increases public health risks by allowing harmful bacteria and nutrients to wash into the storm drain and eventually into local waterbodies.

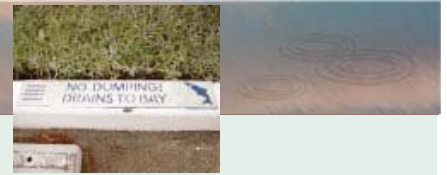

Education is essential to changing people's behavior. Signs and markers near storm drains warn residents that pollutants entering the drains will be carried untreated into a local waterbody.

Residential landscaping

Permeable Pavement—Traditional concrete and asphalt don't allow water to soak into the ground. Instead these surfaces rely on storm drains to divert unwanted water. Permeable pavement systems allow rain and snowmelt to soak through, decreasing stormwater runoff.

Rain Barrels—You can collect rainwater from rooftops in mosquito-proof containers. The water can be used later on lawn or garden areas.



Rain Gardens and Grassy Swales—Specially designed areas planted with native plants can provide natural places for



rainwater to collect and soak into the ground. Rain from rooftop areas or paved areas can be diverted into these areas rather than into storm drains.

Vegetated Filter Strips—Filter strips are areas of native grass or plants created along roadways or streams. They trap the pollutants stormwater picks up as it flows across driveways and streets.



Commercial

Dirt, oil, and debris that collect in parking lots and paved areas can be washed into the storm sewer system and eventually enter local waterbodies.

- ◆ Sweep up litter and debris from sidewalks, driveways and parking lots, especially around storm drains.
- ◆ Cover grease storage and dumpsters and keep them clean to avoid leaks.
- ◆ Report any chemical spill to the local hazardous waste cleanup team. They'll know the best way to keep spills from harming the environment.

Erosion controls that aren't maintained can cause excessive amounts of sediment and debris to be carried into the stormwater system. Construction vehicles can leak fuel, oil, and other harmful fluids that can be picked up by stormwater and deposited into local waterbodies.

- ◆ Divert stormwater away from disturbed or exposed areas of the construction site.
- ◆ Install silt fences, vehicle mud removal areas, vegetative cover, and other sediment and erosion controls and properly maintain them, especially after rainstorms.
- ◆ Prevent soil erosion by minimizing disturbed areas during construction projects, and seed and mulch bare areas as soon as possible.

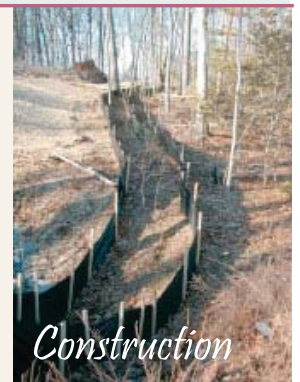

Construction



Agriculture

Lack of vegetation on streambanks can lead to erosion. Overgrazed pastures can also contribute excessive amounts of sediment to local waterbodies. Excess fertilizers and pesticides can poison aquatic animals and lead to destructive algae blooms. Livestock in streams can contaminate waterways with bacteria, making them unsafe for human contact.



- ◆ Keep livestock away from streambanks and provide them a water source away from waterbodies.
- ◆ Store and apply manure away from waterbodies and in accordance with a nutrient management plan.
- ◆ Vegetate riparian areas along waterways.
- ◆ Rotate animal grazing to prevent soil erosion in fields.
- ◆ Apply fertilizers and pesticides according to label instructions to save money and minimize pollution.



Forestry

Improperly managed logging operations can result in erosion and sedimentation.

- ◆ Conduct preharvest planning to prevent erosion and lower costs.
- ◆ Use logging methods and equipment that minimize soil disturbance.
- ◆ Plan and design skid trails, yard areas, and truck access roads to minimize stream crossings and avoid disturbing the forest floor.
- ◆ Construct stream crossings so that they minimize erosion and physical changes to streams.
- ◆ Expedite revegetation of cleared areas.

Automotive Facilities

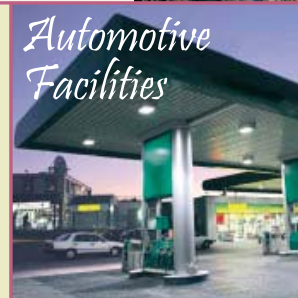

Uncovered fueling stations allow spills to be washed into storm drains. Cars waiting to be repaired can leak fuel, oil, and other harmful fluids that can be picked up by stormwater.

- ◆ Clean up spills immediately and properly dispose of cleanup materials.
- ◆ Provide cover over fueling stations and design or retrofit facilities for spill containment.
- ◆ Properly maintain fleet vehicles to prevent oil, gas, and other discharges from being washed into local waterbodies.
- ◆ Install and maintain oil/water separators.

For Information:

LOCAL SEWERING AGENCIES IN RIVERSIDE COUNTY:

City of Beaumont (909) 769-8520
 City of Banning (909) 277-1414
 Belair Homeowners Association (909) 922-3130
 City of Blythe (760) 922-6161
 City of Coachella (760) 391-5008
 Coachella Valley Water District (760) 398-2651
 City of Corona (909) 736-2259
 Desert Center, CSA #51 (760) 227-3203
 Eastern Municipal Water District (909) 928-3777
 Elsinore Valley MWD (909) 674-3146
 Farm Mutual Water Company (909) 244-4198
 Idyllwild Water District (909) 659-2143
 Jurupa Community Services Dist. (909) 685-7434
 Lake Hemet MWD (909) 658-3241
 Lee Lake Water District (909) 277-1414
 March Air Force Base (909) 656-7000
 Mission Springs Water District (760) 329-6448
 City of Palm Springs (760) 323-8242
 Rancho Caballero (909) 780-9272
 Rancho California Water Dist. (909) 676-4101
 Ripley, CSA #62 (760) 922-4909
 Rubidoux Community Services Dist. (909) 684-7580
 City of Riverside (909) 782-5341
 Silent Valley Club, Inc (909) 849-4501
 Valley Sanitary District (760) 347-2356
 Western Municipal Water District (909) 780-4170

SPILL RESPONSE AGENCY:

HAZ-MAT: (909) 358-5055

HAZARDOUS WASTE DISPOSAL: (909) 358-5055

TO REPORT ILLEGAL DUMPING OR A CLOGGED

STORM DRAIN: 1-800-506-2555

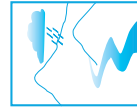

**Storm Water
Clean Water**
PROTECTION PROGRAM

Riverside County gratefully acknowledges the BayArea Stormwater Management Agencies Association and the Cleaning Equipment Trade Association for information provided in this brochure.

StormWater Pollution

What you should know for...

OUTDOOR CLEANING

ACTIVITIES

NON-STORMWATER DISCHARGES

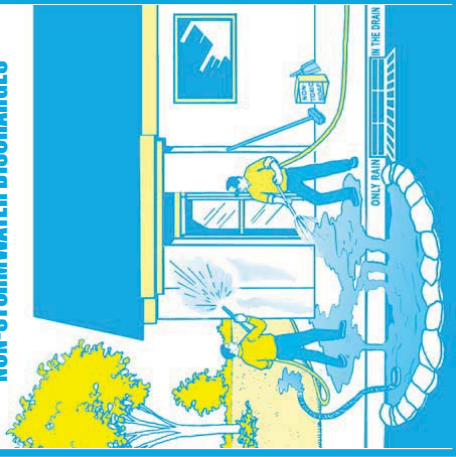

GUIDELINES

for disposal of wastewater
from:

- Sidewalk, plaza or parking lot cleaning
- Vehicle washing or detailing
- Building exterior cleaning
- Waterproofing
- Equipment cleaning or degreasing

Do you know... where the water should go?



Riverside County has two drainage systems - sanitary sewers and storm drains. The storm drain system is designed to prevent flooding by carrying excess rainwater away from streets... it's not designed to be a waste disposal system. Since the storm drain system does not provide for water treatment, it often serves the unintended function of transporting pollutants directly to our waterways.

Unlike sanitary sewers, storm drains are not connected to a treatment plant - they flow directly to our local streams, rivers and lakes.

Non-stormwater discharges such as wastewater generated from outdoor cleaning projects often transport harmful pollutants into storm drains and our local waterways. Polluted runoff contaminates local waterways and poses a threat to groundwater resources.

Soaps, degreasers, automotive fluids, litter, and a host of other materials washed off buildings, sidewalks, plazas, parking areas, vehicles, and equipment can all pollute our waterways.

The Cities and County of Riverside StormWater/CleanWater Protection Program

Since preventing pollution is much easier, and less costly than cleaning up "after the fact," the Cities and County of Riverside StormWater/CleanWater Protection Program informs residents and businesses of pollution prevention activities such as those described in this pamphlet.

The Cities and County of Riverside have adopted ordinances for stormwater management and discharge control. In accordance with state and federal law, these local stormwater ordinances **prohibit** the discharge of wastes into the storm drain system or local surface waters. This includes non-stormwater discharges containing oil, grease, detergents, degreasers, trash, or other waste materials.



PLEASE NOTE: The discharge of pollutants into the street, gutters, storm drain system, or waterways - without a Regional Water Quality Control Board permit or waiver - is **strictly prohibited** by local ordinances and state and federal law.

Help Protect Our Waterways!

Use These Guidelines For Outdoor Cleaning Activities and Washwater Disposal

Do . . . Dispose of small amounts of washwater from cleaning building exteriors, sidewalks, or plazas onto landscaped or unpaved surfaces provided you have the owner's permission and the discharge will not cause flooding or nuisance problems, or flow into a storm drain.

Do NOT . . . Discharge large amounts of these types of washwater onto landscaped areas or soil where water may run to a street or storm drain. Wastewater from exterior cleaning may be pumped to a sewer line with specific permission from the local sewer agency.

Do . . . Check with your local sewer agency's policies and requirements concerning waste water disposal. **Water from many outdoor cleaning activities** may be acceptable for disposal to the sewer system. See the list on the back of this flyer for phone numbers of the sewer agencies in your area.

Do NOT . . . Pour hazardous wastes or toxic materials into the storm drain or sewer system . . . properly dispose of it instead. When in doubt, contact the local sewer agency! The agency will tell you what types of liquid wastes can be accepted.

Do . . . Understand that **water (without soap) used to remove dust from clean vehicles** may be discharged to a street or storm drain. **Washwater from sidewalks, plaza, and building surface cleaning** may go into a street or storm drain if ALL of the following conditions are met:

- 1) The surface being washed is free of residual oil stains, debris and similar pollutants by using dry cleanup methods (sweeping, and cleaning any oil or chemical spills with rags or other absorbent materials before using water).
- 2) Washing is done with water only - no soap or other cleaning materials.
- 3) You have not used the water to remove paint from surfaces during cleaning.

Do NOT . . . Dispose of water containing soap or any other type of cleaning agent into a storm drain or water body. This is a direct violation of state and/or local regulations. Because wastewater from cleaning parking areas or roadways normally contains metallic brake pad dust, oil and other automotive fluids, it should never be discharged to a street, gutter, or storm drain.

Do . . . Understand that mobile auto detailers should divert washwater to landscaped or dirt areas. Note: Be aware that soapy washwater may adversely affect landscaping; consult with the property owner. Residual washwater may remain on paved surfaces to evaporate; sweep up any remaining residue. If there is sufficient water volume to reach the storm drain, collect the runoff and obtain permission to pump it into the sanitary sewer. Follow local sewer agency's requirements for disposal.

Do Not . . . Dispose of left over cleaning agents into the gutter, storm drain or sanitary sewer.

Regarding Cleaning Agents:

If you must use soap, use biodegradable/phosphate free cleaners. Avoid use of petroleum based cleaning products. Although the use of nontoxic cleaning products is strongly encouraged, **do** understand that these products can still degrade water quality and, therefore, the discharge of these products into



the street, gutters, storm drain system, or waterways is prohibited by local ordinances and the State Water Code.

Note: When cleaning surfaces with a high pressure washer or steam cleaning methods, additional precautions should be taken to prevent the discharge of pollutants into the storm drain system. These two methods of surface cleaning, as compared to the use of a low pressure hose, can remove additional materials that can contaminate local waterways.

OTHER TIPS TO HELP PROTECT OUR WATER . . .

SCREENING WASH WATER

A thorough dry cleanup before washing (without soap) surfaces such as building exteriors and decks without loose paint, sidewalks, or plaza areas, should be sufficient to protect storm drains. However, if any debris (solids) could enter storm drains or remain in the gutter or street after cleaning, washwater should first pass through a "20 mesh" or finer screen to catch the solid material, which should then be disposed of in the trash.

DRAIN INLET PROTECTION/ CONTAINING & COLLECTING WASH WATER

WASH WATER

- Sand bags can be used to create a barrier around storm drain inlets.
- Plugs or rubber mats can be used to temporarily seal storm drain openings.
- You can also use vacuum booms, containment pads, or temporary berms to keep wash water away from the street, gutter, or storm drain.

EQUIPMENT AND SUPPLIES

Special materials such as absorbents, storm drain plugs and seals, small sump pumps, and vacuum booms are available from many vendors. For more information check catalogs such as New Pig (800-468-4647), Lab Safety Supply (800-356-0783), C&H (800-558-9966), and W.W. Grainger (800-994-9174); or call the Cleaning Equipment Trade Association (800-441-0111) or the Power Washers of North America (800-393-PWNA).



Stormwater Pollution Found in Your Area!

This is not a citation.

This is to inform you that our staff found the following pollutants in the storm sewer system in your area. This storm sewer system leads directly to

- Motor oil
- Oil filters
- Antifreeze/
transmission fluid
- Paint
- Solvent/degreaser
- Cooking grease
- Detergent
- Home improvement waste (concrete,
mortar)
- Pet waste
- Yard waste (leaves, grass, mulch)
- Excessive dirt and
gravel
- Trash
- Construction debris
- Pesticides and
fertilizers
- Other



**For more information or to report
an illegal discharge of
pollutants, please call:**

**Riverside County Residents, Call . . .
1-800-506-2555**



www.epa.gov/npdes/stormwater

EPA 833-F-03-002

April 2003

Stormwater runoff is precipitation from rain or snowmelt that flows over the ground. As it flows, it can pick up debris, chemicals, dirt, and other pollutants and deposit them into a storm sewer system or waterbody

Anything that enters a storm sewer system is discharged untreated into the waterbodies we use for swimming, fishing, and providing drinking water

**Remember:
Only Rain Down the Drain**

To keep the stormwater leaving your home or workplace clean, follow these simple guidelines:

- ◆ Use pesticides and fertilizers sparingly
- ◆ Repair auto leaks.
- ◆ Dispose of household hazardous waste, used auto fluids (antifreeze, oil, etc.), and batteries at designated collection or recycling locations.
- ◆ Clean up after your pet.
- ◆ Use a commercial car wash or wash your car on a lawn or other unpaved surface.
- ◆ Sweep up yard debris rather than hosing down areas. Compost or recycle yard waste when possible.
- ◆ Clean paint brushes in a sink, not outdoors. Properly dispose of excess paints through a household hazardous waste collection program.
- ◆ Sweep up and properly dispose of construction debris like concrete and mortar.





Riverside County Stormwater Program Members

City of Banning
(951) 922-3105

City of Beaumont
(951) 769-8520

City of Calimesa
(909) 795-9801

City of Canyon Lake
(951) 244-2955

City of Cathedral City
(760) 770-0340

City of Coachella
(760) 398-3502

City of Corona
(951) 736-2447

City of Desert Hot Springs
(760) 329-6411

City of Eastvale
(951) 361-0900

City of Hemet
(951) 765-2300

City of Indian Wells
(760) 346-2489

City of Indio
(760) 391-4000

City of Jurupa Valley
(951) 332-6464

City of Lake Elsinore
(951) 674-3124

City of La Quinta
(760) 777-7000

City of Menifee
(951) 672-6777

City of Moreno Valley
(951) 413-3000

City of Murrieta
(951) 304-2489

City of Norco
(951) 270-5607

City of Palm Desert
(760) 346-0611

City of Palm Springs
(760) 323-8299

City of Perris
(951) 943-6100

City of Rancho Mirage
(760) 324-4511

City of Riverside
(951) 826-5311

City of San Jacinto
(951) 487-7330

City of Temecula
(951) 694-6444

City of Wildomar
(951) 677-7751

Coachella Valley Water District
(760) 398-2651

County of Riverside
(951) 955-1000

Riverside County Flood Control District
(951) 955-1200

Stormwater Pollution

What you should know for...

Industrial & Commercial Facilities

Best Management Practices (BMPS) for:

- Industrial Facilities
- Commercial Facilities



YOU can prevent Stormwater Pollution following these practices...

Industrial and Commercial Facilities

The Riverside County Stormwater Program has identified a number of Best Management Practices (BMPs) for Industrial and Commercial Facilities. These BMPs control and reduce stormwater pollutants from reaching our storm drain system and ultimately our local water bodies. City and County ordinances require businesses to use these BMPs to protect our water quality. Local cities and the County are required to verify implementation of these BMPs by performing regular facility inspections.

Prohibited Discharges

Discontinue all non-stormwater discharges to the storm drain system. It is *prohibited* to discharge any chemicals, paints, debris, wastes or wastewater into the gutter, street or storm drain.

Outdoor Storage BMPs

- Install covers and secondary containment areas for all hazardous materials and wastes stored outdoors in accordance with County and/or City standards.
- Keep all temporary waste containers covered, at all times when not in use.
- Sweep outdoor areas instead of using a hose or pressure washer.
- Move all process operations including vehicle/equipment maintenance inside of the building or under a covered and contained area.
- Wash equipment and vehicles in a contained and covered wash bay which is closed-loop or connected to a clarifier sized to local standards and discharged to a sanitary sewer or take them to a commercial car wash.



Spills and Clean Up BMPs

- Keep the work site clean and orderly. Remove debris in a timely fashion. Sweep up the area.
- Clean up spills immediately when they occur, using dry clean up methods such as absorbent materials or sweep followed by proper disposal of materials.

- Always have a spill kit available near chemical loading dock doors and vehicle maintenance and fueling areas.
- Follow your Business Emergency Plan, as filed with the local Fire Department.
- Report all prohibited discharges and non-implementation of BMPs to your local Stormwater Coordinator as listed on the back of this pamphlet.
- Report hazardous materials spills to 951-358-5055 or call after hours to 951-782-2973 or, if an emergency, call the Fire Department's Haz Mat Team at 911.



Plastic Manufacturing Facilities BMPs

AB 258 requires plastic product manufacturers to use BMPs, such as safe storage and clean-up procedures to prevent plastic pellets (nurdles) from entering the waterway. The plastic pellets are released into the environment during transporting, packaging and processing and migrate to waterways through the storm drain system. AB 258 will help protect fish and wildlife from the hazards of plastic pollution.

Training BMPs

As prescribed by your City and County Stormwater Ordinance(s), train employees in spill procedures and prohibit non-stormwater discharges to the storm drain system. Applicable BMP examples can be found at www.cabmphandbooks.com.

Permitting

Stormwater discharges associated with specific categories for industrial facilities are regulated by the State Water Resources Control Board through an Industrial Stormwater General Permit. A copy of this General Permit and application forms are available at: www.waterboards.ca.gov, select stormwater then the industrial quick link.

To report illegal dumping or for more information on stormwater pollution prevention call: 1-800-506-2555 or e-mail us at: fcnpdes@rcflood.org.

Helpful telephone numbers and links:

| | |
|--|----------------|
| Riverside County Stormwater Protection Partners | |
| Flood Control District | (951) 955-1200 |
| County of Riverside | (951) 955-1000 |
| City of Banning | (951) 922-3105 |
| City of Beaumont | (951) 769-8520 |
| City of Calimesa | (909) 795-9801 |
| City of Canyon Lake | (951) 244-2955 |
| Cathedral City | (760) 770-0327 |
| City of Coachella | (760) 398-4978 |
| City of Corona | (951) 736-2447 |
| City of Desert Hot Springs | (760) 329-6411 |
| City of Eastvale | (951) 361-0900 |
| City of Hemet | (951) 765-2300 |
| City of Indian Wells | (760) 346-2489 |
| City of Indio | (760) 391-4000 |
| City of Lake Elsinore | (951) 674-3124 |
| City of La Quinta | (760) 771-7000 |
| City of Menifee | (951) 672-6777 |
| City of Moreno Valley | (951) 413-3000 |
| City of Murrieta | (951) 304-2489 |
| City of Norco | (951) 270-5607 |
| City of Palm Desert | (760) 346-0611 |
| City of Palm Springs | (760) 323-8299 |
| City of Perris | (951) 943-6100 |
| City of Rancho Mirage | (760) 324-4511 |
| City of Riverside | (951) 361-0900 |
| City of San Jacinto | (951) 654-7337 |
| City of Temecula | (951) 694-6444 |
| City of Wildomar | (951) 677-7751 |

REPORT ILLEGAL STORM DRAIN DISPOSAL

1-800-506-2555 or e-mail us at fcnpdes@rcflood.org

- Riverside County Flood Control and Water Conservation District
www.rcflood.org

Online resources include:

- California Storm Water Quality Association
www.casqa.org
- State Water Resources Control Board
www.waterboards.ca.gov
- Power Washers of North America
www.thepwna.org

Stormwater Pollution

What you should know for...

Outdoor Cleaning Activities and Professional Mobile Service Providers

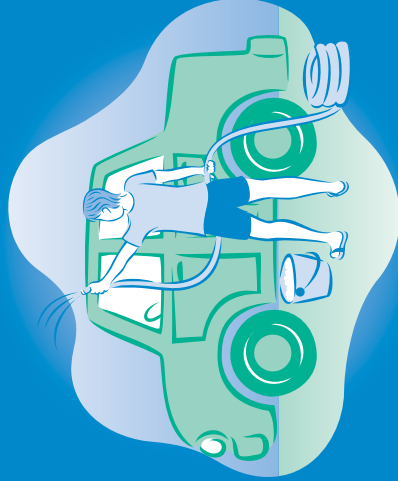

Storm drain pollution prevention information for:

- Car Washing / Mobile Detailers
- Window and Carpet Cleaners
- Power Washers
- Waterproofers / Street Sweepers
- Equipment cleaners or degreasers and all mobile service providers

Do you know where street flows actually go?

Storm drains are NOT connected to sanitary sewer systems and treatment plants!



The primary purpose of storm drains is to carry rain water away from developed areas to prevent flooding. Pollutants discharged to storm drains are transported directly into rivers, lakes and streams. Soaps, degreasers, automotive fluids, litter and a host of materials are washed off buildings, sidewalks, plazas and parking areas. Vehicles and equipment must be properly managed to prevent the pollution of local waterways.

Unintentional spills by mobile service operators can flow into storm drains and pollute our waterways. **Avoid mishaps.** Always have a **Spill Response Kit** on hand to clean up unintentional spills. Only emergency **Mechanical** repairs should be done in City streets, using drip pans for spills. **Plumbing** should be done on private property. Always store chemicals in a leak-proof container and keep covered when not in use. **Window/Power Washing** waste water shouldn't be released into the streets, but should be disposed of in a sanitary sewer, landscaped area or in the soil. Soiled **Carpet Cleaning** wash water should be filtered before being discharged into the sanitary sewer. Dispose of all filter debris properly. **Car Washing/Detailing** operators should wash cars on private property and use a regulated hose nozzle for water flow control and runoff prevention. Capture and dispose of waste water and chemicals properly. Remember, storm drains are for receiving rain water runoff only.

REPORT ILLEGAL STORM DRAIN DISPOSAL
1-800-506-2555

Help Protect Our Waterways!

Use these guidelines for Outdoor Cleaning Activities and Wash Water Disposal

Did you know that disposing of pollutants into the street, gutter, storm drain or body of water is **PROHIBITED** by law and can result in stiff penalties?

Best Management Practices

Waste wash water from Mechanics, Plumbers, Window/Power Washers, Carpet Cleaners, Car Washing and Mobile Detailing activities may contain significant quantities of motor oil, grease, chemicals, dirt, detergents, brake pad dust, litter and other materials.

Best Management Practices, or BMPs as they are known, are guides to prevent pollutants from entering the storm drains. *Each of us* can do our part to keep stormwater clean by using the suggested BMPs below:

Simple solutions for both light and heavy duty jobs:

Do....consider dry cleaning methods first such as a mop, broom, rag or wire brush. Always keep a spill response kit on site.

Do....prepare the work area before power cleaning by using sand bags, rubber mats, vacuum booms, containment pads or temporary berms to keep wash water away from the gutters and storm drains.

Do....use vacuums or other machines to remove and collect loose debris or litter before applying water.

Do....obtain the property owner's permission to dispose of *small amounts* of power washing waste water on to landscaped, gravel or unpaved surfaces.

Do....check your local sanitary sewer agency's policies on wash water disposal regulations before disposing of wash water into the sewer. (See list on reverse side)

Do....be aware that if discharging to landscape areas, soapy wash water may damage landscaping. Residual wash water may remain on paved surfaces to evaporate. Sweep up solid residuals and dispose of properly. Vacuum booms are another option for capturing and collecting wash water.

Do....check to see if local ordinances prevent certain activities.

Do not let...wash or waste water from sidewalk, plaza or building cleaning go into a street or storm drain.



Report illegal storm drain disposal

Call Toll Free

1-800-506-2555

Using Cleaning Agents

Try using biodegradable/phosphate-free products. They are easier on the environment, but don't confuse them with being toxic free. Soapy water entering the storm drain system can impact the delicate aquatic environment.



When cleaning surfaces with a **high-pressure washer** or **steam cleaner**, additional precautions should be taken to prevent the discharge of pollutants into the storm drain system. These two methods of surface cleaning can loosen additional material that can contaminate local waterways.

Think Water Conservation

Minimize water use by using high pressure, low volume nozzles. Be sure to check all hoses for leaks. Water is a precious resource, don't let it flow freely and be sure to shut it off in between uses.

Screening Wash Water

Conduct thorough dry cleanup before washing exterior surfaces, such as buildings and decks **with loose paint**, sidewalks or plaza areas. Keep debris from entering the storm drain after cleaning by first passing the wash water through a "20 mesh" or finer screen to catch the solid materials, then dispose of the mesh in a refuse container. Do not let the remaining wash water enter a street, gutter or storm drain.

Drain Inlet Protection & Collection of Wash Water

- Prior to any washing, block all storm drains with an impervious barrier such as sandbags or berms, or seal the storm drain with plugs or other appropriate materials.
- Create a containment area with berms and traps or take advantage of a low spot to keep wash water contained.
- Wash vehicles and equipment on grassy or gravel areas so that the wash water can seep into the ground.
- Pump or vacuum up all wash water in the contained area.

Concrete/Coring/Saw Cutting and Drilling Projects

Protect any down-gradient inlets by using dry activity techniques whenever possible. If water is used, minimize the amount of water used during the coring/drilling or saw cutting process. Place a barrier of sandbags and/or absorbent berms to protect the storm drain inlet or watercourse. Use a shovel or wet vacuum to remove the residue from the pavement. Do not wash residue or particulate matter into a storm drain inlet or watercourse.

Description

Trash storage areas are areas where a trash receptacle (s) are located for use as a repository for solid wastes. Stormwater runoff from areas where trash is stored or disposed of can be polluted. In addition, loose trash and debris can be easily transported by water or wind into nearby storm drain inlets, channels, and/or creeks. Waste handling operations that may be sources of stormwater pollution include dumpsters, litter control, and waste piles.

Approach

This fact sheet contains details on the specific measures required to prevent or reduce pollutants in stormwater runoff associated with trash storage and handling. Preventative measures including enclosures, containment structures, and impervious pavements to mitigate spills, should be used to reduce the likelihood of contamination.

Suitable Applications

Appropriate applications include residential, commercial and industrial areas planned for development or redevelopment. (Detached residential single-family homes are typically excluded from this requirement.)

Design Considerations

Design requirements for waste handling areas are governed by Building and Fire Codes, and by current local agency ordinances and zoning requirements. The design criteria described in this fact sheet are meant to enhance and be consistent with these code and ordinance requirements. Hazardous waste should be handled in accordance with legal requirements established in Title 22, California Code of Regulation.

Wastes from commercial and industrial sites are typically hauled by either public or commercial carriers that may have design or access requirements for waste storage areas. The design criteria in this fact sheet are recommendations and are not intended to be in conflict with requirements established by the waste hauler. The waste hauler should be contacted prior to the design of your site trash collection areas. Conflicts or issues should be discussed with the local agency.

Designing New Installations

Trash storage areas should be designed to consider the following structural or treatment control BMPs:

- Design trash container areas so that drainage from adjoining roofs and pavement is diverted around the area(s) to avoid run-on. This might include berming or grading the waste handling area to prevent run-on of stormwater.
- Make sure trash container areas are screened or walled to prevent off-site transport of trash.

Design Objectives

- Maximize Infiltration
- Provide Retention
- Slow Runoff
- Minimize Impervious Land Coverage
- Prohibit Dumping of Improper Materials
- Contain Pollutants
- Collect and Convey



- Use lined bins or dumpsters to reduce leaking of liquid waste.
- Provide roofs, awnings, or attached lids on all trash containers to minimize direct precipitation and prevent rainfall from entering containers.
- Pave trash storage areas with an impervious surface to mitigate spills.
- Do not locate storm drains in immediate vicinity of the trash storage area.
- Post signs on all dumpsters informing users that hazardous materials are not to be disposed of therein.

Redeveloping Existing Installations

Various jurisdictional stormwater management and mitigation plans (SUSMP, WQMP, etc.) define “redevelopment” in terms of amounts of additional impervious area, increases in gross floor area and/or exterior construction, and land disturbing activities with structural or impervious surfaces. The definition of “redevelopment” must be consulted to determine whether or not the requirements for new development apply to areas intended for redevelopment. If the definition applies, the steps outlined under “designing new installations” above should be followed.

Additional Information

Maintenance Considerations

The integrity of structural elements that are subject to damage (i.e., screens, covers, and signs) must be maintained by the owner/operator. Maintenance agreements between the local agency and the owner/operator may be required. Some agencies will require maintenance deed restrictions to be recorded of the property title. If required by the local agency, maintenance agreements or deed restrictions must be executed by the owner/operator before improvement plans are approved.

Other Resources

A Manual for the Standard Urban Stormwater Mitigation Plan (SUSMP), Los Angeles County Department of Public Works, May 2002.

Model Standard Urban Storm Water Mitigation Plan (SUSMP) for San Diego County, Port of San Diego, and Cities in San Diego County, February 14, 2002.

Model Water Quality Management Plan (WQMP) for County of Orange, Orange County Flood Control District, and the Incorporated Cities of Orange County, Draft February 2003.

Ventura Countywide Technical Guidance Manual for Stormwater Quality Control Measures, July 2002.



Photo Credit: Geoff Brosseau

Design Objectives

- Maximize Infiltration
- Provide Retention
- Slow Runoff
- Minimize Impervious Land Coverage
- Prohibit Dumping of Improper Materials
- Contain Pollutants
- Collect and Convey

Description

Fueling areas have the potential to contribute oil and grease, solvents, car battery acid, coolant and gasoline to the stormwater conveyance system. Spills at vehicle and equipment fueling areas can be a significant source of pollution because fuels contain toxic materials and heavy metals that are not easily removed by stormwater treatment devices.

Approach

Project plans must be developed for cleaning near fuel dispensers, emergency spill cleanup, containment, and leak prevention.

Suitable Applications

Appropriate applications include commercial, industrial, and any other areas planned to have fuel dispensing equipment, including retail gasoline outlets, automotive repair shops, and major non-retail dispensing areas.

Design Considerations

Design requirements for fueling areas are governed by Building and Fire Codes and by current local agency ordinances and zoning requirements. Design requirements described in this fact sheet are meant to enhance and be consistent with these code and ordinance requirements.

Designing New Installations

Covering



Fuel dispensing areas should provide an overhanging roof structure or canopy. The cover's minimum dimensions must be equal to or greater than the area within the grade break. The cover must not drain onto the fuel dispensing area and the downspouts must be routed to prevent drainage across the fueling area. The fueling area should drain to the project's treatment control BMP(s) prior to discharging to the stormwater conveyance system. Note - If fueling large equipment or vehicles that would prohibit the use of covers or roofs, the fueling island should be designed to sufficiently accommodate the larger vehicles and equipment and to prevent stormwater run-on and runoff. Grade to direct stormwater to a dead-end sump.

Surfacing

Fuel dispensing areas should be paved with Portland cement concrete (or equivalent smooth impervious surface). The use of asphalt concrete should be prohibited. Use asphalt sealant to protect asphalt paved areas surrounding the fueling area. This provision may be made to sites that have pre-existing asphalt surfaces.

The concrete fuel dispensing area should be extended a minimum of 6.5 ft from the corner of each fuel dispenser, or the length at which the hose and nozzle assembly may be operated plus 1 ft, whichever is less.

Grading/Contouring

Dispensing areas should have an appropriate slope to prevent ponding, and be separated from the rest of the site by a grade break that prevents run-on of urban runoff. (Slope is required to be 2 to 4% in some jurisdictions' stormwater management and mitigation plans.)

Fueling areas should be graded to drain toward a dead-end sump. Runoff from downspouts/roofs should be directed away from fueling areas. Do not locate storm drains in the immediate vicinity of the fueling area.

Redeveloping Existing Installations

Various jurisdictional stormwater management and mitigation plans (SUSMP, WQMP, etc.) define "redevelopment" in terms of amounts of additional impervious area, increases in gross floor area and/or exterior construction, and land disturbing activities with structural or impervious surfaces. The definition of "redevelopment" must be consulted to determine whether or not the requirements for new development apply to areas intended for redevelopment. If the definition applies, the steps outlined under "designing new installations" above should be followed.

Additional Information

- In the case of an emergency, provide storm drain seals, such as isolation valves, drain plugs, or drain covers, to prevent spills or contaminated stormwater from entering the stormwater conveyance system.

Other Resources

A Manual for the Standard Urban Stormwater Mitigation Plan (SUSMP), Los Angeles County Department of Public Works, May 2002.

Model Standard Urban Storm Water Mitigation Plan (SUSMP) for San Diego County, Port of San Diego, and Cities in San Diego County, February 14, 2002.

Model Water Quality Management Plan (WQMP) for County of Orange, Orange County Flood Control District, and the Incorporated Cities of Orange County, Draft February 2003.

Ventura Countywide Technical Guidance Manual for Stormwater Quality Control Measures, July 2002.



Design Objectives

- Maximize Infiltration
- Provide Retention
- Slow Runoff
- Minimize Impervious Land Coverage
- Prohibit Dumping of Improper Materials
- Contain Pollutants
- Collect and Convey

Description

Waste materials dumped into storm drain inlets can have severe impacts on receiving and ground waters. Posting notices regarding discharge prohibitions at storm drain inlets can prevent waste dumping. Storm drain signs and stencils are highly visible source controls that are typically placed directly adjacent to storm drain inlets.

Approach

The stencil or affixed sign contains a brief statement that prohibits dumping of improper materials into the urban runoff conveyance system. Storm drain messages have become a popular method of alerting the public about the effects of and the prohibitions against waste disposal.

Suitable Applications

Stencils and signs alert the public to the destination of pollutants discharged to the storm drain. Signs are appropriate in residential, commercial, and industrial areas, as well as any other area where contributions or dumping to storm drains is likely.

Design Considerations

Storm drain message markers or placards are recommended at all storm drain inlets within the boundary of a development project. The marker should be placed in clear sight facing toward anyone approaching the inlet from either side. All storm drain inlet locations should be identified on the development site map.

Designing New Installations

The following methods should be considered for inclusion in the project design and show on project plans:

- Provide stenciling or labeling of all storm drain inlets and catch basins, constructed or modified, within the project area with prohibitive language. Examples include “NO DUMPING



– DRAINS TO OCEAN” and/or other graphical icons to discourage illegal dumping.

- Post signs with prohibitive language and/or graphical icons, which prohibit illegal dumping at public access points along channels and creeks within the project area.

Note - Some local agencies have approved specific signage and/or storm drain message placards for use. Consult local agency stormwater staff to determine specific requirements for placard types and methods of application.

Redeveloping Existing Installations

Various jurisdictional stormwater management and mitigation plans (SUSMP, WQMP, etc.) define “redevelopment” in terms of amounts of additional impervious area, increases in gross floor area and/or exterior construction, and land disturbing activities with structural or impervious surfaces. If the project meets the definition of “redevelopment”, then the requirements stated under “designing new installations” above should be included in all project design plans.

Additional Information

Maintenance Considerations

- Legibility of markers and signs should be maintained. If required by the agency with jurisdiction over the project, the owner/operator or homeowner’s association should enter into a maintenance agreement with the agency or record a deed restriction upon the property title to maintain the legibility of placards or signs.

Placement

- Signage on top of curbs tends to weather and fade.
- Signage on face of curbs tends to be worn by contact with vehicle tires and sweeper brooms.

Supplemental Information

Examples

- Most MS4 programs have storm drain signage programs. Some MS4 programs will provide stencils, or arrange for volunteers to stencil storm drains as part of their outreach program.

Other Resources

A Manual for the Standard Urban Stormwater Mitigation Plan (SUSMP), Los Angeles County Department of Public Works, May 2002.

Model Standard Urban Storm Water Mitigation Plan (SUSMP) for San Diego County, Port of San Diego, and Cities in San Diego County, February 14, 2002.

Model Water Quality Management Plan (WQMP) for County of Orange, Orange County Flood Control District, and the Incorporated Cities of Orange County, Draft February 2003.

Ventura Countywide Technical Guidance Manual for Stormwater Quality Control Measures, July 2002.



Design Objectives

- Maximize Infiltration
- Provide Retention
- Slow Runoff
- Minimize Impervious Land Coverage
- Prohibit Dumping of Improper Materials
- Contain Pollutants
- Collect and Convey

Description

Irrigation water provided to landscaped areas may result in excess irrigation water being conveyed into stormwater drainage systems.

Approach

Project plan designs for development and redevelopment should include application methods of irrigation water that minimize runoff of excess irrigation water into the stormwater conveyance system.

Suitable Applications

Appropriate applications include residential, commercial and industrial areas planned for development or redevelopment. (Detached residential single-family homes are typically excluded from this requirement.)

Design Considerations

Designing New Installations

The following methods to reduce excessive irrigation runoff should be considered, and incorporated and implemented where determined applicable and feasible by the Permittee:

- Employ rain-triggered shutoff devices to prevent irrigation after precipitation.
- Design irrigation systems to each landscape area's specific water requirements.
- Include design featuring flow reducers or shutoff valves triggered by a pressure drop to control water loss in the event of broken sprinkler heads or lines.
- Implement landscape plans consistent with County or City water conservation resolutions, which may include provision of water sensors, programmable irrigation times (for short cycles), etc.



- Design timing and application methods of irrigation water to minimize the runoff of excess irrigation water into the storm water drainage system.
- Group plants with similar water requirements in order to reduce excess irrigation runoff and promote surface filtration. Choose plants with low irrigation requirements (for example, native or drought tolerant species). Consider design features such as:
 - Using mulches (such as wood chips or bar) in planter areas without ground cover to minimize sediment in runoff
 - Installing appropriate plant materials for the location, in accordance with amount of sunlight and climate, and use native plant materials where possible and/or as recommended by the landscape architect
 - Leaving a vegetative barrier along the property boundary and interior watercourses, to act as a pollutant filter, where appropriate and feasible
 - Choosing plants that minimize or eliminate the use of fertilizer or pesticides to sustain growth
- Employ other comparable, equally effective methods to reduce irrigation water runoff.

Redeveloping Existing Installations

Various jurisdictional stormwater management and mitigation plans (SUSMP, WQMP, etc.) define “redevelopment” in terms of amounts of additional impervious area, increases in gross floor area and/or exterior construction, and land disturbing activities with structural or impervious surfaces. The definition of “redevelopment” must be consulted to determine whether or not the requirements for new development apply to areas intended for redevelopment. If the definition applies, the steps outlined under “designing new installations” above should be followed.

Other Resources

A Manual for the Standard Urban Stormwater Mitigation Plan (SUSMP), Los Angeles County Department of Public Works, May 2002.

Model Standard Urban Storm Water Mitigation Plan (SUSMP) for San Diego County, Port of San Diego, and Cities in San Diego County, February 14, 2002.

Model Water Quality Management Plan (WQMP) for County of Orange, Orange County Flood Control District, and the Incorporated Cities of Orange County, Draft February 2003.

Ventura Countywide Technical Guidance Manual for Stormwater Quality Control Measures, July 2002.



Rain Garden

Design Objectives

- Maximize Infiltration
- Provide Retention
- Slow Runoff
- Minimize Impervious Land Coverage
- Prohibit Dumping of Improper Materials
- Contain Pollutants
- Collect and Convey

Description

Various roof runoff controls are available to address stormwater that drains off rooftops. The objective is to reduce the total volume and rate of runoff from individual lots, and retain the pollutants on site that may be picked up from roofing materials and atmospheric deposition. Roof runoff controls consist of directing the roof runoff away from paved areas and mitigating flow to the storm drain system through one of several general approaches: cisterns or rain barrels; dry wells or infiltration trenches; pop-up emitters, and foundation planting. The first three approaches require the roof runoff to be contained in a gutter and downspout system. Foundation planting provides a vegetated strip under the drip line of the roof.

Approach

Design of individual lots for single-family homes as well as lots for higher density residential and commercial structures should consider site design provisions for containing and infiltrating roof runoff or directing roof runoff to vegetative swales or buffer areas. Retained water can be reused for watering gardens, lawns, and trees. Benefits to the environment include reduced demand for potable water used for irrigation, improved stormwater quality, increased groundwater recharge, decreased runoff volume and peak flows, and decreased flooding potential.

Suitable Applications

Appropriate applications include residential, commercial and industrial areas planned for development or redevelopment.

Design Considerations

Designing New Installations

Cisterns or Rain Barrels

One method of addressing roof runoff is to direct roof downspouts to cisterns or rain barrels. A cistern is an above ground storage vessel with either a manually operated valve or a permanently open outlet. Roof runoff is temporarily stored and then released for irrigation or infiltration between storms. The number of rain



barrels needed is a function of the rooftop area. Some low impact developers recommend that every house have at least 2 rain barrels, with a minimum storage capacity of 1000 liters. Roof barrels serve several purposes including mitigating the first flush from the roof which has a high volume, amount of contaminants, and thermal load. Several types of rain barrels are commercially available. Consideration must be given to selecting rain barrels that are vector proof and childproof. In addition, some barrels are designed with a bypass valve that filters out grit and other contaminants and routes overflow to a soak-away pit or rain garden.

If the cistern has an operable valve, the valve can be closed to store stormwater for irrigation or infiltration between storms. This system requires continual monitoring by the resident or grounds crews, but provides greater flexibility in water storage and metering. If a cistern is provided with an operable valve and water is stored inside for long periods, the cistern must be covered to prevent mosquitoes from breeding.

A cistern system with a permanently open outlet can also provide for metering stormwater runoff. If the cistern outlet is significantly smaller than the size of the downspout inlet (say $\frac{1}{4}$ to $\frac{1}{2}$ inch diameter), runoff will build up inside the cistern during storms, and will empty out slowly after peak intensities subside. This is a feasible way to mitigate the peak flow increases caused by rooftop impervious land coverage, especially for the frequent, small storms.

Dry wells and Infiltration Trenches

Roof downspouts can be directed to dry wells or infiltration trenches. A dry well is constructed by excavating a hole in the ground and filling it with an open graded aggregate, and allowing the water to fill the dry well and infiltrate after the storm event. An underground connection from the downspout conveys water into the dry well, allowing it to be stored in the voids. To minimize sedimentation from lateral soil movement, the sides and top of the stone storage matrix can be wrapped in a permeable filter fabric, though the bottom may remain open. A perforated observation pipe can be inserted vertically into the dry well to allow for inspection and maintenance.

In practice, dry wells receiving runoff from single roof downspouts have been successful over long periods because they contain very little sediment. They must be sized according to the amount of rooftop runoff received, but are typically 4 to 5 feet square, and 2 to 3 feet deep, with a minimum of 1-foot soil cover over the top (maximum depth of 10 feet).

To protect the foundation, dry wells must be set away from the building at least 10 feet. They must be installed in solids that accommodate infiltration. In poorly drained soils, dry wells have very limited feasibility.

Infiltration trenches function in a similar manner and would be particularly effective for larger roof areas. An infiltration trench is a long, narrow, rock-filled trench with no outlet that receives stormwater runoff. These are described under Treatment Controls.

Pop-up Drainage Emitter

Roof downspouts can be directed to an underground pipe that daylights some distance from the building foundation, releasing the roof runoff through a pop-up emitter. Similar to a pop-up irrigation head, the emitter only opens when there is flow from the roof. The emitter remains flush to the ground during dry periods, for ease of lawn or landscape maintenance.

Foundation Planting

Landscape planting can be provided around the base to allow increased opportunities for stormwater infiltration and protect the soil from erosion caused by concentrated sheet flow coming off the roof. Foundation plantings can reduce the physical impact of water on the soil and provide a subsurface matrix of roots that encourage infiltration. These plantings must be sturdy enough to tolerate the heavy runoff sheet flows, and periodic soil saturation.

Redeveloping Existing Installations

Various jurisdictional stormwater management and mitigation plans (SUSMP, WQMP, etc.) define “redevelopment” in terms of amounts of additional impervious area, increases in gross floor area and/or exterior construction, and land disturbing activities with structural or impervious surfaces. The definition of “redevelopment” must be consulted to determine whether or not the requirements for new development apply to areas intended for redevelopment. If the definition applies, the steps outlined under “designing new installations” above should be followed.

Supplemental Information

Examples

- City of Ottawa’s Water Links Surface –Water Quality Protection Program
- City of Toronto Downspout Disconnection Program
- City of Boston, MA, Rain Barrel Demonstration Program

Other Resources

Hager, Marty Catherine, Stormwater, “Low-Impact Development”, January/February 2003.
www.stormh2o.com

Low Impact Urban Design Tools, Low Impact Development Design Center, Beltsville, MD.
www.lid-stormwater.net

Start at the Source, Bay Area Stormwater Management Agencies Association, 1999 Edition

Site Design & Landscape Planning SD-10



Design Objectives

- Maximize Infiltration
 - Provide Retention
 - Slow Runoff
 - Minimize Impervious Land Coverage
 - Prohibit Dumping of Improper Materials
 - Contain Pollutants
 - Collect and Convey
-

Description

Each project site possesses unique topographic, hydrologic, and vegetative features, some of which are more suitable for development than others. Integrating and incorporating appropriate landscape planning methodologies into the project design is the most effective action that can be done to minimize surface and groundwater contamination from stormwater.

Approach

Landscape planning should couple consideration of land suitability for urban uses with consideration of community goals and projected growth. Project plan designs should conserve natural areas to the extent possible, maximize natural water storage and infiltration opportunities, and protect slopes and channels.

Suitable Applications

Appropriate applications include residential, commercial and industrial areas planned for development or redevelopment.

Design Considerations

Design requirements for site design and landscapes planning should conform to applicable standards and specifications of agencies with jurisdiction and be consistent with applicable General Plan and Local Area Plan policies.



SD-10 Site Design & Landscape Planning

Designing New Installations

Begin the development of a plan for the landscape unit with attention to the following general principles:

- Formulate the plan on the basis of clearly articulated community goals. Carefully identify conflicts and choices between retaining and protecting desired resources and community growth.
- Map and assess land suitability for urban uses. Include the following landscape features in the assessment: wooded land, open unwooded land, steep slopes, erosion-prone soils, foundation suitability, soil suitability for waste disposal, aquifers, aquifer recharge areas, wetlands, floodplains, surface waters, agricultural lands, and various categories of urban land use. When appropriate, the assessment can highlight outstanding local or regional resources that the community determines should be protected (e.g., a scenic area, recreational area, threatened species habitat, farmland, fish run). Mapping and assessment should recognize not only these resources but also additional areas needed for their sustenance.

Project plan designs should conserve natural areas to the extent possible, maximize natural water storage and infiltration opportunities, and protect slopes and channels.

Conserve Natural Areas during Landscape Planning

If applicable, the following items are required and must be implemented in the site layout during the subdivision design and approval process, consistent with applicable General Plan and Local Area Plan policies:

- Cluster development on least-sensitive portions of a site while leaving the remaining land in a natural undisturbed condition.
- Limit clearing and grading of native vegetation at a site to the minimum amount needed to build lots, allow access, and provide fire protection.
- Maximize trees and other vegetation at each site by planting additional vegetation, clustering tree areas, and promoting the use of native and/or drought tolerant plants.
- Promote natural vegetation by using parking lot islands and other landscaped areas.
- Preserve riparian areas and wetlands.

Maximize Natural Water Storage and Infiltration Opportunities Within the Landscape Unit

- Promote the conservation of forest cover. Building on land that is already deforested affects basin hydrology to a lesser extent than converting forested land. Loss of forest cover reduces interception storage, detention in the organic forest floor layer, and water losses by evapotranspiration, resulting in large peak runoff increases and either their negative effects or the expense of countering them with structural solutions.
- Maintain natural storage reservoirs and drainage corridors, including depressions, areas of permeable soils, swales, and intermittent streams. Develop and implement policies and

Site Design & Landscape Planning SD-10

regulations to discourage the clearing, filling, and channelization of these features. Utilize them in drainage networks in preference to pipes, culverts, and engineered ditches.

- Evaluating infiltration opportunities by referring to the stormwater management manual for the jurisdiction and pay particular attention to the selection criteria for avoiding groundwater contamination, poor soils, and hydrogeological conditions that cause these facilities to fail. If necessary, locate developments with large amounts of impervious surfaces or a potential to produce relatively contaminated runoff away from groundwater recharge areas.

Protection of Slopes and Channels during Landscape Design

- Convey runoff safely from the tops of slopes.
- Avoid disturbing steep or unstable slopes.
- Avoid disturbing natural channels.
- Stabilize disturbed slopes as quickly as possible.
- Vegetate slopes with native or drought tolerant vegetation.
- Control and treat flows in landscaping and/or other controls prior to reaching existing natural drainage systems.
- Stabilize temporary and permanent channel crossings as quickly as possible, and ensure that increases in run-off velocity and frequency caused by the project do not erode the channel.
- Install energy dissipaters, such as riprap, at the outlets of new storm drains, culverts, conduits, or channels that enter unlined channels in accordance with applicable specifications to minimize erosion. Energy dissipaters shall be installed in such a way as to minimize impacts to receiving waters.
- Line on-site conveyance channels where appropriate, to reduce erosion caused by increased flow velocity due to increases in tributary impervious area. The first choice for linings should be grass or some other vegetative surface, since these materials not only reduce runoff velocities, but also provide water quality benefits from filtration and infiltration. If velocities in the channel are high enough to erode grass or other vegetative linings, riprap, concrete, soil cement, or geo-grid stabilization are other alternatives.
- Consider other design principles that are comparable and equally effective.

Redeveloping Existing Installations

Various jurisdictional stormwater management and mitigation plans (SUSMP, WQMP, etc.) define “redevelopment” in terms of amounts of additional impervious area, increases in gross floor area and/or exterior construction, and land disturbing activities with structural or impervious surfaces. The definition of “redevelopment” must be consulted to determine whether or not the requirements for new development apply to areas intended for redevelopment. If the definition applies, the steps outlined under “designing new installations” above should be followed.

SD-10 Site Design & Landscape Planning

Redevelopment may present significant opportunity to add features which had not previously been implemented. Examples include incorporation of depressions, areas of permeable soils, and swales in newly redeveloped areas. While some site constraints may exist due to the status of already existing infrastructure, opportunities should not be missed to maximize infiltration, slow runoff, reduce impervious areas, disconnect directly connected impervious areas.

Other Resources

A Manual for the Standard Urban Stormwater Mitigation Plan (SUSMP), Los Angeles County Department of Public Works, May 2002.

Stormwater Management Manual for Western Washington, Washington State Department of Ecology, August 2001.

Model Standard Urban Storm Water Mitigation Plan (SUSMP) for San Diego County, Port of San Diego, and Cities in San Diego County, February 14, 2002.

Model Water Quality Management Plan (WQMP) for County of Orange, Orange County Flood Control District, and the Incorporated Cities of Orange County, Draft February 2003.

Ventura Countywide Technical Guidance Manual for Stormwater Quality Control Measures, July 2002.



Objectives

- Cover
- Contain
- Educate
- Reduce/Minimize

Description

As a consequence of its function, the stormwater conveyance system collects and transports urban runoff and stormwater that may contain certain pollutants. The protocols in this fact sheet are intended to reduce pollutants reaching receiving waters through proper conveyance system operation and maintenance.

Approach

Pollution Prevention

Maintain catch basins, stormwater inlets, and other stormwater conveyance structures on a regular basis to remove pollutants, reduce high pollutant concentrations during the first flush of storms, prevent clogging of the downstream conveyance system, restore catch basins' sediment trapping capacity, and ensure the system functions properly hydraulically to avoid flooding.

Suggested Protocols

Catch Basins/Inlet Structures

- Staff should regularly inspect facilities to ensure compliance with the following:
 - Immediate repair of any deterioration threatening structural integrity.
 - Cleaning before the sump is 40% full. Catch basins should be cleaned as frequently as needed to meet this standard.
 - Stenciling of catch basins and inlets (see SC34 Waste Handling and Disposal).

Targeted Constituents

| | |
|----------------|---|
| Sediment | ✓ |
| Nutrients | |
| Trash | ✓ |
| Metals | |
| Bacteria | ✓ |
| Oil and Grease | |
| Organics | |



SC-44 Drainage System Maintenance

- Clean catch basins, storm drain inlets, and other conveyance structures before the wet season to remove sediments and debris accumulated during the summer.
- Conduct inspections more frequently during the wet season for problem areas where sediment or trash accumulates more often. Clean and repair as needed.
- Keep accurate logs of the number of catch basins cleaned.
- Store wastes collected from cleaning activities of the drainage system in appropriate containers or temporary storage sites in a manner that prevents discharge to the storm drain.
- Dewater the wastes if necessary with outflow into the sanitary sewer if permitted. Water should be treated with an appropriate filtering device prior to discharge to the sanitary sewer. If discharge to the sanitary sewer is not allowed, water should be pumped or vacuumed to a tank and properly disposed. Do not dewater near a storm drain or stream.

Storm Drain Conveyance System

- Locate reaches of storm drain with deposit problems and develop a flushing schedule that keeps the pipe clear of excessive buildup.
- Collect and pump flushed effluent to the sanitary sewer for treatment whenever possible.

Pump Stations

- Clean all storm drain pump stations prior to the wet season to remove silt and trash.
- Do not allow discharge to reach the storm drain system when cleaning a storm drain pump station or other facility.
- Conduct routine maintenance at each pump station.
- Inspect, clean, and repair as necessary all outlet structures prior to the wet season.

Open Channel

- Modify storm channel characteristics to improve channel hydraulics, increase pollutant removals, and enhance channel/creek aesthetic and habitat value.
- Conduct channel modification/improvement in accordance with existing laws. Any person, government agency, or public utility proposing an activity that will change the natural (emphasis added) state of any river, stream, or lake in California, must enter into a Stream or Lake Alteration Agreement with the Department of Fish and Game. The developer-applicant should also contact local governments (city, county, special districts), other state agencies (SWRCB, RWQCB, Department of Forestry, Department of Water Resources), and Federal Corps of Engineers and USFWS.

Illicit Connections and Discharges

- Look for evidence of illegal discharges or illicit connections during routine maintenance of conveyance system and drainage structures:
 - Is there evidence of spills such as paints, discoloring, etc?

- Are there any odors associated with the drainage system?
- Record locations of apparent illegal discharges/illicit connections?
- Track flows back to potential dischargers and conduct aboveground inspections. This can be done through visual inspection of upgradient manholes or alternate techniques including zinc chloride smoke testing, fluorometric dye testing, physical inspection testing, or television camera inspection.
- Eliminate the discharge once the origin of flow is established.
- Stencil or demarcate storm drains, where applicable, to prevent illegal disposal of pollutants. Storm drain inlets should have messages such as “Dump No Waste Drains to Stream” stenciled next to them to warn against ignorant or intentional dumping of pollutants into the storm drainage system.
- Refer to fact sheet SC-10 Non-Stormwater Discharges.

Illegal Dumping

- Inspect and clean up hot spots and other storm drainage areas regularly where illegal dumping and disposal occurs.
- Establish a system for tracking incidents. The system should be designed to identify the following:
 - Illegal dumping hot spots
 - Types and quantities (in some cases) of wastes
 - Patterns in time of occurrence (time of day/night, month, or year)
 - Mode of dumping (abandoned containers, “midnight dumping” from moving vehicles, direct dumping of materials, accidents/spills)
 - Responsible parties
- Post “No Dumping” signs in problem areas with a phone number for reporting dumping and disposal. Signs should also indicate fines and penalties for illegal dumping.
- Refer to fact sheet SC-10 Non-Stormwater Discharges.

Training

- Train crews in proper maintenance activities, including record keeping and disposal.
- Allow only properly trained individuals to handle hazardous materials/wastes.
- Have staff involved in detection and removal of illicit connections trained in the following:
 - OSHA-required Health and Safety Training (29 CFR 1910.120) plus annual refresher training (as needed).

- OSHA Confined Space Entry training (Cal-OSHA Confined Space, Title 8 and Federal OSHA 29 CFR 1910.146).
- Procedural training (field screening, sampling, smoke/dye testing, TV inspection).

Spill Response and Prevention

- Investigate all reports of spills, leaks, and/or illegal dumping promptly.
- Clean up all spills and leaks using “dry” methods (with absorbent materials and/or rags) or dig up, remove, and properly dispose of contaminated soil.
- Refer to fact sheet SC-11 Spill Prevention, Control, and Cleanup.

Other Considerations (Limitations and Regulations)

- Clean-up activities may create a slight disturbance for local aquatic species. Access to items and material on private property may be limited. Trade-offs may exist between channel hydraulics and water quality/riparian habitat. If storm channels or basins are recognized as wetlands, many activities, including maintenance, may be subject to regulation and permitting.
- Storm drain flushing is most effective in small diameter pipes (36-inch diameter pipe or less, depending on water supply and sediment collection capacity). Other considerations associated with storm drain flushing may include the availability of a water source, finding a downstream area to collect sediments, liquid/sediment disposal, and prohibition against disposal of flushed effluent to sanitary sewer in some areas.
- Regulations may include adoption of substantial penalties for illegal dumping and disposal.
- Local municipal codes may include sections prohibiting discharge of soil, debris, refuse, hazardous wastes, and other pollutants into the storm drain system.

Requirements***Costs***

- An aggressive catch basin cleaning program could require a significant capital and O&M budget.
- The elimination of illegal dumping is dependent on the availability, convenience, and cost of alternative means of disposal. The primary cost is for staff time. Cost depends on how aggressively a program is implemented. Other cost considerations for an illegal dumping program include:
 - Purchase and installation of signs.
 - Rental of vehicle(s) to haul illegally-disposed items and material to landfills.
 - Rental of heavy equipment to remove larger items (e.g., car bodies) from channels.
 - Purchase of landfill space to dispose of illegally-dumped items and material.

- Methods used for illicit connection detection (smoke testing, dye testing, visual inspection, and flow monitoring) can be costly and time-consuming. Site-specific factors, such as the level of impervious area, the density and ages of buildings, and type of land use will determine the level of investigation necessary.

Maintenance

- Two-person teams may be required to clean catch basins with vacuum trucks.
- Teams of at least two people plus administrative personnel are required to identify illicit discharges, depending on the complexity of the storm sewer system.
- Arrangements must be made for proper disposal of collected wastes.
- Technical staff are required to detect and investigate illegal dumping violations.

Supplemental Information

Further Detail of the BMP

Storm Drain Flushing

Flushing is a common maintenance activity used to improve pipe hydraulics and to remove pollutants in storm drainage systems. Flushing may be designed to hydraulically convey accumulated material to strategic locations, such as an open channel, another point where flushing will be initiated, or the sanitary sewer and the treatment facilities, thus preventing resuspension and overflow of a portion of the solids during storm events. Flushing prevents “plug flow” discharges of concentrated pollutant loadings and sediments. Deposits can hinder the designed conveyance capacity of the storm drain system and potentially cause backwater conditions in severe cases of clogging.

Storm drain flushing usually takes place along segments of pipe with grades that are too flat to maintain adequate velocity to keep particles in suspension. An upstream manhole is selected to place an inflatable device that temporarily plugs the pipe. Further upstream, water is pumped into the line to create a flushing wave. When the upstream reach of pipe is sufficiently full to cause a flushing wave, the inflated device is rapidly deflated with the assistance of a vacuum pump, thereby releasing the backed up water and resulting in the cleaning of the storm drain segment.

To further reduce impacts of stormwater pollution, a second inflatable device placed well downstream may be used to recollect the water after the force of the flushing wave has dissipated. A pump may then be used to transfer the water and accumulated material to the sanitary sewer for treatment. In some cases, an interceptor structure may be more practical or required to recollect the flushed waters.

It has been found that cleansing efficiency of periodic flush waves is dependent upon flush volume, flush discharge rate, sewer slope, sewer length, sewer flow rate, sewer diameter, and population density. As a rule of thumb, the length of line to be flushed should not exceed 700 feet. At this maximum recommended length, the percent removal efficiency ranges between 65-75% for organics and 55-65% for dry weather grit/inorganic material. The percent removal efficiency drops rapidly beyond that. Water is commonly supplied by a water truck, but fire hydrants can also supply water. To make the best use of water, it is recommended that reclaimed water be used or that fire hydrant line flushing coincide with storm sewer flushing.

SC-44 Drainage System Maintenance

References and Resources

California's Nonpoint Source Program Plan <http://www.swrcb.ca.gov/nps/index.html>

Clark County Storm Water Pollution Control Manual
<http://www.co.clark.wa.us/pubworks/bmpman.pdf>

Ferguson, B.K. 1991. Urban Stream Reclamation, p. 324-322, Journal of Soil and Water Conservation.

King County Storm Water Pollution Control Manual <http://dnr.metrokc.gov/wlr/dss/spcm.htm>

Oregon Association of Clean Water Agencies. Oregon Municipal Stormwater Toolbox for Maintenance Practices. June 1998.

Santa Clara Valley Urban Runoff Pollution Prevention Program <http://www.scvurppp.org>

The Storm Water Managers Resource Center <http://www.stormwatercenter.net>

United States Environmental Protection Agency (USEPA). 2002. Pollution Prevention/Good Housekeeping for Municipal Operations Storm Drain System Cleaning. On line:
http://www.epa.gov/npdes/menuofbmps/poll_16.htm

Parking/Storage Area Maintenance SC-43



Description

Parking lots and storage areas can contribute a number of substances, such as trash, suspended solids, hydrocarbons, oil and grease, and heavy metals that can enter receiving waters through stormwater runoff or non-stormwater discharges. The protocols in this fact sheet are intended to prevent or reduce the discharge of pollutants from parking/storage areas and include using good housekeeping practices, following appropriate cleaning BMPs, and training employees.

Approach

The goal of this program is to ensure stormwater pollution prevention practices are considered when conducting activities on or around parking areas and storage areas to reduce potential for pollutant discharge to receiving waters. Successful implementation depends on effective training of employees on applicable BMPs and general pollution prevention strategies and objectives.

Pollution Prevention

- Encourage alternative designs and maintenance strategies for impervious parking lots. (See New Development and Redevelopment BMP Handbook)
- Keep accurate maintenance logs to evaluate BMP implementation.

Objectives

- Cover
- Contain
- Educate
- Reduce/Minimize
- Product Substitution

Targeted Constituents

| | |
|----------------|---|
| Sediment | ✓ |
| Nutrients | |
| Trash | ✓ |
| Metals | ✓ |
| Bacteria | |
| Oil and Grease | ✓ |
| Organics | ✓ |



SC-43 Parking/Storage Area Maintenance

Suggested Protocols

General

- Keep the parking and storage areas clean and orderly. Remove debris in a timely fashion.
- Allow sheet runoff to flow into biofilters (vegetated strip and swale) and/or infiltration devices.
- Utilize sand filters or oleophilic collectors for oily waste in low quantities.
- Arrange rooftop drains to prevent drainage directly onto paved surfaces.
- Design lot to include semi-permeable hardscape.
- Discharge soapy water remaining in mop or wash buckets to the sanitary sewer through a sink, toilet, clean-out, or wash area with drain.

Controlling Litter

- Post “No Littering” signs and enforce anti-litter laws.
- Provide an adequate number of litter receptacles.
- Clean out and cover litter receptacles frequently to prevent spillage.
- Provide trash receptacles in parking lots to discourage litter.
- Routinely sweep, shovel, and dispose of litter in the trash.

Surface Cleaning

- Use dry cleaning methods (e.g., sweeping, vacuuming) to prevent the discharge of pollutants into the stormwater conveyance system if possible.
- Establish frequency of public parking lot sweeping based on usage and field observations of waste accumulation.
- Sweep all parking lots at least once before the onset of the wet season.
- Follow the procedures below if water is used to clean surfaces:
 - Block the storm drain or contain runoff.
 - Collect and pump wash water to the sanitary sewer or discharge to a pervious surface. Do not allow wash water to enter storm drains.
 - Dispose of parking lot sweeping debris and dirt at a landfill.
- Follow the procedures below when cleaning heavy oily deposits:
 - Clean oily spots with absorbent materials.
 - Use a screen or filter fabric over inlet, then wash surfaces.

Parking/Storage Area Maintenance SC-43

- Do not allow discharges to the storm drain.
- Vacuum/pump discharges to a tank or discharge to sanitary sewer.
- Appropriately dispose of spilled materials and absorbents.

Surface Repair

- Preheat, transfer or load hot bituminous material away from storm drain inlets.
- Apply concrete, asphalt, and seal coat during dry weather to prevent contamination from contacting stormwater runoff.
- Cover and seal nearby storm drain inlets where applicable (with waterproof material or mesh) and manholes before applying seal coat, slurry seal, etc. Leave covers in place until job is complete and all water from emulsified oil sealants has drained or evaporated. Clean any debris from these covered manholes and drains for proper disposal.
- Use only as much water as necessary for dust control, to avoid runoff.
- Catch drips from paving equipment that is not in use with pans or absorbent material placed under the machines. Dispose of collected material and absorbents properly.

Inspection

- Have designated personnel conduct inspections of parking facilities and stormwater conveyance systems associated with parking facilities on a regular basis.
- Inspect cleaning equipment/sweepers for leaks on a regular basis.

Training

- Provide regular training to field employees and/or contractors regarding cleaning of paved areas and proper operation of equipment.
- Train employees and contractors in proper techniques for spill containment and cleanup.

Spill Response and Prevention

- Keep your Spill Prevention Control and Countermeasure (SPCC) Plan up-to-date.
- Place a stockpile of spill cleanup materials where it will be readily accessible or at a central location.
- Clean up fluid spills immediately with absorbent rags or material.
- Dispose of spilled material and absorbents properly.

Other Considerations

Limitations related to sweeping activities at large parking facilities may include high equipment costs, the need for sweeper operator training, and the inability of current sweeper technology to remove oil and grease.

SC-43 Parking/Storage Area Maintenance

Requirements

Costs

Cleaning/sweeping costs can be quite large. Construction and maintenance of stormwater structural controls can be quite expensive as well.

Maintenance

- Sweep parking lot regularly to minimize cleaning with water.
- Clean out oil/water/sand separators regularly, especially after heavy storms.
- Clean parking facilities regularly to prevent accumulated wastes and pollutants from being discharged into conveyance systems during rainy conditions.

Supplemental Information

Further Detail of the BMP

Surface Repair

Apply concrete, asphalt, and seal coat during dry weather to prevent contamination from contacting stormwater runoff. Where applicable, cover and seal nearby storm drain inlets (with waterproof material or mesh) and manholes before applying seal coat, slurry seal, etc. Leave covers in place until job is complete and all water from emulsified oil sealants has drained or evaporated. Clean any debris from these covered manholes and drains for proper disposal. Only use only as much water as is necessary for dust control to avoid runoff.

References and Resources

California's Nonpoint Source Program Plan <http://www.swrcb.ca.gov/nps/index.html>

Clark County Storm Water Pollution Control Manual
<http://www.co.clark.wa.us/pubworks/bmpman.pdf>

King County Storm Water Pollution Control Manual <http://dnr.metrokc.gov/wlr/dss/spcm.htm>

Pollution from Surface Cleaning Folder. 1996. Bay Area Stormwater Management Agencies Association (BASMAA). <http://www.basmaa.org/>

Oregon Association of Clean Water Agencies. Oregon Municipal Stormwater Toolbox for Maintenance Practices. June 1998.

Santa Clara Valley Urban Runoff Pollution Prevention Program <http://www.scvurppp.org>

The Storm Water Managers Resource Center <http://www.stormwatercenter.net/>



Description

Modifications are common particularly at large industrial sites. The activity may vary from minor and normal building repair to major remodeling, or the construction of new facilities. These activities can generate pollutants including solvents, paints, paint and varnish removers, finishing residues, spent thinners, soap cleaners, kerosene, asphalt and concrete materials, adhesive residues, and old asbestos installation. Protocols in this fact sheet are intended to prevent or reduce the discharge of pollutants to stormwater from building repair, remodeling, and construction by using soil erosion controls, enclosing or covering building material storage areas, using good housekeeping practices, using safer alternative products, and training employees.

Approach

Pollution Prevention

- Recycle residual paints, solvents, lumber, and other materials to the maximum extent practical.
- Buy recycled products to the maximum extent practical.
- Inform on-site contractors of company policy on these matters and include appropriate provisions in their contract to ensure certain proper housekeeping and disposal practices are implemented.

Objectives

- Cover
- Contain
- Educate
- Reduce/Minimize
- Recycle

Targeted Constituents

| | |
|----------------|---|
| Sediment | ✓ |
| Nutrients | |
| Trash | ✓ |
| Metals | ✓ |
| Bacteria | |
| Oil and Grease | ✓ |
| Organics | ✓ |



SC-42 Building Repair and Construction

- Make sure that nearby storm drains are well marked to minimize the chance of inadvertent disposal of residual paints and other liquids.

Suggested Protocols

Repair & Remodeling

- Follow BMPs identified in Construction BMP Handbook.
- Maintain good housekeeping practices while work is underway.
- Keep the work site clean and orderly. Remove debris in a timely fashion. Sweep the area.
- Cover materials of particular concern that must be left outside, particularly during the rainy season.
- Do not dump waste liquids down the storm drain.
- Dispose of wash water, sweepings, and sediments properly.
- Store materials properly that are normally used in repair and remodeling such as paints and solvents.
- Sweep out the gutter or wash the gutter and trap the particles at the outlet of the downspout if when repairing roofs, small particles have accumulated in the gutter. A sock or geofabric placed over the outlet may effectively trap the materials. If the downspout is tight lined, place a temporary plug at the first convenient point in the storm drain and pump out the water with a vacuum truck, and clean the catch basin sump where you placed the plug.
- Properly store and dispose waste materials generated from construction activities. See Construction BMP Handbook.
- Clean the storm drain system in the immediate vicinity of the construction activity after it is completed.

Painting

- Enclose painting operations consistent with local air quality regulations and OSHA.
- Local air pollution regulations may, in many areas of the state, specify painting procedures which if properly carried out are usually sufficient to protect water quality.
- Develop paint handling procedures for proper use, storage, and disposal of paints.
- Transport paint and materials to and from job sites in containers with secure lids and tied down to the transport vehicle.
- Test and inspect spray equipment prior to starting to paint. Tighten all hoses and connections and do not overfill paint containers.
- Mix paint indoors before using so that any spill will not be exposed to rain. Do so even during dry weather because cleanup of a spill will never be 100% effective.
- Transfer and load paint and hot thermoplastic away from storm drain inlets.

- Do not transfer or load paint near storm drain inlets.
- Plug nearby storm drain inlets prior to starting painting and remove plugs when job is complete when there is significant risk of a spill reaching storm drains.
- Cover nearby storm drain inlets prior to starting work if sand blasting is used to remove paint.
- Use a ground cloth to collect the chips if painting requires scraping or sand blasting of the existing surface. Dispose the residue properly.
- Cover or enclose painting operations properly to avoid drift.
- Clean the application equipment in a sink that is connected to the sanitary sewer if using water based paints.
- Capture all cleanup-water and dispose of properly.
- Dispose of paints containing lead or tributyl tin and considered a hazardous waste properly.
- Store leftover paints if they are to be kept for the next job properly, or dispose properly.
- Recycle paint when possible. Dispose of paint at an appropriate household hazardous waste facility.

Training

Proper education of off-site contractors is often overlooked. The conscientious efforts of well trained employees can be lost by unknowing off-site contractors, so make sure they are well informed about what they are expected to do.

Spill Response and Prevention

- Keep your Spill Prevention Control and Countermeasure (SPCC) Plan up-to-date.
- Place a stockpile of spill cleanup materials where it will be readily accessible.
- Clean up spills immediately.
- Excavate and remove the contaminated (stained) soil if a spill occurs on dirt.

Limitations

- This BMP is for minor construction only. The State's General Construction Activity Stormwater Permit has more requirements for larger projects. The companion "Construction Best Management Practice Handbook" contains specific guidance and best management practices for larger-scale projects.
- Hazardous waste that cannot be reused or recycled must be disposed of by a licensed hazardous waste hauler.
- Be certain that actions to help stormwater quality are consistent with Cal- and Fed-OSHA and air quality regulations.

SC-42 Building Repair and Construction

Requirements

Costs

These BMPs are generally low to modest in cost.

Maintenance

N/A

Supplemental Information

Further Detail of the BMP

Soil/Erosion Control

If the work involves exposing large areas of soil, employ the appropriate soil erosion and control techniques. See the Construction Best Management Practice Handbook. If old buildings are being torn down and not replaced in the near future, stabilize the site using measures described in SC-40 Contaminated or Erodible Areas.

If a building is to be placed over an open area with a storm drainage system, make sure the storm inlets within the building are covered or removed, or the storm line is connected to the sanitary sewer. If because of the remodeling a new drainage system is to be installed or the existing system is to be modified, consider installing catch basins as they serve as effective “in-line” treatment devices. See Treatment Control Fact Sheet TC-20 Wet Pond/Basin in Section 5 of the New Development and Redevelopment Handbook regarding design criteria. Include in the catch basin a “turn-down” elbow or similar device to trap floatables.

References and Resources

California’s Nonpoint Source Program Plan <http://www.swrcb.ca.gov/nps/index.html>

Clark County Storm Water Pollution Control Manual
<http://www.co.clark.wa.us/pubworks/bmpman.pdf>

King County Storm Water Pollution Control Manual <http://dnr.metrokc.gov/wlr/dss/spcm.htm>

Santa Clara Valley Urban Runoff Pollution Prevention Program <http://www.scvurppp.org>

The Storm Water Managers Resource Center <http://www.stormwatercenter.net/>



Description

Stormwater runoff from building and grounds maintenance activities can be contaminated with toxic hydrocarbons in solvents, fertilizers and pesticides, suspended solids, heavy metals, abnormal pH, and oils and greases. Utilizing the protocols in this fact sheet will prevent or reduce the discharge of pollutants to stormwater from building and grounds maintenance activities by washing and cleaning up with as little water as possible, following good landscape management practices, preventing and cleaning up spills immediately, keeping debris from entering the storm drains, and maintaining the stormwater collection system.

Approach

Reduce potential for pollutant discharge through source control pollution prevention and BMP implementation. Successful implementation depends on effective training of employees on applicable BMPs and general pollution prevention strategies and objectives.

Pollution Prevention

- Switch to non-toxic chemicals for maintenance when possible.
- Choose cleaning agents that can be recycled.
- Encourage proper lawn management and landscaping, including use of native vegetation.

Objectives

- Cover
- Contain
- Educate
- Reduce/Minimize
- Product Substitution

Targeted Constituents

| | |
|----------------|---|
| Sediment | ✓ |
| Nutrients | ✓ |
| Trash | |
| Metals | ✓ |
| Bacteria | ✓ |
| Oil and Grease | |
| Organics | |



SC-41 Building & Grounds Maintenance

- Encourage use of Integrated Pest Management techniques for pest control.
- Encourage proper onsite recycling of yard trimmings.
- Recycle residual paints, solvents, lumber, and other material as much as possible.

Suggested Protocols

Pressure Washing of Buildings, Rooftops, and Other Large Objects

- In situations where soaps or detergents are used and the surrounding area is paved, pressure washers must use a water collection device that enables collection of wash water and associated solids. A sump pump, wet vacuum or similarly effective device must be used to collect the runoff and loose materials. The collected runoff and solids must be disposed of properly.
- If soaps or detergents are not used, and the surrounding area is paved, wash runoff does not have to be collected but must be screened. Pressure washers must use filter fabric or some other type of screen on the ground and/or in the catch basin to trap the particles in wash water runoff.
- If you are pressure washing on a grassed area (with or without soap), runoff must be dispersed as sheet flow as much as possible, rather than as a concentrated stream. The wash runoff must remain on the grass and not drain to pavement.

Landscaping Activities

- Dispose of grass clippings, leaves, sticks, or other collected vegetation as garbage, or by composting. Do not dispose of collected vegetation into waterways or storm drainage systems.
- Use mulch or other erosion control measures on exposed soils.

Building Repair, Remodeling, and Construction

- Do not dump any toxic substance or liquid waste on the pavement, the ground, or toward a storm drain.
- Use ground or drop cloths underneath outdoor painting, scraping, and sandblasting work, and properly dispose of collected material daily.
- Use a ground cloth or oversized tub for activities such as paint mixing and tool cleaning.
- Clean paintbrushes and tools covered with water-based paints in sinks connected to sanitary sewers or in portable containers that can be dumped into a sanitary sewer drain. Brushes and tools covered with non-water-based paints, finishes, or other materials must be cleaned in a manner that enables collection of used solvents (e.g., paint thinner, turpentine, etc.) for recycling or proper disposal.
- Use a storm drain cover, filter fabric, or similarly effective runoff control mechanism if dust, grit, wash water, or other pollutants may escape the work area and enter a catch basin. This is particularly necessary on rainy days. The containment device(s) must be in place at the beginning of the work day, and accumulated dirty runoff and solids must be collected and disposed of before removing the containment device(s) at the end of the work day.

- If you need to de-water an excavation site, you may need to filter the water before discharging to a catch basin or off-site. If directed off-site, you should direct the water through hay bales and filter fabric or use other sediment filters or traps.
- Store toxic material under cover during precipitation events and when not in use. A cover would include tarps or other temporary cover material.

Mowing, Trimming, and Planting

- Dispose of leaves, sticks, or other collected vegetation as garbage, by composting or at a permitted landfill. Do not dispose of collected vegetation into waterways or storm drainage systems.
- Use mulch or other erosion control measures when soils are exposed.
- Place temporarily stockpiled material away from watercourses and drain inlets, and berm or cover stockpiles to prevent material releases to the storm drain system.
- Consider an alternative approach when bailing out muddy water: do not put it in the storm drain; pour over landscaped areas.
- Use hand weeding where practical.

Fertilizer and Pesticide Management

- Follow all federal, state, and local laws and regulations governing the use, storage, and disposal of fertilizers and pesticides and training of applicators and pest control advisors.
- Use less toxic pesticides that will do the job when applicable. Avoid use of copper-based pesticides if possible.
- Do not use pesticides if rain is expected.
- Do not mix or prepare pesticides for application near storm drains.
- Use the minimum amount needed for the job.
- Calibrate fertilizer distributors to avoid excessive application.
- Employ techniques to minimize off-target application (e.g., spray drift) of pesticides, including consideration of alternative application techniques.
- Apply pesticides only when wind speeds are low.
- Fertilizers should be worked into the soil rather than dumped or broadcast onto the surface.
- Irrigate slowly to prevent runoff and then only as much as is needed.
- Clean pavement and sidewalk if fertilizer is spilled on these surfaces before applying irrigation water.
- Dispose of empty pesticide containers according to the instructions on the container label.

SC-41 Building & Grounds Maintenance

- Use up the pesticides. Rinse containers, and use rinse water as product. Dispose of unused pesticide as hazardous waste.
- Implement storage requirements for pesticide products with guidance from the local fire department and County Agricultural Commissioner. Provide secondary containment for pesticides.

Inspection

- Inspect irrigation system periodically to ensure that the right amount of water is being applied and that excessive runoff is not occurring. Minimize excess watering and repair leaks in the irrigation system as soon as they are observed.

Training

- Educate and train employees on pesticide use and in pesticide application techniques to prevent pollution.
- Train employees and contractors in proper techniques for spill containment and cleanup.
- Be sure the frequency of training takes into account the complexity of the operations and the nature of the staff.

Spill Response and Prevention

- Keep your Spill Prevention Control and Countermeasure (SPCC) Plan up-to-date.
- Place a stockpile of spill cleanup materials, such as brooms, dustpans, and vacuum sweepers (if desired) near the storage area where it will be readily accessible.
- Have employees trained in spill containment and cleanup present during the loading/unloading of dangerous wastes, liquid chemicals, or other materials.
- Familiarize employees with the Spill Prevention Control and Countermeasure Plan.
- Clean up spills immediately.

Other Considerations

Alternative pest/weed controls may not be available, suitable, or effective in many cases.

Requirements

Costs

- Cost will vary depending on the type and size of facility.
- Overall costs should be low in comparison to other BMPs.

Maintenance

Sweep paved areas regularly to collect loose particles. Wipe up spills with rags and other absorbent material immediately, do not hose down the area to a storm drain.

Supplemental Information

Further Detail of the BMP

Fire Sprinkler Line Flushing

Building fire sprinkler line flushing may be a source of non-stormwater runoff pollution. The water entering the system is usually potable water, though in some areas it may be non-potable reclaimed wastewater. There are subsequent factors that may drastically reduce the quality of the water in such systems. Black iron pipe is usually used since it is cheaper than potable piping, but it is subject to rusting and results in lower quality water. Initially, the black iron pipe has an oil coating to protect it from rusting between manufacture and installation; this will contaminate the water from the first flush but not from subsequent flushes. Nitrates, poly-phosphates and other corrosion inhibitors, as well as fire suppressants and antifreeze may be added to the sprinkler water system. Water generally remains in the sprinkler system a long time (typically a year) and between flushes may accumulate iron, manganese, lead, copper, nickel, and zinc. The water generally becomes anoxic and contains living and dead bacteria and breakdown products from chlorination. This may result in a significant BOD problem and the water often smells. Consequently dispose fire sprinkler line flush water into the sanitary sewer. Do not allow discharge to storm drain or infiltration due to potential high levels of pollutants in fire sprinkler line water.

References and Resources

California's Nonpoint Source Program Plan <http://www.swrcb.ca.gov/nps/index.html>

Clark County Storm Water Pollution Control Manual
<http://www.co.clark.wa.us/pubworks/bmpman.pdf>

King County Storm Water Pollution Control Manual <http://dnr.metrokc.gov/wlr/dss/spcm.htm>

Mobile Cleaners Pilot Program: Final Report. 1997. Bay Area Stormwater Management Agencies Association (BASMAA). <http://www.basmaa.org/>

Pollution from Surface Cleaning Folder. 1996. Bay Area Stormwater Management Agencies Association (BASMAA). <http://www.basmaa.org/>

Santa Clara Valley Urban Runoff Pollution Prevention Program <http://www.scvurppp.org>

The Storm Water Managers Resource Center <http://www.stormwatercenter.net/>



Objectives

- Cover
- Contain
- Educate
- Reduce/Minimize
- Product Substitution

Description

Improper storage and handling of solid wastes can allow toxic compounds, oils and greases, heavy metals, nutrients, suspended solids, and other pollutants to enter stormwater runoff. The discharge of pollutants to stormwater from waste handling and disposal can be prevented and reduced by tracking waste generation, storage, and disposal; reducing waste generation and disposal through source reduction, reuse, and recycling; and preventing run-on and runoff.

Approach

Pollution Prevention

- Accomplish reduction in the amount of waste generated using the following source controls:
 - Production planning and sequencing
 - Process or equipment modification
 - Raw material substitution or elimination
 - Loss prevention and housekeeping
 - Waste segregation and separation
 - Close loop recycling
- Establish a material tracking system to increase awareness about material usage. This may reduce spills and minimize contamination, thus reducing the amount of waste produced.
- Recycle materials whenever possible.

Targeted Constituents

| | |
|----------------|---|
| Sediment | |
| Nutrients | |
| Trash | |
| Metals | ✓ |
| Bacteria | ✓ |
| Oil and Grease | ✓ |
| Organics | ✓ |



Suggested Protocols*General*

- Cover storage containers with leak proof lids or some other means. If waste is not in containers, cover all waste piles (plastic tarps are acceptable coverage) and prevent stormwater run-on and runoff with a berm. The waste containers or piles must be covered except when in use.
- Use drip pans or absorbent materials whenever grease containers are emptied by vacuum trucks or other means. Grease cannot be left on the ground. Collected grease must be properly disposed of as garbage.
- Check storage containers weekly for leaks and to ensure that lids are on tightly. Replace any that are leaking, corroded, or otherwise deteriorating.
- Sweep and clean the storage area regularly. If it is paved, do not hose down the area to a storm drain.
- Dispose of rinse and wash water from cleaning waste containers into a sanitary sewer if allowed by the local sewer authority. Do not discharge wash water to the street or storm drain.
- Transfer waste from damaged containers into safe containers.
- Take special care when loading or unloading wastes to minimize losses. Loading systems can be used to minimize spills and fugitive emission losses such as dust or mist. Vacuum transfer systems can minimize waste loss.

Controlling Litter

- Post “No Littering” signs and enforce anti-litter laws.
- Provide a sufficient number of litter receptacles for the facility.
- Clean out and cover litter receptacles frequently to prevent spillage.

Waste Collection

- Keep waste collection areas clean.
- Inspect solid waste containers for structural damage regularly. Repair or replace damaged containers as necessary.
- Secure solid waste containers; containers must be closed tightly when not in use.
- Do not fill waste containers with washout water or any other liquid.
- Ensure that only appropriate solid wastes are added to the solid waste container. Certain wastes such as hazardous wastes, appliances, fluorescent lamps, pesticides, etc., may not be disposed of in solid waste containers (see chemical/ hazardous waste collection section below).

- Do not mix wastes; this can cause chemical reactions, make recycling impossible, and complicate disposal.

Good Housekeeping

- Use all of the product before disposing of the container.
- Keep the waste management area clean at all times by sweeping and cleaning up spills immediately.
- Use dry methods when possible (e.g., sweeping, use of absorbents) when cleaning around restaurant/food handling dumpster areas. If water must be used after sweeping/using absorbents, collect water and discharge through grease interceptor to the sewer.

Chemical/Hazardous Wastes

- Select designated hazardous waste collection areas on-site.
- Store hazardous materials and wastes in covered containers and protect them from vandalism.
- Place hazardous waste containers in secondary containment.
- Make sure that hazardous waste is collected, removed, and disposed of only at authorized disposal areas.
- Stencil or demarcate storm drains on the facility's property with prohibitive message regarding waste disposal.

Run-on/Runoff Prevention

- Prevent stormwater run-on from entering the waste management area by enclosing the area or building a berm around the area.
- Prevent waste materials from directly contacting rain.
- Cover waste piles with temporary covering material such as reinforced tarpaulin, polyethylene, polyurethane, polypropylene or hypalon.
- Cover the area with a permanent roof if feasible.
- Cover dumpsters to prevent rain from washing waste out of holes or cracks in the bottom of the dumpster.
- Move the activity indoor after ensuring all safety concerns such as fire hazard and ventilation are addressed.

Inspection

- Inspect and replace faulty pumps or hoses regularly to minimize the potential of releases and spills.
- Check waste management areas for leaking containers or spills.

- Repair leaking equipment including valves, lines, seals, or pumps promptly.

Training

- Train staff in pollution prevention measures and proper disposal methods.
- Train employees and contractors in proper spill containment and cleanup. The employee should have the tools and knowledge to immediately begin cleaning up a spill should one occur.
- Train employees and subcontractors in proper hazardous waste management.

Spill Response and Prevention

- Keep your Spill Prevention Control and Countermeasure (SPCC) Plan up-to-date.
- Have an emergency plan, equipment and trained personnel ready at all times to deal immediately with major spills
- Collect all spilled liquids and properly dispose of them.
- Store and maintain appropriate spill cleanup materials in a location known to all near the designated wash area.
- Ensure that vehicles transporting waste have spill prevention equipment that can prevent spills during transport. Spill prevention equipment includes:
 - Vehicles equipped with baffles for liquid waste
 - Trucks with sealed gates and spill guards for solid waste

Other Considerations (Limitations and Regulations)

Hazardous waste cannot be reused or recycled; it must be disposed of by a licensed hazardous waste hauler.

Requirements***Costs***

Capital and O&M costs for these programs will vary substantially depending on the size of the facility and the types of waste handled. Costs should be low if there is an inventory program in place.

Maintenance

- None except for maintaining equipment for material tracking program.

Supplemental Information***Further Detail of the BMP******Land Treatment System***

Minimize runoff of polluted stormwater from land application by:

- Choosing a site where slopes are under 6%, the soil is permeable, there is a low water table, it is located away from wetlands or marshes, and there is a closed drainage system

- Avoiding application of waste to the site when it is raining or when the ground is saturated with water
- Growing vegetation on land disposal areas to stabilize soils and reduce the volume of surface water runoff from the site
- Maintaining adequate barriers between the land application site and the receiving waters (planted strips are particularly good)
- Using erosion control techniques such as mulching and matting, filter fences, straw bales, diversion terracing, and sediment basins
- Performing routine maintenance to ensure the erosion control or site stabilization measures are working

Examples

The port of Long Beach has a state-of-the-art database for identifying potential pollutant sources, documenting facility management practices, and tracking pollutants.

References and Resources

California's Nonpoint Source Program Plan <http://www.swrcb.ca.gov/nps/index.html>

Clark County Storm Water Pollution Control Manual
<http://www.co.clark.wa.us/pubworks/bmpman.pdf>

Solid Waste Container Best Management Practices – Fact Sheet On-Line Resources – Environmental Health and Safety. Harvard University. 2002.

King County Storm Water Pollution Control Manual <http://dnr.metrokc.gov/wlr/dss/spcm.htm>

Pollution from Surface Cleaning Folder. 1996. Bay Area Stormwater Management Agencies Association (BASMAA). <http://www.basmaa.org>

Santa Clara Valley Urban Runoff Pollution Prevention Program <http://www.scvurppp.org>

The Storm Water Managers Resource Center <http://www.stormwatercenter.net/>

Spill Prevention, Control & Cleanup SC-11



Photo Credit: Geoff Brosseau

Objectives

- Cover
- Contain
- Educate
- Reduce/Minimize
- Product Substitution

Description

Many activities that occur at an industrial or commercial site have the potential to cause accidental or illegal spills. Preparation for accidental or illegal spills, with proper training and reporting systems implemented, can minimize the discharge of pollutants to the environment.

Spills and leaks are one of the largest contributors of stormwater pollutants. Spill prevention and control plans are applicable to any site at which hazardous materials are stored or used. An effective plan should have spill prevention and response procedures that identify potential spill areas, specify material handling procedures, describe spill response procedures, and provide spill clean-up equipment. The plan should take steps to identify and characterize potential spills, eliminate and reduce spill potential, respond to spills when they occur in an effort to prevent pollutants from entering the stormwater drainage system, and train personnel to prevent and control future spills.

Approach

Pollution Prevention

- Develop procedures to prevent/mitigate spills to storm drain systems. Develop and standardize reporting procedures, containment, storage, and disposal activities, documentation, and follow-up procedures.
- Develop a Spill Prevention Control and Countermeasure (SPCC) Plan. The plan should include:

Targeted Constituents

| | |
|----------------|-------------------------------------|
| Sediment | |
| Nutrients | |
| Trash | |
| Metals | <input checked="" type="checkbox"/> |
| Bacteria | |
| Oil and Grease | <input checked="" type="checkbox"/> |
| Organics | <input checked="" type="checkbox"/> |



SC-11 Spill Prevention, Control & Cleanup

- Description of the facility, owner and address, activities and chemicals present
- Facility map
- Notification and evacuation procedures
- Cleanup instructions
- Identification of responsible departments
- Identify key spill response personnel
- Recycle, reclaim, or reuse materials whenever possible. This will reduce the amount of process materials that are brought into the facility.

Suggested Protocols (including equipment needs)

Spill Prevention

- Develop procedures to prevent/mitigate spills to storm drain systems. Develop and standardize reporting procedures, containment, storage, and disposal activities, documentation, and follow-up procedures.
- If consistent illegal dumping is observed at the facility:
 - Post “No Dumping” signs with a phone number for reporting illegal dumping and disposal. Signs should also indicate fines and penalties applicable for illegal dumping.
 - Landscaping and beautification efforts may also discourage illegal dumping.
 - Bright lighting and/or entrance barriers may also be needed to discourage illegal dumping.
- Store and contain liquid materials in such a manner that if the tank is ruptured, the contents will not discharge, flow, or be washed into the storm drainage system, surface waters, or groundwater.
- If the liquid is oil, gas, or other material that separates from and floats on water, install a spill control device (such as a tee section) in the catch basins that collects runoff from the storage tank area.
- Routine maintenance:
 - Place drip pans or absorbent materials beneath all mounted taps, and at all potential drip and spill locations during filling and unloading of tanks. Any collected liquids or soiled absorbent materials must be reused/recycled or properly disposed.
 - Store and maintain appropriate spill cleanup materials in a location known to all near the tank storage area; and ensure that employees are familiar with the site’s spill control plan and/or proper spill cleanup procedures.
 - Sweep and clean the storage area monthly if it is paved, *do not hose down the area to a storm drain.*

Spill Prevention, Control & Cleanup SC-11

- Check tanks (and any containment sumps) daily for leaks and spills. Replace tanks that are leaking, corroded, or otherwise deteriorating with tanks in good condition. Collect all spilled liquids and properly dispose of them.
- Label all containers according to their contents (e.g., solvent, gasoline).
- Label hazardous substances regarding the potential hazard (corrosive, radioactive, flammable, explosive, poisonous).
- Prominently display required labels on transported hazardous and toxic materials (per US DOT regulations).
- Identify key spill response personnel.

Spill Control and Cleanup Activities

- Follow the Spill Prevention Control and Countermeasure Plan.
- Clean up leaks and spills immediately.
- Place a stockpile of spill cleanup materials where it will be readily accessible (e.g., near storage and maintenance areas).
- On paved surfaces, clean up spills with as little water as possible. Use a rag for small spills, a damp mop for general cleanup, and absorbent material for larger spills. If the spilled material is hazardous, then the used cleanup materials are also hazardous and must be sent to a certified laundry (rags) or disposed of as hazardous waste. Physical methods for the cleanup of dry chemicals include the use of brooms, shovels, sweepers, or plows.
- Never hose down or bury dry material spills. Sweep up the material and dispose of properly.
- Chemical cleanups of material can be achieved with the use of adsorbents, gels, and foams. Use adsorbent materials on small spills rather than hosing down the spill. Remove the adsorbent materials promptly and dispose of properly.
- For larger spills, a private spill cleanup company or Hazmat team may be necessary.

Reporting

- Report spills that pose an immediate threat to human health or the environment to the Regional Water Quality Control Board.
- Federal regulations require that any oil spill into a water body or onto an adjoining shoreline be reported to the National Response Center (NRC) at 800-424-8802 (24 hour).
- Report spills to local agencies, such as the fire department; they can assist in cleanup.
- Establish a system for tracking incidents. The system should be designed to identify the following:
 - Types and quantities (in some cases) of wastes
 - Patterns in time of occurrence (time of day/night, month, or year)

SC-11 Spill Prevention, Control & Cleanup

- Mode of dumping (abandoned containers, “midnight dumping” from moving vehicles, direct dumping of materials, accidents/spills)
- Responsible parties

Training

- Educate employees about spill prevention and cleanup.
- Well-trained employees can reduce human errors that lead to accidental releases or spills:
 - The employee should have the tools and knowledge to immediately begin cleaning up a spill should one occur.
 - Employees should be familiar with the Spill Prevention Control and Countermeasure Plan.
- Employees should be educated about aboveground storage tank requirements. Employees responsible for aboveground storage tanks and liquid transfers should be thoroughly familiar with the Spill Prevention Control and Countermeasure Plan and the plan should be readily available.
- Train employees to recognize and report illegal dumping incidents.

Other Considerations (Limitations and Regulations)

- A Spill Prevention Control and Countermeasure Plan (SPCC) is required for facilities that are subject to the oil pollution regulations specified in Part 112 of Title 40 of the Code of Federal Regulations or if they have a storage capacity of 10,000 gallons or more of petroleum. (Health and Safety Code 6.67)
- State regulations also exist for storage of hazardous materials (Health & Safety Code Chapter 6.95), including the preparation of area and business plans for emergency response to the releases or threatened releases.
- Consider requiring smaller secondary containment areas (less than 200 sq. ft.) to be connected to the sanitary sewer, prohibiting any hard connections to the storm drain.

Requirements

Costs (including capital and operation & maintenance)

- Will vary depending on the size of the facility and the necessary controls.
- Prevention of leaks and spills is inexpensive. Treatment and/or disposal of contaminated soil or water can be quite expensive.

Maintenance (including administrative and staffing)

- This BMP has no major administrative or staffing requirements. However, extra time is needed to properly handle and dispose of spills, which results in increased labor costs.

Spill Prevention, Control & Cleanup SC-11

Supplemental Information

Further Detail of the BMP

Reporting

Record keeping and internal reporting represent good operating practices because they can increase the efficiency of the facility and the effectiveness of BMPs. A good record keeping system helps the facility minimize incident recurrence, correctly respond with appropriate cleanup activities, and comply with legal requirements. A record keeping and reporting system should be set up for documenting spills, leaks, and other discharges, including discharges of hazardous substances in reportable quantities. Incident records describe the quality and quantity of non-stormwater discharges to the storm sewer. These records should contain the following information:

- Date and time of the incident
- Weather conditions
- Duration of the spill/leak/discharge
- Cause of the spill/leak/discharge
- Response procedures implemented
- Persons notified
- Environmental problems associated with the spill/leak/discharge

Separate record keeping systems should be established to document housekeeping and preventive maintenance inspections, and training activities. All housekeeping and preventive maintenance inspections should be documented. Inspection documentation should contain the following information:

- The date and time the inspection was performed
- Name of the inspector
- Items inspected
- Problems noted
- Corrective action required
- Date corrective action was taken

Other means to document and record inspection results are field notes, timed and dated photographs, videotapes, and drawings and maps.

Aboveground Tank Leak and Spill Control

Accidental releases of materials from aboveground liquid storage tanks present the potential for contaminating stormwater with many different pollutants. Materials spilled, leaked, or lost from

SC-11 Spill Prevention, Control & Cleanup

tanks may accumulate in soils or on impervious surfaces and be carried away by stormwater runoff.

The most common causes of unintentional releases are:

- Installation problems
- Failure of piping systems (pipes, pumps, flanges, couplings, hoses, and valves)
- External corrosion and structural failure
- Spills and overfills due to operator error
- Leaks during pumping of liquids or gases from truck or rail car to a storage tank or vice versa

Storage of reactive, ignitable, or flammable liquids should comply with the Uniform Fire Code and the National Electric Code. Practices listed below should be employed to enhance the code requirements:

- Tanks should be placed in a designated area.
- Tanks located in areas where firearms are discharged should be encapsulated in concrete or the equivalent.
- Designated areas should be impervious and paved with Portland cement concrete, free of cracks and gaps, in order to contain leaks and spills.
- Liquid materials should be stored in UL approved double walled tanks or surrounded by a curb or dike to provide the volume to contain 10 percent of the volume of all of the containers or 110 percent of the volume of the largest container, whichever is greater. The area inside the curb should slope to a drain.
- For used oil or dangerous waste, a dead-end sump should be installed in the drain.
- All other liquids should be drained to the sanitary sewer if available. The drain must have a positive control such as a lock, valve, or plug to prevent release of contaminated liquids.
- Accumulated stormwater in petroleum storage areas should be passed through an oil/water separator.

Maintenance is critical to preventing leaks and spills. Conduct routine inspections and:

- Check for external corrosion and structural failure.
- Check for spills and overfills due to operator error.
- Check for failure of piping system (pipes, pumps, flanger, coupling, hoses, and valves).
- Check for leaks or spills during pumping of liquids or gases from truck or rail car to a storage facility or vice versa.

Spill Prevention, Control & Cleanup SC-11

- Visually inspect new tank or container installation for loose fittings, poor welding, and improper or poorly fitted gaskets.
- Inspect tank foundations, connections, coatings, and tank walls and piping system. Look for corrosion, leaks, cracks, scratches, and other physical damage that may weaken the tank or container system.
- Frequently relocate accumulated stormwater during the wet season.
- Periodically conduct integrity testing by a qualified professional.

Vehicle Leak and Spill Control

Major spills on roadways and other public areas are generally handled by highly trained Hazmat teams from local fire departments or environmental health departments. The measures listed below pertain to leaks and smaller spills at vehicle maintenance shops.

In addition to implementing the spill prevention, control, and clean up practices above, use the following measures related to specific activities:

Vehicle and Equipment Maintenance

- Perform all vehicle fluid removal or changing inside or under cover to prevent the run-on of stormwater and the runoff of spills.
- Regularly inspect vehicles and equipment for leaks, and repair immediately.
- Check incoming vehicles and equipment (including delivery trucks, and employee and subcontractor vehicles) for leaking oil and fluids. Do not allow leaking vehicles or equipment onsite.
- Always use secondary containment, such as a drain pan or drop cloth, to catch spills or leaks when removing or changing fluids.
- Immediately drain all fluids from wrecked vehicles.
- Store wrecked vehicles or damaged equipment under cover.
- Place drip pans or absorbent materials under heavy equipment when not in use.
- Use adsorbent materials on small spills rather than hosing down the spill.
- Remove the adsorbent materials promptly and dispose of properly.
- Promptly transfer used fluids to the proper waste or recycling drums. Don't leave full drip pans or other open containers lying around.
- Oil filters disposed of in trashcans or dumpsters can leak oil and contaminate stormwater. Place the oil filter in a funnel over a waste oil recycling drum to drain excess oil before disposal. Oil filters can also be recycled. Ask your oil supplier or recycler about recycling oil filters.

SC-11 Spill Prevention, Control & Cleanup

- Store cracked batteries in a non-leaking secondary container. Do this with all cracked batteries, even if you think all the acid has drained out. If you drop a battery, treat it as if it is cracked. Put it into the containment area until you are sure it is not leaking.

Vehicle and Equipment Fueling

- Design the fueling area to prevent the run-on of stormwater and the runoff of spills:
 - Cover fueling area if possible.
 - Use a perimeter drain or slope pavement inward with drainage to a sump.
 - Pave fueling area with concrete rather than asphalt.
- If dead-end sump is not used to collect spills, install an oil/water separator.
- Install vapor recovery nozzles to help control drips as well as air pollution.
- Discourage “topping-off” of fuel tanks.
- Use secondary containment when transferring fuel from the tank truck to the fuel tank.
- Use adsorbent materials on small spills and general cleaning rather than hosing down the area. Remove the adsorbent materials promptly.
- Carry out all Federal and State requirements regarding underground storage tanks, or install above ground tanks.
- Do not use mobile fueling of mobile industrial equipment around the facility; rather, transport the equipment to designated fueling areas.
- Keep your Spill Prevention Control and Countermeasure (SPCC) Plan up-to-date.
- Train employees in proper fueling and cleanup procedures.

Industrial Spill Prevention Response

For the purposes of developing a spill prevention and response program to meet the stormwater regulations, facility managers should use information provided in this fact sheet and the spill prevention/response portions of the fact sheets in this handbook, for specific activities. The program should:

- Integrate with existing emergency response/hazardous materials programs (e.g., Fire Department)
- Develop procedures to prevent/mitigate spills to storm drain systems
- Identify responsible departments
- Develop and standardize reporting procedures, containment, storage, and disposal activities, documentation, and follow-up procedures
- Address spills at municipal facilities, as well as public areas

Spill Prevention, Control & Cleanup SC-11

- Provide training concerning spill prevention, response and cleanup to all appropriate personnel

References and Resources

California's Nonpoint Source Program Plan <http://www.swrcb.ca.gov/nps/index.html>

Clark County Storm Water Pollution Control Manual
<http://www.co.clark.wa.us/pubworks/bmpman.pdf>

King County Storm Water Pollution Control Manual <http://dnr.metrokc.gov/wlr/dss/spcm.htm>

Santa Clara Valley Urban Runoff Pollution Prevention Program <http://www.scvurppp.org>

The Stormwater Managers Resource Center <http://www.stormwatercenter.net/>

Landscape Maintenance



Photo Credit: Geoff Brosseau

Description

This category includes businesses that provide landscaping and landscape maintenance/gardening services.

Pollutant Sources

The following are sources of pollutants:

- Selecting plants or landscape design
- Installing new landscaping
- Maintaining landscapes
- Using pesticides and fertilizers
- Using gas-powered equipment
- Working near waterbodies

Pollutants can include:

- Nutrients (fertilizers, yard wastes)
- Pesticides
- Heavy metals (copper, lead, and zinc)
- Hydrocarbons (fuels, oils and grease)
- Sediments

Approach

Minimize the potential for stormwater pollution and the need for resources/controls (water, pesticides, fertilizers) by creating and maintaining landscapes in a way that is compatible with the local soils, climate, and amount of rain and sun. Make stormwater



Landscape Maintenance

pollution prevention BMPs a part of standard operating procedures and the employee training program. Provide employee education materials in the first language of employees, as necessary.

Source Control BMPs

The best management practices are listed by activity or area.

Landscape Design

- Specify native, low maintenance, and insectary (attract beneficial insects) plants and landscape designs.
- Design zoned, water-efficient irrigation systems using technologies such drip irrigation, soaker hoses, or microspray systems.
- Do not landscape riparian areas, except to remove non-native plants and replace them with native riparian landscaping.
- Replant with native species where possible when landscaping or building an ornamental pond. Do not assume something is native because you have seen it in your area. Contact the local nursery for information or visit the California Exotic Pest Plant Council website (www.caleppc.org).

Landscape Installation

- Protect stockpiles and landscaping materials from wind and rain by storing them under tarps or secured plastic sheeting.
- Schedule grading and excavation projects during dry weather.
- Divert runoff from exposed soils or lower its velocity by leveling and terracing.
- Use temporary check dams or ditches to divert runoff away from storm drains.
- Protect storm drains with sandbags or other sediment controls.
- Revegetation is an excellent form of erosion control for any site. Keep soils covered with vegetation or temporary cover material (mulch) to control erosion.
- Check plant roots before buying a plant. Do not buy plants with roots that are kinked or circling around the container. Do not buy plants with soft, rotten, or deformed root crowns.
- Do not pile soil around the plant any higher than the root crown.

Landscape Maintenance

Yard Waste

- Allow leaf drop to become part of the mulch layer in tree, shrub, and groundcover areas.
- Keep lawn mower blades sharp and grasscycle.
- Grasscycle – leave grass clippings on the lawn when mowing. Once cut, grass clippings first dehydrate, then decompose, quickly disappearing from view. Proper mowing is required for successful grasscycling. Cut grass when the surface is dry, and keep mower blades sharp. Follow the "1/3 Rule": mow the lawn often enough so that no more than 1/3 of the length of the grass blade is cut in any one mowing. Frequent mowing will produce short clippings that will not cover up the grass surface. The lawn may have to be cut every seven days when the lawn is growing fast but only every 7 to 14 days when the lawn is growing slowly.

Landscape Maintenance

- Do not leave clippings on pavement or sidewalks where they can wash off into the street, gutter, or storm drain.
- Collect lawn and garden clippings, pruning waste, and tree trimmings. Chip if necessary, and compost or take to the local municipal yard waste recycling/composting facility.
- In communities with curbside pick-up of yard waste, place clippings and pruning waste at the curb in approved bags or containers. No curbside pickup of yard waste is available for commercial properties.
- Do not blow or rake leaves or other yard waste into the street, or place yard waste in gutters or on dirt shoulders, unless it is being piled up for recycling (allowed by some municipalities). After pick-up, sweep up any leaves, litter, or residue in gutters or on street.

Fertilizing and Pruning

- Perform soil analysis seasonally to determine actual fertilization need and application rates.
- Fertilize garden areas with a mulch of leaves, bark, or composted manure and/or garden waste.
- Apply chemical fertilizer only as needed, when plants can best use it, and when the potential for it being carried away by runoff is low. Make sure the fertilizer spreader is calibrated.
- Prune plants sparingly, if at all. A healthy plant – one that is native to the area and growing under the right conditions – should not need pruning, except when it is not in the right location (where safety or liability is a concern).

Watering

- Use soil probes to determine soil moisture depth, overall moisture levels, and the need to adjust irrigation schedules.

Pest and Weed Control

- Anyone who is in the business of landscape maintenance and performs pest control as part of providing that service must have a license from the state to apply pesticides. Contact the Department of Pesticide Regulation for more information.
- Become trained in and offer customers less-toxic pest control or Integrated Pest Management (IPM).
- The label on a pesticide container is a legal document. Use a pesticide only as instructed on the label.
- Store pesticides, fertilizers, and other chemicals indoors or in a shed or storage cabinet.
- Use pesticides sparingly, according to instructions on the label. Rinse empty containers, and use rinsewater as product.
- Dispose of rinsed, empty containers in the trash. Dispose of unused pesticides as hazardous waste.
- To control weeds, use drip irrigation and mulch. Hand-pull weeds including roots or cut down to ground. Repeat cutting before they flower, grow new leaves, or go to seed. Use herbicides containing pelargonic acid or herbicidal soap as a last resort.

Landscape Maintenance

Handling Gasoline

- Use only containers approved by a nationally recognized testing lab, such as Underwriters Laboratories (UL). Keep the container tightly sealed. Containers should be fitted with a spout to allow pouring without spilling and to minimize the generation of vapors.
- Fill cautiously. Always use a funnel and/or spout to prevent spilling or splashing when fueling power mowers, blowers, and all other gas-powered equipment.
- Avoid spilling gasoline on the ground, especially near wells. If a spill occurs use kitty litter, saw dust, or an absorbent towel to soak up the spill, then dispose of it properly.
- Store carefully. Gasoline moves quickly through soil and into groundwater, therefore, store and use gasoline and fuel equipment as far away from your drinking water well as possible. Be certain to keep a closed cap on the gasoline container. Store at ground level, not on a shelf to minimize the danger of falling and spilling.
- Do not dispose of gasoline down the drain, into surface water, onto the ground, or in the trash. Contact the local municipality for directions on proper disposal of excess or old gasoline. Transport old gas in an approved gasoline container.

Working Near Waterbodies

- Do not dump lawn clippings, other yard waste, or soil along creek banks or in creeks.
- Do not store stockpiles of materials (soil, mulch) along creek banks. These piles can erode over time into a creek.
- Do not spray pesticides or fertilizers by creeks.
- Do not over water near streams. The excess water may carry pesticides, fertilizers, sediments, and anything else in its path directly into the creek.
- Do not remove native vegetation along creek banks or remove large woody debris from creek banks or creeks. Instead, contact the local municipal planning department and Department of Fish & Game for guidance.

Treatment Control BMPs

Not applicable.

More Information

Bay Area Stormwater Management Agencies Association, 1999. Start at the Source – Design Guidance Manual for Stormwater Quality Protection. (<http://www.basmaa.org>).

Bay Area Water Pollution Prevention Agencies, 1998 - 2002. Less-Toxic Pest Management Fact Sheets, Less-Toxic Product List, and In-store display and promotion materials. (<http://www.basmaa.org>)

California Exotic Pest Plant Council, 1999. Exotic Pest Plant List. (<http://www.caleppc.org>)

California Integrated Waste Management Board, 1999. Grasscycle! Make the Most of Your Lawn. Make the Most of Your Time. (<http://www.ciwmb.ca.gov/organics/Pubs.htm>).

California Integrated Waste Management Board, 2001. Resource-Efficient Turf Management and Resource-Efficient Landscaping. (<http://www.ciwmb.ca.gov/organics/Pubs.htm>).

Contra Costa County, no date. Grasscycle! Clip your waste! (<http://grasscycle.abag.ca.gov>).

Landscape Maintenance

Marin County Stormwater Pollution Prevention Program, no date. Creek Care: A Guide for Urban Marin Residents. (<http://www.mcstoppp.org/>).

Professional Lawn Care Association of America, 1997. Water Quality and Your Lawn. (<http://www.pesp.org/1995/plcaa95-final.htm>).

San Francisquito Watershed Council and San Mateo Countywide Stormwater Pollution Prevention Program, no date. Streamside Planting Guide for San Mateo and Santa Clara County Streams. (<http://www.acterra.org/watershed/>)

The Alliance for Proper Gasoline Handling, 1999. Consumer Tips for Proper Gasoline Handling. (http://www.gas-care.org/consumer_tips.htm).

Videos

California Integrated Waste Management Board, 1999. Grasscycle! Make the Most of Your Lawn. Make the Most of Your Time. (<http://www.ciwmb.ca.gov/organics/Pubs.htm>).

CCCSD, 2001. The Healthy Home & Garden - Less-Toxic Pest Control (for residents). (<http://www.centalsan.org/education/ipm/hgonlineguide.html>).

References

Bay Area Stormwater Management Agencies Association, 1999. Start at the Source – Design Guidance Manual for Stormwater Quality Protection. (<http://www.basmaa.org>).

Bay Area Water Pollution Prevention Agencies, 1998 - 2002. Less-Toxic Pest Management Fact Sheets, Less-Toxic Product List, and In-store display and promotion materials. (<http://www.basmaa.org>)

California Integrated Waste Management Board, 1999. Grasscycle! Make the Most of Your Lawn. Make the Most of Your Time. (<http://www.ciwmb.ca.gov/organics/Pubs.htm>).

California Integrated Waste Management Board, 2001. Resource-Efficient Turf Management and Resource-Efficient Landscaping. (<http://www.ciwmb.ca.gov/organics/Pubs.htm>).

City of Bellevue, 1991. Water Quality Protection for Landscaping Businesses, Business Partners for Clean Water.

Contra Costa County, no date. Grasscycle! Clip your waste! (<http://grasscycle.abag.ca.gov>).

County of Los Angeles, no date. Landscaping and Nursery Facilities – Best Management Practices, Project Pollution Prevention.

Marin County Stormwater Pollution Prevention Program, no date. Creek Care: A Guide for Urban Marin Residents. (<http://www.mcstoppp.org/>).

Professional Lawn Care Association of America, 1997. Water Quality and Your Lawn. (<http://www.pesp.org/1995/plcaa95-final.htm>).

San Francisquito Watershed Council and San Mateo Countywide Stormwater Pollution Prevention Program, no date. Streamside Planting Guide for San Mateo and Santa Clara County Streams. (<http://www.acterra.org/watershed/>)

Santa Clara Valley Urban Runoff Pollution Prevention Program, 2001. Landscaping, Gardening, and Pool Maintenance – Best Management Practices for the Construction Industry.

The Alliance for Proper Gasoline Handling, 1999. Consumer Tips for Proper Gasoline Handling. (http://www.gas-care.org/consumer_tips.htm).

Structural BMPs

Description

Vortex separators: (alternatively, swirl concentrators) are gravity separators, and in principle are essentially wet vaults. The difference from wet vaults, however, is that the vortex separator is round, rather than rectangular, and the water moves in a centrifugal fashion before exiting. By having the water move in a circular fashion, rather than a straight line as is the case with a standard wet vault, it is possible to obtain significant removal of suspended sediments and attached pollutants with less space. Vortex separators were originally developed for combined sewer overflows (CSOs), where it is used primarily to remove coarse inorganic solids. Vortex separation has been adapted to stormwater treatment by several manufacturers.

California Experience

There are currently about 100 installations in California.

Advantages

- May provide the desired performance in less space and therefore less cost.
- May be more cost-effective pre-treatment devices than traditional wet or dry basins.
- Mosquito control may be less of an issue than with traditional wet basins.

Limitations

- As some of the systems have standing water that remains between storms, there is concern about mosquito breeding.
- It is likely that vortex separators are not as effective as wet vaults at removing fine sediments, on the order 50 to 100 microns in diameter and less.
- The area served is limited by the capacity of the largest models.
- As the products come in standard sizes, the facilities will be oversized in many cases relative to the design treatment storm, increasing the cost.
- The non-steady flows of stormwater decreases the efficiency of vortex separators from what may be estimated or determined from testing under constant flow.
- Do not remove dissolved pollutants.
- A loss of dissolved pollutants may occur as accumulated organic

Design Considerations

- Service Area
- Settling Velocity
- Appropriate Sizing
- Inlet Pipe Diameter

Targeted Constituents

- ✓ Sediment ▲
- ✓ Nutrients ●
- ✓ Trash
- ✓ Metals ●
- Bacteria
- ✓ Oil and Grease
- ✓ Organics

Legend (Removal Effectiveness)

- Low
- High
- ▲ Medium



matter (e.g., leaves) decomposes in the units.

Design and Sizing Guidelines

The stormwater enters, typically below the effluent line, tangentially into the basin, thereby imparting a circular motion in the system. Due to centrifugal forces created by the circular motion, the suspended particles move to the center of the device where they settle to the bottom. There are two general types of vortex separation: free vortex and dampened (or impeded) vortex. Free vortex separation becomes dampened vortex separation by the placement of radial baffles on the weir-plate that impede the free vortex-flow pattern

It has been stated with respect to CSOs that the practical lower limit of vortex separation is a particle with a settling velocity of 12 to 16.5 feet per hour (0.10 to 0.14 cm/s). As such, the focus for vortex separation in CSOs has been with settleable solids generally 200 microns and larger, given the presence of the lighter organic solids. For inorganic sediment, the above settling velocity range represents a particle diameter of 50 to 100 microns. Head loss is a function of the size of the target particle. At 200 microns it is normally minor but increases significantly if the goal is to remove smaller particles.

The commercial separators applied to stormwater treatment vary considerably with respect to geometry, and the inclusion of radial baffles and internal circular chambers. At one extreme is the inclusion of a chamber within the round concentrator. Water flows initially around the perimeter between the inner and outer chambers, and then into the inner chamber, giving rise to a sudden change in velocity that purportedly enhances removal efficiency. The opposite extreme is to introduce the water tangentially into a round manhole with no internal parts of any kind except for an outlet hood. Whether the inclusion of chambers and baffles gives better performance is unknown. Some contend that free vortex, also identified as swirl concentration, creates less turbulence thereby increasing removal efficiency. One product is unique in that it includes a static separator screen.

- Sizing is based on the peak flow of the design treatment event as specified by local government.
- If an in-line facility, the design peak flow is four times the peak of the design treatment event.
- If an off-line facility, the design peak flow is equal to the peak of the design treatment event.
- Headloss differs with the product and the model but is generally on the order of one foot or less in most cases.

Construction/Inspection Considerations

No special considerations.

Performance

Manufacturer's differ with respect to performance claims, but a general statement is that the manufacturer's design and rated capacity (cfs) for each model is based on and believed to achieve an aggregate reduction of 90% of all particles with a specific gravity of 2.65 (glacial sand) down to 150 microns, and to capture the floatables, and oil and grease. Laboratory tests of two products support this claim. The stated performance expectation therefore implies that a

lesser removal efficiency is obtained with particles less than 150 microns, and the lighter, organic settleables. Laboratory tests of one of the products found about 60% removal of 50 micron sand at the expected average operating flow rate

Experience with the use of vortex separators for treating combined sewer overflows (CSOs), the original application of this technology, suggests that the lower practical limit for particle removal are particles with a settling velocity of 12 feet per hour (Sullivan, 1982), which represents a particle diameter of 100 to 200 microns, depending on the specific gravity of the particle. The CSO experience therefore seems consistent with the limited experience with treating stormwater, summarized above

Traditional treatment technologies such as wet ponds and extended detention basins are generally believed to be more effective at removing very small particles, down to the range of 10 to 20 microns. Hence, it is intuitively expected that vortex separators do not perform as well as the traditional wet and dry basins, and filters. Whether this matters depends on the particle size distribution of the sediments in stormwater. If the distribution leans towards small material, there should be a marked difference between vortex separators and, say, traditional wet vaults. There are little data to support this conjecture

In comparison to other treatment technologies, such as wet ponds and grass swales, there are few studies of vortex separators. Only two of manufactured products currently available have been field tested. Two field studies have been conducted. Both achieved in excess of 80% removal of TSS. However, the test was conducted in the Northeast (New York state and Maine) where it is possible the stormwater contained significant quantities of deicing sand. Consequently, the influent TSS concentrations and particle size are both likely considerably higher than is found in California stormwater. These data suggest that if the stormwater particles are for the most part fine (i.e., less than 50 microns), vortex separators will not be as efficient as traditional treatment BMPs such as wet ponds and swales, if the latter are sized according to the recommendations of this handbook.

There are no equations that provide a straightforward determination of efficiency as a function of unit configuration and size. Design specifications of commercial separators are derived from empirical equations that are unique and proprietary to each manufacturer. However, some general relationships between performance and the geometry of a separator have been developed. CSO studies have found that the primary determinants of performance of vortex separators are the diameters of the inlet pipe and chamber with all other geometry proportional to these two.

Sullivan et al. (1982) found that performance is related to the ratios of chamber to inlet diameters, D_2/D_1 , and height between the inlet and outlet and the inlet diameter, H_1/D_1 , shown in Figure 3. The relationships are: as D_2/D_1 approaches one, the efficiency decreases; and, as the H_1/D_1 ratio decreases, the efficiency decreases. These relationships may allow qualitative comparisons of the alternative designs of manufacturers. Engineers who wish to apply these concepts should review relevant publications presented in the References.

Siting Criteria

There are no particularly unique siting criteria. The size of the drainage area that can be served by vortex separators is directly related to the capacities of the largest models.

Additional Design Guidelines

Vortex separators have two capacities if positioned as in-line facilities, a treatment capacity and a hydraulic capacity. Failure to recognize the difference between the two may lead to significant under sizing; i.e., too small a model is selected. This observation is relevant to three of the five products. These three technologies all are designed to experience a unit flow rate of about 24 gallons/square foot of separator footprint at the peak of the design treatment event. This is the horizontal area of the separator zone within the container, not the total footprint of the unit. At this unit flow rate, laboratory tests by these manufacturers have established that the performance will meet the general claims previously described. However, the units are sized to handle 100 gallons/square foot at the peak of the hydraulic event. Hence, in selecting a particular model the design engineer must be certain to match the peak flow of the design event to the stated treatment capacity, not the hydraulic capacity. The former is one-fourth the latter. If the unit is positioned as an off-line facility, the model selected is based on the capacity equal to the peak of the design treatment event.

Maintenance

Maintenance consists of the removal of accumulated material with an eductor truck. It may be necessary to remove and dispose the floatables separately due to the presence of petroleum product.

Maintenance Requirements

Remove all accumulated sediment, and litter and other floatables, annually, unless experience indicates the need for more or less frequent maintenance.

Cost

Manufacturers provide costs for the units including delivery. Installation costs are generally on the order of 50 to 100 % of the manufacturer's cost. For most sites the units are cleaned annually.

Cost Considerations

The different geometry of the several manufactured separators suggests that when comparing the costs of these systems to each other, that local conditions (e.g., groundwater levels) may affect the relative cost-effectiveness.

References and Sources of Additional Information

Field, R., 1972, The swirl concentrator as a combined sewer overflow regulator facility, EPA/R2-72-008, U.S. Environmental Protection Agency, Washington, D.C.

Field, R., D. Averill, T.P. O'Connor, and P. Steel, 1997, Vortex separation technology, Water Qual. Res. J. Canada, 32, 1, 185

Manufacturers technical materials

Sullivan, R.H., et al., 1982, Design manual – swirl and helical bend pollution control devices, EPA-600/8-82/013, U.S. Environmental Protection Agency, Washington, D.C.

Sullivan, R.H., M.M. Cohn, J.E. Ure, F.F. Parkinson, and G. Caliana, 1974, Relationship between diameter and height for the design of a swirl concentrator as a combined sewer overflow regulator, EPA 670/2-74-039, U.S. Environmental Protection Agency, Washington, D.C.

Sullivan, R.H., M.M. Cohn, J.E. Ure, F.F. Parkinson, and G. Caliana, 1974, The swirl concentrator as a grit separator device, EPA670/2-74-026, U.S. Environmental Protection Agency, Washington, D.C.

Sullivan, R.H., M.M. Cohn, J.E. Ure, F.F. Parkinson, and G. Caliana, 1978, Swirl primary separator device and pilot demonstration, EPA600/2-78-126, U.S. Environmental Protection Agency, Washington, D.C.

Appendix E

Soils Report



Sladden Engineering

45090 Golf Center Parkway, Suite F, Indio, CA. 92201 (760) 863-0713 Fax (760) 863-0847
6782 Stanton Avenue, Suite C, Buena Park, CA. 90621 (714) 523-0952 Fax (714) 523-1369
450 Egan Avenue, Beaumont, CA. 92223 (951) 845-7743 Fax (951) 845-8863
www.sladdenengineering.com

January 12, 2023

Project No. 644-22060
23-01-004

Bremco Construction, Inc.
3470 East Spring Street
Long Beach, California 90806

Project: Proposed Brown-Strauss Steel Facility
1210 & 1431 West Lincoln Street
APN 540-180-020, 022 & 026
Banning, California

Ref: Geotechnical Investigation, Proposed Brown-Strauss Steel Facility, 1210 & 1431 West Lincoln Street, APN 540-180-020, 022 & 026, Banning California; Prepared by Sladden Engineering; Project No. 644-22060, Report No. 22-12-145, dated January 5, 2023.

Subject: Percolation/Infiltration Testing for On-Site Stormwater Management

In accordance with your request, we have performed percolation testing on the subject site to evaluate the infiltration potential of the near surface soil to assist in stormwater management system design. It is our understanding that on-site stormwater retention including infiltration is proposed for the project.

Percolation testing was performed on December 16, 2022, within two (2) shallow tests bores excavated on the site. Testing was performed at depths of approximately 10.0 feet and 5.0 feet below existing grade for test locations P-1 and P-2, respectively. The approximate locations of the test holes are presented on the attached Exploration Location Plan (Figure 3). Testing was performed by placing water within the test holes and recording the drop in the water surface with time. Testing was performed in general accordance with the *United States Bureau of Reclamation (BOR) Procedure 7300-89 (1999)*. Test results are summarized in the following table.

PERCOLATION TEST RESULTS

| Test No. | Depth (Ft) | USCS | Percolation Rate (in/hr) | Infiltration Rate (in/hr) |
|----------|------------|------|--------------------------|---------------------------|
| P-1 | 10.0 | SC | 25.5 | 2.57 |
| P-2 | 5.00 | SC | 45.75 | 5.03 |

The percolation rates determined represent the ultimate field rates that do not include a safety factor. The corresponding infiltration rates were calculated using the Porchet Method.

Based on our field investigation and our review of groundwater levels¹ within the vicinity, it is our professional opinion that groundwater should not be a controlling factor in on-site stormwater retention/infiltration system design.

If you have any questions regarding this memo or the testing summarized herein, please contact the undersigned.

Respectfully submitted,
SLADDEN ENGINEERING

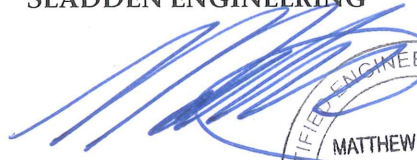

Matthew J. Cohrt
Principal Geologist

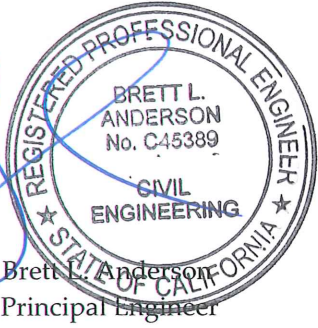

Brett L. Anderson
Principal Engineer

Copies: PDF/Addressee

¹ California Department of Water Resources (CDWR), 2023, Historical Data by Well-Map Interface, available at: <http://wdl.water.ca.gov/waterdatalibrary/Home.aspx>

SITE LOCATION MAP
REGIONAL GEOLOGIC MAP
EXPLORATION LOCATION PLAN



USGS (2015)



Sladden Engineering

SITE LOCATION MAP

| | |
|-----------------|------------------|
| Project Number: | 644-22060 |
| Report Number: | 23-01-004 |
| Date: | January 12, 2023 |

FIGURE

1

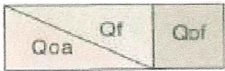

OLDER SURFICIAL SEDIMENTS

Weakly indurated alluvial fan deposits dissected or partially so

Qf Alluvial fan of San Geronimo Pass, sand and gravel of plutonic and gneissic detritus derived from rising San Bernardino mountains to the north, dissected at lower south margins, in part blends into unit **Qoa** to the west

Qoa Dissected alluvial fan sand and gravel, light reddish, crudely bedded

Qof Alluvial gravel and sand of high fans of Banning Bench (Mesa) area, brown, subindurated of mostly gneissic detritus derived from San Bernardino Mountains, dissected and eroded to remnants

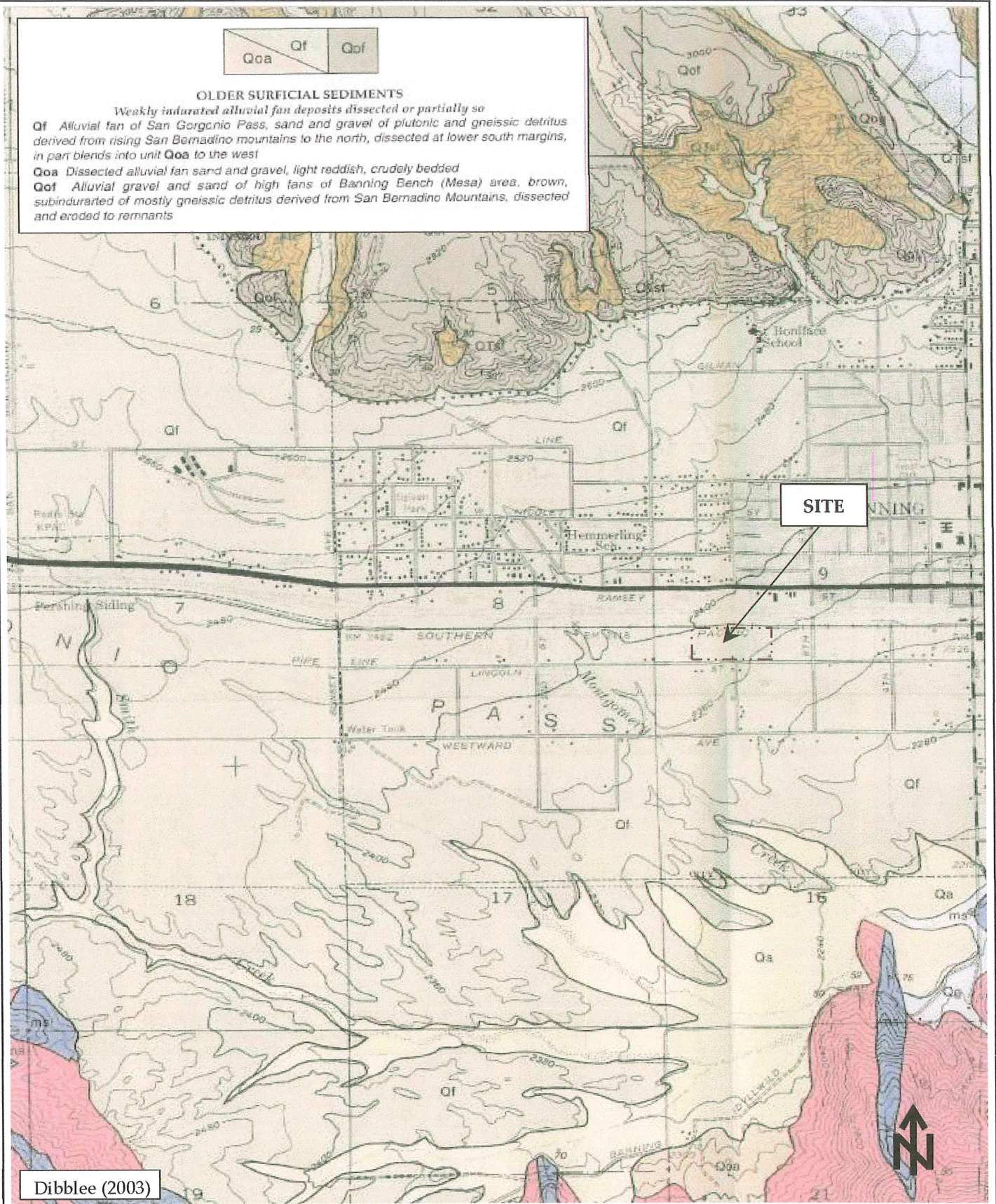

Dibblee (2003)

REGIONAL GEOLOGIC MAP

FIGURE

2



Sladden Engineering

| | |
|-----------------|------------------|
| Project Number: | 644-22060 |
| Report Number: | 23-01-004 |
| Date: | January 12, 2023 |

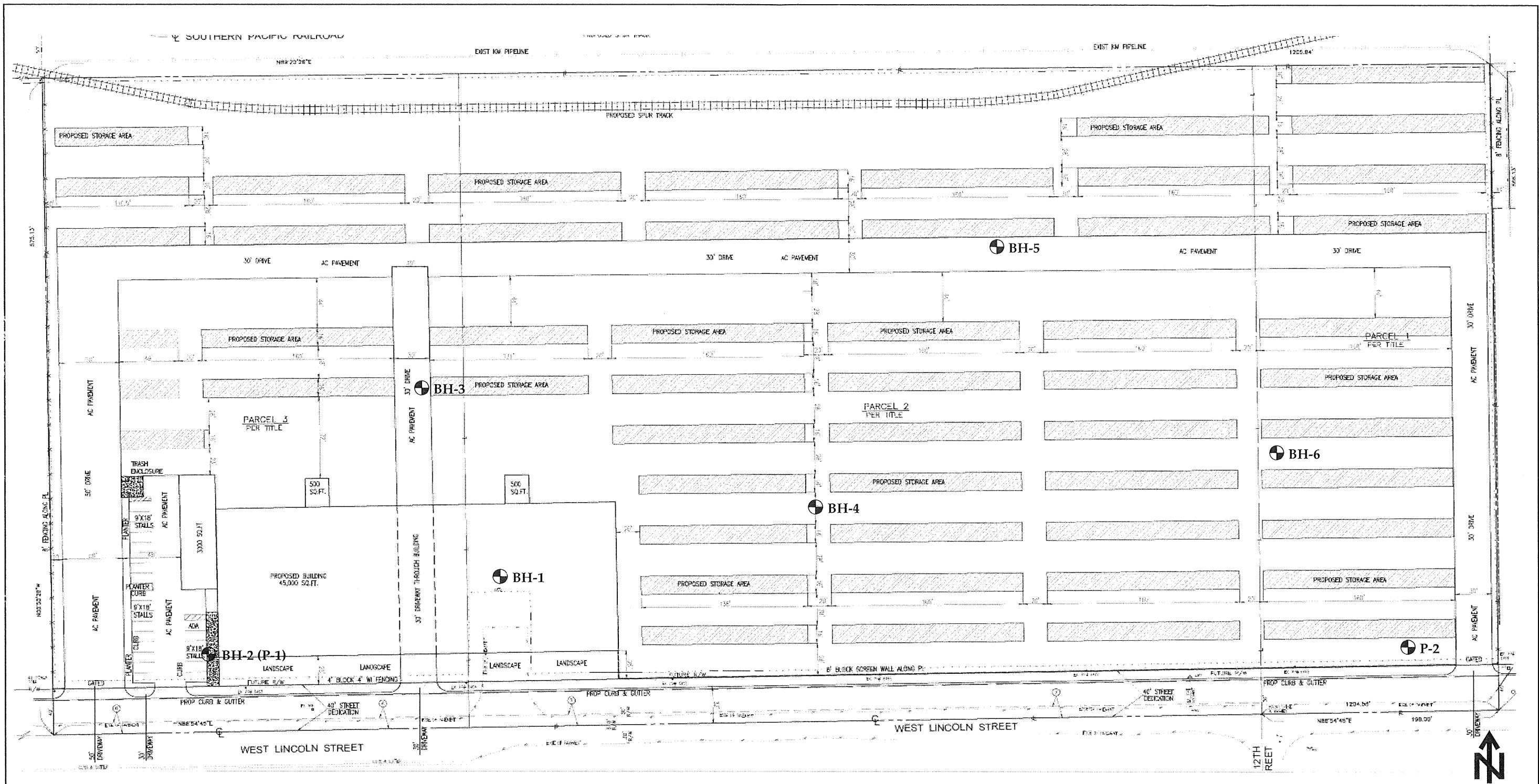

| LEGEND | |
|--------|--|
| | BH-6 (P-2) Borehole Location (Percolation Test Location) |

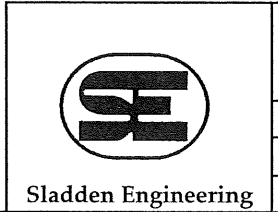

| BOREHOLE LOCAITON PLAN | |
|------------------------|------------------|
| Project Number: | 644-22060 |
| Report Number: | 23-01-004 |
| Date: | January 12, 2023 |

FIGURE
3

PERCOLATION/INFILTRATION TEST DATA SHEETS

STORMWATER PERCOLATION SHEET (LESS THAN 10 FT)

Project: 1210 & 1431 W. Lincoln Street, Banning Depth (ft): 10.00
 Job No. : 644-22060 USCS Soil Class: SC
 Date: 12/16/2022 Sandy Soil: S.D.
 Test Hole #: P-1 Tested By: S.D./E.S.

| READING | TIME (min) | DEPTH (ft) | INITIAL W (in) | FINAL W (in) | ΔW (in) | IN/HR |
|---------|------------|------------|----------------|--------------|---------|-------|
| A | 25.00 | 10.00 | 20 | 8 2/8 | 11 6/8 | 28.20 |
| B | 25.00 | 10.00 | 20 | 9 | 11 | 26.40 |

| READING | TIME (min) | DEPTH (ft) | INITIAL W (in) | FINAL W (in) | ΔW (in) | IN/HR |
|---------|------------|------------|----------------|--------------|---------|-------|
| 1 | 10.00 | 10.00 | 20 | 15 4/8 | 4 4/8 | 27 |
| 2 | 10.00 | 10.00 | 20 | 15 4/8 | 4 4/8 | 27 |
| 3 | 10.00 | 10.00 | 20 | 15 6/8 | 4 2/8 | 25.5 |
| 4 | 10.00 | 10.00 | 20 | 15 6/8 | 4 2/8 | 25.5 |
| 5 | 10.00 | 10.00 | 20 | 15 7/8 | 4 1/8 | 24.75 |
| 6 | 10.00 | 10.00 | 20 | 15 6/8 | 4 2/8 | 25.5 |

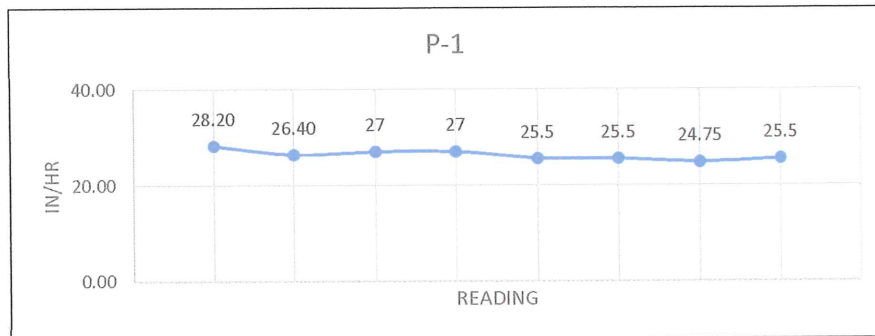

PERCOLATION RATE CONVERSION (PORCHET METHOD)

| | |
|--|---|
| $I_t = \frac{\Delta H \cdot 60 \cdot R}{\Delta t(r+2H_{avg})}$ | Δt (minutes) |
| | D_f (Final Depth to water) |
| | r (hole radius in inches) |
| | D_0 (Initial Depth to water) |
| $\Delta t = 10.00$ | D_t (Total Depth of test hole) |
| $D_f = 104.25$ | H_0 (initial height of water at selected time interval) |
| $r = 4.00$ | $H_0 = D_t - D_0$ |
| $D_0 = 100$ | H_f (final height of water at the selected time interval) |
| $D_t = 120.00$ | $H_f = D_t - D_f$ |
| $H_0 = 20$ | ΔH (change in head over the time interval) |
| $H_f = 15.75$ | $\Delta H = H_0 - H_f$ |
| $\Delta H = 4.25$ | H_{avg} (average head height over the time interval) |
| $H_{avg} = 17.88$ | $H_{avg} = (H_0 + H_f) / 2$ |

Field Rate: 25.5 in/hr
 Infiltration Rate: 2.57 in/hr

STORMWATER PERCOLATION SHEET (LESS THAN 10 FT)

| | |
|---|----------------------|
| Project: 1210 & 1431 W. Lincoln Street, Banning | Depth (ft): 5.00 |
| Job No. : 644-22060 | USCS Soil Class: SC |
| Date: 12/16/2022 | Sandy Soil: S.D. |
| Test Hole #: P-2 | Tested By: S.D./E.S. |

| READING | TIME (min) | DEPTH (ft) | INITIAL W (in) | FINAL W (in) | ΔW (in) | IN/HR |
|---------|------------|------------|----------------|--------------|---------|-------|
| A | 25.00 | 5.00 | 20 | 3 6/8 | 16 2/8 | 39.00 |
| B | 25.00 | 5.00 | 20 | 4 7/8 | 15 1/8 | 36.30 |

| READING | TIME (min) | DEPTH (ft) | INITIAL W (in) | FINAL W (in) | ΔW (in) | IN/HR |
|---------|------------|------------|----------------|--------------|---------|-------|
| 1 | 10.00 | 5.00 | 20 | 11 5/8 | 8 3/8 | 50.25 |
| 2 | 10.00 | 5.00 | 20 | 11 6/8 | 8 2/8 | 49.5 |
| 3 | 10.00 | 5.00 | 20 | 11 7/8 | 8 1/8 | 48.75 |
| 4 | 10.00 | 5.00 | 20 | 12 | 8 | 48 |
| 5 | 10.00 | 5.00 | 20 | 12 2/8 | 7 6/8 | 46.5 |
| 6 | 10.00 | 5.00 | 20 | 12 3/8 | 7 5/8 | 45.75 |

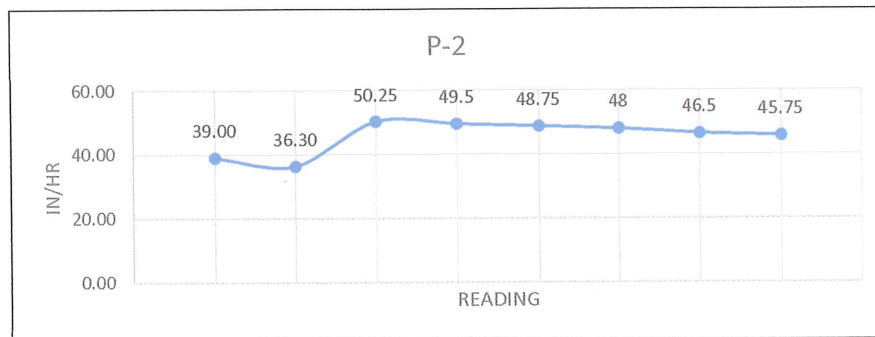

PERCOLATION RATE CONVERSION (PORCHET METHOD)

| | | |
|--------------|--|---|
| $I_t =$ | $\frac{\Delta H \cdot 60 R}{\Delta t(r+2H_{avg})}$ | Δt (minutes) D_f (Final Depth to water) r (hole radius in inches) D_0 (Initial Depth to water) D_t (Total Depth of test hole) |
| $\Delta t =$ | 10.00 | H_0 (initial height of water at selected time interval) $H_0 = D_t - D_0$ |
| $D_f =$ | 47.63 | H_f (final height of water at the selected time interval) $H_f = D_t - D_f$ |
| $r =$ | 4.00 | ΔH (change in head over the time interval) $\Delta H = H_0 - H_f$ |
| $D_0 =$ | 40 | H_{avg} (average head height over the time interval) $H_{avg} = (H_0 + H_f) / 2$ |
| $D_t =$ | 60.00 | |
| $H_0 =$ | 20 | |
| $H_f =$ | 12.375 | |
| $\Delta H =$ | 7.63 | |
| $H_{avg} =$ | 16.19 | |

Field Rate: 45.75 in/hr
 Infiltration Rate: 5.03 in/hr

BORELOGS



Sladden Engineering

BORE LOG

Equipment: MOBILE B-61 Date Drilled: 11/30/2022
 Elevation: 2,380 Feet MSL Boring No: BH-1

| Sample | Blow Counts | Bulk Sample | Expansion Index | % Minus #200 | % Moisture | Density, pcf | Depth (Feet) | Graphic Lithology | Description |
|--------|-------------|-------------|-----------------|--------------|------------|--------------|--------------|--|--|
| | 19 32 29 | 1 | 12 | 41.1 | 6.0 | 119.6 | 2 | | Clayey Sand (SC); reddish brown, dry to slightly moist, dense, fine- to coarse-grained (Qf). |
| | 12 15 26 | | | 43.7 | 11.6 | 114.4 | 4 | | Clayey Sand (SC); reddish brown, slightly moist, medium dense, fine- to coarse-grained (Qf). |
| | 10 13 13 | | | 22.7 | 7.2 | | 6 | | Clayey Sand (SC); reddish brown, slightly moist, medium dense, fine- to coarse-grained (Qf). |
| | 10 14 25 | | | 8.4 | 4.2 | 119.7 | 8 | | Clayey Sand (SC); reddish brown, slightly moist, medium dense, fine- to coarse-grained (Qf). |
| | 14 15 20 | | | 13.6 | 4.7 | | 10 | | Sand (SW); dark yellowish brown, dry, medium dense, fine- to coarse-grained (Qf). |
| | 29 34 38 | | | 9.2 | 3.3 | 125.5 | 12 | | Clayey Sand (SC); reddish brown, dry, medium dense, fine- to coarse-grained (Qf). |
| | 18 20 21 | | | 15.1 | 4.4 | | 14 | | Sand (SW); yellowish brown, dry, dense, fine- to coarse-grained (Qf). |
| | 50-6 | | | 9.8 | 3.4 | 120.2 | 16 | | Clayey Sand (SC); reddish brown, dry, dense, fine- to coarse-grained (Qf). |
| | 50-6 | | | 9.1 | 3.5 | | 18 | | Sand (SP); yellowish brown, dry, very dense, fine-grained with gravel (Qf). |
| | 50-6 | | | 6.9 | 2.6 | | 20 | | Sand (SP); yellowish brown, dry, very dense, fine-grained with gravel (Qf). |
| | | | | | | | 22 | | Sand (SP); yellowish brown, dry, very dense, fine-grained with gravel (Qf). |
| | | | | | | | 24 | | Sand (SP); yellowish brown, dry, very dense, fine-grained with gravel (Qf). |
| | | | | | | | 26 | | Sand (SP); yellowish brown, dry, very dense, fine-grained with gravel (Qf). |
| | | | | | | | 28 | | Sand (SP); yellowish brown, dry, very dense, fine-grained with gravel (Qf). |
| | | | | | | | 30 | Sand (SP); yellowish brown, dry, very dense, fine-grained with gravel (Qf). | |
| | | | | | | | 32 | Sand (SP); yellowish brown, dry, very dense, fine-grained with gravel (Qf). | |
| | | | | | | | 34 | Sand (SP); yellowish brown, dry, very dense, fine-grained with gravel (Qf). | |
| | | | | | | | 36 | Sand (SP); yellowish brown, dry, very dense, fine-grained with gravel (Qf). | |
| | | | | | | | 38 | Sand (SP); yellowish brown, dry, very dense, fine-grained with gravel (Qf). | |
| | | | | | | | 40 | Sand (SP); yellowish brown, dry, very dense, fine-grained with gravel (Qf). | |
| | | | | | | | 42 | Sand (SP); yellowish brown, dry, very dense, fine-grained with gravel (Qf). | |
| | | | | | | | 44 | Sand (SP); yellowish brown, dry, very dense, fine-grained with gravel (Qf). | |
| | | | | | | | 46 | Sand (SP); yellowish brown, dry, very dense, fine-grained with gravel (Qf). | |
| | | | | | | | 48 | Practical Refusal at 45.5 Feet bgs. No Bedrock Encountered. No Groundwater or Seepage Encountered. | |
| | | | | | | | 50 | | |

Completion Notes:

PROPOSED BROWN-STRAUSS STEEL FACILITY
 1210 & 1431 WEST LINCOLN STREET, BANNING, CALIFORNIA

Project No: 644-22060
 Report No: 23-01-004



Sladden Engineering

BORE LOG

| | | | |
|------------|----------------|---------------|------------|
| Equipment: | MOBILE B-61 | Date Drilled: | 11/30/2022 |
| Elevation: | 2,380 Feet MSL | Boring No: | BH-2 (P-1) |

| Sample | Blow Counts | Bulk Sample | Expansion Index | % Minus #200 | % Moisture | Density, pcf | Depth (Feet) | Graphic Lithology | Description |
|--------|-------------|-------------|-----------------|--------------|------------|--------------|--------------|-------------------|---|
| | 4 5 7 | | | 34.0 | 11.3 | | 2 | | Clayey Sand (SC); reddish brown, dry to slightly moist, fine- to coarse-grained (Qf). |
| | | | | | | | 4 | | |
| | | | | | | | 6 | | Clayey Sand (SC); reddish brown, dry to slightly moist, dense, fine- to coarse-grained (Qf). |
| | | | | | | | 8 | | |
| | 12 24 25 | | | 12.5 | 5.2 | 128.5 | 10 | | Silty Sand (SM); yellowish brown, dry to slightly moist, dense, fine- to coarse-grained (Qf). |
| | | | | | | | 12 | | |
| | | | | | | | 14 | | Terminated at 11.5 Feet bgs. |
| | | | | | | | 16 | | No Bedrock Encountered. |
| | | | | | | | 18 | | No Groundwater or Seepage Encountered. |
| | | | | | | | 20 | | |
| | | | | | | | 22 | | |
| | | | | | | | 24 | | |
| | | | | | | | 26 | | |
| | | | | | | | 28 | | |
| | | | | | | | 30 | | |
| | | | | | | | 32 | | |
| | | | | | | | 34 | | |
| | | | | | | | 36 | | |
| | | | | | | | 38 | | |
| | | | | | | | 40 | | |
| | | | | | | | 42 | | |
| | | | | | | | 44 | | |
| | | | | | | | 46 | | |
| | | | | | | | 48 | | |
| | | | | | | | 50 | | |

Completion Notes:

PROPOSED BROWN-STRAUSS STEEL FACILITY

1210 & 1431 WEST LINCOLN STREET, BANNING, CALIFORNIA

Project No: 644-22060

Report No: 23-01-004



Sladden Engineering

BORE LOG

| | | | |
|------------|----------------|---------------|------------|
| Equipment: | MOBILE B-61 | Date Drilled: | 11/30/2022 |
| Elevation: | 2,380 Feet MSL | Boring No: | BH-3 |

| Sample | Blow Counts | Bulk Sample | Expansion Index | % Minus #200 | % Moisture | Density, pcf | Depth (Feet) | Graphic Lithology | Description |
|--------|-------------|-------------|-----------------|--------------|------------|--------------|--------------|-------------------|--|
| | | | | | | | 2 | | Clayey Sand (SC); reddish brown, dry to slightly moist, fine- to coarse-grained (Qf). |
| | 7 11 13 | | | 32.1 | 12.3 | 111.5 | 4 | | |
| | | | | | | | 6 | | Clayey Sand (SC); reddish brown, moist, medium dense, fine- to coarse-grained (Qf). |
| | 6 7 10 | | | 23.9 | 7.2 | | 8 | | |
| | | | | | | | 10 | | Clayey Sand (SC); yellowish brown, moist, medium dense, fine- to coarse-grained (Qf). |
| | | | | | | | 12 | | |
| | 8 17 23 | | | 13.4 | 4.8 | 122.7 | 14 | | |
| | | | | | | | 16 | | Clayey Sand (SC); yellowish brown, slightly moist, medium dense, fine- to coarse-grained (Qf). |
| | | | | | | | 18 | | |
| | 9 11 13 | | | 20.4 | 7.9 | | 20 | | Clayey Sand (SC); yellowish brown, slightly moist, medium dense, fine- to coarse-grained (Qf). |
| | | | | | | | 22 | | |
| | | | | | | | 24 | | Terminated at ~21.5 Feet bgs. |
| | | | | | | | 26 | | No Bedrock Encountered. |
| | | | | | | | 28 | | No Groundwater or Seepage Encountered. |
| | | | | | | | 30 | | |
| | | | | | | | 32 | | |
| | | | | | | | 34 | | |
| | | | | | | | 36 | | |
| | | | | | | | 38 | | |
| | | | | | | | 40 | | |
| | | | | | | | 42 | | |
| | | | | | | | 44 | | |
| | | | | | | | 46 | | |
| | | | | | | | 48 | | |
| | | | | | | | 50 | | |

Completion Notes:

PROPOSED BROWN-STRAUSS STEEL FACILITY
1210 & 1431 WEST LINCOLN STREET, BANNING, CALIFORNIA

Project No: 644-22060

Report No: 23-01-004



Sladden Engineering

BORE LOG

| | | | |
|------------|----------------|---------------|------------|
| Equipment: | MOBILE B-61 | Date Drilled: | 11/30/2022 |
| Elevation: | 2,380 Feet MSL | Boring No: | BH-4 |

| Sample | Blow Counts | Bulk Sample | Expansion Index | % Minus #200 | % Moisture | Density, pcf | Depth (Feet) | Graphic Lithology | Description |
|--------|-------------|-------------|-----------------|--------------|------------|--------------|--------------|-------------------|--|
| | | | | | | | 2 | | Clayey Sand (SC); reddish brown, dry to slightly moist, fine- to coarse-grained (Qf). |
| | | | | | | | 4 | | |
| | 11 16 15 | | | 33.7 | 7.5 | | 6 | | Clayey Sand (SC); reddish brown, slightly moist, medium dense, fine- to coarse-grained (Qf). |
| | | | | | | | 8 | | |
| | 12 18 23 | | | 16.2 | 8.6 | 121.7 | 10 | | Clayey Sand (SC); reddish brown, slightly moist, medium dense, fine- to coarse-grained (Qf). |
| | | | | | | | 12 | | |
| | 13 15 24 | | | 14.6 | 5.6 | | 14 | | Silty Sand (SM); yellowish brown, slightly moist, dense, fine- to coarse-grained with gravel (Qf). |
| | | | | | | | 16 | | |
| | | | | | | | 18 | | Terminated at ~16.5 Feet bgs. No Bedrock Encountered. No Groundwater or Seepage Encountered. |
| | | | | | | | 20 | | |
| | | | | | | | 22 | | |
| | | | | | | | 24 | | |
| | | | | | | | 26 | | |
| | | | | | | | 28 | | |
| | | | | | | | 30 | | |
| | | | | | | | 32 | | |
| | | | | | | | 34 | | |
| | | | | | | | 36 | | |
| | | | | | | | 38 | | |
| | | | | | | | 40 | | |
| | | | | | | | 42 | | |
| | | | | | | | 44 | | |
| | | | | | | | 46 | | |
| | | | | | | | 48 | | |
| | | | | | | | 50 | | |

Completion Notes:

PROPOSED BROWN-STRAUSS STEEL FACILITY

1210 & 1431 WEST LINCOLN STREET, BANNING, CALIFORNIA

Project No: 644-22060

Report No: 23-01-004



Sladden Engineering

BORE LOG

| | | | |
|------------|----------------|---------------|------------|
| Equipment: | MOBILE B-61 | Date Drilled: | 11/30/2022 |
| Elevation: | 2,380 Feet MSL | Boring No: | BH-5 |

| Sample | Blow Counts | Bulk Sample | Expansion Index | % Minus #200 | % Moisture | Density, pcf | Depth (Feet) | Graphic Lithology | Description |
|--------|-------------|-------------|-----------------|--------------|------------|--------------|--------------|-------------------|---|
| | | | | | | | 2 | | Clayey Sand (SC); reddish brown, dry to slightly moist, fine- to coarse-grained (Qf). |
| | 17 18 21 | | | 37.8 | 9.2 | | 4 | | |
| | | | | | | | 6 | | Silty Sand (SM); reddish brown, slightly moist, medium dense, fine- to coarse-grained with gravel (Qf). |
| | 12 16 20 | | | 20.3 | 4.9 | | 8 | | |
| | | | | | | | 10 | | Silty Sand (SM); reddish brown, slightly moist, medium dense, fine- to coarse-grained with gravel (Qf). |
| | 10 11 14 | | | 10.3 | 3.7 | 123.5 | 12 | | |
| | | | | | | | 14 | | |
| | 11 13 16 | | | 9.6 | 3.5 | | 16 | | Sand (SP); yellowish brown, dry, medium dense, fine- to coarse-grained (Qf). |
| | | | | | | | 18 | | |
| | | | | | | | 20 | | Sand (SW); yellowish brown, dry, medium dense, fine- to coarse-grained (Qf). |
| | | | | | | | 22 | | |
| | | | | | | | 24 | | Terminated at ~21.5 Feet bgs. |
| | | | | | | | 26 | | No Bedrock Encountered. |
| | | | | | | | 28 | | No Groundwater or Seepage Encountered. |
| | | | | | | | 30 | | |
| | | | | | | | 32 | | |
| | | | | | | | 34 | | |
| | | | | | | | 36 | | |
| | | | | | | | 38 | | |
| | | | | | | | 40 | | |
| | | | | | | | 42 | | |
| | | | | | | | 44 | | |
| | | | | | | | 46 | | |
| | | | | | | | 48 | | |
| | | | | | | | 50 | | |

Completion Notes:

PROPOSED BROWN-STRAUSS STEEL FACILITY
1210 & 1431 WEST LINCOLN STREET, BANNING, CALIFORNIA

Project No: 644-22060

Report No: 23-01-004



Sladden Engineering

BORE LOG

Equipment: MOBILE B-61 Date Drilled: 11/30/2022

Elevation: 2,380 Feet MSL Boring No: BH-6

| Sample | Blow Counts | Bulk Sample | Expansion Index | % Minus #200 | % Moisture | Density, pcf | Depth (Feet) | Graphic Lithology | Description |
|--------|-------------|-------------|-----------------|--------------|------------|--------------|--------------|-------------------|--|
| | 9 13 22 | | | 37.7 | 4.6 | 108.9 | 2 | | Clayey Sand (SC); reddish brown, dry to slightly moist, fine- to coarse-grained (Qf). |
| | 9 15 23 | | | 32.6 | 7.6 | | 4 | | Clayey Sand (SC); reddish brown, slightly moist, medium dense, fine- to coarse-grained (Qf). |
| | | | | | | | 6 | | Clayey Sand (SC); reddish brown, slightly moist, dense, fine- to coarse-grained (Qf). |
| | | | | | | | 8 | | |
| | | | | | | | 10 | | |
| | | | | | | | 12 | | |
| | | | | | | | 14 | | Terminated at ~11.5 Feet bgs. No Bedrock Encountered. No Groundwater or Seepage Encountered. |
| | | | | | | | 16 | | |
| | | | | | | | 18 | | |
| | | | | | | | 20 | | |
| | | | | | | | 22 | | |
| | | | | | | | 24 | | |
| | | | | | | | 26 | | |
| | | | | | | | 28 | | |
| | | | | | | | 30 | | |
| | | | | | | | 32 | | |
| | | | | | | | 34 | | |
| | | | | | | | 36 | | |
| | | | | | | | 38 | | |
| | | | | | | | 40 | | |
| | | | | | | | 42 | | |
| | | | | | | | 44 | | |
| | | | | | | | 46 | | |
| | | | | | | | 48 | | |
| | | | | | | | 50 | | |

Completion Notes:

PROPOSED BROWN-STRAUSS STEEL FACILITY

1210 & 1431 WEST LINCOLN STREET, BANNING, CALIFORNIA

Project No: 644-22060

Report No: 23-01-004



Sladden Engineering

BORE LOG

| | | | |
|------------|----------------|---------------|------------|
| Equipment: | MOBILE B-61 | Date Drilled: | 11/30/2022 |
| Elevation: | 2,380 Feet MSL | Boring No: | P-2 |

| Sample | Blow Counts | Bulk Sample | Expansion Index | % Minus #200 | % Moisture | Density, pcf | Depth (Feet) | Graphic Lithology | Description |
|--------|-------------|-------------|-----------------|--------------|------------|--------------|--------------|-------------------|---|
| | | | | | | | 2 | | Clayey Sand (SC); reddish brown, dry to slightly moist, fine- to coarse-grained (Qf). |
| | | | | | | 4 | | | |
| | | | | | | | 6 | | Terminated at ~5.0 Feet bgs. No Bedrock Encountered. No Groundwater or Seepage Encountered. |
| | | | | | | 8 | | | |
| | | | | | | 10 | | | |
| | | | | | | 12 | | | |
| | | | | | | 14 | | | |
| | | | | | | 16 | | | |
| | | | | | | 18 | | | |
| | | | | | | 20 | | | |
| | | | | | | 22 | | | |
| | | | | | | 24 | | | |
| | | | | | | 26 | | | |
| | | | | | | 28 | | | |
| | | | | | | 30 | | | |
| | | | | | | 32 | | | |
| | | | | | | 34 | | | |
| | | | | | | 36 | | | |
| | | | | | | 38 | | | |
| | | | | | | 40 | | | |
| | | | | | | 42 | | | |
| | | | | | | 44 | | | |
| | | | | | | 46 | | | |
| | | | | | | 48 | | | |
| | | | | | | 50 | | | |

Appendix F

Structural BMP and/or Retention Facility Sizing Calculations
and Design Details

Whitewater Watershed

BMP Design Volume, V_{BMP} (Rev. 06-2014)

Legend:

Required Entries

Calculated Cells

Company Name Jospeh E. Bonadiman & Associates, Inc Date 3/8/2023

Designed by JTS County/City Case No

Company Project Number/Name 225047

Drainage Area Number/Name DA-1

Enter the Area Tributary to this Feature (A_{TRIB}) $A_{TRIB} =$ 5.95 acres

Determine the Impervious Area Ratio

Determine the Impervious Area within A_{TRIB} (A_{IMP}) $A_{IMP} =$ 5.18 acres

Calculate Impervious Area Ratio (I_f) $I_f =$ 0.87

$$I_f = A_{IMP}/A_{TRIB}$$

Calculate the composite Runoff Coefficient, C for the BMP Tributary Area

Use the following equation based on the WEF/ASCE Method

$$C_{BMP} = 0.858I_f^3 - 0.78I_f^2 + 0.774I_f + 0.04 \quad C_{BMP} = \text{0.69}$$

Determine Design Storage Volume, V_{BMP}

Calculate V_U , the 80% Unit Storage Volume $V_U = 0.40 \times C_{BMP}$ $V_U =$ 0.28 (in*ac)/ac

Calculate the design storage volume of the BMP, V_{BMP} .

$$V_{BMP} \text{ (ft}^3\text{)} = \frac{V_U \text{ (in-ac/ac)} \times A_T \text{ (ac)} \times 43,560 \text{ (ft}^2\text{/ac)}}{12 \text{ (in/ft)}} \quad V_{BMP} = \text{6,048} \text{ ft}^3$$

Notes:

Whitewater Watershed

BMP Design Flow Rate, Q_{BMP} (Rev. 06-2014)

Legend:

Required Entries

Calculated Cells

Company Name Joseph E Bonadiman & Assoc, Inc.

Date 9/7/2023

Designed by JTS

County/City Case No DR 223-7008

Company Project Number/Name

Brown Strauss Steel

Drainage Area Number/Name

DMA-1

Enter the Area Tributary to this Feature (A_{TRIB})

$A_{TRIB} = 5.95$ acres

Determine the Impervious Area Ratio

Determine the Impervious Area within A_{TRIB} (A_{IMP})

$A_{IMP} = 5.18$ acres

Calculate Impervious Area Ratio (I_f)

$I_f = 0.87$

$$I_f = A_{IMP}/A_{TRIB}$$

Calculate the composite Runoff Coefficient, C for the BMP Tributary Area

Use the following equation based on the WEF/ASCE Method

$$C_{BMP} = 0.858I_f^3 - 0.78I_f^2 + 0.774I_f + 0.04$$

$C_{BMP} = 0.69$

BMP Design Flow Rate

$$Q_{BMP} = C_{BMP} \times I \times A_{TRIB}$$

I = Design Rainfall Intensity, 0.2 in/hr

$Q_{BMP} = 0.82$ ft³/s

Notes:

Whitewater Watershed

BMP Design Volume, V_{BMP} (Rev. 06-2014)

Legend:

Required Entries

Calculated Cells

Company Name Josph E. Bonadiman & Associates, Inc

Date 3/8/2023

Designed by JTS

County/City Case No

Company Project Number/Name

225047

Drainage Area Number/Name

DA-2

Enter the Area Tributary to this Feature (A_{TRIB})

$A_{TRIB} = 3.14$ acres

Determine the Impervious Area Ratio

Determine the Impervious Area within A_{TRIB} (A_{IMP})

$A_{IMP} = 3.01$ acres

Calculate Impervious Area Ratio (I_f)

$I_f = 0.96$

$$I_f = A_{IMP}/A_{TRIB}$$

Calculate the composite Runoff Coefficient, C for the BMP Tributary Area

Use the following equation based on the WEF/ASCE Method

$$C_{BMP} = 0.858I_f^3 - 0.78I_f^2 + 0.774I_f + 0.04$$

$C_{BMP} = 0.82$

Determine Design Storage Volume, V_{BMP}

Calculate V_U , the 80% Unit Storage Volume $V_U = 0.40 \times C_{BMP}$

$V_U = 0.33$ (in*ac)/ac

Calculate the design storage volume of the BMP, V_{BMP} .

$$V_{BMP} \text{ (ft}^3\text{)} = \frac{V_U \text{ (in-ac/ac)} \times A_T \text{ (ac)} \times 43,560 \text{ (ft}^2\text{/ac)}}{12 \text{ (in/ft)}}$$

$V_{BMP} = 3,761$ ft³

Notes:

Whitewater Watershed

BMP Design Flow Rate, Q_{BMP} (Rev. 06-2014)

Legend:

Required Entries

Calculated Cells

Company Name Joseph E Bonadiman & Assoc, Inc.

Date 9/7/2023

Designed by JTS

County/City Case No DR 223-7008

Company Project Number/Name

Brown Strauss Steel

Drainage Area Number/Name

DMA-2

Enter the Area Tributary to this Feature (A_{TRIB})

$A_{TRIB} = 3.14$ acres

Determine the Impervious Area Ratio

Determine the Impervious Area within A_{TRIB} (A_{IMP})

$A_{IMP} = 3.10$ acres

Calculate Impervious Area Ratio (I_f)

$I_f = 0.99$

$$I_f = A_{IMP}/A_{TRIB}$$

Calculate the composite Runoff Coefficient, C for the BMP Tributary Area

Use the following equation based on the WEF/ASCE Method

$$C_{BMP} = 0.858I_f^3 - 0.78I_f^2 + 0.774I_f + 0.04$$

$C_{BMP} = 0.87$

BMP Design Flow Rate

$$Q_{BMP} = C_{BMP} \times I \times A_{TRIB}$$

I = Design Rainfall Intensity, 0.2 in/hr

$Q_{BMP} = 0.55$ ft³/s

Notes:

Whitewater Watershed

BMP Design Volume, V_{BMP} (Rev. 06-2014)

Legend:

Required Entries

Calculated Cells

Company Name Jospeh E. Bonadiman & Associates, Inc Date 3/8/2023

Designed by JTS County/City Case No

Company Project Number/Name 225047

Drainage Area Number/Name DA-3

Enter the Area Tributary to this Feature (A_{TRIB}) $A_{TRIB} =$ 4.52 acres

Determine the Impervious Area Ratio

Determine the Impervious Area within A_{TRIB} (A_{IMP}) $A_{IMP} =$ 4.48 acres

Calculate Impervious Area Ratio (I_f) $I_f =$ 0.99

$$I_f = A_{IMP}/A_{TRIB}$$

Calculate the composite Runoff Coefficient, C for the BMP Tributary Area

Use the following equation based on the WEF/ASCE Method

$$C_{BMP} = 0.858I_f^3 - 0.78I_f^2 + 0.774I_f + 0.04 \quad C_{BMP} =$$
 0.88

Determine Design Storage Volume, V_{BMP}

Calculate V_U , the 80% Unit Storage Volume $V_U = 0.40 \times C_{BMP}$ $V_U =$ 0.35 (in*ac)/ac

Calculate the design storage volume of the BMP, V_{BMP} .

$$V_{BMP} \text{ (ft}^3\text{)} = \frac{V_U \text{ (in-ac/ac)} \times A_T \text{ (ac)} \times 43,560 \text{ (ft}^2\text{/ac)}}{12 \text{ (in/ft)}} \quad V_{BMP} =$$
 5,743 ft³

Notes:

Whitewater Watershed

BMP Design Flow Rate, Q_{BMP} (Rev. 06-2014)

Legend:

Required Entries

Calculated Cells

Company Name Joseph E Bonadiman & Assoc, Inc.

Date 9/7/2023

Designed by JTS

County/City Case No DR 223-7008

Company Project Number/Name

Brown Strauss Steel

Drainage Area Number/Name

DMA-3

Enter the Area Tributary to this Feature (A_{TRIB})

$A_{TRIB} = 4.52$ acres

Determine the Impervious Area Ratio

Determine the Impervious Area within A_{TRIB} (A_{IMP})

$A_{IMP} = 4.48$ acres

Calculate Impervious Area Ratio (I_f)

$I_f = 0.99$

$$I_f = A_{IMP}/A_{TRIB}$$

Calculate the composite Runoff Coefficient, C for the BMP Tributary Area

Use the following equation based on the WEF/ASCE Method

$$C_{BMP} = 0.858I_f^3 - 0.78I_f^2 + 0.774I_f + 0.04$$

$C_{BMP} = 0.88$

BMP Design Flow Rate

$$Q_{BMP} = C_{BMP} \times I \times A_{TRIB}$$

I = Design Rainfall Intensity, 0.2 in/hr

$Q_{BMP} = 0.79$ ft³/s

Notes:

Whitewater Watershed

BMP Design Volume, V_{BMP} (Rev. 06-2014)

Legend:

Required Entries

Calculated Cells

Company Name Josph E. Bonadiman & Associates, Inc

Date 3/8/2023

Designed by JTS

County/City Case No

Company Project Number/Name

225047

Drainage Area Number/Name

DA-4

Enter the Area Tributary to this Feature (A_{TRIB})

$A_{TRIB} = 0.65$ acres

Determine the Impervious Area Ratio

Determine the Impervious Area within A_{TRIB} (A_{IMP})

$A_{IMP} = 0.09$ acres

Calculate Impervious Area Ratio (I_f)

$I_f = 0.14$

$$I_f = A_{IMP}/A_{TRIB}$$

Calculate the composite Runoff Coefficient, C for the BMP Tributary Area

Use the following equation based on the WEF/ASCE Method

$$C_{BMP} = 0.858I_f^3 - 0.78I_f^2 + 0.774I_f + 0.04$$

$C_{BMP} = 0.13$

Determine Design Storage Volume, V_{BMP}

Calculate V_U , the 80% Unit Storage Volume $V_U = 0.40 \times C_{BMP}$

$V_U = 0.05$ (in*ac)/ac

Calculate the design storage volume of the BMP, V_{BMP} .

$$V_{BMP} (\text{ft}^3) = \frac{V_U (\text{in-ac/ac}) \times A_T (\text{ac}) \times 43,560 (\text{ft}^2/\text{ac})}{12 (\text{in/ft})}$$

$V_{BMP} = 118$ ft³

Notes:

Summary Sheet:

The size of the stormwater retention/detention chamber volume contains the developed condition hydrograph volumes for a 100-yr, 3-hr storm event, per City of Banning Ordinance No. 1415, Section 6, 1.9698 ac-ft (85,804 cu ft) which included the DCV 15,022 cu-ft. The retention capacity is 2.2472 ac-ft (97,890 cu-ft). The total capacity is 2.9640 ac-ft (129,110 cu-ft) which provides volume for buffering peak storm flows.

Unit Hydrograph Analysis

Copyright (c) CIVILCADD/CIVILDESIGN, 1989 - 2018, Version 9.0
Study date 03/02/23 File: DEVHYD3100.out

Riverside County Synthetic Unit Hydrology Method
RCFC & WCD Manual date - April 1978

Program License Serial Number 6320

English (in-lb) Input Units Used
English Rainfall Data (Inches) Input Values Used

English Units used in output format

225047 BREMCO CONSTRUCTION BROWN STRAUSS STEEL BANNING
DEVELOPED CONDITIONS
100-YEAR STORM
BY: JTS DATE: 03-02-23

Drainage Area = 14.27(Ac.) = 0.022 Sq. Mi.
Drainage Area for Depth-Area Areal Adjustment = 14.27(Ac.) = 0.022 Sq. Mi.
Length along longest watercourse = 2019.00(Ft.)
Length along longest watercourse measured to centroid = 766.00(Ft.)
Length along longest watercourse = 0.382 Mi.
Length along longest watercourse measured to centroid = 0.145 Mi.
Difference in elevation = 28.41(Ft.)
Slope along watercourse = 74.2966 Ft./Mi.
Average Manning's 'N' = 0.015
Lag time = 0.053 Hr.
Lag time = 3.17 Min.
25% of lag time = 0.79 Min.
40% of lag time = 1.27 Min.
Unit time = 5.00 Min.
Duration of storm = 3 Hour(s)
User Entered Base Flow = 0.00(CFS)

2 YEAR Area rainfall data:

| Area(Ac.)[1] | Rainfall(In)[2] | Weighting[1*2] |
|--------------|-----------------|----------------|
| 14.27 | 0.96 | 13.70 |

100 YEAR Area rainfall data:

| Area(Ac.)[1] | Rainfall(In)[2] | Weighting[1*2] |
|--------------|-----------------|----------------|
| 14.27 | 2.23 | 31.82 |

STORM EVENT (YEAR) = 100.00
Area Averaged 2-Year Rainfall = 0.960(In)
Area Averaged 100-Year Rainfall = 2.230(In)

Point rain (area averaged) = 2.230(In)
Areal adjustment factor = 99.99 %
Adjusted average point rain = 2.230(In)

Sub-Area Data:
Area(Ac.) Runoff Index Impervious %

14.270 46.60 0.159
 Total Area Entered = 14.27(Ac.)

| | | | | | | |
|------|-------|-------------|------------|------------------|--------|---------|
| RI | RI | Infil. Rate | Impervious | Adj. Infil. Rate | Area% | F |
| AMC2 | AMC-2 | (In/Hr) | (Dec.%) | (In/Hr) | (Dec.) | (In/Hr) |
| 46.6 | 46.6 | 0.605 | 0.159 | 0.519 | 1.000 | 0.519 |

Sum (F) = 0.519

Area averaged mean soil loss (F) (In/Hr) = 0.519
 Minimum soil loss rate ((In/Hr)) = 0.259
 (for 24 hour storm duration)
 Soil low loss rate (decimal) = 0.259

 U n i t H y d r o g r a p h
 VALLEY S-Curve

Unit Hydrograph Data

| Unit time period (hrs) | Time % of lag | Distribution Graph % | Unit Hydrograph (CFS) |
|---------------------------|---------------|-------------------------|--------------------------|
| 1 | 0.083 | 157.487 | 34.939 |
| 2 | 0.167 | 314.973 | 46.456 |
| 3 | 0.250 | 472.460 | 10.764 |
| 4 | 0.333 | 629.946 | 4.657 |
| 5 | 0.417 | 787.433 | 2.267 |
| 6 | 0.500 | 944.919 | 0.918 |
| | | Sum = 100.000 | Sum= 14.381 |

The following loss rate calculations reflect use of the minimum calculated loss rate subtracted from the Storm Rain to produce the maximum Effective Rain value

| Unit Time (Hr.) | Pattern Percent | Storm Rain (In/Hr) | Loss rate(In./Hr) | | Effective (In/Hr) |
|--------------------|--------------------|-----------------------|-------------------|----------|----------------------|
| | | | Max | Low | |
| 1 | 0.08 | 1.30 | (0.519) | 0.090 | 0.258 |
| 2 | 0.17 | 1.30 | (0.519) | 0.090 | 0.258 |
| 3 | 0.25 | 1.10 | (0.519) | 0.076 | 0.218 |
| 4 | 0.33 | 1.50 | (0.519) | 0.104 | 0.297 |
| 5 | 0.42 | 1.50 | (0.519) | 0.104 | 0.297 |
| 6 | 0.50 | 1.80 | (0.519) | 0.125 | 0.357 |
| 7 | 0.58 | 1.50 | (0.519) | 0.104 | 0.297 |
| 8 | 0.67 | 1.80 | (0.519) | 0.125 | 0.357 |
| 9 | 0.75 | 1.80 | (0.519) | 0.125 | 0.357 |
| 10 | 0.83 | 1.50 | (0.519) | 0.104 | 0.297 |
| 11 | 0.92 | 1.60 | (0.519) | 0.111 | 0.317 |
| 12 | 1.00 | 1.80 | (0.519) | 0.125 | 0.357 |
| 13 | 1.08 | 2.20 | (0.519) | 0.152 | 0.436 |
| 14 | 1.17 | 2.20 | (0.519) | 0.152 | 0.436 |
| 15 | 1.25 | 2.20 | (0.519) | 0.152 | 0.436 |
| 16 | 1.33 | 2.00 | (0.519) | 0.139 | 0.397 |
| 17 | 1.42 | 2.60 | (0.519) | 0.180 | 0.516 |
| 18 | 1.50 | 2.70 | (0.519) | 0.187 | 0.535 |
| 19 | 1.58 | 2.40 | (0.519) | 0.166 | 0.476 |
| 20 | 1.67 | 2.70 | (0.519) | 0.187 | 0.535 |
| 21 | 1.75 | 3.30 | (0.519) | 0.229 | 0.654 |
| 22 | 1.83 | 3.10 | (0.519) | 0.215 | 0.615 |
| 23 | 1.92 | 2.90 | (0.519) | 0.201 | 0.575 |
| 24 | 2.00 | 3.00 | (0.519) | 0.208 | 0.595 |
| 25 | 2.08 | 3.10 | (0.519) | 0.215 | 0.615 |
| 26 | 2.17 | 4.20 | (0.519) | 0.291 | 0.833 |
| 27 | 2.25 | 5.00 | (0.519) | 0.347 | 0.991 |
| 28 | 2.33 | 3.50 | (0.519) | 0.243 | 0.694 |
| 29 | 2.42 | 6.80 | (0.519) | 0.471 | 1.348 |
| 30 | 2.50 | 7.30 | (0.519) | 0.506 | 1.447 |
| 31 | 2.58 | 8.20 | 0.519 | (0.568) | 1.675 |
| 32 | 2.67 | 5.90 | (0.519) | 0.409 | 1.170 |

DESIGN INFORMATION
 MATERIAL FINISH = ALZD TYPE II
 PIPE GAUGE = 16
 PERFORATED = YES
 DIAMETER = 36"
 LOADING = H20/H25
 SYSTEM INV = ---

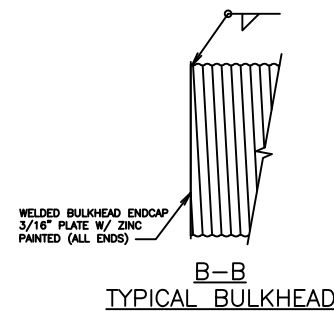
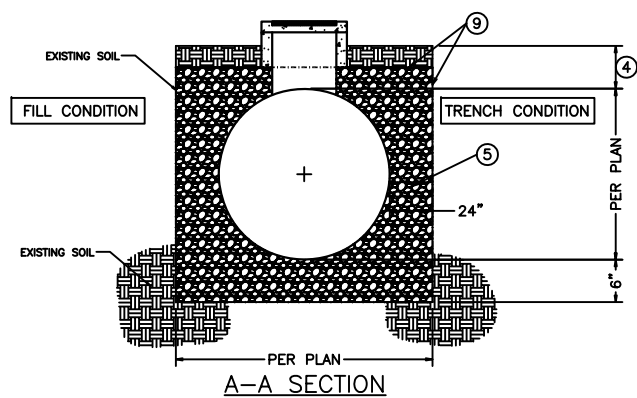
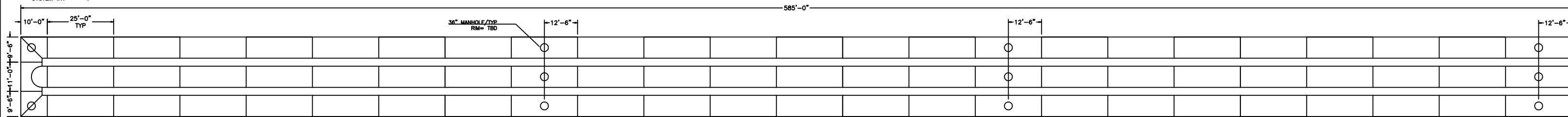

- NOTES:
- RIGID OR FLEXIBLE PAVEMENT.
 - GRANULAR ROAD BASE.
 - NORMAL ROADWAY EMBANKMENT FILL PLACED IN 8" LIFTS AND COMPACTED TO MIN. 90% STANDARD DENSITY PER AASHTO T-99.
 - 12" MIN. FOR DIAMETERS THROUGH 96", 18" MIN. FOR DIAMETERS FROM 102" AND UP. MEASURE FROM TOP OF PIPE TO BOTTOM OF FLEXIBLE PAVEMENT OR TOP OF PIPE TO TOP OF RIGID PAVEMENT.
 - FREE DRAINING ANGULAR WASHED STONE 3/4" - 2" AROUND PIPE ENVELOPE AS SHOWN OR OTHERWISE NOTED.
 - 5 x 1" CSP GAGE PER AASHTO SECTION 12.
 - NOT USED
 - LISTED SPACING CHART IS FOR MULTIPLE PIPE INSTALLATION. FOR SINGLE RUN, THE TRENCH REQUIRES ONLY THE BOTTOM WIDTH OF THE PIPE'S SPAN, PLUS ROOM FOR COMPACTION EQUIPMENT.

| SPACING CHART PER AISI AND NCSIPA GUIDELINES | |
|--|------------------|
| DIAMETER | REQUIRED SPACING |
| UP TO 24" | 12" |
| 24" - 72" | 1/2 PIPE DIA. |
| 72" AND UP | 36" |

- 4 oz. NON WOVEN GEOTEXTILE FABRIC.
- RELATIVELY LOOSE GRANULAR BEDDING ROUGHLY SHAPED TO FIT BOTTOM OF PIPE, 4" TO 6" IN DEPTH. (#57 OR #6 OR OTHER SUITABLE GRANULAR).

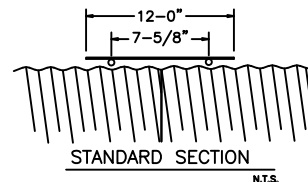
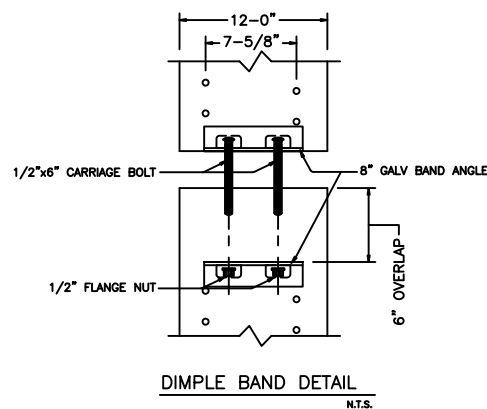
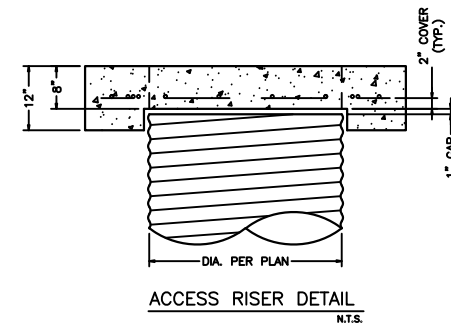
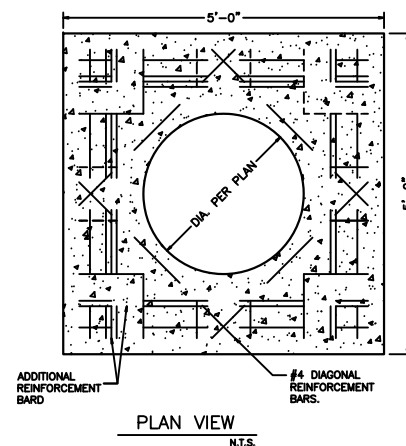

- GENERAL NOTES:
- BANDS ARE FURNISHED AS FOLLOWS:
 12" THRU 48" - 1-PIECE
 54" THRU 96" - 2-PIECE
 102" THRU 144" - 3-PIECE
 - GALV BAND ANGLES ARE ATTACHED WITH SPOT WELDS, RIVETS OR HAND WELDED.
 - DIMENSIONS ARE SUBJECT TO MANUFACTURING TOLERANCES.
 - DIMPLE BANDS FOR ARCHED PIPE ARE THE SAME AS FOR EQUIVALENT ROUND PIPE DIAMETER.

South Bay Foundry
 WWW.SOUTHBAYFOUNDRY.COM
 PHONE (415) 968-0780 FAX (415) 968-0780

SBF 1251
 36" MANHOLE
 FRAME AND COVER
 STEEL GRAB

SECTION A-A

SET WEIGHT
 FRAME 257 LB
 COVER 344 LB
 TOTAL 601 LB

| APPROVED | |
|-----------|--|
| BY: | |
| TITLE: | |
| DESIGN Y: | |
| DATE: | |

PACIFIC CORRUGATED PIPE CO.
 13680 SLOVER AVENUE FONTANA, CA 92337
 800.338.5858 * 909.829.4235
 Fx: 909.829.8035
 SOCAL@PCPIPE.COM

NOTE:
 THE SUITABILITY OF THE INFORMATION PRESENTED FOR USE ON ANY PARTICULAR PROJECT SHOULD BE DETERMINED BY THE ENGINEER RESPONSIBLE FOR THE DESIGN.

| | | | |
|--|---------------------|--------------------|----------------------|
| PROJECT NAME: BANNING | | PROJECT #: | DRAWN BY: C.CLARK |
| SIGN & DATE TO RELEASE FOR MANUFACTURE (SUBJECT TO PRICE VERIFICATION) | | SCALE: AS NOTED | |
| PLANS APPROVED <input type="checkbox"/> (AS NOTED) <input type="checkbox"/> (W/CHANGES) | | DATE: 11/06/23 | SHEET NO: 1 OF 1 |
| DATE | SIGNATURE | DATE | |
| REV. | DESCRIPTION | DATE | |
| | BROWN STRAUSS STEEL | | |

Appendix G

AGREEMENTS – CC&RS, COVENANT AND AGREEMENTS, BMP
MAINTENANCE AGREEMENTS AND/OR OTHER
MECHANISMS FOR ENSURING ONGOING OPERATION,
MAINTENANCE, FUNDING AND TRANSFER OF
REQUIREMENTS FOR THIS PROJECT-SPECIFIC WQMP

RECORDING REQUESTED BY
AND WHEN RECORDED RETURN TO:

*City of Banning
City Clerk
P.O. Box 998
99 E. Ramsey Street
Banning, CA 92220*

EXEMPT FROM RECORDER'S FEES PURSUANT
TO GOVERNMENT CODE SECTIONS 6103 AND
27383.

SPACE ABOVE THIS LINE FOR RECORDER'S USE

APN: 540-180-020, 540-180-022, 540-180-026

**STORM WATER MANAGEMENT WQMP/BMP
FACILITIES AGREEMENT NO. 2023-0X**

City of Banning, Riverside County, California

THIS AGREEMENT, made and entered into this ____ day of _____, 20__, by and between **Brown Strauss, Inc.** hereinafter called the "Landowner", and the City of Banning, California, hereinafter called the "City".

RECITALS

WHEREAS, the Landowner is the owner of certain real property described as APNs 540-180-020, 022, & 026 as recorded by deed in the land records of Riverside County, California, Map Book 9, Page 44, hereinafter called the "Property" more particularly described in Exhibit "A" legal description attached and made a part by this reference; and

WHEREAS, the Landowner is currently the property owner and has built on and developed the property; and

WHEREAS, the Water Quality Management Plan (WQMP) prepared for Brown Strauss Steel – Banning, hereinafter called the "WQMP", which is expressly made a part hereof and is on file in the City Engineer's Office, as approved by the City, provides for storm water quality treatment within the confines of the property; and

WHEREAS, the City and the Landowner, its successors and assigns, including any homeowners association, agree that the health, safety, and welfare of the residents of the City of Banning, require that on-site storm water management/Best Management Practices (BMP) facilities mentioned in the project's approved WQMP be constructed and maintained (to minimize pollutants in urban runoff) by the Landowner, its successors and assigns, including, but not limited to, any new property owner.

NOW THEREFORE, in consideration of the foregoing recitals, the mutual covenants contained herein, and the following terms and conditions, the parties hereto agree as follows:

1. The on-site storm water management/BMP facilities mentioned above shall be constructed by the Landowner, its successors and assigns, in accordance with the plans and specifications identified in the WQMP.
2. The Landowner, its successors and assigns, shall adequately maintain the storm water management/BMP facilities, including source control BMPs. This includes all pipes and channels built to convey storm water on the property, including catch basin inserts, underground detention ponds, swales and vegetation provided to control the quantity and quality of the storm water. Adequate maintenance is herein defined as good working condition so that these facilities are performing in their design functions.
3. The Landowner, its successors and assigns, shall annually inspect the storm water management/BMP facility mentioned above by March and submit an inspection report annually to the Public Works Department by April 1st of each year. The purpose of the Annual BMP Facility Inspection is to assure safe and proper functioning of the facilities. The inspection shall cover the storm water management BMPs listed in the WQMP such as bioretention basins, underground storage systems, bioswales, catch basins and its filter units, storm drains, etc. Deficiencies shall be noted in the inspection report.
4. The Landowner, its successors and assigns, hereby grant permission to the City, its authorized agents and employees, to enter upon the Property and to inspect the storm water management/BMP facilities whenever the City deems necessary and as required by the City's most current National Pollutant Discharge Elimination System (NPDES) Permit. The purpose of inspection is to follow up on reported deficiencies and/or to respond to citizen complaints, and meet the City's NPDES Permit issued by the State Water Resources Control Board – Colorado River Region No. 7. The City shall provide the Landowner, its successors and assigns, copies of the inspection findings and a directive to commence with the repairs if necessary.
5. In the event the Landowner, its successors and assigns, fails to maintain the storm water management/BMP facilities in good working condition acceptable to the City, the City may enter upon the Property and take whatever steps necessary to correct deficiencies identified in any inspection report and to charge the costs of such repairs to the Landowner, its successors and assigns. This provision shall not be construed to allow the City to erect any structure of permanent nature on the land of the Landowner outside of the easement for the storm water management/BMP facilities. It is expressly understood and agreed that the City is under no obligation to routinely maintain or repair said facilities, and in no event shall this Agreement be construed to impose any such obligation on the City.
6. The Landowner, its successors and assigns, will perform the work necessary to keep these facilities in good working order as appropriate. The maintenance schedule for the storm water management/BMP facilities (including sediment removal) is outlined in the approved WQMP and the schedule will be followed. In the future, the City of Banning

may adopt an annual Stormwater/NPDES Inspection Fee that would be assessed to the property owner.

7. In the event the City, pursuant to this Agreement, performs work of any nature, or expends any funds in performance of said work for labor, use of equipment, supplies, materials, and the like, the Landowner, its successors and assigns, shall reimburse the City upon demand, within thirty (30) days of receipt thereof for all actual costs incurred by the City hereunder. This includes paying the City the NPDES Inspection Fee if the City must perform the Annual BMP Facility Inspection and meet the requirements listed in Item No. 3 above because the property owner failed to do so.
8. This Agreement imposes no liability of any kind whatsoever on the City and the Landowner agrees to hold the City harmless, defend and indemnify from any liability whatsoever in the event the storm water management/BMP facilities fail to operate properly.
9. This Agreement shall be recorded through the County of Riverside, retained by the City of Banning, shall constitute a covenant running with the land, and shall be binding on the Landowner, its administrators, executors, assigns, heirs, and any other successors in interests, including any homeowners association.

WITNESS the following signatures and seals:

OWNER:

By: _____

Name: _____
Please Print

Title: _____

Company Name: Brown Strauss, Inc.

ATTEST:

By: _____

(S e a l)

Name: _____
Please Print

Title: _____

Notary must attach an "All-Purpose Acknowledgement"

CITY OF BANNING:

By: _____

Nate Smith, P.E.
Deputy Director of Public Works/ City Engineer
City of Banning

ATTEST:

By: _____

Caroline Patton
Deputy City Clerk, City of Banning

All signatures on this Agreement on behalf of the Owner must be acknowledged before a Notary Public. In the event that the Owner is a corporation, the President/Vice President and the corporate secretary of the corporation must sign and the corporate seal must be affixed thereto.

Appendix H

PHASE 1 ENVIRONMENTAL SITE ASSESSMENT – SUMMARY OF SITE
REMEDICATION CONDUCTED AND USE RESTRICTIONS

Phase I Environmental Site Assessment

Banning Industrial

**1219 and 1431 West Lincoln Street
Banning, Riverside County, California**

September 1, 2022

Terracon Project No. LA227292



Prepared for:

Brown Strauss, Inc.
Aurora, Colorado

Prepared by:

Terracon Consultants, Inc.
Colton, California

terracon.com

Terracon

Environmental



Facilities



Geotechnical



Materials

September 1, 2022



Brown Strauss, Inc.
2495 Uravan Street
Aurora, Colorado 80011

Attn: Mr. Ryan Secrist
P: (303) 576-6215
E: rsecrist@brownstrauss.com

Re: Phase I Environmental Site Assessment
Banning Industrial
1219 and 1431 West Lincoln Street
Banning, Riverside County, California 92220
(Riverside County Assessor Parcel Numbers: 540-020, 540-180-022, and 540-180-026)
Terracon Project No. LA227292

Dear Mr. Secrist:

Terracon Consultants, Inc. (Terracon) is pleased to submit the enclosed Phase I Environmental Site Assessment (ESA) report for the above-referenced site. This assessment was performed in accordance with Agreement for Services associated with the Terracon Proposal No. PLA227292, dated August 2, 2022.

We appreciate the opportunity to be of service to you on this project. In addition to Phase I services, our professionals provide geotechnical, environmental, construction materials, and facilities services on a wide variety of projects locally, regionally and nationally. For more detailed information on all of Terracon's services please visit our website at www.terracon.com. If there are any questions regarding this report or if we may be of further assistance, please do not hesitate to contact us.

Sincerely,
Terracon Consultants, Inc.

A handwritten signature in black ink, appearing to read 'Laura S. Hedman'.

Laura S. Hedman
Staff Geologist

A handwritten signature in black ink, appearing to read 'Jennifer S. Van'.

Jennifer S. Van
Environmental Group Manager

A handwritten signature in black ink, appearing to read 'Tony P. Mikacich'.

Tony P. Mikacich, PG
Senior Geologist / Department Manager I

Attachments

Terracon Consultants Inc. 1355 East Cooley Drive, Colton, California 92324-3954

P 909-824-7311 F 909-301-6016 terracon.com



Environmental

Facilities

Geotechnical

Materials

TABLE OF CONTENTS

| | Page No. |
|---|-----------|
| EXECUTIVE SUMMARY | 1 |
| Findings and Opinions | 1 |
| Significant Data Gaps | 3 |
| Conclusions..... | 3 |
| Recommendations | 3 |
| 1.0 INTRODUCTION | 4 |
| 1.1 Site Description | 4 |
| 1.2 Scope of Services | 4 |
| 1.3 Standard of Care..... | 5 |
| 1.4 Additional Scope Limitations, ASTM Deviations and Data Gaps | 5 |
| 1.5 Reliance | 6 |
| 1.6 Client Provided Information..... | 6 |
| 2.0 PHYSICAL SETTING | 7 |
| 3.0 HISTORICAL USE INFORMATION | 8 |
| 3.1 Historical Topographic Maps, Aerial Photographs, Sanborn Maps | 8 |
| 3.2 Historical City Directories | 10 |
| 3.3 Site Ownership / Title Search | 11 |
| 3.4 Environmental Liens and Activity and Use Limitations | 12 |
| 3.5 Interviews Regarding Current and Historical Site Uses..... | 12 |
| 3.6 Prior Report Review | 12 |
| 4.0 RECORDS REVIEW | 13 |
| 4.1 Federal and State/Tribal Databases | 13 |
| 4.2 Local Agency Inquiries | 16 |
| 4.3 Local Area Knowledge | 17 |
| 5.0 SITE RECONNAISSANCE | 17 |
| 5.1 General Site Information | 17 |
| 5.2 Overview of Current Site Occupants and Site Operations..... | 18 |
| 5.3 Site Observations..... | 18 |
| 6.0 ADJOINING PROPERTY RECONNAISSANCE | 20 |
| 7.0 ADDITIONAL SERVICES | 20 |
| 8.0 DECLARATION | 21 |

TABLE OF CONTENTS (continued)

APPENDICES

| | |
|------------|---|
| APPENDIX A | Exhibit 1 - Topographic Map, Exhibit 2 - Site Diagram |
| APPENDIX B | Site Photographs |
| APPENDIX C | Historical Documentation and User Questionnaire |
| APPENDIX D | Environmental Database Information |
| APPENDIX E | Credentials |
| APPENDIX F | Description of Terms and Acronyms |

EXECUTIVE SUMMARY

This Phase I Environmental Site Assessment (ESA) was performed in accordance with Agreement for Services associated with the Terracon Proposal No. PLA227292, dated August 2, 2022, and was conducted consistent with the procedures included in ASTM E1527-13, *Standard Practice for Environmental Site Assessments: Phase I Environmental Site Assessment Process*. The ESA was conducted under the supervision or responsible charge of Jennifer S. Van, Environmental Professional. Sabrina Chantler performed the site reconnaissance on August 11, 2022.

Findings and Opinions

A summary of findings is provided below. It should be recognized that details were not included or fully developed in this section, and the report must be read in its entirety for a comprehensive understanding of the items contained herein.

Site Description and Use

The site is located at 1219 and 1431 West Lincoln Street in Banning, Riverside County, California 92220. The site consists of three contiguous parcels of generally vacant land, totaling approximately 14.92-acres, and identified by Riverside County assessor parcel numbers (APNs): 540-020, 540-180-022, and 540-180-026. The site is further improved with a small animal enclosure and utilities. At the time of the site reconnaissance, the site was observed to be unoccupied.

Historical Information

Based on review of the historical information, the site consisted of undeveloped land from as early as 1901, followed by agricultural land activities from at least 1938 until sometime between 1953 and 1961. By 1961, the central and eastern portions of the site appeared graded, and another homestead/dwelling and apparent trailers/containers were visible. By 1989, the homestead/dwelling on the eastern portion of the site appeared to have been removed, followed by the apparent removal of the remaining homestead/dwelling on the western portion of the site, by 1990. Based on the 2002 aerial photograph, apparent containers/trailers were visible throughout the site. By 2006, the containers/trailers appeared to have been removed; however, an apparent container/trailer was visible in the 2016 aerial photograph. Based on the 2012 aerial photograph, an apparent water tank and small animal enclosure were visible, on the southwestern portion of the site. Mr. Michael Baldi, site owner, stated that the animal enclosure was used for cattle (for a brief period of time), which were subsequently removed from the site. At the time of the visual reconnaissance, the container/trailer had been removed from the site, and site appeared generally vacant.

Historically, the site has been used for agricultural activities (orchards), from at least 1938 until sometime between 1953 and 1961, which may include the use of pesticides and herbicides. Most

currently used agricultural chemicals do not persist for extended periods of time in the environment if applied appropriately; however, some agricultural chemicals persist in the environment, especially if misapplied. In addition, structures indicative of potential mixing of pesticides and/or herbicides were not observed onsite in the historical aerial photographs reviewed. In Terracon's experience, the application of herbicides and pesticides to agricultural fields can leave trace amounts of the compounds in the soil and/or groundwater; however, these residual amounts are generally below risk-based screening levels. Pesticide and/or herbicide misuse or vegetative stress were not observed on the site during the site reconnaissance.

The surrounding properties consisted of undeveloped land, with a railroad (Southern Pacific) to the north and an existing road (West Lincoln Street) to the south. By 1938, the surrounding properties appeared as agricultural land, with two apparent homesteads/dwellings to the adjacent south. By 1949, portions of the land, north of the railroad, appeared graded, and two more homesteads/dwellings were visible, on the land to the adjacent south. By 1961, the existing highway to the north (Christopher Columbus Transcontinental Highway/Interstate 10 Freeway) appeared to be in the early stages of development, followed by commercial development (further north), an apparent commercial building developed to the east, and the land to the west appeared graded and vacant. By 1967, the freeway to the north appeared fully developed. Commercial development continued, from the 1980s through the early 2000s, with the development of the existing commercial buildings to the east (various automotive businesses such as California Collision Center, Express Tires & Auto Repair, and precision Auto Service, 1143 West Lincoln Street, and Color Fast Industries, Dicks Tire Mart, Entrada Door Inc., EPD Wearness USA Inc., First Place Powder Coating, 1177 West Lincoln Street); an apparent dwelling/structure to the west; existing commercial/construction buildings developed further southeast (Zimmerman Larry Woodworking and Trench Shoring, 1184 West Lincoln Street); and trailers/containers were visible on the land to the south-southwest. Around 2002, homesteads/dwellings appeared to have been removed from the southeast and west. The site has remained consistent through the present. Recognized environmental conditions (RECs) were not identified in connection with the historical documentation.

Records Review

Selected federal and state environmental regulatory databases as well as responses from state and local regulatory agencies were reviewed. The site was not identified in the regulatory database information.

The remaining listed facilities do not constitute RECs based upon facility characteristics, distance, and/or topographic gradient in relation to the site.

Site Reconnaissance

During the site reconnaissance, Terracon observed an approximately 800-gallon water aboveground storage tank, and a pile of asphalt debris/cuttings (approximately 1-cubic yard). RECs were not identified in connection with the site.

Adjoining Properties

The northern adjoining properties consisted of Southern Pacific railroad, followed by the Christopher Columbus Transcontinental Highway (Interstate 10 Freeway), multi-tenant retail building (1510-1431 West Ramsey Street), and a vacant retail building (1374 West Ramsey Street). The eastern adjoining properties consisted of multi-tenant commercial buildings (1143 West Lincoln Street) and multi-tenant commercial building (1177 West Lincoln Street). West Lincoln Street abutted the site to the south, followed by residential dwellings and vacant land (1222-1476 West Lincoln Street), vacant land (1184 West Lincoln Street) to the southeast, and a residential dwelling (1522 West Lincoln Street) to the southwest. The western adjoining property consisted of vacant land (1541 West Lincoln Street). RECs were not observed with the adjoining properties.

Significant Data Gaps

Significant data gaps were not identified.

Conclusions

We have performed a Phase I ESA consistent with the procedures included in ASTM Practice E 1527-13 of the Banning Industrial site, located at 1219 and 1431 West Lincoln Street, Banning, Riverside County, California 92220 (Riverside County Assessor Parcel Numbers: 540-020, 540-180-022, and 540-180-026), the site. RECs or Controlled RECs (CRECs) were not identified in connection with the site.

Recommendations

Based on the scope of services, limitations, and conclusions of this assessment, Terracon does not recommend additional investigation at this time.

1.0 INTRODUCTION

1.1 Site Description

| | |
|------------------------------------|--|
| Site Name | Banning Industrial |
| Site Location/Address | 1219 and 1431 West Lincoln Street, Banning, Riverside County, California (Riverside County Assessor Parcel Numbers: 540-020, 540-180-022, and 540-180-026) |
| Land Area | Consists of an approximately three contiguous parcels totaling approximately 14.92-acres. |
| Site Improvements | The site consisted of generally vacant land. |
| Anticipated Future Site Use | Redevelopment for commercial use |
| Reason for the ESA | Assist the client with acquiring the site. |

The location of the site is depicted on Exhibit 1 of Appendix A, which was reproduced from a portion of the Beaumont, California and Cabazon, California, USGS 7.5-minute series topographic map (2018). The site and adjoining properties are depicted on the Site Diagram, which is included as Exhibit 2 of Appendix A. Acronyms and terms used in this report are described in Appendix F.

1.2 Scope of Services

This Phase I ESA was performed in accordance with Agreement for Services associated with the Terracon Proposal No. PLA227292 dated August 2, 2022, and was conducted consistent with the procedures included in ASTM E1527-13, *Standard Practice for Environmental Site Assessments: Phase I Environmental Site Assessment Process*. The purpose of this ESA was to assist the client in developing information to identify RECs in connection with the site as reflected by the scope of this report. This purpose was undertaken through user-provided information, a regulatory database review, historical and physical records review, interviews, including local government inquiries, as applicable, and a visual noninvasive reconnaissance of the site and adjoining properties. Limitations, ASTM deviations, and significant data gaps (if identified) are noted in the applicable sections of the report.

ASTM E1527-13 contains a new definition of "migrate/migration," which refers to "the movement of hazardous substances or petroleum products in any form, including, for example, solid and liquid at the surface or subsurface, and vapor in the subsurface." By including this explicit reference to migration in ASTM E1527-13, the Standard clarifies that the potential for vapor migration should be addressed as part of a Phase I ESA. This Phase I ESA has considered vapor migration in evaluation of RECs associated with the site.

1.3 Standard of Care

This ESA was performed in accordance with generally accepted practices of this profession, undertaken in similar studies at the same time and in the same geographical area. We have endeavored to meet this standard of care, but may be limited by conditions encountered during performance, a client-driven scope of work, or inability to review information not received by the report date. Where appropriate, these limitations are discussed in the text of the report, and an evaluation of their significance with respect to our findings has been conducted.

Phase I ESAs, such as the one performed at this site, are of limited scope, are noninvasive, and cannot eliminate the potential that hazardous, toxic, or petroleum substances are present or have been released at the site beyond what is identified by the limited scope of this ESA. In conducting the limited scope of services described herein, certain sources of information and public records were not reviewed. It should be recognized that environmental concerns may be documented in public records that were not reviewed. No ESA can wholly eliminate uncertainty regarding the potential for RECs in connection with a property. Performance of this practice is intended to reduce, but not eliminate, uncertainty regarding the potential for RECs. No warranties, express or implied, are intended or made. The limitations herein must be considered when the user of this report formulates opinions as to risks associated with the site or otherwise uses the report for any other purpose. These risks may be further evaluated – but not eliminated – through additional research or assessment. We will, upon request, advise you of additional research or assessment options that may be available and associated costs.

1.4 Additional Scope Limitations, ASTM Deviations and Data Gaps

Based upon the agreed-on scope of services, this ESA did not include subsurface or other invasive assessments, vapor intrusion assessments or indoor air quality assessments (i.e. evaluation of the presence of vapors within a building structure), business environmental risk evaluations, or other services not particularly identified and discussed herein. Credentials of the company (Statement of Qualifications) have not been included in this report but are available upon request. Pertinent documents are referred to in the text of this report, and a separate reference section has not been included. Reasonable attempts were made to obtain information within the scope and time constraints set forth by the client; however, in some instances, information requested is not, or was not, received by the issuance date of the report. Information obtained for this ESA was received from several sources that we believe to be reliable; nonetheless, the authenticity or reliability of these sources cannot and is not warranted hereunder.

An evaluation of the significance of limitations and missing information with respect to our findings has been conducted, and where appropriate, significant data gaps are identified and discussed in the text of the report. However, it should be recognized that an evaluation of significant data gaps is based on the information available at the time of report issuance, and an evaluation of information received after the report issuance date may result in an alteration of our conclusions, recommendations, or opinions. We have no obligation to provide information obtained or discovered by us after the issuance date of the report, or to perform any additional services,

regardless of whether the information would affect any conclusions, recommendations, or opinions in the report. This disclaimer specifically applies to any information that has not been provided by the client.

This report represents our service to you as of the report date and constitutes our final document; its text may not be altered after final issuance. Findings in this report are based upon the site's current utilization, information derived from the most recent reconnaissance and from other activities described herein; such information is subject to change. Certain indicators of the presence of hazardous substances or petroleum products may have been latent, inaccessible, unobservable, or not present during the most recent reconnaissance and may subsequently become observable (such as after site renovation or development). Further, these services are not to be construed as legal interpretation or advice.

1.5 Reliance

This ESA report is prepared for the exclusive use and reliance of Brown Strauss, Inc. Use or reliance by any other party is prohibited without the written authorization of Brown Strauss Inc. and Terracon Consultants, Inc. (Terracon).

Reliance on the ESA by the client and all authorized parties will be subject to the terms, conditions and limitations stated in the proposal, ESA report, and Terracon's Agreement for Services. The limitation of liability defined in the Agreement for Services is the aggregate limit of Terracon's liability to the client and all relying parties.

Continued viability of this report is subject to ASTM E1527-13 Sections 4.6 and 4.8. If the ESA will be used by a different user (third party) than the user for whom the ESA was originally prepared, the third party must also satisfy the user's responsibilities in Section 6 of ASTM E1527-13.

1.6 Client Provided Information

Prior to the site visit, Mr. Ryan Secrist, client's representative, was asked to provide the following user questionnaire information as described in ASTM E1527-13 Section 6.

Client Questionnaire Responses

| Client Questionnaire Item | Client Did Not Respond | Client's Response | |
|--|------------------------|-------------------|----|
| | | Yes | No |
| Specialized Knowledge or Experience that is material to a REC in connection with the site. | | | X |
| Actual Knowledge of Environmental Liens or Activity Use Limitations (AULs) that may encumber the site. | | | X |

| Client Questionnaire Item | Client Did Not Respond | Client's Response | |
|--|------------------------|-------------------|----|
| | | Yes | No |
| Actual Knowledge of a Lower Purchase Price because contamination is known or believed to be present at the site. | | | X |
| Commonly Known or Reasonably Ascertainable Information that is material to a REC in connection with the site. | | | X |
| Obvious Indicators of Contamination at the site. | | | X |

Terracon's consideration of the client provided information did not identify RECs. A copy of the questionnaire is included in Appendix C.

2.0 PHYSICAL SETTING

| Physical Setting Information | | Source |
|------------------------------|--|---|
| Topography | | |
| Site Elevation | Approximately 2,370 to 2,410 feet above mean sea level | USGS Topographic Maps; Beaumont, California and Cabazon, California Quadrangles, dated 2018, and <i>Microsoft Bing Map Data</i> (2022), www.bing.com/maps (Appendix A) |
| Topographic Gradient | Sloping toward the southeast | |
| Closest Surface Water | Montgomery Creek, is located approximately 1,100 feet southwest of the site. | |
| Soil Characteristics | | |
| Soil Type | GyC2: Greenfield sandy loam, 2 to 8 percent slopes, eroded; RaB2: Ramona sandy loam, 2 to 5 percent slopes, eroded. | Riverside County, CA USDA-NRCS Web Soil Survey, issued September 13, 2021, https://websoilsurvey.sc.egov.usda.gov |
| Description | GyC2: Well drained soils. A typical soil profile consists of 0 to 26 inches below ground surface (bgs) sandy loam, 26 to 43 inches bgs fine sandy loam, 43 to 60 inches bgs loam, and 60 to 72 inches bgs stratified loamy sand to sandy loam. The parent material consists of alluvium derived from granite. RaB2: Well drained soils. A typical soil profile consists of 0 to 14 inches bgs sandy loam, 14 to 23 inches bgs fine sandy loam, 23 to 68 inches bgs sandy clay loam, | |

| Physical Setting Information | | Source |
|--|--|---|
| | and 68 to 74 inches bgs gravelly sandy loam. The parent material consists of alluvium derived from granite. | |
| Geology/Hydrogeology | | |
| Formation | Older surficial sediments (Qf) | |
| Description | Weakly indurated alluvial fan deposits dissected or partially so; Alluvial fan of the San Gorgonio Pass, sand and gravel of plutonic and gneissic detritus derived from rising San Bernardino mountains to the north, dissected at lower south margins (Quaternary). | Geologic map of the Beaumont quadrangle, Riverside County, California (Dibblee, T.W. and Minch, J.A.; Dibblee Geological Foundation, 2003); https://ngmdb.usgs.gov/mapview |
| Estimated Depth to First Occurrence of Groundwater | <u>Site</u> : No data readily available. <u>Vicinity</u> : Approximately 519 feet bgs as measured in observation wells, located approximately 4,600 feet west of the site (last measured in October 2010). | Department of Water Resources State of California, Water Data Library; San Gorgonio Pass Subbasin Site Code No. 339231N1169081; State Well No. 03S01E08M001S; https://wdl.water.ca.gov |
| *Hydrogeologic Gradient | Not known - may be inferred to be parallel to topographic gradient (primarily to the southeast). | |

* The groundwater flow direction and the depth to shallow, unconfined groundwater, if present, would likely vary depending upon seasonal variations in rainfall and other hydrogeological features. Without the benefit of on-site groundwater monitoring wells surveyed to a datum, groundwater depth and flow direction beneath the site cannot be directly ascertained.

3.0 HISTORICAL USE INFORMATION

Terracon reviewed the following historical sources to develop a history of the previous uses of the site and surrounding area, in order to help identify RECs associated with past uses. Copies of selected historical documents are included in Appendix C.

3.1 Historical Topographic Maps, Aerial Photographs, Sanborn Maps

Readily available historical USGS topographic maps, selected historical aerial photographs (at approximately 10- to-15-year intervals) were reviewed to evaluate land development and obtain information concerning the history of development on and near the site. Reviewed historical topographic maps and aerial photographs are summarized below.

Historical fire insurance maps produced by the Sanborn Map Company were requested from Environmental Data Resources, Inc. (EDR) to evaluate past uses and relevant characteristics of the site and surrounding properties. EDR provided Sanborn maps were not available.

- Topographic maps:
 - San Jacinto, California; published in **1901** (1:125,000)
 - Banning, California; published in 1943 from **1941** aerial photographs; published in 1956 from **1951** aerial photographs (1:62,500)
 - Banning, California; published in **1948** (1:50,000)
 - Beaumont, California; published in 1953 from **1949** aerial photographs; published in 1972 from **1972** aerial photographs; published in 1988 from **1949** aerial photographs; published in 1996 from **1994** aerial photographs; published in **2012, 2015, 2018** (1:24,000)
 - Cabazon, California; published in 1956 from **1951** aerial photographs; published in 1972 from **1972** aerial photographs; published in 1988 from **1985** aerial photographs; published in 1996 from **1994** aerial photographs; published in **2012, 2015, 2018** (1:24,000)

- Aerial photographs:
 - USDA, **1938, 1949, 1953, 1961, 1967, 1985, 1989, and 1990**, 1"=500'
 - USGS, **1975**, 1"=500'
 - USGS/DOQQ, **1996 and 2002**, 1"=500'
 - USDA/NAIP, **2006, 2009, 2012, and 2016**, 1"=500'

Historical Maps and Aerial Photographs

| Direction | Description |
|-----------|--|
| Site | Undeveloped land (1901); agricultural land (1938); apparent homesteads/dwellings depicted on the southern portion of the site (1949-1953); the central and eastern portions of the site appeared graded, and another homestead/dwelling and apparent trailers/containers were visible (1961-1985); the homestead/dwelling on the eastern portion of the site appeared to have been removed (1989); the remaining homestead/dwelling on the western portion of the site appeared to have been removed (1990-1996); apparent containers/trailers depicted throughout the site (2002); the containers/trailers appeared to have been removed (2006-2009); an apparent water container and small animal enclosure, located on the southwestern portion of the site (2012); an apparent container/trailer was visible (2016). |
| North | A railroad followed by undeveloped land (1901); agricultural land (1938); portions of the land, north of the railroad, appeared graded (1949-1953); early development of the existing highway, followed by commercial development (further north) (1961); the Christopher Columbus Transcontinental Highway appears fully developed (1967-2016). |
| East | Undeveloped land (1901); agricultural land (1938-1953); an apparent commercial building developed (1961-1967); agricultural activities appeared to have ceased (1975); portions of the land appeared graded (1989-2002); the existing commercial buildings developed (2006-2016). |

| Direction | Description |
|-----------|--|
| South | An existing road (West Lincoln Street), followed undeveloped land and a road (South 12 th Street) (1901); agricultural land and two apparent homesteads/dwellings (1938); two more homesteads/dwellings were visible (1949-1967); existing construction buildings developed further southeast (1975); an existing dwelling developed (1985); trailers/containers were visible on the land to the south-southwest (1989); southeastern homesteads/dwellings appeared to have been removed (2002-2016). |
| West | Undeveloped land (1901); agricultural land (1938-1953); appears graded (1961); an apparent dwelling was visible (1985-1996); the dwelling appeared to have been removed (2002-2016). |

Historically, the site has been used for agricultural activities (orchards), from at least 1938 until sometime between 1953 and 1961, which may include the use of pesticides and herbicides. Most currently used agricultural chemicals do not persist for extended periods of time in the environment if applied appropriately; however, some agricultural chemicals persist in the environment, especially if misapplied. In addition, structures indicative of potential mixing of pesticides and/or herbicides were not observed onsite in the historical aerial photographs reviewed. In Terracon’s experience, the application of herbicides and pesticides to agricultural fields can leave trace amounts of the compounds in the soil and/or groundwater; however, these residual amounts are generally below risk-based screening levels. Pesticide and/or herbicide misuse or vegetative stress were not observed on the site during the site reconnaissance.

3.2 Historical City Directories

EDR Digital Archive and Haines Criss-Cross Directory city directories used in this study were made available EDR (selected years reviewed: 1971-2017) and were reviewed at approximate five-year intervals, if readily available. West Lincoln Street listings not available prior to 1971. The current street address for the site was identified as 1219. 1431 West Lincoln Street was not identified in the city directories.

Historical City Directories

| Direction | Description |
|-----------|--|
| Site | 1219 West Lincoln Street: Skare Harlan (1971); Don Cook (1976); Konnie Becerra (1980-1985); no listings (1990-2017). 1431 West Lincoln Street: no listings (1971-2017). |
| North | Unaddressed highway-no listings |

| Direction | Description |
|-----------|---|
| East | <p><u>1177 West Lincoln Street</u>: no listings (1971-2000); Color Fast Industries (2005); Dicks Tire Mart, Entrada Door Inc., EPD Wearness USA Inc., First Place Powder Coating (2010); Entrada Door Inc., EPD Wearness USA Inc., First Place Powder Coating (2014); Entrada Door Inc., EPD Wearness USA Inc., First Place Powder Coating; I-10 Commerce Center SBDO LP (2017).</p> <p><u>1143 West Lincoln Street</u>: Vardanian Armen (1971-1980); no listings (1985); Pearl Vardanian (1990); no listings (1992-2000); "Occupants unknown" (2005); Bell Jeffrey, Belovac, California Collision Ctr, D&S Builders, Down Low Customz, Express Tires & Auto Repair, RTI Industries, Showcase, Tomms Auto Body (2010); Express Tires & Auto Repair, Fastenal, Harrison Air Conditioning, Harrison Contracting, i-10 Commerce Center San Bernardino, Precisions Auto Service, Pulte Homes, RTI Industries, Tomms Auto Body (2014-2017).</p> |
| South | <p><u>1184 West Lincoln Street</u>: no listings (1971-1990); Stretch Plastics (1992-1995); Zimmerman Larry Woodworking (2000-2005); <u>Trench Shoring</u> (2010-2017).</p> <p>1222 West Lincoln Street: Residential listings (1971-1995); "Occupant unknown" (2000); no listings (2005-2017).</p> <p>1380 West Lincoln Street: no listings (1971); Residential listings (1976-2005); Robles Pipeline Laying Inc, Southern Valley Waterfeatures (2010); Robles Toni, Southern Valley Waterfeatures (2014-2017).</p> <p>1430 West Lincoln Street: Residential listings (1971-2017).</p> <p>1450 West Lincoln Street: No listings (1971-1995); "Occupant unknown" (2000-2005); Residential listings (2010); "Occupant unknown" (2014), no listings (2017).</p> <p>1476 West Lincoln Street: no listings (1971); Residential listings (1976-1980); no listings (1985-1992); Residential listing (1995); no listings (2000-2017).</p> <p>1522 West Lincoln Street: Residential listings (1971-1995); no listings (2000); Residential listings (2005-2010); Edwards John P, John Edwards Enterprises (2014-2017).</p> |
| West | Unaddressed vacant land - No listings (1971-2017). |

The above underlined and italicized listings are identified in the regulatory databases and are further discussed in Section 4.1.

3.3 Site Ownership / Title Search

Based on a review of information obtained from Texas Environmental Research of Rockwell, Texas, the site consists of APNs: 540-180-020, 540-180-022, and 540-180-026, is currently owned by Baldi Real Estate. The effective date or date indicated on the provided documents as date of data review is reported as November 7, 2018. No ownership reference is made to industrial, manufacturing, or other entities of potential environmental concern during the time period mentioned.

3.4 Environmental Liens and Activity and Use Limitations

At the direction of the client, performance of a review of environmental liens search was included as part of the scope of services for which Terracon engaged Texas Environmental Research of Rockwell, Texas. Based on a review of the title provider's research, environmental liens were not identified associate with the site. In addition, the EDR regulatory database report included a review of both Federal and State Engineering Control (EC) and Institutional Control (IC) databases. Based on a review of the database report, the site was not listed on the EC or IC databases.

3.5 Interviews Regarding Current and Historical Site Uses

The following individual was interviewed regarding the current and historical use of the site.

Interviewee

| Interviewer | Name / Phone # | Title | Date/Time |
|---------------------|------------------------------------|-------------------------------|--|
| Ms. Laura S. Hedman | Mr. Michael Baldi / (951) 845-9521 | Site Owner, Baldi Real Estate | August 23, 2022 / Approximately 10:30 a.m. |

Terracon interviewed Mr. Michael Baldi, site owner (Baldi Real Estate), telephonically (post site reconnaissance). Mr. Baldi indicated that the site has been in the family for over 30 years, and during that time, the site has been generally vacant, and has remained consistent through the present, with the exception of a small animal enclosure, used briefly for cattle. Mr. Baldi stated that he was unaware of any on-site USTs, ASTs, wells, or septic tanks. Additionally, Mr. Baldi indicated that he was not aware of the following:

- Pending environmental litigation
- Threatened environmental litigation
- Past environmental litigation
- Possible violations of environmental laws
- Possible environmental liability
- Any potential environmental concerns

3.6 Prior Report Review

Terracon requested the client provide any previous environmental reports, permits, registrations, and geotechnical reports they are aware of for the site. Previous reports were not provided by the client to Terracon for review.

4.0 RECORDS REVIEW

Regulatory database information was provided by EDR, a contract information services company. The purpose of the records review was to identify RECs in connection with the site. Information in this section is subject to the accuracy of the data provided by the information services company and the date at which the information is updated. The scope herein did not include confirmation of facilities listed as "unmappable" by regulatory databases.

In some of the following subsections, the words up-gradient, cross-gradient and down-gradient refer to the topographic gradient in relation to the site. As stated previously, the groundwater flow direction and the depth to shallow groundwater, if present, would likely vary depending upon seasonal variations in rainfall and the depth to the soil/bedrock interface. Without the benefit of on-site groundwater monitoring wells surveyed to a datum, groundwater depth and flow direction beneath the site cannot be directly ascertained.

4.1 Federal and State/Tribal Databases

Listed below are the facility listings identified on federal and state/tribal databases within the ASTM-required search distances from the approximate site boundaries. Database definition, descriptions, and the database search report are included in Appendix D.

Federal Databases

| Database | Description | Distance (miles) | Listings |
|--------------------------------|---|-------------------------------|----------|
| CERCLIS (SEMS) | Comprehensive Environmental Response, Compensation, & Liability Information System | 0.5 | 0 |
| CERCLIS / NFRAP (SEMS ARCHIVE) | Comprehensive Environmental Response, Compensation, & Liability Information System/No Further Remedial Action Planned | 0.5 | 0 |
| ERNS | Emergency Response Notification System | Site | 0 |
| IC / EC | Institutional Control/Engineering Control | Site | 0 |
| NPL | National Priorities List | 1.0 | 0 |
| NPL (Delisted) | National Priorities Delisted List | 0.5 | 0 |
| RCRA CORRACTS/ TSD | RCRA Corrective Action Activity | 1.0 | 0 |
| RCRA Generators | Resource Conservation and Recovery Act | Site and adjoining properties | 3 |
| RCRA NonGen / NLR | RCRA- Non-Generator / No Longer Regulated | 0.25 | 16 |

| Database | Description | Distance (miles) | Listings |
|------------------------|-------------------------------------|------------------|----------|
| RCRA Non-CORRACTS/ TSD | RCRA Non-Corrective Action Activity | 0.5 | 0 |

State/Tribal Databases

| Database | Description | Distance (miles) | Listings |
|----------------|---|-------------------------------|----------|
| AST | Aboveground Storage Tank Facilities | Site and adjoining properties | 0 |
| CALSITES | CalSites Database | 1.0 | 0 |
| CALSITES (AWP) | Active Annual Workplan Sites | 1.0 | 0 |
| CERS | California Environmental Reporting System | Site | 0 |
| CERS HAZ WASTE | California Environmental Reporting System Hazardous Waste | 0.25 | 8 |
| CORTESE | Cortese [®] Hazardous Waste & Substance Site List | 0.5 | 8 |
| DRYCLEANERS | Cleaner Facilities | 0.25 | 1 |
| EDR MGP | EDR Proprietary Manufactured Gas Plants | 1.0 | 1 |
| ENVIROSTOR | Envirostor Database | 1.0 | 4 |
| HIST CORTESE | Hazardous Waste and Substance Site List | 0.5 | 7 |
| HIST UST | Hazardous Substance Storage Container Database | 0.25 | 1 |
| LUST | Leaking Underground Storage Tanks | 0.5 | 14 |
| SWEEPS UST | Statewide Environmental Evaluation Planning System Underground Storage Tank | 0.25 | 1 |
| SWF/LF | Solid Waste Facilities/Landfills | 0.5 | 0 |
| UST | Underground Storage Tank Facilities | Site and adjoining properties | 0 |
| VCP | Voluntary Cleanup Program | 0.5 | 0 |

In addition to the above ASTM-required listings, Terracon reviewed other federal, state, local, and proprietary databases provided by the database firm. A list of the additional reviewed databases is included in the regulatory database report included in Appendix D.

The site was not listed in the regulatory database report.

The following table summarizes the site-specific information provided by the database and/or gathered by this office for identified facilities. Facilities within 500 feet of the site are listed in order of proximity to the site. Additional discussion for selected facilities follows the summary table.

Listed Facilities

| Facility Name and Location | Estimated Distance / Direction/Gradient | Database Listings | Is a REC, CREC, or HREC to the Site |
|--|---|---------------------------------|--|
| Poison Spyder Customs, Inc 1177 West Lincoln Street (Suite 100) | Adjoining / East / Cross-gradient | RCRA-NonGen/NLR | No, discussed below |
| Tom Malloy Corp dba Trench Shoring 1184 West Lincoln Street | 65 feet / South-southeast / Down-gradient | RCRA-NonGen/NLR | No, based on status, depth to groundwater, and topographic down-gradient position |
| Class Acts Autobody Inc 1143 West Lincoln Street (Suites 9-10) | 65 feet / East / Cross-gradient | RCRA-NonGen/NLR | No, based on status, depth to groundwater, and topographic cross-gradient position |
| Ochoa Motorsports LLC 1143 West Lincoln Street (Suite 13) | | | |
| Lawrence Equipment Banning 1879 West Lincoln Street | 490 feet / West / Cross-gradient | CERS HAZ Waste, RCRA-NonGen/NLR | No, based on status, depth to groundwater, distance, and topographic cross-gradient position |

Poison Spyder Customs, Inc. (1177 West Lincoln Street (Suite 100))

The above listed facility (vehicle bumper and vehicle exterior accessories manufacturer), identified to the adjacent east, and in a topographic cross-gradient position relative to the site, was identified in the RCRA Non-Generator/No Longer Regulated (NonGen/NLR) regulatory database. The database indicated that Poison Spyder Customs, Inc. operated under EPA ID No. CAC003022297, dated 2019, as a hardware manufacturer, with a current record, and as a non-generator of regulated hazardous waste. No violations were reported in the database. Based on review of the database, absence of release and violations, depth to groundwater, and topographic cross-gradient position relative to the site, the Poison Spyder Customs, Inc. listing does not represent a REC.

The remaining facilities listed in the database report do not appear to represent RECs to the site at this time based upon regulatory status, apparent topographic gradient, and/or distance from the site.

Unmapped facilities are those that do not contain sufficient address or location information to evaluate the facility listing locations relative to the site. The report listed six facilities in the

unmapped section. Determining the location of unmapped facilities is beyond the scope of this assessment; however, none of these facilities were identified as the site or adjacent properties. These facilities are listed in the database report in Appendix D.

4.2 Local Agency Inquiries

| Agency Contacted/ Contact Method | Response |
|--|--|
| County of Riverside, Department of Environmental Health (DEH) / Email: DEHRecordsMgmt@rivco.org | According to the DEH, no records were found associated with the site. |
| South Coast Air Quality Management District (SCAQMD) / online portal: http://www.aqmd.gov/nav/online-services/public-records ; SCAQMD Facility Information Detail (F.I.N.D.), online database: F.I.N.D. (aqmd.gov) | According to the SCAQMD, no records were found associated with the site. Additionally, based on an online search of the SCAQMD F.I.N.D. database, no records were found associated with the site. |
| Santa Ana Regional Water Quality Control Board (RWQCB) / Email: filereview8@waterboards.ca.gov ; State Water Resources Control Board; GeoTracker online portal: http://geotracker.waterboards.ca.gov | According to the RWQCB, no records were found associated with the site. Additionally, based on an online search of the GeoTracker online portal, no records were found associated with the site. |
| Department of Toxic Substances Control (DTSC) / Email: pubreqact@dtsc.ca.gov ; DTSC online EnviroStor Database, www.envirostor.dtsc.ca.gov DTSC online Hazardous Waste Tracking System (HWTS) Database, https://hwts.dtsc.ca.gov | According to Tee Xiong with the Department of Toxic Substances Control, records were not identified for the site addresses. According to the DTSC online EnviroStor and HWTS databases, no records were found associated with the site. |
| Riverside County Building and Safety/ by email https://www.rctlma.org/building/Records-Request/OnSubmit/3258 | According to Sara at the Riverside Building and Safety, records were not identified for the site addresses. |
| Riverside County Land Use/Water Resources Department / by email landuserecords@rivco.org | According to the Land Use Department, no records were found associated with the site. |

| Agency Contacted/ Contact Method | Response |
|--|---|
| City of Banning City Clerk/ by online https://city-of-banning.nextrequest.com | According to the city of Banning City Clerk the following records were identified; <ul style="list-style-type: none"> - 05/02/1985: 1219 West Lincoln Street, building permit for electric service. - 09/25/1989: 1431 West Lincoln Street, building permit, for driveway/curb; plumbing permit for house sewer system. |

4.3 Local Area Knowledge

Based on a review of the California Department of Conservation, Geologic Energy Management Division well finder website ([CalGEM GIS](#)), the site is not identified within an oil field and there are no active or plugged oil production wells located at the site or adjoining properties.

Terracon researched on-line at the State Resources Water Control Board (SRWCB) GeoTracker database – Land Disposal Sites and landfills were not identified on-site or in the site vicinity.

5.0 SITE RECONNAISSANCE

5.1 General Site Information

Information contained in this section is based on a visual reconnaissance conducted while walking through the site and the accessible interior areas of structures, if any, located on the site. The site and adjoining properties are depicted on the Site Diagram, which is included in Exhibit 2 of Appendix A. Photo documentation of the site at the time of the visual reconnaissance is provided in Appendix B. Credentials of the individuals planning and conducting the site visit are included in Appendix E.

General Site Information

| Site Reconnaissance | |
|---------------------------|----------------------------------|
| Field Personnel | Sabrina Chantler |
| Reconnaissance Date | August 11, 2022 |
| Weather Conditions | Sunny, 90° F |
| Site Contact/Title | Mr. Michael Baldi / Site Owner |
| Site / Vicinity Utilities | |
| Drinking Water | City of Banning |
| Wastewater | City of Banning |
| Electric | Southern California Edison (SCE) |

| Site Reconnaissance | |
|---------------------|--|
| Natural Gas | Southern California Gas Company (SoCalGas) |

5.2 Overview of Current Site Occupants and Site Operations

The site consisted of an approximately 14.92-acre parcel of vacant grassy land. The site was observed to be unoccupied.

5.3 Site Observations

The following table summarizes site observations and interviews. Affirmative responses (designated by an “X”) are discussed in more detail following the table.

Site Characteristics

| Category | Item or Feature | Observed or Identified |
|---|---|------------------------|
| Site Operations, Processes, and Equipment | Emergency generators | |
| | Elevators | |
| | Air compressors | |
| | Hydraulic lifts | |
| | Dry cleaning | |
| | Photo processing | |
| | Ventilation hoods and/or incinerators | |
| | Waste treatment systems and/or water treatment systems | |
| | Heating and/or cooling systems | |
| | Paint booths | |
| | Sub-grade mechanic pits | |
| | Wash-down areas or carwashes | |
| | Pesticide/herbicide production or storage | |
| | Printing operations | |
| | Metal finishing (e.g., electroplating, chrome plating, galvanizing, etc.) | |
| | Salvage operations | |
| | Oil, gas or mineral production | |
| Other processes or equipment | | |
| Aboveground Chemical or Waste Storage | Aboveground storage tanks | X |
| | Drums, barrels and/or containers ≥ 5 gallons | |
| | MSDS or SDS | |

| Category | Item or Feature | Observed or Identified |
|---|--|------------------------|
| Underground Chemical or Waste Storage, Drainage or Collection Systems | Underground storage tanks or ancillary UST equipment | |
| | Sumps, cisterns, French drains, catch basins and/or dry wells | |
| | Grease traps | |
| | Septic tanks and/or leach fields | |
| | Oil/water separators, clarifiers, sand traps, triple traps, interceptors | |
| | Pipeline markers | |
| | Interior floor drains | |
| Electrical Transformers/PCBs | Transformers and/or capacitors | |
| | Other equipment | |
| Releases or Potential Releases | Stressed vegetation | |
| | Stained soil | |
| | Stained pavement or similar surface | |
| | Leachate and/or waste seeps | |
| | Trash, debris and/or other waste materials | |
| | Dumping or disposal areas | |
| | Construction/demolition debris and/or dumped fill dirt | X |
| | Surface water discoloration, odor, sheen, and/or free floating product | |
| | Strong, pungent or noxious odors | |
| | Exterior pipe discharges and/or other effluent discharges | |
| Other Notable Site Features | Surface water bodies | |
| | Quarries or pits | |
| | Wastewater lagoons | |
| | Wells | |

Aboveground Chemical or Waste Storage

Aboveground storage tanks

During the site reconnaissance, Terracon observed an apparent approximately 800-gallon capacity water container, located on the southwestern corner of the site. No evidence of chemical waste disposal, noxious odors, or other indications of releases were observed near the vicinity of the water container. Based on visual observations, the water container does not constitute a REC to the site.

Releases or Potential Releases

Construction/demolition debris and/or dumped fill dirt

At the time of the site reconnaissance, Terracon observed a pile of asphalt debris/cuttings (approximately 1-cubic yard), located on the southern portion of the site. No evidence of chemical waste disposal, noxious odors, or other indications of releases were observed near the vicinity of the asphalt debris pile. Based on visual observations, the asphalt debris pile does not constitute a REC to the site.

6.0 ADJOINING PROPERTY RECONNAISSANCE

Visual observations of adjoining properties (from site boundaries) are summarized below.

Adjoining Properties

| Direction | Description |
|-----------|---|
| North | The northern adjoining properties consisted of a Southern Pacific railroad, followed by the Christopher Columbus Transcontinental Highway, multi-tenant retail building (1510-1431 West Ramsey Street), and a vacant retail building (1374 West Ramsey Street). |
| East | The eastern adjoining properties consisted of multi-tenant commercial buildings (1143 West Lincoln Street) and multi-tenant commercial building (1177 West Lincoln Street). |
| South | The southern adjoining properties consisted of West Lincoln Street, followed by residential dwellings and vacant land (1222-1476 West Lincoln Street), vacant land (1184 West Lincoln Street) to the southeast, and a residential dwelling (1522 West Lincoln Street) to the southwest. |
| West | The western adjoining property consists of vacant land (1541 West Lincoln Street). |

RECs were not observed with the adjoining properties.

7.0 ADDITIONAL SERVICES

Per the agreed scope of services specified in the proposal, additional services (e.g. asbestos sampling, lead-based paint sampling, wetlands evaluation, lead in drinking water testing, radon testing, vapor encroachment screening, etc.) were not conducted.

8.0 DECLARATION

I, Jennifer S. Van, declare that, to the best of my professional knowledge and belief, I meet the definition of Environmental Professional as defined in Section 312.10 of 40 CFR 312; and I have the specific qualifications based on education, training, and experience to assess a property of the nature, history, and setting of the site. I have developed and performed the All Appropriate Inquiries in conformance with the standards and practices set forth in 40 CFR Part 312.



Jennifer S. Van
Environmental Group Manager

Appendix I

PROJECT-SPECIFIC WQMP SUMMARY DATA FORM

Project-Specific WQMP Summary Data Form

| Applicant Information | |
|---|---|
| Name and Title | Estes Express Lines C/O: Kevin Fitz |
| Company | Estes Express Lines |
| Phone | (804) 353- 1900 |
| Email | kfitz@estes-express.com |
| Project Information | |
| Project Name <small>(as shown on project application/project-specific WQMP)</small> | Estes Banning Truck Terminal |
| Street Address | Barbour Street |
| Nearest Cross Streets | S Hathaway Street |
| Municipality <small>(City or Unincorporated County)</small> | City of Banning (Riverside County, CA) |
| Zip Code | 92220 |
| Tract Number(s) and/or Assessor Parcel Number(s) | 532-130-008-8 |
| Other <small>(other information to help identify location of project)</small> | |
| Indicate type of project. | Priority Development Projects (Use an "X" in cell preceding project type): |
| | <input type="checkbox"/> SF hillside residence; impervious area \geq 10,000 sq. ft.; Slope \geq 25% |
| | <input type="checkbox"/> SF hillside residence; impervious area \geq 10,000 sq. ft.; Slope \geq 10% & erosive soils |
| | <input type="checkbox"/> Commercial or Industrial \geq 100,000 sq. ft. |
| | <input type="checkbox"/> Automotive repair shop |
| | <input type="checkbox"/> Retail Gasoline Outlet disturbing > 5,000 sq. ft. |
| | <input type="checkbox"/> Restaurant disturbing > 5,000 sq. ft. |
| | <input type="checkbox"/> Home subdivision \geq 10 housing units |
| | <input type="checkbox"/> Parking lot \geq 5,000 sq. ft. or \geq 25 parking spaces |
| Date Project-Specific WQMP Submitted | July 2019 |
| Size of Project Area (nearest 0.1 acre) | 39.07 Acres |
| Will the project replace more than 50% of the impervious surfaces on an existing developed site? | No |
| Project Area managed with LID/Site Design BMPs (nearest 0.1 acre) | 39.07 Acres |
| Are Treatment Control BMPs required? | Yes |
| Is the project subject to onsite retention by ordinance or policy? | Yes |
| Did the project meet the 100% LID/Site Design Measurable Goal? | Yes |
| Name of the entity that will implement, operate, and maintain the post-construction BMPs | Estes Express Lines |
| Contact Name | Kevin Fitz |
| Street or Mailing Address | 3901 W. Broad St. |
| City | Richmond |
| Zip Code | 23230 |
| Phone | (804) 353-1900 |
| Space Below for Use by City/County Staff Only | |
| Preceding Information Verified by <small>(consistent with information in project-specific WQMP)</small> | Name: Date: |
| Date Project-Specific WQMP Approved: | |
| Data Entered by | Name: Date: |

| | |
|-----------------------|--|
| Other Comments | |
|-----------------------|--|