

Appendix I

Campus Town Preliminary Post-Construction Stormwater Control Plan

**Preliminary Post-Construction Stormwater Control Plan
for**

CAMPUS TOWN

City of Seaside
Monterey County, California

July 2018

Prepared for:

KB Bakewell Seaside Venture II
5000 Executive Parkway, Suite 125
San Ramon, CA 94538

Prepared By:



8055 Camino Arroyo
Gilroy, CA 95020
(408) 848-0300
Project Manager: Jim Schul
Project No.: 132018

Table of Contents

1 Project Information 1
 1.1. Purpose of Report 1
 1.2. Project Description..... 1
 1.3. Existing Site Condition..... 3
 1.4. Opportunities and Constraints for Stormwater Control 4
2 Preliminary Stormwater Treatment Evaluation 5
 2.1. Performance Requirement Assessment 5
 2.2. LID Site Design Strategies (Performance Requirement No. 1)..... 6
 2.3. Preliminary Stormwater Control Measure Selection 7
 2.4. Potential Source Control Measures 8
 2.5. Trash Treatment Control Measures 8
3 Preliminary Design of Stormwater Control Measures 9
 3.1. Drainage Management Area Description..... 9
 3.2. Performance Requirement No. 2: Stormwater Quality Treatment 9
 3.3. Performance Requirement No. 3: Runoff Retention 10
 3.4. Performance Requirement No. 4: Peak Flow Management 12

List of Tables

1.1 General Project Information 2
2.1 Potential Stormwater Control Measures 6
2.2 Potential Source Control Measures..... 7
3.1 Preliminary SCM Model Results for the 100-year 24-hour Storm 13

Appendix

- A. Figures
 - 1. Location Map
 - 2. Existing Conditions Map
 - 3. NRCS Soil Classification
 - 4. Preliminary SCM Site Map
- B. SCM & Hydrology Calculations
- C. NRCS/NOAA Atlas 14 Rainfall Distribution
- D. Preliminary *CivilStorm* Model Hydrographs
- E. FORA Stormwater Master Plan Design Manual
- F. Infiltration Test Results

References

1. City of Seaside, Municipal Code, *Chapter 8.46 – Urban Storm Water Quality Management and Discharge Control*. November 2, 2017
2. Torti Gallas & Partners Inc., *Campus Town Specific Plan Draft, Prepared for City of Seaside*. July 17, 2018
3. Central Coast Regional Water Quality Control Board, *Resolution No. R3-2013-0032: Approving Post-Construction Stormwater Management Requirements for Development Projects in the Central Coast Region*. July 12, 2013
4. Natural Resources Conservation Service, *Web Soil Survey 2.0*, websoilsurvey.nrcs.usda.gov/app/WebSoilSurvey.aspx
5. California Stormwater Quality Association, *Stormwater Best Management Practice Handbook: New Development and Redevelopment*. January 2003
6. United States Department of Agriculture – Natural Resources Conservation Service, *National Engineering Handbook Part 630 Hydrology, Chapter 4: Storm Rainfall Depth and Distribution*. September 2015 (draft)
7. Fort Ord Reuse Authority (FORA), *Stormwater Master Plan*. March 2005
8. Berlogar Stevens & Associates, *Surplus II – Seaside (Campus Town) Infiltration Tests*. July 5, 2018.
9. State Water Resources Control Board, *Resolution No. 2015-0009: Amendment to the Water Quality Control Plan for Ocean Waters of California to Control Trash and Part 1 Trash Provisions of the Water Quality Control Plan for Inland Surface Waters, Enclosed Bays, and Estuaries of California*. April 7, 2015

1 Project Information

1.1 Purpose of the Report

The Central Coast Regional Water Quality Control Board (CCRWQCB) adopted Resolution R3-2013-0032 for approving Post-Construction Stormwater Management Requirements for Development Projects in the Central Coast Region. This resolution went into effect on March 6, 2013. All new and redevelopment projects within the City of Seaside shall be designed in accordance with the Resolution and the City's Urban Storm Water Quality Management and Discharge Control Ordinance (Municipal Code, Section 8.46).

The post-construction stormwater requirements apply to all new development and redevelopment projects that create and/or replace 2,500-square feet or more of impervious area. Qualifying developments are required to apply Low Impact Development (LID) techniques and incorporate Stormwater Control Measures (SCM) and Best Management Practices (BMP) to the maximum extent practicable to minimize the impacts of urban runoff on receiving waters and to promote healthy watersheds. These developments are also required to prepare and implement a *Stormwater Control Plan* (SWCP) to detail how runoff and associated water quality impacts resulting from the development will be controlled or managed. The SWCP is required to be prepared under the direction of a Professional Civil Engineer in the State of California, and shall provide sufficient information to evaluate the environmental characteristics of the project area, potential impacts of the proposed development on water resources, and the effectiveness and applicability of measures proposed for managing stormwater runoff.

The purpose of this Preliminary Stormwater Control Plan (PSWCP) is to demonstrate how the project "could" comply with the City's current stormwater requirements if the project was entitled without further modifications by the approving authority. The preliminary design and PSWCP are conceptual in nature and are not intended to represent the final design. The final design of all stormwater management infrastructure including size, type and location, will be subject to the final site plan, site specific geotechnical investigations, and final design of the construction documents.

1.2 Project Description

The project is located within the former Fort Ord cantonment area. A specific plan is currently being developed for the project, referred to as the Campus Town Specific Plan (CTSP). The Campus Town Specific Plan will provide the framework for future growth and development of approximately 85-acres within the former Fort Ord. The CTSP is based on principles that develop a "new urbanist" paradigm, characterized by pedestrian amenity, a flexible mix of uses, network thoroughfares and well-designed public spaces. The CTSP is proposing up to 867 single family and townhouse units with an additional possible 618 multi-family units. The site will also host several commercial and mixed-use facilities, public and private open space areas, and a hotel near the intersection of Lightfighter and First Avenue.

To facilitate civilian redevelopment within the former Fort Ord cantonment area the Fort Ord Reuse

Authority (FORA) was created through the Base Reuse Plan of 1997. FORA prepared a *Stormwater Master Plan* outlining a procedure for eliminating existing ocean outfalls by infiltrating stormwater within the sandy dune topography [Ref. 7]. The FORA Stormwater Master Plan is intended to be an advisory document for stormwater management of the Fort Ord regions of the cities of Marina, Seaside, Monterey County and the CSUMB Campus. The document includes a stormwater management criteria of infiltration of the 100-year 24-hour storm event and provides a list of Best Management Practices (BMP’s) that can be used to achieve stormwater infiltration.

This report has been prepared for the, “Campus Town Tentative Map” prepared by Ruggeri-Jensen-Azar, Dated July 2018. The Campus Town Tentative map shows the proposed subdivision of approximately 837 residential lots, with parcels for commercial, mixed-use, multi-family development and landscape areas. It is understood that future commercial/mixed-use parcels will provide separate stormwater management facilities and associated stormwater control plans. Therefore, this report is does not include calculations for future commercial/mixed-use areas or multi-family development areas. This report does not preclude future commercial/mixed-used areas from being incorporated to the overall site stormwater control measures during final design refinement. However, additional stormwater management facilities may be needed to accommodate these future areas than what is currently shown in this PSWCP.

The Campus Town Specific Plan area is generally bounded by Lightfighter Drive and Colonel Durham Street to the North, Gigling Road to the South, 7th Avenue to the east and 1st Avenue to the west. The project area is bisected by General Jim More Boulevard in the north-south direction. This report will commonly refer to project areas as the “west” or “east”, meaning west of General Jim More Boulevard or east of General Jim More Boulevard.

Refer to Table 1.1 for general project information.

Table 1.1 – General Project Information

Project Information	Description
Project Name	Campus Town
Applicant	KB Bakewell Seaside Venture II 5000 Executive Parkway, Suite 125 San Ramon, CA 94538
Project Location	South of Lightfighter Drive/Colonel Durham Street and North of Gigling Avenue. City of Seaside, CA
Zoning Designation	CMX – Commercial Mixed-use unless otherwise noted in the Campus Town Specific Plan
Existing Land Use	Former Fort Ord Military Base
Proposed Land Use	Single Family Residential, Commercial, Mixed-use & M.F.
Property Area	Approximately 85-acres
Watershed Management Zones	4
Design Storm Frequency and Depth	95 th % 24-hour storm; Rainfall Depth = 1.2-inches 10-year 24-hour storm; Rainfall Depth = 2.95-inches 100-year 24-hour storm; Rainfall Depth = 4.78-inches

1.3 Existing Site Conditions

The west portion of the Campus Town Specific Plan area is mostly vacant with scattered oak trees and shrubs. An existing parking lot and abandoned military building exists on site which will be removed by others as part of the project. The existing ground generally slopes from east to west at ± 0.04 ft/ft. 1st Avenue, located at the lowest point within the specific plan area, bounds the project to the south. The street is higher than the adjacent existing ground and acts as a levee, allowing water to pond. Precipitation occurring during high rainfall intensities will sheet flow and pond in this natural low point just east of 1st Avenue. This existing historical overland release point for the project is at a low point in 1st Avenue approximately 300-ft from the Lightfighter intersection.

The eastern portion of the specific plan area has been extensively developed by the military. The site is currently occupied by abandoned military buildings, barracks, streets, driveways, parking lots and utilities. Several agencies occupy land within the specific plan area which include; the City of Seaside, Monterey College of Law, Presidio Police Department, Fort Ord Cleanup Administrative Record, National Guard, Housing Authority of Monterey, and the Monterey-Salinas Transit Authority. Existing storm drain infrastructure exists within this portion of the site. However, most of this infrastructure will be removed as much of it is estimated to be 50 to 60 years old, and nearing the end of its useful life. In addition, most of the existing storm drain infrastructure is not located within a street right of way and would need to be relocated as part of the project. FORA in conjunction with the City of Seaside have prepared a demolition plan to raze the existing barracks and abandoned military buildings within the east portion of the site. This work is currently scheduled to be completed by 2019.

The sites soils are anticipated to exhibit moderate to high infiltration rates. NRCS classifies the sites soils as "Oceano Loamy Sand" with Hydrologic Soil Group "A". Preliminary infiltration testing was performed by Berlogar Stevens & Associates on July 5, 2018. They performed five infiltration test at a depth of approximately 10-ft to 15-ft below the existing ground surface. Soils encountered during excavation of the infiltration pits consisted of loose silty sand in the upper 4-ft to 5-ft, and cemented sand at depths greater than 5-ft below the ground surface. Stabilized infiltration test rates were on the order of 8-in/hr to 20-in/hr within the cemented sand layer. It is anticipated that infiltration rates will be significantly higher in the top 4-ft of the soil stratum. Furthermore, excavation and placement necessary for site grading may also help to break up the cemented layer, resulting in higher infiltration rates. See Appendix F for infiltration test results.

1.4 Opportunities and Constraints for Stormwater Control

The following is a summary of opportunities for stormwater quality:

- Groundwater – Historical groundwater levels are greater than ten feet below ground surface, allowing for potential infiltration of stormwater.
- Soil Conditions – The site has Class “A” sandy soils located on-site. The project can take advantage of highly permeable soils by utilizing SCMs that optimize infiltration. Permeable soils present opportunities to infiltrate stormwater in perforated pipe systems that can reduce the volume of water tributary to downstream SCMs.
- Curb cuts can be utilized to drain stormwater to landscape areas and promote infiltration.

The following is a summary of constraints for stormwater quality:

- Ground Slope – The site has moderate hillside slopes which creates challenges in providing flat areas necessary for stormwater treatment
- Existing Storm Drain Infrastructure – Limited storm drain infrastructure exists adjacent to the project site which limits the selection and placement of stormwater management facilities.
- Land Use/Site plan – The City and Specific Plan express the desire for “urban” development. Urban development are high density in nature and do not easily accommodate the incorporation of stormwater control measures.
- Narrow Streets – The site is proposing narrow streets which has the advantage of reducing overall impervious surface. However, narrow street sections do not easily accommodate stormwater management facilities.

2 Preliminary Stormwater Treatment Evaluation

Residential land use projects have the potential to impact water quality by concentrating and transporting pollutants to downstream receiving waters.

Stormwater control measures (SCMs), Low Impact Development (LID) site design strategies, and source control measures shall be used to reduce runoff volume, peak flow, and pollutant loadings. All SCMs selected for the improvements shall comply with the CCRWQCB Resolution R3-2013-0032

2.1 Performance Requirement Assessment

The Central Coast Resolution R3-2013-0032 establishes five distinct performance requirements based on the size and location of the project. The performance requirements that apply to the project are listed below, based on Watershed Management Zone 4. Refer to Resolution R3-2013-0032 for complete performance requirement details.

Performance Requirement No. 1: The project shall implement LID site design and runoff reduction strategies.

Performance Requirement No. 2: The project shall implement onsite stormwater quality treatment measures that promote infiltration, harvesting and use, and/or evapotranspiration for the runoff generated by the 85th 24-hour storm. Where infiltration is infeasible, the project shall implement biofiltration or non-retention based treatment systems.

Performance Requirement No. 3: The project shall prevent offsite discharge from events up to the 95th 24-hour rainfall event via optimizing infiltration. When infiltration is infeasible, the project shall devote no less than 10% of the site equivalent impervious surface area to retention based SCMs.

Performance Requirement No. 4: The project shall demonstrate that post-development stormwater runoff peak flows discharged from the site do not exceed pre-project peak flows for the 2- through 10-year storm events. Performance Requirement No. 4 is not applicable for projects located in Watershed Management Zone 4. However, projects located with the Fort Ord redevelopment area must retain runoff produced from the 100-year 24-hour storm event via infiltration [Ref. 7].

Infiltration Feasibility: Infiltration is considered feasible for the project due to the moderate to high site specific infiltration rates. As a result, the project SCM's will be designed to promote infiltration of runoff from the applicable design rain events.

2.2 LID Site Design Strategies (Performance Requirement No. 1)

The following LID strategies may be used in the development to comply with post-construction stormwater management requirements:

- **Limit Impervious Surfaces** – Limiting impervious surface has the benefit of reducing stormwater runoff volume, peak flow, and pollutant concentration by increasing pervious areas and landscaping to promote infiltration and evapotranspiration. The project is proposing “narrow” street sections that have been reduced to the minimum width allowed by the Seaside Fire Department.
- **Disconnect Impervious Surfaces** – The project can disconnect impervious surfaces (street pavement, hardscape, etc.) by directing impervious surface runoff to landscape areas and downstream stormwater BMP’s
- **Landscaping Design** – The project may incorporate canopy trees and shrubs where possible to promote evapotranspiration and to provide shade. The project may also incorporate drought resistant plants and efficient irrigation methods to minimize water use and avoid nuisance water as a result of excessive irrigation.
- **Infiltration Basin Design** – Projects located within the Fort Ord redevelopment area are required to construct infiltration systems that retain the 100-year 24-hour design storm. This requirement provides a greater volume of groundwater recharge than the 95th% retention requirement identified in Performance Requirement No. 3.
- **On-Lot Stormwater Retention** – The project can take advantage of permeable soils by retaining stormwater on residential lots. Perforated area drain pipes can collect rainfall from roof downspouts and provide infiltration. This will manage runoff “at the source” and reduce the overall runoff volume tributary to downstream SCMs.

2.3 Preliminary Stormwater Control Measure Selection

The SCMs described in Table 2.1 have been identified as applicable for use in the development based on the opportunities and constraints identified in Section 1.4 of this PSWCP.

Table 2.1 – Potential Stormwater Control Measures

BMP/SCM	Description
Bioretention Basin	A bioretention basin is a depressed area with porous engineered soil and landscaping that captures, treats, and infiltrates runoff. Bioretention facilities may include a gravel bed underneath the engineered soil to increase volume capacity. Perforated underdrains may be used when full retention is not feasible due to slow infiltration rates, high groundwater, utility constraints, and/or proximity to structures or site improvements. The underdrain should be placed at the top of the gravel layer to maximize retention opportunity.
Self-Treating Areas	A self-treating area is an area that treats rain by falling on itself only, by ponding, infiltration and evapotranspiration. Self-treating areas are flat or slightly concave and are comprised of all pervious surfaces landscaped with natural or LID appropriate vegetation. They do not accept runoff from adjacent impervious areas.
Self-Retaining Areas	Landscaping areas designed with a concave shape and a minimum 3-inch ponding depth. Self-retaining areas infiltrate runoff from the design storm that falls on itself and from an adjacent impervious area. A maximum 2:1 ratio of impervious area to the receiving pervious area is acceptable.
Infiltration Basin	An infiltration basin is similar to a bioretention basin without engineered soil or gravel. Infiltration basins are typically only applicable in soils with moderate to high infiltration rates and they do not contain a subdrain. Infiltration basins within the Fort Ord redevelopment area should be 5-feet deep and provide at least 1-foot of freeboard; side slopes should be no steeper than 3:1. The basin may also include an equipment access ramp to support seasonal maintenance. [Ref. 7]
Subsurface Infiltration Facilities	Subsurface infiltration facilities may be either of the infiltration chamber type or infiltration pipe type. Infiltration chambers are designed with a large open bottom area and provide large storage volume below the ground surface. Infiltration pipes are made of large diameter perforated pipe that requires a large trench bottom area and provides a significant storage volume [Ref. 7]. These facilities are sized to retain and infiltrate a pre-defined volume of runoff within a reasonable drawdown time (e.g., 48 hours). The facility may be designed to be on-line or off-line with a diversion structure and/or overflow release mechanism. This type of facility is considered a direct infiltration facility and is generally only applicable when seasonal high groundwater is greater than 10-feet below subgrade elevation and infiltration rates are higher than 0.5 in/hr. Drawdown times are recommended to be 48-hours or less. Long term maintenance can be challenging with subsurface infiltration facilities. Pretreatment structures are desired to reduce the potential reduction of long term infiltration rates. Without pretreatment measures, it is recommended to apply more stringent safety factors to subsurface infiltration facilities.

2.4 Potential Source Control Measures

The most effective way to reduce stormwater runoff pollution is to manage pollutants at the source as opposed to further downstream. The stormwater source control measures listed in Table 2.2 may be implemented with the project.

Table 2.2 – Potential Source Control Measures

Potential Source	BMP Description
Landscape Management	Ongoing management consistent with the CASQA <i>Stormwater Best Management Practice Handbook: New Development and Redevelopment</i> BMPs SD-10 & SD-12, including limiting pesticide and fertilizer usage and minimizing irrigation and runoff.
BMP Maintenance	Property owner or HOA will be responsible for the inspection and maintenance of private structural BMPs consistent with the SWCP and CCRWQCB Resolution R3-2013-0032 requirements.
Litter Control	Litter should be routinely picked up and properly disposed. If necessary, signage should be installed in common areas to discourage littering.
Drain Inlet Inspection	All inlets should be marked with “No Dumping - Flows to Bay” or similar message. Property owner or HOA will be responsible for inspection and maintenance of all privately owned drain inlets and storm drains.
Street Sweeping	Streets and parking areas should be swept routinely, weather permitting, and prior to the rainy season.
Vehicle Fueling	Vehicle fueling should be prohibited on site.
Outdoor Pesticide Use	Where possible, pest resistant plants should be used. Planting for SCMs should be selected to be appropriate for the soil and moisture conditions. Landscaping should be maintained using integrated pest management principles with minimal or no use of pesticides.
Material Storage	Outdoor material should be prohibited on site.

2.5 Trash Treatment Control Measures

The State Water Resource Control Board adopted Resolution 2015-0019 to prevent trash from entering downstream receiving waters. Trash treatment control devices installed after December 2, 2015 shall meet the State Water Resource Control Board definition for Full Capture System.

Full Capture System: Is a treatment control, or series of treatment controls, including but not limited to, a multi-benefit project or a low impact development control that traps all particles that are 5 mm or greater, and has a design treatment capacity that is either: a) of not less than the peak flow rate resulting from a 1-year, 24-hour storm in the sub +drainage area, or b) appropriately sized to, and designed to carry at least the same flows as the corresponding storm drain.

The Campus Town project is required to infiltrate stormwater on site. This can be achieved through a combination of BMPs/SCMs including; infiltration trenches, perforated pipes, underground infiltration systems and infiltration basins. Each of these BMPs are considered “Multi-Benefit Treatment Systems” and meet the provisions set forth by Resolution 2015-0019.

3 Preliminary Design of Stormwater Control Measures

3.1 Drainage Management Area Description

The project seeks to manage rainfall at the source by infiltrating stormwater as close to the source as practicable, based on the opportunities and constraints identified in Section 1.4 of this PSWCP. The project plans to provide a Low Impact Development approach that includes on-lot retention for individual lots. Sandy dune soils with moderate to high percolation rates underlay most of the site and provide an opportunity to infiltrate on a lot by lot basis. Preliminary routing method models have demonstrated that rainfall runoff, up to the 100-year event, can be infiltrated on each lot without producing runoff that would normally be tributary to a storm drain system. This approach results in approximately 837 (243 west and 594 east) distributed drainage management areas spread across the approximate 85-acre development.

Runoff generated from streets and public hardscape areas will be tributary to the on-site storm drain system. Catch basins that collect runoff can be installed with open bottoms to promote infiltration and reduce sediment load to downstream stormwater management facilities. Nearly all public hardscape is comprised of detached sidewalks that drain to landscape areas. Many of these landscape areas will provide some level of retention as a result of high percolation rates and sandy soils with a high degree of surface roughness. Due to the moderate to steep topography, the site does not easily accommodate self-retaining areas (as defined by the Regional Board with a minimum 3-inches of ponding), as excessive land will be required to create “flat” areas that promote infiltration. Furthermore, the City has expressed the desire for an “Urban Environment” which does not provide the open space needed for sloping to flat areas. Open space, landscaping and residential lots with proposed on-lot retention systems accounts for approximately 61% of the site. Therefore, only 39% of the site is anticipated to contribute runoff to the storm drain system.

Water that enters the storm drain system will be tributary to an infiltration basin located within the project. Four infiltrations basins have been proposed, two on either side of General Jim Moore Boulevard (West and East Basins). The basins have been sized using the Routing Method outlined in the CCRWQCB Resolution with additional criteria from the FORA Stormwater Master Plan. See Section 3.3 and 3.4 for more information regarding basin sizing. A site map showing preliminary drainage management areas can be found on Figure 4 in Appendix A.

Future commercial and mixed-use parcels are not included in the preliminary post-construction stormwater management calculations. Prior to development of these parcels, a separate post-construction stormwater control plan will be required to demonstrate how the future project intends to manage stormwater associated with the proposed development.

3.2 Performance Requirement No. 2: Stormwater Quality Treatment

The projects stormwater management facilities will be sized to retain the 95th% 24-hour rainfall event via infiltration. Since the 95th% 24-hour rainfall depth (1.2-inches) is greater than the 85th% 24-hour rainfall depth (0.8-inches) required for stormwater quality treatment, the SCMs will meet the requirements for stormwater quality treatment.

3.3 Performance Requirement No. 3: Runoff Retention

Preliminary Stormwater Control Measures (SCMs) for the Campus Town Tentative Map were sized to meet the Runoff Retention requirement through the Routing Method described in the CCRWQCB Resolution. A design infiltration rate was selected by applying a safety factor to the site specific infiltration test performed by Berlogar Stevens & Associates [Ref. 8]. Since infiltration tests were performed near proposed SCMs, a separate design infiltration rate was applied to each SCM. Safety factors were applied to in-situ rates based on guidelines in the FORA Stormwater Master Plan, which applies a more stringent safety factor for subsurface infiltration where there is a greater potential for long term reductions in infiltration rates. See Appendix B for the design infiltration rate calculation. The 95th% 24-hour runoff volume was calculated for each DMA using the Simple Method, and is reflected in Table B.1 and B.2 in Appendix B. The *CivilStorm* computer model was then used to perform the routing analysis to determine if the proposed SCMs provided sufficient storage volume to infiltrate the full 95th% 24-hour runoff volume. The following parameters were used in the routing method analysis:

- Hydrograph Analysis Method: NRCS Curve Number
- Pond Routing Method: Storage-Indication
- Design infiltration Rate: See Page 1 in Appendix B for SCM specific infiltration rates.
- Rainfall Distribution: NOAA Atlas 14 rainfall data and NRCS Type CA-5 Distribution.
- Time of Concentration: DMA specific based on flow time. See Table B.3 in Appendix B.
- Time Increment: 0.1 hours

NRCS Curve Numbers were selected such that the resulting runoff volume in the computer model equaled or exceeded the volume calculated with the Simple Method. A description of the SCMs for each DMA is provided below. See Figure 4 for the SCM site map and associated tributary areas.

On-Lot Retention of Individual Lots

A stated goal of the CCRWCB Performance Requirement for Low Impact Development (LID) is to mimic the pre-development hydrologic condition of a site by minimizing disturbed areas and impervious cover by infiltrating, storing, detaining, evapotranspiration, and/or biotreating stormwater runoff close to the source. The Campus Town project meets this goal by retaining runoff produced from the 95th% 24-hour storm on each residential lot. One way this may be achieved is by connecting roof downspouts and area drains to a perforated pipe or trench located on each lot. *CivilStorm* was used to perform the routing analysis for “sample lot” of various sizes to determine the length of piping and trench width necessary to infiltrate the design volume. A 4” perforate pipe was

used in the analysis with a design infiltration rate of 5 in/hr. The design infiltration rate for subsurface infiltration is based on the average infiltration test rate performed by Berlogar Stevens & Associates with a safety factor applied. The design rate is anticipated to be fairly conservative, as preliminary geotechnical investigations have identified loose sands in the upper soil layers.

Table B.2 in Appendix B shows the results of the routing analysis. The analysis is intended to show a proof of concept, additional calculations will be needed in final design based on ultimate lot configuration and impervious surfaces.

West Stormwater Management Facilities

In addition to the approximately 243 distributed drainage management areas from individual lots west of General Jim Moore Boulevard, two additional drainage management areas (W-1 & W-2) have been proposed for runoff retention of street areas. The areas primarily consist of street pavement, hardscape and landscape areas. As discussed in Section 3.1, runoff resulting from the 95th% 24-hour storm is unlikely to produce runoff from hardscape and landscape areas. This is because most hardscape and sidewalks flow to landscape areas, allowing infiltration of stormwater before reaching the storm drain system. Because these landscape areas will not be flat, the exact volume of runoff retained is unknown. Therefore, for the purpose of sizing preliminary SCMs, it has been assumed that all runoff produced from hardscape areas will be tributary to downstream SCMs.

Runoff produced from DMAs W-1 and W-2 flow to a separate infiltration basin located within each DMA. The infiltration basins are typically 5-ft deep and with a 4-ft maximum ponding depth. A design infiltration rate of 6.6-in/hr was applied to each basin. Basin W-1 and W-2 has a capacity of approximately 38,500-cf and 28,000-cf respectively. See Table B.6 and B.7 in Appendix B for the basin volume calculations. Since the basins are sized to provide infiltration for the 100-year 24-hour storm event, the basins are sized to meet the requirements of Performance Requirement No. 3. See section 3.4 for more information regarding sizing for the 100-year 24-hour event.

East Stormwater Management Facilities

In addition to the approximately 594 distributed drainage management areas from individual lots east of General Jim Moore Boulevard, an additional drainage management area E-1 has been proposed for runoff retention of street areas. The areas consist primarily of street pavement, hardscape and landscape areas. Although it is unlikely that runoff from hardscape areas will produce runoff for the 95th% storm, the preliminary SCMS have been sized assuming all runoff produced from hardscape areas will be tributary to downstream SCMs.

Runoff produced from DMA E-1 is tributary to Basin E-1 located within the DMA. The basin is 5-ft deep and with a 4-ft maximum ponding depth and provides a storage volume of approximately 37,600-cf. Refer to Table B.8 in Appendix B for the basin volume calculations. A design infiltration rate of 9.6-in/hr was applied to the basin based on infiltration testing near the proposed basin location. Basin E-1 has been sized to meet Performance Requirement No. 3 for the drainage area. An overflow structure or flow control structure will be employed to convey storms larger than the 95th% storm to

Basin E-2 which will serve as the eastern region flood control facility. Refer to Section 3.4 for information regarding Basin E-2 and sizing for the 100-year 24-hour event.

3.4 Performance Requirement No. 4: Peak Flow Management

Peak flow management is not required for Water Management Zone 4. However, the FORA Stormwater Master Plan requires full infiltration of the 100-year 24-hour storm event for new development and redevelopment. The following section will outline the hydrology and hydraulic methodology and results demonstrating how the 100-year 24-hour event could be infiltrated with the proposed preliminary stormwater control measures.

Methodology

The NRCS Curve Number method was used in conjunction with the *CivilStorm* computer model to perform the hydrologic routing analysis for the Drainage Management Areas. The site was analyzed for the 100-year 24-hour storm event in an effort to prevent offsite discharges from occurring for storms up to the 100-year event. NOAA Atlas 14 was used to determine 24-hour rainfall depths (See table B.10 and B.11 in Appendix B). Curve numbers were selected using Table 2.2a of the NRCS TR 55 Urban Hydrology for Small Watershed [Ref. 6], based on the estimated percent impervious of the drainage areas and the hydrologic soil group (See Table B.4 and B.5 in Appendix B).

Development of Rainfall Runoff Hydrograph

The NRCS rainfall distribution for California was used in the analysis. NOAA National Weather Service (NWS) has recently published updated rainfall frequency information for most U.S. states including California as part of the NOAA Atlas 14. Studies of the NOAA Atlas 14 rainfall data have shown that the standard NRCS Type I through Type III distributions do not accurately represent the relations of rainfall intensity, duration, and frequency. For this reason, NRCS recommends obtaining site specific rainfall data from the NOAA Atlas 14 website. In addition, NRCS has developed updated rainfall distributions for 5 different regions in California; The CA-1 distribution applies to the northwest coast. The CA-2 distribution applies to the northeast. The CA-3 distribution applies to the San Joaquin Valley. The CA-4 distribution applies to the Sierra Nevada Mountains. The CA-5 distribution applies to the southern coast and the CA-6 distribution applies to the southeast desert region. The City of Seaside and the former Fort Ord falls in the CA-5 region.

Rainfall data for the Campus Town project design storm was identified using NOAA Atlas 14 rainfall data. The total rainfall depth for each return period was multiplied by incremental rainfall depth per the NRCS 24-hour distribution for Region CA-5 with time increment of 0.1-hour. Refer to Appendix C for NRCS rainfall distribution documentation. Precipitation data specific to the Campus Town project site can be found in Table C.1 of Appendix C.

Model Results

On-Lot Retention of Individual Lots

Using the same *CivilStorm* parameters discussed in Section 3.3 and Curve Numbers from Table B.5, the *CivilStorm* model demonstrated that it is feasible to infiltrate runoff produced from the 100-year 24-hour event on each residential lot. The minimum perforated pipe size, length and trench width necessary for full infiltration of the 100-year 24-hour event is identified on Table B.2 for “sample lots” of various sizes. The analysis is intended to show a proof of concept, additional calculations will be needed in final design based on ultimate lot configuration and impervious surfaces. The maximum drawdown time identified in the analysis was 26.2 hours.

West and East Stormwater Management Facilities

Routing the 100-year 24-hour storm event through the proposed infiltration basins described in Section 3.3 produced no runoff from the site. Lots intended to have on-lot retention systems were excluded from the calculation as they are not expected to produce runoff during the 100-year event. In addition, future commercial and mixed-use parcels were excluded from the calculation as they are expected to provide separate stormwater facilities for management of the 100-year 24-hour event.

Results from the routing analysis demonstrated basins W-1 and W-2 can infiltrate the 100-year 24-hour runoff volume while maintaining a minimum 1-ft freeboard. Refer to Appendix D for *CivilStorm* model results. A site map of basin W-1 and W-2 is provided in Figure 4.1 of Appendix A.

Basin E-1 and E-2 on the east side area infiltration basins in series. The primary purpose of basin E-1 to meet Performance Requirement No. 3 (retention of the 95th% 24-hour storm). A flow control or diversion structure will be employed to prevent discharges into Basin E-2 during storms that produce runoff less than the 95th% event. One common type of flow control structure applicable for this situation is a manhole with a weir plate. When the hydraulic grade line in Basin E-1 reaches an elevation greater than what is needed to retain the 95th% event, stormwater will flow to Basin E-2 for full retention of the 100-year 24-hour storm. Results from the hydraulic routing analysis demonstrate basin E-1 and E-2 can infiltrate the 100-year 24-hour runoff volume while maintaining a minimum 1-ft freeboard. See Table 3.1 for a summary of the SCM model results, preliminary *CivilStorm* model hydrographs can be found in Appendix D.

Table 3.1 – Preliminary SCM Model Results for the 100-year 24-hour Storm

SCM	100-year 24-hour Rainfall Depth (in)	Design Infiltration Rate (in/hr)	Maximum Facility Ponding Depth (ft)	Maximum Facility Volume (ft ³)	Freeboard (cfs)
W-1	4.78	6.6	4.00	38,500	1.00
W-2	4.78	6.6	2.23	28,000	2.77
E-1	4.78	9.6	4.20	37,600	1.50
E-2	4.78	9.6	3.92	179,200	1.08

Appendix A

Figures

FIGURE 1 - LOCATION MAP
 PRELIMINARY STORMWATER CONTROL PLAN
 CAMPUS TOWN

SEASIDE, CALIFORNIA

JULY 2018



RUGGERI-JENSEN-AZAR

ENGINEERS ■ PLANNERS ■ SURVEYORS
 8055 CAMINO ARROYO GILROY, CA 95020
 PHONE: (408) 848-0300 FAX: (408) 848-0302

JOB NUMBER: 132018

SHEET 1 OF 1 SHEETS



SITE VICINITY

NO SCALE

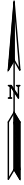

SCALE: 1"=1500'

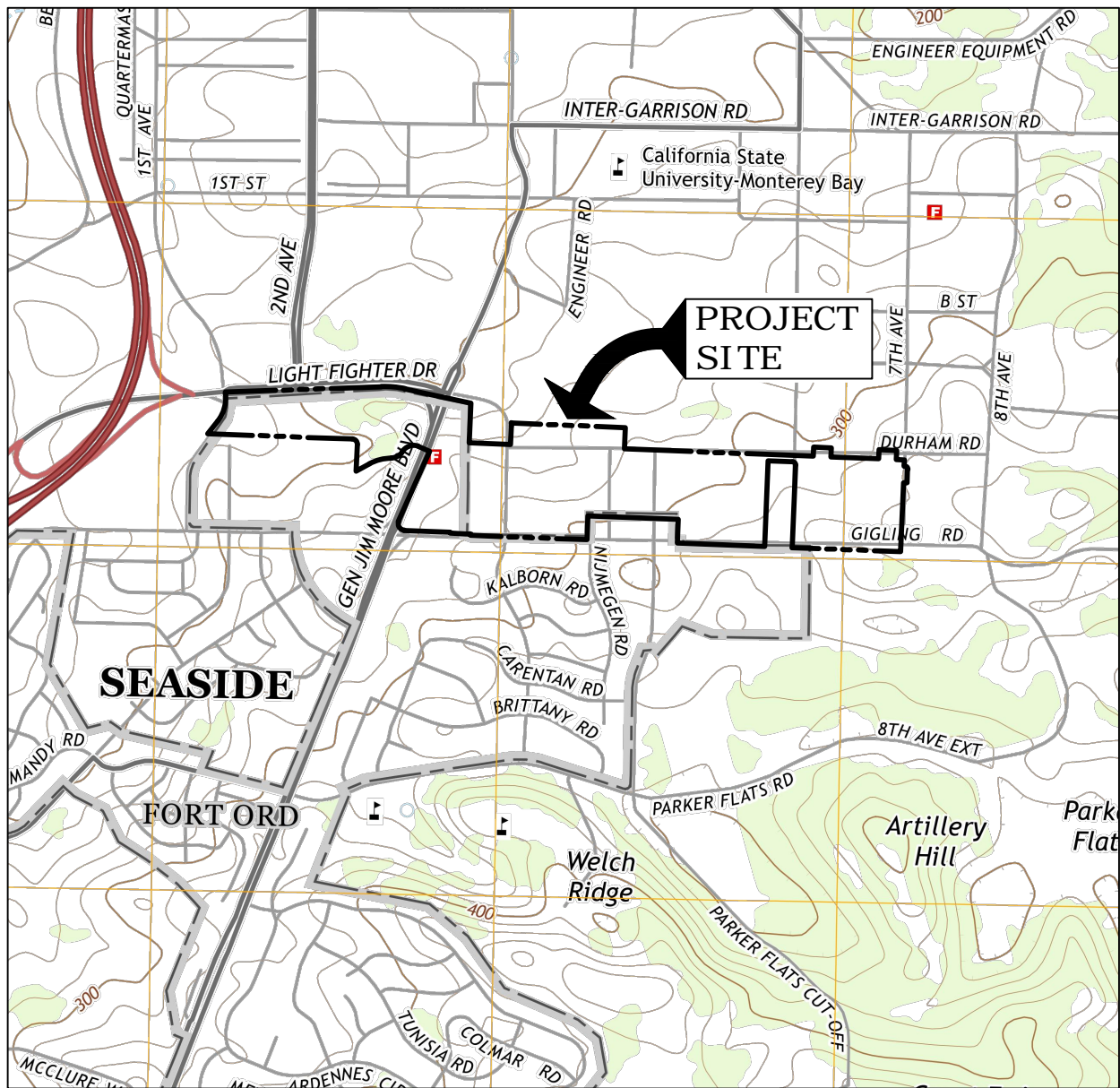

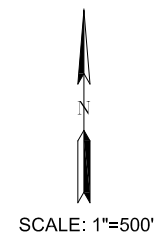
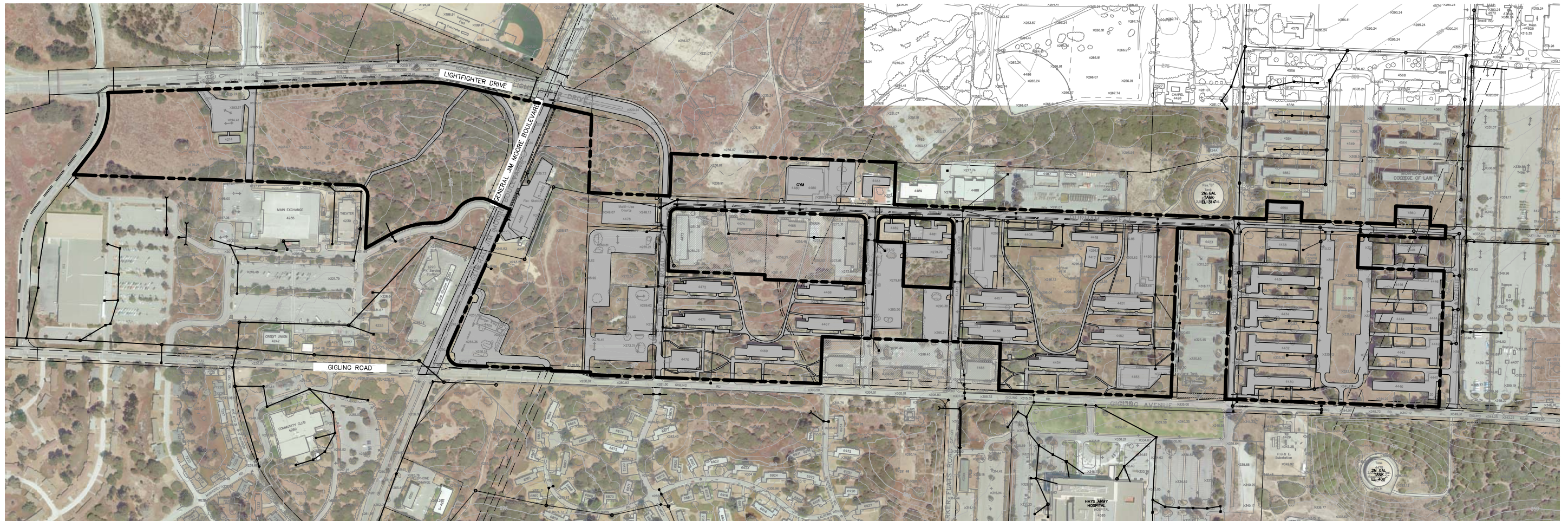

LEGEND







	STUDY AREA BOUNDARY (135 AC)
	EXISTING IMPERVIOUS AREA (42 AC = 31%)
	EXISTING STORM DRAIN PIPE
	EXISTING CULVERT
	EXISTING STORM DRAIN INLET

FIGURE 2 - EXISTING CONDITIONS
 PRELIMINARY STORMWATER CONTROL PLAN
 CAMPUS TOWN
 SEASIDE, CALIFORNIA
 JULY 2018

RJA
RUGGERI-JENSEN-AZAR
 ENGINEERS • PLANNERS • SURVEYORS
 8055 CAMINO ARROYO GILROY, CA 95020
 PHONE: (408) 848-0300 FAX: (408) 848-0302

PLOT DATE: 7/18/2018 5:12 PM
 FILE PATH: W:\Jobs\131\2018\Drawings\Storm\WCP\FIGURE 2 - EX CONDITIONS.dwg

MAP LEGEND









Area of Interest (AOI)
 Area of Interest (AOI)

Soils

Soil Rating Polygons

-  A
-  A/D
-  B
-  B/D
-  C
-  C/D
-  D
-  Not rated or not available

Soil Rating Lines

-  A
-  A/D
-  B
-  B/D
-  C
-  C/D
-  D
-  Not rated or not available





Soil Rating Points

-  A
-  A/D
-  B
-  B/D
-  C
-  C/D
-  D
-  Not rated or not available

Water Features

-  Streams and Canals

Transportation

-  Rails
-  Interstate Highways
-  US Routes
-  Major Roads
-  Local Roads

Background

-  Aerial Photography

FIGURE 3 - NRCS SOIL CLASSIFICATIONS PRELIMINARY STORMWATER CONTROL PLAN CAMPUS TOWN

SEASIDE, CALIFORNIA

JULY 2018



ENGINEERS • PLANNERS • SURVEYORS
 8055 CAMINO ARROYO GILROY, CA 95020
 PHONE: (408) 848-0300 FAX: (408) 848-0302

JOB NUMBER: 132018

SHEET 1 OF 1 SHEETS

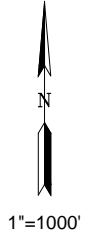

Physical Soil Properties—Monterey County, California														
Map symbol and soil name	Depth	Sand	Silt	Clay	Moist bulk density	Saturated hydraulic conductivity	Available water capacity	Linear extensibility	Organic matter	Erosion factors			Wind erodibility group	Wind erodibility index
										Kw	Kf	T		
	In	Pct	Pct	Pct	g/cc	micro m/sec	In/In	Pct	Pct					
OaD—Oceano loamy sand, 2 to 15 percent slopes														
Oceano	0-80	-80-	-16-	0- 4- 7	1.60-1.65 -1.70	42.00-92.00-14 1.00	0.06-0.07-0. 08	0.0- 1.5- 2.9	0.0- 1.0- 2.0	.24	.24	5	2	134

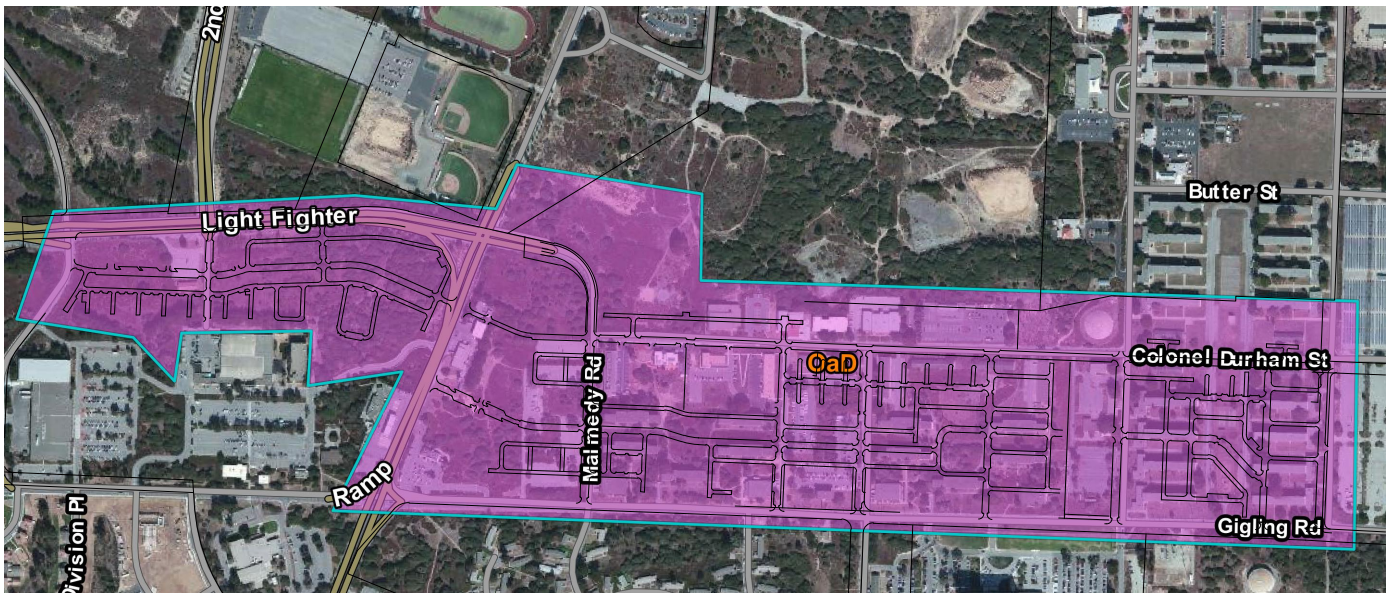

SOURCE: NATURAL RESOURCES CONSERVATION SERVICE, WEBSOILSURVEY.NRCS.USDA.GOV/APP/WEBSOILSURVEY.ASPX

PLOT DATE: 7/18/2018 5:21 PM
 FILE PATH: W:\Jobs\13132018\Drawings\Prelim\Studies & Calculations\Storm\SWCP\FIGURE 3 - NRCS SOIL CLASSIFICATION.dwg

PLOT DATE: 7/23/2018 2:51 PM
 FILE PATH: W:\Jobs\1312018\Drawings\Prelim\Studies & Calculations\Storm\SWCP\FIGURE 4 - PRELIM SCM SITE MAP.dwg

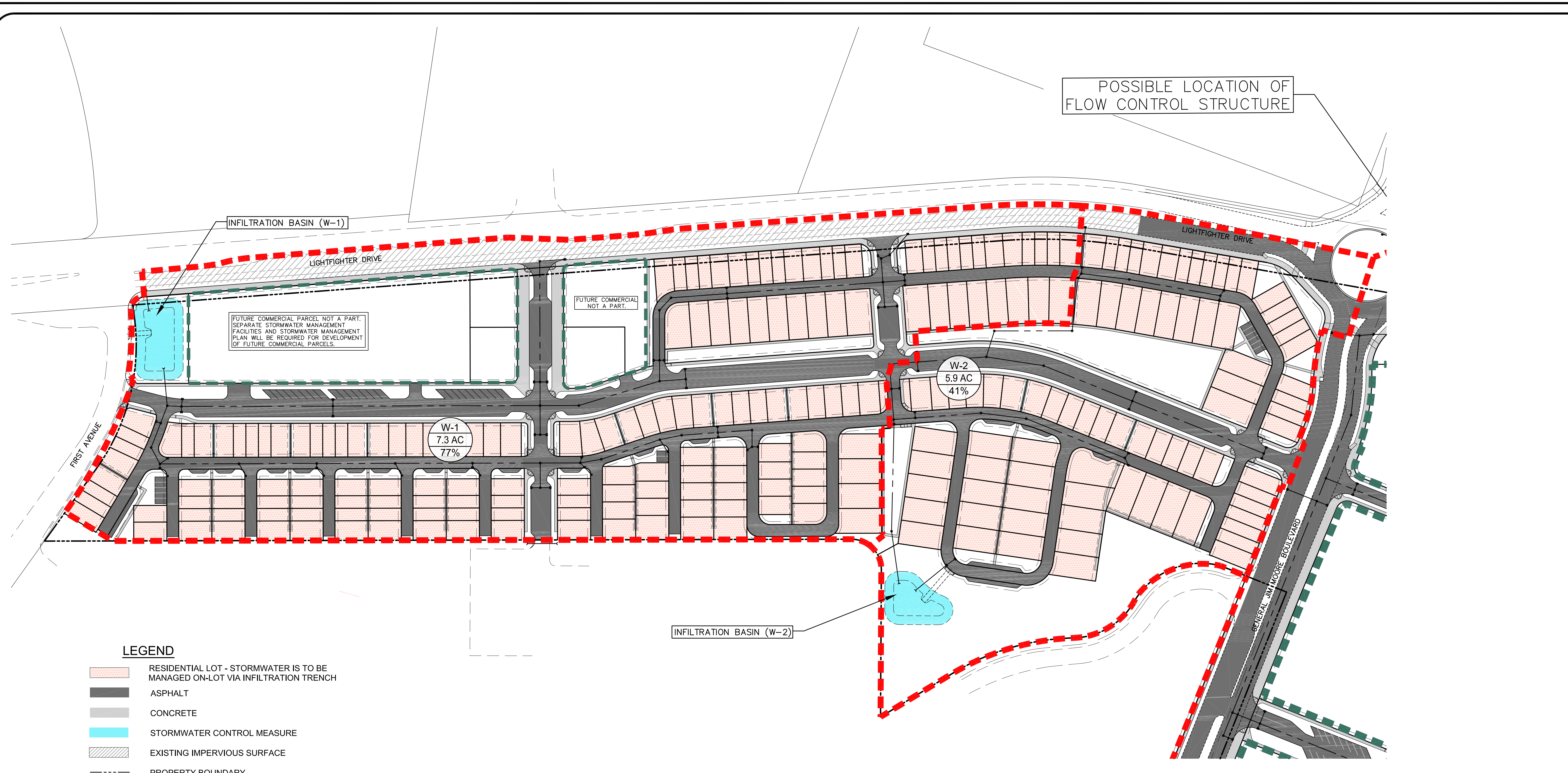

LEGEND

- RESIDENTIAL LOT - STORMWATER IS TO BE MANAGED ON-LOT VIA INFILTRATION TRENCH
- ASPHALT
- CONCRETE
- STORMWATER CONTROL MEASURE
- EXISTING IMPERVIOUS SURFACE
- PROPERTY BOUNDARY
- SCM DRAINAGE AREA
- FUTURE DEVELOPMENT AREA (NOT INCLUDED IN CALCULATIONS)
- STORM DRAIN SYSTEM
- OUTFALL
- DRAIN INLET
- DIRECTION OF FLOW
- W-1
5.9 AC
41% DRAINAGE MANAGEMENT AREA ID
- W-1
7.3 AC
77% TRIBUTARY AREA
- W-2
5.9 AC
41% PERCENT IMPERVIOUS

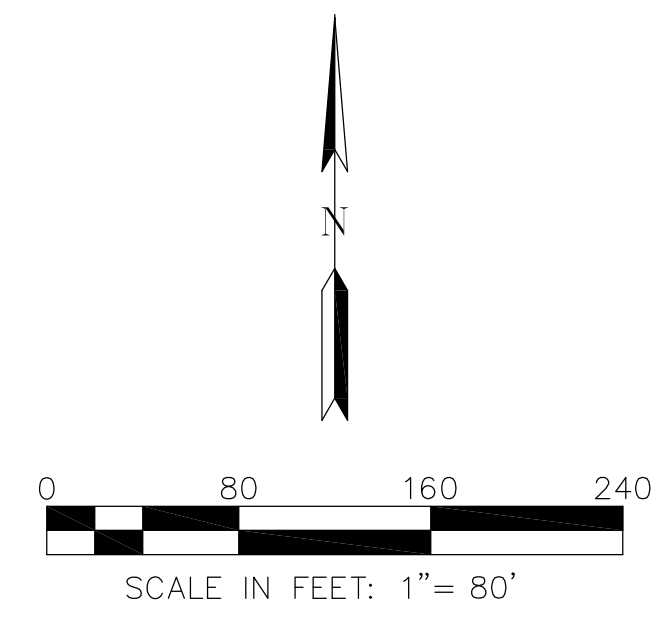

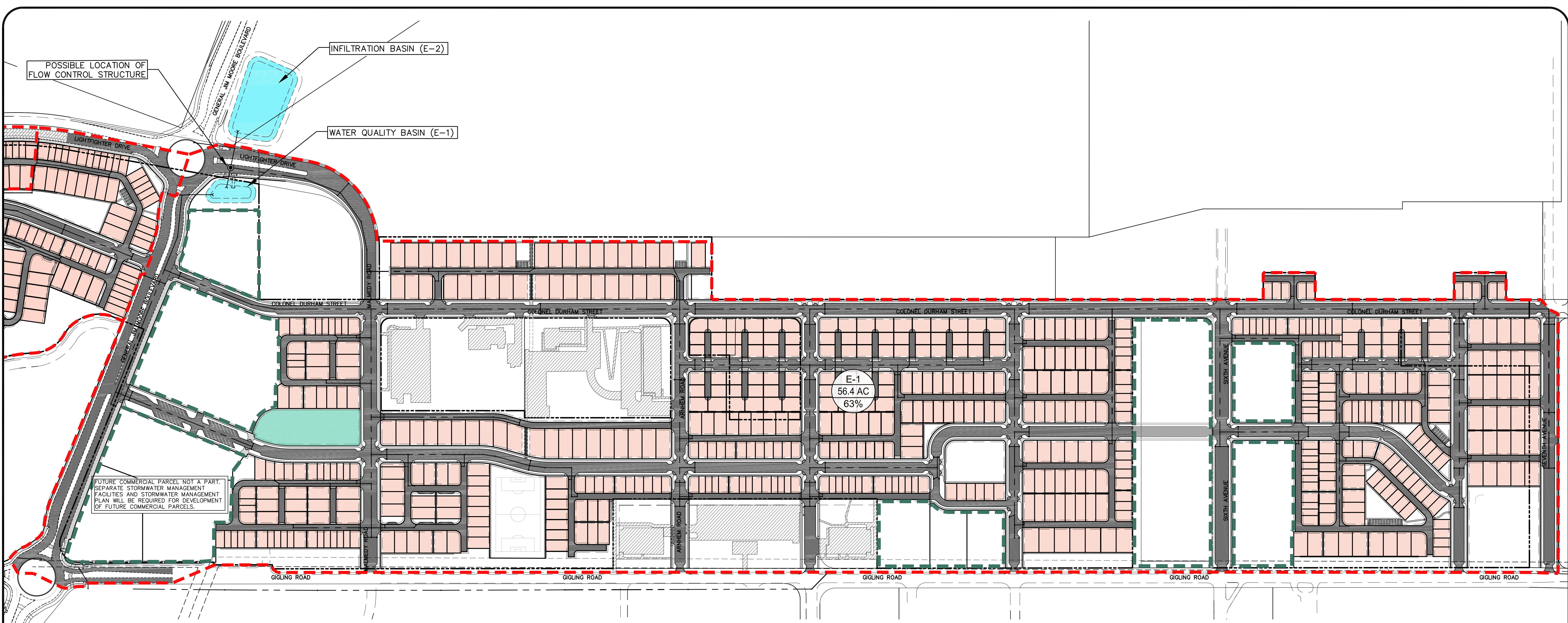

FIGURE 4.1 - SCM SITE MAP (WEST)
PRELIMINARY STORMWATER CONTROL PLAN
CAMPUS TOWN
 SEASIDE, CALIFORNIA
 JULY 2018

RUGGERI-JENSEN-AZAR
ENGINEERS ■ PLANNERS ■ SURVEYORS
8055 CAMINO ARROYO GILROY, CA 95020
PHONE: (408) 848-0300 FAX: (408) 848-0302

JOB NUMBER: 132018
SHEET 1 OF 1 SHEETS



POSSIBLE LOCATION OF FLOW CONTROL STRUCTURE

INFILTRATION BASIN (E-2)

WATER QUALITY BASIN (E-1)

FUTURE COMMERCIAL PARCEL NOT A PART. SEPARATE STORMWATER MANAGEMENT FACILITIES AND STORMWATER MANAGEMENT PLAN WILL BE REQUIRED FOR DEVELOPMENT OF FUTURE COMMERCIAL PARCELS.

E-1
56.4 AC
63%

LEGEND

- RESIDENTIAL LOT - STORMWATER IS TO BE MANAGED ON-LOT VIA INFILTRATION TRENCH
- ASPHALT
- CONCRETE
- STORMWATER CONTROL MEASURE
- "TAVERN ON THE GREEN" (ASSUMED 70% IMPERVIOUS)
- EXISTING IMPERVIOUS SURFACE
- PROPERTY BOUNDARY
- SCM DRAINAGE AREA
- FUTURE DEVELOPMENT AREA (NOT INCLUDED IN CALCULATIONS)
- STORM DRAIN SYSTEM
- OUTFALL
- DRAIN INLET
- DIRECTION OF FLOW
- W-1
5.9 AC
41% DRAINAGE MANAGEMENT AREA ID
- W-1
5.9 AC
41% TRIBUTARY AREA
- PERCENT IMPERVIOUS

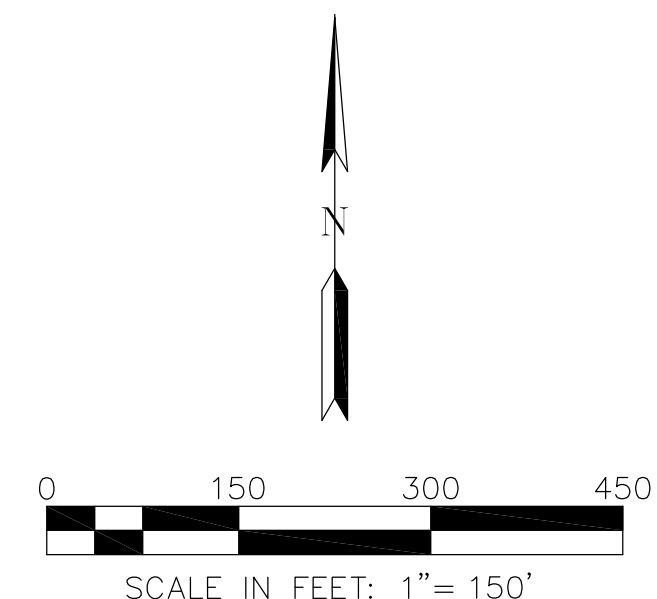

FIGURE 4.2 - SCM SITE MAP (EAST)
PRELIMINARY STORMWATER CONTROL PLAN
CAMPUS TOWN
 SEASIDE, CALIFORNIA
 JULY 2018

RUGGERI-JENSEN-AZAR
ENGINEERS ■ PLANNERS ■ SURVEYORS
8055 CAMINO ARROYO GILROY, CA 95020
PHONE: (408) 848-0300 FAX: (408) 848-0302

JOB NUMBER:132018
SHEET 1 OF 1 SHEETS

PLOT DATE: 7/23/2018 2:51 PM
 FILE PATH: W:\Jobs\1312018\Drawings\Prelim\Studies & Calculations\Storm\SWCP\FIGURE 4 - PRELIM SCM SITE MAP.dwg

Appendix B

SCM & Hydrology Calculations

Project Name: Campus Town TM
Project Location: Seaside, CA
Date: July 2018

Project Information

Area =	5,950,000 ft ²	<i>Approximate area tributary to proposed stormwater control measures</i>
Existing Impervious Area =	1,818,183 ft ²	
	31%	<i>Approximate Existing Percent impervious area</i>
Ex Imperv Area To Remain =	291,911 ft ²	<i>Approximate total existing impervious surface to remain</i>
Replaced Imperv Area =	1,526,272 ft ²	<i>Approximate total existing impervious surface to be replaced as part of project</i>
New Imperv Area =	1,550,728 ft ²	<i>Approximate total new impervious surface to be installed as part of project</i>
Total Impervious Area =	3,077,000 ft ²	<i>Approximate total project impervious area</i>
	52%	<i>Percent impervious area</i>
Water Management Zone =	4	

Performance Requirements

- No. 1 = Implement site design and runoff reduction strategies
- No. 2 = Provide water quality treatment for 85% storm event
- No. 3 = Prevent offsite discharge from events up to the 95th% storm event via optimizing infiltration
- No. 4 = Reduce peak flows to pre-project levels for 2-yr through 10-yr storm events
- No. 5 = Prevent offsite discharge from events up to the 100-year 24-hour storm event via optimizing infiltration

Rainfall Design Information

P _{85%} =	0.8 in	<i>85th% 24-hr rainfall depth</i>
P _{95%} =	1.2 in	<i>95th% 24-hr rainfall depth</i>

Soil Type Design Information

Site HSG =	A	<i>NRCS Hydrologic Soil Group Classification</i>
Test # 1 (West) =	11 in/hr	<i>Infiltration testing performed by Berlogar Stevens & Associates, dated 07-05-2018</i>
Test # 2 (East Basin) =	16 in/hr	<i>Infiltration testing performed by Berlogar Stevens & Associates, dated 07-05-2018</i>
Test # 3 =	20 in/hr	<i>Infiltration testing performed by Berlogar Stevens & Associates, dated 07-05-2018</i>
Test # 4 =	8 in/hr	<i>Infiltration testing performed by Berlogar Stevens & Associates, dated 07-05-2018</i>

Surface Infiltration Safety Factor =	1.7 in/hr	<i>FORA Stormwater Master Plan, March 2005</i>
--------------------------------------	-----------	--

West Basin Design Infiltration Rate =	6.6 in/hr	<i>Test #1 with safety factor applied</i>
--	------------------	---

East Basin Design Infiltration Rate =	9.6 in/hr	<i>Test #2 with safety factor applied</i>
--	------------------	---

Sub-Surface Infiltration Safety Factor =	2.5 in/hr	<i>FORA Stormwater Master Plan, March 2005</i>
--	-----------	--

Design infiltration Rate=	5.0 in/hr	<i>Average of all infiltration tests with safety factor applied</i>
----------------------------------	------------------	---

Campus Town
Preliminary 95th% Rainfall Runoff Retention Calculations for Areas Tributary to Infiltration Basins

Table B.1: 95% Rainfall Depth Runoff Retention Volume for Areas Tributary to Infiltration Basins

DMA	Area Calculations				Impervious Surface (SF)				Pervious Surface Correction Factor					Runoff Retention Volume Calculation			
									0.20	0.10	0.60	0.15	0.10				
	Total Area (SF)	Future Commercial Areas Not Included ¹ (SF)	Total Residential Lot Area Not Included ² (SF)	Total Area Tributary To Basin (SF)	Street/ Parking Lot	Hardscape ²	Ex Impervious Surface to Remain (Offsite)	Total	Managed Turf	Landscape/Grass	Pervious Concrete	Turf Block	Pavers	Total	% Impervious	Runoff Coefficient	95th% Volume, V ₉₅ (ft ³)
W-1	725,000	126,000	280,170	318,830	200,500	46,500	0	247,000		71,830				71,830	77%	0.57	18,187
W-2	427,000	0	168,570	258,430	84,400	22,500	0	106,900		151,530				151,530	41%	0.29	7,428
E-1	4,798,000	977,000	1,365,000	2,456,000	1,064,500	266,900	212,000	1,543,400		912,600				912,600	63%	0.43	105,926
Total	5,950,000	1,103,000	1,813,740	3,033,260	1,349,400	335,900	212,000	1,897,300	0	1,135,960	0	0	0	1,135,960	63%	0.43	131,541

Notes:

1. Future commercial and mixed use parcels are not a part, and will require a separate stormwater management plan prior to future development of the parcel.
2. Single family residential and attached townhouse lots have been excluded from the calculation, as the 100-year 24-hour storm has been demonstrated to be infiltrated within the lot itself. See Table B.2 for more information.
3. 25,000 SF of impervious surface has been assumed for "Tavern on the Green" (70% impervious)

Governing Equations:

$$V_{95} = \frac{C \cdot P_{95} \cdot A}{12}$$

95% Rainfall Depth Runoff Retention Volume (ft³)

$$V_{95} = 0.858i^3 - 0.78i^2 + 0.774i + 0.04$$

C = 1.20

P₉₅ = drainage area (j 24-hr 95th percentile rainfall depth (in)

A = % impervious

Campus Town
Preliminary On-Lot Lot Area Tabulations and Retention Calculations for 95th Percentile and 100-year 24-hour Storm Events

Table B.2: On-Lot Retention Calculations for the 95th Percentile and 100-year 24-hour Storm Event

Lot Type	Area (SF)	Impervious Surface (SF)				Pervious Surface (SF)						95th% Volume, $V_{95\%}$ (ft ³)	100-year Storm Event Volume, V_{100-yr} (ft ³)		
		Roof	Street/ Parking Lot	Hardscape	Total	Pervious Surface Correction Factor		Managed Turf	Landscape/Grass	Native Landscape/Undisturbed	Total			% Impervious	Runoff Coefficient
						0.20	0.10								
Attached Townhome	1,290	890	0	110	1,000		290			290	78%	0.57	74	380	
Detached Townhome	1,740	890	0	110	1,000		740			740	57%	0.39	68	380	
Single Family Small Lot	2,410	1,390	0	110	1,500		910			910	62%	0.43	103	570	
Single Family Medium Lot	2,920	1,500	0	110	1,610		1,310			1,310	55%	0.37	109	610	
Single Family Large Lot	3,600	1,910	0	110	2,020		1,580			1,580	56%	0.38	137	765	
Single Family Court Home	2,840	1,440	0	110	1,550		1,290			1,290	55%	0.37	105	590	
Total	14,800	8,020	0	660	8,680	0	6,120	0	0	6,120	59%	0.40	595	3,295	

SCM Sizing Summary							
SCM Description	Perforated Drain Pipe Diameter (in)	Minimum Gravel Trench Width (in)	Minimum Pipe Length (ft)	Minimum Required Storage Volume (ft ³)	Design Infiltration Rate (in/hr)	Volume Retained During 100-year 24-hour Storm Event (ft ³)	Drawdown Time (hr)
Subsurface Retention	4	10	60	22	5.0	380	25.15
Subsurface Retention	4	10	60	22	5.0	380	26.15
Subsurface Retention	4	12	120	60	5.0	570	24.35
Subsurface Retention	4	12	130	65	5.0	610	24.35
Subsurface Retention	4	16	150	99	5.0	765	24.25
Subsurface Retention	4	12	100	50	5.0	590	24.45

Notes:

1. The purpose of Table B.2 is to demonstrate the feasibility of preventing 100-year 24-hour stormwater discharge from an individual lot within the development. Actual lot dimensions and subsurface retention system may vary based on final design.
2. Lot area and impervious coverages are preliminary and based on the 'standard' lot dimensions. Additional calculations will be required during final design based on actual lot dimensions and impervious coverage.
3. Hydraulic modeling was performed using the "Routing Method" as outlined in the CCRWQCB Resolution R3-2013-0032 in conjunction with Civil Storm computer software by Bentley Systems Inc.
4. Results from the hydraulic routing analysis demonstrates rainfall runoff resulting from the 100-year 24-hour storm event can be retained within the footprint of each lot using perforated storm drain piping with the minimum dimensions shown in the table.
5. Minimum pipe lengths identified for attached products are based on a single unit.
6. 100-year Storm Event Volume is calculated using the curve numbers provided in Table B.5

Governing Equations:

$$V_{95} = \frac{C * P_{95} * A}{12}$$

V_{95} = 95% Rainfall Depth Runoff Retention Volume (ft³)

$$C = 0.858i^3 - 0.78i^2 + 0.774i + 0.04$$

P_{95} = 1.20 24-hr 95th percentile rainfall depth (in)

A = drainage area (ft²)

i = % impervious

$$\text{Area} = \frac{V_{95} * 12}{D_p + D_{BSM} * R_{BSM} + D_G * R_G}$$

Area = Design SCM area based on 95% runoff retention volume (ft²)

D = SCM Layer depth (in)

R = SCM Layer porosity (in)

$$T_D = \frac{V_{95} * 12 * SF}{I * \text{Area}}$$

T_D = Drawdown time (hr)

A = Available SCM area (ft²)

I = 5.0 Infiltration Rate (in/hr)

Campus Town Time of Concentration Calculations

Table B.3: Time of Concentration:

Kirpich Method
 $t_c = 0.0078 * N * (L^2 / S)^{0.385} + 10$
 $N = \text{overland flow surface adjustment factor}$
 $L = \text{length of channel or ditch, longest flow path (ft)}$
 $S = \text{average watershed slope (ft/ft)}$

Shallow Concentrated Flow - Average Velocity
 $t_{\text{shallow}} = L/V$
 $V = 3.28 * k * S^{0.5}$
 where,
 $k = \text{intercept coefficient}$
 $S = \text{effective slope}$
 $L = \text{flow length}$
 $V = \text{velocity}$

Pipe Flow
 $k = 0.457 \text{ Grassed waterway}$
 $k = 0.491 \text{ Unpaved}$
 $k = 0.619 \text{ Paved}$

Watershed ID	Developed Watersheds										
	Initial TC (min)	Shallow Concentrated Flow - Swale/Gutter				Pipe Flow				Total	
		L (ft)	S (ft/ft)	k	V (ft/s)	T _{shallow} (min)	L (ft)	V (ft/s)	T _{pipe} (min)	TC (min)	TC (hr)
West #1	15	280	0.020	0.619	2.87	1.6	1450	4.00	6.0	23	0.38
West #2	15	300	0.043	0.619	4.21	1.2	830	4.00	3.5	20	0.33
East	15	340	0.016	0.619	2.57	2.2	5250	4.00	21.9	39	0.65

**Campus Town
Composite Curve Number Calculations for Infiltration Basins**

Table B.4: Developed Condition Hydrologic Parameters for Infiltration Basins

Area ID	Area Description	Area (acres)	Imperv (acres)	% Imperv	HSG	AMC II	
						Pervious CN	Composite CN
W-1	High Density Residential - Fair	7.3	5.7	77%	A	49	87.0
W-2	High Density Residential - Fair	5.9	2.5	41%	A	49	69.3
E-1/E-2	High Density Residential - Fair	56.4	35.4	63%	A	49	79.8
Total		69.6	43.6	62.5%	-	49.0	79.7

Notes:

1. CN value for impervious or paved surfaces = 98
2. Pervious CN's were selected from Table 2-2a of the NRCS TR-55, Urban Hydrology for Small Watersheds

**Campus Town
Composite Curve Number Calculations for Individual Lots**

Table B.5: Developed Condition Hydrologic Parameters for Individual Lots

Area ID	Sub-Area Description	Area (ft ²)	Imperv (ft ²)	% Imperv	HSG	AMC II	
						Pervious CN	Composite CN
Attached Townhome	High Density Residential - Fair	1290.0	1000.0	78%	A	49	87.0
Detached Townhome	High Density Residential - Fair	1740.0	1000.0	57%	A	49	77.2
Single Family Small Lot	High Density Residential - Fair	2410.0	1500.0	62%	A	49	79.5
Single Family Medium Lot	High Density Residential - Fair	2920.0	1610.0	55%	A	49	76.0
Single Family Large Lot	High Density Residential - Fair	3600.0	2020.0	56%	A	49	76.5
Single Family Court Home	High Density Residential - Fair	2840.0	1550.0	55%	A	50	76.2
Total		14800.0	8680.0	58.6%	-	49.2	77.8

Notes:

1. CN value for impervious or paved surfaces = 98
2. Pervious CN's were selected from Table 2-2a of the NRCS TR-55, Urban Hydrology for Small Watersheds

**Campus Town
Preliminary Basin Volume and Infiltration Calculations**

Table B.6: West Basin W-1 Volume and Infiltration Calculations

West Retention Basin W-1 Volume Calculations					Infiltration Rate = 6.6 in/hr			
Elev (ft)	Stage (ft)	Total Area (SF)	Total Area (AC)	Void Ratio (%)	Increment Volume (CF)	Cumm Volume (CF)	Cumm Volume (AC-FT)	Perc Flow (cfs)
170.0	0.0	5,090	0.117		0	0	0.000	0.78
171.0	1.0	6,070	0.139	100%	5,580	5,580	0.128	0.93
172.0	2.0	7,110	0.163	100%	6,590	12,170	0.279	1.09
173.0	3.0	8,210	0.188	100%	7,660	19,830	0.455	1.25
174.0	4.0	9,350	0.215	100%	8,780	28,610	0.657	1.43
175.0	5.0	10,540	0.242	100%	9,945	38,555	0.885	1.61

Table B.7: West Basin W-2 Volume and Infiltration Calculations

West Retention Basin W-2 Volume Calculations					Infiltration Rate = 6.6 in/hr			
Elev (ft)	Stage (ft)	Total Area (SF)	Total Area (AC)	Void Ratio (%)	Increment Volume (CF)	Cumm Volume (CF)	Cumm Volume (AC-FT)	Perc Flow (cfs)
197.0	0.0	3,430	0.079		0	0	0.000	0.52
198.0	1.0	4,240	0.097	100%	3,835	3,835	0.088	0.65
199.0	2.0	5,100	0.117	100%	4,670	8,505	0.195	0.78
200.0	3.0	6,000	0.138	100%	5,550	14,055	0.323	0.92
201.0	4.0	6,970	0.160	100%	6,485	20,540	0.472	1.06
202.0	5.0	7,950	0.183	100%	7,460	28,000	0.643	1.21

Table B.8: East Basin E-1 (Water Quality Basin) Volume and Infiltration Calculations

East Retention E-1 Basin Volume Calculations					Infiltration Rate = 9.6 in/hr			
Elev (ft)	Stage (ft)	Total Area (SF)	Total Area (AC)	Void Ratio (%)	Increment Volume (CF)	Cumm Volume (CF)	Cumm Volume (AC-FT)	Perc Flow (cfs)
208.0	0.0	4,870	0.112		0	0	0.000	1.08
209.0	1.0	5,870	0.135	100%	5,370	5,370	0.123	1.30
210.0	2.0	6,910	0.159	100%	6,390	11,760	0.270	1.54
211.0	3.0	8,020	0.184	100%	7,465	19,225	0.441	1.78
212.0	4.0	9,180	0.211	100%	8,600	27,825	0.639	2.04
213.0	5.0	10,390	0.239	100%	9,785	37,610	0.863	2.31

Table B.9: East Basin E-2 Volume and Infiltration Calculations

East Retention Basin E-2 Volume Calculations					Infiltration Rate = 9.6 in/hr			
Elev (ft)	Stage (ft)	Total Area (SF)	Total Area (AC)	Void Ratio (%)	Increment Volume (CF)	Cumm Volume (CF)	Cumm Volume (AC-FT)	Perc Flow (cfs)
200.0	0.0	30,400	0.698		0	0	0.000	6.76
201.0	1.0	32,500	0.746	100%	31,450	31,450	0.722	7.22
202.0	2.0	34,700	0.797	100%	33,600	65,050	1.493	7.71
203.0	3.0	36,900	0.847	100%	35,800	100,850	2.315	8.20
204.0	4.0	39,200	0.900	100%	38,050	138,900	3.189	8.71
205.0	5.0	41,500	0.953	100%	40,350	179,250	4.115	9.22

Campus Town
Preliminary Hydrologic Parameters Worksheet

Table B.10: Rainfall Depths (NOAA Atlas 14)

Return Period	Duration (hr)	Precipitation (in)
85th %	24	0.80
85th %	24	1.20
2-yr	24	1.92
5-yr	24	2.48
10-yr	24	2.95
25-yr	24	3.64
50-yr	24	4.19
100-yr	24	4.78

Location Information:
Name: Seaside, California
Latitude: 36.6455
Longitude: -121.8028
Elevation: 263.0

Table B.11: Rainfall Intensities

T _c (min)	T _c (hr)	85th %		95th %		2-year		5-year	
		i _{85%} (in)	i _{85%} (in/hr)	i _{95%} (in)	i _{95%} (in/hr)	i ₂ (in)	i ₂ (in/hr)	i ₅ (in)	i ₅ (in/hr)
5	0.083	0.07	0.81	0.10	1.21	0.16	1.93	0.20	2.44
10	0.167	0.10	0.58	0.14	0.87	0.23	1.39	0.29	1.75
15	0.25	0.12	0.47	0.17	0.70	0.28	1.12	0.35	1.40
30	0.5	0.17	0.33	0.25	0.50	0.40	0.80	0.50	1.00
60	1	0.21	0.21	0.32	0.32	0.50	0.50	0.64	0.64
120	2	0.29	0.15	0.44	0.22	0.71	0.35	0.89	0.44
180	3	0.36	0.12	0.54	0.18	0.87	0.29	1.09	0.36
360	6	0.48	0.08	0.72	0.12	1.15	0.19	1.45	0.24
720	12	0.60	0.05	0.89	0.07	1.43	0.12	1.83	0.15
1440	24	0.80	0.03	1.20	0.05	1.92	0.08	2.48	0.10
2880	48	1.01	0.02	1.51	0.03	2.42	0.05	3.14	0.07
4320	72	1.16	0.02	1.74	0.02	2.78	0.04	3.60	0.05
T _c (min)	T _c (hr)	10-year		25-year		50-year		100-year	
		i ₁₀ (in)	i ₁₀ (in/hr)	i ₂₅ (in)	i ₂₅ (in/hr)	i ₅₀ (in)	i ₅₀ (in/hr)	i ₁₀₀ (in)	i ₁₀₀ (in/hr)
5	0.083	0.24	2.88	0.30	3.55	0.34	4.13	0.40	4.76
10	0.167	0.34	2.06	0.43	2.55	0.49	2.96	0.57	3.41
15	0.25	0.42	1.66	0.51	2.05	0.60	2.38	0.69	2.75
30	0.5	0.59	1.19	0.73	1.47	0.85	1.70	0.98	1.96
60	1	0.75	0.75	0.93	0.93	1.08	1.08	1.24	1.24
120	2	1.04	0.52	1.27	0.64	1.46	0.73	1.67	0.84
180	3	1.28	0.43	1.56	0.52	1.79	0.60	2.04	0.68
360	6	1.70	0.28	2.07	0.35	2.37	0.40	2.70	0.45
720	12	2.17	0.18	2.65	0.22	3.05	0.25	3.47	0.29
1440	24	2.95	0.12	3.64	0.15	4.19	0.17	4.78	0.20
2880	48	3.74	0.08	4.58	0.10	5.25	0.11	5.95	0.12
4320	72	4.28	0.06	5.22	0.07	5.97	0.08	6.74	0.09

Appendix C

NRCS/NOAA Atlas 14 Rainfall Distribution

Appendix C

NRCS/NOAA Atlas 14 Procedure for Developing California Rainfall Distributions

Development of six regional rainfall distributions for California

William Merkel, Hydraulic Engineer, NRCS, Beltsville, MD

February 1, 2013

Introduction/Background

NOAA Atlas 14 was recently published for California. This rainfall-frequency atlas replaces NOAA Atlas 2 which was published in the 1970's. Previously in CA, the rainfall distribution Types I, IA, and II were used in NRCS hydrologic models to estimate peak discharges. Since these rainfall distribution types were developed based on old data, new rainfall distributions based on NOAA 14 were investigated.

The same procedure was used to develop four of the CA rainfall distributions (CA-3, CA-4, CA-5, and CA-6) as was used to develop NOAA 14 rainfall distributions for the Ohio Valley and neighboring states, and the Northeast Regional Climate Center (NRCC) rainfall distributions for New York and the New England states. The rainfall distributions for CA-1 and CA-2 are based on the National Weather Service NOAA Technical Report NWS 27, Interduration Precipitation Relations for Storms – Western United States, published September 1981.

After reviewing rainfall data, WinTR-20 results, and ratios of 60-minute to 24-hour ratios for California, it was decided to set up six regional rainfall distributions.

The CA-1 distribution applies to the northwest coast. The CA-2 distribution applies to the northeast. The CA-3 distribution applies to the San Joaquin Valley. The CA-4 distribution applies to the Sierra Nevada Mountains. The CA-5 distribution applies to the southern coast and the CA-6 distribution applies to the southeast desert region.

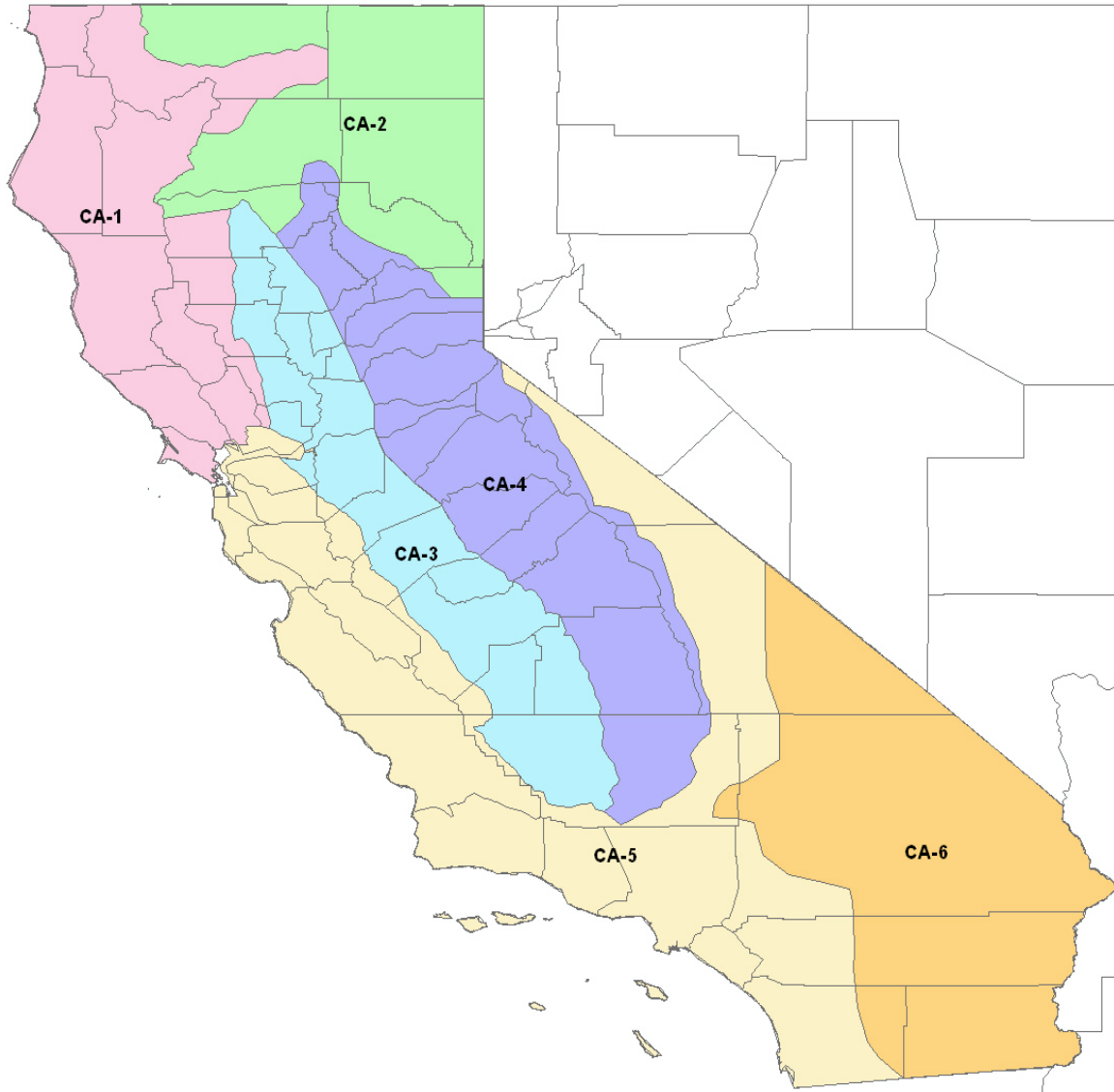

General steps in development of distributions

1. Download and prepare NOAA 14 and state/county GIS data layers.
2. Develop rainfall ratio GIS layers for 25-year return period such as 5-minute /24-hour ratio, 10-minute / 24-hour ratio, up to 12-hour / 24-hour ratio.
3. Develop boundary lines for 6 rainfall distribution regions based on 60-minute / 24-hour ratio map. A rainfall distribution region map was drawn and digitized so the map could be used for further GIS analyses.

General steps in development of distributions CA-3, CA-4, CA-5 and CA-6

1. Determine average ratio for each duration to the 24-hour precipitation from 5-minutes to 12-hours in each rainfall distribution region. This was completed by using the Spatial Analyst/Zonal/Zonal Statistics as Table command.

Duration	CA-3 region ratio	CA-4 region ratio	CA-5 region ratio	CA-6 region ratio
5-minutes	0.074	0.059	0.065	0.120
10	0.107	0.085	0.093	0.172
15	0.129	0.102	0.113	0.208
30	0.178	0.138	0.158	0.292
60	0.245	0.188	0.223	0.398
2-hour	0.329	0.261	0.314	0.489
3	0.395	0.321	0.385	0.547
6	0.534	0.463	0.538	0.654
12	0.727	0.678	0.731	0.779
24	1.0	1.0	1.0	1.0

2. Develop a rainfall distribution for each region based on the smoothing data option in WinTR-20. Ratios for each duration which were derived from the WinTR-20 rainfall table at 0.1 hour increment are in the following table.

Duration	CA-3 region ratio	CA-4 region ratio	CA-5 region ratio	CA-6 region ratio
5-minutes	0.066	0.053	0.056	0.106
10	0.105	0.084	0.090	0.169
15	0.134	0.106	0.116	0.216
30	0.185	0.144	0.164	0.299
60	0.245	0.188	0.223	0.398
2-hour	0.329	0.257	0.306	0.507
3	0.396	0.316	0.374	0.584
6	0.537	0.454	0.516	0.710
12	0.731	0.668	0.717	0.848
24	1.0	1.0	1.0	1.0

The 5-minute and 10-minute ratios were reduced for all 4 distributions during the data smoothing procedure. The 15-minute and 30-minute ratios were increased for all 4 distributions during the data smoothing procedure. The CA-3 and CA-4 region data appear to be the smoothest; the ratios in both tables are reasonably close. For the CA-6 region there are several ratios that were changed significantly. For the CA-6 distribution the 3- 6- and 12—hour ratios were significantly different. The main reason for the data smoothing was to generate a relatively smooth rainfall distribution that would not show irregularities in the generated hydrograph.

These ratios may be compared to those imbedded in the Types IA, I, and II distribution (see following table).

Duration	Type IA ratio	Type I ratio	Type II ratio
5-minute	0.020	0.063	0.1144
10	0.040	0.110	0.201
15	0.060	0.148	0.2704
30	0.115	0.213	0.380

60	0.171	0.281	0.4537
2-hour	0.252	0.370	0.5376
3	0.315	0.437	0.5953
6	0.468	0.578	0.7067
12	0.687	0.761	0.841
24	1.0	1.0	1.0

The ratios for the CA-5 region are less than those for the Type I and the ratios for CA-6 region are less than those of the Type II.

General steps in development of distributions CA-1 and CA-2

Using the methods outlined for CA-3 through CA-6, rainfall distributions were developed for the northwest coast (CA-1 region) and northeast (CA-2 region) parts of California. These distributions resulted in significantly higher peak discharges than the Type IA which has been used for many years. Since the Type IA results have been satisfactory over the years, a procedure was investigated which would provide peak discharges closer to those of the Type IA. The National Weather Service, through funding from the NRCS, completed the report NWS 27 referenced above. The concept of interduration analysis of storm data is that the rainfall distribution of actual storms is used to develop the design rainfall distribution instead of maximizing the rainfall at all durations to build the design rainfall distribution. This concept recognizes that the maximum 15-minute rainfall and the maximum 24-hour rainfall may not occur in the same storm or even in the same season of the year. Traditional methods used by NRCS to develop rainfall distributions assume the maximum 5-minute, maximum 10-minute, through maximum 24-hour rainfalls occur within the same design storm. This consideration is of critical importance in northern California.

Report 27 has several rainfall distribution regions. One of these is the Pacific Northwest western region which includes Del Norte, part of Humboldt, and western Siskiyou counties and the Pacific Northwest eastern region which includes eastern Siskiyou and Modoc counties. Unfortunately, NWS 27 does not cover most of California (the south coast, central valley, and Sierra Nevada mountains). The Pacific Northwest western region was selected for application in the CA-1 region and the Pacific Northwest eastern region was selected for application in the CA-2 region.

NWS 27 considers two major storm characteristics. One is the storm duration and the other is storm magnitude. The 24-hour storm duration was selected based on its historical use within the NRCS and the largest storm magnitude group was selected because it would be more likely to include storms with 2-year or greater return period (of more interest in NRCS project designs).

Pages 97 and 109 of NWS 27 that were used to develop the CA-1 and CA-2 rainfall distributions follow.

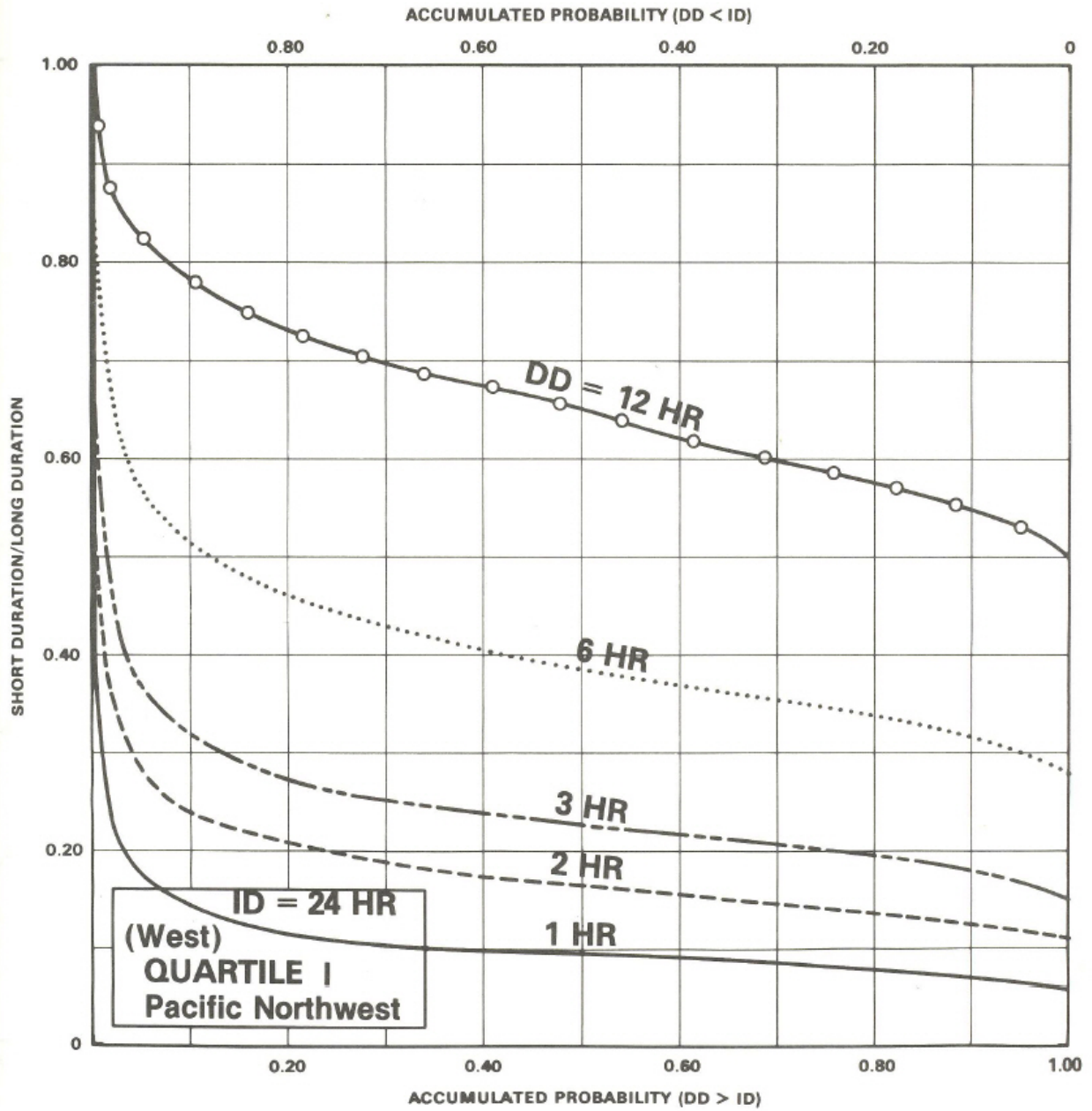

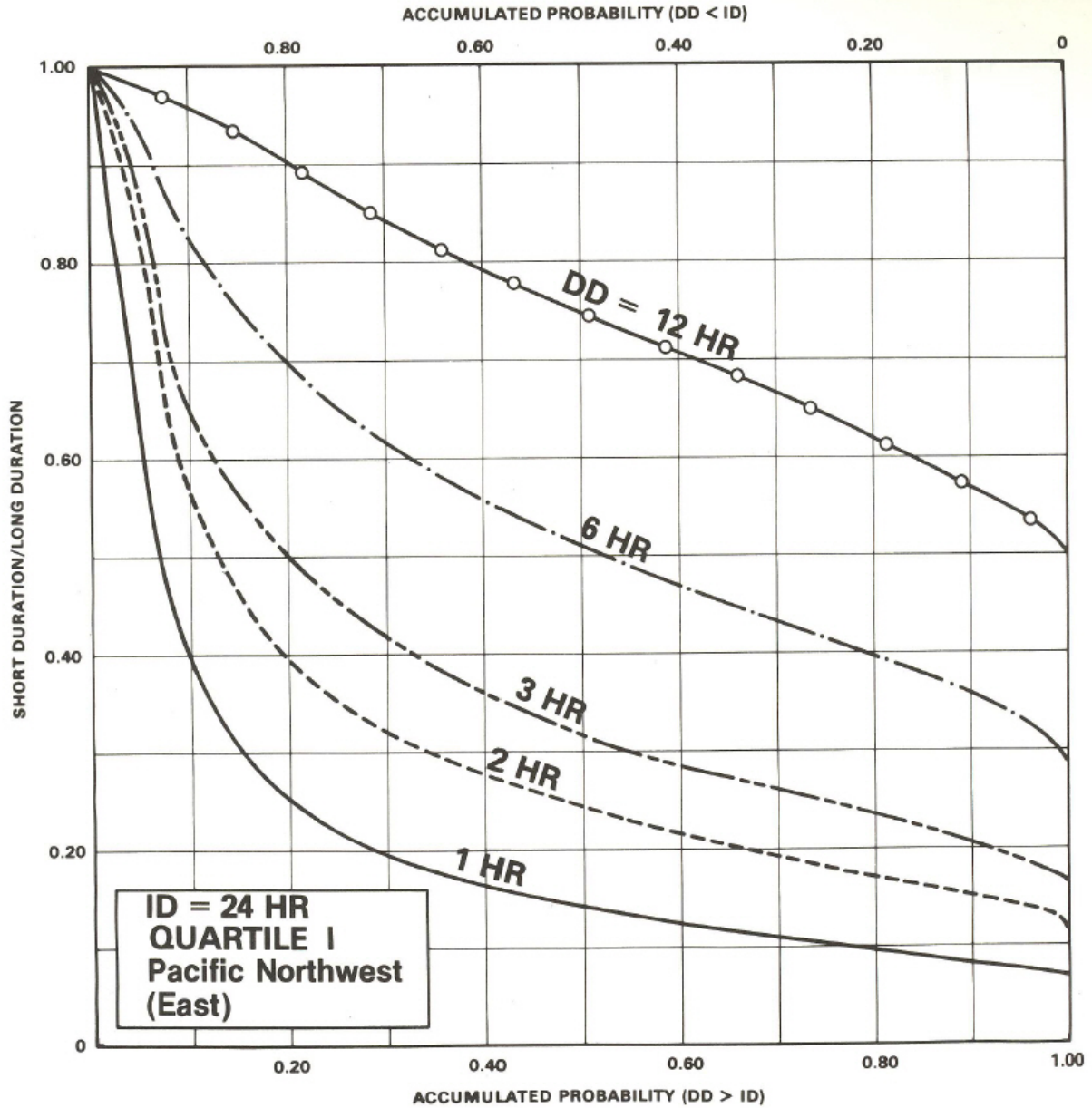

Page 109 of NWS Technical Report 27.

Values at the 50% probability level were read from the plot for the 1-hr, 2-hr, 3-hr, 6-hr and 12-hr curves. This is interpreted to mean that for largest 24-hour storms, there is a 50% probability that the ratio of the 1-hr to 24-hour rainfall is more than the value on the curve. The table of curve values follows.

	Pacific Northwest – West (CA-1)	Pacific Northwest – East (CA-2)
Duration - hours	Ratio at 50% probability	Ratio at 50% probability
1	0.10	0.14
2	0.17	0.24
3	0.23	0.32
6	0.38	0.51
12	0.65	0.75

Ratios from NWS 27 graphs.

NWS 27 does not have ratios for durations under 1 hour. Spreadsheets were set up to extrapolate the 5, 10, 15, and 30 minute ratio values from 1 and 2 hour ratios values on a logarithmic basis.

	Pacific Northwest – West (CA-1)	Pacific Northwest – East (CA-2)
Duration	Ratio to 24-hour rainfall	Ratio to 24-hour rainfall
5-min	0.013	0.018
10	0.024	0.033
15	0.034	0.047
30	0.058	0.082
1-hour	0.100	0.140
2	0.17	0.225
3	0.23	0.296
6	0.37	0.45
12	0.61	0.67

Smoothed ratios for CA-1 and CA-2 rainfall distributions.

Rainfall distributions were developed using WinTR-20 and the ratios in the table above.

Procedure to develop peak discharge curves for EFH-2

1. Run WinTR-20 to develop peak discharge versus time of concentration data for a range of Tc's and Ia/P values. The standard NRCS unit hydrograph (peak rate factor of 484) was used with the CA-1, CA-2, CA-4, CA-5, and CA-6 rainfall distributions. The NRCS flatland unit hydrograph (peak rate factor of 282) was used with the CA-3 rainfall distribution which applies to the Central Valley.
2. Import peak discharge versus Tc data to a spread sheet and develop curve fits and coefficients for Ia/P values for each of the rainfall distribution regions. Standard curve fits for CA-6 were developed where for all Ia/P curves, the unit discharges decreased as Ia/P increased (as expected). For CA-1, CA-2, CA-3, CA-4, and CA-5 some of the Ia/P curves (0.3, 0.4, and/or 0.5) crossed over other curves for longer time of concentrations. The peak discharge equations were revised such that the final curves did not cross other peak discharge curves.
3. Develop type.rf file for the EFH-2 computer program. Coefficients from step 2 were input to a type.rf file for use with EFH-2. The Type IA, Type I, and Type II distributions were added to the type.rf for CA so comparisons can be made. The current version of EFH-2 allows up to five choices in the type.rf file. Two type.rf files were created for CA. One includes CA-1, CA-2, CA-3,

Type IA and Type I. The second includes CA-4, CA-5, CA-6, Type I, and Type II. The type.rf file may be edited to include any combination of five or less rainfall distribution choices.

Rainfall distribution plots

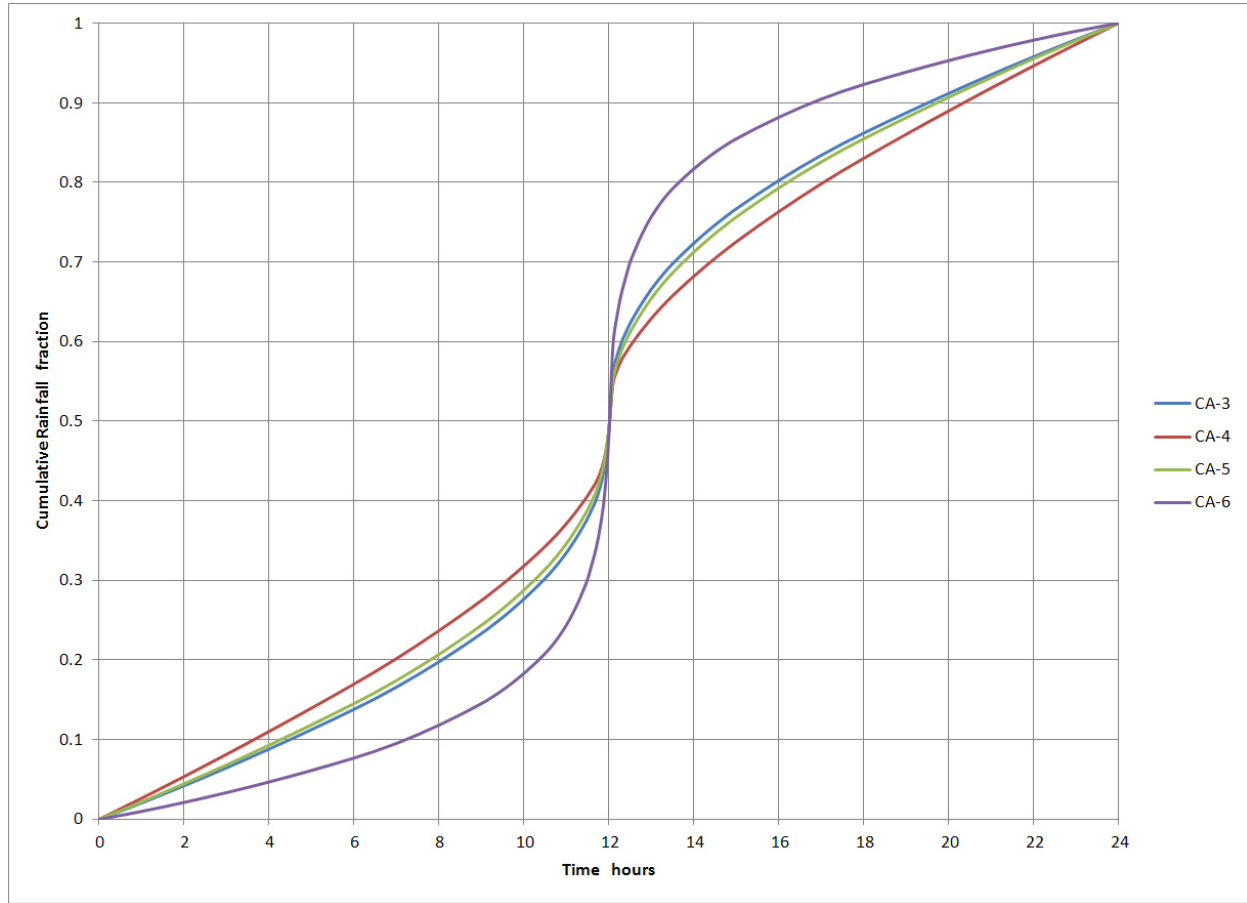

Plot of CA-3, CA-4, CA-5, and CA-6 rainfall distributions.

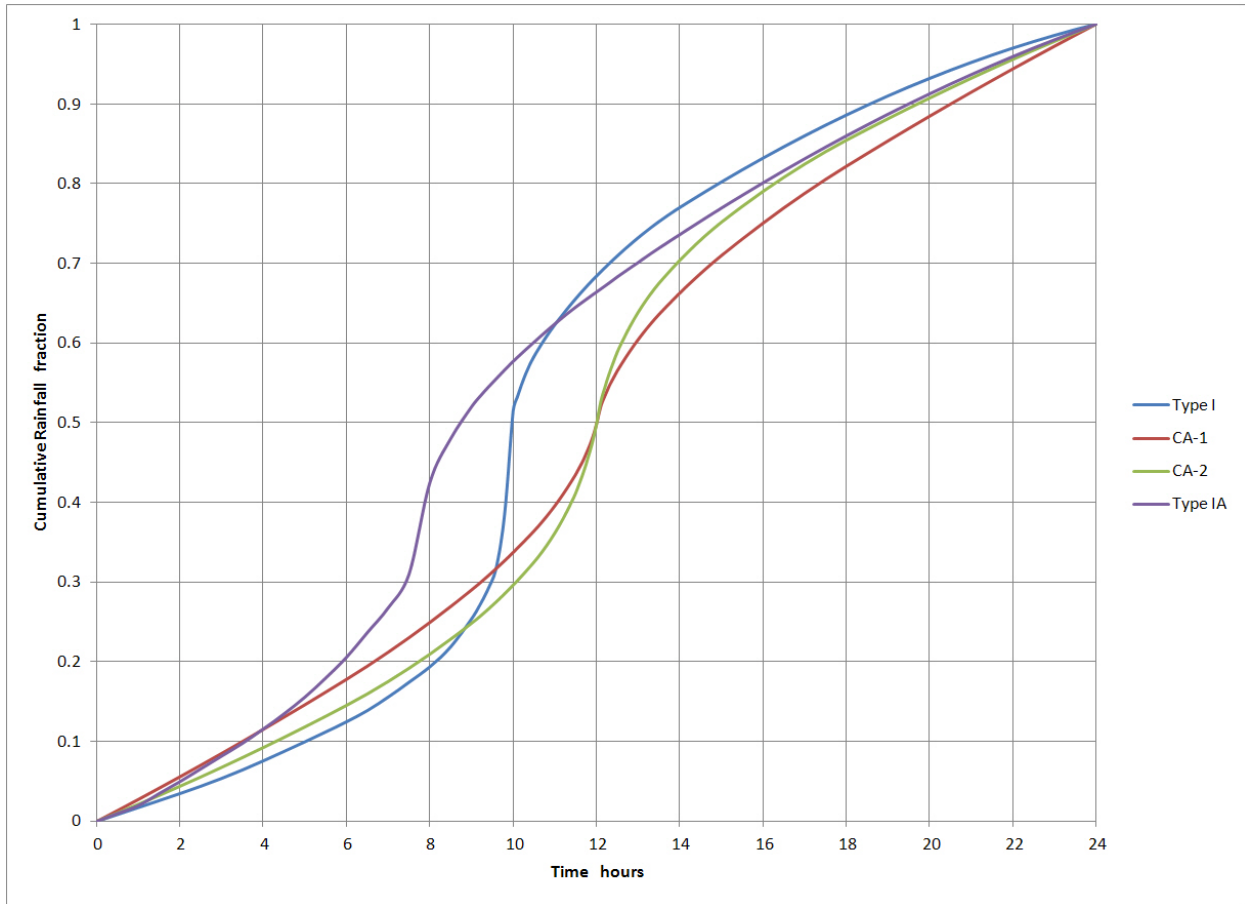

Plot of CA-1 and CA-2 rainfall distributions compared to the Type I and Type IA. The NOAA 14 distributions are centered at 12 hours whereas the Types I and IA are centered well before 12 hours.

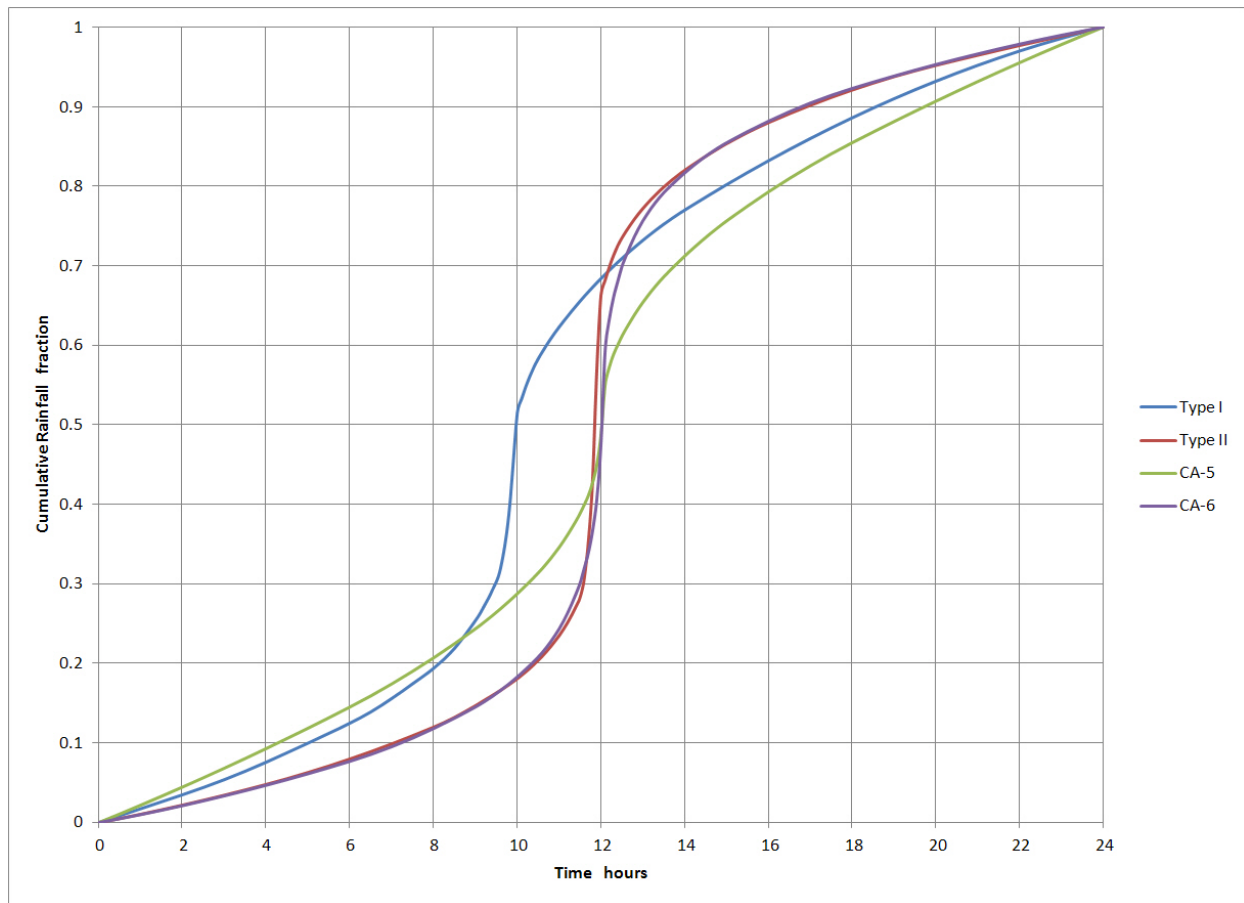

The Type II and CA-6 distributions are very similar. However, the Type II is more intense and so produces higher peak discharges than the CA-6 for the same watershed data (drainage area, curve number, time of concentration and rainfall depth).

Appendix C

CA-5 Rainfall Distribution Applied at Campus Town – Seaside, California

Table C.1: NRCS Rainfall Distribution for California (Region CA-5) Applied at Campus Town

Time (hours)	Type CA-5 Distribution 24-hour	85th % (in)	95th % (in)	2-year (in)	5-year (in)	10-year (in)	25-year (in)	50-year (in)	100-year (in)
0.0	0.0000	0.00	0.00	0.00	0.00	0.00	0.00	0.00	0.00
0.1	0.0022	0.0017	0.0026	0.0041	0.0054	0.0064	0.0079	0.0091	0.0103
0.2	0.0043	0.0034	0.0052	0.0083	0.0107	0.0127	0.0157	0.0181	0.0206
0.3	0.0065	0.0052	0.0078	0.0124	0.0161	0.0191	0.0236	0.0272	0.0310
0.4	0.0087	0.0069	0.0104	0.0166	0.0215	0.0255	0.0315	0.0362	0.0413
0.5	0.0108	0.0087	0.0130	0.0208	0.0269	0.0319	0.0394	0.0454	0.0518
0.6	0.0130	0.0104	0.0156	0.0250	0.0323	0.0384	0.0474	0.0546	0.0622
0.7	0.0152	0.0122	0.0183	0.0292	0.0377	0.0449	0.0554	0.0638	0.0728
0.8	0.0174	0.0139	0.0209	0.0335	0.0432	0.0514	0.0634	0.0730	0.0833
0.9	0.0197	0.0157	0.0236	0.0377	0.0487	0.0580	0.0715	0.0823	0.0939
1.0	0.0219	0.0175	0.0263	0.0420	0.0543	0.0645	0.0796	0.0917	0.1046
1.1	0.0241	0.0193	0.0289	0.0463	0.0598	0.0712	0.0878	0.1011	0.1153
1.2	0.0264	0.0211	0.0316	0.0506	0.0654	0.0778	0.0960	0.1105	0.1260
1.3	0.0286	0.0229	0.0343	0.0550	0.0710	0.0844	0.1042	0.1199	0.1368
1.4	0.0309	0.0247	0.0371	0.0593	0.0766	0.0911	0.1124	0.1294	0.1477
1.5	0.0332	0.0265	0.0398	0.0637	0.0822	0.0978	0.1207	0.1389	0.1585
1.6	0.0355	0.0284	0.0425	0.0681	0.0879	0.1046	0.1290	0.1485	0.1695
1.7	0.0377	0.0302	0.0453	0.0725	0.0936	0.1113	0.1374	0.1581	0.1804
1.8	0.0401	0.0320	0.0481	0.0769	0.0993	0.1181	0.1458	0.1678	0.1914
1.9	0.0424	0.0339	0.0508	0.0813	0.1051	0.1250	0.1542	0.1775	0.2025
2.0	0.0447	0.0357	0.0536	0.0858	0.1108	0.1318	0.1626	0.1872	0.2136
2.1	0.0470	0.0376	0.0564	0.0903	0.1166	0.1387	0.1712	0.1970	0.2248
2.2	0.0494	0.0395	0.0592	0.0948	0.1224	0.1456	0.1797	0.2068	0.2359
2.3	0.0517	0.0414	0.0621	0.0993	0.1282	0.1525	0.1882	0.2167	0.2472
2.4	0.0541	0.0433	0.0649	0.1038	0.1341	0.1595	0.1968	0.2266	0.2585
2.5	0.0564	0.0452	0.0677	0.1084	0.1400	0.1665	0.2054	0.2365	0.2698
2.6	0.0588	0.0471	0.0706	0.1129	0.1459	0.1735	0.2141	0.2465	0.2812
2.7	0.0612	0.0490	0.0734	0.1175	0.1518	0.1805	0.2228	0.2564	0.2925
2.8	0.0636	0.0509	0.0763	0.1221	0.1577	0.1876	0.2315	0.2665	0.3040
2.9	0.0660	0.0528	0.0792	0.1267	0.1637	0.1947	0.2403	0.2766	0.3155
3.0	0.0684	0.0547	0.0821	0.1314	0.1697	0.2018	0.2490	0.2867	0.3270
3.1	0.0709	0.0567	0.0850	0.1360	0.1757	0.2090	0.2579	0.2969	0.3387
3.2	0.0733	0.0586	0.0879	0.1407	0.1818	0.2162	0.2668	0.3071	0.3503
3.3	0.0757	0.0606	0.0909	0.1454	0.1878	0.2234	0.2757	0.3173	0.3620
3.4	0.0782	0.0625	0.0938	0.1501	0.1939	0.2306	0.2846	0.3276	0.3737
3.5	0.0807	0.0645	0.0968	0.1548	0.2000	0.2379	0.2936	0.3379	0.3855
3.6	0.0831	0.0665	0.0997	0.1596	0.2061	0.2452	0.3026	0.3483	0.3973
3.7	0.0856	0.0685	0.1027	0.1644	0.2123	0.2525	0.3116	0.3587	0.4092
3.8	0.0881	0.0705	0.1057	0.1691	0.2185	0.2599	0.3206	0.3691	0.4211
3.9	0.0906	0.0725	0.1087	0.1739	0.2247	0.2672	0.3297	0.3796	0.4330
4.0	0.0931	0.0745	0.1117	0.1788	0.2309	0.2746	0.3389	0.3901	0.4450
4.1	0.0956	0.0765	0.1147	0.1836	0.2371	0.2821	0.3481	0.4006	0.4571
4.2	0.0982	0.0785	0.1178	0.1884	0.2434	0.2895	0.3573	0.4112	0.4692
4.3	0.1007	0.0806	0.1208	0.1933	0.2497	0.2970	0.3665	0.4219	0.4813
4.4	0.1032	0.0826	0.1239	0.1982	0.2560	0.3046	0.3758	0.4326	0.4935
4.5	0.1058	0.0846	0.1270	0.2031	0.2624	0.3121	0.3851	0.4433	0.5057
4.6	0.1084	0.0867	0.1300	0.2081	0.2687	0.3197	0.3944	0.4540	0.5180
4.7	0.1109	0.0888	0.1331	0.2130	0.2751	0.3273	0.4038	0.4648	0.5303
4.8	0.1135	0.0908	0.1362	0.2180	0.2815	0.3349	0.4132	0.4756	0.5426
4.9	0.1161	0.0929	0.1393	0.2230	0.2880	0.3426	0.4227	0.4865	0.5551
5.0	0.1187	0.0950	0.1425	0.2279	0.2944	0.3502	0.4321	0.4974	0.5675
5.1	0.1213	0.0971	0.1456	0.2330	0.3009	0.3580	0.4417	0.5084	0.5800
5.2	0.1240	0.0992	0.1488	0.2380	0.3074	0.3657	0.4512	0.5194	0.5925
5.3	0.1266	0.1013	0.1519	0.2431	0.3139	0.3734	0.4608	0.5304	0.6051
5.4	0.1292	0.1034	0.1551	0.2481	0.3205	0.3812	0.4704	0.5415	0.6177
5.5	0.1319	0.1055	0.1583	0.2532	0.3271	0.3890	0.4800	0.5526	0.6304
5.6	0.1345	0.1076	0.1614	0.2583	0.3337	0.3969	0.4897	0.5637	0.6431

5.7	0.1372	0.1098	0.1647	0.2634	0.3403	0.4048	0.4994	0.5749	0.6559
5.8	0.1399	0.1119	0.1679	0.2686	0.3469	0.4127	0.5092	0.5861	0.6687
5.9	0.1426	0.1141	0.1711	0.2738	0.3536	0.4206	0.5190	0.5974	0.6815
6.0	0.1453	0.1162	0.1743	0.2789	0.3603	0.4286	0.5288	0.6087	0.6944
6.1	0.1480	0.1184	0.1776	0.2842	0.3671	0.4366	0.5388	0.6202	0.7075
6.2	0.1508	0.1206	0.1809	0.2895	0.3740	0.4448	0.5489	0.6318	0.7208
6.3	0.1536	0.1229	0.1843	0.2949	0.3809	0.4531	0.5591	0.6436	0.7342
6.4	0.1565	0.1252	0.1877	0.3004	0.3880	0.4615	0.5695	0.6555	0.7478
6.5	0.1593	0.1275	0.1912	0.3059	0.3951	0.4700	0.5800	0.6676	0.7616
6.6	0.1623	0.1298	0.1947	0.3115	0.4024	0.4786	0.5906	0.6798	0.7756
6.7	0.1652	0.1322	0.1983	0.3172	0.4097	0.4874	0.6014	0.6923	0.7898
6.8	0.1682	0.1346	0.2019	0.3230	0.4172	0.4962	0.6123	0.7048	0.8040
6.9	0.1713	0.1370	0.2055	0.3288	0.4247	0.5052	0.6234	0.7175	0.8186
7.0	0.1743	0.1395	0.2092	0.3347	0.4323	0.5142	0.6345	0.7304	0.8332
7.1	0.1774	0.1419	0.2129	0.3407	0.4400	0.5234	0.6458	0.7434	0.8481
7.2	0.1806	0.1445	0.2167	0.3467	0.4478	0.5327	0.6573	0.7566	0.8632
7.3	0.1838	0.1470	0.2205	0.3528	0.4557	0.5421	0.6689	0.7700	0.8784
7.4	0.1870	0.1496	0.2244	0.3590	0.4637	0.5516	0.6806	0.7835	0.8938
7.5	0.1903	0.1522	0.2283	0.3653	0.4718	0.5612	0.6925	0.7971	0.9094
7.6	0.1936	0.1548	0.2323	0.3716	0.4800	0.5710	0.7045	0.8110	0.9252
7.7	0.1969	0.1575	0.2363	0.3780	0.4883	0.5808	0.7167	0.8250	0.9411
7.8	0.2003	0.1602	0.2403	0.3845	0.4966	0.5908	0.7289	0.8391	0.9572
7.9	0.2037	0.1629	0.2444	0.3910	0.5051	0.6008	0.7414	0.8534	0.9735
8.0	0.2071	0.1657	0.2485	0.3977	0.5137	0.6110	0.7539	0.8678	0.9900
8.1	0.2106	0.1685	0.2527	0.4044	0.5223	0.6213	0.7666	0.8825	1.0067
8.2	0.2141	0.1713	0.2570	0.4111	0.5310	0.6317	0.7794	0.8972	1.0235
8.3	0.2177	0.1742	0.2612	0.4180	0.5399	0.6422	0.7924	0.9121	1.0406
8.4	0.2213	0.1770	0.2655	0.4249	0.5488	0.6528	0.8055	0.9272	1.0578
8.5	0.2249	0.1799	0.2699	0.4319	0.5578	0.6635	0.8187	0.9425	1.0752
8.6	0.2286	0.1829	0.2743	0.4389	0.5669	0.6744	0.8321	0.9578	1.0927
8.7	0.2323	0.1858	0.2788	0.4460	0.5761	0.6853	0.8456	0.9734	1.1104
8.8	0.2361	0.1888	0.2833	0.4532	0.5854	0.6964	0.8593	0.9891	1.1284
8.9	0.2399	0.1919	0.2878	0.4605	0.5948	0.7076	0.8731	1.0050	1.1465
9.0	0.2437	0.1949	0.2924	0.4678	0.6043	0.7188	0.8870	1.0210	1.1647
9.1	0.2476	0.1981	0.2971	0.4754	0.6141	0.7304	0.9013	1.0375	1.1836
9.2	0.2516	0.2013	0.3020	0.4831	0.6241	0.7423	0.9160	1.0544	1.2028
9.3	0.2558	0.2046	0.3069	0.4911	0.6344	0.7546	0.9311	1.0718	1.2227
9.4	0.2600	0.2080	0.3120	0.4993	0.6449	0.7671	0.9465	1.0896	1.2430
9.5	0.2644	0.2115	0.3173	0.5076	0.6557	0.7800	0.9624	1.1078	1.2638
9.6	0.2689	0.2151	0.3226	0.5162	0.6668	0.7932	0.9787	1.1266	1.2852
9.7	0.2734	0.2188	0.3281	0.5250	0.6781	0.8066	0.9953	1.1457	1.3070
9.8	0.2781	0.2225	0.3337	0.5340	0.6897	0.8205	1.0124	1.1653	1.3294
9.9	0.2829	0.2263	0.3395	0.5432	0.7016	0.8346	1.0298	1.1854	1.3523
10.0	0.2878	0.2302	0.3454	0.5526	0.7137	0.8490	1.0476	1.2059	1.3757
10.1	0.2928	0.2342	0.3514	0.5622	0.7261	0.8638	1.0658	1.2268	1.3996
10.2	0.2979	0.2383	0.3575	0.5720	0.7388	0.8788	1.0844	1.2482	1.4240
10.3	0.3031	0.2425	0.3638	0.5820	0.7518	0.8942	1.1034	1.2701	1.4490
10.4	0.3085	0.2468	0.3701	0.5922	0.7650	0.9099	1.1228	1.2924	1.4744
10.5	0.3139	0.2511	0.3767	0.6026	0.7784	0.9259	1.1425	1.3152	1.5003
10.6	0.3196	0.2557	0.3836	0.6137	0.7927	0.9429	1.1635	1.3393	1.5279
10.7	0.3257	0.2606	0.3909	0.6254	0.8078	0.9609	1.1857	1.3649	1.5570
10.8	0.3322	0.2657	0.3986	0.6378	0.8238	0.9799	1.2091	1.3918	1.5878
10.9	0.3389	0.2711	0.4067	0.6507	0.8405	0.9998	1.2337	1.4201	1.6201
11.0	0.3460	0.2768	0.4152	0.6644	0.8582	1.0208	1.2595	1.4499	1.6540
11.1	0.3536	0.2829	0.4243	0.6789	0.8769	1.0431	1.2871	1.4815	1.6902
11.2	0.3616	0.2893	0.4339	0.6943	0.8968	1.0668	1.3163	1.5152	1.7285
11.3	0.3701	0.2961	0.4441	0.7106	0.9179	1.0919	1.3472	1.5508	1.7692
11.4	0.3791	0.3033	0.4549	0.7279	0.9401	1.1183	1.3799	1.5884	1.8121
11.5	0.3885	0.3108	0.4662	0.7459	0.9635	1.1461	1.4141	1.6278	1.8570
11.6	0.3996	0.3197	0.4796	0.7673	0.9911	1.1789	1.4547	1.6745	1.9103
11.7	0.4114	0.3291	0.4936	0.7898	1.0202	1.2135	1.4974	1.7236	1.9663
11.8	0.4274	0.3419	0.5129	0.8206	1.0600	1.2608	1.5557	1.7908	2.0430

11.9	0.4496	0.3597	0.5395	0.8632	1.1149	1.3262	1.6364	1.8837	2.1489
12.0	0.4875	0.3900	0.5850	0.9361	1.2091	1.4382	1.7746	2.0428	2.3304
12.1	0.5504	0.4403	0.6605	1.0568	1.3651	1.6238	2.0036	2.3063	2.6311
12.2	0.5726	0.4581	0.6871	1.0994	1.4200	1.6892	2.0843	2.3992	2.7370
12.3	0.5886	0.4709	0.7064	1.1302	1.4598	1.7365	2.1426	2.4664	2.8137
12.4	0.6004	0.4803	0.7204	1.1527	1.4889	1.7711	2.1853	2.5155	2.8697
12.5	0.6115	0.4892	0.7338	1.1741	1.5165	1.8039	2.2259	2.5622	2.9230
12.6	0.6209	0.4967	0.7451	1.1921	1.5399	1.8317	2.2601	2.6016	2.9679
12.7	0.6299	0.5039	0.7559	1.2094	1.5621	1.8581	2.2928	2.6392	3.0108
12.8	0.6384	0.5107	0.7661	1.2257	1.5832	1.8832	2.3237	2.6748	3.0515
12.9	0.6464	0.5171	0.7757	1.2411	1.6031	1.9069	2.3529	2.7085	3.0898
13.0	0.6540	0.5232	0.7848	1.2556	1.6218	1.9292	2.3805	2.7401	3.1260
13.1	0.6611	0.5289	0.7933	1.2693	1.6395	1.9502	2.4063	2.7699	3.1599
13.2	0.6678	0.5343	0.8014	1.2822	1.6562	1.9701	2.4309	2.7982	3.1922
13.3	0.6743	0.5394	0.8091	1.2946	1.6722	1.9891	2.4543	2.8251	3.2230
13.4	0.6804	0.5443	0.8164	1.3063	1.6873	2.0071	2.4765	2.8507	3.2521
13.5	0.6861	0.5489	0.8233	1.3174	1.7016	2.0241	2.4975	2.8748	3.2797
13.6	0.6916	0.5532	0.8299	1.3278	1.7150	2.0401	2.5172	2.8976	3.3056
13.7	0.6969	0.5575	0.8362	1.3380	1.7282	2.0558	2.5366	2.9199	3.3310
13.8	0.7021	0.5617	0.8425	1.3480	1.7412	2.0712	2.5556	2.9418	3.3560
13.9	0.7072	0.5658	0.8486	1.3578	1.7539	2.0862	2.5742	2.9632	3.3804
14.0	0.7122	0.5698	0.8546	1.3674	1.7663	2.1010	2.5924	2.9841	3.4043
14.1	0.7171	0.5737	0.8605	1.3768	1.7784	2.1154	2.6102	3.0046	3.4277
14.2	0.7219	0.5775	0.8663	1.3860	1.7903	2.1295	2.6276	3.0247	3.4506
14.3	0.7266	0.5812	0.8719	1.3950	1.8019	2.1434	2.6447	3.0443	3.4730
14.4	0.7311	0.5849	0.8774	1.4038	1.8132	2.1568	2.6613	3.0634	3.4948
14.5	0.7356	0.5885	0.8827	1.4124	1.8243	2.1700	2.6776	3.0822	3.5162
14.6	0.7400	0.5920	0.8880	1.4207	1.8351	2.1829	2.6935	3.1004	3.5370
14.7	0.7442	0.5954	0.8931	1.4289	1.8456	2.1954	2.7089	3.1182	3.5573
14.8	0.7484	0.5987	0.8980	1.4369	1.8559	2.2077	2.7240	3.1356	3.5772
14.9	0.7524	0.6019	0.9029	1.4446	1.8659	2.2196	2.7387	3.1525	3.5964
15.0	0.7563	0.6051	0.9076	1.4522	1.8757	2.2312	2.7530	3.1690	3.6153
15.1	0.7602	0.6081	0.9122	1.4595	1.8852	2.2424	2.7669	3.1850	3.6335
15.2	0.7639	0.6112	0.9167	1.4668	1.8946	2.2536	2.7807	3.2009	3.6516
15.3	0.7677	0.6142	0.9212	1.4740	1.9039	2.2647	2.7944	3.2166	3.6696
15.4	0.7714	0.6171	0.9257	1.4811	1.9131	2.2756	2.8079	3.2322	3.6873
15.5	0.7751	0.6201	0.9301	1.4881	1.9222	2.2865	2.8213	3.2475	3.7048
15.6	0.7787	0.6230	0.9345	1.4951	1.9312	2.2972	2.8345	3.2628	3.7222
15.7	0.7823	0.6258	0.9388	1.5020	1.9401	2.3078	2.8476	3.2779	3.7394
15.8	0.7859	0.6287	0.9430	1.5089	1.9490	2.3183	2.8606	3.2928	3.7565
15.9	0.7894	0.6315	0.9473	1.5156	1.9577	2.3287	2.8734	3.3075	3.7733
16.0	0.7929	0.6343	0.9515	1.5223	1.9663	2.3390	2.8861	3.3222	3.7900
16.1	0.7963	0.6371	0.9556	1.5290	1.9749	2.3492	2.8986	3.3366	3.8065
16.2	0.7997	0.6398	0.9597	1.5355	1.9834	2.3592	2.9111	3.3509	3.8228
16.3	0.8031	0.6425	0.9637	1.5420	1.9917	2.3692	2.9233	3.3650	3.8389
16.4	0.8065	0.6452	0.9677	1.5484	2.0000	2.3790	2.9355	3.3790	3.8548
16.5	0.8098	0.6478	0.9717	1.5547	2.0082	2.3888	2.9475	3.3929	3.8706
16.6	0.8130	0.6504	0.9756	1.5610	2.0163	2.3984	2.9594	3.4065	3.8862
16.7	0.8162	0.6530	0.9795	1.5672	2.0243	2.4079	2.9711	3.4200	3.9016
16.8	0.8194	0.6555	0.9833	1.5733	2.0322	2.4173	2.9827	3.4334	3.9168
16.9	0.8226	0.6581	0.9871	1.5793	2.0400	2.4266	2.9942	3.4466	3.9319
17.0	0.8257	0.6605	0.9908	1.5853	2.0477	2.4358	3.0055	3.4596	3.9468
17.1	0.8288	0.6630	0.9945	1.5912	2.0553	2.4448	3.0167	3.4725	3.9614
17.2	0.8318	0.6654	0.9981	1.5970	2.0628	2.4538	3.0277	3.4852	3.9760
17.3	0.8348	0.6678	1.0017	1.6028	2.0703	2.4626	3.0386	3.4977	3.9902
17.4	0.8378	0.6702	1.0053	1.6085	2.0776	2.4714	3.0494	3.5102	4.0044
17.5	0.8407	0.6725	1.0088	1.6141	2.0849	2.4800	3.0600	3.5224	4.0184
17.6	0.8436	0.6748	1.0123	1.6196	2.0920	2.4885	3.0705	3.5345	4.0322
17.7	0.8464	0.6771	1.0157	1.6251	2.0991	2.4969	3.0809	3.5464	4.0458
17.8	0.8492	0.6794	1.0191	1.6305	2.1060	2.5052	3.0911	3.5582	4.0592
17.9	0.8520	0.6816	1.0224	1.6358	2.1129	2.5134	3.1012	3.5698	4.0725
18.0	0.8547	0.6838	1.0257	1.6411	2.1197	2.5214	3.1112	3.5813	4.0856

18.1	0.8574	0.6859	1.0289	1.6462	2.1264	2.5294	3.1210	3.5926	4.0985
18.2	0.8601	0.6881	1.0321	1.6514	2.1331	2.5373	3.1308	3.6039	4.1113
18.3	0.8628	0.6902	1.0353	1.6566	2.1397	2.5452	3.1406	3.6151	4.1241
18.4	0.8655	0.6924	1.0386	1.6617	2.1463	2.5531	3.1503	3.6263	4.1369
18.5	0.8681	0.6945	1.0417	1.6668	2.1529	2.5610	3.1600	3.6374	4.1496
18.6	0.8708	0.6966	1.0449	1.6719	2.1595	2.5688	3.1696	3.6485	4.1623
18.7	0.8734	0.6987	1.0481	1.6769	2.1661	2.5766	3.1792	3.6596	4.1749
18.8	0.8760	0.7008	1.0512	1.6820	2.1726	2.5843	3.1888	3.6706	4.1875
18.9	0.8787	0.7029	1.0544	1.6870	2.1791	2.5920	3.1983	3.6816	4.2000
19.0	0.8813	0.7050	1.0575	1.6921	2.1856	2.5998	3.2079	3.6926	4.2125
19.1	0.8839	0.7071	1.0607	1.6970	2.1920	2.6074	3.2173	3.7035	4.2249
19.2	0.8865	0.7092	1.0638	1.7020	2.1985	2.6151	3.2268	3.7144	4.2374
19.3	0.8891	0.7112	1.0669	1.7070	2.2049	2.6227	3.2362	3.7252	4.2497
19.4	0.8916	0.7133	1.0700	1.7119	2.2113	2.6303	3.2456	3.7360	4.2620
19.5	0.8942	0.7154	1.0730	1.7169	2.2176	2.6379	3.2549	3.7467	4.2743
19.6	0.8968	0.7174	1.0761	1.7218	2.2240	2.6454	3.2642	3.7574	4.2865
19.7	0.8993	0.7194	1.0792	1.7267	2.2303	2.6530	3.2735	3.7681	4.2987
19.8	0.9019	0.7215	1.0822	1.7316	2.2366	2.6605	3.2827	3.7788	4.3108
19.9	0.9044	0.7235	1.0853	1.7364	2.2429	2.6679	3.2919	3.7894	4.3229
20.0	0.9069	0.7255	1.0883	1.7412	2.2491	2.6754	3.3011	3.7999	4.3350
20.1	0.9094	0.7275	1.0913	1.7461	2.2553	2.6828	3.3103	3.8104	4.3470
20.2	0.9119	0.7295	1.0943	1.7509	2.2615	2.6901	3.3194	3.8209	4.3589
20.3	0.9144	0.7315	1.0973	1.7556	2.2677	2.6975	3.3284	3.8313	4.3708
20.4	0.9169	0.7335	1.1003	1.7604	2.2739	2.7048	3.3374	3.8417	4.3827
20.5	0.9194	0.7355	1.1032	1.7652	2.2800	2.7121	3.3464	3.8521	4.3945
20.6	0.9218	0.7375	1.1062	1.7699	2.2861	2.7194	3.3554	3.8624	4.4063
20.7	0.9243	0.7394	1.1091	1.7746	2.2922	2.7266	3.3643	3.8727	4.4180
20.8	0.9267	0.7414	1.1121	1.7793	2.2982	2.7338	3.3732	3.8829	4.4297
20.9	0.9292	0.7433	1.1150	1.7840	2.3043	2.7410	3.3821	3.8931	4.4413
21.0	0.9316	0.7453	1.1179	1.7886	2.3103	2.7482	3.3910	3.9033	4.4530
21.1	0.9340	0.7472	1.1208	1.7933	2.3163	2.7553	3.3997	3.9134	4.4645
21.2	0.9364	0.7491	1.1237	1.7979	2.3223	2.7624	3.4085	3.9235	4.4760
21.3	0.9388	0.7510	1.1266	1.8025	2.3282	2.7695	3.4172	3.9336	4.4875
21.4	0.9412	0.7529	1.1294	1.8071	2.3341	2.7765	3.4259	3.9435	4.4988
21.5	0.9436	0.7548	1.1323	1.8116	2.3400	2.7835	3.4346	3.9535	4.5102
21.6	0.9459	0.7567	1.1351	1.8162	2.3459	2.7905	3.4432	3.9634	4.5215
21.7	0.9483	0.7586	1.1379	1.8207	2.3518	2.7975	3.4518	3.9733	4.5328
21.8	0.9506	0.7605	1.1408	1.8252	2.3576	2.8044	3.4603	3.9832	4.5441
21.9	0.9530	0.7624	1.1436	1.8297	2.3634	2.8113	3.4688	3.9930	4.5552
22.0	0.9553	0.7643	1.1464	1.8342	2.3692	2.8182	3.4774	4.0028	4.5664
22.1	0.9576	0.7661	1.1492	1.8387	2.3749	2.8250	3.4858	4.0125	4.5775
22.2	0.9600	0.7680	1.1519	1.8431	2.3807	2.8319	3.4942	4.0222	4.5886
22.3	0.9623	0.7698	1.1547	1.8475	2.3864	2.8387	3.5026	4.0319	4.5996
22.4	0.9646	0.7716	1.1575	1.8519	2.3921	2.8454	3.5110	4.0415	4.6105
22.5	0.9668	0.7735	1.1602	1.8563	2.3978	2.8522	3.5193	4.0511	4.6215
22.6	0.9691	0.7753	1.1629	1.8607	2.4034	2.8589	3.5276	4.0606	4.6323
22.7	0.9714	0.7771	1.1657	1.8650	2.4090	2.8656	3.5358	4.0701	4.6432
22.8	0.9736	0.7789	1.1684	1.8694	2.4146	2.8722	3.5440	4.0795	4.6540
22.9	0.9759	0.7807	1.1711	1.8737	2.4202	2.8788	3.5522	4.0889	4.6647
23.0	0.9781	0.7825	1.1737	1.8780	2.4257	2.8855	3.5604	4.0983	4.6754
23.1	0.9804	0.7843	1.1764	1.8823	2.4313	2.8920	3.5685	4.1077	4.6861
23.2	0.9826	0.7861	1.1791	1.8865	2.4368	2.8986	3.5766	4.1170	4.6967
23.3	0.9848	0.7878	1.1817	1.8908	2.4423	2.9051	3.5846	4.1262	4.7072
23.4	0.9870	0.7896	1.1844	1.8950	2.4477	2.9116	3.5926	4.1354	4.7178
23.5	0.9892	0.7913	1.1870	1.8992	2.4531	2.9181	3.6006	4.1446	4.7282
23.6	0.9914	0.7931	1.1896	1.9034	2.4585	2.9245	3.6085	4.1538	4.7387
23.7	0.9935	0.7948	1.1922	1.9076	2.4639	2.9309	3.6164	4.1628	4.7490
23.8	0.9957	0.7965	1.1948	1.9117	2.4693	2.9373	3.6243	4.1719	4.7594
23.9	0.9978	0.7983	1.1974	1.9159	2.4746	2.9436	3.6321	4.1809	4.7697
24.0	1.0000	0.8000	1.2000	1.9200	2.4800	2.9500	3.6400	4.1900	4.7800

NRCS/NOAA Atlas 14 Rainfall Distribution for California - Region 5

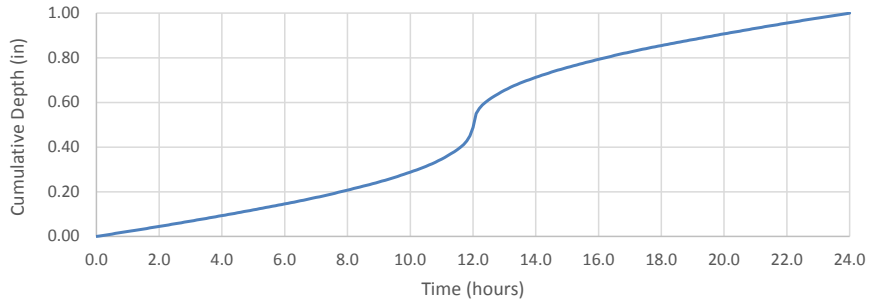

NOAA Atlas 14 Rainfall for Campus Town Applied to Region CA-5 Rainfall Distribution (100-Year Storm)

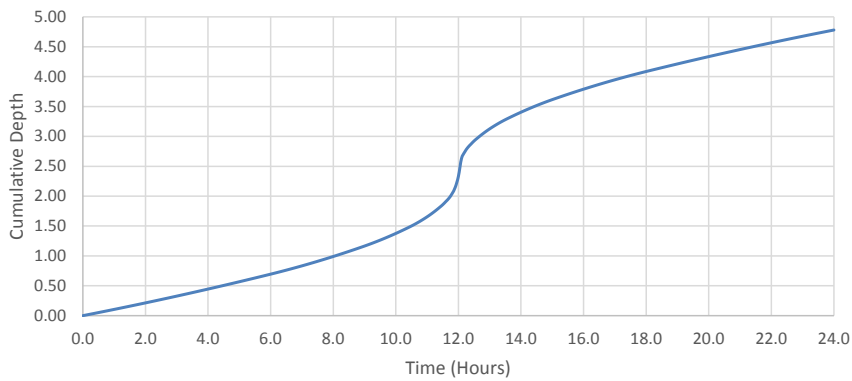

Appendix D

Preliminary *CivilStorm* Model Hydrographs

Basin W-1 100-year 24-hour Storm

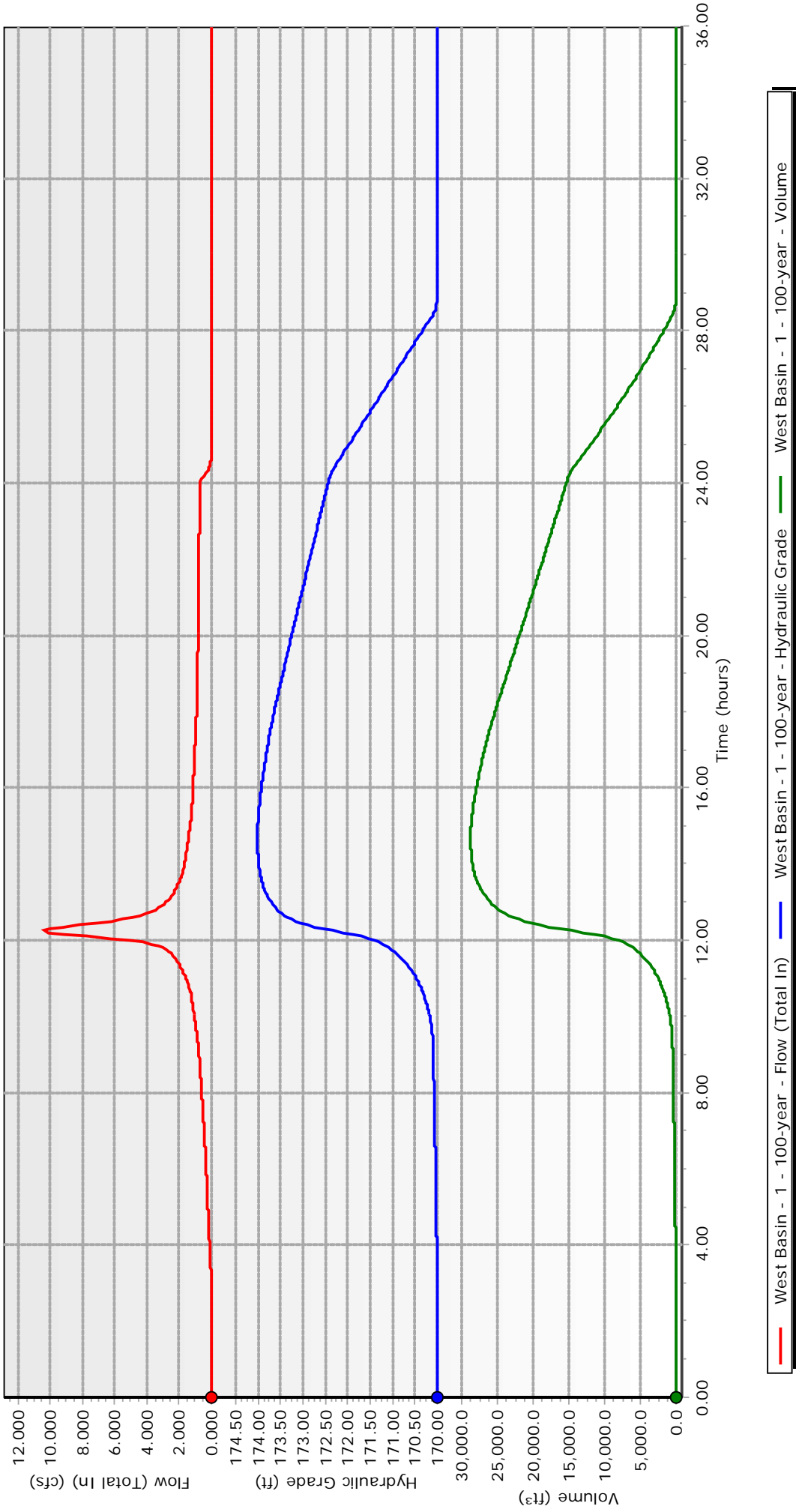

Basin W-2 100-year 24-hour Storm

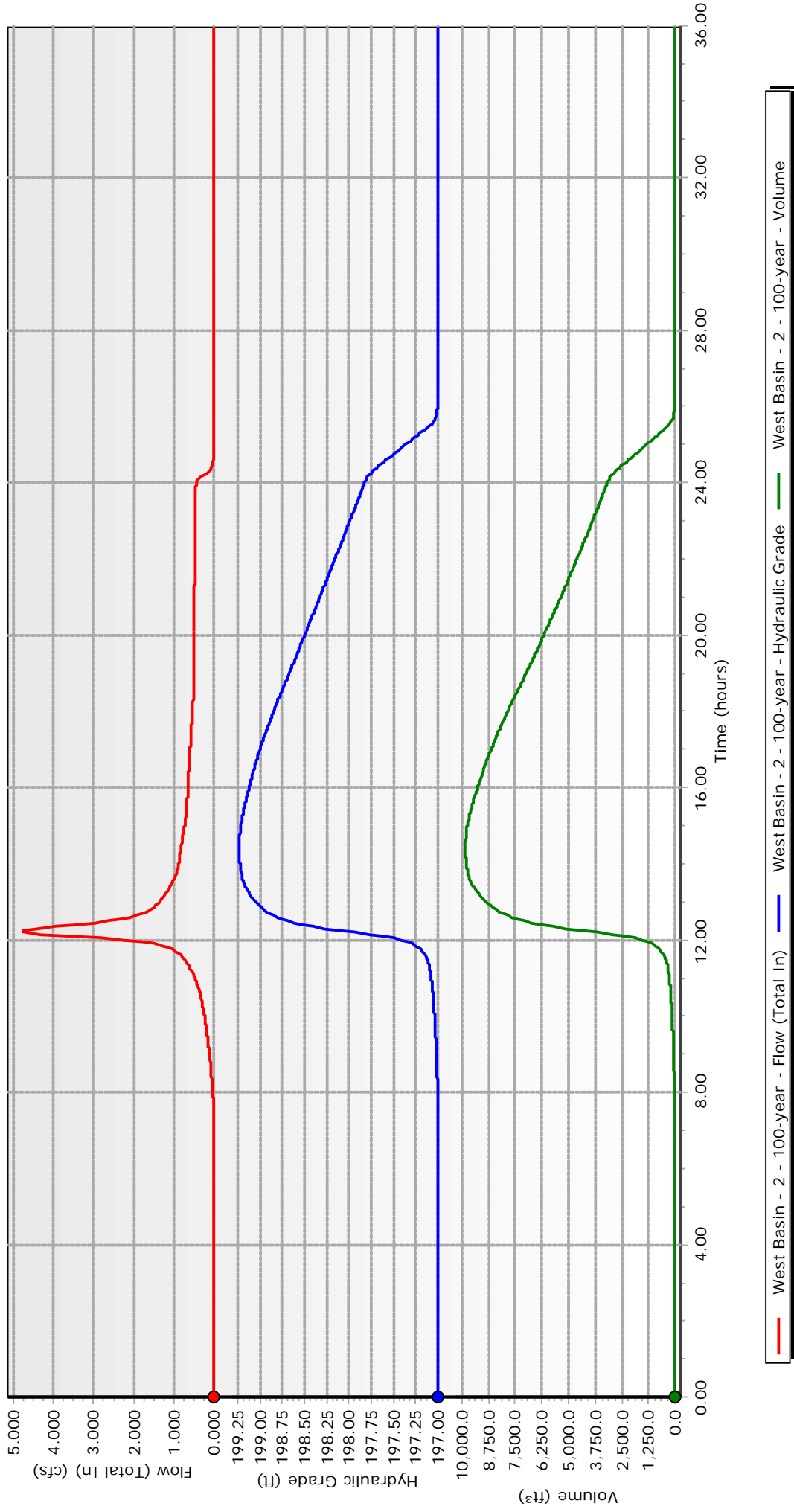

Basin E-1 100-year 24-hour Storm

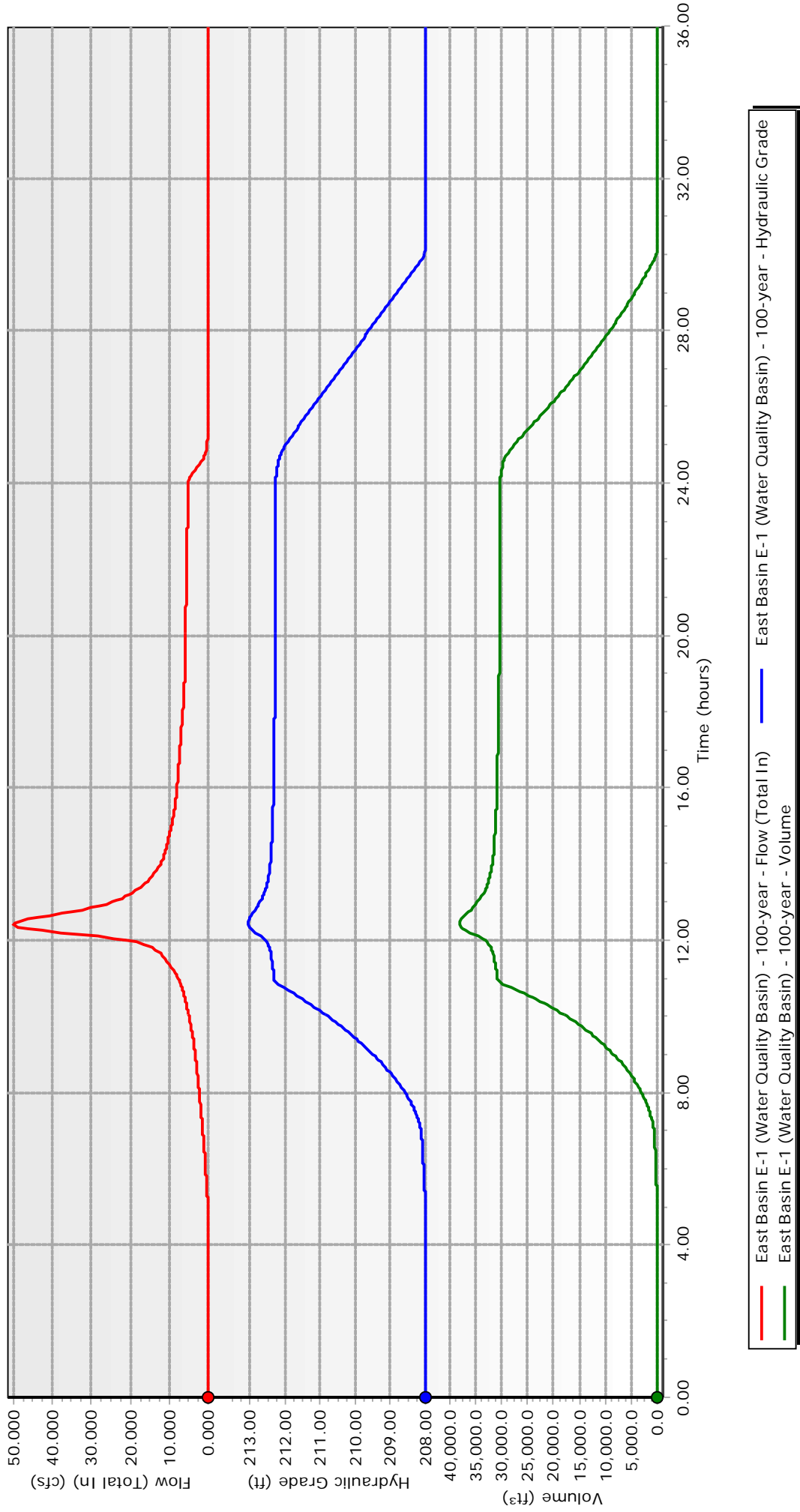

Basin E-2 100-year 24-hour Storm

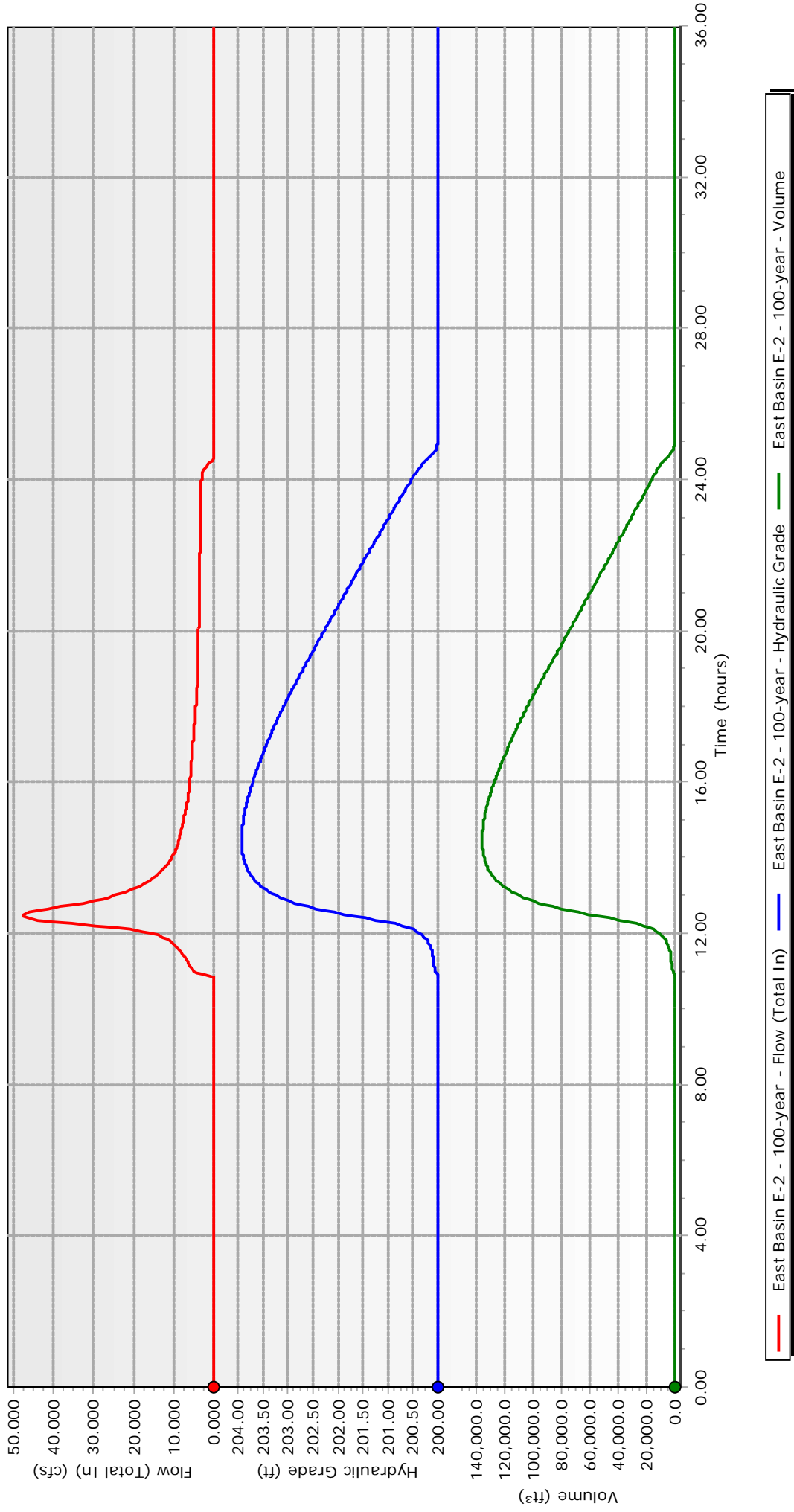

Appendix E

FORA Stormwater Master Plan Design Manual

FORT ORD REUSE AUTHORITY



STORM WATER MASTER PLAN

MARCH 2005



Consulting Civil and Structural Engineers

Appendix D
Storm Water Design Manual

STORM WATER DESIGN MANUAL

This design manual has been developed to provide design standards and typical designs for storm water infiltration systems in the Fort Ord Reuse Authority (FORA) area. Standards and designs for both infiltration basins and subsurface infiltration systems are included in the Manual. The Manual also includes a list of Best Management Practices (BMP's) to be used by developers within the FORA area.

Storm water infiltration systems shall be designed to both store and infiltrate the 100-year, 24-hour storm from the upstream drainage area. Designers shall consider both the protection of property on the land surface and the protection of underground water quality. To protect groundwater from possible contamination, runoff from designated hot spot land uses shall be treated to remove hydrocarbons, trace metals or toxicants as required. Also, no infiltration facility shall be located within 100 feet of a water supply well.

Designers may use both structural and non-structural methods to reduce the runoff from a redeveloped area. Examples of these methods are grassed surfaces, porous pavements, grass-paved surfaces, and dry wells for roof runoff. Design standards for runoff reducing methods will not be addressed in this Storm water Design Manual. However, designers who can verify the effectiveness of these methods may reduce downstream infiltration systems proportionately.

Part 1. Measurement of Infiltration Rates

Infiltration rates shall be measured in situ according to the standards presented in:

- *Annual Book of ASTM Standards*, 1997. Section 4, Vol. 4.08, Soil and Rock (I): Designation D 3385-94, Standard Test Method for Infiltration Rate of Soils in Field Using a Double-Ring Infiltrometer, pp. 331-337.
- *Annual Book of ASTM Standards*, 1998. Section 4, Vol. 4.09, Soil and Rock (II): Designation D 5093-90, Standard Test Method for Field Measurement and Infiltration Rate Using a Double-Ring Infiltrometer with a Sealed-Inner Ring, pp. 87-92.
- Johnson, A.I., 1963, "A field method for measurement of infiltration," United States Geological Survey, Water-Supply Paper, W 1544-F, p. F1-F27.

Alternative methods other than the referenced standards shall use a double-ring apparatus and be acceptable to the local political jurisdiction. The minimum infiltration testing is one infiltration test per 5000 square feet with a minimum of two tests per facility. All tests shall be made within the proposed limits of the facility at the elevation of the proposed infiltration surface. The design infiltration rate shall be no more than 60 percent of the measured infiltration rate for basins and 40% for subsurface systems.

Part 2. Infiltration Basin Design Standards and Standard Plan

Infiltration basins are to be designed to meet the following criteria.

- The basin area is to be 1000 sq-ft per acre of impermeable surface area. Both the basin bottom and the wetted sloping area of the basin up to the design depth are included in this area.
- The design depth of the basin is to be 4 feet with one foot of additional freeboard.
- The 1000-sq-ft area and 4-foot depth requirements provide a storage capacity of 4000 cu-ft per acre of impermeable surface area.
- Basin slopes shall be 3 horizontal to 1 vertical or flatter.
- The depth of excavation shall be a minimum of 5 feet below natural grade.
- The design criterion is based on a design infiltration rate of 12 in/hr. If the design infiltration rate is less than 12 in/hr, the basin area shall be increased proportionately.
- If the basin area is increased because the infiltration rate is less than 6 in/hr, the storage capacity shall continue to be 4000 cu-ft per acre of impermeable surface area.
- All infiltration basins shall be designed to be fully dewatered within 48 hours of the storm event.

Infiltration basins shall be installed in accordance with the Infiltration Basin Detail (Standard Plan) illustrated in Figure D-1. Construction activities shall leave the basin surface uncompacted, and upon completion, the basin surface shall have the same infiltration rate as the undisturbed soil. Before acceptance of the finished basin, all silt and foreign material shall be removed from the basin bottom.

Pretreatment of storm water before it enters an infiltration basin is desirable. The minimum recommended treatment is a stilling basin to allow the larger suspended particles to settle. Flow through a grass filter strip to allow additional settling of suspended solids is also recommended. If a grass filter strip is utilized, it must be equipped with a sprinkler irrigation system to maintain the grass during the dry season. The length of operating time before an infiltration basin must be cleaned is inversely proportional to the amount of suspended solids removed from the storm runoff through pretreatment.

Part 3. Subsurface Infiltration System Designs and Standard Plans

Subsurface infiltration systems may be either of the infiltration chamber type or the infiltration pipe type. Infiltration chambers are designed with a large open bottom area and provide a large storage volume below the ground surface. Infiltration pipes are made of large diameter perforated pipe that requires a large trench bottom area and provides a large storage volume. Because of the large volume of storage required, subsurface infiltration systems consisting of trenches or boreholes filled with gravel or crushed rock are not recommended.

Subsurface infiltration systems are to be designed with the same infiltration area, storage volume and infiltration rate as the infiltration basins. The infiltration area of infiltration chambers is to be the bottom area of the chamber, and the infiltration area for infiltration pipes is to be the bottom of area of the excavated trench. To meet the storage requirement, each acre of impervious area will require 4000 cu-ft (29,900 gal) of storage capacity. This storage volume is equivalent to an

infiltration basin area of 1000 square feet covered to a depth of 4 feet. Storage capacity may be provided upstream of a subsurface infiltration system to reduce the storage capacity required by infiltration chambers or pipes. Infiltration rates shall be measured in the same manner as for infiltration basins. Subsurface infiltration systems are to be suitable for use under either a native soil surface cover or an impervious surface cover. The systems shall have load ratings of H-20 under traffic areas and H-10 under non-traffic areas.

Infiltration chambers shall be installed in accordance with the Infiltration Chamber Detail (Standard Plan) illustrated in Figure D-2. Both concrete and high-density polyethylene (HDPE) are acceptable materials for the chambers. Infiltration chambers can be installed in any desired length, and multiple rows of chambers can be connected together with manifolds.

Infiltration pipes shall be installed in accordance with the Infiltration Pipe Detail (Standard Plan) illustrated in Figure D-3. To meet the storage requirement of 4000 cu-ft per acre of impervious surface only large-diameter perforated pipe is recommended for the infiltration pipes. The storage capacity of the surrounding crushed rock filter is not to be used to satisfy the storage requirement.

Since maintenance of a subsurface infiltration area is not feasible, a pretreatment device must be installed upstream of all subsurface systems. This device is to remove floating and suspended materials that are likely to seal the infiltration surface or to contaminate groundwater. The minimum treatment shall be an oil-sediment separator to remove floating oil and settleable sediment. In addition, filtration to remove silt-size and finer particles is highly recommended. These pretreatment devices should be compact systems that are suitable for underground operation and maintenance. Pretreatment devices must be maintained to continually provide the capacity to remove floating and suspended sediment.

Part 4. Best Management Practices

Best Management Practices (BMP's) are practices designed to reduce the discharge of pollutants from municipal separate storm sewer systems (MS4s). The BMP's were developed by the EPA office of Wastewater Management to provide guidelines for developing and implementing storm water management programs. They are designed to reduce both the volume of storm runoff and the concentration of pollutants in the runoff.

BMP's are based on the National Pollution Discharge Elimination System (NPDES) Phase II's six minimum control measures. The six measures are:

1. Public education and outreach on storm water impact projects.
2. Public involvement/participation.
3. Illicit discharge detection and elimination.
4. Construction site storm water runoff control.
5. Post-construction storm water management in new development and redevelopment.
6. Pollution prevention/good housekeeping for municipal operations.

The main emphasis for both new development and redevelopment will be on control of storm water runoff from construction sites and post-construction storm water management.

Appendix F

Infiltration Test Results

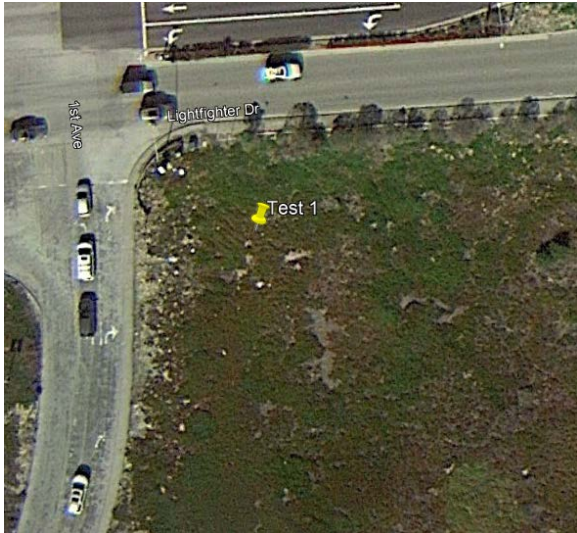

Test 1 – SE Corner Lightfighter Dr. & 1ST Street

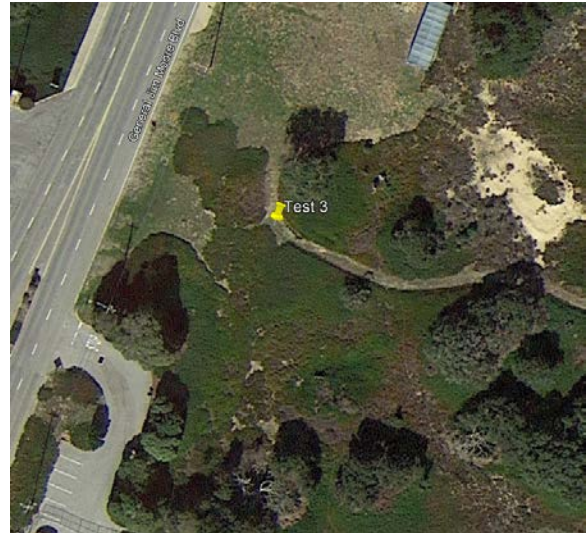

Test 3 – East of Gen. Jim Moore Blvd. and North of Gigling Rd.



Test 2 – SE Corner Lightfighter Dr. & Gen. Jim Moore Blvd.

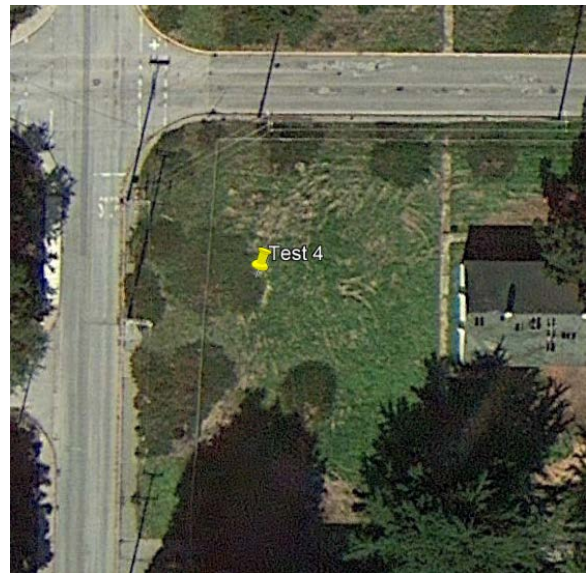

Test 4 – SW Corner Colonel; Durham St. and 6TH Ave.

INFILTRATION TEST SITES
SURPLUS II – SEASIDE
CAMPUS TOWN

