

**GEOTECHNICAL INVESTIGATION
PROPOSED MERCADO APARTMENTS
RESIDENTIAL DEVELOPMENT
MAIN ST AND SOUTH EVANS ST
SAN DIEGO, CALIFORNIA 92111**

Prepared For **MAAC REAL ESTATE DEVELOPMENT**
1355 THIRD AVENUE, CA
CHULA VISTA, CALIFORNIA 91911

Prepared By **LEIGHTON AND ASSOCIATES, INC.**
3934 MURPHY CANYON RD, STE B-205
SAN DIEGO, CA 92123

Project Number 13324.001

December 9, 2021

December 9, 2021

Project No. 13324.001

MAAC Real Estate Development
1355 Third Avenue, CA
Chula Vista, California 91911

Attention: Ms. Thea-Marie Sauca

Subject: Geotechnical Investigation
Proposed Mercado Apartments
Residential Development
Main Street and South Evans Street
San Diego, California 92111

In accordance with your request and authorization, Leighton and Associates, Inc. (Leighton) has conducted a geotechnical investigation for the proposed Mercado Residential development located on Main Street and South Evans Street in San Diego, California. Based on the results of our study, it is our professional opinion that the site is suitable for development of such a project. The accompanying geotechnical report presents a summary of our current investigation and provides geotechnical conclusions and recommendations.

If you have any questions regarding our report, please do not hesitate to contact this office. We appreciate this opportunity to be of service.

Respectfully submitted,

LEIGHTON AND ASSOCIATES, INC.



Mike D. Jensen, CEG 2457
Associate Engineering Geologist
mjensen@leightongroup.com





William D. Olson, RCE 45283
Associate Engineer
dolson@leightongroup.com

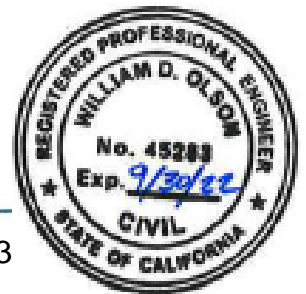

Distribution: (1) Digital Copy

TABLE OF CONTENTS

<u>Sections</u>	<u>Page</u>
1.0 INTRODUCTION	1
1.1 Purpose and Scope of Services	1
1.2 Site Description	1
1.3 Proposed Development	2
2.0 SUBSURFACE EXPLORATION AND LABORATORY TESTING	3
2.1 Site Investigation	3
2.2 Laboratory Testing	3
3.0 SUMMARY OF GEOTECHNICAL CONDITIONS	4
3.1 Geologic Setting	4
3.2 Site Specific Geology	4
3.2.1 Undocumented Artificial Fill (Afu)	4
3.2.2 Quaternary-aged Old Paralic Deposits (Qop)	4
3.3 Surface and Groundwater	5
3.4 Engineering Characteristics of On-site Soils	5
3.4.1 Compressible Soils	5
3.4.2 Expansion Potential	5
3.4.3 Soil Corrosivity	5
3.4.4 Excavation Characteristics	6
3.4.5 Infiltration	6
4.0 SEISMICITY	7
4.1 Regional Tectonic Setting	7
4.2 Local Faulting	7
4.3 Seismicity	7
4.4 Seismic Hazards	8
4.4.1 Shallow Ground Rupture	8
4.4.2 Mapped Fault Zones	8
4.4.3 Site Class	8
4.4.4 Building Code Mapped Spectral Acceleration Parameters	8
4.5 Secondary Seismic Hazards	9
4.5.1 Liquefaction and Dynamic Settlement	9
4.5.2 Lateral Spread	10
4.5.3 Tsunamis and Seiches	10
4.6 Landslides	10
4.7 Flood Hazard	11
5.0 CONCLUSIONS	12
6.0 RECOMMENDATIONS	14
6.1 Earthwork	14

6.2 Site Preparation 14

6.3 Removal and Recompaction 14

6.4 Excavations..... 15

6.5 Structural Fills 15

6.6 Foundation and Slab Considerations 16

 6.6.1 Foundation and Slab Design 16

 6.6.2 Settlement 17

 6.6.3 Foundation Setback 17

 6.6.4 Lateral Resistance and Retaining Wall Design Pressures 18

6.7 Preliminary Pavement Design..... 20

6.8 Geochemical Considerations 22

6.9 Infiltration Best Management Practices..... 22

6.10 Control of Groundwater and Surface Water 22

7.0 LIMITATIONS..... 24

LIST OF TABLES

Table 1. CBC Mapped Spectral Acceleration Parameters..... 9

Table 2. Maximum Slope Ratios 15

Table 3. Allowable Bearing Values for Conventional Footings **Error! Bookmark not defined.**

Table 4. Minimum Foundation Setback from Slope Faces 18

Table 5. Static Equivalent Fluid Weight (pcf)..... 19

Table 6. Preliminary Pavement Sections..... 20

Figures

- Figure 1 - Site Location Map - Rear of Text
- Figure 2 - Geotechnical Map - Rear of Text

Appendices

- Appendix A - References
- Appendix B - Boring Logs
- Appendix C - Laboratory Testing Procedures and Test Results
- Appendix D - General Earthwork and Grading Specifications For Rough Grading

1.0 INTRODUCTION

We recommend that all individuals utilizing this report read the preceding information sheet prepared by the Geoprofessional Business Association (GBA) and the Limitations, Section 7.0, located at the end of this report.

1.1 Purpose and Scope of Services

This report presents the results of our geotechnical investigation for the proposed Mercado Residential development located on Main Street and South Evans Street in San Diego, California (Figure 1). Our investigation included geotechnical exploration and laboratory testing of selected soil samples. The purpose of the geotechnical investigation was to evaluate existing geotechnical conditions and potential geologic hazards present at the site, and provide specific geotechnical conclusions and recommendations for the currently proposed residential development.

The scope of services for our preliminary geotechnical investigation included:

- Coordination with DigAlert to locate potential underground utilities on site.
- Review of pertinent available geotechnical literature, geologic maps, and aerial photographs (Appendix A).
- A subsurface exploration program consisting of four (4) geotechnical borings to depths of 26.5 to 51.5 feet below the existing ground surface (bgs). The borings were excavated to provide soil thickness, type, and distribution across the subject site. Logs of the geotechnical borings are presented in Appendix B.
- Laboratory testing of representative soil samples obtained from the subsurface exploration. Laboratory test results are included in Appendix C.
- Evaluation of site seismicity.
- Compilation and analysis of the geotechnical data obtained from the field investigation and laboratory testing
- Preparation of this geotechnical report presenting the findings of our study and providing conclusions and recommendations relative to the currently proposed development.

1.2 Site Description

The project site is a developed square shaped parcel, which encompasses approximately 1 acre and is currently occupied by an existing paved parking area with associated improvements and landscaping. In general, the property is bound by existing residential development to the north and west, Main Street to the southwest, and South Evans Street

to the southeast. Currently, the site topography is relatively flat, with the ground surface varying from 37 to 41 feet above mean sea level (msl).

Site Latitude and Longitude

32.697355° N

117.143261° W

1.3 Proposed Development

Based on preliminary site plans (Martinez and Cutri, 2021), we understand the project will consist of construction of 92 units, a courtyard, play yard, landscaping with associated improvements. We anticipate site grading will be minor with cuts and fills of 1 to 3 feet. Two of the existing apartment buildings adjacent to Main Street will be demolished to make room for the new residential building. We anticipate the new buildings will be one- to two-story, wood-framed structures with conventional foundations slab on grade floors. Foundation and Civil plans were not available at the time of preparing this report.

2.0 SUBSURFACE EXPLORATION AND LABORATORY TESTING

2.1 Site Investigation

Prior to the subsurface exploration, we marked the proposed locations and notified DigAlert to identify buried utilities. Our subsurface investigation consisted of the excavation, logging and sampling of four (4) 8-inch small diameter hollow-stem augur (HSA) boring (B-1) was drilled to approximately 26.5-51.5 feet below the existing ground surface (bgs). The purpose of our subsurface exploration was to evaluate the underlying stratigraphy, physical characteristics, and specific engineering properties of the soils beneath the site. The geotechnical borings were drilled using a heavy-duty truck-mounted drill rig.

The exploratory excavations were logged by a geologist from our firm. Representative bulk and relatively undisturbed samples were obtained at frequent intervals for laboratory testing. Subsequent to logging and sampling, the boring excavations were backfilled. The approximate locations of the geotechnical borings are shown on the Geotechnical Map (Figure 2) and the logs are presented in Appendix B.

2.2 Laboratory Testing

Laboratory testing performed on representative soil samples obtained during the subsurface explorations included expansion potential, direct shear, moisture & density, and geochemical characteristics of the subsurface soils. A discussion of the laboratory tests performed and a summary of the laboratory test results are presented in Appendix C.

3.0 SUMMARY OF GEOTECHNICAL CONDITIONS

3.1 Geologic Setting

The project area is situated in the Peninsular Ranges Geomorphic Province. This geomorphic province encompasses an area that extends approximately 900 miles from the Transverse Ranges and the Los Angeles Basin south to the southern tip of Baja California and varies in width from approximately 30 to 100 miles (Norris and Webb, 1990). The province is characterized by mountainous terrain on the east composed mostly of Mesozoic igneous and metamorphic rocks, and relatively low-lying coastal terraces to the west underlain by late Cretaceous-age, Tertiary-age, and Quaternary-age sedimentary units. Most of the coastal region of the County of San Diego, including the site, occur within this coastal region and are underlain by sedimentary units. Specifically, the site is located within the coastal plain section of the Peninsular Range Geomorphic Province of California, which generally consists of subdued landforms underlain by sedimentary bedrock.

3.2 Site Specific Geology

Based on our subsurface exploration and review of pertinent geologic literature and maps (Appendix A), the site is underlain by undocumented artificial fill and Quaternary-aged Old Paralic Deposits. A brief description of the geologic units encountered on the site is presented below. The approximate aerial distributions of those units are shown on the Geotechnical Map (Figure 2).

3.2.1 Undocumented Artificial Fill (Afu)

The undocumented artificial fill soils were encountered in all four soil borings and appear to be associated with previous site grading. As encountered, the material consists of medium dense to dense, light brown to dark and reddish-brown, dry to damp, silty sand. The majority of the fill also had few to some gravel, asphalt and concrete pieces throughout. Approximately 5 to 7 feet of undocumented fill was encountered in our borings. All existing fill soils onsite should be considered compressible and unsuitable in their present condition for support of structural elements.

3.2.2 Quaternary-aged Old Paralic Deposits (Qop)

Quaternary-aged Old Paralic Deposits underlie the undocumented fill and extend to the total depth as explored in all of the soil borings (B-1 to B-4). As observed, these deposits generally consist of medium dense to very dense, light tan to mottled brown, damp to wet, silty sand to sandy silt to clayey sand. Abundant shells

were encountered below 20-22 feet bgs in two borings (B-1 and B-4). A consistent gravel bed crosses the entire site at depths ranging 10 to 11.5 feet below the existing ground surface (bgs).

3.3 Surface and Groundwater

No indication of surface water or evidence of surface ponding was encountered during our geotechnical investigation performed at the site. However, surface water may drain as sheet flow across the site during rainy periods.

Ground water was encountered in B-1 during our exploration at a depth of 37 feet bgs. Based on the anticipated grading and foundation depth, groundwater is not anticipated to affect the project.

Seasonal fluctuations in groundwater elevations should be anticipated over time. Local perched groundwater conditions or surface seepage may develop once site development is completed and stormwater infiltration and landscape irrigation commence.

3.4 Engineering Characteristics of On-site Soils

Based on the results of our laboratory testing of representative on-site soils, and our professional experience on similar sites with similar soils conditions, the engineering characteristics of the on-site soils are discussed below.

3.4.1 Compressible Soils

The site is underlain by undocumented artificial fill materials. The upper 5 to 7 feet of the undocumented artificial fill, and the weathered Paralic Deposits are considered compressible in their current state. Recommendations for remedial grading of these soils are provided in the following sections of this report.

3.4.2 Expansion Potential

Based on our testing, the expansion potential of the on-site soil is anticipated to range from very low to medium. However, the on-site clayey soil may have a medium to high expansion potential, therefore, geotechnical observations and/or laboratory testing upon completion of the graded pads is recommended to determine the actual expansion potential of finish grade soils on the site.

3.4.3 Soil Corrosivity

A preliminary screening of the on-site soils was performed to evaluate their potential corrosive effect on concrete and ferrous metals. In summary, laboratory

testing on one representative soil samples obtained during our subsurface exploration evaluated pH, minimum electrical resistivity, and chloride and soluble sulfate content. The sample tested had a measured pH of 7.8, and a measured minimum electrical resistivity of 1300 ohm-cm. Test results also indicated that the samples had a chloride content of 180 parts per million (ppm), and soluble a sulfate content of 165 ppm.

3.4.4 Excavation Characteristics

The site is underlain by Paralic Deposits which consists of silty to clayey sand. With regards to the proposed project, it is anticipated these on-site soils can be excavated with conventional heavy-duty construction equipment. Beds of friable sands may experience caving during unsupported excavation or drilling.

3.4.5 Infiltration

Field percolation tests were not performed at the site due to depth of settlement sensitive undocumented fill. Based on the presence and depth of undocumented fill (i.e., greater than 5 feet), the adjacent underground utilities and existing settlement sensitive improvements, the site is not considered feasible for infiltration and is therefore categorized as “No Infiltration”.

4.0 SEISMICITY

4.1 Regional Tectonic Setting

The site is located within the Peninsular Ranges Geomorphic Province, which is traversed by several major active faults. The Whittier-Elsinore, San Jacinto, and the San Andreas faults are major active fault systems located east of the site, and the Rose Canyon, Newport-Inglewood (offshore), and Coronado Bank are active faults located west to northwest of the site (Jennings, 2010).

The Rose Canyon fault zone consists predominantly of right-lateral strike-slip faults that extend south-southeast bisecting the San Diego metropolitan area. Various fault strands display strike-slip, normal, oblique, or reverse components of displacement. The Rose Canyon fault zone extends offshore at La Jolla and continues north-northwest subparallel to the coastline. The offshore segments are poorly constrained regarding location and character. South of downtown, the fault zone splits into several splays that underlie San Diego Bay, Coronado, and the ocean floor south of Coronado (Treiman, 1993 and 2000; Kennedy and Clarke, 1999). Portions of the fault zone in the Mount Soledad, Rose Canyon, and downtown San Diego areas have been designated by the State of California (CGS, 2003) as being Earthquake Fault Zones.

4.2 Local Faulting

The California Geologic Survey (CGS, 2007) define a Holocene-active fault as a fault which has “had surface displacement within Holocene time (about the last 11,700 years).” Our review of available geologic literature (Appendix A) indicates that there are no known pre-Holocene or Holocene-active faults transecting the site. The subject site is within the Newport-Inglewood Rose Canyon fault zone, specifically the Silver Strand section. CGS has this fault section categorized as a Holocene fault zone without historic record. The nearest active fault is the Rose Canyon (offshore) fault zone located approximately 1.2 miles west of the site (USGS, 2014).

4.3 Seismicity

The site is considered to lie within a seismically active region, as is all of Southern California. As previously mentioned above, the Rose Canyon (offshore) fault zone located approximately 1.2 miles west of the site is considered the ‘active’ fault having the most significant effect at the site from a design standpoint.

4.4 Seismic Hazards

Severe ground shaking is most likely to occur during an earthquake on one of the regional active faults in Southern California. The effect of seismic shaking may be mitigated by adhering to the California Building Code or state-of-the-art seismic design parameters of the Structural Engineers Association of California.

4.4.1 Shallow Ground Rupture

As mentioned above, no pre-Holocene or Holocene-active faults are mapped crossing or projecting toward the site. Due to the absence of faults at the site, surface rupture from faulting is considered low.

4.4.2 Mapped Fault Zones

The site is located within a California State mapped Earthquake Fault Zone (EFZ), the Silver Strand section of the Newport-Inglewood Rose Canyon fault zone. As previously discussed, the subject site is not underlain by known faults. A fault evaluation was not performed as part of this investigation.

4.4.3 Site Class

Utilizing 2019 California Building Code (CBC) procedures, we have characterized the site soil profile to be Site Class D based on our experience with similar sites in the project area and the results of our subsurface evaluation. It should be noted, per Section 11.4.8 of ASCE 7-16, a ground motion hazard analysis shall be performed in accordance with Section 21.2 for structures having a fundamental period of vibration greater than 0.5s on Site Class D sites where S_1 is greater than or equal to 0.2g. However, although S_1 is greater than 0.2g at the site, it is anticipated that the proposed residential buildings will have a fundamental period of vibration of less than 0.5s based on our current understanding. Therefore, a site-specific ground motion analysis is assumed to be not required according to ASCE 7-16 Section 11.4.8; however, the project structural engineer needs to confirm this assumption.

4.4.4 Building Code Mapped Spectral Acceleration Parameters

The effect of seismic shaking may be mitigated by adhering to the California Building Code and state-of-the-art seismic design practices of the Structural Engineers Association of California. Provided below in Table 2 are the spectral acceleration parameters for the project determined in accordance with the 2019 CBC (CBSC, 2019) and the ATC Hazards Web Application.

Table 1. CBC Mapped Spectral Acceleration Parameters

Site Class	D		
Site Coefficients	F_a	=	1
	F_v	=	null
Mapped MCE Spectral Accelerations	S_s	=	1.522g
	S_1	=	0.509g
Site Modified MCE Spectral Accelerations	S_{MS}	=	1.522g
	S_{M1}	=	null
Design Spectral Accelerations	S_{DS}	=	1.015g
	S_{D1}	=	0.608g
Transitional Period	F_v	=	1.791g
	S_{M1^*}	=	0.912g
	S_{D1^*}	=	null
	$T_s = S_{D1}/S_{DS}$	=	0.599s

*Site-specific ground motion hazard analysis is required for determination of S_{M1} and S_{D1} for use in seismic design. Value of S_{D1} presented is only for the purposes of determining T_s as per Supplement 1 to ASCE 7-16 (ASCE, 2018).

Utilizing ASCE Standard 7-16, in accordance with Section 11.8, the following additional parameters for the peak horizontal ground acceleration are associated with the Geometric Mean Maximum Considered Earthquake (MCE_G). The mapped MCE_G peak ground acceleration (PGA) is 0.693g for the site. For a Site Class D, the F_{pga} is 1.1 and the mapped peak ground acceleration adjusted for Site Class effects (PGA_m) is 0.763g for the site.

Since the mapped spectral response at 1-second period is less than 0.75g, then all structures subject to the criteria in Section 1613A.2.5 of the 2019 CBC are assigned Seismic Design Category D.

4.5 Secondary Seismic Hazards

In general, secondary seismic hazards can include soil liquefaction, seismically-induced settlement, lateral displacement, surface manifestations of liquefaction, landsliding, seiches, and tsunamis. The potential for secondary seismic hazards at the subject site is discussed below.

4.5.1 Liquefaction and Dynamic Settlement

Liquefaction and dynamic settlement of soils can be caused by strong vibratory motion due to earthquakes. Granular soils tend to densify when subjected to shear strains induced by ground shaking during earthquakes. Research and historical data

indicate that loose granular soils underlain by a near surface groundwater table are most susceptible to liquefaction, while the most clayey materials are not susceptible to liquefaction. Liquefaction is characterized by a loss of shear strength in the affected soil layer, thereby causing the soil to behave as a viscous liquid. This effect may be manifested at the ground surface by settlement and, possibly, sand boils where insufficient confining overburden is present over liquefied layers. Where sloping ground conditions are present, liquefaction-induced instability can result.

The site is underlain by very dense Paralic Deposits. Since the potentially compressible and weathered upper portions of the surficial materials are recommended for removal, the underlying very dense character of the Paralic Deposits, and the lack of a shallow groundwater table, it is our opinion that the potential for liquefaction and seismic related settlement across the site is nil.

4.5.2 Lateral Spread

Empirical relationships have been derived (Youd et al., 1999) to estimate the magnitude of lateral spread due to liquefaction. These relationships include parameters such as earthquake magnitude, distance of the earthquake from the site, slope height and angle, the thickness of liquefiable soil, and gradation characteristics of the soil.

The susceptibility to earthquake-induced lateral spread is considered to be low for the site because of the nil susceptibility to liquefaction and relatively level ground surface in the site vicinity.

4.5.3 Tsunamis and Seiches

Based upon the California Emergency Management Agency Tsunami Inundation Map (CalEMA, 2009), the site is not located within a tsunami inundation area. In addition, proposed elevation of the site with respect to sea level, the possibility of seiches and/or tsunamis is considered nil.

4.6 Landslides

Several formations within the San Diego region are particularly prone to landsliding. These formations generally have high clay content and mobilize when they become saturated with water. Other factors, such as steeply dipping bedding that project out of the face of the slope and/or the presence of fracture planes, will also increase the potential for landsliding.

No landslides or indications of deep-seated landsliding were indicated at the site during our field exploration or our review of available geologic literature, topographic maps, and stereoscopic aerial photographs. Furthermore, our field reconnaissance and the local geologic maps indicate the site is generally underlain by favorable oriented geologic structure, consisting of massively bedded sandstone. Therefore, the potential for significant landslides or large-scale slope instability at the site is considered low.

4.7 Flood Hazard

According to a Federal Emergency Management Agency (FEMA) flood insurance rate map (FEMA, 2017); the site is not located within a floodplain. Based on our review of topographic maps, the site is not located downstream of a dam or within a dam inundation area. Based on this review and our site reconnaissance, the potential for flooding of the site is considered low.

5.0 CONCLUSIONS

Based on the results of our geotechnical investigation of the site, it is our opinion that the proposed project is feasible from a geotechnical standpoint, provided the following conclusions and recommendations are incorporated into the project plans and specifications.

- As the site is located in the seismically active southern California area, all structures should be designed to tolerate the dynamic loading resulting from seismic ground motions;
- The site is not transected by pre-Holocene or Holocene-active faults;
- Based on our subsurface exploration and review of pertinent geotechnical literature and geologic maps, the site is underlain by Quaternary-aged Old Paralic Deposits, capped by variable but generally limited thicknesses of undocumented artificial fill;
- The undocumented fill and weathered formational materials are loose, dry, and porous and/or potentially compressible in their present state and will require removal and recompaction in areas of proposed development or future fill;
- Based on laboratory testing and visual observation, the undocumented artificial fill, and Paralic Deposits possess a very low to medium expansion potential;
- The existing onsite soils are generally suitable for use as engineered fill, provided they are free of organic material, debris, and rock fragments larger than 8 inches in maximum dimension;
- If import soils are planned, the soils should be granular in nature, and have an expansion index less than 50 (per ASTM Test Method D 4829) and have a low corrosion impact to the proposed improvements;
- Based on the results of our subsurface exploration, it anticipated that the surficial soils and formational materials may be excavated with conventional heavy-duty construction equipment;
- Based on our experience with similar sites and the results of our exploration of the site, excavations within the underlying undocumented fill and Paralic Deposits have zones of cohesionless and friable sands that will likely cave or slough during site excavation deeper than 10 feet (bgs). Care in these cases should be exercised which may include the excavation of shorter open-face segments and shoring. Caving of the friable sand should be anticipated especially when sandy soil loses moisture;
- Groundwater should not be encountered during grading activities. Groundwater was encountered during our exploration at 37 feet below the ground surface. Localized seepage along the contact between the surficial soils and the formational materials may occur;
- Based on the results of our geotechnical evaluation, it is our opinion that the proposed multi-family buildings can be supported on conventional foundations;

- In general, when recompacted as fill soil, the surficial units (undocumented fill and weathered Paralic Deposits) are anticipated to shrink while the denser unweathered Paralic Deposit materials are likely to bulk;
- Although Leighton does not practice corrosion engineering, laboratory test results indicate the soils present on the site have a negligible potential for sulfate attack on normal concrete. However, the onsite soils are considered to have a corrosive potential for buried uncoated ferrous metal. A corrosion consultant may be consulted to provide additional recommendations.
- Based on the results of our geotechnical study, we do not recommend the practice of surface water infiltration into near surface soils at the site due to the depth of compressible undocumented fill that is greater than 5 feet, the and settlement sensitive improvements.

6.0 RECOMMENDATIONS

6.1 Earthwork

Earthwork should be performed in accordance with the following recommendations and the General Earthwork and Grading Specifications for Rough Grading included in Appendix D. In case of conflict, the following recommendations shall supersede those in Appendix D. The contract between the developer and earthwork contractor should be worded such that it is the responsibility of the contractor to place the fill properly and in accordance with the recommendations of this report and the specifications in Appendix D, notwithstanding the testing and observation of the geotechnical consultant during construction.

6.2 Site Preparation

Prior to grading, the proposed residential development and areas with improvements should be stripped of vegetation, cleared of surface and subsurface obstructions, including any existing debris and undocumented or loose fill soils or weathered formational materials. Removed vegetation and debris should be properly disposed of offsite. All areas to receive fill and/or other surface improvements should be scarified to a minimum depth of 6 inches, brought to above-optimum moisture conditions, and recompacted to at least 90 percent relative compaction (based on ASTM Test Method D1557). Any water wells located within the areas of proposed improvements that do not remain in operation should be abandoned in accordance with County of San Diego Health Department guidelines.

6.3 Removal and Recomaction

The undocumented fill and weathered Paralic Deposits that occur on site are potentially compressible in their present state and may settle under the surcharge of fills or foundation loadings. In areas that will receive additional fill soils that will support settlement-sensitive structures or other improvements (such as retaining walls, roadway utility lines, etc.), these soils should be removed down to competent material determined by the geotechnical consultant, moisture-conditioned, and recompacted to a minimum 90 percent relative compaction (based on ASTM D1557) prior to placing fill. Fill soils should be free of debris and organic materials (trees, shrubs, stumps, roots, leaves, and mulch derived from vegetation). The removal limit should be established by a 1:1 projection from the edge of fill soil supporting settlement-sensitive structures downward and outward to competent material identified by the geotechnical consultant. The undocumented fill across the site is generally on the order of up to 7 feet in depth; however, deeper undocumented fills may be encountered. Therefore, we recommend that

the all undocumented fill, soil horizon, and weathered Paralic Deposits be removed during grading. Minimum removal depths should extend to 2 feet below the bottom of foundation footings. The lateral limits of the removal bottom should extend 10 feet outside the building limits where possible. Actual depths and limits of removals should be evaluated by the geotechnical consultant during grading. The bottom of all removals should be evaluated by a Certified Engineering Geologist to confirm conditions are as anticipated.

In non-building areas, such as, the paved parking areas, concrete hardscape, and trash/recycling enclosure areas we recommended that the upper 2 feet of soil materials below pre-graded topography/existing grade or proposed subgrade elevations, whichever is deeper be removed. Horizontally, the limits of the removal bottoms should extend at least 2 feet laterally beyond the limits of the proposed improvements.

6.4 Excavations

Sloping temporary excavations may be utilized when adequate space allows. Based on the results of our evaluation, we provide the following recommendations for sloped excavations in fill soils or competent formational materials without seepage conditions. Friable sand exists at depth at the site and caving should be anticipated especially when sandy soil lose moisture.

Table 2. Maximum Slope Ratios

Excavation Depth (feet)	Maximum Slope Ratio In Fill Soils	Maximum Slope Ratio In Paralic Deposits
0 to 4	1:1 (Horizontal to Vertical)	1:1 (Horizontal to Vertical)
4 to 20	1½ :1 (Horizontal to Vertical)	1½ :1 (Horizontal to Vertical)

The above values are based on the assumption that no surcharge loading or equipment is present within 10 feet of the top of slope. Care should be taken during design of excavations adjacent to the existing structures so that foundation support is preserved. A “competent person” should observe the slope on a daily basis for signs of instability.

6.5 Structural Fills

The onsite soils are generally suitable for use as compacted fill provided they are free of organic materials and debris. Areas to receive structural fill and/or other surface improvements should be scarified to a minimum depth of 6 inches, brought to at least 2% above optimum moisture content, and recompacted to at least 90 percent relative compaction (based on ASTM D1557). The optimum lift thickness to produce a uniformly compacted fill will depend on the type and size of compaction equipment used. In general,

fill should be placed in uniform lifts not exceeding 8 inches in thickness. Fill soils should be placed at a minimum of 90 percent relative compaction (based on ASTM D1557) and moisture conditioned to at least 2 percent above optimum moisture content. Placement and compaction of fill should be performed in accordance with local grading ordinances under the observation and testing of the geotechnical consultant.

Fills placed on slopes steeper than 5 to 1 (horizontal to vertical) should be keyed and benched into dense formational soils (see Appendix D for benching detail). Oversize material may be incorporated into structural fills if placed in accordance with the recommendations in Appendix D.

6.6 Foundation and Slab Considerations

At the time of drafting this report, foundation loads were not known. However, based on our understanding of the project, conventional foundations are considered suitable for support of the proposed improvements. Foundations and slabs should be designed in accordance with structural considerations and the following recommendations. These recommendations assume that the soils encountered within 5 feet of pad grade have a low to medium expansion potential (EI<70). The foundation recommendations below assume that all building foundations will be underlain by properly compacted fill soils.

6.6.1 Foundation and Slab Design

We anticipate that the proposed structure can be supported on properly compacted fill by isolated spread and/or continuous footings designed in accordance with the following criteria.

Table 3: Allowable Bearing Values for Conventional Footings

Depth Below Subgrade (feet) *	Allowable Soil Bearing Value for Isolated Spread Footings (Minimum Width of 2 feet)	Allowable Soil Bearing Value for Continuous Wall Footings (Minimum Width of 1.5 feet)
2	3,000 psf	3,000 psf
3	4,000 psf	4,000 psf

* Does not include the thickness of slab or the sand layer beneath the slab.

The above values are for dead plus live loads and may be increased by one-third for short-term wind or seismic loads.

Shallow conventional foundations for associated ancillary structures, if any, founded in properly compacted engineered fill materials should be designed based on an allowable bearing capacity of 2,000 psf. This capacity assumes a minimum foundation depth of 18 inches and minimum width of 18 and 12 inches for spread and continuous footings, respectively.

Concrete slabs-on-grade should be designed by the project Structural Engineer in accordance with the 2019 California Building Code (CBC) for a soil with low expansion potential. The slab-on-grade should be reinforced with reinforcing bars placed at mid-height in the slab. Slabs should also be designed for the anticipated traffic loading using a modulus of subgrade reaction of 125 pounds per cubic inch. Slabs should have crack joints at spacings designed by the structural engineer. Columns should be structurally isolated from slabs. Slabs should be a minimum of 5 inches thick and reinforced with No. 3 rebars at 18 inches on center or No. 4 rebars at 24 inches on center (each way). A moisture barrier may be placed in areas of the slab where a reduction of moisture vapor up through the concrete slab is desired (such as below equipment, closet areas, etc.).

6.6.2 Settlement

Our recommended allowable bearing capacity is generally based on a total allowable, post construction settlement of approximately 1 inch. Differential settlement is estimated at approximately ½ inch over a horizontal distance of 30 feet. Since settlements are a function of footing size and contact bearing pressures, larger differential settlements can be expected between adjacent columns or walls where a large differential loading conditions exists.

6.6.3 Foundation Setback

We understand the site is essentially flat, however, if slopes are planned the following recommendations may be utilized. We recommend a minimum horizontal setback distance from the face of slopes for all structural foundations, footings, and other settlement-sensitive structures as indicated on the Table 4 below. This distance is measured from the outside bottom edge of the footing, horizontally to the slope face, and is based on the slope height. However, the foundation setback

distance may be revised by the geotechnical consultant on a case-by-case basis if the geotechnical conditions are different than anticipated.

Table 4: Minimum Foundation Setback from Slope Faces

Slope Height	Setback
less than 5 feet	5 feet
5 to 15 feet	7 feet
15 to 30 feet	10 feet

Please note that the soils within the structural setback area possess poor lateral stability, and improvements (such as retaining walls, sidewalks, fences, pavements, etc.) constructed within this setback area may be subject to lateral movement and/or differential settlement. Potential distress to such improvements may be mitigated by providing a deepened footing or a grade beam foundation system to support the improvement.

In addition, open or backfilled utility trenches that parallel or nearly parallel structure footings should not encroach within an imaginary 2:1 (horizontal to vertical) downward sloping line starting 9 inches above the bottom edge of the footing and should also not be located closer than 18 inches from the face of the footing. Deepened footings should meet the setbacks as described above. Also, over-excavation should be accomplished such that deepening of footings to accomplish the setback will not introduce a cut/fill transition bearing condition.

Where pipes may cross under footings, the footings should be specially designed. Pipe sleeves should be provided where pipes cross through footings or footing walls and sleeve clearances should provide for possible footing settlement, but not less than 1 inch around the pipe.

6.6.4 Lateral Resistance and Retaining Wall Design Pressures

The proposed retaining walls should be designed for the lateral soil pressures exerted on them, the magnitude of which depends primarily on the type of soil used as backfill and the amount of deformation the wall can yield under the lateral load. Walls that are under restrained conditions and cannot yield under the applied load (e.g., basement walls) should be designed for the 'at-rest' pressure condition.

Passive pressure is used to compute soil resistance to lateral structural movement.

For design purposes, the following lateral earth pressure values for level backfill are recommended for walls backfilled with onsite soils of very low to low ($EI < 50$) expansion potential or undisturbed in-place materials.

Table 5: Static Equivalent Fluid Weight (pcf)

Conditions	Level
Active	35
At-Rest	55
Passive	350 (Maximum of 3 ksf)

If conditions other than those covered herein are anticipated, the equivalent fluid pressure values should be provided on an individual case basis by the geotechnical engineer.

In addition to the above lateral forces due to retained earth, surcharge due to above grade loads on wall backfill should be considered in design of a retaining wall. A surcharge load for a restrained or unrestrained wall resulting from automobile traffic may be assumed to be equivalent to a uniform lateral pressure of 75 psf which is in addition to the equivalent fluid pressure given above. For other uniform surcharge loads, a uniform pressure equal to $0.35q$ should be applied to the wall (where q is the surcharge pressure in psf).

The provided wall pressures assume walls are backfilled with free draining materials and water is not allowed to accumulate behind walls. Specifically, where walls are not designed to consider hydrostatic conditions, in order to mitigate the potential for hydrostatic build-up behind the basement walls, drainage board should be extended from 2 feet below the ground surface to relief valves or by piping to a sump at the lowest wall elevations. Waterproofing should be designed by the structural engineer and/or architect.

Where wall backfill is utilized, it should be compacted by mechanical methods to at least 90 percent relative compaction, based on ASTM D1557. We recommend compaction effort be increased to 95 percent where backfill will support building foundations of distress sensitive appurtenant improvements. Wall footings should be designed in accordance with the foundation design recommendations and reinforced in accordance with structural considerations.

Lateral soil resistance developed against lateral structural movement can be obtained from the passive pressure value provided above. Further, for sliding resistance, the friction coefficient of 0.35 may be used at the concrete and soil interface. These values may be increased by one-third when considering loads of short duration including wind or seismic loads. The total resistance may be taken as the sum of the frictional and passive resistance provided the passive portion does not exceed two-thirds of the total resistance.

The account for potential redistribution of forces during a seismic event, basement walls should also be checked considering an additional seismic pressure distribution equal to 9H psf applied as a uniform pressure, where H equals the overall retained height in feet. If conditions other than those covered herein are anticipated, the equivalent fluid pressure values should be provided on an individual case basis by the geotechnical engineer.

6.7 Preliminary Pavement Design

The preliminary pavement section design below is based on an assumed Traffic Index (TI), our visual classification of the subject site soils, experience with other projects in the area, and our limited laboratory testing. Actual pavement recommendations should be based on R-value tests performed on bulk samples of the soils that are exposed at the finished subgrade elevations across the site at the completion of the mass grading operations. Preliminary flexible pavement sections have been evaluated in general accordance with the Caltrans method for flexible pavement design. Based on an assumed R-value of 15, preliminary pavement sections for planning purposes is given in Table 6 below:

Table 6. Preliminary Pavement Sections

Assumed Traffic Index (TI)	Asphalt Concrete (inches)	Aggregate Base (inches)
4.5	3.0	7.0
5.0	4.0	6.0
6.0	4.0	10.0

Prior to placement of the aggregate base, the upper 12 inches of subgrade soils should be scarified, moisture-conditioned to at least optimum moisture content and compacted to a minimum 95 percent relative compaction based on American Standard of Testing and Materials (ASTM) Test Method D1557.

Class 2 Aggregate Base or Crushed Aggregate Base should then be placed and compacted at a minimum 95 percent relative compaction in accordance with ASTM Test Method D1557. The aggregate base material (AB) should be a maximum of 6 inches thick below the curb and gutter and extend a minimum of 6 inches behind the back of the curb. The AB should conform to and be placed in accordance with the approved grading plans, and latest revision of the Standard Specifications Public Works Construction (Greenbook).

The Asphalt Concrete (AC) material should conform to Caltrans Standard Specifications, Sections 39 and 92, with a Performance Grade (PG) of 64-10, and the County of San Diego requirements. The placement of the AC should be in accordance with the approved grading plans, Section 203-6 of the "Greenbook" Standard Specifications for Public Works Construction, and the County of San Diego requirements. AC sections greater than 3-inches thick, should be placed in two lifts. The 1st lift should be a 2-inch minimum base course consisting of a 3/4-inch maximum coarse aggregate. The 2nd lift should be a 2-inch minimum surface capping course consisting of a 1/2-inch maximum coarse aggregate. No single lift shall be greater than 3 inches.

If pavement areas are adjacent to heavily watered landscaping areas, we recommend some measures of moisture control be taken to prevent the subgrade soils from becoming saturated. It is recommended that the concrete curbing, separating the landscaping area from the pavement, extend below the aggregate base to help seal the ends of the sections where heavy landscape watering may have access to the aggregate base. Concrete swales should be designed if asphalt pavement is used for drainage of surface waters.

For areas subject to regular truck loading (i.e., trash truck apron), we recommend a full depth of Portland Cement Concrete (PCC) section of 7 inches with appropriate steel reinforcement and crack-control joints as designed by the project structural engineer. We recommend that sections be as nearly square as possible. A 3,500-psi mix that produces a 550-psi modulus of rupture should be utilized.

All pavement section materials should conform to and be placed in accordance with the latest revision of the California Department of Transportation Standard Specifications (Caltrans) and American Concrete Institute (ACI) codes. The upper 12 inches of subgrade soil and all aggregate base should be compacted to a relative compaction of at least 95 percent (based on ASTM Test Method D1557) and to a moisture content above optimum content.

6.8 Geochemical Considerations

Concrete in direct contact with soil or water that contains a high concentration of soluble sulfates can be subject to chemical deterioration commonly known as “sulfate attack.” Soluble sulfate results (Appendix C) indicate negligible soluble sulfate content for a representative soil samples. We recommend that concrete in contact with earth materials be designed in accordance with Section 4 of ACI 318-14 (ACI, 2014). We recommend sulfate testing be performed once finish grades are attained.

Laboratory test results also identified pH, chloride content, and electrical resistivity. Utilizing Caltrans criteria, a site is considered to be corrosive if chloride concentration is 500 ppm or greater, or pH is 5.5 or less. High chloride concentrations can be corrosive to reinforcing steel. Highly acid soils, pH of 5.5 or less, can also affect concrete durability. Low electrical resistivity can cause corrosion of buried ferrous metals. Based on laboratory test results for a representative sample, the onsite soils have an electrical resistivity of 1300 ohm-cm, a pH of 7.8, and a chloride concentration of 180 ppm, therefore, the site is not considered corrosive site per Caltrans criteria.

6.9 Infiltration Best Management Practices

Regarding Best Management Practices (BMP) and Low Impact Development (LID) measures, we are of the opinion that infiltration basins, and other on-site storm water retention and infiltration systems can potentially create adverse perched groundwater conditions, both on-site and off-site, when not installed using proper design recommendations (such as the use of liners) and infiltration design parameters. Based on the results of our geotechnical study, we do not recommend the practice of surface water infiltration into near surface soils at the site due to the depth of undocumented fill greater than 5 feet, the proximity of numerous subterranean structures and settlement sensitive improvements, along with the dense nature of the underlying materials.

6.10 Control of Groundwater and Surface Water

Our experience indicates that surface or near-surface groundwater conditions can develop in areas where groundwater conditions did not exist prior to site development, especially in areas where a substantial increase in surface water infiltration results from landscape irrigation. This sometimes occurs where relatively impermeable bedrock materials are overlain by granular fill soils. In addition, during slope excavations, seepage in cut slopes may be encountered. We recommend that an engineering geologist be present during grading operations to evaluate seepage areas. Drainage devices for reduction of water accumulation can be recommended when these conditions are observed.

We recommend that measures be taken to properly finish grade the building area, such that drainage water from the building area is directed away from building foundations (2 percent minimum grade for a distance of 5 feet), floor slabs, and tops of slopes. Ponding of water should not be permitted, and installation of roof gutters which outlet into a drainage system is considered prudent. Planting areas at grade should be provided with positive drainage directed away from the building. Drainage and subdrain design for these facilities should be provided by the design civil engineer.

7.0 LIMITATIONS

The findings, conclusions and recommendations in this report are based in part upon data that were obtained from widely spaced subsurface investigations and limited geotechnical analysis. Such information is by necessity incomplete. The nature of many sites is such that differing geotechnical or geological conditions can occur within small distances and under varying climatic conditions. Changes in subsurface conditions can and do occur over time. Therefore, the findings, conclusions, and recommendations presented in this report can be relied upon only if Leighton has the opportunity to review final grading plans and to observe the subsurface conditions during grading and construction of the project, in order to confirm that our preliminary findings are representative for the site.

FIGURES

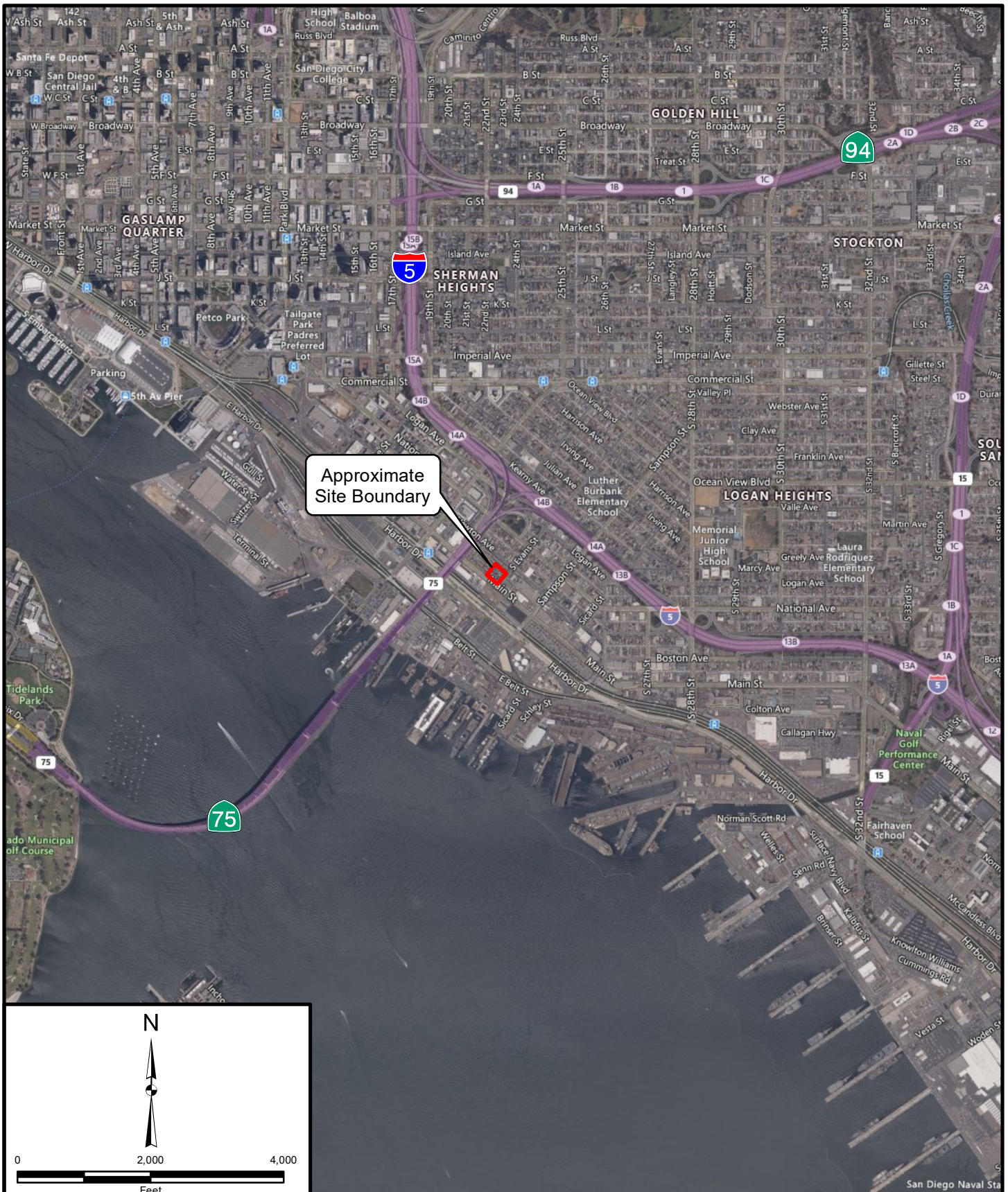

Approximate Site Boundary

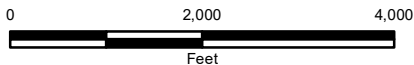

Project: 13324.001	Eng/Geol: NJT/MJD
Scale: 1" = 2,000'	Date: November 2021
Base Map: ESRI ArcGIS Online 2021	

SITE LOCATION MAP

MAAC Mercado Apartments
 South Evans and Main St
 San Diego, CA

FIGURE 1



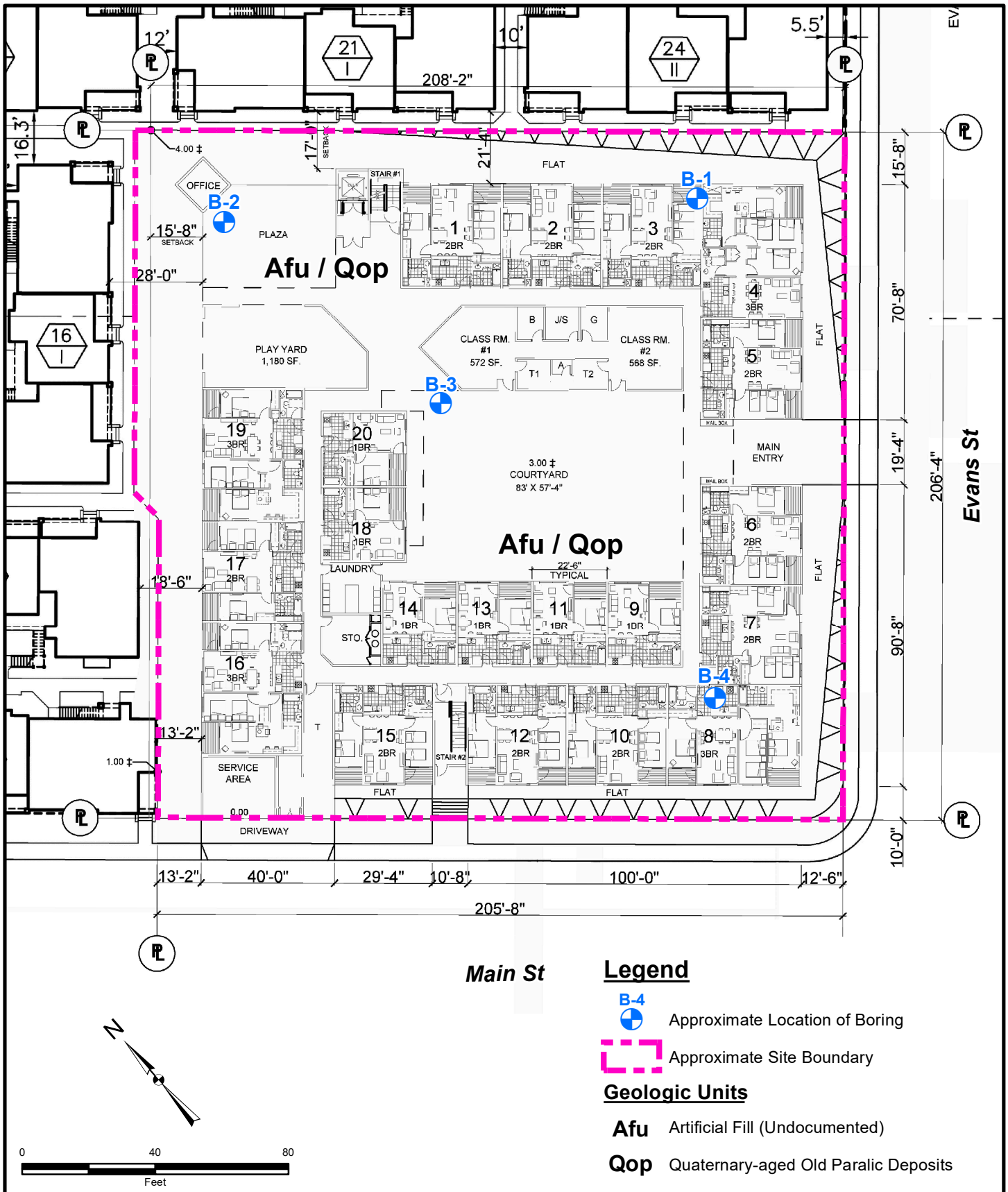

Legend

- B-4 Approximate Location of Boring
- Approximate Site Boundary

Geologic Units

- Afu** Artificial Fill (Undocumented)
- Qop** Quaternary-aged Old Paralic Deposits

Project: 13324.001	Eng/Geol: WDO/MDJ
Scale: 1" = 40'	Date: December 2021
Base Map: Sheet No. A1.0, Site Plan by Martinez & Cutri	

GEOTECHNICAL MAP
 MAAC Mercado Apartments
 South Evans and Main St
 San Diego, California

FIGURE 2

APPENDIX A
REFERENCES

APPENDIX A

REFERENCES

- American Concrete Institute (ACI), 2014, Building Code Requirements for Structural Concrete (ACI 318-14) and Commentary.
- California Geologic Survey (CGS), 2007, Fault Rupture Hazard Zones in California, Special Publication No. 42, Revised 2007 (Interim Version).
- , 1996a, Guidelines for Evaluating, the Hazard of Surface Fault Rupture: Adopted by the Board on May 9, 1996, 6p.
- , 1996b, Probabilistic Seismic Hazard Assessment for the State of California, Open-File Report, 96-08.
- California Emergency Management Agency (CalEMA), California Geological Survey, and University of Southern California, 2009, Tsunami Inundation Map for Emergency Planning, Oceanside/San Luis Rey Quadrangle, Scale 1:52,000, June 1.
- California Building Standards Commission (CBSC), 2019, California Building Code, Volumes 1 and 2.
- Caltrans, 2018, Corrosion Guidelines, Version 3.0, March 2018.
- FEMA, 2017, Flood Insurance Map, dated May 16.
- Jennings, C.W., 2010, Fault Activity Map of California and Adjacent Areas: California Division of Mines and Geology, California Geologic Map Series, Map No. 6
- Kennedy, M.P., and Tan, S.S., 2008, Geologic Map of the northern San Diego Quadrangle, California, California Geologic Survey, 1:100,000 scale.
- Martinez & Cutri, 2021, MAAC Apartments, Site Plan, July 7, 2021.
- Norris, R.M., and Webb, R.W., 1990, Geology of California, Second Edition: John Wiley & Sons, Inc.
- SEAOC, 2019, USGS Seismic Design Data via SEAOC/OSHPD Seismic Design Maps Web Application, accessed February, 2020 at <https://seismicmaps.org>
- Treiman, J.A., 1993, The Rose Canyon Fault Zone, Southern California: California Division of Mines and Geology, Open File Report 93-02, 45p.
- United States Geologic Survey, 2014, U.S. Seismic Design Maps Web Application, June, 23, 2014.
- Youd, T. L., Hanson C. M., and Bartlett, S. F., 1999, Revised MLR Equations for Predicting Lateral Spread Displacement, Proceedings of the 7th U.S.-Japan Workshop on Earthquake Resistant Design of Lifeline Facilities and Countermeasures Against Soil Liquefaction, November 19, 1999, pp. 99-114.

APPENDIX B

BORING LOGS

GEOTECHNICAL BORING LOG B-1

Project No. 13324.001
Project MAAC Mercado Apartments
Drilling Co. Baja Exploration
Drilling Method Hollow Stem Auger - 140lb - Autohammer - 30" Drop
Location See Figure 2

Date Drilled 11-8-21
Logged By DKJ
Hole Diameter 8"
Ground Elevation 41' msl
Sampled By DKJ

Elevation Feet	Depth Feet	Graphic Log	Attitudes	Sample No.	Blows Per 6 Inches	Dry Density pcf	Moisture Content, %	Soil Class. (U.S.C.S.)	SOIL DESCRIPTION	Type of Tests
		N S							<i>This Soil Description applies only to a location of the exploration at the time of sampling. Subsurface conditions may differ at other locations and may change with time. The description is a simplification of the actual conditions encountered. Transitions between soil types may be gradual.</i>	
40	0	3" ASPHALT CONCRETE						SM	3" ASPHALT CONCRETE	
		6" AGGREGATE BASE		B-1 (0.75"-2')					6" AGGREGATE BASE	
		UNDOCUMENTED ARTIFICIAL FILL (Afu)							UNDOCUMENTED ARTIFICIAL FILL (Afu)	
		@ 0.75': Silty SAND with gravel, loose, light brown to brown, damp, concrete and asphalt chunks		B-2 (3.5'-4.5')					@ 0.75': Silty SAND with gravel, loose, light brown to brown, damp, concrete and asphalt chunks	
		@ 3.5': becomes more fine-grained, damp						SM	@ 3.5': becomes more fine-grained, damp	
		QUATERNARY-AGED OLD PARALICS (Qop)							QUATERNARY-AGED OLD PARALICS (Qop)	
35	5	@ 4': Silty SAND, very dense, light brown, damp, medium-grained		R-1 30 39 50/3"	128	9			@ 4': Silty SAND, very dense, light brown, damp, medium-grained	
		@ 5': becomes very dense		S-1 32 50/4"					@ 5': becomes very dense	
		@ 7': Silty SAND, very dense, red-brown, damp, medium-grained							@ 7': Silty SAND, very dense, red-brown, damp, medium-grained	
30	10	@ 11': 0.5' thick gravel layer		R-2 38 42 50/5"	124	5			@ 11': 0.5' thick gravel layer	
		@ 15': Silty SAND, medium dense, brown with black mottling, damp, micaceous, roots, slightly friable, fine-grained		S-2 6 7 10					@ 15': Silty SAND, medium dense, brown with black mottling, damp, micaceous, roots, slightly friable, fine-grained	
		@ 19': increase in clay content							@ 19': increase in clay content	
20	20	@ 20': Silty SAND, very dense, light brown to dark brown, damp, slightly friable, oxidation mottling, micaceous, fine-grained		R-3 33 50/5"	100	9			@ 20': Silty SAND, very dense, light brown to dark brown, damp, slightly friable, oxidation mottling, micaceous, fine-grained	
15	25	@ 25': Clayey SILT, very stiff, dark gray, damp, micaceous, oxidized		S-3 12 13 18				ML	@ 25': Clayey SILT, very stiff, dark gray, damp, micaceous, oxidized	

SAMPLE TYPES:

- B BULK SAMPLE
- C CORE SAMPLE
- G GRAB SAMPLE
- R RING SAMPLE
- S SPLIT SPOON SAMPLE
- T TUBE SAMPLE

TYPE OF TESTS:

- 200 % FINES PASSING
- AL ATTERBERG LIMITS
- CN CONSOLIDATION
- CO COLLAPSE
- CR CORROSION
- CU UNDRAINED TRIAXIAL

- DS DIRECT SHEAR
- EI EXPANSION INDEX
- H HYDROMETER
- MD MAXIMUM DENSITY
- PP POCKET PENETROMETER
- RV R VALUE

- SA SIEVE ANALYSIS
- SE SAND EQUIVALENT
- SG SPECIFIC GRAVITY
- UC UNCONFINED COMPRESSIVE STRENGTH



GEOTECHNICAL BORING LOG B-1

Project No. 13324.001
Project MAAC Mercado Apartments
Drilling Co. Baja Exploration
Drilling Method Hollow Stem Auger - 140lb - Autohammer - 30" Drop
Location See Figure 2

Date Drilled 11-8-21
Logged By DKJ
Hole Diameter 8"
Ground Elevation 41' msl
Sampled By DKJ

Elevation Feet	Depth Feet	Graphic Log	Attitudes	Sample No.	Blows Per 6 Inches	Dry Density pcf	Moisture Content, %	Soil Class. (U.S.C.S.)	SOIL DESCRIPTION	Type of Tests
		N S							This Soil Description applies only to a location of the exploration at the time of sampling. Subsurface conditions may differ at other locations and may change with time. The description is a simplification of the actual conditions encountered. Transitions between soil types may be gradual.	
10	30			R-4	9 15 18	97	28	ML	@ 30': Clayey SILT, very stiff, dark gray, moist, some shell fragments, oxidized @ 34': abundant shell fragments	
5	35			S-4	15 18 27			SM	@ 35': Silty SAND, very dense, light gray with yellow mottling, moist, shell fragments, medium-grained, friable @ 37': Groundwater measured at end of day.	
0	40			R-5	12 20 20	87	30	CH	@ 40': Sandy CLAY, hard, dark gray, saturated, micaceous, oxidized, 3" slightly cemented shell lense @ 45': becomes very stiff, vertical black clay infill noted	
-5	45			S-5	6 7 12					
-10	50			R-6	8 21 44	87	34		@ 50': Sandy CLAY, hard, dark gray, saturated, micaceous, oxidation mottling observed	
-15	55								Total Depth = 51.5 Feet (bgs) Groundwater measured at 37 Feet (bgs) after 5 hours Backfilled on 11/8/2021	
-15	60									

SAMPLE TYPES:

- B BULK SAMPLE
- C CORE SAMPLE
- G GRAB SAMPLE
- R RING SAMPLE
- S SPLIT SPOON SAMPLE
- T TUBE SAMPLE

TYPE OF TESTS:

- 200 % FINES PASSING
- AL ATTERBERG LIMITS
- CN CONSOLIDATION
- CO COLLAPSE
- CR CORROSION
- CU UNDRAINED TRIAXIAL

- DS DIRECT SHEAR
- EI EXPANSION INDEX
- H HYDROMETER
- MD MAXIMUM DENSITY
- PP POCKET PENETROMETER
- RV R VALUE

- SA SIEVE ANALYSIS
- SE SAND EQUIVALENT
- SG SPECIFIC GRAVITY
- UC UNCONFINED COMPRESSIVE STRENGTH



GEOTECHNICAL BORING LOG B-2

Project No. 13324.001
Project MAAC Mercado Apartments
Drilling Co. Baja Exploration
Drilling Method Hollow Stem Auger - 140lb - Autohammer - 30" Drop
Location See Figure 2

Date Drilled 11-8-21
Logged By DKJ
Hole Diameter 8"
Ground Elevation 40' msl
Sampled By DKJ

Elevation Feet	Depth Feet	Graphic Log	Attitudes	Sample No.	Blows Per 6 Inches	Dry Density pcf	Moisture Content, %	Soil Class. (U.S.C.S.)	SOIL DESCRIPTION	Type of Tests
40	0	N S							This Soil Description applies only to a location of the exploration at the time of sampling. Subsurface conditions may differ at other locations and may change with time. The description is a simplification of the actual conditions encountered. Transitions between soil types may be gradual.	
				B-1 (1'-3')				SM	3" ASPHALT CONCRETE 6" AGGREGATE BASE UNDOCUMENTED ARTIFICIAL FILL (Afu) @ 0.75': Silty SAND, medium dense, dark brown to red-brown, moist, oxidation, asphalt and concrete pieces, wood and shell fragments, trace fine gravel	
35	5			R-1	11 11 21	126	11		@ 5': trace fine gravel, asphalt fragments	DS
				S-1	11 18 33			SM	QUATERNARY-AGED OLD PARALIC DEPOSITS (Qop) @ 7': Silty SAND, very dense, light brown, damp, fine- to medium-grained, slightly oxidized	
30	10			R-2	17 33 48	128	9	GM	@ 10': Sandy GRAVEL, increase in gravels at 11'	
								SM	@ 11.5': Silty SAND, very dense, light brown, damp, fine- to medium-grained, slightly oxidized @ 13': becomes brown	
25	15			S-2	13 13 18				@ 15.5': becomes red-brown, oxidized	
20	20			R-3	12 20 35	102	21	ML	@ 20': Silty SAND, very stiff, yellow brown, moist, micaceous, carbonate stringers, oxidation, laminations	
15	25			S-3	8 15 23				@ 25': black mottling observed	
									Total Depth = 26.5 Feet (bgs) No Groundwater Encountered During Drilling Backfilled on 11/8/21	
10	30									

- | | | | |
|---|--|---|--|
| SAMPLE TYPES:
B BULK SAMPLE
C CORE SAMPLE
G GRAB SAMPLE
R RING SAMPLE
S SPLIT SPOON SAMPLE
T TUBE SAMPLE | TYPE OF TESTS:
-200 % FINES PASSING
AL ATTERBERG LIMITS
CN CONSOLIDATION
CO COLLAPSE
CR CORROSION
CU UNDRAINED TRIAXIAL | DS DIRECT SHEAR
EI EXPANSION INDEX
H HYDROMETER
MD MAXIMUM DENSITY
PP POCKET PENETROMETER
RV R VALUE | SA SIEVE ANALYSIS
SE SAND EQUIVALENT
SG SPECIFIC GRAVITY
UC UNCONFINED COMPRESSIVE STRENGTH |
|---|--|---|--|



GEOTECHNICAL BORING LOG B-3

Project No. 13324.001
Project MAAC Mercado Apartments
Drilling Co. Baja Exploration
Drilling Method Hollow Stem Auger - 140lb - Autohammer - 30" Drop
Location See Figure 2

Date Drilled 11-8-21
Logged By DKJ
Hole Diameter 8"
Ground Elevation 38' msl
Sampled By DKJ

Elevation Feet	Depth Feet	Graphic Log	Attitudes	Sample No.	Blows Per 6 Inches	Dry Density pcf	Moisture Content, %	Soil Class. (U.S.C.S.)	SOIL DESCRIPTION	Type of Tests
0		N S							This Soil Description applies only to a location of the exploration at the time of sampling. Subsurface conditions may differ at other locations and may change with time. The description is a simplification of the actual conditions encountered. Transitions between soil types may be gradual.	
								SM	3" ASPHALT CONCRETE 6" AGGREGATE BASE UNDOCUMENTED ARTIFICIAL FILL (Afu) @ 0.75': Silty SAND with gravel, medium dense to dense, dark brown to brown, damp, asphalt and concrete chunks, fine-grained @ 3': becomes dark brown to black @ 4.5': becomes red brown, possible weathered paralic deposits	
35				B-1 (1'-2')						
	5			R-1	17 28 39	126	10			
30				S-1	12 16 16			SM	QUATERNARY-AGED OLD PARALIC DEPOSITS (Qop) @ 7': Silty SAND, dense, light brown with white blebs, damp, fine- to medium-grained @ 11': fine gravel layer encountered @ 14': becomes light brown with black mottling @ 15': Silty very fine SAND to Sandy SILT, very dense to very stiff, dark gray to brown, damp, friable, laminated, micaceous, oxidized	
10				R-2	18 32 34	122	7			
25				S-2	12 15 21					
20				R-3	21 40 50/4"	89	31	ML	@ 21': Sandy SILTSTONE, hard, gray, damp, shell layer below	
15									@ 24': clay content increase	
25				S-3	13 20 25			SM	@ 24.6': Silty SAND, dense, light brown, damp, friable	
10									Total Depth = 26.5 Feet (bgs) No Groundwater Encountered During Drilling Backfilled on 11/8/2021	

SAMPLE TYPES:

- B BULK SAMPLE
- C CORE SAMPLE
- G GRAB SAMPLE
- R RING SAMPLE
- S SPLIT SPOON SAMPLE
- T TUBE SAMPLE

TYPE OF TESTS:

- 200 % FINES PASSING
- AL ATTERBERG LIMITS
- CN CONSOLIDATION
- CO COLLAPSE
- CR CORROSION
- CU UNDRAINED TRIAXIAL

- DS DIRECT SHEAR
- EI EXPANSION INDEX
- H HYDROMETER
- MD MAXIMUM DENSITY
- PP POCKET PENETROMETER
- RV R VALUE

- SA SIEVE ANALYSIS
- SE SAND EQUIVALENT
- SG SPECIFIC GRAVITY
- UC UNCONFINED COMPRESSIVE STRENGTH



GEOTECHNICAL BORING LOG B-4

Project No. 13324.001
Project MAAC Mercado Apartments
Drilling Co. Baja Exploration
Drilling Method Hollow Stem Auger - 140lb - Autohammer - 30" Drop
Location See Figure 2

Date Drilled 11-8-21
Logged By DKJ
Hole Diameter 8"
Ground Elevation 37' msl
Sampled By DKJ

Elevation Feet	Depth Feet	Graphic Log	Attitudes	Sample No.	Blows Per 6 Inches	Dry Density pcf	Moisture Content, %	Soil Class. (U.S.C.S.)	SOIL DESCRIPTION	Type of Tests
This Soil Description applies only to a location of the exploration at the time of sampling. Subsurface conditions may differ at other locations and may change with time. The description is a simplification of the actual conditions encountered. Transitions between soil types may be gradual.										
0		N S							3" ASPHALT CONCRETE	
				B-1 (1'-2')				SM	7" AGGREGATE BASE	
35				B-2 (2.5'-4')				SM	UNDOCUMENTED ARTIFICIAL FILL (Afu) @ 0.83': Silty SAND, medium dense, dark brown, moist, asphalt and concrete chunks QUATERNARY-AGED OLD PARALIC DEPOSITS (Qop) @ 2.5': Silty SAND, medium dense, light brown with white blebs, damp, fine- to medium-grained	CR, EI
5				S-1	10 11 13					
30										
10				R-1	20 37 37	125	7	GM	@ 10': coarse Sandy GRAVEL	
25								SM	@ 11.5': Silty SAND, very dense, brown with black mottling, damp, slightly friable, very fine to fine grained, micaceous, laminated	
15				S-2	14 16 45			ML	@ 15': Sandy SILT, hard, yellow-brown, damp, very fine-grained, calcium carbonate stringers, oxidation	
20										
20				R-2	17 20 24	107	12	SM	@ 20': Silty SAND, dense, light brown, damp, abundant shells	
15									@ 22': shell fragments observed	
25				S-3	12 14 15				@ 25': becomes light brown, some cemented shell fragments	
10									Total Depth = 26.5 Feet (bgs) No Groundwater Encountered During Drilling Backfilled on 11/8/2021	
30										

SAMPLE TYPES:

- B BULK SAMPLE
- C CORE SAMPLE
- G GRAB SAMPLE
- R RING SAMPLE
- S SPLIT SPOON SAMPLE
- T TUBE SAMPLE

TYPE OF TESTS:

- 200 % FINES PASSING
- AL ATTERBERG LIMITS
- CN CONSOLIDATION
- CO COLLAPSE
- CR CORROSION
- CU UNDRAINED TRIAXIAL

- DS DIRECT SHEAR
- EI EXPANSION INDEX
- H HYDROMETER
- MD MAXIMUM DENSITY
- PP POCKET PENETROMETER
- RV R VALUE

- SA SIEVE ANALYSIS
- SE SAND EQUIVALENT
- SG SPECIFIC GRAVITY
- UC UNCONFINED COMPRESSIVE STRENGTH



APPENDIX C

LABORATORY TEST RESULTS

APPENDIX C

Laboratory Testing Procedures and Test Results

Direct Shear Strength Test: Direct shear testing, in accordance with ASTM D3080, was performed on a representative sample which was soaked for a minimum of 24 hours under a surcharge equal to the applied normal force during testing. After transfer of the sample to the shear box, and reloading the sample, pore pressures set up in the sample due to the transfer were allowed to dissipate for a period of approximately 1 hour prior to application of shearing force. The sample was tested under various normal loads, using a motor-driven, strain-controlled, direct-shear testing apparatus. The test results are presented in the accompanying plots.

Expansion Index Test: The expansion potential of selected materials was evaluated by the Expansion Index Text, ASTM Test Method 4829. The specimens were molded under a given compactive energy to approximately 50 percent saturation. The prepared 1-inch thick by 4-inch diameter specimens were loaded to an equivalent 144 psf surcharge and were inundated with water until volumetric equilibrium was reached. The results are presented in the table below:

Sample Location	Sample Description	Expansion Index	Expansion Potential
B-4 @ 2 to 5 Ft	Silty SAND	10	Very Low

Minimum Resistivity and pH Tests: Minimum resistivity and pH tests were performed in general accordance with Caltrans Test Method CT643 for Steel or CT532 for concrete and standard geochemical methods. The results are presented in the table below:

Sample Location	Sample Description	pH	Minimum Resistivity (ohms-cm)
B-4 @ 2 to 5 Ft	Silty SAND	7.8	1300

Chloride Content: Chloride content was tested in accordance with Caltrans Test Method CT422. The results are presented below:

Sample Location	Sample Description	Chloride Content, ppm
B-4 @ 2 to 5 Ft	Silty SAND	180

Soluble Sulfates: The soluble sulfate contents of selected samples were determined by standard geochemical methods (Caltrans Test Method CT417). The test results are presented in the table below:

Sample Location	Sample Description	Sulfate Content, ppm	Potential Degree of Sulfate Attack*
B-4 @ 2 to 5 Ft	Silty SAND	<150	S0

*Based on the 2014 edition of American Concrete Institute (ACI) Committee 318R, Table No. 4.2.1.

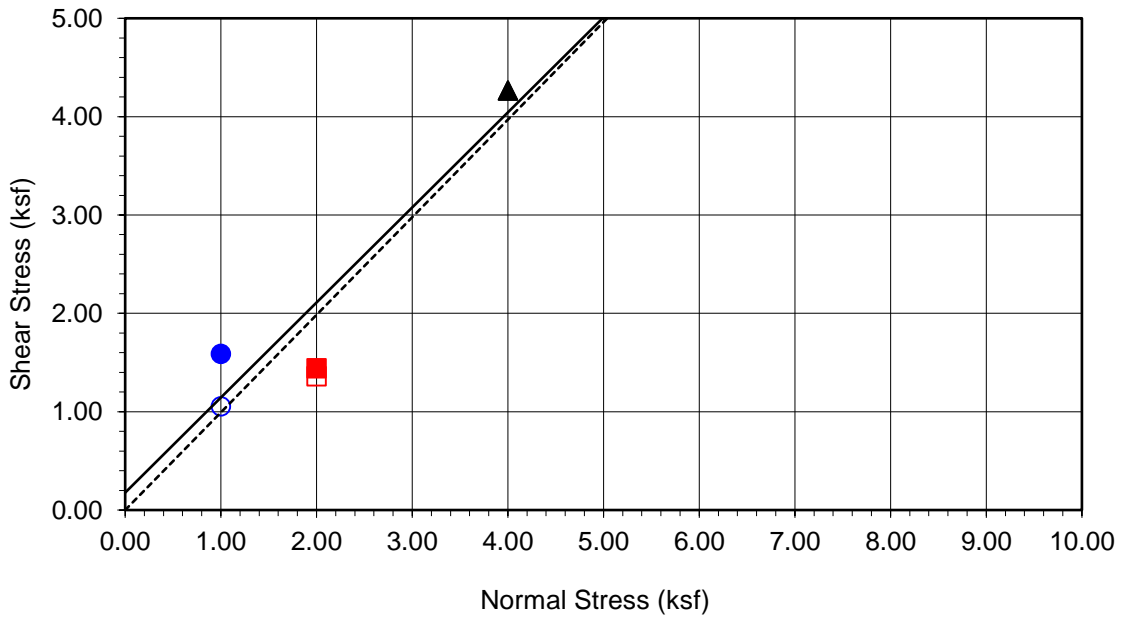
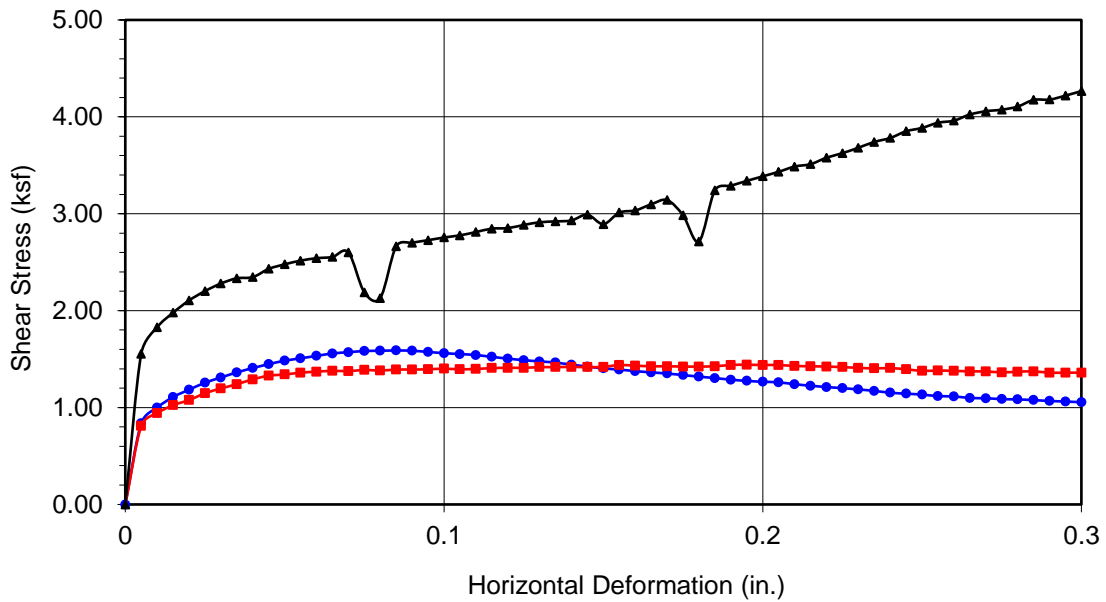

Boring No.	B-2	
Sample No.	R-1	
Depth (ft)	5	
Sample Type:	Ring	
Soil Identification:		
Clayey Sand (SC), Dark Reddish Brown.		
Strength Parameters		
	C (psf)	ϕ (°)
Peak	177	44
Ultimate	0	45

Normal Stress (kip/ft ²)	1.000	2.000	4.000
Peak Shear Stress (kip/ft ²)	● 1.589	■ 1.442	▲ 4.266
Shear Stress @ End of Test (ksf)	○ 1.055	□ 1.360	△ 4.266
Deformation Rate (in./min.)	0.0033	0.0033	0.0033
Initial Sample Height (in.)	1.000	1.000	1.000
Diameter (in.)	2.415	2.415	2.415
Initial Moisture Content (%)	10.87	10.87	10.87
Dry Density (pcf)	120.8	117.7	125.5
Saturation (%)	74.2	68.0	85.4
Soil Height Before Shearing (in.)	0.9919	0.9653	0.9579
Final Moisture Content (%)	13.8	14.1	13.8



DIRECT SHEAR TEST RESULTS
Consolidated Drained - ASTM D 3080

Project No.: 13324.001

Maac Mercado Apts Prelim Geo

APPENDIX D

**GENERAL EARTHWORK AND GRADING SPECIFICATIONS
FOR ROUGH GRADING**

LEIGHTON AND ASSOCIATES, INC.
General Earthwork and Grading Specifications

1.0 General

1.1 Intent

These General Earthwork and Grading Specifications are for the grading and earthwork shown on the approved grading plan(s) and/or indicated in the geotechnical report(s). These Specifications are a part of the recommendations contained in the geotechnical report(s). In case of conflict, the specific recommendations in the geotechnical report shall supersede these more general Specifications. Observations of the earthwork by the project Geotechnical Consultant during the course of grading may result in new or revised recommendations that could supersede these specifications or the recommendations in the geotechnical report(s).

1.2 The Geotechnical Consultant of Record

Prior to commencement of work, the owner shall employ the Geotechnical Consultant of Record (Geotechnical Consultant). The Geotechnical Consultants shall be responsible for reviewing the approved geotechnical report(s) and accepting the adequacy of the preliminary geotechnical findings, conclusions, and recommendations prior to the commencement of the grading.

Prior to commencement of grading, the Geotechnical Consultant shall review the "work plan" prepared by the Earthwork Contractor (Contractor) and schedule sufficient personnel to perform the appropriate level of observation, mapping, and compaction testing.

During the grading and earthwork operations, the Geotechnical Consultant shall observe, map, and document the subsurface exposures to verify the geotechnical design assumptions. If the observed conditions are found to be significantly different than the interpreted assumptions during the design phase, the Geotechnical Consultant shall inform the owner, recommend appropriate changes in design to accommodate the observed conditions, and notify the review agency where required. Subsurface areas to be geotechnically observed, mapped, elevations recorded, and/or tested include natural ground after it has been cleared for receiving fill but before fill is placed, bottoms of all "remedial removal" areas, all key bottoms, and benches made on sloping ground to receive fill.

The Geotechnical Consultant shall observe the moisture-conditioning and processing of the subgrade and fill materials and perform relative compaction testing of fill to determine the attained level of compaction. The Geotechnical Consultant shall provide the test results to the owner and the Contractor on a routine and frequent basis.

1.3 The Earthwork Contractor

The Earthwork Contractor (Contractor) shall be qualified, experienced, and knowledgeable in earthwork logistics, preparation and processing of ground to receive fill, moisture-conditioning and processing of fill, and compacting fill. The Contractor shall review and accept the plans, geotechnical report(s), and these Specifications prior to commencement of grading. The Contractor shall be solely responsible for performing the grading in accordance with the plans and specifications.

The Contractor shall prepare and submit to the owner and the Geotechnical Consultant a work plan that indicates the sequence of earthwork grading, the number of "spreads" of work and the estimated quantities of daily earthwork contemplated for the site prior to commencement of grading. The Contractor shall inform the owner and the Geotechnical Consultant of changes in work schedules and updates to the work plan at least 24 hours in advance of such changes so that appropriate observations and tests can be planned and accomplished. The Contractor shall not assume that the Geotechnical Consultant is aware of all grading operations.

The Contractor shall have the sole responsibility to provide adequate equipment and methods to accomplish the earthwork in accordance with the applicable grading codes and agency ordinances, these Specifications, and the recommendations in the approved geotechnical report(s) and grading plan(s). If, in the opinion of the Geotechnical Consultant, unsatisfactory conditions, such as unsuitable soil, improper moisture condition, inadequate compaction, insufficient buttress key size, adverse weather, etc., are resulting in a quality of work less than required in these specifications, the Geotechnical Consultant shall reject the work and may recommend to the owner that construction be stopped until the conditions are rectified.

2.0 Preparation of Areas to be Filled

2.1 Clearing and Grubbing

Vegetation, such as brush, grass, roots, and other deleterious material shall be sufficiently removed and properly disposed of in a method acceptable to the owner, governing agencies, and the Geotechnical Consultant.

LEIGHTON AND ASSOCIATES, INC.
General Earthwork and Grading Specifications

The Geotechnical Consultant shall evaluate the extent of these removals depending on specific site conditions. Earth fill material shall not contain more than 1 percent of organic materials (by volume). No fill lift shall contain more than 5 percent of organic matter. Nesting of the organic materials shall not be allowed.

If potentially hazardous materials are encountered, the Contractor shall stop work in the affected area, and a hazardous material specialist shall be informed immediately for proper evaluation and handling of these materials prior to continuing to work in that area.

As presently defined by the State of California, most refined petroleum products (gasoline, diesel fuel, motor oil, grease, coolant, etc.) have chemical constituents that are considered to be hazardous waste. As such, the indiscriminate dumping or spillage of these fluids onto the ground may constitute a misdemeanor, punishable by fines and/or imprisonment, and shall not be allowed.

2.2 Processing

Existing ground that has been declared satisfactory for support of fill by the Geotechnical Consultant shall be scarified to a minimum depth of 6 inches. Existing ground that is not satisfactory shall be overexcavated as specified in the following section. Scarification shall continue until soils are broken down and free of large clay lumps or clods and the working surface is reasonably uniform, flat, and free of uneven features that would inhibit uniform compaction.

2.3 Overexcavation

In addition to removals and overexcavations recommended in the approved geotechnical report(s) and the grading plan, soft, loose, dry, saturated, spongy, organic-rich, highly fractured or otherwise unsuitable ground shall be overexcavated to competent ground as evaluated by the Geotechnical Consultant during grading.

2.4 Benching

Where fills are to be placed on ground with slopes steeper than 5:1 (horizontal to vertical units), the ground shall be stepped or benched. Please see the Standard Details for a graphic illustration. The lowest bench or key shall be a minimum of 15 feet wide and at least 2 feet deep, into competent material as evaluated by the Geotechnical Consultant. Other benches shall be excavated a minimum height of 4 feet into competent material or as otherwise recommended by the Geotechnical

LEIGHTON AND ASSOCIATES, INC.
General Earthwork and Grading Specifications

Consultant. Fill placed on ground sloping flatter than 5:1 shall also be benched or otherwise overexcavated to provide a flat subgrade for the fill.

2.5 Evaluation/Acceptance of Fill Areas

All areas to receive fill, including removal and processed areas, key bottoms, and benches, shall be observed, mapped, elevations recorded, and/or tested prior to being accepted by the Geotechnical Consultant as suitable to receive fill. The Contractor shall obtain a written acceptance from the Geotechnical Consultant prior to fill placement. A licensed surveyor shall provide the survey control for determining elevations of processed areas, keys, and benches.

3.0 Fill Material

3.1 General

Material to be used as fill shall be essentially free of organic matter and other deleterious substances evaluated and accepted by the Geotechnical Consultant prior to placement. Soils of poor quality, such as those with unacceptable gradation, high expansion potential, or low strength shall be placed in areas acceptable to the Geotechnical Consultant or mixed with other soils to achieve satisfactory fill material.

3.2 Oversize

Oversize material defined as rock, or other irreducible material with a maximum dimension greater than 8 inches, shall not be buried or placed in fill unless location, materials, and placement methods are specifically accepted by the Geotechnical Consultant. Placement operations shall be such that nesting of oversized material does not occur and such that oversize material is completely surrounded by compacted or densified fill. Oversize material shall not be placed within 10 vertical feet of finish grade or within 2 feet of future utilities or underground construction.

3.3 Import

If importing of fill material is required for grading, proposed import material shall meet the requirements of Section 3.1. The potential import source shall be given to the Geotechnical Consultant at least 48 hours (2 working days) before importing begins so that its suitability can be determined and appropriate tests performed.

4.0 Fill Placement and Compaction

4.1 Fill Layers

Approved fill material shall be placed in areas prepared to receive fill (per Section 3.0) in near-horizontal layers not exceeding 8 inches in loose thickness. The Geotechnical Consultant may accept thicker layers if testing indicates the grading procedures can adequately compact the thicker layers. Each layer shall be spread evenly and mixed thoroughly to attain relative uniformity of material and moisture throughout.

4.2 Fill Moisture Conditioning

Fill soils shall be watered, dried back, blended, and/or mixed, as necessary to attain a relatively uniform moisture content at or slightly over optimum. Maximum density and optimum soil moisture content tests shall be performed in accordance with the American Society of Testing and Materials (ASTM Test Method D1557).

4.3 Compaction of Fill

After each layer has been moisture-conditioned, mixed, and evenly spread, it shall be uniformly compacted to not less than 90 percent of maximum dry density (ASTM Test Method D1557). Compaction equipment shall be adequately sized and be either specifically designed for soil compaction or of proven reliability to efficiently achieve the specified level of compaction with uniformity.

4.4 Compaction of Fill Slopes

In addition to normal compaction procedures specified above, compaction of slopes shall be accomplished by backrolling of slopes with sheepfoot rollers at increments of 3 to 4 feet in fill elevation, or by other methods producing satisfactory results acceptable to the Geotechnical Consultant. Upon completion of grading, relative compaction of the fill, out to the slope face, shall be at least 90 percent of maximum density per ASTM Test Method D1557.

4.5 Compaction Testing

Field-tests for moisture content and relative compaction of the fill soils shall be performed by the Geotechnical Consultant. Location and frequency of tests shall be at the Consultant's discretion based on field conditions encountered. Compaction test locations will not necessarily be selected on a random basis. Test locations shall be selected to verify adequacy of compaction levels in areas that are judged to be prone to

LEIGHTON AND ASSOCIATES, INC.
General Earthwork and Grading Specifications

inadequate compaction (such as close to slope faces and at the fill/bedrock benches).

4.6 Frequency of Compaction Testing

Tests shall be taken at intervals not exceeding 2 feet in vertical rise and/or 1,000 cubic yards of compacted fill soils embankment. In addition, as a guideline, at least one test shall be taken on slope faces for each 5,000 square feet of slope face and/or each 10 feet of vertical height of slope. The Contractor shall assure that fill construction is such that the testing schedule can be accomplished by the Geotechnical Consultant. The Contractor shall stop or slow down the earthwork construction if these minimum standards are not met.

4.7 Compaction Test Locations

The Geotechnical Consultant shall document the approximate elevation and horizontal coordinates of each test location. The Contractor shall coordinate with the project surveyor to assure that sufficient grade stakes are established so that the Geotechnical Consultant can determine the test locations with sufficient accuracy. At a minimum, two grade stakes within a horizontal distance of 100 feet and vertically less than 5 feet apart from potential test locations shall be provided.

5.0 Subdrain Installation

Subdrain systems shall be installed in accordance with the approved geotechnical report(s), the grading plan, and the Standard Details. The Geotechnical Consultant may recommend additional subdrains and/or changes in subdrain extent, location, grade, or material depending on conditions encountered during grading. All subdrains shall be surveyed by a land surveyor/civil engineer for line and grade after installation and prior to burial. Sufficient time should be allowed by the Contractor for these surveys.

6.0 Excavation

Excavations, as well as over-excavation for remedial purposes, shall be evaluated by the Geotechnical Consultant during grading. Remedial removal depths shown on geotechnical plans are estimates only. The actual extent of removal shall be determined by the Geotechnical Consultant based on the field evaluation of exposed conditions during grading. Where fill-over-cut slopes are to be graded, the cut portion of the slope shall be made, evaluated, and accepted by the Geotechnical Consultant prior to placement of materials for construction of the fill portion of the slope, unless otherwise recommended by the Geotechnical Consultant.

LEIGHTON AND ASSOCIATES, INC.
General Earthwork and Grading Specifications

7.0 Trench Backfills

7.1 Safety

The Contractor shall follow all OSHA and Cal/OSHA requirements for safety of trench excavations.

7.2 Bedding and Backfill

All bedding and backfill of utility trenches shall be performed in accordance with the applicable provisions of Standard Specifications of Public Works Construction. Bedding material shall have a Sand Equivalent greater than 30 (SE>30). The bedding shall be placed to 1 foot over the top of the conduit and densified. Backfill shall be placed and densified to a minimum of 90 percent of relative compaction from 1 foot above the top of the conduit to the surface.

The Geotechnical Consultant shall test the trench backfill for relative compaction. At least one test should be made for every 300 feet of trench and 2 feet of fill.

7.3 Lift Thickness

Lift thickness of trench backfill shall not exceed those allowed in the Standard Specifications of Public Works Construction unless the Contractor can demonstrate to the Geotechnical Consultant that the fill lift can be compacted to the minimum relative compaction by his alternative equipment and method.

7.4 Observation and Testing

The densification of the bedding around the conduits shall be observed by the Geotechnical Consultant.

FILL SLOPE

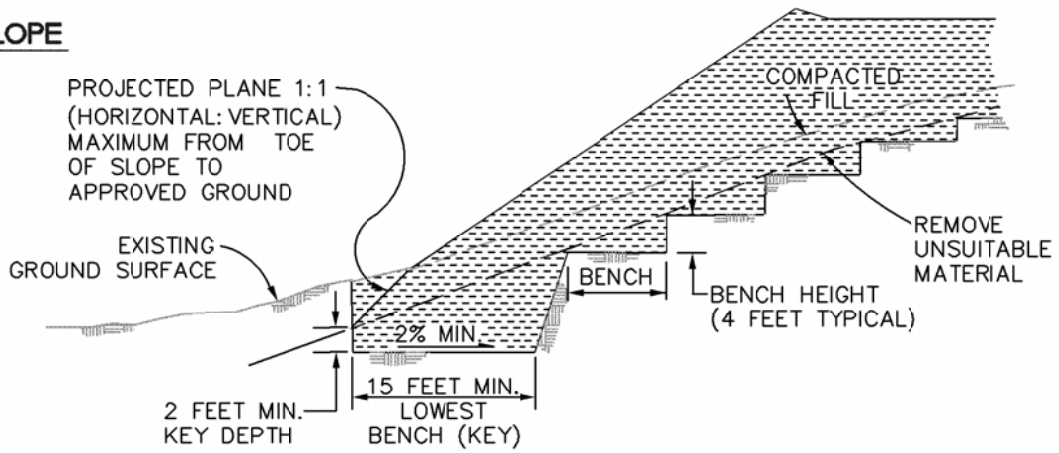

FILL-OVER-CUT SLOPE

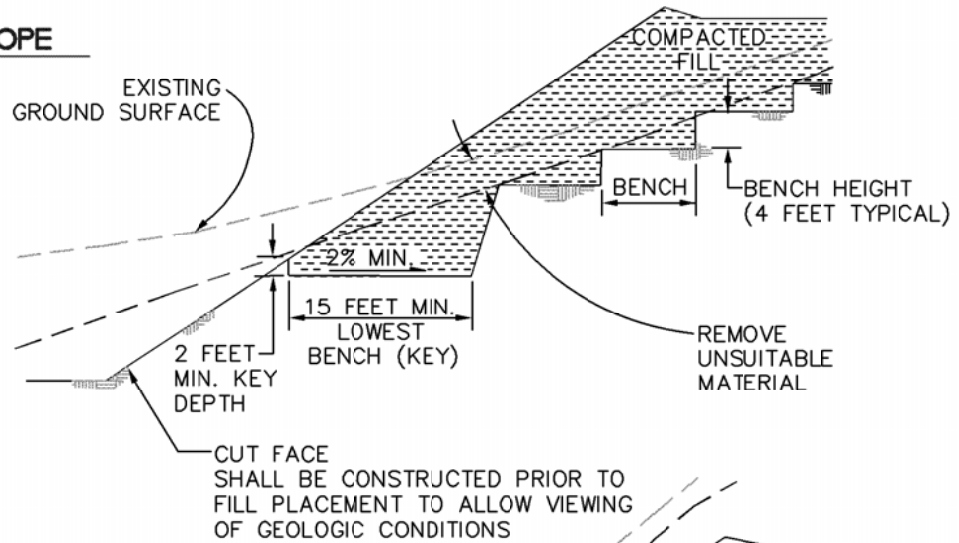

CUT-OVER-FILL SLOPE

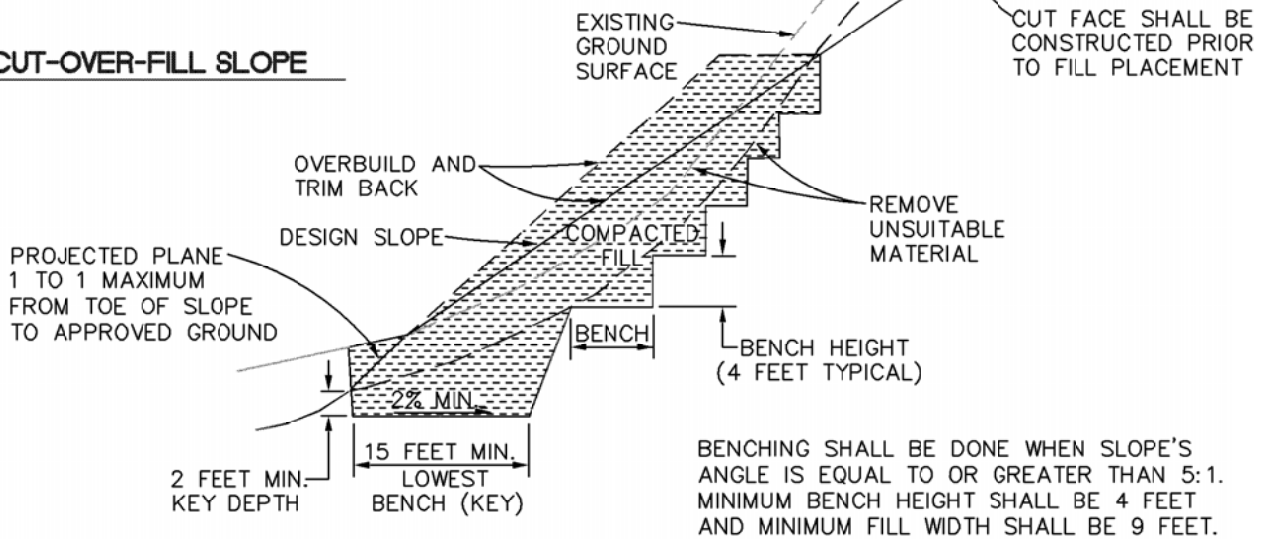

KEYING AND BENCHING

GENERAL EARTHWORK AND
GRADING SPECIFICATIONS
STANDARD DETAIL A



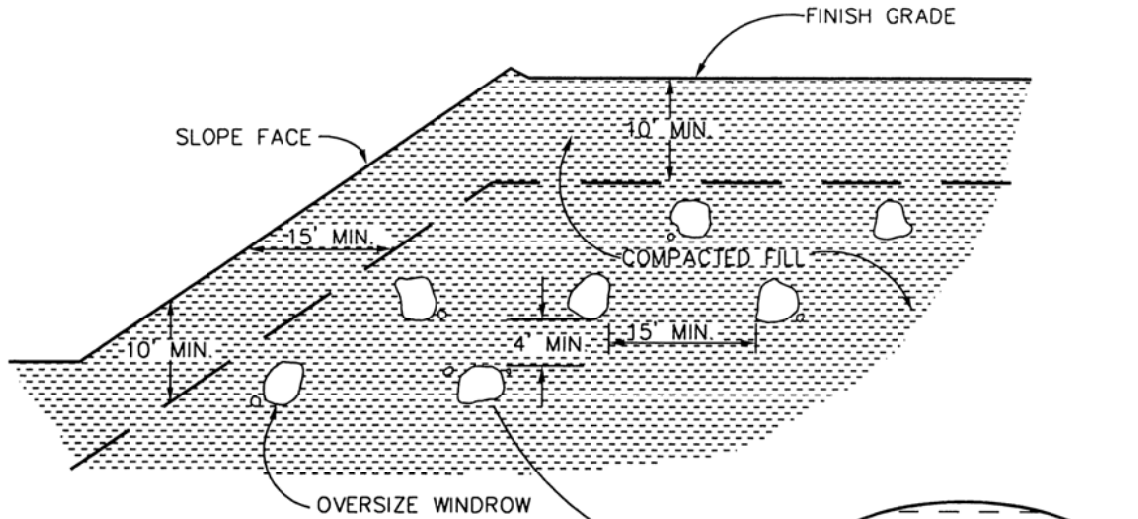

- * OVERSIZE ROCK IS LARGER THAN 8 INCHES IN LARGEST DIMENSION.
- * EXCAVATE A TRENCH IN THE COMPACTED FILL DEEP ENOUGH TO BURY ALL THE ROCK.
- * BACKFILL WITH GRANULAR SOIL JETTED OR FLOODED IN PLACE TO FILL ALL THE VOIDS.
- * DO NOT BURY ROCK WITHIN 10 FEET OF FINISH GRADE.
- * WINDROW OF BURIED ROCK SHALL BE PARALLEL TO THE FINISHED SLOPE.

GRANULAR MATERIAL TO BE DENSIFIED IN PLACE BY FLOODING OR JETTING.

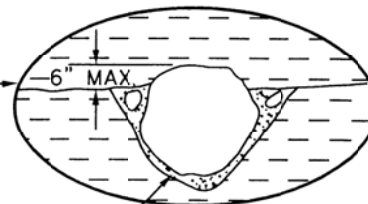

DETAIL

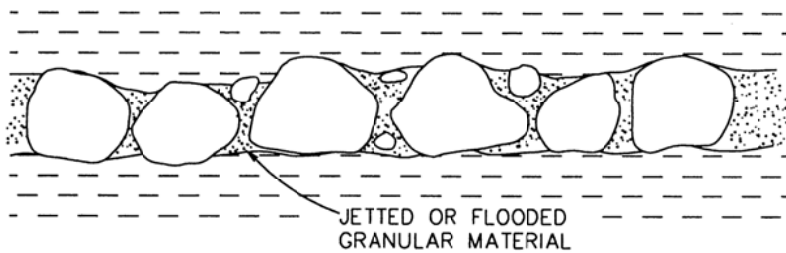

TYPICAL PROFILE ALONG WINDROW

OVERSIZE ROCK DISPOSAL

GENERAL EARTHWORK AND GRADING SPECIFICATIONS
STANDARD DETAIL B



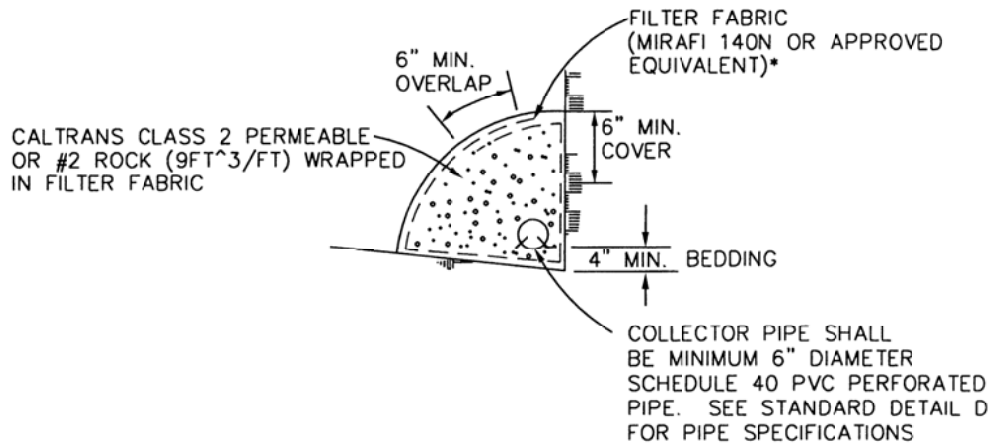
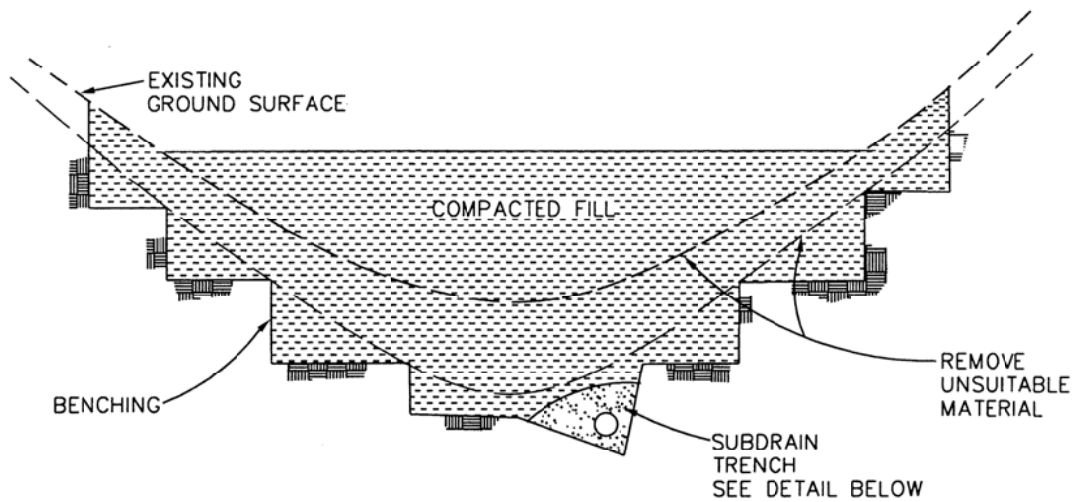

SUBDRAIN DETAIL

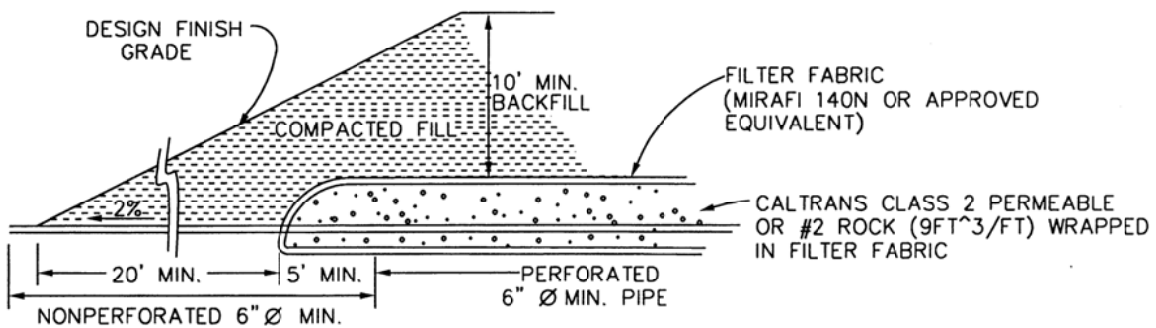

DETAIL OF CANYON SUBDRAIN OUTLET

CANYON SUBDRAINS

GENERAL EARTHWORK AND GRADING SPECIFICATIONS
STANDARD DETAIL C



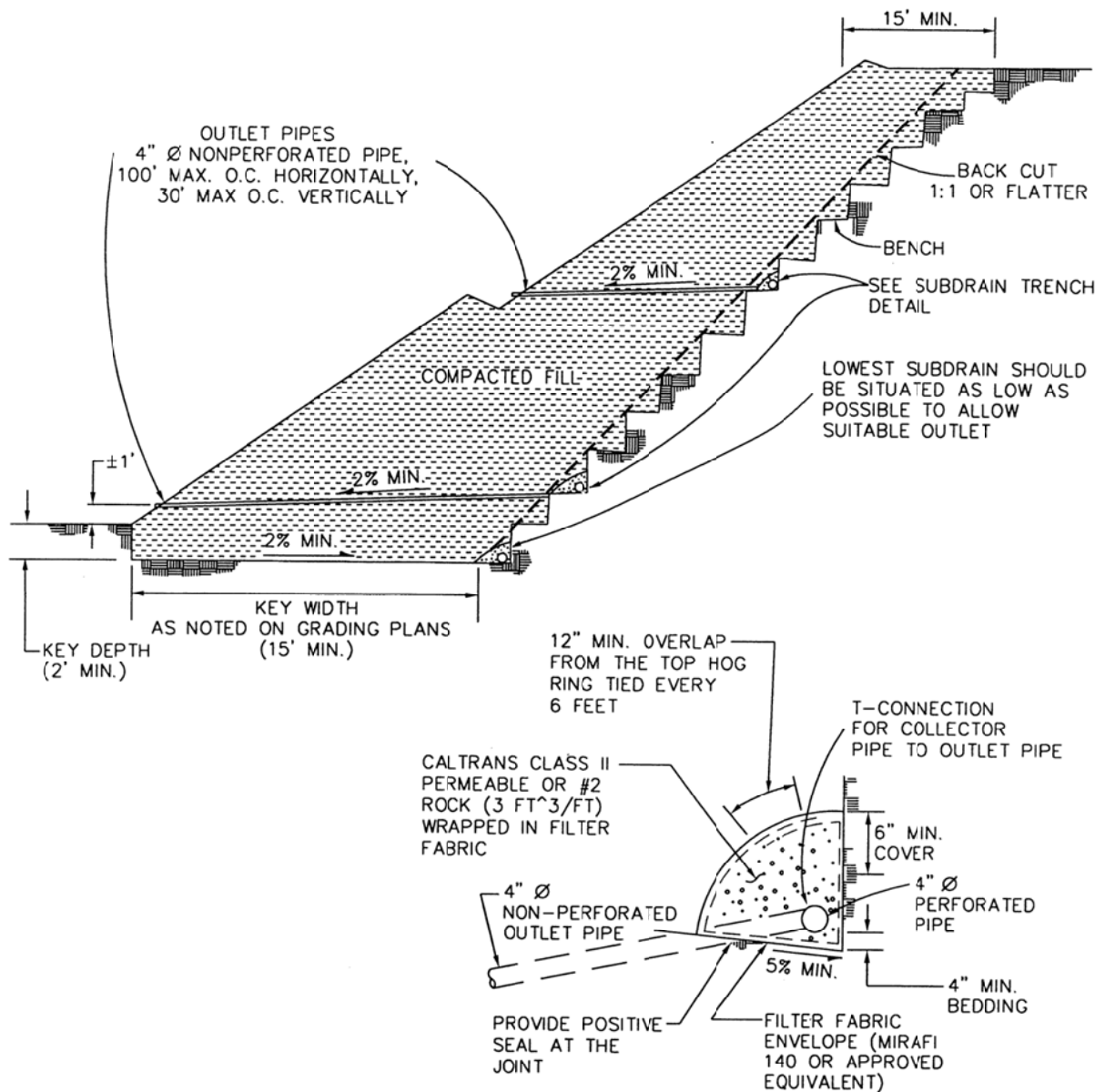

SUBDRAIN TRENCH DETAIL

SUBDRAIN INSTALLATION – subdrain collector pipe shall be installed with perforation down or, unless otherwise designated by the geotechnical consultant. Outlet pipes shall be non-perforated pipe. The subdrain pipe shall have at least 8 perforations uniformly spaced per foot. Perforation shall be 1/4" to 1/2" if drill holes are used. All subdrain pipes shall have a gradient of at least 2% towards the outlet.

SUBDRAIN PIPE – Subdrain pipe shall be ASTM D2751, SDR 23.5 or ASTM D1527, Schedule 40, or ASTM D3034, SDR 23.5, Schedule 40 Polyvinyl Chloride Plastic (PVC) pipe.

All outlet pipe shall be placed in a trench no wider than twice the subdrain pipe.

**BUTTRESS OR
REPLACEMENT
FILL SUBDRAINS**

**GENERAL EARTHWORK AND
GRADING SPECIFICATIONS
STANDARD DETAIL D**



CUT-FILL TRANSITION LOT OVEREXCAVATION

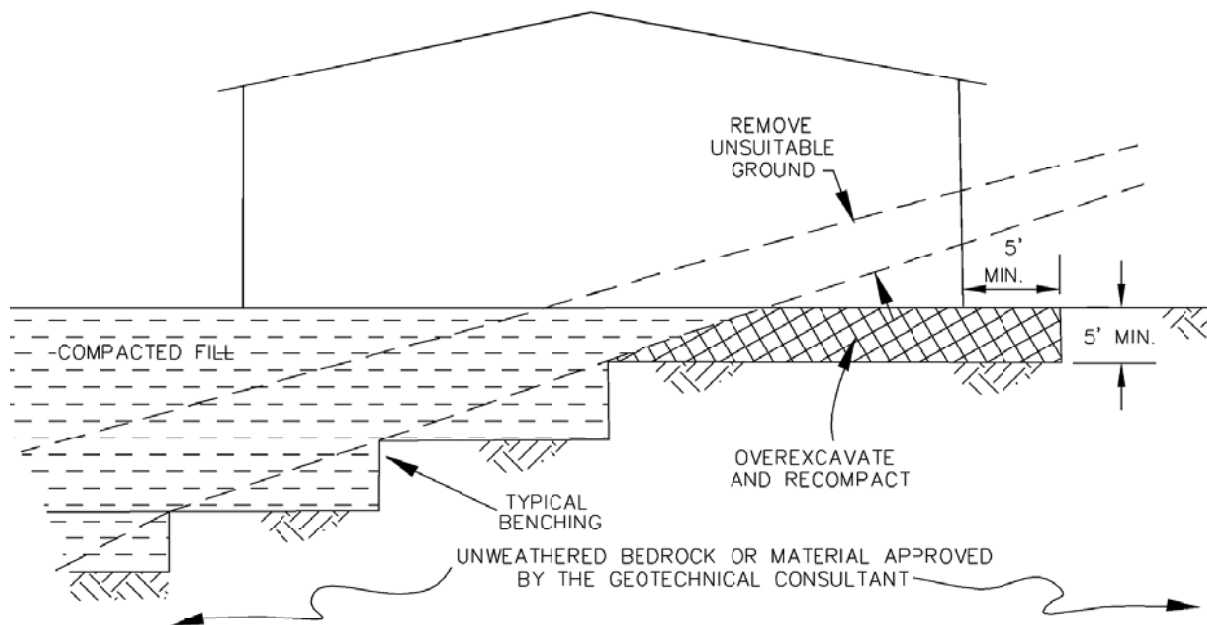

TRANSITION LOT FILLS

GENERAL EARTHWORK AND
GRADING SPECIFICATIONS
STANDARD DETAIL E



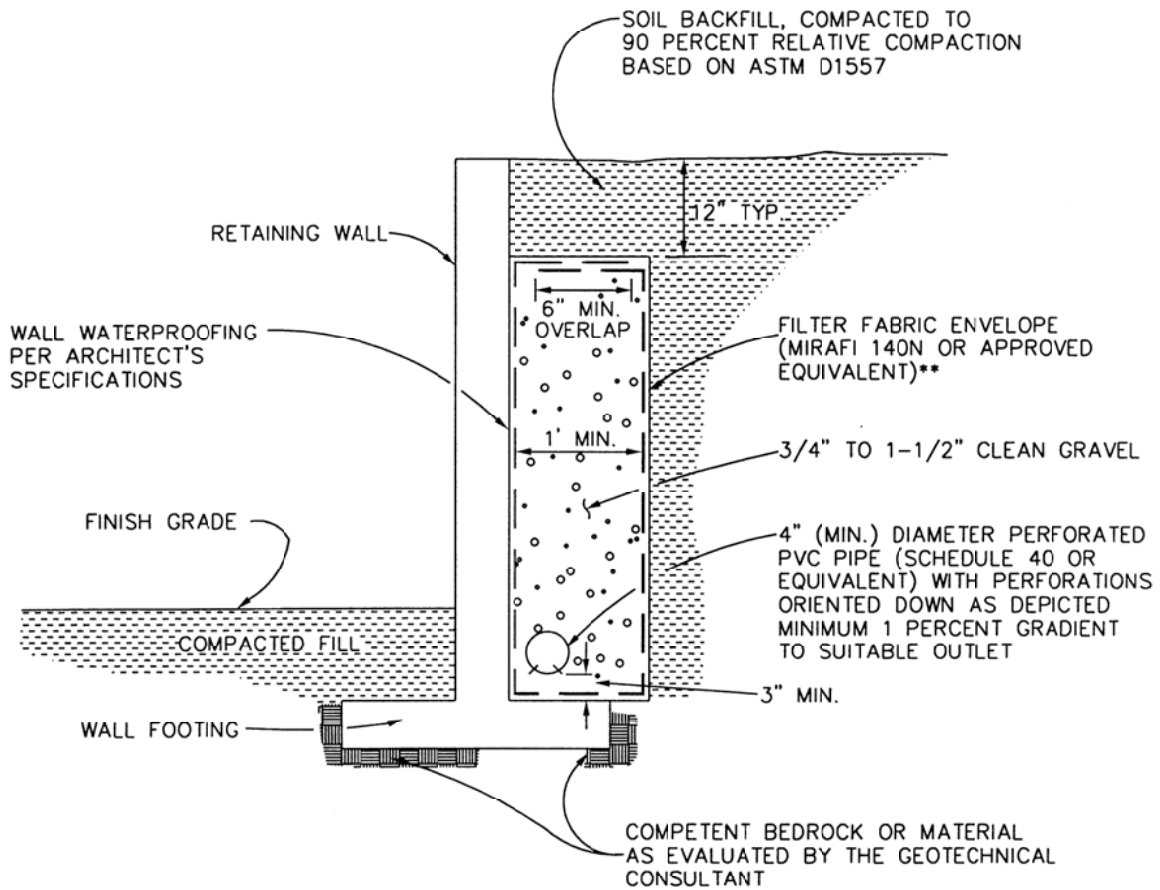

NOTE: UPON REVIEW BY THE GEOTECHNICAL CONSULTANT, COMPOSITE DRAINAGE PRODUCTS SUCH AS MIRADRAIN OR J-DRAIN MAY BE USED AS AN ALTERNATIVE TO GRAVEL OR CLASS 2 PERMEABLE MATERIAL. INSTALLATION SHOULD BE PERFORMED IN ACCORDANCE WITH MANUFACTURER'S SPECIFICATIONS.

RETAINING WALL DRAINAGE

GENERAL EARTHWORK AND
GRADING SPECIFICATIONS
STANDARD DETAIL F



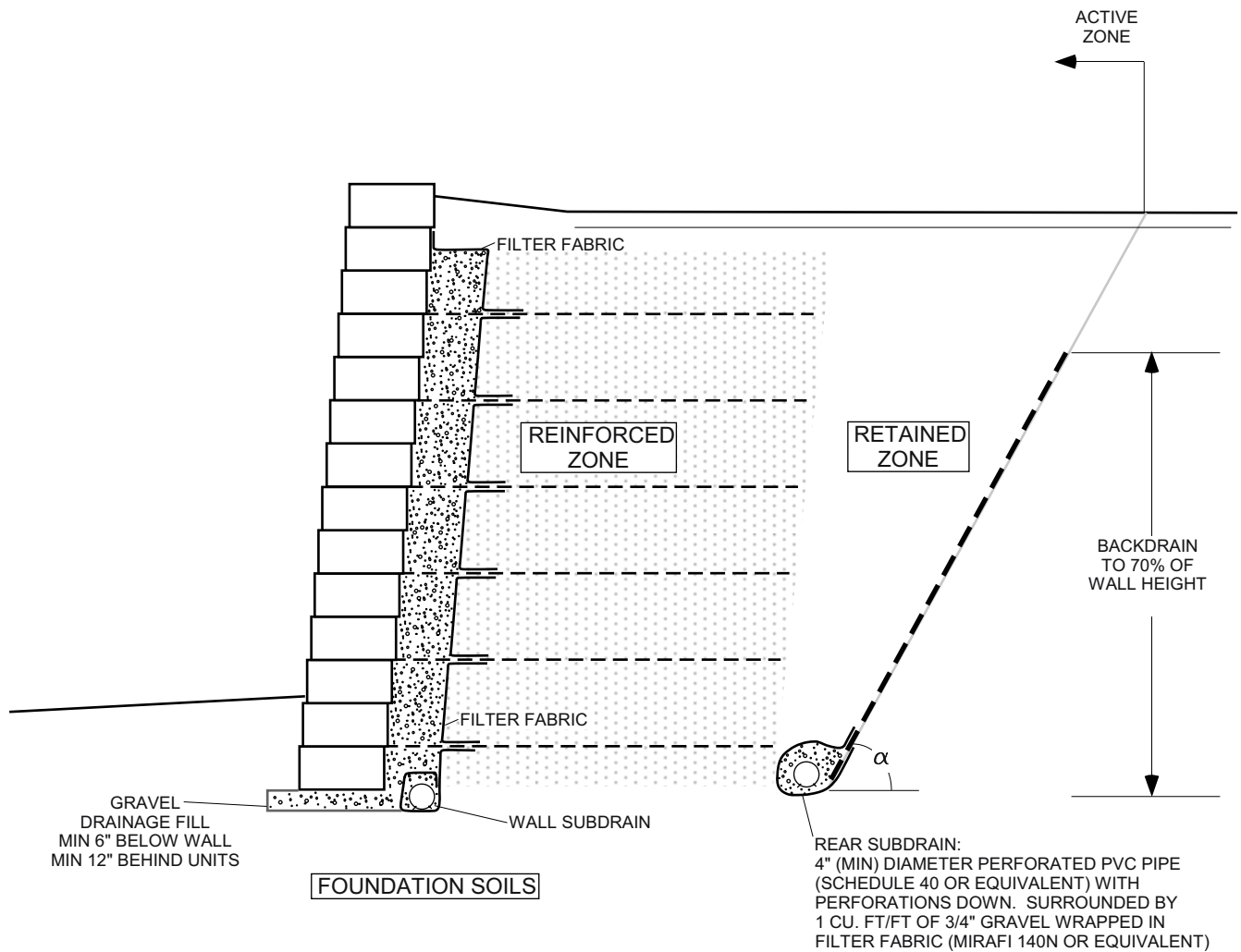

NOTES:

1) MATERIAL GRADATION AND PLASTICITY
REINFORCED ZONE:

SIEVE SIZE	% PASSING
1 INCH	100
NO. 4	20-100
NO. 40	0-60
NO. 200	0-35

FOR WALL HEIGHT < 10 FEET, PLASTICITY INDEX < 20
 FOR WALL HEIGHT 10 TO 20 FEET, PLASTICITY INDEX < 10
 FOR TIERED WALLS, USE COMBINED WALL HEIGHTS
 WALL DESIGNER TO REQUEST SITE-SPECIFIC CRITERIA FOR WALL HEIGHT > 20 FEET

GRAVEL DRAINAGE FILL:

SIEVE SIZE	% PASSING
1 INCH	100
3/4 INCH	75-100
NO. 4	0-60
NO. 40	0-50
NO. 200	0-5

OUTLET SUBDRAINS EVERY 100 FEET, OR CLOSER, BY TIGHTLINE TO SUITABLE PROTECTED OUTLET

- CONTRACTOR TO USE SOILS WITHIN THE RETAINED AND REINFORCED ZONES THAT MEET THE STRENGTH REQUIREMENTS OF WALL DESIGN.
- GEOGRID REINFORCEMENT TO BE DESIGNED BY WALL DESIGNER CONSIDERING INTERNAL, EXTERNAL, AND COMPOUND STABILITY.
- GEOGRID TO BE PRETENSIONED DURING INSTALLATION.
- IMPROVEMENTS WITHIN THE ACTIVE ZONE ARE SUSCEPTIBLE TO POST-CONSTRUCTION SETTLEMENT. ANGLE $\alpha = 45 + \phi/2$, WHERE ϕ IS THE FRICTION ANGLE OF THE MATERIAL IN THE RETAINED ZONE.
- BACKDRAIN SHOULD CONSIST OF J-DRAIN 302 (OR EQUIVALENT) OR 6-INCH THICK DRAINAGE FILL WRAPPED IN FILTER FABRIC. PERCENT COVERAGE OF BACKDRAIN TO BE PER GEOTECHNICAL REVIEW.

SEGMENTAL RETAINING WALLS

GENERAL EARTHWORK AND
GRADING SPECIFICATIONS
STANDARD DETAIL G

