

# Appendix E

---

Geotechnical Report

# DRAFT GEOTECHNICAL REPORT

Kern River Intake Replacement Project  
Kern County, California



Submitted To:

Mr. Andrew Borgic, P.E.  
**WATER WORKS ENGINEERS**  
1515 W 190th Street, Suite 225  
Gardena, CA 90248



Prepared by:  
Bajada Geosciences, Inc.

January 16, 2023  
Project No. 2101.0141



**TABLE OF CONTENTS**  
**GEOTECHNICAL REPORT**  
**KERN RIVER INTAKE REPLACEMENT PROJECT**  
**CALIFORNIA WATER SERVICE**  
**KERNVILLE, KERN COUNTY, CALIFORNIA**

<b>1</b>	<b>GENERAL</b> .....	<b>1</b>
1.1	PROJECT UNDERSTANDING & LOCATION .....	1
1.2	SCOPE OF SERVICES .....	2
1.3	PREVIOUS WORK PERFORMED & REFERENCES REVIEWED.....	3
<b>2</b>	<b>FINDINGS</b> .....	<b>4</b>
2.1	FIELD INVESTIGATION.....	4
2.2	SITE CONDITIONS.....	4
2.2.1	<i>Surface Conditions</i> .....	4
2.2.2	<i>Subsurface Conditions</i> .....	4
2.3	GEOLOGIC CONDITIONS .....	5
2.3.1	<i>Regional Geology</i> .....	5
2.3.2	<i>Local Geologic Setting</i> .....	6
2.3.3	<i>Groundwater</i> .....	6
<b>3</b>	<b>GEOLOGIC HAZARDS</b> .....	<b>7</b>
3.1	REGULATORY SEISMIC SETTING.....	7
3.2	CBC SEISMIC DESIGN RECOMMENDATIONS.....	7
3.3	PROBABILISTIC ESTIMATES OF STRONG GROUND MOTION .....	8
3.4	LIQUEFACTION & LATERAL SPREADING.....	9
3.5	EXPANSION POTENTIAL.....	10
3.6	SOIL CHEMISTRY .....	10
<b>4</b>	<b>CONCLUSIONS AND RECOMMENDATIONS</b> .....	<b>12</b>
4.1	GENERAL.....	12
4.2	GEOLOGIC HAZARDS.....	12
4.3	SITE PREPARATION AND GRADING .....	12
4.3.1	<i>Stripping</i> .....	12
4.3.2	<i>Existing Utilities, Wells, and/or Foundations</i> .....	12
4.3.3	<i>Keying and Benching</i> .....	13
4.3.4	<i>Wet/Unstable Soil Conditions</i> .....	13
4.3.5	<i>Site Drainage</i> .....	13
4.3.6	<i>Excavation Characteristics</i> .....	13
4.3.7	<i>Overexcavation</i> .....	14
4.3.8	<i>On-Site Soil Materials</i> .....	14
4.3.9	<i>Engineered Fill Materials and Placement</i> .....	14
4.3.9.1	General Engineered Fill .....	14
4.3.9.2	Structural Fill.....	14
4.3.10	<i>Controlled Low Strength Material</i> .....	15
4.3.11	<i>Placement &amp; Compaction</i> .....	15
4.4	FOUNDATIONS & SLABS.....	16
4.4.1	<i>Transition Lots</i> .....	16
4.4.2	<i>Foundation Subgrade Preparation</i> .....	16
4.4.3	<i>General Foundation Design Considerations</i> .....	16

**TABLE OF CONTENTS (continued)**  
**GEOTECHNICAL REPORT**  
**KERN RIVER INTAKE REPLACEMENT PROJECT**  
**CALIFORNIA WATER SERVICE**  
**KERNVILLE, KERN COUNTY, CALIFORNIA**

4.4.3.1	Scour and Degradation .....	16
4.4.3.2	Bearing Pressure and Settlement .....	17
4.4.3.3	Sliding Resistance.....	17
4.4.3.4	Passive Resistance.....	17
4.4.3.5	Safety Factors.....	17
4.4.4	<i>Lateral Earth Pressures</i> .....	18
4.4.5	<i>Frost Penetration</i> .....	18
4.4.6	<i>Slab-on-Grade Design</i> .....	18
4.5	PIPELINES & TRENCH BACKFILL.....	19
4.5.1	<i>External Loads on Buried Pipelines</i> .....	19
4.5.2	<i>Modulus of Soil Reaction (E')</i> .....	21
4.5.3	<i>Thrust Resistance</i> .....	22
4.5.4	<i>Excavations, Trenches, Dewatering, &amp; Shoring</i> .....	22
4.5.4.1	Excavation and Trench Slopes.....	22
4.5.4.2	Dewatering .....	24
4.5.4.3	Shoring.....	24
4.5.5	<i>Pipe Zone &amp; Trench Zone Materials</i> .....	26
4.5.5.1	Pipe Zone Backfill .....	26
4.5.5.2	Trench Zone Backfill .....	26
4.5.5.3	Controlled Low Strength Backfill.....	26
4.5.6	<i>Placement &amp; Compaction</i> .....	27
4.5.7	<i>Trench Subgrade Stabilization</i> .....	27
5	<b>REVIEW OF PLANS AND SPECIFICATIONS</b> .....	<b>28</b>
6	<b>LIMITATIONS</b> .....	<b>28</b>
7	<b>REFERENCES</b> .....	<b>30</b>

**PLATES**

Plate 1 .....	Site Location Map
Plate 2 .....	Project Elements
Plate 3 .....	Geotechnical Map
Plate 4 .....	Regional Geology
Plate 5 .....	Regional Fault Map
Plate 6 .....	Marston's Load Coefficients
Plate 7 .....	Vertical Soil Pressures Induced by Live Loads
Plate 8 .....	Preliminary Shoring Pressure Diagrams
Plate 9 .....	Trench Nomenclature

**APPENDICES**

Appendix A.....	Subsurface Exploration
Appendix B.....	Laboratory Testing
Appendix C.....	Previous Work by Others in Project Vicinity

## 1 GENERAL

Bajada Geosciences, Inc. (BAJADA), is pleased to present this geotechnical study to Water Works Engineers, LLC (WWE) to provide geotechnical services for the design of a new water intake structure for California Water Service (Cal Water) along the Kern River in the Kernville area, Kern County, California. The project site location is shown on Plate 1 – Site Location Map. Bajada Geosciences, Inc. (BAJADA) has prepared this report at the request of Water Works Engineers, LLC (WWE). Our services were performed in general accordance with our proposal dated June 10, 2022.

The following sections present our understanding of the project, the purpose of our study, and the geotechnical findings, conclusions, and recommendations for the project.

### 1.1 PROJECT UNDERSTANDING & LOCATION

We understand that Cal Water operates the Kernville Water Treatment Plant to service the Kernville community. Water for the WTP is derived from existing intakes from the adjacent Kern River. We understand that the primary intake infiltration gallery can currently deliver only about 10 to 20 percent of the water needs for the WTP and that a temporary emergency water intake has been installed to increase the water availability.

To improve the water intake for the WTP, we understand that an in-channel intake system with a self-cleaning cone screen is proposed near where the existing emergency water intake pipeline is located. We understand that the project will include a new intake structure and a new pump and vault structure (station). The new intake will be a concrete structure situated along the western bank of the Kern River and will have a bottom depth located about a foot below the river thalweg. The structure will be about 25 feet long (oriented parallel to the river) and 20 feet wide and will have riprap placed upstream and downstream of the structure along the riverbanks. The station structure will be located west of the new intake and will pump the water from the intake to the WTP for treatment. Improvement locations are shown on Plate 2 – Project Elements.

The project property is located east of 2 Sirretta Street, Kernville, California, on Assessor's Parcel Number 082-030-06. Latitude and longitude for the approximate center of the proposed structure are as follows:

## APPROXIMATE PROJECT COORDINATES

Coordinates	Latitude	Longitude
Latitude	35° 45' 20.67"	35.755644°
Longitude	-118° 25' 22.21"	-118.422843°

### 1.2 SCOPE OF SERVICES

Services performed for this study are in general conformance with the proposed scope of services presented in our June 10, 2022, proposal. Our scope of services included:

- Reconnaissance of the site surface conditions;
- Review of pertinent, selected regional geological data;
- Advancement of one exploratory test pit. Exploration procedures and the Log of Test Pit are presented in Appendix A – Subsurface Exploration;
- Performance of laboratory testing on selected samples obtained during our field investigation. Laboratory test procedures and results of those tests are presented in Appendix B – Laboratory Testing;
- Marking exploration locations and contacting Underground Service Alert (USA) to identify potential buried utility conflicts, in accordance with California law;
- Logging of soils and rocks exposed in the explorations using the Unified Soil Classification System (USCS). The test pit was backfilled once logging and sampling were completed;
- Estimating the exploration location using a compass and tape measure from known geographic control points at the site and by use of a handheld Global Position System (GPS) receiver;
- Delivering soil samples obtained during exploration to BAJADA's office for assignment of laboratory testing;
- Preparation of this report, which includes:
  - A description of the proposed project;
  - A summary of our field exploration and laboratory testing programs;
  - A description of site surface and subsurface conditions encountered during our field investigation;
  - 2019 California Building Code (CBC) seismic design criteria;
  - Geotechnical recommendations for:
    - Site preparation, engineered fill, site drainage, and subgrades;
    - Suitability of on-site materials for use as engineered fill; and,
    - Foundation design.

### **1.3 PREVIOUS WORK PERFORMED & REFERENCES REVIEWED**

No previous geotechnical studies are known to have been performed at the site. A search for subsurface explorations proximal to the site was performed through the State's Geotracker database (Geotracker, 2022), and found no nearby reported information. A search through Caltrans GeoDOG database (2022) provided a foundation investigation report (Moore & Taber, 1967) and other pertinent documents for the Kern River Bridge over the Kern River, located adjacent to and south of the proposed intake structure project site. A copy of this information is presented in Appendix C – Previous Work by Others in Project Vicinity. Other information reviewed during this study is referenced in the text and in Section 7 of this report.

DRAFT

## 2 FINDINGS

### 2.1 FIELD INVESTIGATION

Our field geotechnical investigation consisted of reconnaissance-level geologic mapping of the project site and subsurface exploration through advancement of one exploratory test pit to a depth of approximately 10 feet below existing grade. The approximate elevation of the ground surface at the test pit location was estimated to be 2,641 feet based on the Site Plan (Sheet C-002) dated October 2022 provided by WWE. The test pit was advanced on November 22, 2022, using a backhoe (CAT 420F IT with a 2-foot-wide bucket) provided by Golden Excavation Company and was backfilled with the excavated material upon completion. The approximate exploration location is shown on Plate 3 – Geotechnical Map. Descriptions of soils encountered are presented on the test pit log (Plate A-1.1) included in Appendix A.

### 2.2 SITE CONDITIONS

#### 2.2.1 Surface Conditions

The project site consists of an upper, relatively flat and level area with an average elevation of about 2,641 feet, where the proposed station structure will be located, and a lower gently sloping area adjacent to the river where the new intake structure will be constructed. One existing emergency pump house, a raw water intake structure, an electric pull box, and a small portion of exposed intake piping are located on the property. The existing pump house on the property houses instrumentation, equipment, chemicals, and various other supplies within the fenced facility. The site is largely unpaved, except for access to the front gate. The remainder of the site is covered with gravel. West of the site is bounded by the Kernville Riverview Lodge. South and east of the property is the Kern River, and north of the site is the Camp Kernville RV Park.

#### 2.2.2 Subsurface Conditions

Subsurface conditions were explored at a location situated between the existing facility and the proposed new water intake structure, as shown on Plate 2. Based on our observations from the test pit, the subsurface materials in the upper approximately eight feet of the soil column consisted of dry to moist, generally loose to medium dense, interbedded sandy gravel and gravelly sand with some silt and abundant medium to coarse well rounded to rounded gravels and cobbles. Trace amounts of organic materials were observed to a depth of about four feet.

Below a depth of about eight feet, soils consisted of moist to wet, generally loose to medium dense, fine to coarse sand with varying amounts of gravel, cobbles, and boulders. Those materials appeared to be intact alluvial sediments from the Kern River. Groundwater was



observed at a depth of about nine feet below the existing grade with flowing sands experienced above and below the observed water table. This depth corresponds to an elevation of approximately 2,631 feet, which appeared to be at or slightly above the elevation of water in the adjacent Kern River at the time of our subsurface exploration.

## **2.3 GEOLOGIC CONDITIONS**

### **2.3.1 Regional Geology**

The project site is located in the Sierra Nevada Physiographic province. The Sierra Nevada province is bordered to the north by the Cascade Physiographic province, to the east by the Modoc Plateau and Basin and Range Physiographic provinces, to the west by the Great Valley Physiographic province, and to the south by the Mojave Desert Physiographic province.

The Sierra Nevada province is dominated by the strongly asymmetric mountain range of the Sierra Nevada, which has a long, gentle western slope and a high, steep eastern escarpment (Bateman and Wahrhaftig, 1966). The geologic history of the Sierra Nevada can be divided into five broad phases. The first phase consisted of the formation and accretion of an assemblage of metamorphic rocks to the ancestral western North American continent during the Sonoman Orogeny in latest Paleozoic to early Mesozoic time (Schweiekert and Snyder, 1981). In later Mesozoic time, the Paleozoic rocks were intruded and further metamorphosed by large masses of granitic rock, and the area was eroded to a depth of approximately 5 miles (Bateman and Wahrhaftig, 1966). Later in Cenozoic time, after a short period of inactivity, the area was uplifted and tilted as west-flowing rivers cut valleys into the ancestral Sierra Nevada. This was followed by Late Cenozoic volcanic activity that delivered copious amounts of material from volcanoes positioned along the crest and east of the range. Lastly, the area was eroded by fluvial and later glacial processes to form the landscape we see today.

Rocks within the Sierra Nevada are divided into two broad categories: the subjacent series and the superjacent series. The subjacent series rocks form the basement material of the Sierra Nevada and consist of Mesozoic granitic rocks and Mesozoic and Paleozoic metamorphic rocks. The superjacent series generally consist of Cenozoic sedimentary and volcanic rocks that now reside on the ridge tops.

The mapped regional geologic conditions are shown on Plate 4 – Regional Geology.

### **2.3.2 Local Geologic Setting**

Locally, the project area is underlain by quaternary-age non-marine alluvial sediment deposits of the Kern River as shown on Plates 3 and 4. Varying amounts of cobbles and boulders are present with the alluvial sediments.

### **2.3.3 Groundwater**

Groundwater is anticipated to be located at an elevation that is approximately the same as the water level within the adjacent Kern River. Groundwater elevations at the project site will fluctuate over time, especially with fluctuations of river flow levels. The depth to groundwater can vary throughout the year and from year to year. Intense and long duration precipitation or drought conditions, modification of topography, groundwater extraction, and cultural land use changes can contribute to fluctuations in groundwater levels. Localized saturated conditions or perched groundwater conditions near the ground surface could be present during and following periods of heavy precipitation or if on-site sources contribute water.

DRAFT

### 3 GEOLOGIC HAZARDS

#### 3.1 REGULATORY SEISMIC SETTING

The State of California designates faults as Holocene-age or Pre-Holocene-age depending on the recency of movement that can be substantiated for a fault. Fault activity is rated as follows:

FAULT ACTIVITY RATINGS		
Fault Activity Rating	Geologic Period of Last Rupture	Time Interval (Years)
Holocene-Active	Holocene	Within last 11,000 Years <sup>1</sup>
Pre-Holocene	Quaternary & Older	>11,000 Years <sup>1</sup>
Age Undetermined	Unknown	Unknown

<sup>1</sup> – Holocene is defined as 11,700 years before present by the International Commission on Stratigraphy. The California State Mining and Geology Board, which administers the review and application of the Alquist-Priolo Earthquake Fault Zoning Act, currently recognizes the Holocene as 11,000 years before present.

The California Geologic Survey (CGS) evaluates the activity rating of a fault in fault evaluation reports (FER). FERs compile available geologic and seismologic data and evaluate if a fault should be zoned as Holocene-active, pre-Holocene, or age undetermined. If an FER evaluates a fault as Holocene-active, then it is typically incorporated into a Special Studies Zone in accordance with the Alquist-Priolo Earthquake Fault Zoning Act (AP). AP Special Studies Zones require site-specific evaluation of fault location for structures for human occupancy and require a habitable structure setback if the fault is found traversing a project site.

The Kern Canyon fault projects adjacent to or through the project site, as shown on Plate 5 – Regional Fault Map. The Kern Canyon fault is a Holocene-Active fault as mapped by the California Geological Survey (CGS, 2022). At the time of this study, the project area has not been included in an AP Special Studies Zone for fault hazards.

#### 3.2 CBC SEISMIC DESIGN RECOMMENDATIONS

We understand that the proposed project will be designed and constructed under the 2019 California Building Code (CBC) criteria. At a minimum, structures should be designed in accordance with the following seismic design criteria:

<b>CBC SEISMIC DESIGN PARAMETERS</b>		
<b>California Building Code</b>	<b>Parameter</b>	<b>CBC Designation</b>
Site Coordinates	Latitude	35.755644°
	Longitude	-118.422843°
Section 1613.5.3 Table 1613.5.3(1)	Site Coefficient, $F_a$	1.2
Section 1613.5.3 Table 1613.5.3(2)	Site Coefficient, $F_v$	Null
Section 1613.5.1 Figure 1613.5	Site Class Designation	D
	Seismic Factor, Site Class D at 0.2 Seconds, $S_s$	1.119
	Seismic Factor, Site Class D at 1.0 Seconds, $S_1$	0.352
Section 1613.5.3	Site Specific Response Parameter for Site Class D at 0.2 Seconds, $S_{MS}$	1.343
	Site Specific Response Parameter for Site Class D at 1.0 Seconds, $S_{M1}$	NA <sup>1</sup>
Section 1613.5.4	$S_{DS}=2/3S_{MS}$	0.496
	$S_{D1}=2/3S_{M1}$	NA <sup>1</sup>
Per the 2019 CBC.		
<sup>1</sup> - See Section 11.4.8 of ASCE 7-16		

### **3.3 PROBABILISTIC ESTIMATES OF STRONG GROUND MOTION**

Probabilistic evaluations of horizontal strong ground motion that could affect the site were performed using attenuation evaluation methods provided by the U.S. Geological Survey (USGS, 2022). The evaluations were performed using an estimated shear wave velocity in the upper 100 feet of the profile of 360 meters per second. Evaluations were performed for upper-bound (UBE) and design-basis (DBE) probabilistic exposures and maximum considered earthquake (MCEg). The UBE corresponds to horizontal ground accelerations having a 10 percent probability of exceedance in a 100-year exposure period, with a statistical return period of 949 years. The DBE corresponds to horizontal ground accelerations having a 10 percent probability of exceedance in a 50-year exposure period, with a statistical return period of 475 years. The MCEg corresponds to horizontal ground accelerations having a 2 percent probability of exceedance in a 50-year exposure period, with a statistical return period of 2,475 years. The results of these evaluations are presented in the following table:

<b>PROBABILISTIC GROUND MOTION DATA</b>				
<b>Earthquake Level</b>	<b>Probabilistic Estimate Exposure Period (years)</b>	<b>Probability of Exceedance (%)</b>	<b>Return Period (years)</b>	<b>Estimated Peak Horizontal Ground Acceleration (g)</b>
Maximum Considered Earthquake, geometric mean (MCEg)	50	2	2,475	0.36
Upper-Bound Ground-Motion	100	10	949	0.25
Design-Basis Ground-Motion	50	10	475	0.19

It should be noted that although the seismic hazard models used for this study predict the probability of exceedance for various levels of acceleration in a given exposure period, the models are not able to account for the effect that the passage of time since past earthquakes has on future earthquake probability. Thus, while time may affect the incipient risk of earthquakes occurring, the MCEg, UBE, and DBE values are based on any 100-year and 50-year exposure period, respectively, regardless of how recently earthquakes have occurred.

### **3.4 LIQUEFACTION & LATERAL SPREADING**

Liquefaction is described as the sudden loss of soil shear strength due to a rapid increase of soil pore water pressures caused by cyclic loading from a seismic event. In simple terms, it means that a liquefied soil acts more like a fluid than a solid when shaken during an earthquake. For liquefaction to occur, the following are needed:

- Granular soils (sand, silty sand, sandy silt, and some gravels);
- A high groundwater table; and
- A low density in the granular soils underlying the site.

If those criteria are present, then there is a potential that the soils could liquefy during a seismic event. The adverse effects of liquefaction include local and regional ground settlement, ground cracking and expulsion of water and sand, the partial or complete loss of bearing and confining forces used to support loads, amplification of seismic shaking, and lateral spreading. In general, the effects of liquefaction on the site could include:

- Lateral spreading;
- Vertical settlement; and/or
- The soils surrounding lifelines can lose their strength and those lifelines can become damaged or severed.

Lateral spreading is defined as lateral earth movement of liquefied soils, or soil riding on a liquefied soil layer, down slope toward an unsupported slope face, such as a creek bank, or an inclined slope face. In general, lateral spreading has been observed on low to moderate gradient slopes but has been noted on slopes inclined as flat as one degree.

With regard to factors affecting liquefaction potential, the following are noted for this site:

- Site soils below a depth of approximately 8 feet were observed to consist of generally loose to medium dense, interbedded fine to coarse grained sand and gravels;
- Groundwater was observed within the depth of exploration (approximately 9 feet) in the test pit excavated for this study, as noted in Section 2.2.3 – Groundwater.

Although the factors listed above may be indicative of a relatively high potential for liquefaction, we are unable to quantitatively assess the liquefaction potential at this time without additional data from lower depths at the site. Further geotechnical exploration using a drill rig will be required to generate the data necessary to quantify the potential for liquefaction and any associated settlement and lateral spreading.

### **3.5 EXPANSION POTENTIAL**

There is a direct relationship between plasticity of a soil and the potential for expansive behavior, with expansion potential generally increasing as the Plasticity Index (PI) of a soil increases, as shown in the table below (from Day, 1999). Thus, granular soils typically have a low potential to be expansive, whereas fine-grained clay-rich soils can have a low to high expansion potential depending on various factors including the quantity and type of clay minerals present.

As noted on the Log of Test Pit and in the laboratory test results, the soils encountered in our exploration at the site consisted primarily of coarse grained sediments (sands and gravels). Because only granular soils were encountered within about 10 feet of the ground surface, it is our opinion that soils underlying the proposed improvements have a low potential for expansion and are unlikely to adversely impact the proposed project.

### **3.6 SOIL CHEMISTRY**

One bulk sample of near-surface soil (TP1-B1) was subjected to chemical analysis for assessment of corrosion and reactivity with concrete. The sample was tested for soluble sulfates and chlorides, pH, and resistivity. Results are presented below.

<b>SOIL CHEMISTRY RESULTS</b>					
<b>Sample Location</b>	<b>Sample Depth</b>	<b>Sulfates (ppm)</b>	<b>Chlorides (ppm)</b>	<b>pH</b>	<b>Resistivity (ohms-cm)</b>
TP1-B1	1' - 4'	3.2	2.7	7.43	7,240

According to the ACI-318 (2019), a sulfate concentration below 0.10 percent by weight (1,000 ppm) is negligible. A chloride content of less than 500 ppm is generally considered non-corrosive to reinforced concrete. Based on the results of the soil chemistry tests, the site soils have a low potential for corrosion of concrete due to sulfates and chlorides.

Minimum resistivity testing was also performed on soil sample TP1-B1. A commonly accepted correlation between soil resistivity and corrosivity towards ferrous metals (NACE Corrosion Basics, 1984) is provided below:

<b>RESISTIVITY &amp; CORROSION CORRELATION</b>	
<b>Minimum Resistivity (ohm-cm)</b>	<b>Corrosion Potential</b>
0 to 1000	Severely Corrosive
1,000 to 2,000	Corrosive
2,000 to 10,000	Moderately Corrosive
Over 10,000	Mildly Corrosive

Thus, according to the table above, the soils are estimated to be moderately corrosive to ferrous metals based upon the soil resistivity value measured for this study.



## **4 CONCLUSIONS AND RECOMMENDATIONS**

### **4.1 GENERAL**

Recommendations presented, herein, are based upon project information provided by WWE along with stated assumptions. Changes in the configurations from those studied during this investigation, as noted on Plate 2, may require supplemental recommendations.

### **4.2 GEOLOGIC HAZARDS**

It is our opinion that, aside from liquefaction and the related phenomenon of lateral spreading, geologic hazards should not adversely impact the proposed improvements at the Cal Water intake structure and improvements. As noted in Section 3.4 – Liquefaction & Lateral Spreading, the preliminary indications are that the site has a relatively high potential for liquefaction; however, the liquefaction potential has not been fully assessed due to the limited depth of exploration performed at the site. Additional subsurface exploration and geotechnical analyses may be required if liquefaction and lateral spreading are considered to be significant factors in the design of this project.

### **4.3 SITE PREPARATION AND GRADING**

#### **4.3.1 Stripping**

Prior to general site grading and/or construction of planned improvements at the site, existing vegetation, organic topsoil, debris, and deleterious materials should be stripped and disposed of off-site or outside the construction limits. Stripping depths of about 2 to 3 inches should be anticipated, with locally deeper stripping possible depending on the conditions encountered during grading.

#### **4.3.2 Existing Utilities, Wells, and/or Foundations**

If existing pipelines and/or subsurface improvements are located beneath the proposed improvement areas, they should be removed and/or rerouted beyond construction limits. Buried tanks or wells, if present, should be removed in compliance with applicable regulatory agency requirements. Existing, below-grade utility pipelines that extend beyond the limits of the proposed construction and that will be abandoned in-place should be plugged with lean concrete or grout to prevent migration of soil and/or water. All excavations resulting from removal and demolition activities should be cleaned of loose or disturbed material prior to placing any fill or backfill.



### 4.3.3 Keying and Benching

The proposed improvements are not located on a hillside or a surface with any significant slope. Therefore, keying and benching are not anticipated to be needed for improvements associated with this project.

### 4.3.4 Wet/Unstable Soil Conditions

Groundwater was observed approximately 9 feet below the ground surface (approximately elevation 2,641) of our test pit location. This depth corresponds to an elevation of approximately 2,632, which was at or slightly above the approximate water surface elevation of the adjacent Kern River at the time of our exploration. It is unlikely that soils in the upper approximately five feet of the soil column will be impacted by the observed groundwater; however, below a depth of about 5 feet, soils will likely become increasingly wet and possibly have unstable conditions throughout the year. Wet soil conditions due to precipitation or on-site water discharge and usage could hinder equipment access as well as efforts to compact site soils to a specified level of compaction in the upper five feet of the soil column.

If over optimum soil moisture content conditions are encountered during construction, disking to aerate, replacement with imported material, chemical treatment, stabilization with a geotextile fabric or grid, and/or other methods will likely be required to facilitate earthwork operations. The applicable method of stabilization is the Contractor's responsibility and will depend on the Contractor's capabilities and experience, as well as other project-related factors beyond the scope of this investigation. Therefore, if over-optimum moisture within the soil is encountered during construction, BAJADA should review these conditions (as well as the Contractor's capabilities) and, if requested, provide recommendations for their treatment.

### 4.3.5 Site Drainage

Grading should be performed in such a manner that provides a positive surface gradient away from all structures. The ponding of water should not be allowed adjacent to structures, retaining walls, and/or above slopes. Surface runoff should be directed toward engineered collection systems, where available. Discharge from structures should also be collected, conveyed, and discharged at least 20 feet away from structures.

### 4.3.6 Excavation Characteristics

Exploration at the site was performed using a CAT 420F IT backhoe equipped with a two-foot-wide bucket. Penetration of underlying soil materials was performed with little to moderate difficulty. It is our opinion that these materials should be excavatable with heavy grading equipment with slight to moderate difficulty. Zones with concentrated cobbles and boulders could pose more difficult excavation characteristics.

It should be noted that soils above the groundwater level could ravel and/or run, and that soils close to or below the groundwater level will likely flow. Shoring and/or dewatering should be considered by the Contractor to reduce the potential for raveling, running, and/or flowing soils from creating relatively large excavations and possibly impacting improvements in the vicinity of the project.

#### **4.3.7 Overexcavation**

Overexcavation at the site is not anticipated to be necessary for this project unless areas of soft and yielding soils are encountered, deleterious materials are exposed in subgrade soils, or organic-laden soils are observed. If those conditions are encountered, BAJADA should be contacted to help develop recommendations to mitigate those conditions.

#### **4.3.8 On-Site Soil Materials**

It is our opinion that most of the near-surface soils encountered at the site can be used for general engineered fill provided they are free of organics, debris, oversized particles (>3") and deleterious materials. Highly plastic clayey materials (materials having a plasticity index exceeding 30 and a liquid limit more than 50), if encountered, should be segregated and excluded from engineered fill, where possible. If potentially unsuitable soil is considered for use as engineered fill, BAJADA should observe, test, and provide recommendations as to the suitability of the material prior to placement as engineered fill.

#### **4.3.9 Engineered Fill Materials and Placement**

##### **4.3.9.1 General Engineered Fill**

If imported fill materials are used for this project, they should consist of soil and/or soil-aggregate mixtures, generally less than 3 inches in maximum dimension, nearly free of organic or other deleterious debris, and essentially non-plastic. Typically, well-graded mixtures of gravel, sand, non-plastic silt, and minor quantities of clay are acceptable for use as imported general engineered fill. Gradation and plasticity recommendations for general engineered fill are presented in the table below.

##### **4.3.9.2 Structural Fill**

Structural fill materials are defined as those materials specifically intended for support of structures and pavements. General recommendations for structural fill are presented in the table below and should be considered minimum requirements.

All imported fill materials, whether General or Structural, should be sampled and tested prior to importation to the project site to verify that those materials meet the recommended material criteria, in accordance with applicable test procedures to verify material suitability, as shown in the following table.

<b>IMPORTED FILL RECOMMENDATIONS</b>				
<b>GRADATION</b>				
<b>Sieve Size</b>	<b>General Fill</b>	<b>Structural Fill</b>	<b>Test Procedures</b>	
	<b>Percent Passing</b>		<b>ASTM</b>	<b>AASHTO</b>
3-inch	100	100	D422	T88
¾-inch	70 – 100	70 – 100	D422	T88
No. 200	0 – 30	<5	D422	T88
<b>PLASTICITY</b>				
Liquid Limit	<30	NA	D4318	T89
Plasticity Index	<12	Non-plastic	D4318	T90
<b>ORGANIC CONTENT</b>	<1%	<1%	D2974	NA
<b>SOIL CHEMISTRY</b>	Chloride <500 ppm	Sulfate <1,000 ppm	Resistivity >2,000 ohm-cm	pH 6-7

#### 4.3.10 Controlled Low Strength Material

Controlled low strength material (CLSM) can be used to backfill excavated areas or as engineered fill materials. CLSM consists of a fluid, workable mixture of aggregate, cement, and water that is of limited strength as to allow future excavation and maintenance of buried improvements yet capable of supporting the proposed improvements. If CLSM is used as engineered fill, we recommend that those materials conform and be placed according to specifications presented in Sections 19-3.03F and 19-3.03I of the Caltrans Standard Specifications (most current edition).

#### 4.3.11 Placement & Compaction

Soil and/or soil-aggregate mixtures used for general engineered fill should be uniformly moisture-conditioned to near the optimum moisture content, placed in horizontal lifts less than 8 inches in loose thickness, and compacted to at least 90% relative compaction in accordance with standard test method ASTM D1557<sup>1</sup>. All structural fill should be placed in the same manner and compacted to at least 95% relative compaction per ASTM D1557.

It is recommended that fill materials be placed and compacted uniformly in elevation around buried structures and that the vertical elevation differential of contiguous lifts diverge no more than three feet around the structure during compaction. Testing should be performed to verify that the relative compactations are being obtained as recommended herein.

Compaction testing, at a minimum, should consist of one test per every 250 cubic yards of soil being placed or at every 1.5-foot vertical fill interval, whichever comes first.

<sup>1</sup> This test method (ASTM D1557) applies wherever relative compaction, maximum dry density, or optimum moisture content is referenced within this report.

In general, a “sheep’s foot” or “wedge foot” compactor should be used to compact fine-grained fill materials. A vibrating smooth-drum roller could be used to compact granular fill materials and final fill surfaces.

#### **4.4 FOUNDATIONS & SLABS**

##### **4.4.1 Transition Lots**

Transitions lots are those sites where a structure foundation will be supported partially by two different geologic materials, such as artificial fill beneath one portion of the structure and undisturbed native soil beneath the remainder of the structure. Those two materials could cause structures to settle at differing rates and magnitudes. The resulting differential settlement could cause damage to the structure, structure performance, or performance of equipment within the structure.

It is not anticipated that transition lots will be present at the site. We anticipate that proposed improvements will be supported on undisturbed alluvial soils present beneath the site.

##### **4.4.2 Foundation Subgrade Preparation**

The subgrade for all foundations should be smooth and unyielding prior to the placement of concrete or any aggregate base or other structural fill material. If soft and yielding areas are found, BAJADA should review these conditions and, if requested, provide recommendations for their treatment. We recommend that all foundation excavations be observed and tested by a licensed geotechnical material testing consultant to confirm projected site conditions and the requirements of this report.

##### **4.4.3 General Foundation Design Considerations**

The foundations for all structures should be designed by the project civil/structural engineer in accordance with the recommendations presented in this report.

###### **4.4.3.1 Scour and Degradation**

The proposed intake structure will be located within and below the westerly margin of the active channel of the Kern River. Therefore, it should be designed to resist scour that could result from extreme flow events and any degradation of the channel over the design life of the structure. The referenced foundation investigation report for the Kern River Bridge (Moore & Taber, 1967) provides a qualitative discussion of estimated maximum past scour depth but does not provide an elevation. The report recommends that pier and abutment footings be placed below the estimated maximum future scour depth (design scour), also with no design elevation specified. It is possible that the Log of Test Borings for the report would have additional information regarding scour; however, the LOTB was not attached to

the archival information obtained from Caltrans GEODOG database. Other information regarding the design and construction of the bridge obtained from the database indicates that all the piers and one of the abutments are supported on footings with the design elevations shown. This information is included in Appendix C of this report.

#### **4.4.3.2 Bearing Pressure and Settlement**

All foundations should be supported on firm, undisturbed native soils or approved, properly compacted fill material. An allowable bearing pressure of 2,000 psf for isolated or continuous footing foundations can be used for design of foundations supported on firm native soils or approved compacted fill materials.

The anticipated total settlement for foundations under static (i.e., non-seismic) loading conditions, if construction occurs as recommended within this report, should be relatively low (less than 1 inch) for concrete footings or slabs resting on intact soils or approved compacted fill material.

#### **4.4.3.3 Sliding Resistance**

Ultimate sliding resistance generated through a compacted soil/concrete interface can be computed by multiplying the total dead weight structural loads by the friction coefficient of 0.40 for on-site granular soils or approved imported granular engineered fill. If a membrane, such as polysheeting or PVC, is utilized between the fill pad and concrete footings/slabs, then the coefficient of friction between concrete and the sheeting should be established through consultation with the membrane manufacturer.

#### **4.4.3.4 Passive Resistance**

Ultimate passive resistance developed from lateral bearing of foundation elements against compacted soil surfaces for that portion of the foundation element extending below a depth of 1 foot below the lowest adjacent grade can be estimated using an equivalent fluid weight of 400 pcf for foundation soils located above the water table. Where foundations will be located below the water table, such as for the proposed intake structure, the ultimate passive resistance should be estimated using an equivalent fluid weight of 200 pcf to reflect submerged soil conditions. Appropriate factors of safety should be applied to each of these values.

#### **4.4.3.5 Safety Factors**

Sliding resistance and passive pressure may be used together in conjunction with the following recommended safety factors. A minimum factor of safety of 1.5 is recommended for sliding resistance where passive pressure is neglected; a minimum factor of safety of 2.0 is recommended for sliding resistance where passive pressure is included.

#### 4.4.4 Lateral Earth Pressures

Lateral earth pressures provided in the following table are for the permanent subsurface structures planned for this project (intake structure, vault, manholes, etc.) and are based on the type and condition of the soil mapped in the project area and encountered in the exploration test pit at the project site. Walls that are not free to deflect should be designed to resist at-rest earth pressures as well as the additional loading from a seismic event.

<b>LATERAL EARTH PRESSURES</b>	
<b>Condition</b>	<b>Equivalent Fluid Pressure (pcf)</b>
At-Rest	60
Active	40
For structures to a maximum of 15 feet in depth. These pressures do not include (1) lateral surcharge loads from vehicles, fills or structures where an imaginary 1.5H:1V plane projected downward from an existing or planned structure projects above or intersects the side of the structure; (2) hydrostatic pressures; and (3) dynamic pressures from seismic shaking.	

#### 4.4.5 Frost Penetration

Proposed improvements are located below the ground surface at depths unlikely to be impacted by frost heave. Therefore, no recommendations for frost protection have been provided for this project site.

#### 4.4.6 Slab-on-Grade Design

All ground-supported concrete slabs should be designed by a structural or civil engineer to support the anticipated loading conditions. In addition to anticipated structural loads, the design considerations include, but are not limited to, concrete mix design, structural reinforcement, joint spacing, crack control, slab underlayment, moisture control and corrosion resistance. Reinforcement for slabs should meet all applicable code requirements. Reinforcement should be placed in the slab per the design requirements of the structural or civil engineer with provisions to ensure it stays in that position during construction and concrete placement.

A modulus of subgrade reaction ( $k_{s1}$ ) of 200 pounds per cubic inch (pci) is recommended for design of mat-type foundations supported on approved, compacted coarse-grained subgrade soil. The modulus of subgrade reaction value represents a presumptive value based on soil classification. No plate-load tests were performed as part of this study. The modulus value is for a 1-foot-square plate and must be corrected for mat size and shape. Subgrade soils supporting structural concrete slabs should be uniformly moisture-conditioned to near the optimum moisture content and compacted to at least 95% relative compaction to a depth of at least 12 inches.



## 4.5 PIPELINES & TRENCH BACKFILL

### 4.5.1 External Loads on Buried Pipelines

External loads on buried pipes will consist of loads due to the overlying earth materials, loads due to construction activities, loads due to traffic, and other post construction land uses. It is recommended that pipes be designed to resist the imposed loads with a factor of safety and an amount of deflection, as recommended by the pipeline manufacturer.

Loads on the pipe due to the overlying soil will be dependent upon the depth of placement, type and method of backfill, the configuration of the trench, the depth of ground water, and whether any additional fill will be placed above the pipeline, on the ground surface. The earth loads on the pipe can be estimated using formulas developed by Marston (1930) and Spangler (1982).

The following Marston formula can be used to estimate vertical soil loads on rigid pipeline placed in backfilled trenches or tunneled in place (American Concrete Pipe Association [ACPA], 2011):

$$W_d = C_d \gamma B_d^2$$

$$W_t = C_t \gamma B_t^2 - 2c C_t B_t$$

Where:

$W_d, W_t$	=	Vertical soil load on rigid pipe due to trench backfill or overlying soils, respectively (pounds per foot [lb./ft])
$\gamma$	=	145 pounds per cubic foot (pcf) for imported granular trench backfill; and 125 pcf for native soil trench backfill
$B_d, B_t$	=	Trench width, width of tunnel bore, respectively (feet)
$C_d, C_t$	=	See below
$c$	=	Soil cohesion (psf)

Plate 6 – Marston’s Load Coefficients, can be used to estimate  $C_d$  and  $C_t$ . The parameters  $C_d$  and  $C_t$  will depend on: 1) the backfill type; 2) the trench or tunnel width; and 3) the installation depth. For a trench installation with a ratio of backfill depth to trench width at the top of pipe ( $H/B_d$ ) of at least 1 and for a trench width at top of pipe no greater than 3 times the pipe diameter, the value of  $C_d$  and  $C_t$  may be calculated using the following equation (ACPA, 2011):

$$C_{d/t} = \frac{1 - e^{-2K\mu' \frac{H}{B_d \text{ or } B_t}}}{2K\mu'}$$

Where:

K	=	Rankine's lateral earth pressure coefficient
$\mu'$	=	Friction coefficient between fill material and sides of trench
H	=	Backfill height above pipe crown (ft)

The value  $K\mu'$  is dependent on the backfill type, degree of compaction, and moisture content. Where trench backfill materials are compacted as recommended in Section 4.5.6 – Placement and Compaction, the following estimated  $K\mu'$  values are applicable for various types of soil and rock encountered during this study and anticipated to be used within the trench zone:

ESTIMATED $K\mu'$ VALUES FOR PIPE DESIGN	
Soil Type	$K\mu'$
Clay (CL, CH)	0.120
Silt (ML)	0.130
Clayey Sand (SC)	0.150
Sand & Gravel (SM, GM)	0.165
Estimated from ASCE (1982)	

For flexible pipelines, the prism method (Moser & Folkman, 2008) can be used to estimate the vertical soil loads imposed on pipelines in new trenches. That formula is as follows:

$$W = B\gamma H$$

Where:

W	=	Vertical soil load (lb./ft)
B	=	Outside diameter of the pipeline (ft)
$\gamma$	=	145 pounds per cubic foot (pcf) for imported granular trench backfill; and 125 pcf for native soil trench backfill
H	=	Depth of backfill (ft)

In addition to the dead loads noted above, the proposed pipeline will be subjected to vertical live loads within roadways and driveways. Vertical soil pressures due to live vehicular loads can be estimated using the graph presented on Plate 7 – Vertical Soil Pressures Induced by Live Loads.



#### 4.5.2 Modulus of Soil Reaction (E')

Flexible and semi-rigid pipes are typically designed to withstand a certain amount of deflection from applied earth loads. Those deflections can be estimated with the equations developed by Spangler (1982). The modulus of soil reaction (E') values for the project were estimated using relations of Howard (1996). The table below presents E'<sub>b</sub> values, which are recommended E' values for pipe zone backfill materials (pipe zone backfill). The recommended E'<sub>b</sub> values presented in the table below apply to the initial backfill materials along the sides of the pipe at the recommended level of compaction.

MODULUS OF SOIL REACTION FOR PIPE ZONE BACKFILL MATERIALS (E' <sub>b</sub> )		
Soil Type	Depth of Burial	Recommended E' <sub>b</sub> (psi)
Pipe Bedding and Pipe Embedment (clean crushed rock or sand)	5'	1,000
	10'	1,500
	15'	1,600
	15'+	1,700
Soil-Cement Slurry (backfilled within 2 days of placement)	Not Applicable	3,000

Where the zone of backfill beside the pipe is less than five times the pipeline diameter, the E'<sub>b</sub> values above may not be applicable and the constrained soil modulus E'<sub>n</sub> will affect flexible pipe design. E'<sub>n</sub> corresponds to the E' value for the natural trench wall soils. The actual lateral soil modulus at the pipe depth will lie somewhere in between E'<sub>b</sub> and E'<sub>n</sub> depending on the trench width. We recommend that an E'<sub>n</sub> value of 1,000 psi be used for design.

For trench widths of less than five times the diameter of the pipe, the composite design E'<sub>c</sub> (E'<sub>b</sub> and E'<sub>n</sub>) may be calculated using the Soil Support Combining Factors (S<sub>c</sub>) presented in the table below, where B<sub>d</sub> is the trench width at pipe springline and D is the diameter of the pipe.

SOIL SUPPORT COMBINING FACTORS (S <sub>c</sub> )						
E' <sub>n</sub> /E' <sub>b</sub>	B <sub>d</sub> /D=1.5	B <sub>d</sub> /D=2.0	B <sub>d</sub> /D=2.5	B <sub>d</sub> /D=3.0	B <sub>d</sub> /D=4.0	B <sub>d</sub> /D=5.0
0.1	0.15	0.30	0.60	0.80	0.90	1.00
0.2	0.30	0.45	0.70	0.85	0.92	1.00
0.4	0.50	0.60	0.80	0.90	0.95	1.00
0.6	0.70	0.80	0.90	0.95	1.00	1.00
0.8	0.85	0.90	0.95	0.98	1.00	1.00
1.0	1.00	1.00	1.00	1.00	1.00	1.00

<b>SOIL SUPPORT COMBINING FACTORS (<math>S_c</math>)</b>						
$E'_n/E'_b$	$B_d/D=1.5$	$B_d/D=2.0$	$B_d/D=2.5$	$B_d/D=3.0$	$B_d/D=4.0$	$B_d/D=5.0$
1.5	1.30	1.15	1.10	1.05	1.00	1.00
2.0	1.50	1.30	1.15	1.10	1.05	1.00
3.0	1.75	1.45	1.30	1.20	1.08	1.00
>5.0	2.00	1.60	1.40	1.25	1.10	1.00

*Source: "Pipeline Installation," A. Howard, 1996*

The corresponding composite design  $E'_c$  can be calculated by selecting the appropriate  $S_c$  value from the table above and multiplying the appropriate  $E'_b$  value by  $S_c$ , as noted below:

$$E'_c = E'_b(S_c)$$

#### 4.5.3 Thrust Resistance

Where the proposed pipelines change direction abruptly, resistance to thrust, if needed, can be provided by mobilizing frictional resistance between pipe and the surrounding soil, by use of a thrust block, by use of restrained pipe joints, or by a combination of the above.

To design thrust resistance by mobilizing frictional resistance, we recommend that a coefficient of friction of 0.20 for PVC or HDPE pipelines be used. The coefficient of friction value includes a factor of safety of 1.5 and assumes that a sand with a sand equivalent (SE) of 30 or greater will be placed within the pipe zone in accordance with recommendations presented in Section 4.5.5. For design of thrust block resistance, ultimate passive lateral earth pressures of 400 psf/ft of depth and 200 psf/ft of depth may be used for drained and submerged soil conditions, respectively. Appropriate factors of safety should be applied to these values.

#### 4.5.4 Excavations, Trenches, Dewatering, & Shoring

##### 4.5.4.1 Excavation and Trench Slopes

Construction of the proposed project will require temporary excavations and trenching to facilitate construction of earthwork, pipelines, manholes, vaults, and other below ground improvements. All temporary excavations and slope inclinations must comply with applicable local, state, and federal safety regulations, including the current OSHA Excavation and Trench Safety Standards. Construction site safety is the responsibility of the Contractor, who should be solely responsible for the means, methods, and sequencing of construction operations so that a safe working environment is maintained.

Subsurface soil conditions encountered in project excavations are to be monitored and evaluated by the Contractor in accordance with OSHA guidelines. OSHA soil classification typing includes the following:

<b>OSHA SOIL TYPE DETERMINATIONS</b>	
<b>Stable Rock</b>	Natural solid mineral matter that can be excavated with vertical sides and remain intact while exposed. It is usually identified by a rock name such as granite or sandstone. Determining whether a deposit is of this type may be difficult unless it is known whether cracks exist and whether or not the cracks run into or away from the excavation.
<b>Type A Soils</b>	Cohesive soils with an unconfined compressive strength of 1.5 tons per square foot (tsf) (144 kPa) or greater. Examples of Type A cohesive soils are often: clay, silty clay, sandy clay, clay loam and, in some cases, silty clay loam and sandy clay loam. (No soil is Type A if it is fissured, is subject to vibration of any type, has previously been disturbed, is part of a sloped, layered system where the layers dip into the excavation on a slope of 4 horizontal to 1 vertical (4H:1V) or greater, or has seeping water.
<b>Type B Soils</b>	Cohesive soils with an unconfined compressive strength greater than 0.5 tsf (48 kPa) but less than 1.5 tsf (144 kPa). Examples of other Type B soils are: angular gravel; silt; silt loam; previously disturbed soils unless otherwise classified as Type C; soils that meet the unconfined compressive strength or cementation requirements of Type A soils but are fissured or subject to vibration; dry unstable rock; and layered systems sloping into the trench at a slope less than 4H:1V (only if the material would be classified as a Type B soil).
<b>Type C Soils</b>	Cohesive soils with an unconfined compressive strength of 0.5 tsf (48 kPa) or less. Other Type C soils include granular soils such as gravel, sand and loamy sand, submerged soil, soil from which water is freely seeping, and submerged rock that is not stable. Also included in this classification is material in a sloped, layered system where the layers dip into the excavation or have a slope of four horizontal to one vertical (4H:1V) or greater.
<b>Layered Geological Strata</b>	Where soils are configured in layers, i.e., where a layered geologic structure exists, the soil must be classified on the basis of the soil classification of the weakest soil layer. Each layer may be classified individually if a more stable layer lies below a less stable layer, i.e., where a Type C soil rests on top of stable rock.

Preliminary OSHA Soil Types of Type C are anticipated at the project site. Actual OSHA Soil Types at the site should be determined during construction by the Contractor's Competent Person or by a registered design professional retained by the Contractor as soils are exposed within the excavations. OSHA allows designation of slope inclinations based on soil types without the support of a registered design professional if those slopes are less than 20 feet high. To do so, the Contractor is required to designate a "Competent Person" that takes the ultimate responsibility for soil type classification.

The following maximum slope inclinations are allowed based upon OSHA soil types:

OSHA MAXIMUM ALLOWABLE SLOPES	
Soil Type	Slope Ratio <sup>1</sup>
Stable Rock	Vertical
Type A	$\frac{3}{4}$ :1
Type B	1:1
Type C	$1\frac{1}{2}$ :1

<sup>1</sup> – horizontal : vertical

Based on the soils observed at the project site during this investigation, it is anticipated that loose, running, raveling, and/or flowing conditions will be encountered in excavations or trenches. When such conditions are encountered during construction, inclinations of unshored slope excavations may not stand exposed at the slope ratios noted above for OSHA Soil Types. In such situations, proposed excavations in those areas could fail and expand in an area much larger than the proposed width unless the excavation and/or trench is shored and adequately supported.

Heavy construction equipment, building materials, excavated soil, and vehicular traffic should not be allowed within a 1:1 (horizontal to vertical) projection from the toe of an unsupported trench or other excavation to the ground surface. Where the stability of project improvements is endangered by excavation operations, support systems such as shoring, bracing, or underpinning may be required to provide structural stability and to protect personnel working within the excavation.

#### 4.5.4.2 Dewatering

As discussed in Section 2.2.2 – Subsurface Conditions, and elsewhere in this report, groundwater was encountered within the test pit excavated for this study. Control of groundwater in excavations is anticipated to be needed for this project. It is the Contractor's responsibility for developing and implementing the means and measures for capturing and removing or diverting groundwater during construction of the proposed pipeline. If groundwater is encountered during construction, it is recommended that the Contractor install measures to capture and/or divert groundwater from entering the excavations. If this is not possible, then the Contractor should channel groundwater to flow towards collection points to be removed from the excavations and disposed of at an approved area.

#### 4.5.4.3 Shoring

Preliminary design of braced shoring for trenches may be based on the preliminary shoring pressure diagrams provide on Plate 8 - Preliminary Shoring Pressure Diagrams. The preliminary shoring pressure diagrams provided on Plate 8 represent typical soil conditions encountered during this study. Final earth pressures and pressure diagrams for the design and implementation of individual shoring systems will be dependent upon the following:

- The actual subsurface conditions encountered during construction;
- The shoring type, design, and installation method; and
- Surcharge pressures from traffic, equipment, stockpiles, etc.

Cohesionless materials (i.e., sands and gravels) are anticipated to be encountered in excavations made for this project. Those soils could flow or ravel, if in a wet or saturated condition, or ravel or run when dry (Federal Highways Administration, 2014). Flowing soils act like a viscous fluid and can enter a trench from the sidewalls and can flow for relatively long distances. Raveling soils have chunks or flakes of material falling or toppling from trench sidewalls into the trench. Running soils are unstable at angles greater than their angle of repose and will run like pea gravel, granulated sugar or dune sand from a trench side wall into the trench until the slope flattens to that angle of repose.

Hydraulic speed shores and trench box shoring in flowing, running, or raveling ground conditions should not be allowed. Furthermore, soils subject to running, flowing, or raveling will have insufficient strength and stand-up time to safely hold full-depth vertical excavations long enough for complete trench box or speed-shore installations. Vertical excavations in such soils will most likely experience excavation wall loss and related undermining of adjacent pavements, utilities, structures, and improvements.

In localized cases near critical structures or utilities, special shoring or ground improvement (such as grout stabilization) prior to excavation may be needed to reduce consequential damage. The Contractor should be required to provide any special shoring designs for engineering review. Areas requiring special shoring design should receive preconstruction condition surveys and video/photo documentation of conditions.

Shoring systems that do not provide positive support of excavation walls may allow surface settlement and related damage to existing roadways, utilities, structures, and improvements. A summary of the potential surface settlement of passively-shored excavations is provided in the following table:

<b>POTENTIAL SURFACE SETTLEMENT OF PASSIVELY-SHORED EXCAVATIONS</b>		
<b>Soil Type</b>	<b>Surface Settlement (% of Excavation Depth)</b>	<b>Lateral Zone of Disturbance (Multiples of Excavation Depth)</b>
Sand	0.5%H	H
Soft to medium stiff clay	1%-2%H	3-4H
Stiff clay	<1%H	2H
Suprenant and Basham (1993)		

#### **4.5.5 Pipe Zone & Trench Zone Materials**

The use of appropriate pipe zone and trench zone backfill materials is critical for the long-term performance of a buried, flexible pipeline. Pipe zone and trench zone backfill materials are discussed below. Plate 9 - Trench Nomenclature, graphically illustrates the locations of pipe zone and trench zone backfill areas.

##### **4.5.5.1 Pipe Zone Backfill**

The pipe zone, as discussed herein, is that cross-sectional area that extends from the bottom of the trench to 6 inches over the crown of the pipeline, and from trench wall to trench wall, as shown on Plate 9. Pipe zone backfill materials should consist of imported soil having an SE of no less than 30 and having a particle size no greater than 1/2-inch in maximum dimension, per Section 306-1.2.1 of the Greenbook. Some on-site soils might meet these specifications; however, most of those soils will likely not meet these recommendations without screening or other processing to achieve the specified gradational requirements.

##### **4.5.5.2 Trench Zone Backfill**

Trench zone backfill (i.e., material placed between the top of pipe zone backfill and finished subgrade) may consist of on-site soils or imported materials. If on-site soils are used, then those materials should be screened of deleterious materials, organic debris, highly plastic clay, and oversized materials having dimensions of greater than 3 inches in any direction prior to placement within the trench.

Alternatively, imported soils can be used as trench zone backfill. We recommend that imported trench zone materials conform to recommendations presented for imported general engineered fill materials presented in Section 4.3.9 – Engineered Fill Materials and Placement, of this report. Those imported materials should be free of deleterious materials, organic debris, or clasts exceeding 3 inches in diameter in any direction.

##### **4.5.5.3 Controlled Low Strength Backfill**

An alternative to the use of pipe zone and trench zone backfill materials noted above is the use of controlled low strength material (CLSM) as pipe and/or trench zone backfill. CLSM consists of a fluid, workable mixture of aggregate, cement, and water that is of limited strength as to allow future excavation and maintenance of buried improvements yet capable of supporting the proposed pipeline and backfill. If CLSM is used in the pipe zone or trench zone, we recommend that those materials conform and be placed according to specifications presented in Section 19-3.062 of the Caltrans Standard Specifications (most current edition). Care should be taken during placement of CLSM materials to prevent the pipeline from floating.



#### **4.5.6 Placement & Compaction**

Trench backfill should be placed and compacted in accordance with recommendations presented Section 4.3.9 – Engineered Fill Materials and Placement, of this report. Mechanical compaction should be the means in which compaction is achieved. Jetting should not be allowed as a means of compaction.

Special care should be given to ensuring that adequate compaction is made beneath the haunches of the pipeline (that area from the pipe springline to the pipe invert, as shown on Plate 9) and that no voids remain in this space. Compaction tests of pipe zone backfill should be performed at horizontal intervals of no more than 50 feet and vertical intervals of no more than 18 inches. Within the pipe zone, compaction tests should be performed near springline and near the top of the pipe zone backfill. Assessment of the potential presence of voids within the haunch area should be performed following completion of those compaction tests. If voids are observed, then the Contractor should be required to rework the pipe zone materials to eliminate the presence of voids in the pipeline haunches. Retesting of the pipe zone materials should then be performed. All areas of failing compaction tests should be reworked and retested until the specified relative compaction is achieved. Compaction of trench zone backfill should be performed at horizontal intervals of no more than 50 feet and vertical intervals of no more than 18 inches.

Placement of CLSM materials should be performed in accordance with specifications presented in Caltrans Standard Specification 19-3.062. If CLSM is used, then compaction tests are not required; however, a minimum of four hours should be allowed between placement of CLSM and placement of engineered fill materials above the CLSM, as noted in Caltrans Standard Specification 19-3.062.

#### **4.5.7 Trench Subgrade Stabilization**

Soft and yielding trench subgrade could be encountered along the bottom of trench excavations made within the existing site soils. When yielding subgrade is observed, it is recommended that the bottom of trenches be stabilized prior to placement of the pipeline bedding so that, in the judgment of the geotechnical engineer, the trench subgrade is firm and unyielding. The Contractor should have the sole responsibility for design and implementation of trench subgrade stabilization techniques. Some methods that we have observed used to stabilize trench subgrades include the following:

- Use of ¾-inch to 1½-inch floatrock worked into the trench bottom and covered with a geotextile fabric such as Mirafi 500X;
- Placement of a geotextile fabric, such as Mirafi 500X, on the trench bottom and covered with at least one foot of compacted processed miscellaneous base (PMB) conforming to the requirements of Section 200-2.5 of the Greenbook, latest edition;

- Overexcavation of trench subgrade and placement of two-sack sand-cement slurry; and
- In extreme conditions, injection grouting along the trench alignment.

If floatrock is used, typically sand with an SE of 50 or more should be used to fill the voids in the rock prior to placement of pipe bedding materials.

## **5 REVIEW OF PLANS AND SPECIFICATIONS**

We recommend BAJADA conduct a general review of final plans and specifications to evaluate that preliminary recommendations contained herein have been properly interpreted and implemented during design. If BAJADA is not retained to perform this recommended review, we will assume no responsibility for misinterpretation of our recommendations.

## **6 LIMITATIONS**

This report has been prepared in substantial accordance with the generally accepted geotechnical engineering practice, as it existed in the site area at the time our services were rendered. No other warranty, either express or implied, is made.

Conclusions and recommendations contained in this report were based on the conditions encountered during our field investigation and are applicable only to those project features specifically addressed and described herein (see Section 1.1 – Project Understanding). Soil and rock deposits can vary in type, strength, and other geotechnical properties between points of observation and exploration. Additionally, groundwater and soil moisture conditions can also vary seasonally and for other reasons. Therefore, we do not and cannot have a complete knowledge of the subsurface conditions underlying the project site. The conclusions and recommendations presented in this report are based upon the findings at the points of exploration, and interpolation and extrapolation of information between and beyond the points of observation and are subject to confirmation based on the conditions revealed by construction. If conditions encountered during construction differ from those described in this report, or if the scope or nature of the proposed construction changes, we should be notified immediately in order to review and, if deemed necessary, conduct additional studies and/or provide supplemental recommendations. When final site design plans (grading, foundation, retaining walls, etc.) become available, BAJADA should have the opportunity to review the plans to ensure the recommendations presented in this report remain valid and applicable to the proposed project.

Recommendations provided in this report assume that an experienced, properly licensed geotechnical engineering company will conduct an adequate program of testing and



observation during the construction phase to evaluate compliance with our recommendations.

The scope of services provided by BAJADA for this project did not include the investigation and/or evaluation of toxic substances, or soil or groundwater contamination of any type. If such conditions are encountered during site development, additional studies may be required. Further, services provided by BAJADA for this project did not include the evaluation of the presence of critical environmental habitats or culturally sensitive areas. This report may be used only by our client and their agents and only for the purposes stated herein, within a reasonable time from its issuance. Land use, site conditions, and other factors may change over time that may require additional studies. In the event significant time elapses between the issuance date of this report and construction, BAJADA shall be notified of such occurrence in order to review current conditions. Depending on that review, BAJADA may require that additional studies be conducted and that an updated or revised report is issued.

Any party other than our client who wishes to use all or any portion of this report shall notify BAJADA of such intended use. Based on the intended use as well as other site-related factors, BAJADA may require that additional studies be conducted and that an updated or revised report be issued. Failure to comply with any of the requirements outlined above by the client or any other party shall release BAJADA from any liability arising from the unauthorized use of this report.



## 7 REFERENCES

- American Concrete Institute (2019), Building Code Requirements for Structural Concrete (ACI 318-19) and Commentary on Building Code Requirements for Structural Concrete (ACI 318 R-19), 623 p.
- American Concrete Pipe Association (2011), Concrete Pipe Design Manual, 561 p.
- American Society of Civil Engineers (1982), Gravity Sanitary Sewer Line Design and Construction.
- \_\_\_\_\_ (2017), Minimum Design Loads and Associated Criteria for Buildings and Other Structures, ASCE/SEI 7-16, 889 p.
- Bateman, P.C., and Wahrhaftig, C., (1966), Geology of the Sierra Nevada, in Bailey, E.H., Editor, Geology of Northern California, California Division of Mines and Geology Bulletin 190, p. 107-183.
- Boore, D.M. and Atkinson, G.M. (2007), Boore-Atkinson NGA Ground Motion Relations for the Geometric Mean Horizontal Component of Peak and Spectral Ground Motion Parameters, PEER 2007/01, Pacific Earthquake Engineering Research Center, Berkeley, California.
- California Building Standards Commission (2022), 2019 California Building Code Standards, accessed at: <https://up.codes/viewer/california/ca-building-code-2022>.
- California Department of Transportation (2022), GeoDOG – Digital Archive of Geotechnical Data, accessed at: <https://geodog.dot.ca.gov/>.
- California Department of Water Resources (2022), Water Data Library, accessed at: <http://www.water.ca.gov/waterdatalibrary/>.
- California Geological Survey (2002), California Geomorphic Provinces, Note 36, California Geological Survey, 3 p.
- \_\_\_\_\_ (2022), Fault Activity Map of California, accessed online at: <https://maps.conservation.ca.gov/cgs/fam/>.
- Campbell, K.W. and Bozorgnia, Y. (2007), Campbell-Bozorgnia NGA Ground Motion Relations for the Geometric Mean Horizontal Component of Peak and Spectral

- Ground Motion Parameters, PEER 2007/02, Pacific Earthquake Engineering Research Center, Berkeley, California.
- Chiou, B.S., and Youngs, R.R. (2006), Chiou and Youngs PEER-NGA Empirical Ground Motion Model for the Average Horizontal Component of Peak Acceleration and Pseudo-Spectral Acceleration for Spectral Periods of 0.01 to 10 Seconds, Pacific Earthquake Engineering Research Center, Berkeley, California.
- Day, R. (1999), Geotechnical and Foundation Engineering, Design and Construction, McGraw – Hill, New York, NY 10121-2298.
- Geotracker (2022), State Water Resources Control Board, Geotracker Database accessed at <http://geotracker.waterboards.ca.gov/>.
- Hart, E.W. and Bryant, W.A. (1997), Fault-Rupture Zones in California, Alquist-Priolo Earthquake Fault Zoning Act with Index to Earthquake Fault Zone Maps, California Division of Mines and Geology Special Publication 42, with supplements 1 and 2 added in 1999, 38 p.
- Hartley, J.D., and Duncan, J.M. (1987),  $E'$  and Its Variation with Depth, Journal of Transportation Engineering, ASCE, Vol. 113, No. 5, September, pp. 538-553.
- Howard, A. (1996), Pipeline Installation, Relativity Publishing, Lakewood, Colorado 80228.
- Hinds, N.E. (1952), Evolution of the California Landscape, California Division of Mines and Geology Bulletin 158, pp. 145-152.
- Jennings, C.W. (1994), Fault Activity Map of California and Adjacent Area, with Locations and Ages of Recent Volcanic Eruptions, California Division of Mines and Geology, Geologic Data Map No. 6, Scale 1:750,000.
- Jeyapalan, J.K., and Watkins, R. (2004), Modulus of Soil Reaction ( $E'$ ) Values for Pipeline Design, American Society of Civil Engineers Journal of Transportation Engineering, January/February 130(1): 43-48.
- Marston, A. (1930), The Theory of Loads on Closed Circuits in Light of the Latest Experiments, Iowa Engineering Experiment Station Bulletin No. 153.
- Moore & Taber (1967), Foundation Investigation, Kern River Bridge, Kernville, California, dated January 23, 5 p.

- Moser, A.P., and Folkman, S (2008), Buried Pipe Design, McGraw Hill Professional.
- Schwickert, R.A., and Snyder, W.S. (1981), Paleozoic Tectonics of the Sierra Nevada and Adjacent Regions, in Ernst, W.G., editor, The Geotectonic Evolution of California (Rubey Volume I): Prentice Hall, Englewood Cliffs, New Jersey, p. 87-131.
- Seed, H. B., 1979, "Considerations in the Earthquake-Resistant Design of Earth and Rockfill Dams," *Geotechnique*, Vol. 29, No. 3, pp. 215-263.
- Seed, H.B., and Whitman, R. (1970), Design of Earth Retaining Structures for Dynamic Loads, ASCE Specialty Conference on Lateral Stresses in the Ground and Design of Earth Retaining Structures, p. 103-147.
- Smith, A.R. (1964), Geologic Map of California: Bakersfield Sheet, California Division of Mines and Geology, Geologic Atlas of California GAM-02, Scale 1:250,000.
- Spangler, M.G., and Handy, R.L. (1982), Loads on Underground Conduit, Soil Engineering, Harper and Rowe, 4th edition, pp. 727-761.
- Suprenant, B.A. and Basham, K.D. (1993), Excavation Safety: Understanding and Complying with OSHA Standards.
- Topozada and Branum (2002), *Bulletin of the Seismological Society of America*, October 2002; v. 92; no. 7; p. 2555-2601.
- Topozada, T. R., and D. Branum (2002), *California  $M \geq 5.5$  earthquakes, history and areas damaged*, in Lee, W. H., Kanamori, H. and Jennings, P., International Handbook of Earthquake and Engineering Seismology, International Association of Seismology and Physics of the Earth's Interior.
- U.S. Geological Survey (2022), Unified Hazard Tool website accessed at: <https://earthquake.usgs.gov/hazards/interactive/>.
- Youd T.L., Idriss I.M., Andrus R.D., Arango I., Castro G., Christian J.T., et al. 2001. Liquefaction resistance of soils: summary report from the 1996 NCEER and 1998 NCEER/NSF workshops on evaluation of liquefaction resistance of soils. *Journal of Geotechnical and Geoenvironmental Engineering* 127(10): 817-833

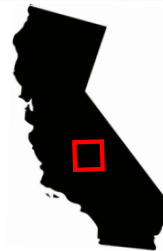
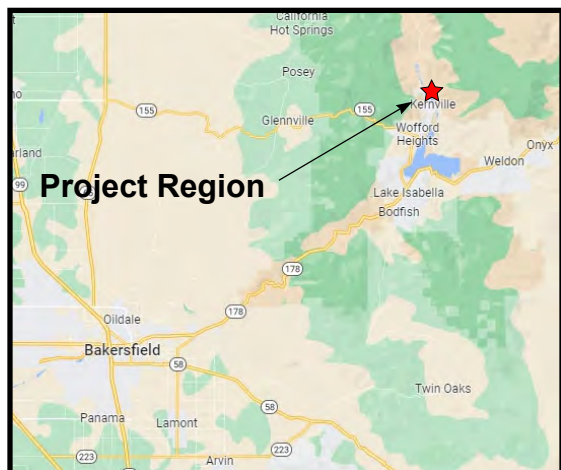
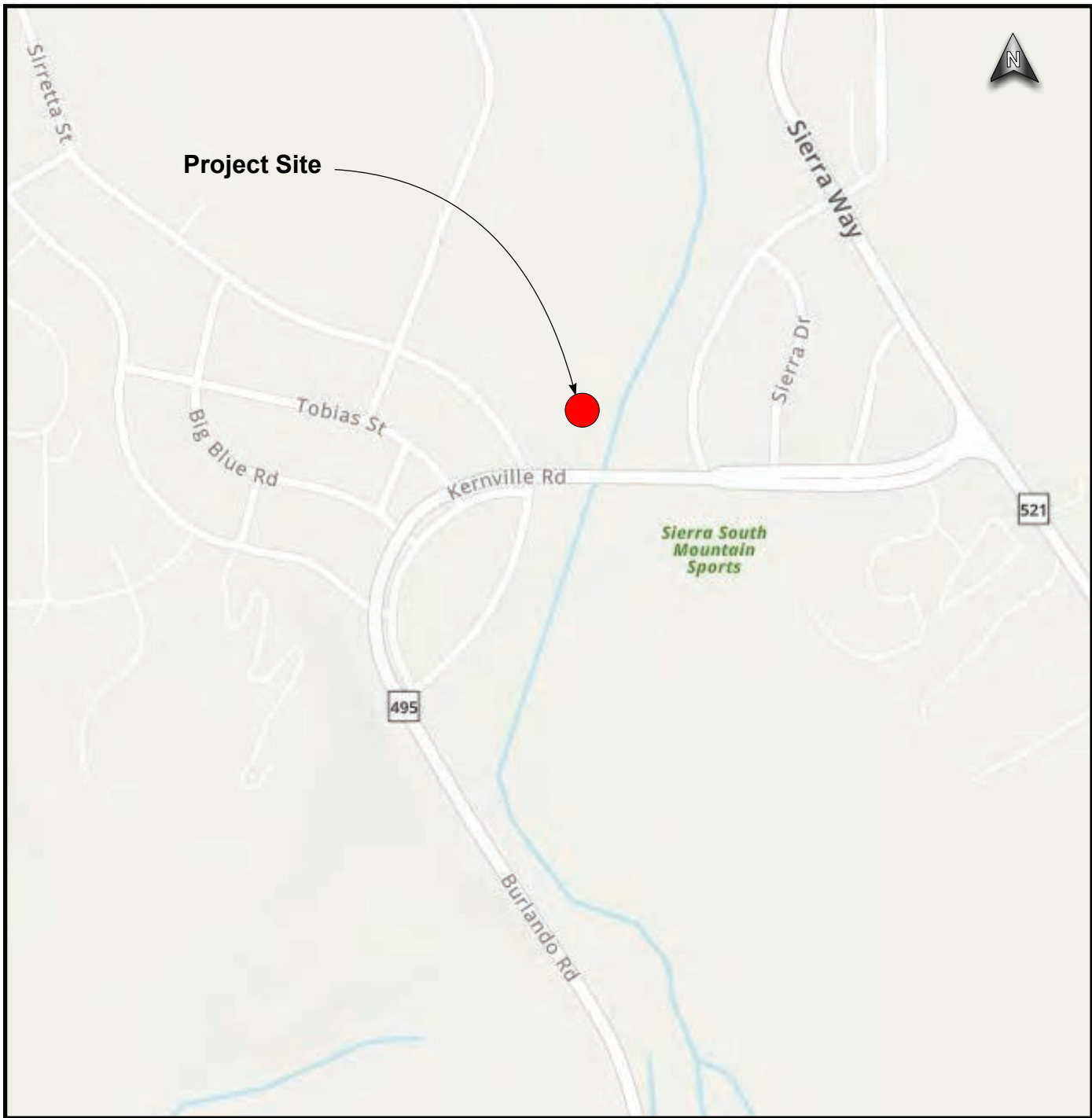

**SITE LOCATION MAP**

Kern River Intake Replacement Project  
 California Water Service  
 Water Works Engineers  
 Kernville Area, Kern County, California

Plate No.

1

 **BAJADA** Geosciences, Inc.

Project no.  
 2201.0141

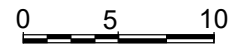
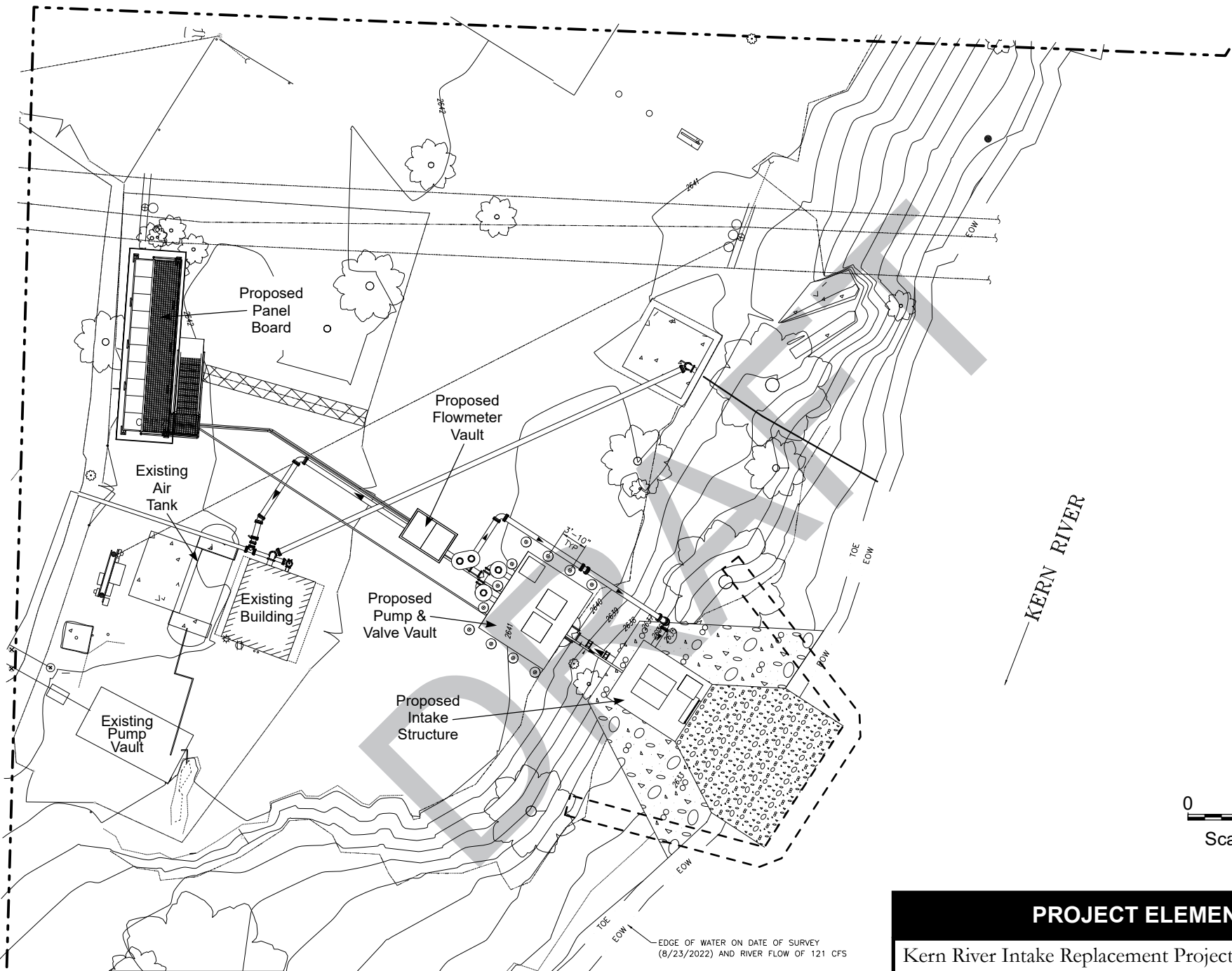

Scale: 1"=10'  
1:120

KERN RIVER

EDGE OF WATER ON DATE OF SURVEY  
(8/23/2022) AND RIVER FLOW OF 121 CFS

<b>PROJECT ELEMENTS</b>	
Kern River Intake Replacement Project California Water Service Water Works Engineers Kernville Area, Kern County, California	Plate No.
	2
 <b>BAJADA</b> Geosciences, Inc.	Project no. 2201.0141



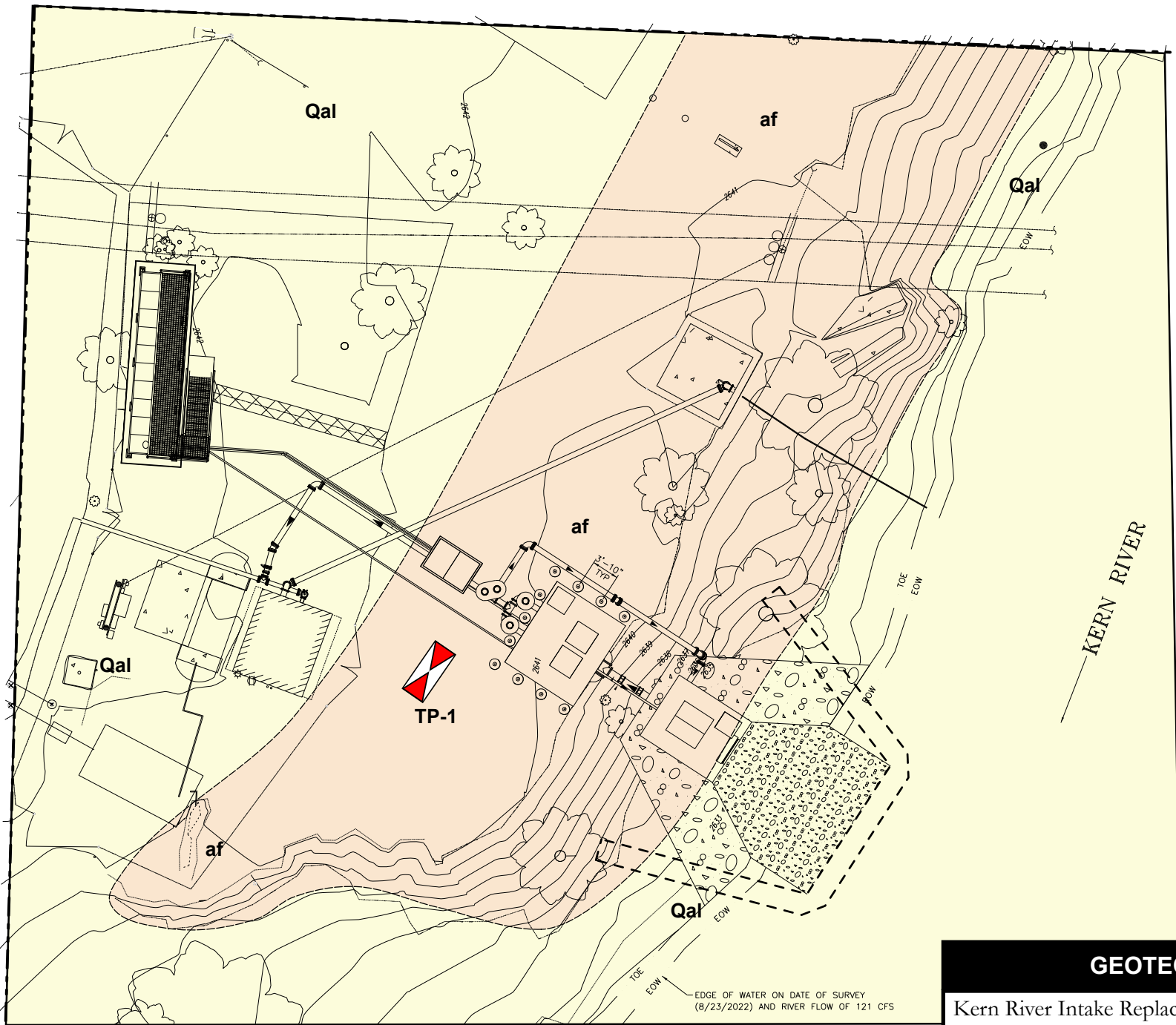

- af Artificial Fill
- Qal Alluvium

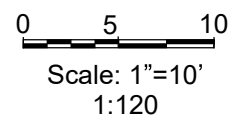

EDGE OF WATER ON DATE OF SURVEY  
(8/23/2022) AND RIVER FLOW OF 121 CFS

Approximate Test Pit Location  
TP-1

Geologic Contact,  
Dashed where approximate

Base map from Water Works Engineers (2022).

<b>GEOTECHNICAL MAP</b>	
Kern River Intake Replacement Project California Water Service Water Works Engineers Kernville Area, Kern County, California	Plate No.  <b>3</b>
<b>BAJADA</b> Geosciences, Inc.	Project no. 2201.0141

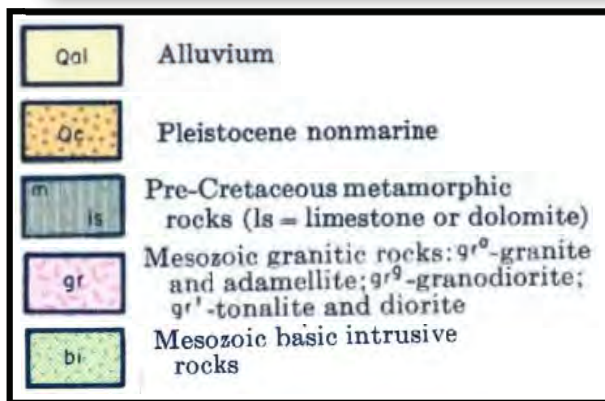
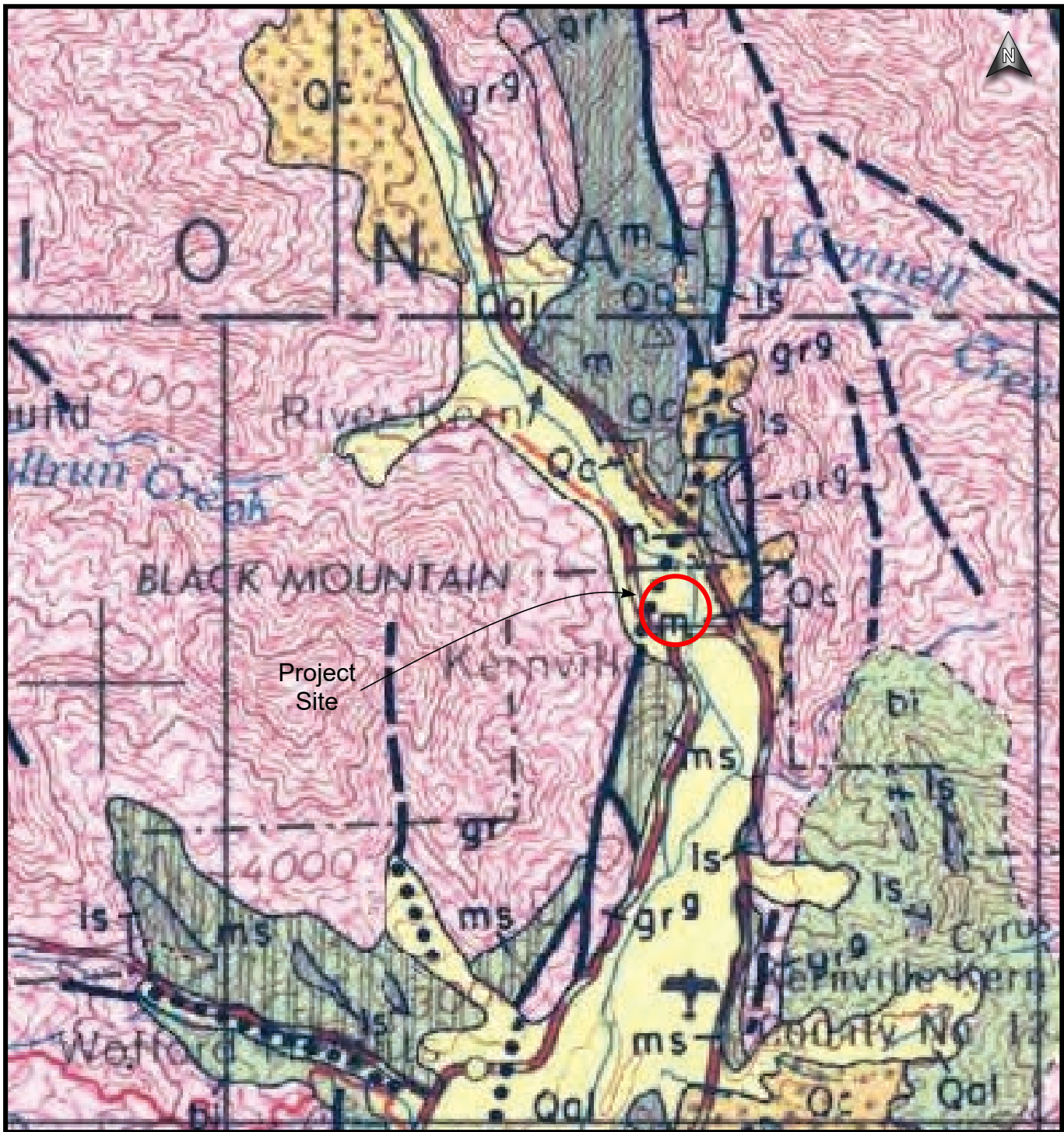

<b>REGIONAL GEOLOGY</b>	
Kern River Intake Replacement Project California Water Service Water Works Engineers Kernville Area, Kern County, California	Plate No.
	4
<b>BAJADA</b> Geosciences, Inc.	Project no. 2201.0141

Base map from Smith (1964). Scale Undetermined.



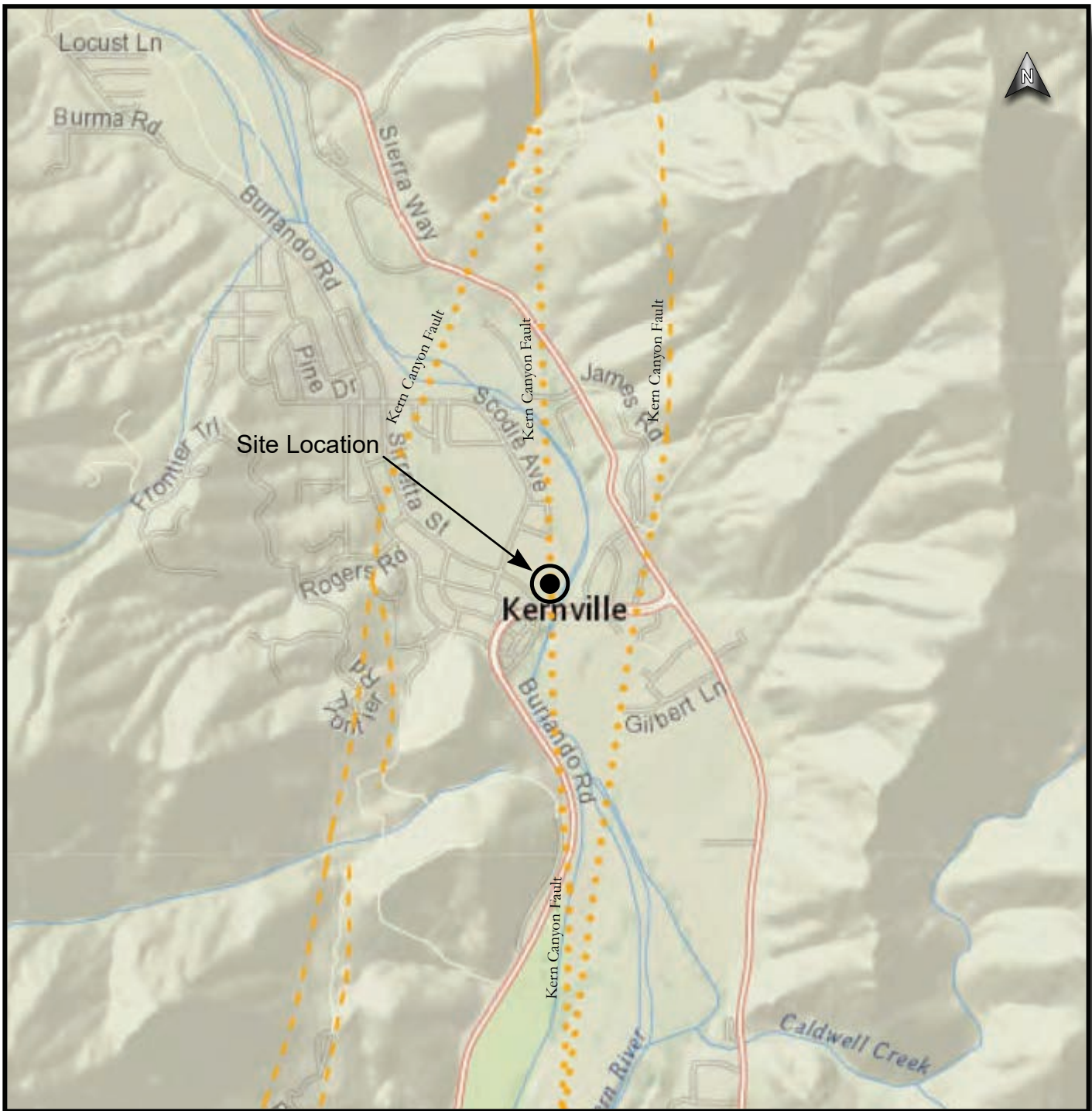

Active	
Historic Displacement (last 200 years)	Holocene Displacement (last 11,700 years)
Potentially Active	Inactive
Late Quaternary Displacement (last 700,000 years)	Quaternary Fault (last 1.6 million years)

<b>REGIONAL FAULT MAP</b>	
Kern River Intake Replacement Project California Water Service Water Works Engineers Kernville Area, Kern County, California	
Plate No.	<b>5</b>
Project no.	2201.0141

Base map from USGS Interactive Fault Map (2022).

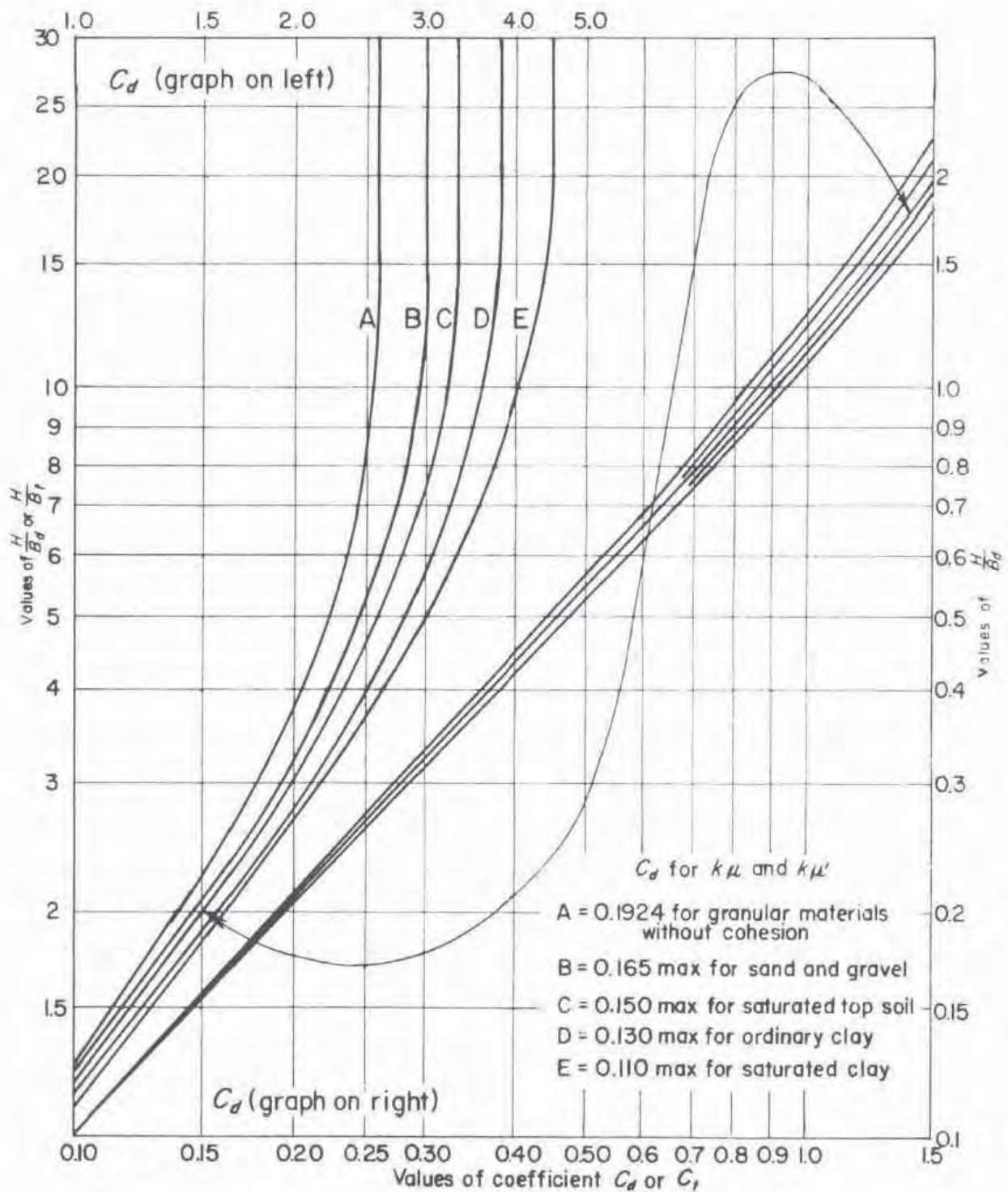

### MARSTON'S LOAD COEFFICIENTS

Kern River Intake Replacement Project  
 California Water Service  
 Water Works Engineers  
 Kernville Area, Kern County, California

Plate No.

6

Project no.  
 2201.0141

 **BAJADA** Geosciences, Inc.

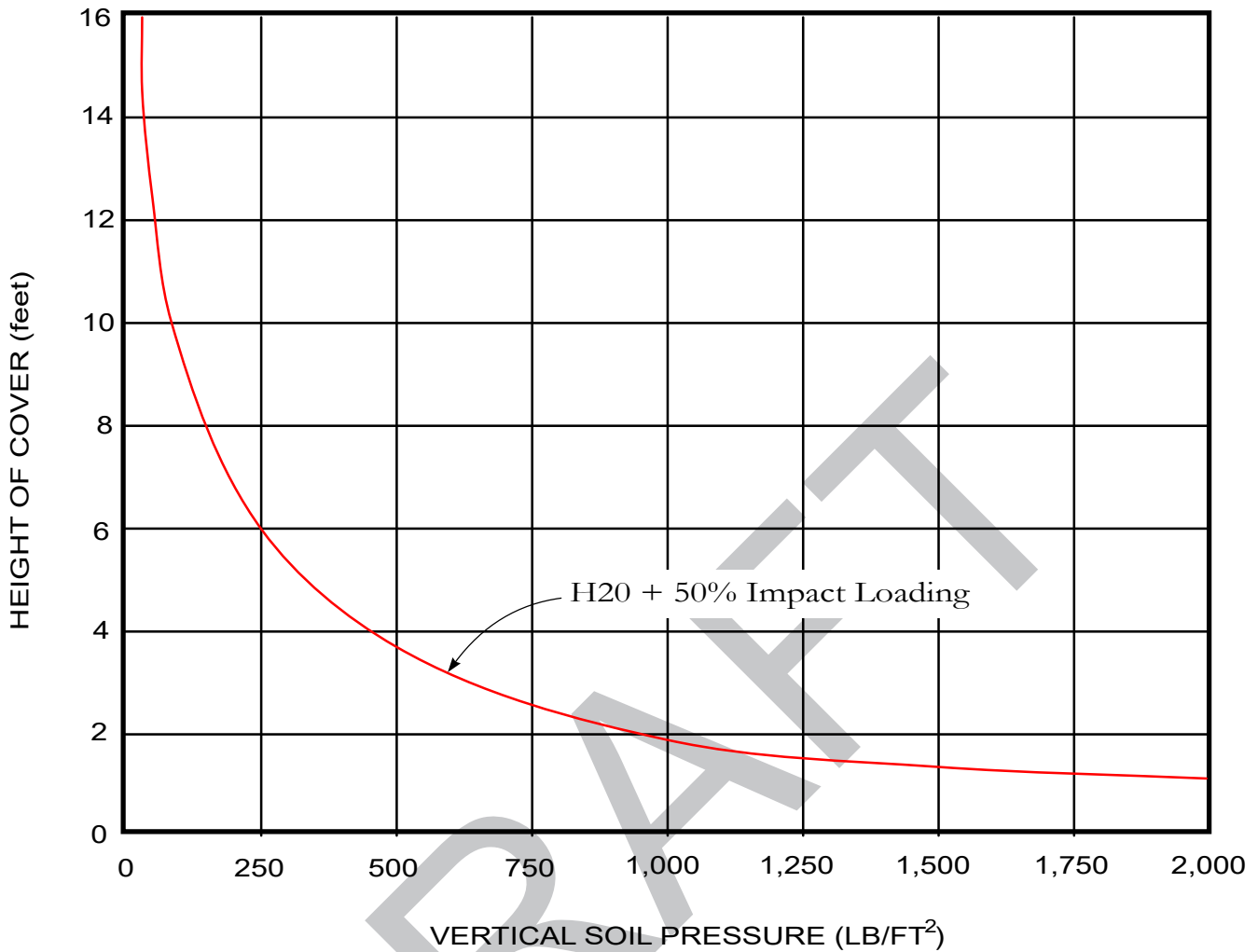

Apply vertical soil pressure to diameter of pipeline (horizontal projection to calculate vertical load

H20 +50% Impact Loading: Simulates a highway load of a 20-ton truck with a 50% impact factor to account for the dynamic effects of traffic

**VERTICAL SOIL PRESSURES INDUCED BY LIVE LOADS**

Kern River Intake Replacement Project California Water Service Water Works Engineers Kernville Area, Kern County, California	Plate No.
	<b>7</b>
 <b>BAJADA</b> Geosciences, Inc.	Project no. 2201.0141

### CLAY PRESSURE DIAGRAM

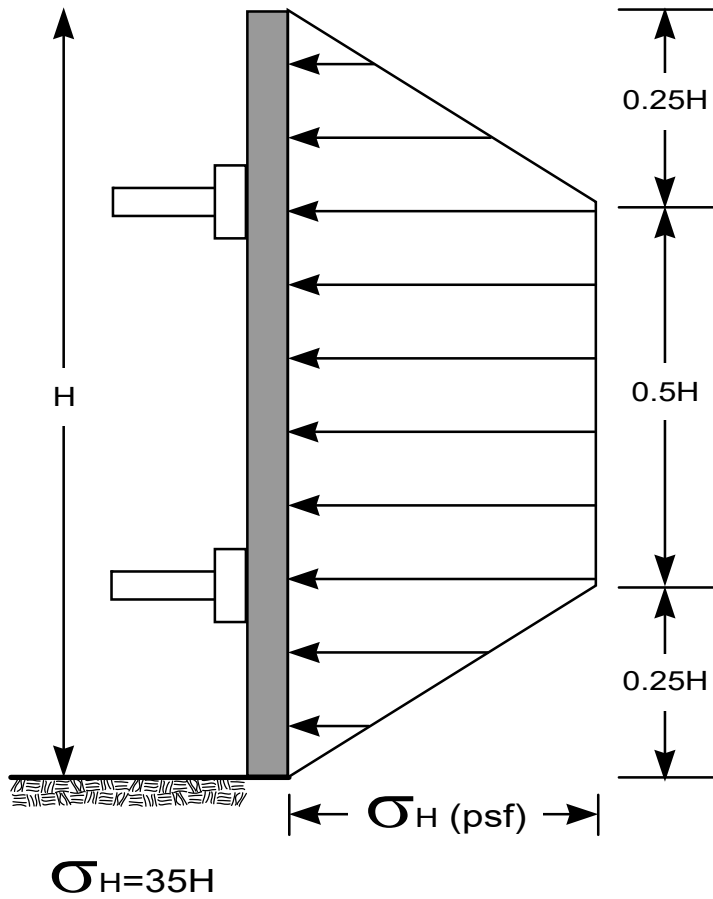

### SAND PRESSURE DIAGRAM

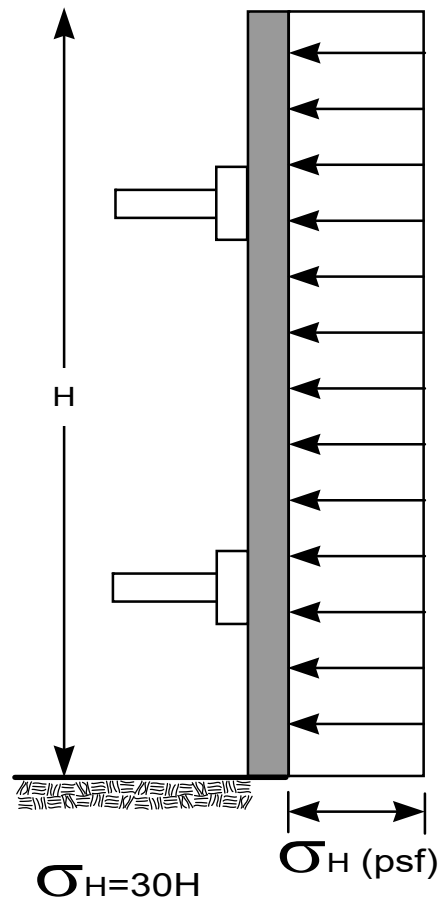

Preliminary shoring pressure diagrams are for excavations in unsaturated soils only.

These preliminary shoring pressure diagrams do not take into account hydrostatic pressures nor surcharge pressures. The effects of these conditions must be added to these pressure diagrams where applicable.

Excavation base stability should be analyzed after base width has been selected.

Final design shoring pressure diagrams will need to be developed by the Contractor based on selection of a shoring system and the actual soil, groundwater, and surcharge conditions encountered during construction.

### PRELIMINARY SHORING PRESSURE DIAGRAMS

Kern River Intake Replacement Project  
California Water Service  
Water Works Engineers  
Kernville Area, Kern County, California

Plate No.

8

 **BAJADA** Geosciences, Inc.

Project no.  
2201.0141

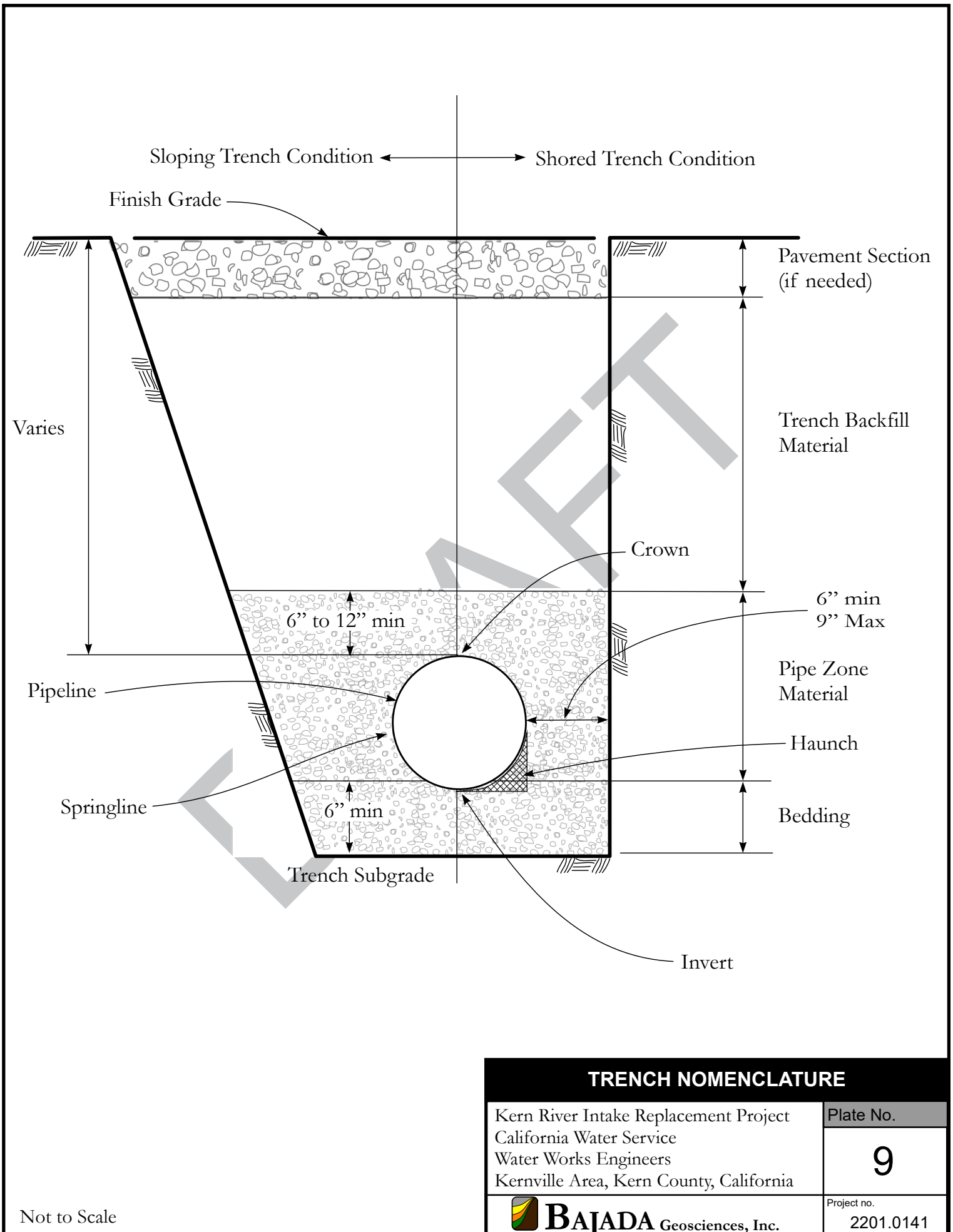

<b>TRENCH NOMENCLATURE</b>	
Kern River Intake Replacement Project California Water Service Water Works Engineers Kernville Area, Kern County, California	Plate No.
	<b>9</b>
 <b>BAJADA</b> Geosciences, Inc.	Project no. 2201.0141

Not to Scale

DRAFT

**APPENDIX A**  
Subsurface Exploration





## APPENDIX A SUBSURFACE EXPLORATION

The subsurface exploration program for this study consisted of the advancement of one exploratory test pits at a selected location shown on Plate 2. The test pit was excavated on November 22, 2022, using a Caterpillar 420F IT backhoe equipped with a 2-foot-wide bucket.

Bulk samples of soil and rock were collected from selected depth increments from the test pit. Sample types and depths are presented on Plate A-1.1. All samples were returned to Bajada's office for later assignment of laboratory testing.

The exploration logs describe the earth materials encountered in each test pit. The log also shows the location, exploration number, date of exploration, and the names of the logger and equipment used. A BAJADA geologist, using ASTM 2488 for visual soil classification, logged the explorations and samples. The boundaries between soil types shown on the log are approximate because the transition between different soil layers may be gradual and may change with time. The test pit was backfilled with the excavated earth materials and wheel rolled.

The test pit log is presented as Plate A-1.1. A legend to the test pit log is presented as Plate A-2.1.



## LOG OF TEST PIT

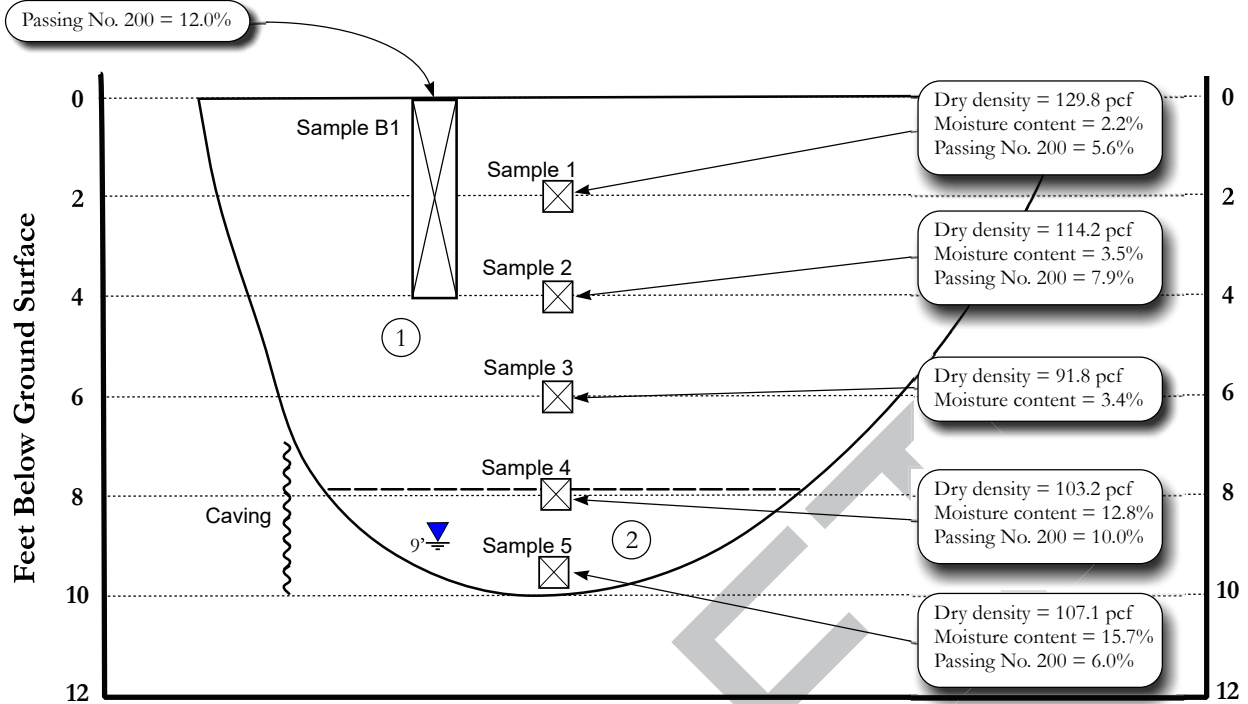

### Soil Descriptions

①	ALLUVIUM (Qal) Sandy GRAVEL to Gravelly SAND (GP/SP), yellowish brown to dark brown, dry to moist, loose to medium dense, fine to coarse grained with abundant medium to coarse well rounded to rounded gravels and cobbles, with trace organics to 4'.
②	SAND (SP), yellowish brown to greyish brown, wet, loose to medium dense, fine to coarse grained, with trace fine to medium well rounded cobbles and possibly boulders. Flowing sands above and below water table.

Estimated Latitude: 35.755705°

Estimated Longitude: -118.422824°

Measured using Solocator application  
Not considered survey quality

### TEST PIT TP-1

Date Logged: November 22, 2022  
 Logged by: Bryan Puleri  
 Excavator: Golden Excavation Co.  
 Excavated With: Cat 420F IT Backhoe  
 Backfilled With: Excavated Cuttings  
 Depth to Water (ft): 9.5 Feet

Cal Water Kernville Intake Facility  
 California Water Services  
 Water Works Engineers  
 Kernville Area, Kern County, California



**BAJADA** Geosciences, Inc.

Plate No.

A-1.1

Project no.

2201.0141

Major Divisions		USCS Symbol	Description		
<b>COARSE-GRAINED SOILS</b> More than 50% of sample or material is larger than the No. 200 Sieve (0.0029 inches)	<b>GRAVELS</b> More than 50% of the coarse fraction is retained on No. 4 sieve (0.187 inches)	<b>GRAVELS</b> Clean Gravels, few fines	GW Well graded gravels and sand mixtures with little to no fines		
		<b>GRAVELS</b> With appreciable fines	GP Poorly graded gravels & gravel/sand mixtures with little to no fines		
		<b>SANDS</b> More than 50% of the coarse fraction passes the No. 4 sieve (0.187 inches)	<b>SANDS</b> Clean Sands, few fines	GM Silty gravels and poorly graded gravel/sand/silt mixtures	
			<b>SANDS</b> With appreciable fines	GC Clayey gravels and poorly graded gravel/sand/clay mixtures	
	<b>FINE-GRAINED SOILS</b> More than 50% of sample or material is smaller than the No. 200 Sieve (0.0029 inches)	<b>SANDS</b> More than 50% of the coarse fraction passes the No. 4 sieve (0.187 inches)	<b>SANDS</b> Clean Sands, few fines	SW Well graded sands and gravelly sands with little to no fines	
			<b>SANDS</b> With appreciable fines	SP Poorly graded sands and gravelly sands with little to no fines	
			<b>SANDS</b> With appreciable fines	SM Silty sands and poorly graded sand/gravel/silt mixtures	
		<b>SILTS &amp; CLAYS</b> Liquid limit less than 50	<b>SILTS &amp; CLAYS</b> Liquid limit greater than 50	<b>SILTS &amp; CLAYS</b> Liquid limit less than 50	SC Clayey sands and poorly graded sand/gravel/clay mixtures
				<b>SILTS &amp; CLAYS</b> Liquid limit less than 50	ML Inorganic silts with very fine sands, silty and/or clayey fine sands, clayey silts with slight plasticity
				<b>SILTS &amp; CLAYS</b> Liquid limit less than 50	CL Inorganic clays with low to medium plasticity, gravelly clays, sandy clays, silty clays, lean clays
<b>SILTS &amp; CLAYS</b> Liquid limit greater than 50	<b>SILTS &amp; CLAYS</b> Liquid limit greater than 50	<b>SILTS &amp; CLAYS</b> Liquid limit greater than 50	OL Organic silts and clays with low plasticity		
		<b>SILTS &amp; CLAYS</b> Liquid limit greater than 50	MH Inorganic silts, micaceous or diatomaceous fine sands or silts		
		<b>SILTS &amp; CLAYS</b> Liquid limit greater than 50	CH Inorganic clays with high plasticity, fat clays		
<b>HIGHLY ORGANIC SOIL</b>	<b>SILTS &amp; CLAYS</b> Liquid limit greater than 50	<b>SILTS &amp; CLAYS</b> Liquid limit greater than 50	OH Organic silts and clays with high plasticity		
		<b>SILTS &amp; CLAYS</b> Liquid limit greater than 50	PT Peat, humus, swamp soil with high organic content		

**Samples**



Bulk or disturbed sample



Relatively undisturbed sample

**Symbols**



Groundwater



Caving



Contact Between Soil/Rock Layers

**GENERAL NOTES**

Dual symbols (such as ML/CL or SM/SC) are used to indicate borderline classifications.  
 In general, USCS designations shown on the logs were evaluated using visual methods. Actual designations (based on laboratory tests) may vary. Logs represent general soil conditions observed on the date and locations indicated. No warranty is provided regarding soil continuity between locations.  
 Lines separating soil strata on logs are approximate. Actual transitions may be gradual and vary with depth.

**TEST PIT LEGEND TO TERMS & SYMBOLS**

Cal Water Kernville Intake Facility  
 California Water Services  
 Water Works Engineers  
 Kernville Area, Kern County, California

Plate No.

A-2.0

 **BAJADA** Geosciences, Inc.

Project no.  
 2201.0141

DRAFT

**APPENDIX B**

Laboratory Testing



## APPENDIX B LABORATORY TESTING

### Laboratory Analyses

Laboratory tests were performed on selected bulk soil samples to estimate engineering characteristics of the various earth materials encountered. Testing was performed under procedures described in one of the following references:

- ASTM Standards for Soil Testing, latest revision;
- Lambe, T. William, Soil Testing for Engineers, Wiley, New York, 1951;
- Laboratory Soils Testing, U.S. Army, Office of the Chief of Engineers, Engineering Manual No. 1110-2-1906, November 30, 1970.

### In-Situ Moisture Density Relations

Estimates of soil moisture content evaluations were performed on selected soil samples collected during this study. Tests were performed using standard test methods ASTM D2216. The results are presented on the respective Log of Test Pit.

### Grain Size Distribution

Grain size distribution was determined for five selected soil samples in accordance with standard test method ASTM D422. The grain size distribution data are shown on the attached plates labeled *Particle Size Distribution*.

### Direct Shear Tests

Direct shear tests were performed on two selected soil samples in accordance with standard test method ASTM D3080. Results of those tests are presented on attached plates labeled *Consolidated Drained Direct Shear*.

### Maximum Density & Optimum Moisture

One selected soil sample was tested to evaluate the maximum density and optimum moisture content of those soils. The tests were performed in accordance with standard test method ASTM D1557. Results of the test is presented on the attached plates labeled *Laboratory Proctor Test Reports*.

### Soil Chemistry Tests for Corrosion

One selected soil sample was tested to evaluate sulfate and chloride contents, pH, and resistivity. Tests were performed in accordance with standard test methods ASTM G51 and G75, and California Test Method 417 and 422. Test results are presented on the attached plate labeled *Corrosivity Test Summary*.



# Materials Testing, Inc.

8798 Airport Road  
Redding, California 96002  
(530) 222-1116, fax 222-1611

865 Cotting Lane, Suite A  
Vacaville, California 95688  
(707) 447-4025, fax 447-4143

**Client:** BAJADA Geosciences, Inc.  
28301 Inwood Road  
Shingletown, CA 96088

**Client No.:** 3237-088  
**Figure No.:** 0300-001  
**Date:** 12/23/2022  
**Page No.:** 1 of 1  
**Submitted by:** Client  
**Date Submitted:** 12/01/2022

**Project:** Kern River Intake Replacement Project #2201.0141  
Kernville, California

## Density of Soil in Place by the Drive-Cylinder Method (ASTM D2937) and Liquid Limit, Plastic Limit & Plasticity Index of Soils (ASTM D4318)

Sample #	Description	Dry Density p.c.f.	Moisture Content %	Liquid Limit	Plastic Limit	Plastic Index
TP-1, 1 @ 2.0'	Brown Gravel with Silt and Sand (visual)	129.8	2.2	---	---	---
TP-1, 2 @ 4.0'	Brown Sand with Silt and Gravel (visual)	114.2	3.5	---	---	---
TP-1, 3 @ 6.0'	Brown Silty Sand (visual)	91.8	3.4	---	---	---
TP-1, 4 @ 8.0'	Brown Sand with Silt (visual)	103.2	12.8	---	---	---
TP-1, 5 @ 9.0'	Brown Sand with Silt (visual)	107.1	15.7	---	---	---

Tested by John Hubbard.

The samples were tested according to the referenced standard test procedures and relate only to the items inspected or tested. Results are not transferable and shall not be reproduced, except in full, without written permission from MTI.



# PARTICLE SIZE DISTRIBUTION REPORT

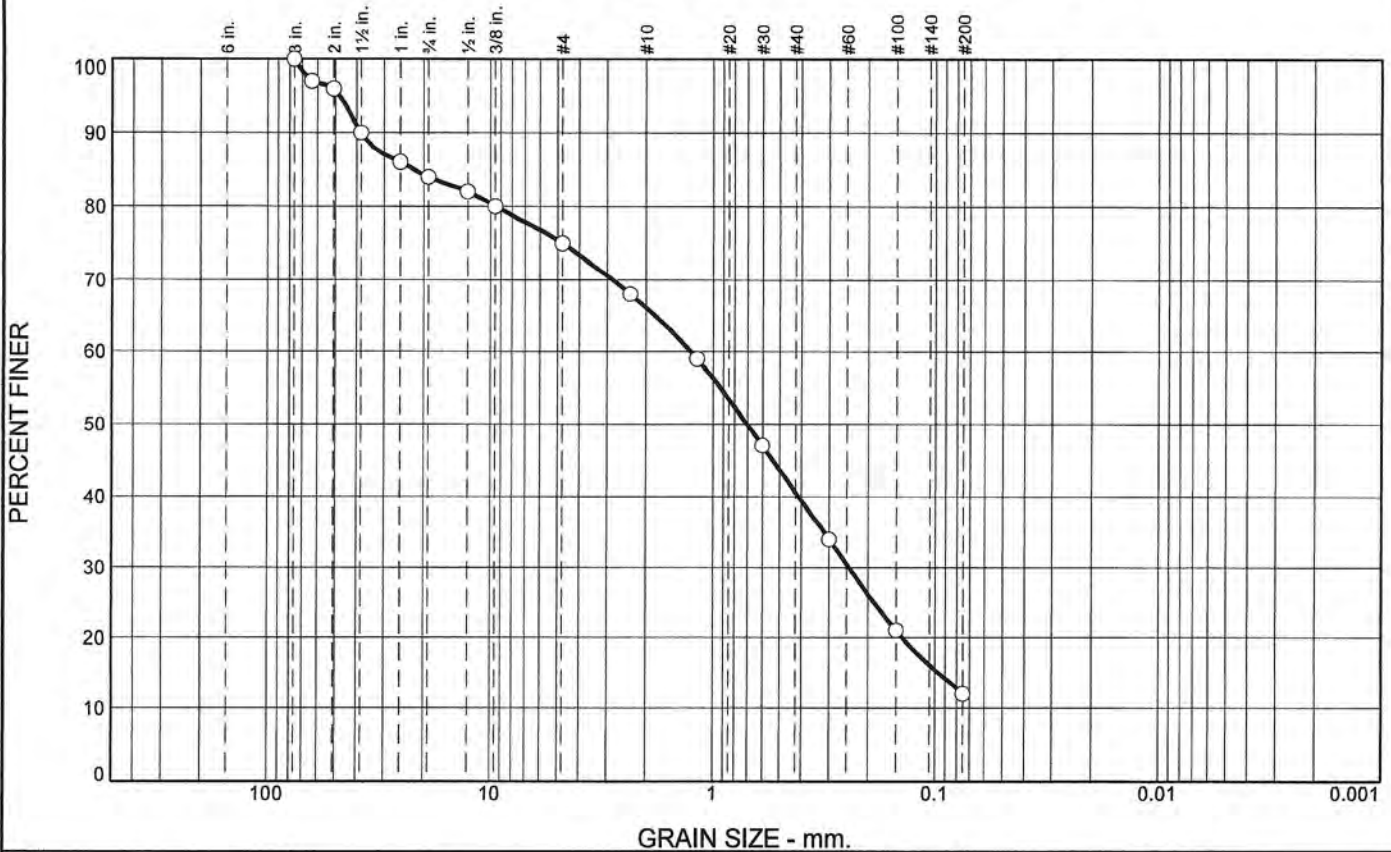

% +3"	% Gravel	% Sand		% Fines	
		Coarse	Fine	Silt	Clay
0	34	25	29	12	

SIEVE SIZE	PERCENT FINER	SPEC.* PERCENT	PASS? (X=NO)
3"	100		
2 1/2"	97		
2"	96		
1 1/2"	90		
1"	86		
3/4"	84		
1/2"	82		
3/8"	80		
#4	75		
#8	68		
#16	59		
#30	47		
#50	34		
#100	21		
#200	12		

**Material Description**

Brown Sand with Silt and Gravel (visual)

**Atterberg Limits**

PL=                      LL=                      PI=

**Coefficients**

D<sub>90</sub>= 38.1000      D<sub>85</sub>= 22.0144      D<sub>60</sub>= 1.2599  
D<sub>50</sub>= 0.7048      D<sub>30</sub>= 0.2448      D<sub>15</sub>= 0.0970  
D<sub>10</sub>=                      C<sub>u</sub>=                      C<sub>c</sub>=

**Classification**

USCS= SP-SM                      AASHTO=

**Remarks**

Material tested in accordance with ASTM D6913.

\* (no specification provided)

Location: TP-1, B1                      Depth: 0'-4.0'                      Date: 12/23/2022  
Sample Number: 1



**Client:** BAJADA Geoscience, Inc.  
**Project:** Kern River Intake Replacement Project #2201.0141  
Kernville, California  
**Project No:** 3237-088                      **Figure** 0300-002

Tested By: Travis Fiscus

# PARTICLE SIZE DISTRIBUTION REPORT

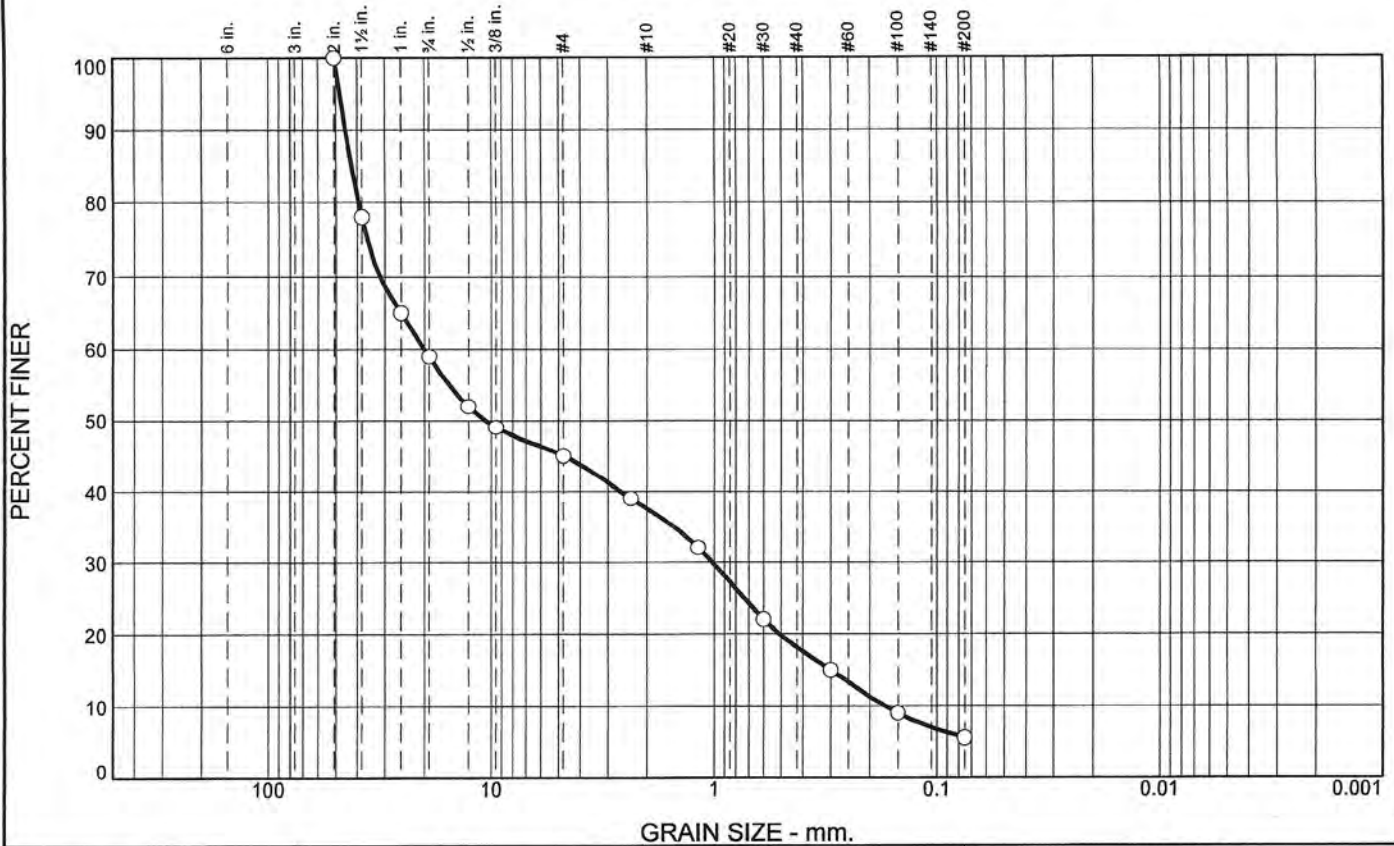

% +3"	% Gravel	% Sand		% Fines	
		Coarse	Fine	Silt	Clay
0	62	20	12	6	

SIEVE SIZE	PERCENT FINER	SPEC.* PERCENT	PASS? (X=NO)
2"	100		
1 1/2"	78		
1"	65		
3/4"	59		
1/2"	52		
3/8"	49		
#4	45		
#8	39		
#16	32		
#30	22		
#50	15		
#100	9		
#200	5.6		

\* (no specification provided)

**Material Description**

Brown Gravel with Silt and Sand (visual)

**Atterberg Limits**

PL=                      LL=                      PI=

**Coefficients**

D<sub>90</sub>= 45.1143      D<sub>85</sub>= 42.3134      D<sub>60</sub>= 19.9993  
D<sub>50</sub>= 10.6706      D<sub>30</sub>= 1.0232      D<sub>15</sub>= 0.3000  
D<sub>10</sub>= 0.1715      C<sub>u</sub>= 116.64      C<sub>c</sub>= 0.31

**Classification**

USCS= GP-GM                      AASHTO=

**Remarks**

Material tested in accordance with ASTM D6913.

**Location:** TP-1, 1  
**Sample Number:** 2

**Depth:** 2.0'

**Date:** 12/23/2022



**Client:** BAJADA Geoscience, Inc.

**Project:** Kern River Intake Replacement Project #2201.0141  
Kernville, California

**Project No:** 3237-088

**Figure** 0300-003

**Tested By:** John Hubbard



# PARTICLE SIZE DISTRIBUTION REPORT

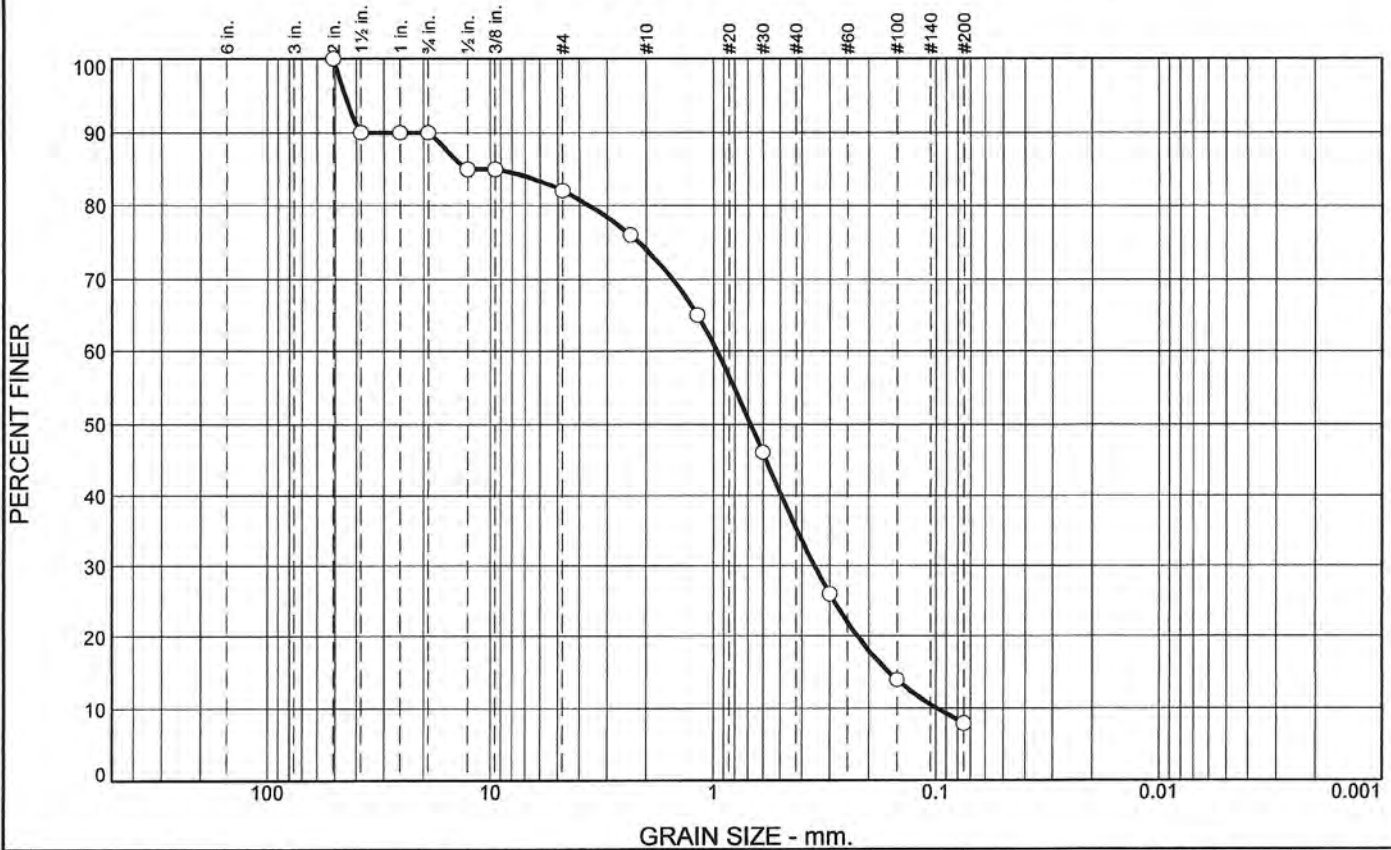

% +3"	% Gravel	% Sand		% Fines	
0	26	Coarse	Fine	Silt	Clay
		39	27	8	

SIEVE SIZE	PERCENT FINER	SPEC.* PERCENT	PASS? (X=NO)
2"	100		
1 1/2"	90		
1"	90		
3/4"	90		
1/2"	85		
3/8"	85		
#4	82		
#8	76		
#16	65		
#30	46		
#50	26		
#100	14		
#200	7.9		

**Material Description**

Brown Sand with Silt and Gravel (visual)

**Atterberg Limits**

PL=                      LL=                      PI=

**Coefficients**

D<sub>90</sub>= 38.1000      D<sub>85</sub>= 12.7000      D<sub>60</sub>= 0.9640  
D<sub>50</sub>= 0.6829      D<sub>30</sub>= 0.3510      D<sub>15</sub>= 0.1627  
D<sub>10</sub>= 0.0991      C<sub>u</sub>= 9.73              C<sub>c</sub>= 1.29

**Classification**

USCS= SW-SM                      AASHTO=

**Remarks**

Material tested in accordance with ASTM D6913.

\* (no specification provided)

Location: TP-1, 2      Sample Number: 3      Depth: 4.0'      Date: 12/23/2022

	<p><b>Client:</b> BAJADA Geoscience, Inc.</p> <p><b>Project:</b> Kern River Intake Replacement Project #2201.0141 Kernville, California</p> <p><b>Project No:</b> 3237-088</p>	<p><b>Figure</b> 0300-004</p>
--	--	-------------------------------

Tested By: John Hubbard

# PARTICLE SIZE DISTRIBUTION REPORT

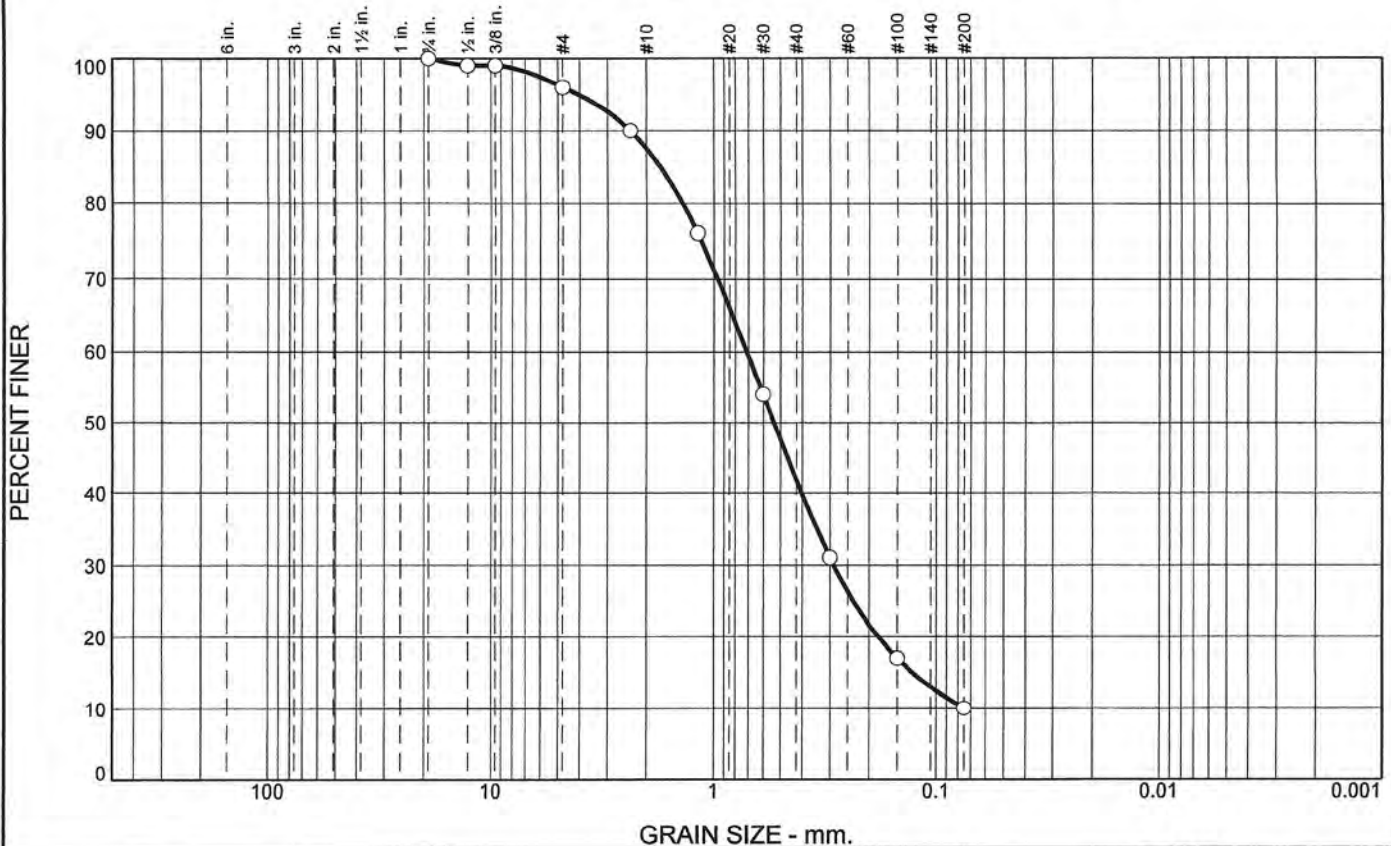

% +3"	% Gravel	% Sand		% Fines	
		Coarse	Fine	Silt	Clay
0	12	46	32	10	0

SIEVE SIZE	PERCENT FINER	SPEC.* PERCENT	PASS? (X=NO)
3/4"	100		
1/2"	99		
3/8"	99		
#4	96		
#8	90		
#16	76		
#30	54		
#50	31		
#100	17		
#200	10		

**Material Description**  
Brown Sand with Silt (visual)

**Atterberg Limits**  
 PL=                      LL=                      PI=

**Coefficients**  
 D<sub>90</sub>= 2.3600              D<sub>85</sub>= 1.7350              D<sub>60</sub>= 0.7117  
 D<sub>50</sub>= 0.5361              D<sub>30</sub>= 0.2892              D<sub>15</sub>= 0.1279  
 D<sub>10</sub>= 0.0750              C<sub>u</sub>= 9.49                  C<sub>c</sub>= 1.57

**Classification**  
 USCS= SW-SM                      AASHTO=

**Remarks**  
 Material tested in accordance with ASTM D6913.

\* (no specification provided)

**Location:** TP-1, 4                      **Depth:** 8.0'                      **Date:** 12/23/2022  
**Sample Number:** 5

	<p><b>Client:</b> BAJADA Geoscience, Inc.  <b>Project:</b> Kern River Intake Replacement Project #2201.0141                  Kernville, California  <b>Project No:</b> 3237-088                      <b>Figure</b> 0300-005</p>
--	---

**Tested By:** John Hubbard



# PARTICLE SIZE DISTRIBUTION REPORT

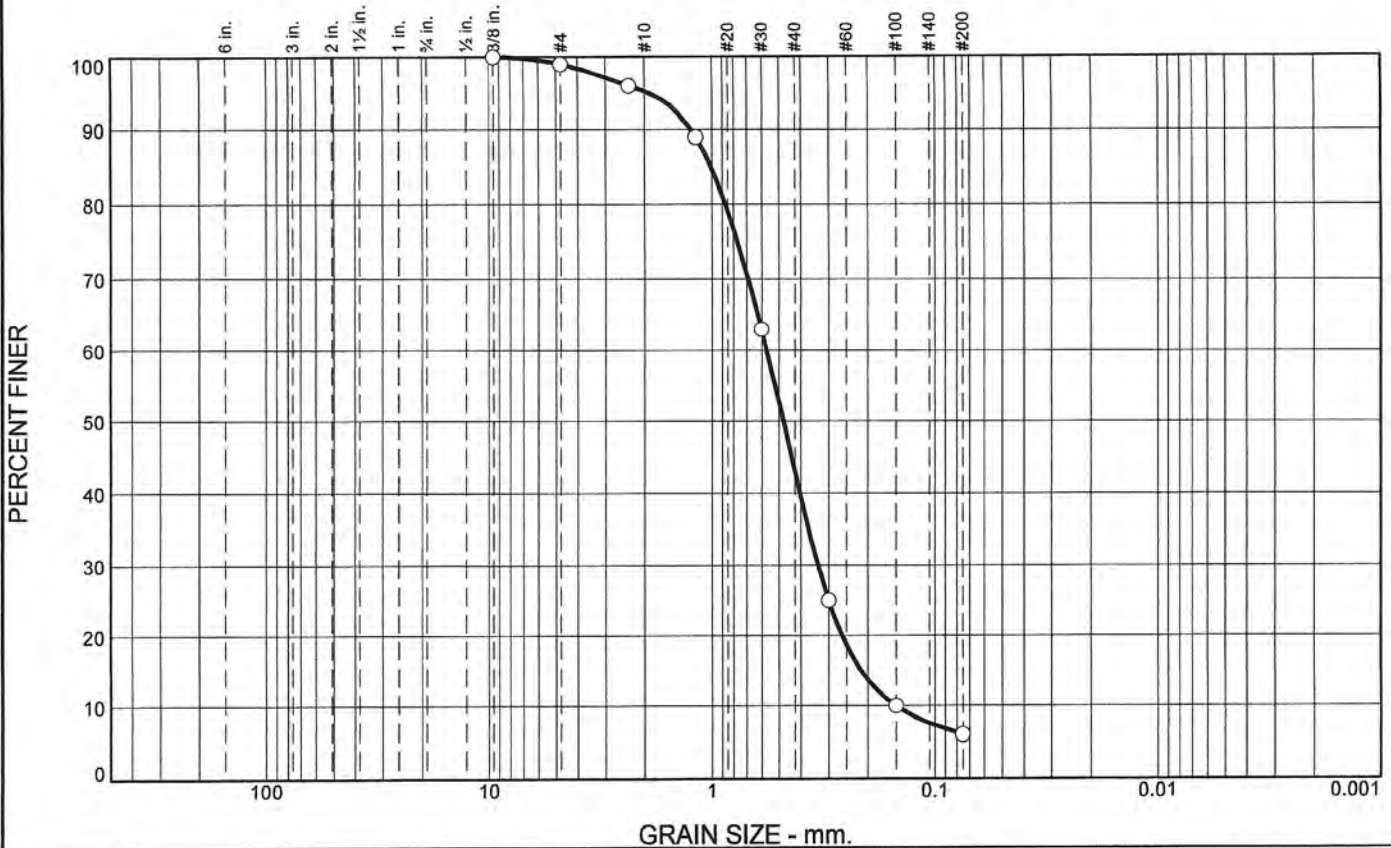

% +3"	% Gravel	% Sand		% Fines	
		Coarse	Fine	Silt	Clay
0	5	52	37	6	6

SIEVE SIZE	PERCENT FINER	SPEC.* PERCENT	PASS? (X=NO)
3/8"	100		
#4	99		
#8	96		
#16	89		
#30	63		
#50	25		
#100	10		
#200	6.0		

**Material Description**

Brown Sand with Silt (visual)

**Atterberg Limits**

PL=                      LL=                      PI=

**Coefficients**

D<sub>90</sub>= 1.2386                      D<sub>85</sub>= 1.0108                      D<sub>60</sub>= 0.5682  
D<sub>50</sub>= 0.4783                      D<sub>30</sub>= 0.3348                      D<sub>15</sub>= 0.2154  
D<sub>10</sub>= 0.1500                      C<sub>u</sub>= 3.79                      C<sub>c</sub>= 1.32

**Classification**

USCS= SP-SM                      AASHTO=

**Remarks**

Material tested in accordance with ASTM D6913.

\* (no specification provided)

Location: TP-1, 5  
Sample Number: 6

Depth: 9.0

Date: 12/23/2022



**Client:** BAJADA Geoscience, Inc.

**Project:** Kern River Intake Replacement Project #2201.0141  
Kernville, California

**Project No:** 3237-088

**Figure** 0300-006

Tested By: John Hubbard

# LABORATORY PROCTOR TEST REPORT

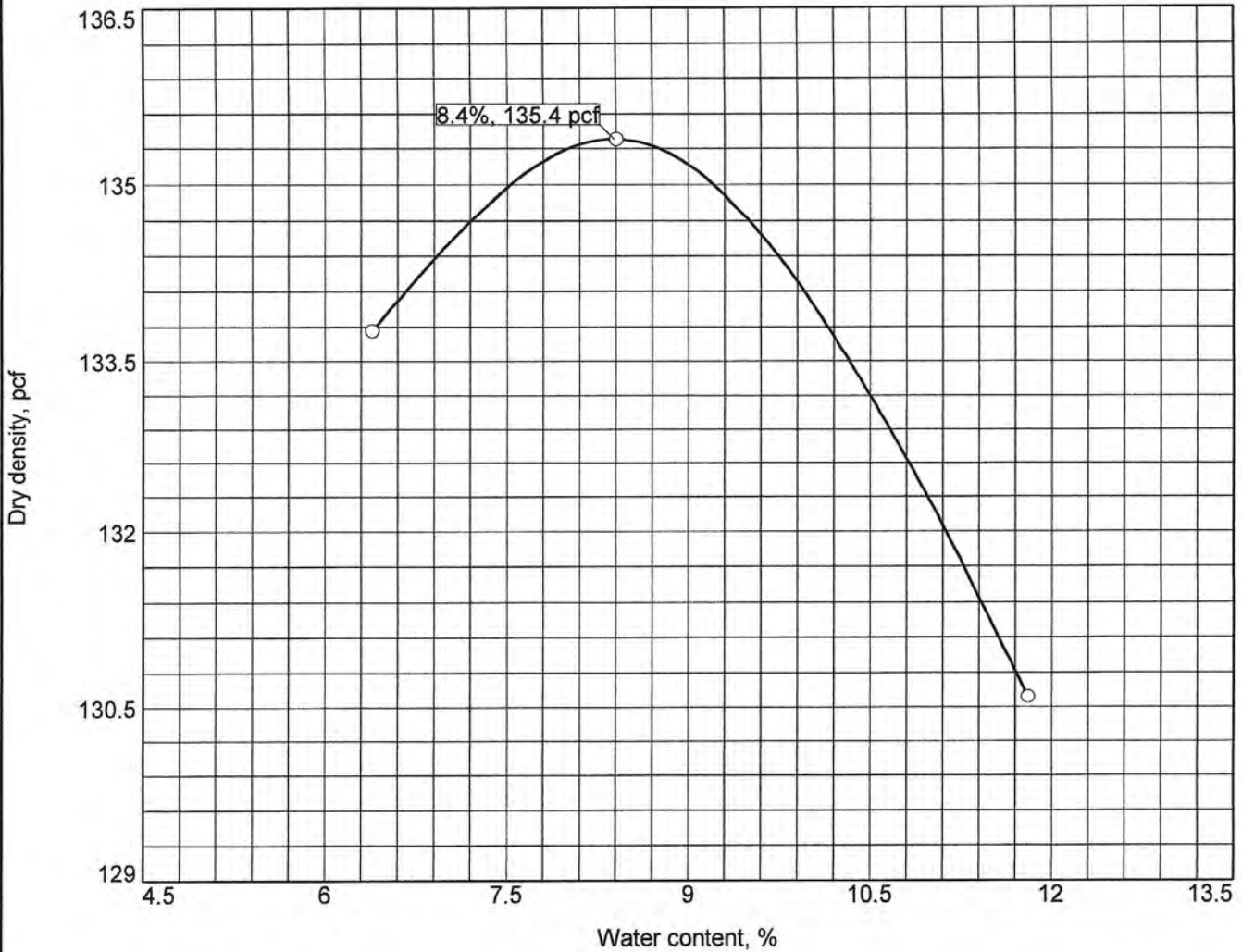

Test specification: ASTM D1557-12 Method C Modified  
 ASTM D4718-15 Oversize Corr. Applied to Each Test Point

Elev/ Depth	Classification		Nat. Moist.	Sp.G.	LL	PI	% > 3/4 in.	% < No.200
	USCS	AASHTO						
0'-4.0'	SP-SM			2.65			16	12

ROCK CORRECTED TEST RESULTS	MATERIAL DESCRIPTION
Maximum dry density = 135.4 pcf Optimum moisture = 8.4 %	Brown Sand with Silt and Gravel (visual)

<b>Project No.</b> 3237-088 <b>Client:</b> BAJADA Geoscience, Inc. <b>Project:</b> Kern River Intake Replacement Project #2201.0141 Kernville, California ○ <b>Location:</b> TP-1, B1 <b>Sample Number:</b> 1	<b>Remarks:</b> Curve # 1 12/23/2022
--	--



**Figure** 0300-007

**Tested By:** Travis Fiscus



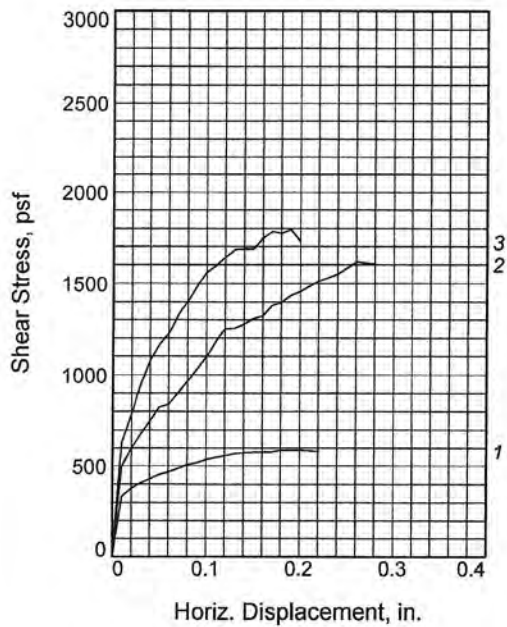
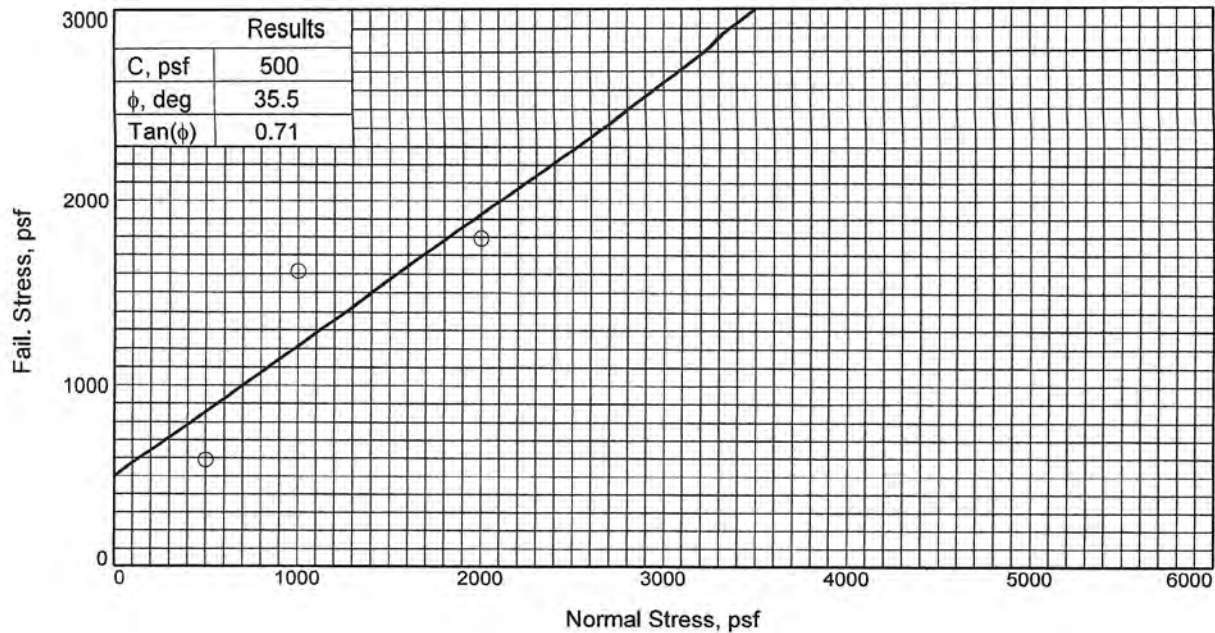

Sample No.	1	2	3	
Initial	Water Content, %	3.5	3.5	3.5
	Dry Density, pcf	92.6	107.9	92.9
	Saturation, %	11.5	16.7	11.6
	Void Ratio	0.8413	0.5792	0.8341
	Diameter, in.	2.41	2.41	2.41
	Height, in.	1.00	1.00	1.00
At Test	Water Content, %	24.6	16.3	19.4
	Dry Density, pcf	94.0	110.6	102.5
	Saturation, %	82.5	82.3	79.9
	Void Ratio	0.8137	0.5411	0.6630
	Diameter, in.	2.41	2.41	2.41
	Height, in.	0.98	0.98	0.91
Normal Stress, psf	500	1000	2000	
Fail. Stress, psf	590	1613	1793	
Displacement, in.	0.18	0.26	0.19	
Ult. Stress, psf				
Displacement, in.				
Strain rate, in./min.	0.002	0.002	0.002	

**Sample Type:** Tube  
**Description:** Brown Sand with Silt and Gravel (visual)  
**Specific Gravity=** 2.73  
**Remarks:** Material tested in accordance with ASTM D3080.

**Client:** BAJADA Geoscience, Inc.  
**Project:** Kern River Intake Replacement Project #2201.0141  
 Kernville, California  
**Location:** TP-1, 2  
**Sample Number:** 3      **Depth:** 4.0'  
**Proj. No.:** 3237-088      **Date Sampled:** 12/23/2022



**Figure** 0300-008

**Tested By:** Jack Bianchin

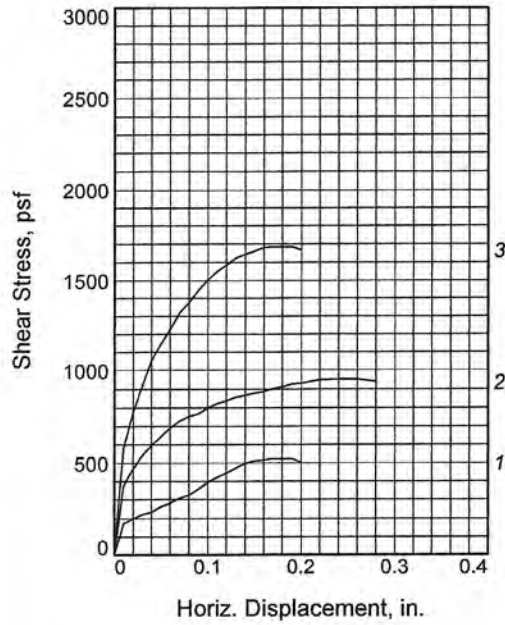
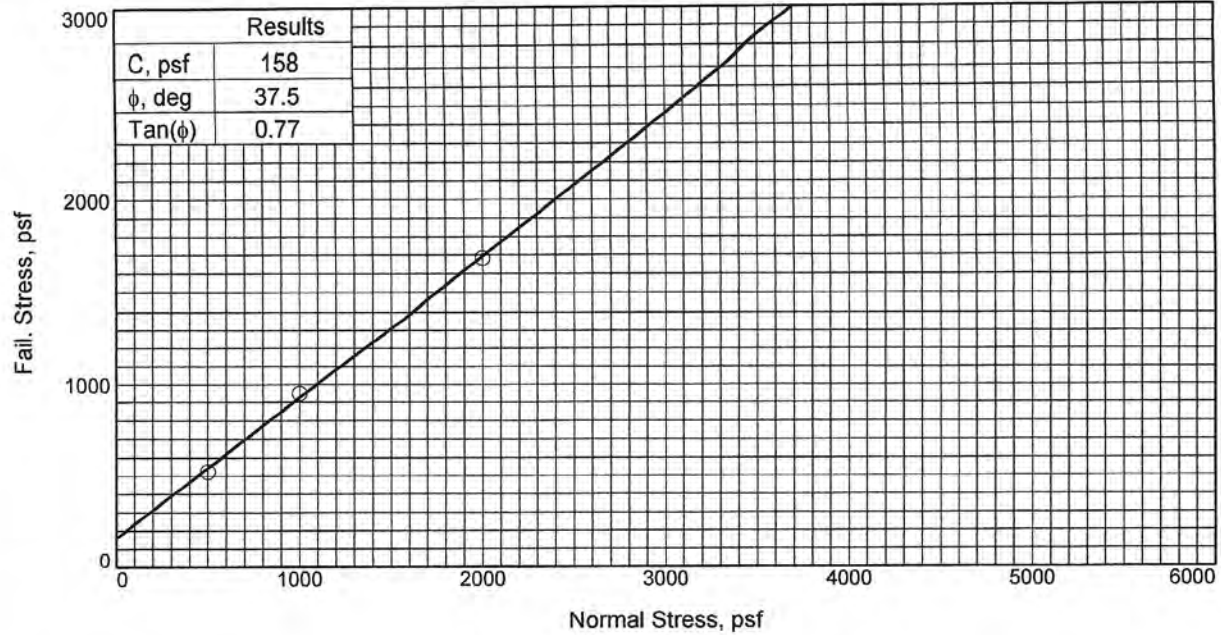

Sample No.	1	2	3	
Initial	Water Content, %	12.8	12.8	12.8
	Dry Density, pcf	93.7	85.3	91.0
	Saturation, %	39.0	32.5	36.8
	Void Ratio	0.9798	1.1746	1.0382
	Diameter, in.	2.41	2.41	2.41
	Height, in.	1.00	1.00	1.00
At Test	Water Content, %	21.6	23.8	27.2
	Dry Density, pcf	95.9	88.7	98.6
	Saturation, %	68.8	64.8	91.7
	Void Ratio	0.9328	1.0898	0.8806
	Diameter, in.	2.41	2.41	2.41
	Height, in.	0.98	0.96	0.92
Normal Stress, psf	500	1000	2000	
Fail. Stress, psf	524	950	1683	
Displacement, in.	0.17	0.24	0.17	
Ult. Stress, psf				
Displacement, in.				
Strain rate, in./min.	0.002	0.002	0.002	

**Sample Type:** Tube  
**Description:** Brown Sand with Silt (visual)  
**Specific Gravity=** 2.97  
**Remarks:** Material tested in accordance with ASTM D3080.

**Client:** BAJADA Geoscience, Inc.  
**Project:** Kern River Intake Replacement Project #2201.0141  
 Kernville, California  
**Location:** TP-1, 4  
**Sample Number:** 5      **Depth:** 8.0'  
**Proj. No.:** 3237-088      **Date Sampled:** 12/23/2022

Figure 0300-009



Tested By: John Hubbard





# Sunland Analytical

11419 Sunrise Gold Circle, #10  
Rancho Cordova, CA 95742  
(916) 852-8557

Date Reported 12/09/2022  
Date Submitted 12/06/2022

To: Andy King  
K.C. Engineerig  
8798 Airport Rd.  
Redding, CA 96002

From: Gene Oliphant, Ph.D. \ Randy Horney  
General Manager \ Lab Manager *RA*

The reported analysis was requested for the following location:  
Location : 3237 KERN RIVER Site ID : TP1, B1 @ 0-4.  
Thank you for your business.

\* For future reference to this analysis please use SUN # 88671-184292.

-----  
EVALUATION FOR SOIL CORROSION

Soil pH	7.43		
Minimum Resistivity	7.24 ohm-cm (x1000)		
Chloride	2.7 ppm	0.00027	%
Sulfate-SO4	3.2ppm	0.00032	%

#### METHODS

pH and Min.Resistivity CA DOT Test #643 Mod.(Sm.Cell)  
Sulfate-SO4 ASTM C1580, Chloride CA DOT Test #422m



DRAFT

## APPENDIX C

Previous Work by Others in Project Vicinity



MOORE & TABER • *Engineers • Geologists*

1125 E. TRUSLOW AVE. • FULLERTON, CALIF., 92631 • PHONE (714) 525-0242

FOUNDATION INVESTIGATION

Kern River Bridge  
Kernville, California

Client  
Kern County Road Department

Job No. 16-773 F

January 23, 1967

50C-18

FOUNDATION INVESTIGATION

This report presents the results of site exploration, soil testing and engineering calculations for the Kern River Bridge across the Kern River at Kernville, in Kern County, California. Tentative information indicates the crossing will be provided by a post-tensioned concrete bridge consisting of five spans 100 feet long.

The purpose of this investigation is to determine the general soil conditions and to provide recommendations for a safe and economical design of the substructure. Site conditions at the time of the investigation reflected the flooding that occurred during the early part of December, 1966. The bridge had sustained severe damage; four piers were undermined by scour and five spans were damaged.

Exploration

Field investigation was completed during January, 1967 and consisted of four 3-inch diameter rotary borings varying from 18 feet to 39.5 feet in depth. Samples were obtained at selected intervals by means of a 2-inch outside-diameter standard penetration sampler. Borings were logged by an engineering geologist supervising the drilling operations. Boring locations, sample depths, and other details of the drilling operations are presented on the accompanying "Log of Test Borings" plate.

Soil Testing

Earth materials were classified in the field according to color, size gradation, and soil type by careful visual examination of the samples and a continuous observation of the boring returns. Consistency classification was determined from standard penetration tests conducted during the drilling operations according to ASTM designation D 1586-58 T. Coarse grained texture of the sediments and difficulty in sampling prevented taking any larger diameter undisturbed samples.

Strength characteristics were determined mainly by insitu field tests. These tests provided the relative density and bearing capacity of the foundation material from the standard penetration rate, according to an empirical formula. Settlement characteristics were also determined by correlation with the penetration resistance. Penetration rates used in these calculations are shown on the accompanying "Test Boring Logs."

#### Earth Materials and Foundation Conditions

The bridge site is located on the Kernville Road at the town of Kernville. The river valley and flood plain is about a mile and one quarter wide at the crossing; the river is entrenched about 30 feet in a channel nearly 380 feet wide near the center of the flood plain.

Geologic units in the area consist of Carboniferous metamorphic sediments, Jurassic granite, Pleistocene sediments, and Recent stream alluvium. Carboniferous metamorphic sediment was encountered in boring two at elevation 2610 and is exposed along the east river bank about two hundred yards north of the bridge. The Jurassic granite formation was not encountered in any of the borings; but most of the boulders in the alluvium and terrace deposits were derived from this formation in the drainage area to the north.

The Pleistocene terrace sediments form the higher ground immediately east of the bridge and are exposed in the river bank immediately north of the bridge. The Pleistocene terrace deposit is composed largely of gravel and boulders with a matrix of brown silty sand. Lenses of coarse sand and gravel occur locally.

Recent stream alluvium, consisting of fine to coarse sand, gravel and cobbles was encountered in all borings with the possible exception of boring four.

Two large faults are located on either side of the river valley in this area and may be the cause of the irregular stream course and the presence of the uplifted Pleistocene terraces as well as the outcrops of metamorphic rock north of the bridge.

## MOORE & TABER • *Engineers • Geologists*

A more detailed description of the earth materials encountered during the field exploration is given on the accompanying "Log of Test Borings."

### CONCLUSIONS AND RECOMMENDATIONS

#### General Discussion

The primary concern at this site is to obtain structure support below maximum future scour depth (design scour). Except at the west abutment (B-2), the boring data indicate the maximum past scour has extended to the base of the Recent alluvium, consequently, the past scour depth would range up to about 13 feet below the low point in the stream bottom. This depth is about normal for a stream of this size and bed material.

Based on rather limited information (including an estimate of the maximum water depth during the study), the low point in the stream was about elevation 2623 in 1950 and is about 2625 at the present time. This would indicate a net aggradation of the stream bottom of 2 feet since 1950. This again is about what normally would be expected, due to the effect of Lake Isabella on the upstream regimen of the river. For the proposed bridge, it is recommended that the bridge design consider a net river bottom aggradation of 4 to 5 feet during the life of the structure. For any given water way opening and flood flow, this would in effect increase the high water elevation by this same amount, during the latter years of the structure's life.

#### Foundation Recommendations

The type of foundations that can be used at this location is severely limited by the foundation material. Except at the west end of the proposed structure, the presence of large boulders will make pile driving unreliable and impractical. For this reason, footing foundations are generally recommended and should be founded below design scour as tabulated below. Since a tremie seal will likely be necessary, the elevations given are for the base of the seal. If any of the piers can be constructed without a tremie seal,

MOORE & TABER · *Engineers · Geologists*

the base of the footing should be placed at the recommended elevation.

<u>Support</u>	<u>Location</u>	<u>Footing Elevation</u>
Abutment 1	Station 321+45	2618
Pier 2	Station 322+45	2611
Pier 3	Station 323+45	2611
Pier 4	Station 324+45	2613
Pier 5	Station 325+45	2620
Abutment 6	Station 326+45	2645

*Handwritten notes:*

- Station numbers: 321+36, 322+26, 323+16, 324+06, 324+96, 325+86
- PLANES 6-15-67 (bracketed next to Pier 4, 5, 6)
- PILES 2610, 2611, 2611, 2611, 2614, 2625 (bracketed next to Footing Elevations)
- PLANES 6-15-67 (bracketed next to Footing Elevations 2611, 2614, 2625)

An allowable bearing pressure of 3.5 tons per square foot is recommended for footings placed at the above elevations.

As an alternate recommendation, abutment 1 can be supported by 12BP53 H piles designed for an allowable load of 57 tons. These piles should attain a minimum penetration to elevation 2610 and have at least 85 tons bearing in accordance with Engineering News formula.

General Conditions

The above recommendations are based on a tentative span length and location. After the structure type and location is determined, these recommendations should be reviewed and revised if necessary. Since site topography is not yet available and could affect the depth of the footing at abutment 6, a revision may be necessary at this support after the topographic map is reviewed.

Respectfully submitted,

MOORE & TABER

*J. L. McNey*  
J. L. McNey

JLMc/co

*R. F. Moore*  
Reviewed by R. F. Moore  
Registered Civil Engineer 8369

Attachment:

Log of Test Boring

Distribution:

(4) Kern County Road Department

Foundation Report  
Kern River Bridge 50C-18

06-Ker-1316  
14-450124  
ER-379 (1) S-1316(2)  
Sierrita Dr. to Sierra Way

The Kern River Bridge at Kernville is a 5-span bridge consisting of precast prestressed concrete girders with a cast in-place concrete deck. The superstructure is supported on reinforced concrete piers on spread footings and on reinforced concrete abutments on spread footings and pile foundations. Abutment 1 is supported on steel bearing piles and Abutment 6 is supported on 4 spread footings.

The thirteen 10BP57 bearing piles in Abutment 1 were driven to a minimum bearing of 85 tons. The piles were driven using a Vulcan 06 air hammer with leads mounted on a 25 ton truck crane by Paramount-Pacific, Inc. of Paramount, California. Specified tip elevation was 2610. All piles were driven to this elevation or below. The maximum pile length was 39.3 feet, minimum pile length, 24.8 feet and average pile length, 28.2 feet.

The plans indicated a need for tremie seal at the piers and at Abutment 6. The estimated seal thickness was indicated as 5 feet. Tremie seal was eliminated at Pier 5 and Abutment 6 entirely and decreased to a minimum thickness of 2½ feet at Piers 2, 3 and 4.

Pumping was necessary to dewater the pier excavation that required the tremie seal. Three 6-inch pumps were used for this purpose, running continuously during the excavation of the footings. The pumps were actually pumping approximately 50% of the time to keep the water level low enough for excavating purposes.

The contractor constructed a dike and working platform of native material around each pier footing in the river prior to excavation. A prefabricated cofferdam was placed inside the excavation and tremie concrete placed inside the cofferdam.



The bottom of footing or seals were constructed at the elevations indicated on the plans with the exception of the two footings to the right of centerline at Abutment 6. Ground water was encountered in this area and the footings were lowered approximately 1 foot to eliminate this problem.

Inspection of the excavated areas indicated that the material in place correlated with the boring log. All pier footings and the Abutment 6 footing excavation were logged as indicated on the log of test borings in the "As-Built" plans. Piles in Abutment 1 were also logged and they are also indicated on the log of test borings.

# P. R. DIV. NO.	DIST.	STATE	COUNTY	ROUTE NO.	FISCAL YEAR	SHEET NO.	TOTAL SHEETS
7	VI	CALIF.	KERN	1316 CR	1968	13	22

COUNTY OF KERN

Design Engineer: *George S. Nolte*  
 R.C.E. No. 15389  
 Road Commissioner: *George S. Nolte*

SUBMITTED BY

George S. Nolte  
 R.C.E. 7595

STATE OF CALIFORNIA

Bridge Engineer: *George S. Nolte*  
 R.C.E. No. 5585

APPROVED September 11, 1967

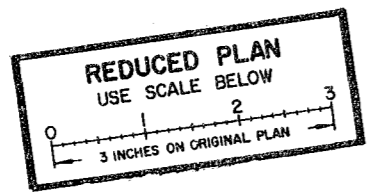
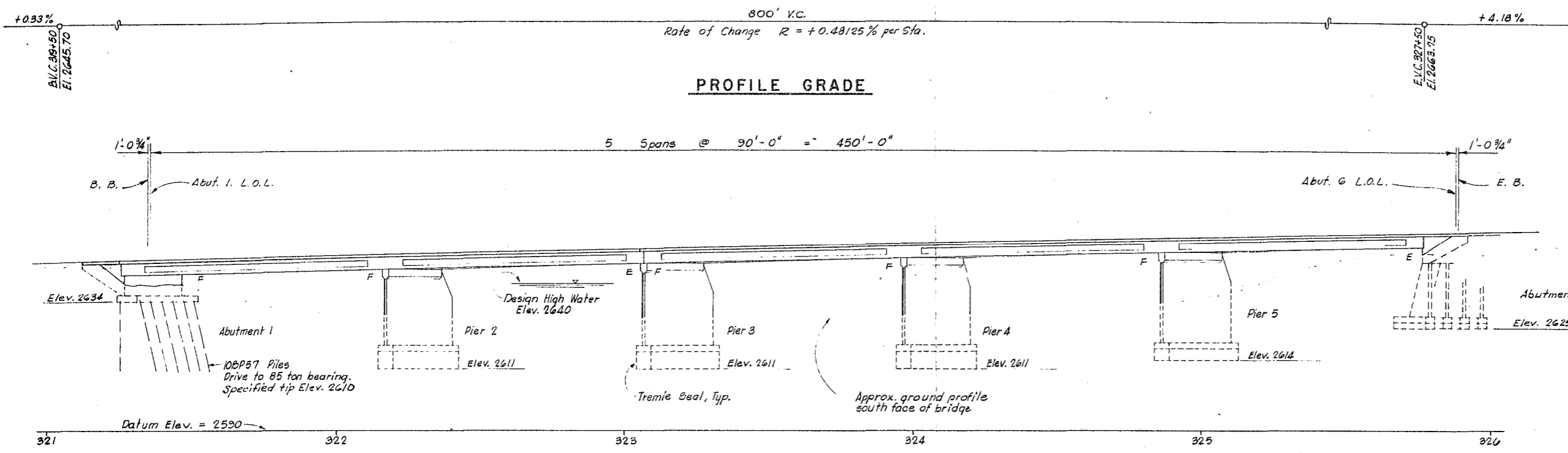

ELEVATION Scale: 1" = 20'

APPROXIMATE QUANTITIES

FURNISHING STEEL PILING (10BP57)	330 LF
DRIVING STEEL PILES (10BP57)	13 EA
FURNISHING PC/PS CONCRETE GIRDERS	40 EA
ERECTING PC/PS CONCRETE GIRDERS	40 EA
CLASS "A" CONCRETE (FOOTING BLOCK)	636 CY
WATERSTOPS	160 LF
MISCELLANEOUS METAL (BRIDGE)	1,325 LBS
BARRIER RAILING	964 LF

  

FINAL QUANTITIES

STRUCTURE EXCAVATION (BRIDGE)	215 CY
STRUCTURE EXCAVATION (TYPE "A")	2,270 CY
STRUCTURE BACKFILL (BRIDGE)	665 CY
PERVIOUS BACKFILL MATERIAL	35 CY
CLASS "A" CONCRETE (BRIDGE)	1,300 CY
BAR REINFORCING STEEL (BRIDGE)	362,000 LBS

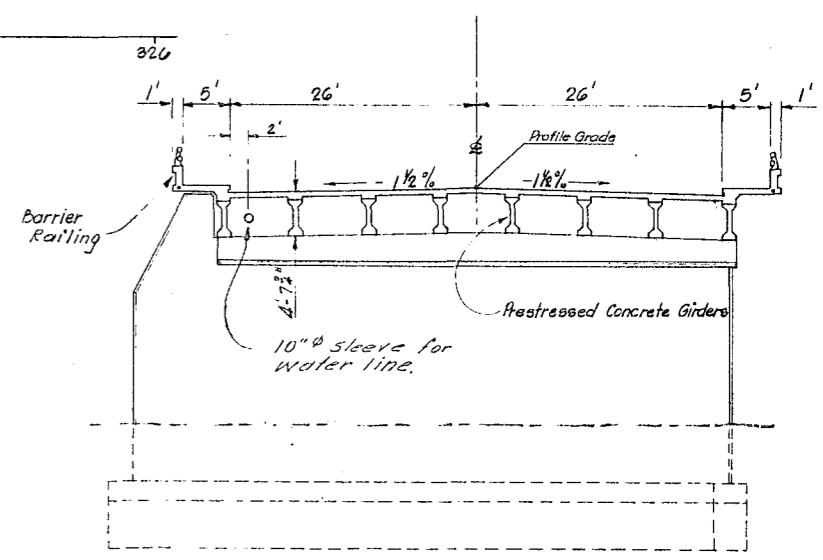

TYPICAL SECTION Scale: 1" = 10'

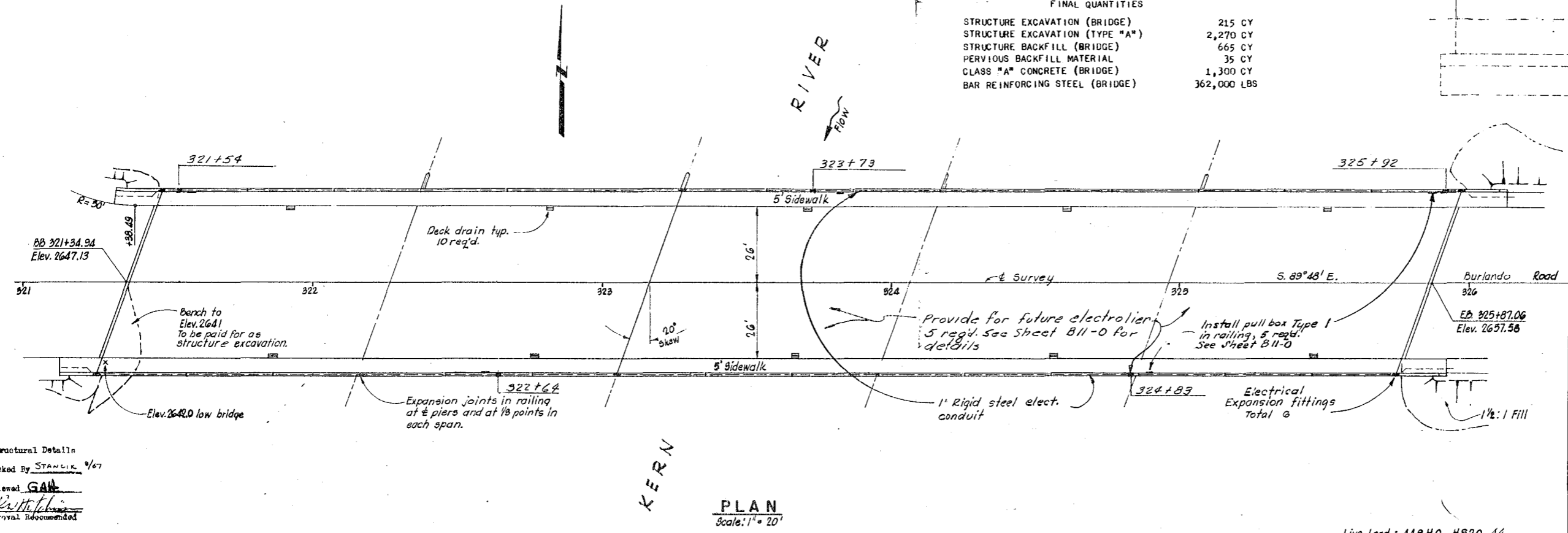

PLAN Scale: 1" = 20'

Structural Detail  
 Checked By: *Stamick* 9/67  
 Revisions: *GAB*  
 Approval Recommended: *George S. Nolte*

State Bridge No. 50C-18  
 COUNTY OF KERN  
 STATE OF CALIFORNIA  
 DEPARTMENT OF HIGHWAYS AND BRIDGES  
 OFFICE OF THE ROAD COMMISSIONER

**KERN RIVER BRIDGE  
 ON BURLANDO ROAD**

GENERAL PLAN

PREPARED BY  
 GEORGE S. NOLTE CONSULTING CIVIL ENGINEERS, INC.  
 PALO ALTO, CALIFORNIA

DRAWN BY: <i>APW</i>	DESIGN BY: <i>APW</i>	CHECKED BY: <i>GSN</i>
DATE: MAY 1967		20 SHEETS
SCALE: AS NOTED		SHEET NO. 11

FILE NO.

Live Load: A.A.S.H.O. HS20-44

COUNTY ENGR.	DATE	F.A.S. ENGR.	DATE	APPR. REC. BY	DATE
<i>R.R. Frank</i>	3/66				

3