

**Draft Post Construction  
Stormwater Management Plan**

Prepared for:

**Dignity Health**

**North State Pavilion**

**Redding, CA**

Prepared by:



**POST-CONSTRUCTION WORKSHEET FOR THE CITY OF REDDING**  
**PROJECT SUMMARY SHEET**

**Project Owner Information:**

Project Owner Name:	Dignity Health				
Name of Contact Person:	Lofton Moore				
Mailing Street Address:	10901 Gold Center Drive				
City:	Rancho Cordova	State:	CA	Zip:	95670
Telephone:	916-631-3312	Email:	Lofton.Moore@DignityHealth.org		

**Project Information:**

Project Name:	North State Pavilion				
Name of Contact Person:	Lofton Moore				
Project Address:	2398 Henderson Rd				
City:	Redding	State:	CA	Zip:	96002
Anticipated construction start date:	February, 2018		Ending date:	September, 2019	
Project size (ft <sup>2</sup> ):	424,445		Subject to the Construction General Permit? (Yes / No)	Yes	

***Information of the Post-Construction Standards Plan Preparer:***

Name of Organization:	Omni-Means, Ltd.				
Name of Contact Person:	Brandon Tenney				
Mailing Street Address:	330 Hartnell Ave, Suite B				
City:	Redding	State:	CA	Zip:	96002
Telephone:	530-242-1700	Email:	btenney@omnimeans.com		

***Project Applicability:***

Type of Project: (Check one)	<input type="checkbox"/>	Small Project (2,500 to 5,000 ft <sup>2</sup> or detached single family home)	
	<input checked="" type="checkbox"/>	Regulated Project (5,000 ft <sup>2</sup> )	
	<input type="checkbox"/>	Not applicable to the Post-Construction Standards Plan <i>(provide reason in the space below)</i>	
Is this a redevelopment project? (Yes / No)	No	Will the project result in an increase of more than 50% of the impervious surface? (Yes / No)	Yes
Has the project or the vesting map received approval from the City? (Yes, No, or N/A)	No	Date of project or vesting map approval:	N/A
Describe the nature and scope of the construction project:	Project is in the Entitlement Phase. This package is intended to supply sufficient information to show general compliance with the MS-4 regulations.		
Number of Drainage Management Areas (DMAs):	42 (See Map)		

4/28/2017 11:26 AM J:\PRJ\1966\1966UPSW001.DWG

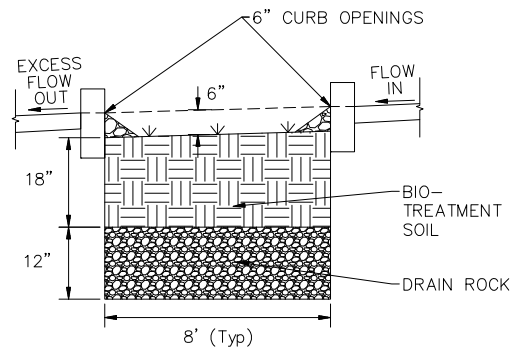

FLOW-THROUGH PLANTER DETAIL  
NO SCALE

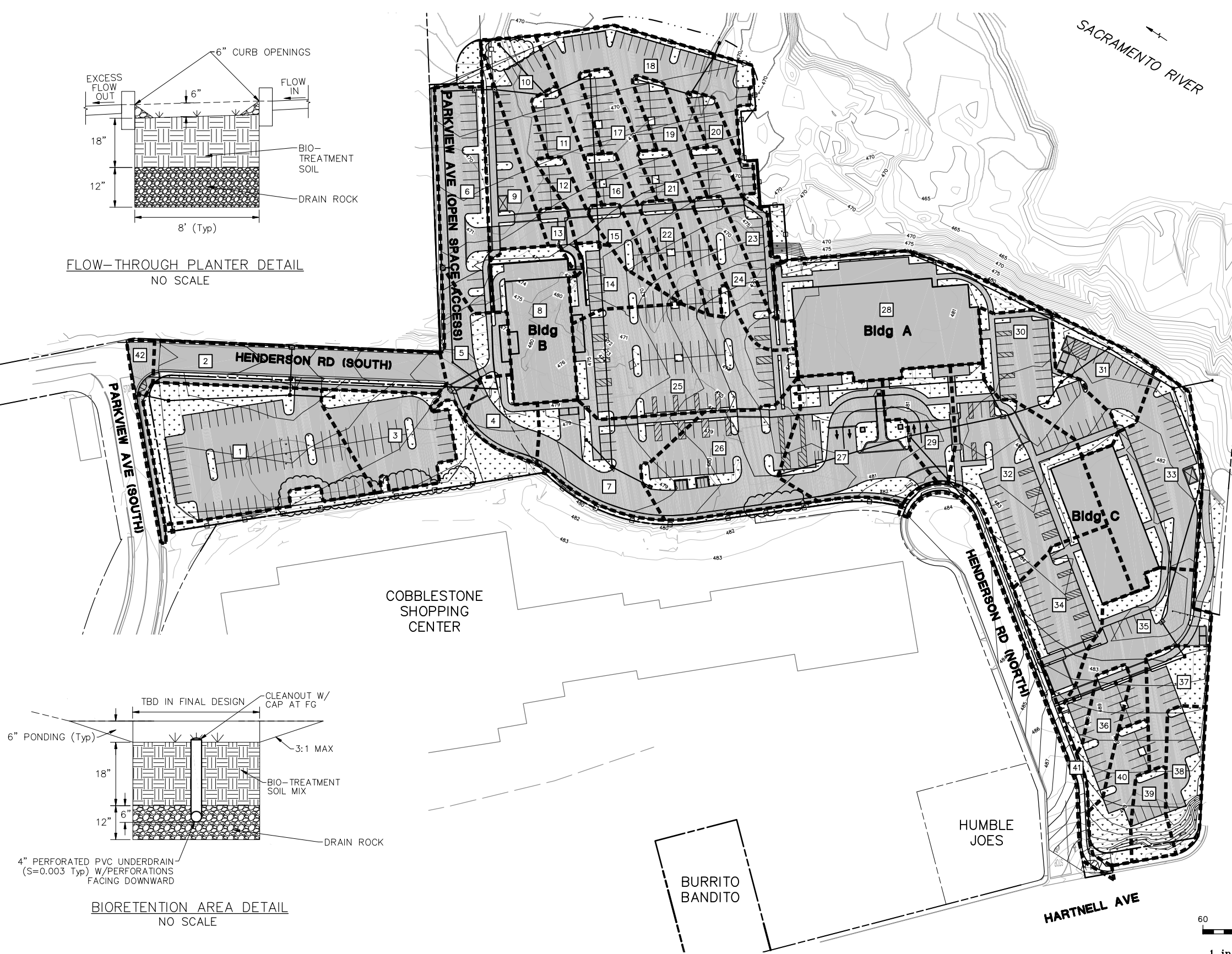

LEGEND

- IMPERVIOUS SURFACE (ALL AREAS ARE ASPHALT, CONCRETE, OR ROOF SURFACES)
- PERVIOUS LANDSCAPE SURFACE
- PROPOSED STORM DRAIN MANHOLE OR DRAINAGE INLET
- PROPOSED CONTOURS
- EXIST CONTOURS
- DRAINAGE MANAGEMENT AREA BOUNDARY
- DRAINAGE MANAGEMENT AREA (DMA) NUMBER
- EXISTING TREE COVER CREDIT AREA

POST-CONSTRUCTION BMP CALCULATIONS

DMA TYPE	TOTAL AREA (SF)	IMPERVIOUS AREA (SF)	BMP AREA (SF)
FLOW-THROUGH PLANTERS (DMA's 11-13, 15-17, 19-24, 36, & 39-40)	65,386	53,722	2,962
BIORETENTION AREAS (DMA's 1, 3, 4, 6-10, 14, 18, 25-35, 37-38)	335,804	269,899	14,810
OTHER (TREE CREDIT) (DMA's 2, 5, 41, & 42)	32,884	27,855	*40,075
<b>TOTAL</b>	<b>434,074</b>	<b>351,476</b>	<b>*57,847</b>

\* - INCLUDES TREE CREDIT TO OFFSET FOR DMA's 2, 5, 41, & 42

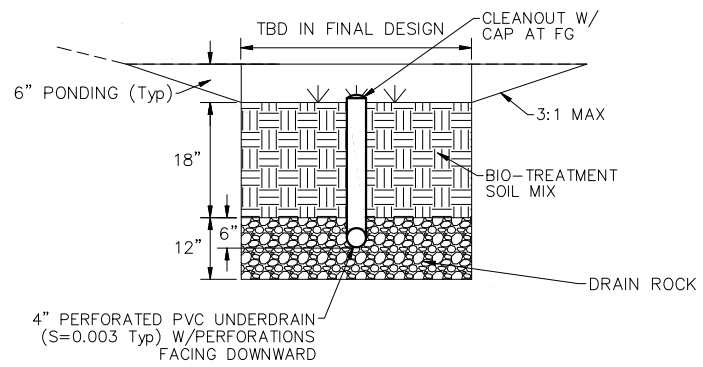

BIORETENTION AREA DETAIL  
NO SCALE

NOTE:  
SEE PRELIMINARY USE PERMIT  
STORMWATER  
POST-CONSTRUCTION  
SUBMITTAL PACKAGE FOR  
ADDITIONAL INFORMATION.

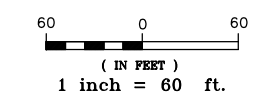

April 28, 2017

# NORTH STATE PAVILION

# STORMWATER CONTROL PLAN



Redding, California



SHEET 11 OF 26

REDDING  
330 Hartnell Ave, Suite B  
Redding, CA 96002  
(530) 242-1700  
www.omnimeans.com

also in:  
ROSEVILLE  
VISALIA  
WALNUT CREEK  
SAN LUIS OBISPO & NAPA

## POST-CONSTRUCTION WORKSHEET FOR THE CITY OF REDDING

### REGULATED PROJECT DMA SUBMITTAL SHEET

#### Drainage Management Area (DMA) & Project Information:

A **separate** Regulated Project DMA Submittal Sheet is required to be completed and submitted for each DMA. Refer to Section 5.1 of the Post-Construction Standards Plan for more information about DMAs.

Project Name:	North State Pavilion
Project Owner Name:	Dignity Health
Project Address:	2398 Henderson Rd, Redding, CA 96002
Name of the DMA:	Flow-through planter treatment areas(DMA's 11-13, 15-17, 19-24, 36, 39, 40)
DMA area (ft <sup>2</sup> )	65,386

#### Selection of Applicable Source Controls:

Indicate which of the following activities or pollutant sources are included in **this DMA** of the new development or redevelopment. For more information about required Source Control refer to Section 5.2.

<i>Site Design Measures</i>	<i>(Yes / No)</i>
Accidental spills or leaks	<input checked="" type="checkbox"/> YES <input type="checkbox"/> NO
Interior floor drains	<input type="checkbox"/> YES <input checked="" type="checkbox"/> NO
Parking / storage areas and maintenance	<input checked="" type="checkbox"/> YES <input type="checkbox"/> NO
Indoor and structural pest control	<input type="checkbox"/> YES <input checked="" type="checkbox"/> NO
Landscape / outdoor pesticide use	<input checked="" type="checkbox"/> YES <input type="checkbox"/> NO
Pools, spas, ponds, decorative fountains, and other water features	<input type="checkbox"/> YES <input checked="" type="checkbox"/> NO
Restaurants, grocery stores, and other food service operations	<input type="checkbox"/> YES <input checked="" type="checkbox"/> NO
Refuse areas	<input checked="" type="checkbox"/> YES <input type="checkbox"/> NO
Industrial processes	<input type="checkbox"/> YES <input checked="" type="checkbox"/> NO
Outdoor storage of equipment or materials	<input type="checkbox"/> YES <input checked="" type="checkbox"/> NO
Vehicle and equipment cleaning	<input type="checkbox"/> YES <input checked="" type="checkbox"/> NO
Vehicle and equipment repair and maintenance	<input type="checkbox"/> YES <input checked="" type="checkbox"/> NO
Fuel dispensing areas	<input type="checkbox"/> YES <input checked="" type="checkbox"/> NO
Loading docks	<input type="checkbox"/> YES <input checked="" type="checkbox"/> NO
Fire sprinkler test water	<input type="checkbox"/> YES <input checked="" type="checkbox"/> NO
Drain or wash water from boiler drain lines, condensate drain lines, rooftop equipment, drainage sumps, and other sources	<input type="checkbox"/> YES <input checked="" type="checkbox"/> NO
Unauthorized non-storm water discharges	<input checked="" type="checkbox"/> YES <input type="checkbox"/> NO
Building and grounds maintenance	<input checked="" type="checkbox"/> YES <input type="checkbox"/> NO

Project Name:	North State Pavilion
Project Owner Name:	Dignity Health
Project Address:	2398 Henderson Rd, Redding, CA 96002
Name of the DMA:	Flow-through planter treatment areas(DMA's 11-13, 15-17, 19-24, 36, 39, 40)
DMA area (ft <sup>2</sup> )	65,386

**Selection of Applicable Site Design and Storm Water Treatment Measures:**

Indicate which of the Site Design or Storm Water Treatment Measures are used in this DMA of the new development or redevelopment. In Column 2 list the 100% compliance area for the chosen Post Construction BMP which is given in the online calculator results and then in column three list the area of the BMP that is actually used. Divide the actual area by the 100% compliance area to calculate the percent treated. The sum of all the rows in column four should be greater than 100%. For more information about required Source Control refer to Section 5.2.

Site Design Measure or Treatment Control Measure	Permit compliant LID BMP Areas (from Online Calc.)	Area used within project	Percent compliant
TC-10 - Flow-Through Planters	2,962 SF	2,962 SF	100%
<b>Total</b>			<b>&gt;=100%</b>

**Variations and Exceptions:**

Identify any applicable variations or exceptions for ***this DMA***.

Condition	Allowed Variation	Applicable to this DMA? If so, explain.
Facilities located within 10 feet of structures or other potential geotechnical hazards established by the geotechnical expert for the project	May incorporate an impervious cutoff wall between the bioretention / infiltration facility and the structure or other geotechnical hazard	No
Facilities with documented high concentrations of pollutants in underlying soil or groundwater, facilities located where infiltration could contribute to a geotechnical hazard, and facilities located on elevated plazas or other structures	May incorporate an impervious liner and may locate the underdrain discharge at the bottom of the subsurface drainage/storage layer (this configuration is commonly known as a “flow-through planter”)	No
Facilities located in areas of high groundwater, highly infiltrative soils or where connection of underdrain to a surface drain or to a subsurface storm drain are infeasible	May omit the underdrain	Yes. Flow through planters will treat and infiltrate the 85th percentile storm, excess runoff will surface drain through the flow-through planters to the storm drain inlets near the site discharge locations.
Facilities serving high-risk areas such as fueling stations, truck stops, auto repairs, and heavy industrial sites	Are required to provide additional treatment to address pollutants of concern prior to the flow reaching the infiltration facility	No

If infiltration is not feasible for ***this DMA***, please provide an explanation of the infeasibility and a description of the alternate non-infiltrating treatment control measure(s) that will be used in accordance with the development requirements in Section 5.4.4.



## SACRAMENTO STATE

Office of Water Programs

Sac State Home | College of Engineering & Computer Science | Department of Civil Engineering | Office of Water Programs

### California Phase II LID Sizing Tool - BMP Details

---

#### Summary

Project name	North State Pavilion-Flow Through Planters
Climate station	REDDING AP
Saturated hydraulic conductivity	0.32 in/hr
Impervious area	1.23 acres (53,722 SF)
LID area	0.068 acres (2,962 SF)
Total area	1.298 acres (56,684 SF)
LID BMP	Bioretention Cell - 18" Soil - 12" Gravel Storage
Methodology	Design Storm User selected design storm is 0.91 inches 85th % design storm is 0.91 inches
Design storm volumetric runoff coefficient	0.892

---

#### Description

Bioretention cells are depressed landscapes into which runoff is directed and allowed to pond, filter, and infiltrate. Some bioretention cells modeled by the CA Phase II LID Sizing Tool consist of the design parameters specified in Section E.12.e.ii.f.3 of the Phase II permit, including a 6" ponding depth underlain by 18" of bioretention soil mix and 12", 24", or 36" of gravel storage. (The Phase II permit requires a minimum storage depth of 12".) The ponding zone allows for temporary storage of runoff and promotes percolation into the bioretention mix. The runoff is also stored in the mix's pore structure, as well as being filtered and biotreated. It eventually drains into the gravel layer below which provides a third storage component. A perforated underdrain is located at the top of the gravel storage component to prevent overflow of the system. This system is unlined to allow infiltration into the underlying native soils. The Central Coast Regional Water Quality Control Board (Region 3) has adopted a variation on the permit-prescribed bioretention cell, where the soil mix depth is to be 24", and so the tool includes bioretention cells having 6" of ponding, 24" of soil mix, and 12", 24", or 36" of gravel storage (with an underdrain).

---

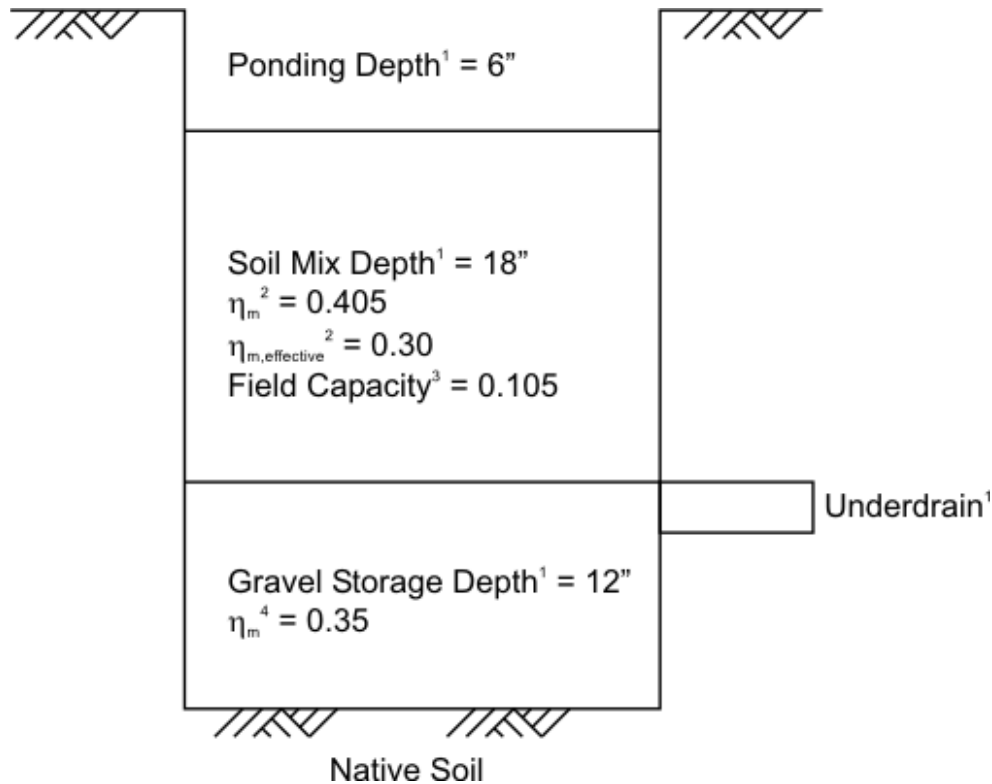
**LID BMP - Bioretention Cell - 18" Soil - 12" Gravel Storage****Depths**

LID Layer	Depth (inches)
Ponding	6
Soil mix	18
Gravel storage	12

**Notes**

1. SWRCB 2013, LID standard for bioretention, p. 54; CCRWQCB 2013, post-construction requirement for water quality treatment, p. 4.
2. Effective porosity (total porosity – field capacity): VA DCR 2011, 25%; District DOE 2013, 30%; WI DNR 2010, 27%; Prince George 2013, 30%; NC Co-op 2009, 30%; LID Center 2010, 30%. Assume Total porosity = 30% + field capacity.
3. Caltrans 2010, 35% for infiltration trenches; City of Santa Barbara 2008, 30-40% commonly 32%; WI DNR 2010, 33%; NC Co-op 2009, effective porosity 25%. Assume field capacity = 0.
4. USEPA 2010. Field capacity for loamy sand = 0.105.

Note: Excavation depths should consider root uplift and expansion within the soil mix layer

**Methodology: Design Storm**

The Design Storm Method is based on Section E.12.e.ii.c.1.a of the permit, which allows LID stormwater retention and treatment facilities that evapotranspire, infiltrate, harvest/use, and biotreat stormwater to be designed as follows (SWRCB 2013):

"The maximized capture storm water volume for the tributary area, on the basis of historical precipitation records, determined using the formula and volume capture coefficients in Urban Runoff Quality Management, WEF Manual of Practice No. 23/ASCE Manual of Practice No. 87 (1998) pages 175-178 (that is, approximately the 85th percentile 24-hour storm runoff event)".



The area reported for the Design Storm Method is based on a default 85th percentile, 24-hour design storm as specified in the Phase II permit. Some areas of the state require use of a different design storm, such as the Central Coast Regional Water Quality Control Board (RWQCB) where the 95th percentile design storm is a common requirement. For such cases, the user may over-ride the default design storm (i.e., the 85th percentile storm) with an alternative precipitation depth in the "Select a design storm depth in inches" cell located below the table and clicking "Submit".

Further details on this method are provided in the [Documentation Manual](#).

---

## Links

[EPA Fact Sheet for Bioretention](#)

## Construction

[Urban Design Tools - Construction Schedule](#)

## Costs

[Urban Design Tools - Costs](#)

## Maintenance

[Urban Design Tools - Maintenance](#)

## Specifications

[Low Density Residential](#)

[High Density Residential](#)

[Commercial/Industrial/Institutional](#)

[Transportation](#)

## Watershed Benefits

[Urban Design Tools - Watershed Benefits](#)

## General

[CASQA LID Portal](#)

[Central Coast LID Initiative](#)

[EPA Low Impact Development Site](#)

[Low Impact Development Urban Design Tools Website](#)

[EPA BMP Fact Sheet for Post-Construction Stormwater Management in New Development and Redevelopment](#)

[EPA BMP Fact Sheet for On-Lot Treatment](#)

Contech LID Site Planner (LID Feasibility Screening Tool – coming soon...)

---

© Office of Water Programs | 2017 All Rights Reserved. Funding for this project has been provided in full or in part through an agreement with the State Water Resources Control Board. The contents of this document do not necessarily reflect the views and policies of the State Water Resources Control Board, nor does mention of trade names or commercial products constitute endorsement or recommendation for use.

## POST-CONSTRUCTION WORKSHEET FOR THE CITY OF REDDING

### REGULATED PROJECT DMA SUBMITTAL SHEET

#### Drainage Management Area (DMA) & Project Information:

A **separate** Regulated Project DMA Submittal Sheet is required to be completed and submitted for each DMA. Refer to Section 5.1 of the Post-Construction Standards Plan for more information about DMAs.

Project Name:	North State Pavilion
Project Owner Name:	Dignity Health
Project Address:	2398 Henderson Rd, Redding, CA 96002
Name of the DMA:	Bioretention Treatment Areas (DMA's 1, 3, 4, 6-10, 14, 18, 25-35, 37, 38)
DMA area (ft <sup>2</sup> )	335,804

#### Selection of Applicable Source Controls:

Indicate which of the following activities or pollutant sources are included in **this DMA** of the new development or redevelopment. For more information about required Source Control refer to Section 5.2.

<i>Site Design Measures</i>	<i>(Yes / No)</i>
Accidental spills or leaks	<input checked="" type="checkbox"/> YES <input type="checkbox"/> NO
Interior floor drains	<input type="checkbox"/> YES <input checked="" type="checkbox"/> NO
Parking / storage areas and maintenance	<input checked="" type="checkbox"/> YES <input type="checkbox"/> NO
Indoor and structural pest control	<input checked="" type="checkbox"/> YES <input type="checkbox"/> NO
Landscape / outdoor pesticide use	<input checked="" type="checkbox"/> YES <input type="checkbox"/> NO
Pools, spas, ponds, decorative fountains, and other water features	<input type="checkbox"/> YES <input checked="" type="checkbox"/> NO
Restaurants, grocery stores, and other food service operations	<input type="checkbox"/> YES <input checked="" type="checkbox"/> NO
Refuse areas	<input checked="" type="checkbox"/> YES <input type="checkbox"/> NO
Industrial processes	<input type="checkbox"/> YES <input checked="" type="checkbox"/> NO
Outdoor storage of equipment or materials	<input type="checkbox"/> YES <input checked="" type="checkbox"/> NO
Vehicle and equipment cleaning	<input type="checkbox"/> YES <input checked="" type="checkbox"/> NO
Vehicle and equipment repair and maintenance	<input type="checkbox"/> YES <input checked="" type="checkbox"/> NO
Fuel dispensing areas	<input type="checkbox"/> YES <input checked="" type="checkbox"/> NO
Loading docks	<input type="checkbox"/> YES <input checked="" type="checkbox"/> NO
Fire sprinkler test water	<input type="checkbox"/> YES <input checked="" type="checkbox"/> NO
Drain or wash water from boiler drain lines, condensate drain lines, rooftop equipment, drainage sumps, and other sources	<input checked="" type="checkbox"/> YES <input type="checkbox"/> NO
Unauthorized non-storm water discharges	<input checked="" type="checkbox"/> YES <input type="checkbox"/> NO
Building and grounds maintenance	<input checked="" type="checkbox"/> YES <input type="checkbox"/> NO

Project Name:	North State Pavilion
Project Owner Name:	Dignity Health
Project Address:	2398 Henderson Rd, Redding, CA 96002
Name of the DMA:	Bioretention Treatment Areas (DMA's 1, 3, 4, 6-10, 14, 18, 25-35, 37, 38)
DMA area (ft <sup>2</sup> )	335,804

**Selection of Applicable Site Design and Storm Water Treatment Measures:**

Indicate which of the Site Design or Storm Water Treatment Measures are used in this DMA of the new development or redevelopment. In Column 2 list the 100% compliance area for the chosen Post Construction BMP which is given in the online calculator results and then in column three list the area of the BMP that is actually used. Divide the actual area by the 100% compliance area to calculate the percent treated. The sum of all the rows in column four should be greater than 100%. For more information about required Source Control refer to Section 5.2.

Site Design Measure or Treatment Control Measure	Permit compliant LID BMP Areas (from Online Calc.)	Area used within project	Percent compliant
TC-32 - Bioretention Treatment Areas	14,810 SF	14,810 SF	100%
<b>Total</b>			<b>&gt;=100%</b>

**Variations and Exceptions:**

Identify any applicable variations or exceptions for ***this DMA***.

Condition	Allowed Variation	Applicable to this DMA? If so, explain.
Facilities located within 10 feet of structures or other potential geotechnical hazards established by the geotechnical expert for the project	May incorporate an impervious cutoff wall between the bioretention / infiltration facility and the structure or other geotechnical hazard	No
Facilities with documented high concentrations of pollutants in underlying soil or groundwater, facilities located where infiltration could contribute to a geotechnical hazard, and facilities located on elevated plazas or other structures	May incorporate an impervious liner and may locate the underdrain discharge at the bottom of the subsurface drainage/storage layer (this configuration is commonly known as a “flow-through planter”)	No
Facilities located in areas of high groundwater, highly infiltrative soils or where connection of underdrain to a surface drain or to a subsurface storm drain are infeasible	May omit the underdrain	No
Facilities serving high-risk areas such as fueling stations, truck stops, auto repairs, and heavy industrial sites	Are required to provide additional treatment to address pollutants of concern prior to the flow reaching the infiltration facility	No

If infiltration is not feasible for ***this DMA***, please provide an explanation of the infeasibility and a description of the alternate non-infiltrating treatment control measure(s) that will be used in accordance with the development requirements in Section 5.4.4.



Sac State Home | College of Engineering & Computer Science | Department of Civil Engineering | Office of Water Programs

## California Phase II LID Sizing Tool - BMP Details

---

### Summary

Project name	North State Pavilion-Bioretenion Areas
Climate station	REDDING AP
Saturated hydraulic conductivity	0.32 in/hr
Impervious area	6.2 acres (269,899 SF)
LID area	0.34 acres (14,810 SF)
Total area	6.54 acres (284,709 SF)
LID BMP	Bioretention Cell - 18" Soil - 12" Gravel Storage
Methodology	Design Storm User selected design storm is 0.91 inches 85th % design storm is 0.91 inches
Design storm volumetric runoff coefficient	0.892

---

### Description

Bioretention cells are depressed landscapes into which runoff is directed and allowed to pond, filter, and infiltrate. Some bioretention cells modeled by the CA Phase II LID Sizing Tool consist of the design parameters specified in Section E.12.e.ii.f.3 of the Phase II permit, including a 6" ponding depth underlain by 18" of bioretention soil mix and 12", 24", or 36" of gravel storage. (The Phase II permit requires a minimum storage depth of 12".) The ponding zone allows for temporary storage of runoff and promotes percolation into the bioretention mix. The runoff is also stored in the mix's pore structure, as well as being filtered and biotreated. It eventually drains into the gravel layer below which provides a third storage component. A perforated underdrain is located at the top of the gravel storage component to prevent overflow of the system. This system is unlined to allow infiltration into the underlying native soils. The Central Coast Regional Water Quality Control Board (Region 3) has adopted a variation on the permit-prescribed bioretention cell, where the soil mix depth is to be 24", and so the tool includes bioretention cells having 6" of ponding, 24" of soil mix, and 12", 24", or 36" of gravel storage (with an underdrain).

---

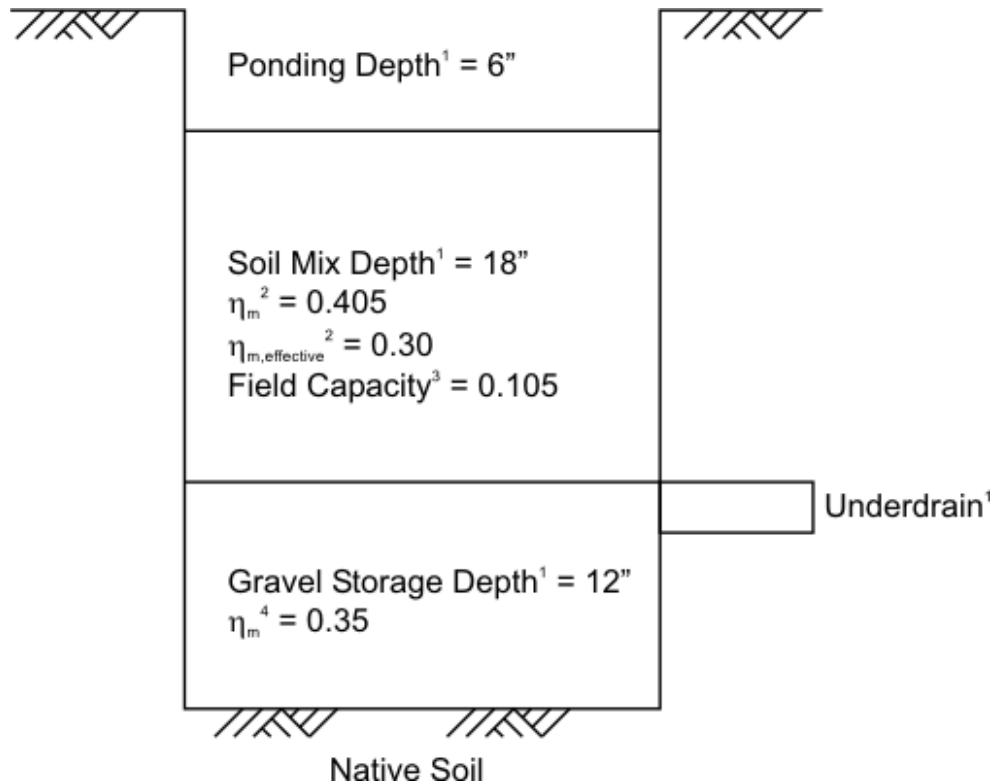
**LID BMP - Bioretention Cell - 18" Soil - 12" Gravel Storage****Depths**

LID Layer	Depth (inches)
Ponding	6
Soil mix	18
Gravel storage	12

**Notes**

1. SWRCB 2013, LID standard for bioretention, p. 54; CCRWQCB 2013, post-construction requirement for water quality treatment, p. 4.
2. Effective porosity (total porosity – field capacity): VA DCR 2011, 25%; District DOE 2013, 30%; WI DNR 2010, 27%; Prince George 2013, 30%; NC Co-op 2009, 30%; LID Center 2010, 30%. Assume Total porosity = 30% + field capacity.
3. Caltrans 2010, 35% for infiltration trenches; City of Santa Barbara 2008, 30-40% commonly 32%; WI DNR 2010, 33%; NC Co-op 2009, effective porosity 25%. Assume field capacity = 0.
4. USEPA 2010. Field capacity for loamy sand = 0.105.

Note: Excavation depths should consider root uplift and expansion within the soil mix layer

**Methodology: Design Storm**

The Design Storm Method is based on Section E.12.e.ii.c.1.a of the permit, which allows LID stormwater retention and treatment facilities that evapotranspire, infiltrate, harvest/use, and biotreat stormwater to be designed as follows (SWRCB 2013):

"The maximized capture storm water volume for the tributary area, on the basis of historical precipitation records, determined using the formula and volume capture coefficients in Urban Runoff Quality Management, WEF Manual of Practice No. 23/ASCE Manual of Practice No. 87 (1998) pages 175-178 (that is, approximately the 85th percentile 24-hour storm runoff event)".

The area reported for the Design Storm Method is based on a default 85th percentile, 24-hour design storm as specified in the Phase II permit. Some areas of the state require use of a different design storm, such as the Central Coast Regional Water Quality Control Board (RWQCB) where the 95th percentile design storm is a common requirement. For such cases, the user may over-ride the default design storm (i.e., the 85th percentile storm) with an alternative precipitation depth in the "Select a design storm depth in inches" cell located below the table and clicking "Submit".

Further details on this method are provided in the [Documentation Manual](#).

---

## Links

[EPA Fact Sheet for Bioretention](#)

## Construction

[Urban Design Tools - Construction Schedule](#)

## Costs

[Urban Design Tools - Costs](#)

## Maintenance

[Urban Design Tools - Maintenance](#)

## Specifications

[Low Density Residential](#)

[High Density Residential](#)

[Commercial/Industrial/Institutional](#)

[Transportation](#)

## Watershed Benefits

[Urban Design Tools - Watershed Benefits](#)

## General

[CASQA LID Portal](#)

[Central Coast LID Initiative](#)

[EPA Low Impact Development Site](#)

[Low Impact Development Urban Design Tools Website](#)

[EPA BMP Fact Sheet for Post-Construction Stormwater Management in New Development and Redevelopment](#)

[EPA BMP Fact Sheet for On-Lot Treatment](#)

Contech LID Site Planner (LID Feasibility Screening Tool – coming soon...)

---

© Office of Water Programs | 2017 All Rights Reserved. Funding for this project has been provided in full or in part through an agreement with the State Water Resources Control Board. The contents of this document do not necessarily reflect the views and policies of the State Water Resources Control Board, nor does mention of trade names or commercial products constitute endorsement or recommendation for use.

## POST-CONSTRUCTION WORKSHEET FOR THE CITY OF REDDING

### REGULATED PROJECT DMA SUBMITTAL SHEET

#### Drainage Management Area (DMA) & Project Information:

A **separate** Regulated Project DMA Submittal Sheet is required to be completed and submitted for each DMA. Refer to Section 5.1 of the Post-Construction Standards Plan for more information about DMAs.

Project Name:	North State Pavilion
Project Owner Name:	Dignity Health
Project Address:	2398 Henderson Rd, Redding, CA 96002
Name of the DMA:	Tree Credit Areas (DMA's 2, 5, 41 and 42)
DMA area (ft <sup>2</sup> )	32,884

#### Selection of Applicable Source Controls:

Indicate which of the following activities or pollutant sources are included in **this DMA** of the new development or redevelopment. For more information about required Source Control refer to Section 5.2.

<i>Site Design Measures</i>	<i>(Yes / No)</i>
Accidental spills or leaks	<input checked="" type="checkbox"/> YES <input type="checkbox"/> NO
Interior floor drains	<input type="checkbox"/> YES <input checked="" type="checkbox"/> NO
Parking / storage areas and maintenance	<input checked="" type="checkbox"/> YES <input type="checkbox"/> NO
Indoor and structural pest control	<input type="checkbox"/> YES <input checked="" type="checkbox"/> NO
Landscape / outdoor pesticide use	<input checked="" type="checkbox"/> YES <input type="checkbox"/> NO
Pools, spas, ponds, decorative fountains, and other water features	<input type="checkbox"/> YES <input checked="" type="checkbox"/> NO
Restaurants, grocery stores, and other food service operations	<input type="checkbox"/> YES <input checked="" type="checkbox"/> NO
Refuse areas	<input checked="" type="checkbox"/> YES <input type="checkbox"/> NO
Industrial processes	<input type="checkbox"/> YES <input checked="" type="checkbox"/> NO
Outdoor storage of equipment or materials	<input type="checkbox"/> YES <input checked="" type="checkbox"/> NO
Vehicle and equipment cleaning	<input type="checkbox"/> YES <input checked="" type="checkbox"/> NO
Vehicle and equipment repair and maintenance	<input type="checkbox"/> YES <input checked="" type="checkbox"/> NO
Fuel dispensing areas	<input type="checkbox"/> YES <input checked="" type="checkbox"/> NO
Loading docks	<input type="checkbox"/> YES <input checked="" type="checkbox"/> NO
Fire sprinkler test water	<input type="checkbox"/> YES <input checked="" type="checkbox"/> NO
Drain or wash water from boiler drain lines, condensate drain lines, rooftop equipment, drainage sumps, and other sources	<input type="checkbox"/> YES <input checked="" type="checkbox"/> NO
Unauthorized non-storm water discharges	<input checked="" type="checkbox"/> YES <input type="checkbox"/> NO
Building and grounds maintenance	<input checked="" type="checkbox"/> YES <input type="checkbox"/> NO



Project Name:	North State Pavilion
Project Owner Name:	Dignity Health
Project Address:	2398 Henderson Rd, Redding, CA 96002
Name of the DMA:	Tree Credit Areas (DMA's 2, 5, 41 and 42)
DMA area (ft <sup>2</sup> )	32,884

**Selection of Applicable Site Design and Storm Water Treatment Measures:**

Indicate which of the Site Design or Storm Water Treatment Measures are used in this DMA of the new development or redevelopment. In Column 2 list the 100% compliance area for the chosen Post Construction BMP which is given in the online calculator results and then in column three list the area of the BMP that is actually used. Divide the actual area by the 100% compliance area to calculate the percent treated. The sum of all the rows in column four should be greater than 100%. For more information about required Source Control refer to Section 5.2.

Site Design Measure or Treatment Control Measure	Permit compliant LID BMP Areas (from Online Calc.)	Area used within project	Percent compliant
See attached tree credit worksheet			100%
<b>Total</b>			<b>&gt;=100%</b>

**Variations and Exceptions:**

Identify any applicable variations or exceptions for ***this DMA***.

Condition	Allowed Variation	Applicable to this DMA? If so, explain.
Facilities located within 10 feet of structures or other potential geotechnical hazards established by the geotechnical expert for the project	May incorporate an impervious cutoff wall between the bioretention / infiltration facility and the structure or other geotechnical hazard	No
Facilities with documented high concentrations of pollutants in underlying soil or groundwater, facilities located where infiltration could contribute to a geotechnical hazard, and facilities located on elevated plazas or other structures	May incorporate an impervious liner and may locate the underdrain discharge at the bottom of the subsurface drainage/storage layer (this configuration is commonly known as a “flow-through planter”)	No
Facilities located in areas of high groundwater, highly infiltrative soils or where connection of underdrain to a surface drain or to a subsurface storm drain are infeasible	May omit the underdrain	No
Facilities serving high-risk areas such as fueling stations, truck stops, auto repairs, and heavy industrial sites	Are required to provide additional treatment to address pollutants of concern prior to the flow reaching the infiltration facility	No

If infiltration is not feasible for ***this DMA***, please provide an explanation of the infeasibility and a description of the alternate non-infiltrating treatment control measure(s) that will be used in accordance with the development requirements in Section 5.4.4.

Tree credit of 0.92 acres is used to offset the impervious area of 0.62 acres within drainage management areas 2, 5, 41 and 42. areas. See attached tree credit worksheet.

**NORTH STATE PAVILION  
DRAINAGE MANAGEMENT AREAS 2, 5, 41, and 42**

**Tree Planting Credit Worksheet**

Please fill out a tree canopy credit worksheet for each project sub-watershed.

Tree Canopy Credit Criteria	Number of Trees Planted	Area Credit (acres)
Number of proposed evergreen trees to be planted (credit = number of trees x 0.005)*		0.00
Number of proposed deciduous trees to be planted (credit = number of trees x 0.0025)*	280	0.70
	Square feet Under Canopy	
Square feet under an existing tree canopy, that will remain on the property, with an average diameter at 4.5 ft above grade (i.e., diameter at breast height or DBH) is LESS than 12 in diameter.		0.00
Square feet under an existing tree canopy that will remain on the property, with an average diameter at 4.5 ft above grade (i.e., diameter at breast height or DBH) is 12 in diameter or GREATER.	9530	0.22
Please describe below how the project will ensure that these trees will be maintained.		

[Return to Calculator](#)

\* credit amount based on credits from Stormwater Quality Design Manual for the Sacramento and South Placer Regions