

Preliminary Hydrology Report

Prepared for:

Dignity Health

North State Pavilion

Redding, CA

Prepared by: Brandon Tenney, PE



Preliminary Hydrology Report

Prepared for:

Dignity Health

North State Pavilion

Redding, CA

Prepared by:

Omni-Means, Ltd.

330 Hartnell Avenue, Suite B

Redding, CA 96002

(530) 242-1700

**This Hydrology Report was completed under the
direct supervision of the below Registered Professional Engineer.**



Brandon Tenney, P.E.

Updated May 2017

45-1335-03

R1966DRN002

TABLE OF CONTENTS

EXECUTIVE SUMMARY	1
PROJECT DESCRIPTION.....	2
Existing Conditions.....	4
Proposed Conditions.....	6
HYDROLOGY	8
PEAK FLOW CALCULATIONS	9
Existing Peak Flows	9
Proposed Peak Flows	10
Analysis of Discharge Locations	11
FLOODPLAIN ANALYSIS.....	12
POST CONSTRUCTION STORMWATER MANAGEMENT.....	12
CONCLUSION	12

LIST OF TABLES

Table 1 Existing Peak Flows.....	10
Table 2 Proposed Peak Flows	11

LIST OF FIGURES

Figure 1 - Location Map	3
Figure 2 - Existing Drainage Area Map.....	5
Figure 3 - Proposed Drainage Area Map	7

APPENDICES

APPENDIX A SUBBASIN PARAMETERS FROM HEC-1 MODEL

APPENDIX B PROJECT STORMWATER CONTROL PLAN

Executive Summary

The proposed Dignity Health - North State Pavilion project is located west of Hartnell Avenue, south of Cypress Avenue, and is approximately 10.5 acres in size. The project is located adjacent to the City of Redding's Henderson Open Space Projects, and within approximately 150 feet of the Sacramento River at the north end of the project. See Figure 1 for the project location.

Portions of the existing site discharge as sheet flow towards the west, while other areas of the site are captured by existing storm drain pipes or existing channels, which then generally discharge towards the west and towards the Sacramento River. The existing project site is approximately 27 percent impervious, including some old asphalt paving areas, concrete pad areas, and existing buildings. The existing 10-year, 25-year, and 100-year peak flows for the entire project site are 26 cfs, 31 cfs, and 46 cfs, respectively. See Figure 2 for a map of the existing site and existing drainage areas.

The proposed project will include construction of three new buildings, with associated drive aisles, parking areas, sidewalks, and landscaping areas. The majority of the project site will discharge similar to existing discharge patterns, with some slight changes. The upper area to the north will discharge into an existing 36" culvert, which discharges into an existing channel near the Sacramento River, just south of the Cypress Avenue Bridge. The majority of the lower section of the site will discharge towards the west at 2 locations which currently receive some runoff, and will connect to 2 new culverts to be installed with the City of Redding's Henderson Open Space projects. The overflow parking area to the south/southeast, will discharge to the south, into an existing 15" culvert that currently receives runoff from this same area. The proposed project will be approximately 77 percent impervious, which is a significant increase from existing conditions. The proposed 10-year, 25-year, and 100-year peak flows for the entire project site are 44 cfs, 51 cfs, and 66 cfs, respectively. This amounts to an increase of 18 cfs, 20 cfs, and 20 cfs for the 10-year, 25-year, and 100-year peak flows, respectively. See Figure 3 for a map of the proposed site and proposed drainage areas.

Although the project increases peak flows, the project discharges directly to government land and into the Sacramento River, so there are no downstream properties that would be adversely affected by the increased runoff. Therefore, this project is not subject to mitigation of increased peak flows.

Project Description

Project Location and Site Description

The proposed site of the Dignity Health - North State Pavilion project is approximately 10.5 acres, made up of some undeveloped areas with scattered trees, as well as some existing buildings, paving, and concrete areas. The project site is located within the City of Redding, at the southwest corner of Cypress Avenue and Hartnell Avenue, and immediately west of the Cobblestone Shopping Center. The project site is approximately 0.5 miles west of Interstate 5. See Figure 1 for a Location Map.

Proposed Project Description

The proposed development of the Dignity Health - North State Pavilion project consists of the construction of three new buildings to be used as medical facilities, including associated uses. Much of the site area will be constructed into parking facilities, landscaping, pedestrian routes, and internal traffic circulation routes.

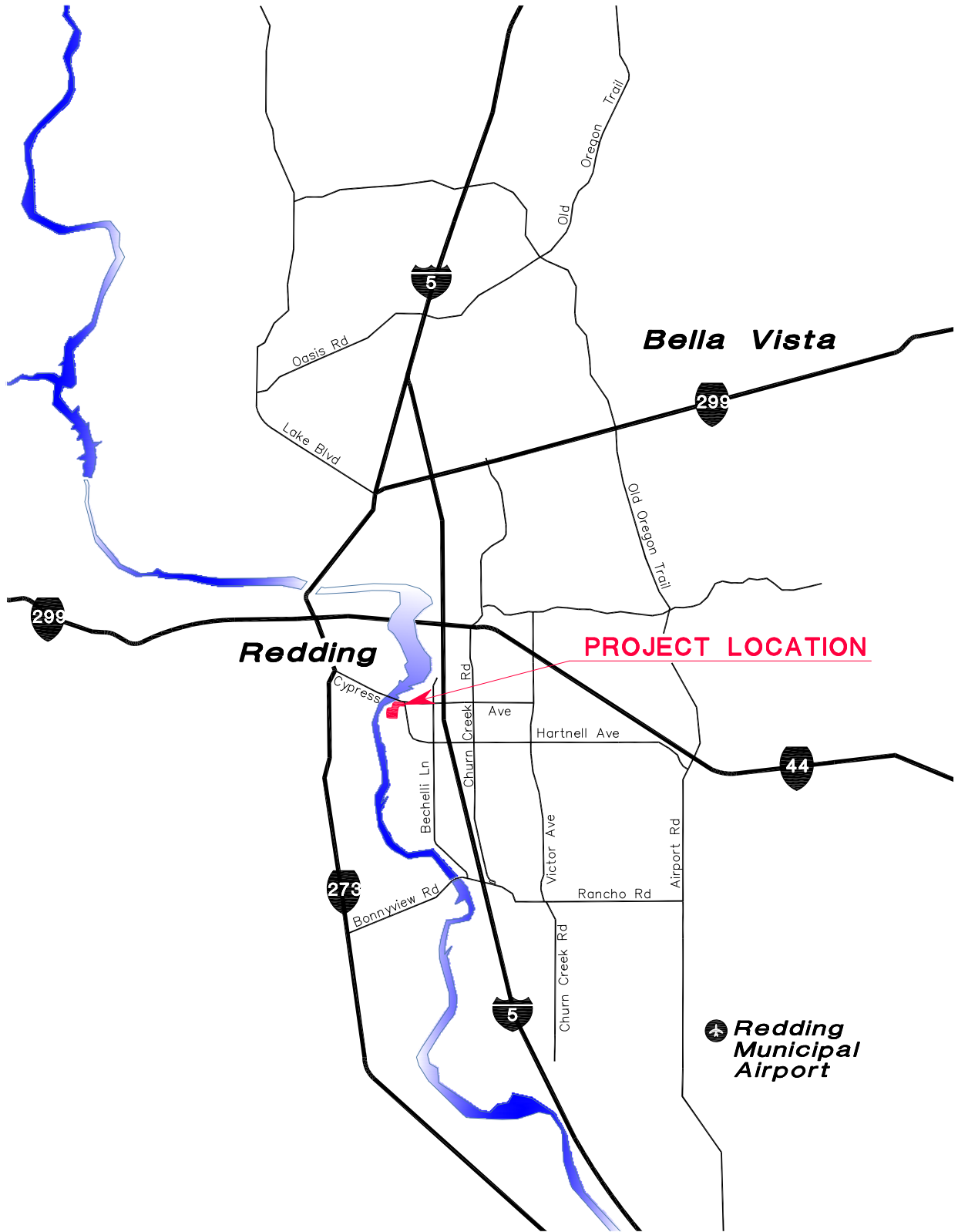

North State Pavilion

Figure 1

Project Location Map







Existing Conditions

The project site is within the local Sacramento River watershed area, and is approximately 27 percent impervious. The impervious areas include some old asphalt paving areas, concrete pad areas, and existing buildings. Overall the project site remains mostly undeveloped, with some scattered trees and other vegetation.

Portions of the existing site discharge as sheet flow towards the west, while other areas of the site are captured by existing storm drain pipes or existing channels, which then generally discharge towards the west and towards the Sacramento River. As shown in Figure 2, the Existing Drainage Area Map, there are six different drainage areas identified for the project. Drainage areas X-1 and X-6 are collected within existing City storm drain pipes, and conveyed south through the City's existing storm drain system. Drainage area X-4 is mostly collected within an existing storm drain pipe, conveyed to the west towards the Sacramento River, and discharges into an existing channel at the bottom of the existing slope, near the westerly limit of the site. Drainage areas X-2, X-3, and X-5 generally discharge through existing channels to the west, but may have some small amount of sheet flow that doesn't reach the existing channels. The existing 10-year, 25-year, and 100-year peak flows for the entire project site are 26 cfs, 31 cfs, and 46 cfs, respectively.

See Figure 2 for a map of the existing site and existing drainage areas.

LEGEND

-  IMPERVIOUS AREAS (BUILDINGS, SIDEWALKS, PARKING & DRIVE AISLES)
-  Exist STORM DRAIN (SIZE AS NOTED)
-  480 Exist CONTOUR
-  Exist 100-YEAR FLOODPLAIN LIMIT

NOTES

1. THE EXISTING 100-YEAR FLOODPLAIN FOR THE SACRAMENTO RIVER IS SHOWN PURSUANT TO THE EXISTING FEMA MAPPING. THIS INFORMATION IS NOT RELIABLE SINCE IT RELIES ON AN INCORRECT BACKWATER MODEL.

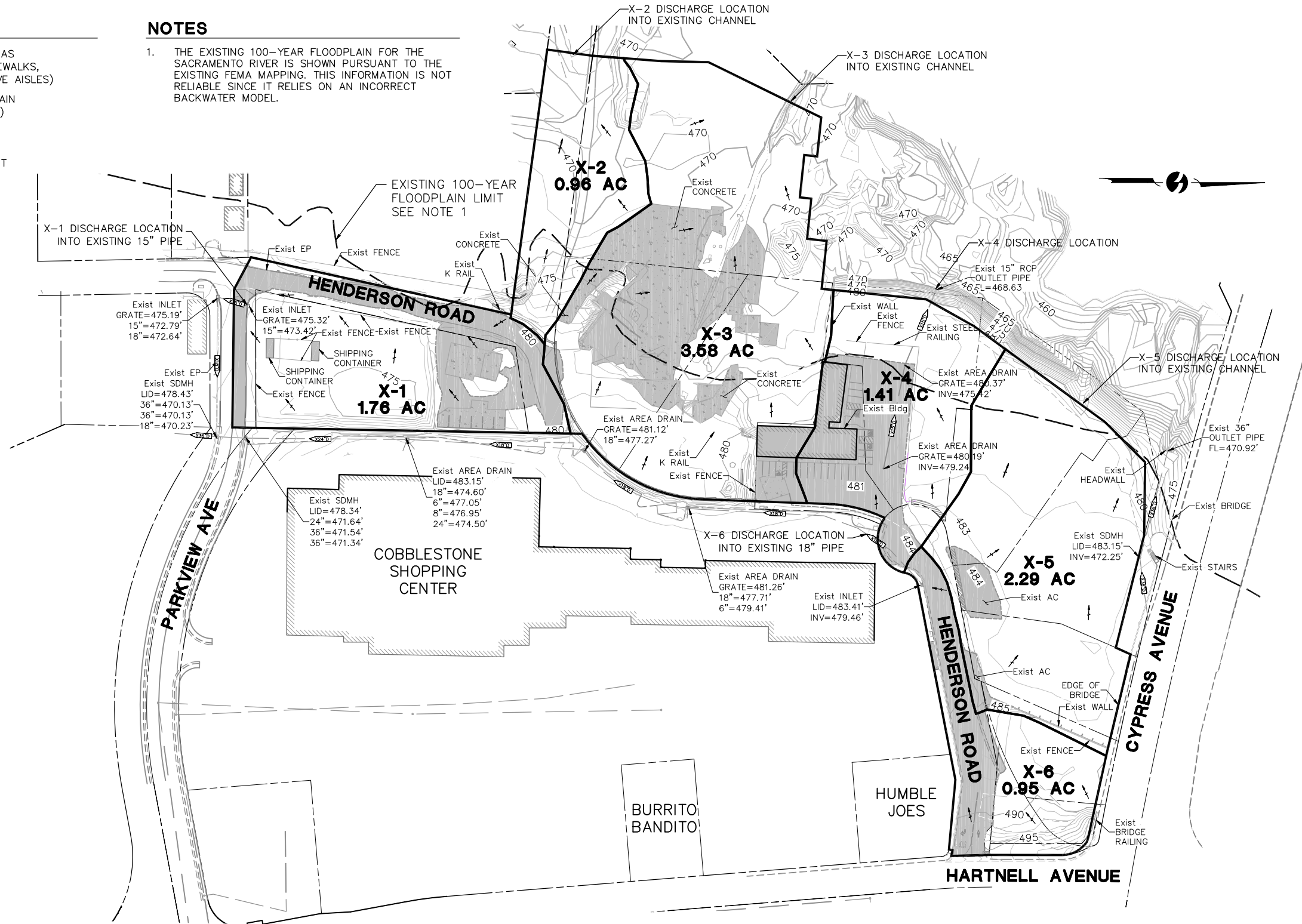

5/1/2017 12:31 PM J:\PRJ\1966\1966EX026.DWG

SCALE: 1"=150'
May 3, 2017

NORTH STATE PAVILION

EXISTING DRAINAGE AREA MAP



Redding, California



FIGURE 2

REDDING
330 Hartnell Ave, Suite B
Redding, CA 96002
(530) 242-1700
www.omnimeans.com

also in:
ROSEVILLE
VISALIA
WALNUT CREEK
SAN LUIS OBISPO & NAPA

Proposed Conditions

The proposed site of the Dignity Health - North State Pavilion project remains within the local Sacramento River watershed area, and is approximately 77 percent impervious. The impervious areas for the proposed condition include new buildings, streets, drive aisles, parking areas, patios, and sidewalks. Pervious areas located throughout the site will be landscaped with trees and shrubs.

As shown in Figure 3, the Proposed Drainage Area Map, there are also six different drainage areas identified for the project for the proposed conditions. Due to the high amount of earthwork and grading anticipated for the project, existing and proposed drainage areas do not represent the same areas. However, the overall project areas and discharge patterns for the existing and proposed conditions will be comparable.

Stormwater from drainage area P-1 will sheet flow to the west, into new landscaped bio-retention areas, near the westerly edge of area P-1. From the bio-retention areas, the stormwater will discharge through new storm drain pipes to the south, and connect to the existing 15" storm drain pipe at the south end of the project site.

Stormwater from drainage area P-2 will be collected into new storm drain pipes within the newly constructed Henderson Road (south) area, and will combine with the stormwater from drainage area P-1, before discharging to the south into the existing 15" storm drain pipe at the south end of the project site.

Portions of the stormwater from drainage area P-3 will be collected into the new storm drain system along the new Parkview Avenue to Henderson Open Space, while the northerly portion of drainage area P-3 will sheet flow across the new parking and drive aisle areas, and will flow into and out of flow-through planters installed for stormwater treatment. Eventually the stormwater from area P-3 will enter into the new storm drain system, and be routed to the west, through the new 24" storm drain pipe installed with the City of Redding's Henderson Open Space project.

Stormwater from drainage area P-4 will sheet flow across the new parking and drive aisle areas, and will flow into and out of flow-through planters installed for stormwater treatment. Eventually the stormwater from area P-4 will enter into the new storm drain system, flowing to the northwest, and will discharge to the west through the new 18" storm drain pipe installed with the City of Redding's Henderson Open Space project.

Stormwater from drainage area P-5 will also sheet flow across the new parking and drive aisle areas, and will flow into/out of flow-through planters, or will flow into landscaped bio-retention areas for stormwater treatment. Once through the stormwater treatment areas, the stormwater will enter into the new storm drain system, and will discharge to the north, into an existing 36" City storm drain pipe. The existing 36" City storm drain pipe then discharges stormwater into an existing channel, just northwest of the project, and immediately south of the Cypress Avenue bridge.









The proposed 10-year, 25-year, and 100-year peak flows for the entire project site are 44 cfs, 51 cfs, and 66 cfs, respectively.

See Figure 3 for a map of the proposed site and proposed drainage areas.

NOTES

1. THE EXISTING 100-YEAR FLOODPLAIN FOR THE SACRAMENTO RIVER IS SHOWN PURSUANT TO THE EXISTING FEMA MAPPING. THIS INFORMATION IS NOT RELIABLE SINCE IT RELIES ON AN INCORRECT BACKWATER MODEL.
2. PACIFIC HYDROLOGIC INC. (PHI) IS CURRENTLY COMPUTING THE CORRECT 100-YEAR FLOODPLAIN LIMITS AND WILL PREPARE LETTER OF MAP REVISION (LOMR-F) APPLICATION FOR SUBMITTAL TO FEMA BY THE CITY OF REDDING.
3. PHI IS CURRENTLY COMPUTING THE PROPOSED 100-YEAR FLOODPLAIN LIMITS (THAT WILL RESULT FROM THE PROPOSED PROJECT) AND WILL PROVIDE THE CALCULATIONS AND CONDITIONAL LETTER OF MAP REVISION (CLOMR-F) APPLICATION.
4. IT IS EXPECTED THAT THE CLOMR-F WILL DEMONSTRATE THAT THE PROPOSED PROJECT DOES NOT HAVE A MEASURABLE IMPACT ON THE FLOODPLAIN.

LEGEND

-  CITY PROJECTS (HENDERSON OPEN SPACE)
-  IMPERVIOUS AREAS (BUILDINGS, SIDEWALKS, PARKING & DRIVE AISLES)
-  PROPOSED STORM DRAIN
-  Exist STORM DRAIN (SIZE AS NOTED)
-  PROPOSED CONTOUR
-  480 Exist CONTOUR
-  Exist 100-YEAR FLOODPLAIN LIMIT
-  PROPOSED 100-YEAR FLOODPLAIN LIMIT

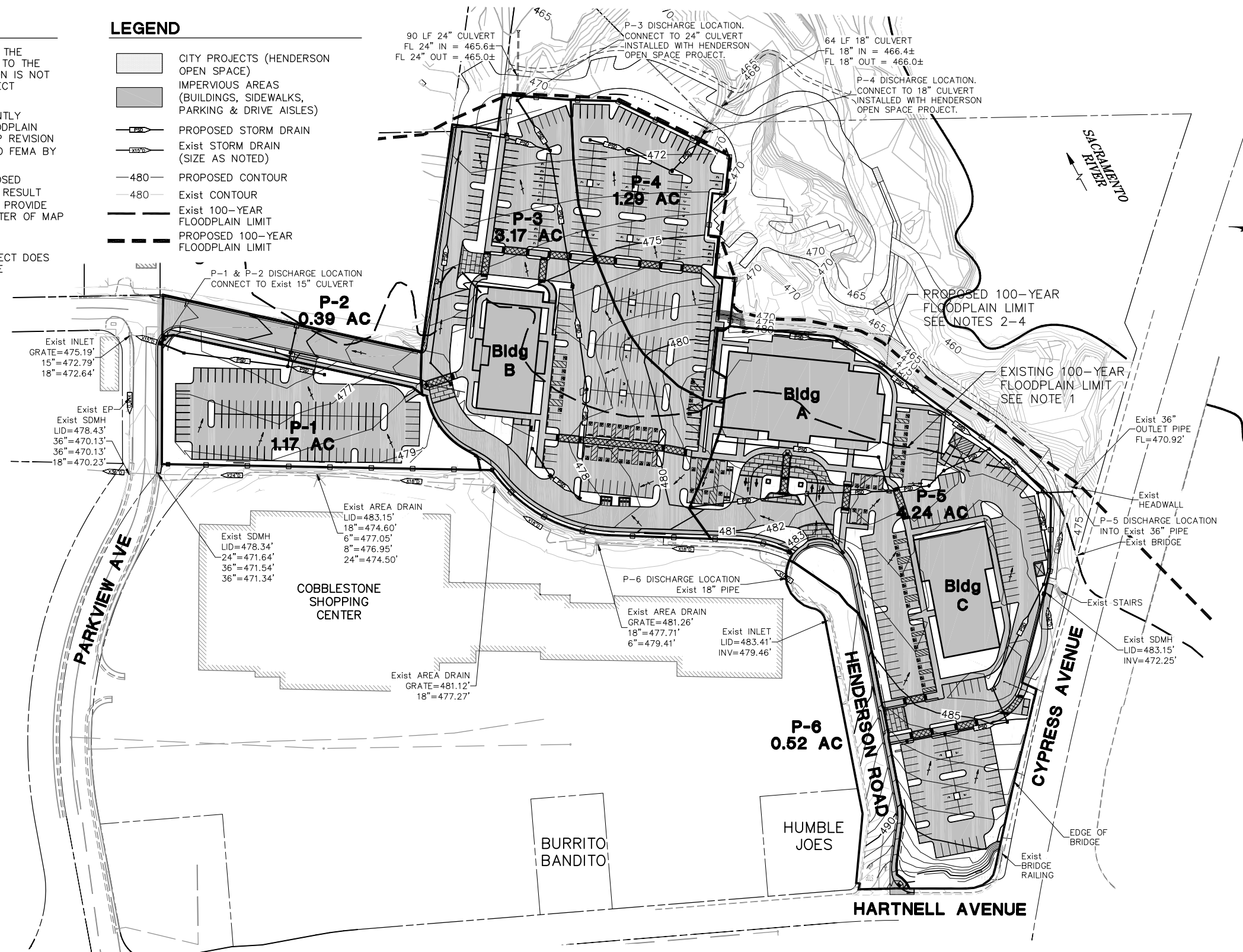

5/3/2017 11:30 AM J:\PRJ\1966\1966EX027.DWG

SCALE: 1"=150'
May 3, 2017

NORTH STATE PAVILION

PROPOSED DRAINAGE AREA MAP



Redding, California



FIGURE 3

REDDING
330 Hartnell Ave, Suite B
Redding, CA 96002
(530) 242-1700
www.omnimeans.com

also in:
ROSEVILLE
VISALIA
WALNUT CREEK
SAN LUIS OBISPO & NAPA

Hydrology

Methodology

The City of Redding HEC-1 Processor was used to generate peak flows for the existing and proposed 10-, 25- and 100-year storm events (24 hour duration). A site-specific HEC-1 Processor Model was created for each of the existing drainage areas and proposed drainage areas. The site-specific HEC-1 model for each of the drainage areas used the flow path component method, for both the existing and proposed conditions. Input values from the site-specific HEC-1 model were then used to generate peak flows for both the existing and proposed conditions. The Rational Method was also used to double check the HEC-1 outputs, with comparable results obtained for all areas.

The "Proposed Condition" for the site adds significant amounts of impervious area, which will increase the peak flows leaving the site and discharging towards the west and eventually into the Sacramento River. Although the project increases peak flows, the project discharges directly to government land and into the Sacramento River, so there are no downstream properties that would be adversely affected by the increased runoff. Therefore, this project is not subject to mitigation of increased peak flows.

Redding HEC-1 Processor

The City of Redding HEC-1 processor (January 2006) is written with XML format and the Microsoft Dot Net Framework. The hydrologic model uses the U.S. Army Corps of Engineers HEC-1 (version 4.1, June 1998) flood hydrograph model¹. The City of Redding HEC-1 Processor uses local rainfall data calibrated to local hydrologic conditions. See Appendix A for a printout of existing and proposed subbasin parameters used for the HEC-1 processor.

Drainage Area Nomenclature

The following drainage area prefixes correspond to different phases of the design:

- X: Existing Site (X-1 through X-6)
- P: Proposed Site (P-1 through P-6)

¹ Redding HEC-1 Processor Documentation, January 16, 2006; Preliminary Draft, Section 7.1.

Peak Flow Calculations

Existing Peak Flows

Existing drainage area X-1 is located near the southerly end of the site, and includes a portion of Parkview Avenue, Henderson Road, as well as other concrete and paved impervious areas. Drainage area X-1 is approximately 1.76 acres and 39% impervious. According to the City of Redding HEC-1 Processor, the existing 100-year peak flow for this drainage area is 8 cfs. Drainage area X-1 discharges through an existing 15" culvert to the south, and into the existing City storm drain system.

Existing drainage area X-2 is located in the southwesterly area of the site, and only includes undeveloped, pervious areas. Drainage area X-2 is approximately 0.96 acres and 0% impervious. According to the City of Redding HEC-1 Processor, the existing 100-year peak flow for this drainage area is 3 cfs. Drainage area X-2 discharges via sheet flow and an existing channel to the west, towards the Sacramento River.

Existing drainage area X-3 is located near the middle area of the site, and includes some various concrete and paved impervious areas. Drainage area X-3 is approximately 3.58 acres and 31% impervious. According to the City of Redding HEC-1 Processor, the existing 100-year peak flow for this drainage area is 15 cfs. Drainage area X-3 discharges via sheet flow and an existing channel to the west, towards the Sacramento River.

Existing drainage area X-4 is located near the middle area of the site, and includes a few small buildings, along with some various concrete and paved impervious areas. Drainage area X-4 is approximately 1.41 acres and 45% impervious. According to the City of Redding HEC-1 Processor, the existing 100-year peak flow for this drainage area is 7 cfs. Drainage area X-4 discharges via an existing culvert to the west, which discharges near the bottom of the slope on the westerly edge of the project site. A small amount of stormwater likely discharges to the west over the existing slope via sheet flow.

Existing drainage area X-5 is located near the northwesterly area of the site, and includes some small paved impervious areas. Drainage area X-5 is approximately 2.29 acres and 6% impervious. According to the City of Redding HEC-1 Processor, the existing 100-year peak flow for this drainage area is 8 cfs. Drainage area X-5 discharges via sheet flow and an existing channel to the northwest, towards the Sacramento River.

Existing drainage area X-6 is located near the northeasterly area of the site, and includes a portion of Henderson Road, as well as other concrete and paved impervious areas. Drainage area X-6 is approximately 0.95 acres and 41% impervious. According to the City of Redding HEC-1 Processor, the existing 100-year peak flow for this drainage area is 5 cfs. Drainage area X-6 discharges into an existing 18" culvert near the end of the Henderson Road cul-de-sac, and is conveyed to the south through the existing City storm drain system.

The overall 100-year peak flow for the project site in the existing conditions is 46 cfs.

See Table 1 for a summary of existing peak flows for each drainage area.

**TABLE 1
EXISTING PEAK FLOWS**

Drainage Area	Area (ac)	% Impervious	Q10 (cfs)	Q25 (cfs)	Q100 (cfs)
X-1	1.76	39%	4	5	8
X-2	0.96	0%	2	2	3
X-3	3.58	31%	8	10	15
X-4	1.41	45%	5	5	7
X-5	2.29	6%	4	5	8
X-6	0.95	41%	3	4	5
Total	10.95	27%	26	31	46

Proposed Peak Flows

Proposed drainage area P-1 is located near the southerly end of the site, and includes the new parking area between Henderson Road, Parkview Avenue, and the Cobblestone Shopping Center. The new parking area will include paved parking and drive aisles, as well as some concrete sidewalk and curbs. Drainage area P-1 is approximately 1.17 acres and 62% impervious. According to the City of Redding HEC-1 Processor, the proposed 100-year peak flow for this drainage area is 7 cfs. Drainage area P-1 discharges into bio-retention areas near the west edge of area P-1, then combines with the stormwater from proposed drainage area P-2 before discharging into the existing 15" storm drain pipe to the south, under Parkview Avenue.

Proposed drainage area P-2 is located in the southerly end of the site, and only includes the area of reconstructed Henderson Road, between Parkview Avenue and the Open Space Access Road. Drainage area P-2 is approximately 0.39 acres and 75% impervious. According to the City of Redding HEC-1 Processor, the proposed 100-year peak flow for this drainage area is 2 cfs. Drainage area P-2 combines with stormwater flows from area P-1, and discharges to the south through the existing 15" storm drain pipe under Parkview Avenue.

Proposed drainage area P-3 is located in the southwesterly area of the site, and includes one of the new buildings, along with the new Henderson Open Space Access Road and a portion of the lower parking area. Drainage area P-3 is approximately 3.17 acres and 73% impervious. According to the City of Redding HEC-1 Processor, the proposed 100-year peak flow for this drainage area is 20 cfs. Drainage area P-3 discharges to the west through the new 24" storm drain pipe installed with the City of Redding's Henderson Open Space project.

Proposed drainage area P-4 is located near the middle area of the site, and includes the northerly portion of the lower parking area. Drainage area P-4 is approximately 1.29 acres and 88% impervious. According to the City of Redding HEC-1 Processor, the proposed 100-year peak flow for this drainage area is 8 cfs. Drainage area P-4 flows into new storm drain pipes, and discharges to the west through the new 18" storm drain pipe installed with the City of Redding's Henderson Open Space project.

Proposed drainage area P-5 is located near the northwesterly area of the site, and includes the other two buildings to be constructed, as well as paved parking and drive aisles, and concrete sidewalks and curbs. Drainage area P-5 is approximately 4.24 acres and 73% impervious. According to the City of Redding HEC-1 Processor, the proposed 100-year peak flow for this drainage area is 26 cfs. Drainage area P-5 discharges via the new storm drain system, and

connects into the existing 36" City culvert to the north of the site, that discharges immediately northwest of the project site.

Proposed drainage area P-6 is located near the northeasterly area of the site, and includes only the City Right of Way for this northerly portion of Henderson Road. Drainage area P-6 is approximately 0.52 acres and 75% impervious. According to the City of Redding HEC-1 Processor, the proposed 100-year peak flow for this drainage area is 3 cfs. Drainage area P-6 discharges into an existing 18" culvert near the end of the Henderson Road cul-de-sac, and is conveyed to the south through the existing City storm drain system.

The overall 100-year peak flow for the project site in the proposed conditions is 66 cfs.

See Table 2 for a summary of the proposed peak flows for each drainage area.

**TABLE 2
PROPOSED PEAK FLOWS**

Drainage Area	Area (ac)	% Impervious	Q10 (cfs)	Q25 (cfs)	Q100 (cfs)
P-1	1.17	62%	4	5	7
P-2	0.39	75%	2	2	2
P-3	3.17	73%	13	15	20
P-4	1.29	88%	6	7	8
P-5	4.24	73%	17	20	26
P-6	0.52	75%	2	2	3
Total	10.78	77%	44	51	66

Analysis of Discharge Locations

The existing discharge locations for drainage areas X-1 and X-6 will continue to have flows discharged through the existing culverts, with similar peak flows. Peak flows for the discharge location for X-6 will be reduced slightly, since a portion of area X-6 will be transferred to the discharge location for area X-5.

In coordination with the City's Henderson Open Space Project, the existing discharge location for drainage area X-2 will continue to receive runoff from the site, but will have increased amounts discharging from this location due to available capacity. This area will see a significant increase in flows from the site because of the ability to discharge into the new 24" culvert through the City's Henderson Open Space project. Peak flows leaving the site at this location will be increased to approximately 20 cfs for the 100-year storm event.

The existing discharge location for drainage area X-3 will see a decrease in peak flows leaving the site, since a portion of the existing drainage area X-3 will be transferred to the new southerly discharge point for area P-3. Peak flows leaving the site at the discharge location for area X-3 will decrease from approximately 15 cfs to approximately 8 cfs. This discharge will connect from the projects new storm drain system, into the new 18" culvert installed with the City's Henderson Open Space projects, which will then discharge into an existing channel west of the City's project.

The existing discharge location for area X-4 will continue to receive small amounts of sheet flow over the slope, but the existing culvert will be eliminated, and flows at this location will be nearly eliminated over the slope and at the existing culvert outlet.

The existing discharge location for drainage area X-5 will also be modified significantly, diverting the flows in this area from sheet flow and existing channel discharge over the slope, to the new storm drain system, and then into the City's existing 36" culvert to the north of the project. It is anticipated that the 26 cfs added to the 36" culvert at this location will be accommodated with the existing 36" culvert, which then discharges immediately west of the connection with the new storm drain pipe.

Floodplain Analysis

According to the existing 100-year floodplain maps produced by FEMA, a portion of the site is within the existing 100-year floodplain. This includes some of the area in the upper level of the site near building A, as well as a good portion of the parking lot between buildings A and B, and to the west.

Pacific Hydrology Inc. (PHI) is currently computing the correct 100-year floodplain limits and will prepare a Letter of Map Revision (LOMR-F) Application for submittal to FEMA by the City of Redding. PHI is also computing the proposed 100-year floodplain limits that will result from the proposed project, and will provide the calculations and conditional Letter of Map Revision (CLOMR-F) Application. It is expected that the CLOMR-F will demonstrate that the proposed project does not have a measurable impact on the floodplain.

See Figure 3 of this report for the existing and proposed 100-year floodplain limits.

Post Construction Stormwater Management

A Draft Post Construction Stormwater Management Plan has been prepared for the project, and submitted with the initial Use Permit Application package. This plan incorporates bio-retention areas and flow-through planters throughout the site for treatment of post construction stormwater, as well as utilizes existing tree canopies and new tree planting for credits towards other impervious areas not fully treated by the treatment areas.

Appendix B includes the Stormwater Control Plan submitted as part of the Use Permit Application package.

Conclusion

While the proposed project alters existing drainage area hydrology and increases impervious surfaces, the increases in runoff for the project area will not adversely affect downstream properties, and therefore will not require mitigation to existing peak flow conditions. Meanwhile, flows to the City's existing storm drain system to the south of the project site will be reduced slightly, which may have a positive effect on downstream properties. In addition, the stormwater management plan will treat runoff in accordance with current MS-4 requirements.

Once the floodplain analysis by PHI is complete, it is anticipated that there will be no floodplain impacts for the project site, and additional information and calculations will be provided once the analysis is complete.

Appendix A

Subbasin Parameters from HEC-1 Model

Existing Subbasin Parameters (X-1 to X-3)

Subbasin:	X-1	X-2	X-3
Mean Subbasin Elevation (ft):	475	465	472
Subbasin Area (Sq. Mi.):	0.0028125	0.0015625	0.005625
Subbasin Area (acres):	1.8	1.0	3.6
Land Use:	Soil C:40% 1- Commercial/Highways/P arking Soil C:60% 17- Open Oak/Pine Woodland/Grassland	Soil C:100% 17- Open Oak/Pine Woodland/Grassland	Soil C:32% 1- Commercial/Highways/P arking Soil C:68% 17- Open Oak/Pine Woodland/Grassland
Pervious Curve Number:	79	73	77
Pervious Overland Length (ft):	200	100	200
Pervious Overland Slope (ft/ft):	0.010	0.020	0.020
Pervious Overland Roughness (overland n):	0.050	0.050	0.050
Pervious Area (%):	61	99	69
Impervious Overland Length (ft):	200	50	200
Impervious Overland Slope (ft/ft):	0.010	0.020	0.020
Pervious Overland Roughness (overland n):	0.020	0.020	0.020
Impervious Area (%):	N0	N0	N0
Ineffective Area (%):	N0	N0	N0
Collector #1(street or rivulet):	street	street	street
Length (ft):	80	100	140
Slope (ft/ft):	0.0100	0.0600	0.0150
Roughness (Mannings n):	0.020	0.050	0.050
Representative Area (acres):	1.80	1.00	3.00
Width (ft)/Diameter (in) :	1.0	1.0	1.0
Sideslopes (ft/ft-H/V):	20.0	40.0	40.0
Collector #2 (pipe or channel):	street	street	street

Length (ft):	200	200	180
Slope (ft/ft):	0.0050	0.0250	0.0500
Roughness (Mannings n):	0.030	0.030	0.030
Representative Area (acres):	1.80	1.00	3.00
Width (ft)/Diameter (in) :	1.0	1.0	1.0
Sideslopes (ft/ft-H/V):	20.0	40.0	20.0
Collector #3 (pipe or channel):	street	street	street
Length (ft):	218	83	265
Slope (ft/ft):	0.0050	0.0300	0.0030
Roughness (Mannings n):	0.030	0.030	0.030
Representative Area (acres):	1.80	1.00	3.60
Width (ft)/Diameter (in) :	1.0	1.0	2.0
Sideslopes (ft/ft-H/V):	20.0	10.0	10.0

Existing Subbasin Parameters (X-4 to X-6)

Subbasin:	X-4	X-5	X-6
Mean Subbasin Elevation (ft):	477	482	488
Subbasin Area (Sq. Mi.):	0.0021875	0.00359375	0.0015625
Subbasin Area (acres):	1.4	2.3	1.0
Land Use:	Soil C:47% 1- Commercial/Highways/Parking Soil C:53% 17- Open Oak/Pine Woodland/Grassland	Soil C:5% 1- Commercial/Highways/Parking Soil C:95% 17- Open Oak/Pine Woodland/Grassland	Soil C:43% 1- Commercial/Highways/Parking Soil C:57% 17- Open Oak/Pine Woodland/Grassland
Pervious Curve Number:	80	74	79
Pervious Overland Length (ft):	100	150	100
Pervious Overland Slope (ft/ft):	0.010	0.020	0.030
Pervious Overland Roughness (overland n):	0.050	0.050	0.050
Pervious Area (%):	55	94	59
Impervious Overland Length (ft):	100	100	100
Impervious Overland Slope (ft/ft):	0.010	0.020	0.030

Pervious Overland Roughness (overland n):	0.020	0.020	0.020
Impervious Area (%):	N0	N0	N0
Ineffective Area (%):	N0	N0	N0
Collector #1(street or rivulet):	street	street	street
Length (ft):	80	100	75
Slope (ft/ft):	0.0080	0.0200	0.1000
Roughness (Mannings n):	0.020	0.050	0.050
Representative Area (acres):	1.40	2.30	1.00
Width (ft)/Diameter (in) :	1.0	1.0	1.0
Sideslopes (ft/ft-H/V):	40.0	40.0	40.0
Collector #2 (pipe or channel):	street	street	street
Length (ft):	58	150	160
Slope (ft/ft):	0.0500	0.0200	0.0300
Roughness (Mannings n):	0.030	0.050	0.030
Representative Area (acres):	1.40	2.30	1.00
Width (ft)/Diameter (in) :	1.0	1.0	1.0
Sideslopes (ft/ft-H/V):	40.0	40.0	20.0
Collector #3 (pipe or channel):	street	street	street
Length (ft):	245	150	172
Slope (ft/ft):	0.0400	0.0200	0.0150
Roughness (Mannings n):	0.030	0.050	0.030
Representative Area (acres):	1.40	2.30	1.00
Width (ft)/Diameter (in) :	1.0	1.0	1.0
Sideslopes (ft/ft-H/V):	10.0	10.0	10.0

Proposed Subbasin Parameters (P-1 to P-3)

Subbasin:	P-1	P-2	P-3
Mean Subbasin Elevation (ft):	477	476	476
Subbasin Area (Sq. Mi.):	0.001875	0.000625	0.005
Subbasin Area (acres):	1.2	0.4	3.2
Land Use:	Soil C:65% 1- Commercial/Highways/Parking Soil C:35% 16- Urban Landscaping	Soil C:79% 1- Commercial/Highways/Parking Soil C:21% 16- Urban Landscaping	Soil C:77% 1- Commercial/Highways/Parking Soil C:23% 16- Urban Landscaping
Pervious Curve Number:	81	84	83
Pervious Overland Length (ft):	100	100	100
Pervious Overland Slope (ft/ft):	0.010	0.010	0.010
Pervious Overland Roughness (overland n):	0.050	0.050	0.050
Pervious Area (%):	38	25	27
Impervious Overland Length (ft):	100	100	100
Impervious Overland Slope (ft/ft):	0.010	0.020	0.010
Pervious Overland Roughness (overland n):	0.020	0.020	0.020
Impervious Area (%):	N0	N0	N0
Ineffective Area (%):	N0	N0	N0
Collector #1(street or rivulet):	street	street	street
Length (ft):	130	70	136
Slope (ft/ft):	0.0150	0.0100	0.0200
Roughness (Mannings n):	0.050	0.020	0.020
Representative Area (acres):	1.20	0.40	0.70
Width (ft)/Diameter (in) :	1.0	1.0	1.0
Sideslopes (ft/ft-H/V):	40.0	40.0	40.0
Collector #2 (pipe or channel):	street	street	street
Length (ft):	112	120	200

Slope (ft/ft):	0.0150	0.0100	0.0200
Roughness (Mannings n):	0.030	0.030	0.030
Representative Area (acres):	1.20	0.40	0.70
Width (ft)/Diameter (in) :	1.0	1.0	1.0
Sideslopes (ft/ft-H/V):	20.0	20.0	20.0
Collector #3 (pipe or channel):	street	street	street
Length (ft):	58	178	50
Slope (ft/ft):	0.0100	0.0100	0.0100
Roughness (Mannings n):	0.030	0.030	0.030
Representative Area (acres):	1.20	0.40	0.70
Width (ft)/Diameter (in) :	1.0	1.0	2.0
Sideslopes (ft/ft-H/V):	10.0	10.0	5.0

Proposed Subbasin Parameters (P-4 to P-6)

Subbasin:	P-4	P-5	P-6
Mean Subbasin Elevation (ft):	475	483	486
Subbasin Area (Sq. Mi.):	0.00203125	0.0065625	0.00078125
Subbasin Area (acres):	1.3	4.2	0.5
Land Use:	Soil C:93% 1- Commercial/Highways/P arking Soil C:7% 16- Urban Landscaping	Soil C:77% 1- Commercial/Highways/P arking Soil C:23% 16- Urban Landscaping	Soil C:79% 1- Commercial/Highways/P arking Soil C:21% 16- Urban Landscaping
Pervious Curve Number:	86	83	84
Pervious Overland Length (ft):	100	100	100
Pervious Overland Slope (ft/ft):	0.010	0.010	0.010
Pervious Overland Roughness (overland n):	0.050	0.050	0.050
Pervious Area (%):	12	27	25
Impervious Overland Length (ft):	100	100	100
Impervious Overland Slope (ft/ft):	0.010	0.010	0.010
Pervious Overland Roughness (overland n):	0.020	0.020	0.020

Impervious Area (%):	N0	N0	N0
Ineffective Area (%):	N0	N0	N0
Collector #1(street or rivulet):	street	street	street
Length (ft):	150	94	75
Slope (ft/ft):	0.0200	0.0100	0.0500
Roughness (Mannings n):	0.020	0.020	0.030
Representative Area (acres):	3.00	3.00	0.50
Width (ft)/Diameter (in) :	1.0	1.0	1.0
Sideslopes (ft/ft-H/V):	40.0	40.0	40.0
Collector #2 (pipe or channel):	street	street	street
Length (ft):	88	92	278
Slope (ft/ft):	0.0200	0.0100	0.0200
Roughness (Mannings n):	0.030	0.030	0.030
Representative Area (acres):	3.00	3.00	0.50
Width (ft)/Diameter (in) :	1.0	1.0	1.0
Sideslopes (ft/ft-H/V):	2.0	20.0	20.0
Collector #3 (pipe or channel):	street	street	street
Length (ft):	600	530	80
Slope (ft/ft):	0.0200	0.0200	0.0100
Roughness (Mannings n):	0.030	0.030	0.030
Representative Area (acres):	3.70	4.20	0.50
Width (ft)/Diameter (in) :	1.0	1.0	1.0
Sideslopes (ft/ft-H/V):	2.0	2.0	2.0

Appendix B

Project Stormwater Control Plan

4/28/2017 11:26 AM J:\PRJ\1966\1966UPSW001.DWG

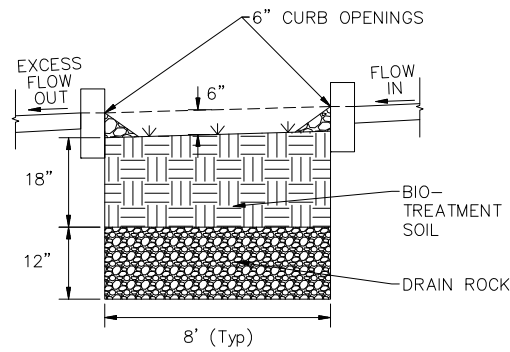

FLOW-THROUGH PLANTER DETAIL
NO SCALE

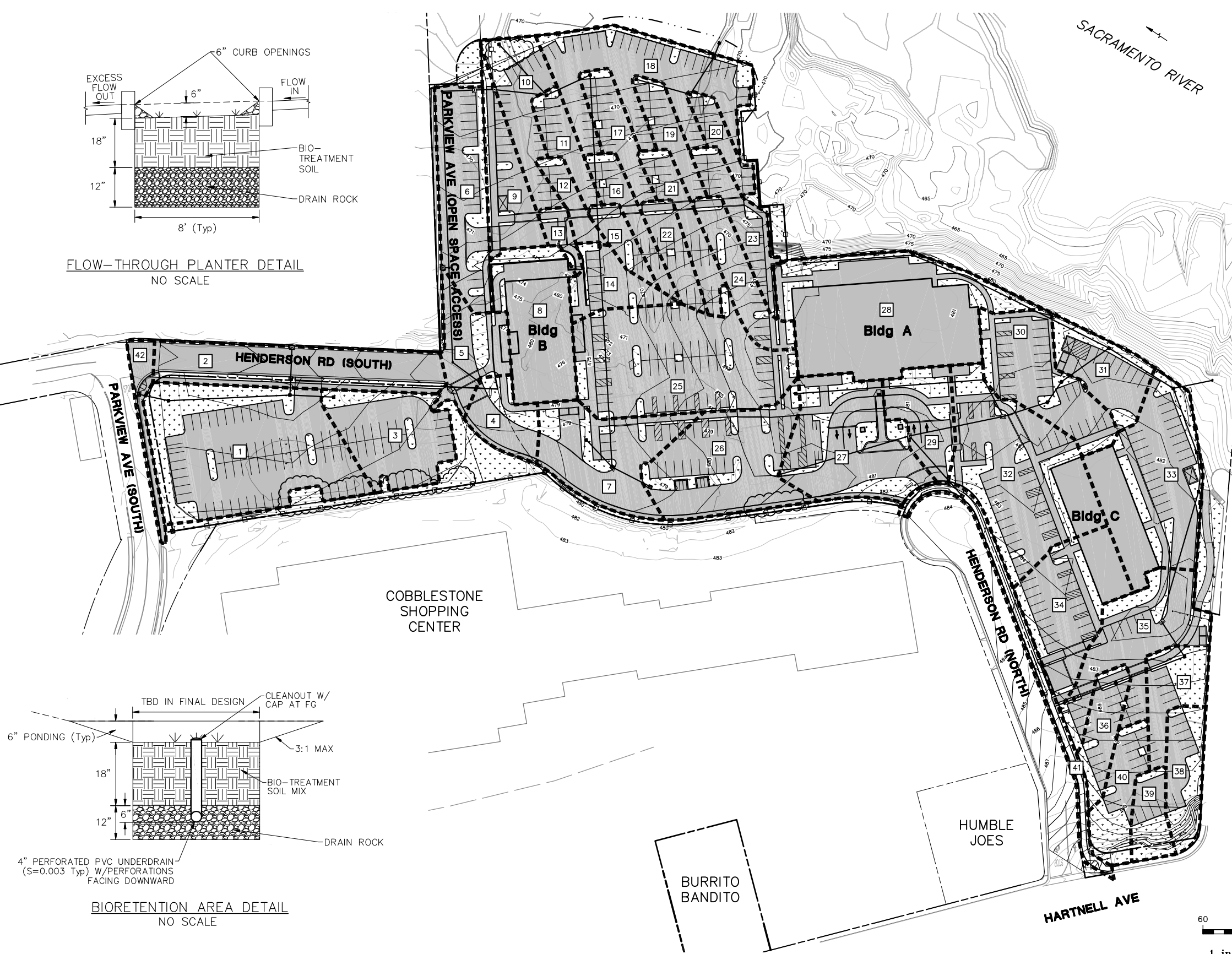

LEGEND

- IMPERVIOUS SURFACE (ALL AREAS ARE ASPHALT, CONCRETE, OR ROOF SURFACES)
- PERVIOUS LANDSCAPE SURFACE
- PROPOSED STORM DRAIN MANHOLE OR DRAINAGE INLET
- PROPOSED CONTOURS
- EXIST CONTOURS
- DRAINAGE MANAGEMENT AREA BOUNDARY
- DRAINAGE MANAGEMENT AREA (DMA) NUMBER
- EXISTING TREE COVER CREDIT AREA

POST-CONSTRUCTION BMP CALCULATIONS

DMA TYPE	TOTAL AREA (SF)	IMPERVIOUS AREA (SF)	BMP AREA (SF)
FLOW-THROUGH PLANTERS (DMA's 11-13, 15-17, 19-24, 36, & 39-40)	65,386	53,722	2,962
BIORETENTION AREAS (DMA's 1, 3, 4, 6-10, 14, 18, 25-35, 37-38)	335,804	269,899	14,810
OTHER (TREE CREDIT) (DMA's 2, 5, 41, & 42)	32,884	27,855	*40,075
TOTAL	434,074	351,476	*57,847

* - INCLUDES TREE CREDIT TO OFFSET FOR DMA's 2, 5, 41, & 42

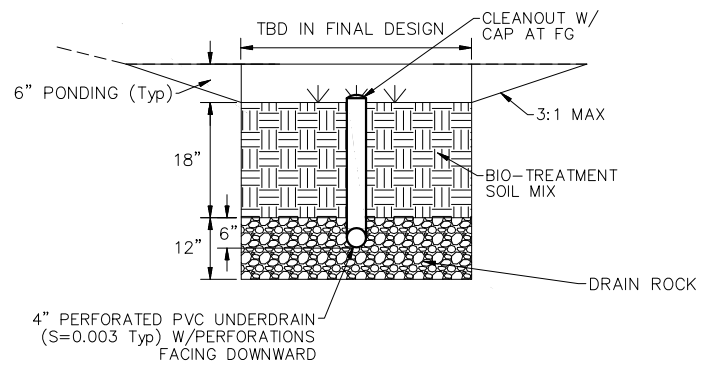

BIORETENTION AREA DETAIL
NO SCALE

E CYPRESS AVE

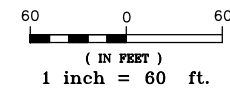

NOTE:
SEE PRELIMINARY USE PERMIT
STORMWATER
POST-CONSTRUCTION
SUBMITTAL PACKAGE FOR
ADDITIONAL INFORMATION.



April 28, 2017

NORTH STATE PAVILION

STORMWATER CONTROL PLAN



Redding, California



SHEET 11 OF 26

REDDING
330 Hartnell Ave, Suite B
Redding, CA 96002
(530) 242-1700
www.omnimeans.com

also in:
ROSEVILLE
VISALIA
WALNUT CREEK
SAN LUIS OBISPO & NAPA